

HP ProLiant DL580 Generation 5 Server User Guide



Part Number 453878-002
September 2008 (Second Edition)

© Copyright 2007 Hewlett-Packard Development Company, L.P.

The information contained herein is subject to change without notice. The only warranties for HP products and services are set forth in the express warranty statements accompanying such products and services. Nothing herein should be construed as constituting an additional warranty. HP shall not be liable for technical or editorial errors or omissions contained herein.

Microsoft, Windows, Windows Server 2003, and Windows NT are U.S. registered trademarks of Microsoft Corporation.

Intended audience

This document is for the person who installs, administers, and troubleshoots servers and storage systems. HP assumes you are qualified in the servicing of computer equipment and trained in recognizing hazards in products with hazardous energy levels.

Contents

Component identification	7
Front panel components	7
Front panel LEDs and buttons	8
Systems Insight Display	9
Rear panel components.....	10
Rear panel LEDs and buttons.....	11
Power supply LED.....	12
System board components.....	13
SPI board components	14
System maintenance switch.....	14
FBDIMM slot locations	15
SAS device numbers.....	16
SAS hard drive LEDs	17
SAS hard drive LED combinations.....	17
Battery pack LEDs.....	18
Fan locations	20
Operations	21
Power up the server	21
Power down the server.....	21
Extending the server from the rack.....	21
Removing the access panel.....	23
Accessing the Systems Insight Display	24
Removing the system battery	24
Setup	26
Optional installation services	26
Rack planning resources.....	26
Optimum environment.....	27
Space and airflow requirements	27
Temperature requirements.....	27
Power requirements	28
Electrical grounding requirements	28
Rack warnings	29
Identifying the contents of the server shipping carton.....	29
Installing hardware options.....	29
Setting up a tower model server	30
Installing the server into the rack.....	31
Powering up and configuring the server	31
Installing the operating system.....	32
Registering the server.....	32
Hardware options installation	33
Introduction	33
Processor options	33
Removing the processor memory module	33
Installing a processor	35

Memory options	39
Memory configurations	39
Advanced ECC memory	40
Online spare memory configuration	41
Mirrored memory configuration	42
Installing FBDIMMs	42
Installing optional memory expansion boards	43
Hot-plug SAS hard drive options	44
Installing a hot-plug SAS hard drive	44
Installing the drive cage	45
Tape drive	49
Redundant hot-plug power supply option	52
Battery-backed write cache	53
Fans	56
Expansion board options	57
Installing non-hot-plug expansion boards	57
Installing the PCI Express x8 3 Slot Option Card	58
Installing the PCI-X 3 Slot Option Card	59
Cabling	61
BBWC cabling	61
Hard drive cabling	62
Tape drive cabling	63
SATA DVD drive cabling	63
DVD drive cabling	63
Server software and configuration utilities	65
Configuration tools	65
SmartStart software	65
SmartStart Scripting Toolkit	65
HP ROM-Based Setup Utility	66
Using RBSU	66
Configuring online spare memory	66
Configuring mirrored memory	67
Auto-configuration process	67
Boot options	68
BIOS Serial Console	68
HP ProLiant Essentials Rapid Deployment Pack	68
Option ROM Configuration for Arrays	68
Array Configuration Utility	69
Re-entering the server serial number and product ID	69
Management tools	70
Automatic Server Recovery	70
ROMPaq utility	70
System Online ROM flash component utility	70
Remote Insight Lights-Out Edition II	70
Integrated Lights-Out 2 technology	71
StorageWorks library and tape tools	71
HP Systems Insight Manager	71
Management Agents	71
Redundant ROM support	72
USB support	72
Diagnostic tools	72
HP Insight Diagnostics	72

Integrated Management Log	73
Array Diagnostic Utility	73
Remote support and analysis tools	73
HP Instant Support Enterprise Edition	73
Keeping the system current	74
Drivers	74
ProLiant Support Packs	74
Operating system version support	74
Change control and proactive notification	74
Care Pack	74
Troubleshooting	75
Troubleshooting resources	75
Pre-diagnostic steps	75
Important safety information	75
Symptom information	77
Prepare the server for diagnosis	78
Loose connections	78
Service notifications	79
Troubleshooting flowcharts	79
Start diagnosis flowchart	79
General diagnosis flowchart	80
Server power-on problems flowchart	82
POST problems flowchart	85
OS boot problems flowchart	86
Server fault indications flowchart	88
POST error messages and beep codes	90
Regulatory compliance notices	91
Regulatory compliance identification numbers	91
Federal Communications Commission notice	91
FCC rating label	91
Class A equipment	91
Class B equipment	91
Declaration of conformity for products marked with the FCC logo, United States only	92
Modifications	92
Cables	92
Canadian notice (Avis Canadien)	93
European Union regulatory notice	93
Disposal of waste equipment by users in private households in the European Union	93
Japanese notice	94
BSMI notice	94
Korean notice	94
Laser compliance	95
Battery replacement notice	95
Taiwan battery recycling notice	96
Power cord statement for Japan	96
Acoustics statement for Germany (Geräuschemission)	96
Electrostatic discharge	97
Preventing electrostatic discharge	97
Grounding methods to prevent electrostatic discharge	97
Specifications	98
Environmental specifications	98

Server specifications	98
Technical support.....	100
Before you contact HP.....	100
HP contact information.....	100
Acronyms and abbreviations.....	101
Index.....	105

Component identification

Front panel components

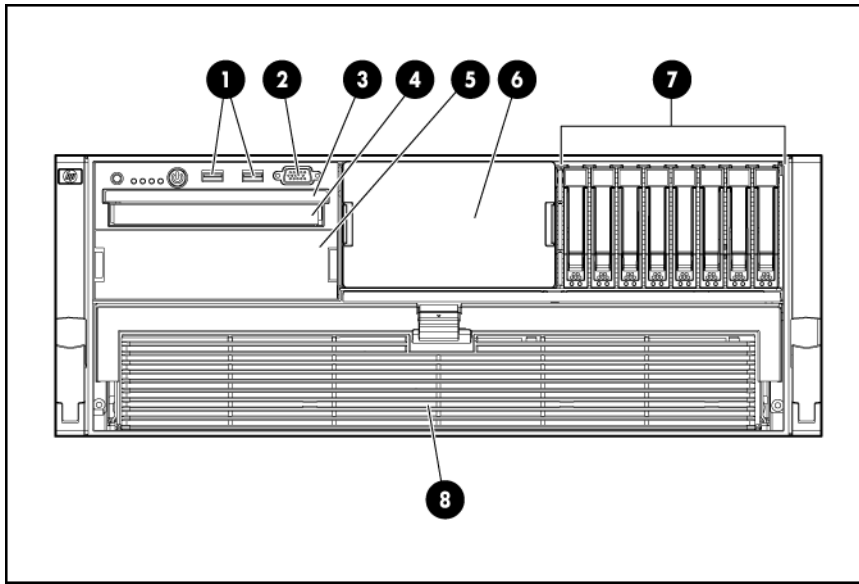

Item	Description
1	USB connectors
2	Video connector
3	Systems Insight Display
4	DVD drive bay
5	Optional tape drive or blank
6	Optional hard drive bay or blank
7	Hard drive bay
8	Processor memory module

Front panel LEDs and buttons

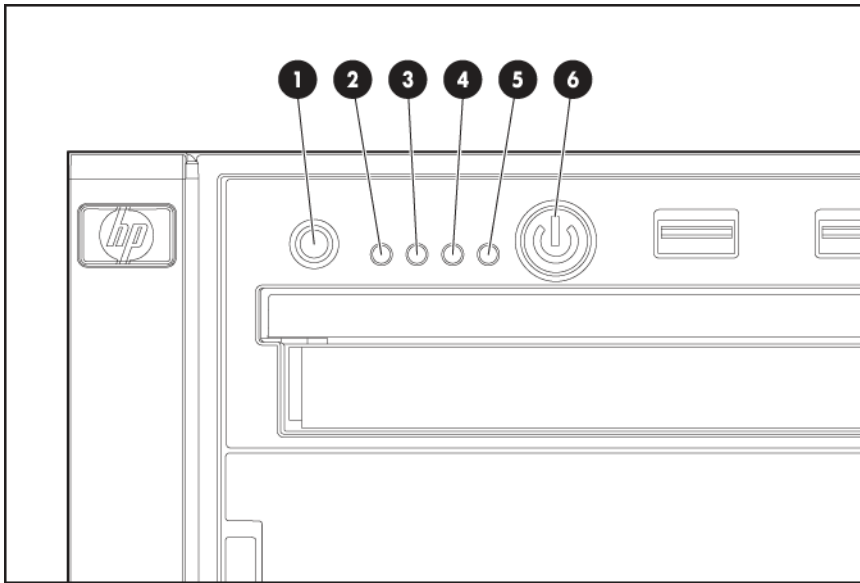

Item	Description	Status
1	UID switch and LED	Blue—Activated Blue (flashing)—Server being managed remotely Off—Deactivated
2	Internal system health LED	Green—Normal (system on) Amber (flashing)—Internal system health degraded Red (flashing)—Internal system health critical Off—Normal (system off)
3	External system health LED	Green—Normal (system on) Amber (flashing)—External system health degraded Red (flashing)—External system health critical Off—Normal (system off)
4	NIC 1 link/activity LED	Green—Linked to network Green (flashing)—Linked with activity on the network Off—No network connection
5	NIC 2 link/activity LED	Green—Linked to network Green (flashing)—Linked with activity on the network Off—No network connection
6	Power on/Standby button and LED	Amber—System has AC power and is in standby mode. Green—System has AC power and is turned on. Off—System has no AC power.

Systems Insight Display

The Systems Insight Display LEDs represent the server and component layout.

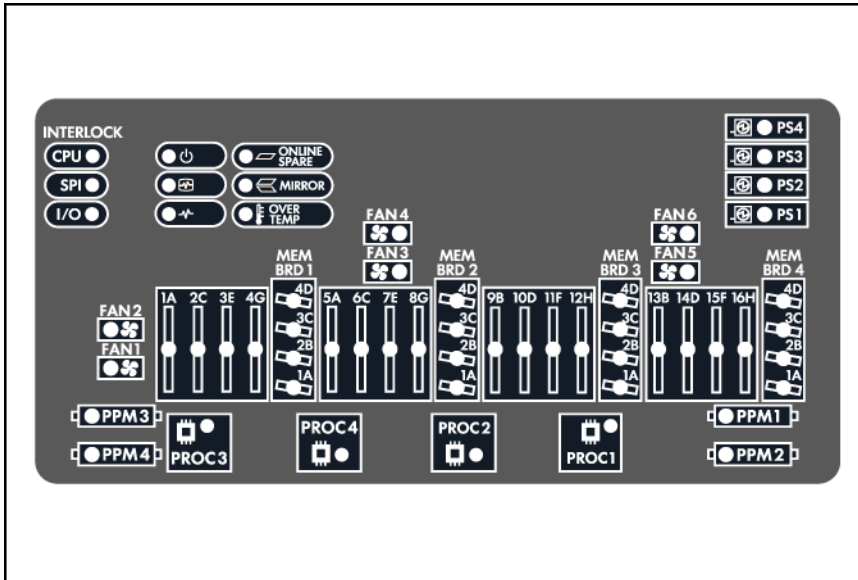

LED	Description
ONLINE SPARE	Off—No protection Green—Protection enabled Amber—Memory failure occurred Amber (flashing)—Memory configuration error
MIRROR	Off—No protection Green—Protection enabled Amber—Memory failure occurred Amber (flashing)—Memory configuration error
All other LEDs	Off—Normal Amber—Failed or missing component

Rear panel components

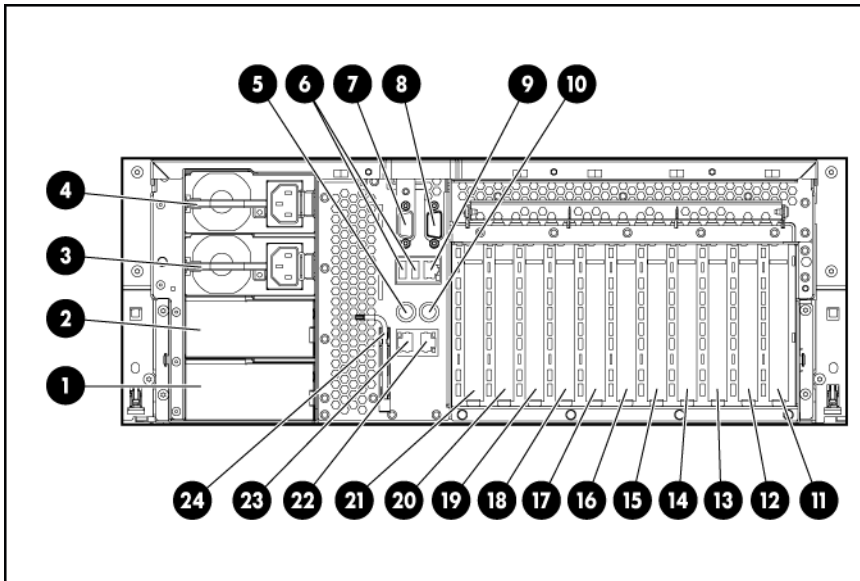

Item	Description	Item	Description
1	Power supply bay 4 (optional)	13	PCI-X non-hot-plug for PCI Express x8 non-hot-plug expansion slot 3 (optional)
2	Power supply bay 3 (optional)	14	PCI Express x8 non-hot-plug expansion slot 4
3	Power supply bay 2	15	PCI Express x8 non-hot-plug expansion slot 5
4	Power supply bay 1	16	PCI Express x8 non-hot-plug expansion slot 6
5	Keyboard connector	17	PCI Express x8 non-hot-plug expansion slot 7
6	USB connectors	18	PCI Express x4 non-hot-plug expansion slot 8
7	Video connector	19	PCI Express x4 non-hot-plug expansion slot 9
8	Serial connector	20	PCI Express x4 non-hot-plug expansion slot 10
9	iLO 2 NIC connector	21	PCI Express x4 non-hot-plug expansion slot 11
10	Mouse connector	22	NIC 2 connector
11	PCI-X non-hot-plug or PCI Express x8 non-hot-plug expansion slot 1 (optional)	23	NIC 1 connector
12	PCI-X non-hot-plug or PCI Express x8 non-hot-plug expansion slot 2 (optional)	24	Torx T-15 tool

Rear panel LEDs and buttons

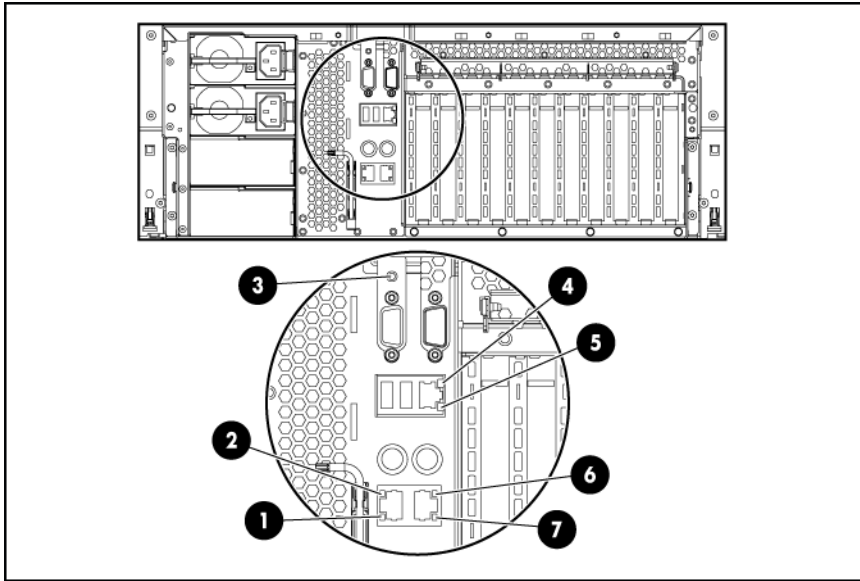

Item	Description	LED color	Status
1	NIC 2 Activity LED	Green	On or flashing—Network activity Off—No network activity
2	NIC 2 Link LED	Green	On—Linked to network Off—Not linked to network
3	UID	Blue	On—Front UID button activated Off—Normal
4	iLO 2 NIC Activity LED	Green	On or flashing—Network activity Off—No network activity
5	iLO 2 NIC Link LED	Green	On—Linked to network Off—Not linked to network
6	NIC 1 Link LED	Green	On—Linked to network Off—Not linked to network
7	NIC 1 Activity LED	Green	On or flashing—Network activity Off—No network activity

Power supply LED

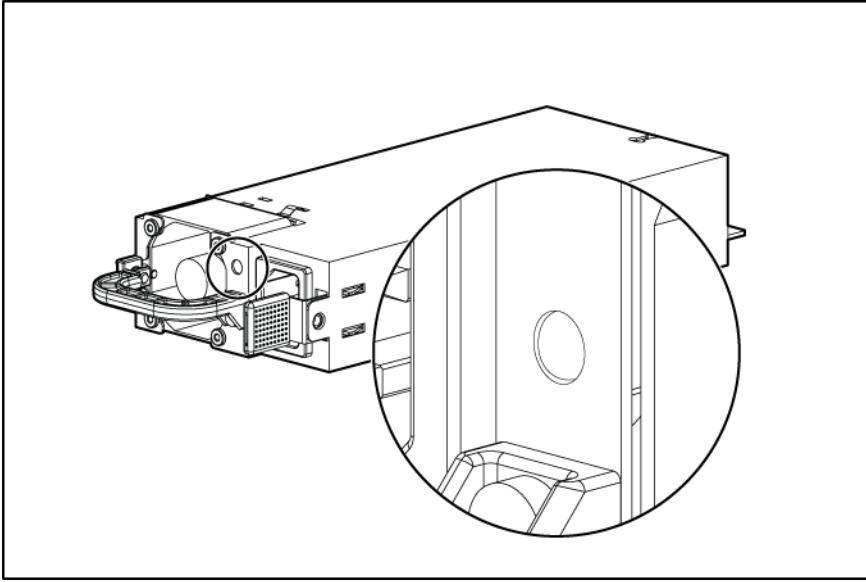

Power LED (green)	Failure LED (amber)	Status
Off	Off	No AC power to power supply units
On	Off	AC present. Standby output on. Power supply DC output on and OK
Off	On	Power supply failure (includes overvoltage and overtemperature)

System board components

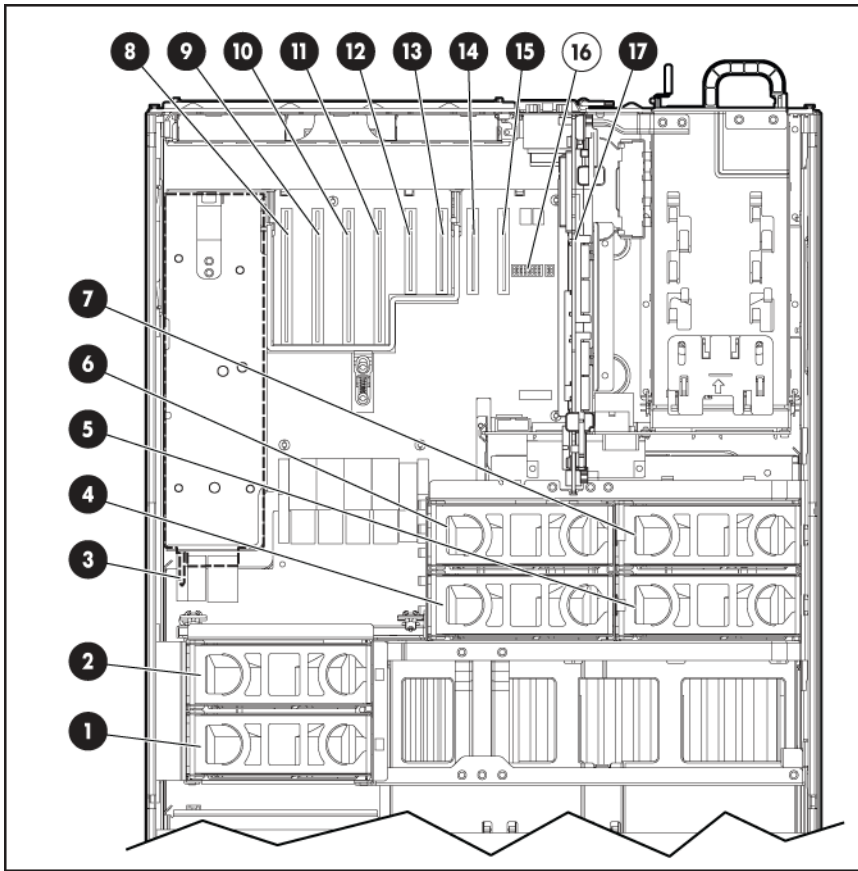

Item	Description
1	Fan 1
2	Fan 2
3	Connector for: <ul style="list-style-type: none"> • PCI Express x8 3 Slot Option Card (optional) • PCI-X 3 Slot Option Card (optional)
4	Fan 3
5	Fan 5
6	Fan 4
7	Fan 6
8	PCI Express x8 non-hot-plug expansion slot 4
9	PCI Express x8 non-hot-plug expansion slot 5
10	PCI Express x8 non-hot-plug expansion slot 6
11	PCI Express x8 non-hot-plug expansion slot 7
12	PCI Express x4 non-hot-plug expansion slot 8
13	PCI Express x4 non-hot-plug expansion slot 9
14	PCI Express x4 non-hot-plug expansion slot 10
15	PCI Express x4 non-hot-plug expansion slot 11

Item	Description
16	System maintenance switch
17	SPI board

SPI board components

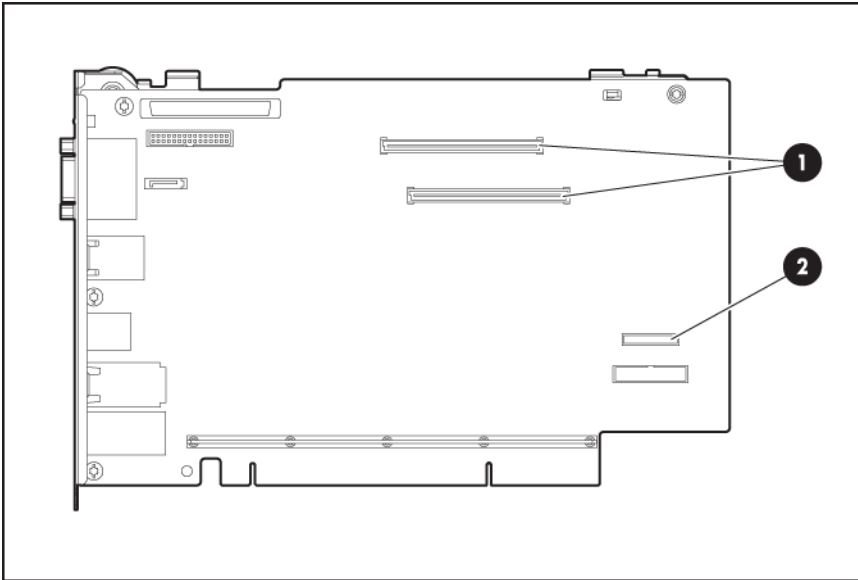

Item	Description
1	BBWC cache module connectors
2	Battery

System maintenance switch

The system maintenance switch (SW1) is an eight-position switch that is used for system configuration. The default position for all eight positions is Off.

Position	Description	Function
S1	iLO 2 Security	Off = iLO 2 security is enabled On = iLO 2 security is disabled
S2	Configuration lock	Off = System configuration can be changed On = System configuration is locked
S3	Reserved	Reserved
S4	Reserved	Reserved
S5	Password protection override	Off = No function On = Clears power-on password and administrator password

Position	Description	Function
S6	Invalidate configuration	Off = Normal On = Clears NVRAM
S7	Reserved	Reserved
S8	Reserved	Reserved

FBDIMM slot locations

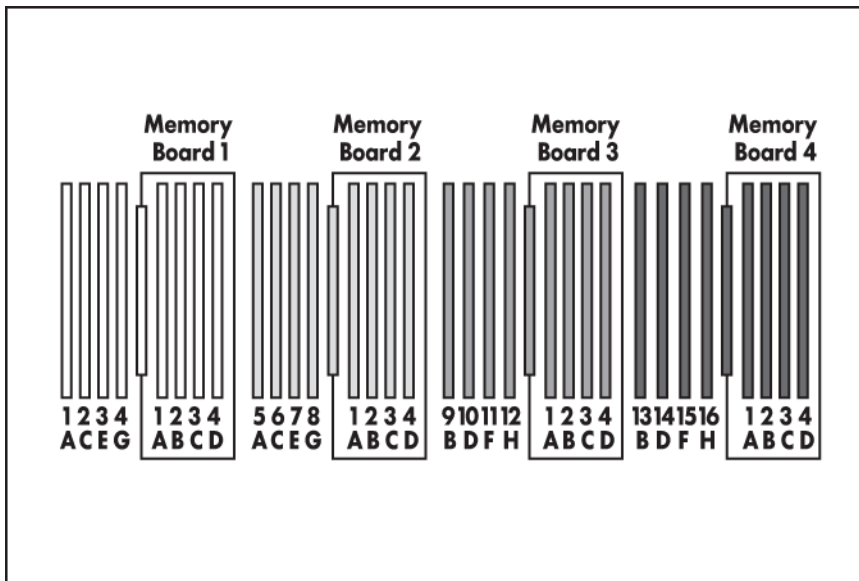

The server contains 16 FBDIMM slots on the processor-memory board, which are numbered sequentially from 1 to 16. The paired banks are identified by the letters A through H.

Four FBDIMM slots located on each optional memory board are numbered from 1 to 4. The paired banks are identified by the letters A through D.

SAS device numbers

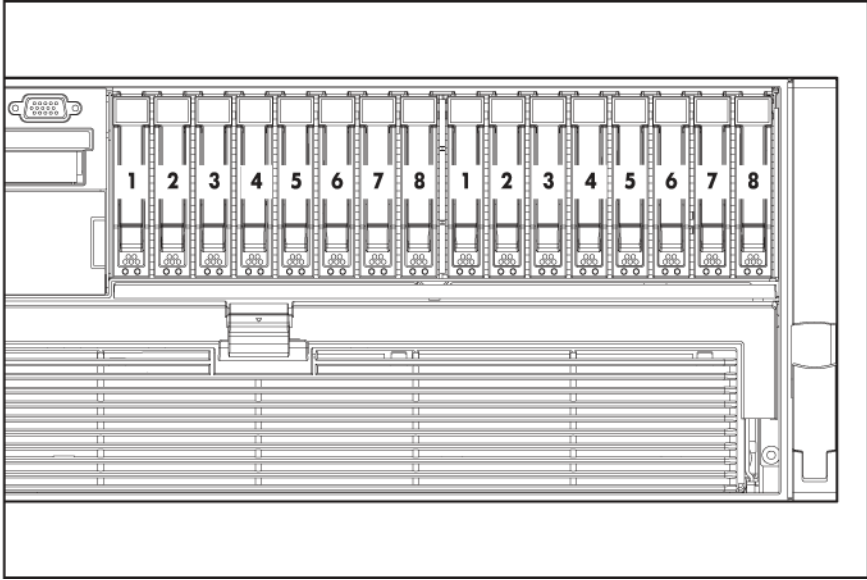
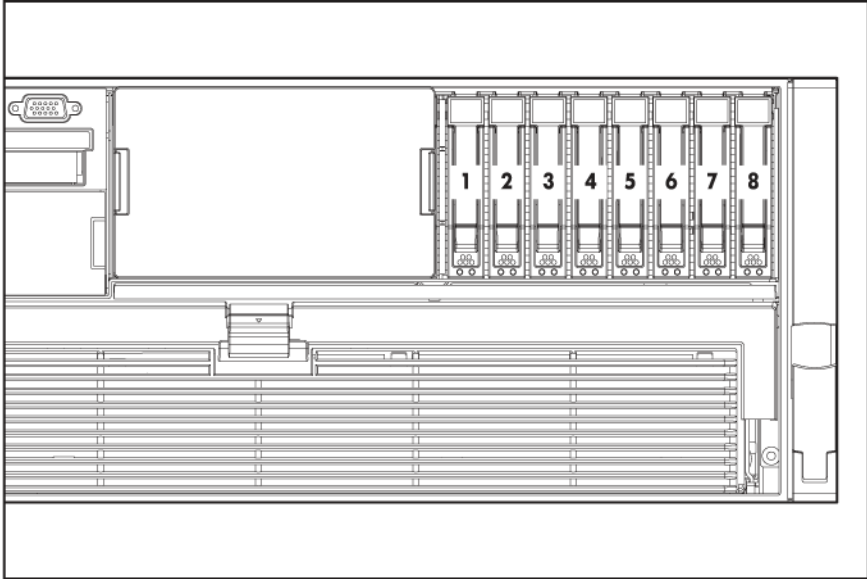

SAS hard drive LEDs

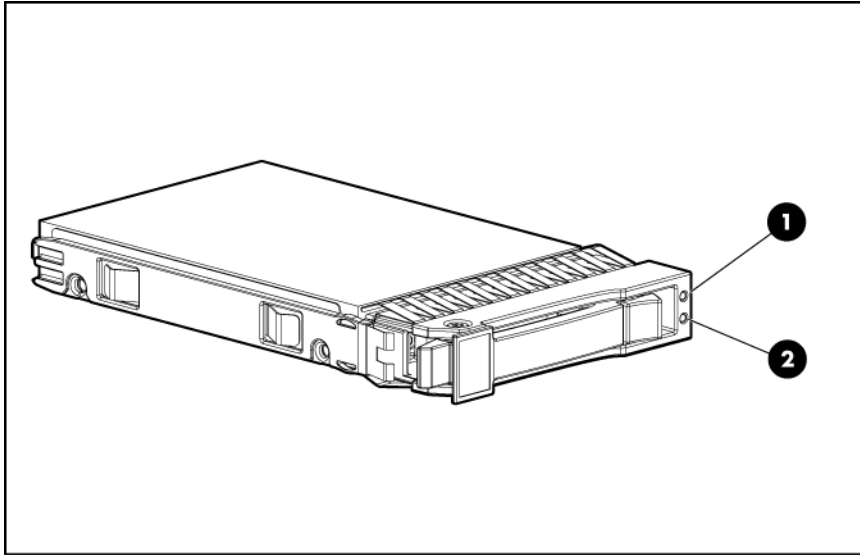

Item	Description
1	Fault/UID LED (amber/blue)
2	Online LED (green)

SAS hard drive LED combinations

Online/activity LED (green)	Fault/UID LED (amber/blue)	Interpretation
On, off, or flashing	Alternating amber and blue	The drive has failed, or a predictive failure alert has been received for this drive; it also has been selected by a management application.
On, off, or flashing	Steadily blue	The drive is operating normally, and it has been selected by a management application.
On	Amber, flashing regularly (1 Hz)	A predictive failure alert has been received for this drive. Replace the drive as soon as possible.
On	Off	The drive is online, but it is not active currently.
Flashing regularly (1 Hz)	Amber, flashing regularly (1 Hz)	Do not remove the drive. Removing a drive may terminate the current operation and cause data loss. The drive is part of an array that is undergoing capacity expansion or stripe migration, but a predictive failure alert has been received for this drive. To minimize the risk of data loss, do not replace the drive until the expansion or migration is complete.
Flashing regularly (1 Hz)	Off	Do not remove the drive. Removing a drive may terminate the current operation and cause data loss. The drive is rebuilding, or it is part of an array that is undergoing capacity expansion or stripe migration.
Flashing irregularly	Amber, flashing regularly (1 Hz)	The drive is active, but a predictive failure alert has been received for this drive. Replace the drive as soon as possible.

Online/activity LED (green)	Fault/UID LED (amber/blue)	Interpretation
Flashing irregularly	Off	The drive is active, and it is operating normally.
Off	Steadily amber	A critical fault condition has been identified for this drive, and the controller has placed it offline. Replace the drive as soon as possible.
Off	Amber, flashing regularly (1 Hz)	A predictive failure alert has been received for this drive. Replace the drive as soon as possible.
Off	Off	The drive is offline, a spare, or not configured as part of an array.

Battery pack LEDs

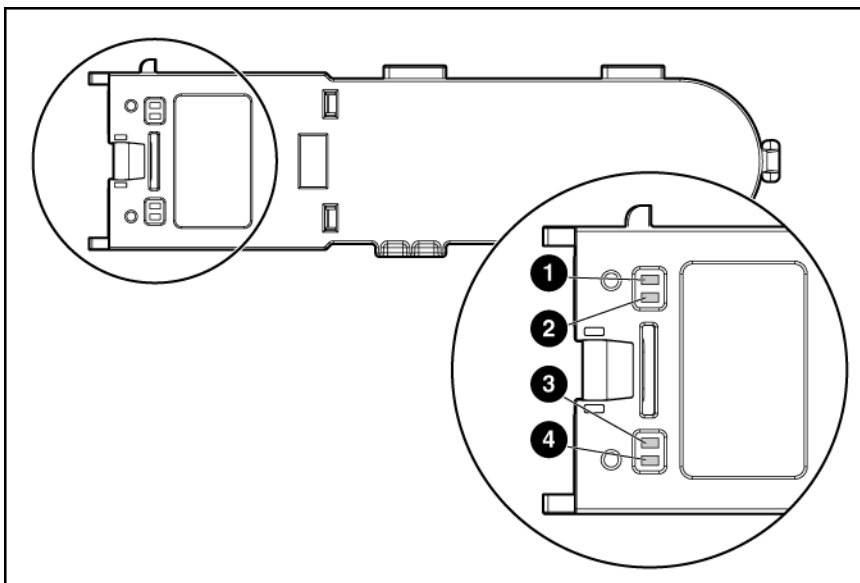

Item ID	Color	Description
1	Green	System Power LED. This LED glows steadily when the system is powered up and 12 V system power is available. This power supply is used to maintain the battery charge and provide supplementary power to the cache microcontroller.
2	Green	Auxiliary Power LED. This LED glows steadily when 3.3V auxiliary voltage is detected. The auxiliary voltage is used to preserve BBWC data and is available any time that the system power cords are connected to a power supply.
3	Amber	Battery Health LED. To interpret the illumination patterns of this LED, see the following table.
4	Green	BBWC Status LED. To interpret the illumination patterns of this LED, see the following table.

LED3 pattern	LED4 pattern	Interpretation
—	One blink every two seconds	<p>The system is powered down, and the cache contains data that has not yet been written to the drives. Restore system power as soon as possible to prevent data loss.</p> <p>Data preservation time is extended any time that 3.3 V auxiliary power is available, as indicated by LED 2. In the absence of auxiliary power, battery power alone preserves the data. A fully-charged battery can normally preserve data for at least two days.</p> <p>The battery lifetime also depends on the cache module size. For further information, refer to the controller QuickSpecs on the HP website (http://www.hp.com).</p>
—	Double blink, then pause	The cache microcontroller is waiting for the host controller to communicate.
—	One blink per second	The battery pack is below the minimum charge level and is being charged. Features that require a battery (such as write cache, capacity expansion, stripe size migration, and RAID migration) are temporarily unavailable until charging is complete. The recharge process takes between 15 minutes and two hours, depending on the initial capacity of the battery.
—	Steady glow	The battery pack is fully charged, and posted write data is stored in the cache.
—	Off	The battery pack is fully charged, and there is no posted write data in the cache.
One blink per second	One blink per second	An alternating green and amber blink pattern indicates that the cache microcontroller is executing from within its boot loader and receiving new flash code from the host controller.
Steady glow	—	There is a short circuit across the battery terminals or within the battery pack. BBWC features are disabled until the battery pack is replaced. The life expectancy of a battery pack is typically more than three years.
One blink per second	—	There is an open circuit across the battery terminals or within the battery pack. BBWC features are disabled until the battery pack is replaced. The life expectancy of a battery pack is typically more than three years.

Fan locations

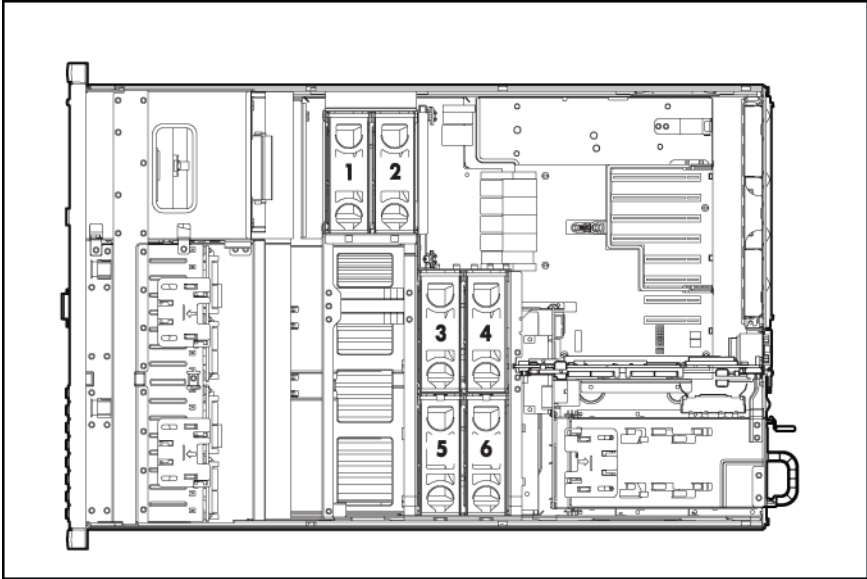

Operations

Power up the server

To power up the server, press the Power On/Standby button.

Power down the server



WARNING: To reduce the risk of personal injury, electric shock, or damage to the equipment, remove the power cord to remove power from the server. The front panel Power On/Standby button does not completely shut off system power. Portions of the power supply and some internal circuitry remain active until AC power is removed.



IMPORTANT: If installing a hot-plug device, it is not necessary to power down the server.

1. Back up the server data.
2. Shut down the operating system as directed by the operating system documentation.

NOTE: If the operating system automatically places the server in Standby mode, omit the next step.

3. Press the Power On/Standby button to place the server in Standby mode. When the server activates Standby power mode, the system power LED changes to amber.



IMPORTANT: Pressing the UID button illuminates the blue UID LEDs on the front and rear panels. In a rack environment, this feature facilitates locating a server when moving between the front and rear of the rack.

4. Disconnect the power cords.

The system is now without power.

Extending the server from the rack

The design of the server enables you to access several components through the front of the server. You do not need to extend the server from the rack to install or access the following components:

- Processors
- PPMs
- Memory
- Processor memory module
- DVD drive

- Hard drives
- Systems Insight Display

⚠ WARNING: To reduce the risk of personal injury or equipment damage, be sure that the rack is adequately stabilized before extending a component from the rack.

⚠ WARNING: To reduce the risk of personal injury, be careful when pressing the server rail-release latches and sliding the server into the rack. The sliding rails could pinch your fingers.

To extend the server from the rack:

1. Pull down the quick-release levers on each side of the server to release the server from the rack.
2. Extend the server on the rack rails until the server rail-release latches engage.

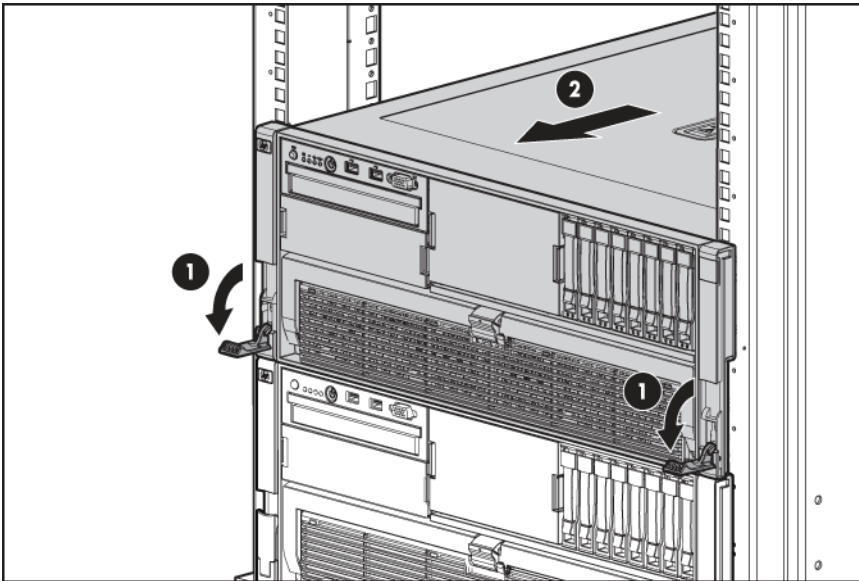

3. After performing the installation or maintenance procedure, slide the server into the rack by pressing the server rail-release latches.

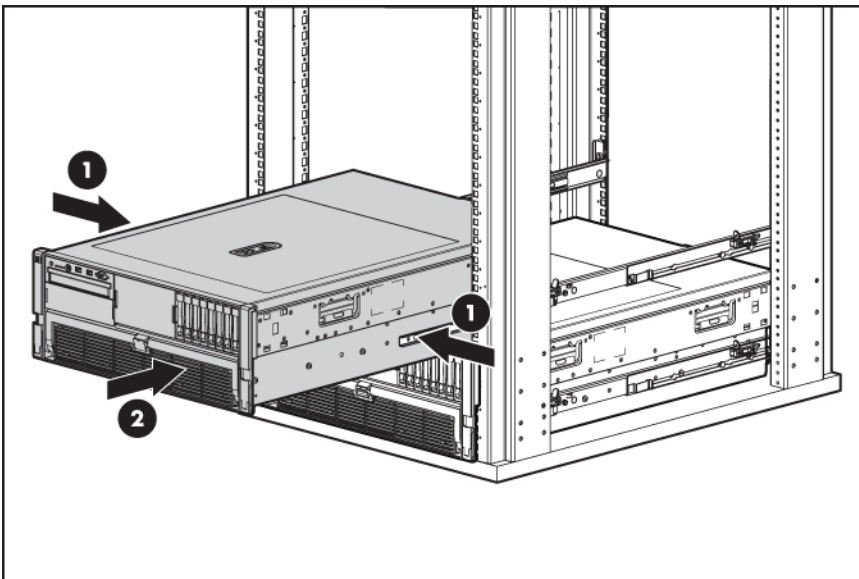

Removing the access panel

⚠ WARNING: To reduce the risk of personal injury from hot surfaces, allow the drives and the internal system components to cool before touching them.

⚠ CAUTION: Do not operate the server for long periods with the access panel open or removed. Operating the server in this manner results in improper airflow and improper cooling that can lead to thermal damage.

1. Extend the server from the rack, if applicable ("[Extending the server from the rack](#)" on page 21).
2. Unlock the latch using a T-15 Torx screwdriver.

NOTE: The T-15 Torx screwdriver is shipped with the server and can be located on the rear panel ("[Rear panel components](#)" on page 10).

3. Lift up on the hood latch, and remove the access panel.

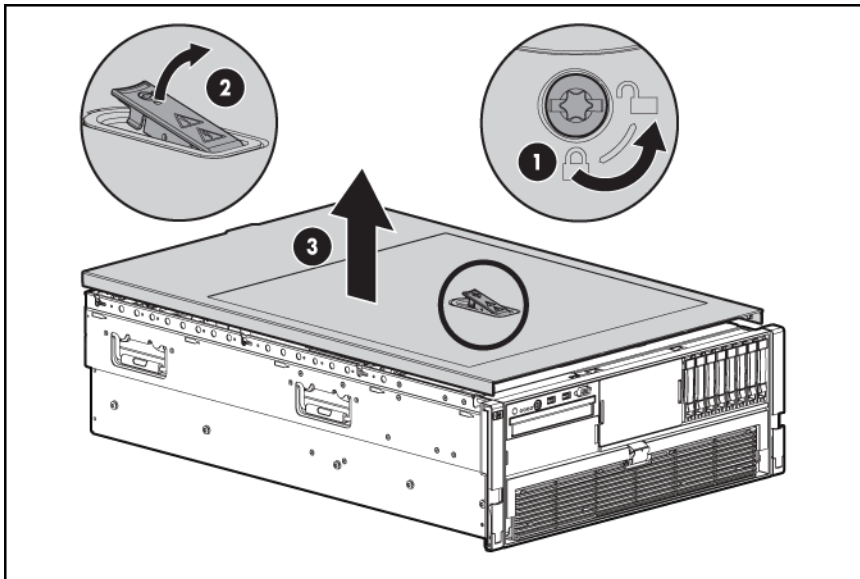

4. After installing hardware options, replace the access panel. Be sure that the panel is securely locked into place before powering up the server.

Accessing the Systems Insight Display

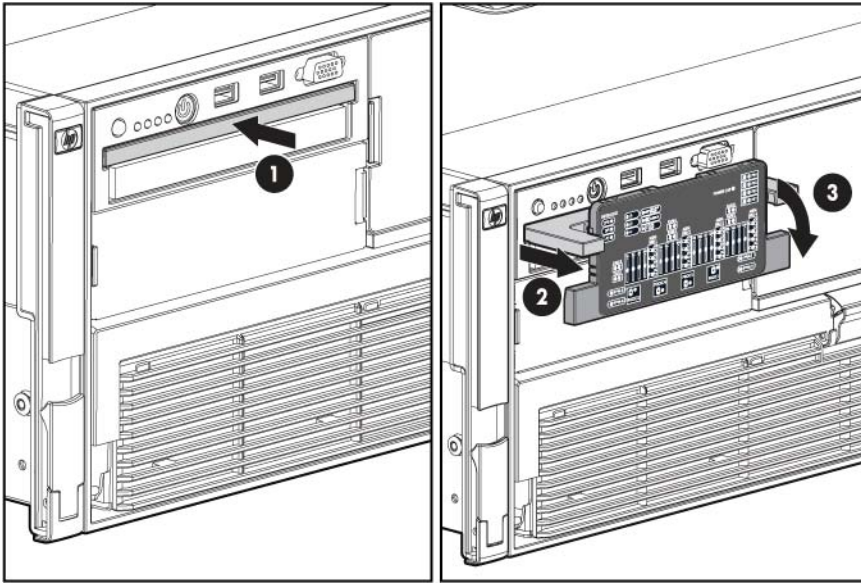

To access the Systems Insight Display:

1. Press and release the panel.
2. After the display fully ejects, rotate the display downward to view the LEDs.

Removing the system battery

If the server no longer automatically displays the correct date and time, you may need to replace the battery that provides power to the real-time clock. Under normal use, battery life is 5 to 10 years.



WARNING: The computer contains an internal lithium manganese dioxide, a vanadium pentoxide, or an alkaline battery pack. A risk of fire and burns exists if the battery pack is not properly handled. To reduce the risk of personal injury:

- Do not attempt to recharge the battery.
- Do not expose the battery to temperatures higher than 60°C (140°F).
- Do not disassemble, crush, puncture, short external contacts, or dispose of in fire or water.
- Replace only with the spare designated for this product.

To remove the battery:

1. Power down the server (on page 21).
2. Extend or remove the server from the rack ("[Extending the server from the rack](#)" on page 21).
3. Remove the access panel ("[Removing the access panel](#)" on page 23).

4. If the bracket is installed, remove the bracket.

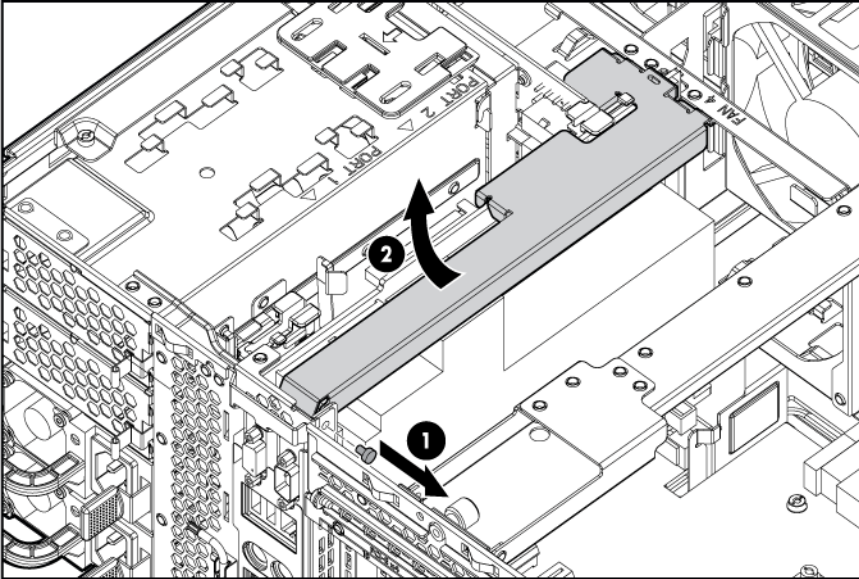

5. Locate the battery ("SPI board components" on page 14).
6. Remove the battery.

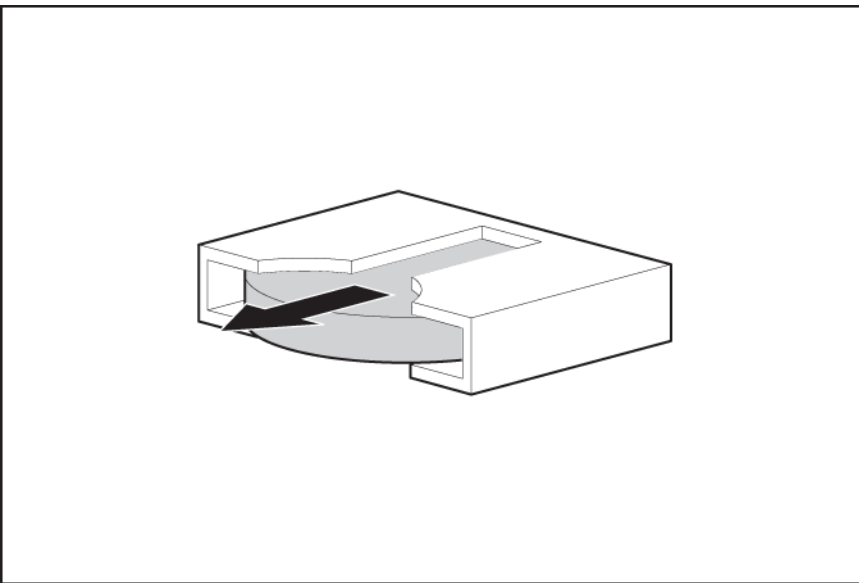

To replace the component, reverse the removal procedure.

Run the RBSU to configure the server after replacing the battery. See the HP ROM-Based Setup Utility User Guide on the Documentation CD for more detailed information.

Setup

Optional installation services

Delivered by experienced, certified engineers, HP Care Pack services help you keep your servers up and running with support packages tailored specifically for HP ProLiant systems. HP Care Packs let you integrate both hardware and software support into a single package. A number of service level options are available to meet your needs.

HP Care Pack Services offer upgraded service levels to expand your standard product warranty with easy-to-buy, easy-to-use support packages that help you make the most of your server investments. Some of the Care Pack services are:

- Hardware support
 - 6-Hour Call-to-Repair
 - 4-Hour 24x7 Same Day
 - 4-Hour Same Business Day
- Software support
 - Microsoft®
 - Linux
 - HP ProLiant Essentials (HP SIM and RDP)
 - VMWare
- Integrated hardware and software support
 - Critical Service
 - Proactive 24
 - Support Plus
 - Support Plus 24
- Startup and implementation services for both hardware and software

For more information on Care Packs, refer to the HP website (http://www.hp.com/hps/carepack/servers/cp_proliant.html).

Rack planning resources

The rack resource kit ships with all HP branded or Compaq branded 9000, 10000, and H9 series racks. For more information on the content of each resource, refer to the rack resource kit documentation.

If you intend to deploy and configure multiple servers in a single rack, refer to the white paper on high-density deployment at the HP website (<http://www.hp.com/products/servers/platforms>).

Optimum environment

When installing the server, select a location that meets the environmental standards described in this section.

Space and airflow requirements

To allow for servicing and adequate airflow, observe the following space and airflow requirements when deciding where to install a rack:

- Leave a minimum clearance of 63.5 cm (25 in) in front of the rack.
- Leave a minimum clearance of 76.2 cm (30 in) behind the rack.
- Leave a minimum clearance of 121.9 cm (48 in) from the back of the rack to the back of another rack or row of racks.

HP servers draw in cool air through the front door and expel warm air through the rear door. Therefore, the front and rear rack doors must be adequately ventilated to allow ambient room air to enter the cabinet, and the rear door must be adequately ventilated to allow the warm air to escape from the cabinet.

 **CAUTION:** To prevent improper cooling and damage to the equipment, do not block the ventilation openings.

When vertical space in the rack is not filled by a server or rack component, the gaps between the components cause changes in airflow through the rack and across the servers. Cover all gaps with blanking panels to maintain proper airflow.

 **CAUTION:** Always use blanking panels to fill empty vertical spaces in the rack. This arrangement ensures proper airflow. Using a rack without blanking panels results in improper cooling that can lead to thermal damage.

The 9000 and 10000 Series Racks provide proper server cooling from flow-through perforations in the front and rear doors that provide 64 percent open area for ventilation.

 **CAUTION:** When using a Compaq branded 7000 Series rack, you must install the high airflow rack door insert [P/N 327281-B21 (42U) or P/N 157847-B21 (22U)] to provide proper front-to-back airflow and cooling.

 **CAUTION:** If a third-party rack is used, observe the following additional requirements to ensure adequate airflow and to prevent damage to the equipment:

- Front and rear doors—If the 42U rack includes closing front and rear doors, you must allow 5,350 sq cm (830 sq in) of holes evenly distributed from top to bottom to permit adequate airflow (equivalent to the required 64 percent open area for ventilation).
 - Side—The clearance between the installed rack component and the side panels of the rack must be a minimum of 7 cm (2.75 in).
-

Temperature requirements

To ensure continued safe and reliable equipment operation, install or position the system in a well-ventilated, climate-controlled environment.

The maximum recommended ambient operating temperature (TMRA) for most server products is 35°C (95°F). The temperature in the room where the rack is located must not exceed 35°C (95°F).

-
-  **CAUTION:** To reduce the risk of damage to the equipment when installing third-party options:
- Do not permit optional equipment to impede airflow around the server or to increase the internal rack temperature beyond the maximum allowable limits.
 - Do not exceed the manufacturer's TMRA.
-

Power requirements

Installation of this equipment must comply with local and regional electrical regulations governing the installation of information technology equipment by licensed electricians. This equipment is designed to operate in installations covered by NFPA 70, 1999 Edition (National Electric Code) and NFPA-75, 1992 (code for Protection of Electronic Computer/Data Processing Equipment). For electrical power ratings on options, refer to the product rating label or the user documentation supplied with that option.

-
-  **WARNING:** To reduce the risk of personal injury, fire, or damage to the equipment, do not overload the AC supply branch circuit that provides power to the rack. Consult the electrical authority having jurisdiction over wiring and installation requirements of your facility.
-

-  **CAUTION:** Protect the server from power fluctuations and temporary interruptions with a regulating uninterruptible power supply (UPS). This device protects the hardware from damage caused by power surges and voltage spikes and keeps the system in operation during a power failure.
-

When installing more than one server, you may need to use additional power distribution devices to safely provide power to all devices. Observe the following guidelines:

- Balance the server power load between available AC supply branch circuits.
- Do not allow the overall system AC current load to exceed 80 percent of the branch circuit AC current rating.
- Do not use common power outlet strips for this equipment.
- Provide a separate electrical circuit for the server.

Electrical grounding requirements

The server must be grounded properly for proper operation and safety. In the United States, you must install the equipment in accordance with NFPA 70, 1999 Edition (National Electric Code), Article 250, as well as any local and regional building codes. In Canada, you must install the equipment in accordance with Canadian Standards Association, CSA C22.1, Canadian Electrical Code. In all other countries, you must install the equipment in accordance with any regional or national electrical wiring codes, such as the International Electrotechnical Commission (IEC) Code 364, parts 1 through 7. Furthermore, you must be sure that all power distribution devices used in the installation, such as branch wiring and receptacles, are listed or certified grounding-type devices.

Because of the high ground-leakage currents associated with multiple servers connected to the same power source, HP recommends the use of a PDU that is either permanently wired to the building's branch circuit or includes a nondetachable cord that is wired to an industrial-style plug. NEMA locking-style plugs or those complying with IEC 60309 are considered suitable for this purpose. Using common power outlet strips for the server is not recommended.

Rack warnings



WARNING: To reduce the risk of personal injury or damage to the equipment, be sure that:

- The leveling jacks are extended to the floor.
- The full weight of the rack rests on the leveling jacks.
- The stabilizing feet are attached to the rack if it is a single-rack installation.
- The racks are coupled together in multiple-rack installations.
- Only one component is extended at a time. A rack may become unstable if more than one component is extended for any reason.



WARNING: To reduce the risk of personal injury or equipment damage when unloading a rack:

- At least two people are needed to safely unload the rack from the pallet. An empty 42U rack can weigh as much as 115 kg (253 lb), can stand more than 2.1 m (7 ft) tall, and may become unstable when being moved on its casters.
- Never stand in front of the rack when it is rolling down the ramp from the pallet. Always handle the rack from both sides.

Identifying the contents of the server shipping carton

Unpack the server shipping carton and locate the materials and documentation necessary for installing the server. All the rack mounting hardware necessary for installing the server into the rack is included with the rack or the server.

The contents of the server shipping carton include:

- Server
- Power cord
- Hardware documentation, Documentation CD, and software products
- Rack-mounting hardware

In addition to the supplied items, you may need:

- Operating system or application software
- Hardware options

Installing hardware options

Install any hardware options before initializing the server. For options installation information, refer to the option documentation. For server-specific information, refer to "Hardware options installation (on page 33)."

Setting up a tower model server

Follow these steps to set up a tower model server. If you are going to install the server into a rack, see the rack installation section ("[Installing the server into the rack](#)" on page 31).

1. Connect the peripheral devices to the server.

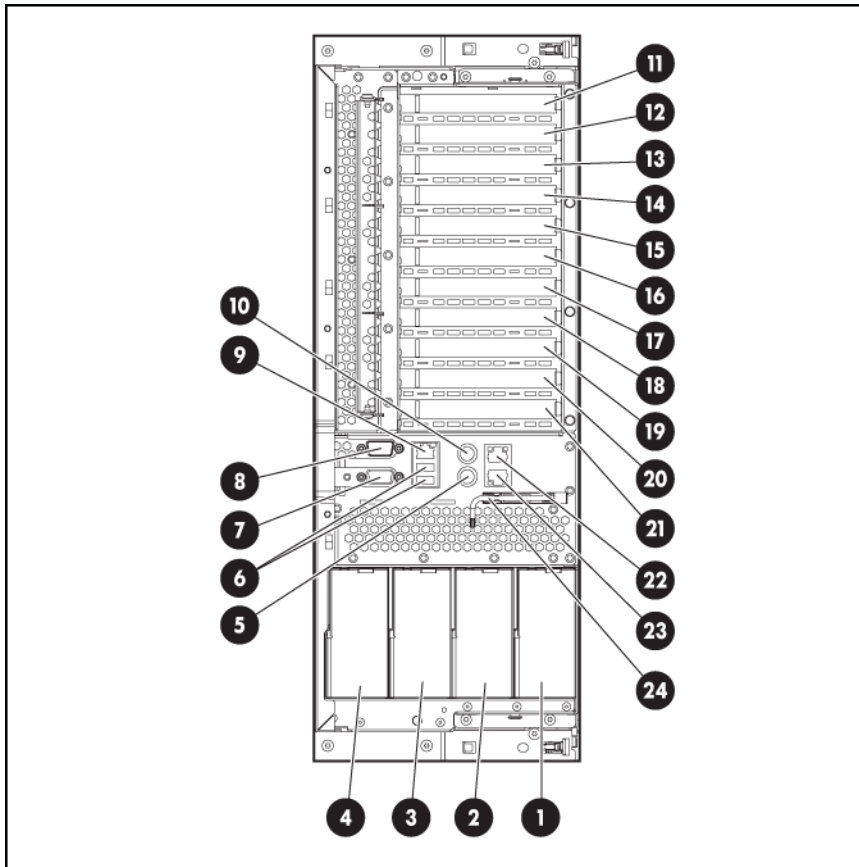

Item	Description	Item	Description
1	Power supply bay 4 (optional)	13	PCI-X non-hot-plug for PCI Express x8 non-hot-plug expansion slot 3 (optional)
2	Power supply bay 3 (optional)	14	PCI Express x8 non-hot-plug expansion slot 4
3	Power supply bay 2	15	PCI Express x8 non-hot-plug expansion slot 5
4	Power supply bay 1	16	PCI Express x8 non-hot-plug expansion slot 6
5	Keyboard connector	17	PCI Express x8 non-hot-plug expansion slot 7
6	USB connectors	18	PCI Express x4 non-hot-plug expansion slot 8
7	Video connector	19	PCI Express x4 non-hot-plug expansion slot 9
8	Serial connector	20	PCI Express x4 non-hot-plug expansion slot 10

Item	Description	Item	Description
9	iLO 2 NIC connector	21	PCI Express x4 non-hot-plug expansion slot 11
10	Mouse connector	22	NIC 2 connector
11	PCI-X non-hot-plug or PCI Express x8 non-hot-plug expansion slot 1 (optional)	23	NIC 1 connector
12	PCI-X non-hot-plug or PCI Express x8 non-hot-plug expansion slot 2 (optional)	24	T-15 Torx tool



WARNING: To reduce the risk of electric shock or damage to the equipment:

- Do not disable the power cord grounding plug. The grounding plug is an important safety feature.
- Plug the power cord into a grounded (earthed) electrical outlet that is easily accessible at all times.
- Unplug the power cord from the power supply to disconnect power to the equipment.
- Do not route the power cord where it can be walked on or pinched by items placed against it. Pay particular attention to the plug, electrical outlet, and the point where the cord extends from the server.

2. Connect the power cords to the power supplies.
3. Connect the power cords to the AC power source.

Installing the server into the rack

Refer to the installation instructions that ship with the rack kit to install the server into the rack.

Powering up and configuring the server

To power up the server, press the Power On/Standby button.

While the server boots, RBSU and the ORCA utility are automatically configured to prepare the server for operating system installation.

To configure these utilities manually:

- Press the **F8** key when prompted during the array controller initialization to configure the array controller using ORCA.
- Press the **F9** key when prompted during the boot process to change the server settings using RBSU. The system is set up by default for the English language.

For more information on the automatic configuration, refer to the *HP ROM-Based Setup Utility User Guide* located on the Documentation CD.

Installing the operating system

To operate properly, the server must have a supported operating system. For the latest information on supported operating systems, refer to the HP website (<http://www.hp.com/go/supportos>).

Two methods are available to install an operating system on the server:

- SmartStart assisted installation—Insert the SmartStart CD into the CD-ROM drive and reboot the server.
- Manual installation—Insert the operating system CD into the CD-ROM drive and reboot the server. This process may require you to obtain additional drivers from the HP website (<http://www.hp.com/support>).

Follow the on-screen instructions to begin the installation process.

For information on using these installation paths, refer to the SmartStart installation poster in the HP ProLiant Essentials Foundation Pack, included with the server.

Registering the server

To register the server, refer to the HP Registration website (<http://register.hp.com>).

Hardware options installation

Introduction

If more than one option is being installed, read the installation instructions for all the hardware options and identify similar steps to streamline the installation process.

 **WARNING:** To reduce the risk of personal injury from hot surfaces, allow the drives and the internal system components to cool before touching them.

 **CAUTION:** To prevent damage to electrical components, properly ground the server before beginning any installation procedure. Improper grounding can cause electrostatic discharge.

Review "Electrostatic Discharge (on page 97)" before installing hardware options into the server.

Processor options

The server supports up to four processors. Observe the following processor installation guidelines:

- Processor socket 1 and PPM 1 must be populated at all times so that the server functions properly.
- Each PPM provides power to each processor. Each PPM must be installed in the slot adjacent to its processor.
- Processors must be installed in the following order: processor 1, processor 2, processor 3, and processor 4.
- When upgrading processor speed, update the system ROM before installing the processor.
- Multiprocessor configurations must contain processors with the same part number.

Removing the processor memory module

The processors and memory are stored in a module at the front of the server. Access to the processor memory module is provided through the front panel, eliminating the need to extend the server from the rack to install new or replace existing processors or upgrade the memory.

To remove the processor memory module:

 **WARNING:** Use caution when installing the processor memory module or removing the processor memory module. The processor memory module is very heavy when fully populated.

1. Power down the server (on page 21).

2. If the shipping screws are installed, remove them. The shipping screw locations are marked with tags on both sides of the server for easy identification.

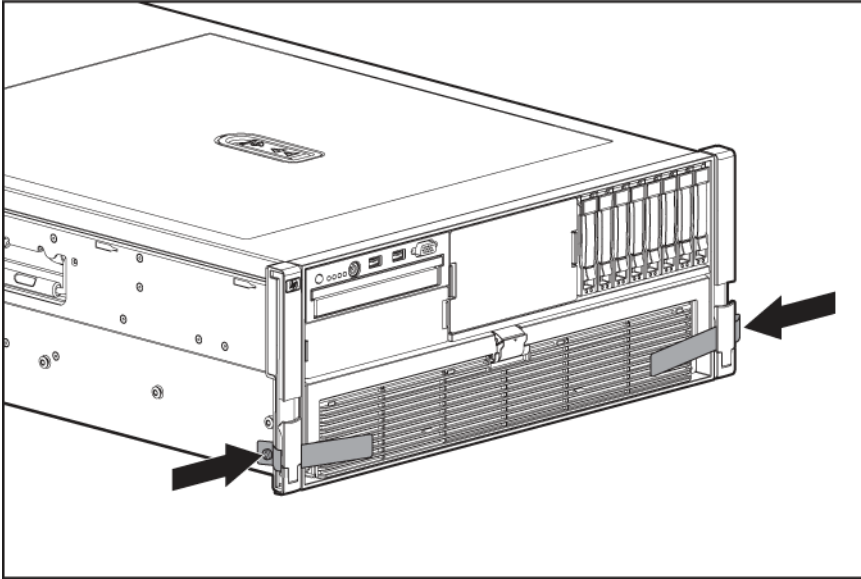

3. Release the latches on the lever.

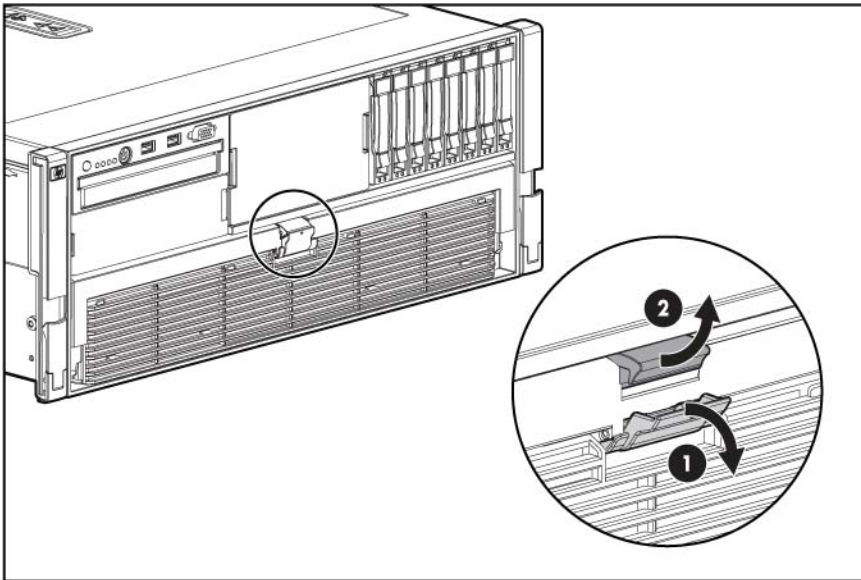

4. Lower the handle, and pull the processor memory module out of the server until the release latches catch.

5. Firmly holding the processor memory module, press the release buttons and pull the module out of the server.

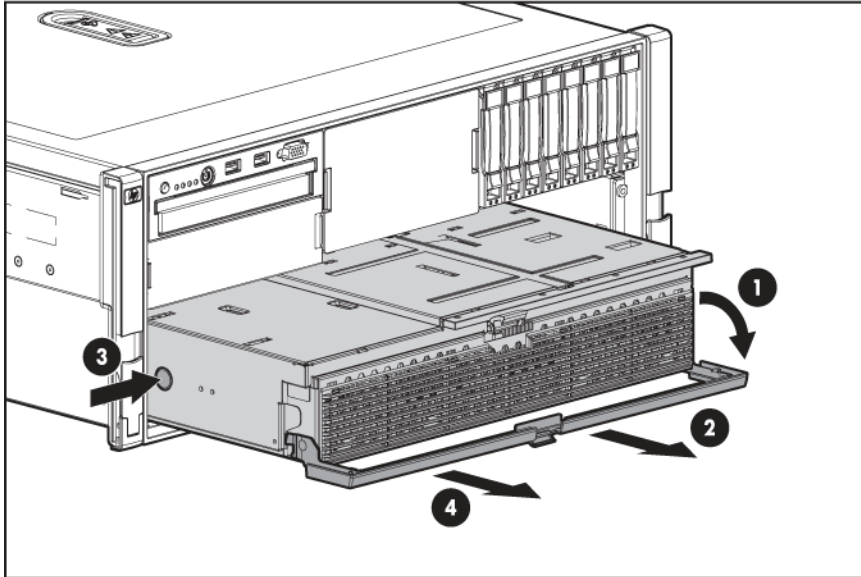

6. Remove the processor memory module cover.

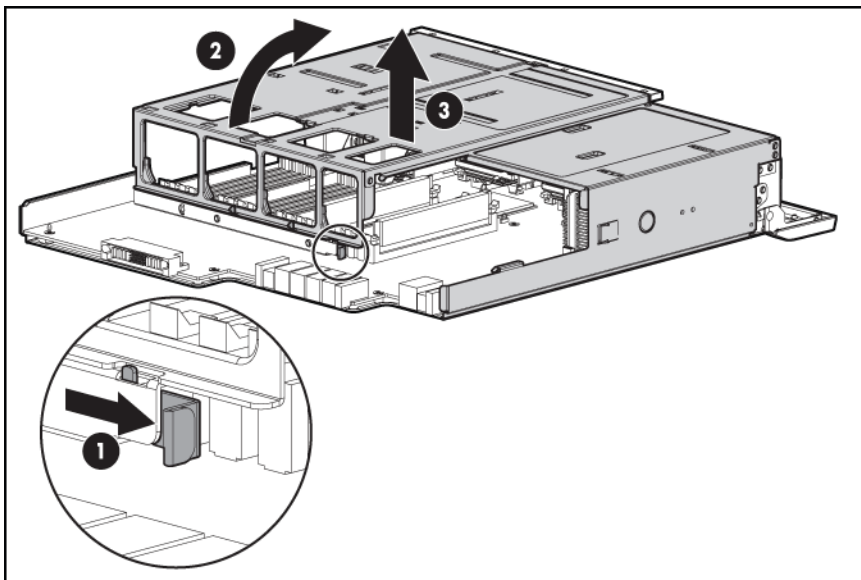

To install the processor memory module, reverse the removal steps.

Installing a processor

1. Locate and download the latest ROM version from the HP website (<http://h18023.www1.hp.com/support/files/server/us/romflash.html>). Follow the instructions on the website to update the system ROM.
2. Power down the server (on page 21).
3. Remove the processor memory module, and open the cover ("Removing the processor memory module" on page 33).

4. Unlock the processor retaining bracket.

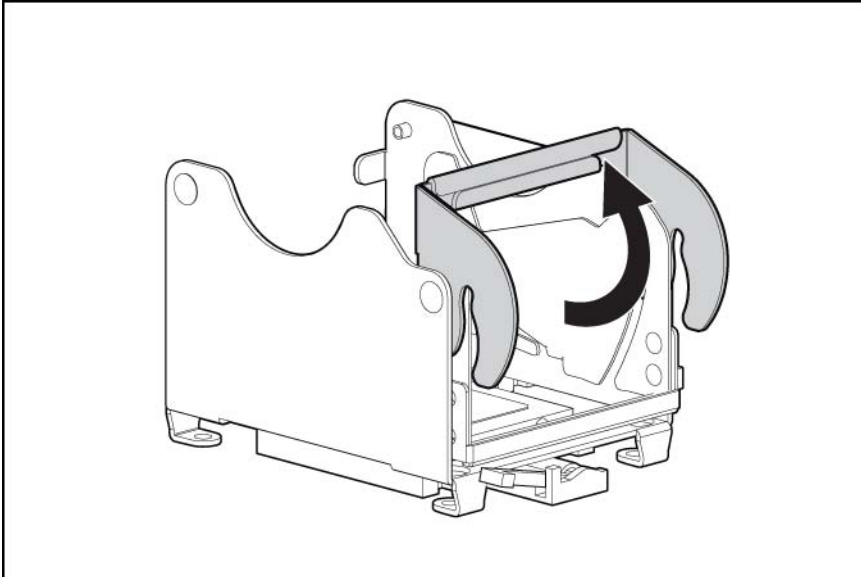

5. Open the processor retaining bracket.
6. Open the processor locking lever.

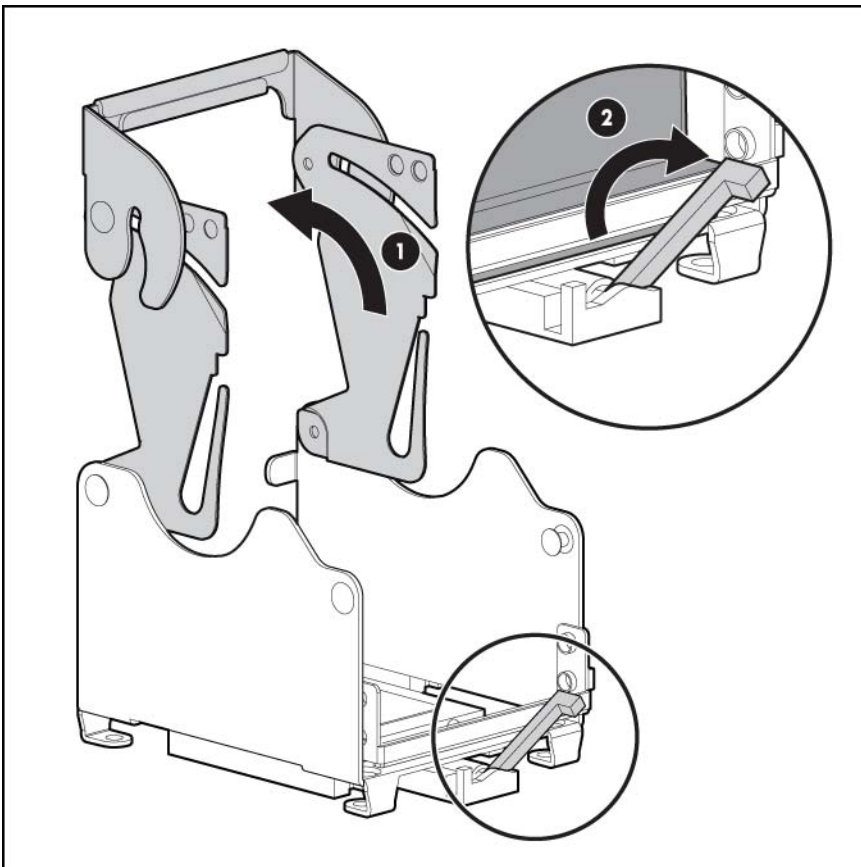

7. Align the guide pins on the base of the processor retaining bracket to the three corresponding guide slots on the processor assembly.

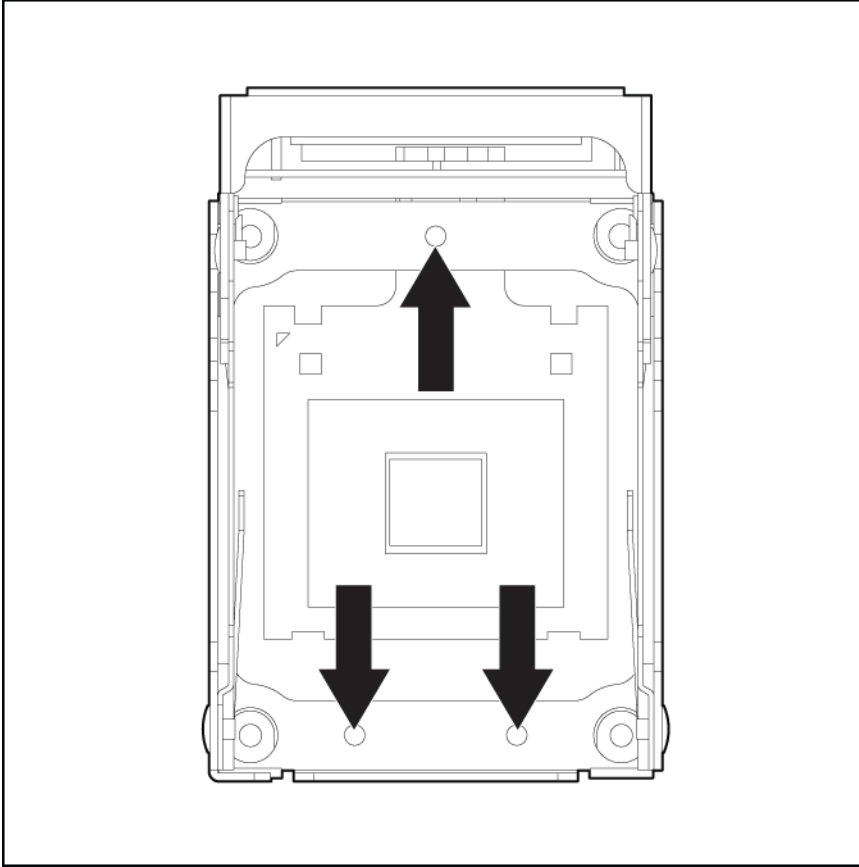

8. Insert the processor assembly into the processor socket, and close the locking lever.



CAUTION: To prevent possible server malfunction or damage to the equipment, be sure to completely close the processor locking lever.

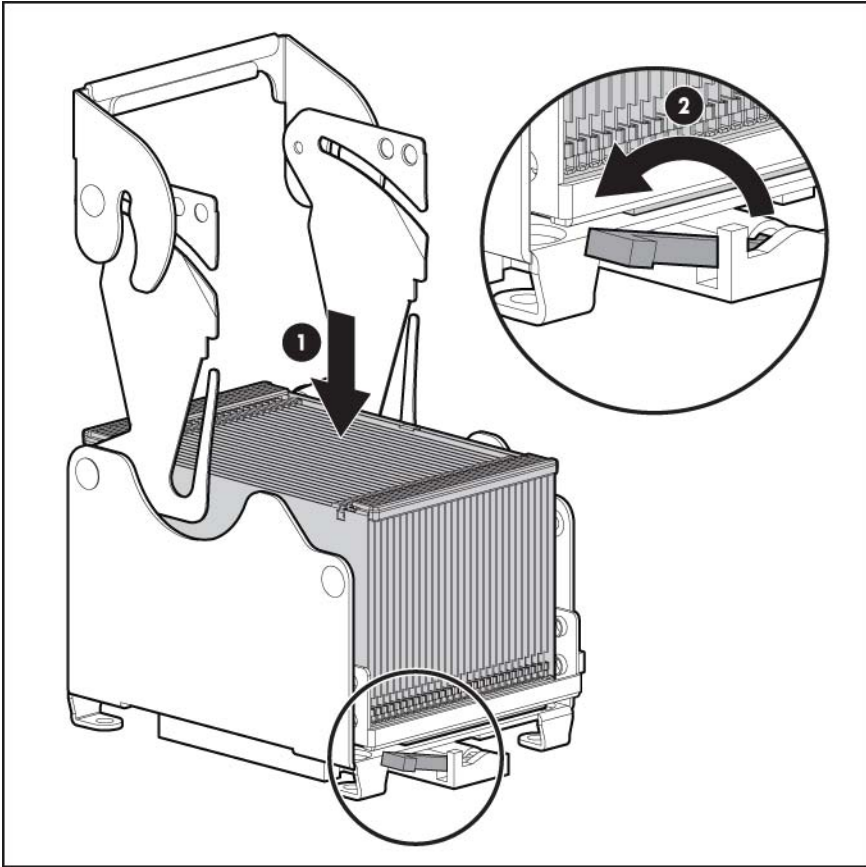

9. Close and lock the processor retaining bracket.

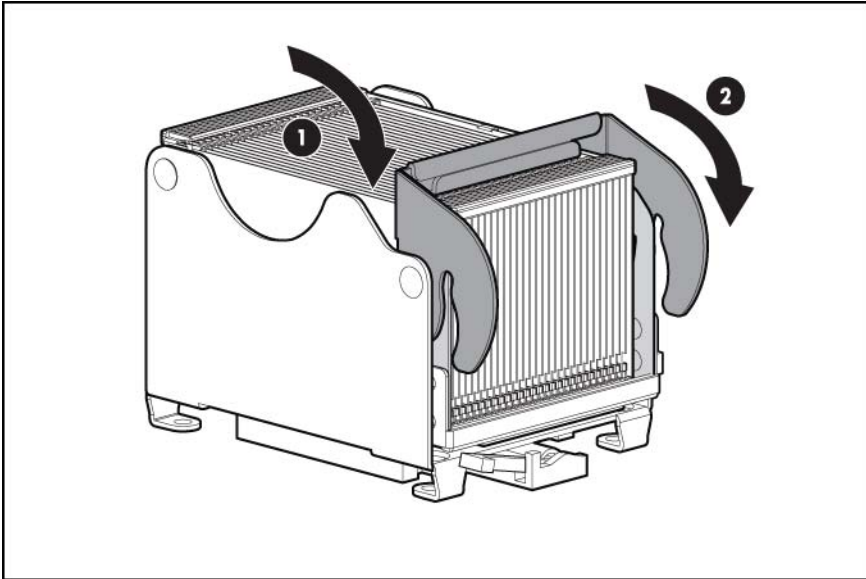

10. Install the PPM.

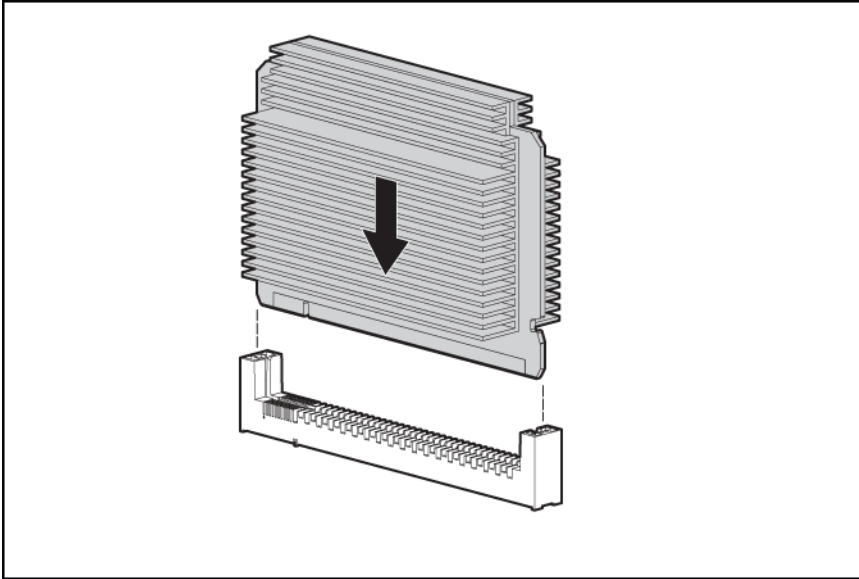

NOTE: The appearance of compatible PPMs may vary.

11. Replace the processor memory module cover.
12. Install the processor memory module into the server.
13. Power up the server (on page 21).

Memory options

This server contains 16 FBDIMM slots on the processor-memory board. You can expand server memory by installing supported registered DDR-2 FBDIMMs and optional memory expansion boards ("Installing optional memory expansion boards" on page 43).

Memory configurations

The server supports the following AMP options to optimize server availability.

- Advanced ECC supporting up to 128 GB of active memory utilizing 4-GB FBDIMMs.
- Online spare memory providing additional protection against degrading FBDIMMs supporting up to 112 GB of active memory and 16 GB of online spare memory utilizing 4-GB FBDIMMs.
- Mirrored memory providing protection against failed FBDIMMs supporting up to 64 GB of active memory and 64 GB of mirrored memory utilizing 4-GB FBDIMMs.

For the latest memory configuration information, see the QuickSpecs on the HP website (<http://www.hp.com>).

The Advanced Memory Protection option is configured in RBSU. By default, the server is set to Advanced ECC mode. For more information, see HP ROM-Based Setup Utility (on page 66). If the configured AMP mode is not supported by the installed FBDIMM configuration, the system boots in Advanced ECC mode.

The following configuration requirements apply to all AMP modes:

- FBDIMMs must be ECC Registered DDR-2 SDRAM FBDIMMs.
- FBDIMMs must be installed in sequential order, beginning with bank A.
- FBDIMMs must be installed in pairs.
- FBDIMM pairs in a memory bank must have identical HP part numbers.
- FBDIMMs must be populated as specified for each AMP memory mode.

The memory subsystem for this server is divided into two branches. Each memory branch is essentially a separate memory controller. The FBDIMMs map to the two branches as indicated in the following table:

Branch 0	Branch 1
FBDIMM 1A	FBDIMM 9B
FBDIMM 5A	FBDIMM 13B
FBDIMM 2C	FBDIMM 10D
FBDIMM 6C	FBDIMM 14D
FBDIMM 3E	FBDIMM 11F
FBDIMM 7E	FBDIMM 15F
FBDIMM 4G	FBDIMM 12H
FBDIMM 8G	FBDIMM 16H
Memory board 1 (optional)	Memory board 3 (optional)
Memory board 2 (optional)	Memory board 4 (optional)

This multi branch architecture provides enhanced performance in Advanced ECC mode. The concept of multiple branches is important for the operation of online spare mode and mirrored memory mode.

If the server contains more than 4 GB of memory, consult the operating system documentation about accessing the full amount of installed memory.

Advanced ECC memory

Advanced ECC memory is the default memory protection mode for this server. In Advanced ECC, the server is protected against correctable memory errors. The server provides notification if the level of correctable errors exceeds a pre-defined threshold rate. The server does not fail because of correctable memory errors. Advanced ECC provides additional protection over Standard ECC because it is possible to correct certain memory errors that would otherwise be uncorrectable and result in a server failure.

Whereas standard ECC can correct single-bit memory errors, Advanced ECC can correct single-bit memory errors and multi-bit memory errors if all failed bits are on the same DRAM device on the FBDIMM.

Advanced ECC memory supports the following FBDIMM configurations:

Configuration	Bank A 1A/5A	Bank B 9B/13B	Bank C 2C/6C	Bank D 10D/14D	Bank E 3E/7E	Bank F 11F/15F	Bank G 4G/8G	Bank H 12H/16H
1	X							
2	X	X						
3	X	X	X					
4	X	X	X	X				

5	X	X	X	X	X			
6	X	X	X	X	X	X		
7	X	X	X	X	X	X	X	
8	X	X	X	X	X	X	X	X

Online spare memory configuration

Online spare memory provides protection against degrading FBDIMMs by reducing the likelihood of uncorrectable memory errors. This protection is available without any operating system support.

An understanding of single-rank and dual-rank FBDIMMs is required to understand memory usage in online spare mode. FBDIMMs can either be single-rank or dual-rank. Certain FBDIMM configuration requirements are based on these classifications. A dual-rank FBDIMM is similar to having two single-rank FBDIMMs on the same module. Although only a single FBDIMM module, a dual-rank FBDIMM acts as two separate FBDIMMs. The purpose of dual-rank FBDIMMs is to provide the largest capacity FBDIMM for the current DRAM technology. If the current DRAM technology allows for 2-GB single-rank FBDIMMs, a dual-rank FBDIMM using the same technology would be 4-GB.

In online spare mode, a single rank of memory acts as the spare memory. For single-rank FBDIMMs, the entire FBDIMM acts as the spare memory. For a dual-rank FBDIMM, only half of the FBDIMM acts as the spare memory while the other half is available for operating system and application usage.

If one of the non-spare FBDIMMs receives correctable memory errors at a higher rate than a specific threshold, the server automatically copies the memory contents of the degraded rank to the online spare rank. The server then deactivates the failing rank and automatically switches over to the online spare. Because FBDIMMs that experience a high rate of correctable memory errors also have a higher probability of receiving an uncorrectable memory error, this configuration reduces the likelihood of uncorrectable memory errors that would result in server downtime.

Online spare is performed per branch of the memory controller. For a server with both branches populated, two ranks are used for online spare memory. One branch can fail over to the associated online spare while the other branch is still protected.

Each branch is comprised of four banks:

- Branch 0 contains banks A, C, E, and G
- Branch 1 contains banks B, D, F, and H

Online spare FBDIMM configuration requirements (in addition to general configuration requirements):

- When only bank A is being used, it must be fully populated with dual-rank FBDIMMs.
- If banks on different branches are used, the banks must be fully populated.

Online spare memory supports the following FBDIMM configurations:

Configuration	Bank A 1A/5A	Bank B 9B/13B	Bank C 2C/6C	Bank D 10D/14D	Bank E 3E/7E	Bank F 11F/15F	Bank G 4G/8G	Bank H 12H/16H
1*	X							
2	X	X						
3	X	X	X	X				
4	X	X	X	X	X	X		

Configuration	Bank A 1A/5A	Bank B 9B/13B	Bank C 2C/6C	Bank D 10D/14D	Bank E 3E/7E	Bank F 11F/15F	Bank G 4G/8G	Bank H 12H/16H
5	X	X	X	X	X	X	X	X

* Configuration 1 is only supported if bank A is populated with dual-rank FBDIMMs.

After installing FBDIMMs, use RBSU to configure the system for online spare memory support ("[Configuring online spare memory](#)" on page 66).

Mirrored memory configuration

Mirroring provides protection against uncorrectable memory errors that would otherwise result in server downtime.

Mirroring is performed on the branch level. Branch 0 and branch 1 mirror each other.

Each branch maintains a copy of all memory contents. Memory *writes* go to both branches. Memory *reads* come from only one of the two branches (unless an uncorrectable error occurs). If a memory read on one branch returns incorrect data due to an uncorrectable memory error, the system automatically retrieves the proper data from the other branch. A branch is not necessarily disabled (thus losing mirroring protection) because of a single uncorrectable error. Mirroring protection is not lost because of transient and soft uncorrectable errors, resulting in systems that maintain mirroring protection (and thus improved uptime) unless there is a failure of both branches.

Mirrored memory FBDIMM configuration requirements (in addition to the general configuration requirements):

- Banks A and B must be fully populated at a minimum.

Mirrored memory supports the following FBDIMM configurations:

Configuration	Bank A 1A/5A	Bank B 9B/13B	Bank C 2C/6C	Bank D 10D/14D	Bank E 3E/7E	Bank F 11F/15F	Bank G 4G/8G	Bank H 12H/16H
1	X	X						
2	X	X	X	X				
3	X	X	X	X	X	X		
4	X	X	X	X	X	X	X	X

After installing FBDIMMs, use RBSU to configure the system for mirrored memory support ("[Configuring mirrored memory](#)" on page 67).

Installing FBDIMMs

1. Power down the server (on page 21).
2. Remove the processor memory module, and open the cover ("[Removing the processor memory module](#)" on page 33).
3. Open the FBDIMM slot latches.

4. Install the FBDIMM.

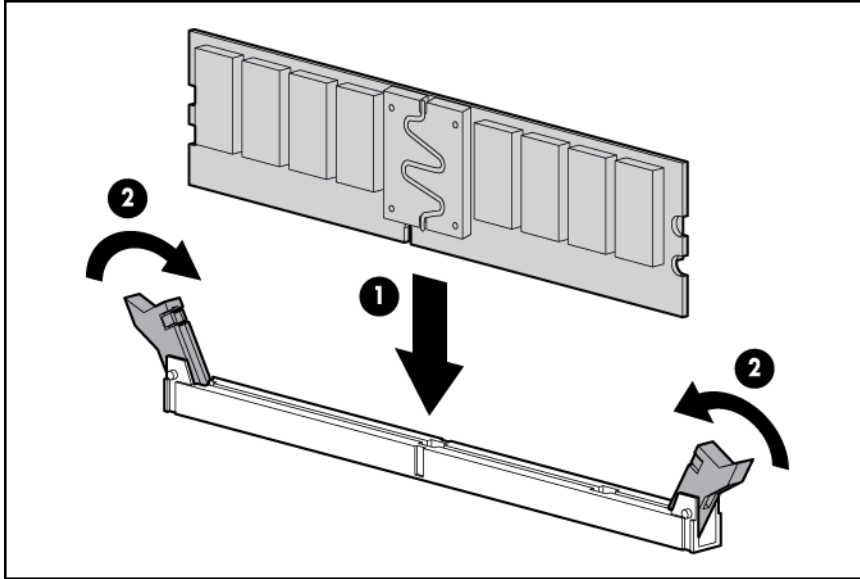

5. If you are installing FBDIMMs in an online spare or mirrored configuration, use RBSU ("HP ROM-Based Setup Utility" on page 66) to configure this feature.

Installing optional memory expansion boards

Installing optional memory expansion boards increases the number of FBDIMM slots in the server to 32.

Use the following guidelines when installing the memory expansion boards:

- Install memory expansion boards in pairs.
 - Memory expansion boards 1 and 2
 - Memory expansion boards 3 and 4
- Install memory expansion boards sequentially beginning with boards 1 and 2.
- Populate memory expansion boards sequentially, beginning with bank A on boards 1 and 2 and proceeding to bank A on boards 3 and 4.

To install the optional memory expansion boards:

1. Power down the server (on page 21).
2. Remove the processor memory module, and open the cover ("Removing the processor memory module" on page 33).
3. Install FBDIMMs on the memory expansion boards.
4. Install the memory expansion boards.

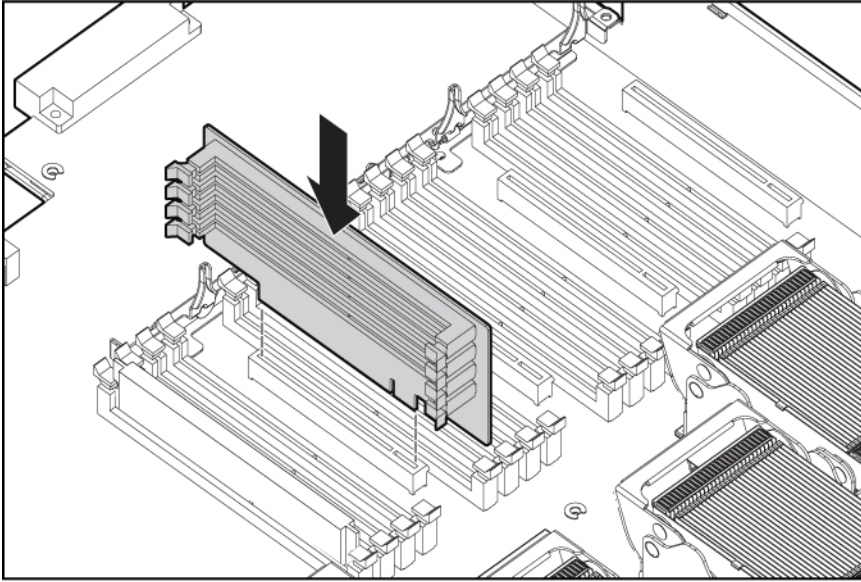

5. If you are installing FBDIMMs in an online spare or mirrored configuration, use RBSU ("HP ROM-Based Setup Utility" on page 66) to configure this feature.

Hot-plug SAS hard drive options

When adding hard drives to the server, observe the following general guidelines:

- The system automatically sets all device numbers.
- If only one hard drive is used, install it in the bay with the lowest device number.
- Hard drives must be SFF types.
- Drives should be the same capacity to provide the greatest storage space efficiency when drives are grouped together into the same drive array.

Installing a hot-plug SAS hard drive

1. Remove the hard drive blank.

2. Prepare the SAS hard drive.

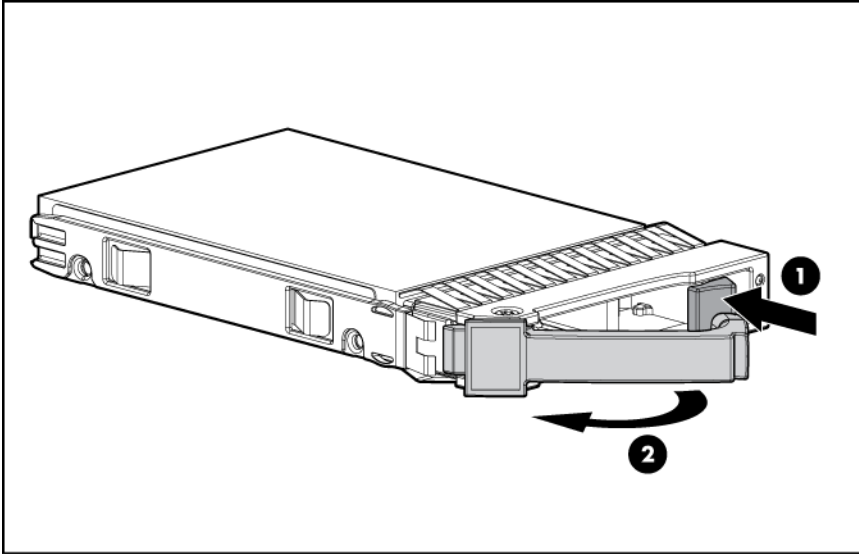

3. Install the hard drive into the server.

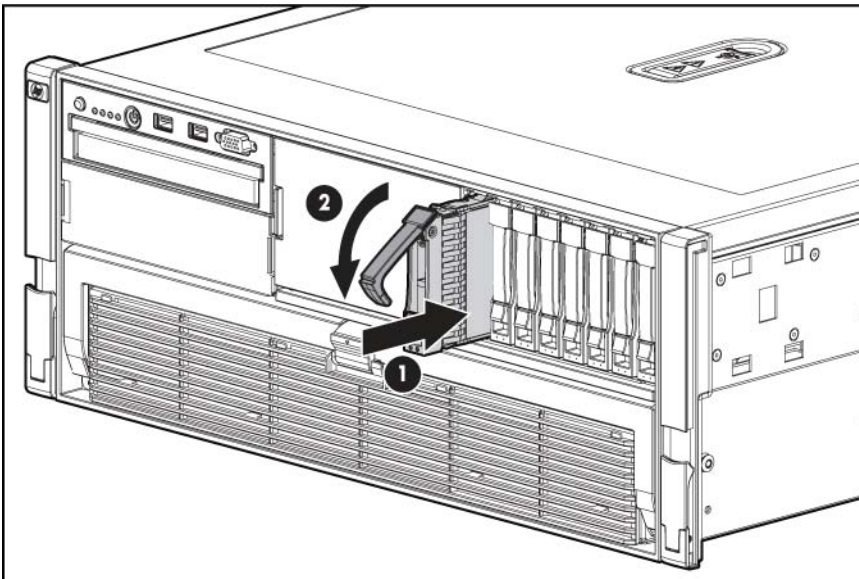

4. Determine the status of the hard drive from the hot-plug SAS hard drive LED combinations ("[SAS hard drive LED combinations](#)" on page 17).

Installing the drive cage

CAUTION: To prevent improper cooling and thermal damage, do not operate the server unless all bays are populated with either a component or a blank.

1. Power down the server (on page 21).
2. Extend the server from the rack ("[Extending the server from the rack](#)" on page 21).
3. Remove the access panel ("[Removing the access panel](#)" on page 23).

4. Remove the blank.

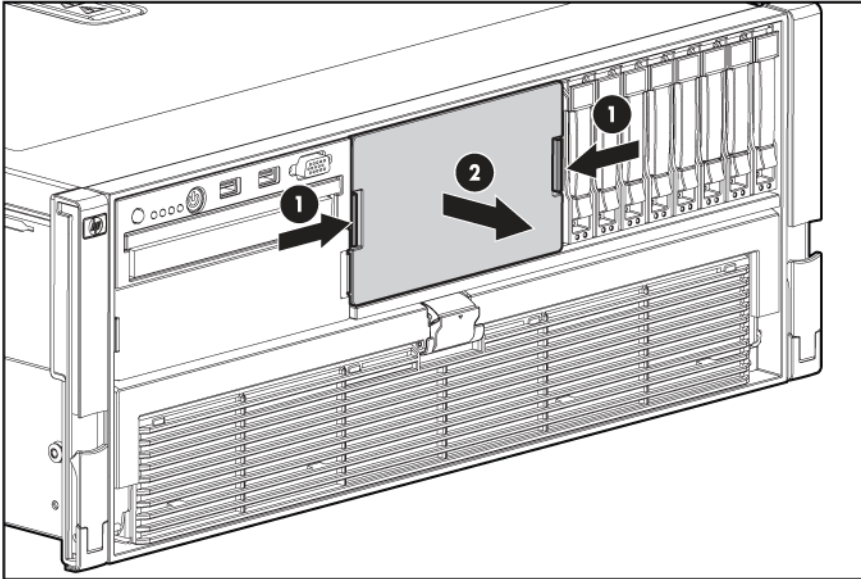

5. Adhere the label to the bezel below the optional drive cage.

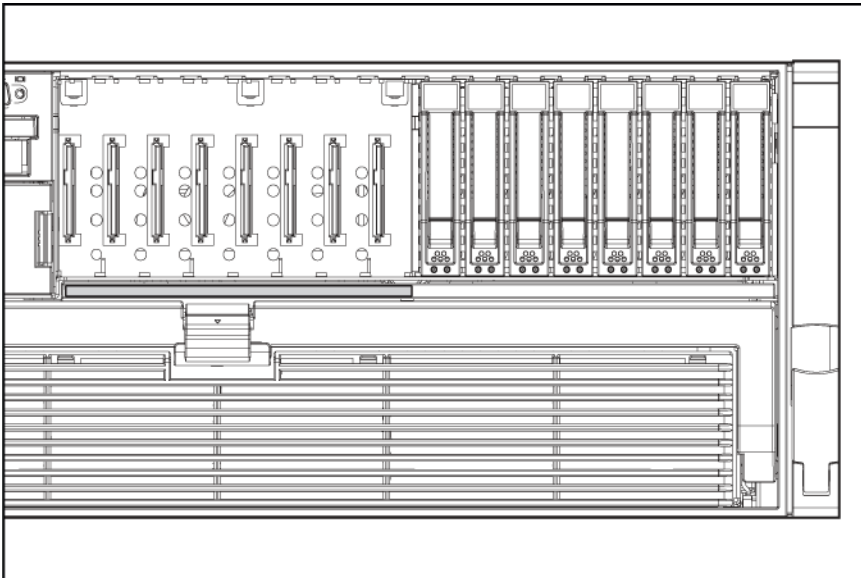

6. Loosen the thumbscrews, and remove the center bracket.

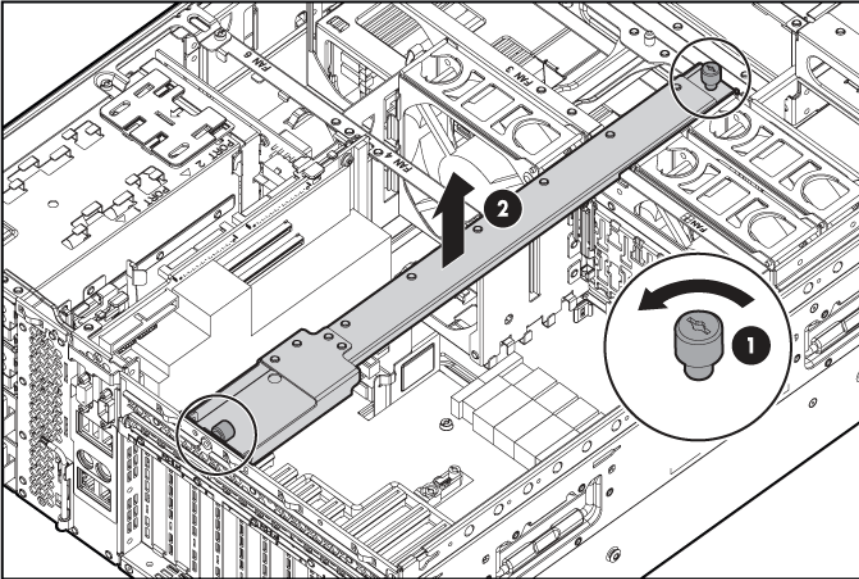

7. Loosen the thumbscrews, and remove the side bracket.

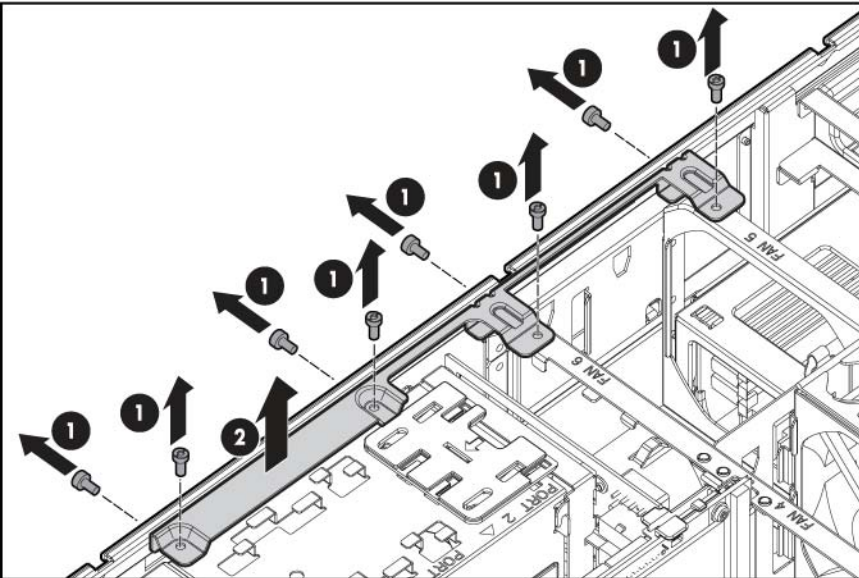

8. Install the SAS controller. See the directions provided with the controller for installation instructions.
9. Slide the plastic retainer to the front of the server.

10. Install the hard drive backplane.

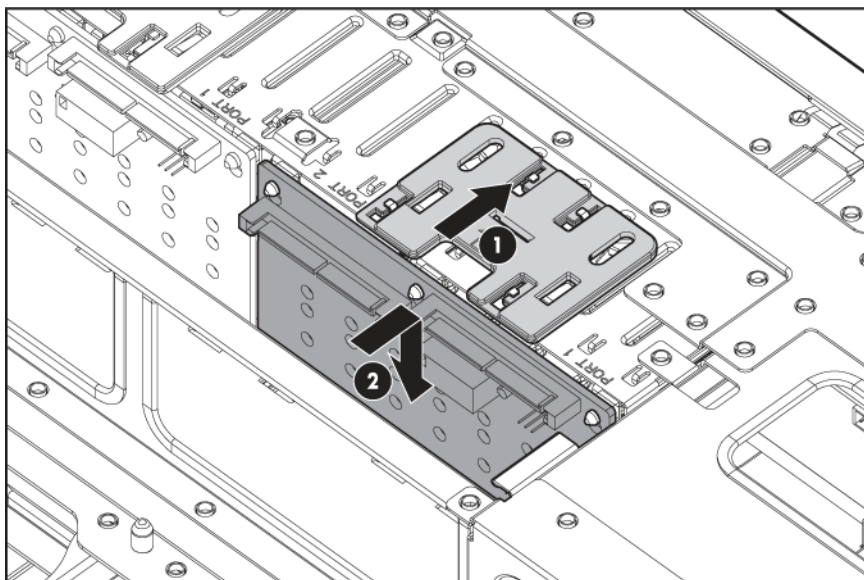

11. Route and connect the data cables from the backplane to the optional controller.
12. Route and connect the power cord.
 - a. Lift the data cables connected to the standard backplane.
 - b. Route the power cord under the data cables along the server wall.
 - c. Connect the power cord to the power backplane.
 - d. Return the data cables to their original position.

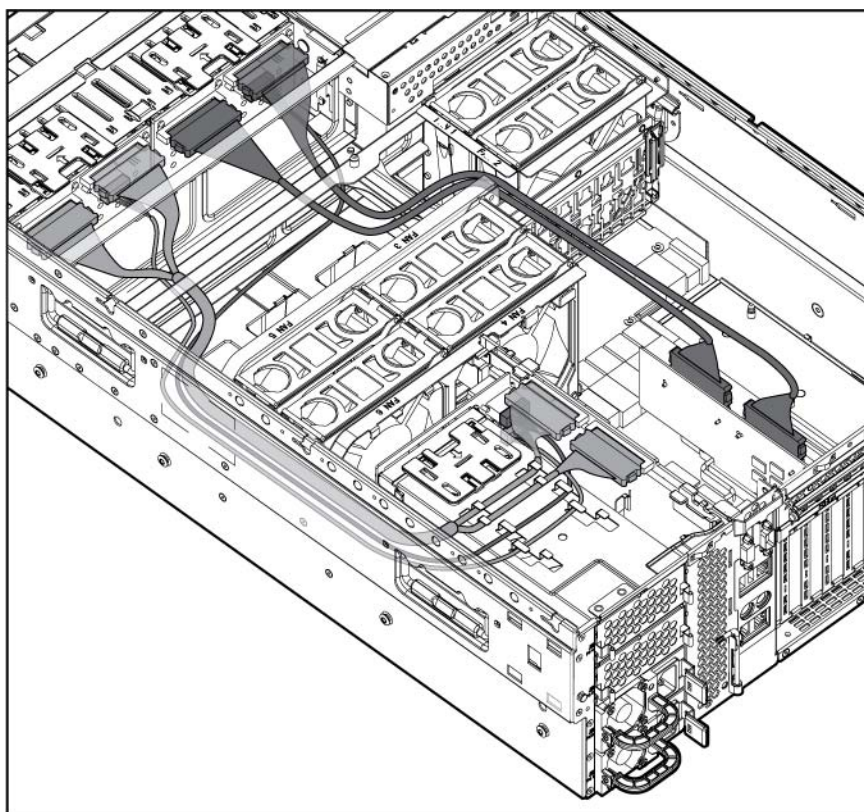

13. Replace the side bracket.

14. Replace the center bracket.
15. Install hard drives or hard drive blanks into each bay.
16. Replace the access panel ("[Removing the access panel](#)" on page 23).
17. Slide the server into the rack.

Tape drive

CAUTION: To prevent improper cooling and thermal damage, do not operate the server unless all bays are populated with either a component or a blank.

1. Power down the server (on page 21).
2. Extend the server from the rack ("[Extending the server from the rack](#)" on page 21).
3. Remove the access panel ("[Removing the access panel](#)" on page 23).
4. Remove the bracket.

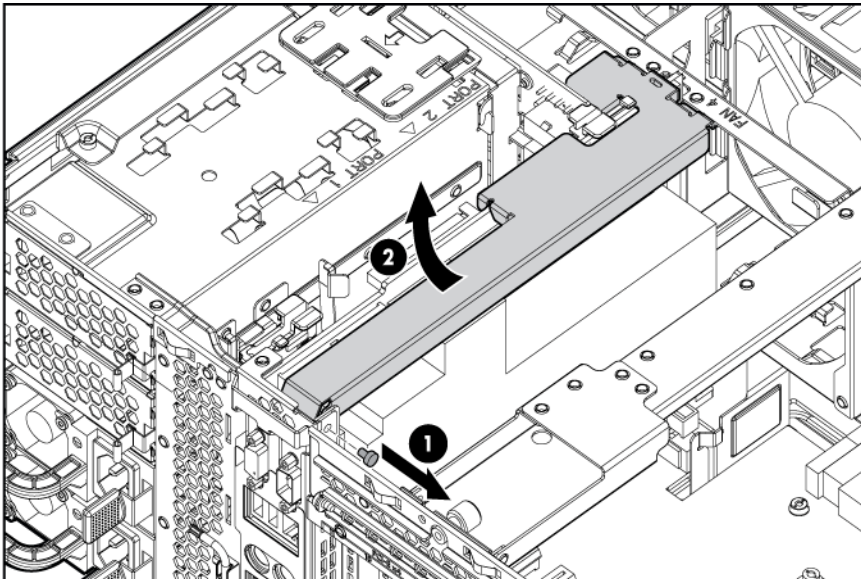

5. Remove the tape drive blank.

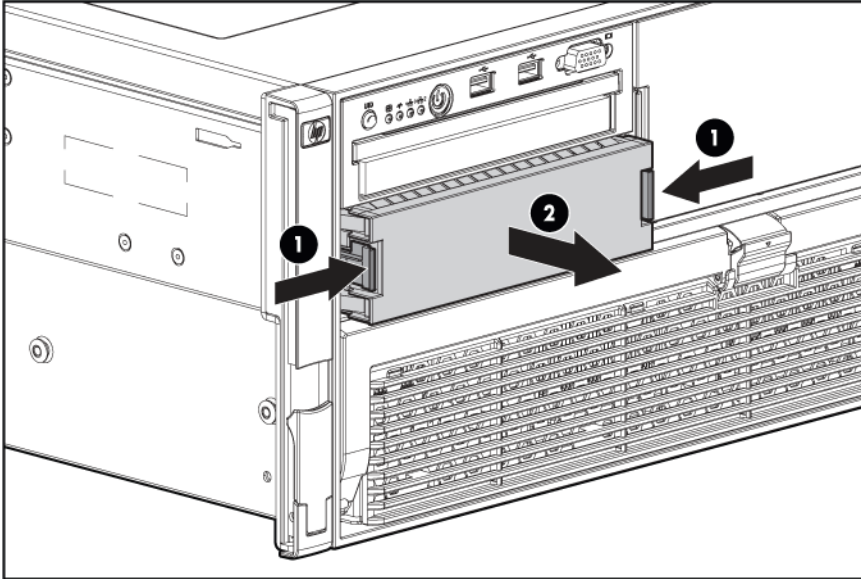

6. Turn the tape drive blank over, and then remove the screws.

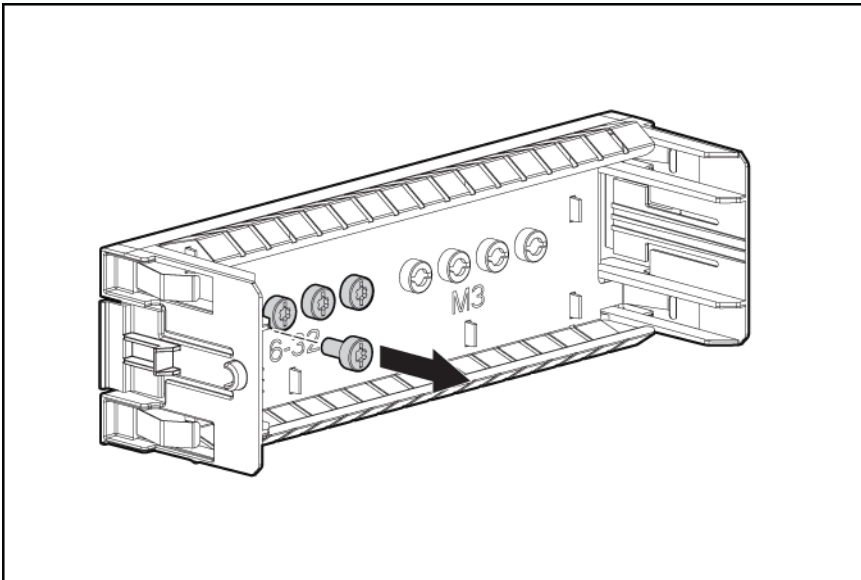

7. Install the screws on each side of the tape drive.

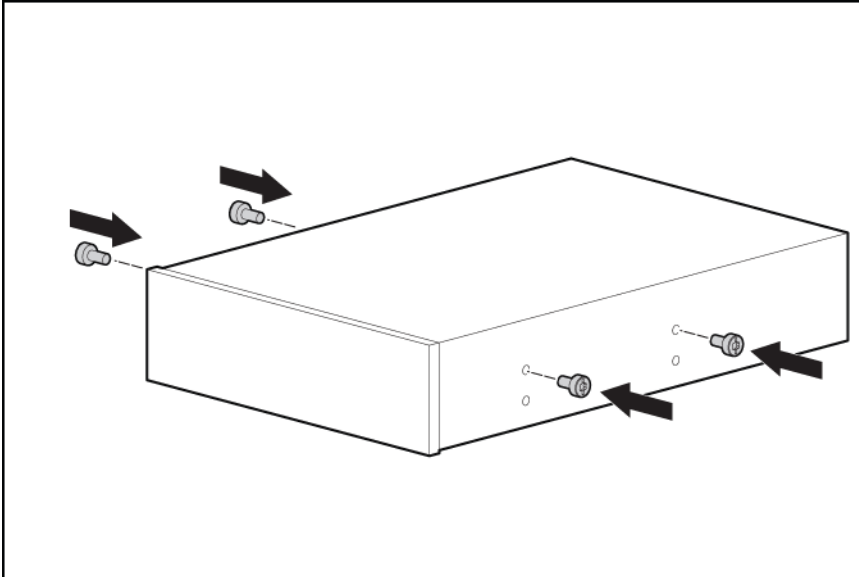

8. Align the screws on the tape drive with the slots in the tape drive bay and slide the drive into the bay.
9. Pull the tab up until the drive locks into place.

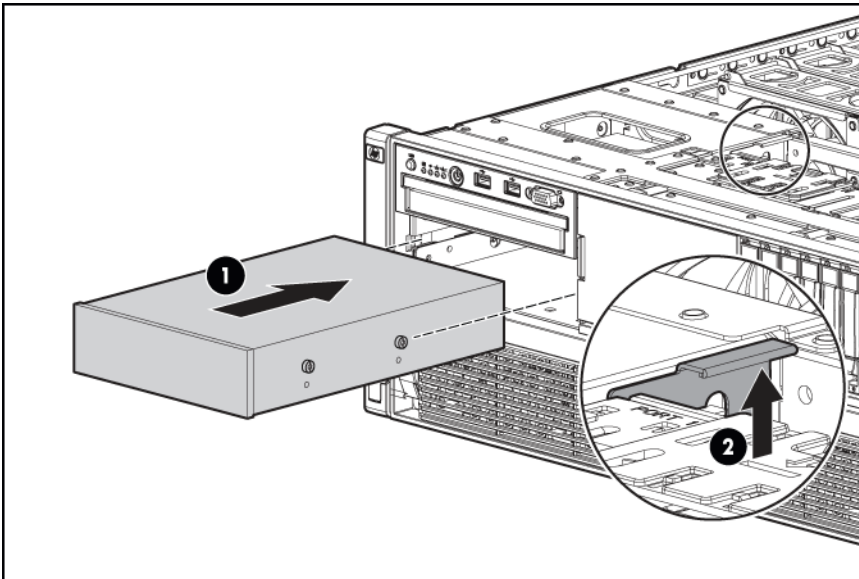

10. Route and connect the cables.

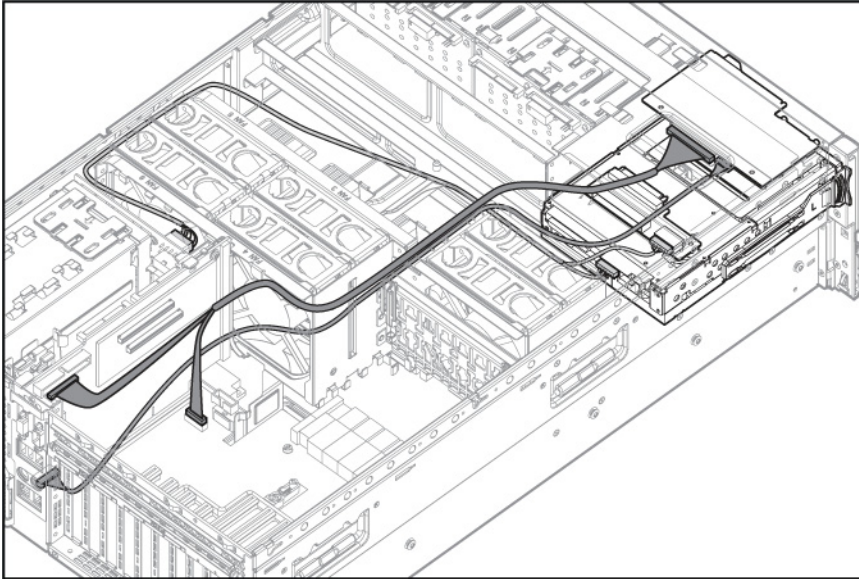

Redundant hot-plug power supply option

The server supports up to four hot-plug power supplies. Install all power supplies to provide full redundancy.



WARNING: To reduce the risk of electric shock or damage to the equipment:

- Do not disable the power cord grounding plug. The grounding plug is an important safety feature.
- Plug the power cord into a grounded (earthed) electrical outlet that is easily accessible at all times.
- Unplug the power cord from the power supply to disconnect power to the equipment.
- Do not route the power cord where it can be walked on or pinched by items placed against it. Pay particular attention to the plug, electrical outlet, and the point where the cord extends from the server.

1. Remove the power supply blank.

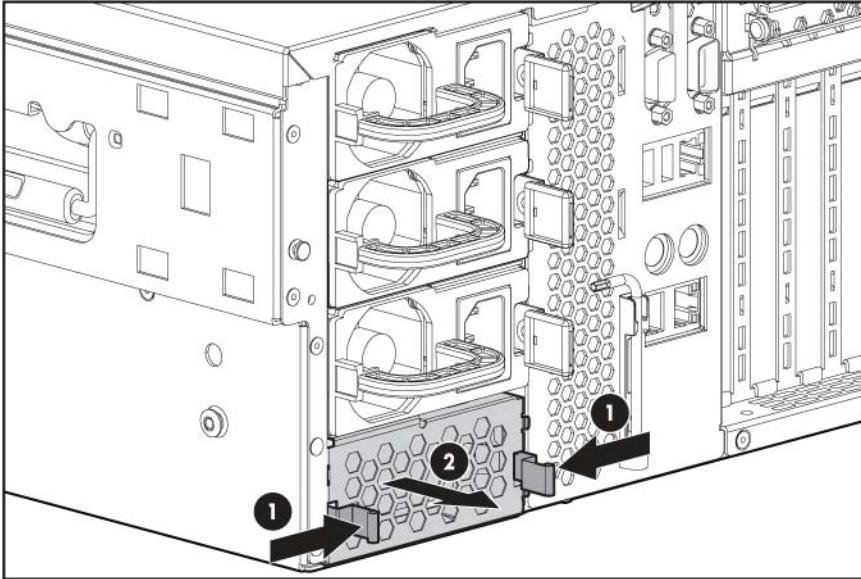

2. Slide the power supply into the power supply bay until the device locks into place.

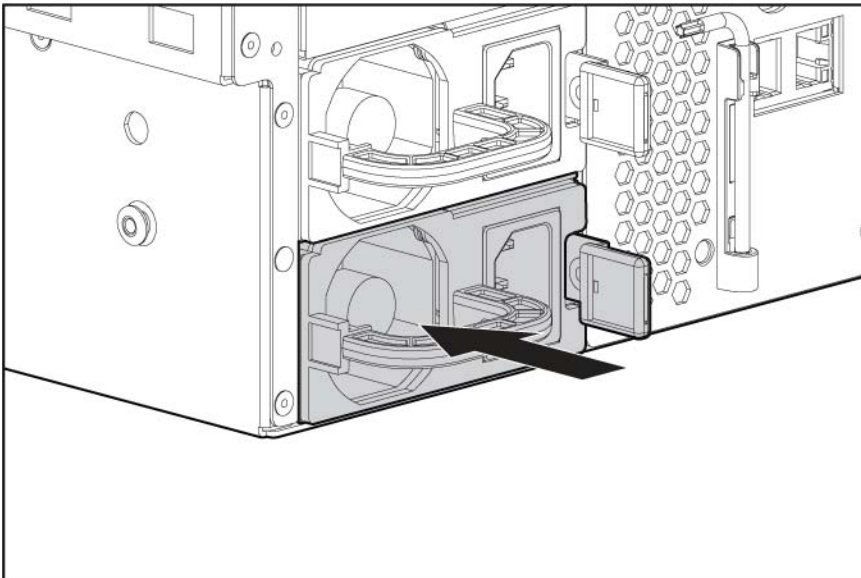

3. Connect the power cord to the power supply.
4. Connect the power cord to the power source.
5. Be sure that the power supply LED is green.
6. Be sure that the front panel external health LED is green ("[Front panel LEDs and buttons](#)" on page 8).
7. To install the remaining power supply, repeat the procedure.

Battery-backed write cache

The HP BBWC protects against hard boot, power, controller, and system board failures. The server supports the following battery-backed options:

- 256-MB cache module (standard)

- 512MB cache module (optional)

The BBWC consists of two parts: a battery pack and a storage cache module.

Along with the cache module, the battery pack provides transportable data protection, increases overall controller performance, and maintains any cached data for up to 72 hours after the server loses power. The NiMH batteries in the battery pack are continuously recharged through a trickle-charging process whenever the system power is on.



CAUTION: To prevent a server malfunction or damage to the equipment, do not add or remove the battery pack while an array capacity expansion, RAID level migration, or stripe size migration is in progress.



CAUTION: After the server is powered down, wait 15 seconds and then check the amber LED before unplugging the cable from the cache module. If the amber LED blinks after 15 seconds, do not remove the cable from the cache module. The cache module is backing up data, and data is lost if the cable is detached.



IMPORTANT: The battery pack might have a low charge when installed. In this case, a POST error message is displayed when the server is powered up, indicating that the battery pack is temporarily disabled. No action is necessary on your part. The internal circuitry automatically recharges the batteries and enables the battery pack. This process might take up to four hours. During this time, the cache module functions properly, but without the performance advantage of the battery pack.

NOTE: The data protection and the time limit also apply if a power outage occurs. When power is restored to the system, an initialization process writes the preserved data to the hard drives.

To upgrade the BBWC:

1. Close all applications, and power down the server (on page 21). This procedure flushes all data from the cache.
2. Extend the server from the rack ("[Extending the server from the rack](#)" on page 21).
3. Remove the access panel ("[Removing the access panel](#)" on page 23).

9. Install the battery pack into the server.

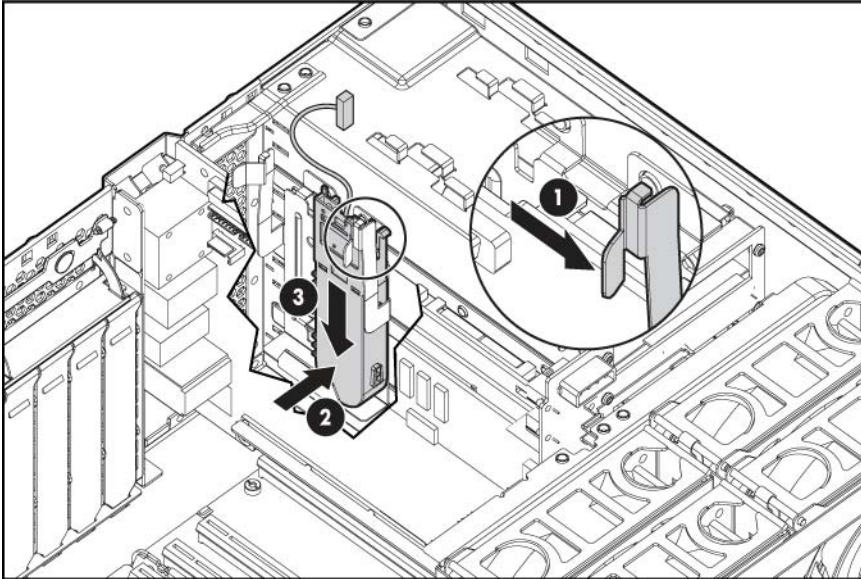

10. Route and connect the cable.

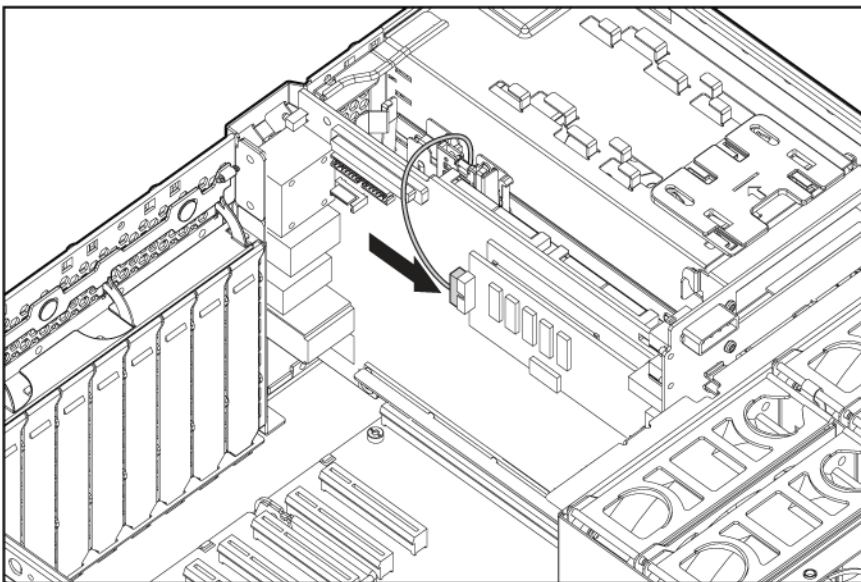

Fans

The server ships standard with six hot-plug fans installed.

In redundant mode:

- All six fans must be installed and operating.
- If one fan fails, the server is no longer in redundant mode.
- If two or more fans fail, then the server shuts down, and the health LED illuminates red.

To install the fans:

1. Extend the server from the rack ("[Extending the server from the rack](#)" on page 21).

2. Remove the access panel ("Removing the access panel" on page 23).
3. Install the fans.

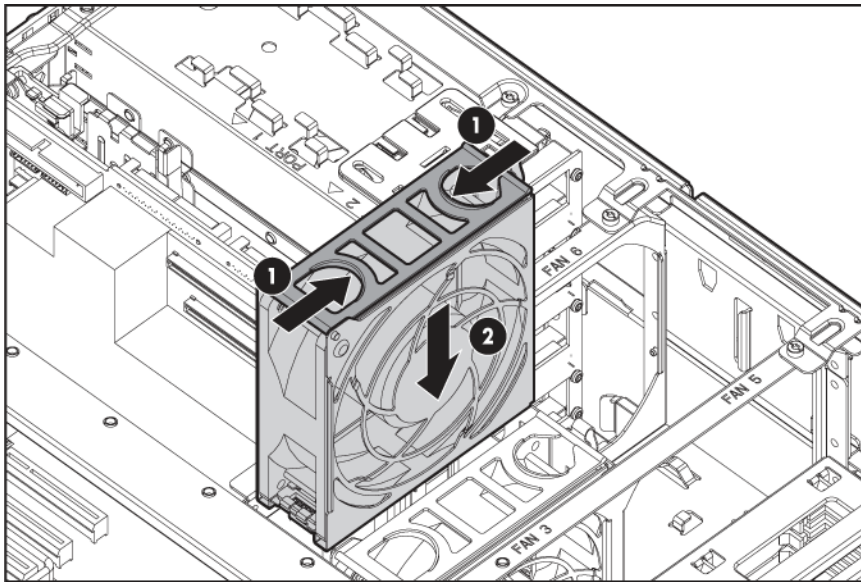

Expansion board options

The server supports up to eleven expansion slots. The server is shipped with eight non-hot-plug expansion slots (slots 4 through 11) and a connector to add three optional non-hot-plug expansion slots (slots 1 through 3).

To support the optional expansion slots, install one of the following options into the server:

- PCI Express x8 3 Slot Option Card ("Installing the PCI Express x8 3 Slot Option Card" on page 58)—Adds three optional PCI Express x8 expansion slots
- PCI-X 3 Slot Option Card ("Installing the PCI-X 3 Slot Option Card" on page 59)—Adds three optional PCI-X expansion slots

Installing non-hot-plug expansion boards

CAUTION: To prevent improper cooling and thermal damage, do not operate the server unless all expansion slots have either an expansion slot cover or an expansion board installed.

1. Power down the server (on page 21).
2. Extend or remove the server from the rack ("Extending the server from the rack" on page 21).
3. Remove the access panel ("Removing the access panel" on page 23).

4. Open the latch, and remove the expansion slot cover.

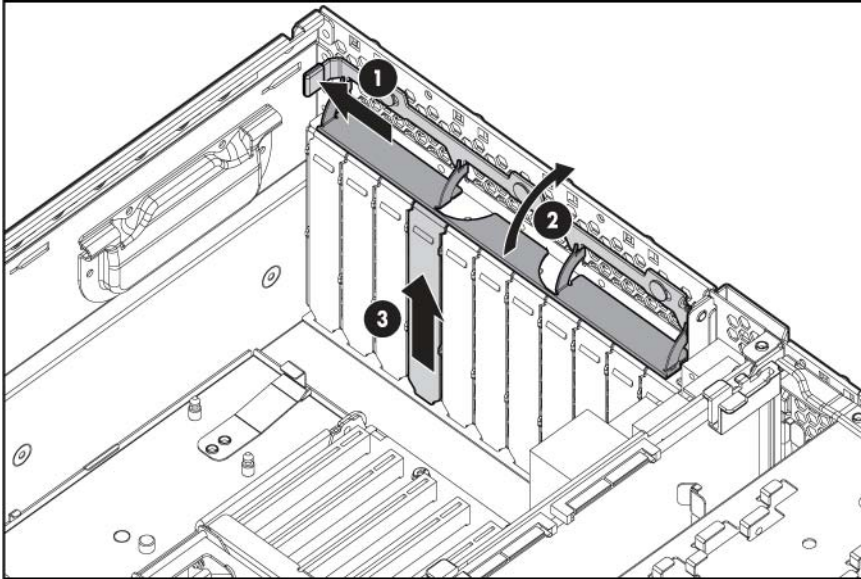

5. Install the expansion board.
6. Close the latch.

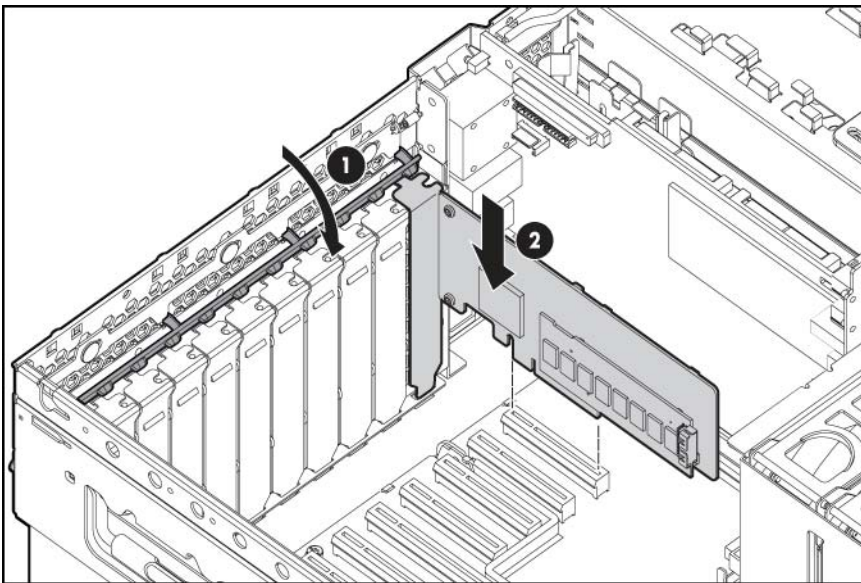

7. Connect any required internal or external cables to the expansion board.
8. Replace the access panel, and resume normal server operations.

Installing the PCI Express x8 3 Slot Option Card

CAUTION: To prevent improper cooling and thermal damage, do not operate the server unless all expansion slots have either an expansion slot cover or an expansion board installed.

1. Power down the server (on page 21).
2. Remove the processor memory module ("Removing the processor memory module" on page 33).
3. Extend or remove the server from the rack ("Extending the server from the rack" on page 21).

4. Remove the access panel ("[Removing the access panel](#)" on page 23).
5. Remove the expansion slot covers from slots 1 through 3.
6. Install the card into the server.

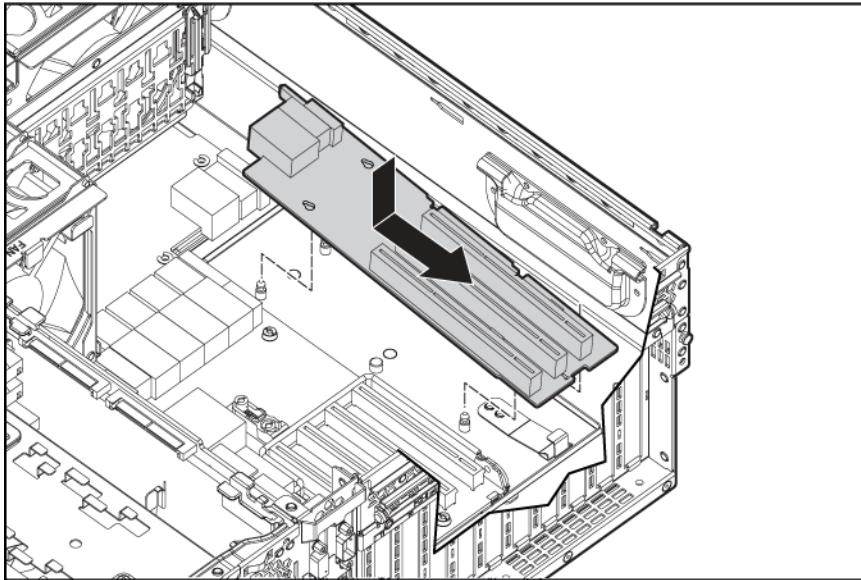

7. Install the expansion board ("[Installing non-hot-plug expansion boards](#)" on page 57).
8. Place expansion slot covers over any empty slots, and close the latch.

△ **CAUTION:** To prevent improper cooling and thermal damage, do not operate the server unless all expansion slots have either an expansion slot cover or an expansion board installed.

9. Replace the access panel ("[Removing the access panel](#)" on page 23).
10. Slide the server into the rack.
11. Install the processor memory module into the server.
12. Power up the server (on page 21).

Installing the PCI-X 3 Slot Option Card

△ **CAUTION:** To prevent improper cooling and thermal damage, do not operate the server unless all expansion slots have either an expansion slot cover or an expansion board installed.

1. Power down the server (on page 21).
2. Remove the processor memory module ("[Removing the processor memory module](#)" on page 33).
3. Extend or remove the server from the rack ("[Extending the server from the rack](#)" on page 21).
4. Remove the access panel ("[Removing the access panel](#)" on page 23).
5. Remove the expansion slot covers from slots 1 through 3.

6. Install the card into the server.

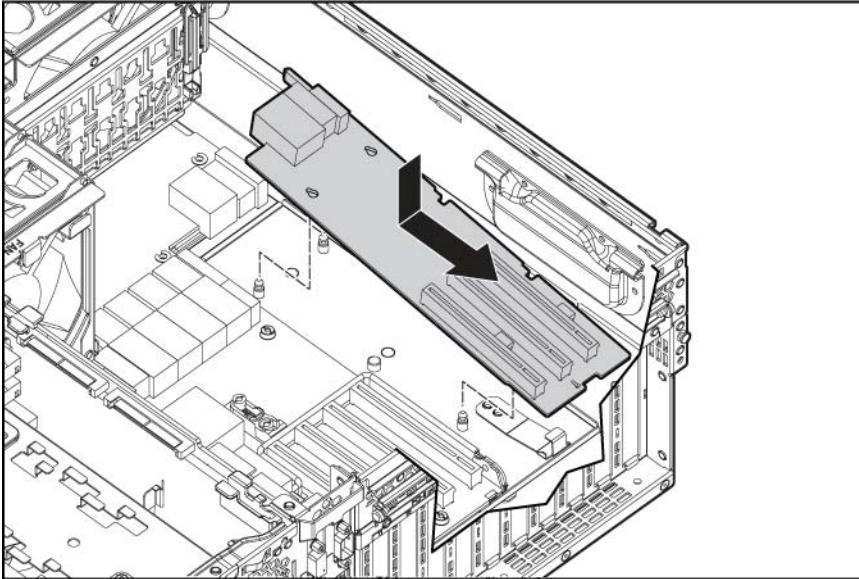

7. Install the expansion board.
8. Place expansion slot covers over any empty slots, and close the latch.
9. Replace the access panel ("[Removing the access panel](#)" on page [23](#)).
10. Slide the server into the rack.
11. Install the processor memory module into the server.
12. Power up the server (on page [21](#)).

Cabling

BBWC cabling

△ **CAUTION:** When routing cables, always be sure that the cables are not in a position where they can be pinched or crimped.

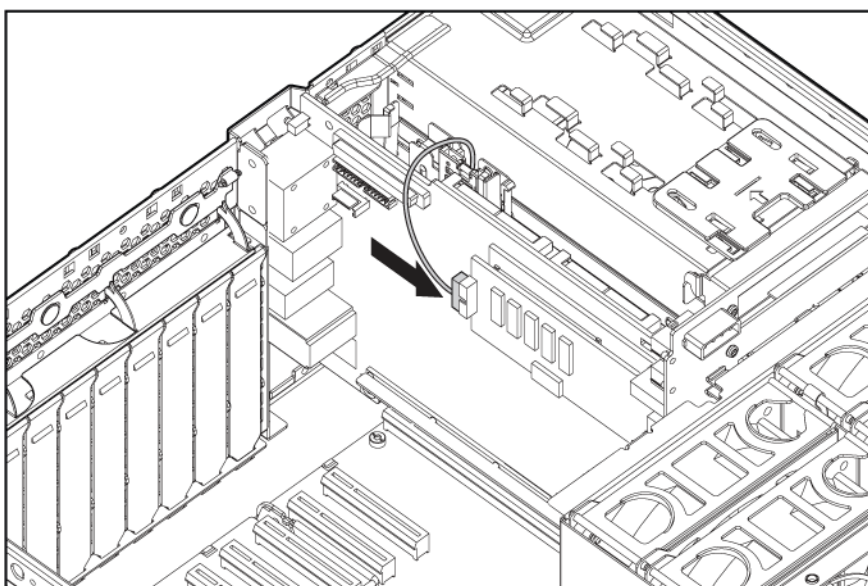

Hard drive cabling

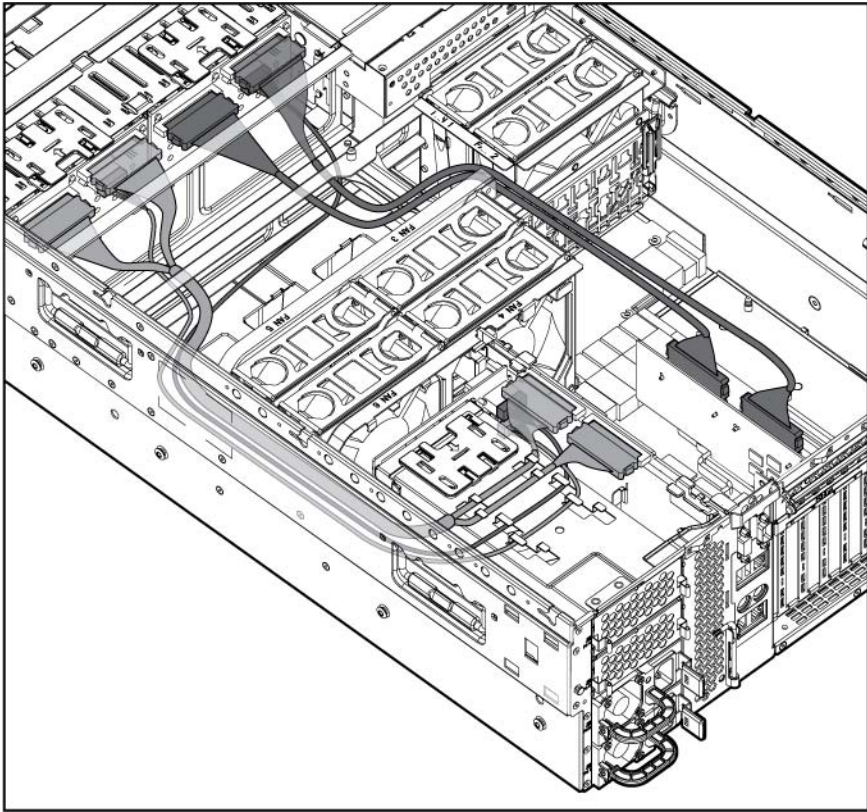
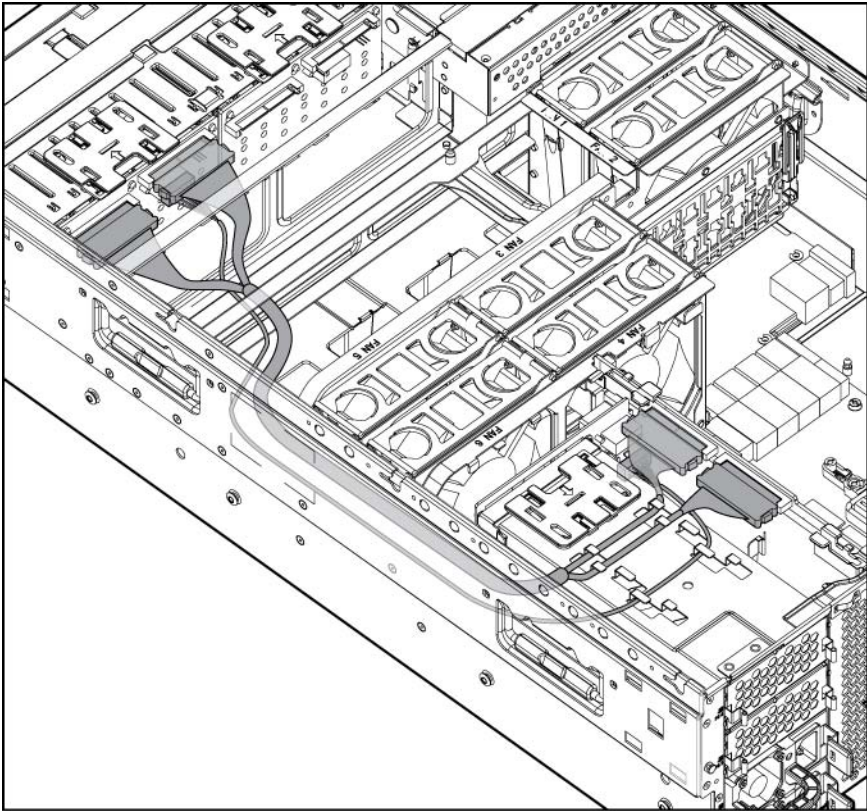

Tape drive cabling

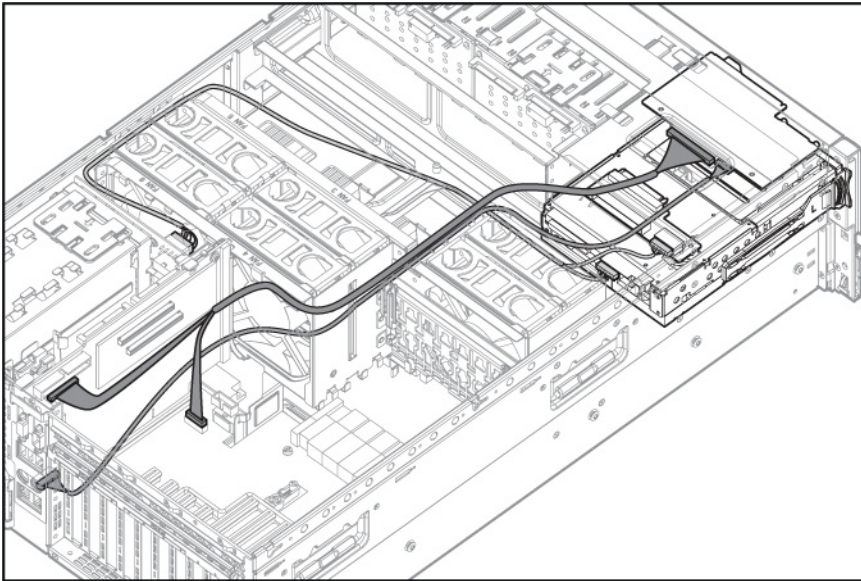

SATA DVD drive cabling

△ **CAUTION:** When routing cables, always be sure that the cables are not in a position where they can be pinched or crimped.

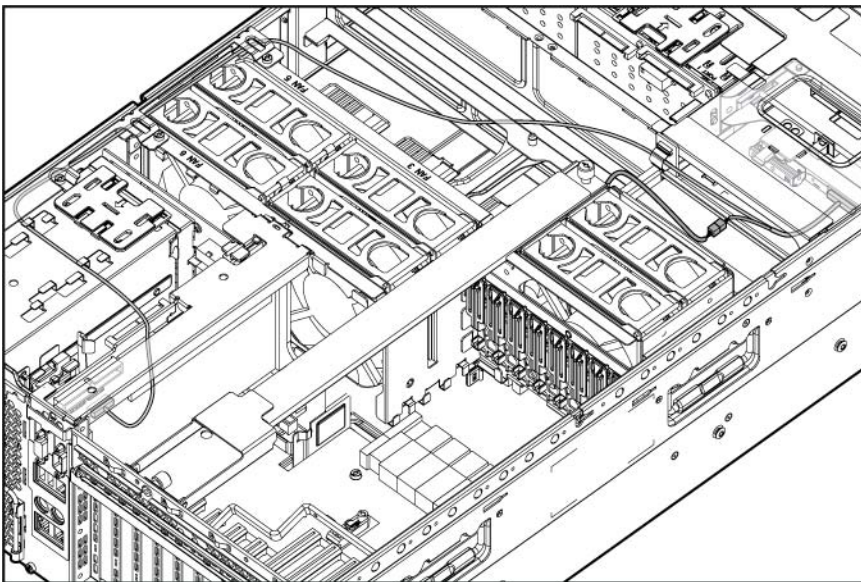

DVD drive cabling

△ **CAUTION:** When routing cables, always be sure that the cables are not in a position where they can be pinched or crimped.

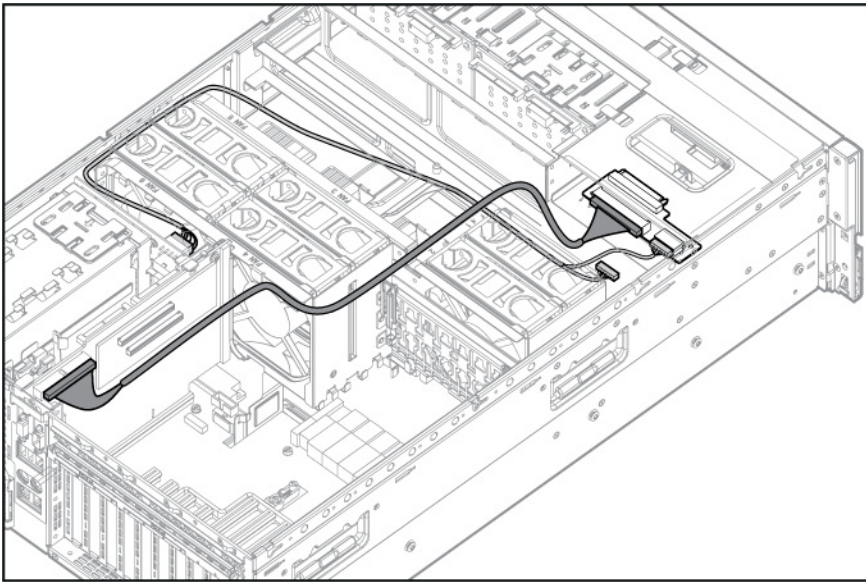

Server software and configuration utilities

Configuration tools

SmartStart software

SmartStart is a collection of software that optimizes single-server setup, providing a simple and consistent way to deploy server configuration. SmartStart has been tested on many ProLiant server products, resulting in proven, reliable configurations.

SmartStart assists the deployment process by performing a wide range of configuration activities, including:

- Configuring hardware using embedded configuration utilities, such as RBSU and ORCA
- Preparing the system for installing "off-the-shelf" versions of leading operating system software
- Installing optimized server drivers, management agents, and utilities automatically with every assisted installation
- Testing server hardware using the Insight Diagnostics Utility ("HP Insight Diagnostics" on page 72)
- Installing software drivers directly from the CD. With systems that have internet connection, the SmartStart Autorun Menu provides access to a complete list of ProLiant system software.
- Enabling access to the Array Configuration Utility (on page 69), Array Diagnostic Utility (on page 73), and Erase Utility

SmartStart is included in the HP ProLiant Essentials Foundation Pack. For more information about SmartStart software, refer to the HP ProLiant Essentials Foundation Pack or the HP website (<http://h18013.www1.hp.com/products/servers/management/smartstart/index.html>).

SmartStart Scripting Toolkit

The SmartStart Scripting Toolkit is a server deployment product that delivers an unattended automated installation for high-volume server deployments. The SmartStart Scripting Toolkit is designed to support ProLiant BL, ML, and DL servers. The toolkit includes a modular set of utilities and important documentation that describes how to apply these new tools to build an automated server deployment process.

Using SmartStart technology, the Scripting Toolkit provides a flexible way to create standard server configuration scripts. These scripts are used to automate many of the manual steps in the server configuration process. This automated server configuration process cuts time from each server deployed, making it possible to scale server deployments to high volumes in a rapid manner.

For more information, and to download the SmartStart Scripting Toolkit, refer to the HP website (<http://www.hp.com/servers/sstoolkit>).

HP ROM-Based Setup Utility

RBSU is a configuration utility embedded in ProLiant servers that performs a wide range of configuration activities that can include the following:

- Configuring system devices and installed options
- Enabling and disabling system features
- Displaying system information
- Selecting the primary boot controller
- Configuring memory options
- Language selection

For more information on RBSU, see the *HP ROM-Based Setup Utility User Guide* on the Documentation CD or the HP website (<http://www.hp.com/support/smartstart/documentation>).

Using RBSU

To use RBSU, use the following keys:

- To access RBSU, press the **F9** key during power-up when prompted.
- To navigate the menu system, use the arrow keys.
- To make selections, press the **Enter** key.
- To access Help for a highlighted configuration option, press the **F1** key.



IMPORTANT: RBSU automatically saves settings when you press the **Enter** key. The utility does not prompt you for confirmation of settings before you exit the utility. To change a selected setting, you must select a different setting and press the **Enter** key.

Default configuration settings are applied to the server at one of the following times:

- Upon the first system power-up
- After defaults have been restored

Default configuration settings are sufficient for proper typical server operation, but configuration settings can be modified using RBSU. The system will prompt you for access to RBSU with each power-up.

Configuring online spare memory

To configure online spare memory:

1. Install the required FBDIMMs ("[Memory options](#)" on page [39](#)).
2. Access RBSU by pressing the **F9** key during power-up when the prompt is displayed in the upper right corner of the screen.
3. Select **System Options**.
4. Select **Advanced Memory Protection**.
5. Select **Online Spare with Advanced ECC Support**.
6. Press the **Enter** key.
7. Press the **Esc** key to exit the current menu, or press the **F10** key to exit RBSU.

For more information on online spare memory, refer to the white paper on the HP website (<http://h18000.www1.hp.com/products/servers/technology/memoryprotection.html>).

Configuring mirrored memory

To configure mirrored memory:

1. Install the required FBDIMMs ("Memory options" on page 39).
2. Access RBSU by pressing the **F9** key during power-up when the prompt is displayed in the upper right corner of the screen.
3. Select **System Options**.
4. Select **Advanced Memory Protection**.
5. Select **Mirrored Memory with Advanced ECC Support**.
6. Press the **Enter** key.
7. Press the **Esc** key to exit the current menu or press the **F10** key to exit RBSU.

For more information on mirrored memory, refer to the white paper on the HP website (<http://h18000.www1.hp.com/products/servers/technology/memoryprotection.html>).

Auto-configuration process

The auto-configuration process automatically runs when you boot the server for the first time. During the power-up sequence, the system ROM automatically configures the entire system without needing any intervention. During this process, the ORCA utility, in most cases, automatically configures the array to a default setting based on the number of drives connected to the server.

NOTE: The server may not support all the following examples.

NOTE: If the boot drive is not empty or has been written to in the past, ORCA does not automatically configure the array. You must run ORCA to configure the array settings.

Drives installed	Drives used	RAID level
1	1	RAID 0
2	2	RAID 1
3, 4, 5, or 6	3, 4, 5, or 6	RAID 5
More than 6	0	None

To change any ORCA default settings and override the auto-configuration process, press the **F8** key when prompted.

By default, the auto-configuration process configures the system for the English language. To change any default settings in the auto-configuration process (such as the settings for language, operating system, and primary boot controller), execute RBSU by pressing the **F9** key when prompted. After the settings are selected, exit RBSU and allow the server to reboot automatically.

For more information on RBSU, see the *HP ROM-Based Setup Utility User Guide* on the Documentation CD or the HP website (<http://www.hp.com/support/smartstart/documentation>).

Boot options

Near the end of the boot process, the boot options screen is displayed. This screen is visible for several seconds before the system attempts to boot from a diskette, CD, or hard drive. During this time, you can do the following:

- Access RBSU by pressing the **F9** key.
- Access the System Maintenance Menu (which enables you to launch ROM-based Diagnostics or Inspect) by pressing the **F10** key.
- Force a PXE Network boot by pressing the **F12** key.

BIOS Serial Console

BIOS Serial Console allows you to configure the serial port to view POST error messages and run RBSU remotely through a serial connection to the server COM port. The server that you are remotely configuring does not require a keyboard and mouse.

For more information about BIOS Serial Console, see the *BIOS Serial Console User Guide* on the Documentation CD or the HP website (<http://www.hp.com/support/smartstart/documentation>).

HP ProLiant Essentials Rapid Deployment Pack

The RDP software is the preferred method for rapid, high-volume server deployments. The RDP software integrates two powerful products: Altiris Deployment Solution and the HP ProLiant Integration Module.

The intuitive graphical user interface of the Altiris Deployment Solution console provides simplified point-and-click and drag-and-drop operations that enable you to deploy target servers, including server blades, remotely. It enables you to perform imaging or scripting functions and maintain software images.

For more information about the RDP, refer to the HP ProLiant Essentials Rapid Deployment Pack CD or refer to the HP website (<http://www.hp.com/servers/rdp>).

Option ROM Configuration for Arrays

Before installing an operating system, you can use the ORCA utility to create the first logical drive, assign RAID levels, and establish online spare configurations.

The utility also provides support for the following functions:

- Reconfiguring one or more logical drives
- Viewing the current logical drive configuration
- Deleting a logical drive configuration
- Setting the controller to be the boot controller

If you do not use the utility, ORCA will default to the standard configuration.

For more information regarding array controller configuration, refer to the controller user guide.

For more information regarding the default configurations that ORCA uses, refer to the *HP ROM-Based Setup Utility User Guide* on the Documentation CD.

Array Configuration Utility

ACU is a browser-based utility with the following features:

- Runs as a local application or remote service
- Supports online array capacity expansion, logical drive extension, assignment of online spares, and RAID or stripe size migration
- Suggests the optimum configuration for an unconfigured system
- Provides different operating modes, enabling faster configuration or greater control over the configuration options
- Remains available any time that the server is on
- Displays on-screen tips for individual steps of a configuration procedure

For optimum performance, the minimum display settings are 800 × 600 resolution and 256 colors. Servers running Microsoft® operating systems require Internet Explorer 5.5 (with Service Pack 1) or later. For Linux servers, refer to the README.TXT file for additional browser and support information.

For more information, refer to the *Configuring Arrays on HP Smart Array Controllers Reference Guide* on the Documentation CD or the HP website (<http://www.hp.com>).

Re-entering the server serial number and product ID

After you replace the system board, you must re-enter the server serial number and the product ID.

1. During the server startup sequence, press the **F9** key to access RBSU.
2. Select the **Advanced Options** menu.
3. Select **Serial Number**. The following warning is displayed:
Warning: The serial number should ONLY be modified by qualified service personnel. This value should always match the serial number located on the chassis.
4. Press the **Enter** key to clear the warning.
5. Enter the serial number.
6. Select **Product ID**. The following warning is displayed:
Warning: The Product ID should ONLY be modified by qualified service personnel. This value should always match the Product ID located on the chassis.
7. Enter the product ID and press the **Enter** key.
8. Press the **Escape** key to close the menu.
9. Press the **Escape** key to exit RBSU.
10. Press the **F10** key to confirm exiting RBSU. The server will automatically reboot.

Management tools

Automatic Server Recovery

ASR is a feature that causes the system to restart when a catastrophic operating system error occurs, such as a blue screen, ABEND, or panic. A system fail-safe timer, the ASR timer, starts when the System Management driver, also known as the Health Driver, is loaded. When the operating system is functioning properly, the system periodically resets the timer. However, when the operating system fails, the timer expires and restarts the server.

ASR increases server availability by restarting the server within a specified time after a system hang or shutdown. At the same time, the HP SIM console notifies you by sending a message to a designated pager number that ASR has restarted the system. You can disable ASR from the HP SIM console or through RBSU.

ROMPaq utility

The ROMPaq utility enables you to upgrade the system firmware (BIOS) or Lights-Out 100 firmware. To upgrade the firmware, insert a ROMPaq diskette into the diskette drive or ROMPaq USB Key into an available USB port and boot the system.

The ROMPaq utility checks the system and provides a choice (if more than one exists) of available firmware revisions.

For more information about the ROMPaq utility, see the HP website (<http://www.hp.com/go/support>).

System Online ROM flash component utility

The Online ROM Flash Component Utility enables system administrators to efficiently upgrade system or controller ROM images across a wide range of servers and array controllers. This tool has the following features:

- Works offline and online
- Supports Microsoft® Windows NT®, Windows® 2000, Windows Server™ 2003, Novell Netware, and Linux operating systems



IMPORTANT: This utility supports operating systems that may not be supported by the server. For operating systems supported by the server, see the HP website (<http://www.hp.com/support>).

- Integrates with other software maintenance, deployment, and operating system tools
- Automatically checks for hardware, firmware, and operating system dependencies, and installs only the correct ROM upgrades required by each target server

To download the tool and for more information, see the HP website (<http://www.hp.com/support>).

Remote Insight Lights-Out Edition II

RILOE II enables browser access to servers through a hardware-based, OS-independent graphical remote console. Some of the features include virtual diskette drive and power button, server management through

any standard browser, dedicated LAN connectivity, automatic network configuration, external power backup, group administration, and functions available with the Remote Insight Board.

For more information about RiLOE II features, refer to the *Remote Insight Lights-Out Edition User Guide* on the Documentation CD or on the HP website (<http://www.hp.com/servers/lights-out>).

Integrated Lights-Out 2 technology

The iLO 2 subsystem is a standard component of selected ProLiant servers that provides server health and remote server manageability. The iLO 2 subsystem includes an intelligent microprocessor, secure memory, and a dedicated network interface. This design makes iLO 2 independent of the host server and its operating system. The iLO 2 subsystem provides remote access to any authorized network client, sends alerts, and provides other server management functions.

Using iLO 2, you can:

- Remotely power up, power down, or reboot the host server.
- Send alerts from iLO 2 regardless of the state of the host server.
- Access advanced troubleshooting features through the iLO 2 interface.
- Diagnose iLO 2 using HP SIM through a web browser and SNMP alerting.

For more information about iLO 2 features, refer to the iLO 2 documentation on the Documentation CD or on the HP website (<http://www.hp.com/servers/lights-out>).

StorageWorks library and tape tools

HP StorageWorks L&TT provides functionality for firmware downloads, verification of device operation, maintenance procedures, failure analysis, corrective service actions, and some utility functions. It also provides seamless integration with HP hardware support by generating and emailing support tickets that deliver a snapshot of the storage system.

For more information, and to download the utility, refer to the StorageWorks L&TT website (<http://h18006.www1.hp.com/products/storageworks/ltt>).

HP Systems Insight Manager

HP SIM is a web-based application that allows system administrators to accomplish normal administrative tasks from any remote location, using a web browser. HP SIM provides device management capabilities that consolidate and integrate management data from HP and third-party devices.



IMPORTANT: You must install and use HP SIM to benefit from the Pre-Failure Warranty for processors, SAS and SATA hard drives, and memory modules.

For additional information, refer to the Management CD in the HP ProLiant Essentials Foundation Pack or the HP SIM website (<http://www.hp.com/go/hpsim>).

Management Agents

Management Agents provide the information to enable fault, performance, and configuration management. The agents allow easy manageability of the server through HP SIM software, and third-party SNMP management platforms. Management Agents are installed with every SmartStart assisted

installation or can be installed through the HP PSP. The Systems Management homepage provides status and direct access to in-depth subsystem information by accessing data reported through the Management Agents. For additional information, refer to the Management CD in the HP ProLiant Essentials Foundation Pack or the HP website (<http://www.hp.com/servers/manage>).

Redundant ROM support

The server enables you to upgrade or configure the ROM safely with redundant ROM support. The server has a 4-MB ROM that acts as two, separate 2-MB ROMs. In the standard implementation, one side of the ROM contains the current ROM program version, while the other side of the ROM contains a backup version.

NOTE: The server ships with the same version programmed on each side of the ROM.

Safety and security benefits

When you flash the system ROM, ROMPaq writes over the backup ROM and saves the current ROM as a backup, enabling you to switch easily to the alternate ROM version if the new ROM becomes corrupted for any reason. This feature protects the existing ROM version, even if you experience a power failure while flashing the ROM.

USB support

HP provides both standard USB support and legacy USB support. Standard support is provided by the operating system through the appropriate USB device drivers. HP provides support for USB devices before the operating system loads through legacy USB support, which is enabled by default in the system ROM. HP hardware supports USB version 1.1 or 2.0, depending on the version of the hardware.

Legacy USB support provides USB functionality in environments where USB support is normally not available. Specifically, HP provides legacy USB functionality for:

- POST
- RBSU
- Diagnostics
- DOS
- Operating environments which do not provide native USB support

For more information on ProLiant USB support, refer to the HP website (<http://h18004.www1.hp.com/products/servers/platforms/usb-support.html>).

Diagnostic tools

HP Insight Diagnostics

HP Insight Diagnostics is a proactive server management tool, available in both offline and online versions, that provides diagnostics and troubleshooting capabilities to assist IT administrators who verify server installations, troubleshoot problems, and perform repair validation.

HP Insight Diagnostics Offline Edition performs various in-depth system and component testing while the OS is not running. To run this utility, launch the SmartStart CD.

HP Insight Diagnostics Online Edition is a web-based application that captures system configuration and other related data needed for effective server management. Available in Microsoft® Windows® and Linux versions, the utility helps to ensure proper system operation.

For more information or to download the utility, refer to the HP website (<http://www.hp.com/servers/diags>).

Integrated Management Log

The IML records hundreds of events and stores them in an easy-to-view form. The IML timestamps each event with 1-minute granularity.

You can view recorded events in the IML in several ways, including the following:

- From within HP SIM ("HP Systems Insight Manager" on page 71)
- From within Survey Utility
- From within operating system-specific IML viewers
 - For NetWare: IML Viewer
 - For Windows®: IML Viewer
 - For Linux: IML Viewer Application
- From within the iLO 2 user interface
- From within HP Insight Diagnostics (on page 72)

For more information, refer to the Management CD in the HP ProLiant Essentials Foundation Pack.

Array Diagnostic Utility

The HP Array Diagnostics Utility is a web-based application that creates a report of all HP storage controllers and disk drives. This report provides vital information to assist in identifying faults or conditions that may require attention. ADU can be accessed from the SmartStart CD ("SmartStart software" on page 65) or downloaded from the HP website (<http://www.hp.com>).

Remote support and analysis tools

HP Instant Support Enterprise Edition

ISEE is a proactive remote monitoring and diagnostic tool to help manage your systems and devices, a feature of HP support. ISEE provides continuous hardware event monitoring and automated notification to identify and prevent potential critical problems. Through remote diagnostic scripts and vital system configuration information collected about your systems, ISEE enables fast restoration of your systems. Install ISEE on your systems to help mitigate risk and prevent potential critical problems.

For more information on ISEE, refer to the HP website (http://www.hp.com/hps/hardware/hw_enterprise.html).

To download HP ISEE, visit the HP website (http://www.hp.com/hps/hardware/hw_downloads.html).

For installation information, refer to the HP ISEE Client Installation and Upgrade Guide (ftp://ftp.hp.com/pub/services/hardware/info/isee_client.pdf).

Keeping the system current

Drivers

The server includes new hardware that may not have driver support on all operating system installation media.

If you are installing a SmartStart-supported operating system, use the SmartStart software (on page 65) and its Assisted Path feature to install the operating system and latest driver support.

NOTE: If you are installing drivers from the SmartStart CD or the Software Maintenance CD, refer to the SmartStart website (<http://www.hp.com/servers/smartstart>) to be sure that you are using the latest version of SmartStart. For more information, refer to the documentation provided with the SmartStart CD.

If you do not use the SmartStart CD to install an operating system, drivers for some of the new hardware are required. These drivers, as well as other option drivers, ROM images, and value-add software can be downloaded from the HP website (<http://www.hp.com/support>).



IMPORTANT: Always perform a backup before installing or updating device drivers.

ProLiant Support Packs

PSPs represent operating system-specific bundles of ProLiant optimized drivers, utilities, and management agents. Refer to the PSP website (<http://h18000.www1.hp.com/products/servers/management/psp.html>).

Operating system version support

Refer to the operating system support matrix (<http://www.hp.com/go/supportos>).

Change control and proactive notification

HP offers Change Control and Proactive Notification to notify customers 30 to 60 days in advance of upcoming hardware and software changes on HP commercial products.

For more information, refer to the HP website (<http://www.hp.com/go/pcn>).

Care Pack

HP Care Pack Services offer upgraded service levels to extend and expand standard product warranty with easy-to-buy, easy-to-use support packages that help you make the most of your server investments. Refer to the Care Pack website (http://www.hp.com/hps/carepack/servers/cp_proliant.html).

Troubleshooting

Troubleshooting resources

The *HP ProLiant Servers Troubleshooting Guide* provides procedures for resolving common problems and comprehensive courses of action for fault isolation and identification, error message interpretation, issue resolution, and software maintenance on ProLiant servers and server blades. This guide includes problem-specific flowcharts to help you navigate complex troubleshooting processes. To view the guide, select a language:

- English (http://www.hp.com/support/ProLiant_TSG_en)
- French (http://www.hp.com/support/ProLiant_TSG_fr)
- Italian (http://www.hp.com/support/ProLiant_TSG_it)
- Spanish (http://www.hp.com/support/ProLiant_TSG_sp)
- German (http://www.hp.com/support/ProLiant_TSG_gr)
- Dutch (http://www.hp.com/support/ProLiant_TSG_nl)
- Japanese (http://www.hp.com/support/ProLiant_TSG_jp)

Pre-diagnostic steps



WARNING: To avoid potential problems, ALWAYS read the warnings and cautionary information in the server documentation before removing, replacing, reseating, or modifying system components.



IMPORTANT: This guide provides information for multiple servers. Some information may not apply to the server you are troubleshooting. Refer to the server documentation for information on procedures, hardware options, software tools, and operating systems supported by the server.

1. Review the important safety information (on page [75](#)).
2. Gather symptom information (on page [77](#)).
3. Prepare the server for diagnosis (on page [78](#)).
4. Use the Start diagnosis flowchart (on page [79](#)) to begin the diagnostic process.

Important safety information

Familiarize yourself with the safety information in the following sections before troubleshooting the server.



Important safety information

Before servicing this product, read the *Important Safety Information* document provided with the server.

Symbols on equipment

The following symbols may be placed on equipment to indicate the presence of potentially hazardous conditions.



This symbol indicates the presence of hazardous energy circuits or electric shock hazards. Refer all servicing to qualified personnel.

WARNING: To reduce the risk of injury from electric shock hazards, do not open this enclosure. Refer all maintenance, upgrades, and servicing to qualified personnel.



This symbol indicates the presence of electric shock hazards. The area contains no user or field serviceable parts. Do not open for any reason.

WARNING: To reduce the risk of injury from electric shock hazards, do not open this enclosure.



This symbol on an RJ-45 receptacle indicates a network interface connection.

WARNING: To reduce the risk of electric shock, fire, or damage to the equipment, do not plug telephone or telecommunications connectors into this receptacle.



This symbol indicates the presence of a hot surface or hot component. If this surface is contacted, the potential for injury exists.

WARNING: To reduce the risk of injury from a hot component, allow the surface to cool before touching.



50 kg

110 lb

This symbol indicates that the component exceeds the recommended weight for one individual to handle safely.

WARNING: To reduce the risk of personal injury or damage to the equipment, observe local occupational health and safety requirements and guidelines for manual material handling.



These symbols, on power supplies or systems, indicate that the equipment is supplied by multiple sources of power.

WARNING: To reduce the risk of injury from electric shock, remove all power cords to completely disconnect power from the system.

Warnings and cautions



WARNING: Only authorized technicians trained by HP should attempt to repair this equipment. All troubleshooting and repair procedures are detailed to allow only subassembly/module-level repair. Because of the complexity of the individual boards and subassemblies, no one should attempt to make repairs at the component level or to make modifications to any printed wiring board. Improper repairs can create a safety hazard.



WARNING: To reduce the risk of personal injury or damage to the equipment, be sure that:

- The leveling feet are extended to the floor.
- The full weight of the rack rests on the leveling feet.
- The stabilizing feet are attached to the rack if it is a single-rack installation.
- The racks are coupled together in multiple-rack installations.
- Only one component is extended at a time. A rack may become unstable if more than one component is extended for any reason.



WARNING: To reduce the risk of electric shock or damage to the equipment:

- Do not disable the power cord grounding plug. The grounding plug is an important safety feature.
- Plug the power cord into a grounded (earthed) electrical outlet that is easily accessible at all times.
- Unplug the power cord from the power supply to disconnect power to the equipment.
- Do not route the power cord where it can be walked on or pinched by items placed against it. Pay particular attention to the plug, electrical outlet, and the point where the cord extends from the server.



50 kg

110 lb

WARNING: To reduce the risk of personal injury or damage to the equipment:

- Observe local occupation health and safety requirements and guidelines for manual handling.
- Obtain adequate assistance to lift and stabilize the chassis during installation or removal.
- The server is unstable when not fastened to the rails.
- When mounting the server in a rack, remove the power supplies and any other removable module to reduce the overall weight of the product.



CAUTION: To properly ventilate the system, you must provide at least 7.6 cm (3.0 in) of clearance at the front and back of the server.



CAUTION: The server is designed to be electrically grounded (earthed). To ensure proper operation, plug the AC power cord into a properly grounded AC outlet only.

Symptom information

Before troubleshooting a server problem, collect the following information:

- What events preceded the failure? After which steps does the problem occur?
- What has been changed since the time the server was working?
- Did you recently add or remove hardware or software? If so, did you remember to change the appropriate settings in the server setup utility, if necessary?
- How long has the server exhibited problem symptoms?
- If the problem occurs randomly, what is the duration or frequency?

To answer these questions, the following information may be useful:

- Run HP Insight Diagnostics (on page 72) and use the survey page to view the current configuration or to compare it to previous configurations.
- Refer to your hardware and software records for information.
- Refer to server LEDs and their statuses.

Prepare the server for diagnosis

1. Be sure the server is in the proper operating environment with adequate power, air conditioning, and humidity control. Refer to the server documentation for required environmental conditions.
2. Record any error messages displayed by the system.
3. Remove all diskettes and CDs from the media drives.
4. Power down the server and peripheral devices if you will be diagnosing the server offline. Always perform an orderly shutdown, if possible. This means you must:
 - a. Exit any applications.
 - b. Exit the operating system.
 - c. Power down the server (on page 21).
5. Disconnect any peripheral devices not required for testing (any devices not necessary to power up the server). Do not disconnect the printer if you want to use it to print error messages.
6. Collect all tools and utilities, such as a Torx screwdriver, loopback adapters, ESD wrist strap, and software utilities, necessary to troubleshoot the problem.
 - You must have the appropriate Health Drivers and Management Agents installed on the server.

NOTE: To verify the server configuration, connect to the System Management homepage and select **Version Control Agent**. The VCA gives you a list of names and versions of all installed HP drivers, Management Agents, and utilities, and whether they are up to date.

- HP recommends you have access to the SmartStart CD for value-added software and drivers required during the troubleshooting process.
- HP recommends you have access to the server documentation for server-specific information.

Loose connections

Action:

- Be sure all power cords are securely connected.
- Be sure all cables are properly aligned and securely connected for all external and internal components.
- Remove and check all data and power cables for damage. Be sure no cables have bent pins or damaged connectors.
- If a fixed cable tray is available for the server, be sure the cords and cables connected to the server are routed correctly through the tray.
- Be sure each device is properly seated. Avoid bending or flexing circuit boards when reseating components.
- If a device has latches, be sure they are completely closed and locked.

- Check any interlock or interconnect LEDs that may indicate a component is not connected properly.
- If problems continue to occur, remove and reinstall each device, checking the connectors and sockets for bent pins or other damage.

Service notifications

To view the latest service notifications, refer to the HP website (<http://www.hp.com/go/bizsupport>). Select the appropriate server model, and then click the **Troubleshoot a Problem** link on the product page.

Troubleshooting flowcharts

To effectively troubleshoot a problem, HP recommends that you start with the first flowchart in this section, "Start diagnosis flowchart (on page 79)," and follow the appropriate diagnostic path. If the other flowcharts do not provide a troubleshooting solution, follow the diagnostic steps in "General diagnosis flowchart (on page 80)." The General diagnosis flowchart is a generic troubleshooting process to be used when the problem is not server-specific or is not easily categorized into the other flowcharts.

The available flowcharts include:

- Start diagnosis flowchart (on page 79)
- General diagnosis flowchart (on page 80)
- Server power-on problems flowchart (on page 82)
- POST problems flowchart (on page 85)
- OS boot problems flowchart (on page 86)
- Server fault indications flowchart (on page 88)

Start diagnosis flowchart

Use the following flowchart to start the diagnostic process.

Item	Refer to
1	"General diagnosis flowchart (on page 80)"
2	"Power-on problems flowchart ("Server power-on problems flowchart" on page 82)"
3	"POST problems flowchart (on page 85)"
4	"OS boot problems flowchart (on page 86)"
5	"Server fault indications flowchart (on page 88)"

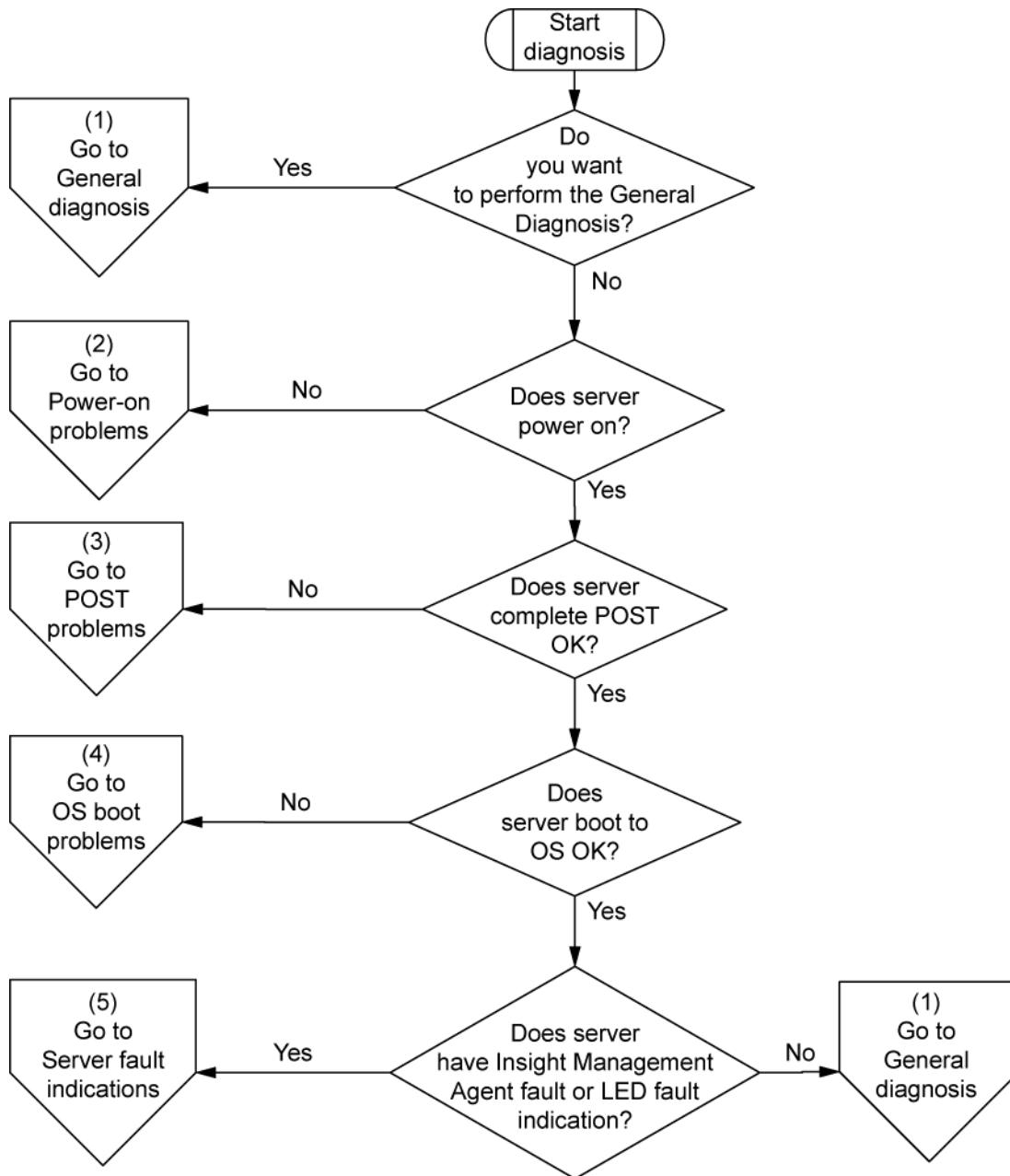

General diagnosis flowchart

The General diagnosis flowchart provides a generic approach to troubleshooting. If you are unsure of the problem, or if the other flowcharts do not fix the problem, use the following flowchart.

Item	Refer to
1	"Symptom information (on page 77)"
2	"Loose connections (on page 78)"
3	"Service notifications (on page 79)"

Item	Refer to
4	<p>The most recent version of a particular server or option firmware is available on the following websites:</p> <ul style="list-style-type: none"> • HP Support website (http://www.hp.com/support) • HP ROM-BIOS/Firmware Updates website (http://h18023.www1.hp.com/support/files/server/us/romflash.html)
5	<p>"General memory problems are occurring" in the <i>HP ProLiant Servers Troubleshooting Guide</i> located on the Documentation CD or on the HP website (http://www.hp.com/support)</p>
6	<p>Server maintenance and service guide, located on the Documentation CD or the HP website (http://www.hp.com/products/servers/platforms)</p>
7	<ul style="list-style-type: none"> • Server maintenance and service guide, located on the Documentation CD or the HP website (http://www.hp.com/products/servers/platforms) • "Hardware problems" in the <i>HP ProLiant Servers Troubleshooting Guide</i> located on the Documentation CD or on the HP website (http://www.hp.com/support)
8	<ul style="list-style-type: none"> • "Server information you need" in the <i>HP ProLiant Servers Troubleshooting Guide</i> located on the Documentation CD or on the HP website (http://www.hp.com/support) • "Operating system information you need" in the <i>HP ProLiant Servers Troubleshooting Guide</i> located on the Documentation CD or on the HP website (http://www.hp.com/support)
9	<p>"HP contact information (on page 100)"</p>

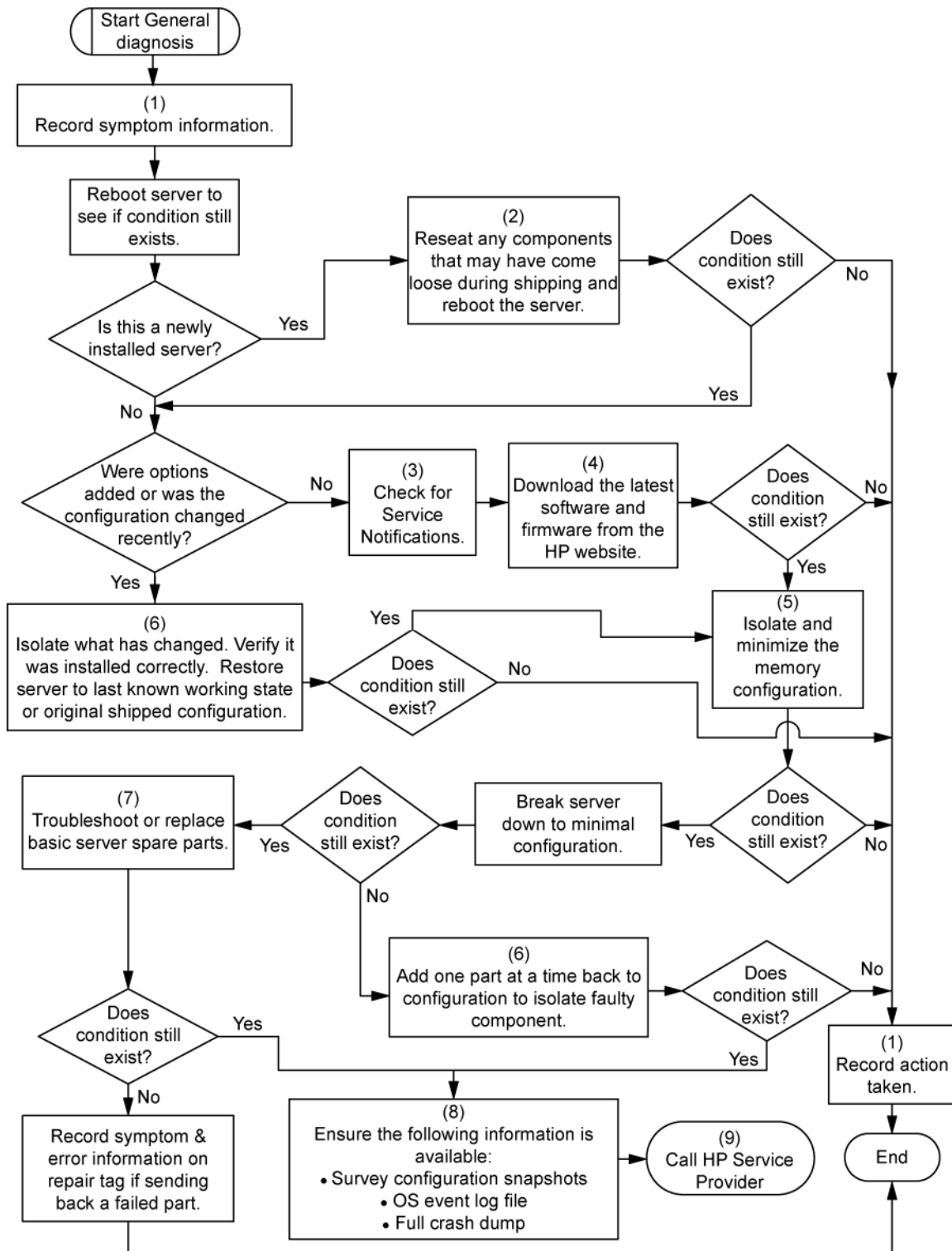

Server power-on problems flowchart

Symptoms:

- The server does not power on.
- The system power LED is off or amber.

- The external health LED is red or amber.
- The internal health LED is red or amber.

NOTE: For the location of server LEDs and information on their statuses, refer to the server documentation.

Possible causes:

- Improperly seated or faulty power supply
- Loose or faulty power cord
- Power source problem
- Power on circuit problem
- Improperly seated component or interlock problem
- Faulty internal component

Item	Refer to
1	"Component identification (on page 7)"
2	"HP Insight Diagnostics (on page 72)" or in the <i>HP ProLiant Servers Troubleshooting Guide</i> located on the Documentation CD or on the HP website (http://www.hp.com/support)
3	"Loose connections (on page 78)"
4	Server maintenance and service guide, located on the Documentation CD, or the HP website (http://www.hp.com/products/servers/platforms)
5	"Integrated Management Log (on page 73)" or in the <i>HP ProLiant Servers Troubleshooting Guide</i> located on the Documentation CD or on the HP website (http://www.hp.com/support)
6	"Power source problems" in the <i>HP ProLiant Servers Troubleshooting Guide</i> located on the Documentation CD or on the HP website (http://www.hp.com/support)
7	<ul style="list-style-type: none"> • "Power supply problems" in the <i>HP ProLiant Servers Troubleshooting Guide</i> located on the Documentation CD or on the HP website (http://www.hp.com/support) • Server maintenance and service guide, located on the Documentation CD, or the HP website (http://www.hp.com/products/servers/platforms)
8	"System open circuits and short circuits" in the <i>HP ProLiant Servers Troubleshooting Guide</i> located on the Documentation CD or on the HP website (http://www.hp.com/support)

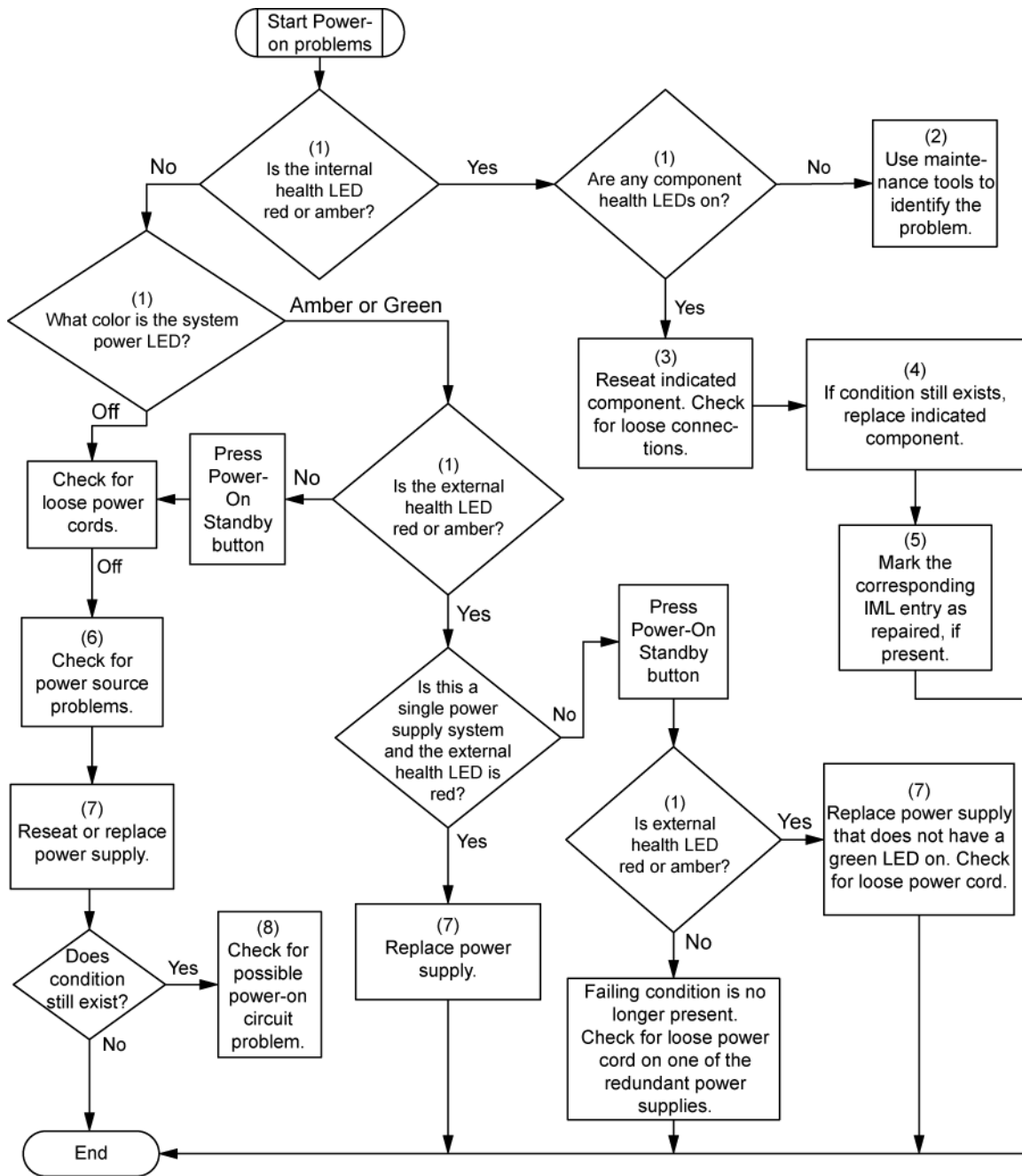

POST problems flowchart

Symptoms:

- Server does not complete POST

NOTE: The server has completed POST when the system attempts to access the boot device.

- Server completes POST with errors

Possible problems:

- Improperly seated or faulty internal component
- Faulty KVM device
- Faulty video device

Item	Refer to
1	"POST error messages and beep codes (on page 90)"
2	"Video problems" in the <i>HP ProLiant Servers Troubleshooting Guide</i> located on the Documentation CD or on the HP website (http://www.hp.com/support)
3	KVM or iLO 2 documentation
4	"Loose connections (on page 78)"
5	"Symptom information (on page 77)"
6	Server maintenance and service guide, located on the Documentation CD or the HP website (http://www.hp.com/products/servers/platforms)
7	"Port 85 and iLO messages" in the <i>HP ProLiant Servers Troubleshooting Guide</i> located on the Documentation CD or on the HP website (http://www.hp.com/support)
8	"General memory problems are occurring" in the <i>HP ProLiant Servers Troubleshooting Guide</i> located on the Documentation CD or on the HP website (http://www.hp.com/support)
9	<ul style="list-style-type: none"> • "Hardware problems" in the <i>HP ProLiant Servers Troubleshooting Guide</i> located on the Documentation CD or on the HP website (http://www.hp.com/support) • Server maintenance and service guide, located on the Documentation CD or the HP website (http://www.hp.com/products/servers/platforms)
10	<ul style="list-style-type: none"> • "Server information you need" in the <i>HP ProLiant Servers Troubleshooting Guide</i> located on the Documentation CD or on the HP website (http://www.hp.com/support) • "Operating system information you need" in the <i>HP ProLiant Servers Troubleshooting Guide</i> located on the Documentation CD or on the HP website (http://www.hp.com/support)

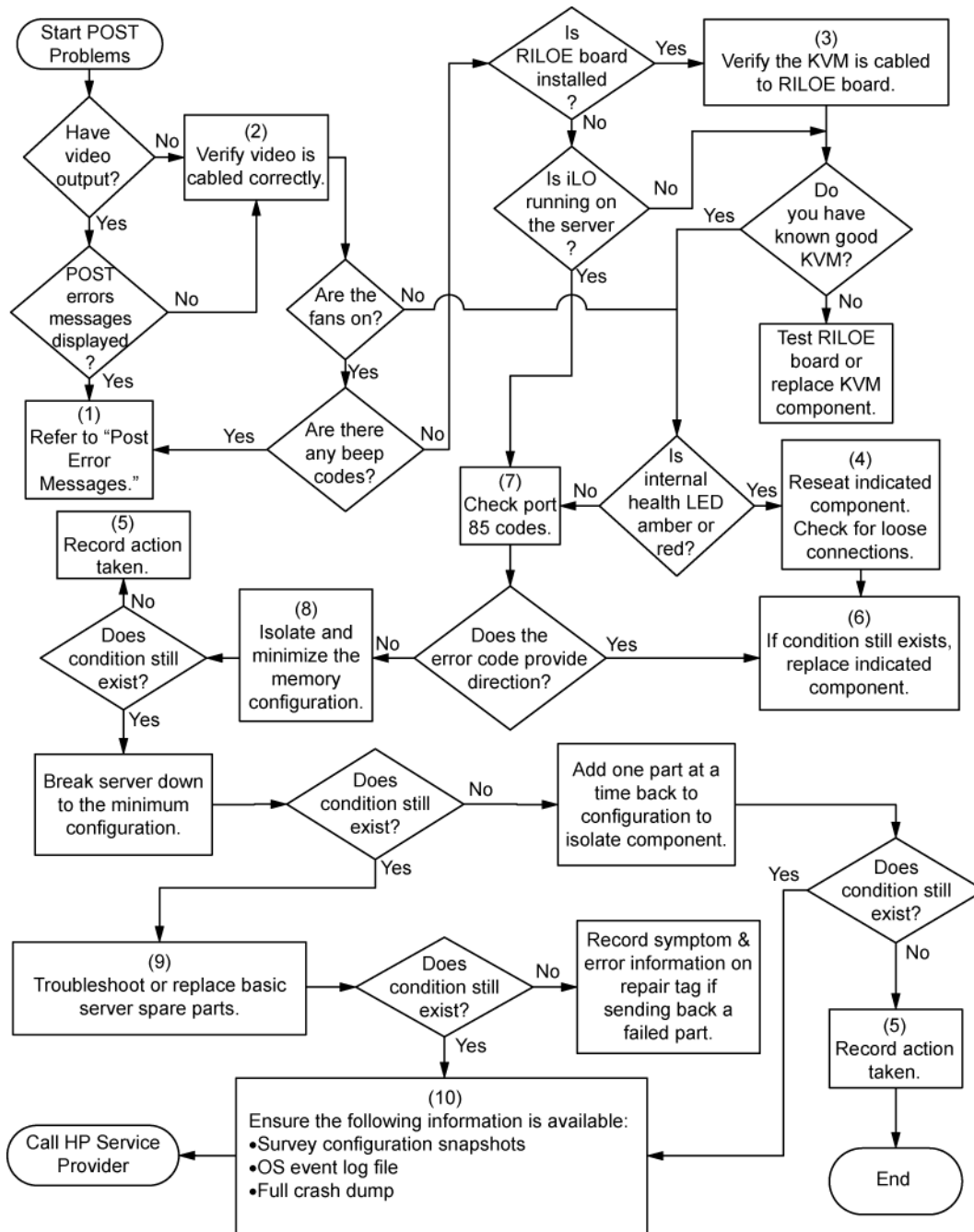

OS boot problems flowchart

Symptoms:

- Server does not boot a previously installed operating system
- Server does not boot SmartStart

Possible causes:

- Corrupted operating system
- Hard drive subsystem problem
- Incorrect boot order setting in RBSU

Item	Refer to
1	<p>HP ROM-Based Setup Utility User Guide http://www.hp.com/servers/smartstart</p>
2	<p>"POST problems flowchart (on page 85)"</p>
3	<ul style="list-style-type: none"> • "Hard drive problems" in the <i>HP ProLiant Servers Troubleshooting Guide</i> located on the Documentation CD or on the HP website (http://www.hp.com/support) • Controller documentation
4	<p>"HP Insight Diagnostics (on page 72)" or in the <i>HP ProLiant Servers Troubleshooting Guide</i> located on the Documentation CD or on the HP website (http://www.hp.com/support)</p>
5	<ul style="list-style-type: none"> • "CD-ROM and DVD drive problems" in the <i>HP ProLiant Servers Troubleshooting Guide</i> located on the Documentation CD or on the HP website (http://www.hp.com/support) • Controller documentation • "Loose connections (on page 78)"
6	<p>"General memory problems are occurring" in the <i>HP ProLiant Servers Troubleshooting Guide</i> located on the Documentation CD or on the HP website (http://www.hp.com/support)</p>
7	<ul style="list-style-type: none"> • "Operating system problems" in the <i>HP ProLiant Servers Troubleshooting Guide</i> located on the Documentation CD or on the HP website (http://www.hp.com/support) • "HP contact information (on page 100)"
8	<ul style="list-style-type: none"> • "Hardware problems" in the <i>HP ProLiant Servers Troubleshooting Guide</i> located on the Documentation CD or on the HP website (http://www.hp.com/support) • Server maintenance and service guide, located on the Documentation CD or the HP website (http://www.hp.com/products/servers/platforms)
9	<p>"General diagnosis flowchart (on page 80)"</p>

NOTE: For the location of server LEDs and information on their statuses, refer to the server documentation.

Possible causes:

- Improperly seated or faulty internal or external component
- Unsupported component installed
- Redundancy failure
- System overtemperature condition

Item	Refer to
1	"Management agents (on page 71)" or in the <i>HP ProLiant Servers Troubleshooting Guide</i> located on the Documentation CD or on the HP website (http://www.hp.com/support)
2	<ul style="list-style-type: none">• "Integrated Management Log (on page 73)" or in the <i>HP ProLiant Servers Troubleshooting Guide</i> located on the Documentation CD or on the HP website (http://www.hp.com/support)• "Event list error messages" in the <i>HP ProLiant Servers Troubleshooting Guide</i> located on the Documentation CD or on the HP website (http://www.hp.com/support)
3	"Component identification (on page 7)"
4	System Management Homepage (https://localhost:2381)
5	"Power-on problems flowchart ("Server power-on problems flowchart" on page 82)"
6	<ul style="list-style-type: none">• "Smart Array SCSI Diagnosis feature" in the <i>HP ProLiant Servers Troubleshooting Guide</i> located on the Documentation CD or on the HP website (http://www.hp.com/support)• Server maintenance and service guide, located on the Documentation CD or the HP website (http://www.hp.com/products/servers/platforms)• "HP contact information (on page 100)"
7	"HP Insight Diagnostics (on page 72)" or in the <i>HP ProLiant Servers Troubleshooting Guide</i> located on the Documentation CD or on the HP website (http://www.hp.com/support)
8	<ul style="list-style-type: none">• "Hardware problems" in the <i>HP ProLiant Servers Troubleshooting Guide</i> located on the Documentation CD or on the HP website (http://www.hp.com/support)• Server maintenance and service guide, located on the Documentation CD or the HP website (http://www.hp.com/products/servers/platforms)

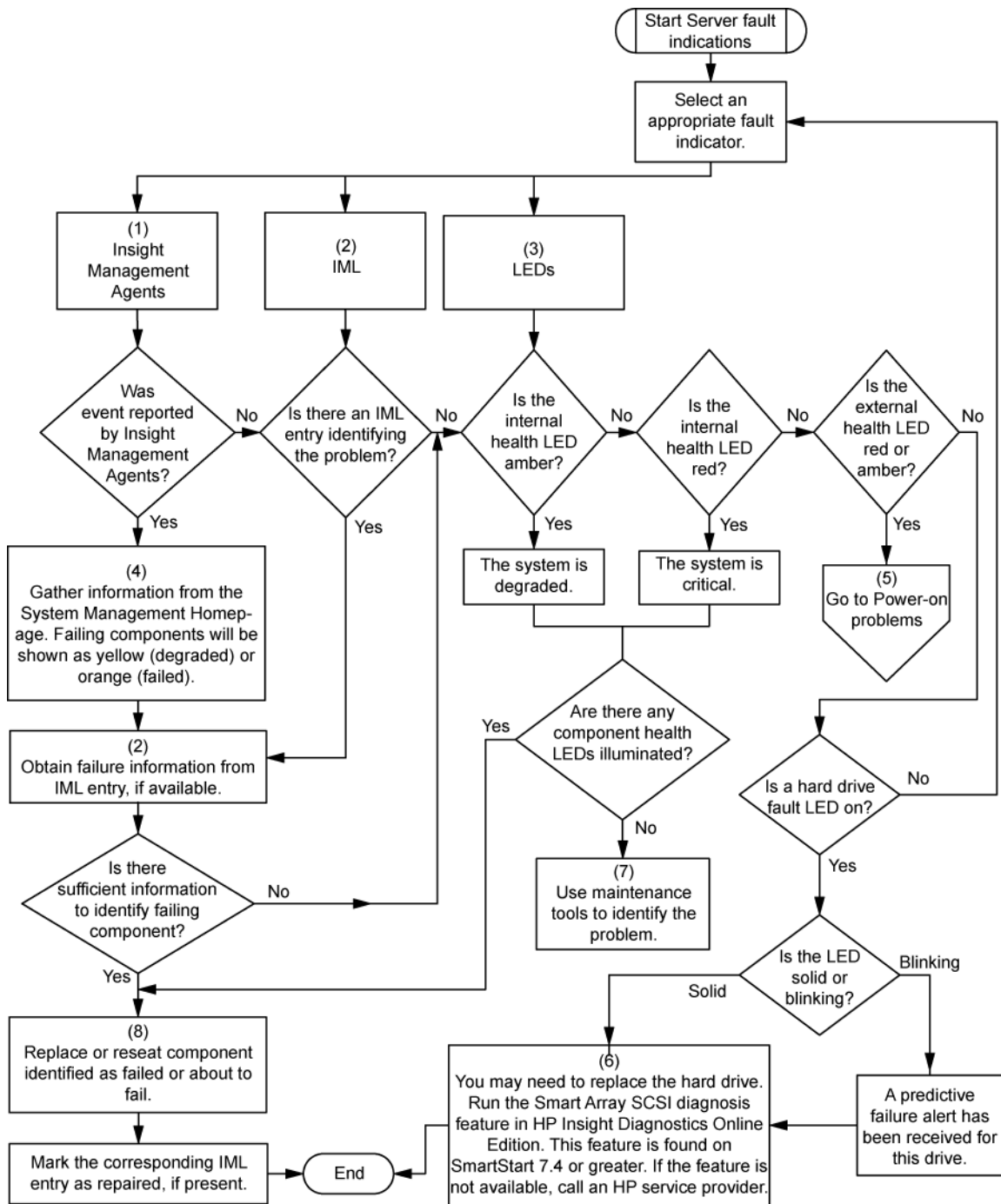

POST error messages and beep codes

For a complete listing of error messages, refer to the "POST error messages" in the *HP ProLiant Servers Troubleshooting Guide* located on the Documentation CD or on the HP website (<http://www.hp.com/support>).



WARNING: To avoid potential problems, ALWAYS read the warnings and cautionary information in the server documentation before removing, replacing, reseating, or modifying system components.

Regulatory compliance notices

Regulatory compliance identification numbers

For the purpose of regulatory compliance certifications and identification, this product has been assigned a unique regulatory model number. The regulatory model number can be found on the product nameplate label, along with all required approval markings and information. When requesting compliance information for this product, always refer to this regulatory model number. The regulatory model number is not the marketing name or model number of the product.

Federal Communications Commission notice

Part 15 of the Federal Communications Commission (FCC) Rules and Regulations has established Radio Frequency (RF) emission limits to provide an interference-free radio frequency spectrum. Many electronic devices, including computers, generate RF energy incidental to their intended function and are, therefore, covered by these rules. These rules place computers and related peripheral devices into two classes, A and B, depending upon their intended installation. Class A devices are those that may reasonably be expected to be installed in a business or commercial environment. Class B devices are those that may reasonably be expected to be installed in a residential environment (for example, personal computers). The FCC requires devices in both classes to bear a label indicating the interference potential of the device as well as additional operating instructions for the user.

FCC rating label

The FCC rating label on the device shows the classification (A or B) of the equipment. Class B devices have an FCC logo or ID on the label. Class A devices do not have an FCC logo or ID on the label. After you determine the class of the device, refer to the corresponding statement.

Class A equipment

This equipment has been tested and found to comply with the limits for a Class A digital device, pursuant to Part 15 of the FCC Rules. These limits are designed to provide reasonable protection against harmful interference when the equipment is operated in a commercial environment. This equipment generates, uses, and can radiate radio frequency energy and, if not installed and used in accordance with the instructions, may cause harmful interference to radio communications. Operation of this equipment in a residential area is likely to cause harmful interference, in which case the user will be required to correct the interference at personal expense.

Class B equipment

This equipment has been tested and found to comply with the limits for a Class B digital device, pursuant to Part 15 of the FCC Rules. These limits are designed to provide reasonable protection against harmful interference in a residential installation. This equipment generates, uses, and can radiate radio frequency

energy and, if not installed and used in accordance with the instructions, may cause harmful interference to radio communications. However, there is no guarantee that interference will not occur in a particular installation. If this equipment does cause harmful interference to radio or television reception, which can be determined by turning the equipment off and on, the user is encouraged to try to correct the interference by one or more of the following measures:

- Reorient or relocate the receiving antenna.
- Increase the separation between the equipment and receiver.
- Connect the equipment into an outlet on a circuit that is different from that to which the receiver is connected.
- Consult the dealer or an experienced radio or television technician for help.

Declaration of conformity for products marked with the FCC logo, United States only

This device complies with Part 15 of the FCC Rules. Operation is subject to the following two conditions: (1) this device may not cause harmful interference, and (2) this device must accept any interference received, including interference that may cause undesired operation.

For questions regarding this product, contact us by mail or telephone:

- Hewlett-Packard Company
P. O. Box 692000, Mail Stop 530113
Houston, Texas 77269-2000
- 1-800-HP-INVENT (1-800-474-6836). (For continuous quality improvement, calls may be recorded or monitored.)

For questions regarding this FCC declaration, contact us by mail or telephone:

- Hewlett-Packard Company
P. O. Box 692000, Mail Stop 510101
Houston, Texas 77269-2000
- 1-281-514-3333

To identify this product, refer to the part, series, or model number found on the product.

Modifications

The FCC requires the user to be notified that any changes or modifications made to this device that are not expressly approved by Hewlett-Packard Company may void the user's authority to operate the equipment.

Cables

Connections to this device must be made with shielded cables with metallic RFI/EMI connector hoods in order to maintain compliance with FCC Rules and Regulations.

Canadian notice (Avis Canadien)

Class A equipment

This Class A digital apparatus meets all requirements of the Canadian Interference-Causing Equipment Regulations.

Cet appareil numérique de la classe A respecte toutes les exigences du Règlement sur le matériel brouilleur du Canada.

Class B equipment

This Class B digital apparatus meets all requirements of the Canadian Interference-Causing Equipment Regulations.

Cet appareil numérique de la classe B respecte toutes les exigences du Règlement sur le matériel brouilleur du Canada.

European Union regulatory notice

This product complies with the following EU Directives:

- Low Voltage Directive 2006/95/EC
- EMC Directive 2004/108/EC

Compliance with these directives implies conformity to applicable harmonized European standards (European Norms) which are listed on the EU Declaration of Conformity issued by Hewlett-Packard for this product or product family.

This compliance is indicated by the following conformity marking placed on the product:



This marking is valid for non-Telecom products and EU harmonized Telecom products (e.g. Bluetooth).



This marking is valid for EU non-harmonized Telecom products.

*Notified body number (used only if applicable—refer to the product label)

Hewlett-Packard GmbH, HQ-TRE, Herrenberger Strasse 140, 71034 Boeblingen, Germany

Disposal of waste equipment by users in private households in the European Union



This symbol on the product or on its packaging indicates that this product must not be disposed of with your other household waste. Instead, it is your responsibility to dispose of your waste equipment by handing it over to a designated collection point for the recycling of waste electrical and electronic equipment. The separate collection and recycling of your waste equipment at the time of disposal will help to conserve natural resources and ensure that it is recycled in a manner that protects human health and the environment. For more information about where you can drop off your waste equipment for recycling, please contact your local city office, your household waste disposal service or the shop where you purchased the product.

Japanese notice

ご使用になっている装置にVCCIマークが付いていましたら、次の説明文をお読み下さい。

この装置は、情報処理装置等電波障害自主規制協議会（VCCI）の基準に基づくクラスB情報技術装置です。この装置は、家庭環境で使用することを目的としていますが、この装置がラジオやテレビジョン受信機に近接して使用されると、受信障害を引き起こすことがあります。

取扱説明書に従って正しい取り扱いをして下さい。

VCCIマークが付いていない場合には、次の点にご注意下さい。

この装置は、情報処理装置等電波障害自主規制協議会（VCCI）の基準に基づくクラスA情報技術装置です。この装置を家庭環境で使用すると電波妨害を引き起こすことがあります。この場合には使用者が適切な対策を講ずるよう要求されることがあります。

BSMI notice

警告使用者:

這是甲類的資訊產品，在居住的環境中使用時，可能會造成射頻干擾，在這種情況下，使用者會被要求採取某些適當的對策。

Korean notice

Class A equipment

A급 기기 (업무용 방송통신기기)	이 기기는 업무용(A급)으로 전자파적합등록을 한 기기이오니 판매자 또는 사용자는 이 점을 주의하시기 바라며, 가정 외의 지역에서 사용하는 것을 목적으로 합니다.
-----------------------	---

Class B equipment

B급 기기 (가정용 방송통신기기)	이 기기는 가정용(B급)으로 전자파적합등록을 한 기기로서 주로 가정에서 사용하는 것을 목적으로 하며, 모든 지역에서 사용할 수 있습니다.
-----------------------	--

Laser compliance

This product may be provided with an optical storage device (that is, CD or DVD drive) and/or fiber optic transceiver. Each of these devices contains a laser that is classified as a Class 1 Laser Product in accordance with US FDA regulations and the IEC 60825-1. The product does not emit hazardous laser radiation.

Each laser product complies with 21 CFR 1040.10 and 1040.11 except for deviations pursuant to Laser Notice No. 50, dated May 27, 2001; and with IEC 60825-1:1993/A2:2001.



WARNING: Use of controls or adjustments or performance of procedures other than those specified herein or in the laser product's installation guide may result in hazardous radiation exposure. To reduce the risk of exposure to hazardous radiation:

- Do not try to open the module enclosure. There are no user-serviceable components inside.
- Do not operate controls, make adjustments, or perform procedures to the laser device other than those specified herein.
- Allow only HP Authorized Service technicians to repair the unit.

The Center for Devices and Radiological Health (CDRH) of the U.S. Food and Drug Administration implemented regulations for laser products on August 2, 1976. These regulations apply to laser products manufactured from August 1, 1976. Compliance is mandatory for products marketed in the United States.

Battery replacement notice



WARNING: The computer contains an internal lithium manganese dioxide, a vanadium pentoxide, or an alkaline battery pack. A risk of fire and burns exists if the battery pack is not properly handled. To reduce the risk of personal injury:

- Do not attempt to recharge the battery.
- Do not expose the battery to temperatures higher than 60°C (140°F).
- Do not disassemble, crush, puncture, short external contacts, or dispose of in fire or water.



Batteries, battery packs, and accumulators should not be disposed of together with the general household waste. To forward them to recycling or proper disposal, use the public collection system or return them to HP, an authorized HP Partner, or their agents.

For more information about battery replacement or proper disposal, contact an authorized reseller or an authorized service provider.

Taiwan battery recycling notice

The Taiwan EPA requires dry battery manufacturing or importing firms in accordance with Article 15 of the Waste Disposal Act to indicate the recovery marks on the batteries used in sales, giveaway or promotion. Contact a qualified Taiwanese recycler for proper battery disposal.



Power cord statement for Japan

製品には、同梱された電源コードをお使い下さい。
同梱された電源コードは、他の製品では使用出来ません。

Acoustics statement for Germany (Geräuschemission)

Schalldruckpegel $L_{pA} < 70$ dB(A)

Zuschauerpositionen (bystander positions), Normaler Betrieb (normal operation)

Nach ISO 7779:1999 (Typprüfung)

Electrostatic discharge

Preventing electrostatic discharge

To prevent damaging the system, be aware of the precautions you need to follow when setting up the system or handling parts. A discharge of static electricity from a finger or other conductor may damage system boards or other static-sensitive devices. This type of damage may reduce the life expectancy of the device.

To prevent electrostatic damage:

- Avoid hand contact by transporting and storing products in static-safe containers.
- Keep electrostatic-sensitive parts in their containers until they arrive at static-free workstations.
- Place parts on a grounded surface before removing them from their containers.
- Avoid touching pins, leads, or circuitry.
- Always be properly grounded when touching a static-sensitive component or assembly.

Grounding methods to prevent electrostatic discharge

Several methods are used for grounding. Use one or more of the following methods when handling or installing electrostatic-sensitive parts:

- Use a wrist strap connected by a ground cord to a grounded workstation or computer chassis. Wrist straps are flexible straps with a minimum of 1 megohm ± 10 percent resistance in the ground cords. To provide proper ground, wear the strap snug against the skin.
- Use heel straps, toe straps, or boot straps at standing workstations. Wear the straps on both feet when standing on conductive floors or dissipating floor mats.
- Use conductive field service tools.
- Use a portable field service kit with a folding static-dissipating work mat.

If you do not have any of the suggested equipment for proper grounding, have an authorized reseller install the part.

For more information on static electricity or assistance with product installation, contact an authorized reseller.

Specifications

Environmental specifications

Specification	Value
Temperature range*	
Operating	10°C to 35°C (50°F to 95°F)
Shipping	-40°C to 70°C (-40°F to 158°F)
Maximum wet bulb temperature	28°C (82.4°F)
Relative humidity (noncondensing)**	
Operating	10% to 90%
Non-operating	5% to 95%

* All temperature ratings shown are for sea level. An altitude derating of 1°C per 300 m (1.8°F per 1,000 ft) to 3048 m (10,000 ft) is applicable. No direct sunlight allowed.

** Storage maximum humidity of 95% is based on a maximum temperature of 45°C (113°F). Altitude maximum for storage corresponds to a pressure minimum of 70 KPa.

Server specifications

Specification	Value
Dimension	—
Height	17.6 cm (6.94 in)
Depth	67.3 cm (26.5 in)
Width	46.3 cm (19.0 in)
Weight (maximum)	47.6 kg (105 lb)
Weight (no drives installed)	36.3 kg (80 lb)
Input requirement	—
Rated input voltage	100–127 VAC 200–240 VAC
Rated input frequency	50–60 Hz
Rated input current	@ 100 VAC–12A @ 200 VAC–8A
Rated input power	@100 VAC–1161 W @200 VAC–1598 W
BTUs per hour	@100 VAC–3960 BTU @200 VAC–5450 BTU
Power supply output	—

Specification	Value
Power supply output	910 W (low line) 1300 W (high line)

Technical support

Before you contact HP

Be sure to have the following information available before you call HP:

- Technical support registration number (if applicable)
- Product serial number
- Product model name and number
- Product identification number
- Applicable error messages
- Add-on boards or hardware
- Third-party hardware or software
- Operating system type and revision level

HP contact information

For the name of the nearest HP authorized reseller:

- See the Contact HP worldwide (in English) webpage (<http://welcome.hp.com/country/us/en/wwcontact.html>).

For HP technical support:

- In the United States, for contact options see the Contact HP United States webpage (http://welcome.hp.com/country/us/en/contact_us.html). To contact HP by phone:
 - Call 1-800-HP-INVENT (1-800-474-6836). This service is available 24 hours a day, 7 days a week. For continuous quality improvement, calls may be recorded or monitored.
 - If you have purchased a Care Pack (service upgrade), call 1-800-633-3600. For more information about Care Packs, refer to the HP website (<http://www.hp.com/hps>).
- In other locations, see the Contact HP worldwide (in English) webpage (<http://welcome.hp.com/country/us/en/wwcontact.html>).

Acronyms and abbreviations

ABEND

abnormal end

ACU

Array Configuration Utility

ADU

Array Diagnostics Utility

AMP

Advanced Memory Protection

ASR

Automatic Server Recovery

BBWC

battery-backed write cache

BIOS

Basic Input/Output System

CSA

Canadian Standards Association

DOS

disk operating system

DRAM

dynamic random access memory

ECC

error checking and correcting

ESD

electrostatic discharge

FBDIMM

fully buffered DIMM

IEC

International Electrotechnical Commission

iLO 2

Integrated Lights-Out 2

IML

Integrated Management Log

ISEE

Instant Support Enterprise Edition

KVM

keyboard, video, and mouse

LED

light-emitting diode

NFPA

National Fire Protection Association

NIC

network interface controller

NVRAM

non-volatile memory

ORCA

Option ROM Configuration for Arrays

OS

operating system

PCI

peripheral component interface

PCI-X

peripheral component interconnect extended

PDU

power distribution unit

POST

Power-On Self Test

PPM

processor power module

PSP

ProLiant Support Pack

RAID

redundant array of inexpensive (or independent) disks

RBSU

ROM-Based Setup Utility

RDP

Rapid Deployment Pack

RILOE II

Remote Insight Lights-Out Edition II

ROM

read-only memory

SAS

serial attached SCSI

SCSI

small computer system interface

SDRAM

synchronous dynamic RAM

SFF

small form-factor

SIM

Systems Insight Manager

SNMP

Simple Network Management Protocol

SPI

system peripheral interface

TMRA

recommended ambient operating temperature

UID

unit identification

UPS

uninterruptible power system

USB

universal serial bus

VCA

Version Control Agent

Index

A

access panel 23
ACU (Array Configuration Utility) 69
additional information 75
ADU (Array Diagnostic Utility) 73
Advanced Memory Protection (AMP) 39, 40, 41, 42
airflow requirements 27
Altiris Deployment Solution 68
Altiris eXpress Deployment Server 68
Array Configuration Utility (ACU) 69
Array Diagnostic Utility (ADU) 73
ASR (Automatic Server Recovery) 70
authorized reseller 100
auto-configuration process 67
Automatic Server Recovery (ASR) 70
Autorun menu 65

B

Basic Input/Output System (BIOS) 68, 70, 80
batteries, replacing 95
battery 14, 95
battery pack LEDs 18
battery replacement notice 95
battery-backed write cache (BBWC) 14, 18, 53, 61
battery-backed write cache battery pack 53
battery-backed write cache cabling 61
BBWC (battery-backed write cache) 14, 18, 53, 61
beep codes 90
BIOS (Basic Input/Output System) 68, 70, 80
BIOS Serial Console 68
BIOS upgrade 70
board, SPI (System Peripheral Interface) 13, 14
boot options 68
BSMI notice 94
buttons, front panel 7, 8
buttons, rear panel 11

C

cables 61, 78, 92
cabling, BBWC 61
cabling, DVD drive 63

cabling, hard drive backplane 62
cabling, SATA DVD drive 63
cabling, tape drive 49, 63
Canadian notice 93
Care Pack 26, 74
Change Control 74
class A equipment 91
class B equipment 91
component identification 7
components, front panel 7, 9
components, rear 10
components, SPI board 14
components, system board 13, 14
configuration of system 31, 32, 65
configuration tools 65
configuration utilities 65
connection problems 78
connector, iLO 2 10
connector, keyboard 10
connector, mouse 10
connector, NIC 10
connector, serial 10
connector, three slot option card 13
connector, USB 7, 10
connector, video 7, 10
contacting HP 100
creating a disk image 68
customer self repair (CSR) 100

D

Declaration of Conformity 92
deployment software 68
diagnosing problems 75, 78
diagnostic tools 65, 68, 70, 72
diagnostics utility 72
diskette image creation 68
drivers 74
DVD drive 63

E

electrical grounding requirements 28
electrostatic discharge 33, 97
environmental requirements 27, 98

environmental specifications 98
error messages 90
European Union notice 93
expansion boards 57, 58, 59
expansion slots 10, 13, 57, 58, 59
extending server from rack 21
external health LED 8

F

fans 20, 56
FBDIMM configuration requirements 39, 40, 41, 42, 43
FBDIMM slot locations 15
FCC rating label 91
features 7
Federal Communications Commission (FCC) notice 91, 92
flowcharts 79, 80, 82, 85, 86, 88
front panel buttons 8
front panel components 7, 9
front panel LEDs 8

G

general diagnosis flowchart 80
grounding methods 97
grounding requirements 28

H

hard drive backplane 45, 62
hard drive bays 7, 16
hard drive LEDs 17
hard drives, installing 44
hardware options 33
hardware options installation 29, 33
health driver 70
help resources 100
HP Insight Diagnostics 72
HP Instant Support Enterprise Edition 73
HP ProLiant Essentials Foundation Pack 32, 71
HP ProLiant Essentials Rapid Deployment Pack 68
HP Systems Insight Manager, overview 71
HP technical support 100

I

identification number 91
iLO 2 (Integrated Lights-Out 2) 71
iLO 2 connector 10
IML (Integrated Management Log) 73

Important Safety Information document 75
Insight Diagnostics 72, 74
installation services 26
installation, server options 29, 33
installing operating system 32
installing server 31
Instant Support Enterprise Edition 73
Integrated Lights-Out 2 (iLO 2) 71
Integrated Management Log (IML) 73
internal health LED 8
internal USB functionality 72

J

Japanese notice 94

K

keyboard connector 10
Korean notices 94

L

laser compliance 95
laser devices 95
LED, external health 8
LED, internal health 8
LED, power button 8
LEDs, battery pack 18
LEDs, front panel 8
LEDs, hard drive 17
LEDs, NIC 8, 11
LEDs, power supply 12
LEDs, rear panel 11
LEDs, SAS hard drive 17
LEDs, troubleshooting 75
LEDs, unit identification (UID) 8
loose connections 78

M

Management Agents 71
management tools 70
memory 15, 39, 40, 41, 42, 43, 66, 67
memory expansion boards 15, 43
memory overview 39
memory, Advanced ECC 40
memory, configuring 66
memory, installing 42
memory, mirrored 42, 67, 69
memory, online spare 41, 66
mirrored memory 42, 69

modifications, FCC notice 92
mouse connector 10

N

NIC connectors 10
NIC LEDs 11
NVRAM, clearing 14

O

Online ROM Flash Component Utility 70
online spare memory 41, 66
operating systems 32, 74
operations 21
optimum environment 27
Option ROM Configuration for Arrays (ORCA) 68
options installation 29, 33
ORCA (Option ROM Configuration for Arrays) 68
OS boot problems flowchart 86

P

PCI (peripheral component interface) 102
PCI Express x8 three slot option card 58
peripheral component interface (PCI) 102
phone numbers 100
POST error messages 90
POST problems flowchart 85
power button 8
power button LED 8
power cord 76, 96
power distribution unit (PDU) 28
Power On/Standby button 8, 21, 31
power requirements 28
power supply 10, 52
power supply LEDs 12
powering down 21
powering up 21, 66
power-on problems flowchart 82
PPM (processor power module) 33, 35
pre-diagnostic steps 75
preparation procedures 78
problem diagnosis 75
processor memory module 33
Processor Power Module (PPM) 33, 35
processors 33, 35
ProLiant Support Pack (PSP) 74
PSP (ProLiant Support Pack) 74
PSPs, overview 74

R

rack installation 26, 29, 31
rack mounting hardware 29
rack resources 26
rack stability 76
rack warnings 29, 76
rack, extending server from 21
RBSU (ROM-Based Setup Utility) 66
RBSU configuration 66
rear panel buttons 11
rear panel components 10
rear panel LEDs 11
recommended ambient operating temperature (TMRA) 27
redundant ROM 72
registering the server 32
regulatory compliance identification numbers 91
regulatory compliance notices 91, 93
Remote Insight Lights-Out Edition II (RILOE II) 70
remote support and analysis tools 73
required information 100
requirements, airflow 27
requirements, electrical grounding 28
requirements, environmental 27, 98
requirements, power 28
requirements, site 27
requirements, space 27
requirements, temperature 27
RILOE II (Remote Insight Lights-Out Edition II) 70
ROM redundancy 72
ROM, updating 70
ROM-Based Setup Utility (RBSU) 66
ROMPaq utility 70, 72

S

safety considerations 29, 75
safety information 72
SAS backplane 44
SAS device numbers 16
SAS hard drive 44
SAS hard drive LEDs 17
SATA DVD drive 63
scripted installation 65
serial connector 10
serial number 69
series number 91
server asset text 69
server fault indications flowchart 88
server features and options 33

- server options, installing 29, 33
- server specifications 98
- server, installation 31
- service notifications 79
- shipping carton contents 29
- site requirements 27
- SmartStart autorun menu 65
- SmartStart Scripting Toolkit 65
- SmartStart software 32
- SmartStart, overview 65
- space requirements 27
- specifications, environmental 98
- specifications, server 98
- SPI (System Peripheral Interface) board 13, 14
- start diagnosis flowchart 79
- static electricity 97
- status lights, battery pack 18
- StorageWorks Library and Tape Tools (L&TT) 71
- support 73, 100
- support packs 65
- supported operating systems 74
- switch, system maintenance 13
- symbols on equipment 76
- symptom information 77
- system battery 14
- system board 69
- system board components 13, 14
- system board switches 14
- system configuration settings 32, 65
- system maintenance switch 13, 14
- system power LED 8, 18
- system, keeping current 74
- Systems Insight Display 7, 9
- Systems Insight Display, ejecting 24
- Systems Insight Manager 71

T

- Taiwan battery recycling notice 96
- tape drive blank 7, 49
- tape drive cabling 63
- tape drives 49
- technical support 100
- telephone numbers 100
- temperature requirements 27
- three slot option card connectors 13
- three slot option card, installing 57, 59
- TMRA (recommended ambient operating temperature) 27
- Torx screwdriver 10
- tower server, setting up 30

- troubleshooting flowcharts 79
- troubleshooting resources 75

U

- UID LED 8, 11
- uninterruptible power supply (UPS) 28
- universal serial bus (USB) 7, 10, 72
- updating the system ROM 72
- UPS (uninterruptible power supply) 28
- USB connectors 7, 10
- USB drive key 72
- USB support 72
- utilities, deployment 65, 66, 68

V

- ventilation 27
- video connector 7, 10

W

- website, HP 100