

10

REVISTA DE
HISTÓRIA
DA ARTE

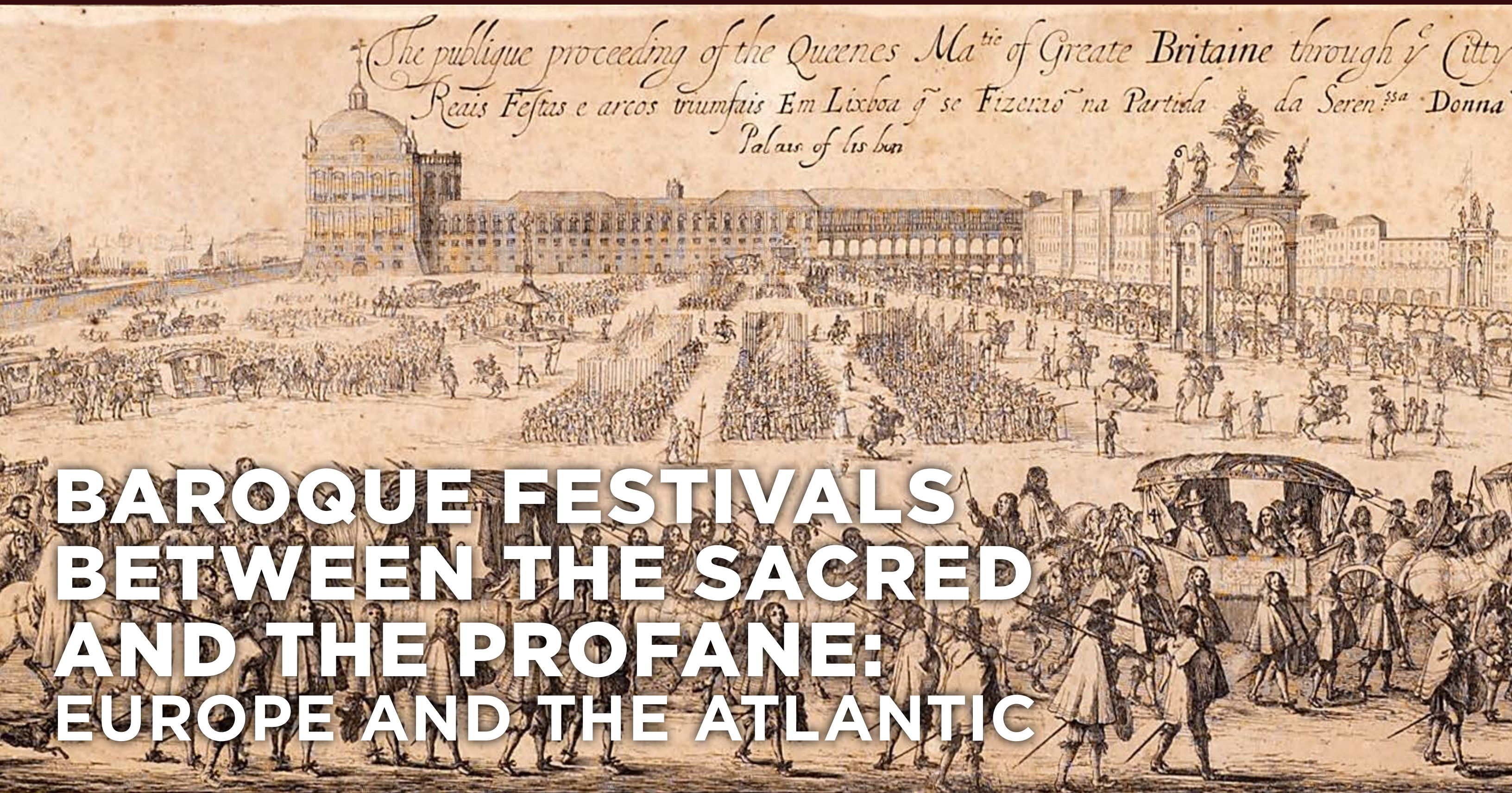

IH | INSTITUTO DE HISTÓRIA DA ARTE
FACULDADE DE CIÊNCIAS SOCIAIS E HUMANAS – UNL



The publique proceeding of the Queenes Ma^{tie} of Greate Britaine through y^e Citty
Reais Festas e arcos triumphais Em Lisboa q̃ se Fizerão na Partida da Seren^{ss}a Donna
Palais of lis bon

BAROQUE FESTIVALS BETWEEN THE SACRED AND THE PROFANE: EUROPE AND THE ATLANTIC

JOURNAL DIRECTORS

Joana Cunha Leal (IHA/NOVA/FCSH)

Margarida Tavares da Conceição (IHA/NOVA/FCSH)

Nuno Senos (IHA/NOVA/FCSH)

JOURNAL COORDINATION

Ana Paula Louro (IHA/NOVA/FCSH)

PUBLISHER

Instituto de História da Arte

EDITORS

Maria João Pereira Coutinho (IHA/NOVA/FCSH)

Sílvia Ferreira (IHA/NOVA/FCSH)

AUTHORS (IN ALPHABETICAL ORDER)

Alexandra Trindade Gago da Câmara (UAb/CHAIA) |

Andrew Horn (University of St Andrews) | **Axel Gampp** (University

of Basel) | **Carlos Moura** (IHA/NOVA/FCSH) | **Isabel Yglesias**

de Oliveira (Palácio Nacional de Mafra) | **Laura García Sánchez**

(Universitat de Barcelona) | **Mónica Martín Molaes** (Universidade

da Coruña) | **Paulo de Assunção** (Instituto Histórico e Geográfico

Brasileiro/CEEC/FLUL) | **Susana Varela Flor** (IHA/NOVA/ FCSH) |

Teresa de Campos Coelho (CHAM/NOVA/FCSH)

REVIEWERS (IN ALPHABETICAL ORDER)

Alex Bohrer (Universidade Federal de Minas Gerais) | **Aline**

Gallasch-Hall de Beuvink (Universidade Autónoma de Lisboa)

| **Ana Isabel Buescu** (CHAM/NOVA/FCSH) | **Aziz Pedrosa**

(Universidade Federal de Minas Gerais) | **Francisco Herrera García**

(Universidad de Sevilla/Facultad de Geografía e Historia) | **Gerard**

Doderer (NOVA/FCSH) | **Isabel Mendonça** (Investigadora

independente) | **María Inmaculada Rodríguez Moya**

(Universidade Jaime I — Castellon) | **Maria do Rosário Salema**

de Carvalho (ARTIS-IHA/FLUL) | **Margaret Shewring** (University

of Warwick) | **Nuno Senos** (IHA/NOVA/FCSH) | **Pedro Flor** (UAb /

IHA/NOVA/FCSH) | **Sandra Costa Saldanha** (CEAAC/UCoimbra)

| **Teresa Leonor M. Vale** (ARTIS-IHA/FLUL)

DESIGN

José Domingues

Cover

Museu de Lisboa. Dirck Stoop, *Reais festas e arcos triunfais que se fizeram em Lisboa na partida da Sereníssima Dona Catarina Rainha da Grã-Bretanha*, 1662.

3

EDITORIAL

Maria João Pereira Coutinho | Sílvia Ferreira

5

DOSSIER

113

BALTASAR AND BLIMUNDA ROUTE: SOME INTRODUCTORY WORDS

EDITORIAL

BAROQUE FESTIVALS BETWEEN THE SACRED AND THE PROFANE: EUROPE AND THE ATLANTIC

The number 10th of the journal *Série W* gathers a selection of updated and extended texts resulting from the communications presented at the International Conference *Baroque festivals between the sacred and the profane: Europe and the Atlantic*, organized by the Institute of Art History and the Institute of Studies of Literature and Tradition of the NOVA School of Social Sciences and Humanities, and the Municipality of Loures, between 17-18 October 2019. This conference was organized in partnership with the project *Baltasar and Blimunda Route*, a cultural and tourist route that, uniting three municipalities — Lisbon, Loures and Mafra — around the book of José Saramago, *Memorial do Convento*, revives the history of its main characters Blimunda and Baltasar, valuing the patrimonial and cultural resources of the three counties. The venue of the congress was the Palace of Correio-mor in the city of Loures.

As we know the feast, a cultural manifestation encompassing all civilizations and creeds, reached its pinnacle of magnificence and extravagance during the Baroque period (17th-18th centuries). Courts, along with religious institutions, were the main promoters and spreaders of grandiose scenographic events witnessed in this period of history. With models and fashions from European courts such as those of France, of the Austro-Hungarian Empire and of the Iberian

Peninsula fanning out to the rest of the Old World, the festive eccentricity of Baroque also reached the overseas territories of South America under the rule of the Iberian monarchies.

Ephemeral art, the visible expression of the festive spectacle, takes over and transforms spaces in dialogue with the perdurable arts and the soundscape. The hegemony of painting, sculpture and architecture blurs in the dialogue established with the so-called decorative arts and with the performative arts. The feast brings together arts, artists, commissioners, participants and the public. A brief jubilatory event, it is the expression of the imagination, of the amalgam of arts and peoples, the apotheosis of the concept of the total work of art that Baroque gave rise to and that Leibniz, in his *Monadology*, understood as the art of finding “the beautiful constructions”, that is, shaping imaginary worlds as possible as that in which we live.

The final composition of the festive display reflects the essence of Baroque: a play of multiple forms in dialogue with each other and in permanent unfolding: “la peinture sort de son cadre et se réalise dans la sculpture de marbre polychrome; et la sculpture se dépasse et se réalise dans l’architecture; et l’architecture à son tour trouve dans la façade un cadre, mais ce cadre décolle lui-même de l’intérieur, et se met en rapport avec les alentours de manière à réaliser l’architecture dans l’urbanisme” (Giles Deleuze, *Le Pli*, Minuit, 1988, pp. 167-168).

With these concepts in mind the Conference addressed the cross-disciplinary and plural studies on Baroque festivals in its several dimensions like baptisms, royal weddings,

MARIA JOÃO PEREIRA COUTINHO
SÍLVIA FERREIRA

embassies, royal entries, canonizations, beatifications, and other solemnities within the civil and religious frames. With this broad scope the Conference focussed in significant areas of knowledge as art, literature and music. The birth and definition of models, the agents and leading subjects as the territorial impact were explored. Finally, it also encompassed the studies related to the 17th and 18th centuries as well as contemporary visions of the baroque festivals concept.

Given the diverse contributions that the arts bring to the Baroque Feast, such approach was necessarily interdisciplinary and considered the phenomenon in the 17th and 18th centuries from renewed viewpoints based on the latest research.

The following topics were suggested:

- Staging, codes and rituals: the arts of the table, christenings, weddings, acclamations, royal entries, embassies;
- Theatres, staging's, beatifications and canonisations, liturgical calendar processions, special devotions;
- Literature, books and prints: model dissemination and consolidation;
- Music and the sound element of the feast;
- The feast and the city: ephemeral scenography, its agents and impact on the urban scape.

The texts that hereby are published reflect some possible approaches to the theme of festivities expressed thorough investigations that resulted in recent readings on the topic that the Scientific Commission joined by other experts, validated.

The contributions are from: Alexandra Gago da Câmara (Universidade Aberta/CHAIA – Universidade de Évora) and Carlos Moura (Instituto de História da Arte da Faculdade de Ciências Sociais e Humanas/Universidade NOVA de Lisboa); Andrew Horn (University of St Andrews); Axel Gampp (University of Basel); Isabel Yglesias de Oliveira (Palácio Nacional de Mafra); Laura García Sánchez (University of Barcelona); Mónica Martín Molares (University of Coruña-Spain); Paulo de Assunção (Instituto Histórico e Geográfico Brasileiro); Susana Varela Flor (Instituto de História da Arte da Faculdade de Ciências Sociais e Humanas da Universidade NOVA de Lisboa); Teresa de Campos Coelho (CHAM – Centro de Humanidades/Faculdade de Ciências Sociais e Humanas da Universidade NOVA de Lisboa).

The second section of this issue presents the project “Baltazar and Blimunda Route”.

The editors would like to acknowledge the municipality of Loures for the support during the days of the Conference and to the owners of the Palace of Correio-mor for lending the space for the venue.

Our recognition also extends to the members of the Scientific Committee of the event and of the present *Série W* number, which, with its comments and suggestions helped us to select the communication proposals and the received texts for the publication.

DOSSIER

6

FEAST (FEST) VERSUS CELEBRATION (FEIER). TOWARDS A THEORY OF THE BAROQUE FESTIVAL

AXEL GAMPP

38

THE SOUND OF POWER: THE BELLS OF MAFRA

ISABEL YGLESIAS DE OLIVEIRA

79

THE IMMORTALITY OF POWER: THE FUNERAL OF KING JOHN V AND THE SAD SPECTACLE OF DEATH

PAULO DE ASSUNÇÃO

113

BALTASAR AND BLIMUNDA ROUTE: SOME INTRODUCTORY WORDS

FLORBELA ESTÊVÃO
PAULA PITACAS

13

A ROMAN MODEL OF THE BAROQUE FESTIVAL IN LISBON...

MARIA ALEXANDRA TRINDADE GAGO DA CÂMARA

CARLOS ALBERTO LOUZEIRO DE MOURA

51

POMPA INTROITUS HONORI SERENISSIMI PRINCIPIS FERDINANDI...

LAURA GARCÍA SÁNCHEZ

91

AQUA TRUMPHALIS: THE BAROQUE WEDDING FESTIVAL FROM THE TAGUS TO THE THAMES

SUSANA VARELA FLOR

25

THE STATE FUNERAL IN SPANISH MILAN: A BAROQUE RITUAL OF COMMEMORATION

ANDREW HORN

66

THE PARAPHERNALIA OF A ROYAL WEDDING...

MÓNICA MARTÍN MOLARES

102

THE DETAILED DESCRIPTION AND INVOLVEMENT OF THE ARCHITECT LUÍS NUNES...

TERESA DE CAMPOS COELHO

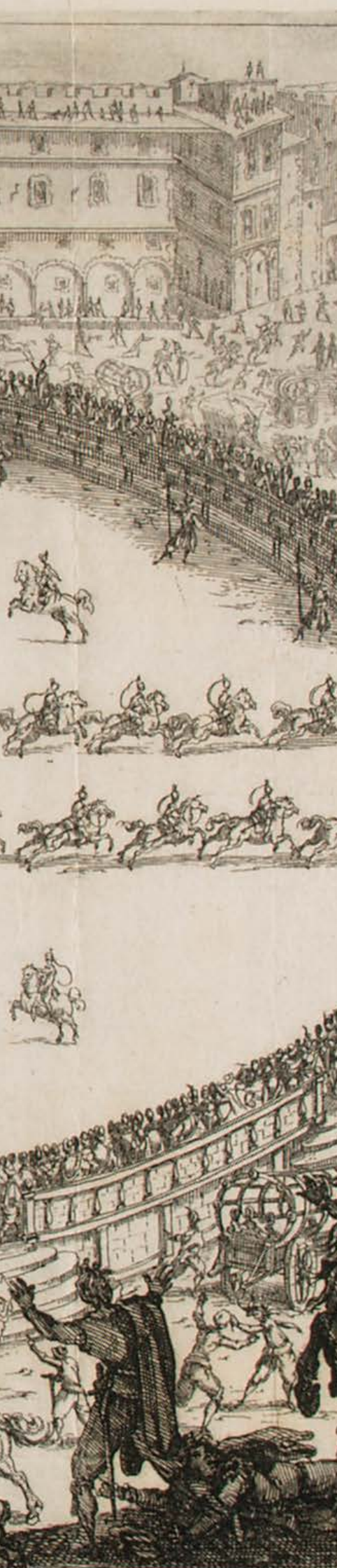

FEAST (*FEST*) VERSUS CELEBRATION (*FEIER*). TOWARDS A THEORY OF THE BAROQUE FESTIVAL

AXEL GAMPP
University of Basel
axel.gampp@unibas.ch

ABSTRACT

The article attempts to explain the difference between *Fest* and *Feier* using the key word of 'festivity'. The distinction is only possible in German, where it has a long tradition going back to Freud. His reflections about the problem are only the starting point for a theory of the baroque festivities, since no contemporary theory of festivities from the baroque period has been discovered.

KEY WORDS BAROQUE FESTIVITIES, BAROQUE FESTIVAL, BAROQUE FEAST, THEORY OF FEAST, *FEST*, *FEIER*

RESUMO

O presente texto pretende analisar, dentro do espectro alargado do conceito de Festividade, as diferenças entre *Fest* e *Feier*. Esta distinção é apenas possível na língua alemã, na qual tem já uma longa tradição que remonta a Freud. As suas reflexões sobre este problema são apenas o ponto de partida para uma teoria das festividades barrocas, já que no período barroco não foi possível encontrar nenhuma teoria contemporânea sobre festividades.

PALAVRAS-CHAVE FESTIVIDADES BARROCAS, FESTIVAL BARROCO, FESTA BARROCA, TEORIA DA FESTA, *FEST*, *FEIER*



Introduction

It is quite remarkable that no theory of the festival was developed during the baroque period. Given that this period gave rise to reflections on all sorts of aspects of life and so many treatises were written, it seems incredible that the festival was not also subject to such consideration, especially as it combined the extraordinary with the ordinary. No period is so closely linked with the idea of pompous feasts as the baroque.

When, at the end of the period, the famous *Encyclopédie* was published, there were several articles concerning the key word *fête* in the sixth volume (Fêtes des Hébreux, Fêtes des Mahométans, Fêtes des Chrétiens (Hist. ecclés.), Fête-Dieu (Théol.), Fête de l'O ou des O (Théol.), Fêtes des Fous (Hist. mod.), Fêtes (Jurispr.), Fête de Village, Fêtes de la Cour de France, Fêtes des grandes Villes du Royaume de France) (Encyclopédie V. VI, p. 564-593)

The inherent problem is revealed under the key phrase *Fêtes des Chrétiens* (Encyclopédie V. VI, 556):

Au surplus, il est certain qu'en considérant les abus inséparables des fêtes, la transposition que je propose est à desirer pour le bien de la religion; attendu que ces saints jours consacrés par l'Eglise à la piété, deviennent dans la pratique des occasions decrapule & de libertinage, souvent même de batteries & de meurtres ; excès déplorables qui font dire à Dieu par Isaïe, & cela sur le même sujet: «A quoi bon tant de victimes? Que sert de répandre pour moi le sang des animaux? Ce n'est point-là ce que j'exige de vous; j'abhorre vos sacrifices, vos cérémonies, vos fêtes, le sabbat même tel que vous l'observez; je ne vois dans tout cela que de l'abus & du desordre capable d'exciter mon indignation. En vain vous élevez les mains vers moi, ces mains sont souillées de sang, je n'écouterai point vos prieres ; mais purifiez votre cœur, ne méditez plus de projets iniques, cessez d'être méchants & pervers, observez la justice, pratiquez la bienfaisance, secourez les opprimés, défendez la veuve & l'orphelin ; après cela venez à moi, venez en toute assurance,

& quand vous seriez tout noircis de crimes, je vous rendrai plus blancs que la neige». [...]. Qui ne voit par-là que nos fêtes, dès-là qu'elles sont profanées par le grand nombre, nous éloignent véritablement du but qu'on s'est proposé dans leur institution?

The most important sentence is the last one, which in English means: 'Who does not see by this that our celebrations, as soon as they are desecrated by their large number, really take us away from the goal we have set for ourselves in their institution?' The article reveals that there might be a tension between the object of the feast or the festival and its concrete execution.

There is another interesting key phrase: *Fêtes des fous* (Encyclopédie Vol. VI, 574). I will not quote all of this text, but it refers to a topsy-turvy celebration, close to the Saturnalia of antiquity.

It seems obvious that these key phrases do not include everything that we would associate with the term 'feast'. We should therefore take another key phrases into consideration:

***Festin: Festins Royaux.* On n'a point dans cet article le vaste dessein de traiter des *festins royaux* que l'histoire ancienne nous a décrits, encore moins de ceux de tant de princes d'Europe qui, pendant les siècles obscurs qui ont suivi la chute de l'Empire, ne se sont montrés magnifiques dans les occasions éclatantes, que par une profusion déplacée, une pompe gigantesque, une morgue insultante. Ces assemblées tumultueuses, presque toujours la source des vaines disputes sur le rang, ne finissoient guere que par la grossiereté des injures, & par l'effusion du sang des convives.**

However, the problem that arises is still the same. It is the fear that a feast or festival may deteriorate. This is more a description than a theory of the feast, but it nevertheless indicates something that should be borne in mind.

A tree model for festivities

Looking at the etymology of the word *feast* or *festival*, we come to the Latin word *festus* (solemn) and *festum* (feast, but in antiquity combined with the sense that you are experiencing something different from ordinary life for a period of time). *Festum* is linked to *feriae*, a period of feast, and in general the syllable *fes-* indicates any ceremony or rite (Lexicon 1865, 69, s.v. *festus*; Thesaurus 1913, 626-632).

Before we actually look for a theory of the baroque feast or festival, it is worth turning our attention to a short overview of the types of baroque feasts that existed. These might be set out as a tree (Fig. 1), showing the distinction between sacred and profane. In the latter, a distinction is made between Court festivals and private festivities. Court festivals would be held in open or closed spaces. Open spaces would serve as the venue for activities for the closed circle of courtiers. All sorts of

performances would be held indoors, while hunts, tournaments and the like would take place outdoors.

Private festivals could take place indoors, such as dinners or balls with specific invitations, or outdoors like coach or slide rides, or riding activities like roundabouts etc.

In some cases, the Court would organize festivities that were accessible to the public. These could take place indoors, with a wider audience admitted, such as events relating to the lives of the rulers. Alternatively, they would be held outdoors, usually in the local town. Private festivities would take place either indoors or outdoors, as befitted the activity.

On the sacred side we see almost the same thing, with open and closed events. If the festival was of a closed nature, it was generally held in a church, such as a mass, etc. We might picture a situation like in the Escorial, where the king could attend from his bedchamber. On the sacred side, a more open

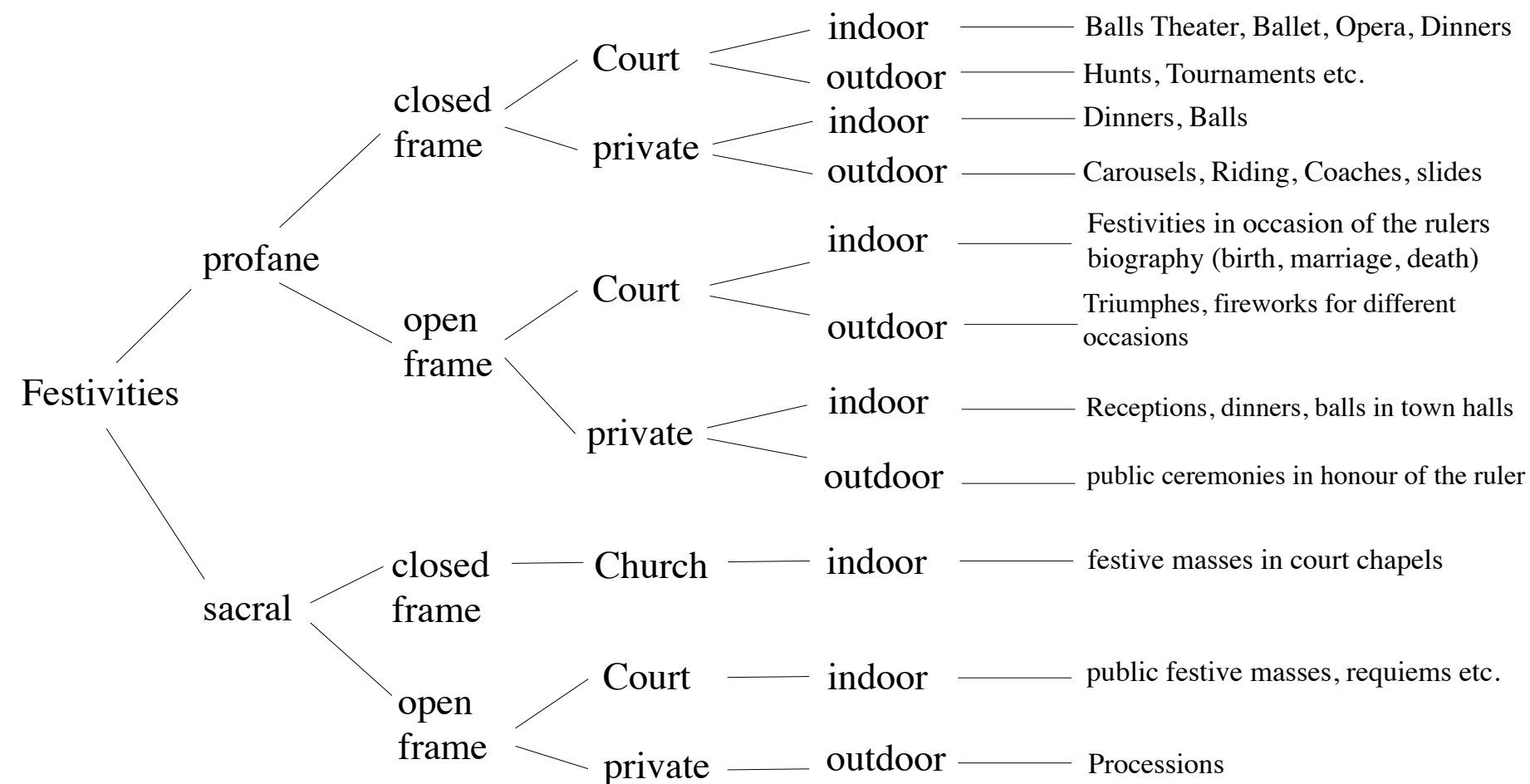

FIG. 1. Distinction between different types of baroque festivities (graphical representation by the author)

context would also apply to churches, where religious services open to the public were held, or public spaces, as in the case of religious processions, etc.

Any of these activities could have been subjected to a theoretical examination. We might imagine that ceremonial books would deliver a sort of theory as to how things should happen during a religious procession, a coronation or the like. Ideally, however, any theory would be more general and take an early stage in this tree model as its starting point. A theory should be able to explain the basic phenomena and seek to answer the question of “What is a festival? What is a feast?”.

In relation to the corpus of baroque feasts in Rome, the author declares that “the feast was a privileged moment for city or court to express itself in its hierarchically articulated entirety and with all the material and symbolism it had at its disposal”.¹ This occurred both at private and public festivities. When the Court was assembled without a wider audience, the baroque feast manifests an increasing tendency towards exhibitions of absolute rule (Aercke 1994, 27). But whether private or public, whether organised by the Court, by the Church or by private persons, the aim was, generally speaking, to impress or obtain a maximum of “*meraviglie*” (Aercke 1994, 27). As Aercke has shown, these *meraviglie* came primarily in the form of allegories (Aercke 1994, 24 ff.) An allegory, the production of something marvellous, is, however, an indicator that the feast and everyday life are quite different, that they are in fact separate worlds. Jean-Jacques Wunenburger expressed it in his study “La fête, le jeu et le sacré” as follows: “[... la fête] est un événement qui engage tous sans exception, qu’elle insinue jusque dans les moindres secteurs de la vie humaine, qu’elle est donc une provocation globale à la rupture avec le quotidien” (Wunenburger 1977, 48) (“[... the celebration] is an event that engages everyone without exception, that works its way into even in the most minor aspects of human life, and is therefore a global provocation to a rupture with everyday life”).

All these different types of feast existed: an example of a profane closed arena would be a feast at court. One instance was the famous *Les Plaisirs de l’Île Enchantée* of

May 1664 at Versailles. In a certain sense, the *Guerra della bellezza*, a feast given in Florence in 1616 in honour of the Duke of Urbino (Fig. 2) was even more telling. Here we see a court society performing a sort of collective ballet in a closed setting. The emotional aspects are strictly channelled and everything happens like clockwork. This is an outdoor festival. Similar things also happened indoors in ballrooms, for example.

An example for a profane feast with an open format is the *Festa della cuccagna*, where the King of Naples had an artificial hill created, covered with food. Ultimately, the people would devour it all and thereby destroy it.

Sacred festivals within a closed setting included all sorts of indoor church events, such as a coronation or catafalque. Outdoor religious feasts in open setting include events like the often sumptuous processions for the feast of Corpus Christi, which were very widespread throughout Catholic Europe.

It is clear that all of these festivities proceeded according to meticulously ordered rules. The only exception was secular festivities in open spaces, which were much more difficult to control. In view of this, one might expect there to be a source for a theory of feasts in books that concerned ceremonies. I know of the famous German works *Einleitung zur Ceremoniel-Wissenschaft Der grossen Herren [...]* (Berlin 1733) and *Einleitung zur Ceremoniel-Wissenschaft Der Privat-Personen* (Berlin 1728), written by Bernhard Julius von Rohr. The former is dedicated to the ceremonies of the nobility, the latter to those in the private sphere. The former contains a chapter entitled “Von den Divertissements der grossen Herren” (“On entertainment of Lords”), but it does not include any theoretical considerations, nor does it really inform us about the character of those divertissements. Neither does the book for private individuals contain any indications of an overarching theory. Chapters 7 to 11 deal with all kinds of festivities in a very general way, and are, incidentally, sandwiched between the problems of how to treat women and how to furnish apartments.

¹ G. Stefani in Fagiolo dell’Arco: *L’effemero barocco*, p. 11, quoted after Aercke 1994, 20.

Freud's approach to a theory of festivities and his German followers

In all that has been said up until this point, there is one common denominator: all festivities interrupt daily life. This might seem to be stating the obvious, but it is worth underlining. Wunenburger emphasised this fact, as did the aforementioned *Encyclopédie*. This aspect has become crucial for theories about feasts that emerged in the 20th century. Sigmund Freud devised the first of these. In his book *Totem und Tabu*, published in 1912/13, he declared: "Ein Fest ist ein gestatteter, vielmehr ein gebotener Exzess, ein feierlicher Durchbruch eines Verbotes. Nicht weil die Menschen infolge irgendeiner Vorschrift froh gestimmt sind, begehen sie die Ausschreitungen, sondern der Exzess liegt im Wesen des Festes; die festliche Stimmung wird durch die Freigebung des sonst Verbotenen erzeugt" (Freud 1912, 425).

("A feast is a permitted, or rather a prescribed excess, a solemn violation of a prohibition. People do not commit the excesses, which at all times have characterised feasts, as a result of an order to be in a festive mood, but because in the very nature of a feast there is excess; the festive mood is brought about by the release of what is otherwise forbidden.")

Since then the feast has generally been considered as something out of the ordinary. There is another line of approach, mainly linked to the German theologian Joseph Pieper, who considered the feast to be an affirmation of daily life. However, it is not my intention to discuss this in greater detail here.

Yet there are two aspects in which Freud's theory contradicts the examples that I have set out here: not every festivity ends in excess, and not every festivity is about dealing with otherwise forbidden behavior.

Following Freud, theories of feasts have been particularly widespread in German scientific literature for one good reason: German makes a distinction that does not exist in most other languages, namely between *Fest* and *Feier*. This makes all the difference to contemporary theory of festivities. In this context, *Fest* relates to the uncontrolled and excessive.

Winfried Gebhardt, an eminent sociologist who is interested in the subject of the festival, stresses that:

Der Begriff des Festes steht [...] für ein emotionales, also durch Affekte bestimmtes Geschehen. Das Fest ist der soziale Ort, an dem rein aktuelles, spontanes emotionales Verhalten, das sich im Grenzfall bis hin zur Ekstase steigern kann, nicht nur sozial erlaubt, sondern sogar gewünscht ist. Im Fest gestaltet sich aktuell und spontan ein ursprüngliches und elementares Aufwallen des Ausseralltäglichen, das, ob es nun als momentane Eingebung ans Licht tritt oder mittels spezifischer Techniken herbeigeführt wird, nicht bewusst vollzogen, sondern nur dunkel gefühlt wird [...]. Das Fest ist ein unregelmäßiges, ungeordnetes und unplanbares Geschehen, ein Freiraum, der von vorneherein für unterschiedlichste Inhalte offen ist. Folgerichtig gehören zum Fest Elemente, die diesen Charakter unterstreichen und verstärken: berauschende Stimulanzien, Tanz, Musik, Licht, Masken und mehr (Gebhardt 2017, 38).

(The concept of *Fest* [...] stands for an emotional event, i.e. one that is determined by effects. The *Fest* is the social place where purely topical, spontaneous emotional behaviour, which can increase to the point of ecstasy in borderline cases, is not only socially permitted, but even desired. In the *Fest*, an original and elementary surging of the extraordinary is created in a topical and spontaneous way, which, whether it is manifested as a momentary inspiration or is brought about by means of specific techniques, is not consciously carried out, but only felt dark [...]. The *Fest* is an unregulated, disordered and unstructured event, a free space that is open from the outset to the most diverse activities. Consequently, the festival includes elements that underline and strengthen this character: intoxicating stimulants, dancing, music, light, masks and more).

As such, among festivities a *Fest* is generally in an open space that not only accommodates a wider audience but actively invites them to participate. The *Festa della cuccagna*

is one example, and the carnivals held in many European countries are another.

All other activities mentioned above do not fall into the category of *Fest*, but rather of *Feier*. According to Gebhardt, the definition of *Feier* is as follows:

Im Gegensatz zum Fest steht der Begriff der Feier [...] für ein weitgehend bewusst gewolltes und reflektiertes, also rationales und damit ‚gefühlshreies‘ Geschehen.

Die Feier macht den an ihr beteiligten Individuen das Woher, Warum und Wozu ihres Lebens, ihrer Gruppe oder der Institution, der sie [...] angehören, bewusst. Sie reflektiert Herkunft, Bedeutung, Aufgabe und Zukunft von Individuum, Gruppe und Institution, rechtfertigt sie so in ihrem Bestand und repräsentiert sie nach innen und aussen als sinnvoll. Anders als dem Fest liegt der Feier immer eine bewusst ausgearbeitete Idee oder ein Weltbild zugrunde, das in ihr aktualisiert wird.

Während für das Fest die typische Handlungsform die Ekstase ist, beruht die Feier auf dem bewusst vollzogenen Glaubensakt. Ruhe, Kontemplation, Besinnung und Nachdenklichkeit zeichnen deshalb die feierliche Handlung aus und grenzen sie gegen die festliche Ausgelassenheit ab.

In diesem Sinne ist die Feier der soziale Ort der Wertesetzung und der Wertebestätigung. Die Feier ist im Gegensatz zum Fest ein durchorganisiertes, bis ins Detail geregeltes Geschehen (Gebhardt 2017, 39 f.).

(In contrast to *Fest*, the term *Feier* [...] stands for a largely intentionally desired and reflected, i.e. rational and thus “emotionless” event. The *Feier* makes the individuals involved aware of the “wherefrom”, the “why” and the “what for” of their lives, their group or the institution to which they [...] belong. It reflects the origin, meaning, goal and future of the individual, group and institution, thus justifying their existence and their representation internally and externally as meaningful. Unlike the *Fest*, the *Feier* is always based on a consciously elaborated idea or a world view that is updated in it.

While ecstasy is the typical form of action for the *Fest*, the *Feier* is based on the consciously performed act of faith. Peace, contemplation, reflection and thoughtfulness therefore characterise the solemn action and set it apart from the festive exuberance. In this sense, the *Feier* is the social value setting and its confirmation. In contrast to the *Fest*, the *Feier* is a well-organised event regulated to the last detail).



FIGS. 2, 3 AND 4. Lars Deile considers the *Fest* to be at the centre of the intersection between meaning, form and society. However, here this is deemed to be the place of the *Feier*, whereas the *Fest* leans more towards the community, insofar as it loses form and meaning.

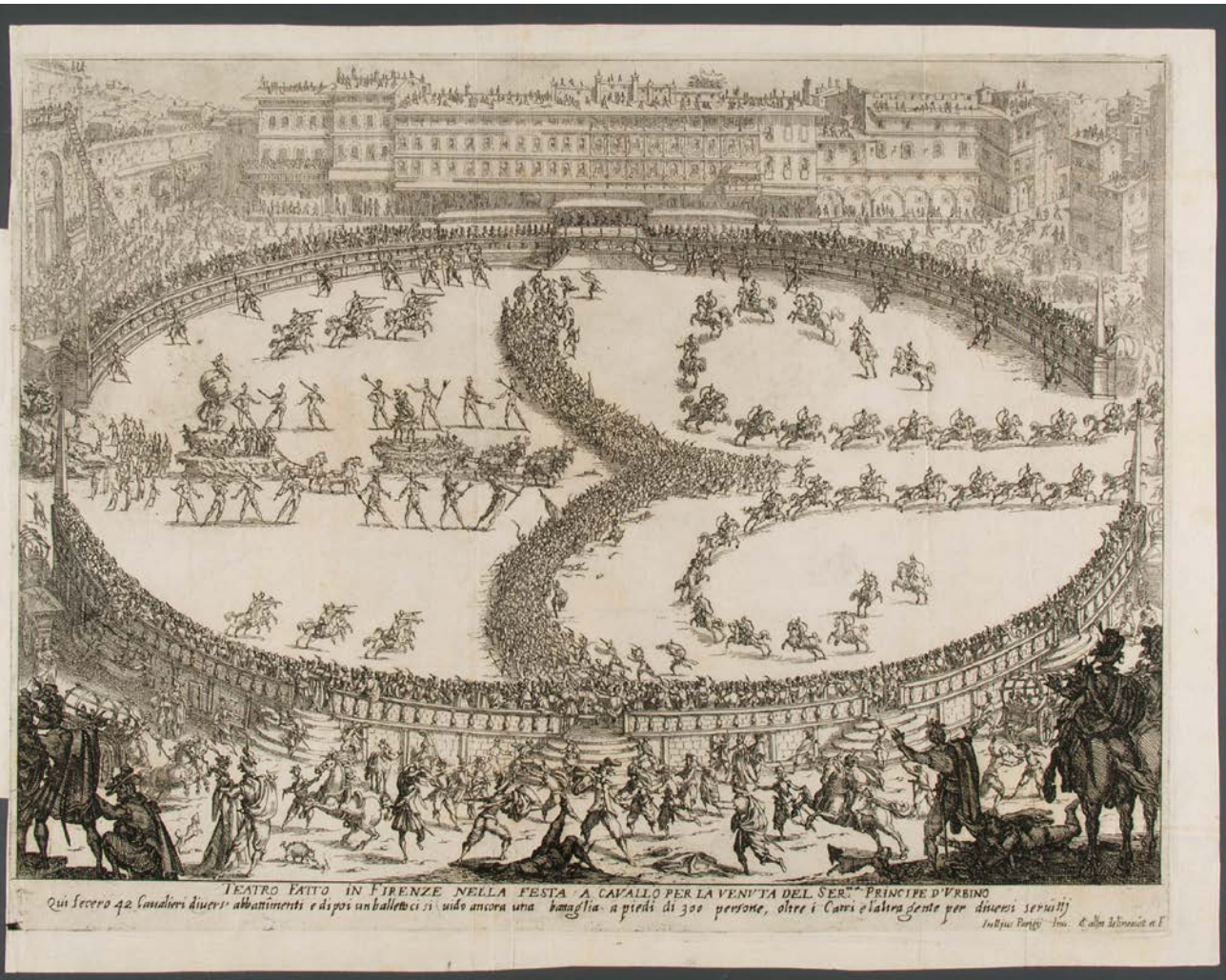

Therefore, an event such as the *Guerra della bellezza* of Florence 1616 (Fig. 2) would always fall into the category of *Feier*: it is about forming groups, about justifying, about meaning, and about a lack of emotion — or perhaps a sort of *choreography of emotions*, as Doris Kolesch once called it (Kolesch 2006, 95-104).

This has been elucidated in graphic form by Lars Deile (Deile 2004, 10-11 and 14) (Fig. 3). Yet this rendering is also somewhat awkward, as the *Fest* of current German theory does not lie right at the centre of meaning, form and society (or perhaps community, if you think of any court in baroque times in this sense). It tends more towards society/community as a phenomenon: the loss of form and meaning (as for example in the *Festa della cuccagna* or at a carnival) nevertheless brings the participants together. The *Feier* is the precisely staged event that enshrines a court society's distinct position,

common values and coherent *Weltbild*. The *Fest* is much less about meaning and form, but more about social events, since getting drunk, celebrating to excess, etc. are only fun within a collective context.

In general, baroque festivals were *Feiern*, not *Festen*. However, there is always a danger that even a well-organised *Feier* could be disrupted and turn into an uncontrollable *Fest*. A close look at Callot's engraving reveals scenes that could hardly have been part of the plan. In the right foreground are two men fighting with each other, and in the background on the left spectators are climbing a wall with a ladder and one seems to be falling headlong. A large number of soldiers is protecting the inner circle in an effort to keep the situation under control.

Callot illustrates that baroque festivities were probably in constant danger of deteriorating from *Feier* into *Festen*. In that sense, both sides are closely linked, and it would have proved impossible to extricate one type of baroque festivity from another, even if it might be desired by the organisers.

BIBLIOGRAPHY

- AERCKE, Kristiaan P. 1994. *Goods of Play. Baroque Festive Performances as Rhetorical Discourse*. New York.
- DEILE, Lars. 2004. "Feste — Eine Definition". In Michael Maurer (Ed.). *Das Fest. Beiträge zu seiner Theorie und Systematik*. Cologne.
- ENCYCLOPÉDIE, ou, *Dictionnaire raisonné des sciences, des arts et des métiers, par une société de gens de lettres; mis en ordre & publié par M. Diderot [...] & quant à la partie mathématique, par M. d'Alembert*. 1756. Geneva, Paris, Neufchâtel: Chez Briasson [and others]. Vol. 6.
- FREUD, Sigmund. 1972. *Totem und Tabu*. In *Studienausgabe* Bd. IX. Frankfurt am Main.
- GEBHARDT Winfried. 2017. "Vom Verschwinden der festlichen Freiheit. Über das 'Management' der Gefühle in hybriden Events". In Gregor J. Betz et al. (Ed.): *Hybride Events. Zur Diskussion zeitgeistiger Veranstaltungen*. Wiesbaden.
- KOLESCH, Doris. 2006. *Theater der Emotionen. Ästhetik und Politik zur Zeit Ludwigs XIV*. Frankfurt.
- TOTIUS latininitatis *Lexicon opera et studio Aegidii Forcellini [...]*. 1865. Prato. Vol. 3.
- THESAURUS *linguae latinae [...]*. 1913. Leipzig. Vol. VI. Fasc. I.
- WUNENBURGER, Jean-Jacques. 1977. *La fête, le jeu et le sacré*. Paris.

FIG. 5. Jacques Callot. 1616. Gesamtansicht des Festes auf der Piazza Santa Croce. Einzug der Wagen der Thetos, der Sonne und des Parnass. Albertina, Vienna, Austria.



A ROMAN MODEL OF THE BAROQUE FESTIVAL IN LISBON. THE TILE PANEL OF THE MONASTERY OF SÃO VICENTE DE FORA AND THE CAVALCATA DI POSSESSO OF POPE INNOCENT XIII

MARIA ALEXANDRA TRINDADE GAGO DA CÂMARA

UAb / IHA / CHAIA
agagodacamara@sapo.pt

CARLOS ALBERTO LOUZEIRO DE MOURA

FCSH-UNL / IHA
carlosmoura@fcs.unl.pt

¹ Boiteux Martine. *Parcours rituels romains à l'époque moderne*. In: *Cérémonial et rituel à Rome (XVIe-XIXe siècle)* Rome: École Française de Rome, 1997, pp. 27-87 (Publications de l'École française de Rome, 231).

² Ibidem.

ABSTRACT

During the reign of King John V, festivities relating to the processional model reached an unusual splendour. Such splendour, associated with ephemeral art forms, greatly contributed to the overall formulation envisaged for this kind of aesthetic.

The ceramic panel reproducing the solemn parade for Pope Innocent XIII's coronation in Rome is therefore particularly important. This panel is part of the *azulejo* cycles found on the terrace of the cloisters of the Monastery of São Vicente de Fora. Since it refers to an exclusive demonstration of Roman practices and ceremonial rites¹ (the *Cavalcata di Possesso*), its transposition to the Portuguese context, conveyed by an art form as quintessentially Portuguese as blue and white *azulejos*, amplified the exaltation of the possibilities of the Baroque feast and its re-enactment within a Portuguese context.

The existence of this tile panel has gone almost unnoticed, although it is briefly mentioned by José Queirós (1856-1920) and João Miguel dos Santos Simões (1907-1972) in the latter's *Corpus of 18th-Century Portuguese Azulejos*. Our research has already allowed us to identify the decoration's graphic sources and its likely authorship, as well as the extraordinarily rich implications and cultural exchanges between the Roman Baroque and the Portuguese artistic environment.

KEYWORDS BAROQUE FEAST, CAVALCATA DI POSSESSO, AZULEJO (GLAZED TILE), MONASTERY OF SÃO VICENTE DE FORA.

RESUMO

Durante o reinado de D. João V, as festividades relacionadas com o modelo processional atingiram um esplendor inusitado que, associado às manifestações da arte efémera, muito contribuiu para a formulação global que esta estética pretendia.

Reveste-se por isso de singular importância o conjunto cerâmico reproduzindo o desfile solene da tomada de posse do Papa Inocêncio XIII em Roma, inserido nos ciclos azulejares do terraço dos claustros do Mosteiro de São Vicente de Fora. Tratando-se de uma manifestação exclusiva das práticas e ritos cerimoniais romanos² (a *Cavalcata di Possesso*), a sua transposição para o meio português, veiculada por uma disciplina artística tão representativa como o azulejo narrativo a azul e branco, significava a exaltação das possibilidades da Festa barroca, a par da sua concretização em ambiente português.

Tendo passado quase despercebida a existência deste núcleo, mencionado por José Queirós (1856-1920) e João Miguel dos Santos Simões (1907-1972) — este no seu *Corpus sobre a Azulejaria Portuguesa do século XVIII* —, temos vindo sobre ele a desenvolver uma investigação que nos permitiu identificar já as fontes gráficas e a provável autoria da sua execução, para além das riquíssimas implicações e cruzamentos culturais entre o barroco romano e a conjuntura artística portuguesa.

PALAVRAS-CHAVE FESTA BARROCA, CAVALCATA DI POSSESSO, AZULEJO, MOSTEIRO DE SÃO VICENTE DE FORA.



Previous note

Our proposal, which is part of an ongoing research project, focuses on the study of a specific artistic object, namely a unique tile panel belonging to the repository of the Joanine period of the monastery of São Vicente de Fora, in Lisbon [Fig. 1].

As is widely known, the extensive series of tiled panels in the cloisters and upper terrace of the Monastery, which belonged to the Canons Regular of St Augustine, is the result of a decorative programme promoted under the patronage of King John V. We will focus on the narrative panel that depicts a long papal procession and has hitherto been overlooked by artistic historiography.

In the 1970s, following the inventory and research work carried out by João Miguel dos Santos Simões, it was possible to locate a graphic source akin to this picture, which soon came to be identified as depicting a papal procession. This ceremony, as much profane as it was religious, was portrayed for the court of John V ('the Magnanimous') in *azulejos*, a distinctive and expressive medium typical of the Portuguese Baroque.

Following our research, we now know that this depiction refers to the *Cavalcata di possesso* — so named upon the inauguration of Innocent XIII's Pontificate on 16 November 1721. It was a procession of great magnificence, with the train moving towards the Basilica of St John Lateran and incorporating the main dignitaries of the Church, the city and their representatives, as was customary after the election of a new pope.

Context | Papal Procession at the Baroque Festival

The main features of the parade depicted on the ceramic panels of the Monastery of São Vicente de Fora (St Vincent Outside the Walls) leave no room for doubt. What is shown is an opulent Baroque feast, one of the many held in Rome to commemorate important events — in this case Pope Innocent XIII's "possession ride" (*Cavalcata di Possesso*), as we will see



shortly. Following the inauguration of each new pontiff, this celebration confirmed his role as bishop of the Eternal City in canonical and civil terms.

Elected on 18 May 1721, the then Cardinal Michelangelo Conti [Fig. 2], son of the Dukes of Poli, chose the name Innocent to evoke the splendours of medieval Christianity associated to the figure of Innocent III, his ancestor. Having been steered towards an ecclesiastical career, he studied at Rome's Jesuit College, where he became widely cultivated, especially in subjects related to theology, jurisprudence and history, and where he acquired a taste for book collecting that would accompany him throughout his life.

FIG. 1. The cloister terrace of the Monastery of São Vicente de Fora. Tile panels on the north wall. Photographic credits ©Alexandra Gago da Câmara and Teresa Verão.



FIG. 2. Michaelangelo Conti, Pope Innocent XIII, 1721-1725. *Constitutiones Summorum Pontificum Innocentii XIII et Clementis XII ad Portugalliae, & Algarbiorum Regem ac ad Patriarcha, necnon ad Patriarchalem, & Archiepiscopalem Ecclesias Ulixbonensis Occidentalem, & respectivè Orientalem pertinentes* | Romae: Typis Rev. Cam. Apost., 1738, Res. BNP.

After serving as prelate in Ascoli, Frosinone and Viterbo, his qualities and diplomatic skill earned him the appointment of nuncio to the Swiss Confederation in 1695, and to Lisbon three years later. There he held the office for a relatively long period, between 1698 and 1710, a time that saw the transition from the reign of King Pedro II to that of King John V. During this period he was appointed cardinal.

As someone close to the Portuguese royal family, the court and the highest ecclesiastical spheres, Cardinal Conti became a popular figure among the common people, especially in Lisbon. After moving into a house owned by the Marquis of Távora, in the parish of Mártires, he was frequently recognised on the street.

Thanks to his Baroque upbringing and mentality, he was admired for the “acuteness of his discourse and the clarity of his expositions”, in the words of one of his most notable friends, Francisco Xavier de Menezes, the 4th Count of Ericeira¹ (*Panegírico*, 1721, 15), whose exquisite library in the Palace of Anunciada, Lisbon, was undoubtedly used by the cardinal.

His knowledge of the country’s problems and affection towards the Portuguese led John V to appoint him, while still in Lisbon, as Cardinal Protector, even though the holder of the office, the Frenchman César d’Estrées, Camerlengo of the Sacred College, was still alive. With this new appointment, he left behind the only serious conflict we know of, which took place during the brief regency of Catherine of Braganza. Siding with the Society of Jesus in the quarrel concerning the payment of the quinquennial tribute to the Holy See, the queen regent went so far as to forbid the nuncio from entering the royal palace, and nearly decreed his expulsion from the kingdom.

The conclave that placed the new pope, Innocent XIII, on the throne of Saint Peter in the spring of 1721 was a brief one. The War of the Spanish Succession, which had coincided with the long pontificate of his predecessor, Clement XI, had come to an end, and the ensuing historical situation, defined by unresolved issues such as the Jansenist movement, called for a compromise. Of the four warring factions, the most

¹ *Panegyric on the election of the Supreme Pontiff Innocent XIII*, delivered by the Count of Ericeira at the Royal Academy of History, of which he was the director, on 5 July 1721.

important were the Bourbon bloc, later the French-Spanish bloc, and the Austrian party, supported by the Viennese Habsburgs, aligned with the imperial politics of Charles IV, John V's brother-in-law. The election of the former nuncio to Lisbon therefore amounted to a unanimous compromise. Moreover, given his age and the fragility of his health, it was an attempt to buy time through a calm and presumably short pontificate (Pastor, 1962, 413-486).

Baroque celebrations were hugely important and considered an essential part of the inauguration of a new pontiff. The election, coronation and appropriation of Rome had both a religious and a civil dimension to them that were only fully recognised through the lavish festivities held in the city over the space of a few days.

These festivities were a global phenomenon, as noted by a leading expert on the subject, Maurizio Fagiolo Dell'Arco, but they were also a mass event, according to José António Maravall's social characterisation of Baroque culture. They were about suspension and attraction, which required wealth, skill, a surprise effect and a short duration (Maravall, 1987).

Although the *Possesso* festivities were closely related to other parades, namely the reception rides of foreign ambassadors, European sovereigns or senators, they were considered a religious celebration. As such, like other similar celebrations held to mark different occasions — holy years, beatifications, canonisations or the consecration of churches, to name but a few examples — they benefited from Rome's legendary grandeur.

But for such splendour to outlast these ephemeral celebrations and become known all over the world, wherever missionaries preached St Peter's spiritual authority, it had to be recorded and promoted. It was thus immortalised in images, enabled by the reproducibility of engravings, and in written accounts, in a short publication describing the details of the parade, the participants and the architecture of the arches along the way.

As we reveal here for the first time, these elements are shown in the engraving [Fig. 3] signed by Giovanni Girolamo Frezza (1659-1741), a well-known engraver from the first half



of the *Settecento* and the disciple of Arnold van Westerhout, a Flemish artist of some importance, whose discreet influence can be felt in this work. Depicting the parade's journey from the Vatican to the Basilica of St John Lateran, passing through the Castle and across the Bridge of Sant'Angelo, the Capitulum and the Colosseum, the narrative wends its way along seven winding rows, moving upwards from the lower right-hand corner to the upper left-hand corner. At the centre of the composition, i.e. at the intersection between the St Peter-Lateran diagonal and the Sant'Angelo-Colosseum diagonal, located in the middle of the third row from the

FIG. 3. Engraving of the *Cavalcata di Possesso* of Pope Innocent XIII (1721) by Giovanni Frezza (1659-1741).



FIG. 4. *Relazione distinta della solenne cavalcata, con la quale il Sommo Pontefice Innocenzo XIII. si portò a prendere il possesso della sacrosanta Basilica di S. Giovanni in Laterano nel giorno di domenica 16. novembre 1721 [...].* Rome: Nella stamparia di Pietro Ferri..., 1721.

bottom, we find Innocent XIII, carried apotheotically upon an open litter.

Along the way, we see two of the temporary structures that were usually created for such ceremonies, made of perishable materials.

This iconographic solution can be traced back to the fresco depicting Sixtus V's *Possesso*, in the Sistine Hall of the Vatican Library, part of the magnificent late Mannerist decorative programme carried out in 1585-89 under the supervision of Giovanni Guerra and Cesare Nebbia. This decoration, which served as a testing ground for many figurative solutions explored during the Catholic Reformation, was the starting point for a vast series of depictions of parades and horse rides during the 17th and 18th centuries.

In the detailed report of the *Relazione*² [Fig. 4] that was published immediately afterwards, in 1722, we find 23 long pages of information concerning the engraving: the route followed on Sunday 16 November; the atmosphere in the streets, which were adorned with precious tapestries; the social and institutional make-up of the participants, including a description of the homages paid by the Hebrew community; the figure of the Pope and his outward appearance; the triumphal arches with their inscriptions; the arrival at the Lateran Basilica; and the names of eminent cardinals, cardinal bishops, cardinal priests and cardinal deacons, as well as other participants.

The procession covered almost three Roman miles (roughly 4.5 km) along a route that can be retraced on a map of the city today. It was conceived as a *sacro trionfo*, in which the Rome of Christianity would upstage the lavishness of the pagan city. The route was probably set out during the pontificate of Gelasius I, in the late 5th century, and comprised four stages: the *exitus*, or departure from the Vatican; the climb, or *adscensus*, to the Capitolium; the descent, *descensio*, to the Forum; and the *adventus et introitus*, or the arrival at the Lateran Basilica.

Furthermore, it is worth mentioning the autonomous edition of two engravings showing the arches built for the parade: one in the Capitolium and one in the Roman Forum.

² *Relazione distinta della solenne cavalcata, con la quale il Sommo Pontefice Innocenzo XIII. si portò a prendere il possesso della sacrosanta Basilica di S. Giovanni in Laterano nel giorno di domenica 16. novembre 1721: con la descrizione degli archi trionfali, eretti in onore di Sua Santità e di tutte le pompe e feste, che in tal funzione si sono ammirate.* Rome: Nella stamparia di Pietro Ferri..., 1721.



The former was commissioned by the Senate, following the Corinthian order and displaying different allegorical figures: Victory, Fame, Justice and Charity. The second arch, commissioned by the Duke of Parma, also displayed allegorical figures such as Prudence, Charity, Justice, Religion, Wealth and Magnificence. They were designed by the architects Pompeo Aldrovandini and Alessandro Specchi, a disciple of Carlo Fontana, who was very experienced in this kind of work. Fontana would later be appointed by Innocent XIII to work at the *Fabbrica di San Pietro*.

The tile panel's narrative

Let us return to the analysis of this tile panel, which was apparently created by the hand and workshop of the tile painter Valentim de Almeida (1692-1779) and installed by the

mestre ladrilhador José da Costa in 1737 (as the documentation confirms).³

We find ourselves looking at a visual route that centres on the experience of space as a support for wall painting, and on specific dimensions of pictorial representation: the papal procession, the space of the architectural structures, the meaning of the path that is taken and the figures represented in the parade.

We do not know how the entire image began and ended, as the oldest photographs reveal that it was truncated by a doorway, which is currently covered. [Fig. 5]

Working our way from left to right and scrutinising the image closely, the aforementioned engraving by Giovanni Frezza (1659-1741) is likely to have been a printed source that the painter followed in certain aspects.

The figure of the Pope sitting in an open litter marks the centre of this extensive composition. [Fig. 6] The piece is unified by a continuous, exuberantly jagged border in the Joanine style, with various decorative motifs: cartouches, shells and cherubs.⁴

Analysing the different sections of the panel, we tried to determine how the tile painter interpreted this graphic source and the idea of a papal procession, in a fantasised image of Rome with altered proportions and synthesised figuration.

The first tiles of the procession, to the left of the observer, show the beginning of the trajectory, punctuated by a tree (a device commonly used in tile imagery of this period to demarcate scenes and narrative rhythms). This tree hides a fortification that resembles the Castel Sant'Angelo, a landmark along the *Via Papalis*.

We have highlighted the figure of the *timbaleiro* playing the cavalry drum — which closely replicates the one in the engraving — and the trumpeters further ahead, in the middle, with a group of several feathered knights, two of them carrying pontifical banners [Fig. 7].

FIG. 5. The Monastery of São Vicente de Fora, Lisbon [Graphic material] / photographs by João Miguel dos Santos Simões (1907-1972), negative, 1960-1970, Art Library | FCG.

³ It seems that José da Costa was the *ladrilhador* responsible for laying the tiles of the cloisters of São Vicente de Fora, as documented by a 1736 receipt: “*E no que se deu ao ladrilhador Joseph da Costa, de assentar quatorze mil e quinhentos e vinte e hum azulejos nos sobre claustros, a rezam de dez mil reis cada milheiro, cento e quarenta e cinco mil duzentos e dez reis*”. This reference to the document was published by Soromenho, Miguel (2010) — “*Hum dos Mayores e Magníficos Templos não só de todo o Reyno mas da Europa: a Obra Filipina: in Saldanha, Sandra (coord.), Mosteiro de S. Vicente de Fora. Arte e História*, Lisbon: Centro Cultural do Patriarcado Português, pp. 129-153.

⁴ It is important to consider the figurative repertoire of the wider pictorial programme for terrace decoration that forms the context for this panel. Such spaces often record everyday scenes from the 18th century.



It should be noted that the timbale has an embroidered cloth bearing Pope Innocent's coat of arms, which has already been decoded.

The procession continues with more horsemen and the introduction of an empty coach drawn by horse teams, a new element in the engraving. Here, in line with the printed source, we also see the Roman Colosseum, another of the symbolic landmarks on this route [Fig. 8].



FIG. 6. The cloister terrace at the Monastery of São Vicente de Fora. Tile panels of the north wall. The Pope's Procession. Innocent XIII on an open litter. Photographic credits: ©Alexandra Gago da Câmara and Teresa Verão.

FIG. 7. The cloister terrace of the Monastery of São Vicente de Fora. Tile panels on the north wall. Detail of the *Timbaleiro*. Photographic credits: ©Alexandra Gago da Câmara and Teresa Verão.

At this point, we would emphasise another highly prevalent detail: the birds in flight all over the panel. This provides a delicate and atmospheric sense of space that is absent from the engraving, which is limited to the condensed depiction of the procession.

Further on, and just ahead of this group, we see a litter or chair carried by two men, escorted by the Pope's halberdiers.



This is followed by the central scene, the most important of the panel, concentrating on the Pope's private retinue of grooms.

Two long-capped figures astride a pair of horses seem to be directing the papal procession and setting the pace. They are followed by a mounted cardinal with a raised cross, who is explicitly identified in the engraving: *Monseignor Auditori di Ruote chi porte la croche avanti la Santita* [Fig. 9].

In the background, a knight wearing a large feathered hat and holding a staff is accompanied by a large group of knights in long cloaks, along with some servants on foot. The endless, winding line of princes, barons, Roman grandees and foreign dignitaries marks the route that has been traversed.

Once again, the painter is referring to the engraving (which he certainly knew) but eliminates most of the figurative elements while seeming to capture and synthesise the most important scenes and moments. The architecture appears to



be that of an imaginary landscape, suggesting an invented Rome with elements of the countryside or wilderness.

Finally, in the last section before the door abruptly cuts off our view, we see the suggestion of a fortification that is remarkably similar to Castel Sant'Angelo, which we first encountered in the company of several armoured cavalry soldiers [Fig. 10].

The structure has been interrupted by the addition of doors, windows and annexes that truncated different sections, and damaged by the installation outdoors and a lack of protection. Sadly, it is in extremely poor condition and requires urgent intervention.

Iconological interpretation

Given that this is a seemingly unique depiction in *azulejos* of the parade following the enthronement of a Roman

FIG. 8. The cloister terrace of the Monastery of São Vicente de Fora. Tile panels on the north wall. Detail of the Colosseum. Photographic credits: ©Alexandra Gago da Câmara and Teresa Verão.

FIG. 9. The cloister terrace of the Monastery of São Vicente de Fora. Tile panels on the north wall. *The Monsignor Auditori di Ruote carrying the Cross.* Photographic credits: ©Alexandra Gago da Câmara and Teresa Verão.



pontiff, it is important to clarify its meaning and iconological implications. The personality of the nuncio who would become pope, the interests and the strategy pursued by King John V with regard to his election and the symbolic projection of this fact, in line with the Baroque mentality, are all promising areas for art historians to explore and elucidate.

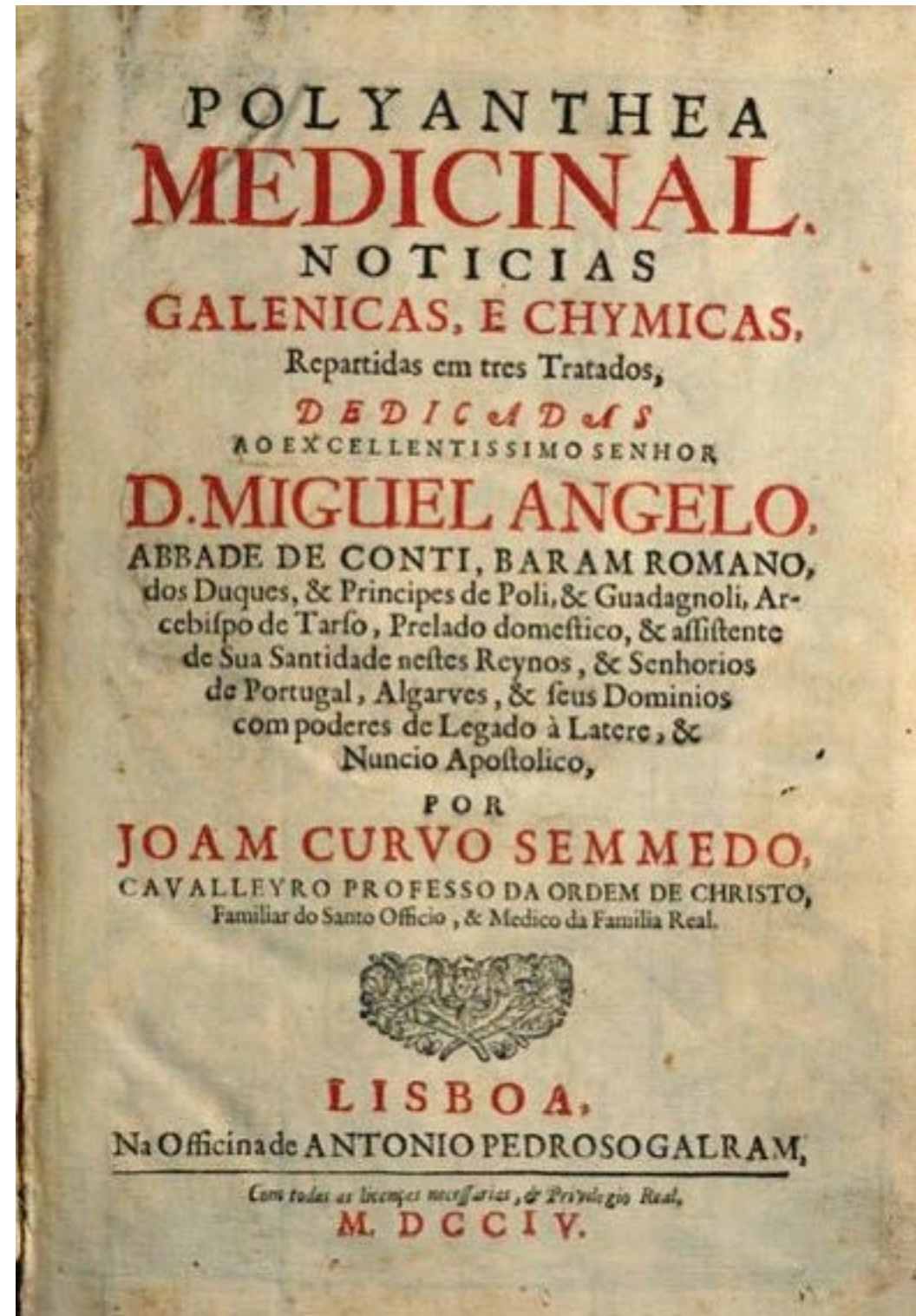

FIG. 10. The cloister terrace of the Monastery of São Vicente de Fora. Tile panels on the north wall. Fortification, very similar to the Castel Sant'Angelo. Photographic credits: ©Alexandra Gago da Câmara and Teresa Verão.

FIG. 11. *Polyanthea Medicinal. Notícias Galenicas e Chymicas Repartidas em três Tratados, Dedicadas ao Excelentíssimo Senhor D. Miguel Angelo, Abbade de Conti, Baram Romano [...], 1704.*

At the centre we find Michelangelo Conti, a Roman baron and member of the illustrious family of the dukes and princes of Poli. He was apostolic nuncio and “assistant to His Holiness in these Kingdoms and Lordships of Portugal”, as stated in the dedication of *Polyanthea Medicinal*,⁵ a monumental treatise

⁵ *Polyanthea Medicinal. Notícias Galenicas e Chymicas Repartidas em três Tratados, Dedicadas ao Excelentíssimo Senhor D. Miguel Angelo, Abbade de Conti, Baram Romano [...], 1704.*

on medicine published in 1704. Written by João Curvo Semedo, this treatise [Fig. 11] was one of the most read therapeutic and pharmacological works during this period and reprinted several times. The fact that one of its editions was dedicated to the Italian prelate is proof of the high regard in which he was held (Flor, 2013, 135-158; Raggi, 2014, 107-129).

Yet it is the panegyric delivered by the Count of Ericeira at the Royal Academy of History, less than two months after the election, that best illustrates the impact of the event in Portugal, duly enhanced by the kind of discourse and oratory that were typical of the Baroque period. In a Lisbon that, according to the author, imitates Rome with its seven hills, people rejoiced at the news, bells rang out and lights were strung up to decorate buildings. The celebrations culminated in a solemn *Te Deum* sung at the Patriarchal Church before the king and the whole court.

Ericeira argues that the newly acclaimed hero, although born into a family whose oldest branch moved from Preneste to Rome at the time of the Republic and held religious and political offices there for twenty centuries, should nonetheless be regarded as a Portuguese pontiff. This supposedly deep-rooted nationality is borne out by his affection for the Portuguese, his proficiency in the Portuguese language and the fact that he resided in the kingdom for a decade as Cardinal Protector.

But there is more to be said about Innocent, whose name is identical to that of the pope who recognised King Afonso Henriques as the founder of Portugal. He was christened Michelangelo and his coronation ended on 18 May, the feast day of St Michael the Archangel, leader of God's heavenly army. Worshipped since the Early Middle Ages in the Gargano mountains, in Puglia, St Michael became popular after appearing above Hadrian's mausoleum during a procession in Rome led by Gregory the Great. The end of the terrible plague epidemic during that same period consolidated his popularity in the papal city, and the angel, with a sword in his hand, became a protective figure. This was the thrust of the panegyric delivered at the Academy.

Crowned on the day of the apparition, Cardinal Conti identified, above all, with the angel, who was also the custodian

and first protector of the kingdom of Portugal. Having appeared in the sky to ensure the victory of Portugal's founding king in Santarém, the saint had inspired various temples, chapels and altars, as is well documented in Friar Bernardo de Brito's *Chronicle of Cister* and Jorge Cardoso's *Agiológio Lusitano*. King Manuel, who was also committed to celebrating St Michael as the kingdom's guardian angel, obtained the permission of Pope Leo X to hold an annual procession in his honour on the third Sunday of July.

This brings us to the coat of arms of the Conti family, which bears an eagle with the crossed keys of Saint Peter. The eagle is both an imperial bird and the symbol of St Michael the Archangel, as well as a general reference to the figure of the pope — the watchful pastor, the magnanimous prince, an example of wisdom, prudence and virtue. The eagle, as the queen of all birds and the enemy of vice, conveys several different meanings, which the director of the Academy's remarkable Baroque erudition does not fully cover. The bird has therefore been deliberately chosen for its symbolism to form part of the tile decoration.

Moreover, the composition evinces a political agenda. It can be seen as a homage to the Cardinal Protector, but also as an evocation of an idealised Rome, which the *Joanine* clergy sought to emulate. Created around 1736, twelve years after the pope's death, at a time when the conflict regarding the different nuncios had already been settled, the decoration illustrates a successful diplomatic move by the Portuguese authorities, committed to what Borges de Macedo described as the achievement of diplomatic parity within the Holy See (Macedo, 1987, 259-263).

Going through the list of participants in the *Possesso* ceremony, we find two Portuguese cardinals, Nuno da Cunha de Ataíde e Melo and José Pereira de Lacerda, who were sent to the conclave with the instruction of voting for "the Portuguese candidate". However, they were unable to do so, as they arrived after the election. There is a partial record of their activities afterwards, but no information regarding the unforgettable event in which they took part.

Likewise, nothing seems to have been written by Father Manuel de Campos, the Jesuit who accompanied the two cardinals and the author of a series of 29 letters filled with relevant artistic information, recently studied by Teresa Leonor Vale (Vale, 2018, 387-393).

It is tempting, therefore, to picture these men as part of this composition, albeit in a vague, merely indicative way – the *azulejo* was never particularly suited to portraiture. Could these cardinals have been responsible for such a unique commission? There is no indication of this, apart from the work's richly allusive depiction of a Baroque parade. Public festivities acquired an added brilliance with the inclusion of the nuncios and, above all, the magnificence that became typical of the Corpus Christi procession from 1719 on.

Regarding this decorative panel, two paintings originally found in São Vicente de Fora are currently on display in the Museum of Aveiro. Possibly of Italian origin, they show St Peter's Square and a view of the Corpus Christi procession. There must have been several other related works, but it is impossible to determine how many. In any case, the vast sequence of images depicting this imaginary Rome represents a unique case in the artistic history of Portugal and Europe, given its transposition to a medium as unexpected as the *azulejo*. The centre is occupied by the majestic profile of Innocent XIII blessing the crowd – and, in a way, the kingdom of Portugal, as the gesture was perceived at the time.

Understood as an opulent display of power, the Baroque feast combines its public dimension with the communicative potency of art, and exhibits a complex visual culture supported by ephemeral architectural structures. This is made particularly clear in António Bonet Correa's important study on this period, highlighting the social and urban aspects of such events, as well as their clear symbolic dimension (Correa, 1990, 5-32). The feast, imbued with religious dogma, was a practical coagulation of the period's institutional verticalism, whose primary function was that of a meta-discourse, as noted by Fernando R. de la Flor in his book on Baroque representation and ideology in the Hispanic world (Flor, 2002, 163-165).

Due to its double significance, both religious and political, the papal *Cavalcata* was embraced by Portugal's absolute monarchy as a celebration of the kingdom and the international politics of its king, guided by Catholic interests. Translated into the narrative processes employed in tile decorations, directed at the select few who could admire them on the terrace of the Monastery, this event tends to lose its documental value as being linked to a specific historical event, and acquires instead a somewhat generic appearance due to its similarity to many of the compositions produced during this period. Hence the failure to identify the subject matter, aggravated by the lack of a caption, and the need for the historical investigation now being presented.

The theme of the enthronement of Pope Innocent XIII is of remarkable artistic and cultural significance—and brought to the cloisters of São Vicente an image of Rome that was not entirely faithful to that of the actual city in 1721, when the papal celebrations took place. This was also known as the year of all wonders, when Alessandro Scarlatti's cantata *La Ninfa del Tago*, commissioned by Cardinal D. Nuno da Cunha, was premiered to celebrate King John V's name day. This work was recently rescued from oblivion by the Lisbon Metropolitan Orchestra (2018), evoking Rome and its inhabitants seen from the river Tagus, painted in blue and white.

BIBLIOGRAPHY

PRINTED SOURCES

- BRITO, Frei Bernardo de. 1602. *Primeira Parte da Chronica de Cister, onde se cantão as cousas principais desta ordem & muitas antiguidades do Reyno de Portugal*, Lisbon: Pedro Crasbeek.
- CARDOSO, João. 1652-1666. *Agiológio Lusitano dos Santos, e varões ilustres em virtudes do Reyno de Portugal, e suas conquistas*. 4 volumes, I, Officina Craesbeekiana.
- PANEGÍRICO na eleição do Sumo Pontífice Innocencio XIII. Read by the Count of Ericeira at the Royal Academy of Portuguese History, of which he was director, on 5 July 1721.
- POLYANTHEA Medicinal. *Notícias Galenicas e Chymicas Repartidas em três Tratados, Dedicadas ao Excelentíssimo Senhor D. Miguel Angelo, Abbade de Conti, Baram Romano [...]*, 1704.
- RELAZIONE distinta della solenne cavalcata, con la quale il Sommo Pontefice Innocenzo XIII. si portò a prendere il possesso della sacrosanta Basilica di S. Giovanni in Laterano nel giorno di domenica 16. novembre 1721: con la descrizione degli archi trionfali, eretti in onore di Sua Santità e di tutte le

pompe e feste, che in tal funzione si sono ammirate. Rome: Nella stamperia di Pietro Ferri..., 1721.

STUDIES

- CÂMARA, Maria Alexandra Trindade Gago da; LOUZEIRO, Carlos Alberto. 2013. "Os Claustros do Mosteiro de S. Vicente de Fora. Da Austeridade Filipina à Pompa Joanina". In *Encontro Internacional sobre Claustros no Mundo Mediterrânico, Séculos X-XVIII. Actas*. Lisbon: Museu Nacional de Arte Antiga.
- CORREA, António Bonet Correa. 1990. *Fiesta, Poder y Arquitectura. Aproximaciones al Barroco Español*; Madrid: Akal.
- DELL'ARCO, Maurizio Fagiolo. 1978. *Baroque and rococo*. Paris: Hachette Realités.
- DELL'ARCO, Maurizio Fagiolo. 1996. *Il Settecento e l'Ottocento. Corpus delle feste a Roma*. Rome: De Luca.
- FLOR, Fernando R.P. de. 2002. *Barroco. Representación e Ideología en el Mundo Hispánico (1580-1680)*. Madrid: Cátedra.
- FLOR, Susana Varela. 2013. "A entrada publica do núncio Giogio Cornaro em Lisboa (1693)". In *Le nove son tanto e tante buone, che dir non se pô — Lisboa dos Italianos: História e Arte (séculos XIV-XVIII)*. Lisbon: pp. 137-158.
- MACEDO, Jorge Borges de. 1987. *História Diplomática Portuguesa. Constantes e linhas de força*. Lisbon: Instituto de Defesa Nacional.
- MARAVALL, José Antonio. 1986. *La Cultura del Barroco. Análisis de una estructura histórica*. Barcelona: Ariel.
- PASTOR, Ludwing Von. 1962. *Storia dei Papi nell' periodo dell'assolutismo, vol XV*. Rome: Déesclée Editori Pontificie.
- QUEIRÓS, José. 1913. "Azulejos de São Vicente de Fora, Terraço grande". In *Revista de História, Sociedade Portuguesa de Estudos Históricos*, vol. 2, no. 8 (Oct-Dec 1913).
- RAGGI, Giuseppina. 2014. "A Formosa maquina do Ceo e da terra: a procissão do *Corpus Domini* de 1719 e o papel dos arquitetos Filippo Juvarra e João Frederico Ludovice". In *Cadernos do Arquivo Municipal*, 2º series, no. 1 (Jan-Jun), 2014, pp. 107-129.
- SALDANHA, Sandra Costa (coord.). 2010. *Mosteiro de São Vicente de Fora, Arte e História*. Lisbon: Centro Cultural, Patriarcado de Lisboa.
- SIMÕES, João Miguel dos Santos. 2010. *Azulejaria portuguesa no século XVIII*. 2nd edition, revision and updating overseen by Maria Alexandra Gago da Câmara. Lisbon: Calouste Gulbenkian Foundation.
- SMITH, Robert Chester. 1973. "French models for portuguese tiles". *Apollo, The international magazine of arts*. London: Apollo Magazine, new series, no. 13, pp. 396-407.
- SOBRAL, Luís de Moura. 1994. "Non Mai Abastanza. Desenho, pintura e prática académica na época do Magnânimo". In *A Pintura em Portugal no Tempo de D. João V, 1706-1750. Joanni V Magnifico*. Lisbon: IPPAR — Instituto Português do Património Arquitetónico e Arqueológico, pp. 109-115.
- SOROMENHO, Miguel. 2010 — "*Hum dos Mayores e Magníficos Templos não só de todo o Reyno mas da Europa: a Obra Filipina*: in Saldanha, Sandra (coord), *Mosteiro de S. Vicente de Fora. Arte e História*, Lisbon: Centro Cultural do Patriarcado Português, pp. 129-153.
- VALE, Teresa Leonor. 2018. "Art and festivities in eighteenth-century Rome: letters from a Portuguese priest, 1721-22.". In *The Burlington Magazine*. May, 2: 389-393.



THE STATE FUNERAL IN SPANISH MILAN: A BAROQUE RITUAL OF COMMEMORATION

ANDREW HORN*

Leverhulme Early Career Fellow
University of St Andrews
drandrewjhorn@gmail.com

* Andrew Horn began last autumn as a Leverhulme Early Career Fellow at the University of St Andrews, after three years as a Teaching Fellow in History of Art at the University of Edinburgh. He received his Bachelor of Arts in Fine Art from the University of Notre Dame and a Master of Science in Design and Production for Opera from Indiana University's Jacobs School of Music. His recently published monograph, titled *Andrea Pozzo and the Religious Theatre of the Seventeenth Century* (Philadelphia: Saint Joseph's University Press, 2019), presents the work and career of the Jesuit artist Andrea Pozzo (1642-1709) as a case study in the relationship of the religious art and architecture of the seventeenth century to the period's culture of ritual and performance. His research, which focuses on Italian art and architecture of the early modern period, is particularly concerned with the roles of ritual, spectacle, performance and scenography within early modern culture, in both religious and secular contexts, and how they inform our reading of the period's major works of art, buildings and spaces.

ABSTRACT

State funerals were among Milan's most distinctive contributions to the world of the early modern spectacle. The ephemeral scenographies constructed for these occasions transformed both the interiors and the exteriors of the churches in which they were held into great "theatres of death". In this paper I offer an examination of three such occasions from the late sixteenth and late seventeenth centuries. Using the engraved and printed records of these events as a means of reconstructing the experience, I consider how visual rhetoric, including image, word and gesture, functions together with light and ritual movement to appeal to both the emotions and the intellect in order to persuade, engaging the participant in the cathartic performance of mourning. As highly choreographed rituals of devotion and reflection, Milanese funerals are eloquent illustrations of early modern understandings and beliefs regarding death, mortality and commemoration.

KEYWORDS MILAN, CATHOLIC REFORM, CARLO BORROMEO, HABSBURG, SCENOGRAPHY

RESUMO

Os funerais de Estado contam-se entre os contributos mais relevantes da cidade de Milão para os espetáculos da época moderna. As cenografias efêmeras construídas para essas ocasiões transformaram tanto os interiores como os exteriores das igrejas, nos quais eram representados, em grandes "teatros da morte". Neste texto analiso três dessas ocasiões, com cronologias que oscilam entre o final do século XVII e o final do XVIII. Fazendo uso das gravuras e estampas executadas para memória futura destes eventos, estudo a forma como a retórica visual, incluindo a imagem, a palavra e os gestos funcionam em simultâneo com a luz e os movimentos rituais para apelar tanto às emoções como ao intelecto, de forma a persuadir e envolver o espectador e participante na performance catártica do luto. Enquanto rituais fortemente coreografados de devoção e reflexão, os funerais milaneses ilustram de forma eloquente as crenças relativamente à morte, à mortalidade e à comemoração, vividas no período moderno.

PALAVRAS-CHAVE MILÃO, REFORMA CATÓLICA, CARLOS BORROMEU, HABSBURG, CENOGRAFIA



INDEX



EDITORIAL



DOSSIER



PRINT

During its period of Spanish rule (1535-1706), the Duchy of Milan was a mighty economic power, a major military centre and the gateway to the Italian peninsula, holding a key strategic position in the defence of Spanish territories to the south as well as the Papal States (D'Amico 2012, 123). Milan's proximity to Protestant lands to the north of the Alps also made it a place of great religious importance: beginning in the late sixteenth century, the austere and zealous archbishop Cardinal Carlo Borromeo (1538-84) sought to make Milan a model diocese of the reformed Catholic Church, and called for city-wide participation in religious rites and devotions, which he saw as urgent appeals for divine mercy as well as opportunities for spiritual renewal (Cattaneo 1958, 51-65; Buzzi and Zardin 1997; Crivelli 2005, 67-78). Spanish kings, in alliance with the papacy, actively sought to maintain Catholic orthodoxy and piety throughout their lands, and as an important centre of the empire and of Catholic reform, Milan became a showcase of Spanish Catholic rule. Under the Spanish Habsburgs, represented in the governor and his court, and the religious leadership of Borromeo and his successors, Milan became a staging ground for elaborate religious and civic festivals marking occasions of celebration, devotion, penitence and mourning.

The state funeral has been recognised by scholars as one of Milan's most distinctive contributions to the world of the early modern spectacle (Horn 2019, 92; Zanlonghi 2002, 175-84; Grandis 1995, 659-715; Berendsen 1961). In these great "theatres of death", word and image functioned together with the funeral ceremony to create a sequenced progression of stories and reflections on the achievements and virtues of deceased rulers which their organisers wished to promote (Carandini 1990, 61). As highly choreographed rituals of devotion, reflection and commemoration, Milanese funerals corresponded to the exequies celebrated for Habsburg rulers in Madrid and other major cities in the empire (Orso 1989, Soto Caba 1988, 123-25). The systems of visual rhetoric and sophisticated metaphors represented in the decorations and recorded in the commemorative printed accounts served

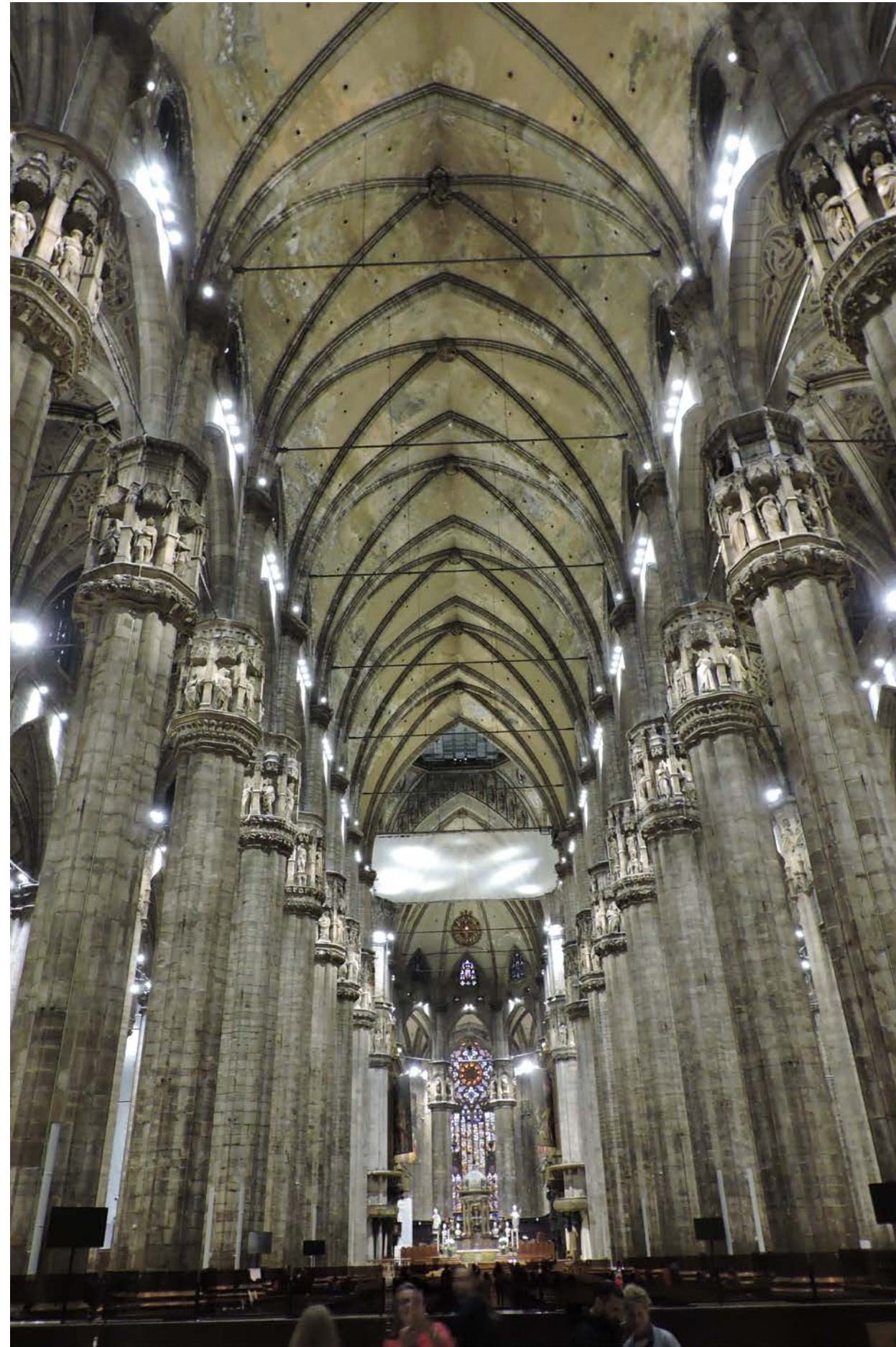

FIG. 1. Simone da Orsenigo (and others), Duomo, Milan, begun 1386. Photo: author.

the characteristic functions of Habsburg royal funerals: celebrating the deceased ruler, ensuring the loyalty of his or her subjects, and promoting the peaceful and prosperous continuation of the dynasty (Mínguez 2014). However, as this essay shall demonstrate, the decorations for state funerals in Milan of the fifteenth and sixteenth centuries took on a monumental scale and a performative character which make them unique even by the grandiose imperial standards of the time. Habsburg funerals have been analysed more for their political function as propagandistic displays of power than as true rites of mourning (Soto Caba 1988, 113). One could argue that the Milanese exequies, as recorded in accounts and engravings, were intended as occasions of sincere individual and collective mourning. Their decorations were designed to engage viewers on an intellectual and emotional level with dramatically gesturing figures and images that demanded their attention, reflection and performed response. The participant was called upon — physically or “virtually” by means of the printed account — to progress through space and through systems of images, guided by the dazzling and symbolic employment of light, as he or she joined in the celebration of the empire, the commemoration of its rulers, and grief at the loss of the sovereign.

This essay will focus on the royal funerals of Anna of Austria in 1581 and Philip IV in 1665, both held in Milan’s Duomo, and close with a brief account of the funeral for the Duchess of Uceda in the church of Santa Maria della Scala in 1671. Although they were designed to glorify Spain and its rulers, these occasions represent two distinct periods in the history of Milan and the Spanish Empire. In the funeral of Anna of Austria, the death of the royal consort of Philip II became the occasion for an emotionally-charged event in which the loss of the “mother” of the realm resulted in a performance of mourning centring on the themes of grief, transformation and hope. In the funeral of Philip IV, an empire which had reached the apex of its power was glorified through the celebration of world conquest and the heroizing of a Catholic ruler whose reign in fact marked the beginning of a decline. Finally, the funeral of the Duchess of Uceda is an example of the particularly emotive

power of recorded words and images in the funerary context and their appeal to the memory and the imagination.

Habsburg exequies celebrated in Milan, which began with Charles V in 1559, more or less followed the Habsburg code of etiquette for royal funerals, including the system of decorations (Horn 2019, 92; Schraven 2014, 62; *Esequie* 1587). However, they reached a level of grandeur which surpassed the funerals held for rulers in Madrid, and possibly anywhere else in the empire, certainly owing in part to the vast interior of the Duomo with its soaring vaulted ceiling (Orso 1989, 60) (Fig. 1).¹ As we see in the engravings of these funerals, the architecture of the Duomo was featured, rather than obscured or disguised by the ephemeral decorations, as was often the case with the churches where royal funerals were held in Spain (Soto Caba 1988, 115-20) (Figs. 2, 5). Moreover, the impact of the catafalques and the other funeral decorations derived not only from their immense size, but from the theatrical spectacle produced by their numerous gesturing figures.

The funeral of Anna of Austria (1549-80), fourth wife of Philip II, in September of 1581, solidified the scenographic language which state funerals in the Duomo would continue to follow until the end of the seventeenth century (Grandis 1995, 667-71). Carlo Borromeo himself presided over the funeral, and Pellegrino Tibaldi, who was then architect of the Duomo, designed the catafalque and the decorations and authored a published, detailed description of the *apparato* (Tibaldi 1581). Unfortunately no engravings accompany this text, so we must rely on Tibaldi’s written account. The nave of the Duomo, following the established tradition for royal funeral decorations throughout the empire, was draped in black and decorated with lamps, statues, emblems and escutcheons in black and gold (Tibaldi 1581, B 3r; Soto Caba 1988, 118-20). Featured was a series of twelve histories, pictorial *imprese* which celebrated the queen’s virtues and deeds, and her importance to the empire and the monarchy. The first of these *imprese* is described thus:

... an old woman, weeping, lies on the columns
of Hercules with an Angel, who shows her

¹ In Madrid, the church used for Habsburg exequies was La Encarnación, considerably smaller than Milan’s Duomo.

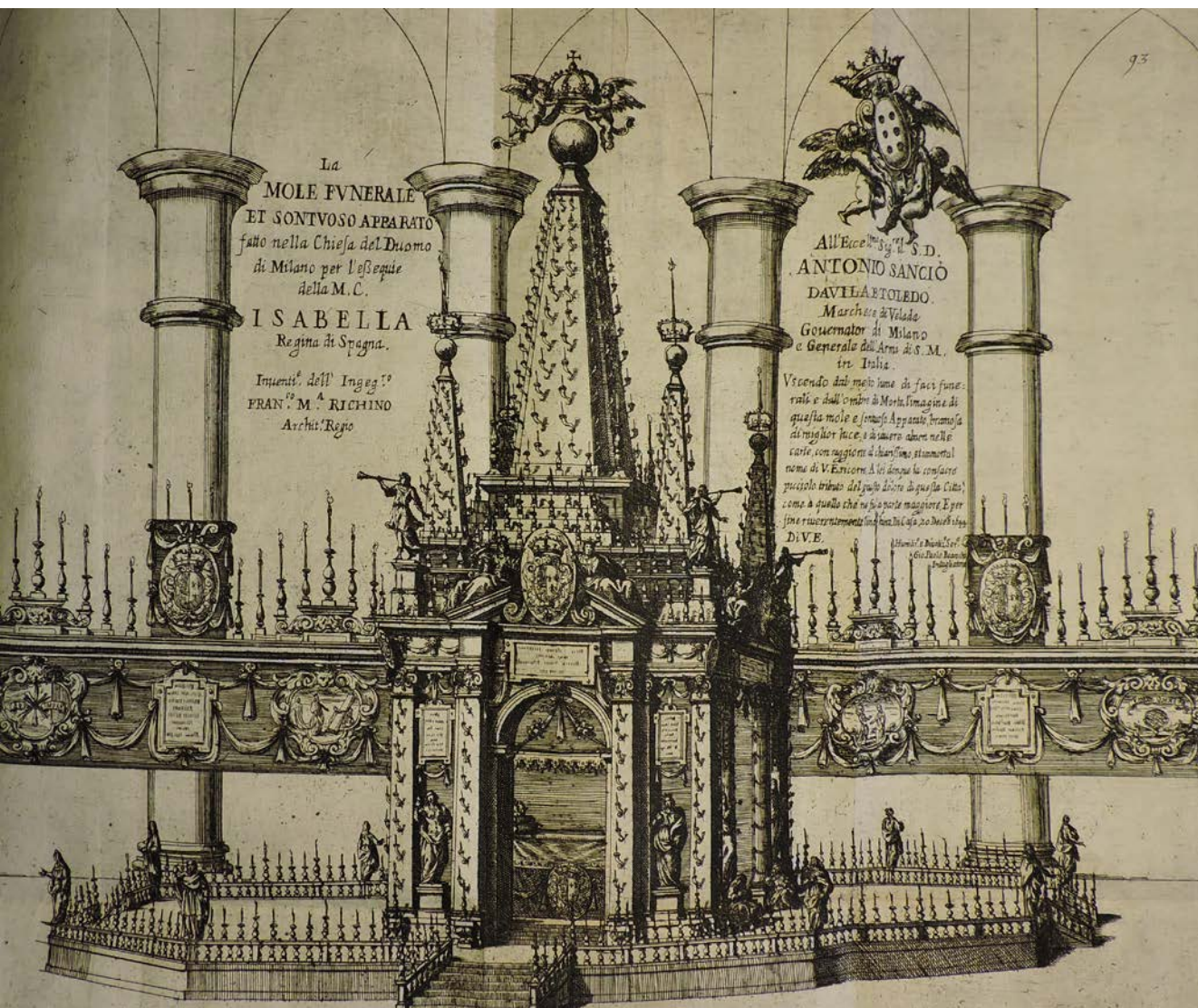

a ship that comes from the high seas, bearing the arms of the House of Austria. This old woman signifies Spain when it found itself without a Prince, and without a Queen; and the Angel signifies the joy, demonstrated in that ship which is the end of her travail, the good that comes from the house of Austria. On the same ship is written the motto which says: **THERE IS YOUR HOPE.**²

This *impresa* illustrates the central message of this funeral: in the midst of despair comes hope for the future of the kingdom (Grandis 1995, 668). Anna of Austria died of influenza while pregnant at the age of 30; the ship refers to her son, the future Philip III, who survived infancy.

The third *impresa* depicted the queen washing the feet of twelve people during Holy Week, demonstrating her Christian

humility; the twelfth depicted two pairs of columns, the first with the motto PLUS ULTRA, and the second NON PLUS ULTRA, “meaning that although the Kingdom of the World is vast, it can however be greater; but the Kingdom of Heaven cannot be equalled, nor can it be other”.³ Thus the decorative system emphasised the queen’s charity and religious devotion, celebrating her as a Catholic monarch and guaranteeing her immortality.

The tradition of the monumental catafalque, which when lit resembled a great funeral pyre, was intended to associate the king and the empire with the greatness of ancient Rome, where the lighting of the pyre and the release of an eagle symbolically sent the soul of the deceased emperor up to heaven (Orso 1989, 27-32; Schraven 2014, 65; Mínguez 2014). Following an imperial standard established by the funerals of Charles V, the catafalque in the form of a pyramid, or formed by a series of obelisks or pyramids, became central to the characteristic visual language of Milanese funerary scenographies from the late sixteenth century to the end of the seventeenth (Horn 2019, 92-93).⁴ In this regard, the Milanese catafalques adhered consistently to the idea of the ancient funerary pyre or *ustrinum*, as well as to Claude-François Menestrier’s definition of the catafalque: a pyramidal wood structure covered with lit candles (Menestrier 1687, 294). Elsewhere the design of imperial catafalques had already begun to vary; the catafalque for Philip IV in Madrid, for example, was a two-level octagonal structure formed by columns, crowned with a dome (Orso 1989, 29, 65-70, 185). The catafalque constructed in Milan for Queen Isabella (Elisabeth of France), first wife of Philip IV in 1644, serves as an example of a traditional Milanese catafalque design: an ephemeral architectural tomb crowned by a central pyramid with obelisks at the four corners (Fig. 2). The catafalque structure always housed and displayed one or more objects symbolizing the monarch: the *tumba* or *letto di duolo*, representing the

FIG. 2. Francesco Maria Richini, catafalque for Queen Isabella of Spain (Elisabeth of France), Duomo, Milan, 1644. Milan, Biblioteca Nazionale Braidense, XA.11.0054/02. Photo: author. Reproduced by permission of the Ministero dei Beni e delle Attività Culturali e del Turismo-Biblioteca Nazionale Braidense.

² “La prima una vecchia piangente, appoggiata alle colonne d’Ercole, con un Angelo, che li mostra una nave, che viene d’alto mare, con l’armi di casa d’Austria. Questa vecchia significa la Spagna quando ritrovò mestissima senza Principe, et senza Regina: et per l’Angelo è significato il gaudio, che dimostra in quella nave esser il fine del suo travaglio, il qual bene le viene da casa d’Austria, et nella propria nave è il motto che dice. IBI SPES TUA” (Tibaldi 1581, B 3r).

³ “Nella duodecima, si dipingono due colonne appresso l’altre due lontane, et nelle prime dice PLUS ULTRA, nelle seconde NON PLUS ULTRA, significando che ancora il Regno del Mondo sia grandissimo, può però esser maggiore, mà il Regno del Cielo non si può agguagliare, ne vi è più altro...” (Tibaldi 1581, C 2r-v).

⁴ The catafalque constructed for Charles V in Brussels, a tiered pyramid of lights held aloft by columns serving as a great canopy over the symbols of the monarch, established a precedent followed elsewhere, including Milan.

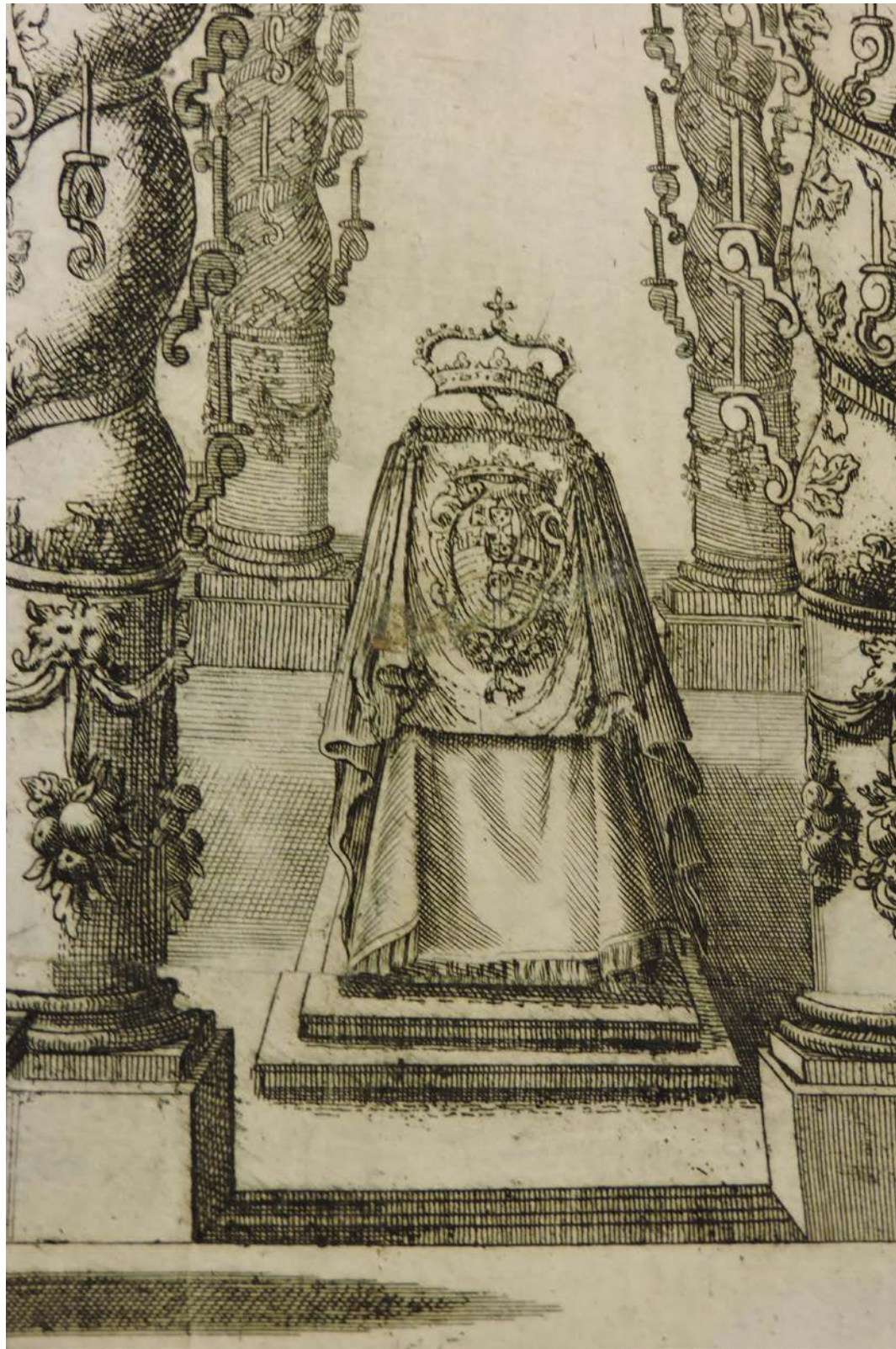

FIG. 3. Detail of Ambrogio Pessina's catafalque for Philip IV, Duomo Milan, engraving. From Barella, *Esequie reali. . . Filippo IV*, 1665. Milan, Biblioteca Nazionale Braidense, XA.11.0054/02. Photo: author. Reproduced by permission of the Ministero dei Beni e delle Attività Culturali e del Turismo-Biblioteca Nazionale Braidense.

presence of the body of the deceased (actually interred at El Escorial), and the royal symbols of the orb, crown and sceptre (Barella 1665, 10; Orso 1989, 15-19) (Fig. 3). The structure was virtually covered in the flames of lamps and candles, quite literally taking on the appearance of a funeral pyre, a pagan tradition of antiquity here reassigned as a Christian symbol of transformation and triumph over death (Carandini 1990, 61-63; Tibaldi 1581, A 2v; Orso 1989, 32).

The catafalque for Anna of Austria consisted of a raised octagonal platform in the crossing, accessed by four staircases, over which rose a tiered structure, which is described by Tibaldi level by level, decorated with pyramids and sculpted figures in diminishing scale (Tibaldi 1581, A 2v-B 3r). On the first level, each point of the octagon was marked by a pedestal crowned by a pyramid, all painted to resemble black marble and covered with many lights. These pyramids represented tombs of four rulers of the House of Austria and their consorts. They included, on the right, Maximilian I, Charles V, Ferdinand I (with arms of Bohemia and Hungary), and Maximilian II (Tibaldi A 3r-v). On the left side were pyramidal monuments representing royal consorts: Isabella, wife of Charles V; Empress Maria of Austria; Eleanor of France (and Portugal); and Joanna, Grand Duchess of Tuscany (Tibaldi 1581, A 3v-4r). Such an arrangement of ephemeral tombs celebrating the Habsburg dynasty might be said to correspond with Philip II's idea of the collective burial and enshrinement of the family, anticipating the monumental royal Pantheon completed by his successors at El Escorial (Mínguez 2014).

Between the pyramids on the first level of the structure were five black, draped female figures representing five Spanish territories: the greater Kingdom of Spain, the Kingdom of the Two Sicilies, the Kingdom of Portugal, the Duchy of Milan, and Flanders. The figure of Milan, emphasised in the account, is described with highly emotive language, "in complete anguish for the premature death of the Most Serene Queen, and with her hand dries the tears which abundantly flow from her eyes ..." ⁵ The figure of Milan, as well as the other figures to be described, "performed" the

⁵ "La quarta statua è fatta per lo Stato di Milano, le qual'è tutta dolente per l'immaturo morte della Serenissima Regina; et con il mano s'asciuga le lagrime, che da gl'occhi abbondantemente si versano ..." (Tibaldi B 1r).

tears and gestures of grief, which were surely intended not only to produce powerful affect and response in the mourners through observation, but to aid in the necessary catharsis brought about by funerary ritual by encouraging imitation of these very actions and gestures.

On the next level, on each side, were five more “performing” statues, “dressed in black and grieving”, and each bearing a torch: the “horrible” winged figure of Time devouring two infants representing night and day; Death with his scythe; Sadness shown in “grieving gestures”; Pain, represented surrounded by flames; and Glory, admiring the luminous heavens (Tibaldi 1581 B 1r-v). On three more levels above this were ten more figures representing Religion, bearing a cross and palm branch, together with the theological virtues of Faith (with a chalice, turning her eyes to heaven), Hope (with Death at her feet), Charity (with rays emanating from her breast), and Innocence (holding an infant, with a dove on her shoulder); and finally the cardinal virtues of Prudence, Temperance, Fortitude and Justice, as well as Concord (Tibaldi B 1v-2v).

The catafalque’s tiered system of ephemeral statues celebrating Anna of Austria’s lineage together with her virtues formed an allegorical programme in which the entire empire was represented both mourning and paying tribute to the queen. The total funeral *apparato* in the Duomo was perhaps a lesson to the Milanese public in the proper veneration that Spanish subjects should pay to their royal family. It expressed the very personal manner in which one was expected to mourn a monarch’s passing, particularly that of a royal consort, whose death had huge implications regarding the royal succession and the stability of the kingdom (Orso 1989, 6; Mínguez 2014). The figures are described as if they were live performers enacting a grand staged tragedy, demonstrating to subjects how they should respond: they were models of mourning to be both contemplated and imitated.

The whole of the catafalque was draped in black with numerous lights and the gilded arms of the Queen, and crowning it was a great flame, “reaching to heaven, in which we place our hopes that the soul of the blessed queen should be raised up”.⁶ Above this were suspended circles of luminous

clouds populated by sculpted cherubs bearing lights, the “angelic choirs” that “accompanied the blessed soul to heaven”. The catafalque structure was thus a performing monument to the queen and her virtues as a Christian ruler, representing her apotheosis while serving as a meditation on the delicacy of life and the fleeting nature of time. The system of the catafalque together with the nave decorations depicted the Queen as the model Christian monarch being received into heaven and the glory of immortality (Grandis 1995, 669).

Included in Tibaldi’s exhaustive account of the funeral decorations for Anna of Austria is a full transcript of the sermon given by archbishop Carlo Borromeo (C. Borromeo 1581). It must have been no small compliment to the great architect that Borromeo’s sermon repeatedly referred to the *apparato* and its symbolism, highlighting its importance to the funeral rite and emphasizing its ephemerality. Within the ritual context of mourning, decorations such as these become the ultimate representation of *vanitas*, symbols of mortality and the transience of this world (Soto Caba 1988, 115-20). Borromeo explained to the congregation that when the lights were extinguished and the structure dismantled, their souls would be marked with the thoughts and emotions of this event, the Holy Mass and the words of God, and the memories of the deceased which were represented in the many symbols of the *apparato* in this “spectacle of death” (Horn 2019, 96).⁷ The participant was led in a process of grief, memory, and understanding, through the reading of the images, the contemplation of the deeds and virtues of the deceased, and finally to a reflection of his or her own life and inevitable death. The funerary ritual was both collective and individual, the catafalque serving both as an ephemeral monument to the deceased queen and as an instrument of meditation.

Spanish royal funerals in the Duomo increased in scale and magnificence throughout the seventeenth century; undoubtedly

⁶ “Et di quà, et di là di esse lettere, vi sono l’arme dorate della Regina, et sopra la detta Arca, per non molto spatio, vi è un ardente fiamma, che vò al Cielo, lo qual’è posta per la speranza che noi habbiamo, che l’anima benedetta della Serenissima Regina vi sia salita. Poi sopra di essa fiamma in molto altezza son cinque circoli fatti à guisa di nuvole in aria lucenti, nelli quali sono molti Cherubini di rilieuo, che sostengono diversi lumi in aria, per li quali circoli posso passar la detta benedetta Anima, et esser accompagnata da, i detti cinque circoli che in forma d’Angelici Chori mostran che vadino all’alto per uscir per il foro della Lanterna della Cuppola, il quale sarà in tanti giri di lumi, et di Cherubini, che fornisci li nove Chori d’Angeli, che tutti poi unitamente accompagnino la detta Santa Anima al Cielo” (Tibaldi B 3r).

⁷ “... et quando anco saranno estinti quei lumi accesi; quando farà sparito quel color nero; quando fara disfatta questa mole, et ornato; quando faranno finiti questi divini officij, ne restarà il suo frutto, et doveranno restare anco ne gli’animi nostri impresse non solamente le considerati noi, et gli affetti, che procura per tutti questi mezzi eciare in noi la chiesa santa, mà anco le parole di vita, con le quali Iddio ci ragiona in questo spettacolo di morte” (C. Borromeo 1581, 14r-v).

the grandest was that held for Philip IV on 17 December, 1665 (Barella 1665). This funeral *apparato* was as much a representation of power as of mourning, meant to serve as a reflection on the deceased king and his virtues, and to glorify a monarchy and a “mighty” empire already in decline (Horn 2019, 93; Grandis 1995, 700; Orso 1989, 1). The unfinished exterior of the Duomo was transformed by a grand triumphal arch “fitting to a monarch who had triumphed with his virtues over death” (Barella 1665, 7) (Fig. 4). On the top of the pediment, flanking the royal crown held by two lions and the Habsburg coat of arms, were reclining figures representing the virtue and power demonstrated by the monarch; in the niches below were figures representing Glory and Benevolence. In the major cartouche over the door, painted in chiaroscuro, was a scene of the funeral of the victorious Joseph in Egypt, thus associating Philip IV with a mighty leader and warrior from scripture. The ensemble sought to celebrate the “triumph” of a ruler whose final days were in fact a miserable end to a rather inglorious and largely unhappy reign, marked by historic setbacks for the empire as well as illness and overwhelming personal loss in the deaths of many of his family and children (Orso 1989, 1-5, Mínguez 2016, 413-14).

From the entrance one passed into the theatre of “royal glory” (Barella 1665, 8). The massive structure of the catafalque and the accompanying decorations throughout the church were produced following the design of engineer Giovanni Ambrogio Pessina, with two Jesuit fathers charged with the task of designing a coherent programme for the numerous, very large-scale decorative components (Horn 2019, 93). Carlo Maria Maggi (1630-99), professor of rhetoric, assisted the Jesuits in the composition of the many inscriptions and *imprese* (Barella 1665, 2-3). The decorations of the nave illustrated Spain’s global empire: above the cornice, installed between the columns and centred in each arch, were figures on pedestals representing, along the right side of the church, the Spanish territories of the Old World, including provinces in Europe, Africa and Jerusalem; while on the left were the figures representing the “New World”, including Christianised territories of the Iberian Peninsula, Central and South America, India and

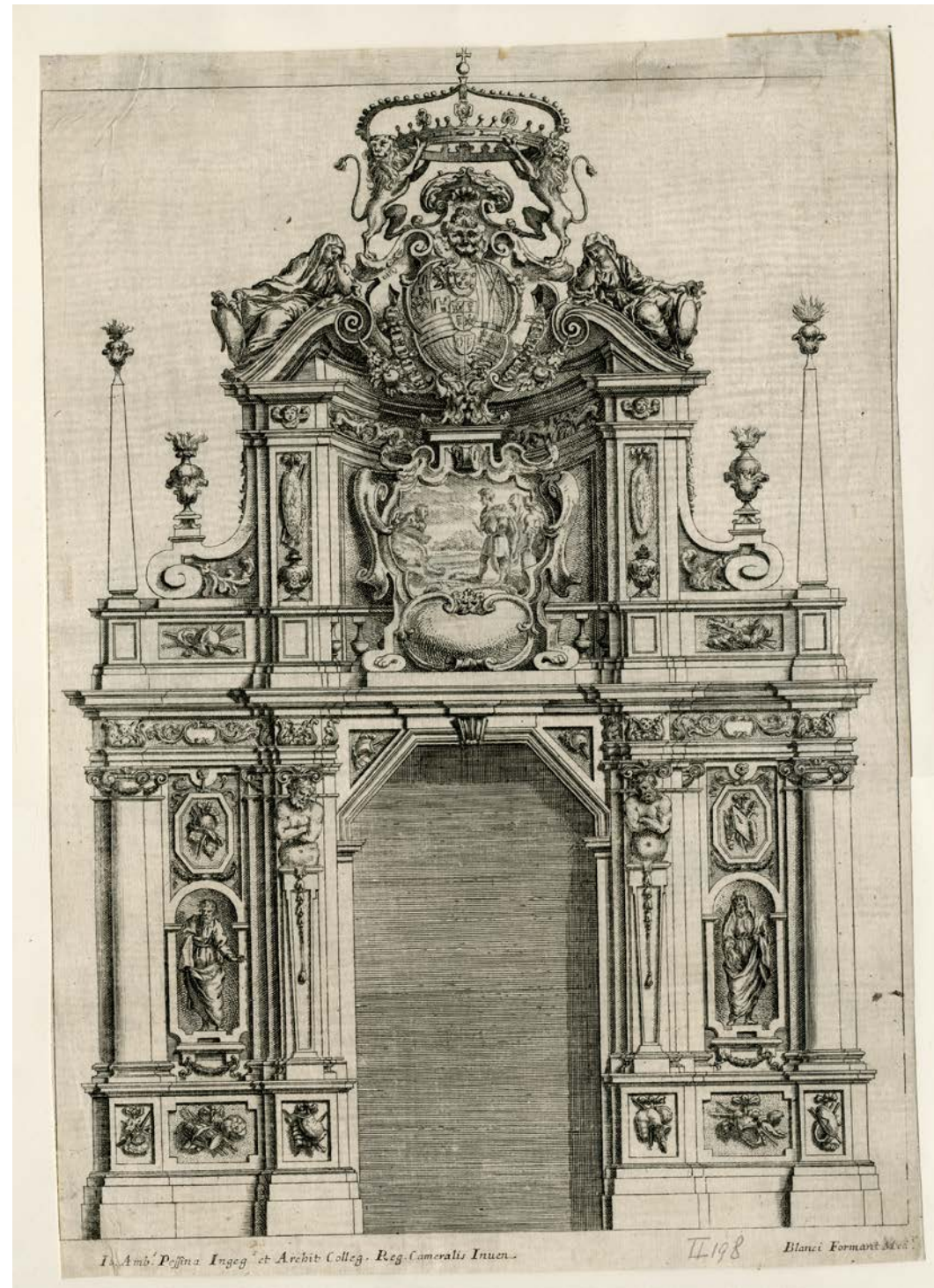
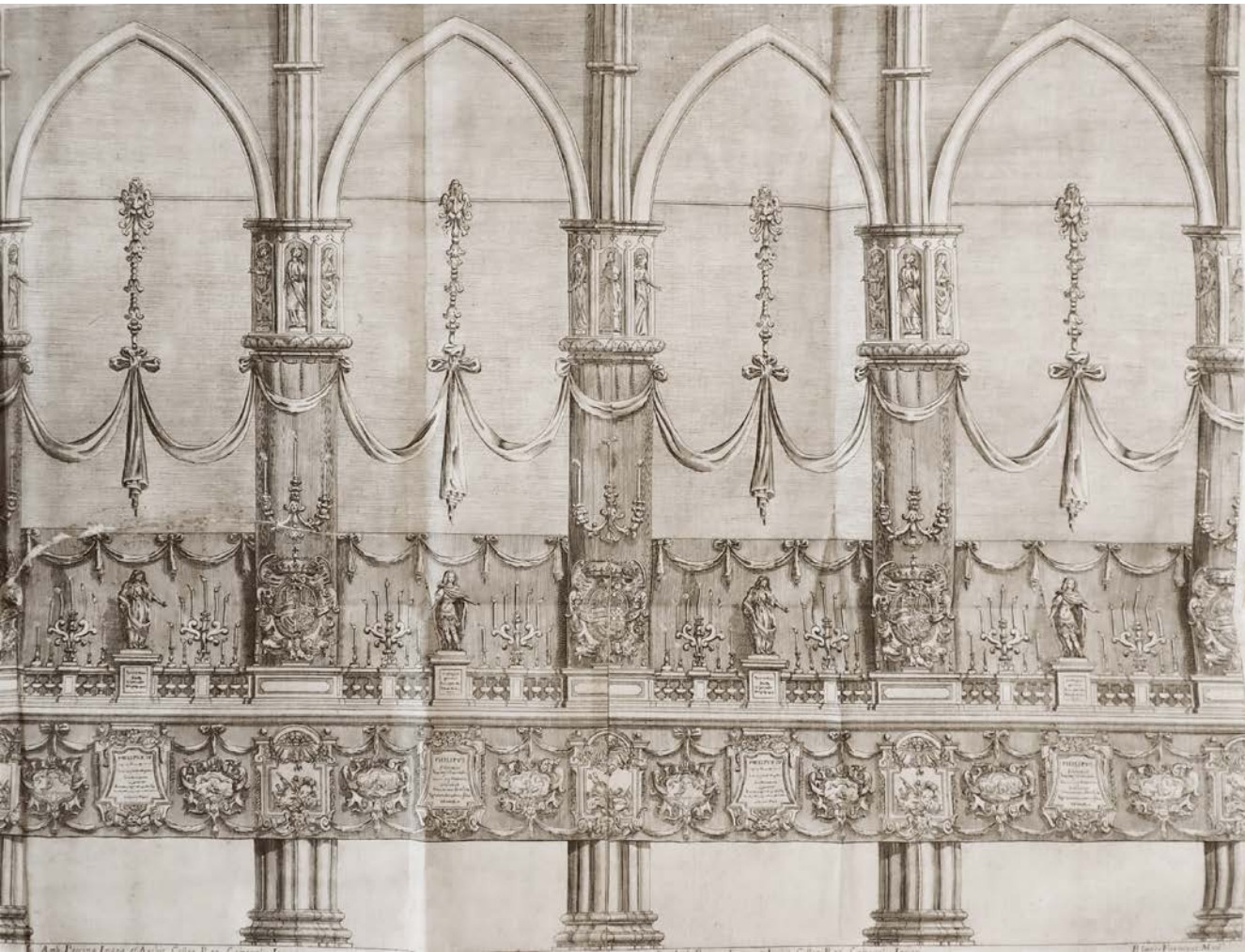

FIG. 4. Ambrogio Pessina, triumphal arch for the main door the Duomo. Funeral of Philip IV, engraving. In Giovanni Battista Barella, *Esequie Reali . . . D. Filippo IV . . .* (Milan, 1665). Milan, Civica Raccolta delle Stampe Achille Bertarelli, Tri. m. 6-9. Copyright © Civica Raccolta delle Stampe Achille Bertarelli-Castello Sforzesco, Milan.

the Philippines (Barella 1665, 11-14) (Fig. 5). By representing Spain’s worldwide territories, the decorations for a Habsburg funeral of this scale served the important political function of demonstrating imperial union, displaying the European possessions together with lands that the king had never visited (Mínguez 2014). All were accompanied by corresponding inscribed tablets and painted *imprese* below; these portrayed



even losses of the empire as political “triumphs”. The *impresa* accompanying Flanders, in the third arch on the right side of the nave, depicted a plant from which some branches had been cut, highlighting as “victories” the compromises made by Philip in the wider interest of maintaining peace and stability in his kingdom since the great revolt of 1648 (Barella 1665, 41; Grandis 1995, 700). To the left of the entrance of the Duomo was painted an exotically-dressed figure representing the territories of the New World to be subdued and converted to the faith (Barella 1665, 51). Images of cultural otherness and the iconography of a world Christianised through Spanish conquest clearly presented the narrative of a continuing imperial global dominance. They also demonstrated Spain’s contribution to the *Propaganda Fidei*: conquering new lands paved the way for missionary orders to convert their peoples to Catholicism.

The catafalque for Philip IV was a towering seventeenth-century interpretation of the original *chappelle ardente* for Charles V in Brussels in 1558, much grander in scale and conception than its counterparts in Rome or even Madrid.⁸ Following the tradition of royal catafalques in the Duomo going back to Charles V, it was situated on an octagonal platform, and each of the four staircases was flanked by two statues representing rivers of the Kingdom of Spain (Horn 2019, 93; Barella 1665, 9-11; Grandis 1995, 664) (Fig. 6). Between the eight obelisks along the outer edge of the platform were twenty statues representing the provinces of Italy and Sicily. The structure was formed by eight Solomonic columns, ornamented with vines and other motifs, which supported a heavy cornice crowned by a balustrade, and above it rose an octagonal pedestal supporting a massive central obelisk. The statues on the first tier of the catafalque structure, above the twisting columns, represented Philip’s royal virtues, which the account extols at length: Providence, Constancy, Justice, Clemency, Magnanimity, Affability, Magnificence and Munificence (Barella 1665, 28-30). Each of these virtues was portrayed as a figure from the Old Testament; Magnificence, for example, was presented as King Solomon receiving a model of his great temple from an engineer. Solomon similarly appeared in Philip IV’s funeral in Mexico the same year; both renditions of the legendary king celebrated Philip’s extensive building projects, among his many “magnificent” achievements, reinforced further in the Milan catafalque by the Solomonic columns supporting this ephemeral “temple” (Mínguez 2014; Mínguez 2016, 415-16). On the upper level, at the base of the central obelisk, were the religious virtues of Zeal, Affection for the Eucharist, Devotion to the Virgin Mary, and Obedience to the Church. These were presided over by a massive figure of Religion on the top of the central obelisk. The prominence of Religion and religious virtues is signal: Philip was known for his professed devotion to the Catholic faith and his particular attachment to the Sacraments (Orso 1989, 3; Barella 1665, 11, 14, 22). The whole mass of the catafalque was

FIG. 5. Ambrogio Pessina, decorations for the nave of the Duomo, Milan, for the funeral of Philip IV, engraving. In Giovanni Battista Barella, *Esequie Reali . . . D. Filippo IV . . .* (Milan, 1665). Milan, Biblioteca Nazionale Braidense, XA.11.0054/02. Photo: author. Reproduced by permission of the Ministero dei Beni e delle Attività Culturali e del Turismo-Biblioteca Nazionale Braidense.

⁸ A hand-painted engraving of the catafalque for Charles V can be found in the album of the funeral and its procession, held in the Museum Platin-Moretus, Antwerp, *La magnifique, et sumptueuse pompe funebre... du... Charles cinquieme*, C. Plantin & H. Cock, 1559. Philip IV’s catafalque in La Encarnación, described earlier, was necessarily smaller due to the limitations of the church. The catafalque designed by Carlo Rainaldi for the same occasion in Rome’s Santa Maria Maggiore was essentially a double pedestal decorated with obelisks and supporting a great imperial crown.

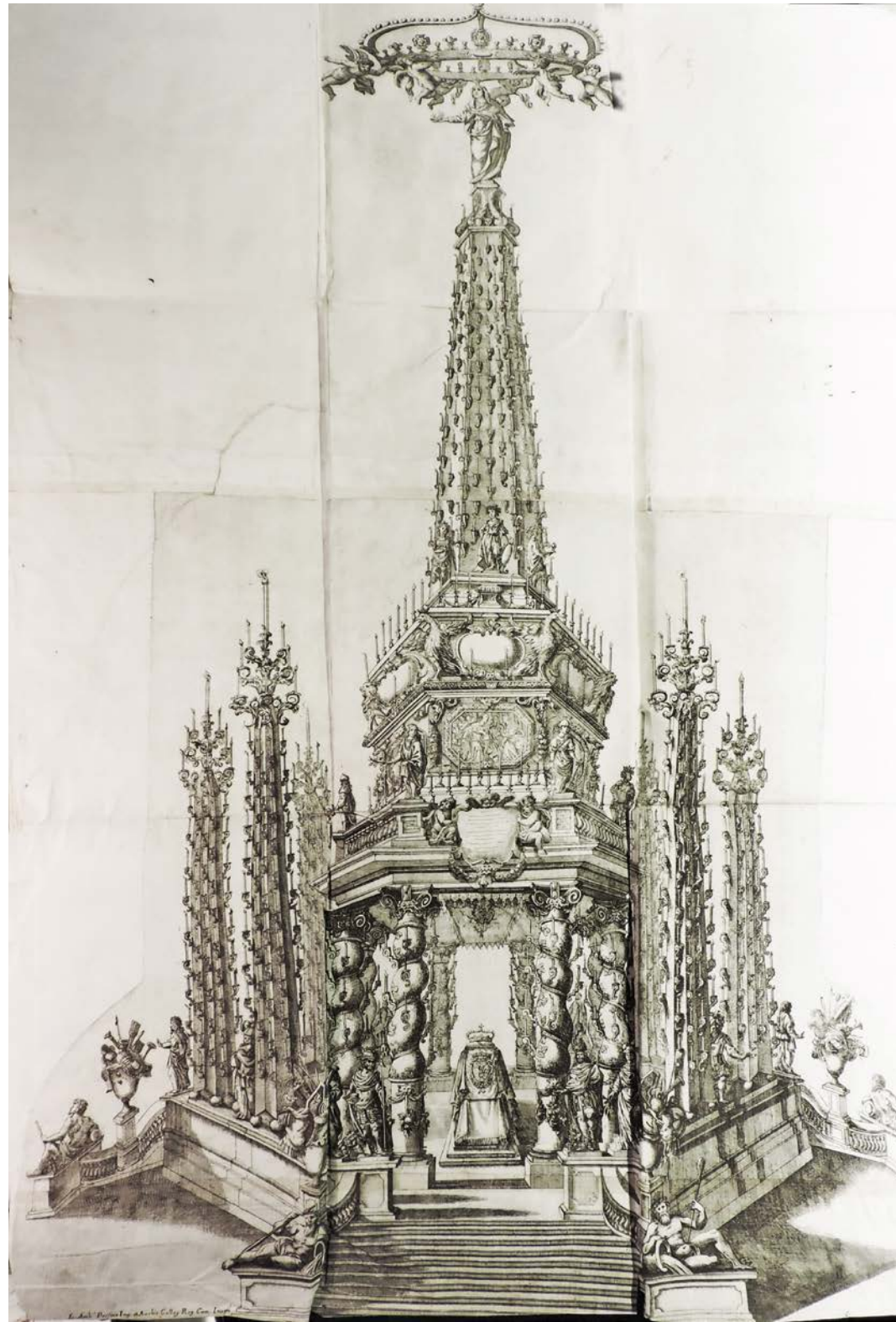

FIG. 6. Ambrogio Pessina, funeral catafalque for Philip IV. Duomo, Milan, engraving. In Giovanni Battista Barella, *Esequie Reali . . . D. Filippo IV . . .* (Milan, 1665). Milan, Biblioteca Nazionale Braidense, XA.11.0054/02. Photo: author. Reproduced by permission of the Ministero dei Beni e delle Attività Culturali e del Turismo-Biblioteca Nazionale Braidense.

quite literally “crowned” by a giant royal diadem suspended from the vault of the crossing, supported by eight angels.

Apart from its remarkable number of sculpted figures and extensive use of allegory, particularly the representation of the virtues, the funeral of Philip IV is noteworthy in another respect: its exceptional “spectacularity and magnificence”, as Giovanna Zanlonghi has described, derived largely from its hierarchical employment of light, which can be read as a visual metaphor for spiritual progression toward the light of the divine essence (Zanlonghi 2002, 183; Horn 2019, 93-94). The account estimates five thousand lights varying from lamps to candles to large candlesticks (Barella 1665, 13). Candelabra and lamps decorated the balusters and columns along the nave, leading the eye to the catafalque, in which lights virtually covered each of the outer obelisks and decorated the Solomonic columns. Lights marked each tier of the central pedestal supporting the central obelisk, which was aflame with lights all the way to its pinnacle. Moreover, individual elements and their surfaces were designed and executed to maximise the effect of the light: the obelisks were faceted to “better reflect the light”, and the sculpted figures were not only gilded; they were treated with *vetro volante*, a glittering material to enhance the reflection of the light (Horn 2019, 94; Barella 1665, 9-10, 12).

Light and fire were of central symbolic importance in the Milanese funerals; as spiritual metaphors, their contextual meanings included transformation, revelation, cleansing, renewal and, as mentioned earlier, the rise of the soul to heaven (Menestrier 1687, 181-82). The hierarchy of light represented in Philip IV’s catafalque calls to mind Pseudo-Dionysius’s *Celestial Hierarchy* (translated and widely available during the early modern period), in which ranks of heavenly beings (angels) derive their power, understanding, “heat” and “brightness” from their relative proximity to the “father of lights” (Pseudo-Dionysius, 1987, 145-61). Corresponding to his hierarchy of vision, St Augustine similarly describes a hierarchy of light, of which the most exalted is the light of reason, “from which there begins everything which was created” (St Augustine *On the Literal Interpretation*, 157-61). Light is used as a metaphor for the divine by St Thomas Aquinas, who

proposes the image of the “light of divine glory” as a means of visualizing God’s essence (St Thomas Aquinas *Summa theologiae* 1a. 12-13). All such images of divine light refer to scripture, especially the Gospel of John, in which Christ is described as the light which “shines in the darkness” (John 1:1), later describing himself as the “light of the world” (John 8:12).

The tiered, hierarchical structures of the Duomo catafalques became a kind of cosmic metaphor: they drew the eye upward to contemplate the earthly realm represented by the figures of rulers, kingdoms and territories; followed by the virtues; and finally the heavens, where the deceased ruler “triumphed” as he or she entered a new, eternal kingdom (Soto Caba 1988, 121). This tiered, hierarchical arrangement, and the manner in which one was intended to interact with it, aligned with a long tradition of mystical prayer and meditation focusing on ascent toward greater understanding and union with the divine.⁹ This approach to spirituality was championed particularly by Spanish saints and clerical writers in the sixteenth and seventeenth centuries (Horn 2019, 95). St Ignatius of Loyola, in his *Spiritual Exercises* (orig. 1548), describes the progress toward the divine through the stages of purgation, illumination and finally union (St Ignatius of Loyola 1989). The method of meditation developed by St John of the Cross in *The Dark Night of the Soul* (1578-79) and *The Ascent of Mount Carmel* (1581-85) is a process of abnegation and purgation as the soul ventures forth in darkness, moving away from the pleasures, burdens and temptations of the flesh, and particularly the delights of the senses, to seek divine illumination and ascend in stages to spiritual union with God. The Jesuit Cardinal Robert Bellarmine (1452-1621), in *The Soul’s Ascension to God by the steps of Creation* (orig. 1615), provides a hierarchically-arranged method of contemplation intended to lead to understanding of the divine by means of fifteen “steps” by which one ascends “from Creatures to the Creator”. The similarly hierarchical view of both society and the universe developed by Carlo Borromeo’s cousin, the Milanese archbishop Cardinal Federico Borromeo (1564-1631), is illustrated in his *Three Books of Divine Praise* (*I tre libri delle laudi divine*, 1632), which celebrates creation by expounding

on the natures of all created things and their respective roles in manifesting the glory of God’s divine plan. Contemplating such hierarchies of creation is meant to lead to union with the divine (Jones 1993, 88).

The account of the funeral of Philip IV, like all accounts of Milanese funerals, emphasises mourning as a cathartic process: virtually the whole city, along with numerous *forestieri* from surrounding regions, “made their way [to the Duomo], not so much to see the very sumptuous *teatro* ... as much to animate it with their piety and with their tears”.¹⁰ Thus the *apparato*, exhaustively described in the account, became a scenography for the performance of mourning and commemoration: after passing in procession through the triumphal arch of the façade, “reading” its figures, inscriptions and *impresa*, “the gaze was lost in the royal glory” as the individual progressed through the space of the Duomo, making a symbolic journey through the entire Spanish-Catholic world (Barella 1665, 12). One then passed around the octagonal platform of the catafalque, and ascended the steps to the ephemeral temple of the deceased king, the eye beckoned upward by the soaring verticality of the flaming structure. Death was conquered as the deceased was carried to the next world.

The careful sequencing and orchestration of movement and images in Milanese funerals indicate a concerted effort to ensure the lasting efficacy of these events and their ability to persuade. Their creators were well aware that sophisticated systems of visual rhetoric primarily addressed the educated and the elite; more universal was the powerful appeal to the emotions produced by dramatic devices, figures, images and words. This appeal to the emotions is well illustrated in one final example of a funeral in Santa Maria della Scala, one of many churches in the city where state funeral rites were often held concurrently with those in the Duomo. On 26 October 1671 Milan mourned the death of the Duchess Felice Sandoval Enriquez of Uceda (1625-71), wife of Juan Francisco Pacheco y Téllez-Girón, Duke of Osuna and the Spanish Governor of Milan (Horn 2019, 94). The exterior façade of Santa

⁹ See especially St Bonaventure (1221-74), *A Soul’s Journey into God*.

¹⁰ “Essendo dunque la sera precedente, e la mattina del giorno all’ora prefissa invitato il popolo colla voce, e mestissimo suono di tutte le campane, chiuse le botteghe per ordine del Vicario di Provisione, votate le case per legge fatta à ciascuno dal proprio affetto, e concorse tutta la Città con molti forestieri di conto, non tanto per vedere il teatro più sontuoso, che habbia mai havuto il dolore, quanto per animarlo colla pietà, e colle lagrime” (Barella 1665, 68-70; Horn 2019, 94).

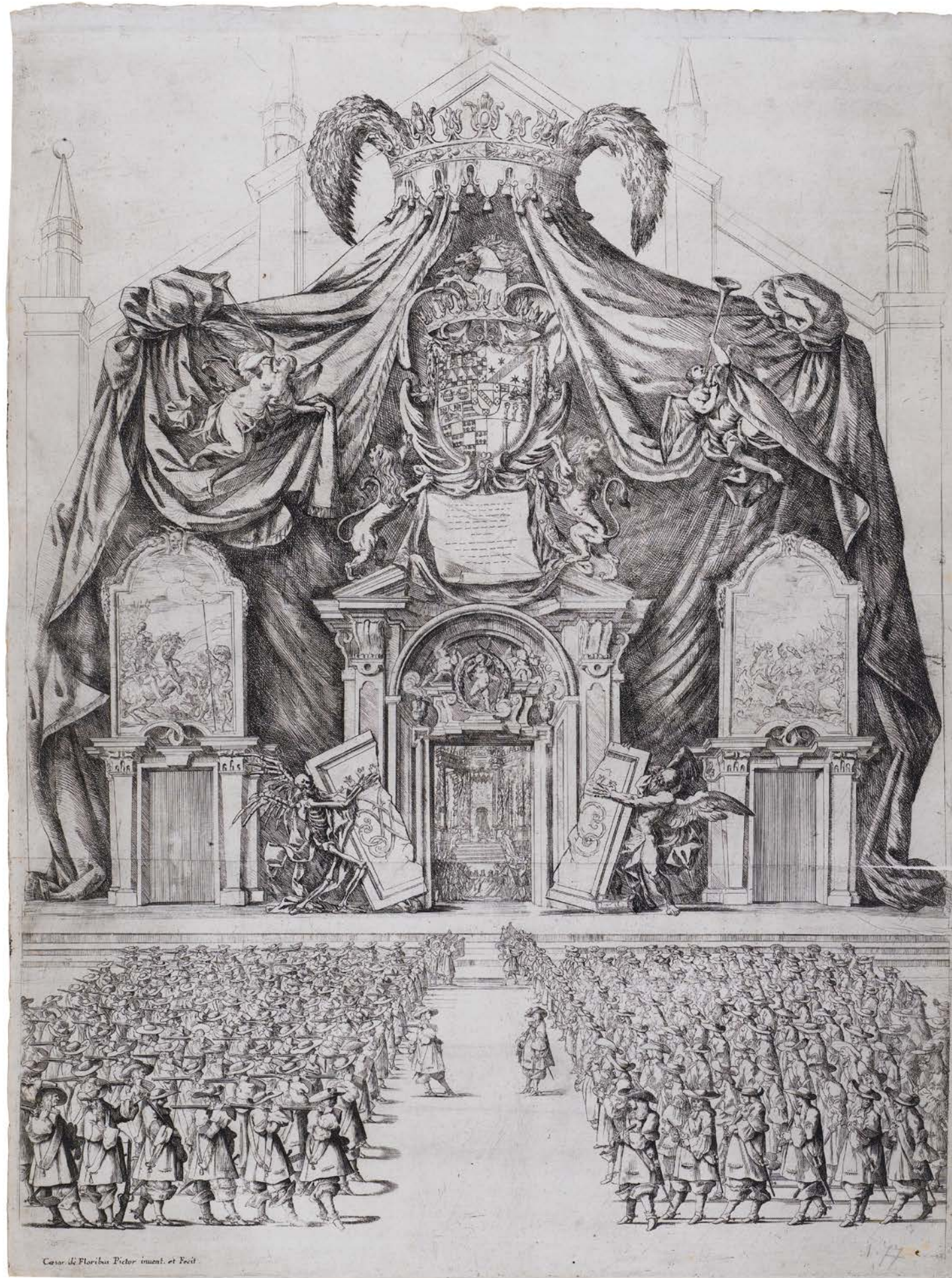

Maria della Scala was draped in an enormous black funeral pall and animated by figures of Death and Time pulling away the broken seal of a tomb (Fig. 7). Through this façade one glimpsed, and eventually approached and entered, “a theatre of sorrow and of majesty, continuously growing with the reflections of innumerable blazing lights ... rendering exquisite the horror and tearful the pleasure”.¹¹ Invoking the paradoxical emotions of “exquisite horror” and “tearful pleasure”, the account of this funeral is among the best examples of the language used to describe the catharsis that these “theatres of death” were designed to bring about.¹² The windows were deliberately covered with black drapery, so that the church interior was illuminated only by the light of the lamps and candles (Barella 1671, 35). The dais of the catafalque was surrounded by obelisks whose lamps were set in spiralling garlands of greenery, the whole crowned by a suspended baldachin above (Fig. 8). The nave of the church was draped in black with inscribed tablets, gilded decorations and the extensive lamps and candles familiar from the Duomo funerals (Barella 1671, 13-15). The sense of progress from exterior to interior, from death to life, and from darkness to light is more pronounced here than in any of the other recorded Milanese funerals. The control of light directed one’s attention, even from outside the church, to the funeral catafalque, the source of light, where the prematurely deceased

FIG. 7. Cesare Fiori, facade of Santa Maria della Scala for the funeral of the Duchess of Uceda by Giovanni Battista Paggi, engraving. In Giovanni Battista Barella, *Teatro della gloria . . .* (Milan, 1671). Milan, Civica Raccolta delle Stampe Achille Bertarelli, A.S. m. 3-64. Copyright © Civica Raccolta delle Stampe Achille Bertarelli-Castello Sforzesco, Milan.

¹¹ “... tutto il tempio era fatto un teatro di dolore, e di maestà, che crescendo sempre co’ riflessi de’ lumi, che senza numero avvampavano, rendea vago l’orrore, e lagrimevole il diletto” (Barella 1671, 14).

¹² Note that the words “orrore” and “orride” frequently appear in accounts of funerals. In this context “orrore” does not connote the modern sense of “horror” (or the modern Italian “orrore”) but something closer to the Latin term *horror*: dread and awe, or a mixture of wonder, fear and great respect particularly associated with religious experience. See Dekoninck and Delfosse 2016.

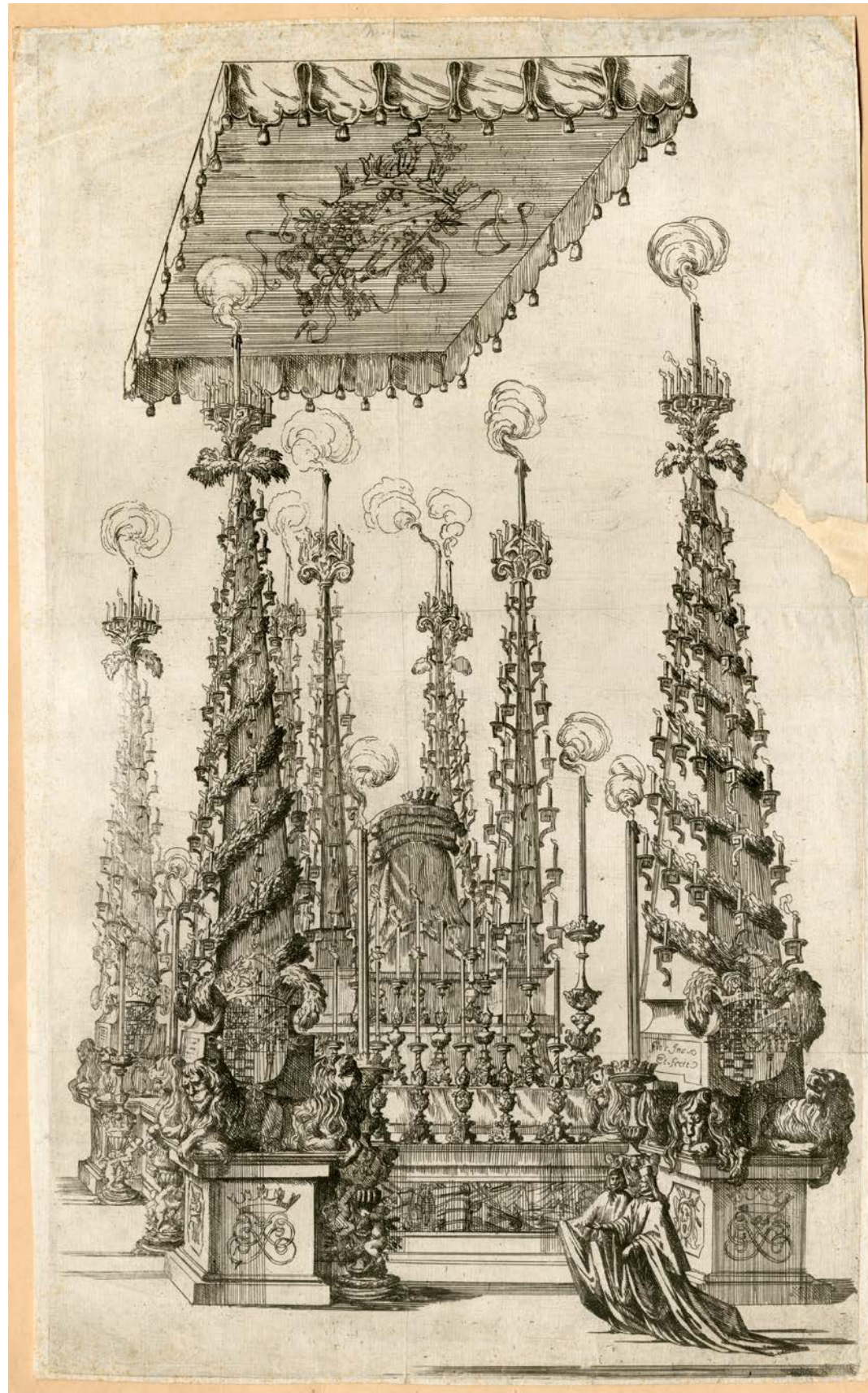

FIG. 8. Cesare Fiori, funeral catafalque for the Duchess of Uceda by Giovanni Battista Paggi, engraving. In Giovanni Battista Barella, *Teatro della gloria . . .* (Milan, 1671). Milan, Civica Raccolta delle Stampe Achille Bertarelli, Tri. g. 19. Copyright © Civica Raccolta delle Stampe Achille Bertarelli-Castello Sforzesco, Milan.

duchess (who died in childbirth) was imagined already resurrected (Barella 1671, 14).¹³

These funerary rituals, their rich and dramatic decorations and their commemorative publications were produced to affix in the mind the memory of the deceased, his or her virtues and achievements; but perhaps more importantly the memory of the event of itself. The power of memory, as Federico Borromeo eloquently describes in his *Three Books of Divine Praise*, lies in its ability to transcend time and mortality:

[Memory] alone can resist the rapid torrent of time, by which all terrestrial things are carried, each of which remains unharmed, alive within her ... she is a new life of things, having the virtue and strength of rendering incorruptible ... those things which are of themselves corruptible, and of very brief life.¹⁴

The elaborate decorations of Milanese state funerals, charged with a particular emotional force and a sense of drama, were a tribute to the deceased and an appeal to the memory of those who were present. They provided images — the most powerful instrument of memory — with which to actively engage, to take away, and to revisit the experience of the funeral.¹⁵ By means of images, movement, figures and gesture, they called for active participation in the performance of mourning, engaging the emotions and emphasizing the themes of transformation and immortality, ultimately leading participants to a collective catharsis and an acceptance of death. For those who were not present, including later generations, these funerals are preserved in the evocative language and the striking images of the printed accounts, which offer us a glimpse inside one of the most fascinating genres of Baroque spectacle.

¹³ The death of the Duchess of Uceda is recorded in ASM *Uffici Regi*, “Governo 1663-1678”, f. 6.

¹⁴ “Ella sola può contrastare al rapido torrente del tempo, che via ne porta tutte quante le cose terrene, ciascuna delle quali nella memoria si rimane illesa, non che viva, ed interna; dimostrandosi in ciò di più divina, e più eccellente natura, che non sono le cose stesse, le quali si vanno tutt’hora rammemorando. Laonde ella, non solo misura il tempo, ma lo ferma ancora: ed ella è una nuova vita delle cose, havendo virtù e forza di rendere incorruttibili, e presso che eterne etiandio quelle, che sono per se medesime corruttibili, e di molto breve vita” (F. Borromeo 1632, 209-10; Horn 2019, 96).

¹⁵ On images and memory, see, among others, Aristotle *De memoria*, chap. 1, 449b4-451a2; and Carruthers 2008, 18-33.

BIBLIOGRAPHY

- ARISTOTLE. 1972. *De memoria et reminiscentia*. Trans. Richard Sorabji. In *Aristotle on Memory*, 47-62. London: Duckworth.
- ASM (Archivio di Stato di Milano), *Uffici Regi*. 1671. "Governo 1663-1678", Folio 6, *Sopra li funerali della Sig. Duchessa di Ossuna*, 8 October 1671, Don Gaspar Tellez Giron, Duca d'Ossuna Governatore e Capitano Generale per Sua Maestà.
- ST Augustine. 1991 (orig. 4th c.). *On the Literal Interpretation of Genesis: an Unfinished Book*. In *On Genesis: Two books on Genesis against the Manichees and On the Literal Interpretation of Genesis: an Unfinished Book*, 143-90. Trans. Roland J. Teske, S.J. Washington: The Catholic University of America Press.
- BARELLA, Giovanni Battista. 1665. *Esequie Reali alla Catt. Maestà del Ré D. Filippo IV. Celebrate in Milano alli 17. Dicembre 1665. Per ordine dell'Eccellentissimo il Sig. D. Luigi de Guzman Ponze de Leon, Capitano della Guardia Spagnuola di S. M. Cattolica del Consiglio Supremo di Guerra, Governatore, e Capitano Generale dello Stato di Milano & c. In esecuzione del comandamento dell'augustissima Reina Maria Anna Nostra Signora*. Milan: Marc'Antonio Pandolfo Malatesta.
- BARELLA, Giovanni Battista. 1671. *Teatro della Gloria Consagrato all'Eccellentissima Signora D. Felice Sandoval Enriquez Duchessa d'Uceda Defonta dall'Eccellentissimo Signore D. Gaspar Tellez Giron Duca d'Ossuna Conte d'Uregna Governatore dello Stato di Milano e Capitano Generale in Italia*.
- BELLARMINE, Robert. 1703 (orig. 1615). *The Soul's Ascension to God by the Steps of Creation (De ascensione mentis in Deum per scales rerum creatarum opusculum)*. Trans. H. Hall. London: Robert Gibson and Jacob Jonson.
- BERENDSEN, Olga. 1961. "The Italian Sixteenth and Seventeenth Century Catafalques", Ph.D. diss. New York University.
- BISCOTTINI, Paolo, ed. 2005. *Carlo e Federico: La luce dei Borromeo nella Milano spagnola*. Milan: Museo Diocesano di Milano.
- ST BONAVENTURE. 1978 (orig. 13th c.). *The Soul's Journey into God. The Tree of Life. The Life of St. Francis*. Trans. Ewert Cousins. New York: Paulist Press.
- BORROMEO, Carlo. 1581. *Sermone di Monsig. Illustriss. Cardinale di S. Prassede, Arcivescovo. In Pellegrino de' Pellegrini (Pellegrino Tibaldi), Descrizione de l'edificio, e di tutto l'apparato, con le cerimonie pertinenti à l'Essequie de la Serenissima D. Anna d'Austria, Regina di Spagna, celebrate ne la Chiesa maggior di Milano, à di vi. di settembre, M.D. LXXXI*. Milan: Paolo Gottardo Pontio, ff. 14r-21r.
- BORROMEO, Federico. 1632. *I tre libri delle laudi divine*. Milan.
- BUZZI, Franco and Danilo Zardin, eds. 1997. *Carlo Borromeo e l'opera della grande Riforma: cultura, religione e arti del governo nella Milano del pieno Cinquecento*. Milan: Credito Artigiano.
- CARANDINI, Silvia. 1990. *Teatro e spettacolo nel Seicento*. Milan: Editori Laterza.
- CARRUTHERS, Mary. 2008. *The Book of Memory: A Study of Memory in Medieval Culture*, 2nd ed. Cambridge: Cambridge University Press.
- CATTANEO, Enrico. 1958. "Carnevale e Quaresima nell'età di san Carlo Borromeo." *Ambrosius* 34 (March -June): 51-65.
- CRIVELLI, Luigi. 2005. "Carlo Borromeo". In *Carlo e Federico: La luce dei Borromeo nella Milano spagnola*, ed. Paolo Biscottini, 67-78. Milan: Museo Diocesano di Milano.
- D'AMICO, Stefano. 2012. *Spanish Milan: A City within the Empire, 1535-1706*. New York: Palgrave MacMillan.
- DEKONINCK, Ralph and Annick Delfosse. 2016. "Sacer Horror: The Construction and Experience of the Sublime in the Jesuit Festivities of the Early Seventeenth-Century Southern Netherlands", *Journal of Historians of the Netherlandish Art* 8/ 2 (Summer 2016) <http://hdl.handle.net/2268/219797>. DOI: 10.5092/jhna.2016.8.2.9
- ESEQUIE celebrate con solenne Pompa nella chiesa del Duomo di Milano per la Cesarea Maestà di Carlo Quinto Imperatore Romano et per la Serenissima Regina Maria d'Inghilterra ...1587. In G. Bugati, *Historia Universale e Aggiunta dell'H.U. e delle cose di Milano dal 1556 sino al 1581*. Milan: Francesco and Simon Tini.
- GRANDIS, Sonia. 1995. "Teatri di sontuosissima e orrida maestà: Trionfo della morte e trionfo del re nelle pompe funebri regali." In *La scena della Gloria. Drammaturgia e spettacolo a Milano in età spagnola*, ed. Annamaria Cascetta and Roberta Carpani, 659-715. Milan: Vita e Pensiero.
- HORN, Andrew. 2019. *Andrea Pozzo and the Religious Theatre of the Seventeenth Century*. Early Modern Catholicism and the Visual Arts Series, vol. 18. Philadelphia: Saint Joseph's University Press.
- ST IGNATIUS of Loyola. 1989 (orig. 1548). *The Spiritual Exercises of Saint Ignatius*. Trans. A. Mottola. New York: Doubleday.
- ST JOHN of the Cross. 2017. *The Collected Works of St. John of the Cross*, Third Edition. Trans. Kieran Kavanaugh, O.C.D. and Otilio Rodriguez, O.C.D. Washington, DC: ICS Publications.
- JONES, Pamela M. 1993. *Federico Borromeo and the Ambrosiana: Art Patronage and Reform in Seventeenth-Century Milan*. Cambridge: Cambridge University Press.
- MENESTRIER, Claude-François. 1687. *Des Decorations Funebres. Ou il est amplement traité des Tentures, des Lumieres, des Mausolées, Catafalques, Inscriptions & autres Ornaments funebres; avec tout ce qui s'est fait de plus considerable depuis plus d'un siecle, pour les Papes, Empereurs, Roise, Reines, Cardinaux, Princes, Prelates, Sçavans & Personnes Illustres en Naissance, Vertu & Dignité, & c.* Paris: Robert Pepie.
- MÍNGUEZ, Víctor. 2014. "Tumbas vacías y cadáveres pintados, el cuerpo muerto del rey en los jeroglíficos novohispanos, siglos XVII y XVIII". *Revue interdisciplinaire d'études hispaniques médiévales et modernes* 17 (February): <https://doi.org/10.4000/e-spania.23282>.
- , 2016. "Reyes enfermos e imperio renovado. Las muertes de Felipe IV, Carlos II, Luis XIV, Luis I y Felipe V en la Nueva España (1665-1746)". *Romance Notes* 56, No. 3: 413-42.
- ORSO, Steven N. 1989. *Art and Death at the Habsburg Court: The Royal Exequies of Philip IV*. Columbia: University of Missouri Press.
- PSEUDO-DIONYSIUS. 1987 (orig. 5th-6th c.). *The Celestial Hierarchy*. In *Pseudo-Dionysius: The Complete Works*. Trans. Colm Luibheid and Paul Rorem. New York: Paulist Press.
- SCHRAVEN, Minou. 2014. *Festive Funerals in Early Modern Italy: The Art and Culture of Conspicuous Commemoration*. Farnham: Ashgate.
- SOTO Caba, Victoria. 1988. "Teatro y ceremonia: algunos apuntes sobre las exequias barrocas". *Revista de la Facultad de Geografía e Historia* 2: 111-38.
- TIBALDI, Pellegrino (Pellegrino de' Pellegrini). 1581. *Descrittione de l'edificio, e di tutto l'apparato, con le cerimonie pertinenti à l'Essequie de la Serenissima D. Anna d'Austria, Regina di Spagna, celebrate ne la Chiesa maggior di Milano, à di vi. di settembre, M.D. LXXXI* (Milan: Paolo Gottardo Pontio).
- ST THOMAS Aquinas. 1963-69 (orig. 1265-74). *Summa theologiae* (60 vols.). Trans. Timothy McDermott, O.P., Herbert McCabe, O.P., Thomas Gornall, S.J., William A. Wallace, W.D. Hughes, Thomas R. Heath, O.P., et al. London and New York: Blackfriars in conjunction with Eyre & Spottiswoode and McGraw-Hill, 1963-69.
- ZANLONGHI, Giovanna. 2002. *Teatri di formazione: Actio, parola e immagine nella scena gesuitica del Sei-Settecento a Milano*. Milan: Vita e Pensiero.

THE SOUND OF POWER: THE BELLS OF MAFRA

ISABEL YGLESIAS DE OLIVEIRA

Palácio Nacional de Mafra, Portugal

isabelyglesias@pnmafra.dgpc.pt

ABSTRACT

Built in the early 18th century at the behest of King John V (1689-1750), in fulfilment of a vow to build a convent if his marriage to Queen Maria Ana of Austria (1683-1754) resulted in offspring, the Royal Building of Mafra is the most important Baroque edifice in Portugal.

The king commissioned not one but two carillons for the Royal Building of Mafra. This was a political demonstration of his prestige and power as such instruments were unusual in southern Europe during that period. As the largest carillons in the world at the time, they became a fundamental element of the Baroque splendour of the complex.

The solemn arrival of the bells in Santo Antão do Tojal between 1730 and 1731, their blessing, their onward transport to Mafra and their placement in the towers were all public ceremonies that caused astonishment.

From then on, the coded ringing of these bells solemnised royal entries, pontifical masses, processions and other religious and civil ceremonies as an element in expressing the King's grandeur.

Based on unpublished documents, this paper is intended to contribute to the study of the use of this musical instrument, as the largest surviving 18th-century carillons in the world, and as an instrument that represented power and prestige in ceremonies at the Royal Palace and Convent of Mafra during in the 18th century.

KEYWORDS MAFRA'S CARILLONS, BELLS, KING JOHN V, WILLIAM WITLOCKX, NICOLAS LEVACHE

RESUMO

Construído no início do século XVIII pela vontade de D. João V (1689-1750), no cumprimento de um voto para construir um convento se do seu casamento com a Rainha Maria Ana de Áustria (1683-1754) resultasse um herdeiro para o trono, o Palácio de Mafra é o mais relevante edifício barroco português.

Para o real edifício de Mafra, o Rei encomendou não um, mas dois carrilhões, instrumentos pouco usuais no Sul da Europa, em sinal do seu prestígio e poder políticos.

Estes instrumentos, ao tempo os maiores que se fabricaram no mundo, tornaram-se um elemento fundamental do cenário barroco do Real Palácio de Mafra.

A solene chegada dos sinos a Santo Antão do Tojal, a cerimónia da sua bênção e a sua colocação nas Torres do edifício, entre os anos de 1730-1731, foram cerimónias públicas que causaram espanto.

Desde então, o toque destes sinos solenizou Entradas Régias, Missas Pontificais, procissões e outras cerimónias religiosas ou civis, como marca de "grandeur" do Rei.

Baseado em documentos inéditos, este texto propõe-se contribuir para o estudo do uso destes instrumentos musicais, os maiores carrilhões do mundo, que desde o século XVIII chegaram até aos nossos dias, como um instrumento representativo do poder e prestígio nas cerimónias levadas a cabo no Real Palácio e Convento de Mafra, no século XVIII.

PALAVRAS-CHAVE CARRILHÕES DE MAFRA, SINOS, D. JOÃO V, WILLIAM WITLOCKX, NICOLAS LEVACHE



Built in the early 18th century at the behest of King John V (1689-1750), in fulfilment of a vow to build a convent if his marriage to Queen Maria Ana of Austria (1683-1754) resulted in offspring, the Palace of Mafra is the most important Baroque edifice in Portugal.

Such magnificence was only possible due to the Brazilian gold that was pouring into the country, allowing the King to provide patronage to the arts and thus strengthen his royal authority.

For the Basilica and the Royal Building of Mafra, the king ordered a total of 58 of Italian sculptures by masters as Carlo Monaldi or Giovanni Battista Maini, the biggest collection of Baroque Italian statues outside Italy. These were joined by

paintings by great Italian and Portuguese artists such as Masucci, Trevisani and Oliveira Bernardes, plus all manner of religious artefacts and church vestments from Italy and France.

For the towers of the Basilica, King John V commissioned not one but two carillons — unusual musical instruments in southern Europe — as a political demonstration of his prestige and power. According to an oft-recounted anecdote, the king asked the Marquis de Abrantes to find out the price of a carillon and was informed that it would cost 3 million cruzados — an amount that would ordinarily have been considered too high for such a small country. Yet John V — at that time the richest king in Europe due to the influx of Brazilian gold — replied, “I never imagined that they were so cheap. I want two!” (Gomes 1866, 26 and Pinho Leal 1875, 27).



FIG. 1. Royal Building of Mafra
© Nuno Trindade 2013



FIG. 2. The belltowers
© Luís Pavão





In his *Quadro elementar das relações políticas e diplomáticas de Portugal* [...], the Viscount of Santarém mentions a cost of 50,000 golden coins (Santarém 1842, 251), while Brother Cláudio da Conceição (1729-30) mentions that “according to tradition, the two carillons cost 3 million” (Conceição 1820, 301).

As the largest such instruments in the world at the time, the carillons became a fundamental element of the Baroque splendour at the Royal Palace of Mafra, as bells have been a symbol of power and prestige since time immemorial.

Like the entire Braganza dynasty, John V was passionate about music. This may have aroused his interest in this unknown and prestigious musical instrument, which was the sole preserve of the privileged few. Curiously, he ordered the instrument without ever having heard it; contrary to popular wisdom, John V never left Portugal to travel to any foreign country.

The North Tower carillon was casted by Nicolas Levache of Liège and the South Tower carillon by William Witlockx of Antwerp. The Jesuit Fr Lochtenberg, living in Belgium, was tasked with overseeing the project. Nicolas Levache (1698-c. 1732) was from a family of bellfounders in Liège, which had excellent relations with Portugal at that time. Born in Dinant, he had moved to Liège, where he worked as a bellfounder alongside Pierre, his brother, and Pierre’s sons Jean-Baptiste and Nicolas. They were active from 1716 to 1742, but it is difficult to determine which one was the founder of which bell, as they worked so closely together. Their bells are not terribly common in Belgium, so they have the unfortunate reputation of not having a very good sound. Mafra’s carillon also had this reputation, although they have not actually been heard since the end of the 19th century.

Nicolas Levache came to Portugal in 1730 to install the carillon, and he and his family settled there, working as bellfounders and blacksmiths.

The bellfounder for the South Tower, Willelms Witlockx (1669-1733), from Antwerp, belonged to a family of makers of musical instruments, specifically bells, but he personally cast only a few carillons over the course of his life. His mother’s

FIG. 3. King John V, marble bust, Alessandro Giusti, 1748 © DGPC

family (the Walschots) was made up of blacksmiths and silversmiths from the late 16th century onwards.

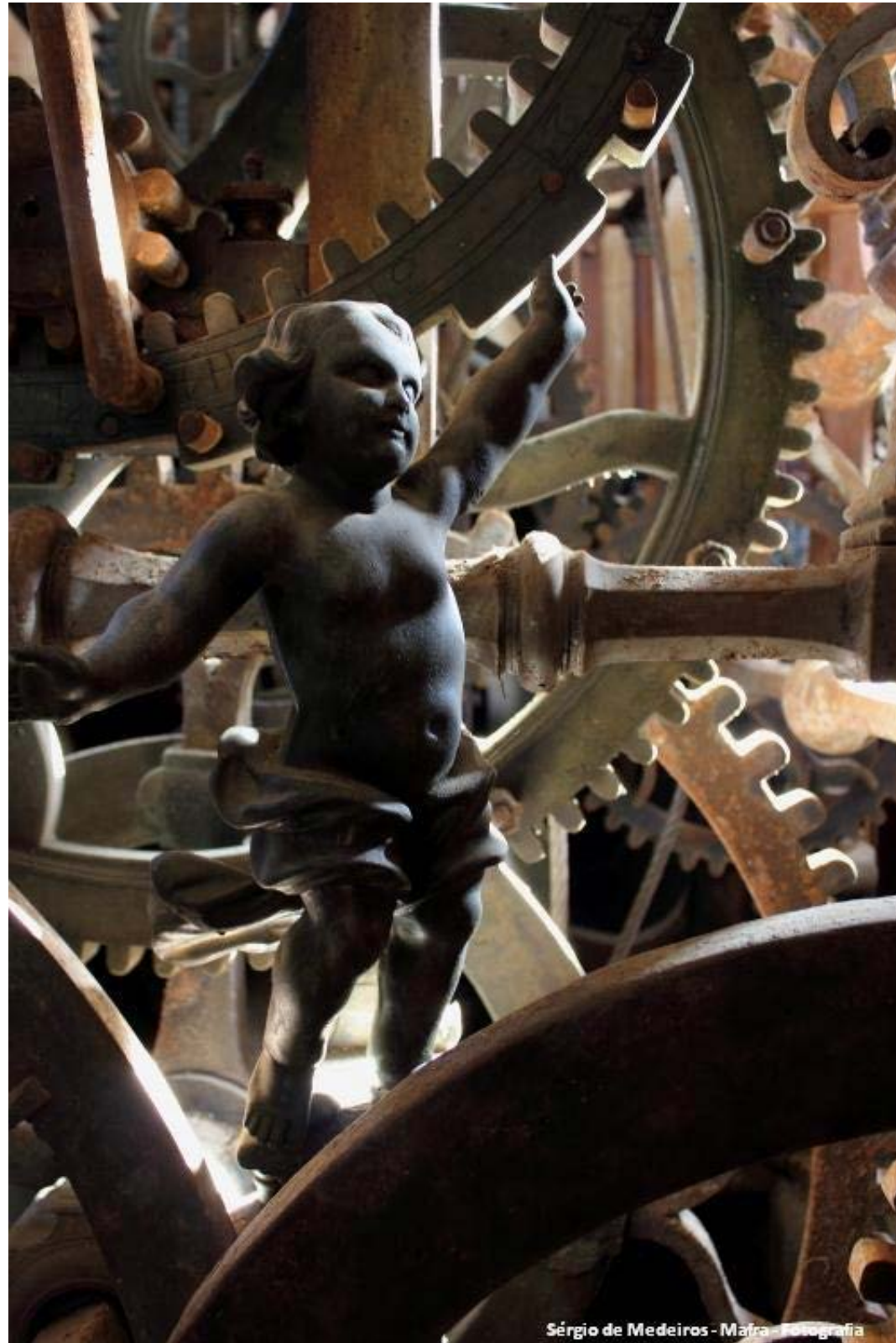

FIG. 4. North carillon figure (Levache carillon) representing Time © Sérgio de Medeiros

Witlockx made his bells between 1730 and 1732. He had the help of his nephew Francis van den Wijngaert, his sister's son, who acted as his foreman. The bells were casted in Sint Jansstraat in Antwerp. This foundry employed at least 100 men, but it is not known how many workers were engaged in the production of this carillon.

After being cast, the bells were sent by sea to Portugal. Due to their weight, everything had to be packed very carefully. The risks were such that the captain who transported Witlockx's bells demanded extra insurance for possible damage to his ship.

Along with the bells, 30 workers from Witlockx's workshop travelled to Mafra to install the carillon. According to Frei Cláudio da Conceição, they earned 3,200 réis per day in addition to travel expenses, and took almost a year to

FIG. 5. South Tower bells (Witlockx carillon) © MHOP/DGEMN

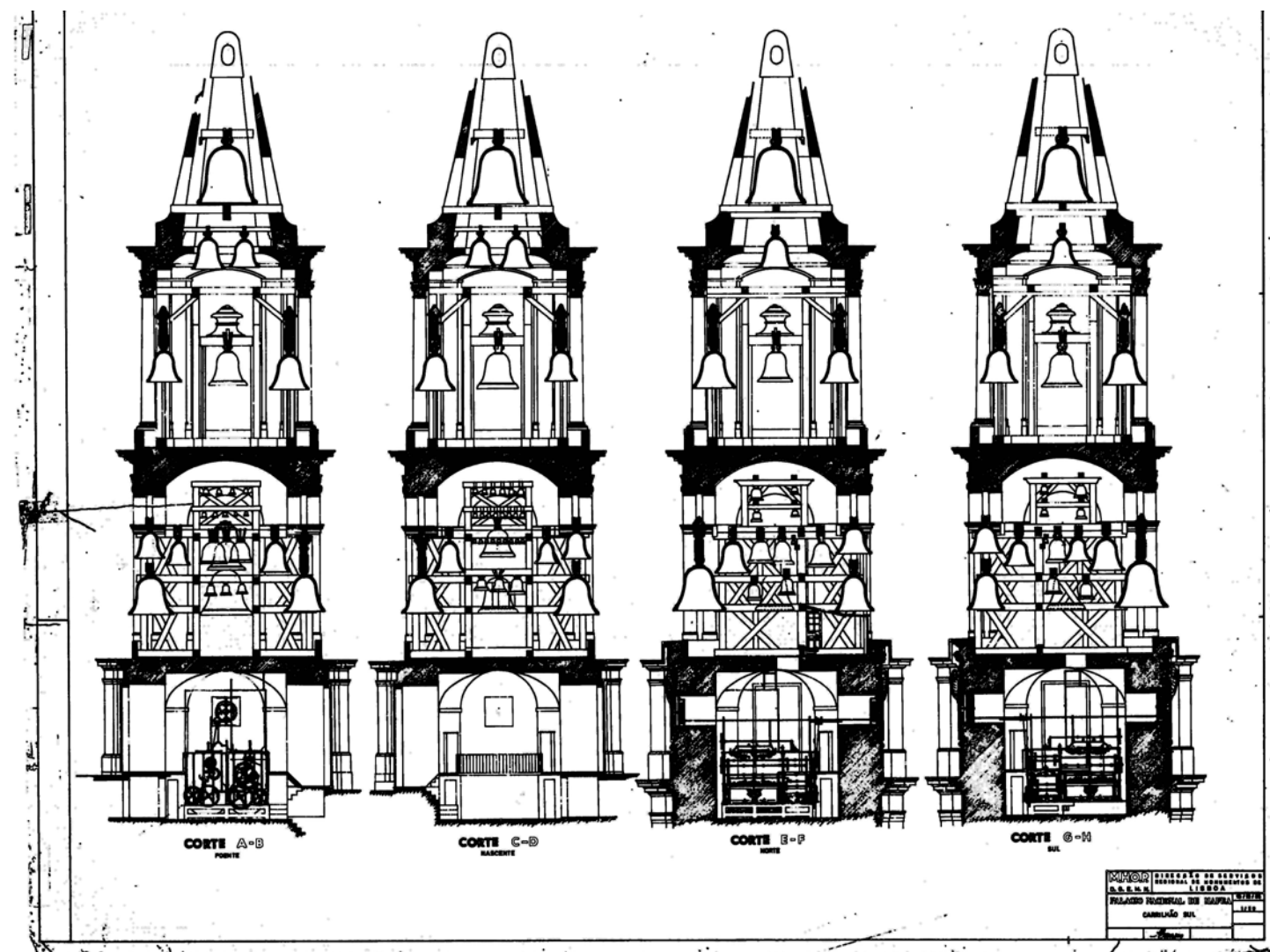



FIG. 6. Bells of the South Tower
© Filipe Ferreira — AOF

install the apparatus (Conceição 1829, 300). This was a huge contract, but in all likelihood Witlockx never actually saw any of the money from Mafra; he died in March 1733, before the works were fully completed and paid for. Some time after his death, his widow complained that she had not yet received the remaining money owed. The carillon of Mafra is, without doubt, biggest and best-preserved Witlockx carillon.

Mafra's towers have bells ranging from 12 tonnes for the 'first-order' bells to 8 kg for the high-pitched bells. By way of comparison, London's Big Ben weighs 13 tonnes. In total, the bells weighed 44,000 kg and their sound was reported to be

heard 13 km from palace. Nowadays, due to construction and sound pollution, the bells can only be heard up to 5 km away.

To be considered a carillon, the set of bells must number at least 23, in tune with each other. Mafra's North Tower has 49 bells in its carillon, plus 7 liturgical bells and 3 hour bells. The South Tower has 53 bells, 4 liturgical bells and 3 hour bells.

Professor João Soeiro de Carvalho writes that "these two carillons are outstanding musical instruments [...] Together, they are the largest surviving 18th-century carillons in the world. Each of them covers a range of four octaves, so they are considered 'concert carillons'" (Soeiro de Carvalho, 2012).



The bells that do not belong to the carillon — liturgical bells and those that chimed to mark the everyday life of the convent — were forged elsewhere, including Genoa, Paris and Portugal.

A document by the French consul, dated 7 August 1730 and quoted by the Viscount of Santarém, says that the John V himself went on board at midnight to see the eight bells cast in Genoa that had arrived in Lisbon that week (Santarém 1842, 252 and Figueiredo 1730, 201). According to another contemporaneous document, these Genoa bells were poorly tuned (Memória 1730, 201).

All of the bells coming from abroad (plus statues, materials, etc.) were sent from Antwerp and Liège to Rotterdam and then shipped to Lisbon. From the River Tagus in Lisbon, they were transported on barges along the Sacavém and Loures rivers until they reached the Palácio da Mitra, the palace of the Patriarchate of Lisbon, in Santo Antão do Tojal. Here they were blessed; after all, they were intended not only for the enjoyment of the king, but also for divine service.

To facilitate this transportation, the king ordered the opening of a channel connecting the River Loures to boundary of the patriarchal palace. This was called the Esteyro da Princesa (Princess's Channel). It's location has been the subject of much discussion, as the land was greatly changed by the 1755 earthquake and a great deal of dredging in the early 20th century.

The *Memórias Paroquias* (parish records) of Santo Antão do Tojal (1758) report that “from the River Sacavém a sea branch leads to Sancto Antonio, called an *esteyro*. It is navigable at high tide by the biggest barges [...]” (*Memórias* 1758, 435).

According to contemporary sources, the *esteyro* has been located and ends near the palace fence. Beside the fence is a stone-paved road that, tellingly, used to be called the *calçada* (promenade) of the bells or boats.

For the blessing of the bells and other artworks destined for Mafra, a wood and canvas tent was built in a large field near the palace — today an orange grove. It boasted impressive decoration, in silk damask, golden lace and fringing,

FIG. 7. Bells or Boats *calçada* alongside the boundary of the patriarchal palace © André Teixeira



FIG. 8. Bells “that flew through the air...”. 2019 restoration © Filipe Ferreira — AOF

heightening the sense of ceremony. Unfortunately, the day before of the arrival of the first bells, a storm ripped through the area, destroying the tent completely. Many labourers had to stay up all night to repair it before the arrival of John V.

Transporting the bells was the responsibility of superintendent Maximo de Carvalho. Special four-wheeled ox

carts were constructed and 400 oxen were used to pull the biggest bells. They and their drivers were escorted by two infantry regiments numbering 400 soldiers. 1,500 horses were also requested for the transportation. The voyage from Santo Antão do Tojal to Mafra (28km) took at least four hours, and up to almost a week for the biggest bells.

A contemporary letter about the construction work at Mafra relates that “The largest of them fell down on the march [...] was almost buried by its colossal weight. [...] An urgent plea for help was hastily sent to Mafra for aid [...] soon arrived the Marquis of Marialva and the son of the Earl of Unhão. [...] But a poor fellow fell under the bell’s cart. His screams were not heard due to the noise and he died smashed by the weight. [...]” (Carta 1730-31). Nobel Prize winner for Literature José Saramago may well have drawn inspiration from this for the episode of the soldier smashed by a stone in his novel *Blathazar and Blimunda*, which is set during the construction of the Royal Palace of Mafra.

The installation of the bells at the top of the towers was another source of astonishment among the local population. Custódio Vieira, architect and engineer, was responsible for inventing an “ingenious machine” to raise the bells, “which flew through the air in search of their places,” as the same letter tells us. This “ingenious machine” consisted of a mechanism or crane with blocks and hoops placed inside the tower. This hoisted a net made of thick cable while, on the other side of the tower, ropes were pulled by oxen.

As for the Portuguese bells, according to the document *Princípio e Fundação* (1763-1770, 32) and as later reaffirmed by Friar João de São José do Prado (Prado 1751, 115), a bell cast by the Portuguese bellfounder Pedro Palavra had “a sound so loud and yet so sweet” that it was dubbed the “bell of grace” and “was rung for sermons and processions”.

We know of other Portuguese bells that were subsequently cast, including by João Craveiro and António Manuel *Scalabitanus* (from Santarém). These were commissioned by King John VI in the early 19th century, in a recasting of the bell *Bizarro* (Bizarre), “the best voice of all the bells in the towers” (Gomes 1800-1832). This bell had broken on St Anthony’s day in 1817.

The *Bizarre* had quite a hard life. First the bellmaker David Quinie tried to repair it but was unsuccessful, having widened the crack by up to four palms. In 1818, three Italian workers came to repair it for a payment of 400,000 reis, but, after a year of work and having raised the bell and removed the

scaffolding, the bell broke again on its first ring. When the Italians witnessed the poor outcome of their work, they ran down the stairs and were never heard from again (Gomes 1800-1832, 35).

A good example of the cross between sacred and profane, since early times bells have served a religious function as well as a civilian or festive one. From the time of their arrival in Mafra, the coded ringing of the bells solemnised the entries of the royals into Mafra, the birth of princes and princesses, anniversaries, pontifical masses, processions such as Corpus Christi, and other religious or civil ceremonies, as an element in the expression of the king’s majesty.

The first bells arrived in September-October 1730, but on 22 October 1730, the day of the consecration of the Basilica, in one of the most solemn and magnificent ceremonies that the kingdom had ever seen, only the 39 carillon bells of the North Tower played, as the South Tower only housed the liturgical bells at this point. (Figueiredo 1730, 126)

Bells were — and still are — used for both religious and public purposes, so we see the same religious and profane themes in their decoration: prayers, psalms, supplications, religious motifs and even an angel playing a carillon, along with ornamental floral motifs, mythological scenes, the king’s coat of arms and the founders’ names, among other elements.

The towers also have an important automatic ringing system connected to two clocks: the Roman clock, marking just six hours; and the common one, also known as the Portuguese clock, marking the usual 12 hours. The origins of Italian six-hour clock, also called the Roman clock, followed the monastic tradition of dividing the day and night according to prayer times, with the day starting at the *Ave Maria*, an evening prayer recited half an hour after sunset. It was used in Italy until the French occupation of Rome by Napoleon, when European time (also dubbed *ora oltramontana* (“time as beyond the mountains”), transalpine time or French time) was introduced. In 1815, however, the Church returned to Italian time.

The clocks and their melodic drums or barrels were made by Gilles De Beefe, a Dutch watchmaker, in the first half of the

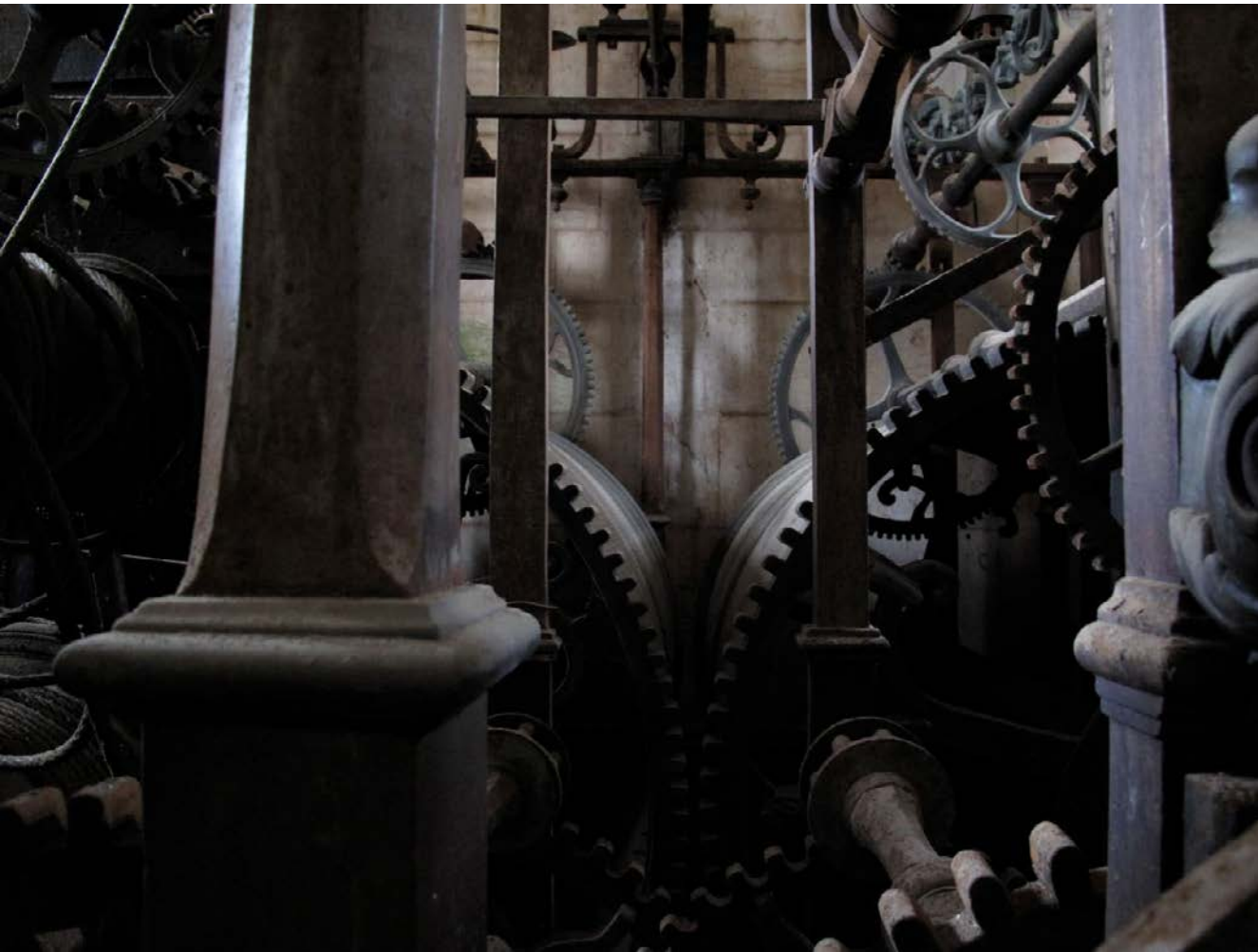

18th century. This set is the largest known melody clock system (four rotating barrels with pegs and levers) and is capable of playing about 16 different pieces of music at any given time.

According to manuscript *Princípio e Fundação*, “The devices of these two clocks, their large mechanism, and the magnificent array of which they are composed, cost 600,000 cruzados each, making up a sum of 1 million and 200,000 cruzados” (*Princípio e Fundação* 1763-1770, 187).

To give an idea of the dimensions, each clock dial has a diameter of 4.3 m and each hand measures 1.54 m.

The mechanical carillon works according to the Barbieri organ system, with two enormous bronze cylinders into which steel pins were inserted, representing different musical notes. When unlocked or driven by the clockwork mechanism, the movement of the cylinders causes these steel pins to strike metal keys or “kites”, which in turn set in motion the hammers of the bells in accordance with the programmed tune. The

rollers are driven individually by means of a lead weight of some 800 kg, which gradually drops down the towers all the way to the ground. The clockwork had to be wound up twice a day.

We don’t have registers of the music placed on the barrels in the 18th century, but merely some references by Portuguese and foreigner visitors to the playing of waltzes, quadrilles, minuets, symphonies and, by the end of the century, some compositions by Marco Portugal (1762-1830).

The bells were used in the solemn masses at the Basilica, as a communication system involving hand bells and small bells allowed them to play along with and emphasise the most important parts of the ceremony. During the *Te Deum Laudamus*, the big bells would ring while the six organs played (Santa Anna 1828, 271). On Good Friday, however, the sound of the carillons was replaced by the heavy, rhythmic sound of two enormous wooden drums on the terraces. It was the ultimate in Baroque drama.

The pieces of music applied to the automatic barrels changed over time, in line with new tastes, fashions and political events. In the middle of the 19th century, for instance, we know that some anthems, like those of Queen Maria II (1818-1853) or her husband King Ferdinand II (1816-1885), were applied to the barrels. In subsequent years this would also be done for the anthems of King Pedro V (1837-1861), Queen Maria Pia of Savoy (1847-1911) and Queen Amelia (1865-1951), along with various pieces that were in vogue at the time, including the waltzes from the operas *Norma*, *Faust* and *La Fille du Régiment*.

Taken as a whole, this complex system produced a highly theatrical Baroque effect, with both automatic carillons playing in dialogue every hour during the daytime, and at sunrise and sunset. According to a contemporary account by the monk Frei João de Santa Anna, the Roman clock of the South Tower played a different symphony at even and odd hours, while the Portuguese clock played minuets. Only one of the systems played, alternating, at the quarter, half and three-quarter hours (Santa Anna 1828, 288).

The manual system, played by a carillonist, consists of a keyboard with as many keys as there are bells. The keys are

FIG. 9. Drums or barrels belonging to the automatic system © Mário Pereira



connected to the clapper of the bell via a lever. When the key is pressed by the musician, the clapper strikes the bell.

As in the automatic system, almost everything can be played by the manual carillons, from classical music to folk, jazz, contemporary or fado.

Mafra's first carillonneur was Gregorio Le Roy, a member of a prominent family of carillon makers from Liège. He arrived with the carillons themselves. In the second half of the 18th century, Giuseppe Baretta, a traveller from Italy, called him 'the Emperor of Bells' because, "besides playing minuets, jigs and sarabands, he also knew how to entertain the royal family with his other skills on the bells" (Baretta 1761, letter XXVIII). Ten years later, João Felix Veberhani of Strasbourg came to share the position of official carillonneur with Le Roy. Le Roy's son, Joseph Le Roy, succeeded his father. A Portuguese carillonneur, Joaquim Gabriel dos Santos Andrade, also played in Mafra at that time.

Besides the carillons, the entire life of convent was governed by the sound of bells. There was the Grace Bell, with its gracious sound, which had been cast by the Portuguese bellfounder Pedro Palavra; the Lessons Bell; the Infirmary or Agony Bell, used to inform the monks of the arrival of the physician and surgeon, or rung whenever a brother was dying; the Refectory Bell, which called the monks to meals; and the Codfish Bell, so called because it was rung only on days of fasting and abstinence.

The religious community placed such importance on the bells (including the carillons) that some 24 *donatos* – lay servants who wore a habit – for 'bell service' alone. These *donatos* had their own accommodation in the rooms between the two towers, comprising a kind of scaled-down convent, with 22 cells, a refectory and a little oratory/chapel, plus a small forge and a workshop for minor repairs (Conceição 1820, 302 and Santa Anna 1828, 288). Occasionally in the late 18th century and regularly in the 19th, the service of the bells was entrusted to "young men paid for that purpose", due to the drastic fall in the number of monks.

Mafra's bells continued to be heard regularly during the 19th century and until the end of the monarchy in 1910, but

FIG. 10. North Tower Roman clock © Gabriela Cordeiro

Automatic system
(connected to the clocks)

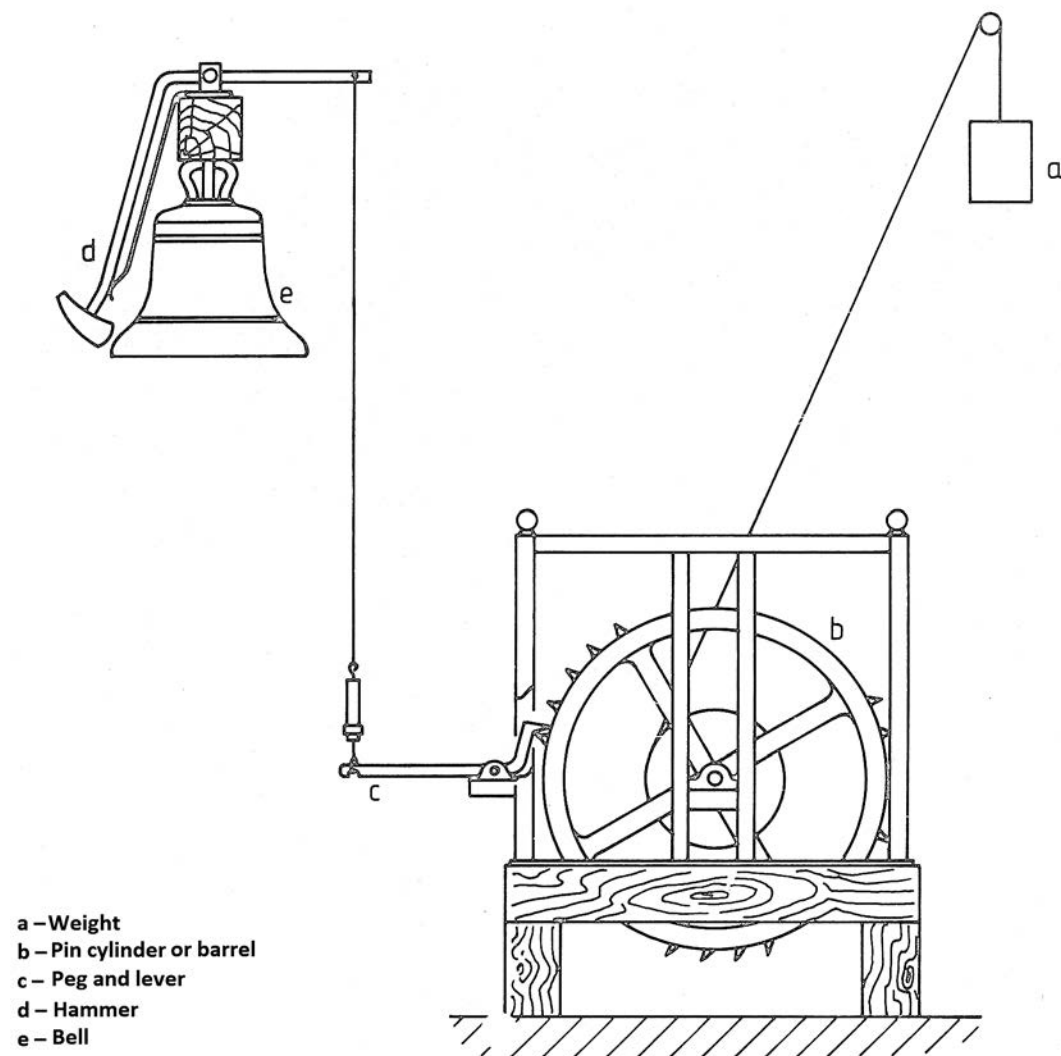

FIG. 11. Automatic system © MHOP/DGEMN

Manual system
(played by a carillonist)

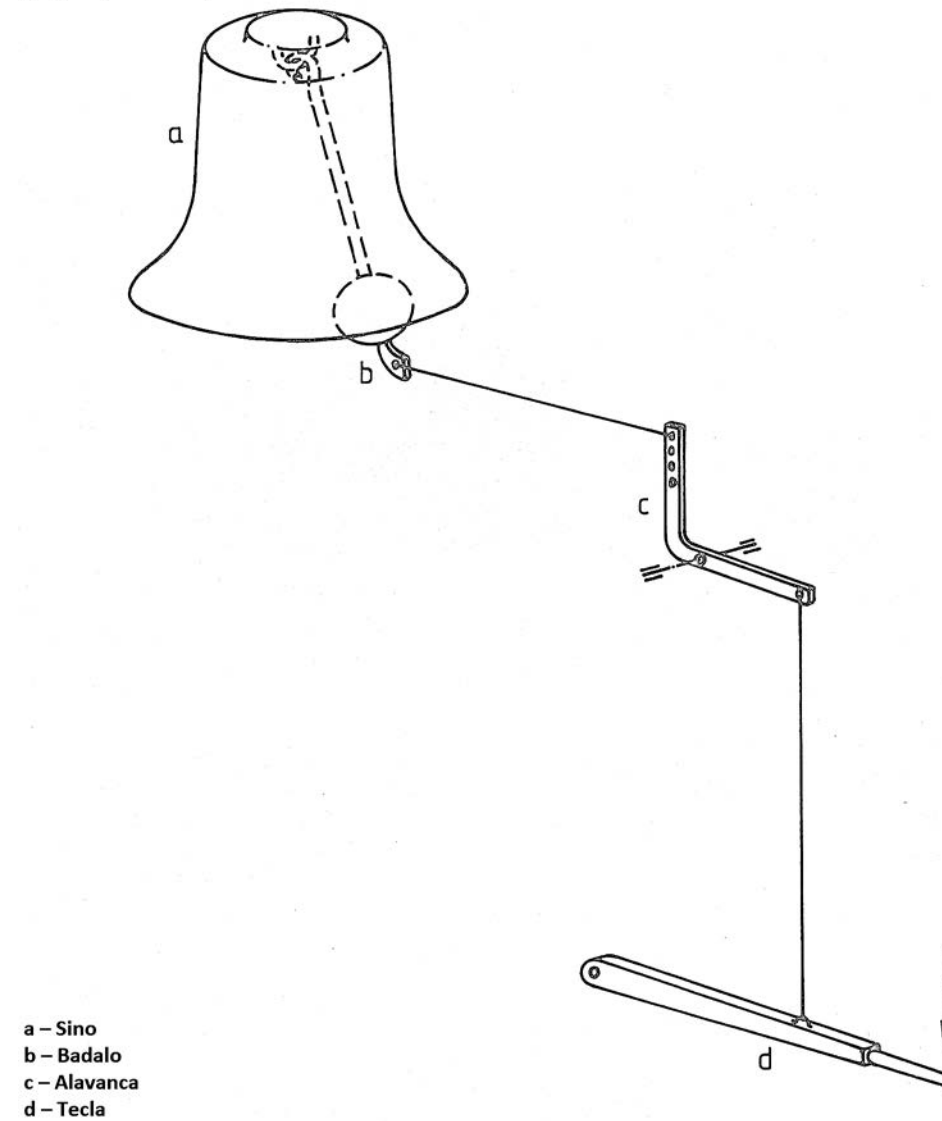

FIG. 12. Manual system © MHOP/DGEMN. A - bell; B - clapper; C - lever; D - key

the North Tower carillon, made by Levache and supposedly inferior, was gradually abandoned in favour of Witlockx's carillon in the South Tower.

After the expulsion of the religious orders from Portugal in 1834, the convent started to be used for military purposes, which has continued up to the present day. The Basilica became the parish church of the town in 1835 and the bells no longer mark conventual life, but everyday life in the parish.

A regular schedule of carillon concerts was maintained during the Republic and up until 2011. In the first half of the 20th century, carillon concerts were broadcast nationwide as a curiosity, and were among the first exterior transmissions made in Portugal.

The carillons were a focus of cultural activity in the Mafra community, and many famous carillon players (including Belgian, Dutch and French musicians) passed through here as they considered playing these carillons an important part of

their important for their musical groundwork. Aware of this interest, the Portuguese Tourism Commission used to include a carillon concert in the programme of visits by heads of state or monarchs to Mafra.

Over time, conservation and restoration work took place, including the major restoration to the south carillon in 1985-87. In the summer 2003, however, some problems emerged in the wooden supporting structure and rapidly worsened, so that the International Carillon Cycle that was taking place had to be suspended. After a long, difficult and complex procedure the bells were finally restored between 2017 and 2020, and the inaugural festival took place on 1 and 2 February 2020.

Acknowledgements

Filipe Ferreira, Inês Menezes (AOF)

Florbela Estevão, Paula Pitacas (Câmara Municipal de Loures)

Tiago Henriques (Real e Venerável Irmandade do Santíssimo Sacramento de Mafra)

Maria Gabriela Cordeiro (Palácio Nacional da Ajuda)

Mário Pereira, João Vaz, Maria Fernanda Santos (Palácio Nacional de Mafra)

André Teixeira (Grupo de Voluntários do Palácio Nacional de Mafra)

Sérgio de Medeiros (Mafra — Fotografia)

BIBLIOGRAPHY

SOURCES

- ARQUIVO Nacional da Torre do Tombo, *Memórias Paroquias de Santo Antão do Tojal*, 1758, PT-TT-MPRQ-36-58-c0229.
- BIBLIOTECA do Palácio Nacional de Mafra (BPNM), Cofre: BANDEIRA, Guilherme José de Carvalho. *Relação do Convento de Santo António de Mafra suas oficinas e Pallácios que se fundarão místicos ao dito Convento. Oferecido a ElRey N. Snr. D. José o 1º por Guilherme José de Carvalho Bandeira, official dos Carros da meza da Consciencia e Ordens*, 1730 a 1744.
- BPNM, Cofre: *Notícia das Reays Ob[r]ais de Mafra*. Mafra, 1730-34.
- BPNM, FM: GOMES, Eusébio, *MEMÓRIAS*, 1800-1832.
- BPNM, FM: *Principio e Fundação Do Real Convento de Mafra, e Sua grandeza, e Sua Sustentação, e Luxo*, 1763-1770.
- BPNM: SANTA ANNA, Frei João de. 1828. *Real Edificio Mafrense visto por fora e por dentro: ou Descrição exacta, e circunstanciada do Regio Palacio, e Convento de Mafra externa, e internamente considerados com a explicação das Plantas, que deste magnifico e admiravel Edificio levantou Amancio Joze Henriques, segundo Tenente da Marinha, e Ajudante Architecto da Caza do Risco das Obras Publicas, e Director das do dito Real Edificio*, 1828.

- BIBLIOTECA Nacional de Portugal (BNP), *Secção de Reservados: Carta sobre as coisas notáveis do edificio de Mafra, 1805, Belas, Agosto, 15.* in *Mafra Virtual* — transcr. Manuel Gandra <http://www.cesdies.net/monumento-de-mafra-virtual/carta-sobre-coisas-notaveis-anonimo>.
- BNP, *Secção de Reservados: Carta escripta para o Brasil em resposta de húa que pedia notissia das novidades*, 1730-31.
- BIBLIOTECA Pública de Évora, Res. Cx 1-6, nº 9: FIGUEIREDO, José Garcia de, *Memoria das pessas de que se compõem cada hum dos ornamentos que ficção na Sachristia do Real Conto de S. Ant. de Mafra, assinado José Garcia de Figueiredo*, 29 Setembro 1730.

STUDIES

- ANONYMOUS. 1730. *Jugement rendu par M. Hérault, lieutenant général de police, et les commissaires en cette partie, contre Joseph Martin, dit Saint-Martin (touchant la rupture d'un marché conclu entre ledit Martin et le Sr Mendès de Goës pour la fonte de six cloches que ledit Martin avait livrées défectueuses)*. Paris: De Imprimerie de P. J. MARIETTE.
- BARETTI, Giuseppe. 1761. *Lettere Familiare di Giuseppe Baretti a' suoi tre fratelli Filippo, Giovanni e Amedeo*. Milan: [u.t.].
- CARVALHO, Armindo Ayres de. 1962. *D. João V e a Arte do seu Tempo*. Lisbon: author's edition.
- CARVALHO, João Soeiro de. 2012. *O conjunto sineiro de Mafra*. In *Europa Nostra 7th Most Dangered Nomination Form*.
- CARVALHO, Miguel Eduardo Portela de Matos. 2012. *Os carrilhões de Mafra: estudo e caracterização acústica dos sinos*. Master's degree dissertation. <http://hdl.handle.net/10362/9229>.
- CONCEIÇÃO, Frei Cláudio da. 1820. *Gabinete Histórico que a Sua Magestade Fidelíssima, o Senhor Rei D. João VI, em o dia de seus felicissimos annos, 13 de Maio de 1818 offerece Fr. Claudio da Conceição, Ex-Definidor, Examinador Synodal do Patriarchado de Lisboa, Prégador Regio, e Padre da Provincia de Sancta Maria d'Arrabida*, Tomo VIII desde 1729 até 1730. Lisbon: Impressão Régia.
- GAMA, Luís Filipe Marques da. 1989. *Os carrilhões de Mafra — subsídios para a sua história*. Lisbon: Direcção-Geral dos Edifícios e Monumentos Nacionais
- GANDRA, M. J. S.d. *Cronocarrilhões*. <http://www.cesdies.net/monumento-de-mafra-virtual/cronocarrilhoes>.
- GANDRA, M. J. and Caetano, A. 1993. *Carrilhões de Mafra: roteiro monográfico*. Mafra: Serviços de Cultura da Câmara Municipal de Mafra.
- GOMES, Joaquim da Conceição. 1866. *O MONUMENTO DE MAFRA: Descrição Minuciosa d'Este Edificio Idéa Geral da sua Origem e Construcção e dos Objectos mais Importantes que o Constituem*. Lisbon.
- LEHR, André. 1984. *De twee klokkenspelen op het nationaal paleis te Mafra*. Asten: Athanasius Kircher Stichting.
- PIMENTEL, António Filipe. 2002. *Arquitectura e poder — O Real Edificio de Mafra*. Lisbon: Livros Horizonte.
- PINHO LEAL, Augusto Soares d'Azevedo Barbosa de. 1875. *Portugal antigo e moderno: diccionario geographico, estatistico, chorographico, heraldico, archeologico, historico, biographico e etymologico de todas as cidades, villas e freguezias de Portugal e de grande numero de aldeias*. Lisbon: Livraria Editora de Mattos Moreira & Companhia.
- PRADO, Frei João de São José do. 1751. *MONUMENTO SACRO DA FABRICA, E SOLEMNISSIMA SAGRAÇÃO da Santa Basílica do Real Convento, que junto á Villa de MAFRA DEDICOU A N. SENHORA E SANTO ANTONIO A Magestade Augusta do Maximo Rey D: JOÃO V. ESCRITO POR Fr. JOÃO DE S. JOSEPH DO PRADO, Religioso da Provincia da Arrabida, e primeiro Mestre das Ceremonias da dita Basílica*. Lisbon: Oficina de Miguel Rodrigues.
- ROMBOUTES, Luc. 2014. *Singing Bronze, A History of Carillon Music*. Leuven: Leuven University Press.
- SANTARÉM, Visconde de. 1842. *Quadro elementar das relações politicas e diplomáticas de Portugal com as diversas potências do Mundo até aos nossos dias*, Tomo Quinto. Paris: J. P. Aillaud.



**POMPA INTROITUS
HONORI SERENISSIMI
PRINCIPIS FERDINANDI
AUSTRIACI
HISPANIARUM INFANTIS.
CARDINAL-INFANTE DON
FERDINAND'S TRIUMPHAL
ENTRY INTO ANTWERP
IN 1635**

LAURA GARCÍA SÁNCHEZ

University of Barcelona

laura.garcia@ub.edu

ABSTRACT

On 15 May, 1635 Cardinal-Infante Don Ferdinand of Austria made his triumphal entry into Antwerp as the new governor of the Spanish Netherlands, following his victory in Nördlingen against the Swedish army and their allies of Saxony. The city decided to devote both its economic and intellectual energies to this celebration with the aim of impressing Don Ferdinand, from whom they were expecting protection. The route that the Cardinal-Infante took through the city was masterfully decorated with five wooden, 22 metre high triumphal arches, four stages -each one with an allegoric decorative scheme- and a portico, painted according to the design by Nicolaes Rockox, burgomaster; humanist Jean Gaspard Gevaerts, secretary of State; and Peter Paul Rubens, who designed, planned and executed these ephemeral decorations. In order for these works to survive in the future, several artists, led by Theodor van Thulden, were asked to engrave Rubens' designs.

KEYWORDS EPHEMERAL DECORATIONS, PIETER PAULUS RUBENS, BAROQUE FLEMISH PAINTING, CARDINAL-INFANTE, DON FERDINAND, TRIUMPHAL ENTRIES.

RESUMO

A 15 de maio de 1635, o Cardeal Infante D. Fernando de Áustria fez a sua entrada triunfal em Antuérpia como novo governador da Holanda Espanhola, depois de ter saído vitorioso da batalha de Nördlingen contra as tropas suecas e os seus aliados da Saxónia. A cidade decidiu investir os seus meios financeiros e intelectuais nesta celebração com o objetivo de impressionar D. Fernando, de quem esperavam proteção. O percurso pelo qual o Cardeal Infante percorreu a cidade estava magnificamente decorado com cinco arcos triunfais de madeira de vinte e dois metros de altura, com quatro palcos — cada um com o seu programa alegórico- e ainda com um pórtico. Este último pintado de acordo com os desenhos do burgomestre Nicolaes Rockox, do humanista Jean Gaspard Gevaerts, secretário de Estado e de Peter Paul Rubens, a quem coube a conceção geral destes aparatos efémeros, bem como o seu desenho e execução. Para memória futura destas festividades e seus aparatos efémeros foram contratados vários artistas liderados por Theodor van Thulden para fixarem em gravura os desenhos de Rubens.

PALAVRAS-CHAVE APARATOS EFÉMEROS, PIETER PAULUS RUBENS, PINTURA FLAMENGA BARROCA, CARDEAL INFANTE D. FERNANDO, ENTRADAS TRIUNFAIS.



Cardinal-Infante Don Ferdinand

Cardinal-Infante Don Ferdinand of Austria, son of Philip III and Queen Marguerite of Austria, was born in San Lorenzo del Escorial on 16 May 1609 and died in Brussels on 9 November 1641.

On the insistence of his father, who wanted Don Ferdinand to form part of the clergy of the Catholic Church, he was named Archbishop of Toledo in 1619 and, a little later, appointed Cardinal. In 1632, he obtained the title of Viceroy of Catalonia in order to carry out the delicate mission of gathering, in name of the king, the Courts, which had been swiftly suspended in 1626 (García 2008). He stayed in Catalonia for a little while, because he was chosen by his brother, King Philip IV, as the successor to their aunt, the Infanta Isabella Clara Eugenia, who was then an elderly and sick woman, to take charge of the Spanish Netherlands (Esteban 2015). However, the post was offered to the king's favourite, Gaspar de Guzmán y Pimentel, Count-Duke of Olivares, who was by then at the peak of his power. His plan was to ensure the control of military and governmental machinery in facing the Dutch rebellion. Confidants were assigned to accompany Ferdinand within the ministerial environment and also to his court, not only to advise him, but also to monitor that he was following the guidelines sent from Madrid. The fact that Olivares placed people in Brussels that shared his political vision clearly indicates that his purpose was to limit, to the best of his ability, the possibility that the governor might act alone (Israel 1987). The mission of Don Ferdinand had great importance for the political career of the Count-Duke and he needed to eliminate any potential risk (Houben 2011, 151-170).

The danger of the Dutch navy prevented the Cardinal-Infante from travelling by ship, and thus led to his decision to go to Geneva accompanied by a large army. Ferdinand set sail from Barcelona on 11 April 1633 and arrived in Italy, accompanied by a large army, on 5 May. His plan was to travel from Milan to the Netherlands through Lombardy, Tyrol, Swabia and to follow the Rhine. The route had to be secured with the establishment of strategic garrisons. At the same time, he had to provide support to the forces of

his cousin, King Ferdinand of Hungary -the future Emperor Ferdinand III- who was the visible leader of the imperial army that fought against the Swedish army during the Thirty Years' War. Under the command of Gómez Suárez de Figueroa, Duke of Feria, members of Don Ferdinand's army opened the pathway, but they also suffered numerous casualties during the confrontation with the Swedish troops of Duke Bernardo de Saxe-Weimer and Gustaf Horn. The unstable situation provoked a request for the help of 4.000 cavalry troops of General Albrecht von Wallenstein, but this was refused and it became necessary to look for alternative resources (Aldea 2008). The situation became more complicated, especially after the news of the death of Infanta Isabella Clara Eugenia in December 1633. Don Ferdinand was able to continue his journey in 1634, and in Bavaria he met with the survivors of the army of the Duke of Feria, who himself died in February of that same year¹.

Ferdinand of Hungary was able to defeat the Swedish army in Regensburg in July 1634 and soon joined his army to his cousin's troops. The Swedish forces of Duke Bernardo and Gustaf Horn tried desperately to prevent the merger, but they were unable to muster the same number of men. The Cardinal-Infante crossed the Danube River in August and, in September of that year, both armies were encamped to the south of the village of Nördlingen, Swabia, arriving on the site shortly after the Swedish forces. These were the preambles to the decisive battle of the same name. Ferdinand and the Cardinal-Infante prepared themselves, as did Duke Bernardo and Horn. The latter, however, made the mistake of leaving their personal differences to fester and underestimated the numerical superiority of their enemies. They ended up being defeated by the two cousins of the House of Austria, the architects of an exceptional military victory. This campaign, one of the most astonishing of the war, interrupted the successes of the Nordics. It left all of southern Germany in the hands of the Habsburgs and also allowed the emperor and his allies to regain confidence.

Shortly after the battle, the Cardinal-Infante moved with his troops to Brussels, where he

¹ The search for new allies led to the recruitment of Gaston of Orleans to the Spanish side. He was the younger brother of Luis XIII, who, from once being an enemy, went on to make a secret deal in which he promised to support the House of Austria in the event of war.

arrived on 4 November 1634. A skilled politician and diplomat, he soon reformed the government and dealt with the military restructuring of the Spanish Netherlands. The day after his arrival in Brussels, to further emphasise the respect due to him, he wore the attire of a cardinal to welcome the high ecclesiastical dignitaries and the representatives of states and both the provincial and central councils². Yet he did not have much time to recover from his long journey and enjoy the Flemish life. Less than half a year later, the war against France would break out.

In commemoration of the significant victory over the Protestant army, the brother of Philip IV was portrayed by Peter Paul Rubens immediately after assuming his new position. Against a background of battle as the framework for his triumph, the painter perfectly synthesised the usual symbols the military and Cardinal-Infante's capacity as a commander with the eagle, symbol of the Habsburgs, and the allegory of the *Divine Revenge*. It is currently one of the most famous paintings of Rubens preserved in the Prado Museum in Madrid.

Triumphal entry into Antwerp

It did not take long for the artist and governor to meet again. After his arrival in Brussels, Don Ferdinand was invited to move to Antwerp, where he was welcomed as a victorious Roman general (Vlieghe and Dhondt 1969) and given great honours. This was all part of the iconography of power (Mulryne 2015). A triumphal entry worthy of great personalities was prepared for him, with the city decorated to this effect along a planned route through the streets of the city. To celebrate this event, five triumphal arches over 22 metres high were made of wood. There were four stages or platforms and a portico, plus other temporary structures all of which were seen by the Cardinal-Infante during his two-hour visit on 17 April 1635 (Rupert 1972). These creations were made according to the proposal devised by Nicolaes Rockox, burgomaster of Antwerp, the humanist Jan Gaspard Gevaerts, and Pieter Paul Rubens, who collaborated with

Jacob Jordaens, Alexander van Adrianssen, Cornelis de Vos, Erasmus Quellenius, Cornelis Schut the Elder and Gerard Seghers to execute the paintings and sculptures³. The result was one of the most spectacular festive stages of the century (Mínguez 2001).

In order to guarantee that these works would be remembered over time, Theodor van Thulden was commissioned to record Rubens original designs and engravings, although other artists such as Ludovico Nunnus also intervened in the process. This is how *Pompa introitus honori serenissimi principis Ferdinandi Austriaci Hispaniarum infantis* was born, which is now considered one of the most interesting illustrated books on ephemeral Baroque architecture. It is a monumental work consisting of 42 engraved etchings, many of them in large format, which allow artists and historians to look back on the constructions created for this occasion. Thanks to the beauty, scope and creativity of this volume, the dissemination of this architecture, which had been destined to disappear after the Cardinal-Infante's visit, made a major impact not only in Spain, but across Europe⁴. The copy discussed here, printed in vellum and illuminated by hand with great quality, is dated 1641 in the colophon, but was not published until the end of 1642 due to a delay caused by the author: the details are unknown. As a consequence of the death of the Cardinal-Infante in 1641, the magistrate ordained that the book should not be dated later than the death of the protagonist of this work⁵.

The exaltation of the House of Austria and, in particular, the figure of Don Ferdinand, was a matter of pride for Antwerp, which is why the municipal authorities had no intention of limiting their spending. Nonetheless, the ongoing crisis curbed the enthusiasm of many, especially some of the members of the *Brede Road*, a kind of municipal council that was well aware of the difficulty that the city was undergoing. They felt that the economic

² In his first audiences, he did not give the impression of being a warm and approachable person, but rather quite the opposite: he appeared to be very much in line with the rigidity of the Court of Madrid. In addition, he had serious linguistic problems, as it is known from his close friends and confidants that he did not know Flemish and barely understood French. It seems that the young governor only enjoyed himself while hunting, which is something he practised often.

³ However, the absence of Anthonis van Dyck, one of the most widely shown Flemish painters of the time, is surprising. For instance, Van Adrianssen made the shields of the 17 provinces of the Netherlands as ephemeral decorations, and Cornelis de Vos made a few portraits for the so-called Arch of Philip.

⁴ Triumphal arches were ideal monuments for expressing the decorative exuberance of that time, while other inventions derived from Flemish Mannerist treatises. Some of Rubens' original sketches are preserved in various museums, such as the State Hermitage Museum in St. Petersburg.

⁵ Both the volume conserved in the National Library of Spain and that of the British Library, both digitised, allow you to enjoy this bibliographic jewel.



FIG. 1. Map of Antwerp. Biblioteca Digital Hispánica, Biblioteca Nacional de España, *Pompa introitus honori serenissimi principis Ferdinandi Austriaci Hispaniarum infantis S.R.E. Card Belgarum et Burgundionum gubernatoris ... a S.P.Q. Antwerp. Drecreta et adornata, cùm mox à nobilissimâ ad Norlingam partâ Victoria Antuerpiam auspaticissimo audentu suo bearet XV Kal. Maii, ann MDCXXXV*, p. 244 <http://bdh-rd.bne.es/viewer.vm?id=0000051898>

hardship of its inhabitants demanded that the celebration be more modest than on other occasions⁶. After long negotiations, an agreement was reached. Once the City Council promised that the Cardinal-Infante would be warned of the need for protection by the city, the pecuniary compensation requested was voted upon favourably (Soly 1984). In the light of this, Gevaerts, Rockox and Rubens devised an iconographic programme in which the trying elements of that time were recorded in a subtle and symbolic way. In other words, through

art they sought to inspire the new governor to look for solutions to the delicate economic state that the region was experiencing due to the exhausting war with Holland.⁷ (Fig. 1) One of the most important episodes of this war was the control of the left bank of the Scheldt River by the future Netherlands, a circumstance that led to the progressive economic impoverishment of Antwerp; commercial traffic practically

⁶ For example, the triumphal arches were intended to reinforce the request for help addressed to the new government. The councillors insisted on their project, but the representatives of the citizens expressed their displeasure at the idea of recovering the costs generated from the temporary application of a series of supplementary taxes on beer.

⁷ In spite of all such efforts, the consistory could not afford all of the planned monuments.



FIG. 2. *The Cardinal-Infante Don Fernando*, painted by Peter Paul Rubens. Biblioteca Digital Hispánica, Biblioteca Nacional de España, *Pompa introitus honori serenissimi principis Ferdinandi Austriaci Hispaniarum infantis S.R.E. Card Belgarum et Burgundionum gubernatoris ... a S.P.Q. Antwerp. Drecreta et adornata, cum mox à nobilissimâ ad Norlingam partâ Victoria Antuerpiam auspiciatissimo audentu suo bearet XV Kal. Maii, ann MDCXXXV*, p. 12 <http://bdh-rd.bne.es/viewer.vm?id=0000051898>

ceased to exist. The iconography depicted at the *Stage of Mercury* refers to this situation.

Allegory and mythology at the service of an idea

Rubens worked at the service of the main European monarchies as an artist and someone passionate about politics. In that cosmopolitan world, where art and diplomacy went hand in hand, the figure of the painter stood out. This was something he felt deeply, as is confirmed by his wide ranging activities⁸. The homage to the Cardinal-Infante is one of his best artistic contributions, with allegorical and mythological figures employed to express a message, but it also tells us about his privileged position as a court artist.

The illuminated chalcographic engraving that comprises the cover of the book *Pompa introitus honori serenissimi principis ...* is a statement of intent for the entire work, which was written in Latin. Thus, apart from figures presented as caryatids with swords, caduceus, torches, palms and crowns in their hands, what draws our attention is the scene depicted on the pediment of the facade of classical temple, where one can see Philip IV naming his brother governor of the Netherlands. The vertex is crowned by a portrait of Philip IV, which is accompanied by *Aurora* and *Luna*, depicting the allegory that includes the words: “the sun did not set on his domains”. Following this is a text dedicated to Don Ferdinand and a preface for the reader to follow up the body of the book. The primary focus is on the brilliant reception of the Cardinal-Infante before one of the gateways to the city, followed by the portrait of him on horseback, signed by Rubens and Paulus Pontius. This is very similar to the aforementioned portrait made earlier by Rubens. (Fig. 2) There is also a family tree of the royal house and a map of the city of Antwerp. From here on, all of the ephemeral constructions are described. (Fig. 3)

The richness of the entire iconographic programme that was presented is evident from the fact that the triumphal arches and

⁸ He met the court of the Duke of Mantua in the early years of the century; the Spanish court, first with Felipe III in Valladolid in 1603 and then with Felipe IV in Madrid in 1628; the court of Luis XIII of France in 1622, when he worked for the queen mother Maria de Medicis; and that of Charles I of England in 1629-30. He became familiar with the Court of Brussels, which was appreciated by his sovereigns, the Archdukes Alberto and Isabella Clara Eugenia, who appointed him court painter in 1609. Between 1628 and 1630, Rubens united the courts of Brussels, Madrid and London, carrying out delicate diplomatic missions.



FIG. 3. Cover of *Pompa introitus honori serenissimi principis*. Biblioteca Digital Hispánica, Biblioteca Nacional de España, *Pompa introitus honori serenissimi principis Ferdinandi Austriaci Hispaniarum infantis S.R.E. Card. Belgarum et Burgundionum gubernatoris ... a S.P.Q. Antwerp. Drecreta et adornata, cùm mox à nobilissimâ ad Norlingam partâ Victoria Antuerpiam auspaticissimo aduentu suo bearet XV Kal. Maii, ann MDCXXXV*, p. 2.

<http://bdh-rd.bne.es/viewer.vm?id=0000051898>

stages were not only decorated at the front, but also at the back. In addition, there are 48 small medal illustrations interspersed with the text, without signatures⁹. The work is now one of the bibliographic treasures of the Museo del Prado Library in Madrid (Docampo 2010). In this part of the study, our theoretical and methodological position is based on the description and examination of some of the monuments that were realised, since their sheer number makes it impossible to analyse them all in full. The work of Cesare Ripa is fundamental here (Ripa 2007). The selection of ephemeral architecture has been made on the basis of importance and theme. In this respect, besides highlighting the dynasty of the House of Austria and the figure of the Cardinal-Infante, its location in the city permitted the establishment of a hierarchy of streets that practically ends at the *Stage of Mercury*, where the message request for help addressed to Don Ferdinand is synthesised.

The first monument. The Cardinal Infante's journey, his meeting with Ferdinand of Hungary and the Entry into Antwerp

The route that Don Ferdinand had to make through the streets of Antwerp was planned not only by Rubens, but also by the burgomaster Rockox and the humanist Gevaerts, who ultimately also wanted the Cardinal-Infante to observe and read the Latin inscriptions of on the monuments that had been the subject of so much effort. Through the strategic placement and the decoration of all of the temporary apparatus created for his reception, the new governor could not only come to understand the city's joy at his arrival and the recognition of the House of Austria, but also the great economic outlay that had been expended as well as the delicate situation of the time (Bellori 2005, 136-143)¹⁰. (Fig. 4)

Once the Cardinal entered the city on horseback, the first construction he saw was *The Stage of Welcome*, located in the square of St. George's Church. This was an Ionic structure, supported over six pilasters of great strength and height. The cavities between the pilasters

⁹ The copy on which we base our commentary is printed on vellum, and bears the date 1641, although it was not actually published until the end of 1642. As the Cardinal-Infante died in 1641, the magistrate considered that the book should not be dated after the death of the person to whom it was dedicated.

¹⁰ For this paper, I used the 2005 edition published by Akal in Madrid. The pages indicated correspond to it.

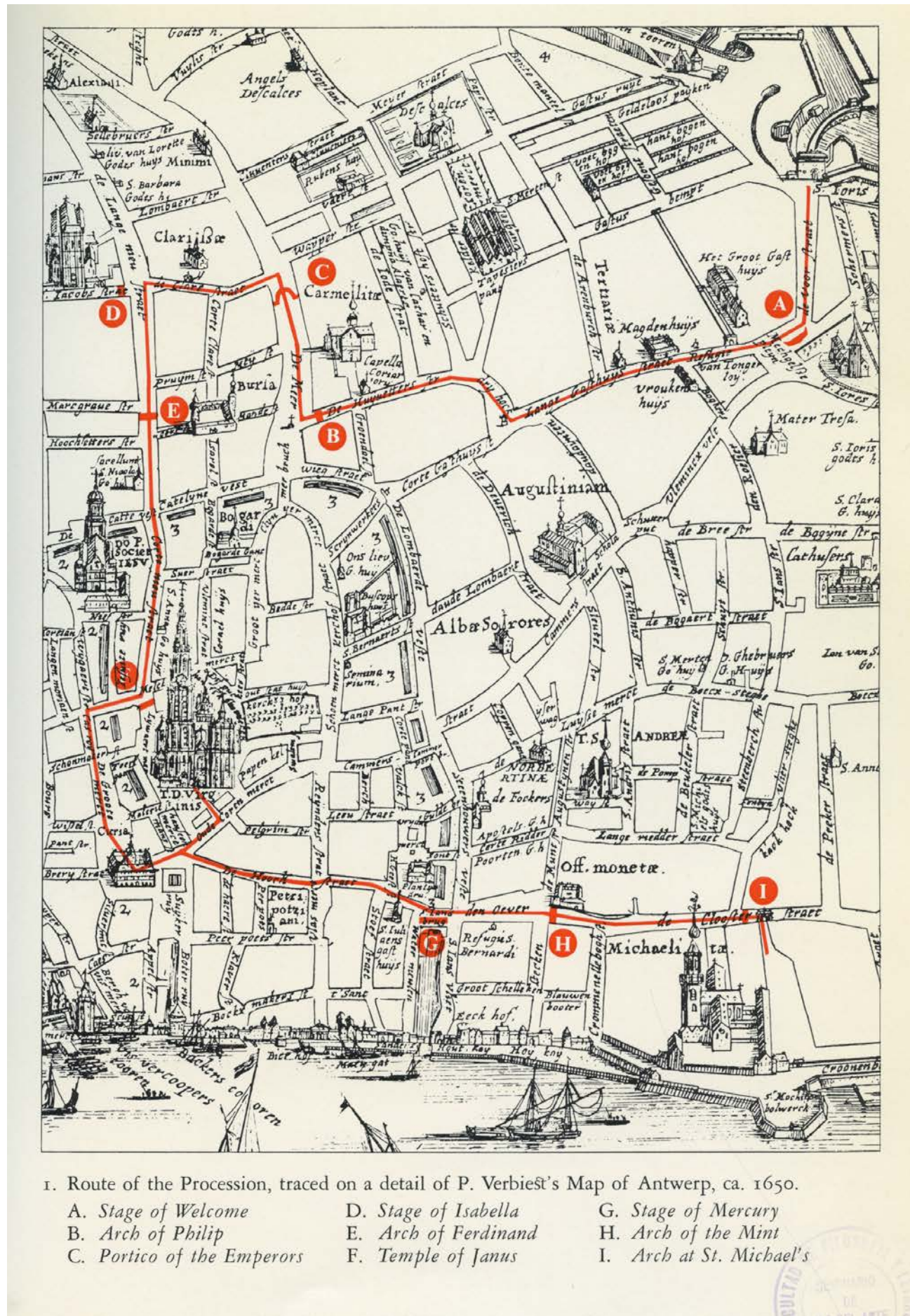

were adorned with statues of the *Genius of the City* along with a patera and the horn of abundance. In addition, they displayed the *Public Allegory*, with a crown and rudder in hand. *Hope* was located in the arch of the upper facade with the habitual emblem of the flower and above it stood a palm tree with a terrestrial globe between its branches and the motto SVMIT DE PONDERE VIRES (A great personage has arrived). On both sides of this palm tree two seated *Famas* held trumpets to their mouths; one was accompanied by the imperial eagle and the other by a lion, the symbol of Flanders. Cupids with palms, banners and crowns accentuated the joy of the moment. (Fig. 5)

The story of the Infante's journey from Barcelona to Genoa was depicted on the left-hand side. *Neptune*, standing on a shell that serves as a chariot, wields his trident with one hand and with the other rejects *Aquilon*, a wind represented by a decrepit man with dishevelled hair and winged arms, which at mid-height transform into feathers, and with snakes twisting around his legs. He is chased by *Austro*, armed with lightning, and *Cephiro Hispano*, with wings in his hair and a rather youthful face, alluding to the future victory against the Swedish army. Four sea horses pull *Neptune's* chariot. At the front, *Triton* sounds his customary conch shell and holds the animal bridles while the *Nereids* push the wheels. This scene comes to a close, giving way to a background on which we see the tranquil advance of the Cardinal-Infante's fleet across the calm sea.

The meeting between Ferdinand of Hungary and his cousin, the Cardinal-Infante, is depicted on the right side of the structure. In the central scene, we witness the entrance of Don Ferdinand whose horse tramples on the corpses of the enemy. Ferdinand's right-hand is extended towards *Flanders*. Following them, *Virtue* appears on one side with her helmet, alongside *Mars*, who is armed and holds a trophy

FIG. 4. Route of the procession through Antwerp. Rupert Martin, John. 1972. *The decorations for the Pompa Introitus Ferdinandi*. Corpus Rubenianum Ludwig Burchard, part XVI. Belgium: Phaidon, p. 281.



FIG. 5. *The Stage of Welcome.* Biblioteca Digital Hispánica, Biblioteca Nacional de España, Pompa introitus honori serenissimi principis Ferdinandi Austriaci Hispaniarum infantis S.R.E. Card Belgarum et Burgundionum gubernatoris ... a S.P.Q. Antwerp. Drecreta et adornata, cùm mox à nobilissimâ ad Norlingam partâ Victoria Antuerpiam auspicatissimo audentu suo bearet XV Kal. Maii, ann MDCXXXV, p. 27. <http://bdh-rd.bne.es/viewer.vm?id=0000051898>

on his shoulders. On the other side, *Fortuna* clasps the horse's bridle with one hand and stretches her other out to *Flanders*, who appears with her head tilted and crowned with towers and a lion at her feet. Behind this, we recognise the figure of *Health*, accompanied by a snake and, above this, *Victory*, who wears a laurel wreath.

The Arch of Philip

The City Council was in charge of making three large triumphal arches stand out: one dedicated to Philip, another to San Miguel (patron of the city) and the third to the governor himself. Their decorations constituted a brilliant evocation of the glorious past of the Habsburgs (Díaz 2008, 233- 251). After stepping through the arch erected for him by the Portuguese nation, the Cardinal-Infante found that on the opposite side, in Tanner's Street, there was another one, which was the largest and most luxurious of them all. It was a composite structure of remarkable height and called the Arch of Philip because of its connection to the King of Spain. The decorative theme is the union of the House of Austria with those of Burgundy, Aragon, Castile and León, followed by the happiness of two marriages. On the front facade, on top of the arch and at the centre of the fascia, the Archduke Maximilian and Mary of Burgundy were painted shaking hands before *Hymenaeus* (who leads the wife, delicately represented standing behind), as well as *Flanders*, crowned with towers and carrying a globe with a lion in her hand. Next to Maximilian, one is able to recognise his father, Emperor Fernand IV, and next to his wife is an armed Charles the Bold. On top of this painting are two putti, depicted in relief with torches. The statue of *Hymenaeus* stand in the middle of a balustrade. He is painted as a winged young man carrying a basket of flowers on his head, his neck decorated with roses and with the horn of plenty.

The offspring of this marriage is depicted between the columns, with the figures of Emperor Maximilian I, Philip I, Charles V, Philip II, Philip III and Philip IV. At the very top, *Jupiter* and *Juno* arrange a marriage. *Jupiter* points to the spouses below with one hand, and with the other he embraces



FIG. 6. The front face of the Arch of Philip. Biblioteca Digital Hispánica, Biblioteca Nacional de España, *Pompa introitus honori serenissimi principis Ferdinandi Austriaci Hispaniarum infantis S.R.E. Card Belgarum et Burgundionum gubernatoris ... a S.P.Q. Antwerp. Drecreta et adornata, cùm mox à nobilissimâ ad Norlingam partâ Victoria Antuerpam auspiciatissimo audentu suo bearet XV Kal. Maii, ann MDCXXXV*, p. 51. <http://bdh-rd.bne.es/viewer.vm?id=0000051898>



FIG. 7. *The rear face of the Arch of Philip.* Biblioteca Digital Hispánica, Biblioteca Nacional de España, *Pompa introitus honori serenissimi principis Ferdinandi Austriaci Hispaniarum infantis S.R.E. Card Belgarum et Burgundionum gubernatoris ... a S.P.Q. Antwerp. Drecreta et adornata, cùm mox à nobilissimâ ad Norlingam partâ Victoria Antuerpam auspiciatissimo audentu suo bearet XV Kal. Maii, ann MDCXXXV, p. 63.* <http://bdh-rd.bne.es/viewer.vm?id=0000051898>

Juno, who holds a globe. To the right we see *Providence*, who has wings, an eye on her forehead and globe in her hand; to the left is *Eternity*, represented under the figure of *Saturn*, with a sickle and a snake biting its tail. A little further down, in the modillions, *Flanders* and *Burgundy* are seated showing their banners. (Fig. 6)

The monarchy of the House of Austria was represented on the rear facade of the arch, with the family enlarged thanks to the marriage of Philip the Fair, Prince of Flanders, to Juana, daughter of the Catholic kings. They are followed by *Flanders* crowned with towers and the lion. *Juno Prónuba* goes to meet him, carrying the globe of the monarchy in her hand and accompanied by *Time*, as a sign of the future succession that should occur between these kingdoms. As in the previous facade, we see the statues of *Hymenaeus*, Ferdinand with the sceptre and Isabel, with the globe of the New World discovered by Columbus. The other figures represent the Archduke Ernest, son of Maximilian II, Governor of Flanders; Archduke Alberto and his wife Isabella; and the Infante Don Ferdinand himself dressed in sacred purple. (Fig. 7)

In the upper part of the arch, the *Austrian Monarchy* is dressed as a noblewoman, a winged genius, who, on her knees, offers a globe, over which she raises the inscribed sceptre and the cross with one hand. At the same time, she holds a caduceus with her other hand between ears of wheat and poppies of happiness. The *Héspero Hispano* star shines over her head. *Apollo* stands on one side wearing a laurel wreath, and with his left hand holds the *Orient* its head surrounded by rays. In his right-hand, he holds the banner of Portugal. At his feet are seated the *East Indies*; their heads adorned with precious stones, and with bare necks and arms. On the other side, *Diana* holds the western moon in one hand and a banner of Castile in the others. At her feet are the *East Indies* crowned with feathers of various colours and ears without earrings, spilling gold and silver coins from their vessels. The mixture of solar elements and deities is somewhat surprising here.

The Portico of Emperors and the monument dedicated to Isabella Clara Eugenia

Meir Street was reached from behind the street of the tanners. This was where the so-called Portico of Emperors was built, according to a design by Theodor van Thulden. It was a large triumphal arch decorated with sculptures of the twelve emperors of the House of Austria. Each had a different classical deity attributed to him and they were placed individually between the niches formed by two columns with a façade, starting with Rodolfo I and ending with Ferdinand II. An obelisk topped by a radiant sun projected from the structure. This three-dimensional emblem bore an inscription on its pedestal, where viewers could read *Orbi sufficit unus* ("The world is enough"). The founder of the Habsburg dynasty, Rodolfo I, appeared to be associated with the Sun god Apollo in a game of assimilation between the warrior side of the latter and the king's endeavours to maintain and expand his power through strategic political decisions. (Fig. 8)

On the route through the city, near the church of San Jacinto stood the monument to the Infanta Isabel Clara Eugenia, known as *Apoteosis de Isabel Clara Eugenia* (*Apotheosis of Infanta Isabella*). Rubens designed an architectural structure similar to the facades of Baroque churches, setting aside the centre of the upper part for a scene to depict the Infanta Isabel. The former governor appears in the upper part of the scene, sitting on the clouds amidst a light coming from the heavens. She is dressed in the habit of a Franciscan tertiary, the clothing she wore from the time of the death of her husband Archduke Albert of Austria, in 1621. Doña Isabel approaches a kneeling figure that symbolises *Belgium*, who extends her hands to Isabel in supplication. Isabel, in turn points to the King of Spain on earth, who is accompanied by the personification of *Affliction*, with both figures located to the left of the scene. Behind the Infanta we see a woman with two naked children. She personifies *Charity*. On the right side of the composition, we see Philip IV, who is advised by *Jupiter*, a symbol of power, and *Minerva*, the goddess of wisdom, as he appoints his brother Don Ferdinand as Governor of the Netherlands. The

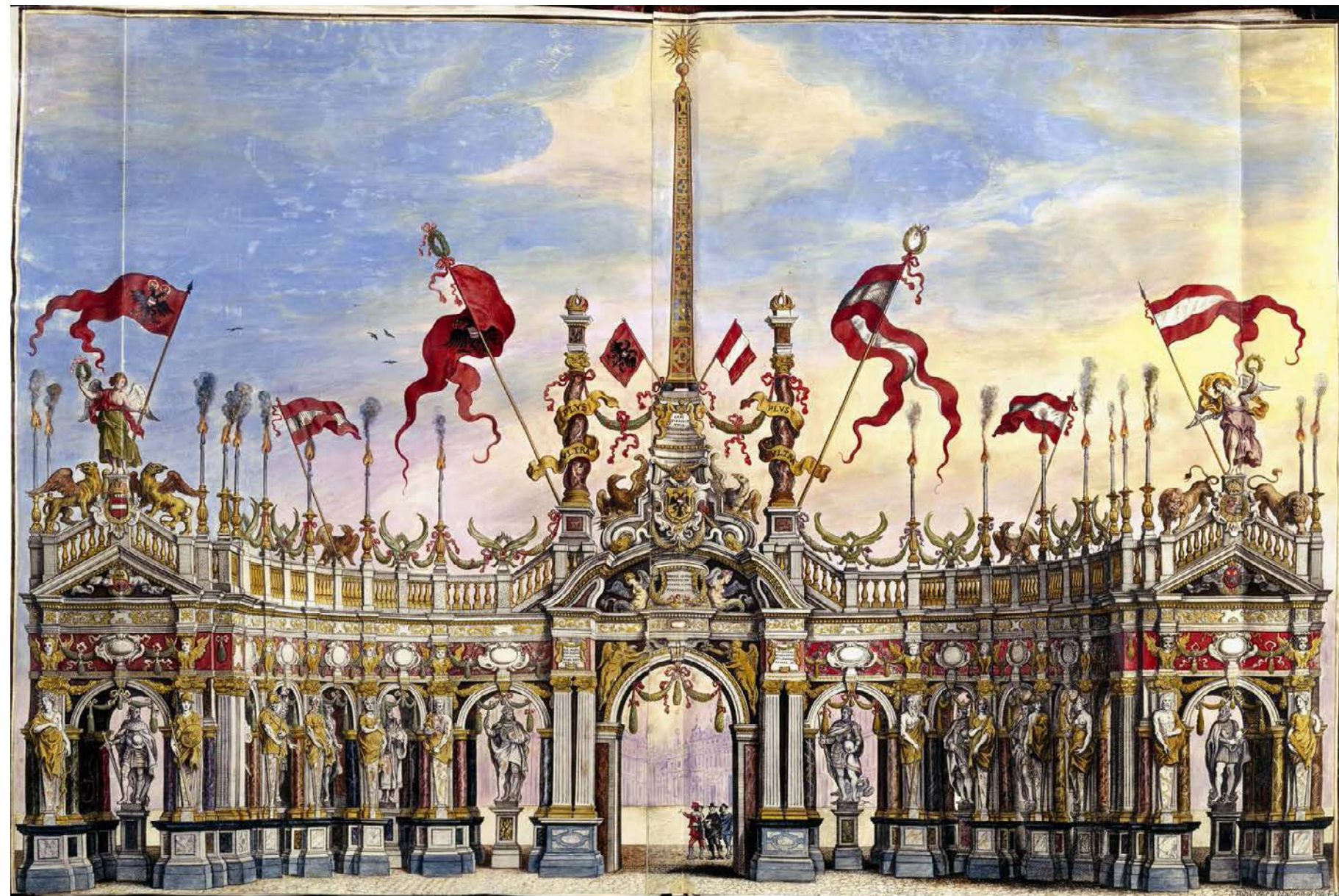

Cardinal-Infante is preceded by two winged geniuses who bear symbols of war along with the shield with the head of Medusa, and symbols of peace, represented by the caduceus and the horn of plenty. With this image, Rubens wanted to appeal to the new governor's sense of responsibility by alluding to the government of the Infanta Isabella. At a moment of dire need for the Spanish Netherlands, Don Ferdinand offers his subjects protection and help. In sum, the *Apoteosis de Isabel Clara Eugenia* expressed a warm welcome to the new governor and offered fond recollections of his aunt. (Fig. 9)

FIG. 8. *Portico of the Emperors*, p. 76. Biblioteca Digital Hispánica, Biblioteca Nacional de España, *Pompa introitus honori serenissimi principis Ferdinandi Austriaci Hispaniarum infantis S.R.E. Card Belgarum et Burgundionum gubernatoris ... a S.P.Q. Antwerp. Drecreta et adornata, cum mox à nobilissimâ ad Norlingam partâ Victoria Antuerpiam auspaticissimo audentu suo bearet XV Kal. Maii, ann MDCXXXV*, p. 76. <http://bdh-rd.bne.es/viewer.vm?id=0000051898>

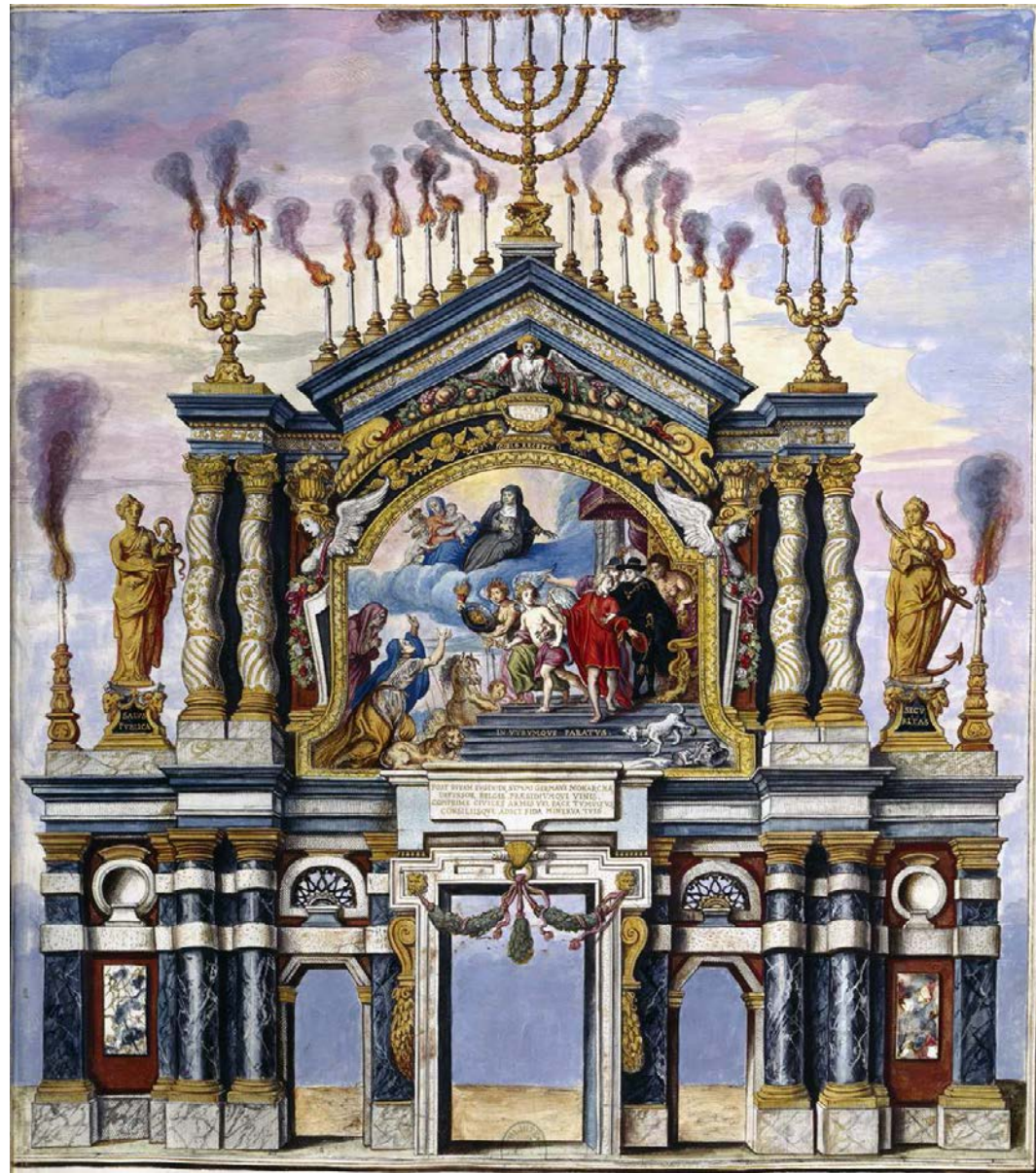

FIG. 9. *Apotheosis of Isabella Clara Eugenia*. Biblioteca Digital Hispánica, Biblioteca Nacional de España, *Pompa introitus honori serenissimi principis Ferdinandi Austriaci Hispaniarum infantis S.R.E. Card Belgarum et Burgundionum gubernatoris ... a S.P.Q. Antwerp. Drecreta et adornata, cùm mox à nobilissimâ ad Norlingam partâ Victoria Antuerpam auspicatissimo audentu suo bearet XV Kal. Maii, ann MDCXXXV*, p. 133. <http://bdh-rd.bne.es/viewer.vm?id=0000051898>

The Arch of the Cardinal-Infante Don Ferdinand of Austria

On Nieuwstraat, the three-span arch dedicated to the Cardinal-Infante also attracted attention. On the front side, the main scene was presided over by his figure, depicted on horseback and dressed in shining armour next to Ferdinand

of Hungary, who is identified by the nail, the fur-lined mortarboard and the Hungarian mantle over his armour. They appear to be galloping through Nördlingen, scaring off their enemies. Above, as ornamentation for the image, are two eagles obliterating a serpent with their beaks and claws, and the motto *CONCORDIA FRATRVM*. On both sides are grisaille statues of *Religion*, hidden by the chalice and paten, and that of *Germany*, showing the imperial eagle on the shield. Statues of both cousins stand in the hollows of the pilasters. Above them, inside the laurel wreaths, are portraits of Emperor Ferdinand II and Philip IV, under whose protection victory had been obtained. Standing on the chariot and carrying two crowns and two palm leaves in her hands, representing the Infante's youth, the winged *Aurora* crowns the arch. Trophies with prisoners are raised on both sides, and at either end, the brothers Castor and Pollux hold horses with one hand and triumphal banners with the other. (Fig. 10)

On the rear side of the arch, Cardinal-Infante Don Ferdinand appears dressed in ceremonial armour with a red sash and leading a chariot of white horses with his face illumiated, while *Victory* crowns him with a laurel. At the front they triumphantly carry the statue of the city of Nördlingen. On both sides of the chariot, prisoners walk with their hands tied in front of them between soldiers with badges and trophies. At another *Victory* appears in the air with the trophy and the palm, accompanied by *Hope* of new conquests¹¹. On either side stand the statues of *Honour*, holding the horn of abundance; of *Virtue*, with the skin of a lion and the mace of Hercules; of *Liberality*, shedding coins from the horn; and of *Providence*, holding the globe on the rudder. Below them we find the medallions of *Nobility* to the left and *Youth* to the right, both alluding to Don Ferdinand's qualities. At the top of the front part, in the very centre, shines the planet Venus, crowned with laurel and with a star on her forehead, raised in the air by the winged *Pegasus*. On both sides, winged *Victories* present prisoners in chains and a series of trophies. (Fig. 11) Nearby, at the Melkmarktplain, the Doric arch dedicated to the god Janus stood out from the rest.

¹¹ This triumphal image recalls the series of the *Life of Constantine*, the cycle of *Henry IV of France* or the set of tapestries destined for the convent of the *Royal Convent of the Discalced Clares of Madrid*, among which the *Triumph of the Eucharist* stands out.



FIG. 10. *The front face of the Arch of Ferdinand.* Biblioteca Digital Hispánica, Biblioteca Nacional de España, *Pompa introitus honori serenissimi principis Ferdinandi Austriaci Hispaniarum infantis S.R.E. Card Belgarum et Burgundionum gubernatoris ... a S.P.Q. Antwerp. Drecreta et adornata, cùm mox à nobilissimâ ad Norlingam partâ Victoria Antuerpam auspicatissimo audentu suo bearet XV Kal. Maii, ann MDCXXXV*, p. 142. <http://bdh-rd.bne.es/viewer.vm?id=0000051898>



FIG. 11. *The rear face of the Arch of Ferdinand.* Biblioteca Digital Hispánica, Biblioteca Nacional de España, *Pompa introitus honori serenissimi principis Ferdinandi Austriaci Hispaniarum infantis S.R.E. Card Belgarum et Burgundionum gubernatoris ... a S.P.Q. Antwerp. Drecreta et adornata, cùm mox à nobilissimâ ad Norlingam partâ Victoria Antuerpam auspicatissimo audentu suo bearet XV Kal. Maii, ann MDCXXXV*, p. 155. <http://bdh-rd.bne.es/viewer.vm?id=0000051898>

The Stage of Mercury: the request by the City of Antwerp

Towards the Scheldt River, next to the bridge of San Juan, another monument of a rather rustic nature was made with materials from the sea. In the centre, a female figure representing *Antwerp* lamented the almost total loss of navigation and commerce. As Don Ferdinand passes, she begs him to stop *Mercurio*. The latter in his role as god of commerce and with the caduceus in his hand, lifts one foot in an unequivocal sign of his intention to leave. Next to *Antwerp*, an idle and melancholy helmsman leans against an overturned ship, with its anchor and rudder on the ground. In front of him the *Scheldt River* is seated, dozing over fishing nets and leaning on a vessel. He appears with his feet in chains. This central picture is positioned in the middle of a large arch on which the head of *Ocean* is hung depicted with a beard and wet, dripping hair. Above *Ocean* is a globe and even higher the god *Neptune* shown with his trident and a rudder, sitting on a breakwater and accompanied by dolphins. Beside him sits *Amphitrite* with the horn of happiness in one hand and the other resting on the mask of a ship. On both sides, two tritons sound the conches holding the city's flags, in memory of the time when Antwerp was a prosperous and commercially active city thanks to navigation.

In another scene, *Opulence* is represented on the right of *Antwerp* sitting on top of goods and scales into which *Abundance* drops all kinds of riches from her horn. *Poverty* appears on the left and is seated in a torn dress with a distaff and spindle, feeding roots and herbs to Cupid. To her side is a sailor who holds a trident in his hand and touches his hair. On the right is *Como*, the god of banquets and dancing, who appears dressed in fur with a bridal torch and a bunch of grapes in his hand. *Industria* is on the left rubbing dry branches to revive the fire. (Fig.12)

In conclusion, from the *Stage of Welcome* to the *Stage of Mercury*, the ephemeral structures described were devised, first, to thank the Cardinal-Infante for his visit and, second, to establish an sequence of depictions through which he was invited to reflect on the responsibility of his new position, the



FIG. 12. *The Stage of Mercury*, painted by Peter Paul Rubens, oil sketch. Rupert Martin, John. 1972. *The decorations for the Pompa Introitus Ferdinandi*. Corpus Rubenianum Ludwig Burchard, part XVI. Belgium: Phaidon, p. 359.

House he represented, the role of his predecessor (Isabella Clara Eugenia) and what the city -once rich and prosperous, now weak and without economic resources- expected of his government.

As governor of the Netherlands and following his victory in Nördlingen, Ferdinand of Austria made several triumphant entries all over the country. One of the most magnificent was his reception in the city of Ghent on 26 January 1635 (Vlieghe 1969; Lloret 2018). However, this was actually the continuation of a tradition. Various members of the Habsburg dynasty had already been received with great pomp following their appointment as rulers of the Netherlands or Portugal (Philip I, Ernest of Austria, Philip III, Archdukes Alberto and Isabella, etc). For the royalty of that period, public celebrations were the best form of propaganda for spreading the image of a virtuous prince and exemplary ruler. The model of representation employed by the Habsburgs was based on a mixture of the classic sobriety of the Trastámaras dynasty¹² and the Burgundy tradition, replete with exquisite symbolic luxury. Emblems, companies, hieroglyphs, currencies, attributes, symbols, allegories and the like were all popular means of creating and disseminating the new image (De la Torre 2000, 15-23), that can be seen in the Triumphal Arches of Antwerp. An examination of these and other elements confirms that we can indeed speak of an iconology of Habsburg power in Europe.

BIBLIOGRAPHY

- ALDEA VAQUERO, Quintín. 2008. *España en Europa en el siglo XVII. Correspondencia de Saavedra Fajardo*. Tomo III: El cardenal infante en el imposible camino de Flandes, 1633-1634. Madrid: Consejo Superior de Investigaciones Científicas-Real Academia de Historia, 2 vols.
- BELLORI, Giovan Pietro. 2005. *Vidas de pintores*. Madrid: Ediciones Akal.
- DE LA TORRE GARCÍA, Encarnación. 2000. "Los Austrias y el poder: la imagen en el siglo XVII". *Historia y Comunicación Social*, nº 5: 13-29.
- DÍAZ PADRÓN, Matías. "Rubens y satélites bajo la égida de los Austrias". 2008. In *Arte, poder y sociedad en la España de los siglos XV al XX*, edited by Bravo Cabañas, Miguel; López-Yarto Elizalde, Amelia; Rincón García, Wifredo: 233-252. Madrid: Biblioteca de Historia del Arte, Consejo Superior de Investigaciones Científicas.
- DOCAMPO CAPILLA, Javier. 2010. "El fondo antiguo de la Biblioteca del Museo del Prado". In *Biblioteca Artis. Tesoros de la Biblioteca del Museo del Prado*. Exhibition catalogue, edited by Docampo Capilla, Javier: 11-21. Madrid: Museo Nacional del Prado.
- ESTEBAN ESTRINGANA, Alicia. 2015. "Los estados de Flandes en el futuro político de los infantes. La designación del Cardenal Infante don Fernando para la lugartenencia real de Bruselas". Martínez Millán, José and Hortal Muñoz, José Eloy (ed). *La corte de Felipe IV (1621-1665). Reconfiguración de la Monarquía católica*. T. I, vol. 3. Madrid: Polifemo Ediciones: 1615- 1678.
- GARCÍA SÁNCHEZ, Laura. 2008. "La Corona versus Cataluña: don Fernando de Austria y las polémicas Cortes de Barcelona de 1632". Pedralbes, Revista de Historia Moderna, nº 28: 203-216.
- HOUBEN, Birgit in ed. Vermeir, René et al. 2011. "Una Corte para un príncipe. La política militar de Olivares y la Corte bruselense del cardenal-infante (1634-1641)". *Agentes e identidades en movimiento. España y los Países Bajos. Siglos XVI-XVIII*. Madrid: Sílex Ediciones: 151-170.
- ISRAEL, J. "España y los Países Bajos Españoles durante la época de Olivares, 1621-1643". Elliott, J.H. and García Sanz. A. (ed.). *La España del conde-duque de Olivares*. Valladolid: Universidad de Valladolid, 1987: 111-127.
- LLORET SOS, Isabel María. 2018. "La entrada triunfal del Cardenal Infante en Gante: Triumphalis introitus ferdinandi". *Potestas [en línea]*, nº 13: 77-100
- MINGUEZ, Víctor. 2001. *Los reyes solares. Iconografía astral de la monarquía hispánica*. Valencia: Publicaciones de la Universitat Jaume I, Col.lecció "Humanitats": 132-133.
- MULRYNE, J.R et al. 2015. *Ceremonial entries in Early Modern Europe. The iconography of power*. Farnham, Ashgate Publishing Company.
- RIPA, Cesare. 2007. *Iconología*. Madrid: Akal.
- RUPERT MARTIN, John. 1972. *The decorations for the Pompa Introitus Ferdinandi*. Corpus Rubenianum Ludwig Burchard, part XVI. Belgium: Phaidon.
- SOLY, Hugo. 1984. "Plechtige intochten in de steden van de Zuidelijke Nederlanden tijdens de overgangs van Middeleeuwen naar Nieuwe Tijd: communicatie, propaganda, spektakel". *Tijdschrift voor Geschiedenis*, 97: 358-359.
- VLIEGHE, Hans and Dhondt, J. 1969. *Stadsversieringen te Gent in 1635 voor de blijde intrede van de kardinaal-infant*. Gent: Oudheidkundig Museum Abdij van de Bijloke.

¹² Minor branch of the reigning House of Burgundy. It reigned with the Crown of Castile from 1369 to 1555; the Crown of Aragon from 1412 to 1555; the Kingdom of Navarre from 1425 to 1479 and from 1512 to 1555; and the Kingdom of Naples from 1458 to 1501 and from 1504 to 1555.

THE PARAPHERNALIA OF A ROYAL WEDDING: LITERARY SOURCES OF THE NEW KING PHILIP'S III MARRIAGE*

MÓNICA MARTÍN MOLARES

Universidade da Coruña

monica.martin.molares@udc.es

* This work has been conducted within the framework of the project *Biblioteca Digital Siglo de Oro 6* (BIDISO 6), reference: PID2019-105673GB-100, financed by the Ministry of Science and Innovation of the Government of Spain from 01/06/2020 to 31/05/2023, part of the Group with Growth Potential HISPANIA (G000208) at the Universidade da Coruña.

ABSTRACT

This work will shed light on a celebration that took place at the beginning of the Baroque period: the double royal wedding of King Philip III to Margaret of Austria and of Princess Isabella Clara Eugenia to the Archduke Albert, whose union would be ratified on the Valencian coast.

Through studying the texts of this era, we have more detailed knowledge of both the organisation and the subsequent development of the royal entrances and marriages. Not a single ceremonial detail typical of these festivities was to be missing: the use of public space, the display of symbolic ornaments, the keeping of order, the processions and cortèges, the rejoicing of the public, etc. Ultimately, thanks to the numerous news pamphlets and preserved document archives, we will attempt to reconstruct this Baroque festival.

KEYWORDS: BAROQUE FESTIVALS, ROYAL WEDDING, PHILIP III, NEWS PAMPHLETS.

RESUMEN

En el presente trabajo se desentraña una fiesta en los inicios del Barroco; en concreto, las dobles bodas reales entre Felipe III y Margarita de Austria y la infanta Isabel Clara Eugenia y el archiduque Alberto, cuyo enlace se ratificaría en la costa valenciana.

A través del estudio de los textos de la época conocemos más al detalle el sinfín de circunstancias que rodearon tanto a la organización como al posterior desarrollo de las entradas regias y casamientos, en los que no faltó ningún detalle del ceremonial típico de estos fastos: la utilización del espacio público, el despliegue de ornamentos simbólicos, el mantenimiento del orden, las comitivas y cortejos, el regocijo popular, etc. En definitiva, gracias a las numerosas relaciones de sucesos y documentos de archivo conservados intentaremos reconstruir esta fiesta barroca.

PALABRAS CLAVE: FIESTAS BARROCAS, BODA REAL, FELIPE III, RELACIONES DE SUCESOS.



Majestades, altezas, señorías,
arcos triunfales, raras invenciones,
ricas libreas, piezas, perlerías,
gallardetes, banderas y pendones.
Artillería, fuegos, armonías,
remota gente, incógnitas naciones
inclinados resciben con gran gusto
tan justa esposa deste Rey tan justo.

1. Introduction

This is one of the many literary compositions made for the marriages of Philip III and Margaret of Austria (Fig. 1) and of Princess Isabella Clara Eugenia and the Archduke Albert (Fig. 2). In it, the key features of a royal wedding are described: the presence of great figures, the construction of ephemeral architecture, adornments in the city and attire, fireworks, music and revelry, and so on.

This composition, like other ephemeral texts, was placed along the route that the monarchs would have taken to enter the city. Such texts would have been fixed to doors, distributed from one person to another or displayed on arches or other structures. Their content has survived to the present day thanks to some sources from the time, including the well-known news pamphlets (*relaciones de sucesos*).¹ These works² reflect on these celebrations at great length. We are apprised of the detail of the ephemeral constructions, as well as the texts which were fixed to them for the delight of the public,³ thus attesting to the use of this literature as a tool for those in power.

In this way, we are able to read verses that were distributed throughout the city, as royal celebrations were a source of generating culture (artistic and literary) that appealed to the senses (visual, auditory, olfactory, etc.). This was magnified when the celebrations in the palatial halls moved to the streets, by way of the public. Hence, it is affirmed that the urban centres were transformed, and that the city was decorated to receive the monarchs with impressive displays and an extraordinary array of ephemeral elements. Furthermore, the



FIG. 1. Pedro Perret (attributed to the Flemish School of the Sadeliers), [Portrait of Philip III and Margaret of Austria], 1598? (National Library of Spain, sign. IH/2947/25).

¹ Ruiz Astiz y Pena Sueiro recently reflected on this product and editorial genre, coming to understand through news pamphlets "aquel texto breve, informativo y de carácter no periódico que surge casi de forma inmediata al hecho acontecido" (2019, 375), although presenting nuances and other peculiarities which extend this brief definition.

² We will consider the news pamphlets printed in 1599 on the occasion of the betrothals, which took place that same year in Valencia. There is an abundance of documents in existence that were intended to perpetuate the ratification of this double marriage (see Martín Molares 2019), but we will focus on four that are longer and contain more information on the relevant events: *Fiestas de Denia*, by Lope de Vega; *Fiestas nupciales que la ciudad de Valencia hizo al casamiento de Felipe III*, by Gaspar Aguilar; the *Tratado copioso y verdadero de la determinación del*



FIG. 2. Jan Collaert, [Portrait of Princess Isabella Clara Eugenia and the Archduke Albert], 1600 (National Library of Spain, sign. ER/647 (28); IH/718/7).

public ceremony, the focus of which was the exaltation of the monarch, was of such importance that the entire kingdom was affected.

2. Preparations for the marriage

After the death of King Philip II on 13 September 1598, the new king — Philip III — was faced with some important decisions. The first of which was to celebrate his wedding with Margaret as soon as possible. Thus the proxy marriage took place in Ferrara at the beginning of October. Another decision concerned the place at which the union should be celebrated.⁴ The Marquess of Denia⁵ played a crucial role here (Fig. 3). It is indisputable that he wanted to distance the king from his biggest rivals. He planned to ingratiate himself with the monarch while he feasted in his Valencian domain, surrounded by his closest collaborators. We must also take other factors into account, such as the richness or abundance of the city, its gardens and scenic orchards, its gentle climate and its proximity to the sea. This created ideal conditions for both Denia and Valencia to carry out diverse maritime activities like galley trips, fishing and the depiction of naval combat. These reasons were marshalled in news pamphlets such as the *Tratado copioso* (Fig. 4) or the *Relación de las fiestas* by Gauna, who adds the proximity to Madrid as another point in the area's favour:

Y por mejor decir, vinieron a envidiar tan señalada merced hecha por su rey a tan noble ciudad de Valencia, todo lo cual pudiera mover su real ánimo a venir a ella fue estar el mar más cercano de la villa de Madrid, donde asiste su real corte y su majestad gozar más presto y con mejor oportunidad la presencia tan esperada de la majestad de la reina doña Margarita (1602, cap. II).

gran monarca Felipe II para el casamiento del III con la serenísima Margarita de Austria, and the manuscript work of Felipe de Gauna, Relación de las fiestas celebradas en Valencia con motivo del casamiento de Felipe III.

³ That being said, one should bear in mind that these news pamphlets are texts which, generally, were written on commission, with the point of including excessive embellishments of certain people as well as omitting or falsifying information. Therefore, comparison of the information contained in the news pamphlets with that contained in the archival documents has been considered indispensable, such as those encountered in the documentary series *Pregons i crides* from the Archivo Municipal de Valencia (AMV).

⁴ For the different options that they considered and the intricacies related to the choice of location, see Pérez Samper (1999, 82), García García (2004, 34-38) and Chamorro Esteban (2012).

⁵ Francisco Gómez de Sandoval y Rojas (Tordesillas, 1553 — Valladolid, 1625): 5th Marquess of Denia, 4th Count of Lerma (and, after 1599, 1st Duke of Lerma), Viceroy of Valencia (1595-1597) and favourite of King Felipe III (1598-1621). The Marquess played a major role in this event, as recorded in various news pamphlets: "Paresciéndole a Su Majestad Real que importaba mucho en hacer elección de lugar y ciudad competente para celebrar el auto de mayor grandeza y gusto a Su Majestad que acá le podía dar el cielo, aconsejado de don Francisco Sandoval y de Rojas, marqués de Denia y su camarero mayor, como quien sabía mejor lo que a Su Majestad Real le importaba para este efecto, escogió para ello la noble ciudad de Valencia" (Gauna 1602, cap. II).



FIG. 3. Pedro Pablo Rubens, Equestrian portrait of the Duke of Lerma, 1603 (Prado Museum).

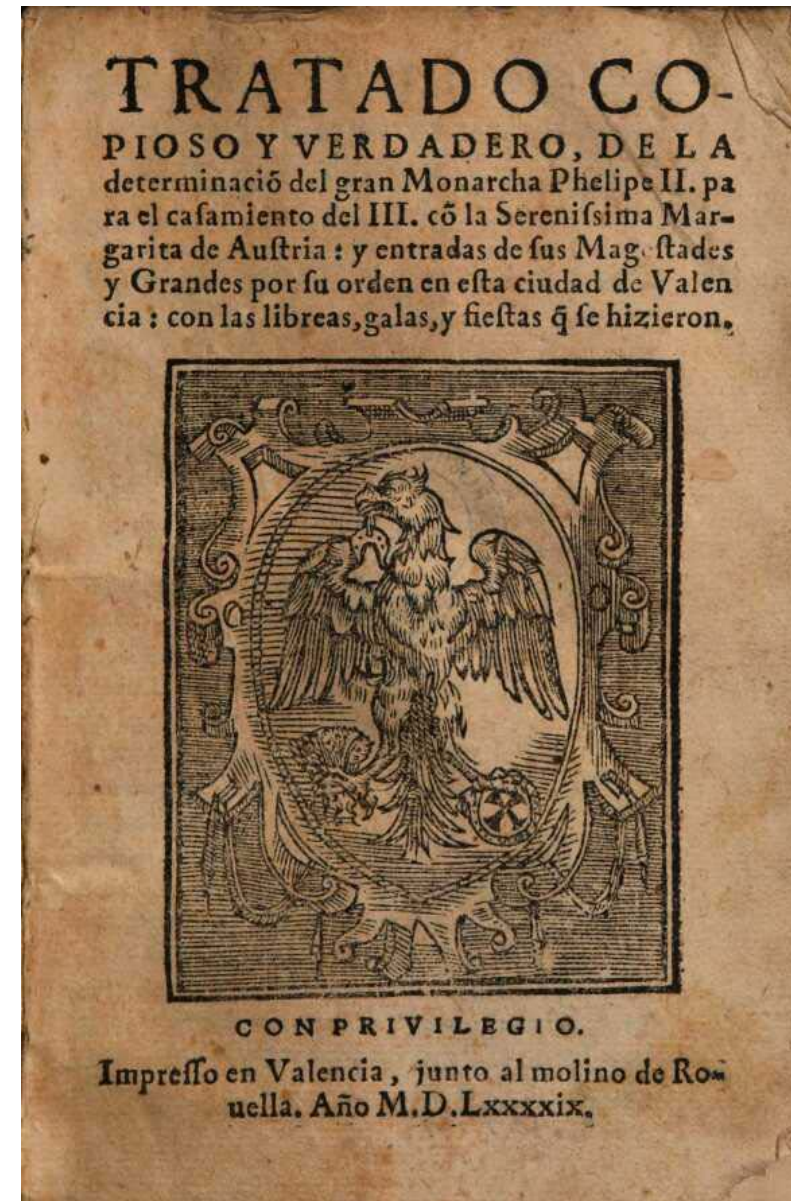

FIG. 4. *Tratado copioso y verdadero de la determinación del gran monarca Felipe II para el casamiento del III con la serenísima Margarita de Austria...* (Österreichische Nationalbibliothek, sign. 60.L.37).

It is evident that the designation of the city was a momentous decision as it benefitted not only the city itself, but also its nobility. The latter aspired to obtain the grace and privileges which the monarch could bestow them in future (such as noble titles, positions at court and other such benefits). Recognition and power were sought, and this circumstance was used as context for negotiations.

Likewise, it was an honour for any people to receive their king. To that end, public spaces were tidied up, as we will see. The choice of city was undoubtedly fundamental to the subsequent development of the upcoming celebrations, as the lucky city would not only be the scene of a historic occasion,

but would also acquire a significant role at the heart of the monarchy.

2.1. The city dresses up as it waits for the royal arrival

In addition to the decoration involved in these celebrations, the city underwent a series of transformations which were not as ephemeral as the arches that it built. Some of the modifications made for the royal receptions have stood the test of time. The celebration thus became a context for carrying out certain urban reforms, as we will see in the Puerta del Real. Furthermore, the planners did not only erect structures, but also eliminated obstacles of all kinds, such as benches that would have hindered the passage of the royal procession towards the city:

La ciudad de Valencia [...] puso grande diligencia en pulir y hermohear todas las calles y plazas, no solo las principales, pero aun las ordinarias, mandando quitar todos los bancos de las puertas de los oficiales y otras casas, sin excepción de personas, para que con menos trabajo las carrozas y coches, sin impedir ni enojar la demás gente, pudiesen caminar (Tratado copioso 1599, cap. XII).

They carried out expansion and remodelling work on plazas, such as Predicadores. An enclosed plaza, although wide and spacious, became the ideal venue for the celebrations: a space “transmutado durante el tiempo de la fiesta en lugar teatral” (Ferrer Valls 1991, 27). It was necessary to have an open space in which the different constructions could be erected. This would facilitate the celebration of different festivities and games in a place where the spectators could enjoy them, as it was necessary to accommodate the multitude of spectators as well as the participants. For this, they used tribunes, terraces and stages. In the plaza del Mercado, for example, levelling work was carried out so that carpenters could install “un tablado de madera desde la Lonja hasta la zona del convento de la Merced, que lograrse crear un recinto cerrado donde los caballeros competirían por el triunfo” (Juliana Colomer 2017, 222). The terraces and tribunes, that would accommodate

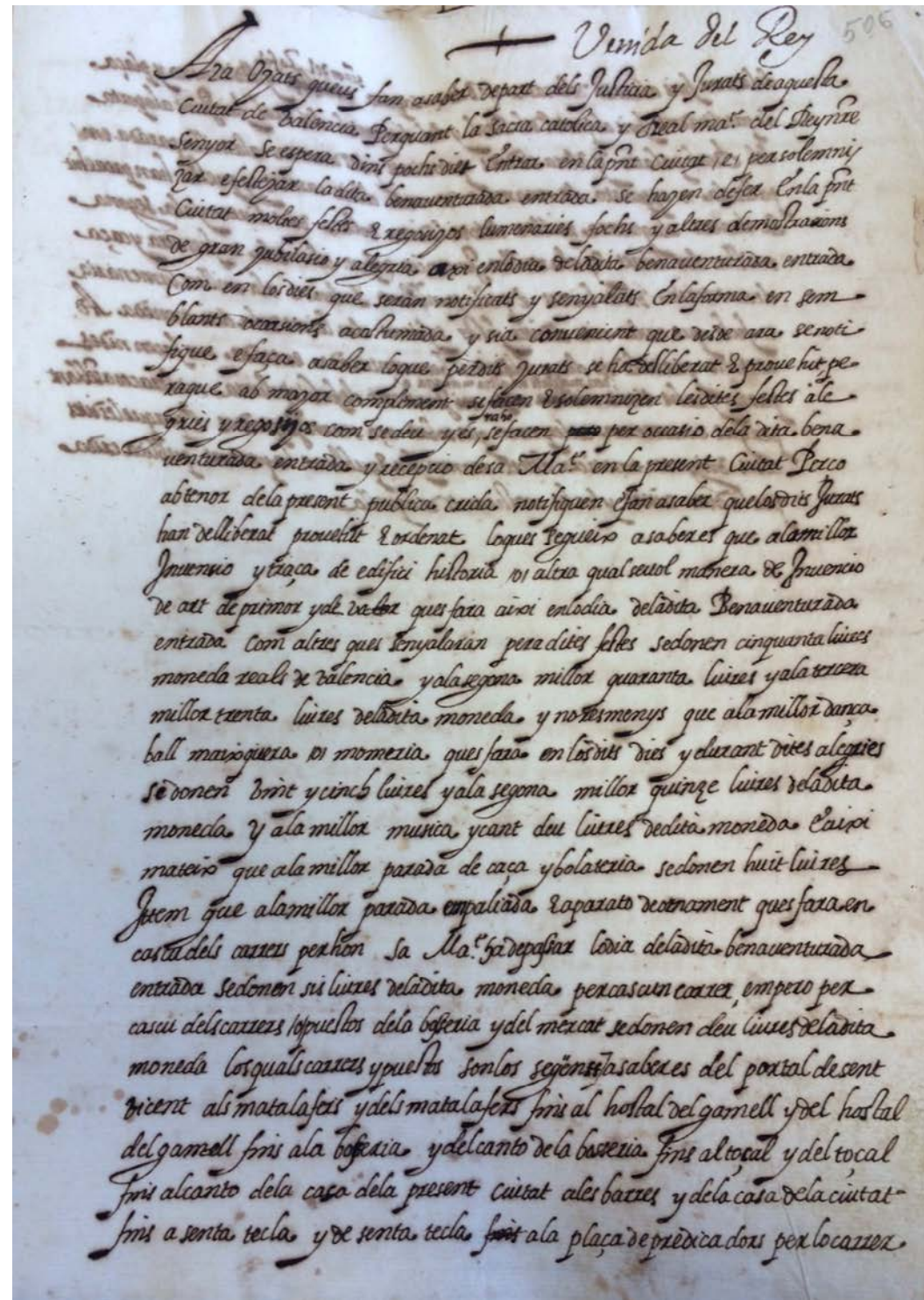

FIG. 5. Venida del Rey (AMV. Pregons i Crides, sign. xx — 2/2 (1579-1601), folder 1599, fol. 506

some members of the public, although not all, enclosed the stage. The celebrations could be enjoyed from anywhere:

Cuando ya fue mediodía, la codiciosa gente de ver esta jornada comenzó a ocupar las ventanas, terrados, tablados y demás, puestos con tanta priesa que ya a la hora que he dicho no había lugar alguno por ocupar. Y fue tanta la gente

que a verlo acudió que quien miraba desde lo más alto de las casa y tablados, tan cubierto de gente y tan apretada hasta lo último y más bajo (*Tratado copioso 1599*, cap. XXII).

The balconies and windows of houses were decorated to create the sense of theatrics necessary for the progression of the festival. Decorations were added to key buildings and the streets were tidied up so that the entire parade and cortège could pass through. Residents were requested to clean, arrange and decorate their houses, and offered monetary incentives in order to achieve a better visual spectacle, as we can read in one report: “publicáronse premios para quien mejor y con más riqueza haría ostención de su tienda” (cap. XII). The pecuniary assistance granted to the royal entrances may have been substantial. Thus, we read in a *crida* dated 26 January 1599 about the coming of the king, that they awarded (Fig. 5): for the best creation, 50 *lliures*; for the best dance or mask, 25 *lliures*; for the best music and song, ten *lliures*; for the best lights or fires, ten *lliures*; for the best-decorated streets through which the royals would pass, six *lliures* (unless it was the streets or stalls of the Bolseria and the Mercado, in which case the prize would be ten *lliures*); and so on.

2.2. Development of the iconographic programme

The development of the iconographic programme for these celebrations was undertaken by people of importance during that era. The participants thus included famous architects and painters, along with prestigious writers. They were tasked with the creation of elements that would fulfil a double function: to win the delight of the social class and to serve as propaganda for the exaltation of the monarchy and local nobility. In this case, the documental archives recount the commissioning of Gaspar Aguilar⁶ and Dr. Jerónimo Virués to develop the elements that would make up the setting for the city, such as the distinctive octaves and other verses that could be read on the arches or the *rocas valencianas*.

With the preparations made, Philip III left Madrid with his entourage at the end of January to receive his wife, who had crossed Italy after leaving Graz, and was travelling from Genoa

to Sagunto by sea.⁷ He was entertained in different localities in the Kingdom of Valencia. Such was the dedication with which the Valencians paid homage to their new monarch that they placed two of the ten arches which are described in the news pamphlets of the king's entrance in Denia. The first of these, at the very gateway to the city, “estaba contrahecho de alabastro y mármol”, while the second, in the area of the castle, was of made of myrtle and oranges — trees and shrubs typical of the region. The streets were frequently decorated with floral and vegetal elements and the arches structures were covered with interlaced branches. This same device was frequently repeated in Valencia, at the entrance to the Bolsería. The reason for such decoration was mainly the fact that it was an inexpensive yet impressive resource, pleasant to both sight and smell (Rodríguez Moya 2011, 734). Likewise, they had affixed four octaves to each pillar of this arch, in which “se rememoran los méritos heroicos de los antepasados del [duque]: Sando, Gutierre, Gómez de Sandoval, Diego de Sandoval [...]” (García García 2004, 60). Here literature is clearly being used as part of a strategy of power.

Leaving the arches of Denia aside, on 19 February Philip III made his entrance into Valencia, where eight more structures had been erected:⁸

Adornó mucho también en esta jornada de la entrada de su majestad y alteza los tan suntuosos y triunfales arcos y portaladas que había por las calles principales y plazas de la ciudad, por donde habían de pasar, los cuales mandó hacer la ciudad a sus costas, no menos curiosos por sus pinturas y versos como muy gallardos y vistosos por sus grandes edificios (Gauna 1602, cap. XV).

The first to receive him was the triumphal arch in the Puerta de San Vicente, upon which, James I, Philip I, Remus and Hercules were depicted, each one with verses exalting

⁶ Lope de Vega also recognises the authorship of this poet in the verses that describe the Arch of Denia: “De murta y de naranjo dio la entrada, / en un arco gentil un verde mayo, / Diana en él, con más primor pintada / que cuando el agua le sirvió de rayo; / la viga en otra parte levantada / estaba el Sando, que valió a Pelayo, / y en dos festones, como mármol tersos, / de Aguilar ingenioso algunos versos” (vs. 417-424).

⁷ A record is made by Andrés Renales (2016) of Queen Margaret's journey with her entourage in 33 news pamphlets published in Italy. In addition to the 13 news pamphlets of the series based in Ferrara (narrating the marriage by proxy in that city), the rest correspond to publications about different Italian cities through which she passed with her entourage. The news pamphlets focus on her entrance to each city, in which she was received with every kind of celebration and decoration: Verona (2 news pamphlets), Venice (1 news pamphlet), Mantua (3), Cremona (2), Milan (4), Pavia (1) and Genoa (1). We could add to this list another, printed in Cremona, in which the itinerary through Italian lands is documented (*Narratione del viaggio cominciando da Ferrara, Ostiglia, Mantova, Cremona et Lodi per sino a Milano...*) and the other 5 news pamphlets about Queen Margaret's journey from Genoa to Spain and her arrival in Valencia.

⁸ Rodríguez Moya (2001) analyses the arches of the entrance of Philip III.

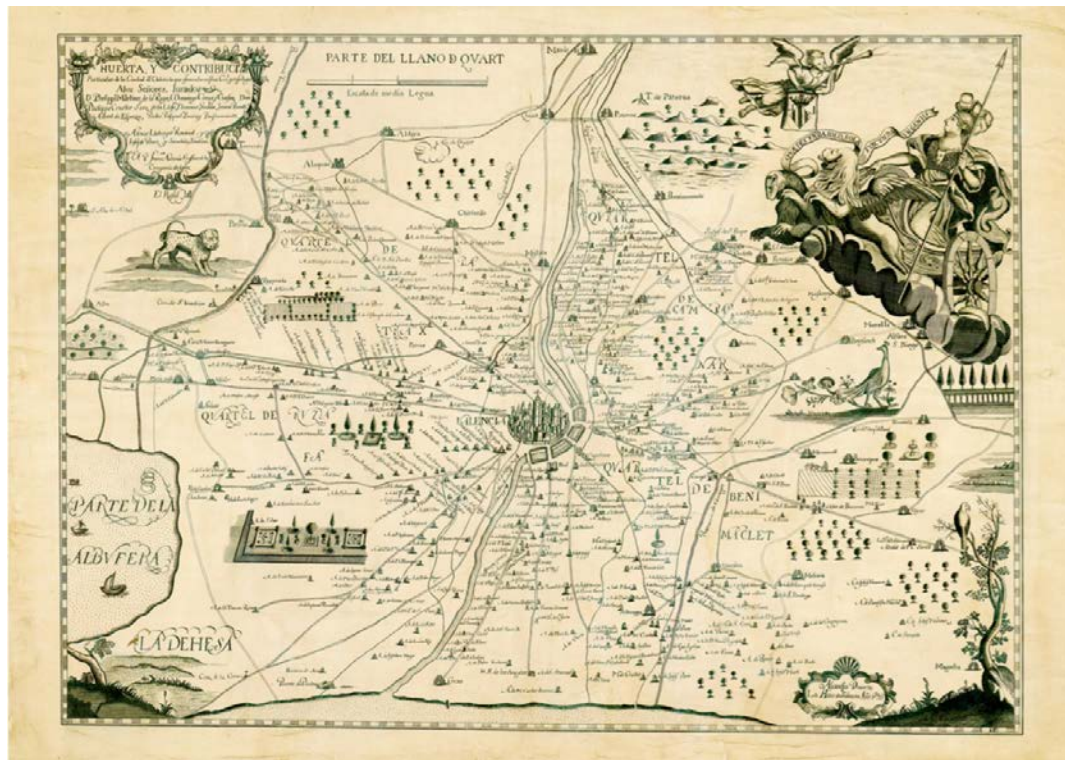

FIG. 6. Francisco Antonio Cassaus, *Huerta y contribución de la ciudad de Valencia*, 1695 (edited by the Societat Bibliogràfica Valenciana Jerònima Galés, 2014)

exalted their valour and heroics. After entering the Puerta de San Vicente and continuing along the street of the same name, he encountered a beautiful and striking Ionic arch. The news pamphlets merely mention that this was of great stature: “sobrepujaba todas las casas de aquel contorno”. On its façade was the city’s coat of arms, which consisted of a rhombus with four stripes in royal red on a golden field, topped with the royal crown. The following arch, situated in the middle of the Mercado, is described in greater detail. This *arco trajónico* was larger than the others, as it was in a space better able to accommodate such dimensions. This temporary structure was adorned with four paintings, two on each side, depicting Alexander the Great, Priam, Time and Fame. At the entrance to the Bolsería, as mentioned above, they encountered another arch of myrtle and oranges. In this case, Gauna described it as an “arco triunfal, de madera, muy bien trazado con sus frontispicios, cornisas y pirámides [...] guarnecido todo de arrayán o mirto verde, naranjas y cidras amarillas” (1602, cap. XVI). Wood, the material for chosen

its creation, was frequently used for the fabrication of this ephemeral architecture, together with papier-mâché.

Both the arch of Tozal and the construction in the Plaza del Campanario were striking creations. The first was a very tall building in the style of an altar with an allegory of Valencia: the personification of the Turia River. On one side were the patron saints of the city, Saint Vincent of Saragossa and Saint Vincent Ferrer, while on the other were Brother Luis Beltrán and Brother Nicolás Factor, with the motto: “más allá, protegen” (*ULTRA QUE TUEOR*). The second creation, in the Plaza del Campanario, was formed of two large trees supported by two giants, who brought together the ends of the branches above. The fruits of these trees, depicted as characters with crowns and royal insignia, represented each of the towns and places of the kingdom of Valencia (Fig. 6). In the middle were the arms of Valencia, at the head of all of them.

Now, as if to finalise this tour, another Ionic arch was built at the entrance to the Plaza de Predicadores, although barely any detail is given. Lastly, the retinue made its way towards the Palacio Real, by way of the Puerta del Real, which had paintings on every one of its towers. On the part facing the city was Saint Louis and Charlemagne, while on the outer facing side (the palace side) were Carlos V and Philip II.

As mentioned previously, not all of the constructions that were built were temporary, as not all of the architects who adorned or furnished the city designed their work to be transient. On occasion, they used large-scale events to create structures that changed the configuration of the city itself. This was the case with the “Puerta nueva del Real”, which was moved several metres so that it coincided with the Puente del Real and thus connected the Palacio Real and the Plaza de Predicadores (Fig. 7). They wanted to finish the construction in time so that the monarchs could enter through it as it was:

Y fuera della se dio gran prisa en acabar y perficionar la linda obra de la puente nueva que se pasa por el río Turia de la ciudad al Palacio, de tal modo que en breves días fue acabada del todo, y para mas perficionar la dicha puente del Real se derribó un pedazo de muralla de la ciudad de

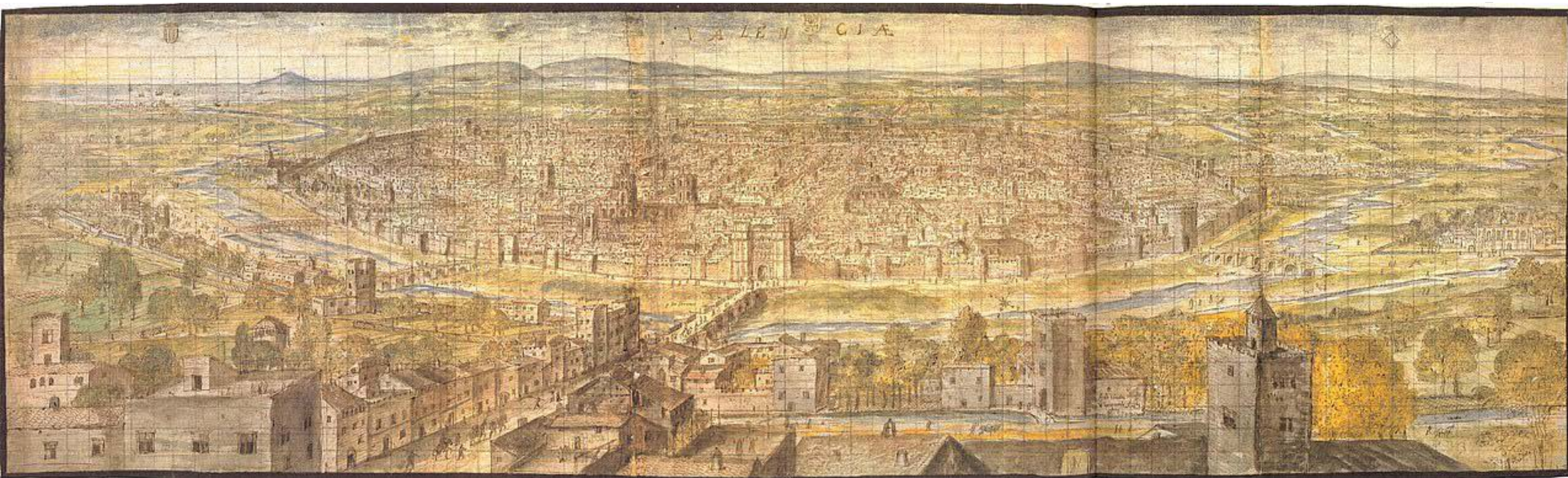

frente de la misma puente, donde se fabricó y labró en muy breves días para presente una espaciosa, alta y ancha puerta para la ciudad, toda labrada de ladrillo y cal muy firme, con sus grandes puertas de fina madera, bien labrada, que para delante se ha de labrar de una grande y extraña traza de piedra picada (Gauna 1602, cap. II)

After their entrance, Philip III and his sister Isabella Clara Eugenia enjoyed the celebrations and entertainment while awaiting the arrival of their respective partners, Margaret of Austria and Archduke Albert. Following some months in Valencian lands, Philip III was reunited with his wife Margaret, who finally, on 18 April, made her triumphant entrance into Valencia, taking a different route from that of her husband. She began her entrance through the Puerta de Serranos (on the opposite side of the city to the Puerta de San Vicente, through which Philip III had entered). At this gate she could

contemplate a spectacular three-tiered archway upon which six monarchs were portrayed: King James; King Ferdinand; Emperor Maximilian; Emperor Rudolf; Ernesto, Archduke of Austria; and Archduke Leopold. The aim was to evoke a momentary connection between the past and the present, as all of these figures represented important milestones in the history of Valencia and the House of Austria. Its mere presence was a homage to the family of the future queen.

Besides this arch, there were two other *artificios*, in the Plaza del Mercado and the Puerta del Real. The triumphal arch built in the Plaza del Mercado was of the same dimensions as the one erected in that same location for the entrance of Philip III. Unlike that one, on which Alexander the Great, Priam, Time and Fame were painted, it was mainly adorned with historical paintings of queens. Thus, Margaret could contemplate Rade Gund, Queen of France, and Isabella I of Castile. On the other side were Otho and Etelcrida.

FIG. 7. Antony van den Wyngaerde, *View of Valencia*, 1563. In *Villes d'Espagne* (mss.) (Österreichische Nationalbibliothek, cod. Min. 41, fol. 18. <<http://data.onb.ac.at/rec/AC14451337>>).

While the figures painted to adorn the Puerta del Real for the entrance of Philip III depicted four monarchs, the decoration of this same gate for the entrance of Margaret alluded to four goddesses: Athena, Diana, Juno and Venus. The only consistent figure was that of Charles V, who in this case appeared in two paintings which represented his coronation and the defeat of the Turks by the Christians respectively. The aforementioned goddesses had accompanying verses. The use of these classical mythological references were intended to show the virtues of the queen as well as her obligations.⁹ These served as a model for the perfect married woman.

Lastly, and inevitably given the location in Valencia, the *rocas* featured large during the entrance of Margaret of Austria. These floats, a type of “máquinas alegóricas rodantes” (García García 2003, 160), take on different forms (as carriages or ships) and carried ephemeral architecture and ornaments of all kinds (verses, hieroglyphics and emblems, as well as ingenious pyrotechnics or other fire creations). These temporary installations were to be found all over the city as an intentional visual and iconographic statement steeped in symbolic and allegorical resonance. As indicated in different news pamphlets, they were placed along the route which the queen took so that she could see, on each of them, the individual letters that made up her name. These were accompanied by octaves and representations or allusions, mainly to women of the Greco-Latin tradition whose initials corresponded with the letter chosen for each float. So, for the M they depicted Medea, Marcia, Merfisa and Melpomene; for the A, Artemis, Amalthea, Atalanta and Arachne; and so on for the rest of the letters.

3. Etiquette of the festivities

As we have seen up until now, the programme of celebrations designed for this teeming event was not far from the model established as canonical for celebrations of this nature. The paraphernalia associated with these celebrations — “arquitectura, pintura, escultura, poesía, emblemas, música, canto, danza, teatro, fuegos de artificio”

(Zapata Fernández de la Hoz 2016, 73) — were intended to display an idealised image of royal matrimony and of the benefits that the union could foster for the kingdom, as well as serving as a context in which to entertain the public. We will look at the festivities that concern us for the study of this celebration as an example to understand how such events were celebrated, with reference to the elements common to the news pamphlets consulted.

3.1. The arrival of the monarchs and their royal entrances

The festive programme typically began outside the city with the reception of the dignitaries — in this case, the royal highnesses — on behalf of the representatives of the local, civil and religious powers. A parade began just outside the city and accompanied them with a salute of gunfire from the arquebusiers. So, for example, we read:

En llegando [a Denia] Su Majestad le rescibieron con salva, respondiendo al castillo los arcabuces del escuadrón y en la mar se descubrió una vistosa galeota con otras naves y bajeles que todos ayudaron a la salva [...]. Sonó un súbito rumor de clarines y tiros que alborotaron el mar con una alegre demostración de una batalla (*Tratado copioso 1599, cap. IV*).

Upon the entry of King Philip III and his sister Princess Isabella Clara Eugenia into Valencia, much of the Valencian nobility wished to welcome them to start the celebrations with pertinent hand-kissing. This type of welcome was usually accompanied by the ceremonious handing-over of keys, in which “es bastante frecuente que sea el santo patrón de la ciudad el personaje encargado de ejecutar la ceremonia de entrega de llaves” (Ferrer Valls 1999, 3), as it was in Valencia on the arrival of Philip III. The complexity of this exchange, compared to the much simpler one celebrated in Denia,¹⁰ lay in the aerial machinery and the

⁹ Athena personified prudence and wisdom; Diana was associated with childbirth (and with the city of Denia); Juno is related to fertility and the sanctity of marriage, while Venus is the goddess of beauty and love.

¹⁰ Gaspar Aguilar includes a very brief mention of this exchange in his verses: “Hizieron los cañones reforzados / la salva que se deve a tu grandeza, / dejando a los mortales admirados / de ver como tembló la fortaleza. / De la cual te ofrecieron los Jurados / las llaves, y te fuiste con presteza / a la lengua del agua, que sin duda / de ver tu grave aspecto quedo muda” (1599, canto primero). Lope de Vega, on his part, alludes to the marquess of Denia: “Llegado al fuerte, ríndele las llaves, / gran señora, de Denia vuestro hermano / al César español, que con suaves / ojos le mira y con semblante humano; / al fin responde, en dos palabras graves, / que están bien empleadas en su mano; / y porque en más favores le anticipe, / recibe dentro al Júpiter Filipe” (1599, vs. 465-472).

theatrical representation that accompanied it, with a globe descending from the arch situated in the St Vincent gate, through which they had entered. From this emerged two children, representing St Vincent Ferrer and St Vincent of Saragossa, and began to sing:

**Gran Rey, las llaves tomad,
debidas a vuestros hechos,
de las puertas y los pechos
de aquesta vuestra ciudad.**

(*Tratado copioso* 1599, cap. XIII and *Gauna* 1602, cap. XV)

The royal entrances¹¹ were political acts of great importance in propaganda terms, especially for the queens (Fig. 8). It would have been the first time that the queen, a foreign consort, had come into contact with what would be her people, wanting to win their affection. One should bear in mind that Margaret had had a long journey, during which she had been received in many different Italian cities. In this sense, bigger efforts were needed to impress the queen.

She entered the city under a canopy. The route to the church was full of monuments of ephemeral architecture: three arches and nine *rocas* were placed along the way. As already mentioned, the decorations of this entrance displayed great ingenuity and gave an idealised image of the marriage and the queen as a person.

Once this symbolic act was complete, they began their tour through the city, which received and welcomed them. To a certain extent, we can trace the set order of the royal procession for the entries into the cities through preserved testimonies. These cover everything from their escort by local authorities and the ladies and gentlemen present to descriptions of their attire, their means of transport, and so on. The list of nobles who accompanied the royals highlights the position which they occupied within the procession. The social classes were arranged in a set order, decked out in their finery, following a procedure that “cumplía con su papel dentro de la escala de valores y categorías de privilegios y profesión” (Bonet Correa 1990, 22).

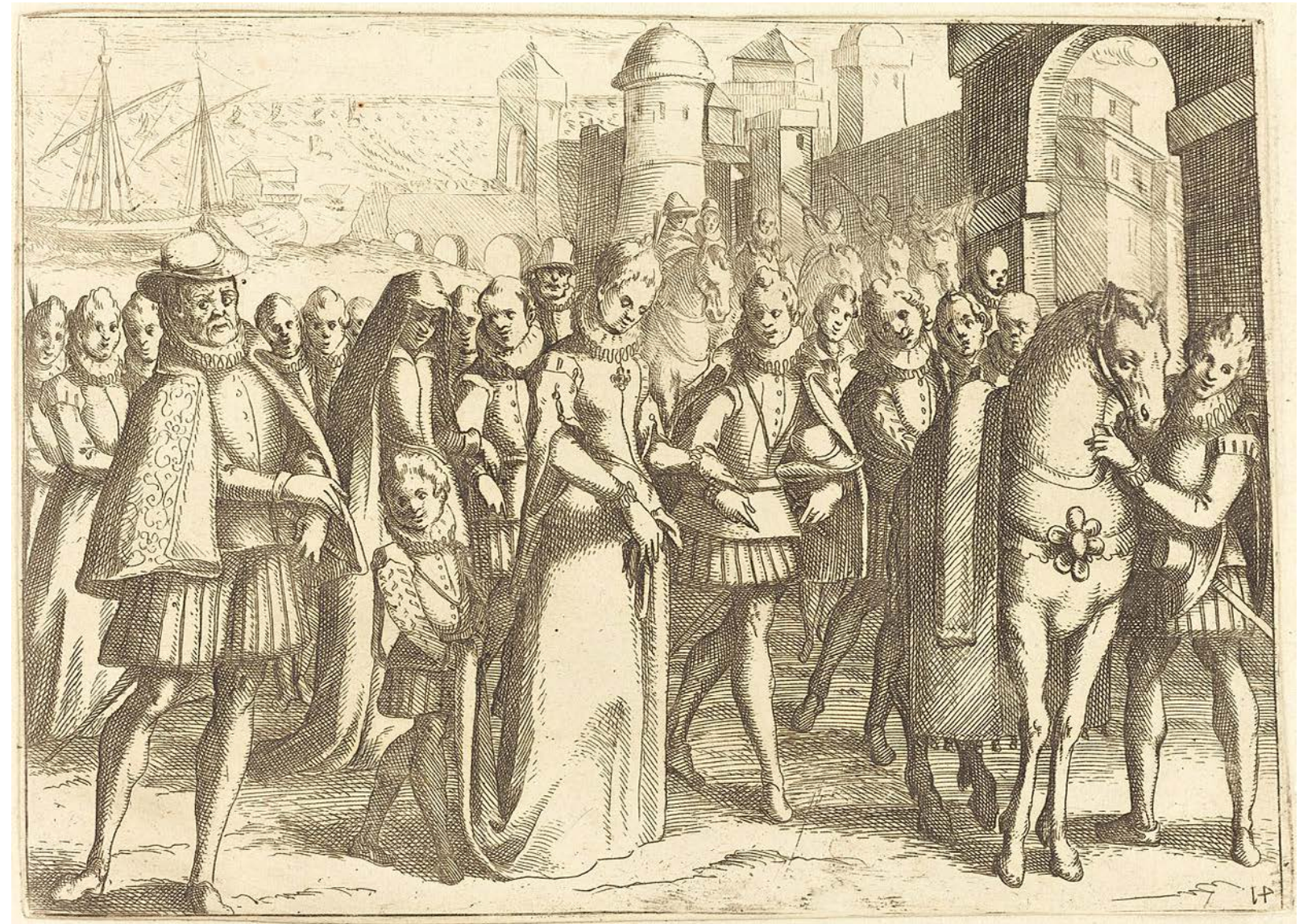

Accompanied by the local nobility and other dignitaries, the royals entered the city under a canopy through the streets, which had been transformed to be fit for such a reception. As the procession drifted through the streets and plazas, it maintained its hierarchy. We must not forget that, although they were entertaining, these acts were also a pretext for showing off, while at the same time presenting the place that they occupied, not only in terms of the physical event, but also in society.

3.2. Battles, jousts and bulls

Everyone wanted to attend and be seen, so they went to the Valencian plazas where the majority of the festivities that followed the

FIG. 8. Jacques Callot, *Margaret of Austria is received in Valencia*. In Giovanni Altoviti, *Essequie della Sacra Santa Cattolica e Real Maesta di Margherita d'Austria Regina di Spagna...* In Firenze, nella stamperia di Bartolommeo Sermartelli e fratelli, 1612, p. 25. (<<https://hdl.handle.net/2027/gri.ark:/13960/t39z9nv6f>>).

¹¹ For more information about the progression of the royal entrances, see Ferrer Valls (1999) or Mulryne et al. (2015). For specific information on the entrance of Margaret of Austria, Labrador Arroyo (2016).

double wedding took place. On Tuesday 20 April, a tournament was held in the Plaza del Real. On Thursday 22, they played combat games on horseback in the Plaza del Mercado, using long sticks called *cañas*. Later that day, bullfights were held. A jousting tournament was held in the same plaza on Saturday 24.

**Después que sus asientos ocuparon
las personas Reales que vinieron,
y que a la placa pública sacaron
toros, que bien sin hacer mal corrieron,
luego, los de la guarda despejaron
gran parte del Mercado porque oyeron
el son de aquella música estremada,
que de las cañas publicó la entrada
(Aguilar 1599, canto tercero)**

Such pastimes brought joy to the masses, and we are able to relive their delight through their news pamphlets. These give a sense of the hustle and bustle, and the roaring excitement that pervaded the city during that period.

Apart from these amusements (bullfights, *cañas* and jousts), there were also representations of battles. These functioned as a reaffirmation of power as well as a type of theatrical combat between good and evil, as in the case of the fight between Moors and Christians or between Turks and Christians. During the monarchs' stay in Denia, before the royal entrance into Valencia, they enjoyed various pastimes, including fireworks, tournaments, mock battles and the attack of a corsair:

Y estando oyendo Su Majestad una comedia, entró un capitán en la sala donde se representaba, con aviso que Morat Arráez estaba en Ibiza con doce galeotas, y que hacían señal las torres que estaba cerca. No pasó adelante la comedia, tocaron a rebato las campanas, alborotose el lugar y castillo disparado mucha artillería. Salieron las cinco compañías de a caballo. Pusiéronse en arma los soldados. Pasose la noche

en este ruido falso [...] hasta que el día descubrió la burla (Tratado copioso 1599, cap. IX).

Comedic performances were a source of great excitement at that time. The presence of comedians in Valencia in the late 16th century and early 17th century was noteworthy, whether in palatial performances or in public places (Ferrer Valls 1993). This fact is substantiated by the news featured in the pamphlets. If we trust what is written in the *Tratado copioso* (1599), it appears that there were three comedy performances, although there may well have been more: “y llegando Su Majestad a Palacio, representó Villalba una comedia” (cap. VII); “el otro día oyó comedia Su Majestad y hicieron los del lugar muchas fiestas” (cap. IX) or “y estando oyendo Su Majestad una comedia, entró un capitán en la sala donde se representaba” (cap. IX).

Some of the celebrations took place in private locations, and due to the brevity of the allusions to them in the news pamphlets we cannot ascertain exactly how many there were. Moreover, the festival coincided with Shrovetide, when nobles would have held soirées in their houses:

Hubo infinitas máscaras en estos días y en particular el domingo de Carnestolendas se celebró un sarao y grande regocijo de muchísimas damas en casa de don Gaspar Mercader, señor de Buñol y baile general [...]. Luego, el día siguiente que se había de celebrar otro sarao en casa el conde de Benavente, volvió Su Majestad a hacerse máscara con dicho conde de Benavente y el marqués de Denia y los demás de la cámara siendo hasta número de deciseis (Tratado copioso 1599, cap. XV).

3.3. The city does not rest: light and sound in the night

Another example of the magnitude of the iconic and festive displays was the light shows. Lighting displays were scattered throughout the festival as a way of adorning the plazas and façades, not only of institutional buildings, but also of residential houses:

Hubo toda esta noche, y las cuatro siguientes, grandes salvas en el baluarte, grandes fuegos y luminarias por la ciudad, grande abundancia de cohetes y piulas, en lo cual se ocupaba toda la gente, por haberse mandado cuatro días de fiestas en señal del regocijo desta jornada [...]. Y no solo la casa de la ciudad, diputación, baluarte y muros estaban adornados con faroles y otros fuegos, pero aún todas las casas de particulares (*Tratado copioso* 1599, cap. XXI).

These lights and fireworks filled the streets and the night skies, as well as the palaces, halls and temples. The displays must have been remarkable, as multiple sources allude to the illuminations, and the idea of night turning into day is an oft-repeated one (Mínguez Cornelles 2016, 12), as we can appreciate in Chapter 15 of the *Tratado copioso* (1599): “quedaron muchos fuegos, ansí enfrente de Palacio como en el puente y por toda la ciudad, con tal orden y abundancia que era muy poca la diferencia entre el día y la noche”, and “ya había grande rato que era cerrada la noche y no se echaba menos su luz por las infinitas antorchas que suplieron su falta”.

The texts evince a desire to vanquish the darkness and fill everything with light. Light and shadow play no small part in the festive world, especially at a time in which the visual was of such importance. The explosion of light and fire, natural or artificial, was all the more enthralling when reflected by a watery surface such as the sea:

Llegaron a la orilla ya de noche. Fue cosa cierto admirable ver la diversidad de ingeniosos fuegos que hubo aquella noche en la villa [...]. Holgose en extremo toda la corte de ver desde el mar los fuegos (*Tratado copioso* 1599, cap. VIII).

Along with light and colour, noise was another stand-out element of the festivities. The noise caused by the pyrotechnic displays was accompanied by the racket of musical instruments such as drums and shots from firearms, such as the arquebus:

Y, visto por los de la villa que ya desembarcaban, los recibieron con mucho aplauso y regocijo de salva, disparando [...] toda la

artillería del fuerte y castillo de Vinaroz correspondiéndoles con la misma salva las galeras, disparando también su artillería al son de muchos pifanos y atambores y, asesegando el estruendo de la artillería, se sentía de las galeras muy suave música de clarines y cornetas (Gauna 1602, cap. XXIX)

In summary, a varied repertoire of festive resources extended the days of celebration even further. Since there was no rest, the programme went on long into the night, showing the importance of the event that the city of Valencia was hosting.

4. Conclusion

All the festive elements that we have mentioned required great ingenuity and craftsmanship. Without a doubt, what stands out most about this wedding is its lavishness, particularly given the ostensible contrast with the politics of the previous monarch (Williams 2009, 24-25). The difference between father and son is apparent from the Valencian celebrations, in which all the aforementioned paraphernalia is combined with the aim of exalting the role of the monarchy. Therefore, most of these representations, present in the festivities, alluded to the greatness of the royalty.

As we have seen, there are certain similarities between the arches designed for Philip and Margaret. Broadly speaking, the ornaments and devices created for both were clearly intended to praise the monarchs and honour their families. The Habsburg Dynasty is practically at the centre of all the allegories shown, as well as a large part of the verses. This would have been particularly effective for propaganda purposes, as part of efforts to enhance the position of the Austrian monarchy, especially in its fight against heresy and in defence of the Catholic faith.

Likewise, we have established the fundamental role of the city, which became a stage for the festive performances. It would have been filled with ephemeral constructions decorated with verses and paintings. The sound of crowds and music, the light of fireworks and torches, and heady aromas

would have engulfed the city. We can assert, then, that the city is another protagonist in this royal celebration, even being used as a symbolic motive in many of the constructions. The configuration of the regional cartography thus becomes significant, as does the exaltation of the public places where the royal entrances and other events took place.

Lastly, it only remains to say that the Baroque culture is one that captivates the senses. Hence, the devices and paraphernalia described were created for the sight. For sound, we have the music and the roar of fireworks. Natural elements such as myrtle and oranges delighted the sense of smell. What about literature? It captivates all of the senses. All of these elements are thus present in the accounts of these double royal wedding celebrations.

BIBLIOGRAPHY

- AGUILAR, Gaspar. 1599. *Fiestas nupciales que la ciudad de Valencia hizo al casamiento de Felipe III*. Valencia: Pedro Patricio Mey, en casa de Agustín Aguilar. [Ed. Carreres Vallò, studied by Francisco Martí Grajales. Valencia: Manuel Pau, 1910].
- ANDRÉS RENALES, Gabriel. 2016. "Relaciones de sucesos italianas y traducciones sobre el viaje triunfal de Margarita de Austria (1598-1599)". In *Cagliari and Valencia during the Baroque Age. Essays on art, history and literature*, ed. Alessandra Pasolini and Rafaella Pilo, 97-110. Valencia: Albatros.
- BONET CORREA, Antonio. 1990. *Fiesta, poder y arquitectura. Aproximación al Barroco español*. Madrid: Akal.
- CHAMORRO ESTEBAN, Alfredo. 2012. "Un éxito efímero: la visita de Felipe III a Barcelona en 1599". In *Scripta Manent. Actas del I Congreso Internacional Jóvenes Investigadores Siglo de Oro (JISO 2011)*, ed. Carlos Mata Induráin and Adrián J. Sáez, 81-103. Pamplona: Servicio de Publicaciones de la Universidad de Navarra.
- CHONÉ, Paulette and Jérôme de LA GORCE. 2015. *Fastes de cour au XVIIe siècle*. Paris: Monelle Hayet.
- FERRER VALLS, Teresa. 1991. *La práctica escénica cortesana: de la época del Emperador a la de Felipe III*. London: Tamesis Books Limited.
- FERRER VALLS, Teresa. 1993. *Nobleza y espectáculo teatral (1535-1622): estudio y documentos*. [Ed. Digital. Alicante: Biblioteca Virtual Miguel de Cervantes, 2014 <<http://www.cervantesvirtual.com/nd/ark:/59851/bmcwd5r7>>].
- FERRER VALLS, Teresa. 1999. "Las fiestas públicas en la monarquía de Felipe II y Felipe III". In *Glorias efímeras: las exequias florentinas por Felipe II y Margarita de Austria*. Madrid: Sociedad Estatal para la Conmemoración de los Centenarios de Felipe II y Carlos V [<<https://entresiglos.uv.es/wp-content/uploads/fiestaspub.pdf>>].
- GAUNA, Felipe de. ms. 1602. *Relación de las fiestas celebradas en Valencia con motivo del casamiento de Felipe III*. [Introduction by Salvador Carreres Zacarés. Valencia: Acción Bibliográfica Valenciana, 1926].
- GARCÍA GARCÍA, Bernardo J. 2003. "El cortejo procesión". In *Teatro y fiesta del Siglo de Oro en tierras europeas de los Austrias [catálogo de exposición]*, 158-171. Madrid: Sociedad Estatal para la Acción Cultural Exterior de España (SEACEX).
- JULIANA COLOMER, Desirée. 2017. *Fiesta y urbanismo. Valencia en los siglos XVI y XVII*. Valencia: Universitat de València. [<<http://roderic.uv.es/handle/10550/61027>>].
- LABRADOR ARROYO, Félix. 2016. "Ceremonias regias en torno a Margarita de Austria y su propagación literaria y artística a través de las entradas de 1598 y 1599". In *La Corte del Barroco. Textos literarios, avisos, manuales de corte, etiqueta y oratoria*, coord. Antonio Rey Hazas, Mariano de la Campa Gutiérrez and Esther Jiménez Pablo, 341-392. Madrid: Ediciones Polifemo.
- MARTÍN MOLARES, Mónica. 2019. "Una boda real como producto editorial: las relaciones de sucesos sobre el casamiento de Felipe III y Margarita de Austria". *Memoria y civilización*, 22: 573-608.
- MÍNGUEZ CORNELLES, Víctor. 2016. "Un imperio simbólico. Cuatro décadas de estudios sobre la escenificación de 'La práctica del poder'". In *Visiones de un imperio en fiesta*, dirs. Inmaculada Rodríguez Moya and Víctor Mínguez Cornelles, 31-60. Madrid: Fundación Carlos de Amberes.
- MULRYNE, J.R., Maria Ines ALIVERTI and Anna Maria TESTAVERDE (eds.). 2015. *Ceremonial Entries in Early Modern Europe. The Iconography of Power*. United Kingdom: Ashgate Publishing.
- PÉREZ SAMPER, María Ángeles. 1999. "La presencia del rey ausente: las visitas reales a Cataluña en la época moderna". In *Imagen del rey, imagen de los reinos. Las ceremonias públicas en la España Moderna (1500-1814)*, dirs. Agustín González Enciso and Jesús M.ª Usunáriz Garayoa, 63-116. Barañáin: Ediciones Universidad de Navarra.
- RENAISSANCE festival books. British Library. [<<https://www.bl.uk/treasures/festivalbooks/homepage.html>>].
- RODRÍGUEZ MOYA, Inmaculada. 2001. "La ciudad como espacio de celebración nupcial en la España de los siglos XVI y XVII". In *Docta Minerva: Homenaje a la profesora Luz de Ullerte Vázquez*, coord. Felipe Serrano Estrella, 323-336. Jaén: Universidad de Jaén.
- RODRÍGUEZ MOYA, Inmaculada. 2011. "Iconografía de la ceremonia nupcial y el matrimonio en la cultura simbólica europea". In *Emblemática trascendente: hermenéutica de la imagen, iconología del texto*, coord. Rafael Zafra Molina and José Javier Azanza López, 731-748. Alcalá de Henares-Pamplona: Sociedad Española de Emblemática-Universidad de Navarra.
- RUIZ ASTIZ, Javier and Nieves PENA SUEIRO. 2019. "Presentación. Las relaciones de sucesos: producto y género editorial en la Monarquía Hispánica". *Memoria y Civilización*, 22: 371-380.
- TRATADO COPIOSO y verdadero de la determinación del gran monarca Felipe II para el casamiento del III con la serenísima Margarita de Austria... Valencia: junto al Molino de Rovella, 1599. [Ed. Mónica Martín Molares. In press].
- VARALLO, Franca. 2015. "Margaret of Austria's travel in the state of Milan between 1598 and 1599". In *Festival Culture in the World of the Spanish Habsburgs*, ed. Fernando Checa Cremades and Laura Fernández-González. London and New York: Routledge.
- VEGA, Lope de. 1599. *Fiestas de Denia*. Valencia: en casa de Juan de Mora, o en casa de Diego de la Torre [ed. Profeti; studied by B. J. García García. Firenze: Alinea Editrice, 2004].
- WILLIAMS, Patrick. 2009. "El duque de Lerma y el nacimiento de la corte barroca en España: Valladolid, verano de 1605". *Studia Histórica: Historia Moderna*, vol. 31: 19-51.
- ZAPATA FERNÁNDEZ DE LA HOZ, María Teresa. 2016. *La corte de Felipe IV se viste de fiesta. La entrada de Mariana de Austria (1649)*. Valencia: Universitat de València [Anejos de *Imago: Revista de Emblemática y Cultura Visual*, nº 5].

THE IMMORTALITY OF POWER: THE FUNERAL OF KING JOHN V AND THE SAD SPECTACLE OF DEATH

PAULO DE ASSUNÇÃO

Instituto Histórico e Geográfico Brasileiro
Universidade de Lisboa — Faculdade de
Letras — Centro de Estudos Clássicos
paulo.assuncao2932@gmail.com

ABSTRACT

The funeral commemorations held to mark the death of a king or queen were celebrated with the rigour that the weighty rituals of the old regime demanded. In Brazil, manifestations of grief occurred in the main colonial cities and were duly recorded by the responsible officials, who zealously detailed the event. The death of King John V in 1750 gave rise to a celebration that helps us understand how death could provide an example to the living. Moreover, it was a spectacle that helped confirm the immortality of power. This article aims to present the funeral celebrations of King John V, especially in the town of Vila Rica, by examining the “*Breve Descrição Funebre narração do Sumptuoso Funeral e triste espectáculo de D. João V*”. I will posit that the celebration of the funeral was a pompous spectacle of death that aimed to educate and control society.

KEYWORDS KING JOHN V, FUNERAL RITES, DEATH, CELEBRATION, BRAZIL

RESUMO

As exéquias fúnebres pela ocasião da morte de um rei ou de uma rainha eram celebradas com o rigor que os rituais do Antigo Regime impunham. No Brasil, as manifestações de luto ocorreram nas principais cidades coloniais e foram fixadas pelos funcionários responsáveis, que meticulosamente descreveram o evento. A morte do rei D. João V em 1750 deu lugar a celebrações, que nos ajudam a compreender como a morte pode consciencializar os vivos. Um espetáculo que intensifica a confirmação da imortalidade do poder. Este texto tem como objetivo apresentar as exéquias de D. João V, especialmente as que tiveram lugar em Vila Rica, tendo em conta a “*Breve Descrição Funebre narração do Sumptuoso Funeral e triste espectáculo de D. João V*”. É nosso objetivo, igualmente, enfatizar que as celebrações fúnebres são espetáculos de pompa, cuja intenção era também de educar e controlar a sociedade.

PALAVRAS-CHAVE D. JOÃO V, EXÉQUIAS FÚNEBRES, MORTE, CELEBRAÇÕES, BRASIL



Death is inherent to all living beings. However, only man is aware of his finitude as a being. This reality is with him from his earliest days, marking his fragility and powerlessness, unable to shirk. Death is a limitation, marking the end of earthly human existence; the lifeless body becomes a symbol of the denial of being. The interpretations established by various societies point to understanding on two distinct and complementary planes: understanding death as the biological finitude of man; and understanding death as a spiritual dimension (Coulanges 1981, 27).

The reflections on death produced in society reveal that death is seen to interfere directly with the life of man himself and that of society: *the living could not pass without the dead, nor the dead without the living* (Coulanges 1981, 38). The ideas formulated and conveyed about death reveal the structuring of a thought system that seeks to contribute to the maintenance and justification of the values of society itself, or even to its very modification, making the living and dead part of this movement in search of balance.

In the 15th century, recipes for a “good death” were elaborated in the *Ars moriendi*, where death took on the public character as something that could be exemplary, constituting a great spectacle involving the group surrounding the dying. Everyone watched the last act of the morbid act. As Georges Duby writes:

To die is, in a way, to preach. Then one has to die in public, to distribute, to give all those around him who are still alive a lesson in renunciation. The “art of dying”, however, recalls how doubtful the struggle is, that it is not possible to save oneself alone, and that the right moment should be extended to the Saviour, that is, Christ crucified. To entrust yourself to him, with hope: the demons will soon flee, and the soul will be saved. (Duby 1988, 146)

Between the 16th and 18th centuries, the Church intensified its mechanisms of persecution, shaping the Christian man and leading him on the search for salvation at the moment of death.

This Christian hope was intended as the culmination of a liturgy that began with the viaticum, including the commissioning of the soul, laying in the casket, entrance into the church, mass, the carrying of the coffin from the church, the journey to the cemetery, and ultimately the burial. The Church reminded men that God shows mercy towards those who were received at baptism and followed the path of faithfulness to Christian dogma.

The Baroque era strengthened the Church’s hold as it spread the image of a madness at force in the world, caused by those who distanced themselves from the Catholic faith. This was a torment to those who feared God and the Inquisition, as we see in Portugal. José Antonio Maravall points out that the Baroque man lives amid the confusion of his period, a crazy world marked by disorder and lack of understanding about his destiny and his happiness. Such disorientation required a sense of purpose that was difficult to grasp by a conscience in crisis and an outlook that saw the world as a confusing maze. (Maravall 1997, 251) rightly describes the man of this period as a being in crisis, beset *in his own inwardness by the clashing values of faith and reason, the soul agonised by his exile in the world and the flesh torn by the suppressed passion of the senses*. The artists and documents of the day thus reflect *the oscillations of ideas and the cross-lines of changing forms of expression* (Ávila 1979, 36). Adalgisa Campos, analysing the man of the 18th century, underlines the concern with death and the incessant search for conversion and redemption. It is a salvation that is always to come (Campos 2007, vol. 2, 407).

The world was seen as a theatre in which human existence played out in a show that began at birth and ended with death. This scenario emphasised the transitory nature of every man on the face of the earth, forced to play his role. In this world marked by contradiction, uncertainty and disillusion, the Baroque man has to develop the drama of his history. This drama leads him to wonder about human existence in the world — an issue that is always brought into sharp focus at the moment of death. In the game of existence, the painful experience of death becomes a doctrinal element, as death sets an example to the living.

The funeral commemorations on the death of a king or queen, as well as their descendants, were celebrated with the ritual solemnity that the etiquette of the old regime demanded during the colonial period. In Brazil, expressions of grief took place in the main cities and were zealously recorded in detail by the responsible officials. At the same time, these events were redolent of hope and brought to mind hope and trust in divine mercy and resurrection.

The death of King John V in 1750 gave rise to a series of celebrations that included the funeral mass and funeral prayers, events that help us to understand how death was fashioned so as to set examples for the living. As a spectacle, it helped to confirm the immortality of power. I will examine these aspects here, with particular focus on the document *Breve Descrição Funebre narração do Sumptuoso Funeral e tryste espectáculo de D. João V*. This work was discovered by José Manuel Alves Tedim, who investigated the relationship between death and glory with reference to the work of Francisco Xavier de Brito, a Portuguese woodcarver who made pieces for the Igreja Matriz of Nossa Senhora do Pilar, in particular representations of Faith, Justice, Prudence and Charity. The document expresses an idea of immortality through the prism of a show that reinforces the bonds of social control (Tedim 1996, 251-257).

The *Breve Descrição Funebre narração do Sumptuoso Funeral e tryste espectáculo de D. João V*, published in 1751, allows us to see the funerals as hugely ceremonial occasions that also sought to educate the living. The speech that recounts



FIG. 1. Portrait of King John V — Oil on canvas, 18th century. It belonged to the chapterhouse of the Cathedral of São Paulo. São Paulo Museum of Sacred Art Collection.

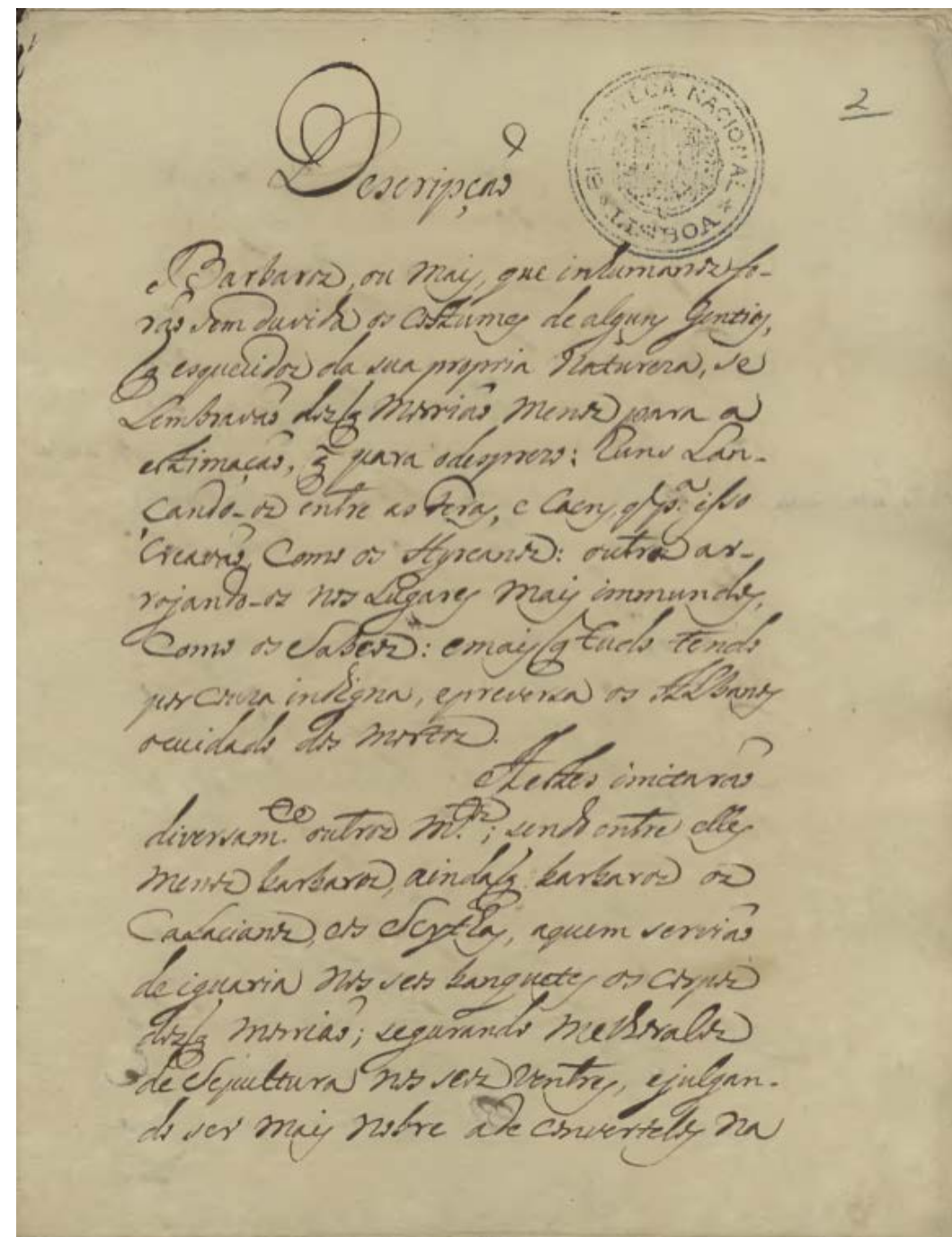
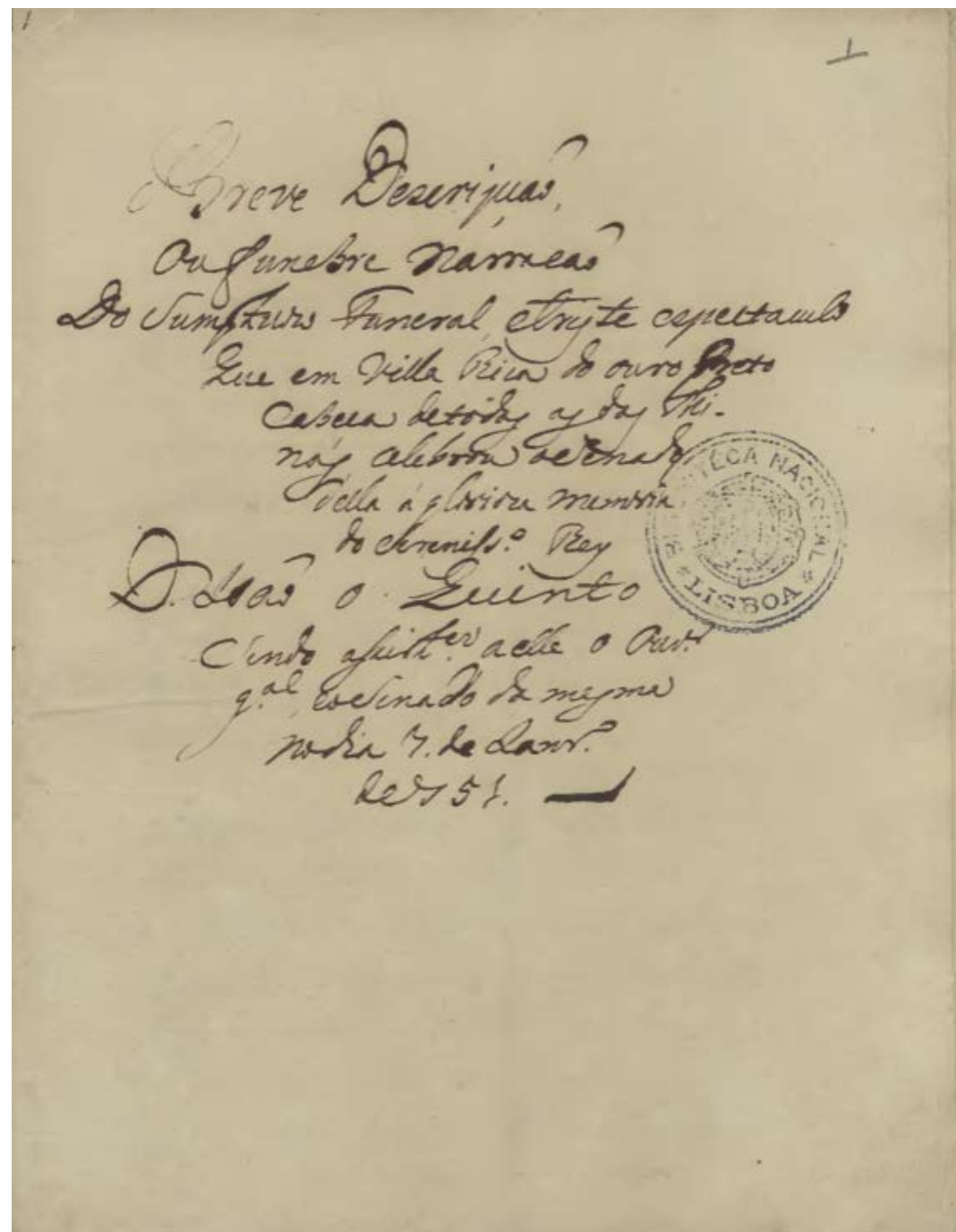

FIG. 2. “Breve Descrição Funebre narração do Sumptuoso Funeral e triste espectáculo de D. João V”, 1751. Biblioteca Nacional de Portugal — Reservados Cod. No. Mss 5, no. 9.

FIG. 3. “Breve Descrição Funebre narração do Sumptuoso Funeral e triste espectáculo de D. João V”, 1751. Biblioteca Nacional de Portugal — Reservados Cod. No. Mss 5, no. 9.

the death of John V draws upon iconographic resources, calling the attention of the faithful to the power of the king. In doing so, his death serves as a painful experience that can teach 18th-century Minas Gerais society to remember the monarch's life is to assert that he will never die, for his offspring will perpetuate and praise his works.

The reign of John V lasted forty-three years and was one of the longest in the history of the Portuguese monarchy. The son of King Pedro II and Maria Sofia Isabel of Neuburg, John

was born in Lisbon on 22 October 1689. Following the death of Pedro II, John was proclaimed king on 1 January 1707. The following year, he married Maria Anna of Austria, daughter of Emperor Leopold I, with whom he had six children.

The discovery and exploitation of Brazil's gold mines in the first half of the 18th century contributed to the kingdom's wealth and the stability of its government. The colonial lands of Portuguese America were given priority, as they required proper defence to preserve the borders against the

covetousness of other states. The large amount of gold that flowed from the colonial lands into Portuguese coffers brought about the long-desired prosperity for the crown. And the monarch did not hide his prosperity during his reign, which was marked by sumptuous ostentation, as he flaunted his wealth before Rome and other, now overshadowed European kingdoms.

John V was an eager patron of the arts and sciences, creating the Royal Portuguese Academy of History, introducing Italian opera to Portugal and spending vast amounts of money on acquiring books and creating libraries, including that of the University of Coimbra, a byword for lofty intellectualism in Portugal. He attended the construction of public works such as the Lisbon Free Water Aqueduct, which stretched over 18,000 metres and had 127 masonry arches. Other new edifices included the Casa da Moeda and Paço de Vendas Novas, and the monarch poured considerable resources into the designs for the new cathedral for the Patriarchate of Lisbon (Serrão 1982 vol. V, 258-9). However, the Convent of Mafra was his great work, bringing together masterpieces by artists including carvers, tile makers, painters and sculptors, many of whom came especially from Rome to work on the construction of the building that would become the Portuguese Escorial. Such great works, accomplished by a noble and generous soul, earned him the epithet of *Magnanimous*.

The sheer grandeur of the works demonstrated the opulence of the royal house, but did not detract from the criticism that the establishments housed within them received for their moral depravity. John V had a number of notorious love affairs, most scandalously with Paula Teresa da Silva, a nun who later became Mother Superior of the Convent of Odivelas. A son, José de Bragança, was born of this relationship — one of the three “Meninos de Palhavã” [Palhavã boys], as the king’s illegitimate children were known (Pimentel 2017, 113).

The literature and baroque art of the period helped to cement the impression of the sovereign’s boundless magnificence. Panegyrics in his praise sought to make his public image that of an active monarch, and thus consolidate his power. In this sense, the portrait of the king was presented

with a deliberate intention of infusing allegory with meaning, because it visually translates his power. As Antonio Filipe Pimentel writes, “the baroque portrait is conceived as a façade, or as a stage, where the presence of the viewer is always implicit” (Pimentel 1992, 72).

However, such ambitions, attributes and the carefully crafted heroic, quasi-immortal image ultimately vanished with the king’s illness. In May 1742, while the monarch was dispatching royal servants, he was struck with syncope, recorded by a witness as a stupor that deprived him of his senses. It was soon found that the attack had left part of his body immobilised, so that his mouth drooped on one side (Serrão 1982 vol. V, 264). Although the king regained consciousness the next day, his health was weak and he required constant care, forcing him to withdraw from power. Queen Mariana, his wife, took over the regency while the king convalesced. Between periods of improvement and relapse, the final years of the monarch’s life were marked by hemiplegia, which affected the left side of his body, and epileptic seizures that intensified every year and would further compromise his poor physical stamina. On 31 July 1750, John V died at the Paço da Ribeira in Lisbon. On the morning of 1 August, the new monarch, José I, still dismayed by the loss, reported the death of the Magnanimous King to the nation, ordering all subjects to mourn for two years.

The funeral commemorations for king’s death were marked in Portugal and across the Lusitanian overseas empire. As soon as the news came of the king’s passing, the towns and cities prepared their tributes. In several villages in Minas Gerais, the commemorations took place between the end of the year 1750 and the beginning of 1751, during the government of Gomes Freire de Andrade, as ordained by King José I.

The service held on 7 January 1751 in Vila Rica reveals how a mining society scrupulously performed the ritual ceremonies for the late king’s funeral, drawn from an elaborate realm of symbolism. The funeral apparatus was set up as though the body of the deceased were *in loco*. In this context, the funeral deliberately assumes the character of a staging, where appearance and reality merge in the profusion of elements that



FIG. 4. Detail of the main chapel of Igreja de Nossa Senhora do Pilar. Ricardo André Frantz -2015. Source: [https://pt.wikipedia.org/wiki/Bas%C3%ADlica_Menor_de_Nossa_Senhora_do_Pilar_\(Ouro_Preto\)#/media/Ficheiro:Igreja_Matriz_de_Nossa_Senhora_do_Pilar_-_Ouro_Preto_-_altar_mor.jpg](https://pt.wikipedia.org/wiki/Bas%C3%ADlica_Menor_de_Nossa_Senhora_do_Pilar_(Ouro_Preto)#/media/Ficheiro:Igreja_Matriz_de_Nossa_Senhora_do_Pilar_-_Ouro_Preto_-_altar_mor.jpg).



FIG. 5. Detail of the altar of Santo Antônio and pulpit of the Igreja de Nossa Senhora do Pilar. Ricardo André Frantz — 2015. Source: [https://pt.wikipedia.org/wiki/Bas%C3%ADlica_Menor_de_Nossa_Senhora_do_Pilar_\(Ouro_Preto\)#/media/Ficheiro:Igreja_Matriz_de_Nossa_Senhora_do_Pilar_-_Ouro_Preto_-_p%C3%ADlpito_e_altar_lateral.jpg](https://pt.wikipedia.org/wiki/Bas%C3%ADlica_Menor_de_Nossa_Senhora_do_Pilar_(Ouro_Preto)#/media/Ficheiro:Igreja_Matriz_de_Nossa_Senhora_do_Pilar_-_Ouro_Preto_-_p%C3%ADlpito_e_altar_lateral.jpg).

make up the celebration, whose objectives transcend the simple veneration of the dead.

The Church of Our Lady of Pilar of Vila Rica was chosen as the venue for the funeral. The construction of the church had begun in 1728 and the works were still unfinished when the sumptuous funeral ceremonies were held. The description of the church's ornamentation allows us to envision a magnificent Baroque setting. Attention is drawn to the perspective, movement and grandeur of the event, which aimed to

satisfy the gaze and the mind. There were three fundamental elements prevail: the playful, the visual and the persuasive (Ávila 1979, 22). The religious celebration was the product of an experience of faith that had the visual and emotive force to engage everyone. It endeavoured to generate a collective sense of unity among those who shared the same beliefs and ideals in both religious and social life.

The sense of drama to the occasion was mixed with a profusion of earthly and divine images, with death being the



FIG. 6. Detail of the altar of Senhor dos Passos in the Igreja de Nossa Senhora do Pilar. Ricardo André Frantz — 2015. Source: [https://pt.wikipedia.org/wiki/Bas%C3%ADlica_Menor_de_Nossa_Senhora_do_Pilar_\(Ouro_Preto\)#/media/Ficheiro:Igreja_Matriz_de_Nossa_Senhora_do_Pilar_-_Ouro_Preto_-_altar_lateral.jpg](https://pt.wikipedia.org/wiki/Bas%C3%ADlica_Menor_de_Nossa_Senhora_do_Pilar_(Ouro_Preto)#/media/Ficheiro:Igreja_Matriz_de_Nossa_Senhora_do_Pilar_-_Ouro_Preto_-_altar_lateral.jpg).

protagonist of the play. According to Affonso Ávila, the Baroque work is presented *through points of view, angles or perspectives that break the classic linearity and rigidity, inviting us to a richer visual relation of fruitive possibilities, in which we freely expand and excite our availability for the experience of the senses and the joy of intelligence.* (Ávila 1979, 31)

Casting a keen eye over proceedings, the narrator, whose identity is unknown, provides a thorough description of the Church's architectural geometry, plus detailed information on the materials, colours and works used to decorate the walls. He seeks to give the reader a vivid picture of the magnificent apparatus that provided the backdrop for the spectacle. The purpose of the discourse is to give them impression of a precisely captured reality, describing the visual impact of a scenic space designed to exert total dominance over the spectator. In doing so, it sought to elicit respect and dedication from the subjects as they gathered to mourn the monarch's death.

Among the images that the author presents as he describes the decoration of the church, skeletons, *skulls with wings* and *dry death* all feature large. The *dry death*, or *vanitas skull*, a common motif from the 14th century and still used with great intensity in the 17th century, was evidence of a predilection for the dismal. The fact that artists tended to depict bone rather than decomposition, a common practice until the Middle Ages, is due to the interpretation of the decomposition of matter as a manifestation of man's ruin. Avoiding it was a way of denying the decrepitude of human beauty, which causes fear and horror (Aries 1988, 36). Moreover, we must not neglect to point out that skeletons and bones provoke man to ponder his existence, revealing what he will become. Representations that use bones and skeletons thus elicit a certain discomfort, unleashing the macabre and stirring a sense of foreboding in the depth of frightened souls. It was undoubtedly effective as a technique of repression. According to Aries, such themes express an acute sense of individual frustration at man's powerlessness in the face of death and his physical destruction. He was both mortal and the bearer of death (Aries 1988, 95).

Death, as man's moment of transition, had a rich visual tradition in Baroque celebrations. The aim of such events was to give concrete form to all reflections on human existence. As such, death and everything related to it was to be made visible. The funeral narratives make it possible to reconstruct the ambience of a ceremony, as well as the selective process of apprehension and appreciation that people applied to death during the colonial era.

The purpose of the celebration was to cater to the interest in a public display of regret, while dignifying the figure of the monarch and confirming his august power. Although each discourse has its own characteristics, defined by the speaker's oratory or rhetoric, the construction and content of most of the speeches do not deviate from the parameters of an exaltation of the monarch interspersed with reflections on human existence and biological finitude.

The funeral Mass was part of the theatrical performance of the return of the body to the church where the individual had received baptism and now wished to reach solemn absolution. In this case, the Christian farewell clearly takes on the nature of a staged performance. It is worth noting that the Baroque mentality has a predilection for scenes of cruelty and pain, which arouse reflections about time, death and human life in their march on the face of the earth. The fear that the soul would go wandering terrified everyone and made individuals hyper-aware. The death of the body was not so terrible compared to the death of the soul, especially of the one who had rejected God. The speech warns that God is a strict judge, but also a compassionate father (Maravall 1997, 265).

In Vila Rica, the celebration was followed by the practices of austerity that the occasion demanded: *the windows of the House Council were to be closed and restricted mourning was decreed for a period of six months for all the population, who must be clothed in black cloth, except the poor, who would express their dismay by wearing hats with leaves of tobacco or insignia.* (Campos 1987, 3-4)

In Minas Gerais society, the externalisation of mourning was essentially symbolic, expressed by wearing black and attaching tobacco leaves to hats. Death triggered a public display of

reverence. While black featured highly in the ceremonial rites, black shields were also interspersed with funereal versions of the royal coat of arms. Such props were kept in a black bag, ready to be taken out for royal funerals. We might expect that the general public would have been aware of how they were expected and intended to act. Keeping up appearances in this way was part of what Ivo Carneiro de Souza called 'the rationality of cutting': *to make believe that appearance is valid for reality, postulating that the thing has no existence except in the figure it exhibits, not recognising the identity of the being except in the appearance of representation* (Souza 1996, 259). Such visible demonstrations of grief were much broader in scope than that offered in the written word.

The symbol in its primeval sense referred to *two halves of an object that had been divided, so that its junction would function as a password, hence the literal meaning of sign that it recognizes.* (Franco 1988, 156).

Being aware of this is crucial to our understanding that the visual representations created during the Baroque establish continuous links between the human and divine worlds, since the very function of the symbol is to enable such communication, thus forging a union between the two worlds (the worldly and the other-worldly). In this way, half of the symbol is in the possession of the individual, who associates it with the other half. This allows a certain transcendence and allows us to grasp the sign at its root. Even if the symbol is inferior to the symbolised reality, it is the means by which man has the possibility of approaching the divine and restoring a *primordial unity*, and because of this the *symbol is not to be understood he affectionately, intuitively establishes a secret relationship with transcendent reality* (Franco 1988, 156).

In this way, the funerals reveal the mechanisms by which individual within Minas Gerais society broke with their everyday universe to dwell on the meaning of death and grasp its transcendent side, all within a mosaic of symbols that interconnected with elements of the reality into which it was inserted.

In the discourse on funerals we find an exaggerated concern with the cult of the dead. The burial, in particular,

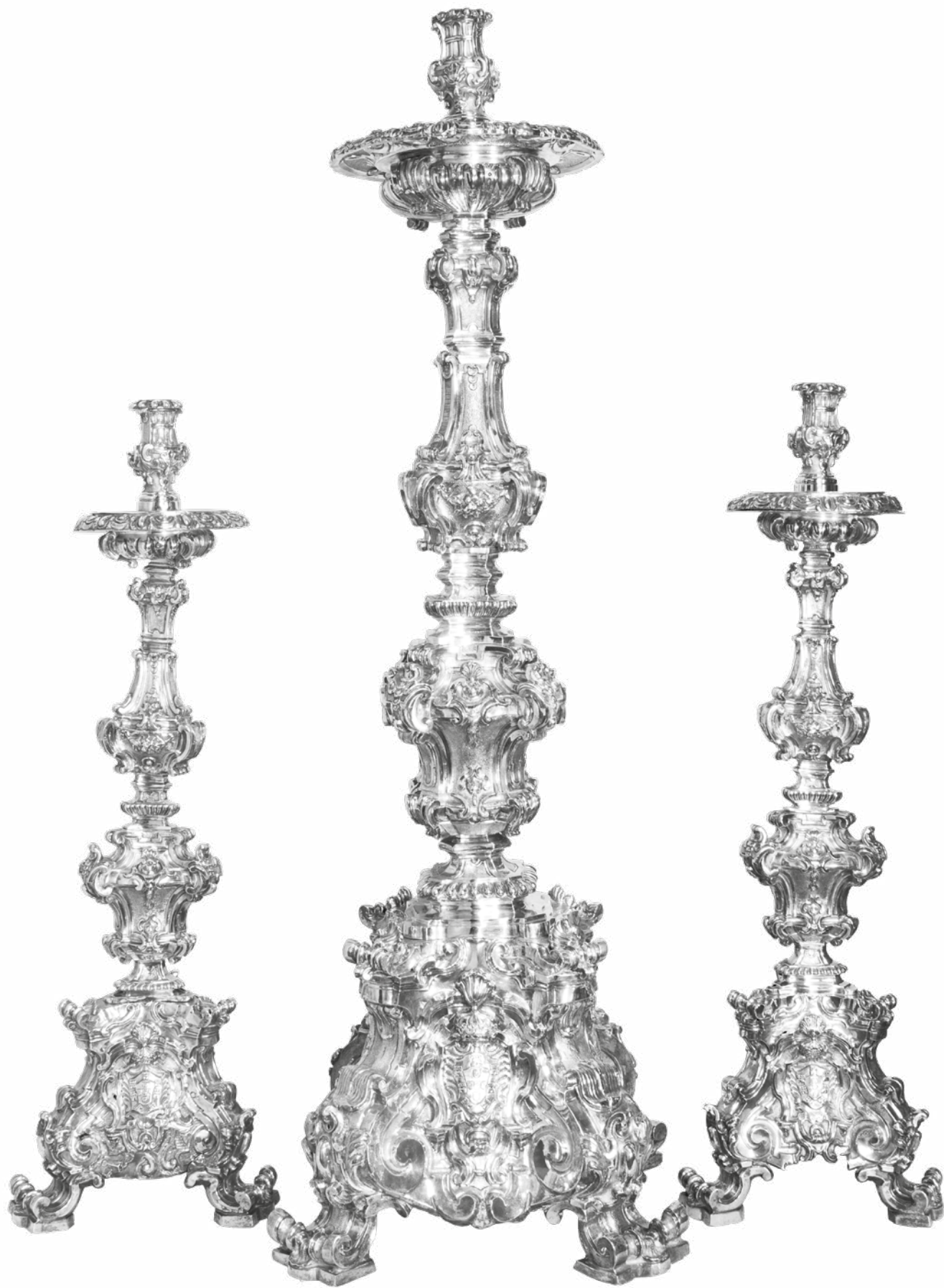

was considered part of civilised human nature, in the mould of the funeral rites of ancient peoples and those practised by the indigenous people of the Americas. The author of the text aims to highlight the marked differences between inhuman barbarity and the civility of customs such as reverence for the body of the dead. The non-burial and anthropophagy performed by the indigenous people, who believed that the dead should be incorporated into their bowels, were seen as brutality, typical of a primitive stage through which man had passed. Such observations, which characterised the behaviour of the indigenous people as savagery, were compounded by a lack of knowledge about their culture. In the minds of the westerners, this confirmed the beneficial effect of domination and colonisation, which sought to eradicate the barbaric customs of the colonial lands. In this worldview, civilisation was proven by a people's custom of preserving the memory of the dead, as well as the funeral rites and honours performed by those who were *cuidadosos a enterrar e honrar os mortos e que fazem acompanhar das sentidas mágoas, e tristes lamentos manifestando a sua saudade na pompa, e ostentação com que lhes celebravão exéquias* (*Breve Descrição...* 1751, 3).

Archaeological evidence suggests that funeral rites were performed in the Egyptian, Greek and Roman civilizations. This form of reverence for the dead later became an act of Christian religion and piety, whose followers came to understand death as a simple change in life. Part of the rite of death was the preparation and aromatisation of the body, the laying out of the deceased, the transportation of the body, its burial in a wooden coffin or similar, and, finally, the funeral repast in the house of a close relative of the deceased. The tomb built for the dead, his final resting place, alluded to the status and dignity of the deceased nobleman and his illustrious actions during his lifetime.

This concern with inhumation can be interpreted in two distinct ways. The first is the wickedness of non-burial by the ancients; death was less feared than the lack of a grave, which was absorbed by Catholic thought (Coulanges 1981, 19). The second concerns the acquisition of a grave, because it was considered dangerous to leave the dead without funeral

FIG. 7. Torch — spun silver, 18th century, offered by King John V to the cathedral of São Paulo when the bishopric was created. São Paulo Museum of Sacred Art Collection.

honours. Furthermore, non-burial was intended for those who had committed a horrendous crime and should therefore be punished with such deprivation.

Since ancient times, honouring ancestors has been one of the main means by which the family unit identifies itself. The dead were necessarily separate from the living world, so the ceremonial rites served to prevent the wandering dead from appearing to the living. Another concern was the differentiated constructions and treatments that social status demanded. The public ceremony was important to reinforce the existing power relations and ties of loyalty within society: *the visible tomb is therefore not a sign of the place of burial: it is a commemoration of the dead, immortal among the saints, celebrated among men* (Aries 1988, 78). The tomb consolidates the glory, power and fame of the one who is buried; the right of the deceased to identity and memory, consolidating his earthly power and its direct connection with divine power, *a singularidade com que o defunto Rey, ainda entre as trevas da morte, resplandecia igualmente, para a memória, e para o respeito, fulcro das exéquias* (*Breve Descrição...* 1751, 11v).

The conception of life highlighted in the various quotations reveals the concern with highlighting its transitory nature, symbolised by death, with wings holding a clock — *verdadeyra demonstração da volabilidade da vida humana, cujo fim he a morte*. This points to the need for a sense of detachment from material things, as what really mattered were the actions taken during life, a behavioural model within a Christian scope (*Breve Descrição...* 1751, 9). In the second instance, we have a speech focusing on the news of the death of King John V as: *a perda de hum Principe em que sobejarão os acertos dos annos, e faltarão as felicidades na repetição dellas de um Rey perfeyto em tudo, e por isso mais amado e chorado de todos* (*Breve Descrição...* 1751, 8). The tears that men shed for the king were an outward demonstration of the public gratitude that the living were expected to render to the dead in remembering their memorable deeds.

The passage that delineates the biography of King John V recounts his practices of government, his prudent politics, the justice of his acts and his successes. By emphasising

these elements, the intention is to highlight the fragility of all earthly glory, imbued with an idea of death *in the sense of the perishable nature of all things, coupled with an inveterate refusal to assimilate the dissolution of being into something purely physical* (Aries 1988, 33). The corporate notion of society, as analysed by Ângela Barreto Xavier and António Manuel Hespanha, understands power as a human body. In this state, the role of the king is to be the “head” of this body, guiding society and ensuring its harmony.

On the other hand, it is not for him to call upon himself all the functions of the members. Increasingly, however, the function of the head is emphasised. This metaphor has always pointed to a limited conception of royal power that, like the head, only symbolically represents the body, but cannot replace the other parts in its functions. (Hespanha 1993 vol. IV, 123)

The funerals reinforce the memory as a way of emphasising the king’s virtuosity throughout his life:

Sendo senhor dos seus affectos; menos se governou pelas payxões naturaes, que pelas razões políticas [...] Teve o reynar, mais por officio, que por herança e sustentando o seo Reyno com prudência, o firmou mais com a Religião, e com a Justiça, fazendo ainda nas partes mais remotas, / que ambas se respeitassem com amor e veneração. Soube advertido conciliar a liberalidade com a parcimônia; a modestia com a gravidade; a clemência com a justiça; e a benignidade com o respeito [...] Facilitou com mão Liberal as ciencias na ereção das Academias; adornou as partes: augmentou a cultura; e enriqueceu o comércio. Conheceo a inconstância da fortuna, preparando-se sempre na prospera para atalhar os revezes da adversa; tão senhor de si em ambos, que huma lhe servia de ensayo para a outra. (*Breve Descrição...* 1751, 6v).

The monarch, acting justly and compassionately, would demonstrate his kindness to his subjects and thus obtain divine mercy. The deceased thus acquires an image of immortality, justified by his earthly actions. It was for this very reason that

he was given the epithet of “magnanimous”, *pela grandeza e heroicidade de suas ações e pela facilidade com que empreendia e conseguia vencendo as maiores dificuldades* (*Breve Descrição...* 1751, 7v).

The enlightened sovereigns were those who gave life to the state, and on whom the order and balance of society depended. The loss of a king required his vassals to suffer, especially when they were ruled with justice and pity. The king’s exaltation centred on the enumeration of virtues and talents, glossing over the privileges life gave to those who ruled. The tears of longing that men shed for John V demonstrated the public gratitude that the living were expected to render unto the deceased, recalling his virtuous deeds and the attendant benefits for those he governed. At the same time, it is implied that the monarch would not be abandoned by the divine hand, which would send the angels to lead him to heaven; surely the late king would not suffer in the mansion of the dead, for his life of magnanimous deeds had bestowed eternal joys upon him.

The narrator’s account of the funeral celebration shows that it *ends only at the end of time and not at the time of death* (Aries 1988, 36). In the representation of the death of the king, it is important to spell out the dependence and faithfulness that his subjects were to reserve for him, not only in life, but also in death: *repetição os mesmos obséquios ainda nos horrores da sepultura* (*Breve Descrição...* 1751, 13v). At the same time, the awareness of another’s death and the pain that comes from his absence lead the subject to reflect on his own existence and eventual death. Such questions about life and death invariably led the faithful to nurture his own faith and exalt monarchical power, to the benefit of the system.

The understanding of death at that time can be understood as a kind of duality: a lamentation of the brevity of life and earthly glories, and gladness at the salvation of the soul. All expressions of sentiment, from piety to consolation, are aimed at externalising a representation of death that is threatening but can bring about the salvation of the human being. Funeral prayer is the triumphal affirmation of Christian hope, while at the same time a collective voice asking the monarch for his

intercession and God for mercy on one who was merciful in life, desiring that the divine blessing be extended to all.

Commemorating the king in funerals meant to exalting his provident administration and affirming his power in the collective memory — a power that was passed on to the new monarch ascending to the throne. The important thing was to confirm that there was a hierarchy and an order that would be preserved, even after death. The society of the dead was organised just as rigorously as that of the living, with divisions and hierarchies that needed to be respected. As such, the subject now mourning the king’s death should submit to his successor. After all, in the world of the dead, his place might be distinct from that reserved for monarchs, but he would have the comfort of divine compassion and eternal joy.

The objective of reinforcing the power structure and the relationships between society and the administrative apparatus was to highlight the efficiency and success with which the king held the position of command, in his inherent superiority. The public demonstration of grief was a way of externalising loyalty to the monarchy. The king is thus described as a conqueror, as one who ruled with justice and brought freedom to his people, a saviour who acted with holiness and justice, and a figure who should be remembered, as his rule would continue with his son ascending to the throne.

In colonial Minas Gerais, the man on the street had a heightened fear of death and the grave that was only emphasised by Baroque culture. Moreover, people feared that if St Michael did not guide souls on their way through the Milky Way, they would continue to roam the Earth. The horror of death and wandering souls whipped up a maelstrom of emotions in relation to human existence. Power, religion, life and death were all intermingled and played their part in shaping an insecure, unstable yet controlled society.

In short, the funeral is an opportunity for representation in which the central spectacle is death, and which is deployed to educate and control society at large. In this antagonistic game, which stems from the Baroque mentality, it appears that a casual connection is drawn between power and the sacred in order to reinforce the structures of domination in colonial

society. The pedagogy of fear teaches everybody good ways of dying. Hell — a place one could not leave — would be the fate of those who rebelled. The Church encouraged apprehension and fear by priming vassals to respect their power and that of the monarch. Those who conducted their lives correctly and died within the Catholic religion, respecting their king, would be happy. The commemoration and grief displayed by the people of Vila Rica's towards the deceased King John V, who now dwelt with the saints, also reveals their belief that he was still powerful within that society, as the sceptre passed to the heir to the crown. In this universe, the immortality of the king's soul was confused with the immortality of his power.

BIBLIOGRAPHY

SOURCES

BIBLIOTECA Nacional de Portugal, "*Breve Descrição Funebre narração do Sumptuoso Funeral e tryste espectáculo de D. João V*", 1751 — Reservados Cod. No. Mss 5, no. 9.

STUDIES

ARIES, Philippe. 1998. *História da Morte no Ocidente*. Lisbon: Teorema.

ÁVILA, Affonso. 1979. *O lúdico e as projeções do Mundo Barroco*. São Paulo: Perspectiva.

BEBIANO, Rui. 1987. *D. João V, poder e espectáculo*. Aveiro: Estante Editora.

CAMPOS, Adalgisa A. 1987. "A presença do macabro na cultura barroca". *Revista do Departamento de História UFMG*, 2-15.

CAMPOS, Adalgisa A. 2007. Escatologia, iconografia e práticas funerárias no barroco das Geraes. In: *As Minas setecentistas*. vol. 2 (org. Maria Efigênia L. de Resende e Luiz C. Villalta. Belo Horizonte: Autêntica.

COULANGES, Fustel. 1981. *A cidade Antiga*. São Paulo: Martins Fontes.

DUBY, Georges. 1988. *A Europa na Idade Média*. São Paulo: Martins Fontes.

FRANCO JR., Hilário. 1986. *A Idade Média — o nascimento do Ocidente*. São Paulo: Brasiliense.

HESPANHA, António Manuel (Coord.). 1993. *História de Portugal*. Lisbon: Editorial Estampa, vol. IV.

MARVALL, José Antonio. 1997. *A cultura do barroco*. São Paulo: Edusp.

PIMENTEL, Alberto. 2017. *As amantes de D. João V*. Lisbon: Sistema Solar.

PIMENTEL, António Filipe. 1992. *Arquitectura e Poder — o real edifício de Mafra*. Coimbra: Instituto de História da Arte da Universidade de Coimbra.

SERRÃO, Joaquim Veríssimo. 1982. *História de Portugal (1640-1750)*. Lisbon: Verbo, Vol. V.

SOUSA, Ivo Carneiro. 1996. *História de Portugal Moderno — economia e sociedade*. Lisbon: Universidade Aberta.

TEDIM, Manuel José Alves. 1996. "Teatro da morte e da glória: Francisco Xavier de Brito e as exéquias de D. João V em Ouro Preto". *Revista Barroco*. Belo Horizonte: UFMG, no. 17, pp. 241-257.



AQUA TRUMPHALIS: THE BAROQUE WEDDING FESTIVAL FROM THE TAGUS TO THE THAMES*

SUSANA VARELA FLOR

IHA-FCSH-NOVA

susanavarelaflor@sapo.pt

* The research undertaken for this contribution has been funded by th FCT, as part of its Norma Transitória Programme; [DL 57/2017/CP1453/CTO032]. The author would like to thank EGEAC – Museu de Lisboa / Palácio Pimenta concerning the publication of images inserted.

RESUMO

Em 1662, o Padre Sebastião da Fonseca e Paiva, capelão da Capela Real do Rei D. Afonso VI, acompanhou D. Catarina de Bragança a Inglaterra (Rau, 1962: 12). Ali recebeu a função de Mestre da Capela da Rainha (Troni, 2008: 273-274), pois era perito na arte da Música e na Poesia. Foi testemunha privilegiada dos acontecimentos, não só pela proximidade junto à Corte, como também pelo domínio das matérias musicais e iconográficas. No texto que escreveu *Festas de Pallacio e grandesas de Londres* colocou, nas palavras do Deus Neptuno, uma estrofe que nos serviu de mote para o presente texto.

*Sempre vos [Carlos II e Catarina de Bragança] guardei respeitos
Ou no Tejo, ou no Tamaso
Tributando cada instante
Cristais a vossos Pallacios* (Fonseca, 1663: 8).

PALAVRAS-CHAVE: BARROCO; CATARINA DE BRAGANÇA; POMPA; TEJO; TAMISA

ABSTRACT

In 1662, Father Sebastião da Fonseca e Paiva, Chaplain at the Royal Chapel of King Afonso VI of Portugal, accompanied Catherine of Braganza to England (Rau, 1962: 12). There he was appointed Master of the Queen's Chapel (Troni, 2008: 273-274), in recognition of his erudition in music and poetry. He was a privileged witness of events, not only because of his proximity to the Court, but also due to his mastery of musical and iconographic materials. In the text "Festas de Pallacio e grandesas de Londres", he lets the god Neptune speak a stanza that I have used in the title of this paper.

I have always shown my respect to you [Charles II & Catherine of Braganza].
Whether in the Tagus, or the Thames
At every instant paying my tribute
Of crystals to your palaces (Fonseca, 1663: 8).

KEYWORDS: BAROQUE; CATHERINE OF BRAGANZA; PAGEANTRY; TAGUS; THAMES



I — The historic figure of Catherine of Braganza (1638-1705)

Catherine of Braganza, Infanta of Portugal, Queen of England from 1662 to 1685, is a historical character who has provoked much dispute over the ages. She was praised for her personal sacrifice in cementing the political and commercial alliance between Portugal and England, but simultaneously accused being insufficiently primed and overly conservative to assist Charles II (1630-1685) in ruling the kingdom. Nonetheless, she gained a certain popularity for allegedly introducing new customs such as tea drinking, although some history, specially the American historiography, has looked on her somewhat harshly due to the fact that Portugal operated a slave trade at that time.

Parallel to these dichotomies, there are various misperceptions about Catherine's life in England (for example, her arrival at Portsmouth and first meeting with Charles II), and there are countless anecdotes that do not coincide with historical events and the reported behaviour of the Queen.

Before I begin my reflection on the topic of Catherine's wedding festivities, I would like to start by getting a sense of the public's perception of the Portuguese Infanta today. A double BAFTA Award-winning television series made in 2003 — *Charles II: The Power and the Passion* — may well reflect the deeply ingrained imagery associated with the Queen. Certain scenes from the series make it only too apparent that the makers applied artistic licence to Catherine of Braganza's life in England. Of course, the Hollywoodesque setting and dialogue can be attributed to the desire to attract the highest number of viewers possible. However, this reworking of historical events does not help us to uncover the real political identity of the Portuguese princess. The scene in which Catherine arrives at the court of Charles II is all wrong, from the area where the action takes place to the number of characters involved, the clothes worn and the language used.

In reality, Charles II met Catherine in Portsmouth, at that time a small town, where she alighted on 14 May 1662. The Queen arrived in England dressed in the English style and it

was at the Duke of York's request that she wore Portuguese attire with the distinctive pannier. This was how her painter, Dirck Stoop, depicted her, although we also know that the Queen alternated her attire over the days that she spent waiting for the King to arrive. When he got to Portsmouth, he visited the Queen in her chamber, where she was ill and recovering from a cold. Unlike the story that is normally told, the Queen did not ask for a cup of tea to help her fight off the symptoms of her cold; there was no custom of drinking tea in Portugal at that time.

Unlike in the film, the first meeting was in a more intimate setting with few people in attendance. The King and Queen spoke in Spanish — a common language that both spoke well — without the need for interpreters. Upon seeing the newly-arrived Queen's face, Charles II did not say "they've brought me a bat instead of a wife". This comment came from the dubious testimony of George Legge, First Baron of Dartmouth. From the report by Francisco de Mello e Torres, the Portuguese ambassador, we know how the first viewing of the royal couple took place, since he was one of the few witnesses: "The King sat next to the Queen's bed in a blue velvet chair matching the bed where she was.... The King was very happy during the visit, revealing himself to be very pleased with the Queen's beauty. The Ambassador even asked him if His Majesty thought that he had misled him. He replied that yes, that he and the painters had misled him because neither the information nor the portraits were as beautiful as the Queen." (Torres, 1661, 36).

Having set out some of the most common problems with a superficial approach to the life of Catherine on English soil, I shall move on to a brief look at her life up until that point. The Infanta was born in Vila-Viçosa, Baixo Alentejo, on 25 November 1638 in the Ducal Palace of the Braganza family, which was highly praised by an 18th-century chronicler (Sousa [1740], 2007:157). She was born two years before the most important event to take place in Portugal in the first half of 17th century: in 1640 her father, King John II, 8th Duke of Braganza, led a separatist movement against the dual monarchy with the Kingdom of Spain and became the first king of the new

Braganza dynasty. The Infanta then moved to a new home (the Royal Palace of Ribeira in Lisbon) and together with her siblings (Teodósio and Joana) became an instrument in the diplomatic game of political alliances between Portugal and other European countries (France, England, the Netherlands and even Spain). This was the way to ensure the political independence of the new dynasty. However, Catherine seemed destined for a more reserved life, since she was a second daughter and the sister of three male infantes who would ensure the line of succession. The death of John IV in 1656 and of the Infante Teodósio (the firstborn) and Joana the following year brought Catherine's name to the fore in efforts to guarantee a political alliance aimed at ending 12 years of war with Spain. In this sense, by seeking to strengthen such ties, the Portuguese diplomats were striving towards the lofty goal of bringing about peace. This was only fully achieved in 1668, during the reign of Catherine's brother Afonso VI (1643-1683), whose achievements owed much to the political and military balance achieved by the marriage of Catherine and Charles II in 1662.

II – The River Tagus as a stage for city festivals

The presence of the River Tagus is integral to the iconography of the city of Lisbon, enriching it not only as a powerful setting for historical events, but also as an element of immense aesthetic importance. Artistic depictions and historical accounts describing the reception of foreign princes and ambassadors, the departure of Portuguese princesses, celebrations commemorating political and religious events, and the arrival of armadas from India or Brazil are vital in acquiring a better understanding of the importance of the river. The Tagus was not limited to celebrating the great events of Lisbon, but was part of the *modus vivendi* of Lisbon's population, either through its connection to the south bank (where lay the Aldeia Galega and the road along which one travelled to Spain), or in the movement of people and goods. The seasonal itinerary of the Portuguese Court is another good example of this: the palace of Salvaterra de Magos, located

about 50 km from Lisbon in good hunting grounds, offered a faster journey that made the most of the navigability of the river, albeit with inherent risks such as drowning and loss of property. On the other hand, those from rural areas used this route to supply the city with fresh goods. By the middle of the 18th century, this fast fluvial access was also being used for the transportation of ice produced in the Serra de Montejunto. The Tagus was thus one of the most important thoroughfares during the Early Modern period in Portugal, like other rivers in the main capitals of Europe. This was certainly true of London, too: "The Thames has played its part through the centuries in bringing different sections of the people together to mark national events as part of a wider iconography of populism" (Shewring, 2015: 221).

The political alliances between Portuguese and European powers played their part in establishing the popular iconography of the Tagus. Before Catherine of Braganza in 1662, the Infanta Beatriz of Portugal (1504-1538) left these waters in 1521 for Savoy, where she married Duke Charles III: "The people of Lisbon crowded in the windows, on foot and on horseback in the Ribeira to watch the departure of the Infanta, signalled by thick and continuous artillery, storming the air" (Buescu, 2019:123). In 1565 it was the turn of Maria of Portugal, Princess of Parma (1538-1577) to embark for Flanders in an armada, with all the usual pomp.

The entries of Princess Joanna of Austria (1535-1573) in 1552 and the Spanish kings Philip II (I of Portugal) and Philip III (II of Portugal) into Lisbon via the Tagus are also worthy of note. For Joanna, a river procession was organised with *tableaux vivants* of religious and mythological iconography: "the Tagus assumed an even greater significance as a stage or mirror of water... it was the river that linked Lisbon to all the commercial warehouses of the Portuguese global empire" (Jordan, 2012: 144-145).

Both Philip I (1581) and Philip II (1619) officially entered Lisbon from the south bank and Belém respectively. The festivities held to welcome Philip II of Portugal have been the object of renewed study due to the discovery of a painting depicting the event (Gehlert, 2008). This image faithfully

captures the celebrations organised on the Tagus and in Lisbon, “a city that concentrated the world within it, thus seeking to argue its superiority over Madrid, perhaps as a future capital of the Iberian empire” (Flor, 2019:70).

In the 17th century, following the royal entrance of Philip II, the most magnificent festivals were those of Catherine of Braganza (Alves, 1986: 70). In 2015, I had the opportunity of analysing her wedding festivities in Lisbon in detail, in comparison with the celebrations held to mark the marriage of Maria Theresa of Spain to Louis XIV. In addition, I listed all the decorative elements organised for the event, studied their context and concluded that the wedding parties of the Portuguese Infanta in Lisbon “were used in a pro-Restoration discourse with a view to countering Philip IV’s hegemony [...]. Indeed, the [...] work [Relacion de las Fiestas by Antonio de Sousa Macedo] [...] is filled with excerpts denoting a discourse of anti-Spanish propaganda” (Flor, 2015:152).

III – Crystals to the Paço da Ribeira

In the late afternoon of 23 April 1662, Queen Catherine embarked next to the bridge of Ribeira das Naus, after having crossed the garden of Royal Palace of Ribeira in Lisbon (Fig. 1). The bridge had been decorated with fine carpets from India and arches covered with embroidered cloth (Macedo, 1662: 31). At its entrance, there was an ephemeral arch, funded by the Ombudsman of the House of India, as well as a mythological painting depicting the god Jupiter and his children: Bacchus, Athena, Mars, Diana and the demigod Hercules (Tojal, 1716: 106). This choice of gods was far from random, as they include two virtuous goddesses, Athena and Diana, both defenders of chastity, a characteristic common to the young Catherine. The presence of Neptune, meanwhile, with his trident, is a reference to the crossing that the Queen and her fleet were about to make under the auspices of that pagan court (Flor, 2012: 138).

Part of the entourage were carried to their ship in a golden barge covered with an awning, whose exterior was of

FIG. 1. Dirck Stoop, *The manner how her Matie Dona Catherina imbarceth from Lisbon for England*, 1662, MC.GRA1076, Museu de Lisboa – Palácio Pimenta.



crimson and golden fabric and the interior lined with damask in the same tones, like the curtains. A damask flag bearing the Portuguese coat of arms was waved by the movement of eighteen rowers dressed in red with silver trimmings. The royal barge was accompanied by another in the same colour, propelled by 16 rowers carrying the ladies and bridesmaids. This was followed by 24 boats decorated in similar fashion carrying members of the councils, courts, lords and knights. The cost of the boats was borne by various institutions. Lisbon's Senate organised a larger boat (Oliveira, 1893: 286-287/336-339), in which the musicians travelled, with their shawms, trumpets and party instruments. They remained on the Tagus even after the royal Portuguese delegation had returned to land and the Queen had departed in the *Royal Charles*. Musicians and dancers boarded smaller boats and plied the water, showing off their art. Members of the general public also went out on the water in small craft to enjoy the festivities, contributing to the excitement of the event.

The city of Lisbon itself added to the festive atmosphere: bells rang from the churches, and guns were fired from the Castle of Saint George on top of the hill and the Fortress of Terreiro do Paço. The British Army also fired shots in celebration from the Tagus as soon as the Queen boarded the *Royal Charles*. The "London" banner was lowered and the "Royal" banner was placed on the top of the large mast, displaying the coats of arms of England and Portugal in honour of the Queen's embarkation (Almeida, 1976: 59-64). The sailors of the *Royal Charles* shouted, "Live and have a good journey", throwing their hats in the sea. Boats from the Netherlands and France fired their guns in honour of the Queen's entry into English territory.

The night brought new splendour. All of the ships set off fireworks, so that spectators witnessed a scene akin to a battle of the four elements, with fire falling on the Tagus, which also seemed to be aflame. Contemporary reports used words like "boom" and "horror" to describe the visual and auditory onslaught (Macedo, 1662: 32). Calm was restored by the musicians of the King's Chamber, who closed the day with gentle chants. The stones of the Royal Palace reflected the

colourful tumult of the Tagus, reminiscent of Father Paiva's metaphor. They were also the last witness to Queen Catherine's journey.

Thus, began the voyage of the Portuguese Infanta to England. She left behind her homeland and her main city, Lisbon, which had been dressed for a party for the last eight months, ever since the news of the alliance and peace and trade treaty between the two nations. The festivities were both religious (masses, *Te Deum*) and profane: bullfights, tournaments, masques, dances, theatres and processions through ephemeral arches (Flor, 2012:133-142).

IV — Crystals at Whitehall Palace

Four months after the festivities on the Tagus, the Queen's reception took place in the city of London, against the backdrop of the River Thames. On 23 August Queen Catherine departed from the pier of the Hampton Court Palace and travelled by boat to Whitehall Palace in London. Father Sebastião da Fonseca e Paiva tells us that there were two reasons for this journey along the Thames. The first was of an aesthetic nature, since a royal water pageant of this kind allowed the new Queen to appreciate the beauty and amenity of London's river. The second was due to practical aspects. The triumphal arches that had been used for the entrance of Charles II into London in 1661 had already been removed, and the British Crown had neither the time nor the money to order new arches for the Queen's entrance (Paiva, 1662:1). The whole event was organised by John Tatham, who devised the festivities and the scenery for the staged performances. He left a written account (Tatham, 1662: s/f) that tallies with the engraving by the Dutch painter Dirck Stoop, who dedicates his work to the Lord Mayor of London (Fig. 2).

At two o'clock in the afternoon on 3 September, the royal couple boarded a golden barge accompanied by the Dukes of York (Ann Hyde and James Stewart) and Prince Edward. According to Father Sebastião da Fonseca e Paiva, the weather was very pleasant, and all the spots along the banks of the



FIG. 2. Dirck Stoop, The triumphall entertainment of ye King and Queenes Maties... on ye River of Thames, 1662, Museum Number Sheepshanks 3095, British Museum.

Thames were crowded with people who had come to see the royal parade and the various performances (Paiva, 1662:1).

As the riverbed widened, the monarchs were able to swap vessels. At Brentford they transferred to a barge with glass windows and in Putney to another propelled by 24 rowers dressed in red with gilded silver streamers embroidered on their chest and back. The royal retinue was accompanied by two gondolas that the Republic of Venice had offered to the English king, and whose perfection and speed caused astonishment, as voiced by John Evelyn (Beer, 1955: 333). Stoop recorded its presence for that very reason (Fig. 3).

In official terms, the reception began in Chelsea, with stops between Vauxhall and Lambeth, and ended at the steps up to Whitehall Palace (Tatham, 1662). In Chelsea, a meeting was scheduled with the Lord Mayor's boat and the 12 city

livery companies, which travelled in stately boats. Dirck Stoop depicted the boats of the Drapers, Mercers, Merchant Taylors and Goldsmiths in detail (Fig. 4), all decked out with great pageantry and alluding to their mystery. Father Sebastião da Fonseca e Paiva described the ornamentation on the garment of the rowers (liveries and coloured silks) in general terms, along with the banners, streamers and coat of arms of each company. He also mentioned that there was a lot of noise made by musicians playing trumpets, shawms and guitars.

In parallel to the presentation of the City Livery Companies, there was a programme of displays of pageantry and maritime triumphs. The first appeared early on in the journey, at Chelsea, where the goddess Isis, depicted as guardian of the Western Meadows and wife of the River Thames, appeared in a chariot pulled by seahorses (Fig. 5). She wore a white silk costume



FIG. 3. Two gondola from Venice (detail)



FIG. 4. Livery companies (detail)



FIG. 5. Goddess Isis (detail)

and her crown was decorated with all kinds of flowers. At her feet, nymphs represented small streams.

**Divinest Pair! whose equal Virtues claim
Affinity with Heav'n, adds life to Fame.
You! Whose conjunctive swetnesse does compleat
What ever can be thought of Good, or Great,
Proud with your Barges weight, Isis (to meet
Your unmatched loves) Kisses your Sacred Feet!
(...) (Tatham, 1662)**

After finishing Isis' speech, a droll dressed as a waterman sang and danced in a less formal tone. This was followed by a speech by another waterman.

The flotilla continued down the river to a new stop between Vauxhall and Lambeth. Here the Thames (Fig. 6) was presented as the King of the Rivers and Deputy King under the goddess Thetis. He appeared as an old man with long hair and a beard, holding the trident in his hand, as he was considered the grandson of the ocean god. At his feet, two nymphs represented the royal castles of Windsor and Greenwich, while on the bow two lieutenants were seated on a lion and a unicorn, representing Scotland and England.

**When You (Great Sir!) did in Caesarean State,
Through the Glad City, Ride to meet your Fate,**



FIG. 6. River Thames (detail)

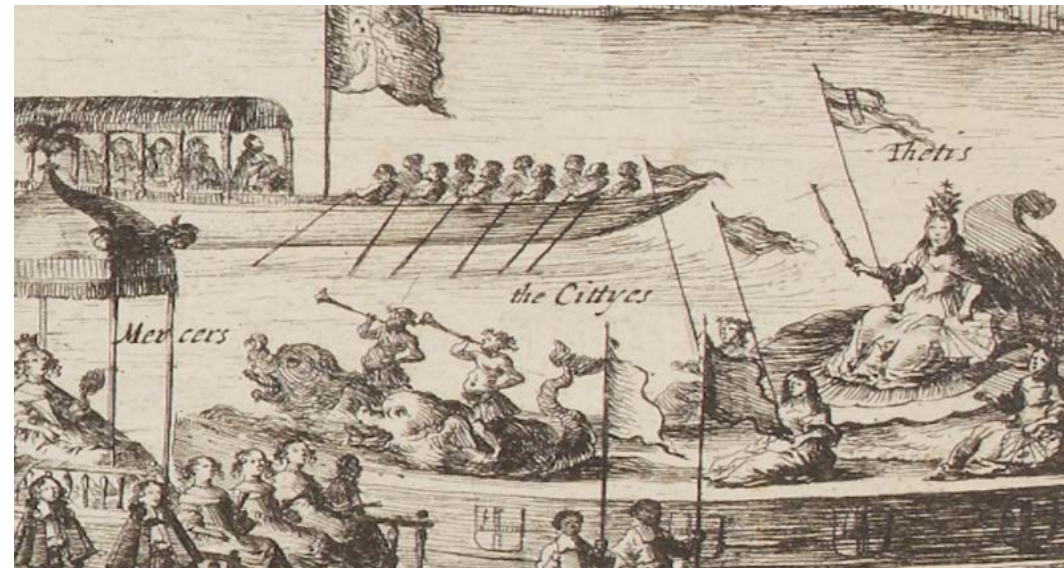

FIG. 7. Goddess Thetis (detail)

**(The Hand-Maid to Your Right) Your Regal Throne
Which had been lost, had it not been Your own
(...) (Tatham, 1662)**

The River Thames concluded his speech and was followed by the dances and songs of drolls dressed as sailors and Indians.

The procession went all the way to the private stairs at Whitehall Palace, where some members of the court could be seen on the balcony, waiting for the royal couple. We know from Portuguese sources that the Henrietta Maria, the Queen Mother, was one of those in attendance (Paiva, 1662:3).

The last acted scene was the parade of the goddess Thetis (Fig. 7), who appeared in a shell-shaped sea carriage pulled by two dolphins. Thetis had long hair and a triple crown on her head, since she was seen as the mother of all the gods; goddess of the sea, empress of all the rivers. Her crown was topped by a star and her garments were of a strong green, accompanied by a mantle of various colours. She held a sceptre and a map, denoting her status and worthiness to address the English monarchs directly.

**Fame having eccho'd in our Ears Your Choice
We summon'd all Our Daughters to rejoice,
That to the five Hill'd city [Lisbon] do belong
Whose Murmurs did consort a Nuptial Song;
The golden Footed Tagus, many more
That wanton' bout the Fam'd Ulyssian shore
(Tatham, 1662)**

After Thetis' speech, the companies bade farewell with music and lit lamps, which made it appear as though crystals were being brought to the Palace of Whitehall. The painting allows us to better visualise how the whole show on the Thames would have looked in colour.

In his account of the entire festivities, Father Sebastião da Fonseca e Paiva noted the "maritime triumphs", in which "fish, animals and figures represented companies with messages of affection and loyalty" (Paiva, 1662:2). However, Tatham did not confine himself to demonstrating these values on the part of the English people. Political messages, advice for governance and hopes for the future were subliminally conveyed through formal speeches and informal (even risqué) songs.

What do we know about the organisation of Aqua Triumphalis? On 29 July 1662, Charles II told the Lord Mayor that he expected "demonstrations of affection from the city of London, as has been customary on such grand and solemn occasions" (Wood, 1995:565). As mentioned above, the whole performance was scripted and arranged by John Tatham, of whom we know very little. According to the Dictionary of National Biography, Tatham (Fig. 8) was the London poet



FIG. 8. John Tatham (1632-1664), by Robert Vaughan, NPG D29054, National Portrait Gallery, London

and regularly wrote pageants for the city between 1657 and 1664 (Seccombe, 1975:384-385). Classical iconography fitted well with aquatic festivities, so the figures of Isis, Thames and Thetis had also appeared on other occasions (Tatham, 1660).

However, the speeches were adapted to this specific occasion. The goddess Isis established the link between Eastern and Western mythology. She praised the virtues of both monarchs and their sublime love by comparing it to that of Leandro and Hero. She announced that the river welcomed them with open arms and compared their arrival to that of spring and the annual cycle of the Proteus, the prophetic sea deity who flattered Pomona, the goddess of Fruits, with whom Isis was associated.

The speech by Thames was more politicised. He regretted the interruption of the monarchy but praised Britannia, who had always been able to incite fear in other nations, despite her geographically isolated condition. He presented the Kingdom of Portugal, declaring that it was famous for its kings and its acts, which deserved to be sung of by the nymph Clio. At that moment, Portugal, who embraced Britannia in peace, had become one with England, so there were no differences between them: Lisbon was London; the Tagus the Thames; the Portuguese English; and the English Portuguese.

The allegorical figure of the River Thames was the one who focused most heavily on Portugal's domains beyond Europe. In this sense, Tatham's speech coincides with the deep-seated aims of the Portuguese crown since the 16th century: "the Portuguese appropriation of an ideology of universal domination with a propagandistic purpose, in other words with the aim of carrying out a reputation-building policy in different courts of Western Europe" (Cardim, 2010: 42). Renewed with the Braganza dynasty, this ancient goal was conveyed not only through verbal communication (the allegorical speeches), but also visually, by including people and animals from outside the European continent.

This was also observed by Margaret Shewring in her analysis of both the Festival Book and the Stoop's etching: "there was also an emphasis on voyages of discoveries and the navigational skills that made journeys to distant lands increasingly possible and, with them, a new interest in exotic creatures" (Shewring, 2015:235).

The last figure to present compliments to the English monarchs was the goddess Thetis, who addressed the royal

couple as the most sacred pair. She alluded to the distant path through the metaphor of the struggle between the giants and the gods and spoke of the golden Tagus and the coast of Ulysses as she lauded the Restoration of the Portuguese throne to King John IV in 1640, when the Braganzas became the reigning dynasty. Thetis welcomed the happy outcome and wished that Charles II would survive the malice of his enemies, and that the monarch would inspire love among their people. Finally, she blessed Queen Catherine, praising her piety and goodness.

In short, the Portuguese and English texts and the engravings by Dirck Stoop give us a general idea of the festivities that took place on the Tagus and Thames. The latter acted as a real stage, with fantastic living pageants presented to the sound of music, fireworks, colour, ornamentation, pomp and excitement. For the new Queen of England, the four-hour journey between Hampton Court and Whitehall would have been a unique moment of entertainment and joy, as she heard the hopes of her subjects: "Live, Ladds, live, good dayes are comming on".

BIBLIOGRAPHY AQUA TRIUMPHALIS

PRINTED SOURCES

- MACEDO, António de Sousa de. 1662. *Relacion de las fiestas que se hizieron en Lisboa, con la nueva del casamiento de la Serenissima Infanta de Portugal Doña Catalina (ya Reyna de la Gran Bretaña,) con el Serenissimo Rey de la Gran Bretaña Carlos Segundo deste nombre: y todo lo que sucedió hasta embarcarse para Inglaterra*. Lisbon. Na Oficina de Henrique Valente de Oliveira.
- PAIVA, Padre Sebastião da Fonseca e. 1662. *Relaçam da entrada de Suas Magestades em Londres, sahindo do Palacio de Hanptamocourt [sic], em três de Setembro de 1662*.
- PAIVA, Padre Sebastião da Fonseca e. 1663. *Relaçam das festas de Palacio e grandesas de Londres dedicada A Magestade da Serenissima Rainha da Gran Bretanha pelo Padre Sebastião da Fonseca Mestre Capelão e Presidente em o Hospital Real de Todos os Santos na Cidade de Lisboa*. London. Oficina de J. Martin, Já. Allestry & Thomas Dicas.
- SOSA. António Caetano de. 1740, "Da Infanta D. Catharina, Rainha da Grã Bretanha". *História Genealógica da Casa Real Portuguesa*, vol. VII, ed. QuidNovi/Público, Academia Portuguesa de História, [2007].
- TATHAM, John. 1660. *London's Glory Represented by Time, Truth, and Fame: at the Magnificent Triumphs and Entertainment of his Sacred Majesty Charles II*.
- TATHAM, John. 1662. *Aqua Triumphalis: Being a true relation of the Honourable the City of Londons Entertaining Their Sacred Majesties upon the River of Thames, and Welcoming them from Hampton-Court to White-hall expressed*

and set forth in several shews and pageants the day 23 of August 1662. London. Printed for the Author by T. Childe and L. Parry dwelling in Dogwell Court in White Fryars.

- TOJAL, Pedro de Azevedo. 1716. *Carlos Reduzido. Inglaterra Ilustrada. Poema Heroico ofrecido à Soberana Magestade del Rey N. S. D. João V ...* Lisbon. Na Officina de Antonio Pedro Galram.
- TORRES, Francisco de Mello e. 1661. *Relação da Embaxada que Francisco De Mello Conde da Ponte fes em Inglaterra para o casamento da Sr^a. D. Catherina Infante de Portugal com Carlos 2, Rey da Grã Bertanha contra o poder de França, Castella, Holanda, Dinamarca, Suecia, Bradamburg, Saxonia e Parma.*
- THE Diary of John Evelyn, ed. E.S. de Beer, Oxford Clarendon Press, 1955, vol 3.

STUDIES

- ALVES, Ana Maria. 1986. *As entradas régias Portuguesas*, Livros Horizonte.
- ALMEIDA, Langhans. 1976. "As bandeiras da Gravura de Rodrigo Stoop — o embarque de Dona Catarina, Rainha da Grã-Bretanha, em 1662." *Armas e Troféus*. III Série, Tomo V. 1976.
- BUESCU, Ana Isabel. 2019. *D. Beatriz de Portugal (1504-1538), a Infanta esquecida*. Lisbon, Manuscrito Editora.
- CARDIM, Pedro. 2010. "La aspiracion imperial de la monarquia (siglos XVI y XVII). Comprenderle le Monarchie Iberiche: Risorse materiali e Rappresentazioni del Potere, Roma, Viella. Gaetano Sabatini (org), Roma, Viella — Università degli Studi — Roma Ter, pp. 37-72.
- FLOR, Pedro. 2019. "Datação". *Praça Universal de todo o orbe — Uma Vista de Lisboa em 1619*, Pedro FLOR (coord), Lisbon, Museu de Lisboa/Egeac.
- FLOR, Susana Varela. 2012. *Aurum Regina or Queen Gold — Retratos de D. Catarina de Bragança entre Portugal e a Inglaterra de Seiscentos*, Caxias, Fundação da Casa de Bragança.
- IDEM. 2015. "Que las riquezas del mundo parecian estar alli cifradas": Catherine of Braganz's wedding festivities in the contexto of the Portuguese Restoration". *Archivo Español del Arte*, LXXXVIII, 350, April-June, pp. 141-156.
- GEHLERT, Andreas. 2008. "Uma esplendida Vista de Lisboa no Castelo de Weilburg, na Alemanga". *Monumentos*, nº 28, Lisbon, IHRU, pp.208-213.
- JORDAN, Annemarie. 2012. *A Rainha Coleccionadora*, RODRIGUES, Ana M.; SÁ, Isabel dos Guimarães; SILVA, Manuela Santos (coord. da colecção *Rainhas de Portugal*), Lisbon, Círculo de Leitores.
- OLIVEIRA, Eduardo Freire de. 1893. *Elementos para a história do Município de Lisboa*. I^a Parte, Tomo VI. Lisboa Typographia Universal.
- RAU, Virgínia. 1962. "No tricentenário do casamento anglo-português de 1662". Separata do *Arquivo de Bibliografia Portuguesa*, Coimbra, year VII: 27-28.
- SHEWRING, Margaret. 2015. "The Iconography of Populism: Waterborne Entries to London for Anne Boleyn (1533), Catherine of Braganza (1662) and Elizabeth II (2012)". J. R. MULRYNE with Maria Ines ALIVERTI and Anna Maria TESTAVERDE (eds), *Ceremonial Entries in Early Modern Europe: the Iconography of Power*. Farnham and Burlington, VT: Ashgate, 221-244.
- SECCOMBE, Thomas. 1975. "John Tatham". *Dictionary of National Biography*, Vol. II, Oxford University Press.
- TRONI, Joana Leandro Pinheiro de Almeida. 2008. *D. Catarina de Bragança (1638-1705)*. Lisbon. Edições Colibri.
- WOOD, Julia K. 1995[November]. "'A Flowing Harmony': Music on the Thames in Restoration London". *Early Music*. Vol. 23, N^o 4 (Music in Purcell's London I), pp. 553-581.



THE DETAILED DESCRIPTION AND INVOLVEMENT OF THE ARCHITECT LUÍS NUNES TINOCO IN THE ROYAL WEDDING BETWEEN KING PEDRO II AND MARIA SOPHIA OF NEUBURG (1687)*

TERESA DE CAMPOS COELHO

CHAM /FCSH/ Universidade Nova de Lisboa
teresacamposcoelho@gmail.com

* On this matter, I would underline the studies by Paulino Montez (Montez, 1931), Eduardo Brazão (Brazão 1936; 1937), Nelson Correia Borges (Borges, 1986), Ana Costa Gomes (Gomes, 2000), Ana Hatherly (Hatherly, 1991), Luís de Moura Sobral (Sobral, 1991), Sandra Sider (Sider, 1997), and Teresa de Campos Coelho (Coelho, 2014:435-442; Coelho, 2017; Coelho, 2018:324-329), all of which have an extensive bibliography.

ABSTRACT

In the second half of the 17th century, more than in any other period of Portuguese history, royal weddings played an important role as vehicles for political propaganda in the consolidation of the Braganza dynasty. Among the marriages celebrated during that period, the union of King Peter II and Maria Sophia of Neuburg in 1687 was of particular significance. I intend to highlight some aspects of the involvement of architect Luís Nunes Tinoco (1642/3-1719) in the realisation of this royal wedding, especially with regard to the texts that he composed about the festivities. Those in which he writes about specific characteristics of the arts, especially architecture, are particularly pertinent, as is a decasyllabic poem entitled *Triumpho da Real Fabrica e Pompa Luzitana*, in which he also describes the arches erected for the occasion. This poem is published here in full for the first time.

KEYWORDS LUÍS NUNES TINOCO, LISBON, BAROQUE, FESTIVITIES, KING PETER II.

RESUMO

Na segunda metade do século XVII, mais do que em qualquer outro período da história de Portugal, os casamentos régios desempenharam um papel relevante como veículos propagandísticos na consolidação da dinastia de Bragança. Dos casamentos que naquela época se realizaram revestiu-se de especial relevância o de D. Pedro II com Maria Sofia de Neuburgo (1687).

Neste estudo pretendemos chamar a atenção para alguns aspetos da participação do arquiteto Luís Nunes Tinoco (1643/3-1719) na realização deste casamento real, especialmente quanto aos textos que compôs sobre as festividades ocorridas nesse evento. Entre os seus escritos são particularmente relevantes aqueles executados sobre as características específicas das *Artes*, especialmente, sobre as da *Arquitetura*, e um poema decassilábico intitulado *Triumpho da Real Fabrica e Pompa Luzitana*, no qual também descreve os arcos das festas, e que aqui se publica na íntegra, pela primeira vez.

PALAVRAS-CHAVE LUÍS NUNES TINOCO, LISBOA, BARROCO, FESTIVIDADES, D. PEDRO II.



Dressing up Lisbon with ephemeral and erudite architecture

The geographical location of Lisbon, spread across hills that descend to the River Tagus, has been lauded by historians and by those who have visited it down the centuries. It represents a natural scenic stage that has been almost mythologised, and which accentuated the scenographic elements of urban festivals during the Baroque.

During the 17th and 18th centuries, views were invariably painted from the River Tagus, which served as the determining element in the city's history and image, and was the main point of access to the city until the end of the 19th century. Such scenes always highlighted the houses and the most important monuments, including palaces, churches and convents, not to mention the two main squares — Rossio and Terreiro do Paço, the latter of which was home to the Royal Palace before the major earthquake in 1755.

In the second half of the seventeenth century, more than any other period of the Portuguese history, royal weddings would play a fundamental role as political alliances and fundamental strategies for the consolidation and affirmation of a state that had newly reacquired its independence after twenty-eight years at war with neighbouring Spain (1640-1668). They also represented the consolidation of the royal house that had reigned since 1640 (the Braganza family) and the ambition of dynastic continuity.

To accomplish this strategy, four royal weddings took place in Portugal over this period, all of them involving the children of King John IV (1604-1656):¹

1662 — Wedding of the Princess Catherine of Braganza (1638-1705), the sister of King Afonso VI, to King Charles II of England (1630-1685) — marriage without heirs;

1666 — Wedding of King Afonso VI (1643-1683) to the French Princess Maria Francisca of Savoy (1646-1683) — marriage without heirs;

1668 — Wedding of Prince Peter (1648-1706), future king Peter II, to his sister-in-law Princess Maria Francisca of

Savoy — marriage with one descendant, Princess Isabel Luísa (1669-1690);

1687 — Wedding of King Peter II to the Princess Maria Sophia of Neuburg (1666-1699) — several children, among them the future King John V (1689-1750).

After the dissolution of King Afonso VI's marriage with Maria Francisca of Savoy, she would marry her brother-in-law, Prince Peter (the future King Peter II). When the Queen died in 1683, consolidating the Braganza dynasty with an heir, preferably a male son, became a matter of urgency (as mentioned above, Maria Francisca's second marriage resulted in only one child, Princess Isabel Luísa, who died unmarried). This compelled King Peter II to marry again.

The choice of future Queen was also an important matter in international policy. Opinions were divided between those who supported the choice of a French Queen (Duke of Cadaval) and those who, fearing the growing power of Louis XIV, advocated another option. Despite the Duke's influence, the choice would fall upon the daughter of the Elector Palatine, Princess Maria Sophia of Neuburg (1666-1699) "para segurança de sua Real [do Rei] descendencia, consolação de seus Vassallos, & soccego da Christandade"² (Costa, 1694:2).

An ambassador, Manuel Telles da Silva (1641-1709), Count of Villar Mayor and future Marquis of Alegrete, left Lisbon for Heidelberg in December 1686, accompanied by many other dignitaries, and tasked with bringing the new Queen to Portugal. The proxy marriage was conducted on 2 July 1687, with Manuel Telles da Silva standing in for the King.

Festivals were important not only as a manifestation of social and political rhetoric, but also as a way of expressing art. In this capacity, it was not merely limited to the construction of artifacts used to adorn the city. Most of these ephemeral and erudite architectures', which are scarce in the built city, were based on designs copied from engravings and architectural treatises. Over time, they contributed to the creation of an image that served as inspiration for all architects and artists. This was the case

¹ For more on these weddings, see the literature referred to in the footnote 1 and also the studies on the marriages of Catarina of Braganza in 1662 (Flor, 2012) and King Afonso VI in 1666 (Xavier et al, 1996), all of which have an extensive bibliography.

² "For the safety of his Royal descendants, consolation of his Vassals, & peace of Christianity".

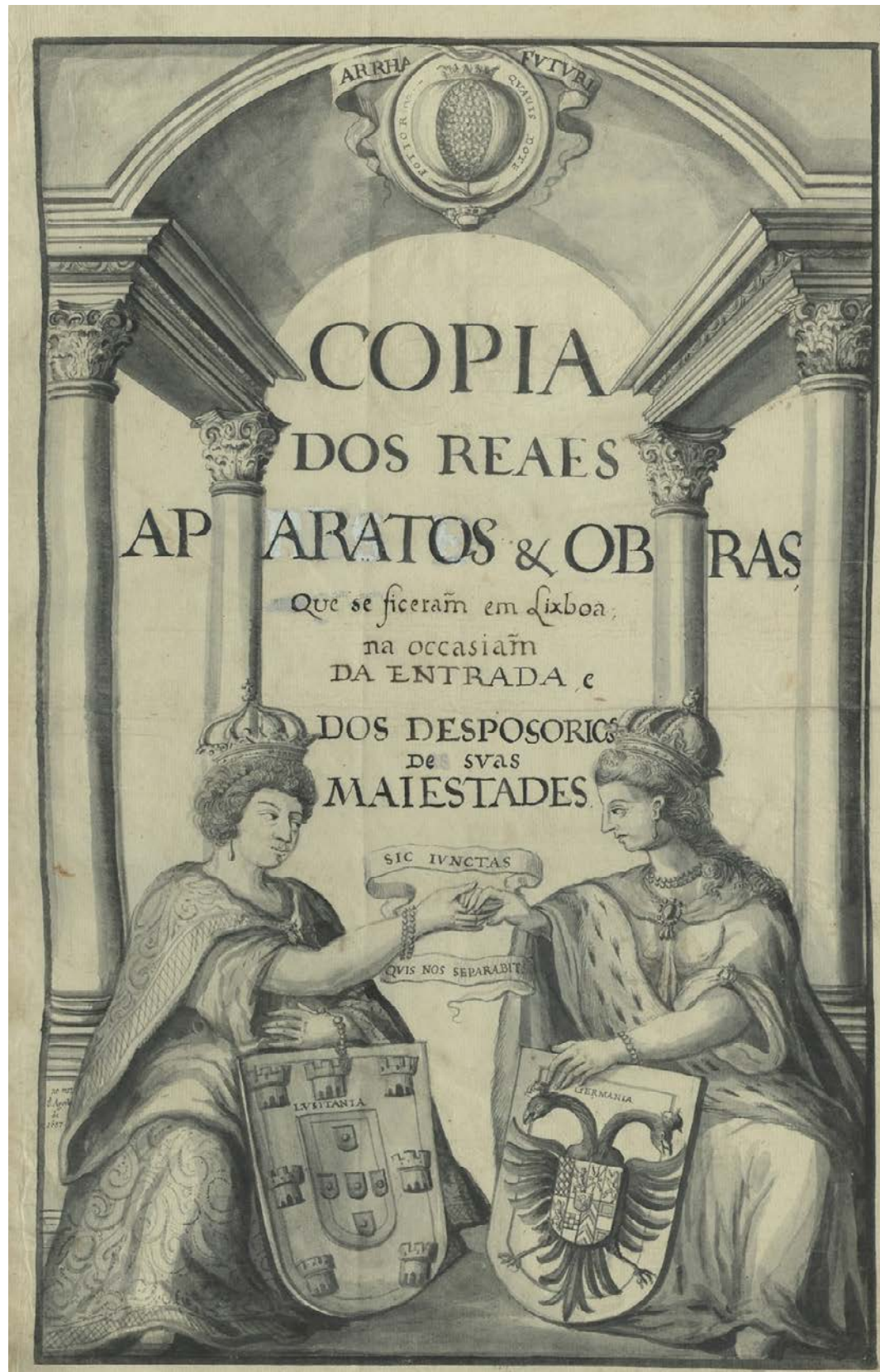

with the receptions to the Habsburgs, which would have a significant influence on the realisation of future royal festivities in Portugal, especially the *Joyeuse Entrée* of Filipe II in Lisbon

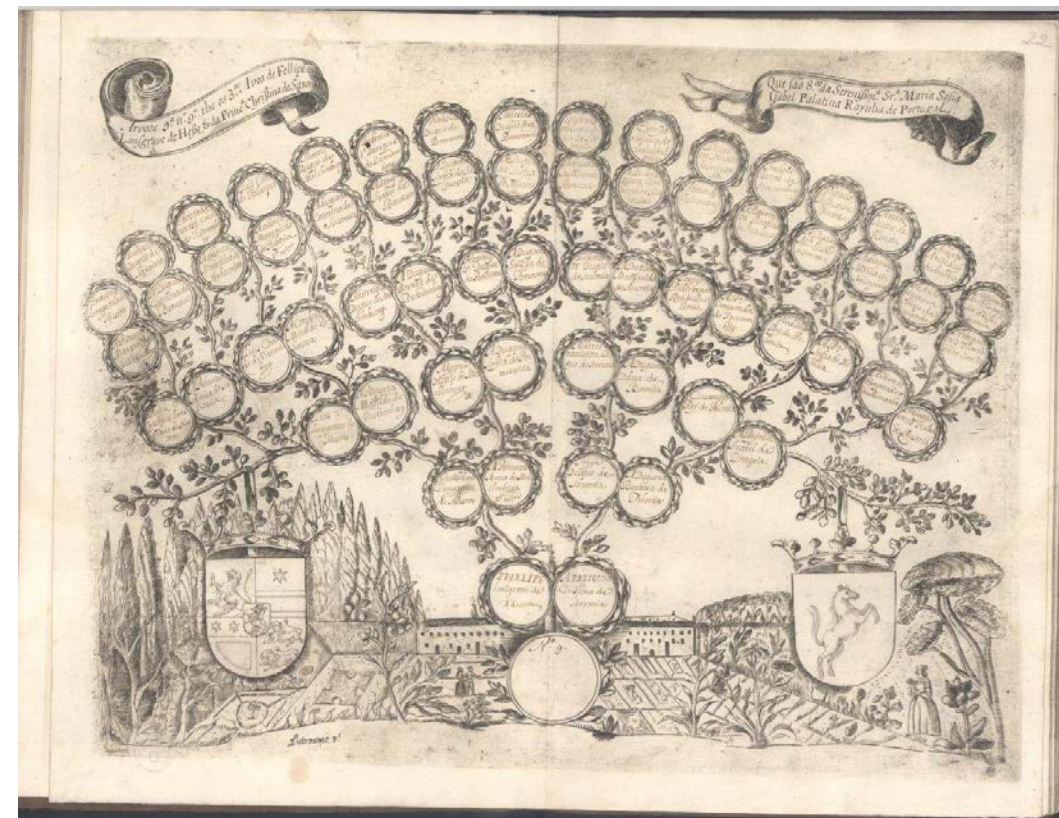

FIG. 1 REIS, João dos. (1687?). *Copia dos reaes aparatos e obras que se ficeram em Lixboa na occasiam da entrada e dos desposorios de Suas Majestades : Imago Ulyssae exultantis in adventu Ser[enissi]mae Portugalliae Reginae Mariae Sophiae*. Biblioteca Nacional de Portugal, Secção de Reservados, A.T./L. 317, fl.1.

FIG. 2 TINOCO, Luís Nunes (attr.). 1687. "Genealogical tree of Filipe Landgrave of Hessen and Princess Christine of Saxony, ancestors of Maria Sofia Isabel of Neuburg". In CUNHA, Antonio Alvares da Cunha. *Arvores genealógicas da real ascendencia....* Biblioteca Nacional de Portugal, Secção de Reservados. Cod.13144, fls. 21v-22.

in 1619, described and recorded by João Baptista Lavanha (Lavanha, 1621).³

The programmes were put together by the royal architects in collaboration with artists and other bodies of the municipal council, funded by the many nations and professional associations.

In accordance with tradition, the Queen's reception was organised by the municipal council, together with the Duke of Cadaval, Count of Ericeira, Count of Villar Mayor and Lourenço Pires de Carvalho, who was in charge of all the royal works. Leading cultural figures of that time also helped to organise the event, including the Theatine Rafael Bluteau and the Jesuit João dos Reis, the top-ranking royal architects, such as Mateus do Couto (the Younger). Couto was assisted by architect Luís Nunes Tinoco (1742/3-1719), who probably had already collaborated with his father, the royal architect João Nunes Tinoco, when King Afonso VI's marriage took place in 1666.

The chroniclers were unanimous in describing the grandeur of the festivities. These were recorded in the album *Reais Aparatos*

³ For more on this subject, see the works of Miguel Soromenho (Soromenho, 2000) and Maria João Pereira Coutinho (Coutinho, 2017). The latter wrote a study on the importance of ephemeral structures on Portuguese architecture, with particular emphasis on similarities between the decoration of portals and arches.



(Fig.1) assembled by the Jesuit João dos Reis (Reis, 1687), containing drawings of the arches and other architectural and decorative elements that punctuated the royal route; the Jesuits were responsible for the triumphal portico next to Casa da Índia (Coimbra s/d, fl.35, Borges 1986,19 footnote 45, 66). These efforts were also captured in the many sketches, texts and poems by Luís Nunes Tinoco. Raphael Bluteau wrote the Latin inscriptions that completed the decoration (Bluteau 1694), and Antonio Álvares da Cunha (1626-1690) composed *Arvores genealogicas da real ascendencia* (Fig.2) about the

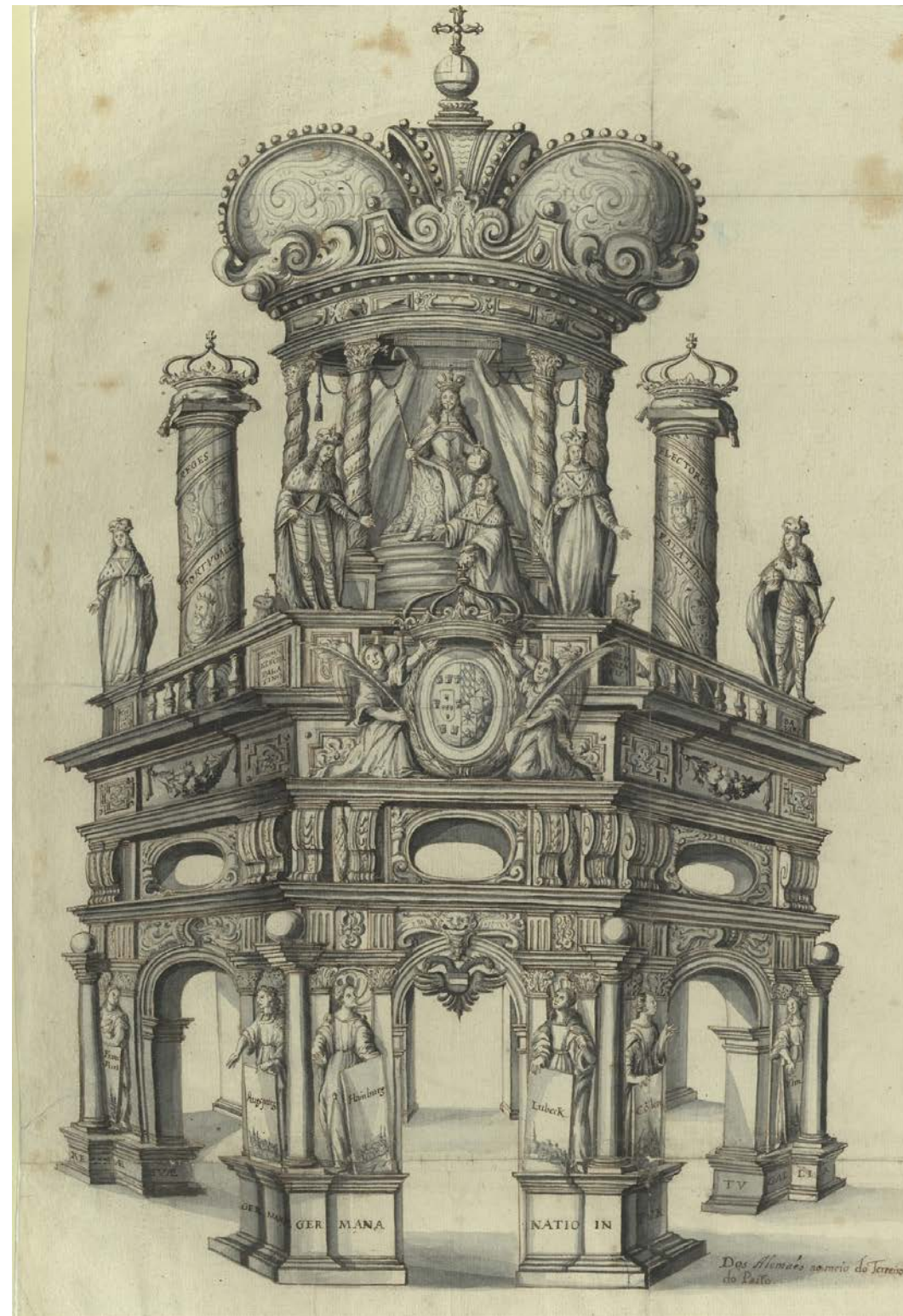

FIG. 3 REIS, João dos. 1687?. *Royal brigantine*. In *Cópia dos reaes aparatos...* Biblioteca Nacional de Portugal, Secção de Reservados, A.T./L. 317, fl.29.

FIG. 4 REIS, João dos. 1687?. "German's Arch". In *Cópia dos reaes aparatos...* Biblioteca Nacional de Portugal, Secção de Reservados, A.T./L. 317, fl. 28.

Queen's genealogy (Cunha 1687). The engravings in Cunha's work have also been attributed to Luís Nunes Tinoco (Caetano and Soromenho 2001, 134). The accumulation of these works leads us to believe that they were probably intended to form part of a commemorative compilation about the royal wedding, which was never published.

The Queen arrived in Lisbon on 11 August 1687; the King was waiting for her in a sumptuous brigantine (Fig.3). A royal procession took place on 30 August, starting from the Royal Chapel. The route was similar to that taken in celebration of the marriage of Afonso VI, punctuated by magnificent triumphal arches located near the most symbolic squares and buildings, such as the City Hall (where the monarchs received the keys to the city) and the Cathedral, to end at Terreiro do Paço, which was decorated with the Germans' Arch. (Fig.4) The festivities would last all summer, with Lisbon staging many other events.

Along with the virtues of the royal couple and of Portugal, the celebrations also highlighted the many enchantments of Lisbon. The city's climate, geographical situation and natural beauty were vaunted as attributes that had made it the capital of a vast empire, which would now be renewed by King Peter II, who "há de ser a 1ª Pedra do alicerce do Imperio Luzitano" (Tinoco 1687a, 23v).⁴

"Thus applauded, famous and notorious is the happy marriage of such enlightened monarchs" (Tinoco 1687c) Artist gifted with many talents — designer, calligrapher, poet and architect — Luís Nunes Tinoco was made an architectural apprentice in September 1677. His learning and skill predated this appointment, as he had previously served as an assistant to his father, the royal architect João Nunes Tinoco (1616-1690), a long career that would lead to his nomination, in 1690, as architect responsible for work on the S. Vicente de Fora Monastery in Lisbon, the most important royal project of its age.

The younger Tinoco's experience in architecture is also evident from the many texts he wrote, which cite figures such as Vitruvius, Serlio, Sagredo, Vignola, Juan de Arfe y Villafañe and Juan Bautista Villalpando. His writings examined the theoretical and practical aspects of the profession, while at the same time incorporating an ethical and moral dimension that sought to guide man in using his own innate knowledge. A document from 1716 mentions that Luís Nunes Tinoco assisted Lourenço Pires de Carvalho and the royal architect Mateus do Couto (the Younger). He is said to have accomplished all of the papers and projects that King Peter II had ordered him to

do, in which he revealed 'great intelligence, dexterity and skill' (Hatherly 1991, 11-12).⁵

Given the important role that Lourenço Pires de Carvalho and Mateus do Couto played in the arrangements for the royal wedding (designing the 'magnificent bridge' praised by all of the chroniclers and by Luís Nunes Tinoco himself (Fig. 5), it is almost certain that Tinoco would also have worked on the programme for the festivities. This hypothesis is reinforced by his detailed descriptions, texts and drawings on the subject:

- The engravings (16 family trees) that illustrate the album composed by António Álvares da Cunha (1626-1690) and dedicated to King Peter II, showing the ancestry of Queen Maria Sophia of Neuburg (Cunha, 1687),⁶ signed *Luís Nunes fecit* and attributed to him (Caetano and Soromenho 2001,134) (Fig. 2);
- two homonymous manuscripts entitled *Pheniz de Portugal Prodigioza*, one in Coimbra University Library⁷ signed by him (Tinoco 1687a), and other in the National Library of Ajuda (Lisbon),⁸ which is also attributed to him (Tinoco, 1687b)⁹ (Fig.6);
- the poem *Triumpho da Real Fabrica e Pompa Luzitana*¹⁰ (Tinoco, 1687c), consisting of 36 decasyllabic stanzas with texts alluding to the decorative elements and architecture of the event, in particular of the arches erected for the occasion.

I do not intend to analyse the royal wedding festivities and some of the related works here, as this has already been done in previous studies.¹¹ Nevertheless, I would like to point out some of their most important aspects and, most importantly, present the poem *Triumpho da Real Fabrica e Pompa Luzitana*, which, despite having been cited before, has never previously been transcribed.

The manuscript *Pheniz de Portugal Prodigioza* from the Ajuda Library differs from

⁴ "will be the 1st stone in the foundation of the Lusitanian Empire".

⁵ Arquivo Nacional da Torre do Tombo. *Registo Geral de Mercês*, D. João V. L.º8, fls 73-73v.

⁶ Biblioteca Nacional de Portugal. *Secção de Reservados*, Cod. 13144.

⁷ Biblioteca Geral da Universidade de Coimbra, ms.346.

⁸ Biblioteca da Ajuda, 52-VIII-37.

⁹ These manuscripts had already been studied by Nelson Correia Borges (1987), Ana Hatherly (1991), Luís de Moura Sobral (1991), Sandra Sider (1997) and Teresa Campos Coelho (Coelho, 2014:441-446; Coelho, 2017; Coelho, 2018:326-330), among others.

¹⁰ Library of the Congress — Washington, ms. P-209, n.º 182, Portuguese Collection, fls. 56-65v. Document referred to in (Sider, 1997:64), (Coelho, 2014:435; Coelho, 2017:61; Coelho, 2018:326). I would like to thank Mrs Edith A. Sandler (Library of Congress, Washington — Manuscript Division) for having given us the full text, which I am transcribing and publishing here for the first time.

¹¹ For a detailed analysis of this marriage, see the studies referred to in footnote 1.



the manuscript from Coimbra. The Ajuda manuscript describes the decorative and architectural details of the festivities, of which the pages devoted to military and civil architecture are of particular note. If, at first glance, *Pheniz de Portugal* appears to be an immense panegyric to the royal marriage and to the historical moment that Portugal was experiencing — indeed, Luís Nunes Tinoco described 1687 as ‘the first year of the renewal of Portugal’s Golden Age’ — it is also a panegyric to the arts themselves, as shown by the many anagrams that he makes using with the name of the Queen.

FIG. 6 TINOCO, Luís Nunes Tinoco (attr.). 1687. *A Pheniz de Portugal Prodigioza... Pavillion and German's Arch*. Watercolor. Biblioteca da Ajuda, Cod. 52-VIII-37, fls. 16v-17.

FIG. 5 REIS, João dos Reis. 1687?. “Bridge projected by Mateus do Couto”. In, *Cópia dos reaes aparatos...* Biblioteca Nacional de Portugal, Secção de Reservados, A.T./L. 317, fl. 32.

For example, when describing the civil architecture, he matches the number of letters in the name of Maria Sofia Isabel (16) to the sum of the fundamental elements in architecture (16): five architectural orders (Tuscan, Doric, Ionian, Corinthian and Composite), each one divided into five parts (pedestal, column, architrave, frieze, cornice), and six indispensable requirements to this art (order, arrangement, proportion, symmetry, decorum and distribution). In his hexagonal anagram he also draws a link between the sixteen letters in the Queen's name and the number of columns in the German Arch (Tinoco 1687b,183v).

By describing the temporary architecture used to adorn the city (with a view of the Terreiro do Paço) or the decorative elements and structures required for the fireworks, Tinoco's description of the different arches (styles, techniques, materials and dimensions) reveals his practical knowledge of architecture and the work that went into organising the festivities.

His tribute to the bridge commissioned by Lourenço Pires de Carvalho and designed by the architect Mateus do Couto deserves a special mention. Tinoco describes this as 'the eighth wonder of the world' and extends the accolade to the Portuguese architects, engineers and artists responsible (Tinoco 1687b, 3).

Unlike in *Pheniz de Portugal Prodigiosa* and *Triumpho da Real Fabrica e Pompa Luzitana*, here Tinoco's description of the iconography and composition of the different arches is somewhat abbreviated (rarely paying heed to materials, techniques or decoration) and voiced in a poetic and panegyric style. The entire poem is an acclamation of the royal event.

Special emphasis is given, once more, to the bridge designed by Mateus do Couto, the 'rare idea' of Lourenço Pires de Carvalho and the Latin inscriptions composed by Rafael Bluteau for the festivities (stanzas 4 and 12).

Final considerations:

As an architect who had also mastered a range of other disciplines — design, calligraphy and poetry — Luís Nunes

Tinoco is the author of a vast body of work and approached his various subjects in an almost encyclopaedic way.

In this poem, the description of the arches is not that of Luís Nunes Tinoco *architect* (as is the case in *Pheniz de Portugal*), but of Luís Nunes Tinoco *poet*, reinforcing his already considerable literary clout in the cultural circles of the time, which centred around the Academies established by the Count of Ericeira and by the Marquis of Alegrete (Count of Villar Mayor).

The poem's laudatory intention is also expressed in the words of its final verses: 'Thus applauded, famous and glorious is the happy marriage of such enlightened monarchs'.

**COMPENDIO TRIUNFAL DA REAL FABRICA, E POMPA
LUZITANA, que a Nobilissima Cidade de Lisboa erigiu a
feliz Entrada, & Reaes Despozorios Del Rey D.PEDRO II de
Portugal com a Seren.^a R.^a MARIA SOFIA ISABEL, Princeza
Palatina. Anno 1687**

1

Da Barbara Antiquidade / Esses Milagres cantados / No
silencio sepultados / Felix a nossa Idade; / Emmudecida a
 vaidade / Fique, e arrogancia do Egipto, / Porque hoje da
Fama ao grito, / Erigir se vem gloriosos / Pasmos inda mais
famosos / Dignos de mais alto espirito.

2

Juno Emperatriz do Ar / Benigno auxilio me preste / E do
seu Arco Celeste / Cores para os meus pintar; / De para
mais os realçar / Aurea húa frecha Cupido / De seu Arco, e
com Luzido / Estylo, neste Papel / Sutil descreva o Pincel, /
Pinte o Calamo subido.

3

Não basta; inda é necessario / Contra a Inveja desumana /
O auxilio de Diana, / O poder de Sagittario; / Porque o ferir
temerario / Seu despreze; e oppoziçoés / Dos Zoylos faça às
Razoés / De todo o Esquadrão Celeste / Seja despojo esta
peste / De Feras, e Escorpioés.

4

Já na Ponte, que me enlea / Cifrada outra India vejo, / Por quem Rio d'ouro o Tejo / Inda hé mais, que pela área; / Foy culta, foy rara Idea / Desse insigne Provedor¹² Se também raro primor / De ouro Livio illustre Conde¹³ / Mas à Fama não se esconde, / Que hé di ambos igual Louvor.

5

Hé tão rara em fermozura, / Que vista por qualquer parte / Ás demais no engenho, e arte / Excede, e na Architectura; / Mas que direy da Pintura / Tam viva, e tam relevante? / Tanto distico elegante, / Tanta elegancia de emblemas? / Em fim das obras supremas / Calle a penna, a Fama cante.

6

Toda era objecto facundo / Da vista, e do entendimento, / Da Alma outro quinto Elemento, / Prodigio Oitavo do Mundo; / Hum Portento sem segundo, / Vindo a ser por este modo / Das quatro Partes hum Todo / Das virtudes Firmamento; / Das Quinas Reaes ornamento, / Inveja do esforço Godo.

7

Com insignes propriedades / Se vião velhos, e frios / Os principaes quatro Rios, / E quatro illustres Cidades; / Nunca virão as Idades, / Por muito que a Fama conte / Obra que mais se Remonte; / E se he pasmo sem segundo / Ver numa Cidade hum Mundo, / Mais hé velho em húa Ponte.

8

Vista com olhos benignos, / Se foi Mundo abreviado, / Tambem foi Ceo Estrellado / De Constellaçoens, e signos; / De muitos Louvores dignos / São os dous Reais Planetas, / Pois já excedendo as Metas / De todo o Humano poder / Fizerão do Ceo descer / Astros já do Amor Cometas.

9

Entrando pelo Passeyo / Desta Ponte, sublimada / Luzitania retratada / De outro Ceo se vé no meyo / Esta do sentido enleyo, Do valor regendo a Esfera / Mostra, que só persevera / Triunfante nas quatro Partes / Poys por seus invictos Martes / Ella só no Mundo Impera

10

Aly a hum lado estava Europa / Das quatro Partes Raynha; / E ali também se continha / Africa, em que a vista topa; / Tambem de fino ouro em opa / Regia, roçagante, e rica / A Asia aqui se dedica, / E a America di outro Lado, / Mostrando, que o Luzo brado / A todas se comunica.

11

E formadas em duas Alas / De dezasseis por fileyra, / Seguindo a Real Bandeyra / Como em Theatro de Palas, / Ricas ostentavão galas / Das Provincias as grandezas / Terras, Ilhas, Fortalezas, / Que o Luso foi conquistando / Ter mais Mundo dezejando / Inda para mais Emprezas.

12

Mas não há mais que dizer, E nesta razão me fundo, / Que quem corre todo o Mundo / Não pode ter mais que ver; / Só para admirada ser / He da Ponte a armação, / Pela elegante inscripção / Da melhor proza Latina / Que à Providencia Divina¹⁴ / Se deve a dispozição.

13

Porem se o dezejo Humano / Nunca no que vio parou, / E por mais Mundo anelou / Aquelle Alexandre Magno; / Não seguindo o dezengano / Buscar foy da Ponte o fim / Porque visse mais; e assim / Logo advertio num Portal / Que tanto, nunca outro tal / Louvou da fama o Clarim.

14

Entrando por elle adiante / Se continua cuberto / Do Corredor o concerto / Pompozamente arrogante; / Outro Oriente brilhante / Hé da India a Caza; Mar / Que rico se hade chamar / Quando benigno o arrebol / De outro Luzitano Sol, / Qual Celeste, a visitar.

15

Fez-se à entrada da Capella / Pompozo hum, e outro Arco, / Donde absorta a fama, o marco / Póz da perfeição mais bella; / Certo se chagára a vella / Cupido nesta occazião, / Da branda, invencivel mão / Ali o seu cahir deyxára, / Das sobrancehas formára / Outros dous de admiração.

¹² Marginal note: Lourenço Piz Carv.º Prov.or das obras dos Paços.

¹³ Surely D. Luís de Meneses (1632-1690), Count of Ericeira.

¹⁴ Marginal note: o P.e D. Rafael Bluteau compoz as inscripções

16

Não se vio, nem se hade ver / Obra de tanto Louvor; /
Que eterniza no valor / Da Magestade o poder / Amor o
Arquitecto ser / Devia de obra tam bella, / Que muito? /
se se desvella / Por ser, para quem ser vinha / Do Mayor
Ceptro Raynha, / Do mayor Monarca Estrella.

17

Levantãose Arcos Triunfaes / Dezoito em tudo primeyros, /
Competindo os Estrangeyros / No amor, com os Naturaes;
/ Forão sitio destes taes / Cubertos, Calcetaria, / Rua
Nova, Sé, Prataria, / Pelourinho, e chão do Paço, / Em cujo
succinto espaço / Cifrado o Mundo se via.

18

Da Fama para braço / O pymeiro Arco Triunfante / Se
levantava arrogante / Gloria do Divino Antão; / Excedia em
perfeção / Por modos mais soberanos / Aos Assírios, aos
Romanos, / Mostrando em tudo excelente / Que dos Medos
mayormente / Triunfou nestes nossos annos.

19

Ergue em espaciozo terreyro / De Italia o primor facundo
/ Outro Arco, na ordem segundo, / Mas na admiração
primeyro; / Ao sentir mais verdadeyro / Que o melhor
foi, me acomodo, / Poys mostrou por novo modo / De
imperfeção singular, / Que fora hum nunca acabar /
Querello acabar de todo.

20

De jaspes mil matizado / Com outro a Esquadra fiel / Do
alado esplendor Miguel / Dá mate ao Ceo Estrellado; / Na
obra hé tam elevado, / Que de único a palma alcança, / E na
grandeza afiança / Aplauzos mil immortais, / Pois no primor
com os mais / Se via em igual Balança.

21

Dos moedeyros raro o estudo / Outro erguer grandiozo
preza; / Mas que muyto haver grandeza / Donde roda em
Ouro tudo? / Este pelo Regio Escudo / Se aparentou sem
igual / Com a Magestade Real / Porque hé das Armas
Cunhado, / Mas que muyto seja honrado, / Se ouro he, o
que ouro val.

22

O dos Ourives se via / Campanha, onde celebrada / Nua da
Belleza a espada / Mostrou que a tudo rendia; / Tanto aos
outros excedia / No capricho, e no desenho, / Que nelle com
novo empenho / Se admirava por grandeza / Como já o fora
a Belleza, / Ser outra victoria o engenho.

23

Parece, que aos mais coroa, / A todos dando mil mates / O
Arco dos Alfayates / Có a melhor Flor de Lisboa; / Já delle
a fama pregoa, / Que da Luza á Oriental praya / No mar do
primor se ensaya, / Pois no Lavor, que continha / Passou
pela Agulha a Linha, / Chegou da grandeza á Raya.

24

Mais adiante peregrina / Em ameno campo razo /
Para inveja do Parnazo / Rebenta outra Caballina; / De
Arquitectura Divina / Hum Arco á corrente pura / Diadema
imortal lhe jura ; / Mas elle com voz de prata / Da gloria, que
em sy retrata / Perennemente murmura.

25

De grande instructura, e arte / Belgico o poder fabrica, /
Outro Iris que a paz publica / Em tanto vario Estendarte;
/ Aqui mais que em toda a parte / Verás seus extremos
grandes / Vendo este Triumphal thezouro, / Nem como a
Mina, mais ouro, / Nem como Olanda mais Flandes.

26

O Arco dos Mercadores / Sobe ás Celestiaes ameas; /
Era a Idea das Ideas, era o primor dos primores; / Raros
se adquirio Louvores; / Fenix no amor sem igual, / Poys
hoje a Estirpe Real / Noutro ardor de heroycos Metro; /
Immortalizando os Cetros / Fazer se soube imortal.

27

Tremerão; e não foy graça / Os Estrangeyros confusos / De
ver os Monarcas Luzos, / Todos juntos numa Praca: / Como
estrondo, que ameaca / De cada hum em todos fora / Rayo
a espada vencedora, / Ignoravão, que obraria / Esta em tam
notável dia / Conjunção maxima agora.

28

Imitando a pedraria / Do Reyno mais singular, / Se vio hum
grande Arco estar / Na entrada da Prataria; / Cercado em

flores se via / O Divino Patriarca / Espozo da melhor Arca,
/ Que abrio da graça o Noé / Ante quem Menino hé / Da
Terra, e Ceo o Monarca.

29

Junto ao Templo da sem par / Santa, que foy com fe pura
/ O exemplar da Fermozeria, / Da Penitencia exemplar; /
Outro Arco se via estar / De Architectura bizarra, / Onde a
Prata (a Fama o narra) / Se ostentará o seu thezouro, / Alem
dos quilates de Ouro / Pudera Lançar a Barra.

30

Mais adiante outro Arco erguerão / De ponto em forma
perfeyto, / Celar, por onde foi feyto, / Solar pelos que
o fizerão; / Que espiritos solares eram / Mostrarão na
perfeção / Dos pontos Reaes então; / Poys se com formal
estudo / A seus pés se rende tudo, / A nada aqui dão de
mão.

31

Brilhou mais que nunca a Cera, / No que se seguia a este, /
Fazendo ao Brandão Celeste / Lá menos Luzir na Esfera; /
Em tudo hum prodigio era, / No Relevo, e relevante; / Delle
sempre a Fama cante / Os applauzos deste Dia; / Poys no
Hymeneo de Sofia / A Tocha foy mais brilhante.

32

Todo o Portico excellente / Do principal raro Templo, /
Maravilha sem exemplo / Foy ser outro Arco eminente; /
Gloria foy de Galia à gente, / Assombro a toda Lisboa, /
Delle, que o vé pregoa / Por cem boccas Monstro alado /
Que foy publica já o brado / Deste Triunfo a Coroa.

33

Valente outro Arco Triunfal / Se vé com as Armas Inglezas
/ Que nas primeyras empresas / Ajudarão a Portugal; /
Gloriozamente fatal / Ali Jacob se via / Quando entam no
zelo ardia / Da Hierusalem Triunfante / Fero empunhando o
montante / Da Fe contra a Hoste impia.

34

Do invicto Jorge a Bandeyra / Outro Arco vistozo, e bello
/ Faz em forma de Castello / Cercado di alta Trincheyra; /
Soberba delle a fronteyra / Estava com o Santo armado /

Em hum cavallo montado / Com a lança, e com o escudo /
Porque foy vencendo a tudo / De Lysia o Marte sagrado.

35

Mas vejamos, que tamanha / Sobe a gloria ao galarim /
De tanta grandeza ao fim / Já coroando o de Alemanha; /
Remata a Maquina estranha / Num trono, que ao Ceo subia
/ Em roda do qual se via / Com Magestade e mysterio /
O como sobe ao Imperio / A Ascendencia de Sofia.

36

Desta maneyra applaudidos, são celebres e notorios / Tam
felices Despozorios / De Reys tam esclarecidos; / E se para
referidos / He breve toda a Historia / Tenha só a Penna
gloria / Que posta em silencio assim / Nos Lavores na poem
fim; / E fica eterna a Memoria. / Fim.

Acknowledgements

The Congress organisers, particularly Maria João Pereira
Coutinho and Sílvia Ferreira

National Library of Portugal and National Library of Ajuda
(Lisbon)

Library of Congress in Washington, particularly Edith A.
Sandler (Manuscript Division)

Municipality of Loures

BIBLIOGRAPHY

SOURCES

BIBLIOTECA GERAL DA UNIVERSIDADE DE COIMBRA

COIMBRA, Manoel. s/d. *Descrição da sumptuosa ponte que se fabricou para o desembarque da augustíssima Rainha de Portugal D. Maria Isabel. Offerecida à mesma sereníssima senhora com huma illustração das inscrições, e emblemas, por Manoel de Coimbra.* Ms. 323.

TINOCO, Luís Nunes. 1687a. *A Pheniz de Portugal Prodigioza em seus nomes Maria Sofia Isabel Raynha Serenissima & Sra Nossa em cuja Augustissima Entrada por Artes Liberaes em curiozos Anagramas se mostra felizmente renovada a Idade do Ouro. Do Anno de 1687.* Ms 346.

BIBLIOTECA NACIONAL DE PORTUGAL, SECÇÃO DE RESERVADOS

CUNHA, António Alvares da, NUNES, Luís. 1687. *Arvores genealogicas da real ascendencia da muito soberana Princesa Maria Sofia Isabel Palatina Raynha de Portugal athe os outavos avós offerecidas ao muito esclarecido Principe D. Pedro II do nome vigessimo Rey de Portugal por D. Antonio Alvares da Cunha seu trinchante.* Cod. 13144.

SOUZA, Manuel Nogueira de. 1687. *Relação dos reaes Despozorios de El Rey D. Pedro II de Portugal com a Serenissima Princeza Eleytoral D. Maria Sofia Izabel. De sua feliz chegada à Corte de Lix.ª Da Triumphal entrada de S. Magestades à Sé, e festas que se lhes fizeraõ.* Cod. 260.

BIBLIOTECA DA AJUDA

TINOCO, Luís Nunes (1687a). *A Pheniz de Portugal Prodigioza em seus nomes Maria Sofia Isabel Raynha Serenissima & Sra Nossa em cuja Augustissima Entrada por Artes Liberaes em curiozos Anagramas se mostra felizmente renovada a Idade do Ouro. Do Anno de 1687.* 52-VIII-37.

LIBRARY OF THE CONGRESS-WASHINGTON

TINOCO, Luís Nunes. 1687c. *Compendio Triunfal da Real Do Anno Fabrica e Pompa Luzitana que a Nobilissima Cidade de Lisboa erigio a feliz Entrada, & Reaes Despozorios Del Rey D. Pedro I de Portugal com a Seren.ª R.ª Maria Sofia Isabel Princeza Palatina. Anno 1687.* Ms. P-209, nº 182, *Portuguese Collection*, fls. 56-65v.

PRINTED SOURCES

BLUTEAU, Padre Rafael. 1694. *Porticus triumphalis, a regali palatio, Quá Meridiem spectat, In Tagum exporrecta, Ad publica receptionem Augustissimae Mariae, Sophiae, Elisabethae, Portugalliae Reginae, Ulyssiponem ingredientis, anno Domini MDCLXXXVII. die 11. Augusti piae, Portugalliae Reginae, Ulyssiponem ingredientis, anno Domini MDCLXXXVII. die 11. Augusti pictis, inscriptisque tabulis Jusso Regis ornata a R. P. D. Raphael Bluteavio Clerico Regulari Theatino sacrae Theologie Professore, Olim Henricette Mariae à Franciá, Anglorum Regine, a concionibus, Nune In Lusitania, in Supremo Sanctae Inquisitionis Denatu, Librorum Censore.* Ulyssipone: ex typographia Michaelis Deslandes.

COSTA, António Rodrigues da. 1694. *Embaixada que fes o Excellentissimo Senhor Conde de Villar-Maior ao Principe Philippe Guilhelmo Conde Palatino do Rhim... Conduçam da Rainha Nossa Senhora a estes Reinos, festas, & applausos, com que foi celebrada sua felix vinda, & as augustas vodas de Suas Magestades.* Lisboa: na officina de Miguel Manescal.

LAVANHA, João Baptista. 1621. *Viagem da Catholica Real Magestade del Rey D. Filipe II N.S. ao Reyno de Portugal e rellação da solene recebimento que nelle se lhe fez. Sua Magestade a mandou escrever por João Baptista Lavanha seu cronista Mayor.* Madrid: Por Tomas Iunti Impressor del Rei N. S.

STUDIES

BORGES, Nelson Coreia. 1986. *A arte nas festas do casamento de D. Pedro II: Lisboa 1687.* Porto: Paisagem.

BRAZÃO, Eduardo. 1936. *O casamento de D. Pedro II com a Princesa de Neuburg: documentos diplomáticos.* Coimbra: Coimbra Editora.

IDEM. 1937. "A recepção de uma rainha — festas lisboetas no século XVII". *Boletim Cultural e Estatístico*, vol. 1, nº 2. Lisboa: Câmara Municipal de Lisboa, pp. 185-200.

CAETANO, Joaquim de Oliveira, SOROMENHO, Miguél Conceição (2001), *A ciência do desenho : a ilustração na coleção de códices da Biblioteca Nacional.* Lisbon: Biblioteca Nacional de Portugal.

CARVALHO, Ayres de. 1960-62. *D. João V e a Arte do seu Tempo* (2 Vols.). Lisbon: author's version.

COELHO, Teresa Maria da Trindade de Campos. 2014. *Os Nunes Tinoco, uma dinastia de architectos régios dos séculos XVII e XVIII.* Lisboa: [s.n.]. PHD, Universidade Nova de Lisboa.

IDEM. 2017. "Luís Nunes Tinoco nas Festas de Casamento de D. Pedro II com Maria Sofia de Neuburg". *Invenire*, nº 14, pp. 58-65.

IDEM. 2018. *Os Nunes Tinoco, uma dinastia de architectos régios dos séculos XVII e XVIII.* Lisbon: Fundação Casa de Bragança/Sistema Solar/Documenta.

COUTINHO, Maria João Pereira. 2017. "Arquitectura e supremacia: analogias entre a decoração de portais e arcos no contexto das festividades filipinas e brigantinas". *Cadernos do Arquivo Municipal de Lisboa*, 2ª série, nº 7, pp. 19-56.

FLOR, Susana Varela. 2012. *Aurum Regina or Queen Gold, retratos de D. Catarina de Bragança: entre Portugal e a Inglaterra de seiscentos.* Vila Viçosa: Fundação Casa de Bragança.

GOMES, Ana Cristina Cardoso da Costa. 2000. "Alianças, poder e festa. Os casamentos de D. Afonso VI e de D. Pedro II". *Arte efémera em Portugal*, Pereira, João Castel-Branco (coord.). Lisbon: Fundação Calouste Gulbenkian, pp. 50-99.

HATHERLY, Ana. 1979. "Para uma arqueologia da poesia experimental. Anagramas Portugueses do século XVII". *Colóquio-Artes*, nº 40. Lisbon: Fundação Calouste Gulbenkian, pp. 32-41.

IDEM. 1980. "Labirintos Portugueses dos séculos XVII e XVIII". *Colóquio-Artes*, nº 45. Lisboa: Fundação Calouste Gulbenkian p. 20-29.

IDEM. 1983. *A experiência do prodígio: bases teóricas e antologia de textos-visuais portugueses dos séculos XVII e XVIII.* Lisbon: Imprensa Nacional/Casa da Moeda.

IDEM. 1991. "A Pheniz de Portugal Prodigioza". *Luís Nunes Tinoco: Elogio da Pintura.* Lisboa: Instituto Português do Património Cultural, Galeria de Pintura do Rei D. Luís, pp. 14-18.

OLIVEIRA, Eduardo Freire de. 1896. *Elementos para a história do município de Lisboa.* (Part IX). Lisbon: Typographia Universal, pp. 1-18.

SIDER, Sandra. 1997. "Luís Nunes Tinoco's Architectural Emblematic Imagery in Seventeenth-Century Portugal: Making a Name for a Palatine Princess". In Grove, Laurence (dir. de?)- *Emblems and the Manuscript Tradition.* Glasgow: Glasgow Emblem Studies, pp. 63-79.

SOBRAL, Luís de Moura. 1991. "Luís Nunes Tinoco e a Teoria da Pintura". In *Luís Nunes Tinoco. Elogio da pintura.* Lisbon: Instituto Português do Património Cultural, Galeria de Pintura do Rei D. Luís, pp. 19-39.

SOROMENHO, Miguél. 2000. "*Ingenhosi ornamenti.* Arquitecturas efémeras em Lisboa no tempo dos primeiros Filipes". *Arte efémera em Portugal*, PEREIRA, João Castel-Branco (coord.). Lisbon: Fundação Calouste Gulbenkian pp. 20-49.

XAVIER, Ângela Barreto, CARDIM, Pedro, Álvarez, Fernando BOUZA. 1996. *Festas que se fizeram pelo casamento do Rei D. Afonso VI.* Lisbon: Quetzal.

BALTASAR AND BLIMUNDA ROUTE SOME INTRODUCTORY WORDS

FLORBELA ESTÊVÃO

(City Council of Loures. Researcher at the Instituto de História Contemporânea /FCSH/NOVA)

PAULA PITACAS

(City Council of Loures)

The *Baltasar and Blimunda Route* is a new cultural and touristic project characterized by a strong literary and heritage component. The epic lyricism of the book *Baltasar and Blimunda* by José Saramago united in 2017 the cultural departments of three municipalities — Loures, Mafra and Lisbon — in the creation of an original itinerary, evoking a series of topics romanticized in that book: the impressive characters of Blimunda and Baltasar, the utopian dream of flying by Bartolomeu de Gusmão, the exaltation around the music of Domenico Scarlatti, the promise of the king D. João V to build a convent-palace, and, finally, the people who built it.

The Route following the narrative of the book, illustrates certain passages through the emphasis given to places referred to in it. In this way, it aims to become a literary journey, bringing together some events and monuments related to the 18th century, a journey that takes place between Lisbon and Mafra, passing through Loures. In that spirit, it chooses three main locations, one in each municipality, which serve as anchors: “Casa dos Bicos”, where the head office of the José Saramago Foundation is located, and which functions as a “gateway” on the Route; the Monumental Square of “Santo Antão do Tojal”, in Loures; and the National Palace-Convent of Mafra. These main poles are then added along the way. This means that the Route highlights a network of locations with classified properties, all related to 18th century Portuguese and European history, and in close articulation with Saramago’s text.

i
INDEX

E
EDITORIAL

d
DOSSIER

This intermunicipal project, led by the municipality of Loures, started in 2017 and for its implementation was decisive the co-financing guaranteed by an application submitted to the “Lisbon Regional Operational Plan 2014-2020”¹.

Since the beginning of the project, the José Saramago Foundation has collaborated in several of the Route initiatives, becoming an important pillar of its success. This partnership was consolidated in November 2020 with the signing of a Collaboration Agreement between the Foundation and the municipalities promoting the project. The signing of this agreement represented an important moment in the process of implementing the Route, and symbolically sealed its inspiration in the work and figure of our Nobel Prize very clearly. At the same time, the Foundation started to play a significant role in the cultural initiatives that the Route aims to implement.

To better understand the objectives of the *Baltasar and Blimunda Route* it is important to mention that it is structured in four fundamental axes: presence in the world of digital communication, through an interactive website and its connection to social networks; physical presence in the territory through informative signs at the various points selected along the Route, in the three counties; implementation of an annual, diversified cultural program, aimed at different audiences; and the creation of a network of local, national and international partnerships, important for their dissemination, promotion and sustainability. Regarding the second axis mentioned, it is also necessary to add two interpretation centers, both located in the municipality of Loures, one of them being installed in the former sacristy of the Franciscan convent “Arrábido do Espírito Santo” (current Municipal Museum of Loures – “Quinta do Conventinho”), and another at the José Saramago Municipal Library. These two cultural facilities allow the visitor to make several “time travels”, one on the territory of the Loures valley in the 18th century (sacristy of “Conventinho”) and another on the characters of Saramago’s novel (Library).

the Route, hand in hand with literary fiction, accompanies fictional characters out of José Saramago’s imagination, alongside with authentic historical figures, on their journeys by roads, paths and places, between Lisbon and Mafra, passing

through Loures. To better find out about all these contents, those interested can visit the Route website, mentioned above, already available through this link: <https://www.rotamemorialdoconvento.pt/>

So, after all, what is the historical, fictional, patrimonial itinerary that this Route seeks to show and promote? Let us see it succinctly, county by county.

In Lisbon, the lines of the novel run in parallel with José Saramago’s work and biography. The itinerary can start or end at “Casa dos Bicos”, (head office of the José Saramago Foundation, as mentioned) in front of which is located the olive tree brought from “Azinhaga do Ribatejo” (birthplace of José Saramago), and whose roots welcome the writer’s ashes. In “Praça do Comércio”, also one of the Route’s visiting points, aspects of the court’s life are explained to the visitor, and above all one of the most emblematic stories in the book: that of Father Bartolomeu de Gusmão, and his invention of the flying machine that aimed to cross the skies of Lisbon. At “Rua dos Fanqueiros”, the old Corpus Christi Convent is evoked, where D. João V’s wife, D. Maria Ana de Austria, used to come to pray. We continue towards “Praça da Figueira”, where the privileged view over the hillside of the Castle reminds us of Blimunda’s house and the flight of the flying machine, “Passarola”. In “Rossio”, Baltasar and Blimunda’s first meeting is remembered, which takes place during an Act of Faith where the protagonist’s mother is punished, condemned for witchcraft. The Inquisition, its establishment in Portugal, its methods and the persecutions that echo in the novel are remembered at the Church of “São Domingos”.

In Loures we intend to signal and highlight the centrality of “Santo Antão do Tojal”, with its magnificent monumental baroque square. The Archbishop’s Palace, a building integrated in the imposing set of the square, served as a hosting place for the King and the Court during the frequent trips he made to Mafra. It was in this square that the bells destined for the convent’s Basilica were blessed and where the Italian statues disembarking at the “Rio Trancão” quay, followed the same destination as the bells. But the Route in Loures includes

¹ A total of 392.397,20€, with the following partial allocation of funding to each of the partner municipalities: Lisbon = 41.272,94€; Loures = 179.592,69€; Mafra = 171.531,57€.

other points of cultural and touristic interest based on two communication axes used at the time: the “Estrada Real Lisboa-Mafra” and the waterways of the “Tejo” and “Trancão” rivers where people and materials (including the mentioned bells along the sculptural ensemble) circulated. Thus, visitors are invited to visit examples of religious built heritage, such as the Church of “Unhos” and the former Franciscan Convent “Arrábido do Espírito Santo” where, as said, the Loures Municipal Museum is currently installed.

In Mafra, the Route values the “Real Obra” through two routes. The first goes from “Vila Velha” to “Alto da Vela” (this being the place where the palace-convent was built) and the second, corresponding to the transport of a huge block of limestone, known as “Pedra Benedictione”, on a route between “Cheleiros” and Mafra. The first, along the path that connected “Alto da Vela” (“Real Obra”) to “Vila Velha”, follows the old royal roads that served for the transport of raw materials, statues, and circulation of workers, master builders and the King himself, when visiting the “Real Obra”. The second route corresponds to the five days that the transport of that monolith took from “Cheleiros” to Mafra.

It remains to add that one of the strategic lines of the Baltasar and Blimunda Route has been, and will be, the realization of a set of a diverse cultural events, of which we highlight international congresses, which result from fruitful collaborations with universities. One of these meetings was the “Congresso Internacional José Saramago e o Memorial do Convento” that took place between 14 and 15 November 2019, at the National Palace of Mafra. Another successful scientific meeting was the International Congress “Baroque Festivities between the sacred and the profane: Europe and the Atlantic”, which took place between 17 and 19 October 2019 in Loures, at the Palace of “Correio-Mor”, framed in a protocol of collaboration with the Faculty of Social and Human Sciences² of the Universidade Nova de Lisboa.

² And in particular with the participation of the following institutes: Instituto de História de Arte (IHA/ NOVA/ FCSH), Instituto de Estudos de Literatura e Tradição (IELT/ NOVA/FCSH) e Instituto de Etnomusicologia/ Centro de Estudos em Música e Dança (INET-MD/ NOVA/ FCSH).

