

# Professional catalogue



improve your life





# CONTENTS

<b>HEAT PUMPS</b>	<b>10</b>
iSERIES: air/air and air/water SPLIT heat pump	12
full DC Inverter outdoors unit	18
hydronic and direct expansion indoor unit	32
built-in solutions for iSERIES heat pumps	68
iM: air/water MONOBLOC heat pump	82
X3 air to water heat pumps: residential and commercial applications	100
Monobloc	106
Split	130
Built-in solution for split heat pumps	148
All in one	156
Heat pumps accessories	170
X3 MODULAR heat pumps	190
X3 heat pumps for Domestic Hot Water	206
<b>FAN COIL</b>	<b>212</b>
Slim floor/ceiling	216
AC Floor/ceiling	224
EC Brushless floor/ceiling	246
Cassette	268
Ducted	284
High-wall	304



<b>X3 AIR CONDITIONING</b>	<b>312</b>
X3 SPLIT: residential single and multisplit air conditioners DC Inverter R32	314
X3 PACKAGE: commercial single split air conditioners DC Inverter R32	344
Cassette	350
Ducted	364
Floor/ceiling	384
Control system	394
HIGH-CAPACITY DUCTED: air conditioners with high external static pressure - R410A	400
X3 FS: floor standing air conditioners	406
LOW AMBIENT: air conditioners single split for special application	412
Air conditioners without OUTDOOR UNIT	418
D-I-Y Console	422



## OUR HISTORY

We are an historical Italian company specialized in the production and sale of air conditioning products and heating systems, founded in 1929 in Cavaria, near Varese, where production, R&D, IT and quality control are still operating on an area of 42.000 sqm. The headquarters are nowadays based in Alfianello, close to Brescia, where the company established its logistic and commercial departments with a warehouse of 20.000 sqm.

---

SINCE 1929

## OUR TEAM

---

We have an extensive sales network all over Europe which allows us to be easily reachable and aligned with local supply needs that, also due to different climatic conditions, require specific know-how.

---



# ARGO ACADEMY

---

**ARGO ACADEMY IS AN INNOVATIVE SPACE THAT HAS RECENTLY  
BEEN OPENED IN THE PRODUCTION PREMISES IN GALLARATE.**

---



Argo Academy is provided with the most modern work equipment and welcomes customers and collaborators for training activities that are structured on several specialisation levels.

To ensure high learning standards, the training offer combines theoretical activities with several operative sessions, thanks to the full functionality of the systems installed inside the training room.

## MAIN GOALS

---

- **TECHNICAL TRAINING** on several levels for operators who work in the air conditioning and heating sector
- **COMMERCIAL TRAINING** with constant updates on the Argo product range

## THE RECIPIENTS OF OUR TRAINING OFFER

---

- INSTALLER
- AGENTS - DISTRIBUTORS - CLIENTS
- DESIGNERS - HEATING ENGINEERS

## TYPES OF TRAINING OFFER

---

To pursue high learning standards, our training offer is divided by type of product, application sector and level of detail in the topics:

1. **Product type:** direct expansion/hydronic solutions
2. **Application sector:** residential/commercial/big systems
3. **Specialisation level:** base - installers/advanced - designers

## THE COURSES

The training offer is initially articulated in the following courses:

1. Residential - air conditioning and direct expansion: monosplit and multiplit systems
2. Residential - hydronic heat pumps: monobloc units (iM/X3) and (iSERIES/X3) split systems
3. Commercial and big systems



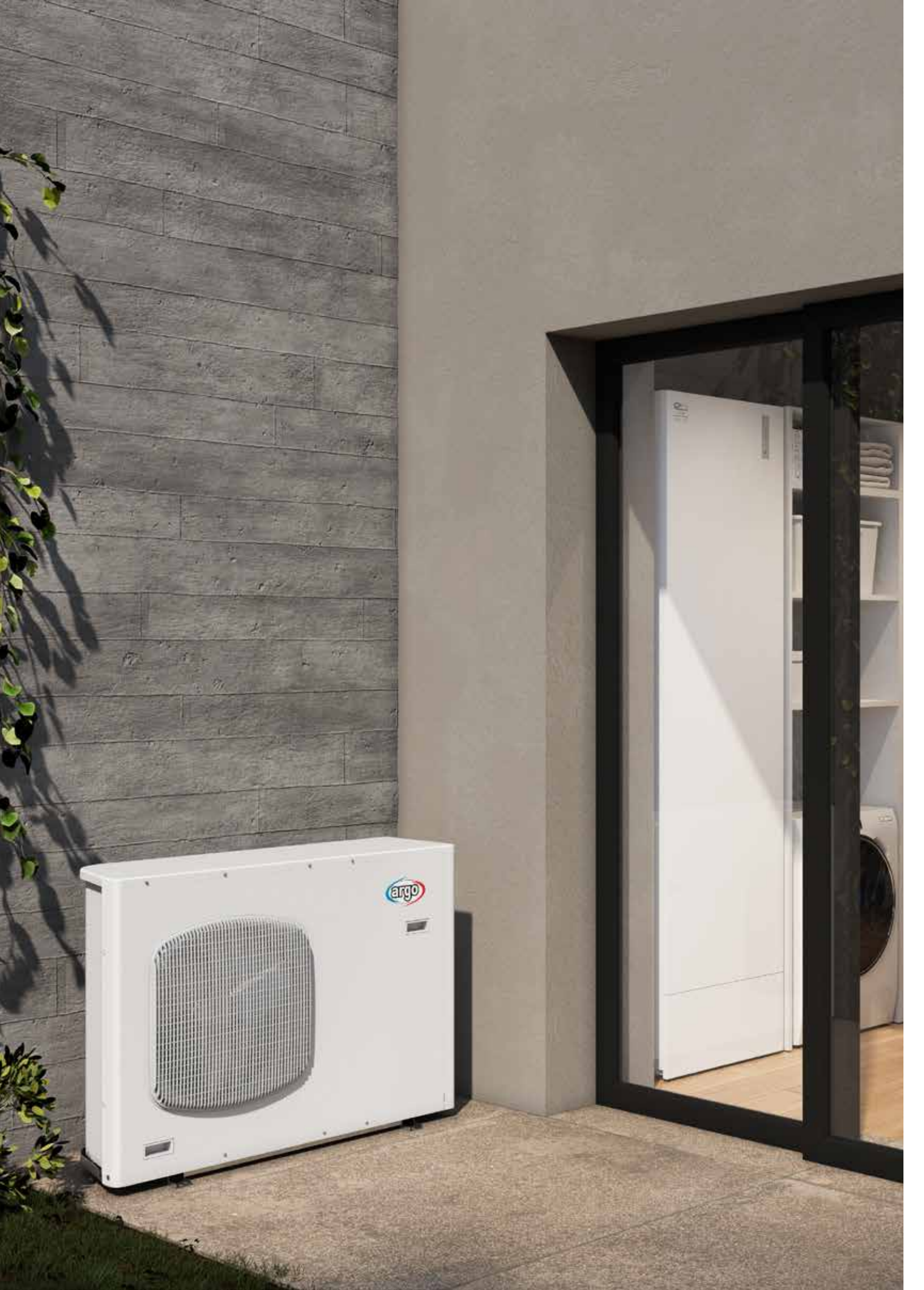

# HEAT PUMPS

---

iSERIES: air/air and air/water SPLIT heat pump

iM: air/water MONOBLOC heat pump

X3 air to water heat pumps: residential and commercial applications

Heat pumps accessories

X3 MODULAR heat pumps

X3 heat pumps for Domestic Hot Water

# RENEWABLE ENERGY SYSTEMS FOR MAXIMUM COMFORT

With iSERIES, you can build your dream home with:

- Heating and cooling of rooms with fan coils, direct-expansion units or using a combination of both
- Domestic hot water production with high-efficiency systems and energy recovery capability (EMIX and EMIX TANK models)
- Domestic hot water production with 3-way valve and DHW tank





# MAIN FEATURES

HEAT PUMPS

## HOW iSERIES WORKS

iSERIES is a system integrated into a heat pump that enables:

- heating
- cooling
- production of domestic hot water

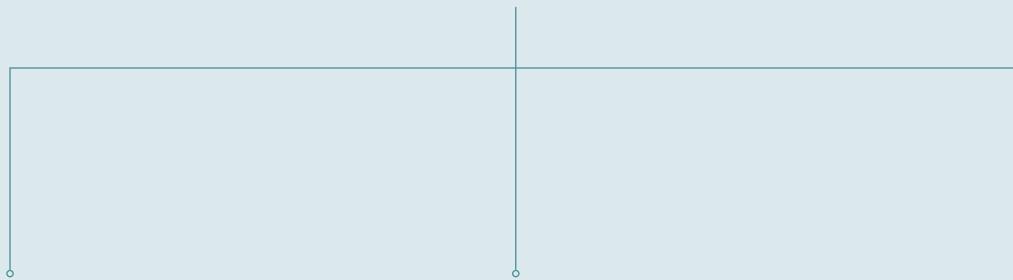

What makes iSERIES unique is that it has both an outdoor unit and corresponding indoor units within the same system, which can exchange energy, either with the hydronic terminals or directly with the ambient air.

iSERIES combines two different technologies:

- Direct-expansion technology (Single and multi-split)
- Technology for heat exchange with water (radiant systems, fan coil units, radiators).

By adding specific indoor units, such as EMIX or EMIX TANK, domestic hot water can be produced at the same time as heating or cooling rooms and during heat recovery in cooling mode during the summer.



A2A



A2W

# WHAT YOU CAN BUILD WITH iSERIES

With iSERIES you can create a vast range of system solutions to meet all kinds of needs, be it for residential or small-scale commercial use. For example, some of the possible and versatile combinations of indoor/outdoor units are listed below.

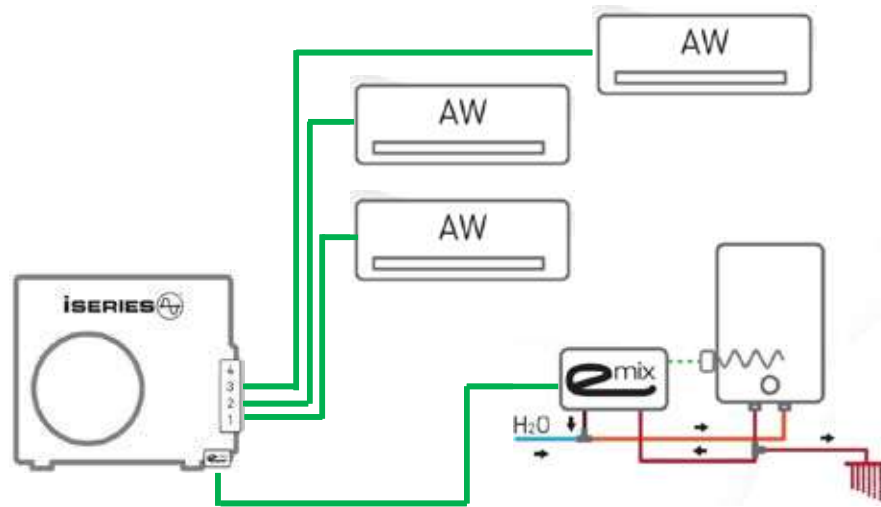

Multisplit system for residential installations with DHW production

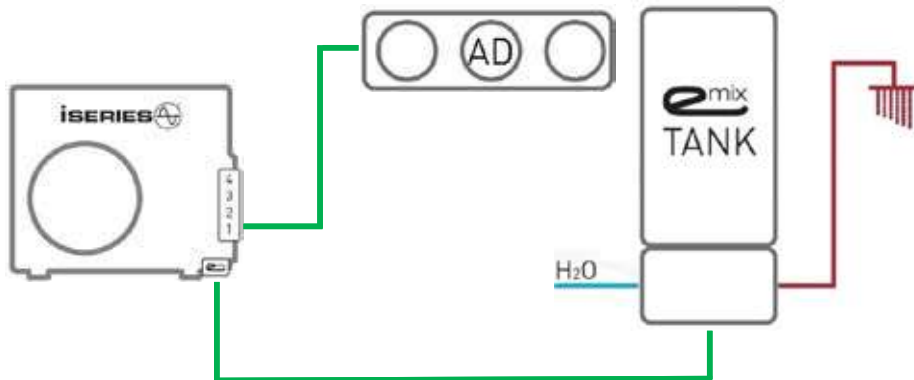

Single split system with DHW production

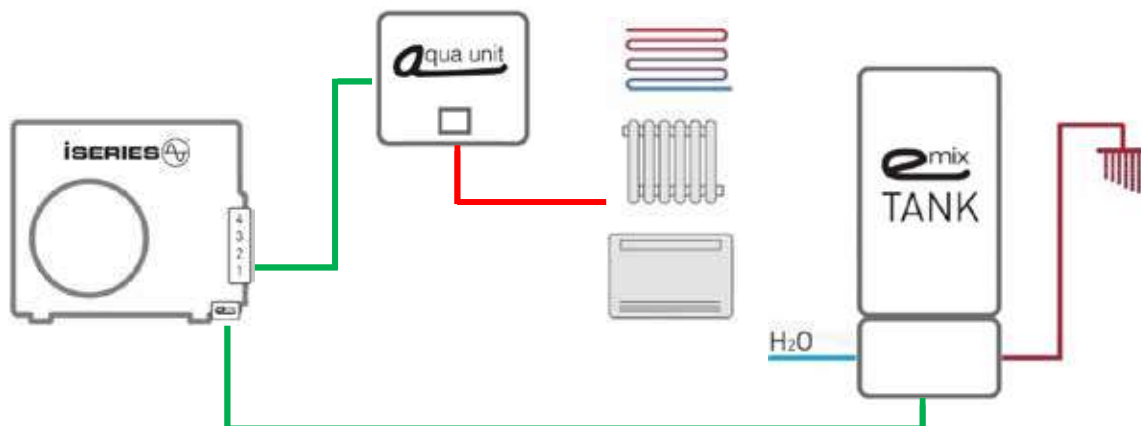

Hydronic system with DHW production

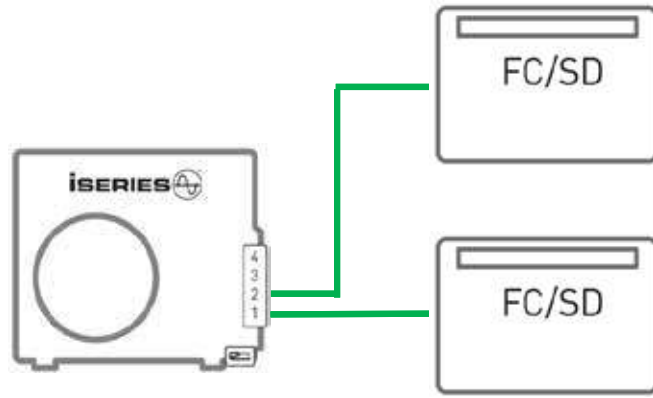

Single/multisplit system for computer rooms

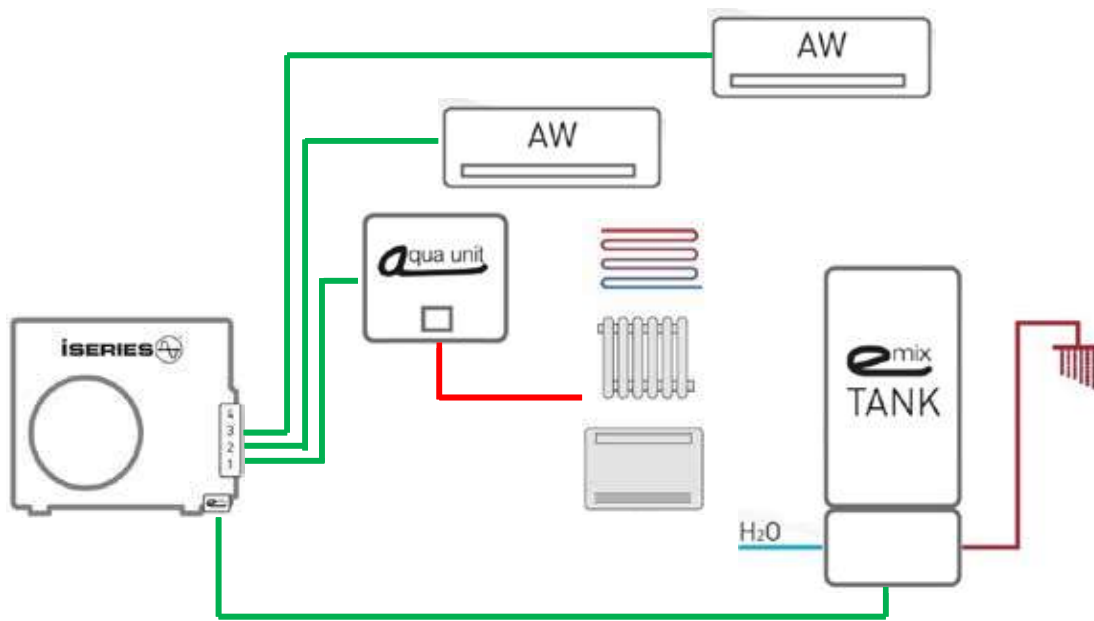

Hydronic and multisplit system with DHW production

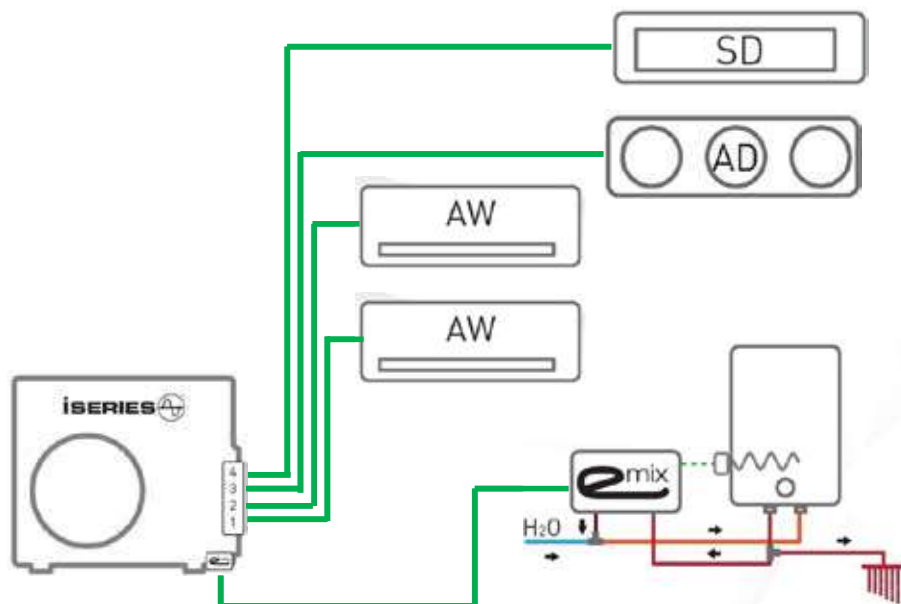

Multisplit system for commercial installations with DHW production

# SIZES AND CAPACITY

## INDOOR UNITS

The graph below shows the nominal heating/cooling capacity of iSERIES indoor units.

Four reference sizes were defined based on the different output values, labelled A, B, C and D respectively. For example, a size A indoor unit represents a nominal heat capacity of 3.9 kW and a cooling capacity of 3.7 kW.

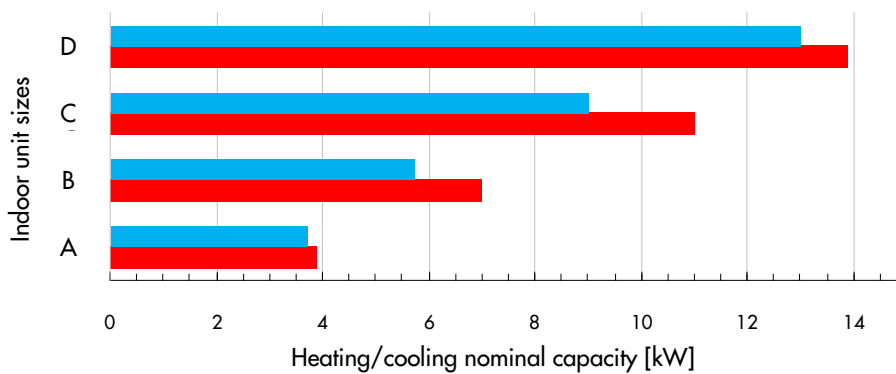

## OUTDOOR UNITS

Giving each indoor unit a size makes it quick and easy to work out the corresponding outdoor unit that it can be linked up to, based on a specific series of combinations between indoor units/outdoor units, so as to ensure that the system operates correctly, in line with the now widely used multisplit systems. Linking up indoor units/outdoor units naturally depends on the capacity of these units, as summarised in the graph below (for more specific data, please refer to individual data sheets).

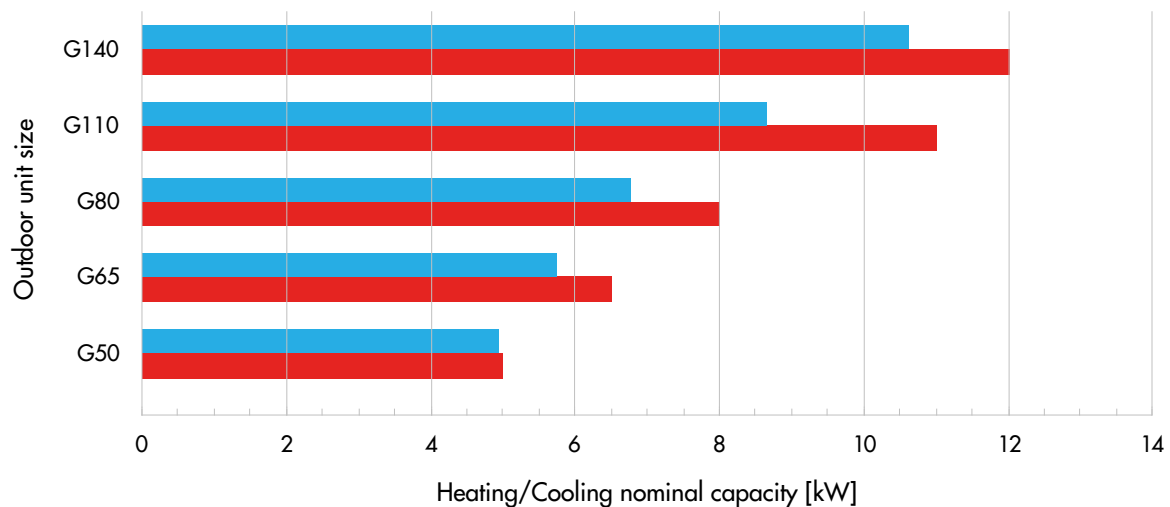

■ Cooling capacity  
■ Heating capacity

The values presented are based on the following operating conditions:

- A2A heating: t outside air = 7 °C, t ambient air = 20 °C
- A2A cooling: t outside air = 35 °C, t ambient air = 27 °C





# OUTDOOR UNITS

---

Full DC Inverter

# iSERIES

iSERIES is a split system heat pump for heating, cooling and production of domestic hot water. The system is composed by a range of 6 outdoor units in R410A with Twin Rotary Full DC Inverter compressor. The models in configuration air/air can also be combined with hydronic indoor units, as AQUA UNIT, for air/water applications. The EMIX door, for EMIX and EMIX TANK connection, allows to achieve mixed applications with production of domestic hot water at the same time. The range is able to satisfy both residential and commercial needs and the working range varies from -20 °C to + 43 °C.



Code	Model	Configuration	*Nominal-max. heating capacity (A2W) [kW]	**Nominal-max. cooling capacity (A2W) [kW]
387007220	AEI1G30EMX	Mono	3.30 (0.93/3.32) (A2A)***	3.25 (1.37/3.60) (A2A)***
387007216	AEI1G50EMX	Dual	5.00 (0.95/6.00) (A2A)***	4.92 (0.84/5.90) (A2A)***
387007217	AEI1G65EMX	Tri	6.40-8.13	5.74-6.10
387007226	AEI1G65EMX3PH	Tri	6.40-8.13	5.74-6.10
387007233	AEI1G80BEMX	Quad	8.00-11.06	8.68-9.50
387007227	AEI1G80EMX3PH	Quad	8.00-11.06	8.68-9.50
387007234	AEI1G110BEMX	Quad	10.45-14.17	9.56-12.10
387007228	AEI1G110EMX3PH	Quad	10.45-14.17	9.56-12.10
387007229	AEI1G140EMX	Penta	13.80-15.89	11.60-12.10
387007230	AEI1G140EMX3PH	Penta	13.80-15.89	11.60-12.10

Reference condition:

\*Heating capacity with outdoor air temperature 7 °C, outlet water temperature 30/35 °C

\*\*Cooling capacity with outdoor air temperature 35 °C, outlet water temperature 23/18 °C

\*\*\*Cooling capacity with outdoor air temperature 35 °C, indoor air temperature 27 °C

Heating capacity with outdoor air temperature 7 °C, indoor air temperature 20 °C



# REFRIGERANT GAS CONNECTIONS

HEAT  
PUMPS

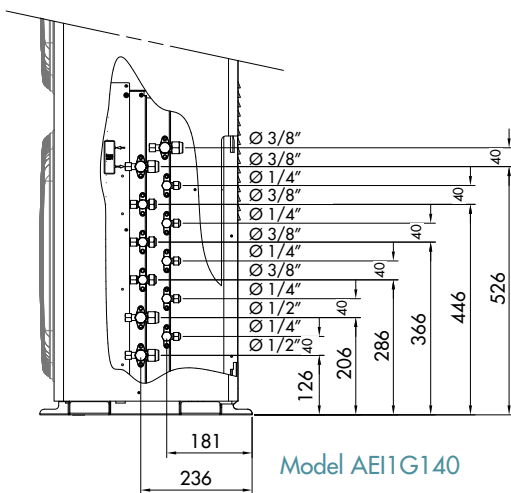
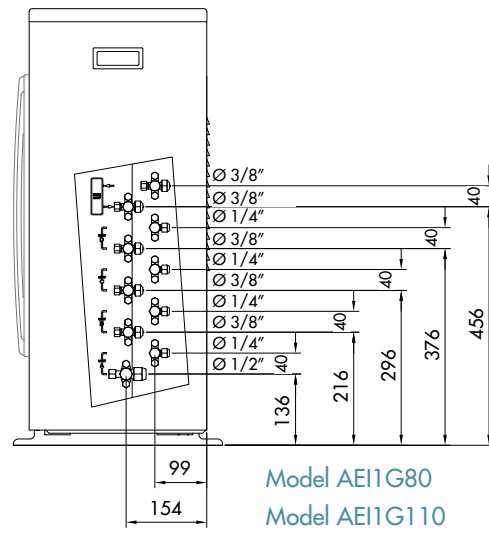
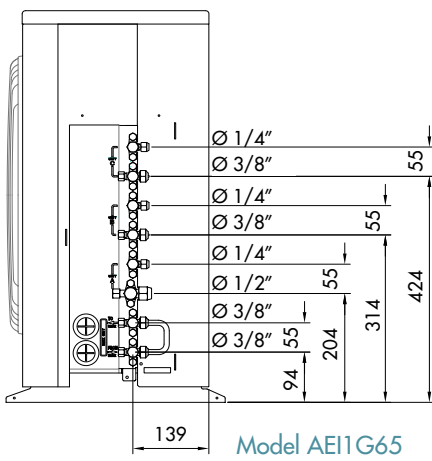
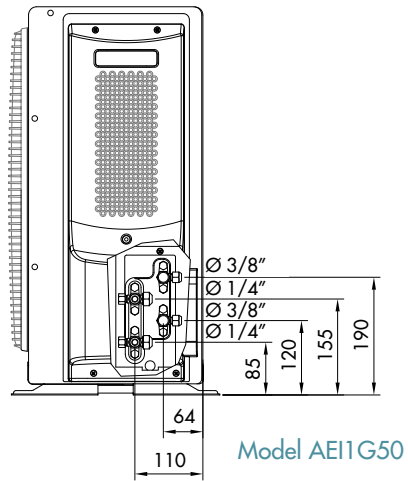
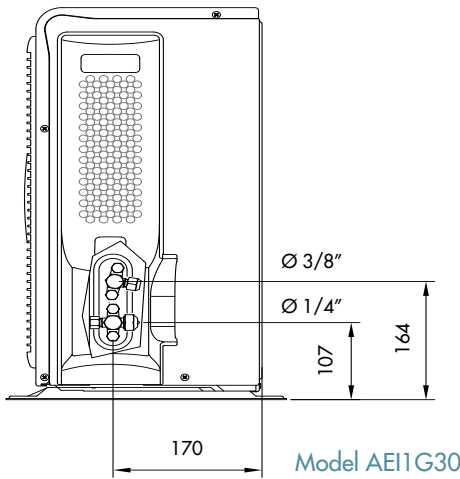

Model	Weight (kg)
AE11G30EMX	35
AE11G50EMX	56
AE11G65EMX	64
AE11G65EMX3PH	64
AE11G80BEMX	87
AE11G80EMX3PH	87
AE11G110BEMX	90
AE11G110EMX3PH	90
AE11G140EMX	145
AE11G140EMX3PH	145

# DIMENSIONAL DRAWINGS

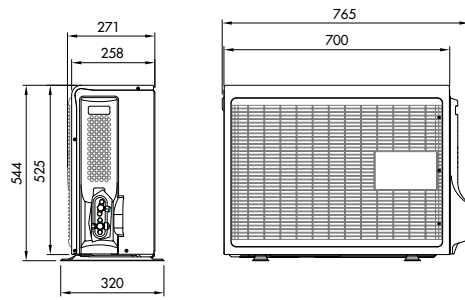

Model  
AE11G30

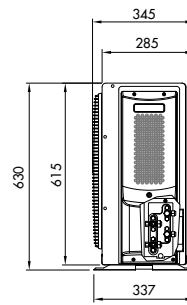
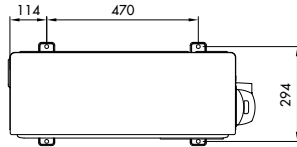

Model  
AE11G50

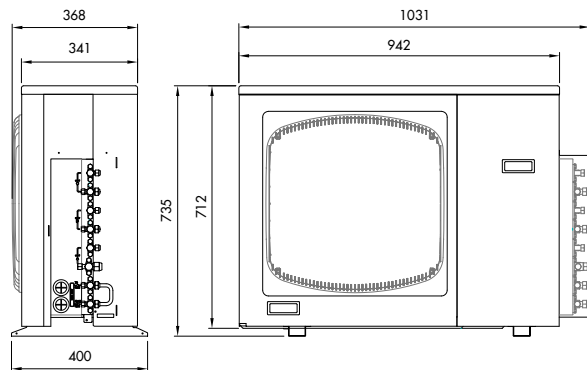
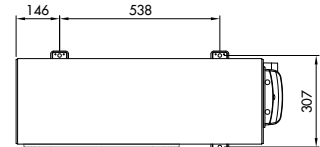
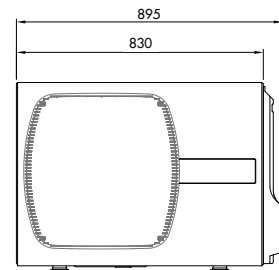

Model  
AE11G65

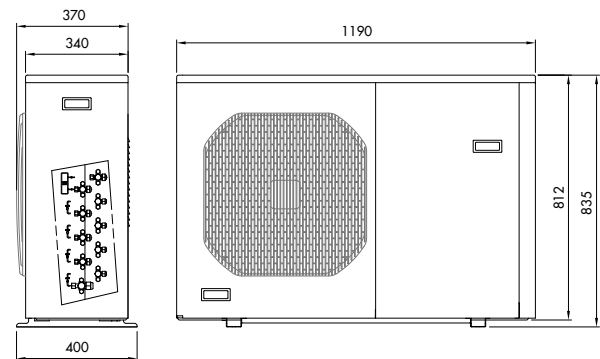
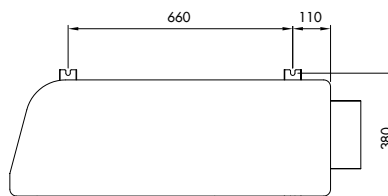

Model  
AE11G80

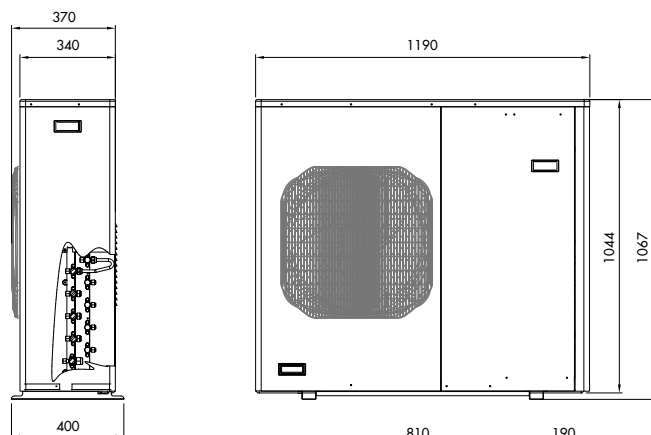
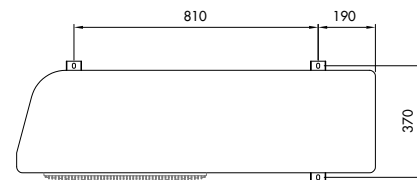

Model  
AE11G110

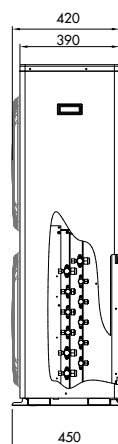
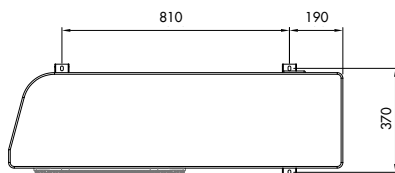



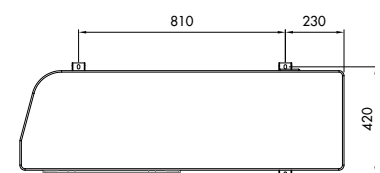
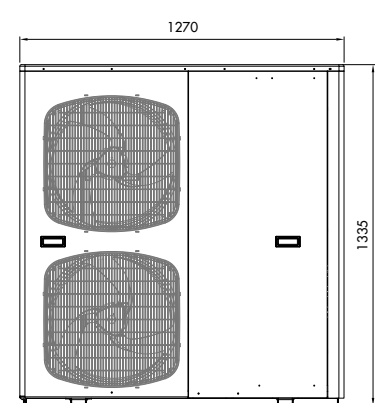

Model  
AE11G140



# POSSIBLE MATCHINGS

HEAT PUMPS

SYSTEM CONFIGURATION	 A2W	 A2A /  A2W	 A2A
<b>Model</b>	<b>AEI1G30EMX</b>		
			A
			●
<b>Model</b>	<b>AEI1G50EMX</b>		
			A ●
			B ●
			A + A
			A + B
<b>Model</b>	<b>AEI1G65EMX/AEI1G65EMX 3PH</b>		
	AUBV	AUBV + A + A ●	B ●
	AUBV ●	AUBV + B ●	A + A ●
			A + B ●
			A + A + A
<b>Model</b>	<b>AEI1G80EMX/AEI1G80EMX 3PH</b>		
	AUCV	A + A + A ●	C ●
	AUCV ●	A + B ●	A + B ●
		AUBV + A + A + A ●	B + B
		AUCV + A + B ●	A + A + A ●
		AUCV + A + A ●	A + A + B ●
			A + A + A + A
<b>Model</b>	<b>AEI1G110BEMX/AEI1G110EMX 3PH</b>		
	AUCV	AUBV + A + A + A ●	D ●
	AUCV ●	AUBV + A + A + B ●	A + C ●
		AUBV + B + B ●	A + B ●
		AUBV + C ●	B + B ●
		AUCV + A + A + A ●	A + A + A ●
		AUCV + A + B ●	A + A + B ●
			A + B + B
			A + A + A + A ●
			A + A + A + B
<b>Model</b>	<b>AEI1G140EMX/AEI1G140EMX 3PH</b>		
	AUDV	AUCV + A + A + A ●	A + D ●
	AUDV ●	AUCV + A + A + B ●	B + C ●
		AUCV + A + A + A + A ●	B + D
		AUCV + A + A + A + B ●	C + C
		AUCV + B + B ●	A + A + D
		AUDV + A + B ●	A + A + C ●
		AUDV + A + A + A ●	A + A + A + C
			A + A + A + A ●
			A + A + A + B ●
			A + A + A + A + A ●
			A + A + A + A + B

● With EMIX/EMIX TANK

● Mixed configuration: air/air for cooling and air/water for heating

AIR/AIR AND AIR/WATER SIMULTANEOUS OPERATION IS NOT POSSIBLE

# TECHNICAL DATA

MODELS				G30EMX	G50EMX	G65EMX G65EMX3PH
Matchable units for Domestic Hot Water (DHW) production				-	EMIX TANK V2 200-300 liters	
				-	EMIX V1 + DHW Tank	
				NO	External Tank + 3-way valve	
Matchable air/air indoor units				see technical datasheets		
Matchable air/water indoor units				NO	NO	AUBV
<b>AIR/WATER</b>						
Performance according to EN 14511	Air +35 °C - Water 23/18 °C	Nominal-max. Cooling capacity	kW	-	-	5.74-6.10
		Nominal electric power input	kW <sub>el</sub>	-	-	1.54
		Nominal EER		-	-	3.64
	Air +35 °C - Water 12/7 °C	Nominal Cooling capacity	kW	-	-	4.14
		Nominal electric power input	kW <sub>el</sub>	-	-	1.89
		Nominal EER		-	-	2.12
	Air +7 °C - Water 30/35 °C	Nominal-max. Heating capacity	kW	-	-	6.40-8.13
		Nominal electric power input	kW <sub>el</sub>	-	-	1.56
		Nominal COP		-	-	4.17
	Air -7 °C - Water 30/35 °C	Nominal Heating capacity	kW	-	-	5.10
		Nominal electric power input	kW <sub>el</sub>	-	-	2.01
		Nominal COP		-	-	2.54
<b>Air/water LOW temperature heating</b>						
Performance according to ERP Ecodesign EN 14825	AVERAGE climate	Nominal Heating capacity	kW	-	-	6.00
		Seasonal energy efficiency $\eta_s$	%	-	-	153
		SCOP		-	-	3.90
		Energy efficiency class		-	-	A++
<b>Air/water MEDIUM temperature heating</b>						
Performance according to ERP Ecodesign EN 14825	AVERAGE climate	Nominal Heating capacity	kW	-	-	5.00
		Seasonal energy efficiency $\eta_s$	%	-	-	110
		SCOP		-	-	2.83
		Energy efficiency class		-	-	A+
<b>AIR/AIR</b>						
Performance according to EN 14511	Outdoor air +35 °C Indoor air 27 °C	Nominal (min./max.) Cooling capacity	kW	3.25 (1.37/3.60)	4.92 (0.84/5.90)	5.75 (1.57/7.65)
		Nominal electric power input	kW <sub>el</sub>	0.82	1.47	1.58
		Nominal EER		3.96	3.35	3.64
		P <sub>design,c</sub> /P <sub>design,h</sub>	kW	3.6	5.4	6.5
	Outdoor air +7 °C Indoor air 20 °C	SEER		6.2	6.4	6.5
		Energy efficiency class		A++	A++	A++
		Nominal (min./max.) Heating capacity	kW	3.00 (0.93/3.32)	5.00 (0.95/6.00)	6.5 (1.82/8.67)
		Nominal electric power input	kW <sub>el</sub>	0.62	1.16	1.50
Performance according to ERP Ecodesign EN14825	AVERAGE climate	COP		4.82	4.29	4.32
		P <sub>design,c</sub> /P <sub>design,h</sub>	kW	3.2	4.3	6.4
		COP		4.4	4	4
		Energy efficiency class		A+	A+	A+
<b>DOMESTIC HOT WATER</b>						
DHW Performance according to EN 16147	With 300 L tank	Load profile		XL	XL	XL
		Energy efficiency class		A	A	A
		COP DHW			2.23	2.21
		ERP efficiency	%		90	90
	With Emix Tank 200 V2	Load profile			L	L
		Energy efficiency class			A	A
		COP DHW			2.57	2.51
		ERP efficiency	%		106	104
		Heating-up time from 10 °C to 48 °C	h:m	2:47	2:36	
<b>GENERAL SPECIFICATIONS</b>						
Operation data	Outdoor temperature operating range	°C		-15/+43		
	Indoor temperature operating range	°C		+10/+47		
	Outdoor temperature operating range	°C		-15/+24		
	Indoor temperature operating range	°C		+5/+27		
	Power supply (Voltage/Phases/Frequency)	V/Ph/Hz	230/1+T/50-60	230/1+T/50-60	230/1+T/50-60 (1ph) 400/3+N+T/50 (3ph)	
	Maximum electric consumption	kW/A	1.55/6.9	1.79/7.8	2,6/12 (1ph) 5,2/10x3 (3ph)	
	Sound pressure	dB(A)	45	45	45	
	Sound power	dB(A)	57	58	64	
Components and refrigerant	Fan air flow rate	m <sup>3</sup> /h	1000	1700	2400	
	Compressor type		Single Rotary	Twin Rotary		
	Refrigerant type and GWP		R410A/2088 kg CO <sub>2</sub> eq.			
	Standard charge	kg/Ton-CO <sub>2</sub> eq.	0.81/1.69	1.3/2.71	2.7/5.63	

Data declared in accordance with REGULATION (EU) N. 811/2013 of 18 February 2013 with regard to the energy labelling of space heaters and combination heaters and with COMMISSION REGULATION (EU) N. 813/2013 of 2 August 2013 implementing Directive 2009/125/EC of the European Parliament and of the Council with regard to ecodesign requirements for space heaters and combination heaters.

MODELS				G80BEMX G80EMX3PH	G110BEMX G110EMX3PH	G140EMX G140EMX3PH
Matchable units for Domestic Hot Water (DHW) production				EMIX TANK V2 200-300 liters		
				EMIX V1 + DHW Tank		
				External Tank + 3-way valve		
Matchable air/air indoor units				see technical datasheets		
Matchable air/water indoor units				AUCV	AUCV	AUDV
<b>AIR/WATER</b>						
Performance according to EN 14511	Air +35 °C - Water 23/18 °C	Nominal-max. Cooling capacity	kW	8.68-9.50	9.56-12.10	11.60-12.10
		Nominal electric power input	kW <sub>d</sub>	2.37	2.64	3.20
		Nominal EER		3.65	3.62	3.63
	Air +35 °C - Water 12/7 °C	Nominal Cooling capacity	kW	4.90	6.50	8.30
		Nominal electric power input	kW <sub>d</sub>	2.30	3.16	3.79
		Nominal EER		2.13	2.06	2.19
	Air +7 °C - Water 30/35 °C	Nominal-max. Heating capacity	kW	8.00-11.06	10.45-14.17	13.80-15.89
		Nominal electric power input	kW <sub>d</sub>	1.92	2.58	3.44
		Nominal COP		4.15	4.05	4.01
	Air -7 °C - Water 30/35 °C	Nominal Heating capacity	kW	6.30	7.30	10.50
		Nominal electric power input	kW <sub>d</sub>	2.47	3.29	4.1
		Nominal COP		2.55	2.22	2.56
<b>Air/water LOW temperature heating</b>						
Performance according to ERP Ecodesign EN 14825	AVERAGE climate	Nominal Heating capacity	kW	7.00	8	12
		Seasonal energy efficiency $\eta_s$	%	153	150	167
		SCOP		3.90	3.83	4.24
		Energy efficiency class		A++	A++	A++
<b>Air/water MEDIUM temperature heating</b>						
Performance according to ERP Ecodesign EN 14825	AVERAGE climate	Nominal Heating capacity	kW	6	7	11
		Seasonal energy efficiency $\eta_s$	%	110	110	112
		SCOP		2.83	2.83	2.87
		Energy efficiency class		A+	A+	A+
<b>AIR/AIR</b>						
Performance according to EN 14511	Outdoor air +35 °C Indoor air 27 °C	Nominal (min./max.) Cooling capacity	kW	6.87 (1.60/9.62)	8.65 (1.8/11.5)	10.60 (2.60/13.70)
		Nominal electric power input	kW <sub>d</sub>	1.86	2.46	3.12
		Nominal EER		3.70	3.51	3.40
		P <sub>design,c</sub> /P <sub>design,h</sub>	kW	9.00	10.60	13.60
	Outdoor air +7 °C Indoor air 20 °C	SEER		6.70	6.60	5.11
		Energy efficiency class		A++	A++	A++
		Nominal (min./max.) Heating capacity	kW	8.00 (1.7/11.2)	11.00 (1.9/13.5)	12.00 (3.10/15.5)
		Nominal electric power input	kW <sub>d</sub>	1.90	2.59	2.18
Performance according to ERP Ecodesign EN14825	AVERAGE climate	COP		4.22	4.24	5.50
		P <sub>design,c</sub> /P <sub>design,h</sub>	kW	7.70	9.40	11.50
		COP		4.10	4.10	4.13
		Energy efficiency class		A+	A+	A+
<b>DOMESTIC HOT WATER</b>						
DHW Performance according to EN 16147	With 300 L tank	Load profile		XL	XL	XL
		Energy efficiency class		A	A	A
		COP DHW		2.23	2.14	2.12
		ERP efficiency	%	87	87	86
	With Emix Tank 200 V2	Load profile		XL	XL	XL
		Energy efficiency class		A	A	A
		COP DHW		2.78	2.57	2.71
		ERP efficiency	%	116	106	112
		Heating-up time from 10 °C to 48 °C	h:m	3:04	2:47	2:08
<b>GENERAL SPECIFICATIONS</b>						
Operation data	Outdoor temperature operating range		°C	-15/+43		
	Indoor temperature operating range		°C	+10/+47		
	Outdoor temperature operating range		°C	-15/+24		
	Indoor temperature operating range		°C	+5/+27		
	Power supply (Voltage/Phases/Frequency)		V/Ph/Hz	230/1+T/50-60 (1ph) 400/3+N+T/50 (3ph)	230/1+T/50-60 (1ph) 400/3+N+T/50 (3ph)	230/1+T/50-60 (1ph) 400/3+N+T/50 (3ph)
	Maximum electric consumption		kW/A	3.3/15 (1ph) 5.2/10x3 (3ph)	4.4/20 (1ph) 5.2/10x3 (3ph)	4.4/20 (1ph) 5.2/10x3 (3ph)
	Sound pressure		dB(A)	45		
Sound power		dB(A)	64			
Components and refrigerant	Compressor type		Twin Rotary			
	Fan air flow rate		m <sup>3</sup> /h	3000	3500	3500
	Refrigerant type and GWP		R410A/2088 kg CO <sub>2</sub> eq.			
	Standard charge		kg/Ton-CO <sub>2</sub> eq.	2.9/6.05	3.38/7.05	4.4/9.18

The equipment described in this catalogue contains HFC-410A-type fluorinated greenhouse gases. These products must be fitted by qualified staff pursuant to European regulations 303/2008 and 517/2014

# TECHNICAL DATA

## AIR/AIR CONFIGURATION

### Heating

LAT: Leaving air temperature  
 Qh: Heat capacity  
 COP: Coefficient of performance

### Cooling

LAT: Leaving air temperature  
 Qc: Cooling capacity  
 EER: Energy efficiency ratio

## G30EMX model

### Heating

LAT [°C]	Outdoor air temperature - Dry Bulb (Wet Bulb) - °C									
	-10 (11)		-7 (-8)		2 (1)		7 (6)		12 (11)	
	Qh [kW]	COP	Qh [kW]	COP	Qh [kW]	COP	Qh [kW]	COP	Qh [kW]	COP
20	2.70	2.43	2.80	2.61	2.70	2.40	3.30	3.51	4.50	4.10

### Cooling

LAT [°C]	Inlet outdoor air temperature °C	
	35	
	Qc [kW]	EER
27 (19)	3.60	2.84

## G50EMX model

### Heating

LAT [°C]	Outdoor air temperature - Dry Bulb (Wet Bulb) - °C									
	-10 (11)		-7 (-8)		2 (1)		7 (6)		12 (11)	
	Qh [kW]	COP	Qh [kW]	COP	Qh [kW]	COP	Qh [kW]	COP	Qh [kW]	COP
20	3.70	2.68	3.90	2.91	3.70	2.57	6.00	3.35	6.70	3.86

### Cooling

LAT [°C]	Inlet outdoor air temperature °C	
	35	
	Qc [kW]	EER
27 (19)	5.90	3.15

## G65EMX/G65EMX3PH models

### Heating

LAT [°C]	Outdoor air temperature - Dry Bulb (Wet Bulb) - °C									
	-10 (11)		-7 (-8)		2 (1)		7 (6)		12 (11)	
	Qh [kW]	COP	Qh [kW]	COP	Qh [kW]	COP	Qh [kW]	COP	Qh [kW]	COP
20	5.30	2.25	5.90	3.09	5.60	2.94	8.70	3.22	9.10	3.50

### Cooling

LAT [°C]	Inlet outdoor air temperature °C	
	35	
	Qc [kW]	EER
27 (19)	7.70	3.32

## G80BEMX/G80EMX3PH models

### Heating

LAT [°C]	Outdoor air temperature - Dry Bulb (Wet Bulb) - °C									
	-10 (11)		-7 (-8)		2 (1)		7 (6)		12 (11)	
	Qh [kW]	COP	Qh [kW]	COP	Qh [kW]	COP	Qh [kW]	COP	Qh [kW]	COP
20	6.50	2.36	6.80	2.45	6.10	2.36	11.20	3.27	11.60	3.55

### Cooling

LAT [°C]	Inlet outdoor air temperature °C	
	35	
	Qc [kW]	EER
27 (19)	9.60	3.74

## G110BEMX/G110EMX3PH models

### Heating

LAT [°C]	Outdoor air temperature - Dry Bulb (Wet Bulb) - °C									
	-10 (11)		-7 (-8)		2 (1)		7 (6)		12 (11)	
	Qh [kW]	COP	Qh [kW]	COP	Qh [kW]	COP	Qh [kW]	COP	Qh [kW]	COP
20	7.50	2.40	8.30	2.36	9.40	2.64	12.50	3.07	13.20	3.45

### Cooling

LAT [°C]	Inlet outdoor air temperature °C	
	35	
	Qc [kW]	EER
27 (19)	11.50	3.36

## G140EMX/G140EMX3PH models

### Heating

LAT [°C]	Outdoor air temperature - Dry Bulb (Wet Bulb) - °C									
	-10 (11)		-7 (-8)		2 (1)		7 (6)		12 (11)	
	Qh [kW]	COP	Qh [kW]	COP	Qh [kW]	COP	Qh [kW]	COP	Qh [kW]	COP
20	8.20	2.29	10.10	2.76	10.90	2.46	15.50	3.10	16.30	3.51

### Cooling

LAT [°C]	Inlet outdoor air temperature °C	
	35	
	Qc [kW]	EER
27 (19)	13.70	2.60

## AIR/WATER CONFIGURATION

### Heating

LWT: Leaving water temperature  
 Qh: Heat capacity  
 COP: Coefficient of performance

Application data  
 Water inlet/outlet temperature  
 difference = 5 °C, 8 °C for LWT = 55 °C

### Cooling

LWT: Leaving water temperature  
 Qc: Cooling capacity  
 EER: Energy efficiency auto

Application data  
 Water inlet/outlet temperature  
 difference = 5 °C

## G65EMX/G65EMX3PH models

### Heating

LWT [°C]	Outdoor air temperature - Dry Bulb (Wet Bulb) - °C									
	-7 (-8)		-2 (-3)		2 (1)		7 (6)		12 (11)	
	Qh [kW]	COP	Qh [kW]	COP	Qh [kW]	COP	Qh [kW]	COP	Qh [kW]	COP
35	5.10	2.54	5.29	3.21	6.05	3.45	6.40	4.17	7.58	4.66
45	4.60	2.02	4.95	2.29	5.53	2.57	6.50	3.10	7.22	3.47
55	4.00	1.59	4.59	1.54	4.76	1.86	5.19	2.19	5.95	2.70

### Cooling

LWT [°C]	Inlet outdoor air temperature °C	
	35	
	Qc [kW]	EER
7	4.14	2.12
18	5.74	3.64

## G80BEMX/G80EMX3PH models

### Heating

LWT [°C]	Outdoor air temperature - Dry Bulb (Wet Bulb) - °C									
	-7 (-8)		-2 (-3)		2 (1)		7 (6)		12 (11)	
	Qh [kW]	COP	Qh [kW]	COP	Qh [kW]	COP	Qh [kW]	COP	Qh [kW]	COP
35	6.30	2.55	7.09	2.89	7.80	3.34	8.00	4.15	11.46	4.62
45	5.70	2.03	6.38	2.48	7.20	2.79	8.00	3.12	10.02	3.64
55	4.90	1.60	4.99	1.99	5.49	2.10	7.08	2.32	7.78	2.71

### Cooling

LWT [°C]	Inlet outdoor air temperature °C	
	35	
	Qc [kW]	EER
7	4.90	2.13
18	8.68	3.65

## G110BEMX/G110EMX3PH models

### Heating

LWT [°C]	Outdoor air temperature - Dry Bulb (Wet Bulb) - °C									
	-7 (-8)		-2 (-3)		2 (1)		7 (6)		12 (11)	
	Qh [kW]	COP	Qh [kW]	COP	Qh [kW]	COP	Qh [kW]	COP	Qh [kW]	COP
35	7.30	2.22	8.14	2.80	9.14	3.29	10.45	4.07	12.15	4.70
45	7.50	1.97	8.73	2.28	9.95	2.61	9.59	3.02	11.94	3.37
55	5.80	1.49	6.24	1.93	7.03	2.02	9.67	2.31	8.85	2.41

### Cooling

LWT [°C]	Inlet outdoor air temperature °C	
	35	
	Qc [kW]	EER
7	6.50	2.06
18	9.56	3.62

## G140EMX/G140EMX3PH models

### Heating

LWT [°C]	Outdoor air temperature - Dry Bulb (Wet Bulb) - °C									
	-7 (-8)		-2 (-3)		2 (1)		7 (6)		12 (11)	
	Qh [kW]	COP	Qh [kW]	COP	Qh [kW]	COP	Qh [kW]	COP	Qh [kW]	COP
35	10.50	2.56	10.14	2.78	11.20	3.21	13.80	4.01	14.65	4.62
45	9.50	1.96	10.20	2.22	11.05	2.58	13.40	3.00	14.15	3.28
55	8.30	1.48	7.73	1.90	8.65	2.00	9.10	2.15	11.15	2.38

### Cooling



LWT [°C]	Inlet outdoor air temperature °C	
	35	
	Qc [kW]	EER
7	8.30	2.19
18	11.60	3.63

# POSSIBLE MATCHINGS AND PRATICAL EXAMPLES

The product information sheet for each outdoor unit lists the matchings that can be used when designing systems with iSERIES. By way of example, the matchings that can be made with the AE11G80EMX outdoor unit and the corresponding system diagrams are shown below.

## 1 MATCHING

G80 outdoor unit in winter mode with size B hydronic module (AUBV) and in summer mode with two size A and size B direct-expansion units. Domestic hot water production with EMIX TANK.

 A2W	 A2A / A2W	 A2A
AUCV	A + A + A ●	C ●
AUCV ●	A + B ●	A + B ●
	AUBV + A + A + A ●	B + B
	<b>AUBV + A + B ●</b>	A + A + A ●
	AUCV + A + A ●	A + A + B ●
		A + A + A + A

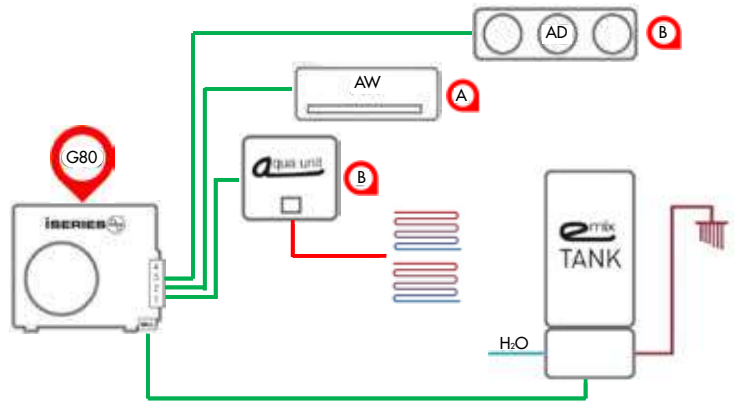

- With EMIX/EMIX TANK
- Mixed configuration: air/air for cooling and air/water for heating

SIMULTANEOUS OPERATION IS NOT POSSIBLE



## 2 MATCHING

G80 outdoor unit in summer/winter mode with three size A direct-expansion units. Domestic hot water production with EMIX.

 A2W	 A2A / A2W	 A2A
AUCV	A + A + A ●	C ●
AUCV ●	A + B ●	A + B ●
	AUBV + A + A + A ●	B + B
	AUBV + A + B ●	<b>A + A + A ●</b>
	AUCV + A + A ●	A + A + B ●
		A + A + A + A

- With EMIX/EMIX TANK
- Mixed configuration: air/air for cooling and air/water for heating

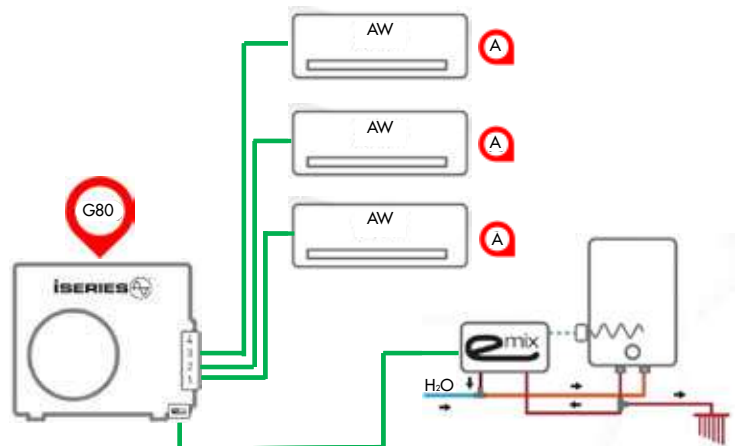

SIMULTANEOUS OPERATION IS NOT POSSIBLE





### 3 MATCHING

G80 outdoor unit in winter mode (and possibly summer mode) with size C hydronic module (AUCV). Domestic hot water production with EMIX TANK.

 A2W	 A2A / A2W	 A2A
AUCV	A + A + A ●	C ●
<b>AUCV ●</b>	A + B ●	A + B ●
	AUBV + A + A + A ●	B + B
	AUBV + A + B ●	A + A + A ●
	AUCV + A + A ●	A + A + B ●
		A + A + A + A

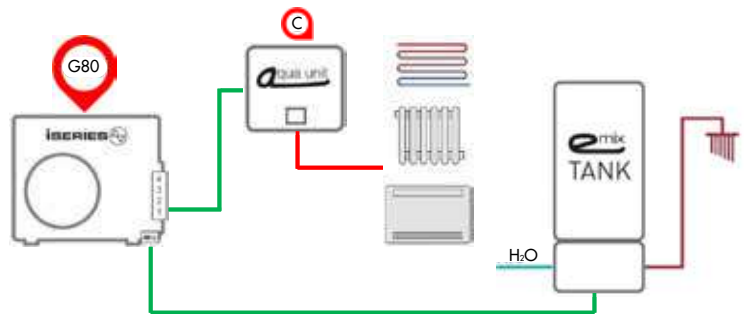

- With EMIX/EMIX TANK
- Mixed configuration: air/air for cooling and air/water for heating

SIMULTANEOUS OPERATION IS NOT POSSIBLE



### 4 MATCHING

G80 outdoor unit in winter mode (and possibly summer mode) with one only size C hydronic module (AUCV). Domestic hot water production with diverter valve and third-party tank.

 A2W	 A2A / A2W	 A2A
<b>AUCV</b>	A + A + A ●	C ●
AUCV ●	A + B ●	A + B ●
	AUBV + A + A + A ●	B + B
	AUBV + A + B ●	A + A + A ●
	AUCV + A + A ●	A + A + B ●
		A + A + A + A

- With EMIX/EMIX TANK
- Mixed configuration: air/air for cooling and air/water for heating

SIMULTANEOUS OPERATION IS NOT POSSIBLE

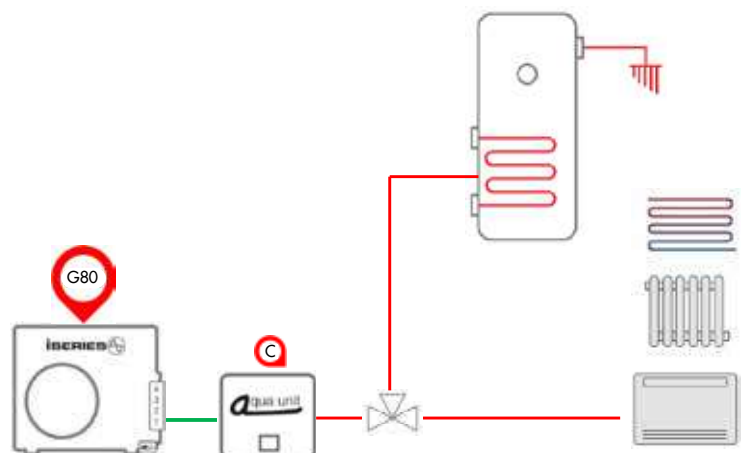

# REFRIGERANT PIPE LENGTHS

For the iSERIES system to operate correctly, the refrigerant gas lines must adhere to the sizes and height differences shown in the table on the next page.

## HOW TO PERFORM A PROPER CHECK?

- 1 Choose the configuration for the outdoor unit based on the number of indoor units to be fitted (include AQUA UNIT and EMIX/EMIX TANK).
- 2 Check that the total length of the pipes (tot L) is less than or equal to the reference length listed in the table in the STANDARD CHARGE column. If the restriction is not adhered to, carry out a further check using the values shown in the ADDITIONAL CHARGE column. In this instance, an additional refrigerant charge calculated following the guidelines specified on the next pages should be provided.
- 3 Similarly, check that the maximum length of each pipe (Ln) falls within the restrictions set.
- 4 Check the limits set for the minimum length, the maximum height difference between the indoor units and the maximum height difference between the indoor units and outdoor unit (including AQUA UNIT and EMIX/EMIX TANK).
- 5 Pay close attention to length L6 in the diagram which represents the length of the EMIX/EMIX TANK pipe: the maximum length allowed is **10 m**.

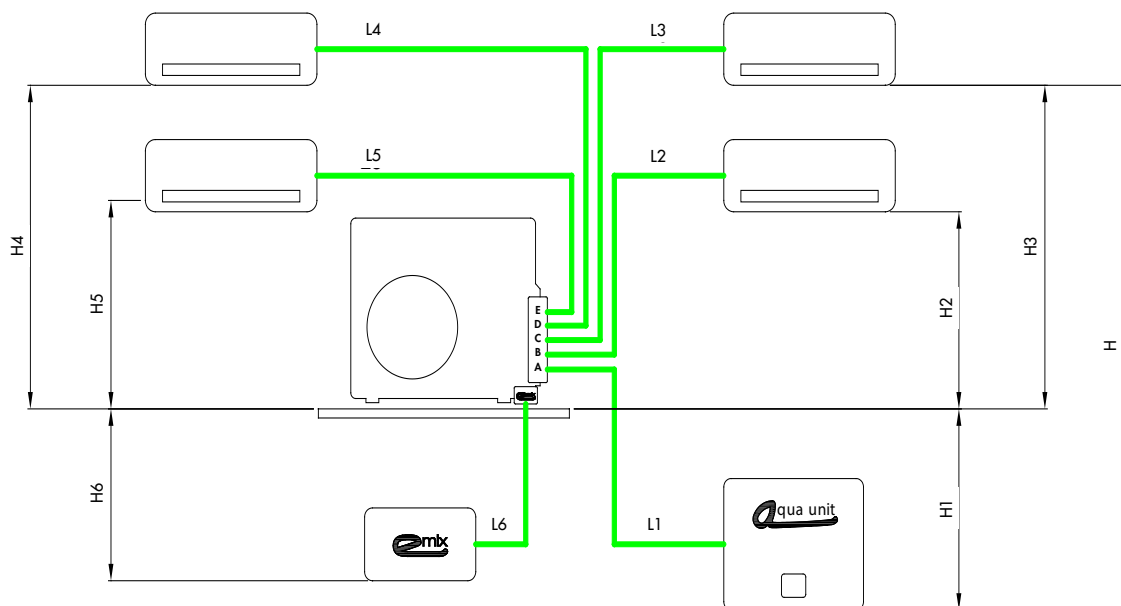

TABLE SHOWING DATA FOR REFRIGERANT GAS PIPE LENGTHS

	Configuration	STANDARD CHARGE		ADDITIONAL CHARGE		MINIMUM LENGHT
		L tot [m]	L n [m]	L tot [m]	L n [m]	L min [m]
AEI1G30EMX	Single	7.5		15		5
AEI1G50EMX	Single	7.5	-	20	-	5
	Dual	15	12	30	25	5
AEI1G65EMX	Single	20	-	35	-	5
	Dual	30	25	45	30	5
	Tri	30	20	45	25	5
AEI1G80EMX	Single	30	-	50	-	5
	Dual	40	30	65	30	5
	Tri	40	30	65	30	5
	Quad	40	30	65	30	5
AEI1G110EMX	Single	30	-	50	-	5
	Dual	40	30	65	30	5
	Tri	40	30	65	30	5
	Quad	40	30	65	30	5
AEI1G140EMX	Single	40	-	50	-	5
	Dual	40	30	100	30	5
	Tri	40	30	100	30	5
	Quad	40	30	100	30	5
	Penta	40	30	100	30	5

L tot = maximum total pipe lenght (L1 + L2 + L3...)

L n = maximum pipe lenght for unit (n = 1,2,3...)

Additional gas charge

For pipes 1/4" - 3/8" = 15 g/m

For pipes 1/4" - 1/2" = 20 g/m

For EMIX pipes 3/8" = 15 g/m

Maximum height difference - outdoor unit/indoor unit (H1, H2, H3, H4, H5, H6) = 10 m

Maximum height difference between indoor units (H) = 5 m

## OPERATING LIMITS

- Maximum conditions in Cooling Mode  
Outdoor temperature: 43 °C D.B.  
Indoor temperature: 32 °C D.B./23 °C W.B.
- Minimum conditions in Cooling Mode  
Outdoor temperature: -15 °C D.B.  
Indoor temperature: 10 °C D.B./6 °C W.B.
- Maximum conditions in Heating Mode  
Outdoor temperature: 24 °C D.B./18 °C W.B.  
Indoor temperature: 27 °C D.B.
- Minimum conditions in Heating Mode  
Outdoor temperature: -20 °C D.B.  
Indoor temperature: 5 °C D.B.



# INDOOR UNITS

---

Hydronic and direct expansion

# AQUA UNIT

## HYDRONIC INDOOR UNIT



Code	Description
387030220	Wired control for iSERIES indoor units - <b>Mandatory accessory</b>

### HYDRONIC UNIT FOR iSERIES

The AQUA UNIT indoor units combined with the outdoor units from the iSERIES range are used to heat and cool hydronic systems, such as radiant systems, low-temperature radiators and fan coil units.

Code	Model	Size	Capacity (kW)	Description
387135037	AUBV V2	B	6.5 kW heating 5.6 kW cooling	Internal Hydronic module, with inverter pump, wall-hung.
387135038	AUCV V2	C	10.6 kW heating 9.1 kW cooling	Internal Hydronic module, with inverter pump, wall-hung.
387135039	AUDV V2	D	13.6 kW heating 11.6 kW cooling	Internal Hydronic module, with inverter pump, wall-hung.

#### Reference condition

Heating: water temperature 35/30 °C, outdoor air temperature 7 °C  
Cooling: water temperature 18/23 °C, outdoor air temperature 35 °C

### DIMENSION AND WEIGHT

TECHNICAL DATA		AUBV	AUCV	AUDV
Water inlet connection		1" M	1" M	1" M
Water outlet connection		1" M	1" M	1" M
Condensate drain connection	mm	Ø 18	Ø 18	Ø 18
Gas refrigerant connection		1/2"	1/2"	5/8"
Liquid refrigerant connection		1/4"	1/4"	3/8"
Grommet		-	-	-
Weight	kg	25	27	28

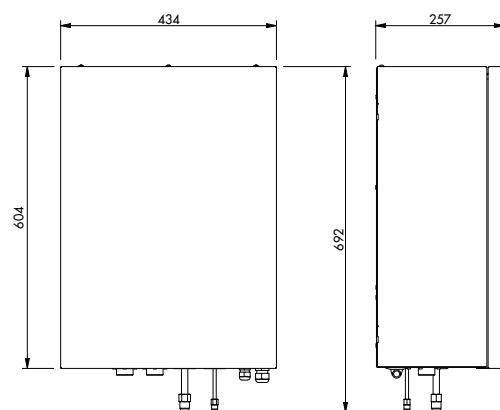
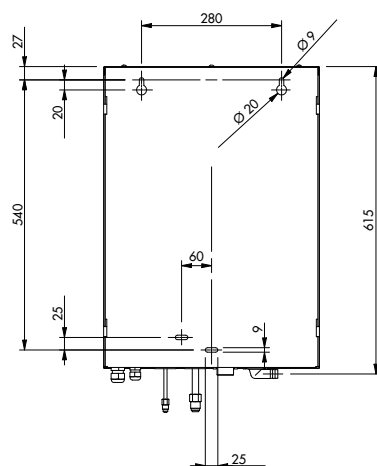
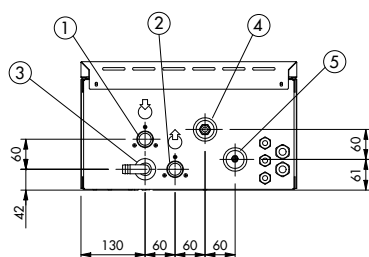

TECHNICAL DATA		AUBV	AUCV	AUDV
Electrical power supply	V/Ph/Hz	220-240/1/50		
Maximum electricity consumption	W	77		
Minimum electricity consumption	W	6		
Hydraulic connection	inch	1" M		
DWV evacuation connection	mm	18		
Outdoor unit connection circuit		circuit A <sup>(1)</sup>		
Cooling circuit connections (gas)	inch	1/2"	1/2"	5/8"
Cooling circuit connections (liquid)	inch	1/4"	1/4"	3/8"
Refrigerant type		R410A		
Minimum cooling pipe length	m	3		
Maximum cooling pipe length	m	Ref. to outdoor unit datasheets		
Maximum height difference between indoor unit and outdoor unit	m			
Maximum height difference between indoor unit (installation with other UI)	m			
Additional gas charge (if required)	g/m			
Minimum operating water pressure	bar	1,5		
Maximum operating water pressure	bar	2		
Pressure relief valve set	bar	3		
Expansion vessel capacity	L	6		
Expansion vessel pre-charge	bar	1		
Maximum water outlet temperature	°C	up to 58 <sup>(2)</sup>		
Minimum water volume	L	40	80	80
Net weight	kg	25	27	28
Net dimension (H./W./D.)	mm	604x434x257		

(1) Connect only to circuit A of the outdoor unit

(2) With reference to diagram of "Maximum outlet water temperature"

## OPERATING CONDITIONS

Maximum outlet water temperature

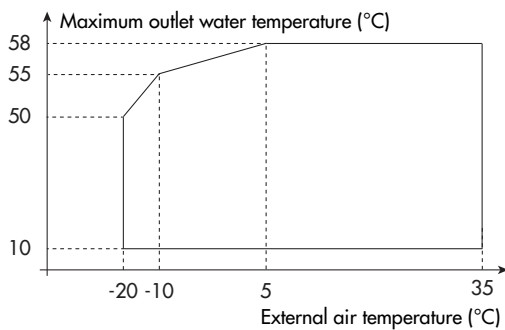

## FLOW RATE CURVES

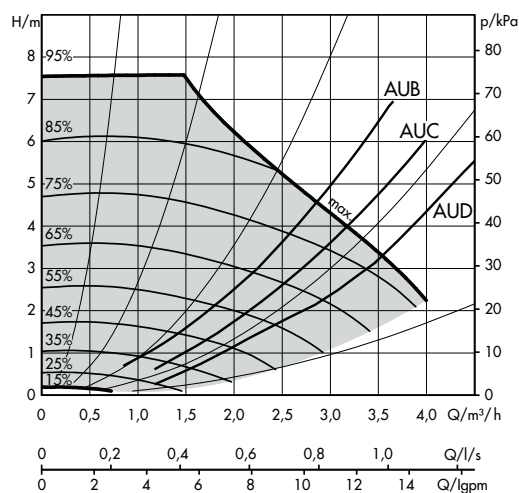

# CONNECTIVITY

## INPUTS AND OUTPUTS OF VERTICAL AQUA UNIT



### N° 3 DIGITAL INPUTS (dry contacts or configurable 24 VAC contacts)

- 1) ON/OFF: stand by or operating;
- 2) Summer/Winter: summer/winter switching.

### N° 5 DIGITAL OUTPUTS

- 1) 230 VAC output for the DHW diverter valve servomotor (deviation towards DHW);
- 2) 230 VAC output for the DHW diverter valve servomotor (re-deviation towards heating system - optional);
- 3) 230 VAC output for ALARM/DEFROST which can be configured individually or in combination;
- 4) 230 VAC output for additional heat source (electric heating element, boiler, etc.) through external relay switch if needed;
- 5) 230 VAC output for DHW tank electric heater through external relay switch.

### N° 1 ANALOGIC INPUT

- 1) DHW temperature sensor input: used for reading the value of the water temperature inside the DHW tank.

### N° 1 MODBUS CONNECTION

- 1) Used to connect the control panel, can be used otherwise for a third-party MODBUS controller.



# NOTES

# A19 DIRECT-EXPANSION INDOOR UNIT HIGH WALL MODEL



Code	Model	Size
387004103	AWIAS19	A
387004104	AWIBS19	B

Built in a compact and efficient high quality PS structure, A19 easily integrates into any type of residential and commercial environment. The rounded design and fine finish, embellished with chrome details and original side processing, make the unit elegant and attractive.

## MAXIMUM COMFORT WITH ECO/HI-POWER/IFEEL/SWING FUNCTIONS

The operation modes "Eco" and "High Power" ensure maximum comfort and can be activated to save energy or have maximum silence, or, on the other side, to enjoy maximum comfort in the shortest possible time. Furthermore, the "iFeel" function ensures comfort conditions in the exact point where the remote controller is. The adjustable flap can be set to different positions or it can automatically swing, ensuring an optimal airflow distribution in the room.

## AIR IS EVEN MORE HEALTY WITH THE PLASMA MONOLITHIC FILTER

A19 is equipped with washable air filters aimed to protect the heat exchanger and with a sophisticated electronic monolithic plasma filter which doesn't need maintenance and can be controlled by the remote controller. The plasma filter allows you to eliminate bacteria and oxidize several polluting organic and inorganic particles. The special Autoclean function, providing a perfect drying, prevents the formation of mold and bacteria.

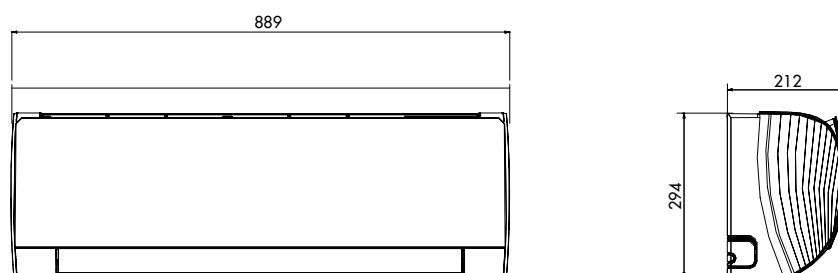
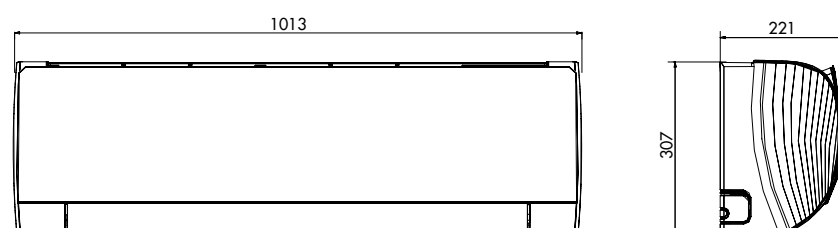

# DIMENSIONAL DRAWINGS

**A** AWIAS19

**B** AWIBS19

## TECHNICAL DATA

Model		AWIAS19	AWIBS19
Heating/Cooling capacity	kW	up to 3.7/4.0	up to 5.7/7.0
Size		A	B
Air flow rate (el.-l.-m.-h.-eh.)	m <sup>3</sup> /h	390-420-490-620-680	470-520-610-720-800
Dehumidification	l/h	1,4	1,8
Fan speed	n°	5	5
Sound pressure at 2 m (el.-l.-m.-h.-eh.)	dB(A)	26-29-34-38-42	31-34-38-43-45
Sound power (el.-l.-m.-h.-eh.)	dB(A)	38-41-46-50-57	45-48-52-57-59
Electric power supply	V/Ph/Hz	230/1/50	230/1/50
Type of motor		DC Inverter	DC Inverter
Power consumption	W	20	35
Liquid pipe diameter	mm (inch)	6.35 (1/4")	6.35 (1/4")
Gas pipe diameter	mm (inch)	9.52 (3/8")	12.7 (1/2")
Net dimension (H./W./D.)	mm	294/889/212	307/1013/221
Net weight	kg	11	13.5
Remote control supplied		Yes	Yes
Ambient temperature adjustment range	°C	from +10 to +32	from +10 to +32
"Cold Plasma" purification system		Yes	Yes

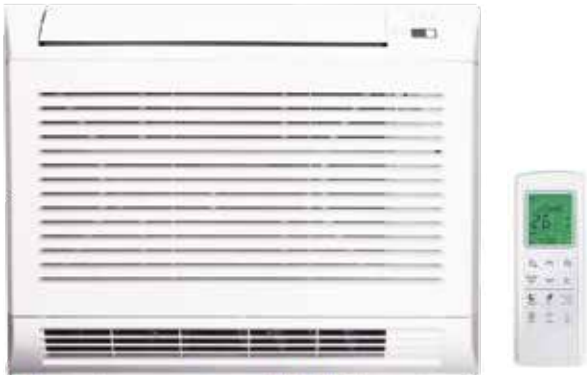
# AF DIRECT-EXPANSION INDOOR UNIT CONSOLE MODEL



Code	Model	Size
387005017	AFIAS11DC V2	A
387005018	AFIBS11DC V2	B

AF is a console unit made of premium ABS for low wall mounting, just a few centimeters above the floor, occupying little space. The airflow is two-way, upper and lower, for maximum comfort both in summer and in winter. At 22 db(A), the unit is extremely quiet thanks to its specially designed structure and two tangential fans with by DC inverter motor.

## RELATIVE HUMIDITY SENSOR

AF is equipped with a humidity sensor that is used to modulate the temperature and adjust the room's humidity percentage. The relative humidity sensor allows the choice between the cooling and dehumidification mode, based on the relative humidity value. If this value exceeds a given threshold, the unit will run in dehumidification mode. Otherwise, the unit will operate in cooling mode or with alternating cooling and dehumidification cycles.

The signal transmitted by this sensor is used by the control software, which takes account of the relative humidity of the room in relation to the temperature. This results in the HUMIDEX index that measures the temperature perceived by the human body (which is a combination of these two factors) and, consequently, adjusts the setpoint to optimise the user's comfort.

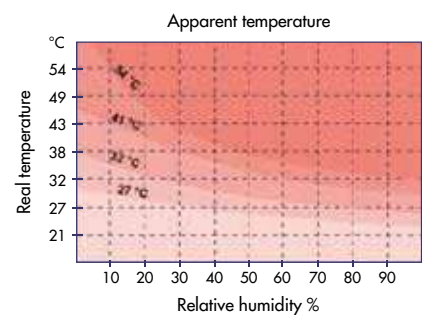

## TITANIUM DIOXIDE PHOTOCATALYTIC FILTER

Photocatalytic filters base their operation on a photocatalyst which is usually a semiconductor material which polarizes the electrons creating a surface electric current. This determines such a high oxidizing power that can oxidize most of the organic contaminants. This type of filter is particularly suitable for eliminating bacteria, inhibiting the activity of viruses, dust abatement as well as in the prevention of bad smells.

Titanium dioxide is a photocatalyst semiconductor that is deposited on a beehive filter, which is very similar to the active carbon filter. The air intake from the indoor unit passes through this filter.

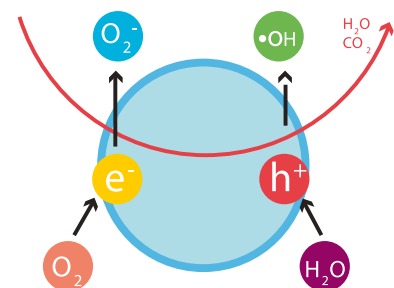

# DIMENSIONAL DRAWINGS

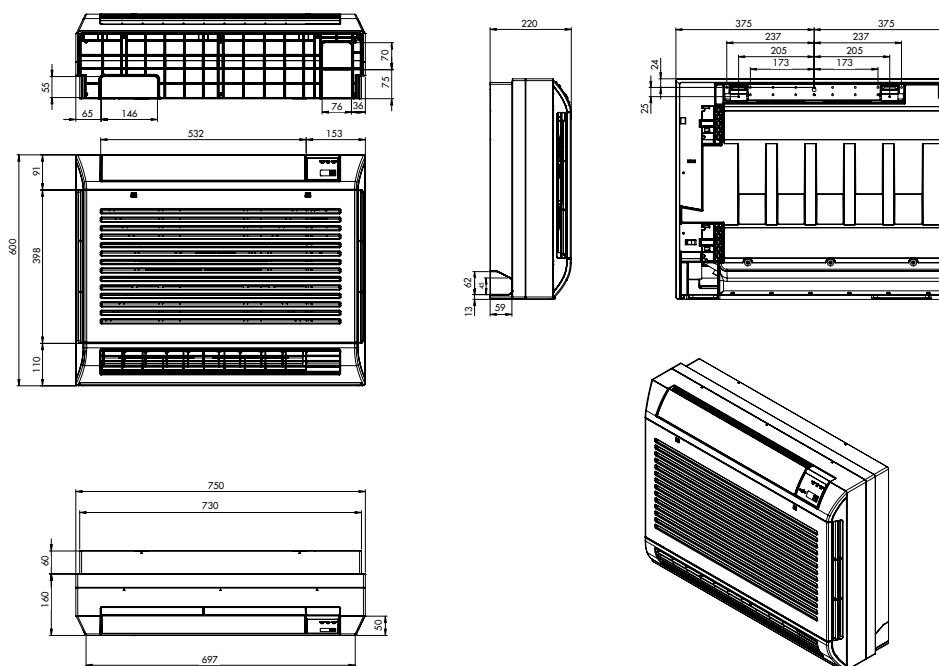

# TECHNICAL DATA

Model		AFIAS1 IDC V2	AFIBS1 IDC V2
Heating/Cooling capacity	kW	up to 3.7/4.0	up to 5.7/7.0
Size		A	B
Air flow rate (sl.-l.-m.-h.)	m <sup>3</sup> /h	450-500-590-700	615-665-760-830
Dehumidification	l/h	1.3	2.3
Fan speed	n°	3 + auto - by remote control	3 + auto - by remote control
Sound pressure at 2 m (sl.-l.-m.-h.)	dB(A)	22-26-30-37	28-30-37-45
Electric power supply	V/Ph/Hz	230/1/50	230/1/50
Type of motor		DC Inverter	DC Inverter
Electric power input	W	12	19
Liquid pipe diameter	mm (inch)	6.35 (1/4")	6.35 (1/4")
Gas pipe diameter	mm (inch)	9.52 (3/8")	12.7 (1/2")
Net weight (H./W./D.)	mm	600/750/220	600/750/220
Net dimension	kg	8	12
Remote control supplied		Yes	Yes
Room temperature adjustment range	°C	from +10 to +32	from +10 to +32
TiO <sub>2</sub> filter		Yes	Yes
Relative humidity sensor		Yes	Yes

# FC DIRECT-EXPANSION INDOOR UNIT FLOOR/CEILING MODEL



Code	Model	Size
387005013	FCIAS8DC	A
387005014	FCIBS9DC	B

Reversible indoor unit for floor or ceiling use and can be fitted in sight. Integrates perfectly into any space. The depth of only 19 cm and quiet operation at 24 dB(A) make this unit an excellent solution for villas, offices, hotel rooms, restaurants and public spaces. Featuring easy installation and condensation discharge, the unit is simple and convenient to maintain. It's equipped with a special humidity sensor.

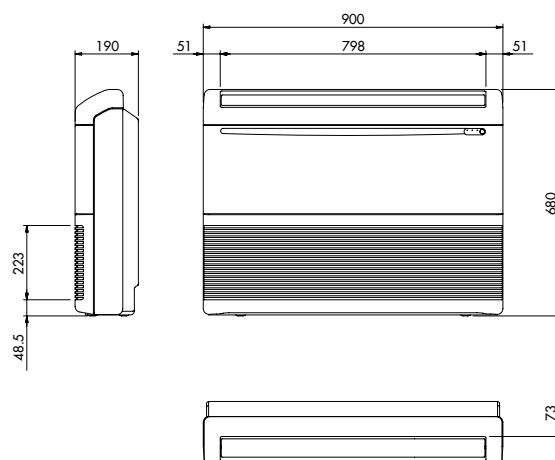

MODEL		FCIAS8DC	FCIBS9DC
Heating/Cooling capacity	kW	up to 3.7/4.0	up to 5.7/7.0
Size		A	B
Air flow rate (sl.-l.-m.-h.)	m <sup>3</sup> /h	310-390-430-520	450-510-610-720
Dehumidification	l/h	1.3	2.3
Fan speed	n°	3 + auto - by remote control	3 + auto - by remote control
Sound pressure at 2 m (sl.-l.-m.-h.)	dB(A)	24-26-30-37	35-40-46-49
Electrical power supply	V/Ph/Hz	230/1/50-60	230/1/50-60
Type of motor		DC Inverter	DC Inverter
Electrical power input	W	0.037	0.075
Power input	A	0.17	0.33
Liquid pipe diameter	mm (inch)	6.35 (1/4")	6.35 (1/4")
Gas pipe diameter	mm (inch)	9.52 (3/8")	12.7 (1/2")
Net Dimension (H./W./D.)	mm	680/900/190	680/900/190
Net weight	kg	23.5	23.5
Remote control supplied		Yes	Yes
Room temperature adjustment range	°C	from +10 to +32	from +10 to +32
Relative humidity sensor		Yes	Yes

# AS DIRECT-EXPANSION INDOOR UNIT CASSETTE MODEL



Code	Model	Size	Description
387006190	ASIAS8DC	A	Cassette with DC Inverter motor - Infrared remote controller - Integrated temperature sensor - Relative humidity sensor
387027154	ASGIDC	-	Grid with temperature and humidity sensor for ASIAS8DC model
387006192	ASICS10DC	C	Cassette with DC Inverter motor - Infrared remote controller - Integrated temperature sensor - Relative humidity sensor
387027155	ASGI25DC	-	Grid temperature and humidity sensor for ASICS10DC model
387006193	ASIDS13DC	D	Cassette with DC Inverter motor - Infrared remote controller - Integrated temperature sensor - Relative humidity sensor
387027156	ASGI48DC	-	Grid temperature and humidity sensor for ASIDS13DC model

Perfect for large to small commercial and public spaces, offices, shops and restaurants. AS is made from insulated metal and consists of a calibrated fan, flaps that can be positioned as desired, a built-in waterspout and air exchange capabilities. The grille is made from high quality plastic



**A** ASIA S8 DC



**C** ASIC S10 DC



**D** ASID S13 DC

MODEL		ASIAS8DC	ASICS10DC	ASIDS13DC
Heating/Cooling capacity	kW	up to 3.7/4.0	up to 9.0/11.0	up to 13.0/14.0
Size		A	C	D
Air flow rate (sl.-l.-m.-h.)	m <sup>3</sup> /h	200-530-630-750	850-1060-1160-1300	1200-1700-1980-2300
Dehumidification	l/h	1.2	3.6	3.6
Condensation pump static pressure	mm.c.a.	250	250	250
Fan speed	n°	3 + auto - by remote control	3 + auto - by remote control	3 + auto - by remote control
Sound pressure at 2 m (sl.-l.-m.-h.)	dB(A)	27-43-46-50	38-43-44-46	38-44-48-52
Electrical power supply	V/Ph/Hz	230/1/50-60	230/1/50-60	230/1/50-60
Type of motor		DC Inverter	DC Inverter	DC Inverter
Electrical power input	W	8-24-28-36	13-20-25-41	22-36-43-64
Liquid pipe diameter	mm (inch)	6.35 (1/4")	6.35 (1/4")	6.35 (1/4")
Gas pipe diameter	mm (inch)	9.52 (3/8")	12.7 (1/2")	12.7 (1/2")
Net dimensions (H./W./D.)	mm	296/575/575	310/760/760	338/1050/760
Net dimensions of grille (H./W./D.)	mm	41/730/730	30/860/860	30/1150/860
Net weight	kg	19	22	27
Remote control supplied		Yes	Yes	Yes
Room temperature adjustment range	°C	from +10 to +32	from +10 to +32	from +10 to +32
Relative humidity sensor		Yes	Yes	Yes

# AS DIRECT-EXPANSION INDOOR UNIT CASSETTE MODEL

## ASIAS8DC unit

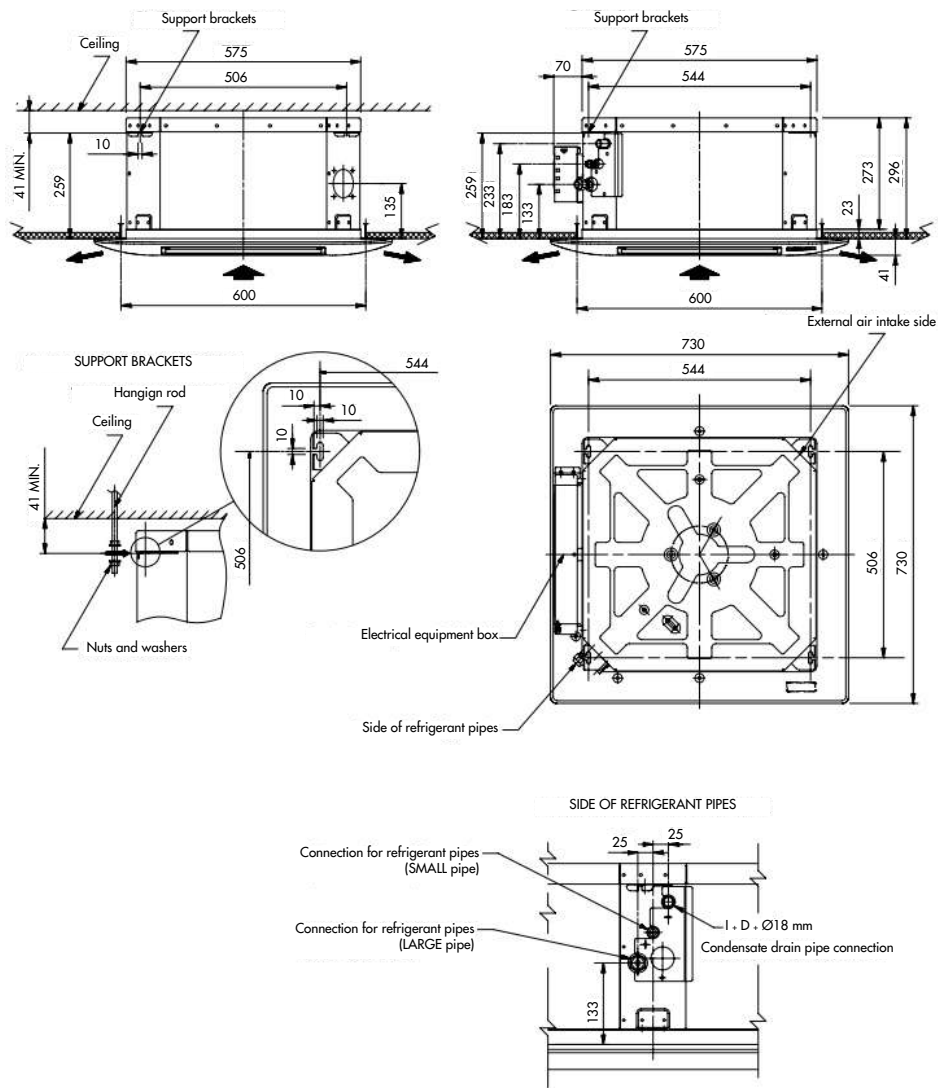

## ASICS10DC and ASIDS13DC units

MODEL	L	H	X	Y	Z
ASIC S10	760	310	260	860	500
ASID S13	1050	340	290	1150	750

A Condensation drain pipe hole: external diameter of 32 mm

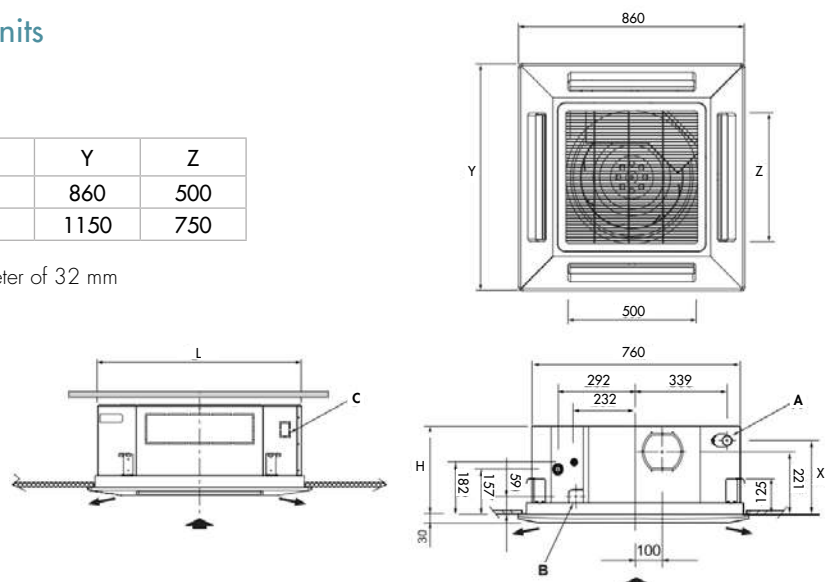



# SD DIRECT-EXPANSION INDOOR UNIT VERTICAL/HORIZONTAL BUILT-IN



Code	Model	Size
387006188	SDIAS8DC	A
387006189	SDIBS9DC	B

Compact and reversible indoor ductable unit with only 19 cm of depth suitable for villas, offices, hotel rooms, restaurants and public spaces. SD can be fitted both vertically and horizontally hidden in specially made spaces. It is operated by remote control by installing a specific infrared receiver and a 5 m cable (supplied).



MODEL		SDIAS8DC	SDIBS9DC
Heating/Cooling capacity	kW	up to 3.7/4.0	up to 5.7/7.0
Size		A	B
Air flow rate (sl.-l.-m.-h.)	m <sup>3</sup> /h	310-390-430-520	450-510-610-720
Dehumidification	l/h	1.3	2.3
Fan speed	n°	3 - auto - by remote control	3 - auto - by remote control
Sound pressure at 2 m (sl.-l.-m.-h.)	dB(A)	24-26-30-37	35-40-46-49
Electrical power supply	V/Ph/Hz	230/1/50-60	230/1/50-60
Type of motor		DC Inverter	DC Inverter
Electrical power input	W	37	75
Power input	A	0.17	0.33
Liquid pipe diameter	mm (inch)	6.35 (1/4")	6.35 (1/4")
Gas pipe diameter	mm (inch)	9.52 (3/8")	12.7 (1/2")
Net dimensions (H./W./D.)	mm	680/900/190	680/900/190
Net weight	kg	25	25
Remote control supplied		Yes	Yes
Room temperature adjustment range	°C	from +10 to +32	from +10 to +32
Relative humidity sensor		Yes	Yes

# SD DIRECT-EXPANSION INDOOR UNIT VERTICAL/HORIZONTAL BUILT-IN

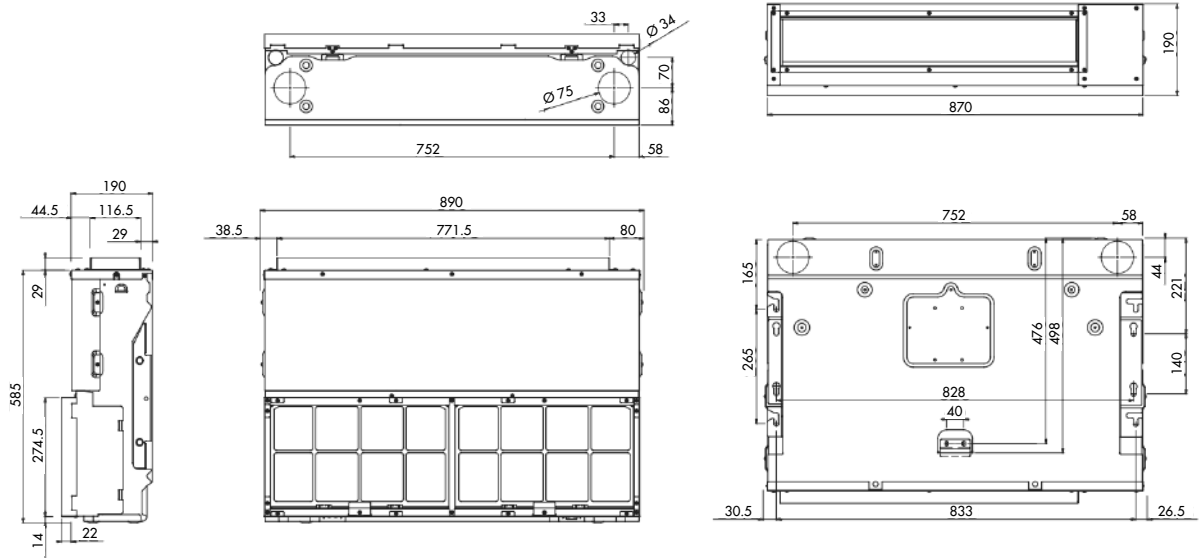

## EXTERNAL STATIC PRESSURE/AIR FLOW RATE DIAGRAM

### SDIAS8DC unit

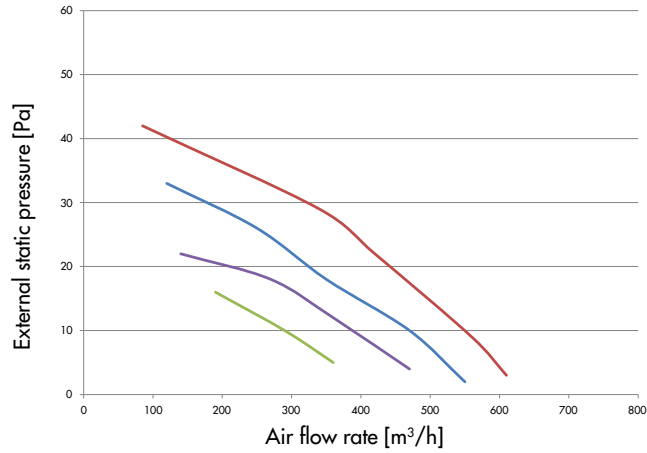

### SDIBS9DC unit

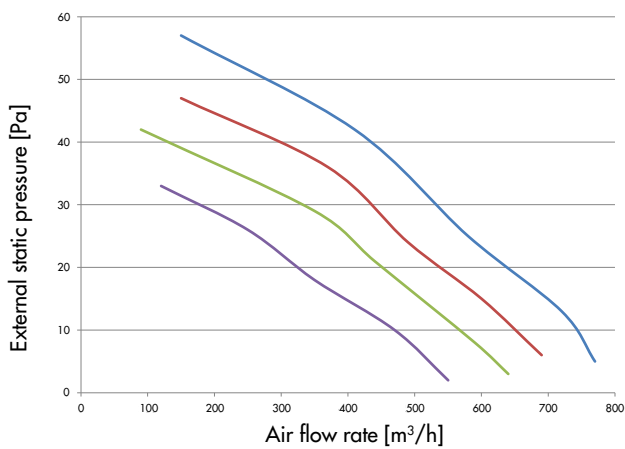

# AD DIRECT-EXPANSION INDOOR UNIT DUCTED



Code	Model	Size
387006196	ADIAS19DC	A
387006194	ADIBS13DC	B
387006195	ADICS13DC	C

Medium prevalence ductable unit, to be combined with build-on-site plenums with or without the aid of the two-way (ADIA) and three-way (ADIB - ADIC) conveyor. It is built with great attention to material selection and assembly of components and it is suitable for mounting on false ceilings. This unit can also be connected to a fresh air inlet. A special function can be activated by removing a "jumper" from the circuit board to increase the static pressure. AD, even though it was designed to be built-in and therefore concealed, can be operated by remote control by installing a receiver.



MODEL		ADIAS19DC	ADIBS13DC	ADICS13DC
Heating/Cooling capacity	kW	up to 4.2/4.4	up to 5.7/7.0	up to 9.0/11.0
Size		A	B	C
Air flow rate (l.-m.-h.-eh.)	m <sup>3</sup> /h	600-720-835-930	630-855-1010-1170	630-855-1010-1170
Dehumidification	l/h	0.8	2.3	2.5
Condensation pump static pressure	mm.c.a	250	250	250
Fan speed	n°	3 + auto - by remote control	3 + auto - by remote control	3 + auto - by remote control
Standard static pressure/JP2 contact	Pa	50/60	50/70	50/70
Sound pressure at 2 m (l.-m.-h.-eh.)	dB(A)	35-40-43-45	32-35-42-47	35-40-46-49
Sound power (l.-m.-h.-eh.)	dB(A)	44-49-53-54	41-44-51-56	44-49-55-58
Electric power supply	V/Ph/Hz	230/1/50-60	230/1/50-60	230/1/50-60
Type of motor		DC Inverter	DC Inverter	DC Inverter
Electric power input	W	56	76	118
Liquid pipe diameter	mm (inch)	6.35 (1/4")	6.35 (1/4")	6.35 (1/4")
Gas pipe diameter	mm (inch)	9.52 (3/8")	12.7 (1/2")	12.7 (1/2")
Diameter of the plenum ducted	mm	200	200	200
Net dimension (H./W./D.)	mm	266/852/572	266/1060/572	266/1060/572
Net dimension with plenum (H./W./D.)	mm	266/852/772	266/1060/772	266/1060/772
Net weight	kg	30	35	35
Remote control with receiver		Yes	Yes	Yes
Room temperature adjustment range	°C	from +10 to +32	from +10 to +32	from +10 to +32
Relative humidity sensor		Yes	Yes	Yes

# AD DIRECT-EXPANSION INDOOR UNIT DUCTED MODEL

ADIAS19DC unit

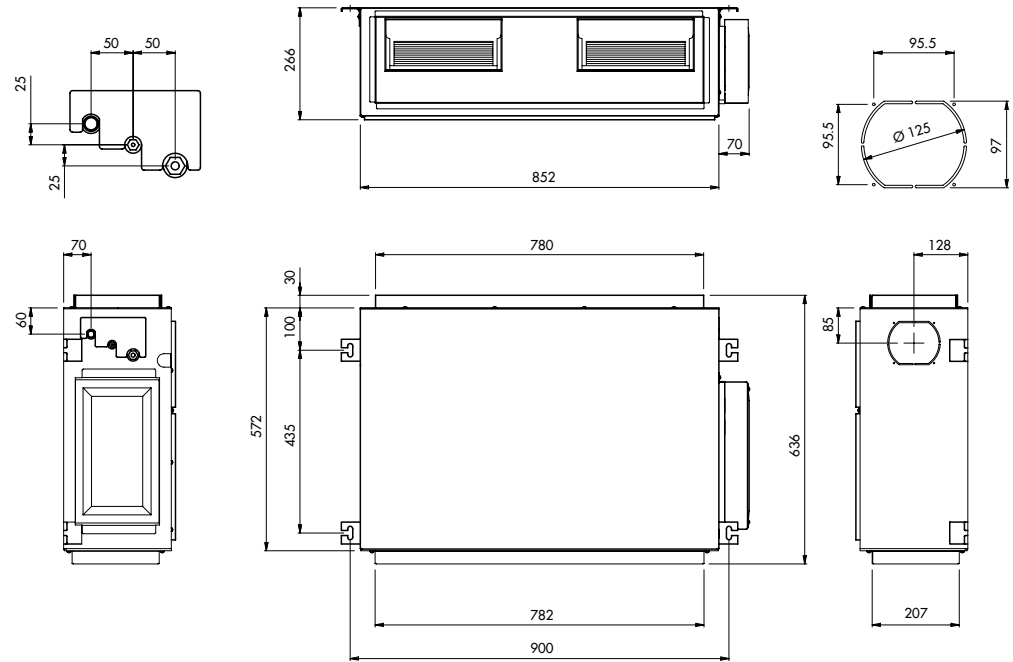

## STATIC PRESSURE/AIR FLOW RATE DIAGRAM - ADIAS19DC UNIT

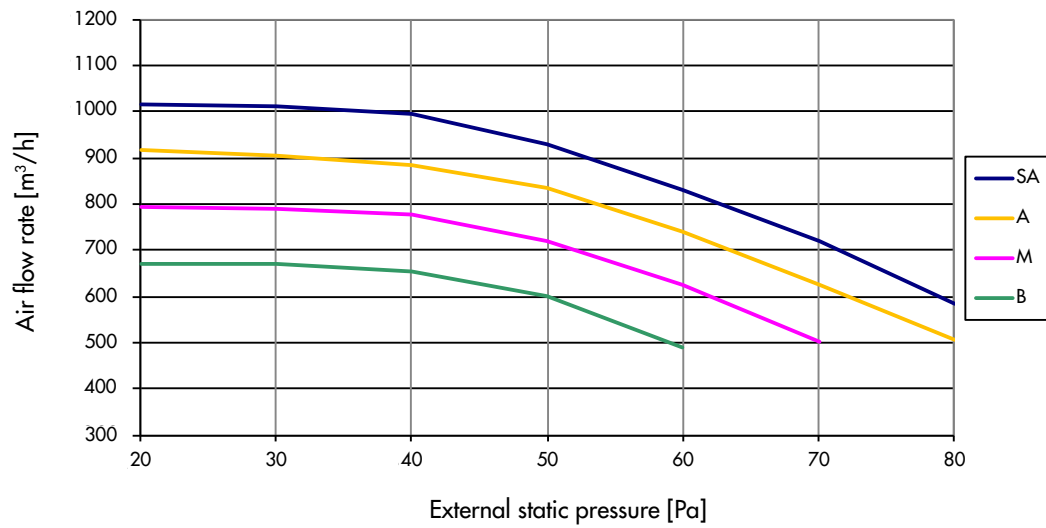

ADIBS13DC unit  
ADICS13DC unit

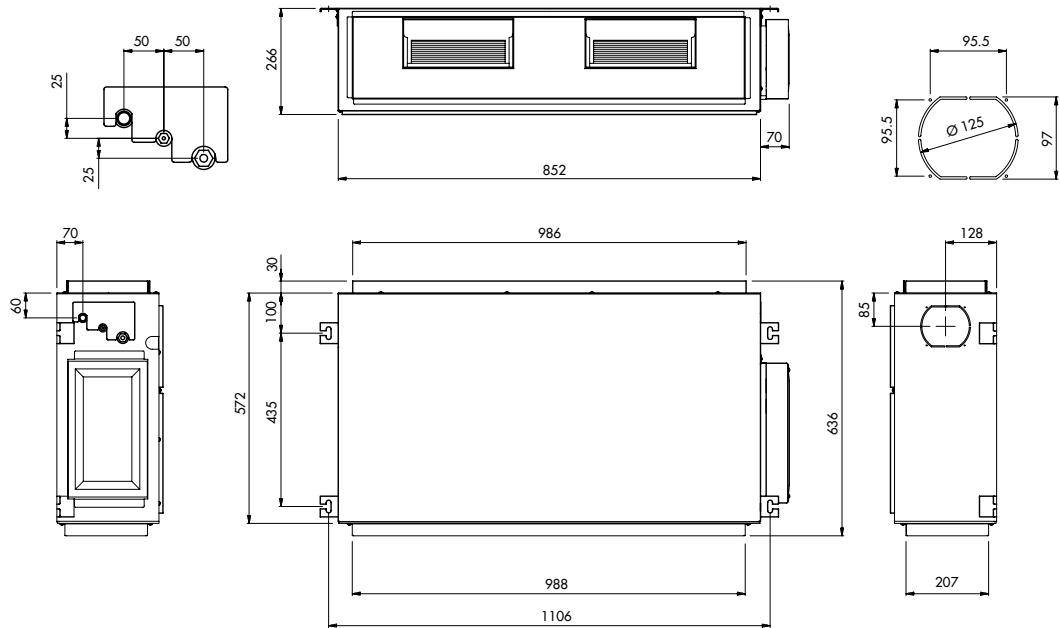

### STATIC PRESSURE/AIR FLOW RATE DIAGRAM - ADIBS13DC - ADICS13DC UNITS

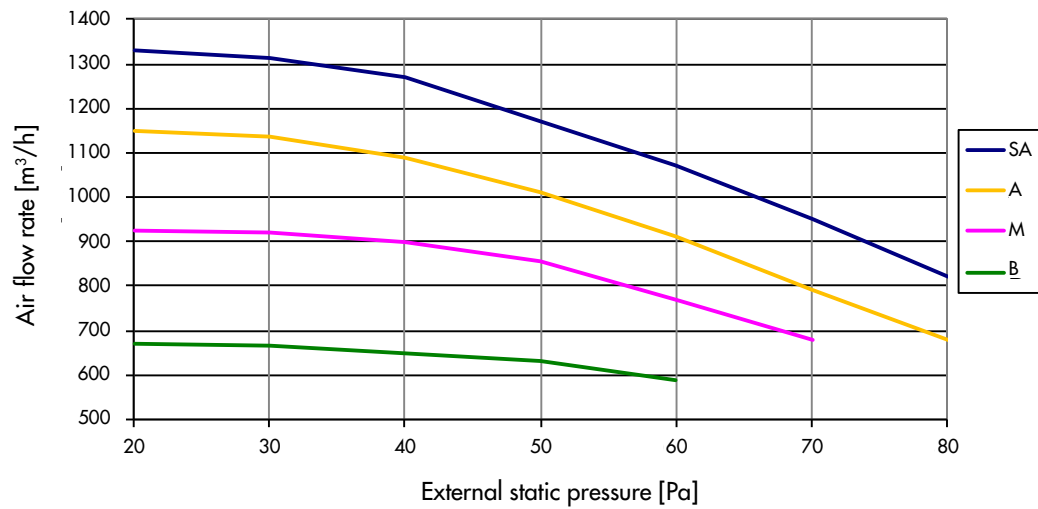

# DHW PRODUCTION SOLUTIONS

## ARGO EXCLUSIVE TECHNOLOGY

1

EMIX is directly connected to the outdoor unit, which is fitted with a special gas connection specifically for this purpose. The storage tank for domestic hot water, to be combined with the unit which can be supplied by third parties, must have a volume between 80 and 300 liters.



## ARGO EXCLUSIVE TECHNOLOGY

2

EMIX TANK is directly connected to the outdoor unit, which is fitted with a special gas connection specifically for this purpose. The EMIX TANK is available in the version with a storage tank designed to hold from 200 to 300 liters of domestic hot water, and is provided with an internal exchanger with forced circulation for solar thermal energy.



## STANDARD TECHNOLOGY

3

The production of domestic hot water occurs by increasing the delivery temperature of the heat-transfer fluid and the switching of a three-way valve towards the exchanger of the dedicated tank. This tank can be supplied by the company (300 liters volume, equipped with suitable exchanger for heat pump, electric heating element and control panel) or by third parties.



## PRODUCTION OF DOMESTIC HOT WATER AND, AT THE SAME TIME, HEATING AND COOLING OF ROOMS

EMIX/EMIX TANK is a component of the iSERIES/iM system and is part of the wide range of indoor units; it can produce domestic hot water using a thermodynamic source all year round, by working simultaneously with the system regardless of its operating mode. This innovative concept goes beyond the 'traditional' methods of producing domestic hot water, which instead involves transferring energy using diverter valves, which actually interrupt the flow of the fluid towards the system.



## FREE PRODUCTION OF DOMESTIC HOT WATER WHILE YOU COOL ROOMS



While the heat pump is operating in cooling mode, EMIX/EMIX TANK is able to transfer the heat extracted from the environment directly to the domestic hot water (ENERGY RECOVERY FUNCTION). By taking advantage of the desuperheating heat from the refrigerating cycle, EMIX/EMIX TANK can actually produce **domestic hot water for free, up to 75 °C** (when at least one indoor unit is operating) by directly using the energy of the single heat pump.

# EMIX and EMIX TANK

## MAIN FEATURES

### CONNECTION OF EMIX/EMIX TANK WITH iSERIES AND iM

The outdoor units from the iSERIES and iM range are fitted with a special connection port exclusively for connecting the EMIX/EMIX TANK unit via refrigerant pipes.

### HOW EMIX WORKS

EMIX does not offer an instantaneous solution for domestic hot water production, like a gas boiler, for example. For EMIX to operate correctly, it must heat the water in any type of tank, from an electric boiler to a storage tank with integration of a solar heat system. The unit will periodically sample water from the storage tank, take the temperature of the water and, if necessary, increase the temperature value until it reaches the setpoint.

Operating one or more electric heating elements (up to three), if built-in to the storage tank, will generate an anti-legionella cycle (if required) and a back-up that can be used if fast heating is needed or in the event of a system malfunction. An optional temperature sensor can be installed in the storage tank to optimise the thermal load.

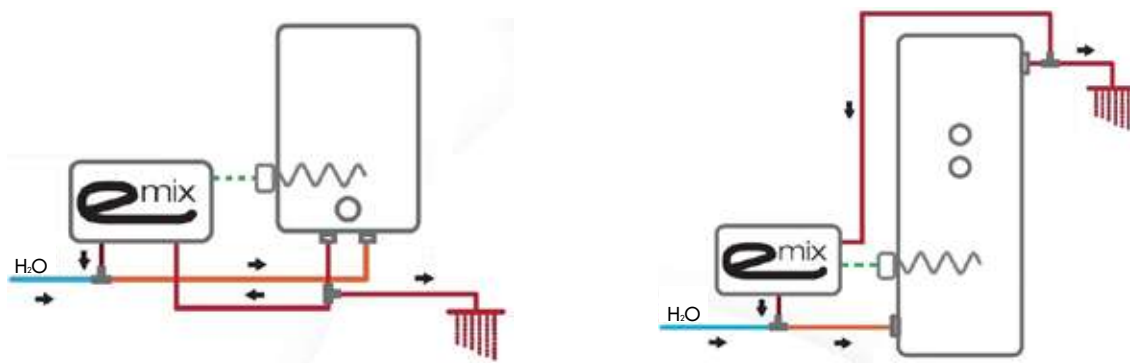

### HOW EMIX TANK WORKS

EMIX TANK integrates a refrigerant gas/domestic hot water heat exchanger and a glazed ceramic-coated steel storage tank all in a single solution.

The unit is fitted with two temperature sensors (which can be selected alternately) based on the set-point, which activate the modulating, variable speed pump. There are two electric heating elements available to produce an anti-legionella cycle (if required) and a back-up that can be used if fast heating is needed or in the event of a system malfunction. The set-up is complete with a thermostatic mixing valve to provide the correct water temperature for the user.

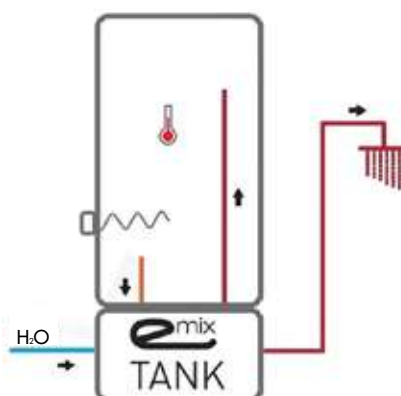



## OPERATING MODE

Setting the desired temperature (set-point) for domestic hot water is very easy. The set-point is configured using one single button and the temperature level is indicated via five green LEDs.

The EMIX/EMIX TANK regulation system will take care of the rest and will aim to meet all the heat load requirements, distributing the energy from the heat pump autonomously to ensure that the rooms are heated and that domestic hot water is produced.

## INTEGRATION WITH SOLAR HEAT SYSTEMS

The solar heat systems that are specifically designed to produce domestic hot water are widely used throughout Europe (especially southern Europe).

There are two types of solar heaters; natural circulation and forced circulation.

EMIX can be connected to both of these types of systems. In this case, it will function as an integrated component, producing hot water when the efficiency of the solar panels is low (in winter or at night), or when the user's water demand becomes significant.

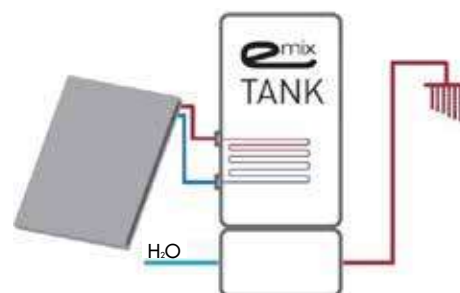
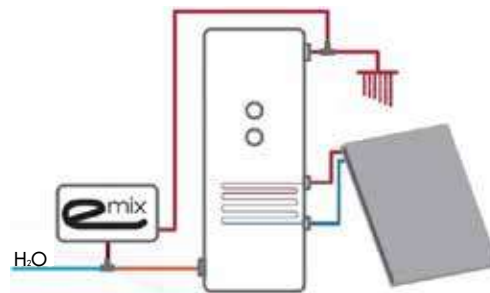
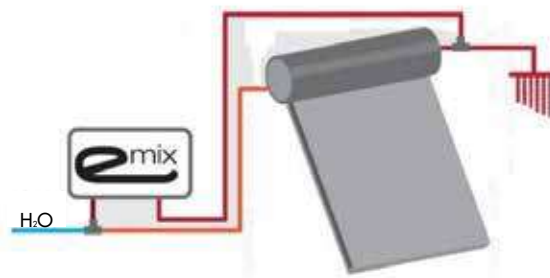

# EMIX

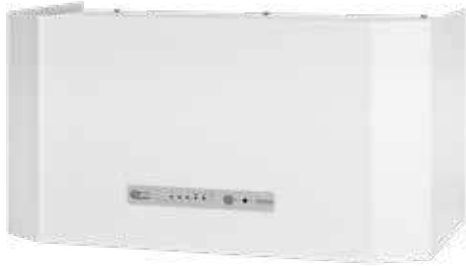

Code	Model
3871 35030	EMIX V1

EMIX V1 is DHW module which can be combined with any tank (min. 80 liters - max. 300 liters). It is provided with inverter pump and stratification sensor and it can be integrated with both natural and forced circulation solar thermal energy systems. The unit is provided with a double-wall exchanger to ensure maximum safe and purified domestic water and is able to manage an integration or backup resistance.

## ACCESSORIES (INCLUDED)

- 3/4" mesh filter
- Temperature sensor



1. Refrigerant inlet from the outdoor unit (port X)
2. Refrigerant outlet to outdoor unit (port Y)
3. Domestic cold water inlet
4. Domestic hot water outlet
5. Wiring of communication cables
6. Wiring of power cables (power cords)

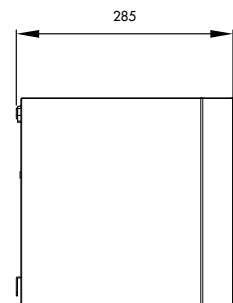
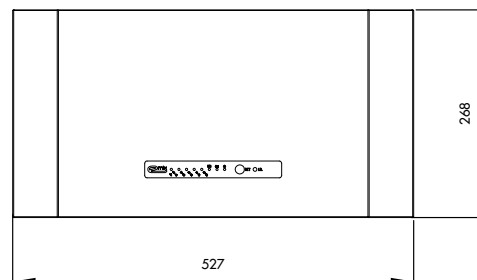
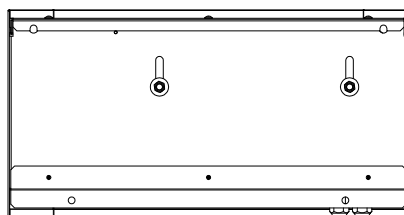
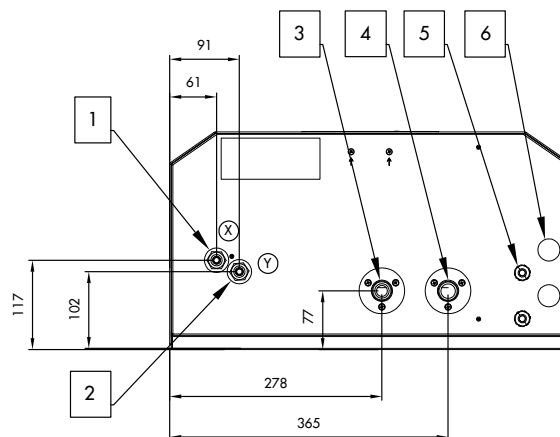

Technical data EMIX V1		
Electrical power supply	V/Ph/Hz	230/1/50
Minimum power/current input	W/A	15/0.20
Maximum power/current input	W/A	70/0.53
Hydraulic connections	inch	3/4" - 3/4" (1/2"-1/2" per AEI1G140EMX)
Gas connections	inch	3/8" - 3/8"
Net weight U.I.	kg	16.5
Net dimension U.I (H./W./D.)	mm	268/527/285
Additional heaters	kW	activation only
Suggested water flow-rate	L/min	10-12
Maximum operating pressure	bar	6
Sound power level	dB(A)	35

MODEL	EMIX V1				
	Connected to	AEI1G65EMX	AIM06EMX	AEI1G80EMX	AIM08EMX
ERP class (*)	-	A	A	A	A
Load profile (tapping)	-	L	L	XL	XL
Reference DHW tank volume	L	200	200	300	300
Water heating energy efficiency (**)	$\eta_{WH}$	104	105	116	106
Annual energy consumption (**)	kWh	981	972	1447	1587
COP <sub>DHW</sub>	-	2.51	2.51	2.78	2.56
Heating-up time (from 10 °C)	h:m	2:36	3:09	3:04	3:33
Final reference water temperature	°C	50	50	48	48
Maximum quantity of mixed water at 40 °C	l	240	240	354	354

MODEL	EMIX V1				
	Connected to	AEI1G110EMX	AIM11EMX	AEI1G140EMX	AIM14EMX
ERP class (*)	-	A	A	A	A
Load profile (tapping)	-	XL	XL	XL	XL
Reference DHW tank volume	L	300	300	300	300
Water heating energy efficiency (**)	$\eta_{HW}$	106	106	112	105
Annual energy consumption (**)	kWh	1581	1586	1490	1601
COP <sub>DHW</sub>	-	2.57	2.55	2.71	2.51
Heating-up time (from 10 °C)	h:m	2:47	2:25	2:08	2:24
Final reference water temperature	°C	48	48	48	48
Maximum quantity of mixed water at 40 °C	l	354	354	354	354

(\*) with test method according to EN 16147  
 (\*\*) average seasons

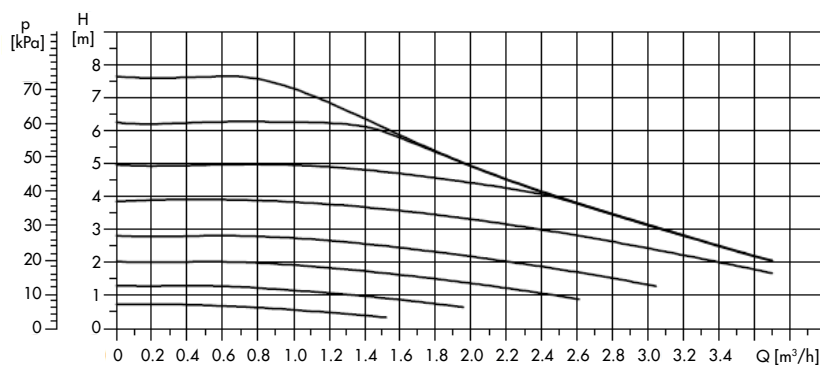

Operating curve of EMIX

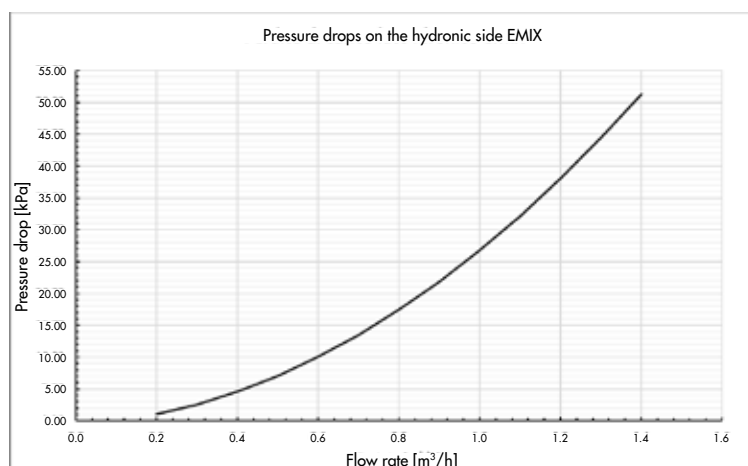

Recommended design flow rate: 10-12 l/min

# INSTALLATION DIAGRAMS

## DIAGRAM 1

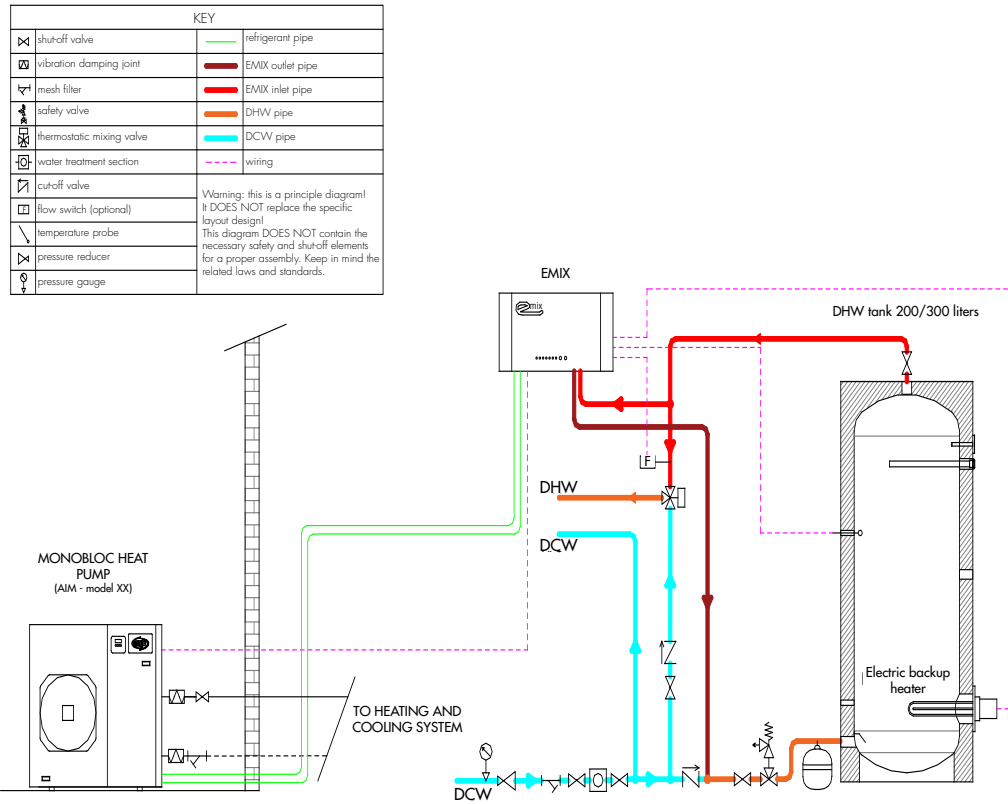

Diagram showing EMIX coupled with a domestic hot water tank with electric backup heater, managed directly by EMIX. Stratification DHW sensor and flow switch (optional) to optimise the anti-legionella cycle. The EMIX is connected to an iM heat pump.

DIAGRAM 2

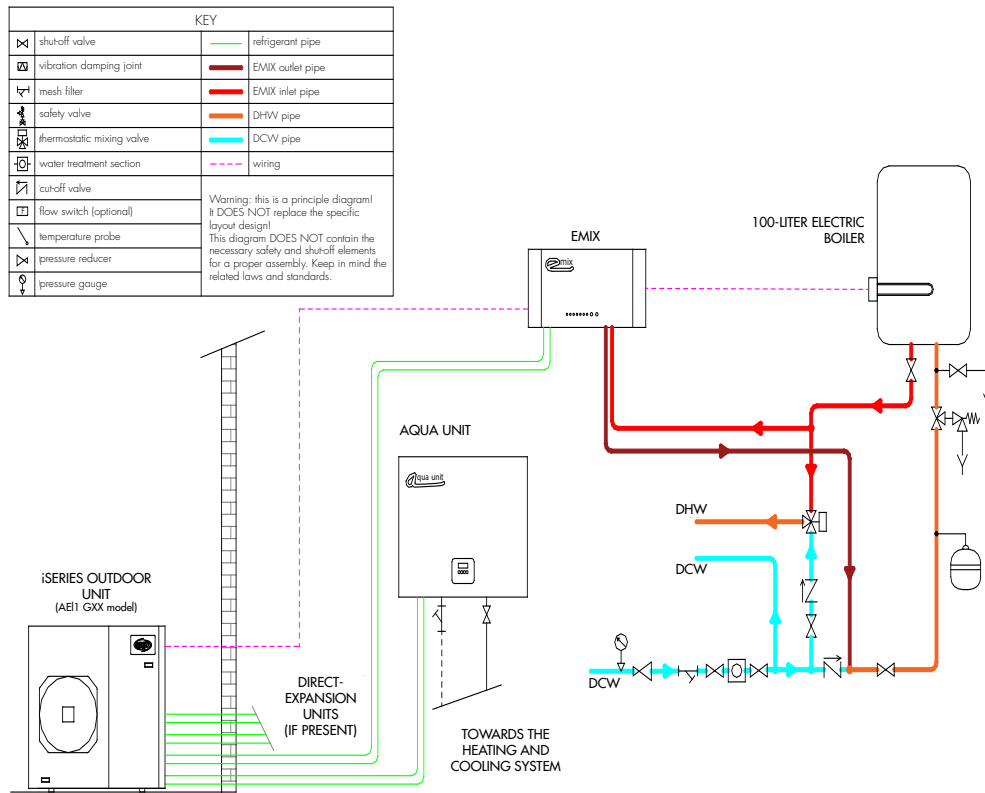

Diagram showing EMIX supplied by a small domestic hot water storage tank with suitable electric heating element, operated directly by EMIX. DHW temperature management by periodic sampling of stored water. The EMIX is connected to an iSERIES system outdoor unit.

# EMIX TANK



EMIX TANK 200 V2    EMIX TANK 300 V2

Code	Model
387030198	EMIX TANK 200 V2
387030199	EMIX TANK 300 V2

EMIX TANK 200 V2 and EMIX TANK 300 V2, with the same features as the EMIX but fitted inside a rectangular white metal chassis, with a built-in ceramic-coated tank with a 200-300 liters capacity, suitable for domestic hot water, provided with backup heater, circulation pump and solar exchanger for connection to third-party solar panels.

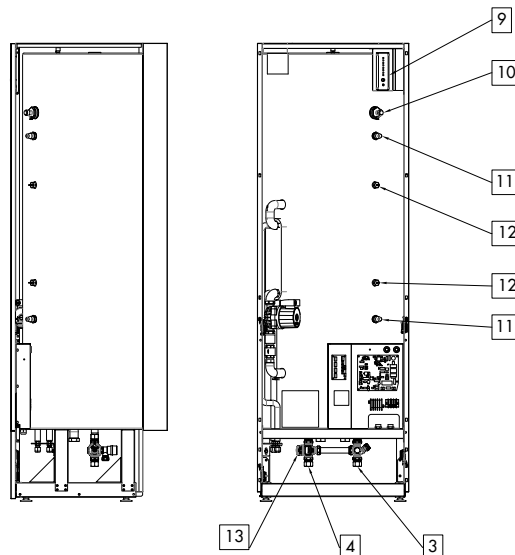
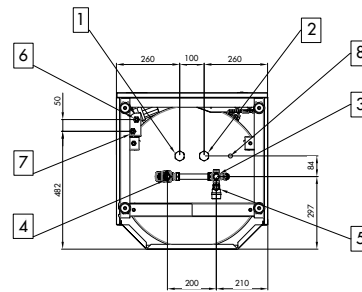

- 1. Solar thermal energy exchanger inlet
- 2. Solar thermal energy exchanger outlet
- 3. Domestic cold water inlet
- 4. Domestic hot water outlet
- 5. Safety valve
- 6. Refrigerant gas inlet
- 7. Refrigerant gas outlet
- 8. Solar thermal energy sensor probe
- 9. Control panel
- 10. Magnesium anode
- 11. Electric backup heater
- 12. Temperature sensors
- 13. Thermostatic mixing valve

Technical data		EMIX TANK 200 V2	EMIX TANK 300 V2
Electric power supply	V/Ph/Hz	230/1/50	
Maximum power input (without electric heater)	W	60	
Maximum power input (with electric heater)	W	2000	
Hydraulic connections	mm	Ø 22	
Gas connections	inch	3/8" - 3/8" (1/2" - 1/2" per AEI1G140EMX)	
Solar thermal energy exchanger connections	inch	G 1"	
Maximum refrigerant pipe length	m	10	
Maximum height difference between indoor unit and outdoor unit	m	10	
Maximum height difference to other iSERIES indoor unit	m	5	
Additional gas charge (if required)	g/m	15 for pipes G 3/8" - G 3/8" (20 per G1/2")	
Tank volume	l	200	300
Net weight	kg	103	133
Weight with packaging	kg	115	145
Net dimension (H./W./D.)	mm	1460/620/640	1875/620/640
Maximum operating pressure (PSV set)	bar	6	
Sound power level	dB(A)	35	

MODEL		EMIX TANK 200 V2		
Connected to		AEI1G50EMX	AEI1G65EMX	AIM06EMX
ERP class (*)	-	A	A	A
Load profile (tapping)	-	L	L	L
Water heating energy efficiency (**)	$\eta_{HW}$	105	104	105
Annual energy consumption (**)	kWh	979	981	972
COP <sub>DHW</sub>	-	2.53	2.51	2.51
Heating-up time (from 10 °C)	h:m	2:47	2:36	3:09
Final reference water temperature	°C	50	50	50
Maximum quantity of mixed water at 40 °C	l	240	240	240

MODEL		EMIX TANK 300 V2					
Connected to		AEI1G80EMX	AIM08EMX	AEI1G110EMX	AIM11EMX	AEI1G140EMX	AIM14EMX
ERP class (*)	-	A	A	A	A	A	A
Load profile (tapping)	-	XL	XL	XL	XL	XL	XL
Water heating energy efficiency (**)	$\eta_{HW}$	116	106	106	106	112	105
Annual energy consumption (**)	kWh	1447	1587	1581	1586	1490	1601
COP <sub>DHW</sub>	-	2.78	2.56	2.57	2.55	2.71	2.51
Heating-up time (from 10 °C)	h:m	3:04	3:33	2:47	2:25	2:08	2:24
Final reference water temperature	°C	48	48	48	48	48	48
Maximum quantity of mixed water at 40 °C	l	354	354	354	354	354	354

(\*) with test method according to EN 16147  
 (\*\*\*) average season

## SOLAR THERMAL ENERGY EXCHANGER PRESSURE DROP

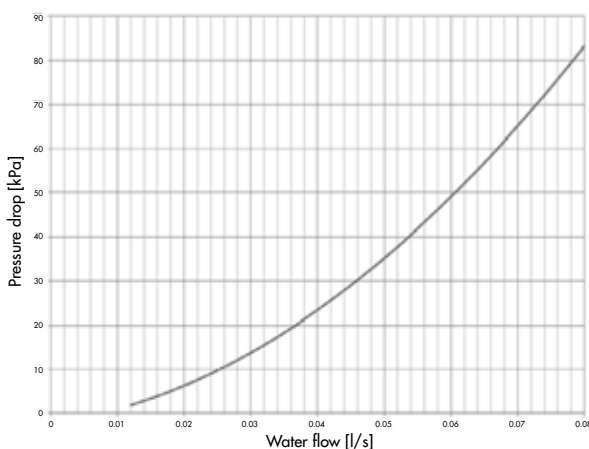

Exchanger surface area: 1.4 m<sup>2</sup>

# INSTALLATION DIAGRAMS

## DIAGRAM 1

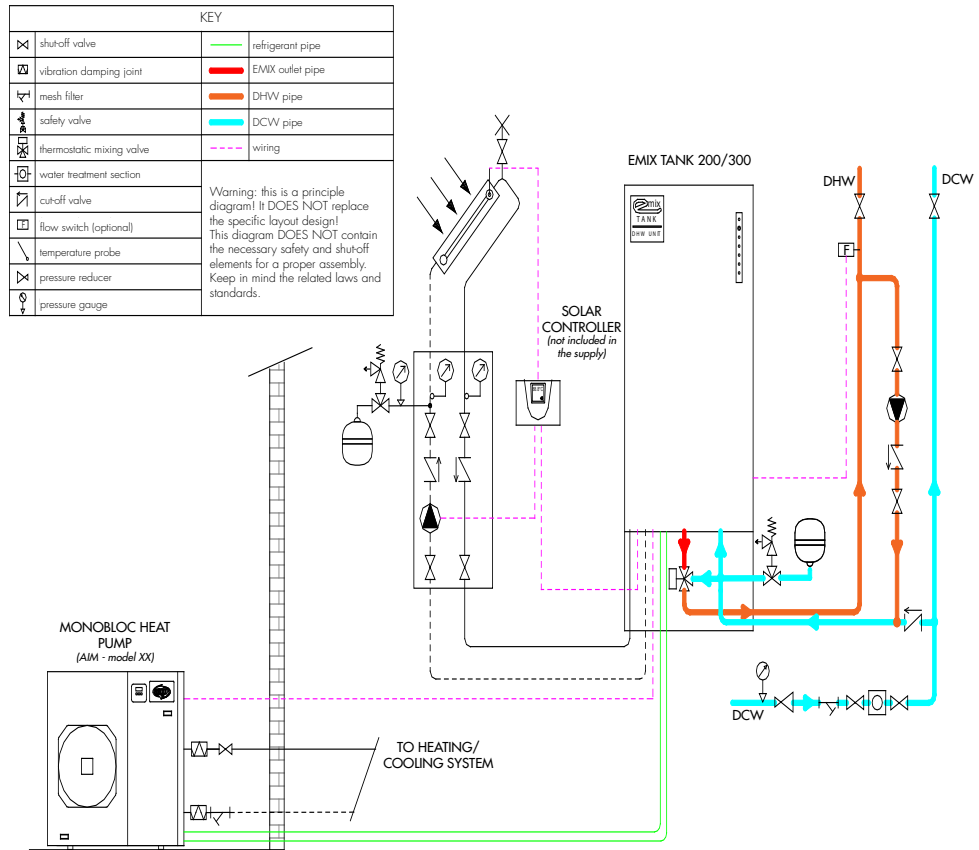

Diagram showing EMIX TANK connected to an iM heat pump.

Flow switch (optional) to optimise the anti-legionella cycle and connection to a solar thermal system (not in our scope of supply).



DIAGRAM 2

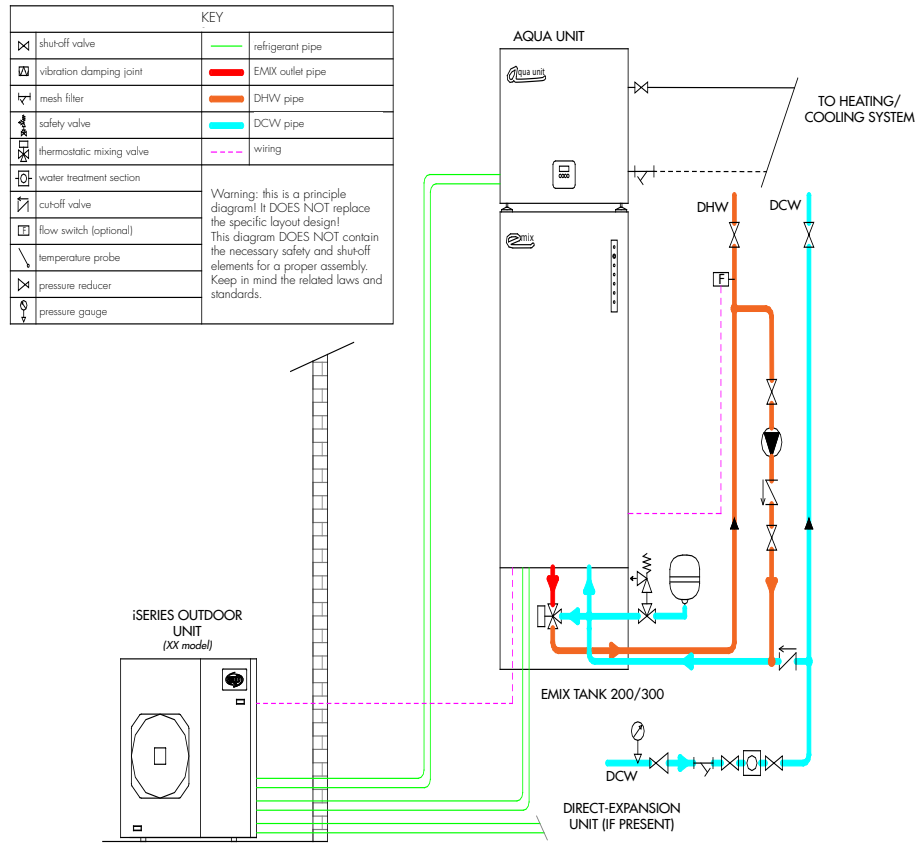
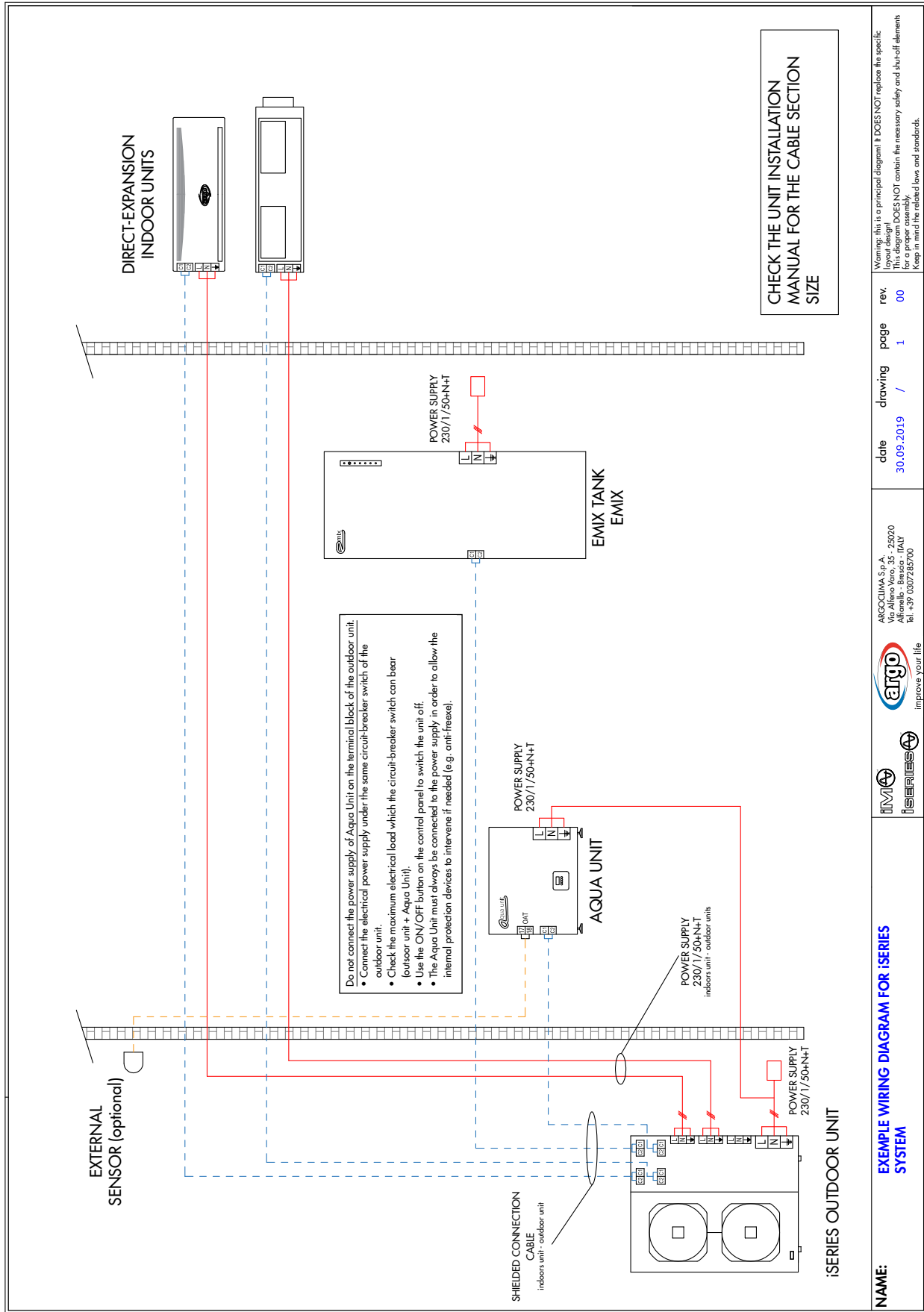

Diagram showing EMIX TANK connected to an iSERIES system.  
 The AQUA UNIT module easily and practically fits on top of the EMIX TANK, reducing the installation space.  
 Flow switch (optional) to optimise the anti-legionella cycle.

# iSERIES

## EXAMPLE WIRING DIAGRAM



<b>NAME:</b>	<b>EXAMPLE WIRING DIAGRAM FOR iSERIES SYSTEM</b>
<b>ARGOCIMA S.p.A.</b> Via Alleno Vero, 35 - 25020 Alleno (Bs) - ITALY Tel. +39 0307185700	<b>date</b> 30.09.2019 / <b>drawing</b> / <b>page</b> 1 / <b>rev.</b> 00
<b>imv</b> <b>iSERIES</b>	<b>improve your life</b>

# iSERIES

## INSTALLATION EXAMPLES

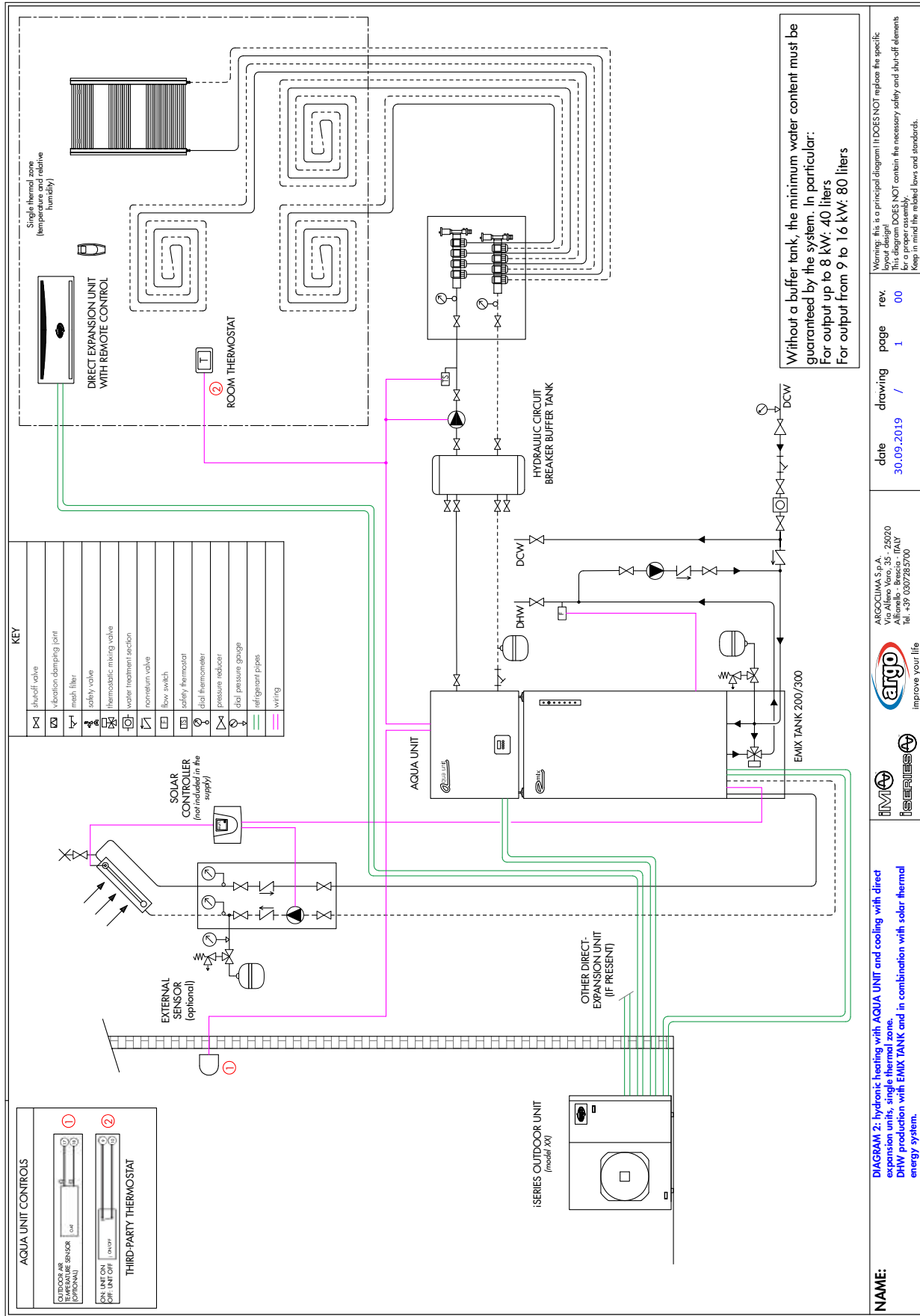

**NAME:** DIAGRAM 2: hydronic heating with AQUA UNIT and cooling with direct expansion units, single thermal zone. DHW production with EMIX TANK and in combination with solar thermal energy system.

**date:** 30.09.2019

**drawing:** /

**page:** 1

**rev:** 00

**ARGOCUIMA S.p.A.**  
 Via Alfeo Vero, 35 - 25020 Alonte (Brescia) (IT)  
 Tel. +39 030 2829760

**argo** improve your life

**IMM** **iSERIES**

Warning: this is a principal diagram. IT DOES NOT replace the specific layout design. IT DOES NOT contain the necessary safety and shut-off elements for a proper assembly. Keep in mind the related laws and standards.

HEAT PUMPS

# INSTALLATION EXAMPLES

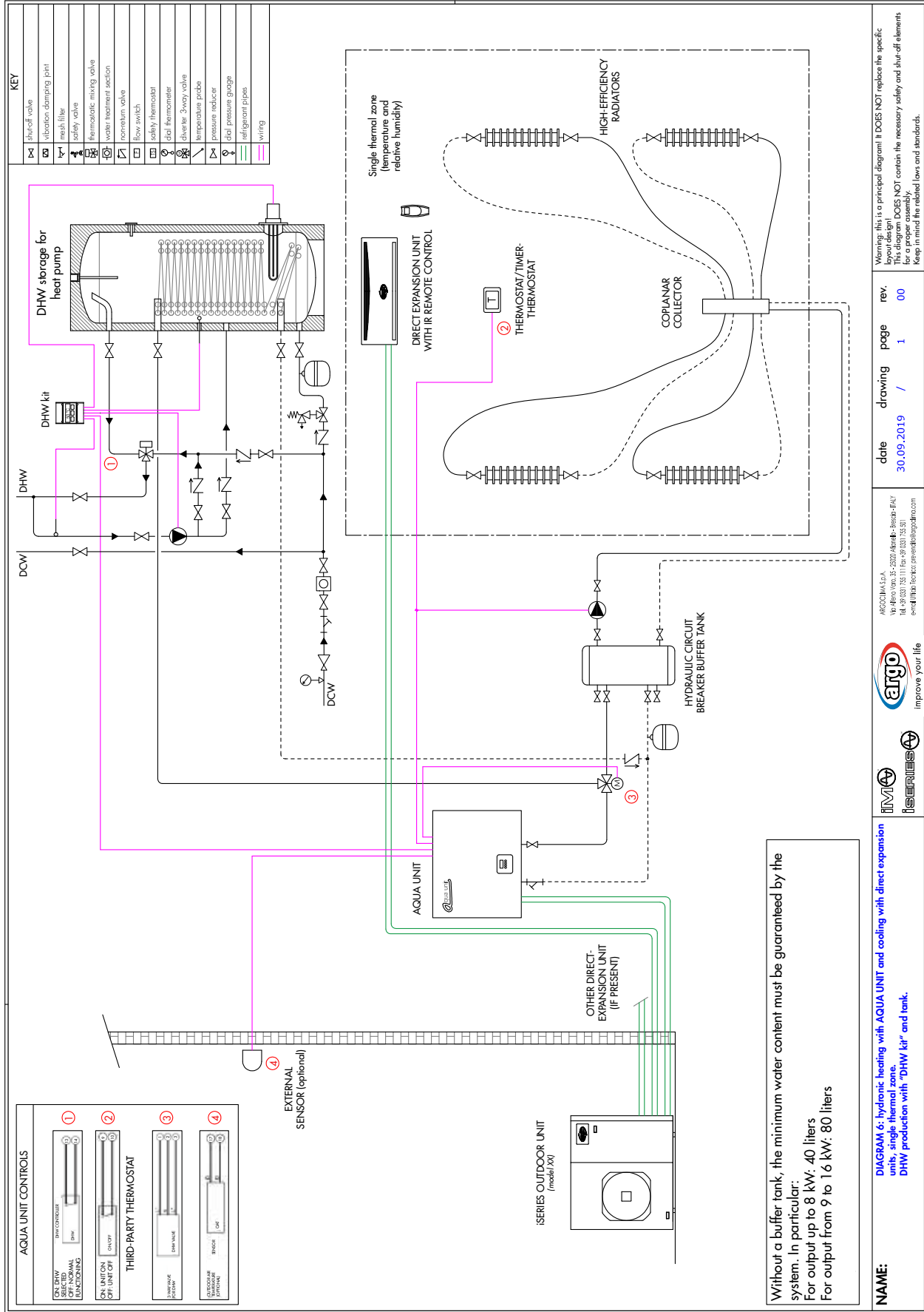

Without a buffer tank, the minimum water content must be guaranteed by the system. In particular:  
 For output up to 8 kW: 40 liters  
 For output from 9 to 16 kW: 80 liters

**NAME:** **DIAGRAM 6:** hydronic heating with AQUA UNIT and cooling with direct expansion units, single thermal zone. DHW production with "DHW kit" and tank.

**date** 30.09.2019 **drawing** / 1 **page** 00 **rev.**

**Warning:** this is a principal diagram! It DOES NOT replace the specific layout design!  
 This diagram DOES NOT contain the necessary safety and shut-off elements or a proper identification of the components.  
 Keep in mind the relevant laws and standards.

**IMMAGINEA**  
 Via della Vite, 35 - 20122 Milano - Italy - 02/58100000  
 Tel. +39 033 238 11 Fax +39 033 238 301  
 e-mail: info@imaginea.com - www.imaginea.com

**Argo** improve your life

**IMMAGINEA** **iSERIES**

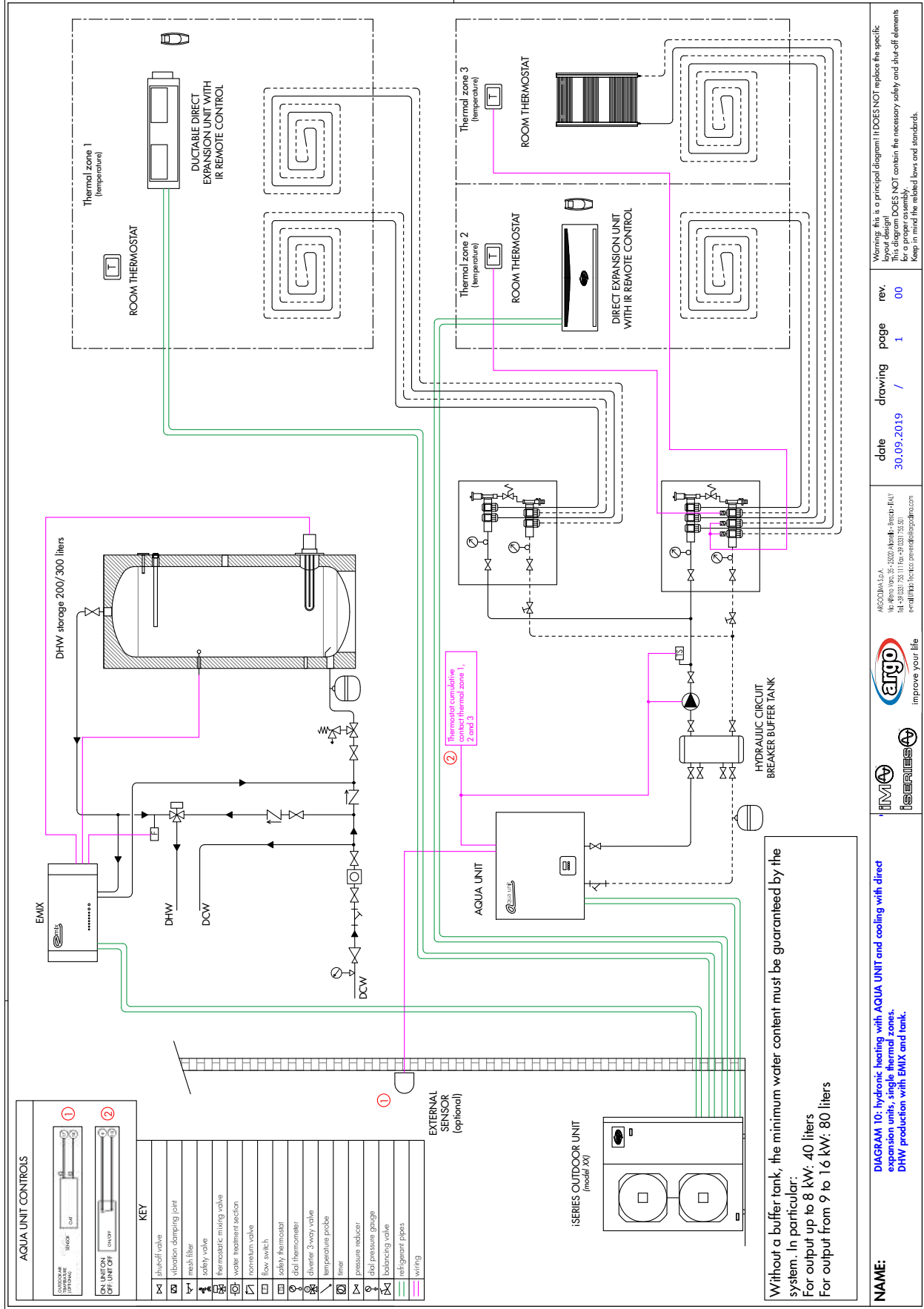

**NAME:** DIAGRAM 10: hydronic heating with AQUA UNIT and cooling with direct expansion units, single thermal zones. DHW production with EMIX and tank.

**date** 30.09.2019 **drawing** / 1 **page** 00 **rev.**

**Warning:** this is a principal diagram! It DOES NOT replace the specific layout design!  
This diagram DOES NOT contain the necessary safety and shut-off elements for the system!  
Keep in mind the related laws and standards.

ARGO S.p.A.  
Via Bello Oasi, 35 - 35020 Aponso (Pd) - 35020 Aponso (Pd)  
Tel. +39 0291 758 111 Fax +39 0291 758 301  
e-mail: info@argo.com website: www.argo.com

improve your life

HEAT PUMPS

# INSTALLATION EXAMPLES

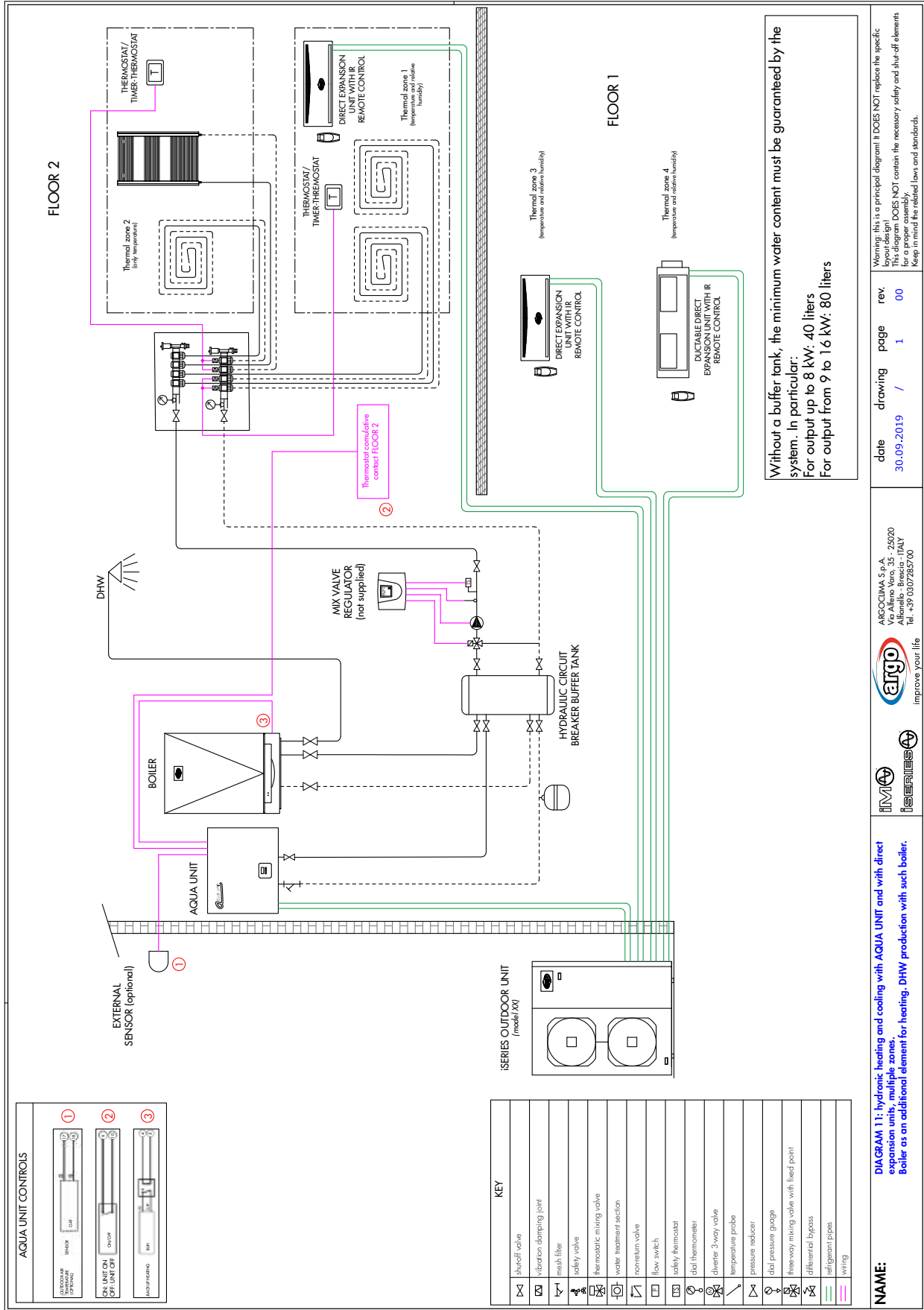

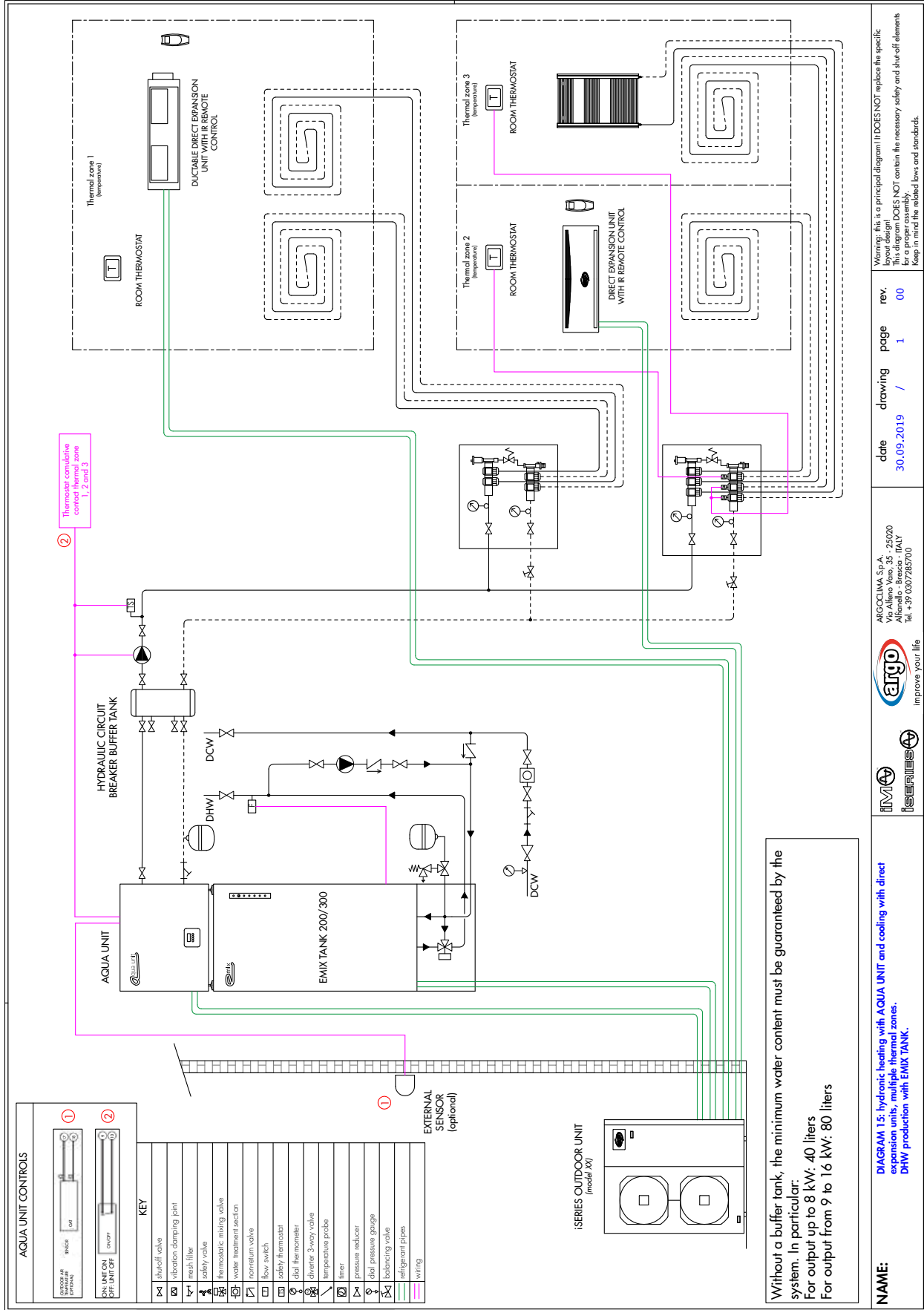

**AQUA UNIT CONTROLS**

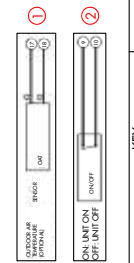

**KEY**

- shutoff valve
- vibration-damping pin
- mesh filter
- safety valve
- thermostatic mixing valve
- water treatment section
- normalisation valve
- flow switch
- safety thermostat
- dial thermometer
- diverter 3-way valve
- temperature probe
- timer
- pressure reducer
- dial pressure gauge
- balancing valve
- refrigerant pipes
- wiring

EXTERNAL SENSOR (optional)

iSERIES OUTDOOR UNIT (model XX)

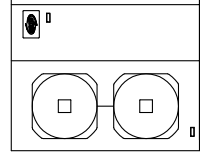

Warning: this is a principal diagram! It DOES NOT replace the specific layout design!  
This diagram DOES NOT contain the necessary safety and shut-off elements for the system.  
Keep in mind the related laws and standards.

ARGOClima S.p.A.  
Via Alleno, Viro, 35 - 25020  
Allanillo - Brescia - ITALY  
Tel. +39 030 7285700

IMM  
iSERIES

DIAGRAM 15: hydronic heating with AQUA UNIT and cooling with direct expansion units, multiple thermal zones.  
DHW production with EMIX TANK.

NAME:

date 30.09.2019 / drawing / page 1 / 00 rev.





# BUILT-IN SOLUTIONS

---

# BUILT-IN SOLUTIONS

## FOR iSERIES SYSTEMS WITH EMIX

### MAIN FEATURES

The cabinet allows built-in wall-mounted installation of EMIX, the unit from the iSERIES range dedicated to DHW production. This specific solution allows you to reduce and optimise installation spaces in situations where rooms are heated and cooled with direct expansion indoor units.

The galvanised sheet metal cabinet contains all the elements required for a DHW production system:

- DHW storage tank in stainless steel;
- Connection kit to the EMIX unit, with suitably arranged and insulated pipes;
- Safety and control devices.

### BUILT-IN MODULE COMPONENTS

Code	Description
387030626	Built-in cabinet
387030627	DHW 200 liters storage tank kit
387030628	EMIX connection kit

### ACCESSORIES

Code	Description
387030630	3/4" domestic water inlet filter
387030631	Pair of 3/4" domestic water shut-off valves
387030632	1.5 kW electric heating element for DHW tank

### INDOOR UNIT

Code	Description
387135030	EMIX V1

### DIMENSIONAL DRAWINGS

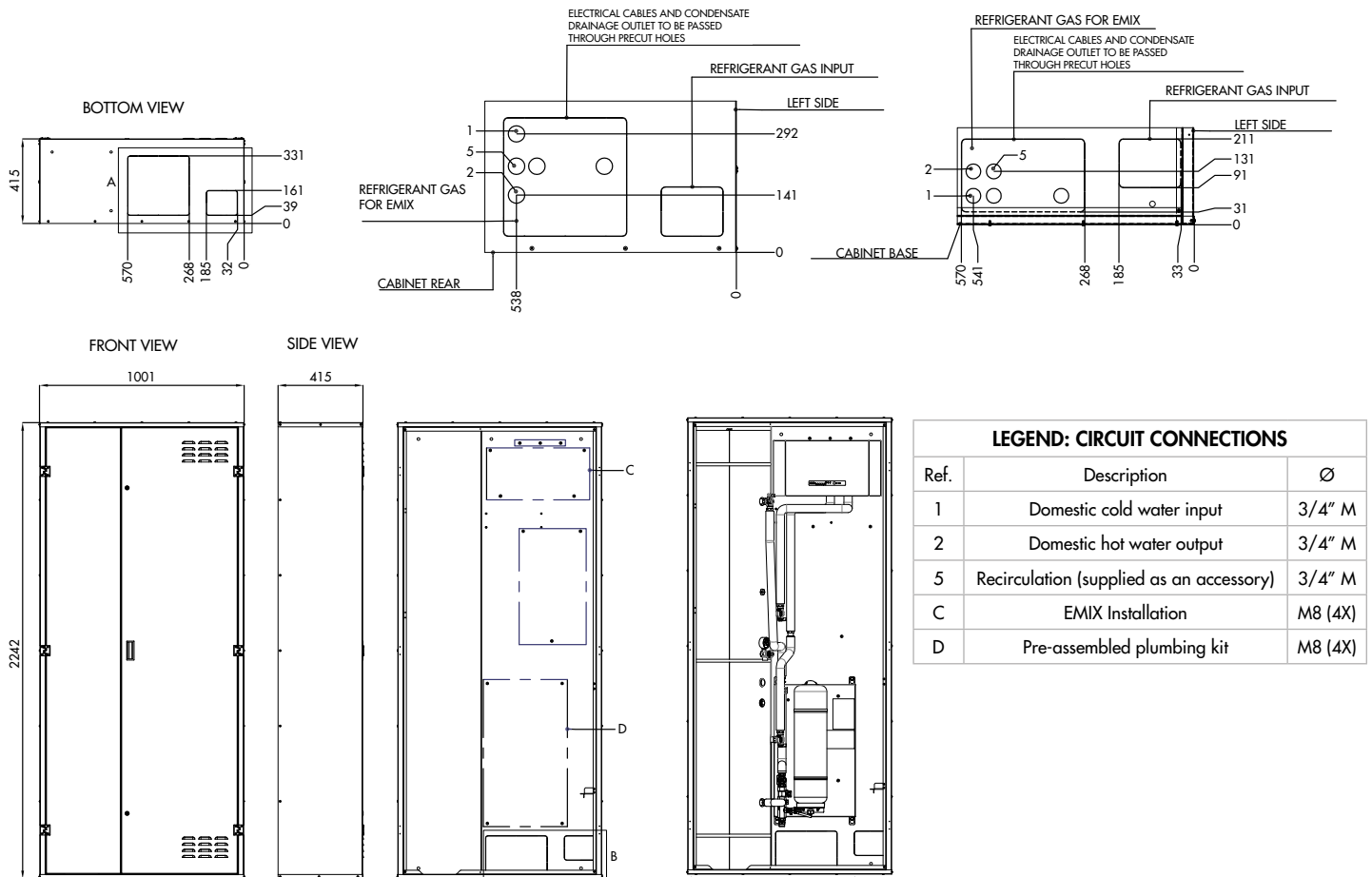

## MAIN COMPONENTS

**1** EMIX

**2** DHW tank with the following characteristics:  
 - volume 200 liters;  
 - structure in AISI 316 L stainless steel;  
 - insulation in EPS with graphite, 25 mm thick.

Kit for plumbing connections to EMIX unit, whose main components are:  
 - thermostatic mixer 25-50 °C;  
 - 6 bar expansion tank on domestic water side, 12 liters;  
 - 6 bar safety valve  
 - insulated connection pipes

**4** Built-in cabinet in galvanised sheet metal, size 1000x415x2242 mm.



# REFERENCE PLUMBING DIAGRAM

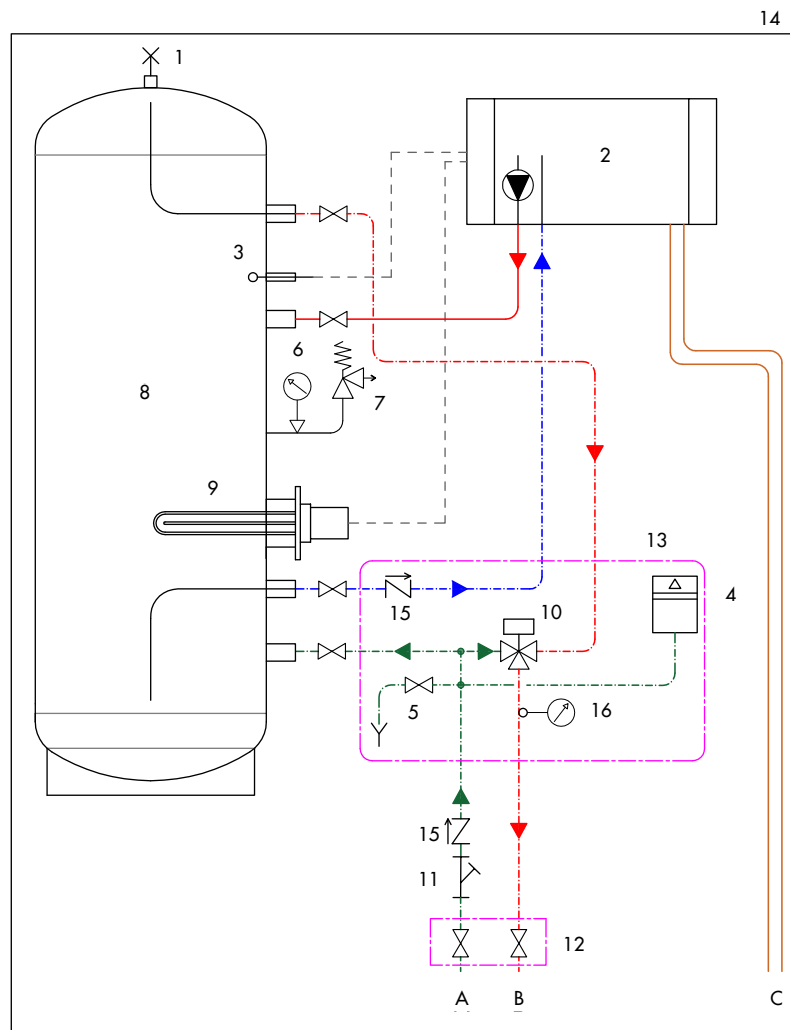

## Legend of components

1. DHW tank manual air release
2. eMIX indoor unit
3. temperature probe well  $\varnothing$  6 mmx130 mm
4. 6 bar domestic water expansion tank - 12 liters
5. drain valve  $\varnothing$  1/2"
6. 0-6 bar pressure gauge
7. 6 bar safety valve for domestic water
8. 200 liters DHW tank in AISI 316L stainless steel - pmax 8 bar
9. 1.5 kW electric heating element (optional)
10. thermostatic mixer valve 25 °C-50 °C  $K_v=2.3$  m<sup>3</sup>/h
11. domestic cold water filter
12. 3/4" shut off valve kit (optional)
13. pre-assembled hydronic module borders
14. metal cabinet border
15. non-return valve
16. contact thermometer

## Legend of connections

- A. 3/4" M domestic cold water input
- B. 3/4" M domestic hot water output
- C. refrigerant pipes connections 3/8" - 3/8"

# INSTALLATION EXAMPLE

HEAT PUMPS

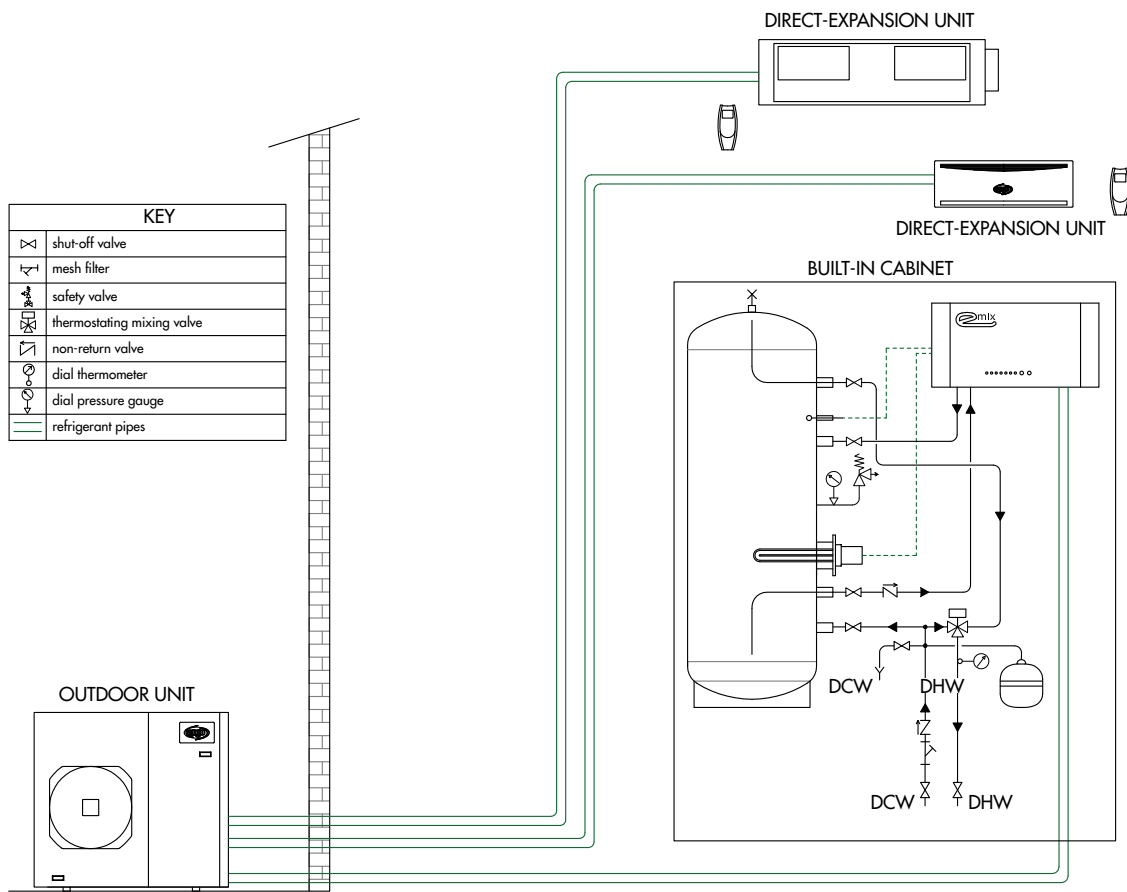

# BUILT-IN SOLUTIONS

## FOR iSERIES SYSTEMS WITH AQUA UNIT

### MAIN FEATURES

The cabinet allows built-in wall-mounted installation of AQUA UNIT, the hydronic unit from the iSERIES system. This specific solution allows you to reduce and optimise installation spaces in situations where rooms are heated and cooled with hydronic terminals (radiating systems, fan coil units, etc.).

DHW is produced by means of a three-way valve. The possibility of room cooling through direct expansion is kept unchanged units. The galvanised sheet metal cabinet contains all the elements required for a room heating and/or cooling system and a DHW production system:

- DHW storage tank in stainless steel, fitted with a corrugated coil heat exchanger to increase heat exchange;
- Connection kit to the AQUA UNIT, with suitably arranged and insulated pipes and buffer tank. Possibility to directly use the pump fitted to the unit or a second one in the primary/secondary circuit configuration;
- Safety and control devices for domestic water and heating system.

### BUILT-IN MODULE COMPONENTS

Code	Description
387030626	Built-in cabinet
387030637	DHW storage tank kit for 200 liters with heat exchanger
387030643	AQUA UNIT connection kit

### ACCESSORIES

Code	Description
387030630	3/4" domestic water inlet filter
387030631	Pair of 3/4" domestic water shut-off valves
387030632	1.5 kW electric heating element for DHW tank
387030633	3/4" system outlet filter
387030634	Pair of 1" system shut-off valves

### INDOOR UNITS

Code	Description
387135037	AUBV - hydronic module AQUA UNIT size B - wall-mounted
387135038	AUCV - hydronic module AQUA UNIT size C - wall-mounted
387135039	AUDV - hydronic module AQUA UNIT size D - wall-mounted
387030220	Wired control for iSERIES indoor units - <b>Mandatory accessory</b>

### DIMENSIONAL DRAWINGS

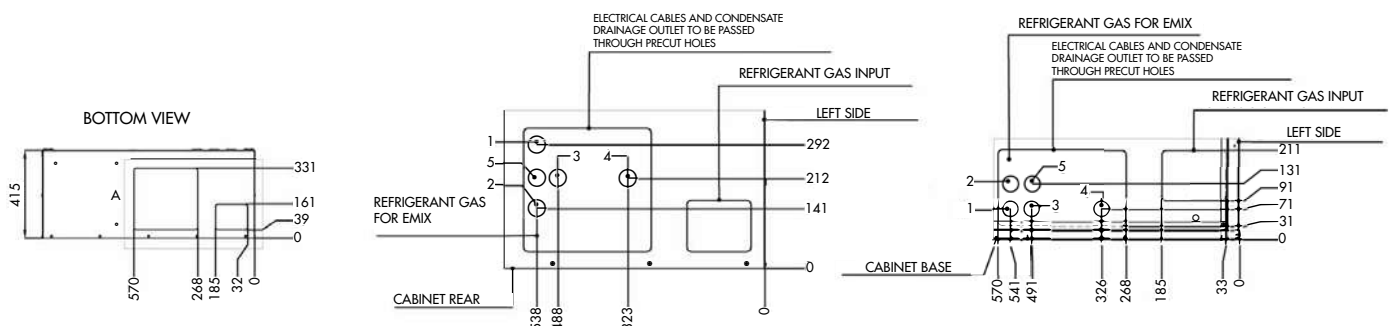

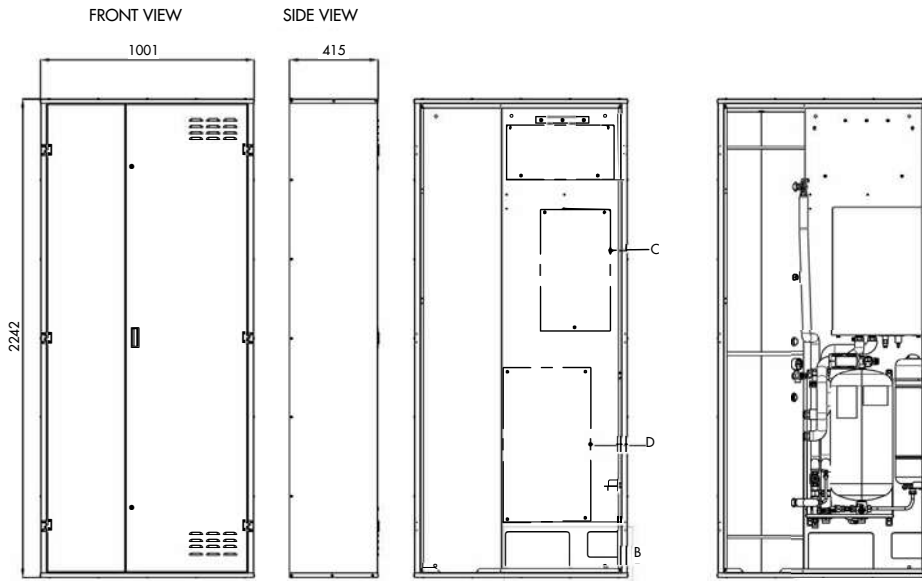

LEGEND: CIRCUIT CONNECTIONS		
Ref.	Description	Ø
1	Domestic cold water input	3/4" M
2	Domestic hot water output	3/4" M
3	Supply to system	1" M
4	Return from system	1" M
5	Recirculation (supplied as an accessory)	3/4" M
C	AQUA UNIT Installation	M8 (4X)
D	Pre-assembled plumbing kit	M8 (4X)

## INSTALLATION EXAMPLE

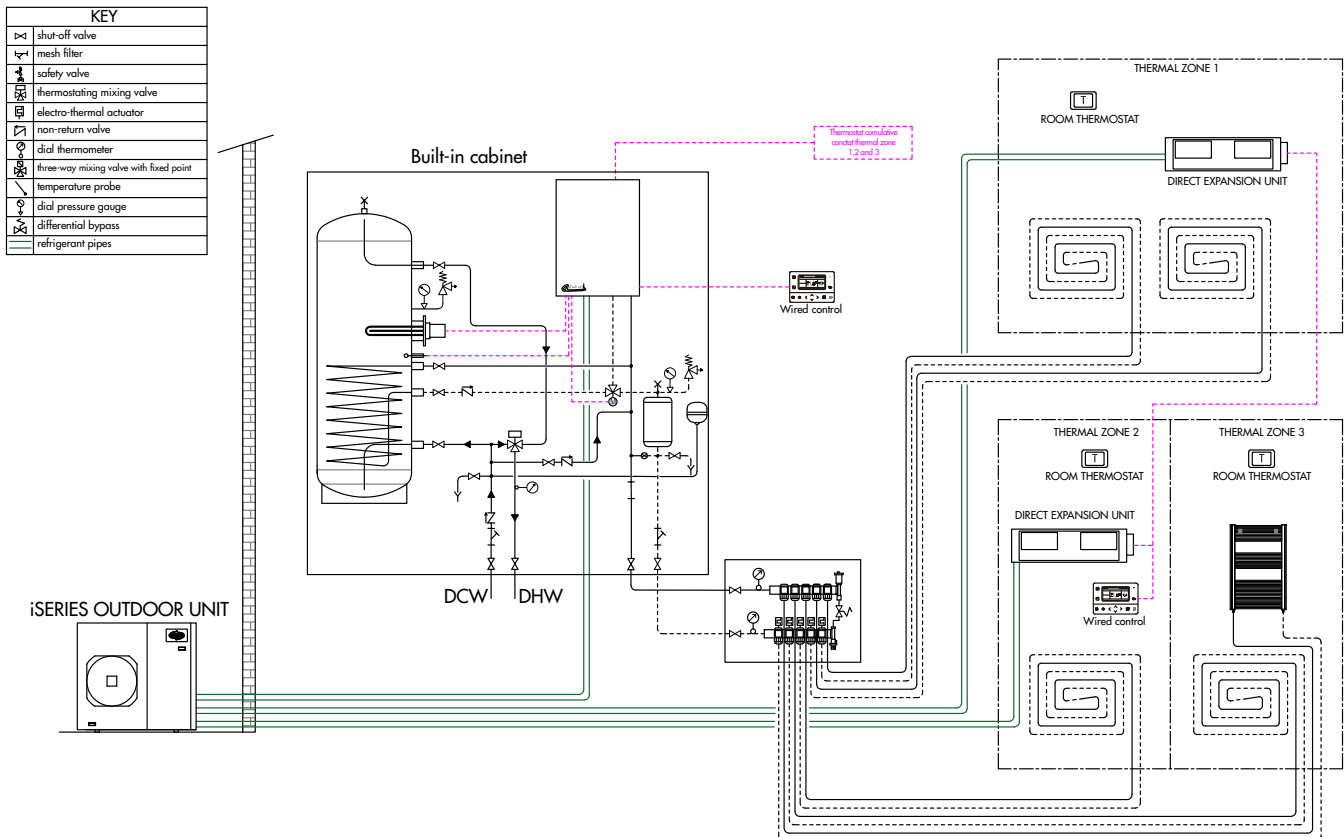

# MAIN COMPONENTS

## 1 AQUA UNIT

DHW tank with the following characteristics:

- 2 - volume 200 liters;
- 2 - structure in AISI 316 L stainless steel;
- 2 - fixed heat exchanger in AISI 316 L stainless steel;
- 2 - insulation in EPS with graphite, 25 mm thick.

Kit for plumbing connections to AQUA UNIT, whose main components are:

- 3 - 25 liters buffer tank in AISI 316 L stainless steel;
- 3 - thermostatic mixer 25-50 °C;
- 3 - 6 bar expansion tank on domestic water side, 12 liters;
- 3 - 6 bar safety valve on domestic water side and 3 bar safety valve on system side;
- 3 - motorised 3-way diverter valve for switching system to domestic water and vice versa;
- 3 - insulated connection pipes

- 4 Built-in cabinet in galvanised sheet metal, size 1000x415x2242 mm.

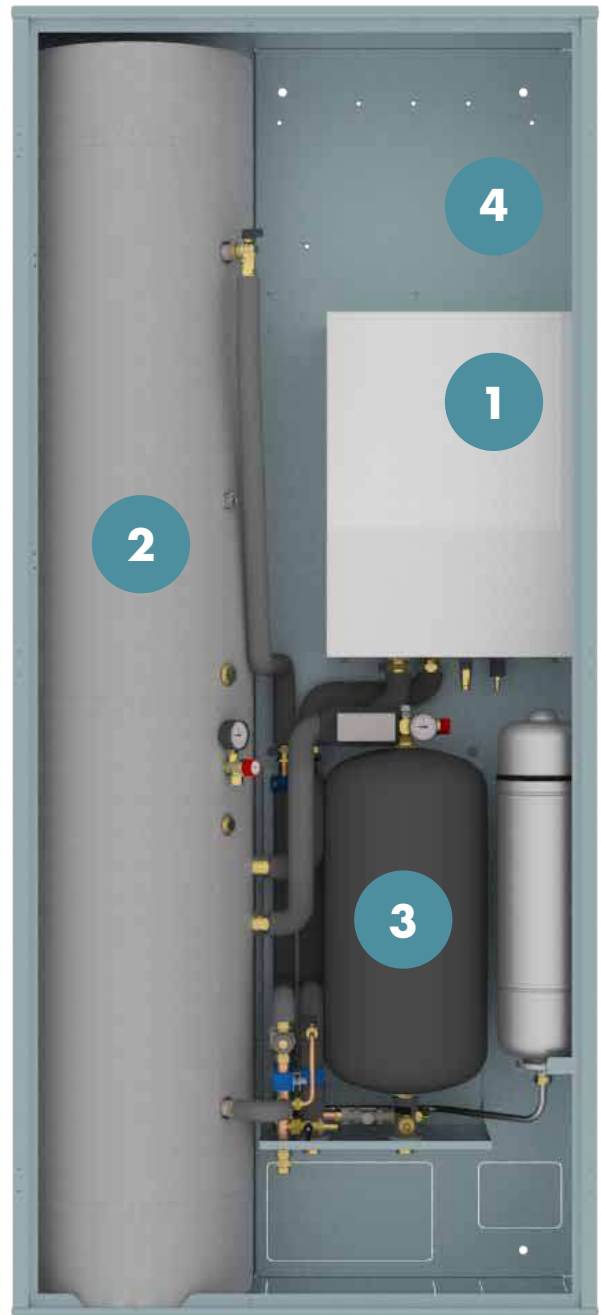



# REFERENCE PLUMBING DIAGRAM

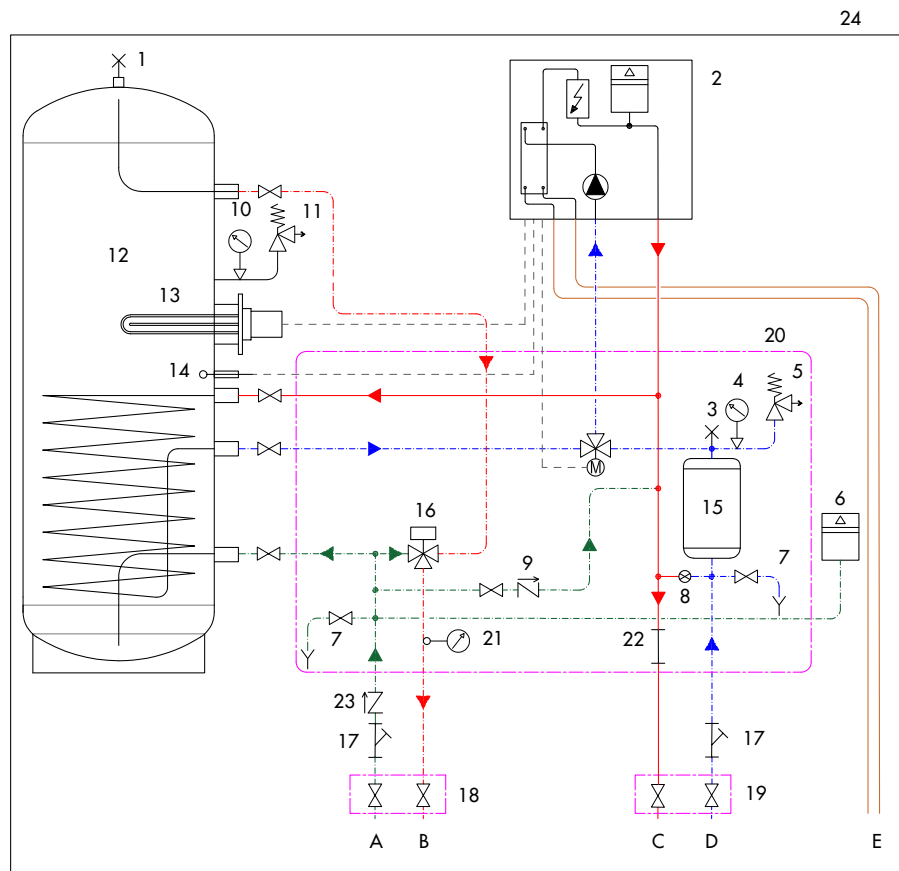

With the simplified solution, the use of an immersion thermostat does not allow direct reading of the DHW storage tank temperature. In addition, the electric heating element (if envisaged) must be managed separately since there is no specific available connection with AQUA UNIT.

## Legend of connections

- A. 3/4" M domestic cold water input
- B. 3/4" M domestic hot water output
- C. 1" M system supply
- D. 1" M system return
- E. refrigerant pipes

## Legend of components

- 1. DHW tank manual air release
- 2. indoor AUBV (AUCV) unit
- 3. system manual air relief valve
- 4. system 0-4 bar pressure gauge
- 5. 3 bar safety valve for system
- 6. 6 bar DHW expansion tank - 12 liters
- 7. drain valve Ø 1/2"
- 8. shut-off valve (normally closed)
- 9. non-return valve
- 10. 0-6 bar pressure gauge
- 11. 6 bar safety valve for domestic water
- 12. 200 liters DHW tank in AISI 316 L stainless steel - pmax 8 bar
- 13. 1,5 kW electric heater
- 14. immersion thermostat well Ø 6 mmx130 mm
- 15. system 25 liters technical storage tank in AISI 316 L stainless steel
- 16. thermostatic mixer valve 25 °C-50 °C Kv=2.3 m<sup>3</sup>/h
- 17. system and DHW filters
- 18. 3/4" shut off valve kit (optional)
- 19. 1" M shut off valve kit (optional)
- 20. pre-assembled hydronic module borders
- 21. contact thermometer
- 22. connection section for secondary circuit hydronic pump
- 23. DHW non-return valve
- 24. metal cabinet border

# BUILT-IN SOLUTIONS

## FOR iSERIES SYSTEMS WITH EMIX AND AQUA UNIT

### MAIN FEATURES

The cabinet allows built-in wall-mounted installation of an indoor hydronic unit (AQUA UNIT) and a DHW production unit (EMIX). This specific solution allows you to reduce and optimise installation spaces in situations where rooms are heated with hydronic terminals (radiating systems, fan coil units, etc.), while maintaining unchanged the specific possibility of cooling by using direct expansion units.

DHW is produced by using the heat recovered when cooling with the direct expansion unit. The galvanised sheet metal cabinet contains all the elements required for a room heating and/or cooling system and for the DHW production system:

- DHW storage tank in stainless steel;
- Connection kit to the EMIX unit and AQUA UNIT, with suitably arranged and insulated pipes and buffer tank. Possibility to directly use the pump fitted to the unit or a second one in the primary/secondary circuit configuration;
- Safety and control devices for domestic water and heating system.

### DIMENSIONAL DRAWINGS

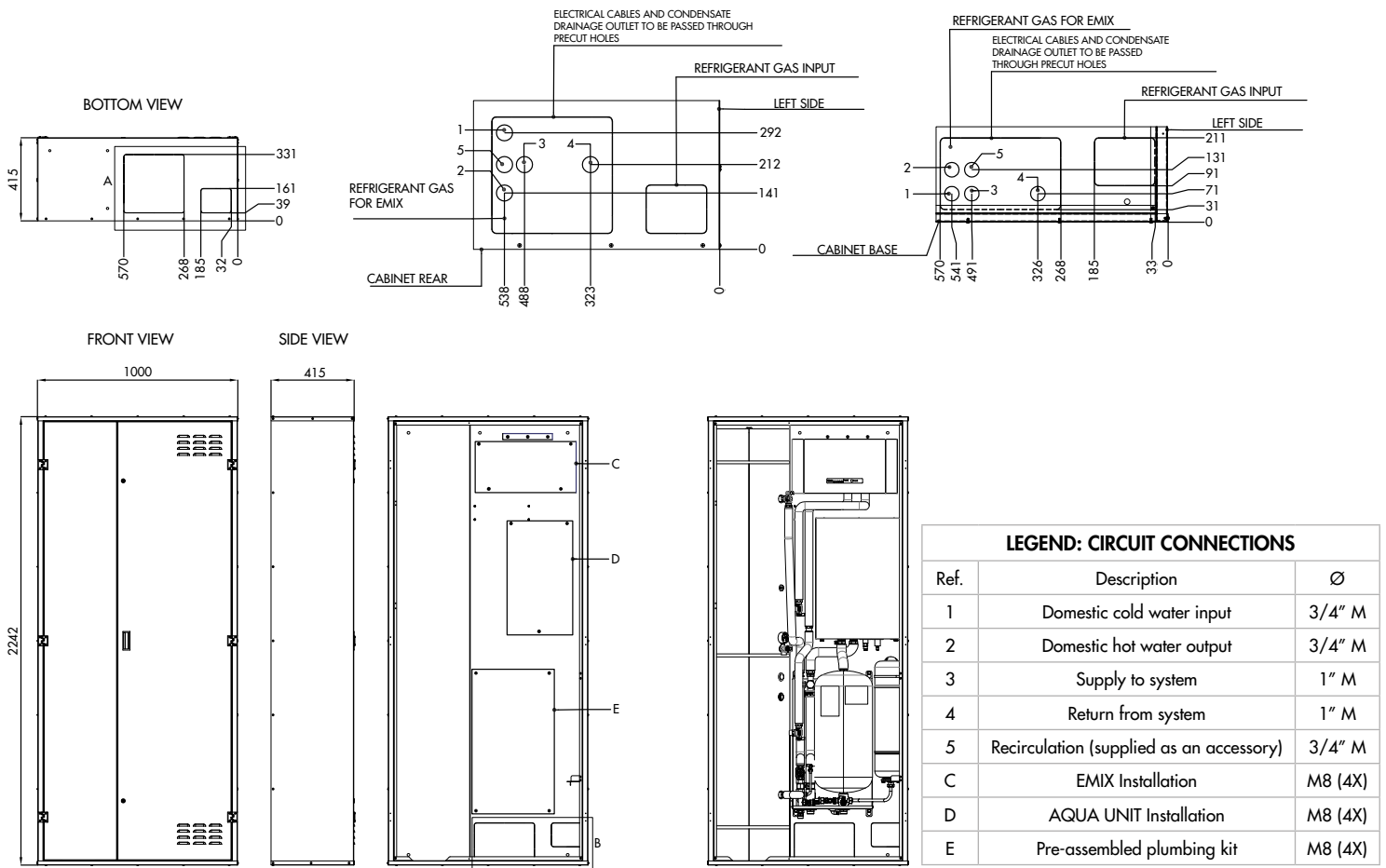

## BUILT-IN MODULE COMPONENTS

Code	Description
387030626	Built-in cabinet
387030627	DHW 200 liters storage tank kit
387030629	EMIX and AQUA UNIT connection kit

## INDOOR UNITS

Code	Description
387135037	AUBV - hydronic module AQUA UNIT size B - wall-mounted
387135038	AUCV - hydronic module AQUA UNIT size C - wall-mounted
387135039	AUDV - hydronic module AQUA UNIT size D - wall-mounted
387030220	Wired control for iSERIES indoor units - <b>Mandatory accessory</b>
387135030	EMIX V1

## ACCESSORIES

Code	Description
387030630	3/4" domestic water inlet filter
387030631	Pair of 3/4" domestic water shut-off valves
387030632	1.5 kW electric heating element for DHW tank
387030633	3/4" system outlet filter
387030634	Pair of 1" system shut-off valves

## MAIN COMPONENTS

- 1 AQUA UNIT
- 2 EMIX
- 3 DHW tank with the following characteristics:
  - volume 200 liters;
  - structure in AISI 316 L stainless steel;
  - insulation in EPS with graphite, 25 mm thick.
- 4 Kit for plumbing connections to AQUA UNIT and EMIX, whose main components are:
  - 25 liters buffer tank in AISI 316 L stainless steel;
  - thermostatic mixer 25-50 °C;
  - 6 bar expansion tank on domestic water side, 12 liters;
  - 6 bar safety valve on domestic water side and 3 bar safety valve on system side;
  - insulated connection pipes
- 5 Built-in cabinet in galvanised sheet metal, size 1000x415x2242 mm.

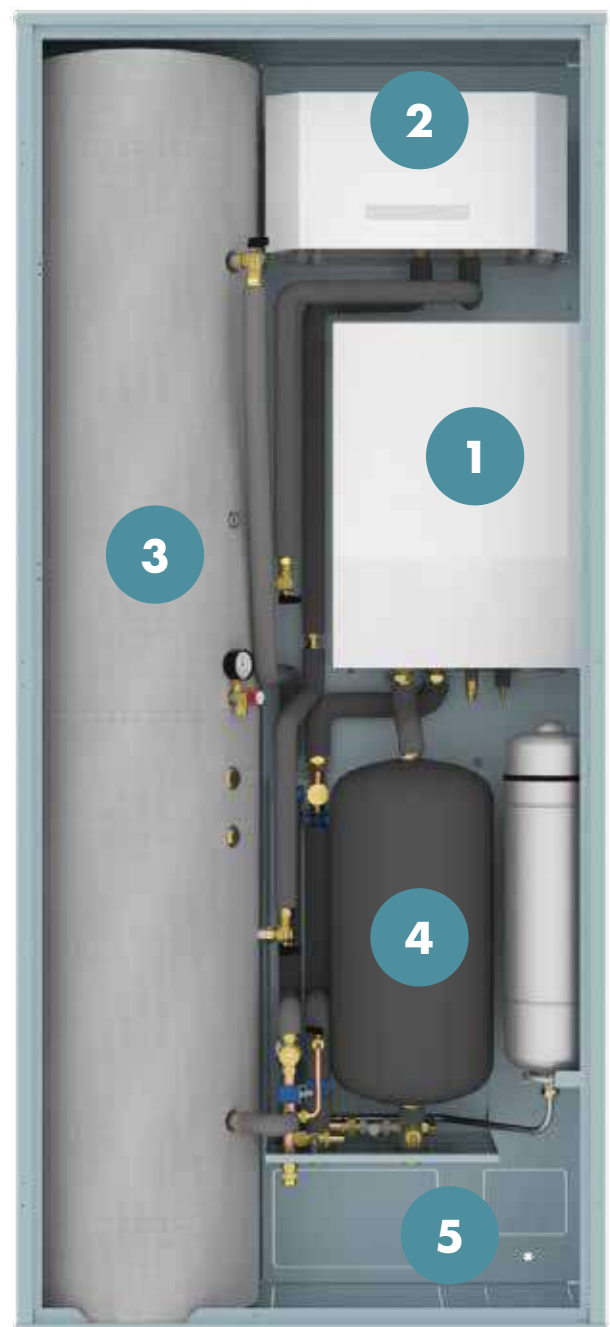

# REFERENCE PLUMBING DIAGRAM

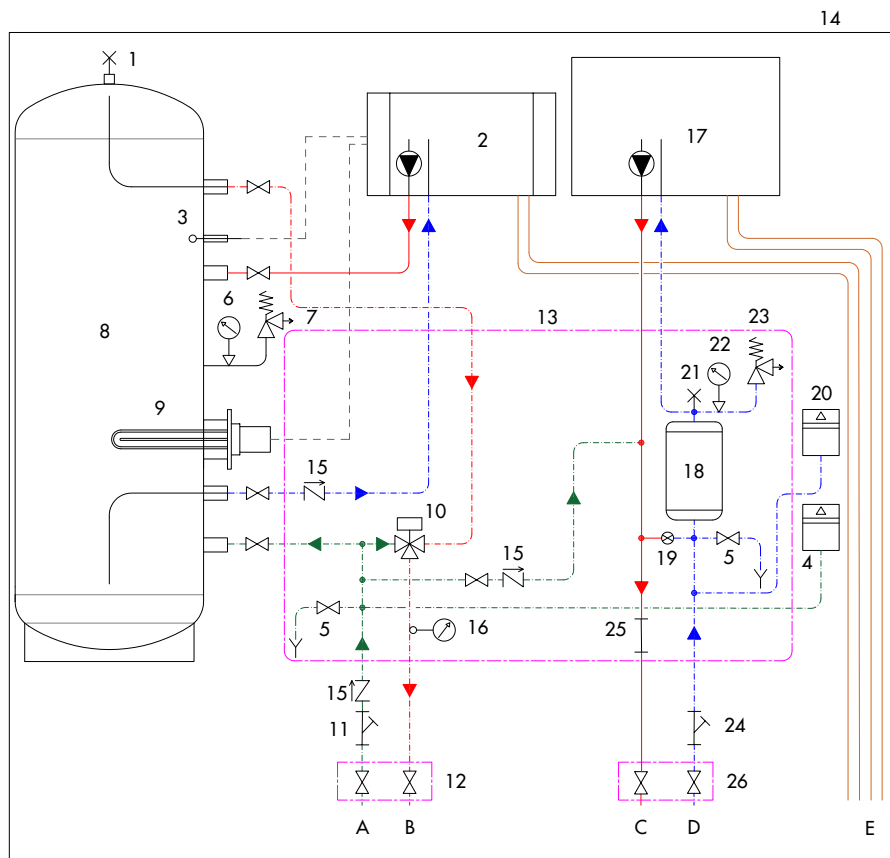

## Legend of components

1. DHW tank manual air release
2. EMIX indoor unit
3. temperature probe well  $\varnothing$  6 mmx130 mm
4. 6 bar domestic water expansion tank - 12 liters
5. drain valve  $\varnothing$  1/2"
6. 0-6 bar pressure gauge
7. 6 bar safety valve for domestic water
8. 200 liters DHW tank in AISI 316 L stainless steel - pmax 8 bar
9. 1.5 kW electric heating element (optional)
10. thermostatic mixer valve 25 °C-50 °C Kv=2.3 m<sup>3</sup>/h
11. domestic cold water filter
12. 3/4" shut off valve kit (optional)
13. pre-assembled hydronic module borders
14. metal cabinet border
15. non-return valve
16. contact thermometer
17. indoor AQUA UNIT
18. system 25 liters technical storage tank in AISI 316 L stainless steel
19. shut-off valve
20. system expansion tank - 12 liters
21. system manual air release
22. 0-4 bar pressure gauge
23. 3 bar safety valve for system
24. system filter
25. connection section for secondary circuit hydronic pump
26. 1" M shut off valve kit (optional)

## Legend of connections

- A. 3/4" M domestic cold water input
- B. 3/4" M domestic hot water output
- C. 1" M system supply
- D. 1" M system return
- E. connection for EMIX and AQUA UNIT refrigerant pipes

# INSTALLATION EXAMPLE

HEAT PUMPS

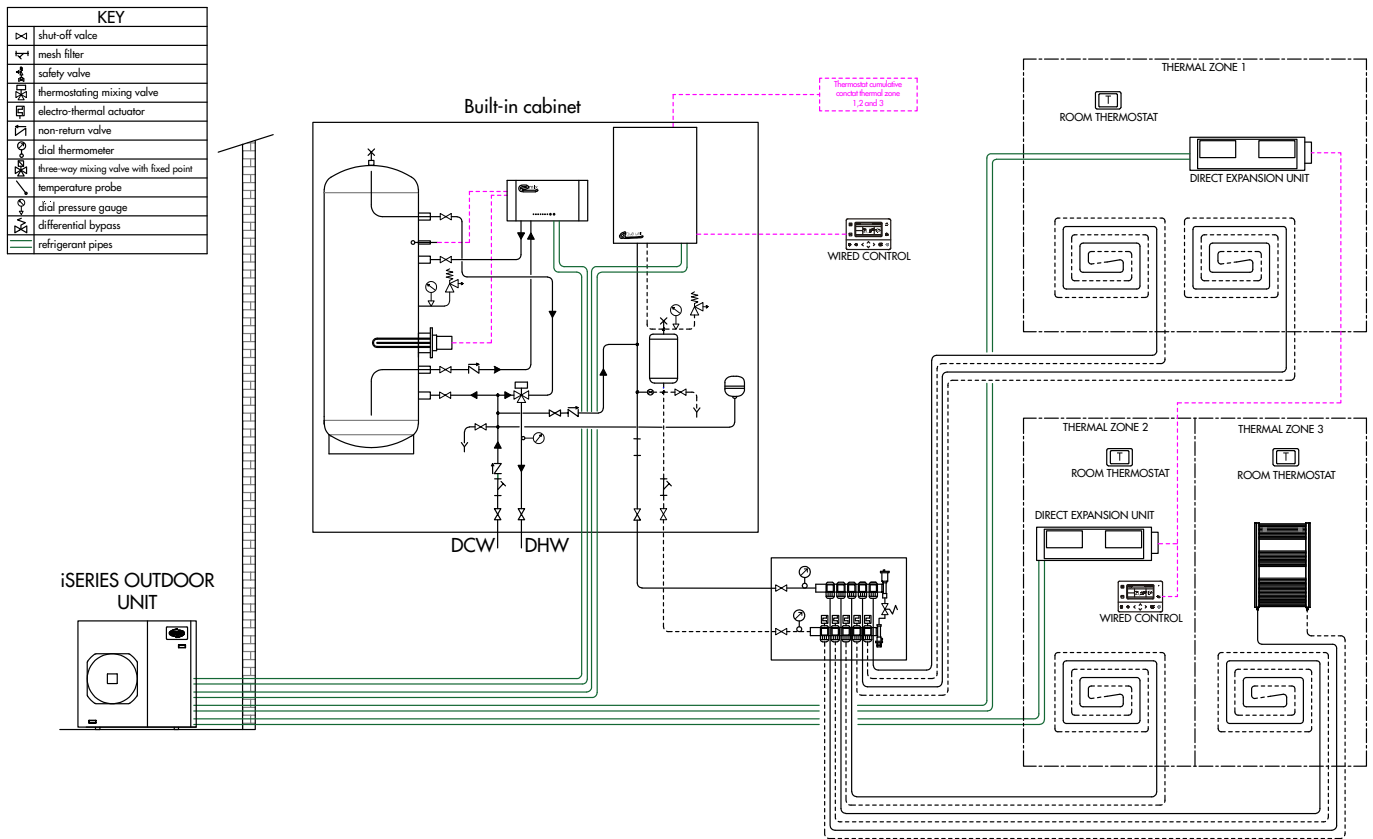

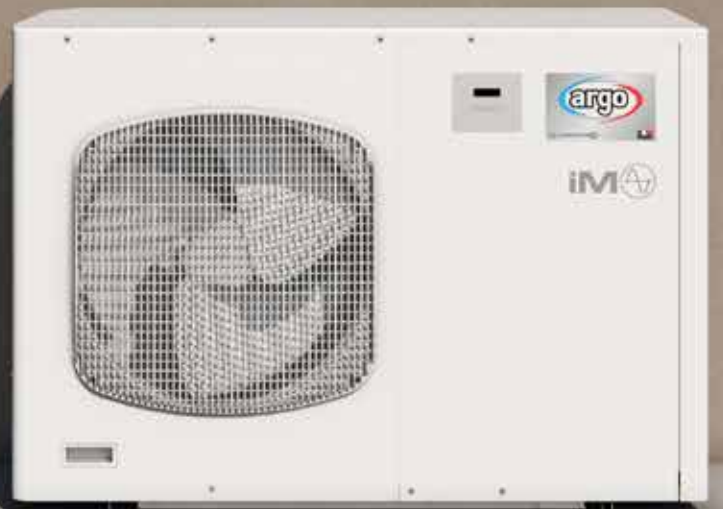

# iM

---

MONOBLOC  
air/water heat pump



## ADVANTAGES

### **Unique and innovative**

---

iM is the only heat pump capable of producing domestic hot water at the same time as heating and cooling rooms, thanks to a special refrigerant gas connection. During cooling mode, water is heated for free using EMIX and EMIX TANK heat recovery technology.

### **High performance and savings**

---

Thanks to the FULL DC INVERTER technology, which can optimise the operation of the compressor and fans, iM achieves an energy efficiency class A++ for heating and an energy efficiency class A for domestic hot water production, ensuring comfort and energy savings.

### **Efficient and silent**

---

iM is equipped with circulation pump, compressor and DC inverter fans that modulate the power and speed based on real needs. The high level of soundproofing, the ability of the Argo-exclusive electronics to optimally operate the compressor cycle ("Smooth defrost") and the implementation of the ECO function all guarantee a low running noise.

### **Everything under control**

---

iM is equipped with temperature control systems for the water and gas so as to optimise the system operation. It is also fitted with control systems for the refrigerant pressure and water flow rate of the system to protect the system under any operating conditions.

### **Open and flexible system**

---

iM is compatible with third-party control systems and advanced systems too, and can be integrated with additional external heating sources (gas boilers, solid-fuel generators, etc.). It can also be combined with solar panels used to provide hot water and heating or to generate electricity.

### **Simple and intuitive interface**

---

Featuring an LCD display, the digital control panel is easy to use, both for operators (fitters and Service Centres) and for end users, who can also decide to add a second panel to their household.



# RENEWABLE ENERGY SYSTEM FOR MAXIMUM COMFORT

With iM, can you build your dream home with:

- Heating and cooling of rooms with hydronic terminals
- Domestic hot water production with high-efficiency systems and energy recovery features (EMIX and EMIX TANK models)
- Domestic hot water production with 3-way valve and DHW tank





iM is a monobloc heat pump for heating, cooling and domestic hot water production. The range features 6 outdoor units in R410A with a Twin Rotary Full DC Inverter compressor. It can be connected to EMIX and EMIX TANK to produce domestic hot water directly from the thermodynamic source, using heat recovery during air-conditioning mode in summer. The range is able to meet residential and commercial needs and the heating capacity spans from 6 kW to 14 kW.



AIM06EMX

AIM08EMX

AIM11EMX  
AIM11EMX3PH

AIM14EMX  
AIM14EMX3PH

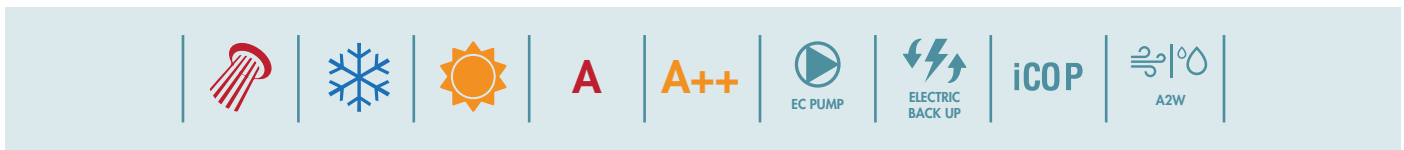

Code	Model	*Nominal-max. heating capacity [kW]	**Nominal-max. cooling capacity [kW]
387032080	AIM06EMX	5.8-6.8	4.69-6.16
387032081	AIM08EMX	8.1-9.1	4.73-6.80
387032082	AIM11EMX	10.16-12.5	6.12-9.78
387032083	AIM11EMX3PH	10.16-12.5	6.12-9.78
387030086	AIM14EMX	13.57-17.10	7.95-12.93
387032084	AIM14EMX3PH	13.57-17.10	7.95-12.93

Reference condition:

\* Heating capacity with outdoor air temperature 12/7 °C, outlet water temperature 30/35 °C

\*\*Cooling capacity with outdoor air temperature 30/35 °C, outlet water temperature 23/18 °C

# CONNECTIVITY

## INPUTS AND OUTPUTS OF iM

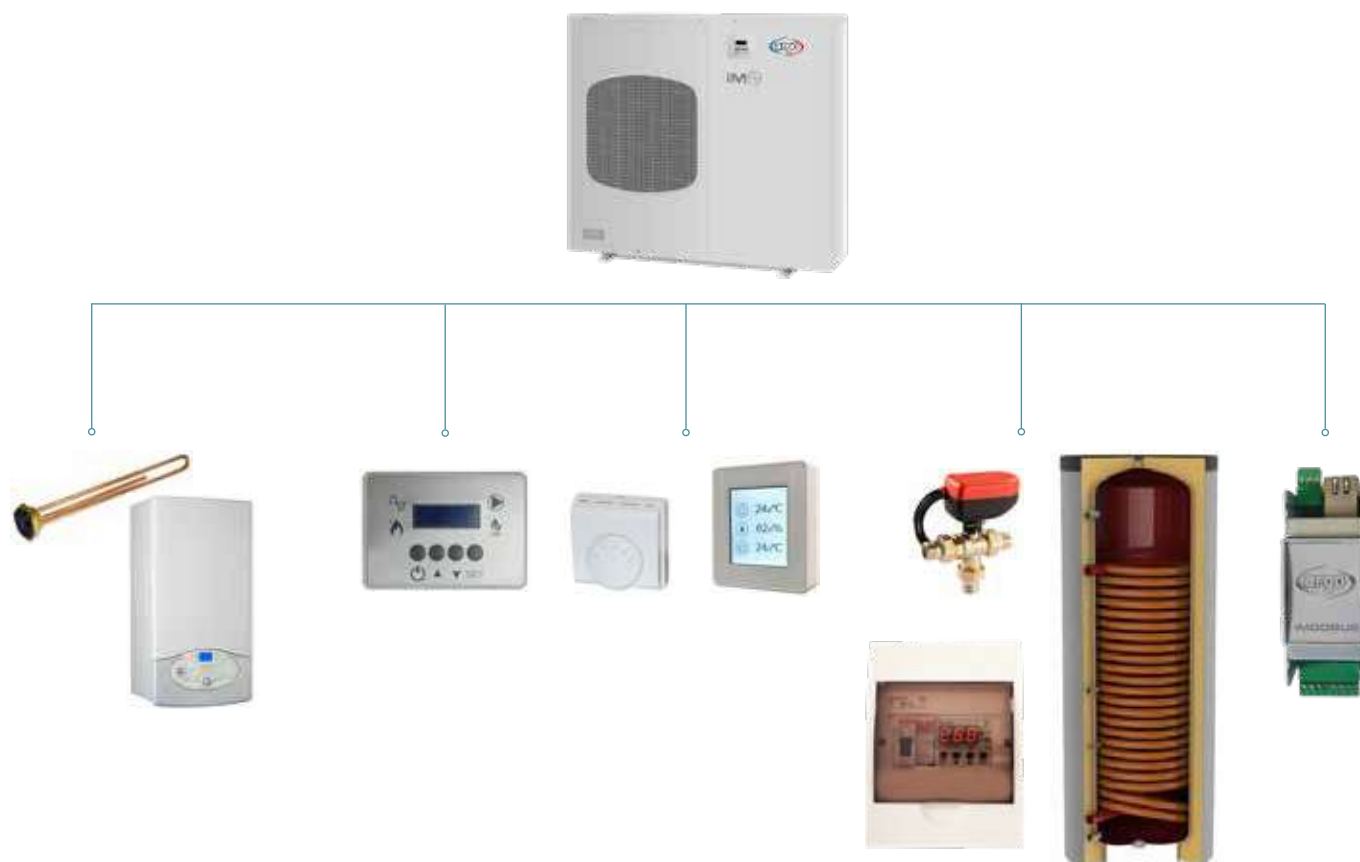

### N° 4 DIGITAL INPUTS (dry contacts or configurable 24 VAC contacts)

- 1) ON/OFF: stand by or operating;
- 2) Summer/Winter: summer/winter switching;
- 3) DHW SET POINT or SECOND SET POINT;
- 4) ECO MODE: if the contact is open, the maximum usable electric power is 100%; if it's closed it can be set with a parameter which is a percentage of the maximum value.

### N° 4 DIGITAL OUTPUTS

- 1) 230 VAC output for the DHW diverter valve servomotor (deviation towards DHW);
- 2) 230 VAC output for the DHW diverter valve servomotor (re-deviation towards system - optional);
- 3) 230 VAC output for ALARM/DEFROST/DHW PRODUCTION which can be configured individually or in combination;
- 4) 230 VAC output for additional element (electric heating element and boiler, etc.) through external dedicated relay switch if required.

### N° 2 ANALOGIC INPUTS

- 1) Analogue input 0÷10 V for external regulator or advanced room thermostat;
- 2) Input for additional external air sensor: installation of a second external air sensor to read the temperature in a more suitable position (if required). Automatic recognition of the unit.

# DIMENSIONAL DATA

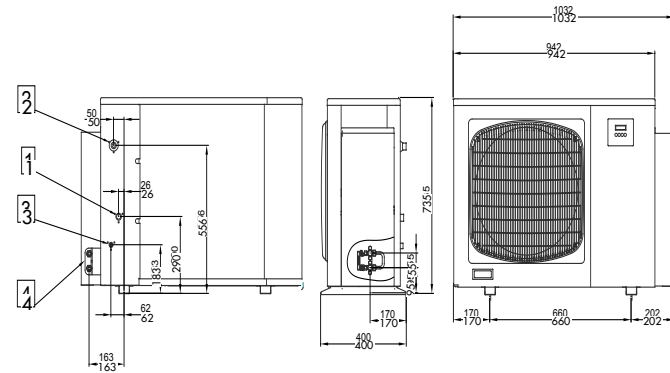

Model  
AIM06EMX



- Key
1. 3/4" M water inlet
  2. 3/4" M water outlet
  3. 1/2" M refilling/drainage water circuit
  4. Inlet/outlet of refrigerant pipes for EMIX

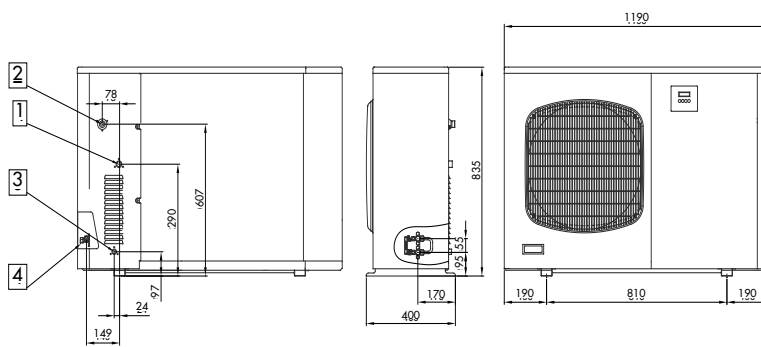

Model  
AIM08EMX



- Key
1. 3/4" M water inlet
  2. 3/4" M water outlet
  3. 1/2" M refilling/drainage water circuit
  4. Inlet/outlet of refrigerant pipes for EMIX

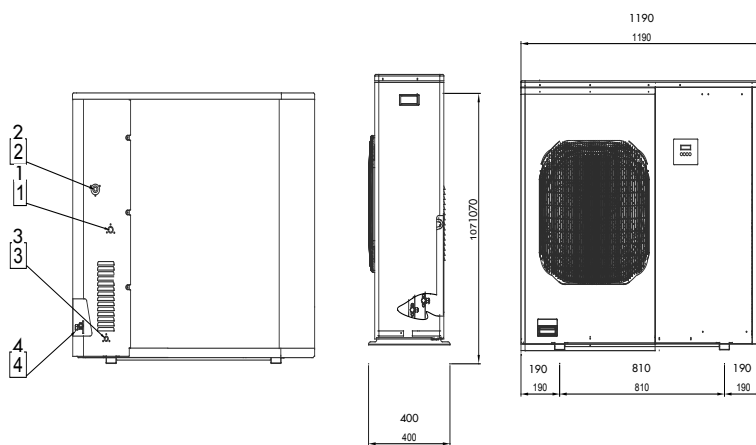

Models  
AIM11EMX  
AIM11EMX3PH



- Key
1. 3/4" M water inlet
  2. 3/4" M water outlet
  3. 1/2" M refilling/drainage water circuit
  4. Inlet/outlet of refrigerant pipes for EMIX

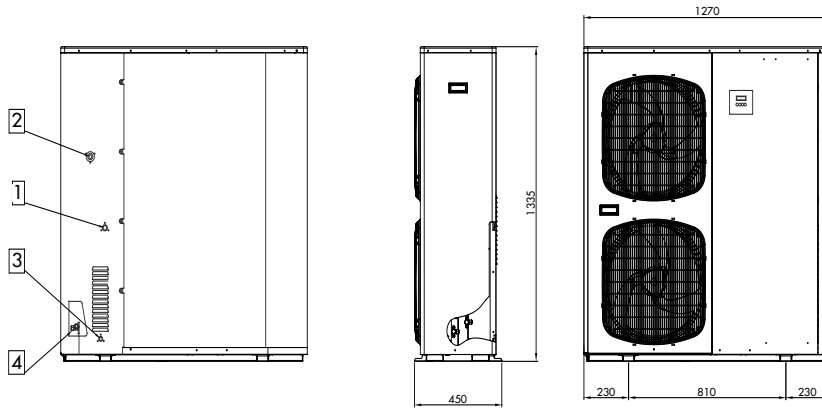

Models  
 AIM14EMX  
 AIM14EMX3PH

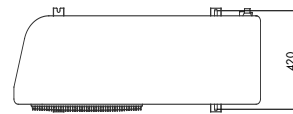

Key  
 1. 3/4" M water inlet  
 2. 3/4" M water outlet  
 3. 1/2" M refilling/draining water circuit  
 4. Inlet/outlet of refrigerant pipes for EMIX

Model	Weight (kg)
AIM06EMX	64
AIM08EMX	73
AIM11EMX	90
AIM11EMX3PH	90
AIM14EMX	160
AIM14EMX3PH	160

# TECHNICAL DATA

MODEL				AIM06EMX	AIM08EMX
Matchable units for Domestic Hot Water (DHW) production				EMIX TANK V2 200-300 liters	
				EMIX V1	
				External Tank	
<b>AIR/WATER</b>					
Performance according to EN 14511	Air +35 °C - Water 23/18 °C	Nominal-max. Cooling capacity	kW	4.69-6.16	4.73-6.80
		Nominal electric power input	kW <sub>el</sub>	1.29	1.31
		Nominal EER		3.64	3.62
	Air +35 °C - Water 12/7 °C	Nominal Cooling capacity	kW	3.36	4.63
		Nominal electric power input	kW <sub>el</sub>	1.48	2.12
		Nominal EER		2.27	2.19
	Air +7 °C - Water 30/35 °C	Nominal-max. Heating capacity	kW	5.8-6.8	8.1-9.1
		Nominal electric power input	kW <sub>el</sub>	1.41	1.93
		Nominal COP		4.12	4.19
	Air -7 °C - Water 30/35 °C	Nominal Heating capacity	kW	4.60	5.76
		Nominal electric power input	kW <sub>el</sub>	1.69	2.11
		Nominal COP		2.71	2.74
<b>Air/water LOW temperature heating</b>					
Performance according to ERP Ecodesign EN 14825	AVERAGE climate	Nominal Heating capacity	kW	5	7
		Seasonal energy efficiency $\eta_s$	%	153	159
		SCOP		3.89	4.05
		Energy efficiency class		A++	A++
<b>Air/water MEDIUM temperature heating</b>					
Performance according to ERP Ecodesign EN 14825	AVERAGE climate	Nominal Heating capacity	kW	4	6
		Seasonal energy efficiency $\eta_s$	%	111	113
		SCOP		2.85	2.91
		Energy efficiency class		A+	A+
<b>DHW with 300 L tank and diverting valve - AVERAGE</b>					
DHW Performance according to EN 16147	Load profile			XL	XL
	Energy efficiency class			A	A
	DHW COP			2.19	2.26
	ERP efficiency		%	91	94
	Heating-up time from 10 °C to 47 °C			04:04	3:41
<b>DHW with EMIX TANK 200 V2 (AIM06) and with EMIX TANK 300 V2 (AIM08) -AVERAGE</b>					
DHW Performance according to EN 16147	Load profile			L	XL
	Energy efficiency class			A	A
	DHW COP			2.52	2.58
	ERP efficiency		%	105	106
	Heating-up time from 10 °C to 50 °C		h:m	03:09	3:33
<b>GENERAL SPECIFICATIONS</b>					
Operation data	Maximum outlet water temperature		°C	up to 58	
	Outdoor temperature range		°C	-20/+35	
	Outdoor temperature range		°C	+10/+47	
	Nominal water flow rate to 35 °C		m <sup>3</sup> /h	1.00	1.39
	Nominal water flow rate to 45 °C			0.76	1.31
	Nominal water flow rate to 55 °C			0.45	0.70
	Minimum efficient water volume of the system		l	40	40
	Power supply (Voltage/Phases/Frequency)		V/Ph/Hz	230/1+T/50	230/1+T/50
	Maximum electric consumption		kW/A	2.3/10	3.5/15.9
Fuse			16 A	20 A	
Sound pressure		dB(A)	40	44	
Components	Expansion vessel		l	2	4
	Maximum pump pressure		mH <sub>2</sub> O	6 (see graphs H/Q)	7 (see graphs H/Q)
	Water connection		inch (")	3/4"	3/4"
	Safety valve		bar	3	
	Compressor type			Twin Rotary	
Refrigerant pipes to EMIX/EMIX TANK	Diameters (gas/liquid)		inch (")	3/8"	3/8"
	Maximum length		m	10	
	Minimum length		m	5	
	Max height difference IU-OU		m	10	
Refrigerant	Type refrigerant and GWP			R410A/2088 kg CO <sub>2</sub> eq.	
	Standard charge		kg/Ton-CO <sub>2</sub> eq.	1.30/2.71	1.46/ 3.05

Data declared in accordance with REGULATION (EU) N. 811/2013 of 18 February 2013 with regards to the energy labelling of space heaters and combination heaters and with COMMISSION REGULATION (EU) N. 813/2013 of 2 August 2013 implementing Directive 2009/125/EC of the European Parliament and of the Council with regards to ecodesign requirements for space heaters and combination heaters.

MODEL			AIM11EMX AIM11EMX3PH	AIM14EMX AIM14EMX3PH	
Matchable units for Domestic Hot Water (DWH) production			EMIX TANK V2 200-300 liters		
			EMIX V1		
			External Tank		
<b>AIR/WATER</b>					
Performance according to EN 14511	Air +35 °C - Water 23/18 °C	Nominal-max. Cooling capacity	kW	6.12-9.78	7.95-12.93
		Nominal electric power input	kW <sub>el</sub>	1.69	2.20
		Nominal EER		3.62	3.61
	Air +35 °C - Water 12/7 °C	Nominal Cooling capacity	kW	6.31	8.03
		Nominal electric power input	kW <sub>el</sub>	2.65	3.50
		Nominal EER		2.38	2.29
	Air +7 °C - Water 30/35 °C	Nominal-max. Heating capacity	kW	10.16-12.5	13.57-17.10
		Nominal electric power input	kW <sub>el</sub>	2.54	3.35
		Nominal COP		4.00	4.06
	Air -7 °C - Water 30/35 °C	Nominal Heating capacity	kW	7.00	9.48
		Nominal electric power input	kW <sub>el</sub>	2.49	3.5
		Nominal COP		2.81	2.71
<b>Air/water LOW temperature heating</b>					
Performance according to ERP Ecodesign EN 14825	AVERAGE climate	Nominal Heating capacity	kW	8	10
		Seasonal energy efficiency $\eta_s$	%	151	153
		SCOP		3.86	3.91
		Energy efficiency class		A++	A++
<b>Air/water MEDIUM temperature heating</b>					
Performance according to ERP Ecodesign EN 14825	AVERAGE climate	Nominal Heating capacity	kW	7	9.52
		Seasonal energy efficiency $\eta_s$	%	114	111
		SCOP		2.92	2.84
		Energy efficiency class		A+	A+
<b>DHW with 300 L tank and diverting valve - AVERAGE</b>					
DHW Performance according to EN 16147		Load profile		XL	XL
		Energy efficiency class		A	A
		DHW COP		2.14	2.06
		ERP efficiency	%	89	85
		Heating-up time from 10 °C to 47 °C		2:40	2:40
<b>DHW with EMIX TANK 300 V2</b>					
DHW Performance according to EN 16147		Load profile		XL	XL
		Energy efficiency class		A	A
		DHW COP		2.57	2.53
		ERP efficiency	%	106	105
		Heating-up time from 10 °C to 50 °C	h:m	2:25	2:24
<b>GENERAL SPECIFICATIONS</b>					
Operation data		Maximum outlet water temperature	°C	up to 58	
		Outdoor temperature range	°C	-20/+35	
		Outdoor temperature range	°C	+10/+47	
		Nominal water flow rate to 35 °C	m <sup>3</sup> /h	1.35	2.31
		Nominal water flow rate to 45 °C		1.68	2.18
		Nominal water flow rate to 55 °C		0.89	1.16
		Minimum efficient water volume of the system	l	80	80
		Power supply (Voltage/Phases/Frequency)	V/Ph/Hz	230/1+T/50-60 (1ph) 400/3+N+T/50 (3ph)	220-240/1+T/50 (1ph) 400/3+N+T/50 (3ph)
		Maximum electric consumption	kW/A	4.5/19.1 (1ph) 4.2/6.7 (3ph)	5.2/23.8 (1ph) 5.2/9 (3ph)
		Fuse		25 A (1ph)/30 A (3ph)	10 A
	Sound pressure	dB(A)	44	45	
Components		Expansion vessel	l	6	8
		Maximum pump pressure	mH <sub>2</sub> O	7.5 (see graphs H/Q)	7.5 (see graphs H/Q)
		Water connection	inch (")	1"	1"
		Safety valve	bar	3	
		Compressor type		Twin Rotary	
Refrigerant pipes to EMIX/EMIX TANK		Diameters (gas/liquid)	inch (")	3/8"	1/2"
		Maximum lenght	m	10	
		Minimum lenght	m	5	
		Max height difference IU-OU	m	10	
Refrigerant		Type refrigerant and GWP		R410A/2088 kg CO <sub>2</sub> eq.	
		Standard charge	kg/Ton-CO <sub>2</sub> eq.	2.50/5.22	3.10/6.47

The equipment described in this catalogue contains HFC-410A-type fluorinated greenhouse gases. These products must be fitted by qualified staff pursuant to European regulations 303/2008 and 517/2014

# TECHNICAL DATA

## AIM06EMX model

### Heating

LWT [°C]	Outdoor air temperature - Dry Bulb (Wet Bulb) - °C									
	-7 (-8)		-2 (-3)		2 (1)		7 (6)		12 (11)	
	Qh [kW]	COP	Qh [kW]	COP	Qh [kW]	COP	Qh [kW]	COP	Qh [kW]	COP
35	4.60	2.71	3.99	3.06	3.50	3.34	5.80	4.12	6.56	4.69
45	3.90	2.01	3.38	2.27	2.97	2.48	4.63	2.73	5.24	3.11
55	3.10	1.70	2.81	1.68	2.57	1.67	4.09	1.98	4.34	2.10

LWT: Leaving water temperature  
Qh: Heat capacity  
COP: Coefficient of performance

**Application data**  
Water inlet/outlet temperature difference = 5 °C, 8 °C  
for LWT = 55 °C

### Cooling

LWT [°C]	Inlet outdoor air temperature - °C	
	35	
	Qc [kW]	EER
7	3.57	2.41
18	5.15	3.63

LWT: Leaving water temperature  
Qc: Cooling capacity  
EER: Energy efficiency ratio

**Application data**  
Water inlet/outlet temperature difference = 5 °C

## AIM08EMX model

### Heating

LWT [°C]	Outdoor air temperature - Dry Bulb (Wet Bulb) - °C									
	-7 (-8)		-2 (-3)		2 (1)		7 (6)		12 (11)	
	Qh [kW]	COP	Qh [kW]	COP	Qh [kW]	COP	Qh [kW]	COP	Qh [kW]	COP
35	5.76	2.74	5.09	3.08	4.54	3.35	8.10	4.19	9.52	4.94
45	5.43	2.38	4.78	2.68	4.27	2.91	7.11	3.31	8.38	3.95
55	4.87	1.83	4.66	2.01	4.50	2.15	6.89	2.37	7.87	2.79

LWT: Leaving water temperature  
Qh: Heat capacity  
COP: Coefficient of performance

**Application data**  
Water inlet/outlet temperature difference = 5 °C, 8 °C  
for LWT = 55 °C

### Cooling

LWT [°C]	Inlet outdoor air temperature - °C	
	35	
	Qc [kW]	EER
7	5.12	2.41
18	6.24	3.61

LWT: Leaving water temperature  
Qc: Cooling capacity  
EER: Energy efficiency ratio

**Application data**  
Water inlet/outlet temperature difference = 5 °C



## AIM11EMX/AIM11EMX3PH models

### Heating

LWT [°C]	Outdoor air temperature - Dry Bulb (Wet Bulb) - °C									
	-7 (-8)		-2 (-3)		2 (1)		7 (6)		12 (11)	
	Qh [kW]	COP	Qh [kW]	COP	Qh [kW]	COP	Qh [kW]	COP	Qh [kW]	COP
35	7.00	2.81	6.44	3.04	6.00	3.23	10.16	4.00	11.61	4.67
45	6.90	2.33	6,35	2.52	5.92	2.68	9.89	3.16	10.80	3.06
55	6.11	1.62	5.90	1.72	5.73	1.81	7.92	1.92	8.94	2.20

LWT: Leaving water temperature  
 Qh: Heat capacity  
 COP: Coefficient of performance

**Application data**  
 Water inlet/outlet temperature difference = 5 °C, 8 °C  
 for LWT = 55 °C

### Cooling

LWT [°C]	Inlet outdoor air temperature - °C	
	Qc [kW]	EER
	35	
7	6.47	2,44
18	7.85	3.62

LWT: Leaving water temperature  
 Qc: Cooling capacity  
 EER: Energy efficiency ratio

**Application data**  
 Water inlet/outlet temperature difference = 5 °C

## AIM14EMX/AIM14EMX3PH models

### Heating

LWT [°C]	Outdoor air temperature - Dry Bulb (Wet Bulb) - °C									
	-7 (-8)		-2 (-3)		2 (1)		7 (6)		12 (11)	
	Qh [kW]	COP	Qh [kW]	COP	Qh [kW]	COP	Qh [kW]	COP	Qh [kW]	COP
35	9.48	2.71	8.21	2.97	7.20	3.18	13.57	4.06	16.20	4.89
45	8.69	1.91	8.05	2.08	7.06	2.23	12.04	3.12	14.37	3.76
55	8.42	1.58	7.97	1.61	7.61	1.64	10.26	2.13	10.58	2.18

LWT: Leaving water temperature  
 Qh: Heat capacity  
 COP: Coefficient of performance

**Application data**  
 Water inlet/outlet temperature difference = 5 °C, 8 °C  
 for LWT = 55 °C

### Cooling

LWT [°C]	Inlet outdoor air temperature - °C	
	Qc [kW]	EER
	35	
7	8.45	2.41
18	10.66	3.62

LWT: Leaving water temperature  
 Qc: Cooling capacity  
 EER: Energy efficiency ratio

**Application data**  
 Water inlet/outlet temperature difference = 5 °C

# FLOW RATE CURVES

AIM06EMX

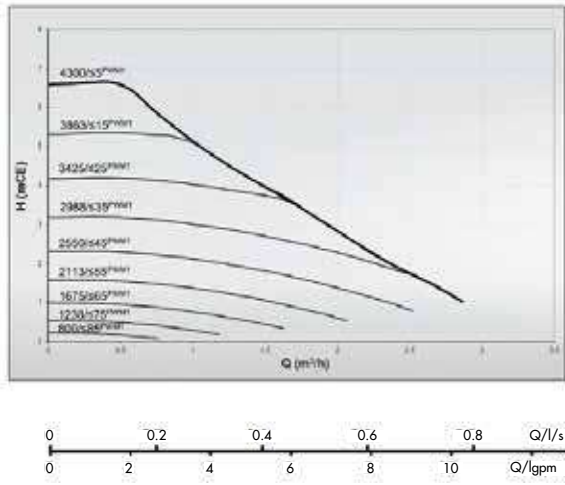

AIM08EMX

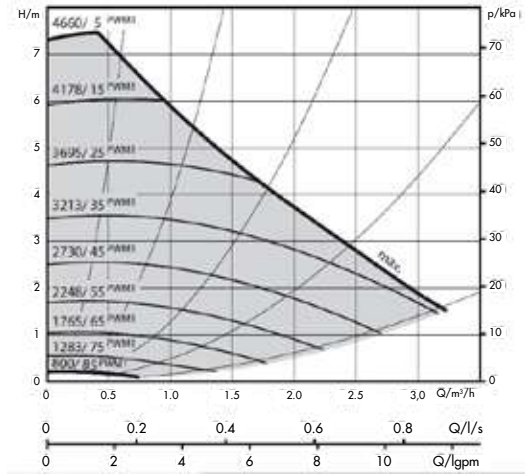

AIM11EMX

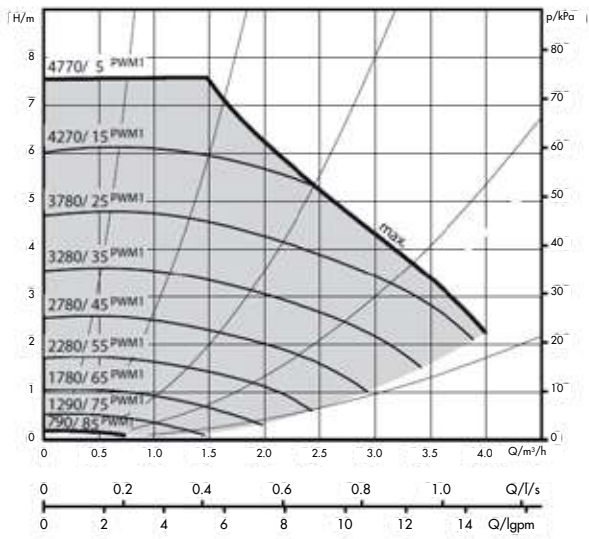

AIM14EMX

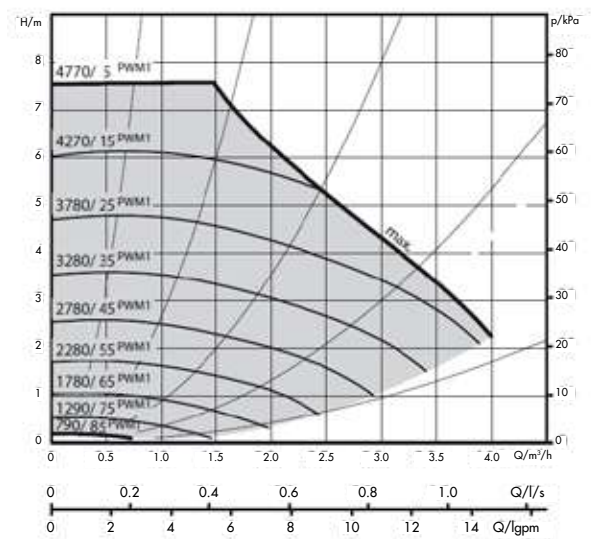

# PRESSURE DROP

HEAT  
PUMPS

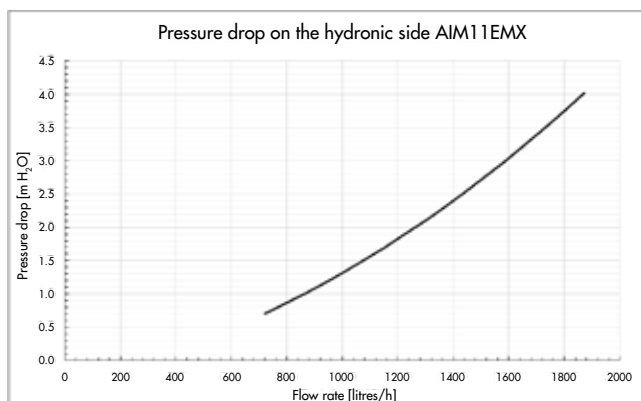
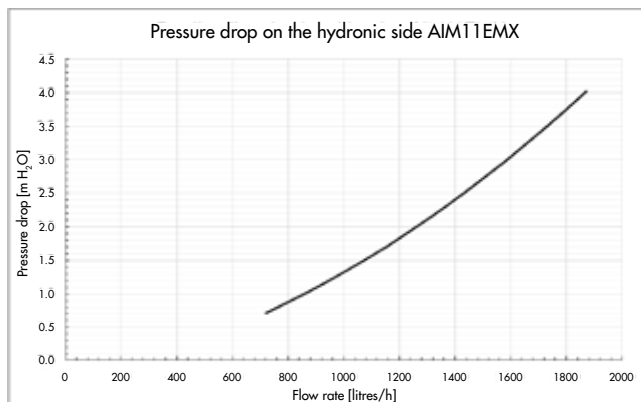
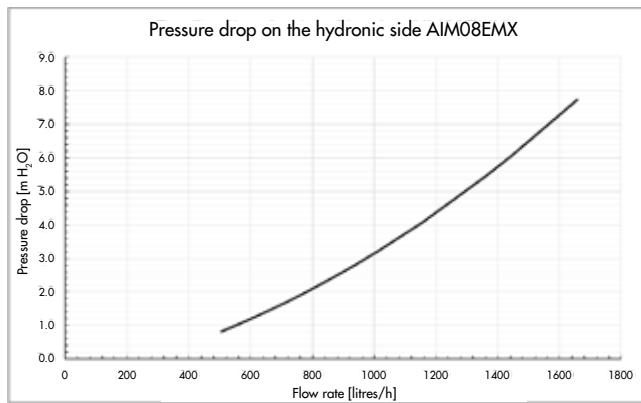
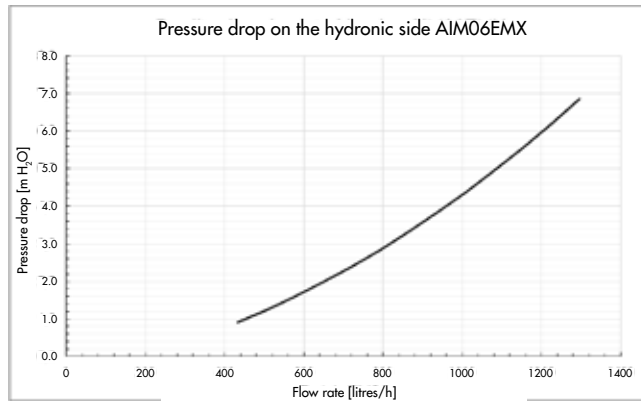

# INSTALLATION EXAMPLES

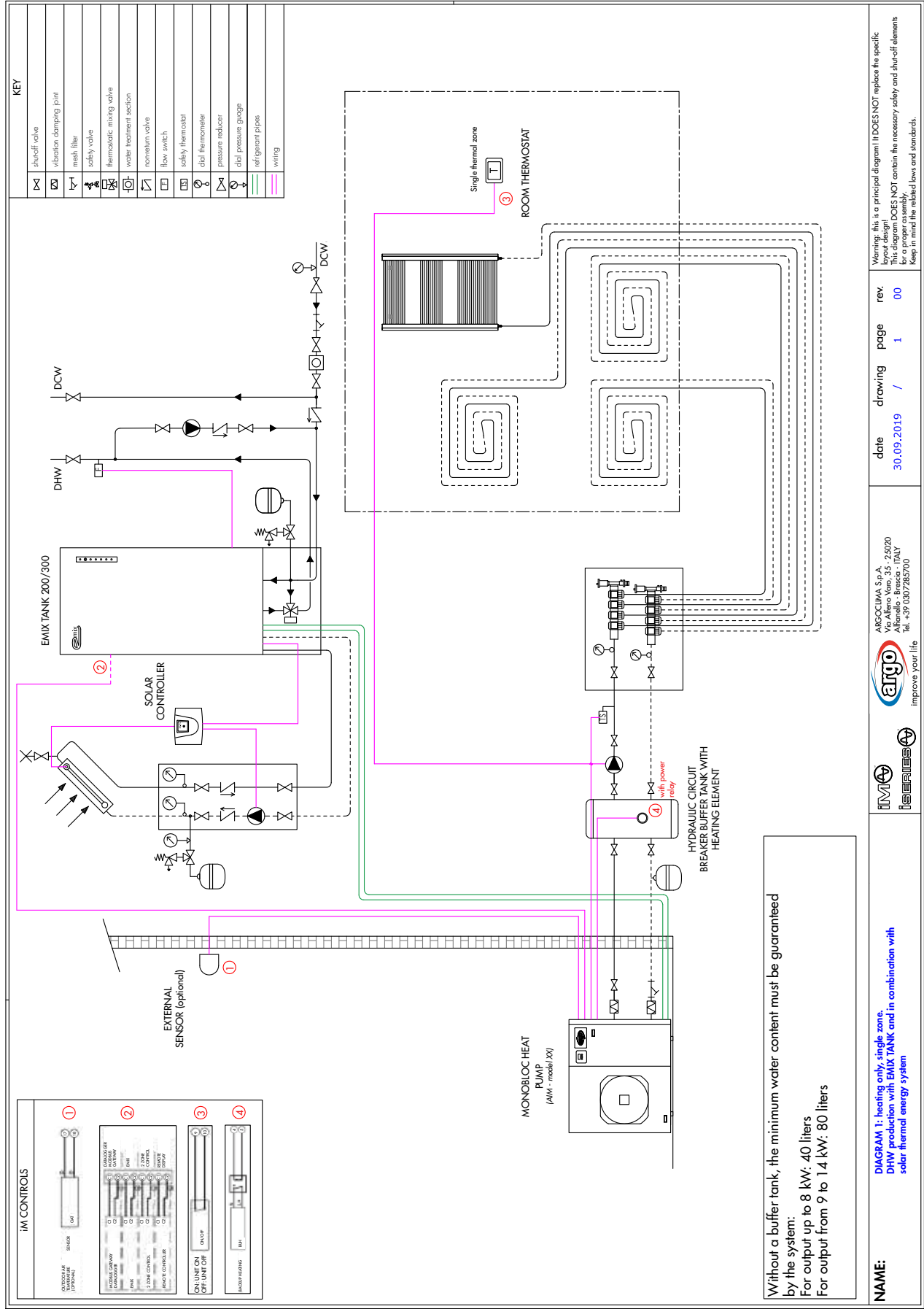

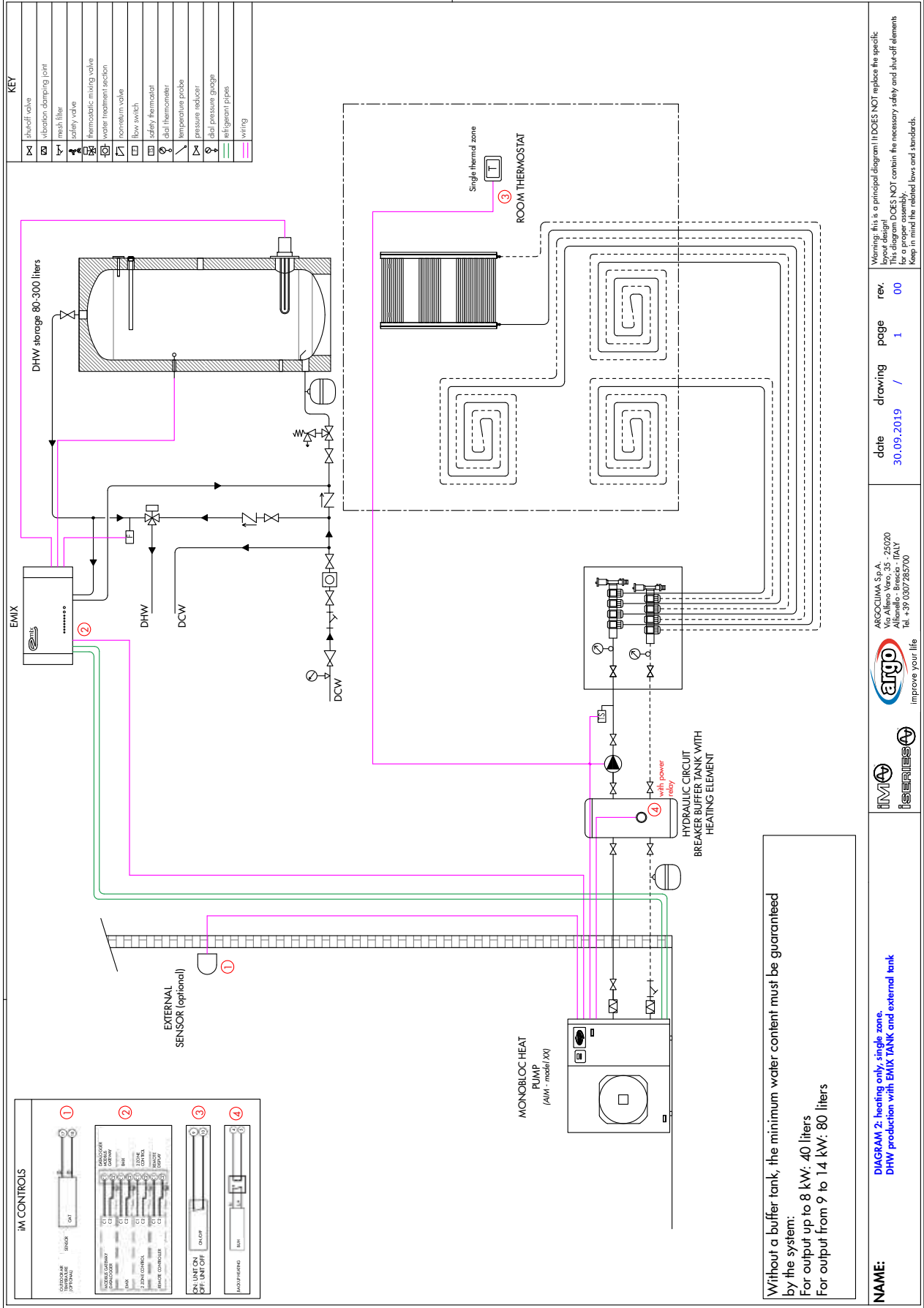

# INSTALLATION EXAMPLES

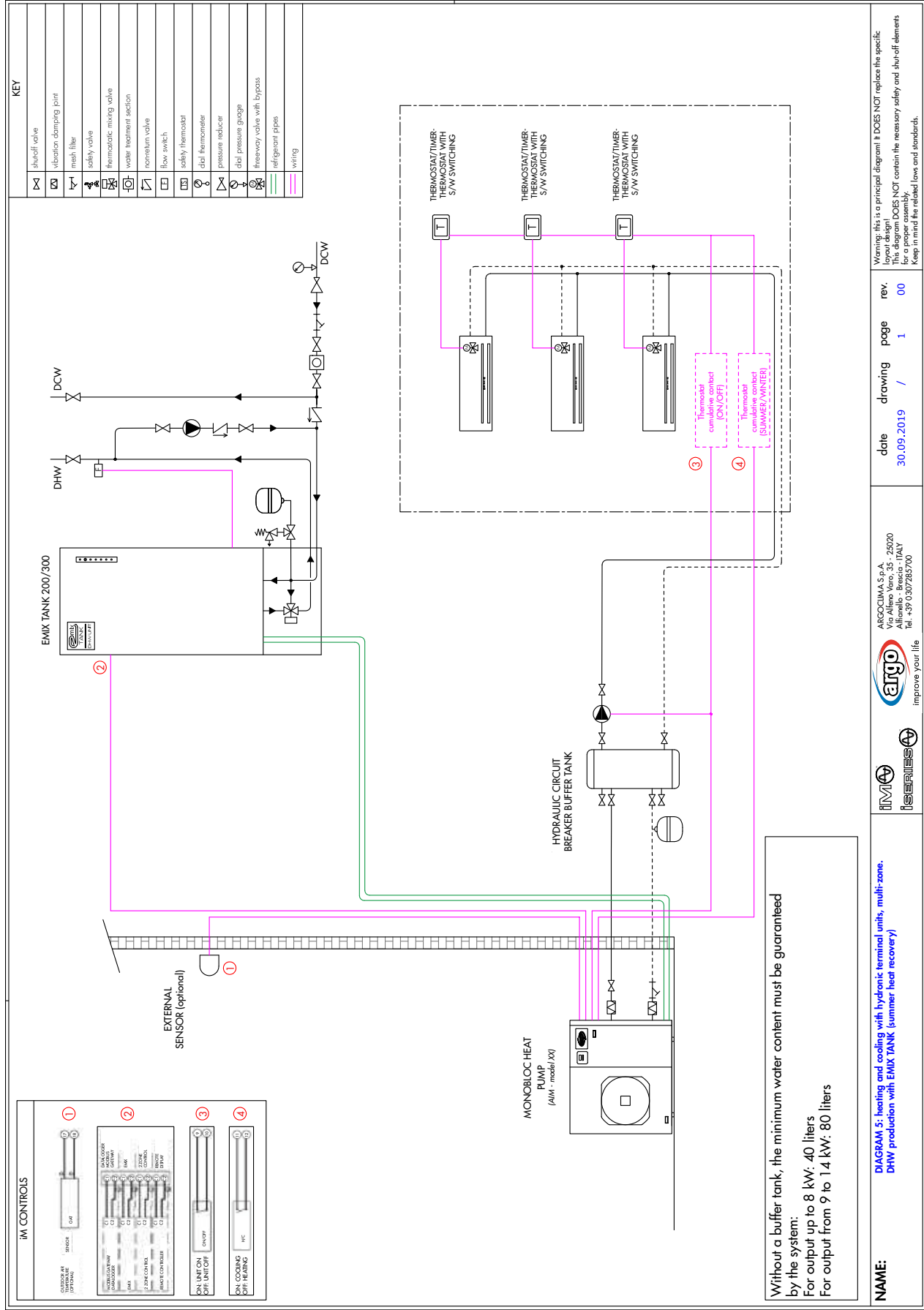

date 30.09.2019 / page 1 / rev. 00

ARCOCLIMA S.p.A.  
 Via Piero Ferrero, 35 - 26020  
 Azzurro - Mantova - ITALY  
 Tel. +39 0307285700

IMV  
 IMV  
 Improve your life

**NAME:**  
 DIAGRAM 5: heating and cooling with hydraulic terminal units, multi-zone.  
 DHW production with EMIX TANK (summer heat recovery)

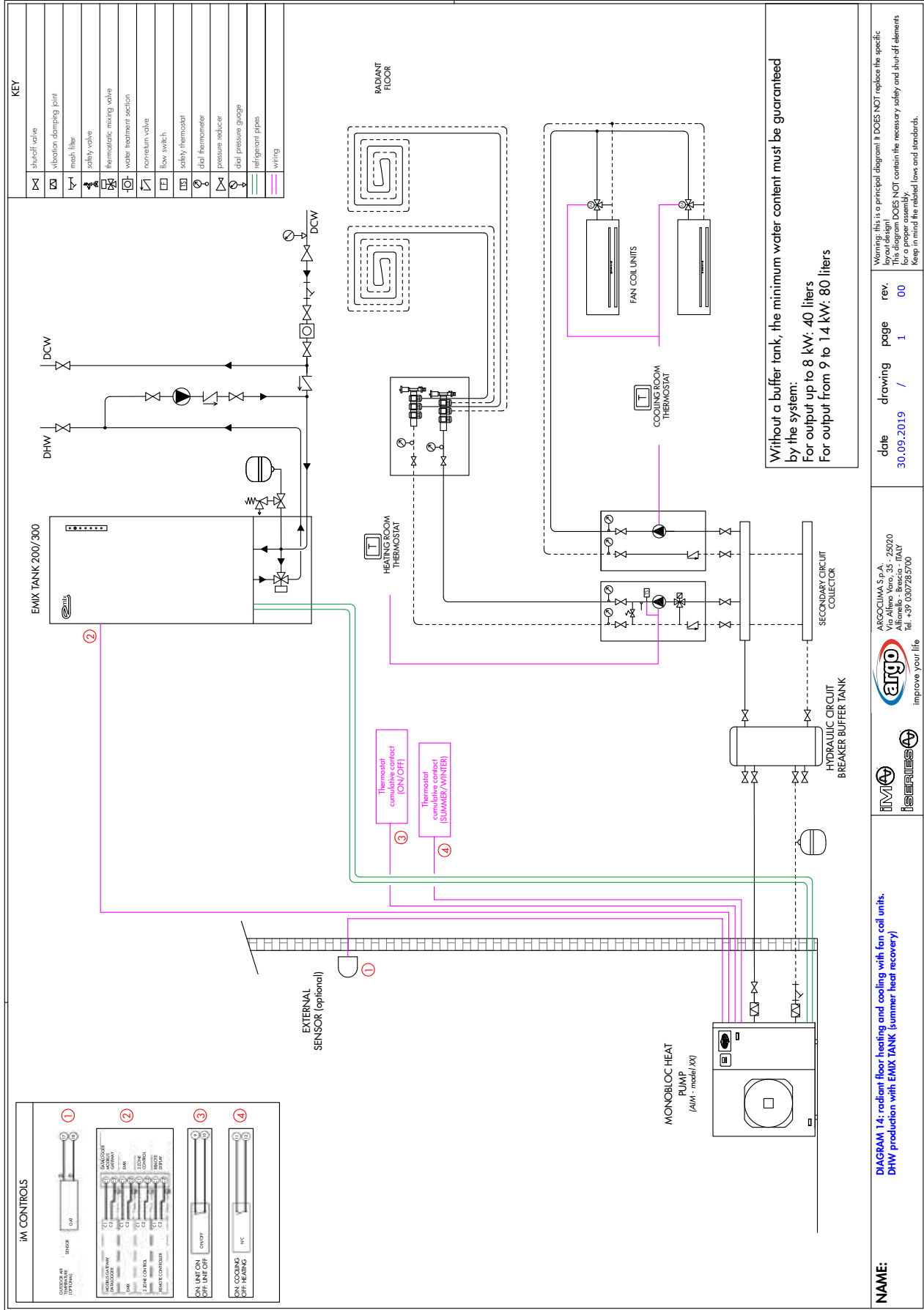



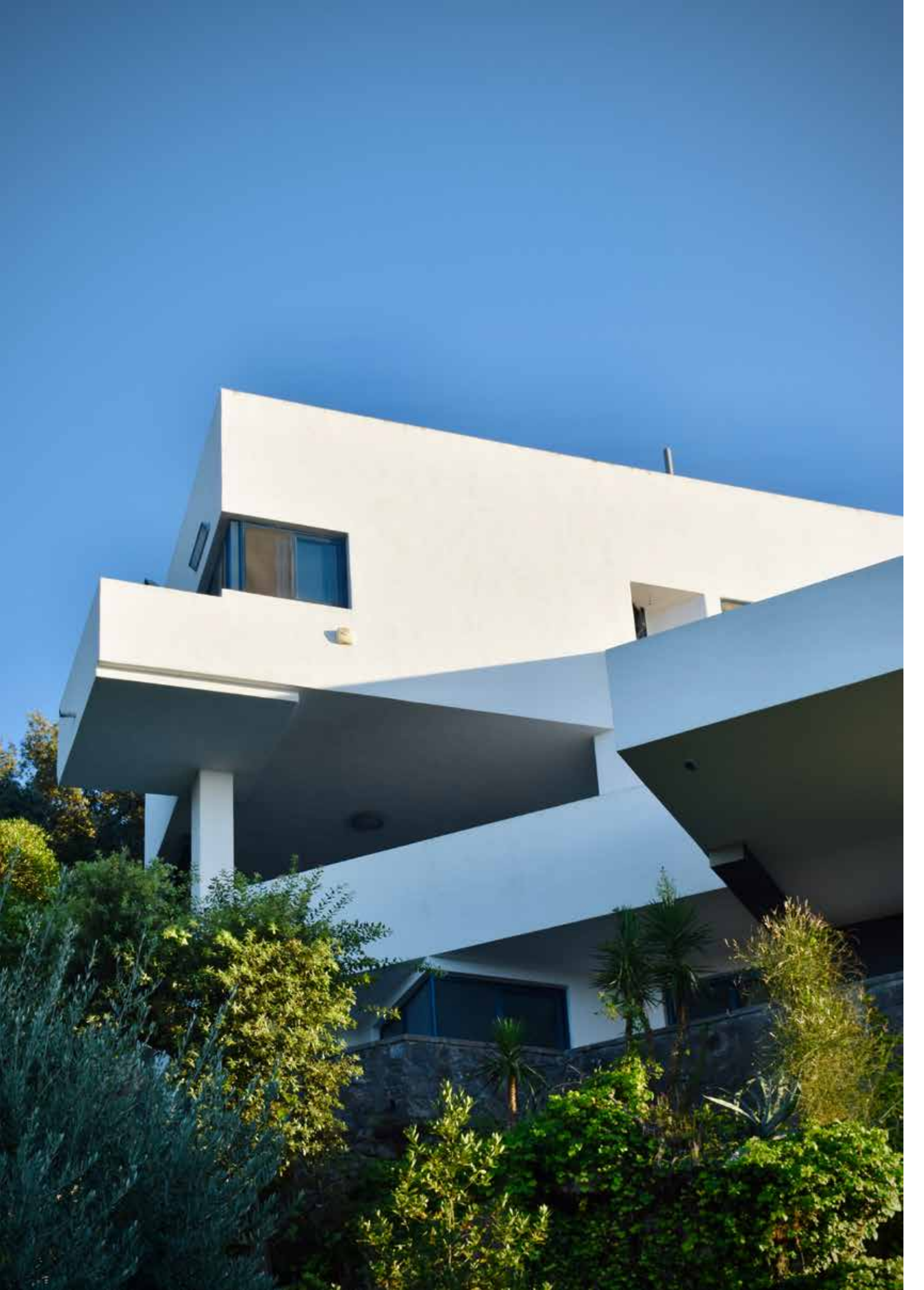



# X3 AIR TO WATER HEAT PUMPS

---

Residential and commercial applications - R32 DC Inverter

Monobloc

Split

Built-in solution for split heat pumps

All in one

# X3 AIR TO WATER HEAT PUMPS

## PLUS



### WIDE OPERATING RANGE

The outdoor temperature range varies between -25 °C and +35 °C, while the leaving water temperature interval is 20-60 °C: this means that the heat pump can be used with radiant floor systems, fan coil units and also medium-temperature radiators.

#### Cooling mode

from -15 °C\* to 48 °C  
 from 5 °C\*\* to 25 °C

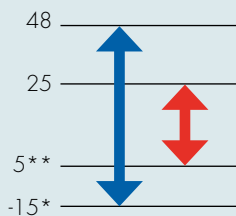

\* +10 °C for split and all-in-one models  
 \*\* +7 °C for split and all-in-one models  
 \*\*\* 60 °C for split and all-in-one models

#### DHM production

from -25 °C to 45 °C  
 from 40 °C to 60 °C  
 (80 °C with electric heater)

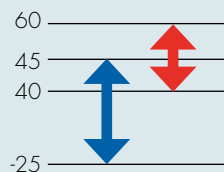

Outdoor air temperature  
 Water temperature

#### Heating mode

from -25 °C to 35 °C  
 from 20 °C to 65 °C\*\*\*

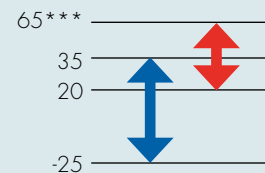

### VERSATILITY AND EASE OF INSTALLATION

The unit is compact and has reduced overall dimensions: it can therefore be used also in tight spaces and is easy to carry and to install. In addition, it can be paired with heating systems that use medium-temperature radiators, as well as with radiant floor systems and fan coil units. It is not necessary to create any connection to the cooling circuit: the hydraulic connections are sufficient.



### R32 REFRIGERANT WITH LOW ENVIRONMENTAL IMPACT

Heat pumps run on GREEN technology that uses renewable energy: this system captures the thermal energy present in the air and transfers it from one place to another, multiplying it. For every kW consumed, it produces over 4 kW of thermal energy: 75% of the energy is free, renewable and clean. The use of R32, a refrigerant gas with a low global environmental impact, makes these heat pumps even more environment-friendly.



### REMOTE CONTROL

The unit can be integrated with a BMS supervision system, using the Modbus protocol.

By installing the EWPE application on the smartphone, most of the heat pump's parameters can be controlled remotely in a comfortable way.

MONOBLOC  
SPLIT  
ALL IN ONE

ETJO



# THE ADVANTAGES



## HIGH ENERGY EFFICIENCY

### Steam-injection compressor

- With low outdoor temperatures, the compressor with steam injection reduces the thermal capacity losses and has a greater efficiency compared to a traditional compressor.
- In the same conditions, the compressor's high discharge temperatures and other problems can be completely avoided, making the compressor significantly more reliable.
- Two-stage compression, two-stage lamination and steam injection increase the leaving water temperature and improve the control accuracy.

### Heat exchanger fins

The heat exchange batteries are subjected to a special "Golden Fin" anti-corrosion protective treatment. The battery fins, made of aluminium-manganese (Al-Mn), are coated with a special layer of epoxy resin, which gives them their typical golden colour, and a further hydrophilic layer.

This special treatment is able to protect the heat exchanger against rust and corrosion in zones where the air is very salty, typical of coastal areas.

### Circulator pump

The high-efficiency Class A inverter hydronic pump satisfies the requirements imposed by the European ErP directive. Its operating frequency adapts to the system's load. In this way, it is possible to improve the efficiency and temperature control of the heat transfer fluid.

### DC brushless axial fans

The DC inverter axial fan with high air flow rate controls the volume of air delivered in a precise way and guarantees operating stability.

### Plate heat exchanger

- The heat exchanger has a compact structure, minimal overall dimensions and a reduced pressure loss. Moreover, it guarantees a highly efficient heat exchange and boasts excellent resistance to corrosion.
- It is coated externally with anti-condensate material and is equipped with a heating element to protect it against frost build-up.

## TOUCH-SCREEN CONTROL PANEL

The control panel, supplied with the heat pump or installed on board the corresponding internal unit, allows the complete management and setup of the unit.



In particular it is possible to:

- Define the operating mode of the heat pump and its priorities (heating, cooling, production of Domestic Hot Water)
- Set all the main operating parameters (set point, hysteresis, etc.)
- Activate external (or internal) systems to integrate or replace the heating and Domestic Hot Water production unit
- Manage the commissioning of the unit
- Display the status of the operating parameters of the main components of the heat pump
- Manage the unit remotely via MODBUS gateway or WiFi module directly integrated into the panel.

Specific auxiliary functions are also available in the control panel, including:

- Automatic management of the flow temperature of the fluid according to the external temperature (climate curve)
- Programming of weekly and hourly operation
- Activation of "silent" operation
- Emergency management in case of unit failure
- Programmable activation of the anti-legionella cycle
- Automatic activation of the antifreeze protection.





# MONOBLOC

---

Single-phase 6-8 kW range

Single/three-phase 10-12-14-16 kW range

# MONOBLOC HEAT PUMPS

## MAIN FEATURES



(Standard)  
Touch-screen control panel

- Monobloc Air/Water heat pump with new-generation DC Inverter technology.
- Equipped with the heating, cooling and domestic hot water production functions.
- Single-phase version with 6-8 kW heating capacity.
- Single/three-phase version with 10-12-14-16 kW heating capacity.
- Achieves very high efficiency levels in heating mode, up to 5 COP.
- Its integrated structure, which includes all the hydraulic components, ensures easy installation and, consequently, savings on the relative costs.
- It uses R32, a refrigerant with low impact on global warming and ozone layer, characterised by high energy efficiency and a 30% lower charge compared to R410A.
- The vapour-injection compressor, thanks to its special technology, guarantees exceptional performances and a wide operating range.
- The leaving water temperature range is 20 °C-65 °C: this means that the heat pump can be used with radiant floor systems, fan coil units and also medium-temperature radiators.
- The DC brushless axial fans are designed to ensure aerodynamic optimisation: they guarantee low noise levels coupled with high efficiency and a high air flow rate.
- It is equipped with a heating element on the base to prevent ice build-up during winter operation.
- It is equipped with an electronic expansion valve.

Internal copper groove	Quiet mode	Weekly timer	Heating down to low temperatures	Door control	Full protection	Timer	Child lock	Wide operating range	Wide voltage range	Auto diagnosis	Low-voltage start-up
Auto restart memory	Intelligent defrosting	°C / °F switching	Long-distance monitoring	Exch. condenser gold fin treatment	-25°C Min. outdoor temp. heating	+35°C Max. outdoor temp. heating	-15°C Min. outdoor temp. cooling	+48°C Max. outdoor temp. cooling	-25°C Min. outdoor temp. DHW	+45°C Max. outdoor temp. DHW	60°C Max. output temp. DHW



**A+++** Heating mode 35 °C

**A++** Heating mode 55 °C

**A** DHW



# THE RANGE

	Model	Code	⚡		Rated capacity according to EN14511 (kW)	
			1PH	3PH	 Heating (1)	 Cooling (2)
	AG4HP061PH	398600069	●		6.0	6.5
	AG4HP081PH	398600071	●		8.2	8.3
	AG4HP101PH	398600072	●		10.2	10.2
	AG4HP121PH	398600073	●		12.0	12.0
	AG4HP141PH	398600074	●		14.2	13.7
	AG4HP161PH	398600075	●		15.7	15.5
	AG4HP103PH	398600076		●	10.2	10.2
	AG4HP123PH	398600077		●	12.0	12.0
	AG4HP143PH	398600078		●	14.2	13.9
	AG4HP163PH	398600079		●	15.7	15.4

(1) Water temperature 30 °C/35 °C, outdoor air temperature 7 °C D.B./6 °C W.B.

(2) Water temperature 23 °C/18 °C, outdoor air temperature 3.5 °C

## INCLUDED ACCESSORIES

Ambient air temperature sensor
DHW temperature sensor
Additional system water temperature sensor
Y-shaped filter
Remote control panel

# TECHNICAL DATA 6 kW

Model				AG4HP061PH				
Matchable units for domestic hot water production (DHW)				200/300 liters external tank with diverting valve				
				Cooling	Heating			
COMFORT IN ENVIRONMENT	Performance according to EN 14511	Air +35 °C - Water 23/18 °C Air +7 °C - Water 30/35 °C	Rated capacity	kW	6.50	6.00		
			Rated electrical power input	kW <sub>el</sub>	1.27	1.11		
			EER/COP		5.10	5.40		
	Performance according to EN 14825	LOW TEMPERATURE (35 °C) AVERAGE climate	Air +35 °C - Water 12/7 °C Air +7 °C - Water 40/45 °C	Rated capacity	kW	5.70	6.80	
				Rated electrical power input	kW <sub>el</sub>	1.65	1.66	
				EER/COP		3.45	4.10	
COMFORT IN ENVIRONMENT	Performance according to Ecodesign (ERP) EN 14825	MEDIUM TEMPERATURE (55 °C) AVERAGE climate	Design thermal load (P <sub>design,h</sub> )	kW	6			
			Seasonal energy efficiency η <sub>s</sub>	%	199			
			Energy efficiency class		A+++			
	Performance according to Ecodesign (ERP) EN 14825	MEDIUM TEMPERATURE (55 °C) AVERAGE climate	MEDIUM TEMPERATURE (55 °C) AVERAGE climate	Design thermal load (P <sub>design,h</sub> )	kW	5		
				Seasonal energy efficiency η <sub>s</sub>	%	135		
				Energy efficiency class		A++		
DHW	DHW performance according to EN 16147	With 300 liters tank and diverting valve AVERAGE climate	Load profile		XL			
			Energy efficiency class		A+			
			ERP efficiency	%	127			
Unit operation data			Maximum delivery water temperature	°C	Up to 65			
			Outdoor temperature range (heating)	°C	-25/+35			
			Outdoor temperature range (cooling)	°C	-15/+48			
			Nominal water flow rate	m <sup>3</sup> /h	at 35 °C		1.03	
					at 45 °C		1.01	
					at 55 °C		0.97	
					at 7 °C		0.84	
					at 18 °C		1.12	
			Minimum efficient water volume of the system	liters	40			
			Power supply (Voltage/Phases/Frequency)	V/Ph/Hz	230/1/50			
			Maximum electricity consumption	A	25			
			Sound pressure level (cooling mode)	dB(A)	56			
			Sound pressure level (heating mode)	dB(A)	58			
Components and dimensions			Expansion vessel	liters	2			
			Maximum circulator pump head	kPa	(see H/Q graphs)			
			Hydraulic connections	inches	G1"			
			Safety valve	bar	3			
			Weight	kg	90			
			Dimensions (H/W/D)	mm	733/1150/372			
			Compressor type		Twin Rotary with vapour injection			
Refrigerant			Type and GWP		R32/675 kg CO <sub>2</sub> eq			
			Quantity	kg	0.95			

The equipments described in this catalogue contain HFC R32-type fluorinated greenhouse gases.  
These products must be fitted by qualified staff pursuant to Regulations (EU) 303/2008 and 517/2014.

Data declared in accordance with REGULATION (EU) No. 811/2013 of 18 February 2013 with regard to the energy labelling of space heaters, combination heaters, packages of space heater, temperature control and solar device and packages of combination heater, temperature control and solar devices, packages of combination heater, temperature control and solar devices, and with COMMISSION REGULATION (EU) No. 813/2013 of 2 August 2013 implementing Directive 2009/125/EC of the European Parliament and of the Council with regard to ecodesign requirements for space heaters and combination heaters.

## CAPACITY AND EFFICIENCY DATA IN RELATION TO THE OUTDOOR TEMPERATURE ACCORDING TO THE EN14511-3:2018 STANDARD

LWT [°C]	COOLING - Dry bulb outdoor air temperature in °C - (AG4HP061PH)																			
	10		15		20		25		30		35		40		45		48			
	Qc [kW]	EER	Qc [kW]	EER	Qc [kW]	EER	Qc [kW]	EER	Qc [kW]	EER	Qc [kW]	EER	Qc [kW]	EER	Qc [kW]	EER	Qc [kW]	EER		
7	5.25	6.31	5.00	5.69	4.79	5.11	6.16	4.52	5.87	3.97	5.70	3.45	3.13	2.99	2.27	2.37	2.08	1.92		
8	5.42	6.53	5.16	5.89	4.94	5.28	6.35	4.68	6.06	4.11	5.88	3.57	3.23	3.09	2.34	2.45	2.15	1.99		
9	5.59	6.75	5.32	6.09	5.09	5.46	6.55	4.83	6.25	4.24	6.06	3.69	3.33	3.20	2.41	2.53	2.21	2.06		
10	5.75	6.97	5.48	6.28	5.25	5.64	6.75	4.99	6.43	4.38	6.25	3.81	3.43	3.30	2.49	2.61	2.28	2.12		
11	5.92	7.19	5.64	6.48	5.40	5.81	6.94	5.15	6.62	4.52	6.43	3.93	3.53	3.40	2.56	2.70	2.35	2.19		
12	6.09	7.41	5.80	6.68	5.55	5.99	7.14	5.30	6.81	4.65	6.61	4.05	3.63	3.50	2.63	2.78	2.41	2.26		
13	6.26	7.62	5.96	6.87	5.71	6.17	7.34	5.46	7.00	4.79	6.79	4.17	3.73	3.61	2.70	2.86	2.48	2.32		
14	6.43	7.84	6.12	7.07	5.86	6.34	7.53	5.61	7.19	4.93	6.98	4.28	3.83	3.71	2.78	2.94	2.54	2.39		
15	6.59	8.06	6.28	7.27	6.01	6.52	7.73	5.77	7.37	5.06	7.16	4.40	3.93	3.81	2.85	3.02	2.61	2.46		
18	7.07	8.71	6.73	7.86	6.44	7.05	8.29	6.24	7.90	5.48	6.50	5.10	4.21	4.12	3.05	3.27	2.80	2.66		
20	7.43	9.14	7.08	8.24	6.78	7.39	8.72	6.54	8.31	5.74	6.87	5.00	4.43	4.33	3.21	3.43	2.94	2.79		
23	7.91	9.80	7.53	8.83	7.21	7.92	9.27	7.01	8.84	6.16	7.35	5.35	4.71	4.64	3.42	3.64	3.13	2.99		
25	8.21	10.23	7.82	9.22	7.49	8.27	9.63	7.32	9.18	6.43	7.64	5.59	4.89	4.84	3.55	3.84	3.25	3.12		

LWT [°C]	HEATING - Dry bulb outdoor air temperature in °C																											
	-25		-20		-15		-10		-7		-2		2		7		10		15		20		25		30		35	
	Qh [kW]	COP	Qh [kW]	COP	Qh [kW]	COP	Qh [kW]	COP	Qh [kW]	COP	Qh [kW]	COP	Qh [kW]	COP	Qh [kW]	COP	Qh [kW]	COP	Qh [kW]	COP	Qh [kW]	COP	Qh [kW]	COP	Qh [kW]	COP	Qh [kW]	COP
25	2.31	2.24	2.48	2.64	2.97	3.04	3.25	3.56	3.58	3.96	4.02	4.52	4.35	5.02	5.94	6.60	6.12	6.77	6.84	7.36	5.88	7.82	6.44	8.28	5.36	8.66	5.80	8.99
30	2.37	2.06	2.53	2.42	3.03	2.79	3.30	3.27	3.63	3.64	4.07	4.15	4.40	4.60	6.00	6.06	6.18	6.21	6.90	6.76	5.92	7.18	6.49	7.60	5.40	7.95	5.83	8.26
35	2.37	1.84	2.53	2.16	3.03	2.49	3.30	2.92	3.63	3.25	4.07	3.71	4.40	4.11	6.00	5.41	6.18	5.55	6.90	6.03	5.92	6.41	6.49	6.79	5.40	7.10	5.83	7.37
40	2.37	1.62	2.53	1.90	3.03	2.19	3.30	2.57	3.63	2.86	4.07	3.26	4.40	3.62	6.00	4.76	6.18	4.88	6.90	5.31	5.92	5.64	6.49	5.97	5.40	6.25	5.83	6.49
45	2.37	1.47	2.53	1.73	3.03	1.99	3.30	2.34	3.63	2.60	4.07	2.96	4.40	3.29	6.80	4.10	6.18	4.44	6.90	4.83	5.92	5.13	6.49	5.43	5.40	5.68	5.83	5.90
50			2.48	1.56	2.97	1.79	3.25	2.10	3.58	2.34	4.02	2.67	4.35	2.96	5.94	3.90	6.12	3.99	6.84	4.34	5.88	4.62	6.44	4.89	5.36	5.11	5.77	5.31
55					2.97	1.57	3.25	1.84	3.58	2.04	4.02	2.33	4.35	2.59	5.80	3.15	6.12	3.49	6.84	3.80	5.88	4.04	6.44	4.28	5.36	4.47	5.77	4.64
60									3.52	1.82	3.96	2.08	4.29	2.30	5.88	3.03	6.06	3.11	6.76	3.38	5.80	3.59	6.36	3.80	5.29	3.98	5.72	4.13
65															5.82	2.71	5.99	2.77	6.69	3.02	5.74	3.21						

LWT: Leaving water temperature  
 Qh: Heating capacity  
 COP: Coefficient of performance

LWT: Leaving water temperature  
 Qc: Cooling capacity  
 EER: Energy efficiency ratio

## FLOW RATE CURVES FOR 6 kW

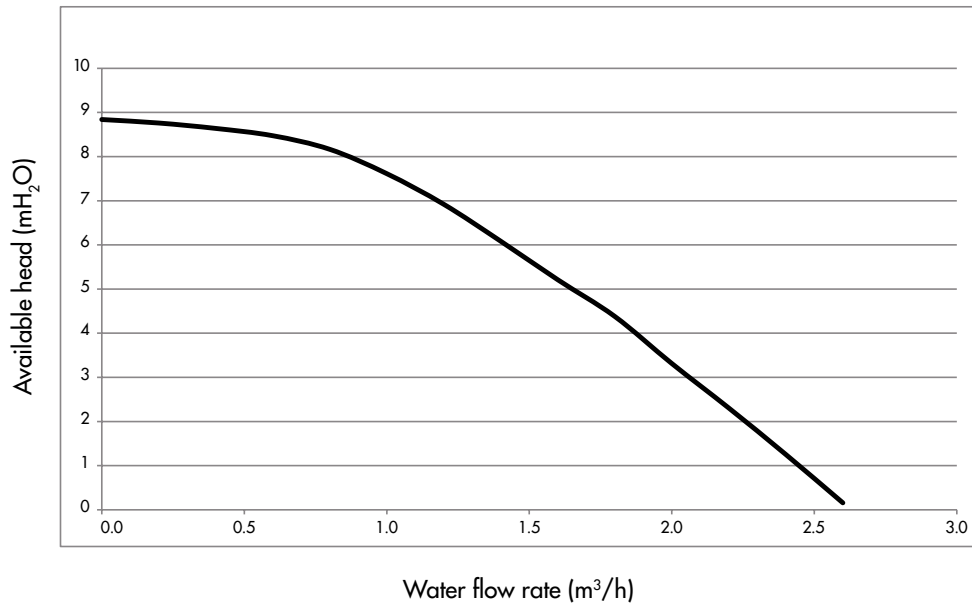

## MAXIMUM TEMPERATURE IN HEATING 6 kW

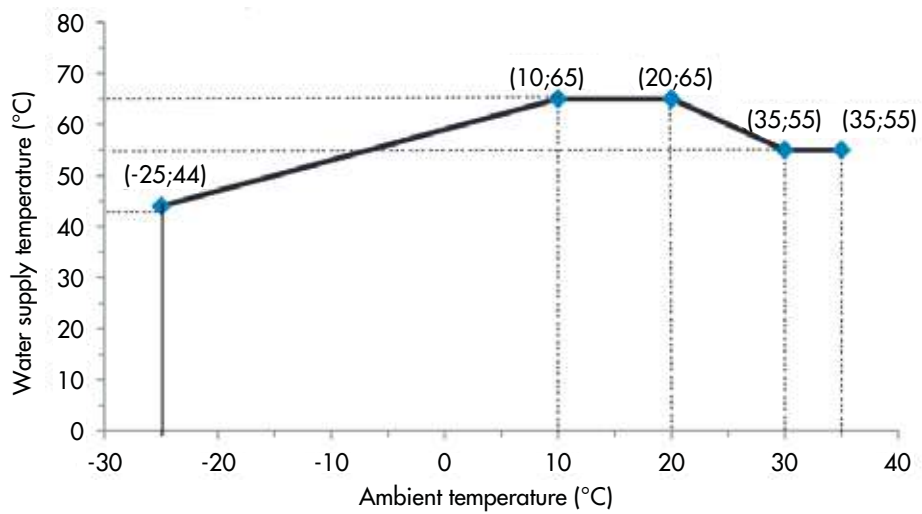

# DIMENSIONAL DRAWINGS 6 kW

HEAT PUMPS

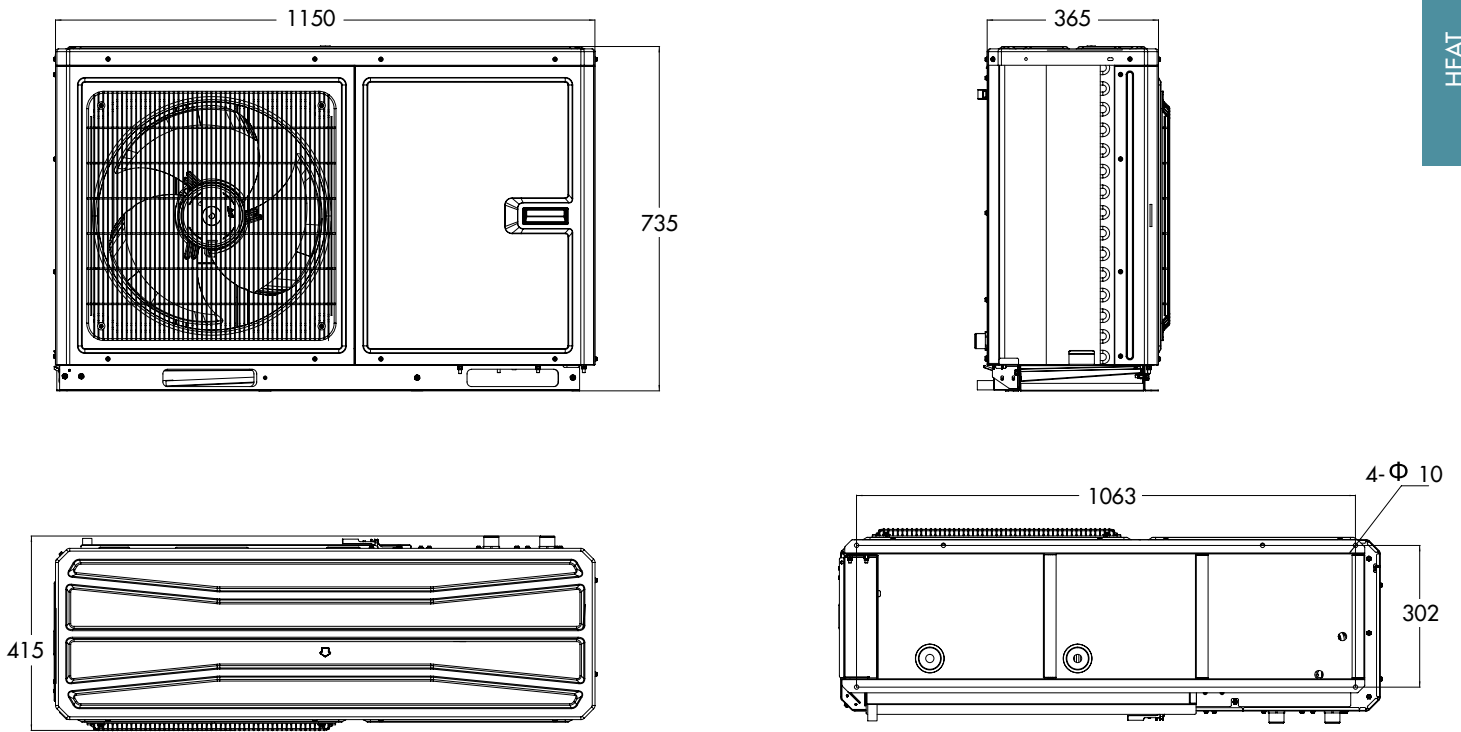

# SPACE REQUIRED FOR INSTALLATION 6 kW

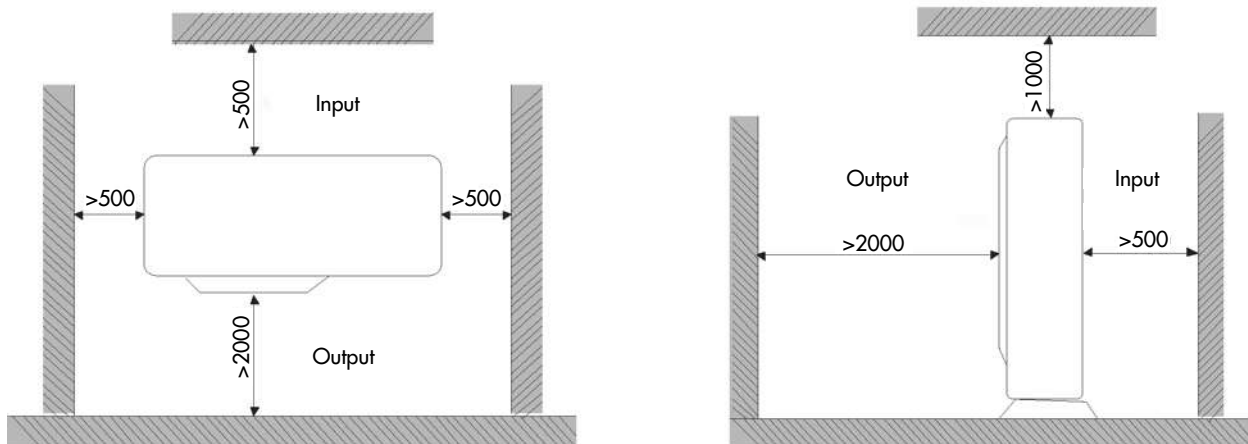

# TECHNICAL DATA FOR 8-10-12-14-16 kW

Model				AG4HP081PH				
Matchable units for domestic hot water production (DHW)				200/300 liters external tank with diverting valve				
				Cooling	Heating			
COMFORT IN ENVIRONMENT	Performance according to EN 14511	Air +35 °C - Water 23/18 °C Air +7 °C - Water 30/35 °C	Rated capacity	kW	8.30	8.20		
			Rated electrical power input	kW <sub>el</sub>	1.56	1.54		
			EER/COP		5.32	5.32		
	Performance according to EN 14825	LOW TEMPERATURE (35 °C) AVERAGE climate	Air +35 °C - Water 12/7 °C Air +7 °C - Water 40/45 °C	Rated capacity	kW	7.40	8.30	
				Rated electrical power input	kW <sub>el</sub>	2.00	1.90	
				EER/COP		3.70	4.36	
COMFORT IN ENVIRONMENT	Performance according to Ecodesign (ERP) EN 14825	MEDIUM TEMPERATURE (55 °C) AVERAGE climate	Design thermal load (P <sub>design,h</sub> )	kW	8			
			Seasonal energy efficiency η <sub>s</sub>	%	187			
			Energy efficiency class		A+++			
	Performance according to Ecodesign (ERP) EN 14825	MEDIUM TEMPERATURE (55 °C) AVERAGE climate	MEDIUM TEMPERATURE (55 °C) AVERAGE climate	Design thermal load (P <sub>design,h</sub> )	kW	9		
				Seasonal energy efficiency η <sub>s</sub>	%	146		
				Energy efficiency class		A++		
DHW	DHW performance according to EN 16147	With 300 liters tank and diverting valve AVERAGE climate	Load profile		XL			
			Energy efficiency class		A			
			ERP efficiency	%	123			
Unit operation data			Maximum delivery water temperature	°C	Up to 65			
			Outdoor temperature range (heating)	°C	-25/+35			
			Outdoor temperature range (cooling)	°C	-15/+48			
			Nominal water flow rate	m <sup>3</sup> /h	at 35 °C		1.41	
					at 45 °C		1.40	
					at 55 °C		1.34	
					at 7 °C		0.98	
					at 18 °C		1.43	
			Minimum efficient water volume of the system	liters	40			
			Power supply (Voltage/Phases/Frequency)	V/Ph/Hz	230/1/50			
			Maximum electricity consumption	A	25			
Sound pressure level (cooling mode)	dB(A)	60						
Sound pressure level (heating mode)	dB(A)	62						
Components and dimensions			Expansion vessel	liters	3			
			Maximum circulator pump head	kPa	(see H/Q graphs)			
			Hydraulic connections	inches	G1"			
			Safety valve	bar	3			
			Weight	kg	120			
			Dimensions (H/W/D)	mm	878/1206/445			
			Compressor type		Twin Rotary with vapour injection			
Refrigerant			Type and GWP		R32/675 kg CO <sub>2</sub> eq			
			Quantity	kg	1.6			

The equipments described in this catalogue contain HFC R32-type fluorinated greenhouse gases.  
These products must be fitted by qualified staff pursuant to European regulations 303/2008 and 517/2014.

Data declared in accordance with REGULATION (EU) No. 811/2013 of 18 February 2013 with regard to the energy labelling of space heaters, combination heaters, packages of space heater, temperature control and solar device and packages of combination heater, temperature control and solar devices, packages of combination heater, temperature control and solar devices, and with COMMISSION REGULATION (EU) No. 813/2013 of 2 August 2013 implementing Directive 2009/125/EC of the European Parliament and of the Council with regard to ecodesign requirements for space heaters and combination heaters.

## CAPACITY AND EFFICIENCY DATA IN RELATION TO THE OUTDOOR TEMPERATURE ACCORDING TO THE EN14511-3:2018 STANDARD

LWT [°C]	COOLING - Dry bulb outdoor air temperature in °C - (AG4HP081PH)																	
	10		15		20		25		30		35		40		45		48	
	Q <sub>c</sub> [kW]	EER	Q <sub>c</sub> [kW]	EER	Q <sub>c</sub> [kW]	EER	Q <sub>c</sub> [kW]	EER	Q <sub>c</sub> [kW]	EER	Q <sub>c</sub> [kW]	EER	Q <sub>c</sub> [kW]	EER	Q <sub>c</sub> [kW]	EER	Q <sub>c</sub> [kW]	EER
7	9.25	6.77	8.81	6.11	8.44	5.48	7.99	4.85	7.62	4.26	7.40	3.70	5.15	3.07	4.70	2.37	3.73	1.98
8	9.55	7.01	9.09	6.32	8.71	5.67	8.25	5.02	7.87	4.40	7.64	3.83	5.32	3.18	4.85	2.45	3.85	2.05
9	9.84	7.24	9.37	6.53	8.98	5.86	8.50	5.18	8.11	4.55	7.87	3.96	5.48	3.28	5.01	2.53	3.97	2.11
10	10.14	7.48	9.65	6.74	9.25	6.05	8.76	5.35	8.35	4.70	8.11	4.08	5.65	3.39	5.16	2.61	4.09	2.18
11	10.43	7.71	9.93	6.95	9.52	6.23	9.01	5.52	8.60	4.84	8.35	4.21	5.81	3.50	5.31	2.70	4.21	2.25
12	10.73	7.94	10.21	7.16	9.79	6.42	9.27	5.69	8.84	4.99	8.58	4.34	5.98	3.60	5.46	2.78	4.33	2.32
13	11.03	8.18	10.50	7.37	10.06	6.61	9.53	5.85	9.09	5.14	8.82	4.47	6.14	3.71	5.61	2.86	4.45	2.39
14	11.32	8.41	10.78	7.58	10.33	6.80	9.78	6.02	9.33	5.28	9.06	4.60	6.31	3.81	5.76	2.94	4.57	2.45
15	11.62	8.64	11.06	7.79	10.60	6.99	10.04	6.19	9.57	5.43	9.29	4.72	6.47	3.92	5.91	3.02	4.69	2.52
18	12.45	9.34	11.85	8.42	11.35	7.56	10.76	6.69	10.26	5.87	8.30	5.32	6.93	4.24	6.33	3.27	5.03	2.73
20	13.10	9.80	12.47	8.84	11.95	7.93	11.32	7.02	10.79	6.16	10.48	5.36	7.30	4.45	6.66	3.43	5.29	2.86
23	13.93	10.51	13.26	9.47	12.70	8.50	12.04	7.52	11.48	6.60	11.14	5.74	7.76	4.76	7.08	3.67	5.62	3.07
25	14.47	10.97	13.77	9.89	13.19	8.87	12.50	7.85	11.92	6.90	11.57	6.00	8.06	4.98	7.36	3.84	5.84	3.20

LWT [°C]	HEATING - Dry bulb outdoor air temperature in °C																											
	-25		-20		-15		-10		-7		-2		2		7		10		15		20		25		30		35	
	Q <sub>h</sub> [kW]	COP	Q <sub>h</sub> [kW]	COP	Q <sub>h</sub> [kW]	COP	Q <sub>h</sub> [kW]	COP	Q <sub>h</sub> [kW]	COP	Q <sub>h</sub> [kW]	COP	Q <sub>h</sub> [kW]	COP	Q <sub>h</sub> [kW]	COP	Q <sub>h</sub> [kW]	COP	Q <sub>h</sub> [kW]	COP	Q <sub>h</sub> [kW]	COP	Q <sub>h</sub> [kW]	COP	Q <sub>h</sub> [kW]	COP	Q <sub>h</sub> [kW]	COP
25	4.73	2.17	4.95	2.56	6.27	2.94	6.49	3.45	7.15	3.84	7.48	4.26	8.10	4.73	8.12	6.49	8.36	6.65	9.35	7.24	8.75	6.48	9.59	6.86	8.94	8.92	9.66	9.26
30	4.84	2.00	5.06	2.35	6.38	2.70	6.60	3.17	7.26	3.52	7.59	3.91	8.20	4.34	8.20	5.96	8.45	6.11	9.43	6.64	8.82	5.95	9.66	6.30	9.00	8.18	9.72	8.50
35	4.84	1.78	5.06	2.10	6.38	2.41	6.60	2.83	7.26	3.14	7.59	3.49	8.20	3.88	8.20	5.32	8.45	5.45	9.43	5.93	8.82	5.31	9.66	5.62	9.00	7.31	9.72	7.59
40	4.84	1.57	5.06	1.84	6.38	2.12	6.60	2.49	7.26	2.77	7.59	3.07	8.20	3.41	8.20	4.68	8.45	4.80	9.43	5.22	8.82	4.67	9.66	4.95	9.00	6.43	9.72	6.68
45	4.84	1.43	5.06	1.68	6.38	1.93	6.60	2.26	7.26	2.52	7.59	2.79	8.20	3.10	8.30	4.36	8.45	4.36	9.43	4.75	8.82	4.25	9.66	4.50	9.00	5.85	9.72	6.07
50			4.95	1.51	6.27	1.74	6.49	2.04	7.15	2.26	7.48	2.52	8.10	2.79	8.12	3.83	8.36	3.93	9.35	4.27	8.75	3.82	9.59	4.05	8.94	5.26	9.62	5.46
55					6.27	1.52	6.49	1.78	7.15	1.98	7.48	2.20	8.10	2.44	7.81	3.20	8.36	3.44	9.35	3.74	8.75	3.34	9.59	3.54	8.94	4.60	9.62	4.78
60									7.04	1.76	7.38	1.96	8.00	2.17	8.04	2.98	8.28	3.05	9.24	3.32	8.64	2.97	9.47	3.15	8.82	4.09	9.53	4.25
65															7.95	2.66	8.19	2.73	9.15	2.97	8.56	2.65						

LWT: Leaving water temperature  
Q<sub>h</sub>: Heating capacity  
COP: Coefficient of performance

LWT: Leaving water temperature  
Q<sub>c</sub>: Cooling capacity  
EER: Energy efficiency ratio

# TECHNICAL DATA FOR 8-10-12-14-16 kW

Model				AG4HP101PH		AG4HP103PH			
Matchable units for domestic hot water production (DHW)				200/300 liters external tank with diverting valve		200/300 liters external tank with diverting valve			
				Cooling	Heating	Cooling	Heating		
COMFORT IN ENVIRONMENT	Performance according to EN 14511	Air +35 °C - Water 23/18 °C Air +7 °C - Water 30/35 °C	Rated capacity	kW	10.20	10.20	10.20	10.20	
			Rated electrical power input	kW <sub>el</sub>	2.00	2.02	2.13	2.06	
			EER/COP		5.10	5.05	4.79	4.95	
	Performance according to Ecodesign (ERP) EN 14825	LOW TEMPERATURE (35 °C) AVERAGE climate	Air +35 °C - Water 12/7 °C Air +7 °C - Water 40/45 °C	Rated capacity	kW	9.00	10.20	9.10	10.20
				Rated electrical power input	kW <sub>el</sub>	2.65	2.50	2.80	2.60
				EER/COP		3.40	4.08	3.25	3.92
COMFORT IN ENVIRONMENT	Performance according to Ecodesign (ERP) EN 14825	MEDIUM TEMPERATURE (55 °C) AVERAGE climate	Design thermal load (P <sub>design,h</sub> )	kW	9		9		
			Seasonal energy efficiency η <sub>s</sub>	%	178		190		
			Energy efficiency class		A+++		A+++		
	Performance according to Ecodesign (ERP) EN 14825	MEDIUM TEMPERATURE (55 °C) AVERAGE climate	Air +35 °C - Water 12/7 °C Air +7 °C - Water 40/45 °C	Design thermal load (P <sub>design,h</sub> )	kW	10		10	
				Seasonal energy efficiency η <sub>s</sub>	%	136		141	
				Energy efficiency class		A++		A++	
DHW	DHW performance according to EN 16147	With 300 liters tank and diverting valve AVERAGE climate	Load profile		XL		XL		
			Energy efficiency class		A		A		
			ERP efficiency	%	123		123		
Unit operation data			Maximum delivery water temperature	°C	Up to 65		Up to 65		
			Outdoor temperature range (heating)	°C	-25/+35		-25/+35		
			Outdoor temperature range (cooling)	°C	-15/+48		-15/+48		
			Nominal water flow rate	m <sup>3</sup> /h	at 35 °C	1.75	at 35 °C	1.75	
					at 45 °C	1.74	at 45 °C	1.74	
					at 55 °C	1.67	at 55 °C	1.67	
					at 7 °C	1.24	at 7 °C	1.24	
					at 18 °C	1.75	at 18 °C	1.75	
			Minimum efficient water volume of the system	liters	80		80		
			Power supply (Voltage/Phases/Frequency)	V/Ph/Hz	230/1/50		400/3/50		
			Maximum electricity consumption	A	25		9		
		Sound pressure level (cooling mode)	dB(A)	60		57			
		Sound pressure level (heating mode)	dB(A)	62		60			
Components and dimensions			Expansion vessel	liters	3		3		
			Maximum circulator pump head	kPa	(see H/Q graphs)		(see H/Q graphs)		
			Hydraulic connections	inches	G1"		G1"		
			Safety valve	bar	3		3		
			Weight	kg	120		134		
			Dimensions (H/W/D)	mm	878/1206/445		878/1206/445		
			Compressor type		Twin Rotary with vapour injection		Twin Rotary with vapour injection		
Refrigerant			Type and GWP		R32/675 kg CO <sub>2</sub> eq		R32/675 kg CO <sub>2</sub> eq		
			Quantity	kg	1.6		1.6		

The equipments described in this catalogue contain HFC R32-type fluorinated greenhouse gases.  
These products must be fitted by qualified staff pursuant to European regulations 303/2008 and 517/2014.

PRELIMINARY data declared in accordance with REGULATION (EU) No. 811/2013 of 18 February 2013 with regard to the energy labelling of space heaters, combination heaters, packages of space heater, temperature control and solar device and packages of combination heater, temperature control and solar devices, packages of combination heater, temperature control and solar devices, and with COMMISSION REGULATION (EU) No. 813/2013 of 2 August 2013 implementing Directive 2009/125/EC of the European Parliament and of the Council with regard to ecodesign requirements for space heaters and combination heaters.



## CAPACITY AND EFFICIENCY DATA IN RELATION TO THE OUTDOOR TEMPERATURE ACCORDING TO THE EN14511-3:2018 STANDARD

LWT [°C]	COOLING - Dry bulb outdoor air temperature in °C - (AG4HP101PH)																	
	10		15		20		25		30		35		40		45		48	
	Qc [kW]	EER	Qc [kW]	EER	Qc [kW]	EER	Qc [kW]	EER	Qc [kW]	EER	Qc [kW]	EER	Qc [kW]	EER	Qc [kW]	EER	Qc [kW]	EER
7	11.25	6.22	10.71	5.61	10.26	5.03	9.72	4.45	9.27	3.91	9.00	3.40	5.65	3.07	5.16	2.37	3.87	1.98
8	11.61	6.44	11.05	5.81	10.59	5.21	10.03	4.61	9.57	4.05	9.29	3.52	5.83	3.18	5.32	2.45	4.00	2.05
9	11.97	6.65	11.40	6.00	10.92	5.38	10.34	4.76	9.86	4.18	9.58	3.64	6.01	3.28	5.49	2.53	4.12	2.11
10	12.33	6.87	11.74	6.19	11.24	5.56	10.65	4.92	10.16	4.32	9.86	3.75	6.19	3.39	5.65	2.61	4.24	2.18
11	12.69	7.08	12.08	6.39	11.57	5.73	10.96	5.07	10.46	4.45	10.15	3.87	6.37	3.50	5.82	2.70	4.37	2.25
12	13.05	7.30	12.42	6.58	11.90	5.90	11.28	5.22	10.75	4.59	10.44	3.99	6.55	3.60	5.98	2.78	4.49	2.32
13	13.41	7.51	12.77	6.77	12.23	6.08	11.59	5.38	11.05	4.72	10.73	4.11	6.73	3.71	6.15	2.86	4.62	2.39
14	13.77	7.73	13.11	6.97	12.56	6.25	11.90	5.53	11.35	4.86	11.02	4.22	6.91	3.81	6.31	2.94	4.74	2.45
15	14.13	7.94	13.45	7.16	12.89	6.42	12.21	5.69	11.64	4.99	11.30	4.34	7.09	3.92	6.48	3.02	4.86	2.52
18	15.14	8.59	14.42	7.74	13.81	6.94	13.08	6.15	12.48	5.40	10.20	5.10	7.60	4.24	6.94	3.27	5.21	2.73
20	15.93	9.01	15.17	8.12	14.53	7.29	13.76	6.45	13.13	5.66	12.74	4.92	8.00	4.45	7.30	3.43	5.48	2.86
23	16.94	9.65	16.13	8.70	15.45	7.81	14.64	6.91	13.96	6.07	13.55	5.28	8.51	4.76	7.77	3.67	5.83	3.07
25	17.60	10.08	16.75	9.09	16.05	8.15	15.20	7.22	14.50	6.34	14.08	5.51	8.83	4.98	8.07	3.84	6.06	3.20

LWT [°C]	HEATING - Dry bulb outdoor air temperature in °C																											
	-25		-20		-15		-10		-7		-2		2		7		10		15		20		25		30		35	
	Qh [kW]	COP	Qh [kW]	COP	Qh [kW]	COP	Qh [kW]	COP	Qh [kW]	COP	Qh [kW]	COP	Qh [kW]	COP	Qh [kW]	COP	Qh [kW]	COP	Qh [kW]	COP	Qh [kW]	COP	Qh [kW]	COP	Qh [kW]	COP	Qh [kW]	COP
25	5.07	2.03	5.31	2.39	6.73	2.75	6.96	3.23	7.67	3.59	8.03	4.38	8.69	4.86	10.10	6.16	10.40	6.32	11.63	6.87	9.25	7.95	10.14	8.42	9.69	8.92	10.47	9.26
30	5.19	1.87	5.43	2.20	6.84	2.52	7.08	2.96	7.79	3.29	8.14	4.02	8.80	4.46	10.20	5.66	10.51	5.80	11.73	6.31	9.32	7.30	10.21	7.73	9.75	8.18	10.53	8.50
35	5.19	1.67	5.43	1.96	6.84	2.25	7.08	2.65	7.79	2.94	8.14	3.59	8.80	3.98	10.20	5.05	10.51	5.18	11.73	5.63	9.32	6.52	10.21	6.90	9.75	7.31	10.53	7.59
40	5.19	1.47	5.43	1.72	6.84	1.98	7.08	2.33	7.79	2.59	8.14	3.16	8.80	3.50	10.20	4.44	10.51	4.56	11.73	4.96	9.32	5.74	10.21	6.07	9.75	6.43	10.53	6.68
45	5.19	1.33	5.43	1.57	6.84	1.80	7.08	2.12	7.79	2.35	8.14	2.87	8.80	3.19	10.20	4.08	10.51	4.14	11.73	4.50	9.32	5.21	10.21	5.52	9.75	5.85	10.53	6.07
50			5.31	1.41	6.73	1.62	6.96	1.91	7.67	2.12	8.03	2.58	8.69	2.87	10.10	3.64	10.40	3.73	11.63	4.05	9.25	4.69	10.14	4.97	9.69	5.26	10.42	5.46
55					6.73	1.42	6.96	1.67	7.67	1.85	8.03	2.26	8.69	2.51	10.30	3.12	10.40	3.26	11.63	3.55	9.25	4.11	10.14	4.35	9.69	4.60	10.42	4.78
60									7.55	1.65	7.92	2.01	8.58	2.23	10.00	2.83	10.30	2.90	11.50	3.15	9.14	3.65	10.01	3.87	9.56	4.09	10.32	4.25
65															9.89	2.53	10.19	2.59	11.38	2.82	9.04	3.26						

LWT [°C]	HEATING - Dry bulb outdoor air temperature in °C - (AG4HP103PH)																											
	-25		-20		-15		-10		-7		-2		2		7		10		15		20		25		30		35	
	Qh [kW]	COP	Qh [kW]	COP	Qh [kW]	COP	Qh [kW]	COP	Qh [kW]	COP	Qh [kW]	COP	Qh [kW]	COP	Qh [kW]	COP	Qh [kW]	COP	Qh [kW]	COP	Qh [kW]	COP	Qh [kW]	COP	Qh [kW]	COP	Qh [kW]	COP
25	5.07	2.05	5.31	2.42	6.73	2.78	6.96	3.26	7.67	3.62	8.03	4.17	8.69	4.63	10.10	6.04	10.40	6.19	11.63	6.73	9.25	7.45	10.14	7.89	9.69	8.34	10.47	8.66
30	5.19	1.88	5.43	2.22	6.84	2.55	7.08	2.99	7.79	3.33	8.14	3.83	8.80	4.25	10.20	5.54	10.51	5.68	11.73	6.18	9.32	6.84	10.21	7.24	9.75	7.66	10.53	7.95
35	5.19	1.68	5.43	1.98	6.84	2.28	7.08	2.67	7.79	2.97	8.14	3.42	8.80	3.79	10.20	4.95	10.51	5.07	11.73	5.52	9.32	6.10	10.21	6.46	9.75	6.84	10.53	7.10
40	5.19	1.48	5.43	1.74	6.84	2.00	7.08	2.35	7.79	2.61	8.14	3.01	8.80	3.34	10.20	4.36	10.51	4.46	11.73	4.86	9.32	5.37	10.21	5.69	9.75	6.02	10.53	6.25
45	5.19	1.35	5.43	1.58	6.84	1.82	7.08	2.14	7.79	2.38	8.14	2.73	8.80	3.03	10.20	3.92	10.51	4.06	11.73	4.42	9.32	4.88	10.21	5.17	9.75	5.47	10.53	5.68
50			5.31	1.43	6.73	1.64	6.96	1.92	7.67	2.14	8.03	2.46	8.69	2.73	10.10	3.56	10.40	3.65	11.63	3.97	9.25	4.39	10.14	4.65	9.69	4.92	10.42	5.11
55					6.73	1.43	6.96	1.68	7.67	1.87	8.03	2.15	8.69	2.39	10.30	3.05	10.40	3.20	11.63	3.48	9.25	3.84	10.14	4.07	9.69	4.31	10.42	4.47
60									7.55	1.66	7.92	1.91	8.58	2.12	10.00	2.77	10.30	2.84	11.50	3.09	9.14	3.42	10.01	3.62	9.56	3.83	10.32	3.98
65															9.89	2.48	10.19	2.54	11.38	2.76	9.04	3.05						

LWT [°C]	COOLING - Dry bulb outdoor air temperature in °C																	
	10		15		20		25		30		35		40		45		48	
	Qc [kW]	EER	Qc [kW]	EER	Qc [kW]	EER	Qc [kW]	EER	Qc [kW]	EER	Qc [kW]	EER	Qc [kW]	EER	Qc [kW]	EER	Qc [kW]	EER
7	11.25	5.89	10.71	5.31	10.26	4.77	9.72	4.22	9.27	3.70	9.10	3.25	5.65	2.81	5.16	2.16	3.87	1.93
8	11.61	6.10	11.05	5.50	10.59	4.93	10.03	4.37	9.57	3.83	9.29	3.33	5.83	2.90	5.32	2.24	4.00	2.00
9	11.97	6.30	11.40	5.68	10.92	5.10	10.34	4.51	9.86	3.96	9.58	3.44	6.01	3.00	5.49	2.31	4.12	2.06
10	12.33	6.51	11.74	5.87	11.24	5.26	10.65	4.66	10.16	4.09	9.86	3.55	6.19	3.10	5.65	2.39	4.24	2.13
11	12.69	6.71	12.08	6.05	11.57	5.43	10.96	4.80	10.46	4.22	10.15	3.67	6.37	3.19	5.82	2.46	4.37	2.20
12	13.05	6.91	12.42	6.23	11.90	5.59	11.28	4.95	10.75	4.34	10.44	3.78	6.55	3.29	5.98	2.54	4.49	2.26
13	13.41	7.12	12.77	6.42	12.23	5.75	11.59	5.09	11.05	4.47	10.73	3.89	6.73	3.39	6.15	2.61	4.62	2.33
14	13.77	7.32	13.11	6.60	12.56	5.92	11.90	5.24	11.35	4.60	11.02	4.00	6.91	3.48	6.31	2.69	4.74	2.40
15	14.13	7.52	13.45	6.78	12.89	6.08	12.21	5.38	11.64	4.73	11.30	4.11	7.09	3.58	6.48	2.76	4.86	2.46
18	15.14	8.13	14.42	7.33	13.81	6.58	13.08	5.82	12.48	5.11	10.20	4.79	7.60	3.87	6.94	2.99	5.21	2.66
20	15.93	8.53	15.17	7.69	14.53	6.90	13.76	6.11	13.13	5.36	12.74	4.66	8.00	4.06	7.30	3.13	5.48	2.79
23	16.94	9.14	16.13	8.24	15.45	7.39	14.64	6.54	13.96	5.75	13.55	5.00	8.51	4.35	7.77	3.36	5.83	2.99
25	17.60	9.55	16.75	8.61	16.05	7.72	15.20	6.84	14.50	6.00	14.08	5.22	8.83	4.55	8.07	3.51	6.06	3.13

LWT: Leaving water temperature  
Qh: Heating capacity  
COP: Coefficient of performance

LWT: Leaving water temperature  
Qc: Cooling capacity  
EER: Energy efficiency ratio

# TECHNICAL DATA FOR 8-10-12-14-16 kW

Model				AG4HP121PH		AG4HP123PH		
Matchable units for domestic hot water production (DHW)				200/300 liters external tank with diverting valve		200/300 liters external tank with diverting valve		
				Cooling	Heating	Cooling	Heating	
COMFORT IN ENVIRONMENT	Performance according to EN 14511	Air +35 °C - Water 23/18 °C Air +7 °C - Water 30/35 °C	Rated capacity	kW	12.00	12.00	12.00	12.00
			Rated electrical power input	kW <sub>el</sub>	2.45	2.43	2.61	2.49
			EER/COP		4.90	4.94	4.60	4.82
	Performance according to EN 14825	LOW TEMPERATURE (35 °C) AVERAGE climate	Rated capacity	kW	11.10	13.00	11.10	13.00
			Rated electrical power input	kW <sub>el</sub>	3.58	3.45	3.58	3.45
			EER/COP		3.10	3.77	3.10	3.77
Performance according to Ecodesign (ERP) EN 14825	MEDIUM TEMPERATURE (55 °C) AVERAGE climate	Design thermal load (P <sub>design,h</sub> )	kW	12		12		
		Seasonal energy efficiency η <sub>s</sub>	%	188		180		
		Energy efficiency class		A+++		A+++		
DHW performance according to EN 16147	With 300 liters tank and diverting valve AVERAGE climate	Load profile		XL		XL		
		Energy efficiency class		A		A		
		ERP efficiency	%	110		110		
Unit operation data	Maximum delivery water temperature		°C	Up to 65		Up to 65		
	Outdoor temperature range (heating)		°C	-25/+35		-25/+35		
	Outdoor temperature range (cooling)		°C	-15/+48		-15/+48		
	Nominal water flow rate	m <sup>3</sup> /h	at 35 °C		2.06	at 35 °C	2.06	
			at 45 °C		2.06	at 45 °C	2.06	
			at 55 °C		1.98	at 55 °C	1.98	
			at 7 °C		1.49	at 7 °C	1.49	
			at 18 °C		2.06	at 18 °C	2.06	
	Minimum efficient water volume of the system		liters	80		80		
	Power supply (Voltage/Phases/Frequency)		V/Ph/Hz	230/1/50		400/3/50		
Maximum electricity consumption		A	29		11.5			
Sound pressure level (cooling mode)		dB(A)	61		61			
Sound pressure level (heating mode)		dB(A)	63		63			
Components and dimensions	Expansion vessel		liters	3		3		
	Maximum circulator pump head		kPa	(see H/Q graphs)		(see H/Q graphs)		
	Hydraulic connections		inches	G1"		G1"		
	Safety valve		bar	3		3		
	Weight		kg	138		144		
	Dimensions (H/W/D)		mm	878/1206/445		878/1206/445		
	Compressor type			Twin Rotary with vapour injection		Twin Rotary with vapour injection		
Refrigerant	Type and GWP			R32/675 kg CO <sub>2</sub> eq		R32/675 kg CO <sub>2</sub> eq		
	Quantity		kg	2.2 kg		2.2 kg		

The equipments described in this catalogue contain HFC R32-type fluorinated greenhouse gases.  
These products must be fitted by qualified staff pursuant to European regulations 303/2008 and 517/2014.

Data declared in accordance with REGULATION (EU) No. 811/2013 of 18 February 2013 with regard to the energy labelling of space heaters, combination heaters, packages of space heater, temperature control and solar device and packages of combination heater, temperature control and solar devices, packages of combination heater, temperature control and solar devices, and with COMMISSION REGULATION (EU) No. 813/2013 of 2 August 2013 implementing Directive 2009/125/EC of the European Parliament and of the Council with regard to ecodesign requirements for space heaters and combination heaters.

## CAPACITY AND EFFICIENCY DATA IN RELATION TO THE OUTDOOR TEMPERATURE ACCORDING TO THE EN14511-3:2018 STANDARD

		COOLING - Dry bulb outdoor air temperature in °C - (AG4HP121PH)																	
		10		15		20		25		30		35		40		45		48	
LWT [°C]		Qc [kW]	EER	Qc [kW]	EER	Qc [kW]	EER	Qc [kW]	EER	Qc [kW]	EER	Qc [kW]	EER	Qc [kW]	EER	Qc [kW]	EER	Qc [kW]	EER
7		11.88	5.67	11.31	5.12	10.83	4.59	10.26	4.06	9.79	3.57	11.10	3.10	8.19	2.95	6.72	2.37	6.16	1.92
8		12.26	5.87	11.67	5.29	11.18	4.75	10.59	4.20	10.10	3.69	11.46	3.21	8.45	3.05	6.94	2.45	6.36	1.99
9		12.64	6.07	12.03	5.47	11.52	4.91	10.92	4.34	10.41	3.81	11.81	3.32	8.71	3.15	7.15	2.53	6.55	2.06
10		13.02	6.26	12.39	5.65	11.87	5.07	11.24	4.48	10.72	3.94	12.17	3.42	8.97	3.25	7.37	2.61	6.75	2.12
11		13.40	6.46	12.75	5.82	12.22	5.22	11.57	4.62	11.04	4.06	12.52	3.53	9.24	3.35	7.58	2.70	6.95	2.19
12		13.78	6.65	13.11	6.00	12.56	5.38	11.90	4.76	11.35	4.18	12.88	3.64	9.50	3.46	7.80	2.78	7.15	2.26
13		14.16	6.85	13.48	6.18	12.91	5.54	12.23	4.90	11.66	4.30	13.23	3.74	9.76	3.56	8.01	2.86	7.34	2.32
14		14.54	7.05	13.84	6.35	13.26	5.70	12.56	5.04	11.98	4.43	13.59	3.85	10.02	3.66	8.23	2.94	7.54	2.39
15		14.92	7.24	14.20	6.53	13.60	5.86	12.89	5.18	12.29	4.55	13.94	3.96	10.28	3.76	8.44	3.02	7.74	2.46
18		15.98	7.83	15.22	7.06	14.58	6.33	13.81	5.60	13.17	4.92	12.00	4.90	11.02	4.07	9.05	3.27	8.29	2.66
20		16.82	8.21	16.01	7.41	15.34	6.64	14.53	5.88	13.86	5.16	15.72	4.49	11.59	4.27	9.52	3.43	8.72	2.79
23		17.88	8.80	17.03	7.94	16.31	7.12	15.45	6.30	14.74	5.53	16.72	4.81	12.33	4.57	10.12	3.67	9.28	2.99
25		18.57	9.19	17.68	8.29	16.94	7.43	16.05	6.58	15.30	5.78	17.36	5.02	12.81	4.77	10.51	3.84	9.63	3.12

		HEATING - Dry bulb outdoor air temperature in °C																											
		-25		-20		-15		-10		-7		-2		2		7		10		15		20		25		30		35	
LWT [°C]		Qh [kW]	COP	Qh [kW]	COP	Qh [kW]	COP	Qh [kW]	COP	Qh [kW]	COP	Qh [kW]	COP	Qh [kW]	COP	Qh [kW]	COP	Qh [kW]	COP	Qh [kW]	COP	Qh [kW]	COP	Qh [kW]	COP	Qh [kW]	COP	Qh [kW]	COP
25		5.80	2.03	6.21	2.39	7.45	2.74	8.14	3.22	8.97	3.58	10.07	4.09	10.90	4.53	11.88	6.03	12.24	6.18	13.68	6.72	11.25	7.60	12.33	8.05	11.92	8.57	12.88	8.89
30		5.93	1.86	6.35	2.19	7.59	2.52	8.28	2.96	9.11	3.29	10.21	3.75	11.04	4.16	12.00	5.53	12.36	5.67	13.80	6.17	11.34	6.98	12.42	7.39	12.00	7.86	12.96	8.16
35		5.93	1.66	6.35	1.96	7.59	2.25	8.28	2.64	9.11	2.93	10.21	3.35	11.04	3.72	12.00	4.94	12.36	5.06	13.80	5.51	11.34	6.23	12.42	6.60	12.00	7.02	12.96	7.29
40		5.93	1.46	6.35	1.72	7.59	1.98	8.28	2.32	9.11	2.58	10.21	2.95	11.04	3.27	12.00	4.35	12.36	4.46	13.80	4.85	11.34	5.49	12.42	5.81	12.00	6.18	12.96	6.42
45		5.93	1.33	6.35	1.56	7.59	1.80	8.28	2.11	9.11	2.35	10.21	2.68	11.04	2.97	13.00	3.77	12.36	4.05	13.80	4.41	11.34	4.99	12.42	5.28	12.00	5.62	12.96	5.83
50				6.21	1.41	7.45	1.62	8.14	1.90	8.97	2.11	10.07	2.41	10.90	2.68	11.88	3.56	12.24	3.65	13.68	3.97	11.25	4.49	12.33	4.75	11.92	5.06	12.83	5.25
55						7.45	1.42	8.14	1.66	8.97	1.85	10.07	2.11	10.90	2.34	12.00	3.05	12.24	3.19	13.68	3.47	11.25	3.93	12.33	4.16	11.92	4.42	12.83	4.59
60								8.83	1.64	9.94	1.88	10.76	2.08	11.76	2.77	12.11	2.84	13.52	3.08	11.11	3.49	12.17	3.70	11.76	3.93	12.70	4.08		
65														11.64	2.47	11.99	2.53	13.39	2.75	11.00	3.12								

		HEATING - Dry bulb outdoor air temperature in °C - (AG4HP123PH)																											
		-25		-20		-15		-10		-7		-2		2		7		10		15		20		25		30		35	
LWT [°C]		Qh [kW]	COP	Qh [kW]	COP	Qh [kW]	COP	Qh [kW]	COP	Qh [kW]	COP	Qh [kW]	COP	Qh [kW]	COP	Qh [kW]	COP	Qh [kW]	COP	Qh [kW]	COP	Qh [kW]	COP	Qh [kW]	COP	Qh [kW]	COP	Qh [kW]	COP
25		5.80	1.95	6.21	2.29	7.45	2.63	8.14	3.09	8.97	3.43	10.07	3.92	10.90	4.35	11.88	5.88	12.24	6.03	13.68	6.56	11.25	7.30	12.33	7.73	11.92	8.22	12.88	8.53
30		5.93	1.79	6.35	2.10	7.59	2.42	8.28	2.84	9.11	3.15	10.21	3.60	11.04	3.99	12.00	5.40	12.36	5.53	13.80	6.02	11.34	6.70	12.42	7.10	12.00	7.54	12.96	7.83
35		5.93	1.59	6.35	1.88	7.59	2.16	8.28	2.53	9.11	2.81	10.21	3.21	11.04	3.56	12.00	4.82	12.36	4.94	13.80	5.37	11.34	5.98	12.42	6.34	12.00	6.73	12.96	6.99
40		5.93	1.40	6.35	1.65	7.59	1.90	8.28	2.23	9.11	2.48	10.21	2.83	11.04	3.14	12.00	4.24	12.36	4.35	13.80	4.73	11.34	5.27	12.42	5.58	12.00	5.93	12.96	6.15
45		5.93	1.28	6.35	1.50	7.59	1.73	8.28	2.03	9.11	2.25	10.21	2.57	11.04	2.85	13.00	3.77	12.36	3.95	13.80	4.30	11.34	4.79	12.42	5.07	12.00	5.39	12.96	5.59
50				6.21	1.35	7.45	1.55	8.14	1.82	8.97	2.03	10.07	2.31	10.90	2.57	11.88	3.47	12.24	3.56	13.68	3.87	11.25	4.31	12.33	4.56	11.92	4.85	12.83	5.03
55						7.45	1.36	8.14	1.60	8.97	1.77	10.07	2.02	10.90	2.25	12.00	2.91	12.24	3.11	13.68	3.39	11.25	3.77	12.33	3.99	11.92	4.24	12.83	4.40
60								8.83	1.58	9.94	1.80	10.76	2.00	11.76	2.70	12.11	2.77	13.52	3.01	11.11	3.35	12.17	3.55	11.76	3.77	12.70	3.92		
65														11.64	2.41	11.99	2.47	13.39	2.69	11.00	2.99								

		COOLING - Dry bulb outdoor air temperature in °C																	
		10		15		20		25		30		35		40		45		48	
LWT [°C]		Qc [kW]	EER	Qc [kW]	EER	Qc [kW]	EER	Qc [kW]	EER	Qc [kW]	EER	Qc [kW]	EER	Qc [kW]	EER	Qc [kW]	EER	Qc [kW]	EER
7		11.88	5.67	11.31	5.12	10.83	4.59	10.26	4.06	9.79	3.57	11.10	3.10	8.19	2.80	6.72	2.25	6.16	1.83
8		12.26	5.87	11.67	5.29	11.18	4.75	10.59	4.20	10.10	3.69	11.46	3.21	8.45	2.89	6.94	2.33	6.36	1.89
9		12.64	6.07	12.03	5.47	11.52	4.91	10.92	4.34	10.41	3.81	11.81	3.32	8.71	2.99	7.15	2.41	6.55	1.96
10		13.02	6.26	12.39	5.65	11.87	5.07	11.24	4.48	10.72	3.94	12.17	3.42	8.97	3.09	7.37	2.49	6.75	2.02
11		13.40	6.46	12.75	5.82	12.22	5.22	11.57	4.62	11.04	4.06	12.52	3.53	9.24	3.18	7.58	2.56	6.95	2.08
12		13.78	6.65	13.11	6.00	12.56	5.38	11.90	4.76	11.35	4.18	12.88	3.64	9.50	3.28	7.80	2.64	7.15	2.15
13		14.16	6.85	13.48	6.18	12.91	5.54	12.23	4.90	11.66	4.30	13.23	3.74	9.76	3.38	8.01	2.72	7.34	2.21
14		14.54	7.05	13.84	6.35	13.26	5.70	12.56	5.04	11.98	4.43	13.59	3.85	10.02	3.47	8.23	2.80	7.54	2.27
15		14.92	7.24	14.20	6.53	13.60	5.86	12.89	5.18	12.29	4.55	13.94	3.96	10.28	3.57	8.44	2.88	7.74	2.34
18		15.98	7.83	15.22	7.06	14.58	6.33	13.81	5.60	13.17	4.92	12.00	4.60	11.02	3.86	9.05	3.11	8.29	2.53
20		16.82	8.21	16.01	7.41	15.34	6.64	14.53	5.88	13.86	5.16	15.72	4.49	11.59	4.05	9.52	3.26	8.72	2.65
23		17.88	8.80	17.03	7.94	16.31	7.12	15.45	6.30	14.74	5.53	16.72	4.81	12.33	4.34	10.12	3.50	9.28	2.84
25		18.57	9.19	17.68	8.29	16.94	7.43	16.05	6.58	15.30	5.78	17.36	5.02	12.81	4.53	10.51	3.65	9.63	2.97

LWT: Leaving water temperature  
Qh: Heating capacity  
COP: Coefficient of performance

LWT: Leaving water temperature  
Qc: Cooling capacity  
EER: Energy efficiency ratio

# TECHNICAL DATA FOR 8-10-12-14-16 kW

Model				AG4HP141PH		AG4HP143PH		
<b>Matchable units for domestic hot water production (DHW)</b>				<b>200/300 liters external tank with diverting valve</b>		<b>200/300 liters external tank with diverting valve</b>		
				Cooling	Heating	Cooling	Heating	
<b>COMFORT IN ENVIRONMENT</b>	<b>Performance according to EN 14511</b>	Air +35 °C - Water 23/18 °C Air +7 °C - Water 30/35 °C	Rated capacity	kW	13.7	14.20	13.90	14.20
			Rated electrical power input	kW <sub>el</sub>	3.00	2.99	3.32	3.09
			EER/COP		4.57	4.75	4.19	4.60
	<b>Performance according to EN 14825</b>	LOW TEMPERATURE (35 °C) AVERAGE climate	Rated capacity	kW	13.30	14.20	13.30	14.20
			Rated electrical power input	kW <sub>el</sub>	4.75	3.84	4.75	3.84
			EER/COP		2.80	3.70	2.80	3.70
<b>COMFORT IN ENVIRONMENT</b>	<b>Performance according to Ecodesign (ERP) EN 14825</b>	MEDIUM TEMPERATURE (55 °C) AVERAGE climate	Design thermal load (P <sub>design,h</sub> )	kW	13		13	
			Seasonal energy efficiency η <sub>s</sub>	%	185		179	
			Energy efficiency class		A+++		A+++	
	<b>Performance according to EN 14825</b>	MEDIUM TEMPERATURE (55 °C) AVERAGE climate	Design thermal load (P <sub>design,h</sub> )	kW	13		13	
			Seasonal energy efficiency η <sub>s</sub>	%	145		138	
			Energy efficiency class		A++		A++	
<b>DHW performance according to EN 16147</b>	With 300 liters tank and diverting valve AVERAGE climate	Load profile		XL		XL		
		Energy efficiency class		A		A		
		ERP efficiency	%	110		110		
<b>Unit operation data</b>	Maximum delivery water temperature		°C	Up to 65		Up to 65		
	Outdoor temperature range (heating)		°C	-25/+35		-25/+35		
	Outdoor temperature range (cooling)		°C	-15/+48		-15/+48		
	Nominal water flow rate	m <sup>3</sup> /h	at 35 °C		2.44	at 35 °C	2.44	
			at 45 °C		2.42	at 45 °C	2.42	
			at 55 °C		2.32	at 55 °C	2.32	
			at 7 °C		1.64	at 7 °C	1.64	
			at 18 °C		2.36	at 18 °C	2.36	
	Minimum efficient water volume of the system		liters	80		80		
	Power supply (Voltage/Phases/Frequency)		V/Ph/Hz	230/1/50		400/3/50		
	Maximum electricity consumption		A	30		12		
Sound pressure level (cooling mode)		dB(A)	61		61			
Sound pressure level (heating mode)		dB(A)	63		63			
<b>Components and dimensions</b>	Expansion vessel		liters	3		3		
	Maximum circulator pump head		kPa	(see H/Q graphs)		(see H/Q graphs)		
	Hydraulic connections		inches	G1"		G1"		
	Safety valve		bar	3		3		
	Weight		kg	138		144		
	Dimensions (H/W/D)		mm	878/1206/445		878/1206/445		
	Compressor type			Twin Rotary with vapour injection		Twin Rotary with vapour injection		
<b>Refrigerant</b>	Type and GWP			R32/675 kg CO <sub>2</sub> eq		R32/675 kg CO <sub>2</sub> eq		
	Quantity		kg	2.2		2.2		

The equipments described in this catalogue contain HFC R32-type fluorinated greenhouse gases.  
These products must be fitted by qualified staff pursuant to European regulations 303/2008 and 517/2014.

Data declared in accordance with REGULATION (EU) No. 811/2013 of 18 February 2013 with regard to the energy labelling of space heaters, combination heaters, packages of space heater, temperature control and solar device and packages of combination heater, temperature control and solar devices, packages of combination heater, temperature control and solar devices, and with COMMISSION REGULATION (EU) No. 813/2013 of 2 August 2013 implementing Directive 2009/125/EC of the European Parliament and of the Council with regard to ecodesign requirements for space heaters and combination heaters.

## CAPACITY AND EFFICIENCY DATA IN RELATION TO THE OUTDOOR TEMPERATURE ACCORDING TO THE EN14511-3:2018 STANDARD

		COOLING - Dry bulb outdoor air temperature in °C - (AG4HP141PH)																	
		10		15		20		25		30		35		40		45		48	
LWT [°C]		Qc [kW]	EER	Qc [kW]	EER	Qc [kW]	EER	Qc [kW]	EER	Qc [kW]	EER	Qc [kW]	EER	Qc [kW]	EER	Qc [kW]	EER	Qc [kW]	EER
7		12.69	5.12	12.08	4.62	11.57	4.14	10.96	3.67	10.45	3.22	13.30	2.80	8.42	2.95	6.80	2.37	6.24	1.92
8		13.09	5.30	12.47	4.78	11.94	4.29	11.31	3.80	10.79	3.33	13.73	2.90	8.69	3.05	7.02	2.45	6.44	1.99
9		13.50	5.48	12.85	4.94	12.31	4.43	11.66	3.92	11.12	3.44	14.15	2.99	8.96	3.15	7.24	2.53	6.64	2.06
10		13.91	5.66	13.24	5.10	12.68	4.57	12.01	4.05	11.46	3.55	14.58	3.09	9.23	3.25	7.46	2.61	6.84	2.12
11		14.31	5.83	13.62	5.26	13.05	4.72	12.37	4.18	11.79	3.67	15.00	3.19	9.50	3.35	7.67	2.70	7.04	2.19
12		14.72	6.01	14.01	5.42	13.42	4.86	12.72	4.30	12.13	3.78	15.43	3.28	9.77	3.46	7.89	2.78	7.23	2.26
13		15.12	6.19	14.40	5.58	13.79	5.00	13.07	4.43	12.46	3.89	15.85	3.38	10.04	3.56	8.11	2.86	7.43	2.32
14		15.53	6.36	14.78	5.74	14.16	5.15	13.42	4.56	12.80	4.00	16.28	3.48	10.31	3.66	8.33	2.94	7.63	2.39
15		15.94	6.54	15.17	5.90	14.53	5.29	13.77	4.68	13.13	4.11	16.70	3.57	10.58	3.76	8.55	3.02	7.83	2.46
18		17.08	7.07	16.26	6.38	15.57	5.72	14.75	5.06	14.07	4.44	13.70	4.57	11.34	4.07	9.16	3.27	8.40	2.66
20		17.97	7.42	17.10	6.69	16.38	6.00	15.52	5.31	14.80	4.66	18.83	4.05	11.93	4.27	9.63	3.43	8.83	2.79
23		19.11	7.95	18.19	7.17	17.43	6.43	16.51	5.69	15.74	5.00	20.03	4.34	12.68	4.57	10.25	3.67	9.39	2.99
25		19.84	8.30	18.89	7.49	18.10	6.72	17.14	5.94	16.35	5.22	20.80	4.54	13.17	4.77	10.64	3.84	9.75	3.12

		HEATING - Dry bulb outdoor air temperature in °C																											
		-25		-20		-15		-10		-7		-2		2		7		10		15		20		25		30		35	
LWT [°C]		Qh [kW]	COP	Qh [kW]	COP	Qh [kW]	COP	Qh [kW]	COP	Qh [kW]	COP	Qh [kW]	COP	Qh [kW]	COP	Qh [kW]	COP	Qh [kW]	COP	Qh [kW]	COP	Qh [kW]	COP	Qh [kW]	COP	Qh [kW]	COP	Qh [kW]	COP
25		6.22	2.01	6.66	2.37	7.99	2.72	8.73	3.20	9.62	3.55	10.80	4.05	11.69	4.50	14.06	5.80	14.48	5.94	16.19	6.46	11.50	7.60	12.60	8.05	12.22	8.53	13.20	8.86
30		6.36	1.85	6.81	2.17	8.14	2.50	8.88	2.93	9.77	3.26	10.95	3.72	11.84	4.13	14.20	5.32	14.63	5.45	16.33	5.93	11.59	6.98	12.70	7.39	12.30	7.83	13.28	8.13
35		6.36	1.65	6.81	1.94	8.14	2.23	8.88	2.62	9.77	2.91	10.95	3.32	11.84	3.69	14.20	4.75	14.63	4.87	16.33	5.30	11.59	6.23	12.70	6.60	12.30	6.99	13.28	7.26
40		6.36	1.45	6.81	1.71	8.14	1.96	8.88	2.30	9.77	2.56	10.95	2.92	11.84	3.24	14.20	4.18	14.63	4.28	16.33	4.66	11.59	5.49	12.70	5.81	12.30	6.16	13.28	6.39
45		6.36	1.32	6.81	1.55	8.14	1.78	8.88	2.10	9.77	2.33	10.95	2.66	11.84	2.95	14.20	3.70	14.63	3.90	16.33	4.24	11.59	4.99	12.70	5.28	12.30	5.60	13.28	5.81
50				6.66	1.40	7.99	1.61	8.73	1.89	9.62	2.10	10.80	2.39	11.69	2.65	14.06	3.42	14.48	3.51	16.19	3.81	11.50	4.49	12.60	4.75	12.22	5.04	13.15	5.23
55						7.99	1.41	8.73	1.65	9.62	1.83	10.80	2.09	11.69	2.32	13.80	2.95	14.48	3.07	16.19	3.34	11.50	3.93	12.60	4.16	12.22	4.41	13.15	4.58
60								9.47	1.63	10.66	1.86	11.54	2.06	13.92	2.66	14.33	2.73	16.00	2.97	11.36	3.49	12.44	3.70	12.05	3.92	13.02	4.07		
65														13.77	2.38	14.19	2.43	15.84	2.65	11.24	3.12								

		HEATING - Dry bulb outdoor air temperature in °C - (AG4HP143PH)																											
		-25		-20		-15		-10		-7		-2		2		7		10		15		20		25		30		35	
LWT [°C]		Qh [kW]	COP	Qh [kW]	COP	Qh [kW]	COP	Qh [kW]	COP	Qh [kW]	COP	Qh [kW]	COP	Qh [kW]	COP	Qh [kW]	COP	Qh [kW]	COP	Qh [kW]	COP	Qh [kW]	COP	Qh [kW]	COP	Qh [kW]	COP	Qh [kW]	COP
25		6.22	1.93	6.66	2.27	7.99	2.61	8.73	3.06	9.62	3.40	10.80	3.89	11.69	4.31	14.06	5.61	14.48	5.75	16.19	6.26	11.50	7.30	12.60	7.73	12.22	8.18	13.20	8.50
30		6.36	1.77	6.81	2.08	8.14	2.40	8.88	2.81	9.77	3.12	10.95	3.57	11.84	3.96	14.20	5.15	14.63	5.28	16.33	5.74	11.59	6.70	12.70	7.10	12.30	7.51	13.28	7.80
35		6.36	1.58	6.81	1.86	8.14	2.14	8.88	2.51	9.77	2.79	10.95	3.19	11.84	3.53	14.20	4.60	14.63	4.72	16.33	5.13	11.59	5.98	12.70	6.34	12.30	6.71	13.28	6.96
40		6.36	1.39	6.81	1.64	8.14	1.88	8.88	2.21	9.77	2.46	10.95	2.80	11.84	3.11	14.20	4.05	14.63	4.15	16.33	4.51	11.59	5.27	12.70	5.58	12.30	5.90	13.28	6.13
45		6.36	1.26	6.81	1.49	8.14	1.71	8.88	2.01	9.77	2.23	10.95	2.55	11.84	2.83	14.20	3.70	14.63	3.77	16.33	4.10	11.59	4.79	12.70	5.07	12.30	5.37	13.28	5.57
50				6.66	1.34	7.99	1.54	8.73	1.81	9.62	2.01	10.80	2.29	11.69	2.54	14.06	3.31	14.48	3.39	16.19	3.69	11.50	4.31	12.60	4.56	12.22	4.83	13.15	5.01
55						7.99	1.35	8.73	1.58	9.62	1.76	10.80	2.01	11.69	2.23	13.80	2.85	14.48	2.97	16.19	3.23	11.50	3.77	12.60	3.99	12.22	4.23	13.15	4.39
60								9.47	1.56	10.66	1.78	11.54	1.98	13.92	2.58	14.33	2.64	16.00	2.87	11.36	3.35	12.44	3.55	12.05	3.76	13.02	3.90		
65														13.77	2.30	14.19	2.36	15.84	2.56	11.24	2.99								

		COOLING - Dry bulb outdoor air temperature in °C																	
		10		15		20		25		30		35		40		45		48	
LWT [°C]		Qc [kW]	EER	Qc [kW]	EER	Qc [kW]	EER	Qc [kW]	EER	Qc [kW]	EER	Qc [kW]	EER	Qc [kW]	EER	Qc [kW]	EER	Qc [kW]	EER
7		12.69	5.12	12.08	4.62	11.57	4.14	10.96	3.67	10.45	3.22	13.30	2.80	8.42	2.80	6.80	2.25	6.24	1.83
8		13.09	5.30	12.47	4.78	11.94	4.29	11.31	3.80	10.79	3.33	13.73	2.90	8.69	2.89	7.02	2.33	6.44	1.89
9		13.50	5.48	12.85	4.94	12.31	4.43	11.66	3.92	11.12	3.44	14.15	2.99	8.96	2.99	7.24	2.41	6.64	1.96
10		13.91	5.66	13.24	5.10	12.68	4.57	12.01	4.05	11.46	3.55	14.58	3.09	9.23	3.09	7.46	2.49	6.84	2.02
11		14.31	5.83	13.62	5.26	13.05	4.72	12.37	4.18	11.79	3.67	15.00	3.19	9.50	3.18	7.67	2.56	7.04	2.08
12		14.72	6.01	14.01	5.42	13.42	4.86	12.72	4.30	12.13	3.78	15.43	3.28	9.77	3.28	7.89	2.64	7.23	2.15
13		15.12	6.19	14.40	5.58	13.79	5.00	13.07	4.43	12.46	3.89	15.85	3.38	10.04	3.38	8.11	2.72	7.43	2.21
14		15.53	6.36	14.78	5.74	14.16	5.15	13.42	4.56	12.80	4.00	16.28	3.48	10.31	3.47	8.33	2.80	7.63	2.27
15		15.94	6.54	15.17	5.90	14.53	5.29	13.77	4.68	13.13	4.11	16.70	3.57	10.58	3.57	8.55	2.88	7.83	2.34
18		17.08	7.07	16.26	6.38	15.57	5.72	14.75	5.06	14.07	4.44	13.90	4.19	11.34	3.86	9.16	3.11	8.40	2.53
20		17.97	7.42	17.10	6.69	16.38	6.00	15.52	5.31	14.80	4.66	18.83	4.05	11.93	4.05	9.63	3.26	8.83	2.65
23		19.11	7.95	18.19	7.17	17.43	6.43	16.51	5.69	15.74	5.00	20.03	4.34	12.68	4.34	10.25	3.50	9.39	2.84
25		19.84	8.30	18.89	7.49	18.10	6.72	17.14	5.94	16.35	5.22	20.80	4.54	13.17	4.53	10.64	3.65	9.75	2.97

LWT: Leaving water temperature  
Qh: Heating capacity  
COP: Coefficient of performance

LWT: Leaving water temperature  
Qc: Cooling capacity  
EER: Energy efficiency ratio

# TECHNICAL DATA FOR 8-10-12-14-16 kW

Model				AG4HP161PH		AG4HP163PH		
<b>Matchable units for domestic hot water production (DHW)</b>				<b>200/300 liters external tank with diverting valve</b>		<b>200/300 liters external tank with diverting valve</b>		
				Cooling	Heating	Cooling	Heating	
<b>COMFORT IN ENVIRONMENT</b>	<b>Performance according to EN 14511</b>	Air +35 °C - Water 23/18 °C Air +7 °C - Water 30/35 °C	Rated capacity	kW	15.50	15.70	15.40	15.70
			Rated electrical power input	kW <sub>el</sub>	3.60	3.45	4.05	3.57
			EER/COP		4.31	4.55	3.80	4.40
	<b>Performance according to EN 14825</b>	LOW TEMPERATURE (35 °C) AVERAGE climate	Rated capacity	kW	13.80	16.20	13.80	16.20
			Rated electrical power input	kW <sub>el</sub>	5.09	4.49	5.09	4.49
			EER/COP		2.71	3.61	2.71	3.61
<b>COMFORT IN ENVIRONMENT</b>	<b>Performance according to Ecodesign (ERP) EN 14825</b>	MEDIUM TEMPERATURE (55 °C) AVERAGE climate	Design thermal load (P <sub>design,h</sub> )	kW	14		13	
			Seasonal energy efficiency η <sub>s</sub>	%	184		179	
			Energy efficiency class		A+++		A+++	
	<b>Performance according to EN 14825</b>	MEDIUM TEMPERATURE (55 °C) AVERAGE climate	Design thermal load (P <sub>design,h</sub> )	kW	14		14	
			Seasonal energy efficiency η <sub>s</sub>	%	144		138	
			Energy efficiency class		A++		A++	
<b>DHW performance according to EN 16147</b>	With 300 liters tank and diverting valve AVERAGE climate	Load profile		XL		XL		
		Energy efficiency class		A		A		
		ERP efficiency	%	110		110		
<b>Unit operation data</b>	Maximum delivery water temperature		°C	Up to 65		Up to 65		
	Outdoor temperature range (heating)		°C	-25/+35		-25/+35		
	Outdoor temperature range (cooling)		°C	-15/+48		-15/+48		
	Nominal water flow rate	m <sup>3</sup> /h	at 35 °C		2.70	at 35 °C	2.70	
			at 45 °C		2.69	at 45 °C	2.69	
			at 55 °C		2.58	at 55 °C	2.58	
			at 7 °C		1.86	at 7 °C	1.86	
			at 18 °C		2.67	at 18 °C	2.67	
	Minimum efficient water volume of the system		liters	80		80		
	Power supply (Voltage/Phases/Frequency)		V/Ph/Hz	230/1/50		400/3/50		
	Maximum electricity consumption		A	30		12.5		
Sound pressure level (cooling mode)		dB(A)	61		61			
Sound pressure level (heating mode)		dB(A)	63		63			
<b>Components and dimensions</b>	Expansion vessel		liters	3		3		
	Maximum circulator pump head		kPa	(see H/Q graphs)		(see H/Q graphs)		
	Hydraulic connections		inches	G1"		G1"		
	Safety valve		bar	3		3		
	Weight		kg	138		144		
	Dimensions (H/W/D)		mm	878/1206/445		878/1206/445		
	Compressor type			Twin Rotary with vapour injection		Twin Rotary with vapour injection		
<b>Refrigerant</b>	Type and GWP			R32/675 kg CO <sub>2</sub> eq		R32/675 kg CO <sub>2</sub> eq		
	Quantity		kg	2.2		2.2		

The equipments described in this catalogue contain HFC R32-type fluorinated greenhouse gases.  
These products must be fitted by qualified staff pursuant to European regulations 303/2008 and 517/2014.

Data declared in accordance with REGULATION (EU) No. 811/2013 of 18 February 2013 with regard to the energy labelling of space heaters, combination heaters, packages of space heater, temperature control and solar device and packages of combination heater, temperature control and solar devices, packages of combination heater, temperature control and solar devices, and with COMMISSION REGULATION (EU) No. 813/2013 of 2 August 2013 implementing Directive 2009/125/EC of the European Parliament and of the Council with regard to ecodesign requirements for space heaters and combination heaters.



## CAPACITY AND EFFICIENCY DATA IN RELATION TO THE OUTDOOR TEMPERATURE ACCORDING TO THE EN14511-3:2018 STANDARD

		COOLING - Dry bulb outdoor air temperature in °C - (AG4HP161PH)																	
		10		15		20		25		30		35		40		45		48	
LWT [°C]		Qc [kW]	EER	Qc [kW]	EER	Qc [kW]	EER	Qc [kW]	EER	Qc [kW]	EER	Qc [kW]	EER	Qc [kW]	EER	Qc [kW]	EER	Qc [kW]	EER
7		13.49	4.96	12.84	4.47	12.30	4.01	11.65	3.55	11.11	3.12	13.80	2.71	9.02	2.95	7.14	2.37	6.55	1.92
8		13.92	5.13	13.25	4.63	12.69	4.15	12.03	3.67	11.47	3.23	14.24	2.80	9.30	3.05	7.37	2.45	6.75	1.99
9		14.35	5.30	13.66	4.78	13.09	4.29	12.40	3.80	11.82	3.33	14.68	2.90	9.59	3.15	7.60	2.53	6.96	2.06
10		14.78	5.48	14.07	4.94	13.48	4.43	12.77	3.92	12.18	3.44	15.12	2.99	9.88	3.25	7.83	2.61	7.17	2.12
11		15.21	5.65	14.48	5.09	13.88	4.57	13.14	4.04	12.54	3.55	15.57	3.09	10.17	3.35	8.05	2.70	7.38	2.19
12		15.65	5.82	14.89	5.25	14.27	4.70	13.52	4.16	12.89	3.66	16.01	3.18	10.46	3.46	8.28	2.78	7.59	2.26
13		16.08	5.99	15.31	5.40	14.66	4.84	13.89	4.29	13.25	3.76	16.45	3.27	10.75	3.56	8.51	2.86	7.80	2.32
14		16.51	6.16	15.72	5.55	15.06	4.98	14.26	4.41	13.60	3.87	16.89	3.37	11.04	3.66	8.74	2.94	8.01	2.39
15		16.94	6.33	16.13	5.71	15.45	5.12	14.64	4.53	13.96	3.98	17.33	3.46	11.32	3.76	8.97	3.02	8.22	2.46
18		18.15	6.84	17.28	6.17	16.56	5.53	15.69	4.90	14.96	4.30	18.50	3.61	12.14	4.07	9.61	3.27	8.81	2.66
20		19.10	7.18	18.18	6.47	17.42	5.81	16.50	5.14	15.74	4.51	19.54	3.92	12.77	4.27	10.11	3.43	9.27	2.79
23		20.31	7.69	19.34	6.94	18.52	6.22	17.55	5.51	16.74	4.84	20.78	4.20	13.58	4.57	10.75	3.67	9.86	2.99
25		21.09	8.04	20.08	7.25	19.24	6.50	18.23	5.75	17.38	5.05	21.58	4.39	14.10	4.77	11.17	3.84	10.24	3.12

		HEATING - Dry bulb outdoor air temperature in °C																											
		-25		-20		-15		-10		-7		-2		2		7		10		15		20		25		30		35	
LWT [°C]		Qh [kW]	COP	Qh [kW]	COP	Qh [kW]	COP	Qh [kW]	COP	Qh [kW]	COP	Qh [kW]	COP	Qh [kW]	COP	Qh [kW]	COP	Qh [kW]	COP	Qh [kW]	COP	Qh [kW]	COP	Qh [kW]	COP	Qh [kW]	COP	Qh [kW]	COP
25		6.64	2.00	7.11	2.35	8.53	2.70	9.32	3.18	10.27	3.53	11.53	4.03	12.48	4.47	15.54	5.55	16.01	5.69	17.90	6.19	11.75	7.53	12.88	7.98	13.11	8.42	14.17	8.74
30		6.79	1.84	7.27	2.16	8.69	2.48	9.48	2.92	10.43	3.24	11.69	3.70	12.64	4.10	15.70	5.10	16.17	5.22	18.06	5.68	11.84	6.91	12.97	7.32	13.20	7.73	14.26	8.03
35		6.79	1.64	7.27	1.93	8.69	2.22	9.48	2.60	10.43	2.89	11.69	3.30	12.64	3.66	15.70	4.55	16.17	4.66	18.06	5.07	11.84	6.17	12.97	6.54	13.20	6.90	14.26	7.17
40		6.79	1.44	7.27	1.70	8.69	1.95	9.48	2.29	10.43	2.54	11.69	2.91	12.64	3.22	15.70	4.00	16.17	4.10	18.06	4.46	11.84	5.43	12.97	5.75	13.20	6.08	14.26	6.31
45		6.79	1.31	7.27	1.54	8.69	1.77	9.48	2.08	10.43	2.31	11.69	2.64	12.64	2.93	16.20	3.61	16.17	3.73	18.06	4.06	11.84	4.94	12.97	5.23	13.20	5.52	14.26	5.73
50				7.11	1.39	8.53	1.60	9.32	1.87	10.27	2.08	11.53	2.38	12.48	2.64	15.54	3.28	16.01	3.36	17.90	3.65	11.75	4.45	12.88	4.71	13.11	4.97	14.11	5.16
55						8.53	1.40	9.32	1.64	10.27	1.82	11.53	2.08	12.48	2.31	15.40	2.90	16.01	2.94	17.90	3.20	11.75	3.89	12.88	4.12	13.11	4.35	14.11	4.52
60										10.11	1.62	11.38	1.85	12.32	2.05	15.39	2.55	15.85	2.61	17.69	2.84	11.61	3.46	12.71	3.66	12.94	3.87	13.97	4.01
65																15.23	2.28	15.69	2.33	17.51	2.54	11.49	3.09						

		HEATING - Dry bulb outdoor air temperature in °C - (AG4HP163PH)																											
		-25		-20		-15		-10		-7		-2		2		7		10		15		20		25		30		35	
LWT [°C]		Qh [kW]	COP	Qh [kW]	COP	Qh [kW]	COP	Qh [kW]	COP	Qh [kW]	COP	Qh [kW]	COP	Qh [kW]	COP	Qh [kW]	COP	Qh [kW]	COP	Qh [kW]	COP	Qh [kW]	COP	Qh [kW]	COP	Qh [kW]	COP	Qh [kW]	COP
25		6.64	1.92	7.11	2.25	8.53	2.59	9.32	3.04	10.27	3.38	11.53	3.86	12.48	4.28	15.54	5.37	16.01	5.50	17.90	5.99	11.75	7.23	12.88	7.66	13.11	8.07	14.17	8.38
30		6.79	1.76	7.27	2.07	8.69	2.38	9.48	2.79	10.43	3.10	11.69	3.54	12.64	3.93	15.70	4.93	16.17	5.05	18.06	5.49	11.84	6.64	12.97	7.03	13.20	7.41	14.26	7.69
35		6.79	1.57	7.27	1.85	8.69	2.13	9.48	2.49	10.43	2.77	11.69	3.16	12.64	3.51	15.70	4.40	16.17	4.51	18.06	4.91	11.84	5.93	12.97	6.28	13.20	6.62	14.26	6.87
40		6.79	1.38	7.27	1.63	8.69	1.87	9.48	2.20	10.43	2.44	11.69	2.78	12.64	3.09	15.70	3.87	16.17	3.97	18.06	4.32	11.84	5.21	12.97	5.52	13.20	5.82	14.26	6.05
45		6.79	1.26	7.27	1.48	8.69	1.70	9.48	2.00	10.43	2.22	11.69	2.53	12.64	2.81	16.20	3.61	16.17	3.61	18.06	3.92	11.84	4.74	12.97	5.02	13.20	5.29	14.26	5.50
50				7.11	1.33	8.53	1.53	9.32	1.80	10.27	2.00	11.53	2.28	12.48	2.53	15.54	3.17	16.01	3.25	17.90	3.53	11.75	4.27	12.88	4.52	13.11	4.76	14.11	4.95
55						8.53	1.34	9.32	1.57	10.27	1.75	11.53	1.99	12.48	2.21	15.40	2.75	16.01	2.84	17.90	3.09	11.75	3.73	12.88	3.95	13.11	4.17	14.11	4.33
60										10.11	1.55	11.38	1.77	12.32	1.97	15.39	2.46	15.85	2.53	17.69	2.75	11.61	3.32	12.71	3.51	12.94	3.71	13.97	3.85
65																15.23	2.20	15.69	2.26	17.51	2.45	11.49	2.96						

		COOLING - Dry bulb outdoor air temperature in °C																	
		10		15		20		25		30		35		40		45		48	
LWT [°C]		Qc [kW]	EER	Qc [kW]	EER	Qc [kW]	EER	Qc [kW]	EER	Qc [kW]	EER	Qc [kW]	EER	Qc [kW]	EER	Qc [kW]	EER	Qc [kW]	EER
7		13.49	4.96	12.84	4.47	12.30	4.01	11.65	3.55	11.11	3.12	13.80	2.71	9.02	2.25	7.14	1.73	6.55	1.41
8		13.92	5.13	13.25	4.63	12.69	4.15	12.03	3.67	11.47	3.23	14.24	2.80	9.30	2.33	7.37	1.80	6.75	1.46
9		14.35	5.30	13.66	4.78	13.09	4.29	12.40	3.80	11.82	3.33	14.68	2.90	9.59	2.41	7.60	1.85	6.96	1.51
10		14.78	5.48	14.07	4.94	13.48	4.43	12.77	3.92	12.18	3.44	15.12	2.99	9.88	2.48	7.83	1.91	7.17	1.56
11		15.21	5.65	14.48	5.09	13.88	4.57	13.14	4.04	12.54	3.55	15.57	3.09	10.17	2.56	8.05	1.97	7.38	1.60
12		15.65	5.82	14.89	5.25	14.27	4.70	13.52	4.16	12.89	3.66	16.01	3.18	10.46	2.64	8.28	2.03	7.59	1.65
13		16.08	5.99	15.31	5.40	14.66	4.84	13.89	4.29	13.25	3.76	16.45	3.27	10.75	2.72	8.51	2.09	7.80	1.70
14		16.51	6.16	15.72	5.55	15.06	4.98	14.26	4.41	13.60	3.87	16.89	3.37	11.04	2.79	8.74	2.15	8.01	1.75
15		16.94	6.33	16.13	5.71	15.45	5.12	14.64	4.53	13.96	3.98	17.33	3.46	11.32	2.87	8.97	2.21	8.22	1.80
18		18.15	6.84	17.28	6.17	16.56	5.53	15.69	4.90	14.96	4.30	18.50	3.80	12.14	3.10	9.61	2.39	8.81	1.94
20		19.10	7.18	18.18	6.47	17.42	5.81	16.50	5.14	15.74	4.51	19.54	3.92	12.77	3.26	10.11	2.51	9.27	2.04
23		20.31	7.69	19.34	6.94	18.52	6.22	17.55	5.51	16.74	4.84	20.78	4.20	13.58	3.49	10.75	2.69	9.86	2.19
25		21.09	8.04	20.08	7.25	19.24	6.50	18.23	5.75	17.38	5.05	21.58	4.39	14.10	3.64	11.17	2.81	10.24	2.28

LWT: Leaving water temperature  
Qh: Heating capacity  
COP: Coefficient of performance

LWT: Leaving water temperature  
Qc: Cooling capacity  
EER: Energy efficiency ratio

## FLOW RATE CURVES FOR 8-10 kW

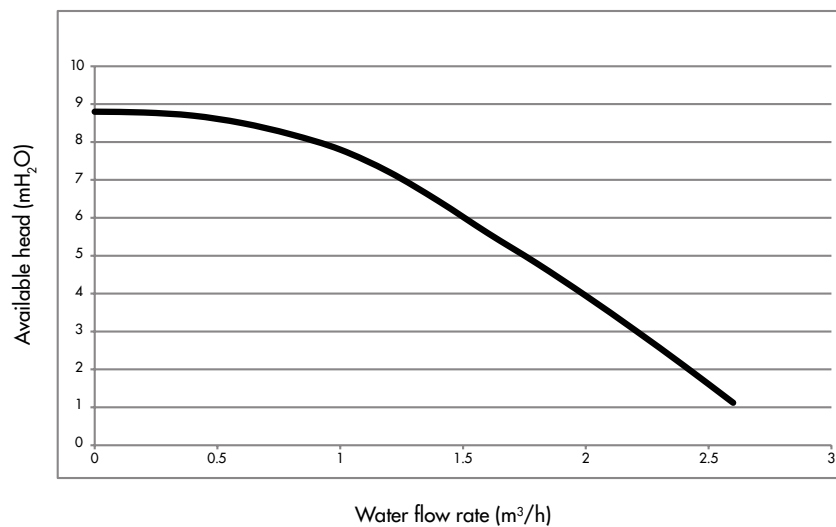

## FLOW RATE CURVES FOR 12-14-16 kW

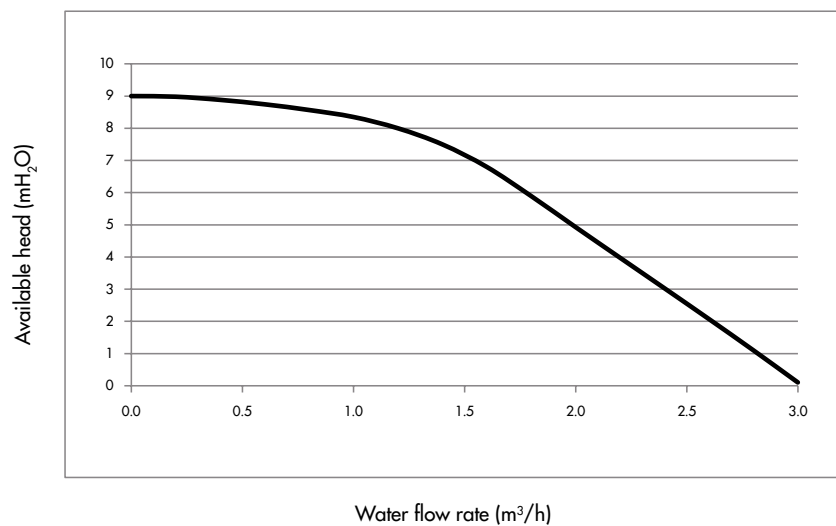

## MAXIMUM TEMPERATURE IN HEATING 8-10-12-14-16 kW

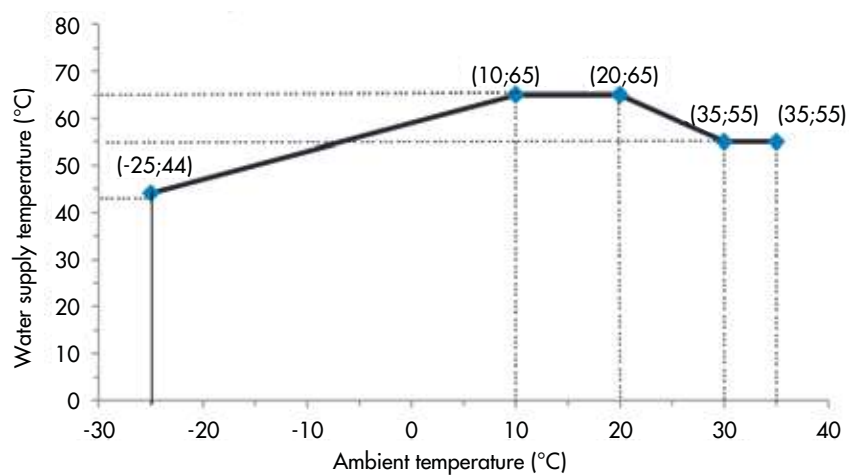



# DIMENSIONAL DRAWINGS 8-10-12-14-16 kW

HEAT  
PUMPS

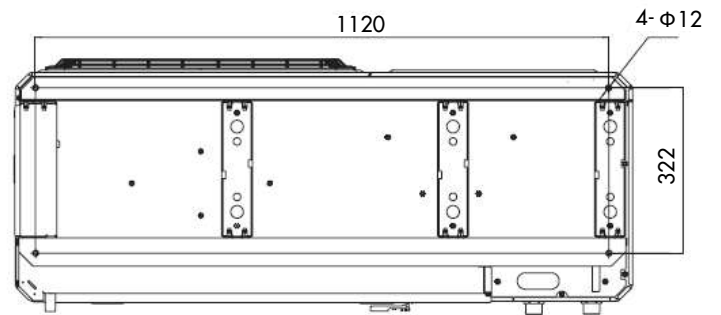
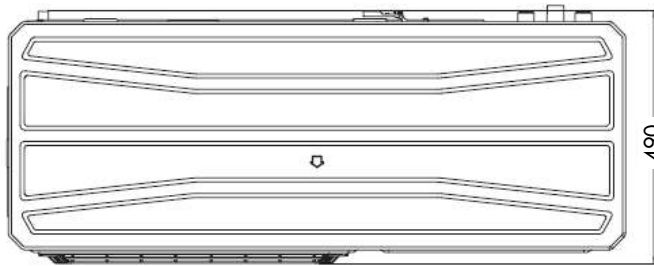
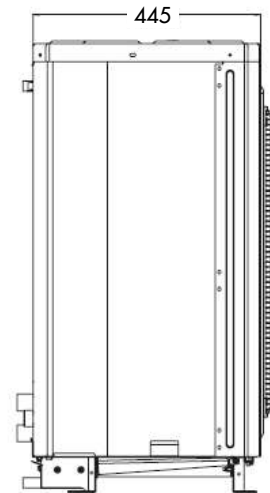
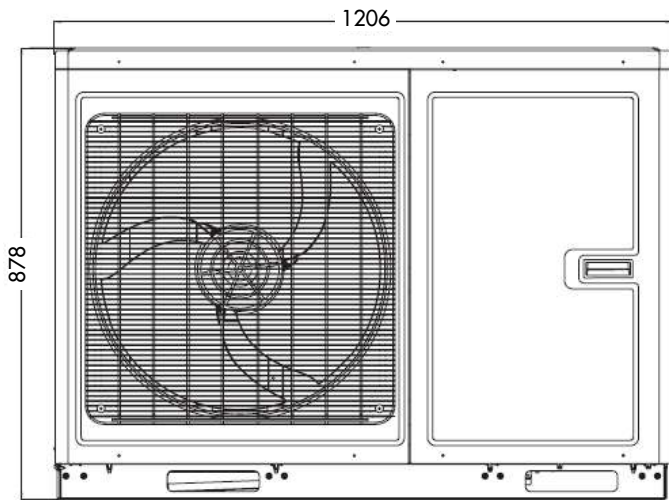

# SPACE REQUIRED FOR INSTALLATION 8-10-12-14-16 kW

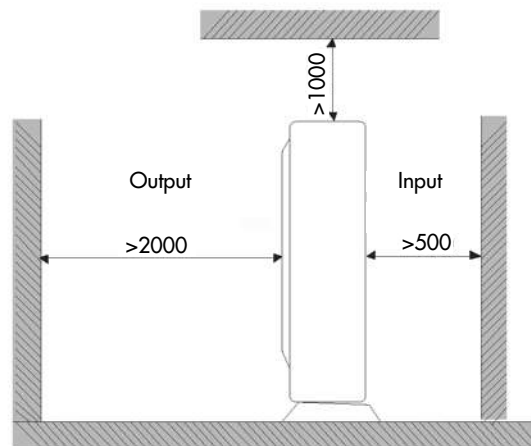
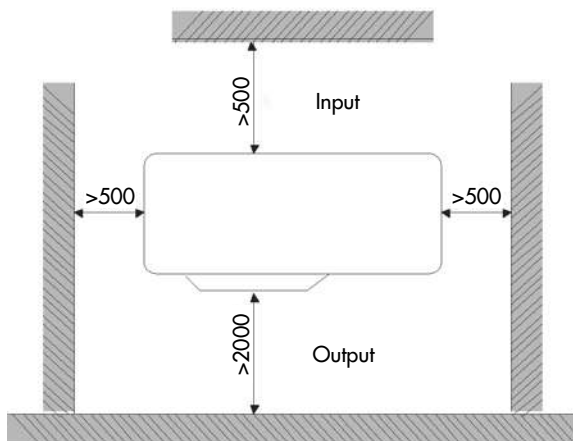

# INSTALLATION EXAMPLES

## EXAMPLE 1

### Radiant heating and DHW with three-way valve and tank

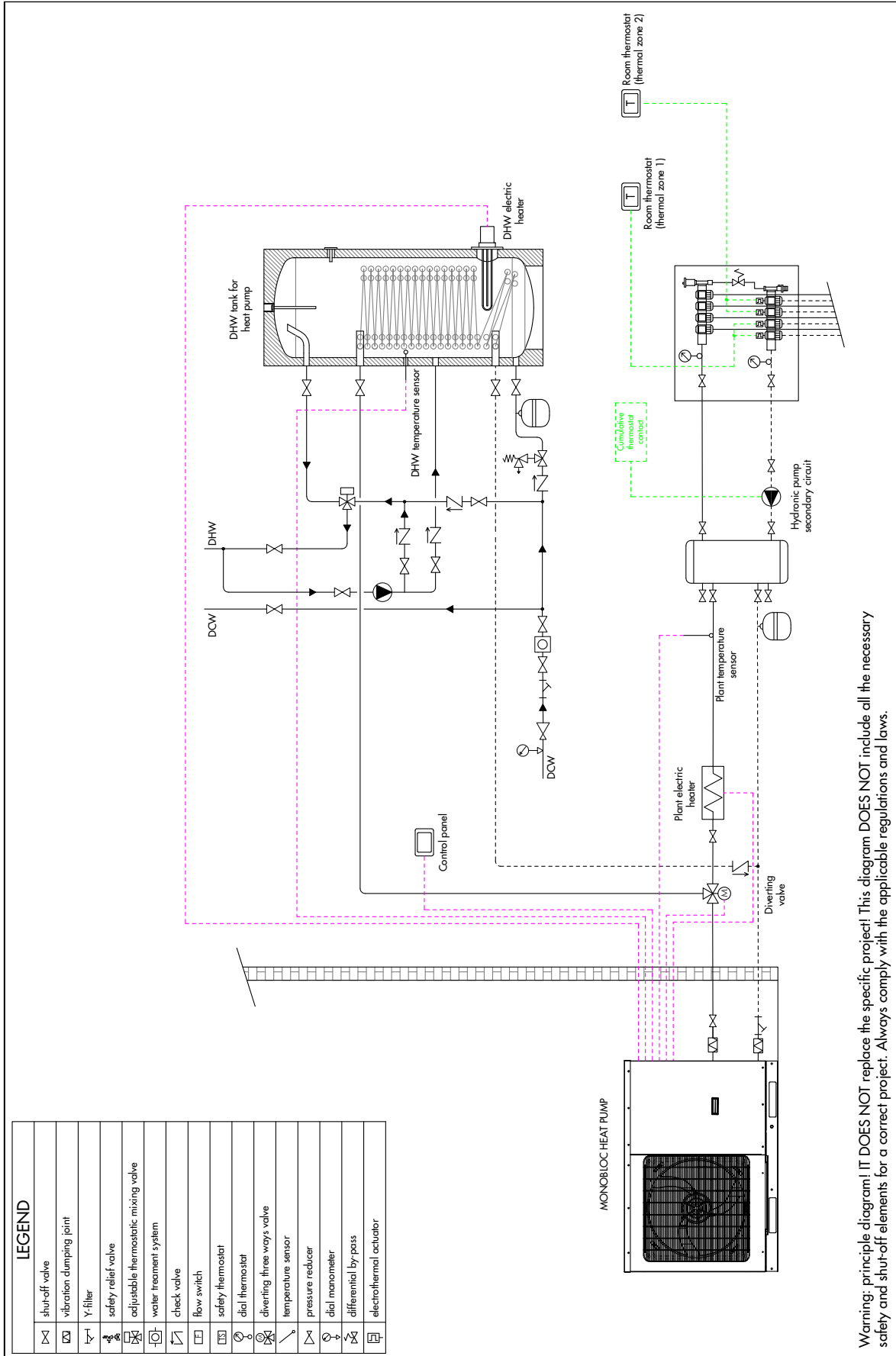

LEGEND	
	shut-off valve
	vibration clumping joint
	Y-filter
	safety relief valve
	adjustable thermostatic mixing valve
	water treatment system
	check valve
	flow switch
	safety thermostat
	dial thermostat
	diverting three ways valve
	temperature sensor
	pressure reducer
	dial manometer
	differential by pass
	electrothermal actuator

Warning: principle diagram! IT DOES NOT replace the specific project! This diagram DOES NOT include all the necessary safety and shut-off elements for a correct project. Always comply with the applicable regulations and laws.

# INSTALLATION EXAMPLES

## EXAMPLE 2

Heating (cooling) with fan coil units and DHW with three-way valve and tank

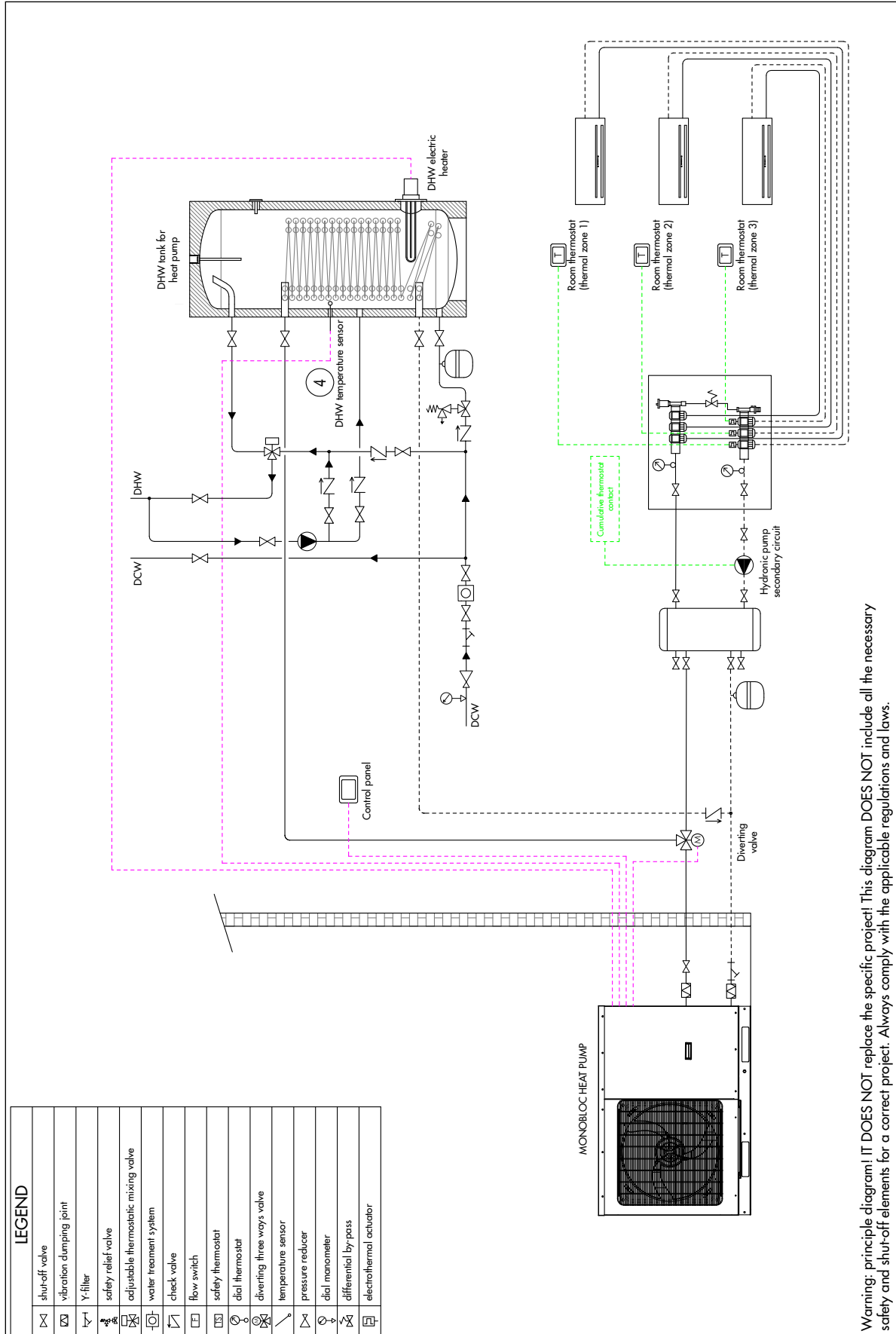

Warning: principle diagram! IT DOES NOT replace the specific project! This diagram DOES NOT include all the necessary safety and shut-off elements for a correct project. Always comply with the applicable regulations and laws.

# INSTALLATION EXAMPLES

## EXAMPLE 3

Radiant heating, single thermal zone and DHW with three-way valve and tank

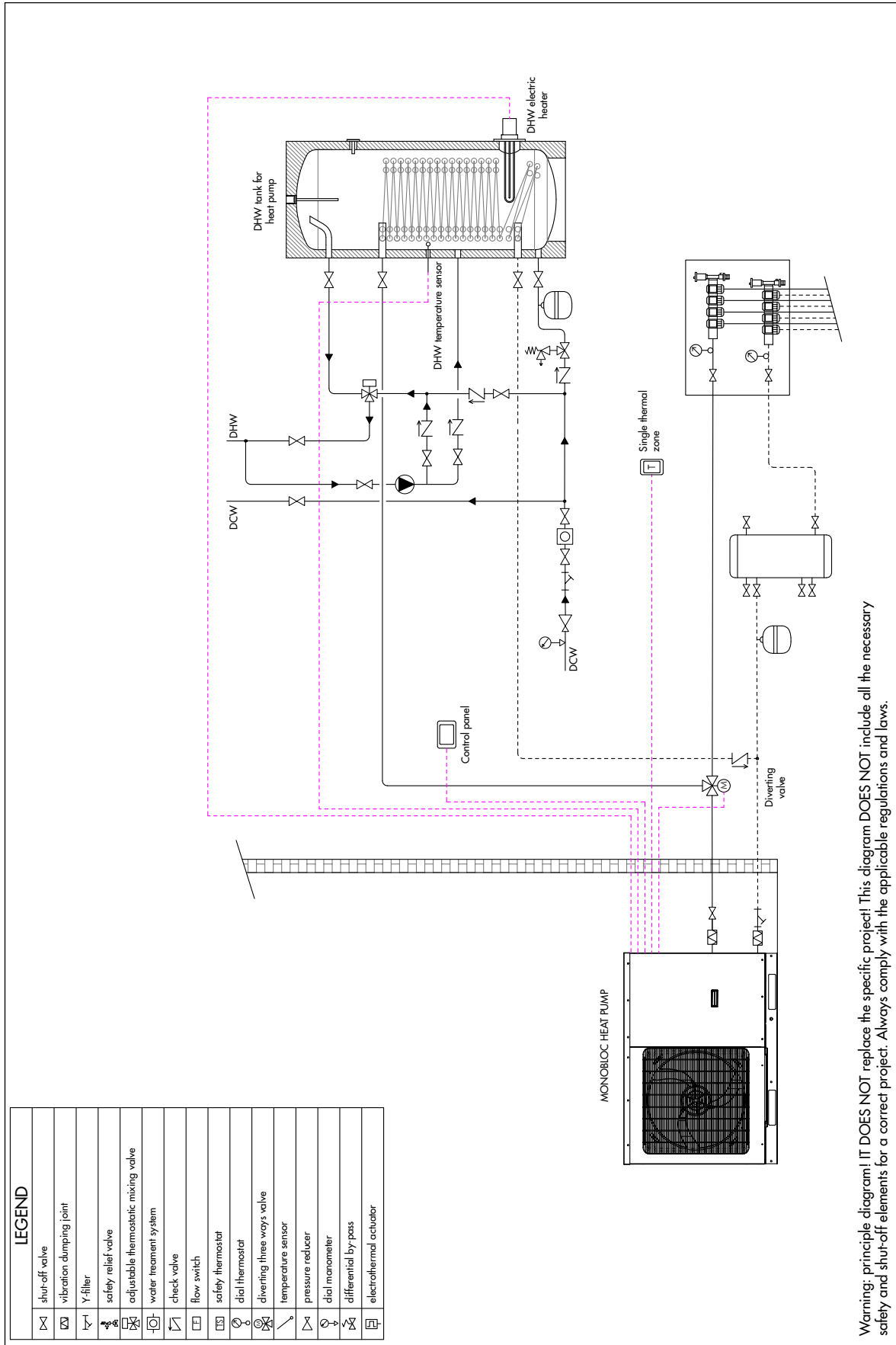

Warning: principle diagram! IT DOES NOT replace the specific project! This diagram DOES NOT include all the necessary safety and shut-off elements for a correct project. Always comply with the applicable regulations and laws.

# INSTALLATION EXAMPLES

## EXAMPLE 4

Radiant heating, integration with gas boiler and DHW with three-way valve and tank

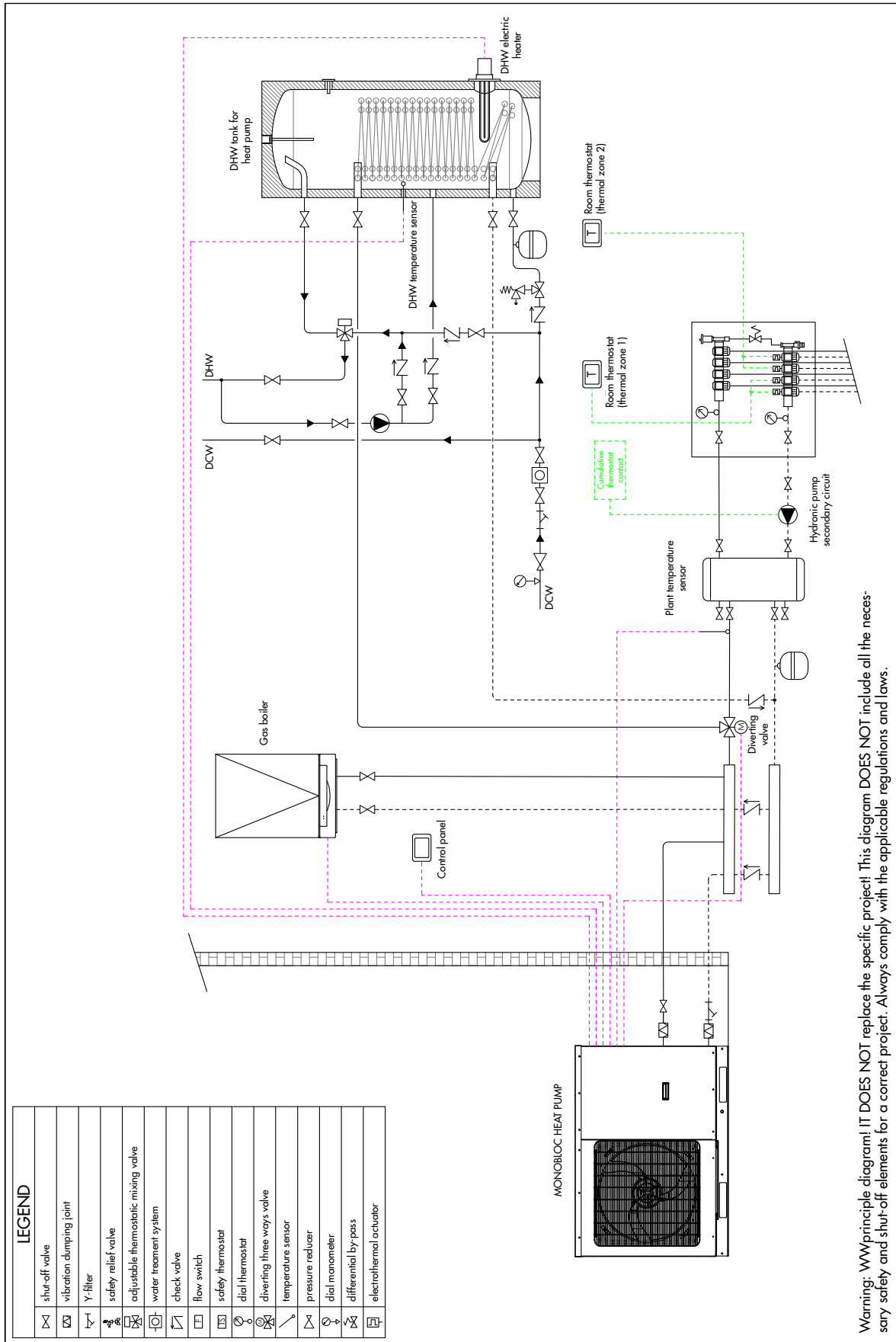

Warning: WW principle diagram! IT DOES NOT replace the specific project! This diagram DOES NOT include all the necessary safety and shut-off elements for a correct project. Always comply with the applicable regulations and laws.





# SPLIT

---

Single-phase 6-8-10 kW range

# SPLIT HEAT PUMPS

## MAIN FEATURES



(Standard on the indoor unit)  
Touch-screen control panel installed on the indoor unit

- Split Air/Water heat pump with new-generation DC Inverter technology.
- Equipped with the heating, cooling and domestic hot water production functions.
- Single-phase version with 6-8-10 kW heating capacity.
- Achieves very high efficiency levels in heating mode, up to 5 COP.
- It uses R32, a refrigerant with low impact on global warming and ozone layer, characterised by high energy efficiency and a 30% lower charge compared to R410A.
- The vapour-injection compressor, thanks to its special technology, guarantees exceptional performances within a wide operating range.
- The leaving water temperature range is 20 °C-60 °C: this means that the heat pump can be used with radiant floor systems, fan coil units and also medium-temperature radiators.
- The DC brushless axial fans are designed to ensure aerodynamic optimisation: they guarantee low noise levels coupled with high efficiency and a high air flow rate.
- It is equipped with a heating element on the base to prevent ice build-up during winter operation.
- The outdoor unit is equipped with an electronic expansion valve, while the indoor unit contains all the hydraulic components: inverter pump, plate heat exchanger, expansion vessel, safety valve, flow switch and water filter supplied (installation mandatory).

Internal copper groove	Quiet mode	Weekly timer	Heating down to low temperatures	Door control	Full protection	Timer	Child lock	Wide operating range	Wide voltage range	Auto diagnosis	Low-voltage start-up
Auto restart memory	Intelligent defrosting	°C / °F switching	Long-distance monitoring	Exch. condenser gold fin treatment	-25°C Min. outdoor temp. heating	+35°C Max. outdoor temp. heating	+10°C Min. outdoor temp. cooling	+48°C Max. outdoor temp. cooling	-25°C Min. outdoor temp. DHW	+45°C Max. outdoor temp. DHW	60°C Max. output temp. DHW







**A+++** Heating mode 35 °C

**A++** Heating mode 55 °C

**A** DHW



# THE RANGE

	Model	Code	 Rated capacity according to EN14511 (kW)	 Heating (1)    Cooling (2)	
				 Heating (1)	 Cooling (2)
OUTDOOR UNIT - 1PH 	AGHPSA061SH	398600012	●	6.0	5.8
	AGHPSA081SH	398600013	●	8.0	7.0
	AGHPSA101SH	398600014	●	9.5	8.5
HYDRONIC INDOOR UNIT 	AGHPS061W	398600016	●	6.0	5.8
	AGHPS081W	398600017	●	8.0	7.0
	AGHPS101W	398600018	●	9.5	8.5

(1) Water temperature 30 °C/35 °C, outdoor air temperature 7 °C D.B./6 °C W.B.

(2) Water temperature 23 °C/18 °C, outdoor air temperature 35 °C

## INCLUDED ACCESSORIES

Ambient air temperature sensor
DHW temperature sensor
Y-shaped filter
Control panel (integrated into the indoor unit)

# TECHNICAL DATA FOR 6 kW

MODEL				AGHPSA061		
Outdoor unit model				AGHPSA061SH		
Hydronic indoor unit model				AGHPS061W		
Matchable units for domestic hot water production (DHW)				200/300 liters external tank with diverting valve		
COMFORT IN ENVIRONMENT	Performance according to EN 14511	Air +35 °C - Water 23/18 °C Air +7 °C - Water 30/35 °C	Rated capacity	kW	5.80	6.00
			Rated electrical power input	kW <sub>el</sub>	1.32	1.20
			EER/COP		4.39	5.00
		Air +35 °C - Water 12/7 °C Air +7 °C - Water 40/45 °C	Rated capacity	kW	4.09	5.90
			Rated electrical power input	kW <sub>el</sub>	1.28	1.51
			EER/COP		3.20	3.91
	Performance according to Ecodesign (ERP) EN 14825	LOW TEMPERATURE (35 °C) AVERAGE climate	Design thermal load (P <sub>design,n</sub> )	kW	6.00	
			Seasonal energy efficiency η <sub>s</sub>	%	178.7	
			Energy efficiency class		A+++	
		MEDIUM TEMPERATURE (55 °C) AVERAGE climate	Design thermal load (P <sub>design,n</sub> )	kW	5.00	
Seasonal energy efficiency η <sub>s</sub>			%	127.4		
Energy efficiency class				A++		
DHW performance according to EN 16147	With 300 liters tank and diverting valve AVERAGE climate	Load profile		XL		
		Energy efficiency class		A		
		Water heating efficiency - ERP η <sub>wh</sub>	%	107.5		
Indoor unit	Nominal water flow rate		m <sup>3</sup> /h	at 35 °C	1.03	
				at 45 °C	1.02	
				at 7 °C	0.70	
				at 18 °C	1.00	
	Minimum efficient water volume of the system	liters	40			
	Maximum delivery water temperature	°C	Up to 60			
	Power supply (Voltage/Phases/Frequency)	V/Ph/Hz	220-240/1/50			
	Electrical power input	kW	3.10			
	Heating element	nxkW	2x1.5			
	Expansion vessel	liters	10			
	Maximum circulator pump head	kPa	see H/Q graph			
	Hydraulic connections	inches	G1" female			
	Safety valve	bar	3			
	Indoor unit sound pressure	dB(A)	29	29		
Net weight	kg	62				
Dimensions (H/W/D)	mm	860/460/318				
Outdoor unit	Outdoor temperature range (heating)	°C	-25/+35			
	Outdoor temperature range (cooling)	°C	+10/+48			
	Electrical power supply	V/Ph/Hz	220-240~/1/50			
	Maximum power input (cooling)	kW	2.30			
	Maximum power input (heating)	kW	2.30			
	Maximum current draw (cooling)	A	10			
	Maximum current draw (heating)	A	10			
	Liquid cooling pipe diameter	mm (inches)	6.35 (1/4)			
	Gas cooling pipe diameter	mm (inches)	12.7 (1/2)			
	Outdoor unit sound pressure	dB(A)	52	52		
	Fan air flow rate	m <sup>3</sup> /h	3200			
	Net weight	kg	55			
	Dimensions (H/W/D)	mm	702/975/396			
	Compressor type		Twin Rotary with vapour injection			
Refrigerant	Type and GWP		R32/675 kg CO <sub>2</sub> eq.			
	Quantity		1 kg/0.675 tons CO <sub>2</sub> eq.			

The equipments described in this catalogue contain HFC R32-type fluorinated greenhouse gases.  
These products must be fitted by qualified staff pursuant to European regulations 303/2008 and 517/2014.

Data declared in accordance with REGULATION (EU) No. 811/2013 of 18 February 2013 with regard to the energy labelling of space heaters, combination heaters, packages of space heater, temperature control and solar device and packages of combination heater, temperature control and solar devices, packages of combination heater, temperature control and solar devices, and with COMMISSION REGULATION (EU) No. 813/2013 of 2 August 2013 implementing Directive 2009/125/EC of the European Parliament and of the Council with regard to ecodesign requirements for space heaters and combination heaters.

## CAPACITY AND EFFICIENCY DATA IN RELATION TO THE OUTDOOR TEMPERATURE ACCORDING TO THE EN14511-3:2013 STANDARD

LWT [°C]	COOLING - Dry bulb outdoor air temperature in °C - (AGHPSA061)																	
	10		15		20		25		30		35		40		45		48	
	Qc [kW]	EER	Qc [kW]	EER	Qc [kW]	EER	Qc [kW]	EER	Qc [kW]	EER	Qc [kW]	EER	Qc [kW]	EER	Qc [kW]	EER	Qc [kW]	EER
7	3.35	4.35	3.72	4.19	3.93	4.06	4.17	3.87	4.25	3.55	4.09	3.20	3.72	2.65	2.90	1.95	2.45	1.57
8	3.48	4.47	3.89	4.31	4.09	4.19	4.34	3.99	4.42	3.64	4.25	3.29	3.89	2.75	3.03	2.01	2.54	1.63
9	3.64	4.67	4.01	4.47	4.21	4.35	4.46	4.12	4.54	3.80	4.38	3.42	4.01	2.84	3.15	2.08	2.66	1.66
10	3.72	4.79	4.13	4.60	4.38	4.47	4.62	4.25	4.70	3.90	4.54	3.51	4.13	2.91	3.23	2.17	2.74	1.73
11	3.84	4.92	4.29	4.76	4.50	4.60	4.79	4.41	4.91	4.06	4.70	3.64	4.29	3.00	3.31	2.20	2.82	1.76
12	3.97	5.08	4.42	4.92	4.66	4.76	4.95	4.54	5.07	4.15	4.87	3.74	4.42	3.10	3.44	2.30	2.90	1.85
13	4.13	5.24	4.58	5.05	4.79	4.89	5.11	4.67	5.19	4.28	4.99	3.87	4.58	3.20	3.56	2.33	2.99	1.89
14	4.25	5.40	4.66	5.21	4.95	5.05	5.28	4.79	5.36	4.41	5.15	3.96	4.66	3.29	3.68	2.43	3.07	1.95
15	4.34	5.53	4.83	5.34	5.11	5.18	5.44	4.92	5.52	4.51	5.32	4.09	4.83	3.39	3.76	2.49	3.19	1.98
18	4.74	5.98	5.24	5.75	5.52	5.59	5.89	5.34	6.01	4.89	5.77	4.41	5.24	3.64	4.09	2.68	3.48	2.17
20	4.95	6.29	5.52	6.07	5.85	5.88	6.18	5.59	6.30	5.14	6.05	4.63	5.52	3.83	4.34	2.84	3.64	2.27
23	5.36	6.74	5.93	6.49	6.26	6.33	6.67	6.01	6.79	5.50	6.54	4.95	5.93	4.12	4.62	3.00	3.93	2.43
25	5.60	7.03	6.22	6.77	6.54	6.58	6.95	6.29	7.12	5.75	6.83	5.18	6.22	4.31	4.87	3.16	4.09	2.56

LWT [°C]	HEATING - Dry bulb outdoor air temperature in °C																											
	-25		-20		-15		-10		-7		-2		2		7		10		15		20		25		30		35	
	Qh [kW]	COP	Qh [kW]	COP	Qh [kW]	COP	Qh [kW]	COP	Qh [kW]	COP	Qh [kW]	COP	Qh [kW]	COP	Qh [kW]	COP	Qh [kW]	COP	Qh [kW]	COP	Qh [kW]	COP	Qh [kW]	COP	Qh [kW]	COP	Qh [kW]	COP
25	2.94	4.34	3.12	4.57	3.72	4.88	4.26	5.08	5.16	5.39	5.76	5.63	6.36	5.86	6.24	6.10	6.42	6.37	6.78	6.95	6.72	7.38	6.12	7.31	5.34	7.97	4.20	8.44
30	2.70	3.52	3.06	3.79	3.60	4.06	4.14	4.30	4.74	4.53	5.22	4.77	5.82	5.00	6.18	5.55	6.36	5.90	6.72	6.29	6.66	6.72	6.06	6.72	5.34	7.27	4.14	7.78
35	2.52	2.97	2.88	3.13	3.36	3.32	3.90	3.59	4.26	3.83	4.80	4.06	5.22	4.18	6.00	5.00	6.30	5.27	6.66	5.74	6.60	5.98	6.00	5.98	5.28	6.64	4.08	7.03
40	2.46	2.54	2.88	2.81	3.36	3.05	3.90	3.24	4.26	3.40	4.74	3.67	5.16	3.91	6.00	4.45	6.24	4.69	6.60	5.08	6.54	5.35	5.94	5.31	5.22	5.86	4.08	6.25
45			2.88	2.46	3.36	2.70	3.90	2.93	4.20	3.05	4.68	3.24	5.10	3.44	6.00	3.91	6.18	4.10	6.54	4.45	6.48	4.69	5.88	4.92	5.16	5.16	4.02	5.47
50					3.24	2.27	3.78	2.46	4.14	2.58	4.62	2.77	5.04	2.85	5.94	3.36	6.12	3.52	6.48	3.87	6.42	4.02	5.82	4.22	5.10	4.42	3.96	4.73
55							3.60	2.03	4.14	2.11	4.56	2.31	4.98	2.42	5.88	2.81	6.06	2.97	6.42	3.20	6.36	3.40	5.76	3.52	5.04	3.71	3.96	3.99
60									4.08	1.72	4.56	1.80	4.92	1.91	5.82	2.27	6.00	2.34	6.36	2.50	6.30	2.62	5.70	2.77	4.98	2.89	3.90	3.09

LWT: Leaving water temperature  
 Qh: Heating capacity  
 COP: Coefficient of performance

LWT: Leaving water temperature  
 Qc: Cooling capacity  
 EER: Energy efficiency ratio

## FLOW RATE CURVES FOR 6 kW

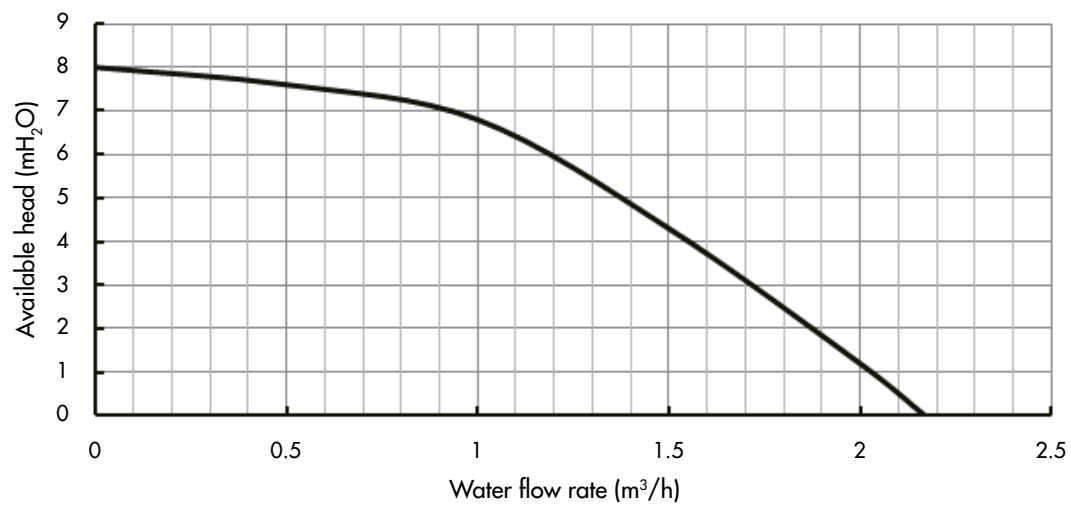

## DIMENSIONAL DRAWINGS 6 kW

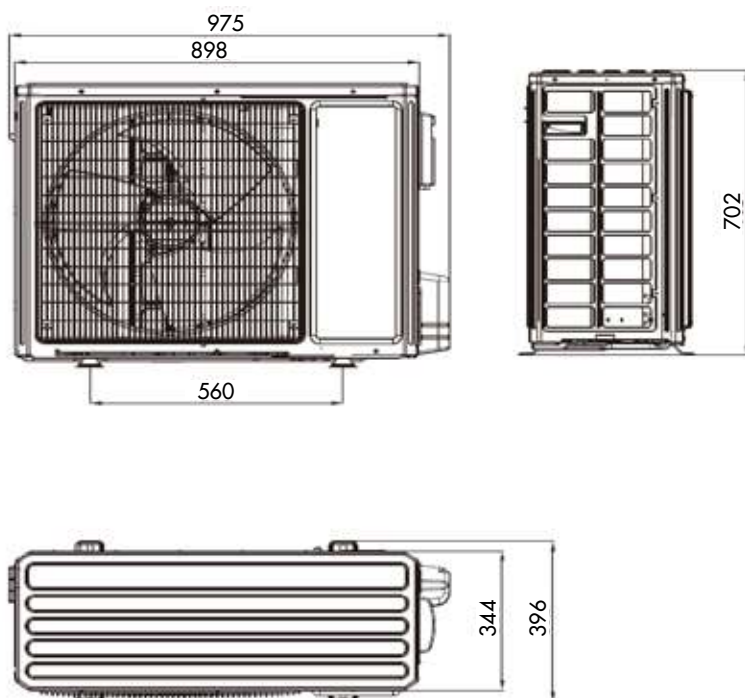

OUTDOOR UNIT 6 kW

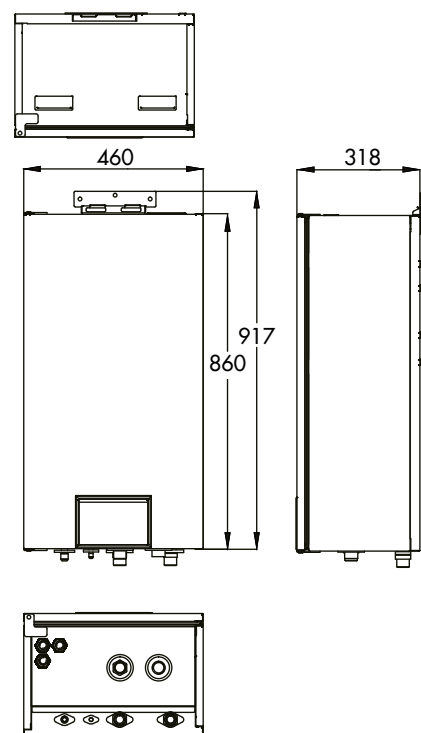

INDOOR UNIT 6 kW

# SPACE REQUIRED FOR OUTDOOR UNIT INSTALLATION 6 kW

HEAT  
PUMPS

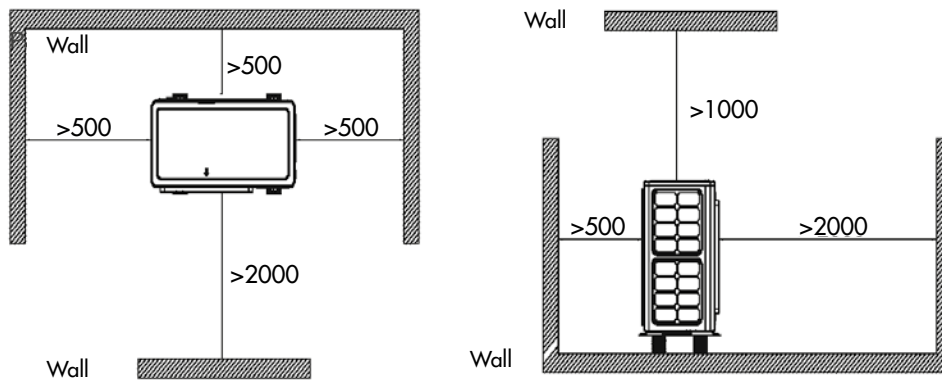

# SPACE REQUIRED FOR INDOOR UNIT INSTALLATION 6 kW

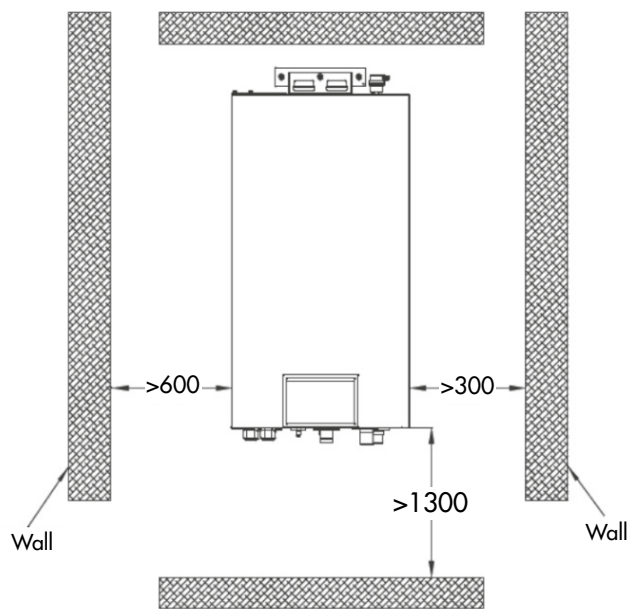

# TECHNICAL DATA FOR 8 kW

MODEL				AGHPSA081			
Outdoor unit model				AGHPSA081SH			
Hydronic indoor unit model				AGHPS081W			
Matchable units for domestic hot water production (DHW)				200/300 liters external tank with diverting valve			
				Cooling	Heating		
COMFORT IN ENVIRONMENT	Performance according to EN 14511	Air +35 °C - Water 23/18 °C Air +7 °C - Water 30/35 °C	Rated capacity	kW	7.00	8.00	
			Rated electrical power input	kW <sub>el</sub>	1.75	1.70	
			EER/COP		4.00	4.71	
	Performance according to EN 14825	LOW TEMPERATURE (35 °C) AVERAGE climate	Air +35 °C - Water 12/7 °C Air +7 °C - Water 40/45 °C	Rated capacity	kW	5.30	8.00
				Rated electrical power input	kW <sub>el</sub>	1.73	2.14
				EER/COP		3.06	3.74
COMFORT IN ENVIRONMENT	Performance according to Ecodesign (ERP) EN 14825	MEDIUM TEMPERATURE (55 °C) AVERAGE climate	Design thermal load (P <sub>design,h</sub> )	kW	7.00		
			Seasonal energy efficiency η <sub>s</sub>	%	181		
			Energy efficiency class		A+++		
	Performance according to EN 14825	MEDIUM TEMPERATURE (55 °C) AVERAGE climate	Air +35 °C - Water 12/7 °C Air +7 °C - Water 40/45 °C	Design thermal load (P <sub>design,h</sub> )	kW	7.00	
				Seasonal energy efficiency η <sub>s</sub>	%	129	
				Energy efficiency class		A++	
DHW performance according to EN 16147	With 300 liters tank and diverting valve AVERAGE climate		Load profile		XL		
			Energy efficiency class		A		
			Water heating efficiency - ERP η <sub>wh</sub>	%	111		
Indoor unit			Nominal water flow rate	m <sup>3</sup> /h	at 35 °C	1.38	
					at 45 °C	1.38	
					at 7 °C	0.91	
					at 18 °C	1.20	
			Minimum efficient water volume of the system	liters	40		
			Maximum delivery water temperature	°C	Up to 60		
			Power supply (Voltage/Phases/Frequency)	V/Ph/Hz	220-240/1/50		
			Electrical power input	kW	3.10		
			Heating element	n×kW	2×3		
			Expansion vessel	liters	10		
			Maximum circulator pump head	kPa	see H/Q graph		
			Hydraulic connections	inches	G1" female		
			Safety valve	bar	3		
			Indoor unit sound pressure	dB(A)	29	29	
			Net weight	kg	62		
Dimensions (H/W/D)	mm	860/460/318					
Outdoor unit			Outdoor temperature range (heating)	°C	-25/+35		
			Outdoor temperature range (cooling)	°C	+10/+48		
			Electrical power supply	V/Ph/Hz	220-240~/1/50		
			Maximum power input (cooling)	kW	4.32		
			Maximum power input (heating)	kW	3.00		
			Maximum current draw (cooling)	A	19		
			Maximum current draw (heating)	A	13		
			Liquid cooling pipe diameter	mm (inches)	6.35 (1/4)		
			Gas cooling pipe diameter	mm (inches)	12.7 (1/2)		
			Outdoor unit sound pressure	dB(A)	55	55	
			Fan air flow rate	m <sup>3</sup> /h	3300		
			Net weight	kg	82		
			Dimensions (H/W/D)	mm	787/982/427		
			Compressor type		Twin Rotary with vapour injection		
			Refrigerant			Type and GWP	
Quantity		1.6 kg/1.08 tons CO <sub>2</sub> eq.					

The equipments described in this catalogue contain HFC R32-type fluorinated greenhouse gases.  
These products must be fitted by qualified staff pursuant to European regulations 303/2008 and 517/2014.

Data declared in accordance with REGULATION (EU) No. 811/2013 of 18 February 2013 with regard to the energy labelling of space heaters, combination heaters, packages of space heater, temperature control and solar device and packages of combination heater, temperature control and solar devices, packages of combination heater, temperature control and solar devices, and with COMMISSION REGULATION (EU) No. 813/2013 of 2 August 2013 implementing Directive 2009/125/EC of the European Parliament and of the Council with regard to ecodesign requirements for space heaters and combination heaters.

## CAPACITY AND EFFICIENCY DATA IN RELATION TO THE OUTDOOR TEMPERATURE ACCORDING TO THE EN14511-3:2013 STANDARD

LWT [°C]	COOLING - Dry bulb outdoor air temperature in °C - (AGHPSA081)																	
	10		15		20		25		30		35		40		45		48	
	Qc [kW]	EER	Qc [kW]	EER	Qc [kW]	EER	Qc [kW]	EER	Qc [kW]	EER	Qc [kW]	EER	Qc [kW]	EER	Qc [kW]	EER	Qc [kW]	EER
7	4.35	4.17	4.82	4.01	5.09	3.89	5.41	3.71	5.51	3.40	5.30	3.06	4.82	2.54	3.76	1.87	3.18	1.50
8	4.51	4.26	4.98	4.11	5.25	4.01	5.57	3.80	6.04	3.49	5.46	3.16	4.98	2.60	3.87	1.90	3.29	1.53
9	4.56	4.41	5.09	4.23	5.35	4.11	5.72	3.92	6.20	3.58	5.62	3.25	5.09	2.70	3.98	1.96	3.34	1.56
10	4.72	4.50	5.25	4.35	5.51	4.23	5.88	4.01	6.36	3.68	5.78	3.31	5.25	2.76	4.08	1.99	3.45	1.62
11	4.88	4.63	5.41	4.47	5.72	4.35	6.04	4.14	6.57	3.80	5.94	3.40	5.41	2.85	4.19	2.08	3.55	1.68
12	4.98	4.75	5.57	4.56	5.88	4.44	6.25	4.20	6.73	3.89	6.10	3.49	5.57	2.91	4.35	2.14	3.66	1.72
13	5.09	4.87	5.67	4.72	5.99	4.56	6.31	4.35	6.89	3.98	6.20	3.58	5.67	3.00	4.40	2.18	3.71	1.75
14	5.25	4.99	5.83	4.81	6.10	4.66	6.47	4.44	7.05	4.07	6.36	3.68	5.83	3.06	4.51	2.24	3.82	1.78
15	5.35	5.15	5.99	4.93	6.25	4.78	6.68	4.53	7.21	4.17	6.52	3.77	5.99	3.12	4.66	2.30	3.92	1.84
18	5.78	5.45	6.36	5.27	6.73	5.12	7.16	4.84	7.69	4.44	7.00	4.01	6.36	3.31	4.98	2.45	4.24	1.96
20	5.99	5.70	6.63	5.48	7.00	5.33	7.42	5.09	8.06	4.66	7.31	4.20	6.63	3.46	5.14	2.54	4.40	2.05
23	6.41	6.04	7.10	5.79	7.47	5.64	7.90	5.39	8.53	4.93	7.79	4.44	7.10	3.68	5.51	2.73	4.66	2.18
25	6.63	6.28	7.37	6.07	7.79	5.85	8.22	5.58	8.85	5.12	8.06	4.63	7.37	3.83	5.72	2.82	4.82	2.27

LWT [°C]	HEATING - Dry bulb outdoor air temperature in °C																											
	-25		-20		-15		-10		-7		-2		2		7		10		15		20		25		30		35	
	Qh [kW]	COP	Qh [kW]	COP	Qh [kW]	COP	Qh [kW]	COP	Qh [kW]	COP	Qh [kW]	COP	Qh [kW]	COP	Qh [kW]	COP	Qh [kW]	COP	Qh [kW]	COP	Qh [kW]	COP	Qh [kW]	COP	Qh [kW]	COP	Qh [kW]	COP
25	3.44	4.04	4.16	4.26	4.96	4.56	5.68	4.75	6.08	5.05	6.80	5.27	7.52	5.46	7.36	5.72	7.60	5.94	8.00	6.50	7.92	6.88	7.20	6.84	6.32	7.44	4.96	7.89
30	3.36	3.29	4.08	3.59	4.80	3.81	5.52	4.04	5.92	4.26	6.56	4.49	7.28	4.71	7.76	5.23	8.00	5.53	8.48	5.94	8.40	6.32	7.60	6.32	6.64	6.84	5.20	7.29
35	3.28	2.77	3.84	2.92	4.48	3.10	5.20	3.40	5.60	3.59	6.24	3.81	6.80	3.93	8.00	4.71	8.24	4.97	8.72	5.38	8.64	5.61	7.84	5.61	6.88	6.24	5.36	6.62
40	3.28	2.39	3.84	2.65	4.48	2.92	5.20	3.10	5.60	3.25	6.24	3.51	6.80	3.70	8.00	4.22	8.24	4.45	8.72	4.86	8.64	5.08	7.84	5.05	6.88	5.57	5.36	5.94
45			3.84	2.36	4.48	2.58	5.20	2.80	5.60	2.92	6.24	3.10	6.80	3.29	8.00	3.74	8.24	3.93	8.72	4.26	8.64	4.49	7.84	4.71	6.88	4.93	5.36	5.23
50					4.32	2.21	5.04	2.39	5.44	2.50	6.08	2.69	6.56	2.77	7.76	3.25	8.00	3.40	8.48	3.74	8.40	3.93	7.60	4.11	6.64	4.30	5.20	4.60
55							4.80	1.98	5.12	2.09	5.76	2.28	6.24	2.39	7.36	2.77	7.60	2.92	8.00	3.18	7.92	3.33	7.20	3.48	6.32	3.66	4.96	3.93
60									4.88	1.72	5.44	1.79	5.92	1.91	6.96	2.28	7.20	2.32	7.60	2.50	7.52	2.62	6.80	2.77	6.00	2.88	4.64	3.10

LWT: Leaving water temperature  
Qh: Heating capacity  
COP: Coefficient of performance

LWT: Leaving water temperature  
Qc: Cooling capacity  
EER: Energy efficiency ratio

# TECHNICAL DATA FOR 10 kW

MODEL				AGHPSA101							
Outdoor unit model				AGHPSA101SH							
Hydronic indoor unit model				AGHPS101W							
Matchable units for domestic hot water production (DHW)				200/300 liters external tank with diverting valve							
				Cooling	Heating						
COMFORT IN ENVIRONMENT	Performance according to EN 14511	Air +35 °C - Water 23/18 °C Air +7 °C - Water 30/35 °C	Rated capacity	kW	8.50	9.50					
			Rated electrical power input	kW <sub>el</sub>	2.24	2.07					
			EER/COP		3.79	4.59					
	Performance according to Ecodesign (ERP) EN 14825	LOW TEMPERATURE (35 °C) AVERAGE climate	Air +35 °C - Water 12/7 °C Air +7 °C - Water 40/45 °C	Rated capacity	kW	6.50	9.50				
				Rated electrical power input	kW <sub>el</sub>	2.27	2.64				
				EER/COP		2.86	3.60				
DHW	Performance according to EN 16147	With 300 liters tank and diverting valve AVERAGE climate	Design thermal load (P <sub>design,h</sub> )	kW	9.00						
			Seasonal energy efficiency η <sub>s</sub>	%	181						
			Energy efficiency class		A+++						
	Performance according to EN 14825	MEDIUM TEMPERATURE (55 °C) AVERAGE climate	Air +35 °C - Water 12/7 °C Air +7 °C - Water 40/45 °C	Design thermal load (P <sub>design,h</sub> )	kW	8.00					
				Seasonal energy efficiency η <sub>s</sub>	%	127					
				Energy efficiency class		A++					
Performance according to EN 16147	With 300 liters tank and diverting valve AVERAGE climate	Air +35 °C - Water 12/7 °C Air +7 °C - Water 40/45 °C	Load profile		XL						
			Energy efficiency class		A						
			Water heating efficiency - ERP η <sub>wh</sub>	%	111						
Indoor unit	Performance according to EN 14511	Air +35 °C - Water 23/18 °C Air +7 °C - Water 30/35 °C	Nominal water flow rate	m <sup>3</sup> /h	at 35 °C	1.63					
					at 45 °C	1.63					
					at 7 °C	1.12					
					at 18 °C	1.46					
	Performance according to EN 14825	MEDIUM TEMPERATURE (55 °C) AVERAGE climate	Air +35 °C - Water 12/7 °C Air +7 °C - Water 40/45 °C	Minimum efficient water volume of the system	liters	80					
				Maximum delivery water temperature	°C	Up to 60					
				Power supply (Voltage/Phases/Frequency)	V/Ph/Hz	220-240/1/50					
				Electrical power input	kW	3.10					
				Heating element	n×kW	2×3					
				Expansion vessel	liters	10					
				Maximum circulator pump head	kPa	see H/Q graph					
				Hydraulic connections	inches	G1" female					
				Safety valve	bar	3					
				Indoor unit sound pressure	dB(A)	29	29				
Outdoor unit	Performance according to EN 14511	Air +35 °C - Water 23/18 °C Air +7 °C - Water 30/35 °C	Nominal water flow rate	m <sup>3</sup> /h	at 35 °C	1.63					
					at 45 °C	1.63					
					at 7 °C	1.12					
					at 18 °C	1.46					
					Performance according to EN 14825	MEDIUM TEMPERATURE (55 °C) AVERAGE climate	Air +35 °C - Water 12/7 °C Air +7 °C - Water 40/45 °C	Minimum efficient water volume of the system	liters	80	
								Maximum delivery water temperature	°C	Up to 60	
								Power supply (Voltage/Phases/Frequency)	V/Ph/Hz	220-240~/1/50	
								Maximum power input (cooling)	kW	5.06	
								Maximum power input (heating)	kW	3.40	
								Maximum current draw (cooling)	A	22	
								Maximum current draw (heating)	A	15	
								Liquid cooling pipe diameter	mm (inches)	6.35 (1/4)	
								Gas cooling pipe diameter	mm (inches)	12.7 (1/2)	
								Outdoor unit sound pressure	dB(A)	55	55
Performance according to EN 16147	With 300 liters tank and diverting valve AVERAGE climate	Air +35 °C - Water 12/7 °C Air +7 °C - Water 40/45 °C	Fan air flow rate	m <sup>3</sup> /h	3300						
			Net weight	kg	82						
			Dimensions (H/W/D)	mm	787/982/427						
			Compressor type		Twin Rotary with vapour injection						
			Type and GWP		R32/675 kg CO <sub>2</sub> eq.						
			Quantity		1.6 kg/1.08 tons CO <sub>2</sub> eq.						

The equipments described in this catalogue contain HFC R32-type fluorinated greenhouse gases.  
These products must be fitted by qualified staff pursuant to European regulations 303/2008 and 517/2014.

Data declared in accordance with REGULATION (EU) No. 811/2013 of 18 February 2013 with regard to the energy labelling of space heaters, combination heaters, packages of space heater, temperature control and solar device and packages of combination heater, temperature control and solar devices, packages of combination heater, temperature control and solar devices, and with COMMISSION REGULATION (EU) No. 813/2013 of 2 August 2013 implementing Directive 2009/125/EC of the European Parliament and of the Council with regard to ecodesign requirements for space heaters and combination heaters.



## CAPACITY AND EFFICIENCY DATA IN RELATION TO THE OUTDOOR TEMPERATURE ACCORDING TO THE EN14511-3:2013 STANDARD

HEAT PUMPS

LWT [°C]	COOLING - Dry bulb outdoor air temperature in °C - (AGHPSA101)																	
	10		15		20		25		30		35		40		45		48	
	Qc [kW]	EER	Qc [kW]	EER	Qc [kW]	EER	Qc [kW]	EER	Qc [kW]	EER	Qc [kW]	EER	Qc [kW]	EER	Qc [kW]	EER	Qc [kW]	EER
7	5.33	3.89	5.92	3.75	6.24	3.64	6.63	3.46	6.76	3.18	6.50	2.86	5.92	2.38	4.62	1.75	3.90	1.40
8	5.46	4.01	6.11	3.87	6.44	3.75	6.83	3.58	6.96	3.26	6.70	2.95	6.11	2.43	4.75	1.78	4.03	1.46
9	5.66	4.15	6.24	4.01	6.57	3.87	7.02	3.69	7.15	3.38	6.89	3.04	6.24	2.52	4.94	1.86	4.10	1.52
10	5.79	4.24	6.37	4.09	6.70	3.95	7.22	3.81	7.35	3.46	7.02	3.12	6.37	2.58	5.01	1.92	4.23	1.52
11	5.92	4.35	6.57	4.21	6.96	4.07	7.35	3.87	7.54	3.58	7.22	3.21	6.57	2.66	5.07	1.95	4.36	1.57
12	6.11	4.47	6.70	4.30	7.15	4.18	7.54	3.98	7.67	3.67	7.41	3.29	6.70	2.72	5.27	2.00	4.49	1.60
13	6.24	4.61	6.89	4.44	7.35	4.30	7.74	4.09	7.87	3.78	7.61	3.38	6.89	2.83	5.40	2.09	4.55	1.66
14	6.44	4.70	7.15	4.52	7.48	4.41	7.93	4.21	8.13	3.84	7.80	3.46	7.15	2.89	5.53	2.12	4.68	1.72
15	6.57	4.84	7.28	4.64	7.67	4.50	8.19	4.30	8.32	3.92	8.00	3.55	7.28	2.95	5.72	2.15	4.81	1.75
18	7.02	5.18	7.74	5.01	8.13	4.84	8.65	4.61	8.91	4.24	8.52	3.81	7.74	3.15	6.05	2.32	5.14	1.86
20	7.35	5.44	8.13	5.21	8.58	5.10	9.10	4.84	9.30	4.44	8.91	3.98	8.13	3.32	6.31	2.43	5.33	1.98
23	7.74	5.76	8.58	5.53	9.04	5.38	9.62	5.13	9.82	4.70	9.43	4.24	8.58	3.49	6.63	2.58	5.66	2.06
25	8.00	5.98	8.91	5.78	9.36	5.58	10.01	5.33	10.21	4.90	9.82	4.41	8.91	3.67	6.96	2.69	6.00	2.18

LWT [°C]	HEATING - Dry bulb outdoor air temperature in °C																											
	-25		-20		-15		-10		-7		-2		2		7		10		15		20		25		30		35	
	Qh [kW]	COP	Qh [kW]	COP	Qh [kW]	COP	Qh [kW]	COP	Qh [kW]	COP	Qh [kW]	COP	Qh [kW]	COP	Qh [kW]	COP	Qh [kW]	COP	Qh [kW]	COP	Qh [kW]	COP	Qh [kW]	COP	Qh [kW]	COP	Qh [kW]	COP
25	4.09	3.99	4.94	4.21	5.89	4.50	6.75	4.68	7.22	4.97	8.08	5.18	8.93	5.40	8.74	5.61	9.03	5.87	9.50	6.41	9.41	6.80	8.55	6.73	7.51	7.34	5.89	7.77
30	3.99	3.24	4.85	3.49	5.70	3.74	6.56	3.96	7.03	4.17	7.79	4.39	8.65	4.61	9.22	5.11	9.50	5.43	10.07	5.79	9.98	6.19	9.03	6.19	7.89	6.69	6.18	7.16
35	3.90	2.73	4.56	2.88	5.32	3.06	6.18	3.31	6.65	3.53	7.41	3.74	8.08	3.85	9.50	4.61	9.79	4.86	10.36	5.29	10.26	5.51	9.31	5.51	8.17	6.12	6.37	6.48
40	3.90	2.34	4.56	2.59	5.32	2.81	6.18	2.99	6.65	3.13	7.41	3.38	8.08	3.60	9.50	4.10	9.79	4.32	10.36	4.68	10.26	4.93	9.31	4.89	8.17	5.40	6.37	5.76
45			4.56	2.27	5.32	2.48	6.18	2.70	6.65	2.81	7.41	2.99	8.08	3.17	9.50	3.60	9.79	3.78	10.36	4.10	10.26	4.32	9.31	4.53	8.17	4.75	6.37	5.04
50					5.13	2.09	5.99	2.27	6.46	2.38	7.22	2.55	7.79	2.63	9.22	3.09	9.50	3.24	10.07	3.56	9.98	3.71	9.03	3.89	7.89	4.07	6.18	4.35
55							5.70	1.87	6.08	1.94	6.84	2.12	7.41	2.23	8.74	2.59	9.03	2.73	9.50	2.95	9.41	3.13	8.55	3.24	7.51	3.42	5.89	3.67
60									5.80	1.58	6.46	1.66	7.03	1.76	8.27	2.09	8.55	2.16	9.03	2.30	8.93	2.41	8.08	2.55	7.13	2.66	5.51	2.84

LWT: Leaving water temperature  
Qh: Heating capacity  
COP: Coefficient of performance  
LWT: Leaving water temperature  
Qc: Cooling capacity  
EER: Energy efficiency ratio

## FLOW RATE CURVES 8-10 kW

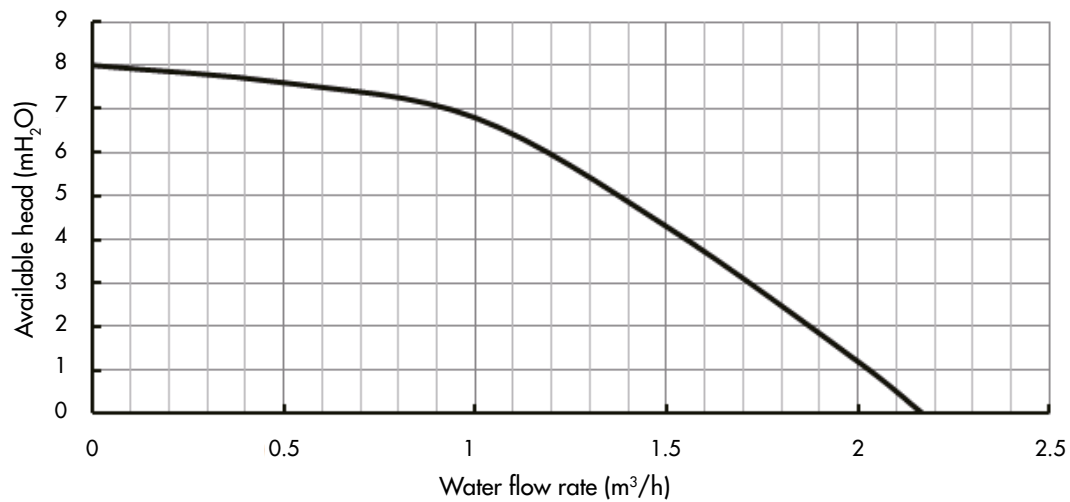

## DIMENSIONAL DRAWINGS 8-10 kW

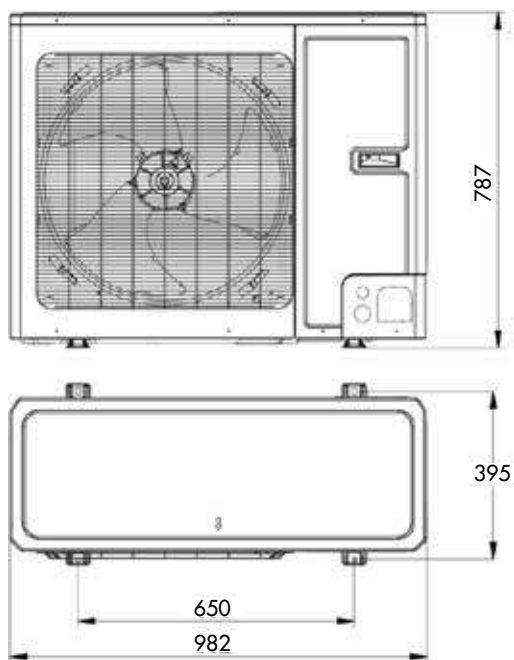

OUTDOOR UNIT 8-10 kW

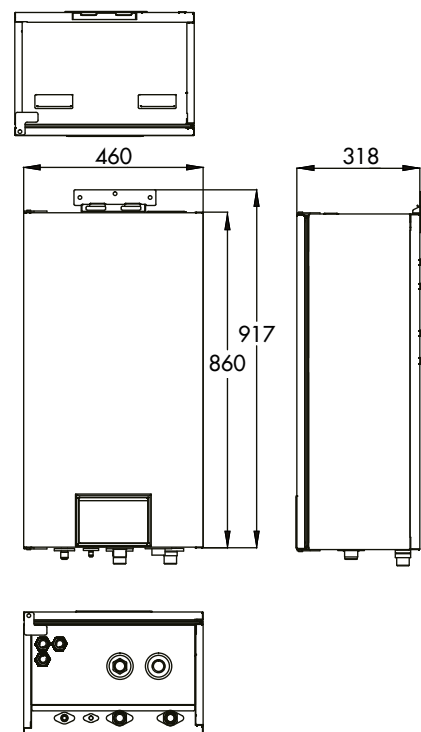

INDOOR UNIT 8-10 kW

# SPACE REQUIRED FOR OUTDOOR UNIT INSTALLATION 8-10 kW

HEAT  
PUMPS

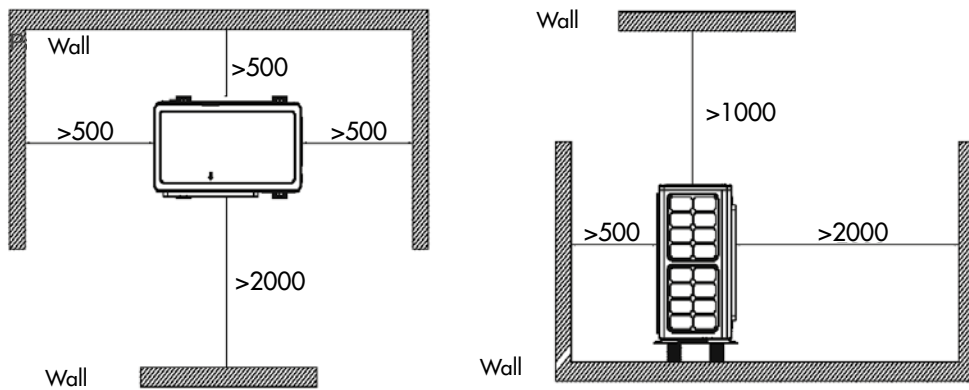

# SPACE REQUIRED FOR INDOOR UNIT INSTALLATION 8-10 kW

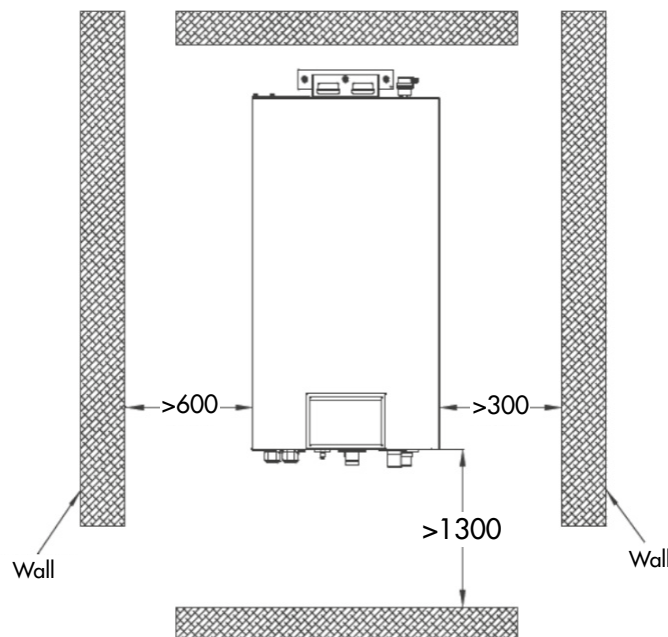

# INSTALLATION EXAMPLES

## EXAMPLE 1

### Radiant heating and DHW with three-way valve and tank

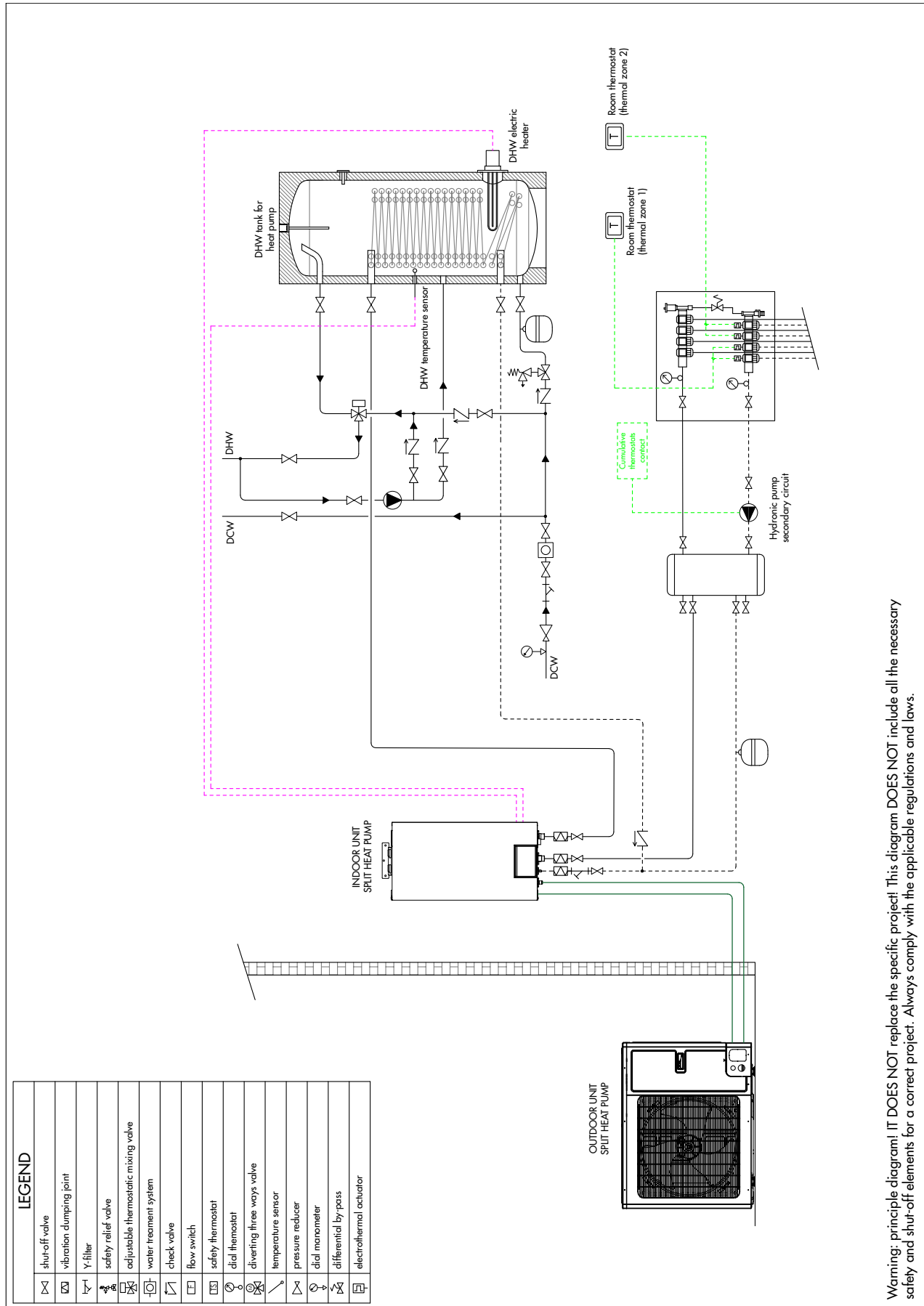

Warning: principle diagram! IT DOES NOT replace the specific project! This diagram DOES NOT include all the necessary safety and shut-off elements for a correct project. Always comply with the applicable regulations and laws.

## EXAMPLE 2

### Heating (cooling) with fan coil units and DHW with three-way valve and tank

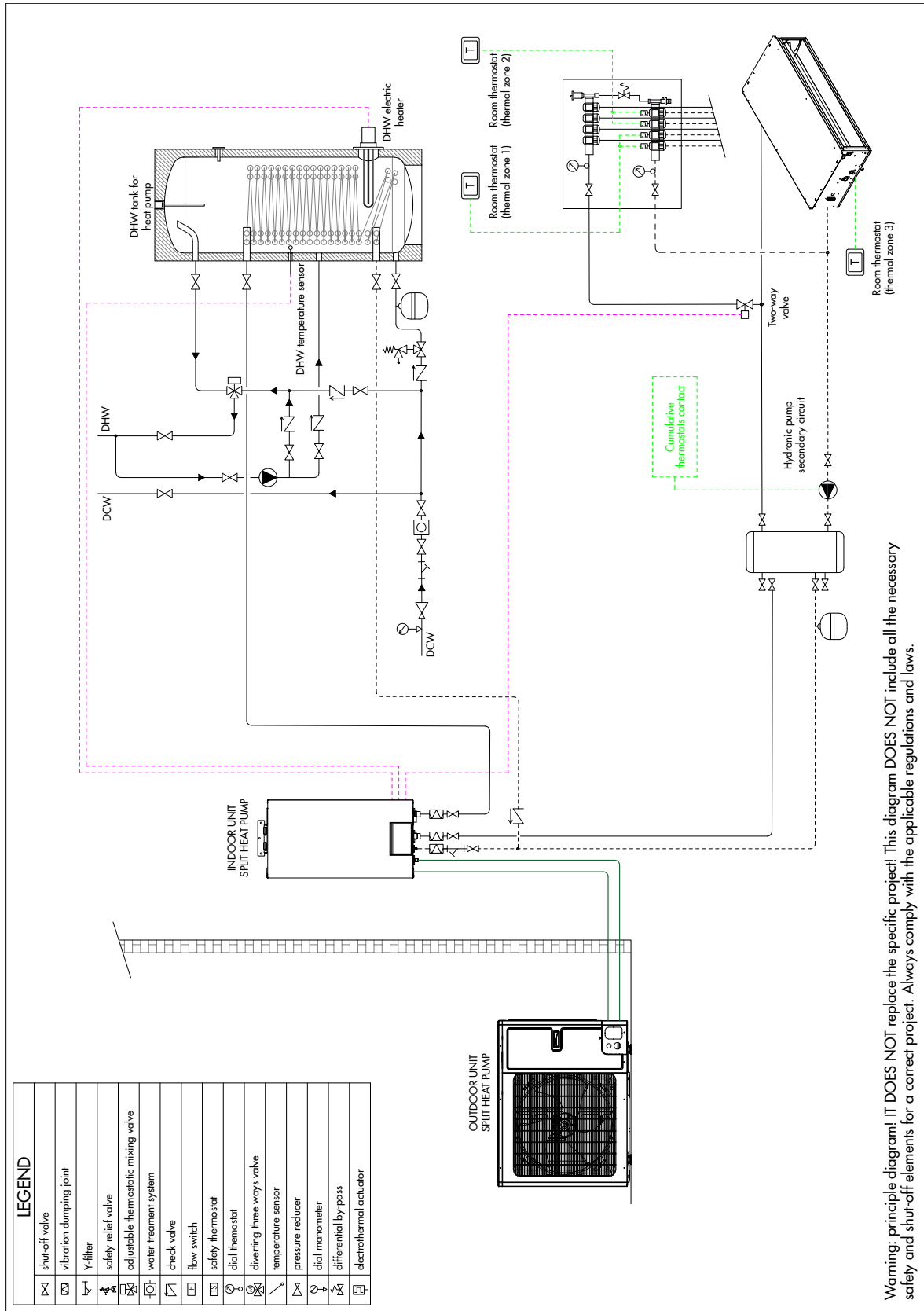

# INSTALLATION EXAMPLES

## EXAMPLE 3

### Radiant heating, single thermal zone and DHW with three-way valve and tank

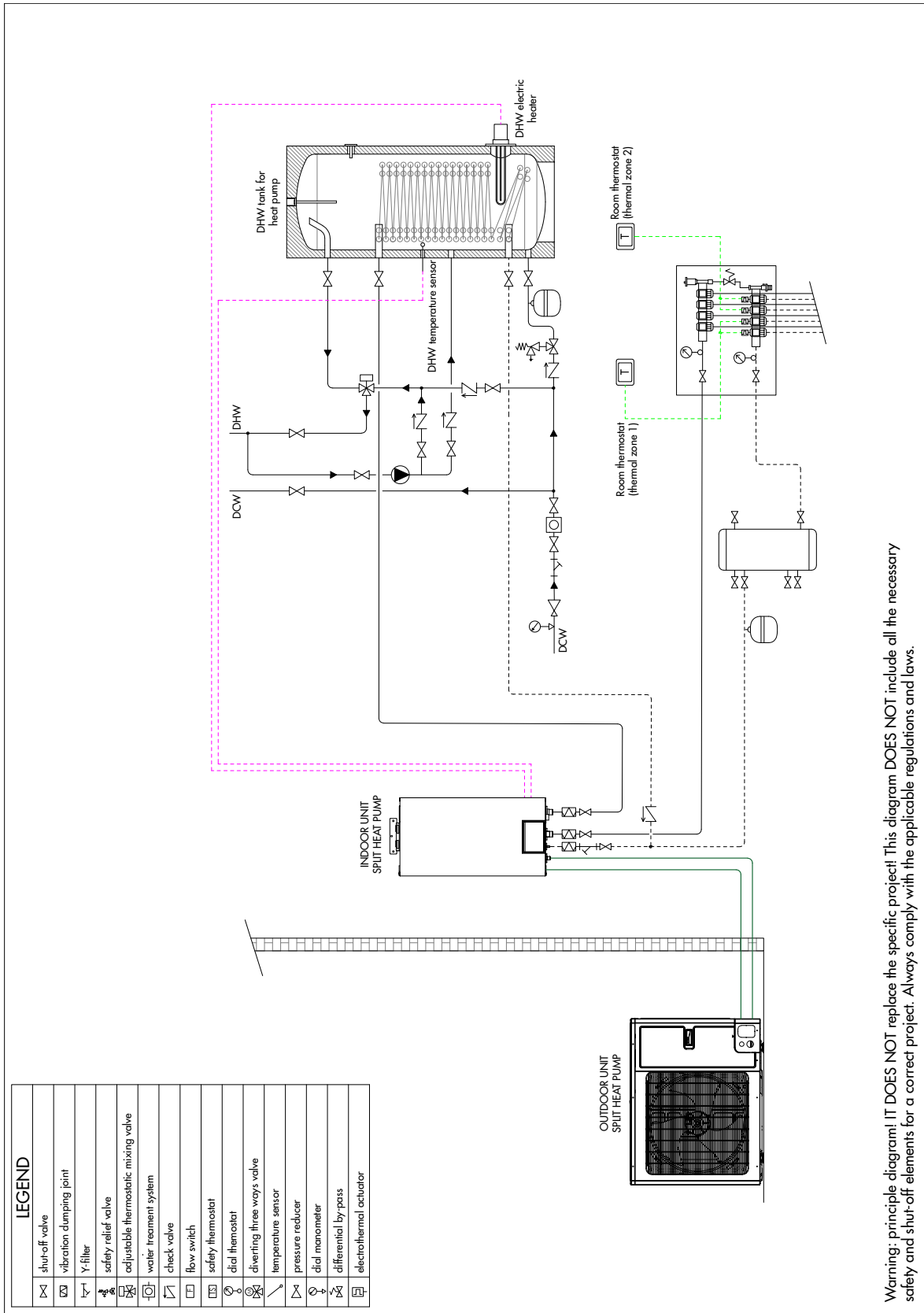

Warning: principle diagram! IT DOES NOT replace the specific project! This diagram DOES NOT include all the necessary safety and shut-off elements for a correct project. Always comply with the applicable regulations and laws.

### EXAMPLE 4

## Heating and Cooling with mixing modules and DHW with three-ways valve and tank

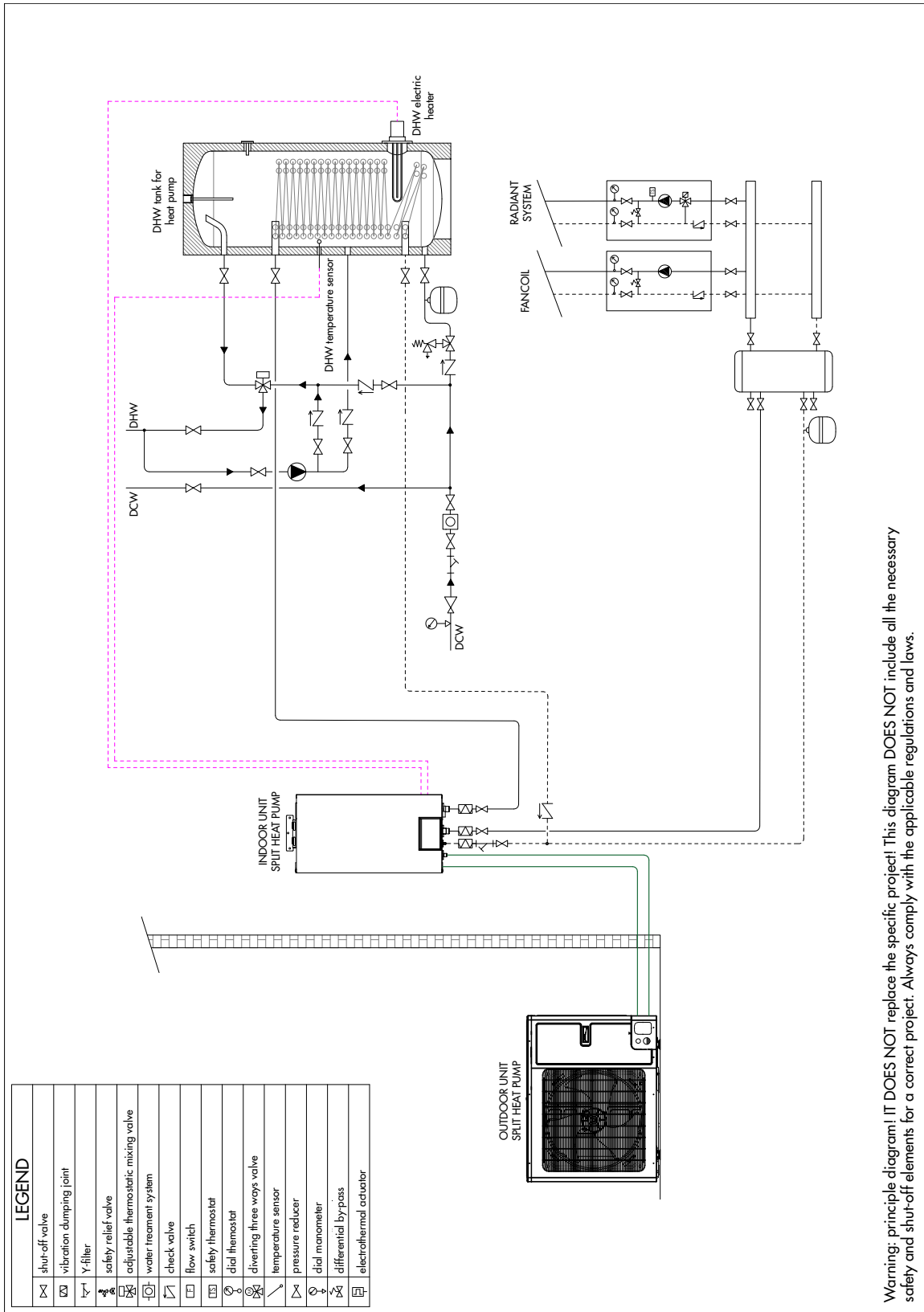

Warning: principle diagram! IT DOES NOT replace the specific project! This diagram DOES NOT include all the necessary safety and shut-off elements for a correct project. Always comply with the applicable regulations and laws.





# BUILT-IN SOLUTION

---

For SPLIT heat pumps

# BUILT-IN SOLUTION

## FOR SPLIT HEAT PUMPS

### MAIN FEATURES

With the cabinet, the hydronic indoor unit of the X3 ARGO split heat pump can be installed built-in. This specific solution allows for reducing and optimising the installation spaces.

The production of DHW occurs by means of a three-way valve, installed directly on the unit. The cabinet, which is made of galvanised sheet steel, contains all the elements for setting up a space heating and/or cooling system and for producing DHW:

- Stainless steel DHW storage tank, equipped with a spiral corrugated fixed heat exchanger for increasing the heat exchange surface;
- Kit for connection to the indoor unit, with adequately configured and insulated pipes and an inertial storage tank. It is possible to directly use the pump supplied with the unit or a second pump in the primary/secondary circuit configuration;
- Safety and control device on the DHW and system sides.

### BUILT-IN SOLUTION COMPONENTS (to be added to the indoor hydronic unit)

Code	Description
387030626	Built-in cabinet 2242 mm (H) x 998 mm (W) x 415 mm (D)
387030637	200 liters DHW storage tank with heat exchanger
387030638	X3 connection kit

### ACCESSORIES

Code	Description
387030630	DHW inlet filter 3/4"
387030631	Pair of DHW shut-off valves 3/4"
387030632	Electrical resistance 1.5 kW for DHW tank
387030633	System output filter 3/4"
387030634	Pair of system shut-off valves 1"

## MAIN COMPONENTS

- 1** X3 ARGO split hydronic indoor unit
- 2** DHW tank with the following characteristics:

  - volume: 200 liters;
  - AISI 316 L stainless steel structure;
  - AISI 316 L stainless steel fixed heat exchanger;
  - EPS insulation with graphite, thickness 25 mm.
- 3** Hydraulic kit for connection to the indoor unit, the main components of which include:

  - AISI 316 L stainless steel 25 liters inertial tank;
  - thermostatic mixer 25-50 °C;
  - DHW-side expansion vessel, 6 bar, 12 liters;
  - 6 bar safety valve on DHW side and 3 bar safety valve on system side;
  - insulated connecting pipes.
- 4** Built-in metal cabinet, made of galvanised sheet steel



# REFERENCE HYDRAULIC DIAGRAM

24

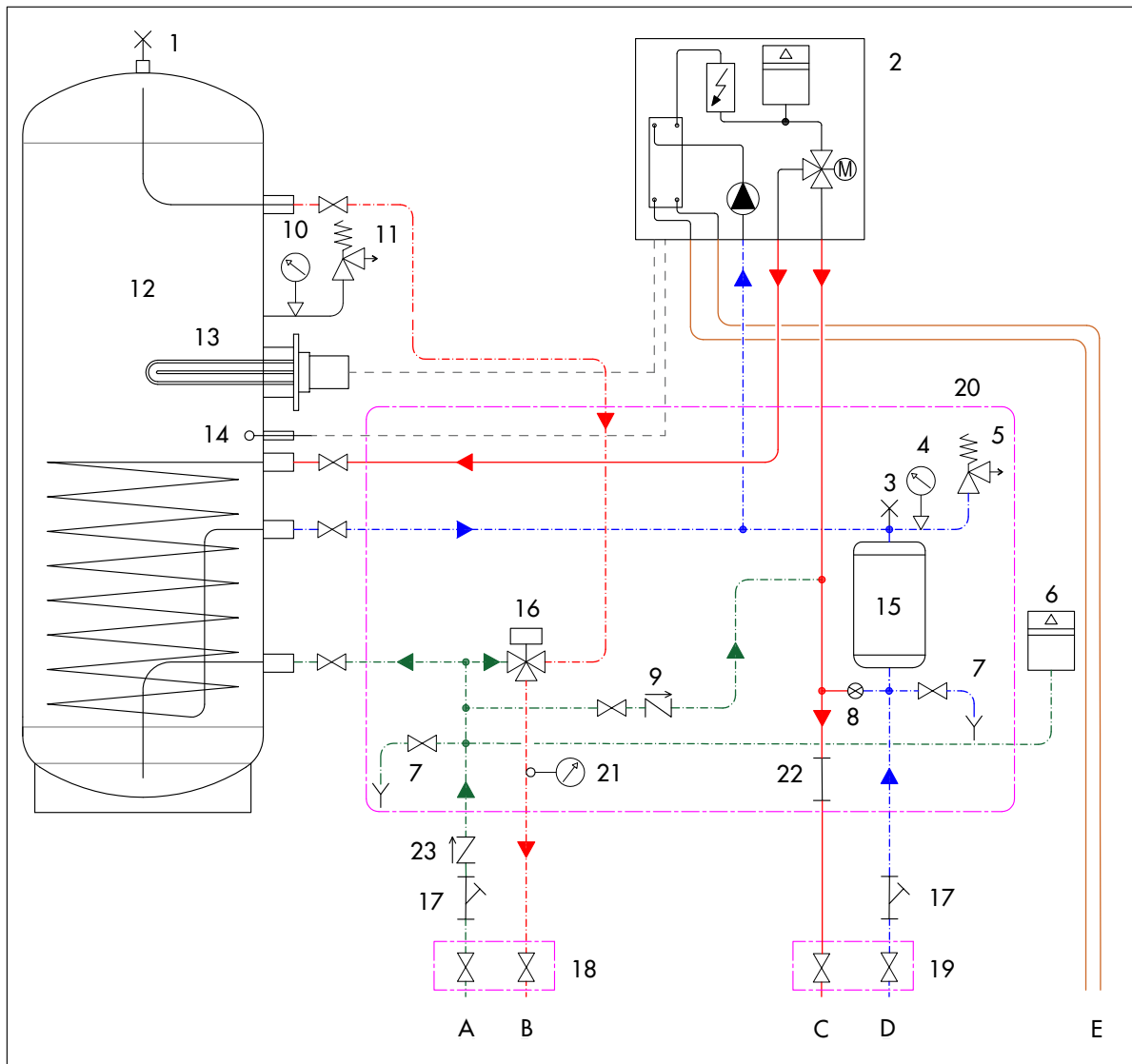

## Key to components

- |  |  |
|--|--|
| <ul style="list-style-type: none"> <li>1. DHW tank manual air relief valve</li> <li>2. X3 ARGO split indoor unit</li> <li>3. system manual air relief valve</li> <li>4. 0-4 bar system pressure gauge</li> <li>5. safety valve for system, 3 bar</li> <li>6. DHW expansion vessel, 6 bar - 12 liters</li> <li>7. discharge valve Ø 1/2"</li> <li>8. shut-off valve</li> <li>9. system filling non-return valve</li> <li>10. 0-6 bar pressure gauge</li> <li>11. safety valve for DHW, 6 bar</li> <li>12. grade AISI 316 L stainless steel 200 liters DHW storage tank - pmax 8 bar</li> <li>13. heating element 1.5 kW (optional)</li> </ul> | <ul style="list-style-type: none"> <li>14. thermowell Ø 6 mmx130 mm</li> <li>15. grade AISI 316 L stainless steel system technical storage tank - 25 liters</li> <li>16. thermostatic mixing valve 25 °C-50 °C Kv=2.3</li> <li>17. system and DHW filters</li> <li>18. 3/4" shut-off valve (optional)</li> <li>19. 1" M shut-off valve (optional)</li> <li>20. pre-assembled hydronic module limits</li> <li>21. contact thermometer</li> <li>22. stub for secondary circuit hydronic pump configuration (not managed by the unit)</li> <li>23. DHW non-return valve</li> <li>24. metal cabinet limit</li> </ul> |
|--|--|

## Key to fittings

- |   |  |
|---|--|
| <ul style="list-style-type: none"> <li>A. 3/4" M domestic cold water inlet</li> <li>B. 3/4" M domestic hot water outlet</li> <li>C. 1" M system supply</li> </ul> | <ul style="list-style-type: none"> <li>D. 1" M system return</li> <li>E. connection for indoor unit refrigerant pipes</li> </ul> |
|---|--|

# DIMENSIONAL DRAWINGS

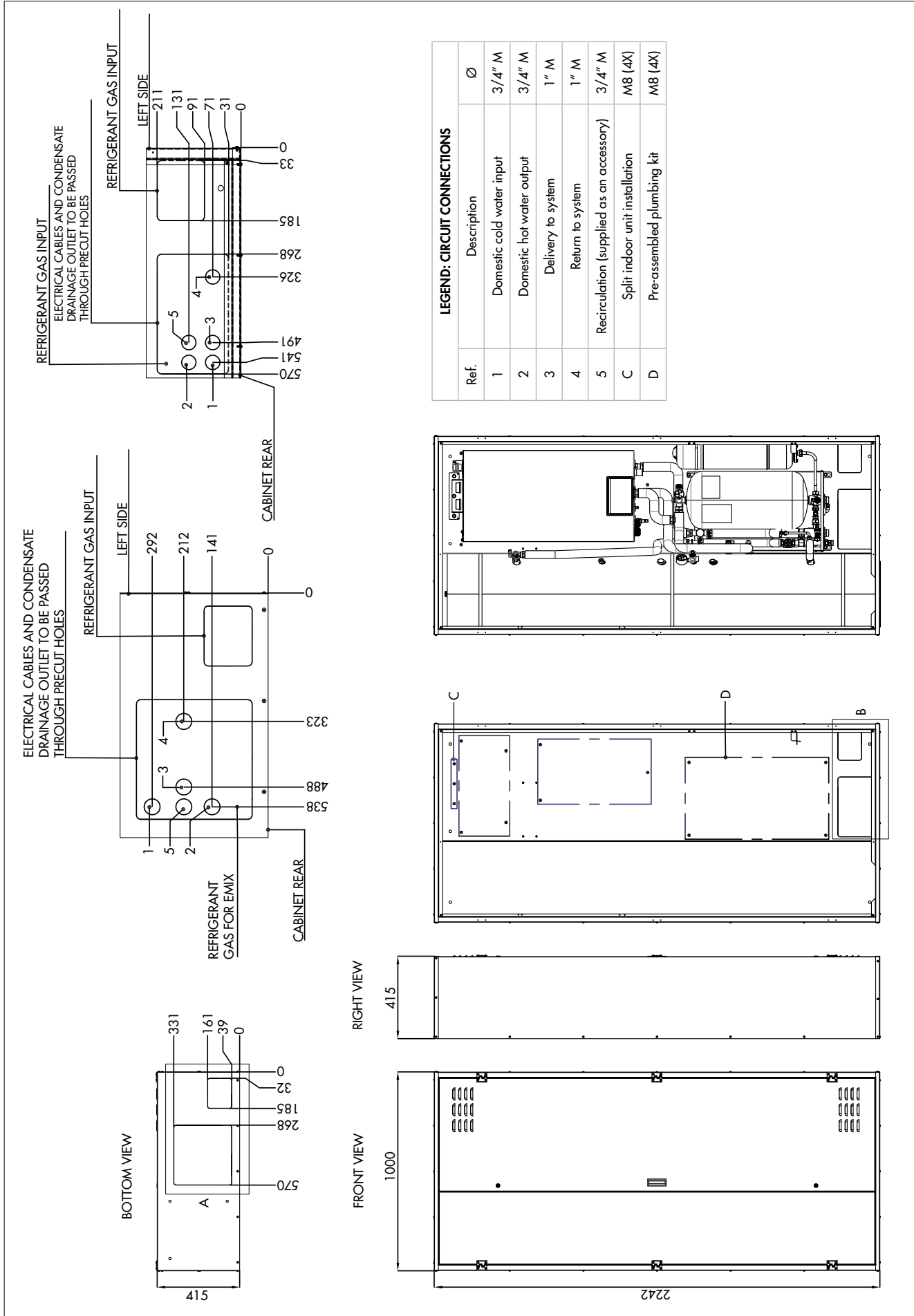

# INSTALLATION EXAMPLE

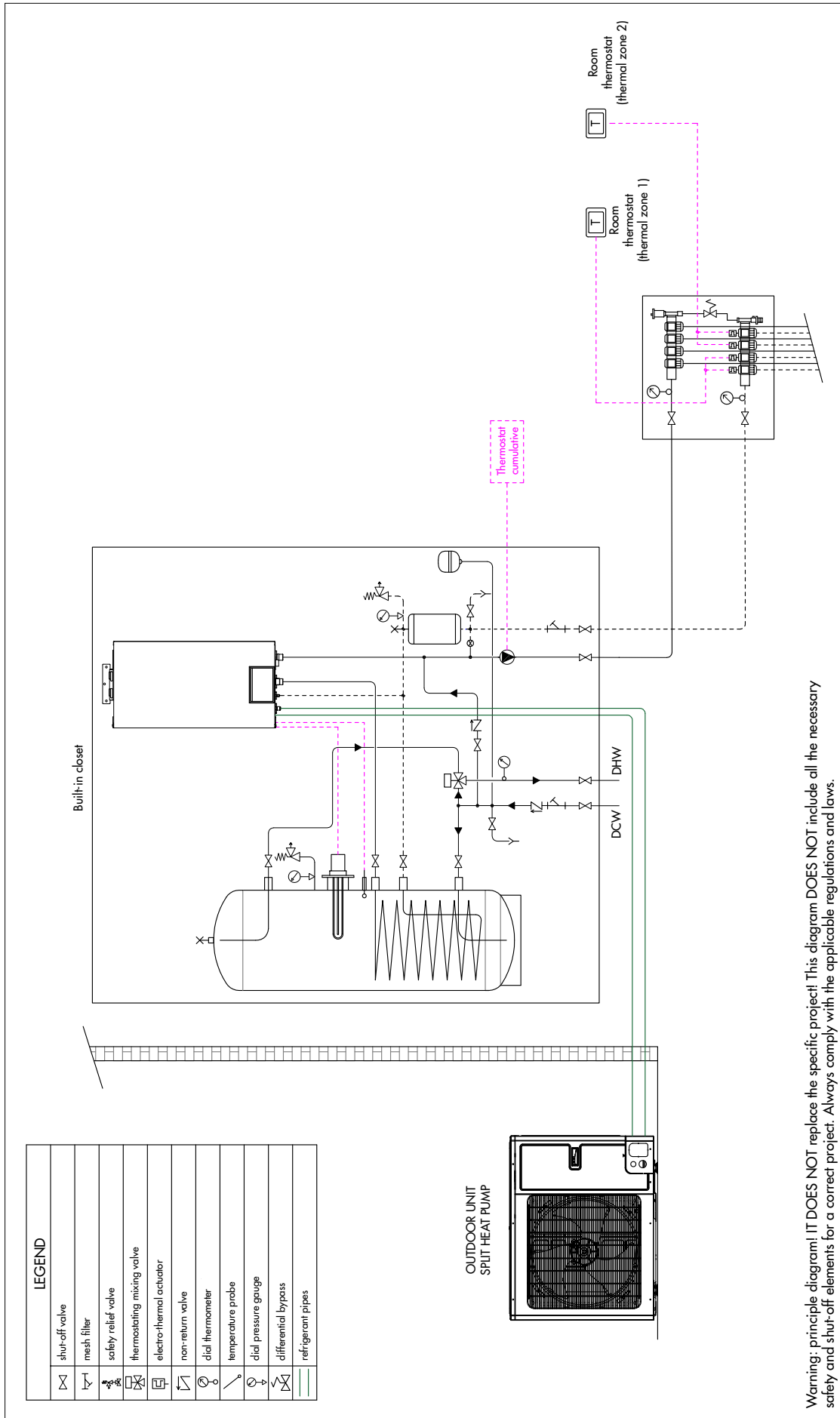

# NOTES

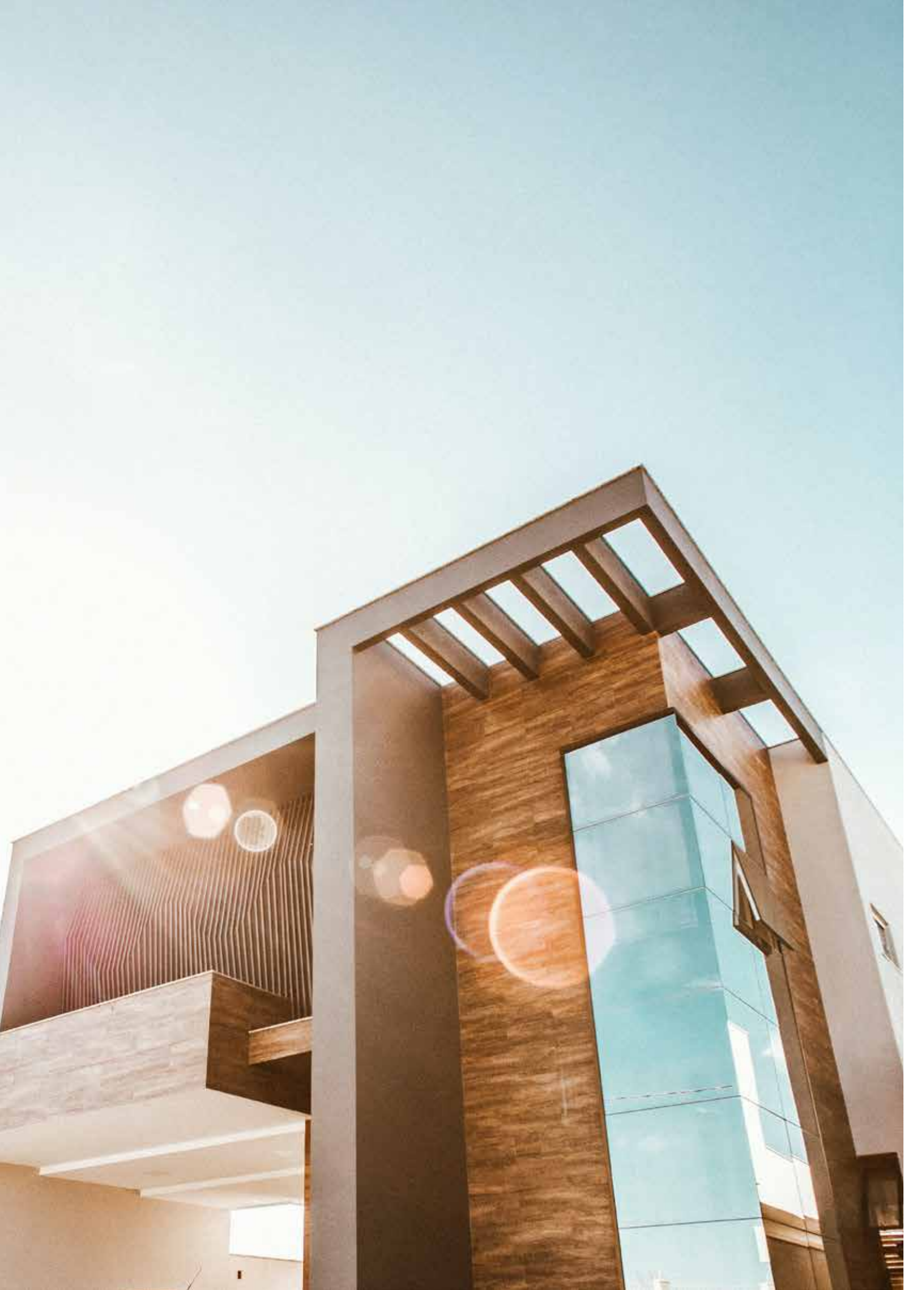



# ALL IN ONE

---

Single-phase 6-8-10 kW range

# ALL-IN-ONE HEAT PUMPS

## MAIN FEATURES



(Standard on the indoor unit)

Touch-screen control panel installed on the indoor unit

- All in one Air/Water heat pump with integrated tank for the production of domestic hot water.
- New-generation DC Inverter technology.
- Equipped with the heating, cooling and domestic hot water production functions.
- Single-phase version with 6-8-10 kW heating capacity.
- Achieves very high efficiency levels in heating mode, up to 5 COP.
- It uses R32, a refrigerant with low impact on global warming and ozone layer, characterised by high energy efficiency and a 30% lower charge compared to R410A.
- The vapour-injection compressor, thanks to its special technology, guarantees exceptional performances within a wide operating range.
- The leaving water temperature range is 20 °C-60 °C: this means that the heat pump can be used with radiant floor systems, fan coil units and also medium-temperature radiators.
- The DC brushless axial fans are designed to ensure aerodynamic optimisation: they guarantee low noise levels coupled with high efficiency and a high air flow rate.
- It is equipped with a heating element on the base to prevent ice build-up during winter operation.
- The outdoor unit is equipped with an electronic expansion valve, while the indoor unit contains - besides the tank - all the hydraulic components: inverter pump, plate heat exchanger, expansion vessel, safety valve, flow switch and water filter supplied (installation mandatory).

Internal copper groove	Quiet mode	Weekly timer	Heating down to low temperatures	Door control	Full protection	Timer	Child lock	Wide operating range	Wide voltage range	Auto diagnosis	Low-voltage start-up
Auto restart memory	Intelligent defrosting	°C / °F switching	Long-distance monitoring	Exch. condenser gold fin treatment	-25°C Min. outdoor temp. heating	+35°C Max. outdoor temp. heating	+10°C Min. outdoor temp. cooling	+48°C Max. outdoor temp. cooling	-25°C Min. outdoor temp. DHW	+45°C Max. outdoor temp. DHW	60°C Max. output temp. DHW





**A+++** Heating mode 35 °C

**A++** Heating mode 55 °C

**A** DHW

# THE RANGE

HEAT  
PUMPS

	Model	Code		Rated capacity according to EN14511 (kW)		Integrated DHW tank capacity (l)
				1PH	 Heating (1)	
OUTDOOR UNIT - 1PH 	AGHPSA061SH	398600012	●	6.0	5.8	
	AGHPSA081SH	398600013	●	8.0	7.0	
	AGHPSA101SH	398600014	●	9.5	8.5	
HYDRONIC INDOOR UNIT 	AGHPA061F	398600028	●	6.0	5.8	185
	AGHPA081F	398600029	●	8.0	7.0	185
	AGHPA101F	398600030	●	9.5	8.5	185

(1) Water temperature 30 °C/35 °C, outdoor air temperature 7 °C D.B./6 °C W.B.

(2) Water temperature 23 °C/18 °C, outdoor air temperature 35 °C

## INCLUDED ACCESSORIES

Ambient air temperature sensor
Y-shaped filter
Control panel (integrated into the indoor unit)

# TECHNICAL DATA FOR 6 kW

MODEL				AGHPSA061					
Outdoor unit model				AGHPSA061SH					
Hydronic indoor unit model				AGHPA061F					
Matchable units for domestic hot water production (DHW)				Tank integrated into the indoor unit 185 liters - diverting valve included in the indoor unit					
COMFORT IN ENVIRONMENT	Performance according to EN 14511	Air +35 °C - Water 23/18 °C Air +7 °C - Water 30/35 °C	Rated capacity	kW	Cooling	5.80	Heating	6.00	
			Rated electrical power input	kW <sub>el</sub>		1.32		1.20	
			EER/COP			4.39		5.00	
		Air +35 °C - Water 12/7 °C Air +7 °C - Water 40/45 °C	Rated capacity	kW		4.09		5.90	
			Rated electrical power input	kW <sub>el</sub>		1.28		1.51	
	Performance according to Ecodesign (ERP) EN 14825	LOW TEMPERATURE (35 °C) AVERAGE climate	Design thermal load (P <sub>design,h</sub> )	kW				6.00	
			Seasonal energy efficiency η <sub>s</sub>	%				179	
			Energy efficiency class						A+++
		MEDIUM TEMPERATURE (55 °C) AVERAGE climate	Design thermal load (P <sub>design,h</sub> )	kW					5.00
			Seasonal energy efficiency η <sub>s</sub>	%					127
Energy efficiency class								A++	
DHW performance according to EN 16147	AVERAGE climate	Load profile						L	
		Energy efficiency class							A
		Water heating efficiency - ERP η <sub>wh</sub>	%						101
Indoor unit	Nominal water flow rate		m <sup>3</sup> /h	at 35 °C			1.03		
				at 45 °C			1.02		
				at 7 °C			0.70		
				at 18 °C			1.00		
	Minimum efficient water volume of the system		liters				40		
	Maximum delivery water temperature		°C				Up to 60		
	Power supply (Voltage/Phases/Frequency)		V/Ph/Hz				220-240/1/50		
	Electrical power input		kW				3.10		
	Heating element		n×kW				2×1.5		
	Expansion vessel		liters				10		
	Maximum circulator pump head		kPa				see H/Q graph		
	Hydraulic connections		inches				G1" female		
	Safety valve		bar				3		
	Indoor unit sound pressure		dB(A)		29		29		
	Net weight		kg				210		
	Dimensions (H/W/D)		mm				1756/600/600		
	DHW integrated capacity tank		liters				185		
	Outdoor unit	Outdoor temperature range (heating)		°C				-25/+35	
		Outdoor temperature range (cooling)		°C				+10/+48	
		Electrical power supply		V/Ph/Hz				220-240~/1/50	
Maximum power input (cooling)			kW				2.30		
Maximum power input (heating)			kW				2.30		
Maximum current draw (cooling)			A				10		
Maximum current draw (heating)			A				10		
Liquid cooling pipe diameter			mm (inches)				6.35 (1/4)		
Gas cooling pipe diameter			mm (inches)				12.7 (1/2)		
Outdoor unit sound pressure			dB(A)		52		52		
Fan air flow rate			m <sup>3</sup> /h				3200		
Net weight			kg				55		
Dimensions (H/W/D)			mm				702/975/396		
Compressor type							Twin Rotary with vapour injection		
Refrigerant		Type and GWP						R32/675 kg CO <sub>2</sub> eq.	
		Quantity						1 kg/0.675 tons CO <sub>2</sub> eq.	

The equipments described in this catalogue contain HFC R32-type fluorinated greenhouse gases.  
These products must be fitted by qualified staff pursuant to European regulations 303/2008 and 517/2014.

Data declared in accordance with REGULATION (EU) No. 811/2013 of 18 February 2013 with regard to the energy labelling of space heaters, combination heaters, packages of space heater, temperature control and solar device and packages of combination heater, temperature control and solar devices, packages of combination heater, temperature control and solar devices, and with COMMISSION REGULATION (EU) No. 813/2013 of 2 August 2013 implementing Directive 2009/125/EC of the European Parliament and of the Council with regard to eco-design requirements for space heaters and combination heaters.

## CAPACITY AND EFFICIENCY DATA IN RELATION TO THE OUTDOOR TEMPERATURE ACCORDING TO THE EN14511-3:2013 STANDARD

LWT [°C]	COOLING - Dry bulb outdoor air temperature in °C - (AGHPSA061)																	
	10		15		20		25		30		35		40		45		48	
	Qc [kW]	EER	Qc [kW]	EER	Qc [kW]	EER	Qc [kW]	EER	Qc [kW]	EER	Qc [kW]	EER	Qc [kW]	EER	Qc [kW]	EER	Qc [kW]	EER
7	3.35	4.35	3.72	4.19	3.93	4.06	4.17	3.87	4.25	3.55	4.09	3.20	3.72	2.65	2.90	1.95	2.45	1.57
8	3.48	4.47	3.89	4.31	4.09	4.19	4.34	3.99	4.42	3.64	4.25	3.29	3.89	2.75	3.03	2.01	2.54	1.63
9	3.64	4.67	4.01	4.47	4.21	4.35	4.46	4.12	4.54	3.80	4.38	3.42	4.01	2.84	3.15	2.08	2.66	1.66
10	3.72	4.79	4.13	4.60	4.38	4.47	4.62	4.25	4.70	3.90	4.54	3.51	4.13	2.91	3.23	2.17	2.74	1.73
11	3.84	4.92	4.29	4.76	4.50	4.60	4.79	4.41	4.91	4.06	4.70	3.64	4.29	3.00	3.31	2.20	2.82	1.76
12	3.97	5.08	4.42	4.92	4.66	4.76	4.95	4.54	5.07	4.15	4.87	3.74	4.42	3.10	3.44	2.30	2.90	1.85
13	4.13	5.24	4.58	5.05	4.79	4.89	5.11	4.67	5.19	4.28	4.99	3.87	4.58	3.20	3.56	2.33	2.99	1.89
14	4.25	5.40	4.66	5.21	4.95	5.05	5.28	4.79	5.36	4.41	5.15	3.96	4.66	3.29	3.68	2.43	3.07	1.95
15	4.34	5.53	4.83	5.34	5.11	5.18	5.44	4.92	5.52	4.51	5.32	4.09	4.83	3.39	3.76	2.49	3.19	1.98
18	4.74	5.98	5.24	5.75	5.52	5.59	5.89	5.34	6.01	4.89	5.77	4.41	5.24	3.64	4.09	2.68	3.48	2.17
20	4.95	6.29	5.52	6.07	5.85	5.88	6.18	5.59	6.30	5.14	6.05	4.63	5.52	3.83	4.34	2.84	3.64	2.27
23	5.36	6.74	5.93	6.49	6.26	6.33	6.67	6.01	6.79	5.50	6.54	4.95	5.93	4.12	4.62	3.00	3.93	2.43
25	5.60	7.03	6.22	6.77	6.54	6.58	6.95	6.29	7.12	5.75	6.83	5.18	6.22	4.31	4.87	3.16	4.09	2.56

LWT [°C]	HEATING - Dry bulb outdoor air temperature in °C																											
	-25		-20		-15		-10		-7		-2		2		7		10		15		20		25		30		35	
	Qh [kW]	COP	Qh [kW]	COP	Qh [kW]	COP	Qh [kW]	COP	Qh [kW]	COP	Qh [kW]	COP	Qh [kW]	COP	Qh [kW]	COP	Qh [kW]	COP	Qh [kW]	COP	Qh [kW]	COP	Qh [kW]	COP	Qh [kW]	COP	Qh [kW]	COP
25	2.94	4.34	3.12	4.57	3.72	4.88	4.26	5.08	5.16	5.39	5.76	5.63	6.36	5.86	6.24	6.10	6.42	6.37	6.78	6.95	6.72	7.38	6.12	7.31	5.34	7.97	4.20	8.44
30	2.70	3.52	3.06	3.79	3.60	4.06	4.14	4.30	4.74	4.53	5.22	4.77	5.82	5.00	6.18	5.55	6.36	5.90	6.72	6.29	6.66	6.72	6.06	6.72	5.34	7.27	4.14	7.78
35	2.52	2.97	2.88	3.13	3.36	3.32	3.90	3.59	4.26	3.83	4.80	4.06	5.22	4.18	6.00	5.00	6.30	5.27	6.66	5.74	6.60	5.98	6.00	5.98	5.28	6.64	4.08	7.03
40	2.46	2.54	2.88	2.81	3.36	3.05	3.90	3.24	4.26	3.40	4.74	3.67	5.16	3.91	6.00	4.45	6.24	4.69	6.60	5.08	6.54	5.35	5.94	5.31	5.22	5.86	4.08	6.25
45			2.88	2.46	3.36	2.70	3.90	2.93	4.20	3.05	4.68	3.24	5.10	3.44	6.00	3.91	6.18	4.10	6.54	4.45	6.48	4.69	5.88	4.92	5.16	5.16	4.02	5.47
50					3.24	2.27	3.78	2.46	4.14	2.58	4.62	2.77	5.04	2.85	5.94	3.36	6.12	3.52	6.48	3.87	6.42	4.02	5.82	4.22	5.10	4.42	3.96	4.73
55					3.60	2.03	4.14	2.11	4.56	2.31	4.98	2.42	5.88	2.81	6.06	2.97	6.42	3.20	6.36	3.40	5.76	3.52	5.04	3.71	3.96	3.96	3.99	
60									4.08	1.72	4.56	1.80	4.92	1.91	5.82	2.27	6.00	2.34	6.36	2.50	6.30	2.62	5.70	2.77	4.98	2.89	3.90	3.09

LWT: Leaving water temperature  
 Qh: Heating capacity  
 COP: Coefficient of performance

LWT: Leaving water temperature  
 Qc: Cooling capacity  
 EER: Energy efficiency ratio

# FLOW RATE CURVES 6 kW

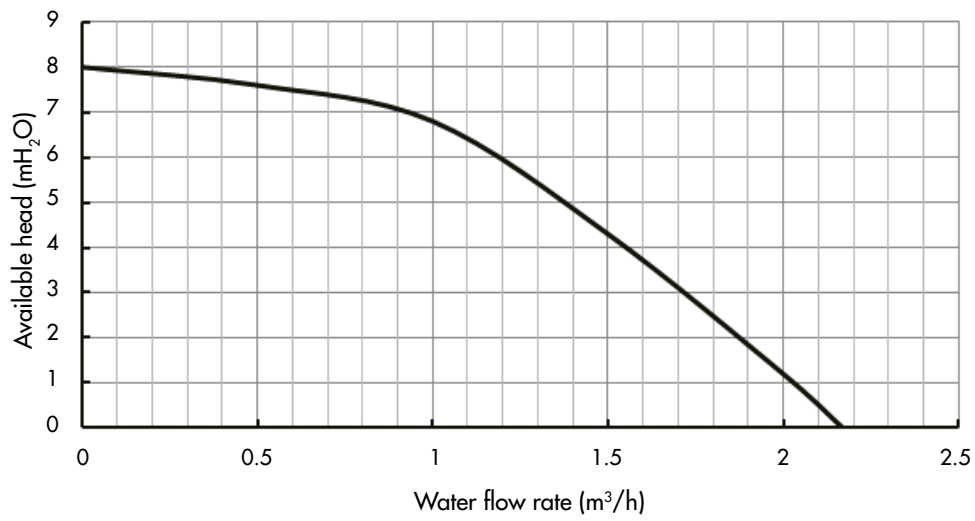

# DIMENSIONAL DRAWINGS 6 kW

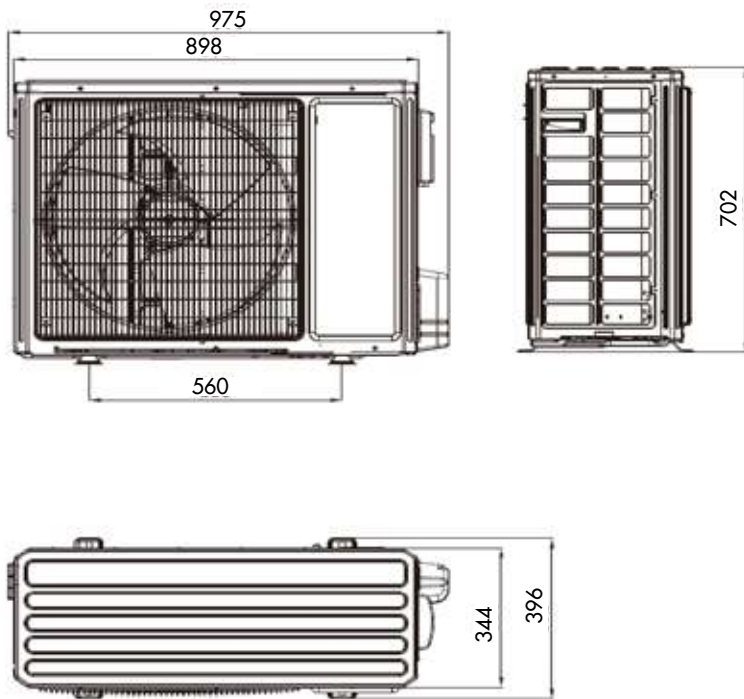

OUTDOOR UNIT 6 kW

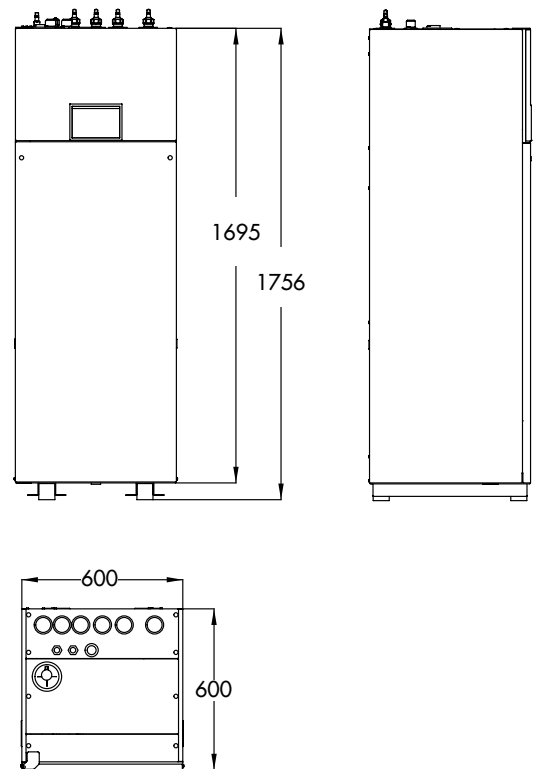

INDOOR UNIT 6 kW

# TECHNICAL DATA FOR 8-10 kW

MODEL				AGHPSA081		
Outdoor unit model				AGHPSA081SH		
Hydronic indoor unit model				AGHPA081F		
Matchable units for domestic hot water production (DHW)				Tank integrated into the indoor unit 185 liters - diverting valve included in the indoor unit		
				Cooling	Heating	
COMFORT IN ENVIRONMENT	Performance according to EN 14511	Air +35 °C - Water 23/18 °C Air +7 °C - Water 30/35 °C	Rated capacity	kW	7.00	8.00
			Rated electrical power input	kW <sub>el</sub>	1.75	1.70
			EER/COP		4.00	4.71
		Air +35 °C - Water 12/7 °C Air +7 °C - Water 40/45 °C	Rated capacity	kW	5.30	8.00
			Rated electrical power input	kW <sub>el</sub>	1.73	2.14
			EER/COP		3.06	3.74
	Performance according to Ecodesign (ERP) EN 14825	LOW TEMPERATURE (35 °C) AVERAGE climate	Design thermal load (P <sub>design,i</sub> )	kW	7.00	
			Seasonal energy efficiency η <sub>s</sub>	%	181	
			Energy efficiency class		A+++	
		MEDIUM TEMPERATURE (55 °C) AVERAGE climate	Design thermal load (P <sub>design,i</sub> )	kW	7.00	
Seasonal energy efficiency η <sub>s</sub>			%	129		
Energy efficiency class				A++		
DHW performance according to EN 16147	AVERAGE climate	Load profile		L		
		Energy efficiency class		A		
		Water heating efficiency - ERP η <sub>wh</sub>	%	89		
Indoor unit	Nominal water flow rate		m <sup>3</sup> /h	at 35 °C	1.38	
				at 45 °C	1.38	
				at 7 °C	0.91	
				at 18 °C	1.20	
	Minimum efficient water volume of the system		liters	40		
	Maximum delivery water temperature		°C	Up to 60		
	Power supply (Voltage/Phases/Frequency)		V/Ph/Hz	220-240/1/50		
	Electrical power input		kW	3.10		
	Heating element		nxkW	2x3		
	Expansion vessel		v	10		
	Maximum circulator pump head		kPa	see H/Q graph		
	Hydraulic connections		inches	G1" female		
	Safety valve		bar	3		
	Indoor unit sound pressure		dB(A)	29	29	
	Net weight		kg	210		
Dimensions (H/W/D)		mm	1756/600/600			
DHW integrated capacity tank		liters	185			
Outdoor unit	Outdoor temperature range (heating)		°C	-25/+35		
	Outdoor temperature range (cooling)		°C	+10/+48		
	Electrical power supply		V/Ph/Hz	220-240~/1/50		
	Maximum power input (cooling)		kW	4.32		
	Maximum power input (heating)		kW	3.00		
	Maximum current draw (cooling)		A	19		
	Maximum current draw (heating)		A	13		
	Liquid cooling pipe diameter		mm (inches)	6.35 (1/4)		
	Gas cooling pipe diameter		mm (inches)	12.7 (1/2)		
	Outdoor unit sound pressure		dB(A)	55	55	
	Fan air flow rate		m <sup>3</sup> /h	3300		
	Net weight		kg	82		
	Dimensions (H/W/D)		mm	787/982/427		
	Compressor type			Twin Rotary with vapour injection		
	Refrigerant	Type and GWP		R32/675 kg CO <sub>2</sub> eq.		
Quantity			1.6 kg/1.08 tons CO <sub>2</sub> eq.			

The equipments described in this catalogue contain HFC R32-type fluorinated greenhouse gases.  
These products must be fitted by qualified staff pursuant to European regulations 303/2008 and 517/2014.

Data declared in accordance with REGULATION (EU) No. 811/2013 of 18 February 2013 with regard to the energy labelling of space heaters, combination heaters, packages of space heater, temperature control and solar device and packages of combination heater, temperature control and solar devices, packages of combination heater, temperature control and solar devices, and with COMMISSION REGULATION (EU) No. 813/2013 of 2 August 2013 implementing Directive 2009/125/EC of the European Parliament and of the Council with regard to ecodesign requirements for space heaters and combination heaters.

# TECHNICAL DATA FOR 8-10 kW

MODEL				AGHPSA101			
Outdoor unit model				AGHPSA101SH			
Hydronic indoor unit model				AGHPA101F			
Matchable units for domestic hot water production (DHW)				Tank integrated into the indoor unit 185 liters - diverting valve included in the indoor unit			
				Cooling	Heating		
COMFORT IN ENVIRONMENT	Performance according to EN 14511	Air +35 °C - Water 23/18 °C Air +7 °C - Water 30/35 °C	Rated capacity	kW	8.50	9.50	
			Rated electrical power input	kW <sub>el</sub>	2.24	2.07	
			EER/COP		3.79	4.59	
	Performance according to Ecodesign (ERP) EN 14825	LOW TEMPERATURE (35 °C) AVERAGE climate	Air +35 °C - Water 12/7 °C Air +7 °C - Water 40/45 °C	Rated capacity	kW	6.50	9.50
				Rated electrical power input	kW <sub>el</sub>	2.27	2.64
				EER/COP		2.86	3.60
DHW	Performance according to EN 14825	MEDIUM TEMPERATURE (55 °C) AVERAGE climate	Design thermal load (P <sub>design,h</sub> )	kW	9.00		
			Seasonal energy efficiency η <sub>s</sub>	%	181		
			Energy efficiency class		A+++		
	DHW performance according to EN 16147	AVERAGE climate		Design thermal load (P <sub>design,h</sub> )	kW	8.00	
				Seasonal energy efficiency η <sub>s</sub>	%	127	
				Energy efficiency class		A++	
Indoor unit			Load profile		L		
			Energy efficiency class		A		
			Water heating efficiency - ERP η <sub>wh</sub>	%	89		
			Nominal water flow rate	m <sup>3</sup> /h	at 35 °C	1.63	
					at 45 °C	1.63	
					at 7 °C	1.12	
					at 18 °C	1.46	
			Minimum efficient water volume of the system	liters	80		
			Maximum delivery water temperature	°C	Up to 60		
			Power supply (Voltage/Phases/Frequency)	V/Ph/Hz	220-240/1/50		
			Electrical power input	kW	3.10		
			Heating element	n×kW	2×3		
			Expansion vessel	liters	10		
			Maximum circulator pump head	kPa	see H/Q graph		
			Hydraulic connections	inches	G1" female		
Safety valve	bar	3					
Indoor unit sound pressure	dB(A)	29	29				
Net weight	kg	210					
Dimensions (H/W/D)	mm	1756/600/600					
DHW integrated capacity tank	liters	185					
Outdoor unit			Outdoor temperature range (heating)	°C	-25/+35		
			Outdoor temperature range (cooling)	°C	+10/+48		
			Electrical power supply	V/Ph/Hz	220-240~/1/50		
			Maximum power input (cooling)	kW	5.06		
			Maximum power input (heating)	kW	3.40		
			Maximum current draw (cooling)	A	22		
			Maximum current draw (heating)	A	15		
			Liquid cooling pipe diameter	mm (inches)	6.35 (1/4)		
			Gas cooling pipe diameter	mm (inches)	12.7 (1/2)		
			Outdoor unit sound pressure	dB(A)	55	55	
			Fan air flow rate	m <sup>3</sup> /h	3300		
			Net weight	kg	82		
			Dimensions (H/W/D)	mm	787/982/427		
			Compressor type		Twin Rotary with vapour injection		
			Refrigerant			Type and GWP	R32/675 kg CO <sub>2</sub> eq.
Quantity	1.6 kg/1.08 tons CO <sub>2</sub> eq.						

The equipments described in this catalogue contain HFC R32-type fluorinated greenhouse gases.  
These products must be fitted by qualified staff pursuant to European regulations 303/2008 and 517/2014.

Data declared in accordance with REGULATION (EU) No. 811/2013 of 18 February 2013 with regard to the energy labelling of space heaters, combination heaters, packages of space heater, temperature control and solar device and packages of combination heater, temperature control and solar devices, packages of combination heater, temperature control and solar devices, and with COMMISSION REGULATION (EU) No. 813/2013 of 2 August 2013 implementing Directive 2009/125/EC of the European Parliament and of the Council with regard to ecodesign requirements for space heaters and combination heaters.





## FLOW RATE CURVES 8-10 kW

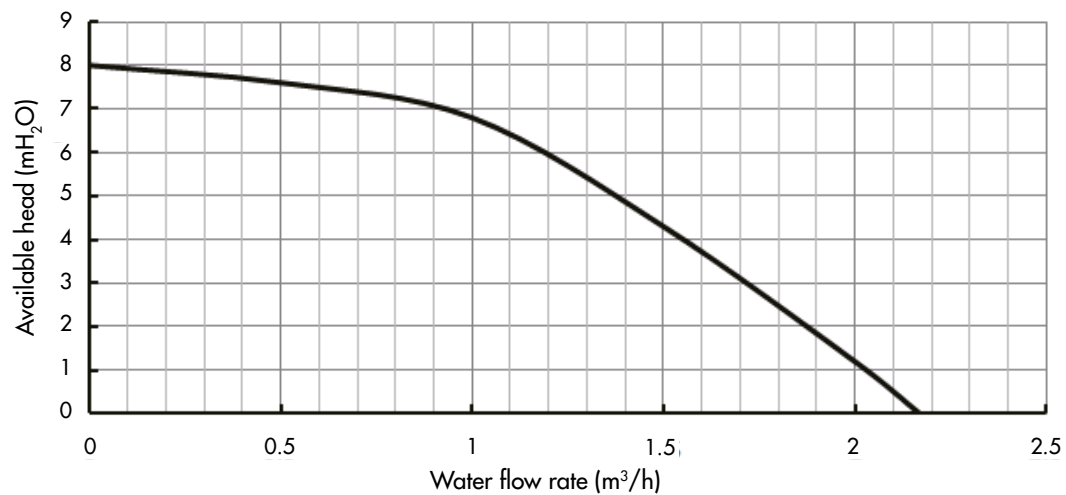

## DIMENSIONAL DRAWINGS 8-10 kW

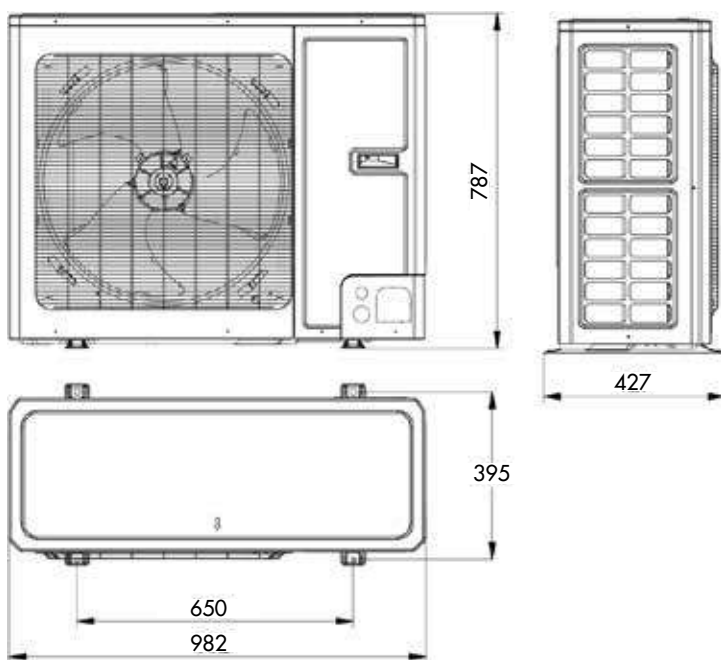

OUTDOOR UNIT 8-10 kW

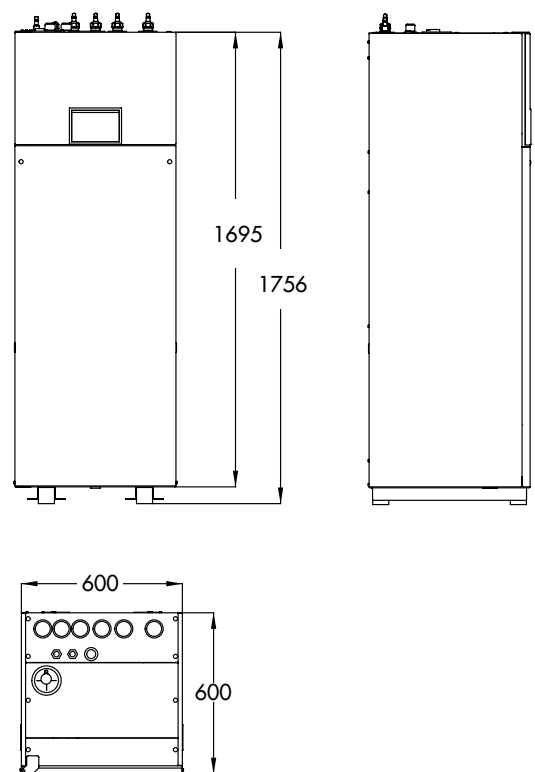

INDOOR UNIT 8-10 kW

# SPACE REQUIRED FOR OUTDOOR UNIT INSTALLATION 6-8-10 kW

HEAT  
PUMPS

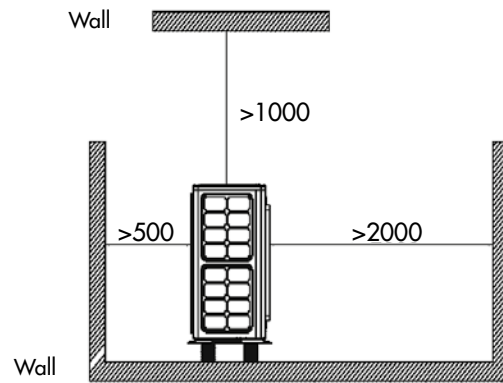
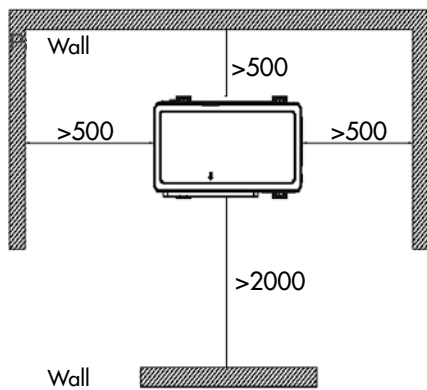

# SPACE REQUIRED FOR INDOOR UNIT INSTALLATION 6-8-10 kW

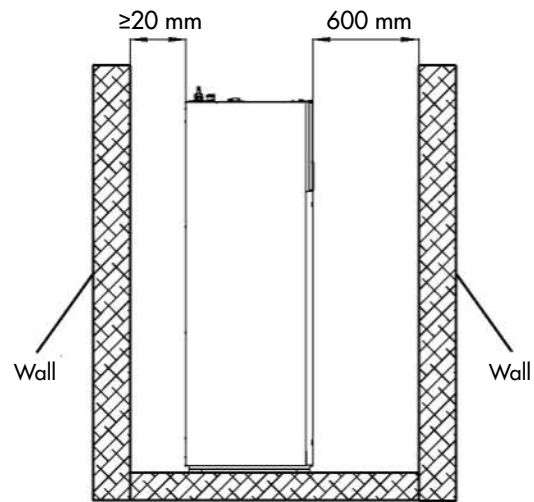
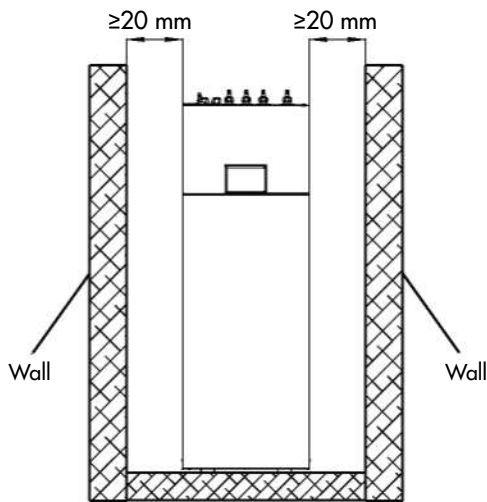

# INSTALLATION EXAMPLES

## EXAMPLE 1

### Radiant heating and DHW integrated in the indoor unit

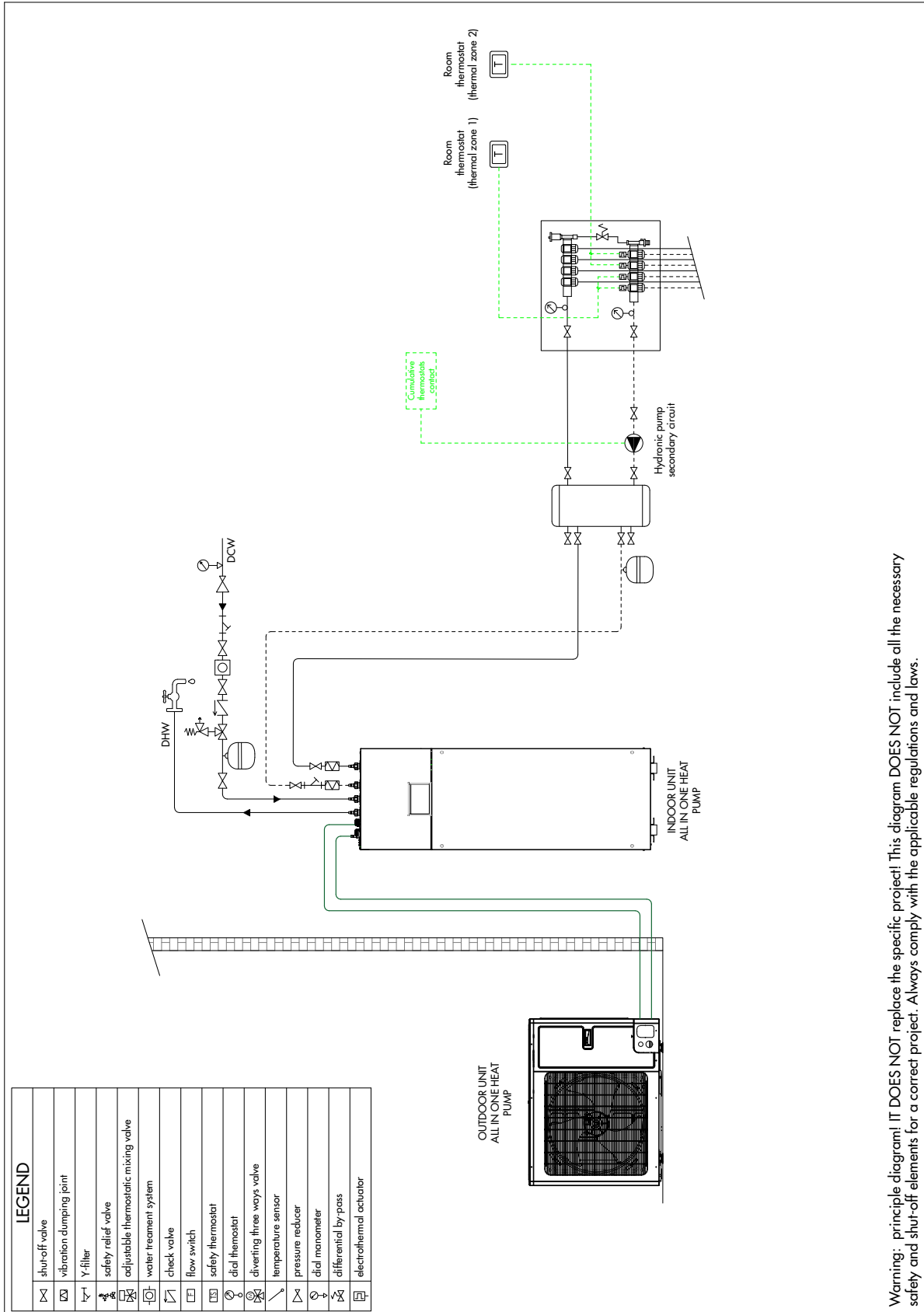

## EXAMPLE 2

Heating by high efficiency radiators, cooling by FCU units and DHW integrated in the indoor unit

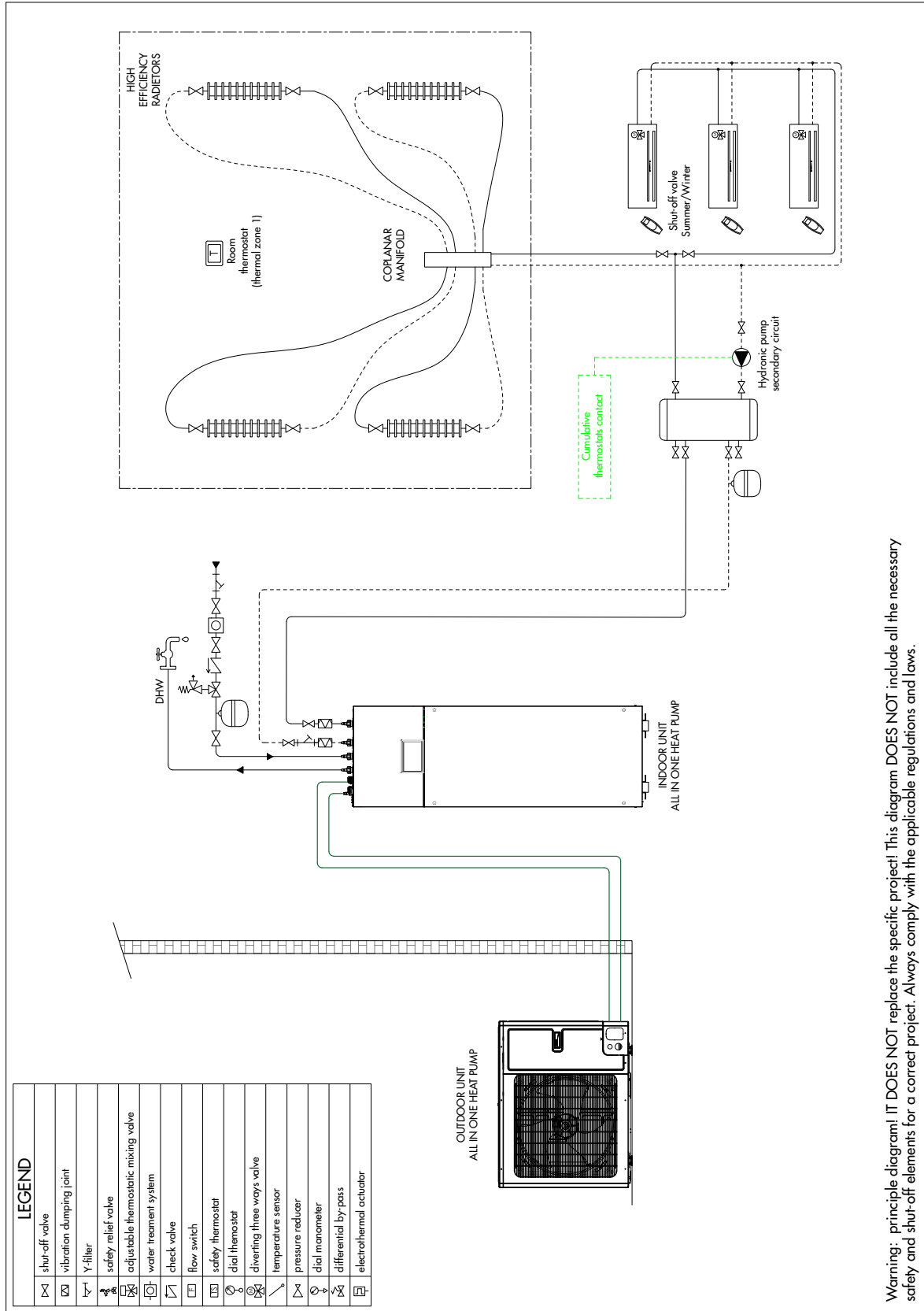

Warning: principle diagram! IT DOES NOT replace the specific project! This diagram DOES NOT include all the necessary safety and shut-off elements for a correct project. Always comply with the applicable regulations and laws.

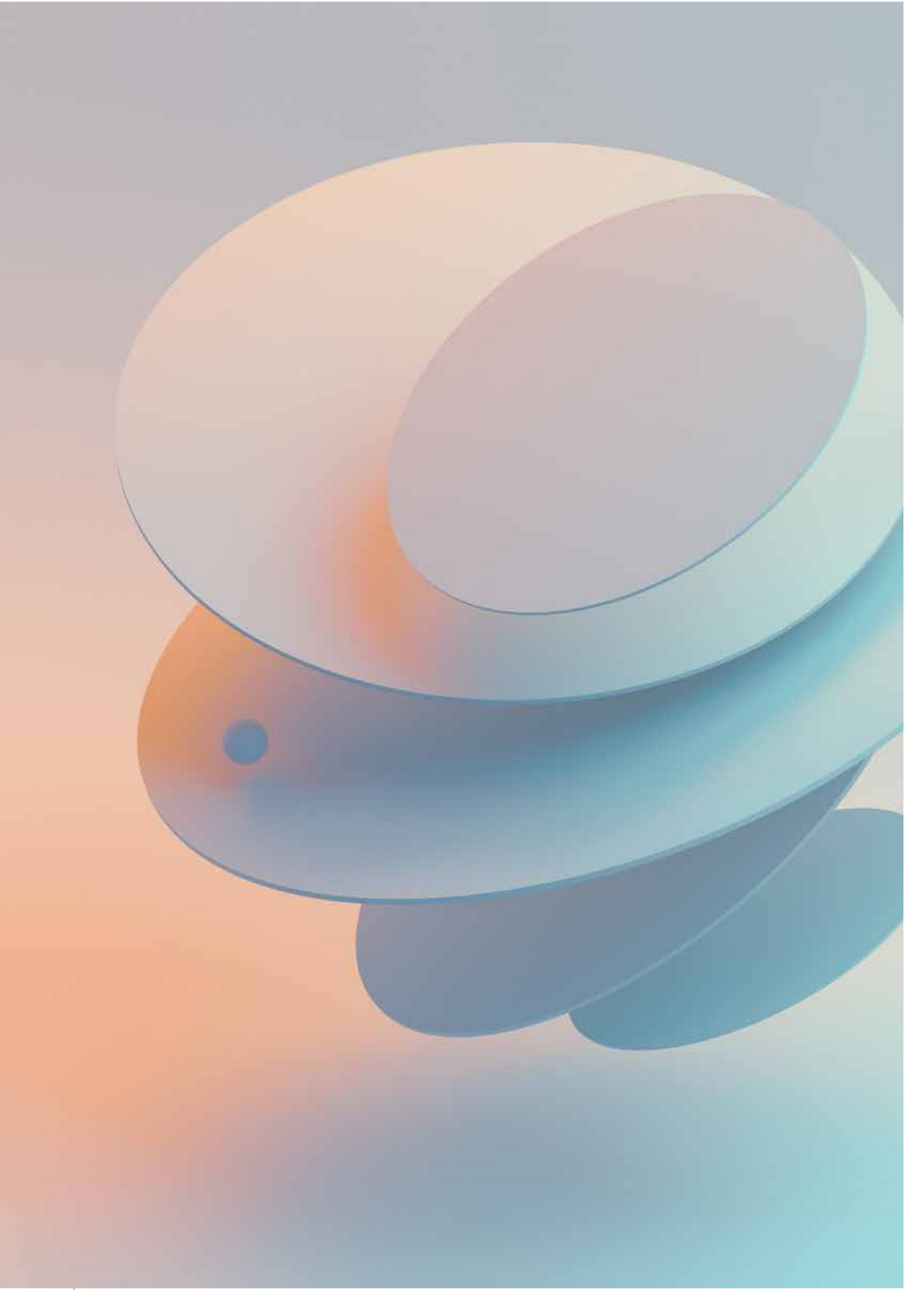

# HEAT PUMPS ACCESSORIES

---

# ACCESSORIES











Image	Code	Description	Applicability				
			iSERIES	iM	X3 MONOBLOC heat pumps	X3 SPLIT heat pumps	X3 ALL IN ONE heat pumps
	387030211	Control panel for management of DHW production		●			
	387030210	Bidirectional servomotor for diverting valve, 230 Vac, three points	●	●	●		
	387030209	3-way diverting valve, 1"	●	●	●		
	387030701	200 liters DHW Tank - 1 heat exchanger for heat pump	●	●	●	●	
	387030702	300 liters DHW Tank - 1 heat exchanger for heat pump	●	●	●	●	
	387030700	300 liters DHW Tank - 2 heat exchangers for heat pump and solar power system	●	●	●	●	
	387030208	3 kW electric heater for DHW tank	●	●	●	●	
	387030727	Additional electric heating element for internal installation 3 kW 1ph	●	●	●		
	387030728	Additional electric heating element for internal installation 3 kW 3ph	●	●	●		



Image	Code	Description	Applicability				
			iSERIES	iM	X3 MONOBLOC heat pumps	X3 SPLIT heat pumps	X3 ALL IN ONE heat pumps
	387030705	45 liters tank/ isolated separator, 6 connections	●	●	●	●	●
	387030706	85 liters tank/ isolated separator, 6 connections	●	●	●	●	●
	387030215	Gateway modbus		●			
	387030214	Remote panel for iM		●			
	387030220	Wired control for iSERIES indoor units - <b>Mandatory accessory</b>	●				

# ACCESSORIES

## THE PRODUCTION OF DHW

It is possible to produce domestic hot water using iM unit and AQUA UNIT (as an alternative to EMIX/EMIX TANK) managing the switching of the heat supply from the heating system to a specific storage tank.

The DHW system, therefore, consists of a domestic hot water tank (with internal exchanger suitable for heat exchange with a heat pump), an electric heating element, a control panel with temperature probe and a diverting valve. Moreover, it features auxiliary functions such as the anti-legionella cycle management, a backup, if provided, and the domestic water recirculation function.



### PRODUCTION OF DHW WITH MONOBLOC UNIT - iM HEAT PUMP

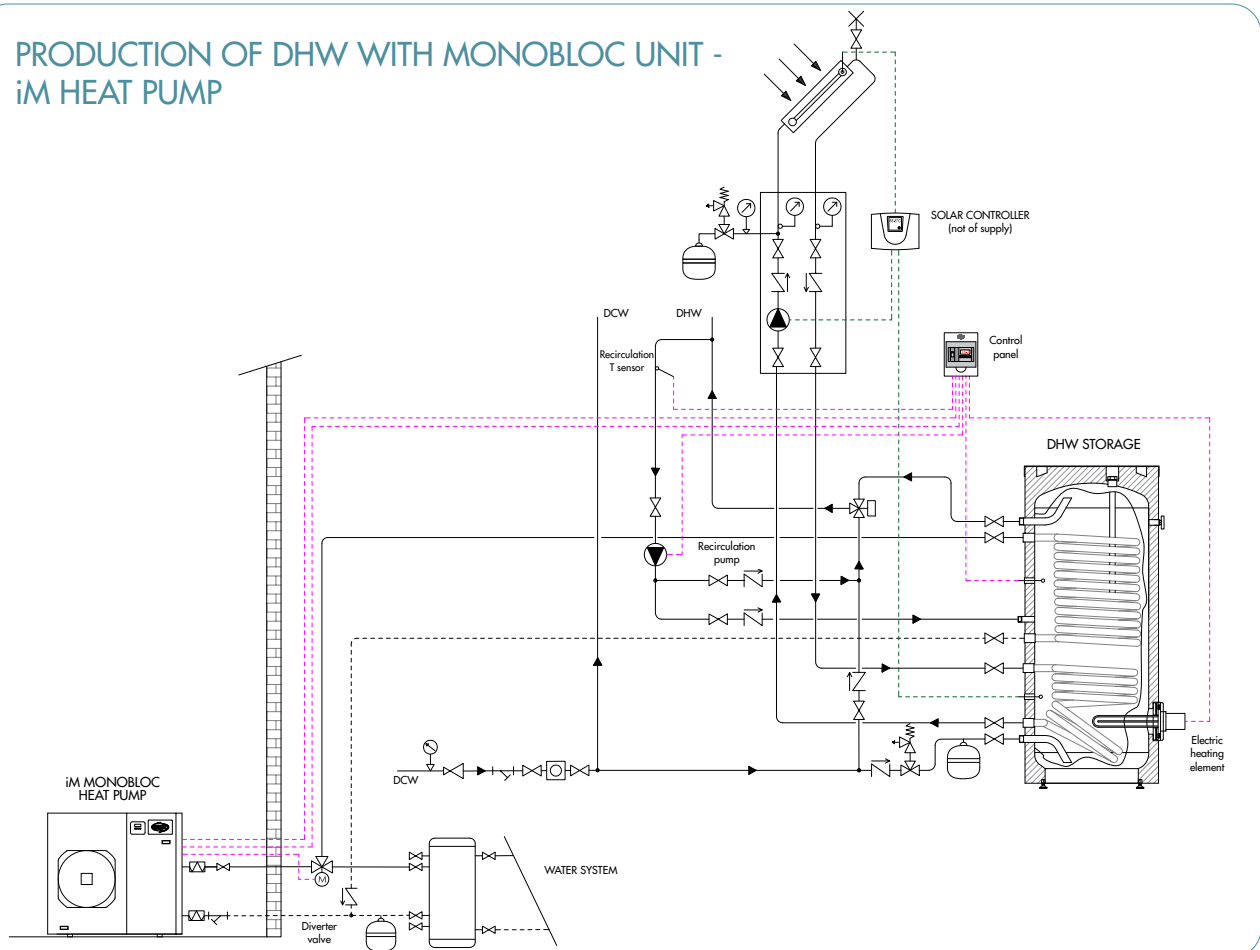

### PRODUCTION OF DHW WITH X3 AIR TO WATER HEAT PUMPS - MONOBLOC UNIT

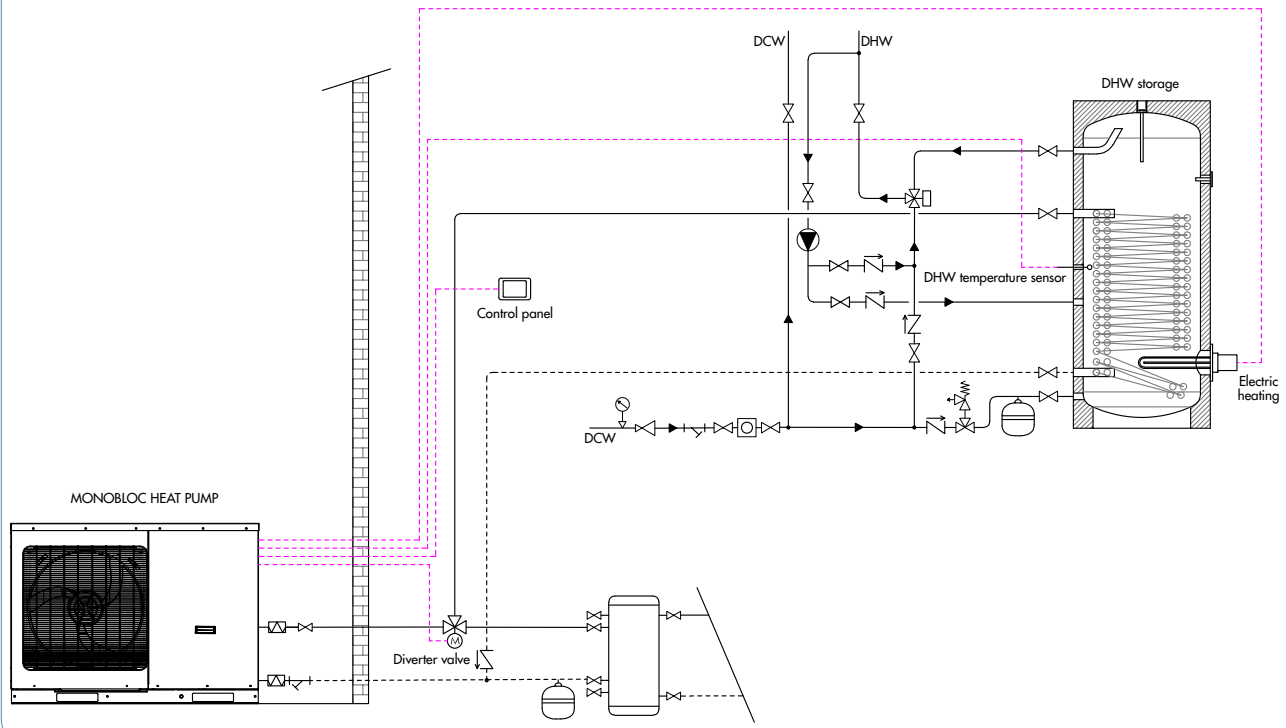

### PRODUCTION OF DHW WITH iSERIES SPLIT UNIT - VERTICAL AQUA UNIT

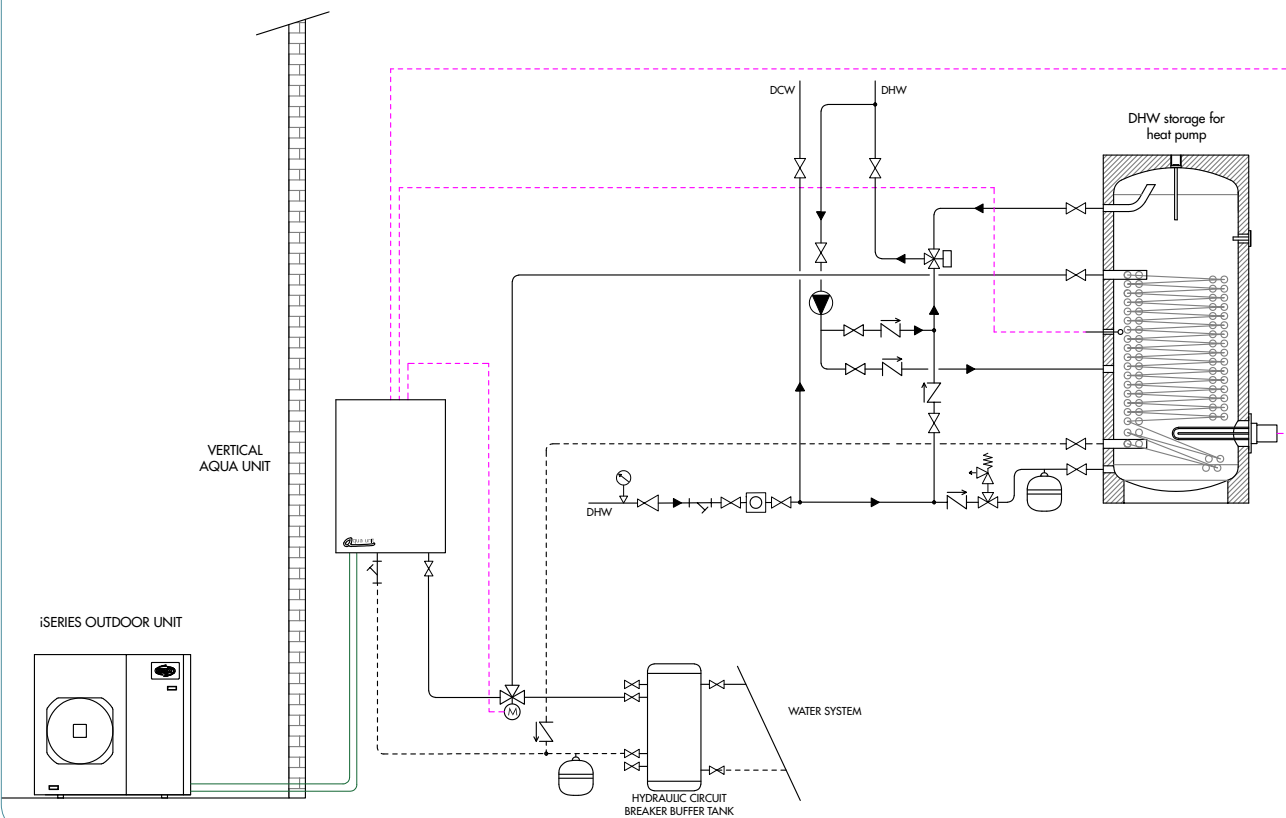

# ACCESSORIES

## CONTROL PANEL



Code	Description
387030211	Control panel for management of DHW production

The control panel of the DHW KIT is an electronic device installed in a special electric panel for the control and management of the domestic hot water production in the iM/iSERIES systems. The unit is capable of controlling a heat pump and a heating element (up to 4 kW) using them to activate the multiple functions and optimising energy consumption.

What the system can do:

- produce Domestic Hot Water in a storage tank using a heat pump and/or a heating element;
- control the recirculation pump of the domestic water circuit;
- control the anti-legionella cycle;
- anti-freeze protection;
- manage any alarm/unavailability of the heat pump.

## REFERENCE WIRING DIAGRAM

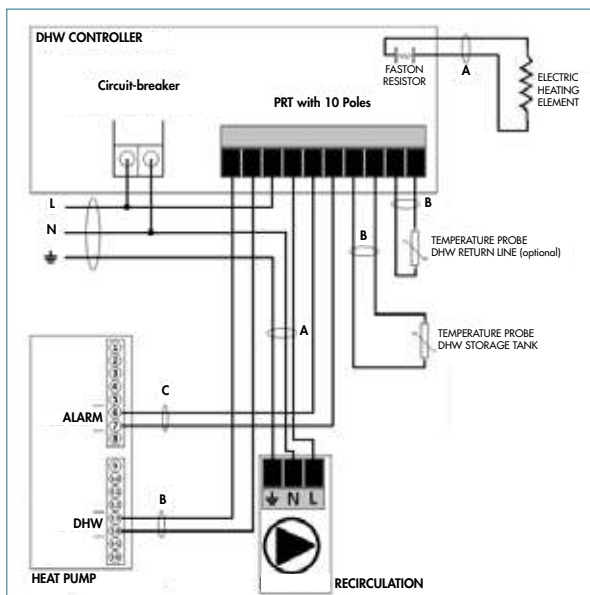

## CONTROL PANEL TECHNICAL DATA

ELECTRICAL SPECIFICATIONS	
Voltage	230 Vac
Power consumption	7 VA
Total breaking capacity	460 VA (relay outputs 1+153)
Breaking capacity for relay	460 VA per R1/185 W
Internal fuse	5 A delayed
Protection category	IP40
Protection calss	II
Measuring range	-40 °C up to 110 °C
PERMITTED CLIMATIC CONDITIONS	
Room temperature for a correct operation	0 °C/40 °C
Ambient temperature for transportation/storage	0 °C/40 °C
Room humidity for a correct operation	85% UR with DBS 25 °C
Ambient humidity for transportation/storage	85% UR with DBS 25 °C
OTHER SPECIFICATIONS	
Casing	Plastic ABS
Type of installation	Wall-mounting
Total dimension	200x147x95 (mm)
Display	LED display 7 seg. 3 digits 4 LED (red, yellowe, green and white)
Programming	4 buttons

## DIVERTING VALVE



The diverting valve consists of 2 elements: the valve body and the servomotor, supplied separately.

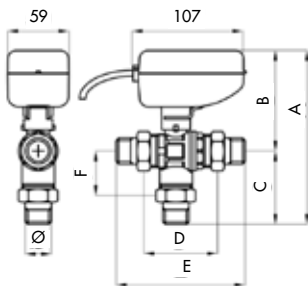

### DIMENSIONS (mm)

ND	Ø OUTLETS	Ø VALVE BODY	A	B	C	D	E	F
20	3/4"	1"	170	100	70	67	128	40

## SERVOMOTOR

Code	Description
387030210	Bidirectional servomotor for diverting valve, 230 Vac, three points



### TECHNICAL DATA

TECHNICAL SPECIFICATIONS	
Electric control	3 points
Valve body connection	quick fitting
Operating mode	ON/OFF
Rotation	90° clockwise and anticlockwise
Internal fuse	5 A delayed
Position indicator	rotating arrow wich indicates the position of the sphere
Motor	bidirectional
Electrical power supply	230 Vac - 50/60 Hz
Power cable lenght	80 cm
Diverting time and related starting torque	15 seconds - 5 Nm
Power usage	3.9 VA
Phase electric capacity in output to grey wire	1 A resistive
Electric capacity of the supplementary micro-switch	1 A resistive - 250 V
Indoor operating temperature	+5 °C ÷ +50 °C
Protection degree	IP 54
Insulation class	II - double insulation
External casing material	polyamide PA 6, 30% glass fibre
Certification	CE

# VALVE BODY

Code	Description
387030209	3-way diverting valve, 1"

The main characteristic of the valve body is the presence of a 3-hole sphere, which has a hole directed to the common way (always open) and two other orthogonal holes to the first and between them.

When one of the last two holes is positioned on one of the two inlet ways, the second way is closed. The sphere turns 90° and the second hole is directed onto the second inlet way, thus closing the first. The 3-way valve body includes a condition in which the 3 ways are simultaneously communicating with one another while the sphere is rotating to switch from one position to the other. When the rotation completes, the valve goes completely back to its diverter function.

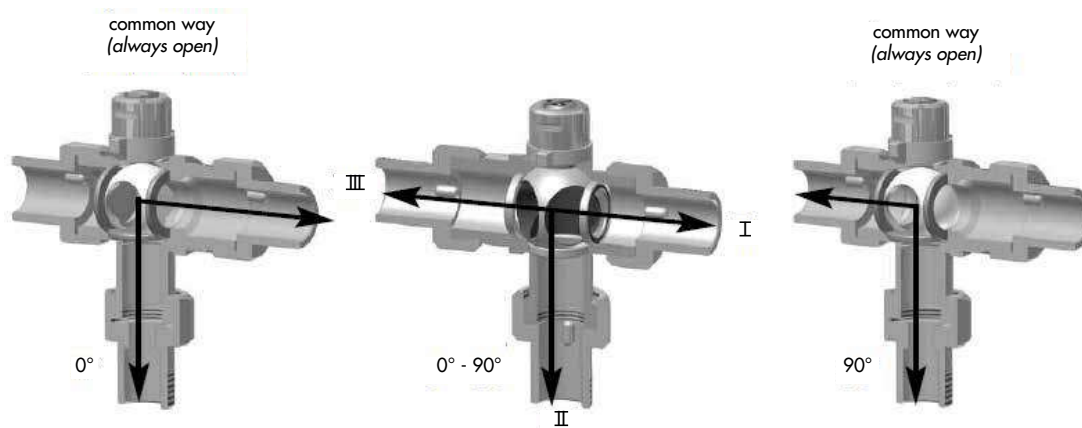

TECHNICAL DATA	
Type	3-way vertical, diverting
Body dimension	1" total flow
Valve body material	brass CW617N UNI EN 12165
Sleeve material	brass CW617N UNI EN 12165
Sphere material	brass CW617N UNI EN 12165
Seal material	P.T.F.E.
K <sub>v</sub>	18.3 m <sup>3</sup> /h
Nominal operating pressure	30 bar
Maximum pressure differential	16 bar
Minimum fluid temperature	+5 °C
Maximum fluid temperature	+160 °C
Suitable fluid	water and fluids compatible with EPDM and P.T.F.E.

# ENAMELED STEEL TANKS FOR HEAT PUMPS



DHW tank  
200-300 L  
1 heat exchanger

DHW tank  
300 L  
2 heat exchangers

Made in enameled steel for the storage of domestic hot water (DHW). They are fitted with one or two fixed internal heat exchangers that can be powered by a heat pump and by a solar power system. The heat exchangers have a large surface area which means that the power supplied by the source can be transmitted faster and more effectively, thus reducing the number of start-up and shutdown cycles of the heat pump that will benefit the duration and reliability of the system. They are also designed and ready to allow the installation of an additional electric heating element

#### Accessories:

Electric heating element kit for DHW tank

Model	Code	Description
ACS 200 LT - 1S	387030701	200 liters DHW Tank - 1 heat exchanger for heat pump
ACS 300 LT - 1S	387030702	300 liters DHW Tank - 1 heat exchanger for heat pump
ACS 300 LT - 2S	387030700	300 liters DHW Tank - 2 heat exchangers for heat pump and solar power system

## TECHNICAL DATA

DOMESTIC WATER STORAGE TANK	
Material	Glazed, ceramic-coated S 235 Jr carbon steel
Internal protective treatment	Inorganic enamelling (DIN 4753-3)
Use limits (P max./T max.)	10 bar/95 °C
Cathodic protection	Magnesium anode
HEAT EXCHANGER	
Material	Glazed, ceramic-coated S 235 Jr carbon steel
Internal protective treatment	Untreated
External protective treatment	Inorganic enamelling (DIN 4753-3)
Type	Fixed coil heat exchanger
Use limits (P max./T max.)	10 bar/95 °C
GENERAL SPECIFICATIONS	
Capacity	200-300 liters
Warranty	2 years
Thermal insulation	Rigid polyurethane + PVC: Fire resistance class B3 (DIN 4102)
Reference legislation	Directive 2014/68/EU (PED) Art. 4 par. 3 (pressure equipment)
	Ministerial Decree No. 174 of 6 April 2004 (suitability of materials in contact with DHW)
	Directive 2009/125/EC (Energy Related Products)

# 200-300 L DHW TANK - 1 HEAT EXCHANGER

Model	Total diameter	Total height	Diagonal height	Insulation thickness	ErP class	Dispersion	Real capacity	Weight - no-load
	mm	mm	mm	mm		W	L	kg
ACS 200 LT - 1S	640	1215	1375	70	B	51	190	90
ACS 300 LT - 1S	640	1615	1735	70	B	63	263	124

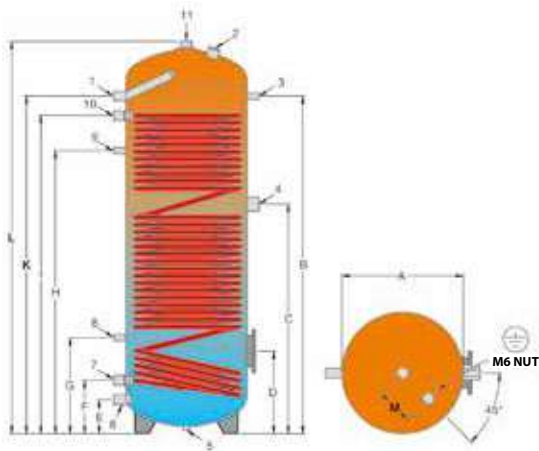

No.	TYPE OF CONNECTION	200-300
1	Hot water supply	1"
2	Anode	1" 1/4
3	Thermometer - Probe	1/2"
4	Electric heater connection	1" 1/2
5	Blind connection for fastening	1/2"
6	Cold water intake	1"
7	Return heat exchanger	1"
8	Probe	1/2"
9	Recirculation	1/2"
10	Supply heat exchanger	1"
11	Hot water supply	1" 1/4

Model	A	B	C	D	E	F	G	H	I	K	L	M
	mm	mm	mm	mm	mm	mm	mm	mm	mm	mm	mm	mm
ACS 200 LT - 1S	500	995	735	320	140	220	370	835	990	1070	1215	150
ACS 300 LT - 1S	500	1390	945	340	140	220	395	1165	1310	1390	1615	150

Model	Heat exchanger surface	Heat exchanger water content	Heating water	Power output	DHW production
			60 °C/50 °C	60 °C/50 °C	10 °C/45 °C
	m <sup>2</sup>	L	m <sup>3</sup> /h	kW	m <sup>3</sup> /h
ACS 200 LT - 1S	3	17.2	1.2	14	0.3
ACS 300 LT - 1S	4	23	1.6	19	0.5



## SPECIFIC PERFORMANCE DIAGRAMS BASED ON HEAT EXCHANGER INLET TEMPERATURE

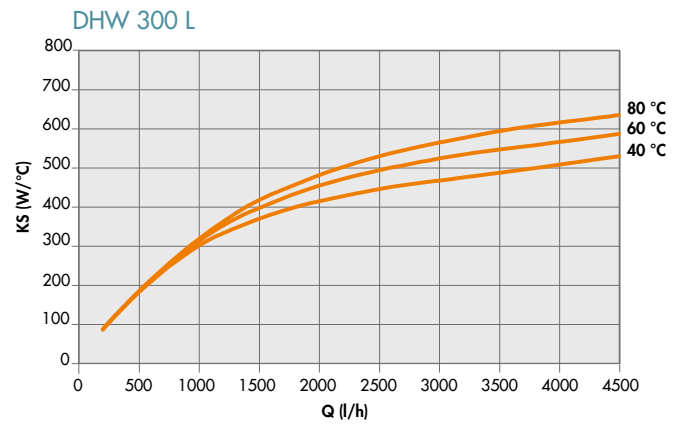
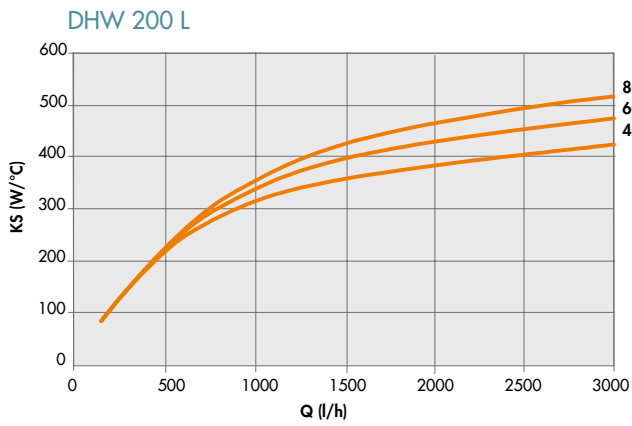

## PRESSURE DROP HEAT EXCHANGERS

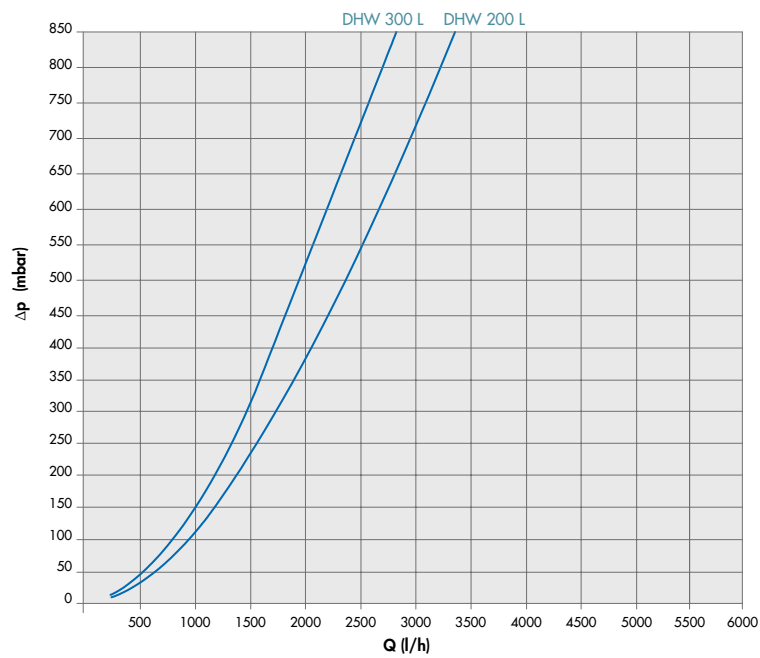

# DHW TANK 300 L - DOUBLE HEAT EXCHANGER

Model	ErP class	Dispersion	Total diameter	Total height	Diagonal height	Insulation thickness
		W	mm	mm	mm	mm
ACS 300 LT - 2S	B	63	640	1615	1735	70

Model	Real capacity	Weight - no-load	Top heat exchanger		Bottom heat exchanger	
			Surface	Water content	Surface	Water content
	L	kg	m <sup>2</sup>	L	m <sup>2</sup>	L
ACS 300 LT - 2S	260	131	3.7	18	1.2	8

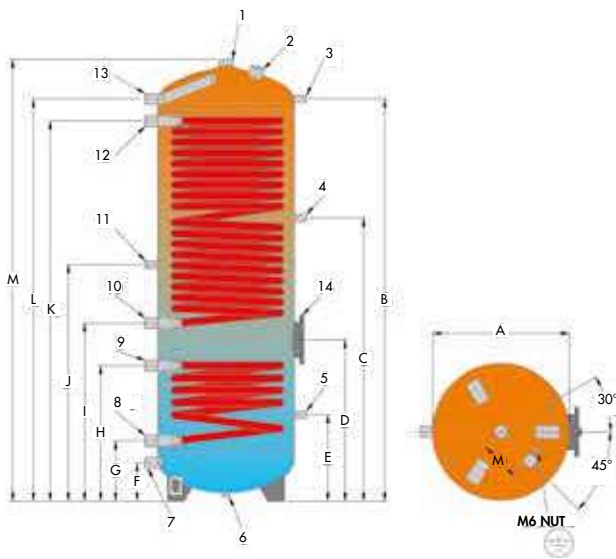

No.	TYPE OF CONNECTION	300
1	Hot water supply	1" 1/4
2	Anode	1" 1/4
3	Thermometer - Probe	1/2"
4	Thermostat	1/2"
5	Thermostat	1/2"
6	Blind connection for fastening	1/2"
7	Cold water intake	1"
8	Return bottom heat exchanger	1"
9	Supply bottom heat exchanger	1"
10	Return top heat exchanger	1"
11	Recirculation	1/2"
12	Supply top heat exchanger	1"
13	Hot water supply	1"
14	Flange with electric heater connection	1" 1/2

Model	A	B	C	D	E	F	G	H	I	J	K	L	M	N
	mm	mm	mm	mm	mm	mm	mm	mm	mm	mm	mm	mm	mm	mm
ACS 300 LT - 2S	500	1470	1035	590	315	140	220	495	650	865	1390	1470	1615	150

## PERFORMANCE

Model	Performance			
ACS 300 LT - 2S	Top heat exchanger			
	Heating water	Power output	DHW production	Pressure drop
	60 °C/50 °C	60 °C/50 °C	10 °C/45 °C	60 °C/50 °C
	m <sup>3</sup> /h	kW	m <sup>3</sup> /h	mbar
	1.59	18.5	0.45	31
	Bottom heat exchanger			
	Heating water	Power output	DHW production	Pressure drop
	80 °C/60 °C	80 °C/60 °C	10 °C/45 °C	80 °C/60 °C
	m <sup>3</sup> /h	kW	m <sup>3</sup> /h	mbar
	1.25	29	0.71	17

## SPECIFIC PERFORMANCE DIAGRAMS BASED ON HEAT EXCHANGER INLET TEMPERATURE

### Bottom heat exchanger

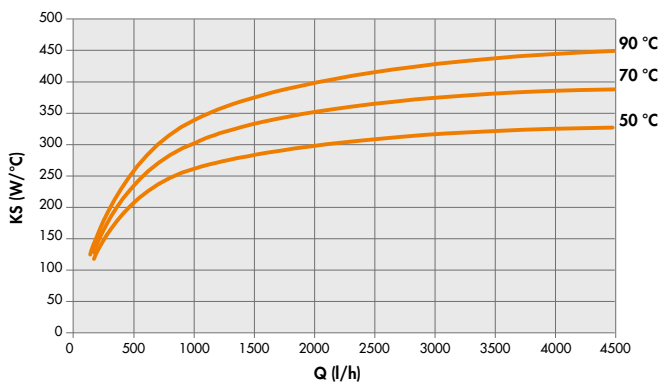

### Top heat exchanger

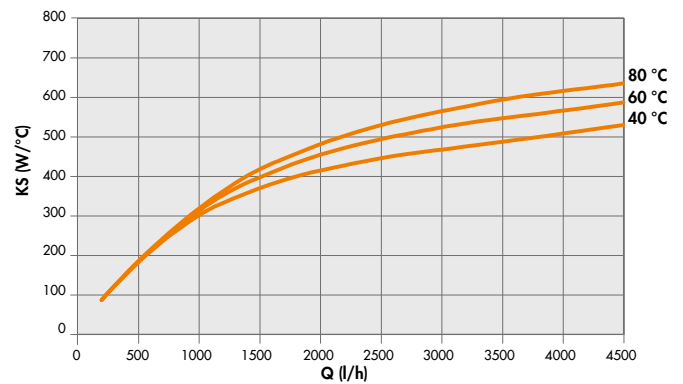

## PRESSURE DROP HEAT EXCHANGERS

### Bottom heat exchanger

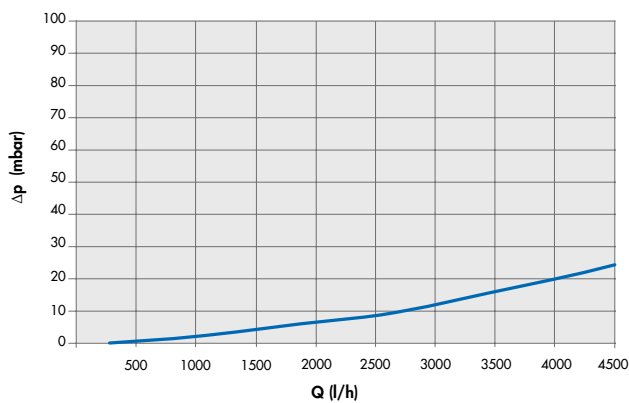

### Top heat exchanger

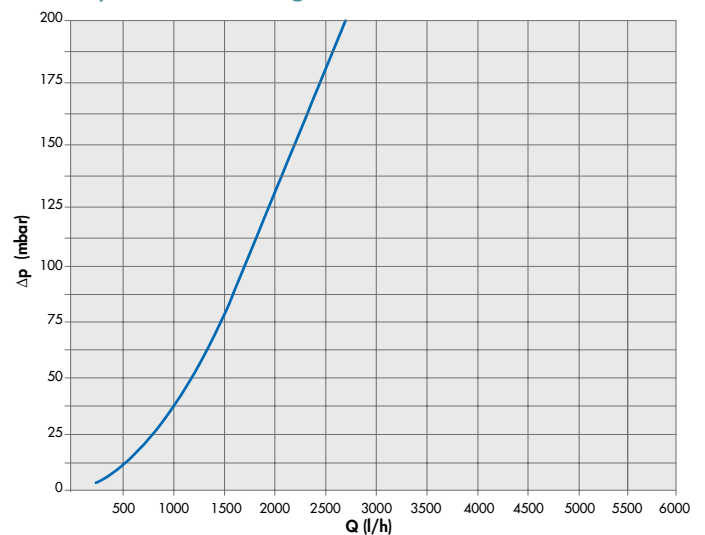

# ELECTRIC HEATER FOR DHW TANK

Code	Description
387030208	3 kW electric heater for DHW tank

The 3 kW electric heater is used in the domestic hot water storage tank as an integrative element and as a backup if needed.

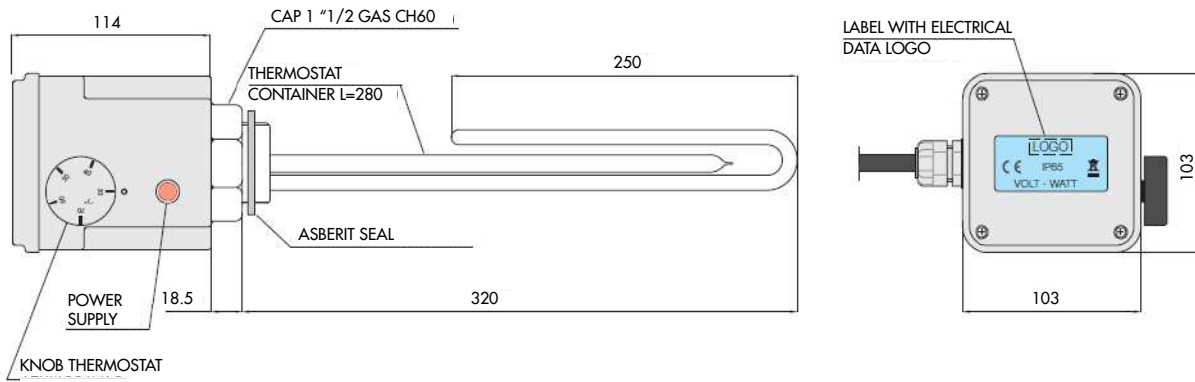

TECHNICAL DATA	
Nominal output	3 kW
Version	MgO
Class	I
Outdoor diameter	8.5 mm
Power supply voltage	230 V
Maximum specific load	13 W/cm <sup>2</sup>
Seal material	AISI 316L
Threaded cup	1"1/2 gas in AISI 304
Protection cover	PP V0 IP 65
Temperature regulation	thermostat 30 ÷ 70 °C
Safety	thermostat 90 °C
Wiring	cable in PVC 3x1.5 mm <sup>2</sup>
Approvals	CE
Tests	EN 60335-1, EN 50106

# ADDITIONAL ELECTRIC HEATER FOR HEATING SYSTEM - INTERNAL INSTALLATION

Code	Description
387030727	Additional electric heating element for internal installation 3 kW 1ph
387030728	Additional electric heating element for internal installation 3 kW 3ph

This accessory is an electric heat exchanger supporting heat pumps which is activated, when necessary, for providing the heat required by the thermal demand. The component must be installed inside.

## DIMENSIONAL DRAWING

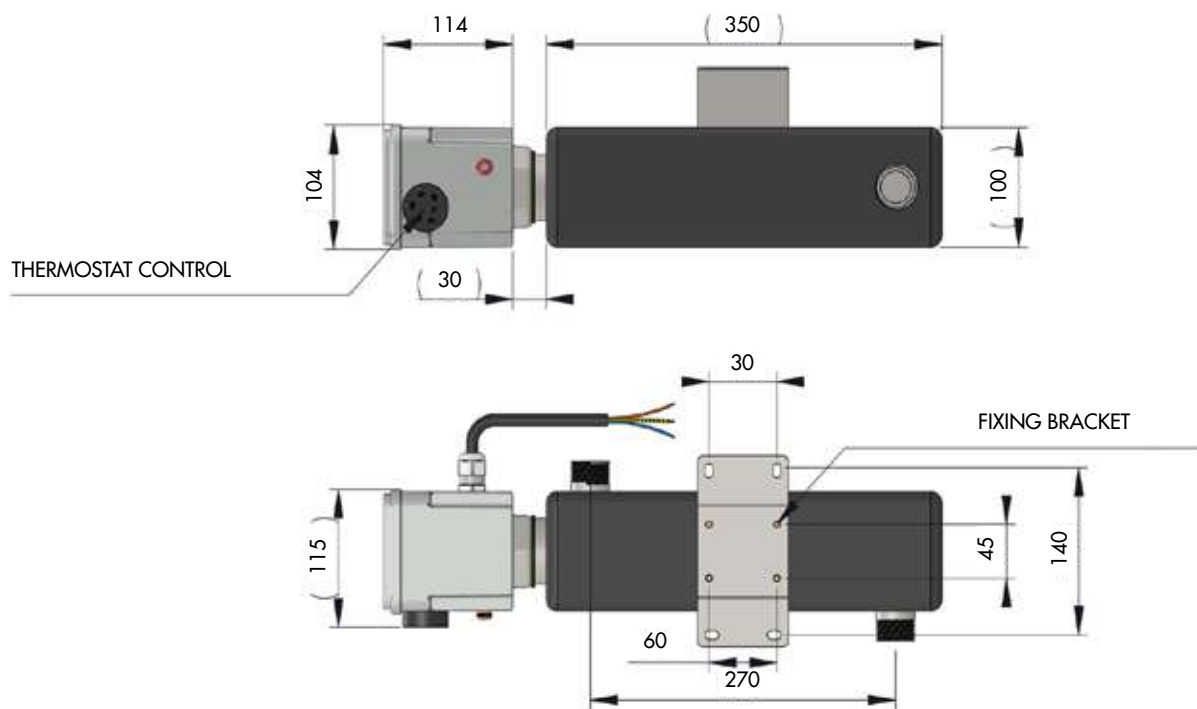

## TECHNICAL DATA

	387030727	387030728
Nominal output	3 kW	3 kW
Power supply voltage - phases	230 V - 1 PH	400 V - 3 PH
Class	I	I
Electrical connection	PVC cable 3x1,5 mm <sup>2</sup>	PVC cable 4x1,5 mm <sup>2</sup>
Length of power cord	2 m	2 m
Maximum specific load	13,5 W/cm <sup>2</sup>	13,1 W/cm <sup>2</sup>
Heating elements material	INCOLOY 800	INCOLOY 800
Seal material	AISI 304	AISI 304
Protection cover	UL94V0	UL94V0
Temperature regulation	thermostat 30 ÷ 70 °C	thermostat 30 ÷ 70 °C
Safety	thermostat 90 °C	thermostat 90 °C
Hydraulic connections	1"	1"
Approvals	CE	CE
Tests	EN 60335-1/EN50106	EN 60335-1/EN50106

# BUFFER TANKS/HYDRAULIC DISJUNCTORS



45 liters

85 liters

Code	Description
387030705	45 liters tank/isolated separator, 6 connections
387030706	85 liters tank/isolated separator, 6 connections

Indoor buffer tanks for air conditioning and heating systems, available in two different capacities, 45 liters and 85 liters. They are particularly suitable to be combined with reversible heat pumps acting as hydraulic circuit breaker (by making the various circuits of the system independent) and as thermal flywheel (minimising the start-ups and ensuring the minimum water supply for the correct operation of the heat pump). The tanks are provided with additional connections for the integration of an additional heat source.

## KEY OF CONNECTIONS:

- D: drain
- G2/G1: plant outlet/inlet
- K1/K2: auxiliary
- P2/P1: energy source outlet/inlet
- T: vent

## CONNECTIONS:

Model	D	G1	G2	K1	K2	P1	P2	T
	(inch)							
45 L	1"1/4	1"1/4	1"1/4	1"1/4	1"1/4	1"1/4	1"1/4	1/2"
85 L	1"1/4	1"1/4	1"1/4	1"1/4	1"1/4	1"1/4	1"1/4	1/2"

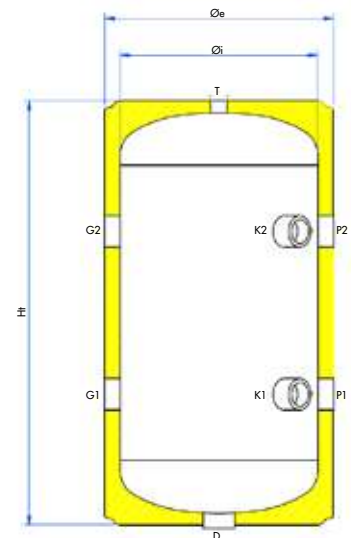

## DIMENSIONS:

Model	Øi	Øe	Ht	R*	G1	G2	K1	K2	P1	P2
	(mm)									
45 L	320	370	700	770	220	485	220	485	220	485
85 L	400	460	780	905	185	535	185	535	185	535

TECHNICAL DATA	
Volume	45 and 85 liters
Material	Carbon steel
Covering	White galvanised sheet metal
Thermal insulation	High-density polyurethane foam
Minimum operating temperature	-10 °C
Maximum operating temperature	90 °C
Maximum operating pressure	6 bar
Energy class	B

## GATEWAY MODBUS - iMODBUS



Code	Description
387030215	Gateway modbus

iMODBUS is an communication device between the iM heating, cooling and DHW units and remote control systems using the MODBUS protocol.

iMODBUS uses the industrial MODBUS protocol for a simple and reliable connection to external monitoring systems.

The device is fitted with two types of MODBUS ports (RS232 and RS485) and has the size of two DIN modules.

The gateway provides several reading, and reading and writing parameters in order to ensure an efficient and accurate management of the iM units. Detailed specifications can be found in the installation manual provided with the device.

## REMOTE PANEL FOR iM



Code	Description
387030214	Remote panel for iM

The remote control panel can be installed on the units in combination with the existing one and provides for the same functions (it is NOT a room temperature probe). The panel requires a separate 12 VDC power supply (by external supply).

### DIMENSIONS (mm)

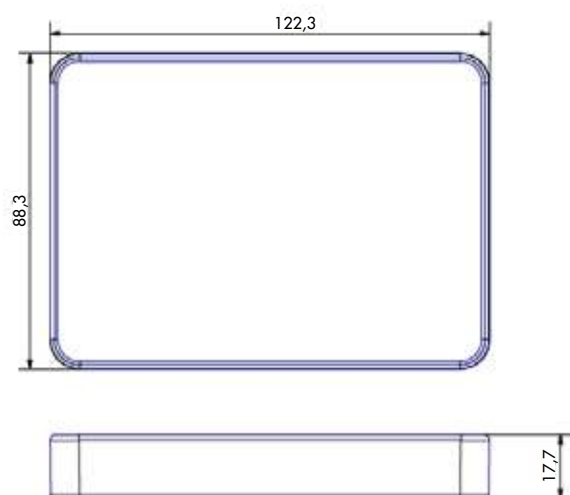

### INSTALLATION

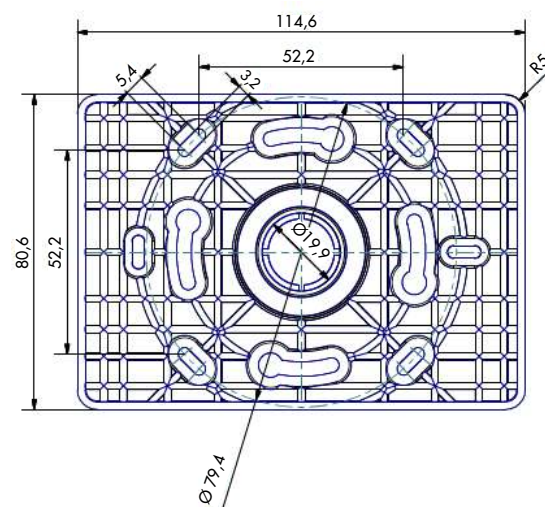

- Directly in a hole on the wall
- On electrical box mod. 503
- On circular electrical box

# WIRED CONTROL UNIT FOR AQUA UNIT



Code	Description
387030220	Wired control for iSERIES indoor units - <b>Mandatory accessory</b>

The wired control for internal units can be set during installation for the management for Aqua Unit. Equipped with touch buttons and graphic display is intuitive to use by the end user. In addition, it can be easily installed both on a recessed box or directly on the wall.

To be paired with the latest versions of Aqua Unit.

The control can be interfaced with third-party BMS systems (via Modbus protocol). The wire control is a mandatory accessory for the operation of the latest versions Aqua Unit, which no longer include the panel on the unit.

## DIMENSIONS (mm)

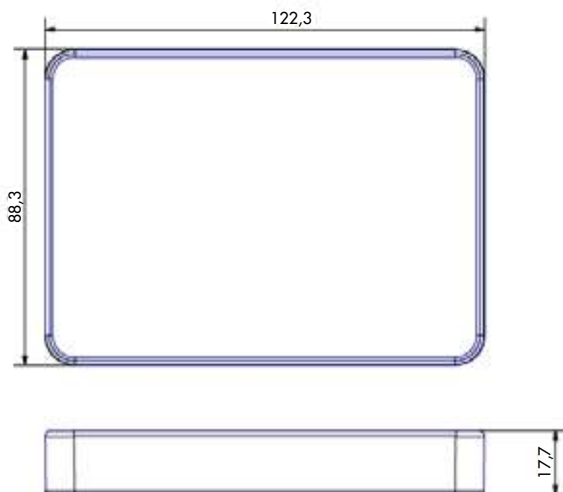

## INSTALLATION

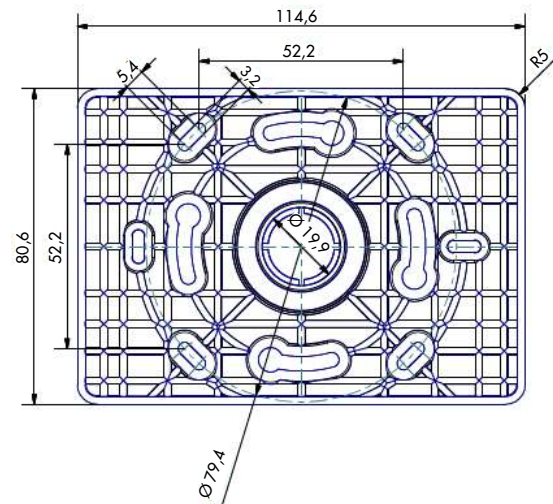

- Directly in a hole on the wall
- On electrical box mod. 503
- On circular electrical box



# NOTES



# X3 MODULAR HEAT PUMPS

---

Commercial applications - R32 DC Inverter

# X3 MODULAR HEAT PUMPS

## MAIN FEATURES



Code	Model	Cooling capacity [kW] (1)	Heating capacity [kW] (2)
398600050	AGCH353PH	32	35
398600051	AGCH603PH	60	65

(1) Water temperature 12 °C/7 °C, outdoor air temperature 35 °C  
 (2) Water temperature 40 °C/45 °C, outdoor air temperature 7 °C D.B./6 °C W.B.

Code	Model	Description	Applicability
398610050	MOD. CH	Wired control*	All

\*Mandatory accessory, one for each modular system

The AGCH series is made up of reversible, modular, full inverter heat pumps for cooling and heating of predominantly commercial environments that use environment-friendly R32 refrigerant. Available in two sizes, they can be used to create single configurations or configurations with up to 16 units, connected by a single central control unit. The versatility and simplicity of the configuration or installation allow these units to easily adapt to the various types of systems.

The series is also equipped with external hydronic modules, with or without inertial tank, with single or double circulator pump, so as to fulfil the various needs of the systems they serve.

Internal copper groove	Quiet mode	Weekly timer	Heating down to low temperatures	Door control	Full protection	Timer on/off	Save energy	EASY Easy maintenance	High efficiency	Auto restart memory
Intelligent defrosting	Central control	Wide operating range	Low-voltage start-up	Wide voltage range	Auto diagnosis	-20 °C Min. outdoor temp. heating	+40 °C Max. outdoor temp. heating	-15 °C Min. outdoor temp. cooling	+52 °C Max. outdoor temp. cooling	

# PLUS

## SILENT OPERATION

- Active noise reduction: broad plastic blades of the fans
- Passive noise reduction: special design of the fan zone
- Passive noise reduction: "QUIET MODE" function
- Passive noise reduction: acoustic insulation of the compressor

At partial loads, the noise generated by the running unit can drop down to 52 dB(A)

## HIGH EFFICIENCY

The units are equipped with a heat exchanger featuring a "DUAL FLOW" design of the tube bundle, for increasing the unit's efficiency and capacity. The special design of the plate and of the relative bottlenecks at the entry to the heat exchanger ensure a regular and uniform refrigerant flow in order to improve the heat exchange efficiency. The U-shaped thread inside the copper pipes improves the laminar flow of the fluid and facilitates the heat exchange.

The unit is able to estimate the building's thermal load on the basis of the outdoor air temperature, thus modifying the delivery water temperature setpoint so as to reduce energy consumption.

## RELIABILITY

With the central control unit, it is possible to balance the work time of the compressors so as to avoid excess work only for some of them, as well as improve the system's efficiency and service life.

Only **one-third of the outdoor units** are simultaneously allowed to perform defrosting, thus reducing fluctuations of the leaving water temperature and, consequently, improving the environmental comfort.

- Each unit can be a MASTER unit;
- Timely communication between the units of the same system;
- A problem on one unit does not hinder the normal operation of the others.

The **anti-freeze protection** is automatically activated by the unit when the outdoor temperature drops to below 5 °C, regardless of whether it is operating in heating or cooling mode.

## WIDE OPERATING RANGE

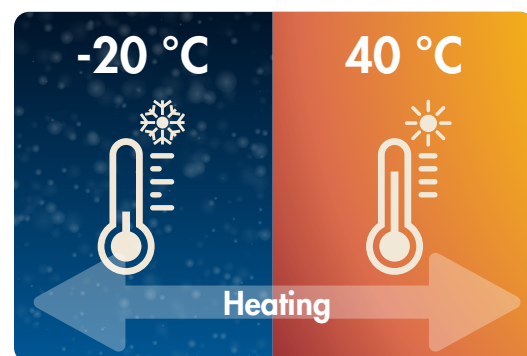
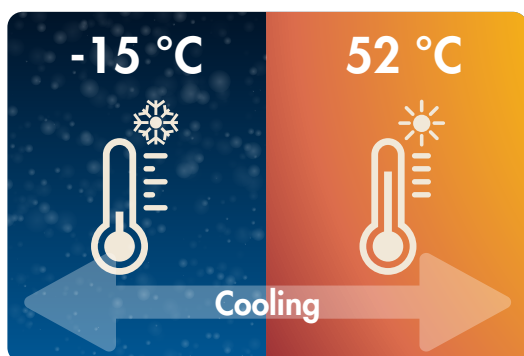



# TOUCH-SCREEN CONTROL PANEL

The control panel, supplied separately as a mandatory accessory, allows the management and set-up of one or more units (up to 16).



In particular it is possible to:

- Define the operating mode of the heat pump and its priorities (heating, cooling)
- Set all the main operating parameters (set point, hysteresis, etc.)
- Activate external (or internal) systems to integrate or replace the heating production unit
- Manage the commissioning of the unit
- Display the status of the operating parameters of the main components of the heat pump
- Manage the unit remotely via MODBUS gateway or Wi-Fi module directly integrated into the panel.

Specific auxiliary functions are also available in the control panel, including:

- Automatic management of the flow temperature of the fluid according to the external temperature (climate curve)
- Programming of weekly and hourly operation
- Activation of "silent" operation
- Emergency management in case of unit failure
- Programmable activation of the anti-legionella cycle
- Automatic activation of the antifreeze protection.

# TECHNICAL DATA

MODEL		AGCH353PH				
Characteristics			Cooling	Heating		
Performances according to EN 14511	Air +35 °C - Water +12/7 °C Air +7 °C - Water +40/45 °C	Rated capacity	kW	32.00	35.00	
		EER/COP		2.74	3.3	
	Air +35 °C - Water +23 °C/18 °C Air +7 °C - Water +30 °C/35 °C	Rated capacity	kW	41.38	36.00	
		EER/COP		3.70	4.09	
		Maximum electrical power input	kW	13.40		
		Capacity correction range	%	31% ~ 100%		
Performances according to Ecodesign (ERP) EN 14825	LOW TEMPERATURE (35 °C) AVERAGE climate	Nominal heat output	kW	24.00		
		Seasonal energy efficiency $\eta_s$	%	153		
		Annual energy consumption	kWh	12504		
		SEER/SCOP		4.4	3.9	
		Energy efficiency class		A++		
	LOW TEMPERATURE (35 °C) WARMER climate	Nominal heat output	kW	26.00		
		Seasonal energy efficiency $\eta_s$	%	138.9		
		Annual energy consumption	kWh	18068		
	LOW TEMPERATURE (35 °C) COOLER climate	Nominal heat output	kW	20.00		
		Seasonal energy efficiency $\eta_s$	%	218		
		Annual energy consumption	kWh	4834		
	Unit operation data		Power supply (Voltage/Phases/Frequency)	V/Ph/Hz	380-415~/3N/50	
		Sound power level	dB(A)	78		
		Sound pressure level (distance 1 m)	dB(A)	62		
Refrigerant		Compressor type/no.		Inverter Rotary/1		
		Type and GWP		R32/675 kg CO <sub>2</sub> eq.		
		Quantity		5.5 kg/3.71 tons CO <sub>2</sub> eq.		
Fan		Type		Axial		
		Number	No.	2		
		Air flow rate	m <sup>3</sup> /h	2x6300		
Water side heat exchanger		Water flow rate	m <sup>3</sup> /h	5.5		
		Head loss	kPa	80.0		
	Hydraulic connections (IN and OUT)	inches	1"1/2			
Water side operating limits	Leaving water temperature	°C	5~20	35~50		
	Water input/output temperature difference	°C	2.5~6			
Air side operating limits		°C	-15~52	-20~40		
Components and dimensions	Net weight /Weight during operation	kg	405/445			
	Dimensions (H/W/D)	mm	1605/1340/920			

# TECHNICAL DATA

MODEL			AGCH603PH		
Characteristics			Cooling	Heating	
Performances according to EN 14511	Air +35 °C - Water +12/7 °C Air +7 °C - Water +40/45 °C	Rated capacity	kW	60.00	65.00
		EER/COP		2.88	3.27
	Air +35 °C - Water +23 °C/18 °C Air +7 °C - Water +30 °C/35 °C	Rated capacity	kW	72.18	62.60
		EER/COP		3.88	4.15
		Maximum electrical power input	kW	28.80	
	Capacity correction range	%	15% ~ 100%		
Performances according to Ecodesign (ERP) EN 14825	LOW TEMPERATURE (35 °C) AVERAGE climate	Nominal heat output	kW	51.00	
		Seasonal energy efficiency $\eta_s$	%	153	
		Annual energy consumption	kWh	25964	
		SEER/SCOP		4.6	3.9
		Energy efficiency class		A++	
	LOW TEMPERATURE (35 °C) WARMER climate	Nominal heat output	kW	39.00	
		Seasonal energy efficiency $\eta_s$	%	238.8	
		Annual energy consumption	kWh	8620	
	LOW TEMPERATURE (35 °C) COOLER climate	Nominal heat output	kW	48.00	
		Seasonal energy efficiency $\eta_s$	%	135.1	
		Annual energy consumption	kWh	34271	
	Unit operation data		Power supply (Voltage/Phases/Frequency)	V/Ph/Hz	380-415~/3N/50
		Sound power level	dB(A)	86	
		Sound pressure level (distance 1 m)	dB(A)	68	
Refrigerant		Compressor type/no.		Inverter Rotary/1	
		Type and GWP		R32/675 kg CO <sub>2</sub> eq.	
		Quantity		5.5x2 kg/3.71x2 tons CO <sub>2</sub> eq.	
Fan		Type		Axial	
		Number	No.	2	
		Air flow rate	m <sup>3</sup> /h	2x12000	
Water side heat exchanger		Water flow rate	m <sup>3</sup> /h	10.3	
		Head loss	kPa	55.0	
	Hydraulic connections (IN and OUT)	inches	2"		
Water side operating limits	Leaving water temperature	°C	5~20	35~50	
	Water input/output temperature difference	°C	2.5~6		
Air side operating limits		°C	-15~52	-20~40	
Components and dimensions	Net weight/Weight during operation	kg	686/755		
	Dimensions (H/W/D)	mm	1675/2200/965		



# DIMENSIONAL DRAWINGS

## Model AGCH353PH

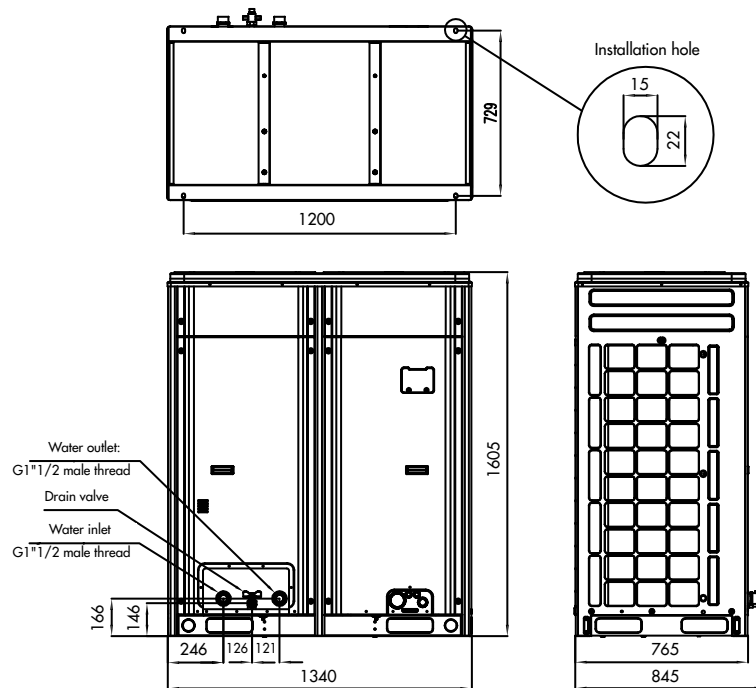

## Model AGCH603PH

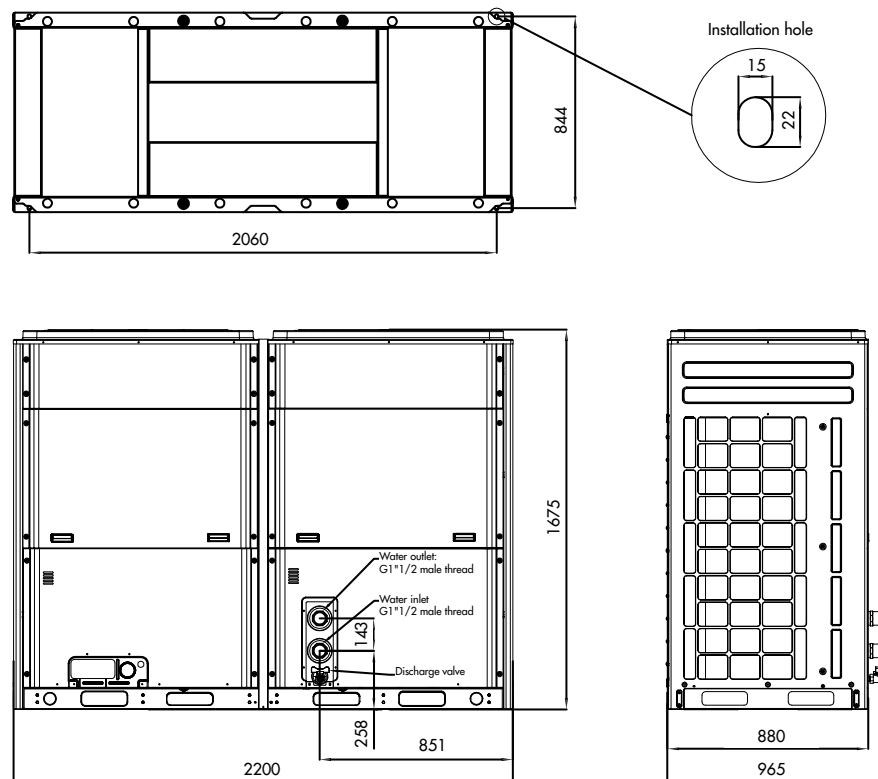

# HYDRONIC UNITS

MOD-HYDRO



MOD-HYDRO VT



They are used to distribute the heat transfer fluid, in heating and cooling mode. Easy to install, they can be positioned outdoors and are equipped with one or two circulator pumps and, sometimes, an buffer tank.

## HYDRONIC KITS

Code	Model	Tank	No. of pumps	Applicability
387030644	MOD-HYDRO 1P 30		1	30 kW
387030645	MOD-HYDRO 2P 30		2	
387030646	MOD-HYDRO 1P 60		1	60 kW
387030647	MOD-HYDRO 2P 60		2	
387030648	MOD-HYDRO 1P 90		1	90 kW and 120 kW
387030649	MOD-HYDRO 2P 90		2	
387030650	MOD-HYDRO V T100 1P 30	100	1	30 kW
387030651	MOD-HYDRO V T100 2P 30		2	
387030652	MOD-HYDRO V T200 1P 60	200	1	60 kW
387030653	MOD-HYDRO V T200 2P 60		2	
387030654	MOD-HYDRO V T300 1P 90	300	1	90 kW and 120 kW
387030655	MOD-HYDRO V T300 2P 90		2	

## HYDRONIC KIT ACCESSORIES

Code	Description	Applicability
387030660	Vibration dampers	MOD-HYDRO V T
387030661	Vibration dampers	MOD-HYDRO
387030656	Fitting kit 1"1/2*	MOD-HYDRO 1P/2P 30
387030657	Fitting kit 2"1/2*	MOD-HYDRO 1P/2P 60-90

\*Mandatory accessory for adapting from Victaulic to threaded connections

## MOD-HYDRO KIT

It can be combined with any type of modular chiller with single or multiple configuration (up to 120 kW) of the proposed range.



The unit includes:

- pipes insulated with anti-condensate elastomer;
- single or double centrifugal pump with shut-off valve;
- power electrical panel with device for pump alternation at every start-up (version with 2 pumps), reserve pump start-up in case of pump malfunction (version with 2 pumps), residual-current devices, contacts for remote signalling of running pumps, IP55 protection rating;
- safety valve;
- deaerator;
- pressure gauge;
- filling/discharge valve;
- base and panel made of galvanised and coated sheet metal, suitable for outdoor installations;
- easily and quickly removable panels.

## MOD-HYDRO KIT VT

It can be combined with any type of modular chiller with single or multiple configuration (up to 120 kW) of the proposed range.



The unit includes:

- carbon steel tanks and pipes insulated with anti-condensate elastomer (100, 200 and 300 liters);
- single or double centrifugal pump with shutoff valves;
- power electrical panel with device for pump alternation at every start-up (version with 2 pumps), reserve pump start-up in case of pump malfunction (version with 2 pumps), residual-current devices, dry contacts for remote signalling of running pumps, IP55 protection rating;
- expansion vessel;
- safety valve;
- deaerator;
- pressure gauge;
- filling/discharge valves;
- base and panel made of galvanised and coated sheet metal, suitable for outdoor installations.

# DIMENSIONAL DRAWINGS

## MOD-HYDRO 1P 30 - MOD-HYDRO 2P 30

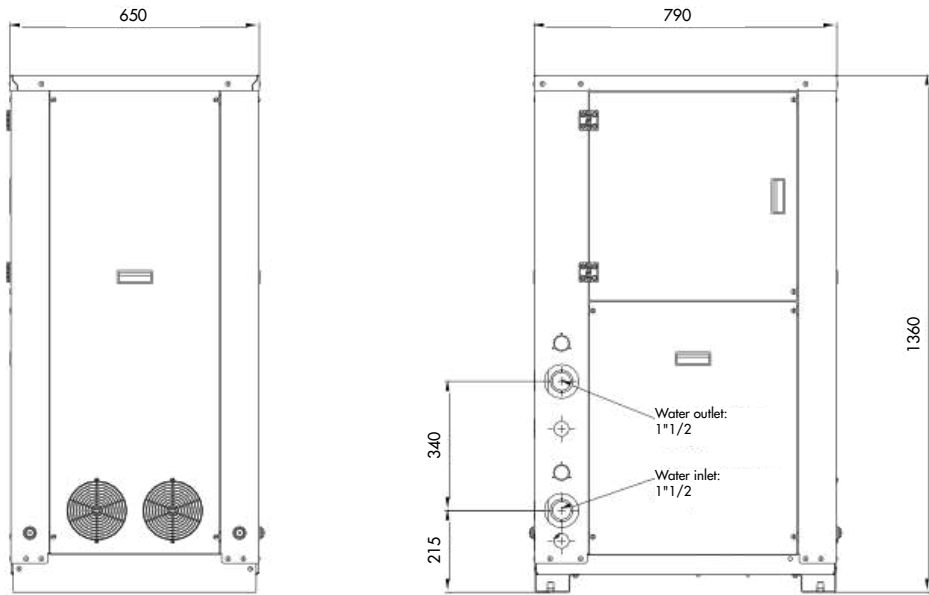

## MOD-HYDRO 1P 60 - MOD-HYDRO 2P 60 MOD-HYDRO 1P 90 - MOD-HYDRO 2P 90

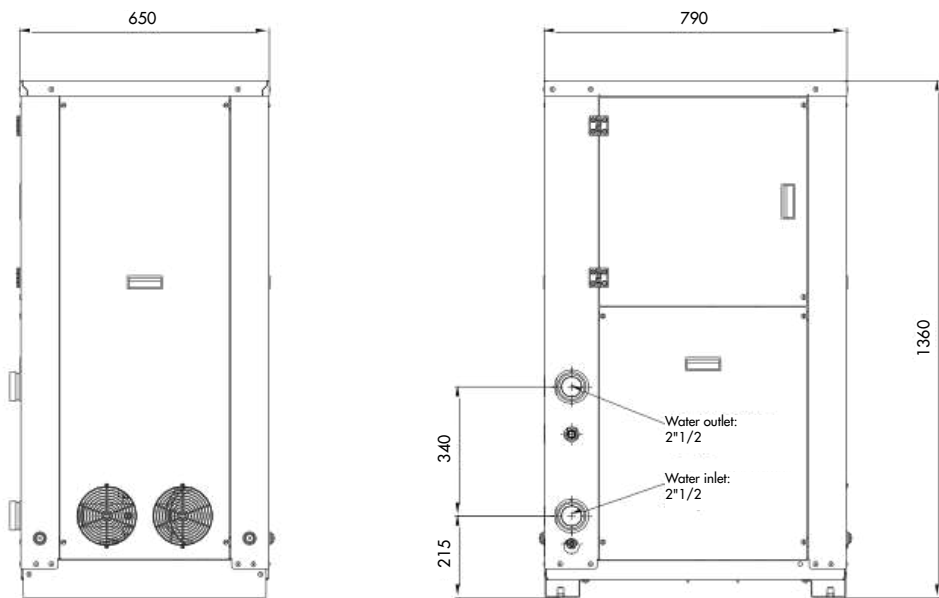

MOD-HYDRO V T100 1P 30  
MOD-HYDRO V T100 2P 30

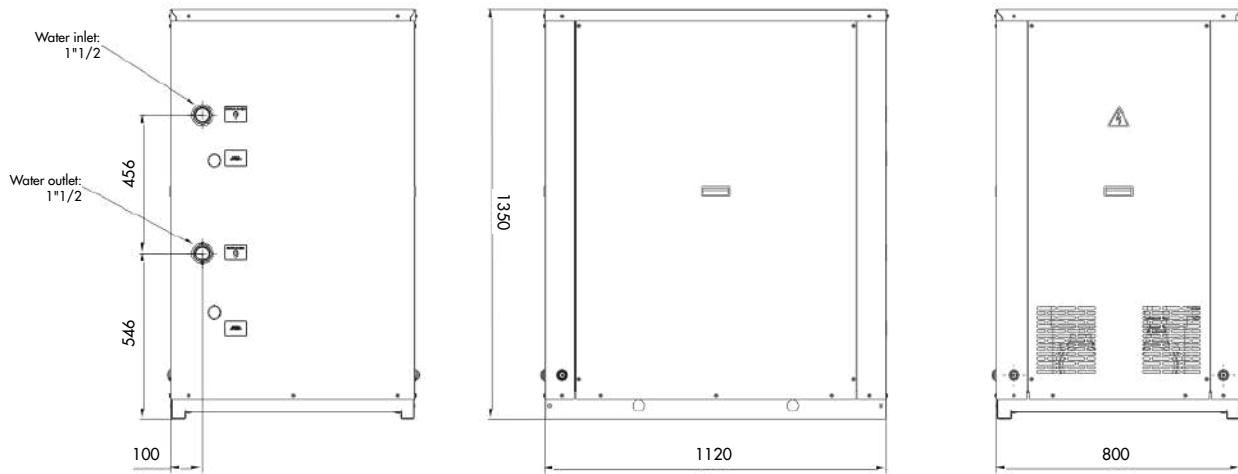

MOD-HYDRO V T200 1P 60 - MOD-HYDRO V T200 2P 60  
MOD-HYDRO V T300 1P 90 - MOD-HYDRO V T300 2P 90

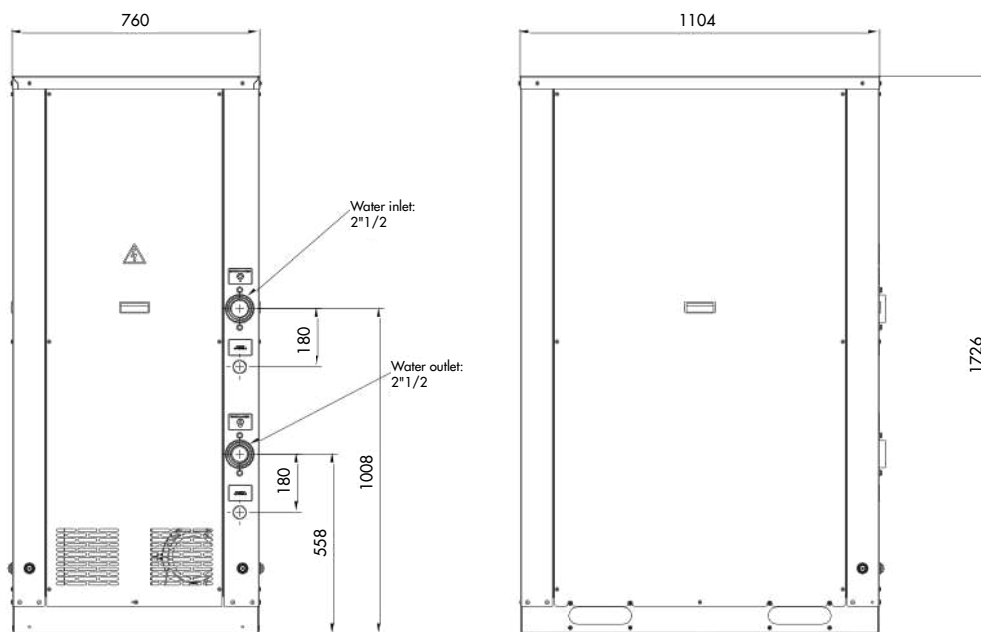

# DIAGRAMS OF THE CIRCULATOR PUMPS FLOW/HEAD

MOD-HYDRO 1P 30 - MOD-HYDRO V T100 1P 30  
 MOD-HYDRO 2P 30 - MOD-HYDRO V T100 2P 30

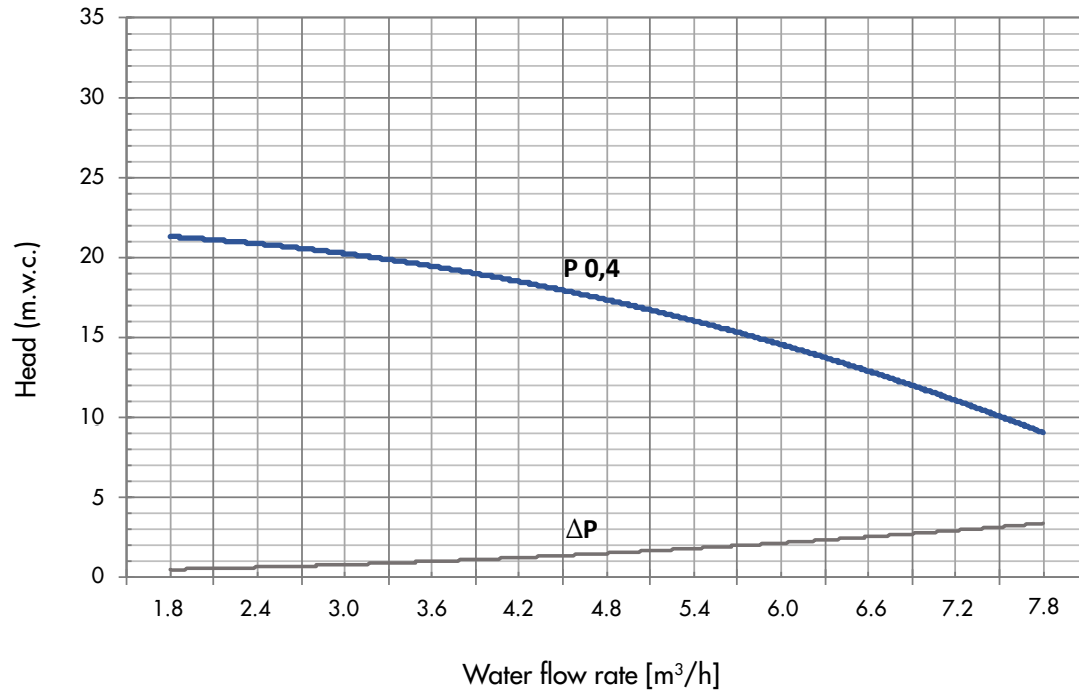

MOD-HYDRO 1P 60 - MOD-HYDRO V T200 1P 60  
 MOD-HYDRO 2P 60 - MOD-HYDRO V T200 2P 60

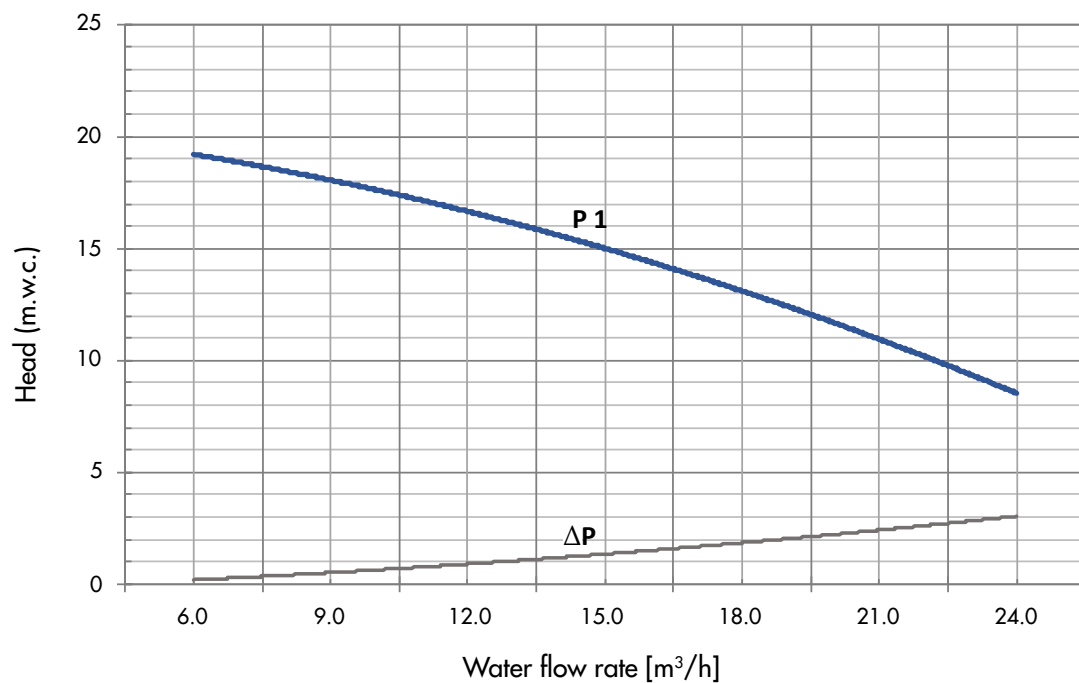

— Circulator head  
 — Unit head loss

# DIAGRAMS OF THE CIRCULATOR PUMPS FLOW/HEAD

HEAT PUMPS

MOD-HYDRO 1P 90 - MOD-HYDRO V T300 1P 90  
 MOD-HYDRO 2P 90 - MOD-HYDRO V T300 2P 90

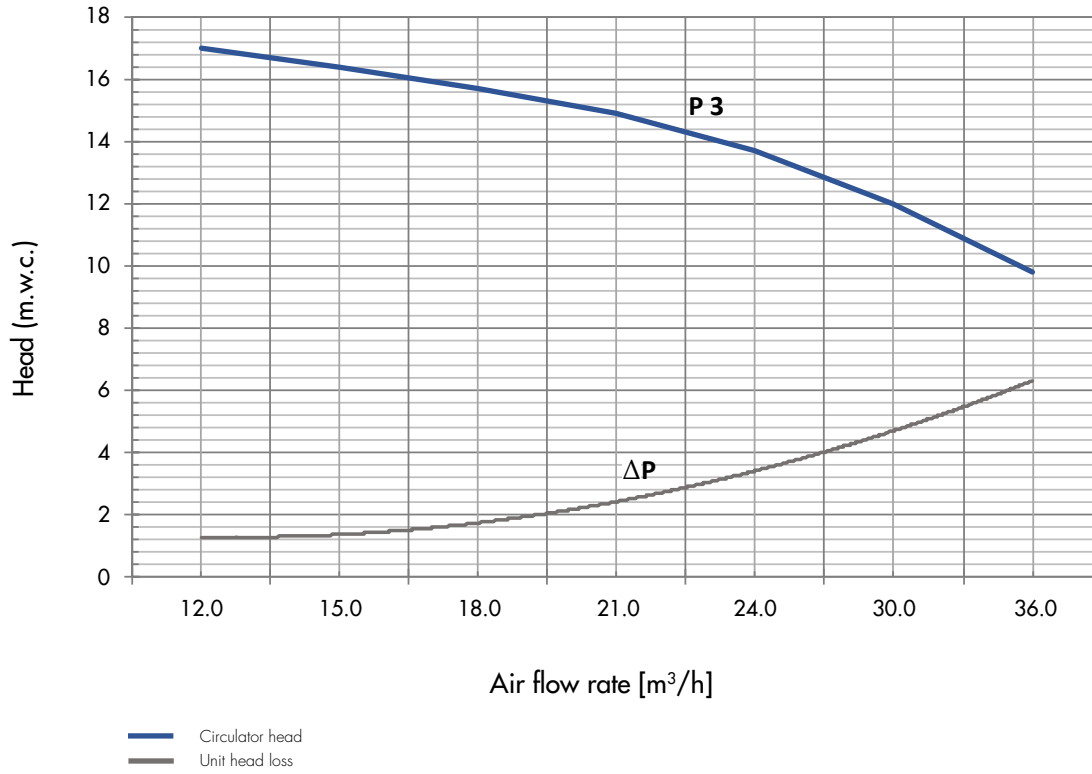

# HYDRONIC UNITS INSTALLATION EXAMPLES

## SOLUTION ONLY UNIT

LEGEND	
	shut-off valve
	vibration dumping joint
	Y-filter
	safety relief valve
	flow switch
	dial thermostat
	check valve
	dial manometer
	temperature sensor
	drain valve
	air relief valve
	electrical heater

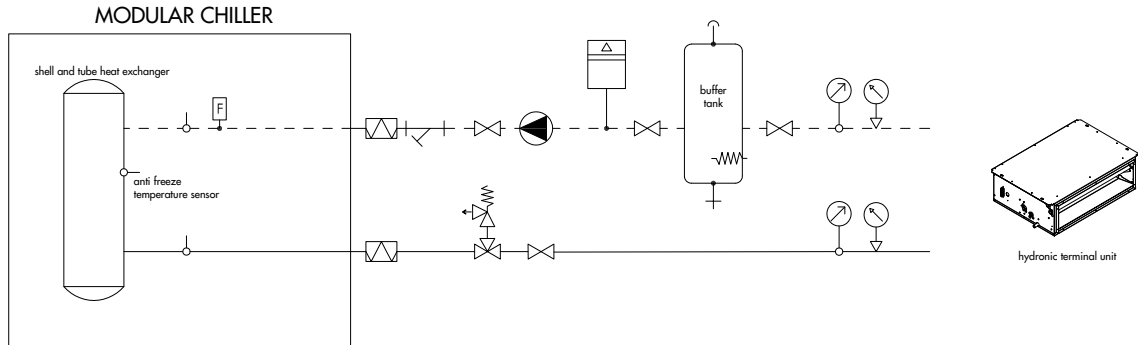

## SOLUTION UNIT AND PUMP GROUP

LEGEND	
	shut-off valve
	vibration dumping joint
	Y-filter
	safety relief valve
	flow switch
	dial thermostat
	check valve
	dial manometer
	temperature sensor
	drain valve
	air relief valve
	electrical heater

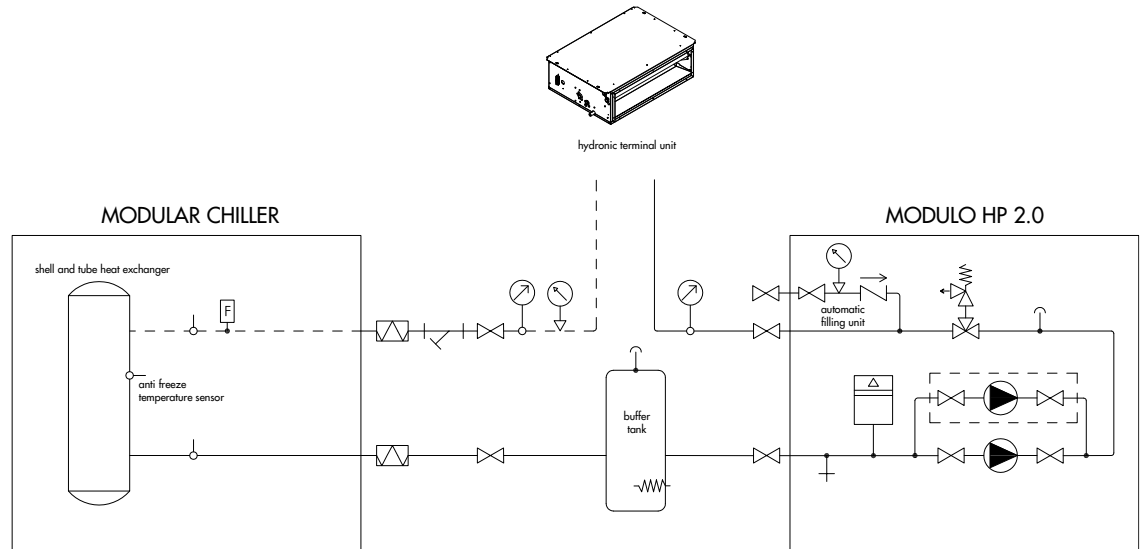

## SOLUTION UNIT AND PUMP GROUP WITH BUFFER TANK

LEGEND	
	shut-off valve
	vibration dumping joint
	Y-filter
	safety relief valve
	flow switch
	dial thermostat
	check valve
	dial manometer
	temperature sensor
	drain valve
	air relief valve
	electrical heater

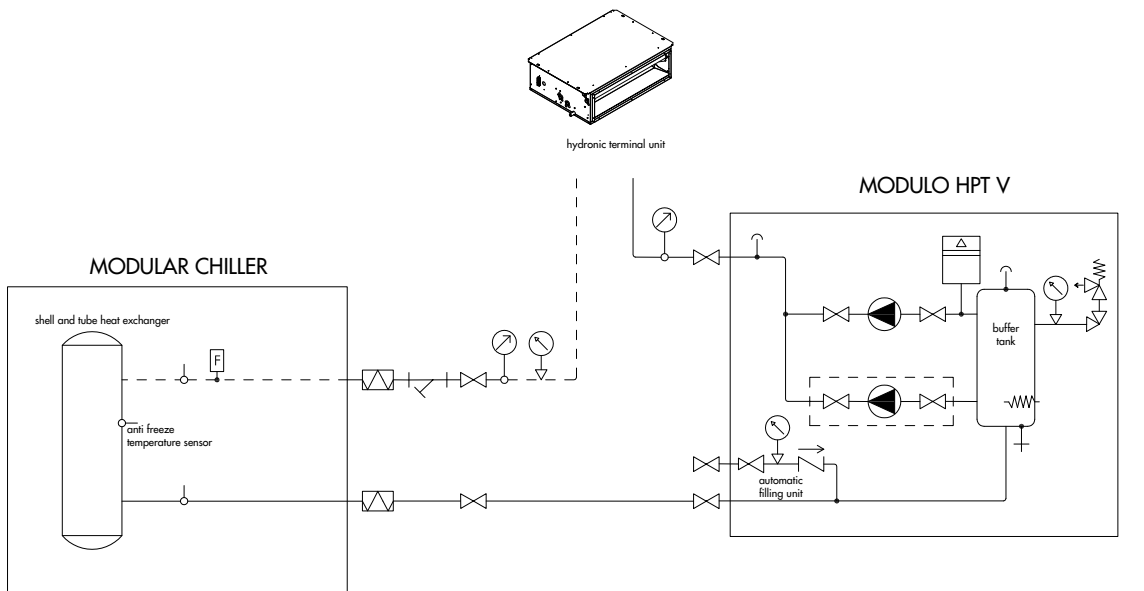



# NOTES



# X3 HEAT PUMPS FOR DOMESTIC HOT WATER

---

# X3 DHW HEAT PUMPS

## MAIN FEATURES



Code	Model	Description
398600080	APHPDHW200	DHW Heat pump - 200 L
398600081	APHPDHW300S	DHW Heat pump with solar coil - 300 L

ARGO introduces the latest generation of heat pump water heater, using ecologic R290 refrigerant. A performing solution, in A+ class, with a modern and pleasant appearance, distinguished for its low noise operation, the noise pressure at 1 m distance is 43 dB(A). The handy touch display easily allows controlling all operating conditions and optimizing the parameters for the best comfort and saving. Two models are available, the size 200 liters is equipped with an integrative electrical resistance, while the size 300 liters has also in addition an internal heat exchanger for solar integration. Thanks to the use of R290 refrigerant and of inverter motor these products stand out for their high performances. With a high COP, above 3, heating time and relevant consumption are greatly reduced.

Material: carbon steel. Internal protective treatment: Food-grade inorganic glass-coating complying with DIN 4753-3.

## OTHER FEATURES

- Micro-channel heat exchanger (heat pump)
- Spiroidal internal heat exchanger (solar, only for model APHPDHW300S)
- Simplified accessibility
- Installation flexibility
- PV contact



## INSTALLATION

The unit must be installed indoors, preferably in spaces where the temperature is always  $> 5\text{ }^{\circ}\text{C}$  (e.g. laundry, garage, technical room, ...). Both the air intake and exhaust, or none, may be ducted to the outside. A 600 mm clearance must be left all around the unit for maintenance. The room must have a minimum surface of  $7\text{ m}^2$ .



# TECHNICAL DATA

Model		APHPDHW300S	APHPDHW200
Power supply	/	230 V~/50 Hz	230 V~/50 Hz
Water-Dust Resistance	IPX	IPX1	IPX1
Electrical Shockproof	I	I	I
Heating capacity	kW	1.5	1.5
Heating Power Input	kW	0.41	0.41
Heating Current Input	A	1.8	1.8
COP*		3.51	3.53
COP**		3.02	3.08
Heating time (Heat pump only)***	h	8.25	5.45
Auxiliary E-heater	kW	1.5	1.5
Max. Power Input	kW	2.2	2.2
Max. Current Input	A	9.3	9.3
Refrigerant/Quantity	g	R290/150 g	R290/150 g
Unit dimensions (H./L./W.)	mm	Ø 640x1905	Ø 640x1600
Net weight	kg	112	96
Rated Outlet Water Temperature	°C	55	55
Air Volume	m <sup>3</sup> /h	350	350
Air Pressure	Pa	40	40
Air Duct Diameter	mm	150	150
Water Inlet-Outlet Size	inch	3/4"	3/4"
Compressor		Rotary	Rotary
Solar coil heat exchange surface	m <sup>2</sup>	1.1	/
Solar coil pressure drop	mbar	see chart	/
Solar coil max. pressure	MPa	1.6	/
Solar coil max. temperature	°C	90	/

Measurement conditions:

\*Ambient temperature 14 °C/13 °C, water inlet 15 °C, water outlet 55 °C (EN16147).

\*\*Ambient temperature 7 °C/6 °C, water inlet 15 °C, water outlet 55 °C (EN16147).

\*\*\*Ambient temperature 15 °C, water inlet 15 °C, water outlet 55 °C.

Work range:

(1) Ambient temperature is -5 °C~43 °C (Heat Pump).

(2) The max temperature of water tank is 60 °C.

Operating parameters:

The range of the operating water temperatures: 10~60 °C.

The range of the operating water pressures: 0.15~0.7 MPa.

# DIMENSIONS AND FITTINGS

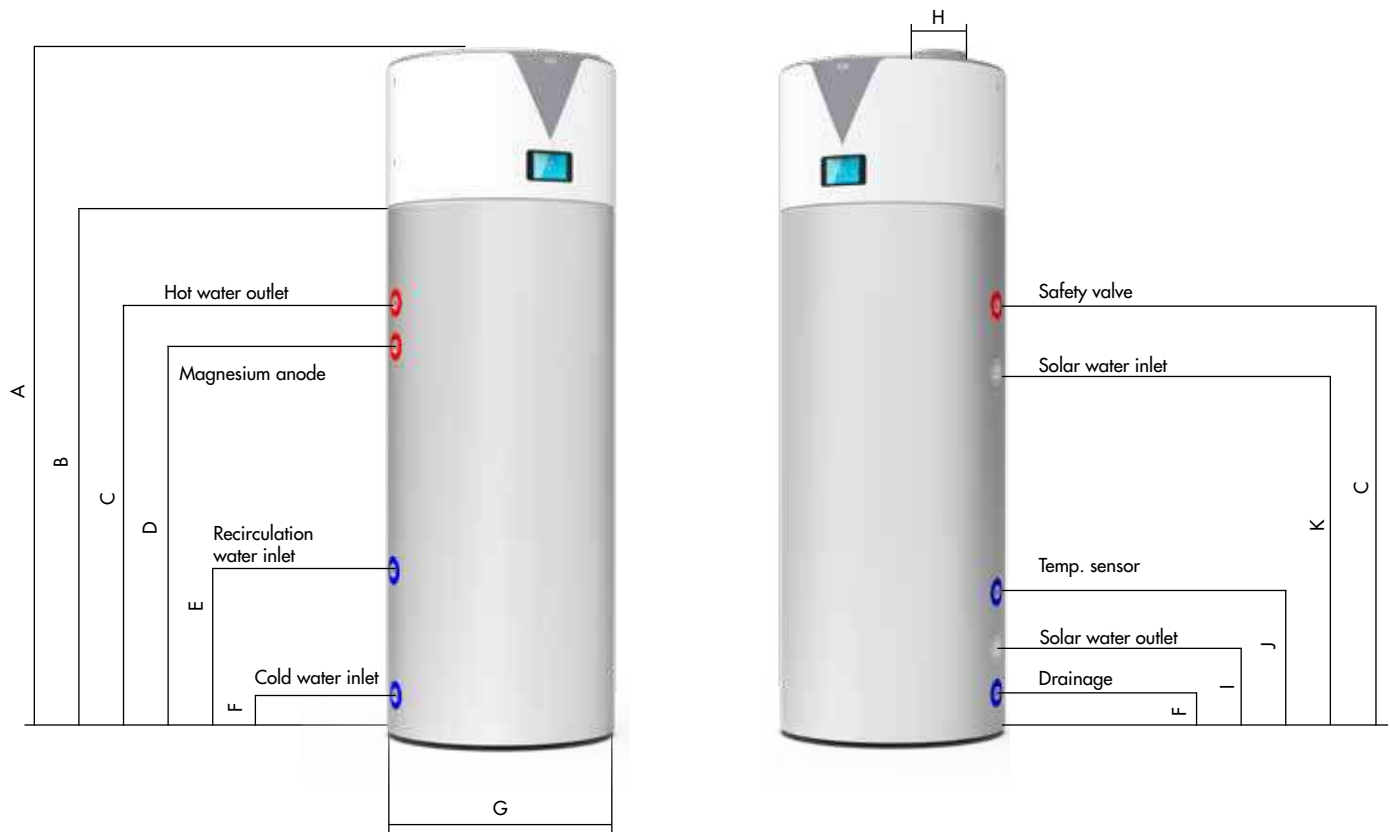

		A	B	C	D	E	F	G	H	I	J	K
APHPDHW300S	[mm]	1905	1467	1208	1088	576	128	Ø 640	Ø 150	226	531	1026
APHPDHW200	[mm]	1600	1162	903	783	-	128	Ø 640	Ø 150	-	-	-
CONNECTIONS	[inch]	-	-	G3/4"	G3/4"	G3/4"	G3/4"	-	-	G3/4"	G3/4"	G3/4"

## OPERATION MODES

Five different operating modes can be selected. In Standard mode the heat pump starts according to the actual temperature and target temperature. The electric heater will not start immediately, but only after a set time, if the target temperature has not been reached. In Eco mode only the heat pump is activated, the electric heater is always off. In High Requirement mode, besides the heat pump also the electric heater is turned on immediately.

In Intelligent mode, the operation changes automatically depending on the ambient temperature. Above a 'high' threshold the unit operates in Eco mode, below a 'low' threshold the unit operates in High Requirement mode, while in the intermediate condition the Standard mode is adopted.

It is also available a Vacation mode, for which a vacation 'end' can be set so that the unit re-starts automatically on the desired date. The disinfection cycle can be activated, so that the unit automatically carries out the periodic high temperature process.

# SOLAR HEAT EXCHANGER PRESSURE DROPS

HEAT PUMPS

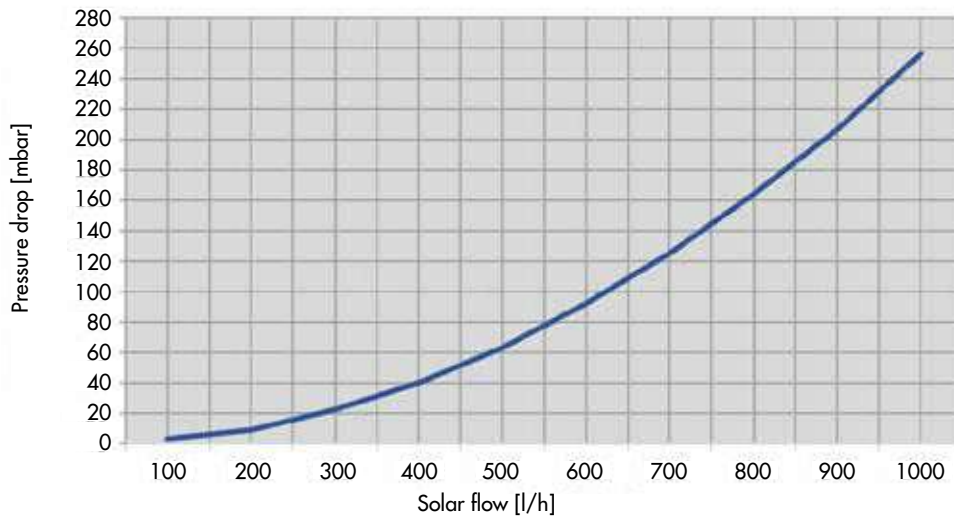

## EXAMPLE SCHEME

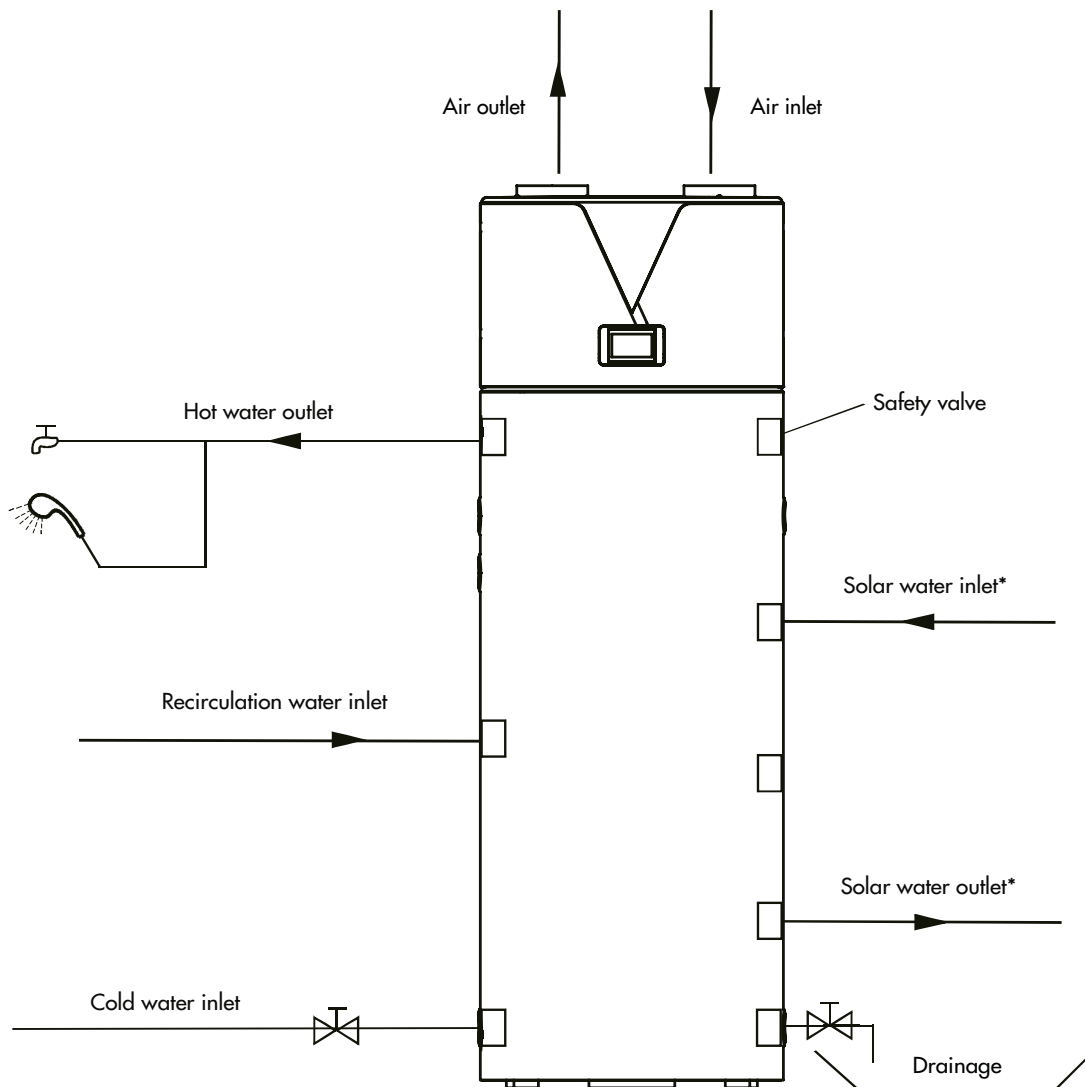

\*Only APHPDHW300S







# FAN COIL

---

Slim floor/ceiling

AC floor/ceiling

EC Brushless floor/ceiling

Cassette

Ductable

Accessories for integration with BMS system and sanification

High-Wall

# UNIT RANGE

	Model	 2 pipes	 4 pipes	 3-speed	 Brushless	Cooling capacity range W (1)	Heating capacity range W (2)
	<b>FCTS</b>	●		●	●	830-3.800	1.090-8.300
	<b>FCT-CV</b>	●		●		1.500-6.420	3.740-13.300
	<b>FCTE-CV</b>	●			●		
	<b>FCT-CA</b>	●		●			
	<b>FCTE-CA</b>	●			●		
	<b>FCT-CH</b>	●		●			
	<b>FCTE-CH</b>	●			●		
	<b>FCT-NV</b>	●		●			
	<b>FCTE-NV</b>	●			●		
	<b>FCT-NH</b>	●		●			
	<b>FCTE-NH</b>	●			●		
	<b>FCC</b>	●		●		2.950-10.530	7.010-23.870
	<b>FCCE</b>	●			●	5.020-15.190	12.350-30.680
	<b>FCCX</b>		●	●		3.070-8.540	4.590-13.100
	<b>DT-NH</b>	●		●		6.820-17.800	15.200-37.200
	<b>DTE-NH</b>	●			●	6.976-17.993	15.569-37.629
	<b>FCW</b>	●		●		2.100-4.200	4.264-8.642

(1) Cooling: air temp. 27 °C dry bulb, 19 °C wet bulb - input/output water temp. 7/12 °C

(2) Heating: air temp. 20 °C - input/output water temp. 70/60 °C

# FITTING CONVENTIONS

Battery fitting conventions for floor/ceiling-mounted fan coil units (FCT/FCTE)

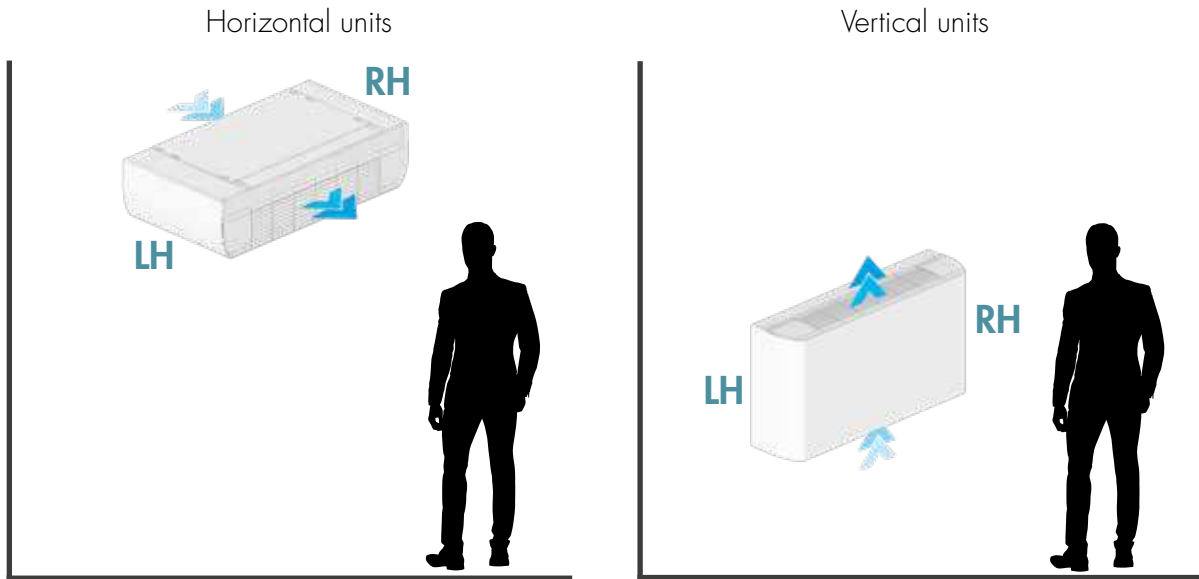

FANCOILS

Battery fitting conventions for ductable fan coil units (DT/DTE)

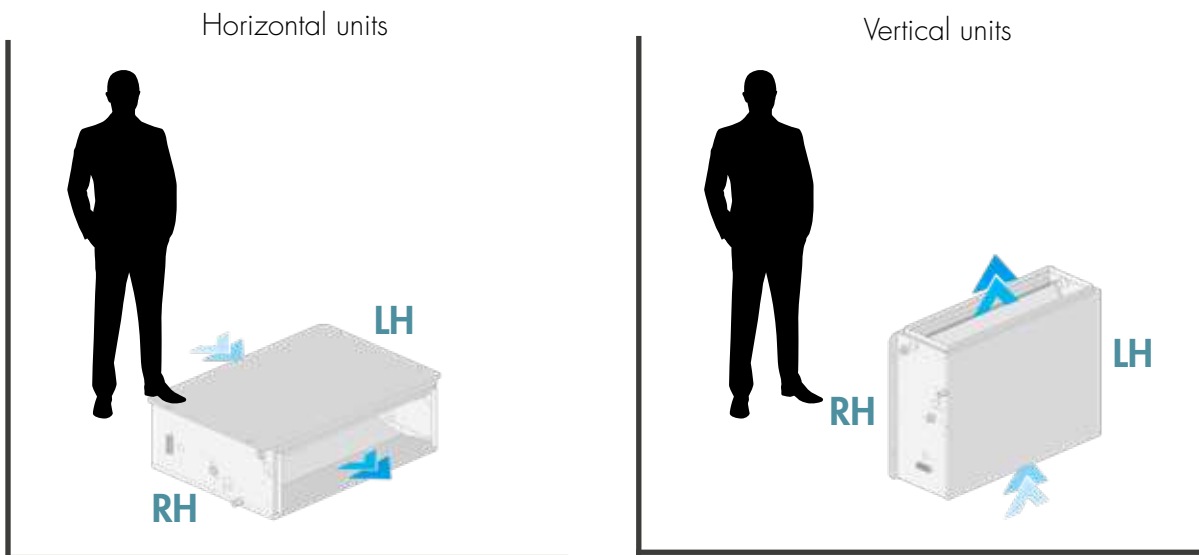

Our fan coil units have the fittings mounted on the left-hand side as a standard feature (unless expressly specified).



# FLOOR | CEILING

---

Slim - Model: FCTS

# FLOOR/CEILING SLIM FAN COILS

## MAIN FEATURES FCTS RANGE

The slim fan coils can be installed on the floor or ceiling in any room thanks to its particularly small size and elegant design. They quickly reach the selected temperature and keep it constant in maximum silence, thanks to the fan in continuous modulation.

The exchange coil in copper-aluminum is suitable for operation with:

- high temperature water (boiler)
- low temperature water (condensing boiler, heat pump, etc.)
- water supplemented with glycol

### RANGE

A range of 5 different capacities (with 2-pipe) is available to always find the perfect product for every need, in white RAL 9003 color.

### THIN AND SILENT

With only 129 mm thickness, these fan coils can be installed in any ambient. Moreover, with the fan in continuous modulation that progressively reduces the speed as the room temperature approaches the set one, they guarantee maximum silence. When heating, the limits develop an effective natural convection motion, similar to that of a radiator. This greatly reduces the need for ventilation.

### MODULATED AIRFLOW AND LOW CONSUMPTION

The fan is tangential with asymmetrical blades and the exchanger has a large frontal surface. In this way, efficient, silent and imperceptible air flows are obtained with low pressure drops. Moreover, the efficiency is very high with low energy consumption thanks to DC inverter technology.

### CONTROLS

FCTS fan coils can be combined with a full range of electronic controls, PI modulating type and more traditional type with three or four fan speeds.

Both on-board controllers, recommended for vertical installations, and remote wired-controllers, recommended for ceiling-mounted installations, are available. It is always necessary to match one of the options to each unit.

### VALVES

Both a 2-way valve assembly with electrothermal actuator and a 3-way diverting valve assembly with electrothermal actuator are available.

### OTHER ACCESSORIES

To complete the installation, several accessories are available: aesthetic feet to hide the hydraulic connection pipes coming from the floor, aesthetic feet for floor fixing, condensate collection trays for horizontal ceiling installation and aesthetic back panels for installations with the rear part of the unit in sight.

# FLOOR/CEILING SLIM FAN COILS

## MODELS

### FAN COIL SLIM MOD. FCTS

Vertical (floor) or horizontal (ceiling) installation.

Code	Model	Cooling capacity (W)* (1)	Heating capacity (W)* (2)
387030666	FCTS-CA 01 L	830	1.890
387030710	FCTS-CA 01 R		
387030667	FCTS-CA 02 L	1.760	3.990
387030711	FCTS-CA 02 R		
387030668	FCTS-CA 03 L	2.650	5.470
387030712	FCTS-CA 03 R		
387030669	FCTS-CA 04 L	3.340	6.980
387030713	FCTS-CA 04 R		
387030670	FCTS-CA 05 L	3.800	8.300
387030714	FCTS-CA 05 R		

\*maximum fan speed

(1) **Cooling:** air temp. 27 °C dry bulb, 19 °C wet bulb - temp. - input/output water temp. 7/12 °C

(2) **Heating:** air temp. 20 °C dry bulb - input/output water temp. 50/45 °C



FCTS-CA	01	L
-	(1)	(2)

FCTS-CA = fan coil model

(1) Capacity = 01

(2) L = left coil connection/R = right coil connection

FANCOILS

NB: Units are supplied without controllers it's always necessary to select a controller among the available options to be matched with the units



ONLY 13 cm  
THICKNESS



# RATED TECHNICAL DATA

## TWO-PIPE UNIT - ONE COIL

Model			01	02	03	04	05
Total cooling capacity (1)		W	830	1760	2650	3340	3800
Sensible cooling capacity (1)		W	620	1270	1960	2650	3010
Heating capacity (2a)		W	1090	2350	3190	4100	4860
Heating capacity (2b)		W	1890	3990	5470	6980	8300
Rated air flow		m <sup>3</sup> /h	162	320	461	576	648
Coil water content		l	0.47	0.8	1.13	1.46	1.8
Water flow rate (4)	Cooling	l/h	143	303	456	574	654
	Heating (2a)	l/h	143	303	456	574	654
	Heating (2b)	l/h	162	343	471	600	714
Pressure drops (5)	Cooling	kPa	7.2	8.4	22.5	18.6	24.9
	Heating (2a)	kPa	5.7	6.6	16.3	14	18.3
	Heating (2b)	kPa	6.7	7.6	16.1	14	19.8
Sound pressure (ls.-ms.-hs.) (3)		dB(A)	24.2-33.2-39.4	25.3-34.1-40.2	25.6-34.4-42.2	26.3-35.0-42.5	27.6-37.6-43.9
Motors/Fans		N/N	1/1				
Rated power input	W		11.9	17.6	19.8	26.5	29.7
	A		0.11	0.16	0.18	0.26	0.28
Electrical power supply		V/Hz	230/50				
Cold/hot coil rows		N	2				
Hydraulic fittings		DN	Eurokonus 3/4"				
Condensate drainage outlet		mm	16				
Net weight		kg	17	20	23	26	29

(1) Water temperature at coil inlet 7 °C, water temperature at coil outlet 12 °C, ambient air temperature 27 °C d.b. and 19 °C w.b. (UNI EN 1397 standard)

(2a) Coil inlet water temperature 50 °C, water flow rate as in cooling mode, ambient air temperature 20 °C (UNI EN 1397 standard)

(2b) Water temperature at coil inlet 70 °C, water temperature at coil outlet 60 °C, ambient air temperature 20 °C

(3) Sound pressure measured in a semi-anechoic chamber according to ISO 7779 standard

## DIMENSIONAL DRAWINGS

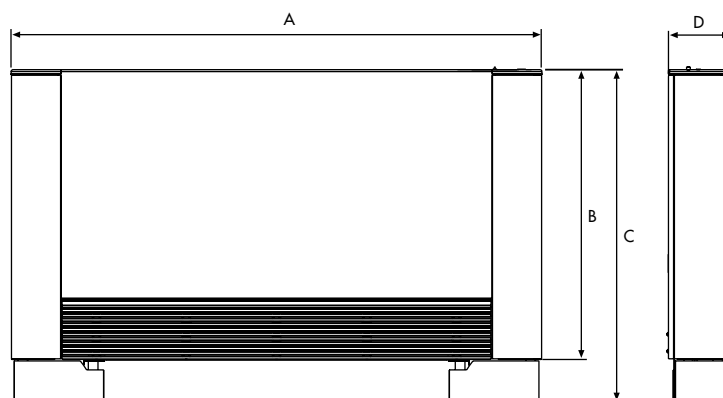

MODEL FCTS		01	02	03	04	05
A	mm	735	935	1135	1335	1535
B	mm	579	579	579	579	579
C	mm	659	659	659	659	659
D	mm	129	129	129	129	129



# MATCHABLE CONTROLLERS

## OPTIONAL OR ACCESSORIES TO BE ORDERED SEPARATELY

FANCOILS

### ONLY PCB



#### PCB

EIX03 for third-party 3-speed electromechanical wall thermostats

EIX04 for control from third party 0-10V analog output systems

### ON-BOARD CONTROLLERS

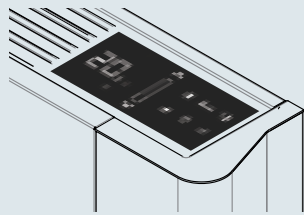

OBC28 PCB included

OBC30 PCB included

### REMOTE WIRED CONTROLLERS







PCB  
EIX02

#### CONTROLLERS







SWC31

SWC33

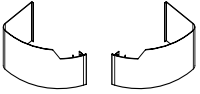
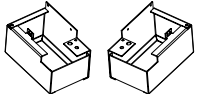
# ACCESSORIES

CONTROLS					
		Code	Model	Description	Applicability
ON BOARD CONTROLLERS		387030671	OBC28	Electronic controller SMART TOUCH LCD with continuous modulation thermostat	All
		387030673	OBC30	Electronic controller SMART TOUCH LCD e with 4 fixed speeds and thermostat	All
REMOTE WIRED CONTROLLERS		387030675	EIX02	PCB on the unit with continuous modulation for connection to wall controller SWC31 - SWC33	All, to be matched with a wall control
		387030676	SWC31	SMART TOUCH electronic wall controller panel with thermostat and ambient probe (to be coupled from 1 to max 30 EIX02), white color	All, to be matched with PCB EIX02
		387030678	SWC33	Wall electronic controller panel TOUCH LCD with thermostat and temperature probe, relative humidity and air quality in the room. White color	All, to be matched with PCB EIX02
		387030680	EMZS	MZS, Single Zone Module	All
ONLY PCB		387030681	EIX03	Electronic board on the unit or connection to 3-speed electromechanical wall thermostats (third party)	All
		387030682	EIX04	Electronic board on the unit for control from systems with 0-10V analog output (third party)	All

VALVES				
Code	Model	Description		Applicability
387030684	2WV08	2-way valve group (inlet valve and lockshield) with thermoelectric motor		All
387030685	3WV08	3-way diverting valve unit with thermoelectric motor (complete with 3-way inlet valve and lockshield)		All

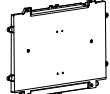
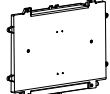
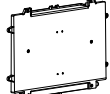
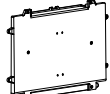
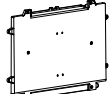
VARIOUS				
	Code	Model	Description	Applicability
	387030686	FE02	Feet for floor pipes hiding in white color	All
	387030687	FE03	Feet to anchor the unit to the floor, white color	All
	387030688	CPBS 01	Back cover in white color - Mod. 01	01
	387030689	CPBS 02	Back cover in white color - Mod. 02	02
	387030690	CPBS 03	Back cover in white color - Mod. 03	03
	387030691	CPBS 04	Back cover in white color - Mod. 04	04
	387030692	CPBS 05	Back cover in white color - Mod. 05	05
	387030694	HB03	Condensate collection tray for horizontal ceiling installation - Mod. 01	01
	387030695	HB04	Condensate collection tray for horizontal ceiling installation - Mod. 02	02
	387030696	HB05	Condensate collection tray for horizontal ceiling installation - Mod. 03	03
	387030697	HB06	Condensate for horizontal ceiling installation - Mod. 04	04
	387030798	HB07	Condensate for horizontal ceiling installation - Mod. 05	05



# FLOOR | CEILING

---

AC - Model: FCT

# AC FLOOR/CEILING

## MAIN FEATURES MOD. FCT

### CONVERGING CABINET

(only for the CV - CA - CH versions)

Standard white finish (RAL 9010). Made of high-thickness galvanised plate pre-coated with a polyvinyl chloride film, it can withstand rust, corrosion, chemicals, solvents, aliphatic compounds and alcohols. Internal thermo-acoustic insulation (Class M1). Compact dimensions: a mere 220 mm thickness. Air supply grid made of white ABS (RAL 9002), with openable side panels for accessing the control panel (accessory).

The double row of manual flaps, each adjustable, allows for directing the air flow in any direction. The flaps can be adjusted in opposite directions to enhance the induction effect. The flow can be directed to graze the ceiling/wall to exploit the Coanda effect.

### LOAD-BEARING STRUCTURE

Load-bearing structure made of high-thickness galvanised plate with holes (slots) for wall/ceiling mounting, made directly on the structure.

### DRAIN PAN

Drain pan equipped with a drainage outlet and thermal insulation. A condensation drain funnel with Ø 20 mm fitting, made of plastic, is mounted only on vertical versions (standard on the same side of the water connections).

### HEAT EXCHANGER

High-efficiency heat exchange coil with copper pipe and aluminium flaps locked by means of mechanical expansion. Coil fittings equipped with anti-torsion system, manual air relief valves and manual water drainage valves. Fittings on the left as a standard feature; on request they can be mounted on the right and are easily reversible on-site. 1 coil for 2-pipe system; 2 coils for 4-pipe system.

Coils tested at 30 bar operating pressure, suitable for working with water up to a maximum pressure of 15 bar.

The coils are suitable for operating with:

- high-temperature water (boiler);
- low-temperature water (condensing boiler, heat pump, etc.);
- cold water (chiller and/or industrial processes)
- water supplemented with glycol.

### VENTILATION UNIT

Ventilation unit consisting of 1, 2 or 3 double-intake centrifugal fans directly coupled with the electric motor with a useful static pressure of up to 75 Pa. Mounted on elastic and elastic supports and shock absorbers. Statically and dynamically balanced fan. Asynchronous electric motor equipped with thermal protection device (Klixon), run capacitor always engaged, IP42, Class B, power cables protected with double insulation. Built according to international standards, 230 VAC-1 Ph-50 Hz.

Standard unit with single-speed motor + 6-output auto-transformer ensuring up to 6 speeds (with performances ranging from max=100% to min=40-50%). Standard electrical pre-wiring in the factory of the 3 intermediate speeds nos. 2-3-5.

### AIR FILTER

Easily removable air filter, built with a metal frame containing the filtration septum. Can be regenerated by washing it with water, blowing, vacuuming. Standard: filtering medium made of polyester acrylic fabric, high-efficiency, resin-coated and needle-punched. Recommended against dust and pollen. Class M1, filtration grade EU3 (EUROVENT 4/5).

# AC FLOOR/CEILING

## MODELS

### AC FLOOR FAN COIL MOD. FCT-CV

Visible wall-mounted vertical installation, covering cabinet with vertical air outflow and intake from the bottom part.

Code	Model	Cooling capacity (W) (1)	Heating capacity (W) (2)
387030239	FCT-CV 01 L	1.500	3.740
387030240	FCT-CV 01 R		
387030241	FCT-CV 02 L	2.000	4.910
387030242	FCT-CV 02 R		
387030243	FCT-CV 03 L	2.530	5.980
387030244	FCT-CV 03 R		
387030245	FCT-CV 04 L	3.020	6.710
387030246	FCT-CV 04 R		
387030247	FCT-CV 05 L	3.750	8.160
387030248	FCT-CV 05 R		
387030249	FCT-CV 06 L	4.250	9.440
387030250	FCT-CV 06 R		
387030251	FCT-CV 07 L	5.520	12.000
387030252	FCT-CV 07 R		
387030253	FCT-CV 08 L	6.420	13.300
387030254	FCT-CV 08 R		
387030255	FCT-CV 09 L	7.530	15.500
387030256	FCT-CV 09 R		



FCT-CV	01	L
-	(1)	(2)

FCT-CV = fan coil model  
 (1) Capacity = 01, 02, 03, 04, 05, 06, 07, 08, 09  
 (2) L = left coil connection/R = right coil connection

FANCOILS

### AC FLOOR FAN COIL MOD. FCT-CA

Visible wall-mounted vertical installation, covering cabinet with vertical air outflow and intake from the front part.

Code	Model	Cooling capacity (W) (1)	Heating capacity (W) (2)
387030257	FCT-CA 01 L	1.500	3.740
387030258	FCT-CA 01 R		
387030259	FCT-CA 02 L	2.000	4.910
387030260	FCT-CA 02 R		
387030261	FCT-CA 03 L	2.530	5.980
387030262	FCT-CA 03 R		
387030263	FCT-CA 04 L	3.020	6.710
387030264	FCT-CA 04 R		
387030265	FCT-CA 05 L	3.750	8.160
387030266	FCT-CA 05 R		
387030267	FCT-CA 06 L	4.250	9.440
387030268	FCT-CA 06 R		
387030269	FCT-CA 07 L	5.520	12.000
387030270	FCT-CA 07 R		
387030271	FCT-CA 08 L	6.420	13.300
387030272	FCT-CA 08 R		
387030273	FCT-CA 09 L	7.530	15.500
387030274	FCT-CA 09 R		



FCT-CA	01	L
-	(1)	(2)

FCT-CA = fan coil model  
 (1) Capacity = 01, 02, 03, 04, 05, 06, 07, 08, 09  
 (2) L = left coil connection/R = right coil connection

(1) Cooling: air temp. 27 °C dry bulb, 19 °C wet bulb - temp. - input/output water temp. 7/12 °C  
 (2) Heating: air temp. 20 °C - input/output water temp. 70/60 °C

# AC FLOOR/CEILING

## MODELS

### AC CEILING FAN COIL MOD. FCT-CH

Visible ceiling-mounted horizontal installation, covering cabinet with air outflow from the front and intake from the bottom.

Code	Model	Cooling capacity (W) (1)	Heating capacity (W) (2)
387030275	FCT-CH 01 L	1.500	3.740
387030276	FCT-CH 01 R		
387030277	FCT-CH 02 L	2.000	4.910
387030278	FCT-CH 02 R		
387030279	FCT-CH 03 L	2.530	5.980
387030280	FCT-CH 03 R		
387030281	FCT-CH 04 L	3.020	6.710
387030282	FCT-CH 04 R		
387030283	FCT-CH 05 L	3.750	8.160
387030284	FCT-CH 05 R		
387030285	FCT-CH 06 L	4.250	9.440
387030286	FCT-CH 06 R		
387030287	FCT-CH 07 L	5.520	12.000
387030288	FCT-CH 07 R		
387030289	FCT-CH 08 L	6.420	13.300
387030290	FCT-CH 08 R		
387030291	FCT-CH 09 L	7.530	15.500
387030292	FCT-CH 09 R		



FCT-CH	01	L
-	(1)	(2)

FCT-CH = fan coil model  
 (1) Capacity = 01, 02, 03, 04, 05, 06, 07, 08, 09  
 (2) L = left coil connection/R = right coil connection

### AC VERTICAL CONCEALED FAN COIL MOD. FCT-NV

Concealed vertical installation, with vertical air outflow and intake from the front part.

Code	Model	Cooling capacity (W) (1)	Heating capacity (W) (2)
387030293	FCT-NV 01 L	1.500	3.740
387030294	FCT-NV 01 R		
387030295	FCT-NV 02 L	2.000	4.910
387030296	FCT-NV 02 R		
387030297	FCT-NV 03 L	2.530	5.980
387030298	FCT-NV 03 R		
387030299	FCT-NV 04 L	3.020	6.710
387030300	FCT-NV 04 R		
387030301	FCT-NV 05 L	3.750	8.160
387030302	FCT-NV 05 R		
387030303	FCT-NV 06 L	4.250	9.440
387030304	FCT-NV 06 R		
387030305	FCT-NV 07 L	5.520	12.000
387030306	FCT-NV 07 R		
387030307	FCT-NV 08 L	6.420	13.300
387030308	FCT-NV 08 R		
387030309	FCT-NV 09 L	7.530	15.500
387030310	FCT-NV 09 R		



FCT-NV	01	L
-	(1)	(2)

FCT-NV = fan coil model  
 (1) Capacity = 01, 02, 03, 04, 05, 06, 07, 08, 09  
 (2) L = left coil connection/R = right coil connection

(1) Cooling: air temp. 27 °C dry bulb, 19 °C wet bulb - temp. - input/output water temp. 7/12 °C  
 (2) Heating: air temp. 20 °C - input/output water temp. 70/60 °C



## AC HORIZONTAL CONCEALED FAN COIL MOD. FCT-NH

Concealed horizontal installation, with horizontal air outflow and intake from the rear part.

Code	Model	Cooling capacity (W) (1)	Heating capacity (W) (2)
387030311	FCT-NH 01 L	1.500	3.740
387030312	FCT-NH 01 R		
387030313	FCT-NH 02 L	2.000	4.910
387030314	FCT-NH 02 R		
387030315	FCT-NH 03 L	2.530	5.980
387030316	FCT-NH 03 R		
387030317	FCT-NH 04 L	3.020	6.710
387030318	FCT-NH 04 R		
387030319	FCT-NH 05 L	3.750	8.160
387030320	FCT-NH 05 R		
387030321	FCT-NH 06 L	4.250	9.440
387030322	FCT-NH 06 R		
387030323	FCT-NH 07 L	5.520	12.000
387030324	FCT-NH 07 R		
387030325	FCT-NH 08 L	6.420	13.300
387030326	FCT-NH 08 R		
387030327	FCT-NH 09 L	7.530	15.500
387030328	FCT-NH 09 R		

(1) Cooling: air temp. 27 °C dry bulb, 19 °C wet bulb - temp. - input/output water temp. 7/12 °C  
 (2) Heating: air temp. 20 °C - input/output water temp. 70/60 °C



FCT-NH	01	L
-	(1)	(2)

FCT-NH = fan coil model  
 (1) Capacity = 01, 02, 03, 04, 05, 06, 07, 08, 09  
 (2) L = left coil connection/R = right coil connection

# RATED TECHNICAL DATA

## TWO-PIPE UNIT - ONE COIL

Models			01	02	03	04
Total cooling capacity (1)		W	1.500	2.000	2.530	3.020
Sensible cooling capacity (1)		W	1.290	1.620	2.070	2.310
Heating capacity (2a)		W	3.740	4.910	5.980	6.710
Heating capacity (2b)		W	1.870	2.455	2.990	3.355
Rated air flow (3)		m <sup>3</sup> /h	370	400	500	550
Water flow rate (4)	Cooling	l/h	258	344	436	520
	Heating	l/h	322	423	515	578
Water pressure drop (5)	Cooling	kPa	13.1	16.3	18.5	20.8
	Heating	kPa	15.9	19.2	20.1	20
Sound pressure (ls.-ms.-hs.) (6)		dB(A)	24-31-38	25-31-38	30-38-44	31-38-45
Motors/Fans		N/N	1/1		1/1	
Rated power absorption (7)		W	55		85	
		A	0.25		0.40	
Electrical power supply			230 Vac - 1 Ph - 50 Hz			
Cold/hot coil rows		N	3R		3R	
Hydraulic fittings		DN	1/2" F		1/2" F	
Condensate drainage outlet		mm	20		20	

Models			05	06	07	08	09
Total cooling capacity (1)		W	3.750	4.250	5.520	6.420	7.530
Sensible cooling capacity (1)		W	2.870	3.230	4.330	4.800	5.670
Heating capacity (2a)		W	8.160	9.440	12.000	13.300	15.500
Heating capacity (2b)			4.080	4.720	6.000	6.650	7.750
Rated air flow (3)		m <sup>3</sup> /h	670	720	1.000	1.050	1.280
Water flow rate (4)	Cooling	l/h	645	731	950	1.105	1.296
	Heating	l/h	702	812	1.032	1.144	1.333
Water pressure drop (5)	Cooling	kPa	22.6	24.1	24.5	27.1	28.8
	Heating	kPa	20.9	23.2	22.6	22.7	23.8
Sound pressure (ls.-ms.-hs.) (6)		dB(A)	26-33-37	27-34-37	34-41-43	35-41-45	39-46-48
Motors/Fans		N/N	1/2		1/2		1/2
Rated power absorption (7)		W	75		145		175
		A	0.35		0.65		0.77
Electrical power supply			230 Vac - 1 Ph - 50 Hz				
Cold/hot coil rows		N	3R		3R		3R
Hydraulic fittings		DN	1/2" F		1/2" F		1/2" F
Condensate drainage outlet		mm	20		20		20

Technical data referred to the following conditions:  
standard unit - atmospheric pressure 1013 mbar - electrical power supply 230 VAC/1 Ph/50 Hz.

(1) (2) (3) (4) (5): Rated technical data, ref. air flow rate (3) at maximum speed and with unit with open mouth (external static pressure ESP=0 Pa).

(1) **Cooling**: air temp. 27 °C dry bulb, 19°C wet bulb - input/output water temp. 7/12 °C - Maximum speed.

(2a) **Heating**: air temp. 20 °C - Input/output water temp. 70/60 °C - Maximum speed.

(2b) **Heating**: air temp. 20 °C - Input/output water temp. 45/40 °C - Maximum speed.

(3) **Air flow rate and static pressure**: rated values measured with casing ref. AMCA210-74 standard Fig. 12 and conduit + diaphragm ref. CNR-UNI10023 standard.

(6) **Sound pressure**: sound pressure in free field environment, distance 2 m. Values calculated from sound power measured in reverberation chamber ref. ISO 3741-ISO 3742 standards.

(7) **Electrical data**: values measured with Jokogawa WT110 wattmeter (nominal value = reference value for the design of the electrical system).

## REDUCTION OF THE COOLING/HEATING CAPACITY (IN RELATION TO THE AIR FLOW REDUCTION)

Air flow rate	1.00	0.95	0.90	0.85	0.80	0.75	0.70	0.65	0.60
Total cooling capacity	1.00	0.97	0.95	0.92	0.89	0.87	0.84	0.81	0.77
Sensible cooling capacity	1.00	0.97	0.93	0.90	0.86	0.83	0.79	0.76	0.72
Heating capacity	1.00	0.97	0.94	0.91	0.87	0.84	0.81	0.77	0.74

Air flow rate	0.55	0.50	0.45	0.40	0.35	0.30	0.25	0.20	0.15
Total cooling capacity	0.74	0.71	0.67	0.63	0.59	0.55	0.50	0.45	0.39
Sensible cooling capacity	0.68	0.64	0.60	0.55	0.51	0.46	0.41	0.35	0.29
Heating capacity	0.70	0.66	0.62	0.58	0.53	0.49	0.44	0.38	0.32

## TABLE OF NET WEIGHTS MOD. FCT (TWO-PIPE UNIT - ONE COIL) IN KG

Products/Models	01	02	03	04	05	06	07	08	09
FCT-CV	13.5	14.0	16.4	17.2	22.5	23.5	26.5	27.5	30.0
FCT-CA	13.8	14.3	16.9	17.7	23.2	24.2	26.9	28.4	31.1
FCT-CH	15.0	15.5	18.5	19.3	25.2	26.2	29.3	30.8	33.9
FCT-NV	10.6	11.1	13.4	14.2	19.4	20.4	22.7	24.2	26.6
FCT-NH	11.2	11.7	14.0	14.8	20.0	21.0	23.4	24.9	27.3

# USEFUL STATIC PRESSURE/ WATER FLOW RATE DIAGRAMS

Key

LFS Upper operating limit  
 LFI Lower operating limit  
 Qa1 ESP/Qa curve at the maximum speed  
 Qa2 ESP/Qa curve at the average speed

Qa3 ESP/Qa curve at the minimum speed  
 I1 I/Qa curve at the maximum speed  
 I2 I/Qa curve at the average speed  
 I3 I/Qa curve at the minimum speed

Model FCT 01

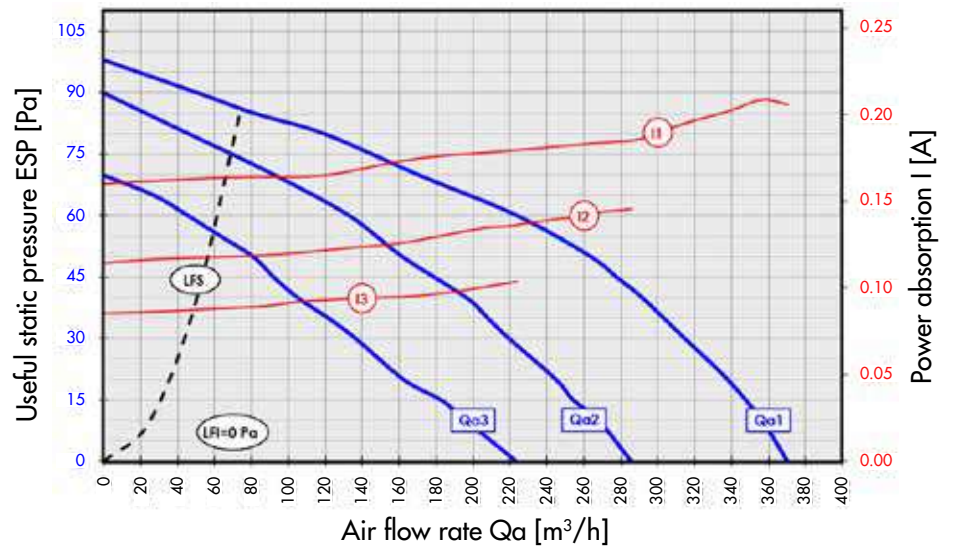

Model FCT 02

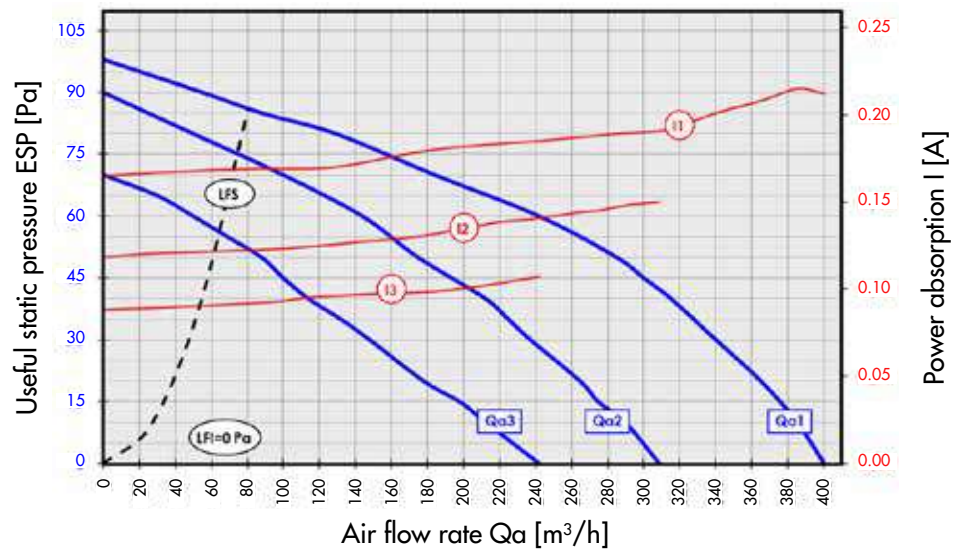

Model FCT 03

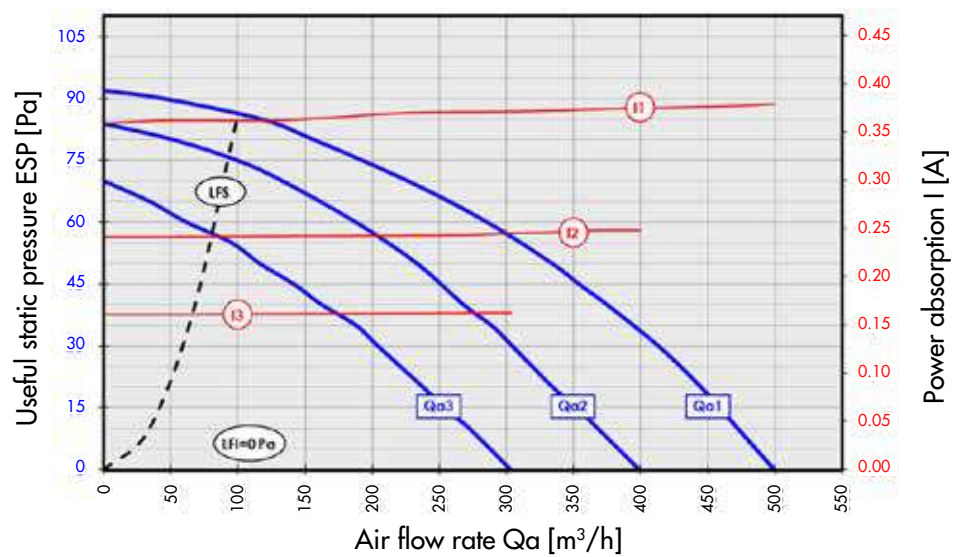

Key

- LFS Upper operating limit
- LFI Lower operating limit
- Qa1 ESP/Qa curve at the maximum speed
- Qa2 ESP/Qa curve at the average speed
- Qa3 ESP/Qa curve at the minimum speed
- I1 I/Qa curve at the maximum speed
- I2 I/Qa curve at the average speed
- I3 I/Qa curve at the minimum speed

Model FCT 04

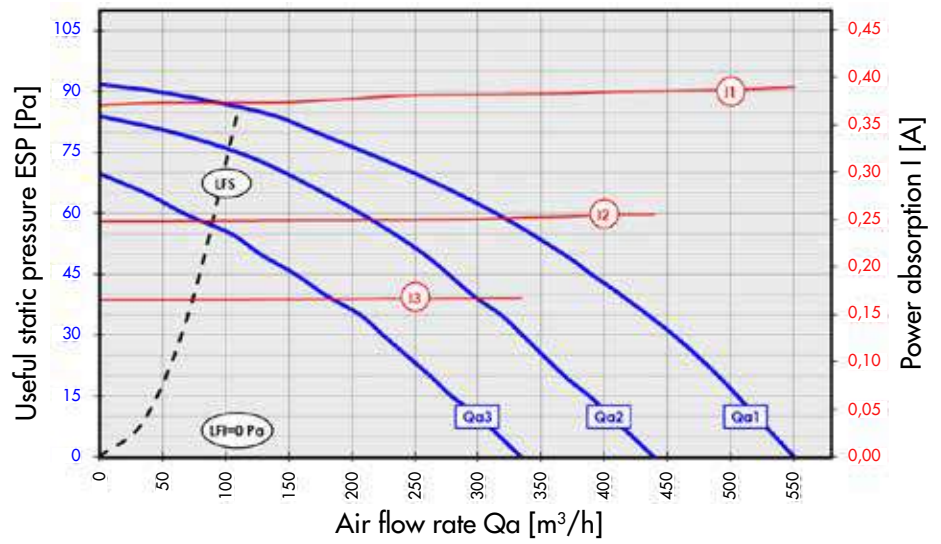

Model FCT 05

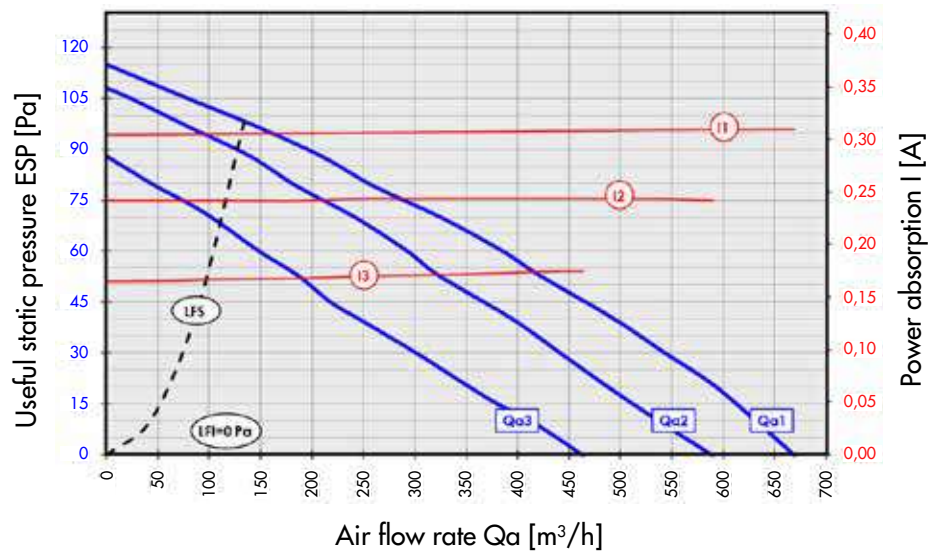

Model FCT 06

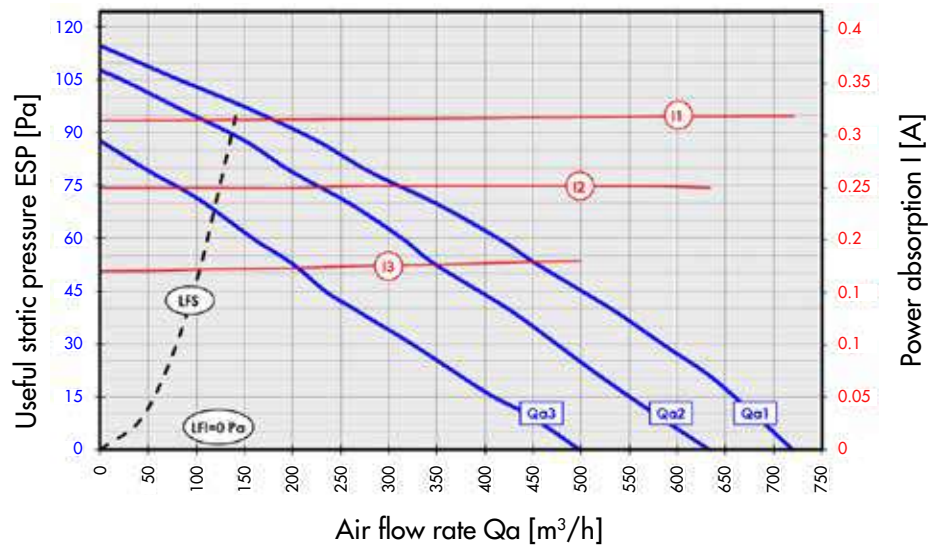



# USEFUL STATIC PRESSURE/ WATER FLOW RATE DIAGRAMS

Key

LFS Upper operating limit  
LFI Lower operating limit  
Qa1 ESP/Qa curve at the maximum speed  
Qa2 ESP/Qa curve at the average speed

Qa3 ESP/Qa curve at the minimum speed  
I1 I/Qa curve at the maximum speed  
I2 I/Qa curve at the average speed  
I3 I/Qa curve at the minimum speed

Model FCT 07

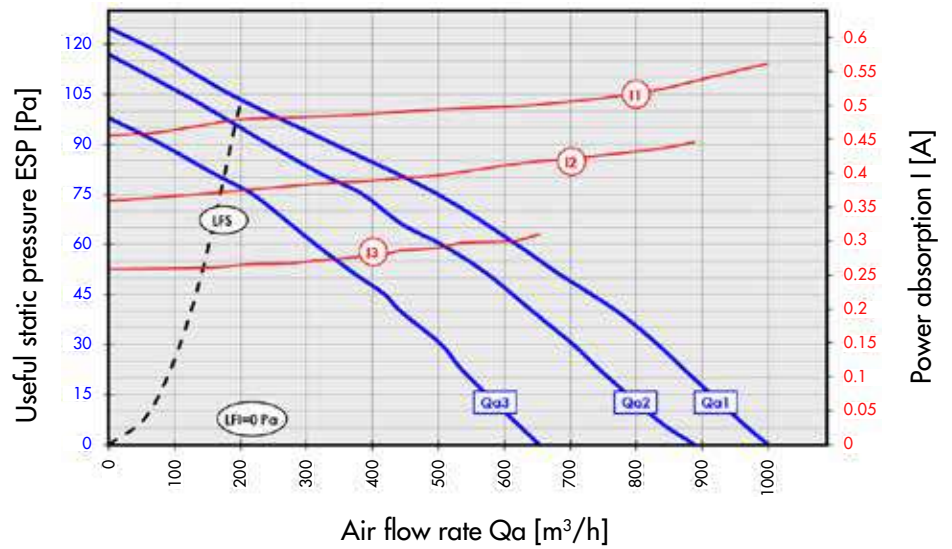

Model FCT 08

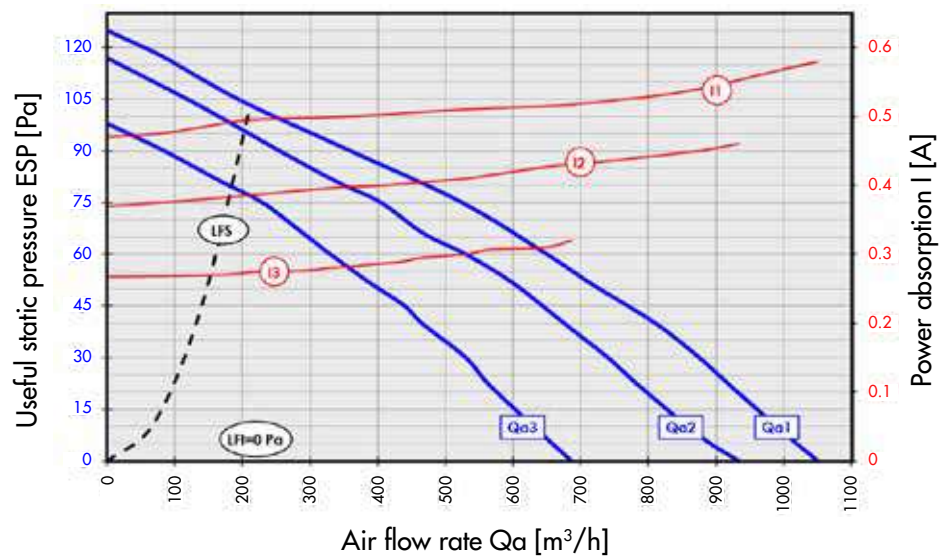

Model FCT 09

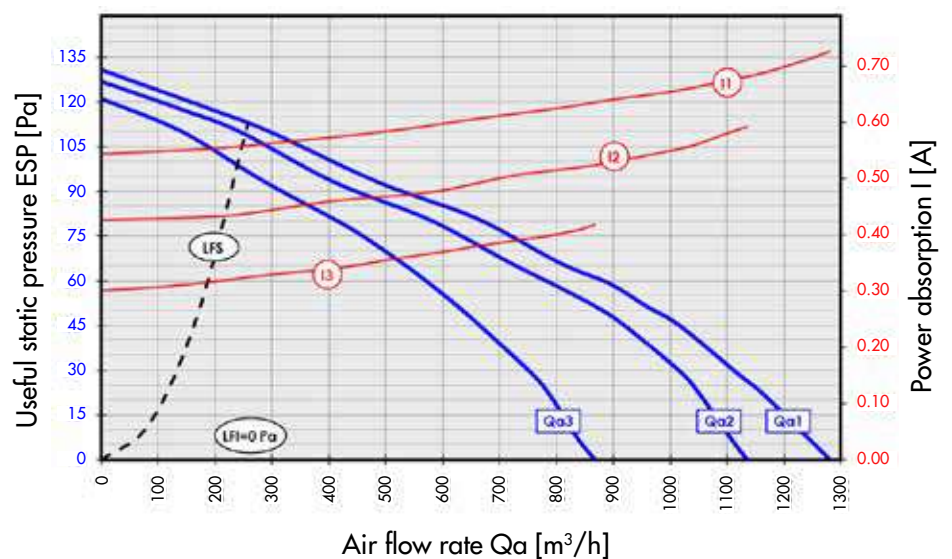

# DIMENSIONAL DRAWINGS

## Model FCT-CV

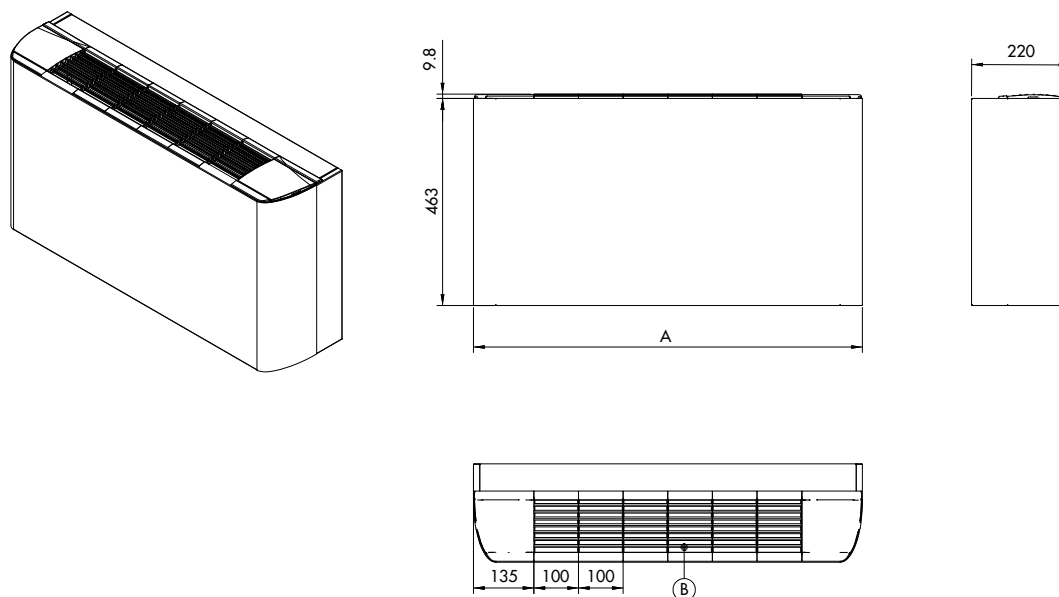

MODEL FCT-CV	01	02	03	04	05	06	07	08	09
A	670	670	870	870	1070	1070	1270	1270	1470
B = N° of grids	4	4	6	6	8	8	10	10	12

## Model FCT-CA/FCT-CH

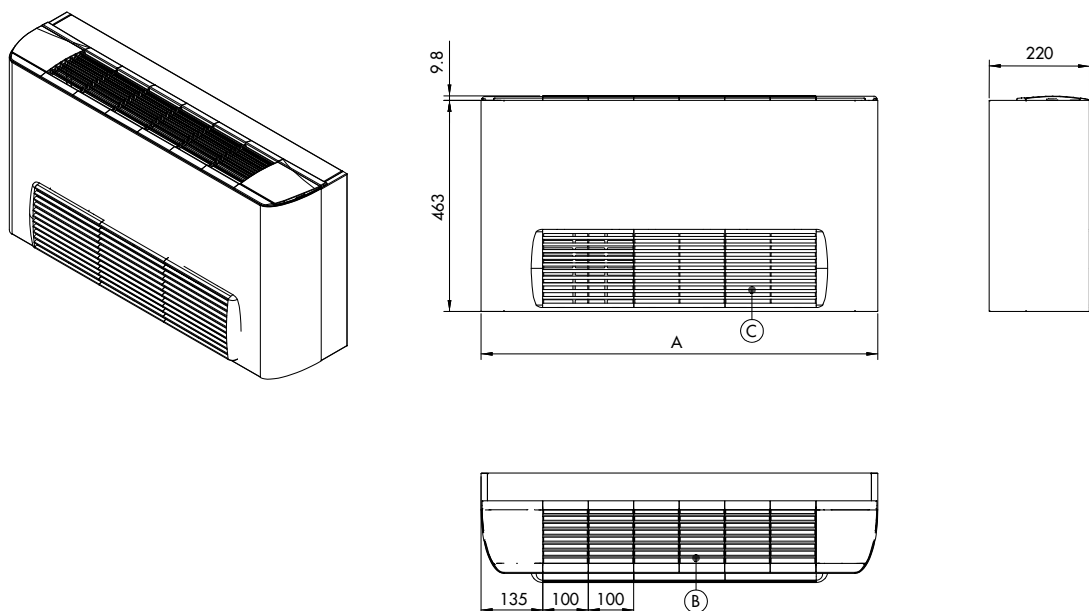

MODEL FCT-CA/FCT-CH	01	02	03	04	05	06	07	08	09
A	670	670	870	870	1070	1070	1270	1270	1470
B = N° of grids	4	4	6	6	8	8	10	10	12
C = N° of grids	2	2	3	3	4	4	5	5	6

# DIMENSIONAL DRAWINGS

## Model FCT-NV

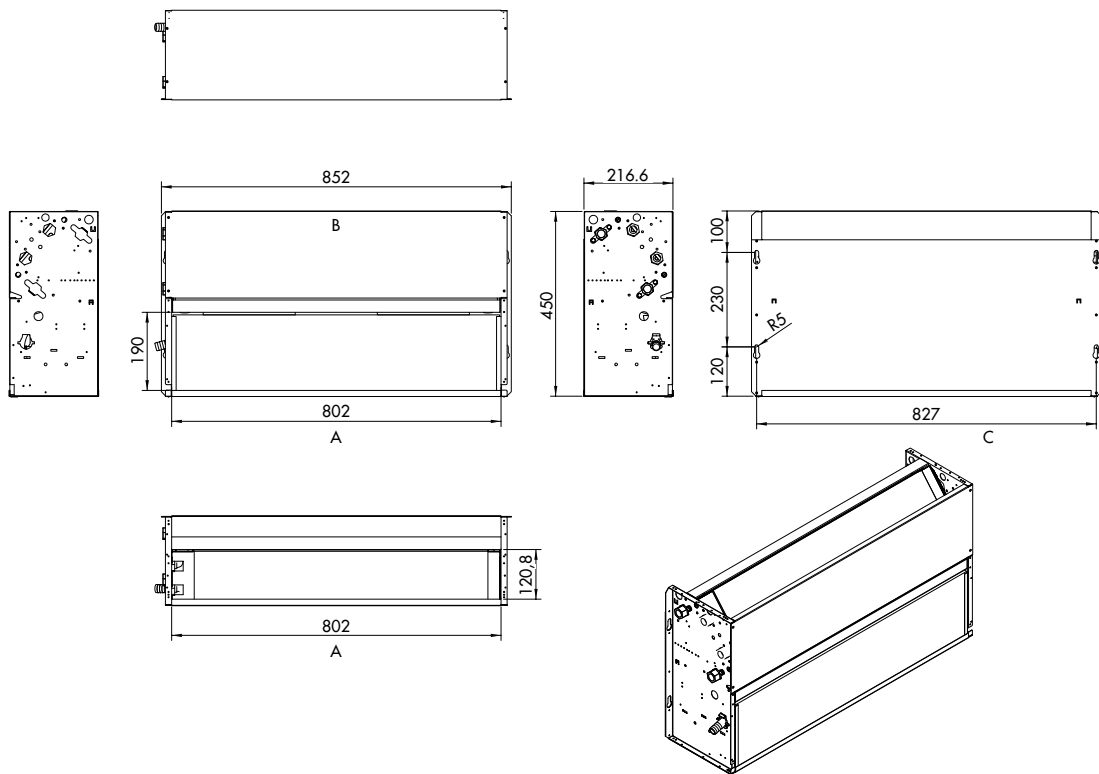

MODEL FCT-NV	01	02	03	04	05	06	07	08	09
A	402	402	602	602	802	802	1002	1002	1202
B	452	452	652	652	852	852	1052	1052	1252
C	427	427	627	627	827	827	1027	1027	1227





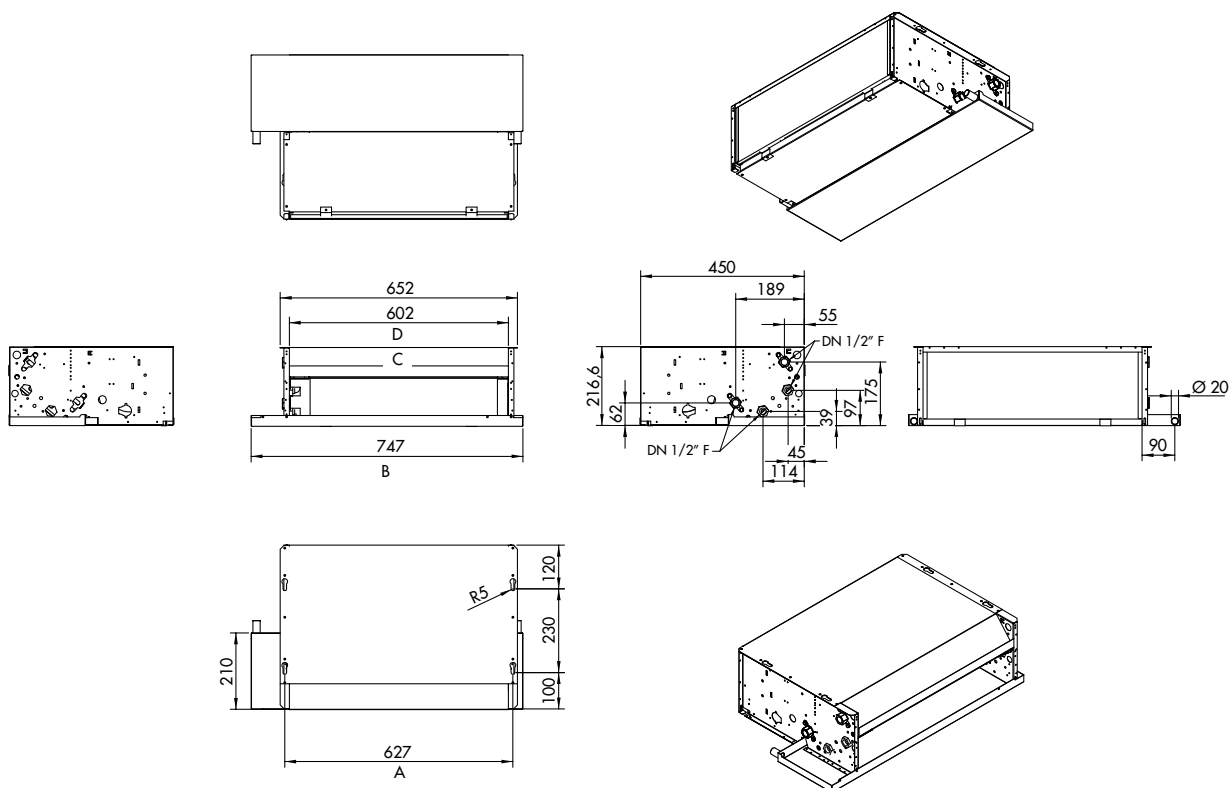





## Model FCT-NH



MODEL FCT-NH	01	02	03	04	05	06	07	08	09
A	427	427	627	627	827	827	1027	1027	1227
B	547	547	747	747	947	947	1147	1147	1347
C	402	402	602	602	802	802	1002	1002	1202
D	452	452	652	652	852	852	1052	1052	1252

# ACCESSORIES

CONTROL UNITS INSTALLED				
	Code	Model	Description	Applicability
	387030464	OBC22	Control unit mounted on the machine for units with 2/4 pipes, with ATS4 air sensor	FCT-CV FCT-CA
	387030465	OBC25	Control unit mounted on the machine for units with 2/4 pipes, with display and ATS4 air sensor	FCT-CV FCT-CA
	387030466	MTT32	Minimum hot water temperature thermostat (calibrated to 32 °C)	All
	387030467	WTS4	Water temperature sensor (type NTC 10.000 ohm @25 °C with cable L=1 m)	For OBC25 control unit as an alternative to MTT32

WIRED CONTROL UNITS AND REMOTE CONTROLS				
	Code	Model	Description	Applicability
	387030468	CL01	IP20 terminal block (mandatory when installing wired control unit)	All
	387030469	SWC22	Simplified thermostat for 2/4-pipe fan coil units	All
	387030470	SWC25	Simplified thermostat for 2/4-pipe fan coil units with display and with advanced functions	All
	387030471	EIX01	Electronic interface for fan coil unit thermostats: enables a single thermostat to control up to 4 fan coil units. Housed in a 6-module container for DIN rail	All
	387030472	IRC01	IR remote control. Kit inclusive of motherboard, air sensor, water sensor and IR receiver	All

**KIT CONTAINING VALVES, PANS, CONDENSATE DISCHARGE PUMPS AND FEET**

	Code	Model	Description	Applicability
	387030473	3WV01	3/4" M three-way valve with PWM-ON/OFF actuator, 230 V (2 pipes)	All
	387030474	3WV02	Three-way valve with PWM-ON/OFF actuator, 230 V, 1/2" ball valve and 1/2" retainer (2 pipes)	All
	387030475	2WV01	3/4" M two-way valve with PWM-ON/OFF actuator, 230 V (2 pipes)	All
	387030476	2WV02	Two-way valve with PWM-ON/OFF actuator, 230 V, 1/2" ball valve and 1/2" retainer (2 pipes)	All
	387030477	VB01	Auxiliary drain pan made of plastic, for two-way or three-way valves	FCT-CV FCT-CA FCT-NV
	387030478	HB01	Auxiliary drain pan with thermal insulation, for two-way or three-way valves	FCT-CH FCT-NH
	387030479	CP01	Condensate discharge pump equipped with alarm contact	FCT-CV FCT-CA FCT-NV
	387030480	CP02	Condensate discharge pump equipped with alarm contact	FCT-CH FCT-NH
	387030481	FE01	Pair of pre-coated feet H=90 mm	FCT-CV

# ACCESSORIES

PANELS				
Code		Model	Description	Applicability
387030482	01/02	CPB 01-02	Lower rear closing panel made of pre-painted plate	FCT-CV FCT-CA
387030483	03/04	CPB 03-04		
387030484	05/06	CPB 05-06		
387030485	01/02	CPC 01-02	Lower closing panel without grid made of pre-painted plate	FCT-CA FCT-CH
387030486	03/04	CPC 03-04		
387030487	05/06	CPC 05-06		
387030488	01/02	CPD 01-02	Lower closing panel made of pre-painted plate with removable ABS grid and flat air filter with grade EU3 filtration (EUROVENT 4/5)	FCT-CV
387030489	03/04	CPD 03-04		
387030490	05/06	CPD 05-06		
387030491	01/02	RF 01-02	Frame for concealed wall-mounted installation	FCT-NV
387030492	03/04	RF 03-04		
387030493	05/06	RF 05-06		
387030494	01/02	FP 01-02	Front panel made of pre-painted plate equipped with air return and supply grid, for fan coil units with remote control	FCT-NV
387030495	03/04	FP 03-04		
387030496	05/06	FP 05-06		

PANELS				
Code		Model	Description	Applicability
387030497	07/08	CPB 07-08	Lower rear closing panel made of pre-painted plate	FCT-CV FCT-CA
387030498	09	CPB 09		
387030499	07/08	CPC 07-08	Lower closing panel without grid made of pre-painted plate	FCT-CA FCT-CH
387030500	09	CPC 09		
387030501	07/08	CPD 07-08	Lower closing panel made of pre-painted plate with removable ABS grid and flat air filter with grade EU3 filtration (EUROVENT 4/5)	FCT-CV
387030502	09	CPD 09		
387030503	07/08	RF 07-08	Frame for concealed wall-mounted installation	FCT-NV
387030504	09	RF 09		
387030505	07/08	FP 07-08	Front panel made of pre-painted plate equipped with air return and supply grid, for fan coil units with remote control	FCT-NV
387030506	09	FP 09		



CPC



CPD



CPB



CPB



RF



CL01

P90M-C

FCT-NV

FP

# ACCESSORIES

PLENUM				
Code		Model	Description	Applicability
387030507	01/02	AJA 01-02	Vibration-damping joint with fan coil unit attachment flange and channel attachment flange, L=150 mm - Intake side	FCT-NH
387030508	03/04	AJA 03-04		
387030509	05/06	AJA 05-06		
387030510	01/02	AJM 01-02	Vibration-damping joint with fan coil unit attachment flange and channel attachment flange, L=150 mm - Supply side	FCT-NH
387030511	03/04	AJM 03-04		
387030512	05/06	AJM 05-06		
387030513	01/02	GDA 01-02	Air grid with simple row or fixed ABS flaps, suitable for connection on the TP, AJA, P90A plenum - Intake side	FCT-NH
387030514	03/04	GDA 03-04		
387030515	05/06	GDA 05-06		
387030516	01/02	GDM 01-02	Air grid with simple row or fixed ABS flaps, suitable for connection on the TP, AJM plenum - Supply side	FCT-NH
387030517	03/04	GDM 03-04		
387030518	05/06	GDM 05-06		
387030519	01/02	P90A 01-02	90° plenum - Intake side	FCT-NH
387030520	03/04	P90A 03-04		
387030521	05/06	P90A 05-06		
387030522	01/02	P90M-C 01-02	90° plenum - Supply side	FCT-NV
387030523	03/04	P90M-C 03-04		
387030524	05/06	P90M-C 05-06		
387030525	01/02	PRM 01-02	Straight plenum L=100 mm - Supply side	FCT-NH
387030526	03/04	PRM 03-04		
387030527	05/06	PRM 05-06		
387030528	01/02	PRA 01-02	Straight plenum L=100 mm - Intake side	FCT-NH
387030529	03/04	PRA 03-04		
387030530	05/06	PRA 05-06		
387030531	01/02	TP 01-02	Telescopic extension L=0-100 mm, suitable for connection with PRA, PRM, P290A plenum	FCT-NH
387030532	03/04	TP 03-04		
387030533	05/06	TP 05-06		
387030534	01/02	PRCA 01-02	Air intake plenum with round fittings and filter	FCT-NH
387030535	03/04	PRCA 03-04		
387030536	05/06	PRCA 05-06		
387030537	01/02	PRCM 01-02	Air supply plenum with round fittings, insulated	FCT-NH
387030538	03/04	PRCM 03-04		
387030539	05/06	PRCM 05-06		

PLENUM				
Code		Model	Description	Applicability
387030540	07/08	AJA 07-08	Vibration-damping joint with fan coil unit attachment flange and channel attachment flange, L=150 mm - Intake side	FCT-NH
387030541	09	AJA 09		
387030542	07/08	AJM 07-08	Vibration-damping joint with fan coil unit attachment flange and channel attachment flange, L=150 mm - Supply side	FCT-NH
387030543	09	AJM 09		
387030544	07/08	GDA 07-08	Air grid with simple row or fixed ABS flaps, suitable for connection on the TP, AJA, P90A plenum - Intake side	FCT-NH
387030545	09	GDA 09		
387030546	07/08	GDM 07-08	Air grid with simple row or fixed ABS flaps, suitable for connection on the TP, AJM plenum - Supply side	FCT-NH
387030547	09	GDM 09		
387030548	07/08	P90A 07-08	90° plenum - Intake side	FCT-NH
387030549	09	P90A 09		
387030550	07/08	P90M-C 07-08	90° plenum - Supply side	FCT-NV
387030551	09	P90M-C 09		
387030552	07/08	PRM 07-08	Straight plenum L=100 mm - Supply side	FCT-NH
387030553	09	PRM 09		
387030554	07/08	PRA 07-08	Straight plenum L=100 mm - Intake side	FCT-NH
387030555	09	PRA 09		
387030556	07/08	TP 07-08	Telescopic extension L=0-100 mm, suitable for connection with PRA, PRM, P290A plenum	FCT-NH
387030557	09	TP 09		
387030558	07/08	PRCA 07-08	Air intake plenum with round fittings and filter	FCT-NH
387030559	09	PRCA 09		
387030560	07/08	PRCM-C 07-08	Air supply plenum with round fittings, insulated	FCT-NH
387030561	09	PRCM-C 09		

# ACCESSORIES

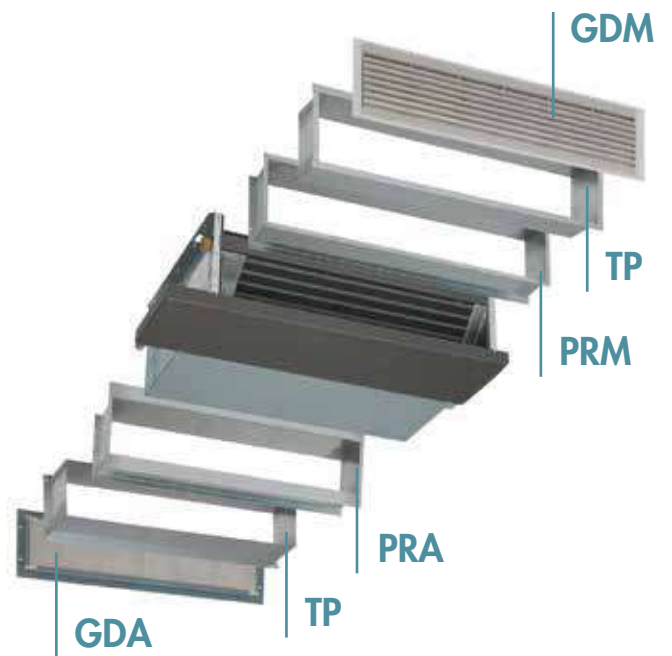
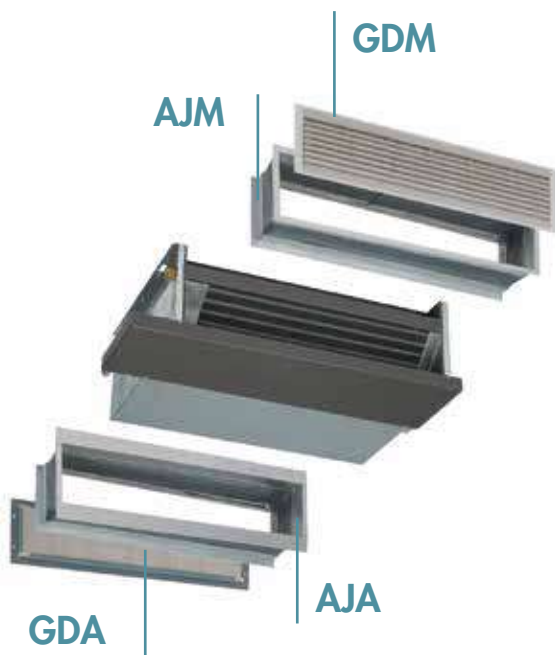
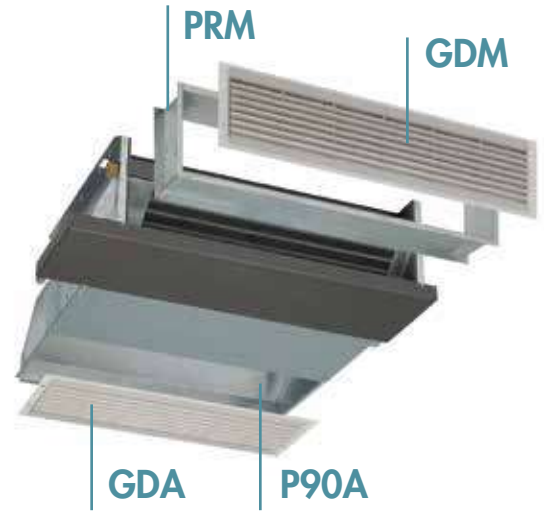
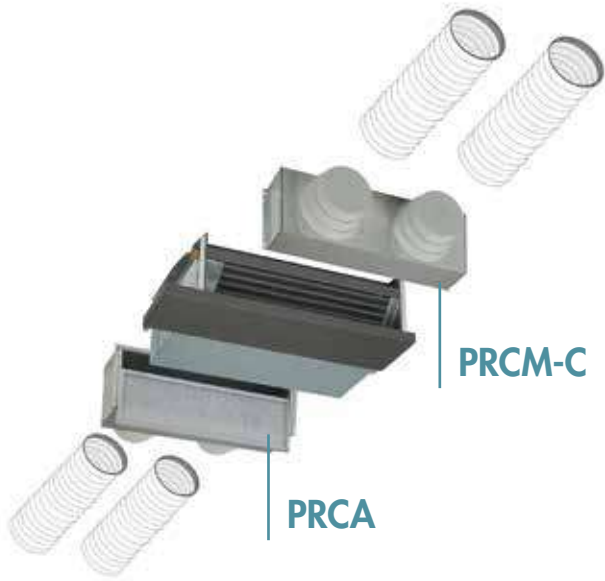







# FLOOR | CEILING

---

EC Brushless - Model: FCTE

# EC BRUSHLESS FLOOR/CEILING

## MAIN FEATURES MOD. FCTE

### COVERING CABINET

(only for the CV - CA - CH versions)

Standard white finish (RAL 9010). Made of high-thickness galvanised plate pre-lined with a polyvinyl chloride film, it can withstand rust, corrosion, chemicals, solvents, aliphatic compounds and alcohols. Internal thermo-acoustic insulation (Class M1). Compact dimensions: a mere 220 mm thickness.

Air supply grid made of white ABS (RAL 9002), with openable side panels for accessing the control panel (accessory).

The double row of manual flaps, each adjustable, allows for directing the air flow in any direction. The flaps can be adjusted in opposite directions to enhance the induction effect. The flow can be directed to graze the ceiling/wall to exploit the Coanda effect.

### LOAD-BEARING STRUCTURE

Load-bearing structure made of high-thickness galvanised plate with holes (slots) for wall/ceiling mounting, made directly on the structure.

### DRAIN PAN

Drain pan equipped with a drainage outlet and thermal insulation. A condensation drain funnel with Ø 20 mm fitting, made of plastic, is mounted only on vertical versions (standard on the same side of the water connections).

### HEAT EXCHANGER

High-efficiency heat exchange coil with copper pipe and aluminium flaps locked by means of mechanical expansion. Coil fittings equipped with anti-torsion system, manual air relief valves and manual water drainage valves. Fittings on the left as a standard feature; on request they can be mounted on the right and are easily reversible on-site. 1 coil for 2-pipe system; 2 coils for 4-pipe system.

Coils tested at 30 bar operating pressure, suitable for working with water up to a maximum pressure of 15 bar.

The coils are suitable for operating with:

- high-temperature water (boiler)
- low-temperature water (condensing boiler, heat pump, etc.)
- cold water (chiller and/or industrial processes)
- water supplemented with glycol.

### VENTILATION UNIT

Ventilation unit consisting of 1 or 2 double-intake centrifugal fans directly coupled with the electric motor with a useful static pressure of up to 75 Pa. Mounted on elastic and elastic supports and shock absorbers. Statically and dynamically balanced fan. Large-diameter fans (high air volume and high static pressure) with low number of revolutions (low noise).

Latest generation EC brushless motor with permanent magnets, direct current, equipped with control electronics (inverter). IP 40, Class B, power cables protected with double insulation.

Built according to international standards, 230 VAC-1 Ph-50/60 Hz. Continuous adjustment 0-100% of the number of revolutions (and hence of the air volume and consequently the cooling/heating capacity) by means of a 0...10 VDC modulating control signal.

Inverter with dip-switches for setting the various types of motor control software programmes + dip-switches for redistributing the work range on a new more limited range (from 0...10 VDC up to 0...6.5 VDC).

### AIR FILTER

Easily removable air filter, built with a metal frame containing the filtration septum. Can be regenerated by washing it with water, blowing, vacuuming. Standard: filtering medium made of polyester acrylic fabric, high-efficiency, resin-coated and needle-punched. Recommended against dust and pollen. Class M1, filtration grade EU3 (EUROVENT 4/5).

# EC BRUSHLESS FLOOR/CEILING

## MODELS

### EC BRUSHLESS FLOOR FAN COIL MOD. FCTE-CV

Visible wall-mounted vertical installation, covering cabinet with vertical air outflow and intake from the bottom part.

Code	Model	Cooling capacity (W) (1)	Heating capacity (W) (2)
387030329	FCTE-CV 01 L	1.500	3.740
387030330	FCTE-CV 01 R		
387030331	FCTE-CV 02 L	2.000	4.910
387030332	FCTE-CV 02 R		
387030333	FCTE-CV 03 L	2.530	5.980
387030334	FCTE-CV 03 R		
387030335	FCTE-CV 04 L	3.020	6.710
387030336	FCTE-CV 04 R		
387030337	FCTE-CV 05 L	3.750	8.160
387030338	FCTE-CV 05 R		
387030339	FCTE-CV 06 L	4.250	9.440
387030340	FCTE-CV 06 R		
387030341	FCTE-CV 07 L	5.520	12.000
387030342	FCTE-CV 07 R		
387030343	FCTE-CV 08 L	6.420	13.300
387030344	FCTE-CV 08 R		
387030345	FCTE-CV 09 L	7.530	15.500
387030346	FCTE-CV 09 R		



FCTE-CV	01	L
-	(1)	(2)

FCTE-CV = fan coil model  
 (1) Capacity = 01, 02, 03, 04, 05, 06, 07, 08, 09  
 (2) L = left coil connection/R = right coil connection

### EC BRUSHLESS FLOOR FAN COIL MOD. FCTE-CA

Visible wall-mounted vertical installation, covering cabinet with vertical air outflow and intake from the front part.

Code	Model	Cooling capacity (W) (1)	Heating capacity (W) (2)
387030347	FCTE-CA 01 L	1.500	3.740
387030348	FCTE-CA 01 R		
387030349	FCTE-CA 02 L	2.000	4.910
387030350	FCTE-CA 02 R		
387030351	FCTE-CA 03 L	2.530	5.980
387030352	FCTE-CA 03 R		
387030353	FCTE-CA 04 L	3.020	6.710
387030354	FCTE-CA 04 R		
387030355	FCTE-CA 05 L	3.750	8.160
387030356	FCTE-CA 05 R		
387030357	FCTE-CA 06 L	4.250	9.440
387030358	FCTE-CA 06 R		
387030359	FCTE-CA 07 L	5.520	12.000
387030360	FCTE-CA 07 R		
387030361	FCTE-CA 08 L	6.420	13.300
387030362	FCTE-CA 08 R		
387030363	FCTE-CA 09 L	7.530	15.500
387030364	FCTE-CA 09 R		



FCTE-CA	01	L
-	(1)	(2)

FCTE-CA = fan coil model  
 (1) Capacity = 01, 02, 03, 04, 05, 06, 07, 08, 09  
 (2) L = left coil connection/R = right coil connection

(1) Cooling: air temp. 27 °C dry bulb, 19 °C wet bulb - temp. - input/output water temp. 7/12 °C  
 (2) Heating: air temp. 20 °C - input/output water temp. 70/60 °C

# EC BRUSHLESS FLOOR/CEILING MODELS

## EC BRUSHLESS CEILING FAN COIL MOD. FCTE-CH

Visible ceiling-mounted horizontal installation, covering cabinet with air outflow from the front and intake from the bottom.

Code	Model	Cooling capacity (W) (1)	Heating capacity (W) (2)
387030365	FCTE-CH 01 L	1.500	3.740
387030366	FCTE-CH 01 R		
387030367	FCTE-CH 02 L	2.000	4.910
387030368	FCTE-CH 02 R		
387030369	FCTE-CH 03 L	2.530	5.980
387030370	FCTE-CH 03 R		
387030371	FCTE-CH 04 L	3.020	6.710
387030372	FCTE-CH 04 R		
387030373	FCTE-CH 05 L	3.750	8.160
387030374	FCTE-CH 05 R		
387030375	FCTE-CH 06 L	4.250	9.440
387030376	FCTE-CH 06 R		
387030377	FCTE-CH 07 L	5.520	12.000
387030378	FCTE-CH 07 R		
387030379	FCTE-CH 08 L	6.420	13.300
387030380	FCTE-CH 08 R		
387030381	FCTE-CH 09 L	7.530	15.500
387030382	FCTE-CH 09 R		



FCTE-CH	01	L
-	(1)	(2)

FCTE-CH = fan coil model  
 (1) Capacity = 01, 02, 03, 04, 05, 06, 07, 08, 09  
 (2) L = left coil connection/R = right coil connection

## EC BRUSHLESS VERTICAL CONCEALED FAN COIL MOD. FCTE-NV

Concealed vertical installation, with vertical air outflow and intake from the front part.

Code	Model	Cooling capacity (W) (1)	Heating capacity (W) (2)
387030383	FCTE-NV 01 L	1.500	3.740
387030384	FCTE-NV 01 R		
387030385	FCTE-NV 02 L	2.000	4.910
387030386	FCTE-NV 02 R		
387030387	FCTE-NV 03 L	2.530	5.980
387030388	FCTE-NV 03 R		
387030389	FCTE-NV 04 L	3.020	6.710
387030390	FCTE-NV 04 R		
387030391	FCTE-NV 05 L	3.750	8.160
387030392	FCTE-NV 05 R		
387030393	FCTE-NV 06 L	4.250	9.440
387030394	FCTE-NV 06 R		
387030395	FCTE-NV 07 L	5.520	12.000
387030396	FCTE-NV 07 R		
387030397	FCTE-NV 08 L	6.420	13.300
387030398	FCTE-NV 08 R		
387030399	FCTE-NV 09 L	7.530	15.500
387030400	FCTE-NV 09 R		



FCTE-NV	01	L
-	(1)	(2)

FCTE-NV = fan coil model  
 (1) Capacity = 01, 02, 03, 04, 05, 06, 07, 08, 09  
 (2) L = left coil connection/R = right coil connection

(1) Cooling: air temp. 27 °C dry bulb, 19 °C wet bulb - temp. - input/output water temp. 7/12 °C  
 (2) Heating: air temp. 20 °C - input/output water temp. 70/60 °C

## EC BRUSHLESS HORIZONTAL CONCEALED FAN COIL MOD. FCTE-NH

Concealed horizontal installation, with horizontal air outflow and intake from the rear part.

Code	Model	Cooling capacity (W) (1)	Heating capacity (W) (2)
387030401	FCTE-NH 01 L	1.500	3.740
387030402	FCTE-NH 01 R		
387030403	FCTE-NH 02 L	2.000	4.910
387030404	FCTE-NH 02 R		
387030405	FCTE-NH 03 L	2.530	5.980
387030406	FCTE-NH 03 R		
387030407	FCTE-NH 04 L	3.020	6.710
387030408	FCTE-NH 04 R		
387030409	FCTE-NH 05 L	3.750	8.160
387030410	FCTE-NH 05 R		
387030411	FCTE-NH 06 L	4.250	9.440
387030412	FCTE-NH 06 R		
387030413	FCTE-NH 07 L	5.520	12.000
387030414	FCTE-NH 07 R		
387030415	FCTE-NH 08 L	6.420	13.300
387030416	FCTE-NH 08 R		
387030417	FCTE-NH 09 L	7.530	15.500
387030418	FCTE-NH 09 R		

(1) Cooling: air temp. 27 °C dry bulb, 19 °C wet bulb - temp. - input/output water temp. 7/12 °C  
 (2) Heating: air temp. 20 °C - input/output water temp. 70/60 °C



FCTE-NH	01	L
-	(1)	(2)

FCTE-NH = fan coil model  
 (1) Capacity = 01, 02, 03, 04, 05, 06, 07, 08, 09  
 (2) L = left coil connection/R = right coil connection

# RATED TECHNICAL DATA

## TWO-PIPE UNIT - ONE COIL

MODELS			01	02	03	04
<b>RATED</b>		Rated performances (ref. Modulation signal guaranteeing "FCTE Brushless air flow rate = corresponding FCT air flow rate")				
Total cooling capacity (1)		W	1.500	2.000	2.530	3.020
Sensible cooling capacity (1)		W	1.290	1.620	2.070	2.310
Heating capacity (2a)		W	3.740	4.910	5.980	6.710
Heating capacity (2b)		W	1.936	2.535	3.068	3.435
Rated air flow (3)		m <sup>3</sup> /h	370	400	500	550
Water flow rate (4)	Cooling	l/h	258	344	436	520
	Heating	l/h	322	423	515	578
Water pressure drop (5)	Cooling	kPa	13.1	16.3	18.5	20.8
	Heating	kPa	15.9	19.2	20.1	20
Sound pressure (6)		dB(A)	36	39	41	43
Rated power absorption (7)		W	19	25	27	34
		A	0.15	0.19	0.20	0.25
Reference control signal		Vdc	5.80	6.80	7.10	8.00
Electrical power supply		230 Vac - 1 Ph - 50 Hz/Signal 0...10 Vdc				
<b>ECO (3 vdc)</b>		Expected operating performances ("Unit performances=requested performances" balance)				
Air flow rate		m <sup>3</sup> /h	240		285	
Sound pressure		dB(A)	23		26	
Rated power absorption		W	9		9	
		A	0.09		0.10	
<b>RANGE 10-1 vdc</b>		MAX performances ref. 10 VDC signal; MIN ref. 1 VDC (for signals <1 VDC the unit remains off)				
Total cooling capacity range		W	1.810-880	2.320-1.130	2.830-1.400	3.220-1.600
Heating capacity range		W	4.680-1.970	5.860-2.470	6.840-2.940	7.250-3.120
Air flow rate range		m <sup>3</sup> /h	537-127		625-153	
Sound pressure range		dB(A)	45-10		47-10	
Rated power absorption		W	48-6		54-6	
		A	0.32-0.07		0.36-0.07	
Cold/hot coil rows		N	3R		3R	
Hydraulic fittings		DN	1/2" F		1/2" F	
Condensate drainage outlet		mm	20		20	
Motors/Fans		N/N	1/1		1/1	
Rated power absorption (7)		W	70		70	
		A	0.50		0.50	

Technical data referred to the following conditions:  
standard unit - atmospheric pressure 1013 mbar - electrical power supply 230 VAC/1 Ph/50 Hz.

(1) (2) (3) (4) (5): Rated technical data, ref. air flow rate (3) at maximum speed and with unit with open mouth (external static pressure ESP=0 Pa).

(1) **Cooling:** air temp. 27 °C dry bulb, 19 °C wet bulb - input/output water temp. 7/12 °C - Maximum speed.

(2a) **Heating:** air temp. 20 °C - Input/output water temp. 70/60 °C - Maximum speed.

(2b) **Heating:** air temp. 20 °C - Input/output water temp. 45/40 °C - Maximum speed.

(3) **Air flow rate and static pressure:** rated values measured with casing ref. AMCA210-74 standard Fig.12 and conduit + diaphragm ref. CNR-UNI10023 standard.

(6) **Sound pressure:** sound pressure in free field environment, distance 2 m. Values calculated from sound power measured in reverberation chamber ref. ISO 3741-ISO 3742 standards.

(7) **Electrical data:** values measured with Jokogawa WT110 wattmeter (nominal value = reference value for the design of the electrical system).



MODELS			05	06	07	08	09
<b>RATED</b>		Rated performances (ref. Modulation signal guaranteeing "FCTE Brushless air flow rate = corresponding FCT air flow rate")					
Total cooling capacity (1)	W		3.750	4.250	5.520	6.420	7.440
Sensible cooling capacity (1)	W		2.870	3.230	4.330	4.800	5.600
Heating capacity (2a)	W		8.160	9.440	12.000	13.300	15.300
Heating capacity (2b)	W		4.376	5.059	6.196	6.857	7.909
Rated air flow (3)	m <sup>3</sup> /h		670	720	1.000	1.050	1.255
Water flow rate (4)	Cooling	l/h	645	731	950	1.105	1.260
	Heating	l/h	702	812	1.032	1.144	1.316
Water pressure drop (5)	Cooling	kPa	22.6	24.1	24.5	27.1	28.1
	Heating	kPa	20.9	23.2	22.6	22.7	23.2
Sound pressure (6)		dB(A)	24	36	42	43	46
Rated power absorption (7)		W	23	26	46	53	73
		A	0.16	0.20	0.31	0.35	0.48
Reference control signal		Vdc	5.70	6.20	8.00	8.50	10.00
Electrical power supply	230 Vac - 1 Ph - 50 Hz/Signal 0...10 Vdc						
<b>ECO (3 vdc)</b>		Expected operating performances ("Unit performances=requested performances" balance)					
Air flow rate		m <sup>3</sup> /h	424		515		536
Sound pressure		dB(A)	22		24		25
Rated power absorption		W	10		11		11
		A	0.09		0.10		0.09
<b>RANGE 10-1 vdc</b>		MAX performances ref. 10 VDC signal; MIN ref. 1 VDC (for signals <1 VDC the unit remains off)					
Total cooling capacity range	W		4.630-2.130	5.070-2.330	6.010-3.060	6.820-3.470	7.440-3.780
Heating capacity range	W		10.510-4.130	11.650-4.580	13.280-5.900	14.300-6.350	15.300-6.780
Air flow rate range		m <sup>3</sup> /h	1.021-215		1.184-306		1.255-323
Sound pressure range		dB(A)	45-12		46-9		46-11
Rated power absorption		W	65-6		74-6		73-6
		A	0.44-0.07		0.49-0.08		0.48-0.07
Cold/hot coil rows		N					3R
Hydraulic fittings		DN					1/2" F
Condensate drainage outlet		mm					20
Motors/Fans		N/N					1/2
Rated power absorption (7)		W					75
		A					0.60

Technical data referred to the following conditions:  
 standard unit - atmospheric pressure 1013 mbar - electrical power supply 230 VAC/1 Ph/50 Hz.

(1) (2) (3) (4) (5): Rated technical data, ref. air flow rate (3) at maximum speed and with unit with open mouth (external static pressure ESP=0 Pa).

(1) **Cooling**: air temp. 27 °C dry bulb, 19 °C wet bulb - input/output water temp. 7/12 °C - Maximum speed.

(2a) **Heating**: air temp. 20 °C - Input/output water temp. 70/60 °C - Maximum speed.

(2b) **Heating**: air temp. 20 °C - Input/output water temp. 45/40 °C - Maximum speed.

(3) **Air flow rate and static pressure**: rated values measured with casing ref. AMCA210-74 standard Fig. 12 and conduit + diaphragm ref. CNR-UNI 10023 standard.

(6) **Sound pressure**: sound pressure in free field environment, distance 2 m. Values calculated from sound power measured in reverberation chamber ref. ISO 3741-ISO 3742 standards.

(7) **Electrical data**: values measured with Jokogawa WT110 wattmeter (nominal value = reference value for the design of the electrical system).

# TECHNICAL DATA

## REDUCTION OF THE COOLING/HEATING CAPACITY (in relation to the air flow reduction)

Air flow rate	1.50	1.40	1.30	1.20	1.10	1.00	0.95	0.90	0.85	0.80	0.75
Total cooling capacity	1.22	1.18	1.14	1.10	1.05	1.00	0.97	0.95	0.92	0.89	0.87
Sensible cooling capacity	1.30	1.24	1.19	1.13	1.06	1.00	0.97	0.93	0.90	0.86	0.83
Heating capacity	1.28	1.22	1.17	1.12	1.06	1.00	0.97	0.94	0.91	0.87	0.84

Air flow rate	0.70	0.65	0.60	0.55	0.50	0.45	0.40	0.35	0.30	0.25	0.20
Total cooling capacity	0.84	0.81	0.77	0.74	0.71	0.67	0.63	0.59	0.55	0.50	0.45
Sensible cooling capacity	0.79	0.76	0.72	0.68	0.64	0.60	0.55	0.51	0.46	0.41	0.35
Heating capacity	0.81	0.77	0.74	0.70	0.66	0.62	0.58	0.53	0.49	0.44	0.38

## TABLE OF NET WEIGHTS MOD. FCTE (TWO-PIPE UNIT - ONE COIL) IN KG

Products/Models	01	02	03	04	05	06	07	08	09
FCTE-CV	14.7	15.2	17.7	18.5	23.9	24.9	27.5	29.0	31.6
FCTE-CA	15.0	15.5	18.2	19.0	24.6	25.6	28.4	29.9	32.7
FCTE-CH	16.2	16.7	19.8	20.6	26.6	27.6	30.8	32.3	35.5
FCTE-NV	11.8	12.3	14.7	15.5	20.8	21.8	24.2	25.7	28.2
FCTE-NH	12.4	12.9	15.3	16.1	21.4	22.4	24.9	26.4	28.9

# USEFUL STATIC PRESSURE/ WATER FLOW RATE DIAGRAMS

## KEY

LFS: Upper operating limit  
 10: EC unit curve with 10 VDC signal  
 (maximum of the working range)  
 1: Minimum curve of the EC unit's  
 working range (1 VDC @0 Pa)  
 M: Average curve of the EC unit's  
 working range

### Model FCTE 01

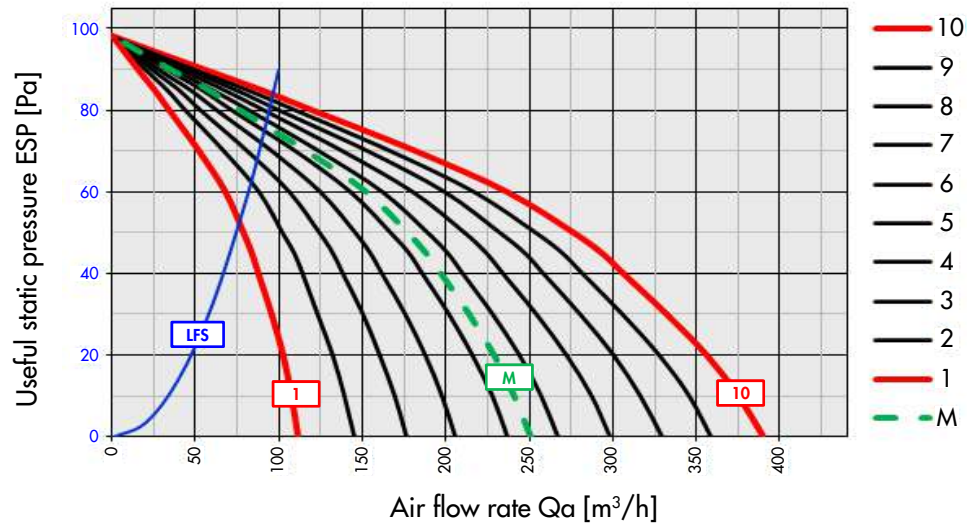

FANCOILS

### Model FCTE 02

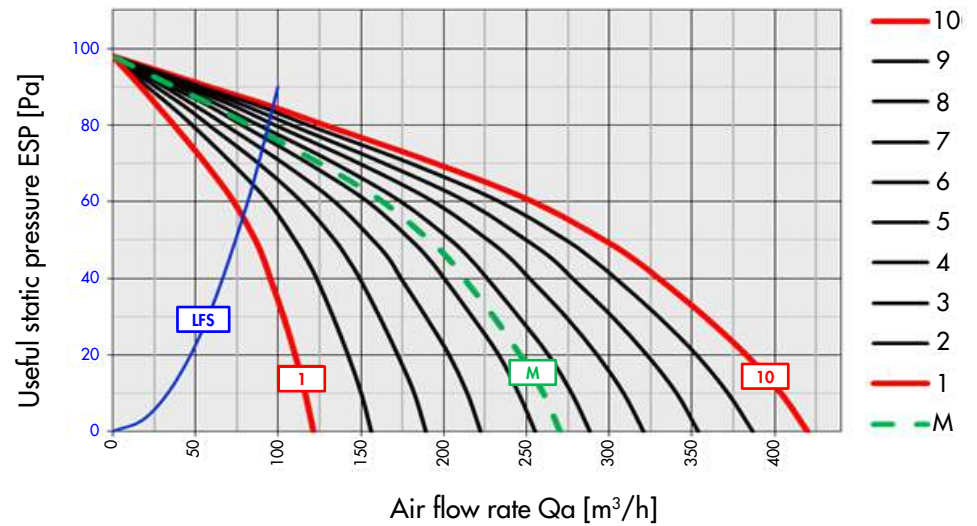

### Model FCTE 03

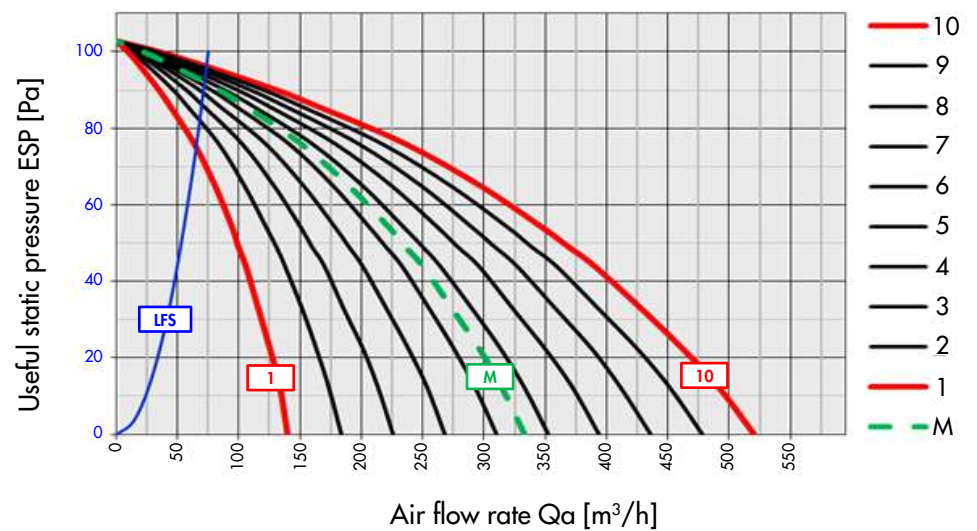

# USEFUL STATIC PRESSURE/ WATER FLOW RATE DIAGRAMS

## KEY

- LFS: Upper operating limit
- 10: EC unit curve with 10 VDC signal (maximum of the working range)
- 1: Minimum curve of the EC unit's working range (1 VDC @0 Pa)
- M: Average curve of the EC unit's working range

Model FCTE 04

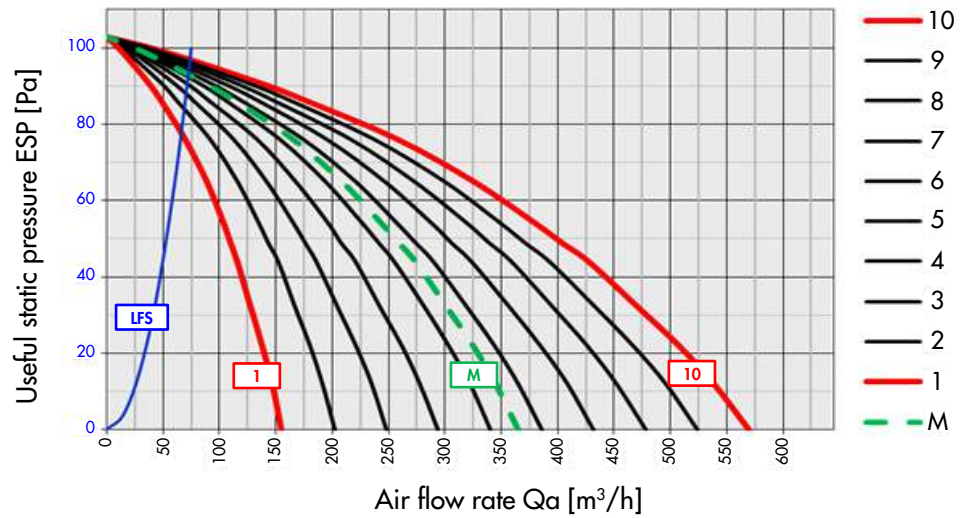

Model FCTE 05

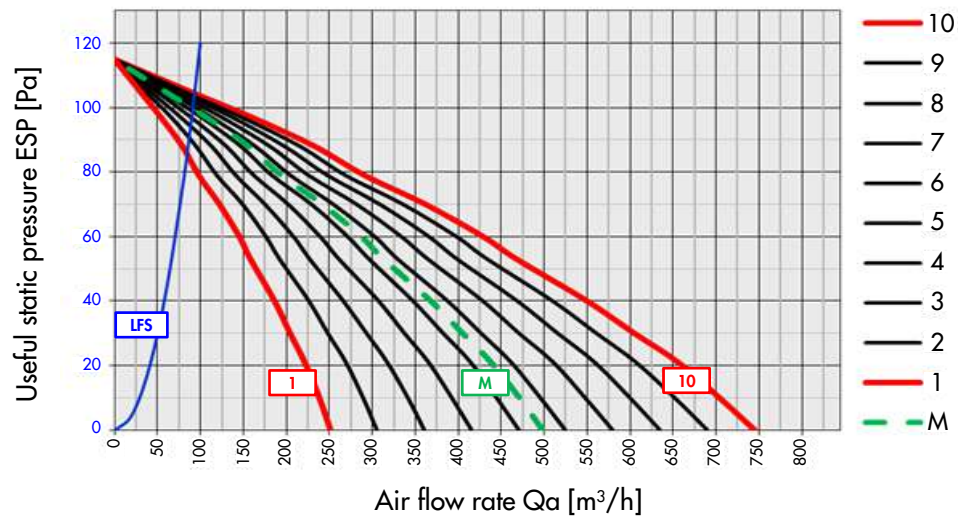

Model FCTE 06

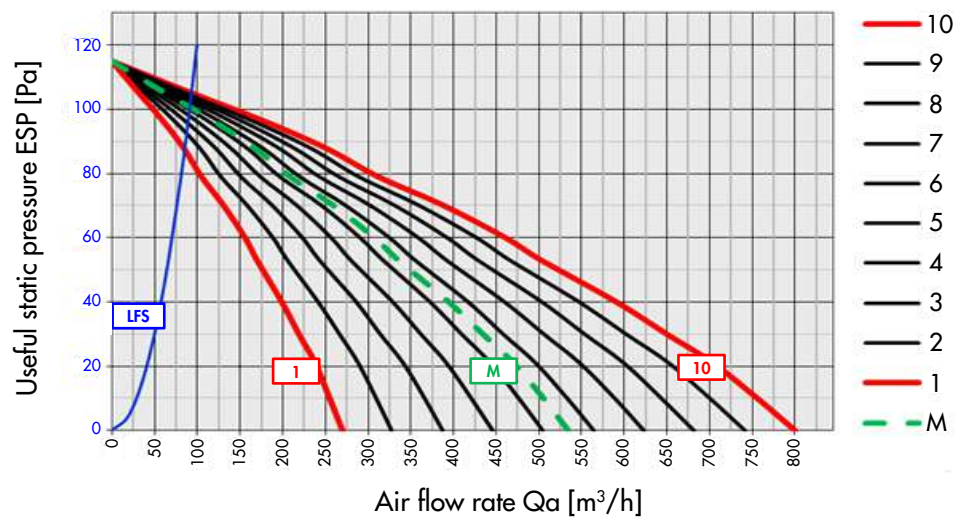



Model FCTE 07

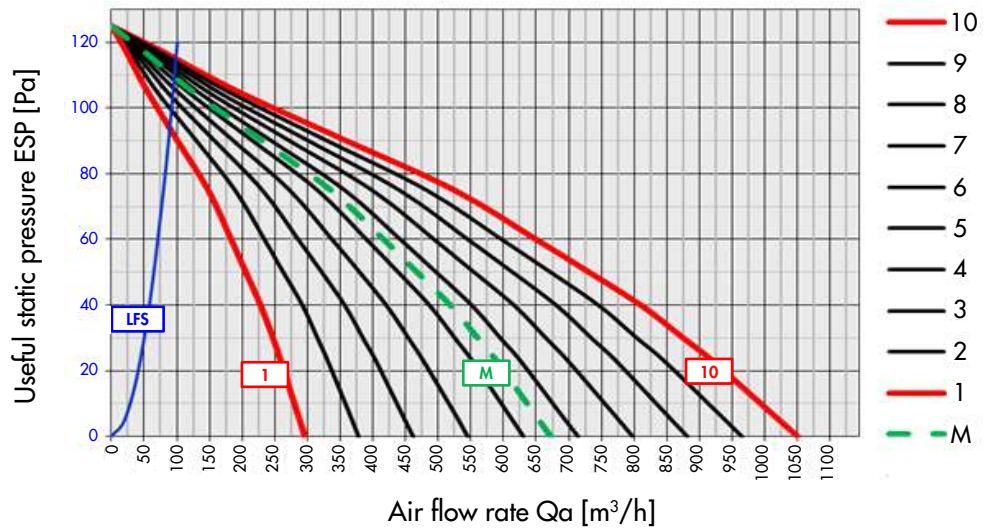

Model FCTE 08

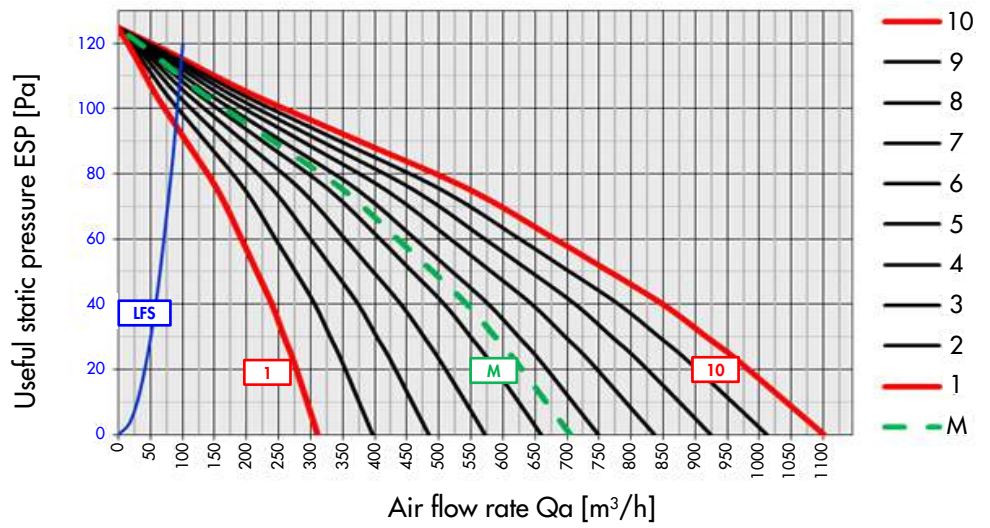

Model FCTE 09

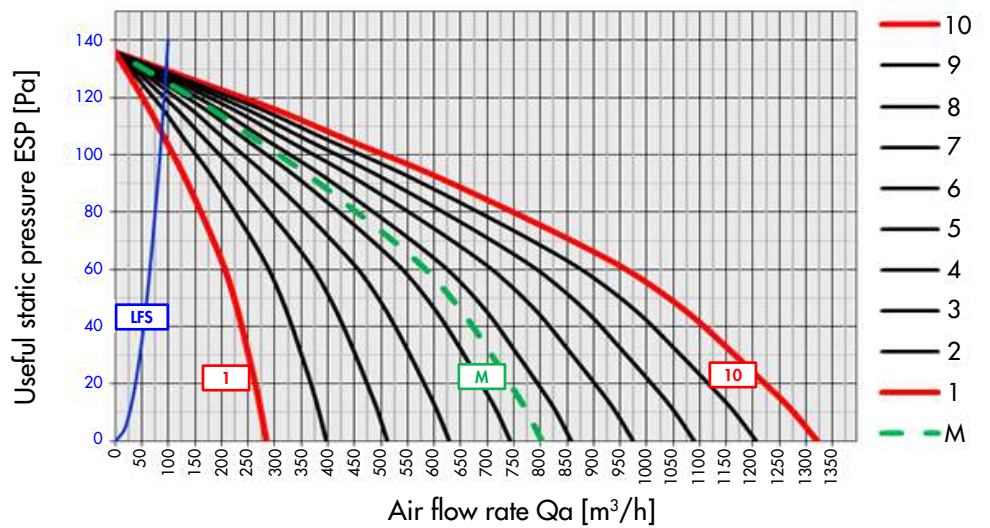

# DIMENSIONAL DRAWING

## Model FCTE-CV

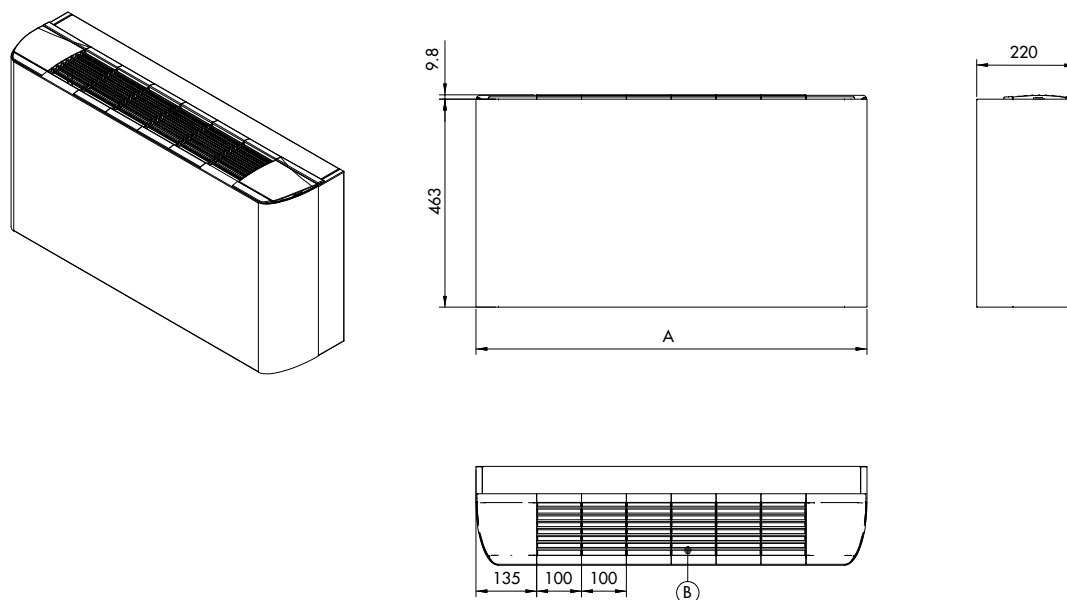

MODEL FCTE-CV	01	02	03	04	05	06	07	08	09
A	670	670	870	870	1070	1070	1270	1270	1470
B = N° grids	4	4	6	6	8	8	10	10	12

## Model FCTE-CA/FCTE-CH

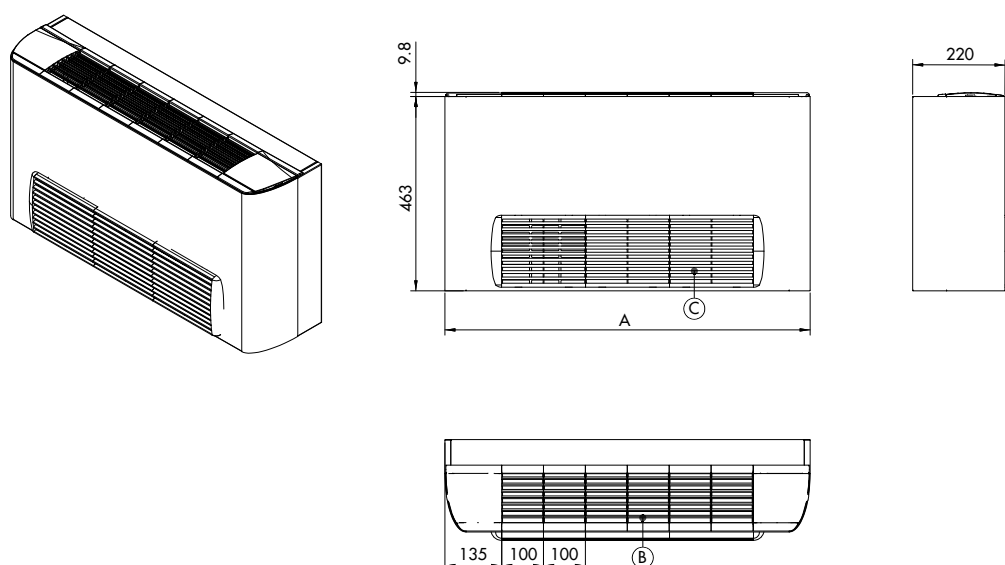

MODEL FCTE-CA/FCTE-CH	01	02	03	04	05	06	07	08	09
A	670	670	870	870	1070	1070	1270	1270	1470
B = N° grids	4	4	6	6	8	8	10	10	12
C = N° grids	2	2	3	3	4	4	5	5	6

## Model FCTE-NV

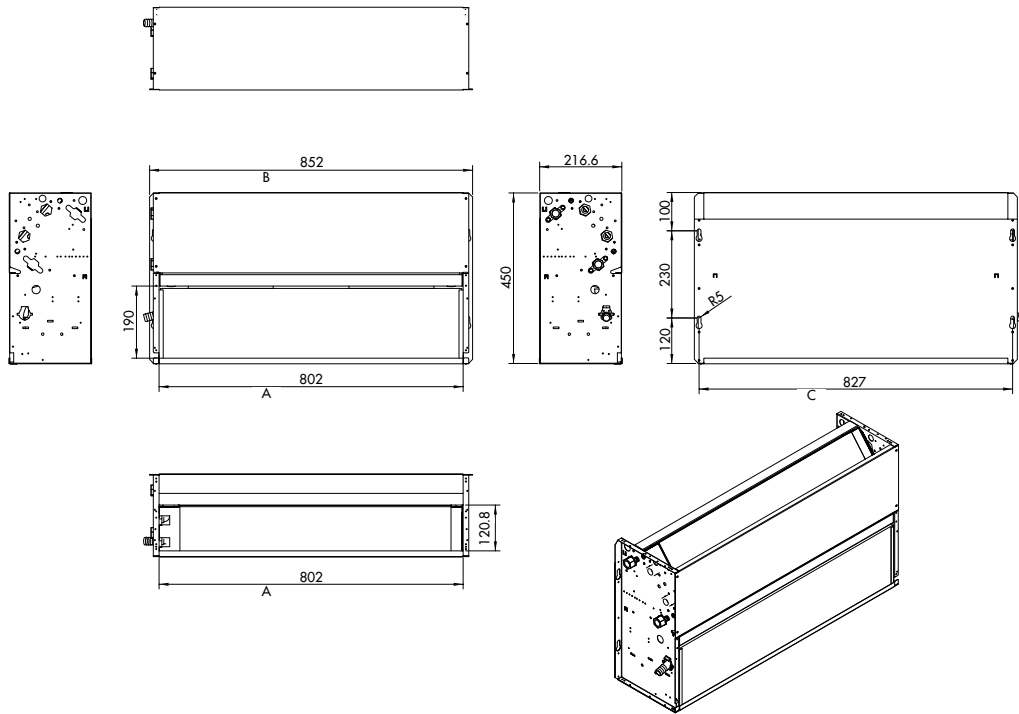



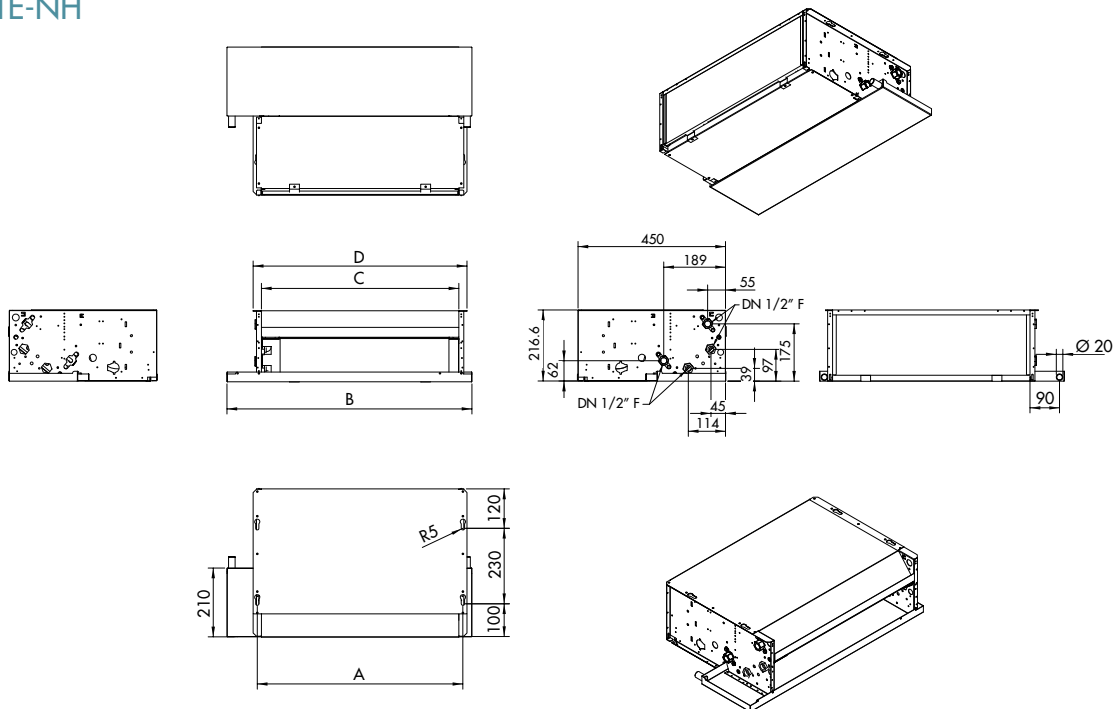

MODEL FCTE-NV	01	02	03	04	05	06	07	08	09
A	402	402	602	602	802	802	1002	1002	1202
B	452	452	652	652	852	852	1052	1052	1252
C	427	427	627	627	827	827	1027	1027	1227



## Model FCTE-NH



MODEL FCTE-NH	01	02	03	04	05	06	07	08	09
A	427	427	627	627	827	827	1027	1027	1227
B	547	547	747	747	947	947	1147	1147	1347
C	402	402	602	602	802	802	1002	1002	1202
D	452	452	652	652	852	852	1052	1052	1252

# ACCESSORIES

CONTROL UNITS INSTALLED				
	Code	Model	Description	Applicability
	387030562	OBC27	Control unit mounted on the machine for units with 2/4 pipes, simplified and with ATS4 air sensor	FC TE-CV FC TE-CA
	387030563	OBC26	Control unit mounted on the machine for units with 2/4 pipes, with display and ATS4 air sensor	FC TE-CV FC TE-CA
	387030466	MTT32	Thermostat of minimum hot water temperature (calibration 32 °C)	All
	387030467	WTS4	Water temperature sensor (type NTC 10.000 ohm @25 °C ±2 with cable L=1 m)	For OBC26 control unit as an alternative to MTT32

WIRED CONTROL UNITS				
	Code	Model	Description	Applicability
	387030468	CL01	IP20 terminal block (only if a wired control unit is necessary)	All
	387030564	SWC26	Thermostat for 2/4-pipe fan coil units, programmable, with display and 0...10 VDC or three-speed output	All



**KIT CONTAINING VALVES, PANS, CONDENSATE DISCHARGE PUMPS AND FEET**

	Code	Model	Description	Applicability
	387030473	3WV01	3/4" M three-way valve with PWM-ON/OFF actuator, 230 V (2 pipes)	All
	387030474	3WV02	Three-way valve with PWM-ON/OFF actuator, 230 V, 1/2" ball valve and 1/2" retainer (2 pipes)	All
	387030475	2WV01	3/4" M two-way valve with PWM-ON/OFF actuator, 230 V (2 pipes)	All
	387030476	2WV02	Two-way valve with PWM-ON/OFF actuator, 230 V, 1/2" ball valve and 1/2" retainer (2 pipes)	All
	387030477	VB01	Auxiliary drain pan made of plastic, for two-way or three-way valves	FCTE-CV FCTE-CA FCTE-NV
	387030478	HB01	Auxiliary drain pan with thermal insulation, for two-way or three-way valves	FCTE-CH FCTE-NH
	387030479	CP01	Condensate discharge pump equipped with alarm contact	FCTE-CV FCTE-CA FCTE-NV
	387030480	CP02	Condensate discharge pump equipped with alarm contact	FCTE-CH FCTE-NH
	387030481	FE01	Pair of pre-coated feet H=90 mm	FCTE-CV

# ACCESSORIES

PANELS				
Code		Model	Description	Applicability
387030482	01/02	CPB 01-02	Lower rear closing panel made of pre-painted plate	FCTE-CV FCTE-CA
387030483	03/04	CPB 03-04		
387030484	05/06	CPB 05-06		
387030485	01/02	CPC 01-02	Lower closing panel without grid made of pre-painted plate	FCTE-CA FCTE-CH
387030486	03/04	CPC 03-04		
387030487	05/06	CPC 05-06		
387030488	01/02	CPD 01-02	Lower closing panel made of pre-painted plate with removable ABS grid and flat air filter with grade EU3 filtration (EUROVENT 4/5)	FCTE-CV
387030489	03/04	CPD 03-04		
387030490	05/06	CPD 05-06		
387030491	01/02	RF 01-02	Frame for concealed wall-mounted installation	FCTE-NV
387030492	03/04	RF 03-04		
387030493	05/06	RF 05-06		
387030494	01/02	FP 01-02	Front panel made of pre-painted plate equipped with air return and supply grid, for fan coil units with remote control	FCTE-NV
387030495	03/04	FP 03-04		
387030496	05/06	FP 05-06		

PANELS				
Code		Model	Description	Applicability
387030497	07/08	CPB 07-08	Lower rear closing panel made of pre-painted plate	FCTE-CV FCTE-CA
387030498	09	CPB 09		
387030499	07/08	CPC 07-08	Lower closing panel without grid made of pre-painted plate	FCTE-CA FCTE-CH
387030500	09	CPC 09		
387030501	07/08	CPD 07-08	Lower closing panel made of pre-painted plate with removable ABS grid and flat air filter with grade EU3 filtration (EUROVENT 4/5)	FCTE-CV
387030502	09	CPD 09		
387030503	07/08	RF 07-08	Frame for concealed wall-mounted installation	FCTE-NV
387030504	09	RF 09		
387030505	07/08	FP 07-08	Front panel made of pre-painted plate equipped with air return and supply grid, for fan coil units with remote control	FCTE-NV
387030506	09	FP 09		



CPC



CPD



CPB



CPB



RF

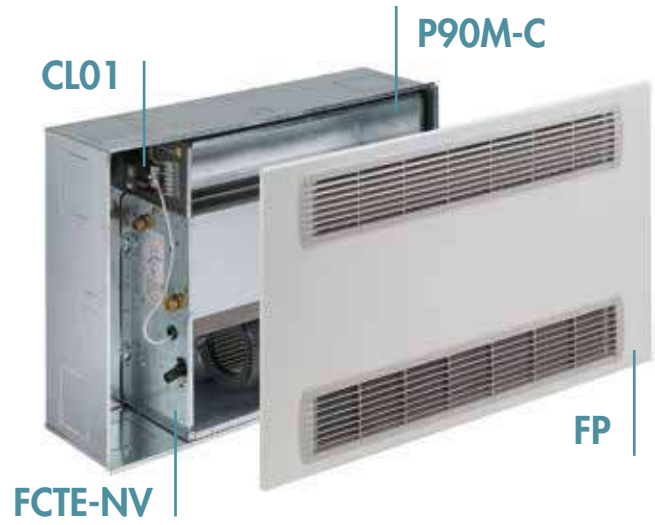

CL01

P90M-C

FCTE-NV

FP

# ACCESSORIES

PLENUM				
Code		Model	Description	Applicability
387030507	01/02	AJA 01-02	Vibration-damping joint with fan coil unit attachment flange and channel attachment flange, L=150 mm - Intake side	FCTE-NH
387030508	03/04	AJA 03-04		
387030509	05/06	AJA 05-06		
387030510	01/02	AJM 01-02	Vibration-damping joint with fan coil unit attachment flange and channel attachment flange, L=150 mm - Supply side	FCTE-NH
387030511	03/04	AJM 03-04		
387030512	05/06	AJM 05-06		
387030513	01/02	GDA 01-02	Air grid with simple row or fixed ABS flaps, suitable for connection on the TP, AJA, P90A plenum - Intake side	FCTE-NH
387030514	03/04	GDA 03-04		
387030515	05/06	GDA 05-06		
387030516	01/02	GDM 01-02	Air grid with simple row or fixed ABS flaps, suitable for connection on the TP, AJM plenum - Supply side	FCTE-NH
387030517	03/04	GDM 03-04		
387030518	05/06	GDM 05-06		
387030519	01/02	P90A 01-02	90° plenum - Intake side	FCTE-NH
387030520	03/04	P90A 03-04		
387030521	05/06	P90A 05-06		
387030522	01/02	P90M-C 01-02	90° plenum - Supply side	FCTE-NV
387030523	03/04	P90M-C 03-04		
387030524	05/06	P90M-C 05-06		
387030525	01/02	PRM 01-02	Straight plenum L=100 mm - Supply side	FCTE-NH
387030526	03/04	PRM 03-04		
387030527	05/06	PRM 05-06		
387030528	01/02	PRA 01-02	Straight plenum L=100 mm - Intake side	FCTE-NH
387030529	03/04	PRA 03-04		
387030530	05/06	PRA 05-06		
387030531	01/02	TP 01-02	Telescopic extension L=0-100 mm, suitable for connection with PRA, PRM, P290A plenum	FCTE-NH
387030532	03/04	TP 03-04		
387030533	05/06	TP 05-06		
387030534	01/02	PRCA 01-02	Air intake plenum with round fittings and filter	FCTE-NH
387030535	03/04	PRCA 03-04		
387030536	05/06	PRCA 05-06		
387030537	01/02	PRCM 01-02	Air supply plenum with round fittings, insulated	FCTE-NH
387030538	03/04	PRCM 03-04		
387030539	05/06	PRCM 05-06		

PLENUM				
Code		Model	Description	Applicability
387030540	07/08	AJA 07-08	Vibration-damping joint with fan coil unit attachment flange and channel attachment flange, L=150 mm - Intake side	FCTE-NH
387030541	09	AJA 09		
387030542	07/08	AJM 07-08	Vibration-damping joint with fan coil unit attachment flange and channel attachment flange, L=150 mm - Supply side	FCTE-NH
387030543	09	AJM 09		
387030544	07/08	GDA 07-08	Air grid with simple row or fixed ABS flaps, suitable for connection on the TP, AJA, P90A plenum - Intake side	FCTE-NH
387030545	09	GDA 09		
387030546	07/08	GDM 07-08	Air grid with simple row or fixed ABS flaps, suitable for connection on the TP, AJM plenum - Supply side	FCTE-NH
387030547	09	GDM 09		
387030548	07/08	P90A 07-08	90° plenum - Intake side	FCTE-NH
387030549	09	P90A 09		
387030550	07/08	P90M-C 07-08	90° plenum - Supply side	FCTE-NV
387030551	09	P90M-C 09		
387030552	07/08	PRM 07-08	Straight plenum L=100 mm - Supply side	FCTE-NH
387030553	09	PRM 09		
387030554	07/08	PRA 07-08	Straight plenum L=100 mm - Intake side	FCTE-NH
387030555	09	PRA 09		
387030556	07/08	TP 07-08	Telescopic extension L=0-100 mm, suitable for connection with PRA, PRM, P290A plenum	FCTE-NH
387030557	09	TP 09		
387030558	07/08	PRCA 07-08	Air intake plenum with round fittings and filter	FCTE-NH
387030559	09	PRCA 09		
387030560	07/08	PRCM-C 07-08	Air supply plenum with round fittings, insulated	FCTE-NH
387030561	09	PRCM-C 09		

# ACCESSORIES

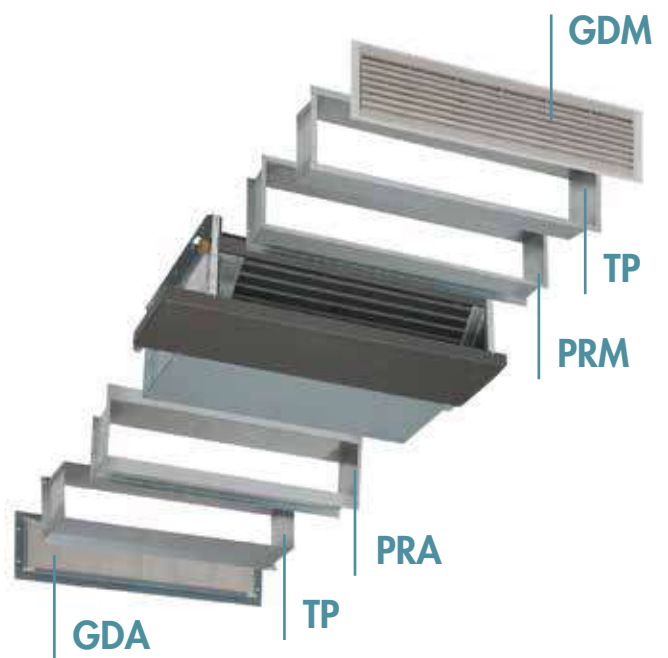
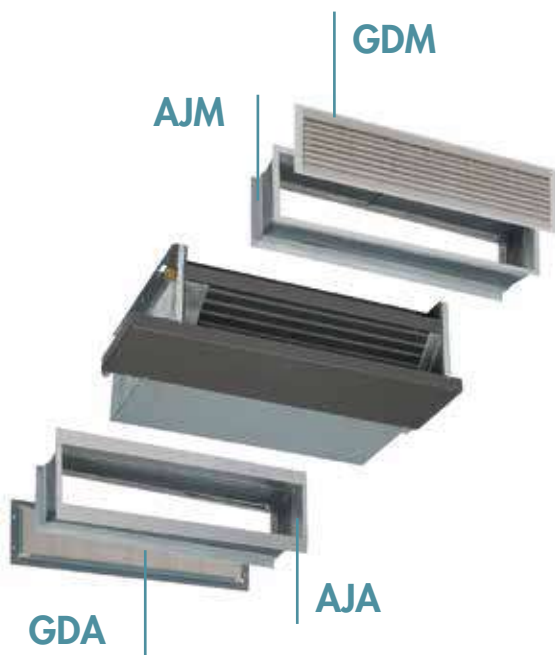
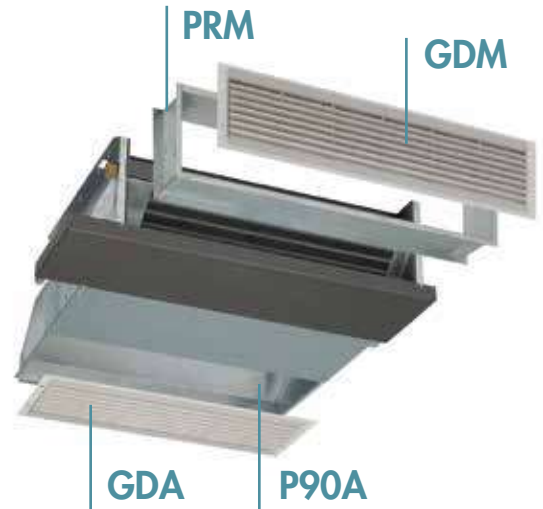
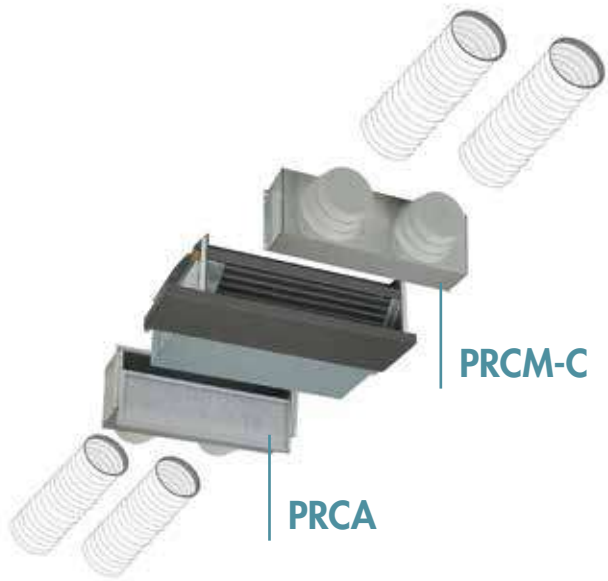







# CASSETTE

---

Models: FCC/FCCX/FCCE

# CASSETTE

## MAIN FEATURES MOD. FCC/FCCX/FCCE

### COVERING PANEL WITH AIR RETURN GRID AND AIR SUPPLY DEFLECTORS (ABS)

Innovative design. Built with injected ABS, it can withstand rust, corrosion and atmospheric agents. White finish RAL 9003. The "Hook & Fix" attachment system facilitates installation, removal and maintenance operations, by eliminating positioning-related inconveniences typically associated with these systems (suspended units/components difficult to handle). The central intake grid and 4 manually adjustable side supply flaps guarantee optimal air diffusion in all 4 directions. Friction-snap flaps for stable and uniform positioning.

### LOAD-BEARING STRUCTURE SUITABLE FOR USE ON 600x600 MM SUSPENDED CEILINGS

High-thickness galvanised plate load-bearing structure with Class M1 internal thermo-acoustic insulation, reinforced thickness for improved acoustic and thermal performances. Outer brackets on the 4 corners for easy fastening to the ceiling. A mere 250 mm height. Includes 1 hole with  $\varnothing$  72 mm for possible external air intake through round conduit and 1 hole with  $\varnothing$  155 mm for possible ducting of treated air supply to adjacent rooms.

- Models FCC 01...06, FCCX 01...06, FCCE 01...03: overall dimensions 570x570 mm, ideal for installation on 1 module size 600x600 mm in suspended ceilings.
- Models FCC 07...08, FCCX 07...08, FCCE 04...05: overall dimensions 570x1.160 mm, ideal for installation on 2 modules size 600x600 mm in suspended ceilings.

### AIR CONVEYOR AND DRAIN PAN

Air conveyor and pan made of ABS through injection. High-thickness material for sturdiness and long-lasting operation. RoHS & REACH compliant. Conveyor with optimised profiles that faithfully replicate the aerodynamic profiles of the air flow. Drain pan obtained from a single piece equipped with an outlet and plug.

### CONDENSATE DISCHARGE PUMP

Centrifugal condensate discharge pump, complete with non-return valve on the supply side to avoid continuous switching on/off,  $\varnothing$  16 mm drainage fitting.

Float with 2 levels: the first for controlling the condensate level and the second for activating the alarm.

Head = 1.00 m from the unit's lower edge; 230 VAC-1 Ph-50/60 Hz.

### HEAT EXCHANGE COIL

Heat exchange coil with copper pipe and aluminium flaps locked by means of mechanical expansion.

Square-shaped coil with rounded corners for guaranteeing a broader exchange surface, thus enhanced performances compared to traditional round coils. Hydrophilic aluminium flaps for improved condensate discharge, resulting in improved air conditioning performances. Coil fittings equipped with manual air relief valve.

For units with 2 pipes: 1 coil with 2 water connections (1 inlet + 1 outlet)

For units with 4 pipes: 1 coil with 4 water connections (2 inlets + 2 outlets)

Mixed circulation on a single coil guarantees improved performances for both heating and air conditioning. Coils tested at 30 bar operating pressure, suitable for working with water up to a maximum pressure of 15 bar.

The coils are suitable for operating with:

- high-temperature water (boiler)
- low-temperature water (condensing boiler, solar panels, heat pump, etc.)
- cold water (chiller and/or industrial processes)
- water supplemented with glycol.

Min/max incoming water temperature limits: 3...75 °C.

## AIR FILTER

Easily removable air filter, built with a metal frame containing the filtration septum. Can be regenerated by washing it with water, blowing, vacuuming. Made of NAN honeycomb polypropylene mesh, high efficiency. Recommended against dust and pollen. Class M1; grade EU3 filtration (EUROVENT 4/5), Group ISO COARSE ePM1=4%, ePM2.5=13%, ePM10=49% (EN ISO 16890:2016).

## ELECTRICAL EQUIPMENT

Terminal block for connection to the remote control (the remote control is an accessory) installed in a corner of the galvanised plate structure.

## VENTILATION UNIT

Radial fan with aerofoil blades and incorporated electric motor. Built according to international standards, mounted on elastic supports and shock absorbers. Statically and dynamically balanced fan. Ventilating unit removable with extreme ease (fastened with 4 screws only).

Several different motors available:

- Models FCC and FCCX: AC electric motor, asynchronous single-phase squirrel-cage version with 3 speeds, equipped with TH thermal protection device, run capacitor always engaged, 4 poles, IP44, Class B double insulation, 230 VAC-1 Ph-50/60 Hz.
- Models FCCE: motor with BLAC (Brushless Alternating Current) technology and permanent magnets, sensorless, 2 thermal protection devices (TP-thermal/Klixon + EP-electronic/SW), IP54, Class B double insulation, 230 VAC-1 Ph-50/60 Hz.

Modulating regulation with 0...10 VDC signal through our control units or independent regulation systems. The 0-100% modulation of the air flow (and hence of the heating and cooling capacities) allows for adapting the performances to the actual needs of the room to be climatized.

# CASSETTE

## MODELS

### CASSETTE FAN COIL MOD. FCC

Code	Model	Cooling capacity (W) (1)	Heating capacity (W) (2)
387030419	FCC 01	2.950	7.010
387030420	FCC 02	3.570	8.590
387030421	FCC 03	4.980	11.220
387030422	FCC 04	5.540	12.560
387030423	FCC 05	6.220	12.380
387030424	FCC 06	6.930	13.870
387030425	FCC 07	9.460	21.300
387030426	FCC 08	10.530	23.870



FCC	01
-	(1)

FCC = fan coil model  
(1) Capacity = 01, 02, 03, 04, 05, 06, 07, 08

### CASSETTE FAN COIL MOD. FCCX

Code	Model	Cooling capacity (W) (1)	Heating capacity (W) (2)
387030427	FCCX 01	3.070	4.590
387030428	FCCX 02	3.720	5.640
387030429	FCCX 03	4.040	6.160
387030430	FCCX 04	4.490	6.890
387030431	FCCX 05	5.150	6.100
387030432	FCCX 06	5.740	6.840
387030433	FCCX 07	7.670	11.690
387030434	FCCX 08	8.540	13.100



FCCX	01
-	(1)

FCCX = fan coil model  
(1) Capacity = 01, 02, 03, 04, 05, 06, 07, 08

### CASSETTE FAN COIL MOD. FCCE

Code	Model	Cooling capacity (W) (1)	Heating capacity (W) (2)
387030435	FCCE 01	5.020	12.350
387030436	FCCE 02	6.460	14.780
387030437	FCCE 03	8.010	16.170
387030438	FCCE 04	12.260	28.060
387030439	FCCE 05	15.190	30.680



FCCE	01
-	(1)

FCCE = fan coil model  
(1) Capacity = 01, 02, 03, 04, 05, 06, 07, 08

(1) Cooling: air temp. 27 °C dry bulb, 19 °C wet bulb - temp. - input/output water temp. 7/12 °C  
(2) Heating: air temp. 20 °C - input/output water temp. 70/60 °C



# RATED TECHNICAL DATA MOD. FCC

## TWO-PIPE UNIT - ONE COIL - THREE SPEEDS

MODELS			01	02	03	04
<b>Dimension</b>		<b>mm</b>	<b>600x600</b>			
Total cooling capacity (1)		W	2.950	3.570	4.980	5.540
Sensible cooling capacity (1)		W	2.390	2.980	3.800	4.300
Heating capacity (2a)		W	7.010	8.590	11.220	12.560
Heating capacity (2b)		W	3.505	4.295	5.610	6.280
Rated air flow (3)		m <sup>3</sup> /h	530	720	810	960
Water flow rate (4)	Cooling	l/h	507	614	857	953
	Heating	l/h	603	739	965	1.080
Water pressure drop (5)	Cooling	kPa	7,0	10,2	12,4	15,3
	Heating	kPa	7,7	11,5	12,2	15,3
Sound pressure (ls.-ms.-hs.) (6)		dB(A)	12-17-25	16-24-34	22-32-36	25-36-38
Ref. Fan-deck			1x R282x146-3 V 50 W-C1 [P=N1-2-3]	1x R282x146-3 V 50 W-C1,5 [P=N1-2-3]	1x R282x146-3 V 88 W-C2,5 [P=N1-2-3]	1x R282x146-3 V 88 W-C3 [P=N1-2-3]
Motors/Fans		N/N	1/1		1/1	
Rated power absorption (7)	W		1x50 W		1x88 W	
	A		1x0.22 A		1x0.39 A	
Electrical power supply			230 Vac - 1 Ph - 50/60 Hz			
Cold/hot coil	Water content	l	0.95		1.5	
	Rows	N	2R		3R	
	Hydraulic fittings	DN	3/4" F		3/4" F	
	Condensate drainage outlet	mm	16		16	
Air flow reduction (8)	<b>0 Pa</b>	MAX	1.00	1.00	1.00	1.00
		MED	0.7	0.71	0.84	0.84
		MIN	0.49	0.49	0.56	0.55

## REDUCTION OF THE COOLING/HEATING CAPACITY (in relation to the air flow reduction)

Air flow rate	1.00	0.95	0.90	0.85	0.80	0.75	0.70	0.65	0.60	0.55
Total cooling capacity	1.00	0.97	0.95	0.92	0.89	0.87	0.84	0.81	0.77	0.74
Cooling capacity	1.00	0.97	0.93	0.90	0.86	0.83	0.79	0.76	0.72	0.68
Heating capacity	1.00	0.97	0.94	0.91	0.87	0.84	0.81	0.77	0.74	0.70

Air flow rate	0.50	0.45	0.40	0.35	0.30	0.25	0.20	0.15	0.10
Total cooling capacity	0.71	0.67	0.63	0.59	0.55	0.50	0.45	0.39	0.32
Cooling capacity	0.64	0.60	0.55	0.51	0.46	0.41	0.35	0.29	0.22
Heating capacity	0.66	0.62	0.58	0.53	0.49	0.44	0.38	0.32	0.25

MODELS			05	06	07	08
<b>Dimension</b>		<b>mm</b>	<b>600x600</b>		<b>600x1.200</b>	
Total cooling capacity (1)		W	6.220	6.930	9.460	10.530
Sensible cooling capacity (1)		W	4.400	4.980	7.220	8.170
Heating capacity (2a)		W	12.380	13.870	21.300	23.870
Heating capacity (2b)		W	6.190	6.935	10.650	11.935
Rated air flow (3)		m <sup>3</sup> /h	800	950	1.540	1.830
Water flow rate (4)	Cooling	l/h	1.070	1.192	1.627	1.811
	Heating	l/h	1.065	1.193	1.832	2.053
Water pressure drop (5)	Cooling	kPa	16.1	20.0	16.2	18.8
	Heating	kPa	12.4	15.6	16.0	18.9
Sound pressure (ls.-ms.-hs.) (6)		dB(A)	22-32-36	25-36-38	25-35-39	28-39-41
Ref. Fan-deck			1x R282x146-3 V 88 W-C2,5 [P=N1-2-3]	1x R282x146-3 V 88 W-C3 [P=N1-2-3]	2x R282x146-3 V 88 W-C2,5 [P=N1-2-3]	2x R282x146-3 V 88 W-C3 [P=N1-2-3]
Motors/Fans		N/N	1/1		2/2	
Rated power absorption (7)	W		1x88 W		2x88 W	
	A		1x0.39 A		2x0.39 A	
Electrical power supply			230 Vac - 1 Ph - 50/60 Hz		230 Vac - 1 Ph - 50/60 Hz	
Cold/hot coil	Water content	l	2.1		3.1	
	Rows	N	4R		3R	
	Hydraulic fittings	DN	3/4" F		3/4" F	
	Condensate drainage outlet	mm	16		16	
Air flow reduction (8)	<b>0 Pa</b>	MAX	1	1	1	1
		MED	0.84	0.84	0.84	0.84
		MIN	0.55	0.56	0.55	0.55

Technical data referred to the following conditions:  
 standard unit - atmospheric pressure 1013 mbar - electrical power supply 230 VAC/1 Ph/50 Hz.

(1) (2) (3) (4) (5): Rated technical data, ref. air flow rate (3) at maximum speed and with unit with open mouth (external static pressure ESP=0 Pa).

(1) **Cooling:** air temp. 27 °C dry bulb, 19 °C wet bulb - input/output water temp. 7/12 °C - Maximum speed.

(2a) **Heating:** air temp. 20 °C - Input/output water temp. 70/60 °C - Maximum speed.

(2b) **Heating:** air temp. 20 °C - Input/output water temp. 45/40 °C - Maximum speed.

(3) **Air flow rate and static pressure:** rated values measured with casing ref. AMCA210-74 standard Fig.12 and conduit + diaphragm ref. CNR-UNI10023 standard.

(6) **Sound pressure:** sound pressure in free field environment, distance 2 m. Values calculated from sound power measured in reverberation chamber ref. ISO 3741-ISO 3742 standards.

(7) **Electrical data:** values measured with Jokogawa WT110 wattmeter (nominal value = reference value for the design of the electrical system).

## TABLE OF NET WEIGHTS MOD. FCC IN KG

Products/Models		01	02	03	04	05	06	07	08
FCC	Unit	17.2	17.2	18.0	18.0	18.9	18.9	35.0	35.0
	Grid	2.1	2.1	2.1	2.1	2.1	2.1	4.1	4.1

# RATED TECHNICAL DATA MODELS FCCX

## FOUR-PIPE UNIT - TWO COILS - THREE SPEEDS

MODELS			01	02	03	04
<b>Dimension</b>		<b>mm</b>	<b>600x600</b>			
Total cooling capacity (1)		W	3.070	3.720	4.040	4.490
Sensible cooling capacity (1)		W	2.350	2.940	3.230	3.650
Heating capacity (2a)		W	4.590	5.640	6.160	6.890
Heating capacity (2b)		W	2.295	2.820	3.080	3.445
Rated air flow (3)		m <sup>3</sup> /h	520	710	810	960
Water flow rate (4)	Cooling	l/h	528	640	695	772
	Heating	l/h	395	485	530	593
Water pressure drop (5)	Cooling	kPa	7.5	11.1	13.1	16.1
	Heating	kPa	12.2	18.5	22.1	27.6
Sound pressure (ls.-ms.-hs.) (6)		dB(A)	12-17-25	16-24-34	22-32-36	25-36-38
Ref. Fan-deck			1x R282x146-3 V 50 W-C1 [P=N1-2-3]	1x R282x146-3 V 50 W-C1,5 [P=N1-2-3]	1x R282x146-3 V 88 W-C2,5 [P=N1-2-3]	1x R282x146-3 V 88 W-C3 [P=N1-2-3]
Motors/Fans		N/N	1/1		1/1	
Rated power absorption (7)		W	1x50 W		1x88 W	
		A	1x0.22 A		1x0.39 A	
Electrical power supply			230 Vac - 1 Ph - 50/60 Hz			
Cold/hot coil	Water content	l	0.95		0.95	
	Rows	N	2R		2R	
	Hydraulic fittings	DN	3/4" F		3/4" F	
	Condensate drainage outlet	mm	16		16	
Hot coil	Water content	l	0.60		0.60	
	Rows	N	1R		1R	
	Hydraulic fittings	DN	3/4" F		3/4" F	
	Condensate drainage outlet	mm	16		16	
Air flow reduction (8)	<b>0 Pa</b>	MAX	1.00	1.00	1.00	1.00
		MED	0.71	0.70	0.84	0.84
		MIN	0.50	0.49	0.56	0.55

## REDUCTION OF THE COOLING/HEATING CAPACITY (in relation to the air flow reduction)

Air flow rate	1.00	0.95	0.90	0.85	0.80	0.75	0.70	0.65	0.60	0.55
Total cooling capacity	1.00	0.97	0.95	0.92	0.89	0.87	0.84	0.81	0.77	0.74
Cooling capacity	1.00	0.97	0.93	0.90	0.86	0.83	0.79	0.76	0.72	0.68
Heating capacity	1.00	0.97	0.94	0.91	0.87	0.84	0.81	0.77	0.74	0.70

Air flow rate	0.50	0.45	0.40	0.35	0.30	0.25	0.20	0.15	0.10
Total cooling capacity	0.71	0.67	0.63	0.59	0.55	0.50	0.45	0.39	0.32
Cooling capacity	0.64	0.60	0.55	0.51	0.46	0.41	0.35	0.29	0.22
Heating capacity	0.66	0.62	0.58	0.53	0.49	0.44	0.38	0.32	0.25



MODELS			05	06	07	08
<b>Dimension</b>		<b>mm</b>	<b>600x600</b>		<b>600x1.200</b>	
Total cooling capacity (1)		W	5.150	5.740	7.670	8.540
Sensible cooling capacity (1)		W	3.930	4.450	6.130	6.940
Heating capacity (2a)		W	6.100	6.840	11.690	13.100
Heating capacity (2b)		W	3.050	3.420	5.845	6.550
Rated air flow (3)		m <sup>3</sup> /h	800	950	1.540	1.830
Water flow rate (4)	Cooling	l/h	886	987	1.319	1.469
	Heating	l/h	525	588	1.005	1.127
Water pressure drop (5)	Cooling	kPa	13.2	16.4	16.8	19.6
	Heating	kPa	12.3	15.5	24.9	29.9
Sound pressure (ls.-ms.-hs.) (6)		dB(A)	22-32-36	25-36-38	25-35-39	28-39-41
Ref. Fan-deck			1x R282x146-3 V 88 W-C2,5 [P=N1-2-3]	1x R282x146-3 V 88 W-C3 [P=N1-2-3]	2x R282x146-3 V 88 W-C2,5 [P=N1-2-3]	2x R282x146-3 V 88 W-C3 [P=N1-2-3]
Motors/Fans		N/N	1/1		2/2	
Rated power absorption (7)		W	1x88 W		2x88 W	
		A	1x0.39 A		2x0.39 A	
Electrical power supply			230 Vac - 1 Ph - 50/60 Hz		230 Vac - 1 Ph - 50/60 Hz	
Cold/hot coil	Water content	l	1.50		2.00	
	Rows	N	3R		2R	
	Hydraulic fittings	DN	3/4" F		3/4" F	
	Condensate drainage outlet	mm	16		16	
Hot coil	Water content	l	0.65		1.30	
	Rows	N	1R		1R	
	Hydraulic fittings	DN	3/4" F		3/4" F	
	Condensate drainage outlet	mm	16		16	
Air flow reduction (8)	<b>0 Pa</b>	MAX	1.00	1.00	1.00	1.00
		MED	0.84	0.84	0.84	0.84
		MIN	0.55	0.56	0.55	0.55

Technical data referred to the following conditions:  
 standard unit - atmospheric pressure 1013 mbar - electrical power supply 230 VAC/1 Ph/50 Hz.

(1) (2) (3) (4) (5): Rated technical data, ref. air flow rate (3) at maximum speed and with unit with open mouth (external static pressure ESP=0 Pa).

(1) **Cooling**: air temp. 27 °C dry bulb, 19 °C wet bulb - input/output water temp. 7/12 °C - Maximum speed.

(2a) **Heating**: air temp. 20 °C - Input/output water temp. 70/60 °C - Maximum speed.

(2b) **Heating**: air temp. 20 °C - Input/output water temp. 45/40 °C - Maximum speed.

(3) **Air flow rate and static pressure**: rated values measured with casing ref. AMCA210-74 standard Fig. 12 and conduit + diaphragm ref. CNR-UNI10023 standard.

(6) **Sound pressure**: sound pressure in free field environment, distance 2 m. Values calculated from sound power measured in reverberation chamber ref. ISO 3741-ISO 3742 standards.

(7) **Electrical data**: values measured with Jokogawa WT110 wattmeter (nominal value = reference value for the design of the electrical system).

## TABLE OF NET WEIGHTS MOD. FCCX IN KG

Products/Models		01	02	03	04	05	06	07	08
FCCX	Unit	18.3	18.3	18.4	18.4	19.3	19.3	36.0	36.0
	Grid	2.1	2.1	2.1	2.1	2.1	2.1	4.1	4.1

# RATED TECHNICAL DATA MODELS FCCE

## TWO-PIPE UNIT - ONE COIL - EC BRUSHLESS

MODELS			01	02	03
<b>Dimension</b>		<b>mm</b>	<b>600x600</b>		
Total cooling capacity (1)		W	5.020	6.460	8.010
Sensible cooling capacity (1)		W	4.420	5.130	5.880
Heating capacity (2a)		W	12.350	14.780	16.170
Heating capacity (2b)		W	6.178	7.394	8.089
Rated air flow (3)		m <sup>3</sup> /h	1.250	1.230	1.200
Water flow rate (4)	Cooling	l/h	863	1.111	1.378
	Heating	l/h	1.062	1.271	1.391
Water pressure drop (5)	Cooling	kPa	20.2	20.8	26.7
	Heating	kPa	23.8	21.2	21.2
Sound pressure (1 V-M-10 V) (6)		dB(A)	<10-32-43	<10-32-43	<10-31-42
Ref. Fan-deck			1x R282x146, 74 V [SWP=N/ FIX.1/10]	1x R282x146, 74 V [SWP=N/ FIX.1/10]	1x R282x146, 74 V [SWP=N/ FIX.1/10]
Motors/Fans		N/N	1/1	1/1	1/1
Rated power absorption (7)		W	1x74 W	1x74 W	1x74 W
		A	1x0.64 A	1x0.64 A	1x0.64 A
Electrical power supply			230 Vac - 1 Ph - 50/60 Hz		
Cold/hot coil	Water content	l	0.95	1.50	2.10
	Rows	N	2R	3R	4R
	Hydraulic fittings	DN	3/4" F	3/4" F	3/4" F
	Condensate drainage outlet	mm	16	16	16
Air flow reduction (8)	<b>0 Pa</b>	10 V (MAX)	1.00	1.00	1.00
		5.5 V (MED)	0.55	0.55	0.55
		1 V (MIN)	0.10	0.10	0.10

## REDUCTION OF THE COOLING/HEATING CAPACITY (in relation to the air flow reduction)

Air flow rate	1.00	0.95	0.90	0.85	0.80	0.75	0.70	0.65	0.60	0.55
Total cooling capacity	1.00	0.97	0.95	0.92	0.89	0.87	0.84	0.81	0.77	0.74
Cooling capacity	1.00	0.97	0.93	0.90	0.86	0.83	0.79	0.76	0.72	0.68
Heating capacity	1.00	0.97	0.94	0.91	0.87	0.84	0.81	0.77	0.74	0.70

Air flow rate	0.50	0.45	0.40	0.35	0.30	0.25	0.20	0.15	0.10
Total cooling capacity	0.71	0.67	0.63	0.59	0.55	0.50	0.45	0.39	0.32
Cooling capacity	0.64	0.60	0.55	0.51	0.46	0.41	0.35	0.29	0.22
Heating capacity	0.66	0.62	0.58	0.53	0.49	0.44	0.38	0.32	0.25

MODELS			04	05
<b>Dimension</b>		<b>mm</b>	<b>600x1.200</b>	
Total cooling capacity (1)		W	12.260	15.190
Sensible cooling capacity (1)		W	9.740	11.170
Heating capacity (2a)		W	28.060	30.680
Heating capacity (2b)		W	14.034	15.346
Rated air flow (3)		m <sup>3</sup> /h	2.340	2.280
Water flow rate (4)	Cooling	l/h	2.109	2.613
	Heating	l/h	2.413	2.639
Water pressure drop (5)	Cooling	kPa	25.5	30.7
	Heating	kPa	26.1	24.4
Sound pressure (1 V-M-10 V) (6)		dB(A)	<10-35-46	<10-34-45
Ref. Fan-deck			1x R282x146, 74 V [SWP=N/ FIX.1/10]	1x R282x146, 74 V [SWP=N/ FIX.1/10]
Motors/Fans		N/N	2/2	2/2
Rated power absorption (7)		W	2x74 W	2x74 W
		A	2x0.64 A	2x0.64 A
Electrical power supply			230 Vac - 1 Ph - 50/60 Hz	
Cold/hot coil	Water content	l	3.10	4.30
	Rows	N	3R	4R
	Hydraulic fittings	DN	3/4" F	3/4" F
	Condensate drainage outlet	mm	16	16
Air flow reduction (8)	<b>0 Pa</b>	10 V (MAX)	1.00	1.00
		5.5 V (MED)	0.55	0.55
		1 V (MIN)	0.10	0.10

Technical data referred to the following conditions:

standard unit - atmospheric pressure 1013 mbar - electrical power supply 230 VAC/1 Ph/50 Hz.

(1) (2) (3) (4) (5): Rated technical data, ref. air flow rate (3) at maximum speed and with unit with open mouth (external static pressure ESP=0 Pa).

(1) **Cooling:** air temp. 27 °C dry bulb, 19 °C wet bulb - input/output water temp. 7/12 °C - Maximum speed.

(2a) **Heating:** air temp. 20 °C - Input/output water temp. 70/60 °C - Maximum speed.

(2b) **Heating:** air temp. 20 °C - Input/output water temp. 45/40 °C - Maximum speed.

(3) **Air flow rate and static pressure:** rated values measured with casing ref. AMCA210-74 standard Fig.12 and conduit + diaphragm ref. CNR-UNI10023 standard.

(6) **Sound pressure:** sound pressure in free field environment, distance 2 m. Values calculated from sound power measured in reverberation chamber ref. ISO 3741-ISO 3742 standards.

(7) **Electrical data:** values measured with Jokogawa WT110 wattmeter (nominal value = reference value for the design of the electrical system).

## TABLE OF NET WEIGHTS MOD. FCCE IN KG

Products/Models		01	02	03	04	05
FCCE	Unit	17.3	18.1	19.0	35.2	37.0
	Grid	2.1	2.1	2.1	4.1	4.1

# DIMENSIONAL DRAWINGS

## Model FCC e FCCE single-cassette configuration

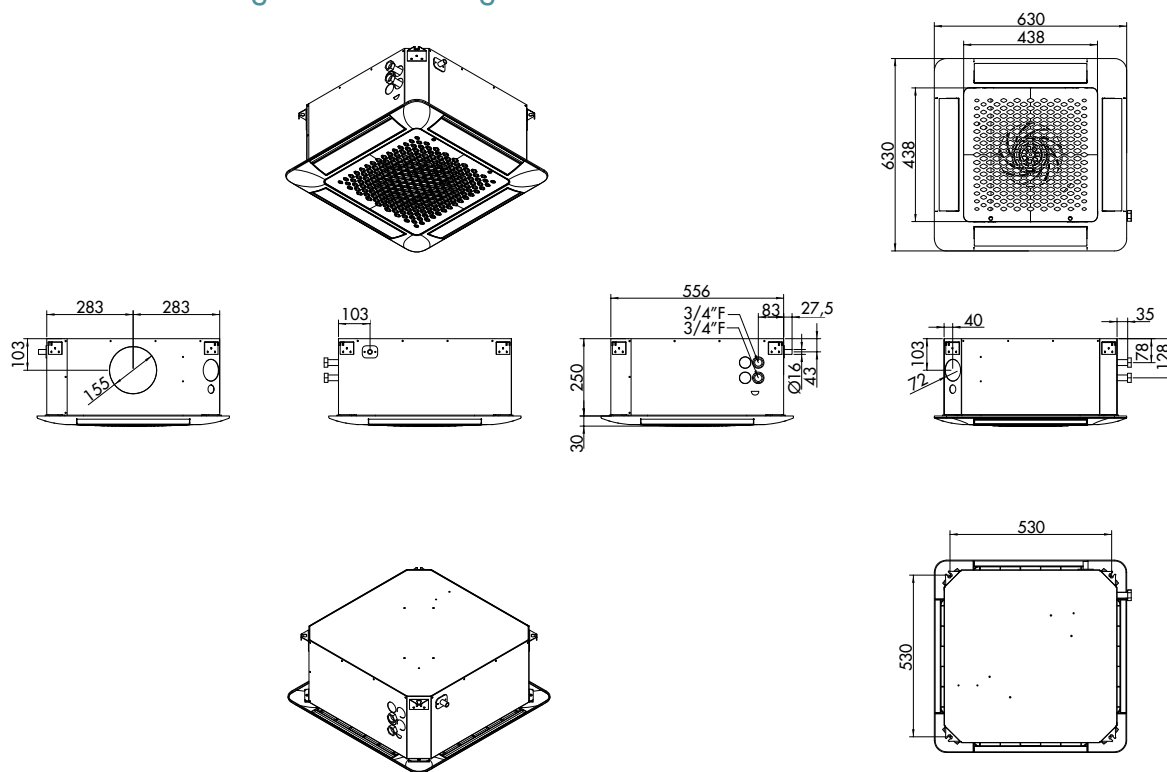

## Model FCC e FCCE double-cassette configuration

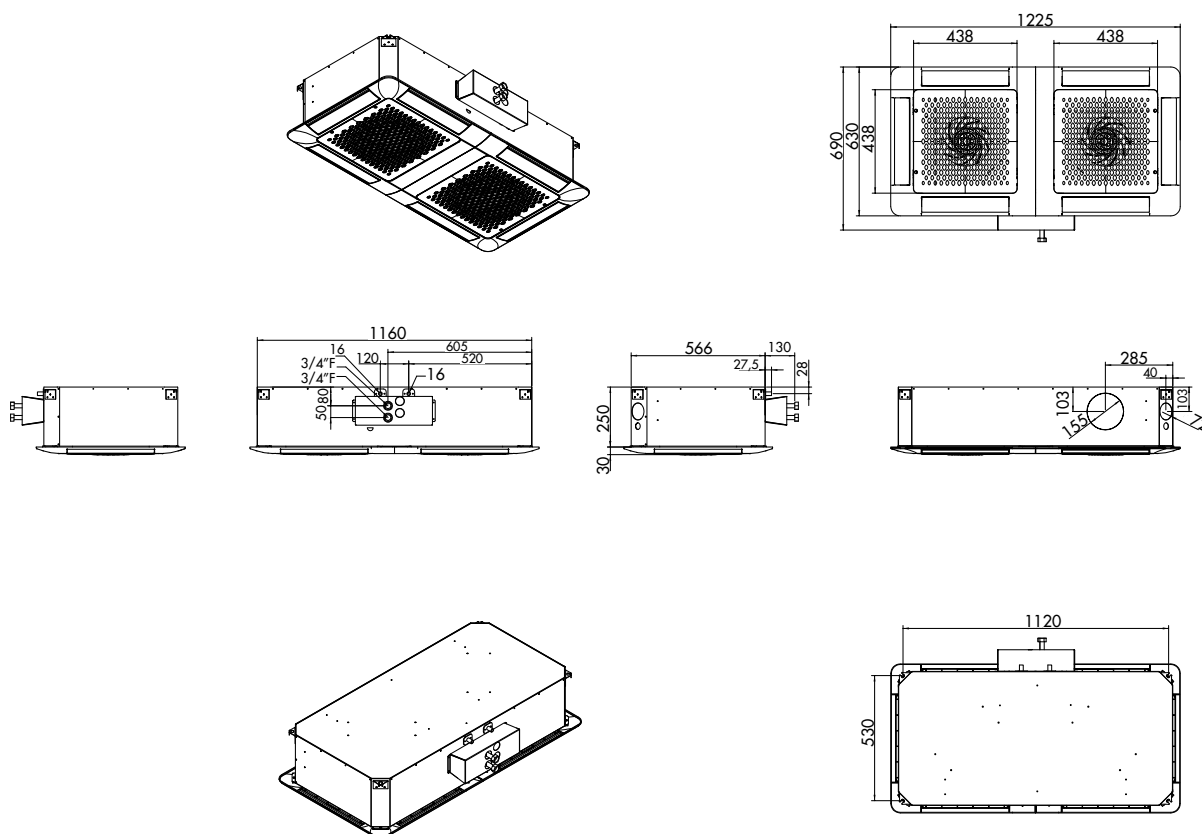

## Model FCCX single-cassette configuration

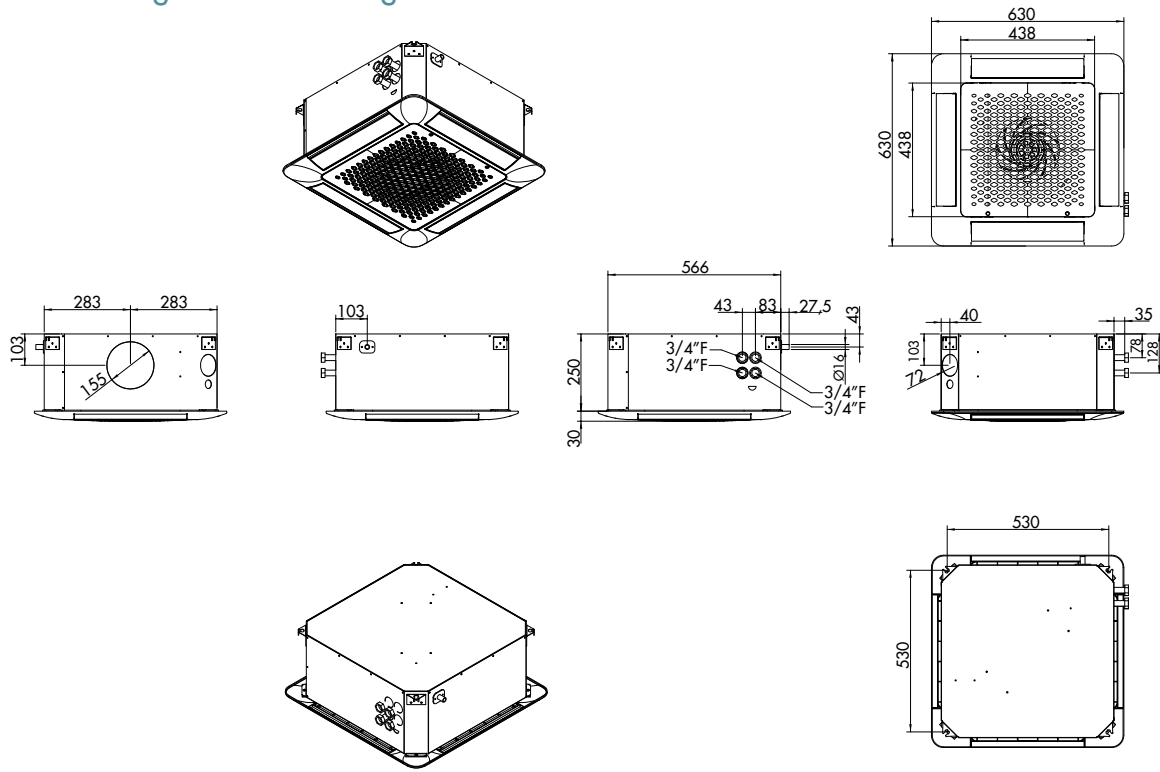



FANCOILS

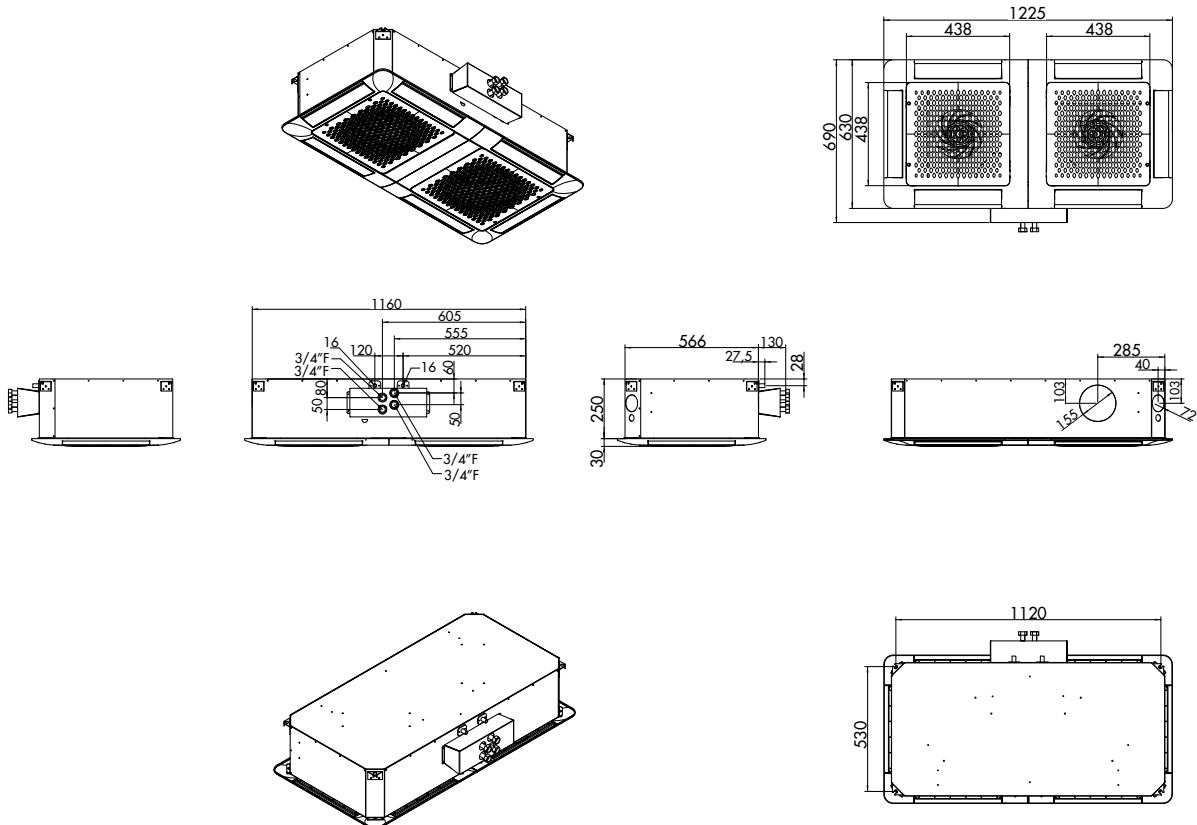



## Model FCCX double-cassette configuration



# ACCESSORIES

CONTROLS UNITS INSTALLED				
	Code	Model	Description	Applicability
	387030468	CL01	IP20 terminal block (only if a wired control unit is necessary) - INCLUDED	All
	387030469	SWC22	Simplified thermostat for 2/4-pipe fan coil units	FCC FCCX
	387030470	SWC25	Programmable thermostat for 2/4-pipe fan coil units with display and with advanced functions	FCC FCCX
	387030564	SWC26	Thermostat for 2/4-pipe fan coil units, programmable, with display and 0...10 VDC output	FCCE
	387030602	IRC02	IR remote control. Kit inclusive of motherboard, air sensor, water sensor and IR receiver	FCC FCCX
	387030471	EIX01	Electronic interface for fan coil unit thermostats: enables a single thermostat to control up to 4 fan coil units. Housed in a 6-module container for DIN rail	FCC FCCX
	387030466	MTT32	Minimum hot water temperature thermostat (calibrated to 32 °C)	SWC22
	387030467	WTS4	Water temperature sensor (type NTC 10.000 ohm @25 °C ±2 with cable L=1 m)	SWC25 SWC26

VARIOUS				
	Code	Model	Description	Applicability
	387030565	CC63	Covering panel with air return grid and air supply deflectors, air filter. Dimensions 630x630 mm	Single boxes
	387030566	CC64	Covering panel with air return grid and air supply deflectors, air filter. Dimensions 630x1225 mm	Double boxes
	387030567	VB63	Auxiliary drain pan made of plastic, for two-way or three-way valves	Single boxes
	387030568	VB64	Auxiliary drain pan made of plastic, for two-way or three-way valves	Double boxes
	387030569	REA01	Galvanised plate ring for outdoor air intake Ø=72 mm L=100 mm	All
	387030570	RIA01	Galvanised plate ring for air entry into adjacent room Ø=155 mm L=100 mm	All

VALVE KIT				
	Code	Model	Description	Applicability
	387030571	3WV03	3/4" M three-way valve with PWM-ON/OFF actuator, 230 V (2 pipes)	FCC FCCE
	387030572	2WV03	3/4" M two-way valve with PWM-ON/OFF actuator, 230 V (2 pipes)	FCC FCCE
	387030573	3WV03-C	2x3/4" M three-way valves with PWM-ON/OFF actuator, 230 V (4 pipes)	FCCX
	387030574	2WV03-C	2x3/4" M two-way valves with PWM-ON/OFF actuator, 230 V (4 pipes)	FCCX





# DUCTED

---

Model: DT/DTE

# DUCTABLE

## MAIN FEATURES MOD. DT/DTE

### COVERING BOX

Covering box (load-bearing structure) made of high-thickness plate resistant to rust, corrosion, chemicals, solvents, aliphatic compounds, alcohols. Pre-cut pieces and holes for configuring the unit as requested, for installing the relevant accessories, for the left-hand or right-hand arrangement of the water connection outlets, for the unit's reversibility on the installation site. Assembled using self-tapping screws for quick, thorough and easy inspection/maintenance. Compact dimensions, optimised overall dimensions. Covering boxes with galvanised plate panel and internal thermo-acoustic insulation (Class M1) of the parts in contact with the coil.

### DRAIN PAN (WITH DOUBLE INCLINATION)

Drain pan with double inclination for optimal condensate discharge, equipped with outlet (standard on the same side of the water connections) + outer thermal insulation.

### HEAT EXCHANGER

High-efficiency heat exchange coil with copper pipe and aluminium flaps locked by means of mechanical expansion.

Coil fittings equipped with anti-torsion system, manual air relief valves and manual water drainage valves. Fittings on the left as a standard feature; on request they can be mounted on the right and are easily reversible on-site. 1 coil for 2-pipe system; 2 coils for 4-pipe system. Coils tested at 30 bar operating pressure, suitable for working with water up to a maximum pressure of 1.5 bar.

The coils are suitable for operating with:

- high-temperature water (boiler)
- low-temperature water (condensing boiler, heat pump, etc.)
- cold water (chiller and/or industrial processes)
- water supplemented with glycol

Sizes with 3-row (3R) coil, normally used for cooling with treatment of all the internal recirculation air.

Sizes with 4-row (4R) coil, normally used for cooling with treatment of all (or part) of the outdoor renewal air, whenever a high dehumidification action is required.

### VENTILATION UNIT (3-SPEED CENTRIFUGAL FAN) - DT

Ventilation unit consisting of 1, 2 or 3 double-intake centrifugal fans with aluminium fans (with forward-curved blades) directly coupled with the electric motor with a useful static pressure of up to 150 Pa.

Mounted on elastic and elastic supports and shock absorbers. Statically and dynamically balanced fan. Large-diameter fans (with high air volume and high static pressure) with low number of revolutions (=low noise). Electric motor with at least 3 speeds, equipped with thermal protection device (Klixon), run capacitor always engaged, IP42, Class B, power cables protected with double insulation.

### VENTILATION UNIT (BRUSHLESS CENTRIFUGAL FAN) - DTE

Motor technology BLAC (Brushless Alternating Current) permanent magnets, brushless, sensor less, 2 protectors (TP-thermal/Klixon + EP-electronic/SW), IP20, Class B, double insulation, Inverter with dry contact alarm, 230vac-1ph-50/60hz.

High Energy Efficiency motor (HEE) with high energy savings (over 50%) and consequential CO<sub>2</sub> reduction (environmentally friendly).

Modulating regulation with 0...10 Vdc signal through our controls or through independent (customer's) control systems: modulation of 0-100% of the air flow (and consequently of the thermal and cooling power), allows to adjust the performance, instant by instant, to the actual needs of the room, ensuring total comfort and noise reduction.

## ELECTRICAL EQUIPMENT (TERMINAL BLOCK WITH MINIMUM 7 PINS)

"Mammut"-type terminal block IP20 (minimum 7 pins: 1 earth + 3 speeds + 1 common + 2 with jumper) mounted outside of the unit (for horizontal units, on the same side of the water connections; for vertical units, on the opposite side).

## AIR FILTER

The standard unit is supplied without air filter. In this way the customer can choose whether to use an air filter section among those available as accessories, or adopt an air recovery grid with air filter, or insert an air filter along the intake ducting.

## AIR INTAKES AND SUPPLY OUTLETS

All standard versions are supplied with free air intake and supply outlets, without any grid/protection.

**WARNING:** it is forbidden to start the machine unless both the unit's intake and outlet have been ducted or protected with grids or a safety mesh (the following items are available as accessories on request: grids, panels, plenums, etc.).

# DUCTABLE MODELS

## DUCTABLE FAN COIL MOD. DT-NH

Concealed horizontal installation, with horizontal air outflow and intake from the rear part.

Code	Model	Cooling capacity (W) (1)	Heating capacity (W) (2)
387030440	DT-NH 01 L	6.820	15.200
387030441	DT-NH 01 R		
387030442	DT-NH 02 L	8.650	18.900
387030443	DT-NH 02 R		
387030444	DT-NH 03 L	10.100	20.000
387030445	DT-NH 03 R		
387030446	DT-NH 04 L	12.000	28.400
387030447	DT-NH 04 R		
387030448	DT-NH 05 L	15.200	35.200
387030449	DT-NH 05 R		
387030450	DT-NH 06 L	17.800	37.200
387030451	DT-NH 06 R		



DT-NH	01	L
-	(1)	(2)

DT-NH = fan coil model  
 (1) Capacity = 01, 02, 03, 04, 05, 06  
 (2) L = left coil connection/R = right coil connection

## DUCTABLE FAN COIL MOD. DTE-NH

Concealed vertical installation, with vertical air outflow and intake from the front part.

Code	Model	Cooling capacity (W) (1)	Heating capacity (W) (2)
387030715	DTE-NH 01 L	6.976	15.569
387030716	DTE-NH 01 R		
387030717	DTE-NH 02 L	8.828	19.313
387030718	DTE-NH 02 R		
387030719	DTE-NH 03 L	10.315	20.452
387030720	DTE-NH 03 R		
387030721	DTE-NH 04 L	12.135	28.739
387030722	DTE-NH 04 R		
387030723	DTE-NH 05 L	15.357	35.586
387030724	DTE-NH 05 R		
387030725	DTE-NH 06 L	17.993	37.629
387030726	DTE-NH 06 R		



DTE-NH	01	L
-	(1)	(2)

DTE-NH = fan coil model  
 (1) Capacity = 01, 02, 03, 04, 05, 06  
 (2) L = left coil connection/R = right coil connection

(1) Cooling: air temp. 27 °C dry bulb, 19 °C wet bulb - temp. - input/output water temp. 7/12 °C  
 (2) Heating: air temp. 20 °C - input/output water temp. 70/60 °C



# RATED TECHNICAL DATA - DT

## TWO-PIPE UNIT - ONE COIL

MODELS			01	02	03
Total cooling capacity (1)		W	6.820	8.650	10.100
Sensible cooling capacity (1)		W	5.300	6.580	7.380
Heating capacity (2a)		W	15.200	18.900	20.000
Heating capacity (2b)		W	7.600	9.450	10.000
Rated air flow (3)		m <sup>3</sup> /h	1.350	1.500	1.450
Water flow rate (4)	Cooling	l/h	1.173	1.488	1.737
	Heating	l/h	1.307	1.625	1.720
Water pressure drop (5)	Cooling	kPa	35,7	39,4	38,4
	Heating	kPa	34,6	36,6	29,4
Sound pressure (ls.-ms.-hs.) (6)		dB(A)	34-43-49	35-44-50	35-44-50
Motors/Fans		N/N	1/1		
Rated power absorption (7)	W		290		
	A		1,3		
Electrical power supply			230 Vac - 1 Ph - 50 Hz		
Cold/hot coil rows		N	3R		4R
Hydraulic fittings		DN	3/4" F		3/4" F
Condensate drainage outlet		mm	20		20

MODELS			04	05	06
Total cooling capacity (1)		W	12.000	15.200	17.800
Sensible cooling capacity (1)		W	9.780	12.100	13.500
Heating capacity (2a)		W	28.400	35.200	37.200
Heating capacity (2b)		W	14.200	17.600	18.600
Rated air flow (3)		m <sup>3</sup> /h	2.750	3.000	2.850
Water flow rate (4)	Cooling	l/h	2.064	2.614	3.062
	Heating	l/h	2.442	3.027	3.199
Water pressure drop (5)	Cooling	kPa	28,0	38,3	30,6
	Heating	kPa	30,6	40,0	26,1
Sound pressure (ls.-ms.-hs.) (6)		dB(A)	37-48-51	38-49-52	38-49-52
Motors/Fans		N/N	1/2		
Rated power absorption (7)	W		560		
	A		2,6		
Electrical power supply			230 Vac - 1 Ph - 50 Hz		
Cold/hot coil rows		N	3R	3R	4R
Hydraulic fittings		DN	3/4" F		
Condensate drainage outlet		mm	20		

Technical data referred to the following conditions:  
standard unit - atmospheric pressure 1013 mbar - electrical power supply 230 VAC/1 Ph/50 Hz.

(1) (2) (3) (4) (5): Rated technical data, ref. air flow rate (3) at maximum speed and with unit with open mouth (external static pressure ESP=0 Pa).

(1) **Cooling:** air temp. 27 °C dry bulb, 19 °C wet bulb - input/output water temp. 7/12 °C - Maximum speed.

(2a) **Heating:** air temp. 20 °C - Input/output water temp. 70/60 °C - Maximum speed.

(2b) **Heating:** air temp. 20 °C - Input/output water temp. 45/40 °C - Maximum speed.

(3) (8) **Air flow rate and static pressure:** rated values measured with casing ref. AMCA210-74 standard Fig.12 and conduit + diaphragm ref. CNR-UNI10023 standard.

(6) **Sound pressure:** sound pressure in free field environment, distance 2 m. Values calculated from sound power measured in reverberation chamber ref. ISO 3741-ISO 3742 standards.

(7) **Electrical data:** values measured with Jokogawa WT110 wattmeter (nominal value = reference value for the design of the electrical system).

# RATED TECHNICAL DATA - DTE

## TWO-PIPE UNIT - ONE COIL

MODELS			01	02	03	
Total cooling capacity (1)		W	6.976	8.828	10.315	
Sensible cooling capacity (1)		W	5.440	6.736	7.561	
Heating capacity (2a)		W	15.569	19.313	20.452	
Heating capacity (2b)		W	7.784	9.656	10.226	
Rated air flow (3)		m <sup>3</sup> /h	1.400	1.550	1.500	
Water flow rate (4)	Cooling	l/h	1.200	1.518	1.774	
	Heating	l/h	1.339	1.661	1.759	
Water pressure drop (5)	Cooling	kPa	37.4	41.1	40.1	
	Heating	kPa	36.3	38.3	30.7	
Sound pressure (ls.-ms.-hs.) (6)		dB(A)	16-37-51	17-39-51	17-39-51	
Engine reference		Ref	1xD180x240, SAM [SWP/FIX.1/10], [SWN/FIX.1/10] 8P, IP42, CL.B, EP+TP, BR, INV180W/CL.1			
Motors/Fans		N/N	1/1			
Rated power absorption (7)		W	180			
		A	1.40			
Electrical power supply			230 Vac - 1 Ph - 50 Hz/Signal 0...10 Vdc			
Cold/hot coil rows		N	3R		4R	
Hydraulic fittings		DN	3/4" F			
Water content		L	1.95	1.96	2.60	
Condensate drainage outlet		mm	20	20	20	
Lower operating limit	ESP = 0 Pa		MAX	1.00	1.00	1.00
			MED	0.63	0.63	0.63
			MIN	0.26	0.26	0.26
<b>REDUCED AIR FLOW RATE</b> Multiplicative coefficients for the definition of "Air Flow/Static Pressure" curves (at 3 speeds MAX-MED-MIN with MAX=10 V, MIN= 1 V) (8)	Ref. Nominal air flow (3)	25 Pa	MAX	0.97	0.97	0.97
			MED	0.61	0.61	0.61
			MIN	0.26	0.26	0.26
		50 Pa	MAX	0.94	0.93	0.94
			MED	0.59	0.59	0.59
			MIN	0.25	0.25	0.25
		75 Pa	MAX	0.90	0.90	0.90
			MED	0.57	0.57	0.57
			MIN	0.24	0.24	0.24
		100 Pa	MAX	0.86	0.85	0.86
			MED	0.54	0.54	0.54
			MIN	0.23	0.23	0.23
		125 Pa	MAX	0.81	0.81	0.81
			MED	0.51	0.51	0.51
			MIN	0.22	0.21	0.21
		150 Pa	MAX	0.76	0.76	0.76
			MED	0.48	0.48	0.48
			MIN	0.20	0.20	0.20
Upper operating limit	ESP (Pa)		MAX	288	288	288
	Qa (x m <sup>3</sup> /h)			x0.15	x0.15	x0.15
	ESP (Pa)		MED	268	268	268
	Qa (x m <sup>3</sup> /h)			x0.14	x0.14	x0.14
	ESP (Pa)		MIN	219	219	219
	Qa (x m <sup>3</sup> /h)			x0.13	x0.13	x0.13

Technical data referred to the following conditions:  
standard unit - atmospheric pressure 1013 mbar - electrical power supply 230 VAC/1 Ph/50 Hz.

(1) (2) (3) (4) (5): Rated technical data, ref. air flow rate (3) at maximum speed and with unit with open mouth (external static pressure ESP=0 Pa).

(1) **Cooling**: air temp. 27 °C dry bulb, 19 °C wet bulb - input/output water temp. 7/12 °C - Maximum speed.

(2a) **Heating**: air temp. 20 °C - Input/output water temp. 70/60 °C - Maximum speed.

(2b) **Heating**: air temp. 20 °C - Input/output water temp. 45/40 °C - Maximum speed.

(1) (2) (9) **Cooling and Heating capacity**: Data calculated by SW and measurements made in calorimetric room ref. UNI 7940 part 1°-2°, UNI-EN 1397/2001 standards.

(3) (8) **Air flow rate and static pressure**: rated values measured with casing ref. AMCA210-74 standard Fig.12 and conduit + diaphragm ref. CNR-UNI10023 standard.

(6) **Sound pressure**: sound pressure in free field environment, distance 2 m. Values calculated from sound power measured in reverberation chamber ref. ISO 3741-ISO 3742 standards.

(7) **Electrical data**: values measured with Jokogawa WT110 wattmeter (nominal value = reference value for the design of the electrical system).

# RATED TECHNICAL DATA - DTE

## TWO-PIPE UNIT - ONE COIL

MODELS			04	05	06	
Total cooling capacity (1)		W	12.135	15.357	17.993	
Sensible cooling capacity (1)		W	9.907	12.244	13.669	
Heating capacity (2a)		W	28.739	35.586	37.629	
Heating capacity (2b)		W	14.370	17.793	18.814	
Rated air flow (3)		m <sup>3</sup> /h	2.800	3.050	2.900	
Water flow rate (4)	Cooling	l/h	2.087	2.641	3.095	
	Heating	l/h	2.472	3.060	3.236	
Water pressure drop (5)	Cooling	kPa	28.7	39.2	31.3	
	Heating	kPa	31.3	40.9	26.7	
Sound pressure (ls.-ms.-hs.) (6)		dB(A)	18-41-52	19-42-53	19-42-53	
Engine reference		Ref	2xD180x240, CYP75% [SWP/FIX.1/10], [SWN/FIX.1/10] 8P, IP20, CL.B, EP+TP, BR, INV550W/CL.1			
Motors/Fans		N/N	1/2			
Rated power absorption (7)		W	400			
		A	1.80			
Electrical power supply			230 Vac - 1 Ph - 50 Hz/Signal 0...10 Vdc			
Cold/hot coil rows		N	3R	4R		
Hydraulic fittings		DN	3/4" F			
Water content		L	2.86	2.87	3.82	
Condensate drainage outlet		mm	20		20	
Lower operating limit	ESP = 0 Pa		MAX	1.00	1.00	1.00
			MED	0.62	0.62	0.62
			MIN	0.23	0.23	0.23
<b>REDUCED AIR FLOW RATE</b> Multiplicative coefficients for the definition of "Air Flow/Static Pressure" curves (at 3 speeds MAX-MED-MIN with MAX=10 V, MIN= 1 V) (8)	Ref. Nominal air flow (3)	25 Pa	MAX	0.95	0.95	0.95
			MED	0.59	0.59	0.59
			MIN	0.22	0.22	0.22
		50 Pa	MAX	0.91	0.91	0.91
			MED	0.56	0.56	0.56
			MIN	0.21	0.21	0.21
		75 Pa	MAX	0.86	0.86	0.86
			MED	0.53	0.53	0.53
			MIN	0.20	0.20	0.20
		100 Pa	MAX	0.81	0.81	0.81
			MED	0.50	0.50	0.50
			MIN	0.19	0.19	0.19
		125 Pa	MAX	0.75	0.75	0.75
			MED	0.46	0.46	0.46
			MIN	0.18	0.18	0.18
		150 Pa	MAX	0.68	0.68	0.68
			MED	0.42	0.42	0.42
			MIN	0.16	0.16	0.16
Upper operating limit	ESP (Pa)		MAX	221	221	221
	Qa (x m <sup>3</sup> /h)			x0.13	x0.13	x0.13
	ESP (Pa)		MED	206	206	206
	Qa (x m <sup>3</sup> /h)			x0.13	x0.13	x0.13
	ESP (Pa)		MIN	181	181	181
	Qa (x m <sup>3</sup> /h)			x0.12	x0.12	x0.12

Technical data referred to the following conditions:  
standard unit - atmospheric pressure 1013 mbar - electrical power supply 230 VAC/1 Ph/50 Hz.

(1) (2) (3) (4) (5): Rated technical data, ref. air flow rate (3) at maximum speed and with unit with open mouth (external static pressure ESP=0 Pa).

(1) **Cooling**: air temp. 27 °C dry bulb, 19 °C wet bulb - input/output water temp. 7/12 °C - Maximum speed.

(2a) **Heating**: air temp. 20 °C - Input/output water temp. 70/60 °C - Maximum speed.

(2b) **Heating**: air temp. 20 °C - Input/output water temp. 45/40 °C - Maximum speed.

(1) (2) (9) **Cooling and Heating capacity**: Data calculated by SW and measurements made in calorimetric room ref. UNI 7940 part 1°:2°, UNIFEN 1397/2001 standards.

(3) (8) **Air flow rate and static pressure**: rated values measured with casing ref. AMCA210-74 standard Fig.12 and conduit + diaphragm ref. CNR-UNI10023 standard.

(6) **Sound pressure**: sound pressure in free field environment, distance 2 m. Values calculated from sound power measured in reverberation chamber ref. ISO 3741-ISO 3742 standards.

(7) **Electrical data**: values measured with Jokogawa WT110 wattmeter (nominal value = reference value for the design of the electrical system).



## REDUCTION OF THE COOLING/HEATING CAPACITY (in relation to the air flow reduction)

Air flow rate (9)	1.00	0.95	0.90	0.85	0.80	0.75	0.70	0.65
Total cooling capacity	1.00	0.97	0.95	0.92	0.89	0.87	0.84	0.81
Sensible cooling capacity	1.00	0.97	0.93	0.90	0.86	0.83	0.79	0.76
Heating capacity	1.00	0.97	0.94	0.91	0.87	0.84	0.81	0.77

Air flow rate (9)	0.60	0.55	0.50	0.45	0.40	0.35	0.30	0.25
Total cooling capacity	0.77	0.74	0.71	0.67	0.63	0.59	0.55	0.50
Sensible cooling capacity	0.72	0.68	0.64	0.60	0.55	0.51	0.46	0.41
Heating capacity	0.74	0.70	0.66	0.62	0.58	0.53	0.49	0.44

## TABLE OF NET WEIGHTS MOD. DT/DTE (TWO-PIPE UNIT - ONE COIL) IN KG

Products/Models	01	02	03	04	05	06
DT-NH	37.0	38.0	40.0	52.0	54.0	57.0
DTE-NH	37.0	38.0	40.0	52.0	54.0	57.0

# USEFUL STATIC PRESSURE/ WATER FLOW RATE DIAGRAMS

Key

- LFS Upper operating limit
- LFI Lower operating limit
- Qa1 ESP/Qa curve at the maximum speed
- Qa2 ESP/Qa curve at the average speed
- Qa3 ESP/Qa curve at the minimum speed
- I1 I/Qa curve at the maximum speed
- I2 I/Qa curve at the average speed
- I3 I/Qa curve at the minimum speed

Model DT 01

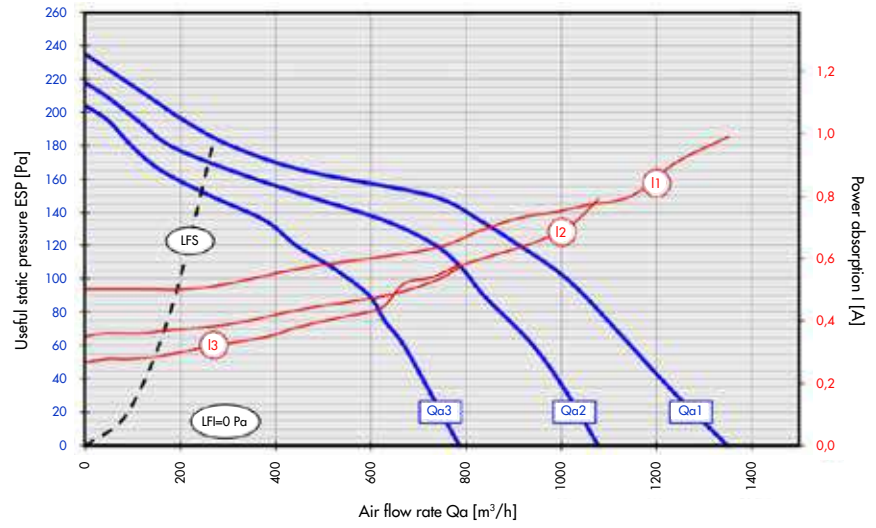

Model DT 02

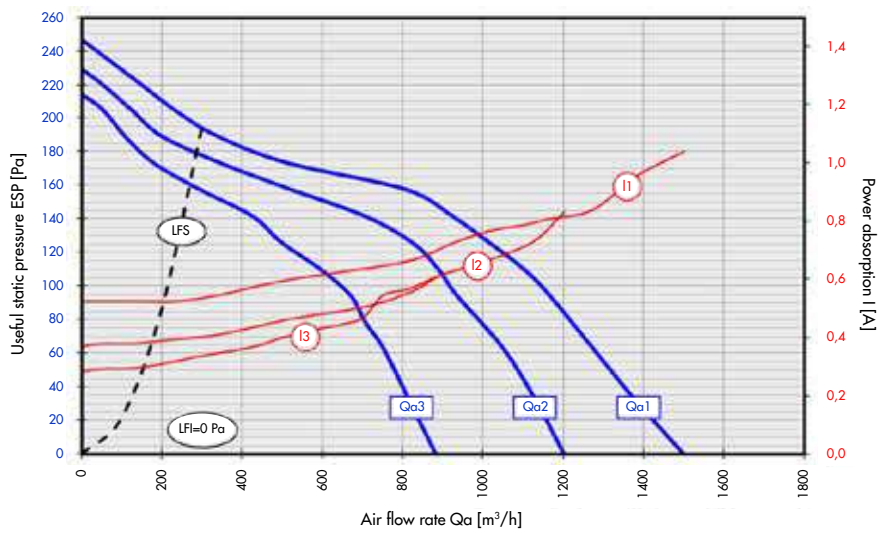

Model DT 03

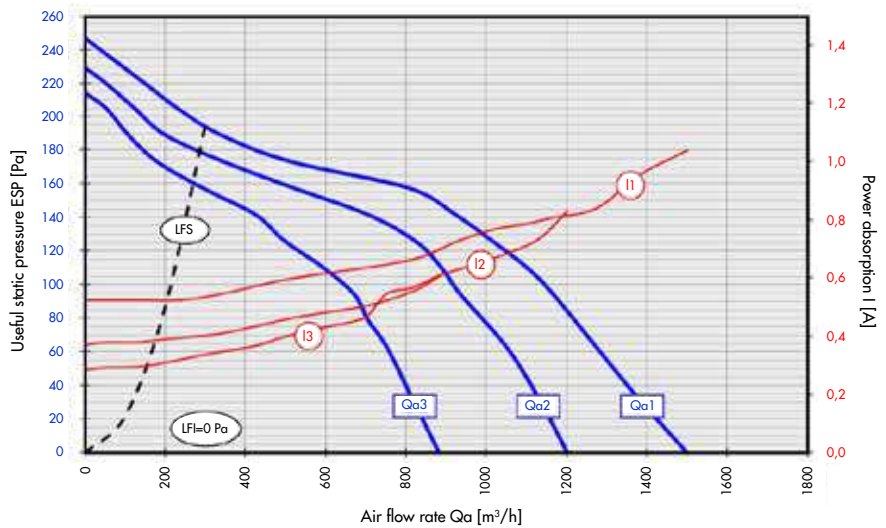

Model DT 04

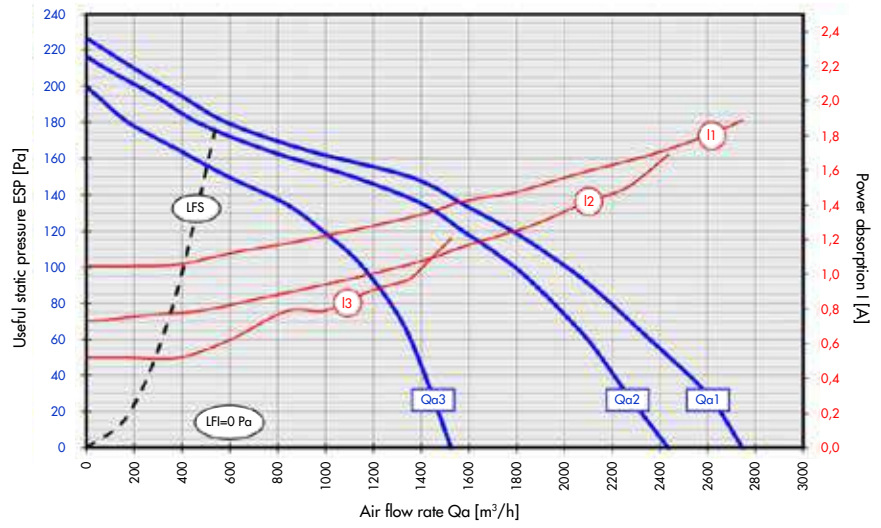

Model DT 05

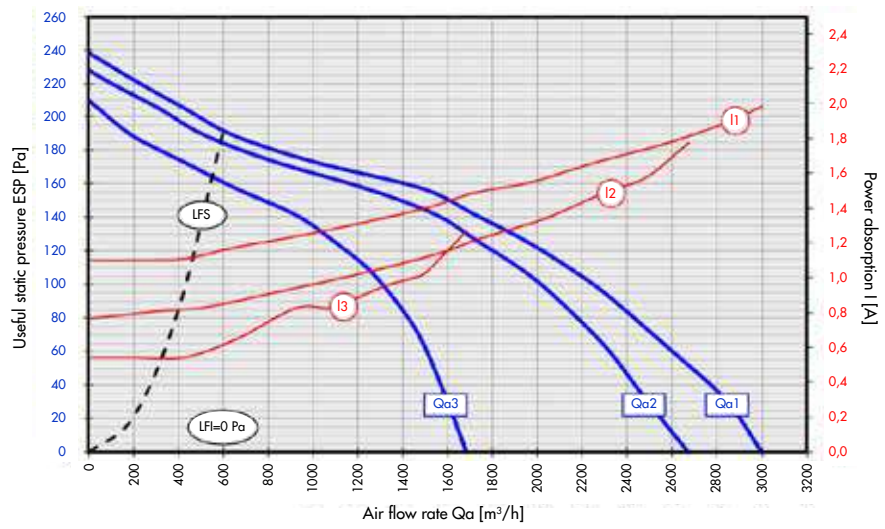

Model DT 06

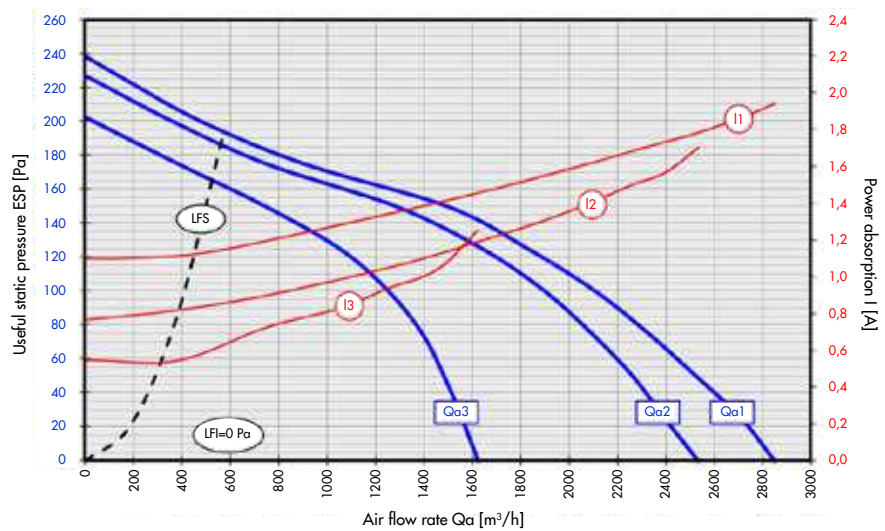

# USEFUL STATIC PRESSURE/ WATER FLOW RATE DIAGRAMS

- KEY
- LS.E Upper operating limit
  - Hi AC unit curve at maximum speed
  - Me AC unit curve at average speed
  - Lo AC unit curve at minimum speed
  - 10 EC unit curve with 10 Vdc signal (maximum speed)
  - 1 EC unit curve with 1 Vdc signal (maximum speed)
  - M EC unit curve at average speed

Model DTE 01

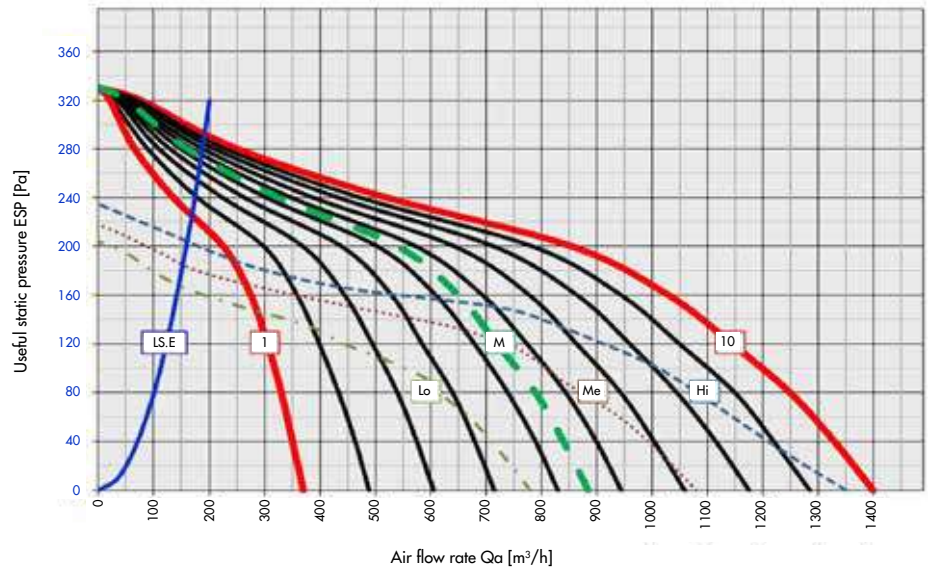

Model DTE 02

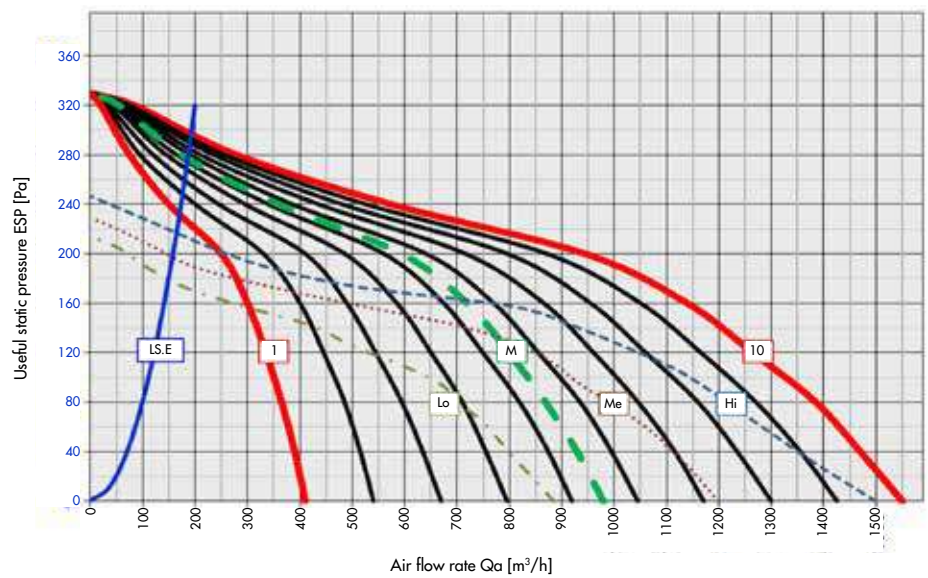

Model DTE 03

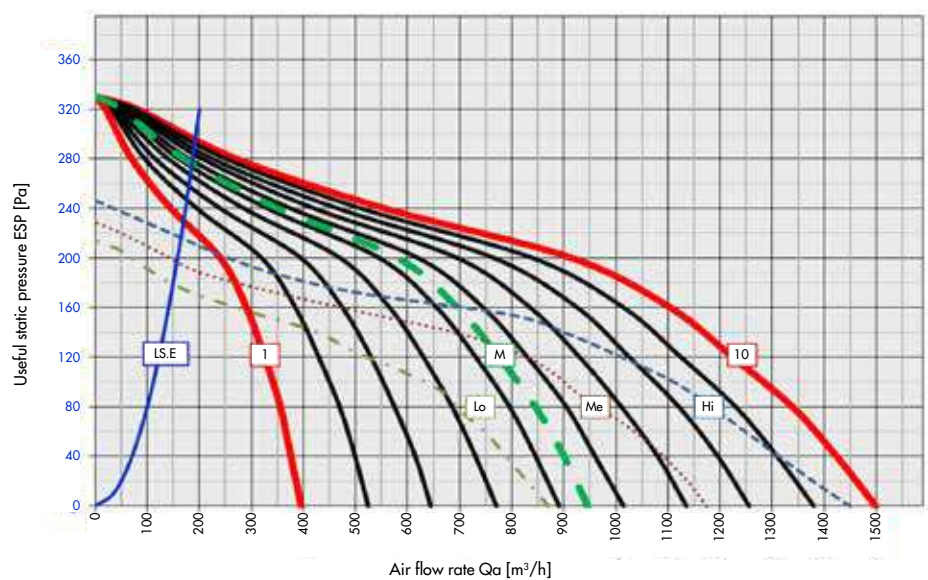



## KEY

- LS.E Upper operating limit
- Hi AC unit curve at maximum speed
- Me AC unit curve at average speed
- Lo AC unit curve at minimum speed
- 10 EC unit curve with 10 Vdc signal (maximum speed)
- 1 EC unit curve with 1 Vdc signal (maximum speed)
- M EC unit curve at average speed

## Model DTE 04

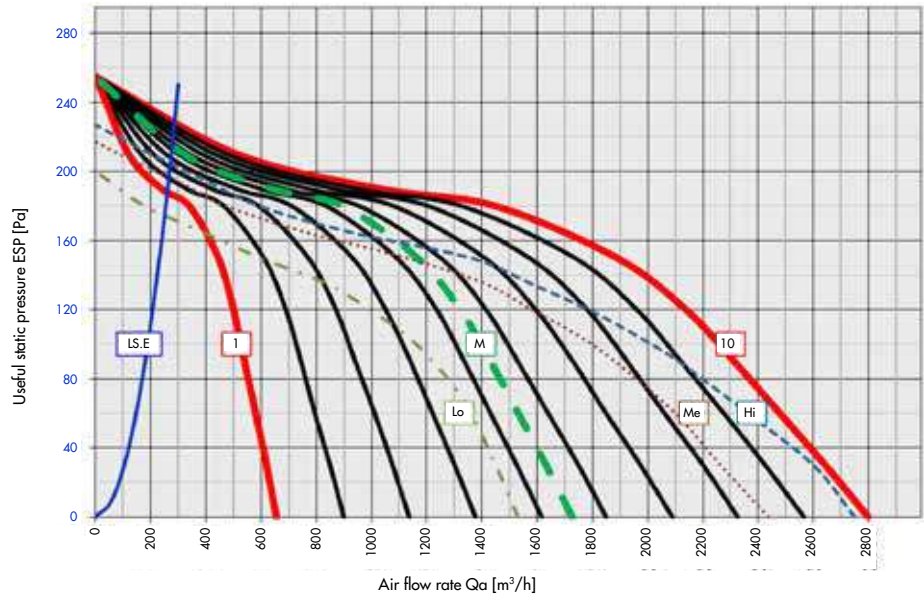

## Model DTE 05

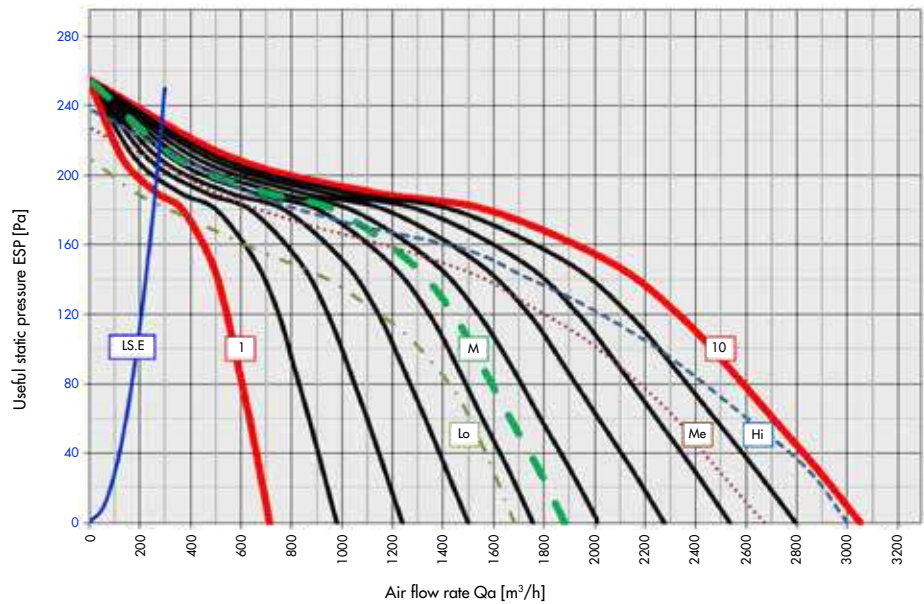

## Model DTE 06

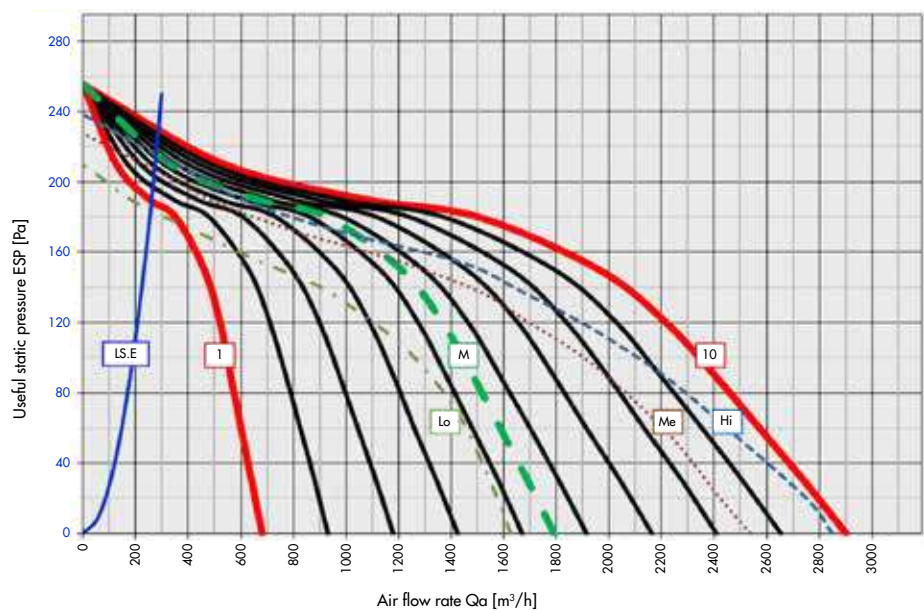

# DIMENSIONAL DRAWINGS



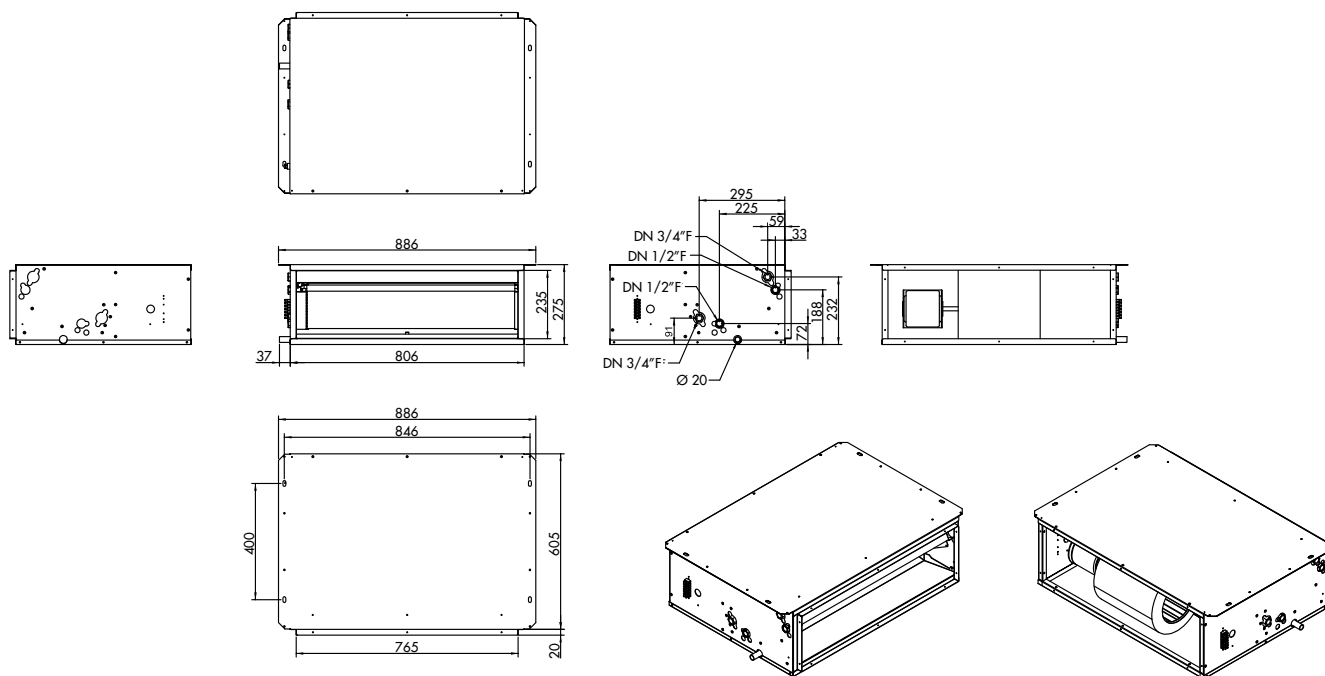



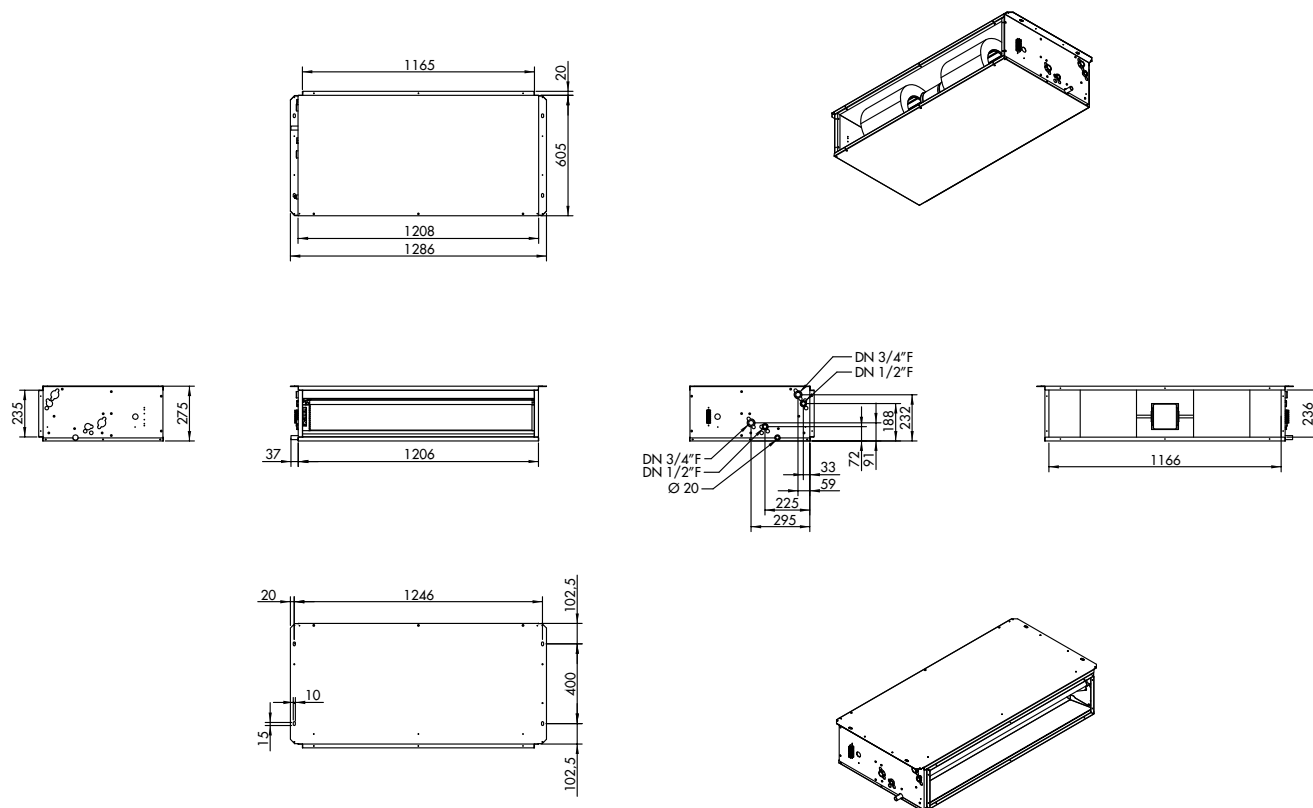

## Models DT-NH 01...03/DTE-NH 01...03







## Models DT-NH 04...06/DTE-NH 04...06



# ACCESSORIES

WIRED CONTROL UNITS AND REMOTE CONTROLS				
	Code	Model	Description	Applicability
	387030468	CL01	IP20 terminal block (only if a wired control unit is necessary) - INCLUDED	All
	387030469	SWC22	Simplified thermostat for 2/4-pipe fan coil units	DT
	387030470	SWC25	Programmable thermostat for 2/4-pipe fan coil units with display and with advanced functions	DT
	387030564	SWC26	Thermostat for 2/4-pipe fan coil units, programmable, with display and 0...10 VDC output	All
	387030471	EIX01	Electronic interface for fan coil unit thermostats: enables a single thermostat to control up to 4 fan coil units. Housed in a 6-module container for DIN rail	DT
	387030472	IRC01	IR remote control. Kit inclusive of motherboard, air sensor, water sensor and IR receiver	DT
	387030466	MTT32	Minimum hot water temperature thermostat (calibrated to 32 °C)	All
	387030467	WTS4	Water temperature sensor (type NTC 10.000 ohm @25 °C ±2 with cable L=1 m)	SWC25 SWC26

# ACCESSORIES





ADDITIONAL SECTIONS				
	Code	Model	Description	Applicability
	387030575	FSC-Z1	Ductable air filter section with flat air filter and frame in 4 parts, removable from all directions - grade EU3 filtration (Eurovent)	DT-NH 01...03 DTE-NH 01...03
	387030576	FSC-Z2		DT-NH 04...06 DTE-NH 04...06
	387030577	FSD-Z1	Ductable air filter section with high-efficiency undulated air filter and frame in 4 parts, removable from all directions - grade EU5 filtration (Eurovent)	DT-NH 01...03 DTE-NH 01...03
	387030578	FSD-Z2		DT-NH 04...06 DTE-NH 04...06
	387030579	FSM-Z1	Outdoor/indoor air mixing section (outdoor air 0-33% - indoor air 100-67% or inversely). Shutters paired with manual controls and configured for being operated with a motor	DT-NH 01...03 DTE-NH 01...03
	387030580	FSM-Z2		DT-NH 04...06 DTE-NH 04...06
	387030581	SM01	ON/OFF 230 V servo motor for shutter	All
	387030582	JS-Z1-M	Vibration damping joint, without flanges	DT-NH 01...03 DTE-NH 01...03
	387030583	JS-Z2-M		DT-NH 04...06 DTE-NH 04...06
	387030584	FSM-Z1-M	Plenum with round conduits 3x200/180/160 mm	DT-NH 01...03 DTE-NH 01...03
	387030585	FSM-Z2-M	Plenum with round conduits 5x200/180/160 mm	DT-NH 04...06 DTE-NH 04...06



VARIOUS				
	Code	Model	Description	Applicability
	387030586	3WV05	3/4" M three-way valve with PWM-ON/OFF actuator, 230 V (2 pipes)	DT-NH 01...03 DTE-NH 01...03
	387030587	3WV06		DT-NH 04...06 DTE-NH 04...06
	387030588	KCP-05	Kit with 90° copper pipes, 3/4" F ball valve and 3/4" F retainer, solution for three-way valves	All
	387030589	2WV05	3/4" M two-way valve with PWM-ON/OFF actuator, 230 V (2 pipes)	DT-NH 01...03 DTE-NH 01...03
	387030590	2WV06		DT-NH 04...06 DTE-NH 04...06
	387030591	KCP-08	Kit with 90° copper pipes, 3/4" F ball valve and 3/4" F retainer, solution for two-way valves	All
	387030592	HB02	Auxiliary drain pan with thermal insulation, made of galvanised plate	All
	387030594	CP05	Condensate discharge pump with alarm contact	All

# ACCESSORIES FOR INTEGRATION WITH BMS SYSTEMS

## E SANITISATION DEVICE

Components for BMS			
	Code	Model	Description
	387030596	PCB-U1.V	Universal circuit board for AC units (asincrona 230 V asynchronus - 3 speeds) or ECMs (electronic/ brushless 230 VAC 0-10 VDC signal). MODBUS+TCP-IP/WEB/03 communication protocol. Without air temperature sensor
	387030597	ATS2	Air temperature sensor (mandatory)
	387030598	WTS2	Water temperature sensor for SUMMER/WINTER changeover (only for two-pipe units)
	387030599	WTS3	Water temperature sensor for measuring minimum hot water temperature
	387030600	SWC06	Simplified wall-mounted digital control unit for exteriors

Accessories for BMS system should not be used with FCW models where the Modbus communication port is already positioned inside the optional wired control.

BIOXIGEN® SANITISATION DEVICE				
	Code	Model	Description	Applicability
	387030601	KSB	Bioxigen® kit equipped with plastic box, power cable, external electrode, 3 self-tapping screws 3.9x13.3 "Mammut" terminals with 2 self-tapping screws 3.5x19 + L/N/PE label. Supplied installed on the unit.	All

# NOTES



# HIGH-WALL

---

Model FCW

# HIGH-WALL

## MAIN FEATURES MOD. FCW



### IRC03

Infrared remote control supplied with the unit

### COVERING BOX

Covering boxes with new and visually appealing design, equipped with LCD. Automatic distribution of the air diversified into cooling and heating for the utmost comfort. The shape of the fan ensures a highly efficient, low-noise air flow.

### HEAT EXCHANGER

High-efficiency heat exchange coil with copper pipe and aluminium flaps locked by means of mechanical expansion.

One coil for 2-pipe system. Coils tested at 30 bar operating pressure, suitable for working with water up to a maximum pressure of 15 bar.

The coils are suitable for operating with:

- high-temperature water (boiler)
- low-temperature water (condensing boiler, heat pump, etc.)
- cold water (chiller and/or industrial processes)
- water supplemented with glycol

Blue hydrophilic flaps and copper pipes equipped with special ridges that increase the fluid's turbulence and sensibly increase the heat exchange.

### CONTROL UNITS AND CONTROLS

Remote control supplied as a standard feature with the unit. Wired control unit available as an optional accessory and equipped with MODBUS protocol for communication with the BMS. Programming of the unit switching on and off. A single wired control unit can manage up to 10 fan coil units. Equipped with a sensor for pairing with a remote control.

### VALVES

Two-way or three-way valves are available as accessories, NOT for enclosed installation.

### HIGH-WALL FAN COIL MOD. FCW

Code	Model	Cooling capacity (W) (1)	Heating capacity (W) (2)
387030228	FCW 01	2.100	4.264
387030229	FCW 02	2.600	5.914
387030230	FCW 03	3.500	7.807
387030231	FCW 04	4.200	8.642

FCW	01
-	(1)

FCW = fan coil model  
(1) Capacity = 01, 02, 03, 04

(1) **Cooling:** air temp. 27 °C dry bulb, 19 °C wet bulb - input/output water temp. 7/12 °C - Maximum speed.  
(2) **Heating:** air temp. 20 °C - Input/output water temp. 70/60 °C - Maximum speed.

# RATED TECHNICAL DATA MOD. FCW

## TWO-PIPE UNIT - ONE COIL

MODELS			01	02	03	04
Total cooling capacity (1)		W	2.100	2.600	3.500	4.200
Sensible cooling capacity (1)		W	1.600	2.000	2.400	3.000
Heating capacity (2a)		W	4.264	5.914	7.807	8.642
Heating capacity (2b)		W	2.132	2.957	3.903	4.321
Rated air flow (3)		m <sup>3</sup> /h	340	510	680	850
Water flow rate (4)	Cooling	l/h	360	432	612	720
	Heating	l/h	360	504	684	756
Water pressure drop (5)	Cooling	kPa	18.0	26.0	38.0	46.0
	Heating	kPa	5.0	9.0	16.0	13.0
Sound pressure (ls.-ms.-hs.) (6)		dB(A)	21-22-27-31	21-28-35-36	26-34-42-43	30-39-46-48
Motors/Fans		N/N	1/1	1/1	1/1	1/1
Rated power absorption (7)		W	10	20	30	40
		A	0.052	0.078	0.126	0.187
Electrical power supply			230 Vac - 1 Ph - 50 Hz			
Cold/hot coil rows		N	2	2	2	2
Hydraulic fittings		DN	1/2"	1/2"	1/2"	1/2"
Condensate drainage outlet		mm	15.6			

Technical data referred to the following conditions:  
 standard unit - atmospheric pressure 1013 mbar - electrical power supply 230 VAC/1 Ph/50 Hz.

(1) (2) (3) (4) (5): Rated technical data, ref. air flow rate (3) at maximum speed and with unit with open mouth (external static pressure ESP=0 Pa).

(1) **Cooling:** air temp. 27 °C dry bulb, 19 °C wet bulb - input/output water temp. 7/12 °C - Maximum speed.

(2a) **Heating:** air temp. 20 °C - Input/output water temp. 70/60 °C - Maximum speed.

(2b) **Heating:** air temp. 20 °C - Input/output water temp. 45/40 °C - Maximum speed.

(3) (8) **Air flow rate and static pressure:** rated values measured with casing ref. AMCA210-74 standard Fig.12 and conduit + diaphragm ref. CNR-UNI10023 standard.

(6) **Sound pressure:** sound pressure in free field environment, distance 2 m. Values calculated from sound power measured in reverberation chamber ref. ISO 3741-ISO 3742 standards.

(7) **Electrical data:** values measured with Jokogawa WT110 wattmeter (nominal value = reference value for the design of the electrical system).

## TABLE OF NET WEIGHTS MOD. FCW (TWO-PIPE UNIT - ONE COIL) IN KG

Products/Models	01	02	03	04
FCW	10.5	10.5	10.5	12.5

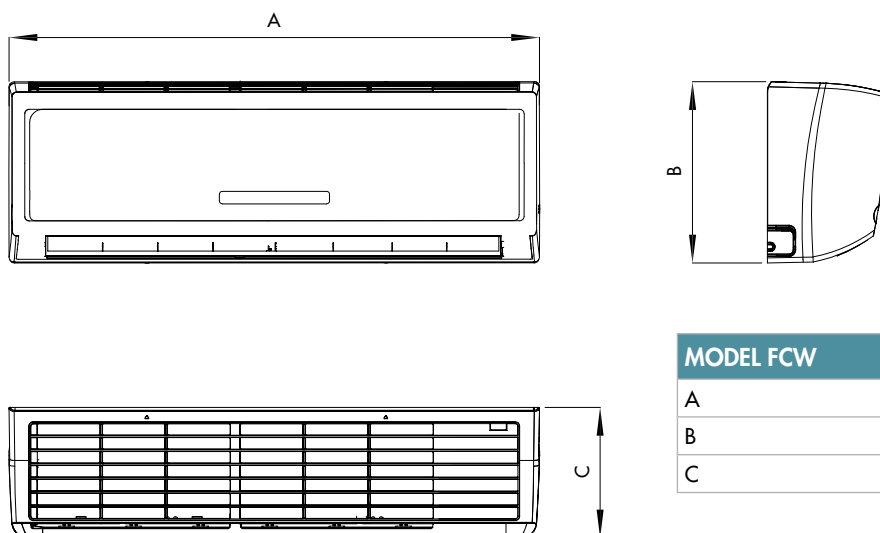

## DIMENSIONAL DRAWING MOD. FCW 01-02-03 AND MOD. FCW 04



MODEL FCW	01	02	03	04
A		845		970
B		289		360
C		209		280

# ACCESSORIES

WIRED CONTROL UNIT				
	Code	Model	Description	Applicability
	387030232	SWC17	Wired control unit for wall-mounted fan coil units	All

VALVE KIT				
	Code	Model	Description	Applicability*
	387030233	KIT VALV 4V: VTX13+ MVX22R+ 54304-04	VTX13 = four-way valves 1/2" M, Kvs=1.6 (2 pipes)  MVX22R = electro-thermal ON/OFF actuator, 230 V, 140 N  54304-04 = casing for VTX13	All
	387030234	KIT VALV 2V: VSX13+ MVX22R+ 54304-01	VSX13 = two-way valves 1/2" M, Kvs=1.6 (2 pipes)  MVX22R = electro-thermal ON/OFF actuator, 230 V, 140 N  54304-01 = casing for VSX13	All

\*Not for installazion inside the unit.







# SELECTION SOFTWARE:



 The FORMULA software programme helps to select the most suitable hydronic terminal units for the various types of systems (residential, tertiary, etc.).



 It enables subjects operating in the thermotechnical and plant engineering sector to verify the operating conditions of a specific model or search for the most functional units on the basis of personalised parameters.



 The results can then be easily exported and shared.

 <b>Argoclima S.p.A.</b> Via Alfeno Varo, 35 - 25020 Alfanello (BS) - ITALY Tel. +39 0331 755111 ; Fax +39 0331 755501										
 <b>Formula 1.5</b> Linea Prodotti: Ventilconvettori Products Line: Fan coils										
Type: FCT	Centrifugal Fan Coils						Circuit type: 2 Pipes			
Model	FCT 01	FCT 02	FCT 03	FCT 04	FCT 05	FCT 06	FCT 07	FCT 08	FCT 09	
Fan Speed	MAX	MAX	MAX	MAX	MAX	MAX	MAX	MAX	MAX	
<b>Cooling</b>										
Air temperature with D.B.	°C	27.0	27.0	27.0	27.0	27.0	27.0	27.0	27.0	
Air temperature with W.B.	°C	19.0	19.0	19.0	19.0	19.0	19.0	19.0	19.0	
Relative humidity	%	47.4	47.4	47.4	47.4	47.4	47.4	47.4	47.4	
Input Water Temp.	°C	7.0	7.0	7.0	7.0	7.0	7.0	7.0	7.0	
Output Water Temp.	°C	12.0	12.0	12.0	12.0	12.0	12.0	12.0	12.0	
Water flow	l/h	258	344	435	519	645	731	949	1,104	
Water pressure drop	MPa	13.1	16.3	18.5	20.8	22.6	24.1	24.5	28.8	
Total cooling capacity	W	1,500	2,000	2,530	3,020	3,750	4,250	5,520	6,420	
	Frig./h	1,290	1,720	2,176	2,597	3,225	3,655	4,747	5,521	
Sensible cooling capacity	W	1,290	1,620	2,070	2,310	2,870	3,230	4,330	4,800	
	Frig./h	1,109	1,393	1,780	1,987	2,468	2,778	3,724	4,128	
<b>General characteristics</b>										
Chool in weight	%	0.0	0.0	0.0	0.0	0.0	0.0	0.0	0.0	
Altitude a.s.l.	m	0.0	0.0	0.0	0.0	0.0	0.0	0.0	0.0	
Air flow	m³/h	370	400	500	550	670	720	1,000	1,050	
Air pressure drops	Pa	0	0	0	0	0	0	0	0	
Sound levels	dBA	38	38	44	45	37	37	43	45	
	NC	32	33	38	38	32	33	38	42	
	NR	33	34	40	40	32	34	40	44	
Max input power	W	55	55	80	80	80	80	145	180	
Max input current	A	0.25	0.25	0.35	0.35	0.35	0.35	0.65	0.80	
<b>Version</b> - General Report (versions / dimensions / weights not indicated)										
Length	mm	0	0	0	0	0	0	0	0	
Width	mm	0	0	0	0	0	0	0	0	
Depth	mm	0	0	0	0	0	0	0	0	
Weight	Kg	0	0	0	0	0	0	0	0	

FANCOILS

 The software programme is available in several languages to further facilitate its use.





# X3 AIR CONDITIONING

---

X3 SPLIT: residential single and multisplit air conditioners DC Inverter R32

X3 PACKAGE: commercial single split air conditioners DC Inverter R32

HIGH-CAPACITY DUCTED: air conditioners with high external static pressure - R410A

X3 FS: floor standing air conditioners

LOW AMBIENT: air conditioner for special application

Air conditioners without OUTDOOR UNIT and ULISSE ECO

# HIGH WALL - single split air conditioners

## MAIN FEATURES



(Standard)  
Infrared remote controller



(Optional)  
Wired controller with weekly timer

3 sleep modes	3D airflow	Cold air prevention	LED	Timer	Intelligent defrosting	Auto+ X-fan	Turbo "Turbo" function	Auto diagnosis	Auto restart memory	7 Fan speeds
Mono&multi compatible	-15 °C Min. temp. heating	-15 °C Min. temp. cooling	8 °C 8 °C heating	iFeel	Save energy	Child lock	Wifi WiFi control	Cold plasma	Wired controller (optional)	Door control (optional)

**A<sup>++</sup>** Cooling

**A<sup>+</sup>** Heating (average season)

**A<sup>+++</sup>** Heating (warmer season)

Model		Code	Nominal (min.-max.) cooling capacity (kW)	Nominal (min.-max.) heating capacity (kW)
Indoor unit model	X3I ECO PLUS 27 HL WF	398000817	2.70 (0.80-3.80)	3.00 (0.90-4.25)
Outdoor unit model	X3I ECO PLUS 27 SH	398000818		
Indoor unit model	X3I ECO PLUS 35 HL WF	398000819	3.51 (0.90-4.40)	3.81 (0.90-4.70)
Outdoor unit model	X3I ECO PLUS 35 SH	398000820		
Indoor unit model	X3I ECO PLUS 52 HL WF	398000821	5.20 (1.00-6.10)	5.60 (1.10-6.60)
Outdoor unit model	X3I ECO PLUS 52 SH	398000822		
Indoor unit model	X3I ECO PLUS 70 HL WF	398000823	7.10 (2.00-8.85)	7.80 (1.80-9.45)
Outdoor unit model	X3I ECO PLUS 70 SH	398000824		



## LONG DISTANCE WIFI

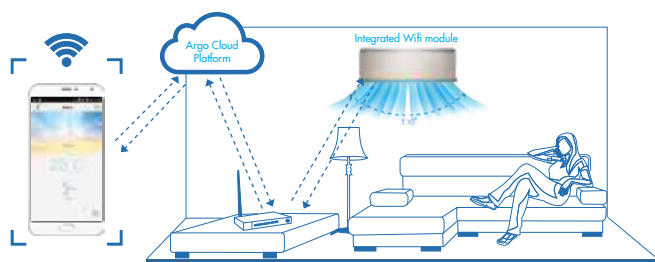

Thanks to the integrated remote WiFi module it is possible to control the units operation via the APP on your smartphone, switch on/off the unit, select the desired mode and temperature, to program your comfort at any time, even when you aren't at home.

## iFEEL FUNCTION



The sensor inside the remote controller perceives the temperature in the environment and transmits the signal to the indoor unit. Thus the indoor unit can adjust air flow volume and temperature to grant the comfort exactly where the remote control is placed.

## AIR PURIFICATION SYSTEM

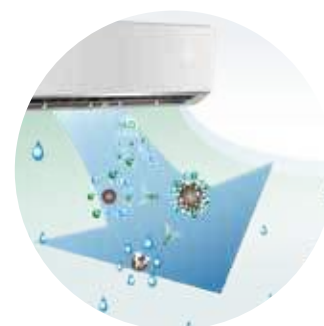

It grants effective sterilization of air removing over 90% of bacteria. It removes odors. The air quality is improved thanks to the emission of many negative oxygen ions.

## INTELLIGENT AUTO RESTART



After power failure, the unit automatically restarts keeping last function settings. (Memory function)

## SOFT START



The startup energy consumption is reduced to lower not to interfere with the use of the other appliances.

# TECHNICAL DATA

MODEL		X3I ECO PLUS 27		X3I ECO PLUS 35		
Indoor unit model		X3I ECO PLUS 27 HL WF		X3I ECO PLUS 35 HL WF		
Outdoor unit model		X3I ECO PLUS 27 SH		X3I ECO PLUS 35 SH		
		Units	Cooling	Heating	Cooling	Heating
Nominal (min.-max.) capacity (EN14511)	kW	2.70 (0.80-3.80)	3.00 (0.90-4.25)	3.51 (0.90-4.40)	3.81 (0.90-4.70)	
	BTU/h	9200	10240	12000	1300	
EER/COP (EN14511)		3.88	4.29	3.65	4.00	
Design Load [Pdesign c/Pdesign h (Average/Warmer/Colder)] (EN14825)*	kW	2.7	2.7/3.0/4.0	3.5	3.2/3.3/4.5	
Seasonal efficiency ratio [SEER/SCOP (Average/Warmer/Colder)] (EN14825)*		7.5	4.2/5.3/3.4	7.1	4.1/5.2/3.1	
Energy efficiency class*		A++	A+/A+++/A	A++	A+/A+++/B	
Annual energy consumption [C/H (Average/Warmer/Colder)]*	kWh/annum	126	900/792/2471	173	1093/888/3048	
Air flow rate indoor (sh.-h.-mh.-m.-ml.-l.-sl.)	m <sup>3</sup> /h	610-570-540-470-440-420-390		700-650-600-540-480-420-360		
Dehumidification	l/h	0.8		1.4		
Fan speeds (Indoor/Outdoor)	n°	7/2		7/2		
Sound pressure Indoor (sh.-h.-mh.-m.-ml.-l.-sl.)	dB(A)	38-36-34-31-29-27-25		42-38-35-32-29-26-25		
Sound pressure Outdoor (h.)	dB(A)	50		52		
Sound power Indoor (sh.-h.-mh.-m.-ml.-l.-sl.)	dB(A)	54-48-46-43-41-39-37		57-50-47-44-41-38-37		
Sound power Outdoor (h.)	dB(A)	61		63		
Power supply	V/Ph/Hz	220-240V~/1/50		220-24V~/1/50		
Power input nominal (min.-max)	kW	0.695 (0.10-1.30)	0.700 (0.15-1.40)	0.962 (0.22-1.40)	0.953 (0.22-1.55)	
Compressor type		Rotary DC Inverter		Rotary DC Inverter		
Refrigerant type		R32		R32		
Refrigerant charge	kg/T.CO <sub>2</sub> eq.	0.53/0.357		0.57/0.384		
Liquid pipe diameter	mm (inch)	6.35 (1/4")		6.35 (1/4")		
Gas pipe diameter	mm (inch)	9.52 (3/8")		9.52 (3/8")		
Min.-max. pipe lenght with gas standard charge	m	3-5		3-5		
Max. pipe lenght	m	15		15		
Additional refrigerant charge	g/m	16		16		
Max. height between units (outdoor on top)	m	10		10		
Max. height between units (indoor on top)	m	10		10		
Net dimension Indoor (H./W./D.)	mm	289/845/209		289/845/209		
Net dimension Outdoor (H./W./D.)	mm	555/732/330		555/732/330		
Net weight Indoor/Outdoor	kg	10.5/24.5		11/24.5		

OPERATING RANGE: outdoor temperature  
Cooling mode: from -15 °C to +50 °C  
Heating mode: from -15 °C to +30 °C  
RANGE OF INDOOR TEMPERATURE ADJUSTMENT: from 16 to 30 °C

\*Data declared in compliance with EU Regulation no. 206/2012, as regards to Ecodesign requirements for air conditioners and comfort fans, and EU Regulation no. 626/2011, concerning the energy labelling of air conditioners, and tested according to standard EN14825.



MODEL		X3I ECO PLUS 52		X3I ECO PLUS 70	
Indoor unit model		X3I ECO PLUS 52 HL WF		X3I ECO PLUS 70 HL WF	
Outdoor unit model		X3I ECO PLUS 52 SH		X3I ECO PLUS 70 SH	
Units		Cooling	Heating	Cooling	Heating
Nominal (min.-max.) capacity (EN14511)	kW	5.20 (1.00-6.10)	5.60 (1.10-6.60)	7.10 (2.00-8.85)	7.80 (1.80-9.45)
	BTU/h	17800	19100	24200	26600
EER/COP (EN14511)		3.30	3.90	3.50	3.90
Design Load [P <sub>design c</sub> /P <sub>design h</sub> (Average/Warmer/Colder)] (EN14825)*	kW	5.2	4.2/4.3/5.0	7.1	5.6/5.7/6.3
Seasonal efficiency ratio [SEER/SCOP (Average/Warmer/Colder)] (EN14825)*		7.1	4.2/5.7/3.4	7.0	4.2/5.4/3.4
Energy efficiency class*		A++	A+/A+++/A	A++	A+/A+++/A
Annual energy consumption [C/H (Average/Warmer/Colder)]*	kWh/annum	256	1400/1056/3088	355	1867/1478/3891
Air flow rate indoor (sh.-h.-mh.-m.-ml.-l.-sl.)	m <sup>3</sup> /h	850-750-680-610-570-520-460		1250-1100-1000-950-900-850-800	
Dehumidification	l/h	1.9		2.4	
Fan speeds (Indoor/Outdoor)	n°	7/2		7/2	
Sound pressure Indoor (sh.-h.-mh.-m.-ml.-l.-sl.)	dB(A)	44-43-41-38-36-34-30		48-44-41-40-38-36-33	
Sound pressure Outdoor (h.)	dB(A)	56		59	
Sound power Indoor (sh.-h.-mh.-m.-ml.-l.-sl.)	dB(A)	60-56-54-51-49-47-43		64-59-56-55-53-51-48	
Sound power Outdoor (h.)	dB(A)	65		70	
Power supply	V/Ph/Hz	220-24V~0/1/50		220-240V~/1/50	
Power input nominal (min.-max)	kW	1.576 (0.10-2.35)	1.436 (0.18-2.40)	2.030 (0.45-2.90)	2.000 (0.35-3.00)
Compressor type		Rotary DC Inverter		Rotary DC Inverter	
Refrigerant type/GWP		R32/675		R32/675	
Refrigerant charge	kg/T.CO <sub>2</sub> eq.	0.82/0.553		1.5/1.0125	
Liquid pipe diameter	mm (inch)	6.35 (1/4")		6.35 (1/4")	
Gas pipe diameter	mm (inch)	12.7 (1/2")		15.88 (5/8")	
Min.-max. pipe lenght with gas standard charge	m	3-5		3-5	
Max. pipe lenght	m	25		25	
Additional refrigerant charge	g/m	16		40	
Max. height between units (outdoor on top)	m	10		10	
Max. height between units (indoor on top)	m	10		10	
Net dimension Indoor (H./W./D.)	mm	300/970/224		325/1078/246	
Net dimension Outdoor (H./W./D.)	mm	555/802/350		660/958/402	
Net weight Indoor/Outdoor	kg	13/30.5		16/41.5	

OPERATING RANGE: outdoor temperature  
 Cooling mode: from -15 °C to +50 °C  
 Heating mode: from -15 °C to +30 °C  
 RANGE OF INDOOR TEMPERATURE ADJUSTMENT: from 16 to 30 °C

\*Data declared in compliance with EU Regulation no. 206/2012, as regards to Ecodesign requirements for air conditioners and comfort fans, and EU Regulation no. 626/2011, concerning the energy labelling of air conditioners, and tested according to standard EN14825.

# HIGH WALL -25 °C - single split air conditioners

## MAIN FEATURES



(Standard)  
Infrared remote controller



(Optional)  
Wired controller with weekly timer

3 sleep modes	3D airflow	Cold air prevention	LED	Timer	Intelligent defrosting	Auto+ X-fan	Turbo "Turbo" function	Auto diagnosis	Auto restart memory	7 Fan speeds
Auto clean	Min. temp. heating -25 °C	Min. temp. cooling -15 °C	8 °C heating	iFeel	Save energy	Child lock	WiFi control	Cold plasma	Wired controller (optional)	Door control (optional)

**A++** Cooling

**A+** Heating (average season)

**A+++** Heating (warmer season)

Model	Code	Nominal (min.-max.) cooling capacity (kW)	Nominal (min.-max.) heating capacity (kW)
Indoor unit model	X3I ECO PLUS 27 HL WF LH	2.70 (0.80-3.80)	3.00 (0.90-4.25)
Outdoor unit model	X3I ECO PLUS 27 SH LH		
Indoor unit model	X3I ECO PLUS 35 HL WF LH	3.51 (0.90-4.40)	3.81 (0.90-4.70)
Outdoor unit model	X3I ECO PLUS 35 SH LH		
Indoor unit model	X3I ECO PLUS 52 HL WF LH	5.20 (1.00-6.10)	5.60 (1.10-6.60)
Outdoor unit model	X3I ECO PLUS 52 SH LH		
Indoor unit model	X3I ECO PLUS 71 HL WF LH	7.10 (2.00-8.85)	7.80 (1.80-9.45)
Outdoor unit model	X3I ECO PLUS 71 SH LH		

## HEATING OPERATION DOWN TO VERY LOW OUTDOOR TEMPERATURES

This range can work in heating even with low outdoor temperatures, down to -25 °C, thanks to the heating element in the bottom of the outdoor unit. It is suitable for harsh climates.

MODEL		X3I ECO PLUS 27 LH		X3I ECO PLUS 35 LH	
Indoor unit		X3I ECO PLUS 27 HL WF LH		X3I ECO PLUS 35 HL WF LH	
Outdoor unit		X3I ECO PLUS 27 SH LH		X3I ECO PLUS 35 SH LH	
	Units	Cooling	Heating	Cooling	Heating
Nominal (min.-max.) capacity (EN14511)	kW	2.70 (0.80-3.80)	3.00 (0.90-4.25)	3.51 (0.90-4.40)	3.81 (0.90-4.70)
	BTU/h	9200	10240	12000	13000
EER/COP (EN14511)		3.89	4.29	3.65	4.00
Design Load [P <sub>design c</sub> /P <sub>design h</sub> (Average/Warmer/Colder)] (EN14825)*	kW	2.7	2.7/3.0/4.0	3.5	3.2/3.3/4.5
Seasonal efficiency ratio [SEER/SCOP (Average/Warmer/Colder)] (EN14825)*		7.5	4.2/5.3/3.4	7.1	4.1/5.2/3.1
Energy efficiency class*		A++	A+/A+++/A	A++	A+/A+++/A
Annual energy consumption [C/H (Average/Warmer/Colder)]*	kWh/annum	126	900/729/2471	173	1093/888/3048
Air flow rate indoor (sh.-h.-mh.-m.-ml.-l.-sl.)	m <sup>3</sup> /h	610-570-540-470-440-420-390		700-650-600-540-480-420-360	
Dehumidification	l/h	0.8		1.4	
Fan speeds (Indoor/Outdoor)	n°	7/2		7/2	
Sound pressure Indoor (sh.-h.-mh.-m.-ml.-l.-sl.)	dB(A)	38-36-34-31-29-27-25		42-38-35-32-29-27-25	
Sound pressure Outdoor (h.)	dB(A)	50		52	
Sound power Indoor (sh.-h.-mh.-m.-ml.-l.-sl.)	dB(A)	54-48-46-43-41-39-37		57-50-47-44-41-39-37	
Sound power Outdoor (h.)	dB(A)	61		63	
Power supply	V/Ph/Hz	220-240V~/1/50		220-240V~/1/50	
Power input nominal (min.-max)	kW	0.695 (0.10-1.30)	0.700 (0.15-1.40)	0.962 (0.22-1.40)	0.953 (0.22-1.55)
Compressor type		Rotary DC Inverter		Rotary DC Inverter	
Refrigerant type/GWP		R32		R32	
Refrigerant charge	kg/T.CO <sub>2</sub> eq.	0.53/0.357		0.57/0.384	
Liquid pipe diameter	mm (inch)	6.35 (1/4")		6.35 (1/4")	
Gas pipe diameter	mm (inch)	9.52 (3/8")		9.52 (3/8")	
Min.-max. pipe length with gas standard charge	m	3-5		3-5	
Max. pipe length	m	15		20	
Additional refrigerant charge	g/m	16		16	
Max. height between units (outdoor on top)	m	10		10	
Max. height between units (indoor on top)	m	10		10	
Net dimension Indoor (H./W./D.)	mm	289/845/209		289/845/209	
Net dimension Outdoor (H./W./D.)	mm	555/732/330		555/732/330	
Net weight Indoor/Outdoor	kg	10.5/24.5		11/24.5	

OPERATING RANGE: outdoor temperature  
 Cooling mode: from -15 °C to +50 °C  
 Heating mode: from -25 °C to +30 °C  
 RANGE OF INDOOR TEMPERATURE ADJUSTMENT: from 16 to 30 °C

\*Data declared in compliance with EU Regulation no. 206/2012, as regards to Ecodesign requirements for air conditioners and fans, and EU Regulation no. 626/2011, concerning the energy labelling of energy consumption of air conditioners.

# TECHNICAL DATA

MODEL		X3I ECO PLUS 52 LH		X3I ECO PLUS 71 LH	
Indoor unit		X3I ECO PLUS 52 HL WF LH		X3I ECO PLUS 71 HL WF LH	
Outdoor unit		X3I ECO PLUS 52 SH LH		X3I ECO PLUS 71 SH LH	
	Units	Cooling	Heating	Cooling	Heating
Nominal (min.-max.) capacity (EN14511)	kW	5.20 (1.00-6.10)	5.60 (1.10-6.60)	7.10 (2.00-8.85)	7.80 (1.80-9.45)
	BTU/h	17800	19100	24200	25300
EER/COP (EN14511)		3.30	3.90	3.50	3.90
Design Load [Pdesign c/Pdesign h (Average/Warmer/Colder)] (EN14825)*	kW	5.2	4.2/4.3/5.0	7.1	5.6/5.7/6.3
Seasonal efficiency ratio [SEER/SCOP (Average/Warmer/Colder)] (EN14825)*		7.1	4.2/5.7/3.4	7.0	4.2/5.4/3.4
Energy efficiency class*		A++	A+/A+++/A	A++	A+/A+++/A
Annual energy consumption [C/H (Average/Warmer/Colder)]*	kWh/annum	256	1400/1056/3088	355	1867/1478/3891
Air flow rate indoor (sh.-h.-mh.-m.-ml.-l.-sl.)	m³/h	850-750-680-610-570-520-460		1250-1100-1000-950-900-850-800	
Dehumidification	l/h	1.9		2.4	
Fan speeds (Indoor/Outdoor)	n°	7/2		7/2	
Sound pressure Indoor (sh.-h.-mh.-m.-ml.-l.-sl.)	dB(A)	44-43-41-38-36-34-30		48-44-41-40-38-36-33	
Sound pressure Outdoor (h.)	dB(A)	56		59	
Sound power Indoor (sh.-h.-mh.-m.-ml.-l.-sl.)	dB(A)	60-56-54-51-49-47-43		64-59-56-55-53-51-48	
Sound power Outdoor (h.)	dB(A)	65		70	
Power supply	V/Ph/Hz	220-240V~/1/50		220-240V~/1/50	
Power input nominal (min.-max)	kW	1.576 (0.10-2.35)	1.436 (0.18-2.40)	2.030 (0.45-2.90)	2.00 (0.35-3.00)
Compressor type		Rotary DC Inverter		Rotary DC Inverter	
Refrigerant type/GWP		R32/675		R32/675	
Refrigerant charge	kg/T.CO <sub>2</sub> eq.	0.82/0.553		1.5/1.0125	
Liquid pipe diameter	mm (inch)	6.35 (1/4")		6.35 (1/4")	
Gas pipe diameter	mm (inch)	12.7 (1/2")		15.88 (5/8")	
Min.-max. pipe lenght with gas standard charge	m	3-5		3-5	
Max. pipe lenght	m	25		25	
Additional refrigerant charge	g/m	16		40	
Max. height between units (outdoor on top)	m	10		10	
Max. height between units (indoor on top)	m	10		10	
Net dimension Indoor (H./W./D.)	mm	300/970/224		352/1078/246	
Net dimension Outdoor (H./W./D.)	mm	555/802/350		660/958/402	
Net weight Indoor/Outdoor	kg	13/33		16/46	

OPERATING RANGE: outdoor temperature  
Cooling mode: from -15 °C to +50 °C  
Heating mode: from -25 °C to +30 °C  
RANGE OF INDOOR TEMPERATURE ADJUSTMENT: from 16 to 30 °C

\*Data declared in compliance with EU Regulation no. 206/2012, as regards to Ecodesign requirements for air conditioners and fans, and EU Regulation no. 626/2011, concerning the energy labelling of energy consumption of air conditioners.

# NOTES

# CONSOLE -22 °C - single split air conditioners

## MAIN FEATURES



3 sleep modes	Cold air prevention	LED	Timer	Intelligent defrosting	Auto+	Turbo	Auto diagnosis	Dehumidification	Auto restart memory	Fan speed
-22 °C Min. temp. heating	-15 °C Min. temp. cooling	8 °C 8 °C heating	Quiet mode	iFeel	Save energy	Cold plasma	Wifi control	Wired controller (optional)		

**A++** Cooling

**A+** Heating (average season)

**A+++** Heating (warmer season)

Model		Code	Nominal (min.-max.) cooling capacity (kW)	Nominal (min.-max.) heating capacity (kW)
Indoor unit model	X3I ECO PLUS AF27 HL	398000739	2.70 (0.70-3.40)	2.90 (0.60-3.50)
Outdoor unit model	X3I ECO PLUS 27 SH LHB	398000740		
Indoor unit model	X3I ECO PLUS AF35 HL	398000741	3.52 (0.80-4.40)	3.80 (1.10-4.40)
Outdoor unit model	X3I ECO PLUS 35 SH LHB	398000742		
Indoor unit model	X3I ECO PLUS AF52 HL	398000743	5.20 (1.26-6.60)	5.33 (1.12-6.80)
Outdoor unit model	X3I ECO PLUS 52 SH LHB	398000744		

## LONG DISTANCE WIFI



Thanks to the integrated WiFi module it is possible to control the units operation via APP on your smartphone, switch on/off the unit, select the desired mode and temperature, to program your comfort at any time, even when you aren't at home.

## iFEEL FUNCTION



The sensor incorporated into the remote controller perceives the surrounding temperature and transmits the signal to the indoor unit. Thus, the indoor unit can adjust the volume and temperature of the air flow to ensure maximum comfort at the exact point where the remote control is located, not where the unit is located..

## AIR PURIFICATION SYSTEM

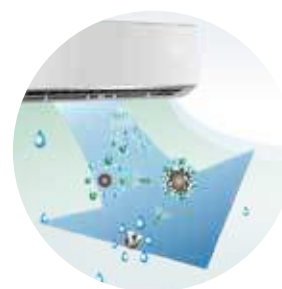

It releases ions able to neutralize bacteria, fungus, viruses, pollen, acarus and in general pollutants present in the air, making the environment healthy and the air light. It ensures effective air sterilization, killing over 90% of bacteria. It removes over 400 types of odors and improves the air quality, enriching it with negative ions.

## SLIM AND ELEGANT DESIGN



The console integrates perfectly in any type of furniture, thanks to its clean, slim and elegant design.

## HEATING OPERATION DOWN TO VERY LOW OUTDOOR TEMPERATURES



The console range can work in heating down to very low outdoor temperatures, -22 °C, thus it is suitable for harsh climate conditions. This is possible thanks to assessments that regulate and optimize the defrosting process and thanks to the heating element on the bottom of the outdoor unit.

# TECHNICAL DATA

Indoor unit model		X3I ECO PLUS AF27 HL		X3I ECO PLUS AF35 HL	
Outdoor unit model		X3I ECO PLUS 27 SH LHB		X3I ECO PLUS 35 SH LHB	
	Units	Cooling	Heating	Cooling	Heating
Nominal (min.-max.) capacity (EN14511)	kW	2.70 (0.70-3.40)	2.90 (0.60-3.50)	3.52 (0.80-4.40)	3.80 (1.10-4.40)
	BTU/h	9200	10000	12000	13000
EER/COP (EN14511)		3.75	3.97	3.52	3.96
Design Load [Pdesign c/Pdesign h (Average/Warmer/Colder)] (EN14825)*	kW	2.7	2.6/2.8/-	3.5	3.20/3.30/-
Seasonal efficiency ratio [SEER/SCOP (Average/Warmer/Colder)] (EN14825)*		7.20	4.0/5.3/-	7.0	4.10/5.30/-
Energy efficiency class*		A++	A+/A+++/-	A++	A+/A+++/-
Annual energy consumption [C/H (Average/Warmer/Colder)]*	kWh/annum	131	910/740	175	1050/961/2953
Air flow rate indoor (sh.-h.-mh.-m.-ml.-l.-sl.)	m <sup>3</sup> /h	500-430-410-370-330-280-250		600-520-480-440-400-360-280	
Dehumidification	l/h	0.8		1.2	
Fan speeds (Indoor/Outdoor)	n°	7/2		7/2	
Sound pressure Indoor (sh.-h.-mh.-m.-ml.-l.-sl.)	dB(A)	39-36-33-31-29-26-23		44-40-38-36-33-29-25	
Sound pressure Outdoor (h.)	dB(A)	49		52	
Sound power Indoor (sh.-h.-mh.-m.-ml.-l.-sl.)	dB(A)	50-48-45-44-42-38-34		54-50-48-46-43-39-35	
Sound power Outdoor (h.)	dB(A)	60		62	
Power supply	V/Ph/Hz	220-240~/1/50		220-240~/1/50	
Power input nominal (min.-max)	kW	0.72 (0.17-1.3)	0.73 (0.13-1.35)	1.00 (0.16-1.5)	0.960 (0.165-1.5)
Compressor type		Rotary DC Inverter		Rotary DC Inverter	
Refrigerant type/GWP		R32/675		R32/675	
Refrigerant charge	kg/T.CO <sub>2</sub> eq.	0.55/0.37		0.75/0.51	
Liquid pipe diameter	mm (inch)	6.35 (1/4")		6.35 (1/4")	
Gas pipe diameter	mm (inch)	9.52 (3/8")		9.52 (3/8")	
Min.-max. pipe length with gas standard charge	m	3-5		3-5	
Max. pipe length with additional gas charge	m	15		20	
Additional refrigerant charge	g/m	16		16	
Max. height between units (outdoor on top)	m	10		10	
Max. height between units (indoor on top)	m	10		10	
Net dimension Indoor (H./W./D.)	mm	600/700/215		600/700/215	
Net dimension Outdoor (H./W./D.)	mm	540/782/320		596/848/320	
Net weight Indoor/Outdoor	kg	15.5/27.5		15.5/30.5	

OPERATING RANGE: outdoor temperature  
Cooling mode: from -15 °C to +43 °C  
Heating mode: from -15 °C to +24 °C  
RANGE OF INDOOR TEMPERATURE ADJUSTMENT: from 16 to 30 °C

\*Data declared in compliance with EU Regulation no. 206/2012, as regards to Ecodesign requirements for air conditioners and comfort fans, and EU Regulation no. 626/2011, concerning the energy labelling of air conditioners, and tested according to standard EN14825.



Indoor unit model		X3I ECO PLUS AF52 HL	
Outdoor unit model		X3I ECO PLUS 52 SH LHB	
	Units	Cooling	Heating
Nominal (min.-max.) capacity (EN14511)	kW	5.20 (1.26-6.60)	5.33 (1.12-6.80)
	BTU/h	17800	18000
EER/COP (EN14511)		3.40	3.55
Design Load [Pdesign c/Pdesign h (Average/Warmer/Colder)] (EN14825)*	kW	5.2	5.0/5.2/-
Seasonal efficiency ratio [SEER/SCOP (Average/Warmer/Colder)] (EN14825)*		6.6	4.1/5.1/-
Energy efficiency class*		A++	A+/A+++/-
Annual energy consumption [C/H (Average/Warmer/Colder)]*	kWh/annum	260	1707/1427/-
Air flow rate indoor (sh.-h.-mh.-m.-ml.-l.-sl.)	m <sup>3</sup> /h	700-650-580-520-460-410-320	
Dehumidification	l/h	1.8	
Fan speeds (Indoor/Outdoor)	n°	7/2	
Sound pressure Indoor (sh.-h.-mh.-m.-ml.-l.-sl.)	dB(A)	47-45-42-40-37-35-31	
Sound pressure Outdoor (h.)	dB(A)	57	
Sound power Indoor (sh.-h.-mh.-m.-ml.-l.-sl.)	dB(A)	57-55-52-50-47-45-41	
Sound power Outdoor (h.)	dB(A)	65	
Power supply	V/Ph/Hz	220-240~/1/50	
Power input nominal (min.-max)	kW	1.55 (0.38-2.45)	1.5 (0.35-2.5)
Compressor type		Rotary DC Inverter	
Refrigerant type/GWP		R32/675	
Refrigerant charge	kg/T.CO <sub>2</sub> eq.	0.95/0.64	
Liquid pipe diameter	mm (inch)	6.35 (1/4")	
Gas pipe diameter	mm (inch)	12.7 (1/2")	
Min.-max. pipe lenght with gas standard charge	m	3-5	
Max. pipe lenght with additional gas charge	m	25	
Additional refrigerant charge	g/m	20	
Max. height between units (outdoor on top)	m	10	
Max. height between units (indoor on top)	m	10	
Net dimension Indoor (H./W./D.)	mm	600/700/215	
Net dimension Outdoor (H./W./D.)	mm	700/965/396	
Net weight Indoor/Outdoor	kg	15.5/46	

OPERATING RANGE: outdoor temperature  
 Cooling mode: from -15 °C to +43 °C  
 Heating mode: from -15 °C to +24 °C  
 RANGE OF INDOOR TEMPERATURE ADJUSTMENT: from 16 to 30 °C

\*Data declared in compliance with EU Regulation no. 206/2012, as regards to Ecodesign requirements for air conditioners and comfort fans, and EU Regulation no. 626/2011, concerning the energy labelling of air conditioners, and tested according to standard EN14825.

# MULTISPLIT AIR CONDITIONERS

## MAIN FEATURES



ARGO DUAL 14 DCI R32  
 ARGO DUAL 18 DCI R32  
 ARGO TRIAL 21 DCI R32  
 ARGO TRIAL 24 DCI R32  
 ARGO QUADRI 28 DCI R32



ARGO QUADRI 36 DCI R32  
 ARGO PENTA 42 DCI R32

Possibility of choice among different types of indoor units and many capacity matchings.



HIGH-WALL



CASSETTE

\*Wifi through wired controller



DUCTED

\*Wifi through wired controller



FLOOR/CEILING



CONSOLE



Compact design



Cold air prevention



EASY  
Easy maintenance



Timer



Intelligent defrosting



"Turbo" function



Auto diagnosis



High efficiency



Auto restart memory



Child lock



Low voltage start-up



Full protection



Wide voltage range



Wide operating range



Central control



Long-distance monitoring



Wired controller (optional)



DC Inverter technology

**A<sup>++</sup>** Cooling

**A<sup>+</sup>** Heating

## LOW AMBIENT COOLING AND HEATING

The ability to work down to -15 °C of outdoor temperature, in both cooling and heating modes, ensures a high product reliability: when the outside temperature changes, the compressor frequency and fan speed adjust accordingly.



## OUTDOOR UNITS

Model	Code	Nominal (max.-min.) cooling capacity (kW)	Nominal (max.-min.) heating capacity (kW)
ARGO DUAL 14 DCI R32	398000791	4.10 (2.05-5.00)	4.40 (2.49-5.40)
ARGO DUAL 18 DCI R32	398000792	5.30 (2.14-5.80)	5.65 (2.58-6.50)
ARGO TRIAL 21 DCI R32	398000793	6.10 (2.20-8.30)	6.50 (3.60-8.50)
ARGO TRIAL 24 DCI R32	398000794	7.10 (2.30-9.20)	8.60 (3.65-9.20)
ARGO QUADRI 28 DCI R32	398000795	8.00 (2.30-11.00)	9.50 (3.65-10.25)
ARGO QUADRI 36 DCI R32	398000796	10.60 (2.60-12.00)	12.00 (3.00-14.00)
ARGO PENTA 42 DCI R32	398000797	12.10 (2.6 -15.20)	13.00 (3.00-15.50)

## INDOOR UNITS

Model	Code	
HIGH-WALL	X3I ECO PLUS 27 HL WF	398000817
	X3I ECO PLUS 35 HL WF	398000819
	X3I ECO PLUS 52 HL WF	398000821
	X3I ECO PLUS 70 HL WF	398000823
8-WAY CASSETTE	X3I ECO AS 28 HL	398000860
	X3I ECO AS 35 HL	398000861
	X3I ECO AS 50 HL	398000862
	GRID CASSETTE COMPACT	398100688
	X3I ECO AS 70 HL	398000863
	GRID BIG CASSETTE	398100677
SLIM DUCTED	X3I ECO SD 27 HL	398000856
	X3I ECO SD 35 HL	398000857
	X3I ECO SD 50 HL	398000858
	X3I ECO SD 70 HL	398000859
FLOOR/CEILING	X3I ECO FC 26 HL	398000666
	X3I ECO FC 35 HL	398000667
	X3I ECO FC 45 HL	398000668
CONSOLE	X3I ECO PLUS AF 27 HL	398000739
	X3I ECO PLUS AF 35 HL	398000741
	X3I ECO PLUS AF 52 HL	398000743

# OUTDOOR UNITS TECHNICAL DATA

Outdoor unit model - DUAL SPLIT		ARGO DUAL 14 DCI R32		ARGO DUAL 18 DCI R32	
	Units	Cooling	Heating	Cooling	Heating
Nominal (min.-max.) capacity (EN14511)	kW	4.10 (2.05-5.00)	4.40 (2.49-5.40)	5.30 (2.14-5.80)	5.65 (2.58-6.50)
	BTU/h	14000	15000	18000	19300
EER/COP (EN14511)		3.72	4.54	3.58	4.53
Design Load [Pdesign c/Pdesign h (Average/Warmer/Colder)] (EN14825)*	kW	4.1	3.8	5.3	4.3
Seasonal efficiency ratio [SEER/SCOP (Average/Warmer/Colder)] (EN14825)*		6.5	4.0	6.6	4.0
Energy efficiency class*		A++	A+	A++	A+
Annual energy consumption [C/H (Average/Warmer/Colder)]*	kWh/annum	220	1330	281	1505
Min.-max. number of connectable indoor units		2		2	
Air flow rate (h.)	m <sup>3</sup> /h	2300		2300	
Fan speeds Outdoor	n°	2		2	
Sound pressure Outdoor (h.)	dB(A)	50	52	50	54
Sound power Outdoor (h.)	dB(A)	62		64	
Power supply	V/Ph/Hz	220-240~/1/50		220-240~/1/50	
Power input nominal (min.-max)	kW	1.10 (0.55-1.40)	0.97 (0.60-1.78)	1.48 (0.56-1.56)	1.25 (0.78-1.78)
Compressor type		Rotary DC Inverter		Rotary DC Inverter	
Refrigerant type/GWP		R32/675		R32/675	
Refrigerant charge	kg/T.CO <sub>2</sub> eq.	0.75/0.506		0.90/0.608	
Liquid pipe diameter	mm (inch)	6.35 (1/4")		6.35 (1/4")	
Gas pipe diameter	mm (inch)	9.52 (3/8")		9.52 (3/8")	
Min.-max. pipe length with gas standard charge	m	3-10		3-10	
Max. pipe length with additional charge	m	40		40	
Max. pipe length for unit	m	20		20	
Additional refrigerant charge	g/m	20		20	
Max. height between indoor units	m	15		15	
Net dimension Outdoor (H./W./D.)	mm	550/745/300		550/745/300	
Net weight Outdoor	kg	30		32	

OPERATING RANGE: outdoor temperature  
Cooling mode: from -15 °C to +43 °C  
Heating mode: from -15 °C to +24 °C  
RANGE OF INDOOR TEMPERATURE ADJUSTMENT: from 16 to 30 °C

\*Data declared in compliance with EU Regulation no. 206/2012, as regards to ECO-design requirements for air conditioners and comfort fans, and EU Regulation no. 626/2011, concerning the energy labelling of air conditioners and tested according to EN14825:2012.

Outdoor unit model - TRIAL SPLIT		ARGO TRIAL 21 DCI R32		ARGO TRIAL 24 DCI R32	
	Units	Cooling	Heating	Cooling	Heating
Nominal (min.-max.) capacity (EN14511)	kW	6.10 (2.20-8.30)	6.50 (3.60-8.50)	7.10 (2.30-9.20)	8.60 (3.65-9.20)
	BTU/h	20800	22200	24200	29300
EER/COP (EN14511)		4.12	4.56	3.77	3.86
Design Load [Pdesign c/Pdesign h (Average/Warmer/Colder)] (EN14825)*	kW	6.1	6.1	7.1	6.1
Seasonal efficiency ratio [SEER/SCOP (Average/Warmer/Colder)] (EN14825)*		6.1	4.0	6.1	4.0
Energy efficiency class*		A++	A+	A++	A+
Annual energy consumption [C/H (Average/Warmer/Colder)]*	kWh/annum	350	2135	407	2189
Min.-max. number of connectable indoor units		2-3		2-3	
Air flow rate (h.)	m <sup>3</sup> /h	3800		3800	
Fan speeds Outdoor	n°	2		2	
Sound pressure Outdoor (h.)	dB(A)	57	58	57	58
Sound power Outdoor (h.)	dB(A)	68		68	
Power supply	V/Ph/Hz	220-240~/1/50		220-240~/1/50	
Power input nominal (min.-max)	kW	1.48 (0.95-2.39)	1.43 (0.78-2.87)	1.88 (1.10-2.87)	2.23 (0.98-2.87)
Compressor type		Rotary DC Inverter		Rotary DC Inverter	
Refrigerant type/GWP		R32/675		R32/675	
Refrigerant charge	kg/T.CO <sub>2</sub> eq.	1.6/1.080		1.7/1.148	
Liquid pipe diameter	mm (inch)	6.35 (1/4")		6.35 (1/4")	
Gas pipe diameter	mm (inch)	9.52 (3/8")		9.52 (3/8")	
Min.-max. pipe length with gas standard charge	m	3-30		3-30	
Max. pipe length with additional charge	m	60		60	
Max. pipe length for unit	m	20		20	
Additional refrigerant charge	g/m	20		20	
Max. height between indoor units	m	15		15	
Net dimension Outdoor (H./W./D.)	mm	654/889/340		654/889/340	
Net weight Outdoor	kg	47.5		47.5	

OPERATING RANGE: outdoor temperature  
 Cooling mode: from -15 °C to +43 °C  
 Heating mode: from -15 °C to +24 °C  
 RANGE OF INDOOR TEMPERATURE ADJUSTAMENT: from 16 to 30 °C

\*Data declared in compliance with EU Regulation no. 206/2012, as regards to ECO-design requirements for air conditioners and comfort fans, and EU Regulation no. 626/2011, concerning the energy labelling of air conditioners and tested according to EN14825:2012.

# OUTODOOR UNITS TECHNICAL DATA

Outdoor unit model - QUADRI SPLIT		ARGO QUADRI 28 DCI R32		ARGO QUADRI 36 DCI R32	
	Units	Cooling	Heating	Cooling	Heating
Nominal (min.-max.) capacity (EN14511)	kW	8.00 (2.30-11.0)	9.50 (3.65-10.25)	10.60 (2.60-12.00)	12.00 (3.00-14.00)
	BTU/h	28000	32400	36200	40900
EER/COP (EN14511)		3.77	4.31	3.53	3.95
Design Load [P <sub>design c</sub> /P <sub>design h</sub> (Average/Warmer/Colder)] (EN14825)*	kW	8.0	7.2	10.6	10.5
Seasonal efficiency ratio [SEER/SCOP (Average/Warmer/Colder)] (EN14825)*		6.1	4.0	7.2	4.0
Energy efficiency class*		A++	A+	A++	A+
Annual energy consumption [C/H (Average/Warmer/Colder)]*	kWh/annum	459	2520	515	3675
Min.-max. number of connectable indoor units		2-4		2-4	
Air flow rate (h.)	m <sup>3</sup> /h	3800		5800	
Fan speeds Outdoor	n°	2		2	
Sound pressure Outdoor (h.)	dB(A)	58		60	
Sound power Outdoor (h.)	dB(A)	68		70	
Power supply	V/Ph/Hz	220-240~/1/50		220-240~/1/50	
Power input nominal (min.-max)	kW	2.12 (1.30-3.58)	2.20 (1.0-2.87)	3.00	3.04
Compressor type		Rotary DC Inverter		Rotary DC Inverter	
Refrigerant type/GWP		R32/675		R32/675	
Refrigerant charge	kg/T.CO <sub>2</sub> eq.	1.8/1.215		2.40/1.62	
Liquid pipe diameter	mm (inch)	6.35 (1/4")		6.35 (1/4")	
Gas pipe diameter	mm (inch)	9.52 (3/8")		9.52 (3/8")	
Min.-max. pipe lenght with gas standard charge	m	3-40		3-40	
Max. pipe lenght with additional charge	m	70		80	
Max. pipe lenght for unit	m	20		25	
Additional refrigerant charge	g/m	20		20	
Max. height between indoor units	m	15		25	
Net dimension Outdoor (H./W./D.)	mm	654/889/340		826/1020/427	
Net weight Outdoor	kg	51		72	

OPERATING RANGE: outdoor temperature

Cooling mode: from -15 °C to +43 °C

Heating mode: from -15 °C to +24 °C

RANGE OF INDOOR TEMPERATURE ADJUSTMENT: from 16 to 30 °C

\*Data declared in compliance with EU Regulation no. 206/2012, as regards to ECO-design requirements for air conditioners and comfort fans, and EU Regulation no. 626/2011, concerning the energy labelling of air conditioners and tested according to EN14825:2012.

Outdoor unit mode - PENTA SPLIT		ARGO PENTA 42 DCI R32	
	Units	Cooling	Heating
Nominal (min.-max.) capacity (EN14511)	kW	12.10 (2.60-15.20)	13.00 (3.00-15.50)
	BTU/h	41300	44400
EER/COP (EN14511)		3.56	4.08
Rated capacity (Prated,c/Prated,h)*	kW	12.10	13.00
Seasonal space energy efficiency (ηs,c/ηs,h)*	%	289.0	165.0
Min.-max. number of connectable indoor units		2-5	
Air flow rate (h.)	m <sup>3</sup> /h	5800	
Fan speeds Outdoor	n°	2	
Sound pressure Outdoor (h.)	dB(A)	60	
Sound power Outdoor (h.)	dB(A)	72	74
Power supply	V/Ph/Hz	220-240~/1/50	
Power input nominal (min.-max)	kW	3.40	3.19
Compressor type		Rotary DC Inverter	
Refrigerant type/GWP		R32/675	
Refrigerant charge	kg/T.CO <sub>2</sub> eq.	2.40/1.62	
Liquid pipe diameter	mm (inch)	6.35 (1/4")	
Gas pipe diameter	mm (inch)	9.52 (3/8")	
Min.-max. pipe length with gas standard charge	m	3-50	
Max. pipe length with additional charge	m	100	
Max. pipe length for unit	m	25	
Additional refrigerant charge	g/m	20	
Max. height between units (outdoor on top)	m	25	
Max. height between units (Indoor on top)	m	25	
Net dimension Outdoor (H./W./D.)	mm	826/1020/427	
Net weight Outdoor	kg	73	

OPERATING RANGE: outdoor temperature  
 Cooling mode: from -15 °C to +43 °C  
 Heating mode: from -15 °C to +24 °C  
 RANGE OF INDOOR TEMPERATURE ADJUSTMENT: from 16 to 30 °C

\*Data declared in accordance with COMMISSION REGULATION (EU) 2016/2281 of 30 November 2016 implementing Directive 2009/125/EC of the European Parliament and of the Council establishing a framework for the setting of ecodesign requirements for energy-related products, with regard to ecodesign requirements for air heating products, cooling products, high temperature process chillers and fan coil units.

# INDOOR UNITS MATCHINGS: COOLING MODE

ARGO DUAL 14 DCI R32	Nominal Cooling capacity (kW)					Total Cooling capacity (kW)			Total power input (kW)			Total current consumption (A) 230V			EER (W/W)	SEER (W/W)	Energy efficiency class
	Unit A	Unit B	Unit C	Unit D	Unit E	Min.	Nom.	Max.	Min.	Nom.	Max.	Min.	Nom.	Max.	X3 ECO PLUS INDOOR UNIT		
9k+9k	2.05	2.05				2.05	4.10	5.00	0.40	1.10	2.20	1.77	4.88	9.76	3.73	6.50	A++
9k+12k	1.76	2.34				2.05	4.10	5.00	0.40	1.10	2.20	1.77	4.88	9.76	3.73	6.50	A++

ARGO DUAL 18 DCI R32	Nominal Cooling capacity (kW)					Total Cooling capacity (kW)			Total power input (kW)			Total current consumption (A) 230V			EER (W/W)	SEER (W/W)	Energy efficiency class
	Unit A	Unit B	Unit C	Unit D	Unit E	Min.	Nom.	Max.	Min.	Nom.	Max.	Min.	Nom.	Max.	X3 ECO PLUS INDOOR UNIT		
9k+9k	2.65	2.65				2.15	5.30	5.80	0.40	1.48	2.50	1.77	6.57	11.09	3.58	6.60	A++
9k+12k	2.30	3.00				2.15	5.30	5.80	0.50	1.48	2.50	2.22	6.57	11.09	3.58	6.60	A++
12k+12k	2.65	2.65				2.15	5.30	5.80	0.50	1.48	2.50	2.22	6.57	11.09	3.58	6.60	A++

ARGO TRIAL 21 DCI R32	Nominal Cooling capacity (kW)					Total Cooling capacity (kW)			Total power input (kW)			Total current consumption (A) 230V			EER (W/W)	SEER (W/W)	Energy efficiency class
	Unit A	Unit B	Unit C	Unit D	Unit E	Min.	Nom.	Max.	Min.	Nom.	Max.	Min.	Nom.	Max.	X3 ECO PLUS INDOOR UNIT		
9k+9k	2.65	2.65				2.20	5.30	6.00	0.40	1.20	2.60	1.77	5.32	11.54	4.42	6.10	A++
9k+12k	2.60	3.50				2.20	6.10	7.20	0.50	1.48	2.90	2.22	6.57	12.87	4.12	6.10	A++
9k+18k	2.03	4.07				2.20	6.10	8.30	0.60	1.48	2.90	2.66	6.57	12.87	4.12	6.10	A++
12k+12k	3.05	3.05				2.20	6.10	8.30	0.60	1.48	2.90	2.66	6.57	12.87	4.12	6.10	A++
12k+18k	2.44	3.66				2.20	6.10	8.30	0.60	1.48	2.90	2.66	6.57	12.87	4.12	6.10	A++
9k+9k+9k	2.03	2.03	2.03			2.20	6.10	8.30	0.60	1.48	2.90	2.66	6.57	12.87	4.12	6.50	A++
9k+9k+12k	1.83	1.83	2.44			2.20	6.10	8.30	0.60	1.48	2.90	2.66	6.57	12.87	4.12	6.50	A++

ARGO TRIAL 24 DCI R32	Nominal Cooling capacity (kW)					Total Cooling capacity (kW)			Total power input (kW)			Total current consumption (A) 230V			EER (W/W)	SEER (W/W)	Energy efficiency class
	Unit A	Unit B	Unit C	Unit D	Unit E	Min.	Nom.	Max.	Min.	Nom.	Max.	Min.	Nom.	Max.	X3 ECO PLUS INDOOR UNIT		
9k+9k	2.65	2.65				2.30	5.30	6.30	0.80	1.40	3.00	3.55	6.21	13.31	3.79	6.10	A++
9k+12k	2.60	3.50				2.30	6.10	7.30	1.00	1.65	3.20	4.44	7.30	14.20	3.71	6.10	A++
9k+18k	2.37	4.73				2.30	7.10	8.50	1.10	1.88	3.40	4.88	8.34	15.08	3.78	6.10	A++
12k+12k	3.55	3.55				2.30	7.10	9.20	1.10	1.88	3.40	4.88	8.34	15.08	3.78	6.10	A++
12k+18k	2.84	4.26				2.30	7.10	9.20	1.10	1.88	3.40	4.88	8.34	15.08	3.78	6.10	A++
18k+18k	3.55	3.55				2.30	7.10	9.20	1.10	1.88	3.40	4.88	8.34	15.08	3.78	6.10	A++
9k+9k+9k	2.37	2.37	2.37			2.30	7.10	9.20	1.10	1.88	3.40	4.88	8.34	15.08	3.78	6.50	A++
9k+9k+12k	2.13	2.13	2.84			2.30	7.10	9.20	1.10	1.88	3.40	4.88	8.34	15.08	3.78	6.50	A++
9k+9k+18k	1.78	1.78	3.55			2.30	7.10	9.20	1.10	1.88	3.40	4.88	8.34	15.08	3.78	6.50	A++
9k+12k+12k	1.94	2.58	2.58			2.30	7.10	9.20	1.10	1.88	3.40	4.88	8.34	15.08	3.78	6.50	A++
12k+12k+12k	2.37	2.37	2.37			2.30	7.10	9.20	1.10	1.88	3.40	4.88	8.34	15.08	3.78	6.50	A++

ARGO QUADRI 28 DCI R32	Nominal Cooling capacity (kW)					Total Cooling capacity (kW)			Total power input (kW)			Total current consumption (A) 230V			EER (W/W)	SEER (W/W)	Energy efficiency class
	Unit A	Unit B	Unit C	Unit D	Unit E	Min.	Nom.	Max.	Min.	Nom.	Max.	Min.	Nom.	Max.	X3 ECO PLUS INDOOR UNIT		
9k+9k	2.65	2.65				2.30	5.30	6.30	0.80	1.40	2.60	3.55	6.21	11.54	3.79	6.10	A++
9k+12k	2.60	3.50				2.30	6.10	7.30	0.80	1.60	2.80	3.55	7.10	12.42	3.81	6.10	A++
9k+18k	2.60	5.00				2.30	7.60	8.50	1.20	2.00	2.80	5.32	8.87	12.42	3.80	6.10	A++
12k+12k	3.50	3.50				2.30	7.00	9.20	1.20	1.80	2.80	5.32	7.99	12.42	3.89	6.10	A++
12k+18k	3.20	4.80				2.30	8.00	10.00	1.20	2.12	3.40	5.32	9.41	15.08	3.77	6.10	A++
18k+18k	4.00	4.00				2.30	8.00	11.00	1.20	2.12	3.60	5.32	9.41	15.97	3.77	6.10	A++
9k+9k+9k	2.67	2.67	2.67			2.30	8.00	10.00	1.30	2.00	3.40	5.77	8.87	15.08	4.00	6.30	A++
9k+9k+12k	2.40	2.40	3.20			2.30	8.00	11.00	1.30	2.12	3.60	5.77	9.41	15.97	3.77	6.30	A++
9k+9k+18k	2.00	2.00	4.00			2.30	8.00	11.00	1.30	2.12	3.60	5.77	9.41	15.97	3.77	6.30	A++
9k+12k+12k	2.18	2.91	2.91			2.30	8.00	11.00	1.30	2.12	3.60	5.77	9.41	15.97	3.77	6.30	A++
9k+12k+18k	1.85	2.46	3.69			2.30	8.00	11.00	1.30	2.12	3.60	5.77	9.41	15.97	3.77	6.30	A++
12k+12k+12k	2.67	2.67	2.67			2.30	8.00	11.00	1.30	2.12	3.60	5.77	9.41	15.97	3.77	6.30	A++
12k+12k+18k	2.29	2.29	3.43			2.30	8.00	11.00	1.30	2.12	3.60	5.77	9.41	15.97	3.77	6.30	A++
9k+9k+9k+9k	2.00	2.00	2.00	2.00		2.30	8.00	11.00	1.30	2.12	3.60	5.77	9.41	15.97	3.77	6.60	A++
9k+9k+9k+12k	1.85	1.85	1.85	2.46		2.30	8.00	11.00	1.30	2.12	3.60	5.77	9.41	15.97	3.77	6.60	A++
9k+9k+12k+12k	1.71	1.71	2.29	2.29		2.30	8.00	11.00	1.30	2.12	3.60	5.77	9.41	15.97	3.77	6.60	A++



ARGO QUADRI 36 DCI R32	Nominal Cooling capacity (kW)					Total Cooling capacity (kW)			Total power input (kW)			Total current consumption (A) 230V			EER (W/W)	SEER (W/W)	Energy efficiency class
	Unit A	Unit B	Unit C	Unit D	Unit E	Min.	Nom.	Max.	Min.	Nom.	Max.	Min.	Nom.	Max.	X3 ECO PLUS INDOOR UNIT		
9k+9k	2.65	2.65				2.60	5.30	6.50	1.60	1.90	3.50	7.10	10.64	15.52	2.79	6.10	A++
9k+12k	2.60	3.50				2.60	6.10	7.50	1.60	2.30	3.50	7.10	10.64	15.52	2.65	6.10	A++
9k+18k	2.60	5.00				2.60	7.60	9.00	1.60	2.40	3.50	7.10	10.60	15.50	3.17	6.10	A++
9k+24k	2.60	7.20				2.60	9.80	11.00	1.60	2.60	3.60	7.10	11.50	16.00	3.77	6.10	A++
12k+12k	3.50	3.50				2.60	7.00	9.20	1.60	2.40	3.50	7.10	10.64	15.52	2.92	6.10	A++
12k+18k	3.50	5.00				2.60	8.50	10.00	1.60	2.40	3.50	7.10	10.64	15.52	3.54	6.10	A++
12k+24k	3.50	7.10				2.60	10.60	12.00	1.60	3.00	4.60	7.10	13.30	20.41	3.53	6.10	A++
18k+18k	5.30	5.30				2.60	10.60	12.00	1.60	3.00	4.60	7.10	13.30	20.41	3.53	6.10	A++
18k+24k	4.55	6.05				2.60	10.60	12.00	1.60	3.00	4.60	7.10	13.30	20.41	3.53	6.10	A++
24k+24k	5.30	5.30				2.60	10.60	12.00	1.60	3.00	4.60	7.10	13.30	20.41	3.53	6.10	A++
9k+9k+9k	2.67	2.67	2.67			2.60	8.00	10.00	1.60	2.40	3.50	7.10	10.64	15.52	3.33	6.10	A++
9k+9k+12k	2.60	2.60	4.20			2.60	9.40	11.00	1.60	2.60	3.60	7.10	11.53	15.97	3.62	6.10	A++
9k+9k+18k	2.65	2.65	5.30			2.60	10.60	12.00	1.60	3.00	4.60	7.10	13.30	20.41	3.53	6.10	A++
9k+9k+24k	2.27	2.27	6.06			2.60	10.60	12.00	1.60	3.00	4.60	7.10	13.30	20.41	3.53	6.10	A++
9k+12k+12k	2.60	3.50	3.50			2.60	9.60	11.00	1.60	3.00	4.60	7.10	13.30	20.41	3.20	6.10	A++
9k+12k+18k	2.45	3.26	4.89			2.60	10.60	12.00	1.60	3.00	4.60	7.10	13.30	20.41	3.53	6.10	A++
9k+12k+24k	2.12	2.83	5.65			2.60	10.60	12.00	1.60	3.00	4.60	7.10	13.30	20.41	3.53	6.10	A++
9k+18k+18k	2.12	4.24	4.24			2.60	10.60	12.00	1.60	3.00	4.60	7.10	13.30	20.41	3.53	6.10	A++
9k+18k+24k	1.87	3.74	4.99			2.60	10.60	12.00	1.60	3.00	4.60	7.10	13.30	20.41	3.53	6.10	A++
12k+12k+12k	3.53	3.53	3.53			2.60	10.60	12.00	1.60	3.00	4.60	7.10	13.30	20.41	3.53	6.10	A++
12k+12k+18k	3.03	3.03	4.54			2.60	10.60	12.00	1.60	3.00	4.60	7.10	13.30	20.41	3.53	6.10	A++
12k+12k+24k	2.65	2.65	5.30			2.60	10.60	12.00	1.60	3.00	4.60	7.10	13.30	20.41	3.53	6.10	A++
12k+18k+18k	2.65	3.98	3.98			2.60	10.60	12.00	1.60	3.00	4.60	7.10	13.30	20.41	3.53	6.10	A++
12k+18k+24k	2.36	3.53	4.71			2.60	10.60	12.00	1.60	3.00	4.60	7.10	13.30	20.41	3.53	6.10	A++
18k+18k+18k	3.53	3.53	3.53			2.60	10.60	12.00	1.60	3.00	4.60	7.10	13.30	20.41	3.53	6.10	A++
9k+9k+9k+9k	2.65	2.65	2.65	2.65		2.60	10.60	12.00	1.60	3.00	4.60	7.10	13.30	20.41	3.53	7.20	A++
9k+9k+9k+12k	2.45	2.45	2.45	3.26		2.60	10.60	12.00	1.60	3.00	4.60	7.10	13.30	20.41	3.53	7.20	A++
9k+9k+9k+18k	2.12	2.12	2.12	4.24		2.60	10.60	12.00	1.60	3.00	4.60	7.10	13.30	20.41	3.53	7.20	A++
9k+9k+9k+24k	1.87	1.87	1.87	4.99		2.60	10.60	12.00	1.60	3.00	4.60	7.10	13.30	20.41	3.53	7.20	A++
9k+9k+12k+12k	2.27	2.27	3.03	3.03		2.60	10.60	12.00	1.60	3.00	4.60	7.10	13.30	20.41	3.53	7.20	A++
9k+9k+12k+18k	1.99	1.99	2.65	3.98		2.60	10.60	12.00	1.60	3.00	4.60	7.10	13.30	20.41	3.53	7.20	A++
9k+9k+12k+24k	1.77	1.77	2.36	4.71		2.60	10.60	12.00	1.60	3.00	4.60	7.10	13.30	20.41	3.53	7.20	A++
9k+9k+18k+18k	1.77	1.77	3.53	3.53		2.60	10.60	12.00	1.60	3.00	4.60	7.10	13.30	20.41	3.53	7.20	A++
9k+12k+12k+12k	2.12	2.83	2.83	2.83		2.60	10.60	12.00	1.60	3.00	4.60	7.10	13.30	20.41	3.53	7.20	A++
9k+12k+12k+18k	1.87	2.49	2.49	3.74		2.60	10.60	12.00	1.60	3.00	4.60	7.10	13.30	20.41	3.53	7.20	A++
12k+12k+12k+12k	2.65	2.65	2.65	2.65		2.60	10.60	12.00	1.60	3.00	4.60	7.10	13.30	20.41	3.53	7.20	A++
12k+12k+12k+18k	2.36	2.36	2.36	3.53		2.60	10.60	12.00	1.60	3.00	4.60	7.10	13.30	20.41	3.53	7.20	A++

# INDOOR UNITS MATCHINGS: COOLING MODE

ARGO PENTA 42 DCI R32	Nominal Cooling capacity (kW)					Total Cooling capacity (kW)			Total power input (kW)			Total current consumption (A) 230V			EER (W/W)	SEER (W/W)	Energy efficiency class
	Unit A	Unit B	Unit C	Unit D	Unit E	Min.	Nom.	Max.	Min.	Nom.	Max.	Min.	Nom.	Max.	X3 ECO PLUS INDOOR UNIT		
9k+12k	2.60	3.50				2.60	6.10	7.50	1.60	2.30	4.60	11.54	15.08	20.41	2.65	6.10	A++
9k+18k	2.60	5.00				2.60	7.60	9.00	1.60	2.60	4.60	11.54	15.08	20.41	2.92	6.10	A++
9k+24k	2.60	7.20				2.60	9.80	11.00	1.60	3.40	4.60	11.54	15.08	20.41	2.88	6.10	A++
12k+12k	3.50	3.50				2.60	7.00	9.20	1.60	2.40	4.60	11.54	15.08	20.41	2.92	6.10	A++
12k+18k	3.50	5.00				2.60	8.50	10.00	1.60	3.00	4.60	11.54	15.08	20.41	2.83	6.10	A++
12k+24k	3.50	7.10				2.60	10.60	12.00	1.60	3.40	4.60	11.54	15.08	20.41	3.12	6.10	A++
18k+18k	5.30	5.30				2.60	10.60	12.00	1.60	3.40	4.60	11.54	15.08	20.41	3.12	6.10	A++
18k+24k	4.55	6.05				2.60	10.60	12.00	1.60	3.40	4.60	11.54	15.08	20.41	3.12	6.10	A++
24k+24k	5.30	5.30				2.60	10.60	12.00	1.60	3.40	4.60	11.54	15.08	20.41	3.12	6.10	A++
9k+9k+9k	2.67	2.67	2.67			2.60	8.00	10.00	1.60	2.80	4.60	11.54	15.08	20.41	2.86	6.10	A++
9k+9k+12k	2.60	2.60	4.20			2.60	9.40	11.00	1.60	3.40	4.60	11.54	15.08	20.41	2.76	6.10	A++
9k+9k+18k	2.60	2.60	5.00			2.60	10.20	13.02	1.60	3.00	4.60	11.54	13.30	20.41	3.40	6.10	A++
9k+9k+24k	2.60	2.60	6.90			2.60	12.10	15.20	1.60	3.40	4.60	11.54	15.08	20.41	3.56	6.10	A++
9k+12k+12k	2.60	3.50	3.50			2.60	9.60	11.94	1.60	3.00	4.60	11.54	13.30	20.41	3.20	6.10	A++
9k+12k+18k	2.60	3.50	5.00			2.60	11.10	14.11	1.60	3.40	4.60	11.54	15.08	20.41	3.26	6.10	A++
9k+12k+24k	2.40	3.20	6.50			2.60	12.10	15.20	1.60	3.40	4.60	11.54	15.08	20.41	3.56	6.10	A++
9k+18k+18k	2.50	4.80	4.80			2.60	12.10	15.20	1.60	3.40	4.60	11.54	15.08	20.41	3.56	6.10	A++
9k+18k+24k	2.10	4.30	5.70			2.60	12.10	15.20	1.60	3.40	4.60	11.54	15.08	20.41	3.56	6.10	A++
9k+24k+24k	1.90	5.10	5.10			2.60	12.10	15.20	1.60	3.40	4.60	11.54	15.08	20.41	3.56	6.10	A++
12k+12k+12k	3.50	3.50	3.50			2.60	10.50	13.02	1.60	3.00	4.60	11.54	13.30	20.41	3.50	6.10	A++
12k+12k+18k	3.50	3.50	5.10			2.60	12.10	15.20	1.60	3.40	4.60	11.54	15.08	20.41	3.56	6.10	A++
12k+12k+24k	3.00	3.00	6.10			2.60	12.10	15.20	1.60	3.40	4.60	11.54	15.08	20.41	3.56	6.10	A++
12k+18k+18k	3.10	4.50	4.50			2.60	12.10	15.20	1.60	3.40	4.60	11.54	15.08	20.41	3.56	6.10	A++
12k+18k+24k	2.70	4.00	5.40			2.60	12.10	15.20	1.60	3.40	4.60	11.54	15.08	20.41	3.56	6.10	A++
12k+24k+24k	2.50	4.80	4.80			2.60	12.10	15.20	1.60	3.40	4.60	11.54	15.08	20.41	3.56	6.10	A++
18k+18k+18k	4.03	4.03	4.03			2.60	12.10	15.20	1.60	3.40	4.60	11.54	15.08	20.41	3.56	6.10	A++
18k+18k+24k	3.60	3.60	4.90			2.60	12.10	15.20	1.60	3.40	4.60	11.54	15.08	20.41	3.56	6.10	A++
9k+9k+9k+9k	2.60	2.60	2.60	2.60		2.60	10.40	13.02	1.60	3.40	4.60	11.54	15.08	20.41	3.06	6.10	A++
9k+9k+9k+12k	2.60	2.60	2.60	3.50		2.60	11.30	14.11	1.60	3.40	4.60	11.54	15.08	20.41	3.32	6.10	A++
9k+9k+9k+18k	2.42	2.42	2.42	4.84		2.60	12.10	15.20	1.60	3.40	4.60	11.54	15.08	20.41	3.56	6.10	A++
9k+9k+9k+24k	2.14	2.14	2.14	5.69		2.60	12.10	15.20	1.60	3.40	4.60	11.54	15.08	20.41	3.56	6.10	A++
9k+9k+12k+12k	2.59	2.59	3.46	3.46		2.60	12.10	15.20	1.60	3.40	4.60	11.54	15.08	20.41	3.56	6.10	A++
9k+9k+12k+18k	2.27	2.27	3.03	4.54		2.60	12.10	15.20	1.60	3.40	4.60	11.54	15.08	20.41	3.56	6.10	A++
9k+9k+12k+24k	2.02	2.02	2.69	5.38		2.60	12.10	15.20	1.60	3.40	4.60	11.54	15.08	20.41	3.56	6.10	A++
9k+9k+18k+18k	2.02	2.02	4.03	4.03		2.60	12.10	15.20	1.60	3.40	4.60	11.54	15.08	20.41	3.56	6.10	A++
9k+9k+18k+24k	1.82	1.82	3.63	4.84		2.60	12.10	15.20	1.60	3.40	4.60	11.54	15.08	20.41	3.56	6.10	A++
9k+12k+12k+12k	2.42	3.23	3.23	3.23		2.60	12.10	15.20	1.60	3.40	4.60	11.54	15.08	20.41	3.56	6.10	A++
9k+12k+12k+18k	2.14	2.85	2.85	4.27		2.60	12.10	15.20	1.60	3.40	4.60	11.54	15.08	20.41	3.56	6.10	A++
9k+12k+12k+24k	1.91	2.55	2.55	5.09		2.60	12.10	15.20	1.60	3.40	4.60	11.54	15.08	20.41	3.56	6.10	A++
9k+12k+18k+24k	1.91	2.55	3.82	3.82		2.60	12.10	15.20	1.60	3.40	4.60	11.54	15.08	20.41	3.56	6.10	A++
9k+12k+18k+18k	1.73	2.30	3.46	4.61		2.60	12.10	15.20	1.60	3.40	4.60	11.54	15.08	20.41	3.56	6.10	A++
9k+18k+18k+18k	1.73	3.46	3.46	3.46		2.60	12.10	15.20	1.60	3.40	4.60	11.54	15.08	20.41	3.56	6.10	A++
12k+12k+12k+12k	3.03	3.03	3.03	3.03		2.60	12.10	15.20	1.60	3.40	4.60	11.54	15.08	20.41	3.56	6.10	A++
12k+12k+12k+18k	2.69	2.69	2.69	4.03		2.60	12.10	15.20	1.60	3.40	4.60	11.54	15.08	20.41	3.56	6.10	A++
12k+12k+12k+24k	2.42	2.42	2.42	4.84		2.60	12.10	15.20	1.60	3.40	4.60	11.54	15.08	20.41	3.56	6.10	A++
12k+12k+18k+18k	2.42	2.42	3.63	3.63		2.60	12.10	15.20	1.60	3.40	4.60	11.54	15.08	20.41	3.56	6.10	A++
9k+9k+9k+9k+9k	2.42	2.42	2.42	2.42	2.42	2.60	12.10	15.20	1.60	3.40	4.60	11.54	15.08	20.41	3.56	6.10	A++
9k+9k+9k+9k+12k	2.27	2.27	2.27	2.27	3.03	2.60	12.10	15.20	1.60	3.40	4.60	11.54	15.08	20.41	3.56	6.10	A++
9k+9k+9k+9k+18k	2.02	2.02	2.02	2.02	4.03	2.60	12.10	15.20	1.60	3.40	4.60	11.54	15.08	20.41	3.56	6.10	A++
9k+9k+9k+9k+24k	1.82	1.82	1.82	1.82	4.84	2.60	12.10	15.20	1.60	3.40	4.60	11.54	15.08	20.41	3.56	6.10	A++
9k+9k+9k+12k+12k	2.14	2.14	2.14	2.85	2.85	2.60	12.10	15.20	1.60	3.40	4.60	11.54	15.08	20.41	3.56	6.10	A++
9k+9k+9k+12k+18k	1.91	1.91	1.91	2.55	3.82	2.60	12.10	15.20	1.60	3.40	4.60	11.54	15.08	20.41	3.56	6.10	A++
9k+9k+9k+12k+24k	1.73	1.73	1.73	2.30	4.61	2.60	12.10	15.20	1.60	3.40	4.60	11.54	15.08	20.41	3.56	6.10	A++
9k+9k+9k+18k+18k	1.73	1.73	1.73	3.46	3.46	2.60	12.10	15.20	1.60	3.40	4.60	11.54	15.08	20.41	3.56	6.10	A++
9k+9k+12k+12k+12k	2.02	2.02	2.69	2.69	2.69	2.60	12.10	15.20	1.60	3.40	4.60	11.54	15.08	20.41	3.56	6.10	A++
9k+9k+12k+12k+18k	1.82	1.82	2.42	2.42	3.63	2.60	12.10	15.20	1.60	3.40	4.60	11.54	15.08	20.41	3.56	6.10	A++
9k+12k+12k+12k+12k	1.91	2.55	2.55	2.55	2.55	2.60	12.10	15.20	1.60	3.40	4.60	11.54	15.08	20.41	3.56	6.10	A++
9k+12k+12k+12k+18k	1.73	2.30	2.30	2.30	3.46	2.60	12.10	15.20	1.60	3.40	4.60	11.54	15.08	20.41	3.56	6.10	A++
12k+12k+12k+12k+12k	2.42	2.42	2.42	2.42	2.42	2.60	12.10	15.20	1.60	3.40	4.60	11.54	15.08	20.41	3.56	6.10	A++

# INDOOR UNITS MATCHINGS: HEATING MODE

ARGO DUAL 14 DCI R32	Nominal Heating capacity (kW)					Total Heating capacity (kW)			Total power input (kW)			Total current consumption (A) 230V			COP (W/W)	SCOP (W/W)	Energy efficiency class
	Unit A	Unit B	Unit C	Unit D	Unit E	Min.	Nom.	Max.	Min.	Nom.	Max.	Min.	Nom.	Max.	X3 ECO PLUS INDOOR UNIT		
9k+9k	2.20	2.20				2.50	4.40	5.40	0.60	0.97	2.25	2.66	4.30	9.98	4.54	4.00	A+
9k+12k	1.89	2.51				2.50	4.40	5.40	0.60	0.97	2.25	2.66	4.30	9.98	4.54	4.00	A+

ARGO DUAL 18 DCI R32	Nominal Heating capacity (kW)					Total Heating capacity (kW)			Total power input (kW)			Total current consumption (A) 230V			COP (W/W)	SCOP (W/W)	Energy efficiency class
	Unit A	Unit B	Unit C	Unit D	Unit E	Min.	Nom.	Max.	Min.	Nom.	Max.	Min.	Nom.	Max.	X3 ECO PLUS INDOOR UNIT		
9k+9k	2.83	2.83				2.58	5.65	6.50	0.70	1.25	2.50	3.11	5.55	11.09	4.52	4.00	A+
9k+12k	2.42	3.23				2.58	5.65	6.50	0.70	1.25	2.50	3.11	5.55	11.09	4.52	4.00	A+
12k+12k	2.83	2.83				2.58	5.65	6.50	0.70	1.25	2.50	3.11	5.55	11.09	4.52	4.00	A+

ARGO TRIAL 21 DCI R32	Nominal Heating capacity (kW)					Total Heating capacity (kW)			Total power input (kW)			Total current consumption (A) 230V			COP (W/W)	SCOP (W/W)	Energy efficiency class
	Unit A	Unit B	Unit C	Unit D	Unit E	Min.	Nom.	Max.	Min.	Nom.	Max.	Min.	Nom.	Max.	X3 ECO PLUS INDOOR UNIT		
9k+9k	2.80	2.80				2.70	5.60	8.50	0.60	1.23	2.50	2.66	5.44	11.09	4.57	4.00	A+
9k+12k	2.70	3.80				2.70	6.50	8.50	0.80	1.43	2.90	3.55	6.34	12.87	4.55	4.00	A+
9k+18k	2.17	4.33				2.70	6.50	8.50	0.80	1.43	2.90	3.55	6.34	12.87	4.55	4.00	A+
12k+12k	3.25	3.25				2.70	6.50	8.50	0.80	1.43	2.90	3.55	6.34	12.87	4.55	4.00	A+
12k+18k	2.60	3.90				2.70	6.50	8.50	0.80	1.43	2.90	3.55	6.34	12.87	4.55	4.00	A+
9k+9k+9k	2.17	2.17	2.17			2.70	6.50	8.50	0.80	1.43	2.90	3.55	6.34	12.87	4.55	3.80	A
9k+9k+12k	1.95	1.95	2.60			2.70	6.50	8.50	0.80	1.43	2.90	3.55	6.34	12.87	4.55	3.80	A

ARGO TRIAL 24 DCI R32	Nominal Heating capacity (kW)					Total Heating capacity (kW)			Total power input (kW)			Total current consumption (A) 230V			COP (W/W)	SCOP (W/W)	Energy efficiency class
	Unit A	Unit B	Unit C	Unit D	Unit E	Min.	Nom.	Max.	Min.	Nom.	Max.	Min.	Nom.	Max.	X3 ECO PLUS INDOOR UNIT		
9k+9k	3.20	3.20				2.80	6.40	8.80	0.60	1.67	2.40	2.66	7.42	10.65	3.83	3.80	A
9k+12k	3.20	4.30				2.80	7.50	8.80	0.60	1.95	2.60	2.66	8.66	11.54	3.84	3.80	A
9k+18k	2.87	5.73				2.80	8.60	8.80	0.80	2.23	3.00	3.55	9.89	13.31	3.86	3.80	A
12k+12k	4.30	4.30				2.80	8.60	8.80	0.80	2.23	3.00	3.55	9.89	13.31	3.86	3.80	A
12k+18k	3.44	5.16				2.80	8.60	8.80	0.80	2.23	3.00	3.55	9.89	13.31	3.86	3.80	A
18k+18k	4.30	4.30				2.80	8.60	8.80	0.80	2.23	3.00	3.55	9.89	13.31	3.86	3.80	A
9k+9k+9k	2.87	2.87	2.87			2.80	8.60	9.20	0.80	2.23	3.00	3.55	9.89	13.31	3.86	3.90	A
9k+9k+12k	2.58	2.58	3.44			2.80	8.60	9.20	0.80	2.23	3.00	3.55	9.89	13.31	3.86	3.90	A
9k+9k+18k	2.15	2.15	4.30			2.80	8.60	9.20	0.80	2.23	3.00	3.55	9.89	13.31	3.86	3.90	A
9k+12k+12k	2.35	3.13	3.13			2.80	8.60	9.20	0.80	2.23	3.00	3.55	9.89	13.31	3.86	3.90	A
12k+12k+12k	2.87	2.87	2.87			2.80	8.60	9.20	0.80	2.23	3.00	3.55	9.89	13.31	3.86	3.90	A

ARGO QUADRI 28 DCI R32	Nominal Heating capacity (kW)					Total Heating capacity (kW)			Total power input (kW)			Total current consumption (A) 230V			COP (W/W)	SCOP (W/W)	Energy efficiency class
	Unit A	Unit B	Unit C	Unit D	Unit E	Min.	Nom.	Max.	Min.	Nom.	Max.	Min.	Nom.	Max.	X3 ECO PLUS INDOOR UNIT		
9k+9k	2.80	2.80				2.80	5.60	10.00	0.70	1.41	2.50	3.11	6.27	11.09	3.96	4.00	A+
9k+12k	2.80	5.43				2.80	8.23	10.25	0.70	1.65	2.60	3.11	7.32	11.54	4.99	4.00	A+
9k+18k	2.80	3.80				2.80	6.60	10.25	1.00	2.12	3.40	4.44	9.41	15.08	3.11	4.00	A+
12k+12k	3.80	3.80				2.80	7.60	10.25	0.90	1.89	2.80	3.99	8.37	12.42	4.03	4.00	A+
12k+18k	3.80	5.60				2.80	9.40	10.25	1.00	2.20	3.60	4.44	9.76	15.97	4.27	4.00	A+
18k+18k	4.75	4.75				2.80	9.50	10.25	1.00	2.20	3.60	4.44	9.76	15.97	4.32	4.00	A+
9k+9k+9k	3.17	3.17	3.17			2.80	9.50	10.25	1.00	2.12	3.40	4.44	9.41	15.08	4.48	4.00	A+
9k+9k+12k	2.85	2.85	3.80			2.80	9.50	10.25	1.00	2.20	3.60	4.44	9.76	15.97	4.32	4.00	A+
9k+9k+18k	2.38	2.38	4.75			2.80	9.50	10.25	1.00	2.20	3.60	4.44	9.76	15.97	4.32	4.00	A+
9k+12k+12k	2.59	3.45	3.45			2.80	9.50	10.25	1.00	2.20	3.60	4.44	9.76	15.97	4.32	4.00	A+
9k+12k+18k	2.19	2.92	4.38			2.80	9.50	10.25	1.00	2.20	3.60	4.44	9.76	15.97	4.32	4.00	A+
12k+12k+12k	3.17	3.17	3.17			2.80	9.50	10.25	1.00	2.20	3.60	4.44	9.76	15.97	4.32	4.00	A+
12k+12k+18k	2.71	2.71	4.07			2.80	9.50	10.25	1.00	2.20	3.60	4.44	9.76	15.97	4.32	4.00	A+
9k+9k+9k+9k	2.38	2.38	2.38	2.38		2.80	9.50	10.25	1.00	2.20	3.60	4.44	9.76	15.97	4.32	4.00	A+
9k+9k+9k+12k	2.19	2.19	2.19	2.92		2.80	9.50	10.25	1.00	2.20	3.60	4.44	9.76	15.97	4.32	4.00	A+
9k+9k+12k+12k	2.04	2.04	2.71	2.71		2.80	9.50	10.25	1.00	2.20	3.60	4.44	9.76	15.97	4.32	4.00	A+

# INDOOR UNITS MATCHINGS: HEATING MODE

ARGO QUADRI 36 DCI R32	Nominal Heating capacity (kW)					Total Heating capacity (kW)			Total power input (kW)			Total current consumption (A) 230V			COP (W/W)	SCOP (W/W)	Energy efficiency class
	Unit A	Unit B	Unit C	Unit D	Unit E	Min.	Nom.	Max.	Min.	Nom.	Max.	Min.	Nom.	Max.	X3 ECO PLUS INDOOR UNIT		
9k+9k	2.80	2.80				3.00	5.60	7.00	1.61	1.90	3.60	7.13	14.20	17.75	2.95	4.00	A+
9k+12k	2.80	3.80				3.00	6.60	8.16	1.61	2.30	3.80	7.13	14.20	17.75	2.87	4.00	A+
9k+18k	2.80	5.60				3.00	8.40	10.50	1.61	2.80	4.20	7.13	14.20	17.75	3.00	4.00	A+
9k+24k	2.80	8.50				3.00	11.30	12.83	1.61	3.04	5.00	7.13	14.20	17.75	3.72	4.00	A+
12k+12k	3.80	3.80				3.00	7.60	9.33	1.61	2.60	4.00	7.13	14.20	17.75	2.92	4.00	A+
12k+18k	3.80	5.60				3.00	9.40	11.66	1.61	2.90	4.80	7.13	14.20	17.75	3.24	4.00	A+
12k+24k	3.80	8.20				3.00	12.00	14.00	1.61	3.04	5.00	7.13	14.20	17.75	3.95	4.00	A+
18k+18k	6.00	6.00				3.00	12.00	14.00	1.61	3.04	5.00	7.13	14.20	17.75	3.95	4.00	A+
18k+24k	5.14	6.86				3.00	12.00	14.00	1.61	3.04	5.00	7.13	14.20	17.75	3.95	4.00	A+
24k+24k	6.00	6.00				3.00	12.00	14.00	1.61	3.04	5.00	7.13	14.20	17.75	3.95	4.00	A+
9k+9k+9k	2.80	2.80				3.00	5.60	7.00	1.61	1.90	3.60	7.13	14.20	17.75	2.95	4.00	A+
9k+9k+12k	2.80	3.80				3.00	6.60	8.16	1.61	2.30	3.80	7.13	14.20	17.75	2.87	4.00	A+
9k+9k+18k	2.80	5.60				3.00	8.40	10.50	1.61	2.80	4.20	7.13	14.20	17.75	3.00	4.00	A+
9k+9k+24k	2.80	8.50				3.00	11.30	12.83	1.61	3.04	5.00	7.13	14.20	17.75	3.72	4.00	A+
9k+12k+12k	3.80	3.80				3.00	7.60	9.33	1.61	2.60	4.00	7.13	14.20	17.75	2.92	4.00	A+
9k+12k+18k	3.80	5.60				3.00	9.40	11.66	1.61	2.90	4.80	7.13	14.20	17.75	3.24	4.00	A+
9k+12k+24k	3.80	8.20				3.00	12.00	14.00	1.61	3.04	5.00	7.13	14.20	17.75	3.95	4.00	A+
9k+18k+18k	6.00	6.00				3.00	12.00	14.00	1.61	3.04	5.00	7.13	14.20	17.75	3.95	4.00	A+
9k+18k+24k	5.14	6.86				3.00	12.00	14.00	1.61	3.04	5.00	7.13	14.20	17.75	3.95	4.00	A+
12k+12k+12k	6.00	6.00				3.00	12.00	14.00	1.61	3.04	5.00	7.13	14.20	17.75	3.95	4.00	A+
12k+12k+18k	3.43	3.43	5.14			3.00	12.00	14.00	1.61	3.04	5.00	7.13	14.20	17.75	3.95	4.00	A+
12k+12k+24k	3.00	3.00	6.00			3.00	12.00	14.00	1.61	3.04	5.00	7.13	14.20	17.75	3.95	4.00	A+
12k+18k+18k	3.00	4.50	4.50			3.00	12.00	14.00	1.61	3.04	5.00	7.13	14.20	17.75	3.95	4.00	A+
12k+18k+24k	2.67	4.00	5.33			3.00	12.00	14.00	1.61	3.04	5.00	7.13	14.20	17.75	3.95	4.00	A+
18k+18k+18k	4.00	4.00	4.00			3.00	12.00	14.00	1.61	3.04	5.00	7.13	14.20	17.75	3.95	4.00	A+
9k+9k+9k+9k	3.00	3.00	3.00	3.00		3.00	12.00	14.00	1.61	3.04	5.00	7.13	14.20	17.75	3.95	4.00	A+
9k+9k+9k+12k	2.77	2.77	2.77	3.69		3.00	12.00	14.00	1.61	3.04	5.00	7.13	14.20	17.75	3.95	4.00	A+
9k+9k+9k+18k	2.40	2.40	2.40	4.80		3.00	12.00	14.00	1.61	3.04	5.00	7.13	14.20	17.75	3.95	4.00	A+
9k+9k+9k+24k	2.12	2.12	2.12	5.65		3.00	12.00	14.00	1.61	3.04	5.00	7.13	14.20	17.75	3.95	4.00	A+
9k+9k+12k+12k	2.57	2.57	3.43	3.43		3.00	12.00	14.00	1.61	3.04	5.00	7.13	14.20	17.75	3.95	4.00	A+
9k+9k+12k+18k	2.25	2.25	3.00	4.50		3.00	12.00	14.00	1.61	3.04	5.00	7.13	14.20	17.75	3.95	4.00	A+
9k+9k+12k+24k	2.00	2.00	2.67	5.33		3.00	12.00	14.00	1.61	3.04	5.00	7.13	14.20	17.75	3.95	4.00	A+
9k+9k+18k+18k	2.00	2.00	4.00	4.00		3.00	12.00	14.00	1.61	3.04	5.00	7.13	14.20	17.75	3.95	4.00	A+
9k+12k+12k+12k	2.40	3.20	3.20	3.20		3.00	12.00	14.00	1.61	3.04	5.00	7.13	14.20	17.75	3.95	4.00	A+
9k+12k+12k+18k	2.12	2.82	2.82	4.24		3.00	12.00	14.00	1.61	3.04	5.00	7.13	14.20	17.75	3.95	4.00	A+
12k+12k+12k+12k	3.00	3.00	3.00	3.00		3.00	12.00	14.00	1.61	3.04	5.00	7.13	14.20	17.75	3.95	4.00	A+
12k+12k+12k+18k	2.67	2.67	2.67	4.00		3.00	12.00	14.00	1.61	3.04	5.00	7.13	14.20	17.75	3.95	4.00	A+

ARGO PENTA 42 DCI R32	Nominal Heating capacity (kW)					Total Heating capacity (kW)			Total power input (kW)			Total current consumption (A) 230V			COP (W/W)	SCOP (W/W)	Energy efficiency class
	Unit A	Unit B	Unit C	Unit D	Unit E	Min.	Nom.	Max.	Min.	Nom.	Max.	Min.	Nom.	Max.	X3 ECO PLUS INDOOR UNIT		
9k+12k	2.80	3.80				3,00	6,60	7,75	1.61	2.30	4.20	7.13	14.20	17.75	2.87	4.00	A+
9k+18k	2.80	5.60				3,00	8,40	9,96	1.61	2.60	4.50	7.13	14.20	17.75	3.23	4.00	A+
9k+24k	2.80	8.50				3,00	11,30	12,17	1.61	2.80	4.50	7.13	14.20	17.75	4.04	4.00	A+
12k+12k	3.80	3.80				3,00	7,60	8,85	1.61	2.60	4.50	7.13	14.20	17.75	2.92	4.00	A+
12k+18k	3.80	5.60				3,00	9,40	11,07	1.61	2.80	4.50	7.13	14.20	17.75	3.36	4.00	A+
12k+24k	3.80	8.50				3,00	12,30	13,28	1.61	2.80	4.50	7.13	14.20	17.75	4.39	4.00	A+
18k+18k	5.60	5.60				3,00	11,20	13,28	1.61	2.80	4.50	7.13	14.20	17.75	4.00	4.00	A+
18k+24k	5.57	7.43				3,00	13,00	15,50	1.61	3.19	5.00	7.13	14.20	17.75	4.08	4.00	A+
24k+24k	6.50	6.50				3,00	13,00	15,50	1.61	3.19	5.00	7.13	14.20	17.75	4.08	4.00	A+
9k+9k+9k	2.80	2.80	2.80			3,00	8,40	9,96	1.61	2.60	4.50	7.13	14.20	17.75	3.23	4.00	A+
9k+9k+12k	2.80	2.80	3.80			3,00	9,40	11,07	1.61	2.80	4.50	7.13	14.20	17.75	3.36	4.00	A+
9k+9k+18k	2.80	2.80	5.60			3,00	11,20	13,28	1.61	2.80	4.50	7.13	14.20	17.75	4.00	4.00	A+
9k+9k+24k	2.79	2.79	7.43			3,00	13,00	15,50	1.61	3.19	5.00	7.13	14.20	17.75	4.08	4.00	A+
9k+12k+12k	2.80	3.80	3.80			3,00	10,40	12,17	1.61	2.80	4.50	7.13	14.20	17.75	3.71	4.00	A+
9k+12k+18k	2.80	3.80	5.60			3,00	12,20	14,39	1.61	3.19	5.00	7.13	14.20	17.75	3.82	4.00	A+
9k+12k+24k	2.60	3.47	6.93			3,00	13,00	15,50	1.61	3.19	5.00	7.13	14.20	17.75	4.08	4.00	A+
9k+18k+18k	2.60	5.20	5.20			3,00	13,00	15,50	1.61	3.19	5.00	7.13	14.20	17.75	4.08	4.00	A+
9k+18k+24k	2.29	4.59	6.12			3,00	13,00	15,50	1.61	3.19	5.00	7.13	14.20	17.75	4.08	4.00	A+
9k+24k+24k	2.05	5.47	5.47			3,00	13,00	15,50	1.61	3.19	5.00	7.13	14.20	17.75	4.08	4.00	A+
12k+12k+12k	4.33	4.33	4.33			3,00	13,00	13,28	1.61	2.80	4.50	7.13	14.20	17.75	4.64	4.00	A+
12k+12k+18k	3.71	3.71	5.57			3,00	13,00	15,50	1.61	3.19	5.00	7.13	14.20	17.75	4.08	4.00	A+
12k+12k+24k	3.25	3.25	6.50			3,00	13,00	15,50	1.61	3.19	5.00	7.13	14.20	17.75	4.08	4.00	A+
12k+18k+18k	3.25	4.88	4.88			3,00	13,00	15,50	1.61	3.19	5.00	7.13	14.20	17.75	4.08	4.00	A+
12k+18k+24k	2.89	4.33	5.78			3,00	13,00	15,50	1.61	3.19	5.00	7.13	14.20	17.75	4.08	4.00	A+
12k+24k+24k	2.60	5.20	5.20			3,00	13,00	15,50	1.61	3.19	5.00	7.13	14.20	17.75	4.08	4.00	A+
18k+18k+18k	4.33	4.33	4.33			3,00	13,00	15,50	1.61	3.19	5.00	7.13	14.20	17.75	4.08	4.00	A+
18k+18k+24k	3.90	3.90	5.20			3,00	13,00	15,50	1.61	3.19	5.00	7.13	14.20	17.75	4.08	4.00	A+
9k+9k+9k+9k	3.25	3.25	3.25	3.25		3,00	13,00	14,00	1.61	3.00	4.80	7.13	14.20	17.75	4.33	4.00	A+
9k+9k+9k+12k	3.00	3.00	3.00	4.00		3,00	13,00	14,39	1.61	3.19	5.00	7.13	14.20	17.75	4.08	4.00	A+
9k+9k+9k+18k	2.60	2.60	2.60	5.20		3,00	13,00	15,50	1.61	3.19	5.00	7.13	14.20	17.75	4.08	4.00	A+
9k+9k+9k+24k	2.29	2.29	2.29	6.12		3,00	13,00	15,50	1.61	3.19	5.00	7.13	14.20	17.75	4.08	4.00	A+
9k+9k+12k+12k	2.79	2.79	3.71	3.71		3,00	13,00	15,50	1.61	3.19	5.00	7.13	14.20	17.75	4.08	4.00	A+
9k+9k+12k+18k	2.44	2.44	3.25	4.88		3,00	13,00	15,50	1.61	3.19	5.00	7.13	14.20	17.75	4.08	4.00	A+
9k+9k+12k+24k	2.17	2.17	2.89	5.78		3,00	13,00	15,50	1.61	3.19	5.00	7.13	14.20	17.75	4.08	4.00	A+
9k+9k+18k+18k	2.17	2.17	4.33	4.33		3,00	13,00	15,50	1.61	3.19	5.00	7.13	14.20	17.75	4.08	4.00	A+
9k+9k+18k+24k	1.95	1.95	3.90	5.20		3,00	13,00	15,50	1.61	3.19	5.00	7.13	14.20	17.75	4.08	4.00	A+
9k+12k+12k+12k	2.60	3.47	3.47	3.47		3,00	13,00	15,50	1.61	3.19	5.00	7.13	14.20	17.75	4.08	4.00	A+
9k+12k+12k+18k	2.29	3.06	3.06	4.59		3,00	13,00	15,50	1.61	3.19	5.00	7.13	14.20	17.75	4.08	4.00	A+
9k+12k+12k+24k	2.05	2.74	2.74	5.47		3,00	13,00	15,50	1.61	3.19	5.00	7.13	14.20	17.75	4.08	4.00	A+
9k+12k+18k+18k	2.05	2.74	4.11	4.11		3,00	13,00	15,50	1.61	3.19	5.00	7.13	14.20	17.75	4.08	4.00	A+
9k+12k+18k+24k	1.86	2.48	3.71	4.95		3,00	13,00	15,50	1.61	3.19	5.00	7.13	14.20	17.75	4.08	4.00	A+
9k+18k+18k+18k	1.86	3.71	3.71	3.71		3,00	13,00	15,50	1.61	3.19	5.00	7.13	14.20	17.75	4.08	4.00	A+
12k+12k+12k+12k	3.25	3.25	3.25	3.25		3,00	13,00	15,50	1.61	3.19	5.00	7.13	14.20	17.75	4.08	4.00	A+
12k+12k+12k+18k	2.89	2.89	2.89	4.33		3,00	13,00	15,50	1.61	3.19	5.00	7.13	14.20	17.75	4.08	4.00	A+
12k+12k+12k+24k	2.60	2.60	2.60	5.20		3,00	13,00	15,50	1.61	3.19	5.00	7.13	14.20	17.75	4.08	4.00	A+
12k+12k+18k+18k	2.60	2.60	3.90	3.90		3,00	13,00	15,50	1.61	3.19	5.00	7.13	14.20	17.75	4.08	4.00	A+
9k+9k+9k+9k+9k	2.60	2.60	2.60	2.60	2.60	3,00	13,00	15,50	1.61	3.19	5.00	7.13	14.20	17.75	4.08	4.20	A+
9k+9k+9k+9k+12k	2.44	2.44	2.44	2.44	3.25	3,00	13,00	15,50	1.61	3.19	5.00	7.13	14.20	17.75	4.08	4.20	A+
9k+9k+9k+9k+18k	2.17	2.17	2.17	2.17	4.33	3,00	13,00	15,50	1.61	3.19	5.00	7.13	14.20	17.75	4.08	4.00	A+
9k+9k+9k+9k+24k	1.95	1.95	1.95	1.95	5.20	3,00	13,00	15,50	1.61	3.19	5.00	7.13	14.20	17.75	4.08	4.00	A+
9k+9k+9k+12k+12k	2.29	2.29	2.29	3.06	3.06	3,00	13,00	15,50	1.61	3.19	5.00	7.13	14.20	17.75	4.08	4.00	A+
9k+9k+9k+12k+18k	2.05	2.05	2.05	2.74	4.11	3,00	13,00	15,50	1.61	3.19	5.00	7.13	14.20	17.75	4.08	4.00	A+
9k+9k+9k+12k+24k	1.86	1.86	1.86	2.48	4.95	3,00	13,00	15,50	1.61	3.19	5.00	7.13	14.20	17.75	4.08	4.00	A+
9k+9k+9k+18k+18k	1.86	1.86	1.86	3.71	3.71	3,00	13,00	15,50	1.61	3.19	5.00	7.13	14.20	17.75	4.08	4.00	A+
9k+9k+12k+12k+12k	2.17	2.17	2.89	2.89	2.89	3,00	13,00	15,50	1.61	3.19	5.00	7.13	14.20	17.75	4.08	4.00	A+
9k+12k+12k+12k+18k	1.95	1.95	2.60	2.60	3.90	3,00	13,00	15,50	1.61	3.19	5.00	7.13	14.20	17.75	4.08	4.00	A+
9k+12k+12k+12k+24k	2.05	2.74	2.74	2.74	2.74	3,00	13,00	15,50	1.61	3.19	5.00	7.13	14.20	17.75	4.08	4.20	A+
9k+12k+12k+12k+18k	1.86	2.48	2.48	2.48	3.71	3,00	13,00	15,50	1.61	3.19	5.00	7.13	14.20	17.75	4.08	4.00	A+
12k+12k+12k+12k+12k	2.60	2.60	2.60	2.60	2.60	3,00	13,00	15,50	1.61	3.19	5.00	7.13	14.20	17.75	4.08	4.20	A+

# HIGH-WALL

## MULTISPLIT INDOOR UNITS



(Standard)  
Infrared remote  
controller



(Optional)  
Wired controller  
with weekly timer

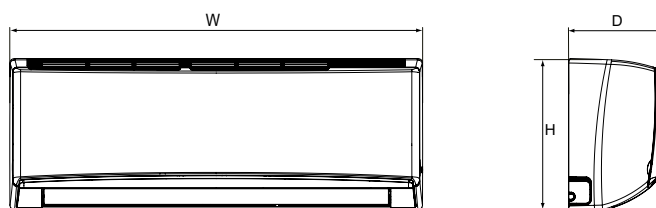
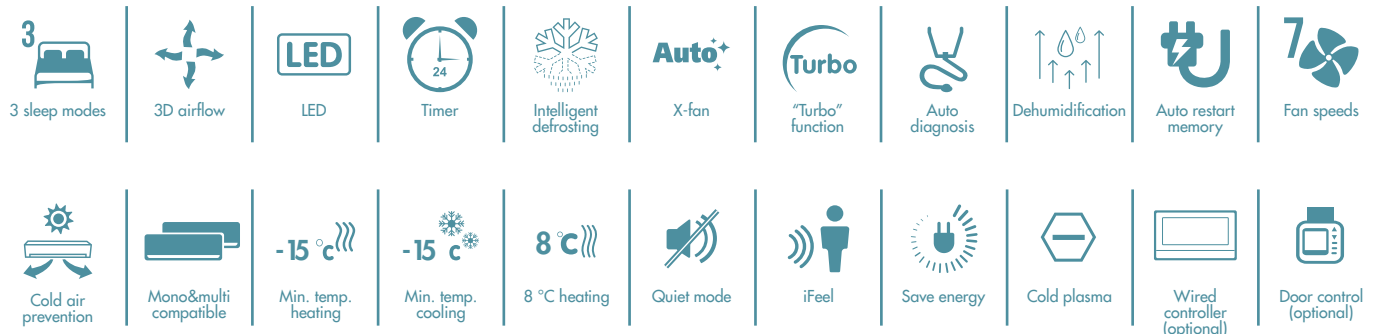

High-wall indoor units		X3I ECO PLUS 27 HL WF		X3I ECO PLUS 35 HL WF		X3I ECO PLUS 52 HL WF		X3I ECO PLUS 70 HL WF	
	Units	Cooling	Heating	Cooling	Heating	Cooling	Heating	Cooling	Heating
Capacity	kW	2.70	2.80	3.50	3.67	5.20	5.30	7.00	7.40
Air flow rate (sh.-h.-mh.-m.-ml.-l.-sl.)	m <sup>3</sup> /h	560-490-460-430-380-330-290		680-620-560-490-450-420-390		800-720-650-610-570-520-470		1250-1100-1000-950-900-850-750	
Dehumidification	l/h	0.8		1.4		1.8		2.4	
Fan speeds	n°	7		7		7		7	
Sound pressure (sh.-h.-mh.-m.-ml.-l.-sl.)	dB(A)	41-37-35-32-29-26-24		42-38-36-34-32-29-26		45-43-41-38-35-34-31		48-45-42-39-37-36-33	
Sound power (sh.-h.-mh.-m.-ml.-l.-sl.)	dB(A)	55-48-46-44-40-37-35		57-50-48-46-44-41-38		59-57-55-52-49-48-45		63-60-57-54-52-51-48	
Liquid pipe diameter	mm (inch)	6.35 (1/4")		6.35 (1/4")		6.35 (1/4")		6.35 (1/4")	
Gas pipe diameter	mm (inch)	9.52 (3/8")		9.52 (3/8")		12.7 (1/2")		15.88 (1/2")	
Net dimension (H/W/D)	mm	275/790/200		289/845/209		300/970/224		325/1078/246	
Net weight Indoor/Outdoor	kg	9		10.5		13.5		16.5	

# 8-WAY CASSETTES

## NEW MULTISPLIT INDOOR UNITS



(Standard)  
Infrared remote controller



(Optional)  
Wired controller with WiFi



(Optional)  
Wired controller with weekly timer



3 sleep modes



Timer



Intelligent defrosting



X-fan



"Turbo" function



Auto diagnosis



Dehumidification



Auto restart memory



Fan speeds



Child lock



Only multisplit



Min. temp. heating



Min. temp. cooling



8 °C heating



Quiet mode



iFeel



Save energy



Drain condensate pump integrated



Wired controller (optional)



Door control (optional)

AIR CONDITIONERS

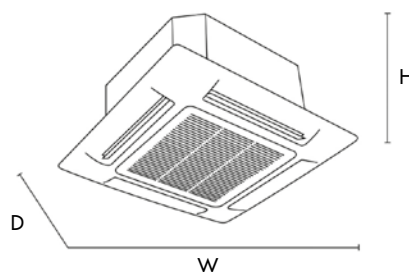

8-WAY CASSETTES		X3I ECO AS28HL		X3I ECO AS35HL		X3I ECO AS50HL		X3I ECO AS70HL	
	Units	Cooling	Heating	Cooling	Heating	Cooling	Heating	Cooling	Heating
Nominal capacity	kW	2.80	2.90	3.50	4.00	5.00	5.50	7.00	8.00
Air flow rate (sh.-h.-mh.-m.-ml.-l.-sl.)	m <sup>3</sup> /h	560-540-490-450-420-380-350		560-540-490-450-420-380-350		650-540-490-450-420-380-350		1100-1050-950-910-870-830-800	
Dehumidification	l/h	1.4		1.8		1.8		2.5	
Fan speed	n°	7+auto		7+auto		7+auto		7+auto	
Sound pressure (sh.-h.-mh.-m.-ml.-l.-sl.)	dB(A)	41-39-36-34-32-30-28		41-39-36-34-32-30-28		43-39-36-34-32-30-28		46-45-44-43-42-41-39	
Sound power U.I. (sh.-h.-mh.-m.-ml.-l.-sl.)	dB(A)	57-55-52-50-48-46-44		57-55-52-50-48-46-44		59-55-52-50-48-46-44		62-61-60-59-58-57-55	
Liquid pipe diameter	mm (inch)	6.35 (1/4")		6.35 (1/4")		6.35 (1/4")		6.35 (1/4")	
Gas pipe diameter	mm (inch)	9.52 (3/8")		9.52 (3/8")		12.7 (1/2")		15.88 (5/8")	
Indoor net dimension without grid (H./W./D.)	mm	265/570/570		265/570/570		265/570/570		240/840/840	
Indoor net dimension with grid (H./W./D.)	mm	312.5/620/620		312.5/620/620		312.5/620/620		292/950/950	
Net dimension grid (H./W./D.)	mm	47.5/620/620		47.5/620/620		47.5/620/620		52/950/950	
Indoor unit weight without grid	kg	17		17		17		29	
Panel net weight	kg	3		3		3		6	

# SLIM DUCTED

## NEW MULTISPLIT INDOOR UNITS



(Standard)  
Wired controller



(Optional)  
Wired controller  
with weekly timer

Sleep mode	Timer	Intelligent defrosting	Save energy	Turbo function	Auto diagnosis	Dehumidification	Auto restart memory	Fan speeds	iFeel	Quiet mode
Mono&multi compatible	Min. temp. heating -15 °C	Min. temp. cooling -15 °C	8 °C heating	Wired controller (optional)	Door control (optional)	Integrated condensate discharge pump				

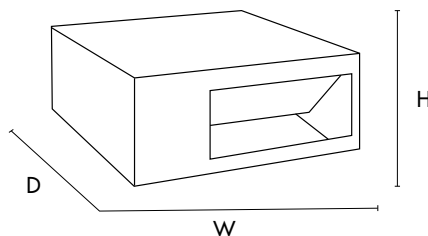

Ducted indoor units with adjustable external static pressure		X3I ECO SD27HL		X3I ECO SD35HL		X3I ECO SD50HL		X3I ECO SD70HL	
	Units	Cooling	Heating	Cooling	Heating	Cooling	Heating	Cooling	Heating
Capacity	kW	2.65	2.80	3.50	3.85	5.00	5.50	7.00	8.00
Air flow rate (sh.-h.-mh.-m.-ml.-l.-sl.)	m <sup>3</sup> /h	650-560-520-480-450-410-380		700-670-640-610-580-550-520		880-840-810-790-770-750-730		1500-1200-1200-1000-1000-900-900	
Min.-max. external static pressure	Pa	25-60		25-60		25-60		25-125	
Dehumidification	l/h	0.8		1.4		1.8		2.5	
Fan speed	n°	7 + auto		7 + auto		7 + auto		7 + auto	
Sound pressure (sh.-h.-mh.-m.-ml.-l.-sl.)	dB(A)	39-37-36-35-34-33-32		41-39-38-37-36-35-34		41-39-39-38-38-37-34		45-40-40-38-38-36-36	
Sound power (sh.-h.-mh.-m.-ml.-l.-sl.)	dB(A)	55-53-52-51-50-49-48		57-55-54-53-52-51-50		57-55-55-54-54-53-50		62-57-57-55-55-53-53	
Liquid pipe diameter	mm (inch)	6.35 (1/4")		6.35 (1/4")		6.35 (1/4")		6.35 (1/4")	
Gas pipe diameter	mm (inch)	9.52 (3/8")		9.52 (3/8")		12.7 (1/2")		15.88 (1/2")	
Net dimension (H./W./D.)	mm	200/710/450		200/710/450		200/1010/450		260/900/655	
Net weight	kg	18,5		19		25		31	



# FLOOR/CEILING

## MULTISPLIT INDOOR UNITS



(Standard)  
Infrared remote  
controller



(Optional)  
Wired controller  
with weekly timer



Sleep mode



LED



Timer



Intelligent  
defrosting



Save energy



"Turbo"  
function



Auto  
diagnosis



Dehumidification



Auto restart  
memory



Fan speeds



iFeel



Only multisplit



Min. temp.  
heating



Min. temp.  
cooling



8 °C heating



Wired  
controller  
(optional)



Door control  
(optional)

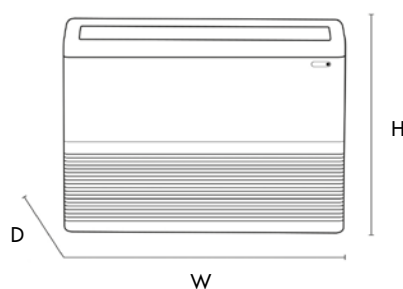

Floor/ceiling indoor units		X3I ECO FC26HL		X3I ECO FC35HL		X3I ECO FC45HL	
	Units	Cooling	Heating	Cooling	Heating	Cooling	Heating
Capacity	kW	2.60	2.70	3.50	4.00	4.50	5.50
Air flow rate (sh.-h.-m.-l.)	m <sup>3</sup> /h	700-610-540-420		700-610-540-420		700-610-540-420	
Dehumidification	l/h	0.8		1.4		1.8	
Fan speeds	n°	7		7		7	
Sound pressure (sh.-h.-m.-l.)	dB(A)	38-35-30-26		38-35-30-26		38-35-30-26	
Sound power (sh.-h.-m.-l.)	dB(A)	52-49-44-40		52-49-44-40		52-49-44-40	
Liquid pipe diameter	mm (inch)	6.35 (1/4")		6.35 (1/4")		6.35 (1/4")	
Gas pipe diameter	mm (inch)	9.52 (3/8")		9.52 (3/8")		12.7 (1/2")*	
Net dimension Outdoor (H/W/D)	mm	665/870/235		665/870/235		665/870/235	
Net weight Indoor/Outdoor	kg	25		25		25,5	

\*For matching with dual split the adaptor kit (optional) is required

# CONSOLE

## MULTISPLIT INDOOR UNITS



(Standard)  
Infrared remote  
controller



(Optional)  
Wired controller  
with weekly timer



3 sleep mode



LED



Timer



Intelligent  
defrosting



Save energy



"Turbo"  
function



Auto  
diagnosis



Dehumidification



Auto restart  
memory



Fan speeds



iFeel



Only multisplit



Min. temp.  
heating



Min. temp.  
cooling



8 °C heating



Wired  
controller  
(optional)

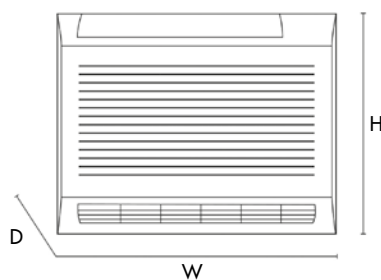

Console indoor units		X3I ECO PLUS AF27HL		X3I ECO PLUS AF35HL		X3I ECO PLUS AF52HL	
	Units	Cooling	Heating	Cooling	Heating	Cooling	Heating
Capacity	kW	2.70	2.90	3.52	3.80	5.20	5.33
Air flow rate (sh.-h.-mh.-m.-ml.-l.-sl.)	m <sup>3</sup> /h	500-430-410-370-330-280-250		600-520-480-440-400-360-280		650-620-550-500-450-410-320	
Dehumidification	l/h	0.8		1.4		1.8	
Fan speeds	n°	7		7		7	
Sound pressure (sh.-h.-mh.-m.-ml.-l.-sl.)	dB(A)	39-36-33-31-29-26-23		44-40-38-36-33-29-25		47-45-42-40-37-35-31	
Sound power (sh.-h.-mh.-m.-ml.-l.-sl.)	dB(A)	50-48-45-44-42-38-34		54-50-48-46-43-39-35		57-55-52-50-47-45-41	
Liquid pipe diameter	mm (inch)	6.35 (1/4")		6.35 (1/4")		6.35 (1/4")	
Gas pipe diameter	mm (inch)	9.52 (3/8")		9.52 (3/8")		12.7 (1/2")	
Net dimension Outdoor (H/W/D)	mm	600/700/215		600/700/215		600/700/215	
Net weight Indoor/Outdoor	kg	15.5		15.5		15.5	



# CONTROLS

## SINGLE AND MULTISPLIT AIR CONDITIONERS

WIRELESS

WIRED

DOOR CONTROL

	High-wall	Cassette	Ducted	Floor/ceiling	Console
	●				
		●	●		
				●	
					●
 Wired controller with WiFi		●	●		
 Wired controller with weekly timer	●	●	●	●	●
 398100673	●	●	●	●	

 AIR  
CONDITIONERS

Code	Description
398100775	Wired controller with WiFi
398100674	Wired controller with weekly timer
398100673	Door control

- Standard controller supplied with the unit
- Optional controller



# X3 PACKAGE

---

Commercial single split air conditioners DC Inverter R32

Cassette

Ducted

Floor/ceiling

Control systems

# LINE-UP

## OUTDOOR UNITS

Energy efficiency class up to A++ in cooling mode and up to A+ in heating mode.

Intelligent adjustment of compressor frequency, accurate temperature control.

Reliable cooling and heating operation down to -20 °C outdoor temperature, up to +52 °C (cooling).

Maximum length of pipe connections 75 m; height difference between units up to 30 m.

Minimization of the sound level thanks to the axial fan.

Fast achievement of comfort conditions: the unit allows rapid cooling and heating and is able to quickly reach the temperature set by the user.

Intelligent defrosting technology: the unit is able to correctly evaluate the presence of frost on the outdoor unit through a temperature sensor. The goal is to “defrost only when needed”, optimizing the heating effect for high environmental comfort.



AEG ECO PLUS 35PIH (1PH)



AEG ECO PLUS 50PIH (1PH)  
AEG ECO PLUS 71PIH (1PH)  
AEG ECO PLUS 85PIH (1PH)



AEG ECO PLUS 100PIH (1PH)  
AEG ECO PLUS 100PIH3 (3PH)  
AEG ECO PLUS 140PIH (1PH)  
AEG ECO PLUS 140PIH3 (3PH)



AEG ECO PLUS 160PIH3 (3PH)





Code	Model	Nominal (max.-min.) heating capacity (kW)	Nominal (max.-min.) cooling capacity (kW)
398700009	AEG ECO PLUS 35PIH	3.50 (0.90-4.69)	4.00 (0.90-4.50)
398700010	AEG ECO PLUS 50PIH	5.00 (1.60-5.80)	5.50 (1.60-6.10)
398700011	AEG ECO PLUS 71PIH	7.00 (2.40-7.60)	8.00 (2.20-8.60)
398700012	AEG ECO PLUS 85PIH	8.50 (2.90-9.00)	8.80 (2.30-9.50)
398700013	AEG ECO PLUS 100PIH	10.50 (3.20-11.00)	11.50 (3.00-12.50)
398700014	AEG ECO PLUS 100PIH3	10.50 (3.20-11.00)	11.50 (3.00-12.50)
398700015	AEG ECO PLUS 140PIH	13.40 (4.00-14.20)	15.50 (3.90-16.00)
398700016	AEG ECO PLUS 140PIH3	13.40 (4.00-14.20)	15.50 (3.90-16.00)
398700017	AEG ECO PLUS 160PIH3	14.50 (6.80-16.80) Cassette-Floor/ceiling	17.00 (4.50-17.50) Cassette-Floor/ceiling
		16.00 (4.80-17.00) Ducted	17.00 (4.50-18.00) Ducted

**A++** Cooling

**A+** Heating

# LINE-UP

## INDOOR UNITS

Code	Model	Features	
398700025	ASG ECO PLUS 35PH	<ul style="list-style-type: none"> <li>- 8-way compact cassette with 360° air discharge</li> <li>- Integrated condensate drain pump</li> <li>- Ideal for installation in false ceiling</li> </ul>	
398100688	GRID CASSETTE COMPACT	Grid for compact cassette (35)	
398700026	ASG ECO PLUS 50PH	<ul style="list-style-type: none"> <li>- 8-way cassette with 360° air discharge</li> <li>- Wide range of flap swinging</li> <li>- Integrated condensate drain pump</li> </ul>	
398700027	ASG ECO PLUS 71PH		
398700028	ASG ECO PLUS 85PH		
398700029	ASG ECO PLUS 100PH		
398700030	ASG ECO PLUS 140PH		
398700031	ASG ECO PLUS 160PH		
398100677	GRID BIG CASSETTE		
398700018	ADG ECO PLUS 35PH	<ul style="list-style-type: none"> <li>- Low external static pressure slim ducted</li> <li>- Silence</li> <li>- Integrated condensate drain pump</li> </ul>	
398700019	ADG ECO PLUS 50PH		
398700020	ADG ECO PLUS 71PH	<ul style="list-style-type: none"> <li>- High external static pressure ducted</li> <li>- Silence</li> <li>- Integrated condensate drain pump</li> </ul>	
398700021	ADG ECO PLUS 85PH		
398700022	ADG ECO PLUS 100PH		
398700023	ADG ECO PLUS 140PH		
398700024	ADG ECO PLUS 160PH		
398700032	ACG ECO PLUS 35PH		
398700033	ACG ECO PLUS 50PH		
398700034	ACG ECO PLUS 71PH		
398700035	ACG ECO PLUS 85PH		
398700036	ACG ECO PLUS 100PH		
398700037	ACG ECO PLUS 140PH		
398700038	ACG ECO PLUS 160PH		

# OUTDOOR UNITS DIMENSIONAL DRAWING

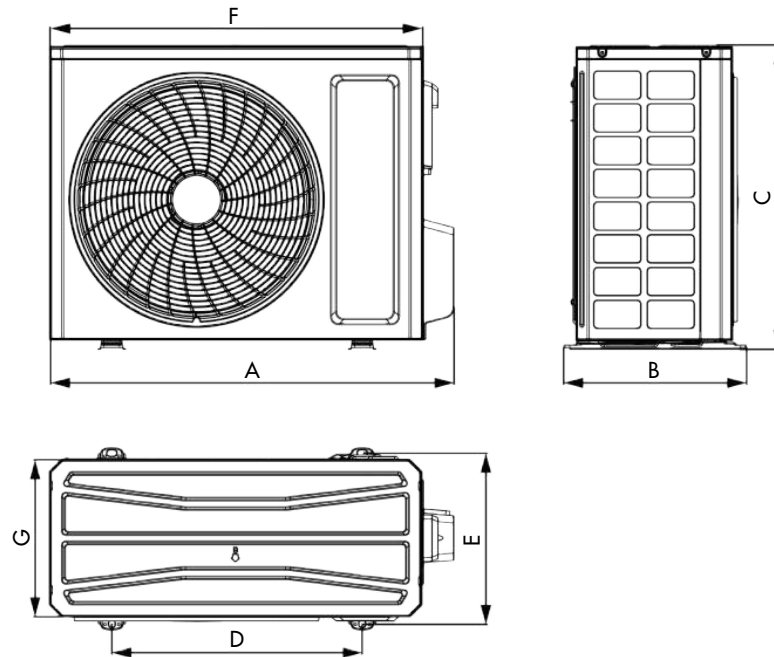

MODEL	DIMENSIONS (mm)						
	A	B	C	D	E	F	G
<b>AEG ECO PLUS 35PIH</b>	732	330	553	455	310	675	285
<b>AEG ECO PLUS 50PIH</b>	802	350	555	512	331	745	300
<b>AEG ECO PLUS 71PIH</b>	958	402	660	570	371	889	340
<b>AEG ECO PLUS 85PIH</b>	958	402	660	570	371	889	340
<b>AEG ECO PLUS 100PIH</b>	1020	427	820	635	396	940	370
<b>AEG ECO PLUS 100PIH3</b>	1020	427	820	635	396	940	370
<b>AEG ECO PLUS 140PIH</b>	1020	427	820	635	396	940	370
<b>AEG ECO PLUS 140PIH3</b>	1020	427	820	635	396	940	370
<b>AEG ECO PLUS 160PIH3</b>	1020	427	960	755	396	990	370



# NOTES



# CASSETTE

---

Compact cassette with 360° air discharge

Cassette with 360° air discharge

# COMPACT CASSETTE

## WITH 360° AIR DISCHARGE



(Standard)  
Infrared remote  
controller



(Optional)  
Wired controller  
with WiFi

- 8-way cassette units for light commercial/industrial applications.
- Suitable for shops, offices, meeting rooms, hotels, restaurants, clubs, gyms and open space areas.
- Compact and attractive design.
- 360° air discharge, with range of flap oscillation between 45 and 80°, different according to the heating/cooling modes, for maximum comfort.
- The dimensions 570x570 mm are convenient for installation in false ceilings with standard modules 600x600 mm.
- Fan has optimized aerodynamic profiles for maximum silence.
- Condensate drain pump is integrated for a height difference up to 1000 mm.
- Double room temperature sensor for customizable comfort:
  - possibility of selecting the return air temperature sensor on the unit or the temperature sensor on the wired control.
- High energy efficiency, at all the capacities, both in cooling and heating modes (seasonal efficiency).
- The special closing system of the refrigerant valve prevents and avoids the risk of refrigerant leaks from inappropriate maintenance.
- The electrical box has a special design and is made of fireproof material, for maximum protection of the electronic board from the risks of fire.
- Optional WiFi, with wired controller, accessory that can be ordered separately.

<b>FAST</b> Quick cooling and heating	Intelligent sensor	Quiet mode	3 sleep modes	iFeel	Cold air prevention	Timer on/off	Intelligent defrosting	Auto mode	Filter cleaning reminder	360° air flow	Automatic swinging	Fixed swinging
Fan speed regulation	Automatic fan speed	Turbo fan speed	Dehumidification 12°C	Dehumidification 8°C heating	WiFi and app (optional) through wired controller	Centralized control	Remote control	Modbus	Auto restart memory	Access control	Dual wired controllers	
Auto diagnosis	Ambient temperature control	System parameters inquiry	Historical errors inquiry									

**A<sup>++</sup>** Cooling

**A<sup>+</sup>** Heating

## TECHNICAL DATA - MATCHING WITH COMPACT CASSETTE WITH 360° AIR DISCHARGE

Indoor unit model		ASG ECO PLUS 35PH	
Outdoor unit model		AEG ECO PLUS 35PIH	
	Units	Cooling	Heating
Nominal (min.-max.) capacity (EN14511)	kW	3.50 (0.90-4.00)	4.00 (0.90-4.50)
	BTU/h	12000	13600
EER/COP (EN14511)		3.80	4.00
Design Load [Pdesign c/Pdesign h (Average)] (EN14825)*	kW	3.5	3.1
Seasonal efficiency ratio [SEER/SCOP (Average)] (EN14825)*		7.1	4.2
Energy efficiency class*		A++	A+
Seasonal energy consumption (Average)*	kWh/annum	173	1034
Air flow rate Indoor (sh.-h.-m.-l.)	m <sup>3</sup> /h	600-550-500-400	
Dehumidification	l/h	1.0	
Fan speeds (Indoor/Outdoor)	n°	4/2	
Sound pressure Indoor (sh.-h.-m.-l.)	dB(A)	36-35-33-29	
Sound pressure Outdoor (h.)	dB(A)	48	
Sound power Indoor (sh.-h.-m.-l.)	dB(A)	47-45-42-39	
Sound power Outdoor (h.)	dB(A)	56	
Power supply	V/Ph/Hz	220-240~/1/50/60	
Power input	kW	0.92	1.30
Maximum electrical power input	kW/A	1.30/6.00	
Compressor type		Rotary DC Inverter	
Refrigerant type/GWP		R32/675	
Refrigerant charge	kg/T.CO <sub>2</sub> eq.	0.57/0.39	
Liquid pipe diameter	mm (inch)	6.35 (1/4")	
Gas pipe diameter	mm (inch)	9.52 (3/8")	
Pipe length with gas standard charge	m	5	
Max. pipe length with additional charge	m	30	
Additional refrigerant charge	g/m	16	
Max. height difference (Outdoor above)	m	15	
Max. height difference (Indoor above)	m	15	
Panel code to match		398100688	
Indoor net dimension without panel (H./W./D.)	mm	260/570/570	
Net dimension panel (H./W./D.)	mm	47.5/620/620	
Indoor net dimension with panel (H./W./D.)	mm	307.5/620/620	
Outdoor net dimension (H./W./D.)	mm	553/675/285	
Indoor unit without panel/Outdoor unit net weight	kg	16.5/24.5	
Panel net weight	kg	3	

OPERATING RANGE: outdoor temperature  
 Cooling mode: from -20 °C to +52 °C  
 Heating mode: from -20 °C to +24 °C  
 RANGE OF INDOOR TEMPERATURE ADJUSTMENT: from 16 to 30 °C.

\*Data declared in compliance with EU Regulation no. 206/2012, as regards to Ecodesign requirements for air conditioners and comfort fans, and EU Regulation no. 626/2011, concerning the energy labelling of air conditioners, and tested according to standard EN14825.

# INDOOR UNIT DIMENSIONAL DRAWING

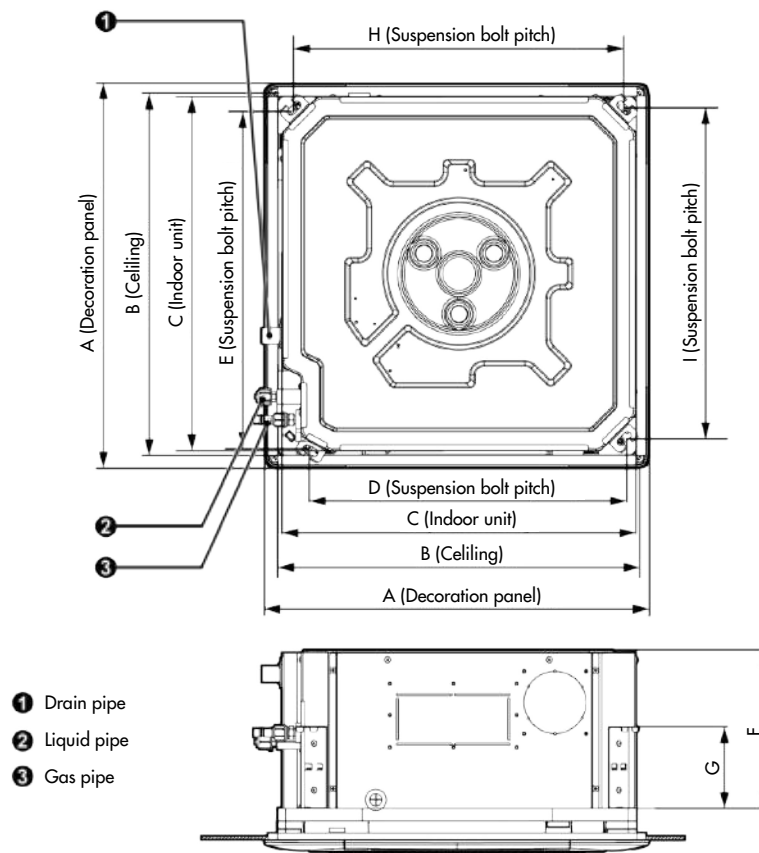

MODEL	DIMENSIONS (mm)								
	A	B	C	D	E	F	G	H	I
ASG ECO PLUS 35PH	620	580	570	505	550	260	140	530	530



# OUTDOOR UNIT DIMENSIONAL DRAWING

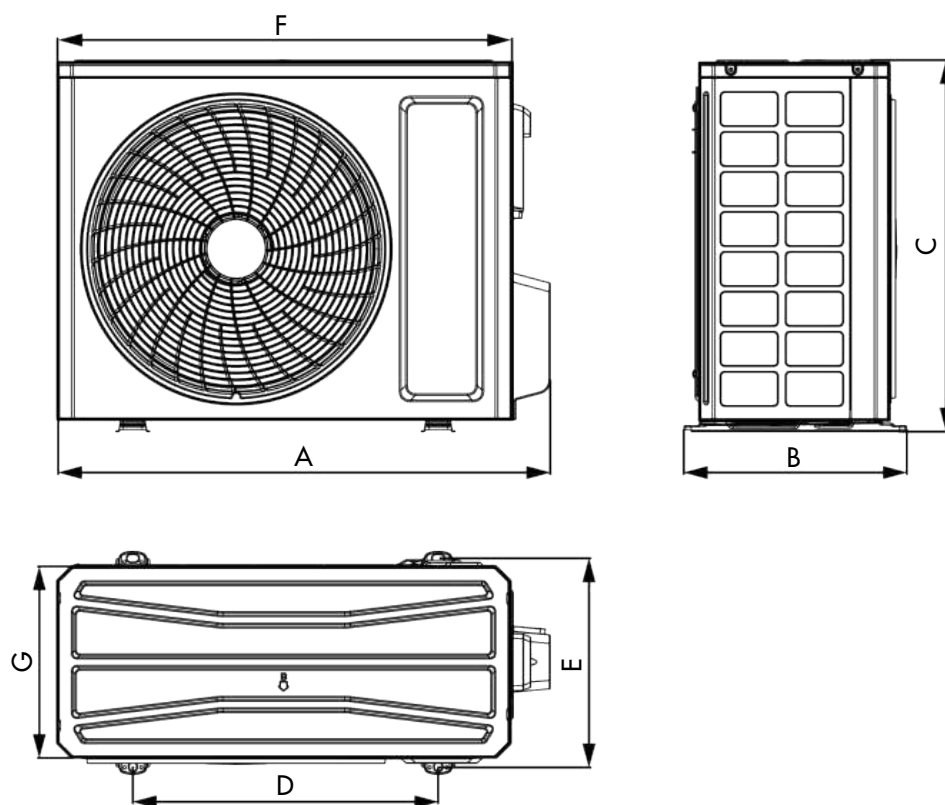

AIR  
CONDITIONERS

MODEL	DIMENSIONS (mm)						
	A	B	C	D	E	F	G
AEG ECO PLUS 35PIH	732	330	553	455	310	675	285

# CASSETTE

## WITH 360° AIR DISCHARGE

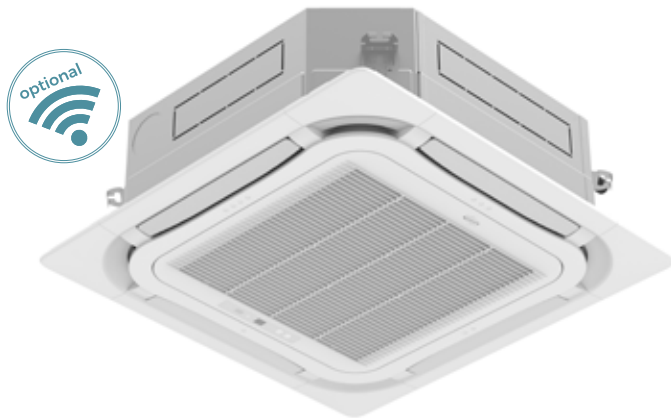

(Standard)  
Infrared remote  
controller



(Optional)  
Wired controller  
with WiFi

- 8-way cassette units for light commercial/industrial applications.
- Suitable for shops, offices, meeting rooms, hotels, restaurants, clubs, gyms and open space areas.
- Attractive design.
- 360° air discharge, with range of flap oscillation between 45 and 80°, different according to the heating/cooling modes, for maximum comfort.
- Fan has optimized aerodynamic profiles for maximum silence.
- Condensate drain pump is integrated for a height difference up to 1000 mm.
- Double room temperature sensor for customizable comfort: possibility of selecting the return air temperature sensor on the unit or the temperature sensor on the wired control.
- High energy efficiency, at all the capacities, both in cooling and heating modes (seasonal efficiency).
- The special closing system of the refrigerant valve prevents and avoids the risk of refrigerant leaks from inappropriate maintenance.
- The electrical box has a special design and is made of fireproof material, for maximum protection of the electronic board from the risks of fire.
- Optional WiFi, with wired controller, accessory that can be ordered separately.

FAST Quick cooling and heating	Intelligent sensor	Quiet mode	3 sleep modes	iFeel	Cold air prevention	Timer on/off	Intelligent defrosting	Auto mode	Filter cleaning reminder	360° air flow	Automatic swinging	Fixed swinging
Fan speed regulation	Automatic fan speed	Turbo fan speed	Dehumidification	Dehumidification 12°C	8°C heating	WiFi and app (optional)	Centralized control	Remote control	Modbus	Auto restart memory	Access control	Dual wired controllers
Auto diagnosis	Ambient temperature control	System parameters inquiry	Historical errors inquiry									

**A<sup>++</sup>** Cooling

**A<sup>+</sup>** Heating



## TECHNICAL DATA-MATCHING WITH CASSETTE WITH 360° AIR DISCHARGE

Indoor unit model	ASG ECO PLUS 50PH		
Outdoor unit model	AEG ECO PLUS 50PIH		
	Units	Cooling	Heating
Nominal (min.-max.) capacity (EN14511)	kW	5.30 (1.60-5.80)	5.80 (1.60-6.10)
	BTU/h	17000	19790
EER/COP (EN14511)		3.45	3.95
Design Load [(Pdesign c/Pdesign h) (Average)] (EN14825)*	kW	5.3	3.9
Seasonal efficiency ratio [(SEER/SCOP) (Average)] (EN14825)*		7.2	4.3
Energy efficiency class*		A++	A+
Seasonal energy consumption (Average)*	kWh/annum	258	1270
Air flow rate Indoor (sh.-h.-m.-l.)	m <sup>3</sup> /h	900-800-700-600	
Dehumidification	l/h	1.8	
Fan speeds (Indoor/Outdoor)	n°	4/2	
Sound pressure Indoor (sh.-h.-m.-l.)	dB(A)	36-35-33-31	
Sound pressure Outdoor (h.)	dB(A)	52	
Sound power Indoor (sh.-h.-m.-l.)	dB(A)	51-46-43-40	
Sound power Outdoor (h.)	dB(A)	65	
Power supply	V/Ph/Hz	220-240~/1/50/60	
Power input	kW	1.54	1.47
Maximum electrical power input	kW/A	1.90/9.50	
Compressor type		Rotary DC Inverter	
Refrigerant type/GWP		R32/675	
Refrigerant charge	kg/T.CO <sub>2</sub> eq.	0.85/0.57	
Liquid pipe diameter	mm (inch)	6.35 (1/4")	
Gas pipe diameter	mm (inch)	12.70 (1/2")	
Pipe lenght with gas standard charge	m	5	
Max. pipe lenght with additional charge	m	30	
Additional refrigerant charge	g/m	16	
Max. height difference (Outdoor above)	m	15	
Max. height difference (Indoor above)	m	15	
Panel code to match		398100677	
Indoor net dimension without panel (H./W./D.)	mm	200/840/840	
Net dimension panel (H./W./D.)	mm	52/950/950	
Indoor net dimension with panel (H./W./D.)	mm	252/950/950	
Outdoor net dimension (H./W./D.)	mm	555/745/300	
Indoor unit without panel/Outdoor unit net weight	kg	21/30.5	
Panel net weight	kg	6	

OPERATING RANGE: outdoor temperature  
 Cooling mode: from -20 °C to +52 °C  
 Heating mode: from -20 °C to +24 °C  
 RANGE OF INDOOR TEMPERATURE ADJUSTMENT: from 16 to 30 °C.

\*Data declared in compliance with EU Regulation no. 206/2012, as regards to Ecodesign requirements for air conditioners and comfort fans, and EU Regulation no. 626/2011, concerning the energy labelling of air conditioners, and tested according to standard EN14825.

# TECHNICAL DATA

Indoor unit model		ASG ECO PLUS 71PH		ASG ECO PLUS 85PH		
Outdoor unit model		AEG ECO PLUS 71PIH		AEG ECO PLUS 85PIH		
		Units	Cooling	Heating	Cooling	Heating
Nominal (min.-max.) capacity (EN14511)	kW	7.10 (2.40-7.60)	8.00 (2.20-8.60)	8.50 (2.90-9.00)	8.80 (2.50-9.50)	
	BTU/h	24200	27200	29000	30000	
EER/COP (EN14511)		3.70	4.00	3.40	3.90	
Design Load [(Pdesign c/Pdesign h) (Average)] (EN14825)*	kW	7.1	5.0	8.5	6.0	
Seasonal efficiency ratio [(SEER/SCOP) (Average)] (EN14825)*		6.7	4.3	6.9	4.3	
Energy efficiency class*		A++	A+	A++	A+	
Seasonal energy consumption (Average)*	kWh/annum	371	1628	432	1954	
Air flow rate Indoor (sh.-h.-m.-l.)	m <sup>3</sup> /h	1100-1000-900-800		1400-1300-1200-1100		
Dehumidification	l/h	2.4		2.8		
Fan speeds (Indoor/Outdoor)	n°	4/2		4/2		
Sound pressure Indoor (sh.-h.-m.-l.)	dB(A)	39-38-36-34		47-46-42-38		
Sound pressure Outdoor (h.)	dB(A)	58		65		
Sound power Indoor (sh.-h.-m.-l.)	dB(A)	51-50-48-47		59-51-48-46		
Sound power Outdoor (h.)	dB(A)	69		70		
Power supply	V/Ph/Hz	220-240~/1/50/60		220-240~/1/50/60		
Power input	kW	2.03	2.80	2.50	2.25	
Maximum electrical power input	kW/A	2.80/14.00		3.30/15.00		
Compressor type		Rotary DC Inverter		Rotary DC Inverter		
Refrigerant type/GWP		R32/675		R32/675		
Refrigerant charge	kg/T.CO <sub>2</sub> eq.	1.5/1.01		1.5/1.01		
Liquid pipe diameter	mm (inch)	9.52 (3/8")		9.52 (3/8")		
Gas pipe diameter	mm (inch)	15.88 (5/8")		15.88 (5/8")		
Pipe lenght with gas standard charge	m	5		5		
Max. pipe lenght with additional charge	m	30		30		
Additional refrigerant charge	g/m	20		20		
Max. height difference (Outdoor above)	m	20		25		
Max. height difference (Indoor above)	m	20		25		
Panel code to match		398100677		398100677		
Indoor net dimension without panel (H./W./D.)	mm	200/840/840		200/840/840		
Net dimension panel (H./W./D.)	mm	52/950/950		52/950/950		
Indoor net dimension with panel (H./W./D.)	mm	252/950/950		252/950/950		
Outdoor net dimension (H./W./D.)	mm	660/889/340		660/889/340		
Indoor unit without panel/Outdoor unit net weight	kg	21/41.5		21/46		
Panel net weight	kg	6		6		

OPERATING RANGE: outdoor temperature

Cooling mode: from -20 °C to +52 °C

Heating mode: from -20 °C to +24 °C

RANGE OF INDOOR TEMPERATURE ADJUSTMENT: from 16 to 30 °C.

\*Data declared in compliance with EU Regulation no. 206/2012, as regards to Ecodesign requirements for air conditioners and comfort fans, and EU Regulation no. 626/2011, concerning the energy labelling of air conditioners, and tested according to standard EN14825.

Indoor unit model		ASG ECO PLUS 100PH		ASG ECO PLUS 100PH	
Outdoor unit model		AEG ECO PLUS 100PIH		AEG ECO PLUS 100PIH3	
		Units		Units	
		Cooling	Heating	Cooling	Heating
Nominal (min.-max.) capacity (EN14511)	kW	10.50 (3.20-11.00)	11.50 (3.00-12.50)	10.50 (3.20-11.00)	11.50 (3.00-12.50)
	BTU/h	35800	39200	35800	39200
EER/COP (EN14511)		3.50	4.10	3.50	4.10
Design Load [(Pdesign c/Pdesign h) (Average)] (EN14825)*	kW	10.5	7.0	10.5	7.0
Seasonal efficiency ratio [(SEER/SCOP) (Average)] (EN14825)*		6.6	4.4	6.6	4.4
Energy efficiency class*		A++	A+	A++	A+
Seasonal energy consumption [cooling/heating (Average)]*	kWh/annum	557	2227	557	2227
Air flow rate Indoor (sh.-h.-m.-l.)	m <sup>3</sup> /h	1500-1400-1200-1000		1500-1400-1200-1000	
Dehumidification	l/h	3.3		3.3	
Fan speeds (Indoor/Outdoor)	n°	4/2		4/2	
Sound pressure Indoor (sh.-h.-m.-l.)	dB(A)	43-41-39-38		43-41-39-38	
Sound pressure Outdoor (h.)	dB(A)	57		57	
Sound power Indoor (sh.-h.-m.-l.)	dB(A)	56-54-52-48		56-54-52-48	
Sound power Outdoor (h.)	dB(A)	70		70	
Power supply	V/Ph/Hz	220-240~/1/50/60		380-415~/3/50-60	
Power input	kW	3.10	2.95	3.10	3.95
Maximum electrical power input	kW/A	4.70/21.00		4.40/7.00	
Compressor type		Rotary DC Inverter		Rotary DC Inverter	
Refrigerant type/GWP		R32/675		R32/675	
Refrigerant charge	kg/T.CO <sub>2</sub> eq.	2.1/1.42		2.1/1.42	
Liquid pipe diameter	mm (inch)	9.52 (3/8")		9.52 (3/8")	
Gas pipe diameter	mm (inch)	15.88 (5/8")		15.88 (5/8")	
Pipe lenght with gas standard charge	m	5		5	
Max. pipe lenght with additional charge	m	75		75	
Additional refrigerant charge	g/m	20		20	
Max. height difference (Outdoor above)	m	30		30	
Max. height difference (Indoor above)	m	30		30	
Panel code to match		398100677		398100677	
Indoor net dimension without panel (H./W./D.)	mm	240/840/840		240/840/840	
Net dimension panel (H./W./D.)	mm	52/950/950		52/950/950	
Indoor net dimension with panel (H./W./D.)	mm	292/950/950		292/950/950	
Outdoor net dimension (H./W./D.)	mm	820/940/370		820/940/370	
Indoor unit without panel/Outdoor unit net weight	kg	23/65		23/75	
Panel net weight	kg	6		6	

OPERATING RANGE: outdoor temperature  
 Cooling mode: from -20 °C to +52 °C  
 Heating mode: from -20 °C to +24 °C  
 RANGE OF INDOOR TEMPERATURE ADJUSTMENT: from 16 to 30 °C.

\*Data declared in compliance with EU Regulation no. 206/2012, as regards to Ecodesign requirements for air conditioners and comfort fans, and EU Regulation no. 626/2011, concerning the energy labelling of air conditioners, and tested according to standard EN14825.

# TECHNICAL DATA

Indoor unit model		ASG ECO PLUS 140PH		ASG ECO PLUS 140PH	
Outdoor unit model		AEG ECO PLUS 140PIH		AEG ECO PLUS 140PIH3	
	Units	Cooling	Heating	Cooling	Heating
Nominal (min.-max.) capacity (EN14511)	kW	13.40 (4.00-14.20)	15.50 (3.90-16.00)	13.40 (4.00-14.20)	15.50 (3.90-16.00)
	BTU/h	45700	52800	45700	52800
EER/COP (EN14511)		2.91	3.30	2.91	3.30
Rated capacity (Prated,c/Prated,h)*	kW	13.40	15.50	13.40	15.50
Seasonal space energy efficiency (ηs,c/ηs,h)*	%	257.8	158.2	257.8	158.2
Air flow rate Indoor (sh.-h.-m.-l.)	m³/h	2000-1800-1600-1400		2000-1800-1600-1400	
Dehumidification	l/h	3.9		3.9	
Fan speeds (Indoor/Outdoor)	n°	4/2		4/2	
Sound pressure Indoor (sh.-h.-m.-l.)	dB(A)	50-48-45-41		50-48-45-41	
Sound pressure Outdoor (h.)	dB(A)	59		59	
Sound power Indoor (sh.-h.-m.-l.)	dB(A)	64-63-60-57		64-63-60-57	
Sound power Outdoor (h.)	dB(A)	75		75	
Power supply	V/Ph/Hz	220-240~/1/50/60		380-415~/3/50/60	
Power input	kW	4.60	4.70	4.60	4.70
Maximum electrical power input	kW/A	5.60/25.00		5.60/11.00	
Compressor type		Rotary DC Inverter		Rotary DC Inverter	
Refrigerant type/GWP		R32/675		R32/675	
Refrigerant charge	kg/T.CO <sub>2</sub> eq.	2.80/1.89		2.80/1.89	
Liquid pipe diameter	mm (inch)	9.52 (3/8")		9.52 (3/8")	
Gas pipe diameter	mm (inch)	15.88 (5/8")		15.88 (5/8")	
Pipe lenght with gas standard charge	m	7.5		7.5	
Max. pipe lenght with additional charge	m	75		75	
Additional refrigerant charge	g/m	35		35	
Max. height difference (Outdoor above)	m	30		30	
Max. height difference (Indoor above)	m	30		30	
Panel code to match		398100677		398100677	
Indoor net dimension without panel (H./W./D.)	mm	290/840/840		290/840/840	
Net dimension panel (H./W./D.)	mm	52/950/950		52/950/950	
Indoor net dimension with panel (H./W./D.)	mm	342/950/950		342/950/950	
Outdoor net dimension (H./W./D.)	mm	820/940/370		820/940/370	
Indoor unit without panel/Outdoor unit net weight	kg	25/73		25/81	
Panel net weight	kg	6		6	

OPERATING RANGE: outdoor temperature  
Cooling mode: from -20 °C to +52 °C  
Heating mode: from -20 °C to +24 °C  
RANGE OF INDOOR TEMPERATURE ADJUSTMENT: from 16 to 30 °C.

\*Data declared in accordance with COMMISSION REGULATION (EU) 2016/2281 of 30 November 2016 implementing Directive 2009/125/EC of the European Parliament and of the Council establishing a framework for the setting of ecodesign requirements for energy-related products, with regard to ecodesign requirements for air heating products, cooling products, high temperature process chillers and fan coil units.

Indoor unit model		ASG ECO PLUS 160PH	
Outdoor unit model		AEG ECO PLUS 160PIH3	
		Cooling	Heating
		Units	
Nominal (min.-max.) capacity (EN14511)	kW	14.50 (4.80-15.00)	17.00 (4.50-17.50)
	BTU/h	49400	58000
EER/COP (EN14511)		2.74	2.98
Rated capacity (Prated,c/Prated,h)*	kW	14.50	17.0
Seasonal space energy efficiency (ηs,c/ηs,h)*	%	239	151.6
Air flow rate Indoor (sh.-h.-m.-l.)	m <sup>3</sup> /h	2300-2100-1900-1600	
Dehumidification	l/h	4.8	
Fan speeds (Indoor/Outdoor)	n°	4/2	
Sound pressure Indoor (sh.-h.-m.-l.)	dB(A)	50-48-46-44	
Sound pressure Outdoor (h.)	dB(A)	60	
Sound power Indoor (sh.-h.-m.-l.)	dB(A)	65-63-61-60	
Sound power Outdoor (h.)	dB(A)	75	
Power supply	V/Ph/Hz	380-415~/3/50/60	
Power input	kW	5.30	5.70
Maximum electrical power input	kW/A	6.80/12.00	
Compressor type		Rotary DC Inverter	
Refrigerant type/GWP		R32/675	
Refrigerant charge	kg/T.CO <sub>2</sub> eq.	3.50/2.363	
Liquid pipe diameter	mm (inch)	9.52 (3/8")	
Gas pipe diameter	mm (inch)	15.88 (5/8")	
Pipe length with gas standard charge	m	7.5	
Max. pipe length with additional charge	m	75	
Additional refrigerant charge	g/m	35	
Max. height difference (Outdoor above)	m	30	
Max. height difference (Indoor above)	m	30	
Panel code to match		398100677	
Indoor net dimension without panel (H./W./D.)	mm	290/840/840	
Net dimension panel (H./W./D.)	mm	52/950/950	
Indoor net dimension with panel (H./W./D.)	mm	342/950/950	
Outdoor net dimension (H./W./D.)	mm	960/990/370	
Indoor unit without panel/Outdoor unit net weight	kg	26/94	
Panel net weight	kg	9.5	

OPERATING RANGE: outdoor temperature  
 Cooling mode: from -20 °C to +52 °C  
 Heating mode: from -20 °C to +24 °C  
 RANGE OF INDOOR TEMPERATURE ADJUSTMENT: from 16 to 30 °C.

\*Data declared in accordance with COMMISSION REGULATION (EU) 2016/2281 of 30 November 2016 implementing Directive 2009/125/EC of the European Parliament and of the Council establishing a framework for the setting of ecodesign requirements for energy-related products, with regard to ecodesign requirements for air heating products, cooling products, high temperature process chillers and fan coil units.

# INDOOR UNITS DIMENSIONAL DRAWING

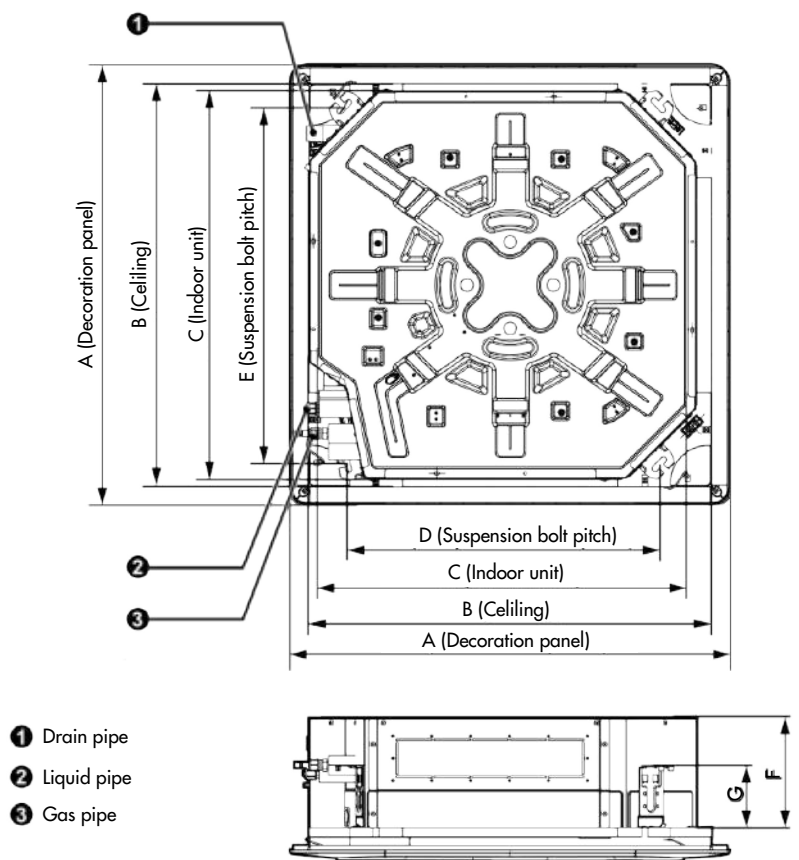

MODEL	DIMENSIONS (mm)								
	A	B	C	D	E	F	G	H	I
ASG ECO PLUS 50PH	950	890	840	680	780	200	135	-	-
ASG ECO PLUS 71PH	950	890	840	680	780	200	135	-	-
ASG ECO PLUS 85PH	950	890	840	680	780	200	135	-	-
ASG ECO PLUS 100PH	950	890	840	680	780	240	135	-	-
ASG ECO PLUS 140PH	950	890	840	680	780	290	135	-	-
ASG ECO PLUS 160PH	950	890	840	680	780	290	135	-	-

# OUTDOOR UNITS DIMENSIONAL DRAWING

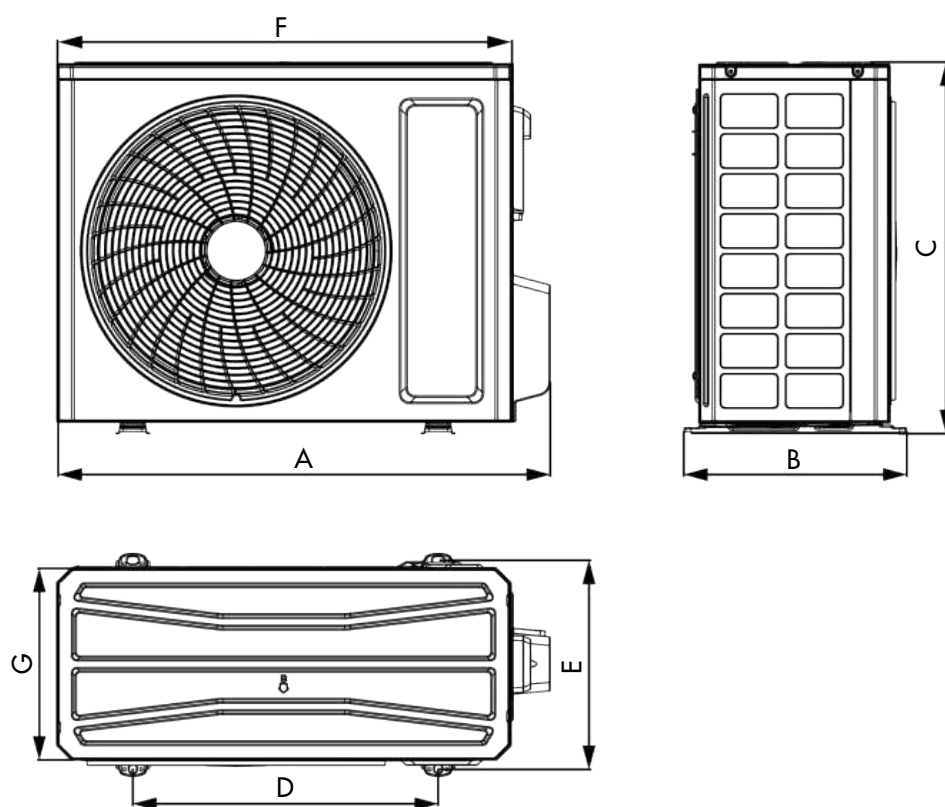

AIR  
CONDITIONERS

MODEL	DIMENSIONS (mm)						
	A	B	C	D	E	F	G
<b>AEG ECO PLUS 50PIH</b>	802	350	555	512	331	745	300
<b>AEG ECO PLUS 71PIH</b>	958	402	660	570	371	889	340
<b>AEG ECO PLUS 85PIH</b>	958	402	660	570	371	889	340
<b>AEG ECO PLUS 100PIH</b>	1020	427	820	635	396	940	370
<b>AEG ECO PLUS 100PIH3</b>	1020	427	820	635	396	940	370
<b>AEG ECO PLUS 140PIH</b>	1020	427	820	635	396	940	370
<b>AEG ECO PLUS 140PIH3</b>	1020	427	820	635	396	940	370
<b>AEG ECO PLUS 160PIH3</b>	1020	427	960	755	396	990	370







# DUCTED

---

Slim ducted

High static pressure ducted

# SLIM DUCTED



(Standard)  
Wired controller



(Optional)  
Wired controller  
with WiFi



(Optional)  
Infrared remote  
controller

- Slim ducted units for light commercial/industrial applications.
- Suitable for shops, offices, meeting rooms, hotels, restaurants, clubs, gyms and open space areas.
- Ultra-thin, these units are characterized by an air discharge design optimized to minimize the sound level and improve performance.
- The thickness is only 200 mm and the width 450 mm: these units are among the thinnest on the market.
- The special design of the evaporating coil (V-shape), covered by a patent, favors a more effective exchange of air.
- The centrifugal fan is also characterized by a patented design and allows higher air flow and greater silence.
- The external static pressure reaches 80 Pa, with 5 selectable levels, according to different needs, ensuring maximum adaptability to different types of installation.
- The combination with the wired control allows to optimize the external static pressure according to the different technical installation requirements.
- The condensate drain pump is integrated for a height difference up to 1000 mm.
- You can choose between rear or bottom air intake.
- The DC motor ensures energy saving and high efficiency.
- Double room temperature sensor for a customizable comfort: possibility to select the sensor of return air temperature on the unit or of the sensor of temperature on the wired control.
- Connection to fresh air intake from outdoors is possible.
- High energy efficiency, at all capacities, both in cooling and heating modes, especially with a view to operating 365 days a year (seasonal efficiency).
- The special closing system of the refrigerant valve prevents and avoids the risk of refrigerant leaks from inappropriate maintenance.
- Optional WiFi, with wired controller, accessory that can be ordered separately.

<b>FAST</b> Quick cooling and heating	Intelligent sensor	Quiet mode	3 sleep modes	iFeel	Cold air prevention	Integrated water heat pump	Intelligent defrosting	Auto mode	Filter cleaning reminder	Fan speed regulation	Automatic fan speed	Turbo fan speed
Dehumidification	Dehumidification 12°C	I-Demand save energy	WiFi and app (optional)	Centralized control	Remote control	Modbus	Timer on/off	Access control	Dual wired controllers	8°C heating	Auto restart memory	Auto diagnosis
Ambient temperature control	System parameters inquiry	Historical errors inquiry	Settable pressure levels									

**A++** Cooling

**A+** Heating

## TECHNICAL DATA-MATCHING WITH SLIM DUCTED UNITS

Indoor unit model		ADG ECO PLUS 35PH		ADG ECO PLUS 50PH	
Outdoor unit model		AEG ECO PLUS 35PIH		AEG ECO PLUS 50PIH	
	Units	Cooling	Heating	Cooling	Heating
Nominal (min.-max.) capacity (EN14511)	kW	3.50 (0.90-4.00)	4.00 (0.90-4.50)	5.30 (1.60-5.80)	5.60 (1.60-6.10)
	BTU/h	12000	13600	18000	19100
EER/COP (EN14511)		3.40	4.00	3.50	3.95
Design Load [(Pdesign c/Pdesign h) (Average)] (EN14825)*	kW	3.5	3.0	5.3	3.9
Seasonal efficiency ratio [(SEER/SCOP (Average)] (EN14825)*		6.5	4.0	6.3	4.0
Energy efficiency class*		A++	A+	A++	A+
Seasonal energy consumption (Average)*	kWh/annum	189	1050	294	1365
Air flow rate Indoor (sh.-h.-m.-l.)	m <sup>3</sup> /h	600-550-500-400		900-800-700-600	
Dehumidification	l/h	1.0		1.7	
Fan speeds (Indoor/Outdoor)	n°	4/2		4/2	
Sound pressure Indoor (sh.-h.-m.-l.)	dB(A)	35-33-32-30		36-35-33-31	
Sound pressure Outdoor (h.)	dB(A)	56		59	
Sound power Indoor (sh.-h.-m.-l.)	dB(A)	48-45-43-41		52-51-48-45	
Sound power Outdoor (h.)	dB(A)	56		65	
Power supply	V/Ph/Hz	220-240~/1/50/60		220-240~/1/50/60	
Nominal rated external static pressure	Pa	25		25	
Rated external static pressure (range)	Pa	0-80		0-80	
Power input	kW	1.03	1.00	1.51	1.42
Maximum electrical power input	kW/A	1.30/6.00		1.90/9.50	
Compressor type		Rotary DC Inverter		Rotary DC Inverter	
Refrigerant type/GWP		R32/675		R32/675	
Refrigerant charge	kg/T.CO <sub>2</sub> eq.	0.57/0.39		0.85/0.57	
Liquid pipe diameter	mm (inch)	6.35 (1/4")		6.35 (1/4")	
Gas pipe diameter	mm (inch)	9.52 (3/8")		12.70 (1/2")	
Pipe length with gas standard charge	m	5		5	
Max. pipe length with additional charge	m	30		30	
Additional refrigerant charge	g/m	16		16	
Max. height difference (Outdoor above)	m	15		20	
Max. height difference (Indoor above)	m	15		20	
Indoor net dimension (H./W./D.)	mm	200/700/450		200/1000/450	
Outdoor net dimension (H./W./D.)	mm	553/675/285		555/745/300	
Net weight Indoor/Outdoor	kg	18/24.5		24/30.5	

OPERATING RANGE: outdoor temperature  
 Cooling mode: from -20 °C to +52 °C  
 Heating mode: from -20 °C to +24 °C  
 RANGE OF INDOOR TEMPERATURE ADJUSTMENT: from 16 to 30 °C.

\*Data declared in compliance with EU Regulation no. 206/2012, as regards to Ecodesign requirements for air conditioners and comfort fans, and EU Regulation no. 626/2011, concerning the energy labelling of air conditioners, and tested according to standard EN14825.

# STATIC PRESSURE CURVES

## ADG ECO PLUS 35PH - static pressure curves

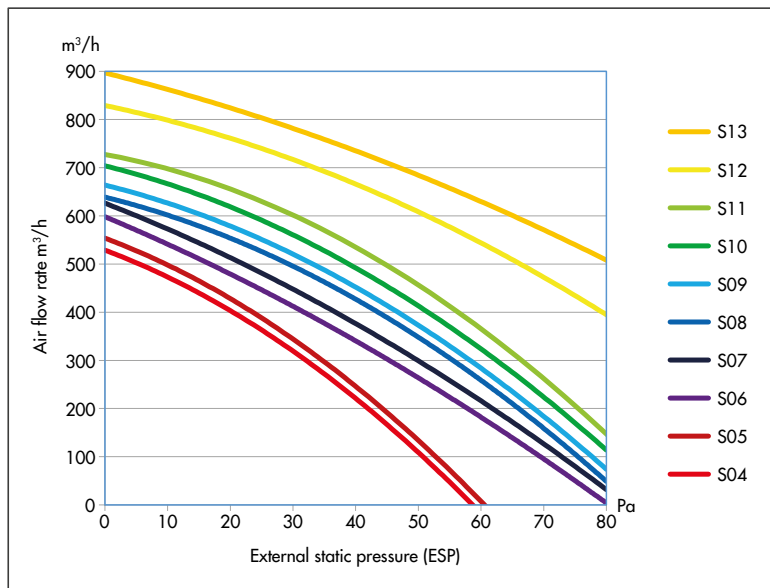

External static pressure	Turbo speed	High	Medium	Low
P03	S09	S08	S06	S04
P04	S10	S09	S07	S05
<b>P05*</b>	<b>S11</b>	<b>S10</b>	<b>S08</b>	<b>S06</b>
P06	S12	S11	S09	S07
P07	S13	S12	S10	S08

\* Default static pressure level

The wired controller can be used to change the external static pressure (ESP) to turbo, high, medium and low fan speeds. 5 are the adjustable external static pressure levels.

## ADG ECO PLUS 50PH - static pressure curves

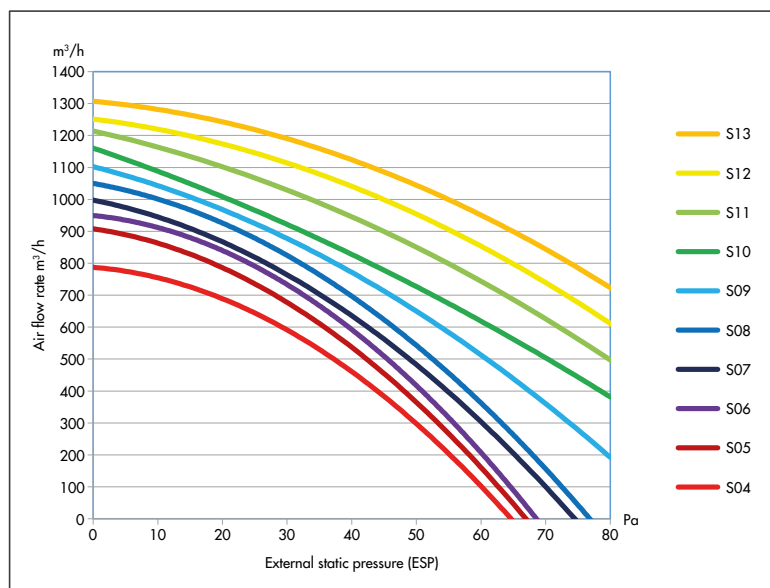

External static pressure	Turbo speed	High	Medium	Low
P03	S09	S08	S06	S04
P04	S10	S09	S07	S05
<b>P05*</b>	<b>S11</b>	<b>S10</b>	<b>S08</b>	<b>S06</b>
P06	S12	S11	S09	S07
P07	S13	S12	S10	S08

\* Default static pressure level

The wired controller can be used to change the external static pressure (ESP) to turbo, high, medium and low fan speeds. 5 are the adjustable external static pressure levels.

# INDOOR UNITS DIMENSIONAL DRAWINGS

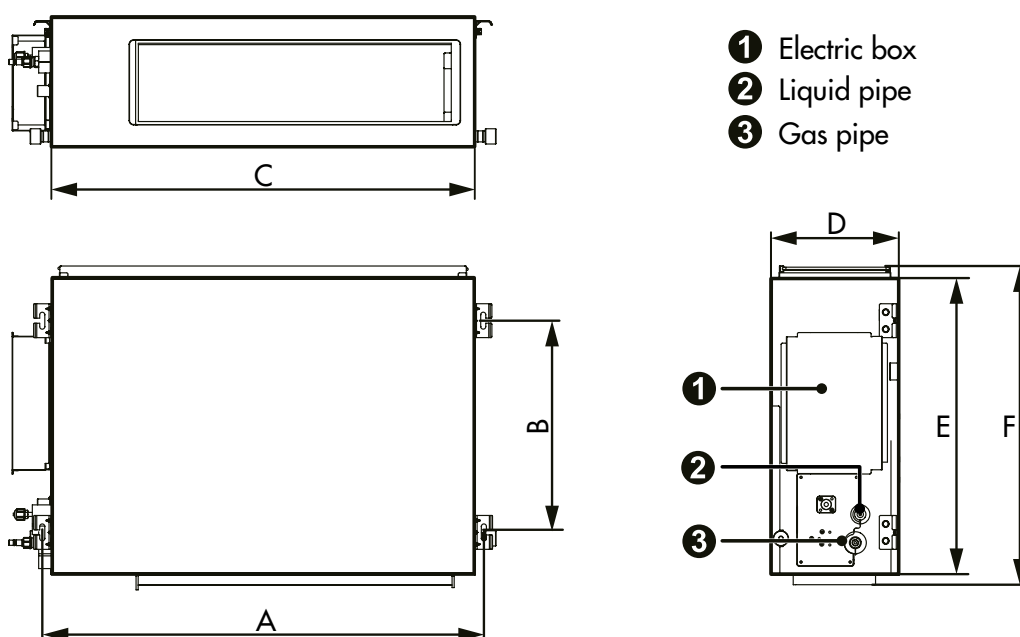

AIR  
CONDITIONERS

MODEL	DIMENSIONS (mm)					
	A	B	C	D	E	F
AEG ECO PLUS 35PIH	760	415	700	200	450	474
AEG ECO PLUS 50PIH	1060	415	1000	200	450	474

# SUPPLY AIR OUTLET/RETURN AIR INLET DIMENSIONAL DRAWING

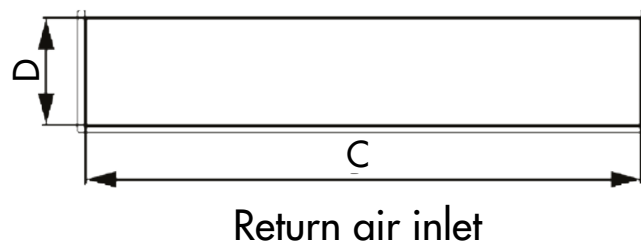
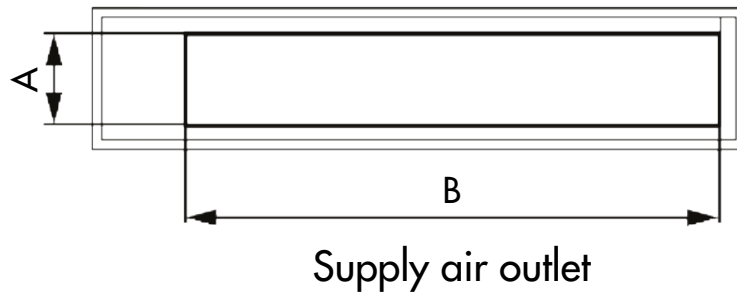

MODEL	SUPPLY AIR OUTLET		RETURN AIR INLET	
	A	B	C	D
ADG ECO PLUS 35PH	122	585	700	200
ADG ECO PLUS 50PH	122	885	1000	200

# OUTDOOR UNITS DIMENSIONAL DRAWING

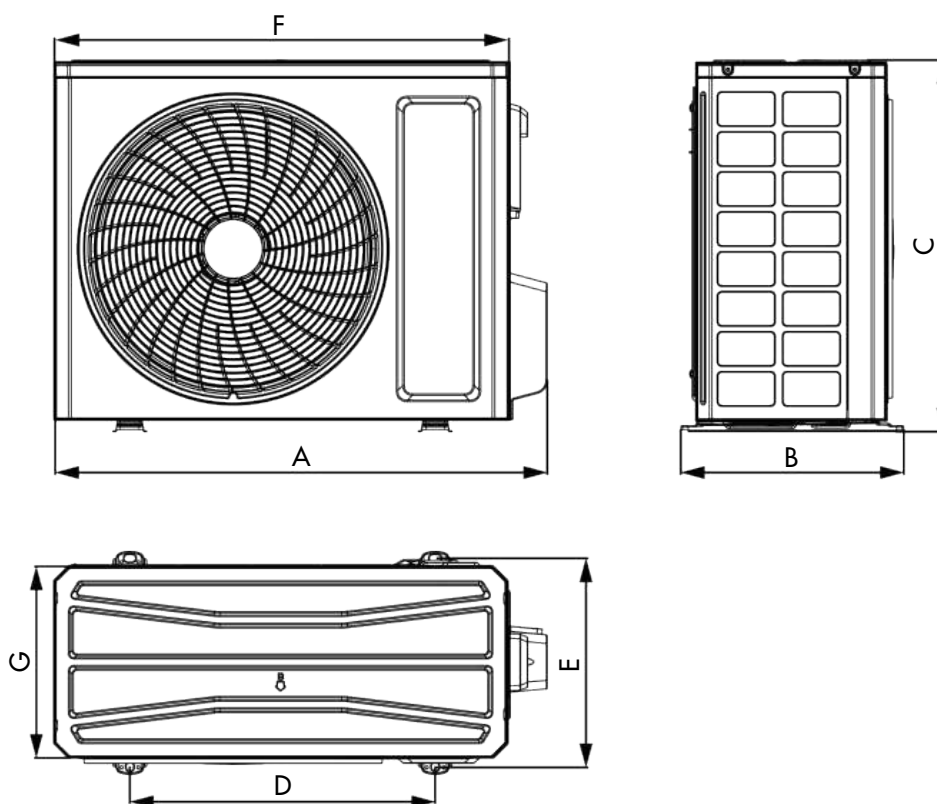

AIR  
CONDITIONERS

MODEL	DIMENSIONS (mm)						
	A	B	C	D	E	F	G
<b>AEG ECO PLUS 35PIH</b>	732	330	553	455	310	675	285
<b>AEG ECO PLUS 50PIH</b>	802	350	555	512	331	745	300

# DUCTED

## HIGH STATIC PRESSURE

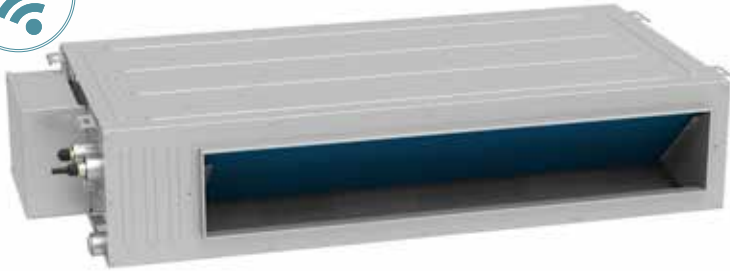

(Standard)  
Wired controller



(Optional)  
Wired controller  
with WiFi



(Optional)  
Infrared remote  
controller

- High static pressure ducted units for light commercial/industrial applications.
- Suitable for shops, offices, meeting rooms, hotels, restaurants, clubs, gyms and open space areas.
- Compact in design, these units have depths of only 260 mm; the 71 and 85 models have a width of only 900 mm, which makes them easy to integrate even in buildings with small ceilings.
- The special design of the evaporating coil (V-shape), covered by a patent, favors a more effective exchange of air.
- The centrifugal fan is also characterized by a patented design and allows higher air flow and greater silence.
- The external static pressure reaches 200 Pa, with 9 selectable levels (models 140-160), according to different needs, ensuring maximum adaptability to different types of installation.
- The combination with the wired controller allows to optimize the external static pressure according to the different technical installation requirements.
- The condensate drain pump is integrated for a height difference of up to 1000 mm.
- You can choose between rear or bottom air intake.
- The DC motor ensures energy saving and high efficiency.
- Double room temperature sensor for a customizable comfort: possibility to select the sensor of return air temperature on the unit or of the sensor of temperature on the wired control.
- Connection to a fresh air intake from outdoors is possible.
- High energy efficiency, at all capacities, both in cooling and heating modes, especially with a view to operating 365 days a year (seasonal efficiency).
- The special closing system of the refrigerant valve prevents and excludes the risk of gas leaks due to inappropriate maintenance.
- Optional WiFi, with wired controller, accessory that can be ordered separately.

<b>FAST</b> Quick cooling and heating	Intelligent sensor	Quiet mode	3 sleep modes	iFeel	Cold air prevention	Integrated water heat pump	Intelligent defrosting	Auto mode	Filter cleaning reminder	Fan speed regulation	Automatic fan speed	Turbo fan speed
Dehumidification	Dehumidification 12°C	I-Demand save energy	WiFi and app (optional)	Centralized control	Remote control	Modbus	Timer on/off	Access control	Dual wired controllers	8°C heating	Auto restart memory	Auto diagnosis
Ambient temperature control	System parameters inquiry	Historical errors inquiry	Settable pressure levels									

**A<sup>++</sup>** Cooling

**A<sup>+</sup>** Heating



## TECHNICAL DATA-MATCHING WITH SLIM DUCTED UNITS

Indoor unit model		ADG ECO PLUS 71PH		ADG ECO PLUS 85PH	
Outdoor unit model		AEG ECO PLUS 71PIH		AEG ECO PLUS 85PIH	
	Units	Cooling	Heating	Cooling	Heating
Nominal (min.-max.) capacity (EN14511)	kW	7.10 (2.40-7.60)	8.00 (2.20-8.60)	8.50 (2.90-9.00)	8.80 (2.50-9.50)
	BTU/h	24200	27200	29000	30000
EER/COP (EN14511)		3.70	4.00	3.40	3.90
Design Load [(Pdesign c/Pdesign h) (Average)] (EN14825)*	kW	7.1	4.7	8.5	6.0
Seasonal efficiency ratio [(SEER/SCOP (Average)] (EN14825)*		6.6	4.1	6.4	4.1
Energy efficiency class*		A++	A+	A++	A+
Seasonal energy consumption (Average)*	kWh/annum	377	1605	465	2049
Air flow rate Indoor (sh.-h.-m.-l.)	m <sup>3</sup> /h	1100-1000-900-800		1400-1300-1100-1000	
Dehumidification	l/h	2.4		2.8	
Fan speeds (Indoor/Outdoor)	n°	4/2		4/2	
Sound pressure Indoor (sh.-h.-m.-l.)	dB(A)	37-35-33-31		43-41-39-37	
Sound pressure Outdoor (h.)	dB(A)	58		65	
Sound power Indoor (sh.-h.-m.-l.)	dB(A)	55-54-53-52		57-54-52-50	
Sound power Outdoor (h.)	dB(A)	69		70	
Power supply	V/Ph/Hz	220-240~/1/50/60		220-240~/1/50/60	
Nominal rated external static pressure	Pa	25		37	
Rated external static pressure (range)	Pa	0-160		0-160	
Power input	kW	1.92	2.00	2.50	2.25
Maximum electrical power input	kW/A	2.80/14.00		3.30/15.00	
Compressor type		Rotary DC Inverter		Rotary DC Inverter	
Refrigerant type/GWP		R32/675		R32/675	
Refrigerant charge	kg/T.CO <sub>2</sub> eq.	1.5/1.01		1.5/1.01	
Liquid pipe diameter	mm (inch)	9.52 (3/8")		9.52 (3/8")	
Gas pipe diameter	mm (inch)	15.88 (5/8")		15.88 (5/8")	
Pipe length with gas standard charge	m	5		5	
Max. pipe length with additional charge	m	30		30	
Additional refrigerant charge	g/m	20		20	
Max. height difference (Outdoor above)	m	20		25	
Max. height difference (Indoor above)	m	20		25	
Indoor net dimension (H./W./D.)	mm	260/900/655		260/900/655	
Outdoor net dimension (H./W./D.)	mm	660/889/340		660/889/340	
Net weight Indoor/Outdoor	kg	29.5/41.5		29.5/46	

OPERATING RANGE: outdoor temperature  
 Cooling mode: from -20 °C to +52 °C  
 Heating mode: from -20 °C to +24 °C  
 RANGE OF INDOOR TEMPERATURE ADJUSTMENT: from 16 to 30 °C.

\*Data declared in compliance with EU Regulation no. 206/2012, as regards to Ecodesign requirements for air conditioners and comfort fans, and EU Regulation no. 626/2011, concerning the energy labelling of air conditioners, and tested according to standard EN14825.

# TECHNICAL DATA

Indoor unit model		ADG ECO PLUS 100PH		ADG ECO PLUS 100PH	
Outdoor unit model		AEG ECO PLUS 100PIH		AEG ECO PLUS 100PIH3	
	Units	Cooling	Heating	Cooling	Heating
Nominal (min.-max.) capacity (EN14511)	kW	10.50 (3.20-11.00)	11.50 (3.00-12.50)	10.50 (3.20-11.00)	11.50 (3.00-12.50)
	BTU/h	35800	39200	35800	39200
EER/COP (EN14511)		3.50	4.10	3.50	4.10
Design Load [(Pdesign c/Pdesign h) (Average)] (EN14825)*	kW	10.5	7.0	10.5	7.0
Seasonal efficiency ratio [(SEER/SCOP (Average)] (EN14825)*		6.4	4.2	6.4	4.2
Energy efficiency class*		A++	A+	A++	A+
Seasonal energy consumption (Average)*	kWh/annum	574	2333	574	2333
Air flow rate Indoor (sh.-h.-m.-l.)	m <sup>3</sup> /h	1700-1600-1400-1200		1700-1600-1400-1200	
Dehumidification	l/h	3.3		3.3	
Fan speeds (Indoor/Outdoor)	n°	4/2		4/2	
Sound pressure Indoor (sh.-h.-m.-l.)	dB(A)	39-38-37-36		39-38-37-36	
Sound pressure Outdoor (h.)	dB(A)	62		62	
Sound power Indoor (sh.-h.-m.-l.)	dB(A)	57-55-53-49		57-55-53-49	
Sound power Outdoor (h.)	dB(A)	70		70	
Power supply	V/Ph/Hz	220-240~/1/50/60		380-415~/3/50/60	
Nominal rated external static pressure	Pa	37		37	
Rated external static pressure (range)	Pa	0-160		0-160	
Power input	kW	3.00	2.80	3.00	2.80
Maximum electrical power input	kW/A	4.70/21.00		4.40/7.00	
Compressor type		Rotary DC Inverter		Rotary DC Inverter	
Refrigerant type/GWP		R32/675		R32/675	
Refrigerant charge	kg/T.CO <sub>2</sub> eq.	2.1/1.42		2.1/1.42	
Liquid pipe diameter	mm (inch)	9.52 (3/8")		9.52 (3/8")	
Gas pipe diameter	mm (inch)	15.88 (5/8")		15.88 (5/8")	
Pipe length with gas standard charge	m	5		5	
Max. pipe length with additional charge	m	75		75	
Additional refrigerant charge	g/m	20		20	
Max. height difference (Outdoor above)	m	30		30	
Max. height difference (Indoor above)	m	30		30	
Indoor net dimension (H./W./D.)	mm	260/1340/655		260/1340/655	
Outdoor net dimension (H./W./D.)	mm	820/940/370		820/940/370	
Net weight Indoor/Outdoor	kg	43/65		43/75	

OPERATING RANGE: outdoor temperature  
Cooling mode: from -20 °C to +52 °C  
Heating mode: from -20 °C to +24 °C  
RANGE OF INDOOR TEMPERATURE ADJUSTMENT: from 16 to 30 °C.

\*Data declared in compliance with EU Regulation no. 206/2012, as regards to Ecodesign requirements for air conditioners and comfort fans, and EU Regulation no. 626/2011, concerning the energy labelling of air conditioners, and tested according to standard EN14825.

Indoor unit model		ADG ECO PLUS 140PH		ADG ECO PLUS 140PH	
Outdoor unit model		AEG ECO PLUS 140PIH		AEG ECO PLUS 140PIH3	
	Units	Cooling	Heating	Cooling	Heating
Nominal (min.-max.) capacity (EN14511)	kW	13.40 (4.00-14.20)	15.50 (3.90-16.00)	13.40 (4.00-14.20)	15.50 (3.90-16.00)
	BTU/h	45700	52800	45700	52800
EER/COP (EN14511)		2.91	3.30	2.91	3.30
Rated capacity (Prated,c/Prated,h)*	kW	13.40	15.50	13.40	15.50
Seasonal space energy efficiency (ηs,c/ηs,h)*		250.4	158.8	250.4	158.8
Air flow rate Indoor (sh.-h.-m.-l.)	m³/h	2200-2000-1730-1490		2200-2000-1730-1490	
Dehumidification	l/h	3.9		3.9	
Fan speeds (Indoor/Outdoor)	n°	4/2		4/2	
Sound pressure Indoor (sh.-h.-m.-l.)	dB(A)	43-42-40-38		43-42-40-38	
Sound pressure Outdoor (h.)	dB(A)	67		67	
Sound power Indoor (sh.-h.-m.-l.)	dB(A)	59-57-46-44		59-57-46-44	
Sound power Outdoor (h.)	dB(A)	75		75	
Power supply	V/Ph/Hz	220-240~/1/50/60		380-415~/3/50/60	
Nominal rated external static pressure	Pa	50		50	
Rated external static pressure (range)	Pa	0-160		0-160	
Power input	kW	4.60	4.70	4.60	4.70
Maximum electrical power input	kW/A	5.60/25.00		5.60/11.00	
Compressor type		Rotary DC Inverter		Rotary DC Inverter	
Refrigerant type/GWP		R32/675		R32/675	
Refrigerant charge	kg/T.CO <sub>2</sub> eq.	2.8/1.89		2.8/1.89	
Liquid pipe diameter	mm (inch)	9.52 (3/8")		9.52 (3/8")	
Gas pipe diameter	mm (inch)	15.88 (5/8")		15.88 (5/8")	
Pipe lenght with gas standard charge	m	7.5		7.5	
Max. pipe lenght with additional charge	m	75		75	
Additional refrigerant charge	g/m	35		35	
Max. height difference (Outdoor above)	m	30		30	
Max. height difference (Indoor above)	m	30		30	
Indoor net dimension (H./W./D.)	mm	300/1400/700		300/1400/700	
Outdoor net dimension (H./W./D.)	mm	820/940/370		820/940/370	
Net weight Indoor/Outdoor	kg	52/73		52/81	

OPERATING RANGE: outdoor temperature  
 Cooling mode: from -20 °C to +52 °C  
 Heating mode: from -20 °C to +24 °C  
 RANGE OF INDOOR TEMPERATURE ADJUSTMENT: from 16 to 30 °C.

\*Data declared in accordance with COMMISSION REGULATION (EU) 2016/2281 of 30 November 2016 implementing Directive 2009/125/EC of the European Parliament and of the Council establishing a framework for the setting of ecodesign requirements for energy-related products, with regard to ecodesign requirements for air heating products, cooling products, high temperature process chillers and fan coil units.

# TECHNICAL DATA

Indoor unit model		ADG ECO PLUS 160PH	
Outdoor unit model		AEG ECO PLUS 160PIH3	
	Units	Cooling	Heating
Nominal (min.-max.) capacity (EN14511)	kW	16.00 (4.80-17.00)	17.00 (4.50-18.00)
	BTU/h	54500	58000
EER/COP (EN14511)		2.96	3.62
Rated capacity (Prated,c/Prated,h)*	kW	16.00	17.00
Seasonal space energy efficiency ( $\eta_{s,c}/\eta_{s,h}$ )*		234.4	151.0
Air flow rate Indoor (sh.-h.-m.-l.)	m <sup>3</sup> /h	2600-2300-2000-1700	
Dehumidification	l/h	4,6	
Fan speeds (Indoor/Outdoor)	n°	4/2	
Sound pressure Indoor (sh.-h.-m.-l.)	dB(A)	44-42-41-40	
Sound pressure Outdoor (h.)	dB(A)	60	
Sound power Indoor (sh.-h.-m.-l.)	dB(A)	70-67-55-54	
Sound power Outdoor (h.)	dB(A)	75	
Power supply	V/Ph/Hz	380-415~/3/50/60	
Nominal rated external static pressure	Pa	50	
Rated external static pressure (range)	Pa	0-200	
Power input	kW	5.40	4.70
Maximum electrical power input	kW/A	6.80/12.00	
Compressor type		Rotary DC Inverter	
Refrigerant type/GWP		R32/675	
Refrigerant charge	kg/T.CO <sub>2</sub> eq.	3.5/2.363	
Liquid pipe diameter	mm (inch)	9.52 (3/8")	
Gas pipe diameter	mm (inch)	15.88 (5/8")	
Pipe length with gas standard charge	m	7.5	
Max. pipe length with additional charge	m	75	
Additional refrigerant charge	g/m	35	
Max. height difference (Outdoor above)	m	30	
Max. height difference (Indoor above)	m	30	
Indoor net dimension (H./W./D.)	mm	300/1400/700	
Outdoor net dimension (H./W./D.)	mm	960/990/370	
Net weight Indoor/Outdoor	kg	55/94	

OPERATING RANGE: outdoor temperature  
Cooling mode: from -20 °C to +52 °C  
Heating mode: from -20 °C to +24 °C  
RANGE OF INDOOR TEMPERATURE ADJUSTMENT: from 16 to 30 °C.

\*Data declared in accordance with COMMISSION REGULATION (EU) 2016/2281 of 30 November 2016 implementing Directive 2009/125/EC of the European Parliament and of the Council establishing a framework for the setting of ecodesign requirements for energy-related products, with regard to ecodesign requirements for air heating products, cooling products, high temperature process chillers and fan coil units.

# STATIC PRESSURE CURVES

## ADG ECO PLUS 71PH - static pressure curves

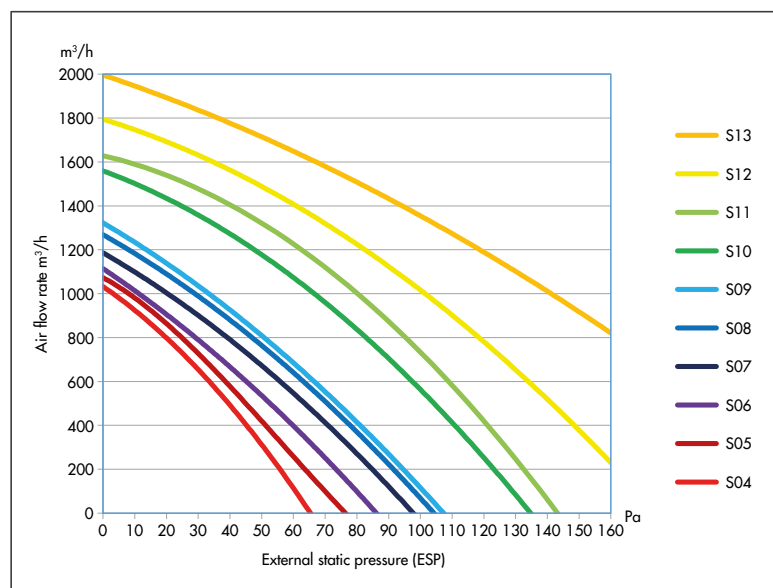

External static pressure	Turbo speed	High	Medium	Low
P1	S05	S03	S02	S01
P2	S06	S04	S03	S02
P3	S07	S05	S04	S03
P4	S08	S06	S05	S04
<b>P5*</b>	<b>S09</b>	<b>S07</b>	<b>S06</b>	<b>S05</b>
P6	S10	S08	S07	S06
P7	S11	S09	S08	S07
P8	S12	S10	S09	S08
P9	S13	S11	S10	S09

\*Default static pressure level

The wired controller can be used to change the external static pressure (ESP) to turbo, high, medium and low fan speeds. 9 are the adjustable external static pressure levels.

## ADG ECO PLUS 85PH - static pressure curves

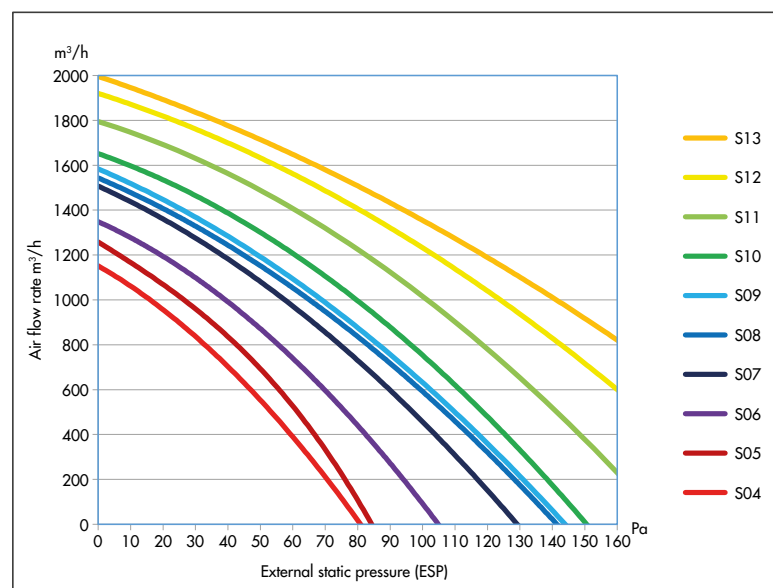

External static pressure	Turbo speed	High	Medium	Low
P1	S05	S03	S02	S01
P2	S06	S04	S03	S02
P3	S07	S05	S04	S03
P4	S08	S06	S05	S04
<b>P5*</b>	<b>S09</b>	<b>S07</b>	<b>S06</b>	<b>S05</b>
P6	S10	S08	S07	S06
P7	S11	S09	S08	S07
P8	S12	S10	S09	S08
P9	S13	S11	S10	S09

\*Default static pressure level

The wired controller can be used to change the external static pressure (ESP) to turbo, high, medium and low fan speeds. 9 are the adjustable external static pressure levels.

# STATIC PRESSURE CURVES

## ADG ECO PLUS 100PH - static pressure curves

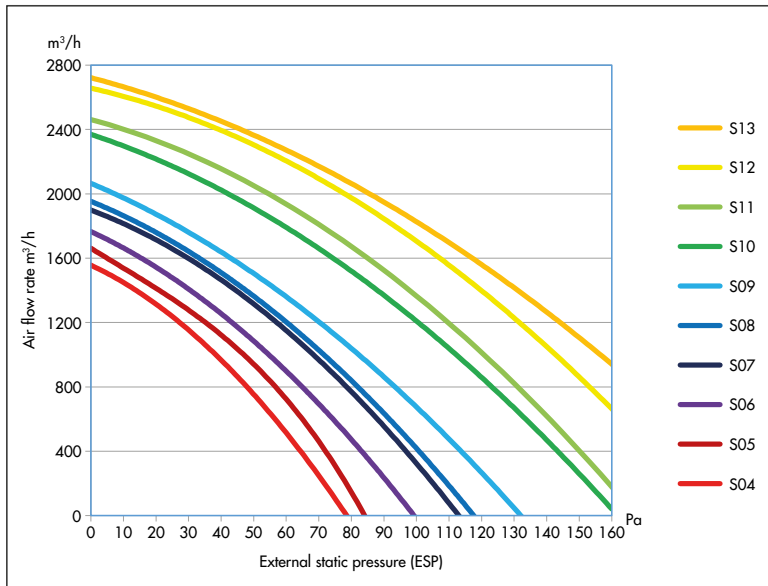

External static pressure	Turbo speed	High	Medium	Low
P1	S05	S03	S02	S01
P2	S06	S04	S03	S02
P3	S07	S05	S04	S03
P4	S08	S06	S05	S04
<b>P5*</b>	<b>S09</b>	<b>S07</b>	<b>S06</b>	<b>S05</b>
P6	S10	S08	S07	S06
P7	S11	S09	S08	S07
P8	S12	S10	S09	S08
P9	S13	S11	S10	S09

\*Default static pressure level

The wired controller can be used to change the external static pressure (ESP) to turbo, high, medium and low fan speeds. 9 are the adjustable external static pressure levels.

## ADG ECO PLUS 140PH - static pressure curves

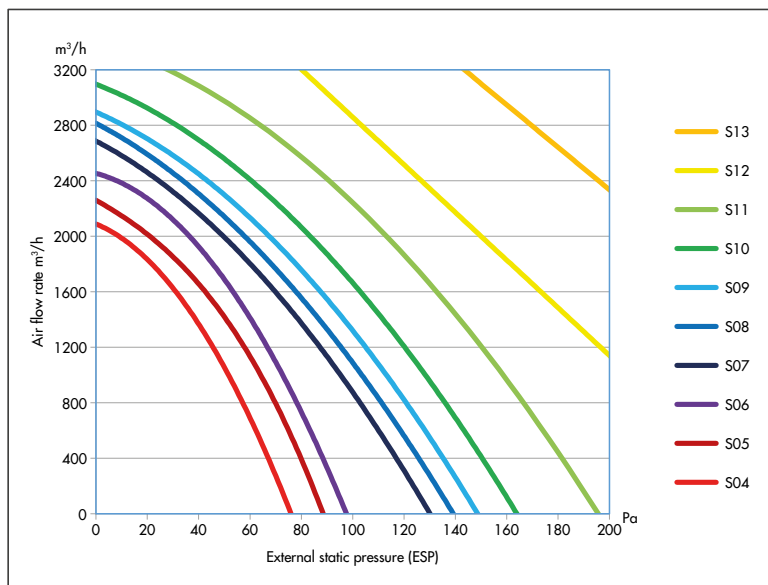

External static pressure	Turbo speed	High	Medium	Low
P1	S05	S03	S02	S01
P2	S06	S04	S03	S02
P3	S07	S05	S04	S03
P4	S08	S06	S05	S04
<b>P5*</b>	<b>S09</b>	<b>S07</b>	<b>S06</b>	<b>S05</b>
P6	S10	S08	S07	S06
P7	S11	S09	S08	S07
P8	S12	S10	S09	S08
P9	S13	S11	S10	S09

\*Default static pressure level

The wired controller can be used to change the external static pressure (ESP) to turbo, high, medium and low fan speeds. 9 are the adjustable external static pressure levels.

## ADG ECO PLUS 160PH - static pressure curves

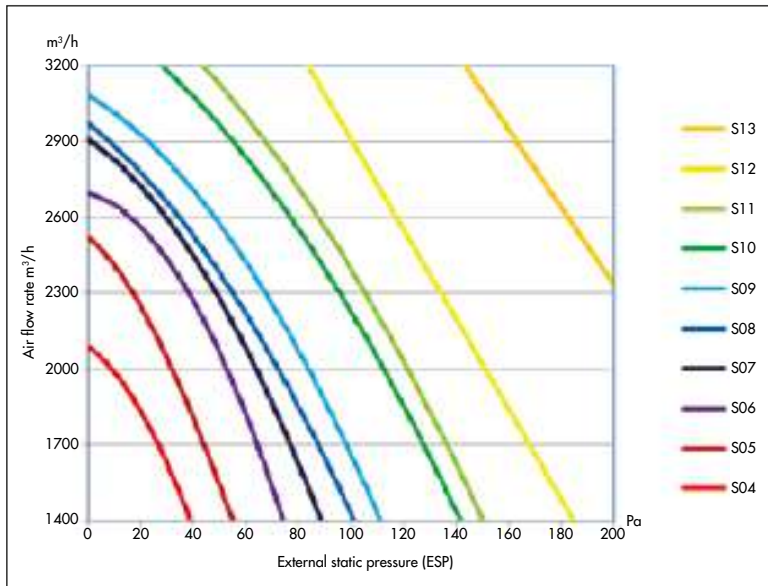

External static pressure	Turbo speed	High	Medium	Low
P1	S05	S03	S02	S01
P2	S06	S04	S03	S02
P3	S07	S05	S04	S03
P4	S08	S06	S05	S04
<b>P5*</b>	<b>S09</b>	<b>S07</b>	<b>S06</b>	<b>S05</b>
P6	S10	S08	S07	S06
P7	S11	S09	S08	S07
P8	S12	S10	S09	S08
P9	S13	S11	S10	S09

\*Default static pressure level

The wired controller can be used to change the external static pressure (ESP) to turbo, high, medium and low fan speeds. 9 are the adjustable external static pressure levels.

# INDOOR UNITS DIMENSIONAL DRAWINGS

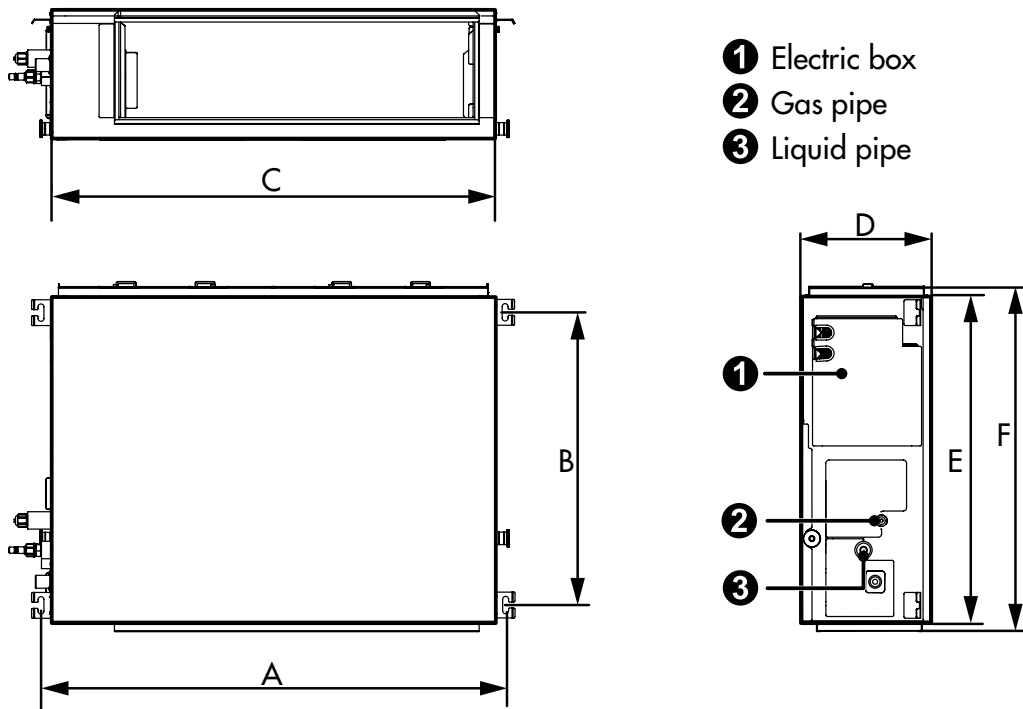

MODEL	DIMENSIONS (mm)					
	A	B	C	D	E	F
ADG ECO PLUS 71PH	942	590	900	260	655	692
ADG ECO PLUS 85PH						
ADG ECO PLUS 100PH	1381	585	1340	260	655	697
ADG ECO PLUS 140PH	1440	500	1400	300	700	754
ADG ECO PLUS 160PH						



# SUPPLY AIR OUTLET/RETURN AIR INLET DIMENSIONAL DRAWING

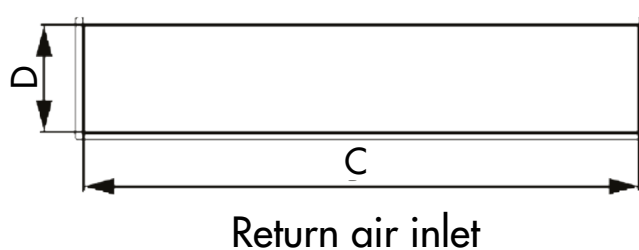
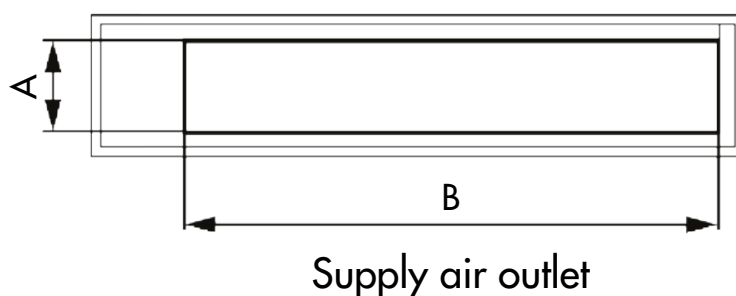

AIR  
CONDITIONERS

MODEL	SUPPLY AIR OUTLET		RETURN AIR INLET	
	A	B	C	D
ADG ECO PLUS 71PH	215	740	871	234
ADG ECO PLUS 85PH	215	740	871	234
ADG ECO PLUS 100PH	215	1153	1188	220
ADG ECO PLUS 140PH	197	1151	1362	264
ADG ECO PLUS 160PH	197	1151	1362	264

# OUTDOOR UNITS DIMENSIONAL DRAWING

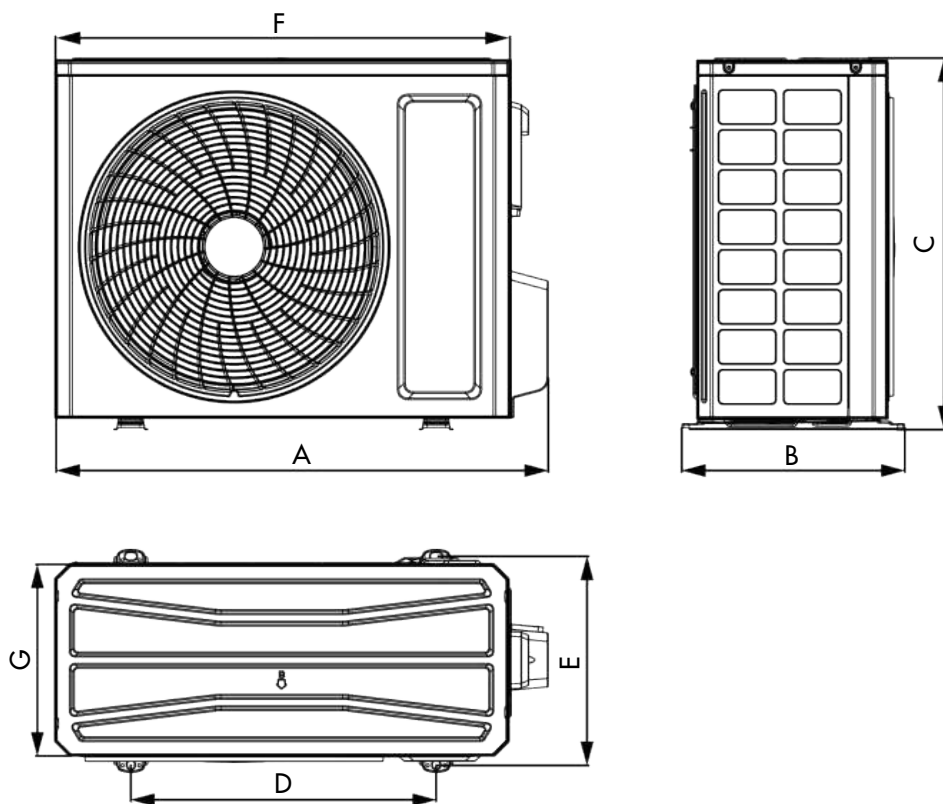

MODEL	DIMENSIONS (mm)						
	A	B	C	D	E	F	G
AEG ECO PLUS 71PIH	958	402	660	570	371	889	340
AEG ECO PLUS 85PIH	958	402	660	570	371	889	340
AEG ECO PLUS 100PIH	1020	427	820	635	396	940	370
AEG ECO PLUS 100PIH3	1020	427	820	635	396	940	370
AEG ECO PLUS 140PIH	1020	427	820	635	396	940	370
AEG ECO PLUS 140PIH3	1020	427	820	635	396	940	370
AEG ECO PLUS 160PIH3	1020	427	960	755	396	990	370

# NOTES



# FLOOR/CEILING

# FLOOR/CEILING



(Standard)  
Infrared remote controller



(Optional)  
Wired controller with WiFi

- Floor or ceiling units for light commercial/industrial applications
- Suitable for shops, offices, meeting rooms, hotels, restaurants, clubs, gyms and open space areas
- Compact structure: only 235 mm of thickness
- Double flap: when the unit is turned off, the air supply can be completely closed in order to prevent the entry of dust
- The wide oscillation angle of the flap allows the flow of horizontal air delivery (ceiling application): this excludes direct air flows on people in the environment
- There are 3 exit options for the connecting pipes, to facilitate installation in any circumstances
- The design of the electrical box side does not affect the return of air and facilitates maintenance
- They are equipped with a double room temperature sensor for customizable comfort: possibility of selecting the return air temperature sensor on the unit or the temperature sensor on the wired control
- High energy efficiency, at all powers expressed, both in cold and in heat, especially with a view to operating 365 days a year (seasonal efficiency)
- The special closing system of the refrigerant valve prevents and excludes the risk of gas leaks due to inappropriate maintenance.
- Optional WiFi, with wired control, accessory can be ordered separately.

<b>FAST</b> Quick cooling and heating	Intelligent sensor	Quiet mode	3 sleep modes	iFeel	Cold air prevention	Double temperature sensors for air return	Intelligent defrosting	Auto mode	Filter cleaning reminder	Timer	Automatic swinging	Fixed swinging
Fan speed regulation	Automatic fan speed	Turbo fan speed	Dehumidification	Dehumidification 12°C	Save energy	WiFi and app (optional)	Centralized control	Remote control	Modbus	Auto restart memory	Access control	Dual wired controllers
Programmable wired controller	8°C heating	Auto diagnosis	Ambient temperature control	System parameters inquiry	Historical errors inquiry							

**A++** Cooling

**A+** Heating

## TECHNICAL DATA MATCHING WITH FLOOR CEILING UNITS

Indoor unit model		ACG ECO PLUS 35PH		ACG ECO PLUS 50PH	
Outdoor unit model		AEG ECO PLUS 35PIH		AEG ECO PLUS 50PIH	
		Units	Units	Units	Units
		Cooling	Heating	Cooling	Heating
Nominal (min.-max.) capacity (EN14511)	kW	3.50 (0.90-4.00)	4.00 (0.90-4.50)	5.30 (1.60-5.50)	5.60 (1.60-6.10)
	BTU/h	11900	13600	18000	19100
EER/COP (EN14511)		3.80	4.30	3.40	3.90
Design Load [(Pdesign c/Pdesign h) (Average)] (EN14825)*	kW	3.80	4.30	5.3	3.9
Seasonal efficiency ratio [(SEER/SCOP (Average)] (EN14825)*		7.2	4.1	6.5	4.2
Energy efficiency class*		A++	A+	A++	A+
Seasonal energy consumption (Average)*	kWh/annum	170	1059	285	1300
Air flow rate Indoor (sh.-h.-m.-l.)	m <sup>3</sup> /h	650-580-500-400		900-800-700-600	
Dehumidification	l/h	1.1		1.7	
Fan speeds (Indoor/Outdoor)	n°	4/2		4/2	
Sound pressure Indoor (sh.-h.-m.-l.)	dB(A)	39-36-32-28		41-40-38-36	
Sound pressure Outdoor (h.)	dB(A)	48		59	
Sound power Indoor (sh.-h.-m.-l.)	dB(A)	49-46-42-38		59-57-54-51	
Sound power Outdoor (h.)	dB(A)	56		65	
Power supply	V/Ph/Hz	220-240~/1/50/60		220-240~/1/50/60	
Power input	kW	0.92	0.93	1.56	1.44
Maximum electrical power input	kW/A	1.30/6.00		1.90/9.50	
Compressor type		Rotary DC Inverter		Rotary DC Inverter	
Refrigerant type/GWP		R32/675		R32/675	
Refrigerant charge	kg/T.CO <sub>2</sub> eq.	0.57/0.39		0.75/0.51	
Liquid pipe diameter	mm (inch)	6.35 (1/4")		6.35 (1/4")	
Gas pipe diameter	mm (inch)	9.52 (3/8")		12.70 (1/2")	
Min.max. pipe lenght with gas standard charge	m	3-5		3-5	
Max. pipe lenght with additional charge	m	30		30	
Additional refrigerant charge	g/m	16		16	
Max. height difference (Outdoor above)	m	15		20	
Max. height difference (Indoor above)	m	15		20	
Indoor net dimension (H./W./D.)	mm	665/870/235		665/870/235	
Outdoor net dimension (H./W./D.)	mm	553/675/285		555/745/300	
Net weight Indoor/Outdoor	kg	24/24.5		25/30.5	

OPERATING RANGE: outdoor temperature  
 Cooling mode: from -20 °C to +52 °C  
 Heating mode: from -20 °C to +24 °C  
 RANGE OF INDOOR TEMPERATURE ADJUSTMENT: from 16 to 30 °C.

\*Data declared in compliance with EU Regulation no. 206/2012, as regards to Ecodesign requirements for air conditioners and comfort fans, and EU Regulation no. 626/2011, concerning the energy labelling of air conditioners, and tested according to standard EN14825.

# TECHNICAL DATA

Indoor unit model		ACG ECO PLUS 71PH		ACG ECO PLUS 85PH	
Outdoor unit model		AEG ECO PLUS 71PIH		AEG ECO PLUS 85PIH	
	Units	Cooling	Heating	Cooling	Heating
Nominal (min.-max.) capacity (EN14511)	kW	7.10 (2.40-7.60)	7.70 (2.20-8.40)	8.50 (2.90-9.00)	8.80 (2.50-9.50)
	BTU/h	24200	26200	29000	30000
EER/COP (EN14511)		3.70	4.00	3.40	3.90
Design Load [(Pdesign c/Pdesign h) (Average)] (EN14825)*	kW	7.1	4.7	8.5	6.0
Seasonal efficiency ratio [(SEER/SCOP (Average)] (EN14825)*		7.2	4.3	6.8	4.5
Energy efficiency class*		A++	A+	A++	A+
Seasonal energy consumption (Average)*	kWh/annum	345	1530	438	1867
Air flow rate Indoor (sh.-h.-m.-l.)	m <sup>3</sup> /h	1250-1100-1000-900		1400-1300-1200-1000	
Dehumidification	l/h	2.4		2.8	
Fan speeds (Indoor/Outdoor)	n°	4/2		4/2	
Sound pressure Indoor (sh.-h.-m.-l.)	dB(A)	41-39-37-35		46-45-43-39	
Sound pressure Outdoor (h.)	dB(A)	55		57	
Sound power Indoor (sh.-h.-m.-l.)	dB(A)	54-53-50-47		62-60-56-52	
Sound power Outdoor (h.)	dB(A)	69		70	
Power supply	V/Ph/Hz	220-240~/1/50/60		220-240~/1/50/60	
Power input	kW	2.03	1.95	2.50	2.25
Maximum electrical power input	kW/A	2.80/14.00		3.30/15.00	
Compressor type		Rotary DC Inverter		Rotary DC Inverter	
Refrigerant type/GWP		R32/675		R32/675	
Refrigerant charge	kg/T.CO <sub>2</sub> eq.	1.5/1.01		1.5/1.01	
Liquid pipe diameter	mm (inch)	9.52 (3/8")		9.52 (3/8")	
Gas pipe diameter	mm (inch)	15.88 (5/8")		15.88 (5/8")	
Min.-max. pipe length with gas standard charge	m	3-5		3-5	
Max. pipe length with additional charge	m	30		30	
Additional refrigerant charge	g/m	20		20	
Max. height difference (Outdoor above)	m	20		25	
Max. height difference (Indoor above)	m	20		25	
Indoor net dimension (H./W./D.)	mm	665/1200/235		665/1200/235	
Outdoor net dimension (H./W./D.)	mm	660/889/340		660/889/340	
Net weight Indoor/Outdoor	kg	31/41.5		32/46	

OPERATING RANGE: outdoor temperature  
Cooling mode: from -20 °C to +52 °C  
Heating mode: from -20 °C to +24 °C  
RANGE OF INDOOR TEMPERATURE ADJUSTMENT: from 16 to 30 °C.

\*Data declared in compliance with EU Regulation no. 206/2012, as regards to Ecodesign requirements for air conditioners and comfort fans, and EU Regulation no. 626/2011, concerning the energy labelling of air conditioners, and tested according to standard EN14825.



Indoor unit model		ACG ECO PLUS 100PH		ACG ECO PLUS 100PH	
Outdoor unit model		AEG ECO PLUS 100PIH		AEG ECO PLUS 100PIH3	
	Units	Cooling	Heating	Cooling	Heating
Nominal (min.-max.) capacity (EN14511)	kW	10.00 (3.20-11.00)	11.50 (3.00-12.50)	10.00 (3.20-11.00)	11.50 (3.00-12.50)
	BTU/h	34100	39200	34100	39200
EER/COP (EN14511)		3.40	3.90	3.40	3.90
Design Load [(Pdesign c/Pdesign h) (Average)] (EN14825)*	kW	10.0	7.0	10.0	7.0
Seasonal efficiency ratio [(SEER/SCOP (Average)] (EN14825)*		6.3	4.2	6.3	4.2
Energy efficiency class*		A++	A+	A++	A+
Seasonal energy consumption (Average)*	kWh/annum	556	2333	556	2333
Air flow rate Indoor (sh.-h.-m.-l.)	m <sup>3</sup> /h	1600-1500-1400-1200		1600-1500-1400-1200	
Dehumidification	l/h	3.3		3.3	
Fan speeds (Indoor/Outdoor)	n°	4/2		4/2	
Sound pressure Indoor (sh.-h.-m.-l.)	dB(A)	48-46-45-43		48-46-45-43	
Sound pressure Outdoor (h.)	dB(A)	55		55	
Sound power Indoor (sh.-h.-m.-l.)	dB(A)	65-63-61-59		65-63-61-59	
Sound power Outdoor (h.)	dB(A)	70		70	
Power supply	V/Ph/Hz	220-240~/1/50/60		380-415~/3/50/60	
Power input	kW	2.94	2.95	2.94	2.95
Maximum electrical power input	kW/A	4.70/21.00		4.40/7.00	
Compressor type		Rotary DC Inverter		Rotary DC Inverter	
Refrigerant type/GWP		R32/675		R32/675	
Refrigerant charge	kg/T.CO <sub>2</sub> eq.	2.10/1.42		2.1/1.42	
Liquid pipe diameter	mm (inch)	9.52 (3/8")		9.52 (3/8")	
Gas pipe diameter	mm (inch)	15.88 (5/8")		15.88 (5/8")	
Min.-max. pipe length with gas standard charge	m	5-7		5-7	
Max. pipe length with additional charge	m	75		75	
Additional refrigerant charge	g/m	20		20	
Max. height difference (Outdoor above)	m	30		30	
Max. height difference (Indoor above)	m	30		30	
Indoor net dimension (H./W./D.)	mm	665/1200/235		665/1200/235	
Outdoor net dimension (H./W./D.)	mm	820/940/370		820/940/370	
Net weight Indoor/Outdoor	kg	32/65		32/75	

OPERATING RANGE: outdoor temperature

Cooling mode: from -20 °C to +52 °C

Heating mode: from -20 °C to +24 °C

RANGE OF INDOOR TEMPERATURE ADJUSTMENT: from 16 to 30 °C.

\*Data declared in compliance with EU Regulation no. 206/2012, as regards to Ecodesign requirements for air conditioners and comfort fans, and EU Regulation no. 626/2011, concerning the energy labelling of air conditioners, and tested according to standard EN14825.

# TECHNICAL DATA

Indoor unit model		ACG ECO PLUS 140PH		ACG ECO PLUS 140PH	
Outdoor unit model		AEG ECO PLUS 140PIH		AEG ECO PLUS 140PIH3	
	Units	Cooling	Heating	Cooling	Heating
Nominal capacity (min.-max.) (EN14511)	kW	13.40 (4.00-14.20)	15.50 (3.90-16.00)	13.40 (4.00-14.20)	15.50 (3.90-16.00)
	BTU/h	45700	52800	45700	52800
EER/COP (EN14511)		3.12	3.69	3.12	3.52
Rated capacity (Prated,c/Prated,h)*		13.40	15.50	13.40	15.50
Seasonal space energy efficiency (ηs,c/ηs,h)*	%	254.7	163.6	253.0	158.2
Air flow rate Indoor (sh.-h.-m.-l.)	m³/h	2300-2100-1800-1500		2300-2100-1800-1500	
Dehumidification	l/h	3.9		3.9	
Fan speeds (Indoor/Outdoor)	n°	4/2		4/2	
Sound pressure Indoor (sh.-h.-m.-l.)	dB(A)	51-48-45-43		51-48-45-43	
Sound pressure Outdoor (h.)	dB(A)	59		59	
Sound power Indoor (sh.-h.-m.-l.)	dB(A)	67-65-63-59		67-65-63-59	
Sound power Outdoor (h.)	dB(A)	70		70	
Power supply	V/Ph/Hz	220-240~/1/50/60		380-415~/3/50/60	
Power input	kW	4.30	4.20	4.30	4.40
Maximum electrical power input	kW/A	5.60/25.00		5.60/11.00	
Compressor type		Rotary DC Inverter		Rotary DC Inverter	
Refrigerant type/GWP		R32/675		R32/675	
Refrigerant charge	kg/T.CO <sub>2</sub> eq.	2.8/1.89		2.8/1.89	
Liquid pipe diameter	mm (inch)	9.52 (3/8")		9.52 (3/8")	
Gas pipe diameter	mm (inch)	15.88 (5/8")		15.88 (5/8")	
Min.-max. pipe lenght with gas standard charge	m	7.5-9.5		7.5-9.5	
Max. pipe lenght with additional charge	m	75		75	
Additional refrigerant charge	g/m	35		35	
Max. height difference (Outdoor above)	m	30		30	
Max. height difference (Indoor above)	m	30		30	
Indoor net dimension (H./W./D.)	mm	665/1570/235		665/1570/235	
Outdoor net dimension (H./W./D.)	mm	820/940/460		820/940/460	
Net weight Indoor/Outdoor	kg	42/73		42/95	

OPERATING RANGE: outdoor temperature

Cooling mode: from -20 °C to +52 °C

Heating mode: from -20 °C to +24 °C

RANGE OF INDOOR TEMPERATURE ADJUSTMENT: from 16 to 30 °C.

\*Data declared in accordance with COMMISSION REGULATION (EU) 2016/2281 of 30 November 2016 implementing Directive 2009/125/EC of the European Parliament and of the Council establishing a framework for the setting of ecodesign requirements for energy-related products, with regard to ecodesign requirements for air heating products, cooling products, high temperature process chillers and fan coil units.

Indoor unit model		ACG ECO PLUS 160PH	
Outdoor unit model		AEG ECO PLUS 160PIH3	
	Units	Cooling	Heating
Nominal (min.-max.) capacity (EN14511)	kW	16.00 (4.80-17.00)	17.00 (4.50-18.00)
	BTU/h	54500	58000
EER/COP (EN14511)		3.02	3.54
Rated capacity (Prated,c/Prated,h)*		16.0	17.0
Seasonal space energy efficiency ( $\eta_{s,c}/\eta_{s,h}$ )*	%	235.5	153.9
Air flow rate Indoor (sh.-h.-m.-l.)	m <sup>3</sup> /h	2400-2200-1900-1600	
Dehumidification	l/h	4.8	
Fan speeds (Indoor/Outdoor)	n°	4/2	
Sound pressure Indoor (sh.-h.-m.-l.)	dB(A)	54-49-48-44	
Sound pressure Outdoor (h.)	dB(A)	60	
Sound power Indoor (sh.-h.-m.-l.)	dB(A)	68-66-62-58	
Sound power Outdoor (h.)	dB(A)	75	
Power supply	V/Ph/Hz	380-415~/3/50/60	
Power input	kW	5.40	5.40
Maximum electrical power input	kW/A	6.80/12.00	
Compressor type		Rotary DC Inverter	
Refrigerant type/GWP		R32/675	
Refrigerant charge	kg/T.CO <sub>2</sub> eq.	3.5/2.363	
Liquid pipe diameter	mm (inch)	9.52 (3/8")	
Gas pipe diameter	mm (inch)	15.88 (5/8")	
Min.-max. pipe length with gas standard charge	m	7.5-9.5	
Max. pipe length with additional charge	m	75	
Additional refrigerant charge	g/m	35	
Max. height difference (Outdoor above)	m	30	
Max. height difference (Indoor above)	m	30	
Indoor net dimension (H./W./D.)	mm	665/1570/235	
Outdoor net dimension (H./W./D.)	mm	960/990/370	
Net weight Indoor/Outdoor	kg	42/94	

OPERATING RANGE: outdoor temperature  
 Cooling mode: from -20 °C to +52 °C  
 Heating mode: from -20 °C to +24 °C  
 RANGE OF INDOOR TEMPERATURE ADJUSTMENT: from 16 to 30 °C.

\*Data declared in accordance with COMMISSION REGULATION (EU) 2016/2281 of 30 November 2016 implementing Directive 2009/125/EC of the European Parliament and of the Council establishing a framework for the setting of ecodesign requirements for energy-related products, with regard to ecodesign requirements for air heating products, cooling products, high temperature process chillers and fan coil units.

# INDOOR UNITS DIMENSIONAL DRAWING

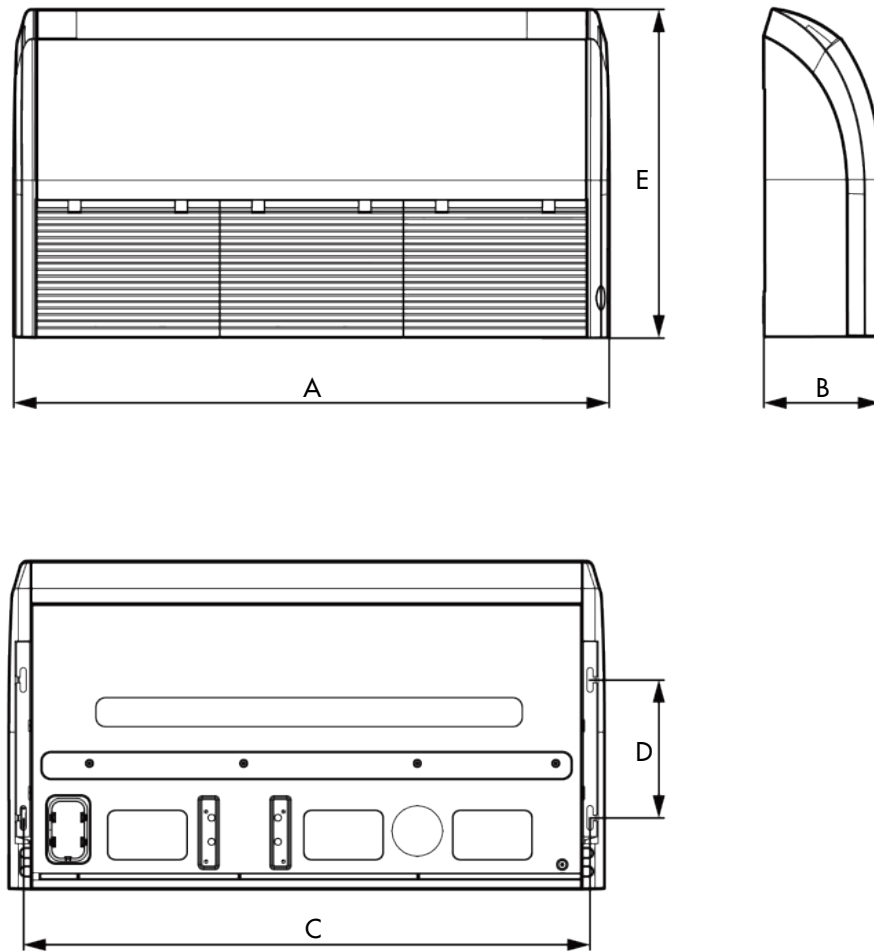

MODEL	DIMENSIONS (mm)				
	A	B	C	D	E
ACG ECO PLUS 35PH	870	235	812	280	665
ACG ECO PLUS 50PH	870	235	812	280	665
ACG ECO PLUS 71PH	1200	235	1142	280	665
ACG ECO PLUS 85PH	1200	235	1142	280	665
ACG ECO PLUS 100PH	1200	235	1142	280	665
ACG ECO PLUS 140PH	1570	235	1512	280	665
ACG ECO PLUS 160PH	1570	235	1512	280	665

# OUTDOOR UNITS DIMENSIONAL DRAWING

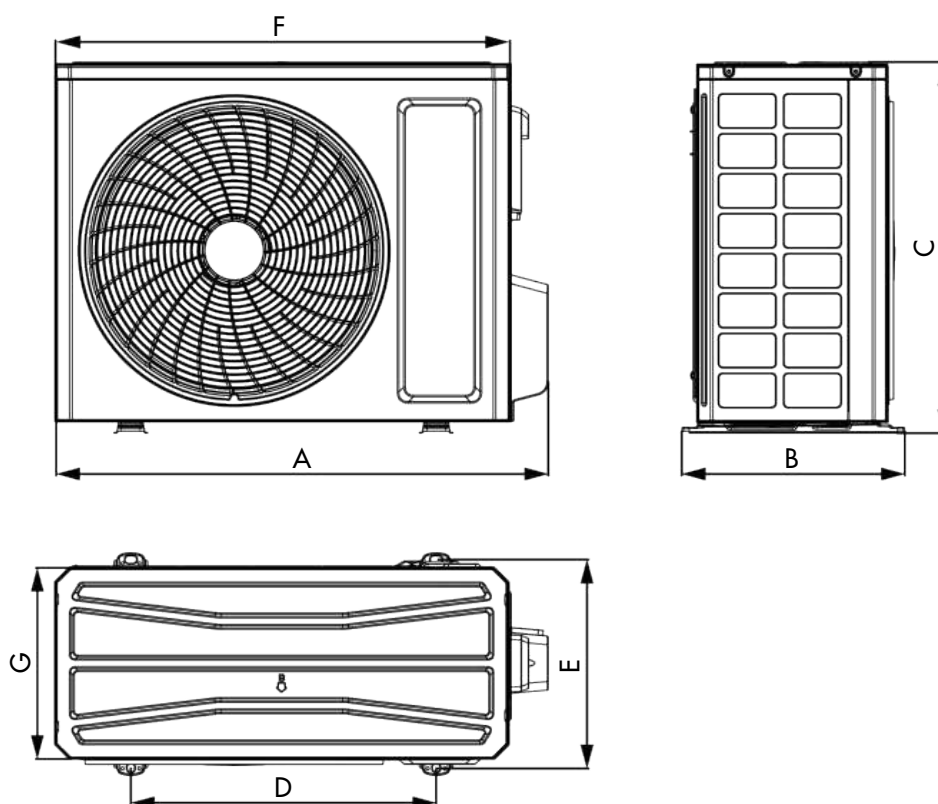

AIR  
CONDITIONERS

MODEL	DIMENSIONS (mm)						
	A	B	C	D	E	F	G
AEG ECO PLUS 35PIH	732	330	553	455	310	675	285
AEG ECO PLUS 50PIH	802	350	555	512	331	745	300
AEG ECO PLUS 71PIH	958	402	660	570	371	889	340
AEG ECO PLUS 85PIH	958	402	660	570	371	889	340
AEG ECO PLUS 100PIH	1020	427	820	635	396	940	370
AEG ECO PLUS 100PIH3	1020	427	820	635	396	940	370
AEG ECO PLUS 140PIH	1020	427	820	635	396	940	370
AEG ECO PLUS 140PIH3	1020	427	820	635	396	940	370
AEG ECO PLUS 160PIH3	1020	427	960	755	396	990	370



# CONTROL SYSTEMS

---

# CONTROL SYSTEMS

## 1 WIRED CONTROLLER FOR LONG DISTANCE WIFI CONTROL

Long distance WiFi control can be made through wired controller with WiFi. This controller must be purchased separately. The units thus equipped with this controller can be controlled remotely, through a dedicated APP (EWPE), easy to be downloaded from Google Play store or Apple store to be installed on smartphone (compatible with both Android and iOS systems).

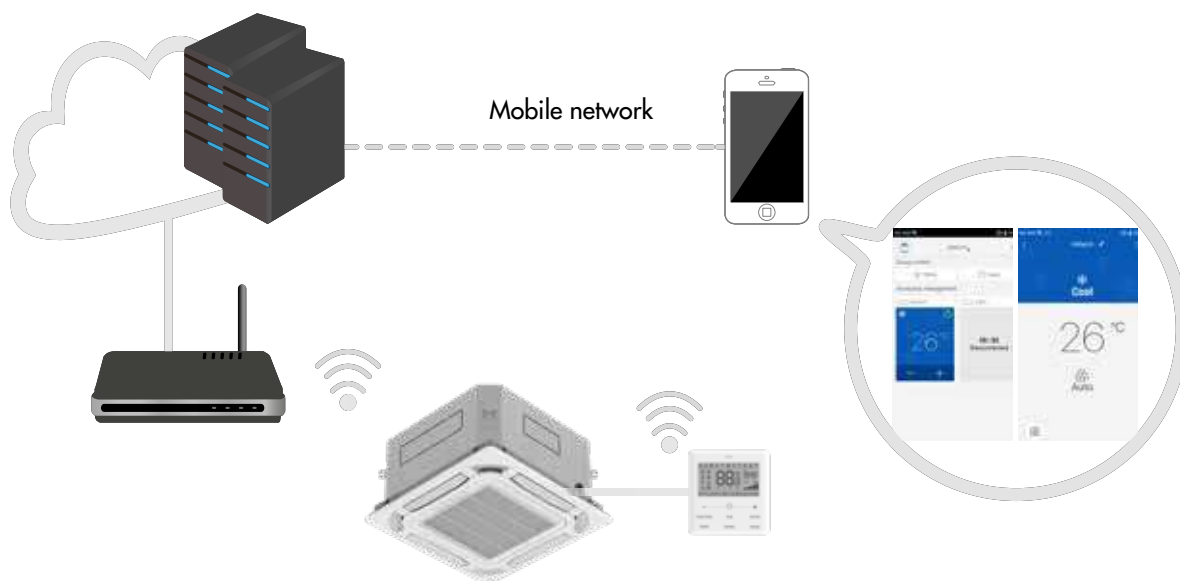

## 2 CENTRALIZED CONTROLLER FOR CENTRAL CONTROL OF SEVERAL INDOOR UNITS



- High-resolution colour LCD;
- 7" capacitive touch screen for ease of use;
- Shielding function of the single unit, of a group and of all indoor units;
- Equipped with the parameter visualisation, fault recording and access management functions;
- Equipped with various functions: centralized control (controls all indoor units), group management (grouping of certain units), programming management (setting of various programmes) and control of the single unit;
- Assignment of names to indoor units, icon selection and personalized settings (background setting, backlight, etc.);
- Up to 255 indoor units and up to 16 outdoor units can be controlled;
- Built-in wall-mounted installation with a mere 11 mm protrusion;
- Independent power supply in a broad range of voltages between 110 V and 240 V.



### 3 REMOTE CONTROL THROUGH MODBUS GATEWAY

All the indoor units must be equipped with MODBUS Gateway to connect the BMS. It's possible to connect up to 255 units to the same network.

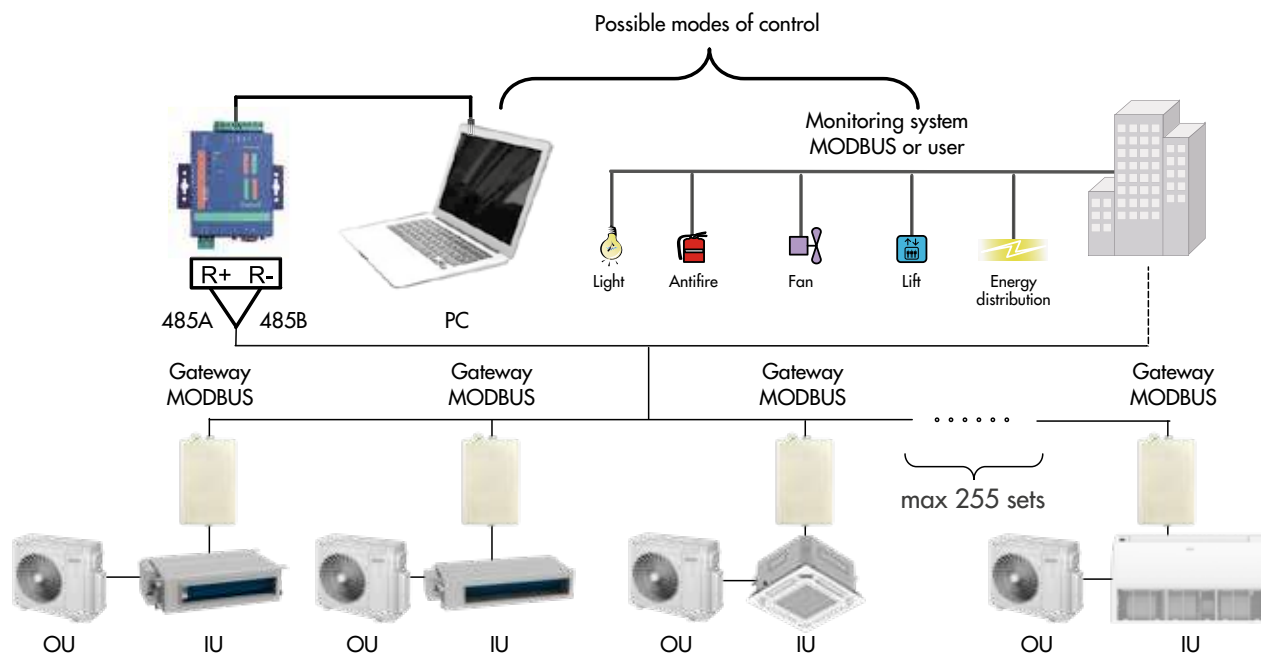

AIR  
CONDITIONERS

#### MODBUS GATEWAY

Dimensions (HxWxD): 54 mmx102 mmx20 mm

MODBUS Gateway interface module to connect indoor units to centralized control FCA or to a BMS.

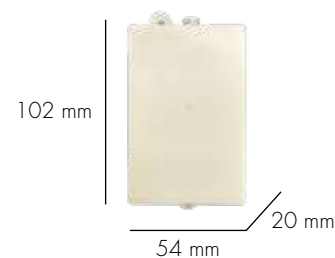

### 4 ACCESS CONTROL SYSTEM INTERFACE

This interface allows, among its different functionalities, control unit switch ON/OFF according to door opening/closing through a card.



# CONTROL SYSTEMS

## 5 DOOR CONTROL (Phase out)

It's applicable in hotel, etc. When the user pulls out the card or opens a window, the air conditioner turns off; insert again the card or close the window to resume previous operation status. This function is compatible with both high and low current access control interfaces.



## 6 DRY CONTACT GATEWAY (Coming soon)

The unit will be easily controlled through the dry contact Gateway.

**Input signal:** on/off, operation mode (heating/cooling), force off signal in the unit;

**Output signal:** on status, operation mode (heating/cooling), error output; on/off cold plasma and on off ventilation;



## 7 PROGRAMMABLE WIRED CONTROLLER WITH WEEKLY TIMER (Coming soon)

# CONTROLS

Code		Description	Cassette	Ducted	Floor ceiling
398700040		Standard wired controller		●	
398700039		Wired controller with WiFi	●	●	●
398100678		Infrared remote controller	●	●	●
398800104		Centralized touch screen controller up to 225 units	●	●	●
398100683		Gateway MODBUS	●	●	●
398700041		Access control system interface	●	●	●

● Standard control

● Optional control

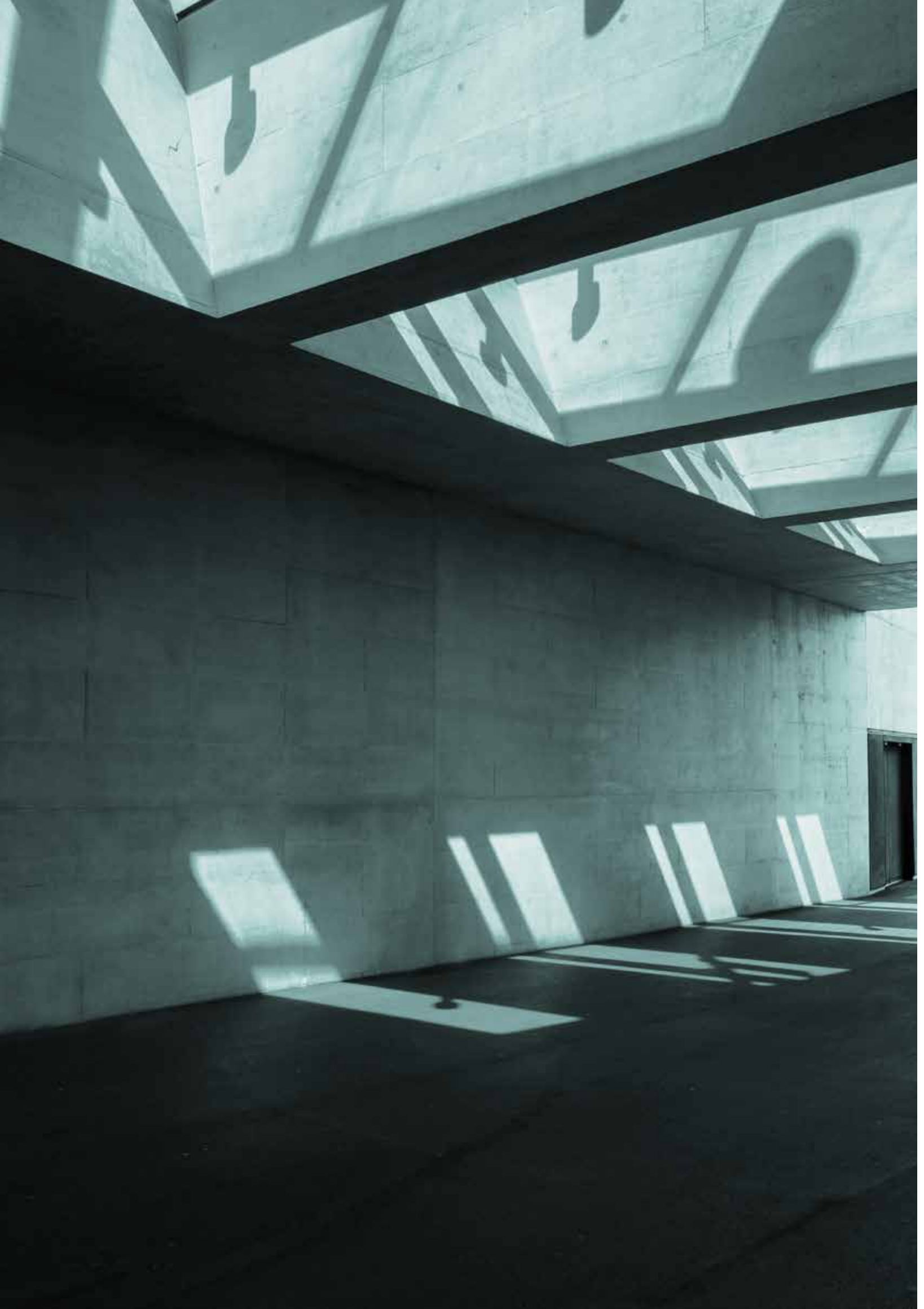

# HIGH-CAPACITY DUCTED

---

Air conditioners with high external static pressure -  
R410A

# HIGH-CAPACITY DUCTED

## WITH HIGH EXTERNAL STATIC PRESSURE



Wired controller

Model	Code	Cooling capacity (kW)	Heating capacity (kW)
ABDGI 20 HW	398700005	20	22
ABDGI 20 SH3	398700006	20	22
ABDGI 25 HW	398700001	25	27.5
ABDGI 25 SH3	398700002	25	27.5
ABDGI 30 HW	398700003	30	33
ABDGI 30 SH3	398700004	30	33

- Ducted air conditioners with high external static pressure for the commercial/tertiary sector
- Suitable for shops, offices, meeting rooms, restaurants, clubs, gymnasiums and open-space areas
- High energy efficiency, in both cooling and heating mode, especially when used year-round (seasonal efficiency) thanks to the motors all of the DC inverter type, for maximum comfort and low consumption
- Advanced torque control technology: adopts the optimised control principle for generating the maximum torque delivered with minimum consumption and reducing the loss of the motor winding and the smart power module for improved energy efficiency
- High nominal external static pressure (120 Pa), adjustable to between 0 and 250 Pa, in manual or automatic mode: this is a very important feature for applications requiring a very long air launch
- 9 static pressure levels available, depending on the installation
- The combination with a wired controller allows for optimising the static pressure in relation to the various technical installation requirements
- 3 selectable fan speeds
- Equipped with a signalling system for filter cleaning: monitors changes in the motor's current draw along with the rotation speed to determine whether the filter needs servicing
- CAN Bus communication: the CAN communication protocol considerably improves the anti-interference capacity, controls the indoor unit precisely and improves the system's efficiency. The conventional communication wire can be used to increase the project's installation flexibility
- Considerable pipe length and large height difference between the units; the pipe connecting the indoor and outdoor units can be up to 70 m long and the height difference between the indoor and outdoor units can reach 30 m
- Broad operating range: the system can work constantly with outdoor temperatures between -7 °C~48 °C in cooling mode and between -1.5 °C~24 °C in heating mode



Auto restart memory



Intelligent defrosting



Auto diagnosis



Child lock



Low-voltage start-up



Full protection



Wide operating range



Compact design



Easy to maintenance



"Turbo" function



Sleep mode



Filter cleaning reminder



X-FAN



Save energy

REFRIGERANT GAS



# TECHNICAL DATA

Indoor unit model		ABDGI 20 HW		ABDGI 25 HW	
Outdoor unit model		ABDGI 20 SH3		ABDGI 25 SH3	
	Units	Cooling	Heating	Cooling	Heating
Nominal capacity* (EN14511)	kW	20	22	25	27.5
	BTU/h	68200	75100	85300	93800
EER/COP* (EN14511)		2.55	3.25	2.65	3.10
Rated capacity (Prated,c/Prated,h)*	kW	2.55	3.25	25	27.5
Seasonal space energy efficiency ( $\eta_{s,c}/\eta_{s,h}$ )*	%	191.1	133.6	181.2	141.4
I.U. air flow rate (H.)	m <sup>3</sup> /h	3700		4200	
Dehumidification	l/h	1.4		1.8	
Fan speed (I.U./O.U.)	No.	4/2		4/2	
Sound pressure I.U. (H.-M.-L.)	dB(A)	52-51-50		53-52-51	
Sound pressure O.U. (H.)	dB(A)	62		63	
Sound pressure I.U. (H.-M.-L.)	dB(A)	62-61-60		63-62-61	
Sound pressure O.U. (H.)	dB(A)	72		73	
Power supply	V/Ph/Hz	380-415/3/50-60		380-415/3/50-60	
Factory external static pressure (ESP)	Pa	120		120	
External static pressure (ESP) (adjustment range)	Pa	0-250		0-250	
Electrical power input	kW	7.8	7.0	9.4	8.9
Compressor type		Scroll Inverter		Scroll Inverter	
Refrigerant type		R410A		R410A	
Refrigerant charge	kg/T.CO <sub>2</sub> eq.	6.4/13.36		8.0/16.70	
Liquid pipe diameter	mm (inch)	9.52 (3/8")		9.52 (3/8")	
Gas pipe diameter	mm (inch)	19.05 (3/4")		22 (7/8")	
Length of pipes with standard charge	m	7.5		7.5	
Maximum length of pipes with additional charge	m	70		70	
Additional charge	g/m	60		60	
Maximum height difference (outdoor unit above)	m	30		30	
Maximum height difference (indoor unit above)	m	30		30	
Net dimensions I.U. (H./W./D.)	mm	385/1315/760		450/1520/840	
Net dimensions O.U. (H./W./D.)	mm	1430/940/320		1615/940/460	
Net weight I.U./O.U.	kg	82/120		99/146	

#### OPERATING LIMITS (outdoor temperature)

Cooling: from -7 °C to +48 °C

Heating: from -15 °C to +24 °C

ROOM TEMPERATURE ADJUSTMENT RANGE: 16-30 °C.

\*Nominal data tested according to EN14511 and certified by EUROVENT. Nominal cooling capacity test conditions: indoor unit 27 °C DB/19 °C WB, outdoor unit 35 °C DB; length of connecting pipe: 5 m, without height difference between the units - Nominal heat capacity test conditions: indoor unit 20 °C DB, outdoor unit 7 °C DB/6 °C WB; length of connecting pipe: 5 m, without height difference between the units - The sum of capacities of the indoor units connected must fall within the interval (50%-135%) of the capacity of the outdoor units. The pertinent parameters can be corrected by referring to correction table of the units' capacity. - The parameters shown above are tested on the basis of the standard length of the connecting pipe. In the actual project, the parameters must be corrected by referring to the correction of the capacities for the long connecting pipe of the units.

\*\*Data declared in accordance with COMMISSION REGULATION (EU) 2016/2281 of 30 November 2016 implementing Directive 2009/125/EC of the European Parliament and of the Council establishing a framework for the setting of ecodesign requirements for energy-related products, with regard to ecodesign requirements for air heating products, cooling products, high temperature process chillers and fan coil units.

# DATI TECNICI

Indoor unit model		ABDGI 30 HW	
Outdoor unit model		ABDGI 30 SH3	
	Units	Cooling	Heating
Nominal capacity* (EN14511)	kW	30	33
	BTU/h	102400	112600
EER/COP* (EN14511)		2.65	3.20
Rated capacity (Prated,c/Prated,h)*	kW	30	33
Seasonal space energy efficiency ( $\eta_{s,c}/\eta_{s,h}$ )*	%	185.2	133.2
I.U. air flow rate (H.)	m <sup>3</sup> /h	5200	
Dehumidification	l/h	2.0	
Fan speed (I.U./O.U.)	No.	4/2	
Sound pressure I.U. (H.-M.-L.)	dB(A)	55-54-53	
Sound pressure O.U. (H.)	dB(A)	65	
Sound pressure I.U. (H.-M.-L.)	dB(A)	65-64-63	
Sound pressure O.U. (H.)	dB(A)	75	
Electrical power supply	V/Ph/Hz	380-415/3/50-60	
Factory external static pressure (ESP)	Pa	120	
External static pressure (ESP) (adjustment range)	Pa	0-250	
Electrical power input	kW	11.3	10.3
Compressor type		Scroll Inverter	
Refrigerant type		R410A	
Refrigerant charge	kg/T.CO <sub>2</sub> eq.	9.5/19.84	
Liquid pipe diameter	mm (inch)	12.7 (1/2")	
Gas pipe diameter	mm (inch)	25.4 (1")	
Length of pipes with standard charge	m	7.5	
Maximum length of pipes with additional charge	m	70	
Additional charge	g/m	120	
Maximum height difference (outdoor unit above)	m	30	
Maximum height difference (indoor unit above)	m	30	
Net dimensions I.U. (H./W./D.)	mm	450/1520/840	
Net dimensions O.U. (H./W./D.)	mm	1615/940/460	
Net weight I.U./O.U.	kg	105/175	

OPERATING LIMITS (outdoor temperature)

Cooling: from -7 °C to +48 °C

Heating: from -15 °C to +24 °C

ROOM TEMPERATURE ADJUSTMENT RANGE: 16-30 °C.

\*Nominal data tested according to EN14511 and certified by EUROVENT. Nominal cooling capacity test conditions: indoor unit 27 °C DB/19 °C WB, outdoor unit 35 °C DB; length of connecting pipe: 5 m, without height difference between the units - Nominal heat capacity test conditions: indoor unit 20 °C DB, outdoor unit 7 °C DB/6 °C WB; length of connecting pipe: 5 m, without height difference between the units - The sum of capacities of the indoor units connected must fall within the interval (50%-135%) of the capacity of the outdoor units. The pertinent parameters can be corrected by referring to correction table of the units' capacity. - The parameters shown above are tested on the basis of the standard length of the connecting pipe. In the actual project, the parameters must be corrected by referring to the correction of the capacities for the long connecting pipe of the units.

\*\*Data declared in accordance with COMMISSION REGULATION (EU) 2016/2281 of 30 November 2016 implementing Directive 2009/125/EC of the European Parliament and of the Council establishing a framework for the setting of ecodesign requirements for energy-related products, with regard to ecodesign requirements for air heating products, cooling products, high temperature process chillers and fan coil units.



# EXTERNAL STATIC PRESSURE CURVES

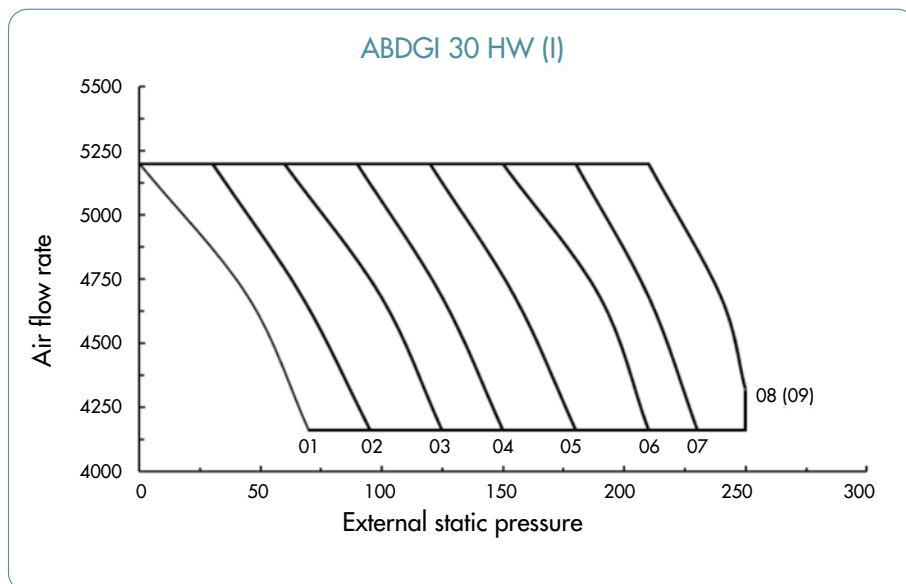
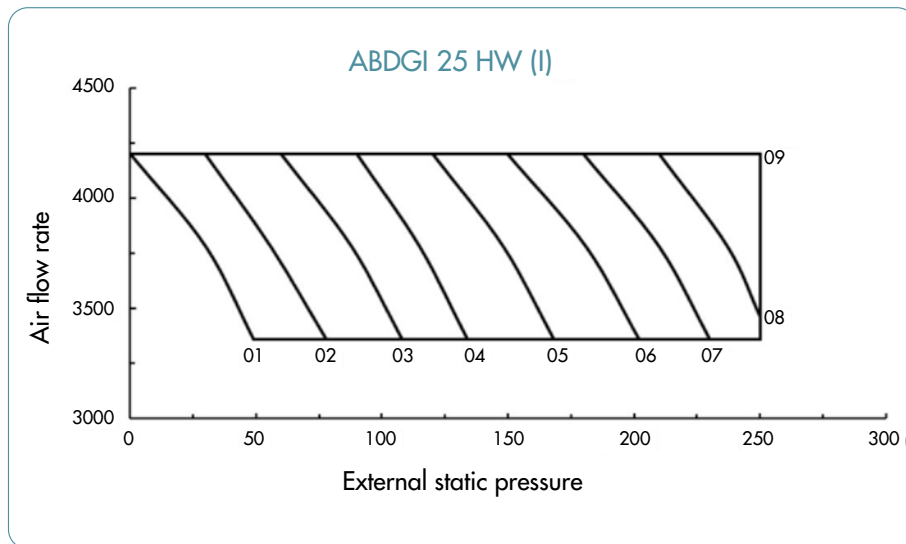
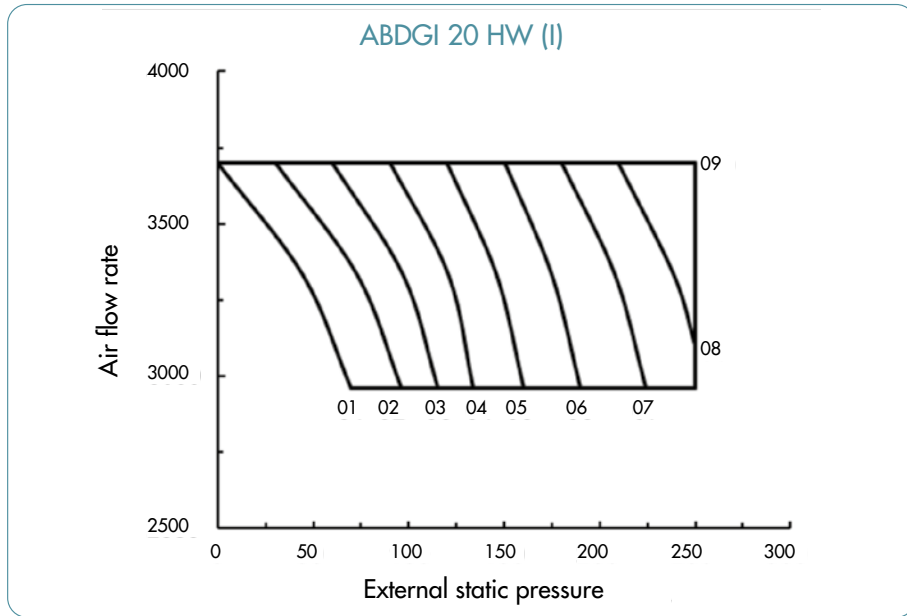



# X3 FS

---

Floor standing air conditioners

# FLOOR STANDING



(Standard)  
Infrared remote controller

## MAXIMUM COMFORT IN EVERY SITUATION THANKS TO THESE FEATURES:

### 1. QUICK COOLING AND HEATING

Cooling/heating at maximum power and speed allows to reach optimal comfort in a very short time.

### 2. TURBO MODE

It allows to have maximum cold in a very short time.

### 3. ENERGY SAVING

A specific energy saving function allows to minimize consumption in cooling.

### 4. AUTOSWING

The automatic oscillation of both horizontal and vertical flaps guarantees maximum comfort for everyone in situations of conviviality.

### 5. AUTO FUNCTION

Automatically adjusts the operation of the unit based on the desired conditions.

Code	Model
398000773	AFSI ECO 120 SH3
398000772	AFSI ECO 120 HL
TBD	Kit WiFi (optional)

<b>FAST</b> Quick cooling and heating	<b>3D airflow</b>	<b>Automatic swinging</b>	<b>Sleep mode</b>	<b>Cold air prevention</b>	<b>Intelligent defrosting</b>	<b>Auto mode</b>	<b>Child lock</b>	<b>Fan speed regulation</b>	<b>Automatic fan speed</b>	<b>Turbo fan speed</b>
<b>Dehumidification</b>	<b>Save energy</b>	<b>Remote control</b>	<b>8 °C heating</b>	<b>Auto restart memory</b>	<b>Auto diagnosis</b>	<b>Timer on/off</b>	<b>Ambient temperature control</b>			

Indoor unit model		AFSI ECO 120HL	
Outdoor unit model		AFSI ECO 120SH3	
	Units	Cooling	Heating
Nominal (min.-max.) capacity (EN14511)	kW	12.50 (3.60-13.50)	13.50 (2.80-14.0)
	BTU/h	42650 (12283-46062)	46062 (9554-47768)
EER/COP (EN14511)		3.63	4.09
Rated capacity (Prated,c/Prated,h)*	kW	12.50	13.50
Seasonal space energy efficiency (ηs,c/ηs,h)*	%	221	145
Air flow rate Indoor (sh.-h.-m.-l.)	m <sup>3</sup> /h	2400-2200-2000-1800	
Dehumidification	l/h	5	
Fan speeds (Indoor/Outdoor)	n°	4/2	
Sound pressure Indoor (sh.-h.-m.-l.)	dB(A)	57-55-53-51	
Sound pressure Outdoor (h.)	dB(A)	69	
Sound power Indoor (sh.-h.-m.-l.)	dB(A)	68-66-64-62	
Sound power Outdoor (h.)	dB(A)	75	
Power supply	V/Ph/Hz	380-415/3/50	
Power input	kW	3.44 (0.40-6.60)	3.30 (0.50-6.60)
Compressor type		Rotary DC Inverter	
Refrigerant type/GWP		R32/675	
Refrigerant charge	kg/T.CO <sub>2</sub> eq.	2.6/1.76	
Liquid pipe diameter	mm (inch)	9.52 (3/8")	
Gas pipe diameter	mm (inch)	15.88 (5/8")	
Min.-max. pipe length with gas standard charge	m	3-5	
Max. pipe length with additional charge	m	30	
Additional refrigerant charge	g/m	40	
Max. height difference (Outdoor above)	m	20	
Max. height difference (Indoor above)	m	20	
Indoor net dimension (H./W./D.)	mm	1882/587/394	
Outdoor net dimension (H./W./D.)	mm	822/1028/530	
Net weight Indoor/Outdoor	kg	57/94	

OPERATING RANGE: outdoor temperature  
 Cooling mode: from -15 °C to +43 °C  
 Heating mode: from -15 °C to +24 °C  
 RANGE OF INDOOR TEMPERATURE ADJUSTMENT: from 16 to 32 °C.

\*Data declared in accordance with COMMISSION REGULATION (EU) 2016/2281 of 30 November 2016 implementing Directive 2009/125/EC of the European Parliament and of the Council establishing a framework for the setting of ecodesign requirements for energy-related products, with regard to ecodesign requirements for air heating products, cooling products, high temperature process chillers and fan coil units.

# DIMENSIONAL DRAWINGS

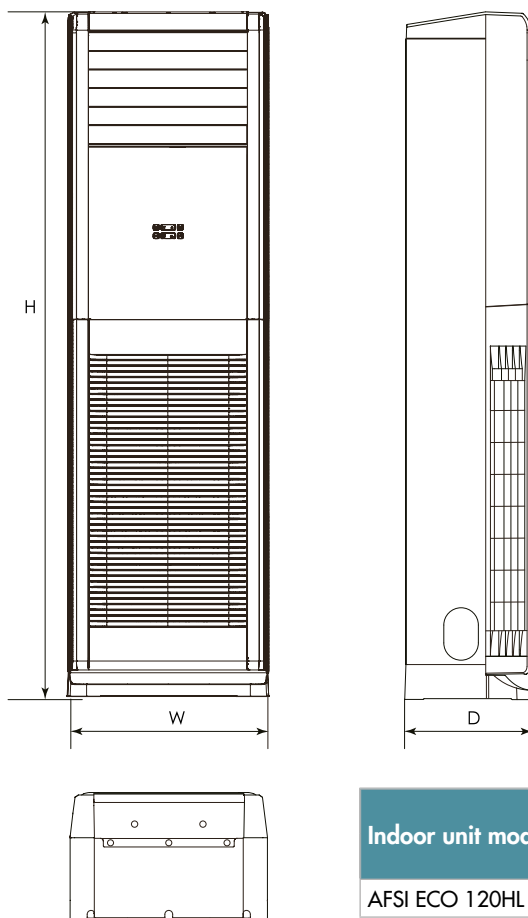

Indoor unit model	DIMENSIONS (mm)		
	W	H	D
AFSI ECO 120HL	587	1882	394

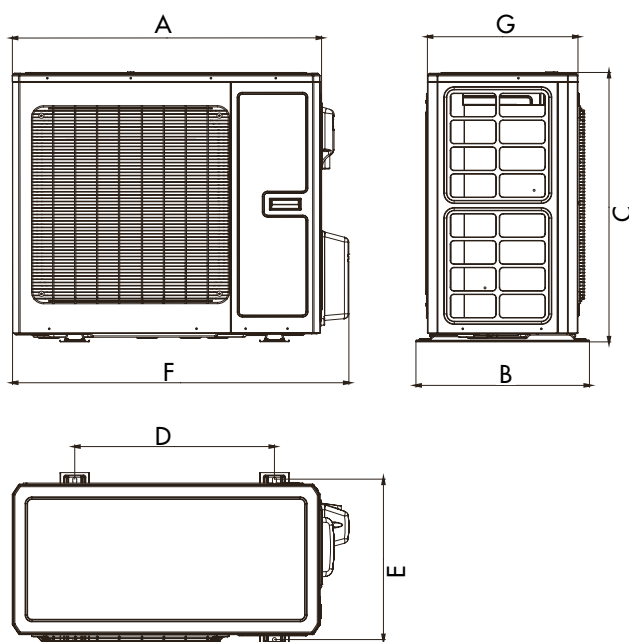

Outdoor unit model	DIMENSIONS (mm)						
	A	B	C	D	E	F	G
AFSI ECO 120SH3	944	530	822	610	490	1028	460

# NOTES







# LOW AMBIENT

---

Air conditioners single split for special applications

# LOW AMBIENT

## AIR CONDITIONERS SINGLE SPLIT FOR SPECIAL APPLICATIONS



- Range ideal for all applications where cooling is required even when the outdoor temperature is low (waste collection rooms, wine cellars, florist, computer rooms, ecc.).
- Full DC Inverter technology.
- Digital remote control with LCD display.
- Several air flow adjustments.
- "Turbo" function: it allows to reach the desired temperature, in the shortest possible time.
- "Night/Eco" mode: comfort during sleep.
- "Memory" function: auto-restart after power failure.
- "iFeel" function: ensures the desired temperature in the exact place where the remote control is placed.
- "Cold Plasma" air purification system.



Cooling



Sleep mode



Timer



iFeel



"Turbo" function



Auto diagnosis



Auto restart memory



Dehumidification



Fan speeds



Cold plasma



Full DC Inverter



Remote control



Min. temp. cooling



Double possibility of condensate drain connection

**A<sup>++</sup>** Cooling

MODEL		ARGO LOW AMBIENT	
Indoor unit model		AWIBS9	AWICS19
Outdoor unit model		AEI1G40LL	
	Units	Cooling	Cooling
Nominal capacity (EN14511)	kW	2.6	3.6
EER/COP (EN14511)		2.28	2.27
Design Load (Pdesign c/Pdesign h) (Average) (EN14825)	kW	3.7	4.6
Seasonal efficiency ratio (SEER/SCOP (Average)) (EN14825)		6.1	6.1
Energy efficiency class		A++	A++
Annual energy consumption	kWh/annum	209	263
Air flow rate indoor unit (l.-m.-h.)	m <sup>3</sup> /h	520/610/720	850/950/1100
Air flow rate outdoor unit (l.-h.)	m <sup>3</sup> /h	590/1900	
Indoor unit sound pressure level (l.-m.-h.) at 2 m dist	dB(A)	39/43/48	42/45/51
Outdoor unit sound pressure level (h.) at 4 m dist.	dB(A)	45	
Indoor unit sound power level (h.)	dB(A)	57	60
Outdoor unit sound power level (h.)	dB(A)	58	
Power supply	V/Ph/Hz	220-240~/1/50 V	
Max electric input	(A)	7.8	
Max. tubing length with standard charge	m	7.5	
Max. tubing length with additional charge	m	20	
Refrigerant type/GWP/standard refrigerant charge	kg	R410A/2088/1	
Additional refrigerant charge > 7.5 m	g/m	15	20
Max. height difference outdoor/indoor units	m	10	
Liquid gas pipe diameter (1)	Inches	1/4"-3/8"	1/4"-1/2"
Net dimension indoor unit (H./W./D.)	mm	307/1013/221	329/1122/247
Net dimension outdoor unit (H./W./D.)	mm	630/895/345	
Net weight Indoor/Outdoor unit	kg	13.5/54	16.5/54
Min./max. outdoor temperature		-15 °C/+43 °C	
Min./max. indoor temperature		12 °C DB (9 °C WB)/32 °C DB (23 °C WB)	

(1) Adaptors

(2) Electrical connection: see installation instructions. With the hydrothermostat: the refrigeration unit and the electric resistances can work at the same time. Installation instructions can be downloaded from our website.

**Nominal conditions:**

Indoor air temperature 12 °C (DB)/9 °C (WB)

Outdoor air temperature 35 °C (DB)

**Note:**

DB = dry bulb

WB = wet bulb

# PERFORMANCE CURVES

AEI1G40LL/AWIBS19

Indoor air temperature (DB): 12 °C

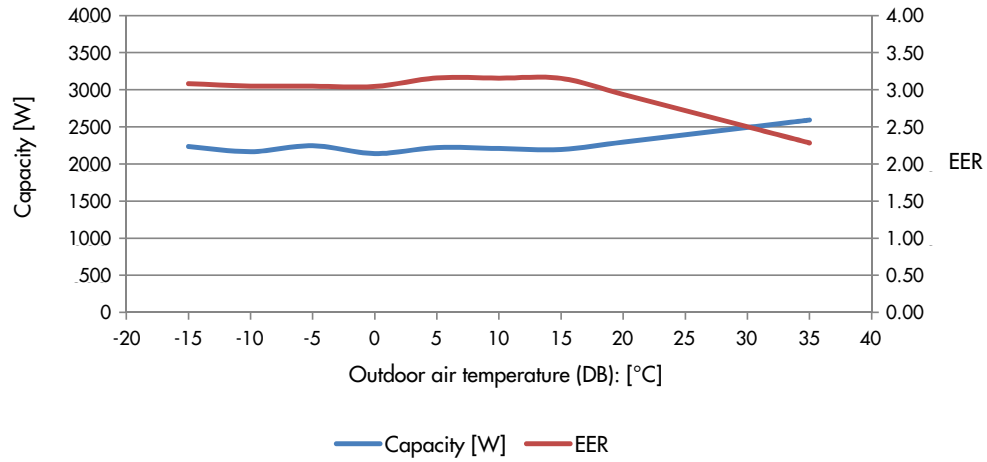

Indoor air temperature (DB): 14 °C

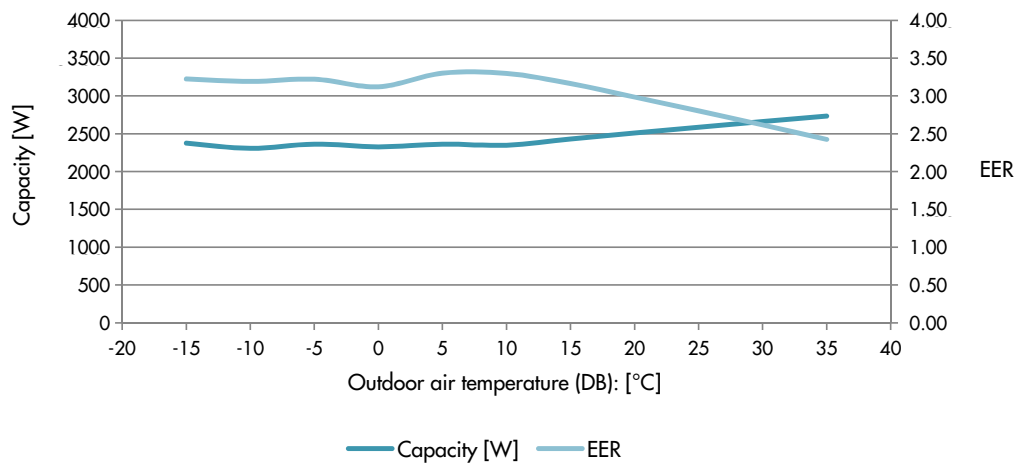

Indoor air temperature (DB): 18 °C

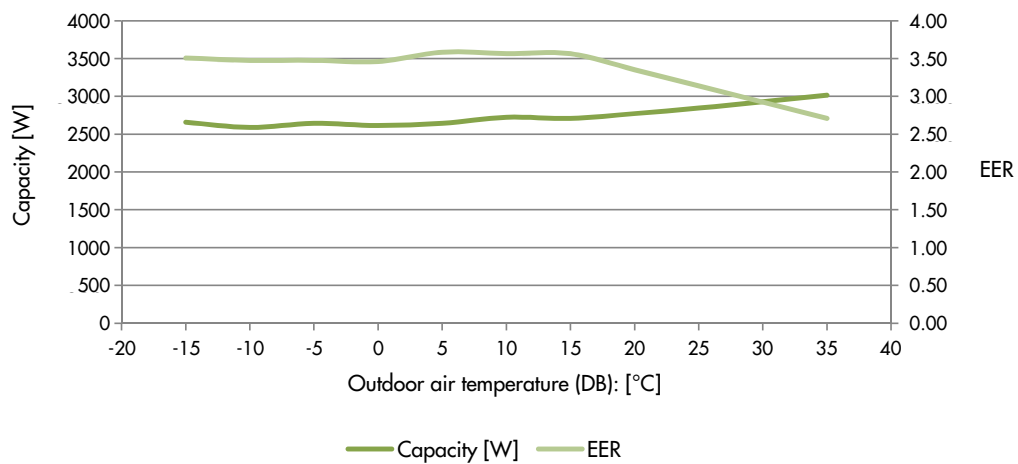

# PERFORMANCE CURVES

AE11G40LL/AWICS19

Indoor air temperature (DB):

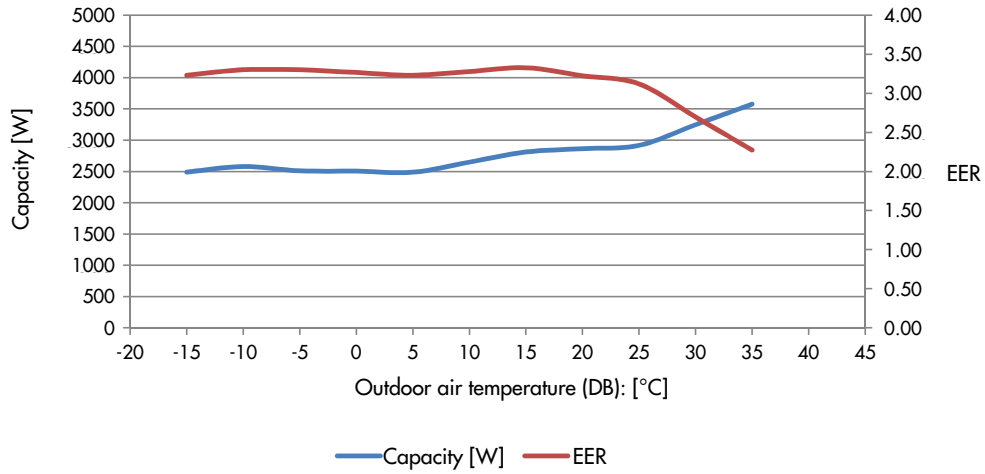

Indoor air temperature (DB):

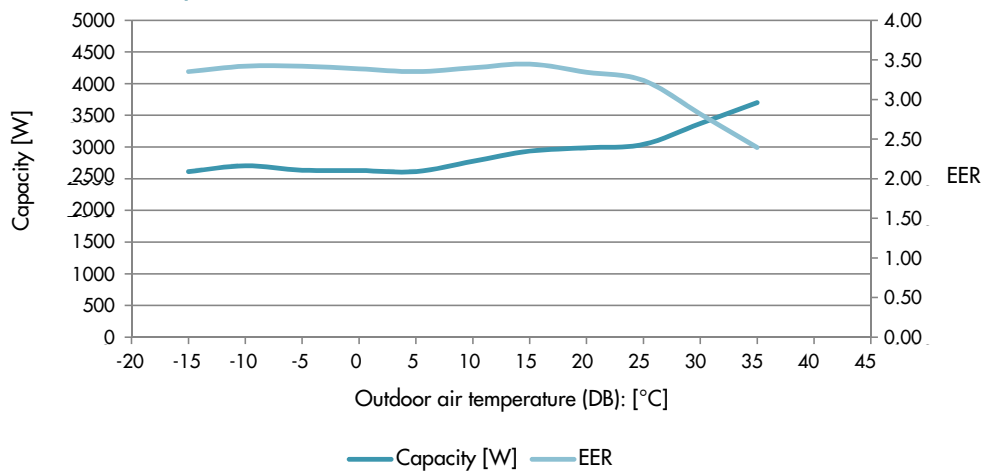

Indoor air temperature (DB):

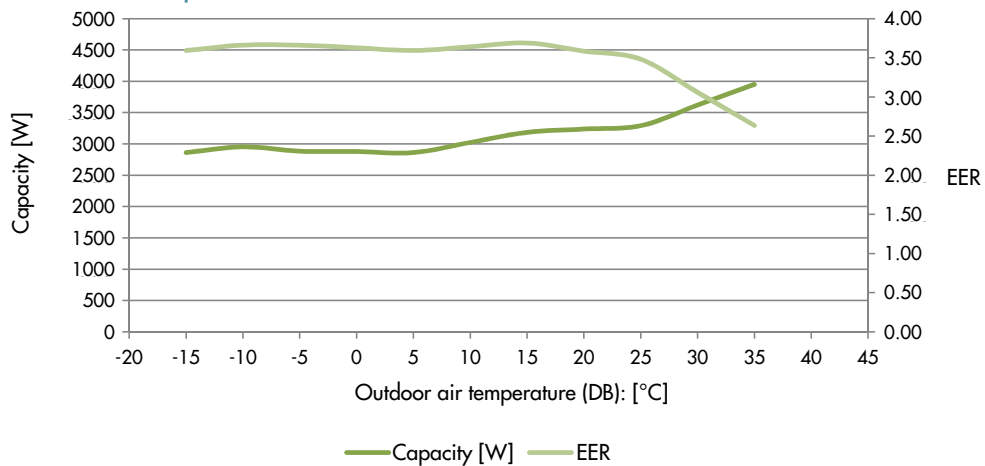

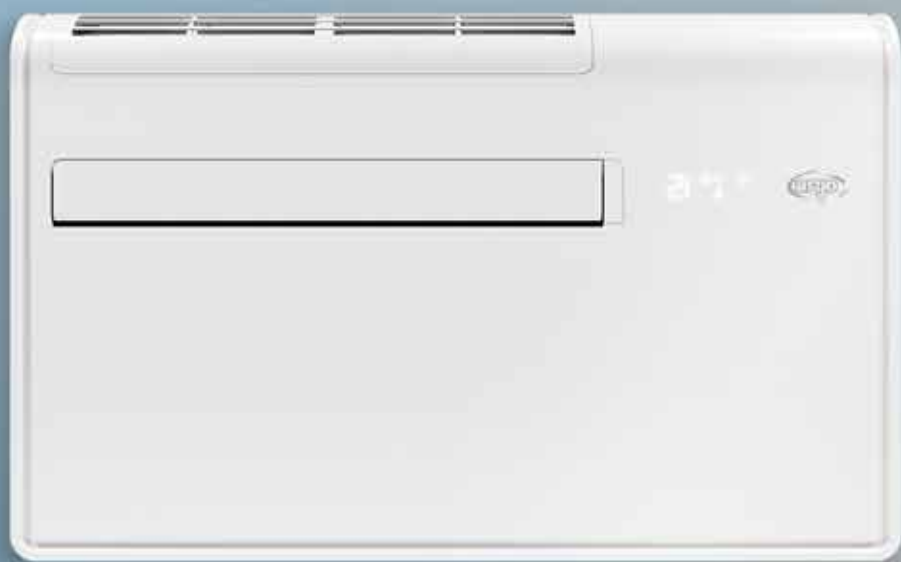

# AIR CONDITIONERS WITHOUT OUTDOOR UNIT

---

Argo Apollo

Argo DD

# APOLLO

## AIR CONDITIONER WITHOUT OUTDOOR UNIT



### APOLLO 12HP and APOLLO 10SC

- Ideal for buildings with urban planning constraints.
- 4 in 1: cooling, heating (12HP), dehumidification, fan.
- R32, gas with a low impact on global warming.
- DC Inverter technology.
- Integrated WiFi for remote control of functions.

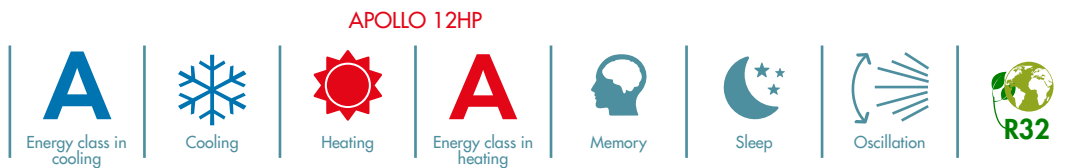

### DIMENSIONAL DATA

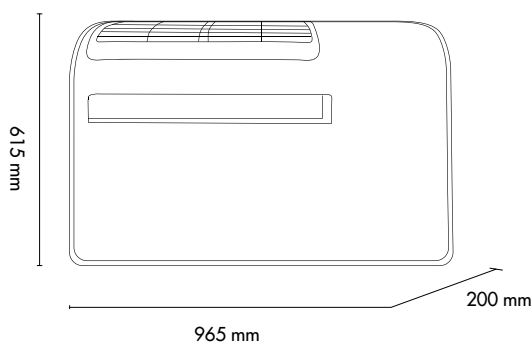

Digital remote control with LCD screen

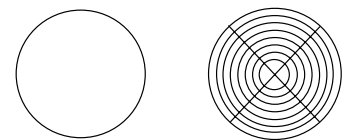

Two holes in the perimeter wall, 200 mm diameter, minimal aesthetic impact

Code	Model	*Cooling capacity [kW]	EER	*Heating capacity [kW]	COP
398000761	APOLLO12HP	2.35	2.62	2.36	3.10
398000763	APOLLO10SC	2.04	2.61		-

Performances related to EN14511:

\* Cooling capacity: Outdoor air temperature 35 °C, Indoor air temperature 27 °C

Heating capacity: Outdoor air temperature 7 °C, Indoor air temperature 20 °C

Code	Accessorio modello
398100689	Installation kit for 160 mm hole installation



# DD

## AIR CONDITIONER WITHOUT OUTDOOR UNIT



### DD ON/OFF and DD FULL DC INVERTER

- Refined design, high quality materials.
- 5 in 1: heat pump and air conditioner with dehumidification, purification and fan functions.
- Ideal for buildings with urban constraints.
- Flexible installation: low or high wall.
- Special titanium dioxide filter (TiO<sub>2</sub> filter).
- Version with methacrylate or aluminium painted panel.

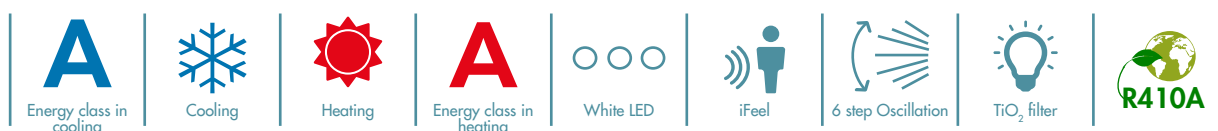

### DIMENSIONAL DATA

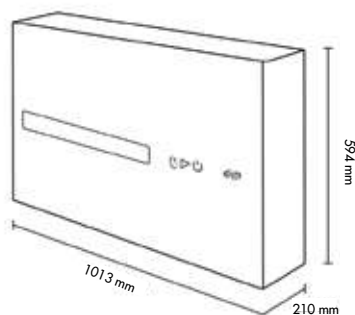

Soft touch remote controller,  
to be ordered separately

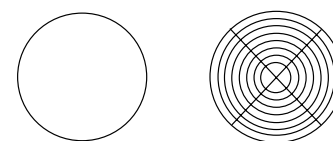

Two holes in the perimeter wall,  
160 mm diameter, minimal  
aesthetic impact

Code	Model	*Cooling capacity nom. (min.-max.) [kW]	EER	*Heating capacity [kW]	COP
397002947	DD ON/OFF	2.30	2.70	2.30	3.10
397002948	DD DCI Full DC Inverter	2.3 (1.1-2.7)	2.70	2.3 (1.1-2.7)	3.10
397002953	DD DCI ALUMINIUM Full DC Inverter	2.3 (1.1-2.7)	2.70	2.3 (1.1-2.7)	3.10

Performances related to EN14511:

\* Cooling capacity: Outdoor air temperature 35 °C, Indoor air temperature 27 °C

Heating capacity: Outdoor air temperature 7 °C, Indoor air temperature 20 °C



ULISSE ECO9

# D-I-Y CONSOLE

---

Argo Ulisse Eco

# ULISSE ECO

## CONSOLE SPLIT



- Just 24 cm depth, this special air conditioner is equipped with the Full DC Inverter technology of iSERIES.
- Thanks to the special Aeroquip quick connection certified for R32, it doesn't require the intervention of an installer for its installation or its transfer.
- The condensate is vaporized through the case positioned outside, so it is not necessary to drain the condensate.
- Equipped with an efficient Twin Rotary Inverter compressor, Ulisse Eco is particularly silent thanks to suitably selected components.
- The new soft-touch remote controller, with an innovative concept, adds important features to the unit.
- Also available with integrated WiFi and dedicated App.



### DIMENSIONAL DATA

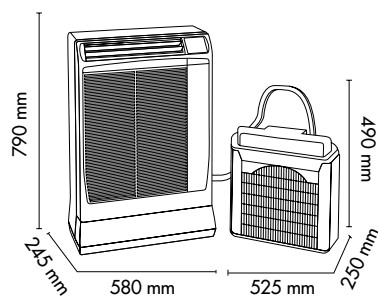

Soft touch remote controller supplied with the unit

Code	Model	*Max Cooling capacity [kW]	SEER
397028967	ULISSE ECO - FULL DC Inverter air conditioner using R32 - infrared remote controller with built-in temperature sensor - refrigeration pipe length 1.8 m	4.00	5.2
397028973	ULISSE ECO WiFi - FULL DC Inverter air conditioner using R32 - infrared remote controller with built-in temperature sensor - refrigeration pipe length 1.8 m - WiFi integrato	4.00	5.2
387027191	Ulisse Bracket kit	-	-
397016929	2 meter pipe extension kit	-	-
397016930	4 meter pipe extension kit	-	-

\*Performance related to cooling capacity: Outdoor air temperature 35 °C, Indoor air temperature 27 °C







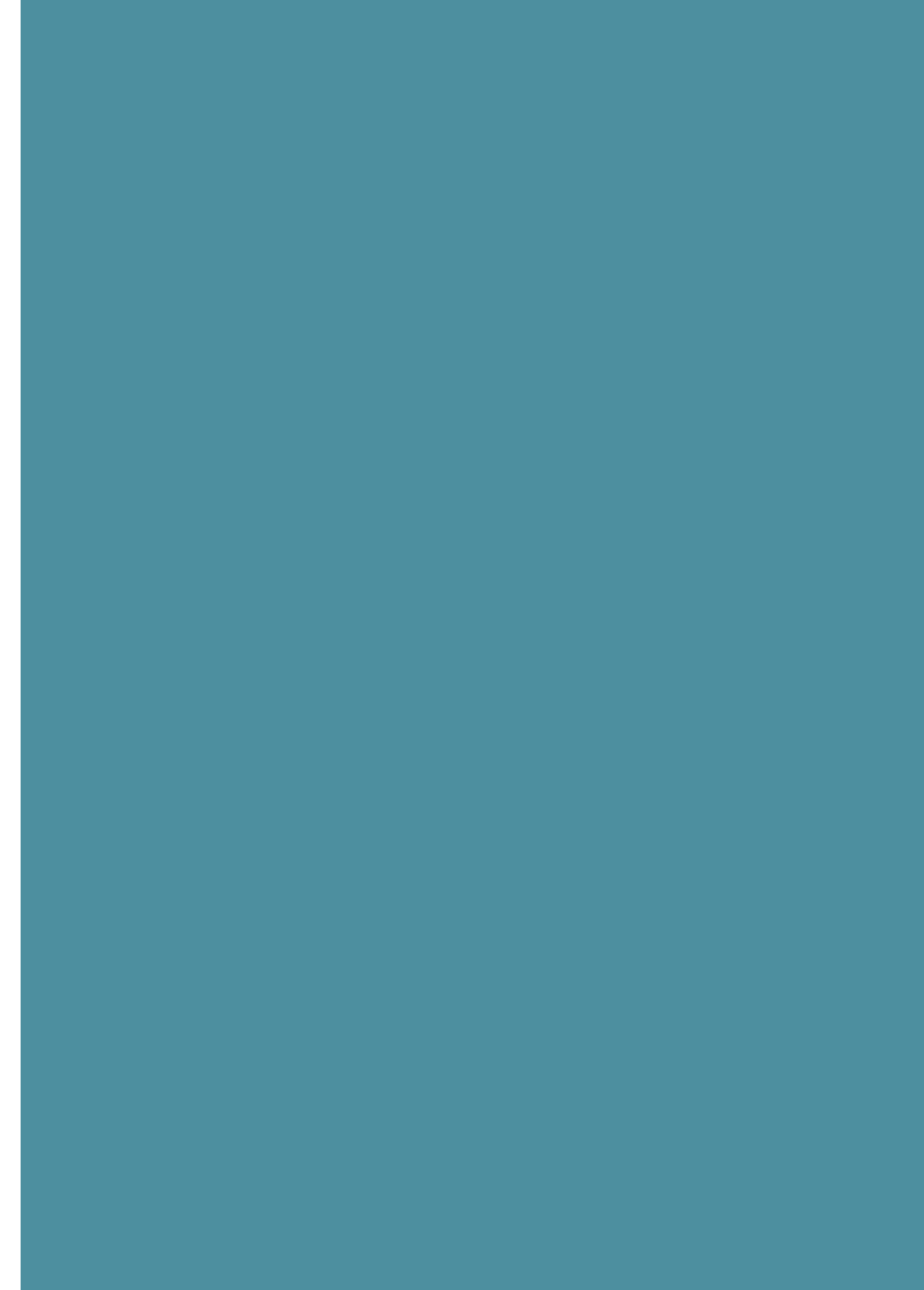



Argoclima S.p.A.

Via Alfeno Varo, 35  
25020 Alfianello (BS) ITALY  
Tel: +39 030 7285700

N.B.: the manufacturer declines all responsibility for any errors or inaccuracies regarding the contents of this catalogue, and reserves the right to make any necessary changes to its products, at any time and without prior notice, for technical or commercial reasons.

Argo is a brand of Argoclima S.p.A., a leading European company in climate control, heating and air treatment.