

PLANTWIDE CONTROL OF ACETYLENE HYDROGENATION PROCESS

SALAM K. AL-DAWERY^{1,*}, HAIDER M. DAKHIL²

¹Chemical and Petrochemical Engineering Department, University of Nizwa, Oman

²Chemical Engineering Department, University of Baghdad, Iraq

*Corresponding Author: salam@unizwa.edu.om

Abstract

As an application of Plantwide control, where few papers have been published about the integrated process design and control of complete plants, the acetylene hydrogenation process has been considered as the goal of this research. Firstly, all plant units were controlled separately using PID controllers, then, complete plant control was based on the 15 steps of Luyben's plantwide control strategy. An acceptable overall plant control behavior was achieved in terms of settling times and overshoot. An improvement was also, noticed on the plantwide control application when cascaded controllers are used for the developed control system. The improvement was clearly on the temperature control.

Keywords: Plantwide control, Acetylene hydrogenation process.

1. Introduction

Plantwide control refers to the control of an entire plant, consisting of many interconnected unit operations. While extensive research has been conducted on the individual unit operations, relatively few attempts have been made on plantwide control. Till a few decades ago, processes were typically designed with a sufficient over-design margin [1].

Effective control schemes have been developed for the traditional chemical unit operations over the last three or four decades. If the structure of units in series, this knowledge can be directly applied to the plantwide control problem. Each downstream unit simply sees disturbance coming from its upstream neighbor. The heart of the plantwide control problem centers on how on to handle recycles, the typical approach in the past for plants with recycle streams has been

Nomenclatures

C_{Co}	Carbon monoxide concentration, mol ppm
C_{out}	Acetylene outlet concentration, mol ppm
F	Feed flow rate, kg/hr
F_s	Steam flow rate, kg/hr
F_w	Cooling water flow rate, kg/hr
T_{in}	Inlet temperature, °C
T_{out}	Outlet temperature, °C
T_w	Cooling water temperature, °C

used to install large surge tanks [2].

The pioneering work on plantwide control was carried by Buckley [2] who introduced the concept of "Dynamic process control" in the 1960s. He proposed decomposing the problem based on time-scale differences, i.e., utilize the surge capacity available in processes to decouple the product quality control and the material balance control problems.

Most of methods are developed for the plantwide control of specific processes [3, 4], however, methods developed were for simple binary recycle process combined with continuous stirred tank reactor. Very few papers have been published about the integrated process design and control of complete plants [5].

A series of papers by Fisher et al. [6-8] presented systematic methods for the integration between design and control of complete plants based on Douglas' hierarchical decision procedure for conceptual process design. They stated that at the preliminary stage of a process design, the optimum steady-state designs of various process alternatives are often uncontrollable and not operable.

However, many strategies since three decades ago were appear to design a systematic methodology for plantwide control. A Systematic Methodology for Multi-Unit Control Design was proposed by [9], their approach allowed the control system design for such a plant to be performed in a systematic manner. In this approach, the overall stability and achievable performance can be examined is based on observing two indicators named by β , decentralized control indicator for multi-unit processing plants and b_{max} , realistic performance indicator for a given plant. Insights into multi-unit control design have been gained from the application of this approach to a reactor/separation process.

Luyben et al. [10, 11] recommended 15 steps as new approach for undertaking the control design problem for multiunit processes (plantwide). This approach is developed assuming that no instrumentation or controls are in place. Obviously, many control projects involve a revamp of existing controls; certain items, such as sensor selection and actuator location can already be completed and are not likely to be modified unless compelling reasons are identified. While this approach was developed for multiunit processes, it can be applied to single-unit systems as well [12]. The systematic approach for plantwide control listed by Luyben is summarized in Table 1.

Synthesis of Plant Wide Control systems Using Optimization was addressed by McAvoy [13] to establish a systematically synthesized plantwide control architectures based on steady state process models coupled to optimization.

Antelo et al. [14] proposed a systematic approach to plantwide control design. The method combines ingredients from process networks, thermodynamics and systems theory to drive robust decentralized controllers that will ensure complete plant stability. As a first step, the considered process system is decomposed into abstract mass and energy inventory networks, the control structure design procedure was completed with the realization of the conceptual inventory and intensive variable control loops over the available degrees of freedom in the system. To that purpose, both PI and feedback linearization controls were employed.

Table 1. The Steps for Luyben Method of Plantwide Control.

1. Identify process objectives
2. Identify the process constraints
3. Identify significant disturbances
4. Determine the type and location of sensors
5. Determine the location of control valves
6. Apply a degree-of-freedom analysis
7. Implement energy management
8. Control process production rate
9. Select the manipulated variables that meet the control objectives
10. Address how disturbances are handled
11. Develop a constraint handling strategy
12. Control inventories
13. Check component balances
14. Control individual unit operations
15. Apply process optimization

Jeffrey et al. [15] considered only steady state process operation to develop plantwide control structures, and test the structures using a rigorous non-linear dynamic process model. They demonstrate that the method produces workable plantwide control structures as a steady-state analysis can be used to screen control structures and eliminate those that give bad steady state performance, and dynamic simulations can be used to test the remaining structures.

A better understanding of plantwide control will lead to a better design of control system; also, better control systems will give plants with lower energy consumption and better utilization of raw material. In spite of accounting for the interaction between different process units, most of the above works are still focused on the control of some state variables in the process plant, and lack of a suitable control of whole plant. In this work, the Plantwide Control problem for the

hydrogenation process is addressed due to the following facts: the process is highly nonlinear and characterized by the coupling of slow and fast dynamics; there exist interactions between different operating units, which cannot be neglected; and finally, the optimization of operation conditions of the process that can be effectively assured as the main control objective of the plantwide strategy. The main purpose of this paper is to present a novel application for the plantwide control of acetylene hydrogenation process, in which the main control objective is to minimize the energy consumption and maximize the profitability of the whole process.

The paper is organized as follows: Section 2 summarizes briefly the description of the acetylene hydrogenation process. Section 3 presents mathematical modeling of the process. Sections 4 and 5 presents the Plantwide Control concept proposed in this work and describes the main steps of this approach. Results and discussions are presented in section 6. Implementation of plantwide control and the conventional control were by using MATLAB SIMULATION software.

2. Case Study Process

A particular process that could possibly benefit from plant wide controllability studies and the use of advanced control technologies is the acetylene hydrogenation process, Fig. 1. Polyethylene has been key product for many industries since 1960's. The feed of the polymerization reactor, which comes from the olefin plant, is a mixture of hydrocarbons mainly consisting ethylene. An undesired impurity in the ethylene stream is acetylene at approximately 2% to 30% of the effluent of the olefin plant which may lead to undesirable polymer properties; the amount of acetylene in the feed of the ethylene polymerization reactor should not exceed 2-3 ppm [16]. It is harmful contaminant in polymer grade ethylene, so the removal of acetylene is a key step in the purification process. The most effective method for removing acetylene, down to typical levels of 2-3 ppm, is selective hydrogenation over palladium catalysts in multi-bed adiabatic reactor. The term selective is used as the conditions which promote the hydrogenation of acetylene to ethane.

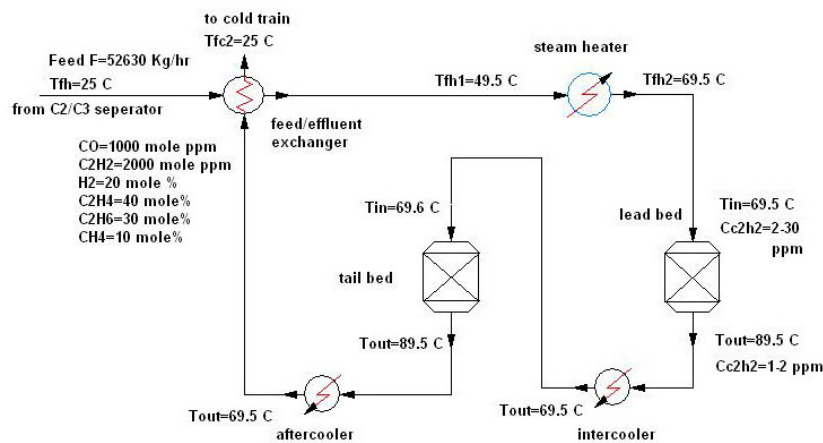

Fig. 1. Acetylene Hydrogenation Process.

3. Mathematical Modeling of Acetylene Hydrogenation Process

The mathematical model of acetylene process presented in Fig. 1 has been developed by Dakhil [17]. The corresponding transfer functions for the main process equipments have been present for control purposes are as follows

- **Acetylene Converter Model**

$$T_{out}(s) = \frac{2.3e^{-2.5s}}{1.96s^2 + 2.8s + 1} T_{in}(s) - \frac{0.322}{1.96s^2 + 2.8s + 1} F(s) - \frac{0.015}{1.96s^2 + 2.8s + 1} C_{co}(s)$$

$$C_{out}(s) = \frac{0.001e^{-2.5s}}{1.96s^2 + 2.8s + 1} T_{in}(s) - \frac{0.322}{1.96s^2 + 2.8s + 1} F(s) - \frac{0.015}{1.96s^2 + 2.8s + 1} C_{co}(s)$$

- **Steam Heater Dynamic Model**

$$T_{out}(s) = \frac{1}{(20s + 1)} T_{in}(s) + \frac{40.22}{(20s + 1)} F_s(s) - \frac{1.368}{(20s + 1)} F(s)$$

- **Intercooler and Aftercooler Dynamic Model**

$$T_{out}(s) = \frac{0.0032}{(0.098s + 1)} T_{in}(s) + \frac{0.0043}{(0.098s + 1)} F(s) - \frac{1.417}{(0.098s + 1)} F_w(s) + \frac{0.997}{(0.098s + 1)} T_w(s)$$

4. Applied Luyben's Plant Wide Control Approach to Acetylene Plant

In this study, the applications of Luyben method of plantwide control for acetylene process, shown in Fig. 1, will be followed. The systematic steps are summarized as follows

Step 1: Identify process objectives

The overall process objectives is to remove acetylene traces that is formed as a by product during the manufacture of ethylene, so the removal of acetylene is a key step in the purification process.

Step 2: Identify the process constraints

The major constrains on this process are the protection of the reactor overheating and the control of the conversion. The control of the outlet temperature of the reactor is very significant to both.

Step 3: Identify significant disturbances

A viable control approach should be able to effectively absorb the full range of process disturbances. Common process disturbances include feed temperature, flow rate, and composition changes, ambient air temperature changes, steam pressure changes and cooling water temperature changes.

Step 4: Determine the type and location of sensors.

Figure 2 shows the sensors location of acetylene process. To measure the acetylene converters outlet temperature, a temperature sensor/transmitter is

placed at the line that delivers the reaction mixture to the intercooler exchanger for lead converter and to the aftercooler exchanger for tail converter. This location is chosen because it is less expensive to install a thermowell in a process line than that in the wall of the reactors vessel.

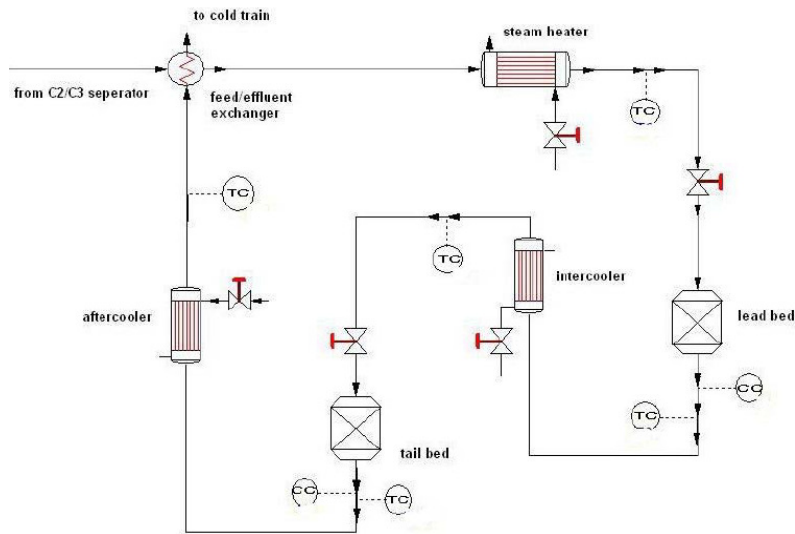

Fig. 2. Schematic of Acetylene Hydrogenation Process with its Sensors and Valves.

Step 5: Determine the location of control valves.

Flow control loops, which include a control valves are shown in Fig. 3. Flow control loops should be installed on the cooling water for intercooler and aftercooler lines and on the heating stream line for steam heater. Flow control loops should be installed on the feed line for Lead and Tail converters.

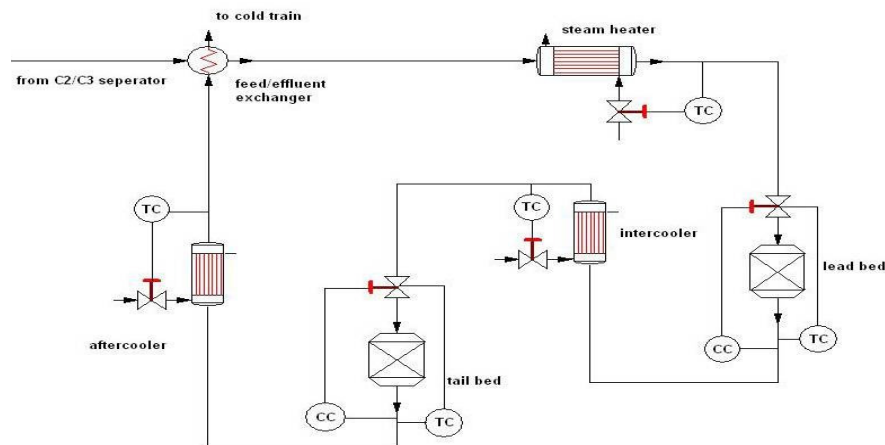

Fig. 3. Acetylene Hydrogenation Process Control using Luyben Plantwide Control Strategy.

Step 6: Apply a degree-of-freedom analysis.

There are five flow control valves and five controlled variables during unconstrained operation (Lead and Tail converter temperature and concentration, temperature for intercooler, steam heater and aftercooler), therefore this system is exactly determined.

Step 7: Implement energy management.

The steam flows into a heater exchanger supplies the energy in order to heat the feed mixture before it delivers to the Lead converter while the intercooler removes heat from the outlet reactants from Lead converter and the aftercooler removes heat from the outlet reactants from Tail converter.

Step 8: Control process production rate.

In this study, the main objective is to control the concentration of acetylene in product of the hydrogenation process, however, the production rate of this process is assumed to be automatically controlled by other flow control system that must exist in the plant.

Step 9: Select the manipulated variables that meet the control objectives.

The temperature of the feed of steam heater is controlled by adjusting the set point of the flow controller on the steam flow to the exchanger while the temperature of the feed effluent of intercooler and aftercooler is controlled by adjusting the set point of the flow controller on the cooling water flow to the exchangers. The temperature and concentration effluent from the Lead and Tail converters are controlled by adjusting the set point of the feed flow controllers on the inlet line to the converters.

Step 10: Address how disturbances are handled.

The only variable available to control the outlet temperature is the inlet temperature, based on the change in the inlet flow rate while the carbon monoxide concentration being the main disturbance, the best solution is to use the inlet temperature to control the outlet temperature and then to control the conversion. The dynamic response to feed rate disturbances was not determined by plant observation since feed rate disturbances were always accomplished by composition disturbances.

Step 11: Develop a constraint handling strategy.

Two constraints should be considered, the condensers duty (intercooler and aftercooler exchanger) and steam heater cooling duty (steam heater). When the steam heater duty constraint is encountered, the feed to the Lead converter temperature is increases. As the temperature increase in the converter, the high conversion of acetylene to ethylene will be achieved.

When the condensers duty constraint is encountered, the feed to the Tail converter temperature is decreases. As the temperature decrease in the line feed to the Tail converter, the maximum conversion of acetylene to ethylene will be achieved. When this limit is encountered, the valve on the steam heater saturates; therefore, an override select controller is used to that, when the

steam heater valve saturates, a select controller adjusts the feed to maintain the temperature of the converter at its set point.

Step 12: Control individual unit operations.

A PID controller was used to control each unit of the acetylene process separately, see responses below.

5. Applied Cascaded Control to Acetylene Hydrogenation Process

The description of such method can be as follows: divide the process into many separate blocks as shown in Fig. 4, each block may contains a single processing unit or a small number of processing units with an inherent common operational goal and then

- Determine the degree of freedom and the number of controlled and manipulated variables for each block
- Determine all feasible loop configurations for each block
- Recombine the blocks with their loop configurations; it is clear that the number of the generated loop configurations for the overall process equal to the product of the retained configurations for all blocks
- Eliminate conflicts among the control systems of the various blocks. The control configuration resulting in step 4 usually lead to an over specification of all overall controlled process

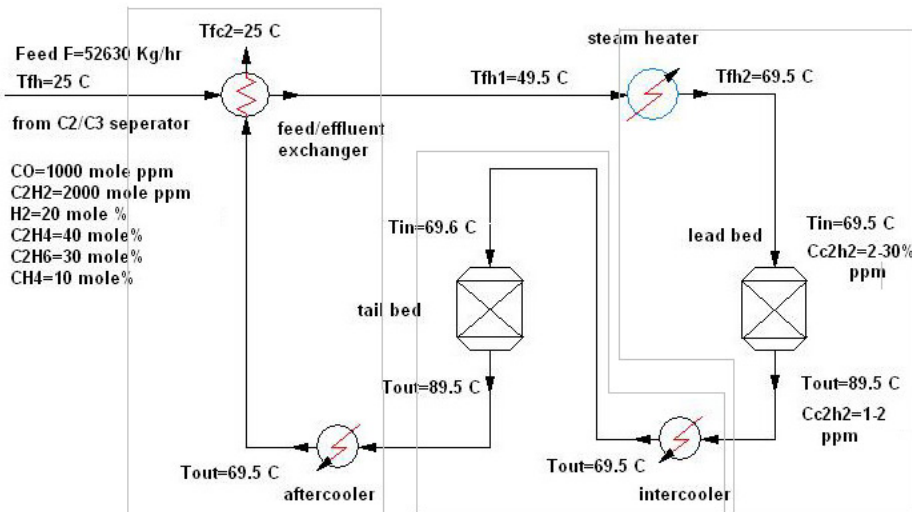

Fig. 4. Process Divisions for Cascaded Control.

The resulting control block diagram of acetylene process based on this method is shown in Fig. 5 below

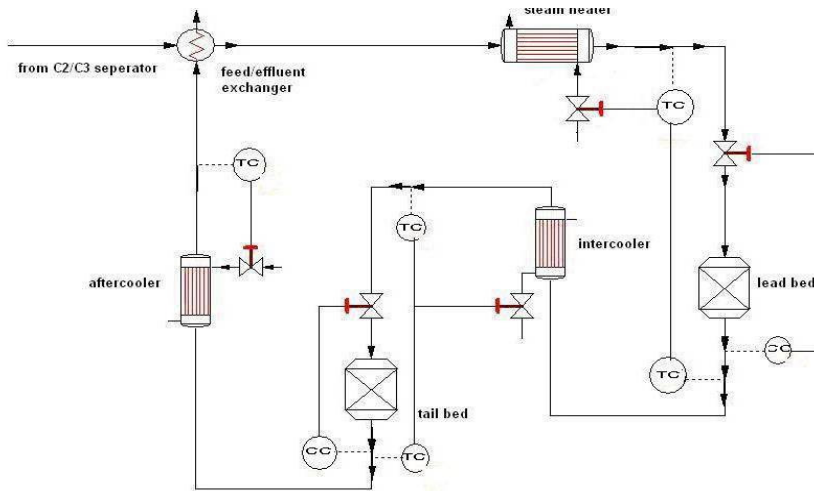

Fig. 5. Acetylene Hydrogenation Process Control using Cascaded Control Strategy.

6. Results and Discussion

The results of the application of stated control strategies are presented below

6.1. Acetylene plant control based on the simple connection of all units together

The plant responses to step changes in feed flow rate, inlet temperature and concentration of carbon monoxide under the simple connection of plant units are shown in Figs. 6 to 8. These responses can be considered at an acceptable level.

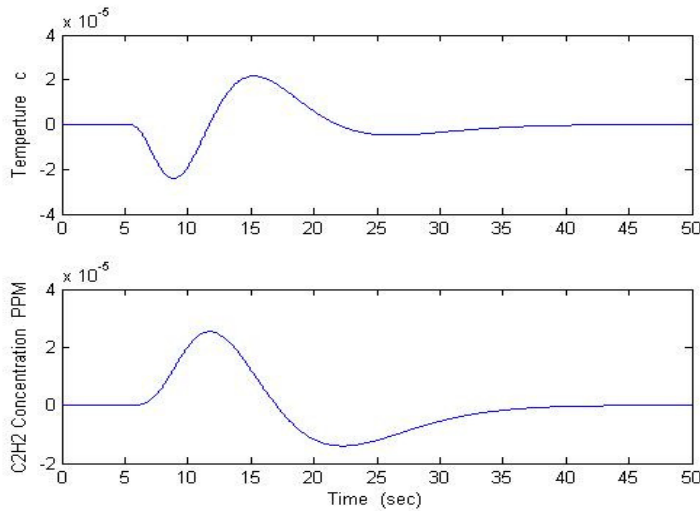

Fig. 6. Temperature and Concentration Responses using Simple Connection of all Units to a Step Change in Feed Flow Rate.

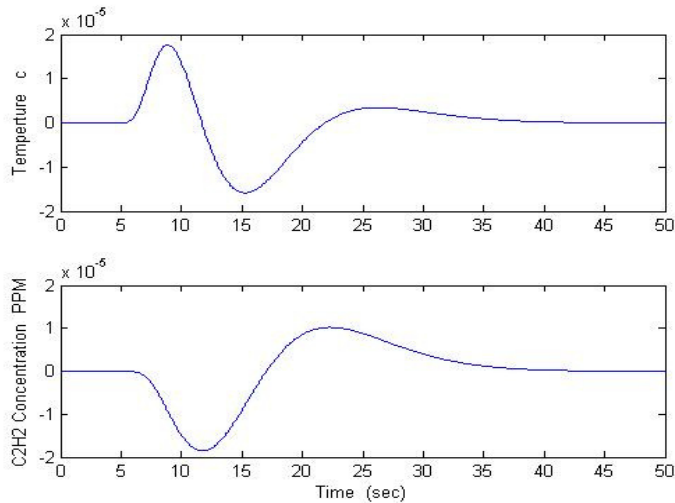

Fig. 7. Temperature and Concentration Responses using Simple Connection of all Units to a Step Change in Inlet Temperature.

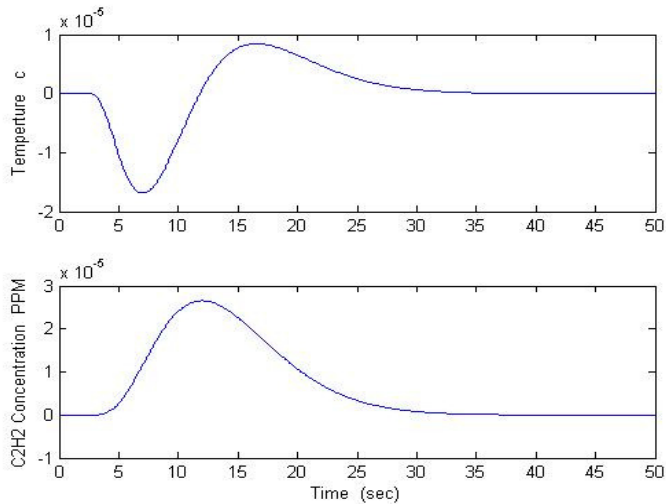

Fig. 8. Temperature and Concentration Responses using Simple Connection of all Units to a Step Change in Carbon Monoxide Concentration.

6.2. Acetylene plant control based on the application of Luyben strategy

The plant responses to step changes in feed flow rate, inlet temperature and concentration of carbon monoxide under Luyben method are shown in Figs. 9 to 11. The responses obtained showed a behavior than that of simple connection, reduction in magnitude of response oscillation.

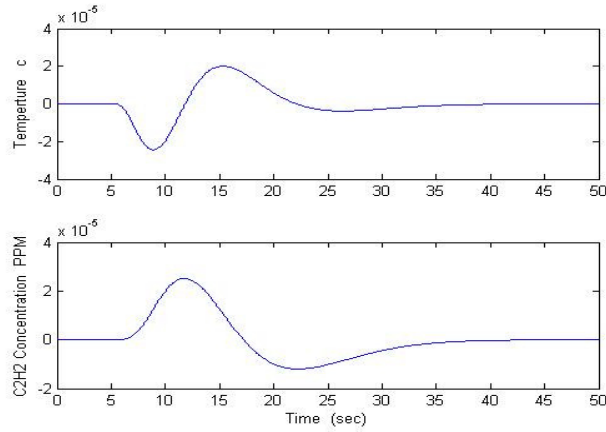

Fig. 9. Temperature and Concentration Responses using Luyben Strategy to a Step Change in Feed Flow Rate.

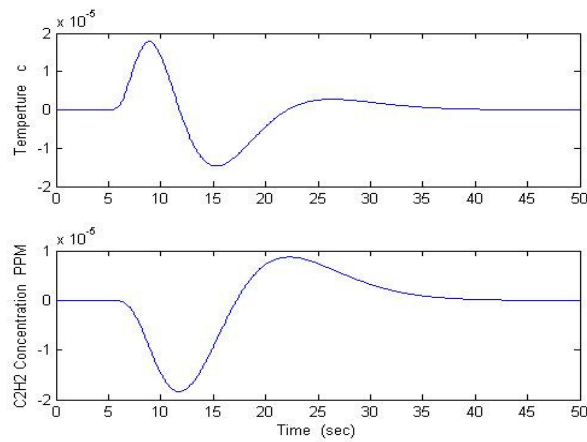

Fig. 10. Temperature and Concentration Responses using Luyben Strategy to a Step Change in Inlet Temperature.

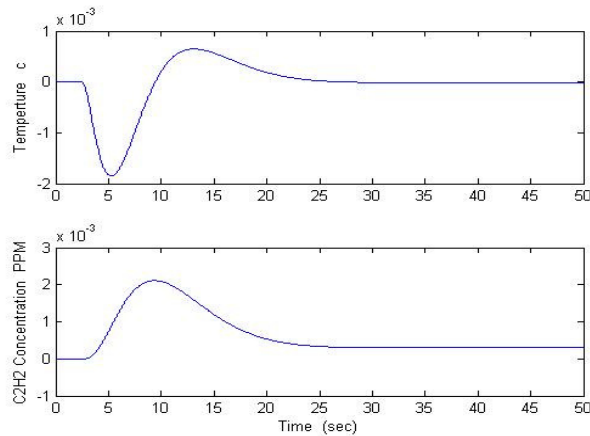

Fig. 11. Temperature and Concentration Responses using Luyben Strategy to a Step Change in Carbon Monoxide Concentration.

6.3. Acetylene plant control using advanced control

The plant responses to step changes in feed flow rate, inlet temperature and concentration of carbon monoxide under the cascaded method are shown in Figs. 12 to 14. Some of these responses gave better behavior than that obtained by other two methods.

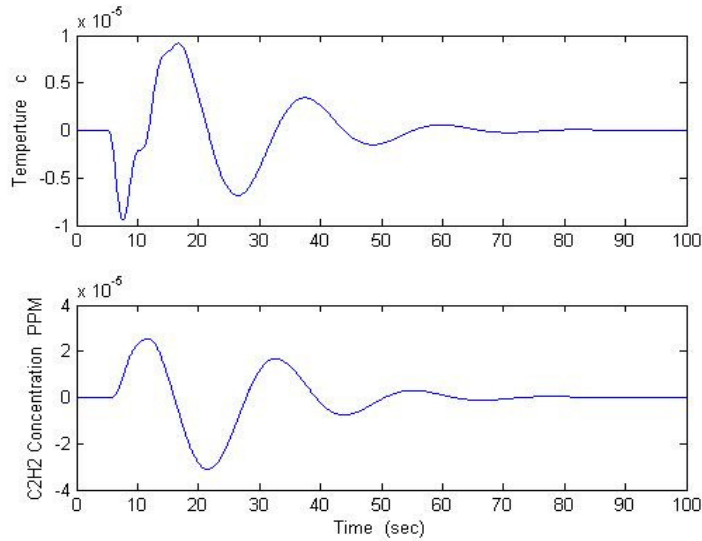

Fig. 12. Temperature and Concentration Responses using Cascade to a Step Change in Feed Flow Rate.

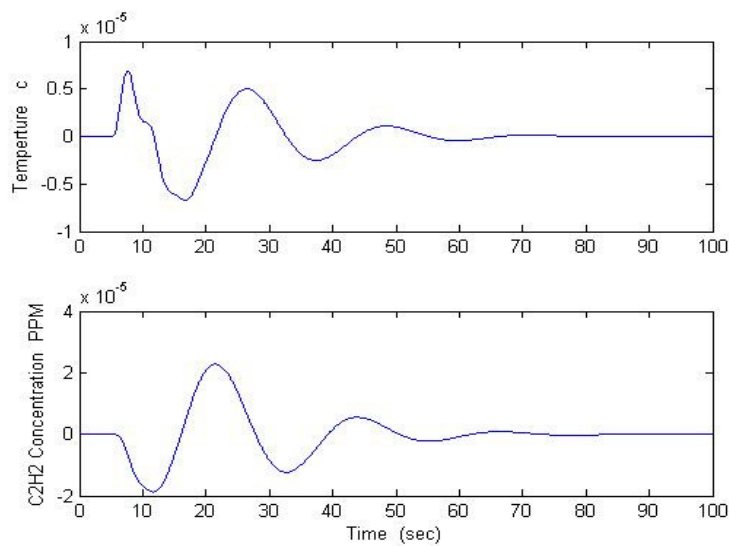

Fig. 13. Temperature and Concentration Responses using Cascade to a Step Change in Inlet Temperature.

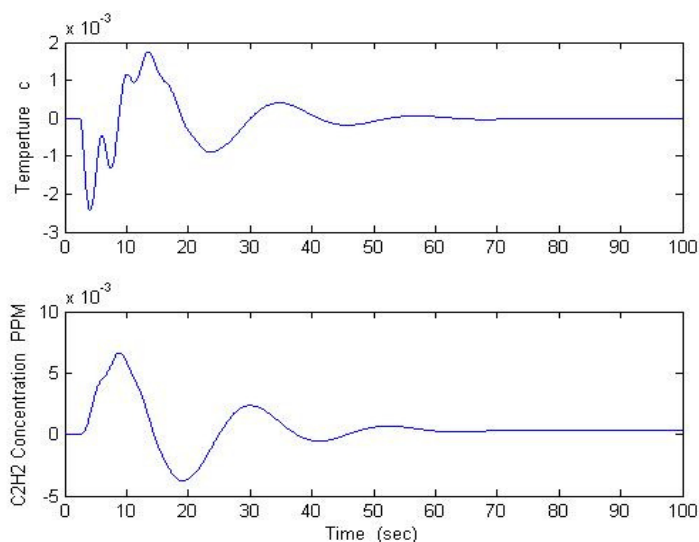

Fig. 14. Temperature and Concentration Responses using Cascade to a Step Change in Carbon Monoxide Concentration.

7. Conclusions

The results presented in this paper demonstrated the use of strategy of plant wide control in order to control a complete plant such as acetylene hydrogenation process. This application showed successful achievement from the use of Luyben's method for plant layout which can also easily applied for any other chemical processes.

For comparison purposes, an acceptable level of control has been achieved from simple connection between all process units (i.e., no plantwide control). However, good improvements in the plant responses over that of simple connection were obtained based on Luyben strategy.

The results, also, showed that the application of cascaded control imbedded in plant wide control showed a greatly improved the behavior of the plant control especially for temperature responses.

References

1. Mahajanam, R.V. (2001). *Design of plantwide control systems*. Ph.D. Thesis, University of Massachusetts Amhrast.
2. Buckley, P.S. (1964). *Techniques of process control*. Wiley, N.Y., USA.
3. Luyben, M.; and Floudas, C.A. (1994). Analyzing the interaction of design and control- I. A multiobjective framework and application to binary distillation synthesis. *Computers and Chemical Engineering*, 18(10), 933-969.

4. Luyben, M.; and Floudas, C.A. (1994). Analyzing the interaction of design and control- 2. Reactor-separator-recycle system. *Computers and Chemical Engineering*, 18(10), 971-993.
5. Ochoa, S.; Wozny, G.; and Repke, J.U. (2010). Plantwide optimizing control of a continuous bioethanol production process. *Journal of Process Control*, 20(9), 983-998.
6. Fisher, W.R.; Doherty, M.F.; and Douglas, J.M. (1988). The interface between design and control. 1. Process controllability. *Industrial and Engineering Chemistry Research*, 27(4), 597-605.
7. Fisher, W.R.; Doherty, M.F.; and Douglas, J.M. (1988). The interface between design and control. 2. Process Operability. *Industrial and Engineering Chemistry Research*, 27(4), 606-611.
8. Fisher, W.R.; Doherty, M.F.; and Douglas, J.M. (1988). The interface between design and control. 3. Selecting a set of controlled variables. *Industrial and Engineering Chemistry Research*, 27(4), 611-615.
9. Samyudia, Y.; Lee, P.L.; Cameron, I.T.; and Green, M. (1994). Control of multi-unit processing plants- A systematic methodology. *Computers and Chemical Engineering*, 20, Supplement 2, S919-S924.
10. Luyben, M.L.; Tyreus, B.D.; and Luyben, W.L. (1997). Plantwide control design procedure. *AIChE Journal*, 43(12), 3161-3174.
11. Luyben, W.L.; Tyreus, B.D.; and Luyben M.L. (1999). *Plantwide process control*. McGraw Hill, New York, USA.
12. Riggs, B.R. (1999). *Chemical process control*. Ferret Publishing Lubbock, Texas, USA.
13. McAvoy, T.J. (1999) Synthesis of plantwide control systems using optimization. *Industrial and Engineering Chemistry Research*, 38(8), 2984-2994.
14. Antelo, L.T.; Otero-Muras, I.; Banga, J.R.; and Alonso, A.A. (2007). A systematic approach to plant-wide control based on thermodynamics. *Computers and Chemical Engineering*, 31(5-6), 677-691.
15. Ward, J.D.; Yu, C.C.; and Doherty. M.F. (2010). Plantwide dynamics and control of processes with crystallization. *Computers and Chemical Engineering*, 34(1), 112-121.
16. Mostoufi, N.; Ghoorchian, A.; and Sotudeh-Gharebagh, R. (2005). Hydrogenation of acetylene: Kinetic studies and reactor modeling. *International Journal of Chemical Reactor Engineering*, 3(1), 1-18.
17. Dakhil, H.M. (2007). *Integrated multi-unit controller design for chemical process plant*. M.Sc. Thesis, University of Baghdad, Iraq.