First-Pass Anger Camera Radiocardiography: Biventricular Ejection Fraction, Flow, and Volume Measurements

Martin L. Nusynowitz, Anthony R. Benedetto, Richard A. Walsh, and Mark R. Starling*

Division of Nuclear Medicine, Department of Radiology, University of Texas Medical Branch, Galveston, and Divisions of Nuclear Medicine and Cardiology, University of Texas Health Science Center, San Antonio, Texas

First-pass (FP) right and left ventricular ejection fraction results were compared with equilibrium radiocardiographic (ER) measurements, and FP left ventricular ejection fraction (LVEF) values were compared with biplane contrast angiographic (CA) measurements in 13 patients with and seven patients without regurgitant valvular disease. Regurgitant fractions were calculated from differences between the FP right and left ventricular stroke volumes. Ejection fractions determined by FP were precise (mean CV = 9.6% RVEF, 13.4% LVEF). Mean LVEF by FP and ER were essentially identical, and both were lower than by CA. $LVEF_{(FP)}$ correlated with LVEF by ER and CA ($r = 0.88$, $p < 0.001$). Mean RVEF by both FP and ER were also correlated ($r = 0.82$, $p < 0.001$). There was correlation between FP (corrected) and CA left ventricular stroke ($r = 0.77$), end-diastolic ($r = 0.88$), and end-systolic ($r = 0.91$) volumes, but underestimates were noted when uncorrected flows were used ($r = 0.52-0.71$). The FP regurgitant fraction measurements separated the patients with regurgitant valvular disease from those without and agreed well with CA grading of regurgitation.

J Nucl Med 28:950-959, 1987

Left ventricular ejection fraction measurements by first-pass (FP) radiocardiographic techniques correlate well with contrast angiography (CA) (1,2), but because of the complexity of the shape of the right ventricle, geometric methods of determining right ventricular ejection fraction (RVEF) are difficult (3,4). A number of radiocardiographic RVEF methods have been described and appear to be satisfactory, as judged by internal consistency of repeated measurements and correlation of FP with equilibrium radiocardiographic (ER) methods (5,6). Because of problems arising from overlying cardiac chambers, first-pass RVEF methods have utilized right anterior oblique (RAO) or anterior projections in order to spatially separate atrial activity from that of the right ventricle; these FP techniques

also allow for temporal separation of the left and right ventricles. Equilibrium radiocardiographic methods (7) performed in the left anterior oblique (LAO) projection have used special collimation (30° slant hole) in an attempt to separate the right atrium from the right ventricle.

First-pass RAO projection techniques, from a theoretical viewpoint at least, allow determination of RVEF; however, none of the techniques, including equilibrium methods, has been subjected to thorough validation by independent means because of the difficulty of defining a widely acceptable "gold standard" for comparison. Furthermore, the RAO projection FP technique does not permit simultaneous calculation of the cardiac output and stroke volume from either ventricle because the spatial overlap of the chambers in the equilibrium phase precludes the determination of equilibrium concentrations for either ventricle, which are necessary for the Stewart-Hamilton calculational method.

First-pass radionuclide methods for the determination of cardiac output (and, hence, stroke volume) have been used successfully with probe and multicrystal detectors (8,9). These studies have shown the validity of

Received Dec. 20, 1985; revision accepted Dec. 23, 1986.

For reprints contact: Martin L. Nusynowitz, MD, Div. of Nuclear Medicine, Dept. of Radiology, Univ. of Texas Medical Branch, Galveston, TX 77550.

* Present address: University of Michigan Medical Center, Department of Internal Medicine, Div. of Cardiology, VA Medical Center, 2215 Fuller Rd., Ann Arbor, MI 48105.

FP measurements as compared with CA results, but widespread application has not ensued. Furthermore, the use of these methods with Anger cameras has been extremely limited.

Because we were interested in the determination of ejection fraction, flow, and volume information from both ventricles, we performed ejection fraction, flow, and volume measurements in a modified LAO projection, which allowed evaluation of both ventricles simultaneously. The purposes of our investigation were to ascertain if valid measurements of left and right ventricular ejection fractions, flows, and volumes could be made using noninvasive FP radiocardiographic methods and Anger scintillation cameras and to determine if the right and left ventricular flow data could be used to estimate the degree of regurgitant valvular disease.

MATERIALS AND METHODS

The study group consisted of 20 patients in whom cardiac catheterization was performed for evaluation of either coronary artery disease, valvular heart disease, or congestive heart failure. The radiocardiographic studies were performed within 48 hr of the catheterization, usually on the day preceding the catheterization procedure.

Right heart catheterization was performed using a balloon-tipped flow-directed catheter, and brachial artery catheterization was performed using an NAMIC[®] catheter. Cardiac output determinations were obtained using both the Fick principle and indocyanine green dye indicator dilution method. All determinations were performed in triplicate.

Left heart catheterization was performed using standard brachial or femoral techniques. Simultaneous biplane left ventricular cineangiograms were obtained in the 30° RAO and 60° LAO/20° caudal projections following injection of 40–60 ml Renografin-76 at 10–15 ml/sec and 500 psi at a framing rate of 60/sec. Left ventricular end-diastolic and end-systolic volumes were calculated using a modified biplane formula (10). Left ventricular ejection fraction was calculated in the standard fashion.

The blood volume (V_b) was determined by using 5 μ Ci iodine-125 (¹²⁵I) radioiodinated human serum albumin,[†] because the rate of egress of this material from the circulation is much lower than that of technetium-99m (^{99m}Tc) albumin albumin preparations (11). Corrections for overestimation of the red cell volume were employed using techniques previously described (12).

Following the determination of V_b , the FP study was undertaken. A rapid bolus injection (without flushing) of 8–10 mCi of [^{99m}Tc]albumin[‡] in a volume of <1 ml into the external jugular vein was used to generate FP curves employing a large crystal camera with a LEAP collimator and a 20% window centered on 140 keV. This dose was established by determining the gamma camera count rate response to increasing quantities of radionuclide, using the high count rate mode. A 100-ml flask filled with ~80 ml of water was placed against the face of the collimator and sequential 1-ml aliquots of 1 mCi each of [^{99m}Tc]pertechnetate were added to the flask and

mixed. The count rate for each activity level was calculated from a computer[§] and plotted. A linear response without significant deadtime loss was observed up to 10 mCi. Deadtime was calculated by the two-source method to be 1.6 μ sec.

With the patient supine, the camera was centered over the heart in the 45° LAO position using 10° caudal tilt. The computer system was used to acquire the data in serial mode for 40 sec after injection, using 10-msec time markers and a 1.30 \times zoom.

Following acquisition of FP data, equilibrium data were obtained 5, 7.5, 10, 12.5, and 15 min after injection for a 10-sec period each, in order to calculate the equilibrium concentration (C_t) by back extrapolation to zero time, assuming monoexponential disappearance of the tracer from the blood pool (11). For calculation of ventricular ejection fractions (and other parameters), the images were first reformatted into 500-msec frames. Regions of interest (ROI) were defined for the superior vena cava, right ventricle (RV), lungs, left ventricle (LV), and left ventricular background. The LV background region was drawn from 3 o'clock to 6 o'clock immediately adjacent to the LV region of interest, avoiding lung and descending aorta. A background region for the RV was deemed unnecessary for the first-pass RVEF determination, because background is extremely low (13). The RV region was defined manually by carefully outlining the RV, taking care to exclude right atrial activity insofar as possible by observing each frame individually and correcting the RV outline as necessary. This ROI was utilized for determination of RVEF by generation of a high frequency FP curve from frames reformatted at 40-msec intervals (8). This curve was smoothed once temporally (1–2–1 filter) to reduce high frequency statistical noise, allowing ready identification of end systole and end diastole. The FP ejection fraction subroutine of the computer system was used to directly calculate the RVEF as the difference between end-diastolic and end-systolic counts divided by end-diastolic counts. An average of 3.3 ± 1.0 s.d. clearly defined individual heart beats were manually identified for the RV, and each patient's mean RVEF and coefficient of variation were calculated. We used only beats following peak ventricular activity because unpredictable results were observed in earlier work in our laboratory when beats prior to the peak were used.

Similar procedures were used to calculate the LVEF, except that the FP gross curves were corrected for background by subtracting the normalized and ten-times temporally smoothed background curves. An average of 5.3 ± 1.1 heart beats were manually identified for the LV.

The patients were injected with an additional 10–12 mCi [^{99m}Tc]albumin after completion of the FP study for acquisition of equilibrium radiocardiograms. Left ventricular equilibrium radiocardiographic ejection fraction [$LVEF_{(ER)}$] was obtained by methods previously described (6); the right ventricular equilibrium radiocardiographic ejection fraction [$RVEF_{(ER)}$] was similarly obtained (5) using a right paraventricular background correction. Note that the FP measurement of EF employed a single ROI drawn to include the entire left or right ventricle (essentially, an end-diastolic ROI), whereas ER measurements used manually drawn end-diastolic and end-systolic ROI. Briefly stated, end-systolic and end-diastolic frames for each ventricle were identified in the equilibrium study, and hand drawn ROI for both ventricles were

defined on the spatially smoothed and background-subtracted images. The FP results were compared with the ER images. Left ventricular FP results were compared with results of CA.

For determination of flow by FP radiocardiography, the Stewart-Hamilton principle was employed. The cardiac output, F , is given by:

$$F \frac{\text{ml}}{\text{min}} = \frac{C_f \times V_b}{A_t}, \quad (1)$$

where C_f (cpm/ml) is the equilibrium concentration of the tracer in the blood, V_b (ml) is the blood volume, and A_t (min-cpm/ml) is the area under the extrapolated FP curve. Stroke volume (SV) was obtained from F and heart rate (HR):

$$SV = F/HR. \quad (2)$$

Using the FP ejection fraction, end-diastolic volume (EDV) and end-systolic volume (ESV) were calculated by the equations:

$$EDV = SV/EF \quad (3)$$

$$ESV = EDV - SV. \quad (4)$$

The stroke volumes, as obtained from the right ventricular region of interest [RVSV_(RV)] and from the lung region of interest [RVSV_(LU)], were used without correction. The stroke volume obtained from the LV was evaluated both in an uncorrected manner and with the following correction for bolus smearing and regurgitation.

Sequential FP determination of the RV, lung, and uncorrected LV flows (stroke volumes) in 13 patients with left-sided regurgitant valvular disease (R+) and seven patients without regurgitation (R-) showed progressive diminution in both groups (Table 1). Because there is no significant difference between the ratios of the R+ and R- group on the side where there was no regurgitation, it can be assumed that both bolus smearing and regurgitation distort the radiocardiograms similarly. That is to say, disruption of the tracer bolus due to the regurgitant process has the same qualitative effect as smearing has on the tracer bolus as it proceeds downstream, as evidenced by declining flows, even in the nonregurgitant group (R-).

Accordingly, identical corrections may be applied to both bolus smearing and regurgitation in order to calculate the total corrected LV flow. The uncorrected left ventricular flow results from the algebraic summation of the forward left ventricular flow (F) and the back flow (regurgitant flow and/or bolus smearing effect, B ; Fig. 1):

$$\text{uncorrected LV flow} = F - B. \quad (5)$$

Solving for B ,

$$B = F - (\text{uncorrected LV flow}). \quad (6)$$

TABLE 1

Flow Ratios of Right Ventricle to Lung and Lung to Left Ventricle in Patients With (R+) and Without (R-) Left-Sided Regurgitant Valvular Disease

	R-	R+	p
RV/lung flow	1.29 ± 0.08	1.24 ± 0.07	N.S.
Lung/LV (uncorrected) flow	1.22 ± 0.09	1.88 ± 0.20	<0.05

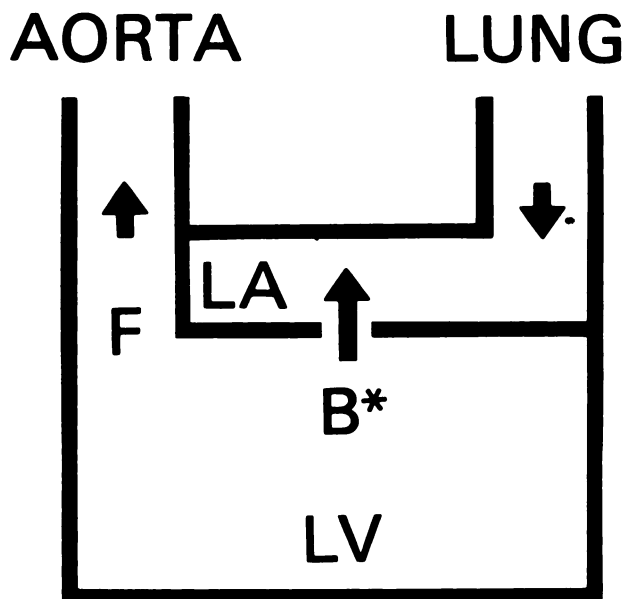

FIGURE 1 Schematic representation of flow in a heart with left-sided regurgitant valvular disease. B^* includes back flow and/or bolus smearing effects.

If it is assumed that there is no right-sided regurgitation, then the forward flow of the LV is equal to the lung flow:

$$F = \text{lung flow}. \quad (7)$$

Substituting in Eq. (6),

$$B = \text{lung flow} - (\text{uncorrected LV flow}). \quad (8)$$

Because the total corrected LV flow is the sum of the forward flow and B , we have:

$$\text{corrected (total) LV flow} = \text{lung flow} + B. \quad (9)$$

Finally, the regurgitant fraction is derived from the total corrected LV flow (CLVF) and B .

$$RF = \frac{B}{\text{CLVF}}. \quad (10)$$

For example,

$$RVSV_{(LU)} = 92 \text{ ml [lung flow]}$$

$$LVSV_{(FPU)} = 97 \text{ ml [uncorrected LV flow]}.$$

From Eq. (8):

$$B = 92 - 97 = -5 \text{ ml}.$$

From Eq. (9):

$$LVSV_{(FPC)} = 92 + (-5) = 87 \text{ ml [CLVF]}.$$

From Eq. (10):

$$RF = \frac{-5 \text{ ml}}{87 \text{ ml}} = -0.06,$$

indicating absence of regurgitation.

Using the 500-msec images, the total area under the FP curve was calculated by a monoexponential extrapolation of the initial downslope of the curve to the region under the recirculation portion. First-pass curves were obtained for the

ROI previously described for RV, lungs, and LV. The heart rate was determined by electrocardiographic monitoring during the FP study and was used in the determination of stroke volume.

Unless stated otherwise, all values are given as $\bar{x} \pm 1$ s.e. Standard parametric statistics were employed and product moment correlation coefficients were calculated (14).

RESULTS

The patients final diagnoses and results of the ejection fraction and coefficient of variation determinations are presented in Table 2. Coefficient of variation, a standard statistical measure of precision, reflects the degree of reproducibility of ejection fraction from beat to beat.

The mean coefficient of variation for the first-pass left ventricular ejection fraction [LVEF_(FP)] was $13.4 \pm 1.4\%$. The mean LVEF_(FP) was $42.9 \pm 3.6\%$, whereas, the mean LVEF_(ER) was $43.9 \pm 4.0\%$; there was no significant difference between methods (paired t-test). The mean contrast angiographic left ventricular ejection fraction [LVEF_(CA)] was $49.0 \pm 4.2\%$; this was significantly higher than the results of FP or ER ($p < 0.01$). The mean LVEF_(FP) in the subgroup of patients with regurgitant valvular disease (R+) was $36 \pm 4\%$, whereas, in those without regurgitation (R-) the mean LVEF_(FP) was $55 \pm 4\%$ ($p < 0.01$).

The mean coefficient of variation for the first-pass right ventricular ejection fraction [RVEF_(FP)] was $9.6 \pm$

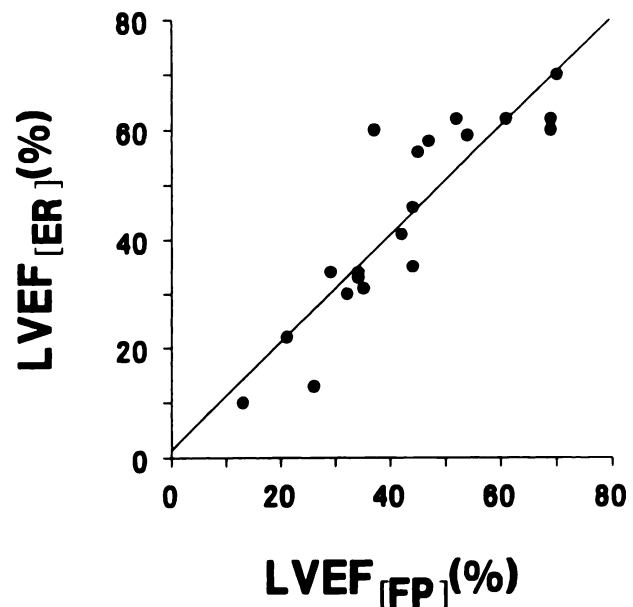

FIGURE 2
Correlation of left ventricular ejection fractions from equilibrium and first-pass radiocardiography. $Y = 0.99X + 1.4$; $r = 0.89$; $p < 0.001$.

1.0%. The mean RVEF_(FP) was $41.4 \pm 3.4\%$ and the mean RVEF_(ER) was $42.8 \pm 3.3\%$, there was no significant difference between the paired results. However, when these patients were divided into those without regurgitant valvular disease (R-) and those with regurgitant valvular disease (R+), the mean RVEF_(FP) for R+

TABLE 2
Final Diagnosis, Degree of Regurgitation, Ejection Fractions and their Coefficients of Variation

Patient no.	Age/sex	Diagnosis*	Degree of regurgitation	RVEF _(FP) (%)	CV (%)	LVEF _(FP) (%)	CV (%)	RVEF _(ER) (%)	LVEF _(ER) (%)	LVEF _(CA) (%)
1	56 F	NL	0	61	11	69	15	62	60	74
2	60 F	CAD, MR	+1	35	10	34	18	33	33	38
3	58 F	NL	0	60	8	69	16	55	62	80
4	50 F	NL	0	63	14	61	17	52	62	64
5	67 F	CAD, MR	+4	49	5	44	4	45	35	46
6	62 F	AS, MS, AR, MR	+1	70	10	70	—	56	70	57
7	58 M	CAD	0	48	12	47	10	63	58	63
8	31 M	CM, MR	+1	24	7	26	14	14	13	14
9	45 F	CAD, MR	+1	19	10	34	12	33	34	38
10	61 M	CAD, MR	+1	55	7	32	9	52	30	46
11	38 M	CAD	0	41	7	42	12	33	41	48
12	53 M	AR	+2	37	7	44	18	54	46	50
13	49 F	MR	+3	25	19	29	20	18	34	30
14	25 M	Repaired Tetralogy, MR	+1	38	3	21	15	43	22	26
15	60 F	MR	+1	24	6	35	9	25	31	40
16	17 M	Infundibular Stenosis	0	54	8	52	4	57	62	75
17	34 M	MS	0	33	6	45	10	39	56	59
18	82 M	AR, MR	+3	38	6	37	13	40	60	57
19	67 M	MR, CAD	+3	31	21	54	8	39	59	59
20	66 F	CM, MR	+1	22	14	13	31	—	10	15
				$\bar{X} = 41.4$	9.6	42.9	13.4	42.8	43.9	49.0
				s.e. = 3.4	1.0	3.6	1.4	3.3	4.0	4.2

* NL, normal, no disease found; CAD, coronary artery disease; MR, mitral regurgitation; AR, aortic regurgitation; MS, mitral stenosis; AS, aortic stenosis; CM, cardiomyopathy.

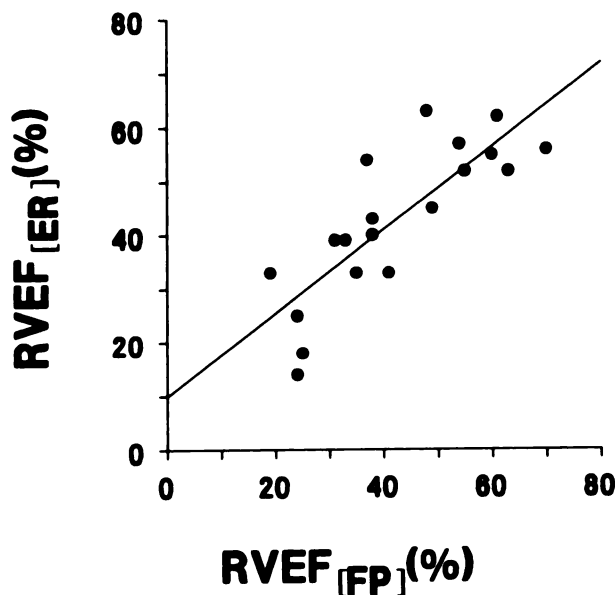

FIGURE 3
Correlation of right ventricular ejection fractions from equilibrium and first-pass radiocardiography. $Y = 0.78X + 9.9$; $r = 0.82$; $p < 0.001$.

was $36 \pm 4\%$, significantly lower than that for R-, $51 \pm 4\%$ ($p < 0.05$).

The validity of the FP method employed for determination of LVEF is confirmed by the correlations with the ER method ($r = 0.89$, $p < 0.001$) and with the CA method ($r = 0.88$, $p < 0.001$). The regression of $LVEF_{(ER)}$ on $LVEF_{(FP)}$ is essentially the line of identity (Fig. 2). Similarly, the correlation of $RVEF_{(ER)}$ and $RVEF_{(FP)}$ was significant ($r = 0.82$, $p < 0.001$; Fig. 3).

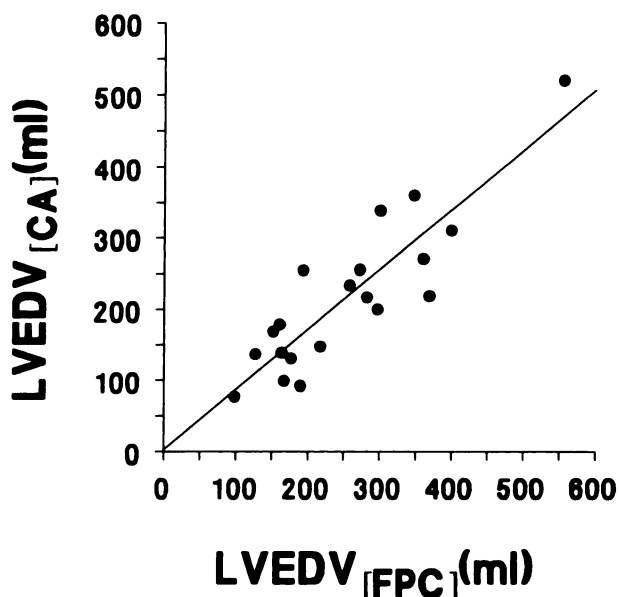

FIGURE 5
Correlation of left ventricular end diastolic volumes by contrast angiocardiology and the corrected first-pass method. $Y = 0.84X + 3$; $r = 0.88$; $p < 0.001$.

The corrected FP left ventricular stroke volumes and the CA stroke volumes correlated (Fig. 4), with no significant difference between paired data [$LVS_{V(FP)} = 96 \pm 5$ ml, $LVS_{V(CA)} = 92 \pm 7$ ml]. The uncorrected values, however, correlated poorly; the $LVS_{V(FPU)}$ was 52 ± 6 ml, significantly lower than for CA ($p < 0.001$).

Correlation was noted between the corrected FP and CA left ventricular end-diastolic volumes (Fig. 5) with a significant difference ($p < 0.01$) between the paired

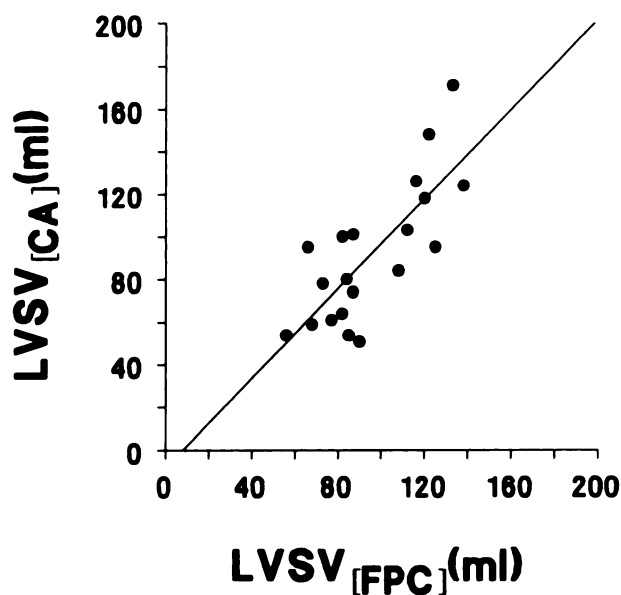

FIGURE 4
Correlation of left ventricular stroke volumes by contrast angiocardiology and the corrected first-pass method. $Y = 1.05X - 8$; $r = 0.77$; $p < 0.001$.

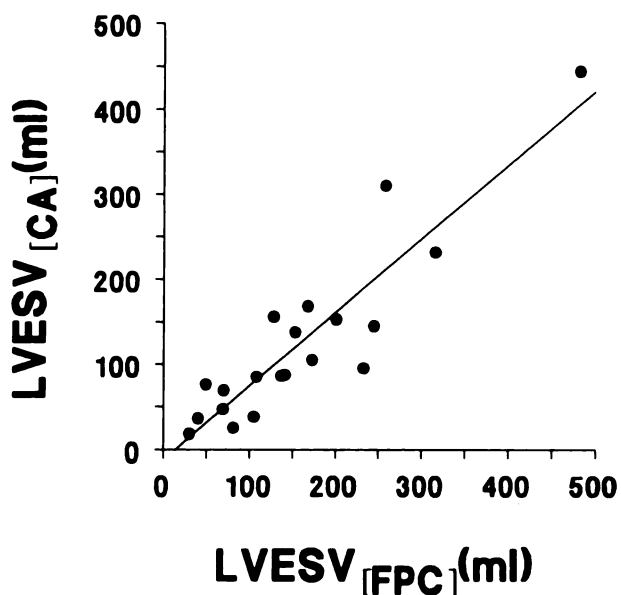

FIGURE 6
Correlation of left ventricular end systolic volumes by contrast angiocardiology and the corrected first-pass method. $Y = 0.86X - 12$; $r = 0.91$; $p < 0.001$.

TABLE 3
Comparison of Right Ventricular Flows as Obtained from First-Pass Right Ventricular and Lung Regions of Interest with Results of Green Dye and Fick Measurements

Linear regression equation	s.e.e. (ml)	Correlation coefficient (r)	p
Right Ventricular ROI			
$RVS_{(GD)} = 0.48[RVS_{(RV)}] + 18.1$	12.3	0.81	<0.001
$RVS_{(FICK)} = 0.64[RVS_{(RV)}] + 2.9$	20.0	0.76	<0.001
Lung ROI:			
$RVS_{(GD)} = 0.82[RVS_{(LU)}] + 1.3$	11.3	0.85	<0.001
$RVS_{(FICK)} = 1.19[RVS_{(LU)}] - 27.6$	14.5	0.88	<0.001

results [$LVEDV_{(FPC)} = 255 \pm 25$ ml; $LVEDV_{(CA)} = 218 \pm 24$ ml]. A weak correlation was noted between the uncorrected results and CA (Table 2) and, again, uncorrected mean values were significantly lower ($p < 0.001$) than those of CA [$LVEDV_{(FPU)} = 128 \pm 14$ ml].

Correlation of the corrected FP left ventricular end-systolic volumes with CA left ventricular end-systolic volumes was also obtained (Fig. 6), and paired t-testing showed the FP data to be higher ($p < 0.01$) than the CA results [$LVESV_{(FPC)} = 159 \pm 24$ ml; $LVESV_{(CA)} = 126 \pm 23$ ml]. There was lesser correlation between the uncorrected left ventricular FP results and CA end-systolic volume determinations; $LVESV_{(FPU)}$ was significantly lower (76 ± 12 ml; $p < 0.01$).

Table 3 summarizes the results of the right ventricular measurements. First-pass right ventricular stroke volume was ascertained from the right ventricular region of interest [$RVS_{(RV)}$] and from the lung region of

interest [$RVS_{(LU)}$]. Both sets of data were correlated with RV stroke volumes as measured at cardiac catheterization by the green dye or Fick methods. The correlation between green dye RV stroke volume and the Fick stroke volume obtained simultaneously at the time of cardiac catheterization was 0.87, without significant differences between paired determinations (Fig. 7). The correlation coefficient between the lung derived data and the green dye method was 0.85 (Fig. 8); the correlation coefficient with the Fick method was 0.88 (Fig. 9). The FP right ventricular stroke volumes derived from the right ventricular region of interest also correlated well with the green dye (GD) and Fick methods ($r = 0.81$ and 0.76 , respectively), but these stroke volumes were considerably higher than the values obtained from the lung region of interest [$GD = 64 \pm 5$ ml, Fick = 62 ± 7 ml, $RVS_{(LU)} = 74 \pm 5$ ml, $RVS_{(RV)} = 93 \pm 8$ ml].

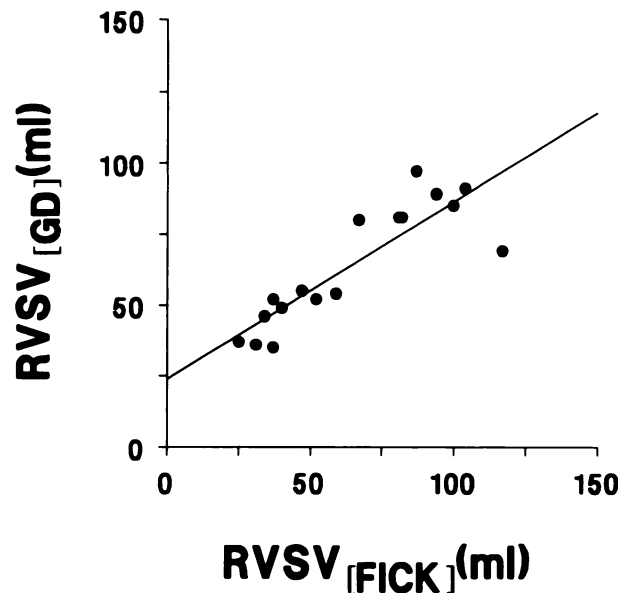

FIGURE 7
Correlation of right ventricular stroke volumes performed simultaneously by Fick and indocyanine green dye techniques during cardiac catheterization. $Y = .062X + 24$; $r = 0.87$; $p < 0.001$.

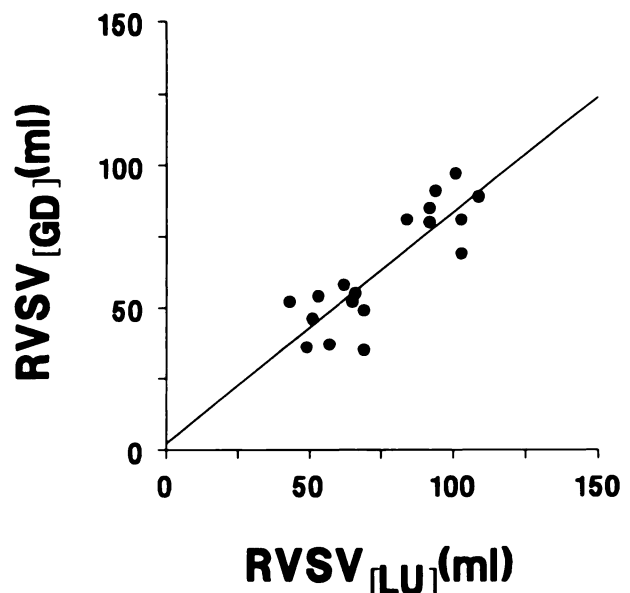

FIGURE 8
Correlation of right ventricular stroke volumes performed by the green dye and first-pass radiocardiographic methods. $Y = 0.81X + 2$; $r = 0.85$; $p < 0.001$.

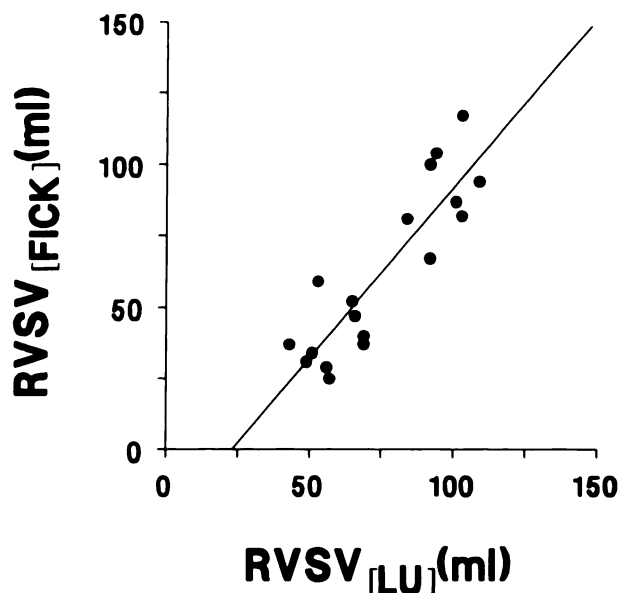

FIGURE 9
Correlation of right ventricular stroke volumes performed by the Fick and first-pass radiocardiographic methods. $Y = 1.19X - 28$; $r = 0.88$; $p < 0.001$.

From the RVEF and the $RVS_{(LU)}$, the right ventricular end-systolic and end-diastolic volumes were calculated for the 13 patients with regurgitant left-sided valvular disease (R+) and for the seven patients without valvular regurgitation (R-). Table 4 presents these data. The mean right ventricular stroke volumes of the R+ group were not significantly different from those in the R- group. The group with regurgitant valvular disease had higher right ventricular end-diastolic and end-systolic volumes, but they did not differ significantly.

Finally, Table 5 compares the R+ with R- groups. Figure 10 compares the grading of the extent of regurgitation at the time of cardiac catheterization and the calculation of regurgitant fraction from the FP method. Values of RF >18% were strongly indicative of regurgitation.

TABLE 4
Comparison of Right Ventricular Parameters of 13 Patients with Left-Sided Regurgitant Valvular Disease (R+) and in Seven Patients Without (R-)

	Mean	s.e.	t	p
RVEF				
R+	36%	4	2.41	<0.05
R-	51	4		
RVS				
R+	68 ml	6	1.82	N.S.
R-	85	7		
RVEDV				
R+	202 ml	16	1.10	N.S.
R-	173	21		
RVESV				
R+	134 ml	16	1.86	N.S.
R-	88	17		

TABLE 5
Comparison of Left Ventricular Regurgitant Fractions in R- and R+ Groups

	R-	R+
Mean	12.3%	28.5%
s.e.	4.2%	2.1%
p	<0.001	

* Includes Patient 16, with infundibular stenosis; $9.5 \pm 3.8\%$ if Patient 16 is excluded.

DISCUSSION

The lack of a standard, universally accepted, and widely applicable radionuclide method of calculating RVEF is due to the inherent difficulty in assessing the accuracy of radiocardiographic RVEF determinations. The problems involved with CA assessment of RV volumes have been outlined by Berger et al. (15) and, even where applied, have been technically demanding (4,16).

Equilibrium radiocardiographic techniques, which are widely used for the determination of LVEF, are not easily applied to RVEF assessments because the right ventricle overlies the right atrium. Nevertheless, Maddahi et al. (5) and other investigators (17) have successfully employed an ER technique using two ROI for the right ventricle. Holman et al. (7) described an ER technique for assessing RVEF using a special 30° slant hole collimator to separate right atrial from right ventricular activity. Correlation with FP methods of determining RVEF was obtained, although this slant hole

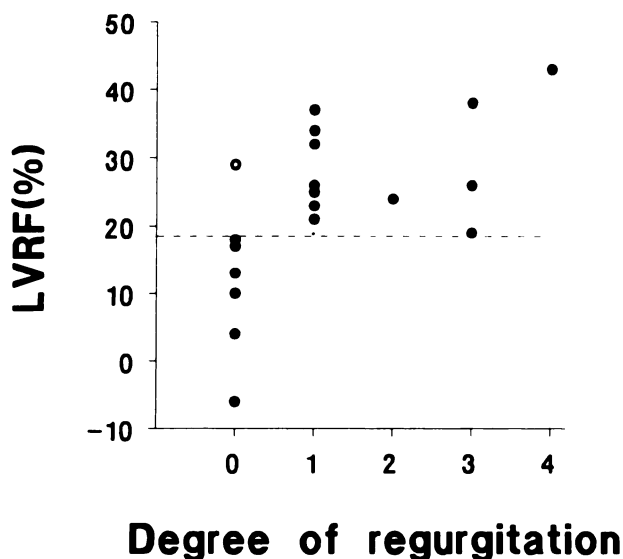

FIGURE 10
Scattergram of left ventricular regurgitant fractions using correction methods described in the text versus the semi-quantitative degree of regurgitation estimated visually during contrast angiography.

technique resulted in overestimation of the ejection fraction.

Steele et al. (16) introduced the FP radiocardiographic technique for the determination of RVEF using an RAO projection. The method appears satisfactory, because the right ventricle can be separated from the surrounding chambers both temporally and spatially; it has had wide application (13,15,17-19). Indeed, the first-pass RVEF in the RAO projection currently is the accepted method of determining RVEF, although there is a paucity of validation studies with other methods. The precision of this technique has been well documented; accuracy of the method is only inferential (13,15). Other FP methods using krypton-81m and xenon-133 have been reported recently (20-22).

A desirable goal in the performance of the noninvasive radiocardiographic study is the opportunity to not only obtain biventricular ejection fractions but also to measure cardiac output and stroke volume for each ventricle. This would enable calculation of end-systolic and end-diastolic volumes for each ventricle as well as permit (theoretically, at least) the quantitation of shunts and valvular regurgitation. The disadvantage of employing the RAO projection is its inability to quantitate stroke volumes of each chamber, because the right and left ventricles superimpose, precluding the measurement of equilibrium concentrations of tracer in the ventricles.

This report demonstrates that the precision of determining RVEF from the LAO projection is as good as that of the left ventricle as judged by similar mean coefficients of variation. The accuracy of this method, indeed, with all other RVEF methods, is difficult to judge. However, the good correlation of $RVEF_{(FP)}$ with $RVEF_{(ER)}$ and the insignificant mean difference between paired determinations is strong supportive evidence for the accuracy of the $RVEF_{(FP)}$, demonstrating internal consistency between methods; the $RVEF_{(ER)}$ has shown high correlation with $RVEF_{(FP)}$ from the RAO projection (18,19).

Further supporting evidence for the validity of the $RVEF_{(FP)}$ can be seen by comparing the results in patients with (R+) and without (R-) regurgitant valvular disease. Those with regurgitation would be expected to have lower RVEF values because of higher pulmonary artery pressures (19,23); supportive evidence for this finding was also observed in the present study.

First-pass radionuclide methods for quantitative determination of ventricular flow, volumes, and regurgitant fraction have had limited application, despite the fact that the theoretical basis of such studies has been known for years. This is attributable to a variety of reasons, predominantly arising from limitations of equipment (for example, deadtime losses and, thus, count rate limitations of early Anger cameras). Hence, FP methodology was limited to multicrystal cameras

not widely available and with spatial resolution inferior to Anger cameras. Modern Anger cameras and computer systems are now widely available and possess high count rate capability, thus, permitting the performance of FP studies with only minimal deadtime losses when using significant amounts of radiopharmaceutical. Nevertheless, the technique of performing such studies is very important, and meticulous attention to detail is necessary.

1. A tight bolus injection is essential. This is readily performed with the patient in a supine position using a jugular vein injection; flushing of the syringe is unnecessary, and the procedure is less painful than antecubital injections. Antecubital injections are adequate, but only if care is taken to use the basilic vein and the dose is rapidly flushed. With either method, valsalva maneuvers by the patient must be avoided.

2. Radioiodinated serum albumin should be used for blood volume determination because the disappearance of [Tc]albumin from the circulation is rapid (11); whether or not such disappearance affects the blood volume (V_b) and equilibrium concentration (C_r) portions of the Stewart-Hamilton equation equally in opposite directions, so that the effects of disappearance of [Tc]albumin from the blood cancel, is unknown and remains to be tested. If it does turn out that the loss from the circulation results in an expanded V_b value balanced by a decrease in C_r , then the technique may be simplified by elimination of the radioiodinated serum albumin determination of V_b . With the present technique, [Tc]albumin losses from the circulation must be corrected. Furthermore, corrections must be made for overestimation of the V_b due to the difference in total body and peripheral venous hematocrit (12).

3. In estimating the area under the FP curve we have used a monoexponential extrapolation of the initial downslope. Alternative methods, such as gamma variate techniques, may also be used, but the adequacy of other methods was not tested in this study.

4. Automation of calculation reduces error and allows answers to be obtained quickly; we have developed programs for this purpose.

As can be seen from the data in Tables 1 and 2 there is a step-down in stroke volume as one proceeds from RV to lung to LV (uncorrected data). Possible reasons for this step-down include deadtime losses, which decrease as the bolus dissipates, inadequate mixing, or bolus smearing, which has the effect of increasing the area under the FP curve, thereby, resulting in a calculated lower flow as one proceeds downstream. When correlations of RSV from analysis of the right ventricular region of interest or the lung region of interest were made with green dye and Fick stroke volumes, better results were obtained with the lung curve (Table 3). This is probably due to both better mixing of the radiopharmaceutical with the blood as it traverses the

lung and elimination of right atrial activity (24,25). Of course, the calculation of RVEF, of necessity, must come from the right ventricular region of interest curve. Accordingly, we have adopted the pulmonary flow as representative of RVSV and calculated RV volumes and regurgitant fractions from these data (Table 2).

The degree of correlation between the RVSV as derived from the first pass lung curve [RVSV_(LU)] and with the Fick and green dye methods is surprisingly high, considering the studies were performed on different days, in different environments, with different degrees of invasiveness, and under different conditions of sedation. The correlation between Fick and green dye stroke volumes performed almost simultaneously at the time of cardiac catheterization was similar ($r = 0.87$). Thus, the validity of the RVSV from both the right ventricular region of interest and the lung region of interest is established, but the latter is preferred.

At the time we performed this study, there was not a good angiographic method available to test the validity of the derived right ventricular end-systolic and end-diastolic volumes. However, if the ejection fraction is valid and the RVSV is valid, then the derived volumes should also be valid. The values for RVEDV and RVESV obtained are certainly reasonable and believable, lending credence to their validity; furthermore, similar techniques applied to the left ventricle result in LVEDV and LVESV that correlate well with contrast angiographic data.

The flow data derived directly from the left ventricular region of interest (uncorrected) resulted in unrealistic volumes for left ventricular stroke, end-diastolic, and end-systolic volumes. Furthermore, the uncorrected LV data correlated poorly with the CA results. In contrast, the results of the left ventricular flow and volumes, when corrected, correlate highly with the CA data. It should be remembered, however, that the CA technique is subject to a number of limitations: (a) the iodinated contrast material employed, unlike radiolabeled tracers, produces inotropic and chronotropic effects that alter the parameters being studied; (b) a limited number of images are obtained and a "representative beat" is selected to determine end-systolic and end-diastolic volumes; (c) the placement of the cardiac edge for determination of the end-systolic and end-diastolic volumes is subject to observer interpretation; (d) with cardiomegaly, the assumption that the heart remains an ellipsoid of revolution becomes less realistic. Notwithstanding these limitations, the CA method has remained the standard method against which newer techniques are compared; it is gratifying, therefore, that the FP corrected left ventricular results described herein correlate so highly. Further support of the validity of the correction of LSVV is derived from the good agreement with the catheterization methods of estimating regurgitant fraction.

In conclusion, FP determination of the LVEF in the LAO projection gives precise and accurate measurements. The precision of the RVEF is similar. Although there is no good way to corroborate the accuracy of the RVEF measurement due to the lack of a widely accepted "gold standard," the values obtained seem to be in keeping with the expectations of this patient group. Furthermore, the significant correlation of the RVEF_(FP) and the RVEF_(ER) lends substance to the accuracy of this method. The corrected left ventricular stroke volume (LVS_(FPC)) correlates highly with LVS_(CA) and the results obtained are similar. Similar high correlations are obtained for LVEDV_(FPC) and LVESV_(FPC) and CA techniques. Right ventricular stroke volume [RVSV_(LU)] results are similar to and correlate highly with both green dye and Fick methods. Right ventricular end-diastolic and end-systolic volumes appear to be reasonable. Finally, the regurgitant fractions derived from the methods employed distinguish the R+ and R- groups of patients and agree well with results of catheterization. Therefore, the LAO projection technique, as described in this investigation, is a valid method for obtaining simultaneous right and left ventricular ejection fractions, flows, volumes, and regurgitant fractions.

NOTES

- * North American Instrument Corp., Hudson Falls, NY.
- † Mallinckrodt, Inc., St. Louis, MO.
- ‡ Medi-Physics, Inc., Richmond, CA.
- § Medical Data Systems, Ann Arbor, MI.

ACKNOWLEDGMENTS

This work was supported by New Investigator Research Award R23 HL-27508, NIH (M.R.S.).

REFERENCES

1. Marshall RC, Berger HJ, Costin JC, et al. Assessment of cardiac performance with quantitative radionuclide angiography: sequential left ventricular ejection fraction, normalized left ventricular ejection rate, and regional wall motion. *Circulation* 1977; 56:820-829.
2. Folland ED, Hamilton GW, Larson SM, et al. The radionuclide ejection fraction: a comparison of three radionuclide techniques with contrast angiography. *J Nucl Med* 1977; 18:1159-1166.
3. Horn V, Mullins CB, Saffer SI, et al. A comparison of mathematical models for estimating right ventricular volumes in animals and man. *Clin Cardiol* 1979; 2:341-347.
4. Dell'Italia LJ, Starling MR, Walsh RA, et al. Validation of attenuation-corrected equilibrium radionuclide angiographic determinations of right ventricular volume: comparison with cast-validated biplane cine-ventriculography. *Circulation* 1985; 72:317-326.
5. Maddahi J, Berman DS, Matsuoka DT, et al. A new

- technique for assessing right ventricular ejection fraction using rapid multiple-gated equilibrium cardiac blood pool scintigraphy. *Circulation* 1979; 60:581-589.
6. Starling MR, Dell'Italia LJ, Walsh RA, et al. Accurate estimates of absolute left ventricular volumes from equilibrium radionuclide angiographic count data using a simple geometric attenuation correction. *JACC* 1984; 3:789-798.
 7. Holman BL, Wynne J, Zielonka JS, et al. A simplified technique for measuring right ventricular ejection fraction using the equilibrium radionuclide angiogram and the slant-hole collimator. *Radiology* 1981; 138:429-435.
 8. Berger HJ, Matthay RA, Pytlik LM, et al. First-pass radionuclide assessment of right and left ventricular performance in patients with cardiac and pulmonary disease. *Semin Nucl Med* 1979; 9:275-295.
 9. Steele P, Kirch D, Vogel R. Evaluation of central circulatory dynamics with the radionuclide angiogram. In: Strauss HW, Pitt B, eds. Cardiovascular nuclear medicine. St Louis: CV Mosby Co., 1979: 105-115.
 10. Wynne J, Green LH, Mann T, et al. Estimation of left ventricular volumes in man from biplane cineangiograms filmed in oblique projections. *Am J Cardiol* 1978; 41:726-732.
 11. Nusynowitz ML, Straw JD, Benedetto AR, et al. Blood clearance rates of technetium-99m albumin preparations [Concise communication]. *J Nucl Med* 1978; 19:1142-1145.
 12. Nusynowitz ML, Blumhardt R. Estimation of true red cell volume from RISA red cell volume. *Am J Roentgenol* 1974; 120:549-552.
 13. Tobinick E, Schelbert HR, Henning H, et al. Right ventricular ejection fraction in patients with acute anterior and inferior myocardial infarction assessed by radionuclide angiography. *Circulation* 1978; 57:1078-1084.
 14. Snedecor GW, Cochran WG. Statistical methods. 7th ed. Ames, IO: Iowa State University Press, 1980.
 15. Berger HJ, Matthay RA, Loke J, et al. Assessment of cardiac performance with quantitative radionuclide angiography: right ventricular ejection fraction with reference to findings in chronic obstructive pulmonary disease. *Am J Cardiol* 1978; 41:897-905.
 16. Steele P, Kirch D, LeFree M, et al. Measurement of right and left ventricular ejection fractions by radionuclide angiography in coronary artery disease. *Chest* 1976; 70:51-56.
 17. Brent BN, Berger HJ, Matthay RA, et al. Physiologic correlates of right ventricular ejection fraction in chronic obstructive pulmonary disease: a combined radionuclide and hemodynamic study. *Am J Cardiol* 1982; 50:255-261.
 18. Starling MR, Dell'Italia LJ, Nusynowitz ML, et al. Estimates of left-ventricular volumes by equilibrium radionuclide angiography: importance of attenuation correction. *J Nucl Med* 1984; 25:14-20.
 19. Reduto LA, Berger HJ, Cohen LS, et al. Sequential radionuclide assessment of left and right ventricular performance after acute transmural myocardial infarction. *Ann Intern Med* 1978; 89:441-447.
 20. Ham HR, Franken PR, Georges B, et al. Evaluation of the accuracy of steady-state krypton-81m method for calculating right ventricular ejection fraction. *J Nucl Med* 1986; 27:593-601.
 21. Caplin JL, Flatman WD, Dymond DS. Gated right ventricular studies using krypton-81m: comparison with first-pass studies using gold-195m. *J Nucl Med* 1986; 27:602-608.
 22. Martin W, Tweddel AC, McGhie I, Hutton I. Gated xenon scans for right ventricular function. *J Nucl Med* 1986; 27:609-615.
 23. Korr KS, Gandsman EJ, Winkler ML, et al. Hemodynamic correlates of right ventricular ejection fraction measured with gated radionuclide angiography. *Am J Cardiol* 1982; 49:71-77.
 24. Swan HJC, Beck W. Ventricular nonmixing as a source of error in the estimation of ventricular volume by the indicator-dilution technic. *Circ Res* 1960; 8:989-998.
 25. Maseri A, Enson Y. Mixing in the right ventricle and pulmonary artery in man: evaluation of ventricular volume measurements from indicator washout curves. *J Clin Invest* 1968; 47:848-859.