

Stormwater Management Devices in the Auckland Region

December 2017

Guideline Document 2017/001 Version 1

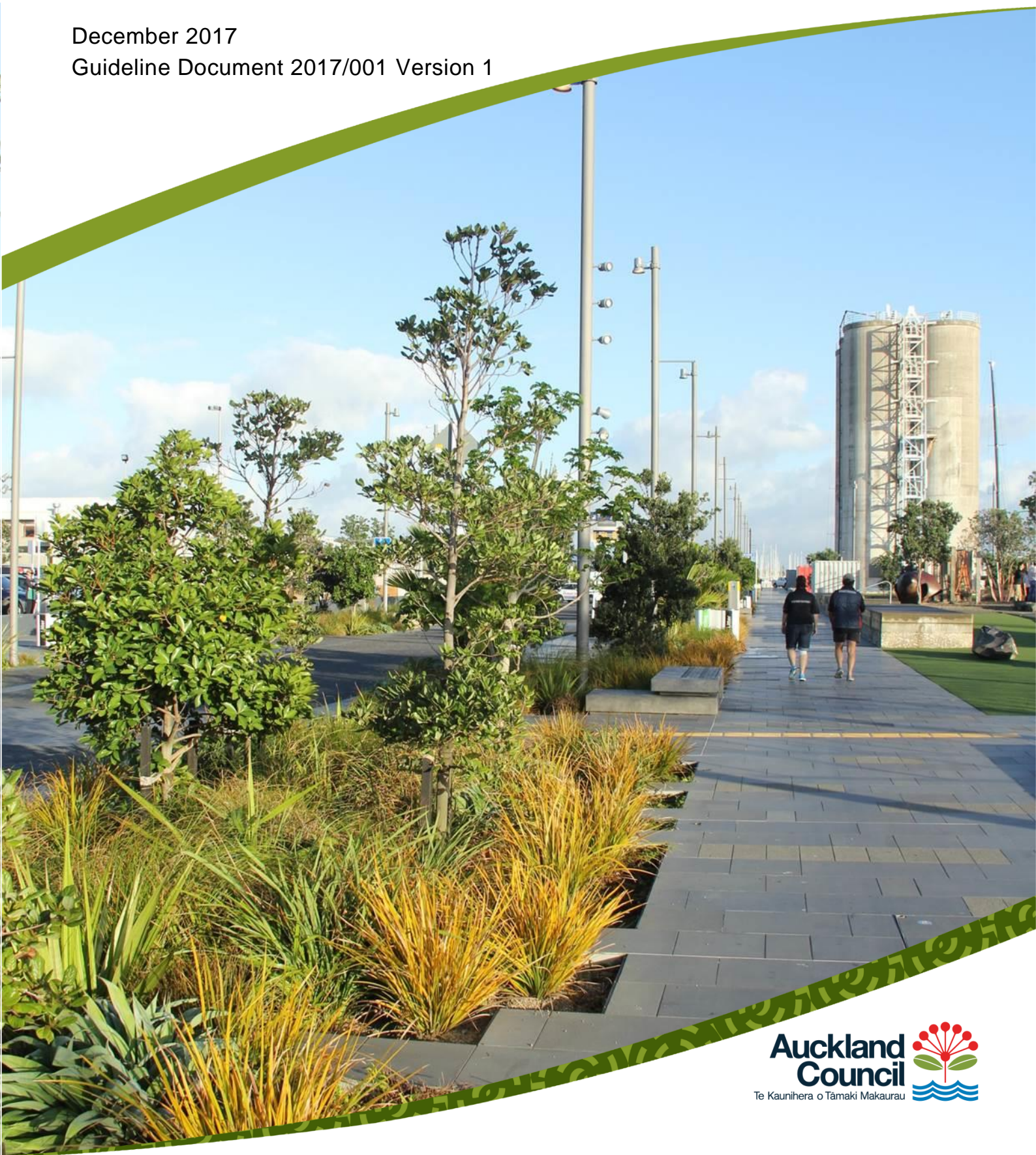

Stormwater Management Devices in the Auckland Region

December 2017

Auckland Council

Guideline Document 2017/001

ISSN 2230-4541 (Print)

ISSN 2230-455X (Online)

ISBN 978-1-98-852976-9 (Print)

ISBN 978-1-98-852977-6 (PDF)

Reviewed and recommended for publication by:

Name: Branko Veljanovski

Position: Manager, Engineering Design Services

Approved for publication by:

Name: Sarah Sinclair

Position: Chief Engineer

Recommended citation:

Cunningham, A., Colibaba, A., Hellberg, B., Roberts, G. S., Symcock, R., Vigar, N and Woortman, W (2017) *Stormwater management devices in the Auckland region*. Auckland Council guideline document, GD2017/001

© 2017 Auckland Council

This publication is provided strictly subject to Auckland Council's copyright and other intellectual property rights (if any) in the publication. Users of the publication may only access, reproduce and use the publication, in a secure digital medium or hard copy, for responsible genuine non-commercial purposes relating to personal or public service, provided that the publication is only ever accurately reproduced and proper attribution of its source, publication date and authorship is attached to any use or reproduction. This publication must not be used in any way for any commercial purpose without the prior written consent of Auckland Council. The use of this publication for professional training purposes, regardless whether payable or free of charge, also requires Auckland Council's prior written consent. Auckland Council does not give any warranty whatsoever, including without limitation, as to the availability, accuracy, completeness, currency or reliability of the information or data (including third party data) made available via the publication and expressly disclaim (to the maximum extent permitted in law) all liability for any damage or loss resulting from your use of, or reliance on the publication or the information and data provided via the publication. The publication, information, and data contained within it are provided on an "as is" basis.

Acknowledgements

This document was prepared with technical input from Council and industry experts including, but not limited to, the following individuals:

Authors

Amelia Cunningham, Alex Colibaba, Bodo Hellberg, Gretel Silyn Roberts, Robyn Symcock, Nick Vigar and Wouter Woortman.

Editor

Gretel Silyn Roberts

Contributors

Formatting: Janet MacKinnon

Technical content: Sue Ira, Wolfgang Kanz, David Kettle, Tamoko Ormsby, Rebecca Stanley, Jack Wang

Graphics: Frances Deamer-Phillips, Anna Tyrell, Freya Xu.

Technical Editorial Panel

Paul Howes – Auckland Council

Andy Irwin – Auckland Transport

David Kettle – D&B Kettle Consulting Ltd

Peter Mitchell – NZ Transport Agency

Sarah Sinclair - Chief Engineer, Engineering and Technical Services

Robyn Symcock – Landcare Research

Branko Veljanovski – Manager Engineering Design Services, Engineering and Technical Services

Thanks are extended to technical experts who contributed significantly to this document including, but not limited to the following individuals: Caleb Clarke, Howell Davies, Jayden Ellis, Michael Hannah, Claudia Hellberg, Mark Lewis, Craig Mountjoy, Mohammed SahimRazak, Sam Sarah, Earl Shaver, Scott Speed, Chris Stumbles, Pranil Wadan, Matthew Wallace, Nick Walmsley, Dean Watts & Damian Young.

Special thanks are also extended to the following Mana Whenua representatives: Geoff Cook, Tina Latimer, Dane Karapu, Scott Lomas, Jeff Lee, Fiona McKenzie, Kowhai Olsen, Adrian Pettit, Berenize Peita, Hero Potini, Lucille Rutherford, Tame Te Rangi, Moana Waa.

Thanks also to Auckland Council staff, both past and present, and industry experts who contributed to the development of the guideline.

This document has drawn on Auckland Council's Technical Publication 10 (TP10) '*Stormwater Management Devices Design Guidance Manual*, (Auckland Regional Council, 1992 and 2003) as well many technical reports. The project team acknowledges the work done by many individuals and organisations over the years to provide technical content for this document.

Preface

What is the purpose of this document?

This guideline document, *Stormwater Management Devices in the Auckland Region* (GD01) provides detailed design considerations aligned with the Auckland Council philosophy of stormwater management – where cultural values, social needs and natural features are considered as part of the functional design of the stormwater network – to achieve a resilient and sustainable outcome under the principles of water sensitive design. While overall guidance on the principles and process of water sensitive design can be found in the Auckland Council Guideline Document GD2015/004 *Water Sensitive Design for Stormwater*, this document focuses on the selection and design of stormwater management devices which achieve:

- Water quality treatment (sediment, nutrients, metals, microbes, hydrocarbons, temperature etc.)
- Retention of stormwater on-site (either as reuse or infiltration)
- Detention of the most frequent storm events (90th and 95th percentile) for stream protection
- Detention of larger storm events (50%, 10% and 1% Annual Exceedance Probability (AEP) design storm events) for flood mitigation.

GD01 is an update of TP10 – *Stormwater Management Devices: Design Guidelines Manual*, (Auckland Regional Council, 1992 and 2003) and will supersede that document once included in the Auckland Unitary Plan. The scope and objective of this guideline is to provide a user-friendly technical design guide to developers, designers and regulators which provides stormwater choice and design advice based on current good practice specific to the requirements of the Auckland Unitary Plan.

It should be noted that this document has been prepared for use in the Auckland region. While many of the principles are universal and can be used elsewhere, the technical specifications have been developed for the geology, geography, climate, receiving environments and context of Auckland. Auckland Council therefore disclaims any responsibility for use of GD01 outside of the Auckland region.

What new inclusions and approaches are in this guideline document?

The key new inclusions and approaches in this document, relative to TP10, are:

- Overall alignment with water sensitive design philosophy with guidance on cultural, social and environmental considerations when designing for stormwater management
- Alignment with the requirements of the Auckland Unitary Plan (2016)
- Inclusion of detailed design considerations for soils and plants
- Additional guidance on other device design considerations such as safety in design and whole-of-life costs.

Who was consulted in the preparation of this guideline document?

Extensive consultation was undertaken in the development of this guideline, including:

- Internal workshops and consultation with Auckland Council's stakeholders
- Workshops and consultation with Mana Whenua
- External workshops with, and input from, industry through a focus group of recognised stormwater practitioners, contractors and council/government staff who regularly use the TP10 manual.

How can I provide feedback on the guideline?

For your comments and suggestions, please fill in a feedback form downloadable from aucklanddesignmanual.co.nz and send to wsd@aucklandcouncil.govt.nz.

How will I be advised of updates to the guideline?

This guideline is a living document and updates will be made, as required, to the web version available on Auckland Council's website at aucklanddesignmanual.co.nz. Hard copies will not be sold or officially issued. It is the responsibility of the user of this guideline to ensure they download the most up-to-date version of GD01.

List of abbreviations

Abbreviation	Definition
AEP	Annual Exceedance Probability
ARC	Auckland Regional Council
ARPS	Auckland Regional Policy Statement
CBR	California Bearing Ratio
CN	Curve Number
CoP	Code of Practice
GD	Guideline Document
HRT	Hydraulic Residence Time
LGA	Local Government Act
NDC	Network Discharge Consent
NES	National Environmental Standards
NPS	National Policy Statement
NPV	Net Present Value
NSCC	North Shore City Council
O&M	Operation and Maintenance
PAW	Plant Available Water
PAUP	Proposed Auckland Unitary Plan
PWL	Permanent Water Level
PWV	Permanent Water Volume
RMA	Resource Management Act
RUB	Rural/Urban Boundary
SMAF	Stormwater Management Area - Flow
TP	Technical Publication
TR	Technical Report
TSS	Total Suspended Solids
UV	Ultraviolet
WQV	Water Quality Volume

List of units and equation nomenclature

	Unit	Description
AEP	%	Annual exceedance probability
A	m ² or ha	Area
A _(hy)	m ²	Area of the hydraulic effective cross-section
A _(connect)	m ²	Area of the connected impervious catchment
A _(cross)	m ²	Area of the cross-section
A _(cd)	m ²	Area of the cross-section of channel at check dam height
A _(orifice)	m ²	Area of orifice
A _(pipe)	m ²	Area of pipe (underdrains)
b _(weir)	m	Width of check dam in swale or weir crest
C	(-)	Runoff coefficient
D _(orifice)	m	Diameter of orifice
D _(tank)	m	Diameter of rainwater tank
d _(WQ)	m	Design water depth during water quality event
d _(10%)	m	Design water depth during 10% AEP event
d _(ret)	m	Design water depth for retention
d _(det)	m	Design water depth for detention
d _(base course)	m	Design depth of base course for pervious paving
d _(weir)	m	Elevation of check dam or weir
d _(tank)	m	Total depth of rainwater tank
e _(void)	%	Void ratio in a media
ET	mm/day	Evapotranspiration rate
H _(hy)	m	Hydraulic head
h _(weir)	m	Height of flow over check dam or weir crest
h _(device)	m	Height of device
h _(orifice)	m	Height of orifice
h _(cd)	m	Height of check dam
h _(ds)	m	Height of dead storage
i	(-)	Gradient or slope as % (degrees in brackets) or V:H
i	(-)	Hydraulic gradient assumed to be 1

	Unit	Description
K	mm/hr	Infiltration rate or hydraulic conductivity
l	m	Length
$l_{(eff)}$	m	Effective length
$l_{(cd)}$	m	Length between check dams
n	(-)	Manning's roughness coefficient
N	(-)	Number of X
Q	m ³ /s or L/s	Discharge or flow rate
$Q_{(total)}$	m ³ /s or L/s	Total flow rate
$Q_{(WQ)}$	m ³ /s or L/s	Peak discharge for water quality event
$Q_{(orifice)}$	m ³ /s or L/s	Discharge through an orifice
$Q_{(spill)}$	m ³ /s or L/s	Discharge through a spillway
$Q_{(R)}$	m ³ /s or L/s	Runoff calculated using the rational method
$Q_{(S)}$	m ³ /s or L/s	Peak flow rate in a storm event
$Q_{(under)}$	m ³ /s or L/s	Design flow rate for underdrains
$Q_{(F)}$	m ³ /s or L/s	Peak flow rate in a flood event
$Q_{(xy\%)}$	m ³ /s or L/s	Peak flow rate resulting from a storm event with x% AEP
$Q_{(avg)}$	m ³ /s or L/s	Average flow rate over a defined period of time
$Q_{(max)}$	m ³ /s or L/s	Maximum flow rate
$Q_{(total)}$	m ³ /s or L/s	Total flow rate
$R_{(hy)}$	m	Hydraulic radius
RL	m	Relative level – in relation to sea level
S	m ³	Available storage
t	hours	Time
t_c	hours	Time of concentration
v	m/s	Flow velocity
$V_{(max-WQ)}$	m ³	Maximum flow velocity for water quality event
$V_{(max-10\%)}$	m ³	Maximum flow velocity for 10% AEP event
$V_{(WQ)}$	m ³	Water quality volume (WQV)
$V_{(10\%)}$	m ³	Volume for 10% AEP event
$V_{(det)}$	m ³	Detention volume (SMAF)

	Unit	Description
$V_{(ret)}$	m^3	Retention volume (SMAF)
$V_{(req)}$	m^3	Required volume (underdrains)
$V_{(tot)}$	m^3	Total volume
$V_{(device)}$	m^3	Total volume/size of device (including aggregate)
$V_{(void)}$	m^3	Volume of void space in a media
ϕ (phi)	(-)	Void space or porosity of soil
π		pi

List of definitions

Term	Definition
Absorption	Physical or chemical process in which atoms, molecules, or ions enter some other bulk phase - gas, liquid or solid material. This is a different process from adsorption, since molecules undergoing absorption are taken up by the volume, not by the surface (as in the case for adsorption).
Adsorption	Process of attraction of atoms or molecules from an adjacent gas, liquid or dissolved substance to an exposed solid surface. Such attraction forces (adhesion or cohesion) align the molecules into layers ("films") onto the existing surface.
Annual Exceedance Probability	AEP is the chance or probability of a natural hazard event (usually a rainfall or flooding event) occurring annually and is usually expressed as a percentage. Bigger rainfall events occur (are exceeded) less often and will therefore have a lesser annual probability.
Backflow	The undesirable reversal of water flow from private plumbing back into the public water supply system.
Backup system	A system which augments the water supply from rain tanks using an alternative water source during extended periods of dry weather.
Biofiltration	Devices which use plants with specific characteristics (e.g. density, height, resistance) to filter stormwater.
Bioretention	Process in which contaminants and sedimentation are removed from stormwater runoff in a filter media with perennial vegetation.
Check dam	A dam installed within a swale perpendicular to the flow direction in order to minimise erosion or increase the hydraulic retention time (HRT).
Connection	This is the link between the private and public infrastructure.
Contaminated land	Land with hazardous substances in, or on, it that are reasonably likely to have significant adverse effects on the environment and potentially human health. Hazardous substances can wash off land and be absorbed by plants or animals within the land, or seep through the soil and contaminate the groundwater, which can affect nearby land or waterways.
Conveyance	The means by which water is transferred from one place to another. Natural systems include rivers and streams, whereas built systems include stormwater pipes and drains.
Dead storage	A permanent storage volume in a device that does not drain out. Equivalent to the permanent water volume.
Detention	Water that enters a stormwater device and is temporarily detained, before being released slowly.
Dry swale	A broad, open, linear channel with perennial, dense vegetation cover that filters water and protects the surface from erosion; plants include groundcovers such as some grasses, sedge rushes and may include trees.
Evapotranspiration	Sum of evaporation and plant transpiration from the land and water surface to the atmosphere. Evaporation accounts for the movement of water to the air from sources such as the soil, canopy interception and water bodies. Transpiration accounts for the movement of water within a plant and the subsequent loss of water as vapour through stomata in its leaves.
Exfiltration	Water outflow from a stormwater device to the underlying soil.

Term	Definition
Extended detention	This is a stormwater management objective devised to provide protection to stream channels and habitats downstream of a development site.
Filter media	Planting soil or planting media is referred to as filter media.
Filtration	Process of removing particulate matter from water by passing it through a porous medium such as sand.
First flush	The initial surface runoff from a storm event. Initial runoff from highly impervious areas typically has high concentrations of pollutants compared to the remainder of the storm.
Groundwater flow	The movement of water through the saturated zone below the water table. Groundwater flow encompasses the flow of water underground or the flow of water from saturated zones into a body of water.
Hydraulic conductivity	Rate at which water can move through a permeable medium (K). Saturated hydraulic conductivity (Ks) is the rate of water movement under saturated conditions. Hydraulic conductivity is dependent on pore geometry, fluid viscosity and density. This value depends on temperature.
Hydraulic residence time	The average travel time for stormwater runoff through a body of water or stormwater treatment device.
Infiltration	The process of water on the ground surface entering the soil.
Infiltration rate	Velocity or speed at which water enters into the soil. It is usually measured by the depth (in mm) of the water layer that can enter the soil over time (usually one hour). The infiltration rate depends on soil texture (the size of the soil particles) and soil structure (the arrangement of the soil particles), crusts or films and head (water depth).
Live storage	A storage area that can drain out via any means (reuse or an orifice). Sits above the dead storage.
Manning's equation	An empirical equation used to describe open channel flow driven by gravity.
Manning's roughness coefficient	An empirically derived co-efficient used in the Manning's equation to represent the channel characteristics not otherwise included in the equation.
Non-potable water	Water which is not considered to be safe for drinking purposes.
Orifice	An outlet of a specific diameter which restricts flows.
Primary conveyance	Includes both open and closed conduits and are designed to cater for the flows generated by a given design event (at least the 10% AEP) and are designed to align with natural flow paths as far as possible.
Permanent water volume	The water permanently stored in a device (equivalent to the dead storage volume).
Permanent water level	The level at which water is permanently stored in a device.
Pre-development	Existing site condition prior to proposed (re)development (including existing buildings and roadways).
Post-development	Site condition after proposed development has been completed (including existing and new buildings and roadways).
Secondary conveyance	Consists of ponding areas and overland flow paths with sufficient capacity to transfer the flows generated by a given design event (at least the 1% AEP) and should be aligned with natural flow paths as far as possible.

Term	Definition
Setbacks	A horizontal setback is the minimum distance from which a structure, in this case the treatment device, would need to be set back from a building, road, river, stream or any other place deemed to require protection. Vertical setbacks deal with the overhead obstacles such as trees which can interfere with public utilities such as power lines.
Slope	A slope is the rise or fall of the land surface. Refer to the equal area method found in TP108 to calculate the slope required for hydrology calculations.
Slope stability	Slope stability is the potential of soil-covered slopes to withstand and undergo movement. The stability is determined by shear stress and shear strength of the soil.
Percentile storm depth	A statistical measure of the percentile ranking of a given rainfall event. This is represented in terms of a numeric value between 0 and 100, for example, the 95 th percentile. In this case, the 95 th percentile storm represents an event which is larger than the smallest 95% of all storms and smaller than the largest 5%.
Percolation	Water movement through the soil driven by gravity.
Permeability	Measure of the ability of soil to transmit water. Permeability value (k) can be determined by hydraulic conductivity multiplied by viscosity and divided by density and gravitational constant. Permeability has the dimension of length.
Potable water	Water which is considered safe for drinking purposes. This is usually provided by public water supply, but can be sourced from rainwater tanks in areas where there is no public water supply available.
Pre-treatment	A pre-treatment device is used to remove pollutants that may affect the performance of the treatment device after it. For example, filter strips, sand filters and catchpit inserts.
Public water supply	A reticulated supply of potable water operated by the local authority.
Retention	Reducing the volume of runoff through disposal/reuse on site. Water that enters a stormwater device and does not leave via an outflow pipe. This can include water lost to exfiltration, reuse and evapotranspiration.
Sedimentation	The settlement of solids within a water body under the forces of gravity.
Surface runoff	The movement of water above the ground (overland flow processes) and may include stormwater, but also water from exfiltration (such as seepage or groundwater surfacing).
Underground services	These are elements of a building service, which may include utilities such as lines for telecommunication, electrical cable or pipes, which are buried in the ground.
Underdrain	A subsurface structure usually comprising perforated drainage pipe laid in gravel backfill to provide drainage of water that infiltrates through the channel base.
Vector	Mammals, birds, insects or other arthropods which carry and transmit diseases.
Water Quality Volume	Total volume of rainfall events that deliver the majority of the stormwater pollutants during a year.
Water table	This is the level below which the ground is saturated with water. It is the surface where water pressure head is equal to atmospheric pressure.

Slope conversion table

% Grade	Degrees	Gradient	
		Y	X
0.9%	0.5°	1	114.6
1.7%	1°	1	57.29
3.5%	2°	1	28.64
5.2%	3°	1	19.08
7%	4°	1	14.30
8.7%	5°	1	11.43
10%	5.7°	1	10
10.5%	6°	1	9.514
12.3%	7°	1	8.144
14.1%	8°	1	7.115
15.8%	9°	1	6.314
17.6%	10°	1	5.671
19.4%	11°	1	5.145
21.3%	12°	1	4.705
23.1%	13°	1	4.331
24.9%	14°	1	4.011
26.8%	15°	1	3.732
28.7%	16°	1	3.487
30.6%	17°	1	3.271
32.5%	18°	1	3.078
34.4%	19°	1	2.904
36.4%	20°	1	2.747
38.4%	21°	1	2.605
40.4%	22°	1	2.475
42.4%	23°	1	2.356
44.5%	24°	1	2.246
46.6%	25°	1	2.145

Contents

Preface	iii
----------------------	------------

SECTION A INTRODUCTION

A1.0 Introduction	1
A1.1 Aims of this guideline document.....	2
A1.2 Scope and application of this guideline document.....	2
A1.3 How to use this guideline document.....	3
A2.0 Urbanisation’s impact on runoff	6
A2.1 Runoff quantity.....	6
A2.2 Runoff quality.....	9
A3.0 Auckland’s regulatory framework for stormwater management	13
A3.1 The Auckland Plan.....	13
A3.2 The Auckland Unitary Plan.....	13
A4.0 Designing for a water-sensitive Auckland	15
A4.1 Overarching design objectives.....	15
A4.2 Designing to reflect Mana Whenua values.....	17
A4.3 Designing for amenity.....	20
A4.4 Designing for biodiversity.....	21

SECTION B DESIGN PROCESS

B1.0 Design process for stormwater management devices	23
B1.1 Introduction.....	23
B1.2 Stormwater management design process.....	25
B1.3 Project scoping.....	26
B1.4 Understand the site.....	30
B1.5 Vesting assets.....	37
B1.6 Design for safety.....	38
B1.7 Define the mitigation requirements.....	40
B1.8 Device choice.....	50
B1.9 Device design.....	65
B1.10 Life-cycle cost considerations.....	65
B1.11 Construction.....	70
B1.12 Operation and maintenance.....	70

SECTION C TECHNICAL GUIDANCE

C1.0	Technical guidance: plants and soils	71
C1.1	Introduction	71
C1.2	Plant design process	74
C1.3	Pre-design considerations	75
C1.4	Assessing and managing on-site soils	78
C1.5	Materials specifications.....	86
C1.6	Plants	89
C1.7	Design for safety.....	108
C1.8	Construction design considerations.....	108
C1.9	Operation and maintenance design considerations	115
C2.0	Technical guidance: pervious pavements	117
C2.1	Introduction	117
C2.2	Pervious paving design.....	121
C3.0	Technical guidance: bioretention	131
C3.1	Introduction	131
C3.2	Bioretention design	141
C3.3	Design examples	158
C4.0	Technical guidance: living roofs	161
C4.1	Introduction	161
C4.2	Living roof design.....	166
C5.0	Technical guidance: rainwater tank systems	177
C5.1	Introduction	177
C5.2	Rainwater tank design	181
C5.3	Design examples	198
C6.0	Technical guidance: swales	203
C6.1	Introduction	203
C6.2	Swale design	207
C6.3	Design examples	221
C7.0	Technical guidance: infiltration devices	227
C7.1	Introduction	227
C7.2	Infiltration device design	230
C7.3	Design examples	235
C8.0	Technical guidance: wetlands	239
C8.1	Introduction	239

C8.2 Constructed wetland design 247

C8.3 Design examples 262

C9.0 Technical guidance: ponds 269

C9.1 Introduction 269

C9.2 Pond design 276

C9.3 Design examples 291

APPENDICES

Appendix A1.0 Life cycle cost toolsA-1

Appendix B1.0 Quality checklists.....B-7

BIBLIOGRAPHY

Tables

Table 1: Primary, secondary and tertiary treatment processes.....	10
Table 2: Detailed secondary and tertiary stormwater treatment processes.....	11
Table 3: Key differences between TP10 and this guideline (GD01) in required hydrological calculations.....	14
Table 4: Design phases for larger developments.....	24
Table 5: Potential project team representatives and responsibilities.....	26
Table 6: Site characteristics and design considerations.....	31
Table 7: Site design and source control as non-structural approaches to minimising stormwater impacts.....	34
Table 8: Transitional function of stormwater management devices.....	36
Table 9: Selection of safety issues for consideration.....	39
Table 10: Mitigation needed to support Auckland Unitary Plan requirements.....	41
Table 11: Suggested hydrological calculations.....	42
Table 12: Area to be considered when calculating retention and detention volumes.....	44
Table 13: Area to be considered when calculating runoff from a high contaminant generating car park.....	49
Table 14: Area to be considered when calculating runoff from a high-use road.....	49
Table 15: Estimated device effectiveness.....	62
Table 16: Multiple benefits of devices.....	63
Table 17: Suggested placement of devices in catchment.....	64
Table 18: Device design and sizing reference chapters.....	65
Table 19: Relevant life-cycle cost parameters and information.....	67
Table 20: Examples of benefits of landscape and ecology in the context of stormwater management.....	71
Table 21: Device-specific planting and media maintenance recommendations.....	72
Table 22: Soils and handling notes.....	82
Table 23: NRCS hydrological soil grouping for Auckland soils.....	85
Table 24: Soil type and associated curve number based on land use.....	86
Table 25: Soil composition of stormwater management devices.....	87
Table 26: Geotextile characteristics and uses.....	89
Table 27: Recommended wetland species: 0.01 – 1 m height at maturity.....	92
Table 28: Recommended wetland species: 1 – 3 m height at maturity.....	93
Table 29: Recommended wetland species: >3 m height at maturity.....	94
Table 30: Recommended bioretention ground species: 0.25 – 2 m height at maturity.....	96
Table 31: Recommended bioretention tree and shrub species (>3 m height at maturity) in low contaminant environments.....	98
Table 32: Recommended bioretention species (<100 mm height at maturity) for underplanting in areas with low sediment and low weed pressure.....	99
Table 33: Recommended swale ground species: 0.25 – 2 m height at maturity.....	101

Table 34: Recommended swale small tree and shrub species: >3 m height at maturity	103
Table 35: Recommended swale ground cover species: <100 mm height at maturity at sites with low sediment and weed pressure	103
Table 36: Recommended living roof species 100 - 300 mm soil depth.....	105
Table 37: Recommended planting specifications	114
Table 38: Pest management	116
Table 39: Pervious paving components	119
Table 40: Site considerations	120
Table 41: Pervious paving design considerations and specifications	121
Table 42: Infiltration systems.....	124
Table 43: Quick reference table for underdrain pipe capacities	125
Table 44: Recommended particle size distribution for base-course aggregate	127
Table 45: Bioretention device components	132
Table 46: Site considerations	138
Table 47: Bioretention device design considerations and specifications	141
Table 48: Bioretention device sizing criteria	143
Table 49: Void space assumptions.....	144
Table 50: Infiltration and evapotranspiration assumptions	144
Table 51: Suggested soil specifications for bioretention devices	151
Table 52: Living roof components	163
Table 53: Design considerations of extensive, intensive and modular living roofs	164
Table 54: Site considerations	165
Table 55: Living roof design considerations and specifications	166
Table 56: Design considerations for living roofs.....	169
Table 57: Design specifications for substrate.....	170
Table 58: Architectural design considerations.....	172
Table 59: Specific planting considerations	174
Table 60: Rainwater tank system key components	179
Table 61: Typical tank types and features for stormwater management	179
Table 62: Site considerations	180
Table 63: Rainwater tank system design considerations and specifications	181
Table 64: Tank dimension parameters.....	189
Table 65: Characteristics of swales and bioretention swales.....	203
Table 66: Swale components	205
Table 67: Site considerations	206
Table 68: Swale design considerations and specifications	207
Table 69: Suggested design iterations	209

Table 70: Example parameters	221
Table 71: Infiltration device components	228
Table 72: Site considerations	229
Table 73: Infiltration device design considerations and specifications	230
Table 74: Residential section design example parameters	235
Table 75: Residential section design example parameters	237
Table 76: Wetland components	240
Table 77: Site considerations	246
Table 78: Wetland design considerations and specifications	248
Table 79: Volume and calculation needs for wetland design	251
Table 80: Outlet structures and application	257
Table 81: Site characteristics	262
Table 82: Storm intensities	263
Table 83: Hydrologic calculation results	263
Table 84: Elevation-storage relationship	264
Table 85: Results of routing model	265
Table 86: Site characteristics	266
Table 87: Storm intensities	266
Table 88: Hydrologic calculation results	266
Table 89: Wet and dry pond components and performance specifications	271
Table 90: Site considerations	274
Table 91: Wet and dry pond design considerations and specifications	276
Table 92: Volume and calculation needs for pond design	281
Table 93: Outlet structures and application	286
Table 94: Site characteristics	291
Table 95: Storm intensities	291
Table 96: Hydrologic calculation results	292
Table 97: Elevation-storage relationship	293
Table 98: Results of routing model	294
Table 1: Glossary of terms for life-cycle costing	A-1

Figures

Figure 1: Retention and detention design for stream protection	8
Figure 2: Detention design for flood mitigation	8
Figure 3: Stormwater treatment processes within vegetated devices	10
Figure 4: Recommended design process for stormwater management	25
Figure 5: Map of 90 th percentile 24-hour rainfall event.....	46
Figure 6: Map of 95 th percentile 24-hour rainfall event.....	47
Figure 7: Pohutukawa transplanting, Albany	77
Figure 8: Soil profile example	79
Figure 9: Examples of different soil structure types	80
Figure 10: Soil management	83
Figure 11: Soil moisture in relation to plant available water	84
Figure 12: The three planting zones that provide for the function of stormwater wetlands and ponds.....	91
Figure 13: Schematic of pervious paving	118
Figure 14: Pervious paving design flow chart.....	126
Figure 15: Schematic of rain garden cross-section	133
Figure 16: Schematic of rain garden cross-section	134
Figure 17: Schematic of planter box.....	135
Figure 18: Schematic of stormwater tree pit.....	136
Figure 19: Recommended soil volume based on expected trunk diameter at tree maturity	136
Figure 20: Schematic of bioretention swale.....	138
Figure 21: Setback limitations for bioretention devices	140
Figure 22: Schematic of slope constraints and liner use.....	140
Figure 23: Schematic of bioretention device parameters	145
Figure 24: Bioretention device design flow chart.....	149
Figure 25: Rain garden design for 1000 m ² carpark.....	160
Figure 26: Schematic of living roof components	162
Figure 27: Examples of ready-to-install modular systems.....	164
Figure 28: Erosion control for sloped or windy sites.....	171
Figure 29: Drainage layers	171
Figure 30: Key components of the rainwater tank system	178
Figure 31: Illustration of impervious catchment area measurement in horizontal plane	183
Figure 32: Total detention volume for impervious surface area 25 m ² to 175 m ² based on rainfall depth and connected area (for detention tank)	184
Figure 33: Total detention volume for impervious surface area 200 m ² to 1000 m ² based on rainfall depth and connected area (for detention tank)	185

Figure 34: Orifice height for dual-purpose tanks, retention volume from 2000 L to 3500 L	187
Figure 35: Orifice height for dual-purpose tanks, retention volume from 4000 L to 6000 L	187
Figure 36: Flow diagram of design process using simplified method.....	188
Figure 37: Illustration of tank parameters	189
Figure 38: Flow diagram of design process using calculation method.....	193
Figure 39: Outlet mesh screen	194
Figure 40: Rainwater tank specifications for mitigation of 800 m ² roof (15000 L)	199
Figure 41: Rainwater tank specifications for mitigation of 500 m ² roof (10000 L).....	201
Figure 42: Schematic of a typical swale cross-section.....	204
Figure 43: Cross-section of trapezoidal swale design	210
Figure 44: Swale design flow chart for water quality treatment design – no check dams.....	216
Figure 45: Swale design flow chart for water quality treatment design – with check dams	217
Figure 46: Infiltration design flow chart	233
Figure 47: Schematic of a gravel trench.....	236
Figure 48: Schematic of an underground infiltration chamber.....	238
Figure 49: Example of sinuous (left) and banded (right) flow paths	243
Figure 50: Example schematic of a banded bathymetry wetland.....	244
Figure 51: Example schematic of a sinuous bathymetry wetland	245
Figure 52: Constructed wetland design flow chart	254
Figure 53: Wetland outlet details	255
Figure 54: Schematic of dry and wet pond profiles	269
Figure 55: Schematic of wet pond layout	274
Figure 56: Pond design process flow chart	283
Figure 57: Pond outlet details	284



A1 Introduction

Table of Contents

A1.0	Introduction	1
A1.1	Aims of this guideline document.....	2
A1.2	Scope and application of this guideline document.....	2
A1.3	How to use this guideline document.....	3
A2.0	Urbanisation’s impact on runoff	6
A2.1	Runoff quantity.....	6
A2.1.1	Problem.....	6
A2.1.2	Solution.....	7
A2.2	Runoff quality.....	9
A2.2.1	Problem.....	9
A2.2.2	Solution.....	9
A3.0	Auckland’s regulatory framework for stormwater management	13
A3.1	The Auckland Plan.....	13
A3.2	The Auckland Unitary Plan.....	13
A4.0	Designing for a water-sensitive Auckland	15
A4.1	Overarching design objectives.....	15
A4.2	Designing to reflect Mana Whenua values.....	17
A4.3	Designing for amenity.....	20
A4.4	Designing for biodiversity.....	21

List of Figures

Figure 1: Retention and detention design for stream protection.....	8
Figure 2: Detention design for flood mitigation.....	8
Figure 3: Stormwater treatment processes within vegetated devices.....	10

List of Tables

Table 1: Primary, secondary and tertiary treatment processes.....	10
Table 2: Detailed secondary and tertiary stormwater treatment processes.....	11
Table 3: Key differences between TP10 and this guideline (GD01) in required hydrological calculations.....	14

A1.0 Introduction

With population forecasts for Auckland projected to increase by over one million people in the next 30 years, more pressure will be placed on our natural systems (and associated ecosystem services¹) and the infrastructure designed to support the city. The Auckland Plan² (Auckland Council, 2012) identifies a need to reduce the impact of stormwater on the receiving environment. A key aspect of reducing the impact of stormwater is water sensitive design which is essential to support the vision of the Auckland Plan.

Water sensitive design is:

“an approach to freshwater management. It is applied to land use planning and development at complementary scales including region, catchment, development and site. Water sensitive design seeks to protect and enhance natural freshwater systems, sustainably manage water resources and mimic natural processes to achieve enhanced outcomes for ecosystems and our communities.”³

The water sensitive design concept is an intrinsic component of the Auckland Unitary Plan⁴ (defined therein as “Integrated Stormwater Management”) which aligns the protection and enhancement of the health of receiving waterways with mitigating flood risk and creating public spaces that harvest, clean and restore a natural hydrologic cycle. The Auckland Unitary Plan seeks to better address the relationship between land use and development, and the corresponding adverse effects through the promotion of water sensitive design principles.

To put this into practice, Auckland needs innovation around stormwater management to help deliver on a range of urban development objectives, including:

- Reducing pollution
- Reducing erosion
- Protecting marine and freshwater systems
- Reducing flooding
- Allowing urban development while preserving and restoring our land and waterways.

In addition, the water sensitive design approach encompasses liveability objectives including cultural significance, connected and empowered communities, biodiversity, enhanced public green space and healthier waterways.

¹ Ecosystem services: The Auckland Plan (2012) defines this as the benefits people obtain from the environment, including goods (soil, food, animals, water, scenery) and services (functions such as water filtration, flood protection, pollination)

² Accessed at: <http://theplan.theaucklandplan.govt.nz>

³ Auckland Council Guideline Document GD2015:004 *Water Sensitive Design for Stormwater* (GD04)

⁴ Auckland Unitary Plan 2016 accessed at: <http://unitaryplan.aucklandcouncil.govt.nz>

This Auckland Council Guideline Document GD2017:001 *Stormwater Management Devices in the Auckland Region* (referred to as GD01), supports the overall vision by building on the principles presented in Auckland Council Guideline Document GD2015:004 *Water Sensitive Design for Stormwater* (GD04), by providing technical guidance for the selection, design and use of stormwater management devices in the Auckland context.

GD01 updates, and will replace, Auckland Regional Council TP10 *Stormwater Management Devices Design Guidance Manual* (1992 and 2003 update). Current reference to TP10 in the Auckland Unitary Plan will be superseded through a plan change; until then, this guideline on stormwater management devices, provides supporting guidance for design per the Auckland Unitary Plan⁴ requirements.

This guideline document has been developed based on extensive review of national and international publications as well as documents developed for, and by, Auckland Council. Where specific standards, codes and regulations are named in this document, readers should assume that, if these have been superseded by later editions, that these later editions apply.

A1.1 Aims of this guideline document

The primary aim of this guideline document is to enable designers to achieve resource consenting. It does this by defining processes and considerations that achieve stormwater treatment to meet regulatory requirements. This document presents:

- Stormwater management device options which manage the impacts of stormwater quality and quantity
- Options which mimic or replicate natural runoff and flow
- Devices which, when designed as an integrated suite, and are correctly constructed and maintained, will meet the stormwater quality requirements of the Auckland Unitary Plan
- Stormwater management devices which align with water sensitive design principles.

A1.2 Scope and application of this guideline document

The scope of this guideline document is confined to the management of stormwater, which is defined in the Auckland Unitary Plan as:

“Rainfall runoff from land, including constructed impervious areas such as roads, pavement, roofs and urban areas which may contain dissolved or entrained contaminants, and which is diverted and discharged to land and water.”

The application of water sensitive design (defined in the Auckland Unitary Plan as “integrated stormwater management”) is required in brownfield and greenfield developments under the Auckland Unitary Plan. Water sensitive design approaches should be considered in all instances as part of an integrated stormwater network.

This guideline document focuses primarily on the hydrologic and hydraulic design considerations for the following stormwater management devices:

- Pervious paving (including porous or permeable paving)
- Bioretention devices (including rain gardens)
- Green roofs (living roofs)
- Rainwater tanks
- Swales
- Infiltration devices
- Wetlands
- Ponds (including dry detention ponds).

This document does not discuss the structural or architectural design considerations of each device.

A1.3 How to use this guideline document

The document is provided in three sections:

Section A	Introduction	<ul style="list-style-type: none"> • An introduction to the key principles of stormwater management, including an outline of environmental effects and management concepts. • It also provides an overview of the Unitary Plan provisions.
Section B	Design process	<ul style="list-style-type: none"> • Provides guidance on the design process and methodology for choosing the right devices and common design aspects, such as hydraulic sizing and engineering principles.
Section C	Technical design guides	<ul style="list-style-type: none"> • Provides specific technical design guidance for a representative selection of devices including those used for water quality treatment, retention and detention. • Each device-specific section contains design parameters including site constraints and design considerations, device sizing and component design. • Design considerations for the construction and operation and maintenance phases are included.

Users of this guideline document are responsible for working within their capabilities - obtained through training and experience - and for seeking the advice and consultation of appropriate experts at all times.

How you should use this guideline will depend on your depth of existing knowledge of stormwater management device design. The following steps are suggested:

- 1) Refer to Auckland Council's guide, GD04⁵, for context on the use of water sensitive design in Auckland.
- 2) Scan the whole of this document to understand its aims, scope and general content and approach.
- 3) Understand the principles – review Section A to gain an appreciation of the fundamental principles of water sensitive design and the impact of development on stormwater quality and quantity in the Auckland region.
- 4) Review the design process provided in Section B, particularly the stormwater mitigation needs and subsequent options for devices.
- 5) Review specific design requirements of the device(s) you have chosen (Section C).
- 6) Understand all the construction implications for the chosen device(s) in Auckland Council Technical Report TR 2010/052 *Construction of Stormwater Management Devices in the Auckland Region*
- 7) Understand the operations and maintenance of chosen device(s) in Auckland Council Technical Report TR 2010/053 *Operation and Maintenance of Stormwater Management Devices in the Auckland Region*.

How this guideline document was developed

In preparing this guideline document, a comprehensive review of national and international stormwater management research and control guidelines was carried out to acknowledge and understand current best practice procedures and guideline approaches. This was accompanied by a gap analysis which identified gaps and issues within currently used guideline documents, including the early stormwater management devices design publication, TP10⁶.

Consultation was carried out through a series of workshops that drew on the technical experience and operational knowledge of a variety of industry bodies, external industry practitioners, consultants and contractors in the Auckland region, as well as extensive consultation with Auckland Council staff. Individual meetings were also held with Auckland Council staff involved in resource consenting and compliance for stormwater management. A number of workshops and consultation sessions, as well as review of the draft document, were held with Mana Whenua to seek input and feedback.

⁵ Auckland Council GD2015:004 *Water Sensitive Design for Stormwater*

⁶ Auckland Regional Council TP10 *Stormwater Management Devices Design Guidance Manual* (1992 and 2003 update)

Exclusions

This document does not include design guidance for:

- **Non-structural source control** (such as behaviour change): These controls are very important in overall stormwater management to reduce pollution at source but are not addressed in this document
- **Managing highly contaminated runoff**: Runoff from industrial sites, or any sites with high contaminant discharges (other than high use roads and car parks defined in the Unitary Plan) should have site-specific management designs and treatment
- **Proprietary devices**: Proprietary devices are appraised on an as-needed basis through a different assessment process in Auckland Council and are therefore not included in this document
- **Soakage**: A separate guideline document is being developed to address the specific needs of designing for soakage in the Auckland region
- **Rural stormwater management**: Readers should refer to Countryside Living Toolbox⁷ for details around stormwater management in the rural environment.

⁷ The Countryside Living Toolbox ISBN978-1-877540-64-6

A2.0 Urbanisation's impact on runoff

With increased urbanisation, legacy urban engineering focused on conveying stormwater into receiving waters as quickly as possible. This approach has reduced flooding and allowed for increases in habitable land use. However, it has not addressed the degradation of our natural waterways, or the growing needs of urban populations to have access to functional green space, water for reuse, nor the impact of increased water volumes and velocity, as well as pollutants, on those receiving waterways. In order to build a resilient and water-sensitive city, it is necessary to reframe our stormwater “problem” into one of opportunity. This section presents the key issues of stormwater quantity and quality, as well as the solutions provided by incorporating water sensitive design.

A2.1 Runoff quantity

A2.1.1 Problem

Urban development in the Auckland region has meant increases in impervious areas (from buildings, hard stand and transportation networks) which prevent infiltration. Urban development can also remove significant amounts of vegetation resulting in reduced plant moisture uptake, evapotranspiration and interception (where a plant's leaves will intercept rainfall and reduce contact with the ground)⁸. The prevalence of Waitematā clays in Auckland can also naturally limit infiltration. These processes can culminate in increases in surface runoff during storm events which may result in:

- Decreased filtering of water. This increases contaminant loads to streams and degrades the quality of the receiving environment
- Increased velocity of runoff during storm events, which increases erosion of streams, rivers and coastal environments and flooding
- Reduced stream flows in dry periods
- Increased water temperatures. Water is no longer cooled as it moves through the ground and/or it absorbs the heat as it runs over impervious surfaces.

Stream topography and bathymetry also change significantly as development takes place, with increases in bank instability, incised channels and reduced connectivity with the floodplain. The natural processes of a stream involve continual changes in its pathway as banks are eroded and sediments are deposited. However, in an urban environment, those changes are restricted through structural constraints (such as bank reinforcement and channelising).

⁸ Many of the key concepts in stormwater management, including key objectives and proposed solutions, are provided in Auckland Council' guidance document, GD2015:004 *Water Sensitive Design for Stormwater* (GD04). Readers are referred to Section B of GD04 which provides information on: the natural water cycle; the impact of urbanisation (with detailed information on changes to stream hydrographs) and key stormwater management concepts.

Key characteristics driving stream channel erosion which are affected by hydrology changes are bankfull flow and effective discharge:

- Bankfull flow is the range of flows that are most important in forming a channel, floodplains (benches) and banks. It is often related to the amount of water flowing in a stream that fills the main channel and begins to spill onto the active floodplain
- Effective discharge is the amount of water that transports the most sediment over the long term.

The increased prevalence of impervious areas changes many aspects of the land and can significantly alter the structure of a stream and the runoff hydrograph. These modifications can alter downstream hydrology and result in more runoff volume and increased velocity. The increased volume, duration and velocity of flows may present problems in the receiving environment, including erosion and habitat degradation in streambeds and banks, accompanied by changes in downstream habitat. Water quantity is managed in the urban environment through both retention and detention processes.

A2.1.2 Solution

To understand the site-specific implications of retention, detention and flood mitigation, designers need a good understanding of the catchment area, as well as the function and effectiveness of the proposed stormwater devices.

Retention for stream protection and groundwater recharge

Specific stormwater devices can be used to retain water for reuse on site or to infiltrate water into the surrounding soils and groundwater. By providing retention, water volumes are not conveyed to the primary or secondary stormwater systems and therefore, do not add to the downstream volumes during storm events. In addition, retention through infiltration may provide for groundwater recharge.

Examples of retention devices include:

- Rainwater tanks with retention: Water collected from roofs is used on site
- Pervious paving: Permeable or a porous hard surface which allows water to infiltrate into the surrounding soils
- Bioretention devices: Planted areas that store, filter and release stormwater through a vegetated soil media layer. Bioretention also provides plant uptake and evapotranspiration.

Detention for stream protection

Detention for stream protection focuses on maintaining the physical structure of the receiving environment as well as providing habitat conditions that allow for a healthy ecosystem. Physical stream health is maintained when detention and storage over 24 hours is provided for in 90th and 95th percentile storm events. Other stream protection measures include riparian planting, or passing water through vegetation (such as in a wetland). The process of retention and detention is illustrated in Figure 1.

Detention devices moderate stormwater peak flows, reduce runoff velocities and allow contaminants to settle. They can be designed as wetlands, ponds, pervious paving, rainwater tanks and others.

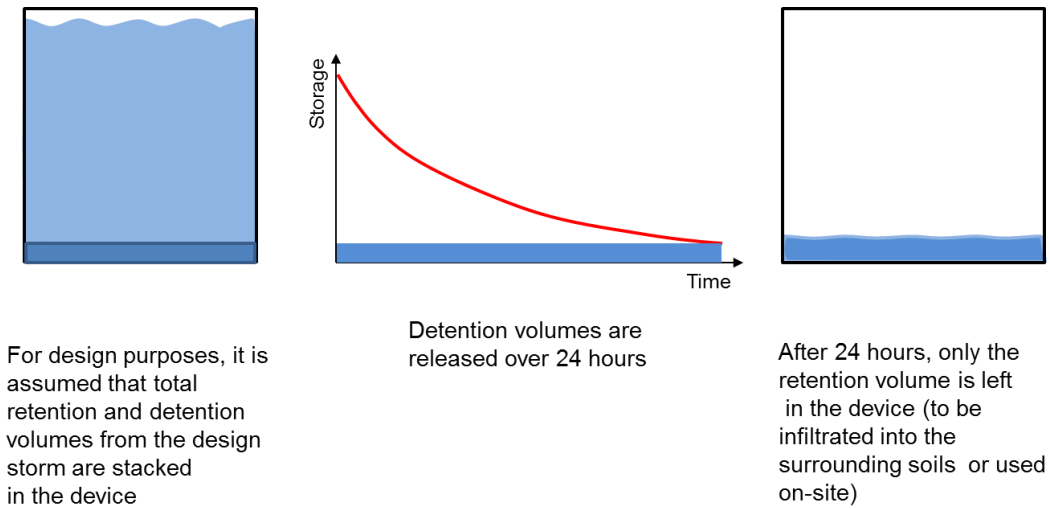

Figure 1: Retention and detention design for stream protection

Detention for flood management

Flood management can be designed for in stormwater management devices by providing detention for the larger design storms (50% and 10% AEP and up to the 1% AEP). These detention volumes and flows can be attenuated through a longer time to relieve flooding potential; wetlands and ponds can be designed to achieve this. The impact of detention for flood protection is illustrated in Figure 2.

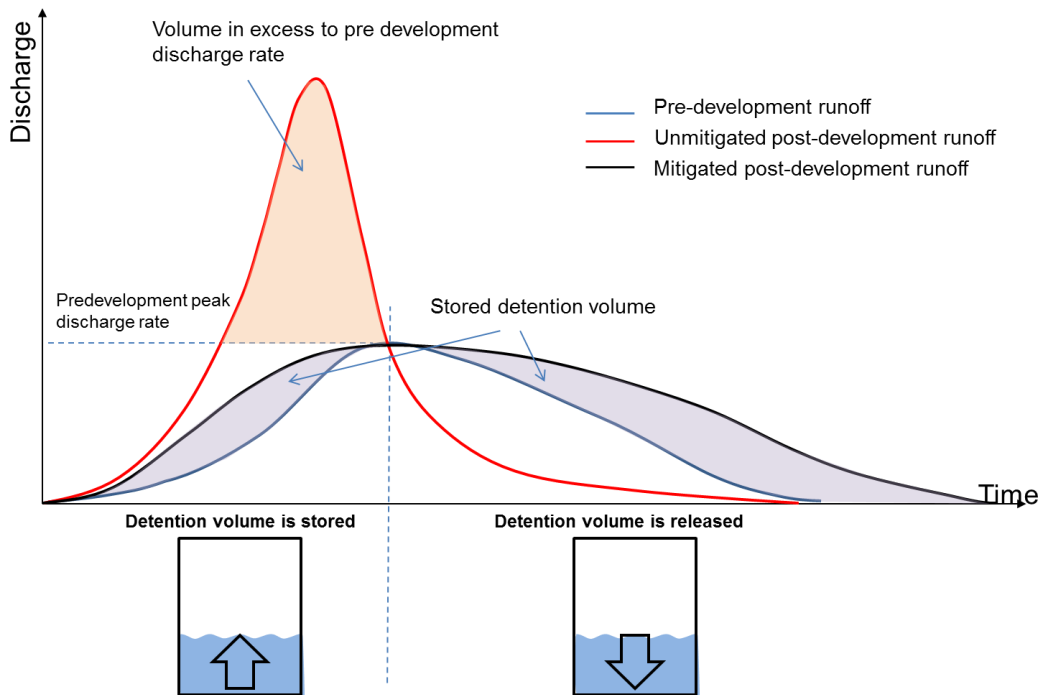

Figure 2: Detention design for flood mitigation

A2.2 Runoff quality

A2.2.1 Problem

Stormwater runoff naturally contains numerous physical, chemical and biological constituents (from soils, plant material and aerial deposition). However, urbanisation and urban activities, including development and redevelopment, typically increase and introduce new constituents into water which impact the health of the receiving ecosystem.

Some of the key pollutants associated with stormwater include sediment, nutrients, bacteria and viruses, oil and grease, total and dissolved metals, organics, pesticides and gross pollutants. An additional impact of urbanisation is an increase in water temperature. For detailed information regarding the pollutants of concern and their specific prevalence in Auckland, refer to Auckland Council's technical report, TR 2013/035⁹.

Managing water quality also requires an understanding of the "first flush" where the initial runoff from a surface contains (by volume) the highest proportion of contaminant load compared to runoff in the remainder of the storm¹⁰. The first flush is generally characterised by a peak in some pollutant loads (such as sediments and metals) immediately prior to the peak in flow volumes. Best practice for water quality improvement therefore promotes the capture and treatment of the first flush, where practicable, as this is often more practical and cost effective than treating flow volumes from the entire storm event.

A2.2.2 Solution

Many pollutants, such as nutrients and fine sediments, require a number of measures, used in sequence, for effective water quality treatment. It is important to select a suite of appropriate devices for the specific development scenario which removes multiple pollutants in the most effective sequence: from primary to secondary and then tertiary (Table 1). The secondary and tertiary treatment processes within these are further detailed in Table 2 and Figure 3.

⁹ Auckland Council TR 2013/035 *Unitary Plan Stormwater Management Provisions: Technical Basis of Contaminant and Volume Management Requirements*

¹⁰ Further information regarding the first flush can be found in Auckland Council TR 2011/07 *First Flush Analysis in the Auckland Region*

Table 1: Primary, secondary and tertiary treatment processes

Treatment	Processes	Pollutants	Example device
Primary	Hydraulic and physical processes resulting in screening and rapid sedimentation.	Litter and coarse sediments.	Catch pit inserts, filter strips, litter traps, sediment ponds.
Secondary	Filtration resulting in fine particle and sediment removal.	Fine sediment and attached pollutants.	Swales, infiltration trenches, pervious pavement, bioretention devices.
Tertiary	Biological, chemical and thermal processes which provide removal through enhanced sedimentation, biological uptake, adsorption to sediments, UV inactivation.	Nutrients, dissolved heavy metals, temperature, pathogens.	Bioretention devices, wetlands.

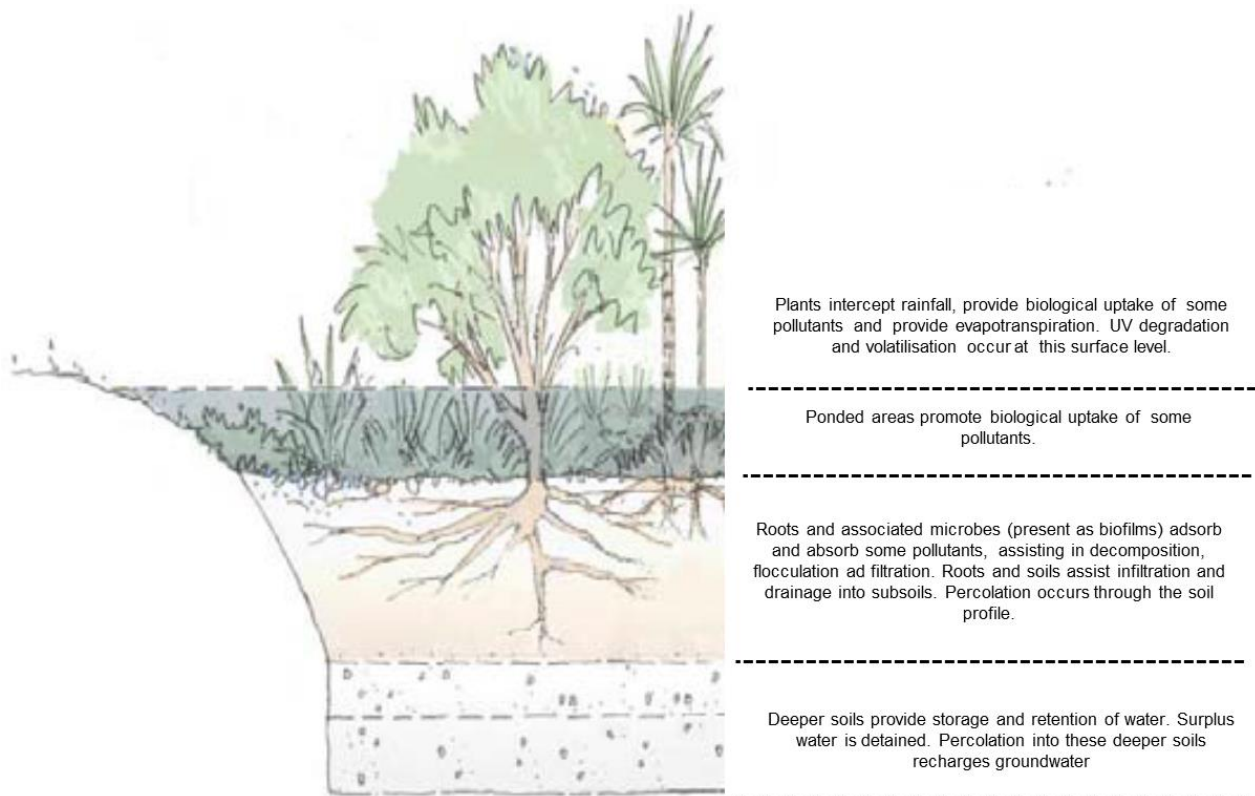

Figure 3: Stormwater treatment processes within vegetated devices

Table 2: Detailed secondary and tertiary stormwater treatment processes

Process	Pollutant examples	Description
Adsorption	Nutrients, total metals, micro-organisms, hydrocarbons, oils and grease	<ul style="list-style-type: none"> • Adsorption is the retention of contaminants onto the surface of a solid media. It is often facilitated by electro-chemical attraction, such as the negative charge generated on very fine clay and activated charcoal. • Dissolved substances can also be removed by adsorption to filter material and biological uptake by micro-organisms living amongst the filter material.
Biofiltration	Organic material, nutrients	<ul style="list-style-type: none"> • This process is similar to filtration, but includes biological components (plants and soil micro-organisms). • Plants' roots can contribute directly to physical filtration and in addition, can contribute organic matter which may adsorb or chelate some contaminants.
Biological uptake	Nutrients, metals, micro-organisms, some PAHs, oils and grease	<ul style="list-style-type: none"> • Microbes play a very large part in facilitating biological uptake with, potentially, a number of different pollutants being removed from the water column. • Plants also take up nutrients and metals from stormwater via absorption processes. However, all biological processes also re-release contaminants to the water column when they die and decay.
Conversion	Hydrocarbons, pesticide and herbicide residues	<ul style="list-style-type: none"> • Chemical or biological conversion can occur where pollutants are converted to less harmful compounds. • A range of chemical and biological processes may render contaminants harmless. • This can also apply to some pathogenic micro-organisms which can be subject to predation by naturally occurring micro-organisms.
Decomposition	Organic material	<ul style="list-style-type: none"> • Either aerobic or anaerobic decomposition is the process whereby micro-organisms reduce soluble biochemical oxygen demand and break down nutrients and organic compounds by aerobic and anaerobic oxidation. • In anaerobic conditions, micro-organisms can remove nitrogen by de-nitrification. This is an important process in constructed wetland function.
Filtration	Sediments and any adsorbed pollutants	<ul style="list-style-type: none"> • Filtration is the physical removal of particles by passing contaminated stormwater through a solid media (or natural soils) and retaining particles in the media. • As sediment particles pass through a filter bed or through soil, they may be removed by filtration processes such as settling into crevices, enmeshment in interstices (sieving) or impingement onto filter particles followed by sticking onto particles (by electrostatic or other bonding). • The retained size of the particles is largely controlled by the pore size of the filter media. Filters can include natural media (peat, sand etc.), geotextile fabrics and biofiltration.

Process	Pollutant examples	Description
Flocculation	Fine sediments	<ul style="list-style-type: none"> Some very fine suspended sediment may be removed by flocculation. This can occur naturally when fresh water mixes with saline water and can also be created by the addition of flocculants to ponds. Flocs larger than 30 µm may not settle out in a sediment or stormwater pond if they have a lower density and mass.
Microbial biofilms	Nutrients, metals, micro-organisms, hydrocarbons, oils and grease	<ul style="list-style-type: none"> Microbial processes occur at the interface of plant roots and soil media with the formation of microbial communities in the form of biofilms. Biofilms can intercept, metabolise and sometimes transform a range of pollutants.
Sedimentation	Sediments and any adsorbed pollutants	<ul style="list-style-type: none"> Sedimentation is the removal of sediment from the water column by gravity. The rate at which particles settle is affected by the mass of the particles – heavier particles settle faster. Particle sizes range from gross solids (>75 µm) through to very fine particles (<10 µm). Most particles suspended in stormwater are less than 120 µm diameter. The particle shape, density, water viscosity, electrostatic forces and flow characteristics affect settling rates.
UV degradation	Micro-organisms, some emerging contaminants of concerns	<ul style="list-style-type: none"> UV light may degrade some contaminants and can contribute to micro-organism die-off. Exposure of contaminants trapped on the surface of treatment devices are rendered prone to further breakdown by UV light.
Volatilisation	Lighter hydrocarbons	<ul style="list-style-type: none"> Volatilisation is the conversion of a liquid to a gas. Lighter hydrocarbons, such as vehicle fuels, can often volatilize off a solid surface and not enter stormwater. The extent of volatilization is dependent on weather conditions, namely temperature and whether a spill coincides with a rainfall event.

A3.0 Auckland's regulatory framework for stormwater management

Details of the statutory context for managing stormwater quantity and quality are provided in Section A, Chapter 6, GD04¹¹; this includes details of the Resource Management Act (RMA) and the Local Government Act 2009 (LGA), as well as a summary of other key statutory documents. The following section focuses on the Auckland Plan¹² and the Auckland Unitary Plan.

A3.1 The Auckland Plan

Section 79 of the LGA requires Auckland Council to prepare and adopt a spatial plan for Auckland. This spatial plan is to set a strategic direction for Auckland and its communities that integrate social, economic, environmental and cultural objectives.

The Auckland Plan, adopted in 2012, provides a 30-year strategic vision for Auckland. There are specific priorities in the Environment Chapter (Chapter 7) of the Auckland Plan that call for the integration of land, water and coast:

- Value our natural heritage
- Sustainable management of natural resources
- Treasure our coastline, harbours, island and marine areas
- Build resilience to natural hazards.

All four of these priorities are pertinent to stormwater and its management.

A3.2 The Auckland Unitary Plan

The Auckland Unitary Plan delivers the vision of the Auckland Plan and has replaced the Auckland Council Regional Policy Statement and 13 district and regional plans, including the Auckland Regional Plan: Air, Land and Water that previously contained the provisions for the management of stormwater.

The Auckland Unitary Plan's objectives for stormwater management are designed to prevent or minimise the adverse effects of stormwater discharges, as they relate to land-use activities that generate stormwater contaminants and increase runoff. Reducing stormwater contaminants and flows at source where possible, is generally considered a more efficient and cost-effective method of reducing adverse effects than end of pipe solutions.

¹¹ Auckland Council GD2015:004 *Water Sensitive Design for Stormwater*

¹² Accessed at: <http://theplan.theaucklandplan.govt.nz>

The key approaches that are proposed in the Auckland Unitary Plan are:

- Adopting water sensitive design (“integrated stormwater management”) as a core development approach
- Adopting both detention and retention measures to reduce stormwater flow rates and volumes:
 - In catchments with sensitive stream environments, known as Stormwater Management Areas – Flow (SMAF)
 - Where development exceeds impervious area thresholds
 - Where areas of impervious surfaces give rise to increased risk of flooding
- Reduce contaminant loads and apply stormwater quality controls with a focus on treating runoff from high contaminant generating carparks and high use roads.

There are a number of distinct changes in the approach to stormwater management brought about through the Auckland Unitary Plan. These changes have an impact on the stormwater management approaches for both water quality and quantity (Table 3).

Table 3: Key differences between TP10 and this guideline (GD01) in required hydrological calculations

	TP10 ¹³	GD01
Regulatory driver	Auckland Regional Plan: Air, Land and Water Plan & and several district plans	Auckland Unitary Plan
Water quality volume	1/3rd of 2-year, 24-hour API (approx. 25 mm)	90 th percentile of 24-hour storm event (approx. 25 mm)
Water quality flow	~18 mm/hr	10 mm/hr
Water quality management	75% TSS removal	Design performance-based (with the understanding that properly sized and designed devices will meet certain aspects of removal requirements for pollutants)
Water quality target areas	None identified	High contaminant generating car parks and roads
Susceptible areas	None identified	SMAF1 and SMAF 2

¹³ Auckland Regional Council TP10 *Stormwater Management Devices Design Guidance Manual* (1992 and 2003 update)

A4.0 Designing for a water-sensitive Auckland

The water sensitive design approach focuses on maintaining the natural hydrological cycle by avoiding, mitigating, or eliminating, stormwater runoff generation through source control, and using natural systems and processes to manage stormwater quantity and quality effects. Water sensitive design uses a combination of conventional stormwater infrastructure, green infrastructure and enhanced natural systems to achieve the best practical stormwater management outcome. This approach also provides the opportunity for stormwater to be regarded as a resource. Readers are directed to Auckland Council's guideline, GD04¹⁴, which provides details around the need and application of water sensitive design practices in the Auckland context.

Within the context of water sensitive design, individual stormwater devices must be aligned with specific design principles, including being:

- Compliant with the Auckland Unitary Plan
- Aligned with natural hydrology
- Reflective of Mana Whenua values
- Functional for the whole intended life of the device
- Designed for safety
- Designed and constructed to support the intended plant functions (such as soil, sun and water requirements)
- Designed for low maintenance
- Evaluated in the context of whole-of-life cost and performance
- Designed for resilience
- Designed to achieve multiple benefits
- Designed to promote native biodiversity.

This guideline document, together with GD04, provides guidance around all these key principles.

A4.1 Overarching design objectives

When implementing the concepts outlined in this document, the following concepts for designing and implementing stormwater management practices can help reflect the water sensitive design approach:

Enhance

- Have a vision for the long term. Consider how this space will function in the decades ahead and adapt to changing needs
- Consider the site in the context of the overall catchment and stormwater management plans

¹⁴ Auckland Council GD2015:004 *Water Sensitive Design for Stormwater*

- Create a space and function that achieves greater benefits than just treatment and volume functions. Consider the catchment's short-term and long-term needs
- Consider stormwater management objectives early in the design process to achieve an integrated approach within the site constraints (water sensitive design objectives)
- Encourage natural processes to remove contaminants.

Empower

- Include cultural narrative and design elements that are distinctive to Auckland's heritage and Māori values
- Look at opportunities for education, such as signage or walking tours so a community can understand the asset and its importance
- Include designs that encourage safety and usage of adjacent landscaping.

Preserve

- It is imperative that Auckland's waterways and marine environment are protected. Understand how your work will preserve natural watercourses and minimise works in and around watercourses to preserve aquatic resources
- Understand how your work will impact on the freshwater and marine receiving environment
- Maintain and enhance riparian margins and vegetative buffers around watercourses and wetlands to preserve stream health
- Seek opportunities for alignment, integration and/or cohesion with other planned activities
- It is important to preserve and buffer remnant existing native vegetation in undisturbed soils and large trees as these take many decades to restore, and earthworked soils have very low ecological value.

Prevent

- Disconnect pipes between impervious surfaces and surface water
- Implement source control as much as possible
- Minimise the impervious area of the development and maximise infiltration, where possible
- Keep mitigation as close as possible to the source of the problem
- Provide effective pre-treatment for sediment and rubbish removal. This is especially important for devices prone to clogging (e.g. infiltration devices) or retaining litter (e.g. wetlands and ponds)
- Protect any devices from construction runoff (such as sediment, paint etc.)
- Maximise on-site storage/detention to minimise changes to the water cycle
- Separate discrete pollution sources from the general stormwater system. Provide additional treatment or dispose of wastes from those sources to the sanitary sewer if necessary
- Implement earthwork controls before starting construction (refer to GD05)¹⁵
- Develop management practices to reduce the risk of contamination during construction and hazardous operations.

¹⁵ Auckland Council GD2016:005: *Erosion and Sediment Control Guide for Land Disturbing Activities*

Restore – how does your site return the water to its natural state?

- If space is limited, focus on the capture and treatment of the first flush
- Consider the need for a large storm event by-pass, spillway or secondary flow path
- No one device can meet all the water quality and quantity objectives; therefore develop a stormwater management suite at the concept design phase to achieve the stormwater management objectives.

A4.2 Designing to reflect Mana Whenua values

Mana Whenua values are intrinsic to the design, construction and management of stormwater devices in the Auckland region. Key concepts pertaining to stormwater management include:

- The understanding of mauri
- The practical application of Mana Whenua values in the appropriate context.

Iwi management plans provide excellent resources for developing approaches to incorporating Mana Whenua values. The information provided in this section does not replace any required need to consult with Mana Whenua.

Mana Whenua and mauri

As kaitiaki, Mana Whenua have the responsibility of ensuring that the spiritual and cultural aspects of resources are maintained for future generations. This involves the on-going protection of mauri from damage, destruction or modification

Mauri is a concept recognised by Mana Whenua as the connection between spiritual, physical and temporal realms. Loosely translated as the life force or life essence which exists within all matter, mauri sits at the very core of sustainable design for Mana Whenua and Te Ao Māori – the Māori worldview.

A key concern to Mana Whenua is the effect on the mauri of water caused by pollution of a stream, river, estuary, catchment or harbour. This can be due to sediment entering waterways, loss of riparian margins and the loss of native habitat to support native flora and fauna.

Degradation of freshwater quality can also affect the ability for customary harvest and manāki¹⁶ due to depletion in, or in some cases the absence of, traditional mahinga kai¹⁷ resources. Modification or destruction of wāhi tapu¹⁸ and wāhi taonga¹⁹ is another potential effect of freshwater degradation.

¹⁶ The ethic of holistic hospitality whereby Mana Whenua have inherited obligations to be the best hosts they can be

¹⁷ Traditional food sources

¹⁸ Any place or feature that has special significance to a particular iwi, hapu or whānau including urupā (burial grounds), pā sites (historic settlements) or wāhi pakanga (historic battlefield)

¹⁹ Anything considered to be of value including socially or culturally valuable objects, resources, phenomenon, ideas and techniques

The revival and enhancement of mauri should be a focus during the design and construction phases through:

- A holistic approach to resource management
- Protection of habitats of edible plants and native aquatic life which are traditional sources of food for local Māori
- Restoring a buffer of native vegetation alongside waterways
- Water conservation
- Avoiding mixing waters from different sources.

The importance of water

Examples of different states and sources of water in the Māori context are provided below. It is also important to consider these as they relate to how the water is changed through urbanisation.

- **Wai-ora:** (pure water): This is water in its purest form
- **Wai-maori:** (freshwater): This is referred to as ordinary water which runs free or unrestrained and it has no sacred associations
- **Wai-kino:** (polluted): The mauri of the water has been altered through pollution or corruption and has the potential to do harm to humans
- **Wai-mate:** (dead water): This class of water has lost its mauri and is dead. It is dangerous to humans because it can cause illness or misfortune
- **Wai-tai:** (salt or water from the ocean): This term also refers to rough or angry water as in surf, waves or sea tides
- **Wai-tapu:** (sacred water): This is water that is used for ritual and ceremony.

Application of Mana Whenua values

Te Aranga Design Principles²⁰ have been developed to provide a clear process for positive engagement with Mana Whenua to shape our built environment and acknowledge our position as a city distinguished by the world's largest population of Māori. The Te Aranga Design Principles arise from a widely held desire to enhance Mana Whenua presence, visibility and participation in the design of the physical realm and are founded on intrinsic Māori cultural values. These core values have been acknowledged by Mana Whenua as appropriate for the Auckland region:

- **Rangatiratanga:** The right to exercise authority and self-determination within one's own iwi/hapū realm
- **Kaitiakitanga:** The exercise of guardianship by the tangata whenua of an area in accordance with tikanga Māori in relation to natural and physical resources; and includes the ethic of stewardship
- **Manākitanga:** The ethic of holistic hospitality whereby Mana Whenua have inherited obligations to be the best hosts they can be

²⁰ Refer to the Te Aranga Design Principles on Auckland Council's Auckland Design Manual website: www.aucklanddesignmanual.co.nz

- **Wairuatanga:** The immutable spiritual connection between people and their environments
- **Kotahitanga:** Unity, cohesion and collaboration
- **Whanaungatanga:** A relationship through shared experiences and working together which provides people with a sense of belonging
- **Mātauranga:** Māori/Mana Whenua knowledge and understanding.

The key objective of the Principles is to enhance the protection, reinstatement, development and articulation of Mana Whenua cultural heritage and cultural landscapes enabling all of us (Mana Whenua²¹, matāwaka²², tauiwi²³ and manuhiri²⁴) to connect to and deepen our 'sense of place'.

The Principles are intended as an enabling strategic foundation for Mana Whenua to adopt, customise and further develop in response to local context. The Principles also provide stakeholders and the design community with a clearer picture as to how Mana Whenua are likely to view, value and participate in the design and development of the built environment within their ancestral rohe²⁵.

The use of the Principles is predicated on the development of high quality, durable relationships being developed between iwi/hapū, their mandated design professionals and local and national government. Robust relationships between these groups provide opportunities for unlocking a rich store of design potential.

The Principles provide guidance around culturally appropriate design processes and design responses that enhance our appreciation of the natural landscape and built environment. These same underlying principles can also help inform culturally appropriate stormwater management design. Examples include:

Mana: The status of iwi and hapū as Mana Whenua is recognised and respected. The principle of mana is that Mana Whenua are enabled to determine how they are to be involved. For example:

- Potential for harvesting of plants (such as flax), or for on-going maintenance contracts
- Cultural monitoring during any construction or excavation works and Mana Whenua inspection of environmental controls.

Taiao: The natural environment is protected, restored and/or enhanced. For example:

- Avoiding the mixing of contaminated water into marine and freshwater receiving environments aligns with the principles of Taiao and Mauri Tu.

Mauri Tu: Environmental health is protected, maintained and/or enhanced. For example:

- The use of organic fertilisers and herbicides and provision for fish passage aligns with the principles of both Taiao and Mauri Tu
- Hand weeding and hand maintenance are preferred.

²¹ Mana Whenua – authority over land and natural resources

²² mataawaka – Māori living within a rohe (territory or boundary of a tribal group) who are not in a Mana Whenua group

²³ tauiwi – non-Māori New Zealanders

²⁴ manuhiri – visitor

²⁵ rohe - the area over which iwi and hapū claim Mana Whenua

Ahi kā: Iwi/hapū have a living and enduring presence and are secure and valued within their rohe. For example:

- Urupā (traditional burial grounds) are commonly located near watercourses and riparian/coastal margins. In alignment with Ahi kā, extra care should be taken when excavating near these zones
- Provision for Mana Whenua to provide native plantings and on-going maintenance contracts, and be point of contact for corrective maintenance
- Recognise Mana Whenua ensure their ahi kā is upheld.

Mahi Toi: Iwi/hapū narratives are captured and expressed creatively and appropriately:

- Enlisting Mana Whenua to provide cultural narrative prior to works can provide workers with an understanding of the rich cultural history and significance of the area. This aligns with Mahi Toi and Tohu
- Cultural narratives can be incorporated into signage around devices and waterways.

Tohu: Mana Whenua significant sites and cultural landscapes and landmarks are acknowledged:

- To align with the principles of Tohu and Mana, developers should have accidental discovery protocols together with an updated register of representatives from Mana Whenua across the area surrounding the works site.

A4.3 Designing for amenity

Creating designs which enhance our communities is a key facet of 'place-making'. Place-making is a collaborative design process which results in a shared and valued public space. One of the most important benefits of an amenity-focused approach is that the area is valued by the community and they feel a shared responsibility in taking care of it. More than just promoting better urban design, place-making makes a place fun, inviting and a pleasure to live in. Designs pay particular attention to the local physical, cultural and social identities that define a place and shape its future. Place-making inspires people to collectively re-imagine and re-invent public spaces as the heart of every community.

Designing for amenity can include the following benefits:

- **Health and well-being:** Trees and open natural areas are essential elements of healthy communities. There are opportunities for play, recreation and relaxation in well-designed green space. Additional benefits can include noise reduction, reduction in air pollution and reducing urban temperatures
- **Resilience:** good designs can incorporate approaches which increase urban resilience to climate change (e.g. heat, drought storms etc.) as well as improving resilience to natural disaster
- **Improved traffic and road safety:** Effective urban design can lead to improvements in public safety, with decreases in traffic speeds and improvements to pedestrian safety, as well as improving air quality and reducing contaminant loads from traffic

- **Incorporating opportunities for learning and art:** Incorporating education and art into stormwater design can promote the idea that stormwater is an asset, rather than a waste product and can significantly enhance the amenity and community connection
- **Economic growth and inward investment:** Water sensitive design can add value to land and can encourage investment from local business
- **Crime prevention through environmental design:** This is a multi-disciplinary approach aiming to deter criminal behaviour through environmental design. This can be achieved by applying key principles of:
 - Improving access and allowing for sightlines and pedestrian choices
 - Allowing people to see and be seen
 - Providing clear and logical layout
 - Allowing for a mix of activities including passive recreation
 - Providing communities with a shared sense of ownership
 - Providing quality environments that are easily maintained and appear well kept.

A4.4 Designing for biodiversity

The values presented here should be used as guidance to maximise the opportunities for biodiversity for any given site and will be dependent on local, site-specific characteristics. Auckland Council advocates the use of local, native plants to improve biodiversity. Key elements of designing for biodiversity include supporting, connecting and creating habitat:

- **Creating habitat that is self-sustaining and resilient:** A self-sustaining and resilient habitat is sized and planted in such a way that vegetation can regenerate without intervention. This can include consideration of final plant density, planting to attract pollinators, planting in phases (to allow for phased regeneration) and planting species which are local to that area. This should also include using eco-sourced plants²⁶, reducing or eliminating invasive species and taking into account the impact of climate change.
- **Supporting and protecting the local habitats and species:** The designer needs to understand the habitat types of the local area and align the design with those current and future habitat and species needs. In many instances, designs can incorporate species which enhance the local habitats. Designers may consider planting for species richness, planting to provide food for native birds and animals and planting for resilience.
- **Contribute to green corridors and connecting habitats:** This is important in creating and maintaining ecological function throughout the hydrological catchment. Green corridors allow animals to locate within a catchment by forming areas of safe passage. Green corridors also negate the impacts of inbreeding and decreased genetic diversity that can occur in isolated populations.

²⁶ Native plants or seeds collected from the immediate vicinity of the development and used in final landscape design



B1 Design processes

Table of Contents

B1.0	Design process for stormwater management devices	23
B1.1	Introduction	23
B1.2	Stormwater management design process	25
B1.3	Project scoping	26
B1.3.1	Identify the project team and stakeholders	26
B1.3.2	Early consultation with Auckland Council	27
B1.3.3	Define outcomes and objectives	28
B1.4	Understand the site	30
B1.4.1	Site considerations	30
B1.4.2	Reducing the need for stormwater management	34
B1.4.3	Understanding transitional management of the device	36
B1.5	Vesting assets	37
B1.6	Design for safety	38
B1.7	Define the mitigation requirements	40
B1.7.1	Calculate hydrologic mitigation requirements	40
B1.7.2	Calculate water quality mitigation requirements	49
B1.8	Device choice	50
B1.8.1	Summary of device options	52
B1.8.2	Placement of stormwater management devices	64
B1.9	Device design	65
B1.10	Life-cycle cost considerations	65
B1.10.1	Benefits and potential uses	66
B1.10.2	Undertaking a life-cycle costing analysis	67
B1.11	Construction	70
B1.12	Operation and maintenance	70

Figures

Figure 4: Recommended design process for stormwater management	25
Figure 5: Map of 90 th percentile 24-hour rainfall event.....	46
Figure 6: Map of 95 th percentile 24-hour rainfall event.....	47

Tables

Table 4: Design phases for larger developments	24
Table 5: Potential project team representatives and responsibilities	26
Table 6: Site characteristics and design considerations	31
Table 7: Site design and source control as non-structural approaches to minimising stormwater impacts....	34
Table 8: Transitional function of stormwater management devices	36
Table 9: Selection of safety issues for consideration	39
Table 10: Mitigation needed to support Auckland Unitary Plan requirements	41
Table 11: Suggested hydrological calculations	42
Table 12: Area to be considered when calculating retention and detention volumes	44
Table 13: Area to be considered when calculating runoff from a high contaminant generating car park	49
Table 14: Area to be considered when calculating runoff from a high-use road.....	49
Table 15: Estimated device effectiveness	62
Table 16: Multiple benefits of devices	63
Table 17: Suggested placement of devices in catchment.....	64
Table 18: Device design and sizing reference chapters.....	65
Table 19: Relevant life-cycle cost parameters and information.....	67

B1.0 Design process for stormwater management devices

B1.1 Introduction

This section of GD01 sets out the general process for designing sustainable stormwater devices for developments. The process sets out the most efficient way for designers to meet the regulatory provisions that govern Auckland's stormwater management. It also considers opportunities to enhance the receiving environment to meet the requirements set out in the Auckland Unitary Plan for water sensitive design and described in Auckland Council Guideline Document GD2015:004 *Water Sensitive Design for Stormwater* (GD04) and Section A of this document.

Stormwater management must be considered early in the overall design process to ensure the site meets the hydrologic needs of the post-development catchment. It is important that a comprehensive land planning assessment is done, taking into consideration the proposed development land use and the effects on the wider catchment, both upstream and downstream. This will ensure stormwater management is designed for, alongside all other aspects of the development.

The design process is separated into three distinct phases: concept, preliminary and detailed design. Each phase is a continual process which requires reconsideration of multiple parameters to achieve an optimised design. Table 4 details the elements and key components of each phase.

In the concept design phase, stormwater considerations must be taken into account before progressing to the preliminary and detailed design phases (a framework for the high-level concept design phase is provided in GD04).

Developers should meet with Auckland Council staff at this early stage in the design process to discuss issues, opportunities and risks to particular projects when considering the wider, long-term management of catchments. This process allows for resource consents and engineering planning approval to run concurrently and more efficiently.

Table 4: Design phases for larger developments

	Design component	Considerations	Reference section	
Concept Phase	Understand project objectives	<ul style="list-style-type: none"> Regulatory requirements for stormwater management Additional benefits (cultural, social and amenity considerations) 	<p>Section B1.4.2</p> <p>Section A and GD04</p>	
	Understand the site	<ul style="list-style-type: none"> Catchment-wide hydrology Soils (including soil type, infiltration rates etc.) and plants (interception, infiltration and water storage etc.) Receiving environment 	<p>GD04 and Section B1.0</p> <p>Section C.1 - Soils and plants</p>	
	Minimise the need for stormwater management	<ul style="list-style-type: none"> Assess the design in terms of minimal impact on the existing hydrology and retaining maximum infiltration 	GD04 and Section B1.4.2	
	Define the effects of development	<ul style="list-style-type: none"> Hydrologic management requirements Water quality management requirements Flood mitigation 	<p>Section B1.7.1</p> <p>Section B1.7.2</p>	
	Device selection	<ul style="list-style-type: none"> Device function and application Minimised maintenance risks and life-cycle costs Multiple benefits Application of suite, meeting multiple design requirements 	Section B1.8	
	Device sizing	Based on device choice and regulatory requirements	Section C	
	Initial layout and location/s	Following, or mimicking, natural hydrology with consideration of site constraints	GD04	
	Preliminary Design	Refined device selection	<ul style="list-style-type: none"> Choice based on treatment suite approach 	Section B1.9
		Detailed sizing	<ul style="list-style-type: none"> Based on volume or flow requirements 	Section C
		Device placement	<ul style="list-style-type: none"> Based on whole-of-catchment analysis 	Section B1.8.2
Safety in design		<ul style="list-style-type: none"> Designs to mitigate potential risk 	Section B1.6	
Costs		<ul style="list-style-type: none"> Whole-of-life costing with +/- 25% accuracy 	Section B1.10	
Connection		<ul style="list-style-type: none"> Connection to primary conveyance 	Design Engineer	
Detailed Design	Design objectives	<ul style="list-style-type: none"> Confirm design objectives are met 	Design Engineer	
	Testing	<ul style="list-style-type: none"> Test hydraulic performance 	Design Engineer	
	Placement and sizing	<ul style="list-style-type: none"> Finalised device placement and sizing 	Design Engineer	
	Costs	<ul style="list-style-type: none"> Whole-of-life costing with +/- 15% accuracy 	Section B1.10	

B1.2 Stormwater management design process

Figure 4 presents a recommended design process specific to stormwater management. However, depending on a number of case-specific factors, not all the steps will be necessary. Site-specific stormwater provisions will provide guidance to the designer on the process required.

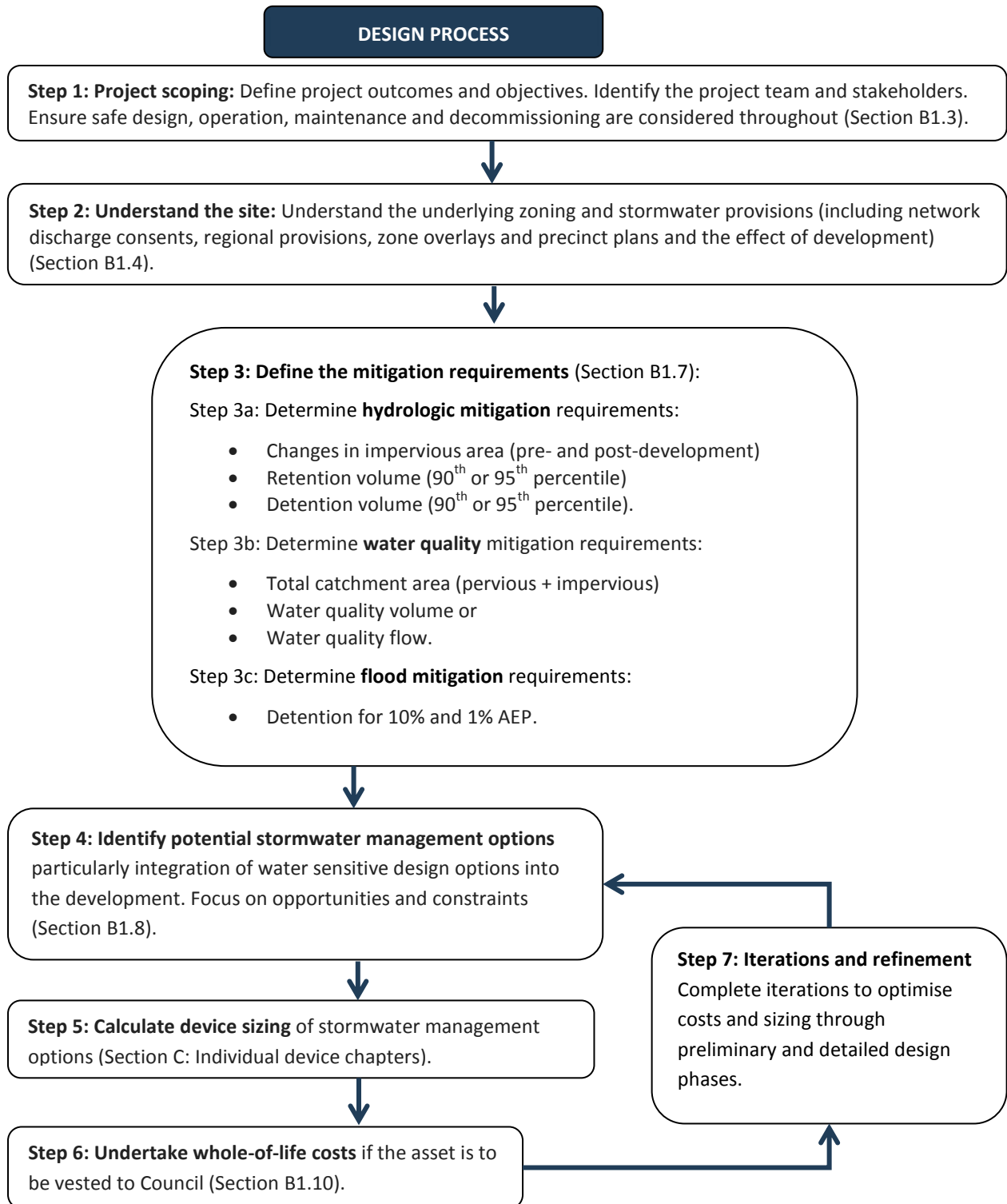

Figure 4: Recommended design process for stormwater management

B1.3 Project scoping

From the outset, the project team should include a wide range of stakeholders and partners who will be responsible for ensuring the development meets multiple objectives and outcomes. This section presents some guidance around project team composition and regulatory objectives.

B1.3.1 Identify the project team and stakeholders

Water sensitive design requires an inter-disciplinary and collaborative approach where multiple benefits are achieved, with project teams varying depending on the project's scale and complexity.

The project team will be responsible for delivering a preliminary design which accommodates catchment-wide hydrology, as well as long-term cultural, amenity and environmental considerations. The design will involve a suite of specific devices designed to manage water quality, as well as flow (detention and retention) with device sizing, layout and location/s. The project team is responsible for:

- Achieving the project objectives in terms of stormwater management
- Minimising risk
- Complying with all legal requirements
- Long-term cultural, amenity and environmental considerations
- Designing and constructing cost effectively for long-term operation and maintenance.

The potential composition of a project team is presented in Table 5.

Table 5: Potential project team representatives and responsibilities

Agent	Responsibilities with regard to stormwater management
Auckland Council and CCOs	<ul style="list-style-type: none"> • Auckland Council, as well as Auckland Transport and Watercare Services. Responsible for providing guidance on the regulatory and statutory requirements of the design.
Building partners	<ul style="list-style-type: none"> • Tradespeople, suppliers, long-term operators and maintainers responsible for providing specific guidance around construction elements that impact designs, function and cost.
Designers	<ul style="list-style-type: none"> • Engineers, architects and urban designers responsible for developing plans, from concept to detailed design.
Future asset owner	<ul style="list-style-type: none"> • Ownership of the stormwater asset/s after construction needs to be determined and the asset owner needs to be consulted as part of the design process. • As the asset owner is responsible for long-term maintenance and renewal of the devices they need to understand and agree to the proposed device and its whole-of-life needs and associated costs and the whole-of-life safety implications.
Landowner/developer	<ul style="list-style-type: none"> • Overall responsibility for ensuring the requirements of the RMA and other statutory requirements are met in the development.
Mana Whenua	<ul style="list-style-type: none"> • Responsible for ensuring kaitiakitanga, as outlined in the RMA and the principles of the Treaty, are upheld and provided for (refer to Section A).

Agent	Responsibilities with regard to stormwater management
Project manager	<ul style="list-style-type: none"> Responsible for bringing together all design elements, ensuring the design is fit-for-purpose and meets project objectives; resource consent requirements; and engineering plan approval. Responsible for facilitating communication with stakeholders.
Specialist advisors and designers	<ul style="list-style-type: none"> Structural engineers, landscape architects, geotechnical experts, environmental specialists, cultural and amenity specialists responsible for critical design elements that ensure designs meet project objectives.

B1.3.2 Early consultation with Auckland Council

Consultation with Auckland Council

A regulatory officer from Auckland Council's Resource Consent Department should be the first point of contact when applying for a resource consent. The officer will be responsible for engaging and coordinating between the applicant and Auckland Council specialists at appropriate times during the resource consent process.

Pre-application phase

Early engagement and involvement of Auckland Council will lead to better designs and a more efficient consenting process. Ideally, before an application is lodged, the design principles and concept plans have been agreed with Auckland Council as part of the pre-application phase.

Minimum requirements for resource consent application

When a stormwater consent application is submitted, the level of detail should be sufficient for a resource consent planner to assess the environmental effects and decide whether the proposed stormwater management devices are capable of mitigating stormwater effects for the entire lifetime of the consent. As a minimum, the following information should be submitted, to support the stormwater consent application:

- Proposed changes in impervious surface:** Overview of pre- and post-development impervious surfaces, clearly identifying the total increase of impervious surface including any estimates of the expected future impervious surface on private lots following subdivision. In urban areas, catchment imperviousness includes roofs (residential, commercial and industrial) and roads (and associated driveways, parking, footpaths etc.)
- Results of site investigations:** Including geotechnical, topographical, existing natural features and contours etc. Any existing stormwater infrastructure and discharge consents and the site's location in relation to SMAF 1¹ and SMAF 2²

¹ SMAF 1 are those catchments which discharge to sensitive or high-value streams that have relatively low levels of existing impervious area

² SMAF 2 are those catchments that typically discharge to streams with moderate to high values and sensitivity to stormwater, but generally with higher levels of existing impervious area within the catchment

- **Development plan:** Provide a clear overview of the entire proposed development (i.e. proposed roads, buildings, parks, car parks and green infrastructure). In addition, the designer should undertake a review of the long-term use of the development to ensure that any high-use roads and car parks are identified for mitigation
- **Catchment plans and drainage plans:** Clearly identifying different stormwater catchments, primary and secondary drainage systems, overland flow paths, existing streams and/or open channels and location of any stormwater treatment devices
- **Calculations:** Stormwater calculations for pre- and post-development scenarios in accordance with recommended design methodology to identify the required mitigation volumes and flows for water quality and quantity
- **Stormwater device designs:** Design drawings including cross-sections of all stormwater devices. Designs must be sufficiently detailed to clarify the total footprint, minimum and maximum water levels, outlet orifice sizing and levels, erosion protection and planting details etc., to ensure the proposed device is appropriately sized to accommodate the required flows and provide the required quality treatment
- **Stormwater management plan:** The above aspects should be summarised in a stormwater management plan. The stormwater management plan describes the overall proposed stormwater management strategy and any alternative options that have been considered
- **Assessment of effects on the receiving environment:** An assessment is needed of the potential effects of the development on the receiving environment.

Depending on the size and complexity of the development, more specific requirements can be agreed on a case-by-case basis, during different stages of the design process. For example, when devices are proposed to vest to Auckland Council, the future asset owner will require more detailed device specifications to ensure easy and cost-effective operation and maintenance.

B1.3.3 Define outcomes and objectives

Project scoping requires a thorough review of applicable regulatory and statutory requirements. These will determine project outcomes and objectives in the context of stormwater management.

Designers should undertake a comprehensive review of available regulatory and statutory documentation applicable to their site to ensure that stormwater provisions are clearly understood and can be used to define stormwater management for the site. Due to the complexity of regulatory and statutory provisions, it is recommended that the designer meets with Auckland Council advisors to assist in the definition of stormwater provisions.

Examples of regulatory and statutory documents that inform the required stormwater provisions include:

- Auckland Unitary Plan – particularly with regard to:
 - Chapter E1: Water quality and integrated management
 - Chapter E8: Stormwater - diversion and discharge
 - Chapter E9: Stormwater quality – high contaminant generating car parks and high-use roads
 - Chapter E10: Stormwater management area – Flow 1 and Flow 2 (SMAF 1 and SMAF 2)
 - Chapter E36: Natural hazards and flooding
 - Chapter I: Precincts – stormwater management plans, where applicable
- Auckland Council Stormwater Bylaw 2015
- Stormwater discharge consents
- Region-wide network discharge consent and associated catchment management plans
- Auckland Council Code of Practice for Land Development and Subdivision, Chapter 1 – *General Requirements and Procedures* (currently in draft)
- Auckland Council Code of Practice for Land Development and Subdivision, Chapter 4 – *Stormwater* (November 2015)
- Auckland Council Code of Practice for Land Development and Subdivision, Chapter 7 – *Green Infrastructure* (currently in draft)
- Auckland Transport Code of Practice for *Land Development and Subdivision*, Chapter 3 – *Transportation* (currently in draft).

It is the responsibility of the developers, in consultation with Auckland Council, to determine the stormwater management requirements pertaining to specific sites.

B1.3.3.1 Target provisions

Overall, the regulatory and statutory provisions (per the Auckland Unitary Plan) require retention, detention and water quality treatment. Stormwater management and the associated rules under the Auckland Unitary Plan consist of four different components:

1. Stormwater discharge and diversion

These discharge rules regulate stormwater runoff from impervious areas that is diverted and discharged into or onto land; or into water or the coastal marine area; pursuant to Sections 14 and 15 of the RMA.

2. Stormwater management: quality

These land-use rules regulate the management of stormwater runoff quality from impervious areas pursuant to Section 9 (2) of the RMA. They apply to runoff from:

- High contaminant generating car parks
- High-use roads.

3. Stormwater Management Area Flow 1 (SMAF 1) and Stormwater Management Area Flow 2 (SMAF 2)

These land-use rules regulate stormwater runoff from impervious areas within SMAF 1 **Error! Bookmark not defined.** and SMAF 2 **Error! Bookmark not defined.** pursuant to Section 9 (2) of the RMA.

4. Natural hazards and flooding

These land-use and development rules specify standards for activities within floodplains and overland flow paths pursuant to Section 9 (3) of the RMA. They control activities and development within:

- 1% Annual Exceedance Probability (AEP) floodplain
- 2% Annual Exceedance Probability (AEP) floodplain
- Overland flow paths.

In addition, designers must also consider the extent of public stormwater infrastructure and account for hydraulic connectivity and conveyance of the primary and secondary stormwater system networks and impacts on the coastal marine area.

B1.4 Understand the site

A comprehensive review of the development site, including historical and proposed land uses, should be undertaken to determine potential issues and opportunities that could impact on stormwater management. General guidance on this process is provided in Auckland Council's guideline for stormwater water sensitive design, GD04³, Section E.

B1.4.1 Site considerations

Key site considerations are summarised in Table 6.

³ Auckland Council GD2015:004 *Water Sensitive Design for Stormwater*

Table 6: Site characteristics and design considerations

Site characteristic	Site considerations	Resources
Receiving environment	<ul style="list-style-type: none"> • What is/are: <ul style="list-style-type: none"> ○ The physical aspects of the site including: the river catchment/s that surround the development site; existing water bodies, streams, estuaries and coastal receiving environments (where applicable), and the presence of permanent and intermittent streams ○ The effect of the development on existing stormwater treatment or attenuation (i.e. stormwater ponds, wetlands, etc.) and stormwater reticulation. 	Auckland Council GeoMaps
Existing services	<ul style="list-style-type: none"> • Locate and understand: <ul style="list-style-type: none"> ○ Existing services including water mains, wastewater, gas mains, underground high voltage cables, wastewater, fibre optic and any nationally or regionally significant services ○ Existing public stormwater infrastructure serving the development area as well as the status of any stormwater discharge/network discharge consents that impact the stormwater requirements for the site. 	Auckland Council GeoMaps beforeUdig.co.nz
Catchment	<ul style="list-style-type: none"> • Locate and understand: <ul style="list-style-type: none"> ○ The land use of the development as well as impervious coverage (current and proposed) ○ Any existing or proposed high contaminant generating car parks and high-use roads, the stormwater catchment or integrated catchment name, floodplain areas and overland flow paths affecting the area including discharge points and intermittent streams ○ Existing drainage patterns through the site, including discharge point/s, overland flow paths through the site and potential flood risks that need to be incorporated into the stormwater management ○ Any potential downstream flooding issues that could be exacerbated by the development. • Historical aerial images can be reviewed to identify potential high-risk contamination land uses that may require mitigation. 	Auckland Council GeoMaps

Site characteristic	Site considerations	Resources
Slopes	<ul style="list-style-type: none"> • The designer should understand the overall catchment, site topography including high and low points, slopes and contours. • A number of issues need to be considered when designing a device for steep slopes: <ul style="list-style-type: none"> ○ The impact on hydraulic storage capacity – available storage capacity generally decreases as slope increases ○ The resultant water velocities and the impact on scouring, erosion and re-suspension of pollutants ○ The risks of infiltrated water reappearing as springs further down the slope ○ The risk of infiltrated water on water table and recharge. • A very flat site may present different challenges: runoff may not drain from a very low gradient or outlet levels may be difficult to align with existing discharge networks. • Geotechnical investigations are needed to establish the underlying soil characteristics and the impact on design. 	Auckland Council GeoMaps
Underlying geology, soil type and groundwater	<ul style="list-style-type: none"> • Information regarding subsoil conditions should be collected. • Generic information regarding native soils can also be found on the Landcare Research S-Maponline website: (http://smap.landcareresearch.co.nz). This site provides overviews of potential soil drainage, depth to hard soil, gravel or rock and soil moisture. • Ideally, site-specific geotechnical borehole information should be collected and assessed for underlying infiltration in accordance with the <i>New Zealand Ground Investigation Specification, 2017</i> (in draft). 	Section C.1 Soils and plants
Groundwater	<ul style="list-style-type: none"> • Groundwater should be well understood: <ul style="list-style-type: none"> ○ Groundwater quality can be significantly impacted by pollutants (such as plumes, spills or discharge) and is extremely difficult to remediate, therefore prevention is essential ○ Groundwater mounding is an important consideration when stormwater runoff from a large area is collected and infiltrated intensively, causing localised increases in groundwater elevation. The risk of groundwater mounding is higher for larger devices but may still occur with smaller infiltration devices and can have geotechnical implications (from soil saturation) ○ Impervious clay fill can result in the groundwater in underlying soils being under artesian pressure due to flow from higher ground. Infrastructure piercing this layer can result in spring behaviour. • All existing groundwater information (both seasonal high and low) should be gathered at the concept design stage. • Piezometers (used to monitor groundwater) may need to be located on private property or within the road corridor and will therefore require landowner consent. • Groundwater levels can also be determined through the soil assessment. 	Section C.1 Soils and plants

Site characteristic	Site considerations	Resources
Presence of contaminated sites	<ul style="list-style-type: none"> • Contaminated land may pose a risk to the environment if exfiltration of surface runoff occurs. Other contaminated land areas may have contaminated groundwater that should not be allowed into the stormwater network. If either of these conditions is present at a site, the device must be fully lined with an impermeable liner. • Sediments retained in a stormwater management device may be considered contaminated at the time of disposal (i.e. during maintenance or decommissioning). This may impose a financial consideration at the design stage. 	Auckland Council
Site history	<ul style="list-style-type: none"> • The history of the site should be well understood. For instance, previous consents can be sourced from Auckland Council to provide some insights into previous work undertaken at the site. 	Auckland Council
Vegetation	<ul style="list-style-type: none"> • Existing vegetation should be assessed as to whether: <ul style="list-style-type: none"> ○ Plants improve the function of the device ○ Weed species are present that need control or elimination ○ Plants are likely to survive in that particular micro-climate ○ Plants suit the character of the proposed landscape ○ Plants or materials might be suitable for reuse or salvage. 	Section C.1 Soils and plants
Future development plans	<ul style="list-style-type: none"> • It is critical that the intended future development is understood when designing stormwater management devices. Designing for increases in housing, roading and utilities will help ensure the device will function as intended and be maintained safely and effectively. • The future asset owner must be considered and consulted in this phase to ensure commitment to the long-term function of the device. • It is important to consider the location of buildings for the collection or discharge of private drainage including overall road cross-sections in relation to footpaths, kerbing and carriageways, etc. so that the general fall direction can be determined. • Stormwater management should inform the design of roading, to optimise location and form of each infrastructure element. 	

B1.4.2 Reducing the need for stormwater management

A key approach to managing the impact of stormwater and associated pollutants is to reduce the need through prevention. Designers should consider all non-structural approaches to minimise the impacts of the development on stormwater. Some examples are provided in Table 7.

Table 7: Site design and source control as non-structural approaches to minimising stormwater impacts

Element	Description and examples
Preserve and use existing site features	<ul style="list-style-type: none"> • An undeveloped site contains an existing drainage network with features such as watercourses, depressions, floodplains, wetlands, vegetation and permeable areas that contribute to the current balance in the hydrological cycle. • Minimise changes to the natural hydrological cycle by identifying, preserving and integrating these features with the development.
Reduce impervious surfaces	<ul style="list-style-type: none"> • Impervious surfaces affect water cycle processes by reducing infiltration and increasing runoff. By reducing imperviousness, the overall percentage of hard surfaces can be reduced. • Using pervious channels or infiltration practices at the start of the treatment process for on-site infiltration, or to collect and transfer stormwater to a downstream treatment, reduces the effective impervious area of the development. • Some methods to reduce impervious areas include: <ul style="list-style-type: none"> ○ Customised road widths to suit actual or forecast traffic densities ○ Placing house lots closer to the main roading network to minimise access way lengths ○ Using grass swales for drainage to encourage infiltration ○ Using pervious paving, gravel or grass for low density access ways and parking areas ○ Minimising parking requirements.
Clustering / lot configuration	<ul style="list-style-type: none"> • Subdivisions often require significant earthworks to produce flat sites with house lots of very similar sizes. Typically, each will have a house, front yard, back yard and separate access to the road. Streams, vegetation and site features are often lost in the drive to maximise the number of lots. • Designers can minimise this by clustering houses together with smaller lot sizes, designing higher density housing and incorporating common recreational areas. Overall site imperviousness is reduced and the existing hydrological channels are retained.
Minimise site disturbance	<ul style="list-style-type: none"> • Earthwork compaction produces high strength (but high density) soil with reduced permeability. • Even when not sealed with impervious surfaces, this reduces infiltration potential and increases runoff. • To minimise changes to the hydrological cycle, it is very important to avoid earthworks on areas that are to be retained as permeable. • Some methods to minimise site disturbance include: <ul style="list-style-type: none"> ○ Minimising bulk earthwork areas during construction ○ Avoiding earthworks on future permeable areas.

Element	Description and examples
Retain vegetation	<ul style="list-style-type: none"> • Existing vegetation plays an important role in maximising infiltration and promoting evapotranspiration. Organic litter acts a sponge by capturing rainfall and holding it while it slowly infiltrates into the ground. • By assessing the existing topography and natural site features and carefully planning around them, it is possible to integrate the works with the environment and minimise the areas of vegetation and earthworks disturbance. Some methods to minimise site disturbance include: <ul style="list-style-type: none"> ○ Maintaining and enhancing riparian margins of watercourses ○ Maintaining vegetated areas to promote long-term infiltration ○ Replanting vegetation on slopes.
Contamination control	<ul style="list-style-type: none"> • Source control and management procedures reduce or avoid contaminants entering stormwater runoff. • Where a contaminant source is necessary for the successful operation of a business or activity, the procedures seek to control the release of contaminants or remove them before they come into contact with stormwater. • Businesses that handle chemicals or produce wastewater should carry out an environmental self-audit to identify actual and potential contaminant sources. • An action plan (e.g. Environmental Management Plan, Stormwater Management Plan, Emergency Spill Response Plan) should then be developed to eliminate any actual pollution and minimise the risk of potential pollution. • Stormwater devices provided in this guide should not be used to treat industrial discharges.
Source control	<ul style="list-style-type: none"> • Source control practices identify contaminant sources and construct physical works to prevent them coming into contact with stormwater (such as using bunding around storage tanks).
Management practices	<ul style="list-style-type: none"> • Management practices are processes that minimise the risk of contaminant transfer to stormwater. • Council initiatives include: <ul style="list-style-type: none"> ○ Street sweeping ○ Community education initiatives ○ Recycling. • Industry initiatives include: <ul style="list-style-type: none"> ○ Refuelling procedures ○ Chemical handling procedures ○ Staff training re proper disposal areas for wastes, chemicals etc. ○ Proper storage for chemicals, fuel etc., i.e. not outside, forgotten.

B1.4.3 Understanding transitional management of the device

Stormwater management devices have different functions depending on the site activities being undertaken and the stage of the development. It is important to understand these transitional functions and manage the device/s accordingly (Table 8).

Table 8: Transitional function of stormwater management devices

Phase	Device role	Notes for consideration
Construction	<ul style="list-style-type: none"> • Device establishment • Managing sediment and erosion control (per GD05⁴ requirements) • Managing construction pollutants and runoff 	<ul style="list-style-type: none"> • Devices comply with TP 90⁵ (replaced by GD05). • Devices are often constructed at the same time as roadways and reserves and therefore are subjected to runoff during the most intensive construction phase. Runoff is often high in sediments and construction pollutants (which might include concrete, sediments, hydrocarbons, chemical spills). • Consents generally require a period of plant establishment prior to handing over an asset. This is to overcome instances where devices are planted and then suffer damage as a result of construction runoff. • Many devices can be constructed with a sacrificial area that can be easily replaced after construction (this may include sand media, grasses, filter strips, boundary soils etc.). For instance, designers can consider using a geotextile with overlaid grass to protect a rain garden or swale during construction. • In order to protect wetlands, forebays can be designed with larger volumes to capture sediments and then be reduced in size once construction is completed.
Transition	<ul style="list-style-type: none"> • Device establishment • Removal of legacy construction pollutants • Management of developing urban pollutant loads and rainfall runoff 	<ul style="list-style-type: none"> • Maintain devices regularly and check for function during this transitional phase. • Where any gross pollutants are observed (such as sediments, loose gravels or litter), these should be removed and infiltration rates confirmed. • If plants are showing signs of stress, they should be restored or replaced.
Long-term operation & maintenance	<ul style="list-style-type: none"> • Management of developed urban pollutant loads and rainfall runoff 	<ul style="list-style-type: none"> • All devices must comply with this guideline, GD01. • To ensure long-term operation of the device, undertake regular maintenance per its operation and maintenance requirements.

⁴ Auckland Council GD2016/005 *Erosion and Sediment Control Guide for Land Disturbing Activities in the Auckland Region*

⁵ Auckland Council TP 90 *Erosion and Sediment Control Guide for Land Disturbing Activities in the Auckland Region* (replaced by GD05)

B1.5 Vesting assets

Vesting is the act of passing an asset to another entity upon completion, for on-going ownership and maintenance. Assets may be vested to Auckland Council as:

- Public stormwater, with rights of connection, or
- Assets for a specific purpose (road drainage, public facility drainage) with no right to connect to them.

New stormwater devices may be vested in Auckland Council's ownership if it can be demonstrated that a significant flow from the public stormwater network discharges to that treatment system. Auckland Council may, at its discretion, approve public treatment systems where there is considerable public benefit, e.g. treatment is available for stormwater runoff from public land, or from properties outside the immediate development site. Prior to vesting such assets, a comprehensive Net Present Value (NPV) analysis must be submitted to Auckland Council. Stormwater devices shall otherwise remain in private ownership.

Where an asset is proposed to be vested to Auckland Council, the developer shall enter into discussions with Auckland Council representatives (at the resource consenting stage) regarding the selection of the devices as early in the design process as possible including:

- **Location:** Devices must be located on public land, or land that will be vested to Auckland Council. Where this is not possible and the device is located on private land, easements must be provided for maintenance and access. Devices should not be located in trafficked areas, nor in areas where there is high amenity open space which might be impinged on. Where a device is installed as part of a road, the ownership lies with Auckland Transport and shall comply with Auckland Transport's Code of Practice (CoP) requirements
- **Quantity:** The number of devices must be optimised for treatment and maintenance cost-effectiveness. Larger and fewer devices are preferred to many smaller devices
- **Asset components:** Any fabricated components must comply with the relevant Building Code and NZ Standard or CoPs (for assets to vest). They must be designed for appropriate asset life, ease of operation, maintenance and renewal
- **Replacement parts:** Applicants must demonstrate that any replacement parts can be readily obtained and not subject to licenses or other restrictions
- **Design for safety:** The device must be proven to be safe for the public as well as operational and maintenance staff. Refer to Section B1.6 for further details
- **Maintenance requirements:** All maintenance considerations should be well understood including planned maintenance and operational costs, renewals and safety. These may include access, sediment removal and drying, storage and disposal and plant maintenance needs (such as watering, pruning and weeding). A device-specific, customised O&M manual is required
- **O&M manual:** An operational and maintenance manual for each stormwater management device must be submitted to Auckland Council for approval and must contain detailed technical data sheets and methods for maintenance (including inspections, weed and pest control and maintenance frequency schedules, access for maintenance vehicles and temporary traffic management plans, where applicable)
- **Whole of life costs:** Refer to Section B1.10 for further details.

Designers are directed to the Auckland Council CoP Chapter 4: *Stormwater*⁶, Section 4.3 which provides further detailed guidance on device choice for assets to be vested to Auckland Council.

B1.6 Design for safety

Safe design, integrating health and safety risk identification and assessment methods throughout the design, should begin early in the design process to eliminate or minimise the risks of death, injury or illness to those who will construct, operate, maintain, inspect, decommission and demolish any asset. The goal is to eliminate hazards wherever possible. Where this cannot be achieved, the risks are to be minimised as far as is reasonably practicable.

Construction site-safety risk management is essential. However, the opportunity to eliminate and/or substantially reduce/mitigate a hazard in the early design stages, by involving decision makers and considering the life-cycle of the project, is invaluable in reducing safety risks. This needs effective collaboration between designers, health and safety professionals, operational and construction staff and other parties, such as decision-makers, developers and project managers.

Safe design begins in a project's conceptual and planning phases with emphasis on making the right choices about the design, methods of construction, on-going operation and maintenance and materials. It is the design stage which provides the greatest opportunity to incorporate improvements that can produce safety, time and cost benefits over the asset's life. Any residual risks remaining at the end of the design phase should then be identified to allow them to be addressed or managed during the project's next phase.

Some examples of safety in design considerations are presented in Table 9. This is not a comprehensive list but is provided as an initial framework for safety in design thinking. A trained and competent person should provide the project manager with a comprehensive overview of safety in design considerations, as part of the design brief.

⁶ Can be found at <http://www.aucklanddesignmanual.co.nz/project-type/infrastructure/codes-of-practice>

Table 9: Selection of safety issues for consideration

Potential safety issue	Description and examples
Construction	
Safety considerations during construction	<ul style="list-style-type: none"> All health and safety considerations for the construction period must be aligned to current standards and legal requirements⁷, including whether the design can be constructed safely.
Locations of existing services	<ul style="list-style-type: none"> Care should be taken that access and maintenance of existing services are designed for, as well as safely working in areas with existing services.
Use and operation	
Crime prevention	<ul style="list-style-type: none"> The principles of Crime Prevention Through Environmental Design should be used in the design.
Public access after construction	<ul style="list-style-type: none"> Public access, particularly in communal space environments (such as detention basins), should be a design consideration. In those areas where fences are not required, consideration should be given to creating natural barriers to entry (such as embankments and vegetation).
Steep embankments	<ul style="list-style-type: none"> Steep embankments can prevent a person from safely exiting a pond or wetland and can lead to accidental drowning. Steep embankments can also be hazardous to maintenance staff such as those using lawnmowers, or other hazardous or sharp equipment.
Inlet and outlet structures	<ul style="list-style-type: none"> During large storm events, strong currents can flow both into and out of a device. Screen devices (such as racks or trash screens) can also pose a risk in high flow conditions.
Polluted sediments	<ul style="list-style-type: none"> The purpose of many devices is to trap polluted sediments during their normal function. These sediments, if mishandled, could be a potential health and safety issue. The design should consider the safety requirements of those maintaining the devices, in terms of safe access, exposure to contaminants, manual handling requirements and location of contaminants when removed from the device.
Maintenance	
Site access	<ul style="list-style-type: none"> Site access, particularly with regards to safe access during maintenance, should be a key design consideration. Where possible, safe, convenient access should be designed to allow for the intended purpose (in some cases, 24/7), and all-weather access to key design features, such as inlets and outlets (for instance, areas where blockages might occur and cause flooding). Below-ground structures, which required confined space access, should be avoided where possible; where it is necessary, all maintenance personnel must have up-to-date confined-space training. Designs should protect against potential falls. There must be a mechanism to unblock any orifice or weir from ground level without confined space entry or use of pump/s.

⁷ This includes the Health and Safety at Work Act 2015 which came into effect on April 4th, 2016

Potential safety issue	Description and examples
Construction	
Flood depths and velocities	<ul style="list-style-type: none"> • A key design feature for all stormwater management devices should include safety considerations for large storm events where inlet and outlet structures can have high flows and velocities, and where devices may cause flooding. • Flow over the embankment (overtopping) for long periods may cause structural failure and so downstream effects of a collapse should be considered.

B1.7 Define the mitigation requirements

It is necessary to quantify the changes to the stormwater quality, volumes and flows as a result of development. Initially, this will require an understanding and documentation of the following:

- Defining the hydrologic mitigation requirements:
 - Changes in imperviousness as a result of the development
 - Retention and detention depths and volumes.
- Defining the water quality mitigation requirements:
 - Water quality flow (WQF) or water quality volume (WQV).

B1.7.1 Calculate hydrologic mitigation requirements

It is up to the designer to determine which storm events need to be designed for to meet regulatory requirements. The key hydrologic calculations needed for Auckland's regulatory provisions are presented in Table 10 and Table 11.

Table 10: Mitigation needed to support Auckland Unitary Plan requirements

Mitigation requirement (Auckland Unitary Plan)	Stormwater management requirement and aim	Devices providing this mitigation
Stormwater management - flow: SMAF 1 and 2: <ul style="list-style-type: none"> Provide retention (volume reduction) of at least 5 mm runoff depth. 	Retention: <ul style="list-style-type: none"> To protect streams and recharge groundwater. 	<ul style="list-style-type: none"> Rainwater tanks (with reuse) Bioretention devices (unlined) Living roofs Pervious paving (unlined) Infiltration devices.
Stormwater management - flow: <ul style="list-style-type: none"> SMAF 1: provide detention and a drain-down period of 24 hours for the difference between the pre- and post-development runoff volumes from the 95th percentile, 24-hour rainfall event minus the 5 mm retention SMAF 2: provide detention and a drain-down period of 24-hours for the difference between the pre- and post-development runoff volumes from the 90th percentile, 24-hour rainfall event minus the 5 mm retention. 	Detention: <ul style="list-style-type: none"> To protect streams. 	<ul style="list-style-type: none"> Pervious pavements Bioretention devices Wetlands Ponds (dry and wet) Rainwater tanks.
Stormwater diversion and discharge: <ul style="list-style-type: none"> Provide detention of 10% AEP Provide detention of 1% AEP. 	Detention: <ul style="list-style-type: none"> To manage and mitigate flood effects and flood risks, including effects on buildings and property. 	<ul style="list-style-type: none"> Rainwater tanks (no reuse) Ponds Wetlands.
Stormwater management – quality: <ul style="list-style-type: none"> Provide treatment of the water quality flow or volume. 	Water quality mitigation: <ul style="list-style-type: none"> To protect water quality. 	<ul style="list-style-type: none"> Bioretention devices Swales Wetlands.

Table 11: Suggested hydrological calculations

Hydrological calculation	Regulatory reference (Auckland Unitary Plan)	Mitigation aim	Preferred method	Calculation requirement	Wetlands	Ponds	Bioretention	Swales	Infiltration devices	Pervious paving	Living roofs	Rainwater tanks
Water quality flow (WQF)	E8 and E9	Water quality effects	Rational method	10 mm/hour			X ^a	X				
Water quality volume (WQV)	E8 and E9	Water quality effects	TP108 ⁸	90 th percentile equivalent	X	X ^b	X					
Retention	E8 and E10	Effects on streams and aquatic biodiversity	TP108	5 mm runoff depth			X		X	X	X	X ^d
Detention	E8 and E10	Effects on streams and aquatic biodiversity	TP108	95 th percentile or 90 th percentile	X	X	X			X		X
Large storms	E8	Flood effects	TP108	10% AEP	X	X		X ^c				X ^f
Extreme storms	E8	Flood effects	TP108	1% AEP	X ^e	X ^e						

Notes:

- a If bioretention devices are designed for water quality treatment only (i.e. no retention or detention), then WQF is used. Specific media and plants are required for this design (refer to Section C.1)
- b Permanent water volume (PWV) is calculated in ponds (equivalent to WQV)
- c Conveyance only, not detention
- d Only with provision for on-site reuse
- e When designed for flood control
- f Can be sized for these events but generally only designed for smaller storms. Detention of up to 10% AEP is currently a Watercare Services requirement in areas discharging to combined sewer.

⁸ Auckland Regional Council TP108 *Guidelines for Stormwater Runoff Modelling in the Auckland Region*, 1999

Calculating impervious area to be mitigated

A critical calculation in the design process is the pre- and post-development changes in imperviousness. As development is undertaken, imperviousness will increase and subsequent runoff volumes will increase (Table 12).

An impervious area is defined as a surface which prevents, or significantly impedes, the soakage of water into the ground and includes:

- Roofs
- Paved areas, including driveways and sealed/compacted metal parking areas, patios
- Sealed and compacted metal roads
- Layers engineered to be impervious such as compacted clay.

The following areas are not considered as an impervious surface under the Auckland Unitary Plan and should be excluded from any impervious area calculation:

- Grass and bush areas
- Gardens and other vegetated areas
- Porous or permeable paving and living roofs
- Slatted decks
- Swimming pools, ponds and dammed water
- Rainwater tanks.

B1.7.1.1 Calculating retention and detention volumes

For the development, or redevelopment, of areas within a SMAF 1 or SMAF 2 area, the runoff should be calculated as specified in Table 12 which presents methods for development areas more than, and less than, or equal to, 50% of the total site.

The curve number used in the calculation should be based on site-specific soils. Soils from the site should be tested for infiltration after any construction works to determine the appropriate curve number, as per methods provided in Auckland Regional Council's technical publication, TP108⁸.

If the discharge from the site being developed is subject to a network discharge consent, then retention volumes for the SMAF area will still be required.

In the context of these rules as they apply in Scenario B, "pre-development" means "pre-any-development" (which represents the natural hydrological state of the land; assumed to be grassed).

Table 12: Area to be considered when calculating retention and detention volumes

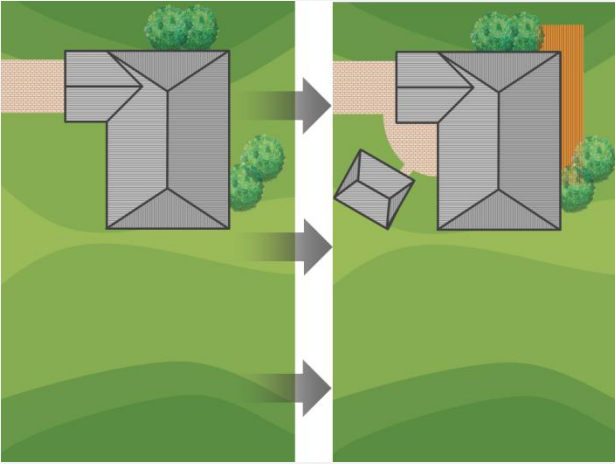
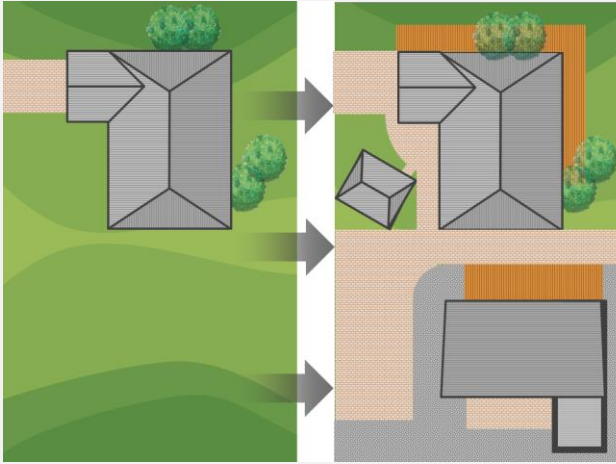
Scenario A	Scenario B
New or redeveloped impervious area: ≤ 50% of total site area	New or redeveloped impervious area: >50% of total site area
<p>Example</p> <p>Total site area: 1000 m²</p> <p>Existing impervious: 300 m²</p> <p>New (re)developed impervious: 60 m²</p> 	<p>Example</p> <p>Total site area: 1000 m²</p> <p>Existing impervious: 300 m²</p> <p>New (re)developed impervious: 550 m²</p> 
Calculate the difference between pre- and post-development runoff from the new or redeveloped impervious area only.	Calculate difference between pre- and post-development runoff from the entire site area (where pre-development is assuming the entire site is grassed, with no existing imperviousness).
<p>Step 1 (Scenario A & B): Figure 5 and Figure 6 illustrate the 90th and 95th percentile rainfall data in millimetres for areas throughout Auckland. These rainfall depths guide the designer for volume calculations needed to protect streams.</p> <p>Use the maps to establish the rainfall event for their specific area (for instance, Devonport would have an estimated 90th percentile storm of 25 mm and a 95th percentile of 35 mm). Use the 95th percentile map when in SMAF 1 and greenfield and 90th percentile when in SMAF 2.</p>	
<p>Step 2 (Scenario A):</p> <p>Pre-development runoff volume</p> <ul style="list-style-type: none"> Calculate runoff from 60 m² pervious area; in this instance, using curve number representative of the underlying soil type in accordance with TP108⁹. <p>Post-development runoff volume</p> <ul style="list-style-type: none"> Calculate runoff from 60 m² impervious area using curve number 98 in accordance with TP108. 	<p>Step 2 (Scenario B):</p> <p>Pre-development runoff volume</p> <ul style="list-style-type: none"> Calculate total site runoff with TP108, based on runoff from 1000 m² pervious areas, with curve number representative of the underlying soil type in accordance with TP108. <p>Post-development runoff volume</p> <ul style="list-style-type: none"> Calculate total site runoff with TP108, based on runoff from 850 m² impervious area, with curve number 98 + runoff from 150 m² pervious area with curve number representative of the underlying soil type.

⁹ Auckland Regional Council TP108 *Guidelines for Stormwater Runoff Modelling in the Auckland Region*, 1999

Scenario A	Scenario B
New or redeveloped impervious area: ≤ 50% of total site area	New or redeveloped impervious area >50% of total site area
<p>Step 3 (Scenario A):</p> <p>Calculate retention volume (m³)</p> <ul style="list-style-type: none"> • 5 mm x new impervious area (60 m²)/1000 <p>Calculate detention volume (m³)</p> <ul style="list-style-type: none"> • Post-development runoff volume minus Pre-development runoff volume minus Retention volume 	<p>Step 3 (Scenario B):</p> <p>Calculate retention volume (m³)</p> <ul style="list-style-type: none"> • 5 mm x total impervious area (850 m²)/1000 <p>Calculate detention volume (m³)</p> <ul style="list-style-type: none"> • Post-development runoff volume minus Pre-development runoff volume minus Retention volume

In instances where the increased impervious area is small, the calculated detention volume may be zero or negative. In these instances, no detention is required and the retention volume remains the same.

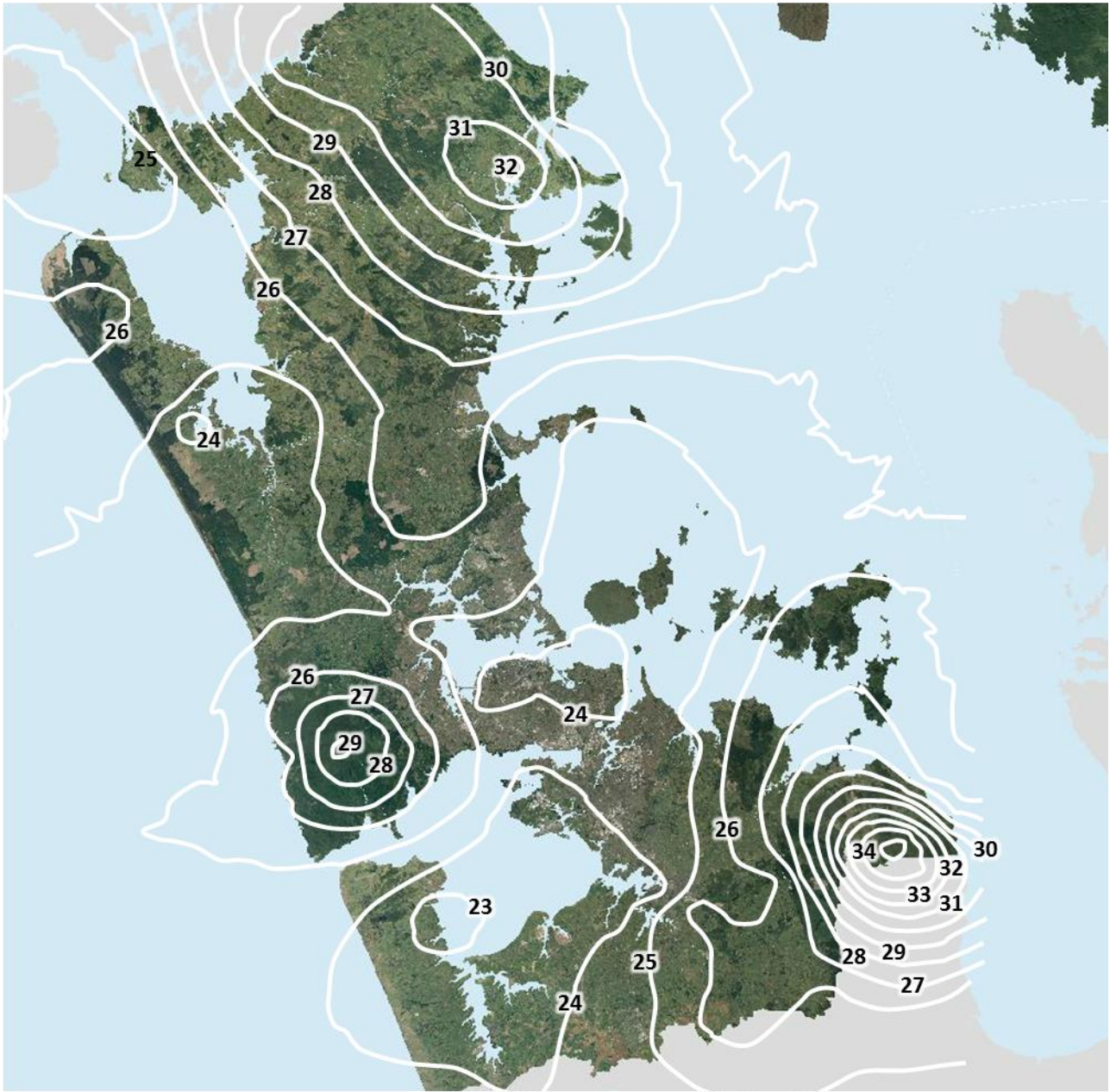

Figure 5: Map of 90th percentile 24-hour rainfall event

Source: Auckland Council TR 2013/035¹⁰

¹⁰ Auckland Council TR 2013/035 *Auckland Unitary Plan Stormwater Management Provisions: Technical Basis of Contaminant and Volume Management Requirements*

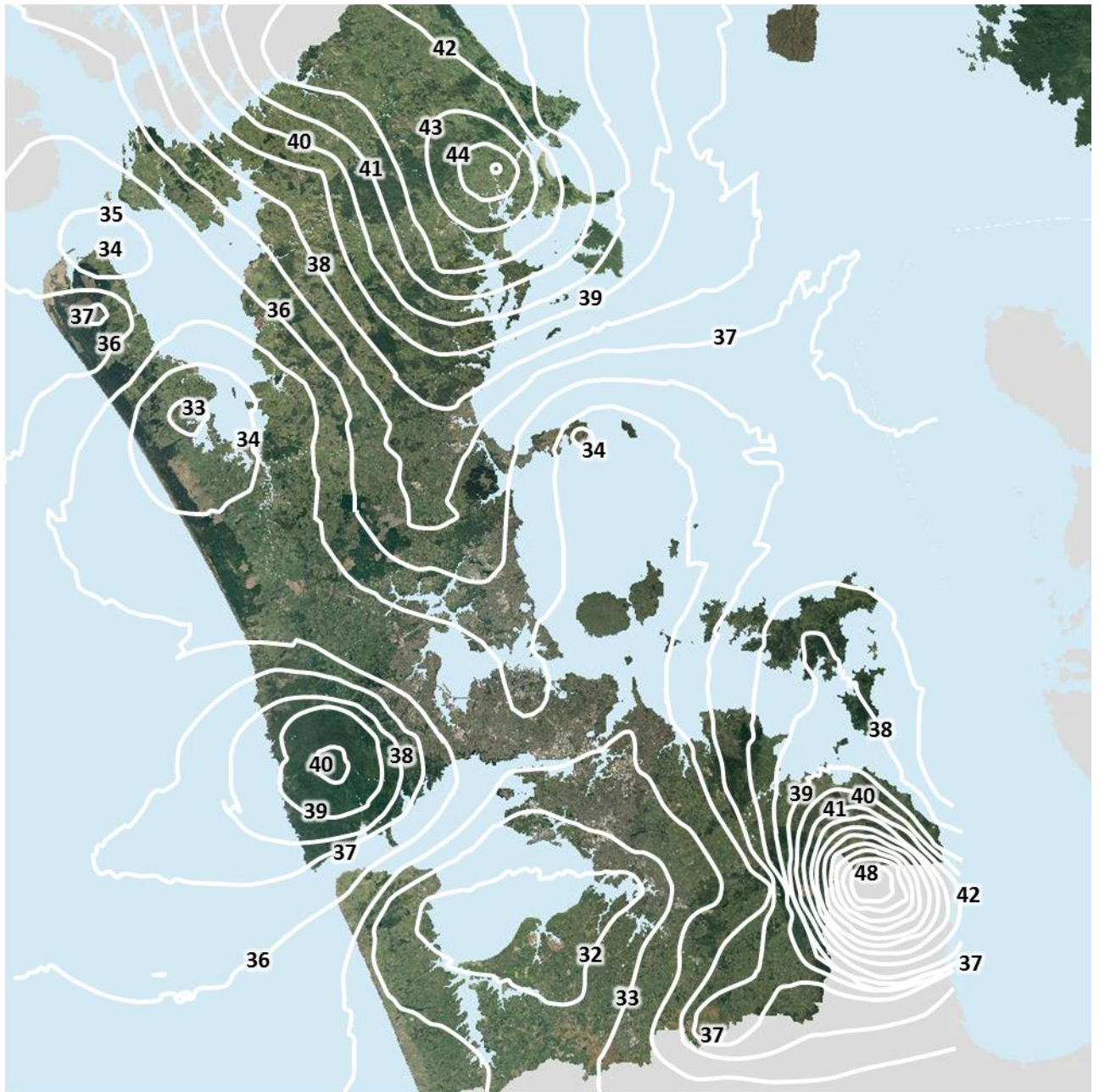

Figure 6: Map of 95th percentile 24-hour rainfall event

Source: Auckland Council TR 2013/035¹⁰

B1.7.1.2 Design for greenfield developments

A higher level of mitigation is generally expected in greenfield areas to avoid (as far as possible), and then minimise, adverse effects. In contrast, the focus in existing developments is minimising and potentially reducing existing adverse effects. In order to mitigate the impact of greenfield development, all aspects of water sensitive design (defined as integrated stormwater management in the Auckland Unitary Plan) should be applied, together with (at a minimum) SMAF 1 requirements.

To sustain streams and underlying aquifers, hydrology mitigation (in order of preference) should consider:

- Retention (infiltration) and detention
- Retention (water reuse) and detention
- Detention only.

B1.7.1.3 Design for larger storm events

Designing for larger storm events may be required for various reasons, including, but not limited to:

- Mitigation of flood effects caused by an increase in impervious surface
- Reduction of existing flooding
- Insufficient network capacity.

Under the Auckland Unitary Plan Standards (Section E8.6) any development must ensure that the diversion and discharge does not result in, or increase, the following:

- Flooding of other properties in rainfall events up to the 10% AEP, or
- Inundation of buildings on other properties in rainfall events up to the 1% AEP.

Devices which may be designed to detain larger storm events include wetlands, ponds and in some instances, rainwater tanks. TP108¹¹ should be used for calculating the detention volumes for 10% and 1% AEP events.

To meet the diversion and discharge requirements of the Auckland Unitary Plan, all developments that lead to an increase in impervious surface must provide detention for larger storm events as follows:

- Detention for the difference between pre- and post-development runoff in a 10% AEP rainfall event for the total site area
- Detention for the difference between pre- and post-development runoff in a 1% AEP event, where Auckland Council flood maps show downstream flooding with an actual or potential risk of inundation of buildings
- Detention of 10% AEP and 1% AEP rainfall events is not required for developments that are located within the lower half of the catchment or for which a validated flood modelling study has shown that the development does not increase downstream flooding
- When designing for larger storm events, the volumes for the larger events are stacked on top of the detention and retention volumes calculated in Section B1.6.1.1.

¹¹ Auckland Regional Council TP108 *Guidelines for Stormwater Runoff Modelling in the Auckland Region*, 1999

B1.7.2 Calculate water quality mitigation requirements

Stormwater runoff from urban land use may contain a variety of pollutants. Where water quality treatment is required for runoff (e.g. from high contaminant generating car parks and high-use roads), the drainage area used to calculate the WQV should be understood. In all instances, the area generating high contamination should be isolated (e.g. through kerbs or bunds) so that only discharge from this area is directed to the treatment device. Where this is not possible, the entire catchment area must be used for the water quality calculation.

Calculation examples for car parks and high-use roads

In accordance with Auckland Unitary Plan requirements, the water quality runoff (flow or volume) should be calculated for car park and high-use road areas as specified in Table 13 and Table 14.

Table 13: Area to be considered when calculating runoff from a high contaminant generating car park

Water quality - high contaminant generating car park	If car park ≤ 50% of total impervious area of the site	If car park >50% of total impervious area of the site
Water quality treatment for high contaminant generating car park	Calculate water quality flow or volume from the new or redeveloped car park	Calculate water quality volume or flow from the total impervious area on the site

Table 14: Area to be considered when calculating runoff from a high-use road

Water quality - high use road	
Water quality treatment for high use road	Calculate water quality flow or volume from the new or redeveloped high use road

Water quality flow

Some stormwater quality devices (such as swales and bioretention devices) have little or no storage volume and as such, are best sized to treat a particular flow rate.

A 10 mm/hour constant rainfall intensity should be used, which is considered equivalent to treating the runoff from approximately 90% of the annual rainfall. The rational equation is the simplest method to determine peak discharge from drainage basin runoff and should be used for the design sizing of swales and for 'water quality only' bioretention devices.

Use the rational method to calculate runoff from design storm depth of 10 mm/hr (Equation 1)¹².

$$Q = i \times \text{Area} \times \text{Rational Coefficient}$$

Equation 1

Where:

Q	-	Peak discharge (m ³ /s)
i	-	Rainfall intensity ¹³ (m/s)
Area	-	Total drainage area (m ²)
Rational coefficient	-	Various for pervious; 0.95 for impervious

Water quality volume

Stormwater devices that are volume based (such as wetlands) are best sized to treat a particular water volume. Water quality volume (WQV) is the amount of stormwater runoff from a rainfall event that must be captured and treated in order to reduce the majority of stormwater contaminants on an annual basis. The water quality volume equates to the runoff volume of the 90th percentile storm. TP108 should be used to calculate the runoff and determine the required water quality volume in a wetland based on the 90th percentile storm event. The same method is also used to calculate permanent water storage in ponds and is referred to as permanent water volume (PWV).

B1.8 Device choice

Each development area will have unique characteristics which will guide the designer's choice of device/s. In addition, individual devices have minimum specifications which dictate where and when they can be used. It is important to determine the limitations of the site as well as the benefits and constraints of each device which will be used in the analysis and selection of the appropriate solution. This section should therefore be used as a guide for device choice with the understanding that multiple parameters should be weighed through the design iteration process.

- Each device has distinct stormwater management benefits (Table 15). These need to be considered when determining which device, or devices, are needed to meet the Auckland Unitary Plan requirements
- Each device has the potential to provide multiple additional benefits (Table 16). These need to be considered in consultation with stakeholders including those who have a vested interest in the liveability of the area (and as such, include cultural, social and environmental benefits).

¹² The rational method overestimates flows when the time of concentration becomes greater than 10 minutes, which is more likely for larger catchments.

¹³ Rainfall is usually reported in mm/hr and therefore needs to be corrected for in the units.

Key considerations when choosing devices include:

- Effectiveness in mitigating water quality and/or quantity issues
- The optimal number and types of devices needed to meet the site's stormwater management needs
- Costs including maintenance and renewal costs
- Safe design
- Maintenance including access, replacement parts not subject to licenses or other restrictions
- Ownership, see Auckland Council CoP Chapter 4: *Stormwater*⁶, Section 4.3.6.5
- Connection to the public stormwater system (per CoP above, Section 4.3.11)
- Designing to maximise benefits over the long term.

The following section provides one-page summaries of the devices found in Section C of this document. They provide an easy to understand summary of the device, its advantages and disadvantages, some minimum design standards and potential innovation opportunities for developers.

Key decisions in the device choice process should be governed by Auckland Council's preference for:

- **Managing stormwater at source where possible:** The overall preference is for stormwater to be managed as close to source as possible. This requires careful consideration of the wider use of smaller devices (such as rainwater tanks, pervious paving, swales and rain gardens) in preference to larger devices such as wetlands. These at-source⁶ devices are most efficient at improving water quality and reducing runoff flows and volumes from frequent short- and medium-duration events but may incur more maintenance costs over the life of the device
- **Designing for the correct storm size:** Larger, more infrequent events generally need to be managed through primary and secondary conveyance systems. Some water sensitive design devices such as wetlands and dry ponds, can be sized for flood mitigation but the preference is for all water sensitive design devices to be off-line from primary conveyance systems. For larger devices (such as ponds and wetlands), climate change factors should be incorporated into the sizing
- **Developing a suite of water sensitive design devices:** Different water sensitive design devices can provide differing levels of pollutant reduction, retention and detention. However, it is rare for a single stormwater management device to achieve all the quality and quantity management requirements for a site. It is therefore very important to consider a suite of devices that will meet the development's design goals. This approach can be used to address water quality, runoff hydrograph, runoff velocity and hydrograph timing. It can also achieve multiple benefits including positive cultural, social and environmental outcomes
- **Including pre-treatment:** Most devices require some pre-treatment of runoff. Pre-treatment should remove gross pollutants (such as litter) and larger sediments; this will increase the lifespan of the device and reduce maintenance frequency
- **Designing for sacrifice:** By using an integrated suite approach, designers should consider devices, or areas within devices, which act as sacrificial layers/areas where the majority of pollutants are collected. This may include grassed areas, or sand layers, which are routinely removed and replaced, leaving the downstream areas/devices undisturbed.

B1.8.1 Summary of device options

The following one-page summaries provide an overview of each of the devices presented in design detail in Section C.

Pervious pavement

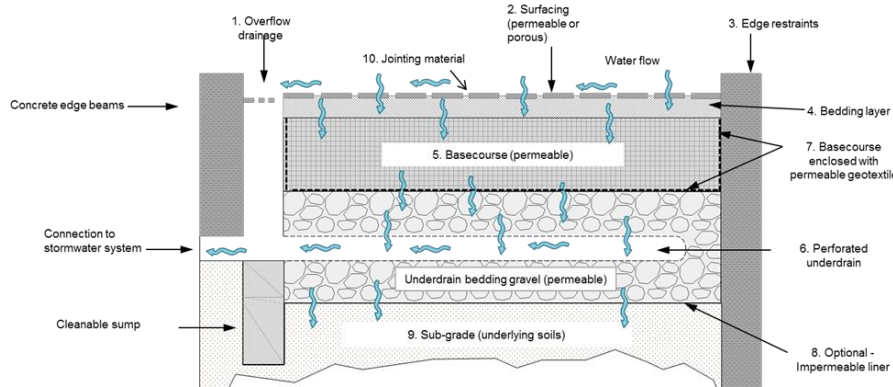

* Not considered to be treatment device if designed as active system. Passive systems do not trigger stormwater management provisions.

1% AEP detention	✗
50% & 10% AEP detention	✗
Detention for stream protection	✓
Retention (unlined)	✓
Water quality	✗

Description	<p>Pervious pavement: Any system providing hard or trafficable areas which also provides for downward percolation of stormwater runoff. This includes no-fines concrete or porous asphalt, permeable pavers (water percolates through gaps between pavers), porous pavers (water percolates through the paver) and stabilised loose material (e.g. pebble or shell held in reinforced units or bound by resin). The flow of stormwater from the surface to the collection system is slowed through infiltration and is temporarily stored and slowly released by the basecourse, resulting in detention of the flow peaks. Passive paving systems receive water only from the paved surface. Active paving systems receive additional runoff from external surfaces (such as adjacent roads). Only active systems trigger stormwater management provisions; for this reason, pervious paving is considered as providing retention (if soils are permeable and a permeable liner is used) and detention, but not treatment.</p>
Mana Whenua alignment	<p>Pervious paving can recharge groundwater but must be used in conjunction with water quality treatment to align with kaitiakitanga, Taiao and Mauri Tu. Also hand weeding and hand maintenance would align with the principles of Taiao. Iwi management plans are a vital resource and should be referred to early in design.</p>
Treatment synergies	<p>Particularly effective if combined with:</p> <ul style="list-style-type: none"> • Upstream: Pre-treatment (to remove sediments) • Downstream: Retention (bioretention or swale) and detention (wetlands and ponds).
Advantages	<ul style="list-style-type: none"> • Improved hydrological response of stormwater peak flow by holding and releasing in a controlled manner • Providing amenity/landscape feature • Passive systems do not trigger stormwater management provisions and therefore do not require any additional land areas outside the paving area to treat the stormwater runoff.
Disadvantages	<ul style="list-style-type: none"> • Prone to clogging, especially if located lower than adjacent landscaping • If pervious paving fails, the surface will be considered out of compliance • Generally not suitable for volume control or extreme storm event management • Not suitable for traffic areas of high acceleration, deceleration or turning.
Design considerations	<p>See design chapter including:</p> <ul style="list-style-type: none"> • Slopes <5% (3°) for active designs, <12% (7°) for passive designs. >15 m from slopes of >15% • Infiltration rates through or around the paver of 120 mm/hour over life of device (therefore 1200 mm/hour at construction). Must be designed and installed according to the manufacturer's specification including joining sand and loading. Pre-treatment must be provided to remove sediments. Aggregate must be free of fines, not crush under loading and have a known void space • Requires notice on land title to inform owner that maintenance is required.
Innovation opportunities	<ul style="list-style-type: none"> • Colour, paving stone shape, interlocking shape, modularisation, including plants.

Bioretention devices

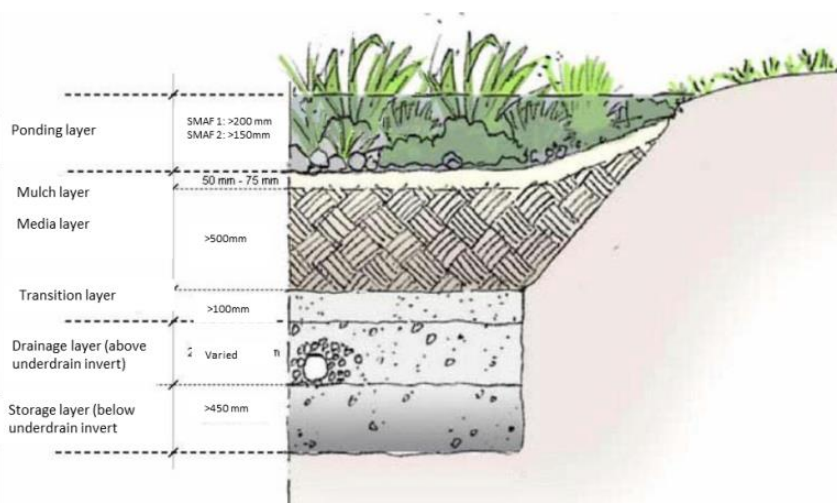

1% AEP detention	✗
50% & 10% AEP detention	✗
Detention for stream protection	✓
Retention	✓
Water quality	✓

Description	<p>A bioretention device (rain gardens, planter boxes, bioretention swales etc.) is a sunken garden with an engineered soil media and an underdrain. These devices pass stormwater through both soil and plants which absorb and filter contaminants before stormwater flows through the underdrain to the surrounding ground or the conveyance system. Bioretention devices help remove pollutants and slow down stormwater flows, recharge freshwater bodies and can have a high aesthetic and amenity value. Two designs are provided for: bioretention devices which provide retention, detention and water quality treatment; and bioretention devices which provide water quality treatment only.</p>
Mana Whenua alignment	<p>Bioretention devices can be planted with native species and act as ecological corridors for birds, invertebrates and reptiles. Planting with harvestable plants can be considered as well as educational signage, with cultural context and history and can include Māori names. Hand weeding of these devices would align with the principles of Taiao and kaitiakitanga. Iwi management plans are a vital resource and should be referred to early in design.</p>
Treatment synergies	<p>Particularly effective if combined with:</p> <ul style="list-style-type: none"> • Upstream: Pre-treatment to remove gross solids and coarse sediments • Downstream: Additional retention (swales) or detention (wetlands).
Advantages	<ul style="list-style-type: none"> • Provides a full suite of stormwater management with detention, retention and water quality treatment • Bioretention devices provide enhanced amenity, safety and aesthetic value through planting and educational opportunities.
Disadvantages	<ul style="list-style-type: none"> • Require very specific construction methods and very specific operation and maintenance • Plant growth and die-off management is needed during establishment phase • Generally not suitable for volume control or managing extreme storm events.
Design considerations	<p>See design chapter including:</p> <ul style="list-style-type: none"> • The device is sized such that it can pass the water quality flow through the device within 72 hours • Specified infiltration and ponding footprints based on mitigation requirements. Specific media with specified infiltration rates. Specified media depths • Bioretention media, transition layer and underdrain aggregate all meet standard specifications.
Innovation opportunities	<ul style="list-style-type: none"> • Planting layout and species. Shape, size and depth can be adjusted (based on detention and retention volume requirements), modularisation.

Living roof



1% AEP detention	✗
50% & 10% AEP detention	✗
Detention for stream protection	✗
Retention	✓
Water quality	*

* Only treats water from rainfall and roof materials.

Description	<p>A green roof is a roof largely covered by vegetation, growing in a substrate on top of waterproof and root-resistant layers. It is designed and constructed to manage stormwater runoff and is made of a waterproof membrane, root barrier, insulation layer, drainage layer, filter fabric, growing medium and plants. Intensive living roofs have a deep soil media and support a wide range of plants and structures (including accessible spaces, gardens or parks). Extensive living roofs have lightweight layers of free-draining media to support drought-resistant vegetation.</p>
Mana Whenua alignment	<p>Living roofs align with Taiao through the protection of the natural environment. They may showcase certain native species and act as an urban sanctuary for certain reptile and insect species. Engaging early with Mana Whenua can help create a design which reflects Mana Whenua values and kaitiakitanga. Iwi management plans are a vital resource and should be referred to early in design.</p>
Treatment synergies	<p>Particularly effective if combined with:</p> <ul style="list-style-type: none"> • Downstream and on-site: rainwater tank (detention and retention) • Other linkages to green urban space.
Advantages	<ul style="list-style-type: none"> • Perceived open space and enhanced building design, or visually mitigating less desirable building aspects • Reduced energy costs through insulation of a building and localised cooling around air conditioner intakes • Decreases urban temperatures. Noise insulation and enhanced air quality and dust interception. Increased service life for underlying roof materials • Is regarded as pervious surface therefore, if used as passive device, does not trigger stormwater management provisions.
Disadvantages	<ul style="list-style-type: none"> • Higher construction and maintenance costs with certain designs • Intensive monitoring period required to ensure that plant stress and die-off is managed • Generally not suitable for volume control or extreme event management.
Design considerations	<p>See design chapter including:</p> <ul style="list-style-type: none"> • Building code compliance, particularly with regard to structural support and safety • Minimum substrate depth of 100 mm, with substrate permeability of 1500 mm/hr (+ drainage layer) or 3600 mm/hr (no drainage layer) • Maximum roof slope of $\leq 15^\circ$ (27%) • Safe design to ensure public and maintenance access is compliant. Access for maintenance requires full Health and Safety compliance (e.g. fall barriers)
Innovation opportunities	<ul style="list-style-type: none"> • Planting layout and species, shape, plant texture and function, amenity aspects, learning opportunities, urban food source, modularisation, retrofitting.

Rainwater tank (non-potable)

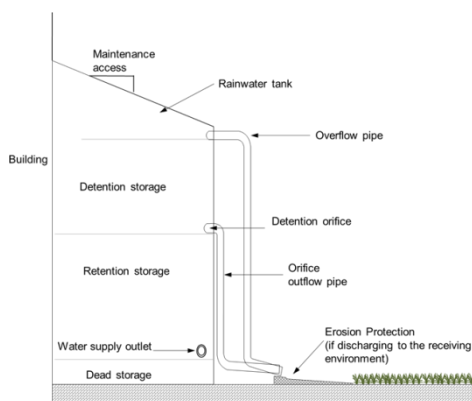

1% AEP detention	✓
50% & 10% AEP detention	✓
Detention for stream protection	✓
Retention (with reuse)	✓
Water quality	✗

Description	Rainwater tanks are used to collect water from the roof and detain it prior to release. Water can also be retained for use on site as supplemental water. The water from these tanks can be for household use (flushing the toilet and laundry supply) or outside purposes (such as garden watering and washing cars).
Mana Whenua alignment	Rainwater tanks that include reuse and/or recharge (in permeable soils) align with kaitiakitanga, Mauri Tu and Taiao and the protection of environmental health. Iwi management plans are a vital resource and should be referred to early in design.
Treatment synergies	Particularly effective if combined with: <ul style="list-style-type: none"> • Multiple households detaining roof runoff volumes to similar tank systems • Upstream: Pre-treatment (such as gutter filters) to remove gross solids • Downstream: Additional retention (such as bioretention) and detention (wetlands etc.).
Advantages	<ul style="list-style-type: none"> • They reduce the use of potable water from the public water supply system for non-potable uses (such as garden irrigation) • They reduce the annual volume of water which runs off from a site and capture the first flush of roof runoff which may contain pollutants from the roof (metals, organic litter etc.).
Disadvantages	<ul style="list-style-type: none"> • Where used for retention, the asset owner must commit to using retained water • Where potable supply is required from the rainwater tank, extensive treatment processes may be required (NB: potable use is not covered in this guideline document) • Size of the tanks can be large and can be perceived as having poor aesthetics • Generally not suitable for volume control or extreme storm event management • Require regular inspection and maintenance by the homeowner.
Design considerations	See design chapter including: <ul style="list-style-type: none"> • Building Code requirements for plumbing (including backflow prevention), Health Act requirements (for potable water use), detention volumes for impervious surfaces. Requires notice on land title to inform owner that maintenance is required • Conveyance (such as guttering) designed to accommodate the size of the storm the tank is designed for.
Innovation opportunities	<ul style="list-style-type: none"> • Shape (multiple options available to accommodate design needs), size (assuming minimum detention volumes are met), location, retrofitting, pump systems, automation. Linking overflows to other devices.

Swale

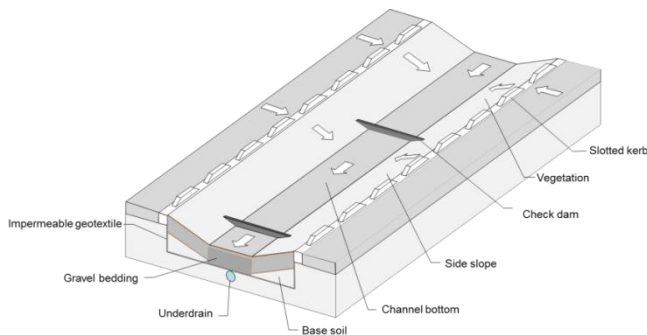

1% AEP detention	✗
50% & 10% AEP detention	✗
Detention for stream protection	✗
Retention	✗
Water quality	✓

Description	Swales are broad, planted channels used to treat stormwater runoff. They direct and slow stormwater across vegetation, grass or similar ground cover and through the soil. Swales help filter sediments, nutrients and contaminants from incoming stormwater before discharging to downstream stormwater system or waterways. Some swales have liners to direct filtered runoff, or rocky linings to slow fast flows. If vegetated, swales are simple to maintain and can fit well in urban design.
Mana Whenua alignment	Mana Whenua preference is for vegetated swales with minimum maintenance (little or no mowing). Swales may be planted with native grasses and other vegetation and can be designed to act as ecological corridors. Filtering sediments aligns with the principles of Taiao and kaitiakitanga. Iwi management plans are a vital resource and should be referred to early in design.
Treatment synergies	<p>Particularly effective if combined with:</p> <ul style="list-style-type: none"> Upstream: Pre-treatment to remove sediments Downstream: Additional detention (wetlands) and/or any retention devices (bioretention).
Advantages	<ul style="list-style-type: none"> Can provide separation of vehicle and foot traffic, amenity and safety Simple to construct with well-understood operation and maintenance Potential to include infiltration through the base in suitable subsoil conditions. Potential to include some detention through use of check dams. Can reduce piped reticulation.
Disadvantages	<ul style="list-style-type: none"> Easily damaged (e.g. compression of soil from vehicles) and requires signage Maintenance access can be difficult, particularly if the device or the adjacent roads are narrow Land take can be large, particularly where storage/volume control is needed Not suitable where slope is greater than 8%. Not suitable on geotechnically unstable ground Generally not suitable for volume control or extreme event management.
Design considerations	<p>See design chapter including:</p> <ul style="list-style-type: none"> Average hydraulic residence time of 9 minutes, with minimum 30 m length Velocity: less than 0.8 m/s for water quality and less than 1.5 m/s for 10% AEP Used on slopes of less than 8% only. Check dams needed for slopes greater than 5% Check dams needed for slopes of greater than 5%. Underdrains needed for slopes of less than 2%. Side slopes: minimum slope 3H:1V for vegetated swales. Minimum slope of 5H:1V for mown grasses Media composition (including compost percentage, void space), loading specification Must be protected from compaction (e.g. vehicles).
Innovation opportunities	<ul style="list-style-type: none"> Including diverse native planting, layout and species, shape, media composition.

Infiltration devices

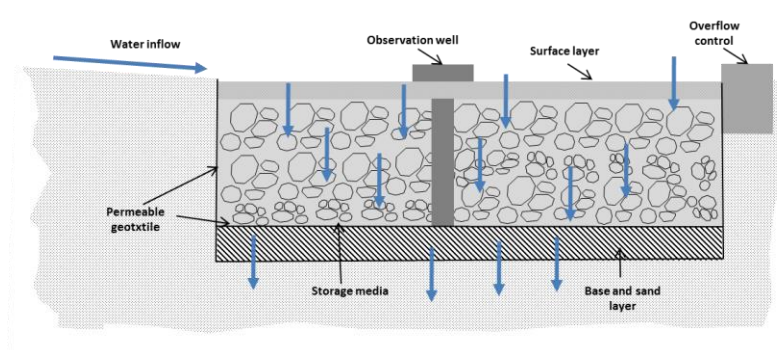

1% AEP detention	✗
50% & 10% AEP detention	✗
Detention for stream protection	✗
Retention	✓
Water quality	✗

Description Infiltration devices (trenches and pits) collect and hold (retain) water below ground for disposal to the groundwater table. Some sediment can be removed by filtering in the stone reservoir or by *in situ* soils adjacent to the excavation where the stormwater is stored but treatment is limited. Soils must be permeable enough to disperse stormwater in a reasonable time and ensure the device is ready to receive further inflow. Only clean water should be discharged to infiltration devices. All other water should be pre-treated to protect aquifers and prolong operational life. They do not function in impermeable soils such as clay.

Mana Whenua alignment Infiltration devices may be designed and constructed to align with Mana Whenua values if they can include such aspects as: pretreatment to ensure the mixing of waters does not lead to contamination; cultural monitoring during excavation. Retained water must be clean water only (e.g. road water only once it has passed through water quality treatment devices). These align with the principles of Taiao. Iwi management plans are a vital resource and should be referred to early in design.

Treatment synergies Particularly effective if combined with:

- Upstream: pre-treatment to remove gross solids, any planted retention device
- Downstream: additional retention (swales, bioretention) or detention (ponds or wetlands).

Advantages

- Provide 100% reduction in load to the surface receiving waters, thereby meeting the pre-development hydrology conditions for retention
- Can be used to recharge groundwater and can be used for retention of up to 50% AEP design storms, if sized correctly. Are underground and therefore generally unobtrusive.

Disadvantages

- High failure rate if no pre-treatment is provided or if surrounding soil conditions are not suitable or if sited on steep slopes. Not suitable on geotechnically unstable ground. If clogged, the device is difficult to refurbish
- Can impact groundwater if located close to high contaminant loads, or where industrial spills might occur
- Upstream drainage must be completely stabilized
- Generally not suitable for volume control (detention) or managing flows from large storms
- Difficult to monitor effectiveness.

Design considerations See design chapter including:

- Slopes of 6° (10.5%) or less only and located 3 m or more from buildings, slopes or trafficked areas
- Soakage and soil testing required. Use in permeable soils (>10 mm/hr), but not so coarse as to allow soakage
- Device invert should be at least 2 m from the seasonal groundwater level
- Pre-treatment needed to reduce sediment loads and prolong device life.

Innovation opportunities

- Location, as part of a suite of devices, shape, depth, groundwater table exploration and recharge.

Wetlands

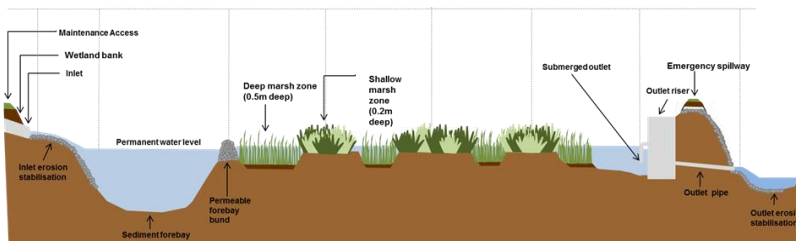

1% AEP detention	✓
50% & 10% AEP detention	✓
Detention for stream protection	✓
Retention	✗
Water quality	✓

Description	Constructed stormwater wetlands are ponded areas, densely vegetated with water-loving plants that mimic the treatment processes of natural wetlands with detention, fine filtration and biological adsorption, to remove contaminants from stormwater runoff.
Mana Whenua alignment	Wetlands provide excellent opportunities for alignment with Mana Whenua values including: opportunities for early design collaboration, species selection (including species for harvest, such as flax), naming, signage, cultural monitoring, sourcing plants, maintenance contracts. Wetlands can align with the principles of kaitiakitanga, Mana, Taiao, Mauri Tu, Ahi kā, Mahi Toi and Tohu. Iwi management plans should be referred to early in design.
Treatment synergies	Particularly effective if combined with: <ul style="list-style-type: none"> • At source: rainwater tanks, living roofs and pervious paving • Mid-catchment: pre-treatment to remove gross solids, any quality treatment (swales, bioretention, proprietary devices) any retention (bioretention, pervious pavement etc.).
Advantages	<ul style="list-style-type: none"> • Reducing downstream flood potential and providing water quality treatment (removing a broad range of pollutants) • Minimising downstream channel erosion. Extreme event flow and volume management • Aesthetics through planting and added amenity value for local communities with educational opportunities • Providing a naturalised haven for aquatic and bird species and enhancing green corridors for existing riparian environments, with improved biodiversity and habitat.
Disadvantages	<ul style="list-style-type: none"> • Does not provide significant retention function • Plant selection can be limited for areas of significant/frequent inundation. Maintenance of vegetation can be difficult, can also promote pests and weeds if poorly maintained • Safety, e.g. potential drowning and vector source • Water temperatures can increase if there is insufficient shade from vegetation.
Design considerations	See design chapter including: <ul style="list-style-type: none"> • Structural design according to relevant dam specifications and guidelines (e.g. NZSOLD 2015 and TP109). At least 60% of wetland area vegetated. Detention volumes (including those for stream protection and flood mitigation). Forebay size (minimum 15% WQV). Emergency spillway • Flow velocities of <0.1 m/s for <50% AEP, <0.5 m/s for up to 1% AEP • Slopes: internal below PWL: <1V:4H, internal above PWL: <1V:3H, mowing: <1V:5H, and safety benches <1V:8H. • Maintenance access: >3.5 m width and 1V:8H slope.
Innovation opportunities	<ul style="list-style-type: none"> • Planting layout and species, shape, bathymetry. Multiple social, cultural and environmental benefits.

Detention ponds (dry)

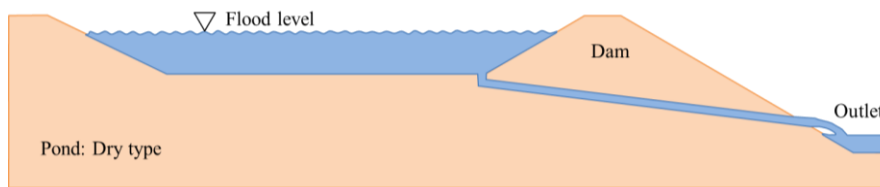

1% AEP detention	✓
50% & 10% AEP detention	✓
Detention for stream protection	✓
Retention	✗
Water quality	✗

Description	Dry ponds have a temporary pool formed (with a planted base) by capturing and releasing stormwater at a slow rate which drains down to the base of the pond between storm events. They provide protection of downstream channels from frequent smaller storms. Dry ponds can service multiple purposes during antecedent periods (such as providing open fields and green space).
Mana Whenua alignment	<p>Dry ponds can provide alignment with Mana Whenua values including:</p> <ul style="list-style-type: none"> • Native species selection (including those for harvesting) • Educational signage • Cultural monitoring • On-going maintenance contracts. <p>Iwi management plans are a vital resource and should be referred to early in design.</p>
Treatment synergies	<p>Particularly effective if combined with:</p> <ul style="list-style-type: none"> • At source: rainwater tanks, living roofs and pervious paving • Mid-catchment: pre-treatment to remove gross solids, any quality treatment (swales, bioretention, proprietary devices) any retention (bioretention, pervious pavement etc.).
Advantages	<ul style="list-style-type: none"> • Reducing downstream flood potential. Minimising downstream channel erosion. Extreme event flow and volume management • Aesthetics and amenity with benefits from accessible open green space between storm events • Provide and enhance green corridors for existing riparian environments, with improved biodiversity and habitat • Distinct advantages over wet ponds (including easier maintenance).
Disadvantages	<ul style="list-style-type: none"> • Does not provide retention or water quality benefits • Temporary standing water can be a potential safety issue • Introduces a dammed water hazard.
Design considerations	<p>See design chapter including:</p> <ul style="list-style-type: none"> • Structural design as required in relevant dam specifications and guidelines (e.g. NZSOLD 2015 and TP109) • Detention volumes (with up to the 1% AEP design event) • Planted in any wetted channel. No trees or shrubs planted on the embankment • Maintenance access to underdrain.
Innovation opportunities	<ul style="list-style-type: none"> • Potential amenity value from open space, planting layout and species, shape.

Ponds (wet)

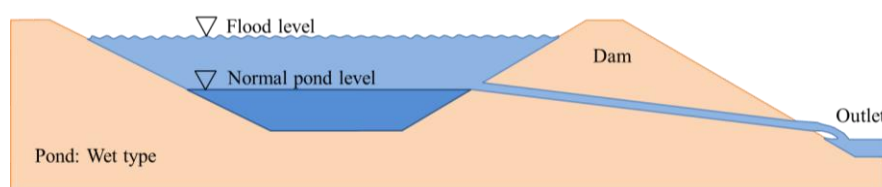

1% AEP detention	✓
50% & 10% AEP detention	✓
Detention for stream protection	✓
Retention	✗
Water quality	✗

Description	Wet ponds detain stormwater inflows within a permanent ponded area. A forebay captures the first flush and provides sediment and gross pollutant reduction, while the body of the pond can promote sedimentation (slow flows allow for longer detention times and minimised turbulence). While water quality treatment occurs in ponds, the negative effects of increased temperature means that they are not considered a water quality treatment device in this document. When constructed in conjunction with extended detention, they provide protection of downstream channels from frequent smaller storms. In all instances, a wetland or dry pond is preferred to a wet pond.
Mana Whenua alignment	Wet ponds are not supported by Mana Whenua as a stormwater detention treatment device.
Treatment synergies	<p>Can be effective if combined with:</p> <ul style="list-style-type: none"> At source: rainwater tanks, living roofs and pervious paving Mid-catchment: pre-treatment to remove gross solids, any quality treatment (swales, bioretention, proprietary devices) any retention (bioretention, pervious pavement etc.).
Advantages	<ul style="list-style-type: none"> Reducing downstream flood potential Reducing downstream channel erosion. Extreme event flow and volume management Aesthetics through planting and added amenity value for local communities with educational opportunities Providing a naturalised haven for aquatic and avian species Provide and enhance green corridors for existing riparian environments, with improved biodiversity and habitat.
Disadvantages	<ul style="list-style-type: none"> Does not provide retention or sufficient water quality treatment. Can cause a significant increase in water temperatures, habitat for pests and weeds Requires resource consent when discharging into streams Standing water can be a potential drowning hazard and vector source (mosquitos and vermin).
Design considerations	<p>See design chapter including:</p> <ul style="list-style-type: none"> Structural design according to relevant dam specifications and guidelines (e.g. NZSOLD 2015 and TP109). Detention volumes (including PWV and up to the 1% AEP design event), forebay size (minimum 15% PWV). Maximum depth of 2 m Must be off-line to waterways with planting for safety and shading Requires maintenance access with >3.5 m width and 1V:8H slope. High grade and durable structure for outlet and erosion control on outlet with sediment drying area Emergency spillway Slopes: internal below PWL: <1V:4H, internal above PWL: <1V:3H, mowing: <1V:5H, and safety benches <1V:8H.
Innovation opportunities	<ul style="list-style-type: none"> Planting layout and species, shape, bathymetry. Can provide multiple social, cultural and environmental benefits.

Each device has differing water quality treatment effectiveness based on multiple site-specific parameters including device type, specific design, contaminant loads and pollutant sources. Table 15 provides a simplified indication of pollutant removal potential for different devices¹⁴.

Table 15: Estimated device effectiveness

Key	Quantity control					Quality control								
	1% AEP	Detention of 50% and 10% AEP	90 th & 95 th percentile detention	Groundwater recharge	Retention	Sediment	Gross pollutants	Heavy metals	Oils and grease	Nutrients	Organics	Hydrocarbons	Indicator bacteria	Temperature
● Effective														
○ Partially effective														
- Not effective														
Pervious pavement - unlined	-	-	●	○	●	●	- _b	- _b	- _b	- _b	- _b	- _b	- _b	- _b
Pervious pavement - lined	-	-	●	-	-	●	- _b	- _b	- _b	- _b	- _b	- _b	- _b	- _b
Living roof	-	-	● ^a	-	●	○	NA	○	NA	○	○	NA	○	●
Rainwater tank (no reuse)	-	○	●	-	-	●	NA	○	NA	○	○	NA	○	○
Rainwater tank (with reuse)	-	○	●	-	●	●	NA	○	NA	○	○	NA	○	○
Infiltration device	-	○	● ^a	●	●	-	-	-	-	-	-	-	-	●
Swale (lined)	-	-	-	-	-	●	○	○	○	○	○	○	○	●
Bioretention swale (unlined)	-	-	●	●	●	●	●	●	●	●	●	●	●	●
Rain garden	-	-	●	●	●	●	●	●	●	●	●	●	●	●
Stormwater tree pit ^c	-	-	○	○	●	●	●	●	●	●	●	●	●	●
Planter box	-	-	○	○	●	●	●	●	●	●	●	●	●	●
Constructed wetland	- ^d	●	●	-	-	●	●	●	●	●	●	●	○	○
Wet pond	●	●	●	-	-	●	●	○	○	○	○	○	○	-
Dry pond (detention basin)	●	●	●	-	-	-	-	-	-	-	-	-	-	●

Notes:

NB: Assumes sizing, construction and maintenance are compliant with this guideline’s requirements

NA: Not applicable, does not treat this pollutant because it is generally not present in the drainage area

●^a: Assumes retention of up to the 90th and 95th percentile events

-_b: Assumes limited water quality treatment for active pervious paving systems. Passive pervious paving is assumed to have some treatment effectiveness if maintained correctly

^c: Stormwater tree pits are different to street tree pits in that they are specifically designed for stormwater management and must be sized accordingly.

-^d Wetlands designs should bypass large storm events to protect vegetation and ensure sediments are not resuspended

¹⁴ Adapted from the International Stormwater Best Management Practice Database, 2014. Sourced from <http://www.bmpdatabase.org>

Table 16: Multiple benefits of devices

Opportunities to improve	Social & cultural values						Environmental values (in addition to water quality)				
	Potential alignment with Mana Whenua values	Incorporating Te Aranga design principles	Improved amenity	Improved community connectedness	Improved public safety	Education	Habitat improvement	Connecting green corridors	Plant diversity	Bird, insect and reptile diversity	Plant ecosourcing
<ul style="list-style-type: none"> ● High potential ○ Some potential - Little/no potential 											
Pervious pavement	●	○	○	●	●	●	-	-	-	-	-
Living roof	●	●	●	●	○	●	○	○	●	●	●
Rainwater tank	●	○	●	○	○	●	-	-	-	-	-
Infiltration device	○	○	-	○	○	●	-	-	-	-	-
Vegetated swale	●	●	○	○	○	●	○	○	○	○	●
Bioretention swale	●	●	○	○	○	●	○	○	○	○	○
Raingardens	●	●	○	●	●	●	○	○	●	●	●
Stormwater tree pits	○	●	○	●	●	●	○	-	○	○	●
Planter boxes	○	●	○	●	●	●	○	-	○	○	○
Constructed wetland	●	●	●	●	○	●	●	●	●	●	●
Wet pond	-	-	●	●	○	●	●	●	●	●	●
Dry pond (detention basin)	○	○	●	●	●	●	○	○	○	○	○

Each site has a variety of constraints which should be designed around, with different devices able to be accommodated in certain circumstances. These design constraints and opportunities are described in more detail in the individual design chapters of Section C.

B1.8.2 Placement of stormwater management devices

Stormwater management devices should be located based on anticipated flows and treatment requirements, as well as the topography and natural flow paths of the catchment (Table 17).

Table 17: Suggested placement of devices in catchment

Location in catchment	Devices	Notes
At source, private and shared space	Pervious paving	Generally used on private driveways and car parking areas. Drainage area generally <1000 m ² .
	Living roof	Used on roof tops of varying area.
	Rainwater tanks	May be used to capture flows from private roof tops or paved areas. Must have asset owner commitment to reuse if designed for retention.
Shared space in the mid-catchment	Bioretention	Can be used in shared areas such as road corridors, pavement areas, recreational areas. Care should be taken to allow for maintenance in shared spaces, particularly in road corridors where safety is a concern.
	Swales	
	Infiltration devices	
Base of catchment, shared space	Wetlands	Placed at the base of a catchment in natural gullies where hydrology will direct flows. Generally used for drainage of more than 2 ha.
	Ponds	

Other key considerations in device placement include:

- Designing to mimic natural hydrology in the catchment
- Safe design - traffic control, heights, confined space, working around water etc.
- Access for construction, maintenance and retrofitting
- Economy of scale – balancing size and placement of devices with capital and operating costs
- Maximising multiple benefits – amenity, biodiversity, neighbourhood design
- Overall intent of the stormwater management suite:
 - Design to remove pollutants as close to source as possible
 - Design to reduce flows and velocity throughout the catchment to reduce erosion.

B1.9 Device design

Individual design chapters in Section C provide direction on design and sizing (Table 18).

Table 18: Device design and sizing reference chapters

Device	Design chapter	Chapter focus and exclusions
Pervious paving	Section C.2	<ul style="list-style-type: none"> Active systems (receiving water from outside of the pervious paving area) which trigger stormwater mitigation requirements.
Bioretention	Section C.3	<ul style="list-style-type: none"> Bioretention swales, rain gardens and stormwater tree pits.
Living roofs	Section C.4	<ul style="list-style-type: none"> Basic living roof design, does not include architectural and structural considerations or the requirements of the Building Code.
Rainwater tanks	Section C.5	<ul style="list-style-type: none"> Above-ground, non-potable rainwater tanks designed to mitigate impervious surfaces.
Swales	Section C.6	<ul style="list-style-type: none"> Swales designed for water quality treatment. Bioretention swales (providing retention) are included in the bioretention chapter.
Infiltration devices	Section C.7	<ul style="list-style-type: none"> Infiltration devices designed to retain water. Does not include soakage devices.
Wetlands	Section C.8	<ul style="list-style-type: none"> Constructed freshwater surface-flow wetlands for stormwater treatment and detention. It does not include ephemeral, saline, floating or subsurface wetlands. Not intended for wetlands treating trade waste discharges, wastewater or agricultural/horticultural runoff.
Ponds	Section C.9	<ul style="list-style-type: none"> Constructed freshwater wet ponds and dry (detention) basins for detention purposes.

B1.10 Life-cycle cost considerations

Life-cycle costing may be defined as “the process of assessing the cost of a product over its life cycle, or portion thereof”¹⁵. Life-cycle costing of stormwater treatment devices is a recognized tool for understanding the long-term cost implications of stormwater management (refer to Appendix A for further details) and is the sum of the acquisition and ownership costs of an asset over its life cycle from design, manufacturing, usage and maintenance through to disposal. The consideration of revenues is excluded from life-cycle costing. A whole-of-life timeframe is warranted because future costs associated with the use and ownership of an asset are often greater than the initial acquisition cost and may vary significantly between alternative solutions to a given operational need (Australian National Audit Office, 2001).

¹⁵ AS/NZ4536:1999 Australian/New Zealand Standards; *Life Cycle Costing – An Application Guide*, Standards Australia, Homebush, NSW, 2001

Life-cycle cost analyses are complex and require in-depth knowledge of a specific site and its constraints; this section (together with Appendix A) provides initial considerations but not comprehensive whole-of-life costing. It provides an overview and guidance to key references which can support a designer's cost estimate needs and provides information on the relative difference in NPV life-cycle costs between different stormwater treatment devices¹⁶. Various models and key references which can support the development of a life-cycle cost analysis are provided in Appendix A.

A full life-cycle cost analysis (together with NPV costing) must be undertaken for any device vested to Auckland Council (see Auckland Council CoP Chapter 4: *Stormwater*⁶). In all instances, life-cycle costs must be discussed in detail with the future asset owner.

B1.10.1 Benefits and potential uses

A life-cycle cost is a means of comparing multiple stormwater management options. For sites where a number of devices are feasible, life-cycle costs should be used to compare capital and operational costs of different options to determine which are the most economical with regard to all benefits (some generic guidance on costs associated with individual devices is provided in Appendix A). Sound reasons are required for proposing options which will have higher operational costs over their life.

A life-cycle cost has a number of additional benefits and supports a number of applications and analyses (Lampe *et al* 2005¹⁷):

- It allows for an improved understanding of long-term investment requirements
- It helps decision-makers make more cost-effective choices at the project scoping phase
- It provides for an explicit assessment of long-term risk¹⁸
- It reduces uncertainties and helps councils determine appropriate development contributions
- It assists councils in their budgeting, reporting and auditing processes.

Decision-making on the use of stormwater treatment devices needs quality data on the technical and financial performance of these devices. The financial performance will depend on the sum and distribution over the life cycle of the device of costs associated with design, construction, use, maintenance and disposal. Life-cycle costing can be used for structuring and analysing this financial information.

¹⁶ Cost information is provided in this document as guidance only. Designers must use current and design-specific costings for any NPV calculation

¹⁷ Lampe, L., Barrett, M., Woods-Ballard, B., Kellagher, R., Martin, P., Jefferies, C., Hollon, M. (2005). *Performance and Whole Life Costs of Best Management Practices and Sustainable Urban Drainage Systems*. WERF Report Number 01-CTS-21T

¹⁸ Risk in this context can be understood as the quantum of maintenance cost liability that councils may face once assets are vested

B1.10.2 Undertaking a life-cycle costing analysis

Undertaking a life-cycle cost analysis is complex and requires detailed knowledge of the site and its constraints, as well as the detailed design of the relevant stormwater device. Each development option or device needs to be subjected to a full life-cycle cost analysis. Until a more prescriptive methodology is available, designers are advised to consult with Auckland Council on proposed methodology and pricing, especially as contract maintenance costs are generally only available from Auckland Council for assets to vest.

The COSTnz model template (as described in Appendix A) can be used, but it is recommended that your own cost and pricing information is used rather than the default values, as this will lead to a more accurate costing assessment. Alternatively, you can create your own life-cycle costing model using a schedule of costs. Generally, proprietary products costs can be sourced from the manufacturers.

Table 19 provides a description of the necessary parameters and information which should be used when undertaking a life-cycle costing assessment.

Table 19: Relevant life-cycle cost parameters and information

	Life-cycle cost element	Key considerations/parameters
Step 1	Specify device parameters	<ul style="list-style-type: none"> The device needs to be sized appropriately for the contributing catchment area, including: <ul style="list-style-type: none"> Device design and expected contaminant removal Landscaping requirements. Sizing and design parameters should be specified within the life-cycle cost analysis.
Step 2	Specify the life span	<ul style="list-style-type: none"> The life span is the functional life of the treatment device in years.
Step 3	Specify the life-cycle analysis period	<ul style="list-style-type: none"> This is the period of time (in years) over which the model will analyse the costs. The life span may differ depending on the type of device, but ensure that the life-cycle analysis period is consistent so that the life-cycle cost results are comparable. TR 2013/043¹⁹ recommends that the total life-cycle analysis period should not exceed 60 years. The Auckland Council Cost Benefit Analysis Primer²⁰ also provides recommendations on the life-cycle analysis period. Life-cycle analysis periods should take account of fabricated elements containing a treatment device that are generally required to have a design life of 100 years, where the device contained might require restorative renewal within that lifetime.
Step 4	Specify the base date for life-cycle cost analysis	<ul style="list-style-type: none"> Ensure that all costs used in the life-cycle cost analysis have the same base date.

¹⁹ Auckland Council TR 2013/043 *Auckland Unitary Plan Stormwater Management Provisions: Cost and Benefit Assessment*

²⁰ Auckland Council TR 2016/018 *Understanding the Costs and Benefits of Planning Regulations: A Guide for the Perplexed*

	Life-cycle cost element	Key considerations/parameters
Step 5	If necessary, specify the inflation rate	<ul style="list-style-type: none"> • Life-cycle cost analyses do not include an inflation component. However, depending on where the cost data is sourced from, costs may need to be inflated or deflated to ensure all the costs in the model have the same base date. • It is recommended that the inflation index provided by Statistics New Zealand (the Producer Index for “Other Construction Activity” rates) is used.
Step 6	Decide on a discount rate in order to inform the final NPV	<ul style="list-style-type: none"> • Discounting is used to find the value at the base year of future costs, in other words, the NPV. The real discount rate should be used. • The discount rate can have a significant impact on the estimated NPV. A discount rate of 4% was used in TR 2013/043¹⁹ and a rate of 3.5% was used in the NIWA costing work. • COSTnz provides an option of either a 3% or 6% discount rate, or users can specify their own rate. • The public sector discount rate is published by the NZ Treasury. It is set at 8% and can be viewed at: http://www.treasury.govt.nz/publications/guidance/planning/costbenefitanalysis/discountrates • The Auckland Council Cost Benefit Analysis Primer²⁰ recommends a 4% discount rate. • A higher discount rate will incur lower NPV maintenance costs over the life of a device than a lower discount rate. • Using a 4% discount rate, in line with Auckland Council recommendations, allows for a cautionary assessment and understanding of long-term maintenance costs.
Step 7	Determine the total acquisition costs	<ul style="list-style-type: none"> • Total acquisition costs relate to the design, planning, consenting and construction costs of a device. It can include, amongst other things: <ul style="list-style-type: none"> ○ Site establishment ○ Materials ○ Equipment hire ○ Locating existing services ○ Traffic management ○ Site clearance ○ Earthworks/excavation ○ Erosion protection ○ Consent compliance and inspections ○ Planting/landscaping ○ Transportation ○ Labour ○ Clean-up ○ Costs of any associated features (e.g. signage, fencing, etc.) ○ Land costs. • All total acquisition costs should be documented in the form of a ‘schedule of quantities’ with costs assigned to each element. Unit costs, units and quantities should be clearly specified.

	Life-cycle cost element	Key considerations/parameters
Step 8	Determine the routine maintenance costs	<ul style="list-style-type: none"> • These are annual costs which relate to routine maintenance events such as mowing grassed areas, weeding, general inspections, etc. They include costs associated with relevant administration, inspections, staff training and waste disposal. • COSTnz and TR 2013/043¹⁹ provide guidance on the different types of routine maintenance activities for devices. • Maintenance costs need to be specified for each identified item of maintenance, along with unit costs, units and frequencies of maintenance.
Step 9	Determine the corrective maintenance costs	<ul style="list-style-type: none"> • These are costs associated with significant corrective interventions to the treatment device. • They occur infrequently and can be incurred as a result of large storm events. They include repairing parts, cleaning out sediments and their disposal, replacing filter media, etc. • Any special or irregular maintenance activities should also be included. • COSTnz and TR 2013/045²¹ provide guidance on the different types of corrective maintenance activities for devices. • Maintenance costs need to be specified for each identified item of maintenance, along with unit costs, units and frequencies of maintenance.
Step 10	Decommissioning costs	<ul style="list-style-type: none"> • If it is envisaged that the device will be decommissioned at the end of the life-cycle analysis period, these costs should be included. • If the device will continue to operate, then corrective maintenance needs to be scheduled for the final year of the life-cycle analysis period and decommissioning costs can be excluded.
Step 11	Total discounted life-cycle costs - NPV	<ul style="list-style-type: none"> • Run your model to determine the total discounted life-cycle costs, i.e. the NPV. • The NPV can be compared for different devices. The lowest NPV equates to the cheapest option.

A costing template is provided in Appendix A and can be used for collating all life-cycle cost results. All life-cycle cost assumptions should be clearly documented.

²¹ Auckland Council TR 2013/045 *Living Roof Review and Design Recommendations for Stormwater Management*

B1.11 Construction

Each specific device chapter contains some design considerations that impact the construction phase. These sections are provided as high-level considerations and are not exhaustive. Construction of devices shall comply with all relevant codes, standards and guidelines, including, but not limited to:

- Auckland Council CoPs
- Auckland Council TR 2010/052 *Construction of Stormwater Management Devices in the Auckland Region*

B1.12 Operation and maintenance

Each specific device chapter contains some design considerations that impact the operation and maintenance phases. These sections are provided as high-level considerations and are not exhaustive. Operation and maintenance requirements of individual devices shall comply with all relevant codes, standards and guidelines, including, but not limited to:

- Auckland Council TR 2010/053 *Operation and Maintenance of Stormwater Management Devices in the Auckland Region*.



C1 Plants and soils

Table of Contents

C1.0	Technical guidance: plants and soils	71
C1.1	Introduction	71
C1.2	Plant design process	74
C1.3	Pre-design considerations	75
	C1.3.1 Assessment of multiple benefits	75
	C1.3.2 Climate.....	77
	C1.3.3 Use of native plants and sourcing locally	78
C1.4	Assessing and managing on-site soils	78
	C1.4.1 Base soil investigation	79
	C1.4.2 Base soil management	81
	C1.4.3 Rainfall retention properties of soil	84
	C1.4.4 Infiltration and permeability testing	84
	C1.4.5 Determining the curve number	85
C1.5	Materials specifications	86
	C1.5.1 Engineered soils	86
	C1.5.2 Aggregates.....	88
	C1.5.3 Amendments.....	88
	C1.5.4 Geotextiles	88
C1.6	Plants	89
	C1.6.1 Planting stormwater wetlands (and pond borders)	90
	C1.6.2 Planting bioretention devices.....	95
	C1.6.3 Planting swales	100
	C1.6.4 Planting living roofs.....	104
	C1.6.5 Planting grassed devices	107
C1.7	Design for safety	108
C1.8	Construction design considerations	108
	C1.8.1 Soil preparation.....	108
	C1.8.2 Planting	112
C1.9	Operation and maintenance design considerations	115
	C1.9.1 Watering.....	115
	C1.9.2 Weeding, pruning, mowing	115
	C1.9.3 Weed and pest control.....	116

Figures

Figure 7: Pohutukawa transplanting, Albany	77
Figure 8: Soil profile example	79
Figure 9: Examples of different soil structure types	80
Figure 10: Soil management	83
Figure 11: Soil moisture in relation to plant available water	84
Figure 12: The three planting zones that provide for the function of stormwater wetlands and ponds	91

Tables

Table 20: Examples of benefits of landscape and ecology in the context of stormwater management	71
Table 21: Device-specific planting and media maintenance recommendations	72
Table 22: Soils and handling notes	82
Table 23: NRCS hydrological soil grouping for Auckland soils	85
Table 24: Soil type and associated curve number based on land use	86
Table 25: Soil composition of stormwater management devices	87
Table 26: Geotextile characteristics and uses	89
Table 27: Recommended wetland species: 0.01 – 1 m height at maturity	92
Table 28: Recommended wetland species: 1 – 3 m height at maturity	93
Table 29: Recommended wetland species: >3 m height at maturity	94
Table 30: Recommended bioretention ground species: 0.25 – 2 m height at maturity	96
Table 31: Recommended bioretention tree and shrub species (>3 m height at maturity) in low contaminant environments	98
Table 32: Recommended bioretention species (<100 mm height at maturity) for underplanting in areas with low sediment and low weed pressure	99
Table 33: Recommended swale ground species: 0.25 – 2 m height at maturity	101
Table 34: Recommended swale small tree and shrub species: >3 m height at maturity	103
Table 35: Recommended swale ground cover species: <100 mm height at maturity at sites with low sediment and weed pressure	103
Table 36: Recommended living roof species 100 - 300 mm soil depth	105
Table 37: Recommended planting specifications	114
Table 38: Pest management	116

C1.0 Technical guidance: plants and soils

C1.1 Introduction

Planted devices (such as wetlands, bioretention devices, ponds, swales, living roofs, pervious paving etc.) need vegetation to grow and be resilient over the life of the device. This section focuses on the choice and use of soils and their role in the establishment of plants for specific stormwater management purposes. Information in this section was sourced primarily from Auckland Council's technical report, TR 2009/083 *Landscape and Ecology Values within Stormwater Management*¹. It identifies soil and plant characteristics that are needed to ensure planted devices are successful at the individual device, site and landscape scale.

Besides the plants' function as stormwater management device components, they also provide ecological and amenity value. At the earliest design stage, decide whether planting will be balanced more towards ecology or amenity (although planting should ideally provide both values). For many urban situations (where the majority of stormwater management will occur), the focus is often on garden-like plant solutions with visual amenity, colour and interesting texture. Where devices may function as an ecological resource, plants should be native to the Auckland region and location-specific (e.g. coastal) and ecosourced² where possible. It is recommended that designers discuss options with a horticultural specialist during the design process.

The non-stormwater benefits delivered by well-designed devices can offset costs (both direct capital and maintenance costs) and indirect costs. Some benefits of planting are presented in Table 20¹.

Table 20: Examples of benefits of landscape and ecology in the context of stormwater management

Aspect	Example benefits
Amenity	<ul style="list-style-type: none"> Enhanced social connection through access to shared green space. Exposure to educational material and information, and interpretation of educational information to multiple audiences, ages and ethnicities. Encouraging walking and cycling.
Cultural	<ul style="list-style-type: none"> Alignment with Mana Whenua values and Te Aranga design principles, including educational opportunities and cultural narrative opportunities (refer to Section A and Section B).
Ecology	<ul style="list-style-type: none"> Soil conservation, protection of ecological communities, habitat diversity, hydrological diversity, biosecurity.
Environmental	<ul style="list-style-type: none"> Heat dissipation in the urban environment, improved air and water quality, mitigation of spills and acute contamination, reduced irrigation and fertilizer requirements for landscaping.
Landscape	<ul style="list-style-type: none"> Protection of existing landscape features, enhanced spatial experience, enhanced safety.

¹ Auckland Council TR 2009/083 *Landscape and Ecology Values within Stormwater Management*

² Ecosourced plants are collected from existing vegetation or seeds in the immediate vicinity of the site

Aspect	Example benefits
Personal safety	<ul style="list-style-type: none"> • Shading of people from direct and reflected UV and heat, especially at corners and stopping places (pedestrian crossings, bus stops, schools). • Physical separation of public and private areas using devices (often combined with changes in ground height).
Stormwater management	<ul style="list-style-type: none"> • Coarse litter trapping and decomposition, sedimentation and filtration, shade, slope stabilization, enhanced microbial processes, uptake of nutrients, adsorption, evapotranspiration and groundwater recharge and a buffer from potential contamination.
Transport and traffic safety	<ul style="list-style-type: none"> • Vegetation reduces damage in crashes. Vegetation height, density and placement can reduce headlight glare and sun-strike risk. • Provides physical separation of pedestrians/cyclists/cars using stormwater devices, reducing potential for harm. • Prevents dangerous parking (e.g. using bump-out rain gardens at corners), and can narrow roads at pedestrian crossings to slow traffic.

Designers should seek advice from a professional horticulturalist, ecologist or landscape architect on design, installation and maintenance plans to maximise these benefits and reduce risks. Input from design through to installation and defects liability sign-off should be required for large-scale projects. Table 21 provides device-specific planting and media recommendations.

Table 21: Device-specific planting and media maintenance recommendations

Device	Ideal plant characteristics	Ideal soil characteristics	Maintenance
All devices	<ul style="list-style-type: none"> • A diverse selection of species to allow self-selection and resilience. • Ensure growth form can meet required clear zones and sight lines; provide adequate root volume. 	<ul style="list-style-type: none"> • Soils should support healthy plant growth with minimal weed and pest presence, as well as minimal maintenance. • Sacrificial soil layers should be used wherever high contaminant loads are present. 	<ul style="list-style-type: none"> • Ensure future asset owner is aware of all maintenance obligations and associated costs. • Ensure design complements maintenance of adjacent areas and edges. • Allow for additional leaf removal from inlets and maybe groundcover if deciduous; allow for pruning.
Wetlands	<ul style="list-style-type: none"> • Plants should be tolerant of drought, stress and inundation and promote shade. • Plants should provide both amenity and ecological value and be designed for safety. 	<ul style="list-style-type: none"> • Impermeable layer to retain water. Bathymetry soils (300 mm soil depth with 50% organic topsoil/sand mix). • Soils need to support plant growth and manage saturation, planting soils need to support dense and tall plant growth. 	<ul style="list-style-type: none"> • Ensure wetland can be drained to allow maintenance. • Ensure soils provide adequate fertility and root depth (flax, trees).

Device	Ideal plant characteristics	Ideal soil characteristics	Maintenance
Bioretention	<ul style="list-style-type: none"> Match plant species to inundation period and depth. Plants should be located appropriately within the bioretention device (e.g. larger species in the centre). Plants should be matched to the expected device life. 	<ul style="list-style-type: none"> Free draining, able to support dense compact plantings, potentially including trees. Soils should settle down to below the inlet to allow ponding in the rain garden. 	<ul style="list-style-type: none"> Ensure irrigation is available for summer. Ensure roadside devices are safe to maintain with minimum impact on traffic flows. Consider sacrificial soil layer for easy maintenance of treatment layers.
Ponds	<ul style="list-style-type: none"> Plants should be tolerant of drought, stress and inundation and promote shade. Plants should provide both amenity and ecological value and designed for safety. 	<ul style="list-style-type: none"> Impermeable layer – compacted clay. Allow for soil settling. Bathymetry and planting soils – amended base soils. 	<ul style="list-style-type: none"> Ensure access to forebay is safe and accessible. Ensure pond can be drained for maintenance.
Grassy swales	<ul style="list-style-type: none"> Plants should be moderately stiff, non-clumping and capable of being maintained between 50 mm and 200 mm height. Preference is for swales not to be mowed. 	<ul style="list-style-type: none"> Uncompacted, allowing laminar flow and supporting growth of grasses and plantings. 	<ul style="list-style-type: none"> Consider sacrificial soil layer for easy maintenance/removal of treatment layers. Design to ensure mowing safety; consider planting to reduce/eliminate mowing needs.
Unmown swales	Dense vegetation with minimum 50 mm and up to 1000 mm height that filters flow, non-clumping vegetation.	<ul style="list-style-type: none"> Top soils and compost, sand. 	<ul style="list-style-type: none"> Consider potential for invasion of weed species from adjacent areas, especially if grassed.
Living roofs	Plants should be tolerant of thin soils, full sun, high winds and drought.	<ul style="list-style-type: none"> Lightweight, free draining. 	<ul style="list-style-type: none"> Allow for irrigation to enable roof survival in droughts. Ensure safety of access for maintenance (anchors, barriers, etc.).
Pervious pavement	Plants should be tolerant of mowing or low enough to avoid the need for mowing (where plants grow between the pavers).	<ul style="list-style-type: none"> Free draining, supports light traffic loads, layered to avoid compaction, designed layered to avoid media migration. 	<ul style="list-style-type: none"> Tolerant of heat, drought stress.

C1.2 Plant design process

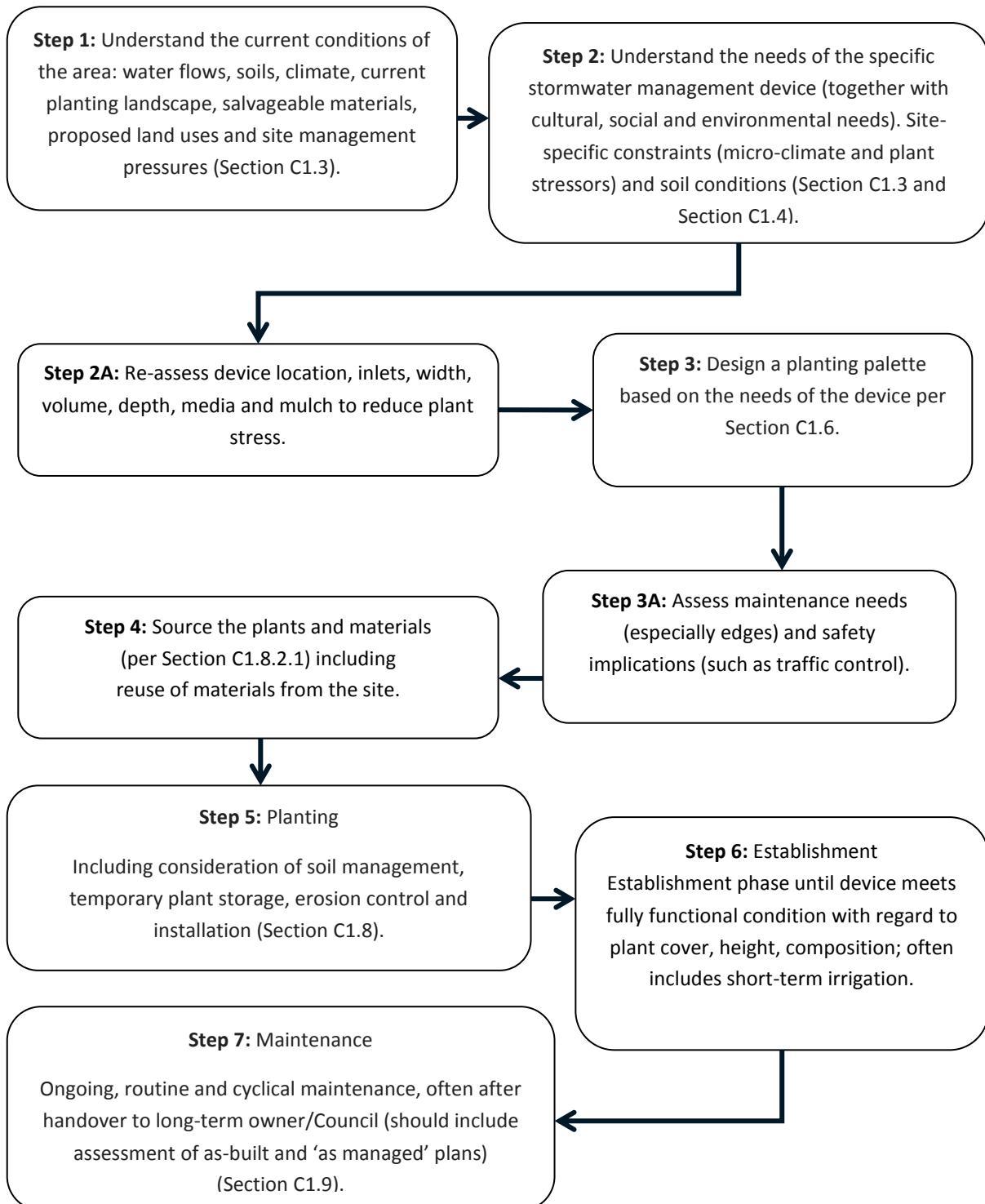

C1.3 Pre-design considerations

This section provides overarching site-specific considerations that include determining the character of the underlying soils, consideration of planting needs, management during construction and pest management.

C1.3.1 Assessment of multiple benefits

Well-designed planting, together with on-site soil management, can meet many objectives and can enhance stormwater control and the cultural, social and environmental liveability of an area. This section provides a brief overview of some of those benefits.

C1.3.1.1 Mana Whenua values

Water:

- Water conservation
- Avoiding mixing waters from different sources
- Acknowledging the importance of water by managing stormwater on site
- Treating stormwater (restoring its mauri) by passing it through land before it is released into natural waterways.

Landscape:

- Protection of habitats of edible plants and native marine life which are traditional sources of food for local Māori
- Restoring a buffer of native vegetation alongside waterways, wetlands and remnant vegetation
- Opportunity to include/reinstate or improve health of remnant landmark species of the region
- Provide native habitat for traditional flora and fauna, including fish passage where appropriate
- Acknowledging the importance of the landscape by accentuating softer, green areas within hard urban spaces.

Education:

- Educational opportunities with schools and communities
- Narrative opportunities (including signage)
- Mana Whenua, matāwaka and tauwiwi making a tangible contribution to the community through planting days
- A holistic approach to resource management
- Mana Whenua can provide karakia for site blessing to enhance overall significance of site.

C1.3.1.2 Environmental

Ecology including:

- Protecting existing ecological communities
- Providing habitat
- Soil conservation including consideration of vulnerability from compaction and protection of valuable soils (Section C1.8.1)
- Plant conservation including ecosourcing and salvage, retained leaf litter, wood mulch and logs, rare species
- Hydrological diversity (where necessary – e.g. wetlands) including spaces for riffle zones, pools refugia, diverse substrates etc.
- Biosecurity including management of invasive species through careful plant sourcing and selection, pest control
- Providing buffers.

Environmental benefits from planting (particularly with regard to stormwater treatment) include:

- Dispersion of flows
- Sedimentation and filtration
- Shade and solar benefits
- Slope stabilisation and erosion prevention
- Enhanced biological function - microbial activity (e.g. biofilm growth), oxygen transport to roots, nitrification, nutrient uptake
- Evapotranspiration.

C1.3.1.3 Amenity

Amenity can be improved through effective planting with:

- Increased community awareness of water sensitive design
- Improved shade and reduced ultraviolet light impacts
- Urban habitat creation
- Improved health including air quality, reduced noise, visual buffers to built environments, visible green space.

If devices are constructed for landscape amenity and function, they are more likely to become a permanent, well-maintained feature of the development, as landowners are more likely to take pride and stewardship over these facilities.

Designs must emphasise that these devices are growing systems that change. Plant size, condition and colour will change with climate, age and stress condition of the plants. In particular, without specific maintenance, the proportion of groundcover plants is likely to change and any sharp planting patterns blurred or lost.

C1.3.1.4 Reuse of materials on site

Both greenfield and brownfield sites will have resources that can be reused if they are adequately protected, stored and/or rehabilitated. Many trees can be shifted, notably nikau palms, tree ferns and pohutukawa (up to 200 tonnes, 10 m canopy height), given suitable expertise and timing. This is particularly valuable for any native planting, as the invertebrate and fungal communities in the soil and litter layers can be retained.



Figure 7: Pohutukawa transplanting, Albany

C1.3.2 Climate

The climate of a specific location, combined with properties of a stormwater management device, will have a long-term impact on planting success. Water stress will vary across a site and even across a device, depending on the distribution of stormwater and ratio of device size to its catchment.

- **Micro-climates:** Climatic conditions of a small area within a catchment may be quite distinct from the characteristics of the wider area around it. This should be understood prior to deciding on the layout of any planted devices. It's also important to consider how the placement of a device might change the area's micro-climate
- **Moisture surplus and stress:** Moisture available for plant growth is influenced by the catchment size and volume of water stored in the soil. The duration and seasonal patterns of moisture stress need to be understood. Taller, deeper-rooting plants use (transpire) more water than grass, while deciduous trees use no water in winter
- **Aspect, slope, shade and irrigation:** Plants' needs are directly impacted by site-specific elements. For instance, a gently sloping southerly aspect with shade and irrigation can help reduce plant stress from moisture loss. The most effective, long-term mitigations for drought stress are to increase the soil volume and water stored (per cubic metre of soil), and ensure plants have a deep enough root system to extract the water.

C1.3.3 Use of native plants and sourcing locally

Designs should include natives and locally sourced plants (ecosourcing) where seeds, cuttings and plants are sourced from local and remnant vegetation. Planting with a preference for local native species has multiple benefits:

- Alignment with Mana Whenua values
- Many Auckland native plants are unique and their use ensures resilience of the species
- Local plants are more likely to survive
- Ecosystems are more resilient.

Ecosourcing can also provide multiple benefits:

- An opportunity to engage with local community groups and schools
- The genetic stock is already pre-adapted to the local environment
- Ecosourcing conserves natural, genetic and phenotypic diversity in local native plant populations
- Plants salvaged and replanted from the site can be more economical.

C1.4 Assessing and managing on-site soils

Designers need to understand the site-specific constraints imposed by existing soils in order to optimise device function. Soils in their natural state are porous and full of living organisms which adsorb and absorb contaminants from stormwater. Between 10 to 30% of topsoil is normally filled with air; a further 10 to 30% is filled with water available for plant roots and soil organisms. This void space (the space filled with water or air) provides retention volume in the media. Large, interconnected pores allow water and air to move into and through the soil aiding both retention and detention functions.

Healthy soils support stormwater management, landscape and ecology by:

- Supporting healthy plant growth
- Retaining or enhancing permeable soils to reduce the area of highly-engineered stormwater control devices. Such soils can serve as non-structural, natural bioretention at low cost
- Minimising runoff by absorbing and infiltrating water into freely draining soil
- Allowing air exchange
- Storing, supplying and cycling nutrients available to plants and minimizing leaching of nutrients into ground and surface water
- Providing structural support for larger plants, while allowing root penetration through friable soils.

Soil investigations will identify opportunities for stormwater use on site (such as groundwater recharge or reuse) and for planting to prevent runoff and extend flow path lengths. Together, these can dramatically reduce the volume of runoff and pollutant loads.

C1.4.1 Base soil investigation

In all cases, geotechnical investigations are needed to establish the characteristics of the underlying soil in order to reduce risks associated with the presence of:

- Soil erosion
- Potentially unstable slopes or tomo-susceptible ground
- Limited permeability soils
- Expansive soils which have the potential for shrinking or swelling as a result of changing moisture conditions
- Collapsible soils which are commonly observed in loosely deposited sediments, separated by clay or carbonate particles, or in insufficiently compacted fills
- Contaminated soils
- High winter water tables.

Soils can be assessed on site by digging test pits or taking soil bores (using an auger) to expose the soil profile which is made up of different horizons (Figure 8). Soil is generally characterised by texture, colour and structure. These characteristics determine the likely permeability of the soil, the potential for infiltration for retention devices and groundwater level.

C1.4.1.1 Colour

Soil colour is used to estimate the soil's drainage properties and can be used to determine the depth to the seasonally high water table and/or perched water table conditions. The colour is affected by the organic matter and mineral content of a soil, with iron minerals providing the greatest variety. Where saturated conditions are present for extended periods of time, lack of oxygen in the soil causes iron to oxidize and leach, resulting in mottles (periodic saturation) or grey colours (associated with longer-term saturation) and results in a very pale, grey soil (chroma). As determining colour is quite subjective, soils are usually assessed using the Munsell soil colour chart, or equivalent.

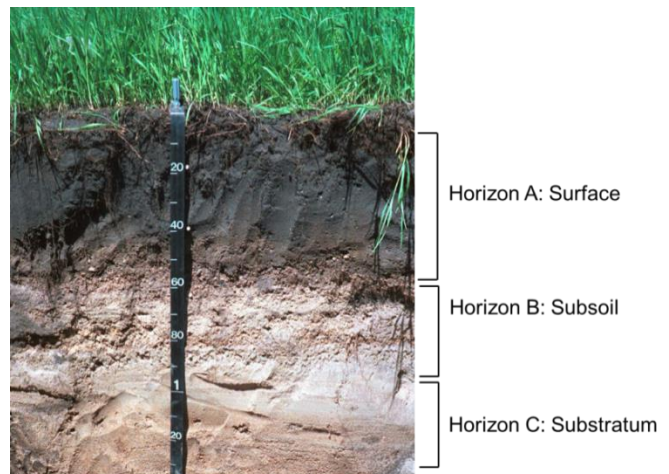

Figure 8: Soil profile example

C1.4.1.2 Structure

Soil structure is the aggregation of individual soil particles into larger units called “peds”. The degree, size, shape and orientation of soil peds influence water movement in the soil profile:

- **Degree:** Degree defines the distinctness of peds. A soil with a “strong” degree of structure has clearly defined fractures or voids between the peds, allowing water to pass through more easily. A “weak” degree of ped structure is less distinct and offers more resistance to water flow
- **Size:** Smaller peds create more inter-pedal fractures, which provide more flow paths for percolating water. Larger peds will have reduced flow paths
- **Shape:** The more common types of structure are granular, angular blocky, sub-angular blocky and platy (Figure 9). Platy and massive soils restrict the vertical movement of water. Structureless soils include single-grain soils (e.g. sand) and massive soils (e.g. hardpan) and have no observable aggregation or no definite orderly arrangement of natural lines of weakness.



Figure 9: Examples of different soil structure types³

³ Photo sources: S. Ormiston (2016), Silyn Roberts (2016) and UK Agriculture and Horticulture Development Board accessed at: http://www.ahdb.org.uk/projects/documents/ThinkSoils_001.pdf

C1.4.1.3 Texture

Texture is determined by the proportions of the three principal mineral-size fractions in soil (clay, silt, sand). The New Zealand Geotechnical Society Field Description of Soil and Rock (2005) provides the following particle size ranges:

- Clay (grain diameter <0.002 mm)
- Silt (grain diameter 0.002 to 0.06 mm)
- Sand (grain diameter 0.06 to 4.76 mm).

Soil texture is determined using the “Feel” method (University of Minnesota Agricultural Extension Service [1990] and USDA [1993]⁴). Table 23 and Table 24 show the approximate correlation of the soil texture to curve numbers.

Clay content is not necessarily a good indicator of permeability; some clays are well-drained and friable (e.g. Pukekohe soils) as the small particles aggregate into larger particles. Note that adding sand to a clay soil may change its texture but may not improve drainage and aeration in the medium term, particularly if a dense network of plant roots is not maintained.

C1.4.2 Base soil management

Designers should understand where soils must be protected and where they may need to be amended or removed. This section provides guidance for designers to understand the base soils on a site.

C1.4.2.1 Special cases

Some soil types or locations are inappropriate for soakage, or require special treatment. These include:

- Infiltration devices: These should not be used if there is evidence of soil erosion in overland flow paths or ephemeral waterways
- Introducing water into the ground (for example when using permeable paving) which can reduce the strength of surrounding soils and increase the risk of geotechnical instability. An assessment should be carried out to determine if infiltration is acceptable for the site
- Subsoils with limited permeability which may need perforated underdrains at the base of the course to drain the design volume within 24 hours.

C1.4.2.2 Identify valuable hydrological soils

A significant amount of valuable soil may be lost through the development process unless identified and managed. If leaving such soils *in situ* is not possible, then these topsoils and subsoils should be separately stripped, stockpiled if necessary, and re-used as permeable fill for vegetated areas, such as constructed swales, grassed areas (playing areas of roadside verges), forested recreational or scenic reserves, or

⁴ Available on the following websites: <http://www.extension.umn.edu>; <http://www.nrcs.usda.gov>

gardens. Areas of organic soils (such as peat) are also valuable and can be used as topsoil conditioners; peat is recognised as being particularly effective at attenuating copper and zinc.

C1.4.2.3 Management of sensitive soils

Some soils require special handling⁵ (Table 22 and Figure 10).

Table 22: Soils and handling notes

Soil type	Soil examples	Handling notes
Poor draining soils	Many Ultic soils, most Podzols and all Gley soils	<ul style="list-style-type: none"> Easily damaged and difficult to remediate. Narrow moisture range. Under poor drainage, adding organic amendments risks generating plant-toxic sulphides and methane.
Organic soils	Peat	<ul style="list-style-type: none"> Not usually difficult to handle, as long as water tables are low enough and low-ground pressure machinery is used, but need special management if maintained <i>in situ</i>. Water tables need to be maintained at a level that minimises oxidation (as this leads to volume loss) and development of hydrophobicity.
Soils with high, or perched, water tables	Gley soils and organic soils	<ul style="list-style-type: none"> Limits depth and efficacy of bio-filtration and infiltration devices. Specialist stormwater engineering and ecological input should be sought in these instances.
Acidic soils	Marine sediments	<ul style="list-style-type: none"> Can be highly acidic when exposed to oxygen. For these, as for contaminated soils, site-specific technical expertise should be sought on best management practices, particularly conditions influencing use of these soils for on-site infiltration of stormwater.

⁵ Auckland Council TR 2009/073 *Hydrological Effect of Compaction Associated with Earthworks*

Figure 10⁶ has been adapted from Toronto and Region Conservation Authority as a guide for how soils may be managed given different site constraints and differing management practices.

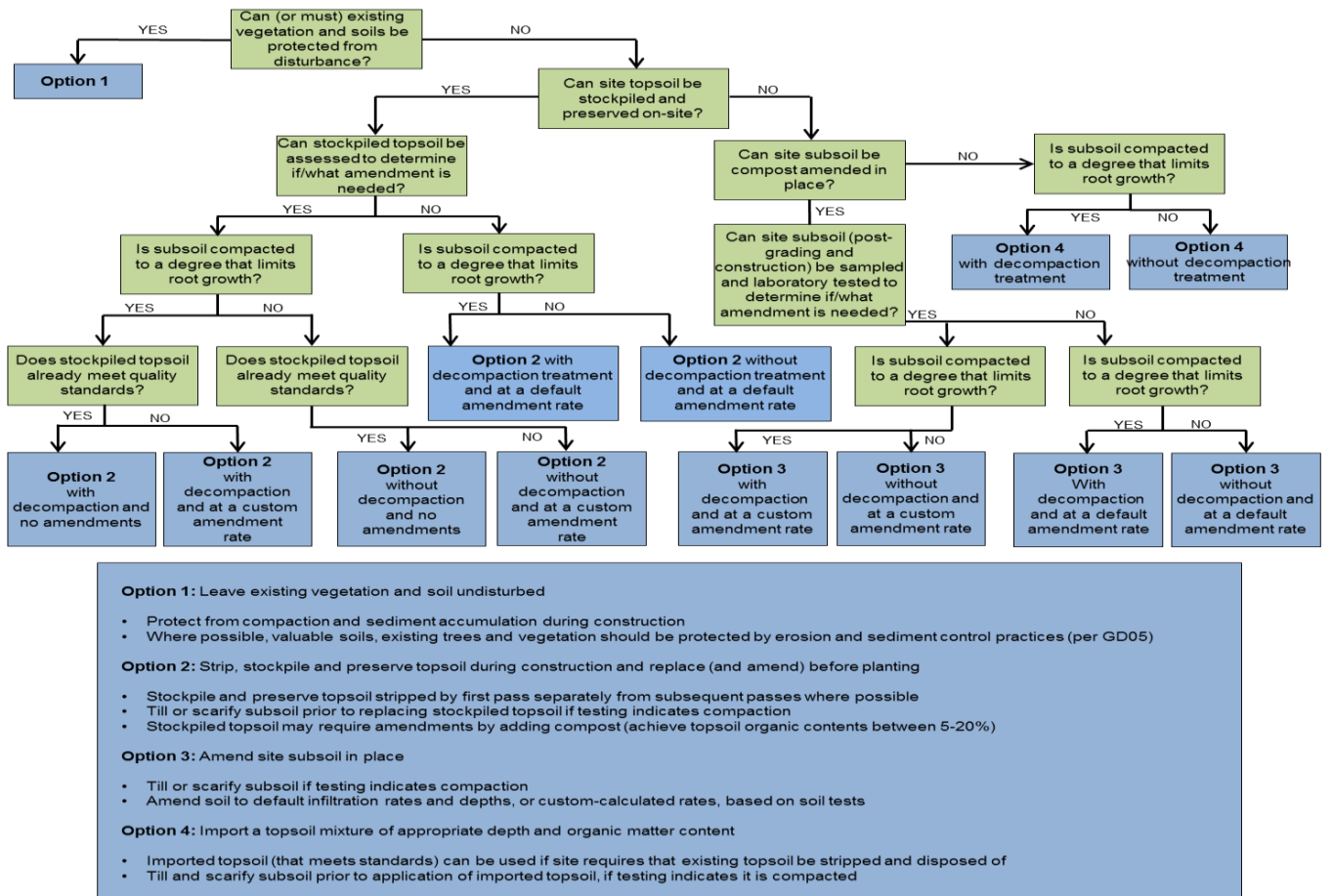
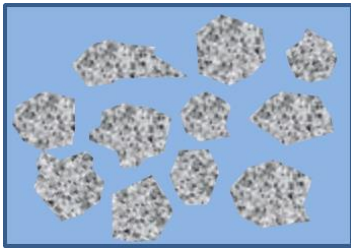

Figure 10: Soil management

⁶ Toronto and Region Conservation Authority. *Preserving and Restoring Healthy Soil: Best Practices for Urban Construction*. Version 1.0. June 2012

C1.4.3 Rainfall retention properties of soil

The rainfall retention properties of a substrate are estimated by the difference between a substrate's 'field capacity' and 'permanent wilting point' (Figure 11). This property is known as plant available water (PAW)⁷ and is expressed as a percentage. When dry, the substrate should be able to store about 25 to 30% by volume PAW, or greater.



Saturation: All pore space (the space between soil particles) in the soil is filled with water.

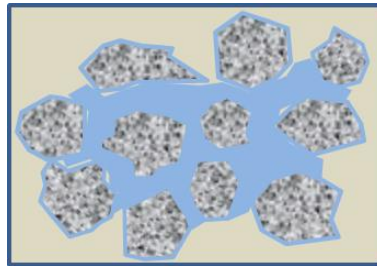

Field capacity: the amount of water held by soil after excess water has drained away (usually 2-3 days after rain).

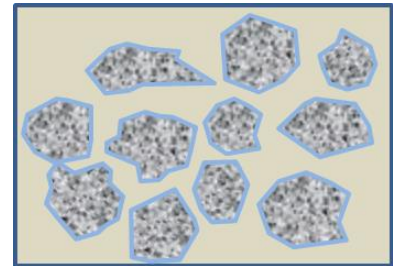

Permanent wilting point: where the water is strongly retained and trapped in the smaller pores and doesn't flow. If soil moisture decreases beyond the permanent wilting point, the plant dies.

Figure 11: Soil moisture in relation to plant available water

C1.4.4 Infiltration and permeability testing

Infiltration is the vertical movement of water, where permeability may be in any direction. Infiltration testing is undertaken at the surface to assess how much surface water will infiltrate naturally and therefore what pre-development soil conditions exist, particularly if soil infiltration may be less than 2 mm/hour (the threshold for retention). This test should be used to assess the soil categories and subsequent runoff (using Auckland Regional Council's technical publication TP108⁸).

Infiltration method:

Infiltration is measured at the surface and should be done using the double-ring infiltrometer method for any site where retention is required. This will include any site where bioretention or pervious paving is being used.

- **Double-ring infiltrometer:** The double-ring infiltrometer measures infiltration rate and capacity and uses two rings: an inner and outer ring in order to create a one-dimensional flow of water from the inner ring to simulate the saturated hydraulic conductivity. An inner ring is driven into the ground and a second bigger ring is placed around the inner ring to help control the flow of water through the first ring. Water is added (constant or falling head) and the amount of water infiltrating from the inner ring into the soil over a given time period is recorded. This method can be used for pervious paving.

⁷ Difference between a substrate's 'field capacity' and 'permanent wilting point'

⁸ Auckland Regional Council TP108 *Guidelines for Stormwater Runoff Modelling in the Auckland Region*, 1999

Permeability methods:

Permeability testing of soils is needed to assess percolation rates for retention devices without drainage (such as infiltration devices). These tests require a borehole and care must be taken to ensure the sides of the borehole are representative of the natural soils. Soils should not be smeared or compacted across the surface. Testing is required to determine the soil's saturated and unsaturated hydraulic conductivity (the rate at which water is able to disperse into the soils). This assessment reduces the risk of bypass, ponding and runoff.

Permeability methods (measured in boreholes):

- **Falling-head** tests determine the percolation rate of an area by filling a borehole with water and recording the rate at which it drains away. This test method is most suitable for use in soils with medium to low permeability
- **Constant-head** tests determine the percolation rate of an area by maintaining a constant head of water in a test pit or borehole. Water draining out of the test hole is replenished at the same rate from a water source such as a fire hydrant or reservoir. The stabilised flow rate of water entering the hole is measured over time to determine the permeability of the soil. This test method is most suitable for use in rock areas (or areas with high permeability).

C1.4.5 Determining the curve number

The curve number of pre-development soils is used in TP108 to determine potential runoff. The soil category is needed in order to estimate the curve number. The USA Natural Resources Conservation Service (NRCS) classified soils into four hydrologic soil groups (A, B, C and D) to describe how well water infiltrates into different soils (Clark et al., 2009). These soil groupings are widely used by regulatory bodies for assessing the suitability of sites for infiltration. Table 23 below summarises the NRCS hydrological soil groups and how they relate to commonly encountered soils in the Auckland region.

Table 23: NRCS hydrological soil grouping for Auckland soils

Auckland soil	NRCS hydrological soil group	NRCS summary (conservative flow rate estimate)
Granular volcanic loam underlain by free-draining basalt	Use CN = 17 for all pervious areas	<ul style="list-style-type: none"> • Assumes no compaction of loams overlying basalt.
Granular volcanic loam (ash, tuff, scoria)	Group A	<ul style="list-style-type: none"> • Deep sand; deep loess, aggregated silts. • Rapidly draining (greater than 8 mm/hr).
Alluvial sediments (Tauranga Group)	Group B	<ul style="list-style-type: none"> • Shallow loess; sandy loam. • Well drained (4 to 8 mm/hr).
Weathered mudstone and sandstone (Waitematā Group and Northland Allochthon); Anthropoc soils	Group C	<ul style="list-style-type: none"> • Clay loams; shallow sandy loam; low organic content; high clay content. • Slow draining (1 to 4 mm/hr).

Auckland soil	NRCS hydrological soil group	NRCS summary (conservative flow rate estimate)
Anthropic soils and peats	Group D	<ul style="list-style-type: none"> • Soils that swell significantly when wet; heavy plastic clays; certain saline soils. • Peat soils with high water tables. • Very poorly drained (0 to 1 mm/hr).

Adapted from Table 3.2 in Auckland Regional Council TP108 *Guidelines for Stormwater Runoff Modelling in the Auckland Region*, 1999

Once the underlying soil type has been estimated, the associated curve number can be assigned (Table 24). Alternatively, a default curve number of 74 may be used. For impervious surfaces, the curve number of 98 is used.

Table 24: Soil type and associated curve number based on land use

Land use	Group A	Group B	Group C
	Volcanic granular loam	Alluvial	Mudstone/sandstone
Urban lawns	39	61	74
Bush, humid climate, not grazed	30	55	70
Pasture, lightly grazed, good grass cover	39	61	74
Crops, straight rows, minimal vegetation cover	72	81	88

C1.5 Materials specifications

C1.5.1 Engineered soils

Generally, as base soils in Auckland do not meet the media requirements of stormwater management devices, engineered soils must be sourced. Engineered soils can be any media brought in from off site. It can also include media manufactured on site by mixing local soil or sand or peat with other materials. Engineered soils are the most common media used in stormwater management devices.

The predominant considerations in substrate design are stormwater control (i.e. meeting design objectives for permeability, retention and detention), and plant viability. Note that quality substrate with accurate performance specifications needs to be used for any living roof design, and any place where poor-quality/failing media cannot be removed and replaced easily.

Unless further defined in individual design sections, required performance specifications for engineered media in devices are:

- Able to support plant life
- Moderate water-holding capacity
- Device-specific permeability (Table 25)
- Low system weight at field capacity and/or saturation (green roofs only)
- Adequate bearing strength to prevent compaction
- Resistance to degradation
- Organic content:
 - The maximum allowable organic matter content is 20% (by volume)
 - The majority of the organic matter used must be stable (bark fines, coir, aged compost, arborist mulch etc.)
 - Small volumes of fully composted, nutrient-rich organic matter can be used to boost plant establishment but are not suitable as the total organic component
 - Composts containing standard fertilizer amendments are not recommended
 - Peat and coconut coir will boost water-holding capacity, but can add to the wet weight of the device.

Table 25: Soil composition of stormwater management devices

Device	Blend	Saturated permeability	Root depth
Living roofs	Mixes of pumice, zeolite, compost, no soil	1500 mm/hr	<ul style="list-style-type: none"> • Must not flood (structural), supports shallow root systems.
Bioretention	Engineered media – sand, top soil and compost mix ⁹	Retention and detention: 50-200 mm/hr (low range) 300+ (high range) Water quality only: <1000 mm/hr	<ul style="list-style-type: none"> • Deep rooting, recommended 2 m² minimum for device sizing to minimize heat stress. • Special design considerations for stormwater tree pits to accommodate root depth.
Swales	Topsoils and compost, sand	<20 mm/hr	<ul style="list-style-type: none"> • Shallow rooting depth, high pore spaces.
Pervious pavement (grassed)	Sand and aggregate	10 mm/hr	<ul style="list-style-type: none"> • Shallow root depths.
Wetlands	Impermeable layer – compacted clay. Bathymetry and planting soils – amended base soils	N/A	<ul style="list-style-type: none"> • Deep rooting, with resistance to inundation in emergent and littoral zones, larger planting on banks with deep roots.

⁹ Auckland Council TR 2013/011 *Media Specification for Stormwater Bioretention Media*

C1.5.2 Aggregates

All bedding sands and aggregates should:

- Be 'washed' (free of fines) to minimise introduction of additional suspended sediments
- Have an optimal void space of 30% at the compacted density
- Have a minimum permeability of 0.03 m/s. Random samples of all granular materials should be taken and tested to verify compliance with the design parameters (i.e. grading, voids ratio and compacted permeability)
- Have good workability without segregation (if this occurs, on-site mixing is needed)
- Be durable.

C1.5.3 Amendments

Most earth-worked soils will be physically, chemically and/or biologically degraded to some extent, especially if they have been stockpiled. In certain instances, these soils can be made viable again through the use of amendments. These may include:

- **Compost:** In urban areas, compost should be mixed into the upper 200 to 300 mm of all areas that are disturbed or compacted to achieve topsoil organic content between 5 and 20%. Compost should be well-aerated and relatively stable and conform to New Zealand composting standards (NZ Standard NZS/AS 4454¹⁰)
- **Gypsum:** Calcium sulphate di-hydrate can be used as a soil conditioner and fertiliser, to improve soil texture, drainage and aeration
- **Mulch:** The application of organic mulch to a minimum depth of 100 mm will suppress weeds, reduce frost heave, and break down over time to enhance organic content in topsoil. Mulches hold water entering the soil, so need to be spread on moist soil before dry weather.

C1.5.4 Geotextiles

Device design may need to include geotextiles which act in both a structural and pollutant-retaining capacity (Table 26):

- **Structural:** Any geotextiles must be carefully specified to:
 - Minimise loss of friction between layers
 - Minimise degradation over time
 - Mitigate the migration of materials from different layers in the device.
- **Pollutant retention:** Positioning a geotextile at certain heights in a device can enable pollutants to be trapped and retained at the geotextile layer. This can act to protect layers within the device and can localise maintenance to other layers, but this approach can increase the clogging potential of the device.

¹⁰ NZS4454:2005: New Zealand Standard: *Composts, soil conditioners and mulches*. (2005)

Table 26: Geotextile characteristics and uses

Component	Description
Geotextile liners	<ul style="list-style-type: none"> • Liners (either permeable or impermeable) can be used on the sides and base of a device to prevent the migration of different media layers. They can also be used to restrict root penetration (e.g. into underdrains). • Liners can become clogged and exfiltration from the device can be reduced. They can also increase the complexity of the device construction. • If the designer chooses to use a geotextile liner, the highest flow-rate filtration class should be specified to reduce the impact of flow retardation on exfiltration rate.
Upper geotextile layer	<ul style="list-style-type: none"> • An upper geotextile layer can be used to provide additional tensile strength within a device and prevent the migration of finer particles between media layers. • Geotextiles are susceptible to clogging and their use should be avoided between layers, unless the manufacturer requires them.
Geogrids	<ul style="list-style-type: none"> • A geogrid is a structural grid with large holes (>10 mm) that provides structural reinforcement within, or around, the device.

Geotextiles must be placed, overlapped and pinned in such a way as to avoid floating, short circuiting or erosion.

C1.6 Plants

This section is intended as guidance for those involved in landscape design and compliance requirements. The planting lists provide specific guidance for plant choice for stormwater management devices in the Auckland region. The plants have been selected on the basis of their availability, suitability for Auckland's climate and soils, as well as durability and function with stormwater devices (such as minimised leaf litter and maintenance needs). It is however, recommended that a professional horticulturalist be consulted on the design, landscaping and planting needs of specific devices.

Key considerations for all plant choices include:

- Contribution to performance of stormwater device (or negative impact) individually and as part of the overall plant selection
- Water supply needs
- Where plants should be placed within a device and the placement's impact on maintenance needs
- Root depth and soil volume required for mature, resilient plants
- Safety considerations including line of sight, impact on traffic and pedestrians
- Maintenance requirements including health and safety, traffic management, plant needs (mowing, pruning, leaf blowing, weeding, fertilising etc.) especially in relation to stormwater device performance
- Non-stormwater benefits delivered (e.g. contribution to place-making, cultural, aesthetic, shade, safety, air quality, native biodiversity, productivity, biosecurity, etc.).

All plant names provided in this section are current at the time of publication based on Nga Tipu Aotearoa NZ Plants Database (managed by Landcare Research)¹¹.

C1.6.1 Planting stormwater wetlands (and pond borders)

Constructed stormwater wetlands are systems built to mimic the water cleansing processes of natural wetlands. Wetland environments represent the intersection of aquatic and terrestrial ecologies and support a wide variety of vegetation types. Hydrophilic (water-loving) plants are an important component in constructed wetlands, with their roles including:

- Providing surfaces (such as roots) for biofilm growth
- Transporting oxygen to soils to support bio-geochemical transformation
- Aiding in the reduction of nutrient and heavy metal concentrations
- Influencing sediment deposition and filtering sediment particles from the water column
- Influencing hydrology and hydraulics in constructed wetlands by promoting even flows
- Providing shade and decreased light to limit algae and reduce water temperatures
- Decreasing erosion by reducing wave energy and flow velocities while binding soil particles with root systems
- Providing a basis for wetland food chains and supplying shelter for invertebrates, reptiles and birds (or role in excluding specific birds)
- Contribution to non-stormwater benefits.

Planting for constructed wetland systems primarily consists of three main vegetation types (Figure 12).

Emergent zone planting (permanently inundated)

An emergent plant is one which grows in the water but is also partially in the air. Emergent plants are generally from 1 m to 0.2 m below design-water level in two zones:

- Deep - inundated up to 0.5 m
- Shallow - inundated up to 0.2 m.

Plants should be placed to form bands perpendicular to flow. Emergent wetland vegetation provides forage and refuge above and below the water line, and diverse microbial assemblages where aerobic environments at the root zones meet anaerobic areas within the sediment.

Littoral zone planting (margins of wetland)

The littoral zone is the portion of the body of water which is close to the banks (in the case of wetlands or ponds). The vegetation at the wetted edge protects batter slopes from erosion (from flooding or continuous wet and dry cycles). The littoral zone also intercepts gross sediments from entering the wetland via overland flow and provides treatment of nitrogen and metals in the root zone entering via influent groundwater.

¹¹ This website provides information on taxa that occur in New Zealand and can be accessed at:
<http://www.landcareresearch.co.nz/resources/data/nzplants>

Terrestrial zone (bank planting)

The terrestrial zone includes areas that are expected to be inundated on rare flood events and therefore comprise a wide variety of floodplain, escarpment, or upland vegetation. The vegetation buffers the wetland environment from physical and climatic extremes, and acts as a physical barrier. It may also provide a visual barrier for undesirable views beyond the wetland. Tall trees provide shade for open water areas and crags for bird roosting. The amount of leaf litter entering from the terrestrial zone must be considered in terms of water quality functioning and shade requirements. Bank planting must be designed in such a way that the fully grown plants will not hinder pond desilting activities.

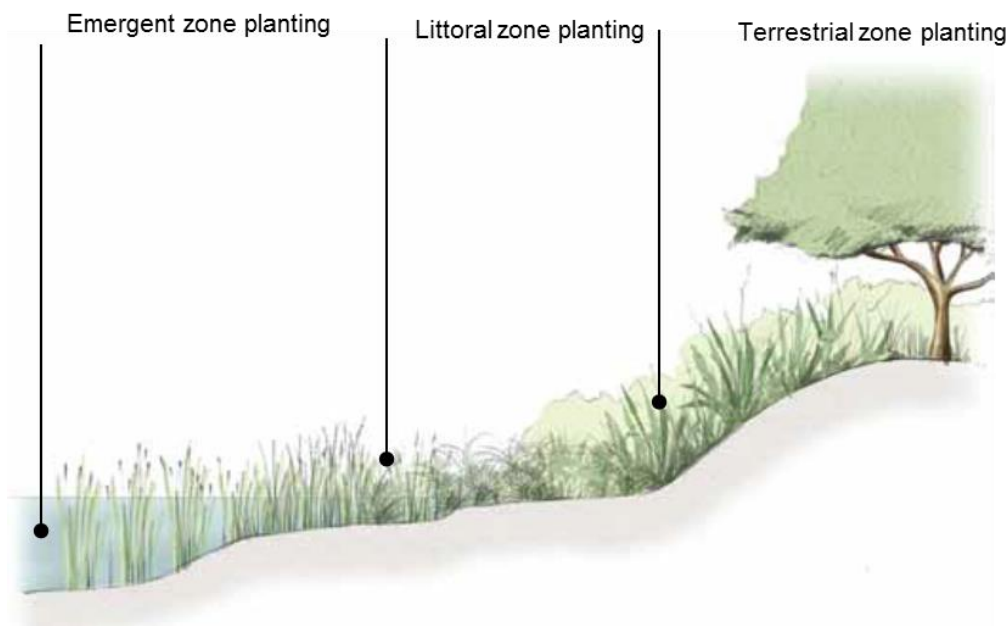

Figure 12: The three planting zones that provide for the function of stormwater wetlands and ponds¹²

Water-level management is the key to determining the success of vegetation. While wetland plants can tolerate temporary changes in water depth, care should be taken not to exceed the tolerance limits of chosen species for extended periods of time.

General wetland planting specifications include:

- Wetland planting should be carried out in early spring (September to October) or early autumn (from March) when water temperatures are warm and plants are growing vigorously
- No fertiliser is to be used in wetland plantings
- Topsoil on wetland shelves require erosion control fabric or can be worked into subsoils and lightly compacted
- Where groundwater levels are lower than the wetland base, an impervious liner should be used in the wetland construction to maintain water levels
- Initially, plants should be planted in water no deeper than 100 mm, with a minimum 150 mm of plant foliage above the water level (with water levels gradually increasing)

¹² Adapted from Auckland Council TR 2009/083 *Landscape and Ecology Values within Stormwater Management*

- Plants should be firmly planted within the substrate to anchor them so that they are less prone to uprooting or floating. A minimum 250 mm of plant foliage must extend above the topsoil
- Vegetation that is intended as a physical barrier may require a temporary fence until established
- Where pukekos are a concern, plants should be PB3 container size (1.5 L) or greater or staked in place with biodegradable stakes at 45°.

C1.6.1.1 Suggested wetland plant species

Table 27, Table 28 and Table 29 provide the principal wetland species recommended for the Auckland region.

Table 27: Recommended wetland species: 0.01 – 1 m height at maturity

Name	Common name	Zone	Description	Height (m)	Spread (m)	Sun	Semi	Shade	Dry	Moist	Wet
<i>Blechnum novae-zelandiae</i>	Kiokio	Littoral	Fern	1.00	2.00	Y	Y	Y	Y	Y	Y
<i>Carex lessoniana</i>	Spreading swamp sedge	Littoral	Sedge & rush-like	1.00	2.00	Y	Y	N	N	Y	Y
<i>Carex virgata</i>		Littoral	Sedge & rush-like	0.80	0.80	Y	Y	N	N	Y	Y
<i>Eleocharis acuta</i>		Emergent	Sedge & rush-like	1.00	1.00	Y	N	N	N	Y	Y
<i>Ficinia nodosa</i>	Knobby club rush, wiwi	Littoral	Sedge & rush-like	1.00	1.50	Y	N	N	Y	Y	N
<i>Macheraina juncea</i>		Littoral	Sedge & rush-like	1.00	1.00	Y	Y	N	Y	Y	Y
<i>Machaerina rubiginosa</i>	Orange nut sedge	Emergent	Sedge & rush-like	1.00	1.50	Y	Y	N	N	Y	Y
<i>Machaerina sinclairii</i>	Tuhara, pepepe	Littoral	Sedge & rush-like	1.00	1.50	Y	Y	N	N	Y	Y
<i>Machaerina tenax</i>		Littoral	Sedge & rush-like	1.00	1.50	Y	Y	Y	Y	Y	Y
<i>Machaerina teretifolia</i>	Pakihi rush	Emergent	Sedge & rush-like	1.00	1.50	Y	Y	N	N	Y	Y

Table 28: Recommended wetland species: 1 – 3 m height at maturity

Name	Common name	Zone	Description	Height (m)	Spread (m)	Sun	Semi	Shade	Dry	Moist	Wet
<i>Apodasmia similis</i>	Oioi, jointed rush	Littoral	Sedge & rush-like	1.50	1.00	Y	Y	N	Y	Y	Y
<i>Astelia grandis</i>	Swamp astelia	Littoral	Lily & iris-like	2.00	2.00	Y	Y	Y	Y	Y	Y
<i>Machaerina articulata</i>	Jointed twig-rush	Emergent	Sedge & rush-like	1.80	2.00	Y	N	N	N	Y	Y
<i>Bolboschoenus fluviatilis</i>	Kukuraho	Emergent	Sedge & rush-like	1.50	2.00	Y	Y	N	N	N	Y
<i>Carex secta</i>	Purei, makura	Emergent	Sedge & rush-like	1.50	2.00	N	Y	Y	N	Y	Y
<i>Coprosma propinqua</i>	Mingimingi	Littoral	Shrub	3.00	2.00	Y	N	N	Y	Y	Y
<i>Cyperus ustulatus</i>	Giant umbrella sedge	Littoral	Sedge & rush-like	1.50	2.00	Y	N	N	N	Y	Y
<i>Eleocharis sphacelata</i>	Kutakuta	Emergent	Sedge & rush-like	2.00	5.00	Y	N	N	N	N	Y
<i>Juncus edgariae</i>	Wiwi	Littoral	Sedge & rush-like	1.50	1.00	Y	N	N	N	Y	Y
<i>Juncus pallidus</i>	Giant rush wiwi	Littoral	Sedge & rush-like	1.70	2.00	Y	N	N	N	Y	Y
<i>Juncus sarophorus</i>	Wiwi	Littoral	Sedge & rush-like	1.50	1.00	Y	Y	N	N	Y	Y
<i>Phormium tenax</i>	Harakeke	Littoral	Flax	3.00	3.00	Y	N	N	Y	Y	Y
<i>Schoenoplectus tabernaemontani</i>		Emergent	Sedge & rush-like	1.50	2.00	Y	N	N	N	N	Y

Table 29: Recommended wetland species: >3 m height at maturity

Name	Common name	Zone	Description	Height (m)	Spread (m)	Sun	Semi	Shade	Dry	Moist	Wet
<i>Carpodetus serratus</i>	Putaputaweta	Littoral	Tree	6.00	3.00	Y	Y	Y	N	Y	Y
<i>Cordyline australis</i>	Cabbage tree	Littoral/ terrestrial	Tree	8.00	3.00	Y	Y	N	Y	Y	Y
<i>Dacrycarpus dactyloides</i>	Kahikatea	Littoral/ terrestrial	Tree	20.00	10.00	Y	Y	Y	N	Y	Y
<i>Dicksonia squarrosa</i>	Wheki	Terrestrial	Tree fern	5.00	2.50	Y	Y	N	Y	Y	N
<i>Geniostoma ligustrifolium</i>	Hangehange	Terrestrial	Tree	4.00	3.00	Y	Y	Y	Y	Y	N
<i>Hebe stricta</i>	North Island koromiko	Terrestrial	Shrub	4.00	2.50	Y	N	N	Y	Y	N
<i>Laurelia novae-zelandiae</i>	Pukatea	Littoral/ terrestrial	Tree	10.00	3.00	Y	Y	Y	N	Y	Y
<i>Leptospermum scoparium</i>	Manuka	Terrestrial	Tree	4.00	2.00	Y	Y	N	Y	Y	Y
<i>Piper excelsum</i>	Kawakawa	Terrestrial	Tree	4.00	2.00	N	Y	Y	Y	N	N
<i>Melicytus ramiflorus</i>	Mahoe	Terrestrial	Tree	6.00	3.00	Y	Y	Y	Y	Y	N
<i>Olearia solandri</i>	Coastal shrub daisy	Littoral	Shrub	4.00	3.00	Y	Y	N	Y	Y	N
<i>Plagianthus regius</i>	Ribbonwood	Littoral	Tree	6.00	2.00	Y	Y	N	Y	Y	N
<i>Pseudopanax arboreus</i>	Five-finger	Terrestrial	Tree	5.00	3.00	Y	Y	Y	Y	N	N
<i>Rhopalostylis sapida</i>	Nikau	Terrestrial	Palm	5.00	3.00	Y	Y	Y	N	Y	N
<i>Schefflera digitata</i>	Pate	Terrestrial	Tree	4.00	3.00	Y	Y	Y	Y	Y	N
<i>Syzygium maire</i>	Swamp maire	Littoral/ terrestrial	Tree	8.00	4.00	Y	Y	Y	N	Y	Y

C1.6.2 Planting bioretention devices

Plants in bioretention devices should be able to tolerate a range of environmental conditions from very dry to inundated with water in open conditions. In most cases, these species should also be able to tolerate silt on their leaves and inundation of sediment at their roots. The plants most likely to fulfil these criteria are those found naturally in places where the water table fluctuates from very wet to very dry. Plants with deep roots are especially good in bioretention devices but care must be taken to ensure their roots are not impeded by geotextile layers.

Soil media for planting should be at least 300 mm for grasses, increasing to 600 mm for shrubs and 1000 mm for trees. Use of large trees should be determined on a case-by-case basis, allowing for spread of surface roots.

Plant selection and installation in bioretention devices should consider:

- Whether the device is for detention, retention and water quality treatment, or only water quality treatment. In water quality only devices, infiltration rates are very fast and plants need to be able to tolerate high draining soils. Establishment may be longer for plants to develop deeper root systems
- Timeframes for filter media cleanout (reset). It is preferable to have designs where active filtering media is planted with grasses/sedges (and can be easily sacrificed) and any trees are in permanent media
- Allowing for plants that can tolerate frequent inundation to the design ponding depth (nominally >200 mm)
- Allowing for plants which maximise uptake of contaminants
- Plants at inlets should have thickly spreading rhizomous roots to hold plants in place against erosive inflows and prevent preferential flow paths eroding soils. These plants should also have fine leaves and allow sheet flow to avoid obstructing flows (spreading rather than clumping forms are more appropriate)
- Edges should have low growing vegetation to retain a distinct and maintainable edge. These species should be tolerant of roadway splashes, temperature extremes, or whatever constraints relate to adjacent land uses
- Plants should be spaced to cover any bare soil areas within 18 months with biodegradable erosion control matting in place until maturity
- Adding trees and shrubs in rain gardens increases interception and evapotranspiration but should be chosen where their roots are not impeded by geotextiles
- Consider the impact of adjacent deciduous trees on the survival of groundcover and the potential for blocking overflow/inflows with leaf litter. Perennials, rather than annuals, are recommended
- Larger trees with extensive root systems should not be planted above geotextiles, existing infrastructure pipes, or where future access is an issue
- Trees should only be planted in devices where the filter media depth is 600 mm or greater.

C1.6.2.1 Suggested bioretention plant species

Suggested plant species for bioretention are presented in Table 30 (0.25 – 2 m height), Table 31 (>3 m height) and Table 32 (<100 mm height).

Table 30: Recommended bioretention ground species: 0.25 – 2 m height at maturity

Name	Common Name	Description	Max. height	Drought	Frost	Salt wind	Water log	Wet	Moist	Dry
<i>Apodasmia similis</i>	Oioi; jointed wire rush	Densely clumping reed	1.2	Med	Med	High	High	Y	Y	Y
<i>Austroderia fulvida</i>	Toetoe	Tall grass	1.5	High	High	High	High	Y	Y	Y
<i>Astelia fragrans</i> ; <i>A solandri</i>	Bush lily; bush flax; kakaha	Tall tussock	1.2	Med	Med	Low	Med	N	Y	Y
<i>Astelia grandis</i>	Swamp astelia	Tall tussock	1.5	Low	Med	Low	High	Y	Y	Y
<i>Blechnum minus</i>	Swamp kiokio	Fern	1	Low	High	Low	High	Y	Y	N
<i>Blechnum novae-zelandiae</i>	Kiokio	Fern	1.5	Med	Med	Med	High	N	Y	N
<i>Blechnum parrisiae</i>	Rasp fern pukupuku	Fern	0.25	Med	Low	Low	Med	N	Y	N
<i>Carex flagellifera</i>	Glen Murray tussock	Short tussock	0.6	Med	High	Low	Med	Y	Y	N
<i>Carex gaudichaudiana</i>	Gaudichaud's sedge	Sedge	0.3	Med	Med	Low	Med	Y	Y	N
<i>Carex lambertiana</i>	Bush sedge	Tall tussock	0.9	Med	Med	Low	Med	N	Y	N
<i>Carex lessoniana</i>	Rautahi	Tall tussock	1.5	Low	Med	Low	High	Y	Y	N
<i>Carex virgata</i>	Pukio, purei	Tall tussock	1	Med	High	Med	High	Y	Y	N
<i>Coprosma acerosa</i>	Sand dune coprosma	Groundcover	0.3	High	High	High	Med	N	Y	Y
<i>Cyperus ustulatus</i>	Giant umbrella sedge; toetoe upokotangata; coastal cutty grass	Tall tussock	1	Med	Med	High	High	Y	Y	N
<i>Deparia petersenii</i>		Fern	0.4	Med	Med	Low	Med	Y	Y	N
<i>Dianella nigra</i>	Inkberry; blueberry	Short tussock	0.5	Med	Med	Med	Low	N	Y	N

Name	Common Name	Description	Max. height	Drought	Frost	Salt wind	Water log	Wet	Moist	Dry
<i>Dianella haemata</i>	Swamp blueberry	Tussock forming herb	1	Low	Low	Low	High	Y	Y	N
<i>Eleocharis acuta</i>	Sharp spike sedge	Sedge	1	Med	Med	Y	Med	N	Y	N
<i>Ficinia nodosa</i>	Knobby clubrush	Rush	0.6	High	Med	High	Low	N	Y	N
<i>Juncus australis</i>	Leafless rush	Rush	0.7	Med	High	Med	High	Y	N	N
<i>Juncus edgariae</i>	Leafless rush	Rush	1	Med	High	Low	High	Y	N	N
<i>Lepidosperma australe</i>	Four square; square-stemmed sedge; square sedge	Rush	0.6	High	Med	Med	Med	N	Y	N
<i>Libertia ixioides</i> , <i>L. grandiflora</i>	Mikoikoi; New Zealand iris	Short tussock	0.7	High	High	Med	Low	N	Y	N
<i>Muehlenbeckia astonii</i>		Shrub	3	High	Med	High	Low	N	Y	Y
<i>Paesia scaberula</i>	Scented fern	Fern	0.5	Med	Med	Low	Med	N	Y	N
<i>Phormium cookianum</i> subsp. <i>hookeri</i>	Coastal flax; wharariki	Tall tussock	1	Med	High	High	Med	N	Y	N
<i>Schoenoplectus pungens</i>	Three-square	Reed	0.7	Low	Med	High	High	Y	N	N

Table 31: Recommended bioretention tree and shrub species (>3 m height at maturity) in low contaminant environments.

Name	Common Name	Growth Form	Max. height	Drought	Frost	Salt Wind	Water log	Wet	Moist	Dry
<i>Alectryon excelsus</i>	Titoki	Tree	17	Low	Low	Low	Med	N	Y	N
<i>Carpodetus serratus</i>	Putaputaweta; marbleleaf	Small tree	10	Med	Med	Low	Med	N	Y	N
<i>Coprosma propinqua</i>	Mikimiki or mingimingi	Tall shrub	3	High	High	High	High	Y	Y	N
<i>Coprosma tenuicaulis</i>	Swamp coprosma; hukihuki	Tall shrub	3	Low	Low	Low	High	N	Y	N
<i>Cordyline australis</i>	Cabbage tree; ti kouka; ti	Medium tree	15	High	High	Med	High	Y	Y	N
<i>Dacrycarpus dacrydioides</i>	Kahikatea; white pine	Tree	40	Med	Med	Low	High	Y	Y	N
<i>Dicksonia squarrosa</i>	Wheki, rough tree fern	Tree fern	7	Med	Med	Med	Med	N	Y	N
<i>Knightia excelsa</i>	Rewarewa; New Zealand honeysuckle	Tree	30	Low	Low	Low	Med	N	Y	N
<i>Kunzea robusta</i>	Kānuka	Tree	15	Med	Med	Med	Med	N	Y	Y
<i>Laurelia novae-zelandiae</i>	Pukatea	Tree	30	Med	Low	Low	High	Y	Y	N
<i>Leptospermum scoparium</i>	Manuka; red tea tree	Small tree	8	High	High	Low	High	Y	Y	N
<i>Lophomyrtus bullata</i>	Ramarama	Small tree	3	Med	Med	Low	Med	N	Y	Y
<i>Melicope ternata</i>	Wharangi	Tall Shrub	4	Med	Low	High	Med	N	Y	Y
<i>Metrosideros excelsa</i>	Pohutukawa	Tree	20	High	Low	High	Low	N	Y	Y
<i>Olearia solandri</i>	Coastal shrub daisy	Tall shrub	4	Med	Med	High	Low	N	Y	N
<i>Plagianthus regius</i>	Lowland ribbonwood; manatu; ribbonwood	Medium tree	15	Med	High	Med	Med	N	Y	N
<i>Rhopalostylis sapida</i>	Nikau palm	Medium tree	10	Low	Low	Med	Med	N	Y	N

Name	Common Name	Growth Form	Max. height	Drought	Frost	Salt Wind	Water log	Wet	Moist	Dry
<i>Podocarpus totara</i>	Totara	Tree	30	High	High	Low	Med	N	Y	N
<i>Sophora microphylla</i>	Kowhai	Tree	25	Med	Med	Med	Med	N	Y	Y
<i>Vitex lucens</i>	Puriri	Tree	20	Med	Low	Med	Low	N	Y	N

Table 32: Recommended bioretention species (<100 mm height at maturity) for underplanting in areas with low sediment and low weed pressure

Name	Common Name	Growth Form	Max. height	Drought	Frost	Salt wind	Water log	Wet	Moist	Dry
<i>Acaena novae-zelandiae</i> and other <i>Acaenas</i>	Piripiri bidi bidi	Mat-forming herb	0.1	High	High	Low	Med	N	Y	N
<i>Blechnum penna-marina</i>	Alpine hard fern	Fern	0.2	High	High	Med	Med	N	Y	N
<i>Blechnum zeelandicum</i>	Tufted fern	Fern	0.15	Med	Med	Med	Med	N	Y	N
<i>Carex breviculmis</i>	Grassland sedge	Sedge	0.2	Med	Med	Med	Med	N	Y	N
<i>Gunnera dentata</i> and <i>G. prorepens</i>		Rosette-forming herb	0.03	Low	Med	Med	High	Y	N	N
<i>Leptinella dioica</i>		Mat-forming herb	0.01	Med	High	Med	High	Y	Y	N
<i>Leptostigma setulosa</i>		Mat-forming herb	0.02	Med	Med	Low	Med	Y	Y	N
<i>Lobelia angulata</i>	Pratia	Mat-forming herb	0.02	Med	Low	Low	Med	Y	Y	N
<i>Mazus radicans</i>		Mat-forming herb	0.05	Low	Med	Low	High	Y	N	N
<i>Selliera radicans</i>	Remuremu	Mat-forming herb	0.01	Med	Med	High	High	Y	N	N

C1.6.3 Planting swales

Planting within a swale is influenced by water conveyance, water quality treatment and inundation levels in the following ways:

- Plants which grow between 50 mm and preferably, 200 mm (or greater), height should be used
- The lowest point of the channel will require plants that can be inundated on a periodic basis and will either flatten, or part, under flows and avoid preferential flow paths. These plants will also require large root systems or rhizomous connections to form a surface that resists channel erosion
- Plants on the side of the channel will require the tensile strength to retain soils during high flow events
- Plants at the upper channel will require tolerance of long periods of drought, with periodic inundation
- Edge plants will require tolerance to climatic extremes (particularly heat), planned maintenance and potentially damage by people including wilful damage.

C1.6.3.1 Suggested plant species

It is best practice to:

- Have rapid establishment with growth of up to 200 mm height
- Have a low/no maintenance/mowing regime
- Place trees and shrubs in deeper media to the side of swales, where roots can access the moisture supply
- Have a minimum media depth of 300 mm. Mown swales need to use media that is resistant to compaction and rutting
- Use trees on the sides of the channel. Trees should ideally be single-bole trunks with upright growth forms and the canopy maintained to avoid shading lower plants. Long-lived trees are most appropriate for moderately trafficked roads (such as side roads and *cul de sacs*) with low contaminant input and reduce likelihood of a swale requiring renovation in the short term.

Suggested plant species for swales are presented in Table 33 (0.25 – 2 m height); Table 34 (>3 m height) and Table 35 (<100 mm height).

Table 33: Recommended swale ground species: 0.25 – 2 m height at maturity

Name	Common name	Growth form	Max. height	Drought	Frost	Salt wind	Water log	Wet	Moist	Dry
<i>Apodasmia similis</i>	Oioi; jointed wire rush	Centrolepid	1.2	Med	Med	High	High	Y	N	N
<i>Astelia grandis</i>	Swamp astelia	Tall tussock	1.5	Low	Med	Low	High	Y	Y	N
<i>Blechnum minus</i>	Swamp kiokio	Fern	1	Low	High	Low	High	Y	Y	N
<i>Blechnum novae-zelandiae</i>	Kiokio	Fern	1.5	Med	Med	Med	High	N	Y	N
<i>Blechnum parrisiae</i>	Rasp fern; pukupuku; was <i>Doodia australis</i> , <i>D. media</i>	Fern	0.25	Med	Low	Low	Med	N	Y	N
<i>Carex dipsacea</i>	Teasel sedge	Short tussock	0.75	Med	Med	Med	Med	Y	Y	Y
<i>Carex flagellifera</i>	Glen Murray tussock	Short tussock	0.75	Med	High	Low	Med	Y	Y	N
<i>Carex gaudichaudiana</i>	Gaudichaud's sedge	Short tussock	0.4	Med	Med	Med	High	Y	Y	Y
<i>Carex lambertiana</i>	Bush sedge; forest sedge	Tall tussock	0.9	Med	Med	Low	Med	N	Y	N
<i>Carex lessoniana</i>	Rautahi, cutty grass	Rautahi, cutty grass	Tall tussock	1.3	Med	Low	Med	High	Y	Y
<i>Carex geminata</i>	Rautahi, cutty grass	Rautahi, cutty grass	Tall tussock	1.2	Med	Med	Med	High	Y	Y
<i>Carex maorica</i>	Maori sedge	Māori sedge	Short tussock	0.7	Med	Med	Med	High	Y	Y
<i>Carex ochrosaccus</i>	Forest sedge	Forest sedge	Tall tussock	1	Med	Med	High	High	Y	Y
<i>Carex secta</i>	Pukio, purei, makura, tussock sedge	Tall tussock	2	Low	Med	Low	High	Y	N	N
<i>Carex solandri</i>	Forest sedge	Short tussock	0.6	Med	Med	Low	High	Y	Y	Y
<i>Carex virgata</i>	Pukio; purei	Tall tussock	1	Med	High	Med	High	Y	Y	N
<i>Coprosma acerosa</i>	Sand dune coprosma	Scrambling prostrate shrub	0.3	High	Low	High	Med	N	Y	Y

Name	Common name	Growth form	Max. height	Drought	Frost	Salt wind	Water log	Wet	Moist	Dry
<i>Cortaderia fulvida</i>	Toetoe	Grass	1.5	Med	High	High	Med	Y	Y	Y
<i>Cyperus ustulatus</i>	Giant umbrella sedge; toetoe upokotangata; coastal cutty grass	Tall tussock	1.5	Med	Med	High	High	Y	Y	N
<i>Dianella nigra</i>	Inkberry; blueberry	Short tussock	0.5	Med	Med	Med	Low	N	Y	N
<i>Dianella haemata</i>	Swamp blueberry		0.5	Med	Med	Low	High	Y	Y	N
<i>Eleocharis acuta</i>	Sharp spike sedge	Lily	1	Med	Med	Med	Med	Y	Y	Y
<i>Ficinia nodosa</i>	Knobby clubrush; leafless sedge; knotted sedge	Rush	1	High	Med	High	Low	N	Y	N
<i>Juncus edgariae</i>	Wiwi, Edgar's rush, leafless rush	Rush	1.5	Med	High	Low	High	Y	N	N
<i>Juncus pallidus</i>	Giant rush; leafless rush	Rush	2	Med	Med	High	High	Y	Y	N
<i>Juncus sarophorus</i>	Fan-flowered rush	Sedge	1.5	Med	Med	Low	Low	N	Y	Y
<i>Lepidosperma australe</i>	Four square; square-stemmed sedge; square sedge	Rush	1	High	Med	Med	Med	N	Y	N
<i>Machaerina articulata</i>	Jointed baumea; jointed twig rush	Sedge	1.8	Med	Med	Med	Med	Y	Y	Y
<i>Machaerina complanata</i>	Shiny sedge	Sedge	0.7	Low	Low	High	High	N	Y	Y
<i>Machaerina juncea</i>	Sedge		1	Med			High	Y	Y	Y
<i>Machaerina sinclairii</i>	Tuhara, pepepe	Tall tussock	1.2	Low	Low	Low	Med	N	Y	N
<i>Machaerina tenax</i>			1	Med	Med	Med	Med	Y	Y	Y
<i>Phormium cookianum</i>	Coastal flax; wharariki	Tall tussock	1	Med	High	High	Med	N	Y	N

Table 34: Recommended swale small tree and shrub species: >3 m height at maturity

Name	Common name	Growth form	Max. height	Drought	Frost	Salt wind	Water log	Wet	Moist	Dry
<i>Carpodetus serratus</i>	Putaputaweta; marbleleaf	Small tree	10	Med	Med	Low	Med	N	Y	N
<i>Coprosma arborea</i>	Mamangi, tree coprosma	Tall shrub	8	High	High	High	High	Y	Y	N
<i>Coprosma propinqua</i>	Mikimiki or mingimingi	Tall shrub	6	High	High	High	High	Y	Y	N
<i>Coprosma tenuicaulis</i>	Swamp coprosma; hukihuki	Tall shrub	3	Low	Low	Low	High	N	Y	N
<i>Cordyline australis</i>	Cabbage tree; ti kouka; ti	Medium tree	15	High	High	Med	High	Y	Y	N
<i>Dicksonia squarrosa</i>	Wheki, rough tree fern	Tree fern	7	Med	Med	Med	Med	N	Y	N
<i>Hoheria populnea</i>	Houhere, lacebark, ribbonwood	Tree	8	Med	Low	Low	High	Y	Y	N
<i>Leptospermum scoparium</i>	Manuka; red tea tree	Small tree	8	High	High	Low	High	Y	Y	N
<i>Phormium tenax</i>	Harakeke, flax	Flax	2.5	High	High	High	High	Y	Y	Y
<i>Sophora microphylla</i>	Kowhai	Tree	30	High	High	Low	Med	N	Y	N

Table 35: Recommended swale ground cover species: <100 mm height at maturity at sites with low sediment and weed pressure

Name	Common name	Growth form	Max. height	Drought	Frost	Salt wind	Water log	Wet	Moist	Dry
<i>Acaena anserinifolia</i> and other <i>Acaena</i> spp.	Local native species	Mat forb/subshrub	0.1	High	High	Low	Med	N	Y	N
<i>Centella uniflora</i>	Local native species	Ground cover	0.10	High	High	High	Med	Y	Y	N
<i>Gunnera dentata</i> and <i>G. monoica</i>	Local native species	Rosette forb	0.03	Low	Med	Med	High	Y	N	N
<i>Leptinella dioica</i>	Shore leptinella	Mat forb	0.04	Med	High	Med	High	Y	Y	N
<i>Lobelia angulata</i>	Panakenake	Ground cover	0.05	Low	Low	Low	Low	Y	Y	Y
<i>Selliera radicans</i>		Mat forb	0.01	Med	Med	High	High	Y	N	N

C1.6.4 Planting living roofs

Living roofs¹³ usually need specialist plant species. Characteristics of vegetation typically used in green roof systems are:

- Drought and heat tolerant (especially tolerance of hot roots)
- Shallow root systems
- Regenerative qualities
- Resistance to direct sunlight, frost and wind.

The following are some of the planting design parameters that aid plant establishment:

- Moisture stress is determined by substrate depth, moisture storage, underlying thermal mass, duration and timing of shade, wind exposure (including discharges from air conditioners), and local climate. Water storage can be improved through amendments to substrates and pre-fabricated reservoirs below substrates
- A shallow substrate can only support specific plants. The plant lists provided in this document are suitable for extensive green roofs. The plants that occur on thicker extensive roofs are only limited by substrate depths (affecting the load on rooftops) and micro-climates
- A roof which has at least some shade during the day will extend the range of native plants that will survive on a roof
- Plant mixes will generally include a high proportion of species that spread rapidly (~75% cover within 2 years), and a few species that are slow growing
- Plant diversity reduces plant failures.

C1.6.4.1 Suggested plant species

Table 36 identifies native species suitable for lightweight (100 to 300 mm soil depth) non-irrigated green roofs in the Auckland environment.

¹³ Auckland Council TR 2013/045 *Living Roof Review and Design Recommendations for Stormwater Management*

Table 36: Recommended living roof species 100 - 300 mm soil depth

Name	Common name	Growth form	Max. height	Spread	Sun	Semi	Shade	Dry	Moist	Wet
<i>Acaena</i> species	Piripiri	Ground cover	0.15	1	Y	Y	Y	Y	Y	Y
<i>Anaphaloides bellidoides</i>	Everlasting flower	Ground cover	0.15	0.5	Y	Y	N	Y	Y	
<i>Apodasmia similis</i>	Oioi, jointed rush	Sedge and rush-like	1	1	Y	Y	N	Y	Y	Y
<i>Arthropodium</i> species	Rengarenga	Lily and iris-like	1	0.75	Y	Y	Y	Y	N	N
<i>Astelia banksii</i>	Wharawhara	Lily and iris-like	1	1.5	Y	Y	N	Y	N	N
<i>Austrostipa stipoides</i>		Grass	1	0.5	Y	Y	N	Y	N	N
<i>Blechnum penna-marina</i>	Alpine hard fern	Fern	0.2	1	Y	Y	Y	Y	Y	Y
<i>Calystegia soldanella</i>	Shore bindweed, rauparaha	Ground cover	0.1	5	Y	N	N	Y	N	N
<i>Carex pumila</i>	Blue dune sedge	Sedge and rush-like	0.3	2	Y	N	N	Y	Y	Y
<i>Carex</i> 'raotest'	Orange dune sedge	Sedge and rush-like	0.6	1	Y	Y	Y	Y	Y	N
<i>Centella uniflora</i>		Ground cover	0.1	1	Y	Y	Y	Y	Y	Y
<i>Coprosma acerosa</i>	Coastal coprosma	Ground cover	0.4	1	Y	Y	N	Y	Y	N
<i>Coprosma brunnea</i>		Ground cover	0.4	1	Y	Y	N	Y	Y	N
<i>Coprosma pumila</i>		Ground cover	0.01	0.5	Y	Y	N	N	Y	Y
<i>Dichondra brevifolia</i>	Mercury Bay groundcover	Ground cover	0.01	1	Y	Y	N	Y	Y	Y
<i>Disphyma australe</i>	Native iceplant	Ground cover	0.02	1	Y	N	N	Y	N	N
<i>Doodia australis</i>	Pukupuku	Fern	0.3	0.5	Y	Y	Y	Y	Y	N
<i>Einadia triandra</i>		Herb	0.1	1	Y	Y	N	Y	Y	N

Name	Common name	Growth form	Max. height	Spread	Sun	Semi	Shade	Dry	Moist	Wet
<i>Festuca actae</i>	Banks Peninsular festuca	Tussock grass	0.3	0.4	Y	Y	N	Y	N	N
<i>Festuca coxii</i>	Chatham Island blue grass	Tussock grass	0.4	0.5	Y	Y	N	Y	Y	N
<i>Festuca matthewsii</i>	Blue grass	Tussock grass	0.3	0.3	Y	Y	N	Y	Y	N
<i>Ficinia nodosa</i>	Knobby club rush, wiwi	Sedge and rush-like	1.5	1.5	Y	Y	N	Y	Y	N
<i>Hebe obtusata</i>	Waitakere coastal hebe	Shrub	0.5	1	Y	Y	N	Y	Y	N
<i>Hibiscus richardsonii</i>		Shrub	1.0	2	Y	Y	N	Y	N	N
<i>Hydrocotyle</i> species		Ground cover	0.1	1	Y	Y	N	N	Y	N
<i>Leptinella</i> aff. <i>dioica</i>	Shore leptinella	Ground cover	0.1	1	Y	Y	Y	N	Y	Y
<i>Leptospermum</i> 'White prostrate'	Manuka	Ground cover	0.5	1.5	Y	N	N	Y	Y	N
<i>Leptostigma setulosa</i>		Ground cover	0.1	0.5	Y	Y	Y	Y	Y	Y
<i>Libertia cranwelliae</i> ; <i>L. peregrinans</i>	Native iris	Ground cover	0.4	1	Y	Y	Y	Y	Y	N
<i>Lobelia anceps</i>	Punakuru	Ground cover	0.1	0.3	Y	Y	Y	Y	Y	Y
<i>Microlaena stipoides</i>	Rice grass	Grass	0.3	1	Y	Y	Y	Y	Y	N
<i>Microsorium pustulatum</i>	Hounds tongue	Fern	0.3	1.5	Y	Y	Y	Y	N	N
<i>Muehlenbeckia axillaris</i>	Pohuehue	Ground cover	0.15	1	Y	Y	N	Y	Y	N
<i>Oplismenus hirtellus</i>	Basket grass	Grass	0.15	3	Y	Y	N	Y	Y	Y

Name	Common name	Growth form	Max. height	Spread	Sun	Semi	Shade	Dry	Moist	Wet
<i>Pimelea</i> species	Toroheke, NZ daphne	Ground cover	0.15	1	Y	Y	Y	Y	Y	N
<i>Polytrichum juniperinum</i>	Moss	Moss	0.01	0.2	Y	Y	Y	N	Y	Y
<i>Pteris tremula</i>	Turawera	Fern	1	1	Y	Y	Y	Y	Y	N
<i>Rubus x barkeri</i>	Bush lawyer hybrid	Ground cover	0.15	2	Y	N	N	Y	Y	N
<i>Scandia rosifolia</i>	Native angelica	Shrub	1	1.5	Y	Y	N	Y	Y	N
<i>Selliera radicans</i>		Ground cover	0.03	2	Y	Y	N	N	Y	Y
<i>Tetragonia implexicoma</i>		Ground cover	0.1	1	N	Y	Y	Y	Y	N
<i>Trisetum arduanum</i>		Grass	0.3	0.3	Y	Y	N	Y	Y	N

C1.6.5 Planting grassed devices

Grasses are often used in devices such as swales, detention basins, filter strips and some pervious pavements. Where grasses are used, they are often laid as seed or instant-turf mats. Seed may be laid within erosion-resistant mats which provide temporary surface reinforcement (e.g. wool or coir mats) or mats or netting laid over the surface.

Grasses generally fall into two distinct groups:

- **Meadow grasses:** These low-maintenance grasses are low fertility systems which do not require mowing. These are preferred particularly where there is a high water table or access to the grassed area is limited. Meadow grasses significantly enhance biodiversity. Unmown grasses also improve stormwater treatment through improved soil storage, deeper root systems and slower velocities
- **Mown grasses:** These grasses can represent a significant on-going maintenance cost with mowing schedules of up to 14 times a year. Mown grasses are discouraged, particularly when the asset is vested to Auckland Council due to high whole-of-life costs and compaction issues. Mown grasses are only appropriate on slopes of less than 1 in 5 (1V:5H).

When considering design which optimises operation and maintenance, mowing should be eliminated or limited. The design should allow for:

- Different mowing schedules across an area to enhance diversity
- Consideration of timing and height of site-specific mowing
- A mowing schedule so plants are able to adapt
- Cues for care. Stressed plants should not be mowed
- Inclusion of flowers and colour to improve public amenity.

C1.7 Design for safety

Examples of safe design considerations include:

- Slopes where mowing is required (must be less than 1V:5H slopes)
- Traffic control during installation and maintenance
- Use of hand tools in confined areas or at heights
- Handling and storage of chemicals
- Working at height
- Water depths including base flow as well as velocity and volume during storms
- Implications for plant replacement
- Public access and safety.

C1.8 Construction design considerations

Designers should consider the impact of construction on the ultimate efficacy of the stormwater devices. Where possible, these impacts should be mitigated for during the design stage and clearly communicated and controlled during the construction phase.

C1.8.1 Soil preparation

Consideration of soil management is vital to ensure that the device works as intended after construction. This includes consideration of final soil depths, how soils are managed in a construction site and how engineered soils are installed.

C1.8.1.1 Soil depth

Deep root zones and top soils support healthy plant growth with a wider range of resilient plant species and allowing taller plants to grow. Benefits of deeper soils include:

- Healthy growth and taller plants, which reduces runoff through interception and evapotranspiration
- Reduced need for irrigation and fertilisation
- Helps rapid plant establishment.

The following soil depths are recommended:

- A minimum depth of 200 mm and up to 400 mm of topsoil is recommended for all landscaped areas. The soil should be loosened for root zone depths of 1 m prior to top soil being added.
- A minimum root zone depth of:
 - 100 mm for living roofs
 - 300 mm for grassed areas
 - 500 mm for shrubs/gardens
 - 1 m for trees and taller scrubs should be established.

Large trees need large root volumes which are deliberately constructed and protected if areas are earth-worked. Designs should provide for root systems and favourable soils under pervious pavements and narrow impervious surfaces (such as footpaths).

C1.8.1.2 Managing soils *in situ*

Many soils of the Waitematā geology are highly vulnerable to degradation, difficult to rehabilitate over large areas and take many years to recover naturally. If soils are trafficked and compacted, their properties will change and may not provide the planned infiltration.

The most appropriate means to preserve soil structure on a site is to limit disturbance through erosion control and restrictions to the limits of work (excluding all vehicles from these areas).

Soils should remain uncompacted (protected from traffic) to support the growth of deep-rooted trees. A less favourable option is to stockpile permeable soils for re-spreading.

Conventional cut-to-fill earthworks typically result in distinct layers of topsoil layered above an impermeable subsoil. This can be exacerbated by multiple earth-moving operations, handling soils in wet conditions, and cuts greater than 0.5 to 1 m depths. This can also result in perched water tables, limited root development and reduced water storage.

Where areas of soil and vegetation are subject to earthworks, the key practices to enhance soil function are:

- Sites with hydrologic Group A and sandy Group B soils, from the Unified Soil Classification System, where practicable, should have earthworks restricted to roads and building footprints, particularly in areas designated for stormwater disposal ('stormwater reserves') and parks
- Areas of vulnerable soils, which are to be replanted post-development, should not be trafficked (unless conditions are dry and vehicles are light)
- Minimise compaction by maintaining vegetation cover and not trafficking with heavy equipment. In the short term, mulches - especially organic mulches - can protect soils from foot traffic and light vehicle traffic. Mulch also retains soil moisture to prevent cracking
- The application of mulch can reduce water entering subsoils, and certain mulches (bark and woodchip) can strip nitrogen and introduce weed seeds. Therefore, the source and depth of mulch should be assessed prior to spreading

- Ensure equipment is cleaned before getting to a site to reduce the risk of spreading weed species and soil pathogens
- Prevent and control erosion, especially of topsoil, by minimizing the extent and duration of bare soils
- Retain existing hydrology (such as wetlands and wet storage areas), but prevent ponding in earth-worked areas
- Divert overland flows from bare soils to vegetated soils
- Evaluate compaction and grading requirements, i.e. paved areas do not require the same level of compaction as building platforms. Use the lightest equipment necessary to get the job done and achieve final grades with as few passes as possible. Restrict soil stripping and replacement, especially the upper 0.3 m of subsoil and topsoil, to dry periods when soils have the highest bearing strength and the most resilience to compaction
- In sensitive areas on highly permeable soils, build houses on piles, rather than slab-on-grade, to avoid erosion, contouring and consequent soil degradation
- Protect root systems of existing large trees by suspending or supporting pavement/road over soil, installing grates around tree trunks, or placing gravel or organic mulch over soil surfaces to reduce compaction pressures.

C1.8.1.3 Soil stripping

Topsoil is a dark-brown layer usually 100 to 400 mm deep, characterised by the presence of organic matter. Other valuable soil structures include peat deposits and freely-draining subsoils (usually bright red-brown in colour with very few mottles). Soil stripping inevitably damages soil fauna, particularly earthworms and large invertebrates that break down and recycle leaf mulch and release nutrients for plant growth. Soil stripping and stockpiling also tends to destroy the soil structure and lower soil carbon content. Where stockpiling is necessary, the quality of stripped topsoils can be optimised in the following ways:

- Ensure machine operators can differentiate between topsoil and subsoil by colour
- Only excavate during daylight hours and when soil moisture conditions ensure wheel ruts are <50 mm depth. Do not excavate during rain
- Use tracked excavators or face-shovels to remove topsoil, not earth-scrapers, particularly for soils vulnerable to degradation (imperfectly to poorly-drained soils on the Waitematā Formation) or where soils are highly variable (e.g. brownfields). Maintain soil structure (large clods) and avoid re-handling topsoil (do not bulldoze into piles that are then removed to stockpiles)
- Remove the entire topsoil depth at one time and restrict traffic to subsoil layers to preserve soil structure and minimise compaction. Where access by machinery is essential, utilise low ground-bearing vehicles to reduce compaction of subsoils, especially in areas intended for replanting. Do not allow access to wetter soils

- If woody vegetation is removed, consider mulching or chipping vegetation and adding to the topsoil. The chips will help reduce compaction, especially in longer-term stockpiles. Be aware that the mulch will also strip nitrogen from the soil as it decomposes, so a slow-release fertiliser or nitrogen-containing compost will need to be added to the soil when re-spread to assist plant growth
- Large branches, tree stumps and rocks that could damage cultivation equipment should be separately stockpiled, preferably after the topsoil has been stripped to reduce topsoil compaction
- Kill herbaceous vegetation 3 to 6 weeks before stripping and identify areas of potentially high-maintenance weeds (e.g. kikuyu) to separate and manage appropriately.

C1.8.1.4 Soil stockpile management

Where possible, stockpiling should be avoided to reduce the impact to topsoils, avoid double handling and minimise the area of bare land. Where it is necessary to stockpile topsoil:

- Designate areas for stockpiling
- Prepare stockpile areas by ensuring surface water is intercepted and diverted around the stockpile. If required, construct sediment control features to capture and treat runoff from stockpiles. Ensure the base is relatively even and well drained to minimise anaerobic conditions developing at the base of the stockpile. Under drainage may be needed
- Construct stockpiles to avoid over compaction; reshape using tracked excavators, not bulldozers. Topsoil stockpiles should not be trafficked by any machinery
- Straw mulch or organic mulch should be applied for stockpiles remaining for more than 3 to 6 months or over winter
- Minimise vegetation on stockpiles before use.

Where anaerobic soils have developed at the base of stockpiles, there will typically be elevated iron and reduced pH (as low as 4 to 5) and should be tested before reuse. These soils should be amended before placement in stormwater management devices to avoid leaching of contaminants (ammonium, metals) or unsightly materials (iron floc) into waterways.

C1.8.1.5 Installing soils

Cultivation

Cultivation of subsoils is the physical loosening of soils to a set depth and is most effective on a two-directional grid. Roto-cultivators should not be used as they tend to create a smooth base that becomes a root barrier. Slopes greater than 17% (10°) to 27% (15°) may require specific cultivation methods with care taken around trees, utility lines, slopes and retaining structures.

Cultivation is effective in Allophanic and Granular soils. Cultivation is not effective in Ultic soils but can be amended with compost. Cultivation at the transition between subsoils and topsoils can provide for increased water percolation and root movement into subsoils. Any amendments (Section C1.5.3) can be added at this stage.

Top soil spreading

Higher value topsoils should be used in areas of permanent vegetation and spread to depths of at least 300 mm to new planting beds and 200 mm to grass areas. When placing topsoils:

- Use low ground-pressure machinery or selected lightweight tracked or balloon-tyred equipment operating along approved traffic routes
- Remove all building debris and contaminated material (debris, road base, oil spills etc.)
- Remediate subgrades before replacing topsoils, with a minimum 300 mm for turf areas and 1000 mm for trees
- Ensure a 100 mm interface with subsoils and mulch to prevent crusts forming
- Cover remediated areas with a full depth of topsoil as soon as possible. Where soils are well-drained, topsoil can be applied in two layers with an initial 50 to 75 mm depth of topsoil rotovated into the subsoil to encourage even drainage and rooting into the subsoil. If soils are imperfectly drained or fine-textured, the risk of re-compaction can be reduced by applying a full depth of topsoil in a single pass
- Check the final contoured surface for ruts, rilling, or dishes where surface water may be concentrated to create erosion pathways
- Hydroseed, mulch, or seed the re-spread topsoil immediately to protect surface from sealing or eroding.

C1.8.2 Planting

C1.8.2.1 Pre-planting considerations

This section provides designers some guidance when considering plant sourcing, sizes and handling prior to installation.

Plant sourcing

Designers should consider where plants will be sourced from. It is essential to ensure plants that are sourced from nurseries are free of environmental weeds (such as African club moss) and pests (such as Argentine ants).

Some key considerations in regarding to plant sourcing include the following:

- Some specimen trees may only be sourced from specific nurseries
- All plants should come from a reputable nursery with attention to weed and pest prevention
- There may be appropriate plants on site already which can be salvaged
- It is important to match plant size with plant installation timing.

Plant sizes

Plant root ball sizes greater than a 3 litre plant bag are more likely to survive. However, smaller plant root ball sizes (such as root trainers) are more economical and can be easily slotted into soils and geotextiles.

Hardening off and on-site storage

Plants should not come directly from an enclosed nursery or hothouse without a period of “hardening off”. This is a process where plants are removed from the sheltered environment of the nursery and are exposed to more typical planting conditions. This can generally be assumed to be two to three weeks prior to planting. This process exposes plants to increased sun and wind exposure prior to delivery to the construction site and is particularly important for some tree species intended for windy sites. The design should therefore accommodate the hardening off stage with shaded space made available on site with access to water. Care should be taken not to use fungicides prior to installation, as copper is a stormwater contaminant. Often plants will need watering immediately on delivery because they are often transported in a dry state to reduce weight.

Plant numbers

Generally, the design should include approximately 10% more plants than are needed for the landscape plan to account for die-off (especially in the hardening-off stage) or breakage during installation.

Plant selection to avoid weeds

No plants should be used that are in any categories of the Auckland Regional Pest Management Strategy or listed on the National Pest Plant Accord. The Auckland Council biosecurity team provides advice on weed control techniques in the plant search database.

C1.8.2.2 Planting specifications

The recommended planting specifications are detailed in Table 37.

Table 37: Recommended planting specifications

Component	Description
Pre-planting saturation	<ul style="list-style-type: none"> Ensure the device's media is moist prior to planting and completely saturated immediately after planting. This is especially critical for high-permeability media.
Set-out	<ul style="list-style-type: none"> Follow approved planting scheme (both composition and spacing). Plants should be staggered in odd numbered groups. Spacing will vary depending on device (e.g. rain gardens – 10-15 plants/m²). Place trees individually.
Planting	<ul style="list-style-type: none"> Make planting holes the size of the root ball in engineered media. In base soils, dig holes three times larger than the pot size and amend with good quality soil mix. Install plants at crown level so that no potting mix is visible. Account for soil settling.
Fertilisers	<ul style="list-style-type: none"> Where fertiliser is determined appropriate (e.g. nutrient-deficient soils), slow-release organic tablet fertilisers can be applied into the base of the planting hole for roots to absorb the nutrients. Fertilisers should be avoided in planted areas immediately adjacent to watercourses. Bioretention and filtering devices should not be fertilised, as they receive nutrients from off site during stormwater flows and any added fertiliser can enter the waterways through infiltration.
Pesticides and herbicides	<ul style="list-style-type: none"> All sprays should be avoided, particularly in bioretention devices where pesticides or herbicides could transfer into the receiving environment through infiltration. Slug control (slug bait) and those containing pyrethroids must not be used.
Planting season	<ul style="list-style-type: none"> The standard planting season is from May to September. Open water and wetland planting should occur either in late spring or early autumn (September to October and March to May). Hardy, frost-tolerant species can be planted in autumn and frost-sensitive species in spring. Plants that need shelter or shade can be planted one or two years later, once adjacent cover has developed.
Mulch	<ul style="list-style-type: none"> Used for weed suppression and stabilisation as well as plant nutrition. Do not use grass clippings or animal waste. Should be laid at a minimum depth of 100 mm with an erosion-control matting.
Erosion control and surface protection	<ul style="list-style-type: none"> Wool mulch should not be used. Where coir mats are used, mats should be heavier than 300 g/m². If needle-punched polypropylene is used, it must be removed after a year.

C1.9 Operation and maintenance design considerations

C1.9.1 Watering

All planted devices must receive sufficient water in the establishment phase of the device to ensure plant survival. In general, irrigation should be provided for the first two years of plant establishment. Additional considerations include:

- Where trees are installed, designers should consider using deep-watering novacoil around the root ball of the tree
- Root exclusion matting should be used on any pipes or irrigation that might be encroached by roots.

C1.9.2 Weeding, pruning, mowing

Future maintenance requirements must be considered during the design phase. Designers should ensure that opportunities for device clogging are minimised. For example:

- Deciduous trees should be excluded from designs to reduce leaf litter
- Plants should be chosen which minimise weeding or pruning. For instance, oioi, raupo and flax should not be planted adjacent to walkways because they can encroach at maturity
- Designs should protect inlets and outlets from clogging (e.g. from clippings or leaf litter)
- Areas which require mowing should be minimised
- Designs should minimise the potential for any activity which exposes soil surface (resuspension of sediment) and limits rooting depth
- Low maintenance plants should be chosen which do not need high nitrogen fertilisers, fungicides or pesticides.

Any design which includes grasses should consider the maintenance requirements. Maintenance of grassed devices depends on the grasses used:

- Meadow grasses can be maintained at any height and should be weeded, where necessary, to maintain the correct species composition. Some trimming may be needed where grasses grow over the footprint of the device
- Mowed devices should be maintained at a height of 50 to 150 mm.

C1.9.3 Weed and pest control

The design should also consider the needs for weed and pest management, as these are critical for the long-term success of the device as well as reduced maintenance costs over its life (Table 38).

Table 38: Pest management

Component	Description
Integrated pest management	<ul style="list-style-type: none"> Maintains pest population at levels below those causing ecological damage by setting action thresholds, monitoring, prevention and control.
Survey and monitoring	<ul style="list-style-type: none"> Requires a thorough survey of weeds and pests prior to development as well as control and management of any pests and weeds brought onto the site. Monthly monitoring for first 6 months, 3 times a year for 2 years, then 2-3 times a year, as well as monitoring after storms.
Weeds	<ul style="list-style-type: none"> Weeds can be controlled by: <ul style="list-style-type: none"> Shading and dense plantings Intermittent flooding – for control non-aquatic weed species Managing flows, temperature and nutrients in ponds and wetlands Hand weeding, grubbing, slashing, ring barking and spraying (herbicide – used very sparingly only when necessary) Ensuring construction equipment is cleaned before transport to site Ensuring topsoil, mulch and plants transported to site are weed-free Removing all weed material from the landscape areas to a designated collection facility off site.
Mosquitoes	<ul style="list-style-type: none"> Controls for mosquitoes include: <ul style="list-style-type: none"> Avoid designing areas where open, high nutrient, ponded water is present Maintain water movement through stormwater devices Include riffle zones and shallow water in designs Establish vegetation within and surrounding devices to create shading Create habitat for native fish species.
Birds	<ul style="list-style-type: none"> Bird management includes: <ul style="list-style-type: none"> Maintaining water depths of at least 100 mm Pinning/staking aquatic plants and grasses Installing bird-proof netting or trip wires Signage to discourage the public from feeding waterfowl.
Mammals	<ul style="list-style-type: none"> Control may include trapping and poisoning, with the most appropriate method depending on the pest species that are present and the use of the space by the public.



C2 Pervious pavements

Table of Contents

C2.0	Technical guidance: pervious pavements	117
C2.1	Introduction	117
C2.1.1	Use in a treatment suite	118
C2.1.2	Pervious paving components	118
C2.1.3	Site considerations	119
C2.2	Pervious paving design	121
C2.2.1	Design considerations	121
C2.2.2	Design for safety	122
C2.2.3	Device sizing	123
C2.2.4	Component design	127
C2.2.5	Construction design considerations	129
C2.2.6	Operation and maintenance design considerations	129

Figures

Figure 13:	Schematic of pervious paving	118
Figure 14:	Pervious paving design flow chart	126

Tables

Table 39:	Pervious paving components	119
Table 40:	Site considerations	120
Table 41:	Pervious paving design considerations and specifications	121
Table 42:	Infiltration systems	124
Table 43:	Quick reference table for underdrain pipe capacities	125
Table 44:	Recommended particle size distribution for base-course aggregate	127

C2.0 Technical guidance: pervious pavements

C2.1 Introduction

Pervious paving is the general term used to describe a constructed hard surface which allows water to pass through to the underlying soil layers. It can be used to reduce runoff and flooding, and help to replenish groundwater.

Within the pervious paving definition, there are two distinct types of surface:

- **Porous paving:** Where water travels through the surface paver into the underlying components
- **Permeable paving:** Where water travels through the gaps between impervious blocks into the underlying components. The paver is laid in such a way that water can pass through to the sub-base.

1% AEP detention	✗
50% and 10% AEP detention	✗
Detention for stream protection	✓
Retention (unlined)	✓
Water quality*	✗

* Limited treatment for active systems

In addition, pervious paving systems can be considered 'passive' or 'active':

- **A 'passive' system** only captures rain which falls on the pervious paving area itself. Since the definition of impervious surface specifically excludes pervious paving, a passive system can be used in developments to meet relevant impervious surface thresholds so that stormwater consenting requirements are not triggered
- **An 'active' system** is one that is designed to capture runoff from adjacent impervious areas in addition to rain which falls on the pervious paving area. Active systems need to be carefully designed for sufficient surface infiltration rates and storage volumes to accommodate the additional runoff from the adjacent catchment area/s in accordance with hydrologic mitigation requirements.

Pervious paving is typically used for small catchment areas with low traffic volumes such as car parks, driveways, footpaths and sidewalks, and can be particularly effective in meeting the detention and retention requirements in Stormwater Management Areas – Flow (SMAF).

Due to its potential to become clogged with sediments, pervious paving is generally not appropriate for high traffic areas, or in areas subject to heavy sediment loads. Since the aggregate is subject to structural loading, its use is also limited to areas where there is light vehicle traffic, little/no acceleration and little/no vehicle turning and no heavy goods vehicles. A structural engineering assessment is needed in all instances where pervious paving is being designed. Treatment processes provided by pervious paving are limited to filtration and sedimentation (with solids settling into the pore spaces of the pavement). Pervious paving, as specified in this section, is unsuitable for treating areas with high contaminant generating activities and should be used in conjunction with water-quality treatment devices in order to comply with Auckland Unitary Plan provisions for stormwater treatment.

Any treatment performance claims from manufacturers or suppliers need to be evaluated and recognised by Auckland Council through a formal treatment performance approval process before a specific pervious paving product can be accepted as an appropriate device for runoff from high contaminant generating car parks.

C2.1.1 Use in a treatment suite

As part of a treatment suite, pervious paving provides:

- On-site, at-source stormwater management
- Retention through infiltration
- Detention
- Some water quality treatment through sediment entrapment (and any attached contaminants such as metals).

Suitable applications include use in residential and commercial hard-scape. These are primarily low-trafficked areas which are assumed not to generate high concentrations of contaminants. Some locations where pervious paving can be applied successfully include residential streets, driveways and small car parks.

C2.1.2 Pervious paving components

A typical pervious paving cross-section design has multiple layers and components. The basic components are illustrated in Figure 13 and described in more detail in Table 39.

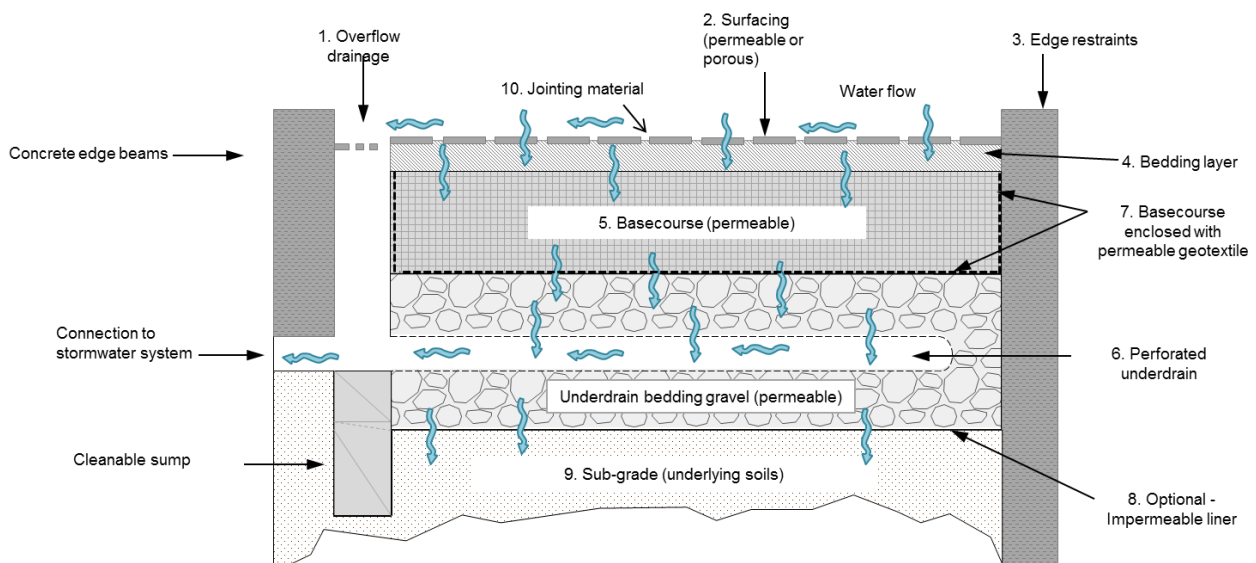

Figure 13: Schematic of pervious paving

Table 39: Pervious paving components

No.	Component	Description
1	Overflow drainage	<ul style="list-style-type: none"> The surface collection system may consist of catchpits, grated drains or defined overland flow paths which can safely convey runoff to the receiving stormwater network. Surface collection inlets should be at-grade with the paving surface to allow for minor surface ponding during regular operation of the pervious paving system.
2	Surfacing	<ul style="list-style-type: none"> Pervious paving surfaces can be any surface providing hard or trafficable areas which also provide for downward percolation of stormwater runoff.
3	Edge restraints	<ul style="list-style-type: none"> Solid-edge restraints, such as concrete kerbs, are placed around all edges of pervious block paving to resist lateral movement of the pavers. Edge restraints are generally not required for continuously laid surfaces (e.g. porous asphalt).
4	Bedding layer	<ul style="list-style-type: none"> This layer provides a stable platform on which to construct the pervious surface layer and should reduce the risk of clogging.
5	Jointing material	<ul style="list-style-type: none"> Jointing material is the granular fill used in the joints between individual pavers. The same material as for the bedding layer should be used.
6	Base course	<ul style="list-style-type: none"> This layer generally consists of a coarse-graded, clean, durable aggregate and provides a solid foundation on which to construct the overlying layers.
7	Underdrain	<ul style="list-style-type: none"> Underdrains collect and discharge infiltrated water to the local stormwater system where soils have low permeability or when an impermeable liner is used.
8	Geotextile layer	<ul style="list-style-type: none"> In infiltration systems, the sides and base of the pervious paving should be lined with a geotextile liner to prevent the migration of <i>in situ</i> soil particles into the base course. Geotextile is placed between layers to prevent the movement of fine sediment between the layers and aid filtration.
9	Impervious liner	<ul style="list-style-type: none"> Impervious liners are required in geotechnically sensitive areas where water cannot be allowed to infiltrate through into the sub-grade, or where the structural integrity of the pavers (e.g. due to traffic load) requires it.
10	Subgrade	<ul style="list-style-type: none"> Subgrade is the underlying <i>in situ</i> soil on which the pervious paving is constructed. The subgrade must be of sufficient strength and durability not to degrade with the wetting and drying action over the life of the pavement.

C2.1.3 Site considerations

Pervious paving can have significant benefits when used correctly, but it is not suitable for every site. Table 40 sets out the recommended design requirements for pervious paving installations. In all instances, a qualified road pavement engineer should be consulted in the design process and the future asset owner must be consulted to ensure that they are aware and are responsible for on-going maintenance and long-term device performance.

Table 40: Site considerations

Item	Description
Catchment size and location	<ul style="list-style-type: none"> • Small/medium catchment. At source, upper catchment locations. • The total pavement catchment area for active designs should be less than two times the area of pervious paving (maximum 2:1 ratio). • Adjacent pervious surfaces should drain away from the pervious paving design. Drainage is required to manage flows from larger events.
Groundwater	<ul style="list-style-type: none"> • Full or partial exfiltration systems should be used only if the seasonal high water table is more than 0.6 m from the invert of the pervious pavement system. • Groundwater mounding analysis should be undertaken. An impermeable liner may be used in some instances.
Slope	<ul style="list-style-type: none"> • Less than 3° (5%) for active designs and less than 7° (12%) for passive designs. Should not be used in areas of instability. • Greater than 15 m from slopes of more than 9° (15%).
Subsoils	<ul style="list-style-type: none"> • Subsoil characteristics (infiltration rates, void space compaction etc.) need to be understood, especially for active designs where sub-design erosion might occur. • Where subsoils have limited permeability, a perforated underdrain at the base may be needed to drain the design volume within 24 hours. Drains via gravity to the public network.
Soils requiring structural support	<ul style="list-style-type: none"> • Geotextiles, impermeable layers or liners are required for both structural support and to prevent media migration. Can become clogged if the device is poorly maintained. May also be needed if pervious paving is designed for detention only. Follow the manufacturer's specifications.
Soils with poor drainage	<ul style="list-style-type: none"> • Infiltration from the base of pervious paving into the subgrade should not be allowed where soils are susceptible to instability.
Pre-treatment	<ul style="list-style-type: none"> • Pervious paving should receive flows after pre-treatment for sediment reduction/removal. Regular maintenance to remove particulate deposits is needed. • Pervious paving should not be located downstream of areas expected to have a high sediment load.
Private connection	<ul style="list-style-type: none"> • Pervious pavements on private land must meet the connection requirements of Auckland Council and remain pervious so as not to trigger consenting requirements.
Contaminated land	<ul style="list-style-type: none"> • Must be fully lined with an impervious layer if contaminated land is present. • The impervious liner should be a minimum 0.25 mm thick polypropylene.
Setback	<ul style="list-style-type: none"> • Should have a lined vertical surface if within 5 m of structures. • Pavement within 3 m of a structure or 6 m upstream of a structure or within 1:1 slope offset from the bottom foundations should be fully lined with no exfiltration.
Traffic	<ul style="list-style-type: none"> • Design traffic loading should be less than 3,000 vehicles per day (private roads). • Auckland Transport does not allow pervious paving to be used on roadways, only on car parking bays. Specific attention should be paid to the loading criteria. A road pavement engineer should be involved to ensure structural integrity. • Pervious paving is not appropriate in turning areas or areas of acceleration and deceleration.

C2.2 Pervious paving design

All pervious paving designs should comply with relevant standards and specifications. This includes (but is not limited to) compliance with the following (applicable at the date of publication):

- The NZ Transport Agency's Bridge Manual SP/M/022, 2013
- Auckland Transport Code of Practice, 2012 (draft)
- Auckland Council Stormwater Code of Practice, 2015
- New Zealand Building Code, 2014
- New Zealand Building Act, 2004
- Transit New Zealand TNZ F/7: 2003 *Specification for Geotextiles*.

Minimum structural compliance must be adhered to for all components (including the product, geotextile and base course) and a qualified road pavement engineer should be consulted in the design.

C2.2.1 Design considerations

Table 41 provides the design considerations for pervious paving.

Table 41: Pervious paving design considerations and specifications

Item	Description
Infiltration rate	<ul style="list-style-type: none"> • 120 mm/hour over life-time of device, with a minimum initial rate of 1,200 mm/hr (factor of 10 times to account for potential clogging of the surface). • Alternatively, surfacing should be designed with projections to keep the pavers apart and these gaps filled with appropriate jointing aggregate to ensure the infiltration rate.
Active system catchment area	<ul style="list-style-type: none"> • The total pavement catchment area for active systems should be less than two times the area of pervious paving (maximum 2:1 ratio). • The infiltration rate must be adjusted accordingly, e.g. with a 2:1 ration the subsequent minimum infiltration rate will be (120 mm/hr x 2 areas) 240 mm/hr (over the life span of the device).
Subgrade	<ul style="list-style-type: none"> • Soaked CBR (California Bearing Ratio) or Equilibrium Moisture Content CBR must be more than 3%.
Slope	<ul style="list-style-type: none"> • Active systems should have a maximum slope of 3° (5%). • Passive systems should have a maximum slope 7° (12%). • Slopes greater than 3° (5%) require paving to have cut-off barriers at intervals to prevent upwelling down slope.
Overflow drainage	<ul style="list-style-type: none"> • All pervious paving systems should be designed with surface collection and conveyance drains, in case of surface blockage or rainfall events which exceed the capacity of the system. • All designs must comply with the New Zealand Building Code for overflow drainage.
Edge restraints	<ul style="list-style-type: none"> • Edge restraints should be provided around all edges of the pervious paving to prevent pavers from getting displaced and to prevent splitting and cracking around the edges.

Item	Description
Bedding layer	<ul style="list-style-type: none"> For porous paving, use Standards New Zealand <i>Concrete Segmental and Flagstone Paving</i> (NZS3116:2002) Sand Category (<5 mm diameter grain size). For permeable paving, use 2-7 mm diameter chips.
Jointing material	<ul style="list-style-type: none"> The same material as for the bedding layer must be used. For porous paving, use NZS3116:2002 Sand Category (<5 mm diameter grain size). For permeable paving, use 2-7 mm diameter chips.
Base course	<ul style="list-style-type: none"> Use coarse-graded, clean, durable aggregate with high void space. Alternatives, such as plastic void formers, may also be used for this layer. If plastic void formers are used, loading and cover requirements must be checked to ensure they are fit for the proposed use.
Underdrain	<ul style="list-style-type: none"> Required in soils with low infiltration or where impermeable liner is used (in which case the device does not provide retention). Where retention is designed for, underdrain must be positioned such that the storage below the invert will retain the 5mm design storm volume (i.e. 15mm depth where aggregate has 30% void space). Underdrain layout must be designed to drain the design volume within 24 hours (detention only) or 72 hours (retention and detention). Heavy duty 100 mm drain coil must be used as the underdrain pipe.
Geotextile	<ul style="list-style-type: none"> Geotextile may be used to prevent migration of aggregate layers; geotextile must be secured at edges of paving area and all joins overlapped. Note that geotextile layers can clog and reduce permeability.
Impervious liner	<ul style="list-style-type: none"> Pervious paving placed adjacent to roadways should have an impervious liner placed on the vertical side adjacent to the roadway or around the adjacent road sub-drain. This is to prevent impounded water flowing into road foundation layers, or short-circuiting retention by entering road subsoil drainage. The impervious liner should be a minimum 0.25 mm thick polypropylene.

Any pervious paving being vested to Council will require:

- Design approval
- An operation and maintenance plan.

C2.2.2 Design for safety

Key considerations for safe design for pervious paving include:

- Ensuring paving blocks do not cause tripping hazards and allow safe pedestrian access (including wheelchairs and prams)
- Ensuring any movement of pavers, or the underlying aggregates and base soils does not lead to subsidence
- Exceeding surface roughness criteria for its users

- Ensuring that space for maintenance access is provided for.

C2.2.3 Device sizing

Pervious paving systems need to be designed and operated in accordance with the criteria specified in Table 40 and Table 41. Meeting these criteria should ensure that permeability continues to be achieved in the long term and that rainfall events that exceed the capacity of the pervious paving will be discharged without causing nuisance. Note that there are no specific sizing requirements for passive systems because it is assumed that the detention and retention volumes (90th and 95th percentile storms) will not produce runoff from the surface.

It is the responsibility of the designer/specifier and the constructor of the pervious paving to ensure that permeability is guaranteed for the life span of the device. When a passive system becomes impermeable or is replaced with an impervious surface, that surface may become a non-complying activity that requires a stormwater consent.

C2.2.3.1 Design base-course storage to meet detention requirements

The required detention volume depends on the relevant 90th or 95th percentile rain depths and should be calculated using the methodology as described in Section B.

The available storage in the base course is based on the known void space of the aggregate (approximately 30%) and can be calculated as follows:

		$V_{(tot)} = A \times d_{(basecourse)} \times \phi$	Equation 2
Where:	$V_{(tot)}$	-	Total storage volume in base course (m ³)
	A	-	Pervious surface area (m ²)
	$d_{(basecourse)}$	-	Depth of base course layer (m)
	ϕ	-	Void space of base-course layer (%)

The above design specification for total available storage volume assumes the following can be ignored:

- Storage in the paving and bedding layer
- Losses due to infiltration into the subgrade
- Storage due to slope (of less than 5% or 3°).

C2.2.3.2 Infiltration systems to meet retention requirement

The Auckland Unitary Plan retention requirement is 5 mm. Passive unlined pervious paving systems, with or without a drain, will be able to achieve this retention requirement through infiltration losses into the underlying soils. Pervious paving should not be used where expansive soils with low infiltration rates are present.

Active systems will have to infiltrate up to 10 mm (5 mm retention depth x 2 areas) in the underlying soils, based on the maximum ratio for active systems of 2:1 to meet the retention requirements. Therefore,

permeability testing of the underlying soils is required where active systems are proposed to prove that the infiltration rates will be sufficient.

There are three different options (Table 42):

Table 42: Infiltration systems

Infiltration system	Description	Underdrain	Performance specification
Full infiltration system	<ul style="list-style-type: none"> Subsoil infiltration rates are sufficiently high so that all runoff from the design event (detention and retention volume) will infiltrate within 72 hours. 	No	To be used only if the storage volume can be infiltrated within 72 hours.
Partial infiltration system	<ul style="list-style-type: none"> Subsoil infiltration rates are too low to fully infiltrate the detention volume within 72 hours. The paving will still be able to provide the full retention volume. 	Yes	Underdrains must be designed to empty base course in 72 hours.
No Infiltration system	<ul style="list-style-type: none"> The system is lined and no infiltration to underlying subgrade will occur. 	Yes	Underdrains must be designed to empty base course in 24 hours.

C2.2.3.3 Underdrain layout

Assuming no infiltration, the underdrain is sized to drain out the required volume for storage over a 24-hour period. There are three steps to designing the underdrain:

- Find the design flow rate
- Determine underdrain layout
- Check underdrain capacity.

Design flow rate

The purpose of the underdrain is to discharge the total of volume of runoff that is collected by the pervious paving within the required timeframe (24 to 72 hours). Therefore, the flow rate can be calculated as:

$$Q_{(under)} = \frac{\text{rainfall depth (mm)} \times \text{contributing area (m}^2\text{)}}{60 \times 60 \times 24 \text{ (s)}}$$

Equation 3

Where:

$Q_{(under)}$ - Underdrain design flow rate (L/s)

Layout

- Minimise the length of pipe and the number of joints whilst meeting the above conditions; this will reduce cost and complexity of the design
- Maintain a minimum fall of 0.5%
- Provide maintenance access at the upstream end of the pipes.

Capacity

Two sizing checks are needed to ensure design capacity is met:

- 1) Check that water can enter through perforations in the underdrain at the required rate
- 2) Check that water can move along the underdrain pipe at the required rate.

Table 43 provides a quick reference for sizing pipes based on the required capacity.

Table 43: Quick reference table for underdrain pipe capacities

Diameter	Type	Peak flow	Required 10 mm holes per m ² of catchment
100 mm	Heavy duty drain coil	1.8 L/s	N/A (comes pre-punched)
150 mm	Heavy duty drain coil	5.6 L/s	N/A (comes pre-punched)
200 mm	Rigid pipe	25.0 L/s	4
250 mm	Rigid pipe	45.0 L/s	4

Once the flow rate into the underdrain pipes has been checked, the capacity of the pipes also needs to be checked.

Standard pipe flow equations can be used to estimate the flow through the underdrain. Apportion flow based on the layout of the underdrains. For example, if half the pavement drains through a pipe, the pipe should be sized for half the flow rate. Manning's formula for pipes flowing full can be used to calculate the capacity of the underdrains:

$$Q_{(\text{pipe})} = \frac{1000}{n} A_{(\text{pipe})} \times R_{(hy)}^{2/3} \times i^{1/2} \quad \text{Equation 4}$$

Where;

$Q_{(\text{pipe})}$	-	Maximum flow rate in pipe (L/s)
n	-	Manning's roughness coefficient: <ul style="list-style-type: none"> ○ 0.012 for smooth plastic pipes ○ 0.025 for pipes with corrugated inner walls
$A_{(\text{pipe})}$	-	Cross-sectional area of pipe (m ²)
$R_{(hy)}$	-	Hydraulic radius (m)
i	-	Longitudinal slope of pipe (m/m)

C2.2.3.4 Curve numbers (CN)

Pervious paving may be considered to completely detain the design storm when designed and maintained appropriately. Therefore, for storm events of less than the design storm, runoff is assumed to be equal to zero (i.e. $CN < 1$). Where runoff volumes are required to be calculated for storms larger than the design storm, calculations should be done using an appropriate curve number method ($CN=98$).

Most pervious paving will be designed to provide retention and detention in accordance with hydrology mitigation requirements for SMAF1 or SMAF2. For any rainfall that exceeds the design capacity, overflow drainage must be installed to capture the runoff in excess of the design storm. The runoff from these larger events should therefore be calculated similar to runoff from an impervious surface, provided that the pervious paving is not designed to detain any of these larger events.

C2.2.3.5 Summary of pervious pavement design process

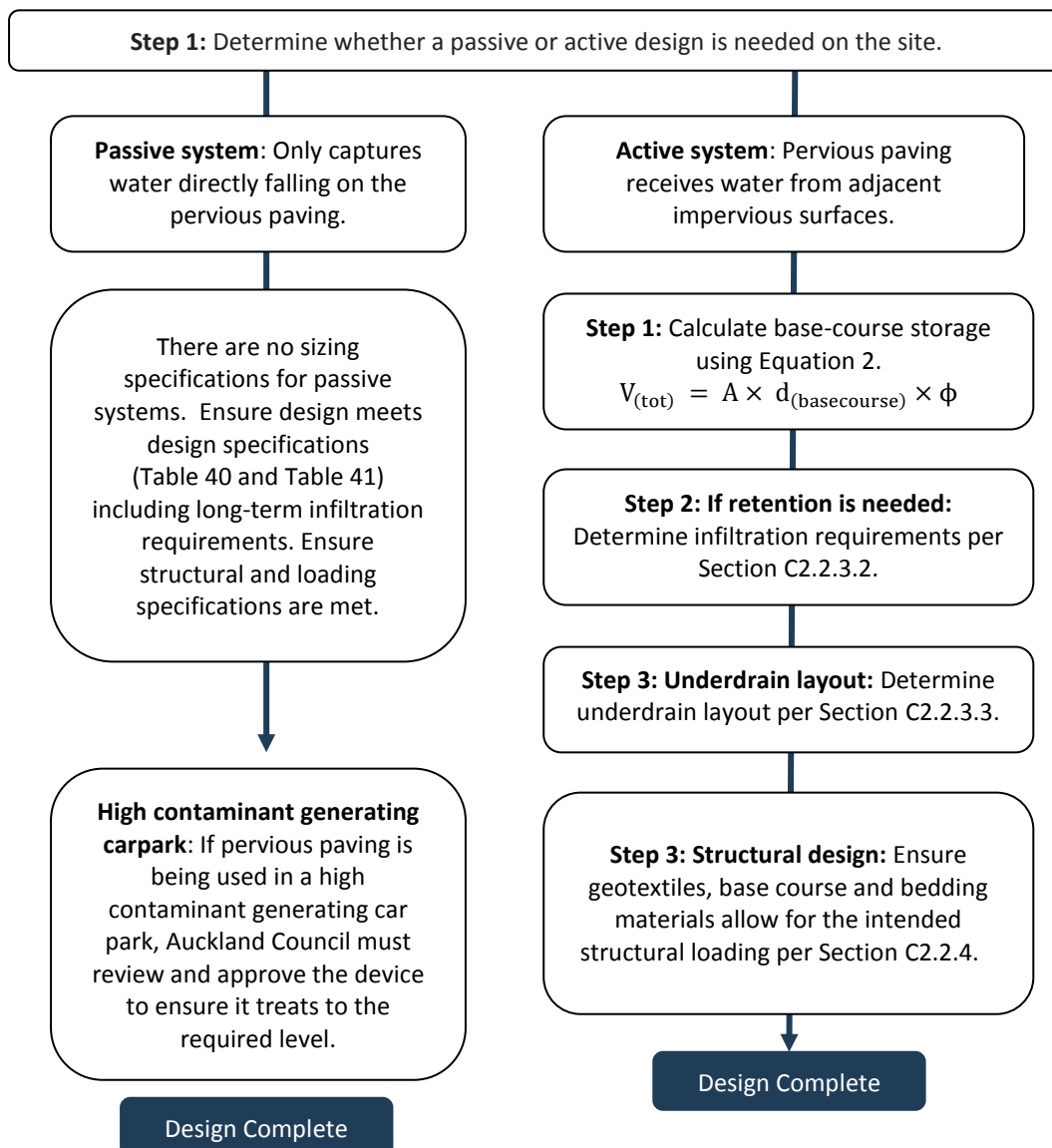

Figure 14: Pervious paving design flow chart

C2.2.4 Component design

The paving thickness required to ensure adequate structural strength is related to both the design loading and the load-bearing properties of the materials selected for the various layers (surfacing, bedding, base course and subgrade). Consideration needs to be given to the underlying soils and groundwater in order to ensure the paving will withstand the structural loading.

A qualified road pavement engineer should provide input into pervious pavement design pertaining to the loading and load-bearing properties of the surface. All designs should comply with applicable standards and codes.

C2.2.4.1 Bedding and jointing materials specification

The chosen bedding layer and jointing material should remain sufficiently permeable over the lifetime of the device and reduce the risk of clogging. When used in public roads or surfaces, the bedding and jointing materials should meet Auckland Transport's Code of Practice requirements for pavement design.

For privately owned surfaces, the following specifications may be followed:

- For porous paving: Use Standards New Zealand *Concrete and Segmental and Flagstone Paving* NZS3116:2002 Sand Category (<5 mm diameter gravel grain size)
- For permeable paving: Use 2-7 mm diameter chips.

Bedding sand and washed aggregate must have a defined void space and be free of fines. It is important to protect infiltration areas from compaction.

C2.2.4.2 Base-course materials specification

Base course media should comply with all the requirements of Transit New Zealand (TNZ M/4 AP40 2006), except for the particle size distribution and requirements specified in Table 44. The particle size distribution of the aggregate should conform to the envelope limits defined in Table 44, or as approved by a qualified road pavement engineer, when the aggregate is tested according to Standards New Zealand *Methods of Sampling and Testing Road Aggregates* NZS 4407:2015, Test 3.8.1 Wet Sieving Test.

Table 44: Recommended particle size distribution for base-course aggregate

Sieve aperture (mm)	Upper limit %	Lower limit %
19.0 mm	100	100
13.2 mm	95	100
9.5 mm	75	90
6. mm	50	75
4.75 mm	30	50
2.36 mm	0	10

- It should have a minimum permeability of 0.03 m/s. Random samples of all granular materials used (e.g. bedding, jointing and base course) should be taken and tested to verify compliance with the design parameters (i.e. grading, voids ratio and compacted permeability)
- It should be 'washed' (free of fines) to minimise introduction of additional suspended sediments
- It should have an optimal void space of 30% at the compacted density
- Good workability without segregation. Care should be taken to avoid segregation during handling of the materials. If segregation has occurred, additional mixing at site prior to installation should be undertaken
- Pavement layer compaction of at least 95% of maximum dry density should be achieved. Maximum density is obtained by vibrating under saturated condition
- The pavement layers should be compacted in layers of uniform thickness not exceeding 150 mm to ensure that the maximum density is achieved for the particular aggregate type and grading, without crushing the individual particles
- Pavement material should not be liable to weathering/aging leading to breakdown under loading.

C2.2.4.3 Geotextiles and geogrids materials specifications

Geotextiles and geogrids act in both a structural and pollutant-retaining capacity:

- **Geogrid:** Geogrids may be used at intermediate depths in the base course to provide additional structural support
- **Geotextile:** Positioning a geotextile near the surface of the pervious paving should enable pollutants to be trapped and retained close to the surface. This can act to protect the sub-base and can make maintenance localised to the upper layers, but can increase the clogging potential of the device. Any geotextile should be specified to:
 - Minimise loss of friction between layers
 - Minimise degradation over time
 - Mitigate the migration of materials from different layers in the pervious paving.

A number of geotextile and grid options are available for structural containment and reinforcement:

- **Lower geotextile liners:** Used in full or partial exfiltration systems to line the sides and base of pervious pavements to prevent migration of surrounding soil into the base course or punching base soils into soft soils. The geotextile should be light-weight, non-woven and needle punched with a minimum Class C strength and Class 1 filtration capacity
- **Upper geotextile layer:** Used to prevent the migration of finer particles between the bedding layer and the base course. Susceptible to clogging and should be avoided between paving layers unless the manufacturer requires them
- **Geogrids:** A structural grid with large holes (< 10 mm) that provides structural reinforcement to the pavement layers. Geogrids are sometimes specified by manufacturers for use in pervious paving.

The performance specifications for the geotextiles used in pervious paving should be based on the Transit New Zealand F/7: 2003 *Specification for Geotextiles*. These include the following:

- Material requirements:
 - Non-woven geotextiles should have filaments bonded by needle punching, heat or chemical bonding processes
 - Woven textiles should have filaments interlaced in two sets at right angles
- Material should be stabilised against UV radiation with a retained strength of at least 50% after 672 hours of exposure when tested in accordance with Australian Standard Geotextiles – *Methods of Test. Method 11: Determination of Durability – Resistance to Degradation by Light, Heat and Moisture*. AS 3706.11- 2012.

C2.2.5 Construction design considerations

Pervious paving must be constructed:

- As the last step in any development
- Protected from sediment during construction
- Such that it is not compacted by any construction machinery.

C2.2.6 Operation and maintenance design considerations

All operation and maintenance considerations should be addressed during design and specification. An operation and maintenance plan must be developed prior to transferring the asset to the owner.

Paving must be maintained to ensure the minimum infiltration rate is 120 mm/hour over the life of the device. If the paving has a lower infiltration rate, it will no longer be considered pervious and must be refurbished to an acceptable infiltration rate (i.e. >120 mm/hour).

Other maintenance considerations which should be considered during design are:

- Movement of pavers and edge restraints: May cause displacement, tripping hazards and uneven paving
- Standard operation of pervious paving: May lead to minor surface ponding which may impact pedestrian safety (slips and falls)
- Jointing materials: These will need to be replaced periodically
- Underdrains: Any underdrains should allow for access and cleaning.



C3 Bioretention

Table of Contents

C3.0	Technical guidance: bioretention	131
C3.1	Introduction	131
C3.1.1	Use in a treatment suite	131
C3.1.2	Bioretention device components	132
C3.1.3	Site considerations	138
C3.2	Bioretention design	141
C3.2.1	Design considerations	141
C3.2.2	Design for safety	142
C3.2.3	Device sizing	142
C3.2.4	Component design	150
C3.2.5	Construction design considerations	157
C3.2.6	Operation and maintenance design considerations	157
C3.3	Design examples	158
C3.3.1	Rain garden to meet SMAF1 and water quality criteria – 1000 m ² carpark	158
C3.3.2	Rain garden to water quality criteria only – 1000 m ² carpark	160

Figures

Figure 15:	Schematic of rain garden cross-section	133
Figure 16:	Schematic of rain garden cross-section	134
Figure 17:	Schematic of planter box	135
Figure 18:	Schematic of stormwater tree pit	136
Figure 19:	Recommended soil volume based on expected trunk diameter at tree maturity	136
Figure 20:	Schematic of bioretention swale	138
Figure 21:	Setback limitations for bioretention devices	140
Figure 22:	Schematic of slope constraints and liner use	140
Figure 23:	Schematic of bioretention device parameters	145
Figure 24:	Bioretention device design flow chart	149
Figure 25:	Rain garden design for 1000 m ² carpark	160

Tables

Table 45: Bioretention device components	132
Table 46: Site considerations	138
Table 47: Bioretention device design considerations and specifications	141
Table 48: Bioretention device sizing criteria	143
Table 49: Void space assumptions.....	144
Table 50: Infiltration and evapotranspiration assumptions	144
Table 51: Suggested soil specifications for bioretention devices	151

C3.0 Technical guidance: bioretention

C3.1 Introduction

Bioretention is a stormwater management practice where runoff is filtered through a vegetated filter bed made of natural soil or engineered media. It performs a water quality function by removing both particulate and dissolved contaminants, and reducing runoff temperature. Depending on its design, bioretention may also perform a hydrological function by reducing runoff volumes (through retention) and detaining runoff flows.

1% AEP detention	✘
50% and 10% AEP detention	✘
Detention (SMAF)	✓
Retention	✓
Water quality	✓

Specific devices which are categorised as bioretention devices include rain gardens, tree pits, stormwater planters and bioretention swales. Typically, these devices are designed with an underdrain beneath the media to convey the treated runoff. Where natural soils are sufficiently free-draining, it may also be possible to design bioretention without an underdrain. This section provides the basis to design all of these various forms of bioretention¹.

In addition, this section describes two different approaches for bioretention design:

- Bioretention for both retention, detention and water quality; standard bioretention design and sizing applies
- Bioretention for water quality treatment only; significantly smaller bioretention devices designed with significantly higher infiltration rates².

C3.1.1 Use in a treatment suite

Bioretention devices may be used at multiple locations in a catchment (at source through to lower catchment) to manage stormwater treatment and retention of flows, as well as detaining flows. Additional benefits include:

- Reduction of a range of stormwater contaminants through sedimentation, physical filtration and biofiltration
- Reduction in peak flow by slowing down the discharge and increasing lag time during smaller storm events
- Increased opportunity for groundwater recharge through infiltration
- Reduced runoff temperature
- Biological uptake; both by plants and microbes
- Reduced runoff volumes (particularly from frequent minor events) through increased evapotranspiration.

¹ A key reference for this section was the superseded North Shore City Council. 2008, *Bioretention Guidelines. First Edition*. Prepared by Sinclair Knight Merz and Boffa Miskell

² Based on learnings from the Wynyard Quarter bioretention designs

C3.1.2 Bioretention device components

Typical components of bioretention devices (including rain gardens, planter boxes, stormwater tree pits and bioretention swales) are provided in Table 45 and Figure 15.

Table 45: Bioretention device components

Component	Description
Ponding area	<ul style="list-style-type: none"> The ponding area is designed to provide temporary storage of runoff. Plants within this area must be tolerant of inundation, as well as dry periods.
Mulch layer	<ul style="list-style-type: none"> The mulch layer protects plants and soils from desiccation and prevents weed growth.
Media	<ul style="list-style-type: none"> The filter media may be <i>in situ</i> soils but is more commonly, engineered soils.
Transition layer	<ul style="list-style-type: none"> The transition layer prevents media migrating into drainage aggregate. It is generally comprised of media of a certain particle size, smaller in diameter than the drainage aggregate.
Drainage layer	<ul style="list-style-type: none"> The drainage aggregate is comprised of larger gravels (such as pea gravel) with a higher void space (compared to the transition layer). This layer conveys infiltrated flows horizontally across the base of the device into the underdrain.
Underdrain	<ul style="list-style-type: none"> Treated water is conveyed to the underdrain from the drainage layer and from there into the conveyance system.
Storage (retention) layer	<ul style="list-style-type: none"> The storage layer is provided to retain stormwater from small storms in the bioretention device to allow for percolation (retention) between storm events. The storage layer can be designed so that stored water is available to vegetation to reduce the need for irrigation in dry periods.
Planting	<ul style="list-style-type: none"> Plants provide key functions including maintaining infiltration rates through root growth/dieback, providing carbon sources in filter media and providing surfaces for biofilm development on roots. They must be carefully chosen for bioretention devices to ensure optimal function. Plants provide some runoff volume loss through evapotranspiration, and provide resistance to media clogging.
Structural support	<ul style="list-style-type: none"> Where bioretention devices are required to be close to structures, or to trafficked roads, structural support may be required. This can be avoided where it is possible to locate devices away from loads producing significant lateral forces.

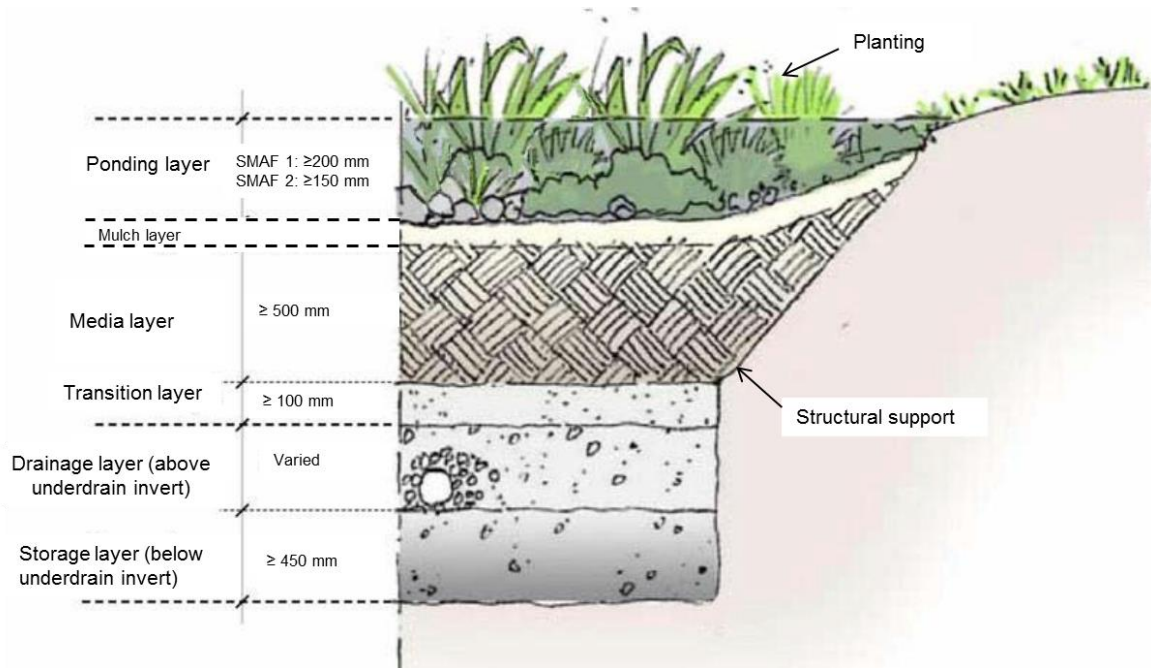

Figure 15: Schematic of rain garden cross-section

(Adapted from North Shore City Council “Bioretention Guidelines”, 2008)

C3.1.2.1 Rain garden

Rain gardens are planted garden beds containing specified soil media that promote filtering and retention. In most situations, rain gardens are directly connected to impervious surfaces, although sometimes there is an intermediary filter strip or rock apron to reduce scouring or to capture entrained sediment. In some situations, where it is not possible to directly connect the rain garden to the impervious areas, stormwater may be piped into the garden (Figure 16).

As stormwater enters the rain garden, it is filtered through plants specifically selected to tolerate the hydrologic conditions and provide water quality treatment. The stormwater then receives additional treatment as it permeates through an organic mulch layer, the root zone of the plants, and through a sequence of specific soil layers. These soil layers are organic in the top layers, such as a sandy loam enriched with compost, followed by porous sandy soil, to a gravel drain with a transition layer. Treated water in the gravel layer is then collected via perforated pipes. These pipes flow to an approved outlet to enter the receiving environment or reticulated systems.

As well as filtering and infiltrating stormwater, rain gardens also provide temporary ponding on the surface of the rain garden. Storm events that are greater than the design storm overflow from the rain garden into a grated overflow and connect to the reticulated system at the base of the rain garden. Alternatively, excess stormwater may overflow from a rain garden to an overflow path or a sequence of stormwater management devices in a treatment train. It should be noted that the grated overflow outlet and/or overflow path is positioned away from the inlet to avoid short-circuiting. Ensure the bioretention device is horizontal to encourage uniform flow over the full surface area.

As illustrated in Figure 16, rain gardens can contain a variety of vegetation and can be accommodated into a number of design landscapes.

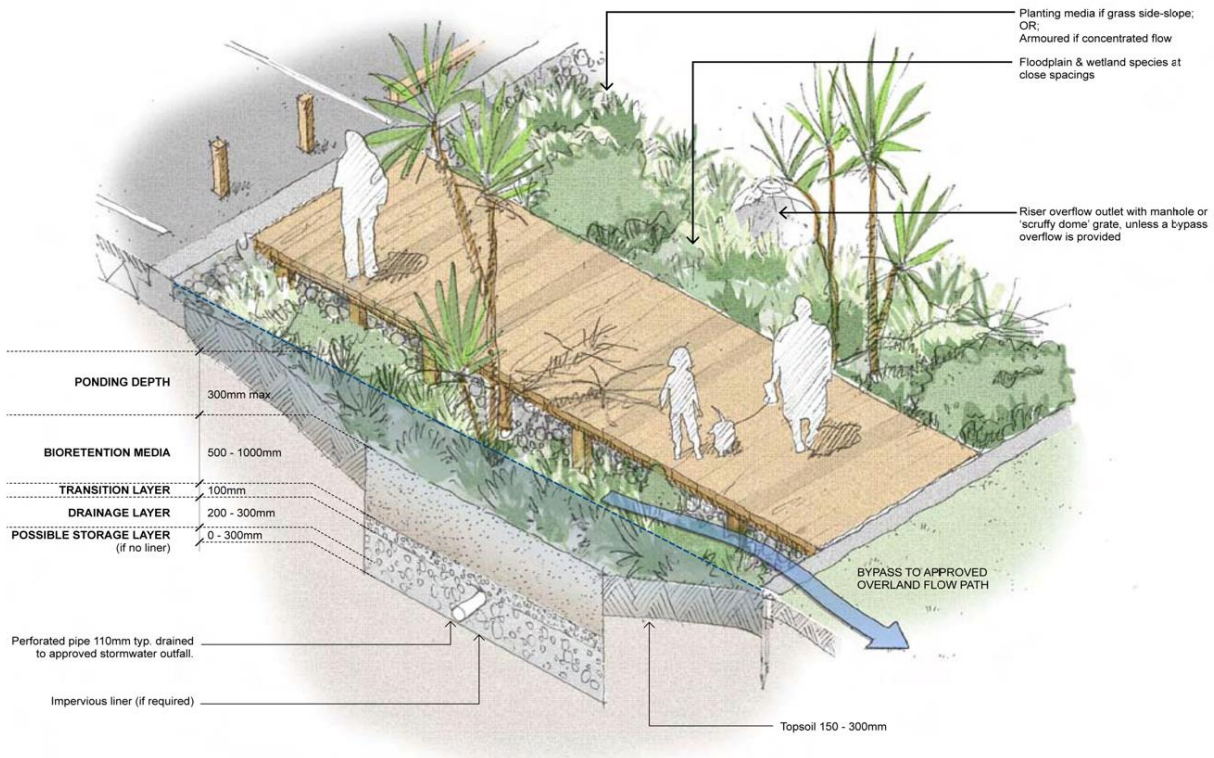

Figure 16: Schematic of rain garden cross-section

(Adapted from North Shore City Council "Bioretention Guidelines", 2008)

C3.1.2.2 Planter box

Bioretention planter boxes are smaller versions of rain gardens often using an above-ground pre-cast concrete unit, with specific soil media in which plants are grown (Figure 17). Stormwater planter boxes operate as follows:

- Roof water is discharged into the planter from a downpipe; this can either be via surface discharge or a bubble-up inlet
- The 'first-flush' of stormwater infiltrates soil layers and is then collected in a drainage layer to be directed to a discharge point
- Ponding occurs as soils become saturated to the top-of-wall level in the planter box. This storage serves to further attenuate flows. An outlet riser comes into operation when the ponding capacity is full. Excess runoff, after the 'first flush' has been retained, is discharged through the outlet riser and standpipe to reticulated systems.

If planters are adjacent to buildings, they should be above ground. Stormwater planters can be partially sunk, but advice from a geotechnical engineer is required if they are within 3 m of a building's foundation.

The device should have a horizontal surface. Stormwater planters are generally lined with impervious geotextile to protect adjacent structures and reduce opportunity for infiltration. Because they receive roof runoff, maintenance and media/plant renewal is generally less frequent than for rain gardens and tree pits.

The minimum size of a planter box should be 2 m².

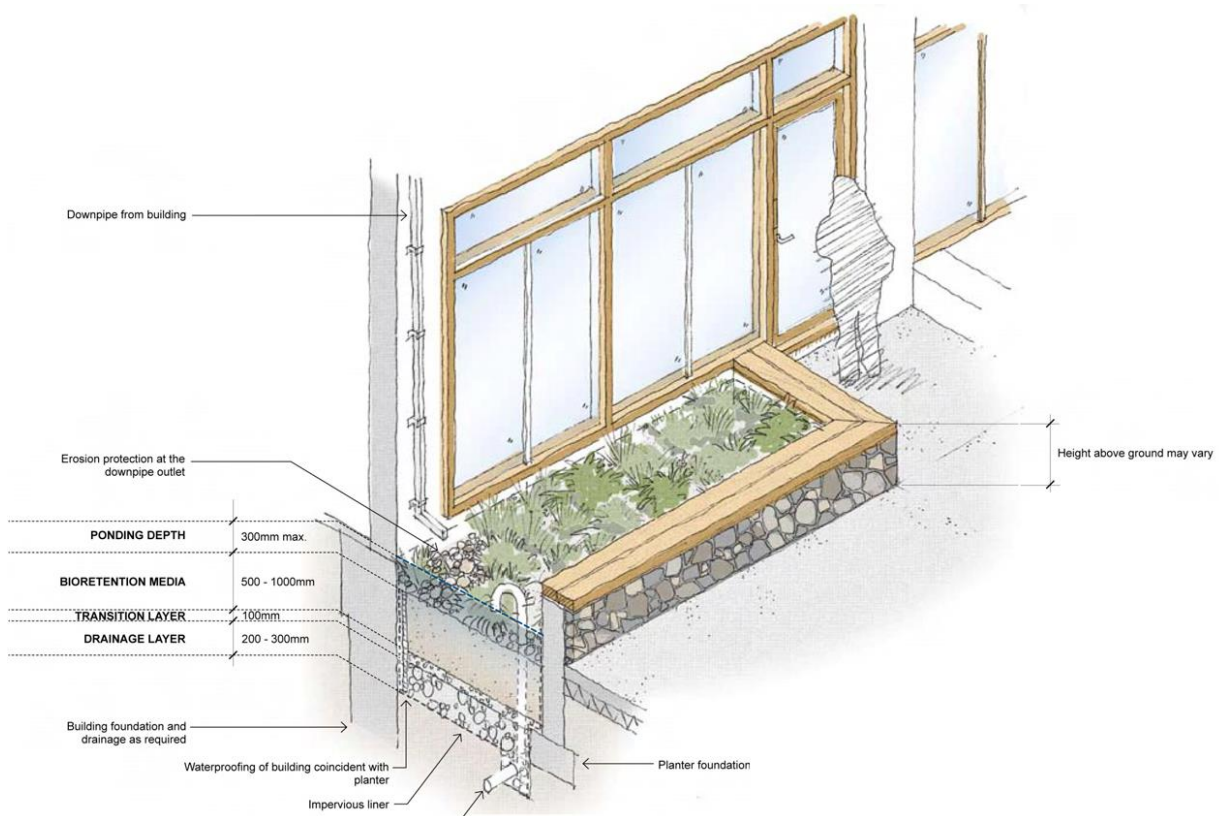

Figure 17: Schematic of planter box

(Source: North Shore City Council "Bioretention Guidelines", 2008)

C3.1.2.3 Stormwater tree pit

A stormwater tree pit (as opposed to a street tree pit) is a bioretention device designed to mitigate stormwater and accommodate trees. They can provide better retention than rain gardens because of the high evapotranspiration rates associated with large trees. They contain the same components as a rain garden (Table 45 and Figure 18) but generally require a greater depth of media to accommodate the tree's root ball (Figure 19). The designer must have an understanding of the root ball size at the tree's maturity and accommodate the future needs of the tree, including the need for additional/replacement soil without the removal of the tree, and increased irrigation needs during establishment. These constraints often make stormwater tree pits an unsuitable device where other services are competing for space.

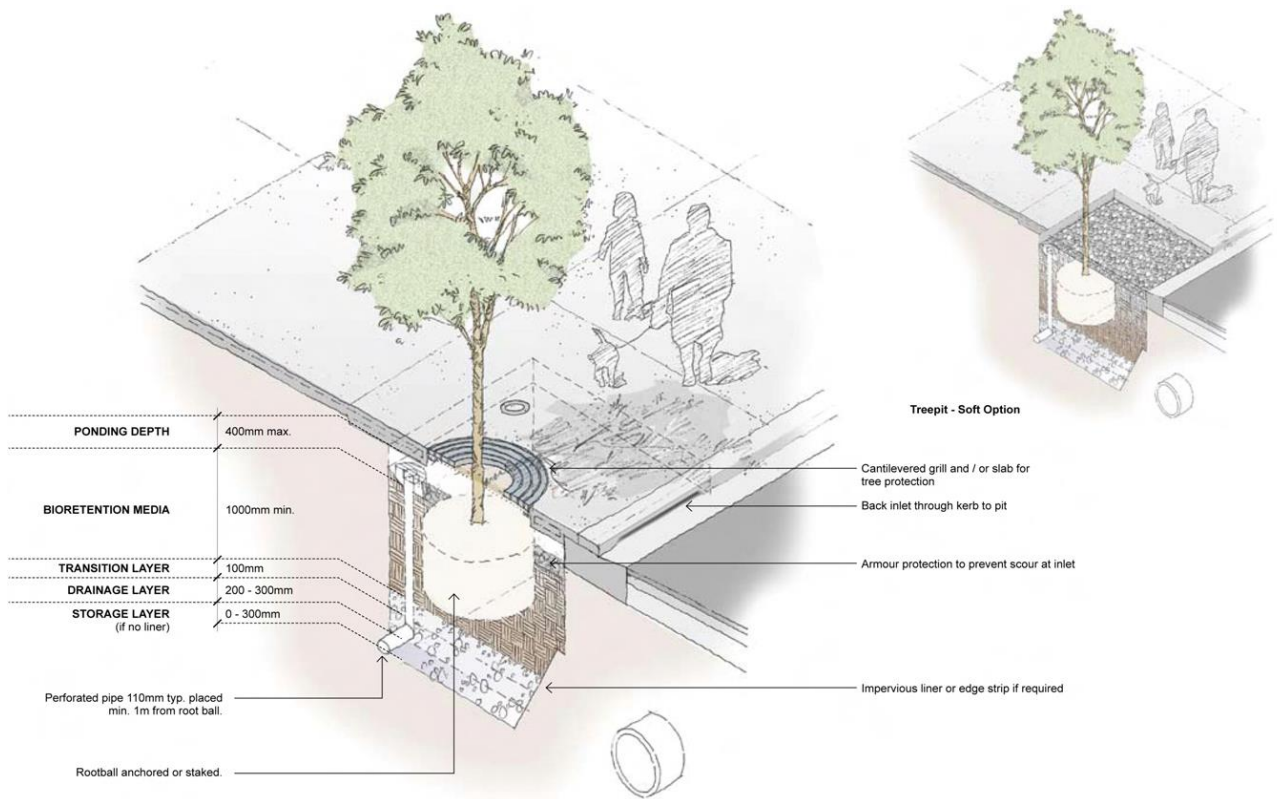

Figure 18: Schematic of stormwater tree pit

(Source: North Shore City Council "Bioretention Guidelines", 2008)

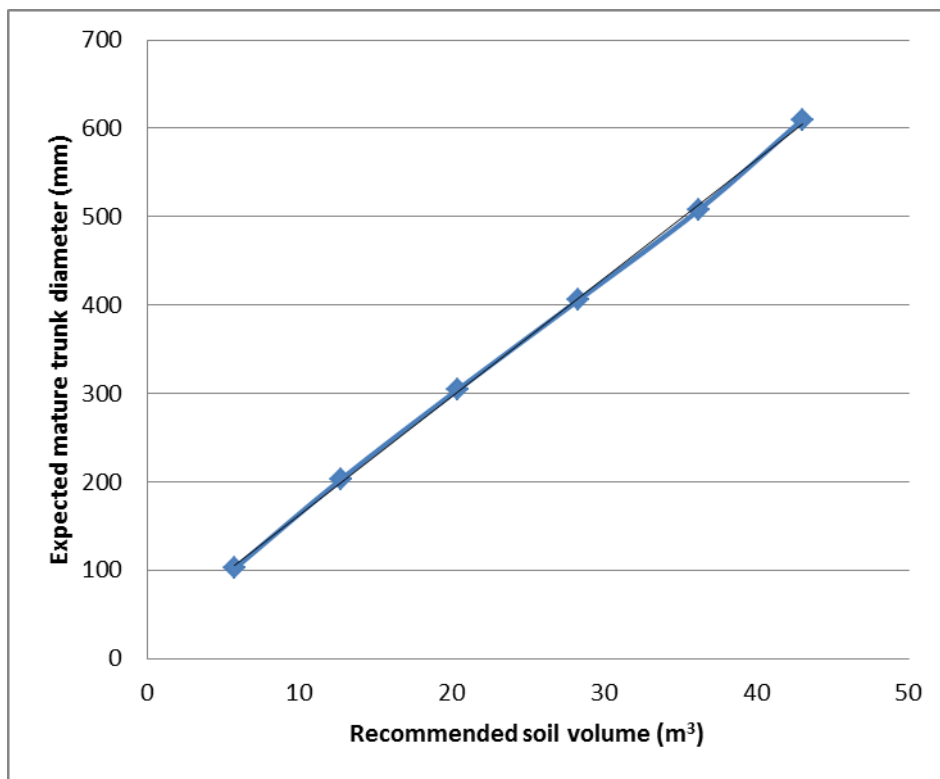

Figure 19: Recommended soil volume based on expected trunk diameter at tree maturity

(Adapted from Urban, J. (2008). *Up by the roots*.)

C3.1.2.4 Bioretention swale

In addition to retention, detention and stormwater treatment, bioretention swales may also provide a conveyance function. Flow needs to be uniformly distributed over the full surface area of the filter media to achieve maximum pollutant removal performance. Swale design should incorporate a flow-spreading device at the inlet such as a shallow weir across the channel bottom or a stilling basin.

When the bioretention trench is located along the full length of the swale base, the desirable maximum longitudinal grade is 4%. To ensure stormwater has sufficient time to filter into the bioretention layers, check dams should be used along the swale length.

A common way to design bioretention swales is to use a system of discrete cells, with each cell having an overflow pit that discharges to the piped stormwater system. Bioretention systems can then be designed upstream of the overflows, thus allowing for a depth of ponding over the bioretention media.

When the bioretention trench is located at the most downstream part, the swale portion should have a grade of between 1% and 4%. If the grade of the swale is greater than 4%, check dams must be used to prevent scour of the swale. The desirable grade of the bioretention zone is horizontal, to encourage uniform distribution of stormwater flows over the full surface area of the bioretention filter media and to allow for temporary storage of flows for treatment before bypass occurs.

When check dams are included in swale designs to facilitate the creation of discrete cells, consideration must be given to potential conflicts with pedestrians or mowers.

The type of vegetation used in a bioretention swale varies according to the landscape requirements. Generally, the denser and higher the vegetation within the swale, the greater the filtration provided. It may not be possible to mow bioretention swales and therefore native grasses, tussocks and sedges are likely to be more appropriate than lawn grass species. Trees should be included only if they comply with acceptable sight lines and safety requirements, and are located at the top of the bioretention swale to avoid the roots damaging the bioretention component.

The minimum performance specifications for swales (in terms of side slopes etc.) apply. These are provided in Section C6: Swales.

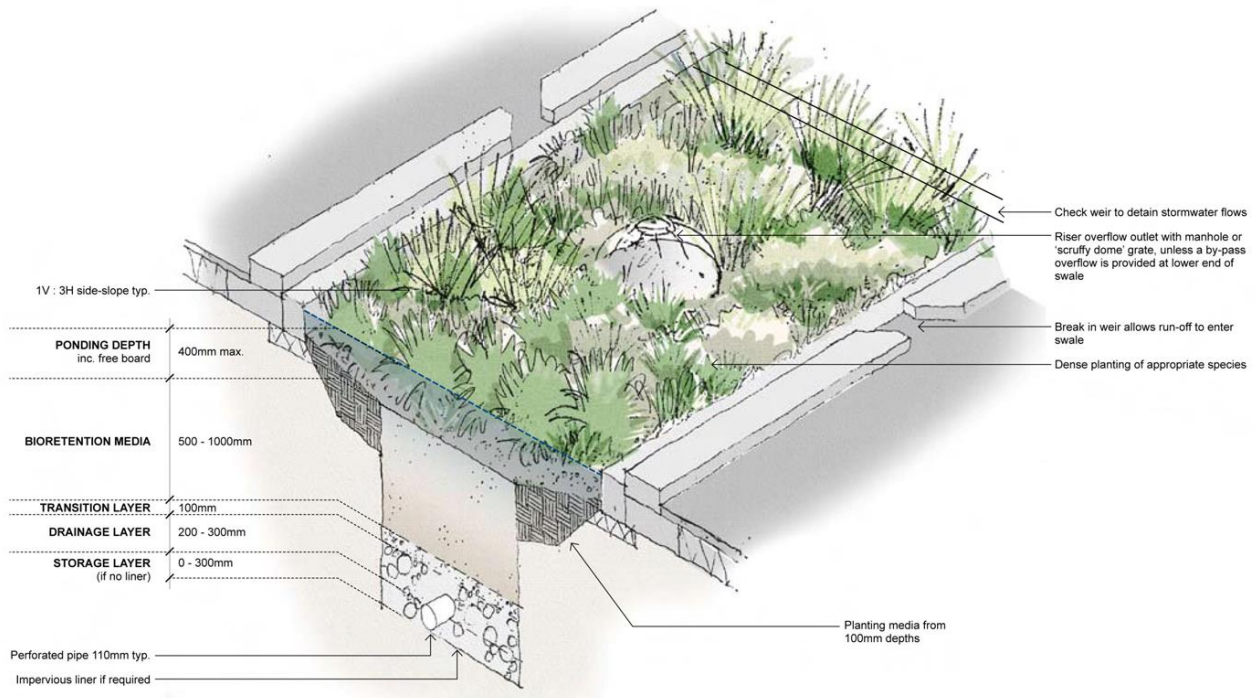

Figure 20: Schematic of bioretention swale

(Source: North Shore City Council “Bioretention Guidelines”, 2008)

C3.1.3 Site considerations

Selected site considerations are presented in Table 46.

Table 46: Site considerations

Item	Description
Catchment size and location	<ul style="list-style-type: none"> • Medium sized catchment. Middle/lower catchment locations. • Bioretention devices should be located away from travelled areas (such as public pathways) to avoid compaction. • Wherever possible, the bioretention gardens should be located to minimise the pervious areas draining to them, and should not be located in overland flow paths.
Groundwater	<ul style="list-style-type: none"> • The base of any bioretention device should be more than 300 mm above the seasonal high water table. If this is not possible, an impervious liner must be used but the device then provides no retention.
Slope	<ul style="list-style-type: none"> • A bioretention garden may only be used on slopes steeper than 14° (25% or 1V:4H) if the effects have been assessed by a geotechnical engineer. • Lined bioretention devices are required for sites that are part of an overall sloping site. For larger sites, lined or unlined bioretention devices can be used, provided they are at least 5 m upslope from the rest of slope. Refer to Figure 22. • The device must be placed more than 15 m away from slopes of 9° (15%) or more.

Item	Description
Subsoils	<ul style="list-style-type: none"> Infiltration rates of subsoil must be understood to ensure retention occurs. It is important to protect subsoils from compaction during construction.
Soils requiring structural support	<ul style="list-style-type: none"> These soils may require geotextiles, impermeable layers or liners. Geotextiles should not be used between media layers. Care should be taken to ensure plant growth is not inhibited by any geotextile.
Soils with poor drainage	<ul style="list-style-type: none"> Retention function is impaired in poor soils. Infiltration of subsoils must be evaluated.
Pre-treatment	<ul style="list-style-type: none"> Pre-treatment of stormwater prior to entry to a bioretention device is needed. Regular maintenance to remove particulate deposits is also needed.
Private connection	<ul style="list-style-type: none"> Private bioretention devices must drain via gravity to the public system or the receiving environment via an approved outfall.
Contaminated land	<ul style="list-style-type: none"> Must be fully lined with impervious layer if contaminated land is present.
Setback	<ul style="list-style-type: none"> Devices must be 1 m minimum from property boundaries. They should not be located within 1V:1H plane taken from the toe of any retaining wall. If located within that, they need concrete edging to reduce surcharge loading. Overhead setback considerations are also needed. They should not be within traffic, or should have an impermeable liner. Refer to Figure 21. They must not be installed within the zone of influence of foundations or within 3 m of the edge of any structure, with the exception of stormwater planters, which are designed to abut buildings. If a bioretention device is installed upslope and within 6 m of a structure, it should be lined (but may only need to be lined on one side) to prevent potential saturation of the foundation soils. These distances may be reduced on the advice of a geotechnical engineer. Bioretention devices installed adjacent to roads should have an impermeable lining on the side adjacent to the road, to prevent stormwater migrating from the device into road sub-grade. A concrete edge beam or wall should be used to provide support on the side adjacent to the road.
Traffic	<ul style="list-style-type: none"> The device's location should allow for safe and easy maintenance. Borders of the device should have low growing vegetation to prevent overhanging vegetation impacting traffic.
Connection	<ul style="list-style-type: none"> The inlet location should not be located too near the intended outfall (this reduces the risk of short circuiting). All bioretention devices will have to be located so that the invert of the device can drain via gravity to the public stormwater system or the receiving environment, via an approved outfall or overland flow path.

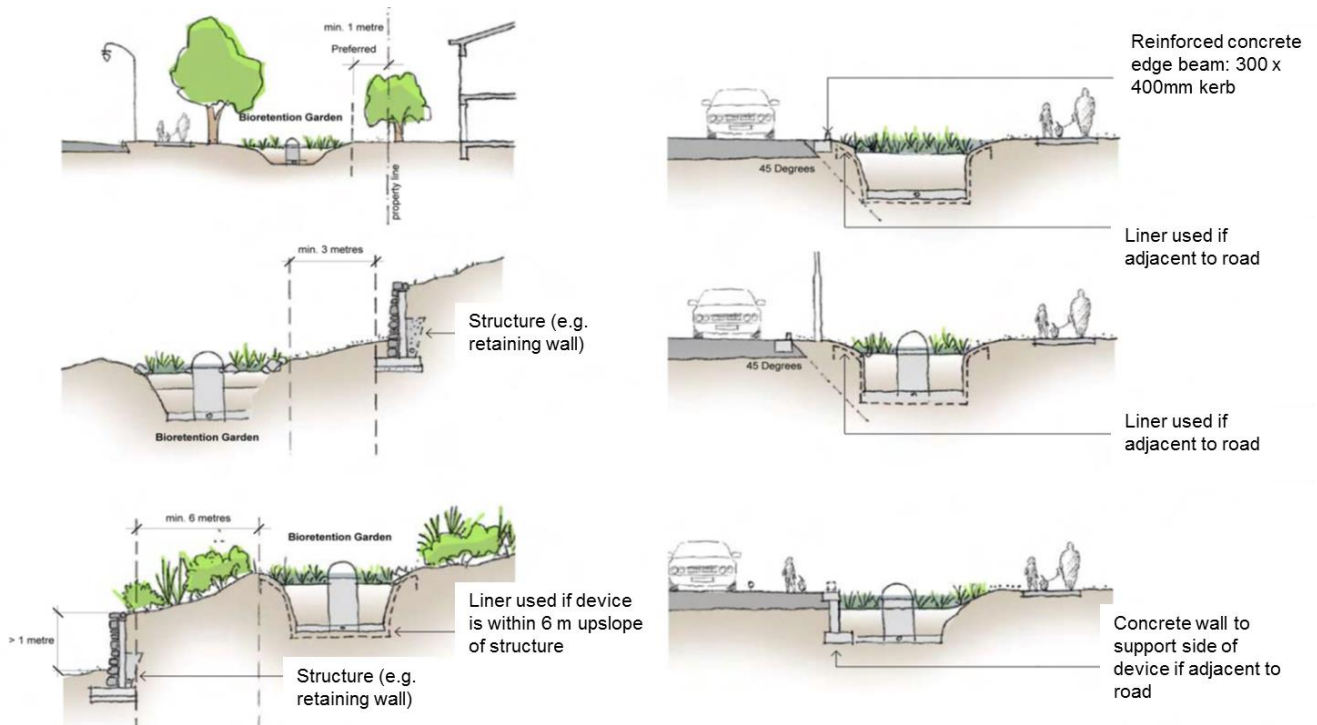

Figure 21: Setback limitations for bioretention devices

(Source: North Shore City Council “Bioretention Guidelines”, 2008)

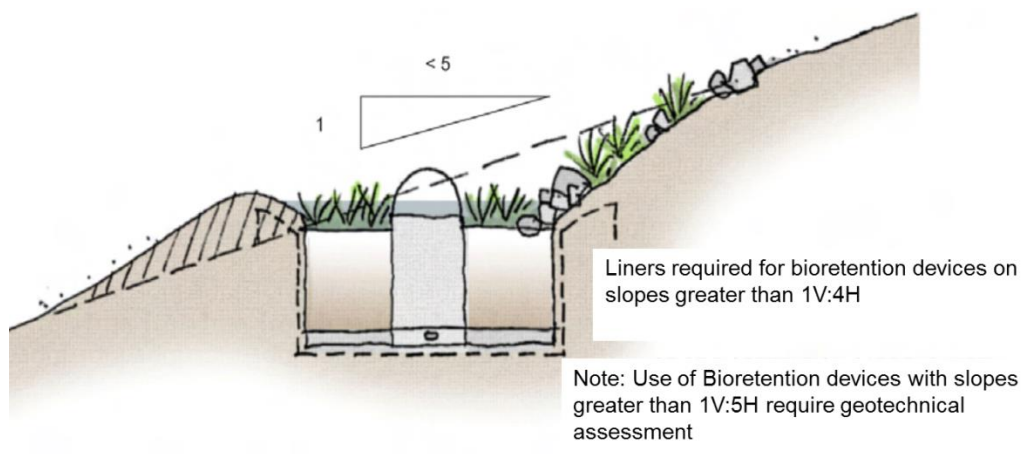

Figure 22: Schematic of slope constraints and liner use

(Source: North Shore City Council “Bioretention Guidelines”, 2008)

C3.2 Bioretention design

C3.2.1 Design considerations

Table 47 and Table 48 provide design considerations for bioretention devices.

Table 47: Bioretention device design considerations and specifications

Item	Requirement
Ponding area	<ul style="list-style-type: none"> The ponding area should drain all pooled water within 24 hours.
Vegetation	<ul style="list-style-type: none"> Suggested plants for bioretention devices are provided in Section C1: Plants and soils as well as Section C3.2.4.8.
Media	<ul style="list-style-type: none"> The specifications for engineered soils are provided in Table 51. All media must be laid below the inlet. <ul style="list-style-type: none"> Mulch: Must be laid below the inlet, not float or blow off the device, and not add to contaminant loads. Further details on mulches are provided in Section C1: Plants and soils. Media: Specifications are provided in Table 51. Transition layer: Clean, well-graded gravel (2-7 mm diameter) with minimal fines, with 100 mm depth. A geotextile must not be used for the transition layer. Drainage layer: A layer of clean, washed pea gravel (~10 mm diameter) with little/no fines and a minimum infiltration rate of 4,000 mm/hr. The layer must be at least 200 mm deep, graded at a minimum of 0.5% towards the outlet and provide at least 50 mm of cover above the drainage pipe. Retention storage: Same media as drainage layer but sits below the underdrain invert. Must be at least 450 mm deep and not have an impervious liner.
Structural support	<ul style="list-style-type: none"> Engineering design is required for retaining structures, which may be made from <i>in situ</i> or precast elements. These can reduce infiltration, which is not generally desirable.
Geotextiles	<ul style="list-style-type: none"> Geotextiles may be permeable or impermeable and should meet the requirements described in Section C3.2.4.6.
Pre-treatment	<ul style="list-style-type: none"> Required for bioretention devices > 50 m² or where high contaminant loads are anticipated.
Underdrain	<ul style="list-style-type: none"> Underdrains must be sized to fully drain the detention layer within 6-24 hours and be placed at a gradient of at least 0.5%. The underdrain must be surrounded by a layer of clean, washed gravel. Underdrain requirements are described in Section C3.2.4.5.

C3.2.2 Design for safety

Some considerations for safe design of bioretention devices include:

- Ensuring structures do not cause tripping hazards and allow safe pedestrian access (including wheelchairs and prams)
- Ensuring any movement of underlying aggregates and base soils does not lead to subsidence
- Ensuring planting does not impinge (through growth or overhanging) on walkways or roads – this is particularly important after rainfall when some planting may droop over the edges of a device
- Ensuring that space for maintenance access is provided for.

C3.2.3 Device sizing

The size of a bioretention device may vary according to the functions it performs:

- **Water quality:** Bioretention devices that provide only contaminant management are required to pass the water quality flow (WQF) through their media bed. Where high infiltration rate media is used, these devices may have relatively small footprints (ca. 2% of impervious catchment area)
- **Retention and detention:** Bioretention devices that are required to perform a hydrological function are required to detain the 90th and 95th percentile volumes determined in Section B, and drain it down over a period of 6 to 24 hours, through low infiltration rate media. In addition, 5 mm retention will be provided through infiltration into the subsoils over a period of 72 hours. These devices will have relatively larger footprints (ca. 3.5% to 5% of impervious catchment area).

Table 48 provides sizing criteria for bioretention devices.

Table 48: Bioretention device sizing criteria

	Retention, detention and water quality treatment		Water quality treatment only
	SMAF1	SMAF2	
Infiltration footprint*	≥ 3.5%	≥ 3.5%	N/A
Ponding footprint*	≥ 5%	≥ 3.5%	≥2%
Ponding depth (including mulch at a depth of 50-75 mm) ³	≥ 200 mm	≥ 150 mm	≥ 100 mm
Media depth	≥ 500 mm	≥ 500 mm	≥ 500 mm
Transition layer	100 mm	100 mm	100 mm
Drainage layer	≥ 200-300 mm	≥ 200-300 mm	≥ 200-300 mm
Storage layer depth (below underdrain invert)	≥ 450 mm	≥ 450 mm	None
Infiltration rate of subsoils for retention	>2 mm/hr	>2 mm/hr	N/A
Infiltration rate of media	50-300 mm/hr	50-300 mm/hr	≤1000 mm/hour

* as a proportion of the catchment's total impervious area

C3.2.3.1 Sizing for hydrologic mitigation

Calculating the detention and retention volumes of bioretention

The detention volume is the volume of water stored above the underdrain invert. It includes (Figure 23):

- The volume of water stored in the ponding area
- The volume of water stored in the void space of the bioretention media
- The volume of water stored in the void space of the drainage layer, above the underdrain invert.

The detention volume is expected to drain down in a period of 6 to 24 hours following the end of a storm event.

³ Because organic mulches break down and are incorporated into surface layer of media, calculations of ponding depth exclude mulch. Where inorganic materials are used, ponding depth should take into account the volume occupied by mulch.

The retention volume is the volume of water that is stored in the device following a storm and that is subsequently lost between events due to infiltration and evapotranspiration. The retention volume includes:

- The volume of pore water in the bioretention media that is lost to evapotranspiration in three days (72 hours)
- The volume of water stored in the void space of the storage layer (i.e. the drainage aggregate below the underdrain invert), that is lost to infiltration in three days.

The depth of this layer can vary but must be at least 450 mm to provide retention. If a storage layer is provided, then an impermeable liner should not be installed.

For the purposes of calculating storage volumes, the following void space assumptions apply (Table 49):

Table 49: Void space assumptions

Layer	Void space
Ponding layer	100%
Mulch layer	100%
Bioretention media	30%
Transition layer	30%
Drainage layer	35%
Storage layer	35%

For the purposes of calculating retention volumes, use the assumptions in Table 50:

Table 50: Infiltration and evapotranspiration assumptions

Design infiltration rate	The greater of: <ul style="list-style-type: none"> • The measured infiltration rate; or • 2 mm/hr
Design evapotranspiration rate	<ul style="list-style-type: none"> • Groundcover/sedges/rushes: 3 mm/day

Use the 'infiltration footprint' (i.e. the area of the base of the rain garden excavation) to calculate the infiltration rate. Use the 'ponding footprint' (i.e. the area of the surface of the bioretention media) to calculate the evapotranspiration rate.

Calculating the detention/retention volumes for bioretention

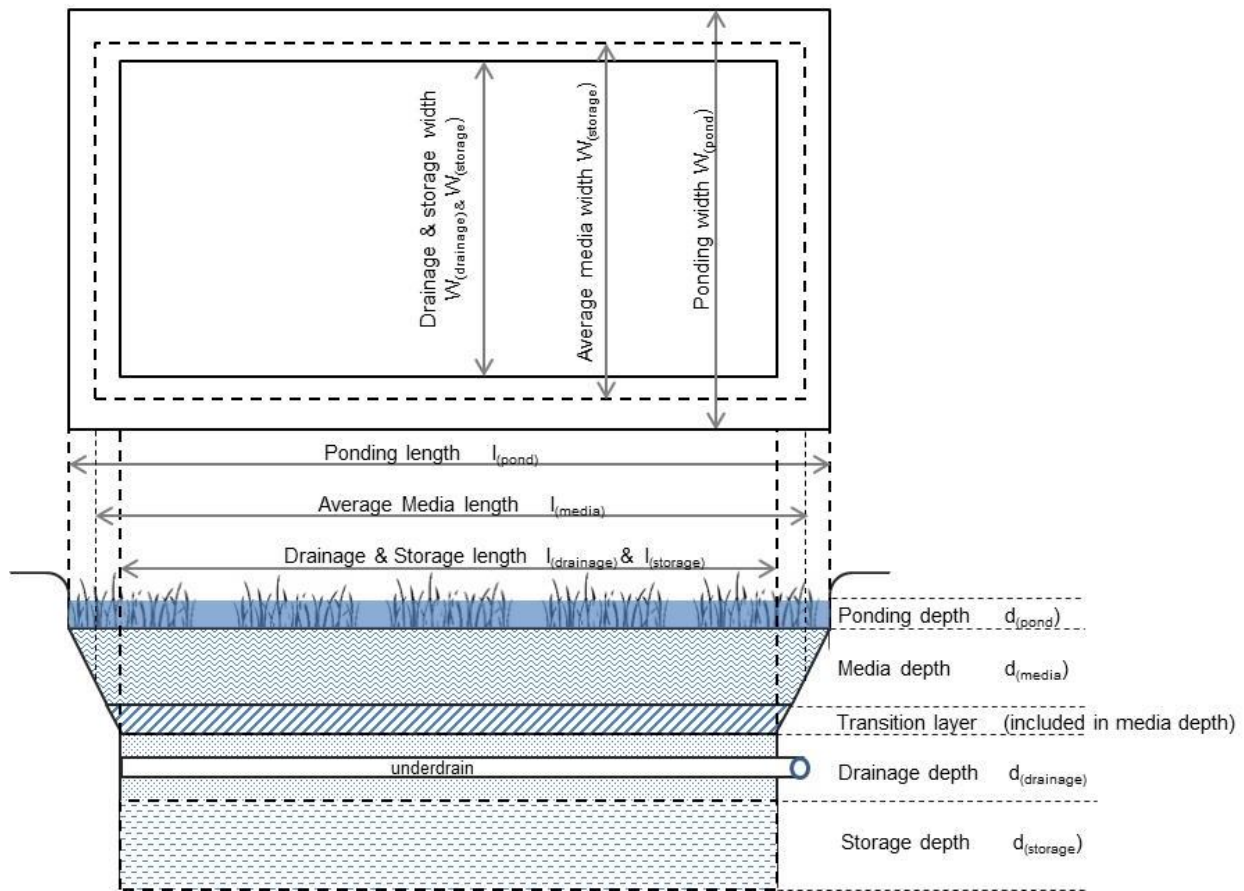

Figure 23: Schematic of bioretention device parameters

The side slopes of a bioretention garden do not need to be vertical, and battered slopes may be preferable for structural purposes. However, to ensure sufficient contact between the soils and stormwater runoff, battered slopes should not exceed 45° (100% or 1V:1H).

Detention volumes

The following equations should be used to calculate the available water storage volumes in the ponding, media and drainage layers. Together, these three volumes determine your total available detention volume.

$$V_{(pond)} = l_{(pond)} \times w_{(pond)} \times d_{(pond)} \quad \text{Equation 5}$$

Where:	$V_{(ponding)}$	-	Volume of water in the ponding area (m ³)
	$l_{(pond)}$	-	Length of ponding area (m)
	$w_{(pond)}$	-	Width of ponding area (m)
	$d_{(pond)}$	-	Ponding depth (m)

$$V_{(media)} = l_{(media)} \times w_{(media)} \times d_{(media)} \times \emptyset \quad \text{Equation 6}$$

Where:	$V_{(media)}$	-	Volume of water in the media layer (m ³)
	$l_{(media)}$	-	Average length of media layer (m)
	$w_{(media)}$	-	Average width of media layer (m)
	$d_{(media)}$	-	Depth of media layer (including depth of transition layer) (m)
	\emptyset	-	Void space of media

$$V_{(drainage)} = l_{(drainage)} \times w_{(drainage)} \times d_{(drainage)} \times \emptyset \quad \text{Equation 7}$$

Where:	$V_{(drainage)}$	-	Volume of water in the drainage layer (around the underdrain) (m ³)
	$l_{(drainage)}$	-	Length of drainage layer (m)
	$w_{(drainage)}$	-	Width of drainage layer (m)
	$d_{(drainage)}$	-	Depth of drainage layer (m)
	\emptyset	-	Void space of drainage aggregate

Calculate the total available detention volume $V_{(detention)}$ in the bioretention device (Equation 8):

$$V_{(detention)} = V_{(ponding)} + V_{(media)} + V_{(drainage)} \quad \text{Equation 8}$$

Retention volumes

The total available retention volume in the bioretention device can be determined by calculating how much water will infiltrate from the storage layer into the underlying soil over a period of three days (72 hours). The total volume that will infiltrate over three days cannot exceed the total volume that is available in the storage layer below the underdrain.

Any losses due to evapotranspiration from vegetation in the bioretention device can be added to the total retention volume.

Calculate the volume in the retention storage layer below the underdrain (Equation 9).

$$V_{(storage)} = l_{(storage)} \times w_{(storage)} \times d_{(storage)} \times \emptyset \quad \text{Equation 9}$$

Where:	$V_{(storage)}$	-	Volume of water in storage layer (below the drainage layer) (m ³)
	$l_{(storage)}$	-	Length of storage layer (m)
	$w_{(storage)}$	-	Width of storage layer (m)
	$d_{(storage)}$	-	Depth of storage layer (m)
	\emptyset	-	Void space

Calculate the infiltration volume; being the volume infiltrated in 3 days (72 hours) and ensure that the storage volume $V_{(storage)}$ can be infiltrated (Equation 10).

$$V_{(infiltration)} = l_{(storage)} \times w_{(storage)} \times 72 \times K_{(subsoil)} \quad \text{Equation 10}$$

$$V_{(infiltration)} \leq V_{(storage)}$$

Where: $V_{(infiltration)}$ - Volume of water that will infiltrate over three days (72 hours) from the storage layer (m³)
 $K_{(subsoil)}$ - Infiltration rate of underlying subsoil (minimum 0.002) (m/hr)

Calculate the evapotranspiration volume; being the volume evapotranspired in 3 days (Equation 11).

$$V_{(evaporation)} = l_{(pond)} \times w_{(pond)} \times 3 \times ET \quad \text{Equation 11}$$

Where: $V_{(evapotranspiration)}$ - Volume of water that will evaporate over three days (m³)
 ET - Evapotranspiration rate (use 0.003 for plants in bioretention devices) (m/day)

Calculate the total retention volume $V_{(retention)}$; being the sum of infiltration volume and evapotranspiration volume (Equation 12).

$$V_{(retention)} = V_{(infiltration)} + V_{(evapotranspiration)} \quad \text{Equation 12}$$

C3.2.3.2 Sizing for water quality treatment only

Where a bioretention device is sized to provide detention and retention in accordance with SMAF1 or SMAF2 requirements, it can be assumed that the water quality sizing objective is met as well.

Where a bioretention device is sized solely for the purposes of water quality treatment, it must be demonstrated that the device can pass the WQF of 10 mm/hr (equivalent of 90% of annual rainfall).

The sizing can be based on a WQF of 10 mm/hr passing through specialised media (Table 51) with a standard depth of 500 mm and an infiltration rate of maximum 1 m/hr, using the following steps⁴:

⁴ Designers may use a simplified version of Darcy's Law to assess infiltration (see Section C7 Infiltration); in this instance, Darcy's law has not been included for simplicity.

Steps for sizing bioretention for water quality treatment

- 1) Calculate the WQF for the catchment draining to the bioretention device, using the rational method and a rainfall intensity of 10 mm/hr.
- 2) Calculate the minimum area of the bioretention device:

$$A = \frac{WQF}{(0.5 \times K_{(media)})} \quad \text{Equation 13}$$

Where	A	-	Area of bioretention media bed at its narrowest point (m ²)
	WQF	-	Water quality flow (m ³ /hr)
	K _(media)	-	Infiltration rate of bioretention media (m/hr)
	Safety factor for clogging	-	0.5

- 3) The minimum size of a water quality bioretention device must be greater than 2% of the total catchment area. Smaller devices will collect too much sediment relative to their size, requiring too much maintenance to operate efficiently. Where the above sizing methodology leads to a device that is smaller than 2% of the catchment, the area of bioretention media should be increased.

Notes:

- For vertical walled rain gardens, A is the same as the surface area of the media bed
- Maximum allowed value for K_(media) is 1 m/hr and should be multiplied by a safety factor of 0.5 to allow for clogging
- The WQF passes through the media without ponding above the media surface
- Alternatively, bioretention devices can be sized using Darcy's Law, which is based on a water quality volume, a maximum ponding depth and a specified time over which the volume should pass through the media, depending on infiltration rates and media depth.

C3.2.3.3 Summary of bioretention device design process

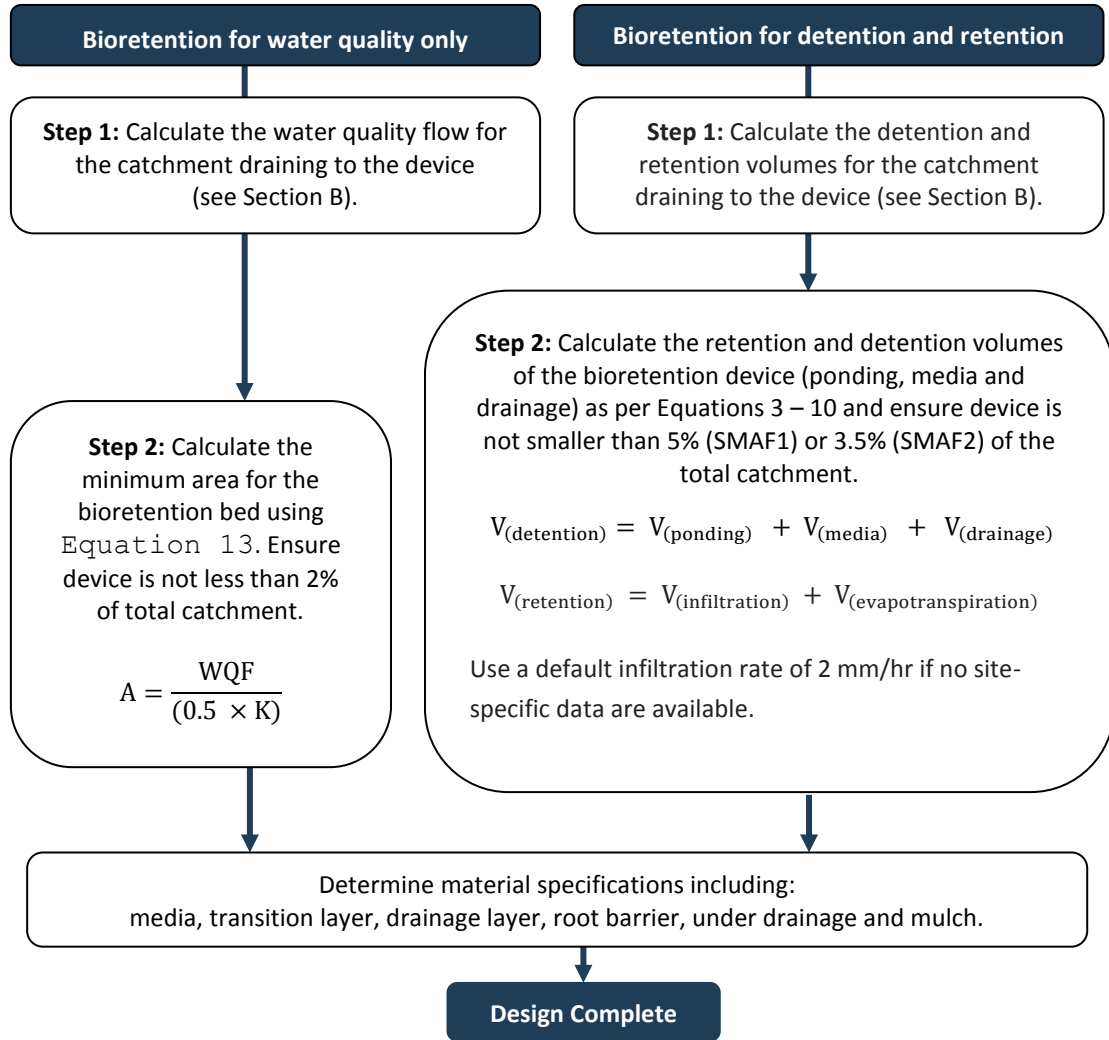

Figure 24: Bioretention device design flow chart

C3.2.4 Component design

This section outlines the design considerations for components within bioretention devices.

C3.2.4.1 Pre-treatment

Once a bioretention area exceeds about 50 m², it will require a structural form of pre-treatment to trap sediments, litter and debris. In these situations, the pre-treatment should involve a two-cell design, with the first cell designed as a forebay, with a 500 mm ponding depth before spilling over to second cell, which is designed in the standard manner for a bioretention device. In most cases, bioretention devices are likely to be smaller than 50 m².

In addition, for catchments such as roadways, carparks and commercial sites, where runoff is likely to have a high contaminant load, the use of pre-treatment upstream of the bioretention device should be considered to reduce the maintenance requirements and extend the life of the device. Pre-treatment can include a grass filter strip or a small forebay. For some sites, it may be appropriate to consider using a gross pollutant trap or other engineered device upstream of the bioretention device.

C3.2.4.2 Inlet design

Bioretention devices require design features so that either:

- The catchment falls towards the garden where stormwater is captured as distributed flow (particularly applicable for bioretention swales)
- The flow will enter the device at concentrated inlet points, through kerb and channel, swale, or piped systems.

Inlet design for smaller bioretention devices can include simple structures such as slotted kerbs. Care must be taken to direct sheet flow from the catchment into the device through the inflow point without scouring or erosion, and without transporting mulch out of the device. A common failing of bioretention devices occurs when a slotted kerb fails to direct flow. Inflow points include edge beams (such as level spreaders) with or without, wheel stops.

More complex inlet structures may be required for larger devices including structures such as bubble-ups and forebays. Details of these structures can be found in Auckland Council's technical report, TR 2013/018 *Hydraulic Energy Management: Inlet and Outlet Design for Treatment Devices*.

C3.2.4.3 Media

Bioretention planting/filter media must:

- Have sufficient available water, air and initial nutrients to support a healthy, resilient plant cover specific to Auckland conditions
- Not generate contaminants and not shrink or structurally collapse
- Be either protected from compaction, or resistant to compaction. The depth, type, area and volume of media should be selected to meet the landscaping/ecology, hydrologic and water quality objectives for a site

- Be sourced from a reputable supplier with high quality assurance, consistency of supply and performance under specified installation.

The following properties are either mandatory, or recommended. Important changes from Auckland Regional Council Technical Report, TP10⁵ are:

- Increased hydraulic conductivity range with maximum values
- Introduction of a maximum organic matter content
- Removal of mandatory textural classification.

General media specifications for soils are presented in Table 51. Low to moderate hydraulic conductivity (K) is important for large rain gardens because it generally reduces risk of plant drought stress and maintenance. Higher K is designed for in water-quality only bioretention devices.

- **Detention:** The detention volume within a device must be refreshed over an average period between rain events (between a minimum of 3 days and up to 6 days)
- **Retention:** The number of days does not affect retention (macropore volume) for under-drained bioretention as the minimum media K ensures macropores are drained (refreshed) within 24 to 48 hours.

Table 51: Suggested soil specifications for bioretention devices

Item	Detention, retention and water quality device	Water quality only device
Organic matter	10–30% v/v	0.5 - 5% v/v
Plant available water	>100 mm (for 600 mm substrate depth)	>100 mm (for 600 mm substrate depth)
Saturated hydraulic conductivity (Ks)	Between 50 mm/hr and 300 mm/hr	≤1000 mm/hr
pH range	6.0 – 7.5	
Particle size distribution	100% < 25 mm 90–100% < 10 mm < 5% < 0.05 mm	
Total nitrogen	< 1,000 mg/kg	
Orthophosphate (PO ₄ ³⁻)	< 80 mg/kg	
Total phosphorus	Leachate testing required if > 100 mg/kg	
Total copper	≤ 80 mg/kg	
Total zinc	≤ 200 mg/kg	

⁵ TP10 *Stormwater Management Devices: Design Guidelines Manual* (2nd ed.) (2003).

Media for bioretention devices designed for water quality treatment only can have a higher hydraulic conductivity. Media designed for water quality treatment only:

- Allows for a smaller device footprint
- Has an increased risk of clogging: vulnerable sites will require pre-treatment
- Can be used to mitigate roof runoff
- Can lead to plant stress, death or dieback, particularly if additional irrigation is not provided during plant establishment
- Needs careful design to reduce short-circuiting.

High K media are generally not suitable for mitigating nitrogen and phosphorus without specialised amendments, and may not adequately attenuate high temperature.

C3.2.4.4 Aggregates

Generally, two types of aggregates are used in bioretention devices:

- 2-7 mm gravel: This gravel is used in the transition layer and should comprise clean, well-graded gravel with minimal fines. It should be placed with 100 mm depth. The aggregate should have a void space of 30%.
- Pea gravel: The drainage layer and the storage layer are made of the same aggregate. This aggregate should comprise a layer of clean, washed pea gravel (~10 mm diameter) with little/no fines and a minimum infiltration rate of 4,000 mm/hr. The layer must be at least 200 mm deep, graded at a minimum of 0.5% towards the outlet and provide at least 50 mm of cover above the drainage pipe. This aggregate should have a void space of 35%.

C3.2.4.5 Underdrain

Perforated pipes can be either a PVC pipe with slots cut into the length of it, or a flexible pipe with smaller holes distributed across its surface. Geofabric wrapping should not be used to avoid blocking. The diameter and number of perforated pipes required to drain a bioretention garden should be sized so that the conveyance of water in the perforated pipe is not a control on the system. To ensure this is the case, it is recommended that perforated pipes are sized to convey peak flows an order of magnitude greater than the peak infiltration rate the bioretention filter media is capable of delivering to the pipe.

A single 110 mm perforated pipe at 5% grade will be sufficient for a bioretention device with an area of 6 m², assuming there is a peak saturated hydraulic conductivity of 100 mm/hr. For larger devices, or more free-flowing bioretention filter media, a larger pipe is likely to be required.

The underdrain must:

- Be graded at a minimum of 0.5% towards the outlet
- Lie on the base of the gravel drainage layer unless infiltration is an output of the design
- Be non-perforated if extending outside of the drainage layer (through *in situ* soils)
- Be connected no less than 200 mm above the invert of a stormwater gully pit or manhole

- Be surrounded by a layer of clean, washed gravel (5-14 mm or pea gravel) with a minimum 50 mm bedding layer
- Not be located within the groundwater zone of saturation. Presence of water pooling at the base of the excavated facility may require a field modification and possibly a plan revision.

C3.2.4.6 Geotextiles

A variety of geotextiles can be used as liners and root barriers in a bioretention device. In most cases, it is not necessary to use concrete lining for bioretention gardens. Exceptions to this may be stormwater planters which are raised above the surrounding ground level and concrete edging as support for devices installed adjacent to roadways.

Permeable liners

Permeable geotextile liners may be used to line the walls of the excavation to prevent the migration of native soil particles into the bioretention media while allowing stormwater to exfiltrate into the surrounding soils. The permeable liner should be lightweight, non-woven, needle punched, geotextile. Permeable liners should not be used between different filter layers of bioretention devices.

Permeable liners must:

- Not extend onto the base of the excavation (except in clay soils where the drainage layer may migrate into the saturated clays), or they are likely to interfere with infiltration from the base of the device
- Be pinned to the base soil and be covered with at least 200 mm of media
- Be resistant to soil acidity and microbial degradation.

Impermeable liners

Impermeable liners should be used to:

- Prevent infiltration from the bioretention device into the surrounding subsoil
- Reduce geotechnical risks
- Prevent contact with contaminated groundwater
- Retain moisture within the device.

Impermeable liners must:

- Have an infiltration rate of less than 1×10^{-9} m/s
- Be used in devices which are designed on slopes of 14° (25% or 1V:4H) or steeper (Figure 22)
- Meet the specifications of geotechnical requirements.

Root barriers

Root barriers should be used in bioretention devices where there is potential for plant or tree roots to penetrate susceptible services (such as sewers) or structures (such as foundations). The root barrier should only be placed adjacent to the services which require protection and not around the whole device. Care should be taken to only plant vegetation that can survive in the soil depth determined by the root barrier. Trees with deeper root systems will not survive long term if root barriers are used in the base of the device. Arborist advice is required to ensure root barrier types and locations are appropriate for the species and for the surrounding infrastructure

C3.2.4.7 Connections

Any connections to public reticulation must comply with Auckland Council's Code of Practice for Land Development and Subdivision, Chapter 4: *Stormwater*.

Pipe joints and storm-drain structure connections must be adequately sealed. Pipe sections must be coupled using suitable connection rings and flanges. Field connections to storm-drain structures and pipes must be sealed with polymer grout material that is capable of adhering to surfaces. The underdrain pipe must be capped (at structure) until completion of the device.

All bioretention devices must be designed with an overflow. The overflow must either be connected to an approved stormwater outlet or to an approved overland flow path. For residential applications, the overflow should divert runoff in up to the 10% Annual Exceedance Probability (AEP) event into the public stormwater system (5% AEP for commercial applications). In some instances, the overflow can be directed as sheet flow to other stormwater devices in a treatment suite (e.g. swale to pond or wetland).

C3.2.4.8 Planting

Mulch specification

Mulch is an organic or inorganic material suitable for placing on soil (not mixing into soil) that has a particle size distribution that ensures rapid permeability of water and air into the underlying soil. It protects the media surface from clogging during plant establishment and prevents weeds. Mulch should be applied in layers about 25 to 75 mm deep over the surface of a device. It should:

- Be laid below the inlet to prevent scouring at a minimum clearance of 300 mm
- Not float or be blown from the device
- Degrade within 12 months
- Not add contaminants. For instance, mulch should not contain animal manure, pesticides or residues (e.g. shredded treated timber, recycled rubber chip or crumb)
- Not be made of straw, hay or grass clippings.

New Zealand bioretention devices are usually designed to achieve a total and dense cover of long-lived (perennial), evergreen plants. This means mulches are usually applied once at construction and are expected to be effective for 12 to 24 months. Any re-mulching is typically restricted to minor areas at inlets or along edges where vegetation is cut back or replaced. Further information on mulches is provided in Section C1.6. Plants and soils.

Mulch must:

- Be laid at a uniform thickness of 50 – 75 mm
- Be laid lower than the inlet
- Must maintain an infiltration rate higher than the underlying media
- Be free of weed seeds and weed propagules
- Be no more than 10% volume to volume floating at installation (i.e. post-irrigation/ saturation)
- Be applied no deeper than 75 mm depth, except where inorganic mulches are used to decrease the depth of open water (for increased safety)
- Comply with Grade A Biosolids' Guidelines for contaminants (notably copper and zinc, pesticides); must not contain animal manure
- Be applied as soon as media is installed where rain garden media requires physical protection or when planting is delayed.

Inorganic mulches should resist physical breakdown and be washed, or have very low proportion of <2 mm material. The recommended particle size range for inorganic material is 4 mm to 20 mm.

Five common mistakes that increase the risk of poor bioretention performance related to mulches are:

- Floating mulches. Three methods can be used to minimise the risk of organic mulches floating:
 - Select fibre type, length and size to create 'binding' mulch; and/or,
 - Add 20 to 30% mature compost to mulch and saturate at installation; or,
 - Partly compost and wet to increase density.

Increasing the proportion of compost beyond 30% reduces effectiveness of weed suppression, longevity and permeability of mulch

- Inadequate mulch depth to effectively suppress weeds. Mulches need to be at least 40 mm deep to suppress weeds, with 60 to 75 mm needed where weed-seed containing soils are used in the media or mulch is coarse and 'open', allowing light to reach the media surface
- Inorganic mulches with appreciable clay and silt content, causing surface sealing of media
- Inadequate initial irrigation of rain gardens, especially those established in late spring to summer using organic mulches. This leads to increases risk of mulch floating and plant drought stress
- Movement of mulch and scouring of media at inlets.

Plant specifications

Plant specifications are provided in Section C1.6.2: Plants and soils: Planting bioretention devices.

Plant selection and installation in bioretention devices should consider:

- In the base of devices, allow for plants that can tolerate frequent inundation to the design ponding depth (nominally > 200 mm), as well as extended dry periods
- Plants at inlets should have thickly spreading roots to hold plants in place against erosive inflows, and prevent preferential flow paths eroding soils. These plants should also have fine leaves and allow sheet flow to avoid obstructing flows (spreading rather than clumping forms are more appropriate)
- Edges should have low growing vegetation to retain a distinct and maintainable edge. These species should be tolerant of roadway splashes, temperature extremes, or whatever constraints relate to adjacent land uses
- Plants should be spaced to cover any bare soil areas within 18 months and should be chosen so that their roots have space to grow to maturity
- Adding trees and shrubs in rain gardens increases interception and evapotranspiration but should be used only where their roots are not impeded
- Consider the impact of adjacent deciduous trees on the survival of groundcover and the potential for blocking overflow/inflows with leaf litter. Perennial, rather than annuals, are recommended
- Larger trees with extensive root systems should not be planted above geotextiles, existing infrastructure pipes, or where future access is an issue
- Trees should only be planted in devices where the filter media depth is 600 mm or greater and where the media volume ensures the growth of the tree for the species' life expectancy (at least 1 m³).

Where plants are used in water-quality only devices:

- If the plant available water of 80 (or 100) mm is achieved and the water is distributed evenly across the rain gardens, then the plant list for high infiltration rain gardens is the same as that of standard rain gardens
- Plants may require additional irrigation during establishment to encourage increased root depth and tolerance.

C3.2.5 Construction design considerations

The following construction considerations should be addressed during design and specification.

Soils

- Prior to construction, areas where bioretention devices are to be located should be fenced off and the soils protected
- Bioretention devices should be excavated such that the sides of the subsoil are not sealed (preventing infiltration)
- Engineered media should be used within bioretention devices with attention to infiltration rates
- Bioretention devices should be constructed as the last step in any development. They must not be installed when any construction sediment is present
- Upstream drainage must be completely stabilised prior to installation.

Planting and mulches

- Mulches are usually applied at the construction stage. They must be laid below the inlet and the outlet. These must be placed to ensure mulches cannot float or blow away
- Irrigation may be required in the establishment phase of planting
- Lines of sight need to be considered during planting.

Other

- Inlets should have directed flows (such as level spreaders), erosion control and protection against short circuiting
- Outlets should be at the intended ponding level, not at the base of the bioretention device
- Any liners or geotextiles should be installed such that they do not puncture or rip and should allow enough media volume and depth for mature root development of the designed vegetation
- All aggregates should be laid flat, but not compacted, in the device and at the correct specified depths
- The underdrain should be enclosed by a layer of pea gravel to prevent clogging and should be designed and installed to allow for inspection and flushing.

C3.2.6 Operation and maintenance design considerations

The following operation and maintenance considerations should be addressed during design and specification:

- The device should be located to allow for easy and safe maintenance with consideration of traffic control and irrigation
- Planting should be designed for minimal maintenance and control (for example, foliage should not droop onto footpaths after rainfall)
- It is important to not use fertiliser or herbicides in bioretention devices
- Irrigation should be allowed for during the vegetation's establishment phase.

C3.3 Design examples

The following examples explain how an iterative design process may be used to design and size a bioretention device, utilising Equations 5 to 11 and incorporating the minimum specifications from Table 48.

C3.3.1 Rain garden to meet SMAF1 and water quality criteria – 1000 m² carpark

A rain garden is required to meet SMAF1 hydrology management criteria for a 1000 m² carpark:

- The total impervious area for the carpark is 1000 m²
- The native soil is hydrologic soil group C (pre-development CN = 74).

Parameter	Value	Ref	Parameter	Value	Ref
95 th %ile rainfall depth	35 mm	-	Evapotranspiration rate	3 mm/day	<i>I</i> _(evapotranspiration)
Pre-development curve number	74	CN _(pre)	Soil infiltration rate	2 mm/hr	<i>I</i> _(infiltration)
Post-development curve number	98	CN _(post)	Aggregate void space	35%	
Media slope	1V:2H	<i>i</i> _(media)	Media void space	30%	

Step 1 – Determine hydrology mitigation requirements

Using Section B and TP108, the post-pre development runoff volume is **23 m³**

Calculate required retention volume (m³) using Section B1.7.1

- 0.005 m x total impervious surface (1000 m²) = **5 m³**

Calculate required detention volume (m³) using Section B1.7.1

- Post-development runoff volume – Pre-development runoff volume – retention volume
- 23 m³ – 5 m³ = **18 m³**

Step 2 – Determine minimum infiltration, ponding and media area

- Minimum infiltration area must be greater than 3.5% of catchment area, 1000 m² x 3.5% = 35 m²
- Minimum ponding areas must be greater than 5% of catchment area, 1000 m² x 5% = 50 m²
- Average media area is (35 + 50) / 2 = 42.5 m²

Step 3 – Confirm depth of the bioretention layers

Design for detention

- Calculate how much water can be stored in each of the three layers of the device based on the minimum specifications for layer depth and areas (Table 48)
- Check that the total required detention volume of 18 m³ can be stored in the ponding, media and drainage layer together $V_{(detention)} = V_{(ponding)} + V_{(media)} + V_{(drainage)}$ (Equation 8)
- Optimise layer depths and areas, within minimum specifications until the total available volumes in the bioretention layers meets the required detention volume (Table 48).

Design for retention

- Check that the required retention volume can be stored in the storage layer (Table 48)
- Check that the required retention volume (5 m³) can be infiltrated into the underlying subsoils over a time of 72 hours. $V_{(infiltration)} = \text{area} \times 72 \times \text{infiltration rate} \leq V_{(storage)}$
- $V_{(infiltration)} = 5.04 \text{ m}^3$ which means that in theory the volume in the storage layer of 5.5 m³ cannot be infiltrated in 72 hours, based on the infiltration rate of 2 mm/hr. The infiltration area should be increased to 38 m².

Design for water quality treatment

- Because the bioretention device is sized to provide detention and retention in accordance with SMAF1 or SMAF2 requirements, it can be assumed that the water quality sizing objective is met as well.

Parameter	Minimum depth (mm)	Minimum area (m ²)	Void space	Available volume (m ³)	Required volume (m ³)
Ponding	200	50	100%	10.0	
Media layer - including transition layer	600	42.5	30%	7.65	
Drainage layer	200	35	35%	2.45	
Total detention				20.1	18
Storage layer	450	35	35%	5.51	
Total retention				5.51	5

Step 4 – Design device dimensions based on site constraints

- Ensure that total depth of the device is 300 mm above seasonal high groundwater table
- Determine shape of the bioretention device in terms of length and width based on the available space and location of the bioretention device.

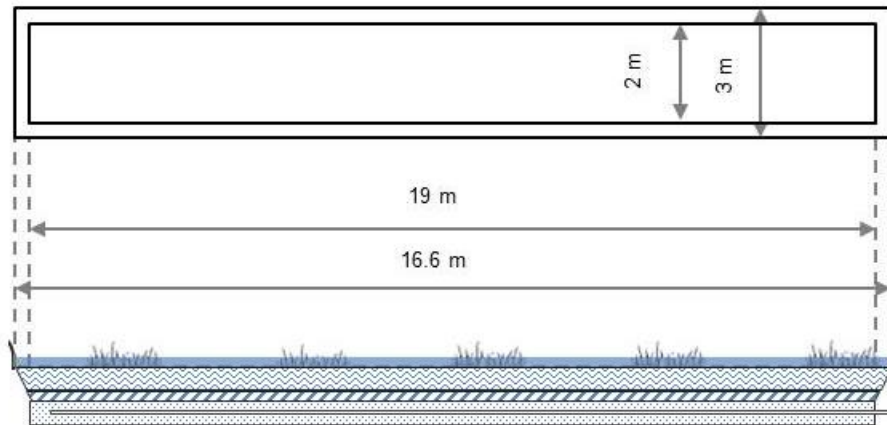

Figure 25: Rain garden design for 1000 m² carpark

C3.3.2 Rain garden to water quality criteria only – 1000 m² carpark

A rain garden is required to meet only water quality requirements for a 1000 m² high contaminant generating carpark.

Step 1: Calculate WQF using rational method

- $10 \text{ mm/hr} \times 0.95 \times 1000 \text{ m}^2 = 9.5 \text{ m}^3/\text{hr}$
- Ensure that WQF is in units of m³/hr.

Step 2: Calculate minimum area of the bioretention device

- $\text{Area} = 9.5 / 0.5 \times 1 = 19 \text{ m}^2$

Step 3: Check that size is greater than 2% of catchment

2% of 1000 m² = 20 m², therefore a rain garden area of 20 m² should be used with standard minimum media depth of 500 m².

Step 4 – Design device dimensions based on site constraints

- Ensure that total depth of the device is 300 mm above seasonal high groundwater table
- Determine the shape of the bioretention device in terms of length and width based on the available space and location of the bioretention device.

A photograph of a modern wooden building with a living roof. The building is constructed of dark wood and features a central door with a wheelchair accessibility icon. The roof is covered with a variety of green plants, including tall grasses and small shrubs. The building is situated in a lush, green environment with trees and a paved path leading to it. A green decorative graphic is visible at the top and bottom of the image.

C4 Living roof

Table of Contents

C4.0	Technical guidance: living roofs	161
C4.1	Introduction	161
C4.1.1	Use in a treatment suite	162
C4.1.2	Living roof components.....	162
C4.1.3	Site considerations	165
C4.2	Living roof design	166
C4.2.1	Design considerations	166
C4.2.2	Design for safety	167
C4.2.3	Device sizing.....	168
C4.2.4	Component design.....	168
C4.2.5	Construction design considerations.....	174
C4.2.6	Operation and maintenance design considerations	175

Figures

Figure 26:	Schematic of living roof components	162
Figure 27:	Examples of ready-to-install modular systems.....	164
Figure 28:	Erosion control for sloped or windy sites.....	171
Figure 29:	Drainage layers	171

Tables

Table 52:	Living roof components	163
Table 53:	Design considerations of extensive, intensive and modular living roofs	164
Table 54:	Site considerations	165
Table 55:	Living roof design considerations and specifications	166
Table 56:	Design considerations for living roofs.....	169
Table 57:	Design specifications for substrate.....	170
Table 58:	Architectural design considerations.....	172
Table 59:	Specific planting considerations	174

C4.0 Technical guidance: living roofs

C4.1 Introduction

Living roofs (green roofs) are vegetated devices located on building roofs or walls. They provide an excellent opportunity for on-site stormwater management by creating pervious surfaces from otherwise impervious surfaces (as either a retrofit or as part of any new construction). Living roofs offer several advantages for urban stormwater management:

- They act as at-source retention devices, preventing runoff (from frequent small storms) from an otherwise impervious area
- Living roofs mitigate the majority of annual surface runoff primarily through control of smaller, more frequent rainfall events, and meaningful reduction of peak runoff rates from larger, infrequent events
- They significantly reduce urban heat and the building's energy demand
- They provide biodiversity and habitat opportunities
- They protect the integrity of the waterproofing on a roof from solar damage
- They provide aesthetic and amenity improvements.

1% AEP detention	✗
50 and 10% AEP detention	✗
Detention for stream protection (as retention volume)	✓
Retention	✓
Water quality	✗

For the purpose of compliance with stormwater management requirements, living roofs are not to be used as water-quality treatment devices. The primary sources of potential contaminants a living roof might treat are limited to rainwater and components of the living roof system itself (metals, fertilisers, herbicides etc.).

The primary purpose of this section is to provide for the design of living roofs suitable for the Auckland climate with the objective of retaining up to the 95th percentile design storm event (as defined in Section B).

This section discusses the design requirements for a living roof solely from the perspective of a stormwater management device. Living roofs must be constructed in alignment with structural engineering and architectural design from the very earliest stages of design, and must comply with the Building Code. Structural, architectural, aesthetic and ecological aspects of the design are complex and other published documents, such as Auckland Council technical reports, provide further details^{1 2}.

¹ Auckland Council TR 2013/045 *Living Roof Review and Design Recommendations for Stormwater Management*. Comprehensive information regarding design, construction and maintenance can be found in this document.

² Auckland Council TR 2010/017 *Extensive Green Roofs for Stormwater Mitigation, Part 1: Design and Construction*

This section therefore does not include:

- Detailed architectural and structural considerations – qualified professionals in both engineering and architecture should be consulted during the full design and construction of any living roof
- The requirements of the Building Code
- Testing procedures for living roof components – TR 2013/045³ provides lists of relevant ASTM standards for various testing procedures.

C4.1.1 Use in a treatment suite

Living roofs are used as an on-site, at-source retention device. If built to the performance specifications of this section, they are designed to retain approximately 25 mm of rainfall in any rainfall event.

While they have the potential to provide water quality treatment, they are not considered as treatment devices for HCGAs.

C4.1.2 Living roof components

A living roof typically consists of multiple layers (Figure 26 and Table 52). Other components of a living roof structure, such as a building insulation layer, are not included as typically these would be considered by an architect in the design of the building structure, rather than as a component of the stormwater management system that sits atop the roof deck.

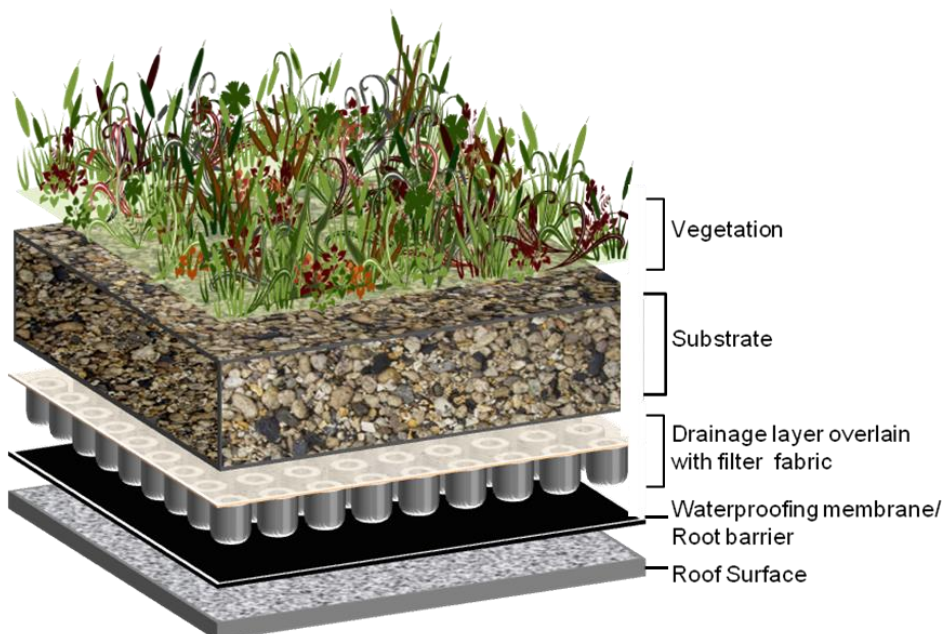

Figure 26: Schematic of living roof components

³ Auckland Council TR 2013/045 *Living Roof Review and Design Recommendations for Stormwater Management*

Table 52: Living roof components

Component	Description
Waterproofing layer	<ul style="list-style-type: none"> • A synthetic membrane which protects the structure from water damage. • A properly designed and installed living roof should extend the useful life of a waterproofing membrane, as the living roof physically blocks incoming UV rays which cause mechanical breakdown of the membrane.
Root barrier	<ul style="list-style-type: none"> • A chemical or physical root barrier which prevents root penetration into the waterproof membrane and the underlying roof surface. • Some synthetic drainage mats are available with an integrated root barrier. Likewise, some waterproofing membranes developed specifically for living roofs contain a root-deterring chemical or metal foil at the seams to prevent damage from roots.
Moisture retention layer (optional)	<ul style="list-style-type: none"> • A moisture retention layer increases the volume of water retained on the roof. It can enhance plant health providing water between rain or irrigation events. • Fabric (e.g. coir, wool, felt), mat (e.g. peat, sphagnum, coir) or foam moisture retention layers are placed at the base of the root zone where the held moisture is accessible by plant roots. • Retention layers have variable longevity and are likely to become less effective over time as they decompose.
Drainage layer	<ul style="list-style-type: none"> • Drainage layers provide rapid drainage for rainfall in excess of the system's rainfall storage capacity to outlets, preventing ponding of water. • The drainage layer is usually a synthetic mat or granular material (e.g. coarse aggregate). • The drainage layer itself does not provide waterproofing, but it can physically protect the waterproof membrane from shovels or other gardening implements that might damage waterproofing during planting or maintenance. In most instances, a drainage layer is recommended.
Geotextile separation	<ul style="list-style-type: none"> • The geotextile supports the substrate and prevents migration of substrate fines to maintain a free-flowing drainage layer. It can be either a separate layer, or bonded to a synthetic drainage layer.
Substrate	<ul style="list-style-type: none"> • The majority of rainfall retention (i.e. runoff volume reduction) by a living roof system occurs within the substrate (soil media) that supports plant growth. • The substrate also stores runoff, reduces runoff velocity and peak flows and provides thermal mass and insulation. • Minimum substrate depth should be 100 mm and is assumed to prevent runoff from storm events of less than 25 mm.
Vegetation	<ul style="list-style-type: none"> • Plants are intrinsic to the living roof design. They provide the evapotranspiration function of the living roof, as well as rainfall interception. They act as a thermal barrier (decreasing urban heat and providing building insulation) and improve air quality. • The choice of species provides environmental and social value by providing green space in the urban environment. Plant recommendations are provided in Section C1: Plants and soils.

There are three key types of living roof: extensive, intensive and modular (Table 53). Examples of modular systems are shown in Figure 27.

Table 53: Design considerations of extensive, intensive and modular living roofs

	Extensive	Intensive	Modular
	Retro-fit	New, bespoke	Off-the-shelf
	Low profile with thin layers	High profile with deep layers	Low profile with thin layers in modular trays, pouches or bags
Plants	Shallow rooted growing in 20–150 mm of substrate. Drought tolerant species.	Wider plant variety, including herbaceous plants to shrubs or trees in >200 mm of substrate.	Shallow rooted growing in 20–150 mm of substrate. Drought tolerant species.
Runoff retention	Low	High	Low
Public access*	No	Yes	No
Additional irrigation	No	Yes	No
Saturated weight	70–170 kg/m ²	300–1000 kg/m ²	70–170 kg/m ²
Cost and maintenance	Low	High	Low

* With associated health and safety requirements



(a) 220 mm plastic tray and 100 mm modular bag



(b) Aluminium and plastic 100 mm modular trays

Figure 27: Examples of ready-to-install modular systems

C4.1.3 Site considerations

Living roofs can be installed on any sized roof, on either new buildings or retrofitted onto existing ones, depending on the structural support available and roof accessibility. Each system will be specifically designed to account for the variations and constraints of each site (i.e. structural support, roof pitch, accessibility for installation, climate, shade, living roof purpose, desired aesthetic etc.) as specified in Table 54.

Table 54: Site considerations

Item	Description
Catchment area	<ul style="list-style-type: none"> • Variable, depending on roof area.
Micro-climate	<ul style="list-style-type: none"> • Consider the prevailing wind direction and impact on soil moisture, as well as the potential impact from surrounding buildings (wind, shade and rain may be changed by the urban surroundings).
Aspect, shade and irrigation	<ul style="list-style-type: none"> • A southerly aspect, shade and irrigation can help mitigate plant moisture stress induced by the harsh growing environment of a rooftop. • North-facing roofs in particular benefit from shade (even temporarily) during mid-afternoon, for example from nearby buildings or trees. • If additional watering is needed for the plants' survival, it may be necessary to include irrigation or moisture retention mats.
Aesthetics	<ul style="list-style-type: none"> • Designers and stakeholders need to consider plant condition and colour, as these will change with climate and with each plant's age and stress condition. • It is important that the range of alternative, low maintenance native and non-native plant options are discussed with stakeholders so that the visual aids used in architectural drawings aren't assumed to represent the finished product.
Access	<ul style="list-style-type: none"> • Access includes installation, maintenance and amenity access. All these access considerations should be designed for, particularly with regards to safety in design principles. Access considerations include: <ul style="list-style-type: none"> ○ Installation: Traffic control, permits, storage of equipment, specialised equipment etc. ○ Maintenance: Minimised health and safety risk, protection of the device, clearly defined access ○ Public amenity: Including safety barriers, handrails, disable access, slip protection, debris removal.

C4.2 Living roof design

C4.2.1 Design considerations

Living roofs for stormwater management must be designed in collaboration and consultation with multiple experts. From the project outset, consultation between the stormwater engineer, structural engineer, architect, horticultural consultant and landscape architect is needed to identify major design elements, constructability and long-term maintenance plans. Considerations include:

- Structural support for the building
- Physical access for maintenance or viewing, and associated safety features
- Vertical drainage features
- Location of other mechanical building services on the rooftop (e.g. HVAC, satellite TV, etc.)
- The presence/absence of a maintenance contract.

Where the living roof is designed specifically for stormwater management (as per this guideline), aesthetics and location of building services should not compromise function for stormwater control.

The design considerations for living roofs to provide retention of storms up to 25 mm are presented in Table 55.

Table 55: Living roof design considerations and specifications

Item	Requirements
Structural	<ul style="list-style-type: none"> • It is essential to obtain a structural evaluation by a structural engineer. • The evaluation will identify the maximum device weight the building is capable of supporting. The living roof will either need to be designed within this range, or additional structural support will be required.
Building consent	<ul style="list-style-type: none"> • Auckland Council will require a building consent for the installation of a living roof, for either new or retrofit designs. Consents are also required under the Building Code. • A structural assessment must be carried out by a suitably qualified and experienced person as part of the design and subsequently submitted with the consent application. • Auckland Council building inspectors should be consulted to verify consent requirements.
Substrate	<ul style="list-style-type: none"> • A minimum substrate depth of 100 mm is required. • Substrate permeability must be 1500 mm/h for living roofs with a dedicated drainage layer and 3600 mm/h for extensive living roofs without dedicated drainage layer (Section C4.2.4.1).
Slope	<ul style="list-style-type: none"> • The maximum slope for a living roof used in stormwater management is 15° (26.8%). • Slopes of between 10° (17.6%) and 15° (26.8%) must have additional structures included such as slope breaks and anti-shear/slip protection. • The minimum slope should be 2° (3.5%) to avoid ponding; where this is unavoidable, a drainage layer must be installed.

Item	Requirements
Protrusions, perforations and services	<ul style="list-style-type: none"> • These include heating, ventilation and air conditioning (HVAC) and can compromise the waterproofing membrane. • They should be minimised and clustered where possible in order to minimise potential integrity issues and access as it relates to a living roof.
Contaminants	<ul style="list-style-type: none"> • In most cases, discharge from living roofs designed to retain the maximum allowable storm depth does not require additional treatment. • The main exception may be in nutrient-sensitive receiving environments, but must be considered on a case-by-case basis.

C4.2.2 Design for safety

Safety considerations specific to living roofs are very different to most other stormwater management devices. This section does not attempt to address all safety concerns; the designer is responsible for the safe design and should include the end user/asset owner in the design development as well as all hazard identification and mitigation/elimination decisions. If the design needs to be altered during construction, all safety aspects of the design must be reconsidered afresh.

For a living roof, hazards should be considered in all the stages of the device life. Some examples include:

Design

- Roof access, via ladders or internal shafts, must be designed for
- Early consideration must be given as to whether the public will have access to the roof area
- Skylights, or other fragile roof materials, need permanent guardrails or protective screens
- Parapets need to be designed to prevent access to certain areas.

Construction

- Fall prevention
- Potential for objects to fall from the roof onto those below
- Traffic management, for example where large cranes are needed to lift pallets onto a roof
- Proximity to hazards, such as power lines (workers and their equipment should not be within 3 m of an overhead power line).

Use and operation

- Access should be through the building's core or use of an external caged ladder
- Roof-edge restraint systems should be included to limit access where falls may occur.

Maintenance

Particular consideration needs to be given as to how the living roof will be maintained over its life, including access for materials and plants to replace elements of the living roof structure or to make repairs to the underlying building structure:

- Design a parapet and guardrail around the roof perimeter to serve as fall-protection during maintenance
- Access to the device should be within safe and easy reach for maintenance.

Decommissioning

The design must consider the safe decommissioning of a living roof, including the safe disposal of aged roof materials.

C4.2.3 Device sizing

Living roofs provide storage within the substrate but this storage may vary by design and site-specific variables (such as vegetation species, roof slope, or climatic influences).

For consenting purposes, a living roof may be considered to completely retain a maximum of 25 mm of precipitation if 100 mm of suitable substrate is provided (per Table 57). The extent of retention depends primarily on a combination of the substrate's moisture retention properties and finished (settled) depth. Therefore, for storm events of less than or equal to 25 mm, runoff is assumed to be equal to zero (i.e. $CN < 1$). Where runoff volumes are required to be calculated for storms larger than 25 mm, calculations should be done using an appropriate curve number method ($CN=98$).

In a living roof system, rainfall retention occurs only on the portion of the roof that is vegetated (but, depending on the design can include any edging used for drainage and media restraint).

C4.2.4 Component design

The design considerations for living roofs are presented in Table 56. Additional information is provided in Auckland Council technical report, TR2010/017 *Extensive Green Roofs for Stormwater Mitigation, Part 1: Design and Construction*.

Table 56: Design considerations for living roofs

Item	Description
Horizontal drainage	<ul style="list-style-type: none"> • A formal drainage layer is recommended on all living roofs. Many synthetic drainage mats are available; some are in the shape of a moulded, dimpled plastic, resembling an egg crate, some are foam or plastic meshes. • A granular drainage layer with a separate geotextile layer laid over the top is an alternative to a synthetic drainage layer. Granular materials such as coarse aggregates could include 7 to 20 mm grade clean pumice, scoria, or gravel at a minimum depth of 30 mm. Products must not contain fine particulates. Examples are shown in Figure 29. • A formal drainage layer must: <ul style="list-style-type: none"> ○ Be used in accordance with the manufacturer’s specifications, particularly as they apply to loading ○ Have a capacity that exceeds the rate of water that passes through the geotextile above, so as to not impede flow, or cause pooling ○ Be placed between the waterproofing membrane and the substrate (Figure 26) ○ Be tested using ASTM E2398M – 15a Standard Test Method for Water Capture and Media Retention of Geocomposite Drain Layers for Green Roof Systems, and ASTM E2396M - 15 Standard Test Method for Saturated Water Permeability of Granular Drainage Media [Falling-Head Method] for Green Roof Systems ○ Consider additional water weight if a synthetic drainage layer with “cups up” (Figure 29) is used ○ Have a minimum weight of 100 g/m, with a typical range of 100–200 g/m² for substrate depths up to 250 mm. For deeper substrates and steeply sloping roofs, it may be necessary to increase the geotextile density ○ Have geotextiles with an apparent opening size of 0.06 – 0.2 mm.
Water proofing	<p>Good specification and installation of the waterproofing system will ensure the system functions and doesn’t damage the underlying roof structure. This must comply with the Building Code.</p> <p>Several key considerations have been observed in specifying and installing waterproofing membranes:</p> <ul style="list-style-type: none"> ○ Use at least a double-ply waterproofing membrane, or a purpose-made, heavy-duty membrane with felt layer ○ Protect the waterproofing membrane throughout construction and the life of the device. Nails, screws, or cutting implements should not be present on the rooftop when the membrane is being laid ○ Drainage mats should be used to provide a physical block for shovels or other gardening implements ○ Flashing, aggregate or substrate should completely cover the waterproofing membrane. Any exposed membrane is susceptible to premature UV damage ○ Extra caution should be used when sealing around protrusions and perforations (e.g. parapets, footings, skylights, mechanical systems, vents, etc.). <p>All waterproofing installations must be thoroughly tested for integrity prior to installation of subsequent layers of the living roof system.</p>
Root barrier	<ul style="list-style-type: none"> • A chemical or physical root barrier should be used to prevent plant roots penetrating the waterproofing membrane. Use of chemical root barriers containing copper or pesticides should be avoided because of the potential to leach contaminants of concern into runoff.

Item	Description
Edging	<ul style="list-style-type: none"> Edging maintains visibility and ease of access for drainage points, protrusions, perforations and other features. Edging materials must allow water to freely drain and help to keep inlets, gutters, scuppers and pipes free of vegetation. Blocked drains can create standing water on rooftops, increasing structural load, even for conventional roofs. Suitable materials include gravel, pumice, or other aggregate, paver blocks or permeable pavers. The material must be non-floating, or confined, to prevent floating or wash-out.
Vertical drainage	<ul style="list-style-type: none"> Guttering must be sized and installed for the conveyance of events larger than the design event and must comply with building codes. Roof gutters, drains, or downspouts should be located to ensure the longest runoff travel distance through the drainage layer. Vertical drainage must be flush with, or below, the roof deck and installed prior to the waterproofing. Levels should be verified during construction. An edge of 200 - 500 mm around vertical drainage points is needed so they are visible and free of vegetation.

C4.2.4.1 Substrate design specification

Substrate design to promote water retention of the target rain event is critical (Table 57). There is significant variation amongst individual plant species' evapotranspiration, interception and other influences (such as roof slope). This section provides recommendations based on a conservative set of assumptions (derived from TR2013/045⁴) and designers may need to validate these assumptions in site-specific designs.

Table 57: Design specifications for substrate

Item	Requirements
Substrate depth	<ul style="list-style-type: none"> Minimum of 100 mm.
Saturated permeability	<ul style="list-style-type: none"> 1500 mm/h for living roofs, with a dedicated drainage layer and 3600 mm/h for extensive living roofs without dedicated drainage layer.
System weight	<ul style="list-style-type: none"> A structural engineer must design for the substrate weight (as dry, field capacity and saturation) in combination with the weight of the waterproofing layer, drainage layer, supplemental moisture retention techniques (if included), and vegetation. This must be done in accordance with the Building Code and structural design.
Substrate sourcing and media specification	<ul style="list-style-type: none"> Material must be sourced (and ensured to be weed-free from covered stockpiles), specified and tested (on the basis of dry bulk density, weight at field capacity, saturated weight, saturated permeability, particle size distribution and plant available water).
Substrate blending	<ul style="list-style-type: none"> Blends must maintain maximum moisture content of 15% with a gentle tumbling. Mixing when the substrate is too wet or too dry will compromise various aspects of the living roof (such as mass-to-weight conversions). An additional 20% of the substrate should be blended to provide for any compaction or losses.

⁴ Auckland Council 2010/017 *Extensive Green Roofs for Stormwater Mitigation, Part 1: Design and Construction*

C4.2.4.2 Structural design

It is beyond the scope of this document to address structural design aspects of a living roof (further information is provided in TR2013/045⁵). A structural engineer is required to assess all aspects of the building's structural design and the construction of a living roof device on the building. Some considerations for the structural design include:

- **Permanent action:** The mean weight of the “regular” roof plus the components of the living roof system under normal operating conditions
- **Imposed action:** Temporary loads (e.g. added load from people, maintenance equipment etc.)
- **Static liquid pressure and rainwater ponding:** Forces imposed by depth and density of the water and the acceleration of gravity
- **Strength:** Structure strength to support specific combinations of loadings with relevant safety factors
- **Wind loads:** The potential for uplift of the living roof materials as well as the roof deck (examples of erosion control are shown in Figure 28)
- **Wind serviceability:** A living roof may provide a damping effect on a building's response to wind loads if the drainage layer is flooded with water
- **Pre-installation load verification:** If the calculated load is less than the pre-installation load then it may be necessary to design additional structural support, re-blend the substrate, or reduce the substrate depth
- **Durability:** the materials used in living roofs should be durable and resistant to corrosion so they do not fail or impact surrounding structures.



Biodegradable coir mats



Permanent plastic lattice

Figure 28: Erosion control for sloped or windy sites



Synthetic “egg-crate” style moulded plastic with “cups up”



Plastic mesh

Figure 29: Drainage layers

⁵ Auckland Council TR 2013/045 *Living Roof Review and Design Recommendations for Stormwater Management*

C4.2.4.3 Architectural design

This section does not address building or landscape architecture requirements (further information is provided in the technical report, TR2013/045⁵). Consultation and regular communication between the architect and stormwater designer is essential. Architectural elements that may affect living roof design for stormwater control include, but are not limited to, those presented in Table 58.

Table 58: Architectural design considerations

Item	Requirements
Parapets, balustrades and anchor points	<ul style="list-style-type: none"> • Provide safe access and egress for maintenance and amenity. • Anchor points, if needed, should not compromise free drainage.
Edging and walkways	<ul style="list-style-type: none"> • Where accessible by public, a dedicated and easily identifiable walkway is required. Walkable areas should be at least 2 m distance from roof edges. • Pervious edging needs to identify safety hazards (i.e. the building edge), to maintain visibility and accessibility for drainage points, mechanical services and other protrusions, and to prevent substrate migration.
Design and location of mechanical services	<ul style="list-style-type: none"> • Cluster and minimize the number of protrusions, perforations and services. • Consider space required for storing/placing temporary maintenance equipment.
Roof pitch (slope)	<ul style="list-style-type: none"> • Factored for erosion control and slope stability. Examples of erosion control for sloped and windy sites are shown in Figure 28.
Method and location of physical access	<ul style="list-style-type: none"> • Maintenance crews must be able to reach all areas of the living roof safely, while potentially carrying equipment and materials. • Public access, if designed for, should be safe and easy, with well-defined areas for public use and signage and barriers where access is not allowed. Access opportunities for the mobility impaired should also be considered.
Building materials	<ul style="list-style-type: none"> • Metal materials containing zinc and copper should not be used as components of the living roof system where they are allowed to come into contact with rainfall or runoff, due to the potential to leach into roof runoff.

C4.2.4.4 Plant selection

The process by which a living roof functions as a stormwater management device, is through plant transpiration (which dries the substrate), while roots maintain its permeability, and above-ground cover provides some rainfall interception. Evapotranspiration is the key mechanism for retention in a living roof device. A healthy, dense plant cover is essential to the stormwater mitigation function of a living roof system. Refer to Section C1.6.4: Plants and soils, for plant species recommendations. The selected plants need to:

- Survive conditions that can be more stressful than ground-level landscaping
- Create pore space to store rainfall by using water from the substrate
- Protect the substrate from erosion by covering it with leaves and binding it with roots
- Maintain infiltration through leaf and root networks keeping surface pores open.

They need the following characteristics:

- Shallow, lateral root system, with no deep, or tap, roots that could penetrate the waterproofing barrier
- Wind-tolerant
- Resilient to cyclic wet and dry conditions, in particular extended drought periods
- Low fertiliser and maintenance needs
- Resistance to insects and disease
- Roots tolerant to high temperatures (most large roofs receive full sun and can have high thermal mass, radiating heat into the substrate).

While this design guide places priority on stormwater management, plant selection for living roofs should be based on the overall objectives for living roof design (including aesthetic, social and environmental benefits). A qualified horticultural or living roof specialist should be consulted about the planting palette, planting method, installation access, long-term maintenance assurance and aesthetic objectives (as described further in Table 59).

Table 59: Specific planting considerations

Item	Requirement
Substrate	<ul style="list-style-type: none"> Shallow (< 200 mm deep) substrate can only support low-growing plants. Taller plants require deeper substrate (either by mounding over structural supports or as specially constructed troughs below grade). Organic mulches are not generally used on roofs as they can blow away or add weight.
Site constraints	<ul style="list-style-type: none"> Shade, wind direction, other facilities on the roof structure (such as overhead lines, antennae, etc.).
Plants	<ul style="list-style-type: none"> Designs should avoid using species with aggressive roots or taproots (e.g. bamboo) which can block drainage outlets or damage the waterproofing layer. Use low-growing succulents (>50%) where there is little shade or irrigation. Establish and maintain a dense (75%) plant cover within 12 to 18 months (this reduces long-term maintenance costs). Plants should be “hardened up” prior to placement on a living roof (those grown in a nursery or at ground level may fail in a roof environment). Some specific plant specimens may be more expensive and limited in supply. Allow for 5-10% more plants than needed to allow for damage or death. Consider the maintenance requirements of certain species (pruning, deheading, trimming etc.). Manage the risk of plant failure.
Maintenance	<ul style="list-style-type: none"> Fertiliser needs. Irrigation needs. Frequency of maintenance visits. Weed management and drainage management. Post-establishment fertiliser rates should be very low (if at all) to minimise nutrient leaching.

Details for performance monitoring of living roofs are provided in TR 2010/018⁶.

C4.2.5 Construction design considerations

The following construction design considerations should be addressed during design and specification:

- Living roofs should be installed in the final phases of a new building construction
- Safety during construction is paramount (refer to Section C4.2.2)
- All waterproofing must be protected during construction
- Plants should be hardened off prior to planting to promote survival. Areas need to be set aside at ground level to provide this
- If permeability testing or performance monitoring is required pre- or post-construction, this needs to be considered during design. Additional considerations regarding testing can be found in Auckland Council’s technical report, TR 2010/017 *Extensive Green Roofs for Stormwater Mitigation, Part 1: Design and Construction*.

⁶ Auckland Council TR2010/018 *Extensive Green (Living) Roofs for Stormwater Mitigation, Part 2: Performance Monitoring*

C4.2.6 Operation and maintenance design considerations

The following operation and maintenance considerations should be addressed during design and specification:

- An operation and maintenance plan must be developed prior to asset transfer
- As with construction, safety is paramount during all operation and maintenance activities (refer to Section C4.2.2)
- On-going irrigation needs for the living roof must be considered at the design stage
- The future asset owner must be included in design discussions in order to ensure commitment to required on-going maintenance.

Additional information can be found Auckland Council's technical report, TR 2013/045⁵.



C5 Rainwater tanks

Table of Contents

C5.0	Technical guidance: rainwater tank systems	177
C5.1	Introduction	177
C5.1.1	Use in a treatment suite	178
C5.1.2	Rainwater tank system components	178
C5.1.3	Site considerations	180
C5.2	Rainwater tank design	181
C5.2.1	Design considerations	181
C5.2.2	Design for safety	182
C5.2.3	Device sizing	182
C5.2.4	Component design	194
C5.2.5	Construction design considerations	196
C5.2.6	Operation and maintenance design considerations	197
C5.3	Design examples	198
C5.3.1	Large rainwater tank to meet SMAF 1 criteria – calculation method	198
C5.3.2	Residential rainwater tank to meet SMAF 1 criteria – simplified method	200

Figures

Figure 30:	Key components of the rainwater tank system	178
Figure 31:	Illustration of impervious catchment area measurement in horizontal plane	183
Figure 32:	Total detention volume for impervious surface area 25 m ² to 175 m ² based on rainfall depth and connected area (for detention tank)	184
Figure 33:	Total detention volume for impervious surface area 200 m ² to 1000 m ² based on rainfall depth and connected area (for detention tank)	185
Figure 34:	Orifice height for dual-purpose tanks, retention volume from 2000 L to 3500 L	187
Figure 35:	Orifice height for dual-purpose tanks, retention volume from 4000 L to 6000 L	187
Figure 36:	Flow diagram of design process using simplified method	188
Figure 37:	Illustration of tank parameters	189
Figure 38:	Flow diagram of design process using calculation method	193
Figure 39:	Outlet mesh screen	194
Figure 40:	Rainwater tank specifications for mitigation of 800 m ² roof (15000 L)	199
Figure 41:	Rainwater tank specifications for mitigation of 500 m ² roof (10000 L)	201

Tables

Table 60: Rainwater tank system key components	179
Table 61: Typical tank types and features for stormwater management	179
Table 62: Site considerations	180
Table 63: Rainwater tank system design considerations and specifications	181
Table 64: Tank dimension parameters	189

C5.0 Technical guidance: rainwater tank systems

C5.1 Introduction

Rainwater tanks are used to collect and store runoff from roofs, or other impervious areas, such as driveways. They provide a simple at-source stormwater management device but do not provide direct water quality benefits. Tanks are particularly useful in areas where detention is required and may be required in subdivisions where stormwater discharges to a combined sewer¹.

Rainwater tanks may not be used as stormwater mitigation for unconnected impervious areas (such as roads, driveways and carparks).

1% AEP detention*	✓
50% and 10% AEP detention*	✓
Detention (SMAF)	✓
Retention	✓
Water quality	✗

*Assuming conveyance (guttering) is sized appropriately

The volume of water retained in a tank can comprise:

- **Dead storage (permanent water volume):** All rainwater tanks are required to provide a certain permanent water volume at the base of the tank in order to allow for sediment accumulation. This is the volume of water below the lowest outlet in the tank. It is recommended to be set at 150 mm from the base of the tank. This could be decreased to 50 mm, but increased maintenance frequency is then needed
- **Retention:** Water is stored for use in the house or garden. If this system is chosen, the home owner or occupier needs to commit to using the retention volumes within 72 hours (e.g. toilet flushing) so that detention volumes aren't negatively impacted in the next storm event. Appropriate plumbing needs to be installed for reuse of this water inside the house
- **Detention:** Runoff is temporarily stored in the tank prior to slower discharge to a stormwater conveyance system. This detention volume can include larger storm events where a tank can be sized to detain up to a 1% Annual Exceedance Probability (AEP) (with appropriately sized guttering).

Rainwater tank sizing involves determining the volume and orifice placement and orifice diameter for retention and detention purposes:

- Retention: 5 mm, 24-hour rainfall event (under Stormwater Management Area – Flow [SMAF] provisions) can be stored as a water supply.
- Detention:
 - Detention for stream protection (90th or 95th percentile storms)
 - Detention for flood mitigation (50%, 10% and 1% AEP detention volumes). In these cases, conveyance (such as guttering) must be sized to accommodate the higher flows.

¹ Detention of up to 10% AEP is currently a Watercare Services requirement in areas discharging to combined sewer. These tanks may not be used for in-house reuse.

Storage available for retention and smaller events can also be utilised in routing calculations for larger events (in some instances up to 1% AEP detention).

The focus of this document is stormwater management. For this reason, some considerations are not included in this design guide. This document does not discuss:

- **Tanks designed for potable water use in non-reticulated areas:** While some content is provided on the use of rainwater for on-site use, readers are directed to North Shore City Council Raintank Guidelines² or the Countryside Living Toolbox³ for further information on rainwater tanks designed for potable water use. Subsequently, this document does not take into account reliability of supply, or days of storage, where the primary purpose of a tank is for potable use. Such systems must comply with the Health Act requirements.
- **Underground tank installation:** This document does not provide guidance for design, installation or maintenance of below-ground tanks.

All tank designs must comply with the requirements of the Building Code.

C5.1.1 Use in a treatment suite

Rainwater tanks are an at-source device and are generally sited on private property for detention and retention purposes. They are an important device for attenuating flows into any devices located in lower portions of the catchment.

C5.1.2 Rainwater tank system components

Rainwater tank components are presented in Table 60 and Figure 30 and may be designed for different purposes (Table 61).

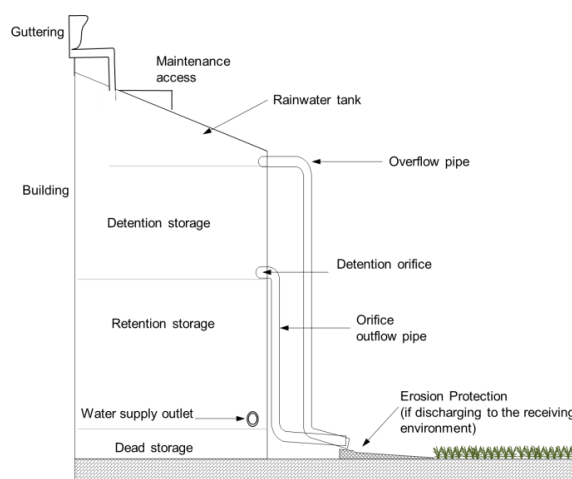

Figure 30: Key components of the rainwater tank system

² A key reference for this section is North Shore City Council, 2009, *North Shore City Raintank Guidelines - Second Edition*

³ Rodney District Council and Waitakere City Council. *The Countryside Living Toolbox - Stormwater Management Device Design Details*. 2010. ISBN978-1-877540-65-3

Table 60: Rainwater tank system key components

Component	Description
Tank	<ul style="list-style-type: none"> This is an impermeable structure which holds: <ul style="list-style-type: none"> Dead storage - water not used or discharged and must be inspected and cleaned out to remove sediment build-up Retention volume (optional) - volumes used on-site Detention volume - water discharged into the primary conveyance over time.
Detention orifice	<ul style="list-style-type: none"> This orifice discharges the detention volume into the receiving environment, or primary conveyance system.
Water supply outlet	<ul style="list-style-type: none"> The outlet for water reuse, either in the household or on-site (e.g. gardening).
Access hatch	<ul style="list-style-type: none"> Periodic maintenance is needed to remove sediments from the base of the tank. Safe access should be designed for (e.g. confined space and working at heights).
Guttering	<ul style="list-style-type: none"> Provides conveyance from the roof into the tanks.
Overflow orifice and pipe	<ul style="list-style-type: none"> The orifice and piping which discharges volumes greater than the detention volume into the receiving environment, or the primary conveyance system.
Erosion protection	<ul style="list-style-type: none"> Needed to mitigate potential scour from high water velocities if the tank discharges into the receiving environment.

Table 61: Typical tank types and features for stormwater management

Tank type	Purpose	Added features	Usual capacity
Detention tank	<ul style="list-style-type: none"> Reduces the peak flow of stormwater leaving a site to meet downstream stormwater infrastructure capacity constraints. Usually used in urban areas. 	<ul style="list-style-type: none"> Controlled small diameter orifice regulates discharge. 	>1,000 L
Dual purpose rainwater tank	<ul style="list-style-type: none"> These tanks are divided into two sections – above and below a small diameter orifice; the lower volume is for retention, the upper volume is for detention. These tanks reduce: <ul style="list-style-type: none"> The volume of stormwater from smaller events The peak flows from less frequent larger events The demand for potable water from the Auckland Council water supply system by providing an on-site source for households. 	<ul style="list-style-type: none"> Plumbing for toilet flushing and laundry supply Can also be used for other non-potable purposes such as garden watering and car washing. 	4,500 to 50,000 L

C5.1.3 Site considerations

Selected site considerations are presented in Table 62.

Table 62: Site considerations

Item	Description
Location	<ul style="list-style-type: none"> • Tanks should be located to allow the hard surface to drain to the tank via gravity. The location should be on stable, flat soils with no ponding. • The tank foundation must be structurally sound to support the weight of a full tank. • The tank must be located so it is sited safely (clear of overhanging branches, placed on stable soils etc.) and have easy and safe access for maintenance, especially where there is a small orifice which requires regular inspection. • Rainwater tanks should not be placed inside the drip-line of a tree canopy as root growth can damage the tank and the tree's health may be affected if rain cannot get to the roots or if the roots are disturbed. • Tanks should be placed on the southern side of a building wherever possible to reduce exposure to sunlight. Presence of buried services needs to be assessed.
Soils	<ul style="list-style-type: none"> • Slope, retaining requirements and groundwater must all be considered. • The tank stand or base must be able to carry the combined weight of the tank and water when it is full. • Special design by a geotechnical engineer is required in geotechnically unstable areas or close to a retaining wall or on slopes (within a 45° angle from the base of the wall).
Runoff quality	<ul style="list-style-type: none"> • Tanks must be directly connected to the impervious area and therefore generally collect water from roof areas, decks or paved areas. • The impervious surface should not discharge paint, metals or other contaminants. • Leaf litter and other organic material should be prevented from entering the tank (refer to Section C5.2.4). Gutter filters are needed.

C5.2 Rainwater tank design

C5.2.1 Design considerations

Table 63 provides the design considerations for rainwater tanks systems.

Table 63: Rainwater tank system design considerations and specifications

Item	Requirements
Impervious area draining to tank	<ul style="list-style-type: none"> The catchment area relates to impervious area draining to the tank only (i.e. excludes offset mitigation). The roof must be above the overflow level of the tank to allow stormwater to flow into the tank under gravity.
Tank	<ul style="list-style-type: none"> The tank must be impermeable, durable (25+ years for private, 100+ years for those vested to Auckland Council), located on suitable, stable and level soils and be gravity-fed. Detention tank sizes must be >1,000 L. Dual purpose retention and detention volumes must be sized as described in Section C5.2.3. All tanks must have a dead storage volume (the recommended minimum is 150 mm depth from the base of the tank).
Detention orifice	<ul style="list-style-type: none"> The minimum orifice diameter must be 10 mm to minimise the chance of clogging. The orifice must be sized to discharge detention volumes over 24 hours (as described in Section C5.2.3.2).
Water supply outlet	<ul style="list-style-type: none"> Retention volumes must be used on site within 72 hours. This connection must comply with all regulations pertaining to water reuse.
Maintenance access	<ul style="list-style-type: none"> All tanks must allow access for maintenance and cleaning with consideration for safety (e.g. confined space and working at heights). Reasonable and safe access to the interior of the tank must be provided for inspection and maintenance purposes and due consideration given to how to collect and dispose of sediment. Refer to AS/NZS 2856 “Safe working in confined spaces”.
Guttering	<ul style="list-style-type: none"> Guttering should be sized for the conveyance of the storm event designed for retention and detention volumes. Excess to this sizing should bypass the tank. Primary screening devices (~6 mm wire mesh) should be placed close to the downspout to prevent the entry of leaf litter. A first flush diversion may also be included to improve the quality of water entering the tank.
Overflow orifice and pipe	<ul style="list-style-type: none"> The overflow pipe outlet must be lower than the roof and there must be sufficient fall for the water to flow into the tank at the designed discharge rate.
Cover	<ul style="list-style-type: none"> A secure, tight-fitting top cover is needed to prevent evaporation, mosquito breeding and to keep insects, rodents, birds or people from entering or falling into the tank.
Pipe work	<ul style="list-style-type: none"> All plumbing must comply with the relevant New Zealand standards. Backflow prevention measures must be included if water is being plumbed to the house. Pipe work should be minimised by locating the tank as close to the roof as possible.
Tank height	<ul style="list-style-type: none"> Above-ground tanks that are located close to a boundary should be less than 1.8 m in height.

Item	Requirements
Outlet	<ul style="list-style-type: none"> The outlet of the tank must be located above the level of the stormwater reticulation, or other proposed receiving environment into which it will discharge. An approved connection point to the primary stormwater system should be identified. Discharge from rainwater tanks must not result in flows onto adjacent properties (causing nuisance or flooding). Erosion protection must be provided at all outlets entering the receiving environment.
Private connection	<ul style="list-style-type: none"> Connection must comply with the Building Code and include backflow prevention. Conveyance (guttering) must be sized for largest designed event.
Vector control	<ul style="list-style-type: none"> Tanks should have adequate ventilation. Vents must have screens to prevent mosquitoes and other insects entering the tank.

C5.2.2 Design for safety

It is the designer's obligation to identify hazards throughout the life of the rainwater tank system and take all reasonable steps to eliminate them in the design process. Some safety considerations for rainwater tanks include:

Safe access

- Safe access into the tank for inspection and maintenance should be designed for; noting that entry into any water tank is considered to be confined space entry
- Access to the tank should be within safe and easy reach for maintenance (including sediment removal), renewal and decommissioning
- Some access to guttering and pipework for inspection and maintenance.

Fall prevention

- Access into and out of the tank should be managed to prevent falls
- Guttering may get clogged reducing water flows into the tank and may require periodic cleaning. Fall prevention measures should be in place to reduce risk during this maintenance.

C5.2.3 Device sizing

This section presents two different approaches for rainwater tank design:

- Simplified method:** Designed for use by plumbers and drainlayers who might purchase off-the-shelf tanks for retrofits or small subdivisions requiring some on-site stormwater mitigation. Rainwater tank sizing methods are provided as graphs which determine detention and retention volumes, as well as orifice sizing and location
- Calculation-based:** Designed for use by design engineers who provide rainwater tanks for complex designs (such as commercial installations or subdivision developments) requiring detention devices needed for the provisions under the Auckland Unitary Plan.

With either method, a number of parameters need to be determined, including:

- The total impervious area to be mitigated
- The impervious area that the rainwater tank will service
- The allowable ground area for the tank installation
- The purpose of the tank (detention, non-potable reuse etc.) and the volume of water the tank will need to store
- Local rainfall patterns: For the simplified method presented in this section, a number of rainfall averages have been used for the range of conditions in the Auckland region. Methods for assessing rainfall are presented in Section B.

Determine the rainfall in your area

Using the maps provided in Section B of this document, determine estimated rainfall in your area. The 24-hour rainfall depth is required to determine hydrology mitigation requirements:

- SMAF 1 – use 95th percentile rainfall depth
- SMAF 2 – use 90th percentile rainfall depth.

Rain tanks may also be sized to detain water from larger events (e.g. 50%, 10% and 1% AEP).

Measure connected impervious area

The total impervious area discharging to the tank must be calculated on the horizontal plane. Multiple tanks may be installed to provide the required mitigation from segmented areas. Only the area draining to the tank should be included in the connected area calculation (Figure 31).

The connected impervious area discharging to the tank should be increased such that the achievable captured runoff volume is equal to, or greater than, the required total hydrology mitigation volume (detention and retention).

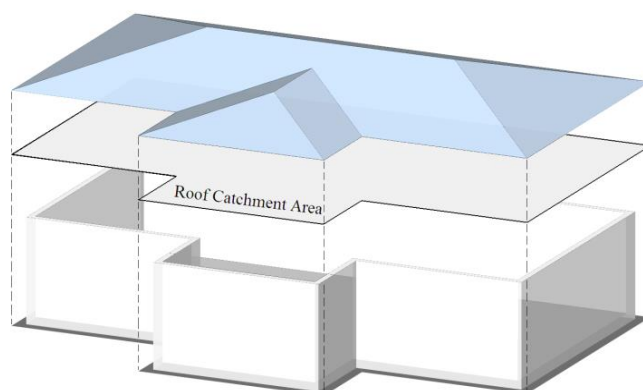

Figure 31: Illustration of impervious catchment area measurement in horizontal plane

C5.2.3.1 Device sizing - simplified method

The simplified method is designed for rapid assessment of tank needs; this may include a household retrofit where a plumber or drainlayer is asked to provide a tank size for retention and detention use. The data are presented as graphs developed for different rainfall events, and roof areas.

Two different tank designs are provided:

- Detention only tanks
- Dual-purpose tanks – for retention (reuse) and detention.

C5.2.3.1.1 Detention tank design

Detention tanks capture and slowly release stormwater runoff from hard surfaces so that the peak flows leaving the site after development are no more than those that would occur pre-development. Detention tanks can be designed to mitigate peak flows for a range of rain events, but are generally not suitable for controlling rainfall events greater than the 10% AEP event because of the limited capacity in the guttering and stormwater reticulation.

Step 1 - Determine the runoff volume into rainwater tank

This is the volume that can be captured by the rainwater tank across the 24-hour rainfall period, given the size of the connected impervious area. To capture a greater runoff volume, the connected area should be increased (Figure 32 and Figure 33). For ease of use (should the user need a value that lies outside of these graphs), the volume can be calculated using rainfall depth multiplied by the roof area, using Equation 14. It should be noted that this simplified method is more conservative than that provided in the calculation method (which uses the TP108 method).

$$V_{(det)} = V_{(total)} = \frac{A_{(connect)} \times \text{rainfall depth}}{1000} \quad \text{Equation 14}$$

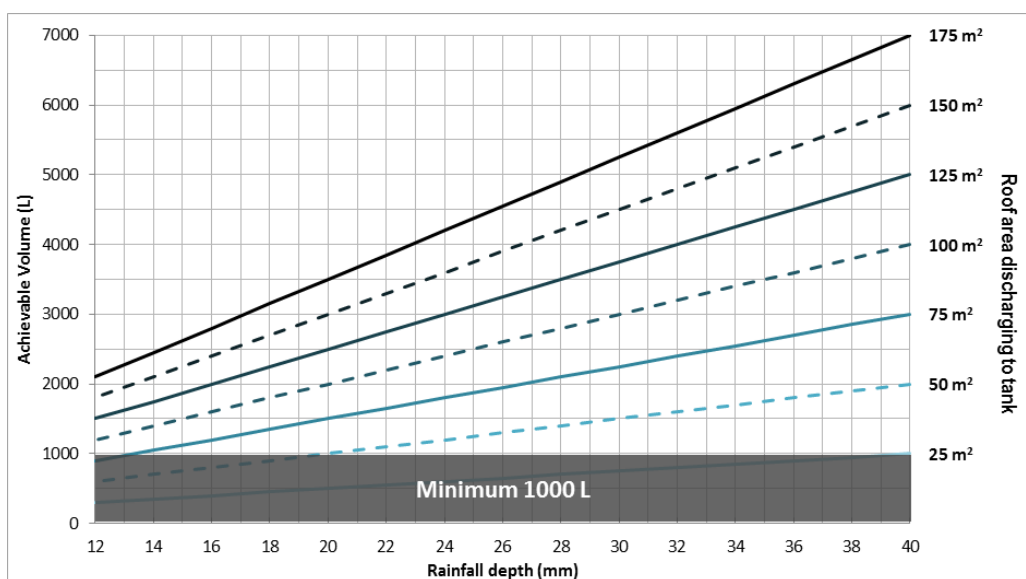

Figure 32: Total detention volume for impervious surface area 25 m² to 175 m² based on rainfall depth and connected area (for detention tank)

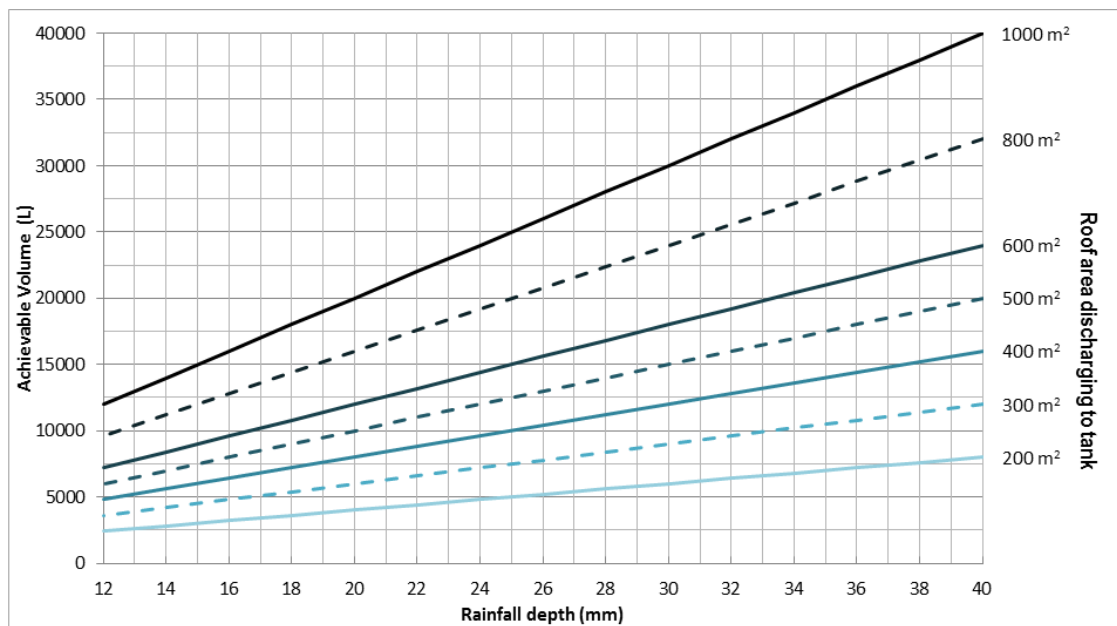

Figure 33: Total detention volume for impervious surface area 200 m² to 1000 m² based on rainfall depth and connected area (for detention tank)

The runoff volume is the volume contained between the small orifice at the bottom of the tank and the level of the overflow. For detention tanks, this corresponds to the total detention volume.

Step 2 – Determine appropriate tank size

The detention tank should be sized to hold the entire achievable detention volume, including a recommended minimum 150 mm of dead storage below the level of the small orifice to allow for sediment build-up. A minimum tank size of 1 m³ (1,000 L) should be used.

Step 3 – Identify tank depth

This is the height between the centre of the outlet orifice and the overflow level (as specified by the tank manufacturer). It is important to ensure that the level of the detention orifice allows it to drain into the stormwater reticulation (or other proposed outfall).

Step 4 – Determine orifice size

The orifice size depends on tank volume and tank depth. The orifice in a detention tank acts to detain the water flow for slow release over a 24-hour period.

For the simplified method, an orifice diameter of 10 mm should be used.

C5.2.3.1.2 Dual purpose tank design

Dual-purpose rainwater tanks combine the benefits of rainwater retention for non-potable purposes and detention into a single rainwater tank.

The minimum size for dual-purpose rainwater tanks is 4.5 m³ (4,500 L).

This approach has been developed to simplify the design of dual-purpose rainwater tanks for typical residential developments by providing standard minimum rainwater tank volumes which are acceptable to meet the mitigation requirements for specific impervious areas.

Step 1 - Determine the runoff volume into rainwater tank

Refer to Step 1 for detention tanks (using Figure 32 and Figure 33 or Equation 14).

For dual-purpose tanks, this volume is divided into retention and detention.

Step 2 - Allocate runoff volume

The runoff volume should be allocated to retention and detention volumes to meet required hydrology mitigation requirements.

For example, with a total runoff volume of 5 m³, and required retention and detention volumes of 2.5 m³ and 4.2 m³ respectively, 2.5 m³ can be used to achieve retention with the remaining 2.5 m³ used for detention. This leaves an outstanding detention volume of 1.7 m³ to be achieved by other means. Alternatively, the connected impervious area can be increased to achieve a greater runoff capture volume.

Step 3 - Determine appropriate tank size

The tank must have sufficient capacity for both retention and detention volumes to sit above the dead storage height. The tank diameter and height can be identified as per the tank manufacturer's specifications. The tank height refers to the height between the water-use outlet (or dead storage) and the overflow level.

Step 4 – Determine detention orifice height

The orifice invert is positioned above the retention volume and can be determined using Figure 34 and Figure 35.

If retention volume is greater than 6 m³, the orifice height should be at least one-third of the height.

Step 5 - Determine detention orifice size

For the simplified method, an orifice diameter of 10 mm should be used.

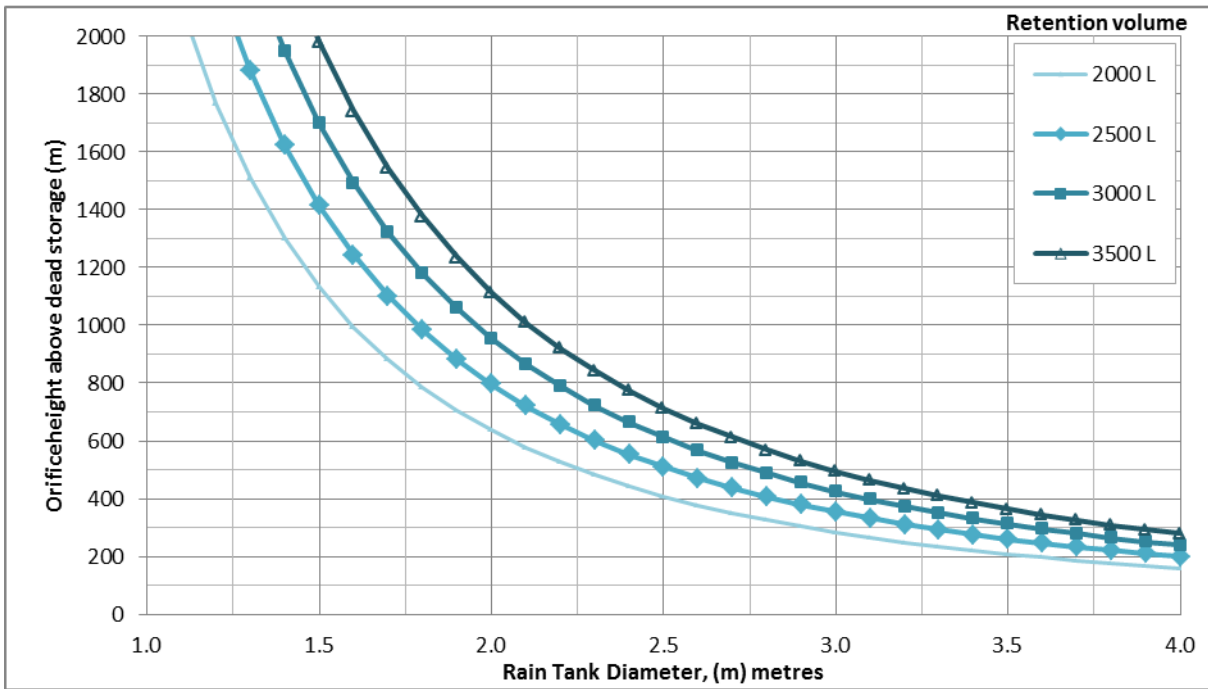

Figure 34: Orifice height for dual-purpose tanks, retention volume from 2000 L to 3500 L

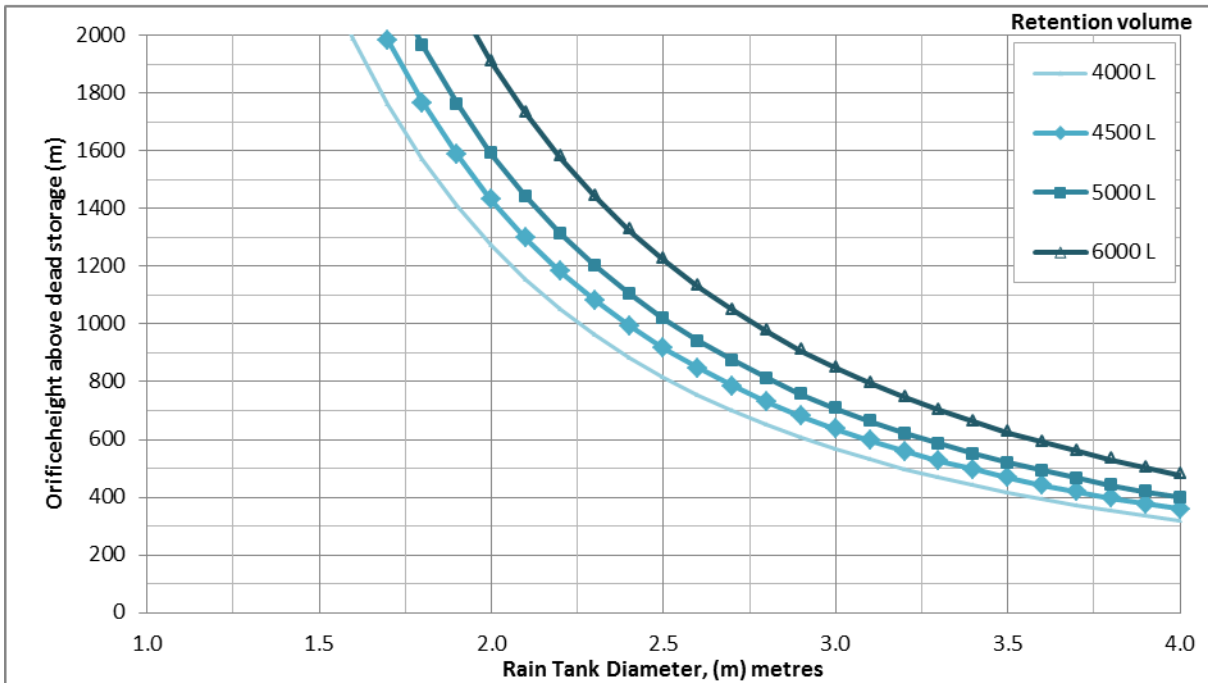

Figure 35: Orifice height for dual-purpose tanks, retention volume from 4000 L to 6000 L

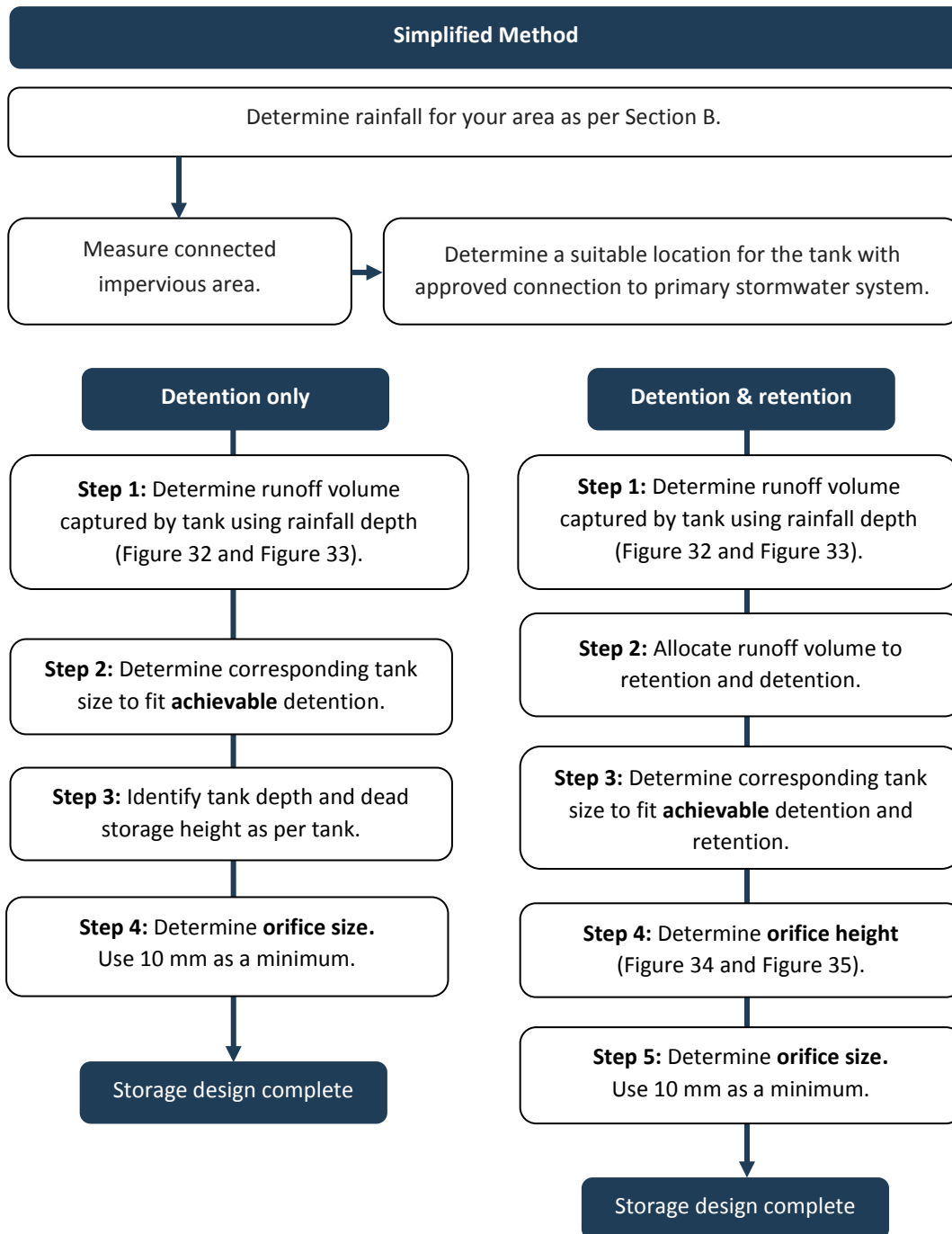

Figure 36: Flow diagram of design process using simplified method

C5.2.3.2 Device sizing – Calculation method

This method is provided for design engineers and is most likely to be useful where large-scale developments require detention. The different tank parameters are presented in Figure 37 and Table 64.

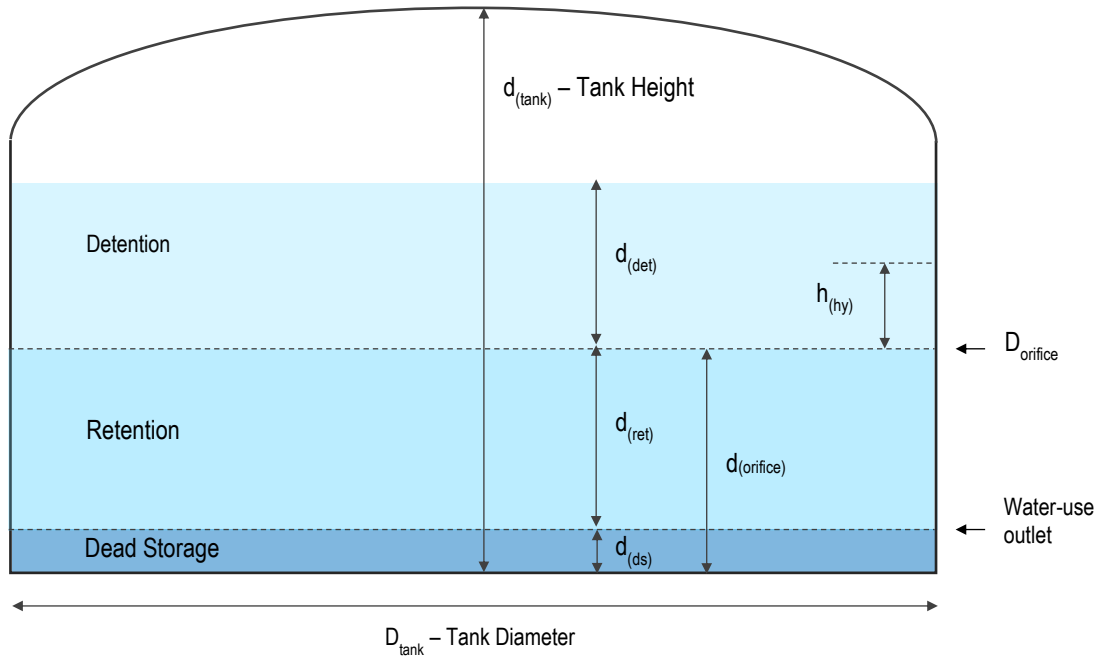

Figure 37: Illustration of tank parameters

Table 64: Tank dimension parameters

Parameter	Ref	Parameter	Ref		
Total runoff volume into rainwater tank	m^3	$V_{(total)}$	Required hydrology mitigation volume	m^3	-
Allocated retention volume	m^3	$V_{(ret)}$	Required retention volume	m^3	-
Allocated detention volume	m^3	$V_{(det)}$	Required detention volume	m^3	-
Connected impervious area	m^2	$A_{(connect)}$	Tank base area	m^2	$A_{(tank)}$
Average discharge rate	m^3	$Q_{(avg)}$	Hydraulic head	m	$h_{(hy)}$
Discharge coefficient (0.62)	-	μ	Gravity (9.81 m/s^2)	m/s^2	g

C5.2.3.2.1 Design event/s

Hydrology mitigation requirements (retention and detention volumes) should be calculated prior to commencing with the calculation-based method (using the TP108 method provided in Section B).

C5.2.3.2.2 Detention tank design

The general design guidelines for an upright cylindrical detention tank are as follows:

Step 1 – Calculate the achievable runoff into rainwater tank – $V_{(tot)}$

Use the methodology provided in Section B1.7.1 (using TP108 method) to calculate the total runoff, and retention and detention volumes from the impervious area.

Step 2 - Calculate tank height - $d_{(tank)}$

Once the runoff volume is determined, the required storage height can be calculated using the tank area.

$$d_{(det)} = \frac{V_{(det)}}{A_{(tank)}} \quad \text{Equation 15}$$

$$A_{(tank)} = \pi \times \left(\frac{D_{(tank)}}{2}\right)^2 \quad \text{Equation 16}$$

As a general guideline, tanks should have a dead storage (recommended as 150 mm from the base of the tank). The total depth of tank ($d_{(tank)}$) should be at least the sum of the dead storage ($d_{(ds)}$) and the storage height for the detention volume ($d_{(det)}$).

$$d_{(tank)} = d_{(det)} + d_{(ds)} \quad \text{Equation 17}$$

Step 3 - Calculate average discharge rate - $Q_{(avg)}$

The required detention should be released over 24 hours. This will provide a discharge rate as (Equation 18).

$$Q_{(avg)} = \frac{V_{(det)}}{86400 \text{ s}} \quad \text{Equation 18}$$

Step 4 - Calculate orifice diameter - $D_{(orifice)}$

Using the average discharge rate and the tank height, the area of the orifice ($A_{(orifice)}$) can be calculated as (Equation 19), with hydraulic head ($h_{(hy)}$) calculated using Equation 20. The orifice diameter is then determined from the required orifice area (Equation 21). When sizing the orifice, a minimum orifice diameter of 10 mm is required.

$$A_{(orifice)} = \frac{Q}{\mu \times (2g \times h_{hy})^{0.5}} \quad \text{Equation 19}$$

$$h_{(hy)} = \frac{d_{(det)}}{2} \quad \text{Equation 20}$$

$$D_{(orifice)} = 2 \times \left(\frac{A_{(orifice)}}{\pi} \right)^{0.5} \quad \text{Equation 21}$$

C5.2.3.2.3 Dual purpose tank design

In situations where both retention and detention are required, the outlet/orifice locations are:

- Retention outlet: At dead storage height
- Detention orifice: At water storage height for retention.

Step 1 – Calculate the achievable runoff into rainwater tank – $V_{(tot)}$

Use 90th or 95th percentile rainfall (based on SMAF zone) and TP108 to calculate the achievable detention volume.

Step 2 - Allocate runoff volume

The runoff volume should be allocated to retention and detention volumes to meet required hydrology mitigation requirements.

For example, with a total runoff volume of 5 m³, and required retention and detention volumes of 2.5 m³ and 4.2 m³ respectively, 2.5 m³ can be used to achieve retention with the remaining 2.5 m³ used for detention. This leaves an outstanding detention volume of 1.7 m³ to be achieved by other means. Alternatively, the connected impervious area can be increased to achieve a greater runoff capture volume.

Step 3 – Calculate tank diameter - $D_{(tank)}$

The tank diameter, $D_{(tank)}$, can be determined either:

- By the tank dimensions, or
- By the ground area.

It is important to note that these calculations are based on a cylindrical tank. The tank base area ($A_{(tank)}$) can then be calculated with Equation 16.

Step 4 – Calculate orifice height – $d_{(orifice)}$

The detention orifice is situated above the water storage height for retention. This height can be calculated using the tank base area ($A_{(tank)}$).

$$d_{(ret)} = \frac{V_{(ret)}}{A_{(tank)}} \quad \text{Equation 22}$$

$$d_{(orifice)} = d_{(ret)} + d_{(ds)} \quad \text{Equation 23}$$

As a general guideline, all tanks should have a 150 mm depth for dead storage ($d_{(ds)}$).

Step 5 - Calculate detention storage height – $d_{(det)}$

$$d_{(det)} = \frac{V_{(det)}}{A_{(tank)}} \quad \text{Equation 24}$$

Step 6 – Calculate orifice diameter - $D_{(orifice)}$

The allocated detention volume should be released over 24 hours. This will provide a discharge rate as:

$$Q_{(avg)} = \frac{V_{(det)}}{86400 \text{ s}} \quad \text{Equation 25}$$

Using the average discharge rate and the tank height, the area of the orifice ($A_{(orifice)}$) can be calculated as (Equation 26), with hydraulic head ($h_{(hy)}$) calculated using Equation 27. The orifice diameter is then determined from the required orifice area (Equation 28).

$$A_{(orifice)} = \frac{Q}{\mu \times (2g \times h_{hy})^{0.5}} \quad \text{Equation 26}$$

$$h_{(hy)} = \frac{d_{(det)}}{2} \quad \text{Equation 27}$$

$$D_{(orifice)} = 2 \times \left(\frac{A_{(orifice)}}{\pi} \right)^{0.5} \quad \text{Equation 28}$$

A minimum orifice diameter of 10 mm is required.

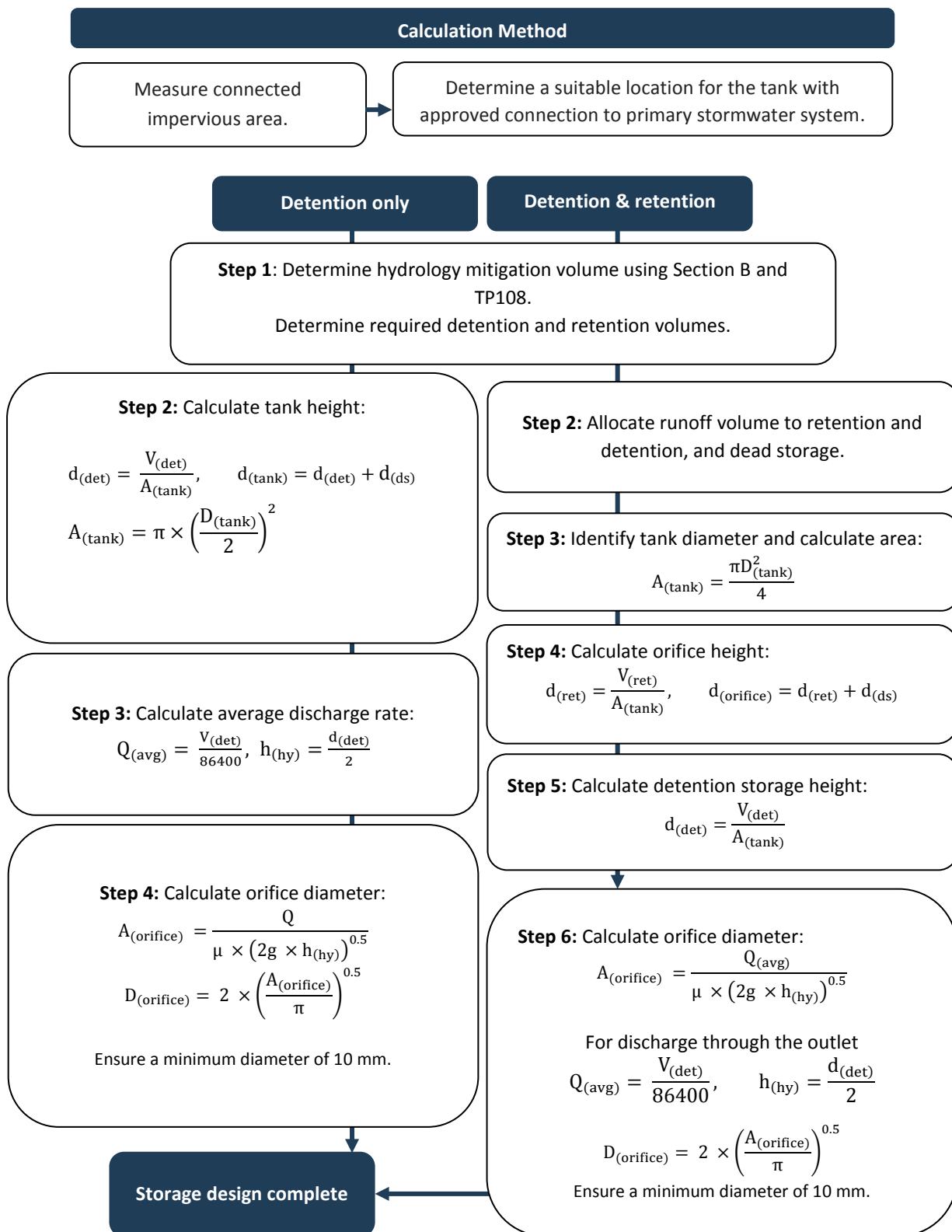

Figure 38: Flow diagram of design process using calculation method

C5.2.4 Component design

All plumbing and pipework must be installed by a registered or certified plumber or drain layer and comply with the Building Code.

C5.2.4.1 Outlet mesh screens

With a minimum detention outlet orifice size of 10 mm, there is potential for clogging; all orifices should be protected from clogging by using mesh screens (Figure 39). Designers should consider the following when choosing the mesh screen:

- The mesh opening must be substantially smaller than the outlet opening to ensure that all particles that pass through the mesh can be flushed through the outlet
- It is important to design the mesh screen large enough to ensure that the flow capacity of the mesh screen is a magnitude higher than the design outlet capacity.

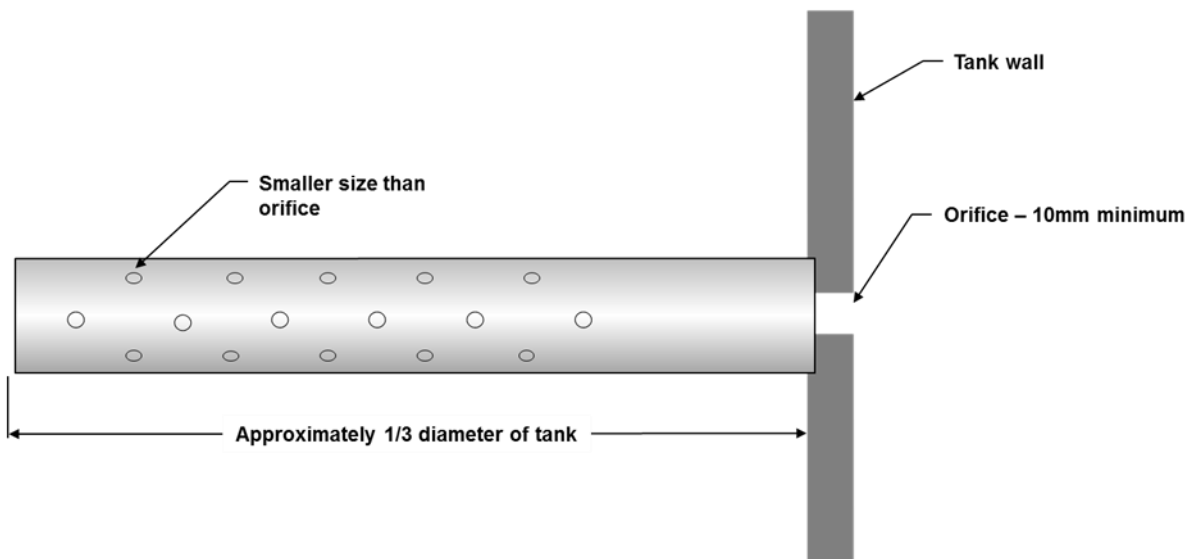

Figure 39: Outlet mesh screen

C5.2.4.2 Between the roof and tank

Additional considerations should include:

- **Plumbing pipes and fittings:** These should be light-proof to minimise daylight penetration and algal growth in the water
- **Gutter connections:** Guttering should be sized for conveyance of the design storm event. Attention needs to be paid to the potential presence of standing water and associated vectors. Fitting gutter outlets on the underside of the roof gutter is recommended to minimise sludge build-up and water retention in the gutter
- **Gutter screens:** Fitting of gutter screens is recommended to prevent a build-up of debris in the gutters

- **Litter diverters:** In-line leaf and debris diverters should be fitted to downpipes to improve water quality, reduce the risk of orifice blockage and reduce tank maintenance requirements
- **First flush diverter:** A 'first flush' device to divert the first portion of roof run-off from the rainwater tank will help to improve water quality
- **Flow diverters:** The installation of flow diverters in the downpipes is recommended to prevent dirty water from entering the tank when cleaning gutters
- **Vector screens:** Should be fitted to all tank openings
- **Sediment traps and inlet controllers:** Discharge of water into the tank in a manner which does not stir up the sediment which has collected at the bottom of the tank
- **Inlet controllers:** These control flows into the tank and reduce the risk of sediment re-suspension.

C5.2.4.3 Between the tank and building

This section applies in all instances where rainwater is collected for use in the house. All aspects of this section should be undertaken or reviewed by a certified plumber.

Considerations include:

- **Power supply**
- **Pump flow rate:** Selection of flow rate is important and differs between applications
- **Pressure:** The pressure to the most disadvantaged fixture outlet (the highest and/or farthest from the pump) needs to be calculated. The minimum pressure should not be less than 50 kPa and the maximum pressure in the system should not exceed 500 kPa
- **Constant or variable pressure:** Variable pressure systems usually work between 140-280 kPa or between 210-345 kPa and rely on a pressure vessel. This means that when a tap is turned on, water is supplied from the pressure vessel and the pump only starts when the pressure drops below 140 kPa and then shuts off again once the pressure reaches 280 kPa. This reduces the number of times the pump starts; however the pressure vessel requires periodic maintenance. Constant pressure systems rely on a special pressure control valve and every time a tap is opened and the pressure drops, the pump starts and it shuts off when the tap is closed. To work out which system is best suited to your situation, it is best to speak to a professional pump dealer
- **Type of pump:** Dry pumps are located outside the tank, while submersible pumps are located inside the tank. A number of factors should be considered including whether the tank is above or below ground, access for maintenance, noise and cost
- **Pump noise:** Minimising the noise of the pump is important. This can include installing a submersible pump, locating it as far away as possible from frequently used living spaces and neighbours, installing an acoustic enclosure or fencing (while still allowing access and ventilation)
- **Water supply outlet:** it is recommended that the water supply outlet be located at least 150 mm above the bottom of the tank to allow for silt build-up in the tank. The outlet can be fitted with a floating inlet that floats 50 mm below the surface of the water in the tank. If a submersible pump is used, then a water supply outlet is not required to be fitted to the tank

- **Filtration:** The need for filters will depend on the use of the harvested rainwater, level of contamination on the roof, other interventions employed and sensitivity of the fixtures. Filtration (together with regular maintenance) is recommended if the water is to be used for potable purposes. They should be easily accessible and well labelled, with spare cartridges available
- **Signage:** Certain signage may be required (for instance, where water is not suitable for drinking, where a backflow device is installed, and where a filter is installed).

C5.2.4.4 Plumbing and pipework between the tank and outfall

This includes the pipework, overflow and orifice outlets which facilitate the flow of water from the tank to the stormwater outfall. Dual-purpose rainwater tanks and detention tanks have both overflows and small diameter orifices, whereas water supply and single-purpose rainwater tanks only have overflows.

Design considerations for the pipework between the tank and stormwater outfall include:

- All plumbing and pipework must be installed by a registered drain layer. This work requires a building consent
- Rainwater discharged from the tank via the overflow and/or orifices must be directed to an approved local stormwater collection system
- Locate the top overflow pipe to maximise the tank's volume
- Install inspection caps on small-diameter orifice discharge pipes to allow for inspection and cleaning
- Prevent backflow into the tank from the stormwater system. This is especially important for below-ground tanks
- Provide vector screens on overflow where appropriate
- Provide erosion control for any areas where water will discharge from the tank and pipework system.

C5.2.5 Construction design considerations

The following construction considerations should be addressed during design and specification:

- The tank should be durable, watertight, opaque with a clean, smooth exterior with a tight fitting top
- The tank should be installed in a way that protects existing infrastructure
- The tank should be installed in a way that protects existing soils and vegetation, including:
 - The drip line of surrounding trees
 - Ensuring soil stability is not changed through construction works
- Installation must comply with regulated setbacks from buildings, structures and boundaries
- Care should be taken to ensure the tank retains imperviousness during installation
- The edges of the orifice should be strengthened to prevent fraying.

C5.2.6 Operation and maintenance design considerations

The following operation and maintenance considerations should be addressed during design and specification. It is essential that appropriate access is provided to all components of the rainwater tank system to enable regular inspection and maintenance (at least annually) to be carried out with the minimum of effort. Regular maintenance is essential to ensure on-going, trouble-free operation of the system and to ensure good water quality.

These considerations include:

- Providing inspection points and access to:
 - All below-ground components, including wet-system pipes
 - Any float valve for the backup water supply so that any overflows are visible and failure of the valve can be easily detected
 - The small diameter orifice, so that it can be inspected and cleaned even when the tank is full.
- Providing easy access to:
 - The tank (and ensuring the tank is secure from unauthorised access)
 - Pre-screening devices (e.g. gutters screens, in-line leaf and debris diverters, first flush diverters and sediment traps etc.)
 - The pump with sufficient room to enable the pump to be removed and replaced
 - Any backflow devices
 - In-line filters.
- Providing easy-to-follow instructions close to the pump which explain the step-by-step procedure required for pump priming (where required).

C5.3 Design examples

C5.3.1 Large rainwater tank to meet SMAF 1 criteria – calculation method

A large community hall is required to meet SMAF2 hydrology management criteria. Both retention and detention requirements will be met with a rainwater tank. The total connected impervious area is 80% of the 800 m² roof area (the other 20% is mitigated through other means).

Step 1 – Determine hydrology management requirements

Using the method described in Section B and TP108 methods, the following volumes are calculated:

Parameter		Value	Unit
Post- pre-runoff volume	(V _{total})	14.7	m ³
Retention volume	(V _{ret})	3.2	m ³
Detention volume	(V _{det})	11.5	m ³

The difference in pre- and post-runoff volumes is **14.7 m³**. This volume should be entirely mitigated through retention (3.2 m³ to be used on-site over 72 hours) and detention (11.5 m³ over 24 hours).

Step 2 – Determine tank dimensions

The total tank volume should be at least **14,700 L**. The next larger available tank size is 15 m³ or 15,000 L. The diameter of the tank is 3.5 m (D_(tank)), with height (d_(tank)) is 2.0 m.

The tank area (A_{tank}) = $\frac{1}{4} \pi D^2 = 9.6 \text{m}^2$

Step 3 – Determine detention orifice height

The retention orifice is pre-installed at 150 mm for dead storage (d_(ds)). The detention orifice height should be calculated as shown:

Parameter	Calculation or selection method	Value	Unit
Detention orifice height	$d_{(\text{orifice})} = \frac{V_{(\text{ret})}}{A_{(\text{tank})}} + d_{(\text{ds})} = \frac{3.2}{9.6} + 0.15$	0.483	m

Step 4 - Determine detention orifice size

The orifice should be designed to release the detention volume over a 24-hour period. From the calculations below, the orifice size is 8.8 mm; this is less than the 10 mm minimum orifice diameter. Therefore, an orifice diameter of 10 mm should be used.

Parameter	Calculation or selection method	Value	Unit
Average discharge rate	$Q_{(avg)} = \frac{V_{(det)}}{24 \times 60 \times 60} = \frac{11.5 \text{ m}^3}{86400 \text{ s}}$	0.00013	m ³ /s
Head above detention orifice	$d_{(det)} = \frac{V_{(det)}}{A_{(tank)}} = \frac{11.5 \text{ m}^3}{9.6}$	1.2	m
Average hydraulic head	$h_{(hy)} = \frac{d_{(det)}}{2} = \frac{1200}{2}$	0.6	m
Orifice area	$A_{(orifice)} = \frac{Q_{(avg)}}{\mu \times (2g \times h_{(hy)})^{0.5}}$ $= \frac{0.00013 \text{ m}^3/\text{s}}{0.62 \times (2 \times 9.81 \times 0.60)^{0.5}}$	6.11×10^{-5}	m ²
Calculated orifice diameter	$D_{(orifice)} = 2 \times \left(\frac{A_{(orifice)}}{\pi}\right)^{0.5} = 2 \times \left(\frac{6.26 \times 10^{-5}}{\pi}\right)^{0.5}$	0.0088	m
Required orifice size	8.8mm < minimum orifice size 10mm, use:	10	mm

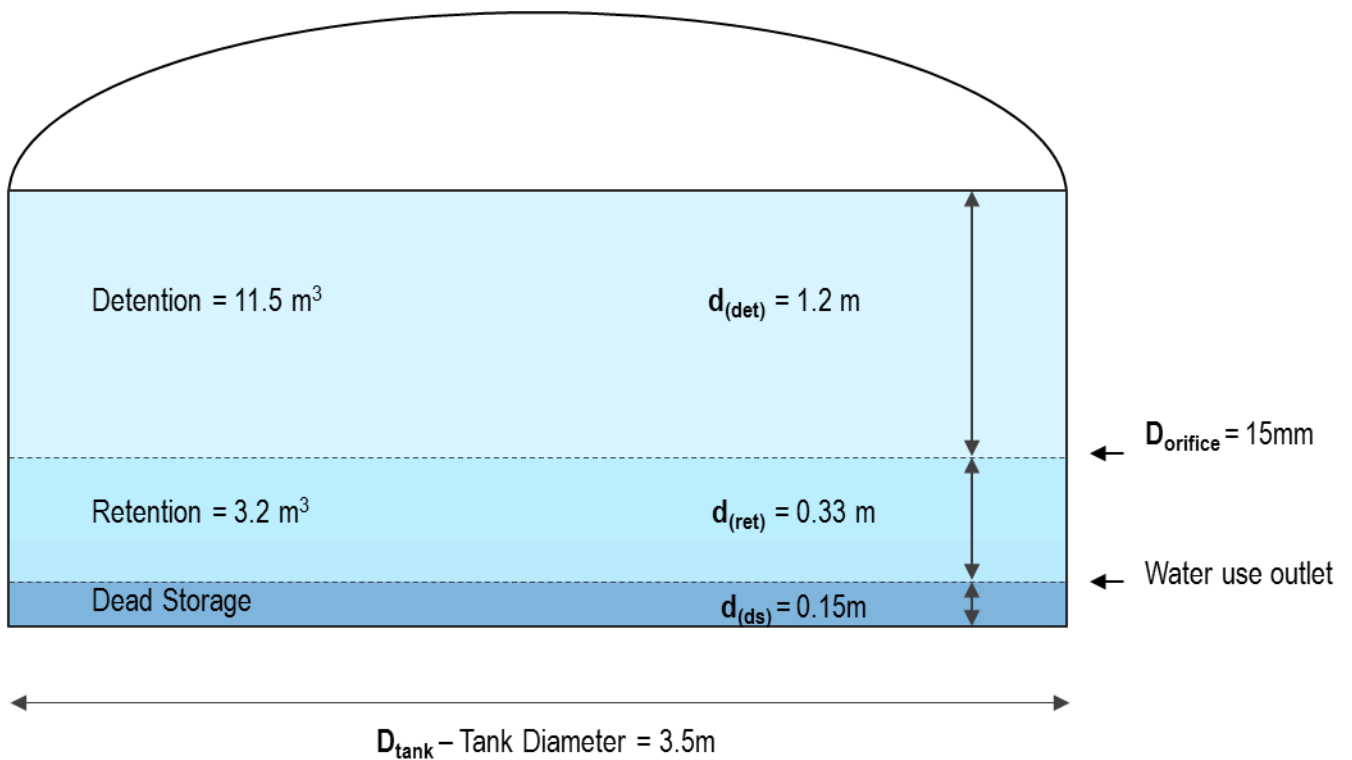

Figure 40: Rainwater tank specifications for mitigation of 800 m² roof (15000 L)

C5.3.2 Residential rainwater tank to meet SMAF 1 criteria – simplified method

A small residential development is required to meet SMAF2 hydrology management criteria. Both retention and detention requirements will be met with a rainwater tank. The total roof area is 500 m², with 80% connected to the rainwater tank.

Step 1 – Determine hydrology management requirements

Parameter	Calculation or selection method	Value	Unit
Rainfall depth		23	mm
Retention		5	mm
Detention	23 mm – 5 mm	18	mm
Roof area connected to tank (A_{connect})	$80\% \times 500 \text{ m}^2$	400	m ²

The total runoff volume was determined using Figure 33.

Step 2 – Allocate runoff volume

The total mitigation volume was then divided into retention and detention volumes:

- Detention volume: $18 \times 400 = \mathbf{7200 \text{ L}}$
- Retention volume: $5 \times 400 = \mathbf{2000 \text{ L}}$.

It should be noted these volumes are larger than those calculated using TP108, but represent a more conservative volume appropriate for a simplified method. Therefore, the total tank volume should be at least **9200 L**. Note that this roof-to-tank set-up can achieve only a maximum hydrology mitigation volume of 9200 L. Therefore, if the hydrology mitigation volume is greater than 9200 L, other devices must be used to meet the balance or, if possible, increasing the connected roof area.

Step 3 – Determine appropriate tank size

The next larger available tank size is assumed to be **10,000 L** (assume 2.5 m diameter, 2.2 m height to overflow). The tank has a dead storage of 150 mm.

Step 4 – Determine detention orifice height

Based on Figure 41, the orifice height is 400 mm above dead storage. Therefore, the detention orifice height is 550 mm.

Step 5 – Determine detention orifice size

A minimum orifice size of 10 mm is used. The final design is illustrated in Figure 41.

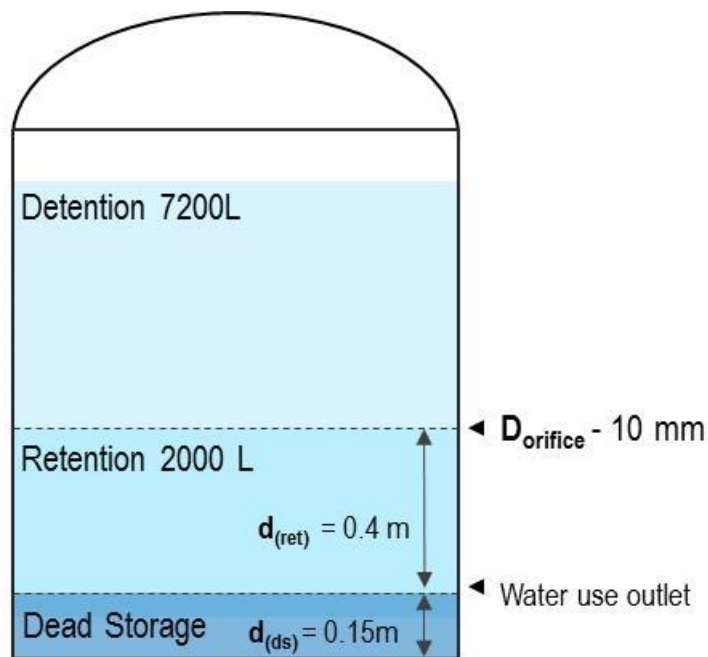

Figure 41: Rainwater tank specifications for mitigation of 500 m² roof (10000 L)



C6 Swales

Table of Contents

C6.0	Technical guidance: swales	203
C6.1	Introduction	203
C6.1.1	Use in a treatment suite	204
C6.1.2	Swale components	204
C6.1.3	Site considerations	206
C6.2	Swale design	207
C6.2.1	Design considerations	207
C6.2.2	Design for safety	209
C6.2.3	Device sizing	210
C6.2.4	Component design	218
C6.2.5	Construction design considerations	219
C6.2.6	Operation and maintenance design considerations	220
C6.3	Design examples	221
C6.3.1	Design notes	221
C6.3.2	Vegetated swale - design example	221
C6.3.3	Swale with check dams - design example	224

Figures

Figure 42:	Schematic of a typical swale cross-section	204
Figure 43:	Cross-section of trapezoidal swale design	210
Figure 44:	Swale design flow chart for water quality treatment design – no check dams	216
Figure 45:	Swale design flow chart for water quality treatment design – with check dams	217

Tables

Table 65:	Characteristics of swales and bioretention swales	203
Table 66:	Swale components	205
Table 67:	Site considerations	206
Table 68:	Swale design considerations and specifications	207
Table 69:	Suggested design iterations	209
Table 70:	Example parameters	221

C6.0 Technical guidance: swales

C6.1 Introduction

A swale (either grassed or vegetated) provides water quality treatment, primarily via interception by vegetation, as runoff flows along the surface of the swale. Swales are generally constructed using *in situ* topsoils, rather than engineered media. As such, whilst they may provide limited infiltration of runoff, they are not primarily designed for this purpose. Any underdrain serves to de-water the swale between events, so that soils can dry out completely.

1% AEP detention	✗
50% and 10% AEP detention	✗
Detention (SMAF)	✗
Retention	✗
Water quality	✓

In contrast, bioretention swales are constructed using engineered bioretention media in order to maximise retention (Table 65). Bioretention swales are primarily designed to provide retention (through infiltration) and detention of flows (via the underdrain). Only flows in excess of the infiltration capacity are conveyed along the surface of the swale. Bioretention swales therefore perform a hydrological function (i.e. retention and detention of flows), as well as a water quality function.

This section does not include bioretention swales. Further information regarding bioretention swales (which provide a bioretention function using engineered media) is provided in Section C3: Bioretention.

Table 65: Characteristics of swales and bioretention swales

	Swale	Bioretention swale (refer to Section C3)
Function	<ul style="list-style-type: none"> Water quality Some retention and detention 	<ul style="list-style-type: none"> Water quality Maximised retention and detention
Planting media	<ul style="list-style-type: none"> Topsoil 	<ul style="list-style-type: none"> Engineered media ($k > 50$ mm/hr)
Vegetation	<ul style="list-style-type: none"> Grassed or vegetated 	<ul style="list-style-type: none"> Vegetated
Underdrain	<ul style="list-style-type: none"> Sometimes, for the purposes of dewatering the swale in between events 	<ul style="list-style-type: none"> Always, for the purposes of conveying treated flows in excess of the storage layer's retention capacity

C6.1.1 Use in a treatment suite

Swales are used for stormwater conveyance, primarily as roadside drains in areas without kerbs and channels. Additional benefits include:

- A reduction of a range of stormwater contaminants through sedimentation, physical filtration and biofiltration
- Some reduction in peak flow rates where check dams are included
- Recharge of groundwater, if the swale is unlined.

C6.1.2 Swale components

The general components in a swale design are illustrated in Figure 42 and detailed in Table 66.

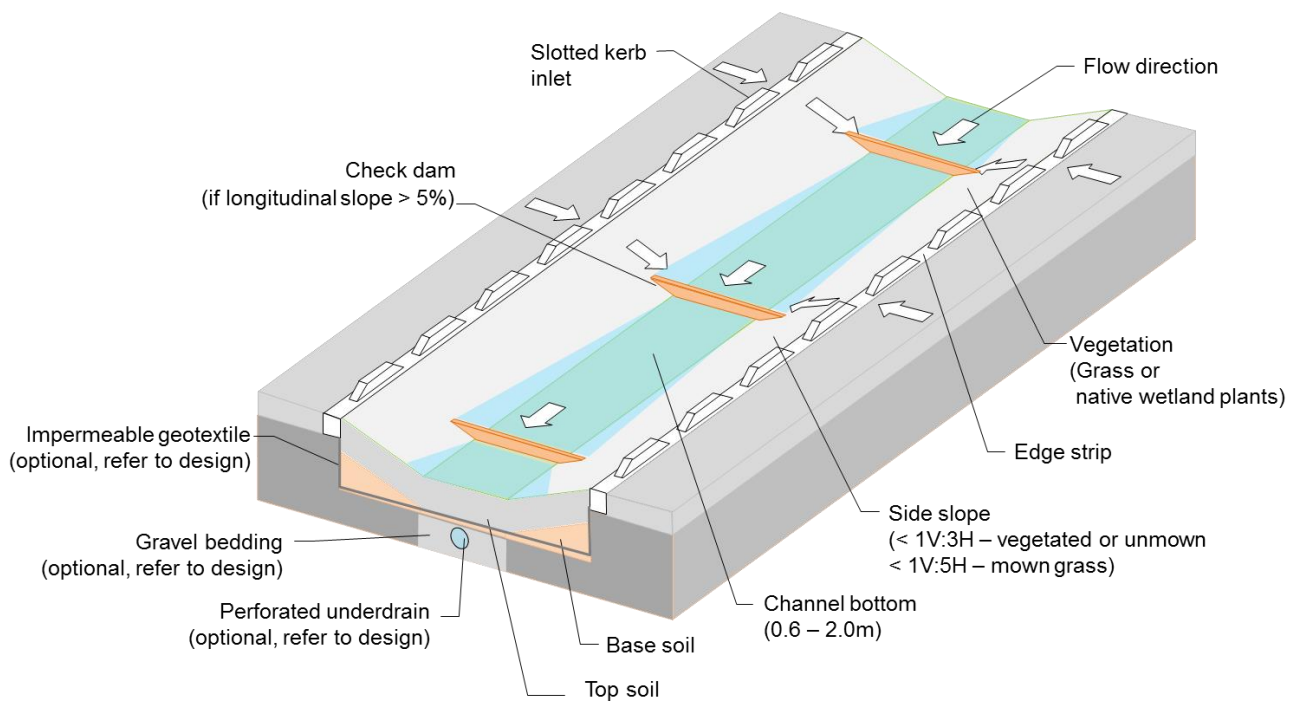

Figure 42: Schematic of a typical swale cross-section

Table 66: Swale components

Component	Description
Inflow points	<ul style="list-style-type: none"> • Where the stormwater enters the swale (e.g. stormwater pipe outlet, or surface runoff from surrounding car parks or open space). • A slotted kerb is commonly used – care should be taken to ensure that sheet flow from the catchment is directed to the swale through the inflow points. • A common failing of swales occurs when a slotted kerb fails to direct flow. In-flow points include edge beams (such as level spreaders) with, or without, wheel stops.
Side slopes	<ul style="list-style-type: none"> • Defines the channel through which the stormwater flows and can allow water to enter the swale as sheet flow (see Figure 42).
Swale length	<ul style="list-style-type: none"> • Important for ensuring >9 min hydraulic residence time (for water quality).
Geotextile	<ul style="list-style-type: none"> • Geotextile is placed between layers to prevent the movement of fine sediment between the layers and aid filtration, and provide additional tensile strength.
Topsoil	<ul style="list-style-type: none"> • Soil which acts as the media for vegetation. Should remain permeable and be resistant to erosion.
Gravel bedding	<ul style="list-style-type: none"> • This layer provides a stable platform on which to construct the swale. This is a high permeability washed aggregate varying in size depending on the design.
Vegetation	<ul style="list-style-type: none"> • All swales are vegetated with plants and/or grasses – further information regarding vegetation is provided in Section C1: Plants and soils.
Channel bottom	<ul style="list-style-type: none"> • Flow is predominantly at the base of the channel (recommended minimum 600 mm width for grass swales) which is sometimes reinforced with gravel or riprap (for conveyance swales or where erosion may be expected).
Underdrain (not always present)	<ul style="list-style-type: none"> • Underdrains are buried under the swale channel to capture filtered stormwater runoff (usually a perforated pipe) and connect directly to the catch pit or stormwater manhole.
Outlet	<ul style="list-style-type: none"> • Exit for filtered stormwater to either the conveyance system or receiving environment. • For swales, outlets are usually a catch pit with a flat grate or a 'scruffy dome'.
Design enhancements (check dams, spreaders etc.)	<ul style="list-style-type: none"> • Design enhancements, such as check dams and spreaders, slow water flow to allow runoff to filter through vegetation and soil and / or spread the flow of water evenly across the width of the channel.

C6.1.3 Site considerations

Swales and filter strips usually follow site contours and are often located on property boundaries or next to hard surfaces (car parks, driveways etc.) or in place of roadside kerb and channel drainage. Swales and filter strips may also be components of a treatment suite where they are just one part of a larger stormwater treatment system as they can provide conveyance to larger detention devices, whilst also providing water quality treatment. Some site constraints and considerations are presented in Table 67.

Table 67: Site considerations

Item	Description
Catchment size and location	<ul style="list-style-type: none"> Swales are suitable for small/medium sized catchments.
Groundwater	<ul style="list-style-type: none"> The swale base should be more than 1 m above the seasonal (winter) high groundwater level. If this is not possible, an impervious liner must be used.
Slope	<ul style="list-style-type: none"> Swales are not suitable on slopes greater than 8%. Slopes of 5-8% (3-5°) require check dams. Swales on slopes less than 2% (1°) require an underdrain.
Subsoils	<ul style="list-style-type: none"> The base soil (as characterised in Section C1: Plants and soils) must be of sufficient strength and durability so as not to degrade with the wetting and drying action over the life of the device. Compaction must be avoided so that the soils remain permeable. Where subsoils have limited permeability, need perforated underdrain at the base to drain the design volume within 24 hours. Drains via gravity to the public network.
Soils requiring structural support (geotextiles, impermeable layers, liners)	<ul style="list-style-type: none"> In retention systems requiring structural support, the sides and base of the swale should be lined with a permeable geotextile liner.
Soils with poor drainage	<ul style="list-style-type: none"> Impermeable liners or underdrains should be used on the base of swales to prevent infiltration to adjacent soils.
Pre-treatment	<ul style="list-style-type: none"> Swales should be protected from high sediment loads with pre-treatment. Dense planting and level spreaders can reduce sediment load.
Private connection	<ul style="list-style-type: none"> Private devices must be designed to ensure infiltration can drain via gravity to the public system or the receiving environment via an approved outfall.
Contaminated land	<ul style="list-style-type: none"> Swales must be fully lined with impervious layer if contaminated land present.
Setback	<ul style="list-style-type: none"> Swales >1 m from a property boundary should have a lined vertical surface if within 5 m of structures. Swales should not be placed within 3 m of a structure.
Traffic	<ul style="list-style-type: none"> Swale placement should be considered based on adjacent traffic – particularly where soils could potentially be compacted. Planted swales should not encroach on traffic or pedestrian areas.

C6.2 Swale design

The recommended design process is presented in this section. A swale is generally considered for water quality treatment (as required in high contaminant generating areas, such as roads and car parks), as opposed to a piped reticulation system. As such, design specifications are not provided in this guidance for detention.

C6.2.1 Design considerations

The hydraulic residence time (HRT) means water is retained in the swale for an average of at least nine minutes in order to achieve the water quality flow (WQF) (calculated using the rational method). All swale designs should meet this key objective. Other key design considerations are provided in Table 68. As swale design is an iterative process, designers may need to test varying values for different design elements to meet the nine-minute HRT requirement.

Table 68: Swale design considerations and specifications

Item	Abbreviation	Description
Water quality flow	$Q_{(WQ)}$	<ul style="list-style-type: none"> Runoff from the water quality storm calculated using the rational method, using only impervious area, peak rainfall rate of 10 mm/hr and a coefficient of 0.95.
10% Annual Exceedance Probability (AEP) storm runoff	$Q_{(10\%)}$	<ul style="list-style-type: none"> Runoff from the 10% AEP storm calculated using the rational method, using both pervious (using a coefficient of 0.5) and impervious area (using a coefficient of 0.95), the peak 10-minute rainfall rate. Freeboard should be designed for on a case-by-case basis; for instance, freeboard may not be required where the swale is located within the designated overland flow path. This is to be calculated from the free-water surface where flow passes over check dams.
Longitudinal slope	i	<ul style="list-style-type: none"> 1.5–3% is ideal, but up to 8% possible. Swales must not be used on slopes >8%. If the slope is 0 - <2%, an underdrain is required. If the slope is 2 - 5%, then neither underdrains or check dams are required, but check dams can be included if HRT is not met. If slope is >5% but <8%, then check dams should be included.
Average hydraulic residence time	HRT	<ul style="list-style-type: none"> 9 minutes or longer. Best design practice is to minimise high contaminant loading within the final third of swale length, given that HRT and water quality treatment in the final portion may not be attained.

Item	Abbreviation	Description
Water quality storm	Velocity $V_{(WQ)}$	<ul style="list-style-type: none"> Less than 0.8 m/s or velocity required to meet HRT and to avoid resuspension of trapped sediment.
	Flow depth $D_{(WQ)}$	<ul style="list-style-type: none"> 100 mm maximum design height for grassed swales and 300 mm for vegetated swales.
	Manning's roughness n	<ul style="list-style-type: none"> As detailed in Section C6.2.3.2, otherwise use the recommended value of 0.25.
10% AEP max	Velocity $V_{(10\%)}$	<ul style="list-style-type: none"> Less than 1.5 m/s.
	Depth $D_{(10\%)}$	<ul style="list-style-type: none"> 150 mm below top of swale (only required if not part of overland flow path).
10% AEP event	Manning's roughness $n_{(10\%)}$	<p>Recommended values:</p> <ul style="list-style-type: none"> 0.03 grassed swale 0.25 vegetated swale.
Design vegetation height	$h_{(veg)}$	<ul style="list-style-type: none"> 150 mm for a grassed swale. Swales should be designed for minimal, or no, mowing. Variable vegetation heights are permitted in a planted swale.
Vegetation type		<p>Grassed:</p> <ul style="list-style-type: none"> Meadow grasses for unmown swales are preferred Fescue and rye for grass swales which may be mown. <p>Planted swales may have various types of vegetation (refer to Section C1: Plants and soils).</p>
Length	l	<ul style="list-style-type: none"> >30 m. Where a swale is interrupted by vehicle crossings or other impervious areas with lower Manning's roughness, the length of the interruption should be deducted from the total length to calculate the residence time.
Base width	b	<ul style="list-style-type: none"> 0.6 - 2 m. Base width should not be reduced below 0.6 m to avoid forming preferential flow path erosion. With V-channel, erosion can produce loss of vegetation and an incised channel quite quickly, negating treatment benefit.
Side slopes		<ul style="list-style-type: none"> Planted: Minimum: 1V:3H to maximum: 1V:5H. Grassed: Minimum slope of 1V:5H if mowing is required.
Check dams		<ul style="list-style-type: none"> Required when longitudinal slope >5% to reduce flow velocities. Max height equal to WQF design depth (recommended 100 mm min. for grassed swales).
Level spreaders		<ul style="list-style-type: none"> It is good practice to allow sheet flow as far as practicable in swale designs.

Item	Abbreviation	Description
Underdrains		<ul style="list-style-type: none"> • Required when grassed swale slope <2 %, optional in other instances. • Access must be provided for backwashing slotted drains.
Gravel bedding		<ul style="list-style-type: none"> • Fine gravel (~5 mm) is generally preferred to improve permeability and reduce the risk of clogging.
Geotextile		<ul style="list-style-type: none"> • Geotextile must be secured at edges of paving area and all joins overlapped. • Geotextiles should be designed to reduce clogging and potential lift (as a result of high groundwater). • In retention systems, the sides and base of the swale should be lined with a permeable geotextile liner to prevent the migration of media into the base course.

Best professional judgment should be used to adjust inputs to achieve specific flow rates, velocities and HRT. Table 69 has been included to provide general design iteration suggestions.

Table 69: Suggested design iterations

Design check	Suggested changes to design inputs
Velocity through swale is greater than 1.5 m/s (for 10% AEP) or 0.8 m/s (for WQF).	<ul style="list-style-type: none"> • Decrease actual longitudinal slope. • Include check dams into design. • Increase cross-sectional area. • Decrease catchment area draining to the swale.
Is the HRT less than 9 minutes?	<ul style="list-style-type: none"> • Decrease velocity (as per above). • Increase actual swale length. • Increase effective swale length by diverting higher proportion of flows to the head of the swale.

C6.2.2 Design for safety

Some considerations for safe design of swales include:

- Minimising the need for maintenance (e.g. mowing)
- Ensuring structures (such as check dams) do not cause tripping hazards and that swales also allow for safe pedestrian access
- Ensuring planting does not impinge (through growth or overhanging) on walkways or roads – this is particularly important after rainfall when some planting may droop over the edges of a device
- Ensuring that space for maintenance access is provided for
- Think about local land use and any particular vulnerability (e.g. narrow roads, access by children etc.).

C6.2.3 Device sizing

C6.2.3.1 Cross-sectional geometry

Trapezoidal channels are the most common design, and are also considered to generally represent the performance of parabolic swales. Therefore, it is recommended that all swales are designed assuming a trapezoidal cross-section (Figure 43) with the equation for cross-sectional area (Equation 29), and hydraulic radius (Equation 30) as follows:

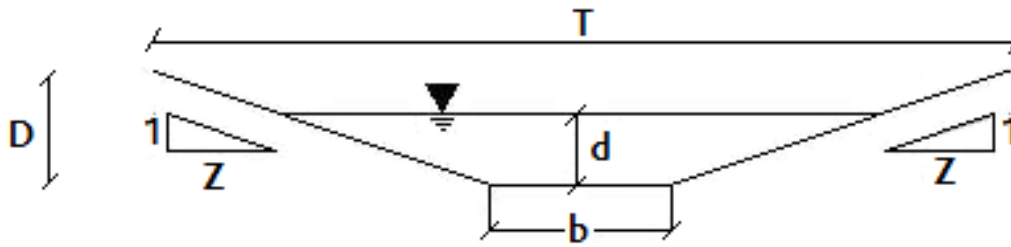

- D = total swale depth (m)
- T = swale width (m)
- d(w₀) = water depth (m)
- b = base width (m)
- z = side slopes (1V: zH)

Figure 43: Cross-section of trapezoidal swale design

$$A_{(cross)} = bd + zd^2 \tag{Equation 29}$$

- Where:
- A_(cross) - Cross-sectional area of channel (m²)
 - b - Base width of channel (m)
 - d - Water depth (m)
 - z - Side slope (1V:zH)

$$R_{(hy)} = \frac{A_{(cross)}}{\text{wetted perimeter}} \rightarrow \frac{A_{(cross)}}{(b + 2d\sqrt{z^2 + 1})} \tag{Equation 30}$$

- Where:
- R_(hy) - Hydraulic radius of channel (m)
 - A_(cross) - Cross-sectional area of channel (m²)
 - b - Base width of channel (m)
 - d - Water depth (m)
 - z - Side slope (1V: zH)

The geometry of the swale is primarily determined by maintenance needs, as the side slopes need to be gentle enough and the bases wide enough, to allow full access for safe mowing. Recommended side slopes and base widths are detailed in Table 68. Swale side slopes should be no steeper than 1V:5H if mowing is required or flatter (where space allows). However, steeper slope designs can be considered where space is constrained and no mowing is needed, assuming the design remains safe for owners, maintenance staff and users.

C6.2.3.2 Manning's equation

Manning's equation is generally used in swale design guidelines to estimate the flow characteristics in the swale (without check dams) during the design storm event. Refer to Section C6.2.3.6 if check dams are required. The equation is used in an iterative process to produce a swale design with characteristics such as length, longitudinal slope, geometry, grass length, flow depth and HRT within a given range.

Manning's equation is an empirical equation that predicts the velocity of water flowing through an open channel based on the physical characteristics of the channel and is represented by Equation 31:

$$v = \frac{1}{n} R_{(hy)}^{0.67} i^{0.5} \quad \text{Equation 31}$$

Where:	v	-	Flow velocity in the channel (m/s)
	n	-	Manning's roughness coefficient
	R _(hy)	-	Hydraulic radius (m)
	i	-	Channel slope (m/m)

The channel flow rate can then be estimated using the following equation (and using the iteration process described in Section C6.2.3.3):

$$Q = vA_{(cross)} \quad \text{Equation 32}$$

Where:	Q	-	Flow rate in the channel (m ³ /s)
	v	-	Flow velocity in the channel (m/s)
	A _(cross)	-	Cross-sectional area of the channel (m ²)

The key variable in the equation is the Manning's roughness 'n', which in this case is used as a measure of the surface roughness provided by the vegetation in the swale. Manning's roughness will vary across different flow conditions. The following roughness coefficients (n) should be used:

Water quality storm Manning's roughness	Recommended value: 0.25
10% AEP event Manning's roughness	Recommended value: 0.03 grassed swale Recommended value: 0.25 vegetated swale

The influence of Manning's roughness means that vegetated swales may be less appropriate in large catchments due to limited capacity to convey the 10% AEP design storm. Design strategies to enable conveyance of the 10% AEP event include using a grassed swale to reduce the Manning's roughness during the 10% AEP event, or reducing contributing catchment size.

C6.2.3.3 Base width and water depth

Given a base width, the swale water depth is found through an iterative process. For ease and efficiency, a computational solver is recommended for the iterative process.

Alternatively, a water depth can be used to estimate the required swale base width that will allow for the water quality flow ($Q_{(WQ)}$). This process provides a close approximation and may not provide a swale that can support WQF runoff (Equation 33). As an initial starting point for the iteration, use Equation 33:

$$b = \frac{Q_{(WQ)} \times n}{d^{1.67} i^{0.5}} - zd \quad \text{Equation 33}$$

Additionally, the swale must be designed for conveyance of the 10% AEP rainfall event. Swale specifications are used in the equation below to predict the flow capacity of the swale. All swale specifications will remain constant from the WQF example, with the exception of flow depth and the roughness coefficient. Increased runoff from the 10% AEP event will result in higher and faster flows through the swale. Equation 34 can be iteratively used with the swale dimensions, changing depth to achieve the required flow.

$$Q_{(10\%)} = \frac{1}{n} \times R_{(hy)}^{0.67} \times i^{0.5} \times A_{(cross)} \quad \text{Equation 34}$$

C6.2.3.4 Hydraulic residence time

The minimum average HRT is nine minutes, with the flow conditions within the swale being estimated using Manning's equation. HRT is used as an indicator of the amount of deposition that will occur over the length of the swale. It is important to take into consideration the reduced treatment efficacy of the final flow length of the swale; high contaminant sources should not flow into the final third of the swale.

The HRT of a swale can be calculated using the Equation 35:

$$HRT = \frac{l}{60v} \quad \text{Equation 35}$$

Where:

HRT	-	Hydraulic residence time (min)
l	-	Swale length (m)
v	-	Flow velocity (m/s)

If check dams are required in the design, then the HRT is influenced by the total storage capacity behind the check dams. The combined volume of ponding by all check dams within the effective length of the swale should be calculated using Equation 36.

$$HRT = \frac{Volume}{Flow Rate} = \frac{V}{Q} \quad \text{Equation 36}$$

C6.2.3.5 Effective swale length

Where a swale has more than one inlet, the average HRT for the entire swale must be a minimum of nine minutes or longer. It is recommended that concentrated flows of contaminants should not enter the final third of the swale as this reduces the effectiveness of the water quality treatment. The average HRT for multiple inlets can be estimated using the effective swale length calculation (Equation 37):

$$l_{(eff)} = \frac{l_1 Q_1 + l_2 Q_2 + l_n Q_n}{Q_{(total)}} \quad \text{Equation 37}$$

Where:

- $l_{(eff)}$ - Effective swale length (m)
- l_n - Length of swale from inlet n to end of swale (m)
- Q_n - Design flow rate into swale from inlet n (m³/s)
- $Q_{(total)}$ - Total flow rate into swale from all inlets (m³/s)

Where a continuous lateral inflow occurs, the length to the end of the swale is taken from the midpoint of the length of lateral contribution (i.e. if a swale is 100 m long and there is lateral inflow throughout then the effective length is 50 m).

C6.2.3.6 Check dams

Check dams are required where the longitudinal slope of the swale exceeds 5% and are used to reduce the flow velocity within the swale and meet design criteria. Equation 38 has been developed to determine the spacing between check dams within a swale, using the crest-to-toe approach:

$$l_{(cd)} = \frac{h_{(cd)}}{i} \quad \text{Equation 38}$$

Where:

- $l_{(cd)}$ - Length between the check dams (m)
- $h_{(cd)}$ - Height of the check dams (m)
- i - Longitudinal slope (%)

Equation 39 can be used to calculate the number of check dams required in the swale:

$$N_{(cd)} = \frac{l}{l_{(cd)}} \quad \text{Equation 39}$$

Where:

- $N_{(cd)}$ - Number of check dams
- l - Total length of the swale (m)

Where check dams are used, designers need to review what the depth of flow over the check dams will be to ensure that minimum freeboard provisions (based on the design storm event and a recommended minimum of 100 mm) are maintained along the full length of the swale. The depth of flow over a check dam can be estimated using Equation 41, which is based on the broad crested weir equation (Equation 40).

$$Q = 1.7 \times d_{(cd)}^{\frac{3}{2}} \times (\text{Top Width}) \rightarrow 1.7 \times d_{(cd)}^{\frac{3}{2}} \times (b + 2zh_{(cd)}) \quad \text{Equation 40}$$

$$\therefore d_{(cd)} = \left(\frac{Q}{1.7(b + 2zh_{(cd)})} \right)^{\frac{2}{3}} \quad \text{Equation 41}$$

Where:	$d_{(cd)}$	-	Depth of flow over a check dam (m)
	Q	-	Peak flow rate during 10% AEP event (m ³ /s)
	b	-	Base width (m)
	z	-	Side slopes (1V: zH)
	$h_{(cd)}$	-	Height of the check dams (m)

HRT along the check dam is calculated using the total volume behind the check dams. The volume can be estimated using Equation 42 and Equation 43.

$$V_{(cd)} = \left(\frac{h \times b \times \frac{h}{i}}{2} \right) \left(\frac{h^2 \times z \times \frac{h}{i}}{2} \right) N_{(cd)} \quad \text{Equation 42}$$

$$HRT = \frac{V_{(cd)}}{60Q} \quad \text{Equation 43}$$

Where	$V_{(cd)}$	-	Volume retained behind check dams in a swale (m ³)
	$h_{(cd)}$	-	Height of the check dams (m)
	$A_{(cd)}$	-	Cross-sectional area of channel at check dam height (m ²)
	i	-	Longitudinal slope (%)
	$N_{(cd)}$	-	Number of check dams within the effective length of the swale

If the system is not anticipated to backwater under design flows (i.e. $d_{(10\%)} < h_{(cd)}$), then the channel depth is equal to $h_{(cd)} + d_{(cd)} + \text{freeboard}$. If calculations demonstrate that the system may backwater (i.e. $d_{(10\%)} > h_{(cd)}$), then a conservative estimate for channel depth is assumed: $d_{(10\%)} + d_{(cd)} + \text{freeboard}$, where $d_{(10\%)}$ is determined according to Equation 34 for 10% AEP event.

Alternatively, a detailed hydraulic grade analysis is required for the 10% AEP flow capacity to analyse tail water effects and confirm freeboard is maintained along the swale length.

Where possible, allow for check dams to drain via underdrains (or another similar maintainable approach) to prevent standing water. Scour protection should consist of a riprap apron at least three times the height of the check dam in length and undercut so that the apron is flush with the surrounding grade. Riprap should be sized to withstand the design flow rate and should be provided downstream of check dams to prevent erosion (note that size and availability of riprap will vary between suppliers). Refer to Auckland Council's technical report, TR 2013/018 *Hydraulic Energy Management: Inlet and Outlet Design for Treatment Devices* for further details on sizing riprap.

Check dams should be constructed of durable, non-toxic materials such as rock, brick, concrete or from inert timber materials that do not leach contaminants. Earthen check dams are to be avoided due to erosion potential and high maintenance effort.

C6.2.3.7 Summary of swale hydraulic design process

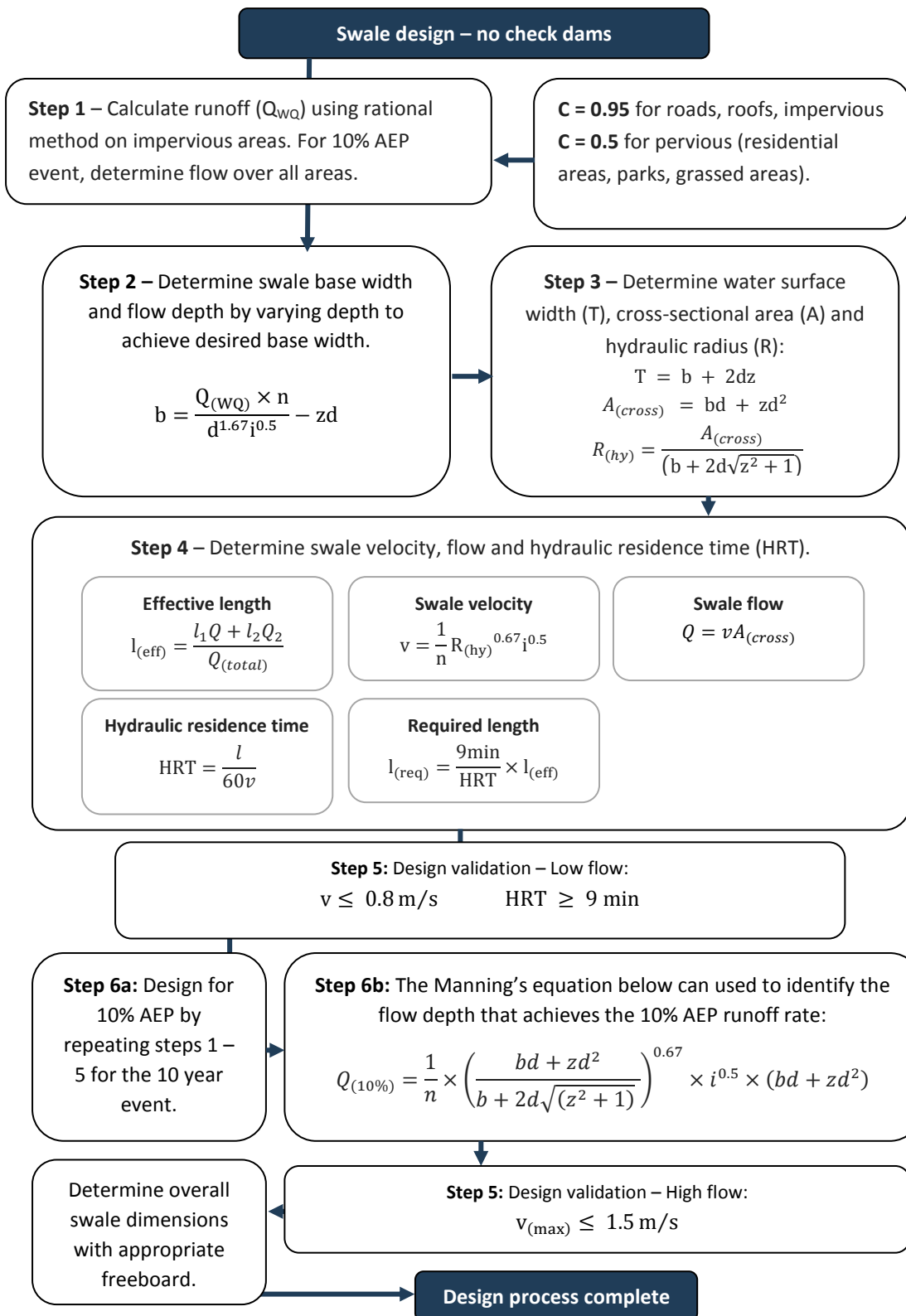

Figure 44: Swale design flow chart for water quality treatment design – no check dams

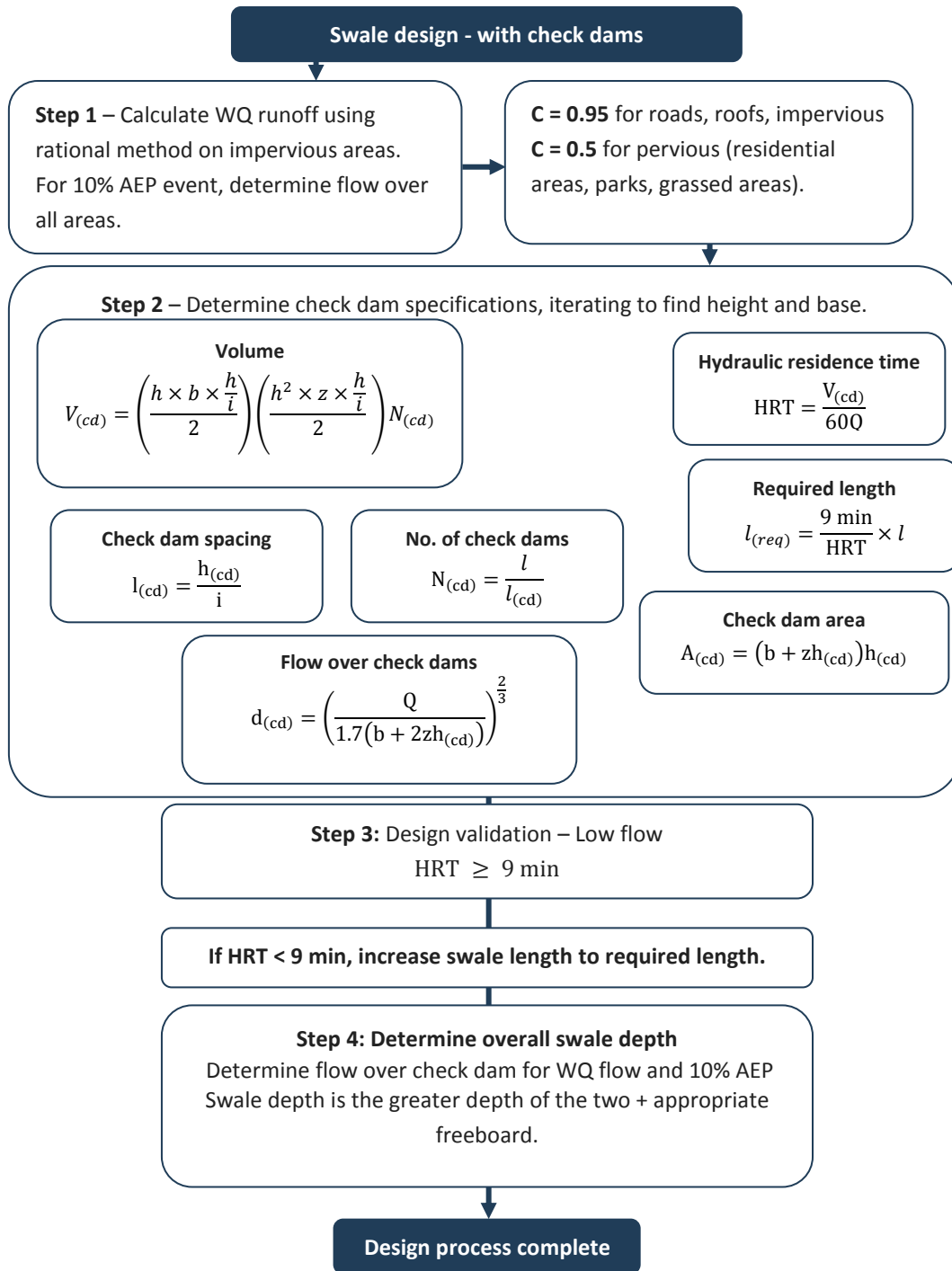

Figure 45: Swale design flow chart for water quality treatment design – with check dams

C6.2.4 Component design

C6.2.4.1 Inlet design

Swale inlets need to be suitably designed to prevent localised scour that could be caused by high inflow velocities. While lateral inflow swales generally don't require inlet protection, swales that are fed by pipes or concentrated overland flows require some manner of protection and flow distribution mechanism to mitigate the erosion potential at the inlets. The most common method used for swales is to use a riprap apron for erosion protection and/or a level spreader for flow distribution. The design of appropriate erosion protection is dependent on the flow characteristics of the incoming pipe or overland flow path (refer to Auckland Council's technical report, TR 2013/018¹, for details on erosion protection).

Swales may have multiple entry points (impacting effective length as discussed in Section C6.2.3.5), which could be either a collection of concentrated flows entering at specific inlet points, or the use of lateral entry continuously along all, or some of, the length of the swale. Where a swale has lateral entry, all, or part, of the inflow will enter along the sides of the swale, generally at an angle perpendicular to the swale centre line. These are common along roads, highways and in car parking lots where the swale is constructed along one boundary of the catchment.

C6.2.4.2 Underdrains

Where swale longitudinal slopes are below 2%, particularly in areas where local soils have poor infiltration capacity, underdrains are recommended to prevent stagnation and saturation of the swale bed. These drains should be constructed along the centreline of the swale underneath the base of the swale topsoil bed. The drains should comprise slotted drainage coil (unsleeved) within a trench of drainage aggregate, lined with a filter cloth constructed at the same grade as the swale (0.5% minimum) to reduce blockage. The sizing of the drainage trenches should be conservative to allow maximum flow with flow control achieved through outlet design. Guidance on underdrain design can be found in Auckland Council's technical report, TR 2013/018. There should also be design consideration for the "keying in" of check dams and the implications for underdrains and geotextiles.

C6.2.4.3 Outlet design

Outlet design should consider connection to the primary conveyance system or receiving environment. The most common outlet structure for a swale is a "scruffy dome". In some cases, the swale is designed to discharge into a detention pond in which case, the typical outlet structure is a culvert with wingwall or a spreader beam.

¹ Auckland Council TR 2013/018 *Hydraulic Energy Management: Inlet and Outlet Design for Treatment*.

C6.2.4.4 Vegetation

Auckland Council's preference is for planted swales, with low maintenance requirements.

- **Planted swales:** Vegetation should be selected primarily for device function, but also landscape, amenity and biodiversity objectives. Plants should provide shade and be tolerant of both drought and inundation, and not shed leaves
- **Grasses:** Vegetative cover of swales commonly consists of a dense and continuous cover of relatively long grass. Two types of grassed swales are common – regular mown grasses and unmown meadow grasses. Auckland Council's preference is for unmown swales (for optimal water quality treatment). In either case, the type of grass used for swales should be able to be maintained at a height of not less than 35 mm and typically, 150 mm. The denser the grass, the better the stormwater function of the swale. Often grass is established using straw mulch which is also used for erosion and sediment control.

Recommended plants for swales can be found in Section C1.6.3: Plants and soils (planting swales) and Section C1.6.6: Plants and soils (planting grassed devices).

C6.2.5 Construction design considerations

The following construction considerations should be addressed during design and specification.

C6.2.5.1 Soils

Swales constructed in areas with high infiltration capacity soils are able to provide improved stormwater quality and quantity benefits. Where site topsoils are of poor quality, it is recommended that the swale bed be prepared using compost-amended topsoil in order to provide an improved media to promote microbial and vegetation establishment. The following is recommended:

- The swale bed grade should be 200-300 mm below the finished level (the top of the finished swale should sit below the adjacent ground level to promote even sheet flow into the device along the perimeter)
- Compacted subsoils should be loosened by ripping to 300 mm. If uncompacted, rake the subsoil 100 mm below the grade
- A mix of 30-40% by volume of approximately 30% moisture-content compost with topsoil or imported soil for the swale bed should be used. Compost at 30% moisture content will prevent dust formation and is not too wet for mixing. Mixing can be done ahead of swale construction and stockpiled on site. Stockpiles should be covered to prevent sediment-laden runoff during rainfall events
- 300 mm of compost amended topsoil mix should be spread and allowed to settle to around 200 mm finished bed depth. This should not be compacted, but the first lift should be ripped to mix with the subsoil
- A minimum of 200 mm finished soil bed depth should be established.

The permeability of the soil must be maintained in order to maintain its functionality as a treatment device. To resist erosion, soil should be permeable and not have high clay content.

It is important to protect devices from compaction. At no stage during construction should the soil be compacted either from tracking machinery across the swale or using the area for stock-piling material.

Use erosion control fabrics or check dams while vegetation is establishing.

C6.2.5.2 Planting

All planting should be done in the season best suited to establish plants and root systems quickly. Planting should not be done in summer where watering may be required.

In some instances, straw mulching is used as an erosion and sediment control measure (refer to Auckland Council's guidance document, GD2016:005 *Erosion and Sediment Control Guide* for further details) to reduce sediment-laden run-off from the treatment device once swales are completed, but not yet vegetated. Heavy rain will remove any straw mulch that has been placed but not yet seeded. To overcome this, straw mulch should not be placed during wet months or prior to heavy rain warnings.

C6.2.5.3 Construction timing

Swales should be constructed in the final stages of a site development to avoid clogging of underdrains and damage from vehicles. Construction timing should ensure the vegetation can stabilise before being brought on-line.

C6.2.6 Operation and maintenance design considerations

The following operation and maintenance considerations should be addressed during design and specification.

- A swale should be limited to light pedestrian traffic only
- If the swale is vegetated (not grassed), the design should allow it to be inspected regularly and weeded
- If a swale is designed to be mown, there should be access so that the grass can be maintained at 100 mm high to reinforce channel stability
- Any scruffy domes or outlet grates should allow for access for mowing and litter removal needs
- Topsoils should remain permeable and be resistant to erosion and should not be compacted during maintenance activities.

For specific maintenance requirements, asset owners should have an Operation and Maintenance Plan.

C6.3 Design examples

A swale is to be constructed in a road median strip in a residential subdivision:

- The total site area is 1000 m², comprising 650 m² of impervious road and 350 m² of pervious road reserve entering the swale laterally
- The access road, as currently designed, is 100 m long, with continuous lateral inflow into a swale along the entire length. This gives an effective swale length of 50 m
- The maximum allowable velocity is 0.8 m/s for water quality flow and 1.5m/s for 10% AEP storm
- The swale runs down a slope with an approximate grade of 3%.

C6.3.1 Design notes

The design parameters for this example are provided in Table 70. A WQF of 10 mm/hr is used with swale dimensions are calculated using the rational method:

- Water quality volume of 10% AEP rainfall runoff calculated using rational method
- For WQF (10 mm/hr), only runoff from impervious areas (road) is considered. For 10% AEP, both pervious and impervious areas are considered.

Table 70: Example parameters

Design check	Velocity	Flow	Hydraulic residence time (HRT)
Without check dams	$v_{(m)} < 0.8 \text{ m/s}$ $v_{(10\%)} < 1.5 \text{ m/s}$ Use Manning's equations	Use Manning's equations	$HRT = l_{(eff)}/60v_{(m)}$ Use velocity and effective length
With check dams	N/A	Use broad-crested weir equation	$HRT = V_{(cd)}/60Q_{(WQ)}$ Use volume behind check dams within the effective length of the swale and WQF runoff

C6.3.2 Vegetated swale - design example

Step 1 – Calculate design runoff flow rate

Use the rational method to calculate runoff from design storm depth of 10 mm/hr.

$$Q_{(WQ)} = \text{Rainfall Rate} \times \text{Area} \times \text{Rational Coefficient}$$

Parameter	Calculation or selection method	Value	Unit	Ref
Runoff from impervious surfaces	$Q_{(WQ)} = \frac{(0.95)(10 \text{ mm/hr})(650 \text{ m}^2)}{3600 \frac{\text{s}}{\text{hr}} \times 1000 \frac{\text{mm}}{\text{m}}}$	0.002	m ³ /s	Q _(WQ)

Step 2 – Determine swale base width and flow depth

$$b = \frac{Q_{(WQ)} \times n}{d^{1.67} i^{0.5}} - zd$$

Using the equation above, an initial estimate of the parameters is calculated. Then through an iterative process, using the Manning equation, it is calculated that a base width of 1.1 m is required to achieve the desired flow depth of 25 mm for a vegetated swale ($n = 0.25$, $z = 3$). Alternatively, Auckland Council's has prepared an Online Calculator for Swales which gives a range of suitable base widths and corresponding flow depths.

Parameter	Value	Comment
Swale slope (i)	3%	No underdrain or check dams required
Side slope (z)	3 (1V:3H)	$z \geq 3$ for vegetated swale, $z \geq 5$ for grassed swale
Base width (b)	0.6 m	Min. 0.6 m, max 2.0 m
Water depth (d)	36.0 mm	Max depths 100 mm for WQF and 300 mm for 10% AEP
Manning's coefficient	0.25	For vegetated swales, use 0.25 for both WQ and 10% AEP

Step 3 – Determine swale velocity and swale flow

The effective swale length is 50 m.

Parameter	Calculation or selection method	Value	Unit	Ref
Swale velocity	$v_{(WQ)} = \frac{1}{n} R^{0.67} i^{0.5}$	0.1	m/s	$v_{(WQ)}$
Swale flow	$Q_{(WQ)} = v_{(WQ)} A$	0.002	m ³ /s	$Q_{(WQ)}$
Hydraulic residence time	$HRT = \frac{l_{(eff)}}{v_{(WQ)}} \div 60$	12.4	mins	HRT

Step 4 - Design Validation – Low flow

- 1) Is swale velocity ($v_{(WQ)}$) less than 0.8 m/sec? Yes. 0.01m/s.
- 2) Is swale flow ($Q_{(WQ)}$) greater than design storm flow ($Q_{(WQ)} = 0.002 \text{ m}^3/\text{s}$)? Yes. 0.002 m³/s.
- 3) Is HRT greater than 9 minutes? Yes. 12.4 min.

Based on the above equations, the proposed swale can meet HRT requirements in an effective length of 36 m.

Step 6a – Determine 10% AEP event runoff

To calculate peak flow rates during the 10% AEP event (120 mm in this case), the peak rainfall within the 24-hour event that occurs over a 10-minute period, is empirically calculated as 11.3% of the 10% AEP rainfall depth.

$$Rainfall_{24hr,10\% AEP} = 120 \text{ mm}$$

$$Rainfall_{mm/10mins} = 120 \times 11.3\% \rightarrow 13.5 \text{ mm}/10 \text{ mins}$$

$$Rainfall_{mm/hour} = 13.5 \times 6 = 81 \text{ mm}/hr$$

Parameter	Rational method runoff coefficient (C)	Value	Unit	Ref
Runoff from pervious road reserve (350 m ²)	0.5 for pervious areas	0.004	m ³ /s	Q _(WQ1, 10%)
Runoff from impervious road (650 m ²)	0.95 for impervious areas	0.014	m ³ /s	Q _(WQ2, 10%)
Total design storm peak flow		0.018	m ³ /s	Q _(R, 10%)

Step 6b – Determine 10% AEP water flow depth that achieves 10% AEP flow

An iterative process must be used to find the flow depth ($d_{(10\%yr)}$) that achieves the 10% AEP flow ($Q_{(10\%)} = 0.018 \text{ m}^3/\text{s}$). The equation below is simply the Manning's flow equation with values of depth identified.

$$Q_{(10\%)} = \frac{1}{n} \times \left(\frac{bd + zd^2}{b + 2d\sqrt{(z^2 + 1)}} \right)^{0.67} \times i^{0.5} \times (bd + zd^2)$$

- 1) Use new values of **d** and current swale specifications in the above equation
- 2) Determine depth **d** that achieves $Q_{(10\%)} = 0.018 \text{ m}^3/\text{s}$ by iterating through different values of **d**.

The purpose of this is to determine the flow depth during the 10% AEP event. This process can be quickly executed using the GD01 Online Calculator for Swales, giving a depth of **130 mm**.

Step 6c – Determine swale velocity and flow

Parameter	Calculation or selection method	Value	Unit	Ref
10% AEP swale velocity	$v_{(m-10\%)} = \frac{1}{n} R^{0.67} i^{0.5}$	0.14	m/s	V _(10%)
10% AEP swale flow	$Q_{(10\%)} = v_{(10\%)} A$	0.02	m ³ /s	Q _(10%)

Step 7 - Design validation – high flow

1) Is swale velocity (v) less than 1.5 m/sec?

Yes. 0.14 m/s.

Parameter	Value	Unit	Ref
Effective length	50	m	$l_{(eff)}$
True length	100	m	l
Base width	0.6	m	b
Side slopes (1V:zH)	3	-	z
Total swale depth (including freeboard)	279	mm	-
Total swale width (top width)	2.3	m	-
Slope	3	%	
Total footprint (2.28 m x 100 m)	228	m ²	

C6.3.3 Swale with check dams - design example

A swale is designed for site which has:

- The total site area is 1000 m² of car parking area entering the swale laterally
- The vegetated swale is limited to 50 m total length, with continuous lateral inflow along the length of the swale. ($l_{(eff)} = 25$ m)
- The swale runs down a slope with an approximate grade of 6%.

Impervious area:	1000 m ²	WQF runoff:	0.003 m ³ /s
		10% AEP runoff:	0.025 m ³ /s

Using the GD01 Online Calculator for Swales spreadsheet, the results for a swale **without** check dams are below:

Base width:	0.6 m	10% AEP flow depth:	120 mm
Hydraulic residence time (HRT)	4.2	WQF depth:	38 mm
Required effective length to achieve HRT	54 m		

Without check dams, the HRT cannot be achieved within the effective swale length of 25 m. To achieve HRT, check dams must be installed. In addition, the gradient is above >5%, therefore check dams must be used. Using check dams, a swale of the following specifications will be considered:

Base width:	0.6 m	Swale length:	50 m
Side slope	1V:3H	Effective length	25 m

Step 1 – Determine check dam specifications

Parameter	Calculation or selection method	Value	Unit	Ref
Check dam spacing	$l_{(cd)} = \frac{h_{(cd)}}{i} = \frac{0.15}{0.06}$	2.5	m	$l_{(cd)}$
No. of check dams within effective length	$N_{(cd)} = \frac{l}{l_{(cd)}} = \frac{50}{2.5}$	10		$N_{(cd)}$
Flow over check dam	$d_{(cd)} = \left(\frac{Q}{1.7(b + 2zh_{(cd)})} \right)^{\frac{2}{3}}$	10	mm	
Check dam area	$A_{(cd)} = (b + zh_{(cd)})h_{(cd)}$	0.16	m ²	
Volume behind check dams	$V_{(cd)} = \left(\frac{h \times b \times \frac{h}{i}}{2} \right) \left(\frac{h^2 \times z \times \frac{h}{i}}{2} \right) N_{(cd)}$	2.16	m ³	
Hydraulic residence time	$HRT = \frac{V_{(cd)}}{60Q}$	13	min	
Required effective length to achieve HRT	$\frac{9 \text{ min}}{25 \text{ min}} \times 50 \text{ m}$	17	m	

Step 2 – Check Design Conditions for swales with check dams

1) Is HRT greater than 9 minutes?

Yes.

The swale built with check dams has a minimum required effective length of 18 m to achieve 9 minute HRT. This is less than the minimum swale length, therefore a **30 m** swale should be used.

Parameter	Value	Unit	Ref
Swale length	30	m	l
Base width	0.6	m	b
Side slopes (1V:zH)	3	-	z
Total swale depth (including freeboard)	220	mm	-
Total swale width (top width)	1.9	m	-
Slope	6	%	
Total footprint (1.9 m x 30 m)	57	m ²	



C7 Infiltration devices

Table of Contents

C7.0	Technical guidance: infiltration devices	227
C7.1	Introduction	227
C7.1.1	Use in a treatment suite	228
C7.1.2	Infiltration device components	228
C7.1.3	Site considerations	229
C7.2	Infiltration device design	230
C7.2.1	Design considerations	230
C7.2.2	Design for safety	230
C7.2.3	Soil permeability testing	231
C7.2.4	Device sizing	231
C7.2.5	Component design	234
C7.2.6	Construction design considerations	234
C7.2.7	Operation and maintenance design considerations	234
C7.3	Design examples	235
C7.3.1	Example 1: Gravel trench for large residential roof & driveway	235
C7.3.2	Example 2: Underground infiltration chamber – 10% AEP event	237

Figures

Figure 46:	Infiltration design flow chart	233
Figure 47:	Schematic of a gravel trench	236
Figure 48:	Schematic of an underground infiltration chamber	238

Tables

Table 71:	Infiltration device components	228
Table 72:	Site considerations	229
Table 73:	Infiltration device design considerations and specifications	230
Table 74:	Residential section design example parameters	235
Table 75:	Residential section design example parameters	237

C7.0 Technical guidance: infiltration devices

C7.1 Introduction

An infiltration device allows water to infiltrate into the ground, provided that the subsoil is sufficiently permeable. The primary function of an infiltration device is to meet retention requirements through the recharge of groundwater. Infiltration devices may form part of a suite, where full mitigation is not achievable due to soil infiltration rate limits (e.g. where retention volumes can be achieved but not detention volumes).

1% AEP detention	✘
50% and 10% AEP detention	✘
Detention for stream protection	✘
Retention	✓
Water quality	✘

A wide variety of design options are available for infiltration devices which allow for multiple functions, in addition to groundwater recharge, to be added to the infiltration device. For the purposes of this section, only those devices which provide solely infiltration are considered; infiltration trenches, perforated infiltration pipes, dry wells and infiltration basins.

The focus of this section is on devices designed to fully infiltrate the design flows into the underlying subsoils and sets out minimum design performance specifications.

This section does not include soakage pits. These generally refer to high capacity systems in areas without stormwater reticulation where all runoff is discharged through soakage pits into fractured basalt or peat. These systems have performance specifications that are limited to only a few areas within the Auckland region¹.

Infiltration devices are effective in:

- Reducing the total volume of stormwater runoff
- Meeting the retention requirements in Stormwater Management Areas - Flow (SMAF areas) through groundwater recharge and maintaining base flow in streams.

The limitation of the infiltration devices include:

- Clogging: they are not appropriate for sites with high contaminant loads. If clogged, the device is difficult and costly to refurbish
- Potential impact on, and contamination of, groundwater and aquifers
- A required minimum soil infiltration rate of 10 mm/hour which makes them unsuitable for clay soils
- Unsuitability on steep slopes, or fill sites, or close to buildings and other structures.

¹ Refer to Auckland Council GeoMaps

C7.1.1 Use in a treatment suite

As part of a stormwater management suite, infiltration devices provide:

- On-site, at-source stormwater management
- Retention through infiltration
- Detention (if designed with storage capacity).

Infiltration devices are a final stormwater mitigation element, discharging runoff to groundwater. It is therefore important to provide pre-treatment and the first flush of any storm event should be diverted to a treatment system.

C7.1.2 Infiltration device components

This section provides details for the standard components for infiltration devices are presented in Table 71.

Table 71: Infiltration device components

Component	Description
Pre-treatment	<ul style="list-style-type: none"> • Pre-treatment, through a device such as a swale or filter, prevents sediment entering the infiltration device and extends the life of the device.
Storage (optional)	<ul style="list-style-type: none"> • There are many different options to provide for a detention volume within an infiltration device including within, above and below the aggregate and can include storage chambers such as crates, arches, pipes.
Aggregate	<ul style="list-style-type: none"> • Aggregate, in the form of gravel, is used to create a storage space within the device.
Geotextile layer	<ul style="list-style-type: none"> • The sides and base of the infiltration device are lined with a geotextile liner to prevent the migration of aggregate and sediments entering the base course.
Underdrains	<ul style="list-style-type: none"> • Generally, infiltration devices should not require underdrains. The infiltration rate of the underlying soils should be sufficient to infiltrate all water into the underlying soils. • If used for detention purposes, the storage capacity should be designed to accommodate for the required design storm. • It should be noted that underdrains are required where permeability of surrounding soils is too low for a full infiltration device.
Overflow	<ul style="list-style-type: none"> • Infiltration systems should be fitted with an overflow system in case a storm event exceeds the infiltration and storage capacity.
Observation well	<ul style="list-style-type: none"> • An observation well should be installed so that future inspections can determine whether the device is functioning as designed.

C7.1.3 Site considerations

Table 72 sets out the recommended site considerations for infiltration devices. In all instances, the future asset owner must be consulted to ensure that they are aware of, and are prepared to be responsible for, on-going maintenance and long-term device performance requirements.

Table 72: Site considerations

Item	Description
Catchment size and location	<ul style="list-style-type: none"> • Medium/large catchment. Middle/lower catchment locations. • Catchments draining to infiltration devices should preferably be no more than 2 ha.
Groundwater	<ul style="list-style-type: none"> • The invert of the infiltration device should be at least 2 m from the seasonal high groundwater level, or any impermeable soil layer.
Slope	<ul style="list-style-type: none"> • Infiltration devices should not be constructed on steep or unstable slopes. • Slopes must not exceed 6° (10.5%) to allow for safe maintenance access.
Subsoils	<ul style="list-style-type: none"> • Geotechnical evaluation is needed prior to choosing this device to ensure infiltration capacity of subsoils. • Infiltration must not be used where soils are susceptible to instability including expansive soils.
Soil	<ul style="list-style-type: none"> • Infiltration devices should be constructed in soils with high permeability only. They are unsuitable for use in soils with poor drainage. • Infiltration devices must not be constructed in fill material.
Aquifers	<ul style="list-style-type: none"> • The potential impact of infiltration devices on aquifers must be assessed and any risks mitigated (e.g. by providing pre-treatment). • Designs must meet setback requirements.
Contaminated land	<ul style="list-style-type: none"> • Not suitable in areas where contamination occurs, or where chemical spillage may occur.
Setback	<ul style="list-style-type: none"> • Infiltration must be located at least 3 m away from structures such as buildings, slopes, on-site wastewater systems and roads.
Traffic	<ul style="list-style-type: none"> • Infiltration devices must be located at least 3 m away from trafficked areas.

C7.2 Infiltration device design

C7.2.1 Design considerations

Table 73 provides design considerations for infiltration devices.

Table 73: Infiltration device design considerations and specifications

Item	Description
Pre-treatment	<ul style="list-style-type: none"> Pre-treatment is required to protect groundwater and for the longevity of the device. The only situation where pre-treatment is not required is when water entering the device has little, or no, contaminant load (such as roof water).
Soil	<ul style="list-style-type: none"> Soakage and soil testing is required to establish suitability of the site and determine local permeability rates. The soils must have a minimum infiltration rate of 10 mm/hr.
Aggregate	<ul style="list-style-type: none"> Clean (fines free) drainage aggregate to provide retention and detention storage comprising washed drain gravel 20 mm to 40 mm diameter, with a defined void ratio of 0.3.
Geotextile layer	<ul style="list-style-type: none"> Geotextile must be secured at edges and base and all joints overlapped to prevent the movement of fine sediment between the infiltration device layer and base soils and provide required tensile strength. It should be designed to prevent internal clogging and reduced permeability.

C7.2.2 Design for safety

Safety in design considerations for infiltration devices should include:

- Easements should be secured to provide facility and maintenance access
- Consideration for all works in enclosed spaces
- Maintain ingress and egress routes to design standards
- Ensure fencing is in good repair
- Access and working space for maintenance
- Consideration of potential tripping and falling hazards
- Mowing considerations (such as slope)
- Design for safe decommissioning.

C7.2.3 Soil permeability testing

The underlying soils must be tested at the proposed site using either falling head or constant head permeability testing (as described in Section C1: Plants and soils). A suitably qualified and experienced professional must undertake the soil testing. Under advisement of this expert, at least one test per 15 m (for infiltration trenches) or 500 m² (for non-linear infiltration surfaces) should be performed; the depth, number of test holes and samples should be increased if soil conditions are highly variable. The test bore hole should be 2.5 times deeper than the invert depth of the device, and not less than 3 m below the proposed invert. Detailed bore logs should be prepared for each test borehole, along with a map showing the location. Further information can be found in the New Zealand Ground Investigation Specification, Volume 1². Further guidance on testing, design procedures and worksheets can also be found in Auckland Council's technical report, TR2013/040³.

C7.2.4 Device sizing

This section provides the sizing methodology for infiltration devices which is determined by detention and retention requirements.

C7.2.4.1 Design considerations

- Calculate the retention and detention volumes and peak flows using guidance provided in Section B
- Size the device based on the total combined volume being infiltrated into the ground. This means that when the detention volume is infiltrated, the retention requirements are automatically met as well
- Void space of the gravel must be known. Optimally, a void space of 30% (0.3) should be used. Calculate using a void space of 100% if a detention storage uses an underground chamber
- Size the device area to allow for complete infiltration within 72 hours, including rainfall falling directly onto the infiltration device.

² New Zealand Geotechnical Society. 2017. *Ground Investigation Specification, Volume 1*, ISBN: 978-1-98-851731-5

³ Auckland Council TR 2013/040 *Stormwater Disposal via Soakage in the Auckland Region*

C7.2.4.2 Retention and detention volume

The design approach is based on Darcy's Law which expresses flow through a porous medium.

- 1) The area of the infiltration device can be calculated using Equation 44:

$$A_{(\text{device})} = \frac{V_{(\text{tot})}}{(k \times t) - d} \quad \text{Equation 44}$$

- 2) The total volume or size of the infiltration device ($V_{(\text{device})}$), including aggregate, can be calculated using Equation 45:

$$V_{(\text{device})} = \frac{V_{(\text{tot})} + (d \times A)}{V_{(\text{void})}} \quad \text{Equation 45}$$

- 3) The height of the infiltration device ($h_{(\text{device})}$), can be calculated using Equation 46:

$$h_{(\text{device})} = \frac{V_{(\text{device})}}{A} \quad \text{Equation 46}$$

Where:

A	-	Area of infiltration device (m ²)
V _(tot)	-	Total runoff volume (m ³)
V _(device)	-	Volume, or size, of device (m ³)
k	-	Infiltration rate (m/hr) (must be >0.01 m/hr); multiplied by 0.5 for factor of safety
t	-	Time to drain (hours) (assumed to be 72 hours)
d	-	Total rainfall depth (m)
V _(void)	-	Void space: assume a minimum of 30% for gravel or 100% for underground storage chamber
h _(device)	-	Height of infiltration device (m)

C7.2.4.3 Summary of infiltration device design process

Figure 46 presents the suggested design process for infiltration devices.

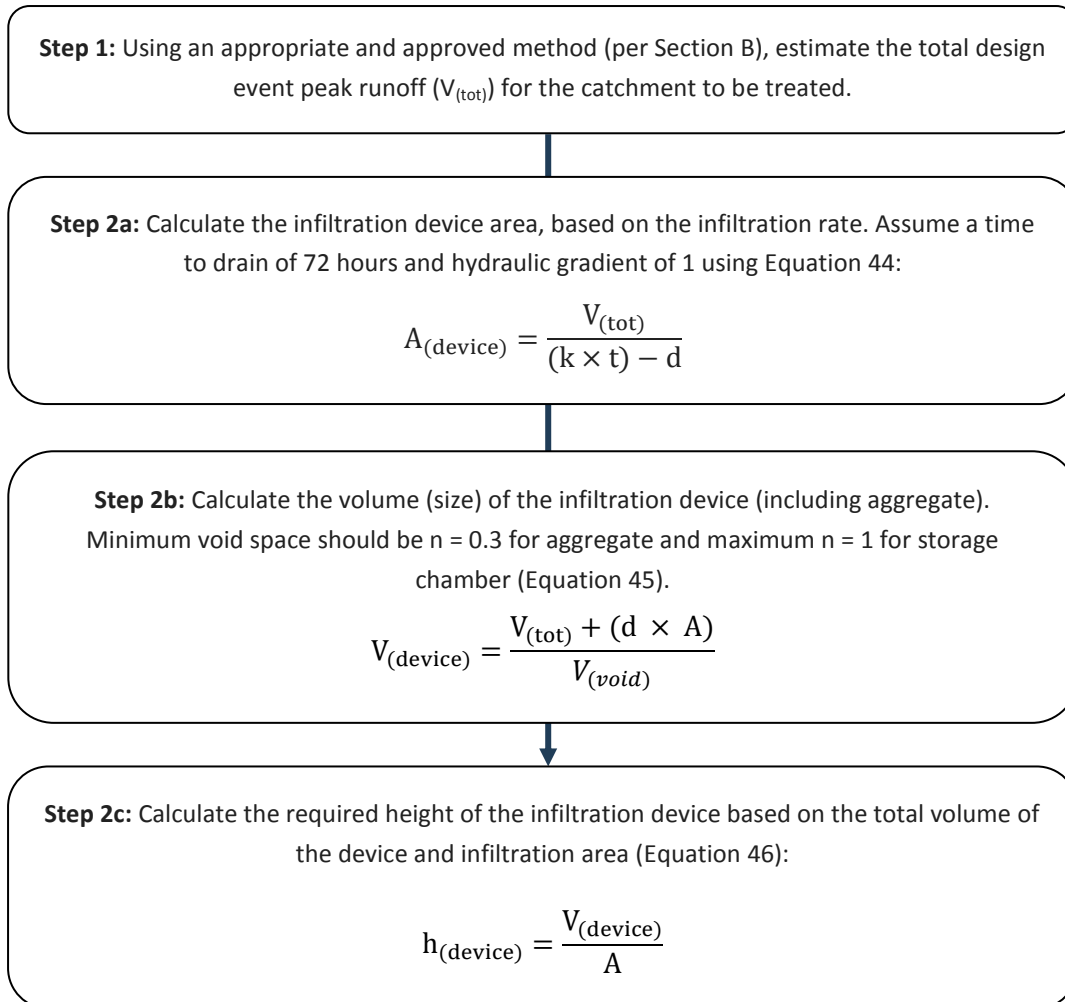

Figure 46: Infiltration design flow chart

C7.2.5 Component design

C7.2.5.1 Aggregate

Clean (fines free) drainage aggregate should be used and should comprise washed drain gravel 20 mm to 40 mm, with a defined void ratio. The void ratio should be 30% (0.3).

C7.2.5.2 Observation well

The observation well should consist of a perforated PVC pipe, 100-200 mm in diameter and have a footplate and a cap. The footplate will prevent the entire observation well from lifting up when the cap is removed during inspections.

C7.2.6 Construction design considerations

The following construction design considerations should be addressed during design and specification:

- Verify dimensions and setbacks of the device prior to construction
- Infiltration devices should be excavated such that the sides of the subsoil are not sealed; front end loaders and bulldozers should not be used
- Infiltration devices should be constructed as the last step in any development to prevent clogging. They must not be installed when any construction sediment is present
- Upstream drainage must be completely stabilised
- In case of accidental discovery during construction, teams should have a protocol in place to address this
- Avoid draining pervious areas to the infiltration devices, as these will increase the sediment load to the device
- Always use washed media (fine free) to avoid potential clogging.

C7.2.7 Operation and maintenance design considerations

The following operation and maintenance considerations should be addressed during design and specification:

- As-built drawings must be prepared
- A cost-effective operation and maintenance plan must be developed prior to asset transfer
- A monitoring plan must be prepared which details what monitoring is needed and how frequently
- Infiltration devices clog very easily but are difficult to refurbish. Maintenance should therefore be preventative with care taken to ensure pre-treatment devices are regularly inspected and maintained
- The location of infiltration devices should be clearly marked at the site to prevent vehicle traffic across the device to avoid compaction of soils.

C7.3 Design examples

C7.3.1 Example 1: Gravel trench for large residential roof & driveway

For this design example, the site is a 300 m² residential roof and driveway that requires hydrology mitigation through retention and detention. The project parameters are provided in Table 74.

Table 74: Residential section design example parameters

Item	Value
Land use category	Residential
Retention requirement	10 mm volume
95% percentile rainfall depth	35 mm, 24-hour event volume
Water table depth	3 m below ground surface
Contaminated land	No
Site slope	5%
Catchment area	300 m ²
Catchment length	30 m
Site soil infiltration rate (k)	0.01 m/hr
Void space ratio (gravel)	0.35
Drain time	72 hours
Proximity to buildings etc.	No

Step 1: Catchment assessment and device selection

After a catchment and site assessment is done, an underground gravel trench design is chosen. A drain-down time of 72 hours is used.

The detention and retention depths for this example are a 35 mm and 5 mm 24-hour event respectively. It is important to note that the detention is inclusive of the retention volume; therefore the detention volume becomes the total volume (V_{tot}).

Step 2: Calculate design volumes

Parameter	Rainfall	Runoff method	Volume	Value	Unit	Ref.
Detention volume	35 mm	TP108 33.25 mm	$V_{(tot)} = 33.25 \text{ mm} \times 300 \text{ m}^2$	9.98	m ³	V_{tot}

Step 3: Calculate infiltration device area, device volume and device height

Parameter	Calculation or selection method	Value	Unit	Ref.
Surface area	$A = \frac{V_{(tot)}}{(0.5 \times k \times t) - d} = \frac{9.98}{(0.5 \times 0.01 \times 72 \text{ hrs}) - 0.035}$	30.69	m ²	A
Device volume	$V_{(device)} = \frac{V_{(tot)} + (d \times A)}{V_{(void)}} = \frac{(9.98 + (0.035 \times 30.69))}{0.35}$	31.6	m ³	$V_{(device)}$
Device height	$h_{(device)} = \frac{V_{(device)}}{A} = \frac{31.6}{30.69}$	1.0	m	$h_{(device)}$

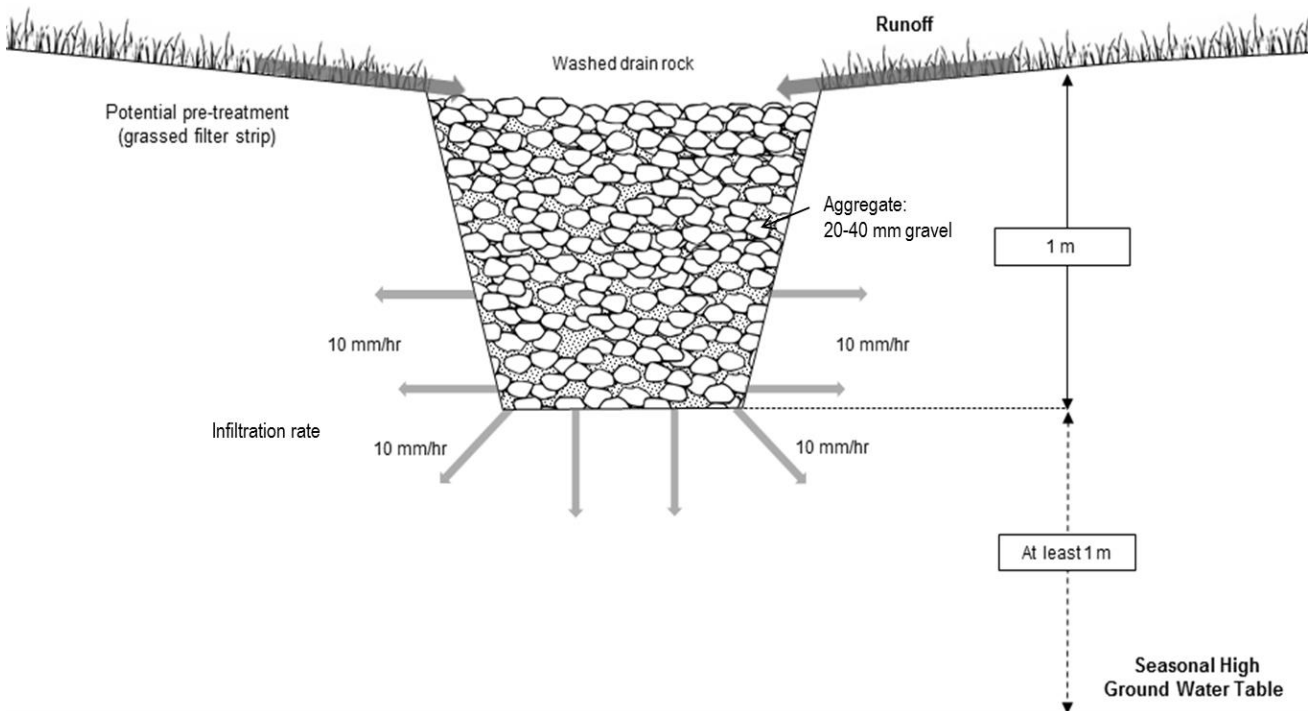

Figure 47: Schematic of a gravel trench

C7.3.2 Example 2: Underground infiltration chamber – 10% AEP event

For this design example, the site is a residential section with 300 m² of impervious area that requires hydrology mitigation through retention for the 10% AEP event. The example parameters are given in Table 75.

Table 75: Residential section design example parameters

Item	Value	Item	Value
Land use category	Residential	Site slope	5%
Retention requirement	5 mm	Catchment area (roof & driveway)	300 m ²
95% percentile rainfall depth	35 mm	Catchment length	30 m
Detention requirement	10% AEP, 24-hour event (120 mm)	Site soil infiltration rate	0.01 m/hr
Water table depth	3 m below ground surface	Void space ratio (chamber)	1
Contaminated land	No	Drain time	72 hours
Proximity to buildings etc.	No	Curve number	61

Step 1: Catchment assessment and device selection

After a catchment and site assessment is done (including subsoil geotechnical assessment), infiltration is determined to be appropriate, with pre-treatment for sediment and retention required. An underground infiltration chamber has been chosen with an additional requirement of detention for the 10% AEP event. A drain time of 72 hours is used.

The detention and retention depths for this example are a 35 mm and 5 mm 24-hour event respectively. It is important to note that the detention is inclusive of the retention volume, therefore the detention volume becomes the total volume ($V_{(tot)}$).

Step 2: Calculate design volumes

In this case, the roof area of 200 m² and driveway area of 100 m² give a total catchment of 300 m². As the 10% AEP runoff volume is greater than the detention volume, the underground infiltration chamber must be designed for the 10% AEP event runoff.

Parameter	Rainfall	Runoff method	Volume	Value	Unit	Ref.
Detention volume	35 mm	TP108: 30.4 mm	$V_{(tot)} = 30.4 \text{ mm} \times 300 \text{ m}^2$	9.12	m ³	$V_{(det)}$
10% AEP volume	120 mm	TP108 - difference between pre/post-development runoff. Pre-dev. R/O: 47.6 mm Post-dev. R/O: 115.0 mm	$V_{(10\%)} = (115.0 - 47.6) \times 300 \text{ m}^2$	20.22	m ³	$V_{(10\%)}$

Step 3: Calculate infiltration device area, device volume and device height

For the underground infiltration chamber, a void space ratio of 1 (100%) is used. This represents an empty, unfilled, chamber.

Parameter	Calculation or selection method	Value	Unit	Ref.
Surface area	$A = \frac{V_{(10\%)}}{(0.5 \times k \times t) - d} = \frac{20.22}{(0.5 \times 0.01 \times 72 \text{ hr}) - 0.12}$	84	m ²	A
Device volume	$V_{(device)} = \frac{V_{(tot)} + (d \times A)}{V_{(void)}} = \frac{(15.06 + (0.12 \times 84))}{1.0}$	30.33	m ³	V _(device)
Device height	$h_{(device)} = \frac{V_{(device)}}{A} = \frac{30.33}{84}$	0.36	m	H _(device)

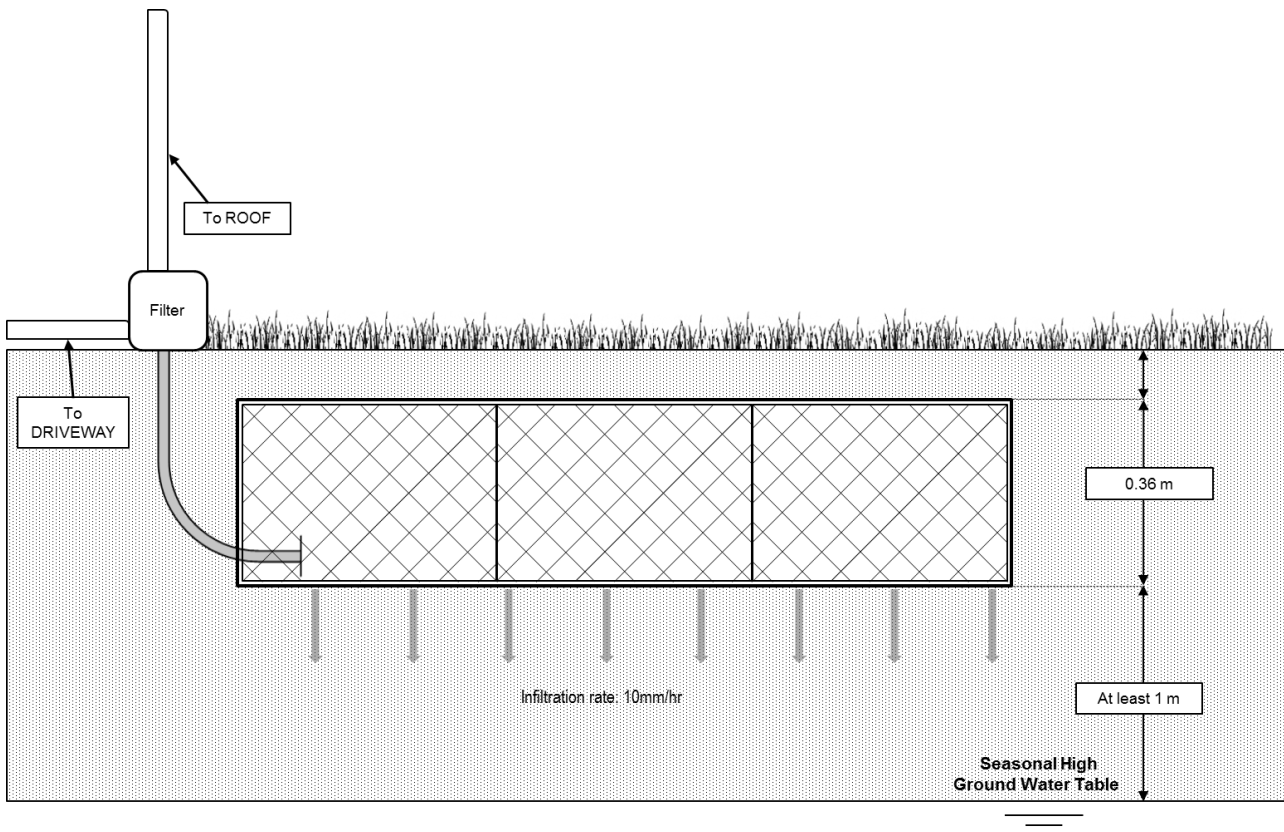

Figure 48: Schematic of an underground infiltration chamber

C8 Wetlands



Table of Contents

C8.0	Technical guidance: wetlands	239
C8.1	Introduction	239
C8.1.1	Use in a treatment suite.....	240
C8.1.2	Wetland components.....	240
C8.1.3	Site considerations.....	246
C8.2	Constructed wetland design	247
C8.2.1	Design considerations.....	248
C8.2.2	Design for safety.....	249
C8.2.3	Device sizing.....	251
C8.2.4	Component design.....	255
C8.2.5	Construction design considerations.....	260
C8.2.6	Operation and maintenance design considerations.....	261
C8.3	Design examples	262
C8.3.1	Example 1: Wetland for water quality treatment and detention.....	262
C8.3.2	Example 2: Wetland for water quality treatment only.....	266

Figures

Figure 49:	Example of sinuous (left) and banded (right) flow paths.....	243
Figure 50:	Example schematic of a banded bathymetry wetland.....	244
Figure 51:	Example schematic of a sinuous bathymetry wetland.....	245
Figure 52:	Constructed wetland design flow chart.....	254
Figure 53:	Wetland outlet details.....	255

Tables

Table 76:	Wetland components.....	240
Table 77:	Site considerations.....	246
Table 78:	Wetland design considerations and specifications.....	248
Table 79:	Volume and calculation needs for wetland design.....	251
Table 80:	Outlet structures and application.....	257
Table 81:	Site characteristics.....	262
Table 82:	Storm intensities.....	263
Table 83:	Hydrologic calculation results.....	263
Table 84:	Elevation-storage relationship.....	264

Table 85: Results of routing model.....265

Table 86: Site characteristics266

Table 87: Storm intensities266

Table 88: Hydrologic calculation results266

C8.0 Technical guidance: wetlands

C8.1 Introduction

Constructed stormwater wetlands provide excellent water quality and quantity management. They contain a very active organic component - made up of plants and microbes - which act to remove, metabolise or inactivate pollutants. A constructed wetland has a designed bathymetry and specific planting to provide two primary stormwater management functions: water quality treatment and detention:

- Water quality treatment:** Wetlands can provide run-off treatment through a combination of physical, chemical and biological processes that remove contaminants from inflowing and impounded waters. Generally, water passes through wetlands as mixed flow being subject to multiple treatment processes, primarily from filtration, sedimentation, adsorption, biological uptake chemical decomposition, volatilisation and microbial activity. This water can pass through as part of a dead storage or live storage volume. Where live storage volume is included for water quality treatment, the service outlet is sized to discharge this volume over a minimum period of 24 hours
- Detention:** Wetlands can be designed for detention purposes (including stream protection and flood control). However, flow velocities must be managed to reduce the risk of re-suspension of captured sediments and associated pollutants, prevent scour of biofilms and protect plants. The wetland should be designed to protect vegetated areas from damage and resuspension of settled sediment caused by high flows. Constructed stormwater wetlands do not perform a significant retention function as water loss in constructed wetlands is relatively insignificant; water loss is therefore not included in hydrological considerations in this section. When constructed correctly, water levels in wetlands remain relatively constant between storm events with a permanent water level (PWL).

In addition, constructed wetlands can be designed to significantly improve cultural value, public amenity and ecological values of urban environments.

This section provides guidance for the design of constructed freshwater surface-flow wetlands for stormwater treatment and detention purposes. It does not consider ephemeral, saline, floating or subsurface wetlands. The guide is not intended for wetlands treating trade-waste discharges, wastewater or agricultural/horticultural runoff. The design of wetlands is complex and constrained by site and outcome considerations. This section of the guide provides minimum design considerations but does not provide detailed design componentry. As such, wetlands should be designed by suitably qualified and experienced professionals with a strong understanding of the desired outcomes for that site. Early and comprehensive collaboration with Auckland Council is needed to ensure the design meets specifications.

1% AEP detention*	✓
50% and 10% AEP detention	✓
Detention for stream protection	✓
Retention	✗
Water quality	✓

* It is preferable that large storm floods bypass wetlands.

C8.1.1 Use in a treatment suite

Wetlands are generally placed in the lower areas of a catchment as a final stage of the treatment suite. Wetlands should be combined with pre-treatment devices located upstream of the wetland to improve longevity and minimise maintenance works. Because they can provide both detention and water quality treatment, wetlands are a versatile device where land space is available.

C8.1.2 Wetland components

The general wetland components are provided in Table 76.

Table 76: Wetland components

Detailed wetland component	Description
Embankment/bund	<ul style="list-style-type: none"> • A dam/bund is usually required to provide the water volume for detention and must be specifically designed to ensure it will not fail as a water retaining structure. • The dam/bund location and dimensions are determined by the site contours, geotechnical characteristics and size requirements. • The dam/bund has to allow for maintenance access and in some instances, the spillway and outlet pipe (which is a component of the wetland service outlet). These areas must be free of large or deep-rooted vegetation.
Forebay	<ul style="list-style-type: none"> • The forebay is the part of the wetland designed to retain coarse sediment and other debris before water enters the rest of the wetland. • Its design must allow for maintenance (access for sediment removal). • A forebay bund separates the forebay from the wetland.
Terrestrial zone	<ul style="list-style-type: none"> • The terrestrial zone consists of the wetland banks that contain the water, provides volume capacity for extended detention and a surface for terrestrial vegetative planting (which can provide shade, temperature control, biological uptake of nutrients and filtering other contaminants and added habitat complexity).
Wetland liner	<ul style="list-style-type: none"> • Where a wetland must be impermeable, a liner or well-compacted clay layer can be used.
Safety bench	<ul style="list-style-type: none"> • The safety bench is a sloped bank which provides safer, easier exit from the wetland in cases of unauthorised or accidental entry. • The minimum 3 m wide bench provides a platform for plants which will provide additional treatment and constitute a natural safety barrier. • These benches may be replaced with other barriers (such as fencing) in certain designs.

Detailed wetland component	Description
Wetland zones	<ul style="list-style-type: none"> • Shallow marsh zone: Shallow marsh areas supporting vegetation at an average depth of 0.20 m below the PWL. • Deep marsh zone: Deep marsh areas support vegetation at a depth of around 0.50 m below the PWL. • Transverse deep pools: These pools act as natural settling areas and flow level spreaders that protect the vegetated areas from concentrated flows, help maintain water in the wetland during drought conditions and increase habitat diversity in a wetland but generally don't support emergent wetland vegetation and are unplanted. Pools should be between 1.2 and 1.5 m deep, placed centrally within the wetland. A maximum of 20% of the wetland area (excluding the forebay but including the outlet pool) should be deep pools.
Tree islands	<ul style="list-style-type: none"> • Tree islands are designed as mounds within the wetland that extend above the PWL and are planted with water-tolerant trees. They should be designed to accommodate extended flow paths and maintenance needs. • Where space is available, tree islands may be incorporated into wetland designs to provide habitat, shade and increased flow paths.
Outlet micropool	<ul style="list-style-type: none"> • Outlet micropools are deep pools located adjacent to the outlet, which protect the outlet from clogging and enable drawdown of water below the PWL for maintenance purposes. The depth should be between 1.2 and 1.5 m.
Fish passage	<ul style="list-style-type: none"> • Many juvenile native fish (such as eels, galaxiids, torrent fish, smelt, lamprey and bullies) develop at sea and migrate to river habitats, where they grow to adulthood. • The design must allow these species to migrate, particularly where there are permanent structures (dams, weirs, falls, tide gates, culverts and screens) and/or high water velocities.
Inlet	<ul style="list-style-type: none"> • The wetland inlet discharges the runoff from the contributing catchment into the wetland and acts as a throttle structure to manage flows into the wetland. There may be more than one inlet into the wetland and all inlets should discharge into a forebay. • Examples of wetland inlets include pipes, channels and swales. • The inlet design has to incorporate flow velocity dissipation structures prior to the forebay to prevent scour and erosion of the forebay and enable diffuse flows into the forebay. Refer to Auckland Council's technical report, TR 2013/018 <i>Hydraulic Energy Management: Inlet and Outlet Design for Treatment Devices</i>.

Detailed wetland component	Description
Service outlet	<ul style="list-style-type: none"> • The service outlet discharges stormwater from the wetland to downstream receiving environments such as coastal areas, streams, engineered open channels or stormwater reticulation. While several other designs may be used, generally, the outlet service includes four components: <ul style="list-style-type: none"> ○ The outlet riser ○ The outlet pipe (penetration through the embankment requires a suitably qualified and experienced professional's involvement in design and construction). Design should provide a mechanism to drain the wet pond within 12 hours, including forebay by gravity without pumping ○ The pipe outlet structure which incorporates erosion protection measures ○ Drain-down outlet located in the outlet pool to drain the wetland. • If the service outlet discharges to stormwater reticulation, the pipe outlet structure is not required. • Depending on the function provided by the wetland (quality treatment and/or detention) several outlet riser arrangements (such as orifices and slots) may be required. These should have measures to prevent blockage (such as scruffy domes or baffle plates). Refer to Auckland Council technical report, TR 2013/018 <i>Hydraulic Energy Management: Inlet and Outlet Design for Treatment Devices</i>.
Permanent water volume	<ul style="list-style-type: none"> • The PWV is calculated as the whole hydrologic mitigation volume (retention plus detention) of the 90th percentile storm event and is equivalent to the water quality volume (WQV).
Live storage	<ul style="list-style-type: none"> • Live storage is the volume of water that needs to be detained above the PWV (i.e. stream protection) and released in a controlled manner over 24 hours. • When live storage has to be provided (i.e. stream protection is required), the PWV can be reduced by 50% if there is evidence that the device will function and there is improved amenity, environmental and cultural outcomes.
Emergency spillway	<ul style="list-style-type: none"> • The emergency spillway is an emergency outlet which starts to discharge stormwater when the service outlet is partially or totally blocked/damaged, or the service outlet has insufficient capacity to convey a larger non-design storm event. • Emergency spillways commonly consist of an overflow channel, although emergency overflow structures that are piped can also be considered. • The invert level of the spillway should be 100 mm above the maximum water level in the wetland. • The spillway can be located anywhere within the wetland (not necessarily close to the service outlet). • Freeboard should be a minimum of 300 mm above the maximum flow depth of the largest design storm.
Sediment drying area	<ul style="list-style-type: none"> • An area is needed for drying sediments that have been removed during maintenance works before off-site disposal. The purpose of drying sediments is to reduce sediment weight and therefore reduce haulage and disposal costs.

Detailed wetland component	Description
Maintenance access	<ul style="list-style-type: none"> • Access is required to allow wetland inspections and maintenance to any pre-treatment devices as well as the inlets, forebay, the service outlet and emergency spillway at a minimum. • Access is also required around the outside (or at least along the length) of the wetland.
Bypass	<ul style="list-style-type: none"> • A high-flow bypass is required for all flows that are not intended to be routed through the wetland. • It is highly recommended that a maintenance bypass be included in the design (such as a weir to isolate the wetland for maintenance).

C8.1.2.1 Bathymetry

There are two bathymetric approaches for the design of constructed wetlands: banded and sinuous (Figure 49). Elements of both approaches may be incorporated into wetland designs to maximise treatment efficacy, while minimising preferential flow paths.

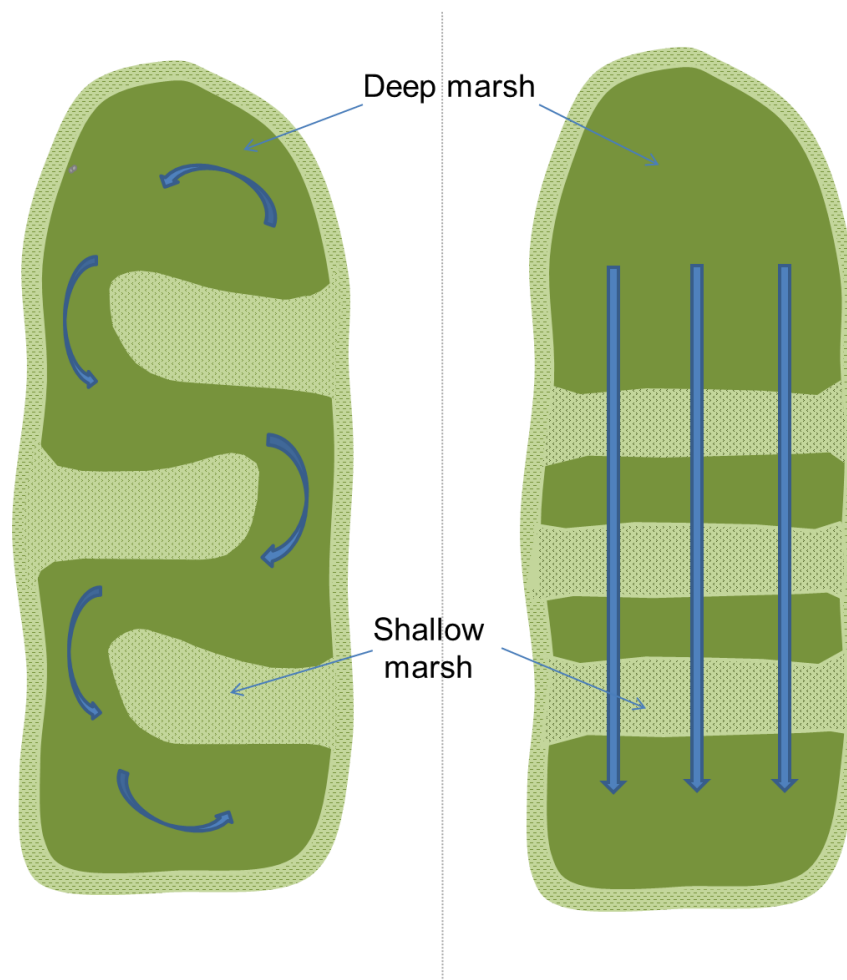

Figure 49: Example of sinuous (left) and banded (right) flow paths

Banded bathymetry, in long section, has variable depths with alternating deep and shallow marsh sections interspersed with occasional open water areas (Figure 50). It is assumed that water spreads evenly across the full width of the wetland as a uniform flow.

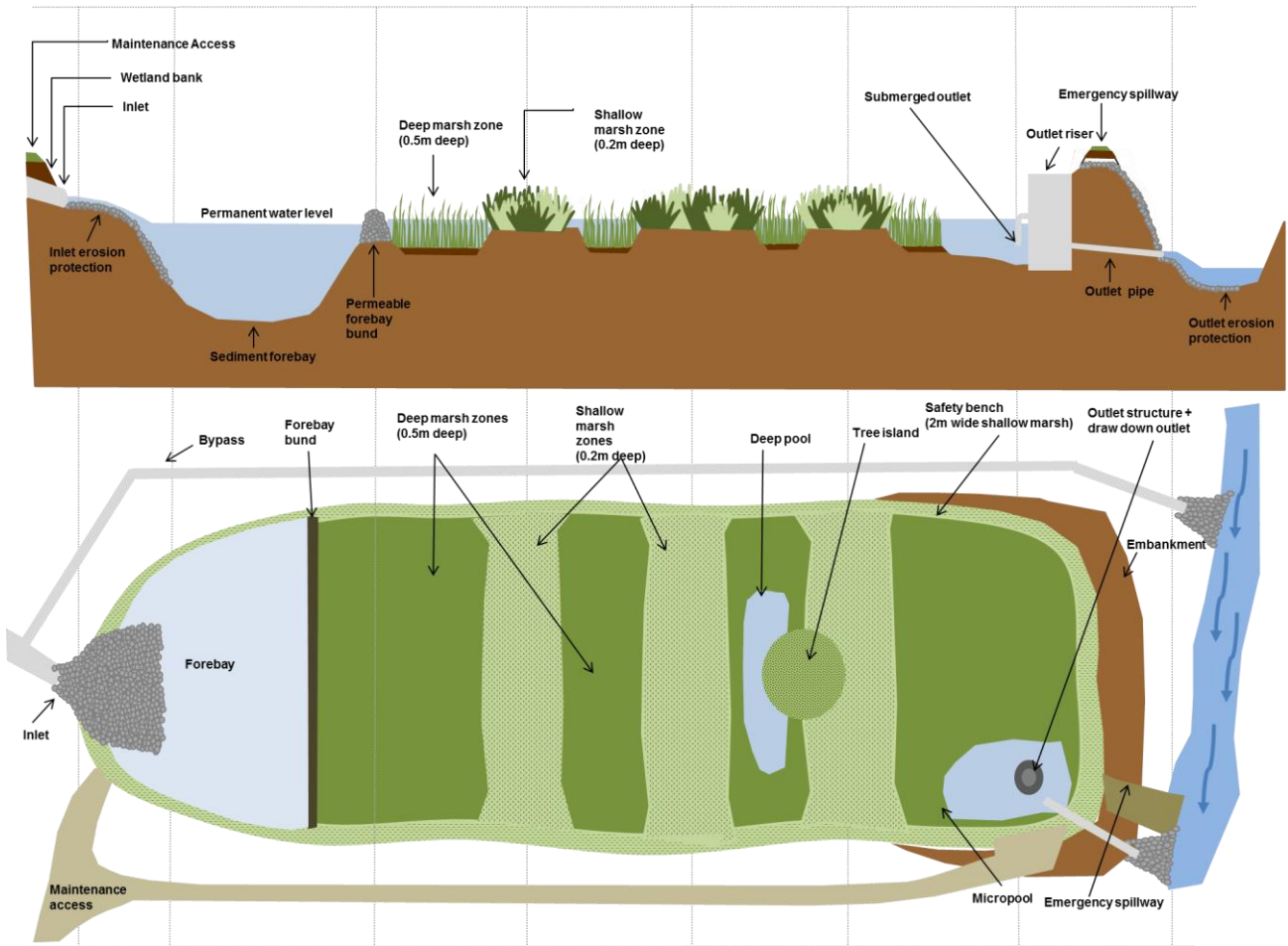

Figure 50: Example schematic of a banded bathymetry wetland

Sinuous bathymetry allows water to flow through a longer path length, providing increased contact time with the biological and physical processes that improve water quality (Figure 51). The adjacent wetland areas (those in the shallow marsh areas) provide additional flow management during larger storm events where water levels in the wetland are higher. The sinuous design provides longer flow paths and creates more diverse flowing and pooling opportunities, but care must be taken not to create preferential flow paths over the life of the wetland.

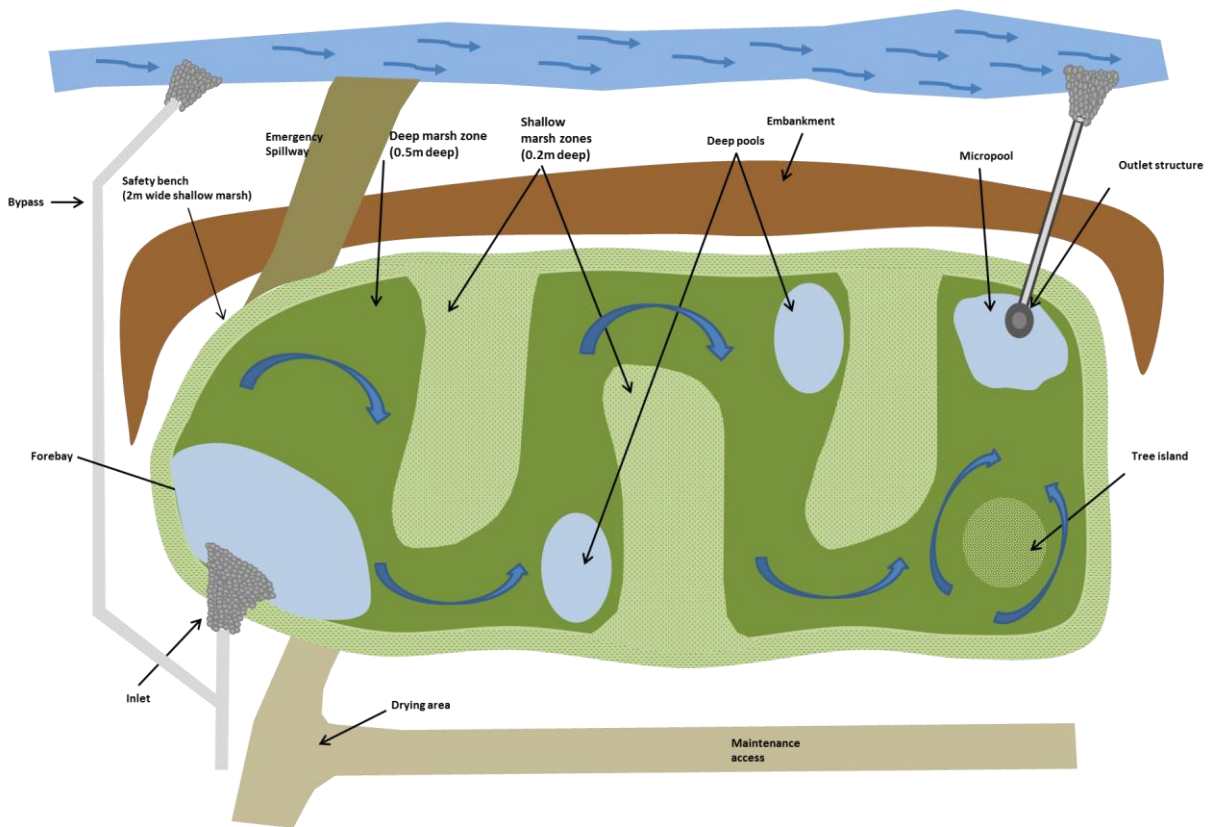

Figure 51: Example schematic of a sinuous bathymetry wetland

C8.1.3 Site considerations

Wetlands are generally located at the base of catchments. General site considerations are presented in Table 77.

Table 77: Site considerations

Item	Consideration
Catchment size and location	<ul style="list-style-type: none"> • Generally used in medium/large catchments and located in the catchment's lower portion. • Wetlands should be designed off-line to open watercourses in greenfield development areas. Where this is not possible, on-line wetlands will require specific design mitigations. • Wetlands should be sized based on the entire contributing catchment, not just the development area. • Designers should ensure the catchment drains naturally by gravity to the wetland and ensure vertical and horizontal space is available for detention, if required. • Attention is needed to ensure associated infrastructure, such as maintenance access and high flow bypasses, can be accommodated within this space.
Groundwater	<ul style="list-style-type: none"> • A geotechnical investigation is needed to inform all wetland designs. Groundwater mounding analysis should be undertaken. • Some permeability may be designed for in instances where groundwater recharge is desired. It is preferable for a wetland to receive baseflow. • Designs should mitigate against too much or too little water draining from wetland. If an impermeable design is needed, an impervious liner must be used.
Slope	<ul style="list-style-type: none"> • Wetland cannot be used on slopes unless terraced and should be placed more than 15 m away from slopes of 9° (15%) or more.
Soils requiring structural support	<ul style="list-style-type: none"> • Geotechnical investigations are needed across the entire design area to understand the underlying soils and designs must accommodate all geotechnical constraints (such as soil instability).
Soils with poor drainage	<ul style="list-style-type: none"> • Wetland functionality is not impacted by poor drainage into surrounding soils as they are generally not designed to provide for retention functions.
Pre-treatment	<ul style="list-style-type: none"> • Pre-treatment of stormwater prior to entry to wetland is needed to reduce long-term maintenance costs. • Regular maintenance to remove litter, debris and sediments is also needed.
Contaminated land	<ul style="list-style-type: none"> • Wetlands should not be located on, or near, contaminated land or fill soils.
Setback	<ul style="list-style-type: none"> • Wetlands should not be located above existing or planned dwellings. • Wetlands should be located at a 3 m minimum from property lines. • Wetlands and ponds should not be located within a 1V:1H plane taken from the toe of any retaining wall. • Wetlands should be located a minimum of 10 m from high voltage (electricity) cables and 5 m from bridge soffits

Item	Consideration
Traffic	<ul style="list-style-type: none"> • Traffic from the road to the wetland should be considered in the design. • Wetlands and ponds should be located at a minimum of 3 m from traffic areas. • Maintenance access must allow for easy access to all pre-treatment areas and the main body of the wetland.
Temperature considerations	<ul style="list-style-type: none"> • Locate the wetland to minimise solar gain in the waterbody. Ensure plant density can provide shade to reduce water temperatures.
Pest and vector considerations	<ul style="list-style-type: none"> • Locate and design the wetland to minimise habitat for pests, weeds and potential vectors of disease.

C8.2 Constructed wetland design

Wetlands must be designed in accordance with:

- New Zealand Society of Large Dams (NZSOLD), *Dam Safety Guidelines*, 2015
- NZSOLD. *Guideline on Inspecting Small Dams*, 1997
- New Zealand Building Act, 2004
- Auckland Council technical publication, TP109 *Dam Safety Guidelines*, 1999.

C8.2.1 Design considerations

Table 78 presents design considerations for constructed wetlands.

Table 78: Wetland design considerations and specifications

Item	Description
Structural design	<ul style="list-style-type: none"> Structural design as required in relevant dam specifications and guidelines (e.g. NZSOLD 2015 and TP109). The structural design has to be completed and certified by a suitably qualified and experienced professional to the standards of relevant dam specifications and guidelines. Any wetland designed with permeability must have geotechnical evidence to support this approach and a permanent water level must be maintained.
Length-to-width ratio	<ul style="list-style-type: none"> Should be maximised to promote flows that engage the full width of the wetland. Recommended minimum ratio of 3L:1W.
Inlets and outlets	<ul style="list-style-type: none"> The design of all inlets and outlets will be influenced by the site constraints and intended flows and must be designed by a suitably qualified and experienced person. Inlets and outlets should be designed as described in Auckland Council technical report, TR 2013/018 <i>Hydraulic Energy Management: Inlet and Outlet Design for Treatment Devices</i> and should have debris screens for safety and to remove rubbish and prevent clogging. Stormwater inlets should be located with a forebay bund, to prevent a short-circuit flow path.
Forebay	<ul style="list-style-type: none"> The forebay must hold a minimum 15% of the PWV (10% of the wetland area). The minimum forebay depth must be 1.5 m. (Section C8.2.4.2). Flow velocities from the forebay during the 10% AEP must be less than 0.25 m/s, in order to avoid resuspension of sediment. Deep marsh should always be located directly adjacent to the forebay. The forebay bund must be accessible for maintenance.
Wetland slopes	<ul style="list-style-type: none"> All slopes must be approved by a geotechnical engineer based on site-specific constraints, with the following guidance: <ul style="list-style-type: none"> Internal wetland banks below the PWL: <math>14^\circ</math> (25% or 1V:4H) Internal side slope above the PWL: <math>18^\circ</math> (32% or 1V:3H) Forebay bund slope: <math>18^\circ</math> (32% or 1V:3H) External side slope: <math>18^\circ</math> (32% or 1V:3H) Any slopes requiring mowing should be less steep than <math>11^\circ</math> (20% or 1V:5H).
Wetland safety bench	<ul style="list-style-type: none"> Ensure that a safety bench at least 3 m wide with a <math>7^\circ</math> (12% or 1V:8H) gradient extends around the entire wetland (no more than 0.3 m below PWL), densely planted to form a natural barrier.

Item	Description
Emergency spillway	<ul style="list-style-type: none"> • Where possible, locate the emergency spillway near the inlet to the wetland to minimise re-suspension in larger storm events. • The invert level of the spillway should be 100 mm above the maximum water level in the wetland. • Freeboard should be a minimum of 300 mm above the maximum peak flow of the design storm event.
Maintenance access	<ul style="list-style-type: none"> • A minimum width of 3.5 m wide and maximum slope of 1V:8H is required. • The service outlet should be accessed directly from the maintenance access if the structure is located close to the wetland bank. Otherwise, a structure such as a bund, pier or gantry may be considered to allow access to the outlet and must be designed to be accessible in all weather.
Bypasses	<ul style="list-style-type: none"> • It is highly recommended that a high-flow bypass and maintenance bypass be incorporated into the design (Section C8.2.4.5).
Sediment drying area	<ul style="list-style-type: none"> • An area designated for drying sediments after maintenance is required (Section C8.2.4.6). • The area set aside must accommodate at least 10% of the PWV and allow for a height of sediment of up to 1 m. • The site should be away from wetland banks and must be flat with vehicle access.
Impervious liner	<ul style="list-style-type: none"> • A liner may be required for certain groundwater conditions. The liner should extend beyond the top of operational water levels (Section C8.2.4.7).
Planting	<ul style="list-style-type: none"> • For a device to be considered a wetland, at least 80% of the wetland zone (excluding forebay area) must be densely planted, at minimum densities of 4 plants/m² (Section C8.2.4.8).
Flow velocities	<p>Flows must not exceed:</p> <ul style="list-style-type: none"> • 0.1 m/s for up to 50% AEP • 0.5 m/s for larger storm events.
Fish passage	<ul style="list-style-type: none"> • Should be included in wetland designs and is compulsory in on-line wetlands or wherever it is necessary for species migration.

C8.2.2 Design for safety

Some key design considerations are presented to ensure safe wetland designs.

C8.2.2.1 Dam safety

A dam structure is often needed to impound the required water volumes within the wetland. Dam safety is a key consideration when designing a wetland. The key objective for dam safety is that people, property and the environment (present and future), should be protected from the harmful effects of a dam failure or an uncontrolled release of the reservoir contents.

Dam safety requires consideration of the total system surrounding the dam and should not be limited to the dam structure. A suitably qualified geotechnical engineer should always be involved in the design of the wetland.

Designs must take account of the following:

- The consequences of dam failure should be understood so that appropriate design, construction and management actions can be applied to protect people, property and the environment
- All natural hazards, loading conditions, potential failure modes and any other threats to the safe design, construction, commissioning, operation and rehabilitation of a dam should be identified
- Dams and associated structures should be designed, constructed, commissioned, operated and rehabilitated in a manner which ensures they meet appropriate performance criteria
- The long-term responsibility for the safety of the dam rests with the asset owner
- There should be no planting of deep rooting or large vegetation on structural bunds of dams.

Dam safety requirements of the RMA and the New Zealand Building Act 2004 must be met.

C8.2.2.2 Other wetland safety considerations

Other wetland safety considerations include:

- Dense, low planting along path edges above slopes to deeper sections
- Access restrictions to inlets/outlets/pre-treatment areas/maintenance areas
- Clear illustrations within signage to cater for adults and children
- Interim fencing or signage during development.

Permanent fencing (1.2 m high) may be considered in the following circumstances:

- The embankments into the wetland main body are steeper than 1H:3V
- Where vertical drops exceed 0.5 m
- Areas are deeper than 0.3 m adjacent to heavily used areas (e.g. pedestrian walkways)
- A pool fence (or similar) should be used where there is a chance of drowning and the surrounding area is specifically intended for use by small children (swings, playgrounds, sporting fields etc.).

The following designs should be considered where the depth of the water is more than 1.5 m:

- Wider safety benches
- Flatter batter slopes above the PWL
- Additional depth of dense planting
- Permanent fencing.

Wetland design should mitigate pest species including mosquito habitat.

C8.2.3 Device sizing

The volume of water detained in a wetland is based on the methodology detailed in Section B. An accurate calculation of the size of the contributing catchment area is needed.

A summary of the hydrologic volume calculations required for wetland design is provided in Table 79.

Table 79: Volume and calculation needs for wetland design

Volume	Calculation notes
Permanent water volume (PWV)	<ul style="list-style-type: none"> The PWV represents the water volume between the wetland base and the PWL and is designed to provide wetland function (sufficient volume to provide some stormwater settling, allow for biodiversity etc.) and amenity. The PWV is calculated using the 90th percentile storm event (approximately 25 mm, as defined in Section B). Time of concentration should be at least 0.17 hours. The PWV includes the forebay volume which represents 15% of the wetland's total volume. When live storage has to be provided (i.e. stream protection is required), the PWV can be reduced by 50% if there is evidence that the device will function and there is improved amenity, environmental and cultural outcomes.
Forebay water volume	<ul style="list-style-type: none"> The forebay volume represents at least 15% of the PWV. Flow velocity from the forebay in a 10% Annual Exceedance Probability (AEP) rainfall event must be less than 0.25 m/s in order to avoid sediment resuspension.
Detention volume for stream protection	<ul style="list-style-type: none"> If the wetland discharges to an open watercourse, a percentage of the annual runoff has to be detained and released over 24 hours in order to provide erosion protection for the stream channel. The detention volume is based on the runoff from the 90th or 95th percentile storm events, for SMAF2 and SMAF1 areas respectively. The detention volume is provided above the PWL and is released through an adequately designed opening (usually an orifice) located at this level which is part of the service outlet.
Detention volume for flood mitigation	<ul style="list-style-type: none"> In most instances, larger storm events will be diverted or by-pass the wetland. When required due to downstream discharge constraints (e.g. inadequate pipe capacity or flooding issues), the wetland can be designed to provide detention for specific peak discharges for higher rainfall events (e.g. 50% and 10% AEP, and in some instances up to the 1% AEP). The detention volumes are provided above the PWL. Any detention for stream protection would be included in the larger detention volume. In order to size the device conservatively, designers should use a pre-development volume estimated using TP108¹, and a post-development volume using TP108 plus an increase factor to accommodate climate change (MfE, 2010²).

¹ Auckland Regional Council TP108 *Guidelines for Stormwater Runoff Modelling in the Auckland Region*, 1999

² Ministry for the Environment *Tools for Estimating the Effects of Climate Change on Flood Flow*, May 2010

C8.2.3.1 Calculating minimum wetland surface area

To design the wetland, the permanent water volume is divided by the assumed depth of the water. However, this depth may be adjusted in the calculation to accommodate site constraints and treatment considerations. This value must be established in consultation with Auckland Council early in the wetland design. For instance, where a smaller wetland can provide effective treatment, a value of up to 1.5 can be used. Where a wetland needs to be larger to provide effective treatment, the value can be as low as 0.5. The minimum surface area at the PWL is calculated using Equation 47. In addition, the PWV may be multiplied by 50% if stream protection is required.

$$\left(\frac{PWV}{d}\right) = A_{(surface)} \quad \text{Equation 47}$$

Where:

- | | | |
|-----------------|---|---|
| PWV | - | Permanent water volume (m ³), may be multiplied by 50% if stream protection is required |
| $A_{(surface)}$ | - | Minimum surface area of wetland (m ²) |
| d | - | Ponding depth coefficient of between 0.5 and 1.5 |

Use a storage-elevation table to calculate detention levels above the PWL for any live storage for water treatment, detention for stream protection and detention for flood mitigation.

C8.2.3.2 Design internal bathymetry

Accounting for flow velocities

Flow velocities need to be minimised to avoid damage to wetland vegetation and biofilms. Peak flow velocities through the forebay and wetland main body need to be calculated for small (frequent) and larger (less frequent) storm events. This section makes provision for integrating maximum flow velocity limitations in the design process, including a test to verify if velocities are acceptable. Peak flow velocities at the minimum cross-sectional areas of the wetland (using TP108) may not exceed:

- 0.1 m/s for the PWV event (90th percentile), the detention for stream protection storm event and all flows up to the 95th percentile design storm event
- 0.5 m/s for flows up to the 10% AEP storm event (unless bypassed).

Where possible, bypasses should be included for any velocities greater than 0.5 m/s.

C8.2.3.3 Iteration

A routing model such as HEC_HMS can be used to design an optimised wetland configuration by calculating peak inflows and discharges, volumes, storage and elevation.

C8.2.3.4 Check design

The designer must compare the peak velocity through the wetland with maximum permissible velocities of 0.1 m/s (for up to 50% AEP storms) and 0.5 m/s (for larger storm events). If flows exceed maximum velocity thresholds, then the wetland needs to be redesigned by:

- Increasing the wetland surface area
- Reconfiguring the internal bathymetry
- Adding live storage (subject to maximum depth constraints).

C8.2.3.5 Summary of constructed wetland design process

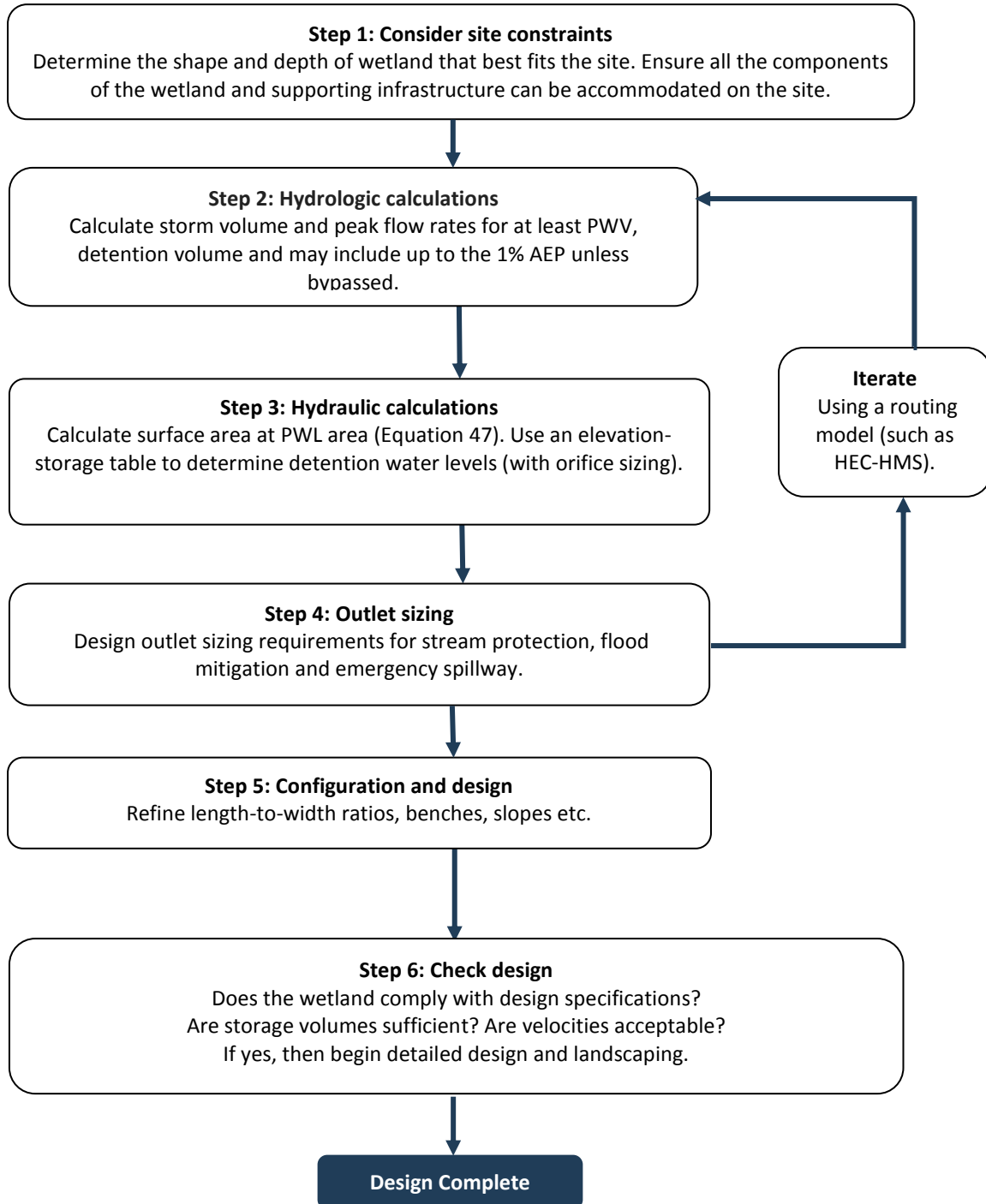

Figure 52: Constructed wetland design flow chart

C8.2.4 Component design

The key wetland design elements are the inlet, forebay, outlet and spillway (Figure 53).

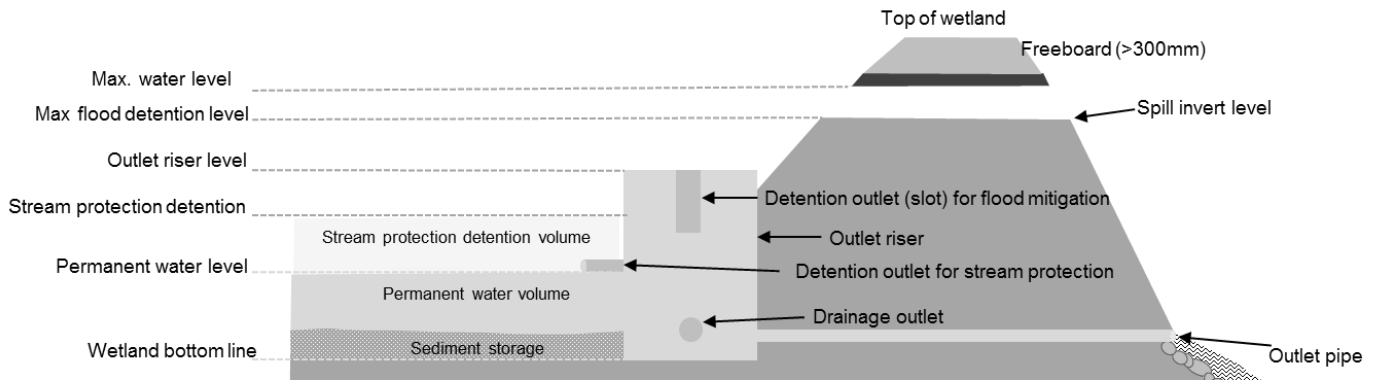

Figure 53: Wetland outlet details

C8.2.4.1 Wetland inlet

The inlet should be located at a maximum flow path distance from the outlet. Inlet pipes must be placed to avoid back-ponding. The flow discharged to the wetland may vary between the water quality flow and 10% AEP rainfall event flow (and in some instances up to the 1% AEP if no bypass is possible). A high-flow bypass should form part of the inlet structure, diverting non-design flows upstream of the forebay with appropriate erosion protection.

For piped reticulation, the wetland inlet consists of either a precast concrete wingwall or equivalent structure or an *in situ* structure made of concrete and/or rocks. For both inlet types, erosion protection placed above and below the PWL has to be provided at the discharge point (rock rip-rap on a geotextile layer should be used). Further details on energy dissipation are provided in Auckland Council's technical report, TR 2013/018³. The design should consider the use of debris screens.

The invert of the inlet must be located no lower than the designed PWL of the wetland.

C8.2.4.2 Wetland forebay

The forebay has to provide a minimum volume of 15% of the PWV (10% of the wetland area) and is designed as follows:

- The base should be lowered below the general wetland base and allow for at least a 1V:3H slope, making the forebay the deepest part of the wetland
- It is recommended that a submerged bund (100 mm to 150 mm below the PWL) is used to delineate the forebay from the rest of the wetland, providing the wetland with a constant depth. The minimum bund slopes must be 1V:3H. The top of the bund should be protected against erosion that might occur during high flows. The forebay bund ends should be keyed into the side slopes.

³ Auckland Council TR 2013/018 *Hydraulic Energy Management: Inlet and Outlet Design for Treatment Devices*

The forebay should meet the following design criteria:

- A minimum length-to-width ratio of 2:1
- The forebay should be at least 1.5 m deep and deeper, where possible
- The forebay velocities should be minimised by optimising the forebay length, width and depth, considering maximum permissible velocities. In some cases, this may necessitate more than the minimum forebay volume
- The base should be hardened for easier maintenance and sediment removal
- Include a method for assessing sediment build-up (e.g. vertical depth marker)
- Maximise flow diffusion and velocity reduction across the forebay bund into the vegetated wetland component
- Provide a maintenance access bay adjacent to the forebay area (to ensure the forebay can be maintained without the use of special equipment) within reach of a long-reach digger (no more than 12 m from the centre of the forebay) or other maintenance vehicles; this should be a minimum of 3.5 m wide and have a maximum slope of 1V:8H
- A stabilised access track is required to enable heavy machinery to access the forebay, unless it is proposed to de-silt with the use of lower weight machinery/vehicles (e.g. sucker trucks). The forebay does not need to be located adjacent to the wetland and can be disconnected, provided there is energy dissipation and spreading of inflows into the wetland body from the connection to the forebay.

C8.2.4.3 Wetland outlet structure

The service outlet structure incorporates all the specific outlets sized for different wetland functions including water quality treatment and flood mitigation (up to 10% AEP, and in some instances 1% AEP). Further detail on design of outlet structures is provided in TR 2013/018.

The service outlet structure should include the following components:

- The outlet riser which incorporates all the specific outlets, a top debris screen and a valve/screw cap located close to the wetland base level to allow for dewatering of the wetland without the use of pumps (drained by gravity) within 12 hours for maintenance
- The outlet pipe which discharges downstream of the wetland. These must be correctly sized. If the discharge is to the coastal area, or to a stream, an erosion protection solution must be located at the discharge point (refer to TR2013/018). This may consist of either a precast concrete wingwall or an *in situ* wingwall made of concrete and/or rocks.

For wetlands, the following requirements should be considered, where possible:

- Fish passage must be provided wherever a wetland is on-line to a waterway
- A design that draws off water from cooler, deeper waters within the outlet pool
- A removable weir plate included in the hydraulic control fitted within an accessible manhole
- The design of the outlet structures should allow for adjusting the permanent water level for management and maintenance purposes

- The design must include anti-seepage solutions along any outlet pipes
- Where wetlands are adjacent to coastal areas, consideration of coastal inundation zones, and potential impact of climate change, is needed.

Note: *The outlet orifice for the water quality storm can also act as the outlet for detention for stream protection, i.e. there is no additional outlet for detention for stream protection (and the outlet size is not increased for the latter detention).*

As a consequence, there is a slightly longer detention time for the volume detained for stream protection, which has been assessed and is considered acceptable. Importantly, using the water quality storm orifice for the detention for stream protection volume ensures that the PWV is discharged over a minimum of 24 hours.

A wide variety of outlet structures can be used (a small selection is provided in Table 80 and further detail is provided in Auckland Council technical report, TR 2013/018³, and each type listed can also have various designs. The final design of the outlet structure(s) is determined by a combination of site characteristics, desired wetland treatment functions (both in terms hydrology and water quality improvement) and ecosystem connectivity.

Table 80: Outlet structures and application

Outlet structures	Application
Box weir	<ul style="list-style-type: none"> • Can be fitted with reverse slope pipes to draw water from deeper below the PWL, enabling cooler discharge temperatures where the wetland discharges to a stream. • More resilient to vegetation build-up, this is of benefit in heavily vegetated wetlands.
Circular inlet	<ul style="list-style-type: none"> • Can be fitted with reverse slope pipes to draw water from deeper below the PWL, enabling cooler discharge temperatures where the wetland discharges to a stream.
Drop inlet	<ul style="list-style-type: none"> • Should not be used where wetlands discharge to streams (unless it can be demonstrated that sufficient alternate temperature mitigation is provided).
Weir with channel	<ul style="list-style-type: none"> • Should not be used where wetlands discharge to streams (unless it can be demonstrated that sufficient alternate temperature mitigation is provided).

C8.2.4.4 Emergency spillway

An emergency spillway must be incorporated into the wetland design. The emergency spillway should be armoured, located in natural ground and not placed on fill material. Operating velocities must be calculated for spillways in natural ground in order to determine the need for additional armoured. The emergency spillway embankment should be carefully compacted during constructing to prevent settlement. The spillway needs to be maintained free from large and deep rooting vegetation which can restrict flows, cause blockages and potentially destabilise slopes.

In situations where embankment failure may lead to loss of life or extreme property damage (as determined by a qualified geotechnical engineer in accordance with dam safety requirements), the emergency spillway must be able to:

- Pass an extreme flood, which may be the Probable Maximum Flood, with no freeboard (after post-construction settlement) and with the service outlet blocked
- Pass the full 1% AEP event flow ($Q_{(1\%)}$) assuming the service outlet is blocked 100%, with at least 0.3 m of freeboard (after construction settlement).

This will be the minimum top level of the embankment of the device. The emergency spillway is normally designed as a trapezoidal broad-crested weir as specified in Auckland Council technical report, TR 2013/018.

In all cases, it is essential that designers discuss site-specific constraints with Auckland Council stormwater engineers from the earliest design stages.

C8.2.4.5 High flow management

Off-line wetlands should be designed with a high-flow bypass incorporated into the design where possible to protect the vegetated wetland components from damage during large flood events. The bypass should divert high flows upstream of any of the wetland components. In cases where this isn't possible, the bypass should divert flows upstream of the main wetland body (from within the forebay, as close to the inlet as possible). A similar bypass facility or flow reduction capacity (for example, floodplain connectivity) should be incorporated into online devices.

Bypasses must be:

- Constructed to withstand high flows without resultant scour and instability, and are usually designed as vegetated trapezoidal channels adjacent to the wetland
- Designed and sized accurately using standard hydraulic calculations
- Designed to take into account any downstream conveyance capacity constraints.

High flow management requirements are significantly reduced where the wetland is off-line. Where the only option is an on-line wetland, the bypass should at a minimum, include flows up to the 50% AEP event and preferably also cater for the 10% and 1% AEP flood events, if possible.

C8.2.4.6 Sediment drying area

The wetland must include a land area set aside for maintenance vehicle parking and turning, as well as drying out of sediments removed from the wetland when maintenance occurs. Design criteria are as follows:

- The area set aside must accommodate at least 10% of the PWV at a maximum depth of 1 m
- The area set aside must be suitable for desilting of the wetland (slope, bunding, bagging areas etc.).

The area and slope set aside may be modified if an alternative area or method of disposal is approved on a case-by-case basis.

C8.2.4.7 Liners

The bed materials are important structural and water-quality treatment components, controlling the final shape and contouring of the wetland design, supporting vegetation, influencing water losses and providing a treatment medium.

The recommended performance specifications are:

- The liner design must consider all design aspects including slope stability, subgrade conditions, overlapping and sealing
- An impermeable liner is required where subsoils are too porous and infiltration is not designed for, or where there is a potential contamination or fill soil. A liner is required to be impermeable and should extend to above the top of operational water levels (> 200 mm) and be anchored, overlapped and sealed appropriately
- Slope stability must be assessed to ensure there is no sloughing or slumping
- Liners can be either:
 - Compacted clay (*in situ* or imported) - that has been tested for suitable imperviousness. *In situ* soils should be compacted to a minimum of 300 mm depth
 - Synthetic products (such as geosynthetic clay liners, PVC and HDPE liners) in accordance with the manufacturer's specifications. All imported clay liner material must be tested and approved prior to delivery to site. Any geotextile must be installed to prevent potential floatation.

C8.2.4.8 Planting and plant selection

Selection of suitable plants for wetlands is important for optimal contaminant removal, as well as providing amenity and ecological benefits. Designers must select species adaptable to the required ranges of depth, frequency and duration of inundation. An experienced professional should provide detailed designs for wetland planting. Plant selection should be informed by the wetland plant species tables in Section C1.6.1: Plants and soils, as well as relevant Auckland Council technical publications, including:

- Auckland Council TR 2009/083 *Landscape and Ecology Values within Stormwater Management*
- Auckland Council TR 2013/007 *Comparative Suitability of Native Submerged Macrophyte Species in Wetlands in the Auckland Region, Literature Review.*

The key considerations for wetland planting include the following:

- Plants must thrive in the designed water depth (permanent and intermittent) in which they are planted
- At maturity, plant biomass in deep marsh zones should be similar to plant biomass (and therefore similar roughness) to the shallow marsh zones
- Taller marsh species should be selected as far as practical within deep marsh zones
- Initial planting densities in deep marsh zones should be higher than in shallow marsh zones, so that hydraulic resistance is as similar as practical between shallow and deep marsh (when plants have reached maturity)

- Plants should have dense, rigid, fibrous, upright growth forms
- Tall marsh species with spreading aerial cover should be planted adjacent to open water areas
- Perennial species should be planted
- Raupo is generally not recommended where a diverse plant assemblage is desired, clogging of outlets is a significant risk, and there are concerns over die-back in winter and high organic biomass generation
- A diverse range of plant species should be designed for. Up to 10% of plants can be diversity planting (i.e. not purely selected for treatment characteristics) to increase overall biodiversity, particularly around the perimeter of the wetland. Native local species (with seed eco-sourced by nurseries) should be used where practical
- Vegetation should be limited to plants with a root structure that will not damage wetland lines or compromise the structural integrity of any bunds. The use of large tree species must be carefully considered to avoid potential instability and risks of damage to any synthetic liners
- Where feeding by waterfowl is a concern (i.e. where birds pull up plants), plants with a substantial root and soil mass (e.g. plants from large pots) should be planted. Alternately, the planting needs to be protected from waterfowl until the vegetation is sufficiently established
- The depths at which emergent macrophytes can survive in constructed stormwater wetlands are typically less than within natural wetlands due to reduced water clarity. Plants must be healthy and robust, with vegetation extending well above the planted water depth
- Plants should be installed with a minimum density of 4 plants/m² (depending on the wetland location, slope and species) to form full coverage of the shallow and deep marsh areas
- Appropriate plant species must be used where there is potential for the planting zone to dry up
- Vegetation that provides a high level of shading (including trees, shrubs and reeds/tall sedges) should be planted around, and within, the wetted margin of the wetland. Tall species with spreading crowns provide aerial cover, especially if located on the northern aspect of a wetland, which will reduce water temperature increases. Shade-tolerant herbaceous marsh vegetation should be selected for shaded areas.

C8.2.5 Construction design considerations

The following construction considerations should be addressed during design and specification:

- Structural features in the embankment (such as anti-seep collars, diaphragms, core trenches, and clay cores) must be included in the design to reduce the movement of water through the embankment. Since these features are hidden, the construction and quality of construction must be verified during their installation and certified by a registered engineer. Failure to inspect these features at critical times may result in embankment failure in the future
- Penetration through wetland base/embankment should be suitably sealed and protected against water seepage, internal erosion and piping
- Ensure any impermeable layer is protected during construction
- Plant to ensure quick, dense vegetation growth (considering season, irrigation, soil volumes etc.)

- Post-construction settling of soils must be considered, with effective compaction during construction
- Clear design instructions need to be given in instances where a sediment retention basin (for erosion and sediment control needed during construction) is transitioning to a constructed wetland for stormwater management
- Inlets and outlets should be stabilised to prevent erosion
- Sediments must be managed during construction and prevented from entering the wetland. The forebay should be cleaned prior to beginning operation
- The design must include provision for adjusting the PWL at different stages of development to support vegetation establishment and allow maintenance.

C8.2.6 Operation and maintenance design considerations

The following operation and maintenance considerations should be addressed during design and specification.

Access:

The layout of the wetland and all structures must include access for maintenance purposes, including the following:

- Access is required to all areas of a wetland (including structures and planting) and should include a turning bay (or double access) for vehicles
- Vehicle access should be 3.5 m wide and no steeper than 1V:8H with no sharp bends
- Access should be designed for maintenance benches around the sediment forebay and the main wetland body
- The access should allow large heavy trucks and machinery with sufficient run-up during both summer and winter. Smaller vehicle access should be provided for at least 50% of the wetland perimeter
- Maintenance access for larger wetlands can be incorporated into the wetland design by incorporating structural elements into bunds to support vehicles
- Design of the access track must also consider other site users and public safety
- All access should incorporate safety in design features to ensure maintenance does not pose any health and safety risk, or that any risk is minimised and well identified and mitigated.

An operation and maintenance manual is required for all wetlands.

Function:

- Maintenance responsibility should be assigned prior to final design for wetlands and future asset owners should be included in all design discussions. If maintenance responsibility cannot be defined during the design phase, wetlands should not be selected for a given site
- Regular inspections for seepage through the embankment are required
- The health of the vegetation must be monitored. If vegetation cover decreases below 80% of the wetland area (excluding the forebay), then supplementary planting is required
- The wetland form is to be evaluated when carrying out inspections, looking for any signs of short-circuiting and erosion within the wetland. Differences in plant density are indicators of short-circuiting
- The service outlet should be accessed directly from the maintenance access if the structure is located close to the wetland bank
- The sediment drying area must include a turning bay or double access for vehicles
- Every design should include a draw-down mechanisms (preferably dewatering via gravity)
- The forebay should be cleared of sediment when it is 50% of the design volume.

Aesthetic:

- Designs should minimise opportunities for graffiti, vectors and accumulation of debris (such as rubbish and vegetation litter)
- All designs should minimise mowing. Where needed, slopes needing mowing must be no steeper than 1V:5H.

C8.3 Design examples

C8.3.1 Example 1: Wetland for water quality treatment and detention

The site characteristics for the constructed wetland design are presented in Table 81. The wetland will discharge to a SMAF1 area; therefore detention for stream protection is required. No bypass has been allowed for and 1% AEP storm events will enter the wetland via overland flow paths. The downstream catchment has flooding issues for all rain events. For downstream flood mitigation, the peak flow control for 50%, 10% and 1% AEP storm events requires that stormwater discharge rates in post-development scenario cannot exceed pre-development discharge rates.

Table 81: Site characteristics

Item	Value		
Catchment area	36.52 ha		
Pre-development land-use	75% pervious (27.40 ha)	CN = 74	Time of concentration = 0.315 hours
Post-development land-use	65% impervious (23.74 ha)	CN = 98	Time of concentration = 0.274 hours
	35% pervious (12.78 ha)	CN = 74	

The following storm intensities apply (Table 82).

Table 82: Storm intensities

Design storm	Rainfall across 24 hours (mm)	Rainfall including climate change factor
90 th percentile	25 mm	-
95 th percentile	34 mm	-
50% AEP	80 mm	87.2 mm
10% AEP	140 mm	158.5 mm
1% AEP	228 mm	267 mm

* Including increase factor to accommodate climate change as per MfE (released 2010).

Step 1 – Hydrologic calculations

The pre-development rainfall excludes the adjustment for climate change; post-development includes the factor assuming a 2.1°C increase.

Table 83: Hydrologic calculation results

Item	Value	Item	Value
PWV	5,384 m ³	10% AEP pre-development flow	5.31 m ³ /s
Forebay volume (PWV x 15%)	808 m ³	10% AEP post-development flow	7.56 m ³ /s
Detention volume for stream protection	7,913 m ³	10% AEP runoff volume difference	8,248 m ³
50% AEP pre-development flow	2.45 m ³ /s	1% AEP pre- development flow	9.80 m ³ /s
50% AEP post-development flow	3.82 m ³ /s	1% AEP post- development flow	13.40 m ³ /s
50% AEP runoff volume difference	6,271 m ³	1% AEP runoff volume difference	9,720 m ³

Step 2 – Hydraulic calculations

Step 2a: Permanent water level area

To calculate this area, (and after consultation with Auckland Council) we consider a wetland with depth coefficient of 1.5 m. Consequently, the permanent water level area of the wetland is:

$$\frac{PWV \times 50\%}{1.5} = 1,795 \text{ m}^2$$

Step 2b: Elevation – storage calculations

Consider that, based on the site topography, the preliminary wetland sizing provides the elevation storage relationship as detailed in Table 84. For this example, consider that the permanent water level is at RL35.90 m.

Table 84: Elevation-storage relationship

Water level (m, RL)	Storage volume (m ³)	Water level (m, RL)	Storage volume (m ³)
35.90	3,084	38.00	15,920
36.00	3,499	38.20	17,492
36.20	4,472	38.40	19,121
36.40	5,502	38.60	20,809
36.60	6,589	38.80	22,557
36.80	7,735	39.00	24,364
37.00	8,942	39.10	25,310
37.20	10,215	39.20	26,271
37.40	11,553	39.30	27,246
37.60	12,951	39.40	28,236
37.80	14,406	39.50	29,240

Step 3 – Outlet design

Step 3a: for stream protection

- Outlet pipe: Consider a 1200 mm diameter pipe 33 m long, upstream invert level at RL34.60 m and a gradient of 1.5% acting as a culvert
- Outlet manhole riser: Consider a 1,800 mm diameter riser with the top level at RL37.40 m and a 270 mm diameter orifice with the invert level at RL 35.90 m.

Step 3b: Outlet design for flood mitigation

- The spillway has to convey the 1% AEP peak flow with a minimum freeboard of 300 mm to the top of embankment
- Consider the spillway characteristics to be:
 - Invert level: RL39.00 m
 - Base width: 25 m
 - Lateral slope : 1:5
 - Transversal base slope : 0.5%
 - Manning's roughness: 0.030 (reinforced grass).
- The spillway will discharge the 1% AEP peak flow of 13.40 m³/s with a depth of 650 mm. The maximum water level over the spillway will be:

$$\text{RL39.00 m} + 0.650 \text{ m} = \text{RL39.65 m}$$

Step 3c: Top of embankment level

- The minimum level of the top of embankment will be 300 mm above the maximum water level over the spillway:

$$\text{RL39.65 m} + 0.300 \text{ m} = \text{RL39.95 m}$$

Step 4: Routing model

In order to confirm the wetland sizing together with the post-development discharges to the stream, a HEC-HMS model is run. The model incorporates the above information (catchment, elevation-storage, service outlet structure and spillway data) and provides the following results (Table 85):

Table 85: Results of routing model

Event	Wetland discharge	Maximum water level
50% AEP	1.24 m ³ /s	RL37.62 m
10% AEP	5.24 m ³ /s	RL38.08 m
1% AEP	6.16 m ³ /s	RL38.91 m

In the post-development scenario, all wetland discharges are below the pre-development values with the spillway not being engaged. Consequently, the wetland sizing has achieved the desired outcomes.

Step 5 – Wetland configuration and design

The following design configurations are used:

- For a 3:1 ratio: length is 105 m and width is 35 m
- A 3 m wide safety bench is provided 300 mm below permanent water level around the wetland body
- The inlet and outlet structures are located centrally on opposite ends of the wetland body
- An anti-seepage solution is included in the design of the outlet pipe
- Erosion protection solutions are provided for the inlet and outlet structures at the discharge points
- A maintenance access of 3.5 m width, with a maximum longitudinal slope of 1V:8H, is provided along the wetland to allow access to the forebay and outlet structure. A drying area is allowed for near the forebay.

C8.3.2 Example 2: Wetland for water quality treatment only

The site characteristics for the constructed wetland design are presented in Table 81. The wetland discharges to the marine area and therefore no further detention has to be provided. In a 1% AEP design storm, the water enters the wetland via overland flow paths. No bypass is allowed for.

Table 86: Site characteristics

Item	Value		
Catchment area	12 ha		
Pre-development land-use	100% pervious (12 ha)	CN = 74	Time of concentration = 0.167 hours
Post-development land-use	65% impervious (7.8 ha)	CN = 98	Time of concentration = 0.167 hours
	35% pervious (4.2 ha)	CN = 74	

The following storm intensities apply (Table 87).

Table 87: Storm intensities

Design storm	Rainfall across 24 hours (mm)	Rainfall including climate change factor (mm)*
90 th percentile	26 mm	-
50% AEP	70 mm	76.3 mm
10% AEP	130 mm	147.2 mm
1% AEP	220 mm	257 mm

* Including increase factor to accommodate climate change as per MfE (released 2010).

Step 1 – Hydrologic calculations

The hydrologic calculations based on Section B and TP108⁴ requirements provide the results shown in Table 83.

Table 88: Hydrologic calculation results

Item	Value
PWV	1,808 m ³
Forebay volume (PWV x 15%)	271 m ³
50% AEP peak flow	1.23 m ³ /s
10% AEP peak flow	2.60 m ³ /s
1% AEP peak flow	4.82 m ³ /s

⁴ Auckland Council TP108 *Guidelines for Stormwater Runoff Modelling in the Auckland Region*, 1999

Step 2 – Hydraulic calculations

Step 2a: Permanent water level area

To calculate this area, (and after consultation with Auckland Council) we consider a wetland with depth of 1.5m. Consequently, the permanent water level area of the wetland is:

$$\frac{PWV}{1.5} = 1,205 \text{ m}^2$$

Step 2b: Determine size of wetland:

Based on the site topography, allow for a permanent water level area of 1,205 m². For this example, consider that the permanent water level is at RL5.00 m. With a forebay of minimum 1.5 m depth, its invert level will be at RL3.5 m. Also allow for the wetland to extend at least 1.5 m above RL5.00 (for this example) to include the spillway and embankment. Final levels are dictated by the outlet design below.

Step 3 – Outlet design

Step 3a: Service outlet structure

- Outlet pipe: Consider a 1200 mm diameter pipe 35 m long, upstream invert level at RL2.5 m and a gradient of 1.5% acting as a culvert
- Outlet manhole riser: Consider a 1,800 mm diameter riser with the top level at RL5.00 m (permanent water level).

Step 3b: outlet structure

- The outlet structure combining these two elements will discharge:
 - The 50% AEP peak flow of 1.23 m³/s at RL5.25 m
 - The 10% AEP peak flow of 2.60 m³/s at RL5.40 m
 - The 1% AEP peak flow of 4.82 m³/s at RL5.60 m.

Step 3c: Emergency spillway

- The spillway has to convey the 1% AEP peak flow with a minimum freeboard of 300 mm to the top of the embankment
- Consider the spillway characteristics to be:
 - Invert level: RL5.70 m - at least 100 mm above the 1% AEP level of RL5.60 m
 - Base width: 12 m
 - Lateral slope : 1:5
 - Transversal base slope : 0.5%
 - Manning's roughness: 0.030.
- The spillway will discharge the 1% AEP peak flow of 4.82 m³/s with a depth of 337 mm. The maximum water level over the spillway will be:

$$\text{RL5.70 m} + 0.337 \text{ m} = \text{RL6.037 m} - \text{rounded at RL6.04 m}$$

Step 3d: Top of embankment level

- The minimum level of the top of embankment will be 300 mm above the maximum water level over the spillway:

$$\text{RL6.04 m} + 0.300 \text{ m} = \text{RL6.34 m}$$

Step 4 – Wetland configuration and design

The following design configurations are used:

- Dimensions: for a 3:1 ratio: length is 59 m and width is 21 m. A check of velocities confirms that this length-to-width ratio design is feasible
- A 3 m wide safety bench is provided 300 mm below permanent water level around the wetland body
- The inlet and outlet structures are located centrally on opposite ends of the wetland body
- An anti-seepage solution is included in the design of the outlet pipe
- Erosion protection solutions are provided for the inlet and outlet structures at the discharge points
- A maintenance access of 3.5 m width is provided along the wetland allow access to the forebay and outlet structure. A sediment drying area is allowed for near the forebay.



C9 Ponds

Table of Contents

C9.0	Technical guidance: ponds	269
C9.1	Introduction	269
C9.1.1	Use in a treatment suite	270
C9.1.2	Pond components	270
C9.1.3	Site considerations	274
C9.2	Pond design	276
C9.2.1	Design considerations	276
C9.2.2	Design for safety	278
C9.2.3	Device sizing	280
C9.2.4	Component design	284
C9.2.5	Construction design considerations	289
C9.2.6	Operation and maintenance design considerations	289
C9.3	Design examples	291
C9.3.1	Example 1: Wet pond for detention only	291

Figures

Figure 54:	Schematic of dry and wet pond profiles	269
Figure 55:	Schematic of wet pond layout	274
Figure 56:	Pond design process flow chart	283
Figure 57:	Pond outlet details	284

Tables

Table 89:	Wet and dry pond components and performance specifications	271
Table 90:	Site considerations	274
Table 91:	Wet and dry pond design considerations and specifications	276
Table 92:	Volume and calculation needs for pond design	281
Table 93:	Outlet structures and application	286
Table 94:	Site characteristics	291
Table 95:	Storm intensities	291
Table 96:	Hydrologic calculation results	292
Table 97:	Elevation-storage relationship	293
Table 98:	Results of routing model	294

C9.0 Technical guidance: ponds

C9.1 Introduction

A stormwater management pond is a constructed stormwater treatment device designed to collect and retain stormwater runoff generated by an upstream catchment. A pond will provide detention of flows generated by specific storm events to the pre-development values, or less, to protect streams from downstream erosion and mitigate downstream flooding risks. In this document, ponds are not considered to comply with Auckland Unitary Plan requirements for stormwater treatment and any pond design will require consent (other consents will be required also).

1% AEP detention	✓
50% and 10% AEP detention	✓
Detention for erosion control*	✓
Retention	✗
Water quality*	✗

* for the purposes of this guideline, ponds are not considered to provide water quality treatment

There are two types of pond (Figure 54):

- Wet pond:** A pond that has a standing pool of water with a permanent water level (PWL). The wet pond provides some level of water quality treatment as the sediments (especially larger particles) can settle over a long period of time. However, increased water temperature can have a significant negative impact on receiving waters
- Dry pond:** A dry pond (also called a detention basin) temporarily stores stormwater runoff to control the peak rate of discharges without having a standing pool of water. Dry ponds empty between rainfall events, depending on the time interval between the rainfall events.

Catchment and site features, and constraints (such as treatment and detention requirements, topographical and geotechnical characteristics etc.), together with associated implementation costs, are considered in the pond design.

In all instances, wetlands are preferred to ponds, with dry ponds preferred to wet ponds. Ponds must be designed to be off-line from waterways.

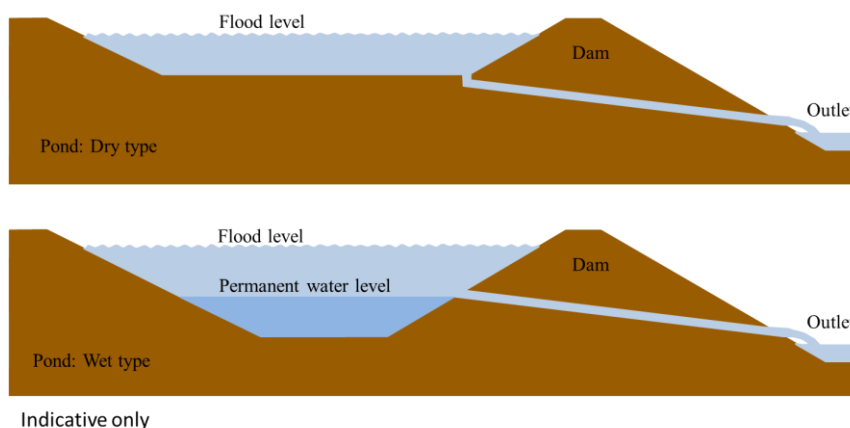

Figure 54: Schematic of dry and wet pond profiles

C9.1.1 Use in a treatment suite

C9.1.1.1 Wet ponds

Wet ponds are used as a final design feature in a suite of devices. They must be located off-line at the base of the catchment and are designed primarily to provide detention.

Long-term maintenance of a pond is improved where pre-treatment is provided. While the pond forebay acts to retain some sediment, this does not constitute pre-treatment. Ponds should be used downstream of water quality and retention devices.

Particular attention needs to be paid to the receiving environment where temperatures may have a negative impact. Ponds that regularly exceed 25°C in summer can surpass the lethal threshold for a number of native fish species. Due to the slow rate of stream water cooling (1°C/100 m), elevated temperatures may persist for hundreds of metres downstream of ponds. Where there is a high probability of downstream temperature effects occurring, a wet pond should not be used. Even off-line ponds can have negative effects on downstream environments.

C9.1.1.2 Dry ponds

Dry ponds may be effectively located in the mid- to lower-catchment (where flows accumulate) and can be more effectively maintained at a lower cost than wet ponds. They do not impose the same environmental and amenity issues (with temperatures, vectors and pests) as wet ponds. Dry ponds may be used for other amenity values (such as open space amenity) when not inundated.

In all instances, wetlands are the preferred stormwater management device over ponds, as they provide water quality treatment and flow management.

C9.1.2 Pond components

The main components of a wet pond are detailed in Table 89 and illustrated in Figure 55. Stormwater ponds or other devices constructed with a retaining wall are generally not permitted by Auckland Council. Auckland Council will exercise its discretion on case-by-case basis and specific design and approval will be required.

Table 89: Wet and dry pond components and performance specifications

Component	Description
Embankment/bund	<ul style="list-style-type: none"> • A dam/bund is usually required to provide the water volume for detention and must be specifically designed to ensure it will not fail as a water retaining structure. • The dam/bund location and dimensions are determined by the site contours, geotechnical characteristics and size requirements. • The dam/bund has to allow for maintenance access and in some instances, the spillway and pond outlet pipe (which is a component of the pond service outlet). These areas must be free of large or deep-rooted vegetation.
Forebay*	<ul style="list-style-type: none"> • The forebay is the part of the pond designed to retain coarse sediment and other debris before water enters the rest of the pond. • Its design must allow for maintenance (access for sediment removal). • A forebay bund separates the forebay from the pond.
Pond banks	<ul style="list-style-type: none"> • Pond banks contain the water and also provide a surface for vegetative planting, which can provide shading (for temperature control), some biological uptake of nutrients and filtering other contaminants.
Pond liner	<ul style="list-style-type: none"> • The base and banks of a wet pond should be impermeable to ensure a permanent water level is maintained. This can be achieved using a liner or well-compacted clay layer.
Safety bench*	<ul style="list-style-type: none"> • The safety bench is a sloped bank which provides safer, easier exit from the pond in cases of unauthorised or accidental entry. • The minimum 3 m wide bench provides a platform for plants which will provide additional treatment and constitute a natural safety barrier. • These benches may be replaced with other barriers (such as fencing) in certain designs.
Inlet	<ul style="list-style-type: none"> • The pond inlet discharges the runoff from the contributing catchment into the pond. There may be more than one inlet into the pond and the inlet(s) has to discharge to the forebay. • Examples of pond inlets include pipes, channels and swales. • The inlet design has to incorporate flow velocity dissipation structures prior to the forebay to prevent scour and erosion of the forebay and enable diffuse flows into the forebay. Refer to Auckland Council's technical report, TR 2013/018 <i>Hydraulic Energy Management: Inlet and Outlet Design for Treatment Devices</i>.

Component	Description
Service outlet	<ul style="list-style-type: none"> • The service outlet discharges stormwater from the pond to downstream recipients such as coastal areas, streams, engineered open channels or stormwater reticulation. • Generally, the outlet service includes three components: <ul style="list-style-type: none"> ○ The outlet riser ○ The outlet pipe (penetration through the embankment requires a suitably qualified and experienced professional's involvement in design and construction). Design should provide a mechanism to drain the wet pond within 12 hours, including forebay by gravity without pumping ○ The downstream pipe outlet structure which incorporates erosion protection measures. • If the service outlet discharges to a stormwater reticulation, the pipe outlet structure is not required. • Depending on the function provided by the pond, several outlet riser arrangements (such as orifices and slots) may be required. These should have measures to prevent blockage (such as scruffy domes or baffle plates). Refer to Auckland Council technical report, TR 2013/018 <i>Hydraulic Energy Management: Inlet and Outlet Design for Treatment Devices</i>.
Permanent water volume	<ul style="list-style-type: none"> • The PWV is calculated as the whole hydrologic mitigation volume (retention plus detention) of the 90th percentile storm event.
Live storage	<ul style="list-style-type: none"> • Live storage is the volume of water that needs to be detained above the PWV (i.e. stream protection) and released in a controlled manner over 24 hours. • When live storage has to be provided (i.e. stream protection is required), the PWV can be reduced by 50% if there is evidence that the device will function and there is improved amenity, environmental and cultural outcomes.
Fish passage*	<ul style="list-style-type: none"> • Many juvenile native fish (such as eels, galaxiids, torrent fish, smelt, lamprey and bullies) develop at sea and migrate to river habitats, where they grow to adulthood. • The migration of these species must be designed for in wet pond design, particularly where permanent structures (dams, weirs, falls, tide gates, culverts, and screens) and/or high water velocities may be present.
Emergency spillway	<ul style="list-style-type: none"> • The emergency spillway is an emergency outlet which starts to discharge stormwater when the service outlet is partially or totally blocked/damaged, or the service outlet has insufficient capacity to convey a larger non-design storm event. • Emergency spillways commonly consist of an overflow channel, although emergency overflow structures that are piped can also be considered. • The invert level of the spillway should be 100 mm above the maximum water level in the pond. • The spillway can be located anywhere within the pond (not necessarily close to the service outlet). • Freeboard should be a minimum of 300 mm above the maximum flow depth of the largest design storm.

Component	Description
Sediment drying area*	<ul style="list-style-type: none"> An area is needed for drying sediments that have been removed during maintenance works before off-site disposal. The purpose of drying sediments is to reduce sediment weight and therefore reduce haulage and disposal costs.
Edge form *	<ul style="list-style-type: none"> Edge form influences the appearance of a pond, increases the range of plant and wildlife habitats and has implications for pond maintenance. Edges should include sloping margins where water level fluctuations cause greater areas of wet soils. Generally, sloping margins require a more sophisticated management approach to ensure growth of plants. Areas of gradually varied wetness should be identified and specific planting strategies should be developed for these areas. Such gradually sloping areas can appear a more natural part of the landscape than steep banks and they provide opportunities for a greater range of plants and habitat.
Maintenance access	<ul style="list-style-type: none"> Access is required to allow inspections and maintenance to any pre-treatment devices as well as the inlets, forebay, the service outlet and emergency spillway at a minimum. Access is also required around the outside (or at least along the length) of the pond.
Bypass	<ul style="list-style-type: none"> A high-flow bypass is highly recommended for all flows that are not intended to be routed through the pond. It is highly recommended that a maintenance bypass be included in the design (such as a weir to isolate the pond for maintenance).

* Wet ponds only

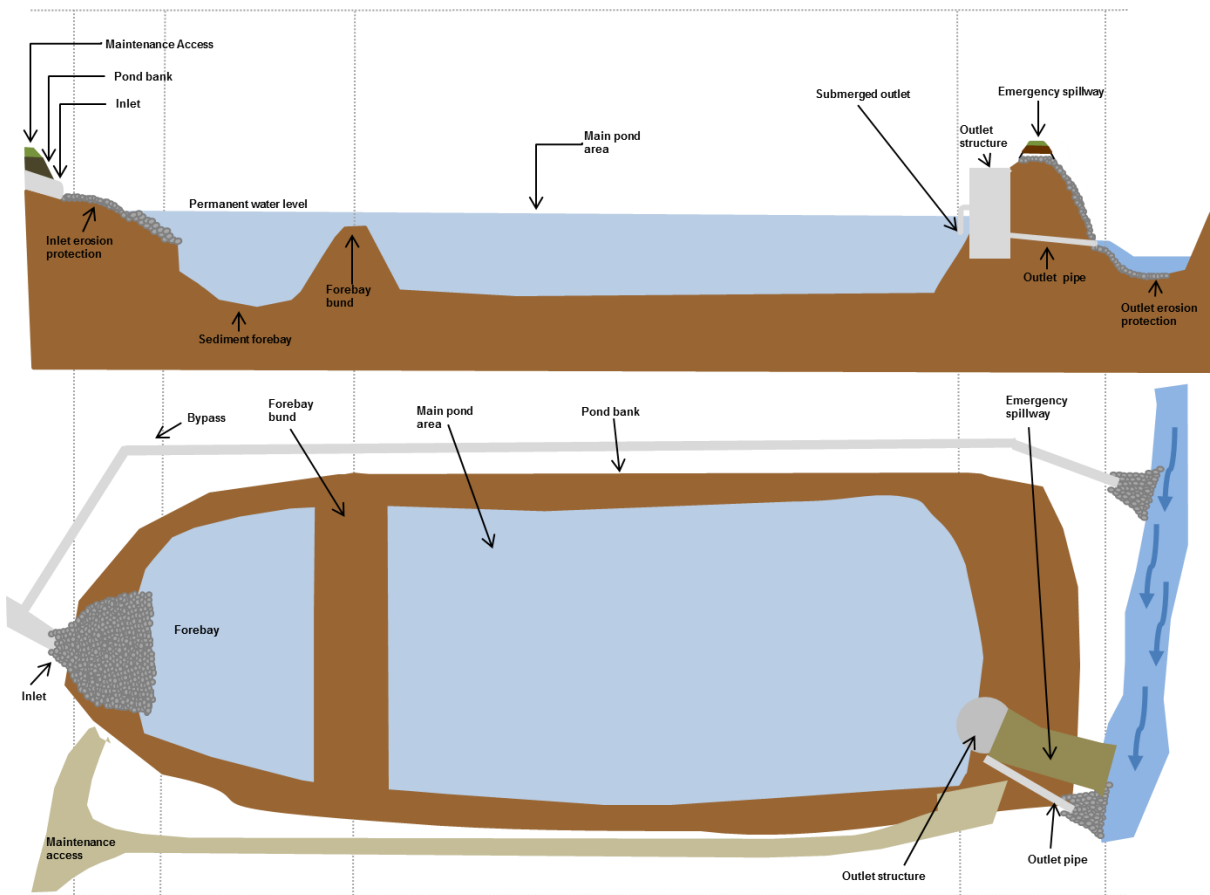

Figure 55: Schematic of wet pond layout

C9.1.3 Site considerations

General site considerations are presented in Table 90.

Table 90: Site considerations

Item	Description
Catchment size and location	<ul style="list-style-type: none"> • Generally used in medium/large catchments and located in catchment’s lower portion. • Wet ponds must be designed off-line to open watercourses. Where this is not possible, a wetland must be used. Any deviations from this will require specific design mitigations which must be discussed with Auckland Council. • Dry and wet ponds should be sized based on the entire contributing catchment, not just the development area. • Designers should ensure the catchment drains naturally by gravity to the pond and ensure vertical and horizontal space is available for detention. • Attention is needed to ensure associated infrastructure, such as maintenance access and high flow bypasses, can be accommodated within this space.

Item	Description
Groundwater	<ul style="list-style-type: none"> • A geotechnical investigation is needed to inform all pond designs. Groundwater analysis should be undertaken. • Designs should mitigate against too much or too little water draining from the pond; for this reason most wet ponds are designed to be impermeable.
Slope	<ul style="list-style-type: none"> • Ponds cannot be used on slopes unless terraced. Ponds should be placed more than 15 m away from slopes with gradients of 9° (15%) or more.
Soils requiring structural support	<ul style="list-style-type: none"> • Geotechnical investigations are needed across the entire design area to understand the underlying soils and designs must accommodate all geotechnical constraints (such as soil instability).
Soils with poor drainage	<ul style="list-style-type: none"> • Pond functionality is generally not impacted by poor drainage into surrounding soils as they are generally not designed to provide for retention functions.
Pre-treatment	<ul style="list-style-type: none"> • Pre-treatment of stormwater prior to entry to the pond is needed to reduce potential long-term maintenance costs. • Regular maintenance to remove litter, debris and sediments is also needed.
Contaminated land	<ul style="list-style-type: none"> • Ponds should not be located on, or near, contaminated land or on fill soils.
Setback	<ul style="list-style-type: none"> • Ponds should not be located above existing or planned dwellings. • Ponds should be located at a 3 m minimum from property lines. • Ponds should not be located within a 1V:1H plane taken from the toe of any retaining wall. • Ponds should be located a minimum of 10 m from high voltage (electricity) cables and 5 m from bridge soffits.
Traffic	<ul style="list-style-type: none"> • Traffic from the road to the pond should be considered in the design. • Ponds should be located at a minimum of 3 m from traffic areas. • Maintenance access: allow for easy access to all pre-treatment areas and the main body of the pond.
Temperature considerations	<ul style="list-style-type: none"> • In all cases, ponds will likely raise water temperatures to a level where negative impacts on the receiving environment occur. Wetlands are preferred devices for this reason. • An outlet positioned in the mid-point of the water column may draw lower temperatures but may also draw anoxic water. • Site the pond to minimise solar gain in the water body. Ensure planting can provide shade to reduce water temperatures.
Pest and vector considerations	<ul style="list-style-type: none"> • Locate and design of the pond needs to minimise habitat for pests, weeds and potential vectors of disease.

C9.2 Pond design

Ponds must be designed in accordance with (but not limited to):

- New Zealand Society of Large Dams (NZSOLD), *Dam Safety Guidelines*, 2015
- NZSOLD. *Guideline on Inspecting Small Dams*, 1997
- New Zealand Building Act, 2004
- Auckland Regional Council technical publication, TP109 *Dam Safety Guidelines*, 1999.

C9.2.1 Design considerations

Table 91 provides design considerations for ponds.

Table 91: Wet and dry pond design considerations and specifications

Item	Description
Structural design	<ul style="list-style-type: none"> • Structural design as required in relevant dam specifications and guidelines (e.g. NZSOLD 2015 and TP109). • The structural design must be completed and certified by a suitably qualified and experienced professional to the standards of relevant dam specifications and guidelines. • Any pond designed with permeability must have geotechnical evidence to support this approach. • For wet ponds, a permanent water level must be maintained. • The wet pond depths should ≥ 0.5 m and ≤ 2 m.
Length to width	<ul style="list-style-type: none"> • Maximise the length-to-width ratio and promote flows that engage the full width of the pond.
Inlets and outlets	<ul style="list-style-type: none"> • The design of all inlets and outlets will be influenced by the site constraints and intended flows and must be designed by a suitably qualified and experienced person. • Inlets and outlets should be designed as described in Auckland Council's technical report, TR 2013/018 <i>Hydraulic Energy Management: Inlet and Outlet Design for Treatment Devices</i> and should have debris screens for safety, to remove rubbish and prevent clogging. • Stormwater inlets should be located to prevent a short-circuit flow path.
Forebay*	<ul style="list-style-type: none"> • The forebay must hold a minimum 15% of the PWV (10% of the pond area). • The minimum forebay depth must be 1.5 m. • The forebay bund must be accessible for maintenance.

Item	Description
Pond slopes	<ul style="list-style-type: none"> • All slopes must be approved by a geotechnical engineer based on site-specific constraints, with the following guidance: <ul style="list-style-type: none"> ○ Internal pond banks below the PWL: < 14° (25% or 1V:4H) ○ Internal side slope above the PWL: < 18° (32% or 1V:3H) ○ Forebay bund slope: < 18° (32% 1V:3H) ○ External side slope: < 18° (32% 1V:3H) ○ Any slopes requiring mowing: < 11° (20% or 1V:5H).
Pond safety bench*	<ul style="list-style-type: none"> • Ensure that a safety bench at least 3 m wide, with a 7° (12% or 1V:8H) gradient, extends around the entire pond (no more than 0.3 m below PWL) with densely planted vegetation to form a natural barrier.
Emergency spillway	<ul style="list-style-type: none"> • Where possible, locate the emergency spillway near the inlet to the pond to minimise re-suspension in larger storm events. • The invert level of the spillway should be 100 mm above the maximum water level in the pond. • Freeboard should be a minimum of 300 mm above the maximum peak flow of the design storm event.
Maintenance access	<ul style="list-style-type: none"> • Wet pond: Access is required around the outside or at least along the length of the pond between the forebay and the service outlet to allow pond inspections and maintenance work to be carried out. The minimum width of the access is 3.5 m and maximum slope of 1V:8H is required. The service outlet should be accessed directly from the maintenance access if the structure is located close to the pond bank. Otherwise, a structure (such as a bund, pier or gantry) may be considered to allow access to the outlet. The maintenance access has to incorporate a turning bay for the maintenance vehicles and must be designed to be accessible in all weather conditions. • Dry pond: Access to the inlet and outlet structures is required together with access throughout the dry pond for plant maintenance, including mowing.
Bypasses	<ul style="list-style-type: none"> • It is highly recommended that a high-flow bypass and maintenance bypass be included in all designs.
Sediment drying area	<ul style="list-style-type: none"> • An area designated for drying sediments after maintenance is required. • The site should be away from pond banks and must be flat with vehicle access. • The area set aside must accommodate at least 10% of the PWV and allow for a height of sediment of up to 1 m.
Impervious liner	<ul style="list-style-type: none"> • A liner may be required for certain groundwater conditions. • In wet ponds, the liner should extend beyond the top of operational water levels.

* applies to wet ponds

There are a number of design constraints when deciding whether a wet or dry pond should be used.

Wet ponds

- Are not suitable on fill sites or near steep slopes (unless confirmed through geotechnical analysis) and designed with impermeable liner
- May need a liner system to maintain a permanent pool if not dug below groundwater level
- May not be feasible in very dense urban areas or areas with high land costs due to large surface area needs
- Are not suitable if the receiving water is temperature-sensitive due to warming of the pond surface area
- Need a variety of safety issues to be addressed including public access, pond depth and dam safety
- Are unsuitable where there is a high probability of exotic pest fish and aquatic weed establishing either from downstream spread (on-line) or from deliberate introduction (off-line). Ponds dominated by aquatic pest weeds and pest fish can impose a sizeable maintenance burden on the asset owner and cause water quality issues
- Are unsuitable where there is a high likelihood of a decline in water quality (particularly temperature and nutrients).

Dry ponds

- Need porous soils or subsurface drainage to ensure that the bottom stays dry between storms
- Are not suitable in areas with high water tables
- Are not suitable on fill sites or steep slopes unless geotechnically checked.

C9.2.2 Design for safety

Ponds pose very specific safety concerns and should be designed to minimise risk. This section presents some of those considerations.

C9.2.2.1 Dam safety

A dam structure is often needed to impound the required water volumes within the pond and is a specific safety consideration. The key objective for dam safety is that people, property and the environment (present and future), should be protected from the harmful effects of dam failure or uncontrolled discharges from the pond.

Dam safety requires consideration of the total system surrounding the dam and should not be limited to the dam structure. A suitably qualified dam engineer should always be involved in the design of the dam.

Designs must consider the following:

- The consequences of dam failure should be understood so that appropriate design, construction and management actions can be applied to protect people, property and the environment
- All natural hazards, loading conditions, potential failure modes and any other threats to the safe design, construction, commissioning, operation and rehabilitation of a dam should be identified
- Dams and associated structures should be designed, constructed, commissioned, operated and rehabilitated in a manner which ensures they meet appropriate performance criteria
- The long-term responsibility for the safety of the dam rests with the dam owner.

Dam safety requirements of the RMA and the New Zealand Building Act 2004 must be met.

C9.2.2.2 Other pond safety considerations

Other pond safety considerations include:

- No large or deep root planting on structural bunds
- Any mown slopes must be no steeper than 1V:5H
- The slope of the internal banks below the PWL must be no steeper than 1V:4H, to allow easier access from the pond should someone fall in
- Access restrictions to inlets / outlets / pre-treatment areas / maintenance areas
- Clear illustrations within signage to cater for adults and children
- Interim fencing or signage during construction.

Fencing is not preferred due to its aesthetic impacts and general restrictions for access and interaction compared with more natural safety measures. However, permanent fencing (at least 1.2 m high) may be considered in the following circumstances:

- If embankments into the pond main body are steeper than 1H:3V
- Where vertical drops exceed 0.5 m
- Areas deeper than 0.3 m are adjacent to heavily used areas (e.g. pedestrian walkways)
- A pool fence (or similar) should be used where there is a chance of drowning and the surrounding area is specifically intended for use by small children (swings, playgrounds, sporting fields etc.).

Where the depth of the water is more than 1 m, consideration should be given to additional safety mitigations such as:

- Wider safety benches
- Flatter batter slopes above PWL
- Additional depth of dense planting
- Permanent fencing.

Pond design should mitigate pest species including mosquito habitat.

C9.2.3 Device sizing

The volumes of water detained in a pond are based on the methodology detailed in Section B. An accurate calculation of the size of the contributing catchment area is needed. Using the preliminary pond design, an elevation–storage table has to be prepared that indicates pond volumes at different levels.

A summary of the hydrologic volume calculations required for pond design is provided in Table 92.

Table 92: Volume and calculation needs for pond design

Volume calculation	Calculation notes
Permanent water volume (PWV)	<ul style="list-style-type: none"> The PWV represents the water volume between the pond base level and the PWL and is designed to provide pond function (sufficient volume to provide some sediment settling, allow for biodiversity etc.) and amenity. Pond depth should be designed to prevent nuisance pests and elevated temperatures. The PWV is calculated based on 90th percentile design storm runoff (approximately 25 mm, as defined in Section B). The PWV includes the forebay volume which represents 15% of a wet pond's total volume. The PWV is provided as 100% dead storage below the PWL. When live storage has to be provided (i.e. stream protection is required), the PWV can be reduced by 50% if there is evidence that the device will function and there is improved amenity, environmental and cultural outcomes.
Forebay water volume and velocity	<ul style="list-style-type: none"> The forebay volume represents at least 15% of the PWV. Flow velocity from the forebay up to the 10% Annual Exceedance Probability (AEP) rainfall event must be less than 0.25 m/s in order to avoid sediment resuspension.
Detention volume for stream protection	<ul style="list-style-type: none"> The detention volume is based on the runoff from the 90th or 95th percentile storm events, for SMAF2 and SMAF1 areas respectively, and has to be released over 24 hours in order to provide erosion protection for the stream channel. The detention volume is provided above the PWL of the pond and is released through an appropriately designed opening (usually an orifice) located at this level which is part of the service outlet.
Detention volume for flood mitigation	<ul style="list-style-type: none"> In most instances, larger storm events will be diverted or bypass the pond; when required due to downstream discharge constraints (e.g. inadequate pipe capacity or flooding issues), the pond can be designed to provide detention for specific post-development peak discharges for rainfall events up to the 1% AEP event. Flood mitigation detention volumes are to be provided above the PWL and include the stream protection detention volume. In order to size the device conservatively, designers should use a pre-development volume estimated using TP108¹, and a post-development volume using TP108 plus an increase factor to accommodate climate change (MfE, 2010²).

¹ Auckland Regional Council TP108 *Guidelines for Stormwater Runoff Modelling in the Auckland Region*, 1999

² Ministry for the Environment *Tools for Estimating the Effects of Climate Change on Flood Flow*, May 20

C9.2.3.1 Permanent water level - wet ponds only

The PWL provides for proper function and helps prevent nuisance pests and elevated temperatures. In wet pond design, the elevation-storage table indicates the level below which the pond volume equates to the calculated PWV and this level becomes the PWL. Detention volumes are provided above this level. The PWL should be an average of at least 0.5 m to allow for proper pond function. The maximum depth should not be more than 2 m (and, where it is this deep, must provide sufficient safety features). In a dry pond, there is no PWL.

C9.2.3.2 Detention for stream protection

The elevation-storage table determines the level where the detention volume calculated based on the 90th or 95th percentile storm (SMAF 1 and 2 respectively) is provided above the PWL. The detention outlet is located at the PWL in a wet pond. In a dry pond, the outlet is at the pond base level.

In both dry and wet ponds, the steps detailed below should be followed to calculate the outlet size:

- Conservatively assume that the entire detention volume is in the pond at one time (even though this will not actually be the case since the outlet will be sized to release this volume over a 24-hour period. This will be refined at a later stage.)
- Calculate the average release rate (equal to the volume/duration) = $Q_{(avg)}$
- At the full detention design elevation, the maximum release rate is assumed to be $Q_{(max)} = 2 \times Q_{(avg)}$
- Calculate the required outlet size by trialling various outlet sizes. If calculations indicate an outlet orifice size of less than 70 mm (70 mm diameter orifice or 50 mm wide slot), then 70 mm should be used (for maintenance and operation). Ensure the orifice is designed to minimise the risk of blockage.

Different outlets may be considered for detention design and detailed design can be found in Auckland Council's technical report, TR 2013/018³.

C9.2.3.3 Detention for flood mitigation

For both wet and dry ponds, the elevation-storage table indicates the level where the required detention volumes are provided (above the PWL for wet ponds and above pond base level for dry ones). Each of these volumes includes the detention volume for the 90th or 95th percentile storms (if required to be provided). The specific outlets for each detention volume (or rainfall event) are located at the maximum level of the previous volume: the 50% AEP outlet is located at the maximum level of the detention volume for stream protection; the 10% AEP outlet is located at the maximum level of the 50% AEP detention volume, etc.

C9.2.3.4 Iteration

A routing model such as HEC-HMS can be used to design an optimised pond configuration by calculating peak inflows and discharges, volumes, storage and elevation.

³ Auckland Council TR 2013/018 *Hydraulic Energy Management: Inlet and Outlet Design for Treatment Devices*

C9.2.3.5 Summary of pond design process

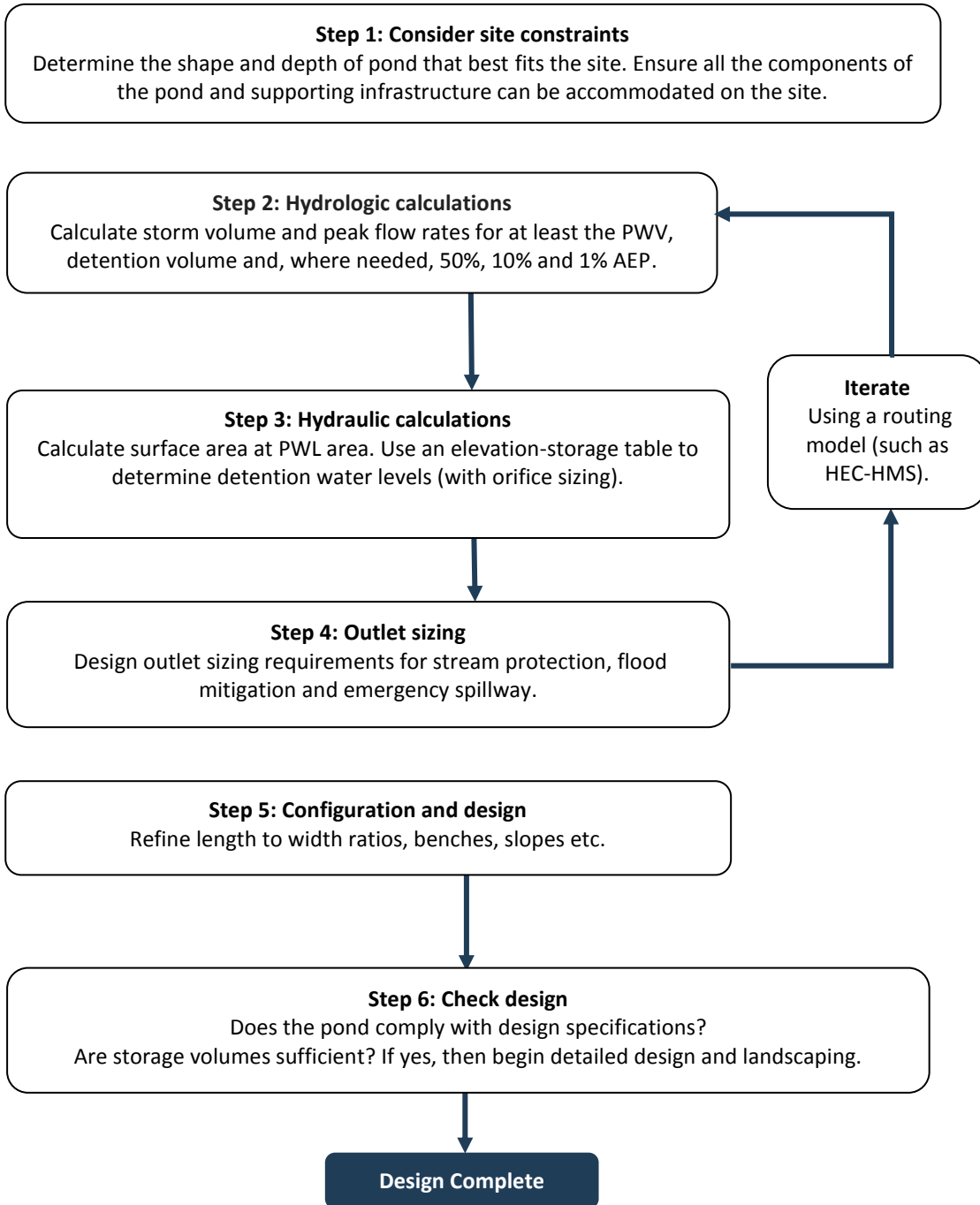

Figure 56: Pond design process flow chart

C9.2.4 Component design

The key pond design elements are the pond inlet, forebay, outlet and spillway (Figure 57).

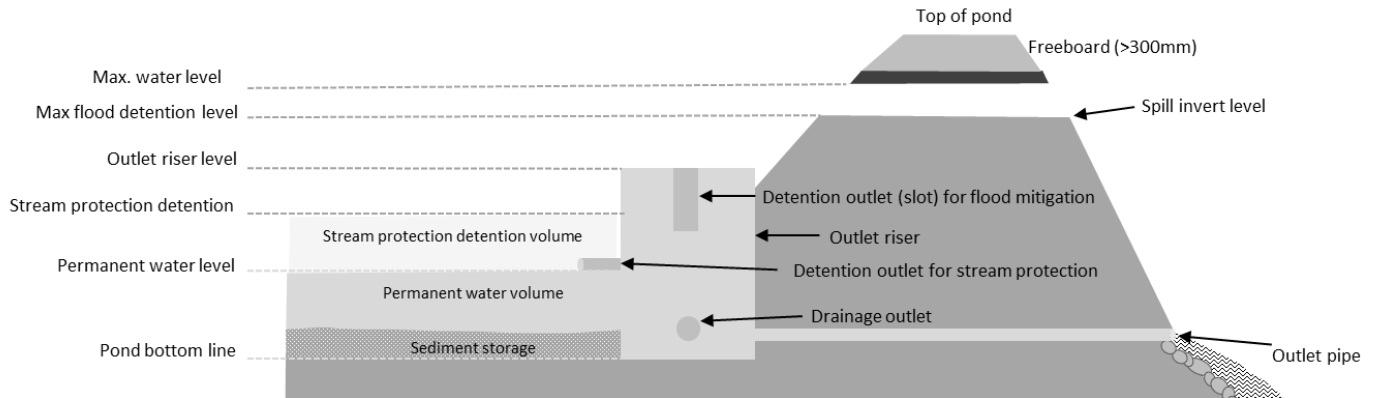

Figure 57: Pond outlet details

C9.2.4.1 Pond inlet

Inlet pipes must be located in order to avoid back ponding. The flow discharged to the pond may vary between the water quality flow and the 1% AEP rainfall event flow depending on the design. Flows up to the 10% AEP storm flow are usually conveyed and discharged through piped reticulation while the difference up to the 1% AEP storm flow is discharged by way of overland flow path. For piped reticulation, the dry or wet pond inlet consists of either a precast concrete wingwall or an *in situ* wingwall made of concrete and/or rocks. For both inlet types, erosion protection placed above and below the PWL has to be provided at the discharge point (rock rip-rap on a geotextile layer should be used). Further details on energy dissipation are provided in Auckland Council technical report, TR2013/018³. The design should consider the use of debris screens.

The invert of the inlet must be located no lower than the PWL.

C9.2.4.2 Pond forebay - wet ponds

The forebay has to provide a minimum volume of 15% of the PWV and is designed as follows:

- The base should be lowered below the general pond base and allow for at least a 1V:3H slope, making the forebay the deepest part of the pond
- It is recommended that a submerged bund (100 mm to 150 mm below the PWL) is used to delineate the forebay from the rest of the pond, providing the pond with a constant depth. The minimum bund slopes must be 1V:3H. This is recommended to protect the top of the bund against erosion caused by flows discharged over it during higher rain events. A permeable barrier (such as gabions or rocks) may be included on top of the bund, extending above the PWL. This feature can be designed to add amenity and mitigate potential visual impacts.

The forebay should meet the following design criteria:

- A minimum length to width ratio of 2:1 is required
- The forebay should be at least 1.5 m deep and deeper, where this is possible
- The forebay velocities should be minimised by optimising the forebay length, width and depth, considering maximum permissible velocities. In some cases, this may necessitate more than the minimum forebay volume
- The base should be hardened for easier maintenance and sediment removal
- A method for assessing sediment build-up (e.g. vertical depth marker) may be included
- Provide an access bay adjacent to the forebay area (to ensure the forebay can be dug out without the use of special equipment) within reach of a long-reach digger (no more than 12 m from the centre of the forebay) or other maintenance vehicles
- A stabilised access track is required to enable heavy machinery to access the forebay, unless it is proposed to de-silt with the use of lower weight machinery/vehicles (e.g. sucker trucks). The forebay does not need to be located adjacent to the pond and can be disconnected, provided there is energy dissipation and spreading of inflows from the connection to the forebay.

C9.2.4.3 Pond outlet structure

The service outlet structure incorporates all the specific outlets sized for different pond functions including detention for stream protection (90th or 95th percentile) and flood mitigation (50%, 10% and 1% AEP). Further detail on design of outlet structures is provided in Auckland Council's technical report, TR 2013/018.

The service outlet structure includes the following components:

- The outlet riser which incorporates all the specific outlets, a top debris screen and a valve/screw cap located close to the pond base level to allow for dewatering of the pond without the use of pumps (drained by gravity) within 12 hours for maintenance
- The outlet pipe which discharges downstream of the pond. This must be correctly sized. If the discharge is to the coastal area, or to a stream, an erosion protection solution must be located at the discharge point. This may consist of either a precast concrete wingwall or an *in situ* wingwall made of concrete and/or rocks.

For ponds, the following requirements must be met:

- Fish passage must be designed for where it is necessary for species migration
- A submerged pipe outlet is recommended for wet ponds. This outlet will draw off water from cooler, deeper waters within the outlet pool and reduce downstream effects associated with discharge of elevated surface water temperatures that can occur in ponds during warmer summer months. Subsurface outlet structures also have the advantage of less frequent clogging as floating debris is not trapped in the outlet and support easy maintenance with the hydraulic control situated in a structure on the pond batter. The pipe can be designed to be adjustable to allow for adaptive management (e.g. with swivel elbow)

- The hydraulic control should, where feasible, include a removable weir plate fitted to the outside of an accessible manhole, to allow for modifications to be made, if required, following commissioning (e.g. to correct unforeseen design issues)
- The design of the outlet structure should allow for adjusting the permanent water level for management and maintenance purposes
- In the case of discharge to coastal areas, backflow of seawater into the pond needs to be avoided
- The design should prevent seepage along the outlet pipe (to be approved by a geotechnical engineer and in accordance with dam safety requirements)
- If the pond discharges to a stream or coastal area, the outlet design must include erosion control and energy dissipation (Auckland Council technical report, TR 2013/018³).

A wide variety of outlet structures can be used (a small selection is provided in Table 93 and further detailed in TR 2013/018 and each type listed can also have various designs. The final design of the outlet structure(s) is determined by a combination of site characteristics, functions and ecosystem connectivity.

Table 93: Outlet structures and application

Outlet structures	Application
Box weir/broad crested weir	<ul style="list-style-type: none"> • Can be fitted with reverse slope pipes to draw water from deeper below the PWL, enabling cooler discharge temperatures where the pond discharges to a stream. • These structures are more resilient to vegetation build-up.
Circular inlet	<ul style="list-style-type: none"> • Can be fitted with reverse slope pipes to draw water from deeper below the PWL, enabling cooler discharge temperatures where the pond discharges to a stream.
Drop inlet	<ul style="list-style-type: none"> • Should not be used where ponds discharge to streams (unless it can be demonstrated that sufficient alternate temperature mitigation is provided).
Weir with channel	<ul style="list-style-type: none"> • Should not be used where ponds discharge to streams (unless it can be demonstrated that sufficient alternate temperature mitigation is provided).

C9.2.4.4 Emergency spillway

An emergency spillway must be incorporated into the pond design. The emergency spillway should be armoured, and preferably located in natural ground and not placed on fill material. Operating velocities must be calculated for spillways in natural ground in order to determine the need for additional armouring. The emergency spillway embankment should be carefully compacted during construction to prevent settlement. The spillway needs to be maintained free from large and deep rooting vegetation which can restrict flows, cause blockages and potentially destabilise slopes.

In situations where embankment failure may lead to loss of life or extreme property damage (as determined by a qualified geotechnical engineer in accordance with dam safety requirements), the emergency spillway must be able to:

- Pass an extreme flood, which may be the Probable Maximum Flood, with no freeboard (after post-construction settlement) and with the service outlet blocked
- Pass the full 1% AEP event flow ($Q_{(1\%)}$) assuming the service outlet is blocked with at least 0.3 m of freeboard (after construction settlement).

This will determine the minimum top level of the embankment of the device. The emergency spillway is normally designed as a trapezoidal broad-crested weir as specified in Auckland Council's technical report, TR 2013/018.

In all cases, it is essential that the designers discuss site-specific constraints with Auckland Council stormwater engineers from the earliest design stages.

C9.2.4.5 High flow management

Where possible, ponds should be designed as off-line devices with a high-flow bypass for events exceeding the pond design capacity. The bypass should divert high flows upstream of any of the pond components. In cases where this isn't possible, it should divert flows upstream of the main pond body (from within the forebay, as close to the inlet as possible). The emergency/overflow spillway conveys events too large for the bypass; again, if possible, the emergency spillway should discharge from the forebay, as opposed to the pond main body.

Bypasses and overflows must be:

- Constructed to withstand high flows without resultant scour and instability. They are usually designed as vegetated trapezoidal channels adjacent to the pond
- Designed and sized accurately using standard hydraulic calculations
- Designed to take into account any downstream conveyance capacity constraints.

High flow management requirements are significantly reduced where the pond is off-line. Where the only option is an on-line pond, the bypass should include flows above the 50% AEP event and preferably also cater for the 10% and 1% AEP flood events, if possible.

C9.2.4.6 Sediment drying area

In wet ponds, land area adjacent to the pond must be set aside for drying sediments removed from the pond when maintenance is performed. This area should include maintenance vehicle parking and turning, as well as drying out of sediments removed from the pond when maintenance occurs. Design criteria are as follows:

- The area set aside must accommodate at least 10% of the PWV at a maximum depth of 1 m
- The area set aside must be suitable for desilting of the pond (slope, bunding, bagging areas etc.)

The area and slope set aside may be modified if an alternative area or method of disposal is approved on a case-by-case basis.

In dry ponds, the detention area is where the sediments will dry between storm events and should be designed to allow for any maintenance resulting from sedimentation.

C9.2.4.7 Liners

The bed materials are important structural components, controlling the final shape and contouring of the pond design, supporting vegetation and influencing water losses. The recommended performance specifications for liners are:

- The liner design must consider all design aspects including slope stability, subgrade conditions, overlapping and sealing
- In wet ponds: An impermeable liner is required where subsoils are too porous and infiltration is not designed for, or where there is potential contamination, or fill soils. A liner is required to be impermeable and should extend to above the top of operational water levels (> 200 mm) and be anchored, overlapped and sealed appropriately
- Liners can be either:
 - Compacted clay (*in situ* or imported) - that has been tested for suitable imperviousness. *In situ* soils should be compacted to 300 mm depth. All imported clay liner material must be tested and approved prior to delivery to site
 - Synthetic products (such as geosynthetic clay, PVC and HDPE liners) in accordance with the manufacturer's specifications. All imported clay liner material must be tested and approved prior to delivery to site. Any geotextile must be installed to prevent potential floatation.

C9.2.4.8 Planting and plant selection

Design of a stormwater pond should ensure that the pond fits with the surrounding landscape. General landscape design principles will apply. The area should develop a strong and definite theme or character. This might be generated from particular trees, or views from the site, topographical features, or the cultural character of the surrounding neighbourhood. The landscape design for the area will provide a setting for the pond so that the pond will appear a natural component of the overall setting.

Although ponds function in a fundamentally different way to constructed wetlands and provide limited biodiversity potential, there is opportunity to introduce native wetland elements to pond design. Vegetation should be limited to plants with a root structure that will not damage pond liners or compromise the structure

integrity of any bunds/embankment. The use of large tree species must be carefully considered to avoid potential instability and risks of any damage to any liners. Maintenance access must not be affected by planting.

Further details on landscaping for ponds can be found in Section C8: Constructed wetlands and Section C1.6.1: Plants and soils.

C9.2.5 Construction design considerations

The following construction considerations should be addressed during design and specification:

- Structural features in the embankment (such as anti-seep collars, diaphragms, core trenches, and clay cores) must be included in the design to reduce the movement of water through the embankment. Since these features are hidden, the construction and quality of construction must be verified during their installation and certified by a registered engineer. Failure to inspect these features at critical times may result in embankment failure in the future
- Penetration through pond base/embankment should be suitably sealed and protected against water seepage, internal erosion and piping
- Ensure the pond's impermeable layer is protected during construction
- Any planting should ensure quick, dense vegetation growth (considering season, irrigation, soil volumes etc.)
- Post-construction settling of soils must be considered, with effective compaction during construction
- Clear design planning needs to be given in instances where a sediment retention basin (for erosion and sediment control needed during construction) is transitioning to a pond for stormwater management
- Inlets and outlets should be stabilised to prevent erosion
- Sediments must be managed during construction and prevented from entering the pond. The forebay should be cleaned prior to beginning pond operation.

C9.2.6 Operation and maintenance design considerations

The following operation and maintenance considerations should be addressed during design and specification. An operation and maintenance manual is required for all ponds.

Access:

The layout of the pond and all structures must include access for maintenance purposes including the following:

- Access is required to all areas of a pond (including structures and planting) and should include a turning bay (or double access) for vehicles
- Vehicle access should be 3.5 m wide and no steeper than 1V:8H with no sharp bends

- Access should be designed for maintenance benches around the sediment forebay and the main pond body
- The access should allow large heavy trucks and machinery with sufficient run-up during both summer and winter. Smaller vehicle access should be provided for at least 50% of the pond perimeter
- Maintenance access for larger ponds can be incorporated into the pond design by incorporating structural elements into bunds to support vehicles
- The design must also consider other site users and public safety
- All access should incorporate safety in design features to ensure maintenance does not pose any health and safety risk, or that any risk is minimised and well identified and mitigated.

An operation and maintenance manual is required for all ponds.

Function:

- Maintenance responsibility should be assigned prior to final design for ponds and future asset owners should be included in all design discussions. If maintenance responsibility cannot be defined during the design phase, ponds should not be selected for a given site
- Regular inspections for seepage through the embankment are required
- The service outlet should be accessed directly from the maintenance access if the structure is located close to the pond bank
- The pond design must include a sediment drying area and a turning bay or double access for vehicles
- Every design should include a draw down mechanism (preferably dewatering via gravity)
- The forebay should be cleared of sediment when it is 50% of the design volume.

Aesthetic:

- Designs should minimise opportunities for graffiti, vectors and accumulation of debris (such as rubbish and vegetation litter)
- All designs should minimise mowing. Where needed, slopes must be no steeper than 1V:5H.

C9.3 Design examples

C9.3.1 Example 1: Wet pond for detention only

The site characteristics for the wet pond design are presented in Table 94. The pond will discharge to a SMAF1 area; therefore detention for stream protection is required. No bypass has been allowed for and 1% AEP storm events will enter the pond via overland flow paths. The downstream catchment has flooding issues for all rain events. For downstream flood mitigation, the peak flow control for 50%, 10% and 1% AEP storm events requires that stormwater discharge rates in post-development scenario cannot exceed pre-development discharge rates.

Table 94: Site characteristics

Item	Value		
Catchment area	19 ha		
Pre-development land-use	95% pervious (18.05 ha)	CN = 74	Time of concentration = 0.26 hours
Post-development land-use	65% impervious (12.35 ha) 35% pervious (6.65 ha)	CN = 98 CN = 74	Time of concentration = 0.167 hours

The following storm intensities apply (Table 95).

Table 95: Storm intensities

Design storm	Rainfall across 24 hours (mm)	Rainfall including climate change*
90 th percentile	25 mm	-
95 th percentile	32 mm	-
50% AEP	70 mm	75 mm
10% AEP	120 mm	136 mm
1% AEP	180 mm	210 mm

* Including increase factor to accommodate climate change as per MfE (released 2010).

Step 1 – Hydrologic calculations

The hydrologic calculations based on Section B and the TP108 requirements provide the results shown in Table 96.

Table 96: Hydrologic calculation results

Item	Value	Item	Value
PWV	2,800 m ³	10% AEP pre-development flow	2.14 m ³ /s
Forebay volume (PWV x 15%)	420 m ³	10% AEP post-development flow	3.77 m ³ /s
Detention volume for stream protection	3,818 m ³	10% AEP runoff volume difference	6,052 m ³
50% AEP pre-development flow	0.91 m ³ /s	1% AEP pre- development flow	3.83 m ³ /s
50% AEP post-development flow	1.91 m ³ /s	1% AEP post- development flow	6.13 m ³ /s
50% AEP runoff volume difference	4,490 m ³	1% AEP runoff volume difference	7,081 m ³

Step 2 – Hydraulic calculations

Step 2a: Permanent water level area

To calculate this area, we consider a pond with a PWV reduced by 50% because detention volume for stream erosion is provided. Also, we consider that the calculated pond depth is 1.5m.

Consequently, the permanent water level area of the pond is:

$$\frac{PWV \times 50\%}{1.5} = 934 \text{ m}^2$$

Step 2b: Elevation – storage calculations

Consider that, based on the site topography, the preliminary pond sizing provides the elevation storage relationship as detailed in Table 97. For this example, consider that the permanent water level is at: RL46.30 m

Table 97: Elevation-storage relationship

Water level (m, RL)	Storage volume (m ³)	Water level (m, RL)	Storage volume (m ³)
46.30	2282	47.60	7458
46.40	2550	47.70	8000
46.60	3156	48.00	9717
46.80	3854	48.20	10936
47.00	4635	48.40	12216
47.10	5055	48.60	13570
47.20	5493	48.80	14990
47.40	6431	49.00	16470

Step 3 – Outlet design

Step 3a: Outlet design for stream protection

- Outlet pipe: Consider a 800 mm diameter pipe 30 m long, upstream invert level at RL44.00 m and a gradient of 1.5% acting as a culvert
- Outlet manhole riser: Consider a 1,200 mm diameter riser with the top level at RL47.40 m and a 200 mm diameter orifice with the invert level at RL 46.30 m.

Step 3b: Outlet design for flood mitigation

The spillway has to convey the 1% AEP peak flow with a minimum freeboard of 300 mm to the top of embankment.

Consider the spillway characteristics to be:

- Invert level: RL48.40 m
- Base width: 15 m
- Lateral slope : 1:5
- Transversal base slope : 0.5%
- Manning's roughness: 0.030 (reinforced grass).

The spillway will discharge the 1% AEP peak flow of 6.13m³/s with a depth of 341 mm. The maximum water level over the spillway will be:

$$\text{RL48.40 m} + 0.341 \text{ m} = \text{RL48.741 m} - \text{rounded at RL48.75 m}$$

Step 3c: Top of embankment level

The minimum level of the top of embankment will be 300 mm above the maximum water level over the spillway:

$$\text{RL48.75 m} + 0.300 \text{ m} = \text{RL49.05 m}$$

Step 4: Routing model

In order to confirm the pond sizing together with the post-development discharges to the stream, a HEC-HMS model is run. The model incorporates the above information (catchment, elevation-storage, service outlet structure and spillway data) and provides the following results (Table 98):

Table 98: Results of routing model

Event	Pond discharge	Maximum water level
50% AEP	0.38 m ³ /s	RL47.51 m
10% AEP	2.16 m ³ /s	RL47.90 m
1% AEP	2.76 m ³ /s	RL48.29 m

In the post-development scenario, all pond discharges are below the pre-development values with the spillway not being engaged. Consequently, the pond sizing has achieved the desired outcomes.

Step 5 – Pond configuration and design

The following design configurations are used:

- Dimensions: For a 3:1 ratio: length is 54 m and width is 18 m.
- A 3 m wide safety bench is provided 300 mm below permanent water level around the pond body
- The inlet and outlet structures are located centrally on opposite ends of the pond body
- An anti-seepage solution is included in the design of the outlet pipe
- Erosion protection solutions are provided for the inlet and outlet structures at the discharge points
- A maintenance access of 3.5 m width, with a maximum longitudinal slope of 1V:8H, is provided along the pond to allow access to the forebay and outlet structure. A drying area is allowed for near the forebay.



Appendices

Contents

Appendix A1.0	Life cycle cost tools	A-1
Appendix A1.1	Glossary of terms	A-1
Appendix A1.2	Costing models and key references.....	A-2
Appendix A1.3	Cost template.....	A-3
Appendix A1.4	Sample cost template	A-5
Appendix B1.0	Quality checklists.....	B-1
Appendix B1.1	Pervious paving.....	B-2
Appendix B1.2	Bioretention device	B-3
Appendix B1.3	Living roof.....	B-5
Appendix B1.4	Rainwater tank.....	B-6
Appendix B1.5	Swale	B-7
Appendix B1.6	Infiltration device.....	B-8
Appendix B1.7	Wetlands	B-9
Appendix B1.8	Dry pond.....	B-11
Appendix B1.9	Wet pond	B-12

Tables

Table 1: Glossary of terms for life-cycle costing	A-1
---	-----

Appendix A1.0 Life cycle cost tools

Appendix A1.1 Glossary of terms

Table 1: Glossary of terms for life-cycle costing

Term	Abbreviation	Definition
Corrective maintenance costs		These are costs associated with significant corrective interventions to the treatment device. They occur infrequently over the life of a device.
Decommissioning costs		Costs associated with the decommissioning or complete removal of the treatment device at the end of its life span.
Discount rate	DR	The discount rate is a percentage rate used to discount the costs. The real discount rate should be used. Discounting is used to find the value at the base year of future costs, in other words, the NPV.
Life-cycle cost		The life-cycle cost is the sum of the acquisition and ownership costs of an asset over its life cycle from design, manufacturing, usage and maintenance through to disposal.
Life-cycle costing		The process of assessing the cost of a product over its life cycle or portion thereof.
Life span		The functional life of the treatment device in years.
Life-cycle analysis period		This is the period of time (in years) over which the life-cycle costing analysis is conducted.
Net present value	NPV	The value of future costs when discounted back to the present time (i.e. the present day value of all future costs).
Routine maintenance costs		These are annual costs which relate to routine maintenance events such as mowing grassed areas, weeding, general inspections, etc.
Total acquisition cost	TAC	The total acquisition cost relates to the design, planning, consenting and construction costs of a device.

Appendix A1.2 Costing models and key references

There are four key references for designers wanting to estimate life-cycle costs associated with stormwater management devices:

1) Landcare Research COSTnz Model (2009).

The COSTnz Model¹ is a simple life-cycle costing model (based on a unit-costing approach) that allows users to quantify the relative costs of individual stormwater management devices². The model provides default low, medium and high costing values which can be used and also recommends frequencies for maintenance activities. However, the user can also input their own costing and frequency data, if this is known. The model can therefore be used as a framework template for users to assess life-cycle costs using their own cost and frequency data. The model was completed in 2009 and was the first costing model to be used in New Zealand. The value of the model lies in its structured framework that can support user-defined cost information and in its ability to provide a relative comparison of costs between different stormwater treatment scenarios, rather than absolute cost values.

2) Auckland Unitary Plan Stormwater Management Provisions: Cost and Benefit Assessment TR 2013/043³. This document provides specific guidance regarding costs and benefits of the Auckland Unitary Plan provisions.

3) Auckland Unitary Plan Stormwater Management Provisions: Cost and Benefit Assessment TR 2013/043 Appendix 2⁴. Appendix 2 of TR2013/043 provides detail on representative device costs for:

- Bioretention (Section 2)
- Porous (pervious) pavement (Section 3)
- Rain water tanks (Section 4)
- Living roofs (Section 5)
- Sand filters (Section 6)
- Wetlands (Section 7)
- Gravel storage/retention (Section 8)
- Water sensitive design cost/benefit evaluation
- Water sensitive design (Section 9)
- Benefits/values (Section 10).

¹ Available at: <http://www.costnz.co.nz>

² Ira, S.J.T, Vesely, E-T., McDowell, C. and Krausse, M. 2009. COSTnz – *A Practical Stormwater Life Cycle Costing Model for New Zealand*. NZWWA Stormwater Conference.

³ Auckland Council. 2013. *Auckland Unitary Plan Stormwater Management Provisions: Cost and Benefit Assessment*. Technical Report 2013/43.

⁴ Auckland Council. 2013. *Auckland Unitary Plan Stormwater Management Provisions: Cost and Benefit Assessment*. Appendix 2. Technical Report 2013/45.

4) The NIWA-Cawthron UPSW Spatial Decision Support System (SDSS)⁵:

This model is a computer-based SDSS which aims to aid the evaluation of the effects of urban development on freshwater and estuarine urban waterbodies in terms of the four wellbeings: environmental, cultural, social and economic. An economic costing methodology, based on a life-cycle costing approach, was used to contribute to the overall economic indicator in the model. The life-cycle costing module used numerous COSTnz model runs to determine NPV \$/ha/yr costs based on a 50-year life-cycle analysis period⁶.

Appendix A1.3 Cost template

The spreadsheet requires that an annual maintenance cost be provided as the NPV process underestimates the quantum of in-period maintenance expenditures. An example cost template is attached.

For example, a NPV life-cycle cost for maintenance of \$1,330 in Year 12, using a discount rate of 3.5%, would be in the order of \$2,009 for real cash flows. A higher discount rate would lead to even greater underestimation of maintenance costs in the long term.

Determining an annual maintenance cost, which accounts for both routine and corrective maintenance expenditure, will assist in better quantifying potential future expenditure and in the development of the long term OPEX budgets. The annual maintenance cost is the yearly routine maintenance cost plus the yearly corrective maintenance cost. Routine maintenance costs are annualised for the life-cycle cost analysis. To determine the yearly corrective maintenance cost, divide the total undiscounted corrective maintenance cost by the life-cycle analysis period.

The spreadsheet also requests information on other costs such as:

- **Evaluation of benefit generation capacity:** Any direct or indirect benefits should be estimated. As an example, benefits could be related to multiple uses of stormwater practices (such as ponds for irrigation or fire-fighting purposes). Additionally, they can relate to amenity benefits such as increased house prices as a result of proximity to the device⁷. Offset costs (i.e. if the device saves the end-user money) should also be estimated⁸. Environmental services, such as biodiversity, health, cultural and other amenity items can be evaluated as direct benefits
- **Evaluation of risk cost (buffer cost):** This includes estimating costs which could be incurred for mitigating accidental failure or repair of the device and insurance costs

⁵ Urban Planning that Sustains Waterbodies (UPSW) research programme (funded by the NZ Ministry of Science and Innovation - Contract No. C01X0908) and the Resilient Urban Futures programme (funded by the Ministry for Business, Innovation and Employment – Contract No. UOOX1203, led by the University of Otago).

⁶ Ira, S. 2011. *The Development of Catchment Scale Life Cycle Costing Methods for Stormwater Management*. Report commissioned by Cawthron Institute. Cawthron Report No 2082, and the Addendum to Report No. 2082 issued in February 2014.

⁷ Polyakov, M., Iftehar, S., Zhang, F., and J. Fogarty, (2015), *The Amenity Value of Water Sensitive Urban Infrastructure: A Case Study of Rain Gardens*. Poster Presentation to the 59th Annual Conference of the Australian Agricultural and Resource Economists Society, Rotorua, New Zealand, February 11 - 13th, 2015.

⁸ Ira, S.J.T., Roa, A. and Carter, R. *Understanding and determining the cost of long term maintenance and resilience of water sensitive design*.

- **Evaluation of avoided costs as a result of water sensitive design features:** Many studies⁹ show a clear saving in total acquisition cost for water sensitive design over traditional developments. This saving generally seems to be related to “avoided costs” of site development such as reduced earthworking, concreting, impervious areas and piping. The spreadsheet can also be used to estimate any of these avoided costs for water sensitive design approaches.

⁹ As documented in Ira, S.J.T, Batstone, C.J. and Moores, J.P. 2015. “Does water sensitive design deliver beneficial net economic outcomes?”. NZWater Conference.

Appendix A1.4 Sample cost template

Title of project:				
Description of Stormwater Management Device:				
Location:				
Life cycle costing assumptions				
Device type				
Surface area (including landscaped areas surrounding device)				
Catchment area				
Life span				
Life cycle analysis period (LCAP)				
Base date				
Discount rate				
Have any of the costs been inflated / deflated to the base date?	Yes	No	If yes, please enter the inflation rate:	
Please specify the cost information source (e.g. own data, model data and type, etc.)				
Estimate life-cycle cost				
Cost by Project Phase	Total Cost	Discounted Cost	Notes	
Total acquisition costs:				
• Planning and design related costs				
• Construction costs				
Operation and maintenance costs:				
• Routine maintenance costs (RMC)				
• Corrective maintenance costs (CMC)				
Decommissioning/disposal costs:				
Total life cycle cost				

Other Costs			
Land costs (if excluded from the LCC analysis)			
Evaluation of risk costs (if excluded from the LCC analysis)			
Other (please specify)			
TOTAL QUANTIFIABLE COST			
Annualised Maintenance Cost		AMC = (Annual RMC + Yearly CMC) [yearly CMC can be worked out by divi	
Evaluation of benefit generation capacity			
Benefit Generation Type	Total Benefits/ Saving		Details
Direct benefits estimation			
Indirect benefits estimation			
Offset costs/ savings			
Estimation of avoided costs			
WSD Measure			Total Cost
Reduced disturbance/ earthworks	Yes	No	
Reduced impervious areas - streetscape & parking	Yes	No	
Reduced kerbing	Yes	No	
Reduced piping	Yes	No	
Reduced landscaping by maximising existing natural areas	Yes	No	
TOTAL AVOIDED COSTS			
Fill out one worksheet for each option under consideration. All categories must be completed in order to gain an understanding of the benefits and costs involved in each option.			

Appendix B1.0 Quality checklists

The design and construction of each device will differ and have unique features based on site and function. Larger, more complex devices will also have specific consenting conditions. As such, the following checklists provide a starting point but do not represent a comprehensive quality check list for individual device designs.

In addition, the final construction must comply with the design and must be signed off at critical points within the construction. It is the responsibility of the developer to ensure that these reviews and sign-offs occur in compliance with the consent conditions.

Appendix B1.1 Pervious paving

Contractor:	Date: Time:	Consent #:	Site:
Construction checklist (refer to Section C2 for full details)		Pass Y/N	Comments to explain
PRECONSTRUCTION			
Design has been reviewed and approved by final asset owner and does not receive more than 2:1 ratio of contributing catchment.			
Device sizing calculations have been reviewed and approved, together with overflow and connection designs.			
Final design has been reviewed and approved by road pavement engineer and Council.			
CONSTRUCTION			
Subsoils have been assessed to have >2 mm/hr infiltration rate where retention is required.			
Groundwater is confirmed to be >0.6 m from invert.			
Slope is <5% for designs receiving runoff from other impervious areas.			
Installation is in accordance with design and manufacturers' specifications. All materials, including gravels, bedding material, geotextiles and pavers comply with manufacturers' specifications and do not contribute to contaminant load.			
Construction is timed to minimise contaminants entering the device.			
FINAL INSPECTION			
Infiltration rate of device is confirmed to be >1,200 mm/hr.			
Final design does not create hazard –such as tripping or falls, wheelchair accessible etc.			
An operation and maintenance plan has been developed and provided to the final asset owner. Final asset owner understands the operation and maintenance requirements of the paving material and understands that clogging of the paving will result in non-compliance with consent.			

Note: The final asset owner must understand the need for maintenance (including declogging, weeding and replacement of any media). If the device becomes clogged it will no longer be considered impervious and will be out of compliance.

Appendix B1.2 Bioretention device

Contractor:	Date: Time:	Consent #:	Site:
Construction checklist (refer to Section C3 for full details)		Pass Y/N	Comments to explain
PRECONSTRUCTION			
Design has been reviewed and approved by final asset owner and is at least 3.5% of the contributing catchment if providing retention and detention.			
Device sizing calculations have been reviewed and approved.			
Final design has been reviewed and approved by Council.			
Subsoil infiltration is confirmed to be >2 mm/hr.			
CONSTRUCTION			
Geotextile is confirmed as specified in design and is not laid between gravel layers.			
Drainage layer is washed pea gravel (~10 mm) or equivalent and laid ≥200-300 mm deep, with at least 50 mm above underdrain.			
Underdrain is included as designed and surrounded by gravel.			
Storage layer below the underdrain is ≥450 mm for retention and detention.			
Transition layer is washed 2-7 mm gravel, laid 100 mm depth.			
Soil media is confirmed as specified in design and sourced from reputable supplier and is laid 500 mm depth.			
VEGETATION			
Mulch is laid throughout the device to a level below the inlet and will not float or blow away.			
Planting complies with planting plan.			
Diverse planting is confirmed suitable for inundation and drought.			

FINAL INSPECTION		
Any check dams (size, level and spacing) comply with design and function as designed.		
Inlets and outlets are installed as designed and flow bypasses are provided.		
Any pre-treatment devices are installed according to the design.		
Kerb cuts are installed according to design and allow directional flow to enter the device.		
Flow is confirmed to enter correctly and pass through the device with no short circuiting, and exit the device as designed.		
Device is protected from compaction (e.g. construction machinery and cars).		
An operation and maintenance plan has been developed, including irrigation and plant replacement if needed.		

Note: The bioretention device must be protected during construction:

- Kerbs must have protection from sediments and spills, using silt socks or inserts
- Machinery must be kept away from the device
- The establishment period must be adhered to. If plants are damaged due to construction, the device may not be accepted at hand over by the asset owner.

Appendix B1.3 Living roof

Contractor:	Date: Time:	Consent #:	Site:
Construction checklist (refer to Section C4 for full details)		Pass Y/N	Comments to explain
PRECONSTRUCTION			
Design has been developed by a structural engineer with input from architect/s and planting specialist/s.			
The final asset owner has been involved from the early design stages and accepts operation and maintenance responsibilities for the life of the device.			
Final design has been reviewed and approved by Council. All design aspects comply with the Building Code.			
CONSTRUCTION			
Waterproofing has been tested for integrity prior to installation of media and plants.			
Soils have been adequately blended before use.			
A minimum soil depth of 100 mm has been used.			
All components have been installed according to the manufacturers' specifications and the device design.			
VEGETATION			
Plants have been chosen which will not result in penetration of the root barrier and which will survive exposure and drought conditions specific to that site.			
All planting is in accordance with the planting plan.			
FINAL INSPECTION			
All safety design measures have been included in final construction.			
The constructed device has been inspected and approved by a structural engineer as conforming with the original design specifications.			
An operation and maintenance plan has been developed and provided to the final asset owner.			

Appendix B1.4 Rainwater tank

Contractor:	Date: Time:	Consent #:	Site:
Construction checklist (refer to Section C5 for full details)		Pass Y/N	Comments to explain
PRECONSTRUCTION			
Design has been reviewed and approved by final asset owner who agrees that any designed retention volumes will be used within 72 hours.			
Device sizing calculations have been reviewed and approved.			
Final design has been reviewed and approved by Council and complies with the Building Code.			
CONSTRUCTION			
The tank is durable, watertight and provides suitable and safe access.			
Tank is located suitably with regard to setbacks and soil stability.			
The orifice size is >10 mm with an outlet screen.			
All guttering is sized to convey the tank's design storm volume with appropriate bypass for all larger events.			
Gutter screens or filters have been installed.			
A dead storage space is provided below the lowest orifice.			
Erosion protection has been provided at the outlet if discharges directly to receiving environment.			
FINAL INSPECTION			
All plumbing and pipework complies with New Zealand standards and the Building Code and includes backflow prevention.			
An operation and maintenance plan has been developed and provided to the final asset owner.			

Note: The homeowner must understand the required use of retention volumes in the tank (if provided) within 72 hours of a rainfall event. The maintenance requirements must also be understood. In instances where an underground tank has been designed, the owner must know there is a tank on their site and understand their responsibilities.

Appendix B1.5 Swale

Contractor:	Date: Time:	Consent #:	Site:
Construction checklist (refer to Section C6 for full details)		Pass Y/N	Comments to explain
PRECONSTRUCTION			
Design has been reviewed and approved by Council and the final asset owner.			
Device sizing calculations have been reviewed and approved.			
Site considerations, including slope, have been accommodated in design.			
CONSTRUCTION			
Construction is timed for the final stages of the development and no contaminants associated with construction will enter the swale.			
All components, including the geotextiles, underdrains, aggregates and soil, have been sourced and installed per design.			
Subsoils have been loosened and mixed with appropriate blends and allowed to settle with a final bed depth of 200 mm.			
All slopes (longitudinal and horizontal) comply with design.			
Check dams (size and spacing) comply with design and function as designed.			
Inlets and outlets are installed as designed and flow bypasses are provided.			
VEGETATION			
Vegetation has been chosen which minimises / eliminates the need for mowing and weeding.			
Planting complies with planting plan.			
FINAL INSPECTION			
Flow is confirmed to enter correctly and pass through the device with no short circuiting, and exit the device as designed. Kerb cuts are installed according to design and allow directional flow to enter swale.			
Swales are protected from compaction – particularly traffic.			
An operation and maintenance plan has been developed and provided to the final asset owner.			

Appendix B1.6 Infiltration device

Contractor:	Date: Time:	Consent #:	Site:
Construction checklist (refer to Section C7 for full details)		Pass Y/N	Comments to explain
PRECONSTRUCTION			
Design has been reviewed and approved by final asset owner.			
Device sizing calculations have been reviewed and approved.			
Final design has been reviewed and approved by Council.			
Site considerations, including slope, setbacks and distance to groundwater have been accommodated in design.			
Subsoils have been assessed in terms of infiltration to be >10 mm/hr.			
CONSTRUCTION			
Geotextile is correct specification and is laid per design.			
Aggregate material is correct specification (size, washed, void space) and is laid per design.			
Observation well is installed with removable cap.			
Inlets, outlets and bypasses are installed correctly.			
FINAL INSPECTION			
Pre-treatment is in place.			
Device is stabilised.			
Flow enters/exits the device as designed.			
An operation and maintenance plan has been developed and provided to the final asset owner.			

Appendix B1.7 Wetlands

Contractor:	Date: Time:	Consent #:	Site:
Construction checklist (refer to Section C8 for full details)		Pass Y/N	Comments to explain
PRECONSTRUCTION			
Design has been reviewed and approved by final asset owner.			
Device sizing calculations have been reviewed and approved.			
Final design has been reviewed and approved by Council.			
CONSTRUCTION			
All materials are correct as specified in the design (including geotextiles, liners, aggregates, soils etc.).			
Any pre-cast components (including anti-seep collars, outlets etc.) are correct as specified in the design.			
Excavation is done in accordance with required slopes and bathymetry of the approved design.			
If designed as impermeable, the liner has been installed to ensure integrity on base and banks of wetland with appropriate overlap and anchoring. Any compacted clay has been installed using sequential compaction to ensure impermeability of base and banks of wetland.			
All connectors, gaskets and anti-seep collars are confirmed watertight.			
All inverts, inlets and outlets are at the correct location, grade and level.			
Emergency spillway has been constructed per design.			
Bypass has been constructed per design.			
Forebay has been constructed to correct depth and compaction and located for access and maintenance.			
Outlet protection has been included and is appropriately stabilised.			
Dewatering device has been installed.			
Fencing is installed per design.			
All bunds have been stabilised and are not planted with deep rooting vegetation.			

VEGETATION		
Planting is done as specified in approved planting plan.		
Correct soil preparation and plant installation have been done.		
Erosion control matting or grassing has been installed as per design.		
Plants are protected from disturbance (staked or fenced).		
Access for maintenance of planting.		
FINAL INSPECTION		
Trash screens and sediment drying areas are installed per design.		
All components of the wetland are stabilised.		
Flow enters/exits the device as designed.		
All designed safety features have been correctly installed.		
An operation and maintenance plan has been developed and provided to the final asset owner.		

Note: The design and construction of wetlands is complex and site-specific. The final construction must comply with the design and must be signed off at critical points within the construction. This check list is generic and may not represent the comprehensive compliance check list for individual device designs.

Appendix B1.8 Dry pond

Contractor:	Date: Time:	Consent #:	Site:
Construction checklist (refer to Section C9 for full details)		Pass Y/N	Comments to explain
PRECONSTRUCTION			
Design has been reviewed and approved by final asset owner.			
Device sizing calculations have been reviewed and approved.			
Final design has been reviewed and approved by Council.			
CONSTRUCTION			
All materials are correct as specified in the design (including geotextiles, liners, aggregates, soils etc.).			
Any pre-cast components (including anti-seep collars, outlets etc.) are correct as specified in the design.			
Excavation is done in accordance with required slopes and bathymetry of the approved design.			
All inverts, inlets and outlets are at the correct location, grade and level.			
Bypass, inlet and outlet structures have been constructed per design.			
Outlet protection has been included and is appropriately stabilised.			
VEGETATION			
Planting is done as specified in approved planting plan.			
Correct soil preparation, grassing and plant installation has been done.			
Erosion control matting or grassing, or mulching has been installed as per design.			
Plants are protected from disturbance (staked or fenced).			
FINAL INSPECTION			
Pre-treatment is in place.			
All components of the dry pond are stabilised.			
Flow enters/exits the device as designed.			
All designed safety features have been correctly installed.			
Trash screens are installed per design.			
An operation and maintenance plan has been developed and provided to the final asset owner.			

Appendix B1.9 Wet pond

Contractor:	Date: Time:	Consent #:	Site:
Construction checklist (refer to Section C8 for full details)		Pass Y/N	Comments to explain
PRECONSTRUCTION			
Design has been reviewed and approved by final asset owner.			
Device sizing calculations have been reviewed and approved.			
Final design has been reviewed and approved by Council.			
CONSTRUCTION			
All materials are correct as specified in the design (including geotextiles, liners, aggregates, soils etc.).			
Any pre-cast components (including anti-seep collars, outlets etc.) are correct as specified in the design.			
Excavation is done in accordance with required slopes and bathymetry of the approved design.			
Pond is impermeable with the liner installed to ensure integrity on base and banks of pond, with appropriate overlap and anchoring. Any compacted clay has been installed using sequential compaction to ensure impermeability of base and banks of pond.			
All connectors, gaskets and anti-seep collars are confirmed watertight.			
All inverts, inlets and outlets are at the correct location, grade and level.			
Emergency spillway has been constructed per design.			
Bypass, inlets and outlets have been constructed per design.			
Forebay has been constructed to correct depth and compaction and located for access and maintenance.			
Outlet protection has been included and is appropriately stabilised.			
Dewatering device has been installed.			
Fencing is installed per design.			
All bunds have been stabilised and are not planted with deep rooting vegetation.			

VEGETATION		
Planting is done as specified in approved planting plan.		
Correct soil preparation and plant installation has been done.		
Erosion control matting or grassing have been installed as per design.		
Plants are protected from disturbance (staked or fenced).		
Access for maintenance of planting.		
Fish passage has been installed.		
FINAL INSPECTION		
All components of the pond are stabilised.		
Flow enters/exits the device as designed.		
Trash screens and sediment drying areas are installed per design.		
All designed safety features have been correctly installed.		
An operation and maintenance plan has been developed and provided to the final asset owner.		

Note: The design and construction of wet ponds is complex and site-specific and will have specific consenting conditions. The final construction must comply with the design and must be signed off at critical points within the construction. This check list is generic and may not represent the comprehensive compliance check list for individual device designs.

A photograph of a field of tall, green grasses with several white and purple iris flowers in bloom. The flowers have yellow centers and purple markings on their petals. The background is a solid light green color.

Bibliography

Bibliography

Auckland Council Guidance Documents

GD2016:004 *Water sensitive design for stormwater*

GD2016:005 *Erosion and sediment control for land disturbing activities in the Auckland region*

Auckland Council Technical Reports

Auckland Council. (2008). *Urban sources of copper, lead and zinc*. Technical Report TR2008/023.

Auckland Council. (2008). *The impacts of urban stormwater in Auckland's aquatic receiving environment: A review of information 1995 to 2005*. Technical Report TR2008/029.

Auckland Council. (2009). *Hydrological effect of compaction associated with earthworks*. Technical Report TR2009/073.

Auckland Council. (2009). *Identification of permeable soils within the Waitemata Formation*. Technical Report TR2009/074.

Auckland Council. (2009). *Landscape and ecology values within stormwater management*. Technical Report TR2009/083.

Auckland Council. (2009). *Hydrology of wetlands*. Technical Report TR2009/095.

Auckland Council. (2010). *Extensive green roofs for stormwater management: Part 1 Design and construction*, 2010 Technical Report TR2010/017.

Auckland Council. (2010). *Extensive living roofs for stormwater mitigation: Part 2 Performance monitoring, Auckland*: Auckland Regional Council.

Auckland Council. (2010). *Construction of stormwater management devices in the Auckland region*. Technical Report TR2010/052.

Auckland Council. (2010). *Operation and maintenance of stormwater management devices in the Auckland region*. Technical Report TR 2010/053.

Auckland Council. (2011). *Literature review: Gross pollutant traps as a stormwater management practice*. Technical Report TR2011/006.

Auckland Council. (2011). *First flush analysis in the Auckland region*. Technical Report TR2011/007.

Auckland Council. (2013). *Media specification for stormwater bioretention devices*. Technical Report TR2013/011.

Auckland Council. (2013). *Hydraulic energy management: inlet and outlet design for treatment devices*, 2013 Technical Report TR2013/018.

Auckland Council. (2013). *Auckland Unitary Plan stormwater management provisions: Technical basis of contaminant and volume management requirements*. Technical Report TR2013/035.

Auckland Council. (2013). *Stormwater disposal via soakage in the Auckland region*. Technical Report TR2013/040.

Auckland Council. (2013). *Auckland Unitary Plan stormwater management provisions: Cost and benefit assessment*. Technical Report TR 2013/043

Auckland Council. (2013). *Temperature as a contaminant in streams in the Auckland region, stormwater issues and management options*. Technical Report TR2013/044

Auckland Council. (2013). *Living roof review and design recommendations for stormwater management*. Technical Report TR 2013/045.

Auckland Council.(2013). *Mulch specification for stormwater bioretention devices*. Technical Report TR2013/056.

Auckland Council Codes of Practice

Auckland Council Code of Practice. (2013). Land Development and Subdivision Chapter 4: *Stormwater*.

Auckland Regional Council Technical Publications

Auckland Regional Council. (1992). *Stormwater treatment devices: design guideline manual*. Technical Publication TP10.

Auckland Regional Council. (2003). *Stormwater management devices: Design guidelines manual (Second Edition)*. Technical Publication TP10.

Auckland Regional Council. (2009). TP84 *Fish passage in the Auckland region*. Technical Publication TP84.

Auckland Regional Council. (1999). *Erosion and sediment control guidelines for land disturbing activities in the Auckland region*. Technical Publication TP90.

Auckland Regional Council. (1999). *Guidelines for stormwater runoff modelling in the Auckland region*. Technical Publication TP108.

Auckland Regional Council. (1999). *Dam safety guidelines*. Technical Publication TP109

Auckland Regional Council. (2000). *Low impact design manual for the Auckland region*. Technical Publication TP124.

Auckland Regional Council (2000). *Fish passage guidelines for the Auckland region*. Technical Publication TP131.

Auckland Regional Council. (2001). *Riparian zone management*. Technical Publication TP148.

Bibliography

Auckland Regional Council. (2004). *A study of roof runoff quality in Auckland, New Zealand: Implications for stormwater management*. Technical Publication TP213.

Auckland Council: Other

Auckland City Council. (2002). *On-site stormwater management manual*. Auckland, New Zealand

Auckland Council. (2011). *Rain garden construction guide: Stormwater device information series*. Retrieved from: <https://beta.aucklandcouncil.govt.nz/environment/stormwater/docsconstructionguides/rain-gardens-construction-guide.pdf> (March 2017).

Auckland Regional Council (2008). *Making the most of Auckland's stormwater ponds, wetlands and rain gardens*. ISBN number 978-1-877483-40-0.

Standards

ASTM. Standards. (2009). *Standard test method for infiltration rate of in place pervious concrete (C1701)*. West Conshohocken, PA: ASTM International.

ASTM Standards. (2015). *Standard test method for saturated water permeability of granular drainage media [Falling-Head Method] for Green Roof Systems (E2396M – 15)*. West Conshohocken, PA, ASTM International.

ASTM Standards. (2015). *Standard test method for water capture and media retention of geocomposite drain layers for vegetative (green) roof systems (E2398 / E2398M - 15a)*. West Conshohocken, PA, ASTM International.

Standards Australia. (2012) *Geotextiles - Methods of test - Determination of durability - Resistance to degradation by light, heat and moisture (AS 3706.11-2012)*

Standards Australia/New Zealand. (2001). *Life cycle costing – An application guide (AS/NZ4536:1999)*. Standards Australia, Homebush, NSW, 2001.

Standards Australia/New Zealand. (2002). *Part 2: Buried flexible pipelines – Installation (AS/NZS 2566.2:2002)*. Joint Technical Committee WS-028, Council of Standards Australia and Council of Standards New Zealand.

Standards Australia/New Zealand. (2008). *Installation of polyethylene pipe system (AS/NZS 2033:2008)*. Joint Technical Committee PL-006, Council of Standards Australia and Council of Standards New Zealand.

Standards New Zealand. (1979). *Code of practice for the installation of unplasticized PVC pipe system (SNZ 7643:1979)*. Committee P7643, Council of Standards New Zealand.

Standards New Zealand. (2002). *Code of practice for working in the road (SNZ HB 2002:2003)*. Committee P2002, Council of Standards New Zealand.

Standards New Zealand. (2002). *Concrete segmental and flagstone paving* (NZS3116:2002)

Standards New Zealand. (2010). *New Zealand Standard: Land development and subdivision infrastructure* (NZS 4404: 2010). Committee P4404, Council of Standards New Zealand.

Standards New Zealand. (2005). *Composts, soil conditioners and mulches*. (NZS4454:2005).

Standards New Zealand. (2015). *Methods of sampling and testing road aggregates* (NZS 4407:2015).

Publications

Alberta Environmental Protection. (1999). *Stormwater management guidelines for the Province of Alberta*. Municipal Program Development Branch, Environmental Sciences Division, Environmental Service Publication T/378.

American Concrete Institute. (2006). *Report on pervious concrete* (522R-06). Farmington Hills, Michigan, USA.

American Concrete Institute. (2008). *Specification for pervious concrete pavement* (522.1-08). Farmington Hills, Michigan, USA.

American Concrete Pavement Association. (2010). *StreetPave concrete pavement design software*. Available from <http://www.pavement.com>.

American Society for Testing and Materials International. (2009). *Standard test method for infiltration rate of in place pervious concrete* (ASTM C1701). West Conshohocken, Pennsylvania, USA.

American Society for Testing and Materials International. (2013). *Standard practice for non-destructive testing (NDT) for determining the integrity of seams used in joining flexible polymeric sheet geomembranes* (ASTM D4437). West Conshohocken, Pennsylvania, USA.

AUSTROADS. (2008). *Guide to pavement technology Part 2: Pavement structural design* (AGPT02/08). Sydney, Australia.

Bean, EZ. (2005). *A field study to evaluate permeable pavement surface infiltration rates, runoff quantity, runoff quality, and exfiltrate quality* (Unpublished master's thesis). Graduate Faculty of North Carolina State University, Raleigh, North Carolina, USA.

Bioengineering Group, Inc. (2003). *Operation and maintenance manual*. Western Branch Putuxent River LID Retrofit Project. Prince George's County, Maryland.

Birch, GF., Matthai, C., Fazeli, MS. and Suh, JY. (2004). *Efficiency of a constructed wetland in removing contaminants from stormwater*. *Wetlands* 24(2): 459-466.

Brisbane City Council. (2005). *Draft water sensitive urban design engineering guidelines*.

Brisbane City Council. (2006). *Stormwater gardens bioretention basins for urban streets*.

Bibliography

- Brisbane City Council. (2006). *Water sensitive urban design technical design guidelines for South East Queensland*.
- Brix, H. (1993). *Wastewater treatment in constructed wetlands system design, removal processes, and treatment performance*. Pp. 9-22 in *Constructed Wetlands for Water Quality Improvement*, G. A. L&E Moshiri (ed). Boca Raton, Fla.; CRC Press, 632 pp.
- Burgess, H. (2004). *An assessment of the potential of green roofs for bird conservation in the UK*. BSc Hons Geography Thesis, University of Sussex.
- California Stormwater Quality Association. (2003). *Bioretention TC-32*. California, USA
- California Stormwater Quality Association. (2009). *Stormwater best management practice handbooks*. California, USA
- Cappiella, K., Fraley-McNeal, L., Novotney, M. and Schueler, T. (2008). *Article 5: The next generation of stormwater wetlands*. Center for Watershed Protection.
- Charles River Watershed Association. (2008). *Constructed stormwater wetlands*. Types: Shallow marsh system, basin/wetland system, extended detention wetland, pocket wetland. Low Impact Best Management Practice (BMP) Information Sheet.
- Chopra, M., Wanielista, M., Ballock, C. and Spence, J. (2007). *Construction and maintenance assessment of pervious concrete pavements*. Orlando, Florida, USA: Stormwater Management Academy, University of Central Florida.
- Christchurch City Council. (2012). *Chapter 6 Stormwater treatment systems. waterways, wetlands and drainage guide — Ko Te Anga Whakaora mo- Nga- Arawai Re-po- . Part B: Design*.
- CIRIA. (2001). *Sustainable urban drainage systems - Best practice manual (C523)*. London, UK: Construction Industry Research and Information Association.
- CIRIA. (2002). *Source control using constructed pervious surfaces. Hydraulic, structural and water quality performance issues (C582)*. London, UK: Construction Industry Research and Information Association.
- City of Gold Coast. (2007). *Land development guidelines, Section 13: Water sensitive urban design guidelines*. Gold Coast, Australia
- City of Melbourne. (2004). *Water sensitive urban design guidelines*. City of Melbourne.
- City of Portland Bureau of Environmental Services. (2008). *Portland stormwater management manual, Chapter 1: Requirements and policies*. Portland, Oregon, USA
- City of Seattle. (2009). *Stormwater manual, Volume 3: Stormwater flow control and water quality treatment technical requirements manual*. Seattle, Washington, USA: City of Seattle, Seattle Public Utilities, Department of Planning and Development.

- Clar, M., Barfield, B.J. and O'Connor, T.P. (2004a). *Stormwater best management practice guide, Volume 1: General considerations*. Washington, USA: US Environmental Protection Agency.
- Clar, M., Barfield, B.J. and O'Connor, T.P. (2004b). *Stormwater best management practice design guide, Volume 2: Vegetative biofilters*. Washington, USA: US Environmental Protection Agency.
- Clayton, R. (1996). *Design of stormwater filtering systems*. Ellicott City, Maryland, USA: Center for Watershed Protection.
- Collins, K.A., Hunt, W.F. and Hathaway, J.M. (2007). *Hydrologic and water quality comparison of four types of permeable pavement and standard asphalt in eastern North Carolina*. Washington, USA: Interlocking Concrete Pavement Institute.
- Colwell, S.R. (2000). *Characterisation of performance predictors and evaluation of mowing practices in biofiltration swales* (Unpublished master's thesis). University of Washington, Seattle, Washington, USA.
- Construction Industry Research and Information Association. (2001). *Sustainable urban drainage systems: Best practice manual (C523)*. London, UK.
- Construction Industry Research and Information Association. (2002). *Source control using constructed pervious surfaces: Hydraulic, structural and water quality performance issues (C582)*. London, UK.
- Construction Industry Research and Information Association. (2004). *Sustainable drainage systems: Hydraulic, structural and water quality advice (C609B)*. London, UK.
- Construction Industry Research and Information Association. (2007). *The SuDS manual (C697)*. London, UK.
- Decagon Devices. (2013). *Electrical conductivity of soil as a predictor of plant response*. Pullman, Washington, USA
- Department of Building and Housing. (1992). *Building regulations 1992 – Schedule 1 – The building code*.
- Digiovanni, K.A. (2013). *Evapotranspiration from urban green spaces in a northeast United States city* (Unpublished doctoral dissertation). Drexel University, Philadelphia, USA.
- Dunnett, N. and Clayden, A. (2007). *Rain gardens: Managing water sustainability in the garden and designed landscape*. Timber Press, Portland.
- Dunnett, N. and Kingsbury, N. (2008). *Planting green roofs and living walls*. Timber Press, L&E Portland.
- Eadie, M. (2009). *Urban stormwater: Queensland best practice environmental management guidelines 2009*. Prepared by EDAA (AECOM) for the Environmental Protection Agency.
- Eadie, M. (2011). *Water sensitive urban design for the coastal dry tropics (Townsville): Design objectives for stormwater management*. Townsville City Council.

Bibliography

- Ermilio, J. (2005). *Characterization study of a bio-infiltration stormwater BMP* (unpublished master's thesis). Villanova University, Philadelphia, USA.
- Facility for Advancing Water Biofiltration. (2006). *Bioretention and tree pit media specification*. Melbourne, Victoria, Australia
- Facility for Advancing Water Biofiltration. (2009a). *Guidelines for filter media in biofiltration systems: Version 3.01*. Melbourne, Victoria, Australia.
- Facility for Advancing Water Biofiltration. (2009b). *Stormwater biofiltration systems adoption guidelines: Planning, design and practical implementation*. Melbourne, Victoria, Australia: Monash University.
- Fassman, E. and Blackbourn, S. (2011). *Urban runoff mitigation by a permeable pavement system over impermeable soils. Auckland, New Zealand: The University of Auckland*.
- Federal Highway Administration, US Department of Transportation. (2009). *Stormwater best management practices in an ultra-urban setting: Selection and monitoring*. Washington, USA
- Firth Ecopave Installation Guide. (November 2011).CB11 8211, 8231.
- Galli, FJ. (1992). *Preliminary analysis of the performance and longevity of urban BMPs installed in Prince George County, Maryland*. Prepared for the Department of Environmental Resources. Prince George's County, Maryland.
- Geosyntec Consultants, Inc. (2011). *International stormwater best management practices (BMP) Database, Pollutant Category Summary: Metals*.
- Geosyntec Consultants, Wright Water Engineers, Inc. (2008). *Analysis of treatment system performance. International Stormwater Best Management Practices database (1999 – 2008)*. Prepared for Water Environment Research foundation, American Society of Civil Engineers, U.S. Environmental Protection Agency, Federal Highway Administration, American Public Work Association.
- Gold Coast City Council. (2007). *Policy 11: Land development guidelines: Section 13 Water sensitive urban design guidelines*. Gold Coast, Queensland, Australia
- Grasscrete. (2009). *Cast insitu paving system design and specification guide*. West Yorkshire, England, UK.
- Harper, HH. and Baker, DM. (2007). *Evaluation of current stormwater design criteria within the State of Florida*. Florida Department of Environmental Protection.
- Heinrich, M. (2007). *Water end use and efficiency project (WEEP): Final Report (SR 159)*. Wellington, New Zealand: Building Research Association of New Zealand.
- Hinman, C. (2007). *Raingarden handbook for western Washington homeowners*. Washington, USA: Washington State University Pierce County Extension.
- Hinman, C. (2009). *Bioretention soil mix review and recommendations for Western Washington*. Washington: Washington State University.

- Horner, RR. and Gretz, J. (2011). *Investigation of the feasibility and benefits of low-impact site design practices applied to meet various potential stormwater runoff regulatory standards*. Washington, USA: US Environmental Protection Agency.
- Hunt, WF. Burchell, MR., Wright, JD. and Bass, KL. (2007). *Stormwater wetland design update* (AG-588-12). Retrieved from: <https://www.bae.ncsu.edu/extension/ext-publications/water/protecting/ag-588-12-stormwater-wetland-design-update.pdf> (Oct 2016).
- Hunt, WF. and White, N. (2001). *Designing rain gardens (bio-retention areas)*. North Carolina, USA: North Carolina Cooperative Extension Service.
- Hunt, W. and Lord, W. (2006). *Bioretention performance design, construction and maintenance*. North Carolina, USA: North Carolina Cooperative Extension Service.
- Idaho Department of Environmental Quality. (2005). *Catalog of stormwater best management practices for Idaho Cities and Counties*. Retrieved from: <http://www.deq.idaho.gov/media/622263-Stormwater.pdf> (May 2016).
- Interpave. (2008a). *Understanding permeable paving*. Leicester, England, UK.
- Interpave. (2008b). *Guide to the design, construction and maintenance of concrete block permeable pavements (5th ed.)*. Leicester, England, UK
- IPENZ. (2015). *New Zealand dam safety guideline*, NZSOLD, ISBN: 978-0-908960-65-1.
- Johnson, JL. (2006). *Evaluation of stormwater wetland and wet pond forebay design and stormwater wetland pollutant efficiency*. MSc thesis, Biological and Agricultural Engineering, Raleigh, NC.
- Jurries, D. (2003). *Guidance for using bioswales, vegetative buffers, and constructed wetlands for reducing, minimizing, or eliminating pollutant discharges to surface waters*. State of Oregon, DEQ Northwest Region Document.
- Kadlec, RH. and Wallace, SD. (2009). *Treatment wetlands*, (Second Edition). CRC Press.
- Khan, Z., Thrush, C., Cohen, P. et al. (1992). *Biofiltration swale performance, recommendations, and design considerations*. Municipality of Metropolitan Seattle: Water Pollution Control Department.
- Kidd, J. (2005). *Water sensitive urban design: Optimum green roof for Brisbane*. Retrieved from: <http://www.greenroofs.com/pdfs/student-OptimumGreenRoofforBrisbane> (Feb 2016)
- Knapton, J., Cook, I. and Morrell, D. (2002). *A new design method for permeable pavements surfaced with pavers*. London, England, UK: The Institution of Highways & Transportation.
- Kouvelis, B. and Armstrong, W. (Editors). 2004. *Integrated stormwater management guidelines for the New Zealand roading network*. Transfund New Zealand Research Report No. 260.
- Law, S. and Jansons, K. (2007). *Impact of bathymetry on a case study stormwater treatment pond. water sensitive urban design*.

Bibliography

- Li, Y. (2008). *Modelling sediment behaviour in constructed stormwater wetlands*. Department of Civil Engineering, Monash University
- Limouzin, M., Lawler, DF. and Barrett, ME. (2011). *Performance comparison of stormwater biofiltration designs*. Austin, Texas, USA: Centre for Research in Water Resources, The University of Texas at Austin.
- Liu, K. (2003). *Engineering performance of rooftop gardens through field evaluation*, Toronto, Canada. National Research Council Canada.
- Martin, T., Barham, J. and Reeves, P. (2008). *Making the most of Auckland's stormwater, ponds, wetlands and raingardens*. Auckland Regional Council. ISBN number 978-1-877483-40-0.
- Maryland Department of Environment. (2009). *BMP Selection - Stormwater treatment suitability. Chapter 4, guide to BMP selection and location in Maryland*. Maryland Stormwater Design Manual, Volumes I and II, October 2000, revised May 2009.
- Maryland Department of the Environment. (2009). *Maryland stormwater design manual*. Maryland, USA
- Melbourne Water. (2005). *Constructed stormwater wetlands. WSUD Technical design guidelines for the coastal dry tropics. constructed wetland systems*, Design Guidelines for Developers Version 3.
- Melbourne Water. (2005). *WSUD engineering procedures: Stormwater*. Melbourne, Victoria, Australia: CSIRO Publishing.
- Metropolitan Environmental Council. (2004). *Constructed wetlands, stormwater wetlands*. Minnesota Urban Small Sites BMP Manual.
- Michigan Department of Environmental Quality, Surface Water Quality Division. (1992). *Best management practice guidebook for Michigan watersheds*. Lansing, Michigan, USA.
- Ministry for the Environment (2010). *Tools for Estimating the effects of climate change on flood flow*. Retrieved from https://www.wqa.org/Portals/0/Technical/Technical%20Fact%20Sheets/2014_Ps-PCPs-EDCs.pdf (June 2017)
- Ministry of Health. (2013). *Guidelines for drinking-water quality management for New Zealand*. Retrieved from <http://www.health.govt.nz/publication/guidelines-drinking-water-quality-management-new-zealand> (Sept 2016).
- Ministry of Justice. (2005). *National guidelines for crime prevention through environmental design in New Zealand* Wellington, Ministry of Justice.
- National Institute of Water and Atmospheric Research. (2010). *How clean are our rivers?* Retrieved from <http://www.niwa.co.nz/publications/wa/water-atmosphere-1-july-2010/how-clean-are-our-rivers> (Mar 2015).
- New Jersey Stormwater. (2004). *Best management practices manual*. Chapter 9.2, Standard for Constructed Wetlands.

- New York State Department of Environmental Protection. (2003). *New York State stormwater management design manual*.
- New Zealand Society on Large Dams. (1997). *Guidelines on inspection small dams*. Retrieved from: <http://www.ipenz.org.nz/NZSOLD/Resources/guide001.pdf> (May 2015).
- New Zealand Society on Large Dams. (2015). *Dam safety guidelines*. Retrieved from: http://www.ipenz.org.nz/NZSOLD/Files/NZSOLD_Dam_Safety_Guidelines%20-%20MAY%202015.pdf (May 2017).
- New Zealand Water Environment Research. (2004). *On-site stormwater management guideline*. New Zealand Water Environment Research Foundation. Wellington, New Zealand.
- NZ Transport Agency. (2010). *Stormwater treatment standard for State Highway infrastructure*. Auckland, New Zealand.
- North Carolina Denr. 1997. *Stormwater best management practices manual*. Raleigh, N.C.: North Carolina Department of Environment and Natural Resources. Division of Water Quality. 85 pp.
- North Carolina State University, North Carolina A&T State University, U.S. Department of Agriculture, and local governments cooperating. (Oct 2016). *Designing rain gardens (Bio-retention areas)*. Retrieved from: <https://www.bae.ncsu.edu/extension/ext-publications/water/protecting/ag-588-03-designing-rain-gardens.pdf>.
- North Carolina Department of Natural Resources and Community Development. (1993). *An evaluation of street sweeping as a runoff pollution control*, EPA Publication, PB85-102507.
- North Shore City Council. (2009). *North Shore City rainwater tank guidelines* (Second Edition)
- North Shore City Council. (2008) *Bioretention guidelines* (First Edition)
- Permapave. (2009). *Permapave permeable pavers technical data sheet*. Kippa-Ring, Queensland, Australia. Retrieved from www.permapave.com.au (Jun 2016).
- Prince George's County, Department of Environmental Resources. (1999). *Low-impact development design strategies: An integrated design approach*. Prince George's County, Maryland, USA: Department of Environmental Resources Programs and Planning Division.
- Prince George's County: Department of Environmental Resources. (2007). *Bioretention manual*. Prince George's County, Maryland, USA
- Rodney District Council and Waitakere City Council. (2010). *The Countryside Living Toolbox - Stormwater management device design details*. ISBN978-1-877540-65-3.
- Rushton, B. and Hastings, R. (2001). *Florida aquarium parking lot: A treatment train approach to stormwater management*. Florida, USA: Southwest Florida Water Management District.

Bibliography

- Schueler, T. and Lane, C. (2012). *Recommendations of the expert panel to define removal rates for New State stormwater performance standards*. Urban Stormwater Group, Chesapeake Bay Partnership, USA.
- Schueler, TR. (1992). *Metropolitan Washington Council of Government's design of stormwater wetland system: Guidelines for creating diverse and effective stormwater wetlands in the Mid-Atlantic region*. Washington, D.C.
- Schueler, TR, Kumble, PA. and Heraty, MA. (1992). *A current assessment of urban best management practices: Techniques for reducing non-point source pollution in the coastal zone*. Washington, USA: Metropolitan Washington Council of Governments.
- Seattle Public Utilities, Department of Planning and Development. (2009). *Stormwater manual, Vol. 3: Stormwater flow control and water quality treatment technical requirements manual*. Seattle, Washington, USA.
- Shackel, B. and Pearson, A. (2003). *Permeable concrete eco-paving as best management practice in Australian urban road engineering*. Artarmon, New South Wales, Australia: Concrete Masonry Association of Australia.
- Sharkey, L. (2006). *The performance of bioretention areas in North Carolina: A study of water quality, water quantity, and soil media* (Master's thesis). North Carolina State University, North Carolina, USA.
- Shaver, E. (2009). *Hawke's Bay waterway guidelines - low impact design*. Hawke's Bay, New Zealand: Hawke's Bay Regional Council.
- Shutes, RBE., Ellis, JB., Revitt, DM. et al. (2004). *Urban and highway runoff treatment by constructed wetlands*. In *Ecosystems in Asia: Function and Management*, Wong MH (Editor) ISBN 0-444-51691-3.
- Skeen, M., Jayaratne, R., Timperley, M. and Davis, M. (2010). Waitakere city vehicle testing station raingarden: Stormwater quality monitoring and performance. In: *The World Environmental and Water Resources Congress, Rhode Island, USA*.
- Smith, DR. (2001). *Permeable interlocking concrete pavements: Selection, design, construction, maintenance* (Second Edition.). Washington, USA: Interlocking Concrete Pavement Institute.
- Sureset UK. (2009). *Commercial after care & maintenance guide*. Warminster, Wiltshire, UK
- Susilo, FX., Neutel, AM., van Noordwijk, M. et al. (2004) *Soil biodiversity and food webs*. In: van Noordwijk, M., Cadisch, G. and Ong, CK. (eds.), *Below-ground Interactions in Tropical Agroecosystems*. CAB International, Wallingford.
- Tanner, CC., Champion, PD. and Kloosterman V. (2006). *New Zealand constructed wetland planting guidelines*. National Institute of Water and Atmospheric Research report published in association with the New Zealand Water and Wastes Association.
- Texas Water Development Board. (2005). *The Texas manual on rainwater harvesting (3rd ed.)*. Austin, Texas.

- Tornes, LH. (2005). *Effects of rain gardens on the quality of water in the Minneapolis-St. Paul metropolitan area of Minnesota*. Minnesota, USA: US Geological Survey.
- Toronto and Region Conservation Authority. (2008). *Performance evaluation of permeable pavement and a bioretention swale*. Toronto, Ontario, Canada.
- Toronto and Region Conservation Authority. (2012). *Preserving and restoring healthy soil: Best practices for urban construction*. Version 1.0.
- Transit New Zealand. (2003). *Specification for geotextiles (F/7: 2003)*
- Transit New Zealand. (2006). *M/4 Specification for basecourse aggregates*. Wellington, New Zealand.
- Transit New Zealand. (2006). *Specification for base course aggregates (TNZ M/4)*. Wellington, New Zealand.
- Transit New Zealand. (2007). *Specification for porous asphalt (SP/SP11 070704)*. Wellington, New Zealand.
- Transit New Zealand. (2007). *Specification for open graded porous asphalt (SP/SP11 070704)*. Wellington, New Zealand.
- UDFCD. 2008. *Urban storm drainage criteria manual, Volume 3. Structural BMPs*. Denver, Colorado: Urban Drainage and Flood Control District.
- Urban, J. (2008). *Up by the roots*. International Society for Arboriculture. ISBN-10 1881956652.
- University of New Hampshire Stormwater Center. (2007). *2007 Annual report*. Durham, New Hampshire, USA.
- University of New Hampshire Stormwater Center. (2009). *Design specifications for porous asphalt pavement and infiltration beds*. Durham, New Hampshire, USA.
- Upper Parramatta River Catchment Trust & URS Australia. (2004). *Water sensitive urban design technical guidelines for western Sydney*. Sydney, New South Wales, Australia.
- Urban Drainage and Flood Control District. (2008). *Urban storm drainage criteria manual, Volume 3: Structural BMPs*. Denver, Colorado, USA.
- US Environmental Protection Agency & American Society of Civil Engineers. (2013). *International stormwater BMP database*. Retrieved from: <http://www.bmpdatabase.org/> (Jun 2016).
- US Environmental Protection Agency. (1999). *Storm water technology fact sheet: Bioretention*. Washington, USA.
- US Environmental Protection Agency. (2004). *Stormwater best management practice design guide: Volume 1 General considerations*. Washington, USA.
- US EPA. (undated). *A handbook of constructed wetlands, Volume 5: Stormwater*.

Bibliography

- USEPA. (2004). *Stormwater best management practice design guide: Volume 2 vegetative biofilters*. Washington DC: United States Environmental Protection Agency Office of Research and Development.
- Vermont Agency of Natural Resources. (2002). *The Vermont stormwater management manual*. Retrieved from http://www.watershedmanagement.vt.gov/stormwater/docs/sw_manual-vol1.pdf.
- Villarreal, EL. (2005). *Beneficial use of stormwater: opportunities for urban renewal and water conservation*. Doctoral Thesis, Department of Water Resources Engineering, Lund Institute of Technology, Lund University, Coden.
- Virginia Department of Conservation and Recreation. (2011). *Virginia DCR stormwater design specification No. 13 Constructed Wetlands, Version 1.9*.
- Virginia Department of Conservation and Recreation. (2011). *Virginia stormwater management handbook, Volumes 1 and 2*. Richmond, Virginia, USA.
- Voyde, E. (2011). *Quantifying the complete hydrologic budget for an extensive living roof, Auckland*: University of Auckland.
- Ward, A., D'Ambrosio, JL. and Witter, J. (2008). *Channel forming discharges*. The Ohio State University Extension. Columbus, Ohio: Ohio State University.
- Washington State Department of Ecology. (2005). *Stormwater management manual for Western Washington, Volume V Runoff treatment BMPs*. Washington State Department of Ecology, Water Quality Program, Lacey, Washington.
- Water by Design. (2006). *Water sensitive urban design technical design guidelines for South East Queensland*. South East Queensland, Australia: Healthy Waterways Initiative.
- Waitakere City Council. (2004). *Stormwater solutions for residential sites*. Retrieved from <http://www.tritonsws.com/downloads/107-swsolut-res-site.pdf>.
- Williams, P., Biggs, J., Whitfield, M. et al. (1999). *The pond book: a guide to the management and creation of ponds*. The Ponds Conservation Trust, Oxford.
- Wong, THF., Breen, PF., Somes NLG. and Lloyd SD. (1999a). *Managing urban stormwater using constructed wetlands*. Cooperative Research Centre for Freshwater Ecology and Melbourne Water Corporation Industry Report 98/7 September 1999. Melbourne, Australia.
- Woods-Ballard, B., Kellagher, R., Martin, P. et al. (2007). *The SUDS manual*. United Kingdom: CIRIA.
- Yu, SL. and Stanford, RL. (2007). Field evaluation of a stormwater bioretention filtration system. In: *The World Environmental and Water Resources Congress, Tampa, Florida, USA*.
- Yu, SL. and Stopinski, MD. (2001). *Testing of ultra-urban stormwater best management practices*. Charlottesville, Virginia, USA: Virginia Department of Transportation.

Publications – Conferences

- Bond, PC., Pratt, CJ. and Newman, AP. (1999). A review of stormwater quantity and quality performance of permeable pavements in the UK. In: *The 8th International Conference on Urban Storm Drainage, Sydney, Australia*.
- Borgwardt, S. (2006). Long-term in-situ infiltration performance of permeable concrete block pavement. In: *The 8th International Conference on Concrete Block Paving, San Francisco, California, USA*.
- Bracey, S., Scott, K. and Simcock, R. (2009). Talbot Park community renewal project integrating low-impact urban design. *Sixth South Pacific Stormwater Conference, 28-30 April 2009, Auckland*.
- Bratieres, K. et al. (2008). Removal of nutrients, heavy metals and pathogens by stormwater biofilters. In: *The 11th International Conference on Urban Drainage, Edinburgh, Scotland, UK*.
- Burak, RJ. (2004). Permeable interlocking concrete pavements: Selection, design, construction and maintenance. In: *The Annual Conference of the Transportation Association of Canada, Québec City, Québec, Canada*.
- Fletcher, TD., Zinger, A., Deletic, A. and Bratieres, K. (2007). Treatment efficiency of biofilters: Results of a large scale biofilter column study. In: *The 13th International Rainwater Catchment Systems Conference and 5th International Water Sensitive Urban Design Conference, Sydney, Australia*.
- Greenway, M. (2003). Stormwater Wetlands: Design criteria to maximise water quality improvement and minimise mosquito breeding. *Stormwater Industry Association 2003 Regional Conference, Yamba, NSW*.
- Illgen, M., Harting, K., Schmitt, TG. and Welker, A. (2007). Runoff and infiltration characteristics of permeable pavements: Review of an intensive monitoring program. In: *NOVATECH: 6th International Conference on Sustainable Techniques and Strategies in Urban Water Management, Lyon, France*.
- Li, Y., Deletic, A. and Fletcher, TD. (2005). A novel approach in modelling performance of urban stormwater wetlands. *Engineering Australia, 29th Hydrology and Water Resources Symposium*, pp 21-23.
- Muthukrishnan, S. and Selvakumar, A. (2006). Evaluation of retention pond and constructed wetland BMPs for treating particulate-bound heavy metals in urban stormwater runoff. *Proceedings of the World Environmental and Water Resources Congress*.
- Muthukrishnan, S. (2006). Treatment of heavy metals in stormwater runoff using wet pond and wetland Mesocosms. *Proceedings of the Annual International Conference on Soils, Sediments, Water and Energy, Volume 11, Article 9*. Retrieved from: <http://scholarworks.umass.edu/soilsproceedings/vol11/iss1/9> (Aug 2015)
- Moran, A. and Hunt, WF. 2005. Green roof hydrologic and water quality performance in North Carolina, s.l.: 2005 ASAE Annual International Meeting. Tampa, Florida.
- Shackel, B. (2006). Design of permeable paving subject to traffic. In: *The 8th International Conference on Concrete Block Paving, San Francisco, California, USA*.

Bibliography

- Smith, D. (2000). North American design guidelines for permeable interlocking concrete pavements: Parts 1 and 2. In: *The JIPEA World Congress, Tokyo, Japan*.
- Wong, THF., Breen, PF. and Somes, NLG. (1999b). Ponds Vs Wetlands – Performance Considerations in Stormwater Quality Management. *Proceedings of the 1st South Pacific Conference on Comprehensive Stormwater and Aquatic Ecosystem Management, Auckland, New Zealand, 2*: 223-231.
- Zinger, Y., Fletcher, TD., Deletic, A. et al. (2007). *Optimisation of the nitrogen retention capacity of stormwater biofiltration systems*. Paper presented at NOVATECH, Lyon, France.

Publications: Journals

- Bean, EZ., Hunt, WF. and Bidelspach, DA. (2007). Evaluation of four permeable pavement sites in eastern North Carolina for runoff reduction and water quality impacts. *Journal of Irrigation and Drainage Engineering, 133*(6), 583-592.
- Bean, EZ., Hunt, WF. and Bidelspach, DA. (2007). Field survey of permeable pavement surface infiltration rates. *Journal of Irrigation and Drainage Engineering, 133*(3), 249-255.
- Brattebo, BO. and Booth, DB. (2003). Long-term stormwater quantity and quality performance of permeable pavement systems. *Water Research, 37*(18), 4369-4376.
- Brenneisen, S. (2006). Space for urban wildlife: Designing green roofs as habitats in Switzerland. *Urban Habitats 4*(1): 27-36.
- Brueske, CC. and Barrett, GW. (1994). Effects of vegetation and hydrologic load on sedimentation patterns in experimental wetland ecosystems. *Ecological Engineering 3*: 429–447.
- Carleton JN., Grizzard TJ., Godrej AN. and Post HE. (2001). Factors affecting the performance of stormwater treatment wetlands. *Water Research 35*(6):1552-1562.
- Carter, T. and Rasmussen, T. (2006). Hydrologic behavior of vegetated roofs, s.l.: *Journal of the American Water Resources Association, 42*: 1261-1274.
- Cheng, XY., Liang, MQ., Chen, WY., Liu, XC. and Chen, ZH. (2009). Growth and contaminant removal effect of several plants in constructed wetlands. *Journal of Integrated Plant Biology 51*(3): 325–335.
- Clark, SE., Siu, CY., Pitt, R. et al. (2009). Peristaltic pump auto-samplers for solids measurement in stormwater runoff. *Water Environment Research. 2009 Feb; 81*(2):192-200.
- Conn RM. and Fiedler FR. (2006). Increasing hydraulic residence time in constructed stormwater treatment wetlands with designed bottom topography. *Water Environment Research 78* (13): 2514-2523.
- Davis, AP. (2007). Field performance of bioretention: Water quality. *Environmental Engineering Science, 24*(8), 1048-1064.

- Davis, A P. (2008). Field performance of bioretention: Hydrology impacts. *Journal of Hydrologic Engineering*, 13(2), 90-95.
- Davis, A., Hunt, W., Traver, F. and Clar, M. (2009). Bioretention technology: Overview of current practice and future needs. *Journal of Environmental Engineering*, 135(3), 109-117.
- Denardo, J. et al. (2005). Stormwater mitigation and surface temperature reduction by green roofs, s.l.: *Transactions of the American Society of Agricultural Engineers*, 48: 1491-1496.
- Dibiasi, C.J., Li, H., Davis, AP. and Ghosh, U. (2009). Removal and fate of polycyclic aromatic hydrocarbon pollutants in an urban stormwater bioretention facility. *Environmental Science and Technology*, 43(2), 494-502.
- Dietz, ME. and Clausen, JC. (2005). A field evaluation of rain garden flow and pollutant treatment. *Water, Air and Soil Pollution*, 167(1-4), 123-138.
- Dietz, ME. and Clausen, JC. (2006). Saturation to improve pollutant retention in a rain garden. *Environmental Science and Technology*, 40(4), 1335-1340.
- Fassman, E. and Simcock, R. (2012). Moisture measurements as performance criteria for extensive living, s.l.: *Journal of Environmental Engineering*, 138(8):841-851.
- Fassman-Beck, E., Simcock, R., Voyde, E. and Hong, Y. (2013). Living roofs in 3 locations: Does configuration affect runoff mitigation?, s.l.: *Journal of Hydrology*, 490:11-20.
- Gedge, D. and Kadas, G. (2005). Green roofs and biodiversity. *Biologist* 52 (3): 161-169.
- Getter, K., Rowe, D. and Andresen, J. (2007). Quantifying the effect of slope on extensive green roof stormwater retention, s.l.: *Ecological Engineering*, 31: 225-231.
- Grant, G. (2006). Extensive green roofs in London. *Urban Habitats* 4(1): 51-65.
- Grant, G., Engleback, L. and Nicholson, B. (2003). Green roofs: their existing status and potential for conserving biodiversity in urban areas. English Nature *Research Reports Number 498*. English Nature, UK.
- Hatt, BE. and Fletcher, T. (2008). Hydraulic and pollutant removal performance of fine media stormwater filtration systems. *Environmental Science and Technology*, 42(7), 2535-2541.
- Hatt, BE., Fletcher, T. and Deletic, A. (2009). Hydrologic and pollutant removal performance of stormwater biofiltration systems at the field scale. *Journal of Hydrology*, 365(3-4), 310-321.
- Holland, JF., Martina, JF, Granatab, T. et al. (2004). Effects of wetland depth and flow rate on residence time distribution characteristics. *Ecological Engineering* 23: 189-203.
- Hsieh, C. and Davis, A. (2005). Evaluation and optimization of bioretention media for treatment of urban storm water runoff. *Journal of Environmental Engineering*, 131(11), 1521-1531.

Bibliography

- Hsieh, C., Davis, AP. and Needelman, BA. (2007). Bioretention column studies of phosphorus removal from urban stormwater runoff. *Water Environment Research*, 79(2), 177-184.
- Hunt, W., Jarrett, A., Smith, J. and Sharkey, L. (2006). Evaluating bioretention hydrology and nutrient removal at three field sites in North Carolina. *Journal of Irrigation and Drainage Engineering*, 132(6), 600-608.
- Hunt, W., Smith, J., Jadlocki, S. and Hathaway, J. (2008). Pollutant removal and peak flow mitigation by a bioretention cell in urban Charlotte, N.C. *Journal of Environmental Engineering*, 134(5), 403-408.
- Jenkins, GA. and Greenway, M. (2004). The impact of water level on the hydraulic efficiency of constructed stormwater wetlands. *Advances in Hydro-Science and Engineering Volume 1*.
- Jenkins, GA. and Greenway, M. (2005). The hydraulic efficiency of fringing versus banded vegetation in constructed wetlands. *Ecological Engineering* 25: 61–72.
- Jones, M. and Hunt, W. (2009). Bioretention impact on runoff temperature in trout sensitive waters. *Journal of Environmental Engineering*, 135(8), 577-585.
- Knight, RL., Hilleke, J. and Grayson, S. (1994). Design and performance of the Champion pilot-constructed wetland treatment system. *Tappi Journal* 77(5): 240-245.
- Li, Y., Deletic, A. and Fletcher, TD. (2007). Modelling wet weather sediment removal by stormwater constructed wetlands: Insights from a laboratory study. *Journal of Hydrology* 338: 285– 296.
- Li, H. and Davis, AP. (2008). Urban particle capture in bioretention media. 1: Laboratory and field studies. *Journal of Environmental Engineering*, 134(6), 409-418.
- Lightbody, AF., Avenier, ME. and Nepf, HM. (2008). Observations of short-circuiting flow paths within a free-surface wetland in Augusta, Georgia, U.S.A. *Limnology and Oceanography* 53 (3): 1040-1053.
- Lightbody, AF., Nepf, HM. and Bays, JS. (2009). Modeling the hydraulic effect of transverse deep zones on the performance of short-circuiting constructed treatment wetlands. *Ecological Engineering* 35: 754-768.
- Lloyd, S.D., Wong, THF. and Porter, B. (2002). The planning and construction of an urban stormwater management scheme. *Water Science and Technology*, 45(7), 1-10.
- Mazer, G., Booth, D. and Ewing, K. (2001). Limitations to vegetation establishment and growth in biofiltration swales. *Ecological Engineering*, 17(4), 429-443.
- Kadas, G. (2006). Rare invertebrates colonizing green roofs in London. *Urban Habitats* 4(1): 66-86.
- Merriman, L., Wilson, C., Winston, R. and Hunt, W. (2013). Assessing the importance of temporary storage volume occupied by emergent vegetation in constructed stormwater wetlands. *Journal of Hydrological Engineering* 10.1061 1372-1376.
- Mungasavalli, DP. and Viraraghavan, T. (2006). Constructed wetlands for stormwater management: A review. *Fresenius Environmental Bulletin* 15(11): 1363-1372.

- Muthanna, TM., Viklander, M., Blecken, GT. and Thorolfsson, ST. (2007). Snowmelt pollutant removal in bioretention areas. *Water Research*, 41, 4061-4072.
- Passeport, E., Hunt, W., Line, D., Smith, R. and Brown, R. (2009). Field study of the ability of two grassed bioretention cells to reduce storm-water runoff pollution. *Journal of Irrigation and Drainage Engineering*, 135(4), 505-510.
- Roseen, RM., Ballestero, TP., Houle, JJ. et al. (2009). Seasonal performance variations for storm-water management systems in cold climate conditions. *Journal of Environmental Engineering*, 135(3), 128-137.
- Su, TM., Yang, SC., Shih, SS. and Lee, HY. (2009). Optimal design for hydraulic efficiency performance of free-water-surface constructed wetlands. *Ecological Engineering* 35: 1200-1207.
- Temmerman, S., Bouma, TJ., Govers, G. et al. (2005) Impact of vegetation on flow routing and sedimentation patterns: Three-dimensional modeling for a tidal marsh. *Journal of Geophysical Research* 110.
- US Department of Agriculture, Natural Resources Conservation Service, Conservation Engineering Division. (1986). *Urban Hydrology for Small Watersheds*: TR-55. Washington, USA.
- Vanwoert, N. et al. 2005. Green roof stormwater retention: Effects of roof surface, slope and media depth, s.l.: *Journal of Environmental Quality*, 34:1036-1044.
- Walker, DJ. (2001). Modelling sedimentation processes in a constructed stormwater wetland. *The Science of the Total Environment* 266: 61-68.
- Wong, THF. and Somes, NLG. (1995). A stochastic approach to designing wetlands for stormwater pollution control. *Water Science and Technology*, 32(1): 145-151.

Find out more:
Phone 09 301 0101
Email wsd@aucklandcouncil.govt.nz
or visit aucklandcouncil.govt.nz

