

Functional characterization of LINC complex protein assemblies and their role in laminopathies

INAUGURAL-DISSERTATION

zur

Erlangung des Doktorgrades

der Mathematisch-Naturwissenschaftlichen Fakultät

der Universität zu Köln



vorgelegt von

Liu Yang

aus

Runan, Henan, P. R. China

Köln, 2013

Referees/Berichterstatter: Prof. Dr. Angelika A. Noegel

Prof. Dr. Arnd Baumann

Prüfungsvorsitzender: Prof. Dr. Siegfried Roth

Date of oral examination: 25.06.2013

Tag der mündlichen Prüfung

The present research work was carried out under the supervision of Prof. Dr. Angelika A. Noegel and Dr. Sascha Nuemann, in the Institute of Biochemistry I, Medical Faculty, University of Cologne, Cologne, Germany from October 2009 to March 2013.

Diese Arbeit wurde von Oktober 2009 bis März 2013 am Institut für Biochemie I der Medizinischen Fakultät der Universität zu Köln unter der Leitung von Prof. Dr. Angelika A. Noegel und Dr. Sascha Nuemann durchgeführt.

Summary

LINC (Linker of nucleoskeleton and cytoskeleton) complexes connect the nucleoskeleton to the cytoskeleton by interactions among LINC complex proteins and their interactions to proteins in the nucleus and the cytosol. Nesprins (nuclear envelope spectrin repeat proteins) are core components of the LINC complex, together with their interaction partners along the nuclear envelope, such as lamins that form meshwork along inner nuclear membrane, they play critical roles in regulating many cellular functions including the maintenance of the structural integrity of nucleus and cytoskeleton or proper signal transduction across the NE. Mutations in LINC complex or associated proteins, especially in lamin A/C, result in a variety of human diseases such as muscular dystrophies, neuropathies, lipodystrophy and progeria, that are collectively known as laminopathies.

Here we narrowed down the binding site between nesprin-2 and lamin A to aa 403-425 in lamin A and aa 6146-6347 in nesprin-2. Additionally, laminopathy causing mutations in or near the binding sites of both proteins were analyzed in this study. Currently only mutations in *LMNA* encoding lamin A/C have been described along the interaction sites. The lamin A mutations R401C (1201 C>T), G411D (1232G>A), G413C (1237G>T), V415I (1243G>A), R419C (1255T>C), L421P (1261T>C), R427G (1279C>G) and Q432X (1294C>T) were analyzed in this study. All lamin A mutations analyzed here lie in a loop between the central alpha helical rod and the C-terminal globular tail and are thus accessible for interaction. They modulate the interaction with nesprin-2 in a range from increasing to decreasing. The wide range of variations reflects the wide range of diseases caused by the mutations analyzed here, indicating that altered biochemical properties among distinct LINC complex components contribute to the formation of distinct laminopathies with different phenotypes. The most notable mutation was the lamin A mutation Q432X that formed aggregates along the NE and altered LINC complex protein assemblies by the sequestration of nesprin-2, lamin B1, emerin or lamin A/C. Additionally Q432X aggregates altered chromatin structure and transcription factor arrangements.

Zusammenfassung

LINC (Linker of nucleoskeleton and cytoskeleton)Komplexe verbinden das Zellkerngerüst mit dem Zytoskelett durch Interaktionen von LINC Komplex Komponenten und weiteren Interaktionen mit Proteinen des Zellkerns und des Zytoplasmas. Nesprine (nuclear envelope spectrin repeat proteins) sind Kernkomponenten des LINC Komplexes, die zusammen mit ihren Interaktionspartnern an der Kernhülle, wie den Laminen, die entlang der inneren Kernmembran ein Geflecht bilden, essentielle Funktionen in der Regulation verschiedener zellulärer Prozesse wie die Aufrechterhaltung der strukturellen Integrität des Zellkerns, des Zytoskeletts oder einer geregelten Signaltransduktion entlang die Zellkernhülle, übernehmen. Mutationen in Komponenten des LINC Komplexes oder in assoziierten Proteinen, insbesondere in Lamin A/C, führen zu einer Vielzahl von menschlichen Krankheiten wie Muskeldystrophien, Neuropathien, Lipodystrophien oder Progerie, die als Laminopathien zusammengefasst werden.

Wir haben hier die Bindestellen zwischen nesprin-2 und lamin A auf die Aminosäuresequenzen 403-425 in lamin A und 6146-6347 in Nesprin-2 eingeeengt. Zusätzlich wurden in der vorgelegten Arbeit Laminopathien verursachende Mutationen in bzw. nahe der Bindestellen beider Proteine untersucht. Bisher wurden in den Interaktionsbereichen beider Proteine lediglich Mutationen in LMNA, welches für Lamin A/C kodiert, beschrieben. Die Lamin A Mutationen R401C (1201 C>T), G411D (1232G>A), G413C (1237G>T), V415I (1243G>A), R419C (1255T>C), L421P (1261T>C), R427G (1279C>G) und Q432X (1294C>T) wurden in dieser Studie untersucht. Jede dieser Mutationen befindet sich in in einer Schleifenstruktur, die zwischen der alpha helikalen, zentralen Domäne und der C-terminalen globulären Domäne von Lamin A/C liegt, was sie zugänglich für Interaktionen macht. Die Ergebnisse zeigen, dass alle hier untersuchten Lamin A Mutationen die Interaktion zu Nesprin-2 modulieren, in einem Spektrum das von einer verstärkten bis hin zu einer abgeschwächten Interaktion reicht. Dieses große Spektrum an Variationen in den Bindungseigenschaften beider Proteine, spiegelt das große Spektrum an Krankheiten wieder, die durch die einzelnen Mutationen verursacht werden. Dies gibt einen Hinweis darauf, dass veränderte biochemische Eigenschaften zwischen LINC Komplex Komponenten zur Ausbildung spezifischer Phänotypen beitragen. Die bemerkenswerteste Mutation war die

Lamin A Mutation Q432X, welche zur Bildung von Aggregaten entlang der Kernhülle führt, in denen die LINC Komplexe Komponenten Nesprin-2, Emerin, lamin B1 und lamin A/C akkumulieren. Zusätzlich konnten entlang der Q432X Aggregate Veränderungen in der Chromatin-Struktur und in der Verteilung von Transkriptionsfaktoren beobachtet werden.

Contents

Summary	I
Zusammenfassung	II
1 Introduction	3
1.1 Nuclear envelope.....	3
1.2 NE proteins	4
1.3 The LINC complex in human diseases.....	14
1.4 Aim of the study	18
2 Results	19
2.1 Narrowing down of binding sites between lamin A and nesprin-2.....	19
2.2 Study on mutations in the binding sites of nesprin-2 and lamin A	25
2.3 Study on mutated SUN proteins in Emery-Dreifuss muscular dystrophy/Charcot-Marie-Tooth syndrome or Duchenne muscular dystrophy patients fibroblasts	50
2.4 Analysis the distribution of nesprin-2 and lamin A in ageing nesprin-2 knockout mice	54
3 Discussion	55
3.1 The binding sites between lamin A and nesprin-2	55
3.2 Laminopathies causing lamin A mutations lie in or near the binding site of nesprin-2 to lamin A.....	56
3.3 Mutations in <i>LMNA</i> modulate binding affinities of lamin A for nesprin-2.....	58
3.4 Mutated GFP lamin A proteins localize along the NE and Q432X proteins additionally form aggregates.....	60
3.5 <i>LMNA</i> mutation Q432X affect the localizations of several NE proteins	61
3.6 <i>LMNA</i> mutations do not alter NPC assemblies along the NE.....	63
3.7 The lamin A mutation Q432X causes alterations in the chromatin organization and SREBP1/ZNF239 misplacement	63
3.8 Study on mutated SUN proteins in Emery-Dreifuss muscular dystrophy/Charcot-Marie-Tooth syndrome or Duchenne muscular dystrophy patients' fibroblasts	66
4 Materials and Methods	69
4.1 Plasmid constructs.....	69
4.2 Cell culture and transfections.....	72
4.3 In vitro pull-down Assays.....	73
4.4 Immunofluorescence and microscopy	76

4.5 Heat stress experiments	77
4.6 Protein lysates from mouse tissues.....	77
4.7 Sequence alignment and lamin A fragment structure prediction.....	78
References	79
Appendix	90

1 Introduction

1.1 Nuclear envelope

As the largest organelle found in eukaryotic cells, the nucleus contains most of the genetic material that is organized as chromatin consisting of DNA and associated proteins.

A main structural characteristic of the nucleus is the **nuclear envelope (NE)**, which is a double lipid bilayer that encloses the genetic material in eukaryotic cells (Figure 1.1). It serves as a physical barrier, separating nucleoplasmic components from the cytosol. The double lipid bilayers that together form the NE are referred to as **inner nuclear membrane (INM)** or **outer nuclear membrane (ONM)** that are joined together at the **nuclear pore complexes (NPC)**. NPCs are large macromolecular protein assemblies responsible for the selective exchange between the nucleoplasm and the cytoplasm that prevents the exchange of materials not destined to cross the NE (Schirmer EC and Gerace L, 2002; Hertzler MW, 2010).

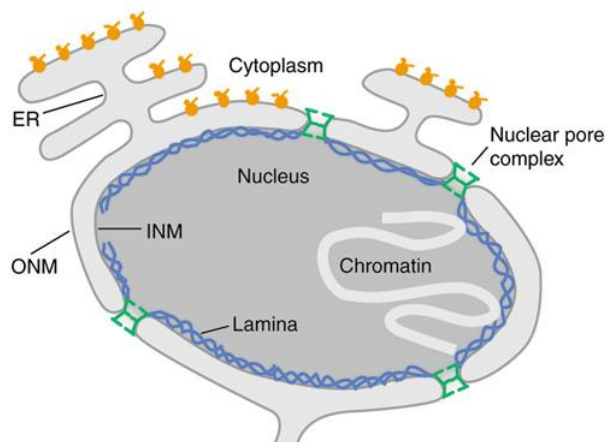

Figure 1.1 The nuclear envelope encloses the genetic material in eukaryotes.

The nuclear envelope is composed of an inner and an outer nuclear membrane (INM, ONM). A network of proteins termed the nuclear lamina underlies the inner membrane. Nuclear pore complexes bridge this system and regulate nucleo-cytoplasmic exchange of macromolecules. Additionally, the ONM continuous into the endoplasmic reticulum (ER). The genetic material is organized as chromatin (Schirmer EC and Gerace L, 2002).

Electron microscopy technique revealed that ONM and INM are continuous and the ONM additionally extends into the endoplasmic reticulum (ER). A variety of techniques were applied during the last decades to reveal the complex and unique structures of the NE membrane system and their associated proteins. Despite the membrane continuity between ONM, INM and ER, recent evidence demonstrates the presence of particular proteins assemblies (Watson ML, 1955; Hetzer MW, *et al.*, 2005; Hetzer MW, 2010).

1.2 NE proteins

Along the NE one can observe the formation of distinct protein networks. In the following parts structures and functions of NE protein components will be described.

1.2.1 Nuclear pore complexes

NPCs are formed at sites where the inner and outer membranes of the nuclear envelope are joined, and are constructed of multiple copies of approximate 30 different proteins named **nucleoporins** (Nups). NPCs consist of three functional regions: First, the NPC scaffold and central transport channel, which is embedded in the plane of the nuclear envelope; second, peripheral structures, nuclear ring/nuclear basket; third, cytoplasmic ring/cytoplasmic filaments, which extend to the cytoplasmic or nucleoplasmic end of the NPCs.

The primary function of NPCs is that they regulate molecular trafficking between cytoplasm and nucleus that is crucial for maintaining the unique composition of both compartments. NPCs allow the free transport of ions and small molecules without specific transport partner. Large molecules like m-RNA or proteins with a molecular weight of more than 40~60 kDa are transported between nucleoplasm and cytoplasm by binding to nuclear transport receptors (Strambio-De-Castillia C, *et al.*, 2010; Chow KH, *et al.*, 2012; Raices M and D'Angelo MA, 2012).

1.2.2 The LINC Complex

Along nuclear membranes, proteins assemble to form large protein complexes. At the INM, lamins form a meshwork that stabilizes nuclear morphology. NPCs are integrated into the NE and allow the passive and selective transport across the nuclear membranes. SUN proteins, lamins and nesprins, which will be described later in detail, are part of large protein complexes that traverse the NE to connect the nuclear interior to the cytoplasm, known as the LINC complex (**l**inker of **n**ucleoskeleton and **c**ytoskeleton). At the heart of the LINC complex are the SUN (**S**ad1 and **U**NC-84) proteins and the nesprins (**n**uclear envelope **s**pectrin repeat proteins). The KASH (**K**larsicht, **A**NC1 and **S**YNE1 homology) domain of the nesprins interacts with the SUN domain of the SUN proteins in the **perinuclear space (PNS)** between the INM and the ONM (Figure 1.2).

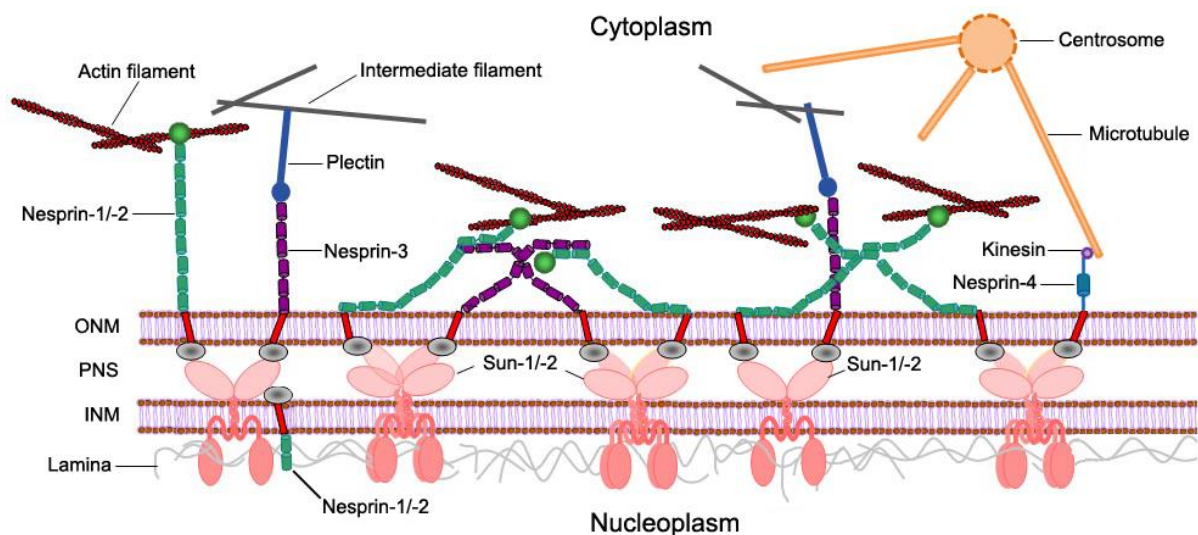

Figure 1.2 Typical structure of the LINC complex. The LINC complex is composed of two major parts, ONM KASH domain proteins and INM SUN domain proteins. KASH domain proteins are anchored in the ONM by the interaction with the SUN domain of the SUN proteins in the perinuclear space (PNS) between ONM and INM. Together they form a physical connection between nucleoplasm and cytoplasm. On the nucleoplasmic side, LINC complex components interact with the lamina and INM-associated proteins such as emerin. At the cytoplasmic side, nesprins directly or indirectly connect the NE to cytoskeletal components, F-actin, microtubules and intermediate filaments (Taranum S, *et al.*, 2012).

At the nucleoplasmic side LINC complex components interact with lamina proteins or INM-associated protein such as emerin or chromosomes. On the cytoplasmic side they directly or

indirectly bind to cytoskeletal components like F-actin, microtubules or the intermediate filament network (Starr DA and Fischer JA, 2005; Zhang Q, *et al.*, 2005; Crisp M, *et al.*, 2006; Tzur YB, *et al.*, 2006; Méjat A and Misteli T, 2010; Starr DA and Fridolfsson HN, 2010;).

1.2.3 Nesprins

Nesprins also known as SYNE (**synaptic nuclear envelope protein**), ENAPTIN and NUANCE (**nucleus and actin connecting element**) belong to a group of proteins that are primarily found along both, the INM and the ONM. Nesprins are spectrin repeat (SR)-containing type II transmembrane proteins with evolutionarily conserved orthologous in lower eukaryotes such as in *Dictyostelium discoideum* (interaptin), *C. elegans* (ANC-1) and *Drosophila* (MSP-300) (Rivero F, *et al.*, 1998; Apel ED, *et al.*, 2000; Zhang Q, *et al.*, 2001; Starr DA and Han M, 2002; Zhen YY, *et al.*, 2002; Padmakumar VC, *et al.*, 2004; Yu J, *et al.*, 2006).

Four different nesprins have been described in mammals until now (nesprin-1, -2, -3 and -4). Each is encoded by a single gene. A multitude of isoforms has been described so far differing in size and domain composition which result from differential splicing and initiation of transcription. The largest nesprin isoforms are nesprin-1/2-giant with molecular weights of 1014/796 kilodalton (kDa) respectively (Figure 1.3).

Nesprin-1/2 giant contain N-terminal **actin-binding domains (ABD)** that interact with actin filaments. Nesprin-3 binds to plectin, which in turn binds to intermediate filaments. Nesprin-2/4 bind to kinesin-1 and in this way they connect the nucleus to the microtubule network.

At the C-terminus of almost all nesprin isoforms, there is a highly conserved KASH domain that contains a transmembrane region. Nesprins are anchored along the ONM or INM through their KASH domain that interacts with the SUN domain of the SUN proteins in the lumen between the INM and ONM (Zhang Q, *et al.*, 2001; Wilhelmsen K, *et al.*, 2005; Roux KJ, *et al.*, 2009; Gob E, *et al.*, 2010; Noegel AA and Neumann S, 2011; Taranum S, *et al.*, 2012)

Introduction

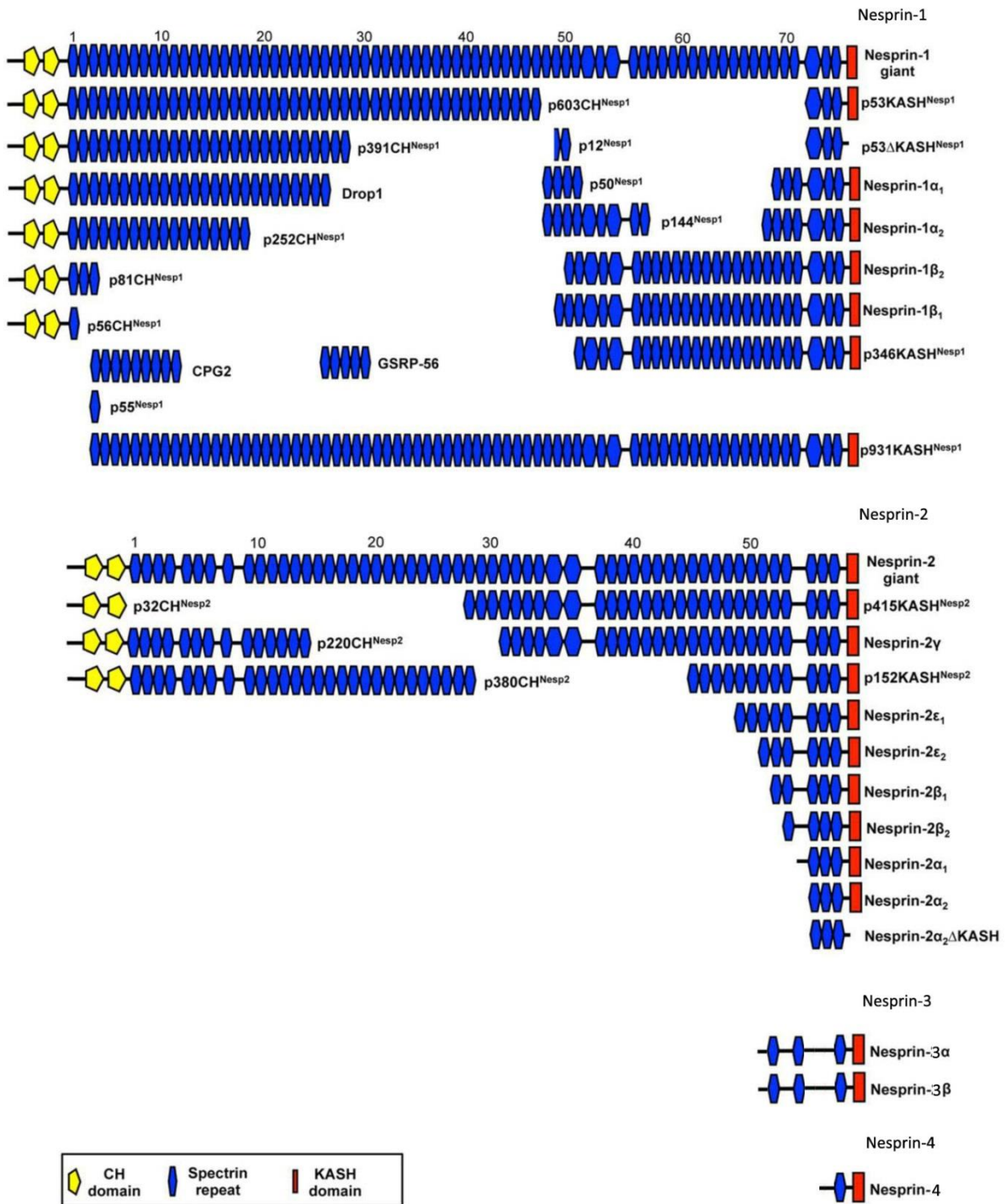

Figure 1.3 Summary of mammalian nesprins and their isoforms.

Four different nesprins have been described in mammals (nesprin-1, -2, -3 and -4). Each is encoded by a single gene that gives rise to several isoforms. Main structural components of the nesprins are paired calponin homology (CH) domains, spectrin repeats (SRs) and a KASH (Klarsicht, ANC1 and SYNE1 homology) – transmembrane domain (Taken and combined from Rajgor D, *et al.*, 2012 and Mellad JA, *et al.*, 2011).

Nesprins play an important role in maintaining nuclear architecture. A loss of nesprin-2 for example results in misshapen nuclei or nuclear blebbing. Furthermore nesprins have been shown to play roles in cellular processes like muscle development, cell proliferation, nuclear positioning and anchorage. Wound healing studies in nesprin-2 giant deficient mice showed that a loss of nesprin-2 giant affects wound healing particularly at later stages during fibroblast differentiation and keratinocyte proliferation leading to delayed wound closure. A loss of nesprin-1 and nesprin-2 furthermore shows those both mediate centrosome positioning and migration and are essential for ciliogenesis by remodeling of the actin cytoskeleton, indicating important roles of the nesprins during cellular and developmental processes. Analysis of nesprins during human muscle development revealed isoform- and tissue-specific roles for nesprins in nuclear positioning. Nesprin-1 knockout studies show that nuclear positioning and anchorage are dysfunctional in skeletal muscle from knockout mice. (Luke Y, *et al.*, 2008; Dawe HR, *et al.*, 2009; Warren DT, *et al.*, 2010; Randles KN, *et al.*, 2010; Zhang J, *et al.*, 2010; Mellad JA, *et al.*, 2011).

Most of the functions described before refer to structural roles of the nesprins. However nesprins are also involved in regulating signaling events across the NE or inside the nucleus. At the NE nesprin-2 interacts with α - and β -catenin and with emerin that has an impact on Wnt signaling. Inside the nucleus, nesprin-2 acts as a scaffolding protein for nuclear extracellular signal-regulated kinases 1 and 2 (ERK1/2, also known as MAPK1/2). A loss of nesprin-2 leads to sustained ERK1/2 activation and increased cell proliferation (Neumann S, *et al.*, 2010; Warren DT, *et al.*, 2010; Rashmi RN, *et al.*, 2011; Yu J, *et al.*, 2011)

1.2.4 SUN proteins

SUN proteins are type-II transmembrane proteins of the INM with an N-terminus facing the nucleoplasm, and a C-terminal conserved SUN domain localizing between INM and ONM. The eponymous SUN domain is a conserved ~200 amino acid residues spanning C-terminal motif that follows a trans-membrane domain and a coiled coil segment that reaches into the PNS. SUN proteins contain at least one transmembrane domain (Figure 1.4). The name of the SUN domain is derived from homologous sequences that have originally been described in

Schizosaccharomyces pombe Sad1 and *Caenorhabditis elegans* UNC-84 proteins. Later these sequences have additionally been found in mammalian proteins.

Five SUN proteins have been identified until now: SUN1 (UNC-84A), SUN2 (UNC-84B), SUN3, SUN4 (SPAG4), and SUN5 (SPAG4L). To date, SUN domain proteins have been described in several species, such as *mus musculus*, *Caenorhabditis elegans*, *Drosophila melanogaster* (Klaroid and Giacomo), *Schizosaccharomyces pombe* (Sad1) and *Saccharomyces cerevisiae* (Mps3). SUN domain proteins also been reported in plants such as *Arabidopsis thaliana* (Shao X, et al., 1999; Tzur YB, et al., 2006; Hiraoka Y and Dernburg AF, 2009; Graumann K, et al., 2010; Jiang XZ, et al., 2010; Rothballer A, et al., 2013).

SUN proteins play important roles in a wide range of cellular processes. SUN1 and SUN2 double knockout mice die shortly after birth due to a breath system defect, suggesting that SUN proteins are essential. SUN1 specifically associates with telomeres during meiosis. Studies on SUN1-deficient mice indicate that disruption of SUN1 in mice prevents telomere attachment to the nuclear envelope and meiosis. As the critical processes of maintaining genomic stability, DNA damage response and DNA repair were described to be regulated by SUN proteins according their interactions with DNA-dependent protein kinase, a protein known to function in DNA repair. Based on the SUN1 and SUN2 double knockout mice research, embryonic fibroblasts displayed premature proliferation arrest in S phase of cell cycle, increased apoptosis and DNA damage, and decreased perinuclear heterochromatin. Mps3, a SUN protein found in yeast, has been described to play a role in the repair of DNA double strand breaks, indicating that SUN proteins have a role in maintaining genome stability. Studies on *LMNA* null or progeroid *LMNA* Δ 9 mutant mice described SUN1 abnormally accumulated at the Golgi. Furthermore, it has been described that high levels of SUN proteins at the NE in lamin A mutant cells result in toxicity through a hyperactivity of the DNA damage response (Ding X, et al., 2007; Oza P, et al., 2009; Chen CY, et al., 2012; Lei K, et al., 2012; Star DA, 2012).

Introduction

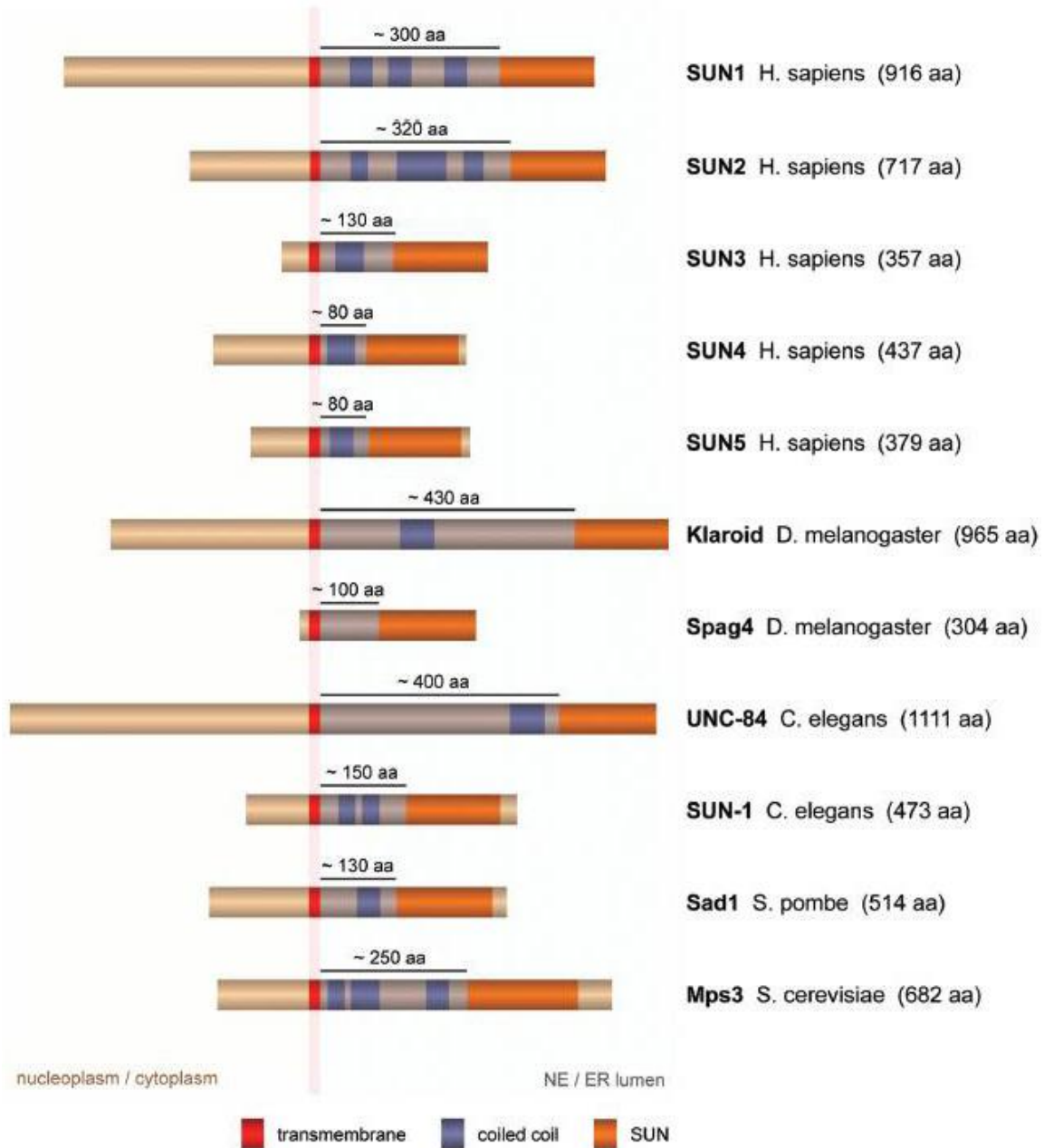

Figure 1.4 Basic structures of SUN proteins.

Main structural characteristics shared by SUN proteins are the SUN domain (orange), and at least one transmembrane region (red) that mediates the anchorage to the NE. The SUN domain localizes in the lumen between the INM and ONM, where it interacts with the KASH domain of the nesprins (Rothballer A *et al.*, 2013).

1.2.5 Cellular functions of the LINC complex

As the core components of the LINC complex, KASH domain proteins nesprins are anchored along both ONM and INM through the interaction of the KASH domain with the SUN domain

of the SUN proteins in the PNS. Based on the localization between cytoplasm and nucleoplasm LINC complex components interact with proteins from both compartments. INM nesprins and SUN proteins interact with NE proteins like emerin and lamin A/C. ONM nesprins directly or indirectly interact with all cytoskeletal systems of a cell.

As a linker of nucleoskeleton and cytoskeleton, the LINC complex plays an important role in many crucial cellular processes. The LINC complex and LINC complex-associated proteins form an essential connection between the cytoskeleton and the nucleoskeleton that is critical for intracellular force transmission and transfer of mechanical induced signals across the NE. Additionally, studies on the nesprin-4 and SUN1 KO mice revealed that mice lacking either nesprin-4 or SUN1 show hair cell defects and hearing impairments, that demonstrated the LINC complex is essential for hearing (Razafsky D, *et al.*, 2009; Méjat A and Misteli T, 2010; Lombardi ML, *et al.*, 2011; Horn HF, *et al.*, 2013).

1.2.6 Nuclear lamins

Lamins are type V intermediate filaments proteins that form a meshwork that lines the nucleoplasmic surface of the INM.

They are grouped into A- and B-type lamins. A-type lamins include lamin A, AΔ10, C and C2 that are encoded by *LMNA* and formed by alternative splicing and posttranslational modifications. Lamin A and C are the major components of the nuclear lamina. B-type lamins are encoded by *LMNB1* (lamin B1) and *LMNB2* (lamin B2 and B3) (Worman HJ and Bonne G, 2007).

1.2.5.1 Lamins assemble to form a meshwork along the INM

Basic structural aspects of mammalian lamins are the tripartite organization into an N-terminal head domain, a central α -helical rod domain and a C-terminal globular tail domain. The C-terminal domain contains a structural Ig-fold and a nuclear localization signal (NLS), and in most cases contains a carboxy-terminal CAAX box (except lamin C). After four post-

translational processing steps for pre-lamin A, the farnesylation of a carboxyl-terminal cysteine, release of the last three amino acids –AAX of the protein, methylation of the farnesylcysteine, and the endoproteolytic release of the carboxyl-terminal 15 amino acids of the protein, the mature lamin A protein is generated (Figure 1.5).

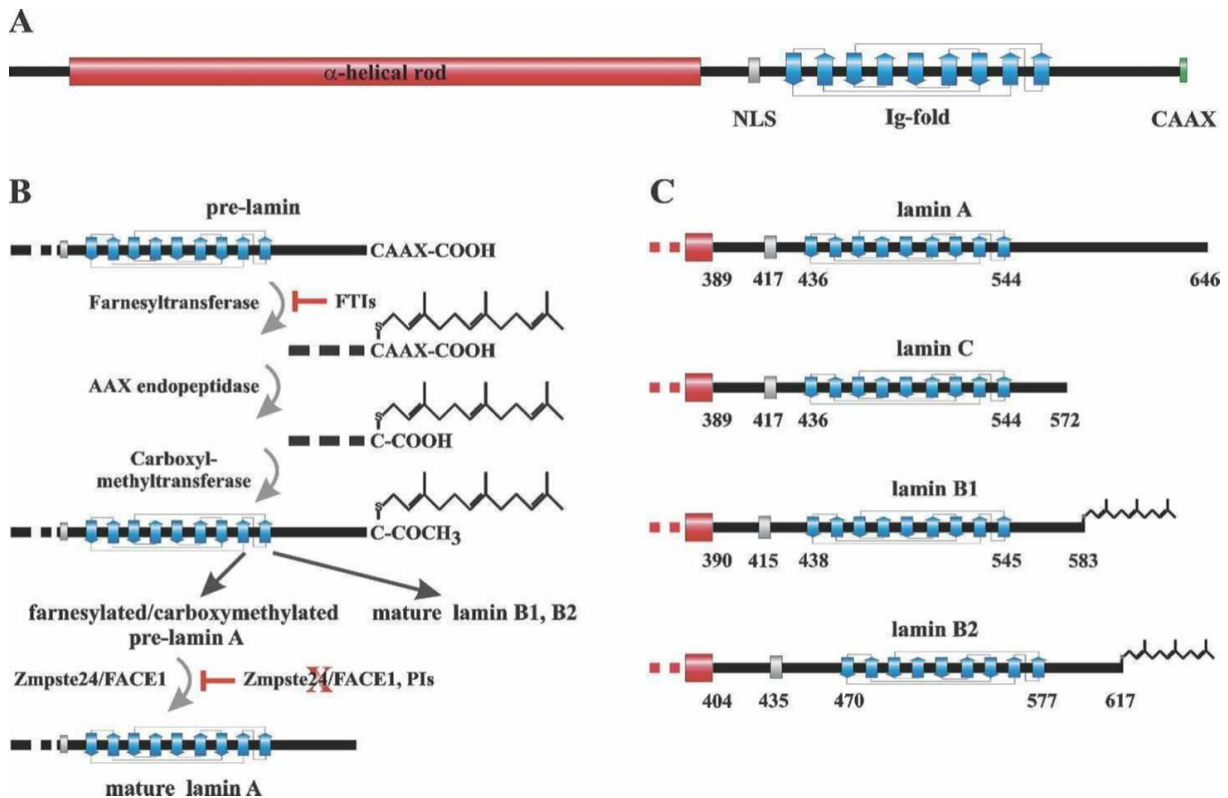

Figure 1.5 Schemes summarizing structures and processing of lamins.

(A) Main structural components of pre-lamin A are the globular N-terminal head domain, a central α -helical rod domain and a C-terminal globular tail domain with a carboxy-terminal CAAX motive.

(B) Summary of post-translational processing of the pre-lamins A, B1 and B2. After four post-translational processing steps namely farnesylation of a carboxyl-terminal cysteine, release of the last three amino acids of the protein, methylation of the farnesylcysteine, and the endoproteolytic release of the carboxyl-terminal 15 amino acids of the protein, the mature lamin A protein is generated. In lamin B1 and B2 maturation ends with the methylation of the C-terminal cysteine and does not include the cleavage of the C-terminal 15 residues.

(C) C-terminal structures of mature lamins. The indicated amino acid positions are: start of the tail domain, first residue of the NLS, Ig-fold and most C-terminal residue of mature lamins (Dechat, *et al.*, 2008).

For the formation of higher order structures (Figure 1.6), initially two lamin polypeptides (about 55nm) assemble to form parallel head to tail dimer, which is driven by coiled-coil formation to a two stranded α -helical coiled-coil structure (around 48 nm from tail to tail).

Dimers then assemble into head-to-tail polar polymers, which require an overlapping interaction between the head and tail domains. Higher order structure is achieved by anti-parallel, side-by-side association of polymers, the proto-filaments that underlay the NE (Stuurman N, *et al.*, 1998; Prokocimer M, *et al.*, 2009; Ho CY and Lammerding J., 2012).

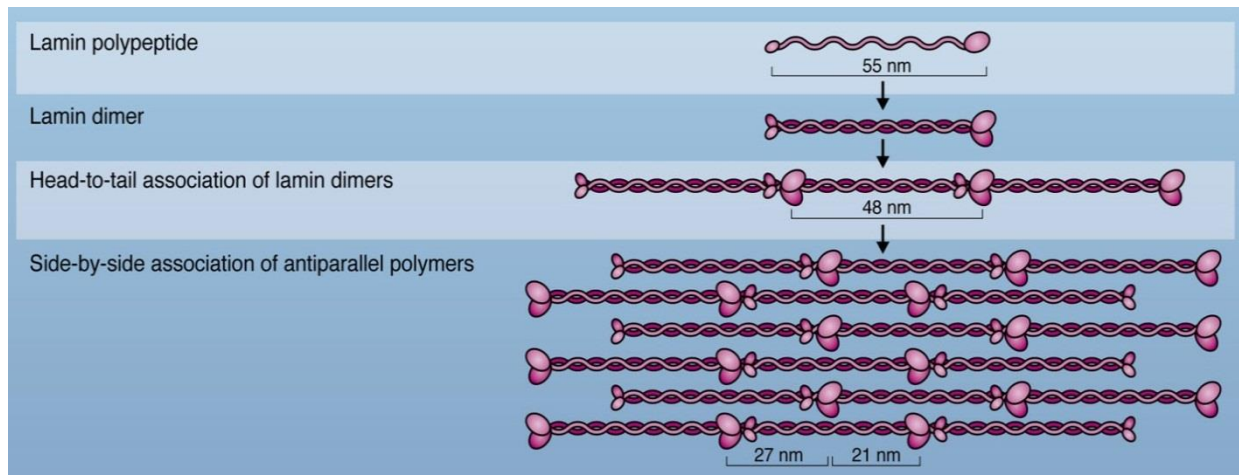

Figure 1.6 Assembly of lamins into filaments.

Initially two lamin monomers assemble along their central alpha helical rod domain to form a parallel head to tail dimer. Following, lamin dimers assemble into head to tail polar polymers based on overlapping interactions between head and tail domains. Polymers then laterally assemble anti-parallel into non-polar filaments that form a meshwork underlying the inner surface of the INM (Ho CY and Lammerding J., 2012).

1.2.5.2 Functions of lamins

Nuclear lamins were identified more than 30 years ago. At the early stage of research on lamins, they were described as nuclear matrix components, fulfilling structural functions such as maintaining shape and mechanical stability of the nucleus. Along with research progress, it became increasingly evident that lamina proteins are involved in basic cellular processes such as maintaining nuclear shape and mechanical stability, as well as regulating gene expression, signaling pathways and functional chromatin organization. Lamina functions have additionally been shown to play a role in mitosis, DNA replication and repair and transcription (Dechat T, *et al.*, 2010; Dittmer TA and Misteli T, 2011; Gerace L and Huber MD, 2012; Worman HJ, 2012).

Introduction

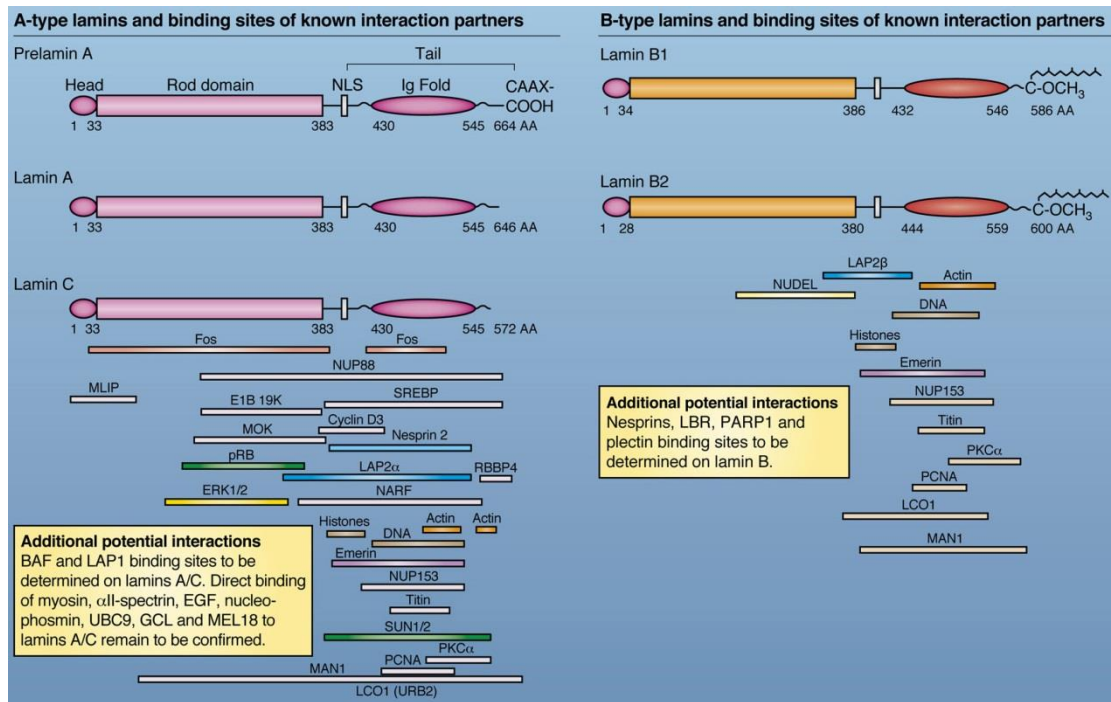

Figure 1.7 Interaction partners of A- and B-type lamins.

The scheme summarizes interaction partners that have been identified for A- and B-type lamins so far including their interaction sites in the lamin proteins. The interaction partners reflect the wide range of lamin functions along the NE and in organizing chromosomal structures as well as regulating gene expression. The majority of interactions have been shown for A-type lamins (Ho CY and Lammerding J., 2012).

The wide range of cellular functions in which lamins have been shown to play a role, is reflected by the large and constantly increasing number of interaction partners that have been described, especial for A-type lamins (Figure 1.7). The currently described interaction partners include nuclear membrane associated proteins such as nesprin-2 and emerin. Lamins interact with chromosomal structures through interactions with histones or direct binding to DNA. They additionally interact with transcriptional regulators like sterol regulatory element-binding protein 1 (SREBP1) and ZNF239 (zinc finger transcription factor proteins, also known as MOK2) (Wilson KL and Foisner R, 2010; Ho CY and Lammerding J., 2012).

1.3 The LINC complex in human diseases

Introduction

Several hundred mutations in NE proteins have been described that can result in a variety of human diseases such as **Hutchinson-Gilford progeria syndrome (HGPS)**, **Emery-Dreifuss muscular dystrophy (EDMD)**, **Dunnigan-type familial partial lipodystrophy (FPLD)**, and cardiomyopathy that are collectively known as nuclear envelopathies. Due to the large number of mutations in the *LMNA*, the gene encoding for A-type lamins, these diseases are also known as laminopathies (Table 1.1).

Human diseases	Associated mutated gene	References
Emery-Dreifuss muscular dystrophy Cerebellar ataxia Arthrogryposis	<i>SYNE</i> , encoding nesprins	Zhang Q, <i>et al.</i> , 2007 Gros-Louis F, <i>et al.</i> , 2007 Attali R, <i>et al.</i> , 2009
Duchenne muscular dystrophy Emery-Dreifuss muscular dystrophy Charcot-Marie-Tooth syndrome	<i>SUN</i> , encoding SUN domain proteins	Taranum S., <i>et al.</i> , 2012
Emery-Dreifuss muscular dystrophy	<i>EMD</i> , encoding emerin	Bione S, <i>et al.</i> , 1994 Bione S, <i>et al.</i> , 1995
Hutchinson-Gilford progeria Emery-Dreifuss muscular dystrophy Familial partial lipodystrophy Dilated cardiomyopathy Charcot-Marie-Tooth disease Mandibuloacral dysplasia	<i>LMNA</i> , encoding A-type lamins	DeBusk FL, 1972 Wessely R, <i>et al.</i> , 2005 Garg A, 2004 Olson TM and Keating MT, 1996 Bouhouche A, <i>et al.</i> , 1999 Garavelli L., <i>et al.</i> , 2009

Table 1.1 LINC complexes proteins and human diseases.

The table summarizes examples of mutations in NE genes and the resulting diseases. Most of them belong to a group of human diseases collectively known as laminopathies.

The first identified LINC complex component associated with human diseases was emerin. As a component of the NE, emerin interacts with several proteins at the inner and outer surface of the NE. These proteins are involved in regulating the activity of certain genes, controlling the cell cycle and maintaining the structure and stability of the nucleus. Emerin and related proteins also play a role in assembling the nucleus during cell division. Mutations in *EMD*, encoding for emerin, lead to an **X-linked form of Emery-Dreifuss muscular dystrophy (XL-EDMD)**. More than 400 different mutations (Figure 1.8) have been identified in *LMNA* so far (www.umd.be/LMNA/). Only a few mutations have been identified in B-type lamins.

Mutations in nesprin-1/2 and SUN proteins have also been implicated in the formation of laminopathies like EDMD. Mutations in nesprin-1 and -2 additionally result in disorders which are not characterized by NE defects such as autosomal recessive cerebellar ataxia. Along with research insight, more and more genes encoding NE components have been associated with human diseases (Bione S, *et al.*, 1994; Cao H, *et al.*, 2000; Vergnes L, *et al.*, 2004; Méjat A and Misteli T, 2010; Worman HJ, *et al.*, 2010; Meinke P, *et al.*, 2011; Lombardi ML, *et al.*, 2011).

To date, at least 15 different diseases have been linked to mutations in NE proteins like lamins, emerin, nesprins and SUN proteins. However, due to partially overlapping clinical manifestations the exact number of disease phenotypes may differ. Laminopathies range from skeletal muscle dystrophies to cardiac defects, metabolic diseases, diseases affecting the nervous system or diseases associated with early aging. Most laminopathies have a postnatal onset and are progressively developing during childhood or adolescence. Currently, there is no cure for laminopathies and treatment is symptomatic and supportive, without treatment some laminopathies may lead to early death. It is still not clear how mutations in NE proteins result in phenotypically different laminopathies with tissue-specific pathologies, especially when considering that most NE proteins such as lamins, are expressed in almost all differentiated somatic cell types. Currently, three mutually non-exclusive hypotheses have been postulated. The first one is the structural hypothesis that focusses on the role of NE proteins in maintaining nuclear integrity. Mutations in NE proteins lead to structural weakness, and decreased ability of nuclei to maintain mechanotransduction along LINC complexes or to resist high mechanical strain. The second hypothesis is the gene-expression hypothesis, which refers to the role of NE proteins like nesprins or lamins in regulating gene expression. The third hypothesis, refers to the pathological impact of accumulated mutated NE proteins and their resulting cell toxic functions (Lammerding J, *et al.*, 2004; Capanni C, *et al.*, 2005; Columbaro M, *et al.*, 2005; Markiewicz E, *et al.*, 2006; Kandert S, *et al.*, 2007; Furukawa K, *et al.*, 2009; Brosig M, *et al.*, 2010; Dubinska-Magiera M, *et al.*, 2012; Simon DN and Wilson KL., 2013).

Introduction

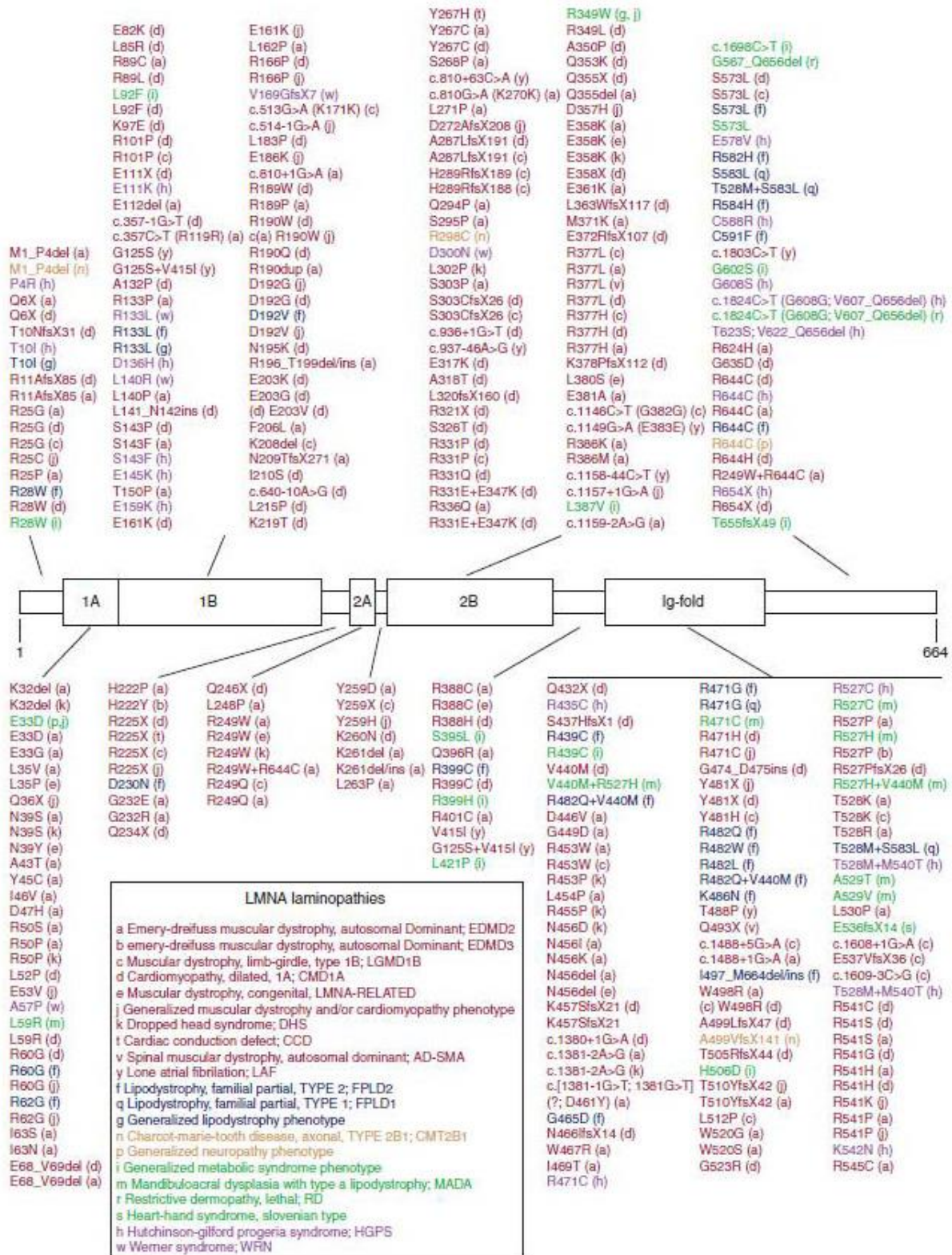

Figure 1.8 Summary of laminopathy causing mutations in human lamin A .

The scheme summarizes mutations in lamin A and the resulting laminopathies are classified with a colour code. Mutations shown in red affect skeletal or cardiac muscles. Mutations shown in blue lead to lipodystrophies, brown refers to neuropathies, green to systemic laminopathies and mutations in purple belong to premature aging disorders (Dittmer T and Misteli T, 2011).

1.4 Aim of the study

LINC complexes connect the nucleoskeleton to the cytoskeleton by interactions among LINC complex proteins and their interactions to proteins in the nucleus and the cytosol. LINC complexes reside along the interface between cytoplasm and nucleoplasm and they are involved in regulating many cellular functions including maintenance of the structural integrity of nucleus and cytoskeleton or proper signal transduction across the NE. Mutations in LINC complex components have been described in a wide range of human diseases that include muscle diseases, metabolic syndromes neuropathies or premature ageing diseases that are collectively known as laminopathies. For this reason it is of particular importance to have a detailed knowledge about LINC complex interactions.

The aim of my thesis is to further characterize interactions among LINC complex components and to study the pathological role of distinct mutations in these proteins. Nesprins interact with the INM proteins lamin A/C. The binding site between nesprin-1, -2 and lamin A/C have been mapped near their C-termini (Mislow JM, *et al.*, 2002; Libotte T, *et al.*, 2005). One aim of my project is to further narrow down the binding site between nesprin-2 and lamin A. Additionally we want to find out how laminopathy causing mutations in or near the binding sites of both proteins affect their interaction, which will help to answer the question how different mutations in one gene lead to the formation of phenotypically different diseases.

To substantiate our knowledge about LINC complex protein assemblies I additionally characterize the novel interaction of SUN proteins to the microtubule network under normal or laminopathic conditions. The studies on SUN proteins include the characterization of the SUN1 mutation Q93P and T33A in SUN2 and their impact on NE protein assemblies.

Laminopathies include early ageing diseases like HGPS that resembles aspects of ageing at an early age, for this reason the expression of lamin proteins in the context of ageing nesprin-2 giant knockout (KO) mice will be analyzed.

2 Results

2.1 Narrowing down of binding sites between lamin A and nesprin-2

As a component of the LINC complex, nesprins interact with INM proteins, like lamin A/C. The corresponding binding sites have been mapped near the C-terminus of nesprin-1 and nesprin-2 (Libotte T, *et al.*, 2005).

In order to get a better understanding of the interaction between both proteins, we further narrowed down the binding sites between lamin A and nesprin-2 by using His-Tag and GST Pull down assays.

A

Lamin A (LA)

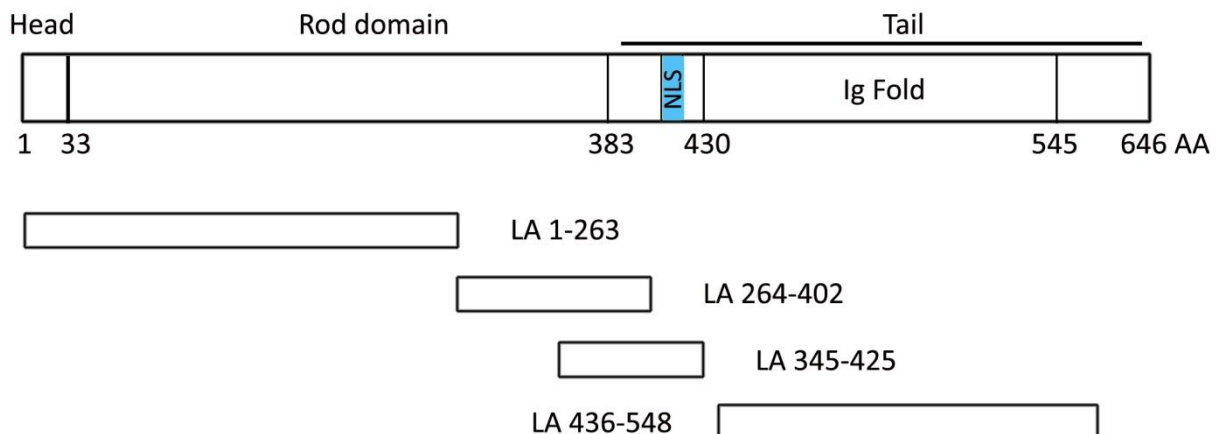

B

Nesprin-2 giant

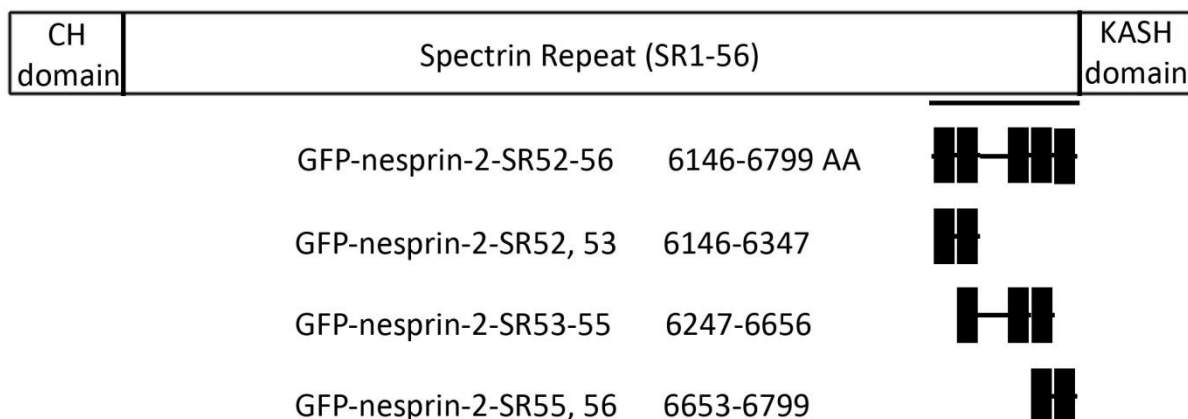

Figure 2.1 Lamin A and nesprin-2 constructs used for His-tag pull down.

(A) Lamin A constructs used in this study. The plasmids we used cover almost the entire sequence of lamin A.

(B) Nesprin-2 constructs used in this study. On top nesprin-2 giant is shown. The C-terminal part that is known to interact with lamin A is underlined. The nesprin-2 constructs we used for our binding studies include five C-terminal spectrin repeats of nesprin-2 giant (SR52-56).

2.1.1 Identification of the lamin A amino acids that mediate the binding to nesprin-2

First we narrowed down the interaction site of nesprin-2-SR52-56 to lamin A. For this His-tag pull downs were performed by using pPET-TEV-LA (1-263), pPET-TEV-LA (264-402), pPET-TEV-LA (345-425) and Pet24d His-TEV- (436-548) lamin A expression constructs. Proteins were coupled to Ni-NTA beads, incubated with lysates of COS7 cells expressing GFP-nesprin-2-SR52-56, and analyzed by western blot. The nesprin-2-SR plasmids used in this study are GST-nesprin-2-SR52-56, -SR52, 53, -SR53-55 and -SR55, 56. In western blots we obtained signals for GFP-nesprin-2-SR52-56 in the LA 345-425 fraction (Figure 2.2 A). From this we conclude that the interaction site of nesprin-2-SR52-56 to lamin A lies within the lamin A amino acid sequence from 345 to 425.

By taking a closer look at the lamin A constructs we used in the in vitro binding studies, one can see that there is an overlap between lamin A constructs LA 264-402 and LA 345-425.

Results

Since we did not detect GFP-nesprin-2-SR52-56 together with LA 264-402, the binding site for lamin A to nesprin-2 must lie within lamin A amino acid 403-425 (Figure 2.2 B).

A

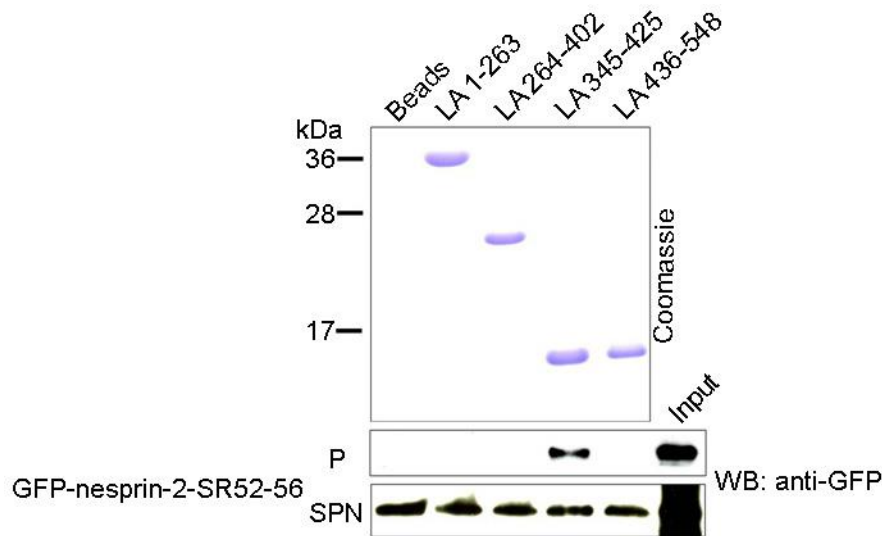

B

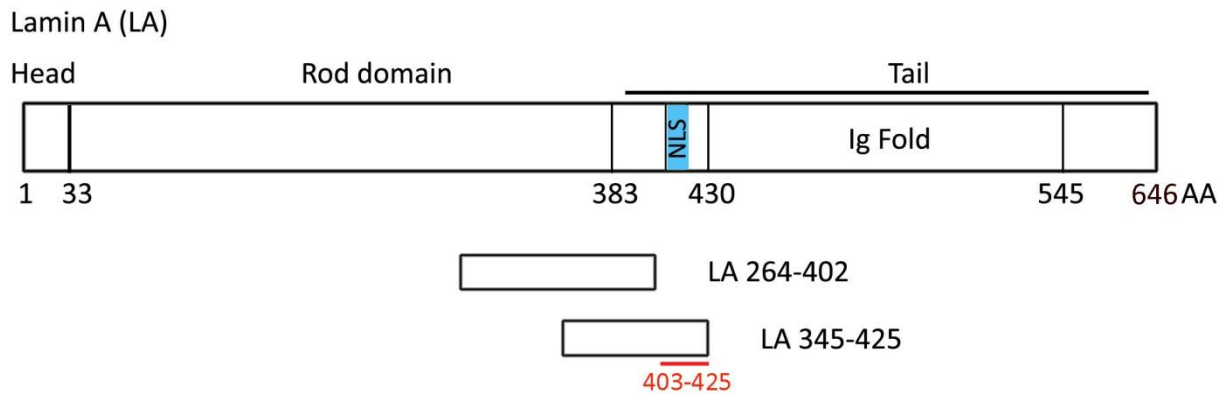

Figure 2.2 Amino acids 345-425 of human lamin A interact with GFP-nesprin2-SR52-56.

(A) His-tag pull down experiment with His tagged lamin A proteins and GFP-tagged nesprin-2-SR52-56. GFP-nesprin-2-SR52-56 precipitates only with LA 345-425. We did not get any signals from the other lamin A polypeptides (LA1-263, LA 264-402 and LA 436-548). That suggests nesprin-2 interacts with lamin A through the amino acids 345-425. *WB*: western blot, *P*: pellet, *SPN*: supernatant.

(B) Lamin A polypeptides 264-402 and 345-425 share an overlapping sequence. Since GFP-nesprin-2-SR52-56 precipitates with LA 345-425, but not with LA 264-402, the binding site for lamin A to nesprin-2 can be narrowed down to lamin A amino acid 403-425 (highlight in red).

2.1.2 Identification of nesprin-2 giant amino acids that mediate the binding to lamin A

Results

Next we performed His-tag pull down experiments to narrow down the binding site in nesprin-2 to lamin A. We used the lamin proteins LA 345-425 as positive controls, since we identified the binding site of GFP-nesprin-2-SR52-56 to these lamin A amino acids (Figure 2.2). LA 264-402 was used as a negative control, because this protein fragment does not interact with GFP-nesprin-2-SR52-56 (Figure 2.3B). His-tagged lamin A proteins that were bound to Ni-NTA beads were incubated with lysates of COS7 cells expressing GFP-nesprin-2-SR52, 53, -SR53-55, -SR55, 56 proteins, respectively (Figure 2.3 A).

In western blots we detected signals for GFP-nesprin-2-SR52, 53 and GFP-nesprin-2-SR53-55. We did not obtain signals for GFP-nesprin-2-SR55, 56. The nesprin-2 constructs -SR52, 53 and -SR53-55 we used in the in vitro binding studies share an overlapping sequence. We got signals for both polypeptides in the western blot, however the signal for nesprin-2-SR53-55 was always very weak compare to -SR52, 53, indicating the interaction site of nesprin-2 to lamin A resides within the SRs 52 and 53 (Figure 2.3 B).

Results

A

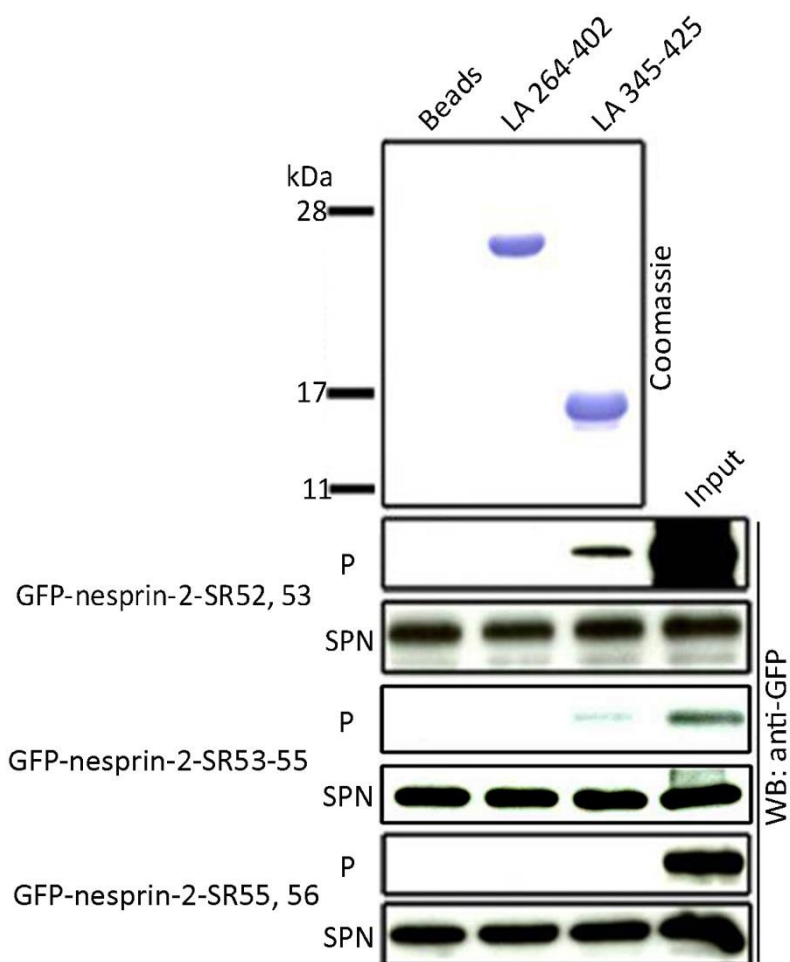

B

Nesprin-2 giant

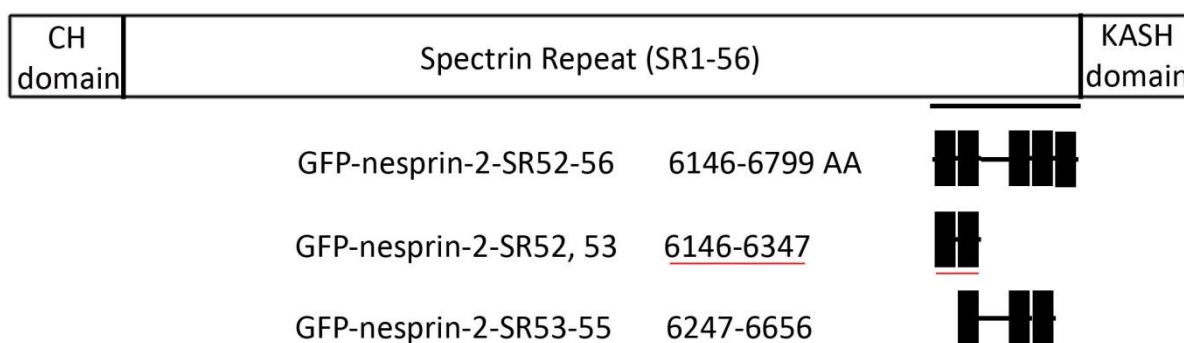

Figure 2.3 Nesprin-2-SR52, 53 and -SR53-55 interact with LA 345-425.

(A) His-tag pull downs were performed with lamin A proteins LA264-402, LA 345-425 that were bound to beads and the GFP nesprin-2 fusion polypeptide nesprin-2-SR52-56, nesprin-2-SR52, 53, -SR53-55 and -SR55, 56. We got signals for nesprin-2-SR52, 53 and -SR53-55.

Results

(B) Nesprin-2-SR52, 53 and -SR53-55 share an overlapping sequence and GFP immunoblotting signals for -SR53-55 were always much weaker compared to -SR52, 53. We concluded the binding site of nesprin-2 to lamin A lies within nesprin-2-SR52, 53, aa 6146-6347 (underline in red).

2.1.3 Nesprin-2-SR53 is sufficient to mediate the interaction to lamin A

In pull down experiments we found an interactions between lamin A aa 345-425 and GFP-nesprin-2-SR52, 53, and GFP-nesprin-2-SR53-55 (Figure 2.3). Since the signal for GFP-nesprin-2-SR52, 53 was always much stronger compared to GFP-nesprin-2-SR53-55 we concluded that the nesprin-2 interaction to lamin A mainly depends on SRs 52 and 53. To answer the question which one of these SRs is sufficient for the interaction, GST-pull down experiments were performed in which GFP-LA 403-425 and GST-nesprin-2-SR52, -SR53, and -SR52, 53 proteins were used. GST-nesprin-2-SR proteins coupled to beads were incubated with lysates of COS7 cells expressing GFP-LA 403-425. By western blot analysis, we obtained signals for GST-nesprin-2-SR53 and -SR52, 53. The signal for nesprin-2-SR53 was always much weaker compared to the signal of nesprin-2-SR52, 53, however this SR is sufficient to precipitate GFP-LA 403-425 (Figure 2.4).

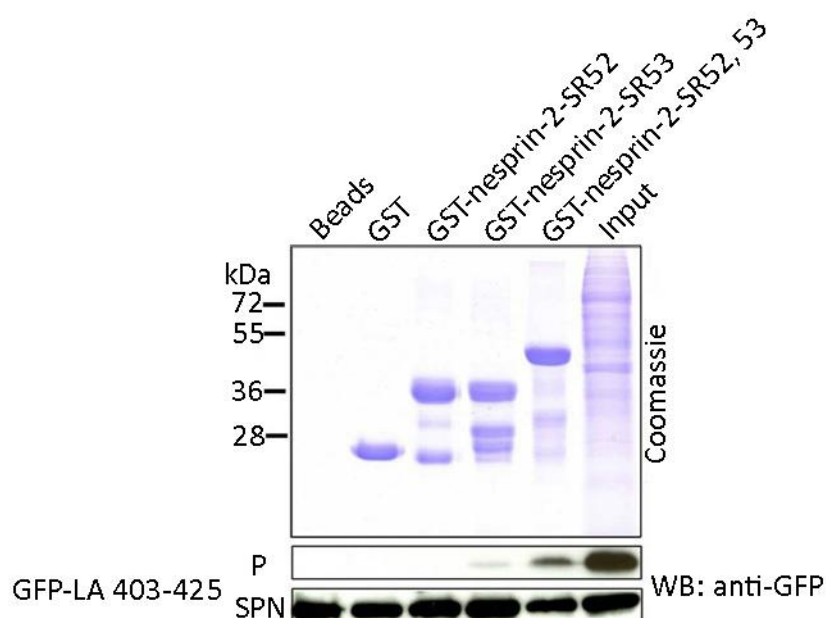

Figure 2.4 GFP-nesprin-2-SR53 is sufficient to mediate the interaction to LA 403-425.

The GST-pull down experiment was performed by using lamin A proteins (GFP-LA 403-425) and GST-nesprin-2-SR proteins (-SR52, -SR53, and -SR52, 53). GFP-LA 403-425 was precipitated by nesprin-2-SR53 and -SR52, 53. Nesprin-2-SR53 is sufficient for mediating the interaction between lamin A 402-425, but the signal was much

weaker compared to the longer fragments, indicating that additional amino acids are necessary for strengthening the interaction between both proteins.

2.2 Study on mutations in the binding sites of nesprin-2 and lamin A

2.2.1 Laminopathy causing mutations reside in the nesprin-2 binding site of lamin A

Currently there is accumulating evidence that lamins and further LINC complex or NE proteins play roles in the formation of laminopathies. For this reason we wanted to analyze if mutations which have been described in laminopathies that lie within or near the binding sites of lamin A and nesprin-2 affect the interaction between both proteins which might contribute to the formation of these diseases.

Many mutations in lamin A have been identified until now. Most are summarized on the website <http://www.umd.be/LMNA/>. Several mutations have been reported in or near lamin A aa 403-425, the binding site to nesprin-2, namely R401C (1201 C>T), G411D (1232G>A), G413C (1237G>T), V415I (1243G>A), R419C (1255T>C), L421P (1261T>C), R427G (1279C>G) and Q432X (1294C>T). These mutations are characterized by large differences in their clinical manifestation that include lipodystrophies or metabolic syndromes for G411D, R419C, L421P and skeletal or cardiac muscle dystrophies in case of R401C, G413C, V415I, R427G and Q432X (Vytopil M, *et al.*, 2001; Haque WA, *et al.*, 2003; Decaudain A, *et al.*, 2007; Brauch KM, *et al.*, 2009; Møller DV, *et al.*, 2009; Dutour A, *et al.*, 2011). No mutations in nesprin-2 have been described so far that might affect the interaction to lamin A. For this reason in the following we focused on characterizing the described mutations afore in *LMNA*.

Above all, we aim to analyze if changes in the binding ability between nesprin-2 and lamin A contribute to the formation of laminopathies.

2.2.2 Generation of mutated full length or short GFP lamin A constructs

The first mutation we found in the binding site between lamin A and nesprin-2 was the mutation L421P. cDNAs encoding WT and mutated lamin A amino acid 403-425, that were

Results

shown to interact with nesprin-2 (Figure 2.2) were cloned into GFP vectors and confirmed by DNA-sequencing (Figure 2.5 A) and western blot analysis (Figure 2.5 B). The predicted molecular weight of GFP-LA 403-425 is approximate 30 kDa and thus differs only slightly from GFP that has a molecular weight of approximate 27 kDa (Figure 2.5 B).

A

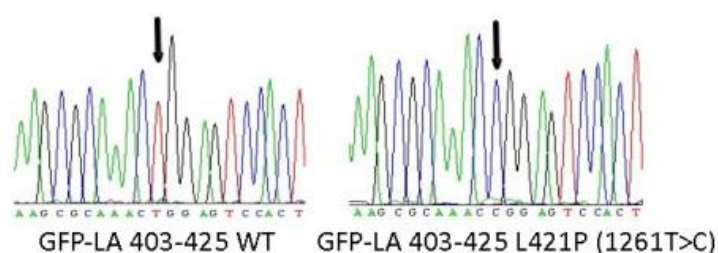

B

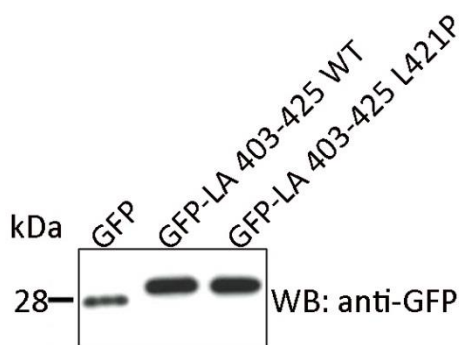

Figure 2.5 Sequencing results and western blot analysis of GFP-LA 403-425 WT and -L421P.

(A) cDNAs encoding WT or L421P mutated lamin A amino acids 403-425 were cloned into GFP vectors and confirmed by DNA sequencing. WT and mutated nucleotides are highlighted by arrows.

(B) Western blot analysis of GFP-LA 403-425 fusion proteins. The proteins were transiently expressed in COS7 cells. Lysates were analyzed by SDS-PAGE followed by western blot with mAb K3-184-2 that confirmed the predicted molecular weights.

During our studies further mutations in lamin A have been described including [Arg401Cys (1201 C>T), Gly411Asp (1232G>A), Gly413Cys (1237G>T), Val415Ile (1243G>A), Arg419Cys (1255T>C), Leu421Pro (1262T>C), Ar427Gly (1279C>G), Gln432X (1294C>T)]. All mutations reside within a region of lamin A that is encoded by *LMNA* exon 7 and all are point mutations causing single nucleotide exchanges (Figure 2.6 A and B). Seven mutations result in amino acid changes whereas the mutation Q432X (1294C>T) causes the formation of a premature stop codon and thus a shorten lamin A (Figure 2.6 C and D). All *LMNA* mutations were

Results

inserted into GFP full length lamin A by site directed mutagenesis. The success of mutagenesis was confirmed by DNA sequencing (Figure 2.6 B). Additionally all GFP plasmid were transiently expressed in COS7 cells and lysates of these cells were analyzed by western blot to confirm the molecular weight of each mutated protein. The predicted molecular weight for GFP WT lamin A and all mutations is 100 kDa. The truncated GFP-LA Q432X protein has a predicted molecular weight of 76 kDa. According to DNA sequencing and immunoblotting, all constructs are correct (Figure 2.6).

A

```

Lamin A WT --GGCCGTGCTTCTCTCACTCATCCCAGACACAGGGTGGGGGCGAGCGTCACCAAAAAGCGCAAACCTGGAGTCCACTGAGAGCCGCAGCAGCTTCTCACAG--
R401C 1201C>T .....T.....
G411D 1232G>A .....A.....
G413C 1237G>T .....T.....
V415I 1243G>A .....A.....
R419C 1255C>T .....T.....
L421P 1262T>C .....C.....
R427G 1279C>G .....G.....
Q432X 1294C>T .....T.....
  
```

B

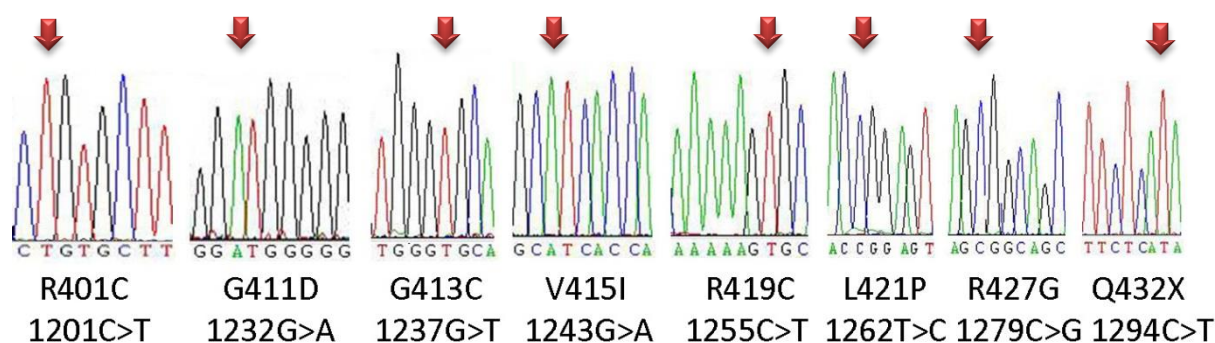

C

```

LA WT      (399) RGRASSHSSQTQGGGSVTKKRKLESTESRSSFQHA (434)
LA R401C   ... C .....
LA G411D   .....D.....
LA G413C   .....C.....
LA V415I   .....I.....
LA R419C   .....C.....
LA L421P   .....P.....
LA R427G   .....G.....
LA Q432X   .....X.....
  
```

D

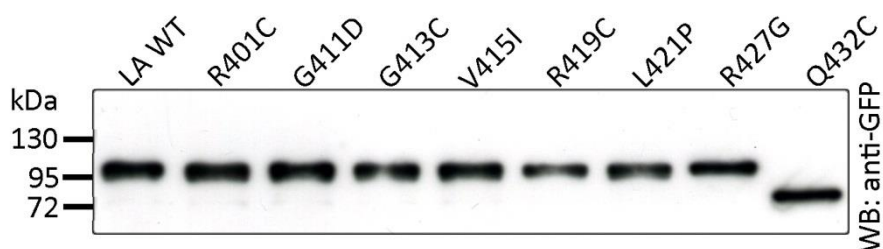

Figure 2.6 DNA Sequencing and western blot analysis of full length WT and mutated lamin A constructs.

(A) Nucleotides 1198 to 1296 of human *LMNA* are shown. Nucleotides encoding the amino acids that interact with nesprin-2 are underlined. *LMNA* mutations analyzed in the present study are highlighted below in red. Similarities to the WT sequence are shown as dotted lines.

(B) *LMNA* mutations shown in (A) were inserted into plasmids encoding GFP tagged full length lamin A by site directed mutagenesis. Sequencing confirmed the success of the mutagenesis. Mutated nucleotides are highlighted by an arrow in each peak diagram.

(C) Aa residues 399 to 434 of WT lamin A are shown. The interaction site of lamin A to nesprin-2 is underlined. Similarities to the WT sequence are shown as dotted lines, aa changes are indicated in red. The mutation Q432X leads to a stop codon (X).

(D) Western blot analysis of GFP lamin A fusion proteins. The proteins were transiently expressed in COS7 cells. Lysates were analyzed by SDS-PAGE followed by western blot with mAb K3-184-2 that confirmed the predicted molecular weights.

2.2.3 The interaction site of lamin A to nesprin-2 is in a loop

The lamin A mutations that we analyzed here reside between aa 401 and 432 of human lamin A. In an alignment one can see highly conserved residues between human and *Mus musculus* lamin A along the binding site of lamin A to nesprin-2 (Figure 2.7 A). A main aim of the study is to characterize the impact of these *LMNA* mutations on the binding capacity to nesprin-2. For this we addressed the question in which structural region of lamin A aa 403-425 are located. Currently only parts of the three dimensional lamin A structure are available. Therefore we performed a structural prediction of human lamin A aa 351-490 that are part of the coil2B and C-terminal globular domain (Figure 2.7 A), by using the MULTICOM server and 1UFGA (C-terminal immunoglobulin like domain of mouse Lamin A), 1IFRA (globular tail of human Lamin A), and 2LLA (chain A of Mannose-6-phosphate/insulin-like

Results

growth factor II receptor) structures from the **protein data bank (PDB)** as templates and pyMOL for presentation.

A

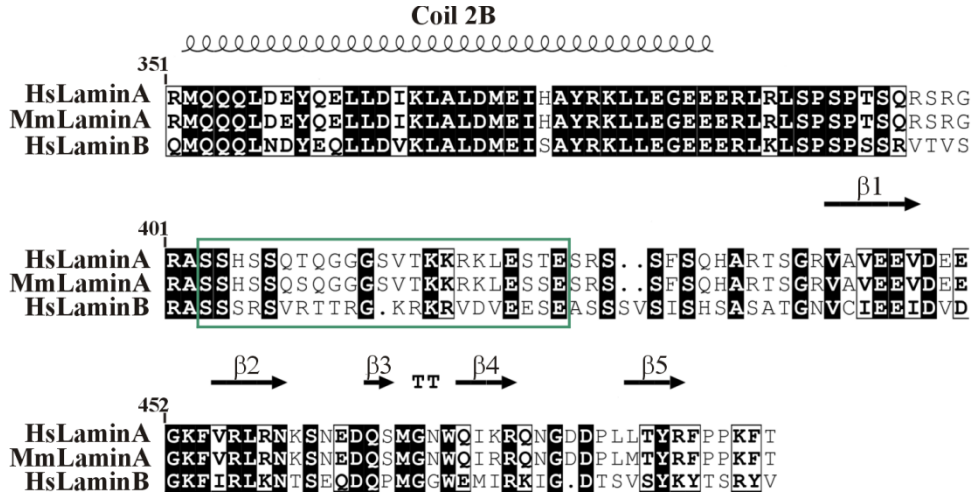

B

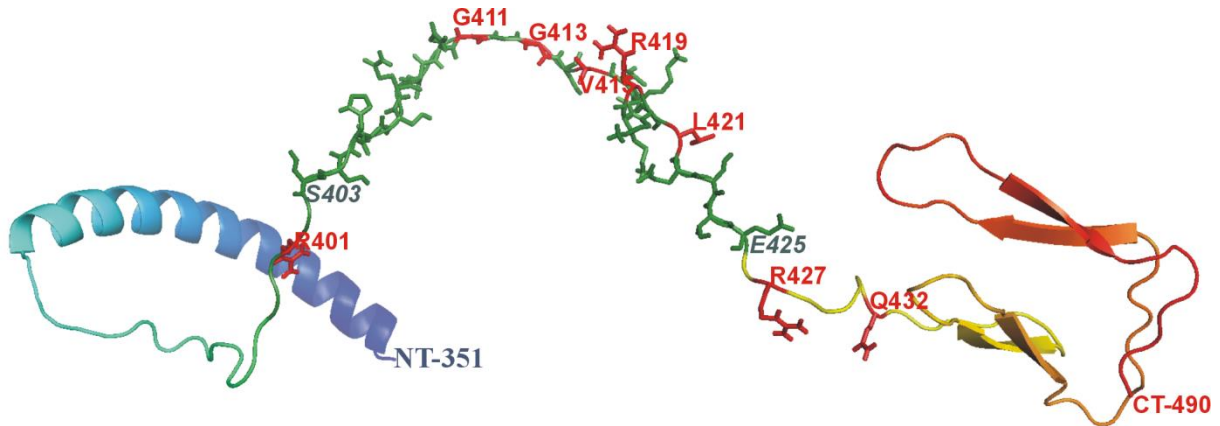

C

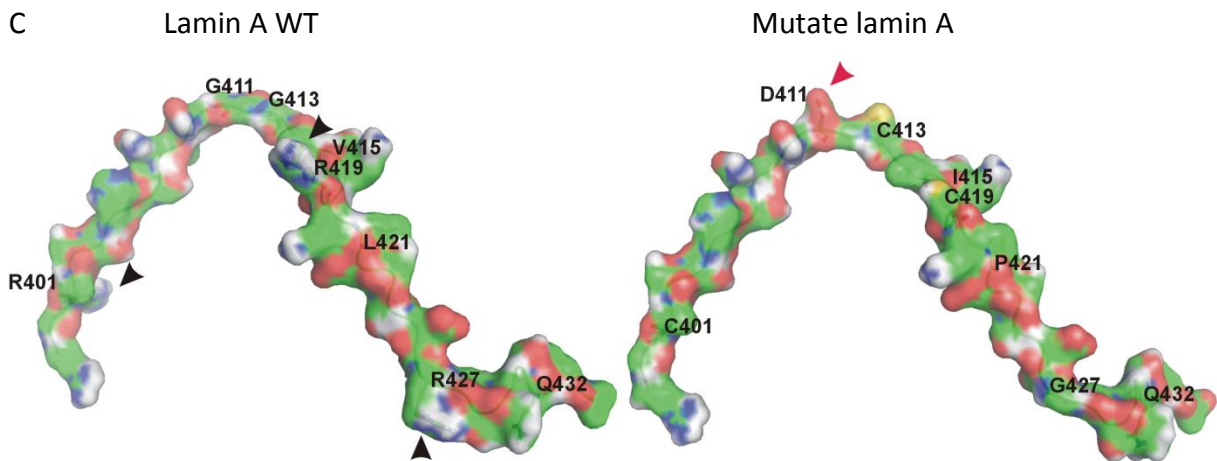

Results

Figure 2.7 The interaction site of lamin A to nesprin-2 is in a loop.

(A) An amino acid alignment was performed between human lamin A/C amino acids 351-490 and the corresponding sequence in human lamin B and *Mus musculus* lamin A. The interaction region of nesprin-2 to lamin A is highlighted in a green frame. Secondary structure elements are shown on top of the alignment and conserved residues are highlighted black, similar residues are framed.

(B) Three dimensional structure prediction of human lamin A aa 351-490. The three dimensional structure of human lamin A351-490 was predicted by using multiple PDB structures as templates (1UFGA, 1IFRA, and 2LLA) in the MULTICOM server. The interaction region of nesprin-2 to lamin A aa 403-425 is highlighted in green. Lamin A mutations that lie in or near the binding site of nesprin-2 analyzed in this study are highlighted in red. The prediction was performed by using pyMOL v1.3.

(C) Molecular surface properties of WT lamin A and laminopathies causing lamin A mutations lie in or near the binding site for nesprin-2, aa 403-425. The comparison of the surface between WT lamin A aa 403-425 and the mutate lamin A with the mutations analyzed in this study. Highly positive and negative charged residues are shown in blue and red, respectively. The positive charged groups that are lost due to mutations are highlighted with black arrowheads, the negative charged group lamin A mutation G411D is highlighted with red arrowhead.

The lamin A interaction site aa 403-425 to nesprin-2 lies in a loop (Figure 2.7 B) that is located between the α helical rod domain and the globular domain at the C-terminus. The amino acids should therefore be accessible for interactions. Interactions among proteins mainly base on hydrophobic or electrostatic interactions between amino acid residues. To analyze the impact of amino acid exchanges caused by mutations in lamin A, analyzed here on the electrostatic surface properties, we additionally generated a model predicting surface charges from which we can say that amino acid exchanges reach from charge neutrality to the generation of positively or negatively charged residues (Figure 2.7 C).

2.2.4 Both LA 403-425 and LA 403-425 L421P interact with nesprin-2

First we focused on characterizing the lamin A mutation L421P that lies within the binding site of lamin A to nesprin-2. We analyzed if this mutation has an effect on the interaction between nesprin-2 and lamin A by performing GST-pull down experiments using GST-nesprin-2-SR52, 53 and -SR54-56 polypeptides and lysates of COS7 cells expressing GFP-LA 403-425 wild type or LA 403-425 L421P, respectively.

Results

In GST-pull down experiments, we observed an interaction between GST-nesprin-2-SR, -SR52, 53 and both WT GFP-LA 403-425 and GFP-LA 403-425 carrying the mutation L421P (Figure 2.8). That suggested that the lamin A mutation L421P does not inhibit the interaction with nesprin-2.

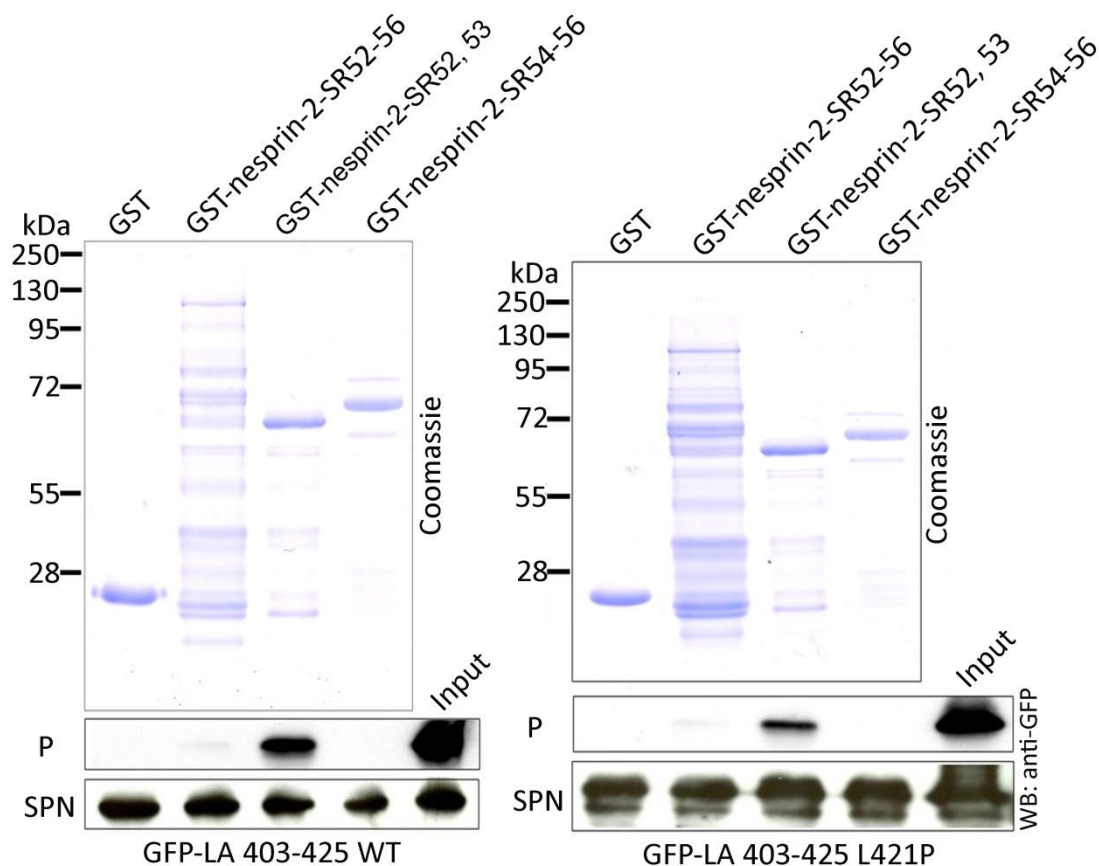

Figure 2.8 Both GFP-LA 403-425 WT and L421P interact with nesprin-2-SR52-56 and -SR52, 53.

GST-pull down experiments of WT GFP-LA 403-425 and 403-425 L421P together with GST-nesprin-2 proteins, show that nesprin-2-SR52-56 and -SR52, 53 interact with WT LA 403-425 and LA 403-425 L421P. The GFP western blot signal observed in precipitates of nesprin-2-SR52-56 polypeptides were always very weak compared to the signal in nesprin-2-SR52, 53 precipitates.

2.2.5 Mutations in LMNA modulate binding affinities of lamin A to nesprin-2

Figure 2.8 shows that the lamin A mutation L421P does not inhibit the interaction with nesprin-2. However, it remains to be determined if the binding affinity of lamin A to nesprin-2 is increased, decreased or unaffected. To address that question, following series of GST pull down experiments were performed. Based on the interaction study between nesprin-2

Results

and lamin A (Figure 2.8) we used GST tagged nesprin-2-SR52, 53 that interacts with lamin A and -SR55, 56 that does not shown an interaction to nesprin-2 together with lysates of COS7 cells expressing GFP full length WT or mutated lamin A proteins.

Interestingly mutated lamin A proteins precipitated in varying amounts with GST-nesprin-2-SR52, 53 (Figure 2.9 A, exemplified shown for lamin A mutations R419C, L421P, R427G and Q432X). Of special note are the lamin A mutations R401C and V415I that caused an enhanced binding, whereas of the mutation Q432X was precipitated less efficient by GST-nesprin-2-SR52, 53, indicating a reduced binding. All further mutations influenced the interaction moderately (summarized in Figure 2.9 B).

A

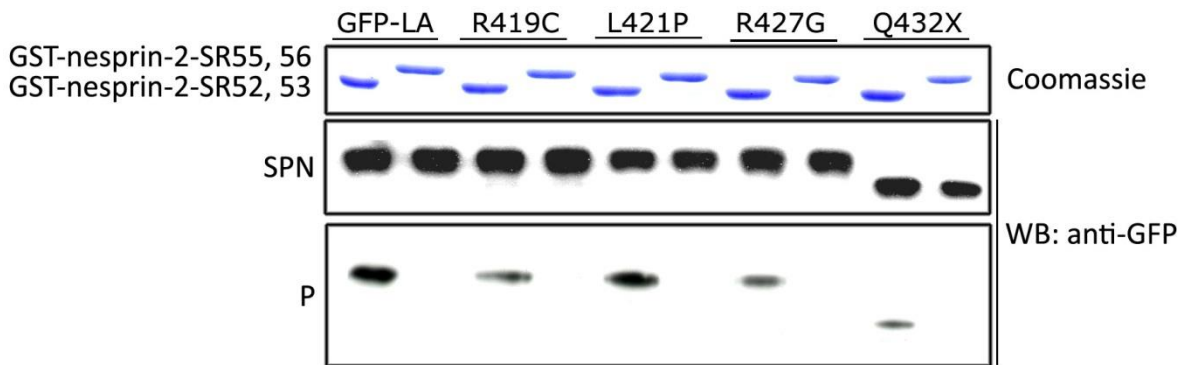

B

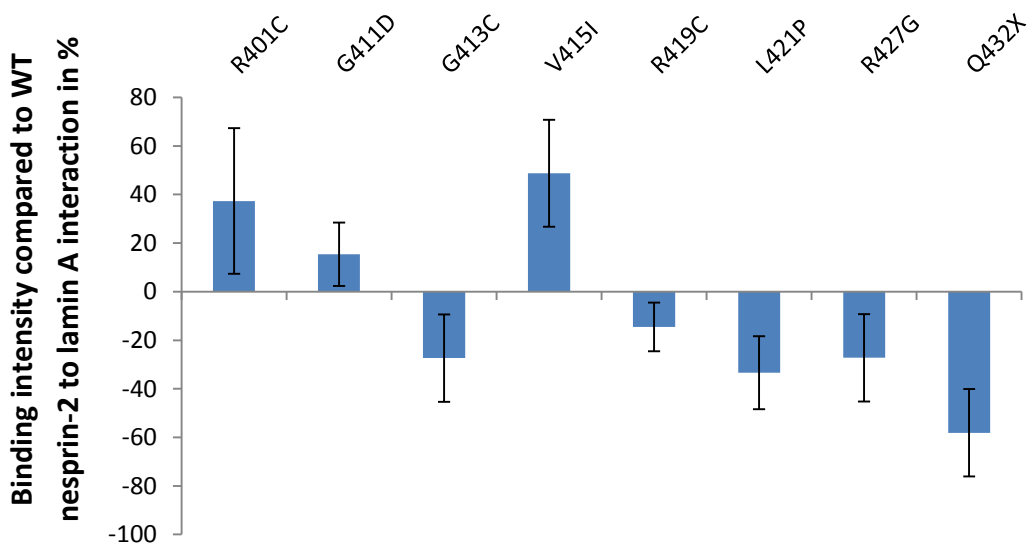

Figure 2.9 Mutations in *LMNA* modulate the interaction to nesprin-2.

Results

(A) COS7 cells expressing WT or mutated GFP lamin A proteins were lysed and incubated with recombinant GST-nesprin-2-SR52, 53 proteins. The use of equal amounts of GST fusion protein was confirmed by a Coomassie stained SDS PAGE. GST-nesprin-2-SR55, 56 proteins were used as negative controls. After incubating beads bound GST-nesprin-2-SR fusion proteins with lysates of GFP lamin A expressing COS7 cells, the supernatants were collected and subjected to western blot analysis to confirm equal GFP protein amounts among the experiments.

(B) WT and mutant GFP-LA proteins show distinct binding properties to WT GST-nesprin-2-SR52, 53. The zero base line represents the 100 % binding strength between WT GST-nesprin-2-SR52, 53 and GFP-LA WT. Deviations caused by distinct mutations in *LMNA* are given in percent each mutation was analyzed by four to seven independent experiments.

2.2.6 GFP-lamin A 403-425 WT and GFP-lamin A 403-425 L421P are distributed all over the nuclei

To study the impact of distinct mutations in lamin A on the localization of nesprin-2 and further NE or LINC complex components, we performed immunofluorescence studies on COS7 and HaCaT cells transfected with GFP-tagged lamin A, aa 403-425 that contain the binding site to nesprin-2 as WT or with the mutation L421P. GFP alone was used as a control. It has been demonstrated that lamin A L421P fibroblasts have misshapen nuclei (Decaudain A, *et al.*, 2007). GFP signals we observed for cells expressing GFP lamin LA 403-425 WT or LA 403-425 L421P showed similar distributions compared with cells expressing GFP only, all over and around the nucleus (Figure 2.10). Differences between the localization of endogenous lamin A along the NE and the accumulation of the lamin A 403-425 might be due to the small size of the fusion proteins. GFP-LA 403-425 WT carries only 23 amino acids in addition to GFP, which adds only 2 kDa to GFP.

Results

A HaCaT

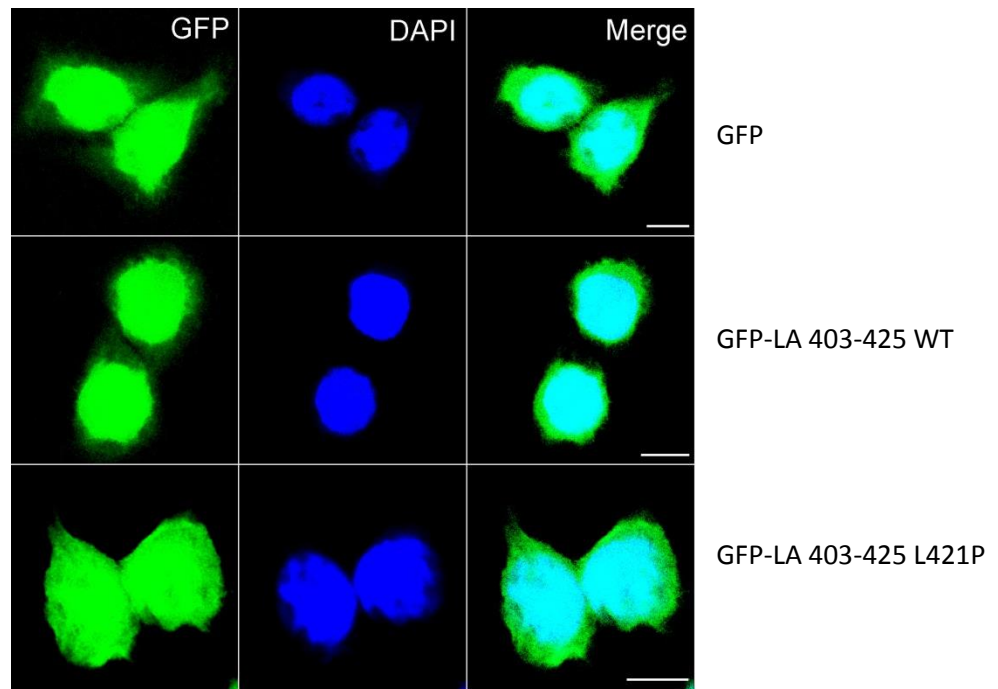

B COS7

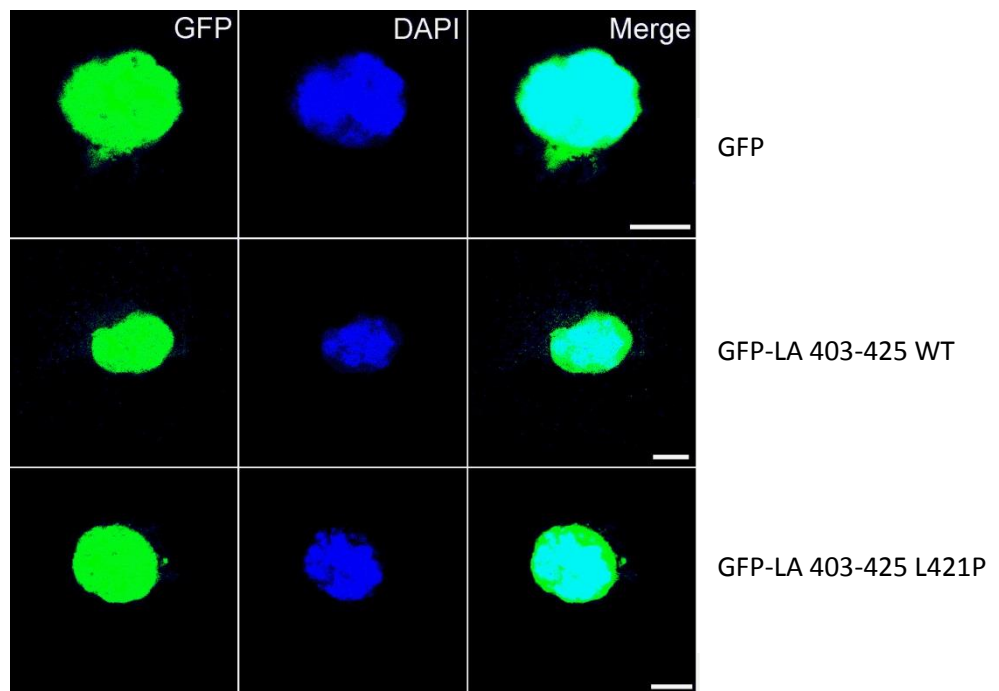

Figure 2.10 In HaCaT and COS7 cells lamin A 403-425 WT and 403-425 L421P accumulate in the nucleus.

Nuclei of HaCaT (A) and COS7 cells (B) transfected with GFP-tagged LA 403-425 WT or LA 403-425 L421P are stained with DAPI. GFP-LA 403-425 or LA 403-425 L421P signals were observed throughout and around the transfected cells nuclei, especially inside the nucleus, similar to GFP alone.

Scale bar, 10 μ m.

2.2.7 Mutated full length lamin A proteins localize to the NE

Since we did not observe the characteristic NE localization for the short GFP-LA 403-425 WT or mutated L421P proteins in HaCaT cells (Figure 2.10), we continued our localization studies by transiently expressing WT or mutated full length lamin A in the cells. Interestingly all full length lamin A proteins localized along the NE in these cells undistinguishable from WT lamin A. The only exception was the truncation mutation Q432X that showed a more versatile distribution pattern. We found cells in which the protein localized along the NE like WT lamin A. However we found in the majority of cells aggregates formed by GFP-LA Q432X (Figure 2.11). These aggregates differed in size and amount.

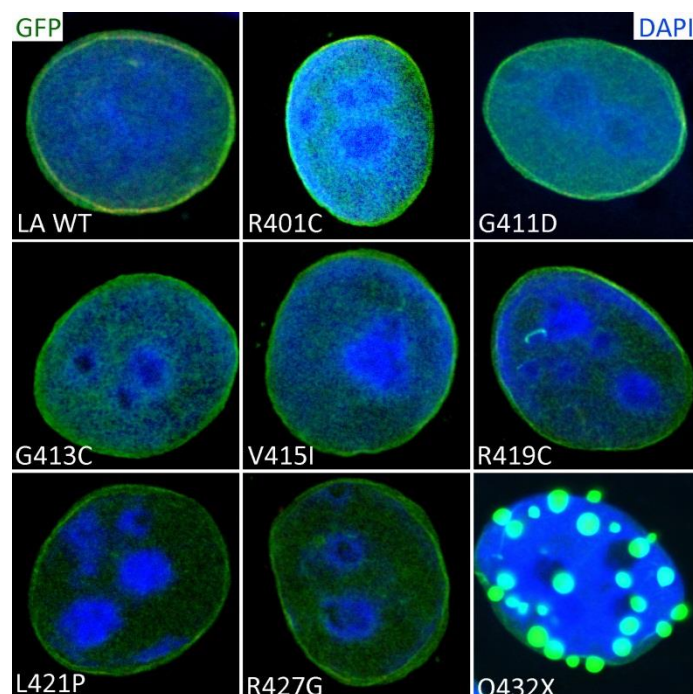

Figure 2.11 Mutated full length lamin A proteins localize to the nuclear envelope.

HaCaT cells transiently transfected with plasmids encoding WT or mutated GFP-LA. DNA was stained with DAPI. All the mutated lamin A proteins localized along the NE, like WT lamin A. Lamin A Q432X additionally formed aggregates along the NE.

2.2.8 The lamin A mutation Q432X modulates the localization of nesprin-2

To evaluate the impact of mutated lamin A proteins on the localization of endogenous proteins, plasmids encoding the different full length lamin A proteins were transiently

Results

expressed in HaCaT and COS7 cells. First transfected cells were stained with antibodies targeted against endogenous nesprin-2.

Nesprin-2 was observed along the nuclear envelope in HaCaT and COS7 cells transfected with GFP-tagged full length WT LA and all mutant lamins (Figure 2.12 A and B). The only exception was the truncation mutation Q432X (Figure 2.13 A and B). GFP-LA Q432X proteins showed a different distribution compare to WT lamin A and the other mutated lamins. They formed aggregates along the NE, in which nesprin-2 accumulates. These results indicate only the mutation LA Q432X affects the distributions of lamin A and nesprin-2 along the NE.

Results

A HaCaT

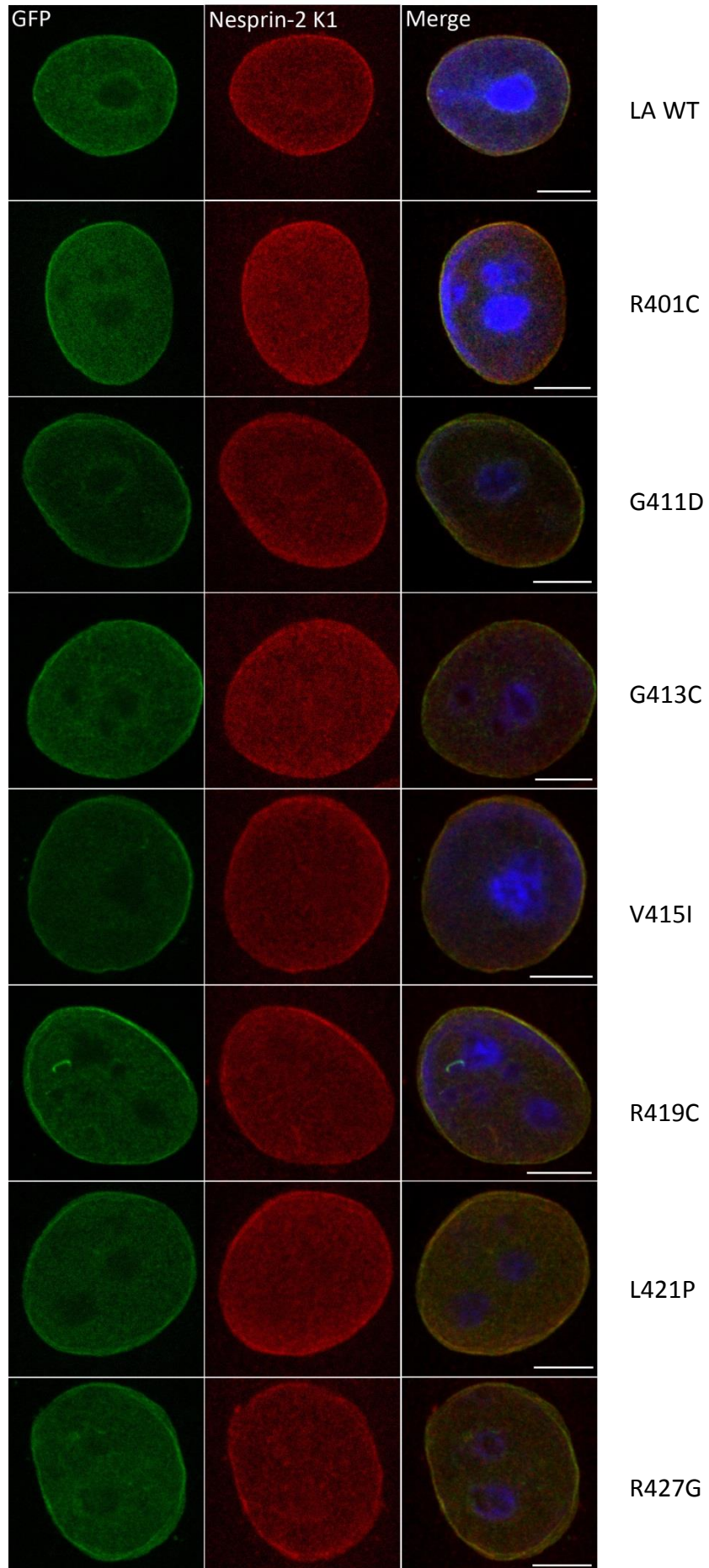

Results

B COS7

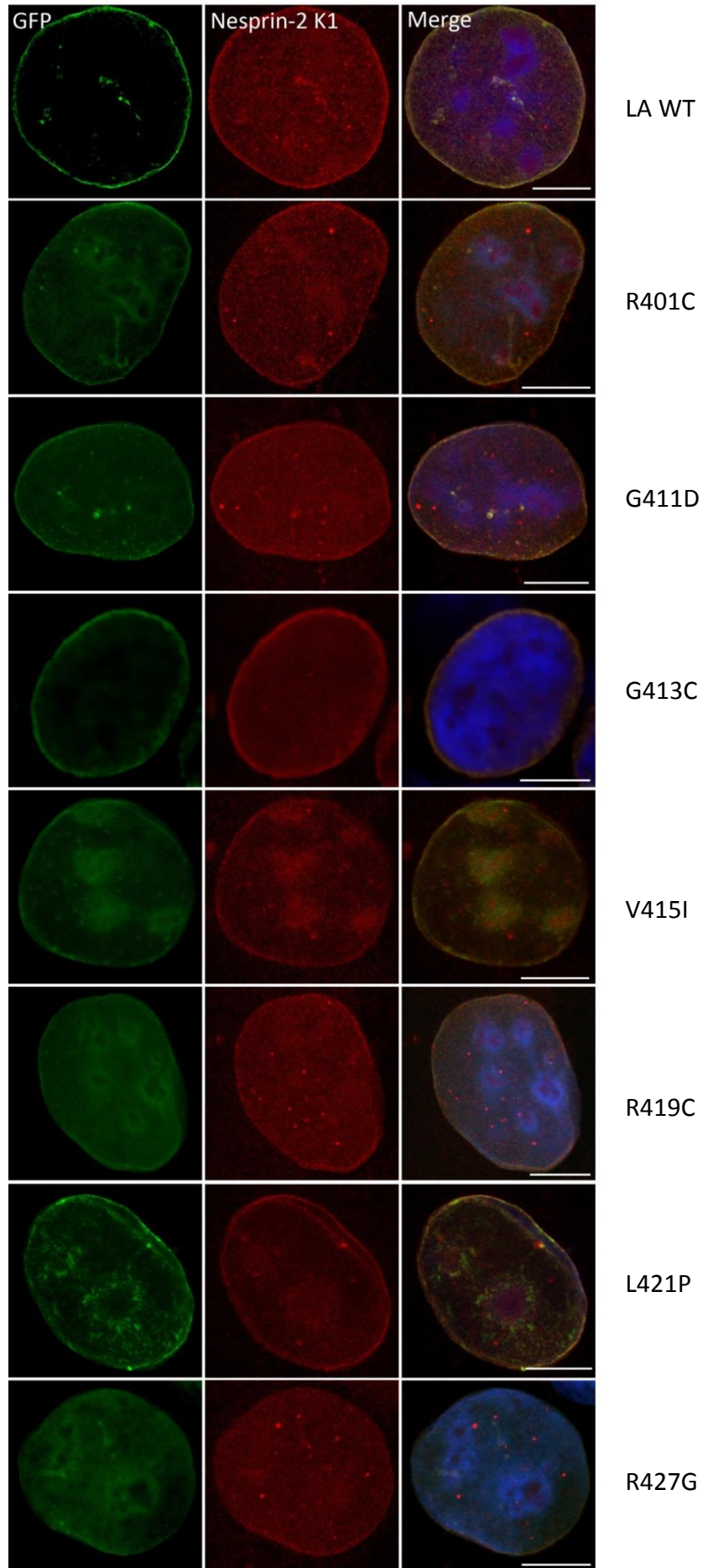

Results

Figure 2.12 In HaCaT and COS7 cells, GFP-tagged WT or mutated lamin A localizes along the nuclear envelope without disturbing the localization of nesprin-2.

HaCaT and COS7 cells transiently transfected with plasmids encoding WT or mutated GFP-LA were stained with the nesprin-2 specific antibody pAb K1 and DAPI to visualize DNA. Signals for both WT and mutated GFP lamin A proteins and nesprin-2 were observed along the NE in HaCaT (A) and COS7 (B) cells. That suggests the lamin A mutations analyzed here do not change the distribution of nesprin-2.

Scale bar, 10 μ m.

A

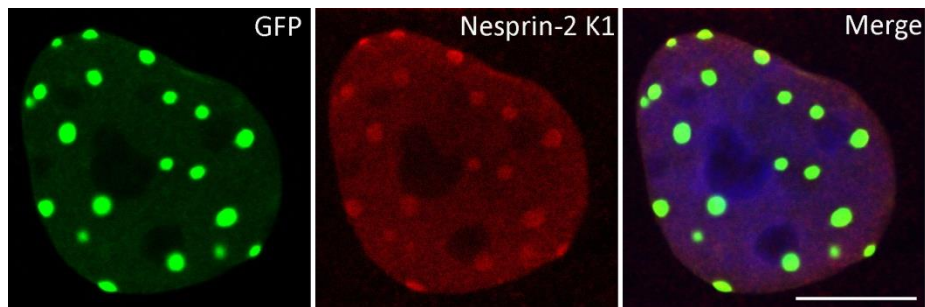

B

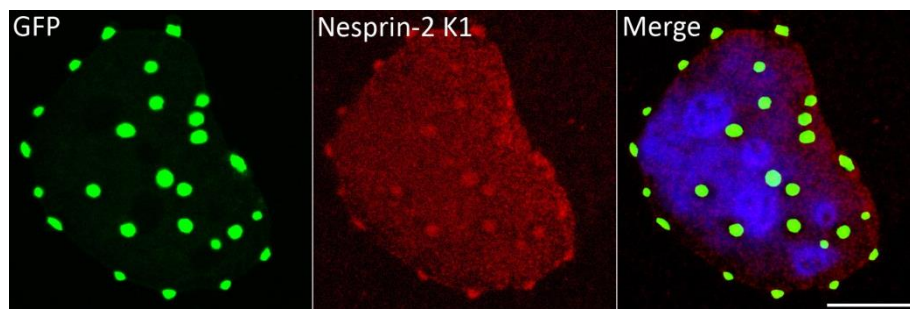

Figure 2.13 In HaCaT and COS7 cells, GFP-tagged lamin A Q432X localizes along the NE and forms aggregates that sequester nesprin-2.

HaCaT and COS7 cells transiently transfected with plasmids encoding mutated GFP-LA Q432X were stained with nesprin-2 specific antibody pAb K1 and DAPI to visualize DNA. Signals for both mutated GFP-LA Q432X protein and nesprin-2 were observed co-localizing in aggregates along the NE in HaCaT (A) and COS7 (B) cells.

Scale bar, 10 μ m.

2.2.9 The lamin A mutation Q432X affects the localizations several nuclear envelope proteins

Pull down experiments show modulated binding capacities between GST-nesprin-2-SR52, 53 and mutated full length GFP lamin A proteins (Figure 2.9). To study the impact of mutated

Results

lamin A proteins on further NE proteins such as lamin B1 and emerin, immunofluorescence studies were performed.

Lamin B1 and emerin were observed along the nuclear envelope in HaCaT cells transfected with WT or mutated lamin A proteins (Figure 2.14). Differences in the localization patterns compared to cells expressing GFP WT lamin A were only observed for the lamin A mutation Q432X where aggregates formed by the mutated protein sequester both emerin and lamin B1 (Figure 2.15).

Results

A

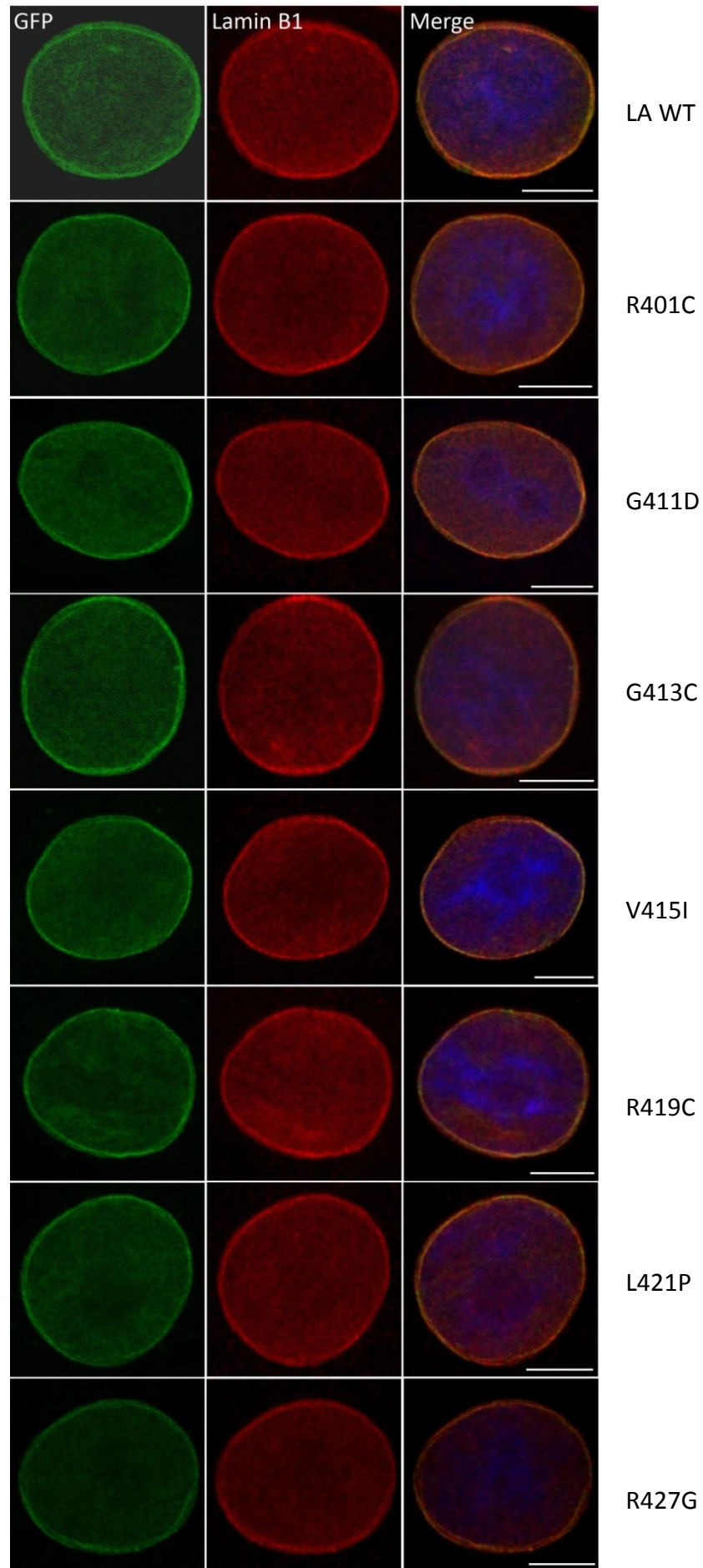

Results

B

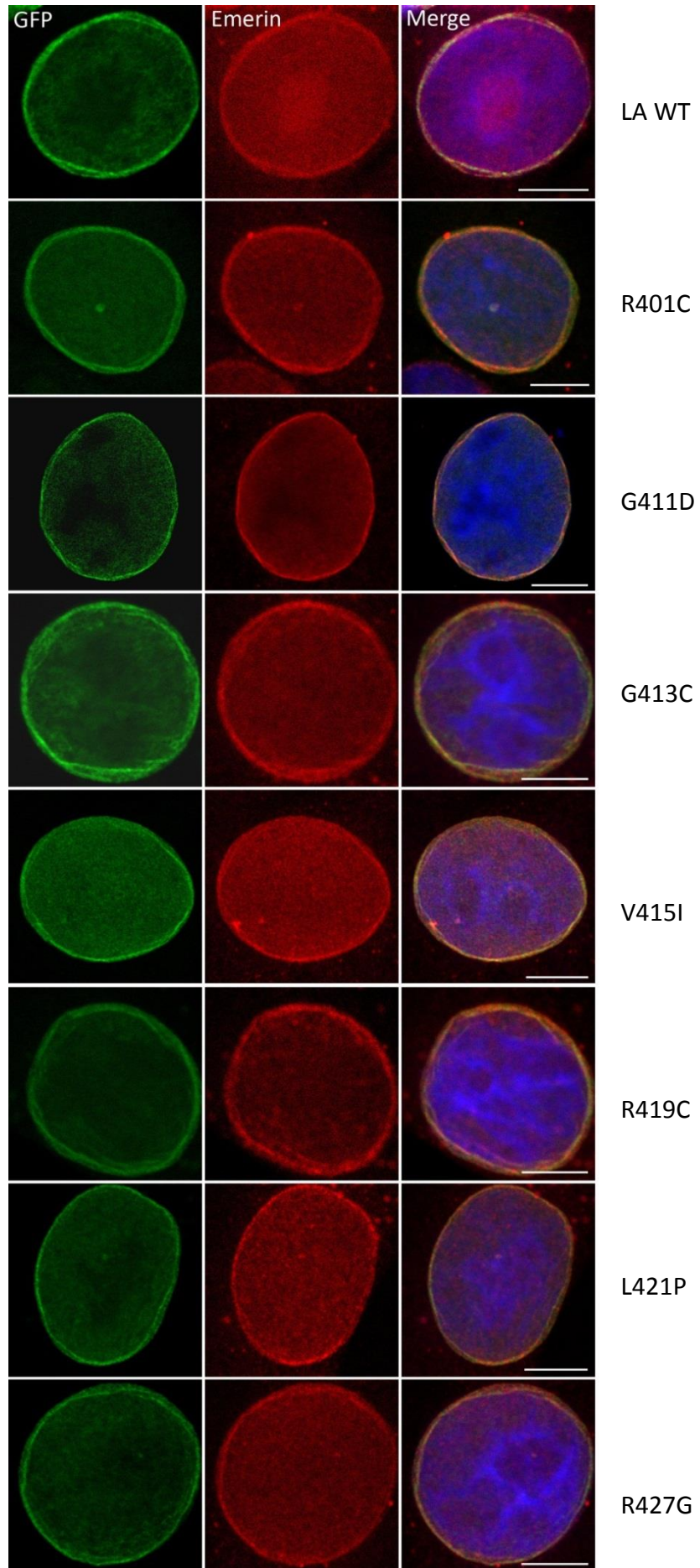

Results

Figure 2.14 In HaCaT cells, GFP-tagged WT or mutated lamin A localizes along the nuclear envelope without modulating the localizations of nuclear envelope proteins lamin B1 and emerin.

HaCaT cells transiently transfected with GFP tagged WT or mutant lamin A were stained with antibodies targeted against lamin B1 or emerin. DNA is stained with DAPI. GFP tagged WT or mutant lamin A, emerin and lamin B1 localize along the nuclear envelope in HaCaT cells. These lamin A mutations do not alter the distributions of the NE proteins lamin B1, emerin.

Scale bar, 10 μm .

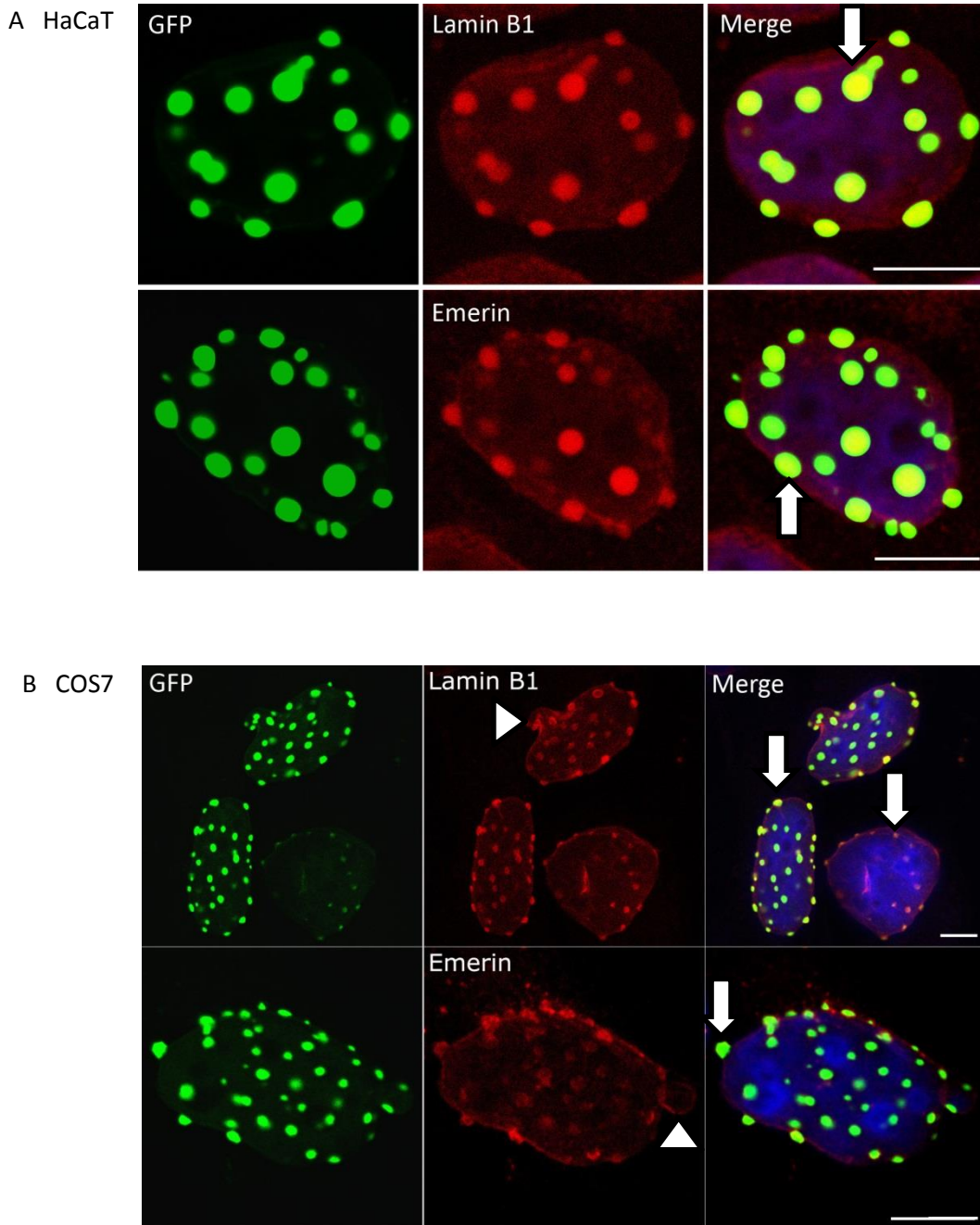

Results

Figure 2.15 In HaCaT and COS7 cells, GFP-tagged lamin A Q432X localizes along the nuclear envelope and in aggregates that sequester lamin B1 and emerin.

HaCaT (A) and COS7 (B) cells were transiently transfected with plasmids encoding GFP-LA Q432X and stained with antibodies targeted against lamin B1 or emerin, and DAPI to visualize DNA. All proteins localized along the NE. Lamin B1 and emerin additionally accumulated in aggregates formed by lamin a Q432X (arrows). Additionally, nuclear blebs were observed in COS7 cells expressing GFP-LA Q432X (arrow heads). Scale bar, 10 μm .

2.2.7 All lamin A mutations do not alter the localization of nuclear pore complexes

NPCs are major components of the nuclear envelope and play crucial roles in NE structure and for example the nucleocytoplasmic transfer of proteins and RNAs. We analyzed whether the lamin A mutations analyzed here, which lie in or near the binding site to nesprin-2, have an effect on the localization of NCPs by performing immunofluorescence analysis on HaCaT cells that transiently expressing the corresponding mutated proteins.

Results

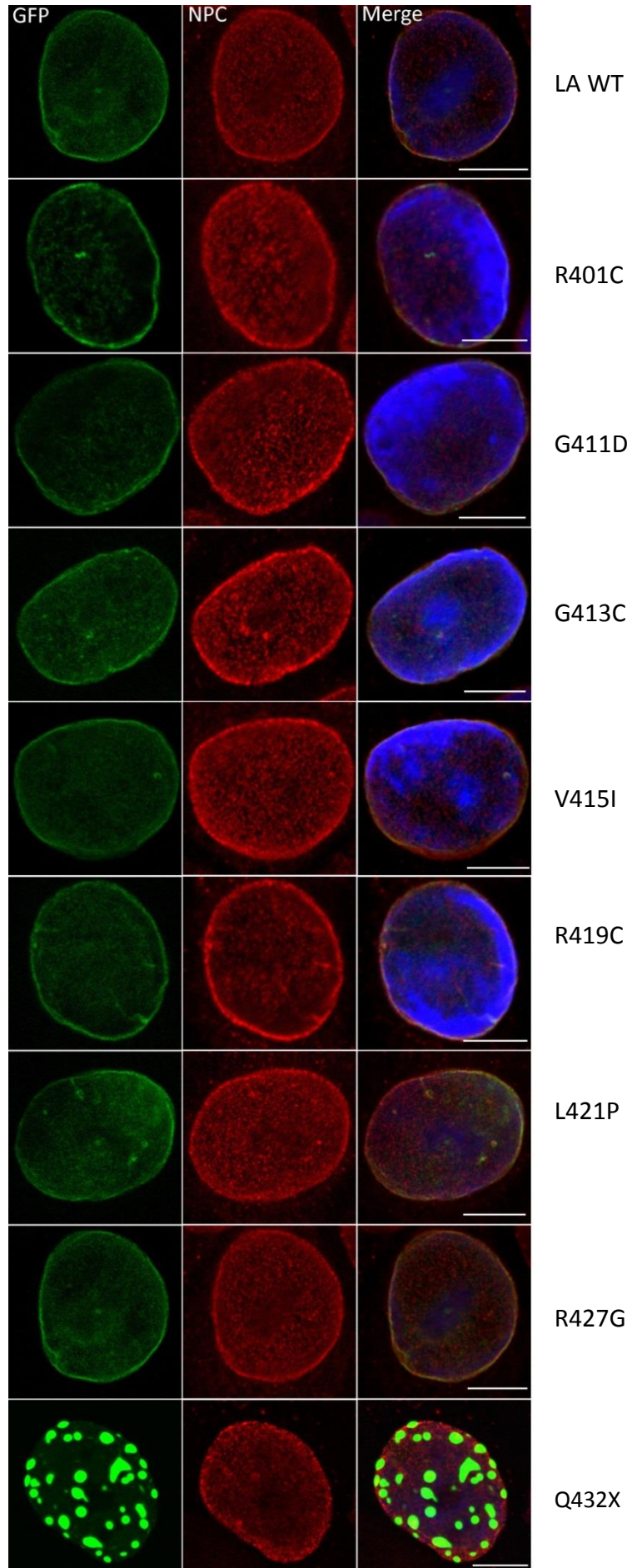

Results

Figure 2.16 In HaCaT cells, mutated lamin A proteins do not alter the localizations of nuclear pore complexes.

HaCaT cells transiently expressing WT or mutated GFP-tagged LA stained with antibodies targeted against NPCs (red). NPCs localized along the NE in transfected cells. Aggregates formed by GFP lamin A Q432X have no impact on the distribution of NCPs along the NE.

Scale bar, 10 μ m.

The signals of GFP lamin A and NPCs co-localized along the NE were observed in all transfected cells (Figure 2.16). This result suggests that the lamin A mutations focused on in this study, even Q432X, which sequesters several NE proteins, do not impair the even distribution of NPCs along the NE.

2.2.8 Mutations in lamin A cause the formation of misshapen nuclei after heat exposure

Laminopathies often affect tissues that are under pronounced mechanical strain like skeletal muscle or cardiac muscle. We exemplarily explored the effect of two lamin A mutations, lamin A V415I and lamin A Q432X on nuclear stability in heat stress assays. These mutations were chosen because they exhibited significantly different binding affinities to nesprin-2 and lamin A Q432X showed the most aberrant nuclear distribution (Figure 2.11).

For heat shock experiments WT and mutated GFP lamin A proteins were expressed in primary human fibroblasts and exposed to a 15 min heat shock at 42°C, followed by immunofluorescence and a statistical evaluation of misshapen nuclei before and after the heat shock. No significant changes were observed between LA WT and LA V415I before the heat shock (4.33 % for LA WT and 7.5 % for LA V415I). The number of misshapen nuclei in GFP LA Q432X transfected cells was significantly increased compared to the WT already before the heat shock (4.33 % in the WT compared to 10.33 % for Q432X). No significant changes in the number of misshapen nuclei were observed after heat shock in GFP WT LA expressing cells (4.33 % before and 6.8 % after heat shock). However the number of misshapen nuclei was increased in cells expressing LA V415I (11.33 % compared to 6.8 % in the WT) and strongly increased in cells expressing LA Q432X (17.33 % compared to 6.8 % in the WT) (Figure 2.15 B).

Results

A

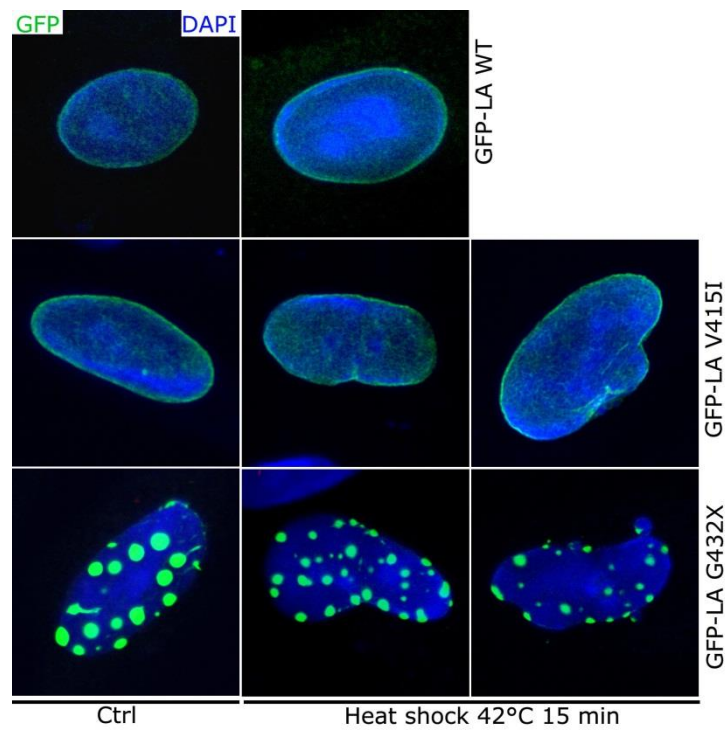

B

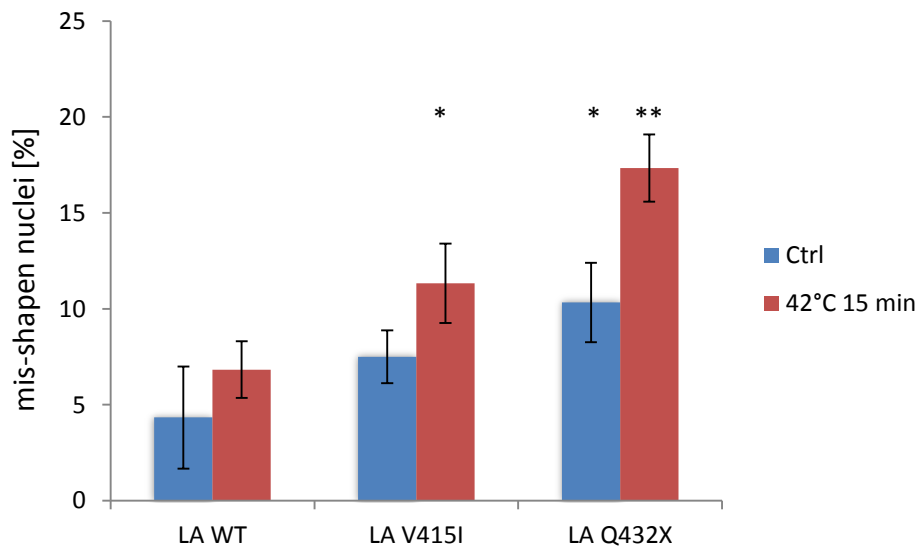

Figure 2.15 Lamin A mutations V415I and Q432X trigger the formation of misshapen nuclei after heat exposure.

Primary human fibroblasts transiently expressing GFP-tagged WT, V415I or Q432X lamin A were treated with a 15 min heat shock at 42 °C. After fixation the nuclear morphology was analyzed by immunofluorescence (A) and statistically evaluated (B). WT GFP-LA was used as control. Two independent experiments were performed and 300 nuclei were analyzed for each group. Cells expressing GFP lamin A Q432X showed significant nuclear deformations even before heat shock compared with cells expressing GFP WT lamin A. Both cells expressing

Results

GFP lamin A V415I or Q432X showed significant changes of misshapen nuclei compared to cells expressing GFP WT lamin A after heat shock. Student's t-tests were performed and statistically significant changes are highlighted with an asterisk ($P < 0.01$), highly significant changes are shown by two asterisks ($P < 0.001$).

2.2.9 The lamin A mutation Q432X causes alterations in the chromatin structure, and SREBP1/ZNF239 displacements

NE proteins have functions in maintaining nuclear structure which plays an important role in transcriptional regulation and chromatin organization. Furthermore, lamins interact with numerous transcription factors such as SREBP1 and ZNF239, and NE proteins like lamins or nesprins interact with chromatin or numerous transcription factors (Simon DN and Wilson KL, 2013).

To explore the impact of aggregates formed by GFP-LA Q432X on chromatin structures and transcription factors, cells transiently expressing GFP lamin A Q432X were stained with antibodies against SREBP1, ZNF239, and DNA was visualized by DAPI. At sites of strong aggregates the DAPI staining showed gaps indicating alterations in the chromatin structure (Figure 2.16 A, arrow). The opposite effect was detected for SREBP1 and ZNF239. Both were sequestered into large aggregates of Q432X mutated lamin A proteins (Figure 2.16 B, C, arrows). Taken together our data point towards an impact of the mutation Q432X on the topology of chromatin and transcription factor distribution.

A

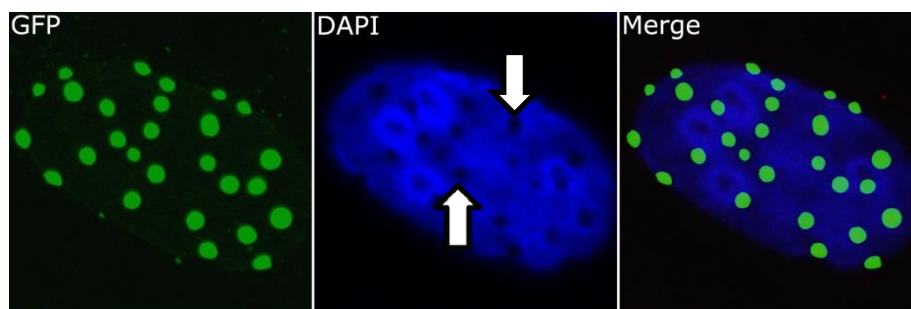

B

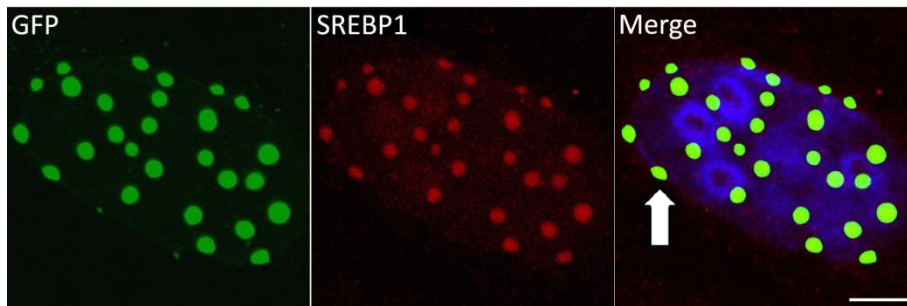

C

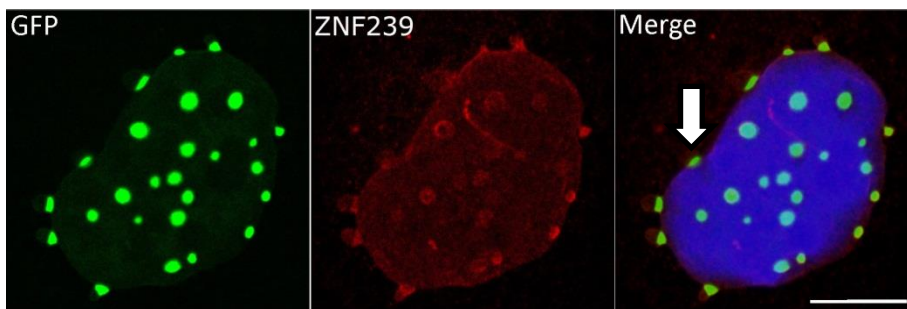

Figure 2.16 Aggregates formed by lamin A Q432X cause alterations in chromatin organization, and sequester transcription factors SREBP1 and ZNF239.

HaCaT cells expressing GFP-LA Q432X were stained with antibodies against SREBP1 or ZNF239. DNA was stained with DAPI. (A) The otherwise even DNA staining showed gaps along strong aggregates formed by lamin A Q432X proteins (arrow). (B) Both SREBP1 (B) and ZNF239 (C) accumulate in lamin A Q432X aggregates (arrows).

Scale bar, 10 μm .

2.2.10 Endogenous lamin A accumulates in GFP lamin A Q432X aggregates

To analyse the impact of lamin A Q432X proteins and aggregates on the distribution of endogenous lamin A, immunofluorescence experiments were performed on HaCaT cells expressing GFP-LA Q432X protein. The epitope of the antibody that was used to detect endogenous lamin A resides in the C-terminus of lamin A that is missing in LA Q432X due to the mutation. Endogenous lamin A is sequestered into lamin A Q432X aggregates (Figure 2.17). Furthermore, weaker lamin A signals were observed in lamin A Q432X expressing cells compared to un-transfected cells.

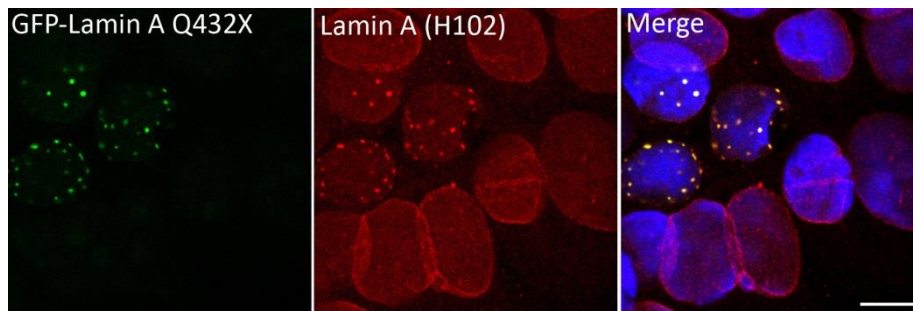

Figure 2.17 Endogenous lamin A co-localizes with GFP-LA Q432X.

HaCaT cells expressing GFP-LA Q432X were stained for endogenous lamin A with an antibody. The epitope of this antibody resides in the C-terminus of lamin A that is missing in lamin A Q432X. Co-localizations of both proteins along the NE and in lamin A Q432X-aggregate were observed. Furthermore, weaker lamin A (H102) signals were observed in lamin A Q432X expressing cells (except the aggregates) compared to un-transfected cells. DNA was stained with DAPI.

Scale bar, 10 μ m.

2.3 Study on mutated SUN proteins in Emery-Dreifuss muscular dystrophy/Charcot-Marie-Tooth syndrome or Duchenne muscular dystrophy patients fibroblasts

2.3.1 SUN2 interacts with tubulin

To identify and study novel interaction partners of SUN2 GST-pull down experiments were performed in the context of a PhD work that was done earlier at our institute (Eva MV, PhD thesis, 2011). Interestingly Tubulin was among the potential novel interaction partners (Taranum S., *et al.*, 2012). To confirm the interaction between SUN2 and Tubulin GST-pull down experiments were performed by using the GST tagged SUN2 N-terminus (NT) and cell lysates of wild type fibroblast, Emery-Dreifuss muscular dystrophy/Charcot-Marie-Tooth syndrome (EDMD/CMT) fibroblast or Duchenne muscular dystrophy (DMD) fibroblast. We observed signals for all cell types when western blotting was performed with the antibody against α -tubulin (Figure 2.18), which suggests that SUN2 interacts with tubulin through the N-terminal region in all cell lines tested. Interestingly, the signal observed from the DMD fibroblasts much weaker compared with other fibroblast cell lines.

Results

In these experiments additionally the interaction between the N-terminus of SUN2 and lamin A/C was shown, demonstrating that is the interaction between both proteins is not disturbed in the mutant fibroblasts. This interaction has been demonstrated previously (Crisp M, *et al.*, 2006).

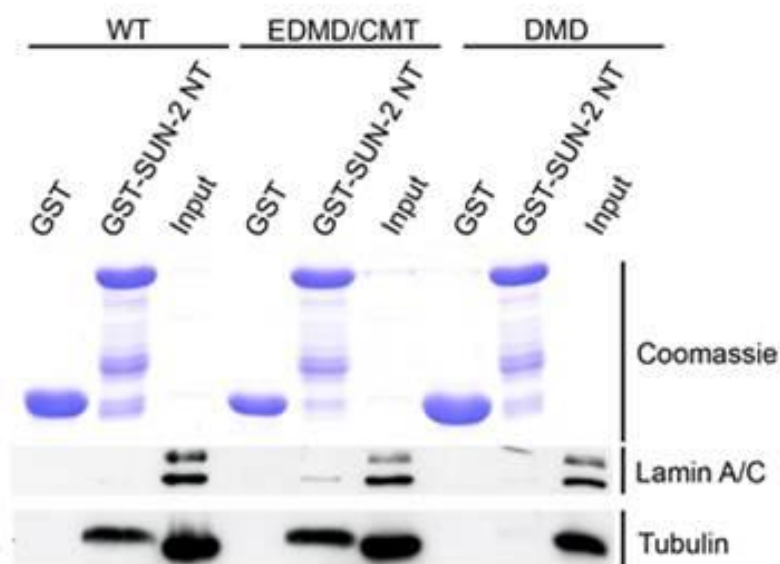

Figure 2.18 SUN2 interacts with tubulin and lamin A/C.

GST-pull down experiments with GST-SUN2 NT protein and cell lysates from control, EDMD/CMT and DMD fibroblasts. The pull down was probed for lamin A/C and tubulin using mAb lamin A/C and mAb α -tubulin.

2.3.2 The SUN mutations SUN1 Q93P and SUN2 T33A do not alter the localizations of nesprin-2, emerin and lamin B1

As core components of the LINC complex, SUN proteins play essential roles in maintaining NE integrity and several important cellular processes. To explore the impact of the SUN mutations SUN1 Q93P and SUN2 T33A that were found in patients with EDMD/CMT or DMD on LINC complex proteins assemblies, immunofluorescence studies were performed. The mutagenesis plasmids GFP-hSun1 (Taranum S., *et al.*, 2012) and Sun2-V5-His (Lu WS, *et al.*, 2008) were used in this study.

We observed no changes with regard to the distribution pattern or abundance of nesprin-2, emerin and lamin B1 (Figure 2.19). The low transfection efficiency prevented us from

Results

carrying out biochemical analysis which could give information on the stability of the LINC complex.

A GFP-hSUN1 Q93P

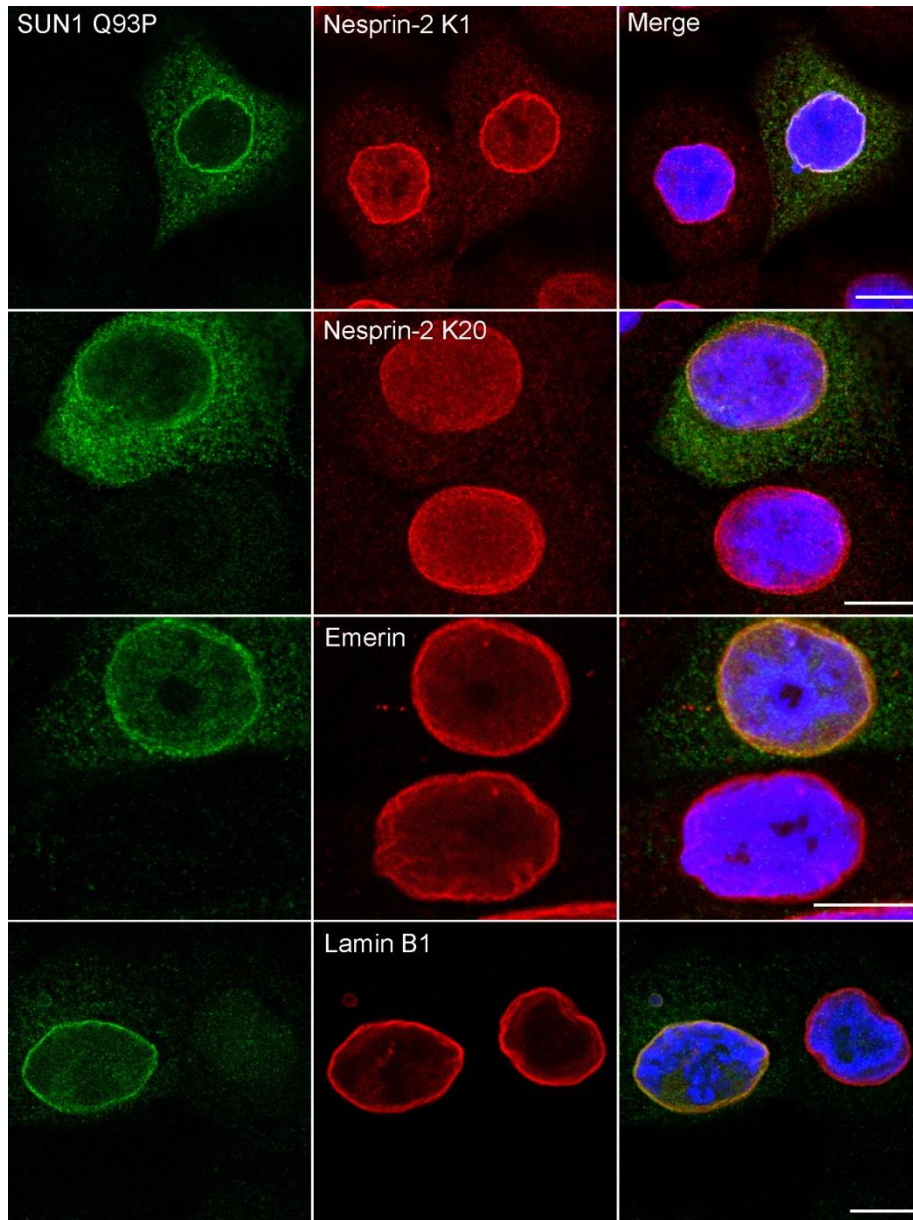

Results

B SUN2-V5 his T33A

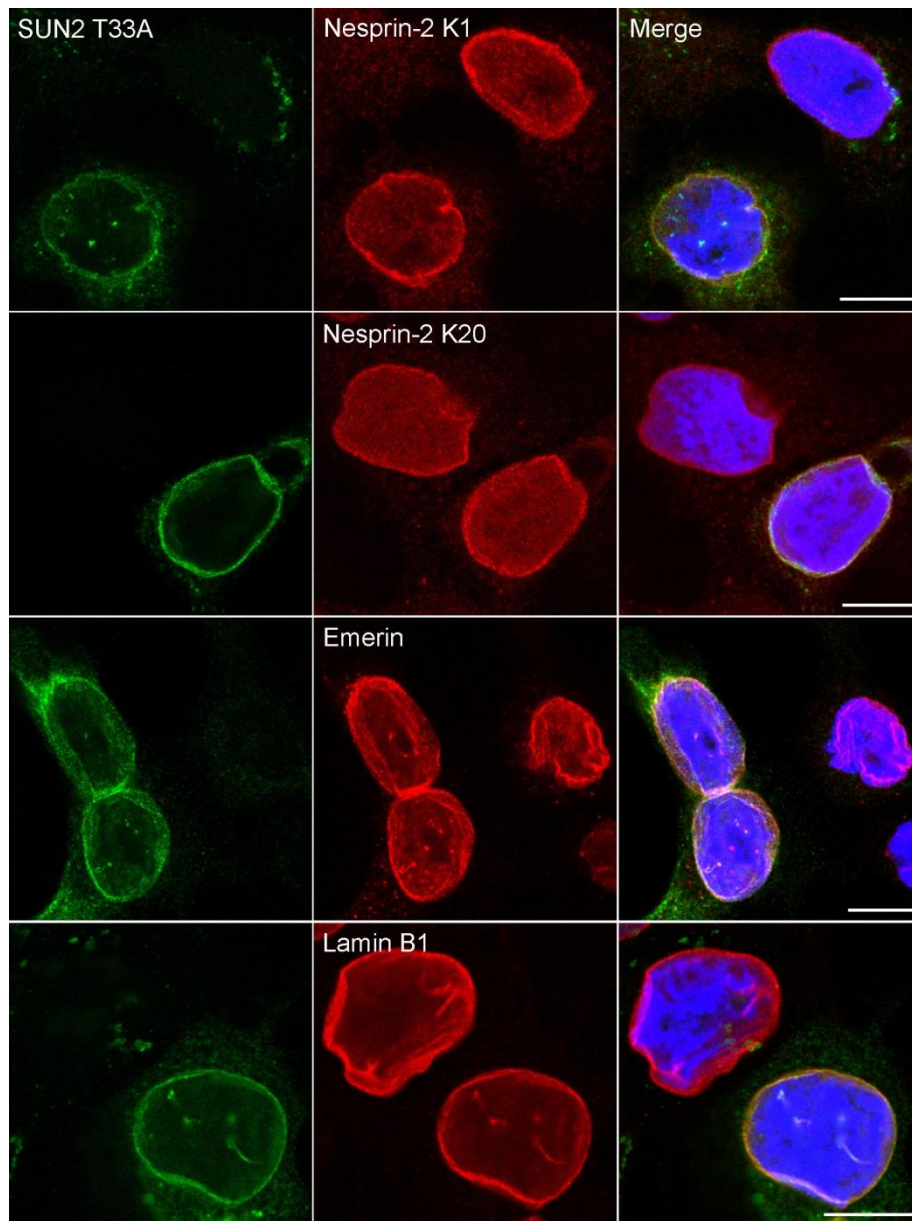

Figure 2.19 HaCaT cells expressing SUN1 Q93P or SUN2 T33A do not show alterations in the distributions of nesprin-2, emerin and lamin B1 along nuclear envelope.

(A) HaCaT cells expressing GFP-SUN1 carrying the mutation Q93P were analyzed for nesprin-2, emerin and lamin B1 distributions by using the corresponding antibodies.

(B) The subcellular distribution of nesprin-2, emerin and lamin B1 was analyzed in HaCaT cells expressing SUN2-V5-His carrying the mutation T33A by using the corresponding antibodies. SUN2-V5-His was recognized using a V5-specific antibody.

Scale bar, 10 μm .

2.4 Analysis the distribution of nesprin-2 and lamin A in ageing nesprin-2 knockout mice

Laminopathies include early ageing diseases like HGPS that resembles aspects of ageing at an early age, for this reason the nesprin-2 giant KO mice were constructed in our lab. In this study, the expressions of lamin proteins in the context of ageing nesprin-2 giant KO mice were analyzed.

To assess the distribution and expression of nesprin-2 and lamin A in ageing nesprin-2 KO mice (24 months), western blot was performed on mouse muscle tissues from WT and KO mice by using lamin A/C antibodies (Figure 2.20). The amounts of lamin A/C are similar between WT and KO mice according to the western blot result. Our preliminary results suggest nesprin-2 giant has no or limited effect on the expression of lamin A proteins in mouse muscle.

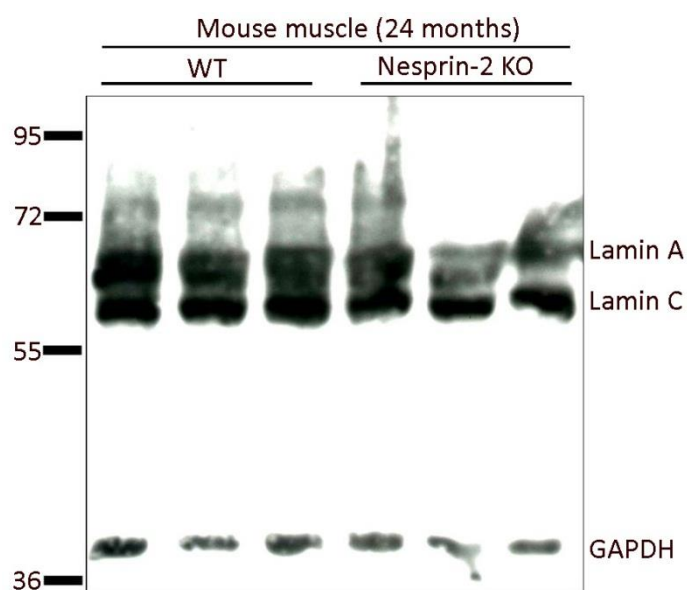

Figure 2.20 Analysis of the expression of lamin A/C in ageing nesprin-2 knockout mice.

Muscle tissues from nesprin-2 giant KO mice and WT mice were analyzed by WB. GAPDH was used as a loading control.

According to the western blot analysis by using lamin A/C antibody, and GAPDH antibody as loading control. Our preliminary results suggest that the amounts of lamin A/C are similar in muscle tissues between WT and nesprin-2 giant KO ageing mice.

3 Discussion

3.1 The binding sites between lamin A and nesprin-2

As a component of the LINC complex, nesprins are part of protein assemblies including actin filaments, microtubules, plectin, kinesin, SUN proteins and emerin. Furthermore nesprins interact with the INM proteins lamin A/C. Previous data from Libotte and colleagues from our laboratory indicated that the corresponding binding sites between lamin A and nesprins resides near the C-terminus of nesprin-1 and nesprin-2, amino acid sequence 6146-6545 corresponding to nesprin-2-SR52-54 (Libotte T, *et al.*, 2005). To get a better understanding of the binding properties between both proteins, we further narrowed down the binding sites between lamin A and nesprin-2 to amino acids 403-425 in lamin A and amino acids 6146-6347 in nesprin-2, that together form SR52 and SR53 (Figure 2.2 and 2.3).

The binding site of lamin A to nesprin-2 (aa 403-425) lies between the central rod domain and the Ig fold of the carboxyterminal tail, including the NLS (aa 417-422), which is required for the localization of lamins to the nucleus (Ho CY and Lammerding J, 2012). For nesprin-2, the binding site to lamin A spans aa 6146-6347 which lie near the KASH domain. Nesprin-2 giant, like other nesprin isoforms, even the small ones, are anchored to the NE by their KASH domains and connected to lamin A by their SRs near the C-terminal KASH domain.

In our pull down assays, the signals for GST-nesprin-2-SR52-56 were always weak (Figure 2.8). That might be a consequence of the low protein expression levels of nesprin-2-SR52-56, which is always expressed at a low amounts in *E. coli*. A reason for the low expression might be the molecular weight of about 130 kDa. Interestingly, signals we obtained for nesprin-2-SR53 and -SR53-55 to lamin A were always weak too (Figure 2.3A and 2.4). They are not as strong as for nesprin-2-SR52, 53, which suggest that primarily nesprin-2-SR52, 53, not only -SR53, or -SR53-55, play a role in the binding of nesprin-2 to lamin A. Another possible reason might be the folding of nesprin-2-SR protein. The amino acids that are responsible for mediating the interaction between both proteins might be better accessible in nesprin-2-SR52, 53. From that we conclude that amino acids in nesprin-2-SR53 are sufficient for

mediating the interaction to lamin A. However additional amino acids in the neighboring SRs are necessary for strengthening the interaction.

Previously two interaction sites in lamin A to nesprin-2 have been reported that contain lamin A aa 243-387 and 384-566 (Libotte T, *et al.*, 2005). In the present study we have confirmed and further narrowed down the interaction site around lamin A amino acids 384-566. The interaction site around lamin A aa 243-387 could not be confirmed, which might be a consequence of different experimental procedures or sterical properties of the lamin A peptides that were used.

3.2 Laminopathies causing lamin A mutations lie in or near the binding site of nesprin-2 to lamin A

A main aim in this project was to characterize the impact of laminopathy causing mutations on the interaction between lamin A and nesprin-2 and to find answers to the question how these mutations might contribute to the formation of phenotypically different diseases. Eight mutations in or near the binding site to nesprin-2 have been analyzed here. These are the lamin A mutations G411D, G413C, V415I, R419C, L421P, that lie within the binding site and R401C, R427G, Q432X that are close to the binding site between both proteins. Mutations in nesprin-2 have not been analyzed here. Laminopathies are rare human diseases and currently most laminopathy causing mutations have been mapped in *LMNA* (<http://www.umd.be/LMNA/>; Dittmer T and Misteli T, 2011). *LMNA* encodes for A-type lamins and compared to nesprins these proteins have already been described about 30 years ago (Gerace L and Blobel G, 1980). Since both proteins have overlapping functions at the nuclear envelope and some cases of laminopathy causing mutations in nesprins have already been described (Meinke P *et al.*, 2011; Zhang Q *et al.*, 2007), one can assume that accompanying to the progress in the research about laminopathies and the progress in the field of DNA sequencing and identification of disease causing mutations, more mutations in nesprins will be identified in the future.

The lamin A mutation R401C was identified from the patients with EDMD (Vytopil M *et al.*, 2002; Capanni C *et al.*, 2003; Dittmer TA and Misteli T, 2011), G411D (Dutour A *et al.*, 2011)

and L421P (Caron M *et al.*, 2007; Decaudain A *et al.*, 2007) were found from the patients with metabolic syndrome (G411D) or lipodystrophy (L421P). The mutations G413C and R427G cause the formation of a striated muscle laminopathy (<http://www.umd.be/LMNA/>). V415I causes the formation of a lone atrial fibrillation (Brauch KM *et al.*, 2009; Dittmer TA and Misteli T, 2011), R419C (Haque WA *et al.*, 2003) was identified in patients with FPLD and Q432X (Møller DV *et al.*, 2009) in the patients with idiopathic dilated cardiomyopathy. According to the affected tissues, laminopathies can be subdivided into several groups, ranging from muscular dystrophies to cardiomyopathies, lipodystrophies, neuropathies, dermatopathies to progeroid syndromes. According to the affected tissues, the eight lamin A mutations described here can be classified into two groups, lipodystrophy and metabolic syndrome (G411D, R419C, L421P) and skeletal and cardiac muscular dystrophies (R401C, G413C, V415I, R427G, Q432X) causing mutations.

The binding site of nesprin-2 to lamin A resides in the tail domain of lamin A (aa 403-425), between the central rod domain and Ig fold at the carboxy terminus, including the NLS. In this study a prediction of the three dimensional structure of human lamin A aa 351-490 was performed. The binding site of lamin A to nesprin-2 resides in a loop between the α -helical rod domain and the C-terminal globular domain of lamin A. The described mutations afore in lamin A cause amino acid exchanges or the formation of a premature stop codon and therefore a truncated protein (Q432X) (Figure 2.6).

According to the side chains and biochemical properties at a physiological pH of 7.4, amino acids are classified into 4 groups: amino acids with electrically charged side chains (positive: Arg, His, Lys; negative: Asp, Glu), amino acids with polar uncharged side chains (Ser, Thr, Cys, Asp, Glu), amino acids with unpolar aliphatic side chain (Gly, Ala, Val, Ile, Leu, Met, Pro), and amino acids with aromatic side chains (Phe, Trp, Tyr). Amino acids with electrically charged or polar uncharged side chains are classified as hydrophilic due to their ability of water solubility. Amino acids with hydrophobic side chain are water insoluble.

Ser and Thr are phosphorylation sites in proteins, they add a negatively charged group to the protein and often function as a switch to control the start or stop in biochemical reactions. For lamin A, phosphorylation sites are enriched in the head and tail domains, with the

highest density between the rod domain and NLS (Maraldi NM et al., 2011; Simon DN and Wilson KL, 2013).

The lamin A mutations analyzed in this study, do not affect phosphorylation sites, however they affect electric charges and thus the surface and biochemical properties of the loop that contains the lamin A amino acids 403-425 that interact with nesprin-2 (Figure 2.7 C). Of special note are the amino acid exchanges caused by the mutations R401C, G413C and R427G that result in a loss of positively charges along the peptide surface (Figure 2.7 C). Contrary to that is the mutation G411D that inserts a novel negative charge. We have narrowed down the interaction site between both proteins to 23 amino acids in lamin A and amino acids 6146-6347 in nesprin-2. These amino acids in nesprin-2 form SRs 52 and 53. We have additionally demonstrated that SR53 is sufficient for mediating the interaction between both proteins. However immunoblotting signals were always weak compared to the larger nesprin-2 polypeptide that spans SRs 52 and 53 (Figure 2.8). From this we conclude that especially on the side of nesprin-2 the amino acids that mediate the binding between both proteins are spread along a larger distance compared to the compact binding site of lamin A to nesprin-2. Crystal structure analysis of both proteins will be necessary to analyze exact consequence of distinct amino acid and charge changes on the interaction between both proteins.

3.3 Mutations in *LMNA* modulate binding affinities of lamin A for nesprin-2

Laminopathies are rare human diseases with complex genotype/phenotype relationships. It is particularly surprising that most of the proteins that are targets for mutations in laminopathies like emerin, lamin A/C or nesprins are almost ubiquitously expressed (Worman HJ *et al.*, 2010). However distinct mutations in genes encoding these proteins lead to the formation of diseases with strong differences in their clinical manifestations (Lu W *et al.*, 2012; Taranum S *et al.*, 2012; Worman HJ, 2012). Along the nuclear envelope nesprins and lamins are part of large protein assemblies and both proteins have a high number of cellular functions and interaction partners. These interactions include cytoskeletal or nuclear envelope associated proteins, transcription factors or chromatin (Hetzer MW, 2010; Ho CY and Lammerding J, 2012; Dubinska-Magiera M, *et al.*, 2013). To explore if the LMNA

mutations analysed here have an impact on the binding capacities between both proteins series of GST-pull down assays were performed. Since both proteins are integrated into protein networks altered binding strength among certain components of these networks, for example between nesprin-2 and lamin A, might modulate the ability of these proteins to interact with other proteins and thus to fulfill their normal function in the cell. This would contribute to explain how different mutations in one gene lead to the formation of phenotypically different diseases.

The first mutation that was analyzed in this work was the lamin A mutation L421P. To characterize the interaction between nesprin-2 and L421P mutated lamin A, pull down experiments were performed between GFP-LA 403-425 WT/L421P and GST tagged nesprin-2-SR52-56 polypeptides and smaller SR polypeptides. Both the WT or mutated lamin A proteins with nesprin-2-SR52-56 (Figure 2.8). From that we conclude that the interaction between both proteins is not abolished by the mutation, even though the amino acid exchange from a lysine to a proline is known to cause severe structural changes, but these are especially known to be critical in alpha helical structures (Sakai H and Tsukihara T, 1998) and probably less severe in the loop that contains the lamin A binding site to nesprin-2. At that point it remained an open question if the binding affinity of lamin A to nesprin-2 is increased, decreased or unaffected. Therefore, following GST pull down experiments were performed between nesprin-2 and full length WT lamin A or mutated GFP lamin A, followed by a quantitative evaluation of the corresponding binding intensities (Figure 2.9). The advantage of the experimental setting that was chosen here is that we used GST-tagged nesprin-2 polypeptides that were bound to beads together with WT or mutated GFP lamin A proteins that were purified from otherwise normal cells. The COS7 cells that we used are a well-established laboratory cell system and they contain LINC complex components like nesprins, lamin A/C (Libotte T, *et al.*, 2005). This brings the binding studies closer to normal cell conditions than interaction studies performed on purified lamin A/C protein and nesprin-2 polypeptides.

From the experiments one can see that the *LMNA* mutations R401C, G411D and V415I increased the binding affinity between lamin A and nesprin-2-SR proteins, oppositely the binding ability for mutations G413C, R419C, L421P, R427G and Q432X were decreased

compared to the WT lamin A /nesprin-2 interaction. Especially the mutations Q432X and V415I, affect the binding affinity by increasing or decreasing the binding strength about $\sim\pm 50\%$ (Figure 2.9). The lamin A mutation Q432X leads to the formation of a truncated lamin protein (Figure 2.6). Mature human lamin A contains 646 amino acids (Dechat T, *et al.*, 2008). The newly formed stop code (X) result in the shorten protein (Figure 2.6 D). One approach to explain the reduced binding capacity between nesprin-2 and lamin A might be that due to the loss of the lamin A C-terminus lamin A Q432X mutated proteins might not properly be folded and amino acids that are necessary for the interaction are no longer present in the correct formation or no longer accessible.

3.4 Mutated GFP lamin A proteins localize along the NE and Q432X proteins additionally form aggregates

In binding studies we found that each mutation analyzed here has a distinct impact on the interaction between nesprin-2 and lamin A (Figure 2.9). To address the question if such altered biochemical properties have consequences on their subcellular localization, immunofluorescence studies were performed.

We started our experiments with short lamin A polypeptides that only contained the binding site of lamin A to nesprin-2. WT and mutated L421P lamin A aa 403-425 were analyzed by immunofluorescence. Similar signals were obtained among cells expressing GFP-LA 403-425 WT, GFP-LA 403-425 L421P or cells transfected with the empty GFP vector. GFP signals were detectable all over the nucleus and dispersed throughout the cell (Figure 2.10). The small lamin polypeptides do not show the typical NE localization that is known for lamins. This might be because the GFP fusion proteins contained only a small part of lamin A (23 amino acids) and this short sequence might not be sufficient to be integrated into the lamina. In general lamins are characterized by a tripartite organization into an N-terminal head, a central alpha helical rod and a c-terminal tail. The head and tail parts play a critical role in lamin A assembly (Ho CY and Lammerding J, 2012). The nuclear localization of the small lamins might be explained due to the presence of the NLS (aa 417-422) or the ability of GFP alone to accumulate inside the nucleus (Figure 2.10).

For this reason in the following experiments full length GFP lamin A proteins were used. Surprisingly all lamin A mutations analyzed here localize along the NE and were thus not distinguishable from WT GFP lamin A (Figure 2.11). The only mutation that differed from this was the truncation mutation Q432X that showed a more versatile distribution pattern. GFP signals were detectable along the NE and additionally in aggregates that presumably occur along the NE rather than inside the nucleus. GFP lamin A Q432X NE signals were always very weak compared to the intensity of the aggregated proteins and thus NE signals are barely visible in IF pictures (Figure 2.11, 2.15).

It has not been described before that mutated Q432X lamin A proteins form aggregates, however the formation of aggregates has been reported for other lamin A mutations like D192G, N195K, M371K, R386K, R482L (Hübner S, *et al.*, 2006; Sylvius N *et al.*, 2008). These mutations localize along different positions of lamin A. From this one can conclude that aggregate formation in lamin A might have different reasons that reach from single amino acids exchanges to a truncation of the protein as it is the case for the mutation Q432X.

Studies on the distributions of lamin A WT, or with the mutations G465D R482L and R527P suggested that 24 hours after transfection the proteins localized to the nucleus or the NE. A prolonged expression resulted in the formation of aggregates with varying intensities among mutated, even in the cells expressing WT lamin A (Bechert K, *et al.*, 2003). The results observed on lamin A Q432X in this study are different. 24 hours after transfection the mutated protein aggregated in contrast to all other mutant or WT lamin A proteins analyzed here. We tried to exclude the possibility that protein aggregation is a sole consequence of the overexpressed protein. For this reason we tried to obtain primary cultures from patients. No primary cell cultures were available.

3.5 The *LMNA* mutation Q432X alters the localizations of several nuclear envelope proteins

Lamins are LINC complex components. To explore the impact of mutated lamin A on the subcellular distribution of further LINC complex component, immunofluorescence studies were performed with HaCaT and COS7 cells. These cell lines were chosen because they are established in the lab and they are known to differ in respect to the expression levels of

nesprin-2 and nuclear stability. HaCaT keratinocytes seem to have a more stable nuclear morphology and are thus less prone for deformation than the fibroblasts like COS7 cells (Kandert S, *et al.*, 2007).

First the distribution of nesprin-2 was analyzed (Figure 2.12). No differences in the localization of nesprin-2 along the NE were observed between cells expressing GFP WT or the lamin A mutations R401C, G411D, G413C, V415I, R419C, L421P and R427G. In cells expressing lamin A Q432X, the situation is different. Here nesprin-2 signals were observed along the NE and in aggregates formed by the mutated lamin A. The sequestration of nesprin-2 into the aggregates was especially strong in COS 7 (Figure 2.13). Since binding studies between nesprin-2 and lamin A show a reduced binding between both proteins in pull down experiments (Figure 2.9) it appears surprising that nesprin-2 is sequestered into these aggregates. To answer the question why nesprin-2 is nevertheless sequestered into the aggregates cells expressing Q432X mutated lamin A proteins were stained with antibodies targeted against the C-terminus of lamin A that is not present in the mutated lamin. These experiments showed that endogenous lamin A was present and accumulated in these aggregates (Figure 2.11) and might sequester nesprin-2.

The impact of mutated lamin A on the localizations of further LINC complex components like emerin and lamin B1 was also analyzed. The result was similar to the subcellular distribution of nesprin-2. The only lamin A mutation that had an impact on the distribution of endogenous LINC complex components was Q432X. Aggregates formed by this particular mutation sequester lamin B1 and emerin (Figure 2.15).

Mutations in lamins are rare and the number of reported cases and detailed information for example on the impact of the mutated proteins on further nuclear envelope proteins are often not available. However the mutation L421P was analyzed in more detail and it was found that in fibroblasts from L421P patients lamin A/C showed an intranuclear staining of lamins A/C and B (Decaudain A, *et al.*, 2007). The difference between the localization of lamins in the nucleus of patient's fibroblasts and along the nuclear envelope in our cell culture experiments with GFP lamin A L421P expressing cells might be due to the cell lines that were used or the expression levels between the overexpressed GFP proteins and

endogenous lamin A/C in fibroblasts. For this reason we tried to expand our studies on primary cultures of patient's cells, but these cells were not available.

3.6 LMNA mutations do not alter NPC assemblies along the NE

As a major component of the NE, NPCs play important roles in nuclear and cellular structures and functions. Approximate 30 Nups have been described till now, among them Nup153 and Nup88 have been confirmed to interact with lamin *in vitro* (Al-Haboubi T, *et al.*, 2011; Lussi YC, *et al.*, 2011). Therefore, immunofluorescences were performed on HaCaT cells expressing WT or mutant GFP lamin A proteins and these cells were stained with a Nups specific antibody. The NPC antibody used for these studies specifically recognizes the repeated FXFG repeat sequence of Nup62, Nup152 and Nup90. Immunofluorescence showed that any of the mutations analyzed here changes the even distribution of NPCs along the NE. Of special note is the mutation lamin A Q432 that forms aggregates along the NE (Figure 2.16). These aggregates sequester LINC complex components like lamin A (Figure 2.11), nesprin-2 (Figure 2.13), emerin and lamin B1 (Figure 2.15). However the distribution pattern of NPCs in the vicinity of Q432X aggregates was not altered (Figure 2.16).

Earlier findings on mutated A type lamins showed a partially different effect. In 2006 Hübner and colleagues published a work about the lamin A mutations N195K and R386K (Hübner S, *et al.*, 2006). Overexpressed FLAG tagged lamin A N195K and R386K proteins formed aggregates, comparable to those described here for lamin A Q432X. Interestingly Nup153 was recruited into these aggregates whereas the situation was different for Nup98. The authors analyzed the sequestration capacity of FLAG tagged lamin A N195K and found that Nup98 was not recruited into the aggregates. Together these data support our findings that aggregates formed by mutated lamins have the ability to sequester NE proteins, however sequestration follows a distinct pattern and is not a generalized mechanism.

3.7 The lamin A mutation Q432X causes alterations in the chromatin organization and SREBP1/ZNF239 misplacement

NE proteins such as lamins and LINC complex proteins either directly or indirectly interact with DNA or chromatin and play roles in chromatin organization and DNA transcription (Maraldi NM, *et al.*, 2010; Wilson KL and Foisner R, 2010; Ho CY and Lammerding J, 2012; Simon DN and Wilson KL, 2013). Lamins directly interact with DNA or histones, which are critical for DNA packaging and higher order organization into nucleosomes and play roles in gene regulation. The DNA binding site of lamins A/C was mapped to aa 411-553 (Stierlé V, *et al.*, 2008) and aa 396-430 interact with histones (Taniura H, *et al.*, 1995). In this study the binding sites of nesprin-2 to lamin A was narrowed down to aa 403-425. These amino acids reside within a loop between the central alpha helical rod and the C-terminal globular tail that is part of a major binding zone of lamin A interaction partners (Simon DN and Wilson KL, 2013). Studies on the lamin A mutations causing HGPS patient cells demonstrated that the mutant lamin A protein causes abnormal chromatin anchorage and chromosome positioning. Our finding that aggregates formed by lamin A Q432X causes alterations in the chromatin organization (Figure 2.16 A, arrow) provide further evidence for the role of lamins in chromatin organization. The mutation Q432X results in the formation of a stop codon at position aa 432 of lamin A which leads to a loss of most of the DNA binding site (aa 411-553) in lamin A. Furthermore the mutation might affect the interplay between lamins and histone because the truncation eliminates a part of the histone interaction site (aa 396-430). Taken together the loss of carboxyterminal amino acids in lamin A Q432X alters the interaction to chromatin/DNA which might lead to the formation of the chromatin gaps (Figure 2.16 A).

Recent studies more and more uncover the role of NE proteins in regulating signaling processes at the NE (Heessen S and Fornerod M, 2007). Both lamins and nesprins have been described being involved in various signaling pathways such as the Wnt/ β -catenin pathway and MAPK signaling (mitogen-activated protein kinase) (Ivorra C, *et al.*, 2006; Tilgner K, *et al.*, 2009; Neumann S, *et al.*, 2010; Rashmi RN, *et al.*, 2012). As a target and/or anchoring protein of signaling molecules, lamin A has been demonstrated to interact with transcription factors like SREBP1 and ZNF239 (Dreuillet C, *et al.*, 2002; Lloyd DJ, *et al.*, 2002) and play roles in regulating the subcellular distribution localizations of both SREBP1 and ZNF239 (Dreuillet C, *et al.*, 2008; Duband-Goulet I, *et al.*, 2011). The interaction site of lamin A to ZNF239 was mapped to lamin A aa 243-387 (Dreuillet C, *et al.*, 2002) and aa 389-664 interact with SREBP1 (Lloyd DJ, *et al.*, 2002). These sites include the lamin A binding site to nesprin-2, aa

403-425. The lamin A mutation Q432X induced lamin A protein aggregates along NE that sequester LINC complex components. To further explore the pathological role of this mutation, we analyzed the impact of the mutated proteins on the subcellular distribution of the transcription factors SREBP1 and ZNF239. Both SREBP1 and ZNF239 were sequestered into the lamin A Q432X aggregates in cells expressing GFP lamin A Q432X, which suggested the mutation Q432X affects the subcellular distributions of both SREBP1 and ZNF239.

SREBP1 is an ubiquitously expressed transcription factors with functions in a wide range of cellular processes including cholesterol and fatty acid metabolism or the regulation of muscle size and protein content (Horton JD, *et al.*, 2002; Dessalle K, *et al.*, 2012). In muscle they regulate the expression of proteins involved in controlling contractility like Titin and Troponins (Lecomte V, *et al.*, 2010; Dessalle K, *et al.*, 2012). SREBP1 attaches to the ER membrane and the NE as an inactive precursor. Cleavage of the SREBP1 precursor is initiated by sterol deficiency that releases the N-terminal part as a mature protein from the membrane that is translocate into the nucleus where it binds to the sterol regulatory element-1 DNA sequence in the promoter region of target genes (Wang X, *et al.*, 1993; 1994). Malfunctions in SREBP1 target genes have been described result in the formation of dilated cardiomyopathies (Harvey PA and Leinwand LA, 2011; Herman DS *et al.*, 2012).

ZNF239 proteins are transcription factors able to recognize both DNA and RNA through their zinc finger motifs and involved in transcription and post-transcriptional regulation of their target genes. The lamin A mutation Q432X results in lamin A aggregates that sequester ZNF239, which may deregulate ZNF239 activity and thus alter the expression of target genes. Dreuillet C and his colleagues observed similar aggregates of mutant lamin A proteins, and aberrant cellular localization of ZNF239 induced by A type lamins mutations such as Δ K261, R249Q, Q294P and R377H (Dreuillet C, *et al.*, 2008).

It remains an open question if mutated lamin A Q432X in patient's cells shows similar characteristics like the ectopically overexpressed GFL lamin A protein analyzed here and if the transcription factors ZNF239 and SREBP1 are sequestered as well in these cells. If they are sequestered transcriptomics will help to identify the expression profiles and identify

cellular malfunctions that lead to the formation of idiopathic dilated cardiomyopathy that is caused by the lamin A mutation Q432X.

3.8 Study on mutated SUN proteins in Emery-Dreifuss muscular dystrophy/Charcot-Marie-Tooth syndrome or Duchenne muscular dystrophy patients' fibroblasts

In the context of a PhD project that was done earlier at our institute potential SUN2 interaction partners were identified in WT fibroblast and in fibroblasts from DMD or EDMD/CMT patients (Eva-Mawina Vaylann, Interactions and subcellular distribution of human SUN2. 2011). In DMD patients a mutation in *DMD* was identified. For the EDMD/CMT patient no mutation in classical candidate genes (*STA*, *LMNA* and *FHL1*) was identified. However, both harbored mutations in nesprin-1 or SUN1/2, respectively (Taranum S, *et al.*, 2012). The DMD patient had a mutation in the 5'UTR present in nesprin-1 α 2. Additionally the SUN1 mutation c.278A>C, p.Q93P was identified. For the EDMD/CMT patient the nesprin-1 α 1 mutation p.N323H was identified in addition to the SUN2 mutation c.97A>G, p.T33A. For both patients the nesprin mutations were defined as primarily not pathogenic. For this reason the following studies were focused on the SUN mutations.

In the context of this project tubulin was identified as a potential novel SUN2 interaction partner. The GST-pull down experiments that were performed in this study confirmed the interaction between the GST-SUN2-NT and tubulin in control and EDMD/CMT, DMD cell lysates. The tubulin immunoblotting signal was always strongly reduced in the DMD patient compared to the WT control or the EDMD/CMT patient, indicating a disturbed interaction or protein network in these cells. SUN proteins are INM proteins and tubulin localizes throughout the cytoplasm and is involved in cellular processes like mitosis and meiosis (Chen JG, *et al.*, 2003). Based to the presence in different cellular compartments, SUN2 along the INM and tubulin in the cytoplasm, we proposed that the interaction between SUN2 and tubulin might happen in cell division during nuclear envelope breakdown. It has been described that SUN proteins co-localize with condensed chromosomes in mitosis and play roles in in neurogenesis and neuronal migration and DNA damage response (Eva-Mawina Vaylann, Interactions and subcellular distribution of human SUN2. 2011; Zhang X, *et al.*, 2009; Lei K, *et al.*, 2012). However, it is not clear how SUN proteins are involved in mitosis.

Discussion

Together with our results, we proposed that SUN proteins and tubulin might play a role in cell proliferation.

To further study the pathological role of the SUN1/2 mutations on nuclear envelope protein assemblies, additional immunofluorescence studies were performed. These studies were performed with HaCaT cells transiently expressing SUN1 Q93P or SUN2 T33A constructs. However, we did not identify obvious changes in the subcellular distribution of nesprin-2, emerin and lamin B1 (Figure 2.19). These results were similar to the ones observed for the lamin A mutations R401C G411D, G413C, V415I, R419C, L421P and R427G, where no differences in the localization of LINC complex components were detected under normal cell culture conditions (Figure 2.12, 2.14). However we cannot exclude that the mutations analyzed here affect the assembly of LINC complexes. For the lamin A mutations analyzed here we identified that each mutation has a distinct impact on the interaction to nesprin-2 (Figure 2.9). These modified interactions might lead to enhanced or decreased interactions among NE proteins. Since NE proteins are always present in large protein complexes, altered interactions among certain components might have consequences on the ability of the proteins to interact with further interaction partners and to fulfill their cellular functions. Further studies will be necessary to unravel the pathological role of the SUN mutations described here.

Discussion

4 Materials and Methods

4.1 Plasmid constructs

4.1.1 Cloning strategies

The amino acid positions of nesprin-2 proteins refer to nesprin-2 giant (Swiss-Prot: Q8WXH0.3). GFP-nesprin-2-SR/-SR1+2/-SR2+3/-SR3+4, pGEX-4T-1-nesprin-2-SR/-SR1/-SR2/-SR1+2/-SR3+4 (Libotte T., *et al.*, 2005, Neumann S, *et al.*, 2010), pGEX-4T-1-SUN2-NT, SUN2-V5 His T33A and GFP-hSUN1 Q93P (Lu W, *et al.*, 2008; Taranum S., *et al.*, 2012) were generated in our lab before. pPET-TEV-LA (aa 1-263), pPET-TEV-LA (aa 264-402), pPET-TEV-LA (aa 345-425) and Pet24d His-TEV-(aa 436-548) expression constructs are kind gifts from Larisa Kapinos (Kapinos LE, *et al.*, 2010). The binding site of lamin A to nesprin-2, amino acids 403-425 (NCBI Reference Sequence: NM_170707) were cloned into the pEGFP-C2 vector (Clontech) by using *EcoR* I and *Bam*H I restriction sites and the following primers:

LA 403-425 WT

Forward: 5'
AATTTCTCTCACTCATCCCAGACACAGGGTGGGGGCAGCGTCACCAAAAAGCGCAAACCTGGAGTCC
ACTGAG 3'

Reverse: 5'
GATCCTCAGTGGACTCCAGTTTTCGCTTTTTGGTGACGCTGCCCCACCTGTGTCTGGGATGAGTGA
GAGGA 3'

For LA 403-425 L421P, the mutation L421P (1262T>C) was introduced into pEGFP-C2-LA 403-425 WT by QuickChange site directed mutagenesis (Stratagene) according to the manufacturer's instructions, by using the following primers:

Forward: 5' CCAAAAAGCGCAAACCGGAGTCCACTGAG 3'

Reverse: 5' CTCAGTGGACTCCGTTTTCGCTTTTTGG 3'

Full length lamin A mutations R401C (1201C>T), G411D (1232G>A), G413C (1237G>T), V415I (1243G>A), R419C (1255C>T), L421P (1262T>C), R427G (1279C>G) and Q432X (1294C>T) were introduced into pEGFP-C2-LA (Broers JL, *et al.*, 1999) by QuickChange site directed mutagenesis with the following primers:

LA R401C (1201C>T)

Forward: 5' CCTCGCAGCGCAGCCGTGGCIGTGCTTCTCTCACTCATCC 3'

Reverse: 5' GGATGAGTGAGAGGAAGCACAGCCACGGCTGCGCTGCGAGG 3'

LA G411D (1232G>A)

Forward: 5' CTCATCCCAGACACAGGATGGGGGCAGCGTCACC 3'

Reverse: 5' GGTGACGCTGCCCCACTGTGTCTGGGATGAG 3'

LA G413C (1237G>T)

Forward: 5' CCCAGACACAGGGTGGGIGCAGCGTCACCAAAAAG 3'

Reverse: 5' CTTTTTGGTGACGCTGCACCCACCCTGTGTCTGGG 3'

LA V415I (1243G>A)

Forward: 5' CCAGACACAGGGTGGGGGCAGCATCACCAAAAAGCGCAAAGTGG 3'

Reverse: 5' CCAGTTTGCCTTTTTGGTGAIGCTGCCCCACCCTGTGTCTGG 3'

LA R419C (1255C>T)

Forward: 5' GGCAGCGTCACCAAAAAGIGCAAAGTGGAGTCCACTG 3'

Reverse: 5' CAGTGGACTCCAGTTTGCACTTTTTGGTGACGCTGCC 3'

LA L421P (1262T>C)

Forward: 5' CACCAAAAAGCGCAAACCGGAGTCCACTGAGAGCC 3'

Reverse: 5' GGCTCTCAGTGGACTCCGTTTTGCGCTTTTTGGTG 3'

LA R427G (1279C>G)

Forward: 5' CTGGAGTCCACTGAGAGCGGCAGCAGCTTCTCACAGC 3'

Reverse: 5' GCTGTGAGAAGCTGCTGCGCTCTCAGTGGACTCCAG 3'

LA Q432X (1294C>T)

Forward: 5' GAGCCGCAGCAGCTTCTCAIAGCACGCACGCACTAGCGG 3'

Reverse: 5' CCGTAGTGCGTGCGTGCTATGAGAAGCTGCTGCGGCTC 3'

4.1.2 Mini/Midi-preparation DNA assays

After site directed mutagenesis, PCR products were first analyzed on 0.8 % agarose gel (w/v). Plasmids running on the size of around 6.7k bp were confirmed by DNA-sequencing. Correct clones were transformed into competent *E.coli* XL1 blue. For the purpose bacteria were thawed on ice for 5 min. Afterwards 2 ng plasmid DNA were added to a solution of 100 µl

competent bacteria and incubated at 4 °C for 15 min. The mixture was exposed to a heat-shock at 42 °C for 90 sec followed by an incubation at 4 °C for 2 min. 1 ml SOC-medium (2 % Bacto-Trypton (w/v), 0.5 % Yeast extract (w/v), 10 mM NaCl, 2.5 mM KCl, 10 mM MgCl₂, 10 mM MgSO₄ and 20 mM Glucose) was added followed by an incubation in a shaker for 1 h at 37 °C. Afterwards the bacteria were centrifuged at 6.000 rpm for 10 min and pellets were dissolved in a minimum amount of LB medium to completely transfer them onto an agarose plate staggered with the corresponding antibiotic. The plates were incubated o/n at 37 °C. Single clones were selected and incubated with 5 ml LB medium (1 % Bacto-Trypton (w/v), 0.5 % Yeast extract (w/v), 0.5 % NaCl (w/v)) supplemented with the corresponding antibiotic o/n.

2 ml of the o/n cultures were centrifuged for 2 min at 6.000 rpm, and the pellets was re-suspended in 300 µl re-suspension buffer (50 mM Tris-HCl, pH 8.0, 10 mM EDTA, 100 µg/ml RNase), followed by a 3 min incubation in 300 µl lysis buffer (0.2 N NaOH, 1 % SDS (w/v)) that was added by gently mixing. Finally the reaction was stopped by adding 300 µl stop buffer (3 M KAc, pH 5.5) and a centrifugation at 12.000 rpm for 20 min. Each supernatant was carefully transferred into a fresh 1.5 ml reaction tube without transferring proteins that appear as white flakes in the solution. Plasmid DNA was precipitated by the addition of 0.8 ml isopropanol and a centrifugation at 14.000 rpm for 20 min. The pellet was additionally washed with 200 µl 70 % ethanol (v/v) and dried on air. Finally the DNA plasmid was re-suspended in 100 µl 5 mM Tris-HCl, pH 8.0 and heated at 65 °C for 10 min to destroyed DNases. DNA sequencing was performed to confirm the success of the site directed mutagenesis. The following primers were used for the sequencing of GFP full length lamin A plasmids. Nucleotide positions refer to the WT LA (NCBI Reference Sequence: NM_170707.3).

WT LA, Nucleotides: 342-363

Forward: 5' GGAGCTGAAAGCGCGCAATACC 3'

WT LA, Nucleotides: 768-790

Forward: 5' GGAGCAGTATAAGAAGGAGCTGG 3'

WT LA, Nucleotides: 1080-1102

Forward: 5' GGAGCTTCTGGACATCAAGCTGG 3'

WT LA, Nucleotides: 1672-1693

Forward: 5' GGAGATGACCTGCTCCATCACC 3'

Plasmid DNA for transfection was extracted from bacteria by using the PureYield Plasmid Midi-prep System Kit (Promega) according to the standard DNA purification protocol.

4.2 Cell culture and transfections

All cells lines (Table 4.1) used here were cultured in incubators at 37 °C in a humidified atmosphere with 5 % CO₂. COS7, HaCaT and human primary fibroblast were grown in Dulbecco's modified Eagle's medium (DMEM, PAA) supplemented with 10 % fetal bovine serum (FBS, w/v), 1 % penicillin-streptomycin (v/v) and 2 mM L-glutamine. Fibroblasts from patients with duchenne muscular dystrophy (DMD) or Emery-Dreifuss muscular dystrophy/Charcot-Marie-Tooth syndrome (EDMD/CMT) were grown in Minimum Essential Medium (MEM, GIBCO) supplemented with 20 % fetal calf serum (FCS, w/v), 1 % penicillin-streptomycin (v/v) and 2 mM L-glutamine. COS7 cells were transfected by using GenePulser-II (Bio-Rad) at 180 V and 950 microfarads. HaCaT cells (program: U-020) and fibroblasts (program: A-014) were transfected using the Amaxa cell line Nucleofector-kit V (Lonza) according to the manufacturer's instructions.

Cell line	Species	Tissue	Resource
COS7	<i>Cercopithecus aethiops</i>	African green monkey kidney	Gluzman Y., 1981
HaCaT	<i>Homo sapiens</i>	Human keratinocytes	Boukamp P., <i>et al.</i> , 1988
Primary human fibroblast	<i>Homo sapiens</i>	Human foreskin	Lu W, <i>et al.</i> , 2012
DMD	<i>Homo sapiens</i>	Human primary fibroblasts	Zhang Q, <i>et al.</i> , 2007
EDMD/CMT	<i>Homo sapiens</i>	Human primary fibroblasts	Zhang Q, <i>et al.</i> , 2007

Table 4.1 Cell lines used in this study.

The table summarizes the cell lines that were used in this study, including information about species, tissue and literature reference.

4.3 *In vitro* pull-down assays

4.3.1 *Protein lysates from cells*

COS7 cells expressing GFP-tagged proteins, or primary human fibroblast were trypsinized and the pellets were resuspended in 1 ml lysis buffer (50 mM Tris-HCl, pH 7.5, 150 mM NaCl, 1 % Nonidet-P 40 (w/v), and 0.5 % sodium deoxycholate (SDS, w/v)) supplemented with protease inhibitors (1 x proteinase inhibitor cocktail (Sigma), 1 mM DL-Dithiothreitol (DTT), 1 mM benzamidine, and 1 mM Phenylmethanesulfonyl fluoride (PMSF)). In the next step the cell suspension was pushed and pulled six times through a needle (0.4 × 19mm) followed by an incubation at 4 °C for 15 min. Following the suspension was sonicated for 2 min (35 % amplitude, Hielscher Ultrasonics) and centrifuged at 16.000 rpm for 30 min at 4 °C. Supernatants were separated from the pellets and used in the following experiments.

4.3.2 *His-tag pull-down and GST pull-down*

Plasmids encoding His- or GST-tagged proteins were transformed into the bacterial strain *E.coli* XL1 blue, and protein production was initiated by the addition of 0.5 mM Isopropyl-1-thio-D-galactopyranoside (IPTG) o/n at 20 °C starting in the stage of exponential growth at an OD600 between 0.6 and 0.8.

For His-tagged proteins; *E.coli* expressing the corresponding protein was centrifuged and the pellets were lysed in STE buffer (10 mM Tris-HCl, pH 8.0, 150 mM NaCl, 1 mM EDTA) supplemented with protease inhibitors. Next the bacteria suspension was supplemented with lysozyme to a final concentration 100 µg/ml and treated in a dounce homogenizer by pushing and pulling for 10 times followed by incubation at 4 °C for 15 min. The bacteria suspension was sonicated for 1 min (35 % amplitude) and centrifuged at 16.000 rpm for 30 min at 4 °C. The supernatants were transferred into fresh tubes and pellets were discarded.

For GST-tagged proteins; *E.coli* expressing the corresponding proteins were centrifuged and resuspended in STE buffer that was supplemented with lysozyme to a final concentration of

100 µg/ml. After processing the bacteria suspensions in a dounce homogenizer and an incubation at 4 °C for 15 min, sarcosyl was added to a final concentration of 1.5 % (w/v) followed by an 1 min sonication (35 % amplitude) step. Subsequently bacteria lysates were centrifuged at 16.000 rpm for 30 min at 4 °C. Finally pellets were discarded and the supernatants were transferred into 15 ml reaction tubes and mixed with triton X-100 to a final concentration of 2 % (w/v).

His- and GST-tagged fusion proteins were isolated from *E. coli* lysates by the addition of Ni-NTA (QIAGEN) or glutathione Sepharose 4B (GST) (Macherey-Nagel) beads to the supernatants and an incubation o/n at 4 °C on a shaker. Beads coupled with proteins were collected from the bacteria suspension by centrifugation (2.000 rpm, 1 min) and washed five times with PBS supplemented with protease inhibitors. His- or GST-tagged fusion proteins that were coupled to beads were stored in PBS supplemented with inhibitors at 4 °C for short time.

To avoid unspecific signals in the pull down experiments, lysates of COS7 cells were pre-cleared by incubation with empty Ni-NTA or GST-beads for 1 h at 4 °C. Beads were separated from the lysates by centrifugation (2.000 rpm, 1 min). Afterwards GST- or His- tagged fusion proteins bound to beads were incubated with lysates of COS7 cells expressing the corresponding GFP fusion proteins at 4 °C o/n on a shaker. Ni-NTA or GST-beads alone were used as negative controls. Finally, beads were collected by centrifugation (2.000 rpm, 1 min) and washed 5 times with PBS supplemented with protease inhibitors.

4.3.3 Western blot and quantitative analysis

Protein samples collected from His- or GST--pull-down experiments were re-suspended in SDS sample buffer (0.5 M Tris-HCl, pH 6.8, 10 % Glycerol, 2 % sodium dodecyl sulfate (SDS), 2.5 % Bromophenol Blue) and heated for 5 min at 95 °C. Subsequently they were separated on 15 % sodium dodecyl sulfate polyacrylamide gels (SDS-PAGE) and stained either with coomassie brilliant blue R 250 or transferred onto nitrocellulose membranes for western blot analysis. Western blot membranes were blocked with 5 % (w/v) non-fat milk powder

diluted in TBST buffer (0.1 M Tris-HCl pH 7.0, 0.5 M NaCl, 2 % Tween20 (v/v), 1 % Nonidet-P 40 (w/v)) prior to the appropriate antibody detections. Primary antibodies were detected by using the according peroxidase-conjugated secondary antibodies and visualized by enhanced chemiluminescence (ECL) reactions with ECL solution (0.1 M Tris-HCl, pH 8.5, 2.5 mM luminol, 0.4 mM p-coumaric acid in DMSO, luminol, p-coumaric acid and 6.1 μ l 30% H₂O₂ per 10 ml ECL solution that were added immediately before the reaction).

ECL reactions on nitrocellulose membranes were documented on X-ray films (GE Healthcare) and developed in a developing machine (OptiMax). Antibodies used for western blot analysis are summarized in table 4.2. Secondary antibodies were horseradish-peroxidase (POD) conjugated.

Primary antibodies	Dilution	Resource
Mouse monoclonal anti-GFP (K3-184-2)	1:20	Noegel AA, <i>et al.</i> , 2004
Rabbit polyclonal anti-lamin A/C (H-110)	1:500	Santa Cruz
Rat monoclonal anti-YL ½ α/β -tubulin	1:20	Scholey AB, <i>et al.</i> , 1992
Rabbit polyclonal anti-GAPDH (FL-335)	1:500	Santa Cruz
Second antibodies	Dilution	Resource
Anti-mouse-IgG	1:10.000	Sigma
Anti-rabbit-IgG	1:10.000	Sigma

Table 4.2 Antibodies used in western blot.

Antibodies used in this study for western blot analysis are shown in this table, including specification about working dilution and reference or company.

AlphaEaseFC software (version 4.0.0) was used to quantify band intensities on scanned X-ray films and coomassie gels. The expression levels of GFP-tagged proteins were normalized to coomassie stained GST-fusion proteins. The ratio between GST-nesprin-2 WT and GFP-LA WT was used as a reference and corresponds to 100 %. Binding intensities between mutated GFP tagged lamin A proteins and WT GST-nesprin-2 were compared to the WT. Data are

expressed as mean \pm standard deviation. Statistical comparisons were operated by using unpaired student's t-tests. A difference was considered significant at a value of $P < 0.01$.

4.4 Immunofluorescence and microscopy

Cells transfected with the plasmids of interest were transferred onto coverslips in 24-well plates. Cells grown on coverslips over 1 or 2 days were fixed with 4 % paraformaldehyde (PFA) (All the solutions used in IF were diluted in PBS) for 15 min and permeabilized with 0.5 % Triton X-100 for 5 min followed by extensive washing with PBS buffer. Alternatively, cells were fixed and permeabilized with ice cold methanol for 10 min at -20°C . The appropriate antibodies were diluted in blocking solution PBG (0.5 % BSA, 0.045 % fish gelatin, pH 7.4) to the working concentration and applied to the fixed cells after blocking them with PBG at RT for 30 min. Unbound antibodies were removed by washing with PBS prior to the incubation with the according secondary antibodies, nuclei were stained with 4, 6-diamino-2-phenylindone (DAPI) added to the secondary antibodies. Coverslips were embedded in gelvatol (0.1 M Tris-HCl, pH 8.5, 10 % gelvatol (w/v), 25 % glycerol (v/v), 2.7 % 1, 4-diazobicyclo-[2.2.2] octanes (DABCO, w/v, Sigma)) and left to dry and polymerize o/n at R.T.. Samples were analyzed by confocal laser scanning microscopy (TCS-SP, Leica). LAS-AF lite application suite software (soft version: 2.6.0 build 7266) from Leica and Photoshop (Adobe, soft version: 8.0) were used for analysis and preparation of the figures.

Antibodies used in immunofluorescence analysis (IF) are shown in table 4.3. As secondary antibodies, Alexa Fluor 488/568 conjugates were applied.

Primary antibodies	Dilution	Resource
Rabbit polyclonal anti-nesprin-2 (pAbK1)	1:500	Padmakumar VC, <i>et al.</i> , 2004
Mouse monoclonal anti-emerin (4G5)	1:50	Acris
Rabbit polyclonal anti-lamin B1 (ab16048)	1:400	Abcam
Rabbit polyclonal	1:200	Santa Cruz

anti-ZNF239 (H-24)		
Rabbit polyclonal	1:200	Santa Cruz
anti-SREBP-1 (C-20)		
Mouse monoclonal	1:500	COVANCE
anti-NPC (MAb414)		
Rabbit polyclonal	1:500	Santa Cruz
anti-lamin A/C (H-102)		
Mouse monoclonal anti-V5	1:200	Invitrogen
Second antibodies		
Alexa 568 goat anti-rabbit IgG	1:1.000	Sigma
Alexa 568 Goat anti-mouse IgG	1:1.000	Sigma

Table 4.3 Antibodies applied in immunofluorescence analysis.

Antibodies used in this study for immunofluorescence are shown in this table, including specification about working dilution and company.

4.5 Heat stress experiments

Primary human fibroblasts transfected with plasmids encoding GFP-LA WT, GFP-LA Q432X or GFP-LA V415I were transferred onto coverslips in 24-well plates. Cells were grown on coverslips for one or two days at 37 °C in a humidified atmosphere with 5 % CO₂ o/n. For heat shock, cells were placed in an incubator set at 42 °C for 15 min and fixed immediately after treatment with ice cold methanol at -20 °C for 10 min followed by immunofluorescence analysis as described before. Fibroblasts that were not exposed to heat stress were used as controls.

4.6 Protein lysates from mouse tissues

Nesprin-2-Giant KO mice were generated by our lab (Lüke Y, *et al.*, 2008). Tissues were washed in ice-cold PBS to remove the blood, shock frozen in liquid nitrogen and stored at -80 °C. Next 400 µl lysis buffer were applied per 100 mg tissue. After grinding the tissues within liquid nitrogen tissues were stored on ice for 15 min followed by 1 min sonication (35

% amplitude). After 30 min centrifugation at 12.000 rpm, -4° C, the samples were supplemented with SDS-loading buffer and separated on SDS-PAGE followed by coomassie blue staining or western blot analysis.

4.7 Sequence alignment and lamin A fragment structure prediction

Lamin sequence from *H. sapiens* lamin A (P02545), *Mus musculus* lamin A (P48678), and *H. sapiens* lamin B (P20700) were retrieved from UniProt database and aligned using clustalW2 online program (Larkin MA, *et al.*, 2007). The aligned sequence was performed by using ESPript 2.2 for representation (Gouet P, *et al.*, 1999). For lamin A structural model construction, the lamin A fragment aa 351-490 that encompassing part of its N-terminal coil2B and C-terminal globular domain is modeled by using the MULTICOM server (Wang Z, *et al.*, 2010). 1UFGA(C-terminal immunoglobulin like domain of mouse lamin A) (Dhe-Paganon S, *et al.*, 2002), 1IFRA (globular tail of human lamin A), and 2LLA (chain A of Mannose-6-phosphate/insulin-like growth factor II receptor) (Williams C, *et al.*, 2012) were used as templates for modeling. The WT and exchanged amino acids corresponding to lamin A mutations analyzed in this study were generated by using SwissPDB Viewer v4.1.0 (Guex N and Peitsch MC, 1997) and the molecular surface was generated using pyMOL v1.3.

References

Al-Haboubi T, Shumaker DK, Köser J, Wehnert M, Fahrenkrog B (2011) Distinct association of the nuclear pore protein Nup153 with A- and B-type lamins. *Nucleus* 2(5):500-9

Apel ED, Lewis RM, Grady RM, Sanes JR (2000) Syne-1, a dystrophin- and Klarsicht-related protein associated with synaptic nuclei at the neuromuscular junction. *J Biol Chem* 275(41):31986-95

Attali R, Warwar N, Israel A, Gurt I, McNally E, Puckelwartz M, Glick B, Nevo Y, Ben-Neriah Z, Melki J (2009) Mutation of SYNE-1, encoding an essential component of the nuclear lamina, is responsible for autosomal recessive arthrogryposis. *Hum Mol Genet* 18(18):3462-9

Bione S, Maestrini E, Rivella S, Mancini M, Regis S, Romeo G, Toniolo D (1994) Identification of a novel X-linked gene responsible for Emery-Dreifuss muscular dystrophy. *Nat Genet* 8(4):323-7

Bione S, Small K, Aksmanovic VM, D'Urso M, Ciccodicola A, Merlini L, Morandi L, Kress W, Yates JR, Warren ST, Tonlolo D (1995) Identification of new mutations in the Emery-Dreifuss muscular dystrophy gene and evidence for genetic heterogeneity of the disease. *Hum Mol Genet* 4(10):1859-63

Bouhouche A, Benomar A, Birouk N, Mularoni A, Meggouh F, Tassin J, Grid D, Vandenberghe A, Yahyaoui M, Chkili T, Brice A, LeGuern E (1999) A locus for an axonal form of autosomal recessive Charcot-Marie-Tooth disease maps to chromosome 1q21.2-q21.3. *Am J Hum Genet* 65(3):722-7

Boukamp P, Petrussevska RT, Breitkreutz D, Hornung J, Markham A, Fusenig NE (1988) Normal keratinization in a spontaneously immortalized aneuploid human keratinocyte cell line. *J Cell Biol* 106(3):761-71

Brauch KM, Chen LY, Olson TM (2009) Comprehensive mutation scanning of LMNA in 268 patients with lone atrial fibrillation. *Am J Cardiol* 103(10):1426-8

Brosig M, Ferralli J, Gelman L, Chiquet M, Chiquet-Ehrismann R (2010) Interfering with the connection between the nucleus and the cytoskeleton affects nuclear rotation, mechanotransduction and myogenesis. *Int J Biochem Cell Biol* 42(10):1717-28

Broers JL, Machiels BM, van Eys GJ, Kuijpers HJ, Manders EM, van Driel R, Ramaekers FC (1999) Dynamics of the nuclear lamina as monitored by GFP-tagged A-type lamins. *J Cell Sci* 112 (Pt 20):3463-75

Cao H, Hegele RA (2000) Nuclear lamin A/C R482Q mutation in canadian kindreds with Dunnigan-type familial partial lipodystrophy. *Hum Mol Genet* 9(1):109-12

- Caron M, Auclair M, Donadille B, Béréziat V, Guerci B, Laville M, Narbonne H, Bodemer C, Lascols O, Capeau J, Vigouroux C (2007) Human lipodystrophies linked to mutations in A-type lamins and to HIV protease inhibitor therapy are both associated with prelamin A accumulation, oxidative stress and premature cellular senescence. *Cell Death Differ* 14(10):1759-67
- Capanni C, Cenni V, Mattioli E, Sabatelli P, Ognibene A, Columbaro M, Parnaik VK, Wehnert M, Maraldi NM, Squarzoni S, Lattanzi G (2003) Failure of lamin A/C to functionally assemble in R482L mutated familial partial lipodystrophy fibroblasts: altered intermolecular interaction with emerin and implications for gene transcription. *Exp Cell Res* 291(1):122-34
- Capanni C, Mattioli E, Columbaro M, Lucarelli E, Parnaik VK, Novelli G, Wehnert M, Cenni V, Maraldi NM, Squarzoni S, Lattanzi G (2005) Altered pre-lamin A processing is a common mechanism leading to lipodystrophy. *Hum Mol Genet* 14(11):1489-502
- Chen CY, Chi YH, Mutalif RA, Starost MF, Myers TG, Anderson SA, Stewart CL, Jeang KT (2012) Accumulation of the inner nuclear envelope protein Sun1 is pathogenic in progeric and dystrophic laminopathies. *Cell* 149(3):565-77
- Chow KH, Factor RE, Ullman KS (2012) The nuclear envelope environment and its cancer connections. *Nat Rev Cancer* 12(3):196-209
- Columbaro M, Capanni C, Mattioli E, Novelli G, Parnaik VK, Squarzoni S, Maraldi NM, Lattanzi G (2005) Rescue of heterochromatin organization in Hutchinson-Gilford progeria by drug treatment. *Cell Mol Life Sci* 62(22):2669-78
- Crisp M, Liu Q, Roux K, Rattner JB, Shanahan C, Burke B, Stahl PD, Hodzic D (2006) Coupling of the nucleus and cytoplasm: role of the LINC complex. *J Cell Biol* 172(1):41-53
- Dawe HR, Adams M, Wheway G, Szymanska K, Logan CV, Noegel AA, Gull K, Johnson CA (2009) Nesprin-2 interacts with meckelin and mediates ciliogenesis via remodelling of the actin cytoskeleton. *J Cell Sci* 122(Pt 15):2716-26
- DeBusk FL (1972) The Hutchinson-Gilford progeria syndrome. Report of 4 cases and review of the literature. *J Pediatr* 80(4):697-724
- Decaudain A, Vantyghem MC, Guerci B, Hécart AC, Auclair M, Reznik Y, Narbonne H, Ducluzeau PH, Donadille B, Lebbé C, Béréziat V, Capeau J, Lascols O, Vigouroux C (2007) New metabolic phenotypes in laminopathies: LMNA mutations in patients with severe metabolic syndrome. *J Clin Endocrinol Metab* 92(12):4835-44
- Dechat T, Adam SA, Goldman RD (2009) Nuclear lamins and chromatin: when structure meets function. *Adv Enzyme Regul* 49(1):157-66

- Dechat T, Pflughaar K, Sengupta K, Shimi T, Shumaker DK, Solimando L, Goldman RD (2008) Nuclear lamins: major factors in the structural organization and function of the nucleus and chromatin. *Genes Dev* 22(7):832-53
- Dechat T, Adam SA, Taimen P, Shimi T, Goldman RD (2010) Nuclear lamins. *Cold Spring Harb Perspect Biol* 2(11):a000547
- Dechat T, Gesson K, Foisner R (2010) Lamina-independent lamins in the nuclear interior serve important functions. *Cold Spring Harb Symp Quant Biol* 75:533-43
- Dessalle K, Euthine V, Chanon S, Delarichaudy J, Fujii I, Rome S, Vidal H, Nemoz G, Simon C, Lefai E (2012) SREBP-1 transcription factors regulate skeletal muscle cell size by controlling protein synthesis through myogenic regulatory factors. *PLoS one* 7:e50878
- Dhe-Paganon S, Werner ED, Chi YI, Shoelson SE (2002) Structure of the globular tail of nuclear lamin. *The Journal of biological chemistry* 277:17381-17384.
- Ding X, Xu R, Yu J, Xu T, Zhuang Y, Han M (2007) SUN1 is required for telomere attachment to nuclear envelope and gametogenesis in mice. *Dev Cell* 12(6):863-72
- Dittmer TA, Misteli T (2011) The lamin protein family. *Genome Biol* 12(5):222
- Duband-Goulet I, Woerner S, Gasparini S, Attanda W, Kondé E, Tellier-Lebègue C, Craescu CT, Gombault A, Roussel P, Vadrot N, Vicart P, Ostlund C, Worman HJ, Zinn-Justin S, Buendia B (2011) Subcellular localization of SREBP1 depends on its interaction with the C-terminal region of wild-type and disease related A-type lamins. *Exp Cell Res* 317(20):2800-13
- Dubinska-Magiera M, Zaremba-Czogalla M, Rzepecki R (2012) Muscle development, regeneration and laminopathies: how lamins or lamina-associated proteins can contribute to muscle development, regeneration and disease. *Cell Mol Life Sci* 2012 Nov 10 [Epub ahead of print]
- Dutour A, Roll P, Gaborit B, Courrier S, Alessi MC, Tregouet DA, Angelis F, Robaglia-Schlupp A, Lesavre N, Cau P, Lévy N, Badens C, Morange PE (2011) High prevalence of laminopathies among patients with metabolic syndrome. *Hum Mol Genet* 20(19):3779-86
- Dreuillet C, Harper M, Tillit J, Kress M, Ernoult-Lange M (2008) Mislocalization of human transcription factor MOK2 in the presence of pathogenic mutations of lamin A/C. *Biol Cell* 100(1):51-61
- Dreuillet C, Tillit J, Kress M, Ernoult-Lange M (2002) In vivo and in vitro interaction between human transcription factor MOK2 and nuclear lamin A/C. *Nucleic Acids Res* 30(21):4634-42
- Eva MV (2011) Interactions and subcellular distribution of human SUN2. PhD thesis

Furukawa K, Ishida K, Tsunoyama TA, Toda S, Osoda S, Horigome T, Fisher PA, Sugiyama S (2009) A-type and B-type lamins initiate layer assembly at distinct areas of the nuclear envelope in living cells. *Exp Cell Res* 315(7):1181-9

Garavelli L, D'Apice MR, Rivieri F, Bertoli M, Wischmeijer A, Gelmini C, De Nigris V, Albertini E, Rosato S, Viridis R, Bacchini E, Dal Zotto R, Banchini G, Iughetti L, Bernasconi S, Superti-Furga A, Novelli G (2009) Mandibuloacral dysplasia type A in childhood. *Am J Med Genet A* 149A(10):2258-64

Garg A (2004) Acquired and inherited lipodystrophies. *N Engl J Med* 350(12):1220-34

Gerace L, Blobel G (1980) The nuclear envelope lamina is reversibly depolymerized during mitosis. *Cell* 19:1047-57

Gluzman Y (1981) SV40-transformed simian cells support the replication of early SV40 mutants. *Cell* 23(1):175-82

Gerace L, Huber MD (2012) Nuclear lamina at the crossroads of the cytoplasm and nucleus. *J Struct Biol* 177(1):24-31

Göb E, Schmitt J, Benavente R, Alsheimer M (2010) Mammalian sperm head formation involves different polarization of two novel LINC complexes. *PLoS One* 5(8):e12072

Gouet P, Courcelle E, Stuart DI, Métoz F (1999) ESPript: analysis of multiple sequence alignments in PostScript. *Bioinformatics* 15(4):305-8

Graumann K, Runions J, Evans DE (2010) Characterization of SUN-domain proteins at the higher plant nuclear envelope. *Plant J* 61(1):134-44

Gros-Louis F, Dupré N, Dion P, Fox MA, Laurent S, Verreault S, Sanes JR, Bouchard JP, Rouleau GA (2007) Mutations in SYNE1 lead to a newly discovered form of autosomal recessive cerebellar ataxia. *Nat Genet* 39(1):80-5

Guex N, Peitsch MC (1997) SWISS-MODEL and the Swiss-PdbViewer: an environment for comparative protein modeling. *Electrophoresis* 18:2714-2723

Haque WA, Oral EA, Dietz K, Bowcock AM, Agarwal AK, Garg A (2003) Risk factors for diabetes in familial partial lipodystrophy, Dunnigan variety. *Diabetes Care* 26(5):1350-5

Harvey PA, Leinwand LA (2011) The cell biology of disease: cellular mechanisms of cardiomyopathy. *J Cell Biol* 194:355-65

Heessen S, Fornerod M (2007) The inner nuclear envelope as a transcription factor resting place. *EMBO Rep* 8(10):914-9

Herman DS, Lam L, Taylor MR, Wang L, Teekakirikul P, Christodoulou D, Conner L, DePalma SR, McDonough B, Sparks E, Teodorescu DL, Cirino AL, Banner NR, Pennell DJ, Graw S, Merlo

M, Di Lenarda A, Sinagra G, Bos JM, Ackerman MJ, Mitchell RN, Murry CE, Lakdawala NK, Ho CY, Barton PJ, Cook SA, Mestroni L, Seidman JG, Seidman CE (2012) Truncations of titin causing dilated cardiomyopathy. *N Engl J Med* 366:619-28

Hetzer MW, Walther TC, Mattaj JW (2005) Pushing the envelope: structure, function, and dynamics of the nuclear periphery. *Annu Rev Cell Dev Biol* 21:347-80

Hetzer MW (2010) The nuclear envelope. *Cold Spring Harb Perspect Biol* 2(3):a000539

Hiraoka Y, Dernburg AF (2009) The SUN rises on meiotic chromosome dynamics. *Dev Cell* 17(5):598-605

Ho CY, Lammerding J (2012) Lamins at a glance. *J Cell Sci* 125(Pt 9):2087-93

Horn HF, Brownstein Z, Lenz DR, Shivatzki S, Dror AA, Dagan-Rosenfeld O, Friedman LM, Roux KJ, Kozlov S, Jeang KT, Frydman M, Burke B, Stewart CL, Avraham KB (2013) The LINC complex is essential for hearing. *J Clin Invest* 123(2):740-50

Horton JD, Goldstein JL, Brown MS (2002) SREBPs: activators of the complete program of cholesterol and fatty acid synthesis in the liver. *J Clin Invest* 109(9):1125-31

Hübner S, Eam JE, Hübner A, Jans DA (2006) Laminopathy-inducing lamin A mutants can induce redistribution of lamin binding proteins into nuclear aggregates. *Exp Cell Res* 312(2):171-83

Hübner S, Eam JE, Wagstaff KM, Jans DA (2006) Quantitative analysis of localization and nuclear aggregate formation induced by GFP-lamin A mutant proteins in living HeLa cells. *J Cell Biochem* 98(4):810-26

Ivorra C, Kubicek M, González JM, Sanz-González SM, Alvarez-Barrientos A, O'Connor JE, Burke B, Andrés V (2006) A mechanism of AP-1 suppression through interaction of c-Fos with lamin A/C. *Genes Dev* 20:307-20

Lammerding J, Schulze PC, Takahashi T, Kozlov S, Sullivan T, Kamm RD, Stewart CL, Lee RT (2004) Lamin A/C deficiency causes defective nuclear mechanics and mechanotransduction. *J Clin Invest* 113(3):370-8

Larkin MA, Blackshields G, Brown NP, Chenna R, McGettigan PA, McWilliam H, Valentin F, Wallace IM, Wilm A, Lopez R, Thompson JD, Gibson TJ, Higgins DG (2007) Clustal W and Clustal X version 2.0. *Bioinformatics* 23(21):2947-8

Lecomte V, Meugnier E, Euthine V, Durand C, Freyssenet D, Nemoz G, Rome S, Vidal H, Lefai E (2010) A new role for sterol regulatory element binding protein 1 transcription factors in the regulation of muscle mass and muscle cell differentiation. *Mol Cell Biol* 30:1182-98

- Lei K, Zhu X, Xu R, Shao C, Xu T, Zhuang Y, Han M (2012) Inner nuclear envelope proteins SUN1 and SUN2 play a prominent role in the DNA damage response. *Curr Biol* 22(17):1609-15
- Libotte T, Zaim H, Abraham S, Padmakumar VC, Schneider M, Lu W, Munck M, Hutchison C, Wehnert M, Fahrenkrog B, Sauder U, Aebi U, Noegel AA, Karakesisoglou I (2005) Lamin A/C-dependent localization of Nesprin-2, a giant scaffold at the nuclear envelope. *Mol Biol Cell* 16(7):3411-24
- Lloyd DJ, Trembath RC, Shackleton S (2002) A novel interaction between lamin A and SREBP1: implications for partial lipodystrophy and other laminopathies. *Hum Mol Genet* 11(7):769-77
- Lombardi ML, Jaalouk DE, Shanahan CM, Burke B, Roux KJ, Lammerding J (2011) The interaction between nesprins and sun proteins at the nuclear envelope is critical for force transmission between the nucleus and cytoskeleton. *J Biol Chem* 286(30):26743-53
- Lu W, Gotzmann J, Sironi L, Jaeger VM, Schneider M, Lüke Y, Uhlén M, Szigyarto CA, Brachner A, Ellenberg J, Foisner R, Noegel AA, Karakesisoglou I (2008) Sun1 forms immobile macromolecular assemblies at the nuclear envelope. *Biochim Biophys Acta* 1783(12):2415-26
- Lu W, Schneider M, Neumann S, Jaeger VM, Taranum S, Munck M, Cartwright S, Richardson C, Carthew J, Noh K, Goldberg M, Noegel AA, Karakesisoglou I (2012) Nesprin interchain associations control nuclear size. *69(20):3493-509*
- Lüke Y, Zaim H, Karakesisoglou I, Jaeger VM, Sellin L, Lu W, Schneider M, Neumann S, Beijer A, Munck M, Padmakumar VC, Gloy J, Walz G, Noegel AA (2008) Nesprin-2 Giant (NUANCE) maintains nuclear envelope architecture and composition in skin. *J Cell Sci* 121(Pt 11):1887-98
- Lussi YC, Hügi I, Laurell E, Kutay U, Fahrenkrog B (2011) The nucleoporin Nup88 is interacting with nuclear lamin A. *Mol Biol Cell* 22(7):1080-90
- Jiang XZ, Yang MG, Xing XW (2010) Prokaryotic expression and purification of SPAG4L, a novel human testis gene. *Nan Fang Yi Ke Da Xue Xue Bao* 30(9):2047-50
- Kandert S, Lüke Y, Kleinhenz T, Neumann S, Lu W, Jaeger VM, Munck M, Wehnert M, Müller CR, Zhou Z, Noegel AA, Dabauvalle MC, Karakesisoglou I (2007) *Hum Mol Genet* 16(23):2944-59
- Kapinos LE, Schumacher J, Mücke N, Machaidze G, Burkhard P, Aebi U, Strelkov SV, Herrmann H (2010) Characterization of the head-to-tail overlap complexes formed by human lamin A, B1 and B2 "half-minilamin" dimers. *J Mol Biol* 396(3):719-31

- Maraldi NM, Capanni C, Cenni V, Fini M, Lattanzi G (2011) Laminopathies and lamin-associated signaling pathways. *J Cell Biochem* 112(4):979-92
- Markiewicz E, Tilgner K, Barker N, van de Wetering M, Clevers H, Dorobek M, Hausmanowa-Petrusewicz I, Ramaekers FC, Broers JL, Blankesteyn WM, Salpingidou G, Wilson RG, Ellis JA, Hutchison CJ (2006) The inner nuclear membrane protein emerin regulates beta-catenin activity by restricting its accumulation in the nucleus. *EMBO J.* 25(14):3275-85
- Meinke P, Nguyen TD, Wehnert MS (2011) The LINC complex and human disease. *Biochem Soc Trans* 39(6):1693-7
- Mellad JA, Warren DT, Shanahan CM (2011) Nesprins LINC the nucleus and cytoskeleton. *Curr Opin Cell Biol* 23(1):47-54
- Méjat A, Misteli T (2010) LINC complexes in health and disease. *Nucleus* 1(1):40-52
- Møller DV, Pham TT, Gustafsson F, Hedley P, Ersbøll MK, Bundgaard H, Andersen CB, Torp-Pedersen C, Køber L, Christiansen M (2009) The role of Lamin A/C mutations in Danish patients with idiopathic dilated cardiomyopathy. *Eur J Heart Fail* 11(11):1031-5
- Noemann S, Schneider M, Daugherty RL, Gottardi CJ, Eming SA, Beijer A, Noegel AA, Karakesisoglou I (2010) Nesprin-2 interacts with α -catenin and regulates Wnt signaling at the nuclear envelope. *J Biol Chem* 285(45):34932-8
- Noegel AA, Blau-Wasser R, Sultana H, Müller R, Israel L, Schleicher M, Patel H, Weijer CJ (2004) The cyclase-associated protein CAP as regulator of cell polarity and cAMP signaling in *Dictyostelium*. *Mol Biol Cell* 15(2):934-45
- Noegel AA, Neumann S (2011) The role of nesprins as multifunctional organizers in the nucleus and the cytoskeleton. *Biochem Soc Trans* 39(6):1725-8
- Olson TM, Keating MT (1996) Mapping a cardiomyopathy locus to chromosome 3p22-p25. *J Clin Invest* 97(2):528-32
- Oza P, Jaspersen SL, Miele A, Dekker J, Peterson CL (2009) Mechanisms that regulate localization of a DNA double-strand break to the nuclear periphery. *Genes Dev* 23(8):912-27
- Padmakumar VC, Abraham S, Braune S, Noegel AA, Tunggal B, Karakesisoglou I, Korenbaum E (2004) Enaptin, a giant actin-binding protein, is an element of the nuclear membrane and the actin cytoskeleton. *Exp Cell Res* 295(2):330-9
- Prokocimer M, Davidovich M, Nissim-Rafinia M, Wiesel-Motiuk N, Bar DZ, Barkan R, Meshorer E, Gruenbaum Y (2009) Nuclear lamins: key regulators of nuclear structure and activities. *J Cell Mol Med* 13(6):1059-85

- Randles KN, Lam le T, Sewry CA, Puckelwartz M, Furling D, Wehnert M, McNally EM, Morris GE (2010) Nesprins, but not sun proteins, switch isoforms at the nuclear envelope during muscle development. *Dev Dyn* 239(3):998-1009
- Raices M, D'Angelo MA (2012) Nuclear pore complex composition: a new regulator of tissue-specific and developmental functions. *Nat Rev Mol Cell Biol* 13(11):687-99
- Rajgor D, Mellad JA, Autore F, Zhang Q, Shanahan CM (2012) Multiple novel nesprin-1 and nesprin-2 variants act as versatile tissue-specific intracellular scaffolds. *PLoS One* 7(7):e40098
- Rashmi RN, Eckes B, Glöckner G, Groth M, Neumann S, Gloy J, Sellin L, Walz G, Schneider M, Karakesisoglou I, Eichinger L, Noegel AA (2012) The nuclear envelope protein Nesprin-2 has roles in cell proliferation and differentiation during wound healing. *Nucleus* 3(2):172-86
- Razafsky D, Hodzic D (2009) Bringing KASH under the SUN: the many faces of nucleocytoplasmic connections. *J Cell Biol* 186(4):461-72
- Rivero F, Kuspa A, Brokamp R, Matzner M, Noegel AA (1998) Interaptin, an actin-binding protein of the alpha-actinin superfamily in *Dictyostelium discoideum*, is developmentally and cAMP-regulated and associates with intracellular membrane compartments. *J Cell Biol* 142(3):735-50
- Rothballer A, Schwartz TU, Kutay U (2013) LINCing complex functions at the nuclear envelope: what the molecular architecture of the LINC complex can reveal about its function. *Nucleus* 4(1):29-36
- Roux KJ, Crisp ML, Liu Q, Kim D, Kozlov S, Stewart CL, Burke B (2009) Nesprin 4 is an outer nuclear membrane protein that can induce kinesin-mediated cell polarization. *Proc Natl Acad Sci U S A* 106(7):2194-9
- Sakai H, Tsukihara T (1998) Structures of membrane proteins determined at atomic resolution. *J Biochem* 124(6):1051-9
- Schirmer EC, Gerace L (2002) Organellar proteomics: the prizes and pitfalls of opening the nuclear envelope. *Genome Biol* 3(4):REVIEWS1008
- Scholey AB, Bullock S, Rose SP (1992) Passive avoidance learning in the young chick results in time- and locus-specific elevations of alpha-tubulin immunoreactivity. *Neurochem Int* 21(3):343-50
- Shao X, Tarnasky HA, Lee JP, Oko R, van der Hoorn FA (1999) Spag4, a novel sperm protein, binds outer dense-fiber protein Odf1 and localizes to microtubules of manchette and axoneme. *Dev Biol* 211(1):109-23
- Simon DN, Wilson KL (2013) Partners and post-translational modifications of nuclear lamins. *Chromosoma* 122(1-2):13-31

- Starr DA (2012) Laminopathies: too much SUN is a bad thing. *Curr Biol* 22(17):R678-80
- Starr DA, Han M (2002) Role of ANC-1 in tethering nuclei to the actin cytoskeleton. *Science* 298(5592):406-9
- Starr DA, Fischer JA (2005) KASH 'n Karry: the KASH domain family of cargo-specific cytoskeletal adaptor proteins. *Bioessays* 27(11):1136-46
- Starr DA, Fridolfsson HN (2010) Interactions between nuclei and the cytoskeleton are mediated by SUN-KASH nuclear-envelope bridges. *Annu Rev Cell Dev Biol* 26:421-44
- Stierlé V, Couprie J, Ostlund C, Krimm I, Zinn-Justin S, Hossenlopp P, Worman HJ, Courvalin JC, Duband-Goulet I (2003) The carboxyl-terminal region common to lamins A and C contains a DNA binding domain. *Biochemistry* 42:4819-28
- Stuurman N, Heins S, Aebi U (1998) Nuclear lamins: their structure, assembly, and interactions. *J Struct Biol* 122(1-2):42-66
- Strambio-De-Castillia C, Niepel M, Rout MP (2010) The nuclear pore complex: bridging nuclear transport and gene regulation. *Nat Rev Mol Cell Biol* 11(7):490-501
- Sylvius N, Hathaway A, Boudreau E, Gupta P, Labib S, Bolongo PM, Rippstein P, McBride H, Bilinska ZT, Tesson F (2008) Specific contribution of lamin A and lamin C in the development of laminopathies. *Exp Cell Res* 314:2362-75
- Taniura H, Glass C, Gerace L (1995) A chromatin binding site in the tail domain of nuclear lamins that interacts with core histones. *J Cell Biol* 131:33-44
- Taranum S, Sur I, Müller R, Lu W, Rashmi RN, Munck M, Neumann S, Karakesisoglou I, Noegel AA (2012) Cytoskeletal interactions at the nuclear envelope mediated by nesprins. *Int J Cell Biol* 2012:736524
- Taranum S, Vaylann E, Meinke P, Abraham S, Yang L, Neumann S, Karakesisoglou I, Wehnert M, Noegel AA (2012) LINC complex alterations in DMD and EDMD/CMT fibroblasts. *Eur J Cell Biol* 91(8):614-28
- Tilgner K, Wojciechowicz K, Jahoda C, Hutchison C, Markiewicz E (2009) Dynamic complexes of A-type lamins and emerin influence adipogenic capacity of the cell via nucleocytoplasmic distribution of beta-catenin. *J Cell Sci* 122(Pt 3):401-13
- Vergnes L, Péterfy M, Bergo MO, Young SG, Reue K (2004) Lamin B1 is required for mouse development and nuclear integrity. *Proc Natl Acad Sci U S A* 101(28):10428-33
- Vohanka S, Vytopil M, Bednarik J, Lukas Z, Kadanka Z, Schildberger J, Ricotti R, Bione S, Toniolo D (2001) A mutation in the X-linked Emery-Dreifuss muscular dystrophy gene in a patient affected with conduction cardiomyopathy. *Neuromuscul Disord* 11(4):411-3

Vytopil M, Ricci E, Dello Russo A, Hanisch F, Neudecker S, Zierz S, Ricotti R, Demay L, Richard P, Wehnert M, Bonne G, Merlini L, Toniolo D (2002) Frequent low penetrance mutations in the Lamin A/C gene, causing Emery Dreifuss muscular dystrophy. *Neuromuscul Disord* 12(10):958-63

Wang X, Briggs MR, Hua X, Yokoyama C, Goldstein JL, Brown MS (1993) Nuclear protein that binds sterol regulatory element of low density lipoprotein receptor promoter. II. Purification and characterization. *J Biol Chem* 268(19):14497-504

Wang X, Sato R, Brown MS, Hua X, Goldstein JL (1994) SREBP-1, a membrane-bound transcription factor released by sterol-regulated proteolysis. *Cell* 77:53-62

Wang Z, Eickholt J, Cheng J (2010) MULTICOM: a multi-level combination approach to protein structure prediction and its assessments in CASP8. *Bioinformatics* 26:882-8

Warren DT, Tajsic T, Mellad JA, Searles R, Zhang Q, Shanahan CM (2010) Novel nuclear nesprin-2 variants tether active extracellular signal-regulated MAPK1 and MAPK2 at promyelocytic leukemia protein nuclear bodies and act to regulate smooth muscle cell proliferation. *J Biol Chem* 285(2):1311-20

Watson ML (1955) The nuclear envelope; its structure and relation to cytoplasmic membranes. *J Biophys Biochem Cytol* 1(3):257-70

Wessely R, Seidl S, Schömig A (2005) Cardiac involvement in Emery-Dreifuss muscular dystrophy. *Clin Genet* 67(3):220-3

Wilhelmsen K, Litjens SH, Kuikman I, Tshimbalanga N, Janssen H, van den Bout I, Raymond K, Sonnenberg A (2005) Nesprin-3, a novel outer nuclear membrane protein, associates with the cytoskeletal linker protein plectin. *J Cell Biol* 171(5):799-810

Williams C, Hoppe HJ, Rezgui D, Strickland M, Forbes BE, Grutzner F, Frago S, Ellis RZ, Wattana-Amorn P, Prince SN, Zaccheo OJ, Nolan CM, Mungall AJ, Jones EY, Crump MP, Hassan AB (2012) An exon splice enhancer primes IGF2:IGF2R binding site structure and function evolution. *Science* 338:1209-13.

Wilson KL, Foisner R (2010) Lamin-binding Proteins. *Cold Spring Harb Perspect Biol* 2(4):a000554

Worman HJ (2012) Nuclear lamins and laminopathies. *J Pathol* 226(2):316-25

Worman HJ, Bonne G (2007) "Laminopathies": a wide spectrum of human diseases. *Exp Cell Res* 313(10):2121-33

Worman HJ, Östlund C, Wang Y (2010) Diseases of the nuclear envelope. *Cold Spring Harb Perspect Biol* 2(2):a000760

- Tzur YB, Wilson KL, Gruenbaum Y (2006) SUN-domain proteins: 'Velcro' that links the nucleoskeleton to the cytoskeleton. *Nat Rev Mol Cell Biol* 7(10):782-8
- Yu J, Lei K, Zhou M, Craft CM, Xu G, Xu T, Zhuang Y, Xu R, Han M (2011) KASH protein Syne-2/Nesprin-2 and SUN proteins SUN1/2 mediate nuclear migration during mammalian retinal development. *Hum Mol Genet* 20(6):1061-73
- Yu J, Starr DA, Wu X, Parkhurst SM, Zhuang Y, Xu T, Xu R, Han M (2006) The KASH domain protein MSP-300 plays an essential role in nuclear anchoring during *Drosophila* oogenesis. *Dev Biol* 289: 336-45
- Zhang J, Felder A, Liu Y, Guo LT, Lange S, Dalton ND, Gu Y, Peterson KL, Mizisin AP, Shelton GD, Lieber RL, Chen J (2010) Nesprin 1 is critical for nuclear positioning and anchorage. *Hum Mol Genet* 19(2):329-41
- Zhang Q, Bethmann C, Worth NF, Davies JD, Wasner C, Feuer A, Ragnauth CD, Yi Q, Mellad JA, Warren DT, Wheeler MA, Ellis JA, Skepper JN, Vorgerd M, Schlotter-Weigel B, Weissberg PL, Roberts RG, Wehnert M, Shanahan CM (2007) Nesprin-1 and -2 are involved in the pathogenesis of Emery Dreifuss muscular dystrophy and are critical for nuclear envelope integrity. *Hum Mol Genet* 16(23):2816-33
- Zhang Q, Skepper JN, Yang F, Davies JD, Hegyi L, Roberts RG, Weissberg PL, Ellis JA, Shanahan CM (2001) Nesprins: a novel family of spectrin-repeat-containing proteins that localize to the nuclear membrane in multiple tissues. *J Cell Sci* 114(Pt 24):4485-98
- Zhang X, Lei K, Yuan X, Wu X, Zhuang Y, Xu T, Xu R, Han M (2009) SUN1/2 and Syne/Nesprin-1/2 complexes connect centrosome to the nucleus during neurogenesis and neuronal migration in mice. *Neuron* 64(2):173-87
- Zhen YY, Libotte T, Munck M, Noegel AA and Korenbaum E (2002) NUANCE, a giant protein connecting the nucleus and actin cytoskeleton. *J Cell Sci* 115(Pt 15):3207-22

Appendix

Abbreviations

aa	Amino acid
ABD	Actin-binding domains
CH	Calponin homology
CMT	Charcot-Marie-Tooth syndrome
DAPI	4, 6-diamino-2-phenylindone
DMD	Duchenne muscular dystrophy
DMEM	Dulbecco`s modified Eagle medium
DMSO	Dimethylsulfoxide
DNA	Desoxyribonucleic acid
DTT	DL-Dithiothreitol
ECL	Enhanced chemiluminescence
EDMD	Emery-Dreifuss muscular dystrophy
EDTA	Ethylenediaminetetraacetic acid
ER	Endoplasmic reticulum
ERK1/2	Extracellular signal-regulated kinases 1/2
FPLD	Familial partial lipodystrophy
GAPDH	Glycerinaldehydphosphate dehydrogenase
GFP	Green fluorescent protein
GST	Glutathione S-transferase
h	Hour (s)
HGPS	Hutchinson-Gilford progeria syndrome
IgG	Immunglobulin
INM	Inner nuclear membrane
IPTG	Isopropyl- β -Dthiogalactopyranoside

KASH	Klarsicht, ANC1 and SYNE1 homology
kb	Kilobases
kDa	kilodalton
KO	Knockout
LA	Lamin A
LAP	Lamina-associated polypeptide
LINC	Linker of nucleoskeleton to the cytoskeleton
min	Minute (s)
NE	Nuclear envelope
Nesprins	Nuclear envelope spectrin repeat proteins
NPC	Nuclear pore complexes
NLS	Nuclear localization signal
Nups	Nucleoporins
NT	N-terminal
OD	Optical density
ONM	Outer nuclear membrane
o/n	Overnight
P	Pellet
PBS	Phosphate buffered saline
PDB	Protein data bank
PFA	Paraformaldehyde
PMSF	Phenylmethanesulfonyl fluoride
PNS	Perinuclear space
POD	Horseradish-peroxidase
sec	Second (s)
SDS-PAGE	Sodium dodecyl sulfate polyacrylamide gels
SPN	Supernatant
SR	Spectrin repeats

SREBP1	Sterol regulatory element-binding protein 1
SUN	Sad1 and UNC84 homology
Taq	Thermophilus aquaticus
TBS	Tris buffered saline
WB	Western blot
WT	Wild type

Amino acid code

A	Ala	Alanine	M	Met	Methionine
C	Cys	Cysteine	N	Asn	Asparagine
D	Asp	Aspartic acid	P	Pro	Proline
E	Glu	Glutamic acid	Q	Gln	Glutamine
F	Phe	Phenylalanine	R	Arg	Arginine
G	Gly	Glycine	S	Ser	Serine
H	His	Histidine	T	Thr	Threonine
I	Ile	Isoleucine	V	Val	Valine
K	Lys	Lysine	W	Trp	Tryptophane
L	Leu	Leucine	Y	Tyr	Tyrosine

Acknowledgement

First, I would like to express my heartiest gratitude to Prof. Dr. Noegel for giving me an opportunity to work under her supervision. Her positive attitude, constant encouragement and sustained interest in my project proved essential for my PhD work.

I convey my sincere heartfelt gratitude to Dr. Sascha Nuemann, our group leader, for providing valuable guidance, excellent advice with my work. His constant encouragement and immense optimism are highly acknowledged. It was a privilege to work with him.

Special thanks to Martina who helped me a lot in the beginning with the laboratory techniques. I would forward my thanks to her for being so nice. Thanks to Rolf, Maria, Rosi and Berthold for being really friendly and cooperative. Special thanks to Budi and Gudrun for rendering help with the computer problems.

I also owe my thanks to all my dear colleagues in lab 10. Thanks to Sandra and Xin for their valuable friendship and making my stay in the lab extremely wonderful. Thanks also to my ex lab members Linlin, Martin for their encouragement and help. I would also like to thank all the nice persons in biochemistry for being so kind, friendly and helpful.

I would like to thank all the people who directly or indirectly helped me in the completion of my PhD project and my life in cologne, I like this beautiful city.

Specially, I owe my acknowledgement to China Scholarship Council for offering me the fellowship to my PhD study here.

Finally, I would like to dedicate all of this to my family.

Erklärung

Ich versichere, dass ich die von mir vorgelegte Dissertation selbständig angefertigt, die benutzten Quellen und Hilfsmittel vollständig angegeben und die Stellen der Arbeit einschließlich Tabellen und Abbildungen-, die anderen Werke im Wortlaut oder dem Sinn nach entnommen sind, in jedem Einzelfall als Entlehnung kenntlich gemacht habe; dass diese Dissertation noch keiner anderen Fakultät oder Universität zur Prüfung vorgelegen hat; dass sie- abgesehen von unten angegebenen beantragten Teilpublikationen- noch nicht veröffentlicht ist, sowie, dass ich eine Veröffentlichung vor Abschluss des Promotionsverfahrens nicht vornehmen werde. Die Bestimmungen dieser Promotionsordnung sind mir bekannt. Die von mir vorgelegte Dissertation ist von Frau Prof. Dr. Angelika A. Noegel betreut worden.

Köln den

Liu Yang

Teilpublicationen:

1, Yang L, Munck M, Swaminathan K, Karakesisoglou I, Neumann S, Noegel AA (2013).

Mutations in LMNA modulate the Lamin A - Nesprin-2 interaction and cause LINC complex alterations. Plos One. Accepted

2, Taranum S, Vaylann E, Meinke P, Abraham S, Yang L, Neumann S, Karakesisoglou I,

Wehnert M, Noegel AA (2012) LINC complex alterations in DMD and EDMD/CMT fibroblasts.

Euro J Cell Biol 91:614-28

Curriculum Vitae

Name: Liu Yang
Date of Birth: Oct.16.1983
Place of Birth: Henan, P. R. China
Nationality: Chinese

University studies

2003.09-2007.07 Bachelor of Science (Biotechnology),
Henan Normal University, Xin Xiang, P.R. China
2007.09-2009.07 Master of Science (Biochemistry and Molecular Biology),
Jilin University, Chang Chun, P.R. China

Doctoral studies

2009.10- Faculty of Mathematics and Natural Science
University of Cologne
Supervisor: Prof. Dr. Angelika A. Noegel
Group leader: Dr. Sascha Neumann
Institute for Biochemistry I, Medical Faculty
University of Cologne, Cologne, Germany

Lebenslauf

Name: Liu Yang
Geburtsdatum: 16.10.1983
Geburtsort: Henan, V.R. China
Nationalität: Chinesisch

Universitätsstudium

Sep 2003-Jul 2007 Bachelor of Science (Biotechnologie),
Henan Normal University, Xinxiang, V.R. China
Sep 2007-Jul 2009 Master of Science (Biochemie und Molekularbiologie),
Jilin University, Chang Chun, V.R. China

Promotionsstudium

Okt 2009-
Mathematisch-Naturwissenschaftliche Fakultät
Universität zu Köln
Betreuerin: Prof. Dr. Angelika A. Noegel
Gruppenleiter: Dr. Sascha Neumann
Institut Für Biochemie I, Medizinische Fakultät
Universität zu Köln, Köln, Deutschland