

Service Manual

HP Designjet
Ultra Low End
Printers



For HP Internal Use Only

©Copyright Hewlett-Packard Company 2006

This document contains proprietary information that is protected by copyright. All rights are reserved. No part of this document may be photocopied, reproduced, or translated to another language without the prior written consent of Hewlett-Packard Company.

First Edition, March 2006

Warranty

The information contained in this document is subject to change without notice.

Hewlett-Packard makes no warranty of any kind with regard to this material, including, but not limited to, the implied warranties of merchantability and fitness for a particular purpose.

Hewlett-Packard shall not be liable for errors contained herein or for incidental or consequential damages in connection with the furnishing, performance, or use of this material.

WARNING

The procedures described in this manual are to be performed by HP-qualified service personnel only.

Electrical Shock Hazard

Serious shock hazard leading to death or injury may result if you do not take the following precautions:

- Ensure that the ac power outlet (mains) has a protective earth (ground) terminal.
- Disconnect the Printer from the power source prior to performing any maintenance.
- Prevent water or any other liquids from running onto electrical components or circuits, or through openings in the enclosure.

Electrostatic Discharge

Refer to the beginning of Chapter 4 of this manual, for precautions you should take to prevent damage to the Printer circuits from electrostatic discharge.

Safety Symbols

General definitions of safety symbols are given immediately after the table of contents.

WARNING

The Warning symbol calls attention to a procedure, practice, or the like, which, if not correctly performed or adhered to, could result in personal injury. Do not proceed beyond a Warning symbol until the indicated conditions are fully understood and met.

CAUTION

The Caution symbol calls attention to an operating procedure, practice, or the like, which, if not correctly performed or adhered to, could result in damage to or destruction of part or all of the product. Do not proceed beyond a Caution symbol until the indicated conditions are fully understood and met.

Content Management Department,
Barcelona Division,
Hewlett-Packard Espanola, S.A.
Avda. Graells, 501
08190 Sant Cugat del Valles
Spain



Service Manual

HP Designjet
Ultra Low End
Printers

Using this Manual

Purpose

This Service Manual contains information necessary to test, calibrate and service:

- HP Designjet 10ps Printer (Model C7790A)
- HP Designjet 20ps Printer (Model C7790B)
- HP Designjet 30 Printer (Model C7790D)
- HP Designjet 30n Printer (Model C7790E)
- HP Designjet 50ps Printer (Model C7790C)
- HP Designjet 70 Printer (Model Q6655A)
- HP Designjet 90 Printer (Model Q6656A)
- HP Designjet 90r Printer (Model Q6656B)
- HP Designjet 100 Printer (Model C7796A)
- HP Designjet 100+ Printer (Model C7796C)
- HP Designjet 110 Printer (Model C7796B)
- HP designjet 110+ Printer (Model C7796D)
- HP Designjet 110+nr Printer (Model C7796E)
- HP designjet 120 Printer (Model C7791A)
- HP Designjet 120nr Printer (Model C7791B)
- HP Designjet 130 Printer (Model C7791C)
- HP Designjet 130nr Printer (Model C7791D)

For information about using these printers, refer to the corresponding User and Quick Reference Guides.

Readership

The procedures described in this Service Manual are to be performed by HP Certified service personnel only.

Part Numbers

Part Numbers for Printer options, accessories and service parts are located in Chapter 7.

Conventions

A small arrow \Rightarrow is used to indicate other parts of the Service Manual where you can find information related to the topic you are consulting.

Table of Contents

Test Prints *1-1*

System Error Codes *2-1*

System Maintenance Utility *3-1*

Utilities *4-1*

Calibrations *5-1*

Parts and Diagrams *6-1*

Removal and Installation *7-1*

Maintenance *8-1*

--	--



Test Prints

7

Usage Report Page 1-2
Information Page 1-3
NVM Contents Page 1-5

Usage Report Page

The Usage Report Page contains the following information:

- Printer Model Name.
- Printer Model Number.
- Printer Serial Number.
- Date of last print job received.
- Total ink consumed.
- Date of first print job received.
- Number of pages printer (media size/media type/print quality setting).

To print the Usage Report Page, hold the power button down and press the resume button **once**.

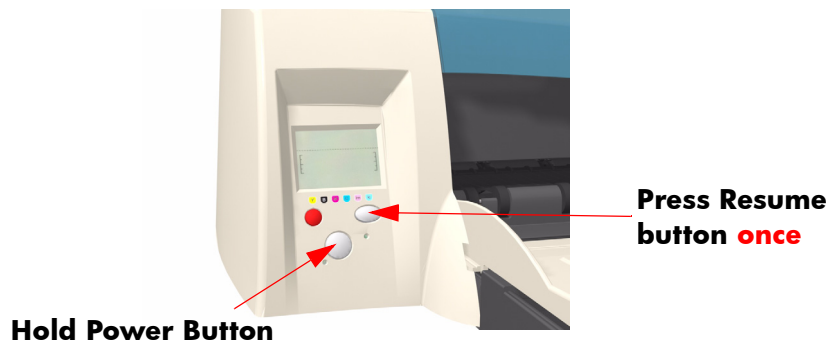

Sample of the Usage Report Page

USAGE REPORT PAGE			
Printer model name=hp designjet 16ps			
Printer model number=C7798A			
Printer serial number=SG7CU172MC00			
Date: UNKNOWN			
Total Ink Consumed: K=0 cc C=0 cc M=0 cc Y=0 cc LC=0 cc LM=0 cc			
Born-on Date: 7-25-2002			
Pages Printed			
	Draft	Normal	Best/SuperBest
A4/A			
Bond:	10	0	0
Plain:	0	10	0
Transparency:	0	0	0
Coated:	0	0	0
HeavyWeight:	0	0	0
Glossy Photo:	0	0	0
Glossy Paper:	0	0	0
Brochure:	0	0	0
Proofing 1:	0	0	0
Proofing 2:	0	0	0
Others:	20	3	0
A3/B/B+			
Bond:	0	0	0
Plain:	0	0	0
Transparency:	0	0	0
Coated:	0	0	0
HeavyWeight:	0	0	0
Glossy Photo:	0	0	0
Glossy Paper:	0	0	0
Brochure:	0	0	0
Proofing 1:	0	0	0
Proofing 2:	0	0	0
Others:	0	0	0
Total Printer Jobs=51			

Information Page

The Information Page contains the following information:

- Printer Identification.
- Printer Status.
- Printer Usage.
- Ink Consumable Identification.
- Ink Consumables Status.
- Ink Consumables Usage.
- Network Card Information.

To print the Information Page, hold the power button down and press the resume button **4 times**.

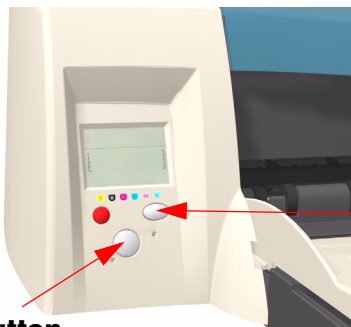

Hold Power Button

Press Resume button 4 times

Sample of the Information Page (page 1 of 3)

```

A INFORMATION PAGE A
Printer Identification Section
Printer model name=hp designjet 10ps
Printer model number=C7790A
Printer serial number=SG7CU1Z2MC00
Firmware release=alfa
Service Id=12235
Type Eeom=Flash
Tray2 Present=No
Duplexer Present=No
Num I/O cards present=1

Printer Status Section
Date: UNKNOWN
Printer Status=OK
Printer Latest Errors:
#0 Error Code: 7904 Filename: intheadsPhys.c Line: 114 Date: 5-17-2001 Page Count: 1151
#1 Error Code: 7904 Filename: MechCommand.c Line: 2081 Date: 5-17-2001 Page Count: 1151
#2 Error Code: 7904 Filename: intheadsPhys.c Line: 114 Date: 5-17-2001 Page Count: 147
#3 Error Code: 7904 Filename: MechCommand.c Line: 2081 Date: 5-17-2001 Page Count: 147
#4 Error Code: 7904 Filename: intheadsPhys.c Line: 114 Date: 5-17-2001 Page Count: 146
#5 Error Code: 7904 Filename: MechCommand.c Line: 2081 Date: 5-17-2001 Page Count: 146
#6 Error Code: 7904 Filename: ppm/RedSP/PPM.c Line: 372 Date: UNKNOWN Page Count: 180
#7 Error Code: 7904 Filename: ventMonitor.c Line: 192 Date: UNKNOWN Page Count: 101
#8 Error Code: 7904 Filename: redSP/RedSP.c Line: 4422 Date: 7-25-2002 Page Count: 79
#9 Error Code: 7904 Filename: ventMonitor.c Line: 192 Date: UNKNOWN Page Count: 56
Printer Latest Warnings: NOT IMPLEMENTED
Printhead Alignment=Yes
Latest Print jobs:
#0 "INFORMATION PAGE" PMode: plain_normal
#1 "INFOR PAGE 2" PMode: plain_normal
#2 "INFORMATION PAGE" PMode: plain_normal
#3 "todoblack.jpg" PMode: plain_best
#4 "todocyan.jpg" PMode: plain_best
#5 "USAGE REPORT" PMode: plain_normal
#6 "PAGENUM 6" PMode: plain_normal
#7 "PAGENUM 5" PMode: plain_normal
#8 "PAGENUM 4" PMode: plain_normal
#9 "PAGENUM 3" PMode: plain_normal

Printer Usage Section
Total Ink Consumed: K=0 cc C=0 cc M=0 cc Y=0 cc LC=0 cc LM=0 cc
Printheads used by color: K=1 C=1 M=1 Y=1 LC=1 LM=1
Total Page Count=187
Scan Axis Usage: 0% Paper Axis Usage: 0% Service Station Usage: 0%
Carriage Usage: 0% Tube Usage: 0%

```

Sample of the Information Page (page 2 of 3)

```

Ink Consumable Identification Section
-----
Printhead Information
Model Name: K=HP No. 84 C=HP No. 11 M=HP No. 11 V=HP No. 11 LC=HP No. 84 LM=HP No. 84
Serial Number: K=01-01-0543769 C=01-01-0533852 M=01-01-0732532
V=01-01-0534348 LC=01-01-0767223 LM=01-01-0787389
Out of Warranty Date: K=7-15-2002 C=7-15-2002 M=7-22-2002 V=7-15-2002 LC=7-1-2002 LM=7-1-2002

Cartridge Information
Model Name: K=HP No. 84 C=HP No. 11 M=HP No. 11 V=HP No. 82 LC=HP No. 84 LM=HP No. 84
Serial Number: K=04-02-9432848 C=04-02-2815341 M=04-02-1252464
V=06-01-1374270 LC=04-02-2264597 LM=04-02-2337128
Expiration Date: K=UNKNOWN C=UNKNOWN M=UNKNOWN V=UNKNOWN LC=UNKNOWN LM=UNKNOWN

Ink Consumable Status Section
-----
Printhead Status: K=Inserted - 8888 C=Inserted - 8888 M=Inserted - 8888
V=Inserted - 8888 LC=Inserted - 8888 LM=Inserted - 8888
Scan Axis Shutdown: K=Yes C=Yes M=Yes V=Yes LC=Yes LM=Yes
Cartridge Status: K=Inserted - 9999 C=Inserted - 9999 M=Inserted - 9999
V=Inserted - 9999 LC=Inserted - 9999 LM=Inserted - 9999

Ink Consumable Usage Section
-----
Ink Consumed Printhead: K: 11 cc (2 %) C: 4 cc (2 %) M: 3 cc (1 %)
V: 5 cc (2 %) LC: 5 cc (2 %) LM: 4 cc (2 %)
Usage Time Printhead: K=0 days C=0 days M=0 days V=0 days LC=0 days LM=0 days
Ink Consumed Cartridge: K: 19 cc (26 %) C: 12 cc (41 %) M: 12 cc (41 %)
V: 12 cc (16 %) LC: 8 cc (11 %) LM: 9 cc (12 %)

Printhead history:
K: #1 - Inserted - 10 cc (1%) - 0 days - Max. Recovery Level 0
C: #1 - Inserted - 4 cc (2%) - 0 days - Max. Recovery Level 0
M: #1 - Inserted - 3 cc (1%) - 0 days - Max. Recovery Level 0
V: #1 - Inserted - 4 cc (2%) - 0 days - Max. Recovery Level 0
LC: #1 - Inserted - 5 cc (2%) - 0 days - Max. Recovery Level 0
LM: #1 - Inserted - 4 cc (2%) - 0 days - Max. Recovery Level 0
    
```

Sample of the Information Page (page 3 of 3)

```

I/O Section
-----
HP JetDirect Configuration
Status: I/O Card Ready Port Config: 10BASE-T HALF
Auto Negotiation: On
Manufacturing ID: 40444041902007
Date Manufactured: 11/2000
SNMP Set Cnty Name: Not Specified

Network Statistics
Total Packets Received: 6387 Total Packets Transmitted: 381
Unicast Packets Received: 385
Bad Packets Received: 0
Framing Errors Received: 0
Transmit Collisions: 32
Transmit Late Collisions: 0

Protocol Information
----- TCP/IP -----
Status: Ready
Host Name: eiffel043
IP Address: 15.190.10.86
Subnet Mask: 255.255.240.0
Default Gateway: 15.190.0.1
Config By: 800TP
BOOTP Server: 15.190.4.222
TFTP Server: Not Specified
Config File: Not Specified

Domain Name: Not Specified
DNS Server: Not Specified
WINS Server: Not Specified
Syslog Server: Not Specified
Idle Timeout: 270 sec
SLP: Enabled
Access List: Not Specified
Web JetAdmin URL: Not Specified

----- Novell/NetWare -----
Status: 16
Node Name: NPI280C30
Netware Mode: Queue Server
NDS Tree Name:
NDS Context:

Attached Server:
Queue Poll Interval: 2 sec
SAP Interval: 60 sec

----- IPX/SPX -----
Status: Ready
Primary Frame Type: Auto Select
Network Frame Type: Rcvd
Unknown EN.II: 21
00000001 EN.802.2: 1249

----- AppleTalk -----
Status: Ready
Name: hp designjet 10ps4
Zone: ICD-R&D
Type 1: LaserWriter
Type 2: DeskWriter
Network Number: 1500
Node Number: 224

----- DLC/LLC -----
Status: Ready
    
```

NVM Contents Page

The NVM Contents Page contains the following information:

- EEROM values dump containing all the values stored in the EEROM (Calibration, etc.)
- Printheads Acumen dump
- Cartridges Acumen dump.

To print the NVM Contents Page, hold the power button down and press the cancel button **once** and the resume button **twice**.

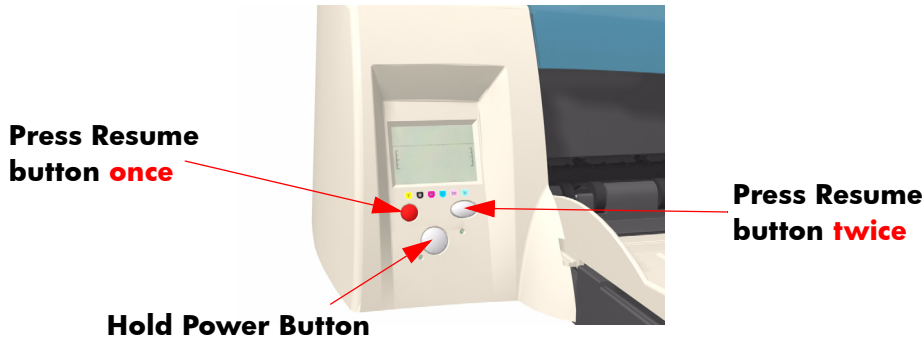

```

A                               NUM CONTENTS PAGE                               A
-----
NUM Dump 0 to 2K
Printer model name=hp designjet 10ps
Printer serial number=507CU129C00
Dates: 10/20/04
NUM Dump:
0000:00 00 00 ff 00 00 00 ff 00 00 00 ff 00 00 00 ff 00 00 00 ff 00 00 00 ff 00 00 00 ff
0020:00 00 00 ff 00 00 00 ff 00 00 00 ff 00 00 00 ff 00 00 00 ff 00 00 00 ff 00 00 00 ff
0040:7c ff 05 20 ff 00 00 00 00 00 00 00 00 00 00 00 00 00 00 00 00 00 00 00 00 00 00
0060:28 00 00 00 00 00 00 00 00 00 00 00 00 00 00 00 00 00 00 00 00 00 00 00 00
0080:10 00 00 00 00 00 00 00 00 00 00 00 00 00 00 00 00 00 00 00 00 00 00 00 00
00a0:00 00 00 00 00 00 00 00 00 00 00 00 00 00 00 00 00 00 00 00 00 00 00 00 00
00c0:00 00 00 00 00 00 00 00 00 00 00 00 00 00 00 00 00 00 00 00 00 00 00 00 00
00e0:10 00 00 00 00 00 00 00 00 00 00 00 00 00 00 00 00 00 00 00 00 00 00 00 00
0100:00 00 00 00 00 00 00 00 00 00 00 00 00 00 00 00 00 00 00 00 00 00 00 00 00
0120:00 00 00 00 00 00 00 00 00 00 00 00 00 00 00 00 00 00 00 00 00 00 00 00 00
0140:00 00 00 00 00 00 00 00 00 00 00 00 00 00 00 00 00 00 00 00 00 00 00 00 00
0160:00 00 00 00 00 00 00 00 00 00 00 00 00 00 00 00 00 00 00 00 00 00 00 00 00
0180:00 00 00 00 00 00 00 00 00 00 00 00 00 00 00 00 00 00 00 00 00 00 00 00 00
01a0:00 00 00 00 00 00 00 00 00 00 00 00 00 00 00 00 00 00 00 00 00 00 00 00 00
01c0:00 00 00 00 00 00 00 00 00 00 00 00 00 00 00 00 00 00 00 00 00 00 00 00 00
01e0:00 00 00 00 00 00 00 00 00 00 00 00 00 00 00 00 00 00 00 00 00 00 00 00 00
0200:00 00 00 00 00 00 00 00 00 00 00 00 00 00 00 00 00 00 00 00 00 00 00 00 00
0220:00 00 00 00 00 00 05 1b 00 05 05 18 00 00 00 00 00 00 00 00 00 00 00 00 00
0240:00 00 00 00 00 00 00 00 00 00 00 00 00 00 00 00 00 00 00 00 00 00 00 00 00
0260:00 00 00 00 00 00 00 00 00 00 00 00 00 00 00 00 00 00 00 00 00 00 00 00 00
0280:00 00 00 00 00 00 00 ff 03 70 26 04 05 73 03 07 0790:fa 5a 63 74 20 31 30 70 73 00 73 00 3e 20 93 da
02a0:4b a0 0c c3 00 a0 c3 11 ff 00 00 00 00 00 00 00 00 02:00 00 ff a0 00 00 00 00 00 00 00 4c fc 37 00 00
02c0:00 00 2a 06 fc 27 00 00 00 30 43 0f 70 70 72 0200:63 0f 00 ff 00 00 00 ff 00 00 00 ff 00 00 00
02e0:00 00 ff 00 00 00 00 ff 00 00 00 00 ff 00 00 00 00 00 00 00 00 00 00 00 00 00 00
0300:ff 00 00 00 00 ff a0 00 00 00 00 00 00 40 fc 0310:07 00 00 00 00 00 00 00 00 00 00 00 00 3e ff
0320:1b 00 00 10 1c ea 1e e1 d0 00 00 19 e6 1f e7 0330:ff a0 00 00 00 a0 a0 00 00 46 fc 37 00 00 00
0340:3a 48 fc 37 00 00 00 00 00 00 00 00 00 00 00 00 00 00 00 00 00 00 00 00 00 00 00
0360:00 00 00 3c 43 ff 31 33 20 31 22 21 37 21 20 20 00 00 00 00 00 00 00 00 00 00 00 00 00
0380:00 00 00 ff 00 70 00 ff 41 25 54 4f 00 00 00 00 00 00 00 00 00 00 00 00 00 00 00 00 00
03a0:00 00 00 ff 00 01 02 00 04 05 06 07 05 0a 00 00 00 00 00 00 00 00 00 00 00 00 00 00
03c0:01 23 44 54 0a ff 00 01 02 00 04 05 06 07 06 00 00 00 00 00 00 00 00 00 00 00 00 00
03e0:0c 13 1b 23 44 04 0a ff ff ff ff 04 ff 00 00 00 00 00 00 00 00 00 00 00 00 00 00 00 00
0400:00 ff 73 82 47 42 ff 53 57 4f 50 ff 73 52 47 42 0410:00 ff 00 00 ff 00 00 ff 00 00 00 00 00 00 00 00 00 00 00
0420:00 00 00 00 00 00 00 00 00 00 00 00 00 00 00 00 00 00 00 00 00 00 00 00 00 00
0440:50 00 00 00 00 00 00 00 00 00 00 00 00 00 00 00 00 00 00 00 00 00 00 00 00 00
0460:00 00 00 00 00 00 00 00 00 00 00 00 00 00 00 00 00 00 00 00 00 00 00 00 00 00
0480:00 00 00 00 00 43 0f 01 74 05 04 00 00 00 00 00 00 00 00 00 00 00 00 00 00 00
04a0:00 00 00 ff 00 00 00 00 ff 00 00 00 00 ff 00 00 00 00 00 00 00 00 00 00 00 00 00 00
04c0:ff 21 00 ff 00 00 00 5a ff 00 00 00 11 ff 00 00 00 00 00 00 00 00 00 00 00 00 00 00
04e0:14 c9 1f 00 c3 ff 00 00 ff 04 4b 4c 13 ff 04 00 00 00 00 00 00 00 00 00 00 00 00 00
0500:17 ff 04 4c 01 0d ff 10 04 00 05 ff 10 04 05 0d 0510:01 ff 00 00 00 00 00 00 00 00 00 00 00 00 00 00 00 00
0520:00 00 00 00 00 00 00 00 00 00 00 00 00 00 00 00 00 00 00 00 00 00 00 00 00 00
0540:00 3d ff 00 3d ff 00 3d ff 00 3d ff 00 3d ff 00 3d ff 00 3d ff 00 3d ff 00 3d ff 00 3d ff 00 3d ff 00 3d ff
0560:00 00 00 00 00 00 00 00 00 00 00 00 00 00 00 00 00 00 00 00 00 00 00 00 00 00
0580:00 00 00 00 00 00 00 00 00 00 00 00 00 00 00 00 00 00 00 00 00 00 00 00 00 00
05a0:04 4b 25 2e 00 00 02 00 03 00 00 0d e4 01 ff 05b0:00 00 00 00 00 00 00 00 00 00 00 00 00 00 00 00 00 00 00
05c0:00 00 00 00 00 00 00 00 00 00 00 00 00 00 00 00 00 00 00 00 00 00 00 00 00 00
05e0:00 00 00 00 00 00 00 00 00 00 00 00 00 00 00 00 00 00 00 00 00 00 00 00 00 00
0600:00 00 00 00 00 00 00 00 00 00 00 00 00 00 00 00 00 00 00 00 00 00 00 00 00 00
0620:00 00 00 00 00 00 00 00 00 00 00 00 00 00 00 00 00 00 00 00 00 00 00 00 00 00
0640:00 00 00 00 00 00 00 00 00 00 00 00 00 00 00 00 00 00 00 00 00 00 00 00 00 00
0660:04 4b 25 2e 00 00 02 00 03 00 00 0d e4 01 ff 0670:00 00 00 00 00 00 00 00 00 00 00 00 00 00 00 00 00 00 00
0680:00 00 00 00 00 00 00 00 00 00 00 00 00 00 00 00 00 00 00 00 00 00 00 00 00 00
06a0:00 00 00 00 00 00 00 00 00 00 00 00 00 00 00 00 00 00 00 00 00 00 00 00 00 00
06c0:00 00 00 00 00 00 00 00 00 00 00 00 00 00 00 00 00 00 00 00 00 00 00 00 00 00
06e0:00 00 00 00 00 00 00 00 00 00 00 00 00 00 00 00 00 00 00 00 00 00 00 00 00 00
0700:00 00 00 00 00 00 00 00 00 00 00 00 00 00 00 00 00 00 00 00 00 00 00 00 00 00
0720:00 00 00 00 00 00 00 00 00 00 00 00 00 00 00 00 00 00 00 00 00 00 00 00 00 00
0740:00 00 00 00 00 00 00 00 00 00 00 00 00 00 00 00 00 00 00 00 00 00 00 00 00 00
0760:00 00 00 00 00 00 00 00 00 00 00 00 00 00 00 00 00 00 00 00 00 00 00 00 00 00
0780:00 00 00 00 00 00 00 00 00 00 00 00 00 00 00 00 00 00 00 00 00 00 00 00 00 00
07a0:00 00 00 00 00 00 00 00 00 00 00 00 00 00 00 00 00 00 00 00 00 00 00 00 00 00
07c0:00 00 00 00 00 00 00 00 00 00 00 00 00 00 00 00 00 00 00 00 00 00 00 00 00 00
07e0:00 00 00 00 00 00 00 00 00 00 00 00 00 00 00 00 00 00 00 00 00 00 00 00 00 00

```

Sample of the NVM Contents Page (page 1 of 3)

**Sample of the
NVM Contents Page
(page 2 of 3)**

```

Printheads Acumen Dump

Ph Acumen K:
00: 0c 10 42 34 2b 00 00 20 4e 00 00 00 00 00 00
10: 0b ff c3 2a 15 21 30 64 44 21 66 8f a5 19 28 7b
20: 04 73 76 36 70 00 00 00 1d 00 03 b3 00 fe 27 00
30: 0d 00 00 00 00 00 6d 53 46 a1 30 40 7c 19 00 00
40: ca 00 c6 ff 00 00 00

Ph Acumen C:
00: 09 11 02 34 2b 00 00 20 4e 00 00 00 00 00 00
10: 0b ff c3 2a 15 20 35 70 44 21 66 81 e3 96 28 7b
20: 04 73 76 23 76 00 00 00 1d 00 03 b3 00 fe 27 00
30: 0b 00 00 00 00 00 6d 52 66 a1 30 40 7c 19 cf 38
40: ca 00 1b ff 00 00 00

Ph Acumen M:
00: 0a 12 02 34 2b 00 00 20 4e 00 00 00 00 00 00
10: 0b ff c4 2a 15 2c b5 00 44 21 66 94 e6 96 28 7b
20: 04 73 76 03 76 00 00 00 1d 00 03 b3 00 fe 27 00
30: 2d 00 00 00 00 00 6d 52 86 a1 30 40 7c 19 cf 38
40: ca 00 f6 ff 00 00 00

Ph Acumen V:
00: 0b 13 02 34 2b 00 00 20 4e 00 00 00 00 00 00
10: 0b ff c1 2a 15 30 0c b4 44 21 66 7a a4 96 28 7b
20: 04 73 76 03 76 00 00 00 1d 00 03 b3 00 fe 27 00
30: 46 00 00 00 00 00 6d 52 e6 a1 30 40 7c 19 cf 38
40: ca 00 32 ff 00 00 00

Ph Acumen LC:
00: 0d 11 22 34 2b 00 00 20 4e 00 00 00 00 00 00
10: 0b ff c1 2a 15 30 0c b4 44 21 66 7f e3 96 28 7b
20: 04 73 76 03 76 00 00 00 1d 00 03 b3 00 fe 27 00
30: 4d 00 00 00 00 00 6d 51 e6 a1 30 40 7c 19 00 00
40: ca 00 32 ff 00 00 00

Ph Acumen LM:
00: 0e 12 22 34 2b 00 00 20 4e 00 00 00 00 00 00
10: 0b ff c1 2a 15 30 0d b4 44 21 66 86 e6 96 28 7b
20: 04 73 76 06 76 00 00 00 1d 00 03 b3 00 fe 27 00
30: 47 00 00 00 00 00 6d 52 66 a1 30 40 7c 19 00 00
40: ca 00 ae ff 00 00 00
    
```

**Sample of the
NVM Contents Page
(page 3 of 3)**

```

Cartridges Acumen Dump

Cart Acumen K:
00: 00 00 42 34 2c 00 03 00 00 00 00 4f aa 5d 33
10: 97 2a 65 cc 0b ff c4 20 15 d1 83 21 09 c1 33 12
20: 14 34 39 00 00 00 00 26 00 61 40 00 00 00 1f
30: ff cb 03 00 09 b9 a0 43 2a 41 00 00 00 00 00
40: 00 00 be ff 00 00 00

Cart Acumen C:
00: 00 01 02 34 2c 00 07 00 00 00 00 4f aa 5d 33
10: 97 2a 65 cc 0b ff e8 20 15 ab d5 b3 08 81 33 07
20: 64 34 39 00 00 00 00 26 00 45 10 00 00 00 1f
30: ff c9 03 00 09 b5 a0 43 c8 1a 00 00 00 00 00
40: 00 00 3d ff 00 00 00

Cart Acumen M:
00: 0e 02 02 34 2c 00 07 00 00 00 00 4f aa 5d 33
10: 97 2a 65 cc 0b ff e9 20 15 4c 71 c1 08 81 33 07
20: 64 34 39 00 00 00 00 26 00 45 10 00 00 00 1f
30: ff cb 03 00 09 b9 a0 43 a2 f2 00 00 00 00 00
40: 00 00 ca ff 00 00 00

Cart Acumen V:
00: 0f 03 02 34 2c 00 01 00 00 00 00 4f aa 5d 33
10: 97 2a 65 cc 0b ff e8 20 15 53 e0 f9 84 81 33 12
20: 14 34 39 00 00 00 00 26 00 61 20 00 00 00 1f
30: ff cb 03 00 09 b9 a0 43 94 e4 00 00 00 00 00
40: 00 00 41 ff 00 00 00

Cart Acumen LC:
00: 09 01 22 34 2c 00 00 00 00 00 00 4f aa 5d 33
10: 97 2a 65 cc 0b ff c4 20 15 8a 39 55 09 c1 33 12
20: 14 34 39 00 00 00 00 26 00 61 40 00 00 00 1f
30: ff cb 03 00 09 b9 a0 43 e7 67 00 00 00 00 00
40: 00 00 4a ff 00 00 00

Cart Acumen LM:
00: 0a 02 22 34 2c 00 00 00 00 00 00 4f aa 5d 33
10: 97 2a 65 cc 0b ff c4 20 15 8e a5 81 09 c1 33 12
20: 14 34 39 00 00 00 00 26 00 61 40 00 00 00 1f
30: ff cb 03 00 09 b9 a0 43 fe e3 00 00 00 00 00
40: 00 00 07 ff 00 00 00
    
```



System Error Codes

2

System Error Codes 2-4
Warnings 2-11
Startup track mode 2-19
Emergency Firmware Upgrade 2-26
System Error Codes - Explanation 2-27

Introduction

The following pages contain a list of system error codes and their respective descriptions and recommended corrective actions. Only try one recommended action at a time and check if the error code has disappeared.

Since the front panel can only display graphics, the error code needs to be determined by counting the bars on the front panel (as shown below).

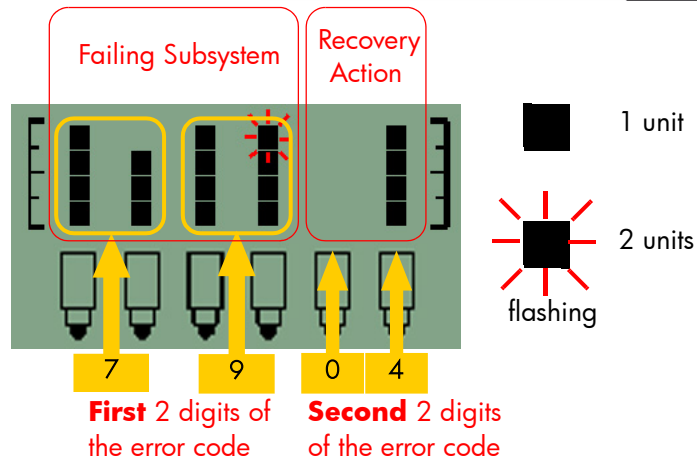
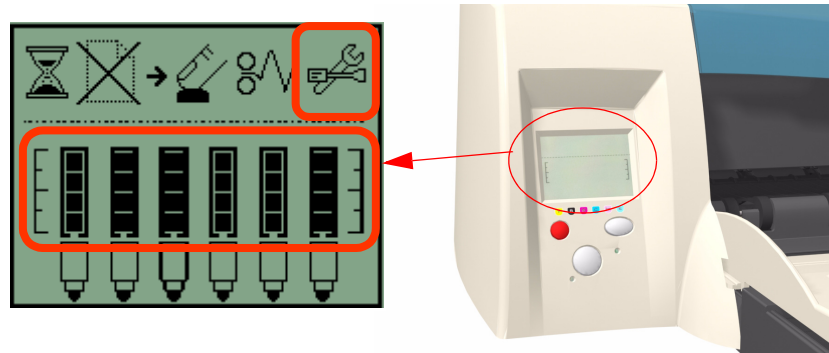

Refer to Page 2-27 for an explanation on the construction of the Error Codes and Warnings.

Errors and Warnings

Error Codes will normally be displayed directly on the front panel (but can also be seen on the Information Page) and will require some kind of intervention to resolve the problem. **Warnings** will **not** be displayed on the front panel, but will instead only appear on the Information Page, therefore allowing the user to continue operating the printer without the need of an intervention.

```
Printer Information Page
Printer Identification Section
Printer model number: 3600/3700/3800
Printer model number: C7700
Printer serial number: 01000000000000000000
Firmware revision: 01.00
Serial ID: 000000
Top deck path:
Tray 1 presence:
Tray 2 presence:
Max I/O cards supported:

Printer Status Section
Printer status: OK
Printer Latest Errors:
#0 Error Code: 8101 Filename: 1/PaperCtrl.c Line: 292 Date: 7-31-2001 Page Count: 93
#1 Error Code: 7904 Filename: ids.c Line: 542 Date: UNKNOWN Page Count: 88
#2 Error Code: 7904 Filename: MechCommand.c Line: 1161 Date: UNKNOWN Page Count: 79
#3 Error Code: 7904 Filename: MechCommand.c Line: 2494 Date: UNKNOWN Page Count: 79
#4 Error Code: 8101 Filename: 1/PaperCtrl.c Line: 292 Date: 7-31-2001 Page Count: 79
#5 Error Code: 8681 Filename: MechCommand.c Line: 655 Date: UNKNOWN Page Count: 75
#6 Error Code: 7904 Filename: StationCtrl.c Line: 399 Date: UNKNOWN Page Count: 75
#7 Error Code: 8101 Filename: 1/PaperCtrl.c Line: 292 Date: UNKNOWN Page Count: 75
#8 Error Code: 7904 Filename: alignment.c Line: 482 Date: UNKNOWN Page Count: 75
#9 Error Code: 0 Filename: Line: 0 Date: UNKNOWN Page Count: 0
Printer Latest Warnings:
#0 Warning Code: 0 Filename: gnmentUtils.c Line: 454 Date: UNKNOWN Page Count: 99
#1 Warning Code: 0 Filename: Line: 0 Date: UNKNOWN Page Count: 0
#2 Warning Code: 0 Filename: Line: 0 Date: UNKNOWN Page Count: 0
#3 Warning Code: 0 Filename: Line: 0 Date: UNKNOWN Page Count: 0
#4 Warning Code: 0 Filename: Line: 0 Date: UNKNOWN Page Count: 0
#5 Warning Code: 0 Filename: Line: 0 Date: UNKNOWN Page Count: 0
#6 Warning Code: 0 Filename: Line: 0 Date: UNKNOWN Page Count: 0
#7 Warning Code: 0 Filename: Line: 0 Date: UNKNOWN Page Count: 0
#8 Warning Code: 0 Filename: Line: 0 Date: UNKNOWN Page Count: 0
#9 Warning Code: 0 Filename: Line: 0 Date: UNKNOWN Page Count: 0

Printer Usage Section
Total ton consumed: 500.00 mg
Printed pages: 1000
Total page count: 1000
Total ton usage: 500.00 mg
Service Station target: 0%
```

System Errors

Printer Status Section

```
Date: UNKNOWN
Printer Status=OK
Printer Latest Errors:
#0 Error Code: 8101 Filename: 1/PaperCtrl.c Line: 292 Date: 7-31-2001 Page Count: 93
#1 Error Code: 7904 Filename: ids.c Line: 542 Date: UNKNOWN Page Count: 88
#2 Error Code: 7904 Filename: MechCommand.c Line: 1161 Date: UNKNOWN Page Count: 79
#3 Error Code: 7904 Filename: MechCommand.c Line: 2494 Date: UNKNOWN Page Count: 79
#4 Error Code: 8101 Filename: 1/PaperCtrl.c Line: 292 Date: 7-31-2001 Page Count: 79
#5 Error Code: 8681 Filename: MechCommand.c Line: 655 Date: UNKNOWN Page Count: 75
#6 Error Code: 7904 Filename: StationCtrl.c Line: 399 Date: UNKNOWN Page Count: 75
#7 Error Code: 8101 Filename: 1/PaperCtrl.c Line: 292 Date: UNKNOWN Page Count: 75
#8 Error Code: 7904 Filename: alignment.c Line: 482 Date: UNKNOWN Page Count: 75
#9 Error Code: 0 Filename: Line: 0 Date: UNKNOWN Page Count: 0
Printer Latest Warnings:
#0 Warning Code: 7904 Filename: gnmentUtils.c Line: 454 Date: UNKNOWN Page Count: 99
#1 Warning Code: 0 Filename: Line: 0 Date: UNKNOWN Page Count: 0
#2 Warning Code: 0 Filename: Line: 0 Date: UNKNOWN Page Count: 0
#3 Warning Code: 0 Filename: Line: 0 Date: UNKNOWN Page Count: 0
#4 Warning Code: 0 Filename: Line: 0 Date: UNKNOWN Page Count: 0
#5 Warning Code: 0 Filename: Line: 0 Date: UNKNOWN Page Count: 0
#6 Warning Code: 0 Filename: Line: 0 Date: UNKNOWN Page Count: 0
#7 Warning Code: 0 Filename: Line: 0 Date: UNKNOWN Page Count: 0
#8 Warning Code: 0 Filename: Line: 0 Date: UNKNOWN Page Count: 0
#9 Warning Code: 0 Filename: Line: 0 Date: UNKNOWN Page Count: 0
```

Warnings

You can also obtain report of the System Error and Warnings through the DesignJet System Maintenance Tool.

System Error Codes

System Error: 01:10

Problem Description: Electronics Module failure.

Corrective Action: Replace the Electronics Module ⇒ Page 7-18.

System Error: 01:12

Problem Description: Electronics Module failed during the firmware upgrade OR the Electronics Module failed during initialization.

Corrective Action: Try the following:

- If the Electronics Module failed during initialization, you must perform the Electronics Test to determine the cause of the failure.
- If the Electronics Module failed during the firmware upgrade, first perform an emergency firmware upgrade (⇒ Page 2-26).
- If an emergency firmware upgrade is NOT possible or it didn't work, replace the Electronics Module ⇒ Page 7-18.

System Error: 02:10

Problem Description: Carriage failure.

Corrective Action: Replace the Carriage Assembly ⇒ Page 7-35.

System Error: 04:13

Problem Description: Generic Firmware Error (Network Card).

Corrective Action: Unplug the power cable from the printer and wait a few seconds. Plug in the power cable again and check if the Error Code has disappeared. If the error code continues, refer to the Jetdirect Card Service Manual and Service Notes.

System Error: 08:11

Problem Description: Front Panel cannot be detected.

Corrective Action: Reconnect the Front Panel.

System Error: 11:10
Problem Description: Trailing Cable Failure.
Corrective Action: Try the following:
■ Replace the Carriage Assembly ⇒ Page 7-35.
■ If the Error Code continues, replace the Electronics Module ⇒ Page 7-18.

Only replace one component at a time and check if the error has gone before replacing another component. Using this procedure you will be able to determine exactly which component failed.

System Error: 11:11
Problem Description: Trailing Cable is badly connected.
Corrective Action: Try the following:
■ Reconnect the Trailing Cable correctly to the Electronics Module.
■ If the Error Code continues, replace the Carriage Assembly ⇒ Page 7-35.

System Error: 21:10
Problem Description: Service Station failure.
Corrective Action: Replace the Service Station Assembly ⇒ Page 7-24.

System Error: 22:10
Problem Description: Ink Supply Station failure.
Corrective Action: Replace the Ink Supply Station ⇒ Page 7-14.



System Error: 35:01
Problem Description: No Cleanout Assembly detected while loading media.
Corrective Action: Try the following:
■ Remove the Cleanout Assembly and install it again correctly.
■ Replace the Cleanout Interconnect PCA.
■ If the Error Code continues, replace the Cleanout Assembly.

Only replace one component at a time and check if the error has gone before replacing another component. Using this procedure you will be able to determine exactly which component failed.

System Error:	37:01
Problem Description:	Automatic roll motor shutdown.
Corrective Action:	Try the following: <ul style="list-style-type: none">■ If this error code was caused by a paper jam, unplug the power cable from the printer and clear the blockage. Plug in the power cable again and check if the Error Code has disappeared.■ If there is no paper jam or if recovering the paper jam does not resolve the problem, then replace the Automatic Roll System (the error could be caused by anything that stalls the motor).
System Error:	37:10
Problem Description:	Automatic roll home position error.
Corrective Action:	Replace the Automatic Roll System (the error could be caused by anything that causes the home position not to be detected or not to be the correct one - electrical sensors, internal mechanical problems, etc.).
System Error:	42:10
Problem Description:	Carriage Motor failure (short-circuit).
Corrective Action:	Replace the Carriage Motor Assembly ⇒ Page 7-29.

System Error:	56:10
Problem Description:	Error during the calibration of the motor encoder system or a problem finding the zero position on the Encoder Disc.
Corrective Action:	Try the following: <ul style="list-style-type: none">■ Replace the Paper-Axis Motor Drive Assembly ⇒ Page 7-75.■ Replace the Encoder Disc.
Make sure you recalibrate the Paper-Axis after replacing the Paper-Axis Motor Drive Assembly or the Encoder Disc.	
Only replace one component at a time and check if the error has gone before replacing another component. Using this procedure you will be able to determine exactly which component failed.	
System Error:	56:13
Problem Description:	Error during the calibration of the Line-feed Motor/Encoder system.
Corrective Action:	Unplug the power cable from the printer and wait a few seconds. Plug in the power cable again and check if the Error Code has disappeared.
System Error:	61:05
Problem Description:	Firmware Upgrade or Color Calibration was rejected because the file was sent in the wrong format.
Corrective Action:	Upgrade the RIP software or the Designjet System Maintenance Tool.
System Error:	62:04, 63:04, 64:04 and 65:04
Problem Description:	I/O module error (62 = parallel; 63 = Network; 64 = USB).
Corrective Action:	Try the following: <ul style="list-style-type: none">■ Unplug the power cable from the printer and wait a few seconds. Plug in the power cable again and check if the Error Code has disappeared.■ If the Error Code reappears, upgrade the firmware.
System Error:	71:03
Problem Description:	Generic Firmware Error (Out of memory).
Corrective Action:	Try the following: <ul style="list-style-type: none">■ Unplug the power cable from the printer and wait a few seconds. Plug in the power cable again and check if the Error Code has disappeared.■ If the Error Code reappears, check for a new Firmware release.

System Error:	71:14
Problem Description:	Memory Management Error (Out of memory during firmware upgrade).
Corrective Action:	Try the following: <ul style="list-style-type: none">■ Unplug the power cable from the printer and wait a few seconds. Plug in the power cable again and check if the Error Code has disappeared.■ If the Error Code reappears, perform an emergency firmware upgrade ⇒ Page 26.
System Error:	72:04
Problem Description:	Generic Firmware Error (expected).
Corrective Action:	Try the following: <ul style="list-style-type: none">■ Unplug the power cable from the printer and wait a few seconds. Plug in the power cable again and check if the Error Code has disappeared.■ If the Error Code reappears, check for a new Firmware release.■ If possible, request the user to provide the following information which can be found on the information page:<ul style="list-style-type: none">– Firmware Release.– Filename.– Line.
System Error:	74:12
Problem Description:	Firmware Upgrade Error (Memory size check failed during firmware upgrade).
Corrective Action:	Try the following: <ul style="list-style-type: none">■ Perform the automatic troubleshooting procedure (requires a special firmware upgrade file that must be provided by the manufacturing division).
System Error:	79:04
Problem Description:	Generic Firmware Error (unexpected).
Corrective Action:	Try the following: <ul style="list-style-type: none">■ Unplug the power cable from the printer and wait a few seconds. Plug in the power cable again and check if the Error Code has disappeared.■ If the Error Code reappears, check for a new Firmware release.■ If possible, request the user to provide the following information which can be found on the information page:<ul style="list-style-type: none">– Firmware Release.– Filename.– Line.

System Error:	81:01 
Problem Description:	Paper-Axis shutdown - usually a paper-jam caused by a blockage of the Paper-axis System.
Corrective Action:	<p>Try the following:</p> <ul style="list-style-type: none"> ■ If this error code was caused by a paper-jam, unplug the power cable from the printer and clear the blockage. Plug in the power cable again and check if the Error Code has disappeared ■ If this error code appeared but was NOT caused by a paper jam, replace the Paper-Axis Motor Drive Assembly ⇒ Page 7-75.
System Error:	81:12
Problem Description:	Media Advance error.
Corrective Action:	This error usually appears during the paper-advance calibration - Retry the paper-advance calibration.
System Error:	83:10
Problem Description:	Sheet feeding failure.
Corrective Action:	<p>Try the following:</p> <ul style="list-style-type: none"> ■ Replace the Out-Of-paper Sensor. ■ Replace the Electronics Module ⇒ Page 7-18.
System Error:	85:10
Problem Description:	Paper-Axis Encoder error.
Corrective Action:	<p>Try the following:</p> <ul style="list-style-type: none"> ■ Make sure that the Encoder Sensor cable is connected correctly. ■ Replace the Paper-Axis Motor Drive Assembly ⇒ Page 7-75. ■ Replace the Electronics Module ⇒ Page 7-18.
System Error:	86:01 
Problem Description:	Scan-axis shutdown - usually a paper-jam caused by a blockage of the Scan-axis System.
Corrective Action:	<p>Try the following:</p> <ul style="list-style-type: none"> ■ Check that there are no obstacles in the Scan-Axis which stops the Carriage from moving freely. ■ Too much friction in the Slider Rod, try lubricating the Slider Rod. ■ The Carriage is bumping into the Service Station. If the Carriage is stuck at the right hand side of the Printer and cannot be moved out to the center of the Print Platen it is because the Service Station cannot uncap

the printheads. In this case replace the Service Station Assembly ⇒ Page 7-24.

- Check that the belt is correctly installed and not damaged.
- Check that the Turnaround Pulley is correctly installed.
- Replace the Carriage Motor Assembly ⇒ Page 7-29.

System Error: 86:11

Problem Description: Scan-axis shutdown during initialization. Typically, this error occurs when the printer detects an incorrect length.

Corrective Action: Try the following:

- Unplug the power cable from the printer and wait a few seconds. Plug in the power cable again and check if the Error Code has disappeared.
- Check that the Paper-Axis Drive Motor Assembly is correctly installed and that the bushing is correctly locked into position.
- Check that the Carriage moves freely and DOES NOT bump into the Service Station.
- If the Printheads are not installed, maybe the carriage cover is not closed completely.
- If the Error Code continues, replace the Carriage Assembly ⇒ Page 7-35.

Warnings

- System Error:** 01:11
Problem Description: The Electronics Module is incorrectly positioned.
Corrective Action: Reseat the Electronics Module by Removing it from the Printer (⇒ Page 7-18) and installing it again in the correct position.
- System Error:** 01:12
Problem Description: Electronics Module Error.
Corrective Action: The Electronics Module EEPROM is flagged as empty and must be upgraded with the contents of the Carriage EEPROM, but the Carriage is also flagged as empty. The backup is not performed. This is the result of an error during the manufacturing or the repair process. Therefore the Electronics Module must be reconfigured.
- System Error:** 02:10
Problem Description: Carriage failure.
Corrective Action: Replace the Carriage Assembly ⇒ Page 7-35.
- System Error:** 270:00
Problem Description: Black Color Calibration Failure - Black Color Calibration cancelled.
Corrective Action: Try the following:
■ Clean the electrical contacts on the **black** printhead.
■ If the error code continues, replace the **black** printhead.
- System Error:** 271:00
Problem Description: Cyan Color Calibration Failure - Cyan Color Calibration cancelled.
Corrective Action: Try the following:
■ Clean the electrical contacts on the **cyan** printhead.
■ If the error code continues, replace the **cyan** printhead.

System Error:	272:00
Problem Description:	Magenta Color Calibration Failure - Magenta Color Calibration cancelled.
Corrective Action:	Try the following: <ul style="list-style-type: none">■ Clean the electrical contacts on the magenta printhead.■ If the error code continues, replace the magenta printhead.
System Error:	273:00
Problem Description:	Yellow Color Calibration Failure - Yellow Color Calibration cancelled.
Corrective Action:	Try the following: <ul style="list-style-type: none">■ Clean the electrical contacts on the yellow printhead.■ If the error code continues, replace the yellow printhead.
System Error:	274:00 (Not applicable to HP DesignJet 70, 100, 100+, 110+)
Problem Description:	Light Cyan Color Calibration Failure - Light Cyan Color Calibration cancelled.
Corrective Action:	Try the following: <ul style="list-style-type: none">■ Clean the electrical contacts on the light cyan printhead.■ If the error code continues, replace the light cyan printhead.
System Error:	275:00 (Not applicable to HP DesignJet 70, 100, 100+, 110+)
Problem Description:	Light Magenta Color Calibration Failure - Light Magenta Color Calibration cancelled.
Corrective Action:	Try the following: <ul style="list-style-type: none">■ Clean the electrical contacts on the light magenta printhead.■ If the error code continues, replace the light magenta printhead.
System Error:	35:01
Problem Description:	No Cleanout Assembly (or Duplexer, if installed) detected while loading media.
Corrective Action:	Try the following: <ul style="list-style-type: none">■ Remove the Cleanout Assembly (⇒ Page 7-31) (or Duplexer, if installed) and install it again correctly.■ Replace the Duplexer Interconnect PCA.■ If the Error Code continues, replace the Cleanout Assembly ⇒ Page 7-31.

System Error:	58:10
Problem Description:	Problem detected in the color sensor system.
Corrective Action:	Replace the Carriage Assembly ⇒ Page 7-35.
System Error:	61:05
Problem Description:	Language interpreting error. This is usually an error produced while parsing a file. There is probably an incompatibility between the driver and the firmware.
Corrective Action:	Upgrade the RIP software or the Designjet System Maintenance Tool.
System Error:	65:01
Problem Description:	Communication Failure.
Corrective Action:	Try the following: <ul style="list-style-type: none">■ Unplug the power cable from the printer and check the cable connections (Parallel, USB and Network cables). Plug in the power cable again and check if the Error Code has disappeared.
System Error:	66:02:1 (Only applicable to HP DesignJet 30, 30n, 90, 90r, 130, 130nr)
Problem Description:	Horizontal clipping. May happen when the roll ends in the middle of printing an image. Could also happen when multi-pick occurs and two sheets are loaded together and they do not completely overlap.
Corrective Action:	Make sure the image size is within the selected WIDTH of the sheet.
System Error:	66:02:2 (Only applicable to HP DesignJet 30, 30n, 90, 90r, 130, 130nr)
Problem Description:	Vertical clipping. May happen when the roll ends in the middle of printing an image. Could also happen when multi-pick occurs and two sheets are loaded together and they do not completely overlap.
Corrective Action:	Make sure the image size is within the selected LENGTH of the sheet.
System Error:	71:14
Problem Description:	Out-of-memory while trying to process the firmware upgrade file. Probably this is a firmware bug, because the firmware should free up enough memory to perform the firmware upgrade process correctly.
Corrective Action:	Perform an emergency firmware upgrade (⇒ Page 2-26).

System Error:	74:12
Problem Description:	Firmware bug in the firmware upgrade process
Corrective Action:	<p>Try the following:</p> <ul style="list-style-type: none"> ■ Download the special file in order to update the bootlog. ■ If possible, request the user to provide the following information which can be found on the information page: <ul style="list-style-type: none"> – Firmware Release. – Printer Serial Number.
System Error:	81:01 
Problem Description:	Paper-Axis shutdown - usually a paper-jam caused by a blockage of the Paper-axis System.
Corrective Action:	<p>Try the following:</p> <ul style="list-style-type: none"> ■ If this error code was caused by a paper-jam, unplug the power cable from the printer and clear the blockage. Plug in the power cable again and check if the Error Code has disappeared ■ If this error code appeared but was NOT caused by a paper jam, replace the Paper-Axis Motor Drive Assembly ⇒ Page 7-75.
System Error:	83:01:1 (Only applicable to HP DesignJet 30, 30n, 70, 100+, 110+, 90, 90r, 120, 120nr, 130, 130nr)
Problem Description:	The paper is rejected from the Bypass due to skew.
Corrective Action:	When manually loading paper from the front of the paper, make sure that it is loaded straight.
System Error:	83:01:3 (Only applicable to HP DesignJet 70/100plus/110plus)
Problem Description:	The paper is rejected from the roll due to skew.
Corrective Action:	When loading paper from the roll, make sure that it is loaded straight.
System Error:	94:02:1 (Only applicable to HP DesignJet 30, 30n, 90, 90r, 120, 120nr, 130, 130nr)
Problem Description:	User selected Coated Paper and Best mode, but the Color Calibration profile was obsolete or missing for Coated Paper and the selected print quality setting.
Corrective Action:	Using the System Maintenance Tool, perform Color Calibration for Coated Paper and the selected print quality setting.

System Error:	94:02:2 (Only applicable to HP DesignJet 120/120nr)
Problem Description:	User selected Glossy Paper and Best mode, but the Color Calibration profile was obsolete or missing for Glossy Paper and the selected print quality setting.
Corrective Action:	Using the System Maintenance Tool, perform Color Calibration for Glossy Paper and the selected print quality setting.
System Error:	94:02:3 (Only applicable to HP DesignJet 30, 30n, 90, 90r, 120, 120nr, 130, 130nr)
Problem Description:	User selected Photo Paper and Best mode, but the Color Calibration profile was obsolete or missing for Photo Paper and the selected print quality setting.
Corrective Action:	Using the System Maintenance Tool, perform Color Calibration for Photo Paper and the selected print quality setting.
System Error:	94:02:4 (Only applicable to HP DesignJet 30, 30n, 90, 90r, 120, 120nr, 130, 130nr)
Problem Description:	User selected Heavy-Weight Coated Paper and Best mode, but the Color Calibration profile was obsolete or missing for Heavy-Weight Coated Paper and the selected print quality setting.
Corrective Action:	Using the System Maintenance Tool, perform Color Calibration for Heavy-Weight Coated Paper and the selected print quality setting.
System Error:	94:02:5 (Only applicable to HP DesignJet 30, 30n, 90, 90r, 120, 120nr, 130, 130nr)
Problem Description:	User selected Proofing Semi-Gloss Paper and Best mode, but the Color Calibration profile was obsolete or missing for Proofing Semi-Gloss Paper and the selected print quality setting.
Corrective Action:	Using the System Maintenance Tool, perform Color Calibration for Proofing Semi-Gloss Paper and the selected print quality setting.
System Error:	94:02:6 (Only applicable to HP DesignJet 30, 30n, 90, 90r, 130, 130nr)
Problem Description:	User selected Photo Matte Paper and Best mode, but the Color Calibration profile was obsolete or missing for Photo Matte Paper and the selected print quality setting.
Corrective Action:	Using the System Maintenance Tool, perform Color Calibration for Photo Matte Paper and the selected print quality setting.
System Error:	94:02:7 (Only applicable to HP DesignJet 30, 30n, 90, 90r, 120, 120nr, 130, 130nr)
Problem Description:	User selected Photo Satin Paper and Best mode, but the Color Calibration profile was obsolete or missing for Photo Satin Paper and the selected print quality setting.

	quality setting.
Corrective Action:	Using the System Maintenance Tool, perform Color Calibration for Photo Satin Paper and the selected print quality setting.
System Error:	94:02:8 (Only applicable to HP DesignJet 30, 30n, 90, 90r, 120, 120nr, 130, 130nr)
Problem Description:	User selected Coated Paper and Max dpi, but the Color Calibration profile was obsolete or missing for Coated Paper and the selected print quality setting.
Corrective Action:	Using the System Maintenance Tool, perform Color Calibration for Coated Paper and the selected print quality setting.
System Error:	94:02:9 (Only applicable to HP DesignJet 120/120nr)
Problem Description:	User selected Glossy Paper and High Resolution mode, but the Color Calibration profile was obsolete or missing for Glossy Paper and the selected print quality setting.
Corrective Action:	Using the System Maintenance Tool, perform Color Calibration for Glossy Paper and the selected print quality setting.
System Error:	941:02:1 (Only applicable to HP DesignJet 30, 30n, 90, 90r, 120, 120nr, 130, 130nr)
Problem Description:	User selected Photo Paper and Max dpi, but the Color Calibration profile was obsolete or missing for Photo Paper and the selected print quality setting.
Corrective Action:	Using the System Maintenance Tool, perform Color Calibration for Photo Paper and the selected print quality setting.
System Error:	941:02:2 (Only applicable to HP DesignJet 30, 30n, 90, 90r, 120, 120nr, 130, 130nr)
Problem Description:	User selected Heavy-Weight Coated Paper and Max dpi, but the Color Calibration profile was obsolete or missing for Heavy-Weight Coated Paper and the selected print quality setting.
Corrective Action:	Using the System Maintenance Tool, perform Color Calibration for Heavy-Weight Coated Paper and the selected print quality setting.
System Error:	941:02:3 (Only applicable to HP DesignJet 30, 30n, 90, 90r, 120, 120nr, 130, 130nr)
Problem Description:	User selected Proofing Semi-Gloss Paper and Max dpi mode, but the Color Calibration profile was obsolete or missing for Proofing Semi-Gloss Paper and the selected print quality setting.
Corrective Action:	Using the System Maintenance Tool, perform Color Calibration for Proofing

Semi-Gloss Paper and the selected print quality setting.

System Error: 941:02:4 (Only applicable to HP DesignJet 30, 30n, 90, 90r, 130, 130nr)

Problem Description: User selected Photo Matte Paper and Max dpi mode, but the Color Calibration profile was obsolete or missing for Photo Matte Paper and the selected print quality setting.

Corrective Action: Using the System Maintenance Tool, perform Color Calibration for Photo Matte Paper and the selected print quality setting.

System Error: 941:02:5 (Only applicable to HP DesignJet 30, 30n, 90, 90r, 130, 130nr)

Problem Description: User selected Photo Satin Paper and Max dpi mode, but the Color Calibration profile was obsolete or missing for Photo Satin Paper and the selected print quality setting.

Corrective Action: Using the System Maintenance Tool, perform Color Calibration for Photo Satin Paper and the selected print quality setting.

System Error: 94:04

Problem Description: Firmware Error (during color calibration).

Corrective Action: Try the following:

- Unplug the power cable from the printer and wait a few seconds. Plug in the power cable again and check if the Error Code has disappeared.
- If the Error Code reappears, check for a new Firmware release.

System Error: 94:08

Problem Description: Color Calibration Warning - Color Calibration not cancelled but Color Calibration values are likely to be incorrect.

Corrective Action: Try the Color Calibration again, but this time using a different type of media (preferably **HP** media).

System Error: 94:10

Problem Description: Color Calibration Failure - Color Calibration cancelled.

Corrective Action: Try the following:

- Unplug the power cable from the printer and wait a few seconds. Plug in the power cable again and try the Color Calibration again.
- If this error code appears again, check the Color Calibration print:
 - If the Color Calibration was printed correctly without any print defects, then check that the media is moving freely (backwards and forwards) while the printer is scanning it.
 - If the Color Calibration was printed incorrectly, with some print defects,

replace the faulty Printhead of the color where the defects were noticeable.

- If the Error Code continues, replace the Carriage Assembly ⇒ Page 7-35.

System Error: 95:00

Problem Description: Printhead Alignment Failure - Printhead Alignment cancelled.

Corrective Action: Try the following:

- Clean the printhead indicated by the printer.
- If the error code continues, replace the faulty printhead.

System Error: 95:02

Problem Description: Printhead Alignment Failure - Printhead Alignment cancelled.

Corrective Action: Try the following:

- Unplug the power cable from the printer and wait a few seconds. Plug in the power cable again and try the Printhead Alignment again.
- If this error code appears again, check the Printhead Alignment print:
 - If the Printhead Alignment was printed correctly without any print defects, then check that the media is moving freely (backwards and forwards) while the printer is scanning it.
 - If the Printhead Alignment was printed incorrectly, with some print defects, replace the faulty Printhead of the color where the defects were noticeable.

System Error: 95:04

Problem Description: Firmware Error (during Printhead Alignment).

Corrective Action: Upgrade the printer to the latest firmware release.

Startup track mode

Introduction

The startup track mode is designed to enable you to identify a failing subsystems while the printer is initializing. Startup track mode provides a specific indication of which particular subsystem is failing. This mode is not intended for use by end-users.

Initializing the printer in Startup track mode

To initialize the printer in Startup track mode:

- 1 Hold the 'Continue' button while connecting the printer to the power supply.
- 2 During the initialization of the printer, the front panel will display a range of code numbers in the form of squares, these code numbers added together represent the various subsystems about to be initialized.
- 3 Once the printer comes to initializing the failing subsystem, the front panel will hang, and all that will be displayed is the failing subsystem.

Interpreting the numbered code system

While the printer is initializing, the front panel will display a sequence of squares in the last two columns. Each position in the last two columns represents a number, all the numbers represented are shown below. To find the failing subsystem, add the numbers together that have a square and refer to the list of numbers with their associated subsystems page 20.

0	0	0	0	16	1
0	0	0	0	32	2
0	0	0	0	64	4
0	0	0	0	128	8

In the example below the printer is initializing and the front panel has stopped and is displaying squares in positions 16, 32, 64 and 4. Add these four values together and you get 116, refer to the list on page 20, and we can see the failing subsystem is the Trailing Cable.

0	0	0	0	■	
0	0	0	0	■	
0	0	0	0	■	■
0	0	0	0		

If the display reaches 191, you will need to turn On the printer from the power button. If all the subsystems pass the initialization, the printer will initialize normally and go to the ready status.

Subsystem Code Description

This is the list of the subsystems and their associated Startup Track Numbers. Many of the descriptions of the Subsystems will not be immediately obvious, when this is the case contact the lfp help desk and they can assist you

Startup track number: Associated Subsystem
Startup Track 004: Calling EiffelMain
Startup Track 005: Initializing Classes
Startup Track 006: Initializing SM
Startup Track 007: Initializing Memory
Startup Track 008: Initializing MemoryVolatile
Startup Track 009: Initializing MemoryEndian
Startup Track 010: Initializing MemoryVolatileEndian
Startup Track 011: Initializing Impala
Startup Track 012: Initializing ColdFire
Startup Track 013: Initializing ImpalaInterruptController
Startup Track 014: Initializing MechProcTaskHilntA
Startup Track 015: Initializing IsardInterruptA
Startup Track 016: Initializing Watchdog
Startup Track 017: Initializing Chronometer
Startup Track 018: Initializing EddTimer
Startup Track 019: Initializing IsardInterruptB
Startup Track 020: Initializing PciSlot2Interrupt
Startup Track 021: Initializing PciSlot3Interrupt
Startup Track 022: Initializing PciSlot4Interrupt
Startup Track 023: Initializing PciSlot5Interrupt
Startup Track 024: Initializing MagentaFireLow
Startup Track 025: Initializing BongoGpio
Startup Track 026: Initializing SecondTraySensor
Startup Track 027: Initializing CleanoutSensor
Startup Track 028: Initializing RearPathPaperSensor
Startup Track 029: Initializing BlackCartridgeSensor
Startup Track 030: Initializing CyanCartridgeSensor
Startup Track 031: Initializing MagentaCartridgeSensor
Startup Track 032: Initializing YellowCartridgeSensor
Startup Track 033: Initializing LightMagentaCartridgeSensor
Startup Track 034: Initializing LightCyanCartridgeSensor
Startup Track 035: Initializing SynergyReset
Startup Track 036: Initializing FrontPanelReset
Startup Track 037: Initializing PowerFan
Startup Track 038: Initializing FrontPanelInterrupt
Startup Track 039: Initializing CoverWindowSensor
Startup Track 040: Initializing nUSB_ENABLE
Startup Track 041: Initializing USB_CONNECT

Startup track number: Associated Subsystem
Startup Track 042: Initializing TrailingCable3Sensor
Startup Track 043: Initializing TrailingCable12Sensor
Startup Track 044: Initializing PrintheadSensor
Startup Track 045: Initializing BongoBrake
Startup Track 046: Initializing Dma
Startup Track 047: Initializing BongoEncoder
Startup Track 048: Initializing ServiceStationEncoder
Startup Track 049: Initializing SSPwm
Startup Track 050: Initializing PaperPwm
Startup Track 051: Initializing RampPwm
Startup Track 052: Initializing CarriagePwmForward
Startup Track 053: Initializing CarriagePwmReverse
Startup Track 054: Initializing BomboPwm
Startup Track 055: Initializing EddPwm
Startup Track 056: Initializing ImpalaCarriagePosition
Startup Track 057: Initializing I2c0
Startup Track 058: Initializing I2c1
Startup Track 059: Initializing I2c2
Startup Track 060: Initializing I2c3
Startup Track 061: Initializing Darwin
Startup Track 062: Initializing PciCtrl
Startup Track 063: Initializing PciDma
Startup Track 064: Initializing MbandToPixel
Startup Track 065: Initializing PixelData
Startup Track 066: Initializing BlackCSDData
Startup Track 067: Initializing CyanCSDData
Startup Track 068: Initializing MagentaCSDData
Startup Track 069: Initializing YellowCSDData
Startup Track 070: Initializing LightCyanCSDData
Startup Track 071: Initializing LightMagentaCSDData
Startup Track 072: Initializing BlackPrintHead
Startup Track 073: Initializing CyanPrintHead
Startup Track 074: Initializing MagentaPrintHead
Startup Track 075: Initializing YellowPrintHead
Startup Track 076: Initializing LightCyanPrintHead
Startup Track 077: Initializing LightMagentaPrintHead
Startup Track 078: Initializing BlockBlack
Startup Track 079: Initializing BlockColor
Startup Track 080: Initializing ContoneToRaster
Startup Track 081: Initializing Enhancer
Startup Track 082: Initializing RasterToMband
Startup Track 083: Initializing MechProcA
Startup Track 084: Initializing MemoryUncached
Startup Track 085: Initializing Isard

Startup track number: Associated Subsystem
Startup Track 086: Initializing IsardInterruptController
Startup Track 087: Initializing PaperInterrupt
Startup Track 088: Initializing IsardPMTimer
Startup Track 089: Initializing IsardKFort
Startup Track 090: Initializing IsardCarriagePosition
Startup Track 091: Initializing IsardPaperPosition
Startup Track 092: Initializing MediaPosition
Startup Track 093: Initializing PaperEncoderPosition
Startup Track 094: Initializing IsardMotorShortcut
Startup Track 095: Initializing Eridani
Startup Track 096: Initializing EddOn
Startup Track 097: Initializing ServiceStationLed
Startup Track 098: Initializing FetRegulator
Startup Track 099: Initializing EddOut
Startup Track 100: Initializing DuplexerConversor
Startup Track 101: Initializing EridaniConversorAuto
Startup Track 102: Initializing EridaniConversorAB
Startup Track 103: Initializing EridaniConversorAnA
Startup Track 104: Initializing EridaniConversorBnB
Startup Track 105: Initializing PaperDriver
Startup Track 106: Initializing ServiceStationDriver
Startup Track 107: Initializing RampDriver
Startup Track 108: Initializing DuplexerSensor
Startup Track 109: Initializing PaperMotorHw
Startup Track 110: Initializing CarriageMotorHw
Startup Track 111: Initializing ServiceStationMotorHw
Startup Track 112: Initializing BongoEncoderWindowHw
Startup Track 113: Initializing BongoMotorHw
Startup Track 114: Initializing RampMotorHw
Startup Track 115: Initializing FrontPanelHw
Startup Track 116: Initializing TrailingCable
Startup Track 117: Initializing CarriageBoardHw
Startup Track 118: Initializing SynergyA
Startup Track 119: Initializing VPPA
Startup Track 120: Initializing VPPB
Startup Track 121: Initializing SynergyInternalRegulatorA
Startup Track 122: Initializing Led1Voltage
Startup Track 123: Initializing EndeavourA
Startup Track 124: Initializing EndeavourAcumenA
Startup Track 125: Initializing CLC_Channel0
Startup Track 126: Initializing CLC_Channel1
Startup Track 127: Initializing CLC_Channel2
Startup Track 128: Initializing EndeavourVRefConversor
Startup Track 129: Initializing CLC_ChannelDACConversor

Startup track number: Associated Subsystem
Startup Track 130: Initializing IS_Channel3Conversor_A
Startup Track 131: Initializing CLC_Channel0Conversor
Startup Track 132: Initializing CLC_Channel1Conversor
Startup Track 133: Initializing CLC_Channel2Conversor
Startup Track 134: Initializing Led2Voltage
Startup Track 135: Initializing Black5V
Startup Track 136: Initializing Yellow5V
Startup Track 137: Initializing Magenta5V
Startup Track 138: Initializing Cyan5V
Startup Track 139: Initializing Black12V
Startup Track 140: Initializing Yellow12V
Startup Track 141: Initializing Magenta12V
Startup Track 142: Initializing Cyan12V
Startup Track 143: Initializing VPen_Current_Sense_A
Startup Track 144: Initializing VPen_OV_Latch_A
Startup Track 145: Initializing VPen_OV_Clear_Latch_A
Startup Track 146: Initializing VPen_UV_Latch_A
Startup Track 147: Initializing VPen_UV_Clear_Latch_A
Startup Track 148: Initializing VPen_OV_Present_A
Startup Track 149: Initializing VPen_UV_Present_A
Startup Track 150: Initializing EndeavourB
Startup Track 151: Initializing EndeavourAcumenB
Startup Track 152: Initializing IS_Channel3Conversor_B
Startup Track 153: Initializing Led3Voltage
Startup Track 154: Initializing LightMagenta5V
Startup Track 155: Initializing LightCyan5V
Startup Track 156: Initializing LightMagenta12V
Startup Track 157: Initializing LightCyan12V
Startup Track 158: Initializing VPen_Current_Sense_B
Startup Track 159: Initializing VPen_OV_Latch_B
Startup Track 160: Initializing VPen_OV_Clear_Latch_B
Startup Track 161: Initializing VPen_UV_Latch_B
Startup Track 162: Initializing VPen_UV_Clear_Latch_B
Startup Track 163: Initializing VPen_OV_Present_B
Startup Track 164: Initializing VPen_UV_Present_B
Startup Track 165: Initializing Eerom
Startup Track 166: Initializing EeromCarriage
Startup Track 167: Initializing PrintheadControl
Startup Track 168: Initializing BlackPrintheadAcumen
Startup Track 169: Initializing CyanPrintheadAcumen
Startup Track 170: Initializing MagentaPrintheadAcumen
Startup Track 171: Initializing YellowPrintheadAcumen
Startup Track 172: Initializing LightCyanPrintheadAcumen
Startup Track 173: Initializing LightMagentaPrintheadAcumen

Startup track number: Associated Subsystem
Startup Track 174: Initializing BlackCartridgeAcumen
Startup Track 175: Initializing CyanCartridgeAcumen
Startup Track 176: Initializing MagentaCartridgeAcumen
Startup Track 177: Initializing YellowCartridgeAcumen
Startup Track 178: Initializing LightCyanCartridgeAcumen
Startup Track 179: Initializing LightMagentaCartridgeAcumen
Startup Track 180: Initializing ColorSensor
Startup Track 181: Initializing ColorSensorLed1
Startup Track 182: Initializing ColorSensorLed2
Startup Track 183: Initializing ColorSensorLed3
Startup Track 184: Initializing ColorSensorConversorA
Startup Track 185: Initializing ColorSensorConversorB
Startup Track 186: Initializing ColorSensorConversorC
Startup Track 187: Initializing V5_V12_ISDetection
Startup Track 188: Initializing VPP_ISDetection
Startup Track 189: Initializing InterruptController
Startup Track 190: SM Initialized
Startup Track 191: Back from EiffelMain!!! PRESS POWER BUTTON HERE!!
Startup Track 192: Initializing VPPA
Startup Track 193: Initializing VPPB
Startup Track 194: Initializing SynergyInternalRegulatorA
Startup Track 195: Initializing Led1Voltage
Startup Track 196: Initializing EndeavourAcumenA
Startup Track 197: Initializing CLC_Channel0
Startup Track 198: Initializing CLC_Channel1
Startup Track 199: Initializing CLC_Channel2
Startup Track 200: Initializing EndeavourVRefConversor
Startup Track 201: Initializing CLC_ChannelDACConversor
Startup Track 202: Initializing IS_Channel3Conversor_A
Startup Track 203: Initializing CLC_Channel0Conversor
Startup Track 204: Initializing CLC_Channel1Conversor
Startup Track 205: Initializing CLC_Channel2Conversor
Startup Track 206: Initializing Led2Voltage
Startup Track 207: Initializing Black5V
Startup Track 208: Initializing Yellow5V
Startup Track 209: Initializing Magenta5V
Startup Track 210: Initializing Cyan5V
Startup Track 211: Initializing Black12V
Startup Track 212: Initializing Yellow12V
Startup Track 213: Initializing Magenta12V
Startup Track 214: Initializing Cyan12V
Startup Track 215: Initializing VPen_Current_Sense_A

Startup track number: Associated Subsystem
Startup Track 216: Initializing VPen_OV_Latch_A
Startup Track 217: Initializing VPen_OV_Clear_Latch_A
Startup Track 218: Initializing VPen_UV_Latch_A
Startup Track 219: Initializing VPen_UV_Clear_Latch_A
Startup Track 220: Initializing VPen_OV_Present_A
Startup Track 221: Initializing VPen_UV_Present_A
Startup Track 222: Initializing EndeavourAcumenB
Startup Track 223: Initializing IS_Channel3Conversor_B
Startup Track 224: Initializing Led3Voltage
Startup Track 225: Initializing LightMagenta5V
Startup Track 226: Initializing LightCyan5V
Startup Track 227: Initializing LightMagenta12V
Startup Track 228: Initializing LightCyan12V
Startup Track 229: Initializing VPen_Current_Sense_B
Startup Track 230: Initializing VPen_OV_Latch_B
Startup Track 231: Initializing VPen_OV_Clear_Latch_B
Startup Track 232: Initializing VPen_UV_Latch_B
Startup Track 233: Initializing VPen_UV_Clear_Latch_B
Startup Track 234: Initializing VPen_OV_Present_B
Startup Track 235: Initializing VPen_UV_Present_B

Emergency Firmware Upgrade

- 1 Unplug the power cord from the printer and wait a few seconds.
- 2 Press and hold the Cancel (red) button while plugging in the power cord.
- 3 The printer will initialize in emergency mode (the front panel will display just the arrow icon).
- 4 Connect the printer to the computer with a parallel cable.
- 5 Send the firmware file through the parallel port from the DOS command prompt. Type: **copy /b firmware_file lpt1:** and then press ENTER.

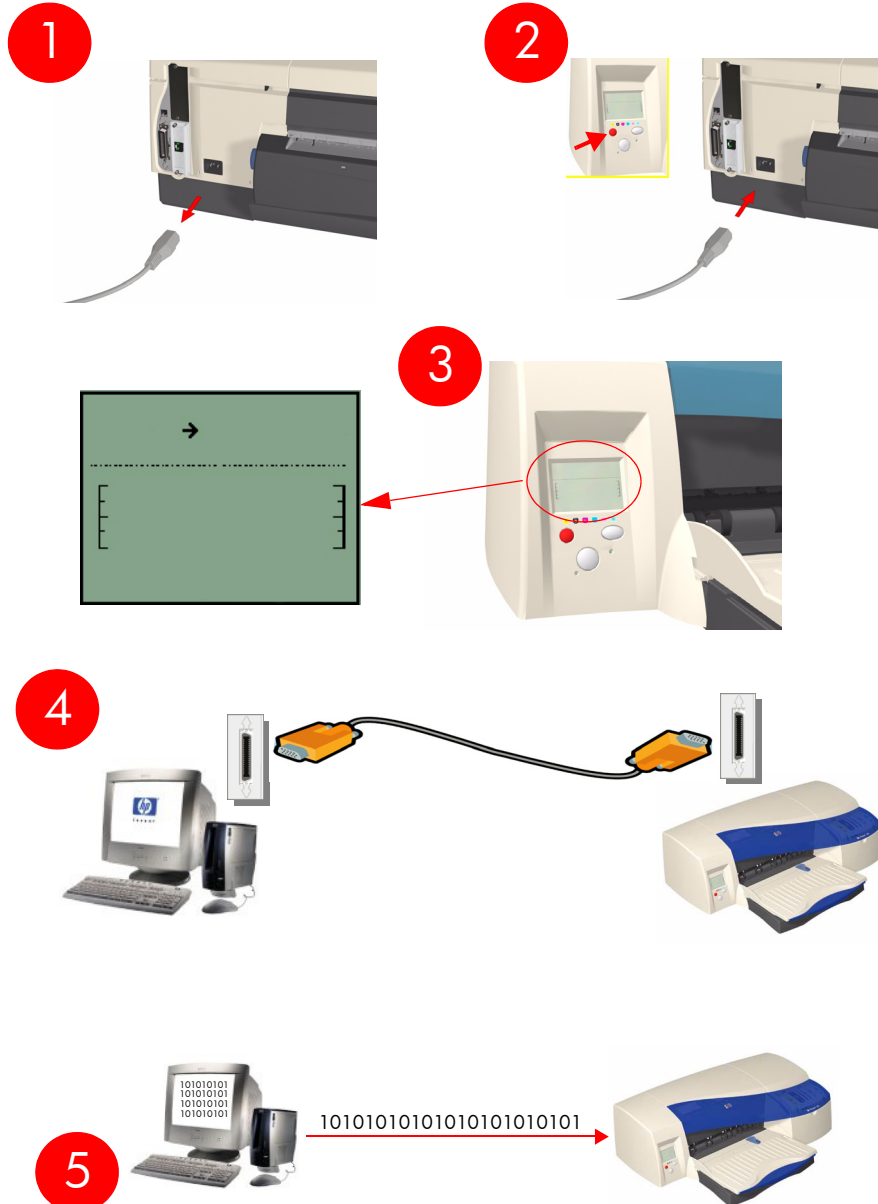

System Error Codes - Explanation

System Error Codes explain which component/system is failing and what action should be taken to resolve the problem.

System Error Codes are displayed directly on the front panel (but can also be seen on the Information Page) and have been defined in the format **XX.YZ**.

Warnings will **not** be displayed on the front panel, but will instead only appear on the Information Page and have been defined in the format **XXn.YZ.m**.

- **XX**: Service Part (2 digits).
- **n**: Service Part Index (if more than one used in the product) - Optional.
 - e.g. Identify the Ink Supply (color and number).
- **Y**: Who should perform the action (1 digit) - (User or Service Engineer).
- **Z**: Action to perform (1 digit).
- **m**: additional actions/information to consider (1 digit) - Optional.
 - e.g. Non-authorized ink was detected, PM was triggered or Printhead in/out of Warranty.

The following table explains the **XX** part of the System Error Code or Warning:

Items in **red** are not applicable to the printers.

Code	Component/System
01	Main PCA/Electronics Module
02	Carriage/Carriage PCA
03	Power Supply Unit
04	Network Card
05	Formatter
06	Hard Disk Drive
07	Interconnect PCA
08	Front Panel
11	Trailing Cable
12	Carriage Flex Circuit
17	Interconnect Cable
21	Service Station
22	Ink Supply Station
23	Pressure System (APS)
24	Ink Delivery Tubes
25	Spittoon
26n	Ink Cartridge (color n)
26n	Printhead (color n)
31	Cutter
32	Take-up Reel
33	Sheet Feeder

Code	Component/System
34	Dryer/Blower
35	Cleanout Assembly
36	Duplexer
37	ARSS/Rollfeed
38	Output Tray
41	Paper-Axis Motor
42	Scan-Axis Motor
43	Vacuum Fan
44	Aerosol fan
51	Window Sensor
52	Drop Detector
53	Media Sensor
54	Pinch-Arm Sensor
55	Line Sensor
56	Drive Roller Encoder Sensor
57	Ink Leak Detector
58	Color Sensor
59	Media Type Sensor
61	Language Interpreting
62	Input/Output through Parallel Port
63	Input/Output through Network Card
64	Input/Output through USB Port
65	Input/Output (not know what port)
66	Print Job Configuration
71	Memory Management
72	Generic Firmware
73	Motor Control Functions
74	Firmware Upgrade
79	Firmware Crash
81	Media Advance
82	Media Cut
83	Single-Sheet Feeding
84	Roll Feeding
85	Media-Axis Encoder Reading
86	Carriage Movement
87	Scan-Axis Encoder Reading
91	Printhead Firing
92	Servicing
93	Ink Pumping
94	Color Calibration
95	Printhead Alignment
96	Image Quality Troubleshooting

The following table explains the **YZ** part of the System Error Code or Warning:

Code	Recovery Action	Response
00	Replace	Possible for customer to perform action
01	Reseat/Reconnect/Clean/Adjust (manually)	
02	Calibrate/Adjust (using Automatic Process)	
03	Power OFF	
04	Upgrade System Firmware	
05	Upgrade Driver	
06	Add Accessory	
07	Escalate	
08	Send Plot Again	
09	Wrong Part Installed	
10	Replace	HP qualified personnel assistance required
11	Reseat/Reconnect/Clean/Adjust (manually)	
12	Calibrate/Adjust (using Automatic Process)	
13	Power OFF	
14	Upgrade System Firmware	
15	Upgrade Driver	
16	Add Accessory	
17	Escalate	
18	Send Plot Again	
19	Wrong Part Installed	

System Maintenance Utility

3

Introduction	3-2
Launching the System Maintenance Utility (Designjet 120/120nr)	3-2
Launching the System Maintenance Utility (Designjet 30, 30n, 90, 90r, 130, 130nr)	3-3
System Maintenance Utility (HP Designjet 120/120nr)	3-4
Color Calibration	3-4
Get Printer Information	3-6
Align Printheads	3-7
Clean Printheads	3-8
Update Firmware	3-9
Print Test Page	3-10
Calibrate Paper Feed	3-11
Reset Jetdirect Card	3-13
System Maintenance Utility (Designjet 30, 30n, 90, 90r, 130, 130nr)	3-14
Main Menu - Printer Front Panel Replication	3-14
Color Calibration	3-15
Align Printheads	3-19
Clean Printheads	3-20
Check Image Quality	3-21
Calibrate Paper Feed	3-22
Get Printer Information	3-24
Update Firmware	3-25
Reset Jetdirect Network Card	3-26

Introduction

The System Maintenance Utility is designed to assist the customer with common maintenance tasks for the printer and also to resolve common problems that they may encounter.

Print jobs must not be sent to the printer while the system maintenance utility is in use.

Since the design of the System Maintenance Tool is different between the Designjet 120/120nr and Designjet 130/130, this chapter will explain how to use the tool for each product separately:

- Explanation on how to use the System Maintenance Utility for the Designjet 120, 120nr is found on Page 2.
- Explanation on how to use the System Maintenance Utility for the Designjet 30, 30n, 130, 130nr is found on Page 3.

Launching the System Maintenance Utility (Designjet 120/120nr)

The System Maintenance Utility is launched via the HP printer driver.

Step 1 - Click on the "Advanced" tab

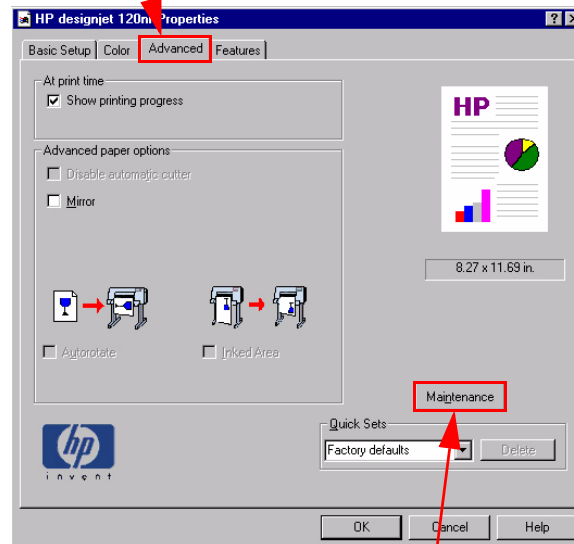

Step 2 - Click on the "Maintenance" box

When you finish using the System Maintenance Utility, you must click on exit on the left hand column before closing the browser.

Launching the System Maintenance Utility (Designjet 30, 30n, 90, 90r, 130, 130nr)

There are two ways of launching the System Maintenance Utility.

From your computer's desktop (Windows, Mac OS 9 and X)

- 1 Double click the *hp designjet system maintenance* icon on the desktop.

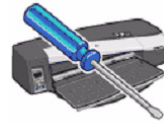

- 2 A printer selector window opens - select your printer from the list.

Step 1 - Select Printer

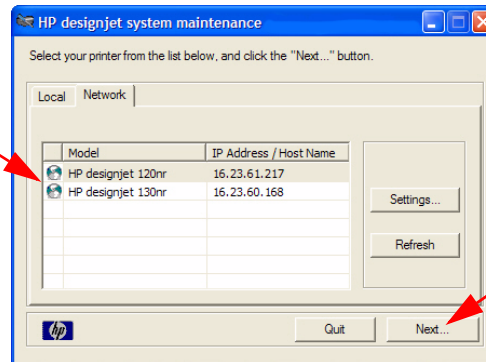

Step 2 - Click on next

- 3 Click **Next** (in Windows) or **Configure** (in Mac OS).

From the Printer Driver (Windows, Mac OS X)

In the Windows driver click the *hp designjet system maintenance* icon in the **Services** tab. In Mac OS X, select the Printer in the *Print Center* or *Print Setup Utility* and click **configure**.

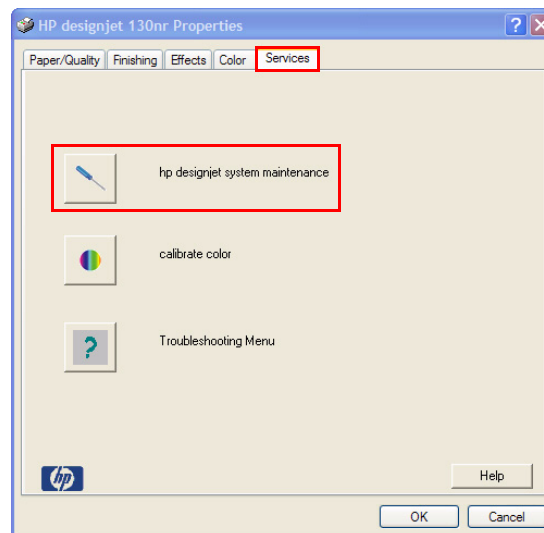

When you finish using the System Maintenance Utility, you must click on exit on the left hand column before closing the browser.

System Maintenance Utility (HP Designjet 120/120nr)

Color Calibration

The Color Calibration should ONLY be performed by the user when required.

Why calibrate color?

Calibrate color performs a maintenance function to ensure color consistency. If you calibrate correctly, the colors printed on printers with different printheads will look very similar.



This picture shows an exaggerated example of how a printout could look like before and after color calibration.

When do I calibrate color?

It is recommended that you **calibrate color** every time you replace a printhead or when you perceive color degradation on the printouts. There is no need to perform this operation each time you print. The results of the color calibration will be applied to all print jobs that follow, even if you power off the printer.

Perform color calibration if you print with the regular hp designjet 120 printer driver, which was included with the printer or which you downloaded from the Web. If you use a PostScript driver such as Adobe PS or LaserWriter to print through a PostScript RIP provided by HP or another third-party company, the results of **calibrate color** will not be applied to your print jobs. In this case, refer to your PostScript RIP documentation for information on how to perform color calibration.

How do I calibrate color?

You have to **calibrate color** for every Paper Type that requires color consistency. For example, if you require consistent colors on glossy paper and on heavy weight coated paper, you must perform one color calibration for the former and another for the latter Paper Type.

When you want to calibrate color, remember to select the Print Quality option that you are going to use to print. For example, if you want to print with the High Resolution option, select High Resolution before performing the color calibration.

If the Color calibration fails, print the information page and check the list of warnings under the printer status section.

Calibrate Color as shown below:

Step 1 - Select "calibrate color"

- calibrate color
- get printer information
- align printheads
- clean printheads
- print test page
- calibrate paper feed
- reset jetdirect card

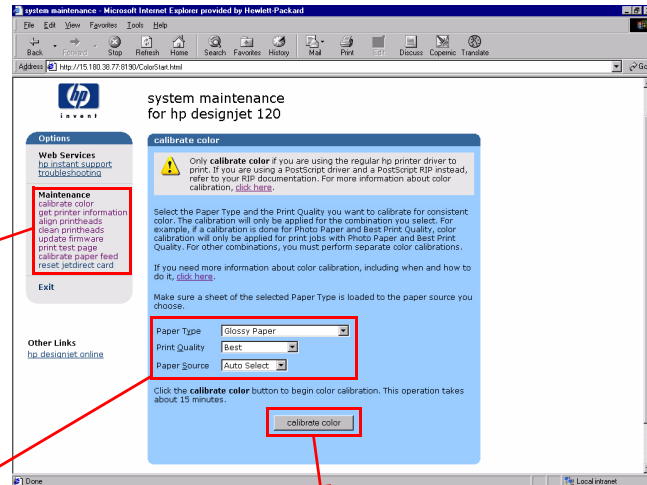

Step 3 - Press "Calibrate Color"

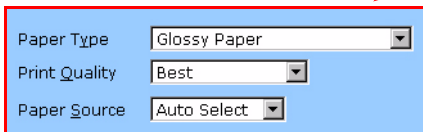

Step 2 - Select Paper Type and Print Quality

Sample of the Color Calibration Print



Get Printer Information

This option allows you to view all the information available on the Printer:

- Printer Identification.
- Printer Status.
- Printer Job Queue.
- Printer Errors and Warnings.
- Printer Usage.
- Ink Consumable Identification.
- Ink Consumable Status.
- Ink Consumable Usage.
- Network Card Information.

Refer to the **Test Prints** chapter for explanations on each section.

Step 1 - Select "Get Printer Information"

Maintenance
calibrate color
get printer information
align printheads
clean printheads
update firmware
print test page
calibrate paper feed
reset jetdirect card

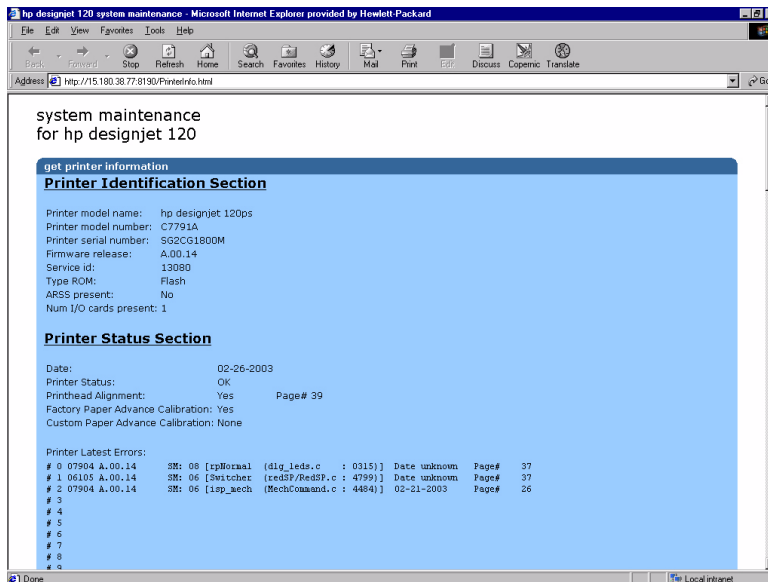
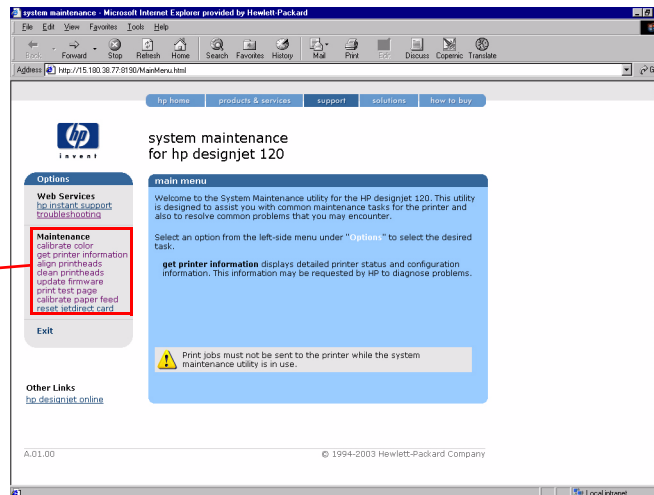

Sample of the information page

Align Printheads

Align printheads performs a maintenance function with the printheads. Proper alignment insures correct registration between ink colors while printing. This is only recommended if you are experiencing problems with print quality.

Before you continue, please verify that three sheets of paper are loaded in the default tray. If the printhead alignment fails on the first attempt, the printer will retry the alignment twice.

Do not power off the printer during this operation. The printer display will indicate busy until the operation is finished.

Step 1 - Select "align printheads"

- Maintenance
- calibrate color
- get printer information
- align printheads
- clean printheads
- update firmware
- print test page
- calibrate paper feed
- reset jetdirect card

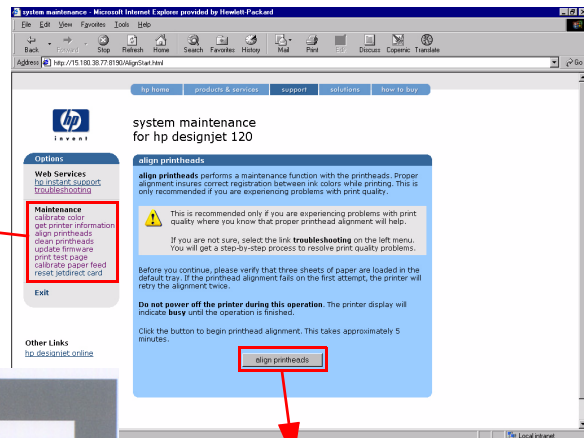

Step 2 - Press "align printheads"

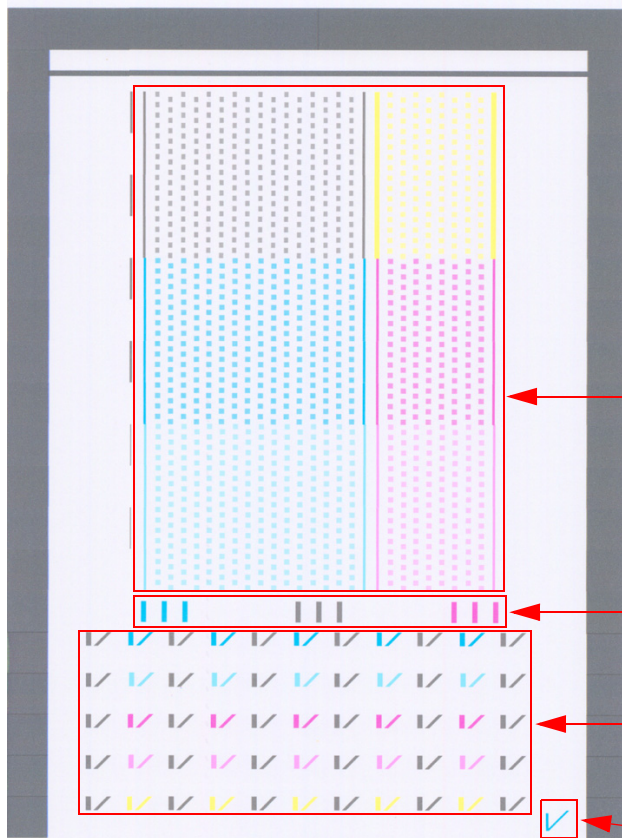

Sample of the Printhead Alignment Page

Pattern for Bidirectional compensation and directionality on Scan-Axis

To calibrate the sensors

Pattern for directionality on Paper-Axis

Test Result
✓ Pass ✗ Fail

Clean Printheads

Clean printheads helps maintain proper operation of all nozzles in the printheads. This is only recommended if you are experiencing problems with print quality such as banding.

Three levels of cleaning are available: soft, medium and hard. As a first step, the soft cleaning should be used. If you still experience the same image problems, then select medium. Hard cleaning should only be used as a last resort.

Do not power off the printer during this operation. The printer display will indicate busy until the operation is finished.

Before cleaning the printheads, first check the maximum recovery level already performed on the printheads. If hard level (Recovery Level 3) has already been performed, then do not try performing hard level again. The Maximum Recovery Level can be seen on the Printer Information page in the "Printhead History" section.

Ink Consumable Usage Section

Ink Consumed Printhead: K= 0 cc (0 %) C= 0 cc (0 %) M= 0 cc (0 %) Y= 0 cc (0 %) LC= 1 cc (0 %) LM= 1 cc (0 %)

Usage Time Printhead: K= 6 days C= 6 days M= 6 days Y= 6 days LC= 6 days LM= 6 days

Ink Consumed Cartridge: K= 2 cc (2 %) C= 1 cc (3 %) M= 1 cc (3 %) Y= 1 cc (1 %) LC= 1 cc (1 %) LM= 1 cc (1 %)

Printhead history:

K:	#1 - Inserted - 0 cc (0%) - 6 days -	Max. Recovery Level 1
C:	#1 - Inserted - 0 cc (0%) - 6 days -	Max. Recovery Level 1
M:	#1 - Inserted - 0 cc (0%) - 6 days -	Max. Recovery Level 1
Y:	#1 - Inserted - 0 cc (0%) - 6 days -	Max. Recovery Level 1
LC:	#1 - Inserted - 1 cc (0%) - 6 days -	Max. Recovery Level 1
LM:	#1 - Inserted - 1 cc (0%) - 6 days -	Max. Recovery Level 1

Maximum Recovery Level already performed

Step 1 - Select "clean printheads"

- Maintenance**
- calibrate color
 - get printer information
 - align printheads
 - clean printheads
 - update firmware
 - print test page
 - calibrate paper feed
 - reset jetdirect card

- Soft
- Medium
- Hard

Step 2 - Select the recovery level to be performed

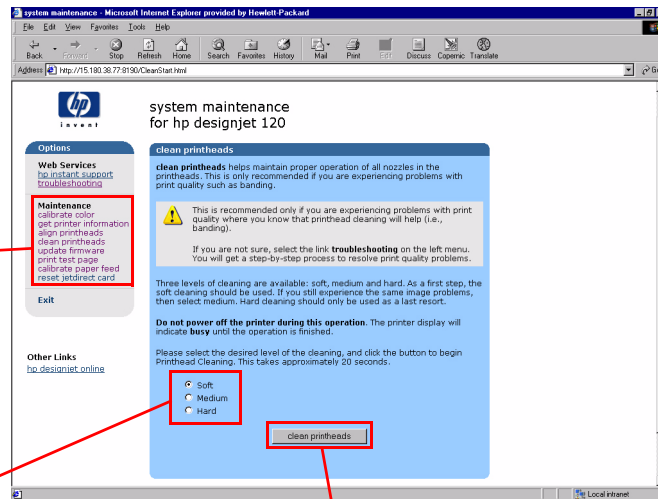

Step 3 - Press "clean printheads"

Update Firmware

Update firmware updates the built-in software of the printer. The update process will check the printer's version with the latest version available from HP. Before trying this utility, first make sure that you have an internet connection.

Do not power off the printer during this operation. The printer display will indicate busy until the operation is finished.

The first step will be to check if newer printer software is available. If newer software is available, then follow the instructions in the window in order to upgrade the printer software.

Step 1 - Select "update firmware"

Maintenance
calibrate color
get printer information
align printheads
clean printheads
update firmware
print test page
calibrate paper feed
reset jetdirect card

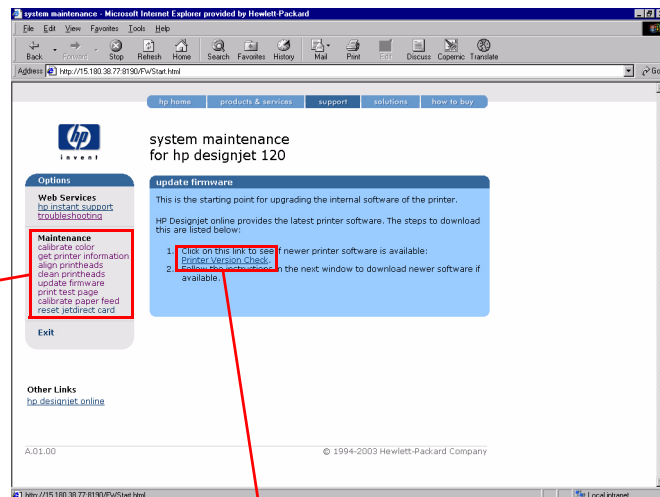

Step 2 - Click on this link

System Software (firmware)

System Software (firmware)

Your printer already has the latest firmware. No need to download.

Click [here](#) to return to the System Maintenance main menu.

If newer printer software is not available, then this message will be displayed

Print Test Page

Print test page provides two diagnostic pages for printing. The following test pages are available:

- Image Quality Diagnostic page.
- Skew Diagnostic page.

These commands only print the diagnostic pages and do not provide analysis of the results. A full troubleshooting process is available using the **troubleshooting** command under the **Web Services** option.

Select "troubleshooting" for the analysis of the test pages

Web Services
[hp instant support](#)
[troubleshooting](#)

Maintenance
 calibrate color
 get printer information
 align printheads
 clean printheads
 update firmware
 print test page
 calibrate paper feed
 reset jetdirect card

Step 1 - Select "print test page"

Maintenance
 calibrate color
 get printer information
 align printheads
 clean printheads
 update firmware
 print test page
 calibrate paper feed
 reset jetdirect card

Step 2 - Click on "Image Quality" or "Skew"

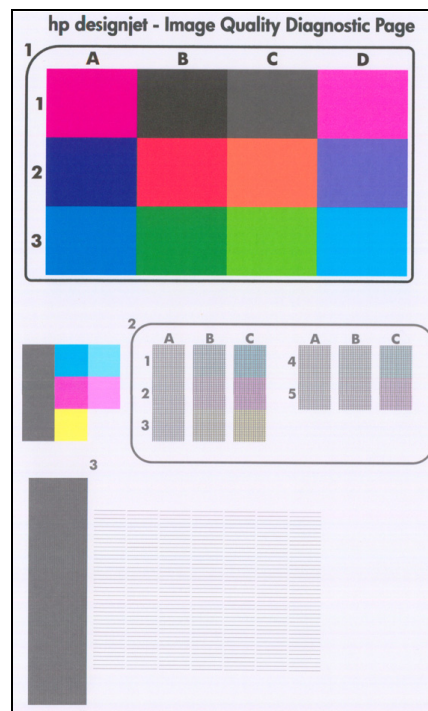

Calibrate Paper Feed

Calibrate paper feed is used to adjust the printer parameters for use with different types of print media. This only affects the physical movement of paper and does not affect the color calibration profiles.

This calibration is a two-step process. Step one is to print a special test page with the paper calibration test pattern. This page must be printed on A3 or 11x17 paper sizes. After printing the test page, you must feed the test page back into the printer via the front single-sheet paper feed.

Step 1 - Select "calibrate paper feed"

- Maintenance
- calibrate color
- get printer information
- align printheads
- clean printheads
- update firmware
- print test page
- calibrate paper feed
- reset jetdirect card

Media Source: TRAY1
Media Type: Plain Paper

Step 2 - Select Media Source and Media Type

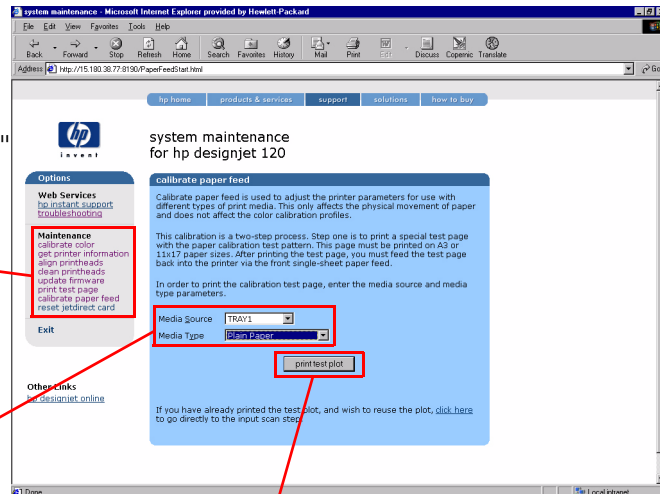

Step 3 - Press "print test plot"

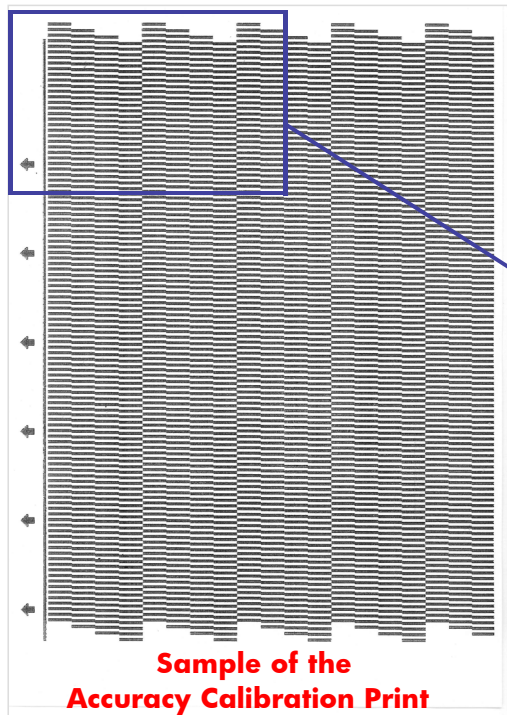

Indication that tells you how to load the paper to scan the pattern

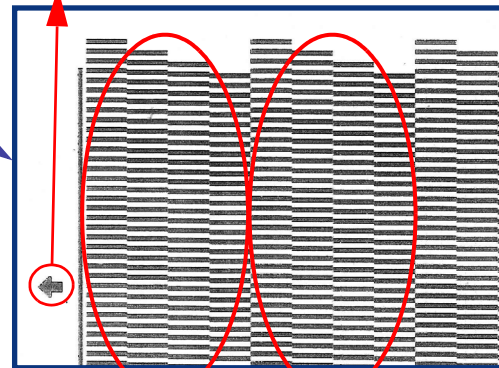

Pattern printed several times
Optimize for different areas of the print zone

Once the Accuracy Calibration has been printed, rotate the page and reload it upside down (image facing down).

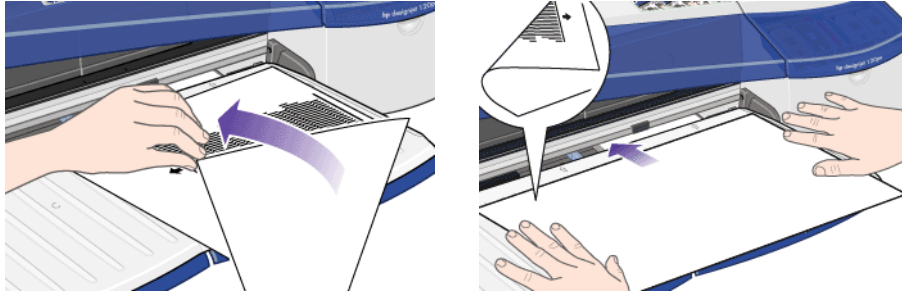

Step 1 - Rotate the page and reload it upside down (image facing down)

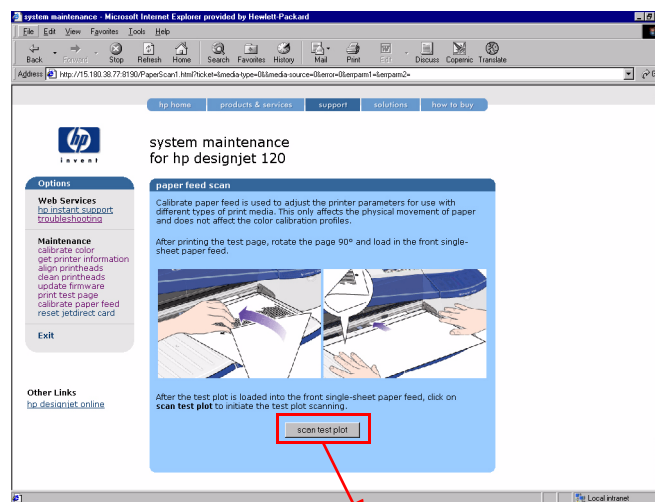

Step 2 - Press "scan test plot"

Reset Jetdirect Card

Use this function to reset the HP Jetdirect card configuration to the factory defaults. This should only be used if the HP Jetdirect card is not responding and no other recovery method works.

Any user configuration information, for example the IP address, will be lost. In this case the *system maintenance* utility will not be able to communicate with the printer using the network.

The HP Jetdirect card will need to be reconfigured, using WebJetAdmin for example, after this reset.

Step 1 - Select "reset jetdirect card"

Maintenance
calibrate color
get printer information
align printheads
clean printheads
update firmware
print test page
calibrate paper feed
reset jetdirect card

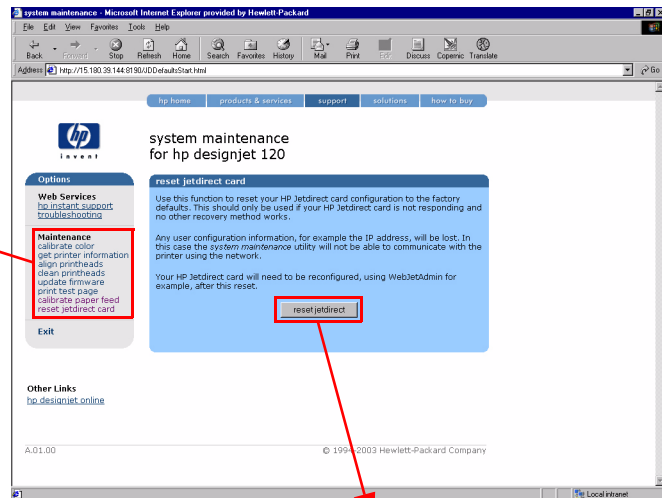

Step 2 - Press "reset jetdirect"

System Maintenance Utility (Designjet 30, 30n, 90, 90r, 130, 130nr)

Main Menu - Printer Front Panel Replication

The main page of the System Maintenance Utility includes a replica of the Printer's Front Panel showing the status of the Printer.

The replica Front Panel does not show the real-time status. It is a snapshot which can be refreshed by pressing the refresh button either on the web browser toolbar or in the actual replica window.

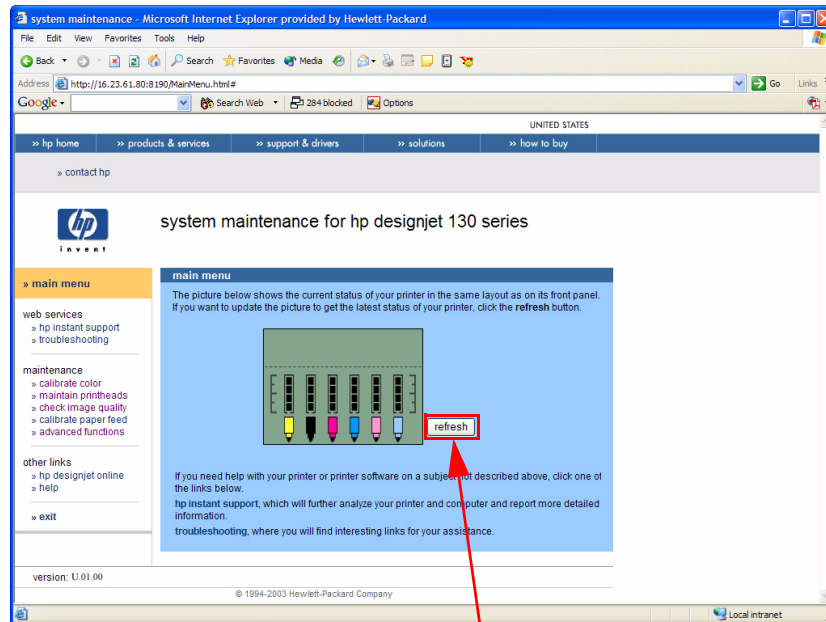

Click to refresh status of Front Panel

Color Calibration

The Color Calibration should ONLY be performed by the user when required.

Why calibrate color?

Calibrate color performs a maintenance function to ensure color consistency. If you calibrate correctly, the colors printed on printers with different printheads will look very similar.



This picture shows an exaggerated example of how a printout could look like before and after color calibration.

When do I calibrate color?

It is recommended that you **calibrate color** every time you replace a printhead or when you perceive color degradation on the printouts. There is no need to perform this operation each time you print. The results of the color calibration will be applied to all print jobs that follow, even if you power off the printer.

Perform color calibration if you print with the regular hp designjet 120 printer driver, which was included with the printer or which you downloaded from the Web. If you use a PostScript driver such as Adobe PS or LaserWriter to print through a PostScript RIP provided by HP or another third-party company, the results of **calibrate color** will not be applied to your print jobs. In this case, refer to your PostScript RIP documentation for information on how to perform color calibration.

How do I calibrate color?

You have to **calibrate color** for every Paper Type that requires color consistency. For example, if you require consistent colors on glossy paper and on heavy weight coated paper, you must perform one color calibration for the former and another for the latter Paper Type.

When you want to calibrate color, remember to select the Print Quality option that you are going to use to print. For example, if you want to print with the High Resolution option, select High Resolution before performing the color calibration.

If the Color calibration fails, print the information page and check the list of warnings under the printer status section.

Performing the Color Calibration (HP DesignJet 30, 30n,130, 130nr)

Step 1 - Select "calibrate color"

main menu

- web services
 - hp instant support
 - troubleshooting
- maintenance
 - calibrate color
 - maintain printheads
 - check image quality
 - calibrate paper feed
 - advanced functions
- other links
 - hp designjet online
 - help
 - exit

OR

Double click on the "calibrate color" icon on the computer desktop

system maintenance for hp designjet 130 series

calibrate color

calibrate color only if you are using the regular HP printer driver to print. If you are using a PostScript driver and a PostScript RIP instead, refer to your RIP documentation. For more information about color calibration, click here.

The table below tells you the color calibration status for every possible combination of Color Calibration Paper Type and Print Quality. Please check this table to decide which combination you want to calibrate for.

For deleting a Color Calibration Profile for a combination of Color Calibration Paper Type and Print Quality, select it from the following table and click on **delete calibration profile** button.

Color Calibration Paper Type	Print Quality		
	Best	Delete	Maximum DPI
Coated Paper	OK	<input checked="" type="checkbox"/>	Not calibrated
Heavyweight Coated Paper	Not calibrated	<input type="checkbox"/>	Not calibrated
Photo Matte	Not calibrated	<input type="checkbox"/>	Not calibrated
Photo Paper	Not calibrated	<input type="checkbox"/>	Not calibrated
Photo Satin	Not calibrated	<input type="checkbox"/>	Not calibrated
Proofing Semi-Gloss	Not calibrated	<input type="checkbox"/>	Not calibrated

select all clear all delete calibration profile

Select the Color Calibration Paper Type and the Print Quality you want to calibrate for consistent color. The calibration will be applied only for the combination you selected. For example, if a calibration is done for Photo Paper and Best Print Quality, color calibration will be applied only for print jobs with Photo Paper and Best Print Quality. For other combinations, you must perform separate color calibrations.

If you need more information about color calibration, including when and how to do it, click here.

To find out which paper belongs to which Color Calibration Paper Type, click here.

Make sure a sheet of the selected Color Calibration Paper Type is loaded into the paper source you choose.

Color Calibration Paper Type: HeavyWeight Coated Paper
 Print Quality: Best
 Paper Source: Automatic

Click the **calibrate color** button to begin color calibration. This operation takes about 15 minutes.

calibrate color

Step 2 - Select Paper Type and Print Quality

Color Calibration Paper Type: HeavyWeight Coated Paper
 Print Quality: Best
 Paper Source: Automatic

Step 3 - Press "Calibrate Color"

This table gives you the color calibration status for each type of paper and print quality. You can also use this table to delete color calibration profiles that you don't need.

Color Calibration Paper Type	Print Quality		
	Best	Delete	Maximum DPI
Coated Paper	OK	<input checked="" type="checkbox"/>	Not calibrated
Heavyweight Coated Paper	Not calibrated	<input type="checkbox"/>	Not calibrated
Photo Matte	Not calibrated	<input type="checkbox"/>	Not calibrated
Photo Paper	Not calibrated	<input type="checkbox"/>	Not calibrated
Photo Satin	Not calibrated	<input type="checkbox"/>	Not calibrated
Proofing Semi-Gloss	Not calibrated	<input type="checkbox"/>	Not calibrated

select all clear all delete calibration profile

Step 1 - Select color calibration profile

Step 2 - Press "delete calibration profile"

Performing the Color Calibration (HP DesignJet 90, 90r)

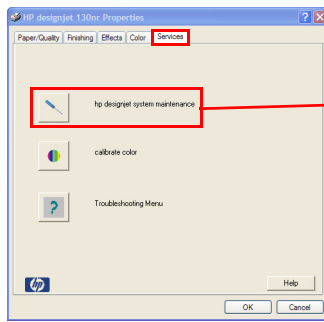

Launch system maintenance tool via the hp driver

Double click on the "calibrate color" icon on the computer desktop

Step 1 - Select "calibrate color"

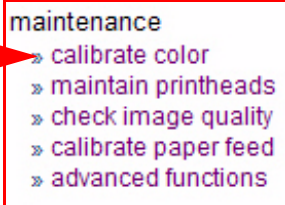

Calibrate Color

Calibrate Color only if you are using the regular HP printer driver to print. If you are using a PostScript driver and a PostScript RIP instead, refer to your RIP documentation. For more information about color calibration, click here.

Select the Color Calibration Paper Type and the Print Quality you want to calibrate for consistent color. This calibration will be applied only for the combination you select. For example, if a calibration is done for Photo Paper and Best Print Quality, color calibration will be applied only for print jobs with Photo Paper and Best Print Quality. For other combinations, you must perform separate color calibrations.

Make sure a sheet of the selected Color Calibration Paper Type is loaded into the paper source you choose.

Color Calibration Paper Type: Photo Gloss/Semi-Gloss / Proofing Gloss
 Print Quality: Best Maximum Detail
 Paper Source: Automatic

Click the **calibrate color** button to begin color calibration. This operation takes about 15 minutes.

The table below tells you the color calibration status for every possible combination of Color Calibration Paper Type and Print Quality. Please check this table to decide which combination you want to calibrate for. For resetting a Color Calibration Profile for a combination of Color Calibration Paper Type and Print Quality to its factory defaults, select it from the following table and click on the **Reset Calibration Profile** button.

Color Calibration Paper Type	Print Quality			
	Best	Reset	Maximum Detail	Reset
Photo Gloss/Semi-Gloss / Proofing Gloss	OK (07-08-2004)	<input type="checkbox"/>	Not calibrated	<input type="checkbox"/>
Photo Satin	Not calibrated	<input type="checkbox"/>	Not calibrated	<input type="checkbox"/>

Color Calibration Paper Type	Print Quality			
	Normal	Reset	Best	Reset
Photo Matte	Not calibrated	<input type="checkbox"/>	Not calibrated	<input type="checkbox"/>
Proofing Semi-Gloss	Not calibrated	<input type="checkbox"/>	Not calibrated	<input type="checkbox"/>
Coated	Not calibrated	<input type="checkbox"/>	Not calibrated	<input type="checkbox"/>
Heavyweight Coated / Proofing Matte	Not calibrated	<input type="checkbox"/>	OK (08-04-2004)	<input type="checkbox"/>

Select All Clear All Reset Calibration Profile

If you need more information about color calibration, including when and how to do it, click here. To find out which paper belongs to which Color Calibration Paper Type, click here.

Step 2 - Select Paper Type and Print Quality

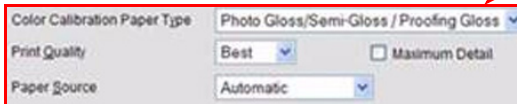

Step 3 - Press "Calibrate Color"

This table gives you the color calibration status for each type of paper and print quality. You can also use this table to delete color calibration profiles that you don't need.

Step 1 - Select color calibration profile

Step 2 - Press "delete calibration profile"

Color Calibration Paper Type	Print Quality			
	Best	Reset	Maximum Detail	Reset
Photo Gloss/Semi-Gloss / Proofing Gloss	OK (07-08-2004)	<input type="checkbox"/>	Not calibrated	<input type="checkbox"/>
Photo Satin	Not calibrated	<input type="checkbox"/>	Not calibrated	<input type="checkbox"/>

Color Calibration Paper Type	Print Quality			
	Normal	Reset	Best	Reset
Photo Matte	Not calibrated	<input type="checkbox"/>	Not calibrated	<input type="checkbox"/>
Proofing Semi-Gloss	Not calibrated	<input type="checkbox"/>	Not calibrated	<input type="checkbox"/>
Coated	Not calibrated	<input type="checkbox"/>	Not calibrated	<input type="checkbox"/>
Heavyweight Coated / Proofing Matte	Not calibrated	<input type="checkbox"/>	OK (08-04-2004)	<input type="checkbox"/>

Select All Clear All Reset Calibration Profile

Sample of the Color Calibration Print:



Align Printheads

Align printheads performs a maintenance function with the printheads. Proper alignment insures correct registration between ink colors while printing. This is only recommended if you are experiencing problems with print quality.

Before you continue, please verify that three sheets of paper are loaded in the default tray. If the printhead alignment fails on the first attempt, the printer will retry the alignment twice.

Do not power off the printer during this operation. The printer display will indicate busy until the operation is finished.

Step 1 - Select "maintain printheads" and then "align printheads"

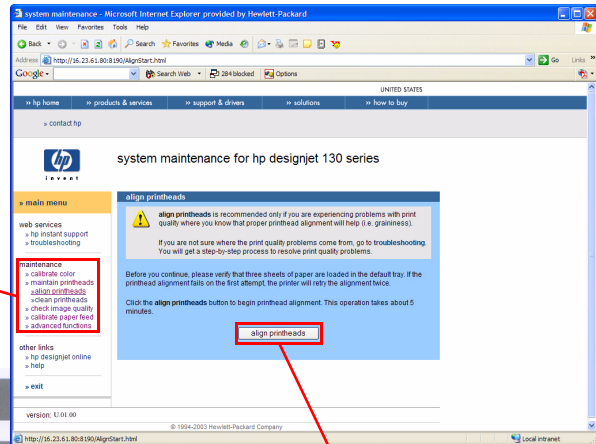
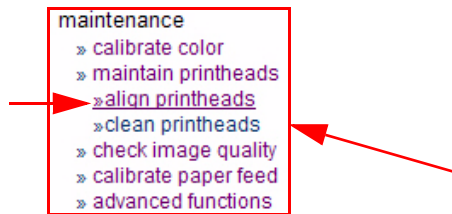

Step 2 - Press "align printheads"

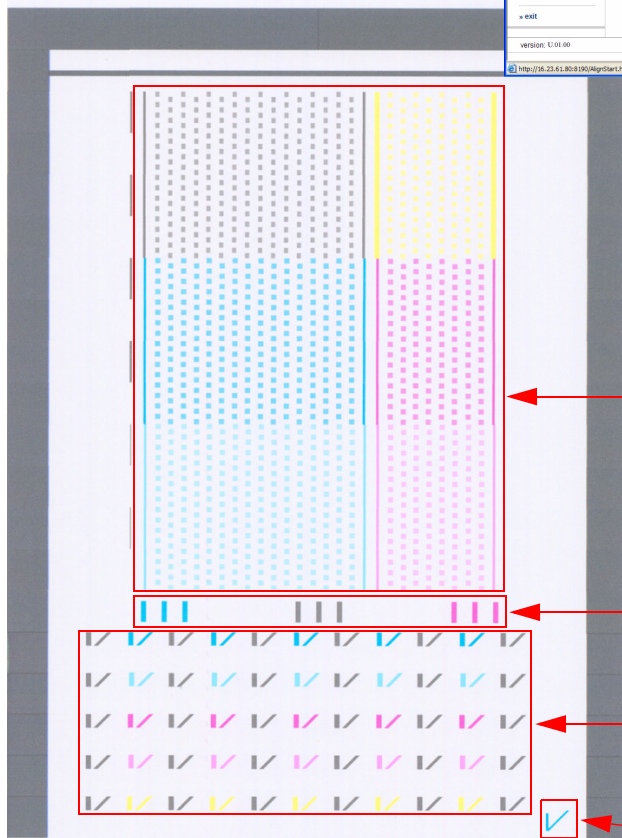

Pattern for Bidirectional compensation and directionality on Scan-Axis

To calibrate the sensors

Pattern for directionality on Paper-Axis

Test Result
 ✓ Pass ✗ Fail

Sample of the Printhead Alignment Page

Clean Printheads

Clean printheads helps maintain proper operation of all nozzles in the printheads. This is only recommended if you are experiencing problems with print quality such as banding.

Three levels of cleaning are available: soft, medium and hard. As a first step, the soft cleaning should be used. If you still experience the same image problems, then select medium. Hard cleaning should only be used as a last resort.

Do not power off the printer during this operation. The printer display will indicate busy until the operation is finished.

Before cleaning the printheads, first check the maximum recovery level already performed on the printheads. If hard level (Recovery Level 3) has already been performed, then do not try performing hard level again. The Maximum Recovery Level can be seen on the Printer Information page in the "Printhead History" section.

Ink Consumable Usage Section

Ink Consumed Printhead: K= 0 cc (0 %) C= 0 cc (0 %) M= 0 cc (0 %) Y= 0 cc (0 %) LC= 1 cc (0 %) LM= 1 cc (0 %)
 Usage Time Printhead: K= 6 days C= 6 days M= 6 days Y= 6 days LC= 6 days LM= 6 days
 Ink Consumed Cartridge: K= 2 cc (2 %) C= 1 cc (3 %) M= 1 cc (3 %) Y= 1 cc (1 %) LC= 1 cc (1 %) LM= 1 cc (1 %)

Printhead history:

K:	#1 - Inserted - 0 cc (0%) - 6 days -	Max. Recovery Level 1
C:	#1 - Inserted - 0 cc (0%) - 6 days -	Max. Recovery Level 1
M:	#1 - Inserted - 0 cc (0%) - 6 days -	Max. Recovery Level 1
Y:	#1 - Inserted - 0 cc (0%) - 6 days -	Max. Recovery Level 1
LC:	#1 - Inserted - 1 cc (0%) - 6 days -	Max. Recovery Level 1
LM:	#1 - Inserted - 1 cc (0%) - 6 days -	Max. Recovery Level 1

Maximum Recovery Level already performed

Step 1 - Select "maintain printheads" and then "clean printheads"

- » [calibrate color](#)
- » [maintain printheads](#)
- » [align printheads](#)
- » [clean printheads](#)
- » [check image quality](#)
- » [calibrate paper feed](#)
- » [advanced functions](#)

- Soft
- Medium
- Hard

Step 2 - Select the recovery level to be performed

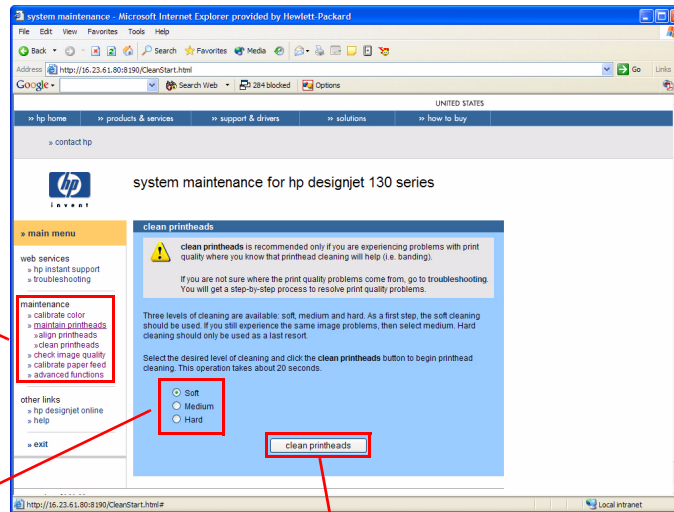

Step 3 - Press "clean printheads"

Check Image Quality

Check image quality provides two diagnostic pages for printing. The following test pages are available:

- Image Quality Diagnostic page.
- Skew Diagnostic page.

These commands only print the diagnostic pages and do not provide analysis of the results. A full troubleshooting process is available using the **troubleshooting** command under the **Web Services** option.

Select "troubleshooting" for the analysis of the test pages

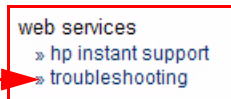

Step 1 - Select "check image quality"

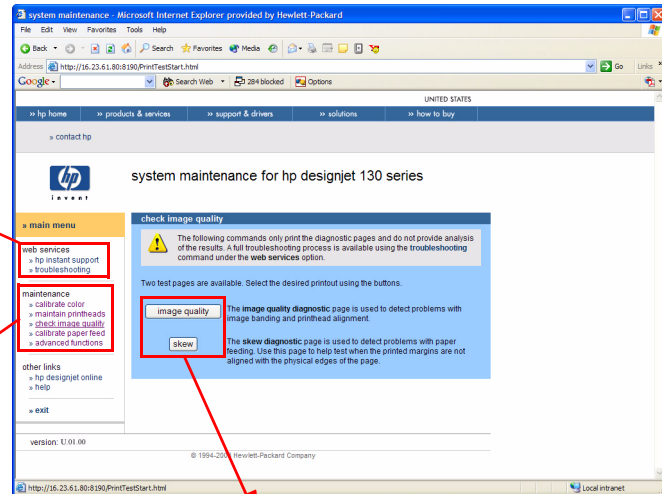
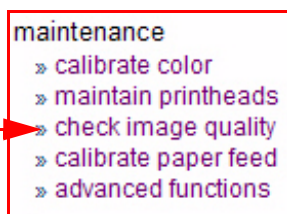

Step 2 - Click on "Image Quality" or "Skew"

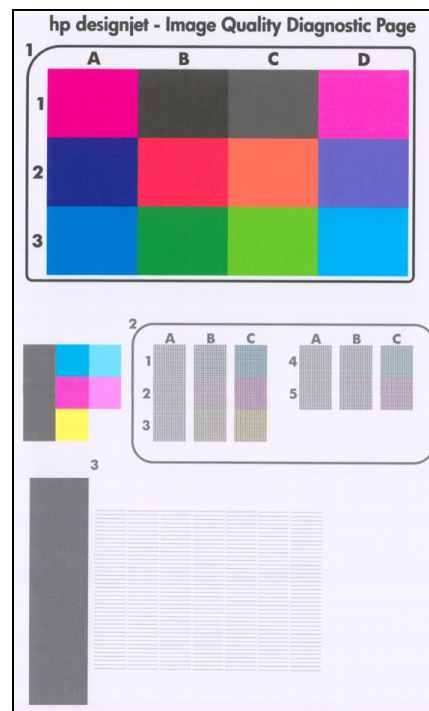

Calibrate Paper Feed

Calibrate paper feed is used to adjust the printer parameters for use with different types of print media. This only affects the physical movement of paper and does not affect the color calibration profiles.

This calibration is a two-step process. Step one is to print a special test page with the paper calibration test pattern. This page must be printed on A3 or 11x17 paper sizes. After printing the test page, you must feed the test page back into the printer via the front single-sheet paper feed.

Step 1 - Select "calibrate paper feed"

- maintenance
 - » calibrate color
 - » maintain printheads
 - » check image quality
 - » calibrate paper feed
 - » advanced functions

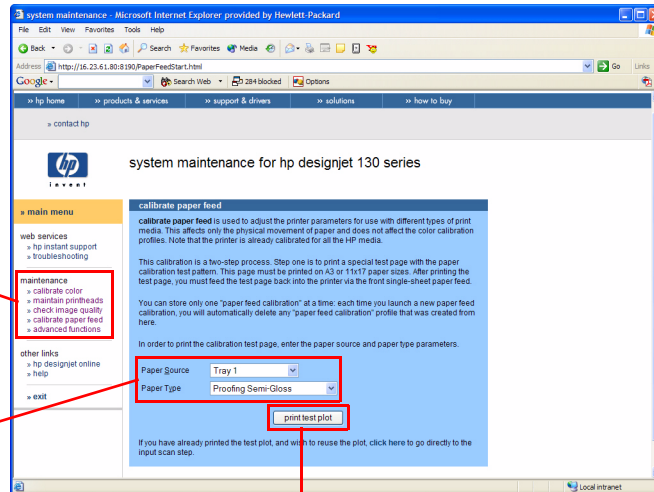

Paper Source: Tray 1
 Paper Type: Proofing Semi-Gloss

Step 2 - Select Media Source and Media Type

Step 3 - Press "print test plot"

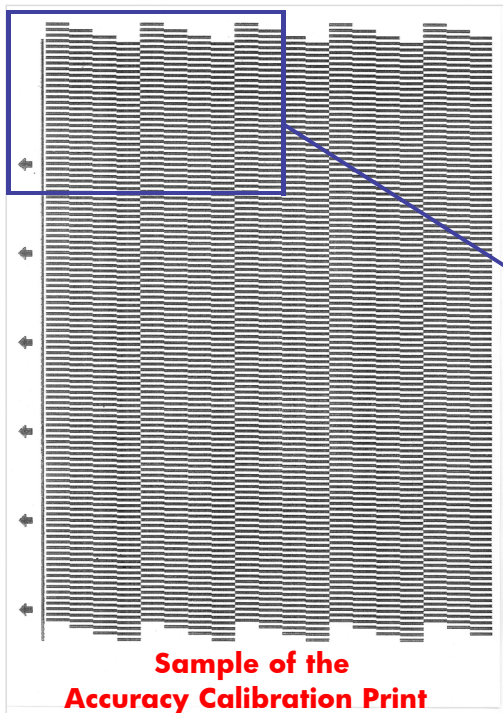

Indication that tells you how to load the paper to scan the pattern

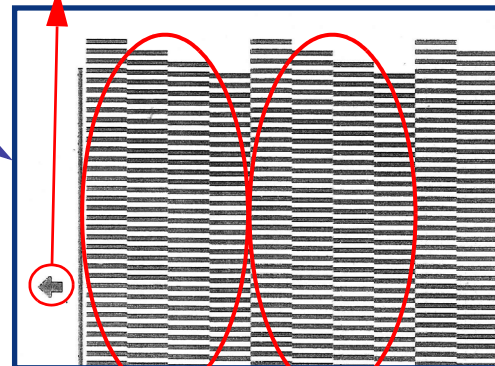

Pattern printed several times
Optimize for different areas of the print zone

Once the Accuracy Calibration has been printed, rotate the page and reload it upside down (image facing down).

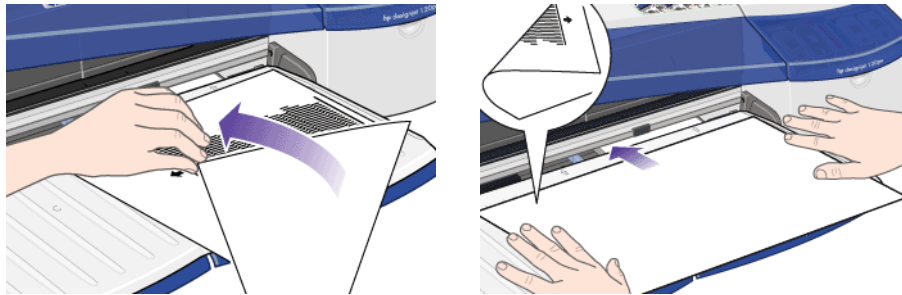

Step 1 - Rotate the page and reload it upside down (image facing down)

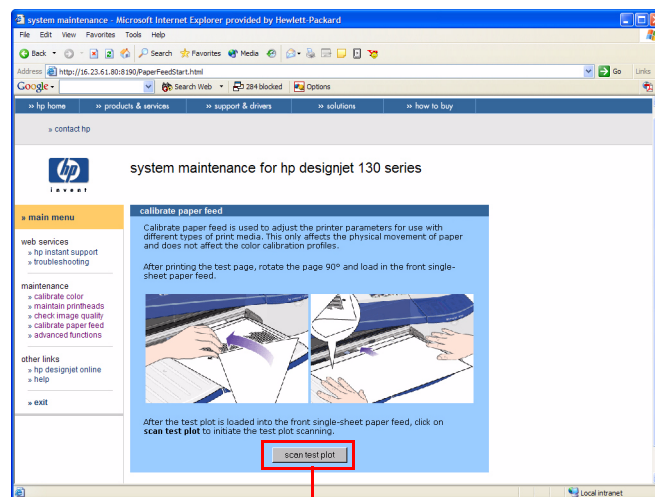

Step 2 - Press "scan test plot"

Get Printer Information

This option allows you to view all the information available on the Printer:

- Printer Identification.
- Printer Status.
- Printer Job Queue.
- Printer Errors and Warnings.
- Printer Usage.
- Ink Consumable Identification.
- Ink Consumable Status.
- Ink Consumable Usage.
- Network Card Information.

Refer to the **Test Prints** chapter for explanations on each section.

Step 1 - Select "advanced functions" and then "get printer information"

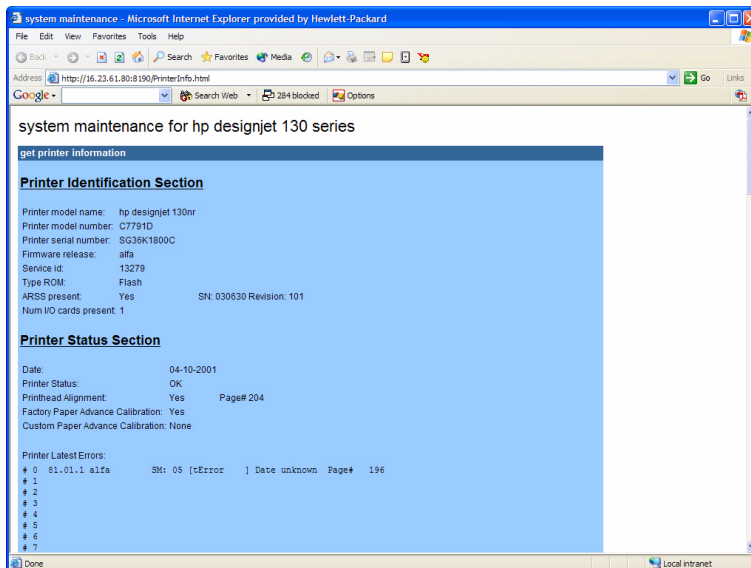
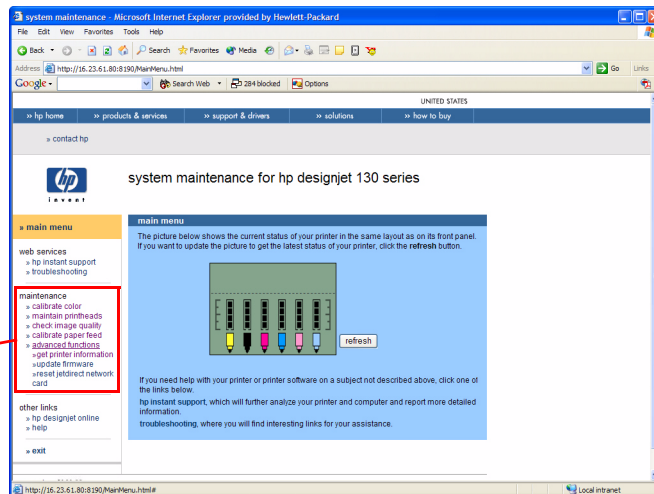

Sample of the information page

Update Firmware

Update firmware updates the built-in software of the printer. The update process will check the printer's version with the latest version available from HP. Before trying this utility, first make sure that you have an internet connection.

Do not power off the printer during this operation. The printer display will indicate busy until the operation is finished.

The first step will be to check if newer printer software is available. If newer software is available, then follow the instructions in the window in order to upgrade the printer software.

Step 1 - Select "advanced functions" and then "update firmware"

- » maintenance
 - » calibrate color
 - » maintain printheads
 - » check image quality
 - » calibrate paper feed
 - » **advanced functions**
 - » get printer information
 - » update firmware
 - » reset jetdirect network card

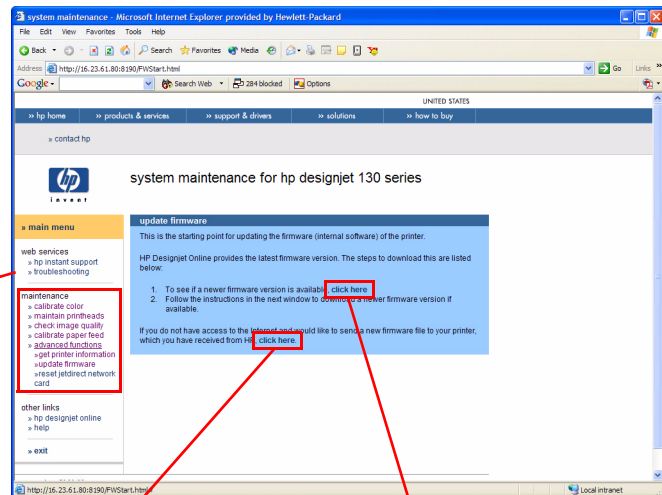

Step 2 - Click on this link

If you do not have Internet access, you can still send a new firmware file (which you have received on CD from HP) from your computer to the Printer.

System Software (firmware)

Your printer already has the latest firmware. No need to download.

Click [here](#) to return to the System Maintenance main menu.

If newer printer software is not available, then this message will be displayed

Reset Jetdirect Network Card

Use this function to reset the HP Jetdirect Network card configuration to the factory defaults. This should only be used if the HP Jetdirect Network card is not responding and no other recovery method works.

Any user configuration information, for example the IP address, will be lost. In this case the *system maintenance* utility will not be able to communicate with the printer using the network.

The HP Jetdirect Network card will need to be reconfigured, using WebJetAdmin for example, after this reset.

Step 1 - Select "advanced functions" and then "reset jetdirect network card"

maintenance
 » calibrate color
 » maintain printheads
 » check image quality
 » calibrate paper feed
 » advanced functions
 » get printer information
 » update firmware
 » reset jetdirect network card

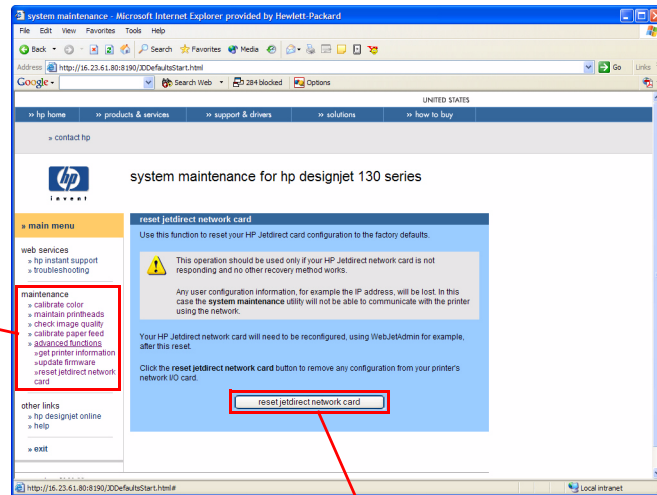

Step 2 - Press "reset jetdirect network card"

Utilities

4

Utilities 4-2

How to Access Restricted Access Utilities 4-2

Enable/Disable Buzzer 4-3

Transport Position 4-3

Printhead Recovery 4-4

Network Card Reset 4-6

Set to Factory Defaults 4-6

Hard EEPROM reset 4-7

Set Flag to Prime Tubes 4-8

Utilities

The following Utilities are available through the printer:

- 1 Enable/disable buzzer ⇒ Page 3
This utility allows you to switch Off or On the internal buzzer.
- 2 Transport Position ⇒ Page 3.
This utility allows you to put the printer in a stable condition before transporting it to another location.
- 3 Printhead Recovery ⇒ Page 4
This utility helps maintain proper operation of all nozzles in the printheads. This is only recommended if you are experiencing problems with print quality such as banding.
- 4 Network Card Reset ⇒ Page 6.
Use this utility to reset the HP Jetdirect card configuration to the factory defaults. This should only be used if the HP Jetdirect card is not responding and no other recovery method works.
- 5 Set to Factory Defaults ⇒ Page 6. **RESTRICTED ACCESS**
Use this utility to return to the default settings that were set in the factory.
- 6 Hard EEPROM reset ⇒ Page 7. **RESTRICTED ACCESS**
This utility allows you to reset the EEPROM inside the Printer.
- 7 Set Flag to Prime Tubes ⇒ Page 8. **RESTRICTED ACCESS**
The purpose of this utility is to prime the Ink Supply Tubes after they have been replaced (or if a situation arises where you need to force the priming).

How to Access Restricted Access Utilities

Some of the Service Utilities are restricted to hp qualified personnel only. To access these restricted service utilities, while the printer is switched OFF, press both the **resume** and **power** buttons together until the Tool icon appears on the front panel.

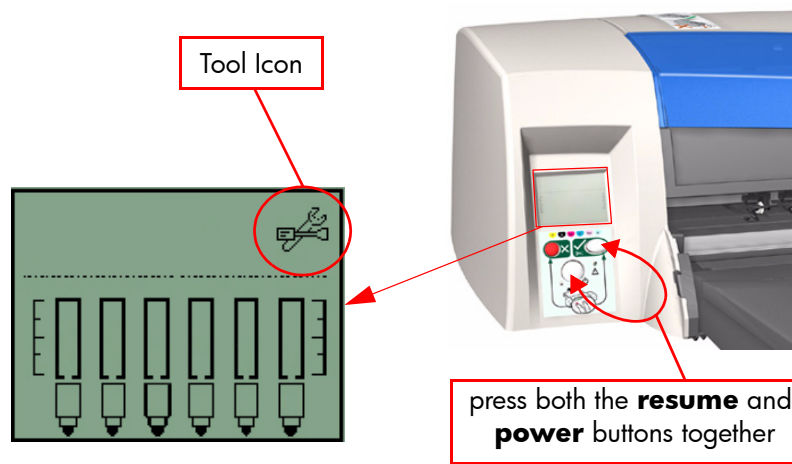

Enable/Disable Buzzer

This utility allows you to switch Off or On the internal buzzer.

Switch Off or On the buzzer as follows:

- 1 Hold the power button down and press the cancel button **five times**.



Hold Power Button

Press Resume button five times

- 2 Turn the Printer Off and then On again.

Transport Position

This utility allows you to put the printer in a stable condition before transporting it to another location.

Place the Printer in Transport Position as follows:

- 1 Hold the power button down and press the cancel button **twice** and the resume button **three times**.



Press Cancel button twice

Hold Power Button

Press Resume button three times

Printhead Recovery

This utility helps maintain proper operation of all nozzles in the printheads. This is only recommended if you are experiencing problems with print quality such as banding.

Three levels of recovery are available: soft, medium and hard. As a first step, the soft recovery should be used. If you still experience the same image problems, then select medium. Hard recovery should only be used as a last resort.

Before recovering the printheads, first check the maximum recovery level already performed on the printheads. If hard level (Recovery Level 3) has already been performed, then do not try performing hard level again. The Maximum Recovery Level can be seen on the Printer Information page in the "Printhead History" section.

Perform the Printhead Recover as follows:

- 1 Depending on the Recovery level, hold the power button down and then press:
 - For level 1 (soft) - the cancel button **twice**.
 - For level 2 (medium) - the cancel button **twice** and the resume button **once**.
 - For level 3 (hard) - the cancel button **twice** and the resume button **twice**.

Some Light Magenta Printheads will show degradation after 150cc of usage. This results in certain shift to green. If both of these conditions, 150cc and up and shift to green are apparent, then the following Printhead Recovery has to be performed.

Warning, this Printhead Recovery is quite strong and should only be executed when both of the above conditions occur. Also, before performing the Light Magenta Printhead Recovery, make sure that the Network, USB or Parallel cable is disconnected from the Printer.

- For Light Magenta Printhead degradation (standard recovery) - the cancel button **twice** and the resume button **5 times**.

A less aggressive recovery can be performed as well, currently it is not in use:

- For Light Magenta Printhead degradation (light recovery) - the cancel button **twice** and the resume button **4 times**.

Ink Consumable Usage Section

Ink Consumed Printhead: K= 0 cc (0 %) C= 0 cc (0 %) M= 0 cc (0 %) Y= 0 cc (0 %) LC= 1 cc (0 %) LM= 1 cc (0 %)
 Usage Time Printhead: K= 6 days C= 6 days M= 6 days Y= 6 days LC= 6 days LM= 6 days
 Ink Consumed Cartridge: K= 2 cc (2 %) C= 1 cc (3 %) M= 1 cc (3 %) Y= 1 cc (1 %) LC= 1 cc (1 %) LM= 1 cc (1 %)

Printhead history:

K:	#1 - Inserted - 0 cc (0%) - 6 days	Max. Recovery Level 1
C:	#1 - Inserted - 0 cc (0%) - 6 days	Max. Recovery Level 1
M:	#1 - Inserted - 0 cc (0%) - 6 days	Max. Recovery Level 1
Y:	#1 - Inserted - 0 cc (0%) - 6 days	Max. Recovery Level 1
LC:	#1 - Inserted - 1 cc (0%) - 6 days	Max. Recovery Level 1
LM:	#1 - Inserted - 1 cc (0%) - 6 days	Max. Recovery Level 1

Maximum Recovery Level already performed



Press Cancel button **twice**

Hold Power Button

Press Resume button:
zero times for level 1 (soft)
once for level 2 (medium)
twice for level 3 (hard)
4 times for level 4 (light)
5 times for level 5 (standard)

Network Card Reset

Use this utility to reset the HP Jetdirect card configuration to the factory defaults. This should only be used if the HP Jetdirect card is not responding and no other recovery method works.

Any user configuration information, for example the IP address, will be lost. In this case the computer will not be able to communicate with the printer using the network.

The HP Jetdirect card will need to be reconfigured, using WebJetAdmin for example, after this reset.

Reset the Network Card as follows:

- 1 Hold the power button down and press the cancel button **three times** and the resume button **once**.



Set to Factory Defaults

Use this utility to return to the default settings that were set in the factory.

Return to Factory Defaults as follows:

- 1 Hold the power button down and press the cancel button **three times** and the resume button **twice**.



Hard EEPROM reset

This utility allows you to reset the EEPROM inside the Printer. A hard EEPROM reset is **ONLY** recommended when you need to install a used Electronics Module in a different Printer. This is because there is a discrepancy between the values of the Carriage EEPROM and the Electronics Module EEPROM and since the values of the Electronics Module EEPROM are incorrect, a hard EEPROM reset will empty the Electronics Module EEPROM. This will then force the Electronics Module EEPROM to collect the values from the Carriage EEPROM when the Printer is next powered up.

After a hard EEPROM reset, the Printer will act like a new Printer and try to prime the Ink Supply Tubes when the Printer is next powered up.

Reset the EEPROM as follows:

- 1 Hold the power button down and press the cancel button **three times** and the resume button **four times**.

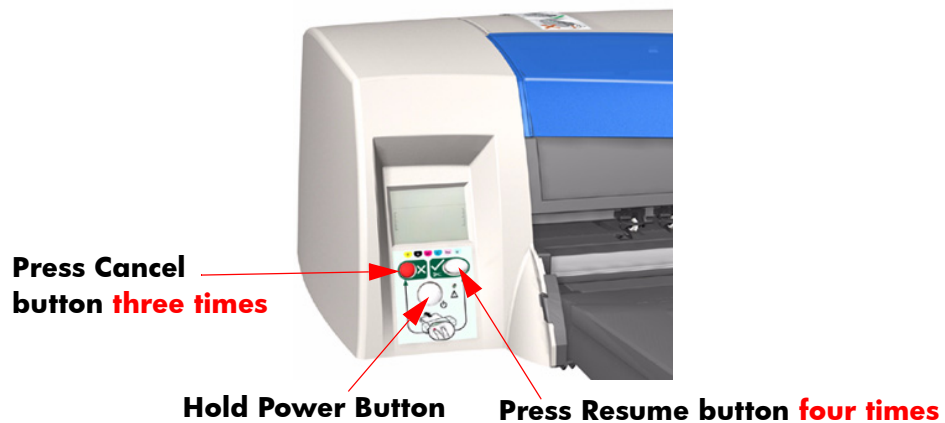

Set Flag to Prime Tubes

The purpose of this utility is to prime the Ink Supply Tubes after they have been replaced (or if a situation arises where you need to force the priming procedure).

Prime the Ink Supply Tubes as follows:

Make sure that you install Printheads that haven't had priming already done to them.

- 1 Hold the power button down and press the cancel button **three times** and the resume button **three times**.

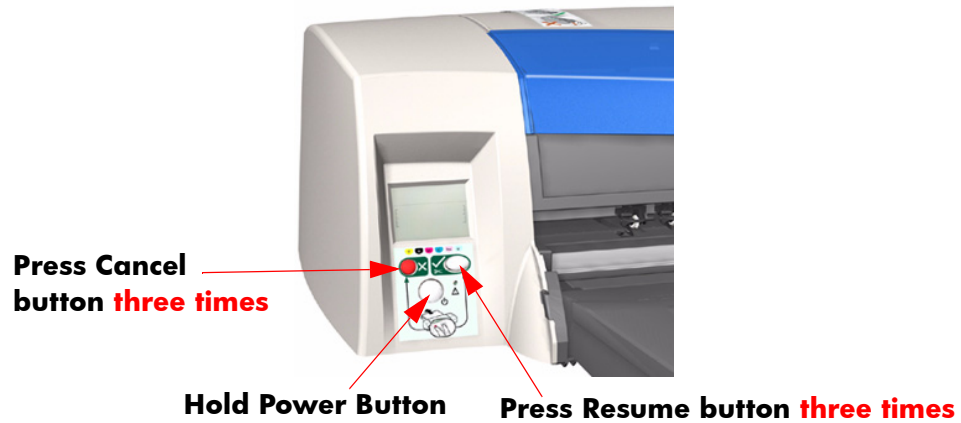

- 2 Switch Off the printer and then On again in order to start the priming of the Ink Supply Tubes.



Calibrations

5

PRS Adjustment 5-2
When Required 5-2
Factory Accuracy Calibration 5-13

PRS Adjustment

When Required

It is very important that you perform the PRS Adjustment whenever:

- The Pivot Assembly is removed **or** replaced.
- The Feed Roller Assembly is removed **or** replaced
- The Carriage Assembly is replaced (it is not necessary to perform the PRS Adjustment if the carriage is resealed).

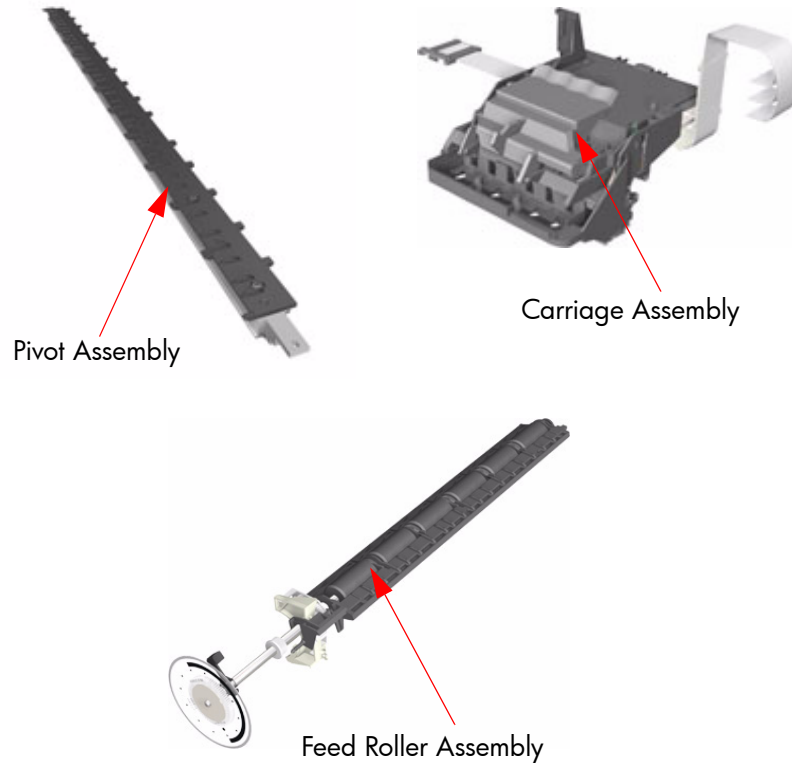

Note: B-size printers do not need Prs Adjustment

Manual PRS Adjustment

The purpose of the Manual PRS Adjustment is to adjust the distance between the Carriage Assembly and the Pivot Assembly. This adjustment is necessary in order to prevent problems like Printhead crashes.

Perform the Manual PRS Adjustment as follows:

The Manual PRS Adjustment should be carried out using the Carriage Height Tool.

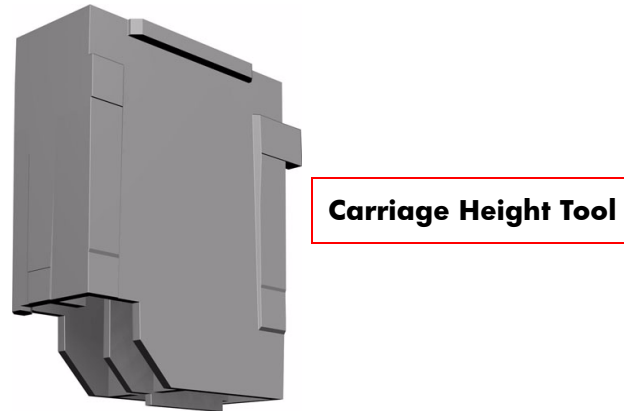

During the Manual PRS Adjustment procedure the Carriage Assembly has to be moved along the length of the printer. Make sure that the Carriage Assembly is only ever moved by pulling the belt and never by direct contact with the Carriage itself.



Correct: move using the belt.



Incorrect: never move using Carriage Assembly.

- 1 Turn On the Printer and open the Printhead Access Door.

Make sure that you turn ON the Printer, otherwise you will NOT be able to open the Carriage Cover.

- 2 Open the Carriage Cover and install the Carriage Height Tool into the Magenta Stall - Make sure ALL the other printheads are already removed from the Carriage Assembly.



- 3 Close the Carriage Cover and switch OFF the Printer.

Make sure that you turn OFF the Printer, otherwise you will NOT be able to manually move the Carriage Assembly.

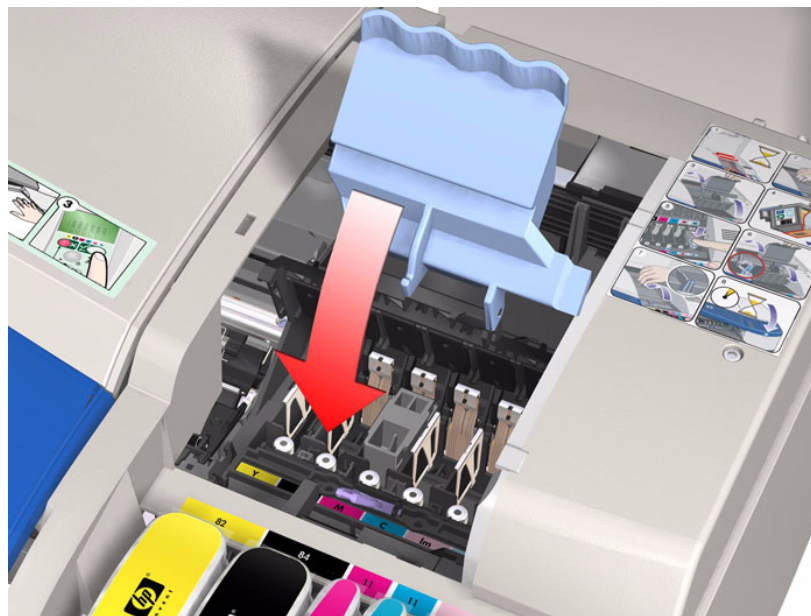

- 4** Move the Carriage Assembly to the left hand side of the Printer (to the position shown).



- 5** Using the belt, move the Carriage Assembly backwards and forwards over the Pivot Assembly (but staying on the left hand side of the printer), carefully listening for a scraping sound.

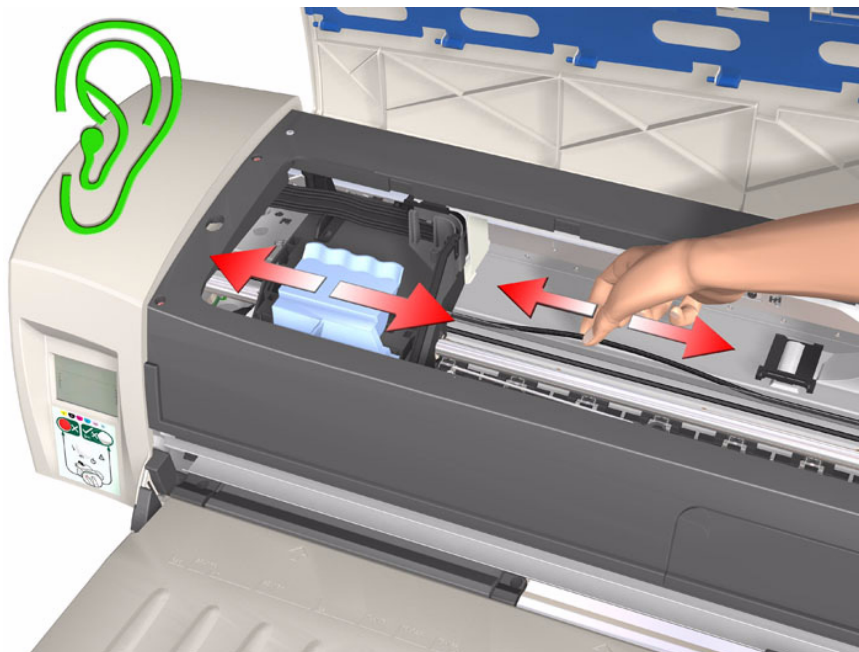

- 6 If you hear a scraping sound, that means that the Pivot Assembly is too high and needs to be lowered slightly. Lower the Pivot Assembly slightly by turning the T-8 screw 1/8th of a turn clockwise and then check for a scraping sound again as shown previously in **step 5**.

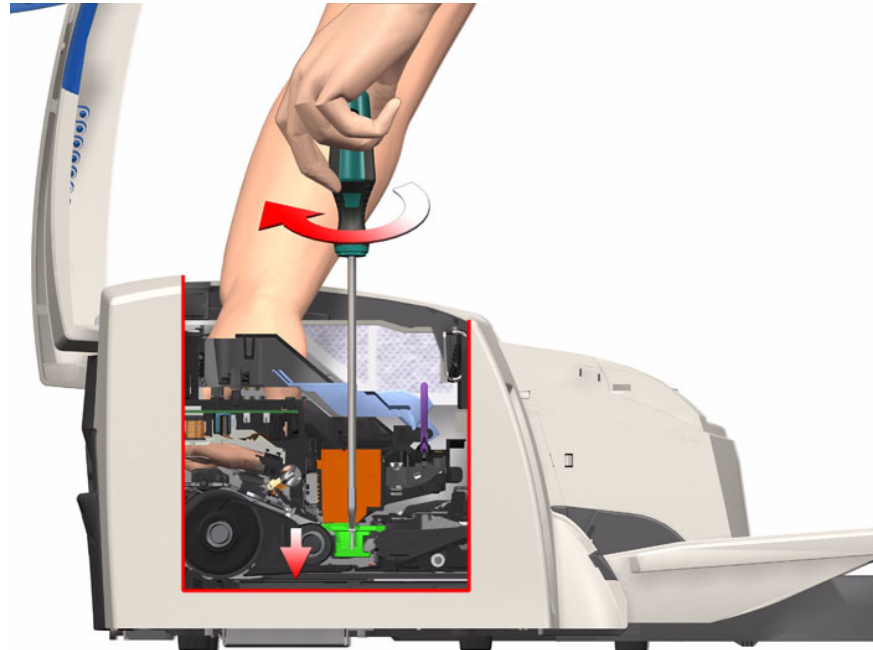
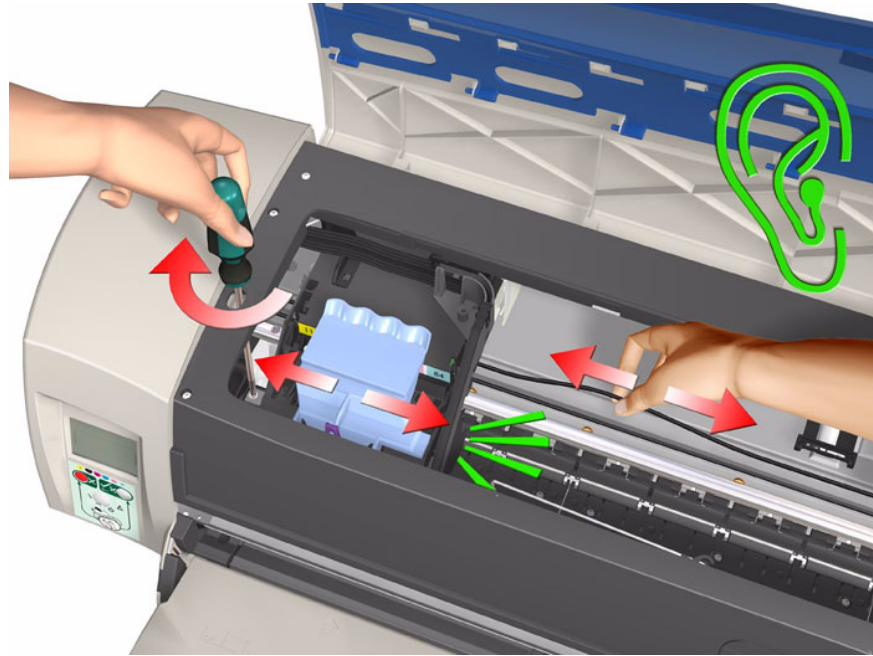

Cross-Section - Lowering the Pivot Assembly

- 7** If you don't hear a scraping sound, that means that the Pivot Assembly is too low and needs to be raised slightly. Raise the Pivot Assembly slightly by turning the T-8 screw 1/8th of a turn anti-clockwise and then check for a scraping sound again as shown previously in **step 5**.

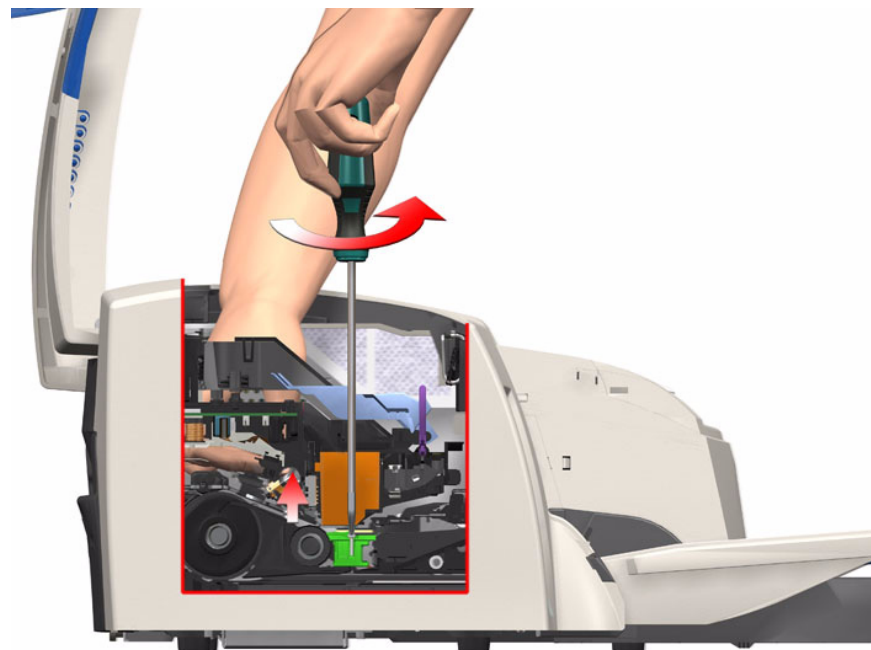
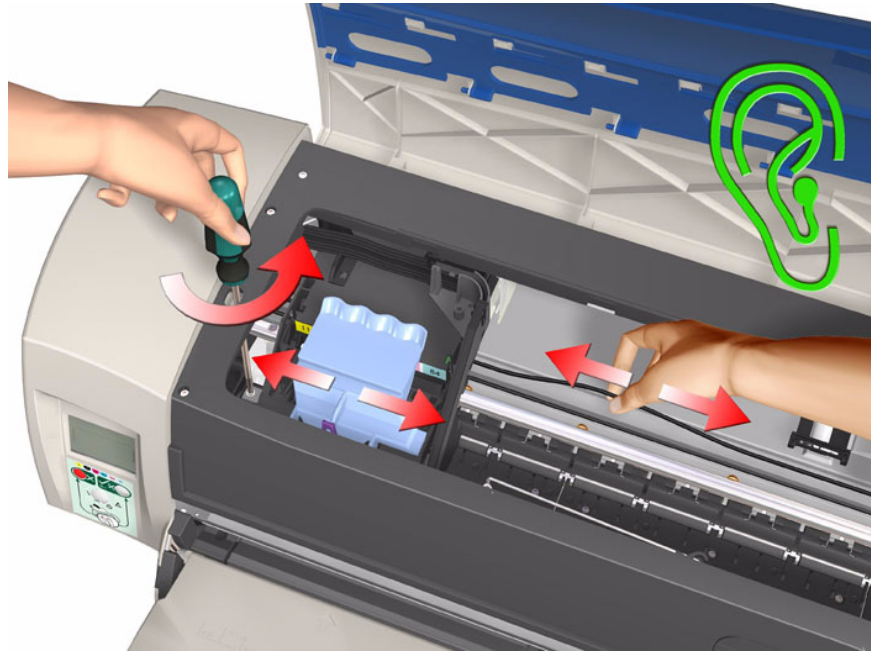

Cross-Section - Raising the Pivot Assembly

- 8** Repeat steps 5 to 7 until you reach a point where you will hear the scraping sound and by turning the screw just 1/8th of a turn clockwise, the scraping sound will disappear.

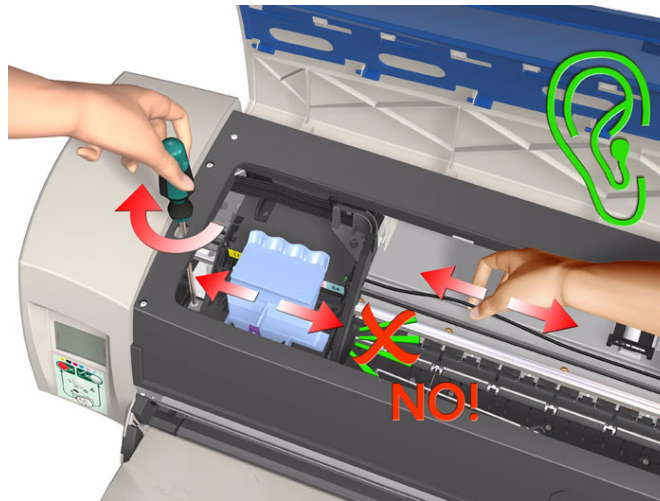

- 9** Move the Carriage Assembly to the right hand side of the Printer (to the position shown).

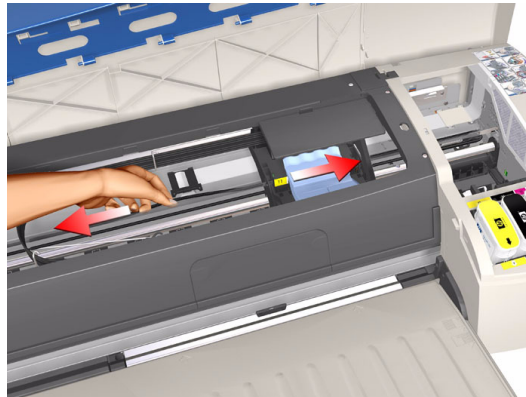

- 10** Using the belt, move the Carriage Assembly backwards and forwards over the Pivot Assembly (but staying on the right hand side of the printer), carefully listening for a scraping sound.

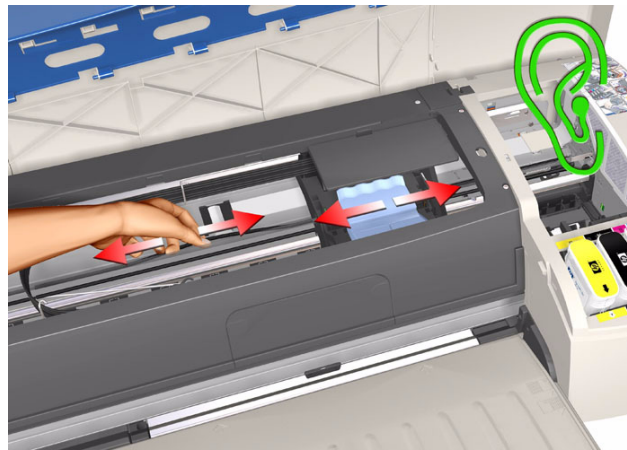

- 11** If you hear a scraping sound, that means that the Pivot Assembly is too high and needs to be lowered slightly. Lower the Pivot Assembly slightly by turning the T-8 screw 1/8th of a turn clockwise and then check for a scraping sound again as shown previously in **step 10**.

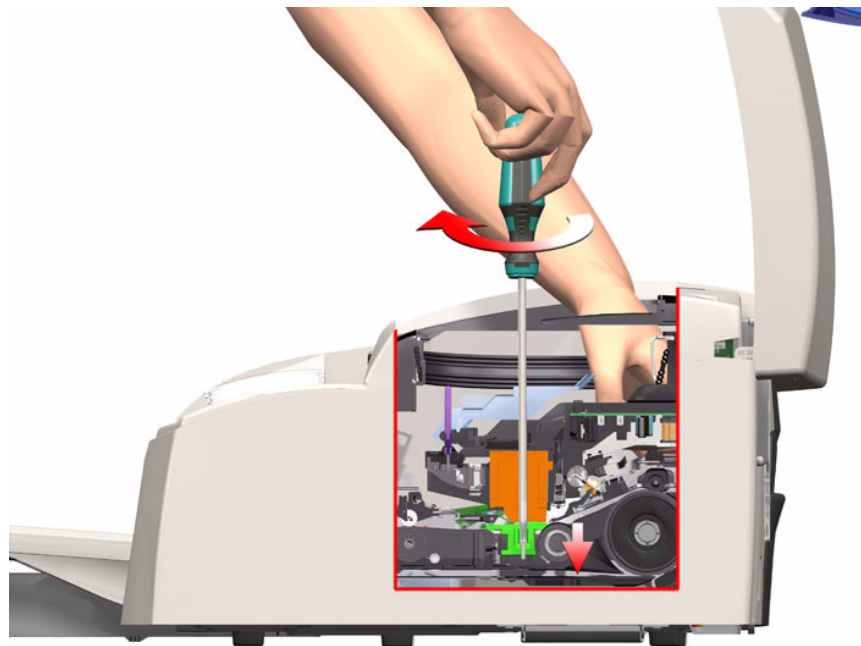
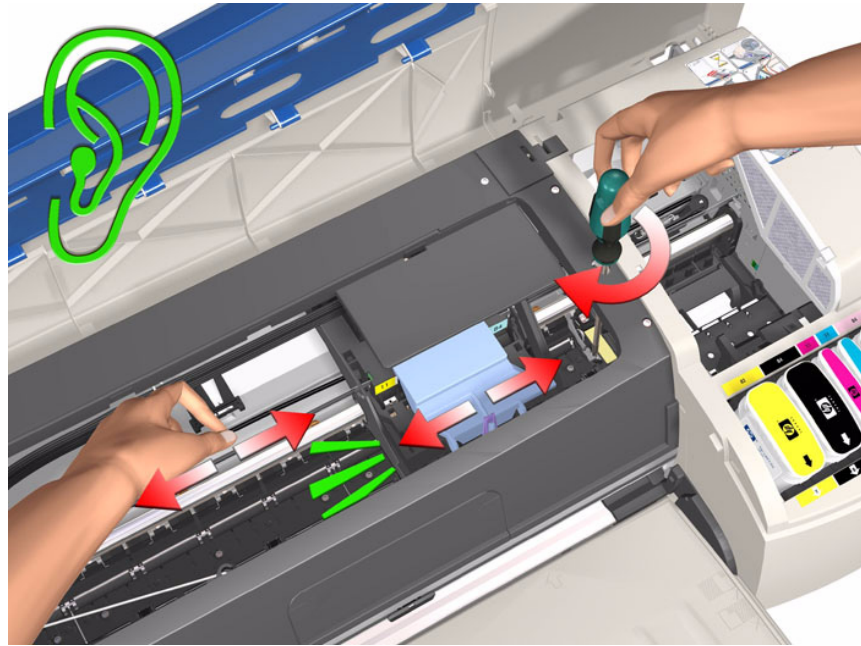

Cross-Section - Lowering the Pivot Assembly

- 12** If you don't hear a scraping sound, that means that the Pivot Assembly is too low and needs to be raised slightly. Raise the Pivot Assembly slightly by turning the T-8 screw 1/8th of a turn anti-clockwise and then check for a scraping sound again as shown previously in **step 10**.

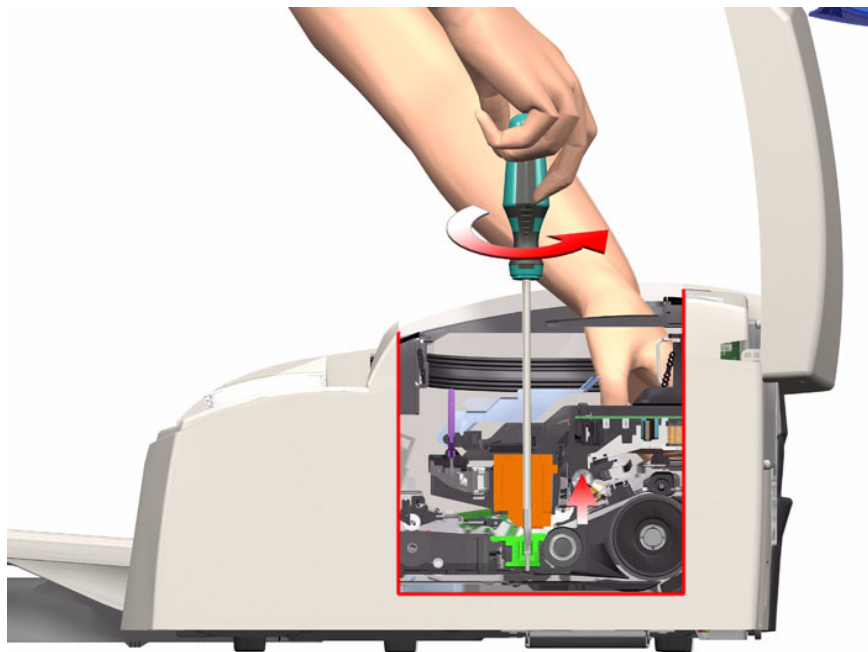
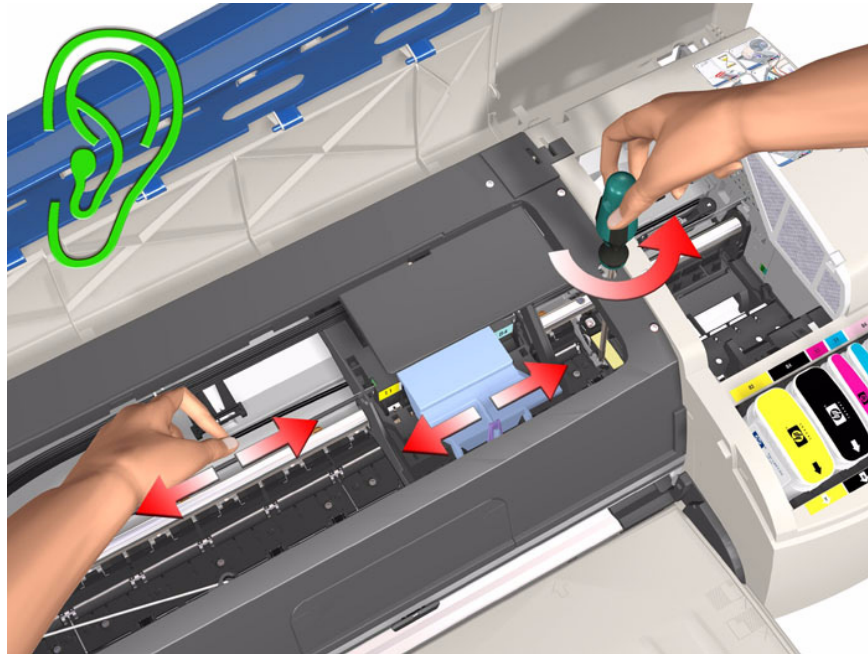

Cross-Section - Raising the Pivot Assembly

- 13** Repeat steps 10 to 12 until you reach a point where you will hear the scraping sound and by turning the screw just $1/8$ th of a turn clockwise, the scraping sound will disappear.

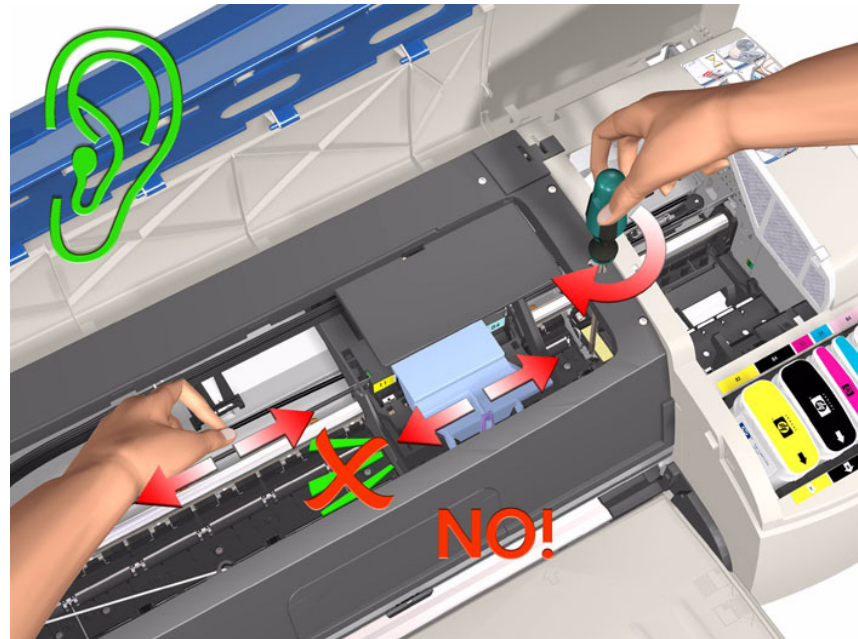

- 14** Move the Carriage Assembly along the length of the Printer, listening carefully for the scraping sound.
- 15** If you don't hear the scraping sound, then the PRS Adjustment is correct, go to **step 17**.

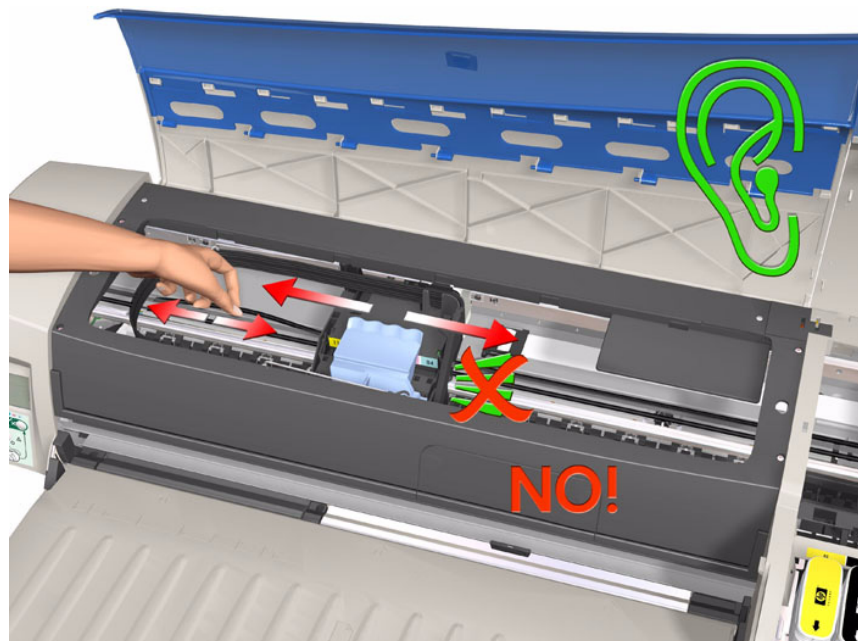

- 16** If you hear the scraping sound, then you will need to lower the Pivot Assembly slightly by turning the T-8 screw 1/8th of a turn clockwise on both the left and right hand side of the Pivot Assembly. Check for a scraping sound again as shown previously in **step 14**.

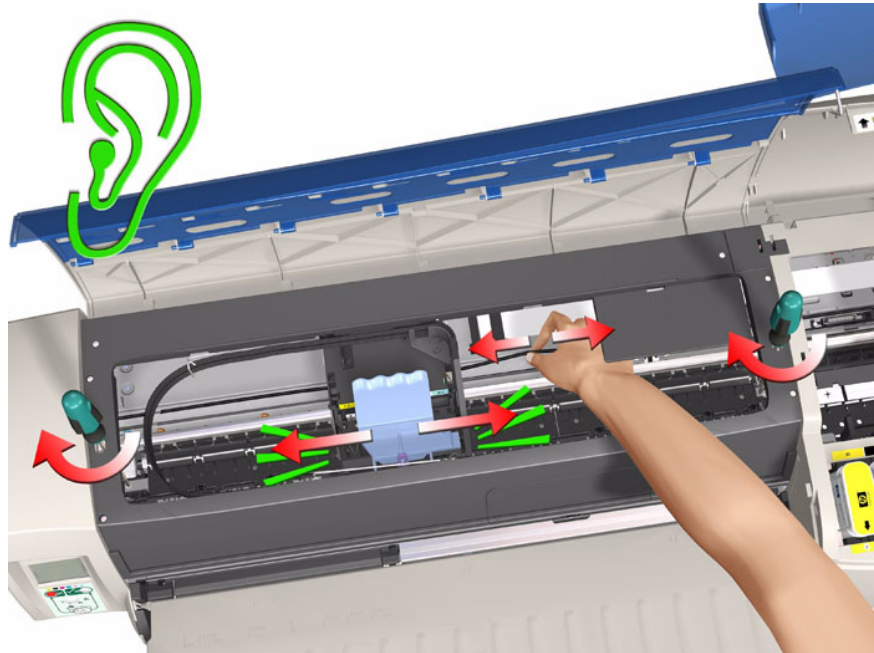

- 17** Remove the Carriage Height Tool.



**Restricted
Access**

Factory Accuracy Calibration

The Accuracy Calibration should ONLY be performed by a qualified Service Engineer.

The Factory Accuracy Calibration needs to be performed whenever:

- Banding is detected in printed images.
- The Feed Roller Assembly is disassembled **or** replaced.
- The Paper-Axis Motor Drive Assembly is disassembled **or** replaced.
- The Encoder Disc is removed **or** replaced.

Ensure that you use HP Proofing Gloss or HP Premium Photo Gloss in order to perform the Factory Accuracy Calibration.

The B size printer (HP Designjet 30 Printer series) needs at least firmware B.05.XX to be able to perform this calibration

Perform the Accuracy Calibration as follows:

- 1 Load an A3/B-size sheet of HP Proofing Gloss in to the input tray.
- 2 To manually print the Factory Accuracy Calibration, hold the power button down and press the cancel button **once** and the resume button **once**.

**To Print the
Factory Accuracy
Calibration**

Press Cancel
button **once**

Hold Power Button



Press Resume
button **once**

- 3 Once the Accuracy Calibration has been printed, rotate the page and reload it upside down (image facing down).
- 4 To scan the Accuracy Calibration, hold the power button down and press the cancel button **once** and the resume button **four times**.

**To Scan the
Accuracy Calibration**

Press Cancel
button **once**

Hold Power Button



Press Resume
button **four times**

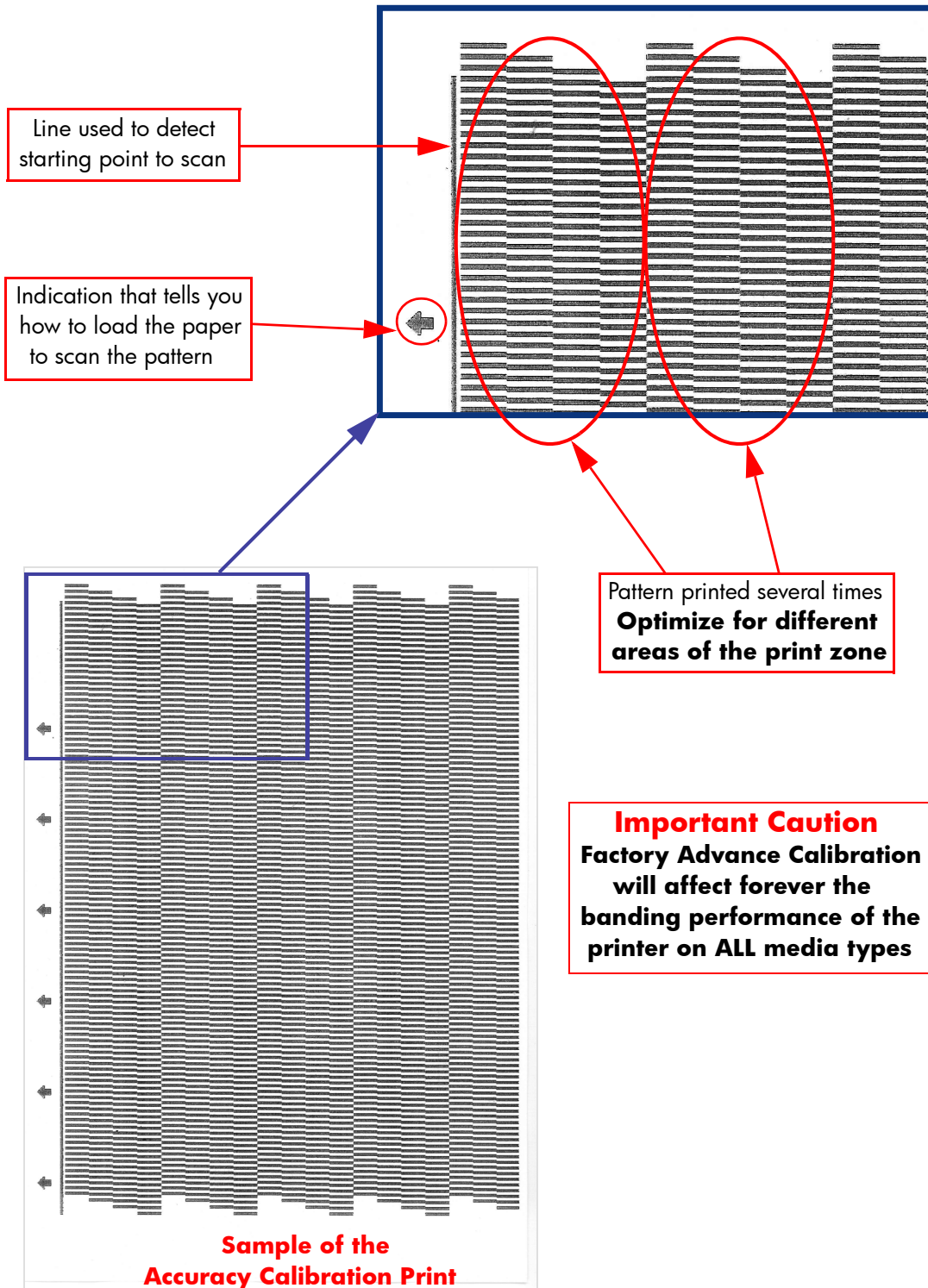

Parts replacement and associated calibrations

Following the removal and replacement of some components, it is important that calibrations are performed immediately afterwards. Shown below is a table describing which parts require calibrations when they are replaced, and the order in which you should perform the calibrations.

Description of service part	Media Advance Calibration	PRS Calibration	Printhead Alignment
Print Platen SV		1	2
Pick Roller SV	1	2	3
Feed Roller	1	2	3
Inner Paper G SV	1	2	3
Carriage Belt SV			1
Lower Paper Guide Bits SV	1	2	3
Bypass Platen	1	2	3
Bypass Actuator	1	2	3
Carriage SV		1	2
Tubes SV			1
Pivot SV		1	2
Electronics Module			1
Disk Encoder	1		2



Parts and Diagrams

6

- Cover Assemblies 6-2
- Cover Assemblies 6-5
- Printer Labels 6-8
- Right Hand Assemblies 6-11
- Left Hand Assemblies 6-14
- Scan-Axis Assemblies 6-16
- Top Paper Path Assemblies (1 of 2) 6-19
- Top Paper Path Assemblies (2 of 2) 6-21
- Rear Paper Path Assemblies 6-23
- Paper Feed Assemblies 6-25
- Cable Harnesses 6-27
- Ink Supplies & Accessories (1 of 4) 6-29
- Ink Supplies & Accessories (3 of 4) 6-33
- Ink Supplies & Accessories (4 of 4) 6-35
- Rollfeed Components 6-37

Cover Assemblies

Applicable Designjets: Only 10ps, 20ps, 50ps, 30, 30n

Cover Assemblies			
Reference on Drawing	HP Part Number	Quantity	Description/Comments
1	C7790-60118	1	Left Cover (Includes Front Panel Label) (Applicable to 10ps,20ps,50ps)
1	C7790-60447	1	Left Cover (Includes Front Panel Label) (Applicable to 30 & 30n)
2	C7790-60108	1	Left Trim (Applicable to 10ps,20ps,50ps)
2	C7790-60444	1	Left Trim (Applicable to 30 & 30n)
3	0515-2811	2	Screw
4	C7790-60117	1	Right Cover (includes the Right Trim, Instruction Label, Ink Family Number Label and Ink Color Label) (Applicable to 10ps,20ps,50ps)
	C7790-60456	1	Right Cover (includes the Right Trim, Instruction Label, Ink Family Number Label and Ink Color Label) (Applicable to 30 & 30n)
5	0515-2812	1	Screw
6	C7790-60295	1	Filter Assembly
7	C7790-60100	1	Back Cover (Center Cover) (Applicable to 10ps,20ps,50ps)
	C7790-60100	1	Back Cover (Center Cover) (Applicable to 30 & 30n)
8	0515-2811	4	Screw
9	C7790-60102	1	Front Cover (Applicable to 10ps,20ps,50ps)
10	Q1293-60054	1	Door Sensor Assembly
11	C7790-60292	1	Ink Cartridge Door 10ps
	C7790-60293	1	Ink Cartridge Door 20ps
	C7790-60452	1	Ink Cartridge Door 30
	C7790-60453	1	Ink Cartridge Door 30n
	C7790-60294	1	Ink Cartridge Door 50ps
12	C7790-60106	1	Printhead Door Assembly (includes Ink Cartridge Door Hinge and Printhead Door Label) (Applicable to 10ps,20ps,50ps)

	C7790-60457	1	Printhead Door Assembly (includes Ink Cartridge Door Hinge and Printhead Door Label) (Applicable to 30 & 30n)
13	C7790-60086	1	Access Door Assembly (Applicable to 10ps, 20ps, 50ps)
	C7790-60443	1	Access Door Assembly (Applicable to 30 & 30n)

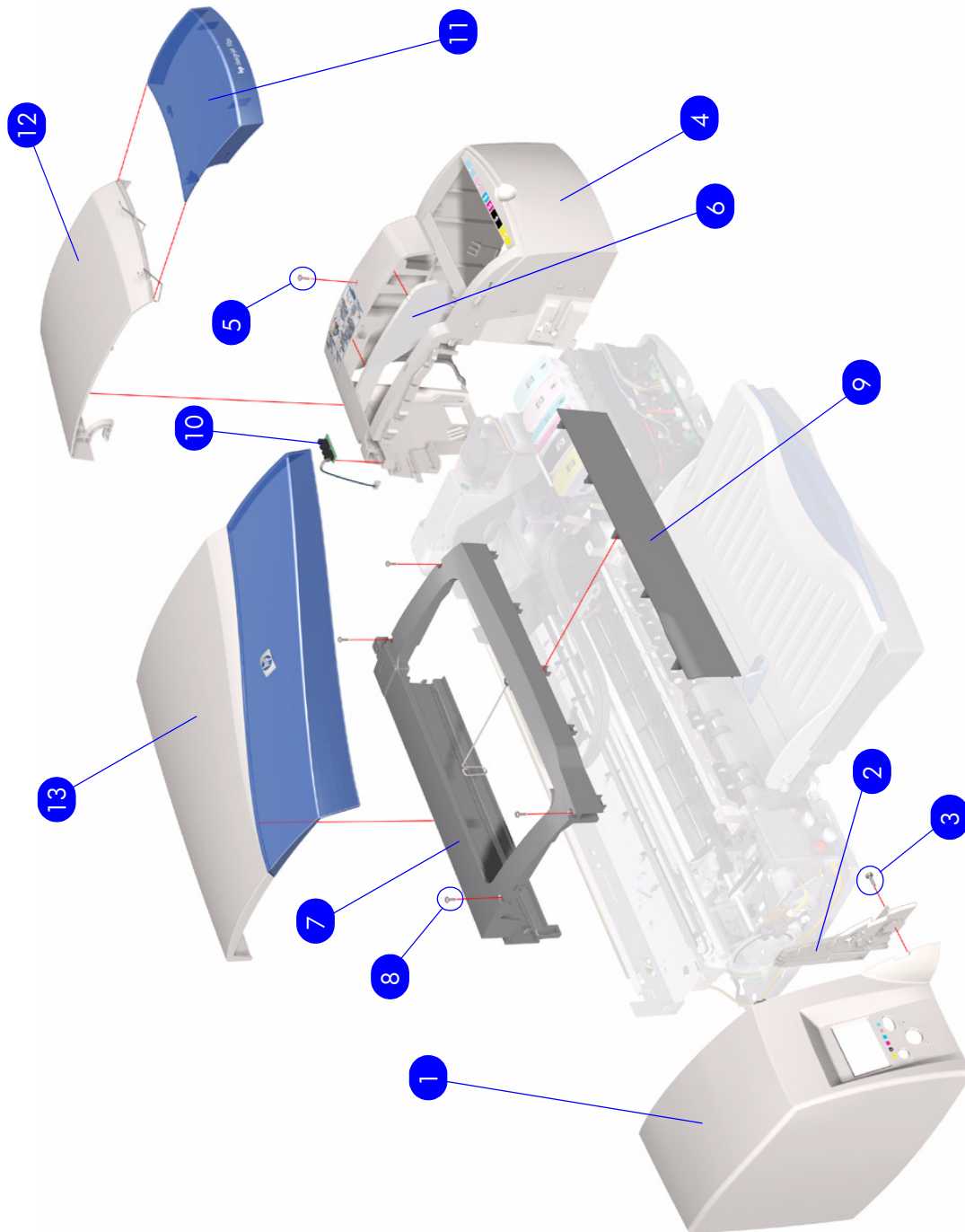

Figure 1: Cover Assemblies

Cover Assemblies

Cover Assemblies			
Reference on Drawing	HP Part Number	Quantity	Description/Comments
1	C7791-60300	1	Left Cover (Includes Front Panel Label) (Applicable to 130 & 130nr)
	C7796-60018	1	Left Cover (Includes Front Panel Label) (Applicable to 100, 100+, 110, 110+, 110+nr)
	C7791-60137	1	Left Cover (Includes Front Panel Label) (Applicable to 120 & 120nr)
	Q6655-60091	1	Left Cover (Includes Front Panel Label) (Applicable to 70)
	Q6656-60062	1	Left Cover (Includes Front Panel Label) (Applicable to 90, 90r)
2	0515-2811	2	Screw
3	C7791-60286	1	Right Cover (Applicable to 90, 90r, 130 & 130nr)
	C7796-60064	1	Right Cover (Applicable to 70, 100, 100+, 110, 110+, 110+nr)
	C7791-60311	1	Right Cover (Applicable to 120 & 120nr)
4	0515-2812	1	Screw
5	C7790-60295	1	Filter Assembly
6	C7791-60285		Back Cover (Center Cover) (Applicable to 130 & 130nr)
	C7791-60310	1	Back Cover (Applicable to 100, 100+, 110, 110+, 110+nr, 120 & 120nr)
	Q6655-60092	1	Back Cover (Applicable to 70)
	Q6656-60063	1	Back Cover (Applicable to 90, 90r)
7	0515-2811	4	Screw
8	Q1293-60054	1	Door Sensor Assembly
9	Q6655-60093		Ink Cartridge Door (Applicable to 70)
	Q6656-60064		Ink Cartridge Door (Applicable to 90)
	Q6656-60079		Ink Cartridge Door (Applicable to 90r)
	C7791-60294	1	Ink Cartridge Door (Applicable to 130)
	C7791-60295	1	Ink Cartridge Door (Applicable to 130nr)
	C7796-60015	1	Ink Cartridge Door (Applicable to 100)
	C7796-60094		Ink Cartridge Door (Applicable to 100+)

	C7791-60244	1	Ink Cartridge Door (Applicable to 110)
	C7796-60095		Ink Cartridge Door (Applicable to 110+)
	C7796-60106		Ink Cartridge Door (Applicable to 110+nr)
	C7791-60130	1	Ink Cartridge Door (Applicable to 120)
	C7791-60131	1	Ink Cartridge Door (Applicable to 120nr)
10	C7790-60457	1	Printhead Door Assembly (includes Ink Cartridge Door Hinge and Printhead Door Label) (Applicable to 90, 90r, 130 & 130nr)
	C7796-60021	1	Printhead Door Assembly (includes Ink Cartridge Door Hinge and Printhead Door Label) (Applicable to 70, 100, 100+, 110, 110+, 110+nr)
	C7790-60106	1	Printhead Door Assembly (includes Ink Cartridge Door Hinge and Printhead Door Label) (Applicable to 120 & 120nr)
11	C7791-60277	1	Access Door Assembly (Applicable to 130 & 130nr)
	C7791-60139	1	Access Door Assembly (Applicable to 120 & 120nr)
	C7796-60020	1	Access Door Assembly (Applicable to 100, 100+, 110, 110+, 110+nr)
	Q6655-60094	1	Access Door Assembly (Applicable to 70)
	Q6656-60065	1	Access Door Assembly (Applicable to 90, 90r)
12	C7791-60216	1	Rear Trim Kit (Applicable to 100, 110+, 110, 110+, 120, 130)

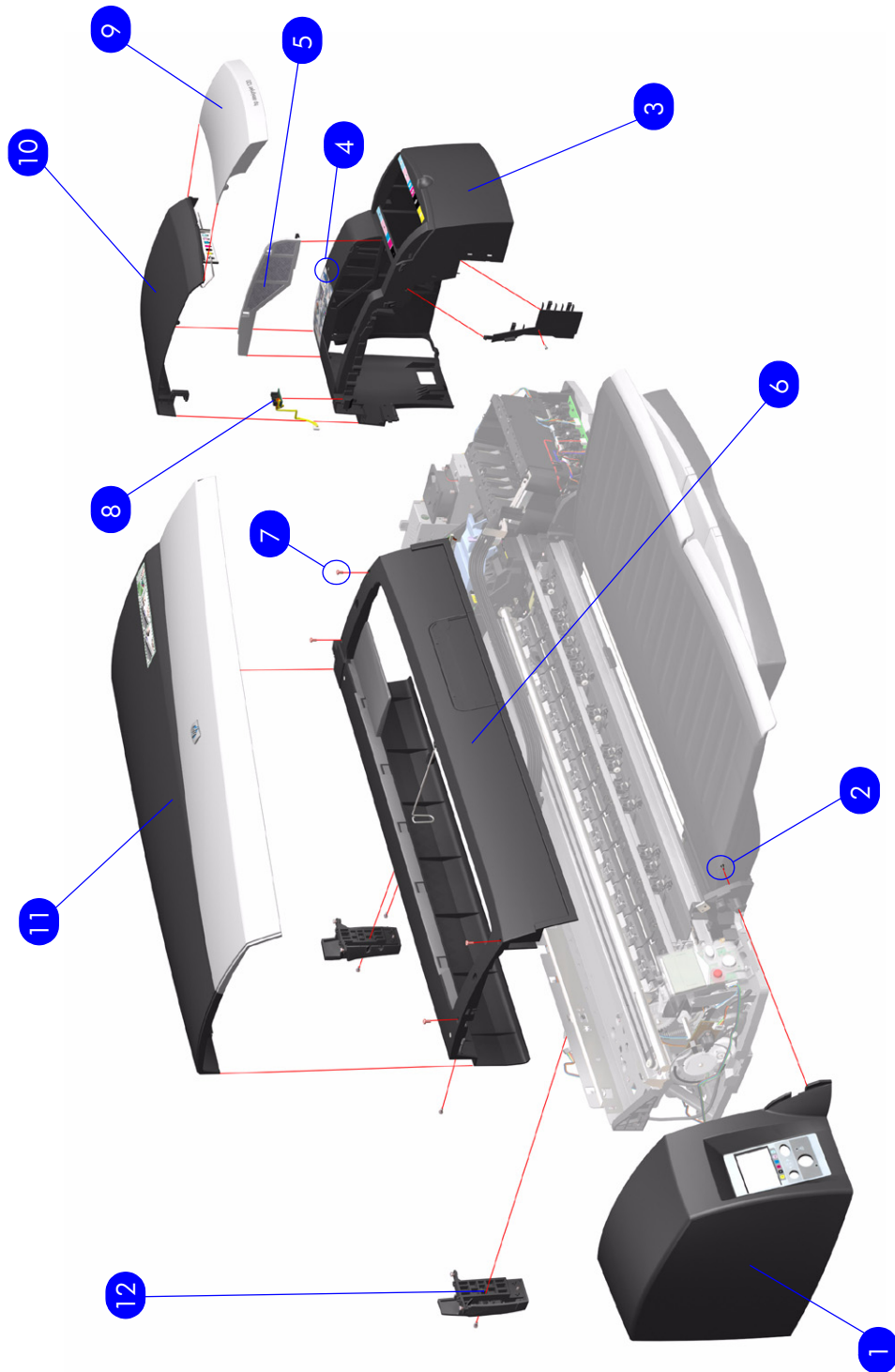

Figure 2: Cover Assemblies

Printer Labels

Printer Labels			
Reference on Drawing	HP Part Number	Quantity	Description/Comments
1	C7790-60202	1	Printhead Access Instructions Label (Applicable to 10ps, 20ps and 50ps)
	C7790-60450	1	Printhead Access Instructions Label (Applicable to 30, 30n, 90, 90r, 130 & 130nr)
	C7796-60041	1	Printhead Access Instructions Label (Applicable to 70, 100, 100+, 110, 110+, 110+nr)
	C7790-60202	1	Printhead Access Instructions Label (Applicable to 120 and 120nr)
2	C8109-67002		Ink Cartridge Color Label (Applicable to 70, 100, 100+, 110, 110+, 110+nr)
	C7790-60201		Ink Cartridge Color Label (Applicable to 10ps, 20ps, 30, 30n, 50ps, 90, 90r, 120, 120nr)
3	C7790-60148		Ink Cartridge Family Label (Applicable to 10ps, 20ps, 50ps, 120, 120nr)
	C7790-60449	1	Ink Cartridge Family Label (Applicable to 30, 30n, 90, 90r, 130 & 130nr)
	C8109-67003	1	Ink Cartridge Family Label (Applicable to 70, 100, 100+, 110, 110+, 110+nr)
4	C7790-60139	1	Serial Number Label 10ps
	C7790-00041	1	Serial Number Label 20ps
	C7790-60477	1	Serial Number Label 30
	C7790-60478	1	Serial Number Label 30n
	C7790-00042	1	Serial Number Label 50ps
	Q6655-60095	1	Serial Number Label 70
	Q6656-60066	1	Serial Number Label 90
	Q6656-60080	1	Serial Number Label 90r
	C7796-60027	1	Serial Number Label 100
	C7796-60098	1	Serial Number Label 100+
	C7796-60033	1	Serial Number Label 110
	C7796-60099	1	Serial Number Label 110+
	C7791-60334	1	Serial Number Label 110+nr
	C7791-60148	1	Serial Number Label 120

	C7791-60149	1	Serial Number Label 120nr
	C7791-60303	1	Serial Number Label 130
	C7791-60305	1	Serial Number Label 130nr
5	C7790-60213	1	Front Panel Label (Applicable to 10ps, 20ps and 50ps)
	Q6655-60096	1	Front Panel Label (Applicable to 70)
	Q6656-60067	1	Front Panel Label (Applicable to 90, 90r)
	C7790-60451	1	Front Panel Label (Applicable to 30, 30n and 130, 130nr)
	C7796-60042		Front Panel Label (Applicable to 100, 110+, 110, 110+, 110+nr)
	C7791-60255		Front Panel Label (Applicable to 120, 120nr)
-	C7791-60228	1	Load Rollfeed Label (Applicable to 90r, 130nr, 110, 110+, 110+nr, 120nr, 130nr)

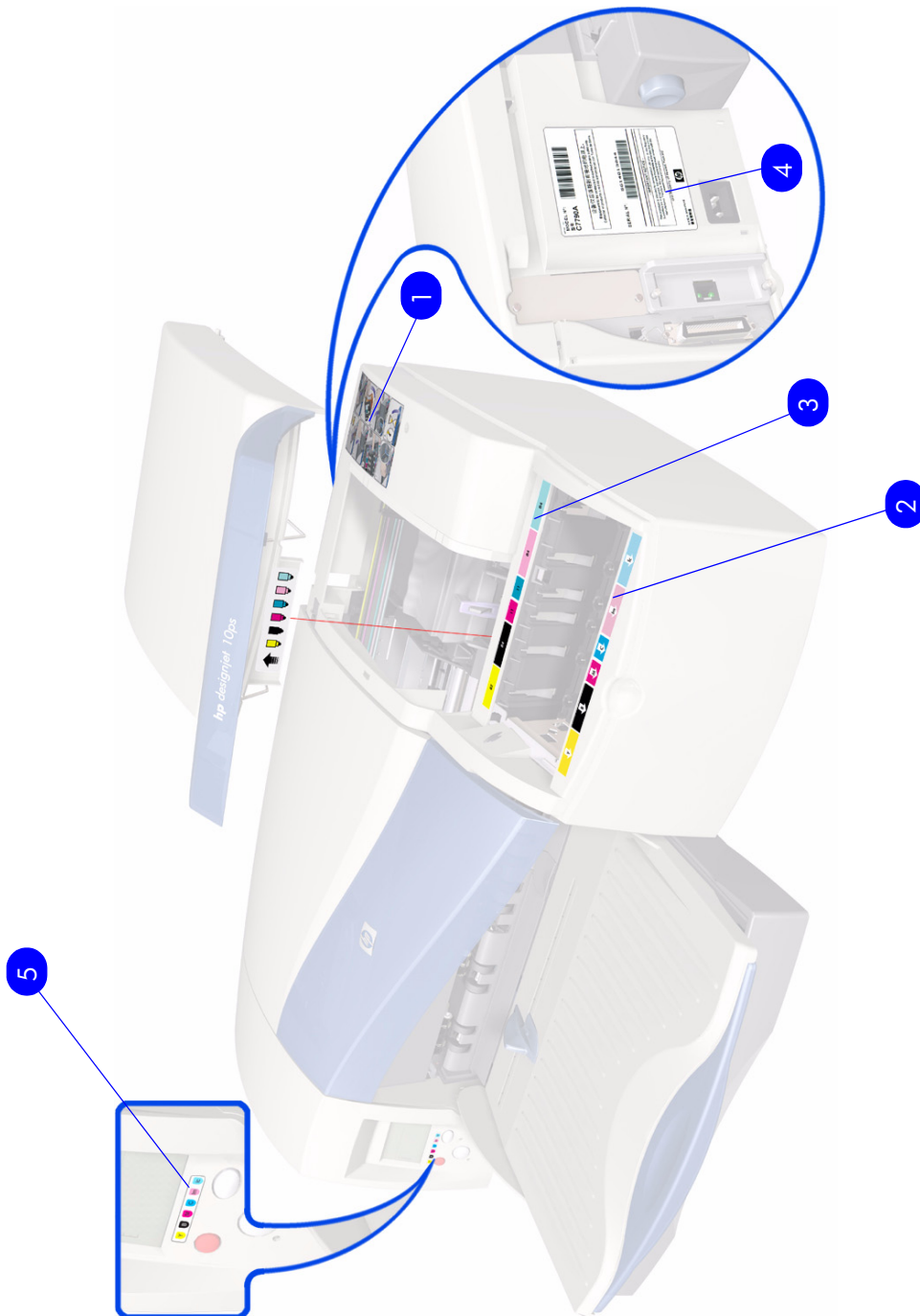

Figure 3: Printer Labels

Right Hand Assemblies

Right Hand Assemblies			
Reference on Drawing	HP Part Number	Quantity	Description/Comments
1	C7790-60419	1	Ink Supply Station Assembly (Applicable to 10ps, 20ps and 50ps)
	C1296-60049	1	Ink Supply Station Assembly (Applicable to 30, 30n, 90, 90r, 130, 130nr)
	C7796-60029		Ink Supply Station Assembly (Applicable to 70, 100, 100+, 110, 110+, 110+nr)
	C7790-60419		Ink Supply Station Assembly (Applicable to 120 and 120nr)
2	0515-2812	2	Screw
3	C7790-60145	1	ISS Bottom Foam (Applicable to 10ps, 20ps and 50p, 30, 30n, 90, 90r, 120, 120nr, 130, 130nr)
	C8109-67022	1	ISS Bottom Foam (Applicable to 70, 100, 100+, 110, 110+, 110+nr)
4	C7790-60144	1	ISS Rear Foam (Applicable to 10ps, 20ps, 50ps, 70, 100, 100+, 110, 110+, 110+nr, 120, 120nr)
	C7790-60470	1	ISS Rear Foam (Applicable to 30, 30n, 90, 90r, 130, 130nr)
5	C7790-60418	1	Electronics Module Assembly (Applicable to 10ps, 20ps and 50ps)
	C1293-60048	1	Electronics Module Assembly (Applicable to 30 and 30n)
	Q6655-60120		Electronics Module Assembly (Applicable to 70)
	Q6656-60093	1	Electronics Module Assembly (Applicable to 90, 90r)
	C1293-60203	1	Electronics Module Assembly (Applicable to 130 and 130nr)
	C7796-60204	1	Electronics Module Assembly (Applicable to 100, 110)
	C7796-60149	1	Electronics Module Assembly (Applicable to 100+, 110+, 110+nr)
	C7791-60132		Electronics Module Assembly (Applicable to 120, 120nr)
6	0515-2599	2	Screw
7	Q1293-60053	1	Power Supply Unit

8	0515-2599	2	Screw
9	0515-2812	1	Screw
10	C7790-60435	1	Service Station Assembly (Applicable to 10ps, 20ps and 50ps, 120, 120nr)
	Q1293-60052	1	Service Station Assembly (Applicable to 30 and 30n)
	Q1292-60206	1	Service Station Assembly (Applicable to 90, 90r, 130 and 130nr)
	C7796-60203	1	Service Station Assembly (Applicable to 70, 100, 100+, 110, 110+, 110+nr)
11	C8108-67031	1	Duplexer Interconnect PCA (Applicable to 10ps, 20ps, 50ps, 30, 30n)
	Q1292-60208	1	Duplexer Interconnect PCA (Applicable to 70, 90, 90r, 100, 110, 120, 120nr, 130 and 130nr)
12	0515-2812	1	Screw

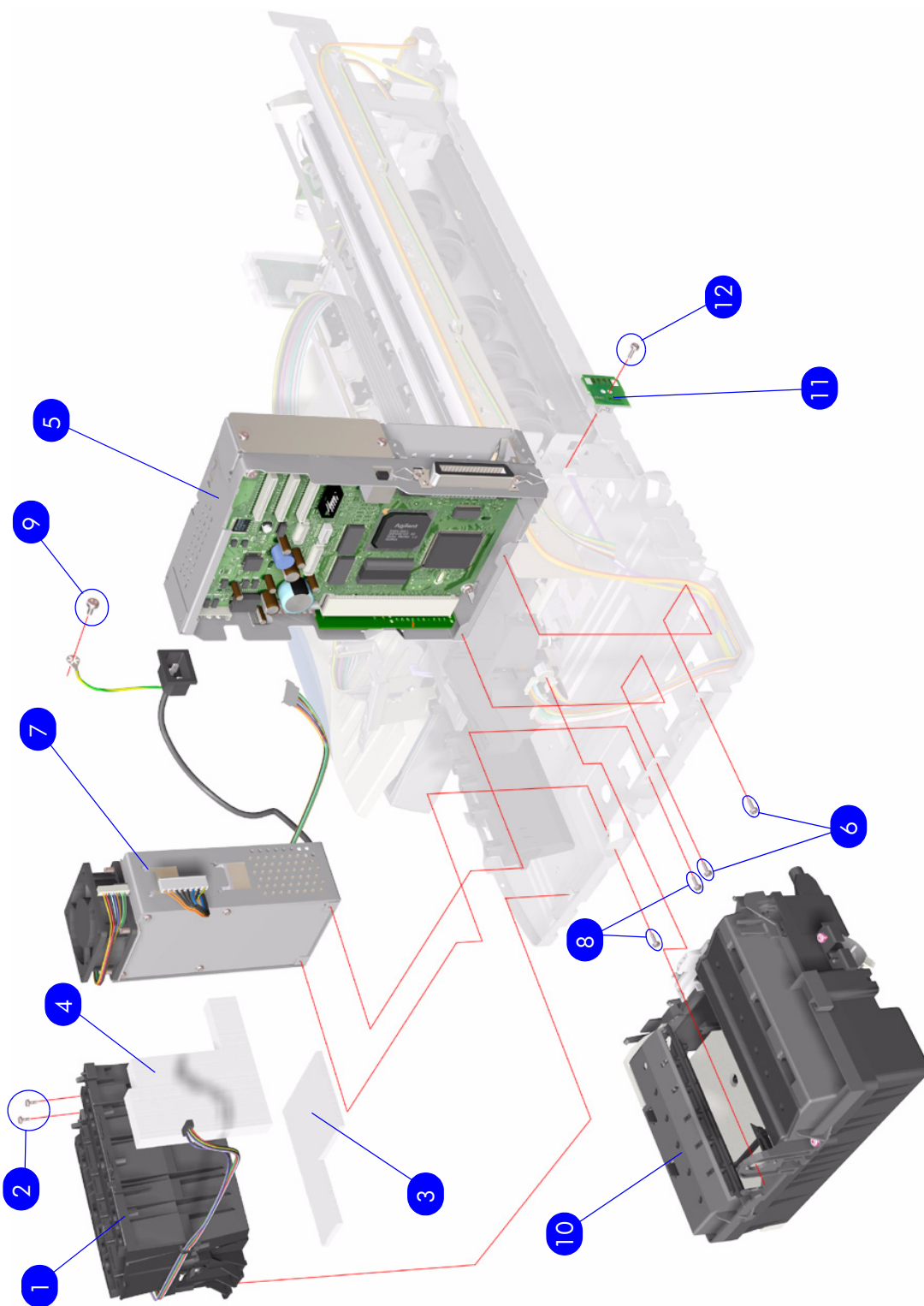

Figure 4: Right Hand Assemblies

Left Hand Assemblies

Left Hand Assemblies			
Reference on Drawing	HP Part Number	Quantity	Description/Comments
1	C7790-60109	1	Front Panel Assembly (Includes Front Panel Cable) (Applicable to 10ps, 20ps and 50ps)
	Q1293-60047	1	Front Panel Assembly (Includes Front Panel Cable) (Applicable to 30, 30n, 130, 130nr Printer)
	C7796-60208	1	Front Panel Assembly (Includes Front Panel Cable) (Applicable to 100, 110, 110+, 110+nr, 120, 120nr)
2	Q1292-60218	1	LF Motor Assembly (Paper-Axis Motor)
3	0515-2812	1	Screw
4	Q1292-60219	1	Ramp Drive Assembly
5	0515-2812	1	Screw
6	Q1293-60068	1	Output Mechanism Support Assembly
7	0515-2812	2	Screw
8	C8108-67051	1	Encoder Disc
9	C7790-60200	1	2nd Bin PCBA (Interconnect PCA) (Applicable to 10ps, 20ps and 50ps)
10	0515-2812	1	Screw
11	Q1292-60207	1	Carriage Motor Assembly
12	0515-2812	2	Screw
13	C8108-67048	1	Output Belt

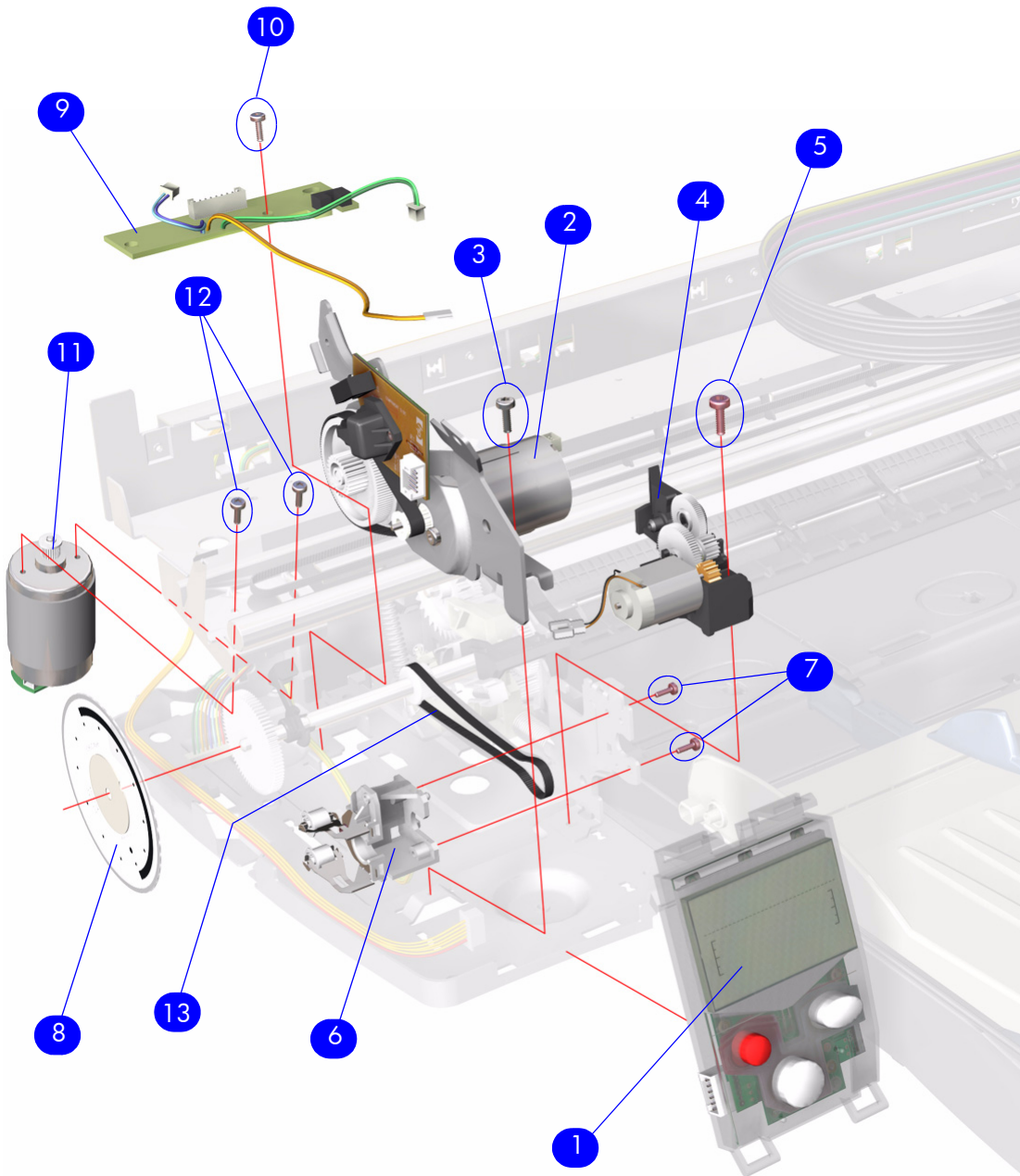

Figure 5: Left Hand Assemblies

Scan-Axis Assemblies

Scan-Axis Assemblies			
Reference on Drawing	HP Part Number	Quantity	Description/Comments
1	C7790-60278	1	Carriage Assembly (Includes Trailing Cable) (Applicable to 10ps, 20ps and 50ps)
	Q1293-60046	1	Carriage Assembly (Includes Trailing Cable) (Applicable to 30 and 30n)
	Q1292-60202	1	Carriage Assembly (Includes Trailing Cable) (Applicable to 130 and 130nr)
	Q6655-60121	1	Carriage Assembly (Includes Trailing Cable) (Applicable to 70)
	Q6656-60094	1	Carriage Assembly (Includes Trailing Cable) (Applicable to 90, 90r)
	C7796-60205	1	Carriage Assembly (Includes Trailing Cable) (Applicable to 100, 100+, 110, 110+, 110+nr)
	C7791-60142	1	Carriage Assembly (Includes Trailing Cable) (Applicable to 120 and 120nr)
	C7790-60112	1	Tubes Assembly (Applicable to 10ps, 20ps and 50ps)
	Q1293-60065	1	Tubes Assembly (Applicable to 30 and 30n)
	Q6655-60140	1	Tubes Assembly (Applicable to 70)
2	Q6656-60103	1	Tubes Assembly (Applicable to 90, 90r)
	Q1292-60235	1	Tubes Assembly (Applicable to 130 and 130nr)
	C7796-60219	1	Tubes Assembly (Applicable to 100, 100+, 110, 110+, 110+nr)
	C7791-60129	1	Tubes Assembly (Applicable to 120 and 120nr)
	0515-2675	3	Screw
	3	C7790-60203	1
Q6655-60069		1	Carriage Belt (Applicable to 70, 90, 90r)
C7791-60233		1	Carriage Belt (Applicable to 100, 100+, 110, 110+, 110+nr, 120, 120nr, 130 and 130nr)
Q6655-60064		1	Carriage Belt (Applicable to 70, 90, 90r)
4	C7790-60099	1	Encoder Strip (Applicable to 10ps, 20ps, 30, 30n, 50ps)

	C7791-60205	1	Encoder Strip (Applicable to 100, 100+, 110, 110+, 110+nr, 120, 120nr, 130 and 130nr)
6	C7790-60104	1	Encoder Strip Holder
7	0515-2812	1	Screw
8	C7790-60124	1	Tube Holder
9	C7790-60125	1	Belt Tension Spring
10	C7790-60147	1	Carriage Rod (Applicable to 10ps, 20ps, 30, 30n, 50ps)
11	0515-2598	2	Screw
12	-	1	Left Encoder Strip Holder
-	C7790-60216	1	Turnaround Assembly (Applicable to 10ps, 20ps, 30, 30n, 50ps)
-	C7791-60212		Turnaround Assembly (Applicable to (Applicable to 70, 90, 90r, 100, 100+, 110, 110+, 110+nr, 120, 120nr, 130 and 130nr)

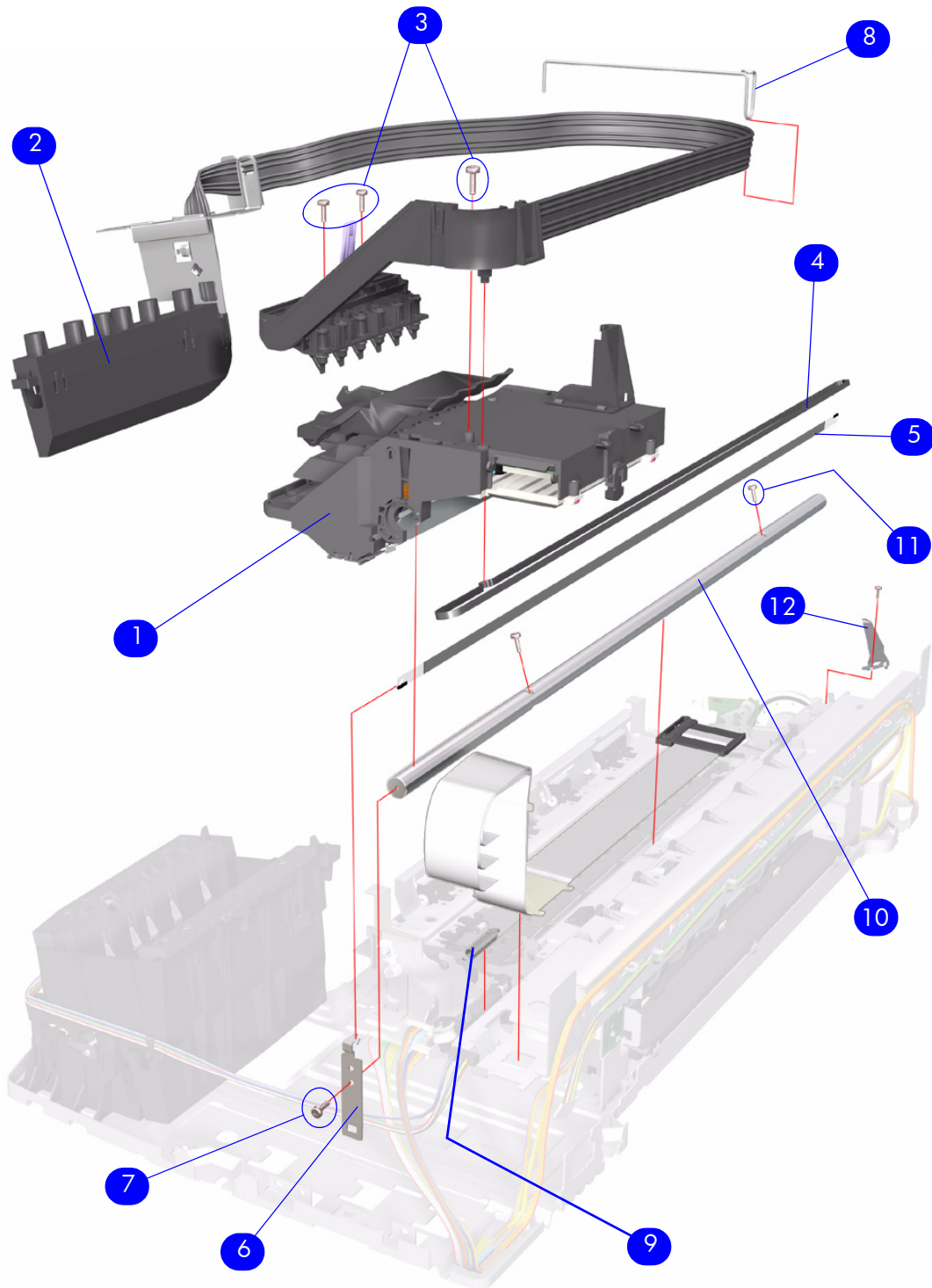

Figure 6: Scan-Axis Assemblies

Top Paper Path Assemblies (1 of 2)

Applicable Designjets: 10ps, 20ps, 30, 30n, 50ps

Top Paper Path Assemblies			
Reference on Drawing	HP Part Number	Quantity	Description/Comments
1	C8108-67049	1	Inner Paper Guide
2	C8108-67043	1	Lower Paper Guide
3	C7790-60129	1	Feed Roller Assembly (Includes Encoder Disc)
4	C8108-67035	1	Pin Linkage Assembly
5	C8108-67033	1	Starwheel Assembly
6	0515-2812	2	Screw
7	C8108-67041	1	Print Platen (Includes Output Separator)
8	C8108-67039	1	Pick Roller Assembly
9	C8108-67029	1	Kicker Assembly
-	C8108-67030	1	Miscellaneous Plastic Parts (includes Plift Block, Pin Caber, Pick Cam, FDRLR Idler Gear)
-	Q1292-60209	1	OPPS Sensor Kit

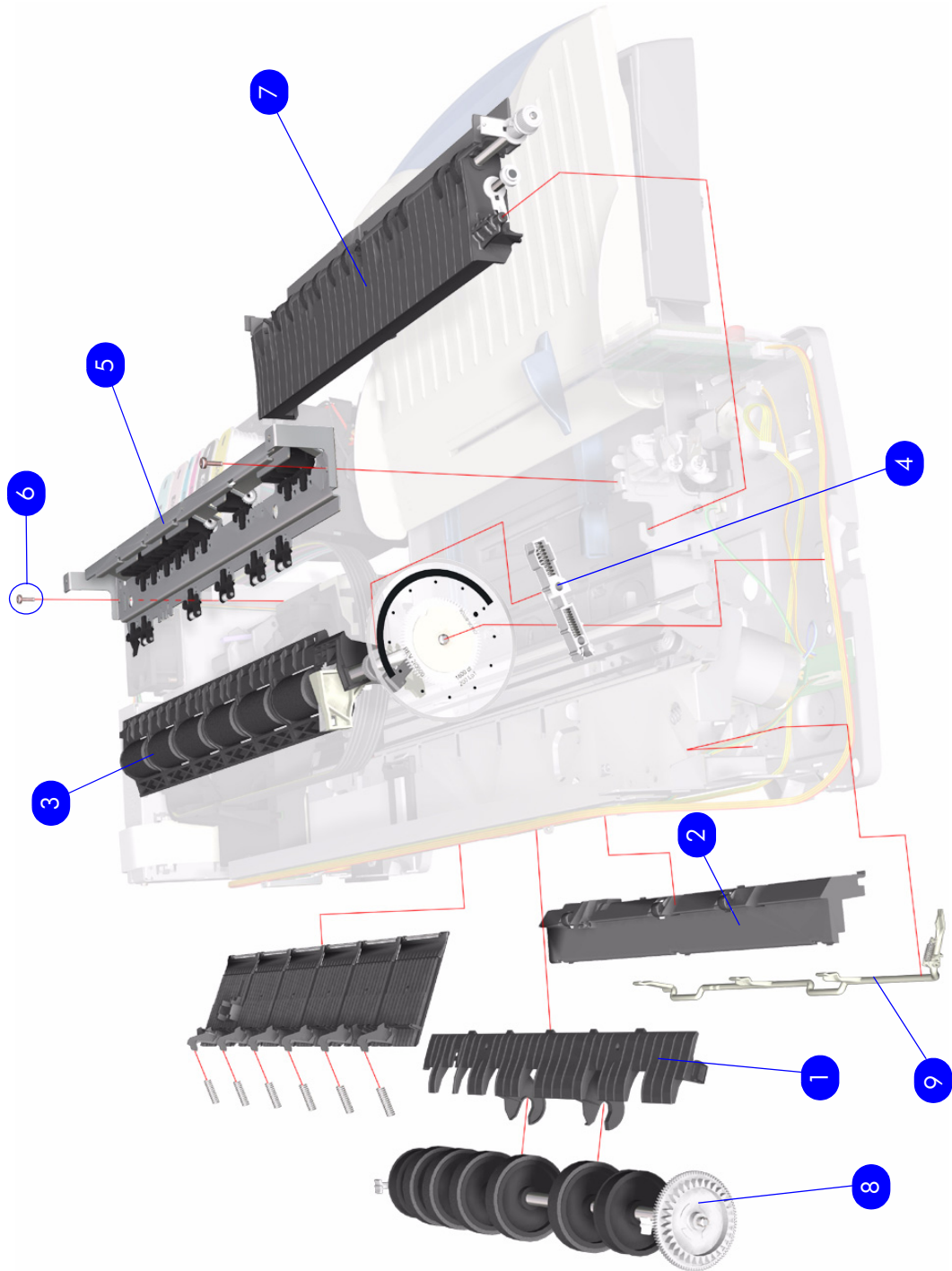

Figure 7: Top Paper Path Assemblies

Top Paper Path Assemblies (2 of 2)

Top Paper Path Assemblies			
Reference on Drawing	HP Part Number	Quantity	Description/Comments
1	Q1292-60209	1	OPPS Sensor Kit
2	Q6655-60122	1	Feed Roller Assembly (Includes Encoder Disc and Paper Axis Motor Assembly) (Applicable to 70, 90, 90r)
	Q1292-60211	1	Feed Roller Assembly (Includes Encoder Disc and Paper Axis Motor Assembly) (Applicable to 100, 100+, 110, 110+, 110+nr, 120, 120nr, 130 and 130nr)
3	Q6655-60082	1	Starwheel Assembly (Applicable to 70, 90, 90r)
	C7791-60245	1	Starwheel Assembly (Applicable to 100, 100+, 110, 110+, 110+nr, 120, 120nr, 130 and 130nr)
4	0515-2812	2	Screw
5	Q6655-60139	1	Print Platen (Applicable to 70, 90, 90r)
	Q1292-60227		Print Platen (Applicable to 100, 100+, 110, 110+, 110+nr, 120, 120nr, 130 and 130nr)
6	C7791-60287	1	Bypass Platen Kit (Applicable to 100, 100+, 110, 110+, 110+nr, 120, 120nr, 130 and 130nr)
	Q6655-60074	1	Bypass Platen Kit (Applicable to 70, 90, 90r)
7	C7796-60217	1	Pivot Assembly (Applicable to 100, 100+, 110, 110+, 110+nr, 120, 120nr, 130 and 130nr)
	Q6656-60102	1	Pivot Assembly (Applicable to 70, 90, 90r)
8	0515-2555	2	Screw
9	C7791-60232	1	Pick Cam (Applicable to 70, 90, 90r, 100, 100+, 110, 110+, 110+nr, 120, 120nr, 130 and 130nr)
10	Q1292-00002	1	Bypass Platen Actuator & Spring (Applicable to 100+, 110+, 110+nr, 120, 120nr, 130 and 130nr)
	Q6655-60088	1	Bypass Platen Actuator & Spring (Applicable to 70, 90, 90r)
-	C8108-67030	1	Miscellaneous Plastic Parts (includes Plift Block, Pin Caber, Pick Cam, FDRLR Idler Gear)

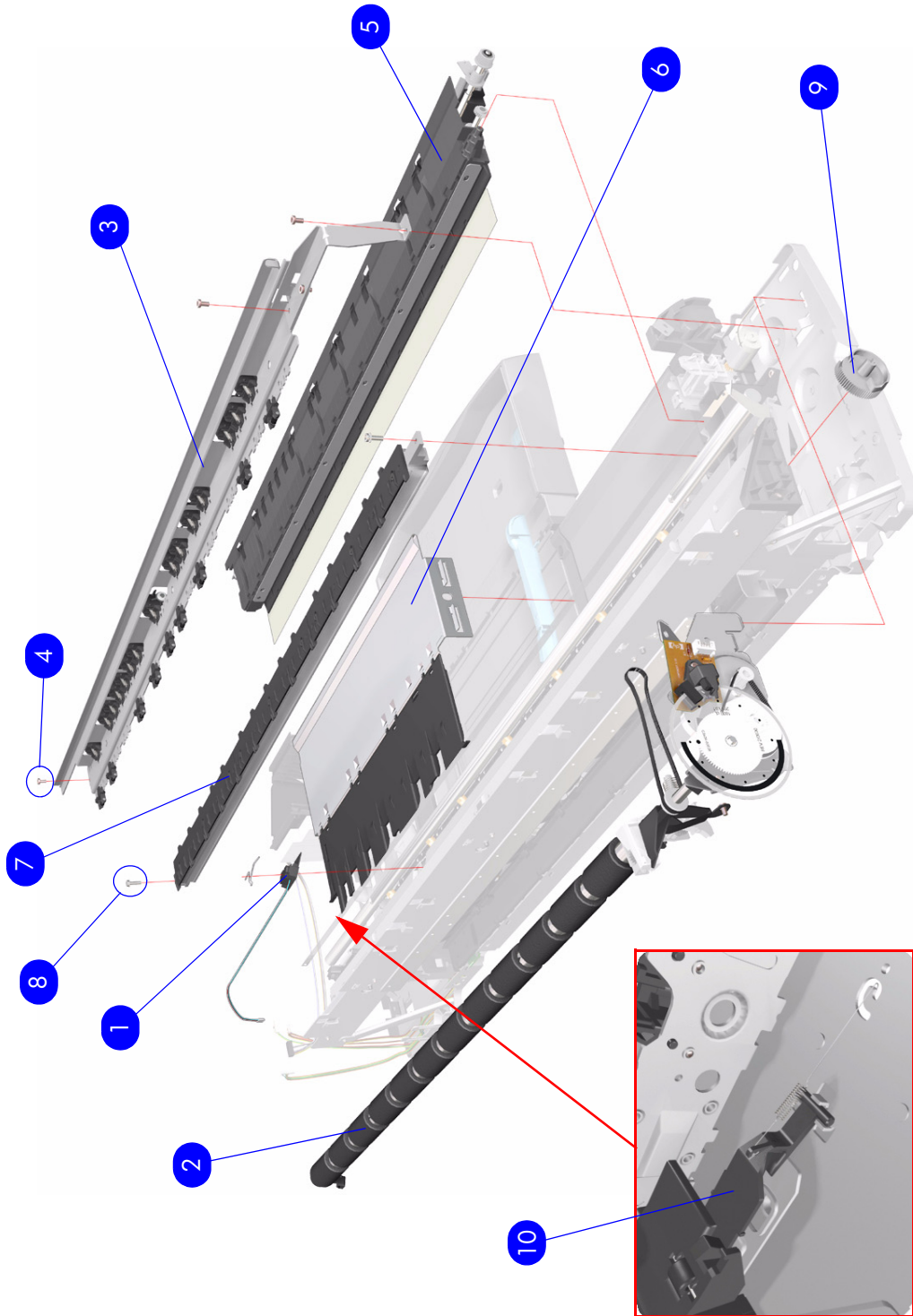

Figure 8: Top Paper Path Assemblies

Rear Paper Path Assemblies

Rear Paper Path Assemblies			
Reference on Drawing	HP Part Number	Quantity	Description/Comments
1	Q6655-60063	1	Inner Paper Guide (Applicable to 70, 90, 90r)
	C7791-60202	1	Inner Paper Guide (Applicable to 100, 100+, 110, 110+, 110+nr, 120, 120nr, 130 and 130nr)
2	Q1292-60210	1	Pick Roller Assembly
	Q6655-60123	1	Pick Roller Assembly (Applicable only to 70, 90, 90n)
3	C7791-60230	1	Upper Roller Kit
4	C7791-60235	1	Lower Paper Guide Bits

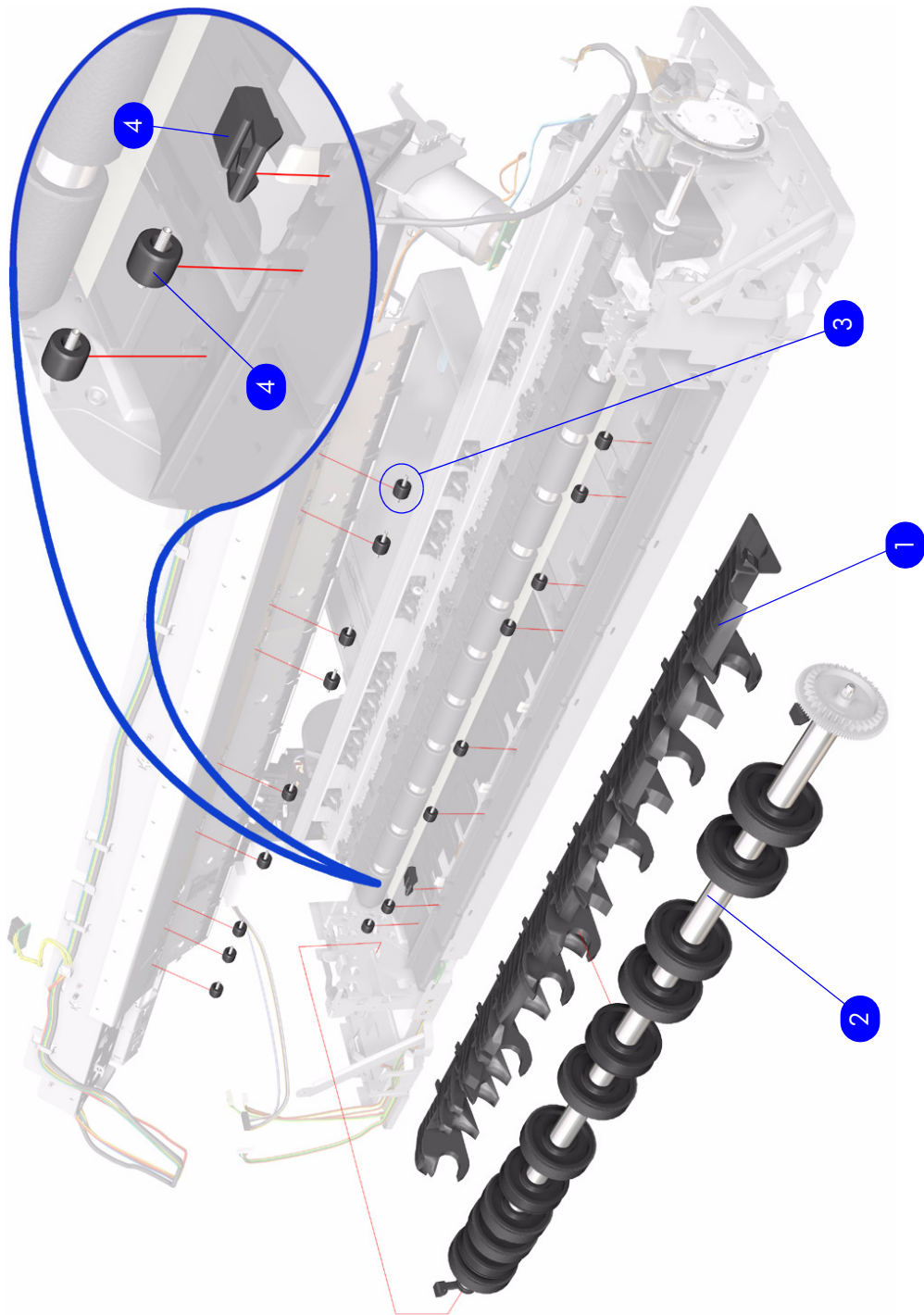

Figure 9: Rear Paper Path Assemblies

Paper Feed Assemblies

Paper Feed Assemblies				
Reference on Drawing	HP Part Number	Quantity	Description/Comments	
1	C8108-67044	1	Main Tray Assembly (Applicable to 10ps, 20ps, 30, 30n, 50ps)	
	Q1292-60097	1	Main Tray Assembly (Applicable to 70, 90, 90r, 100+, 110+, 110+nr, 130 and 130nr)	
2	C7791-60146	1	Main Tray Assembly (Applicable to 100, 110, 120, 120nr)	
	C7790-60149	1	Output Tray Assembly (Applicable to 10ps, 20ps and 50ps)	
	C7790-60448	1	Output Tray Assembly (Applicable to 30 and 30n)	
	Q6655-60101	1	Output Tray Assembly (Applicable to 70)	
	Q6656-60072	1	Output Tray Assembly (Applicable to 90, 90r)	
	C7791-60280	1	Output Tray Assembly (Applicable to 130 and 130nr)	
	C7796-60063	1	Output Tray Assembly (Applicable to 100, 100+, 110, 110+, 110+nr)	
	C7791-60145	1	Output Tray Assembly (Applicable to 120, 120nr)	
	3	C8108-67050	2	Drawer and Spring Cam
	4	Q1293-60067	1	Cleanout Assembly (Rear-Feed) (Applicable to 10ps, 20ps, 30, 30n, 50ps)
C1292-60215		1	Cleanout Assembly (Rear-Feed) (Applicable to 100, 100+, 110, 110+, 110+nr, 120, 120nr, 130 and 130nr)	
Q6655-60125		1	Cleanout Assembly (Rear-Feed) (Applicable to 70, 90, 90r)	
5	C7791-60297		Input tray Cover (Applicable to 70, 90, 90r, 100+, 110+, 110+nr, 130 and 130nr)	

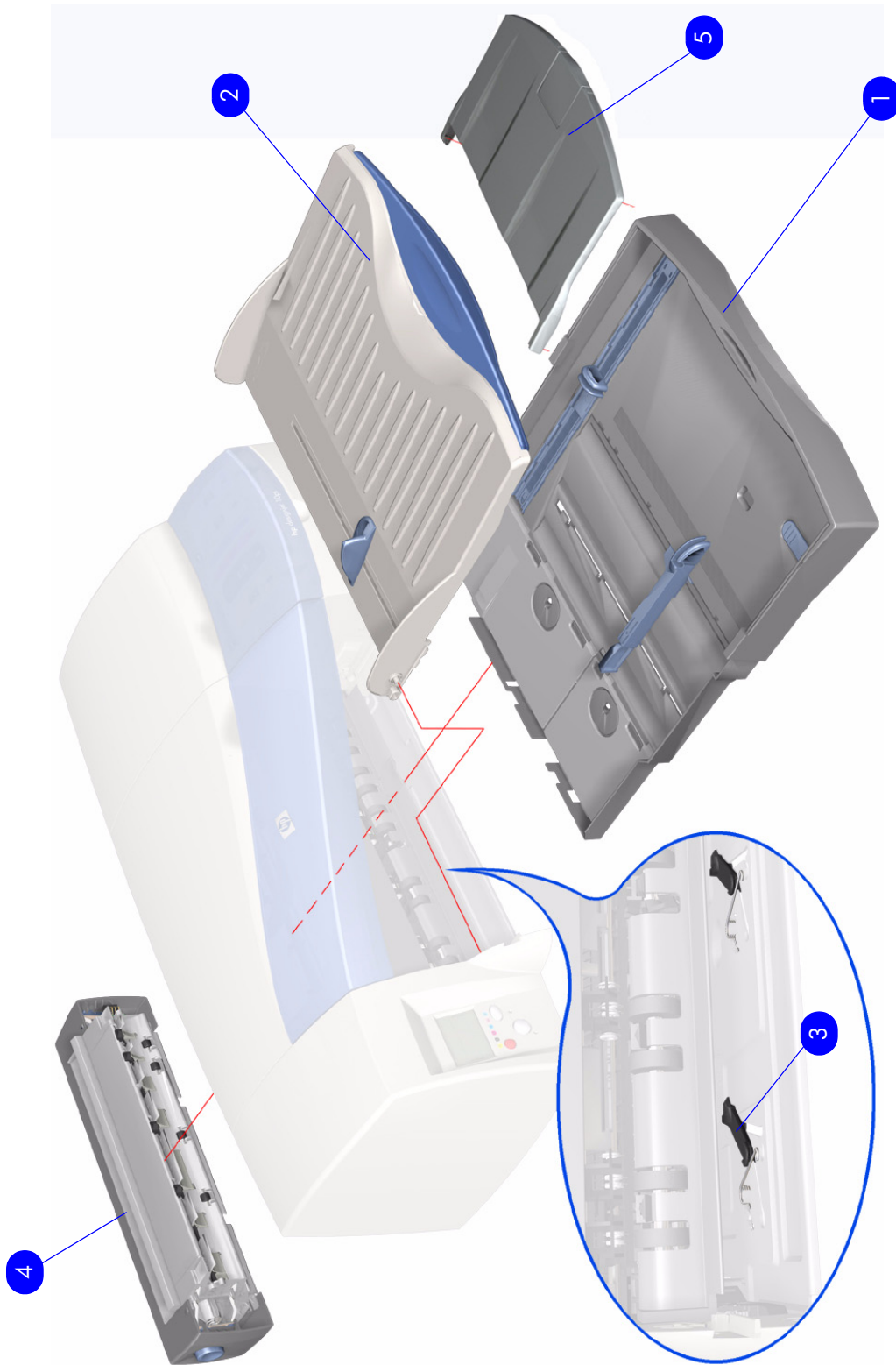

Figure 10: Paper Feed Assemblies

Cable Harnesses

Cable Harnesses			
Reference on Drawing	HP Part Number	Quantity	Description/Comments
1	C7790-60120	1	Motor Harness (Applicable to 10ps, 20ps, 30, 30n, 50ps)
	C7791-60213	1	Motor Harness (Applicable to 70, 90, 90r, 100, 100+, 110, 110+, 110+nr, 120, 120nr, 130 and 130nr)
2	C7790-60121	1	Encoder Harness (Applicable to 10ps, 20ps, 30, 30n, 50ps)
	C7791-60214	1	Encoder Harness (Applicable to 70, 90, 90r, 100, 100+, 110, 110+, 110+nr, 120, 120nr, 130 and 130nr)
3	C7790-60122	1	Duplexer OOP Sensor Harness (Applicable to 10ps, 20ps and 50ps)
-	C7790-60421	1	Front Panel Harness
-	C7791-60231	1	Duplexer OOPS Harness (Applicable to 70, 90, 90r, 100, 100+, 110, 110+, 120, 120nr, 130 and 130nr)

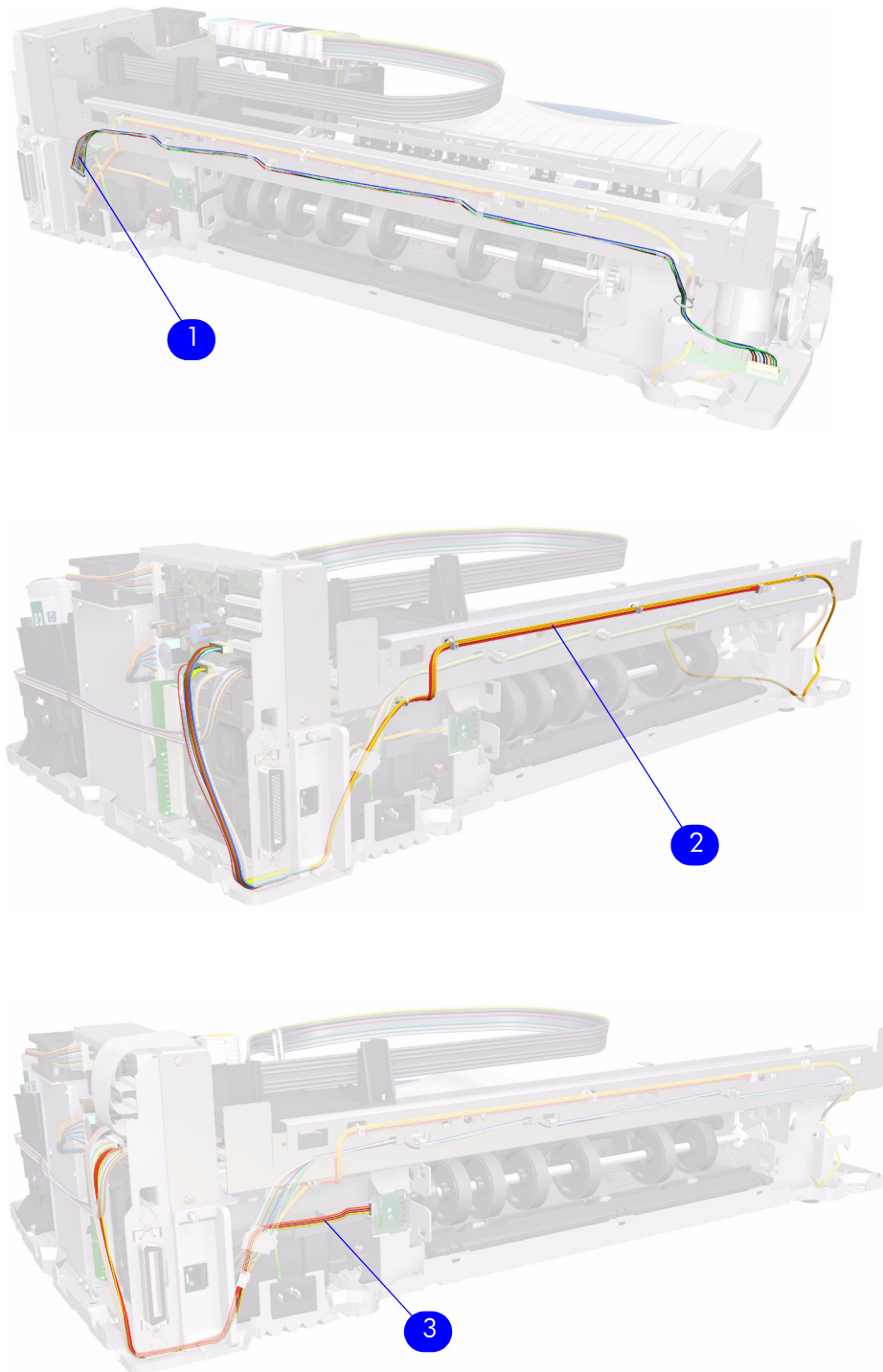

Figure 11: Cable Harnesses

Ink Supplies & Accessories (1 of 4)

Applicable to Designjets: 10ps, 20ps & 50ps

Ink Supplies and Accessories			
Reference on Drawing	HP Part Number	Quantity	Description/Comments
1	C8109-67016	1	Secondary Tray
2	C8108-67053	1	Duplexer
3	J4169-61001	1	Network Card (Replacement)
	J4169-69001	1	Network Card (Exchange)
4	C5019-80008	1	Black Printhead
	C4810-60067	1	Cyan Printhead
	C4812-60005	1	Magenta Printhead
	C4813-60004	1	Yellow Printhead
	C5020-80008	1	Light Cyan Printhead
	C5021-80008	1	Light Magenta Printhead
5	C5016-80014	1	Black Ink Cartridge
	C4911-61002	1	Cyan Ink Cartridge
	C4912-61003	1	Magenta Ink Cartridge
	C4913-61003	1	Yellow Ink Cartridge
	C5017-80016	1	Light Cyan Ink Cartridge
	C5018-80014	1	Light Magenta Ink Cartridge
-	C7790-60217	1	Electronics End Cap

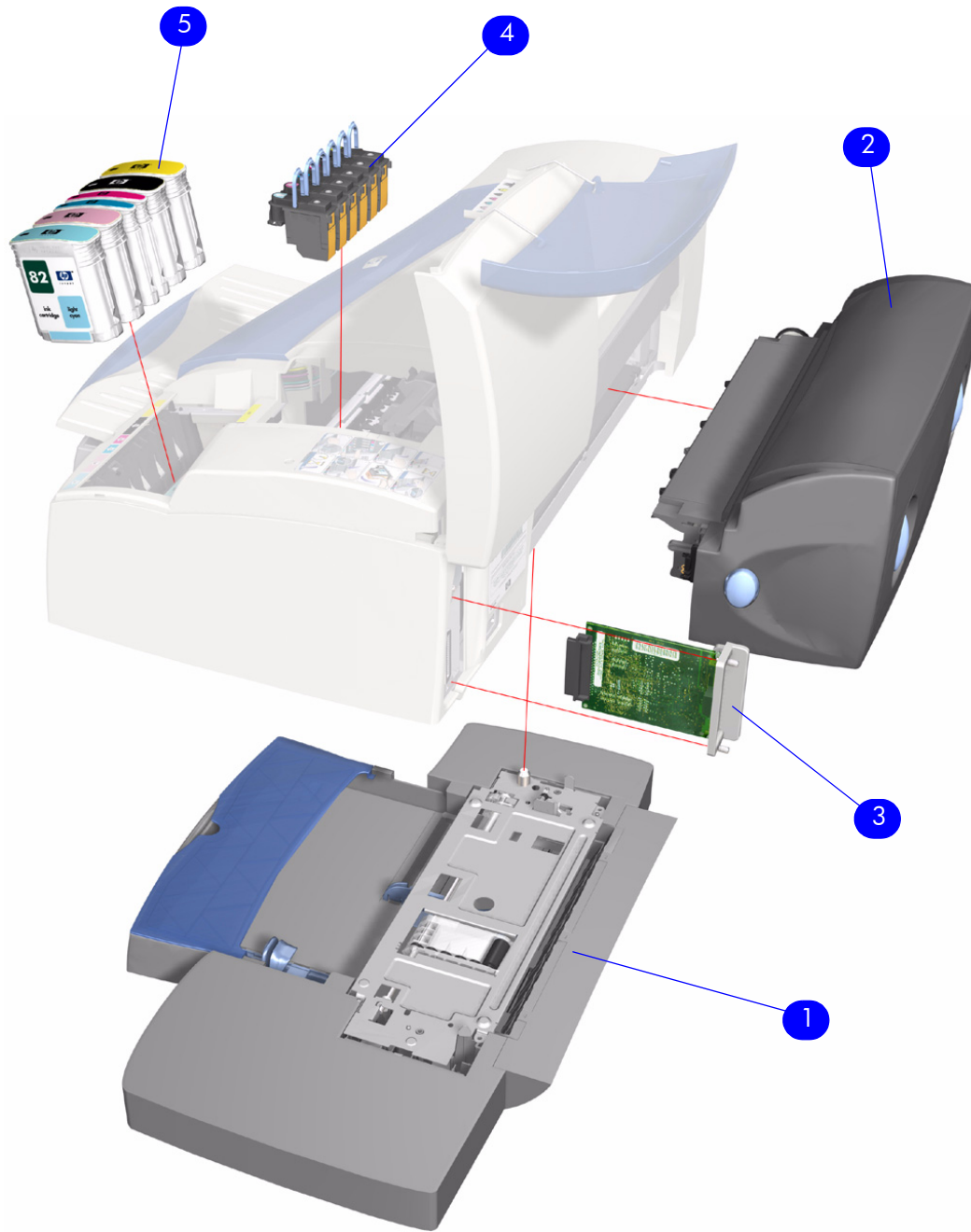

Figure 12: Ink Supplies and Accessories (Applicable to 10ps, 20ps and 50ps)

Ink Supplies and Accessories (2 of 4)

Applicable to Designjets: 100, 100+

Ink Supplies and Accessories			
Reference on Drawing	HP Part Number	Quantity	Description/Comments
1	J6057-61001	1	Network Card (New)
	J6057-69001	1	Network Card (Exchange)
2	C4810-60066	1	Black Printhead
	C4810-60067	1	Cyan Printhead
	C4812-60005	1	Magenta Printhead
	C4813-60004	1	Yellow Printhead
3	C4844-60053	1	Black Ink Cartridge
	C4911-61002	1	Cyan Ink Cartridge
	C4912-61003	1	Magenta Ink Cartridge
	C4913-61003	1	Yellow Ink Cartridge
4	C7790-60217	1	Electronics End Cap
-	C7790-60425	1	USB Cable (5m)

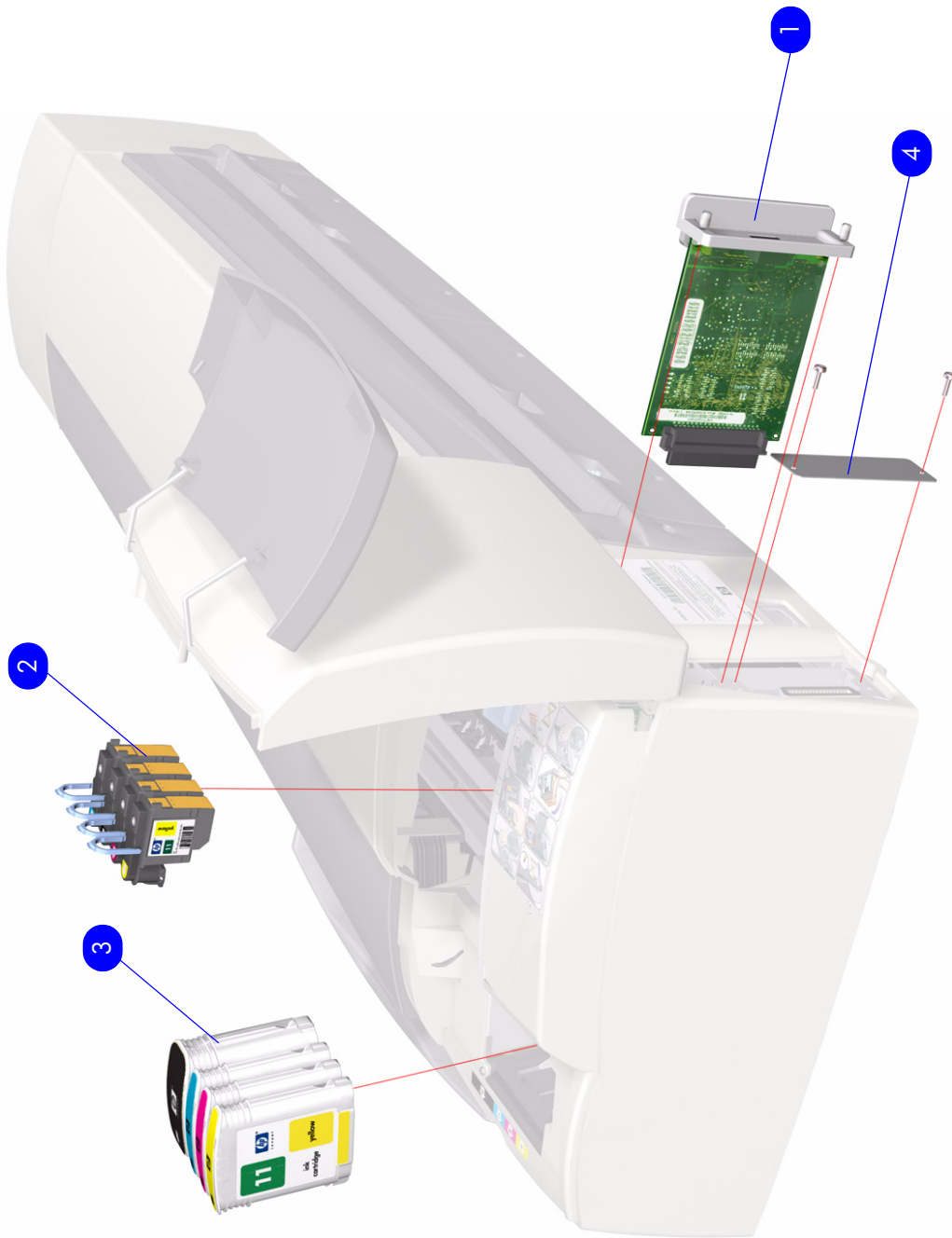

Figure 13: Ink Supplies and Accessories

Ink Supplies & Accessories (3 of 4)

Applicable to DesignJets 120, 120nr)

Ink Supplies and Accessories			
Reference on Drawing	HP Part Number	Quantity	Description/Comments
1	J6057-61001	1	Network Card (New)
	J6057-69001	1	Network Card (Exchange)
2	C5019-80008	1	Black Printhead
	C4810-60067	1	Cyan Printhead
	C4812-60005	1	Magenta Printhead
	C4813-60004	1	Yellow Printhead
	C5020-80008	1	Light Cyan Printhead
	C5021-80008	1	Light Magenta Printhead
	3	C5016-80014	1
C4911-61002		1	Cyan Ink Cartridge
C4912-61003		1	Magenta Ink Cartridge
C4913-61003		1	Yellow Ink Cartridge
C5017-80016		1	Light Cyan Ink Cartridge
C5018-80014		1	Light Magenta Ink Cartridge
4	C7790-60217	1	Electronics End Cap
-	C7790-60425	1	USB Cable (5m)

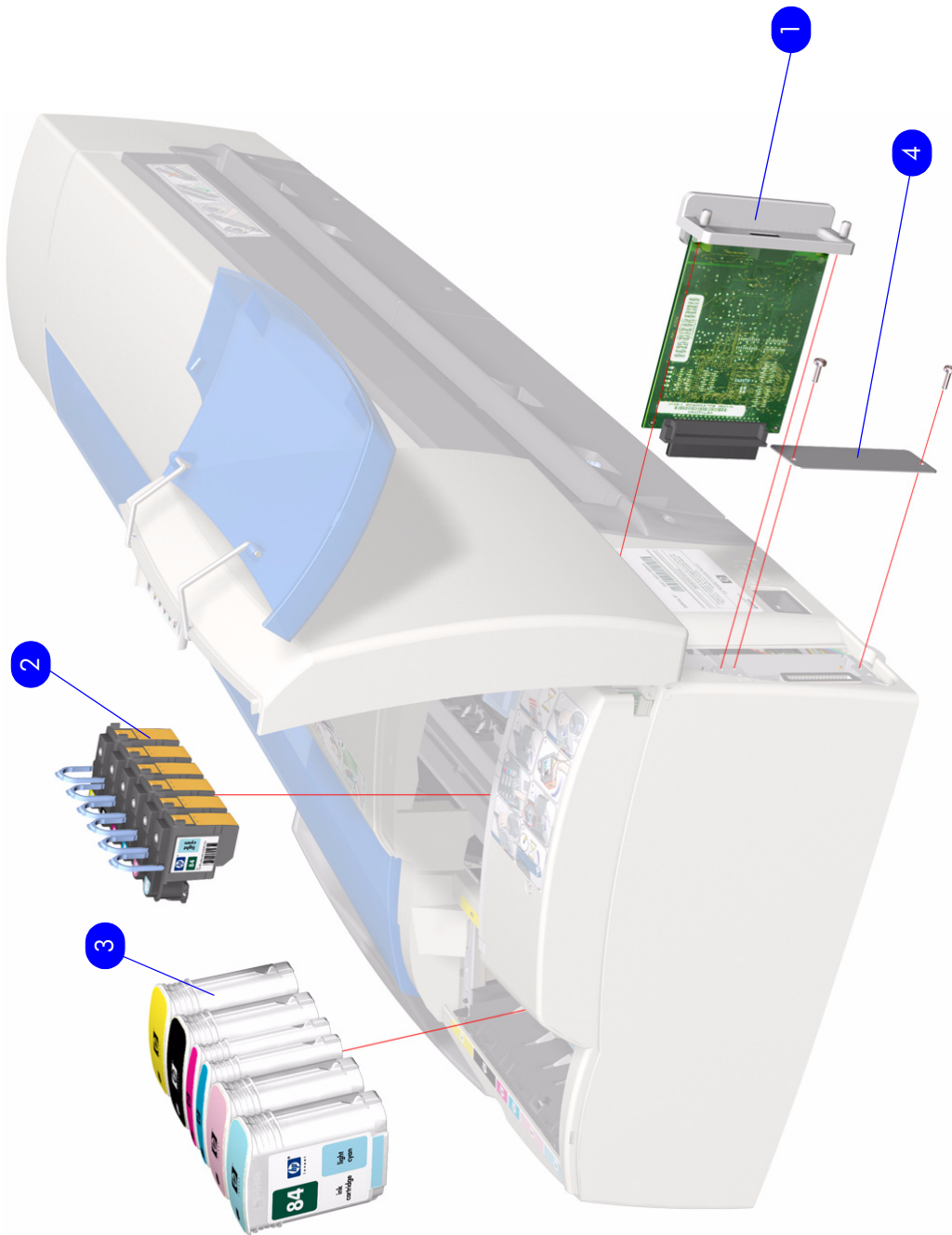

Figure 14: Ink Supplies & Accessories (Applicable to DesignJet 120/120nr)

Ink Supplies & Accessories (4 of 4)

Applicable to Designjets: 30, 30n, 70, 90, 90r, 130, 130nr

Ink Supplies and Accessories			
Reference on Drawing	HP Part Number	Quantity	Description/Comments
1	J4169-61001	1	Network Card (Replacement)
	J4169-69001	1	Network Card (Exchange)
2	C5019-80008	1	Black Printhead
	C9420-88001	1	Cyan Printhead
	C9421-88001	1	Magenta Printhead
	C9422-88001	1	Yellow Printhead
	C9423-88001	1	Light Cyan Printhead
	C9424-88001	1	Light Magenta Printhead
3	C5016-80014	1	Black Ink Cartridge
	C9425-88001	1	Cyan Ink Cartridge
	C9426-88001	1	Magenta Ink Cartridge
	C9427-88001	1	Yellow Ink Cartridge
	C9428-88001	1	Light Cyan Ink Cartridge
	C9429-88001	1	Light Magenta Ink Cartridge
-	C7790-60217	1	Electronics End Cap
-	C7790-60425	1	USB Cable (5m)

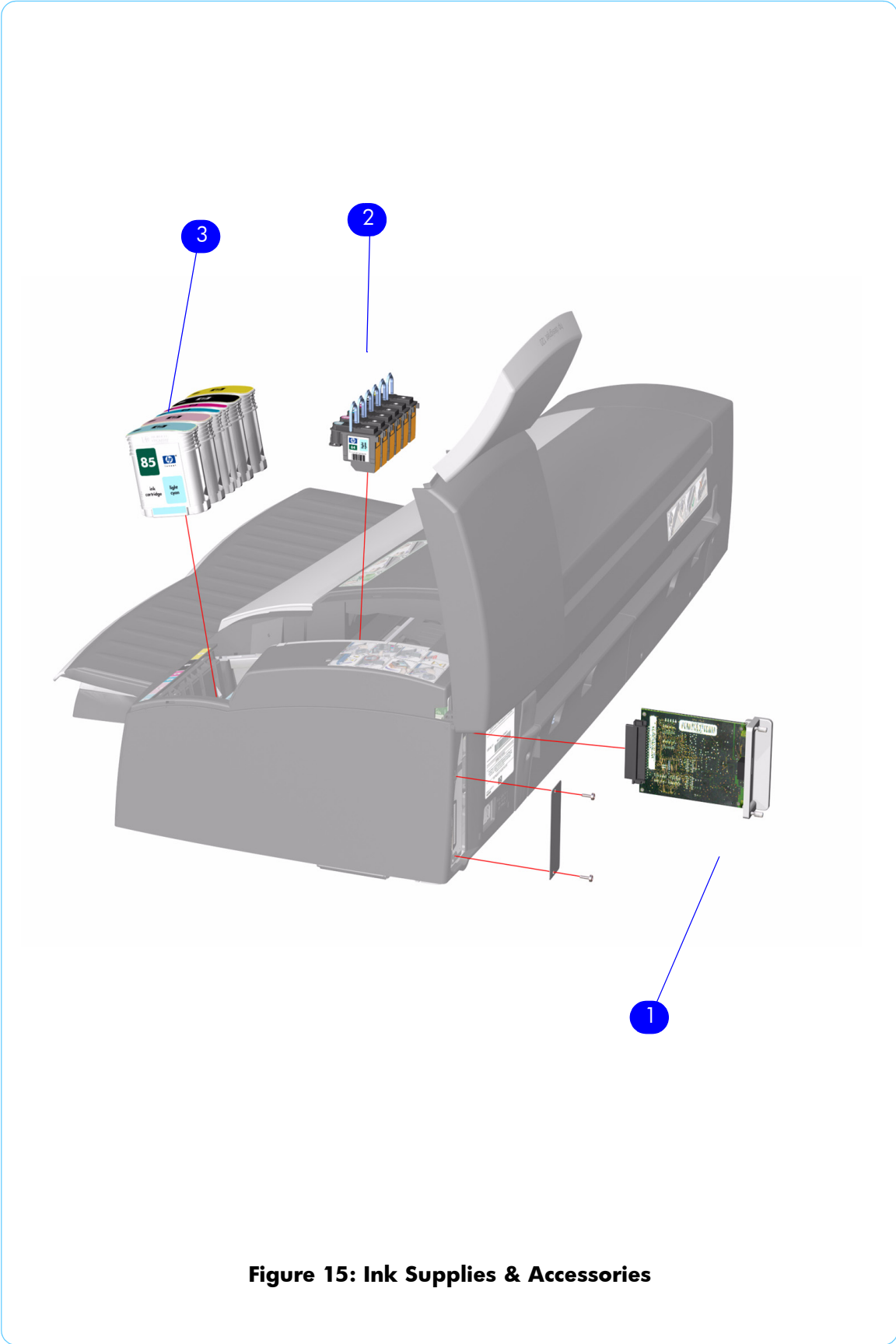

Figure 15: Ink Supplies & Accessories

Rollfeed Components

Applicable to Designjets: 90r, 110, 110+, 110+nr, 120nr, 130nr

Rollfeed Components			
Reference on Drawing	HP Part Number	Quantity	Description/Comments
1	Q1292-60238	1	Rollfeed Bracket Kit (ROHS)
2	C7797-60064	1	Cutter
3	C7797-60008	1	Spindle
	Q6655-60081	1	Spindle (Applicable only to 70, 90, 90r)
4	Q1247-60023	1	Automatic Roll Replacement Kit (Only applicable to 110+nr, 120nr, 130nr)

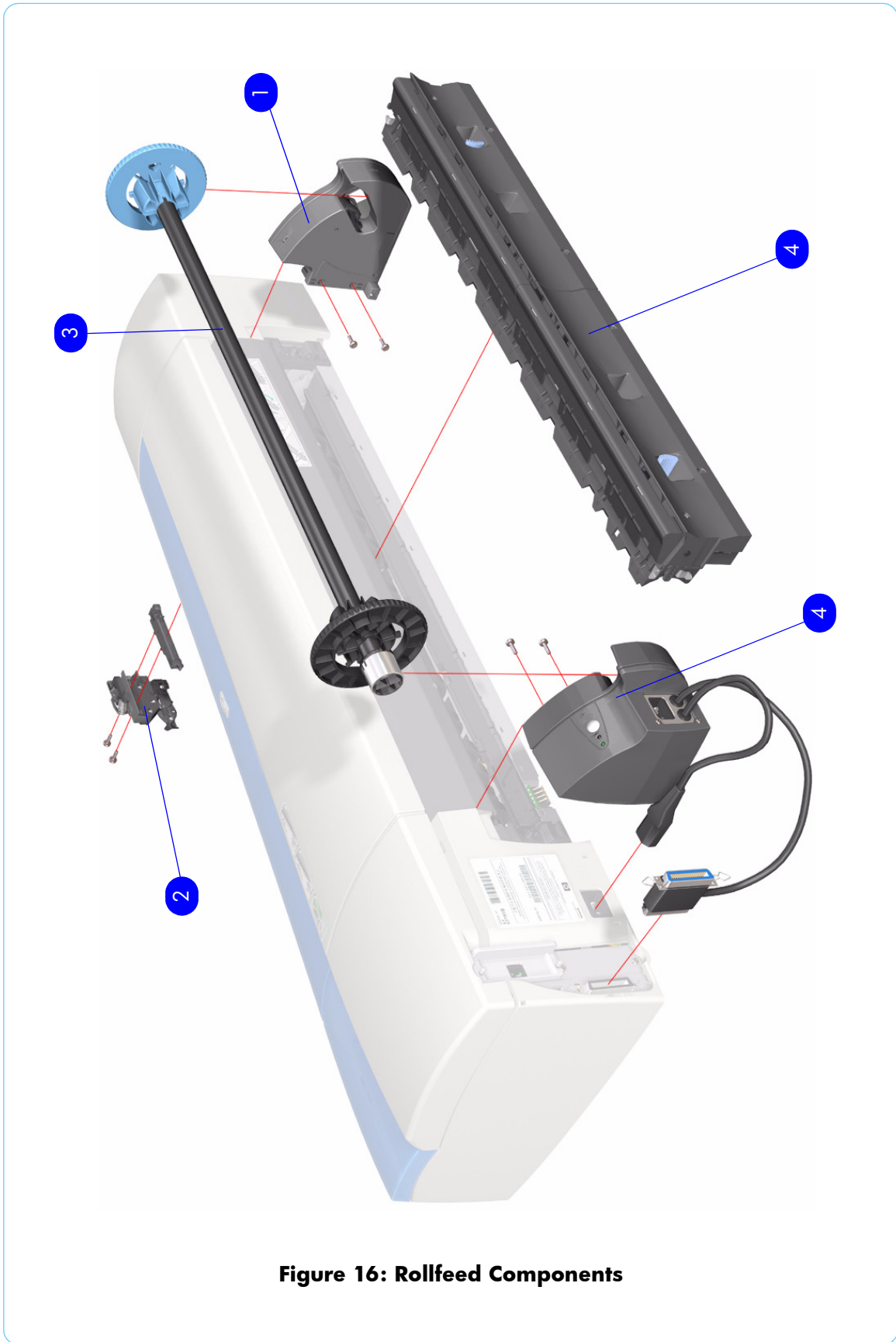

Figure 16: Rollfeed Components

Printer Stand and Basket

Applicable Designjet 100, 100+, 120, 120nr, 130, 130nr

Printer Stand and Basket			
Reference on Drawing	HP Part Number	Quantity	Description/Comments
1	Q1246-60007	2	Legs Assembly
2	Q1246-60008	1	X-Brace Assembly
3	Q1246-60009	2	Foot Assembly
4	Q1246-60010	1	Basket Kit
5	Q1246-60011	1	Base Adaptor (Left and Right)
6	Q1246-60012	1	Input Tray Support
-	Q1246-60013	1	Hardware Kit

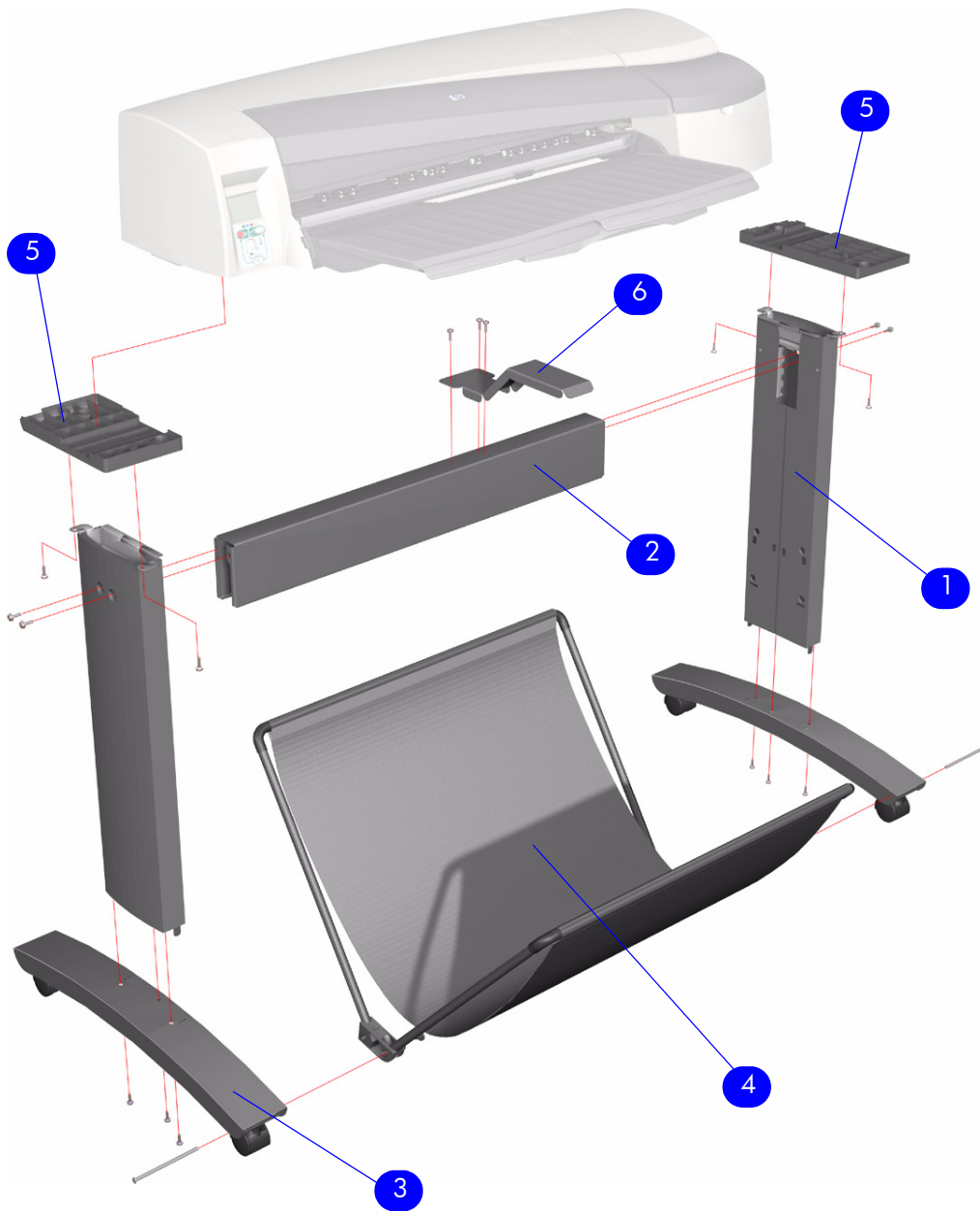

Figure 17: Printer Stand and Basket

Removal and Installation



Introduction	7-3
Top Cover	7-5
Front Cover (Applicability: 10ps, 20ps, 30, 30n, 50ps)	7-6
Center Cover	7-7
Right End Cover	7-9
Left End Cover	7-11
Ink Supply Station Cover (Applicability: 70, 100, 100plus, 110plus)	7-13
Ink Supply Station	7-14
Electronics Module	7-18
Power Supply Unit	7-22
Service Station	7-24
Front Panel	7-27
Encoder Strip	7-28
Carriage Motor	7-29
Cleanout Assembly	7-31
Ink Supply Tubes	7-32
Carriage Assembly (Applicability: 70, 100, 100+, 110+, 120, 120nr)	7-35
Carriage Assembly (Applicability: 10ps, 20ps, 30, 30nr, 50ps, 90, 90r, 130, 130nr)	7-37
Carriage Belt	7-41
Starwheel Assembly (Applicability: 10ps, 20ps, 30, 30n, 50ps)	7-42
Starwheel Assembly	7-43
Print Platen Assembly	7-44
Output Separator (Applicability: 10ps, 20ps, 30, 30n, 50ps)	7-46
Ramp Motor Assembly	7-47
Output Mechanism Assembly (Applicability: 10ps, 20ps, 30, 30n, 50ps)	7-49
Spittoon (If Installed in the Printer)	7-51
Pivot Assembly	7-52
Feed Roller Assembly (Applicability: 10ps, 20, 30, 30n, 50ps)	7-54
Feed Roller Assembly	7-56
Pick Assembly	7-62
Pinch Assembly (Applicability: 10ps, 20ps, 30, 30n, 50ps)	7-68
Inner Paper Guide (Applicability: 10ps, 20ps, 30, 30n, 50ps)	7-71
Inner Paper Guide	7-72

OOPS Sensor 7-73

Paper-Axis Motor Drive Assembly (Applicable only to 10ps, 20ps, 30, 30n, 50ps) 7-75

Paper-Axis Motor Assembly (Applicability: 90, 90r, 120, 120nr, 130, 130nr) 7-77

Bypass Platen (Applicability: 90, 90r, 120, 120nr, 130, 130nr) 7-78

Bypass Platen Actuator (Applicability: 90, 90r, 130, 130nr) 7-81

Introduction

This chapter is a step by step guide to the removal and installation of the key components in the printer. You may find it useful to tick off the steps as they are performed. Use the illustration at each procedure to identify the parts referred to in the text.

The procedures appear in order of removal. So the whole machine can be stripped down by starting at the beginning of this chapter and working through the subsequent procedures.

Before using this chapter to remove and install a new component, always make sure that you have performed the relevant service test from Chapter 4. If the test passes you will not need to replace the component.

Safety Precautions

Review WARNING and CAUTION symbols and instructions before you service the printer. Follow these warnings and cautions for your protection and to avoid damaging the printer.

Serious shock hazard leading to death or injury may result if you do not take the following precautions:

Ensure that the ac power outlet (mains) has a protective earth (ground) terminal.

Switch the plotter off, and disconnect it from the power source prior to performing any maintenance.

Prevent water or other liquids from running onto electrical components or circuits, or through openings in the module.

Electrostatic Discharge (ESD) Precautions

To prevent damage to the Printer circuits from high-voltage electrostatic discharge (ESD):

1. Do not wear clothing that is subject to static build-up.
2. Do not handle integrated circuits (ICs) in carpeted areas.
3. Do not remove an IC or a printed circuit assembly (PCA) from its conductive foam pad or conductive packaging until you are ready to install it.
4. Ground (earth) your body while disassembling and working on the Printer.
5. After removing a cover from the Printer, attach an earthing (ground) lead between the PCA common and earth ground. Touch all tools to earth ground to remove static charges before using them on the Printer.
6. After removing any PCA from the Printer, place it on a conductive foam pad or into its conductive packaging to prevent ESD damage to any ICs on the PCA.

Required Tools

The following tools are required to disassemble and repair the Printer.

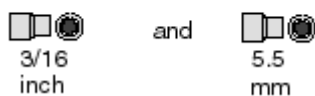
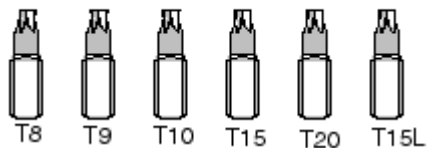

Top Cover

Removal

Switch off the product and remove the power cable.

1. Open the Top Cover.



2. Release the clips that secure the Top Cover and remove from the Printer.

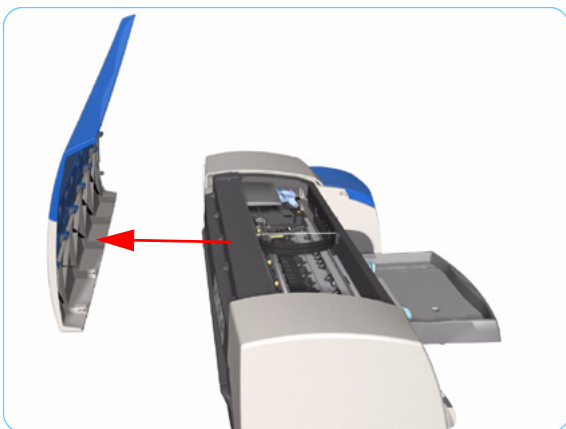

Front Cover (Applicability: 10ps, 20ps, 30, 30n, 50ps)

Removal

Switch off the product and remove the power cable.



1. Open the Access Cover.

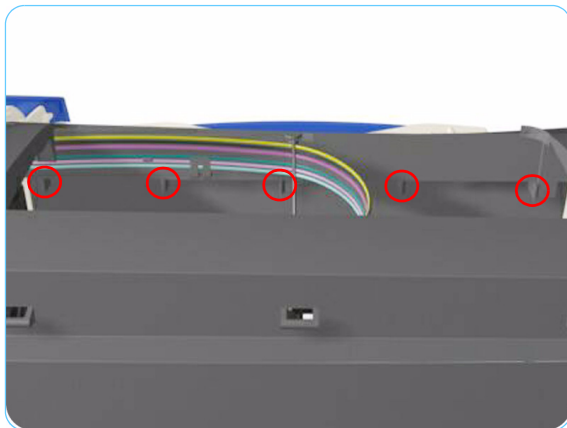

2. Release the clips (from the inside) that secure the Front Cover.



3. Remove the Front Cover from the Printer.

Center Cover

Removal

Switch off the product and remove the power cable.

1. Remove the Top Cover ⇒ Page 7-5.
2. Release the Ink Supply Tubes from the Raceway Holder. Remove the Raceway Holder from the Printer.



3. Release the Tubes from the retaining clips in the Center Cover.

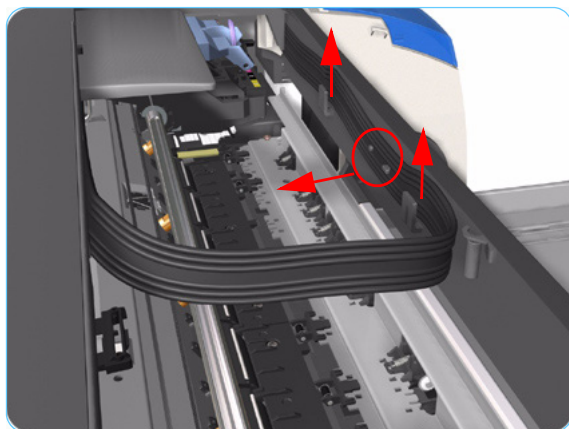

4. Remove 4 T-10 screws that secure the Center Cover to the Printer.





5. Remove 2 T-10 screws that secure the Center Cover from the rear.

Step 5 not applicable to 10ps, 20ps, 30, 30n, 50ps



6. Open the Printhead Door.

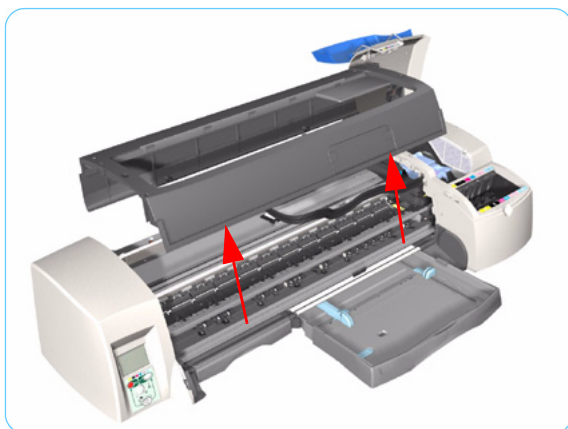

7. Remove the Center Cover from the Printer.

Right End Cover

Removal

Switch off the product and remove the power cable.

1. Remove the Center Cover ⇒ Page 7-7.
2. Open the Printhead Door.

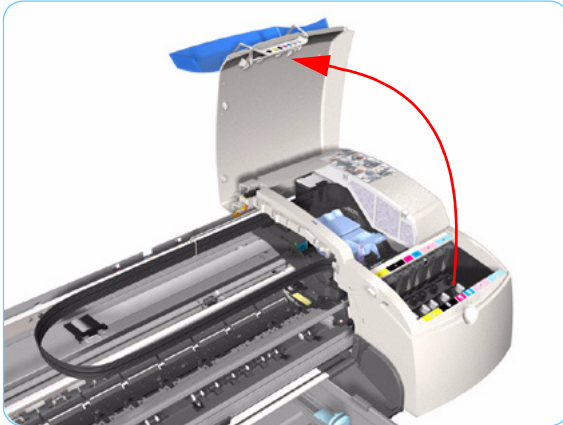

3. Release the Door Sensor from the Right End Cover.

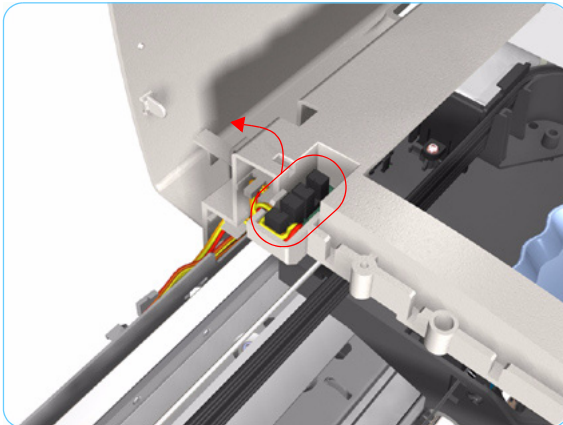

4. Remove 1 T-10 screw that secures the Right End Cover to the Printer.



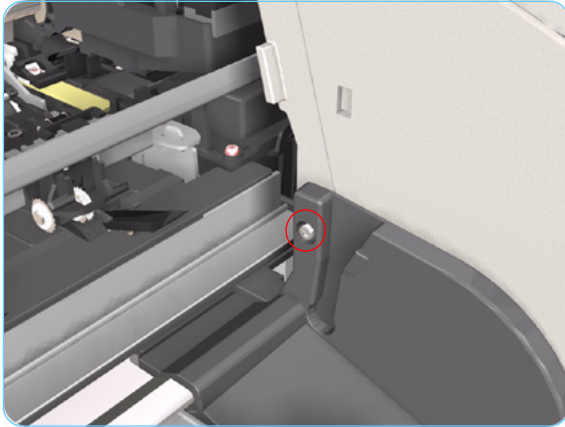

5. Remove 1 T-10 screw from the Right Side Bracket.

Step 5 not applicable to 10ps, 20ps, 30, 30n, 50ps

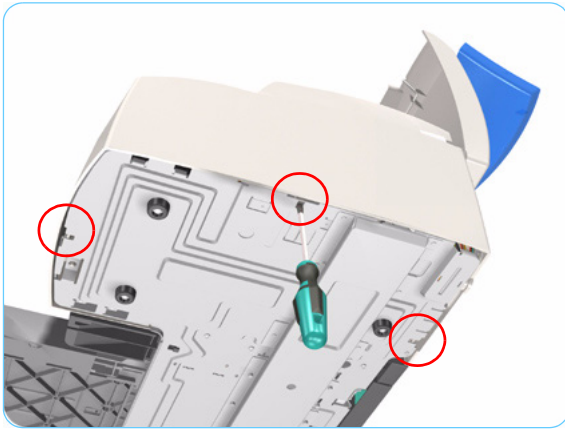

6. Release the clips that secure the Right End Cover to the Printer (use a flat-blade screwdriver if necessary).

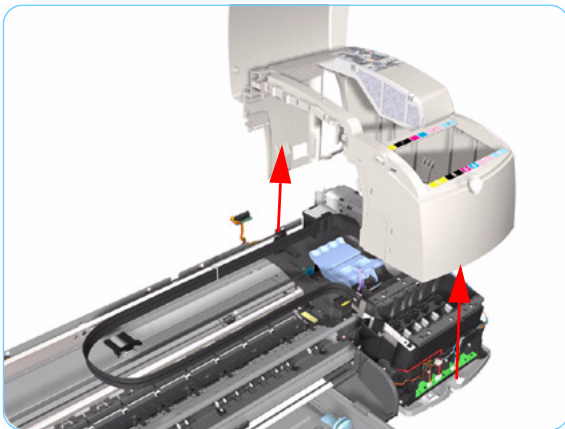

7. Remove the Right End Cover from the Printer.

Left End Cover

Removal

Switch off the product and remove the power cable.

1. Remove the Center Cover ⇒ Page 7-7.
2. Disconnect the Front Panel cable from the rear of the Printer.

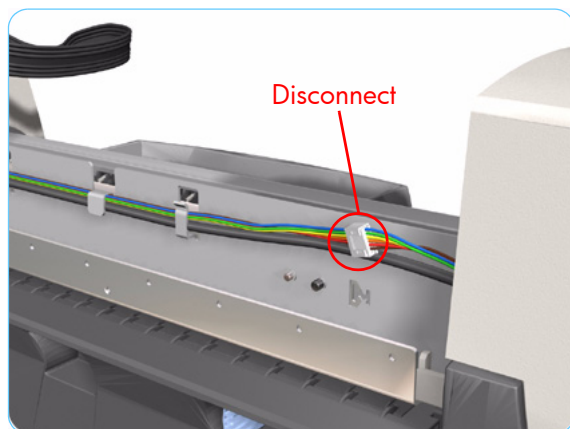

Following steps 3, 4 and 5 not applicable to 10ps, 20ps, 30, 30n, 50ps

3. Remove 1 T-10 screw from the Rear Left Trim.

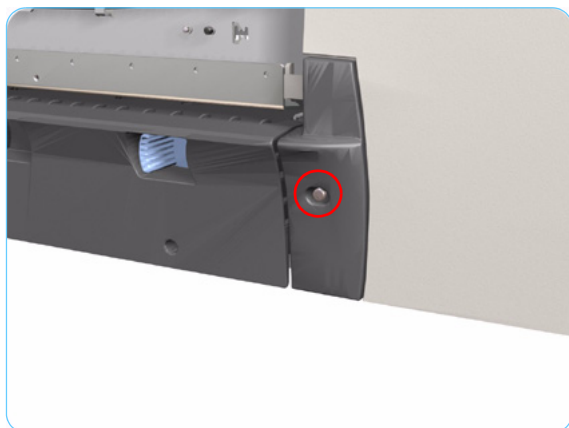

4. Remove the Rear Left Trim from the Printer.

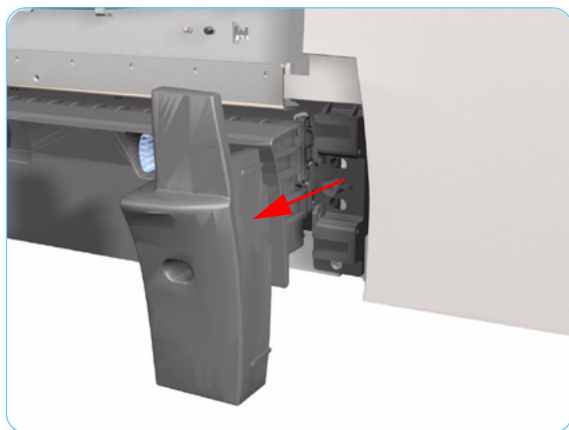



5. Remove 1 T-10 screw from the Left Side Bracket.

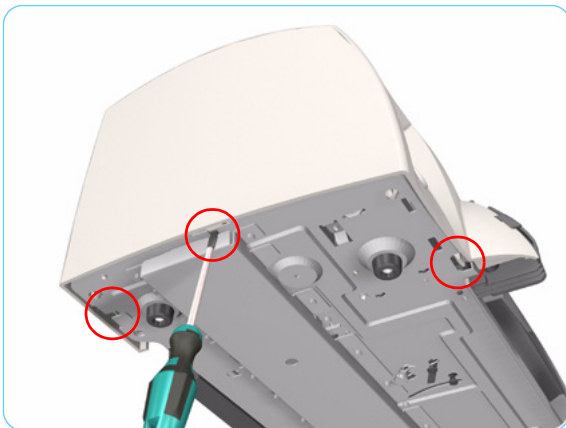

6. Release the clips that secure the Left End Cover to the Printer (use a flat-blade screwdriver if necessary).

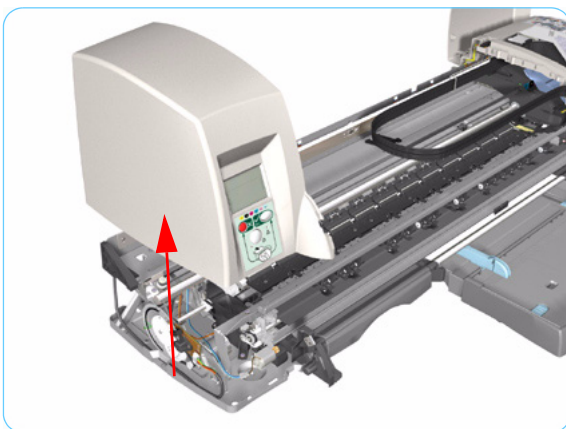

7. Remove the Left End Cover from the Printer.

Before installing the Left End Cover, make sure you first check that the Front Panel Cable is routed correctly as shown on Page 7-27.

Ink Supply Station Cover (Applicability: 70, 100, 100plus, 110plus)

Removal

Switch off the product and remove the power cable.

1. Remove the Center Cover ⇒ Page 7-7.
2. Remove the Right End Cover ⇒ Page 7-9.
3. Release the Ink Tubes from the clip on the ISS Cover.

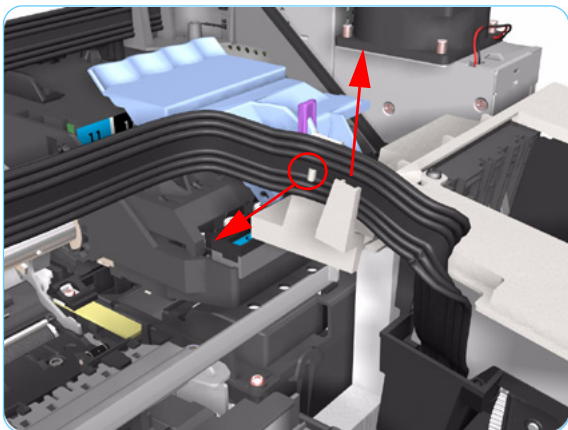

4. Remove 2 screws that secure the ISS Cover to the Ink Supply Station.

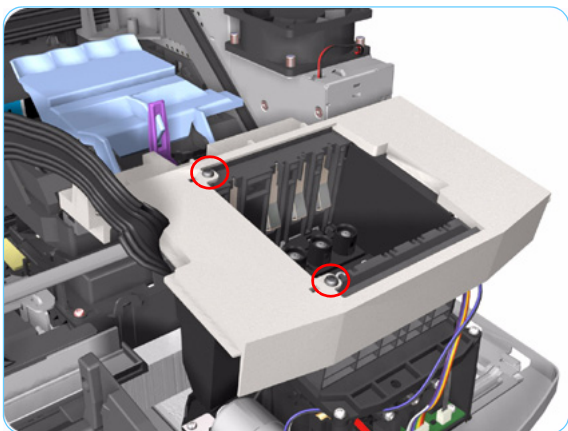

5. Remove the ISS Cover from the Printer.

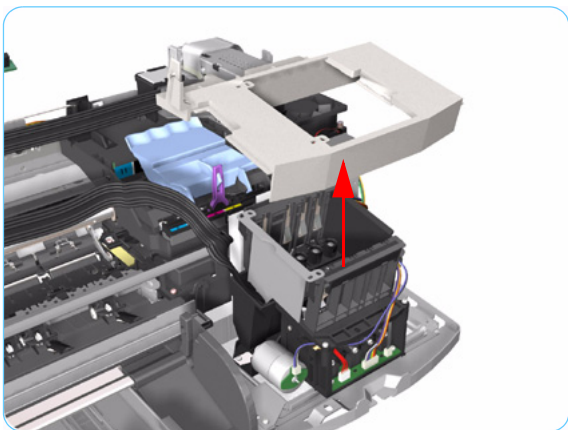

Ink Supply Station

Removal

Switch off the product and remove the power cable.

1. Remove the Center Cover ⇒ Page 7-7.
2. Remove the Right End Cover ⇒ Page 7-9.

Following step only applicable to Designjet 70, 100, 100+, 110+

3. Remove the ISS Cover ⇒ Page 7-13.

Following step not applicable to Designjet 10ps, 20ps, 30, 30n, 50ps

4. Release the Plastic Cover protecting the Electronics Module.

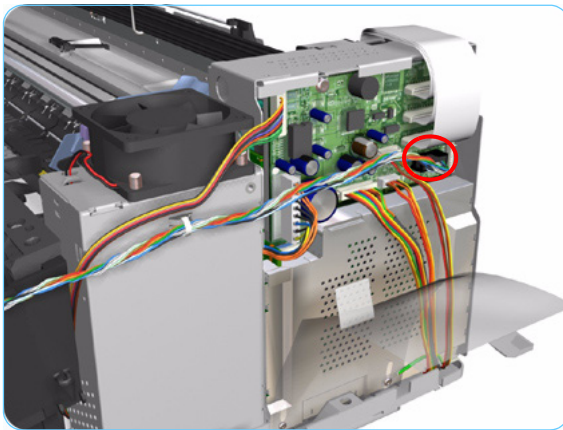
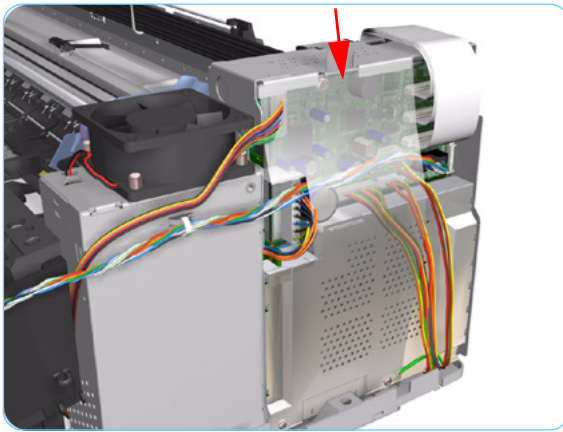

5. Disconnect the Ink Supply Station Cable from the Main PCA.

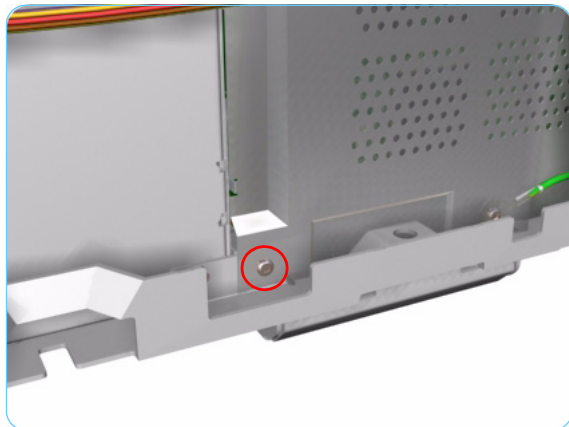

6. Remove 1 T-10 screw securing the Plastic Cover. Remove the Plastic Cover from the Printer.

Step 6 only applicable to 70, 100, 100+, 100+

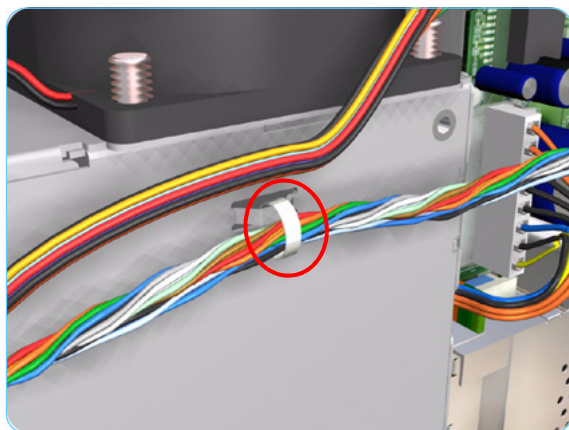

7. Cut the Plastic Tie that secures the Ink Supply Station Cable to the Power Supply Unit.

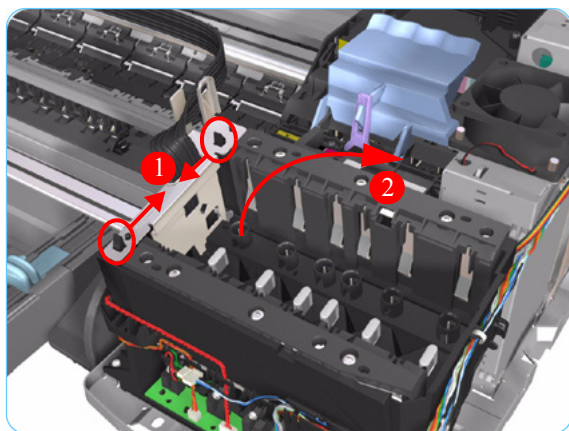

8. Release the Tubes Bracket from the Ink Supply Station by pushing the clips inwards and lifting up the Bracket.

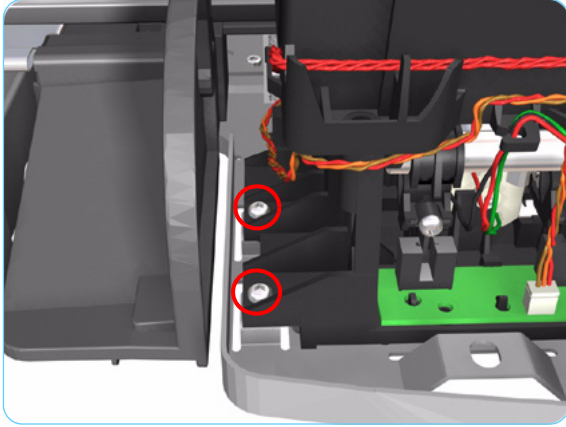

9. Remove 2 T-10 screws that secure the Ink Supply Station.

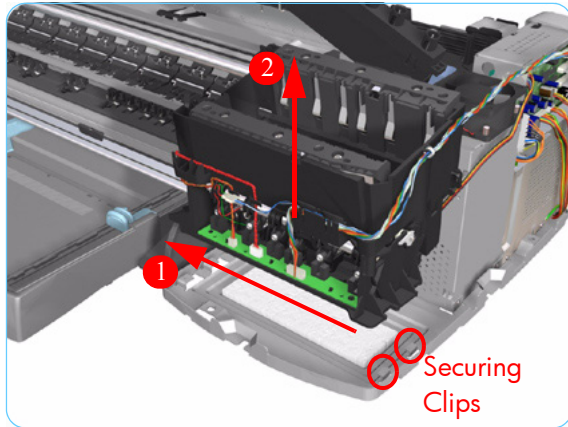

10. Move the Ink Supply Station to the left to release it from the securing clips.

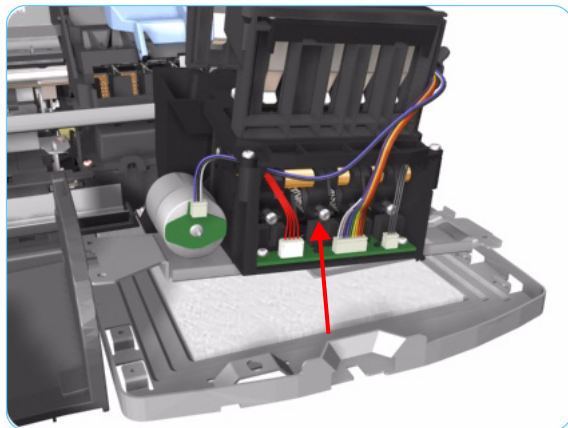

11. Remove the Ink Supply Station from the Printer.

Electronics Module

Removal

Switch off the product and remove the power cable.

1. Remove the Center Cover ⇒ Page 7-7.
2. Remove the Right End Cover ⇒ Page 7-9.

Following step not applicable to Designjet 10ps, 20ps, 30, 30n, 50ps

3. Release the Plastic Cover protecting the Electronics Module.

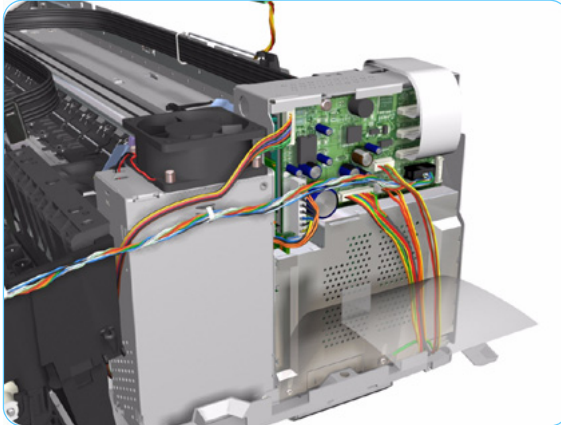
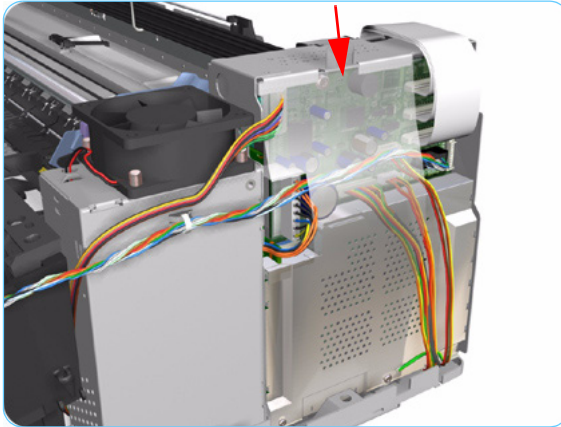

4. Disconnect ALL the cables from the Main PCA.

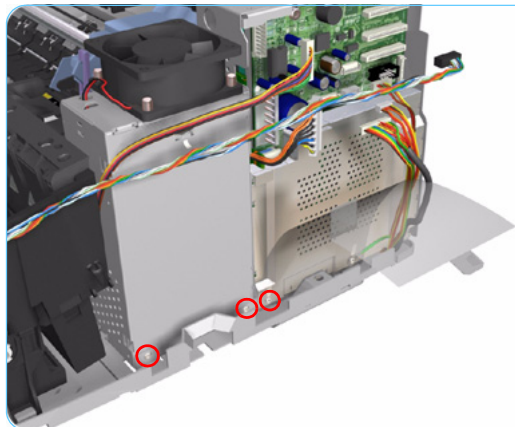

5. Remove 3 T-10 (**Type B**) screws that secure the Electronics Module and the Power Supply Unit to the Printer.

Following step not applicable to Designjet 10ps, 20ps, 30, 30n, 50ps

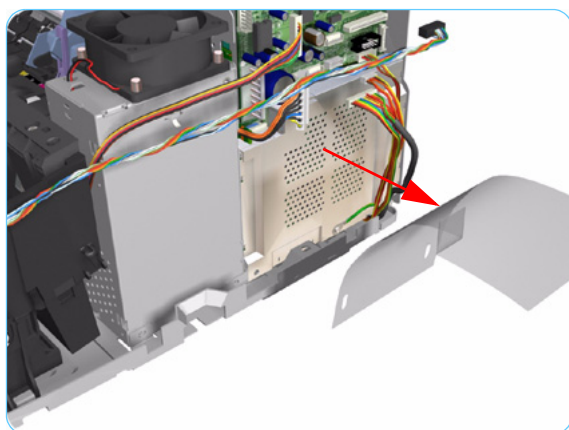

6. Remove the Plastic Cover from the Printer.

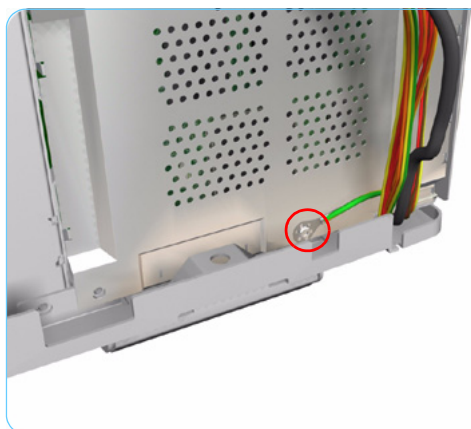

7. Remove 1 T-10 screw that secures the Electronics Module.

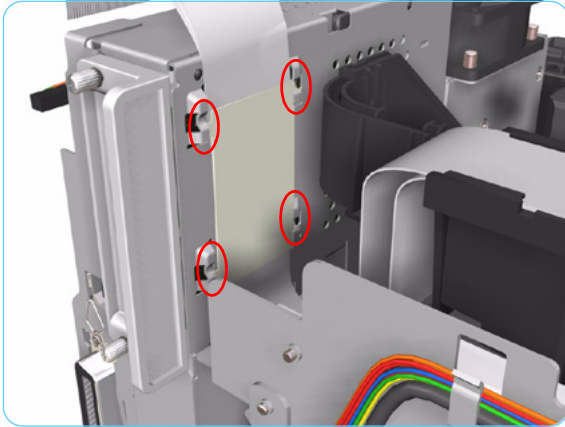

8. Release the plastic sheet that secures the Trailing Cable to the back of the Electronics Module.

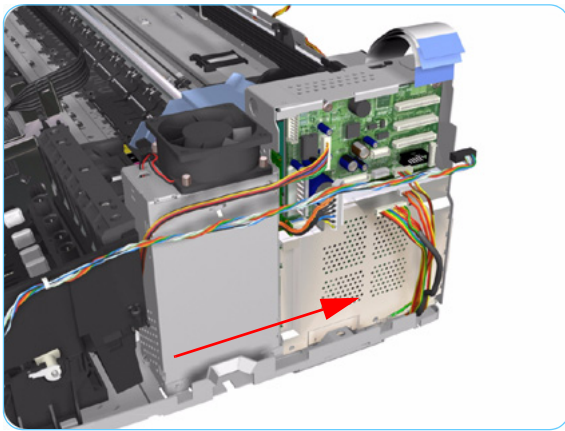

9. Slide out the Electronics Module and the Power Supply Unit (**as one assembly**) to the right.

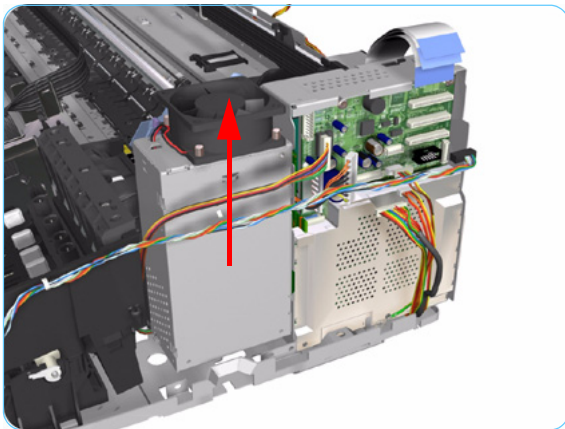

10. Slide the Power Supply Unit upwards to release it from the Electronics Module.

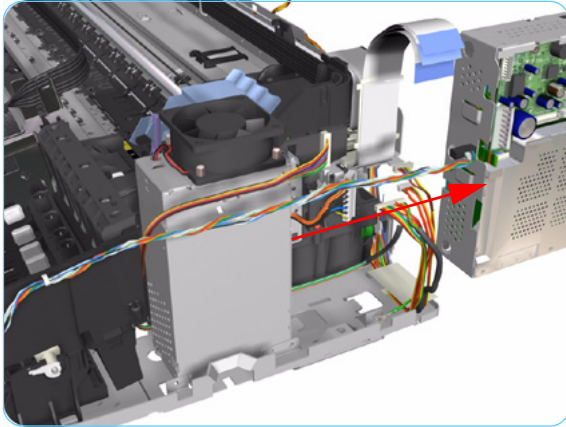

11. Remove the Electronics Module from the Printer.

Check if the cable ties need to be cut before separating the Power Supply Unit and the Electronics Module.

Power Supply Unit

Removal

Switch off the product and remove the power cable.

1. Remove the Center Cover ⇒ Page 7-7.
2. Remove the Right End Cover ⇒ Page 7-9.
3. Remove the Electronics Module ⇒ Page 7-18.

**Following two steps only
applicable to Designjet 10ps, 20ps,
30, 30n, 50ps**

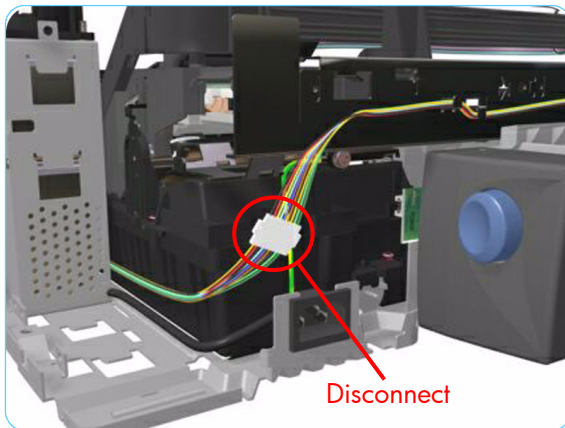

4. Disconnect the Motor Harness Cable.

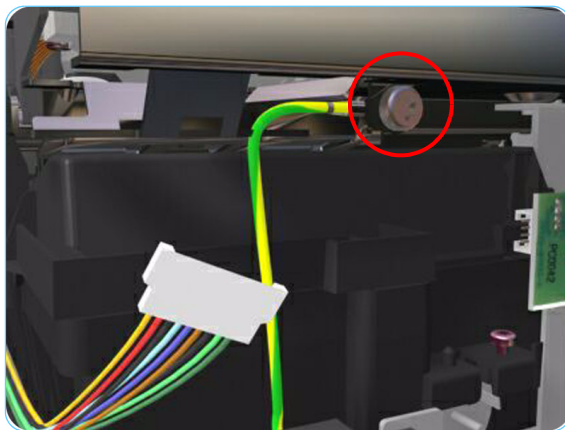

5. Remove 1 T-10 screw (**Type A**) that secures the Grounding Strip.

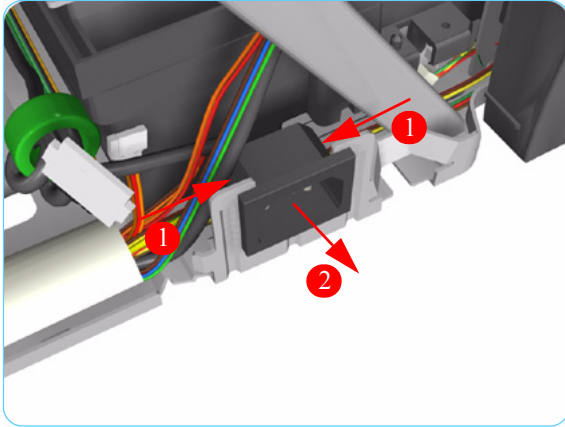

6. Press in the clips on either side and release the Power Socket.

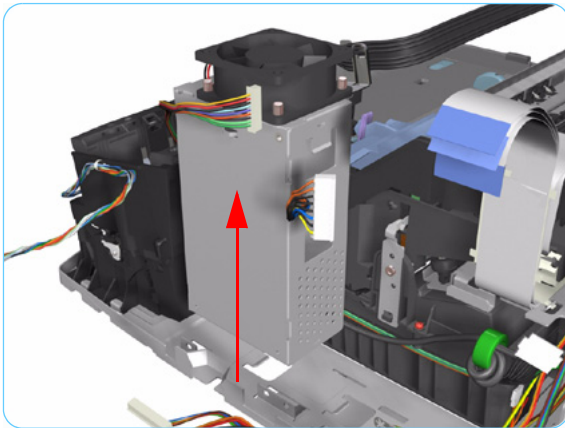

7. Remove the Power Supply from the Printer.

Service Station

Removal

Switch off the product and remove the power cable.

1. Remove the Center Cover ⇒ Page 7-7.
2. Remove the Right End Cover ⇒ Page 7-9.
3. Remove the Electronics Module ⇒ Page 7-18.
4. Remove the Power Supply Unit ⇒ Page 7-22.

Following step is not applicable to Designjet 10ps, 20ps, 30, 30n, 50ps

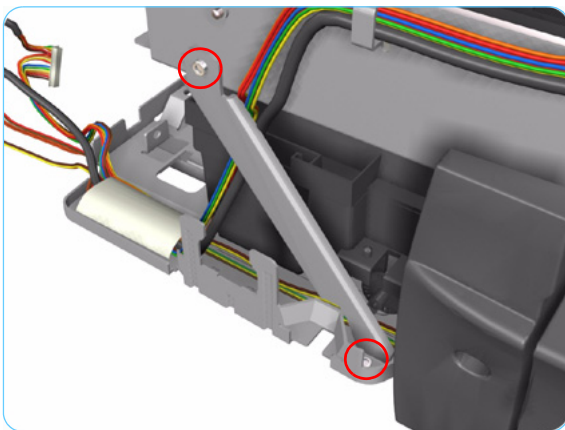

5. Remove 2 screws that secure the Reinforcement Bracket. Remove the Reinforcement Bracket from the Printer.

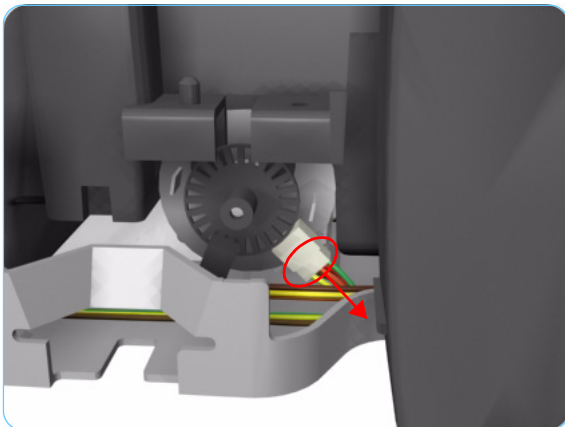

6. Disconnect the Service Station Cable.

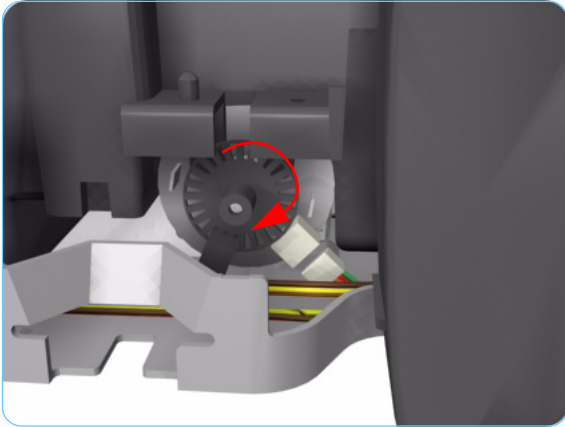

7. Uncap the Carriage Assembly by turning the Service Station Motor clockwise.

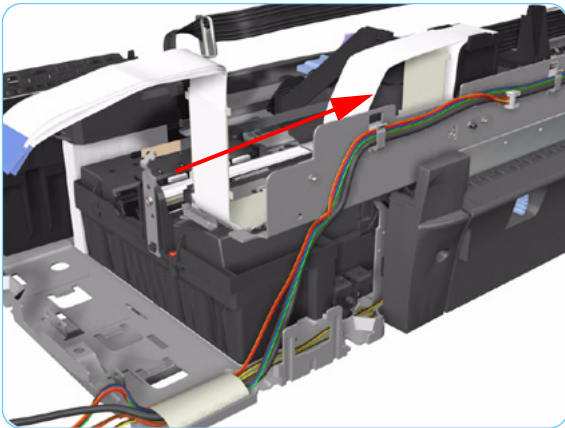

8. Move the Carriage Assembly out of the Service Station.

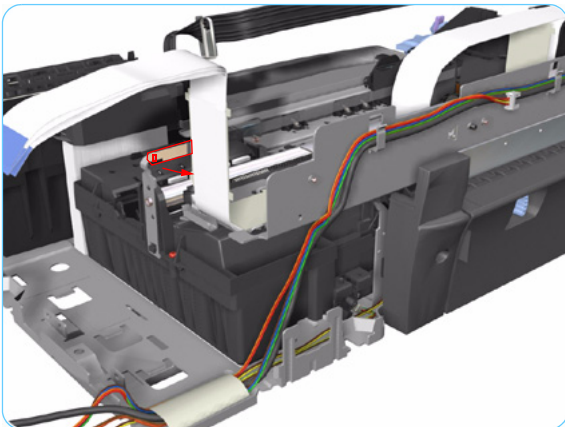

9. Release the Encoder Strip from the Encoder Strip Holder.

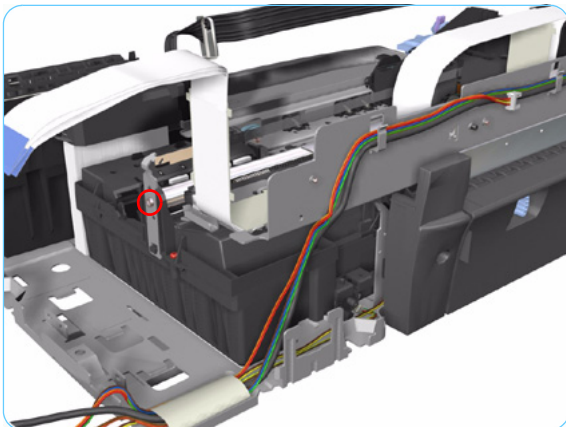

- 10.** Remove 1 T-10 screw that secures the Encoder Strip Holder on the right hand side of the Printer.

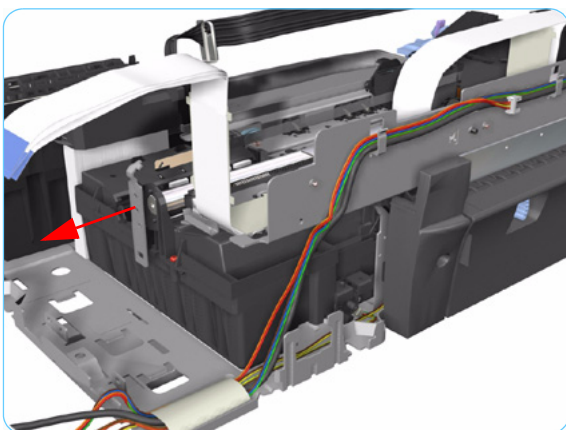

- 11.** Remove the Encoder Strip Holder from the Printer.

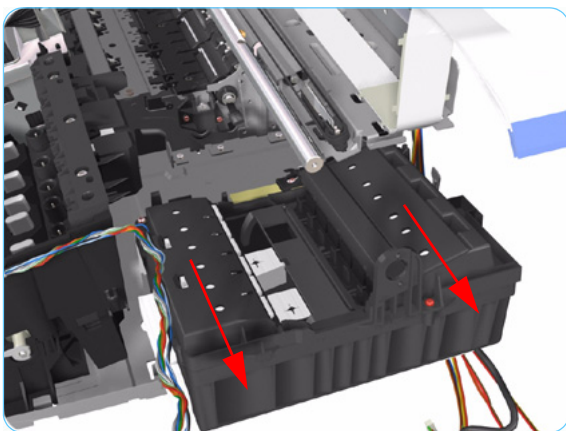

- 12.** Slide the Service Station out of the Printer.

If the Service Station is replaced, make sure that you check that the Pen to Rib Space (PRS) is within specifications.

Front Panel

Removal

Switch off the product and remove the power cable.

1. Remove the Center Cover ⇒ Page 7-7
2. Remove the Left End Cover ⇒ Page 7-11.
3. Release the Front Panel from inside the Left Hand Cover.

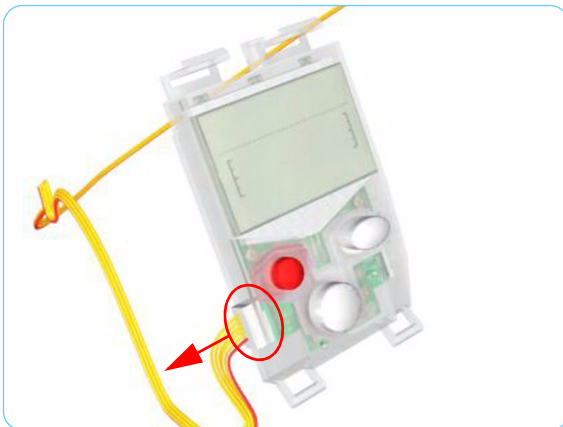
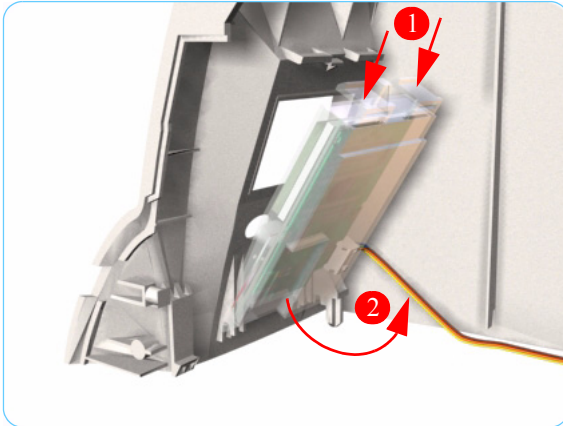

4. Disconnect the cable from the Front Panel and remove from the Printer.

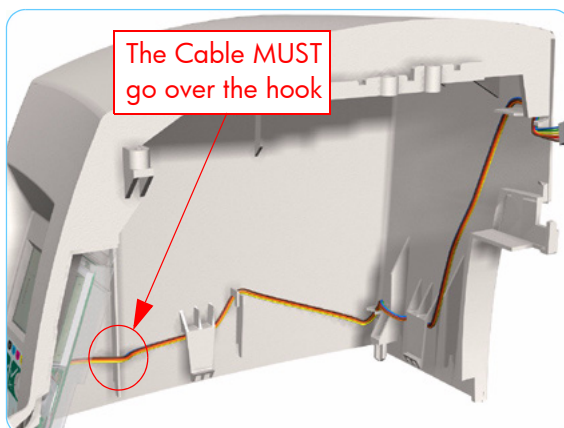

5. **Important:** When installing the Front Panel, make sure you route the cable as shown:

Encoder Strip

Removal

Switch off the product and remove the power cable.

1. Remove the Center Cover ⇒ Page 7-7
2. Remove the Right End Cover ⇒ Page 7-9.
3. Remove the Left End Cover ⇒ Page 7-11.
4. Release the Encoder Strip from the left hand side of the Printer.

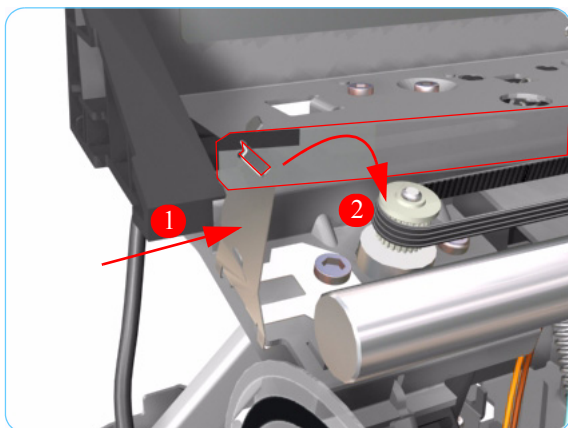

5. Release the Encoder Strip from the right hand side of the Printer.

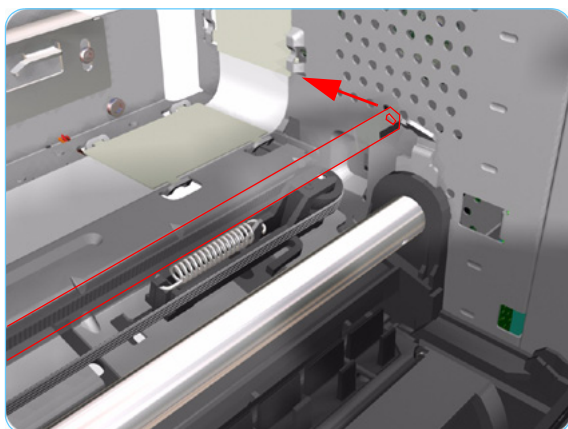

6. Gently slide out the Encoder Strip through the Carriage Assembly and remove from the Printer.

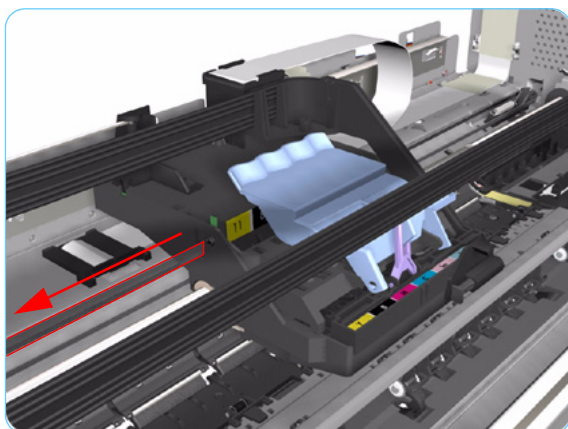

Carriage Motor

Removal

Switch off the product and remove the power cable.

1. Remove the Center Cover ⇒ Page 7-7
2. Remove the Right End Cover ⇒ Page 7-9.
3. Remove the Left End Cover ⇒ Page 7-11.
4. Disconnect the cable from the Carriage Motor.

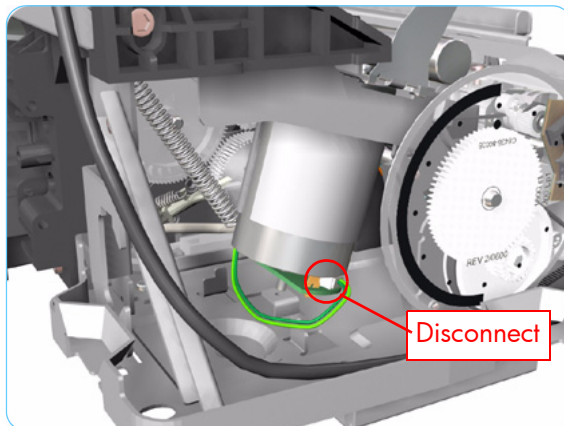

5. Release the Belt from the Carriage Motor by pushing in the Turnaround Assembly (right hand side of the printer) and at the same time releasing the Belt from the Motor on the left hand side of the printer.

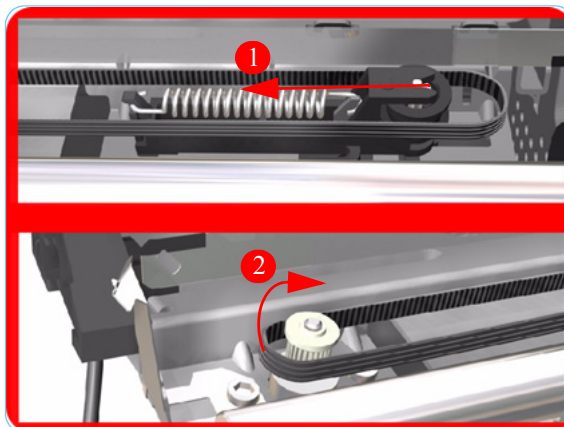

6. Remove 2 T-10 screws that secure the Carriage Motor.

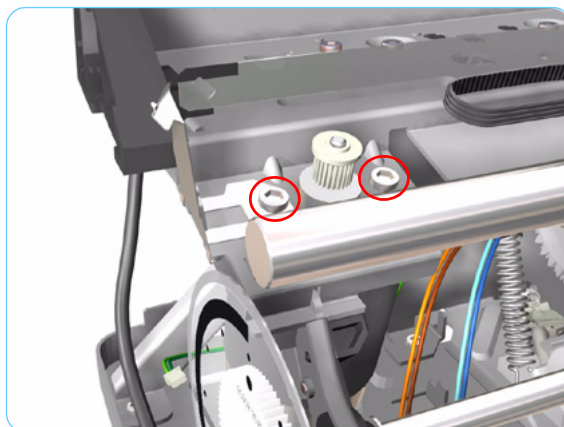

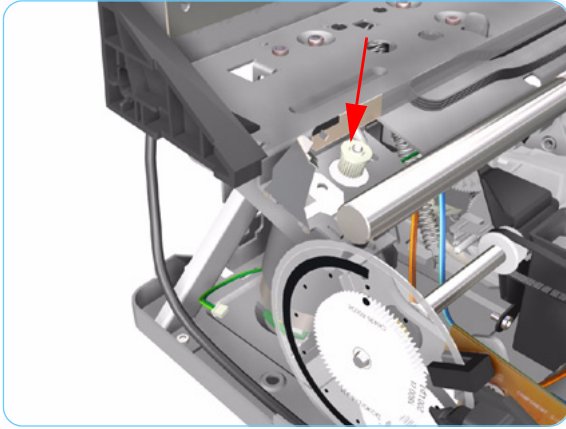

7. Remove the Carriage Motor from the Printer (needs to be removed from underneath).

Cleanout Assembly

Removal

Switch off the product and remove the power cable.

1. To release the Cleanout Assembly, push in the 2 buttons on either side.

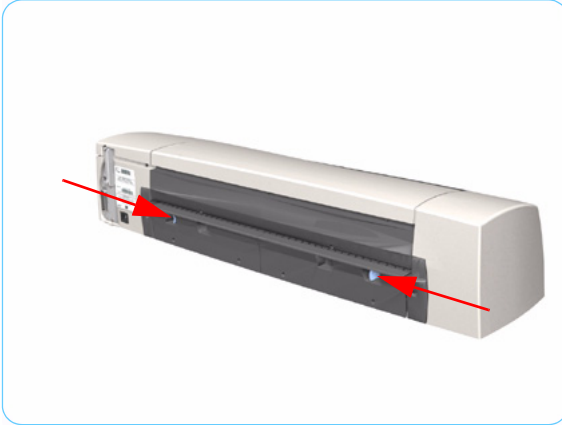

2. Remove the Cleanout Assembly from the Printer.

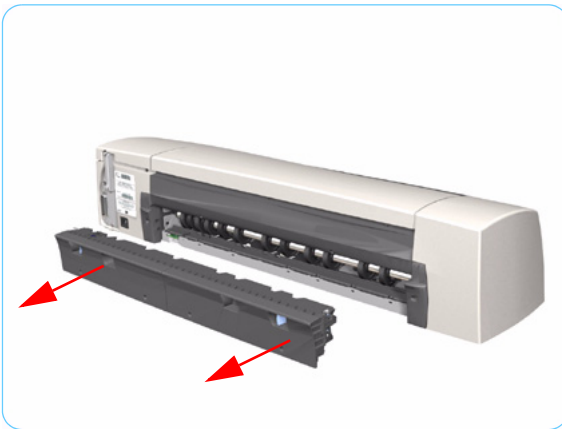

Ink Supply Tubes

Removal

Switch off the product and remove the power cable.

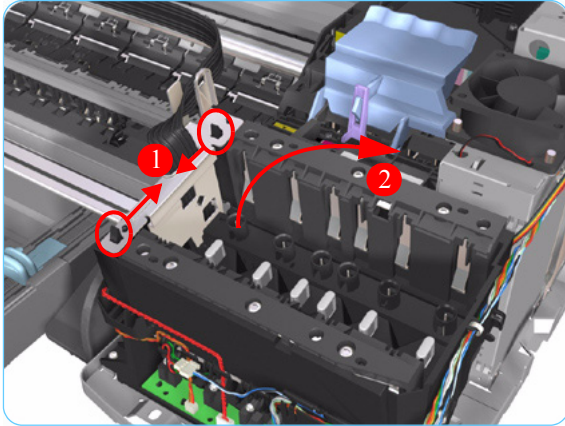

1. Remove the Center Cover ⇒ Page 7-7
2. Remove the Right End Cover ⇒ Page 7-9.
3. Release the Tubes Bracket from the Ink Supply Station by pushing the clips inwards and lifting up the Bracket.

The following step is not applicable to 10, 20, 30, 30n, 50ps

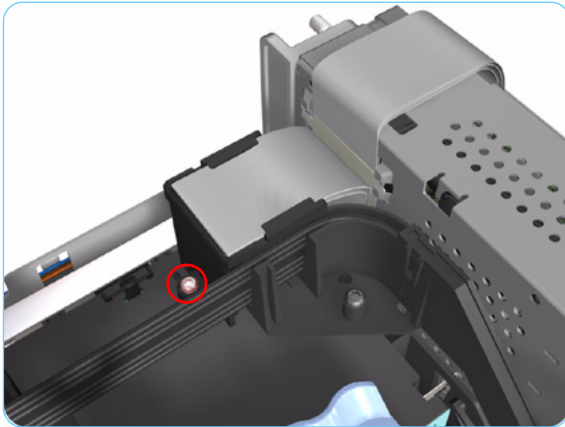

4. Remove 1 T-10 screw that secures the Trailing Cable Support to the Carriage Assembly. Release the Trailing Cable Support from the Carriage Assembly.



5. Remove 1 T-10 screw that secures the Tube Crane to the Carriage Assembly.

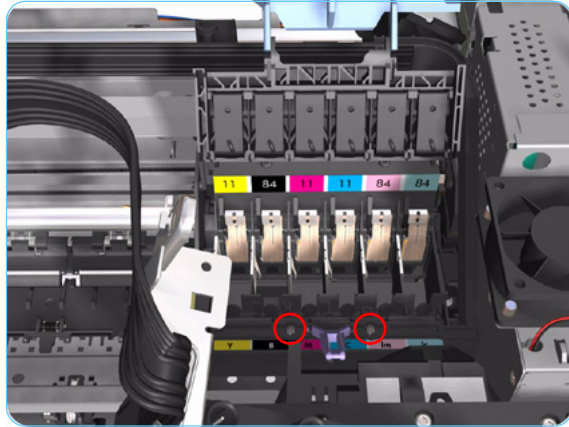

- Open the Printhead Cover and remove 2 T-8 screws that secure the Tube Crane to the Carriage Assembly.

The following step only applicable to 70, 100, 100+, 110plus

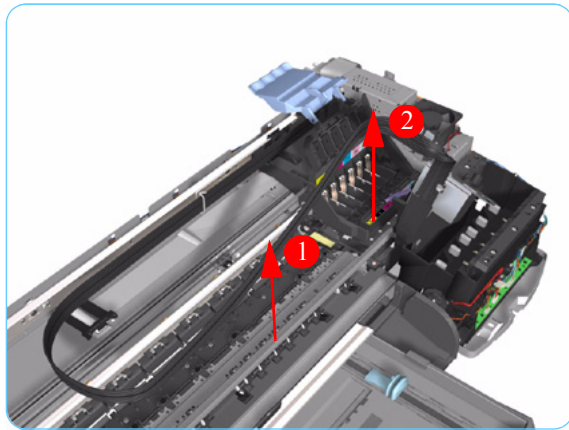

- Lift up the Tube Crane (1) to release the PH Cover (2) from the Carriage Assembly and remove from the Printer.

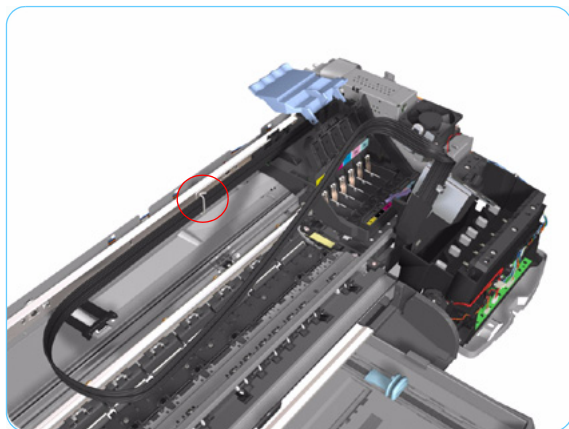

- Release the Ink Supply Tubes from the Raceway Holder.

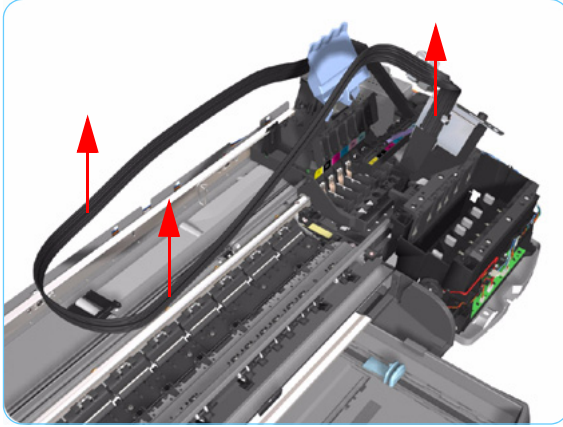

9. Release the Ink Supply Tubes and remove from the Printer.

After installing NEW Ink Supply Tubes, make sure that you prime the tubes (Refer to "Set Flag to Prime Tubes" in the "Utilities" Section).

Carriage Assembly (Applicability: 70, 100, 100+, 110+, 120, 120nr)

Removal

Switch off the product and remove the power cable.

1. Remove the Center Cover ⇒ Page 7-7
2. Remove the Right End Cover ⇒ Page 7-9.
3. Remove the Left End Cover ⇒ Page 7-11.
4. Remove the Electronics Module ⇒ Page 7-18.
5. Remove the Power Supply Unit ⇒ Page 7-22.
6. Remove the Service Station ⇒ Page 7-24.
7. Remove the Ink Supply Tubes ⇒ Page 7-32.
8. Release the Belt from the Carriage Motor by pushing in the Turnaround Assembly (right hand side of the printer) and at the same time releasing the Belt from the Motor on the left hand side of the printer.

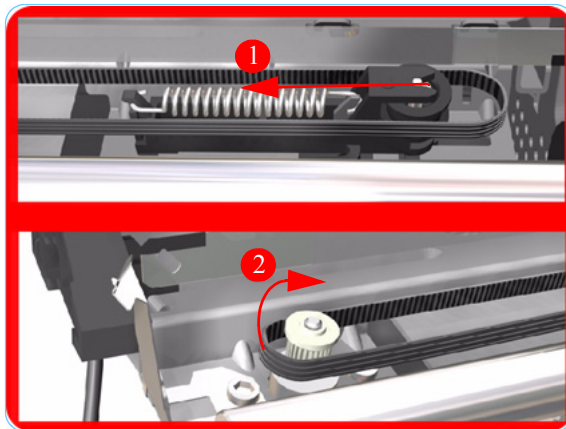

The following step is only applicable to 120, 120nr

9. Remove 3 T-10 screws that secure the Trailing Cable Clip to the Chassis.

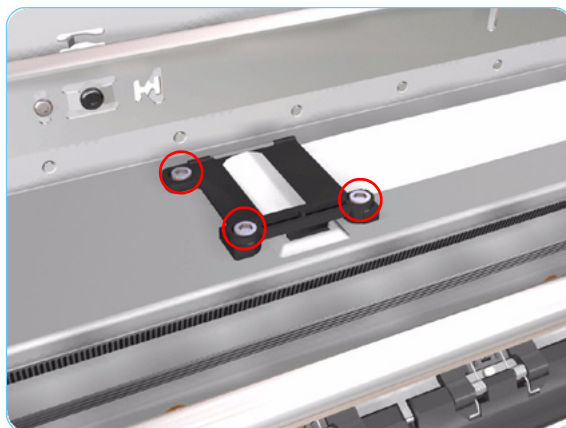

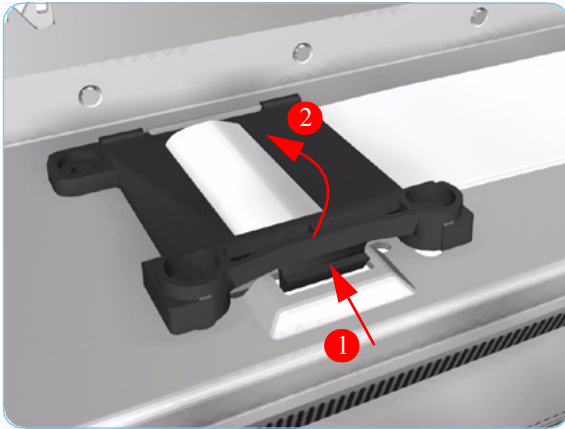

10. Release the Trailing Cable Clip from the Chassis.

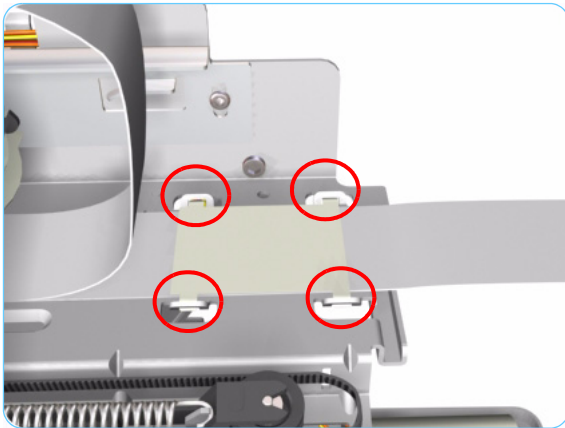

11. Release the Trailing Cable from the Chassis.

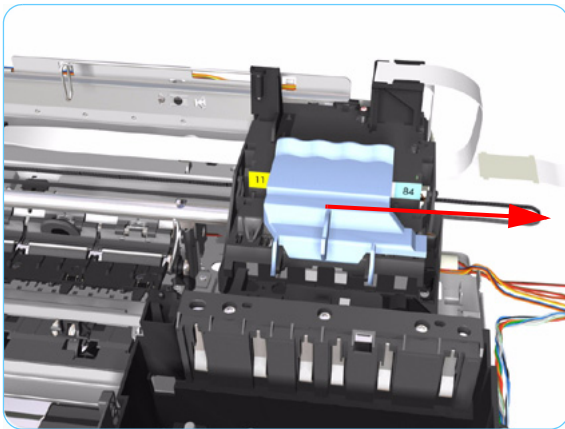

12. Slide the Carriage Assembly to the right and out of the Printer.

13. If the Carriage Assembly is to be replaced, make sure that you remove the belt (in order to install it on the new carriage). To remove the belt ⇒ Page 7-41.

If the Carriage is replaced by a new one, make sure that you perform the PRS Adjustment procedure.

Carriage Assembly (Applicability: 10ps, 20ps, 30, 30nr, 50ps, 90, 90r, 130, 130nr)

Removal

Switch off the product and remove the power cable.

1. Remove the Center Cover ⇒ Page 7-7
2. Remove the Right End Cover ⇒ Page 7-9.
3. Remove the Left End Cover ⇒ Page 7-11.
4. Remove the Electronics Module ⇒ Page 7-18.
5. Remove the Power Supply Unit ⇒ Page 7-22.
6. Remove the Service Station ⇒ Page 7-24.
7. Remove the Ink Supply Tubes ⇒ Page 7-32.

Following step only applicable to 90, 90r, 130, 130nr

8. Remove 3 T-10 screws that secure the Trailing Cable Clip to the Chassis.

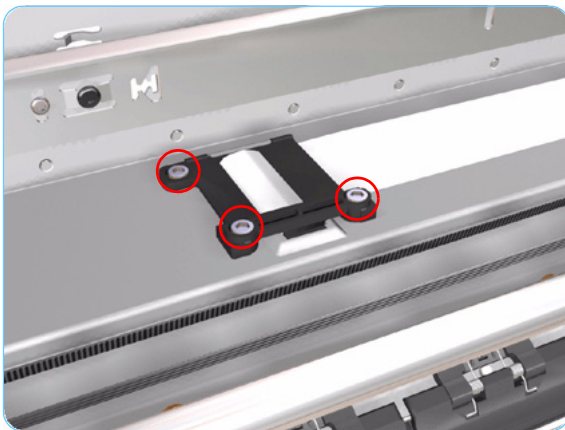

9. Release the Trailing Cable Clip from the Chassis.

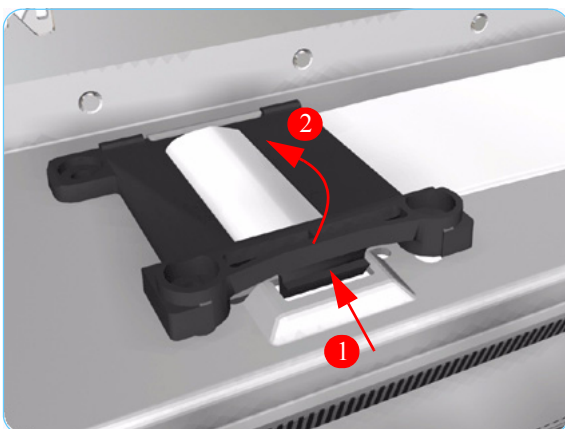

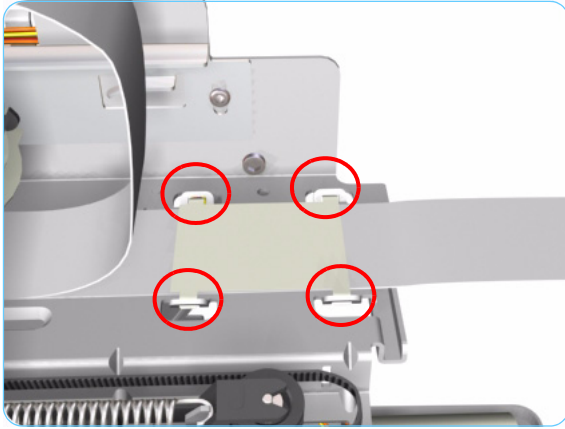

- 10.** Release the Trailing Cable from the Chassis.

Following step only applicable to 90, 90r, 130, 130nr

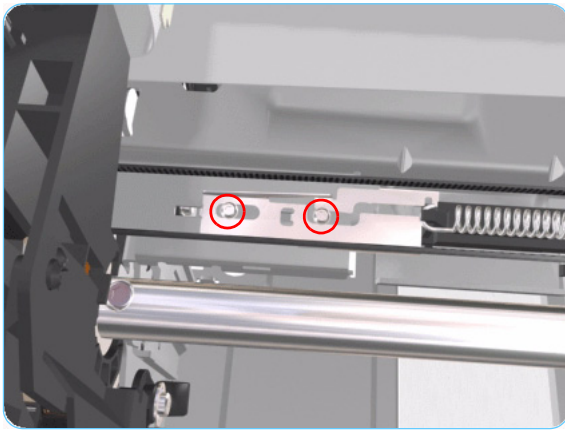

- 11.** Remove 2 T-10 screws that secure the Turnaround Stopper. Remove the Turnaround Stopper from the Printer.

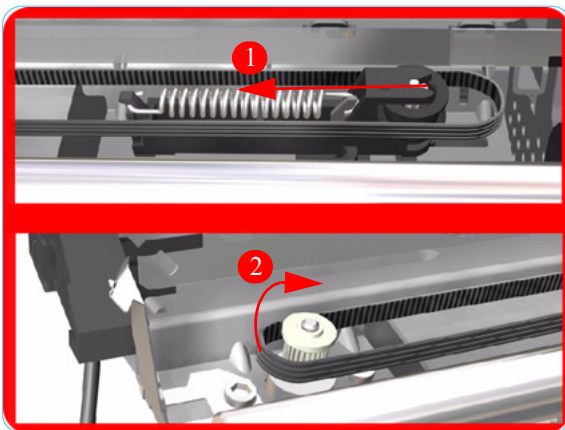

- 12.** Release the Belt from the Carriage Motor by pushing in the Turnaround Assembly (right hand side of the printer) and at the same time releasing the Belt from the Motor on the left hand side of the printer.

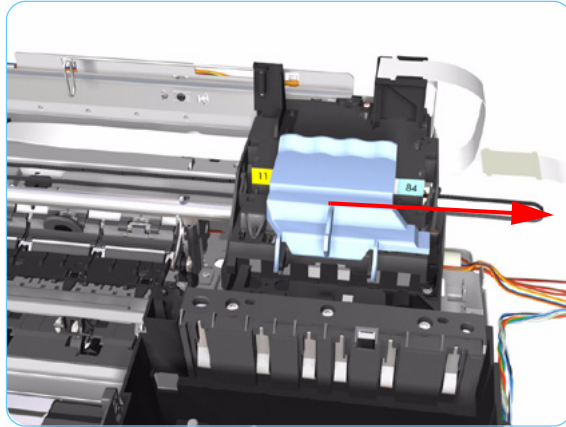

13. Slide the Carriage Assembly to the right and out of the Printer.
14. If the Carriage Assembly is to be replaced, make sure that you remove the belt (in order to install it on the new carriage). To remove the belt ⇒ Page 7-47.

If the Carriage is replaced by a new one, make sure that you perform the PRS Adjustment procedure.

Installation of the Carriage Assembly - IMPORTANT (Only applicable to 90, 90r, 130, 130nr)

After re-installing the Carriage Assembly and Belt, take note of these steps for the correct installation of the Turnaround Stopper. These steps must be followed in exactly the same sequence:

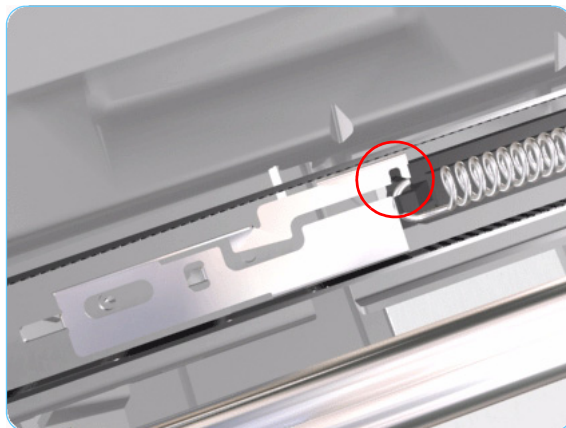

1. Place the Turnaround Stopper in to position and locate the slot in the Stopper on to the Turnaround Assembly. This step is very important since it will determine the space between the Stopper and the Turnaround Assembly.

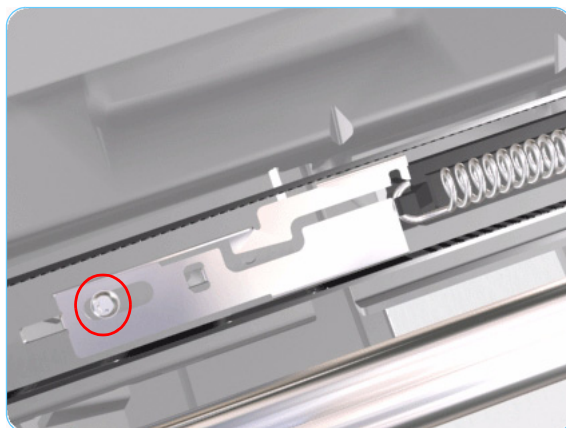

2. Insert the first screw (left) and tighten it.



3. Insert the 2nd screw (right) and tighten it. As you tighten the screw you should notice that the slot in the Stopper will rise away from the Turnaround Assembly.

After the installation of the Carriage Assembly and the Turnaround Stopper, you must first check that the Cutter cuts the media correctly (if the Printer has the Rollfeed and Cutter installed).

Carriage Belt

Removal

Switch off the product and remove the power cable.

1. Remove the Center Cover ⇒ Page 7-7
2. Remove the Right End Cover ⇒ Page 7-9.
3. Remove the Electronics Module ⇒ Page 7-18.
4. Remove the Power Supply Unit ⇒ Page 7-22.
5. Remove the Service Station ⇒ Page 7-24.
6. Remove the Ink Supply Tubes ⇒ Page 7-32.
7. Remove the Carriage Assembly ⇒ Page 7-35.
8. Release the Belt from the bottom of the Carriage Assembly.

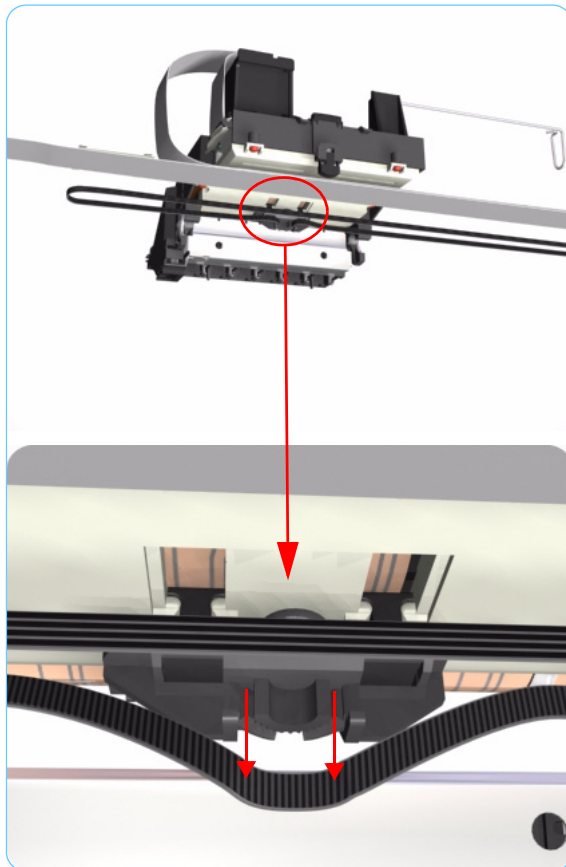

Starwheel Assembly (Applicability: 10ps, 20ps, 30, 30n, 50ps)

Removal

Switch off the product and remove the power cable.

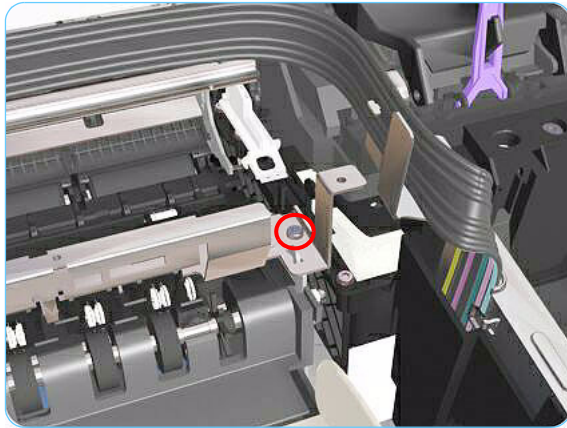

1. Remove the Center Cover ⇒ Page 7-7.
2. Remove 1 T-10 screw (**Type A**) that secures the Starwheel Assembly to the right hand side of the printer.

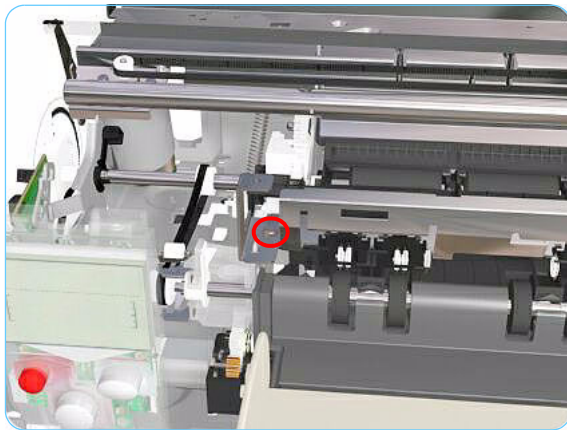

3. Remove 1 T-10 screw (**Type A**) that secures the Starwheel Assembly to the left hand side of the printer.

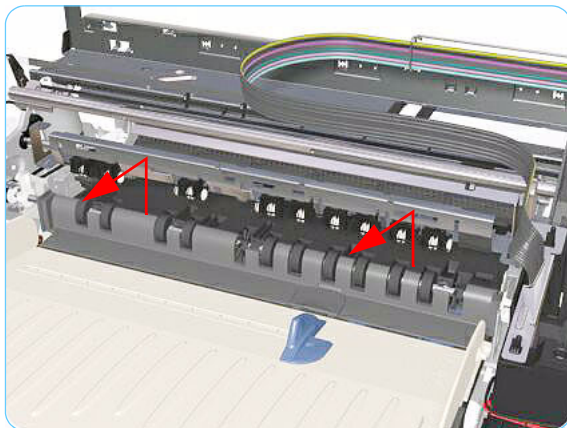

4. Remove the Starwheel Assembly.

Starwheel Assembly

Removal

Switch off the product and remove the power cable.

1. Remove the Center Cover ⇒ Page 7-7.
2. Remove the Right End Cover ⇒ Page 7-9.
3. Remove the Left End Cover ⇒ Page 7-11.
4. Remove 1 T-10 screw that secures the Starwheel Assembly to the right hand side of the printer.

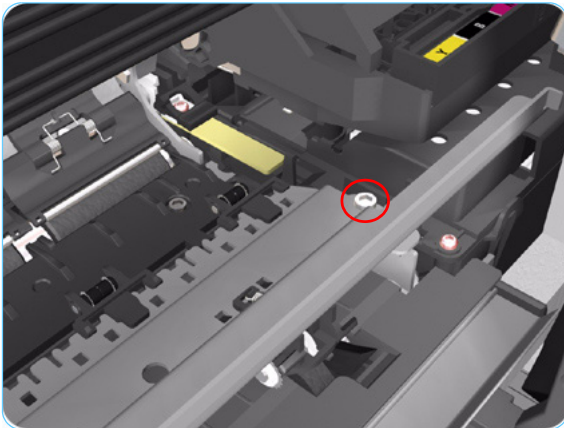

5. Remove 2 T-10 screws that secure the Starwheel Assembly to the left hand side of the printer.

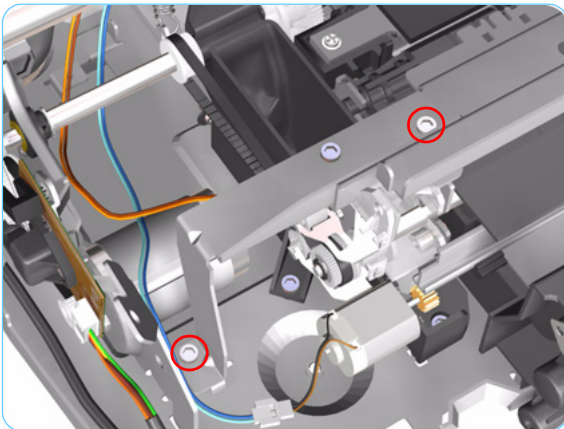

6. Remove the Starwheel Assembly.

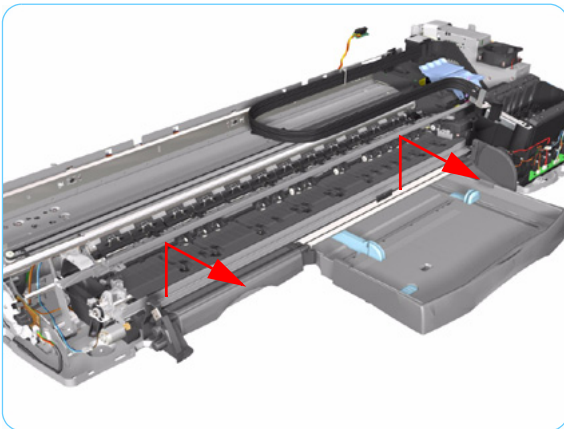

Print Platen Assembly

Removal

Switch off the product and remove the power cable.

1. Remove the Center Cover ⇒ Page 7-7.
2. Remove the Right End Cover ⇒ Page 7-9.
3. Remove the Left End Cover ⇒ Page 7-11.
4. Remove the Starwheel Assembly ⇒ Page 7-43.
5. Release the Belt from the Print Platen Assembly.

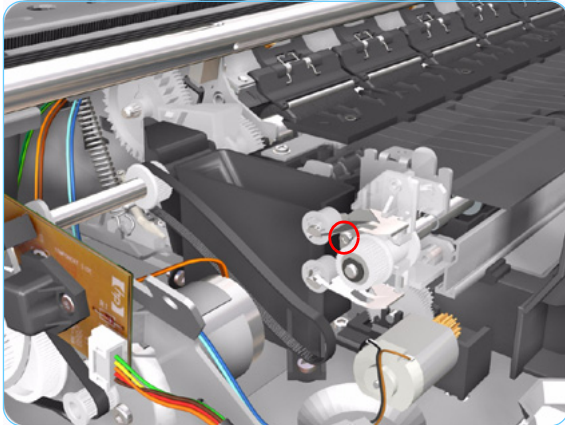
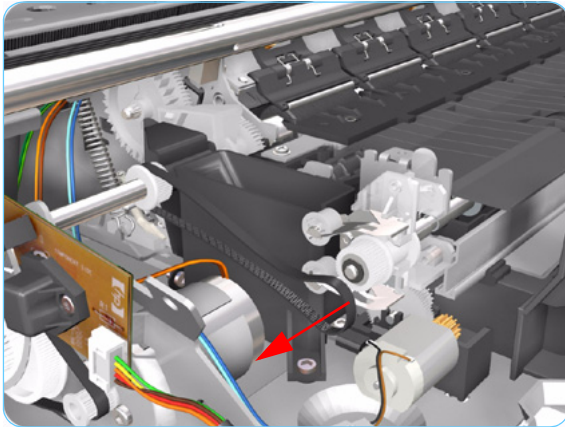

6. Remove 1 T-10 screw that secures the Spring Idler. Remove the Spring Idler from the Printer.

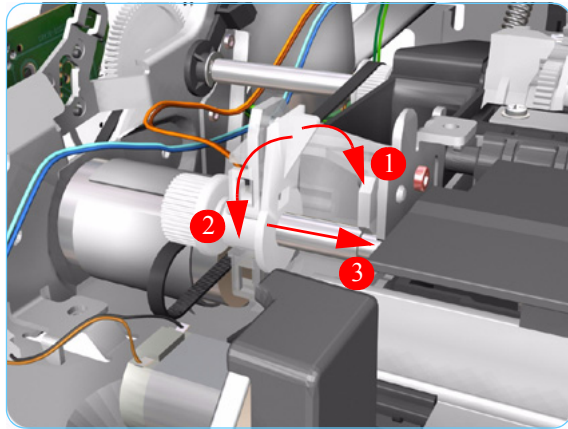

7. Release the locking mechanism from the left hand side of the Printer.

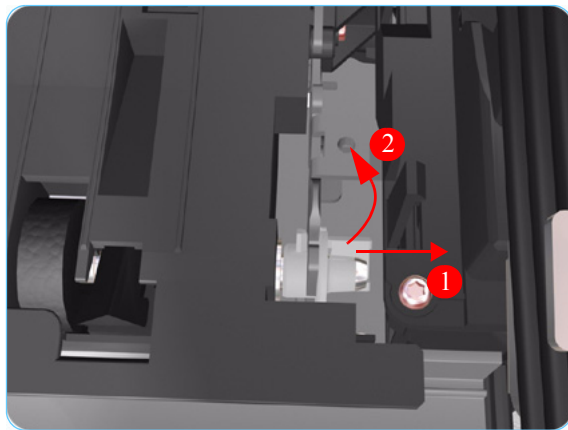

8. Release the locking mechanism from the right hand side of the Printer.

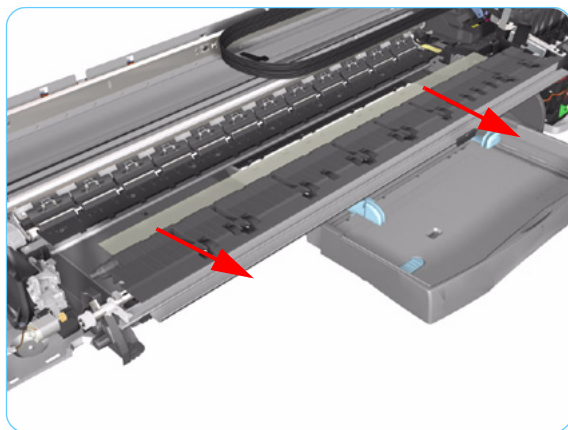

9. Slide out the complete Print Platen Assembly.

Output Separator (Applicability: 10ps, 20ps, 30, 30n, 50ps)

Removal

Switch off the product and remove the power cable.

1. Remove the Front Cover ⇒ Page 7-7.
2. Remove the Center Cover ⇒ Page 7-7.
3. Remove the Output Tray.
4. Unclip the Output Separator and remove from the Printer.

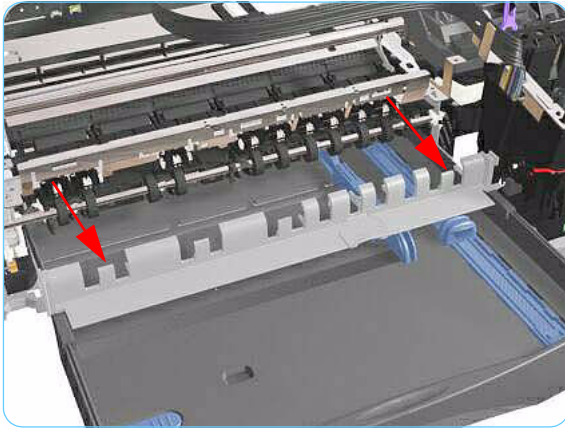

Ramp Motor Assembly

(Not applicable to 10ps, 20ps, 30, 30n, 50ps)

Removal

Switch off the product and remove the power cable.

1. Remove the Center Cover ⇒ Page 7-7.
2. Remove the Left End Cover ⇒ Page 7-11.
3. Remove the Starwheel Assembly ⇒ Page 7-43.
4. Remove the Print Platen Assembly ⇒ Page 7-44.
5. Remove 2 T-10 screws that secure the Front Left Bracket.

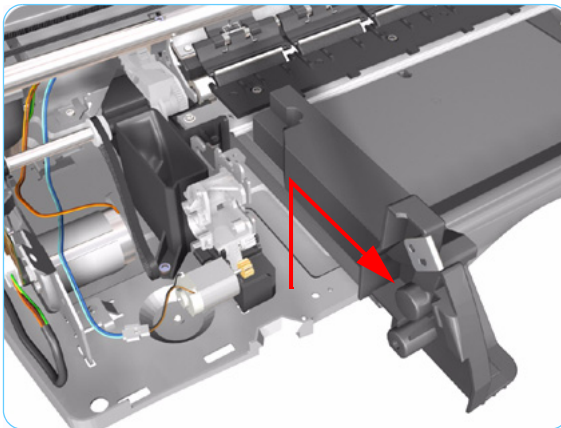
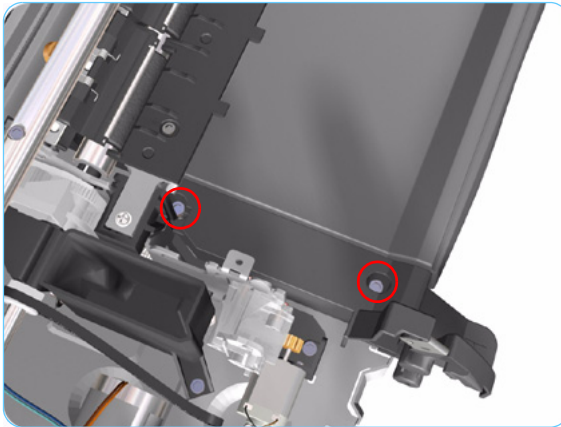

6. Remove the Front Left Bracket from the Printer.

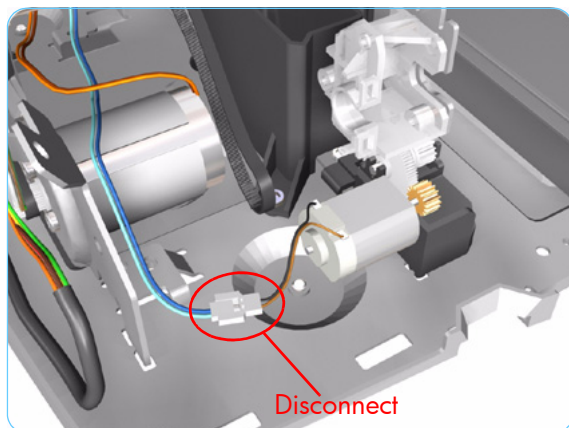

7. Disconnect the Ramp Motor cable.

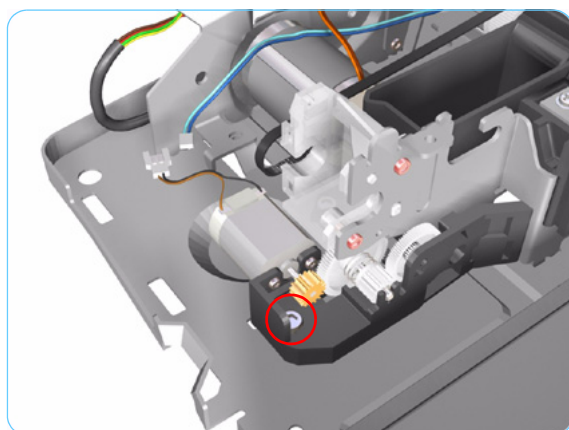

8. Remove 1 T-10 screw from the Ramp Motor Assembly.

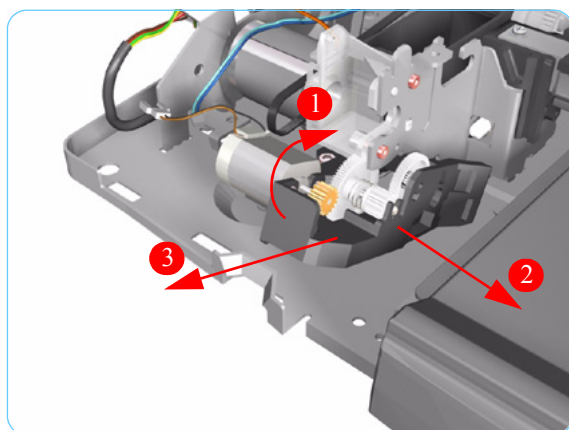

9. Remove the Ramp Motor Assembly from the Printer.

Output Mechanism Assembly (Applicability: 10ps, 20ps, 30, 30n, 50ps)

Removal

Switch off the product and remove the power cable.

1. Remove the Front Cover ⇒ Page 7-6.
2. Remove the Center Cover ⇒ Page 7-7.
3. Remove the Right End Cover ⇒ Page 7-9.
4. Remove the Left End Cover ⇒ Page 7-11.
5. Remove the Output Separator ⇒ Page 7-46.
6. Remove the Starwheel Assembly ⇒ Page 7-43.
7. Release the Belt from the Output Mechanism Assembly.

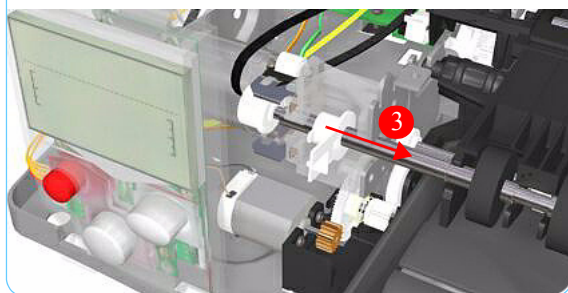
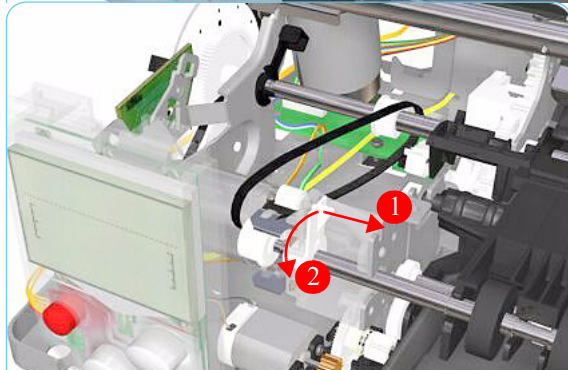
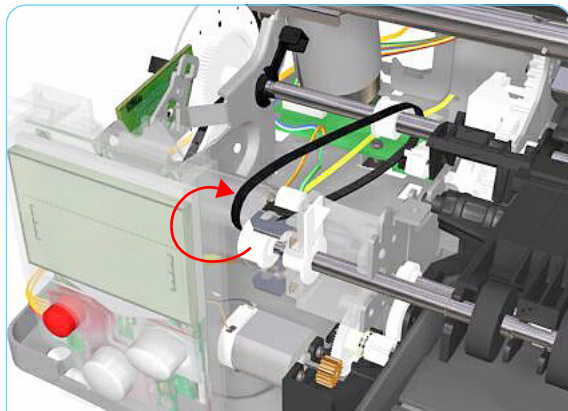

8. Release the locking mechanism from the left hand side of the Printer.

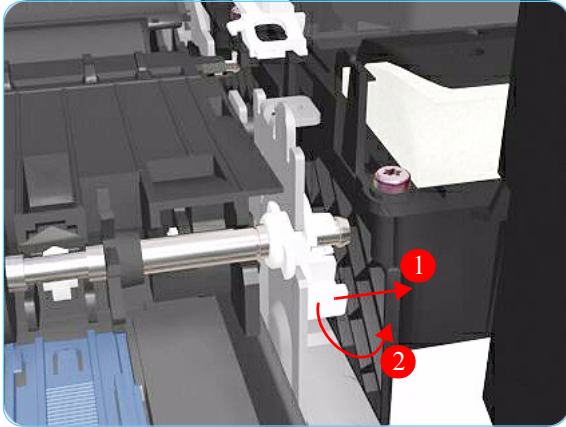

- 9.** Release the locking mechanism from the right hand side of the Printer.

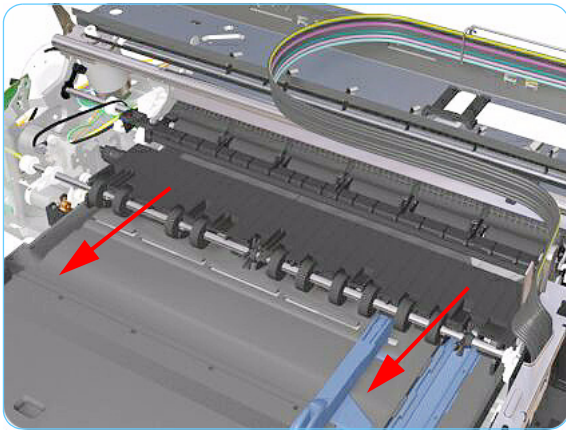

- 10.** Slide out the complete Output Mechanism Assembly.

Spittoon (If Installed in the Printer)

(Not applicable to 10ps, 20ps, 30, 30n, 50ps)

Removal

Switch off the product and remove the power cable.

1. Remove the Center Cover ⇒ Page 7-7.
2. Remove the Left End Cover ⇒ Page 7-11.
3. Remove the Starwheel Assembly ⇒ Page 7-43.
4. Remove 1 T-10 screw that secures the Spittoon.

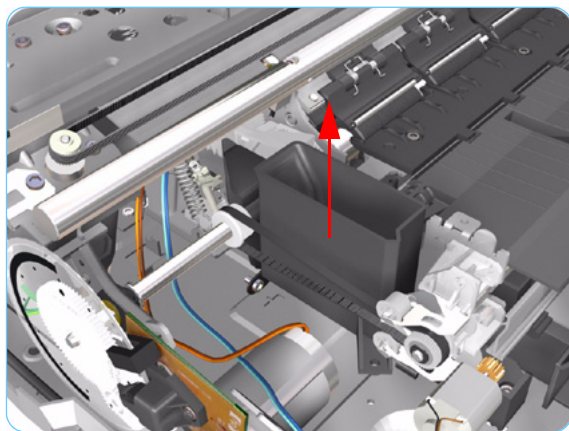
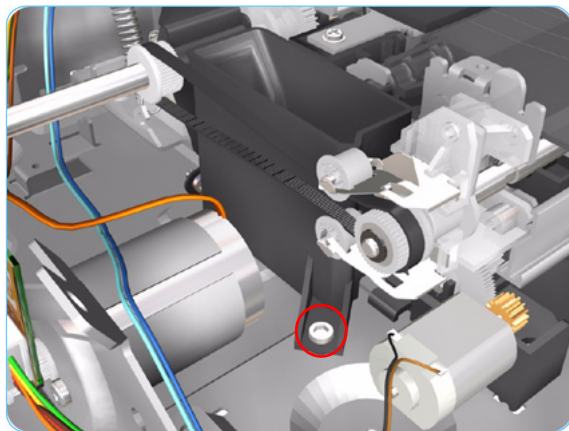

5. Remove the Spittoon from the Printer.

Pivot Assembly

(Not applicable to 10ps, 20ps, 30, 30n, 50ps)

Removal

Switch off the product and remove the power cable.

1. Remove the Center Cover ⇒ Page 7-7.
2. Remove the Left End Cover ⇒ Page 7-11.
3. Remove the Right End Cover ⇒ Page 7-9.
4. Remove the Starwheel Assy ⇒ Page 7-43.
5. Remove 1 T-8 screw and washer that secure the Pivot Assembly on the left hand side of the Printer.

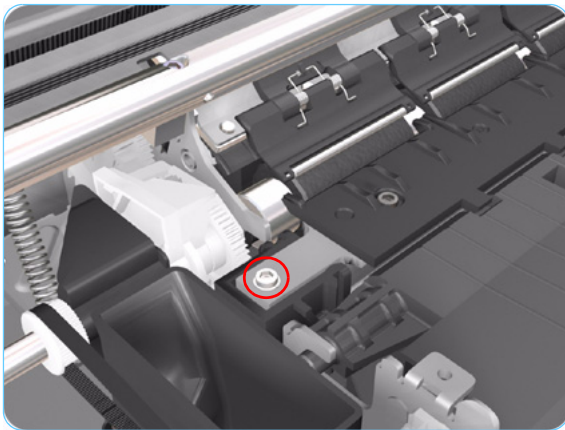

6. Remove 1 T-8 screw and washer that secure the Pivot Assembly on the right hand side of the Printer.

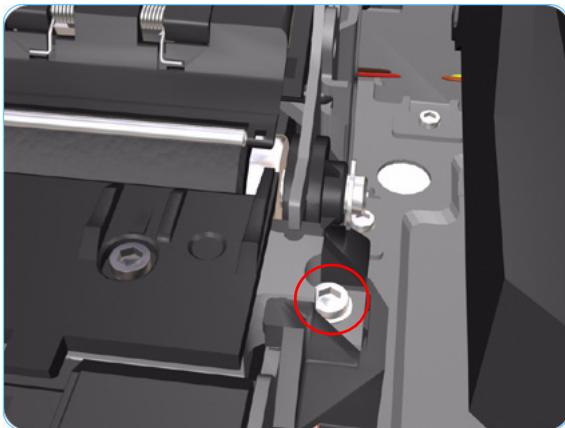

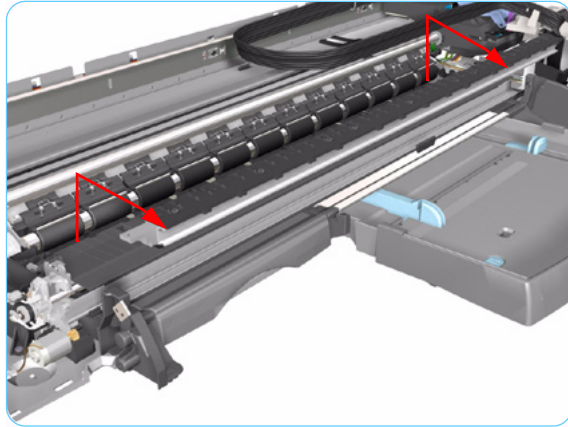

7. Remove the Pivot Assembly from the Printer.

After removing or replacing the Pivot Assembly, make sure that you perform the PRS Adjustment procedure.

Make sure you use NEW screws to install the Pivot Assembly when it has been removed or replaced.

Feed Roller Assembly (Applicability: 10ps, 20, 30, 30n, 50ps)

Removal

Switch off the product and remove the power cable.

1. Remove the Front Cover ⇒ Page 7-6.
2. Remove the Center Cover ⇒ Page 7-7
3. Remove the Right End Cover ⇒ Page 7-9.
4. Remove the Left End Cover ⇒ Page 7-11.
5. Remove the Electronics Module ⇒ Page 7-18.
6. Remove the Starwheel Assembly ⇒ Page 7-43.
7. Remove the Output Separator ⇒ Page 7-46.
8. Remove the Output Mechanism Assembly ⇒ Page 7-49.
9. Remove the Paper-Axis Motor Drive Assembly ⇒ Page 7-56.
10. Release the locking mechanism from the left hand side of the Printer.

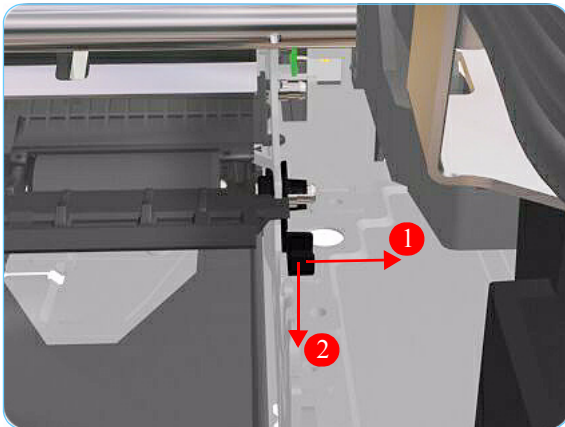
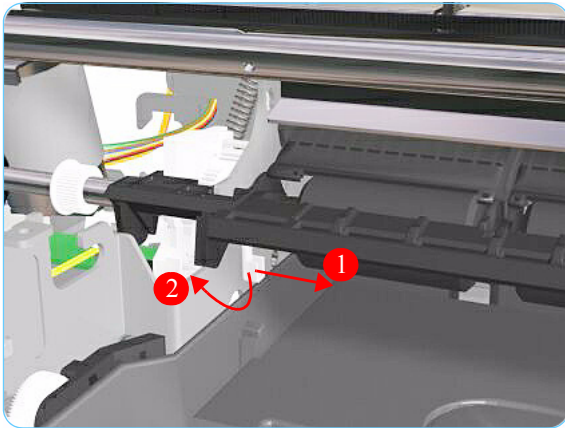

11. Release the locking mechanism from the right hand side of the Printer.

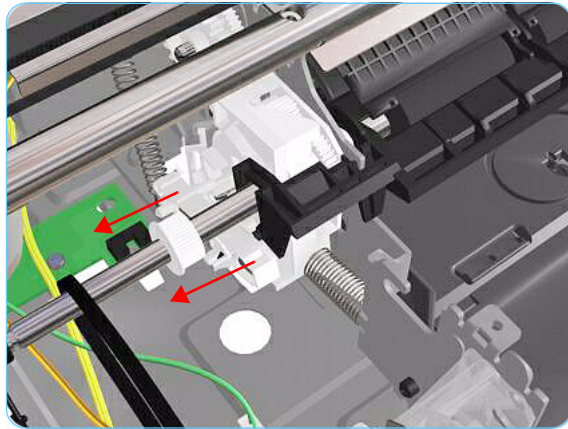

12. Release the Pin Caber and remove from the Printer.

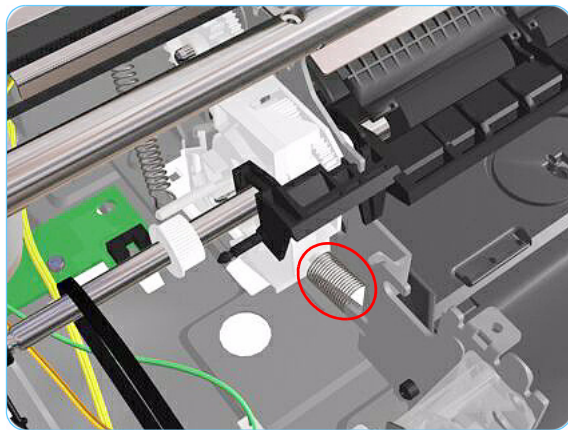

13. Release the Spring.

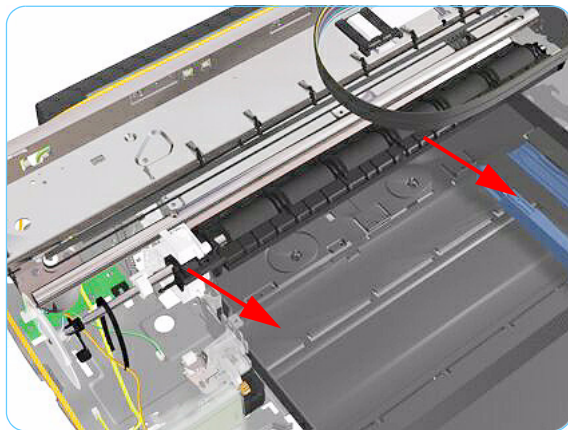

14. Raise the locks so that they are aligned with the cutouts and lift out the Feed Roller Assembly from the Printer.

After removing or replacing the Feed Roller Assembly, make sure that you perform the PRS Adjustment procedure and the Accuracy Calibration.

Feed Roller Assembly

(Not applicable to Designjets 10ps, 20ps, 30, 30n, 50ps)

Removal

Switch off the product and remove the power cable.

1. Remove the Center Cover ⇒ Page 7-7
2. Remove the Right End Cover ⇒ Page 7-9.
3. Remove the Left End Cover ⇒ Page 7-11.
4. Remove the Electronics Module ⇒ Page 7-18.
5. Remove the Power Supply Unit ⇒ Page 7-22.
6. Remove the Service Station ⇒ Page 7-24.
7. Remove the Starwheel Assembly ⇒ Page 7-43.
8. Remove the Print Platen Assembly ⇒ Page 7-44.
9. Remove the Spittoon (if installed) ⇒ Page 7-51.
10. Remove the Pivot Assembly ⇒ Page 7-52.
11. Disconnect the Paper-Axis and Encoder cables.

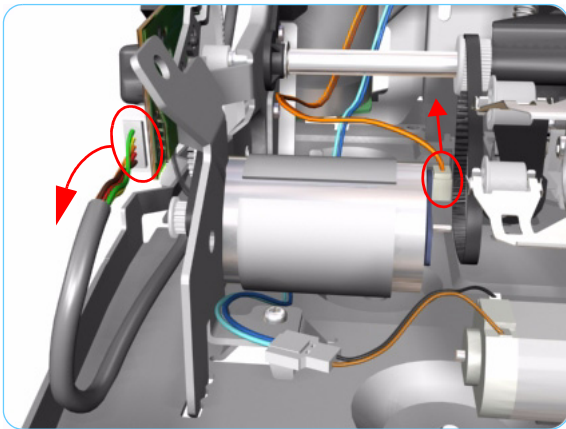

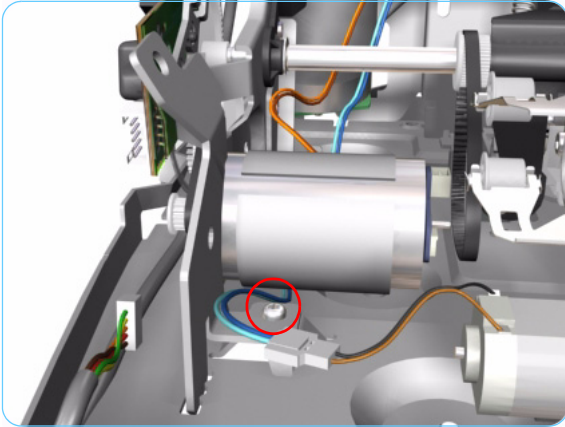

- 12.** Remove 1 T-10 screw that secures the Paper-Axis Motor Mount.

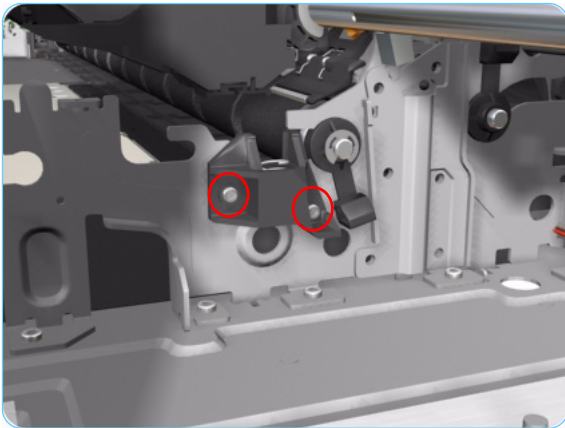

- 13.** Remove 2 T-10 screws that secure the Pivot Assembly Support on the right hand side of the Printer.

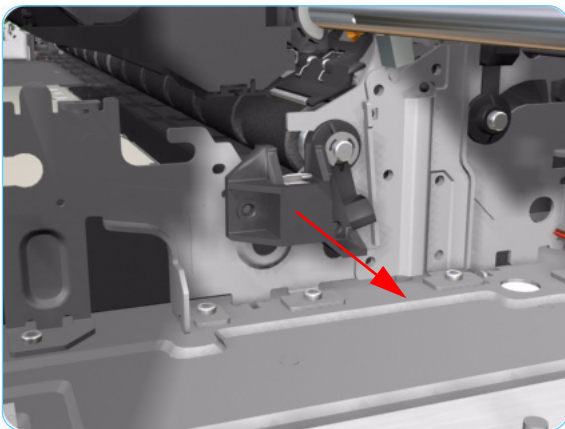

- 14.** Remove the Pivot Assembly Support from the Printer.

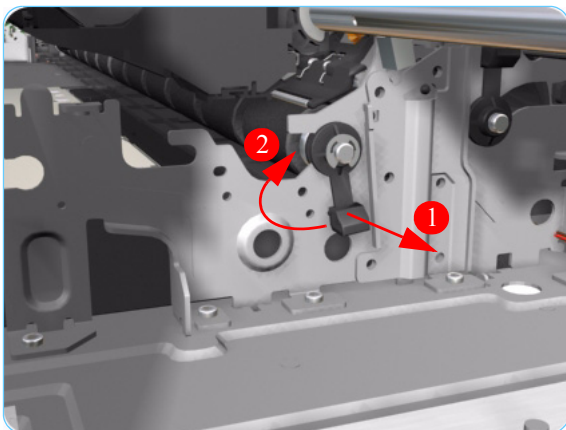

- 15.** Release the locking mechanism from the right hand side of the Printer.



- 16.** Remove 1 T-10 screw and nut that secures the Feed-Roller Support on the left hand side of the Printer.

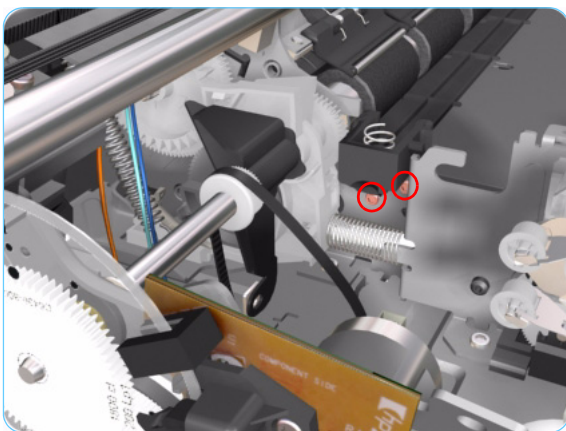

- 17.** Remove 2 T-10 screws that secure the bracket on the left hand side of the Printer.

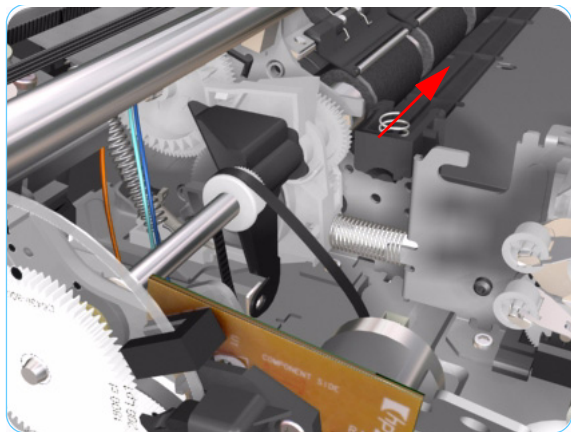

18. Remove the Bracket from the Printer.

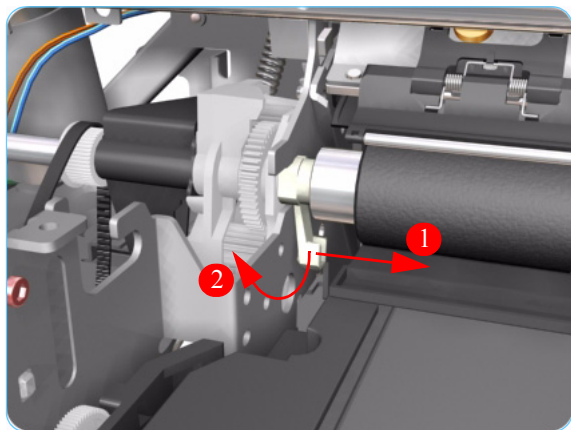

19. Release the locking mechanism from the left hand side of the Printer.

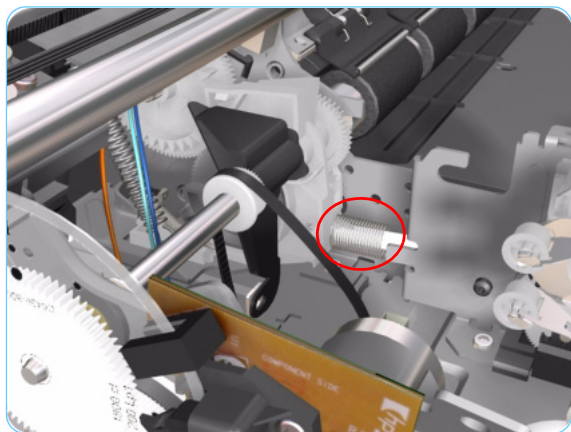

20. Release the Spring from the Bracket.

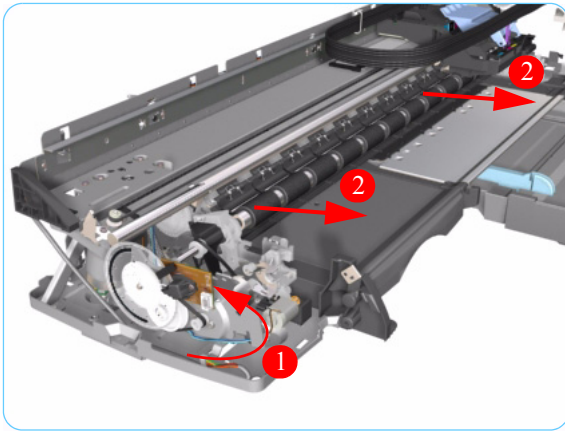

- 21.** Raise the locks so that they are aligned with the cutouts and lift out the Feed Roller Assembly (including the Paper-Axis Motor) from the Printer.

After removing or replacing the Feed Roller Assembly, make sure that you perform the PRS Adjustment procedure and the Accuracy Calibration.

Pick Assembly (Applicability: 10ps, 20ps, 30, 30n, 50ps)

Removal

Switch off the product and remove the power cable.

1. Remove the Cleanout Assembly ⇒ Page 7-37.
2. Release the locking mechanism that secures the Pick Assembly on the right hand side of the printer (looking from the rear).

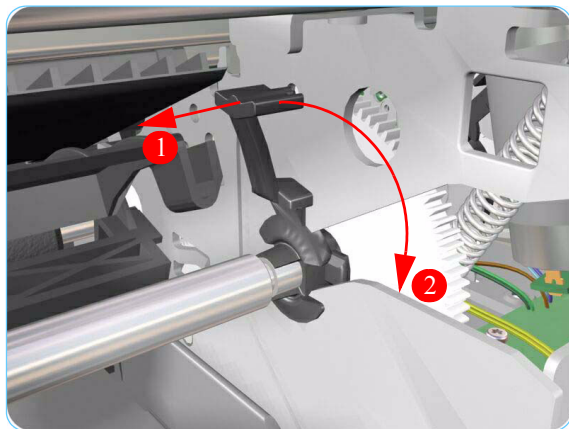

3. Release the locking mechanism that secures the Pick Assembly on the left hand side of the printer (looking from the rear)

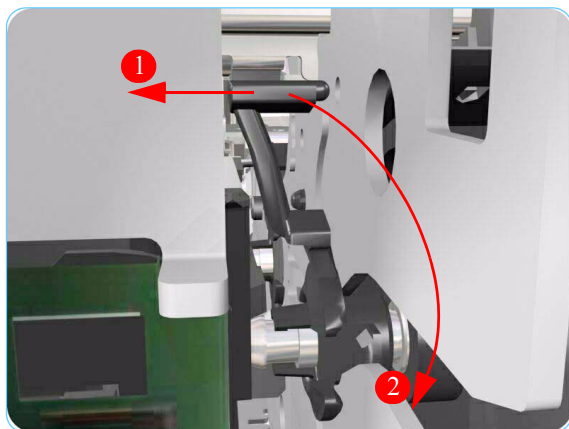

4. Raise the locks so that they are aligned with the cutouts and lift out the Pick Assembly from the Printer.

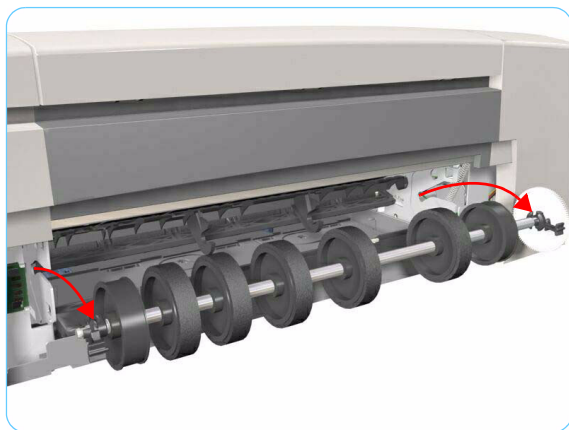

Pick Assembly

(Not applicable to 10ps, 20ps, 30, 30n, 50ps)

Removal

Switch off the product and remove the power cable.

1. Remove the Cleanout Assembly ⇒ Page 7-31.
2. Remove the Center Cover ⇒ Page 7-7
3. Remove the Right End Cover ⇒ Page 7-9.
4. Remove the Left End Cover ⇒ Page 7-11.
5. Remove the Electronics Module ⇒ Page 7-18.
6. Remove the Power Supply Unit ⇒ Page 7-22.
7. Remove the Service Station ⇒ Page 7-24.
8. Remove the Encoder Strip ⇒ Page 7-28.
9. Remove the Ink Supply Tubes ⇒ Page 7-32.
10. Remove the Carriage Assembly ⇒ Page 7-35.
11. Remove 4 screws that secure the Hanger Assembly on the left hand side of the Printer.



12. Remove 1 screw that secures the Hanger Assembly on the left hand side of the Printer.

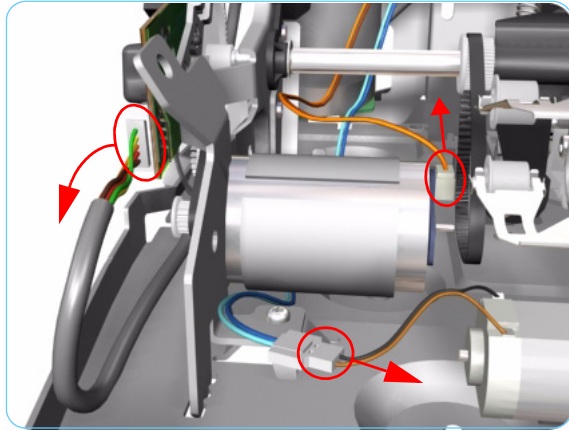

- 13.** Disconnect the Paper-Axis, Encoder and Ramp Motor cables.

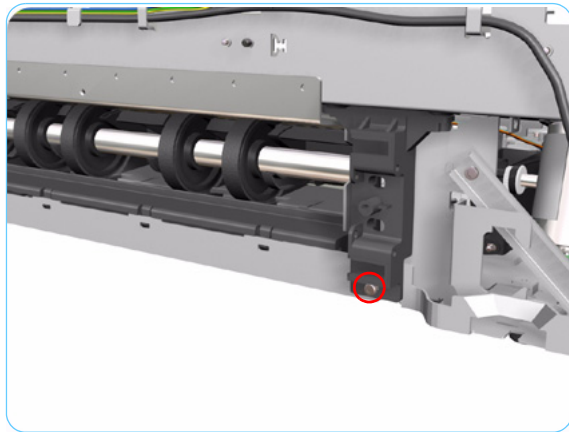

- 14.** Remove 1 screw from the Rear Left Trim Bracket.

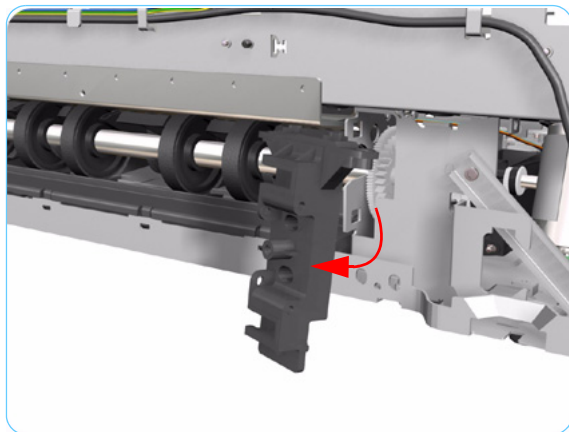

- 15.** Remove the Rear Left Trim Bracket from the Printer.

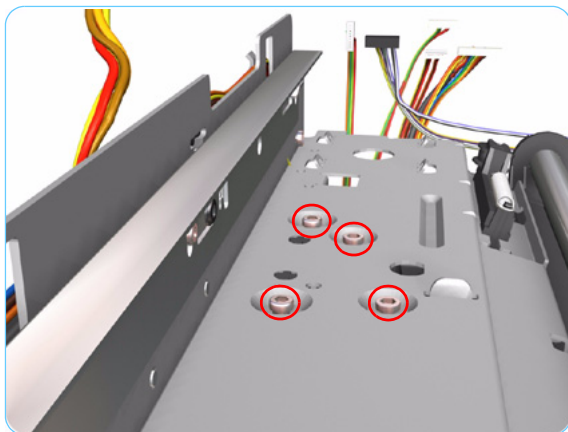

16. Remove 4 screws that secure the Hanger Assembly on the right hand side of the Printer.

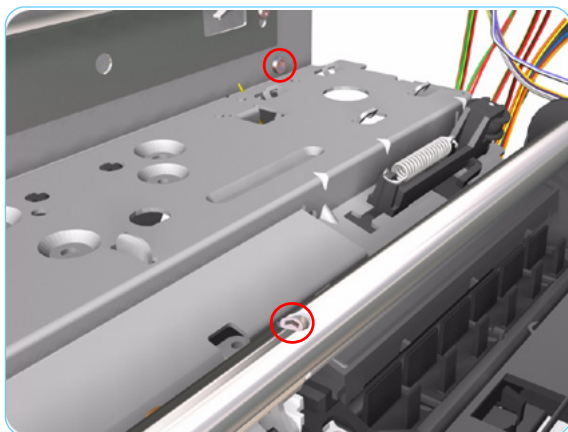

17. Remove 2 screws that secure the Hanger Assembly on the right hand side of the Printer.

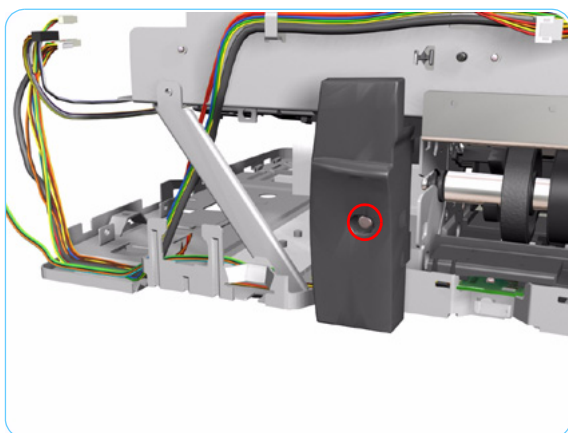

18. Remove 1 T-10 screw from the Rear Right Trim.

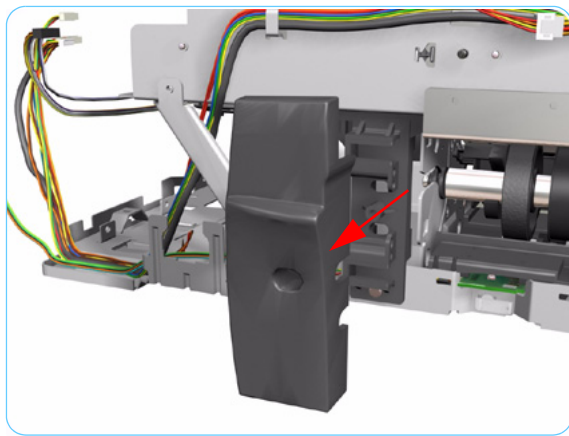

19. Remove the Rear Right Trim from the Printer.

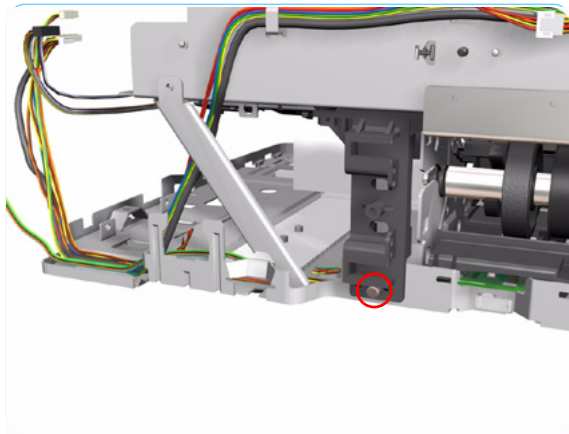

20. Remove 1 screw from the Rear Right Trim Bracket.

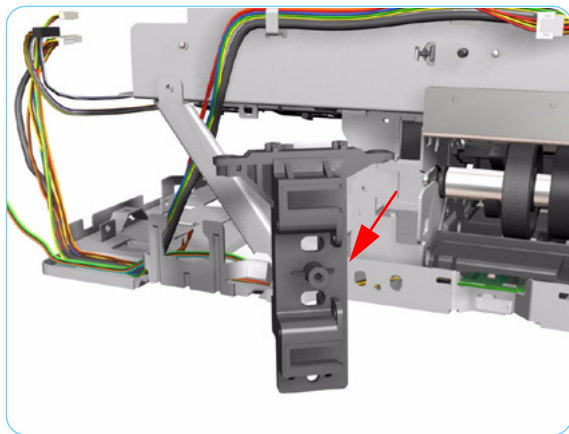

21. Remove the Rear Right Trim Bracket from the Printer.

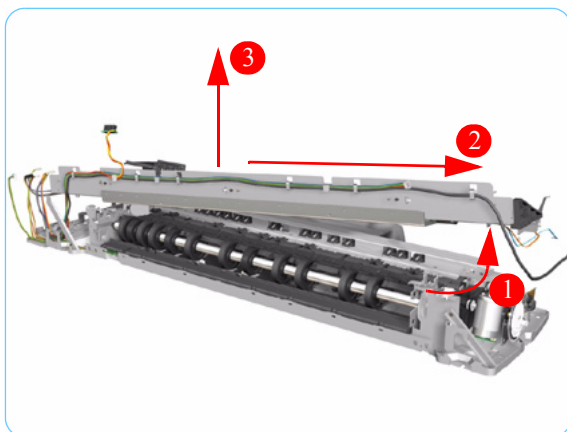

22. Remove the Hanger Assembly from the Printer.

If there are any cables still attached between the Hanger Assembly and the Printer then disconnect them before removing the Hanger Assembly.

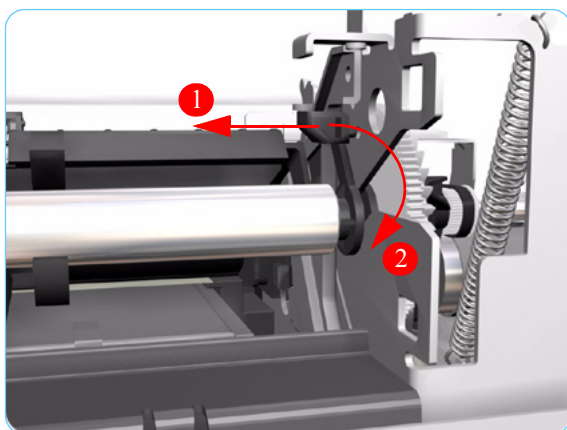

23. Release the locking mechanism that secures the Pick Assembly on the right hand side of the printer (looking from the rear).

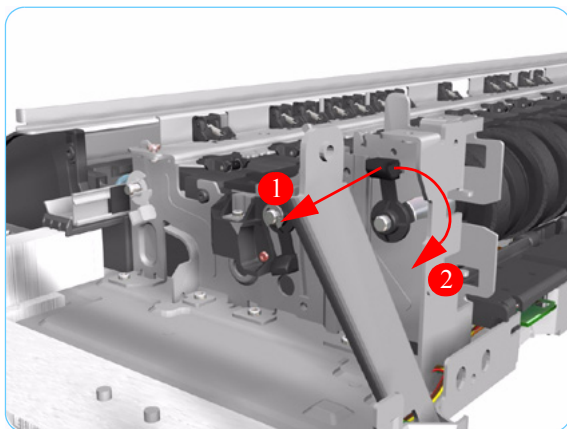

24. Release the locking mechanism that secures the Pick Assembly on the left hand side of the printer (looking from the rear)

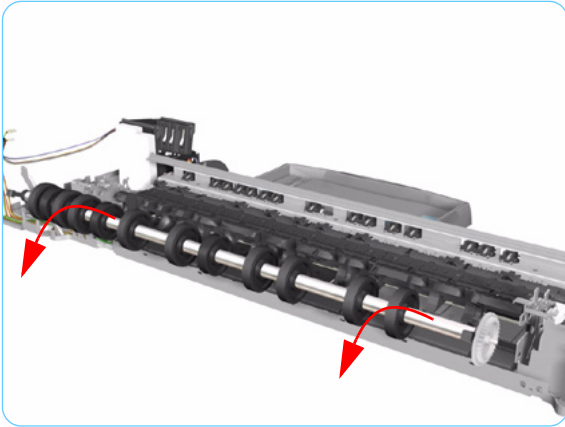

- 25.** Raise the locks so that they are aligned with the cutouts and lift out the Pick Assembly from the Printer.

Pinch Assembly (Applicability: 10ps, 20ps, 30, 30n, 50ps)

Removal

Switch off the product and remove the power cable.

1. Remove the Center Cover ⇒ Page 7-7.
2. Remove the Cleanout Assembly ⇒ Page 7-31.
3. Remove the Pick Assembly ⇒ Page 7-62.
4. Release the Out-of-Paper Sensor from the Pinch Assembly by pinching the tabs on either side.

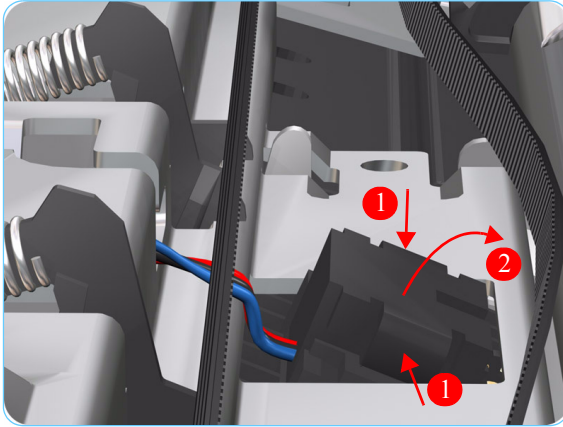

5. Release ALL the Pinch Springs from the Pinch Assembly.

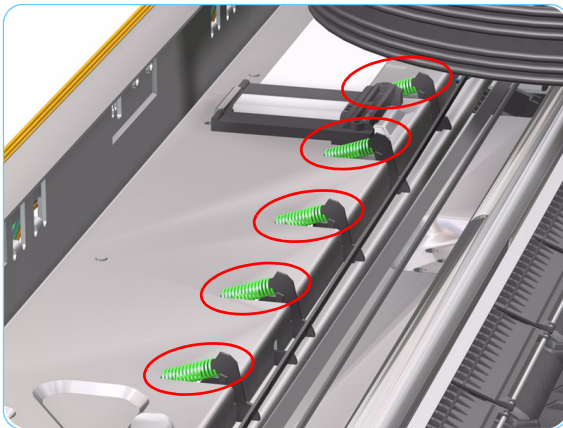

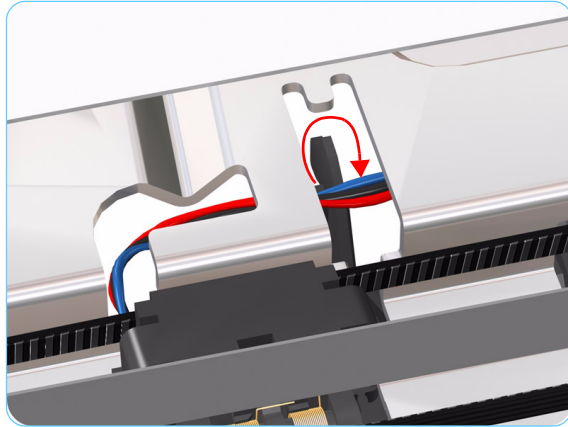

6. Release the Out-of-Paper Sensor cable that is looped underneath the Pinch Assembly.

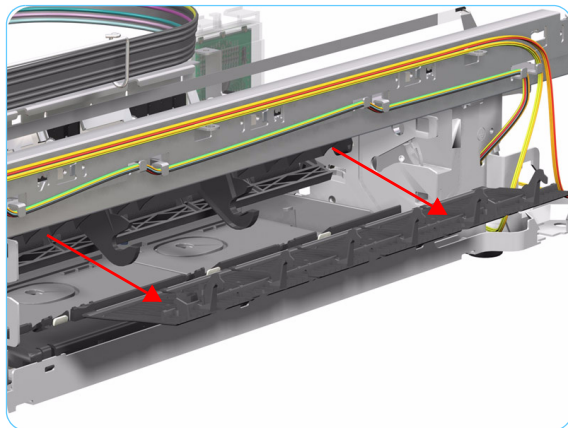

7. Working from the rear, pull out the Pinch Assembly from the Printer.

After removing or replacing the Pinch Assembly, make sure that you perform the PRS Adjustment procedure.

Lower Paper Guide (Applicability: 10ps, 20ps, 30, 30n, 50ps)

Removal

Switch off the product and remove the power cable.

1. Remove the Cleanout Assembly ⇒ Page 7-37.
2. Remove the Pick Assembly ⇒ Page 7-67.
3. Release the tabs that secure the Lower Paper Guide (use a flat blade screwdriver to help you if necessary).

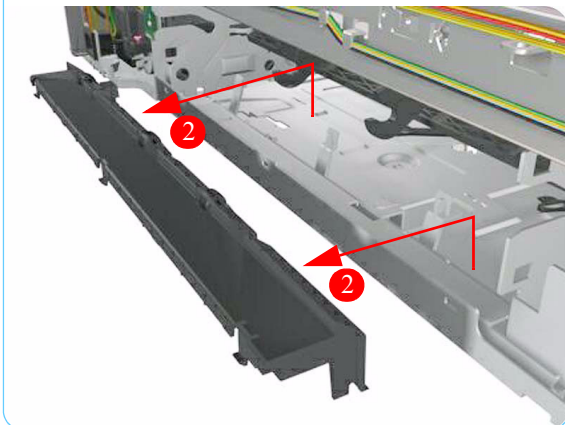
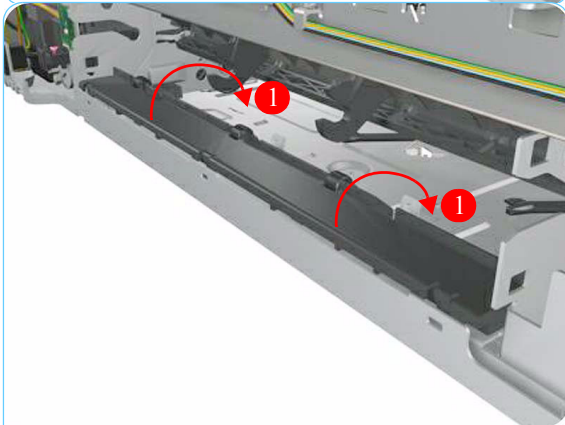
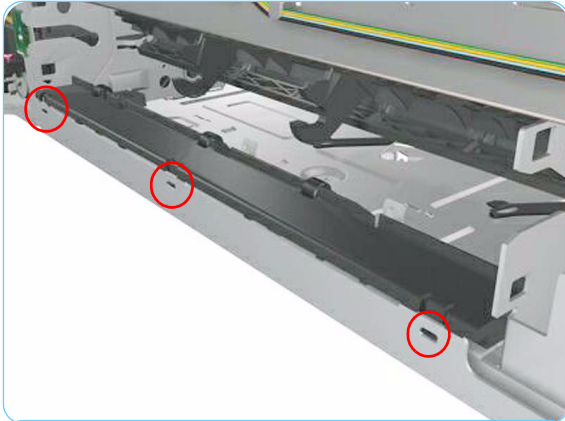

4. Remove the Lower Paper Guide from the Printer.

Inner Paper Guide (Applicability: 10ps, 20ps, 30, 30n, 50ps)

Removal

Switch off the product and remove the power cable.

1. Remove the Cleanout Assembly ⇒ Page 7-31.
2. Remove the Pick Assembly ⇒ Page 7-61.
3. Release the locating pins on the left hand side (looking from the rear) by pushing the Inner Paper Guide to the right and then removing it from the Printer.

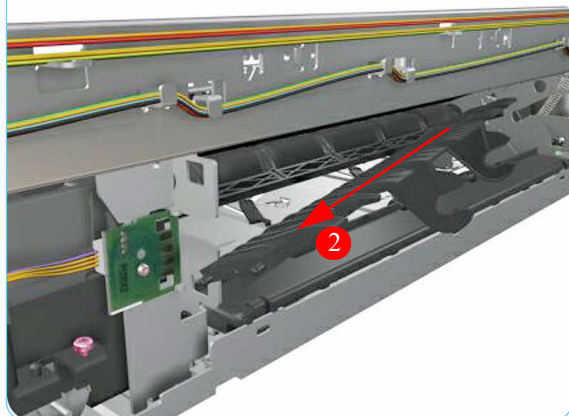
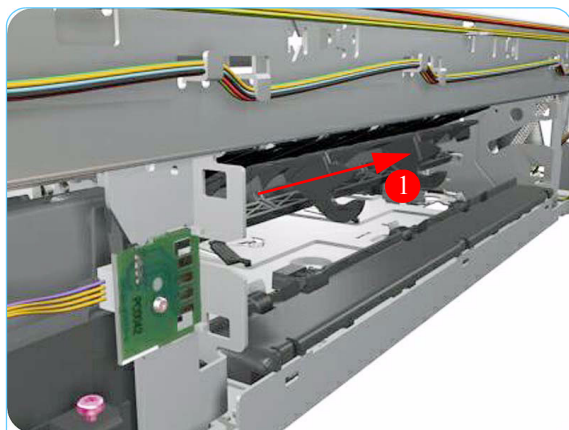

Inner Paper Guide

Not applicable to 10ps, 20ps, 30, 30n, 50ps

Removal

Switch off the product and remove the power cable.

1. Remove the Cleanout Assembly ⇒ Page 7-31.
2. Remove the Top Cover ⇒ Page 7-5.
3. Remove the Center Cover ⇒ Page 7-7
4. Remove the Right End Cover ⇒ Page 7-9.
5. Remove the Left End Cover ⇒ Page 7-11.
6. Remove the Electronics Module ⇒ Page 7-18.
7. Remove the Power Supply Unit ⇒ Page 7-22.
8. Remove the Service Station ⇒ Page 7-24.
9. Remove the Encoder Strip ⇒ Page 7-28.
10. Remove the Ink Supply Tubes ⇒ Page 7-32.
11. Remove the Carriage Assembly ⇒ Page 7-35.
12. Remove the Pick Assembly ⇒ Page 7-62.
13. Pull the Inner Paper Guide from the middle to release it from the Printer.

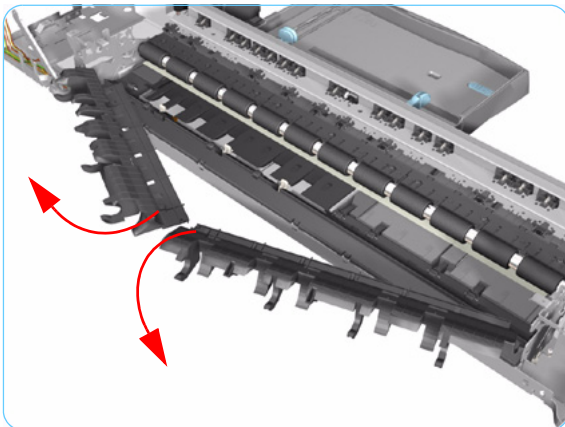
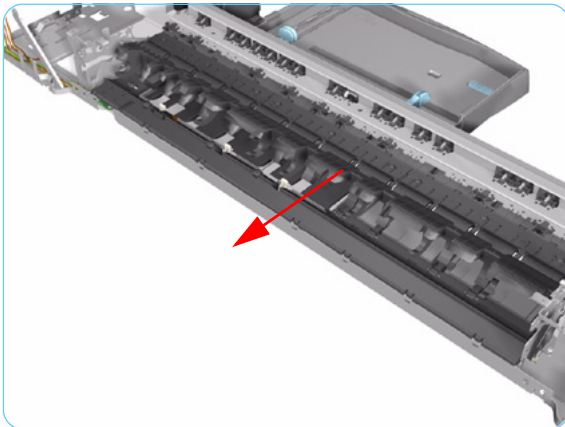

14. Remove both pieces of the Inner Paper Guide from the Printer.

OOPS Sensor

Removal

Switch off the product and remove the power cable.

1. Remove the Center Cover ⇒ Page 7-7.
2. Remove the Right End Cover ⇒ Page 7-9.
3. Remove the Electronics Module ⇒ Page 7-18.
4. Remove the Power Supply Unit ⇒ Page 7-22.
5. Remove the Service Station ⇒ Page 7-24.
6. Disconnect the OOPS Sensor Cable.

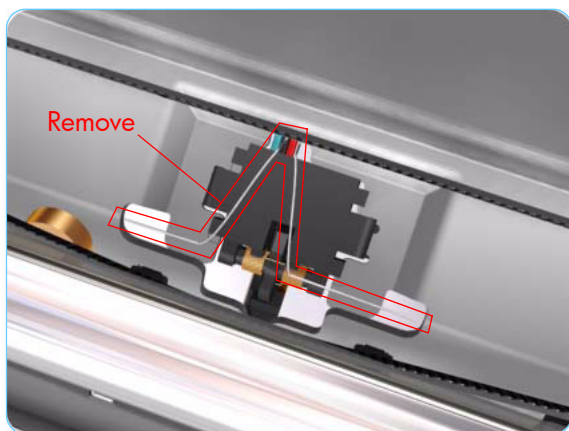
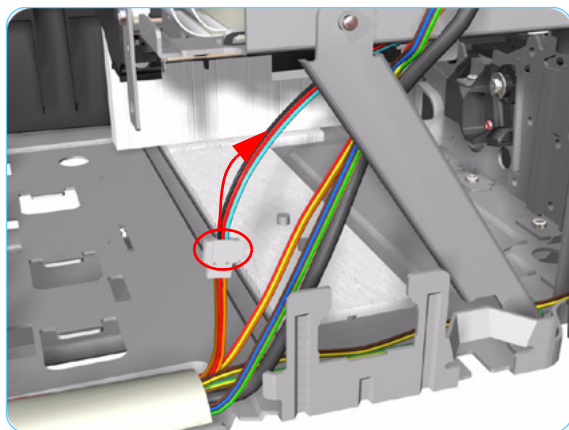

7. Remove the Spring that secures the OOPS Sensor.

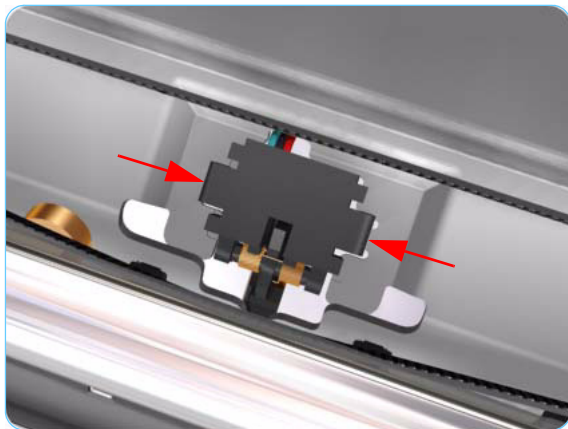

8. Press the OOPS Sensor clips inwards to release it.

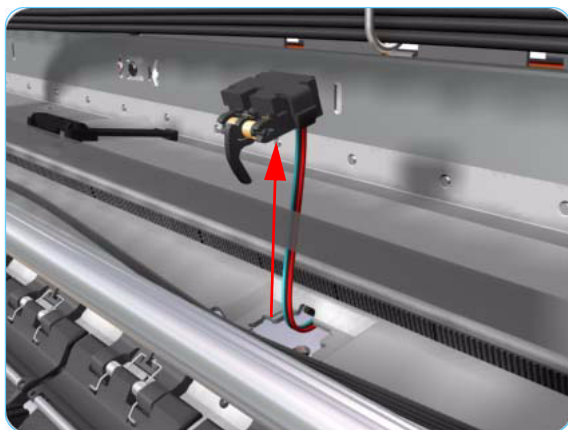

9. Remove the OOPS Sensor (including the cable) from the Printer.

Check if any Cable Ties need to be cut before removing the OOPS Sensor.

Paper-Axis Motor Drive Assembly (Applicable only to 10ps, 20ps, 30, 30n, 50ps)

Removal

Switch off the product and remove the power cable.

1. Remove the Center Cover ⇒ Page 7-7.
2. Remove the Left End Cover ⇒ Page 7-11.
3. Disconnect the Paper-Axis and Encoder cables.

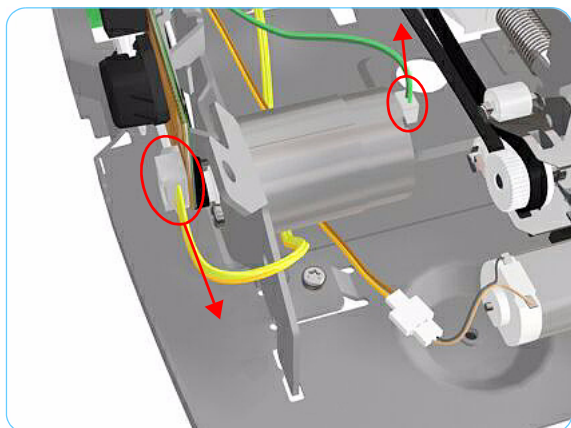

4. Remove 1 T-10 screw (**Type A**) that secures the Paper-Axis Motor Mount.

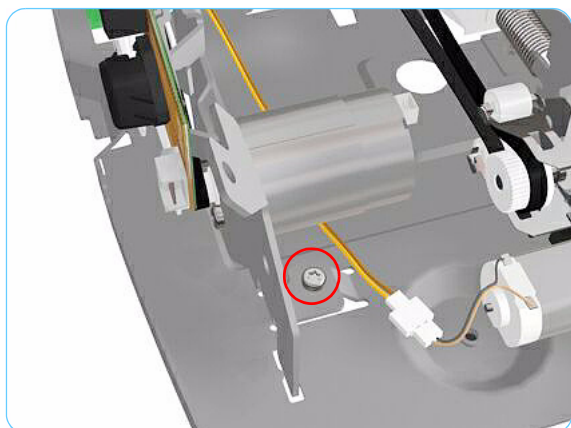

5. Release the locking mechanism that secures the Paper-Axis Motor Mount.

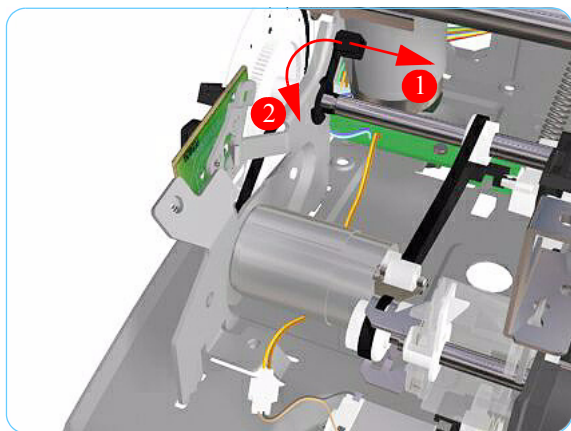

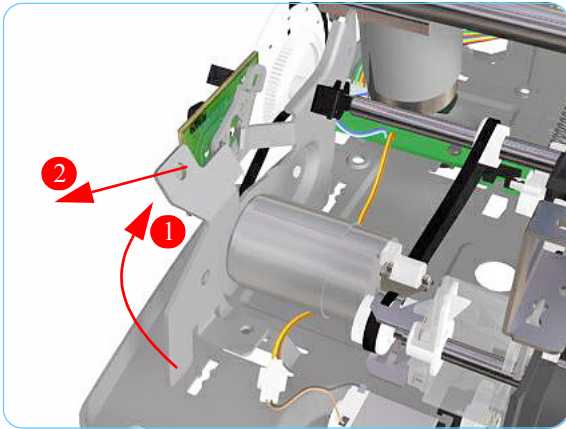

6. Remove the Paper-Axis Motor Assembly from the Printer.

After removing or replacing the Paper-Axis Motor Assembly, make sure that you perform the Accuracy Calibration.

Paper-Axis Motor Assembly (Applicability: 90, 90r, 120, 120nr, 130, 130nr)

Removal

Switch off the product and remove the power cable.

1. Remove the Center Cover ⇒ Page 7-7.
2. Remove the Left End Cover ⇒ Page 7-11.
3. Remove 2 T-10 screws that secure the Paper-Axis Motor Assembly.

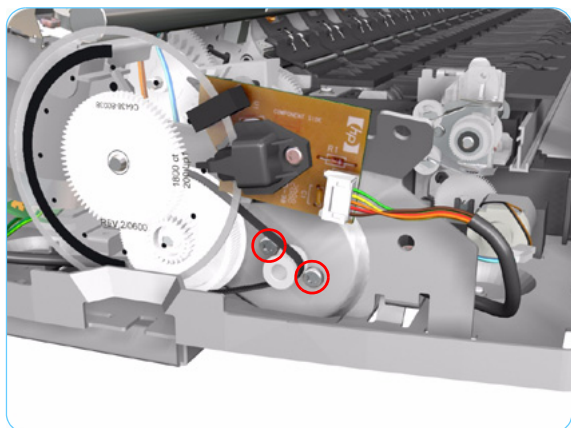

4. Disconnect the Paper-Axis Motor cable.

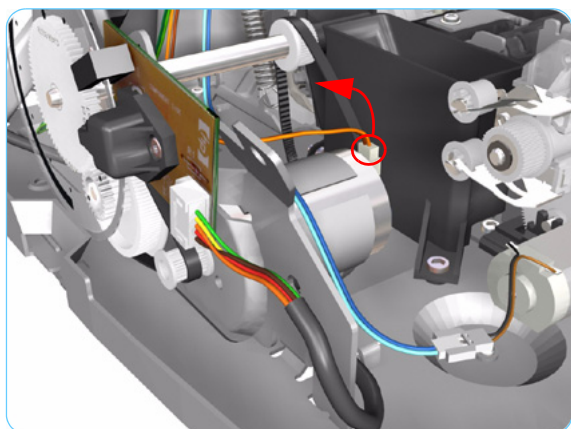

5. Release the belt from the Paper-Axis Motor. Remove the Paper-Axis Motor Assembly from the Printer.

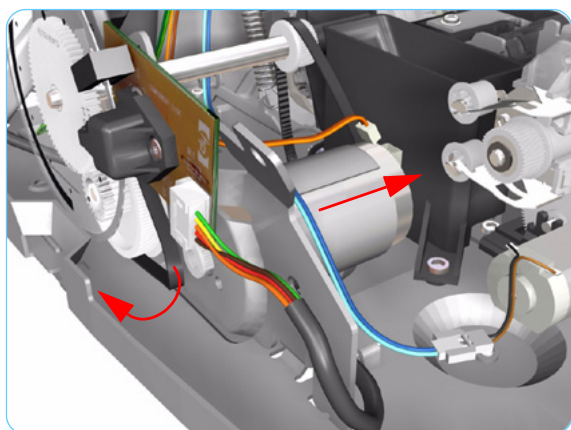

Bypass Platen (Applicability: 90, 90r, 120, 120nr, 130, 130nr)

Removal

Switch off the product and remove the power cable.

1. Remove the Cleanout Assembly ⇒ Page 7-31.
2. Remove the Top Cover ⇒ Page 7-5.
3. Remove the Center Cover ⇒ Page 7-7.
4. Remove the Right End Cover ⇒ Page 7-9.
5. Remove the Left End Cover ⇒ Page 7-11.
6. Remove the Electronics Module ⇒ Page 7-18.
7. Remove the Power Supply Unit ⇒ Page 7-22.
8. Remove the Service Station ⇒ Page 7-24.
9. Remove the Encoder Strip ⇒ Page 7-28.
10. Remove the Ink Supply Tubes ⇒ Page 7-32.
11. Remove the Carriage Assembly ⇒ Page 7-35.
12. Remove the Starwheel Assembly ⇒ Page 7-43.
13. Remove the Print Platen Assembly ⇒ Page 7-44.
14. Remove the Pivot Assembly ⇒ Page 7-52.
15. Remove the Feed Roller Assembly ⇒ Page 7-56.
16. Remove the Pick Assembly ⇒ Page 7-62.
17. Remove the Inner Paper Guide ⇒ Page 7-72.
18. Remove 2 T-10 screws that secure the Left Bracket to the Chassis.

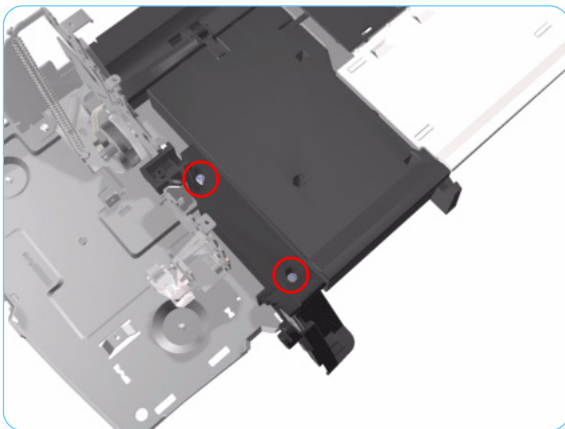

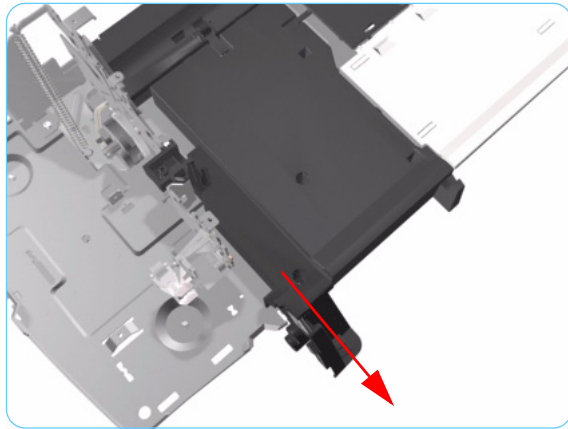

19. Slide the Left Bracket out of the Printer.

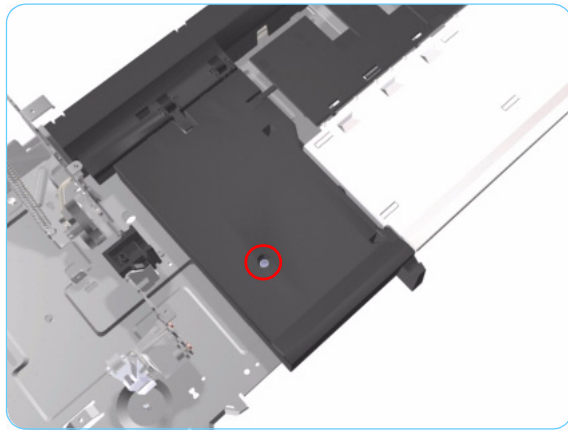

20. Remove 1 T-10 screw that secures the Side Guide to the Chassis.

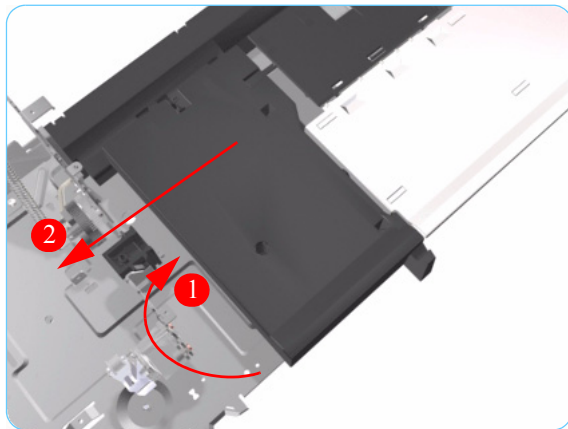

21. Raise the Side Guide and then slide it out to the left.

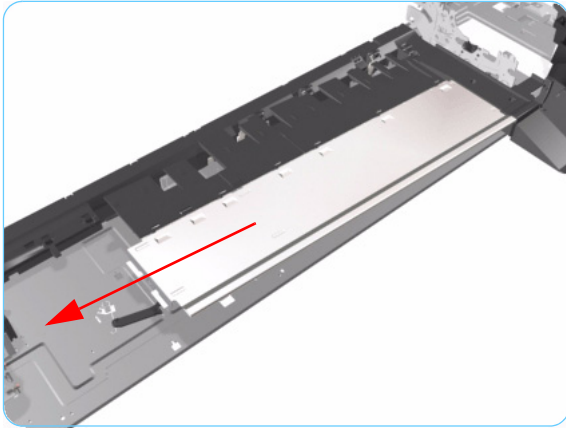

22. Slide the Bypass Platen to the left and remove from the Printer.

Bypass Platen Actuator (Applicability: 90, 90r, 130, 130nr)

Removal

Switch off the product and remove the power cable.

1. Remove the Cleanout Assembly ⇒ Page 7-31.
2. Remove the Top Cover ⇒ Page 7-5.
3. Remove the Center Cover ⇒ Page 7-7.
4. Remove the Right End Cover ⇒ Page 7-9.
5. Remove the Left End Cover ⇒ Page 7-11.
6. Remove the Electronics Module ⇒ Page 7-18.
7. Remove the Power Supply Unit ⇒ Page 7-22.
8. Remove the Service Station ⇒ Page 7-24.
9. Remove the Encoder Strip ⇒ Page 7-28.
10. Remove the Ink Supply Tubes ⇒ Page 7-32.
11. Remove the Carriage Assembly ⇒ Page 7-35.
12. Remove the Starwheel Assembly ⇒ Page 7-43.
13. Remove the Print Platen Assembly ⇒ Page 7-44.
14. Remove the Pivot Assembly ⇒ Page 7-52.
15. Remove the Feed Roller Assembly ⇒ Page 7-56.
16. Remove the Pick Assembly ⇒ Page 7-62.
17. Remove the Inner Paper Guide ⇒ Page 7-72.
18. Remove the Bypass Platen ⇒ Page 7-78.
19. Remove 1 T-10 screw that secures the Right Bracket to the Chassis.

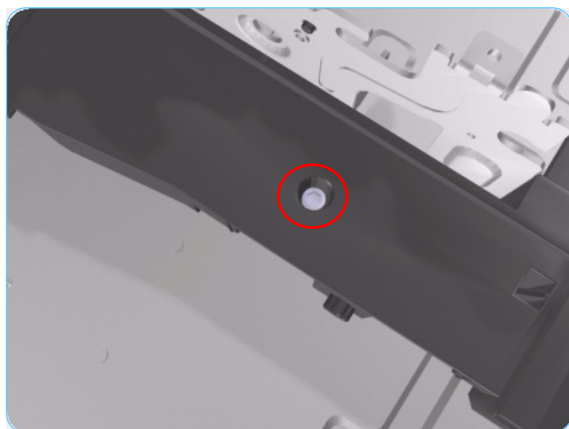

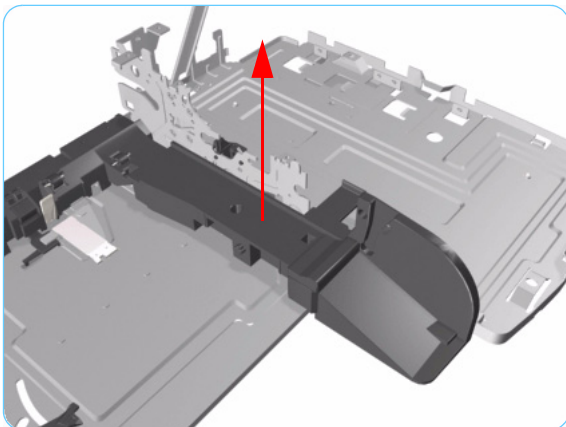

20. Lift the Right Bracket out of the Printer.

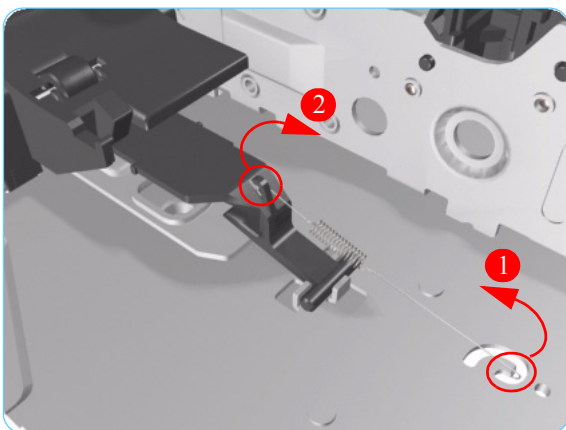

21. Release the Spring from the Bypass Platen Actuator.

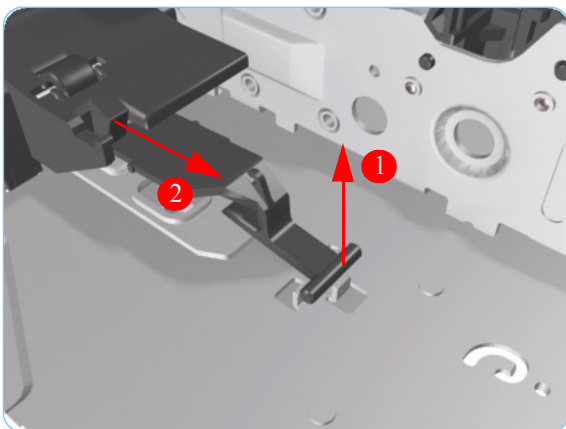

22. Remove the Bypass Platen Actuator from the Printer.



Maintenance



Cleaning Information 8-2
Lubrication Information 8-4

Maintenance

Cleaning Information

IMPORTANT

Do NOT clean the following:

Pinch Rollers, Drive Belt, Service Station (unless otherwise noted), Main PCA and other Electronic components such as Cables and Motors.

Case Parts: Use mild detergents such as PK 200 or Simple Green with water on a clean lint-free cloth. Solvents and water on a clean lint-free cloth can be used to remove stubborn stains on external case parts.

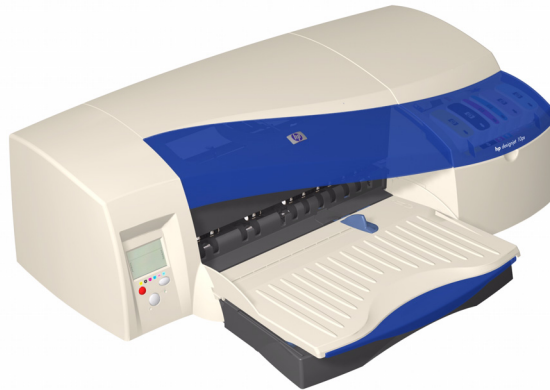

Paper Dust: It is recommended that vacuuming be used to remove paper dust from inside the printer. Do NOT use compressed air.

Carriage Flex-Contacts: Use water on a clean lint-free cloth.

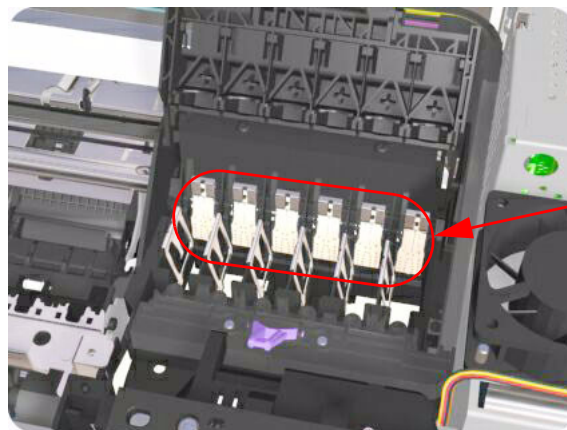

Flex-Contacts

Carriage Rod: Cleaning is NOT recommended. If extremely dirty, wipe with a clean lint-free cloth. Do NOT use water or solvents.

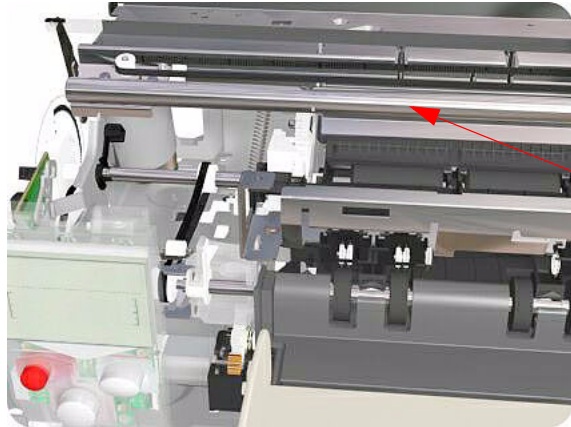

Carriage Rod

Encoder Strip: Wipe from left to right (viewed from front) with a clean lint-free cloth. Do NOT pull hard on the Encoder Strip.

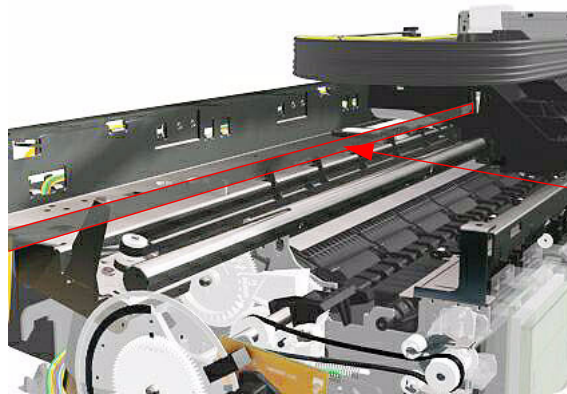

Encoder Strip

Drive Roller: Use water on a clean lint-free cloth. Do Not use solvents.

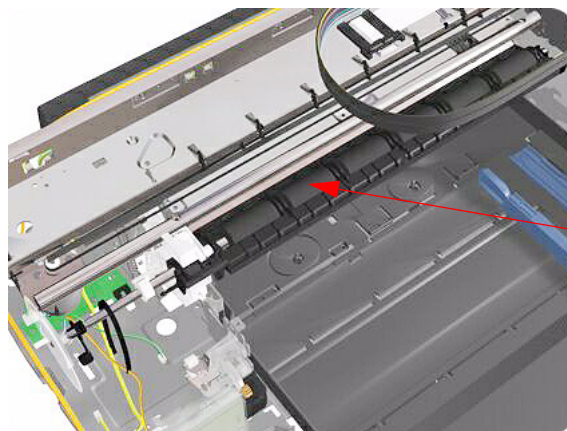

Drive Roller

Backbone: Use water on a clean lint-free cloth. Dry carefully, parts left damp may rust.

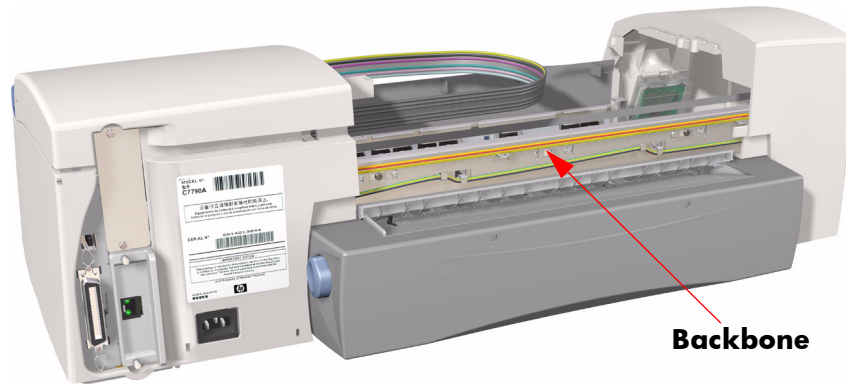

Duplexer: Check for ink on connector to module. If ink is present, wipe clean with a clean lint-free cloth.

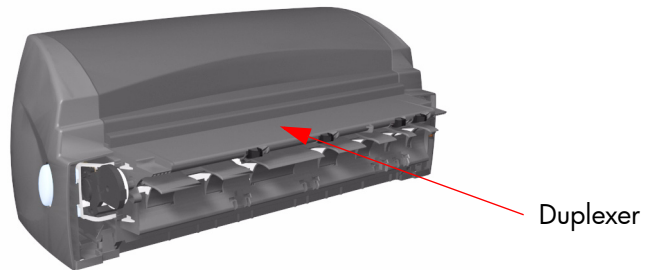

Lubrication Information

Lubrication: Cleaning the Carriage Rod is NOT recommended. If, however, the Carriage was wiped clean, replace the felt washers on the Carriage Assembly. The felt washers are impregnated with oil to provide the necessary lubrication for the Carriage Rod.

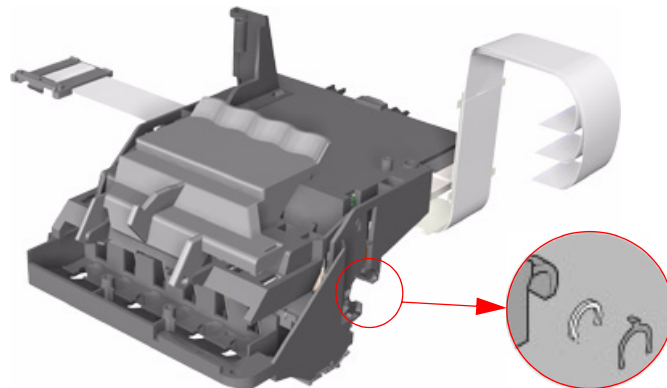

About this Edition

This is the 1st edition of this Service Manual

1st edition

What's in this Service Manual

This manual contains information necessary to test, calibrate and service:

HP Designjet 10ps Printer (Model C7790A)

HP Designjet 20ps Printer (Model C7790B)

HP Designjet 30 Printer (Model C7790D)

HP Designjet 30n Printer (Model C7790E)

HP Designjet 50ps Printer (Model C7790C)

HP Designjet 70 Printer (Model Q6655A)

HP Designjet 90 Printer (Model Q6656A)

HP Designjet 90r Printer (Model Q6656B)

HP Designjet 100 Printer (Model C7796A)

HP Designjet 100+ Printer (Model C7796C)

HP Designjet 110 Printer (Model C7796B)

HP Designjet 110+ Printer (Model C7796D)

HP Designjet 110+nr Printer (Model C7796E)

HP Designjet 120 Printer (Model C7791A)

HP Designjet 120nr Printer (Model C7791B)

HP Designjet 130 Printer (Model C7791C)

HP Designjet 130nr Printer (Model C7791D)

For information about using these printers, refer to the corresponding User Guide.

The procedures described in this manual are to be performed by HP-qualified Service Personnel only.

