

# Application manual

## REL 501\*2.3

### Line distance protection terminal



#### **About this manual**

DocID: 1MRK 506 108-UEN

Issue date: July 2001

Status: New

Version: 2.3

Revision: 00

## **COPYRIGHT**

WE RESERVE ALL RIGHTS TO THIS DOCUMENT, EVEN IN THE EVENT THAT A PATENT IS ISSUED AND A DIFFERENT COMMERCIAL PROPRIETARY RIGHT IS REGISTERED. IMPROPER USE, IN PARTICULAR REPRODUCTION AND DISSEMINATION TO THIRD PARTIES, IS NOT PERMITTED.

THIS DOCUMENT HAS BEEN CAREFULLY CHECKED. IF THE USER NEVERTHELESS DETECTS ANY ERRORS, HE IS ASKED TO NOTIFY US AS SOON AS POSSIBLE.

THE DATA CONTAINED IN THIS MANUAL IS INTENDED SOLELY FOR THE PRODUCT DESCRIPTION AND IS NOT TO BE DEEMED TO BE A STATEMENT OF GUARANTEED PROPERTIES. IN THE INTERESTS OF OUR CUSTOMERS, WE CONSTANTLY SEEK TO ENSURE THAT OUR PRODUCTS ARE DEVELOPED TO THE LATEST TECHNOLOGICAL STANDARDS. AS A RESULT, IT IS POSSIBLE THAT THERE MAY BE SOME DIFFERENCES BETWEEN THE HW/SW PRODUCT AND THIS INFORMATION PRODUCT.

### **Manufacturer:**

ABB Automation Products AB  
Substation Automation Division  
SE-721 59 Västerås  
Sweden  
Tel: +46 (0) 21 34 20 00  
Fax: +46 (0) 21 14 69 18  
Internet: <http://www.abb.se>

---

<b>Chapter</b>	<b>Page</b>
<b>Chapter 1 Introduction .....</b>	<b>1</b>
Introduction to the application manual .....	2
About the complete set of manuals to a terminal.....	2
Intended audience .....	3
Related documents.....	3
Revision notes .....	3
<b>Chapter 2 General.....</b>	<b>5</b>
Features.....	6
Application .....	7
Design.....	8
Requirements .....	9
Terminal identification.....	17
Application .....	17
Calculations .....	17
<b>Chapter 3 Common functions .....</b>	<b>19</b>
Time synchronisation (TIME).....	20
Application .....	20
Functionality .....	20
Calculations .....	20
Setting group selector (GRP).....	22
Application .....	22
Functionality .....	22
Design .....	23
Setting lockout (HMI) .....	24
Application .....	24
Functionality .....	24
I/O system configurator (IOP) .....	26
Application .....	26
Functionality .....	26
Logic function blocks .....	30
Application .....	30
Functionality .....	30
Calculations .....	44
Self supervision (INT) .....	46
Application .....	46
Functionality .....	47
Blocking of signals during test .....	50
Functionality .....	50

---

## Chapter 4 Line impedance ..... 53

Distance protection (ZM1-5) .....	54
Application .....	54
Functionality.....	61
Design.....	68
Calculations .....	73
Configuration .....	93
Automatic switch onto fault logic (SOTF).....	96
Application .....	96
Functionality.....	96
Calculations .....	97
Local acceleration logic (ZCLC).....	98
Application .....	98
Functionality.....	98
Calculations .....	99
General fault criteria (GFC).....	101
Application .....	101
Functionality.....	104
Design.....	109
Calculations .....	114
Pole slip protection (PSP) .....	119
Application .....	119
Functionality.....	127
Design.....	136
Calculations .....	149
Radial feeder protection (PAP) .....	162
Application .....	162
Functionality.....	162
Design.....	163
Calculations .....	168

## Chapter 5 Current ..... 169

Instantaneous overcurrent protection (IOC).....	170
Application .....	170
Functionality.....	171
Design.....	171
Calculations .....	175
Time delayed overcurrent protection (TOC) .....	185
Application .....	185
Functionality.....	185
Design.....	186
Calculations .....	189
Two step time delayed phase overcurrent protection (TOC2) .....	193
Application .....	193
Functionality.....	193
Calculations .....	194
Two step time delayed directional phase overcurrent protection (TOC3) .....	199
Application .....	199

---

Functionality .....	200
Calculations .....	206
Definite and inverse time-delayed residual overcurrent protection (TEF) .....	211
Application .....	211
Functionality .....	213
Calculations .....	217
Four step residual overcurrent protection (EF4) .....	221
Application .....	221
Functionality .....	222
Calculations .....	229
Sensitive directional residual overcurrent protection (WEF1) .....	240
Application .....	240
Functionality .....	240
Sensitive directional residual power protection (WEF2) .....	244
Application .....	244
Functionality .....	244
Calculations .....	248
Scheme communication logic for residual overcurrent protection (EFC) .....	252
Application .....	252
Functionality .....	252
Design .....	255
Calculations .....	255
Current reversal and weak end infeed logic for residual overcurrent protection (EFCA) .....	257
Application .....	257
Functionality .....	258
Design .....	261
Calculations .....	262
Thermal overload protection (THOL) .....	264
Application .....	264
Functionality .....	264
Calculations .....	265
Breaker failure protection (BFP) .....	268
Application .....	268
Functionality .....	270
Design .....	274
Calculations .....	275
Unbalance protection for capacitor banks (TOCC) .....	277
Application .....	277
Functionality .....	277
Calculations .....	278
<b>Chapter 6 Voltage .....</b>	<b>279</b>
Time delayed undervoltage protection (TUV) .....	280
Application .....	280
Design .....	280
Calculations .....	280
Time delayed overvoltage protection (TOV) .....	281

Application .....	281
Functionality.....	281
Design.....	281
Calculations .....	284
Intercircuit bridging protection (TOVI) .....	286
Application .....	286
Functionality.....	286
Calculations .....	286
<b>Chapter 7 Power system supervision .....</b>	<b>287</b>
Broken conductor check (BRC) .....	288
Application .....	288
Functionality.....	288
Design.....	288
Calculations .....	289
Loss of voltage check (LOV).....	292
Application .....	292
Functionality.....	292
Design.....	292
Calculations .....	294
Overload supervision (OVL).....	296
Application .....	296
Functionality.....	296
Design.....	296
Calculations .....	297
Dead line detection (DLD).....	299
Application .....	299
Design.....	299
Calculations .....	301
<b>Chapter 8 Secondary system supervision.....</b>	<b>303</b>
Current circuit supervision (CTSU) .....	304
Application .....	304
Functionality.....	304
Calculations .....	306
Fuse failure supervision (FUSE).....	307
Application .....	307
Functionality.....	307
Calculations .....	314
Voltage transformer supervision (TCT).....	319
Application .....	319
Functionality.....	319
Calculations .....	322

---

<b>Chapter 9 Control .....</b>	<b>325</b>
Synchrocheck (SYN) .....	326
Application .....	326
Functionality .....	343
Calculations .....	361
Automatic reclosing function (AR) .....	368
Application .....	368
Functionality .....	370
Calculations .....	376
Single command (CD) .....	383
Application .....	383
Design .....	384
Calculations .....	385
Multiple command (CM).....	386
Application .....	386
Design .....	386
Calculations .....	387
<b>Chapter 10 Logic.....</b>	<b>389</b>
Trip logic (TR) .....	390
Application .....	390
Functionality .....	390
Pole discordance protection (PD) .....	391
Application .....	391
Functionality .....	391
Design .....	392
Calculations .....	394
High speed binary output logic (HSBO).....	395
Application .....	395
Functionality .....	395
Design .....	399
Communication channel logic (CCHL).....	402
Application .....	402
Functionality .....	402
Calculations .....	405
Communication channel test logic (CCHT).....	406
Application .....	406
Design .....	406
Binary signal transfer to remote end (RTC) .....	409
Application .....	409
Design .....	409
Event function (EV).....	411
Application .....	411
Functionality .....	411
Design .....	411
Calculations .....	413
Event counter (CN) .....	415
Application .....	415
Functionality .....	415

---

Calculations .....	416
<b>Chapter 11 Monitoring .....</b>	<b>417</b>
LED indication function (HL, HLED).....	418
Application .....	418
Functionality.....	418
Calculations .....	431
Disturbance report (DRP) .....	432
Application .....	432
Functionality.....	432
Calculations .....	437
Indications .....	444
Application .....	444
Functionality.....	444
Calculations .....	445
Disturbance recorder .....	446
Application .....	446
Functionality.....	446
Design.....	449
Calculations .....	450
Event recorder .....	452
Application .....	452
Functionality.....	452
Calculations .....	452
Fault locator (FLOC) .....	454
Application .....	454
Functionality.....	454
Measuring principle.....	455
Design.....	461
Calculations .....	461
Trip value recorder.....	463
Application .....	463
Design.....	463
Calculations .....	464
Monitoring of AC analog measurements.....	465
Application .....	465
Functionality.....	465
Design.....	475
Calculations .....	476
Monitoring of DC analog measurements .....	481
Application .....	481
Functionality.....	481
Design.....	490
Calculations .....	492
<b>Chapter 12 Metering .....</b>	<b>497</b>
Pulse counter logic (PC) .....	498
Application .....	498



---

Functionality .....	498
Design .....	499
Calculations .....	500
<b>Chapter 13 Data communication .....</b>	<b>503</b>
Remote end data communication .....	504
Application .....	504
Design .....	505
Optical fibre communication module.....	507
Application .....	507
Design .....	508
Galvanic data communication module.....	510
Application .....	510
Design .....	511
Short range galvanic module .....	512
Application .....	512
Short range optical fibre module .....	514
Application .....	514
G.703 module .....	516
Application .....	516
Carrier module .....	517
Application .....	517
Design .....	517
Serial communication .....	519
Application .....	519
Serial communication, SPA .....	520
Application .....	520
Functionality .....	520
Design .....	520
Calculations .....	521
Serial communication, IEC .....	523
Application .....	523
Functionality .....	523
Design .....	523
Calculations .....	524
Serial communication, LON .....	529
Application .....	529
Functionality .....	529
Design .....	529
Calculations .....	530
Serial communication modules (SCM) .....	532
SPA/IEC .....	532
LON .....	532
<b>Chapter 14 Hardware modules .....</b>	<b>533</b>
Platform .....	534
General.....	534
Platform configuration.....	535

# Contents

---

3/4x19" platform.....	539
1/2x19" platform.....	539
Transformer input module (TRM).....	540
A/D-conversion module (ADM) .....	543
Optical receiver module (ORM) .....	545
Main processing module (MPM) .....	546
Signal processing module (SPM).....	548
Input/Output modules .....	549
General .....	549
Binary input module (BIM) .....	551
Binary output module (BOM) .....	552
Binary I/O module (IOM).....	554
Power supply module (PSM) .....	556
mA input module (MIM).....	557
Human-machine interface (HMI).....	558

# Chapter 1 Introduction

## **About this chapter**

This chapter introduces you to the manual as such.

# 1 Introduction to the application manual

## 1.1 About the complete set of manuals to a terminal

The complete package of manuals to a terminal is named users manual (UM). The *Users manual* consists of four different manuals:

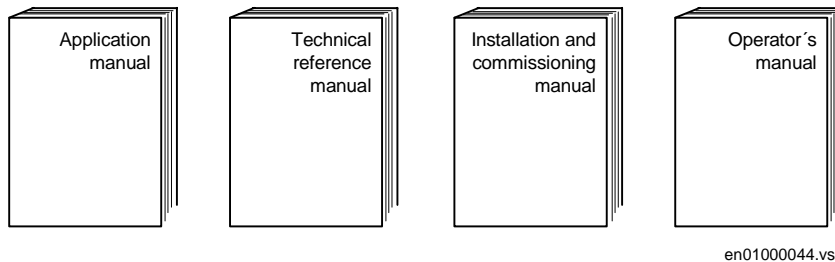

**The Application Manual (AM)** contains descriptions, such as application and functionality descriptions as well as setting calculation examples sorted per function. The application manual should be used when designing and engineering the protection terminal to find out when and for what a typical protection function could be used. The manual should also be used when calculating settings and creating configurations.

**The Technical Reference Manual (TRM)** contains technical descriptions, such as function blocks, logic diagrams, input and output signals, setting parameter tables and technical data sorted per function. The technical reference manual should be used as a technical reference during the engineering phase, installation and commissioning phase and during the normal service phase.

**The Operator's Manual (OM)** contains instructions on how to operate the protection terminal during normal service (after commissioning and before periodic maintenance tests). The operator's manual could be used to find out how to handle disturbances or how to view calculated and measured network data in order to determine the reason of a fault.

**The Installation and Commissioning Manual (ICM)** contains instructions on how to install and commission the protection terminal. The manual can also be used as a reference if a periodic test is performed. The manual covers procedures for mechanical and electrical installation, energising and checking of external circuitry, setting and configuration as well as verifying settings and performing a directionality test. The chapters and sections are organised in the chronological order (indicated by chapter/section numbers) the protection terminal should be installed and commissioned.

---

## 1.2 Intended audience

### 1.2.1 General

The application manual is addressing the system engineer/technical responsible who is responsible for specifying the application of the terminal.

### 1.2.2 Requirements

The system engineer/technical responsible must have a good knowledge about protection systems, protection equipment, protection functions and the configured functional logics in the protection.

## 1.3 Related documents

### Documents related to REL 501\*2.3

Operator's manual

Installation and commissioning manual

Technical reference manual

Application manual

Technical overview brochure

### Identity number

1MRK 506 056-UEN

1MRK 506 058-UEN

1MRK 506 057-UEN

1MRK 506 108-UEN

1MRK 506 055-BEN

## 1.4 Revision notes

Revision	Description
2.3-00	First revision



# **Chapter 2 General**

## **About this chapter**

This chapter describes the terminal in general.

---

**1****Features**

- Open terminal with extensive configuration possibilities and expandable hardware design to meet specific user requirements
- Additional protection function library available
- Extensive disturbance report with:
  - 10 most recent disturbances recorded
  - 40 seconds disturbance recorder
- Wide range of control functionality available
- 18 LEDs for extended indication capabilities
- Versatile local human-machine interface (HMI)
- Simultaneous dual protocol serial communication facilities
- Extensive self-supervision with internal event recorder
- Time synchronization with 1 ms resolution
- Four independent groups of complete setting parameters
- Powerful software ‘tool-box’ for monitoring, evaluation and user configuration
- Full scheme phase-to-phase distance protection with:
  - general fault criterion
  - three to five zones
- Wide range of residual overcurrent protection functions



---

**2****Application**

The main purpose of the REL 501 terminal is the protection, control and monitoring of overhead lines and cables in high impedance or solidly grounded distribution and sub-transmission networks. The terminal can also be used in transmission networks up to the highest voltage levels. It is suitable for the protection of heavily loaded lines and multi-circuit lines, and where the requirement for tripping is three-pole. The terminal may also be used to provide backup protection for power transformers, busbars, etc.

---

**3****Design**

Type tested software and hardware that comply with international standards and ABB's internal design rules together with extensive self monitoring functionality, ensure high reliability of the complete terminal.

The terminal's closed and partly welded steel case makes it possible to fulfill the stringent EMC requirements.

All serial data communication is via optical connections to ensure immunity against disturbances.

An extensive library of protection, control and monitoring functions is available. This library of functions, together with the flexible hardware design, allows this terminal to be configured to each user's own specific requirements. This wide application flexibility makes this product an excellent choice for both new installations and the refurbishment of existing installations.

---

## 4 Requirements

### 4.0.1 General

The operation of a protection measuring function is influenced by distortion, and measures need to be taken in the protection to handle this phenomenon. One source of distortion is current transformer saturation. In this protection terminal, measures are taken to allow for a certain amount of CT saturation with maintained correct operation. This protection terminal can allow relatively heavy current transformer saturation.

Protection functions are also affected by transients caused by capacitive voltage transformers (CVTs) but as this protection terminal has a very effective filter for these transients, the operation is hardly affected at all.

### 4.0.2 Voltage transformers

Magnetic or capacitive voltage transformers can be used.

Capacitive voltage transformers (CVTs) should fulfil the requirements according to IEC 186A, Section 20, regarding transients. According to the standard, at a primary voltage drop down to zero, the secondary voltage should drop to less than 10% of the peak pre-fault value before the short circuit within one cycle.

The protection terminal has an effective filter for this transient, which gives secure and correct operation with CVTs.

### 4.0.3 Current transformers

#### Classification

The performance of the REx 5xx terminal depends on the conditions and the quality of the current signals fed to it. The terminal REx 5xx has been designed to permit relatively heavy current transformer saturation with maintained correct operation. To guarantee correct operation, the CTs must be able to correctly reproduce the current for a minimum time before the CT will begin to saturate. To fulfil the requirement on a specified time to saturation the CTs must fulfil the requirements of a minimum secondary e.m.f. that is specified below.

There are several different ways to specify CTs. Conventional magnetic core CTs are usually specified and manufactured according to some international or national standards, which specify different protection classes as well. However, generally there are three different types of current transformers:

- high remanence type CT
- low remanence type CT
- non remanence type CT

**The high remanence type** has no limit for the remanence flux. This CT has a magnetic core without any airgap and a remanence flux might remain for almost infinite time. In this type of transformers the remanence flux can be up to 70-80% of the saturation flux. Typical examples of high remanence type CT are class P, TPS, TPX according to IEC, class P, X according to BS (British Standard) and nongapped class C, K according to ANSI/IEEE.

**The low remanence type** has a specified limit for the remanence flux. This CT is made with a small airgap to reduce the remanence flux to a level that does not exceed 10% of the saturation flux. The small airgap has only very limited influence on the other properties of the CT. Class TPY according to IEC is a low remanence type CT.

**The non remanence type CT** has practically negligible level of remanence flux. This type of CT has relatively big airgaps in order to reduce the remanence flux to practically zero level. At the same time, these airgaps minimize the influence of the DC-component from the primary fault current. The airgaps will also reduce the measuring accuracy in the non-saturated region of operation. Class TPZ according to IEC is a non remanence type CT.

The rated equivalent limiting secondary e.m.f.  $E_{al}$  according to the IEC 60044-6 standard is used to specify the CT requirements for REx 5xx. The requirements are also specified according to other standards.

### Conditions

The requirements are a result of investigations performed in our network simulator. The tests have been carried out with an analogue current transformer model with a settable core area, core length, air gap and number of primary and secondary turns. The setting of the current transformer model was representative for current transformers of high remanence and low remanence type. The results are not valid for non remanence type CTs (TPZ).

The performance of the distance protection was checked at both symmetrical and fully asymmetrical fault currents. A source with a time constant of about 120 ms was used at the tests. The current requirements below are thus applicable both for symmetrical and asymmetrical fault currents.

Both phase-to-earth, phase-to-phase and three-phase faults were tested in fault locations backward, close up forward and at the zone 1 reach. The protection was checked with regard to directionality, dependable tripping, and overreach.

All testing was made without any remanence flux in the current transformer core. The requirements below are therefore fully valid for a core with no remanence flux. It is difficult to give general recommendations for additional margins for remanence flux. They depend on the reliability and economy requirements.

---

When current transformers of low remanence type (TPY) are used, practically no additional margin is needed.

For current transformers of high remanence type (e.g. TPX), the small probability of a fully asymmetrical fault, together with maximum remanence flux in the same direction as the flux generated by the fault, has to be kept in mind at the decision of an additional margin. Fully asymmetrical fault current will be achieved when the fault occurs at zero voltage ( $0^\circ$ ). Investigations have proved that 95% of the faults in the network will occur when the voltage is between  $40^\circ$  and  $90^\circ$ .

#### **Fault current**

The current transformer requirements are based on the maximum fault current for faults in different positions. Maximum fault current will occur for three-phase faults or single-phase-to-earth faults. The current for a single phase-to-earth fault will exceed the current for a three-phase fault when the zero sequence impedance in the total fault loop is less than the positive sequence impedance.

When calculating the current transformer requirements, maximum fault current should be used and therefore both fault types have to be considered.

#### **Cable resistance and additional load**

The current transformer saturation is directly affected by the voltage at the current transformer secondary terminals. This voltage, for an earth fault, is developed in a loop containing the phase and neutral conductor, and relay load. For three-phase faults, the neutral current is zero, and only the phase conductor and relay phase load have to be considered.

In the calculation, the loop resistance should be used for phase-to-earth faults and the phase resistance for three-phase faults.

#### **Current transformer requirements for CTs according to the IEC 60044-6 standard**

The current transformer ratio should be selected so that the current to the protection is higher than the minimum operating value for all faults that are to be detected. The minimum operating current is 10-30% of the nominal current.

All current transformers of high remanence and low remanence type that fulfil the requirements on the rated equivalent secondary e.m.f.  $E_{a1}$  below can be used. The current transformers should have an accuracy class comparable to 5P or better. The characteristic of the non remanence type CT (TPZ) is not well defined as far as the phase angle error is concerned, and we therefore recommend contacting ABB Automation Products AB to confirm that the type in question can be used.

The current transformers must have a rated equivalent secondary e.m.f.  $E_{a1}$  that is larger than the maximum of the required secondary e.m.f.  $E_{alreq}$  below:

$$E_{al} > E_{alreq} = \frac{I_{kmax} \cdot I_{sn}}{I_{pn}} \cdot a \cdot \left( R_{CT} + R_L + \frac{0.25}{I_R^2} \right)$$

(Equation 1)

$$E_{al} > E_{alreq} = \frac{I_{kzone1} \cdot I_{sn}}{I_{pn}} \cdot k \cdot \left( R_{CT} + R_L + \frac{0.25}{I_R^2} \right)$$

(Equation 2)

where

- $I_{kmax}$  Maximum primary fundamental frequency current for close-in forward and reverse faults (A)
- $I_{kzone1}$  Maximum primary fundamental frequency current for faults at the end of zone 1 reach (A)
- $I_{pn}$  The rated primary CT current (A)
- $I_{sn}$  The rated secondary CT current (A)
- $I_R$  The protection terminal rated current (A)
- $R_{CT}$  The secondary resistance of the CT ( $\Omega$ )
- $R_L$  The resistance of the secondary cable and additional load ( $\Omega$ ). The loop resistance should be used for phase-to-earth faults and the phase resistance for three-phase faults.
- $a$  This factor is a function of the network frequency and the primary time constant for the dc component in the fault current, see figure 1.
- $k$  A factor of the network frequency and the primary time constant for the dc component in the fault current for a three-phase fault at the set reach of zone 1, see figure2. The time constant is normally less than 50 ms.

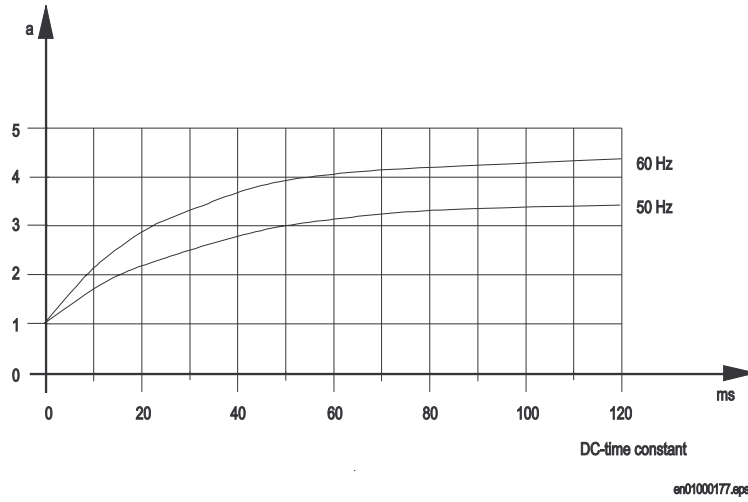

Figure 1: Factor  $a$  as a function of the frequency and the time constant

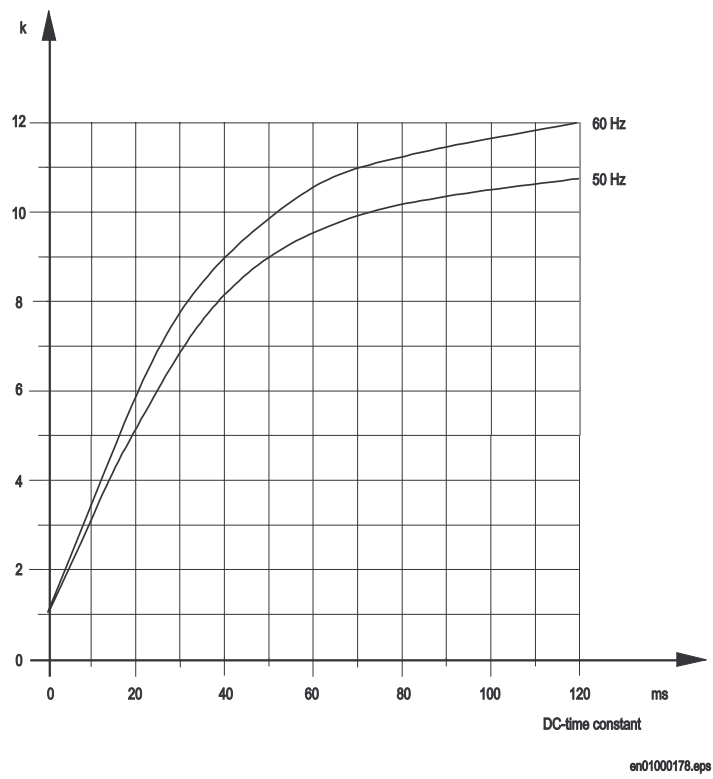

Figure 2: Factor  $k$  as a function of the frequency and the time constant

**Current transformer requirements for CTs according to other standards**

All kinds of conventional magnetic core CTs are possible to be used with REx 5xx terminals if they fulfil the requirements that correspond to the above specified according to the IEC 60044-6 standard. From the different standards and available data for relaying applications it is possible to approximately calculate a secondary e.m.f. of the CT. It is then possible to compare this to the required secondary e.m.f.  $E_{alreq}$  and judge if the CT fulfils the requirements. The requirements according to some other standards are specified below.

**Current transformer according to IEC 60044-1**

A CT according to IEC 60044-1 is specified by the secondary limiting e.m.f.  $E_{2max}$ . The value of the  $E_{2max}$  is approximately equal to  $E_{al}$  according to IEC 60044-6.

$$E_{al} \approx E_{2max}$$

(Equation 3)

The current transformers must have a secondary limiting e.m.f.  $E_{2max}$  that fulfills the following:

$$E_{2max} > \text{maximum of } E_{alreq}$$

(Equation 4)

**Current transformer according to British Standard (BS)**

A CT according to BS is often specified by the rated knee-point e.m.f.  $E_{kneeBS}$ . The value of the  $E_{kneeBS}$  is lower than  $E_{al}$  according to IEC 60044-6. It is not possible to give a general relation between the  $E_{kneeBS}$  and the  $E_{al}$  but normally the  $E_{kneeBS}$  is 80 to 85% of the  $E_{al}$  value. Therefore, the rated equivalent limiting secondary e.m.f.  $E_{alBS}$  for a CT specified according to BS can be estimated to:

$$E_{alBS} \approx 1.2 \cdot E_{kneeBS}$$

(Equation 5)

The current transformers must have a rated knee-point e.m.f.  $E_{kneeBS}$  that fulfills the following:



$$1.2 \cdot E_{\text{kneeBS}} > \text{maximum of } E_{\text{alreq}}$$

(Equation 6)

### Current transformer according to ANSI/IEEE

A CT according to ANSI/IEEE is specified in a little different way. For example a CT of class C has a specified secondary terminal voltage  $U_{\text{ANSI}}$ . There is a few standardized value of  $U_{\text{ANSI}}$  (e.g. for a C400 the  $U_{\text{ANSI}}$  is 400 V). The rated equivalent limiting secondary e.m.f.  $E_{\text{alANSI}}$  for a CT specified according to ANSI/IEEE can be estimated as follows:

$$E_{\text{alANSI}} = |20 \cdot I_{\text{sn}} \cdot R_{\text{CT}} + U_{\text{ANSI}}| = |20 \cdot I_{\text{sn}} \cdot R_{\text{CT}} + 20 \cdot I_{\text{sn}} \cdot Z_{\text{bANSI}}|$$

(Equation 7)

where

$Z_{\text{bANSI}}$  The impedance (i.e. complex quantity) of the standard ANSI burden for the specific C class ( $\Omega$ )

$U_{\text{ANSI}}$  The secondary terminal voltage for the specific C class (V)

The CT requirements are fulfilled if:

$$E_{\text{alANSI}} > \text{maximum of } E_{\text{alreq}}$$

(Equation 8)

Often an ANSI/IEEE CT also has a specified knee-point voltage  $U_{\text{kneeANSI}}$ . This is graphically defined from the excitation curve. The knee-point according to ANSI/IEEE has normally a lower value than the knee-point according to BS. The rated equivalent limiting secondary e.m.f.  $E_{\text{alANSI}}$  for a CT specified according to ANSI/IEEE can be estimated to:

$$E_{\text{alANSI}} \approx 1.3 \cdot U_{\text{kneeANSI}}$$

(Equation 9)

The current transformers must have a knee-point voltage  $U_{\text{kneeANSI}}$  that fulfills the following:

$$1.3 \cdot U_{\text{kneeANSI}} > \text{maximum of } E_{\text{alreq}}$$

## 5 Terminal identification

### 5.1 Application

Serial number, software version and the identification names and numbers for the station, the object and the terminal (unit) itself can be stored in the REx 5xx terminal. Also the serial numbers of included modules are stored in the terminal. This information can be read on the local HMI or when communicating with the terminal through a PC or with SMS/SCS.

The base currents, voltages and rated frequency must be set since the values affect many functions. The input transformers ratio must be set as well. The ratio for the current and the voltage transformer automatically affects the measuring functions in the terminal.

The internal clock is used for time tagging of:

- Internal events
- Disturbance reports
- Events in a disturbance report
- Events transmitted to the SCS substation control system

This implies that the internal clock is very important. The clock can be synchronized (see Time synchronization) to achieve higher accuracy of the time tagging. Without synchronization, the internal clock is useful for comparisons among events within the REx 5xx terminal.

### 5.2 Calculations

$U_{xr}$  and  $I_{xr}$  ( $x = 1-5$ ) are the rated voltage and current values for the analog input transformers within the REx 5xx terminal.  $U_xScale$  and  $I_xScale$  are the actual ratio for the main protection transformer at the protected object. These values will be used to calculate the present voltage and current in the protected object.  $U_{xb}$  and  $I_{xb}$  defines base voltage and current values, used to define the per-unit system used in the terminal for calculation of setting values.

The current transformer secondary current ( $I_{S_{SEC}}$ ) is:

$$I_{S_{SEC}} = \frac{I_{SEC}}{I_{PRIM}} \cdot I_S$$

(Equation 10)

---

where:

$I_{SEC}$  = secondary rated current of the main CT

$I_{PRIM}$  = primary rated current of the main CT

$I_s$  = primary setting value of the current

The relay setting value  $IP_{>>}$  is given in percentage of the secondary base current value,  $I_{xb}$ , associated to the current transformer input  $I_x$ :

$$IP_{>>} = \frac{I_{s_{SEC}}}{I_{xb}} \cdot 100$$

(Equation 11)

The value of  $I_{xb}$  can be calculated as:

$$I_{xb} = \frac{\text{Rated primary current}}{\text{CT ratio}}$$

(Equation 12)

# **Chapter 3 Common functions**

## **About this chapter**

This chapter presents the common functions in the terminal.

# 1 Time synchronisation (TIME)

## 1.1 Application

Use time synchronisation to achieve a common time base for the terminals in a protection and control system. This makes comparison of events and disturbance data between all terminals in the system possible.

Time-tagging of internal events and disturbances is an excellent help when evaluating faults. Without time synchronisation, only the events within the terminal can be compared to one another. With time synchronisation, events and disturbances within the entire station, and even between line ends, can be compared during an evaluation.

## 1.2 Functionality

Two main alternatives of external time synchronisation is available. Either the synchronisation message is applied via any of the communication ports of the terminal as a telegram message including date and time, or as a minute pulse, connected to a binary input. The minute pulse is used to fine tune already existing time in the terminals.

The REx 5xx terminal has its own internal clock with date, hour, minute, second and millisecond. It has a resolution of 1 ms.

The clock has a built-in calendar for 30 years that handles leap years. Any change between summer and winter time must be handled manually or through external time synchronisation. The clock is powered by a capacitor, to bridge interruptions in power supply without malfunction.

The internal clock is used for time-tagging disturbances, events in Substation monitoring system (SMS) and Substation control system (SCS), and internal events.

## 1.3 Calculations

The internal time can be set on the local human-machine interface (HMI) at:

### Settings

#### Time

The time is set with year, month, day and time.

The source of the time synchronisation is set on the local HMI at:

---

## Configuration

### Time

When the setting is performed on the local HMI, the parameter is called TimeSync-Source. The time synchronisation source can also be set from the CAP 531 tool. The setting parameter is then called SYNCSCR. The setting alternatives are:

- None (no synchronisation)
- LON
- SPA
- IEC
- Minute pulse positive flank
- Minute pulse negative flank

The function input to be used for minute-pulse synchronisation is called TIME-MIN-SYNC.

The internal time can be set manually down to the minute level, either via the local HMI or via any of the communication ports. The time synchronisation fine tunes the clock (seconds and milliseconds). If no clock synchronisation is active, the time can be set down to milliseconds.

---

## 2 Setting group selector (GRP)

### 2.1 Application

Different conditions in networks of different voltage levels require high adaptability of the used protection and control units to best provide for dependability, security and selectivity requirements. Protection units operate with higher degree of availability, especially, if the setting values of their parameters are continuously optimised regarding the conditions in power system.

The operational departments can plan different operating conditions for the primary equipment. The protection engineer can prepare in advance for the necessary optimised and pre-tested settings for different protection functions. Four different groups of setting parameters are available in the REx 5xx terminals. Any of them can be activated automatically through up to four different programmable binary inputs by means of external control signals.

### 2.2 Functionality

Select a setting group by using the local HMI, from a front connected personal computer, remotely from the station control or station monitoring system or by activating the corresponding input to the GRP function block.

Each input of the function block is configurable to any of the binary inputs in the terminal. Configuration must be performed under the menu:

#### Configuration

##### Functions

##### Active Group

##### FuncInputs

Use external control signals to activate a suitable setting group when adaptive functionality is necessary. Input signals that should activate setting groups must be either permanent or a pulse longer than 200 ms.

More than one input may be activated simultaneously. In such cases the lower order setting group has priority. This means that if for example both group four and group two are set to activate, group two will be the one activated.



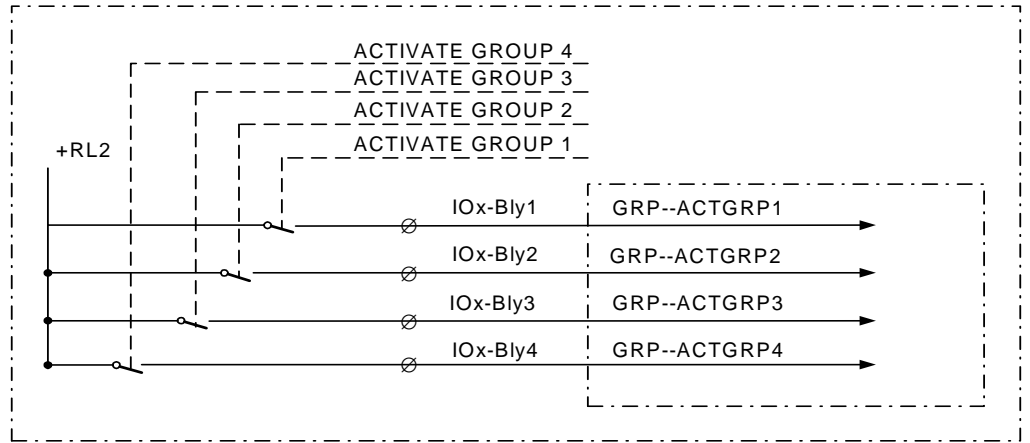

en01000144.vsd

### 2.3

#### Design

The GRP function block has four functional inputs, each corresponding to one of the setting groups stored within the terminal. Activation of any of these inputs changes the active setting group. Four functional output signals are available for configuration purposes, so that continuous information on active setting group is available.

---

## 3 Setting lockout (HMI)

### 3.1 Application

Unpermitted or uncoordinated changes by unauthorized personnel may cause severe damage to primary and secondary power circuits. Use the setting lockout function to prevent unauthorized setting changes and to control when setting changes are allowed.

By adding a key switch connected to a binary input a simple setting change control circuit can be built simply allowing only authorized keyholders to make setting changes. Security can be increased by adding SA/SMS overrides that prevents changes even by keyholders.

### 3.2 Functionality

Activating the setting restriction prevents unauthorized personell to purposely or by mistake change terminal settings.

The HMI--BLOCKSET functional input is configurable only to one of the available binary inputs of a REx 5xx terminal. For this reason, the terminal is delivered with the default configuration, where the HMI--BLOCKSET signal is connected to NONE-NOSIGNAL.

The function permits remote changes of settings and reconfiguration through the serial communication ports. The setting restrictions can be activated only from the local HMI.

All other functions of the local human-machine communication remain intact. This means that an operator can read all disturbance reports and other information and setting values for different protection parameters and the configuration of different logic circuits.

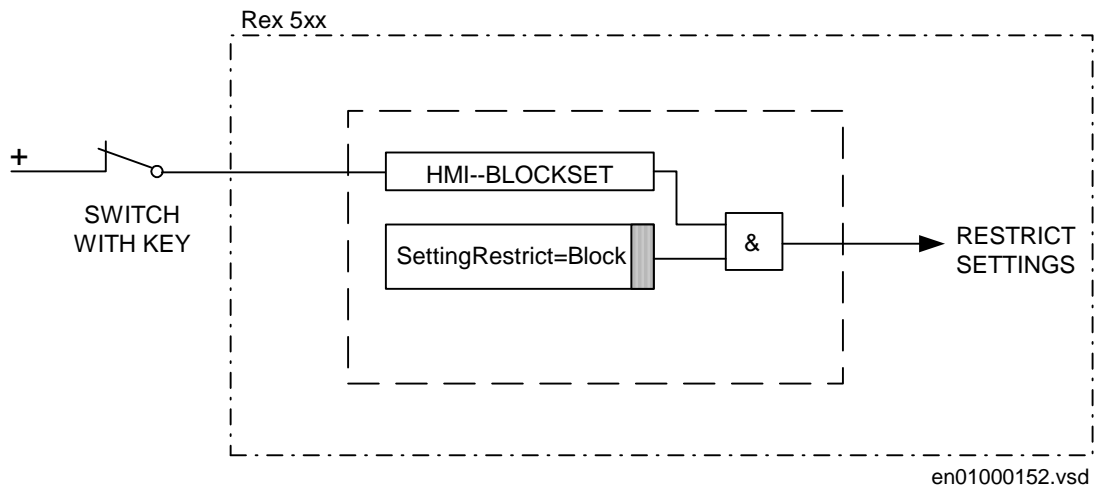

Figure 3: Connection and logic diagram for the BLOCKSET function

## 4 I/O system configurator (IOP)

### 4.1 Application

The I/O system configurator must be used in order to recognize added modules and to create internal address mappings between modules and protections and other functions.

### 4.2 Functionality

The I/O system configurator is used to add, remove or move I/O modules in the REx 5xx terminals. To configure means to connect the function blocks that represent each I/O module (BIM, BOM, IOM, IOPSM, DCM and MIM) to a function block for the I/O positions (IOP1) that represent the physical slot in the rack.

Available I/O modules are:

- BIM, *Binary Input Module* with 16 binary input channels.
- BOM, *Binary Output Module* with 24 binary output channels.
- IOM, *Input/Output Module* with 8 binary input and 12 binary output channels.
- MIM, *mA Input Module* with six analog input channels.
- IOPSM, *Input Output Power Supply Module* with four inputs and four outputs.
- DCM, *Data Communication Module*. The only software configuration for this module is the I/O Position input.

An REx 5xx terminal houses different numbers of modules depending of the casing size and which kind of modules chosen.

- The 1/1 of 19-inch size casing houses a maximum of 13 modules. But when Input/Output- or Output modules are included, the maximum of these modules are six. The maximum number of mA Input modules are also limited to six.
- The 3/4-size casing houses a maximum of eight modules. The limitation is four modules for Input/Output- or Output modules. The maximum number of mA Input modules are three.
- The 1/2-size casing houses a maximum of three binary modules or one analogue mA Input module.

It is possible to fit modules of different types in any combination in a terminal, but the total maximum numbers of modules must be considered.

Each I/O-module can be placed in any CAN-I/O slot in the casing with one exception. The DCM-module has a fixed slot position which depends on the size of the casing.

---

To add, remove or move modules in the terminal, the reconfiguration of the terminal must be done from the graphical configuration tool CAP 531.

Users refer to the CAN-I/O slots by the physical slot numbers of the CAN-I/O slots, which also appear in the terminal drawings.

If the user-entered configuration does not match the actual configuration in the terminal, an error output is activated on the function block, which can be treated as an event or alarm.

The BIM, BOM, IOM, IOPSM and DCM share the same communication addresses for parameters and configuration. So they must share I/O module 1-13 (IOxx), which are the same function block. A user-configurable function selector per I/O module function block determines which type of module it is.

All names for inputs and outputs are inputs on the function blocks and must be set from the graphical tool CAP 531.

#### **I/O position**

The IOP1 (I/O position) function block is the same for the different casings, independent of the number of slots available. Anyway, it looks different depending of actual configuration. All necessary configuration is done in the CAP 531 configuration tool.

The Sxx outputs are connected to the POSITION inputs of the I/O Modules and MIMs.

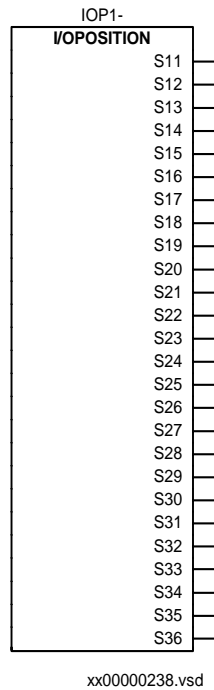

Figure 4: Function block of the I/O position block (IOP1-).

### Configuration

The I/O-configuration can only be performed from CAP 531, the graphical configuration tool.

To configure from the graphical tool:

- First, set the function selector for the logical I/O module to the type of I/O module that is used, BIM, BOM, IOM, IOPSM or DCM.
- Secondly, connect the POSITION input of the logical I/O module to a slot output of the IOP function block.

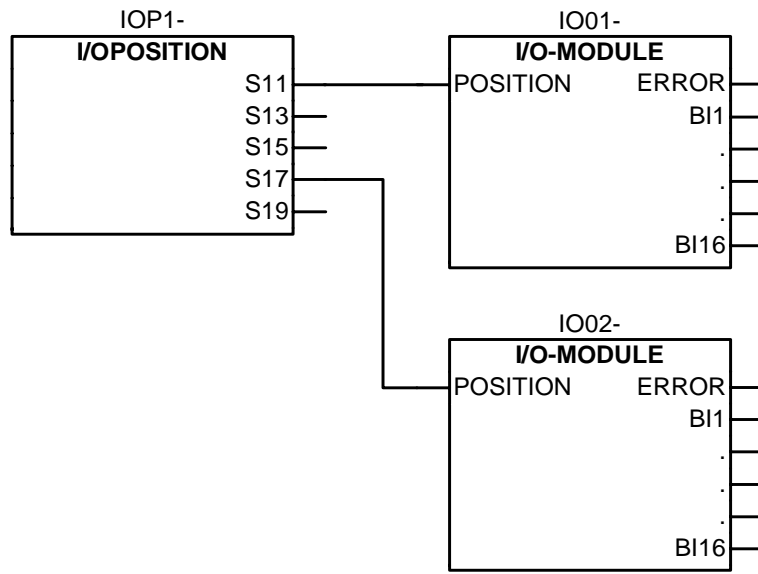

en01000142.vsd

Figure 5: Example of an I/O-configuration in the graphical tool CAP 531 for a REx 5xx with two BIMs.

## 5 Logic function blocks

### 5.1 Application

#### 5.1.1 Application

Different protection, control, and monitoring functions within the REx 5xx terminals are quite independent as far as their configuration in the terminal is concerned. The user cannot enter and change the basic algorithms for different functions, because they are located in the digital signal processors and extensively type tested. The user can configure different functions in the terminals to suit special requirements for different applications.

For this purpose, additional logic circuits are needed to configure the terminals to meet user needs and also to build in some special logic circuits, which use different logic gates and timers.

### 5.2 Functionality

#### Inverter (INV)

The INV function block is used to invert the input boolean variable. The function block (figure 6) has one input designated IVnn-INPUT where nn presents the serial number of the block. Each INV circuit has one output IVnn-OUT.

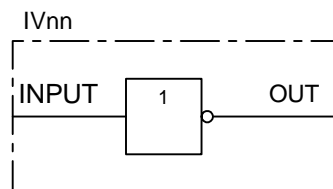

99000021.vsd

Figure 6: Function block diagram of the inverter (INV) function

Table 1: Truth table for the INV function block

INPUT	OUT
1	0
0	1



**Controllable gate (GT)**

The GT function block is used for controlling if a signal should be able to pass or not depending on a setting. The function block (figure 7) has one input, designated GTnn-INPUT, where nn presents the serial number of the block. Each GT circuit has one output, GTnn-OUT. Each gate further has a Operation On/Off which controls if the INPUT is passed to the OUT or not.

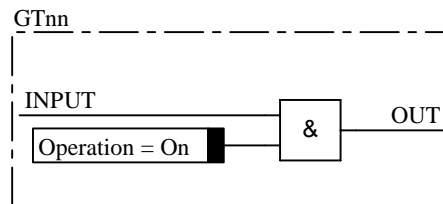

xx00000530.vsd

Figure 7: Function block diagram of the controllable gate (GT) function

The output signal from the GT function block is set to 1 if the input signal is 1 and Operation = On elsewhere it is set to 0. See truth table below.

**Table 2: Truth table for the GT function block**

INPUT	Operation	OUT
0	Off	0
1	Off	0
0	On	0
1	On	1

**OR**

OR function blocks are used to form general combinatory expressions with boolean variables. The function block (figure 8) has six inputs, designated Onnn-INPUTm, where nnn presents the serial number of the block, and m presents the serial number of the inputs in the block. Each OR circuit has two outputs, Onnn-OUT and Onnn-NOOUT (inverted).

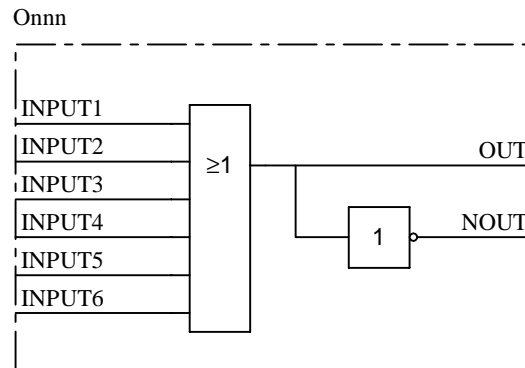

xx00000514.vsd

Figure 8: Function block diagram of the OR function

The output signal (OUT) is set to 1 if any of the inputs (INPUT1-6) is 1. See truth table below.

Table 3: Truth table for the OR function block

INPUT1	INPUT2	INPUT3	INPUT4	INPUT5	INPUT6	OUT	NOUT
0	0	0	0	0	0	0	1
0	0	0	0	0	1	1	0
0	0	0	0	1	0	1	0
...	...	...	...	...	...	1	0
1	1	1	1	1	0	1	0
1	1	1	1	1	1	1	0

### AND

AND function blocks are used to form general combinatory expressions with boolean variables. The function block (figure 9) has four inputs (one of them inverted), designated Annn-INPUTm (Annn-INPUT4N is inverted), where nnn presents the serial number of the block, and m presents the serial number of the inputs in the block. Each AND circuit has two outputs, Annn-OUT and Annn-NOUT (inverted).

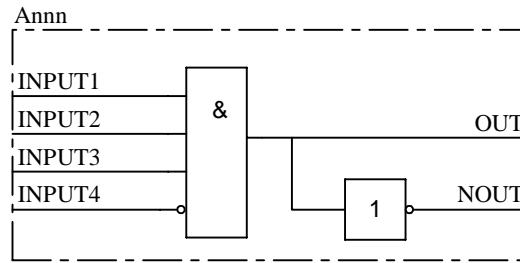

xx00000515.vsd

Figure 9: Function block diagram of the AND function

The output signal (OUT) is set to 1 if the inputs INPUT1-3 are 1 and INPUT4N is 0. See truth table below.

Table 4: Truth table for the OR function block

INPUT1	INPUT2	INPUT3	INPUT4N	OUT	NOUT
0	0	0	1	0	1
0	0	1	1	0	1
0	1	0	1	0	1
0	1	1	1	0	1
1	0	0	1	0	1
1	0	1	1	0	1
1	1	0	1	0	1
1	1	1	1	0	1
0	0	0	0	0	1
0	0	1	0	0	1
0	1	0	0	0	1
0	1	1	0	0	1
1	0	0	0	0	1
1	0	1	0	0	1
1	1	0	0	0	1
1	1	1	0	1	0

**Timer**

The function block TM timer has outputs for delayed input signal at drop-out and at pick-up. The timer (figure 10) has a settable time delay  $TM_{nn}-T$  between 0.00 and 60.00 s in steps of 0.01 s. The input signal for each time delay block has the designation  $TM_{nn}-INPUT$ , where  $nn$  presents the serial number of the logic block. The output signals of each time delay block are  $TM_{nn}-ON$  and  $TM_{nn}-OFF$ . The first one belongs to the timer delayed on pick-up and the second one to the timer delayed on drop-out. Both timers within one block always have the same setting.

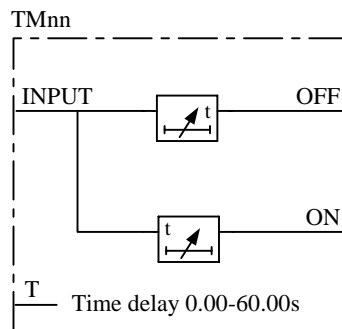

xx00000523.vsd

Figure 10: Function block diagram of the Timer function

The function block TL timer (figure 11) with extended maximum time delay at pick-up and at drop-out, is identical with the TM timer. The difference is the longer time delay  $TL_{nn}-T$ , settable between 0.0 and 90000.0 s in steps of 0.1 s.

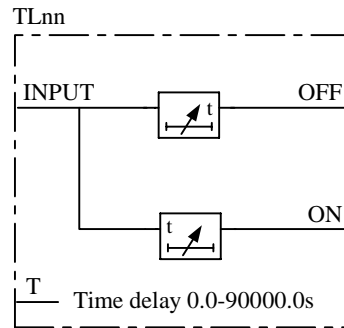

xx00000526.vsd

Figure 11: Function block diagram of the TimerLong function

The input variable to INPUT is obtained a settable time  $T$  at output OFF when the input variable changes from 1 to 0 in accordance with the time pulse diagram, figure 12. The output OFF signal is set to 1 immediately when the input variable changes from 0 to 1.

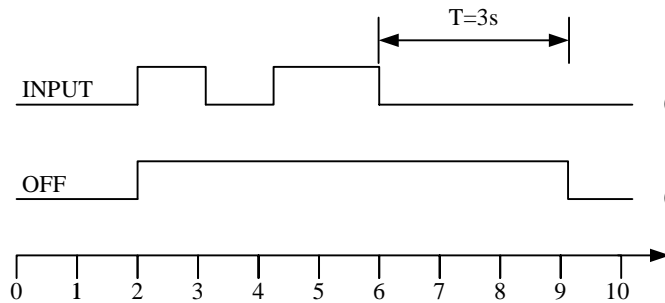

xx00000528.vsd

Figure 12: Example of time diagram for a timer delayed on drop-out with preset time  $T = 3 \text{ s}$

The input variable to INPUT is obtained delayed a settable time  $T$  at output ON when the input variable changes from 0 to 1 in accordance with the time pulse diagram, figure 13. The output ON signal returns immediately when the input variable changes from 1 to 0.

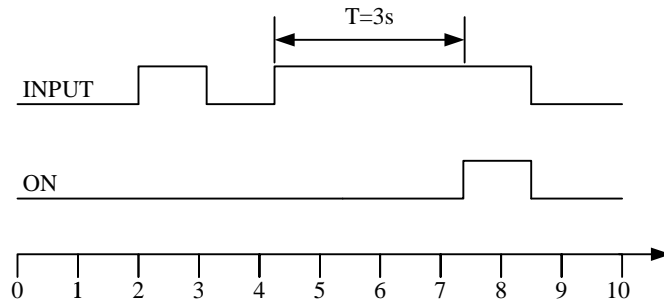

xx00000529.vsd

Figure 13: Example of time diagram for a timer delayed on pick-up with preset time  $T = 3\text{ s}$

If more timers than available in the terminal are needed, it is possible to use pulse timers with AND or OR logics. Figure 14 shows an application example of how to realize a timer delayed on pick-up. Figure 15 shows the realization of a timer delayed on drop-out. Note that the resolution of the set time must be 0.2 s, if the connected logic has a cycle time of 200 ms.

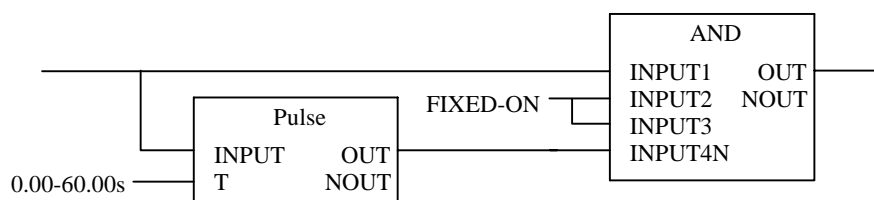

xx00000533.vsd

Figure 14: Realization example of a timer delayed on pick-up

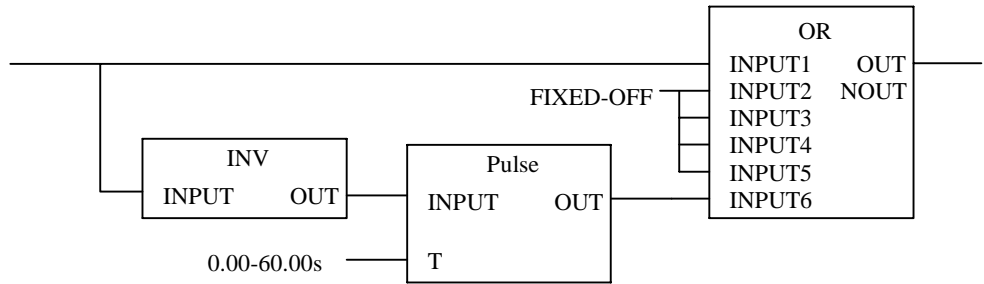

xx00000534.vsd

Figure 15: Realization example of a timer delayed on drop-out

**Timer settable through HMI/SMS/PST**

The function block TS timer has outputs for delayed input signal at drop-out and at pick-up. The timer (figure 16) has a settable time delay TSnn-T between 0.00 and 60.00 s in steps of 0.01 s. It also has an Operation setting On, Off which controls the operation of the timer. The input signal for each time delay block has the designation TSnn-INPUT, where nn presents the serial number of the logic block. The output signals of each time delay block are TSnn-ON and TSnn-OFF. The first one belongs to the timer delayed on pick-up and the second one to the timer delayed on drop-out. Both timers within one block always have the same setting.

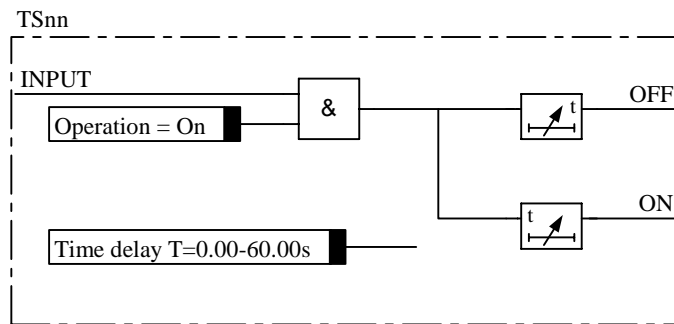

xx00000531.vsd

Figure 16: Function block diagram of the Settable timer function

For details about the function see the description of TM Timer.

**Pulse**

The pulse function can be used, for example, for pulse extensions or limiting of operation of outputs. The pulse timer TP (figure 17) has a settable length of a pulse between 0.00 s and 60.00 s in steps of 0.01 s. The input signal for each pulse timer has the designation TPnn-INPUT, where nn presents the serial number of the logic block. Each pulse timer has one output, designated by TPnn-OUT. The pulse timer is not retriggable, that is, it can be restarted first after that the time T has elapsed.

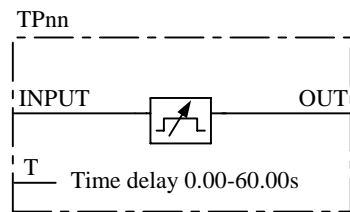

xx00000524.vsd

Figure 17: Function block diagram of the Pulse function

The function block TQ pulse timer (figure 18) with extended maximum pulse length, is identical with the TP pulse timer. The difference is the longer pulse length TQnn-T, settable between 0.0 and 90000.0 s in steps of 0.1 s.

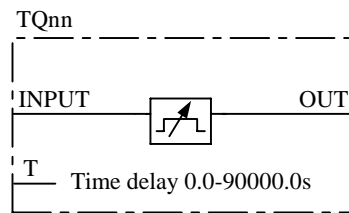

xx00000525.vsd

Figure 18: Function block diagram of the PulseLong function, TQ



A memory is set when the input INPUT is set to 1. The output OUT then goes to 1. When the time set  $T$  has elapsed, the memory is cleared and the output OUT goes to 0. If a new pulse is obtained at the input INPUT before the time set  $T$  has elapsed, it does not affect the timer. Only when the time set has elapsed and the output OUT is set to 0, the pulse function can be restarted by the input INPUT going from 0 to 1. See time pulse diagram, figure 19.

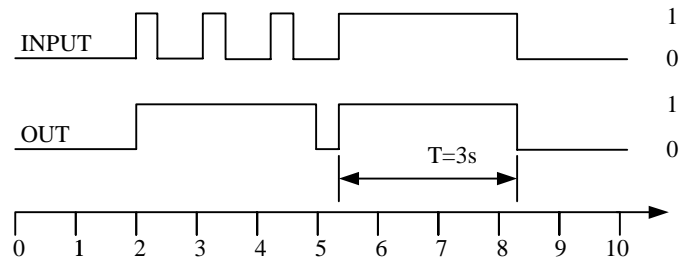

xx00000571.vsd

Figure 19: Example of time diagram for the pulse function with preset pulse length  $T = 3\text{ s}$

### Exclusive OR (XOR)

The function block exclusive OR (XOR) is used to generate combinatory expressions with boolean variables. XOR (figure 20) has two inputs, designated  $X_{\text{Onn-INPUTm}}$ , where  $nn$  presents the serial number of the block, and  $m$  presents the serial number of the inputs in the block. Each XOR circuit has two outputs,  $X_{\text{Onn-OUT}}$  and  $X_{\text{Onn-NOUT}}$  (inverted). The output signal (OUT) is 1 if the input signals are different and 0 if they are equal.

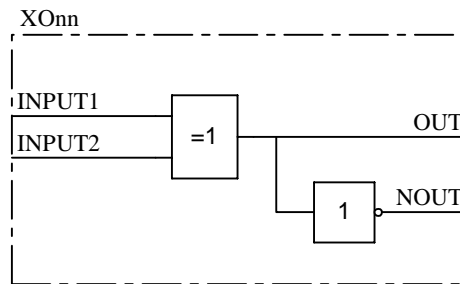

xx00000517.vsd

Figure 20: Function block diagram of the XOR function

The output signal (OUT) is set to 1 if the input signals are different and to 0 if they are equal. See truth table below.

Table 5: Truth table for the XOR function block

INPUT1	INPUT2	OUT	NOUT
0	0	0	1
0	1	1	0
1	0	1	0
1	1	0	1

### Set-Reset (SR)

The function block Set-Reset (SR) (figure 21) has two inputs, designated SRnn-SET and SRnn-RESET, where nn presents the serial number of the block. Each SR circuit has two outputs, SRnn-OUT and SRnn-NOUT (inverted). The output (OUT) is set to 1 if the input (SET) is set to 1 and if the input (RESET) is 0. If the reset input is set to 1, the output is unconditionally reset to 0.

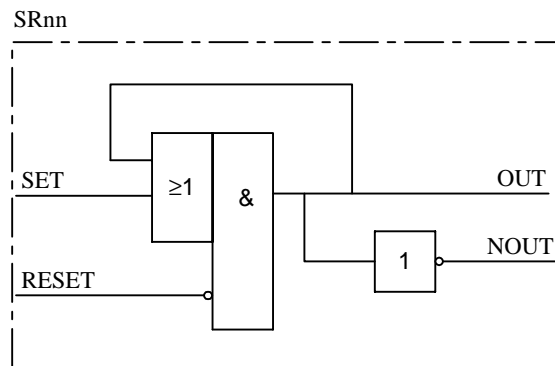

xx00000519.vsd

Figure 21: Function block diagram of the Set-Reset function

#### Set-Reset with/without memory (SM)

The function block Set-Reset (SM) (figure 22) with/without memory has two inputs, designated SMnn-SET and SMnn-RESET, where nn presents the serial number of the block. Each SM circuit has two outputs, SMnn-OUT and SMnn-NOUT (inverted). The output (OUT) is set to 1 if the input (SET) is set to 1 and if the input (RESET) is 0. If the reset input is set to 1, the output is unconditionally reset to 0. The memory setting controls if the flip-flop after a power interruption will return to the state it had before or if it will be reset.

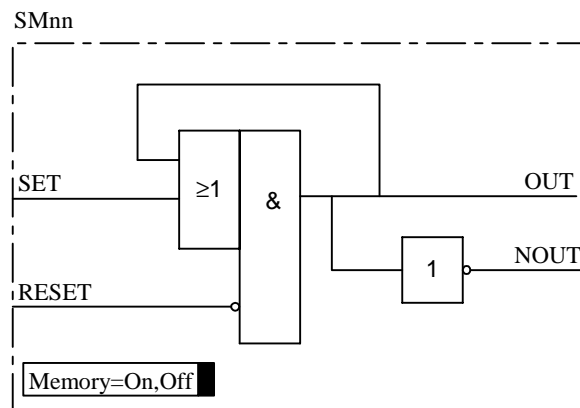

xx00000520.vsd

Figure 22: Function block diagram of the Set-Reset with/without memory function

### MOVE

The MOVE function blocks, also be called copy-blocks, are used for synchronization of boolean signals sent between logics with slow execution time and logics with fast execution time.

There are two types of MOVE function blocks - MOF located First in the slow logic and MOL located Last in the slow logic. The MOF function blocks are used for signals coming into the slow logic and the MOL function blocks are used for signals going out from the slow logic.

The REx 5xx terminal contains 3 MOF function blocks of 16 signals each, and 3 MOL function blocks of 16 signals each. This means that a maximum of 48 signals into and 48 signals out from the slow logic can be synchronized. The MOF and MOL function blocks are only a temporary storage for the signals and do not change any value between input and output.

Each block of 16 signals is protected from being interrupted by other logic application tasks. This guarantees the consistency of the signals to each other within each MOVE function block.

Synchronization of signals with MOF should be used when a signal which is produced outside the slow logic is used in several places in the logic and there might be a malfunction if the signal changes its value between these places.

Synchronization with MOL should be used if a signal produced in the slow logic is used in several places outside this logic, or if several signals produced in the slow logic are used together outside this logic, and there is a similar need for synchronization.

Figure 23 shows an example of logic, which can result in malfunctions on the output signal from the AND gate to the right in the figure.

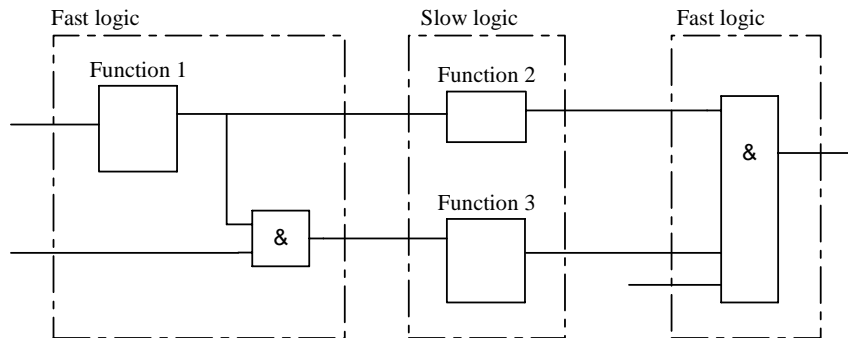

xx00000537.vsd

Figure 23: Example of logic, which can result in malfunctions

Figure 24 shows the same logic as in figure 23, but with the signals synchronized by the MOVE function blocks MOFn and MOLn. With this solution the consistency of the signals can be guaranteed.

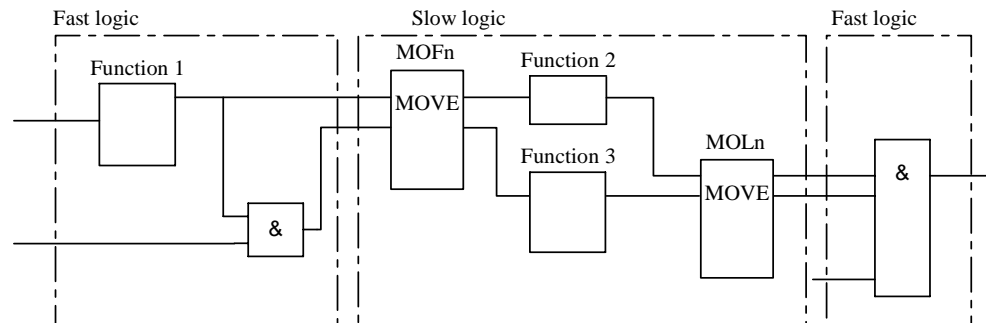

xx00000541.vsd

Figure 24: Example of logic with synchronized signals

MOFn and MOLn,  $n=1-3$ , have 16 inputs and 16 outputs. Each  $INPUT_m$  is copied to the corresponding  $OUTPUT_m$ , where  $m$  presents the serial number of the input and the output in the block. The MOFn are the first blocks and the MOLn are the last blocks in the execution order in the slow logic.

### 5.3

#### Calculations

For the AND gates, OR gates, inverters, normal SR (Set-Reset) flip-flops, XOR gates and MOVE elements no settings exist.

For the normal On/Off delay timers and pulse timers the time delays and pulse lengths are set from the CAP 531 configuration tool.

Both timers in the same logic block (the one delayed on pick-up and the one delayed on drop-out) always have a common setting value. Setting values of the pulse length are independent of one another for all pulse circuits.

For the controllable gates, settable timers, SR flip-flops with/without memory the setting parameters are accessible through the HMI and SMS.

#### Configuration

The configuration of the logics is performed from the CAP 531 configuration tool.

Execution of functions as defined by the configurable logic blocks runs in a fixed sequence in two different cycle times, typical 6 ms and 200 ms.

---

For each cycle time, the function block is given an execution serial number. This is shown when using the CAP 531 configuration tool with the designation of the function block and the cycle time, for example, TMnn-(1044, 6). TMnn is the designation of the function block, 1044 is the execution serial number and 6 is the cycle time.

Execution of different function blocks within the same cycle time should follow the same order as their execution serial numbers to get an optimal solution. Always remember this when connecting in series two or more logical function blocks. When connecting function blocks with different cycle times, the MOVE function blocks can be used. These function blocks synchronize boolean signals sent between logics with slow execution time and logics with fast execution time. The MOVE functions are available as additional configurable logic circuits.

**Note!**

*Be always careful when connecting function blocks with a fast cycle time to function blocks with a slow cycle time.*

*So design the logic circuits carefully and check always the execution sequence for different functions. In other cases, additional time delays must be introduced into the logic schemes to prevent errors, for example, race between functions.*

## 6 Self supervision (INT)

### 6.1 Application

The REx 5xx protection and control terminals have a complex design with many included functions. The included self-supervision function and the INTERNAL signals function block provide good supervision of the terminal. The different safety measures and fault signals makes it easier to analyze and locate a fault.

Both hardware and software supervision is included and it is also possible to indicate possible faults through a hardware contact and/or through the software communication.

Internal events are generated by the built-in supervisory functions. The supervisory functions supervise the status of the various modules in the terminal and, in case of failure, a corresponding event is generated. Similarly, when the failure is corrected, a corresponding event is generated.

Apart from the built-in supervision of the various modules, events are also generated when the status changes for the:

- built-in real time clock (in operation/out of order).
- external time synchronization (in operation/out of order).

Events are also generated:

- whenever any setting in the terminal is changed.
- when the content of the Disturbance report is erased.

The internal events are time tagged with a resolution of 1 ms and stored in a list. The list can store up to 40 events. The list is based on the FIFO principle, that is, when it is full, the oldest event is overwritten. The list cannot be cleared and its content cannot be modified.

The list of internal events provides valuable information, which can be used during commissioning and fault tracing.

The information can only be retrieved with the aid of the SMS. The PC can be connected either to the port at the front or at the rear of the terminal.



## 6.2

**Functionality**

The self-supervision status can be monitored from the local HMI or via the PST Parameter Setting Tool or a SMS/SCS system.

Under the Terminal Report menu in the local HMI the present information from the self-supervision function can be viewed. A detailed list of supervision signals that can be generated and displayed in the local HMI is found in the Installation and Commissioning Manual.

In the PST under Terminal Report these summary signals are available:

- InternalStatus
- CPU-Status

When an internal fault has occurred, extensive information about the fault from the list of internal events can be retrieved from the PST under the menu Terminal Report - Internal Events.

A self-supervision summary can be obtained by means of the potential free alarm contact located on the power supply module. The function of this output relay is an OR-function between the INT--FAIL signal (figure 27) and a couple of more severe faults that can happen in the terminal (figure 26).

Some signals are available from the function block InternSignals (INT), see figure 25. The signals from this function block can be connected to an Event function block, which generates and sends these signals as events to the station level of the control system. The signals from the INT-function block can also be connected to binary outputs for signalization via output relays or they can be used as conditions for other functions if required/desired.

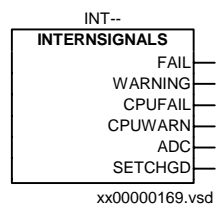
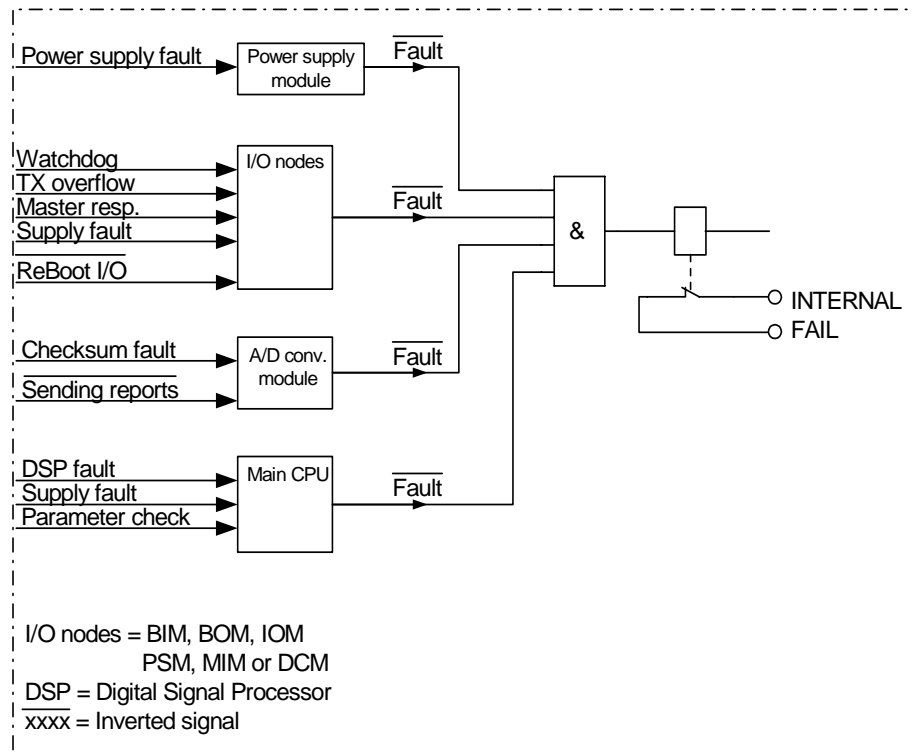

Figure 25: Function block INTernal signals.

Individual error signals from I/O modules and time synchronization can be obtained from respective function block of IOM-, BIM-, BOM-, MIM-, IOPSM-modules and from the time synchronization block TIME.



99000034.vsd

Figure 26: Hardware self-supervision, potential-free alarm contact.

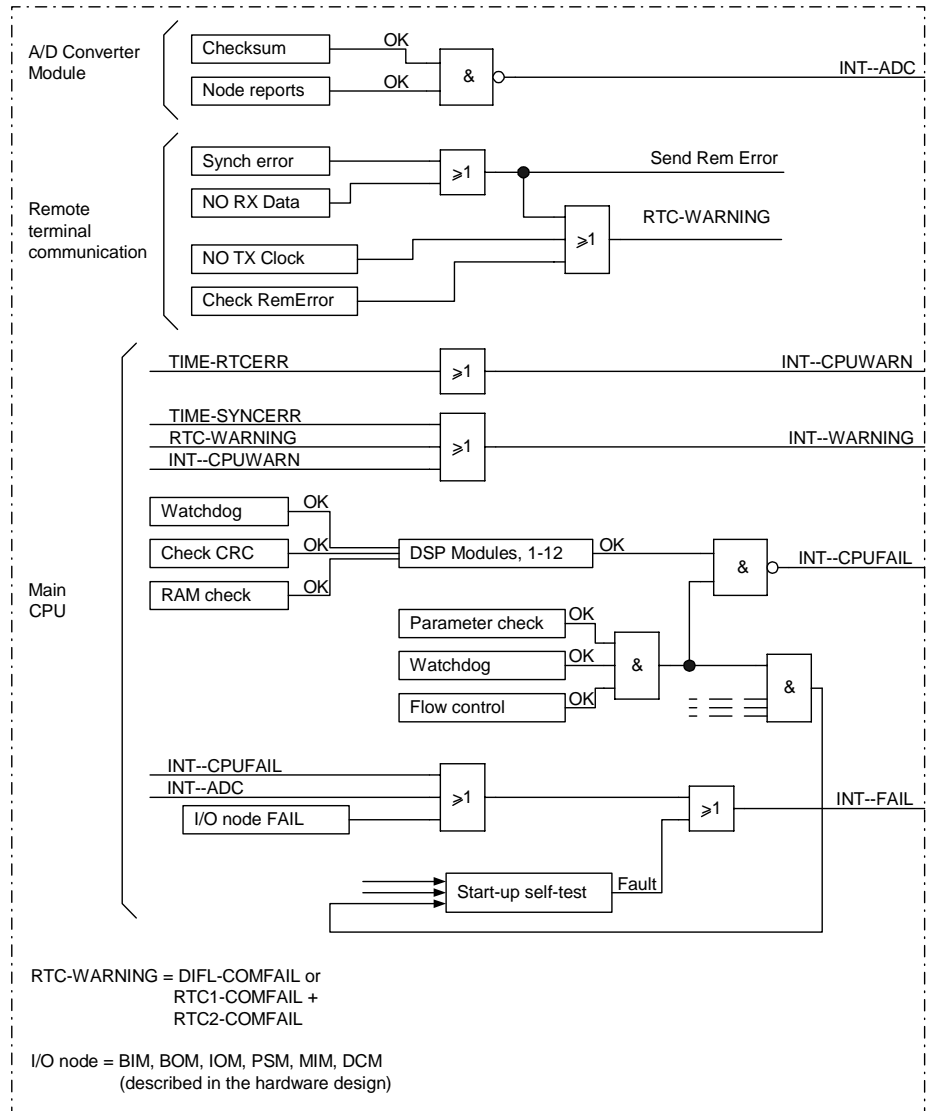

99000035.vsd

Figure 27: Software self-supervision, function block INTERNAL signals.

---

## 7 Blocking of signals during test

### 7.1 Functionality

This blocking function is only active during operation in the test mode, see example in Figure 28. When exiting the test mode, entering normal mode, this blocking is disabled and everything is set to normal operation. All testing will be done with actually set and configured values within the terminal. No settings etc. will be changed. Thus no mistakes are possible.

The blocked functions will still be blocked next time entering the test mode, if the blockings were not reset.

The blocking of a function concerns all output signals from the actual function, so no outputs will be activated.

Each of the terminal related functions is described in detail in the documentation for the actual unit. The description of each function follows the same structure (where applicable).

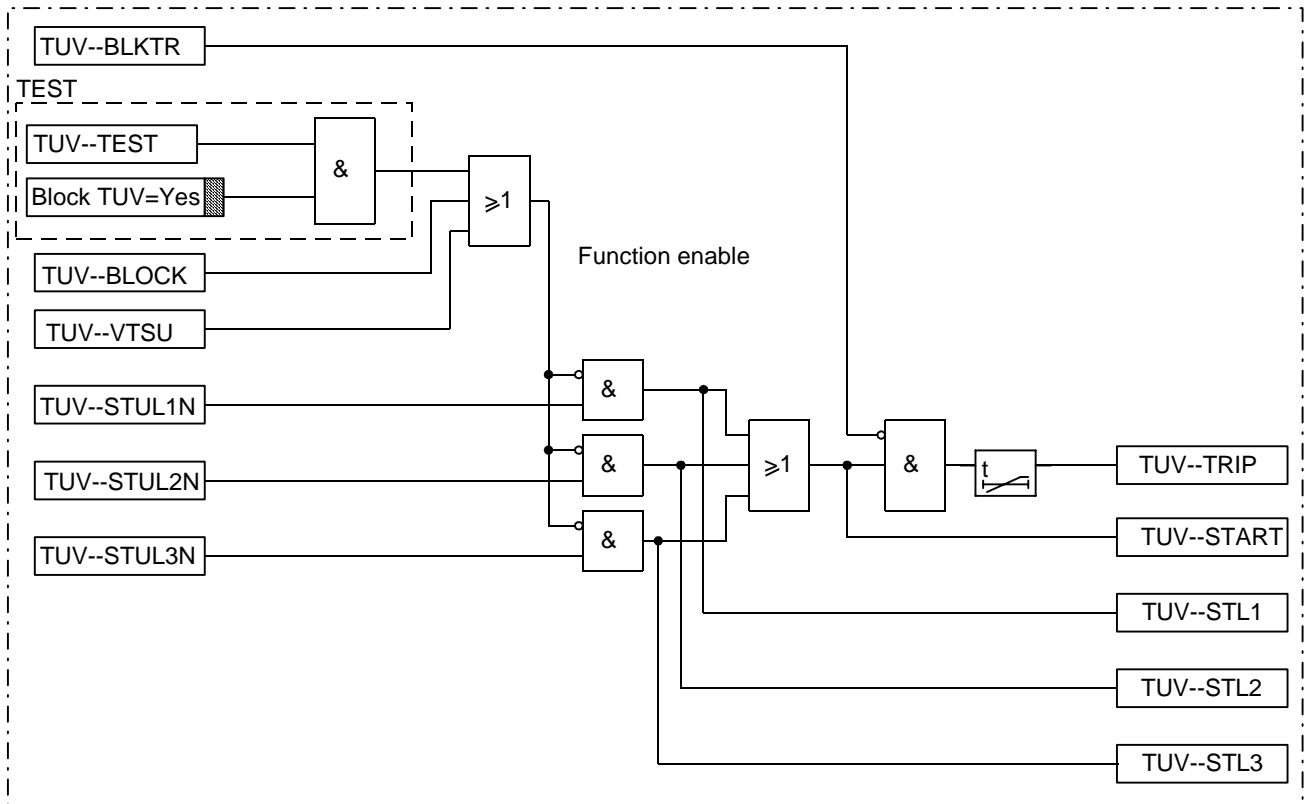

en00000121.vsd

Figure 28: Example of blocking the Time delayed Under-Voltage function.



# **Chapter 4 Line impedance**

## **About this chapter**

This chapter describes the line impedance functions in the terminal.

---

# 1 Distance protection (ZM1-5)

## 1.1 Application

### General

The distance protection function is the most widely spread protection function in transmission and subtransmission networks. It is also becoming increasingly important in distribution networks. The main reasons for this are:

- Its independence on communication links between the line ends, because for its operation, it uses information about the locally available currents and voltages.
- The distance protection forms a relatively selective protection system (non-unit protection system) in the power network. This means that it can also operate as a remote back-up protection for other primary elements in the network.

The basic requirements for modern line protection, such as speed, sensitivity and selectivity, with their strict requirements for dependability and security (availability), are getting more stringent. In addition, modern distance protections must be able to operate in networks with existing distance relays, which are mostly designed in a different technology (static or even electromechanical relays).

Older distance relays protect in many cases power lines only at phase-to-phase and three-phase faults. Some other protection is used for phase-to-earth faults.

The flexibility of modern distance protection is for this reason very important. This especially applies when it is used in a complex network configuration, for example, on parallel operating multicircuit lines and on multiterminal lines.

The selective operation of the distance protection does not depend on communication facilities between two line ends. At the same time, the distance protection can detect faults beyond the current transformers at the remote terminal. This functionality makes it an ideal complement to the line differential protection function that cannot detect faults beyond the current transformer at the opposite terminal.



**Distance protection zones**

The distance protection function in REx 5xx line protection, control, and monitoring terminals consists of three to five independent distance protection zones, each of them comprising three measuring elements for phase-to-earth (Ph-E) faults and/or three measuring elements for phase-to-phase (Ph-PH) faults. Different terminals suit different requirements in different networks on various voltage levels. For this reason, some characteristic parameters of the distance protection function differ from terminal to terminal. For detailed information, please refer to ordering particulars for each line protection terminal REx 5xx separately.

Distance protection zone five differs from other zones with respect to its speed of operation. It starts faster than other distance protection zones and might have for this reason higher overreaching for different system transients. It is for this reason suggested to use it only for the applications, which permit higher overreaching, (i.e. switch-onto-fault function) or as a time delayed distance protection zone with time delay longer than 100 ms.

**Complement to the line differential protection**

The distance protection function can become optional protection in some line differential protection terminals (REL 561, for example). At the same time it represents the primary protection for faults beyond the current transformers at the opposite terminal. This functionality is achieved by the time delayed overreaching zone (generally zone 2), which covers at least the adjacent busbar and thus forms a primary or back-up protection for the busbar. So the overreaching zone should be continuously in operation.

An underreaching zone (generally zone 1) can form a back-up to the line differential protection. There is no need for this function as long as the differential protection is in operation. To minimize the risk of unwanted operation from zone 1, this function can be activated only when the differential function is out of operation. The most likely cause to lose the differential protection is a failure within the communication system.

The communication scheme used with the distance protection should for this reason use another communication channel than the one used by the line differential protection.

**Set of simplified setting parameters**

Each distance protection zone comprises basically completely independent setting parameters for phase-to-earth, and for phase-to-phase measurement. This is an application advantage in complex network configurations and in networks, where it is required to adjust the newly applied distance protection functions to the existing other types of relays (overcurrent earth fault, for example).

A set of simplified optional parameters is available optionally for applications, where equal zone reaches for all kinds of faults are a standard practice. See the table of setting parameters and the setting instructions.

### Basic characteristics

The distance protection function, as built into the REx 5xx line protection terminals, is a full-scheme distance protection. This means that it has individual measuring elements for different types of faults within different zones.

Depending on the type of terminal, it consists of up to five (for details see the corresponding ordering details) independent, impedance-measuring zones, each has a quadrilateral characteristic, as symbolically illustrated in figure 29.  $R_L$  and  $X_L$  represent line resistance and reactance and  $R_F$  represents the resistive reach of a protective zone.

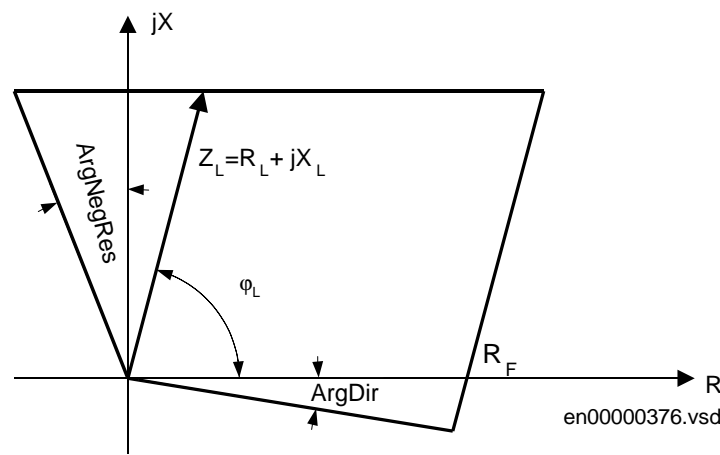

Figure 29: Typical characteristic of a distance protection zone.

The static characteristic in reactive direction is a straight line, parallel with the R-axis. The measuring algorithm used for the reactance part of the characteristic for phase-to-earth faults compensates for the influence of the load current on the impedance measurement for distance zone 1. So the static characteristic has no declination against the R-axis. Setting of the reach in a reactive direction is independent for each separate zone. It can also differ for ph-ph and for ph-E measuring elements.

A straight line limits the reach of the distance protection zone in resistive direction. It is generally parallel with  $Z_L$ , the line-impedance characteristic. This means that it forms, with the R-axis, a  $\phi_L$  line-characteristic angle. Setting of the reach in resistive direction is independent for each separate zone. Different setting values are also possible for phase-to-earth faults (RFPE) and for phase-to-phase faults (RFPP).

With the X-axis, the directional characteristic in the second quadrant forms an ArgNegRes settable angle (default value  $25^\circ$ ). With the R-axis, the corresponding part forms a settable ArgDir angle in the fourth quadrant (default value  $-15^\circ$ ), as in figure 29 and figure 30. All distance protection zones have the same directional characteristics.

The characteristics of the distance zones are independent of one another as far as their directionality and reach in different directions are concerned. One can program the directionality of each distance zone. Figure 30 shows a typical example of the characteristics of an impedance-measuring zone when directed into forward or reverse directions. A polygon, completed with dashed lines, represents the characteristic of a non-directional zone.

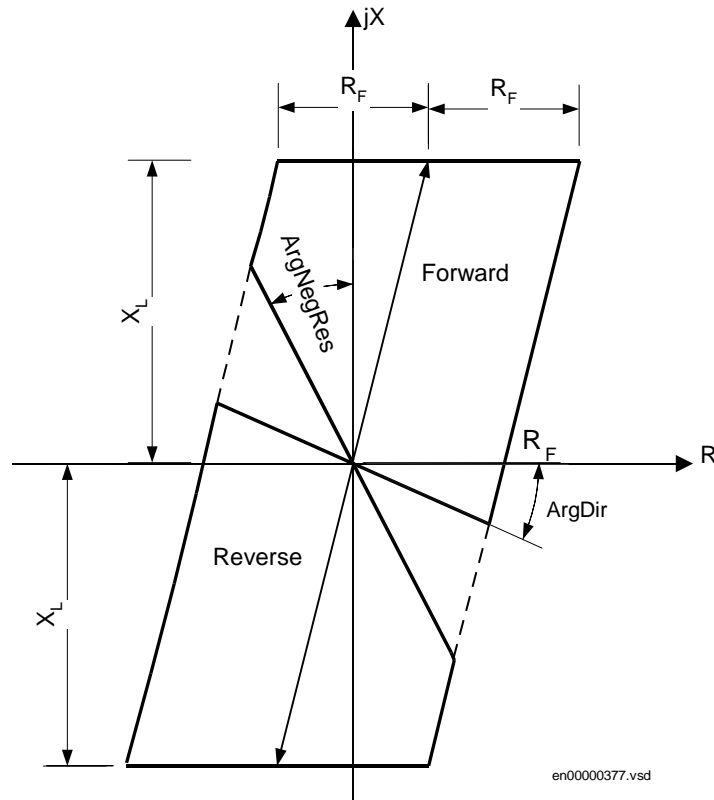

Figure 30: Nondirectional and directional (forward and reverse) operating characteristic

The set value of a reach in resistive direction determines whether the directional line in the second quadrant meets, as first, the reactive or the resistive characteristic. Compare the characteristics in figure 29 and 30.

The values of the reaches in reactive and resistive direction for a particular zone are the same for forward and reverse impedance-measuring elements and for the non-directional mode of operation.

The terminal automatically adapts the line characteristic angle according to the line parameters. Thus, the measurement of different faults follows the real conditions in a power system. Figure 31 shows an example of an operating characteristic for the ph-E fault, which faces the forward direction. Here, a  $Z_{loop}$ , phase-to-earth loop measuring impedance, consists of a  $Z_1$  line operational impedance,  $Z_N$  earth return impedance, and the RFPE fault resistance. The characteristic angle of the complete measuring loop automatically follows the real system conditions and the complete line characteristic.

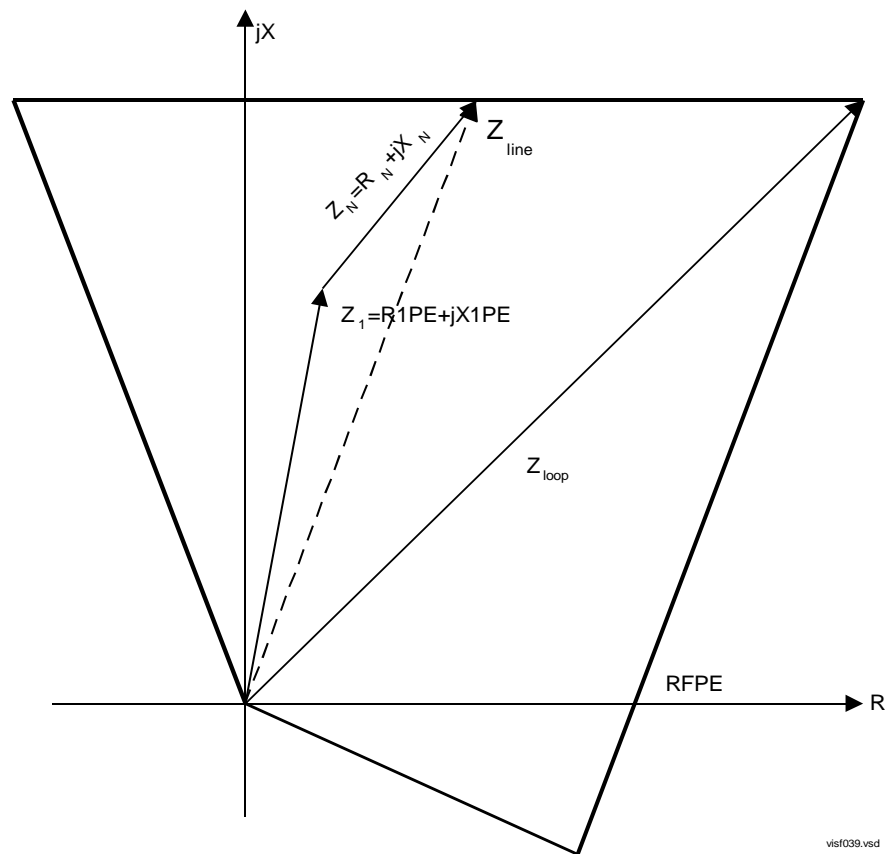

Figure 31: Characteristic of the phase-to-earth measuring loop.

The earth return impedance follows for each particular zone the expression:

$$\bar{Z}_N = \frac{1}{3} \cdot (\bar{Z}_0 - \bar{Z}_1)$$

(Equation 13)

with:

$$\bar{Z}_1 = R1PE + j \cdot X1PE$$

(Equation 14)

and

$$\bar{Z}_0 = R0PE + j \cdot X0PE$$

(Equation 15)

Where *R1PE*, *X1PE*, *R0PE* and *X0PE* are the reach setting parameters.

It is possible to make the characteristic independent of line angle by setting the corresponding line resistances *R1PE* and *R0PE* to their minimum possible values. For more details see setting instructions.

The possibility to cover a sufficient fault resistance is a major consideration in short-line applications. Load encroachment problems are not so common. The independent setting option of the reach in reactive and resistive direction is a function that greatly improves the flexibility of distance protection. For these short line applications, an optional overreaching scheme communication logic, also improves, the resistive coverage. The optimum solution in some applications is to add the optional, directional-comparison, earth-fault, overcurrent protection to the distance protection scheme.

In long line applications, the margin to the load impedance (to avoid load encroachment) is usually a major consideration. Quadrilateral characteristics with independent settings of the reach in reactive (to cover sufficient length of a line) and resistive (to avoid load encroachment) direction greatly diminish the conflict that is very characteristic for circular characteristics.

A wide setting range of the reach in a reactive direction, which one set independently for each zone with good current sensitivity — down to 10% of the rated current — is an important factor that improves the performances of the distance protection when used on long transmission lines.

High-voltage power cables have two main characteristics that make them, from the distance protection perspective, different from overhead lines:

- They are relatively short, compared to overhead lines.
- The value of their zero-sequence reactance is very low, in many cases even lower than the positive-sequence reactance. This results in a negative value of the characteristic angle for the earth-return impedance.

Without approximation, the value of the earth-return compensation automatically follows the parameters of a power cable for positive and zero sequence reactance and resistance. This makes the impedance measuring function, as built into the REx 5xx line-protection terminals, suitable for the protection of short, EHV power cables. The independent setting of the reach (in reactive and resistive direction, separately and independently for each distance zone) improves these basic performances.

Zero-sequence, mutual impedance between different circuits of the multicircuit parallel operating lines is a factor that particularly influences the performance of distance protection during single-phase-to-earth fault conditions. Distance protection must also operate selectively for intersystem faults and simultaneous faults to the greatest possible extent.

The separate and independent setting of the parameters that determine the value of earth-return compensation for different distance-protection zones, enables the compensation of the influence of the zero-sequence, mutual impedance on the measurement of the impedance-measuring elements for single-phase-to-earth faults.

Separate, optional, phase selectors usage, with their reach setting independent of the reach of the zone measuring elements, greatly improves the performance of distance protection on the multicircuit parallel operating lines. At the same time and to the lowest possible level, these selectors reduce the influence of the heavy load current, that is present during a fault, on the phase selection function within the terminals.

Additional phase-segregated, scheme communication logic (refer to the ordering information for its availability within the different types of terminals) enables absolute phase selectivity of the distance protection of multi-circuit, parallel operating lines.

For the selective operation of distance protection on tied and multiterminal lines, flexibility in scheme communication logic associated with the distance protection function is a great advantage. Scheme communication logic built into the REx 5xx line protection terminals enables the adaptation of any communication scheme to the existing system conditions. The free selection of overreaching and underreaching zones, with the free selection of a conditional zone, and independent settings of the reach for different zones, makes the REx 5xx line protection terminals extremely flexible for such applications.

## 1.2 Functionality

### 1.2.1 Measuring principle

Fault loop equations use the complex values of voltage, current, and changes in the current. Apparent impedances are calculated and compared with the set limits. The calculation of the apparent impedances at ph-ph faults follows the equation (example for a phase L1 to phase L2 fault):

$$\overline{Z}_{\text{ap}} = \frac{\overline{U}_{L1} - \overline{U}_{L2}}{\overline{I}_{L1} - \overline{I}_{L2}}$$

(Equation 16)

Here represent  $U$  and  $I$  the corresponding voltage and current phasors in the respective phase  $L_n$  ( $n = 1, 2, 3$ )

The earth return compensation applies in a conventional manner for ph-E faults (example for a phase L1 to earth fault):

$$\overline{Z}_{\text{ap}} = \frac{\overline{U}_{L1}}{\overline{I}_{L1} + \overline{K}_N \cdot \overline{I}_N}$$

(Equation 17)

Here  $I_N$  is a phasor of the residual current in relay point. This results in the same reach along the line for all types of faults.

The apparent impedance is considered as an impedance loop with resistance  $R$  and reactance  $X$ , as presented in figure 32.

The measuring elements receive information about currents and voltages from the A/D converter. The check sums are calculated and compared, and the information is distributed into memory locations. For each of the six supervised fault loops, sampled values of voltage ( $U$ ), current ( $I$ ), and changes in current between samples ( $\Delta I$ ) are brought from the input memory and fed to a recursive Fourier filter.

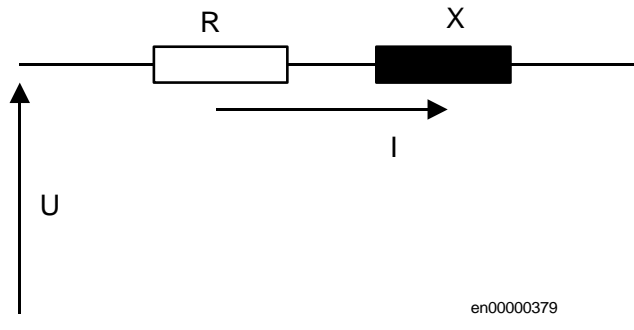

Figure 32: Apparent impedance with resistance and reactance connected in series

The filter provides two orthogonal values for each input. These values are related to the loop impedance according to the formula:

$$\bar{U} = R \cdot \bar{i} + \frac{X}{\omega_0} \cdot \frac{\Delta \bar{I}}{\Delta t}$$

(Equation 18)

in complex notation, or:

$$\text{Re}(\bar{U}) = R \cdot \text{Re}(\bar{I}) + \frac{X}{\omega_0} \cdot \frac{\Delta \text{Re}(\bar{I})}{\Delta t}$$

(Equation 19)

$$\text{Im}(\bar{U}) = R \cdot \text{Im}(\bar{I}) + \frac{X}{\omega_0} \cdot \frac{\Delta \text{Im}(\bar{I})}{\Delta t}$$

(Equation 20)

with

$$\omega_0 = 2 \cdot \pi \cdot f_0$$

(Equation 21)



Where:

Re	designates the real component,
Im	designates the imaginary component of current and voltage and
$f_0$	designates the rated system frequency

The algorithm calculates  $R_m$  measured resistance from the equation for the real value of the voltage and substitute it in the equation for the imaginary part. The equation for the  $X_m$  measured reactance can then be solved. The final result is equal to:

$$R_m = \frac{\text{Im}(\overline{U}) \cdot \Delta \text{Re}(\overline{I}) - \text{Re}(\overline{U}) \cdot \Delta \text{Im}(\overline{I})}{\Delta \text{Re}(\overline{I}) \cdot \text{Im}(\overline{I}) - \Delta \text{Im}(\overline{I}) \cdot \text{Re}(\overline{I})}$$

(Equation 22)

$$X_m = \omega_0 \cdot \Delta t \cdot \frac{\text{Re}(\overline{U}) \cdot \text{Im}(\overline{I}) - \text{Im}(\overline{U}) \cdot \text{Re}(\overline{I})}{\Delta \text{Re}(\overline{I}) \cdot \text{Im}(\overline{I}) - \Delta \text{Im}(\overline{I}) \cdot \text{Re}(\overline{I})}$$

(Equation 23)

The calculated  $R_m$  and  $X_m$  values are updated each millisecond and compared with the set zone reach. The adaptive tripping counter counts the number of permissive tripping results. This effectively removes any influence of errors introduced by the capacitive voltage transformers or by other causes. The algorithm is insensitive to changes in frequency, transient dc components, and harmonics because a true replica of the protected line is implemented in the algorithm.

The directional evaluations are simultaneously performed in forward and reverse directions, and in all six fault loops. Positive sequence voltage and a phase locked positive sequence memory voltage are used as a reference. This ensures unlimited directional sensitivity for faults close to the relay point.

### Measured impedance

#### Phase-to-earth measurement

The impedance measurement for the phase-to-earth faults is performed on the loop basis by comparing the calculated  $R_m$  resistance and  $X_m$  reactance with the set values of the reach in the resistive and reactive direction:

$$R_m \geq \left[ R_{1PE} + \frac{1}{3} \cdot (R_{0PE} - R_{1PE}) \right] \cdot p - RFPE$$

(Equation 24)

$$R_m \leq \left[ R_{1PE} + \frac{1}{3} \cdot (R_{0PE} - R_{1PE}) \right] \cdot p + RFPE$$

(Equation 25)

$$X_m \geq -X_{1PE} - \frac{1}{3} \cdot (X_{0PE} - X_{1PE})$$

(Equation 26)

$$X_m \leq X_{1PE} + \frac{1}{3} \cdot (X_{0PE} - X_{1PE})$$

(Equation 27)

The  $p$  factor represents the relative fault position ( $-1 \leq p \leq 1$ ) within the reactive operating limits in forward and reverse direction.

Equations for resistive measurement represent in the impedance plane non-directional operating limits in resistive direction (see figure 33). For the faults on radial lines equation 24 represents a straight line (left side operating characteristic in loop domain), which passes the  $R$  axis at point  $D = -RFPE + j0$  and forms with it an angle of:

$$\alpha = \operatorname{atan} \left[ \frac{X_{1PE} + \frac{1}{3} \cdot (X_{0PE} - X_{1PE})}{R_{1PE} + \frac{1}{3} \cdot (R_{0PE} - R_{1PE})} \right]$$

(Equation 28)

Equation 25 represents for the same conditions a straight line (right side operating limit) passing the  $R$  axis in set point  $B = RFPE + j0$  and is parallel to the left side operating characteristic. Equations 26 and 27 represent in the impedance plane the operating limits in reactive direction (see figure 33). For faults on radial lines equation 26 represents in impedance plane (loop domain) a straight line, which is parallel with the  $R$  axis and passes the point

$$C = 0 - j \left[ X_{1PE} + \frac{1}{3} \cdot (X_{0PE} - X_{1PE}) \right]$$

(Equation 29)

Similarly represents equation 27 a straight line, which is also parallel with the R axis and passes the point

$$A = 0 + j \left[ X_{1PE} + \frac{1}{3} \cdot (X_{0PE} - X_{1PE}) \right]$$

(Equation 30)

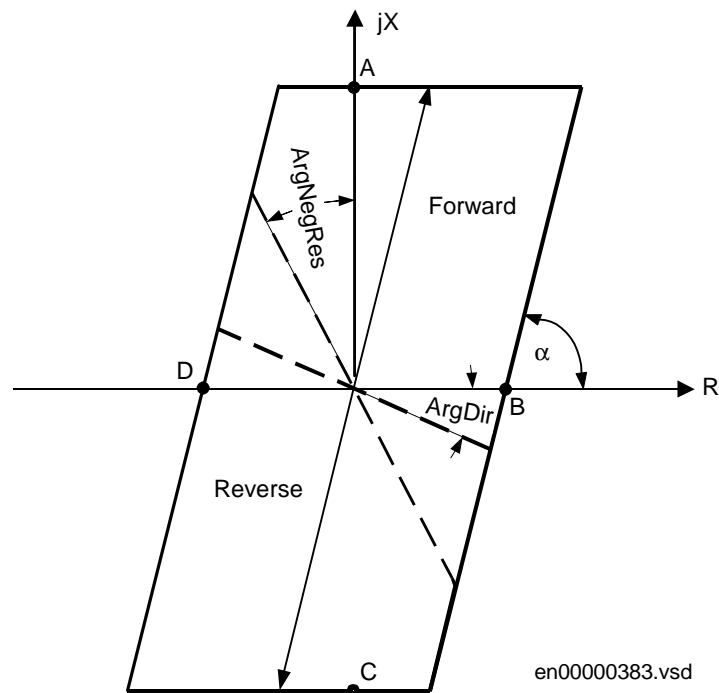

Figure 33: General operating characteristic of impedance measuring elements

#### Phase-to-phase measurement

The impedance measurement for the phase-to-phase faults is performed on a phase basis by comparing the calculated  $R_m$  resistance and  $X_m$  reactance with the set values of the reach in the resistive and reactive direction:

$$R_m \geq R1PP \cdot p - \frac{1}{2} \cdot RFPP$$

(Equation 31)

$$R_m \leq R1PP \cdot p + \frac{1}{2} \cdot RFPP$$

(Equation 32)

$$X_m \geq -X1PP$$

(Equation 33)

$$X_m \leq X1PP$$

(Equation 34)

Here represents  $p$  factor the relative fault position ( $-1 < p < 1$ ) within the reactive zone reach. Parameters  $R1PP$ ,  $X1PP$  and  $RFPP$  are the reach setting parameters for the ph-p and three-phase faults. The first two equations represent the left and right side operating boundaries, see figure 33. For the faults on radial feeders represent these two equations straight lines in impedance plain, which cross the R axis in points:

$$D = -\frac{1}{2} \cdot RFPP + j0$$

(Equation 35)

and

$$B = \frac{1}{2} \cdot RFPP + j0$$

(Equation 36)

respectively.

Both operating limits are parallel and form with the R axis an angle of:

$$\alpha = \operatorname{atan}\left(\frac{X_{1PP}}{R_{1PP}}\right)$$

(Equation 37)

The third and the fourth equations represent the reactive operating boundaries in forward and reverse direction, see figure 33. They cross in impedance plane the X axis in operating points:  $A = X_{1PP}$  and  $C = -X_{1PP}$  respectively. For the faults on radial feeders this two boundaries are straight lines, parallel with the R axis.

### Directional lines

The results of impedance measurement are combined in “and” combination with the directional measurement, to obtain the desired directionality for each distance protection zone separately, see figure in “Phase-to-earth measurement”.

The directional measurement is based on the use of a positive-sequence voltage for the respective fault loop. For the L1-N element, the equation for forward direction is:

$$-\operatorname{ArgDir} < \arg \frac{0.8 \cdot U_{1L1} + 0.2 \cdot U_{1L1M}}{I_{L1}} < \operatorname{ArgNegRes}$$

(Equation 38)

For the L1-L2 element, the equation in forward direction is:

$$-\operatorname{ArgDir} < \arg \frac{0.8 \cdot U_{1L1L2} + 0.2 \cdot U_{1L1L2M}}{I_{L1L2}} < \operatorname{ArgNegRes}$$

Where:

**ArgDir** is the setting for the lower boundary of the forward directional characteristic, by default set to 15 (= -15 degrees) and

**ArgNegRes** is the setting for the upper boundary of the forward directional characteristic, by default set to 115 (degrees)

The reverse directional characteristic is equal to the forward characteristic rotated by 180 degrees.

The polarizing voltage is available as long as the positive-sequence voltage exceeds 4% of the rated voltage  $U_r$ . So the directional element can use it for all unsymmetrical faults including close-in faults.

For close-in three-phase faults, the  $U_{ILIM}$  memory voltage, based on the same positive sequence voltage, ensures correct directional discrimination.

The memory voltage is used for 100 ms or until the positive sequence voltage is restored. After 100 ms, the following occurs:

- If the current is still above the set value of the minimum operating current (between 10 and 30% of the terminal rated current  $I_r$ ), the condition seals in.
- If the fault has caused tripping, the trip endures.
- If the fault was detected in the reverse direction, the measuring element in the reverse direction remains in operation.
- If the current decreases below the minimum operating value, the memory resets until the positive sequence voltage exceeds 10% of its rated value.

## 1.3

### Design

#### Full-scheme measurement

Up to three digital signal processors execute algorithms for up to five, full-scheme distance protection zones, depending on the type of the REx 5xx line protection terminal. Figure 34 presents an outline of the different measuring loops for the basic five, impedance-measuring zones when both, ph-E and ph-ph fault measuring loops are included into the terminal.

The first digital-signal processor (DSP) measures different fault loops for different single-phase-to-earth faults and for different zones. This way, it forms the resistive and reactive part of a characteristic for single-phase-to-earth faults. The second DSP performs the same task for the phase-to-phase fault loops. The third DSP separately performs the directional measurement for all types of faults in forward and reverse directions. The presence of the first or the second DSP within the terminal depends on its type and the fault type, for which the distance protection is ordered (see ordering particulars for each REx 5xx terminal separately).

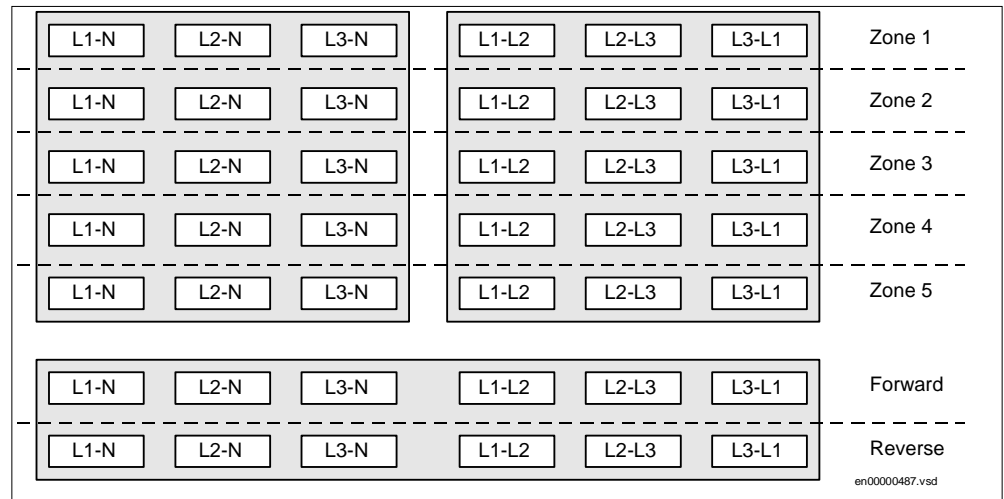

Figure 34: Location of different measuring loops within the three digital signal processors

The parallel execution of measurements in up to three different DSPs permits the separate evaluation of each impedance measuring loop for each zone every millisecond. This gives the distance protection function the same features as those known for the full-scheme design of conventional distance relays (REZ 1, RAZFE). So each distance protection zone performs like one independent distance protection relay with six measuring elements.

#### Distance protection zone one

The design of distance protection zone 1 is presented for all measuring loops: phase-to-earth as well as phase-to-phase. Different terminals REx 5xx have built-in different measuring circuits, dependent on ordering details. In the following description consider only the phase-to-earth related signals, if only phase-to-earth measurement is included in terminal. Similarly consider only the phase-to-phase related signals, if only phase-to-phase measurement is included in terminal.

The phase-to-earth related signals are designated by LnE, where n represents the corresponding phase number (L1E, L2E, and L3E). The phase-to-phase signals are designated by LnLm, where n and m represent the corresponding phase numbers (L1L2, L2L3, and L3L1).

Fulfillment of two different measuring conditions is necessary to obtain the logical one signal for each separate measuring loop:

- Zone measuring condition, which follows the operating equations described above.
- Group functional input signal (ZM1--STCND), as presented in figure 35.

The ZM1--STCND input signal represents a connection of six different integer values from other measuring functions within the terminal, which are converted within the zone measuring function into corresponding boolean expressions for each condition separately (see “ZMn--STCND functional input” in “Basic configuration”).

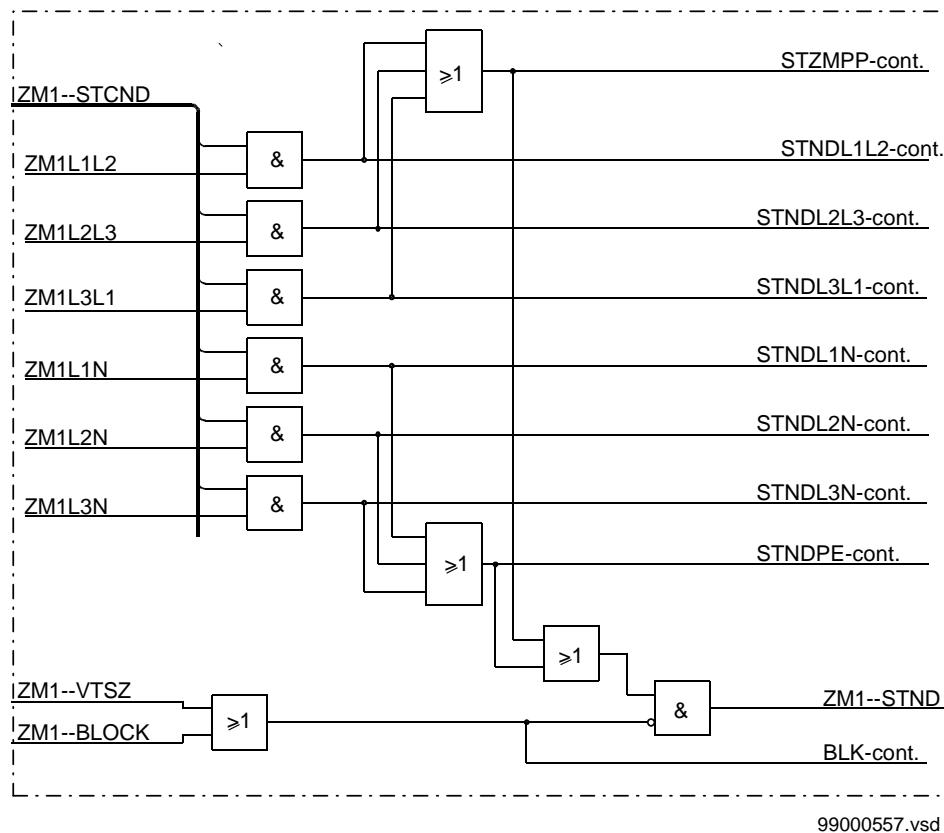

Figure 35: Conditioning by a group functional input signal ZM1--STCND

Composition of the phase starting signals for a case, when the zone operates in a non-directional mode, is presented in figure 36.



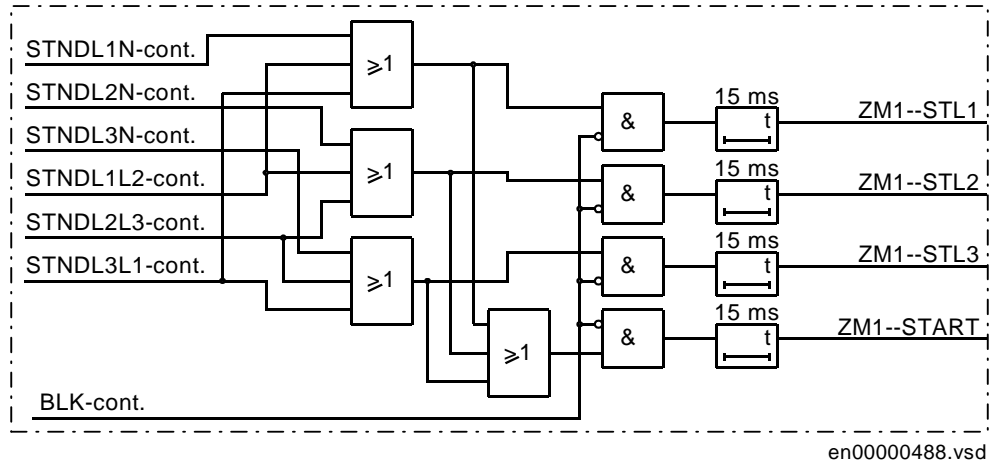

Figure 36: Composition of starting signals in non-directional operating mode

Results of the directional measurement enter the logic circuits, when the zone operates in directional (forward or reverse) mode, see figure 37.

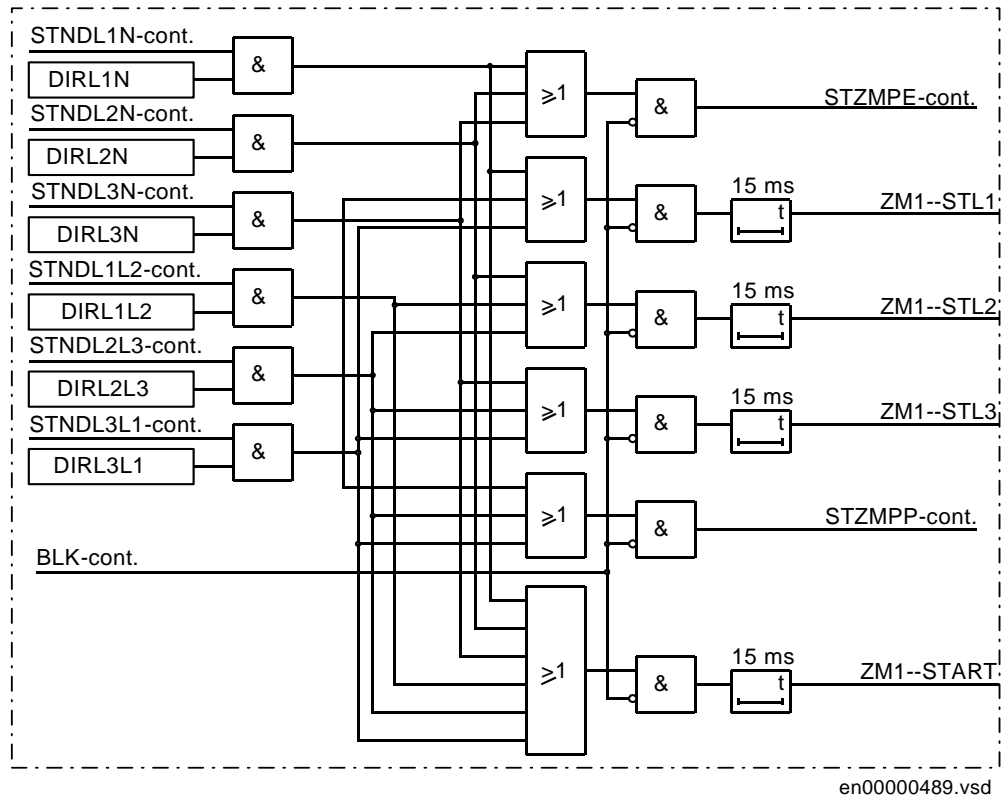

Figure 37: Composition of starting signals in directional operating mode

Tripping conditions for the distance protection zone one are symbolically presented on figure 38.

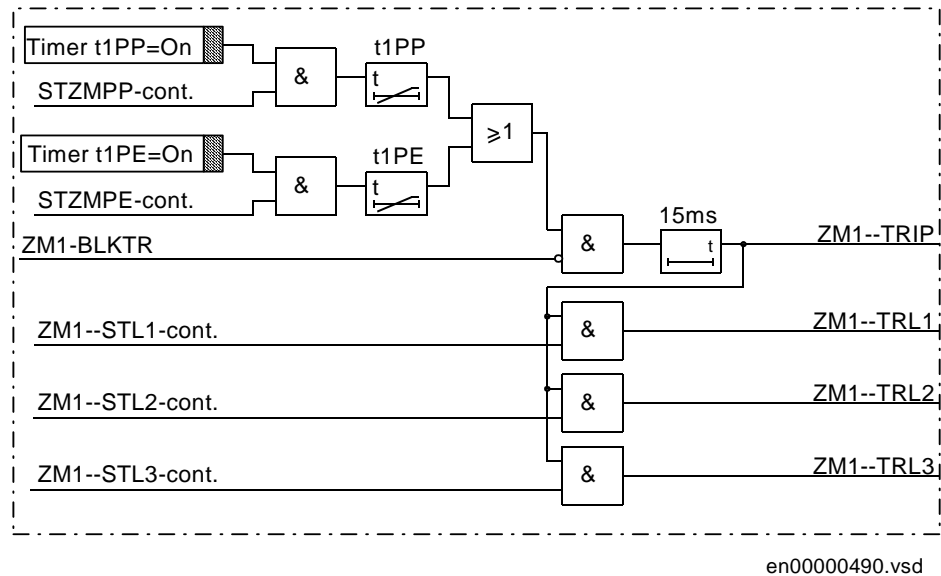

Figure 38: Tripping logic for the distance protection zone one

Phase related starting and tripping signals are available only in case, when the 1/2/3 phase tripping unit is ordered within the terminal. Please, refer to ordering particulars for each REx 5xx terminal separately.

### Remaining distance protection zones

Distance protection zones two and three have the same composition as distance protection zone 1. All descriptions for the distance protection zone 1 are for this reason valid also for the distance protection zones two and three. It is only necessary to replace the ZM1- designation with corresponding designations ZM2- for zone two and ZM3- for zone three respectively.

Distance protection zones four (ZM4-) and five (ZM5-) are based on the same principles as the other distance protection zones. The only difference is in the presentation of phase selective signals, belonging to these two zones. The phase selective signals are not available with distance protection zones four and five.

## 1.4

### Calculations

#### 1.4.1

#### Setting instructions

The setting values of all parameters that belong to distance protection within the REx 5xx line-protection terminals, must correspond to the parameters of the protected line and to the selectivity plan for the network.

**Reach setting recommendations**

Before starting the setting activities for the distance protection function, check that the setting values of the secondary rated current within the terminal correspond to the current transformers used for the same purposes for a specific REx 5xx terminal.

**Conversion to secondary impedances**

Convert the primary line impedances to the secondary sides of the current and voltage instrument transformers. The following relation applies to these purposes:

$$Z_{\text{sec}} = \frac{U_{\text{sec}}}{U_{\text{prim}}} \cdot \frac{I_{\text{prim}}}{I_{\text{sec}}} \cdot Z_{\text{prim}}$$

(Equation 39)

<b>Where:</b>	
<b>Abbreviation:</b>	<b>Is a set value of:</b>
$I_{\text{prim}}$	Rated primary current of the used current instrument transformers
$I_{\text{sec}}$	Rated secondary current of the used current instrument transformers
$U_{\text{prim}}$	Rated primary voltage of the used voltage instrument transformers
$U_{\text{sec}}$	Rated secondary voltage of the used voltage instrument transformers
$Z_{\text{prim}}$	Primary impedance
$Z_{\text{sec}}$	Calculated secondary impedance

**Basic zone setting recommendations**

An impedance seen by the distance protection might differ from the calculated values due to:

- Errors introduced by current and voltage instrument transformers, particularly under transient conditions.
- Inaccuracies in the line zero-sequence impedance data, and their effect on the calculated value of the earth-return compensation factor.
- The effect of infeed between the relay and the fault location, including the influence of different  $Z_0/Z_1$  ratios of the various sources.
- The phase impedance of untransposed lines is not identical for all fault loops. The difference between the impedances for different phase-to-earth loops can be as large as 5-10% of the total line impedance.
- The effect of a load transfer between the terminals of the protected line. When the fault resistance is considerable, the effect must be recognized.
- Zero-sequence mutual coupling from parallel lines.

Usually, these errors require a limitation of the underreaching zone (normally zone 1) to 85-90% of the protected line. For the same reason, it is necessary to increase the reach of the overreaching zone (normally zone 2) to at least 120% of the protected line — to ensure that the overreaching zone always covers a complete line. The zone 2 reach can be even higher, but in general it should never exceed 80% of the following impedances:

- The impedance corresponding to the protected line, plus the first zone reach of the shortest adjacent line.
- The impedance corresponding to the protected line, plus the impedance of the maximum number of transformers operating in parallel on the bus at the remote end of the protected line.

The back-up overreaching zone (normally zone 3) must never exceed 90% of the shortest zone 2 reach of any of the lines connected to the remote end bus. It must be at least 2 times the zone 1 reach.

The reverse zone is applicable for purposes of scheme communication logic, current reversal logic, weak-end-infeed logic, and so on. The same applies to the back-up protection of the busbar or power transformers. It is necessary to secure, that it always covers the overreaching zone, used at the remote line terminal for the telecommunication purposes.

In the case of a long line followed by a short line, or by a large bank of low impedance transformers, the mandatory 120% setting might overreach zone 1 of the adjacent line, or reach through the transformer bank at the other line end. In such cases, one must increase the zone 2 time delay and thus secure the selectivity. The zone 2 reach must not be reduced below 120% of the protected line section. It must be covered under all conditions.

In networks with lines tied at an intermediate location, consider an increase in the measured impedance due to the fault current fed into the system at the teed point.

If a fault occurs at point F (see figure 39 also for the explanation of all abbreviations used), the relay at point A senses the impedance:

$$\bar{Z}_m = \bar{Z}_{AC} + \frac{\bar{I}_A + \bar{I}_B}{\bar{I}_A} \cdot \bar{Z}_{CF} = \bar{Z}_{AC} + \left(1 + \frac{\bar{I}_B}{\bar{I}_A}\right) \cdot \bar{Z}_{CF}$$

(Equation 40)

$I_A$  and  $I_B$  are fault currents from sources A and B respectively.

Assume that the reach of zone 1 of the relay in C covers 85% of  $Z_{CD}$ , and the reach of zone 2 of the relay in A covers 80% of  $(Z_{AC} + 85\% \text{ of } Z_{CD})$ .

The impedance from station A up to the reach limit of the first zone at C corresponds to:

$$\bar{Z}_{AC} + 0.85 \cdot \left(1 + \frac{\bar{I}_B}{\bar{I}_A}\right) \cdot \bar{Z}_{CD}$$

(Equation 41)

The reach of zone 2 can not be longer than 80% of the apparent impedance at the limit of the first zone at C, which means that:

$$\bar{Z}_2 = 0.8 \cdot \left[ \bar{Z}_{AC} + 0.85 \cdot \left(1 + \frac{\bar{I}_B}{\bar{I}_A}\right) \cdot \bar{Z}_{CD} \right]$$

(Equation 42)

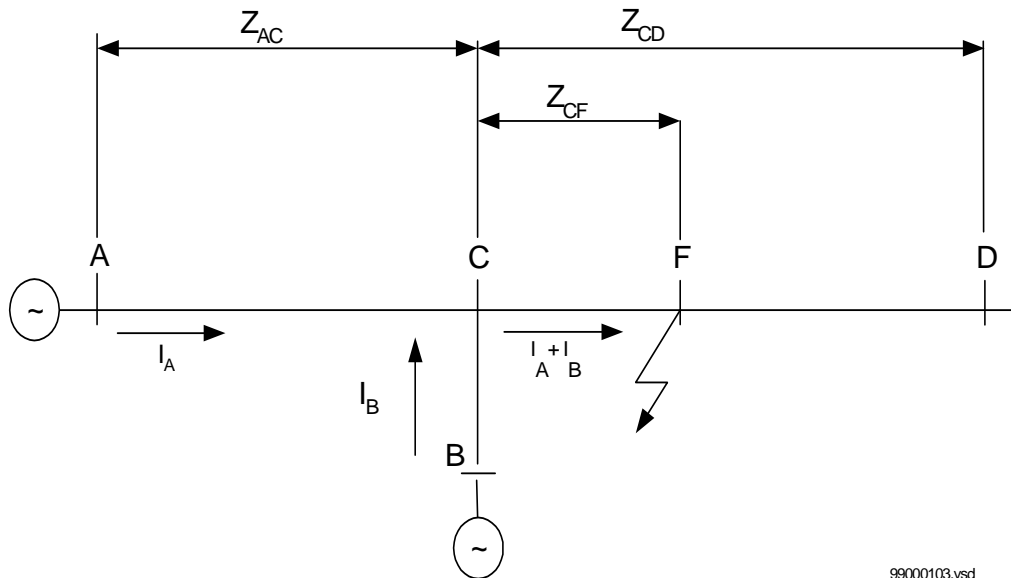

99000103.vsd

Figure 39: Network with line tied at an intermediate location

Also consider the apparent increase of measured impedance due to the power fed into the system for the zone 3 setting.

When calculating the setting, consider the lowest value of the current ratio from two sources that can occur when only one group of setting parameters is used for all operating conditions.

The distance protection function performs best in the power system with its setting values optimized to specific system conditions. So use different pre-set and pre-test groups of setting parameters for different expected system operating conditions.

REx 5xx terminals have a built-in memory capacity for four groups of setting parameters, all completely independent of one another. It is possible to set and pre-test all of them during the commissioning. Their activation is possible:

- Locally — with the local HMI or a PC
- Remotely — with the SMS or/and SCS (depending on whether the optional remote communication is built into the terminal or not).

**Earth return compensation**

A simplified measuring loop at the single-phase-to-earth faults consists of three impedances, as shown in figure 40:.

<b>Where:</b>	
<b>Abbreviation:</b>	<b>Is a set value of:</b>
Z1	Positive sequence impedance of the line
Rf	Fault resistance
ZN	Earth-return impedance
Z0	Zero sequence impedance of the line

The earth return impedance is equal to:

$$\bar{Z}_N = \frac{1}{3} \cdot (\bar{Z}_0 - \bar{Z}_1)$$

(Equation 43)

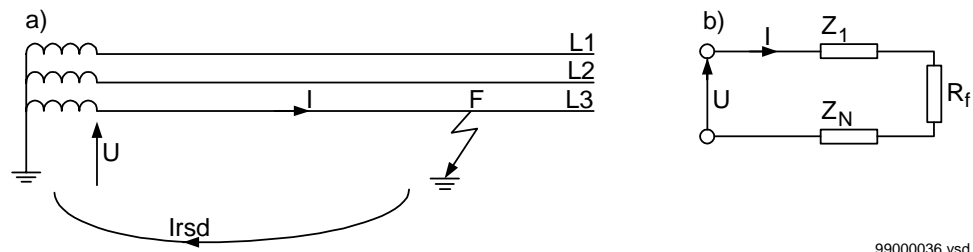

99000036.vsd

Figure 40: Equivalent circuits for measurement at single-phase-to-earth faults.

The complete measuring impedance, according to Figure 40 is equal to:

$$\bar{Z}_{\text{loop}} = \bar{Z}_1 + \bar{Z}_N + R_f = \frac{1}{3} \cdot (2 \cdot \bar{Z}_1 + \bar{Z}_0) + R_f$$

(Equation 44)



The reach of distance protection zone is related to the positive sequence line impedance. So an earth-return compensation factor has been introduced into the measuring algorithm. Its value is equal to:

$$\overline{Z}_{\text{loop}} = \overline{Z}_1 \cdot (1 + \overline{K}_N) + R_F = \frac{1}{3} \cdot (2\overline{Z}_1 + \overline{Z}_0) + R_f \Rightarrow$$

(Equation 45)

$$\Rightarrow \overline{K}_N = \frac{\overline{Z}_N}{\overline{Z}_1} = \frac{1}{3} \cdot \frac{\overline{Z}_0 - \overline{Z}_1}{\overline{Z}_1}$$

(Equation 46)

The impedance measuring algorithm within the REL 5xx terminals calculates automatically the complex value of the earth-return compensation factor KN on the basis of the set values for the

- Positive sequence reactance of protected line section *XIPE*
- Positive sequence resistance of protected line section *RIPE*
- Zero-sequence reactance of protected line section *XOPE*
- Zero-sequence resistance of protected line section *ROPE*

### Fault resistance

The performance of distance protection for single-phase-to-earth faults is very important, because normally more than 70% of the faults on transmission lines are single-phase-to-earth faults.

At these faults, the fault resistance is composed of three parts: arc resistance, resistance of a tower construction, and tower-footing resistance.

The arc resistance can be calculated according to Warrington's formula:

$$R_{\text{arc}} = \frac{28707 \cdot L}{I^{1.4}}$$

(Equation 47)

Where:

- L represents the length of the arc (in meters). This equation applies for the distance protection zone 1. Consider approximately three-times arc foot spacing for the zone 2 with time delay of 0.7 seconds and wind speed of approximately 50 km/h.
- I is the actual fault current in A.

Calculate or measure the tower-footing resistance for the specific case, because the variation of this parameter is very large.

The distance protection cannot detect very high-resistive earth faults, because the load impedance and load transfer limit its reach. For faults with resistance higher than those that can be detected by the impedance measurement, an optional earth-fault overcurrent protection can be included in the REx 5xx terminals.

#### **Zero-sequence mutual coupling on multicircuit lines**

When calculating the settings for distance-protection ph-E fault measuring elements, one must consider zero-sequence mutual coupling between the circuits of the multicircuit lines. The positive and the negative-sequence mutual coupling generally have no significant influence on the operation of the impedance-measuring protection schemes.

The distance protection within the REx 5xx terminals can compensate for the influence of a zero-sequence mutual coupling on the measurement at single-phase-to-earth faults in the following ways, by using:

- The possibility of different values that influence the earth-return compensation for different distance zones within the same group of setting parameters.
- Different groups of setting parameters for different operating conditions of a protected multicircuit line.

Most multicircuit lines have two parallel operating circuits, as shown in figure 41. The application guide mentioned below recommends in more detail the setting practice for this particular type of line. The basic principles also apply to other multicircuit lines. The Application Guide on Protection of Complex Transmission Network Configurations describes the problems in more detail. The CIGRE Working Group 04 of Study Committee 34 (Protection), published the guide in November 1991.

Zm0 in figure 41 represents the zero-sequence mutual-coupling impedance between circuits of a double-circuit, parallel operating line.

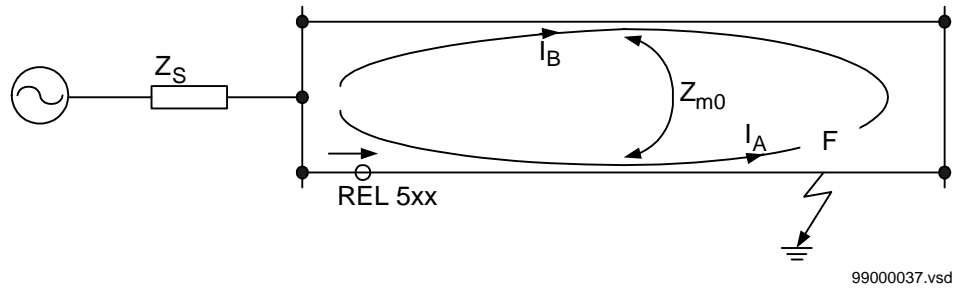

Figure 41: Double-circuit parallel operating line

**The parallel circuit disconnected and earthed at both ends**

Figure 42 represents an equivalent zero-sequence impedance circuit for the double-circuit parallel operating line. Input terminals A and B are related to the input terminals of each circuit close to the busbar A in figure 41. Terminal C is related to the F fault point, moved towards the B busbar.

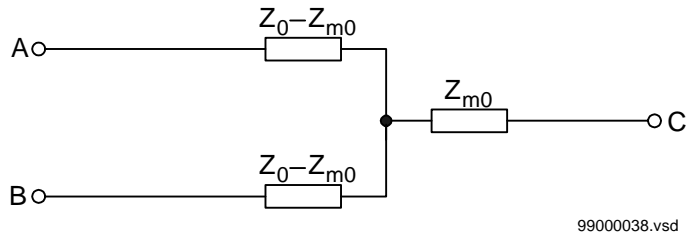

Figure 42: Equivalent zero sequence impedance circuit of the double-circuit, parallel, operating line with a single phase-to-earth fault at the remote busbar

The distance protection overreaches for single-phase-to-earth faults on the protected line when the parallel circuit is disconnected and earthed on both ends. The equivalent zero-sequence impedance circuit gets the configuration as in figure 43.

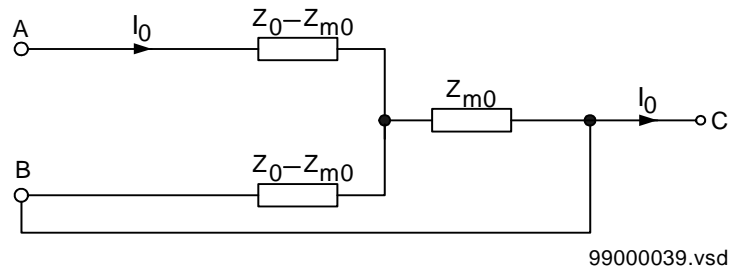

Figure 43: Equivalent zero-sequence impedance circuit for the double-circuit line that operates with one circuit disconnected and earthed at both ends

Here the equivalent zero-sequence impedance is equal to:

$$\bar{Z}_{0E} = \frac{\bar{Z}_0^2 - \bar{Z}_{m0}^2}{\bar{Z}_0}$$

(Equation 48)

This influences the value of the total loop impedance as measured by the distance-protection function, thus causing it to overreach. It is necessary to compensate for this overreaching by setting the compensated zero-sequence impedance for the particular underreaching zone.

All expressions below are proposed for practical use. They assume the value of zero-sequence, *mutual resistance*  $R_{m0}$  equals to zero. They consider only the zero-sequence, mutual reactance  $X_{m0}$ .

Calculate the equivalent  $X_{0E}$  and  $R_{0E}$  zero-sequence parameters according to the equations below for each particular line section and set them for the particular underreaching zone of distance protection function.

$$R_{0E} = R_0 \cdot \left( 1 + \frac{X_{m0}^2}{R_0^2 + X_0^2} \right)$$

(Equation 49)

$$X_{0E} = X_0 \cdot \left( 1 - \frac{X_{m0}^2}{R_0^2 + X_0^2} \right)$$

(Equation 50)

### The parallel circuit out of service and not earthed

When the parallel circuit is out of service and not earthed, it has the equivalent zero-sequence impedance circuit for faults at the remote busbar as shown in figure 44. The line zero-sequence mutual impedance does not influence the measurement of the distance protection in a faulty circuit. This means that the reach of the underreaching distance-protection zone is reduced if, due to operating conditions, the equivalent zero-sequence impedance is set according to the conditions when the parallel system is out of operation and earthed at both ends.

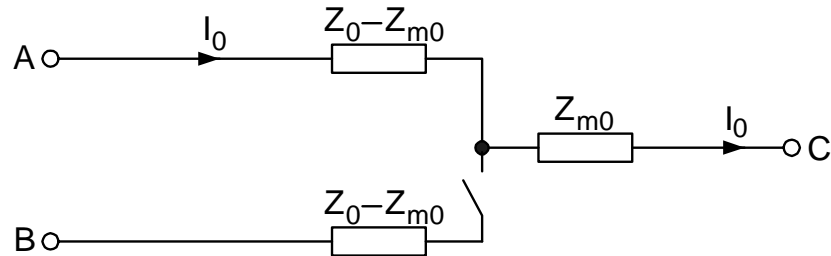

99000040.vsd

Figure 44: Equivalent zero-sequence impedance circuit for a double-circuit line with one circuit disconnected and not earthed

The reduction of the reach is equal to:

$$\bar{K}_U = \frac{\frac{1}{3} \cdot (2 \cdot \bar{Z}_1 + \bar{Z}_{0E}) + R_f}{\frac{1}{3} \cdot (2 \cdot \bar{Z}_1 + \bar{Z}_0) + R_f} = 1 - \frac{\bar{Z}_{m0}^2}{\bar{Z}_0 \cdot (2 \cdot \bar{Z}_1 + \bar{Z}_0 + 3R_f)}$$

(Equation 51)

This means that the reach is reduced in reactive and resistive directions. If the real and imaginary components of the constant  $A$  are equal to:

$$\operatorname{Re}(\bar{A}) = R_0 \cdot (2 \cdot R_1 + R_0 + 3 \cdot R_f) - X_0 \cdot (2 \cdot X_1 + X_0) \quad (\text{Equation 52})$$

$$\operatorname{Im}(\bar{A}) = X_0 \cdot (2 \cdot R_1 + R_0 + 3 \cdot R_f) + R_0 \cdot (2 \cdot X_1 + X_0) \quad (\text{Equation 53})$$

The real component of the KU factor is equal to:

$$\operatorname{Re}(\bar{K}_U) = 1 + \frac{\operatorname{Re}(\bar{A}) \cdot X_{m0}^2}{[\operatorname{Re}(\bar{A})]^2 + [\operatorname{Im}(\bar{A})]^2} \quad (\text{Equation 54})$$

The imaginary component of the same factor is equal to:

$$\operatorname{Im}(\bar{K}_U) = \frac{\operatorname{Im}(\bar{A}) \cdot X_{m0}^2}{[\operatorname{Re}(\bar{A})]^2 + [\operatorname{Im}(\bar{A})]^2} \quad (\text{Equation 55})$$

Ensure that the underreaching zones from both line ends will overlap a sufficient amount (at least 10%) in the middle of the protected circuit.

#### Parallel circuit in service

The zero-sequence mutual coupling can reduce the reach of distance protection on the protected circuit when the parallel circuit is in normal operation. The reduction of the reach is most pronounced with no infeed in the line terminal closest to the fault. This reach reduction is normally less than 15%. But when the reach is reduced at one line end, it is proportionally increased at the opposite line end. So this 15% reach reduction does not significantly affect the operation of a permissive underreach scheme.

#### Setting of the overreaching zones

Overreaching zones (in general, zones 2 and 3) must overreach the protected circuit in all cases. The greatest reduction of a reach occurs in cases when both parallel circuits are in service with a single-phase-to-earth fault located at the end of a protected line. The equivalent zero-sequence impedance circuit for this case is equal to the one in figure 42.

The components of the zero-sequence impedance for the overreaching zones must be equal to at least:

$$R_{0E} = R_0 + R_{m0} \quad (\text{Equation 56})$$

$$X_{0E} = X_0 + X_{m0} \quad (\text{Equation 57})$$

Check the reduction of a reach for the overreaching zones due to the effect of the zero-sequence mutual coupling. The reach is reduced for a factor:

$$\bar{K}_0 = 1 - \frac{\bar{Z}_{m0}}{2 \cdot \bar{Z}_1 + \bar{Z}_0 + \bar{Z}_{m0} + 3R_f} \quad (\text{Equation 58})$$

If the real and imaginary components of the B constant are equal to:

$$\text{Re}(\bar{B}) = 2 \cdot R_1 + R_0 + R_{m0} + 3 \cdot R_f \quad (\text{Equation 59})$$

$$\text{Im}(\bar{B}) = 2 \cdot X_1 + X_0 + X_{m0} \quad (\text{Equation 60})$$

The real and the imaginary value of the reach reduction factor for the overreaching zones are equal to:

$$\text{Re}(\bar{K}_0) = 1 - \frac{X_{m0} \cdot \text{Im}(\bar{B})}{[\text{Re}(\bar{B})]^2 + [\text{Im}(\bar{B})]^2} \quad (\text{Equation 61})$$

$$\operatorname{Im}(\overline{K_0}) = \frac{-X_{m0} \cdot \operatorname{Re}(\overline{B})}{[\operatorname{Re}(\overline{B})]^2 + [\operatorname{Im}(\overline{B})]^2}$$

(Equation 62)

**Use of different setting groups on double circuit lines**

Each of the REx 5xx line-protection terminals has a built-in possibility for setting and activating four different groups of setting parameters according to the system conditions. Different setting groups can also suit different operating conditions of a multicircuit, parallel operating line.

The advantage of such an approach is a better coverage of the line during normal and abnormal operating conditions.

**The parallel circuit out of operation with both ends earthed**

Apply the same measures as in the case with a single set of setting parameters. This means that an underreaching zone must not overreach the end of a protected circuit for the single-phase-to-earth faults. Set the values of the corresponding zone (zero-sequence resistance and reactance) equal to:

$$R_{0E} = R_0 \cdot \left( 1 + \frac{X_{m0}^2}{R_0^2 + X_0^2} \right)$$

(Equation 63)

$$X_{0E} = X_0 \cdot \left( 1 - \frac{X_{m0}^2}{R_0^2 + X_0^2} \right)$$

(Equation 64)

**Double-circuit parallel line in normal operation**

Normally, the underreaching zone of distance protection underreaches for the single-phase-to-earth faults located closer to the opposite end of the circuit. To overcome this underreaching and trip without a sequential tripping for the faults along the greatest possible percentage of a line, increase the value of the equivalent zero-sequence impedance to the one also recommended for the overreaching zones. This means that the values of the equivalent zero-sequence resistance and reactance are equal to:



$$R_{0E} = R_0 + R_{m0}$$

(Equation 65)

$$X_{0E} = X_0 + X_{m0}$$

(Equation 66)

### Overreaching distance protection zones

The same rules apply to the overreaching zones as in cases with a single set of setting parameters. Ensure that they will always overreach. So increase the setting of the zero-sequence resistance and reactance to the values that correspond to at least:

$$R_{0E} = R_0 + R_{m0}$$

(Equation 67)

$$X_{0E} = X_0 + X_{m0}$$

(Equation 68)

In many cases, it is sufficient if the influence of the zero-sequence mutual impedance is compensated only in the first overreaching zone (generally, zone 2). The setting of the back-up overreaching zones (zone 3 and higher) is usually so high that no such compensation is necessary.

Instructions for overreaching zones are applicable for normal network configurations. Always reconsider their settings if any special lines or other elements (cables, power transformers, etc.) follow the double-circuit, parallel operating line.

Pay special attention to the distance protection of double-circuit, parallel operating multiterminal or tapped lines.

### Setting of the reach in resistive direction

Set the resistive reach independently for each zone, and separately for phase-to-phase, and phase-to-earth loop measurement.

Set separately the expected fault resistance for phase-to-phase faults (RFPP) and for the phase-to-earth faults (RFPE) for each zone. Set all remaining reach setting parameters independently of each other for each distance zone.

The final reach in resistive direction for phase-to-earth fault loop measurement automatically follows the values of the line-positive and zero-sequence resistance, and at the end of the protected zone is equal to:

$$R = \frac{1}{3}(2 \cdot R_{1Zn} + R_{0Zn}) + R_{FNZn} \quad (\text{Equation 69})$$

The blinder in the resistive direction forms an angle with the R-axis equal to:

$$\varphi_{\text{loop}} = \arctan \frac{2 \cdot X_1 + X_0}{2 \cdot R_1 + R_0} \quad (\text{Equation 70})$$

Setting of the resistive reach for the underreaching zone 1 should follow the condition:

$$R_{FPE} \leq 4.5 \cdot X_{1PE} \quad (\text{Equation 71})$$

The fault resistance for phase-to-phase faults is normally quite low, compared to the fault resistance for phase-to-earth faults. Limit the setting of the zone 1 reach in resistive direction for phase-to-phase loop measurement to:

$$R_{FZ1} \leq 3 \cdot X_{1Z1} \quad (\text{Equation 72})$$

### Load impedance limitation

Check the maximum permissible resistive reach for any zone to ensure that there is a sufficient setting margin between the relay boundary and the minimum load impedance.

The minimum load impedance [ $\Omega$ /phase] is calculated as:

$$Z_{\text{loadmin}} = \frac{U^2}{S} \quad (\text{Equation 73})$$

Where:

U is the minimum phase-to-phase voltage in kV

S is the maximum apparent power in MVA

The load impedance [ $\Omega$ /phase] is a function of the minimum operation voltage and the maximum load current:

$$Z_{\text{load}} = \frac{U_{\text{min}}}{\sqrt{3} \cdot I_{\text{max}}}$$

(Equation 74)

Minimum voltage  $U_{\text{min}}$  and maximum current  $I_{\text{max}}$  are related to the same operating conditions. Minimum load impedance occurs normally under emergency conditions.



**Note!**

*Because a safety margin is required to avoid load encroachment under three-phase conditions and to guarantee correct healthy phase relay operation under combined heavy three-phase load and earth faults, consider both: phase-to-phase and phase-to-earth fault operating characteristics.*

To avoid load encroachment for the phase-to-earth measuring elements, the set resistive reach of any distance protection zone must be less than 80% of the minimum load impedance.

$$RFPE \leq 0.8 \cdot Z_{\text{load}}$$

(Equation 75)

This equation is applicable only when the loop characteristic angle for the single-phase-to-earth faults is more than three times as large as the maximum expected load-impedance angle. More accurate calculations are necessary according to the equation below:

$$RFPE \leq 0.8 \cdot Z_{\text{loadmin}} \cdot \left[ \cos \vartheta - \frac{2 \cdot R_{1PE} + R_{0PE}}{2 \cdot X_{1PE} + X_{0PE}} \cdot \sin \vartheta \right]$$

(Equation 76)

Where

$\vartheta$  is a maximum load-impedance angle, related to the minimum load impedance conditions.

To avoid load encroachment for the phase-to-phase measuring elements, the set resistive reach of any distance protection zone must be less than 160% of the minimum load impedance.

$$RFPP \leq 1.6 \cdot Z_{loadr}$$

(Equation 77)

This equation is applicable only when the loop characteristic angle for the phase-to-phase faults is more than three times as large as the maximum expected load-impedance angle. More accurate calculations are necessary according to the equation below:

$$RFPP \leq 1.6 \cdot Z_{loadmin} \cdot \left[ \cos\vartheta - \frac{R1PP}{X1PP} \cdot \sin\vartheta \right]$$

(Equation 78)

All this is applicable for all measuring zones when no power swing detection element is in the protection scheme. Use an additional safety margin in cases when a power-swing detection element is in the protection scheme; see document “Power swing detection”.

### Setting of minimum operating current

Minimum operating fault current  $I_{MinOp}$  defines the sensitivity of the distance protection as built in REx 5xx terminals. Default setting value, which is 20% of basic terminal current, proved in practice as the optimum value for the most of applications.

Sometimes it is necessary to increase the sensitivity by reducing the minimum operating current down to 10% of terminal basic current. This happens especially in cases, when the terminal serves as a remote back-up protection on series of very long transmission lines.

The minimum operating fault current is automatically reduced to 75% of its set value, if the distance protection zone has been set for the operation in reverse direction.

### Setting of timers for the distance protection zones

The required time delays for different distance-protection zones are independent of each other. Distance protection zone 1 can also have a time delay, if so required for selectivity reasons. One can set the time delays for all zones (basic and optional) in a range of 0 to 60 seconds. The tripping function of each particular zone can be inhibited by setting the corresponding Operation parameter to Off. Different time delays are possible for the ph-E (tnPE, n = 1...5) and for the ph-ph (tnPP, n = 1...5) measuring loops in each distance protection zone separately, to further increase the total flexibility of a distance protection.

### Setting the directional lines

ArgDir and ArgNegRes setting parameters define the position of the directional lines in impedance plane (see figure 45). Their default values are  $15^\circ$  and  $25^\circ$  respectively and should not be changed unless the simulation studies for the application on very long and heavily loaded transmission lines show the need to change them accordingly.

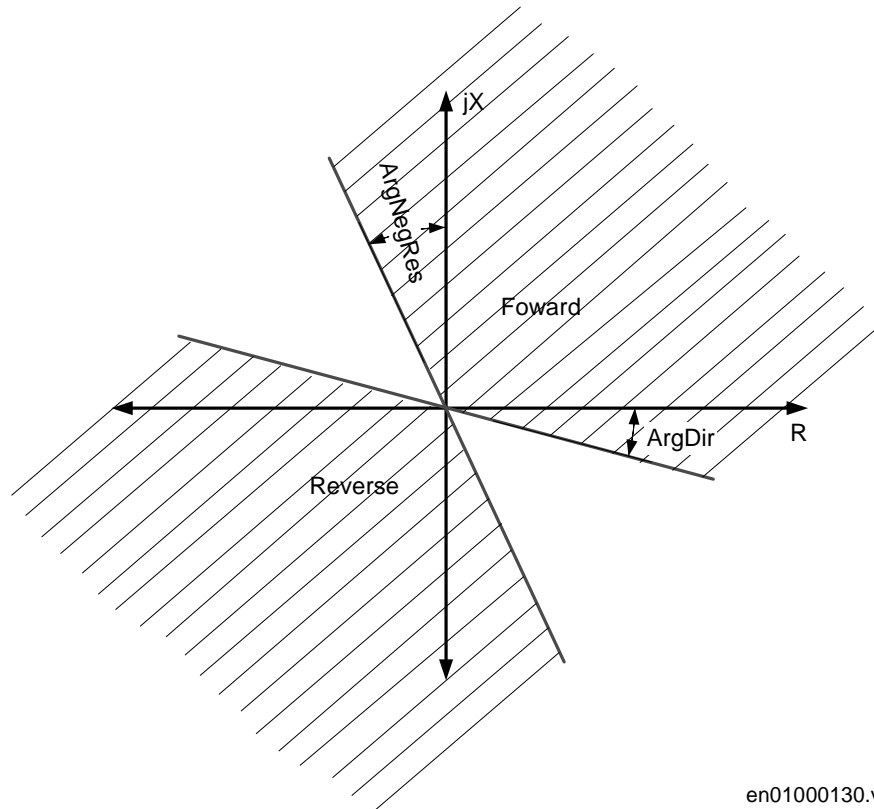

en01000130.vsd

Figure 45: Directional lines define the forward and reverse operating area for each distance protection zone

### Simplified operating characteristic

Distance protection operating characteristic follows with its reach in resistive direction automatically the line characteristic angle. The R1PP setting parameter influences the line characteristic angle for the phase-to-phase measurement while R1PE and R0PE influence the characteristics for the phase-to-earth faults.

The operating characteristic for phase-to-phase faults becomes independent on line characteristic angle when RFPP is set to its minimum possible value (0.1 ohm for terminals with rated current  $I_r = 1A$  and 0.02 ohm for terminals with rated current  $I_r = 5A$ ). Similarly becomes independent the operating characteristic for phase-to-earth faults, when R1PE and R0PE are set to their minimum values. In such case it is necessary to consider the reduction of a fault resistance coverage for the faults at the end of the protection zone. The simplified operating characteristic is schematically presented on

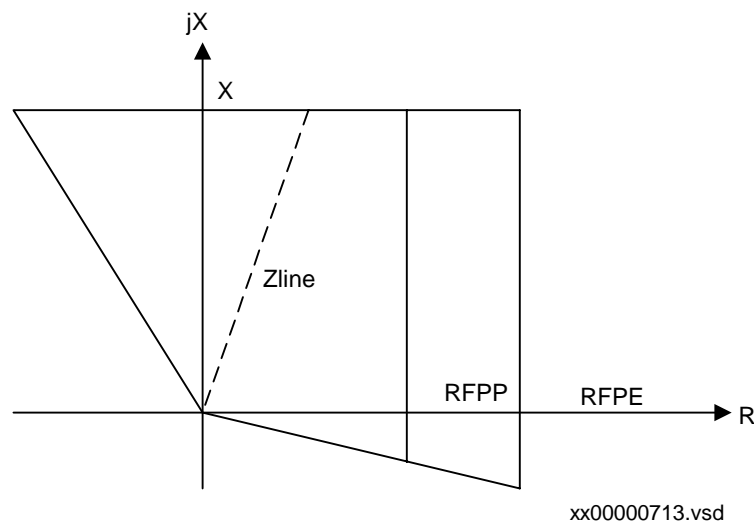

Figure 46: Simplified operating characteristic with R1PP or (R1PE and R0PE) or (R1 and R0 with simplified setting parameters) are set to their minimum values

### Set of simplified setting parameters

All statements presented under this subject apply also in case when the set of simplified setting parameters has been ordered instead of a complete set. It is only necessary to consider the fact, that in this case the reactive reach setting is equal for the phase-to-phase as well as for the phase-to-earth measuring elements. This way the setting parameter X1 replaces the parameters X1PP and X1PE. Similarly replaces X0 the X0PE parameter.

---

## 1.5 Configuration

### 1.5.1 Basic configuration

Each distance protection zone comprises different functional inputs, which influence its operation in different ways.

#### **ZMn--BLOCK functional input**

Logical one on ZMn--BLOCK functional input blocks completely the operation of the distance protection zone. The input should be connected to the functional outputs of those protection and logic functions, which are supposed to block instantaneously and completely the operation of the zone. Functional output PSD--START of the power swing detection function is a typical example.

#### **ZMn--VTSZ functional input**

The operation of the distance protection function must be blocked in cases of different faults within the secondary voltage measuring circuits. The ZMn-VTSZ functional input should be configured to the functional output FUSE-VTSZ of the fuse-failure supervision function or to the binary inputs of a terminal, connected to the output contacts of external fuse-failure relays and MCBs.

#### **ZMn--BLKTR functional input**

The ZMn--BLKTR functional input blocks only the tripping function of each particular distance protection zone, but it does not block its measurement and starting output signals. It is possible to use it in different cases together with internal logic circuits for different application purposes.

#### **ZMn--STCND functional input**

The ZMn--STCND functional input brings into each distance protection zone information on external measuring conditions, which influence the zone operation. It is necessary to configure it to one of the following functional outputs within the terminal:

- PHS--STCNDI functional output of the phase selection function. The operation of the distance protection zone depends in this case only on the fault current conditions, as used for the operation of the phase selection elements (see the document “Phase selection for distance protection”).
- PHS--STCNDZ functional output of the phase selection function. The operation of the distance protection depends in this case on the operation of different phase selection elements for a particular fault. The fault must be seen by the phase selection impedance measuring elements, to release the operation of the distance protection zone (see the document “Phase selection for distance protection”).
- GFC--STCND functional output of the general fault criteria (GFC). The operation of a particular distance protection zone is released only, if the fault has been detected also within the operating characteristic of a GFC element (see the document “General fault criteria”).
- FIXD-INTONE functional integer output signal. The operation of a particular distance protection function does not depend in this case on any external current or impedance measuring condition. All measuring loops are permitted to operate only on the basis of the measured impedance for a particular fault conditions.

#### **ZMn--START functional output**

The ZMn--START functional output becomes logical one at any detection of the measured impedance within a particular distance protection zone. It is not time delayed. It is possible to configure it as an input signal to the scheme communication logic (as a carrier send signal) or for a signalling purposes.

Phase selective starting signals (ZMn--STL1, ZMn--STL2, and ZMn--STL3) are available in units with built-in single pole tripping function. They have the same functionality as the general starting signal ZMn--START with the addition, that they always relate to a specific faulty phase.

#### **ZMn--TRIP functional output**

The ZMn--TRIP functional output represents a time delayed operation of a particular distance protection zone. It is generally used for tripping purposes. It is also possible to configure the trip output signals of time-delayed distance protection zones to the inhibit conditions of the autoreclosing function, when used within the terminal.

Phase selective tripping signals (ZMn--TRL1, ZMn--TRL2, and ZMn--TRL3) are available in units with built-in single pole tripping function. They have the same functionality as the general tripping signal ZMn--TRIP with the addition, that they always relate to a specific faulty phase.



**ZMn--STND functional output**

Informs about the non-directional start of the distance protection zone (see figure in “Basic characteristics”). It is possible, among others, to configure it to the functional input SOTF-NDACC functional input of the switch-onto-fault function.

## 2 Automatic switch onto fault logic (SOTF)

### 2.1 Application

The switch-onto-fault function is a complementary function to the distance protection function (ZMn--) and to the high-speed protection function (HS---).

With the switch-onto-fault (SOTF-) function, a fast trip is achieved for a fault on the whole line, when the line is being energized. The SOTF tripping is generally non-directional in order to secure a trip at a nearby three-phase fault when a line potential transformer is used.

Automatic activation can be used only when the potential transformer is situated on the line side of a circuit breaker.

### 2.2 Functionality

The switch-onto-fault function can be activated either externally or automatically, internally, by using the information from a dead-line-detection (DLD) function (see figure 47).

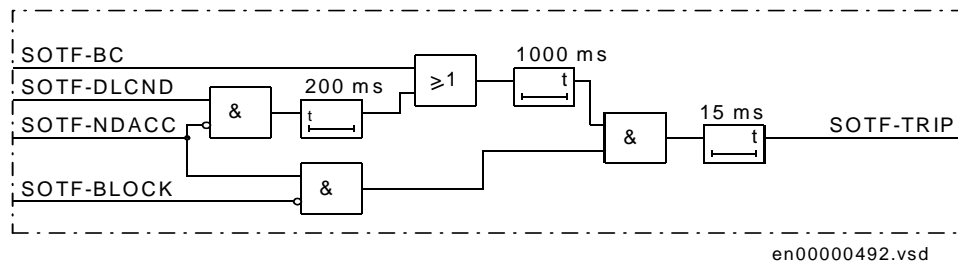

Figure 47: SOTF function - simplified logic diagram

After activation, a distance protection zone (usually its non-directional starting signal) is allowed to give an instantaneous trip. The functional output signal ZMn--STND (n represents the corresponding zone number) should be connected to the SOTF-NDACC functional input of the SOTF function, see figure 47. The distance protection zone used together with the switch-onto-fault function shall be set to cover the entire protected line. Always use distance protection zone 5 as a criteria for the SOTF function, if the high-speed protection function is used in the REx 5xx line protection terminal. It is also suggested to use the distance protection zone 5, when faster operation of SOTF function is required. The non-directional instantaneous condition is maintained for 1 s after closing the line circuit breaker.

The external activation is achieved by an input (SOTF-BC), which should be set high for activation, and low when the breaker has closed. This is carried out by an NC auxiliary contact of the circuit breaker or by the closing order to the breaker.

The internal automatic activation is controlled by the DLD function and its functional output DLD--START. The DLD--START functional output is activated when all three phase voltages and phase currents have been below their set operate values. The DLD--START functional output is usually configured to the SOTF-DLCND functional input. It activates the operation of the SOTF function, if present for more than 200 ms without the presence of a non-directional impedance starting signal SOTF-NDACC.

Operation of a SOTF function can be blocked by the activation of a SOTF-BLOCK functional input.

## 2.3

### Calculations

#### 2.3.1

#### Setting instructions

The operation of a switch-onto-fault function is set in the menu tree:

**Settings**  
**Functions**  
**Group n (n=1-4)**  
**Impedance**  
**SwitchOntoFlt**

The low voltage and low current criteria for automatic activation is settable under the DLD-- function under the menu tree:

**Settings**  
**Functions**  
**Group n (n=1-4)**  
**DeadLineDet**

This setting is not critical as long as it is lower than the lowest operation voltage during normal and emergency conditions.

The distance protection zone used for a switch-onto-fault criterion (SOTF zone) have to be set to cover the entire protected line with a safety margin of minimum 20%.

## 3 Local acceleration logic (ZCLC)

### 3.1 Application

To achieve fast clearing of faults on the whole line, also in cases where no communication channel is available, local acceleration logic is used. This logic enables fast fault clearing during certain conditions, but naturally, it can not fully replace a communication channel.

The logic can be controlled either by the auto-recloser (zone extension) or by the loss of load current (loss-of-load acceleration).

### 3.2 Functionality

#### Zone extension

When the auto-recloser controls the function, a signal “auto-recloser ready” (ZCLC-ARREADY) allows an overreaching zone (ZCLC-EXACC) to trip instantaneously (see figure 48). For this reason, configure the ZCLC-ARREADY functional input to a AR0n-READY functional output of a used auto-reclosing function or via the selected binary input to an external autoreclosing device.

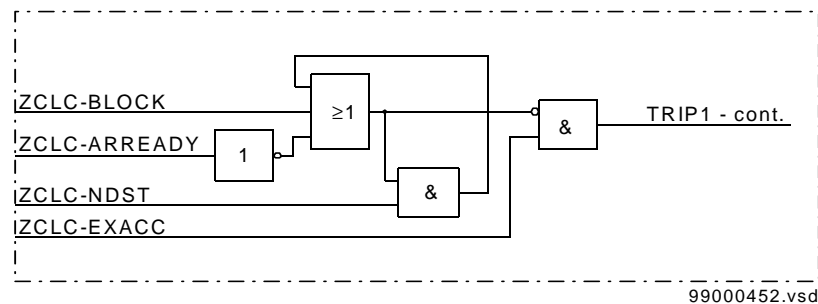

Figure 48: Simplified logic diagram for the local acceleration logic

After the auto-recloser initiates the close command and remains in the reclaim state, there will be no ZCLC-ARREADY signal, and the protection will trip normally with step distance time functions. In case of a fault on the adjacent line within the overreaching zone range, an unwanted auto-reclosing cycle will occur. The step distance function at the reclosing attempt will prevent an unwanted retrip when the breaker is reclosed. On the other hand, at a persistent line fault on line section not covered by instantaneous zone (normally zone 1) or on adjacent line, only the first trip will be “instantaneous”.

**Loss-of-load acceleration**

When the “acceleration” is controlled by a loss of load, the overreaching zone used for “acceleration” (ZCLC-LLACC) is not allowed to trip “instantaneously” during normal non-fault system conditions. When all three-phase currents have been  $>10\%$  of  $I_r$  for more than 35 ms, an overreaching zone will be allowed to trip “instantaneously” during a fault condition when one or two of the phase currents will become low due to a three-phase trip at the opposite terminal, see figure 49. The current measurement is performed internally in one of the built-in digital signal processors and the STILL signal becomes logical one under the described conditions. The load current in a healthy phase is in this way used to indicate the tripping at the opposite terminal. Note that this function will not operate in case of three-phase faults, because none of the phase currents will be low when the opposite terminal is tripped.

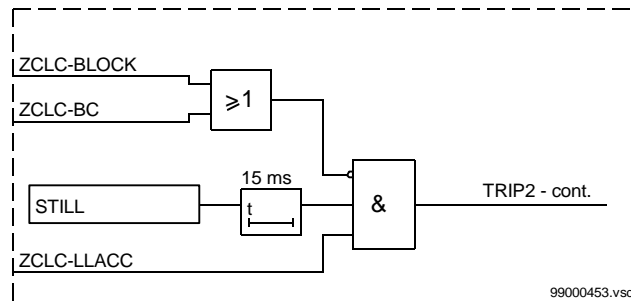

Figure 49: Loss-of-load acceleration - simplified logic diagram

**3.3****Calculations****3.3.1****Setting instructions**

The operation of the local acceleration functions is set in the menu under:

**Setting****Functions****Group n (n=1-4)****Impedance****ComLocal**

To allow the “overreaching” trip controlled by the auto-recloser at earth-faults only, the zone used for this function can be set with a normal reach of 85% for phase-to-phase faults, but with an increased X1PE and X0PE setting that gives an overreach for earth-faults. This setting generally excludes the use of this zone for any purpose other than local acceleration logic.

---

## 4 General fault criteria (GFC)

### 4.1 Application

General fault criterion is a basic function in line protection terminals REL 501 and REL 511 as well as in their C-series variants. The following description is relevant for all of them, with the exception of all functionality for the earth-faults related to REL 501 and its C-series variants. It is also possible to apply it to different other, customer specific REx 5xx terminals. Please, check the ordering details for each specific terminal.

The distance protection function remains the most widely used protection function in all networks. It is a common practice to have two line protection units installed on the transmission, and in many cases also on the subtransmission lines, to achieve a sufficient degree of availability for the selected protection system. The remote back-up protection systems play an important, but not essential role.

A different type of practice is applied in distribution and in certain subtransmission networks. Here, the economical reasons dictate the use of a single line protection at each line end. If it is a line differential protection, which depends very much on the availability of a communication link, it is necessary to add a relative selective protection scheme (distance protection), either locally as a local backup, or also on all the adjacent lines, as a remote back-up.

Therefore, the security of the used protection schemes is very important. Many utilities require that two different measuring elements - which must operate for the same fault - are built into the existing distance relays.

- The first one is generally an overall impedance measuring element with a very high reach and a long time delay for its tripping function. Since many older distance relays used for these purposes are switched scheme relays and these overall measuring elements are used for the course detection of a fault type and starting the zone measurement and related timers, they are called starting elements.
- The second measuring element must measure impedance in the fault loop more precisely, according to the selectivity planning in the network. In the existing protection schemes, these measuring relays are called measuring elements, and usually only one of them is built into each of the conventional distance relays.

---

The distance protection, as built into the REx 5xx line protection terminals, is a full scheme distance protection (see the document “Distance protection”). This means that it has separate and independent measurement for each separate fault loop in each respective distance protection zone. Besides the full scheme design, separate measuring elements can be added to perform the functions of the overall measuring elements in the existing protection schemes. They determine only whether there is a fault in the bigger part of a network around the terminal. They are therefore called “General fault criteria” elements (GFC).

The underimpedance based GFC function has an advanced operate characteristic as presented principally in figure 50. The overcurrent based GFC function has built-in separate phase and residual current measuring elements. It is also possible to use both the underimpedance and overcurrent criteria at the same time. Please, refer to the ordering particulars for each terminal separately for more details about the included options.

Settings of the reach for impedance based GFC elements are independent of each other to the greatest possible extent. It is therefore possible to set the reactive reach in reverse direction independent of the one in forward direction. It is also possible to set different reactive reach for the phase-to-phase and for the phase-to-earth measurement. The zero-sequence reactance for the setting of the reach in forward and reverse direction can differ from one another. The algorithm calculates automatically the earth return compensation according to the set values.



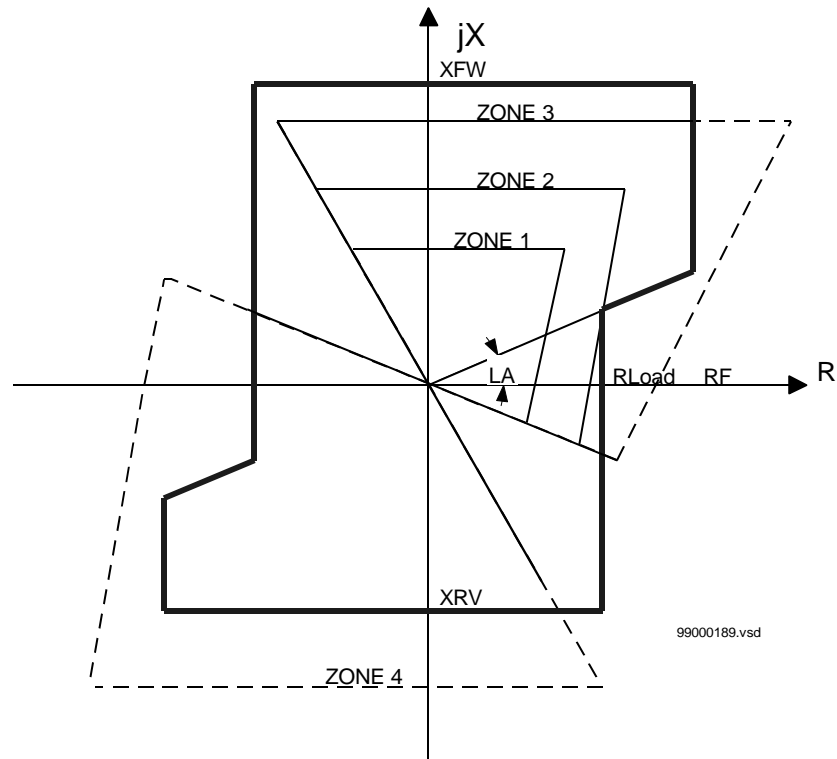

*Figure 50: Operating characteristics of the GFC (impedance measuring principle) and zone measuring elements*

Figure 50 presents principally a shaped operate characteristic for an impedance based GFC function. Different designations have the following meaning:

- XFW: reactive reach in forward direction
- XRV: reactive reach in reverse direction
- RF: resistive reach within the unlimited area
- RLoad: resistive reach restricted by the minimum load impedance
- LA: expected load impedance angle

The setting of the resistive reaches is independent of that of the reactive reaches. It is possible to have the resistive reach different for phase-to-earth (ph - E) and phase-to-phase (ph-ph) or three-phase faults. To make the GFC function as sensitive as possible to faults with higher fault resistances, a separate setting of the reach in resistive direction in the possible load impedance area has been introduced. In addition to this, a characteristic is also adaptable to the possible load impedance with a settable load impedance angle.

## 4.2

### Functionality

#### Impedance measuring elements

The basic algorithm for the operation of the impedance based GFC is the same as that for the distance protection measuring function (see section “Distance protection”). The difference, compared to the zone-measuring elements, is in the combination of the measuring quantities (currents and voltages) for different types of faults.

#### Measuring elements for the ph-E faults

The GFC elements for the ph-E faults measure the impedance according to the following equation:

$$\overline{Z}_{MLn} = \frac{\overline{U}_{Ln}}{\overline{I}_{Ln} \cdot (1 + K_{NF})}$$

(Equation 79)

Where:

$\overline{U}_{Ln}$  is a phasor of measured voltage in phase Ln

$\overline{I}_{Ln}$  is a phasor of measured current in phase Ln

$K_{NF}$  is an earth return compensation factor, calculated automatically according to the equation:

$$K_{NF} = \frac{X0FwPE - X1FwPE}{3 \cdot X1FwPE}$$

(Equation 80)

Where:

$X1FwPE$  and  $X0FwPE$  are the reactive reach setting parameters for forward direction.

A separate earth return compensation is calculated according to similar formula with the reactive reach setting parameters for reverse direction,  $X1RvPE$  and  $X0FwRv$  respectively.

The operation of the corresponding measuring loop occurs, when the following conditions are satisfied.

$$\text{Im}(\overline{Z_{MLn}}) < X1FwPE \quad (\text{Equation 81})$$

and

$$X1RvPE < \text{Im}(\overline{Z_{MLn}}) \quad (\text{Equation 82})$$

as well as:

$$\left| \text{Re}(\overline{Z_{MLn}}) \right| < \frac{RFPE}{1+K_{NF}} \quad (\text{Equation 83})$$

The resistive reach is limited within the load impedance area, which is defined by the load angle  $ARGLd$ . The resistive reach conditional equation changes in this case to:

$$\left| \text{Re}(\overline{Z_{MLn}}) \right| < \frac{RLd}{1+K_{NF}} \quad (\text{Equation 84})$$

Where:

$R_{Ld}$  is a set resistive reach within the load impedance area.

Besides this, the relation between the measured currents must correspond to the following conditions:

$$I_{ph} > 0.5 \cdot I_{MinOp} \quad (\text{Equation 85})$$

and

$$3 \cdot I_0 > 0.5 \cdot I_{MinOp} \quad (\text{Equation 86})$$

and

$$3 \cdot I_0 > \frac{IN_{ReleasePE}}{100} \cdot I_{phmax} \Rightarrow IN1 \quad (\text{Equation 87})$$

Where:

$I_{MinOp}$  is the set value of a minimum operating current for the distance protection

$I_{phmax}$  is a maximum current among all three phase currents.

$IN_{ReleasePE}$  is the setting for the minimum residual current needed to enable operation in the ph-E fault loops (in %)

$IN1$  is a corresponding logic signal.

### Measuring elements for ph-ph and three-phase faults

The GFC elements for the ph-ph faults measure the impedance according to the equation

$$\overline{Z_{MLmLn}} = \frac{\overline{U_{Lm}} - \overline{U_{Ln}}}{\overline{I_{Lm}} - \overline{I_{Ln}}}$$

(Equation 88)

The operation occurs under the following conditions:

$$\text{Im}(\overline{Z_{MLmLn}}) < X1FwPP$$

(Equation 89)

and

$$X1RvPP < \text{Im}(\overline{Z_{MLmLn}})$$

(Equation 90)

as well as:

$$|\text{Re}(\overline{Z_{MLmLn}})| < \frac{RFPE}{1+K_{NF}}$$

(Equation 91)

Where:

X1FwPP	is a forward reactive reach for the phase-to-phase measurement
X1RvPP	is a reverse reactive reach for the phase-to-phase measurement
RFPP	is an unlimited resistive reach for the phase-to-phase measurement

The resistive reach is limited within the load impedance area, which is defined by the load angle  $ARGLd$ . The resistive reach conditional equation changes in this case to:

$$|\text{Re}(\overline{Z_{MLmLn}})| < \frac{RLd}{2}$$

(Equation 92)

Besides this, the relation between the measured currents must correspond to the following conditions:

$$I_{\text{ph-ph}} > I_{\text{MinOp}} \quad (\text{Equation 93})$$

and

$$3 \cdot I_0 < (0, 2 \cdot I_r) \quad (\text{Equation 94})$$

or

$$3 \cdot I_0 < \frac{\text{INBlockPP}}{100} \cdot I_{\text{phmax}} \Rightarrow \text{IN2} \quad (\text{Equation 95})$$

$I_r$  is the rated current of the terminal and IN2 is a corresponding logic signal.  $I_{\text{phmax}}$  is the maximum current of all three phase currents. INBlockPP is the setting for the residual current level below which operation of the ph-ph fault loops is allowed.  $I_{\text{ph-ph}}$  is a difference of phase currents in observed faulty phases.

### Current-based GFC elements

The current-based GFC measuring elements measure continuously three phase currents and the residual current, comparing them with the set values. Fourier's recursive filter filters the current signals, and a separate trip counter prevents too high overreaching of the measuring elements.

If  $I_{\text{lim}}$  is a set value of the operating current for the phase measuring elements (designated by I> in the terminal), and  $I_{\text{Nlim}}$  for the measuring element that measures the residual current (designated by IN> in the terminal), the operating conditions are as follows:

$$I_{L1} > I_{\text{lim}} \Rightarrow \text{IL1} \quad (\text{Equation 96})$$

for the phase L1 current measuring element

$$I_{L2} > I_{lim} \Rightarrow IL2$$

(Equation 97)

for the phase L2 current measuring element

$$I_{L3} > I_{lim} \Rightarrow IL3$$

(Equation 98)

for the phase L3 current measuring element

$$3 \cdot I_0 > I_{Nlim} \Rightarrow IN$$

(Equation 99)

for the residual current measuring element

where  $IL_n$  and  $IN$  are corresponding logical signals.

### 4.3

#### Design

A separate digital signal processor, independent of the zone measuring elements, performs the measurement for the general fault criteria. The built-in logic follows the following Boolean equations:

$$GFCL1 = I > \cdot IL1 + Z < \cdot IN1 \cdot ZML1 + Z < \cdot IN2 \cdot (ZML1L2 + ZML1L3)$$

(Equation 100)

$$GFCL2 = I > \cdot IL2 + Z < \cdot IN1 \cdot ZML2 + Z < \cdot IN2 \cdot (ZML2L3 + ZML1L2)$$

(Equation 101)

$$GFCL3 = I > \cdot IL3 + Z < \cdot IN1 \cdot ZML3 + Z < \cdot IN2 \cdot (ZML3L1 + ZML2L3)$$

(Equation 102)

$$GFCN = I> \cdot IN + Z< \cdot IN1 \cdot ZML1 + ZML2 + ZML3$$

(Equation 103)

Where:

Z< represents active underimpedance mode of operation (setting)

I> represents active overcurrent mode of operation (setting)

Later on, the signals produced by the GFC measuring elements serve for different parts of the distance protection. These are:

- indication of the faulty phases
- phase selection for the zone measuring elements
- general criteria for the operation of the trip logic
- time delayed trip as a backup function to the zone measuring elements
- phase preference logic, when included in a terminal

Figure 51 presents basic logic circuits dealing with current conditions for the detection of ph-E and ph-ph faults (consider only the parts and signals, which correspond to the actual functionality of a used terminal)

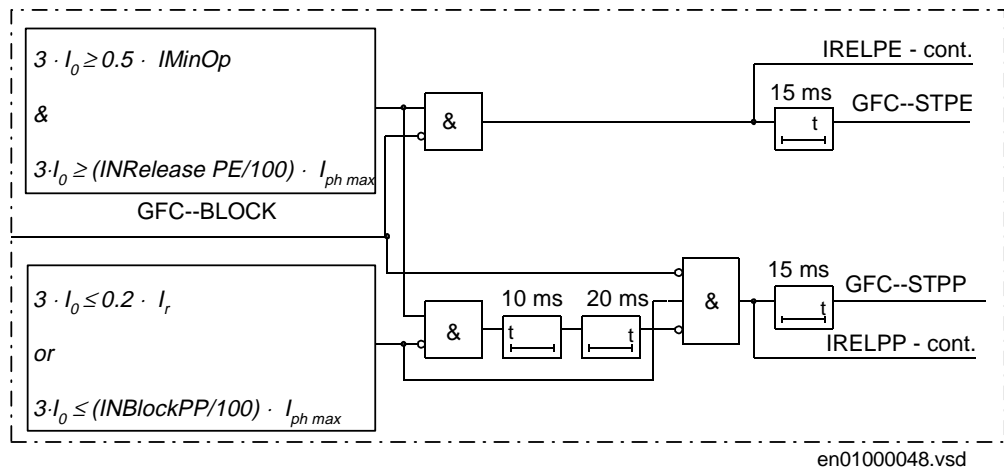
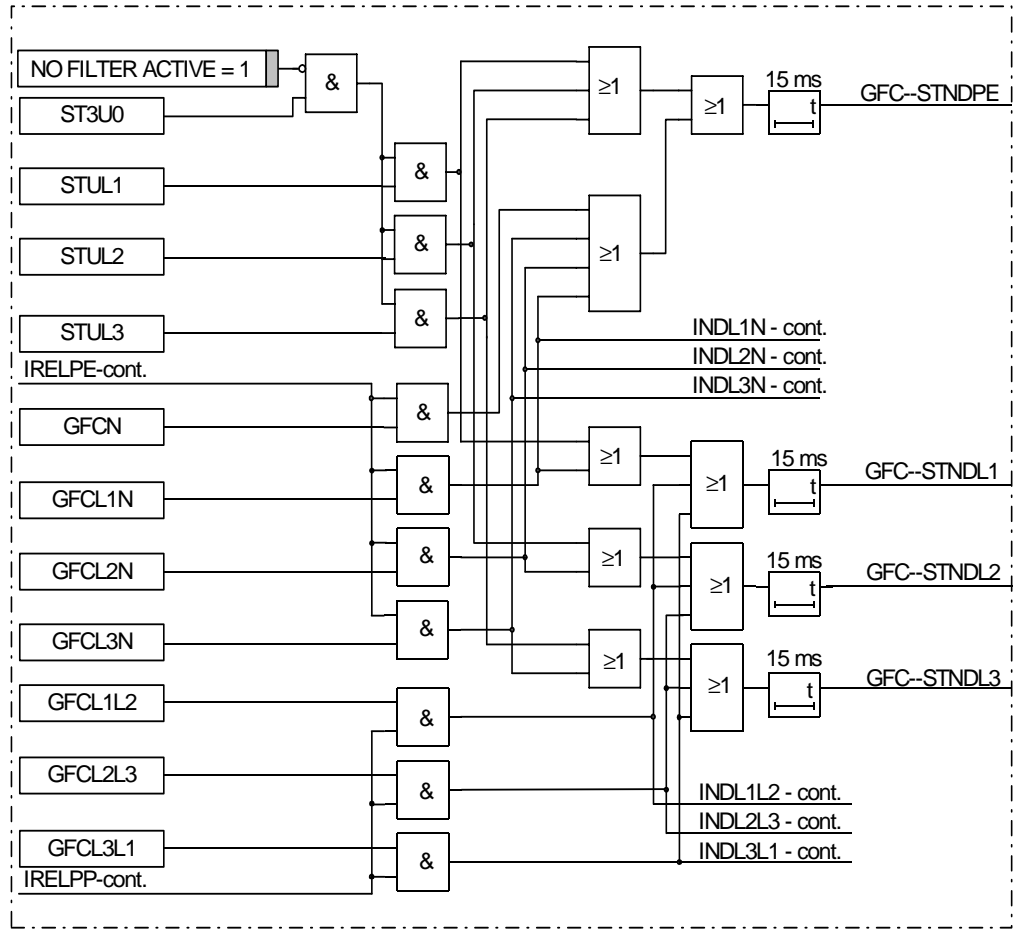

Figure 51: Detection of ph-E and ph-ph fault conditions





99000546.vsd

Figure 52: Composition of non-directional GFC signals

Figure 52 presents schematically the composition of non-directional general criteria signals GFC--STNDLn, where n presents the corresponding phase number. Signals GFCLnN and GFCLmLn (m and n change between 1 and 3 according to the phase number) represent the fulfilled operating criteria for each separate loop measuring element.

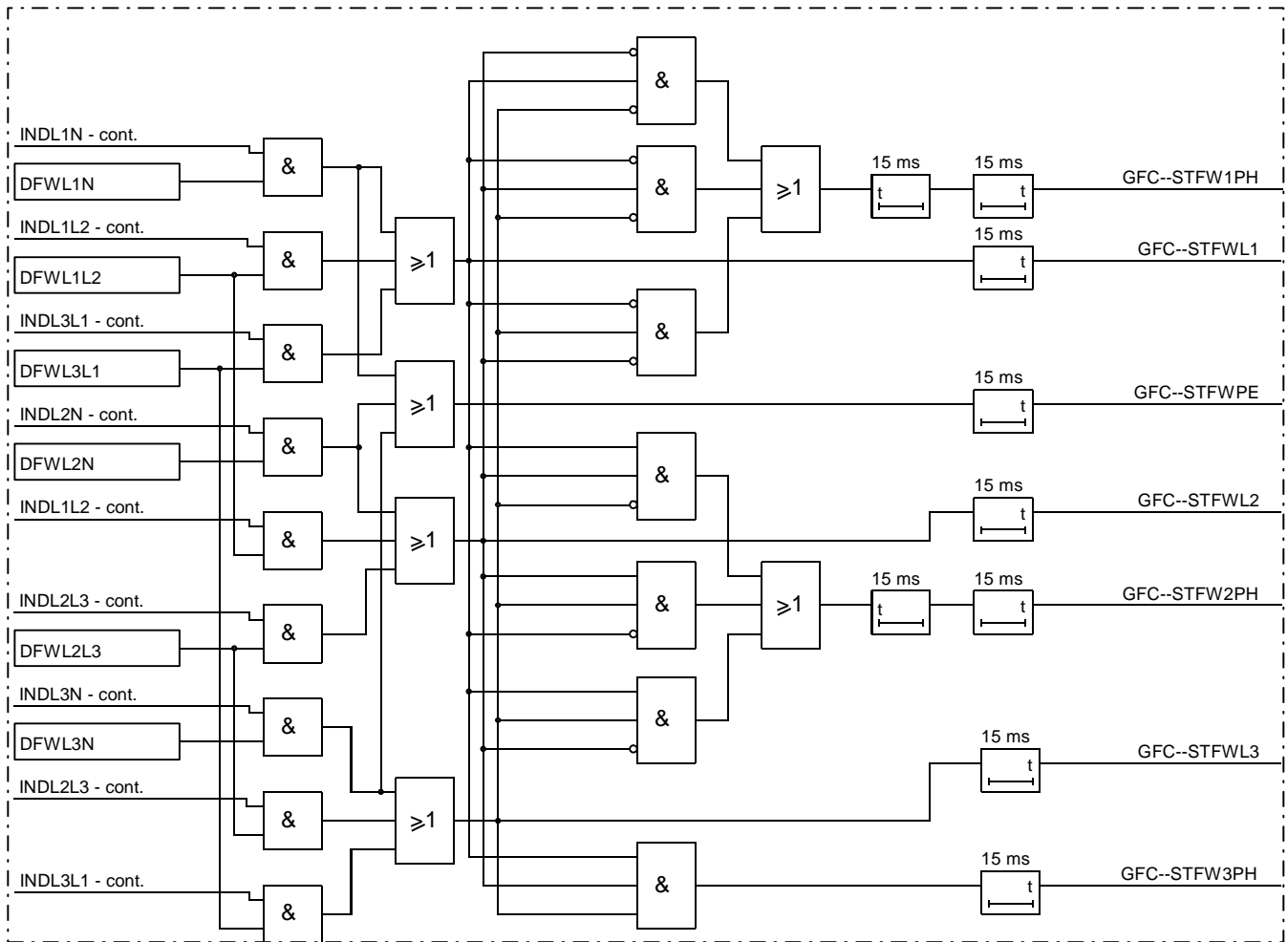

en00000483.vsd

Figure 53: Composition of forward directed GFC signals.

Composition of the directional (forward and reverse) phase selective signals is presented schematically in figure 53 and figure 54. The directional criteria appears as a condition for the correct phase selection in order to secure a high phase selectivity for simultaneous and evolving faults on lines within the complex network configurations.

Signals DFWLn and DFWLnLm present the corresponding directional signals for measuring loops with phases Ln and Lm (m and n are running between 1 and 3). Designation FW (figure 53) represents the forward direction as well as the designation RV (figure 54) represents the reverse direction. All directional signals are derived within the corresponding digital signal processor.

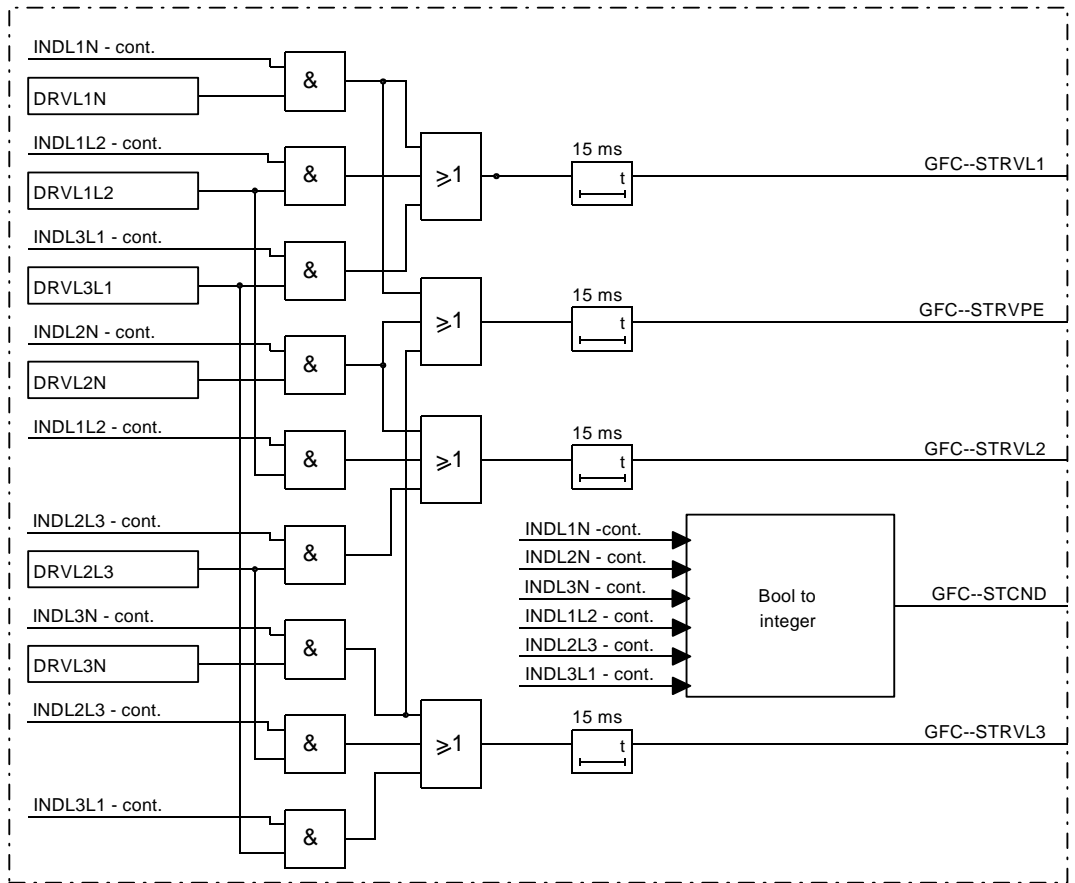

en00000484.vsd

Figure 54: Composition of reverse directed GFC signals and measured impedance related zone starting conditions

Figure 55 presents a composition of a GFC tripping signal, which consists of two different conditions: earth fault and phase-to-phase fault operating conditions. Each path has its own timer (tPE and tPP), to further increase the flexibility of a complete function

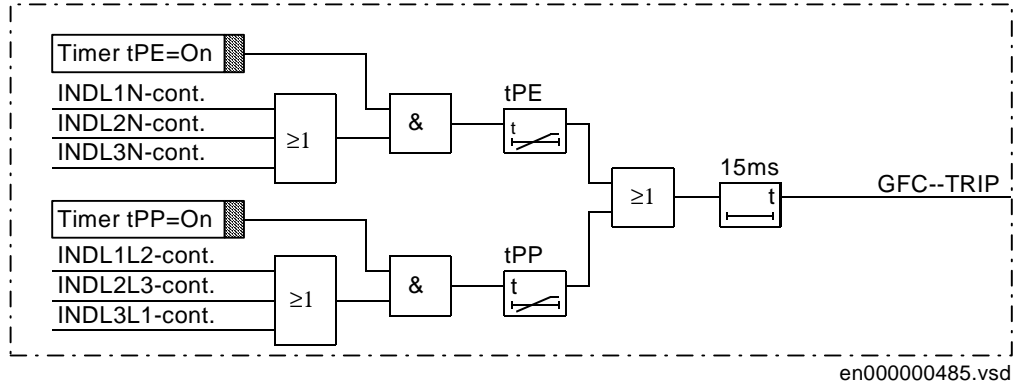

Figure 55: Composition of time-delayed tripping signal

Figure 56 presents a composition of a starting condition integer signal, which is supposed to be configured to the distance protection zones and their starting condition inputs (ZMn--STCND). The signal controls the operation of different measuring loops in each distance protection separately.

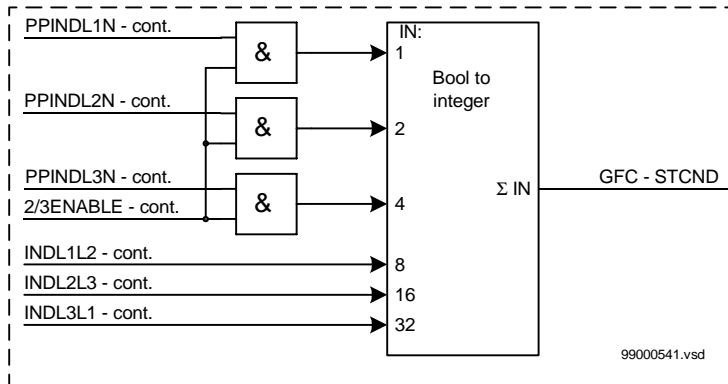

Figure 56: GFC start condition with phase preference

## 4.4

### Calculations

#### 4.4.1

#### Setting instructions

All the setting parameters for the GFC are available in the menu tree of the local HMI unit under the menu:

**Settings****Functions****Group n****Impedance****GenFltCriteria**

For the remote setting facilities and local HMI via a personal computer, please refer to the corresponding SMS or SCS documents.

The first parameter under the GFC is the operating mode, which is selectable among two different possibilities:

Operation Z< = On	the GFC will operate on an underimpedance basis
Operation I> = On	the GFC will operate on an over current basis

It is also possible to have active both operating modes at the same time. The available operating mode depends on the functions available within the terminal. Only one of two or both operating modes are available depending on ordering. Please, refer to ordering particulars for each terminal separately.

**General setting parameters**

Operation of the GFC measurement is enabled or disabled by setting the Operation = On or Off respectively. Setting the parameters Timer tPP and Timer tPE On or Off enables or disables the time delayed tripping, caused by the GFC measurement for the ph-ph and ph-E faults respectively.

If not the 2 out of 3 logic is active it is recommend to set Timer tPP and Timer tPE to Off in isolated or high-impedance earthed networks, if the distance protection is not intended or permitted to operate at single-phase-to-earth faults.

Setting of tPP and tPE timers define the tripping time delay of the GFC function, if activated.

**Setting parameters for the I> mode of operation**

The setting of the operating value for the overcurrent GFC phase measuring elements IP> must be higher than the maximum expected load current in the protected feeder. It is necessary to consider an additional margin of at least 10% to the declared inaccuracy of the current instrument transformers and measuring elements.

There will always be a certain low value of measured residual current  $3I_0$  in the measuring circuits due to the differences in the current instrument transformers. Higher values can be expected on longer lines with a higher operating voltage. The presence of the close untransposed lines, where the zero-sequence mutual coupling effect is significant, will additionally increase the apparent residual current measured by the terminal.

Therefore, it is usually necessary to set the operating value of the earth-fault current measuring element  $I_{N>}$  at a minimum of 10% of the line nominal current. The setting value must be increased on the longer, untransposed lines and in cases where the zero-sequence mutual coupling effect is significant.

### Setting parameters for the Z< mode of operation

The setting instructions refer to the operating characteristic of the GFC elements as shown principally in a figure in “Application”. The GFC characteristic should, in general, cover all the impedance measuring zones used for the distance protection, regardless of their directionality.

The following parameters should be set for the GFC, operating in the underimpedance mode:

- $X1FwPP$  is a positive-sequence reactance that corresponds to the reactive reach of the GFC elements in forward direction for ph-ph faults.
- $X1FwPE$  is a positive-sequence reactance that corresponds to the reactive reach of the GFC elements in forward direction for ph-E fault (not available in REL 501).
- $X0FwPE$  is a zero-sequence reactance that defines the total reactive reach of the GFC earth-fault loop measuring elements in forward direction (not available in REL 501) for the ph-E faults.
- $X1RvPP$  is a positive-sequence reactance that corresponds to the reactive reach of the GFC elements in reverse direction for the ph-ph faults. We recommend having  $X1RvPP \geq 10\%$  of  $X1FwPP$  in order to guaranty a correct measurement for close up faults.
- $X1RvPE$  is a positive-sequence reactance that corresponds to the reactive reach of the GFC elements in reverse direction for the ph-E faults. We recommend having  $X1RvPE \geq 10\%$  of  $X1FwPE$  in order to guaranty a correct measurement for close up faults.
- $X0RvPE$  is a zero-sequence reactance that defines the complete reactive reach of the GFC earth-fault loop measuring elements in reverse direction (not available in REL 501) for ph-E faults. We recommend having  $X0RvPE \geq 10\%$  of  $X0FwPE$  in order to guaranty a correct measurement for close up faults.
- $RFPP$  is the resistive reach of the GFC elements for multi-phase faults. It should be set as a loop value of the measured resistances, according to the formula:

$$RFPP > 2 \cdot R1PP + RF$$

(Equation 104)

Where:

R1PP is a corresponding line positive sequence resistance

RF is the expected fault resistance between two faulty phases.

- RFPE is the resistive reach of the GFC elements for the phase-to-earth-faults (not available in REL 501). It should be set as a loop value of the measured resistances, according to the formula:

$$RFPE > \frac{1}{3} \cdot (2 \cdot R1PE + R0PE) + RF$$

(Equation 105)

Where:

R1PE is a corresponding line positive-sequence resistance

R0PE is a corresponding line zero-sequence resistance

RF is a fault resistance as expected for the single-phase-to-earth-faults.

- RLd is the resistive reach in the load impedance area. For the corresponding instructions, please refer to the “Setting instructions” for the distance protection function (document *Distance protection*). Observe the loop character of this setting parameter. It should be set generally to:

$$RLd < 1.6 \cdot R_{Lmin}$$

(Equation 106)

Where:

$R_{Lmin}$  represents the minimum expected load resistance

- ARGLd is the maximum expected load angle that could appear under the maximum load conditions on a protected line. One of the following expressions can be used for its calculation:

$$ARGLd = \arccos \frac{P}{S} = \arcsin \frac{Q}{S} = \arctan \frac{Q}{P}$$

(Equation 107)

Where:

S is the apparent power

P is the active power

Q is the reactive power

- Setting parameters INReleasePE and INBlockPP (both are settable in percentage of the terminal rated current  $I_r$ ) control the operation of the phase-to-earth and the phase-to-phase measuring elements. They should in general be set to the default values, which are INReleasePE = 20%, and INBlockPP = 40%. Special system studies and calculations of fault currents are necessary in cases, when the remote end positive sequence source impedance is much higher than the zero sequence source impedance. The results of these studies may require in some special cases to set these parameters different from their default values.



---

## 5 Pole slip protection (PSP)

### 5.1 Application

Sudden events in an electrical power system such as large jumps in load, fault occurrence or fault clearance, which disturb the balance of energy in the system, can cause oscillations of mechanical masses referred to as power swings. In a recoverable situation the oscillations will decay and stable operation will be resumed; in a non-recoverable situation the power swings become so severe that the synchronism is lost between the generators of the system, a condition referred to as pole slipping. In the case of pole slipping, the excitation of the machines is generally intact, but there are strong oscillations of real and reactive power.

Even though the modern power systems are designed and operate with high degree of security against power swings and even more against pole slipping, these two phenomena may occur especially during abnormal system conditions.

If the pole slipping condition is allowed to persist in smaller parts of a power system than other machines may follow and the stability of a system as a whole is in danger. Apart from the electrical phenomena, oscillations of mechanical masses also expose the generators and other equipment to considerable pulsating mechanical stresses.

Available technology and the costs of the corresponding protection devices dictated in the past the use of the pole slip protection relays only close to the power generators. They were for this reason treated as a part of a generator protection scheme. Their use deeper in the network was not so common. Such approach resulted often in unselective splits of already troubled power systems, which have lost some valuable generating capacities.

Modern, functional library oriented approach within the microprocessor based protection terminals makes it possible to utilize the pole slip protection function more often and deeper in the power network. This way it enables better selectivity of the pole slip protection and intact power generation in different islands. A separate pole slip protection function still remains as a dedicated generator protection in the vicinity of synchronous machines, to protect them against the oscillations which could harm in great extent their functionality

The Pole Slip Protection (PSP) function as built in REx 5xx protection, control and monitoring terminals, and described in this document comprises all functionality necessary for the detection, evaluation and corresponding reaction on the pole slipping phenomena in power systems. It is applicable together with different line protection functions (distance protection, line differential protection) deeper in the power network as well as a part of a generator protection system in power plants.

**Oscillations of mechanical masses in power system**

Figure 57 presents a two machine system with a power line between busbars A and B. The electromotive forces  $E_A$  and  $E_B$  can differ in their magnitude. It is important, that their relative phase angle

$$\delta = \delta_A - \delta_B$$

(Equation 108)

changes with time. The voltage difference

$$U_D = \dot{E}_A - \dot{E}_B$$

(Equation 109)

changes in its magnitude and direction and causes this way the current between both generators to change accordingly.

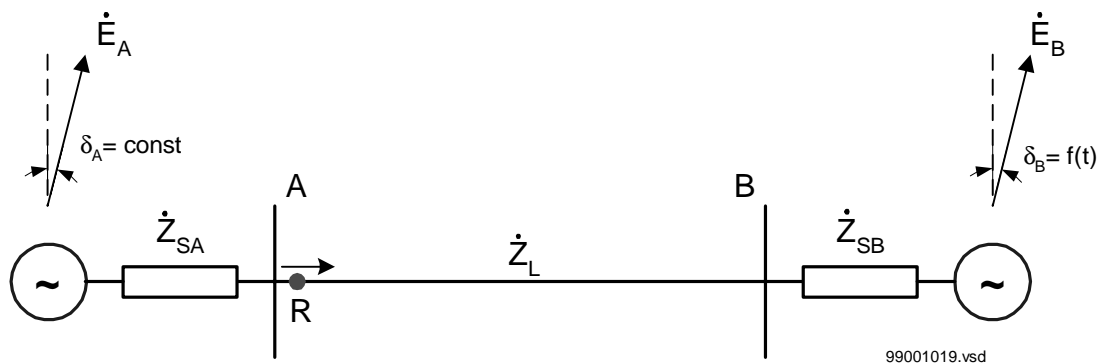

*Figure 57: Two machine system.*

Figure 58 presents an example of the voltage and current measured in one phase of a line between two generators during the oscillations caused by the changing of the relative angle  $\delta$ . The minimum value of current corresponds to the minimum angle between the electromotive forces. The maximum value of the current corresponds to the condition when the voltages

$$\dot{E}_A$$

(Equation 110)

and

$$\dot{E}_B$$

(Equation 111)

have the opposite direction.

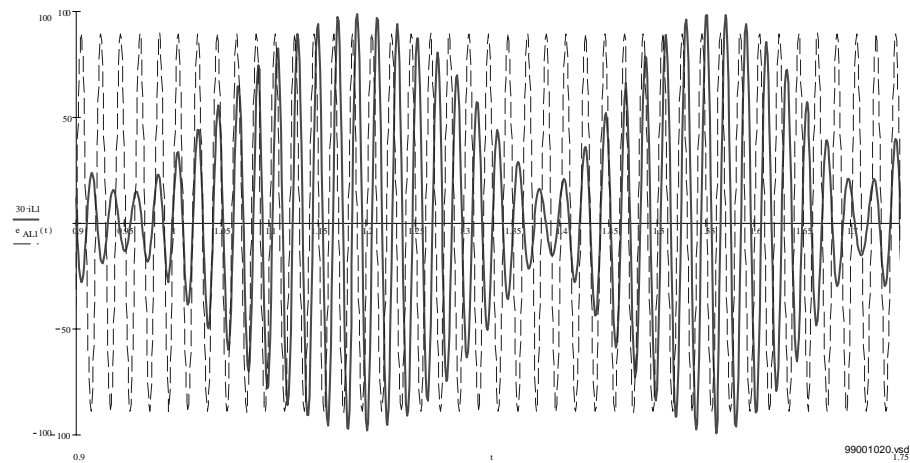

Figure 58: Current (solid line) and voltage (dashed line) in relay point during the pole slip condition.

Oscillations in measured voltage and current reflect naturally also in impedance, measured by the impedance (distance) relays.

Figure 59 a) and 59 b) present two examples of the impedance trajectories in impedance plane during the system oscillations. Both figures include also the example of an operating characteristics of a modern distance protection. The measured impedance can enter the operating area of the distance protection and causes its unwanted operation. It is for this reason necessary to detect the oscillations and prevent such unwanted operations before the measured impedance enters the distance protection operating characteristics.

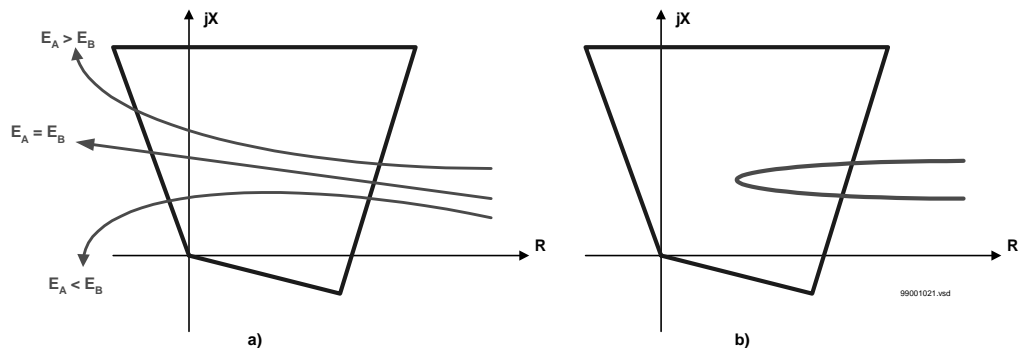

Figure 59: Impedance trajectories in relay point during the pole slip (figure a) and power swing (figure b) phenomena.

The recoverable oscillations are understood under the expression "power-swing". The generators in a two-machine system remain during the disturbance in synchronism. They only change their relative angle  $\delta$  from one to another value over a transient period. The impedance locus might enter the operating characteristic of the distance relay (see Figure 59 b), but generally does not cross the complete R-X plain.

In a non-recoverable situation the oscillations are so severe, that the synchronism is lost between the generators of a system. The condition is referred to as a pole-slip. At least one generator starts to change its frequency and the resulting slip frequency may increase up to 10 Hz (in 50 Hz system).

The measured impedance usually enters the distance relay's operating characteristic and crosses the complete impedance plain, as presented schematically on Figure 59 a.

### Oscillations during abnormal system conditions

Modern power systems operate very close to their technical limits but are also built with higher security against the mechanical oscillations than ever before. Today it is nearly impossible to start the oscillations only by very big difference in produced and consumed power. At the same time some short oscillations are much more frequent than before. They are initiated by some bigger events (faults) in power systems and disappear relatively fast after the normal operating conditions have been restored (e.g. single-pole autoreclosing).

Figure 60 presents an impedance trajectory as seen on protected power line by a distance protection function in phase L2 during the dead time of a single pole autoreclosing, after the single phase-to-earth fault L1-N has been cleared. The circuit breaker has been successfully closed after the dead time of the single pole autoreclosing has expired.

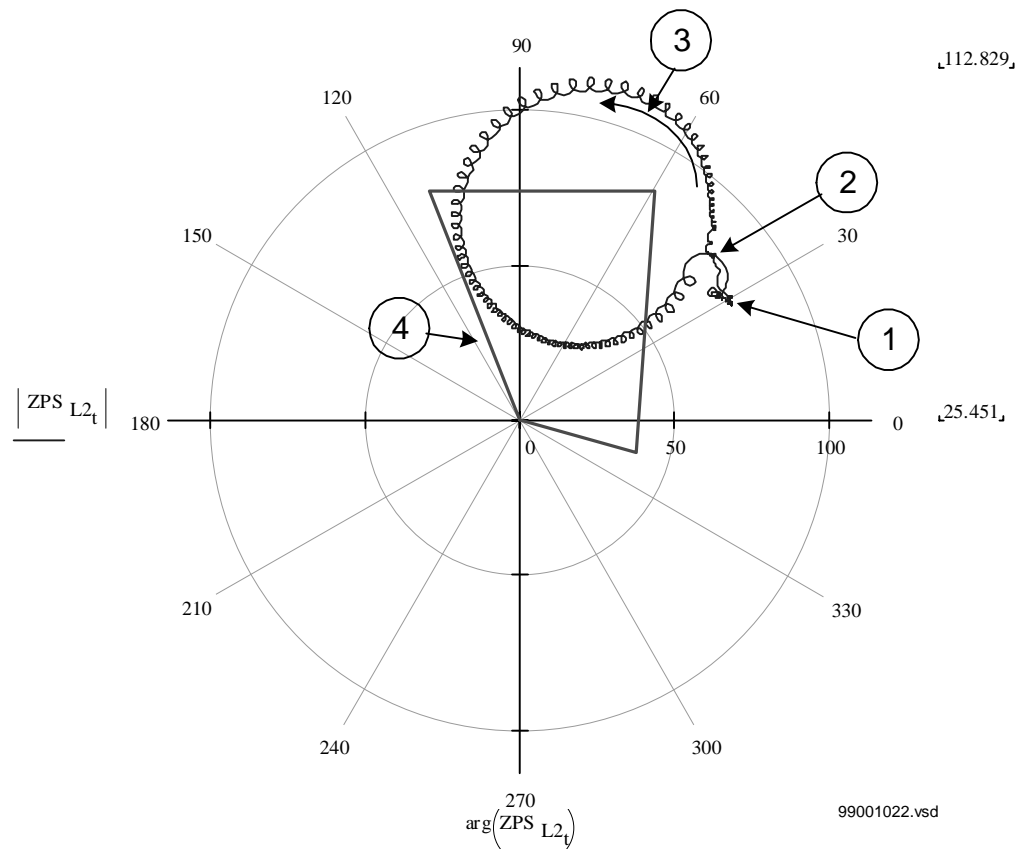

Figure 60: Impedance trajectory as seen by a L2-N impedance measuring element.

The remarks on Figure 60 have the following meaning:

1. Load impedance in phase L2 during normal operating conditions.
2. Impedance measured during the L1-N fault.
3. Impedance trajectory and its direction during the dead time of a single pole autoreclosing in phase L1.
4. Operating characteristic of the line distance protection.

The impedance as measured by a healthy phase measuring elements (phase L2 in case on Figure 60) might enter the operating area of the distance protection in impedance plain and initiate an unwanted trip. Modern distance protection devices must incorporate a corresponding functionality, which detects the oscillations in each phase separately and prevents the unnecessary operation of the main protection function.

The oscillation in power system should be recognized preferably by the measuring elements, if detected simultaneously in more than one phase. The operating logic, which requires the detection in two out of three phases increases in great extent the security and dependability of an applied protection scheme in special operating conditions, like:

- Oscillations during dead time of single pole auto-reclosing.
- Slow increase of initial fault currents at different kinds of high resistive earth faults.

A special logic circuit, as applied in the pole slip protection used by the REx 5xx terminals makes possible an adaptive use of the so called "one out of three" or "two out of three" phase detection criteria. This possibility becomes important for the correct detection of the oscillations in power systems with multipole tripping and reclosing function applied on double-circuit parallel operating EHV transmission lines.

### Speed of oscillations

Figure 61 presents informatively the phase currents as recorded at one end of the protected 500 kV transmission line during the pole-slip situation in a power system. The oscillations have been initiated by a single-phase-to-earth fault in phase L1 (increased magnitude of the phase current).

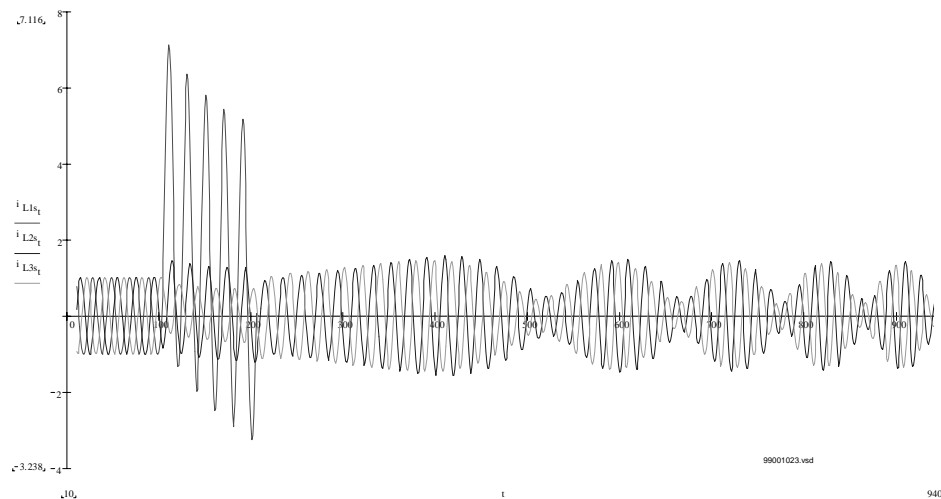

Figure 61: Phase currents in relay point during the pole slip conditions caused by a L1-N fault.

The pole-slip frequency is in most cases not constant. The initial oscillation speed is generally low and increases with time if the system starts the non recoverable oscillation.

The described dependency might influence the dependability of the distance protection scheme at slowly developing single-phase-to-earth faults. It can at the same time jeopardize the security of the same protection scheme when the oscillations obtain higher speed. The pole slip protection in REx 5xx terminals uses the adaptive criteria for the impedance speed to distinguish between the slow initial faults and increased speed of the measured impedance at consecutive oscillations.

#### Requirements on protection systems during pole slip conditions in network

Two, generally contradictory requirements apply today on the protection systems when mechanical masses in power systems start to oscillate. The requirements depend on the general role, which the protected element plays within the power system.

Figure 62 presents a transmission line connecting a big production (power plants) with the rest of the power system, which depends very much on the delivered electric energy from the external resources.

The goal in such case is to keep the protected element (power line) of a power system in operation under all system conditions as long as possible. This requirement is extended even to emergency conditions, i.e. two phase operation of power line during dead time of a single-pole autoreclosing. It is at the same time expected from the line protection system to operate selectively for all line faults, which may occur during the oscillations. In such case it is recommended to use within the REx 5xx terminals the so called Power Swing Detection (PSD) function together with Power Swing Logic (PSL).

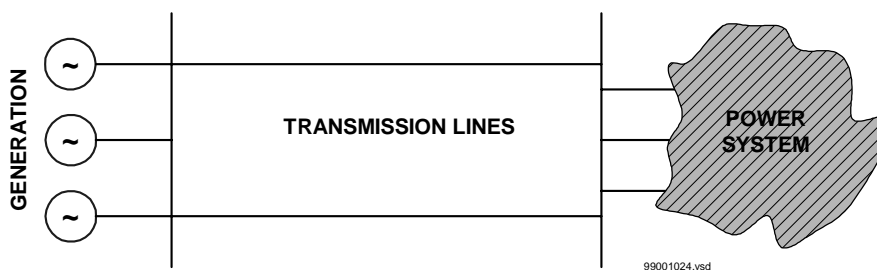

Figure 62: Power line delivering the electrical power to the consuming area.

Generator protection must prevent damages to the generators in the power plant independent of all other system conditions. The pole slip protection is in such case used closed to the generators.

The second typical network configuration is presented in Figure 63. Inter-connection transmission lines connect two big and generally independent power systems. Mechanical oscillations appear in this case between two different systems and are dangerous for the stability of each system separately.

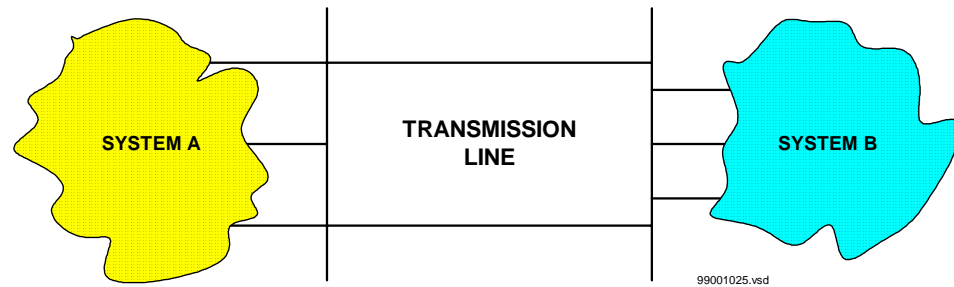

Figure 63: Transmission lines interconnecting two big power systems.

The goal in this particular case of a pole slip situation is to trip selectively (from the power system point-of-view) the connecting element(s) between two different systems. The disconnection of a healthy power line is not selective in a classical way of understanding, but prevents the total collapse of at least one independent system. The pole slip protection is in such case installed on the interconnection lines and sometimes even deeper in each power system.

#### Oscillations and faults in power system

It has been already mentioned that the oscillations in modern power systems appear as the consequences of sudden changes, caused either by big changes of a load or by different faults. Faults on different elements may appear also during the mechanical oscillations. Very high demands are put today in such cases on modern protection equipment. The modern power utilities permit no more any decrease of either dependability or security of the protection systems for the faults in primary system when their mechanical masses oscillate due to one or another reason. The protection system must remain stable for all kinds of external faults and must operate reliably for all internal faults. Some longer operating times are acceptable but should not jeopardize the complete system selectivity.

Integration of different protection functions within the same modern numerical protection terminals makes it possible to combine their operation and program their interdependence under different system operating conditions. Fast development of modern digital communication systems increases additionally the application of such adaptive functionality.



5.2 **Functionality**

5.2.1 **Theory of operation**

Measured impedance in relay point on a protected power line (see figure in “Application”) may follow different trajectories when the generators of a two machine system start to oscillate. Some of the most characteristic trajectories are presented on figure 64.

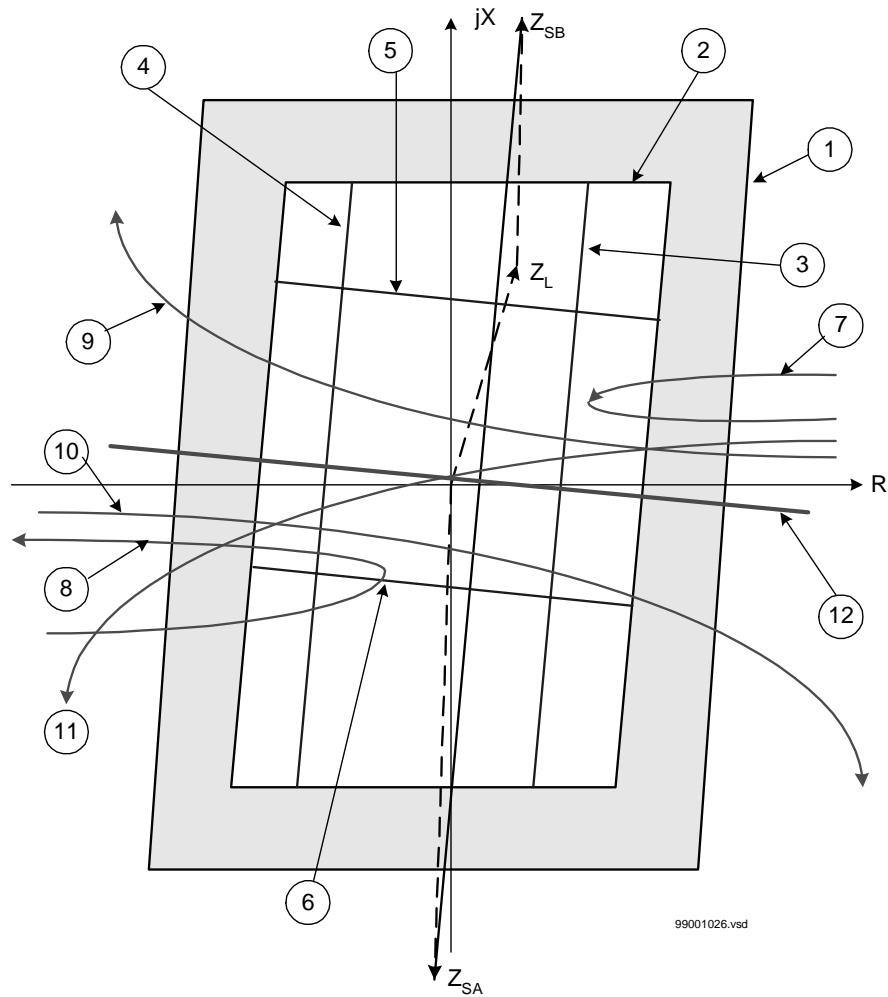

Figure 64: Impedance trajectories during oscillations in power system and basic operating characteristics of the pole slip protection.

The impedance measuring device is located in the origin of the R-X plane. The  $Z_{SA}$  source impedance is located behind the relay. The  $Z_{SB}$  source impedance presents the continuation of the line impedance  $Z_L$ . The complete impedance between the ends of vectors  $Z_{SA}$  and  $Z_{SB}$  is called a system impedance  $Z_S$ . The magnitude and the position of the system impedance within the impedance plain determines the electrical centre of the possible oscillation. The electrical center  $Z_{CO}$  is located in the middle of the system impedance, when both EMFs have the same magnitude.

$$\dot{Z}_S = \dot{Z}_{SA} + \dot{Z}_L + \dot{Z}_{SB} = R_S + jX_S \quad (\text{Equation 112})$$

$$Z_{CO} = \frac{1}{2} \cdot Z_S - Z_{SA} = R_{CO} + jX_{CO} \quad (\text{Equation 113})$$

The following equation apply in general conditions, when the EMFs at both generators are not equal:

$$\dot{Z}_{CO} = \frac{\dot{Z}_S}{1 + \frac{|\dot{E}_B|}{|\dot{E}_A|}} - \dot{Z}_A \quad (\text{Equation 114})$$

The oscillation detection characteristics 1 and 2 in figure 64 are in their resistive part parallel to the system impedance as long as its characteristic angle  $\varphi_S$  exceeds 75 degrees. The same applies also to the resistive tripping characteristics 3 and 4.

$$\varphi_S = \text{atan}\left(\frac{X_S}{R_S}\right) \quad (\text{Equation 115})$$

The reactive tripping characteristics 5 and 6 (see figure 64) are rectangular on the system impedance characteristic and form with the R axis an angle of

$$\varphi_S - 90^\circ \quad (\text{Equation 116})$$

as long as

$$\varphi_S \geq 75^\circ$$

(Equation 117)

Impedance trajectory 7 on figure 64 presents a typical trajectory during a (probably) recoverable power swing, when the load current flows from A towards B (see figure in “Application”). Similarly presents the impedance trajectory 8 a power swing, which started from the reverse load condition. Characteristic for both trajectories is that they do not pass the complete system impedance, which means that there is no pole slip condition in power system. The second trajectory passes the left tripping characteristic (4 on figure 64), which could be a necessary condition for the non-recoverable oscillation and might require a tripping action.

Impedance trajectories 9, 10, 11, and 12 on figure 64 are characteristic for the pole slip conditions. They pass the system impedance line and complete impedance plain. Their shapes depend on particular system conditions. The measured impedance would follow the 12 trajectory only in case, when  $E_A$  and  $E_B$  voltages have exactly the same magnitude. Trajectory 9 is characteristic for the case when

$$|E_A| > |E_B|$$

(Equation 118)

and trajectory 11 for the opposite case.

The results of system studies should determine the necessary operating conditions for the pole slip protection in different situations.

#### **Detection of the oscillations and transitions**

The operating principle used for the detection of the oscillations over the protected primary element is based on a well proven

$$(\Delta Z)/(\Delta t)$$

(Equation 119)

method as presented schematically in figure 65.

An oscillation is recognized by the measuring element if the measured impedance needs to change from a ZEXT external impedance boundary to a ZINT internal impedance boundary (see also boundaries 1 and 2 on figure 64) a time, which is longer than the time  $\Delta t$  set on the corresponding timer. Faster changes of the measured impedance are recognized as faults.

Power swing and pole slip are not only a three-phase phenomena. It is for this reason necessary to monitor the impedance in each phase separately. The pole slip protection in REx 5xx terminals has built-in oscillation detectors in each phase separately.

Impedance may change relatively slow also at developing high resistive faults, which might influence the unwanted operation of the oscillation detectors, when set to detect the oscillations with the highest possible speed (slip frequency up to 10Hz). The pole slip protection in REx 5xx terminals has a built in adaptive criterion. The operation of this criterion is based on the fact that the initial oscillations are usually slow. They increase their speed after a certain number of slips. First oscillations are this way detected by a timer (see figure 65) with longer set time delay. The consecutive oscillations are detected by an additional timer, which has its operating time set shorter to be able to detect also the high speed oscillations

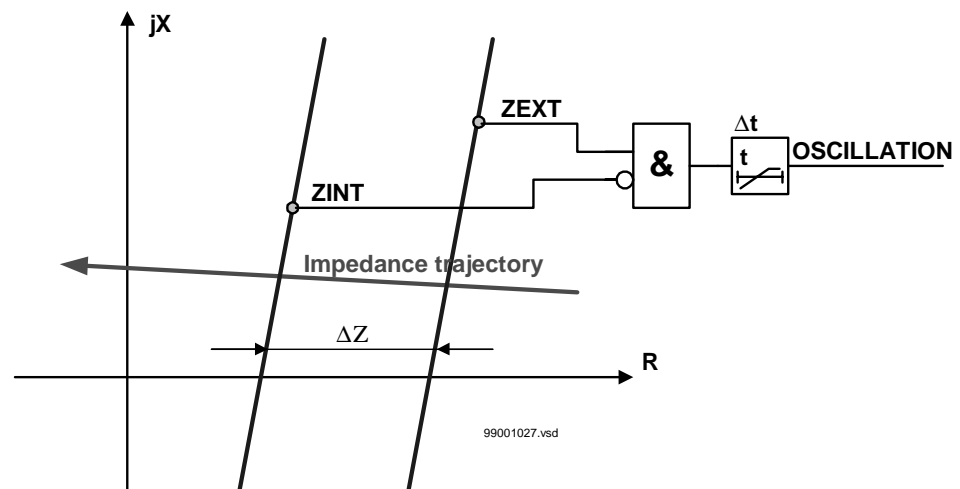

Figure 65: Detection of the oscillation by the  $(DZ)/(Dt)$  method.

The oscillation is recognized as a transition only, if the transition impedance enters the impedance operating characteristic (see figure 64) at one side of the impedance plane and leaves it on the other side. Two different transitions are recognized by the PSP:

- Transition from forward to reverse (FwRv), when the measured impedance first enters the right side (R) or upper part (X) and leaves at the left (-R) or bottom (-X) part of the oscillation detection characteristic.
- Transition from reverse to forward (RvFw), when the measured impedance first enters the left (-R) or bottom (-X) part and leaves at the right (R) or upper (X) part of the oscillation detection characteristic.

It is not always necessary to trip the circuit breaker after that the first pole slip has been detected. This especially applies to recoverable slips, which occur during the abnormal system conditions. If one slip occurs during the dead time of a single pole autoreclosing on a power line it is still possible that the system will recover after the circuit breaker reconnects the third phase (see example in figure in “Oscillations during abnormal system conditions” in “Application”). However, if more consecutive slips occur, than it is better to disconnect the line and prevent this way the collapse of a complete system as well as big electrical and mechanical stresses of the primary equipment. The PSP in REx 5xx terminals has built in counters, which count the number of the consecutive slips in the system. Separate counters count:

- The slips which enter the impedance area between the reactive tripping characteristics 5 and 6 (see figure 64).
- The slips with remote electrical centers, which enter the inner boundary of the oscillation detection characteristic (boundary 2 on figure 64), but remain outside the first operating area.

Settings of the resistive reach for the external and for the internal boundary of the oscillation detection element depend on the minimum load impedance  $Z_{Lmin}$  of the protected element, which is calculated according to the equation:

$$Z_{Lmin} = \frac{(\dot{U}_{min})^2}{\dot{S}_{max}}$$

(Equation 120)

Where:

$U_{min}$ [kV]	Minimum possible system phase to phase voltage (real value).
$S_{max}$ [MVA]	Maximum possible loading of a protected element.

The resistive reach of the external boundary depends on the line length as follows.

$$R1EXT = |\dot{Z}_{Lmin}| \cdot K_L$$

(Equation 121)

The  $K_L$  factor depends on the line length and has the following values:

- $K_L=0.9$  for lines longer than 150 km
- $K_L=0.85$  for lines longer than 80 km and shorter than 150 km
- $K_L=0.8$  for lines shorter than 80 km

The corresponding load angle is this way equal to:

$$\delta_{ext} = 2 \cdot \operatorname{atan} \left[ \frac{|\dot{Z}_{SA} + \dot{Z}_L + \dot{Z}_{SB}|}{2 \cdot R1EXT} \right]$$

(Equation 122)

Maximum frequency  $f_{si}$  of the initial slips is mostly between 2Hz and 3Hz. It should be known from the system stability studies. The suggested setting value for the initial timer tP1 is 45ms. The corresponding value of the internal load angle is this way equal to:

$$\delta_{int} = 360^\circ \cdot f_{si} \cdot tP1 + \delta_{ext}$$

(Equation 123)

This determines the required setting of the internal resistive boundary:

$$R1INT = \frac{|\dot{Z}_{SA} + \dot{Z}_L + \dot{Z}_{SB}|}{2 \cdot \tan\left(\frac{\delta_{int}}{2}\right)}$$

(Equation 124)

Setting for the tP2 timer, determining the maximum slip frequency for the consecutive slips, follows the equation:

$$tP2 = \frac{\delta_{int} - \delta_{ext}}{360^\circ \cdot f_{sm}}$$

(Equation 125)

$f_{sm}$  is a maximum slip frequency of the consecutive slips, which are still supposed to be detected by the pole slip protection.

The PSP issues a tripping command after any of counters reaches the set number of consecutive slips and the measured impedance passes one of the resistive tripping characteristics (3 and 4 on figure 64).

### Tripping on way in and on way out

The PSP protection in REx 5xx terminals has built-in two resistive tripping characteristics (see figure 66):

- Right tripping characteristic, which passes in the impedance plain the first and the fourth quadrant.
- Left tripping characteristic, which passes in the impedance plain the second and the third quadrant.

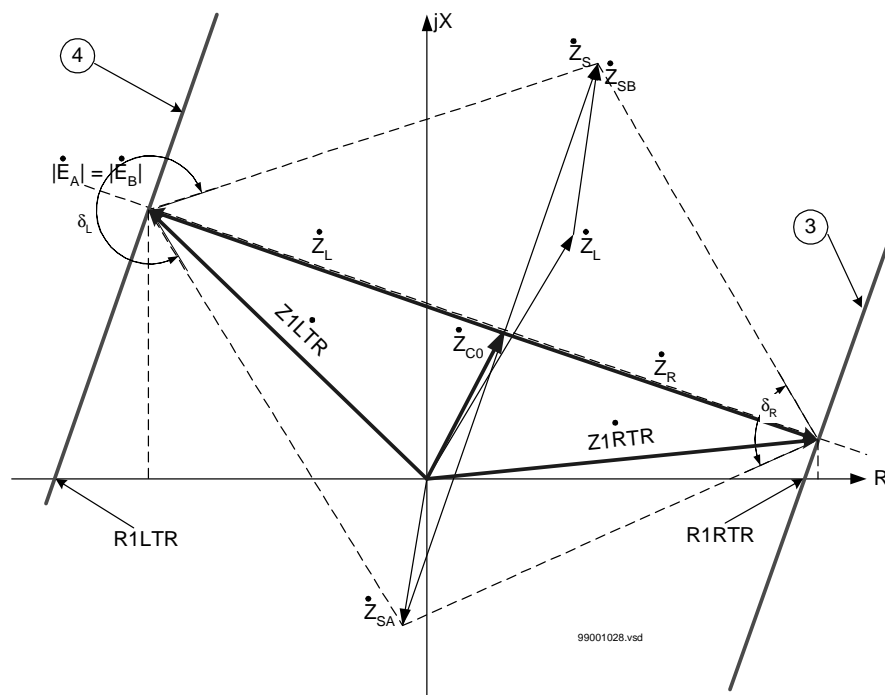

Figure 66: Left (4) and right (3) tripping characteristics and setting of their resistive reach R1LTR and L1RTR respectively.

Both tripping characteristics are parallel with the system impedance  $Z_s$  as long as the system characteristic angle

$$\varphi_s \geq 75^\circ$$

(Equation 126)

In other cases the declination angle is automatically set equal to  $75^\circ$ .

The resistive tripping characteristics make possible to control the tripping angle between the EMFs of both generators and this way prevent extremely high electrical and mechanical stresses of circuit breakers. Two operating modes are available, dependent on which characteristic is selected for tripping at particular type of the impedance transition. If we simplify the expressions and equalize the characteristics with their resistive reach settings R1LTR and R1RTR respectively, than the following operating modes are possible:

- Operation “on way in” for the transition from forward to reverse (FwRv). The PSP will issue the tripping command, if the necessary number of FwRv transitions has been detected and the measured impedance enters the area left of the R1RTR operating characteristic (3 in figure 64 and figure 66).
- Operation “on way out” for the transition from forward to reverse (FwRv). The PSP will issue the tripping command, if the necessary number of FwRv transitions has been detected and the measured impedance enters the area left of the R1LTR operating characteristic (4 in figure 64 and figure 66).
- Operation “on way in” for the transition from reverse to forward (RvFw). The PSP will issue the tripping command, if the necessary number of RvFw transitions has been detected and the measured impedance enters the area right of the R1LTR operating characteristic (4 in figure 64 and figure 66).
- Operation “on way out” for the transition from reverse to forward (RvFw). The PSP will issue the tripping command, if the necessary number of RvFw transitions has been detected and the measured impedance enters the area right of the R1RTR operating characteristic (3 in figure 64 and figure 66)

It is possible to activate each operating mode separately, to suit the operation the best to the particular system conditions.

Setting of the resistive reach for the left resistive tripping characteristic follows the equations:



$$R1LTR = \operatorname{Re}(Z1\dot{L}TR) + \operatorname{Im}(Z1\dot{L}TR) \cdot \tan(90^\circ - \varphi_S)$$

(Equation 127)

$$Z1\dot{L}TR = \frac{1}{2} \cdot \dot{Z}_S \cdot \left[ 1 + \frac{j}{\tan\left(180^\circ - \frac{\delta_L}{2}\right)} \right] - \dot{Z}_{SA}$$

(Equation 128)

See in figure 64 and figure 66 for the explanation of different parameters.

Setting of the resistive reach for the right tripping characteristic follows the equations:

$$R1RTR = \operatorname{Re}(Z1\dot{R}TR) - \operatorname{Im}(Z1\dot{R}TR) \cdot \tan(90^\circ - \varphi_S)$$

(Equation 129)

$$Z1\dot{R}TR = \frac{1}{2} \cdot \dot{Z}_S \cdot \left[ 1 - \frac{j}{\tan\left(\frac{\delta_R}{2}\right)} \right] - \dot{Z}_{SA}$$

(Equation 130)

Equations 13 to 16 are derived according to in figure 66, which means when

$$|\dot{E}_A| = |\dot{E}_B|$$

(Equation 131)

This calculation satisfies also in great extent the system requirements, when both EMFs differ in their magnitude.

**Close-in and remote end tripping areas**

The number of slips usually permitted by the pole slip protection is lower for the slips with electrical center closer to the relay point (within the protected element) and higher for the slips with electrical center deeper in the network (external to the protected element). The PSP in REx 5xx terminals has for this reason built-in a possibility to distinguish between the slips with close-in and remote electrical centers as well as to distinguish the number of slips required for the tripping command in one or another region. Two reactance characteristics (5 and 6 in figure 64) divide the complete operating area into two different parts.

The first area is a so called close-in operating area. This area is limited in the impedance plain by four operating characteristics (3, 4, 5, and 6 in figure 64). The number of required slips for tripping within this area is usually lower than the number of slips required for tripping in the remote tripping area.

The second area is a so called remote tripping area. This area is limited in the impedance plain by the operating characteristics 2, 3, 4, and 5 in forward direction as well as 2, 3, 4, and 6 in reverse direction (see figure 64).

PSP also provides a delayed back-up trip (TRIPSUM) for oscillation in close-in operating area or remote tripping area. This trip will work when the center of the oscillation is detected either on the protected line or on the neighbor line or next zone. In both cases PSP compares the number of slips to nDel, therefore, to enable this functionality TR-Fast and TRDel should be set to ON.

**5.3****Design**

The pole slip protection in REx 5xx terminals measures the phase impedance separately in each phase according to the following equation:

$$Z_{mLn} = \frac{U_{Ln}}{i_{Ln}}$$

(Equation 132)

Where:

$U_{Ln}$  are measured phase voltages (n = 1, 2,3)

$i_{Ln}$  are measured phase currents (n = 1, 2, 3)

Figure 67 presents the operating characteristic for the pole slip protection in impedance plane with all the corresponding setting parameters. For detailed information on setting parameters see the setting parameters in the “Technical reference manual”.

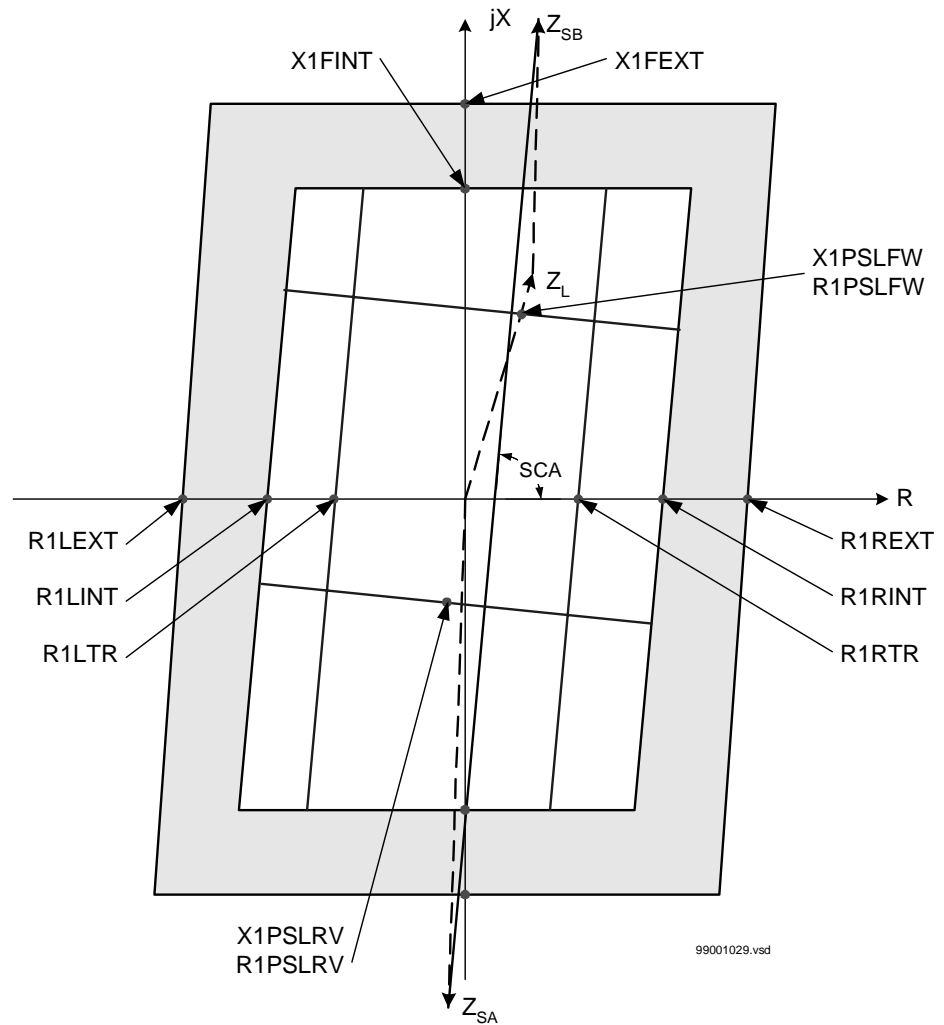

Figure 67: Operating characteristic of the pole slip protection with corresponding settings in the impedance plane.

The phase impedances are calculated in a digital signal processor and the following binary signals are used later on within the functional logic:

- ZOUTPSLn when the measured impedance enters the external impedance detection boundary in phase Ln (n = 1, 2, 3). See figure in “Application”.
- ZINPSLn when the measured impedance enters the internal impedance detection boundary in phase Ln (n = 1, 2, 3). See figure in “Application”.67
- FwRvLn when transition from forward to reverse direction has been detected in phase Ln.
- RvFwLn when transition from reverse to forward direction has been detected in phase Ln.
- Additional signals, which determine the position of the measured impedance regarding all specified operating characteristics. The positioning is performed in each phase separately.

**Detection of oscillations**

The oscillations are recognized, if detected in one or two out of all three phases. The user can select by the configuration, which of the operating modes is active during different system conditions. It is possible to have the “one out of three” mode active during normal three-phase operating conditions and switch to “two out of three” mode during the dead time of the single pole autoreclosing on a protected line

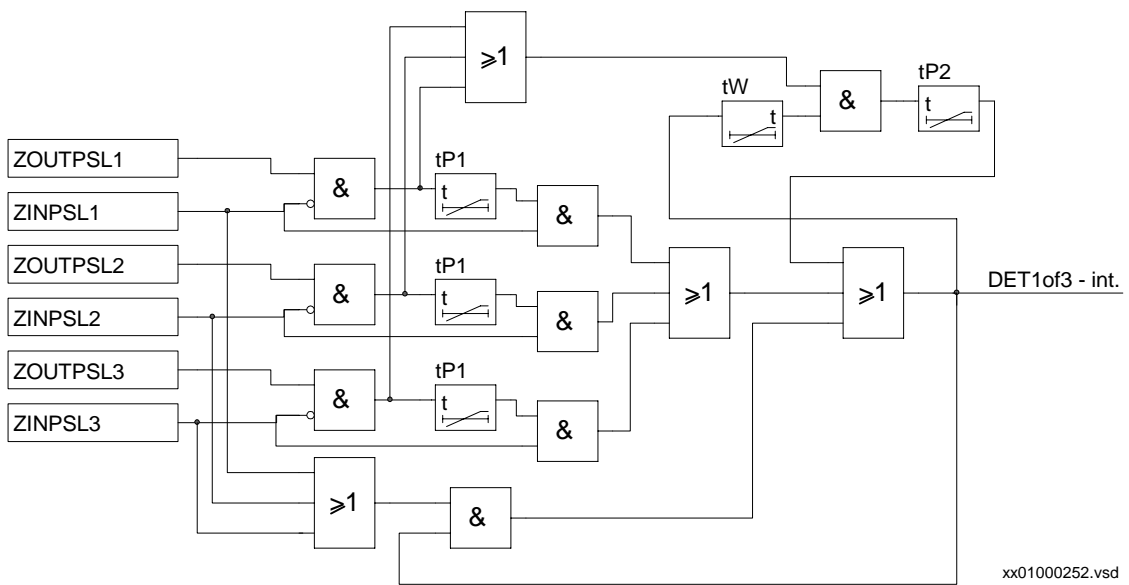

Figure 68: Simplified logic diagram for a one-out-of-three oscillation detection logic

The oscillation is detected in “one out of three” operating mode (see figure 68 and 69) if in at least one phase the time difference, when the measured impedance enters the external ( $Z_{OUTPSL_n}$ ) and the internal ( $Z_{INPSL_n}$ ) impedance boundary, is longer than the time set on the  $t_{P1}$  timer. The output signal  $DET1_{of3}$  remains logical one as long as the measured impedance in at least one phase remains within the external boundary.

The oscillation is recognized as the consecutive one, if the measured impedance re-enters in at least one phase the external boundary within the time interval set on  $t_W$  waiting timer. In such case the  $t_{P2}$  timer becomes the relevant one for the determination of a consecutive oscillation. This makes it possible to detect the consecutive slips with higher speed than the initial one.

Figure 69 presents a simplified logic diagram for the “two out of three” operating mode of the oscillation detection logic. The basic operating principle is the same as for the “one of three” operating mode with the difference that the initial oscillation must be detected in at least two phases, before the  $DET2_{of3}$  output signal becomes logical one.

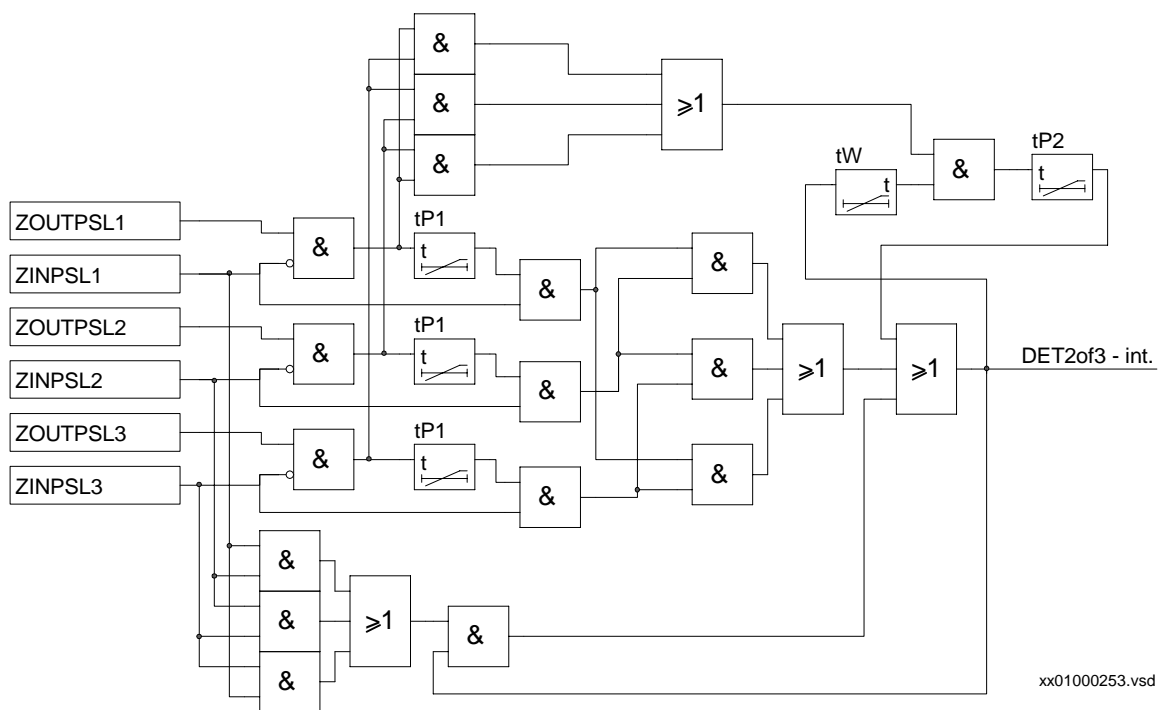

Figure 69: Simplified logic diagram for a two-out-of-three oscillation detection logic.

**Logic for cooperation with the line distance protection**

It has already been mentioned that the transition impedance might enter the operating area of the line distance protection function and cause its unwanted operation, if the necessary counter measures have not been provided. The pole slip protection detects the transient impedance and can be used as a disabling function for the line distance protection function within the same REx 5xx protection and control terminal.

Figure 70 presents in simplified form the logic diagram used for the cooperation with the associated line distance protection, when necessary.

The PSP-START output logical signal can be used within the terminal configuration, to block the operation of different distance protection zones. Its appearance depends on the selection of the “one out of three” or “two out of three” operating mode, which is possible by the corresponding connection of the following functional input signals:

- PSP--REL1P, which releases the “one out of three” operating mode.
- PSP--BLK1P, which blocks the “one out of three” operating mode.
- PSP--REL2P, which releases the “two out of three” operating mode.
- PSP--BLK2P, which blocks the “two out of three” operating mode

The following conditions block the PSP--START output signal and might this way release the operation of the distance protection function even during the oscillation conditions.

- PSP--BLOCK - input functional signal, which blocks the operation of the complete pole slip protection
- The PSP--START signal is disabled, if the measured impedance remains within the external impedance boundary for the time, which is longer as the time interval set on tR2 timer. It is possible to disable this functionality by the continuous presence of a logical one signal on functional input PSP--BLK1.

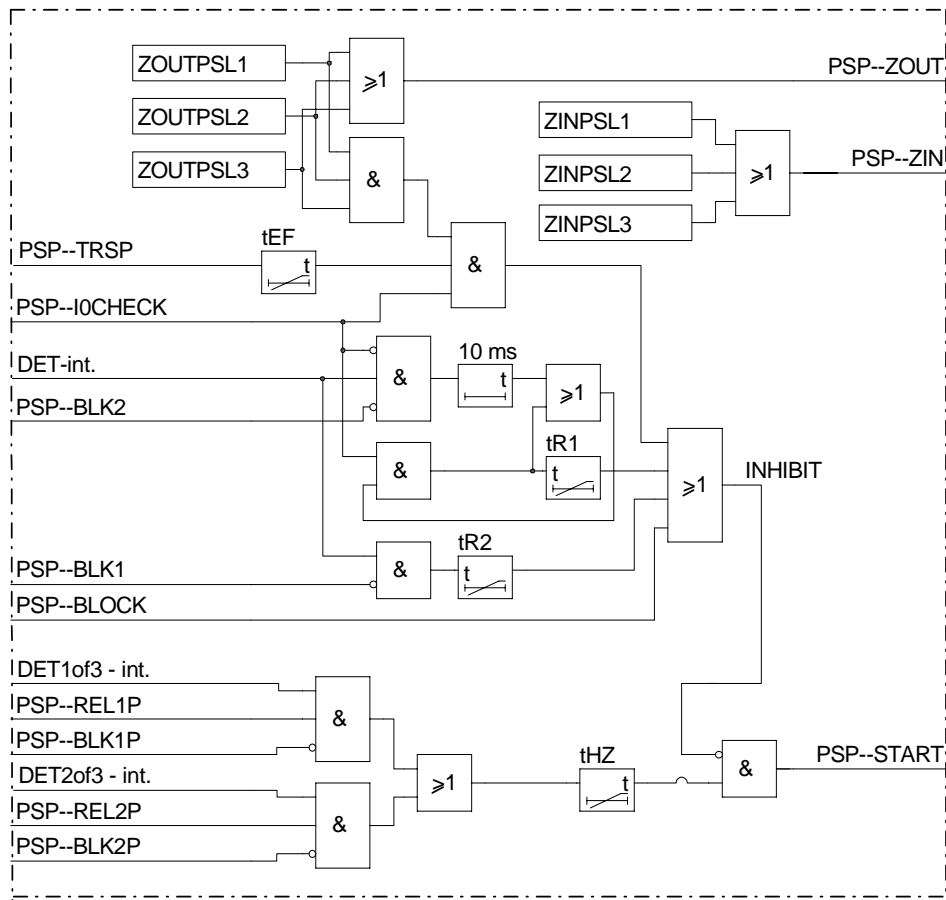

99001032.vsd

Figure 70: Logic for cooperation with distance protection function.

- 
- The PSP--START output signal is disabled after the time delay set on the tR1 timer, if the oscillation appears before the functional input signal PSP--IOCHECK becomes logical one. This way it is possible to block the PSP function and release the operation of the line distance protection, if for example, an earth fault appears in the network during the oscillations. This functionality can be disabled by the logical one signal on the PSP--BLK2 functional input.
  - The PSP--START functional input is disabled, if the measured impedance have been detected within the external operating boundary in all three phases and the PSP--IOCHECK functional input signal became logical one within the time interval shorter than the time delay set on timer tEF after the PSD--TRSP logical input changed from logical one to logical zero. This function prevents the appearance of the PSP--START output signal in cases, when one pole of the circuit breaker closes on persistent single phase fault after the single pole autoreclosing dead time, if the initial single phase fault and single pole opening of the circuit breaker causes the power swinging in the remaining two phases.

**Tripping criteria**

The complete impedance operating area is divided on two detection and two trip regions as presented schematically on figure 71. Detection area is divided on forward-reverse detection region i.e transition from forward to reverse (TRANFwRv) and reverse-forward detection region i.e transition from reverse to forward (TRANRvFw). Trip area is divided on fast trip region and delayed trip region.



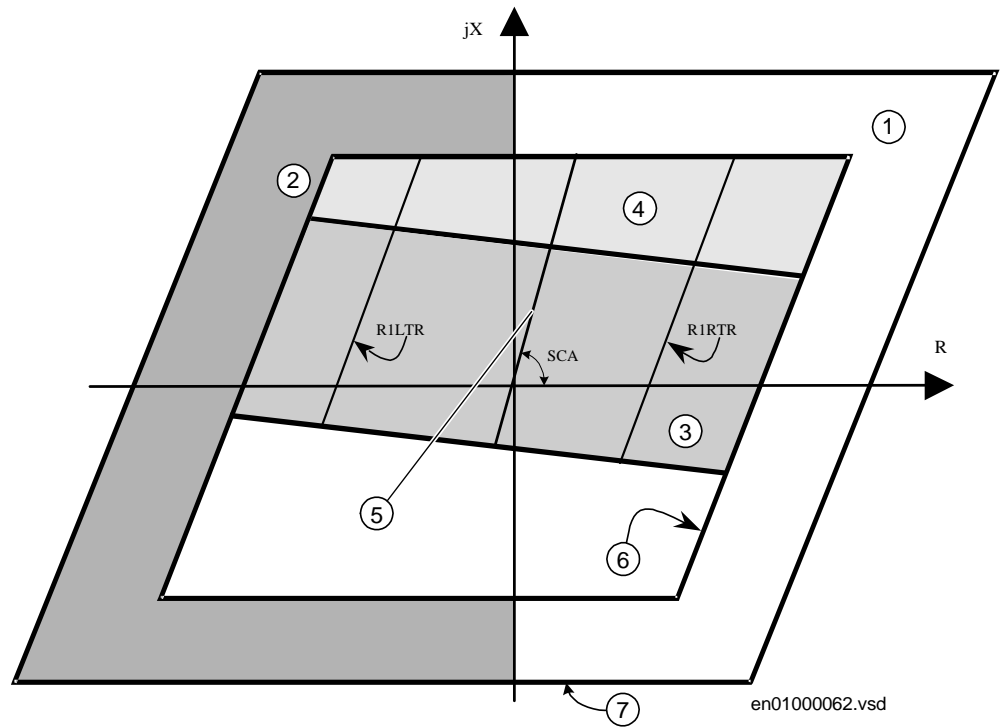

Where:

- |   |                                    |
|---|------------------------------------|
| 1 | Forward - reverse detection region |
| 2 | Reverse - forward detection region |
| 3 | Fast trip region                   |
| 4 | Delayed trip region                |
| 5 | System impedance                   |
| 6 | Internal operating boundary        |
| 7 | External operating boundary        |

*Figure 71: The impedance operating plain is divided on two detection regions and two trip regions.*

The flow charts on figure 72 and figure 73 present completely the operation of the PSP for the FwRv transitions and the RvFw transitions respectively.

PSP also provides a delayed back-up trip (TRIPSUM) for oscillation in fast or delayed region. Summation trip will work if the center of the oscillation is detected either on the protected line (fast region) or on the adjacent line (delayed region). In both cases PSP compares number of slips to nDel, therefore to enable this functionality TRFast and TRDel should be set to On. Summation trip operation is shown on figure 74 and figure 75 for the FwRv transitions and the RvFw transitions respectively.

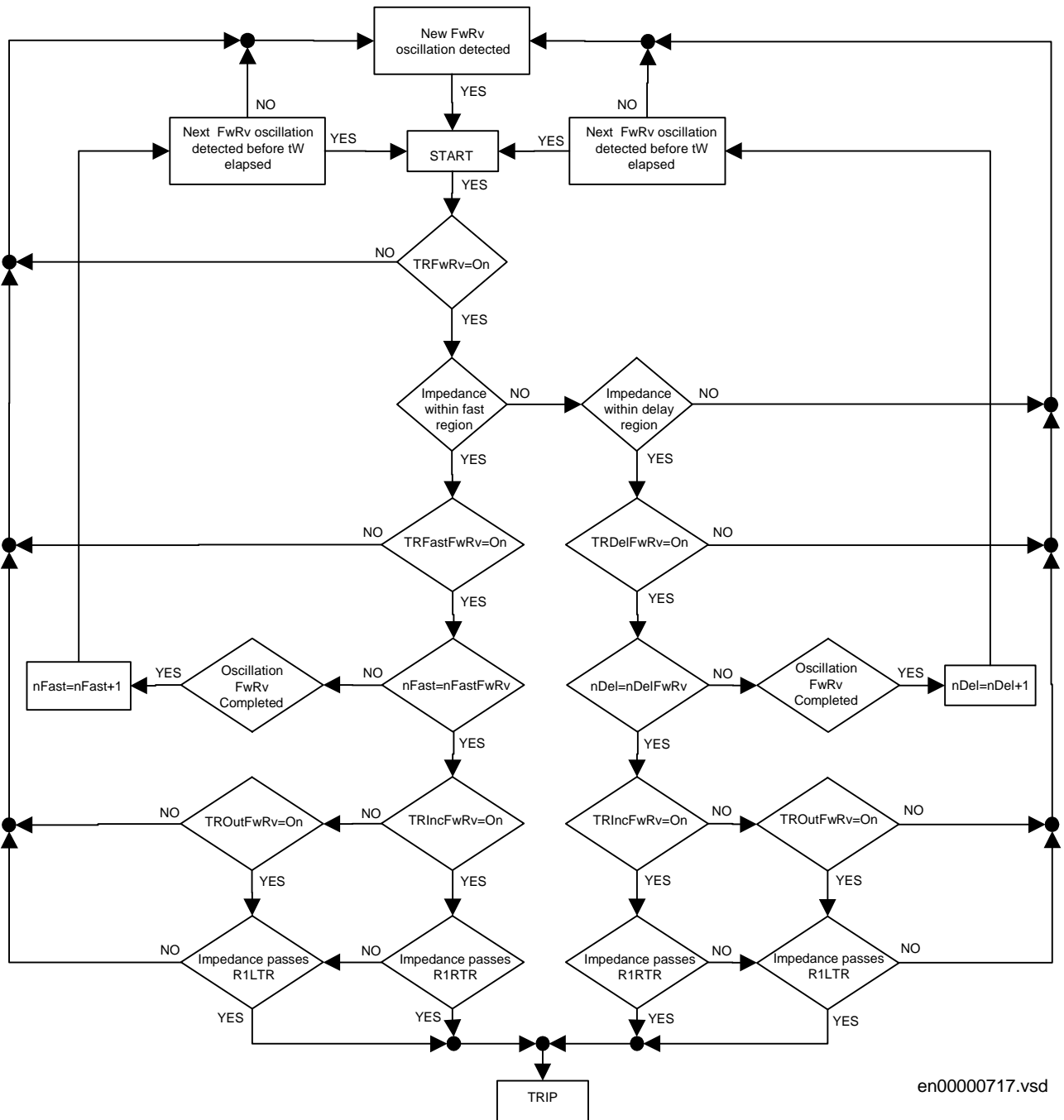

en00000717.vsd

Figure 72: Flow-chart presenting the operation of the pole slip protection for the forward to reverse transition (FwRv) after the oscillation has been detected.

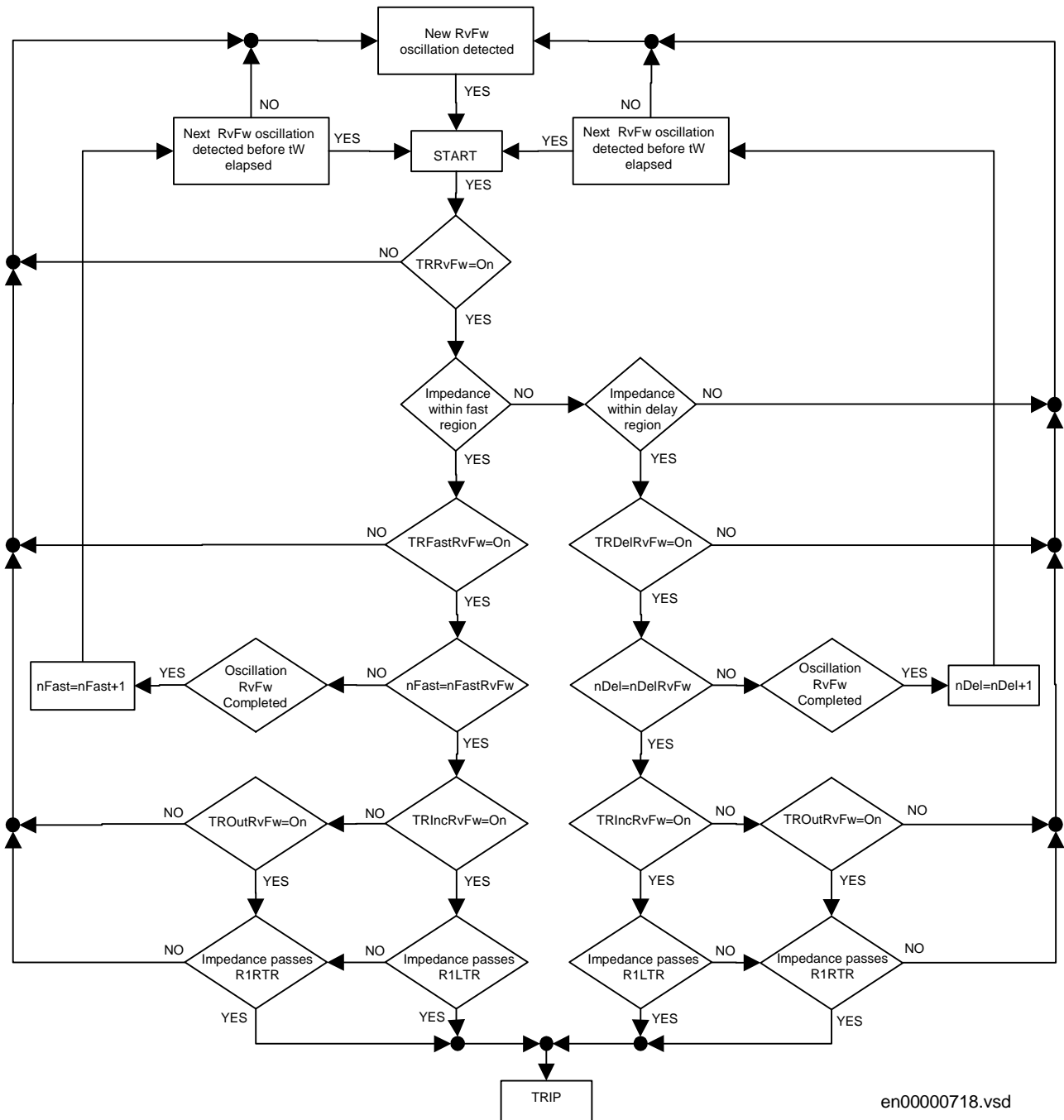

en0000718.vsd

Figure 73: Flow-chart presenting the operation of the pole slip protection for the reverse to forward transition (RvFw) after the oscillation has been detected.

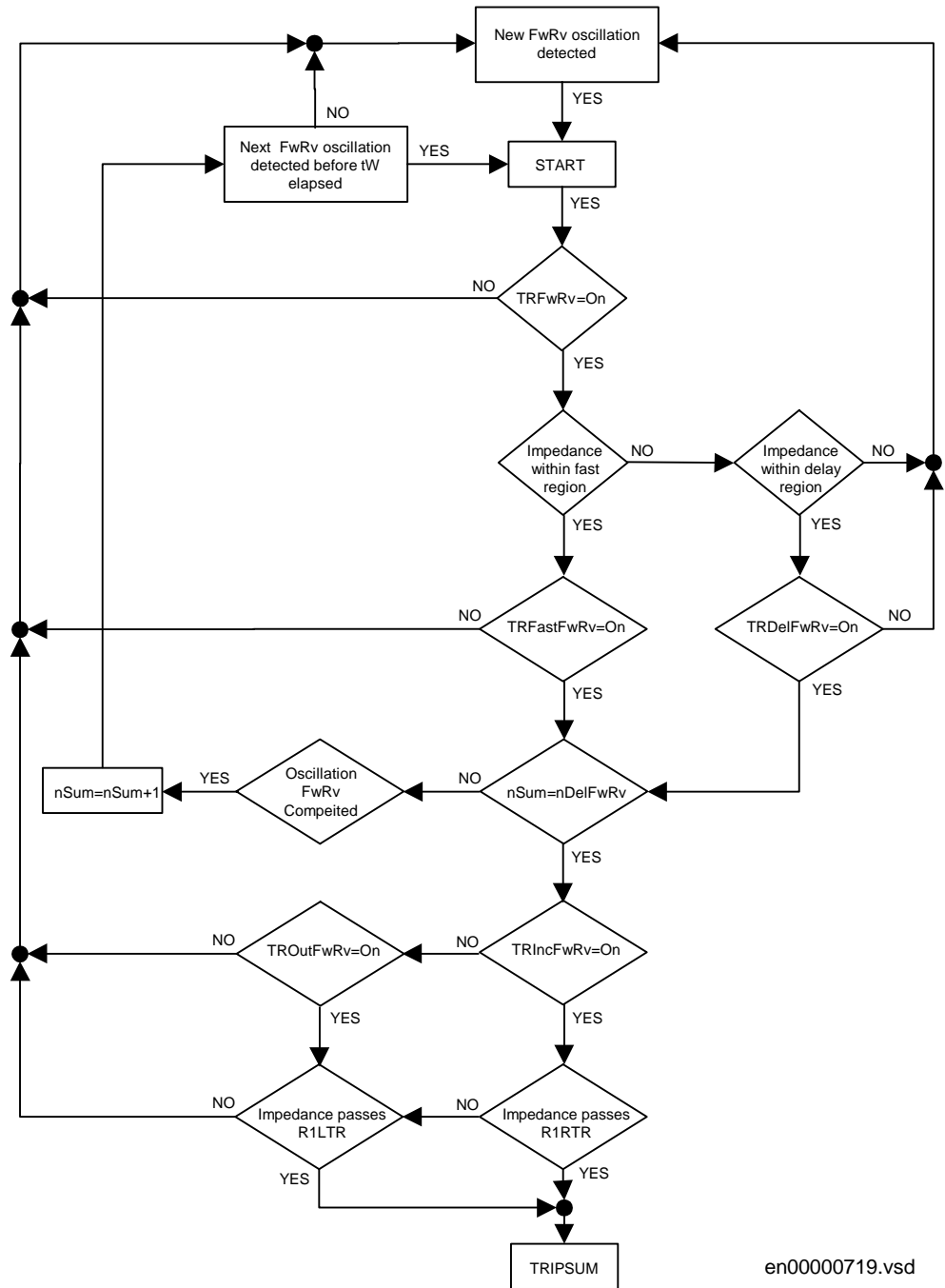
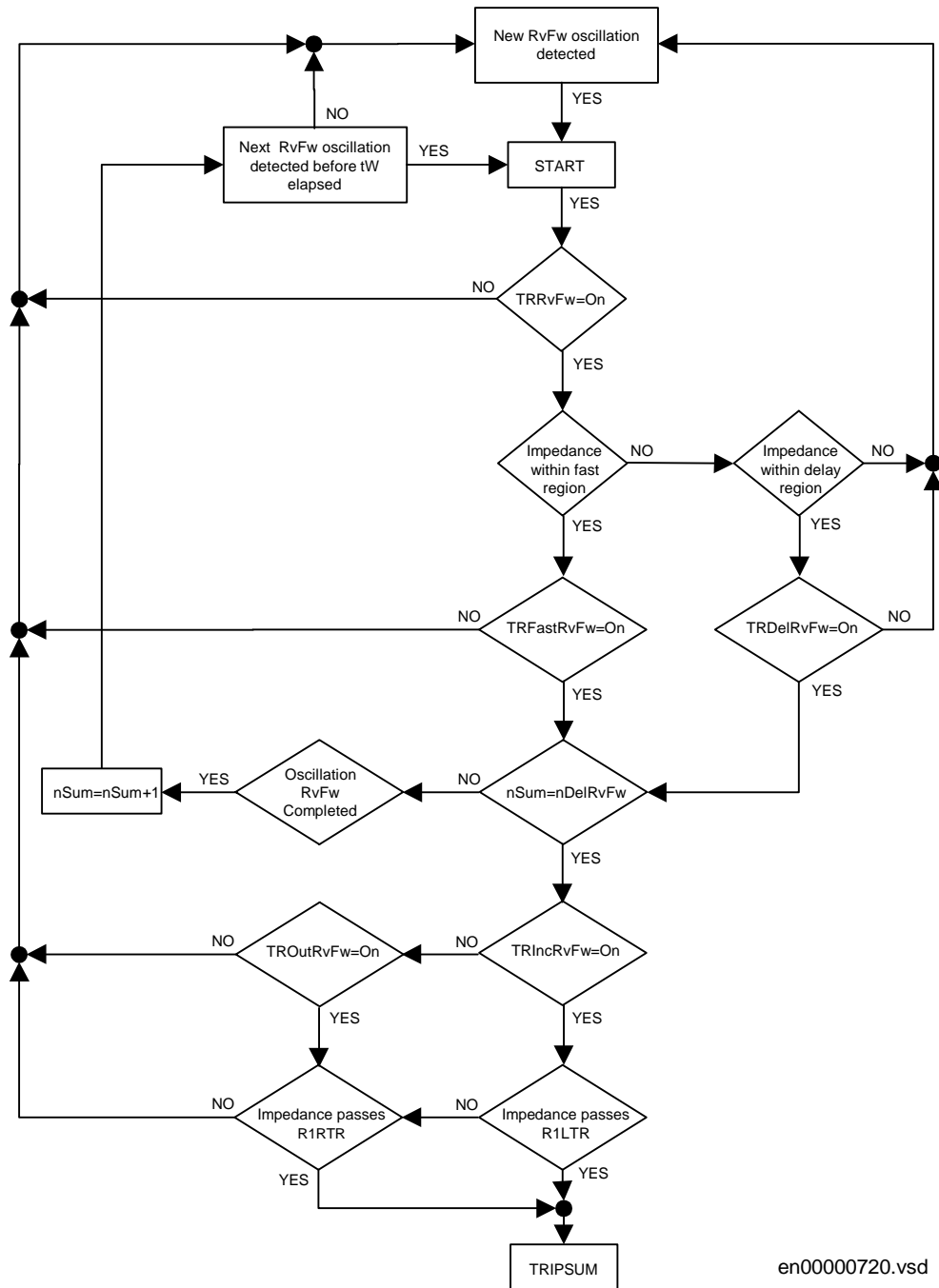

Figure 74: Flow-chart presenting summation trip (TRIPSUM) of the pole slip protection for the forward to reverse transition (FwRv).



en00000720.vsd

Figure 75: Flow-chart presenting summation trip (TRIPSUM) of the pole slip protection for the reverse to forward transition (RvFw).

## 5.4 Calculations

### 5.4.1 Setting instructions

The complete operation together with reach setting of the pole slip protection can locally be set under the menu:

**Settings**  
**Functions**  
**Group n**  
**Impedance**  
**PoleSlipProt**

#### Necessary technical data

These setting instructions are prepared as a setting example for the power network reduced to the two machine system as presented on figure 76.

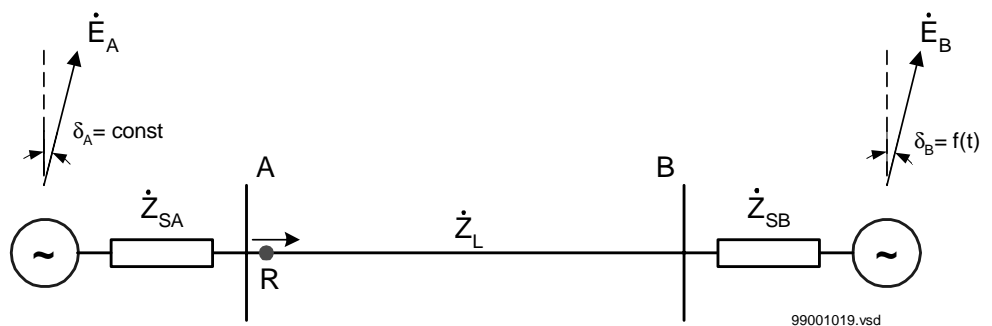

Figure 76: Power system reduced to a two machine system.

Following are the necessary technical data:

Rated system voltage:

$$U_r = 400\text{kV}$$

(Equation 133)

Minimum expected system voltage:

$$U_{\min} = 380\text{kV}$$

(Equation 134)

Rated system frequency:

$$f_r = 50\text{Hz}$$

(Equation 135)

Ratio of voltage instrument transformers:

$$\frac{U_p}{U_s} = \frac{\frac{400}{\sqrt{3}}[\text{kV}]}{\frac{0.11}{\sqrt{3}}[\text{kV}]} = 3636$$

(Equation 136)

Ratio of current instrument transformers used:

$$\frac{I_p}{I_s} = \frac{1200[\text{A}]}{1[\text{A}]} = 1200$$

(Equation 137)

Line length:

$$L = 210\text{km}$$

(Equation 138)

Line positive sequence impedance:

$$\dot{Z}_{Lp} = (10.71 + j75.6)\text{ohm}$$

(Equation 139)

Source A positive sequence impedance:



$$Z_{SAp} = (1.15 + j43.5)\text{ohm}$$

(Equation 140)

Source B positive sequence impedance:

$$Z_{SBp} = (5.3 + j35.7)\text{ohm}$$

(Equation 141)

Maximum expected load in forward direction (at minimum system voltage  $U_{\min}$ ).

$$S_{\max} = 1000\text{MVA}$$

(Equation 142)

with power factor

$$\cos(\varphi_{\max}) = 0.95$$

(Equation 143)

Maximum expected slip frequency for consecutive slips:

$$f_{s\max} = 8\text{Hz}$$

(Equation 144)

Expected initial slip frequency:

$$f_{si} = 2.5\text{Hz}$$

(Equation 145)

The required tripping angle at pole slip conditions must be between the following values (determined by the system studies and electrical characteristics of the used primary equipment):

$$\delta_{trL} \leq 115^\circ$$

(Equation 146)

$$\delta_{trR} \geq 245^\circ$$

(Equation 147)

It is supposed that similar pole slip protection device will be used on the remote line end. In such case it is suggested to program the operation of the pole slip protection for the slips in forward direction only.

The result of the system studies has shown that:

- It is possible to have one slip over the remaining two phases between both systems during the dead time of the single pole autoreclosing. It is a high probability that the system will remain stable after the successful single pole autoreclosing.
- The second slip, if detected on the protected line, should be disconnected as fast as possible. For this reason the trip in incoming mode of operation is suggested.
- The selective operation of the pole slip protections in the complete network is obtained, if the number of the remote slips is less than four, before the system is split by the pole slip protection in the observed point.

#### Impedance transformation factor

System data are generally presented by their primary values. This is also the case for this setting example. The corresponding impedance transformation factor is equal to:

$$K_{IMP} = \frac{\frac{I_p}{U_p}}{\frac{I_s}{U_s}} = \frac{\frac{1200[A]}{400[kV]}}{\frac{1[A]}{\frac{0.11[kV]}{\sqrt{3}}}} = 0.33$$

(Equation 148)

The secondary values of the corresponding impedances are equal to:

$$\dot{Z}_L = K_{IMP} \cdot \dot{Z}_{Lp} = (3.53 + j24.95) \text{ ohm}$$

(Equation 149)

$$\dot{Z}_{SA} = K_{IMP} \cdot \dot{Z}_{SAp} = (0.38 + j14.36)\text{ohm}$$

(Equation 150)

$$\dot{Z}_{SB} = K_{IMP} \cdot \dot{Z}_{SBp} = (1.75 + j11 - 78)\text{ohm}$$

(Equation 151)

**Minimum load impedance**

Minimum load impedance appears in forward direction and is calculated according to equation 152:

$$\dot{Z}_{Lmin} = \frac{(U_{min})^2}{S_{max}} \cdot K_{IMP} = 47.63\text{ohm}$$

(Equation 152)

**System impedance and center of oscillations**

The system impedance is according to equation 148 equal to:

$$\dot{Z}_S = \dot{Z}_{SA} + \dot{Z}_L + \dot{Z}_{SB} = (5.63 + j51.08)\text{ohm}$$

(Equation 153)

The system characteristic angle (equation 151) is equal to:

$$\varphi_S = \text{atan}\left(\frac{X_S}{R_S}\right) = 83.7^\circ$$

(Equation 154)

The corresponding setting of the system characteristic angle is this way:

$$SCA = 83.7^\circ$$

(Equation 155)

The center of the oscillation has the coordinates (equation 149):

$$\dot{Z}_{CO} = \frac{1}{2} \cdot \dot{Z}_S - \dot{Z}_{SA} = (2.45 + j11.19)\text{ohm}$$

(Equation 156)

**Resistive reach of the external boundary in forward direction**

The external boundary for the oscillation detection characteristic in forward direction (right side boundary) has its resistive reach equal to (equation 153).

$$R1REXT = |\dot{Z}_{Lmin}| \cdot K_L = 42.87\text{ohm}$$

(Equation 157)

We considered in this case

$$K_L = 0.9$$

(Equation 158)

because the line is longer than 150km.

The corresponding load angle is according to equation 154 equal to:

$$\delta_{ext} = 2 \cdot \text{atan} \left[ \frac{|\dot{Z}_{SA} + \dot{Z}_L + \dot{Z}_{SB}|}{2 \cdot R1REXT} \right] = 61.88^\circ$$

(Equation 159)

**Resistive reach of the internal boundary in forward direction**

We assume the setting of the first transition timer  $tP1 = 45\text{ms}$ . This brings the necessary load angle for the right internal boundary of the oscillation detection characteristic (equation 154):

$$\delta_{int} = 360^\circ \cdot f_{si} \cdot tP1 + \delta_{ext} = 102.4^\circ$$

(Equation 160)

The corresponding resistive reach setting is this way (equation 155):

$$R1RINT = \frac{|Z_{SA} + Z_L + Z_{SB}|}{2 \cdot \tan\left(\frac{\delta_{int}}{2}\right)} = 20.69 \text{ohm}$$

(Equation 161)

It is necessary to check that this operating characteristic (see “Application”, boundary 2 on figure 1) covers completely the distance protection zones, which should be blocked during the power swings in system, if the pole slip protection is used also for these purposes. In this particular case we check only the primary fault resistance, which could be covered by the corresponding distance protection zones:

$$R_{FP} = \frac{1}{KIMP} \cdot R1RINT \cdot 0.95 = 59.5 \text{ohm}$$

(Equation 162)

This resistive reach satisfies in most practical cases for the resistive covering of the distance protection zones one and two. Factor 0.95 in equation 162 is considered as a safety factor. In this way we can keep the setting of the first transition timer to  $tP1 = 45\text{ms}$ .

#### Setting of the tP2 timer

The tP2 timer serves the detection of (generally faster) consecutive slips. Its setting is calculated according to equation 157 and the specified value of the maximum expected slip frequency:

$$tP2 = \frac{\delta_{int} - \delta_{ext}}{360^\circ \cdot f_{sm}} = 14\text{ms}$$

(Equation 163)

The required value is well over the minimum suggested value of 10ms. The maximum detectable slip frequency with setting of the tP2 timer equal to  $tP2_{min} = 10\text{ms}$  and with unchanged settings of the impedance oscillation detection boundaries is equal to:

$$f_{smax} = \frac{\delta_{int} - \delta_{ext}}{360^\circ \cdot tP2_{min}} = 11.25\text{Hz}$$

(Equation 164)

This is a very high value, which usually does not appear in a real power system.

**Settings of the reverse oscillation detection resistive boundaries**

It has been mentioned that the similar pole slip protection device is intended to be used at the remote line end. The maximum load in reverse direction is also much smaller than in forward direction. The system requirements require this way only the operation for the pole slips with their electrical center in forward direction. The reverse (left side) resistive reach of the oscillation detection characteristics can be for this reason equal to the one in forward direction:

$$R1LEXT = R1REXT = 42.87\text{ohm}$$

(Equation 165)

$$R1LINT = R1RINT = 20.69\text{ohm}$$

(Equation 166)

**Setting of the right and left tripping characteristics**

The necessary setting of the resistive reach for the right tripping characteristic is calculated according to equation 161 and equation 162:

$$Z1\dot{R}TR = \frac{1}{2} \cdot Z_S \cdot \left[ 1 - \frac{j}{\tan\left(\frac{\delta_{trR}}{2}\right)} \right] - Z_{SA} = (18.72 + j9.38)\text{ohm}$$

(Equation 167)

$$R1RTR = \text{Re}\langle Z1\dot{R}TR \rangle - \text{Im}\langle Z1\dot{R}TR \rangle \cdot \tan(90^\circ - \varphi_S)$$

(Equation 168)

$$R1RTR = 17.68 \text{ ohm}$$

(Equation 169)

The condition  $R1RTR < R1RINT$  is in this way fulfilled.

Necessary setting of the resistive reach for the left tripping characteristic is calculated according to equations.

$$Z1\dot{L}TR = \frac{1}{2} \cdot Z_S \cdot \left[ 1 + \frac{j}{\tan \left( 180^\circ - \frac{\delta_{trL}}{2} \right)} \right] - Z_{SA}$$

(Equation 170)

$$Z1\dot{L}TR = (18.72 + j9.38)\text{ohm}$$

(Equation 171)

$$R1LTR = \text{Re}(Z1\dot{L}TR) + \text{Im}(Z1\dot{L}TR) \cdot \tan(90^\circ - \varphi_S)$$

(Equation 172)

$$R1LTR = 19.76\text{ohm}$$

(Equation 173)

The condition  $R1RTR < R1RINT$  is in this way fulfilled.

### Setting of the reactive tripping characteristics

The reactive operating characteristics are presented in “Application”, figure 1, and marked by 5 for the operation in forward direction and by 6 for the operation in reverse direction.

Since it is required to operate only for the pole slip situation with centers of slips in forward direction, and because a similar device will be used at the remote line terminal, only the operation for the transition from forward to reverse direction (FwRv) is required. This kind of operation does not require any reverse reach. It is recommended for this reason to set the corresponding setting parameters to their minimum values.

$$R1PSLRv = 0.1\text{ohm}$$

(Equation 174)

$$X1PSLRv = 0.1\text{ohm}$$

(Equation 175)

The tripping characteristic in forward direction should cover the slips with their electrical center on the protected power line. 10% of safety margin is sufficient in order not to overreach for the slips with their centers on the adjacent power lines. The necessary settings are equal to:

$$R1PSLFw = 0.9 \cdot \operatorname{Re}(\dot{Z}_L) = 3.18 \text{ohm}$$

(Equation 176)

$$X1PSLFw = 0.9 \cdot \operatorname{Im}(\dot{Z}_L) = 22.45 \text{ohm}$$

(Equation 177)

### Setting of the reactive reach of the oscillation detection characteristics

The reactive reach of the oscillation detection characteristic should cover in forward and in reverse direction with sufficient margin (10 to 15%) the power lines and other elements, for which the pole slip protection should provide also the back up protection for the slips with remote centers of the oscillations. System studies should determine the necessary reach as well as the number of permitted remote slips more in details.

We assume in this example that the pole slip protection should also block the operation of the distance protection zones one and two. Zone two must be set to at least 120% of the protected line. The necessary reactive reach of the internal boundary in the forward direction is this way equal to:

$$X1FINT = 1.15 \cdot 1.2 \cdot \operatorname{Im}(\dot{Z}_L) = 34.43 \text{ ohm}$$

(Equation 178)

Reactive reach of the external oscillation detection boundary should permit the same speed of detected slips as the one determined in the resistive direction. We can even provide some additional margin (5%).

$$X1FEXT = 1.05 \cdot (R1REXT - R1RINT) + X1FINT$$

(Equation 179)

$$X1FEXT = 57.73 \text{ohm}$$

(Equation 180)



Setting of the reactive reach in the reverse direction depends on the system conditions. In our case we do not need to cover any special distance protection zone. It is also not necessary to operate for the slips with their center in the reverse direction, since the remote end pole slip protection takes care of such cases.

It is anyway suggested to set the reactive reach in reverse direction to at least 10% of the one in forward direction. The impedance difference between the internal and the internal boundary should also in this case permit detection of the same slip frequency as in the forward direction. The necessary values are:

$$X1RINT = 0.1 \cdot X1FINT = 3.44 \text{ ohm}$$

(Equation 181)

$$X1REXT = 1.05 \cdot (R1REXT - R1RINT) + X1RINT$$

(Equation 182)

$$X1REXT = 26.75 \text{ ohm}$$

(Equation 183)

### Setting of the tW waiting timer

Setting of the waiting timer influences the detection of the consecutive slips. The tW timer must be set higher than the time the measured impedance needs after leaving the impedance detection area and entering it again on the other side of the impedance plain. It is necessary to consider the minimum possible speed of the oscillations, which might occur in the system. The time necessary for the impedance to move from the internal left impedance boundary (after the FwRv transition has been completed) to the external right impedance boundary (to start the detection of the new oscillation) is calculated according to the equation:

$$tW = 1.3 \cdot \frac{\delta_{Rext} + (360^\circ - \delta_{Lint})}{360^\circ \cdot f_{smin}} = 1.79 \text{ s}$$

(Equation 184)

Where:

$\delta_{\text{Rext}}$	Corresponding load angle at the right external resistive boundary (in our case they equal to 61.9 deg)
$\delta_{\text{Lint}}$	Corresponding load angle at the left internal resistive boundary (in our case equal to 298.1 deg)
$f_{\text{smin}}$	Minimum expected slip frequency in a system (should not be considered less than 0.2 Hz)

Factor 1.3 is a safety factor, which could be considered also in most other cases, when the exact technical characteristics of the system are not known.

### Setting of the tripping modes and the transition counters

The pole slip protection should according to the system requirements operate only for the slips with their electrical center on the protected power line and for the transitions from the forward to the reverse direction. It is for this reason necessary to set the parameters related to the reverse to forward (RvFw) transition to the following values:

- TrRvFw = Off
- TrIncRvFw = Off
- TrOutRvFw = Off
- TrFastRvFw = Off
- TrDelRvFw = Off
- nFastRvFw = 10
- nDelRvFw = 10

According to the results of the system studies the following settings are applicable for the transitions detected from forward to the reverse direction:

- TrFwRv = On
- TrIncFwRv = On
- TrOutFwRv = Off
- TrFastFwRv = On
- TrDelFwRv = On
- nFastFwRv = 1
- nDelFwRv = 3

**Additional timers in the oscillation detection circuits**

Timers  $t_{R1}$ ,  $t_{R2}$ ,  $t_{EF}$ , and  $t_{HZ}$  are used in the oscillation detection logic (see figure in “Design”) to suit the oscillation detection to different system conditions. Their settings must be co-ordinated with the time delays set on different protection devices, like distance protection, directional or non directional residual overcurrent protection, dead time of the single pole autoreclosing, etc.

 **$t_{HZ}$  hold timer**

The  $t_{HZ}$  hold timer prolongs the duration of the PSP--START signal, which can be used for blocking the distance protection zones. Its setting should be with a certain margin (10 to 15%) longer than the time required for the detection of the consecutive slips with fastest slip frequency in a system. In our case the required value is equal to:

$$t_{HZ} = 1.15 \cdot \frac{1}{f_{sm}} = 144 \text{ ms}$$

(Equation 185)

 **$t_{R1}$  inhibit timer**

The  $t_{R1}$  inhibit timer delays the influence of the detected residual current  $3 \cdot I_0$  on the inhibit criteria for the PSP function. It prevents the operation of the function for short transients in the residual current as measured by the terminal. The time delay of 50 ms is suggested as default, when the residual current criteria is used.

 **$t_{R2}$  inhibit timer**

The  $t_{R2}$  inhibit timer disables the output PSP--START signal, if the measured impedance remains within the impedance detection area for more than the set time. This time delay is generally set to 2 seconds, when used in the protection.

 **$t_{EF}$  timer**

The setting of the  $t_{EF}$  timer must cover with sufficient margin the opening time of the associated circuit breaker and the dead time of the single pole autoreclosing together with the circuit breaker closing time.

## 6 Radial feeder protection (PAP)

### 6.1 Application

The most common application of Radial feeder protection is to provide tripping at the remote end of lines with passive load or with weak end infeed.

The radial feeder protection function must be included in the terminal at the weak in-feed end of the feeder.

Permissive communication schemes can basically operate only when the protection at the remote end of a feeder can detect the fault. The detection requires a minimum of fault current, normally  $> 20\%$  of  $I_r$ .

The fault current can be low due to absence of generated power or low short circuit current of the source.

The fault current can initially be too low due to the fault current distribution.

In this case the fault current increases when the breaker opens at the strong line end, and a sequential tripping is achieved.

The detection of the fault by an independent tripping zone 1 is then required.

To avoid sequential tripping as described or when zone 1 is not available, the protection terminal must be provided with the radial feeder protection function.

### 6.2 Functionality

The radial feeder protection function performs phase selection using the measured voltages.

The selection logic is common for both fast and delayed tripping. The fast tripping makes use of scheme communication whilst the delayed tripping operates independently. The latter is activated in case of failure of the communication channel.

---

On reception of the communication signals, the phase selective tripping outputs are activated on the relevant faulty phases. At single-phase fault the tripping can be subject to residual current check. The delay time is independently settable for single-pole and three-pole tripping. Furthermore it is possible to select or not the three-pole tripping as well to select three-pole tripping also for single-phase fault. Fault on more than one phase will always result in a three-pole tripping. In case of fuse failure, the normal single and three-phase operation is inhibited, but three-pole tripping will anyhow occur if the residual current exceeds the set level for a longer time than the three-pole trip delay time  $t_T$ .

## 6.3

### Design

The function consists of two subfunctions.

- one measuring part evaluating the measurands
- one logical part processing internal and external signals

The logical part consists of four subfunctions.

- fast fault clearing
- delayed fault clearing
- detection of residual current
- generation of commands for breaker tripping and autorecloser starting

#### Measuring functions

The inputs for the measuring function are the three-phase voltages  $UL1$ ,  $UL2$ ,  $UL3$  and either the three-phase currents  $IL1$ ,  $IL2$ ,  $IL3$  or the residual current  $IN$

#### Phase selection

The phase selection is based on voltage measurement. The logical flow for phase L1 is shown in figure 77:

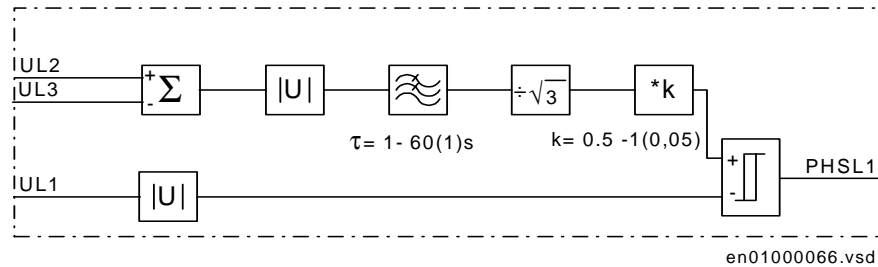

Figure 77: Phase selection function

The phase selection for phase L2 and L3 is performed in the same way. The function operates by comparing each phase voltage e.g. UL1 with the perpendicular main voltage UL2 – UL3. The magnitude of phase – phase voltage is monitored by feeding the full-wave rectified signal through a filter. This updates continuously the output voltage if it is lower than the input voltage but when the input signal is lower than the output this will decrease according to an exponential function with a time constant settable between 1 and 60 s. See figure 78:

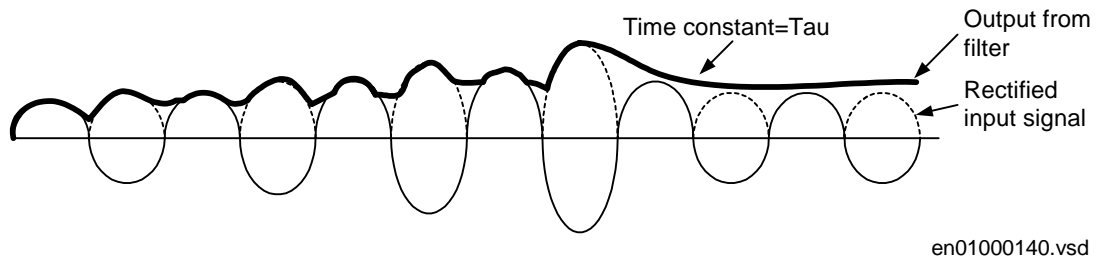

Figure 78: Filtering function

The phase selection time becomes <40 ms when the phase voltage drops below 70 % of the setting for phase – phase voltage.

#### Residual current detection

The magnitude of the neutral current  $I_N$  is obtained by summing the three-phase currents or it is directly detected by an appropriate monophasic current transformer. See figure 79:

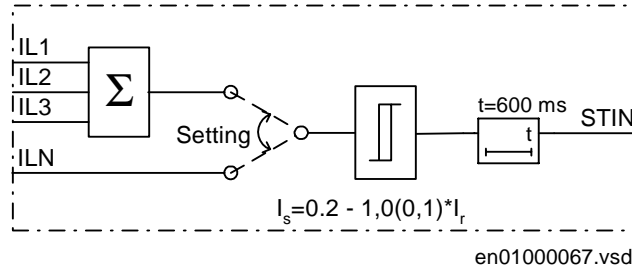

Figure 79: Residual current measurement

The choice between using the sum of phase currents or the residual current is made by setting. The residual current detection time is <40 ms when the current exceeds 150 % of the set level.

**Function for fast fault clearing**

The logic diagram for this function is shown in figure 80:

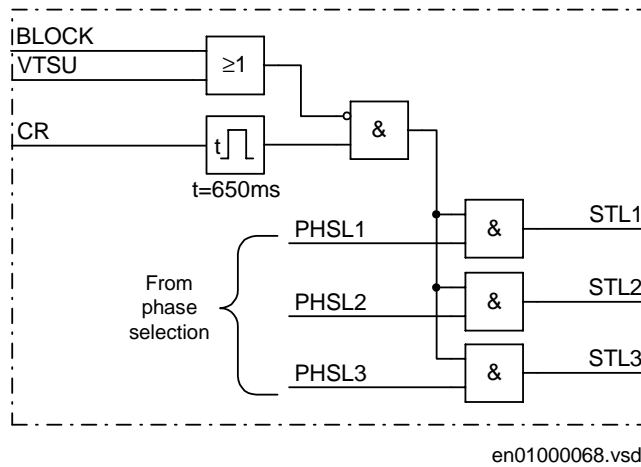
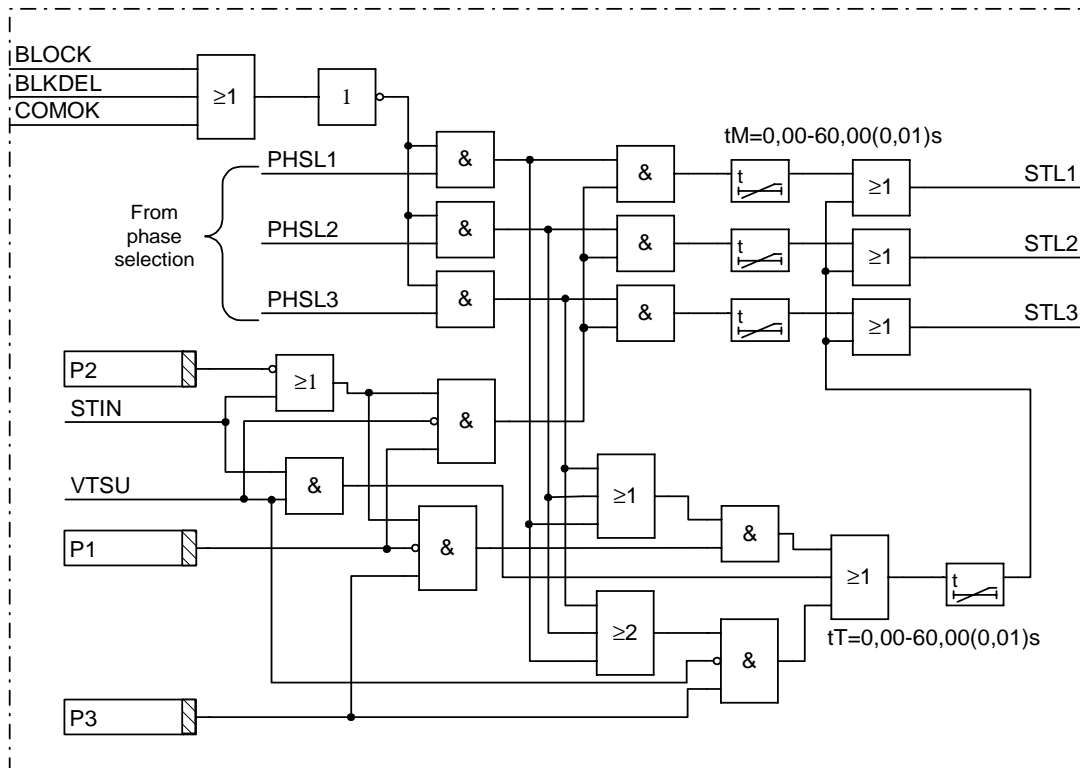

Figure 80: Function for fast fault clearing

Tripping at the remote end of lines with passive load or with weak end infeed is obtained with the following criteria: The fault clearing is initiated by a received signal from the remote end terminal. The function is enabled for 650 ms after the signal is received. This is a “one shoot” circuit, i.e. once the pulse element is triggered it will emit a single pulse regardless of successive triggering under the set time. If no blocking signal is present, (BLOCK + VTSU where VTSU is fuse failure detection signal), the “and” circuits, will generate the start signals STL1, STL2 or STL3, depending on the status of the phase selection outputs PHSL1, PHSL2, PHSL3. The presence of either the signal BLOCK or VTSU will inhibit the operation.

**Function for delayed fault clearing**

This function entails a slower tripping than the remotely initiated tripping time. See figure 81:



en01000069.vsd

Figure 81: Function for delayed fault clearing



The inputs BLOCK (block of radial feeder protection) BLKDEL (block of delayed fault clearing) and COMOK (telecommunication link healthy) inhibit the delayed function. In case of fuse failure, signal VTSU high, the normal single and three-phase operation is inhibited. If during a fuse failure the residual current signal STIN is high for a longer time than the three-phase trip time  $t_T$ , a three-phase tripping will occur. The settings P1, P2, P3, control the operating mode of the delayed fault clearing according to table 1 Selection of operating mode.

**Table 6: Selection of operating mode**

Parameter	Selection	On	OFF
P1	Del1PhFitTrip	Single-phase tripping for single-phase fault in time $t_M$	Three-phase tripping for single-phase fault in time $t_T$
P2	ResCurrCheck	Single-phase operation with residual current check	Single-phase operation without residual current check
P3	Del3PhTrip	Time delayed trip for three-phase fault	No time delayed trip for three-phase fault

For a better understanding of figure 81 see also tables 2.3.4 in section 4 Appendix

#### Function for residual current detection

This function indicates the presence of residual current when its value exceeds the set level for a longer time than the set time  $t_{PIR}$ , see figure 82:

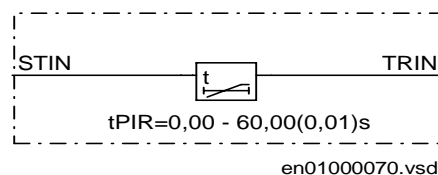

*Figure 82: Function for residual current detection*

#### Trip and autorecloser start logic

The start signals STL1, STL2, STL3, are generated in the function for fast fault clearing and delayed fault clearing. A trip signal will be issued in the relevant faulty phase(s), TRL1, TRL2, TRL3. The general trip signal TRIP will also be issued. These output signals will activate the standard trip functions included in the protection terminal. Both the minimum length of the trip pulse and the command for a three-phase trip at two

phase start are controlled in the logic of the normal trip circuitry. The single/three-phase operation of the autorecloser depends on the status of the C.B signal CBCLOSED and on the existence of pole discrepancy signal POLDISC. If the conditions for a reclosing are fulfilled, a start signal will be issued in the concerned phase(s) ARSTL1, ARSTL2 and ARSTL3. A general start signal, ARSTART will also be issued. In the case of multiphase fault the issued signal will be ARST3P. The functional diagram of the relevant logic is shown in figure 83.

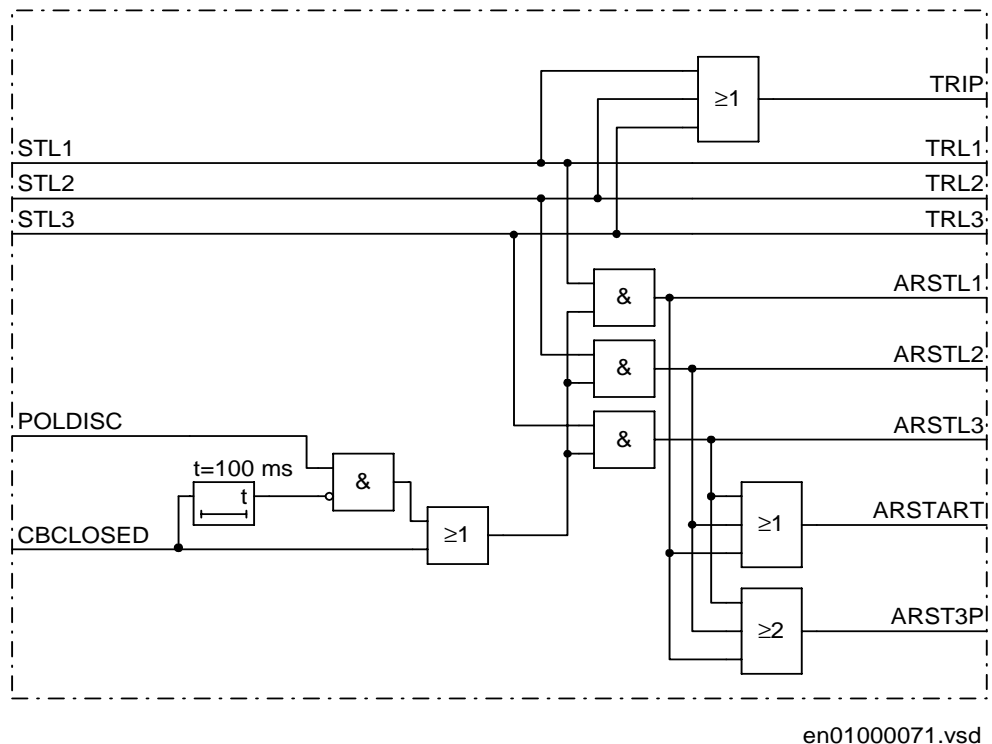

Figure 83: Trip and autorecloser start logic

## 6.4

### Calculations

#### Setting instructions

The phase selection logic and residual current measurement are set in the menu under :

#### Settings

#### Functions

#### Group (n)

#### RadialFeederP

# Chapter 5 Current

## **About this chapter**

This chapter describes the current protection functions.

---

# 1 Instantaneous overcurrent protection (IOC)

## 1.1 Application

Long transmission lines often transfer great quantities of electrical power from production to consumption areas. The unbalance of the produced and consumed electrical power at each end of the transmission line is very large. This means that a fault on the line can easily endanger the stability of a complete system.

The transient stability of a power system depends mostly on three parameters (at constant amount of transmitted electrical power):

- The type of the fault. Three-phase faults are the most dangerous, because no power can be transmitted through the fault point during fault conditions.
- The magnitude of the fault current. A high fault current indicates that the decrease of transmitted power is high.
- The total fault clearing time. The phase angles between the EMFs of the generators on both sides of the transmission line increase over the permitted stability limits if the total fault clearing time, which consists of the protection operating time and the breaker opening time, is too long.

The fault current on long transmission lines depends mostly on the fault position and decreases with the distance from the generation point. For this reason the protection must operate very quickly for faults very close to the generation (and relay) point, for which very high fault currents are characteristic.

For this reason instantaneous, non-directional, phase-segregated, overcurrent protection (IOC), which can operate in 15 ms (50 Hz nominal system frequency) for faults characterized by very high currents, is included in some of the REx 5xx terminals. Refer to the ordering information for more details.

The conventional distance protection can manage the fault clearance of earth-faults in most of the cases. In some applications, especially applications with long lines, the clearance can be improved by use of an instantaneous earth-fault protection. Those are for instance:

- In the case of high infeed of fault current from the opposite end of the line, this might increase the fault resistance seen by the distance relay to such a value that the instantaneous step of the distance protection will not operate.
- In applications with series compensated lines, where the capacitor is located at the end of the line and very strong infeed of fault current from that end, will result in a difficult problem for the distance protection to perform a selective fault clearance. This due to the voltage reversal that might occur.

The use of instantaneous overcurrent earth-fault protection is most suitable for long lines in meshed transmission systems. It can also be used for radial lines with low fault current infeed from the opposite end of the line.

The instantaneous residual overcurrent function is very suitable as back-up protection for phase to earth faults close to the terminal. This enables a short back-up faults clearance time for the phase to earth faults with high fault current.

The instantaneous, non-directional, earth-fault overcurrent protection (IOC), which can operate in 15 ms (50 Hz nominal system frequency) for faults characterized by very high currents, is included in some of the REx 5xx terminals. Refer to the ordering information for more details.

## 1.2

### Functionality

The current-measuring elements within one of the built-in digital signal processors continuously measure the current in all three phases, and compare them with the IP>> set value. The logical value of each phase current signal on the output of the digital signal processor (STIL1, STIL2 and STIL3 respectively) is equal to 1 if the measured phase current exceeds the preset value.

The measuring technic is based on measuring of the incoming residual current to the terminal.

The current-measuring elements within one of the built-in digital signal processors continuously measure the zero sequence current, and compare it with the IN>> set value. A recursive Fourier filter filters the current signals, and a separate trip counter prevents high overreaching of the measuring elements. The logical value of the signal on the output of the digital signal processor (IOC--STIN) is equal to 1 if the measured zero sequence current exceeds the pre-set value.

## 1.3

### Design

The simplified logic diagram of the instantaneous phase overcurrent function is shown in figure 84.

The overcurrent function is disabled if:

- The terminal is in TEST mode (TEST-ACTIVE is high) and the function has been blocked from the HMI (BlockIOC=Yes)
- The input signal IOC--BLOCK is high.

The IOC--BLOCK signal is a blocking signal of the instantaneous phase overcurrent function. It can be connected to a binary input of the terminal in order to receive a block command from external devices or can be software connected to other internal functions of the terminal itself in order to receive a block command from internal functions. Through OR gate it can be connected to both binary inputs and internal function outputs. The IOC--BLOCK signal blocks also the instantaneous residual overcurrent function, if this is installed in the terminal.

When the instantaneous phase overcurrent function is enabled, the output tripping signals IOC--TRL1, IOC--TRL2, IOC--TRL3, IOC--TRP and IOC--TRIP can operate. The duration of each output signal is at least 15 ms. This enables continuous output signals for currents, which go just a little above the set operating value.

The single phase trip signals IOC--TRL1, IOC--TRL2, and IOC--TRL3 are related to L1, L2, and L3 phases and therefore also suitable for the single phase tripping with single-phase auto-reclosing.

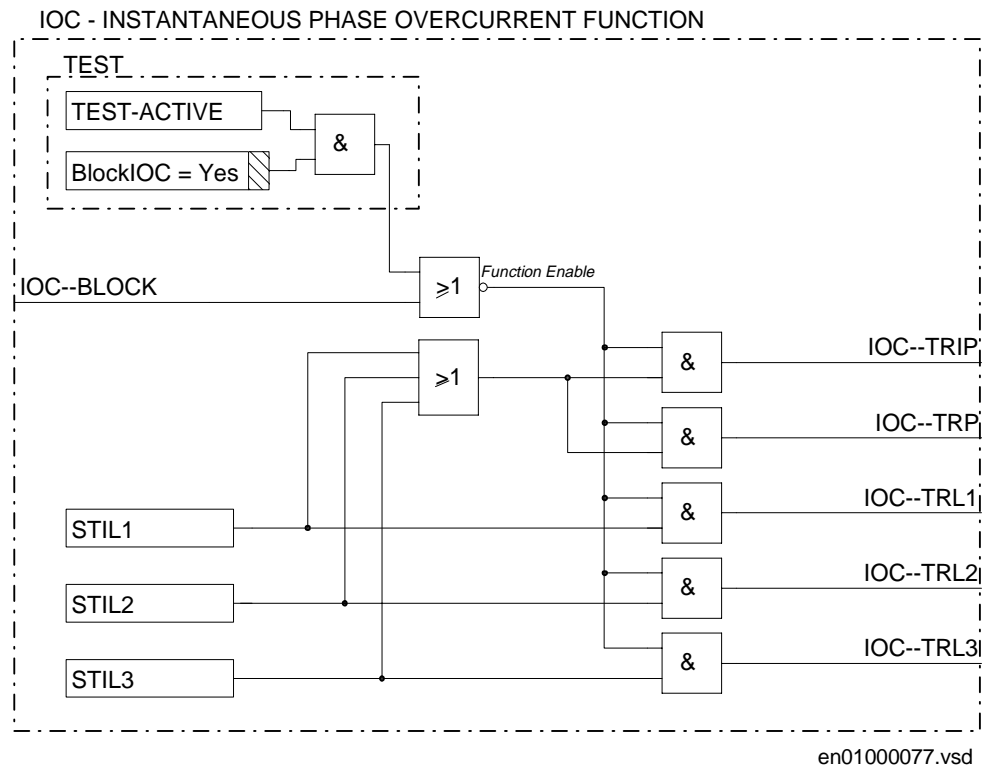

Figure 84: Simplified logic diagram of instantaneous overcurrent protection

The signal IOC--TRP is the logic OR of the three single phase trips. It can be used to trip the circuit breaker if only three phase operation is desired.

The IOC--TRIP output signal behaves as general instantaneous overcurrent trip when in the REx 5xx terminal also the instantaneous residual overcurrent function is implemented; i.e. this signal will be activated in case of any single phase overcurrent or residual overcurrent detection. If only the instantaneous phase overcurrent function is installed in the terminal, then this signal behaves exactly as the signal IOC--TRP and can be used for signalization.

The simplified logic diagram of the instantaneous phase overcurrent function is shown in figure 85.

The overcurrent function is disabled if:

- The terminal is in TEST status (TEST-ACTIVE is high) and the function has been blocked from the HMI (BlockIOC=Yes)
- The input signal IOC--BLOCK is high.

The IOC--BLOCK signal is a blocking signal of the overcurrent function. It can be connected to a binary input in order to receive a block command from external devices or it can be configured (software connection) to other internal functions within the terminal itself, in order to receive a block command from internal functions. Through OR gates it can be connected to both binary inputs and internal function outputs.

When the overcurrent function is enabled, the output tripping signals IOC--TRN and IOC--TRIP can operate. The duration of each output signal is at least 15 ms. This enables continuous output signals for currents, which go just beyond the set operating value.

The IOC--TRN signal is related to the residual overcurrent trip.

The IOC--TRIP output signal behaves as general instantaneous overcurrent trip when in the REX 5xx terminal also the instantaneous phase overcurrent function is implemented. I.e. this signal will be activated in case of residual overcurrent detection or in case of any single-phase overcurrent detection (IOC--STIL\_: IOC--STIL1 or IOC--STIL2 or IOC--STIL3). If only the residual overcurrent function is implemented in the terminal, then this signal behaves exactly as the signal IOC--TRN and can be used for signalling.



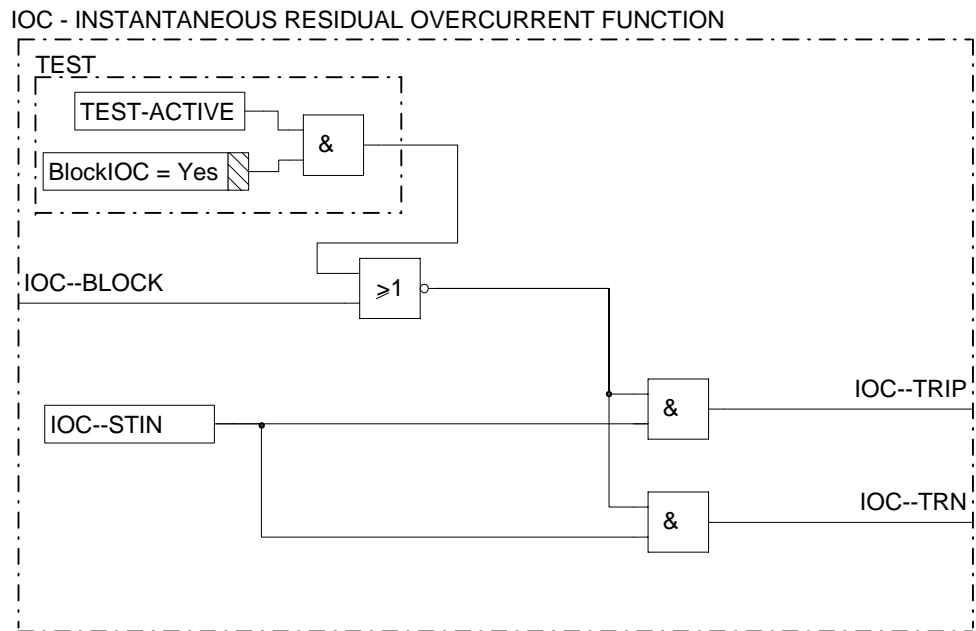

en01000078.vsd

Figure 85: Simplified logic diagram of instantaneous residual overcurrent protection.

## 1.4

### Calculations

#### 1.4.1

##### Setting instructions

This protection function must operate only in a selective way. So check all system and transient conditions that could cause its unwanted operation.

Only detailed network studies can determine the operating conditions under which the highest possible fault current is expected on the line. In most cases, this current appears during three-phase fault conditions. But also examine single-phase-to-earth and two-phase-to-earth conditions.

Also study transients that could cause a high increase of the line current for short times. A typical example is a transmission line with a power transformer at the remote end, which can cause high inrush current when connected to the network and can thus also cause the operation of the built-in, instantaneous, overcurrent protection.

**Meshed network without parallel line**

The following fault calculations have to be done for three-phase, single-phase-to-earth and two-phase-to-earth faults. With reference to figure 86, apply a fault in B and then calculate the relay through fault phase current  $I_{fB}$ . The calculation should be done using the minimum source impedance values for  $Z_A$  and the maximum source impedance values for  $Z_B$  in order to get the maximum through fault current from A to B.

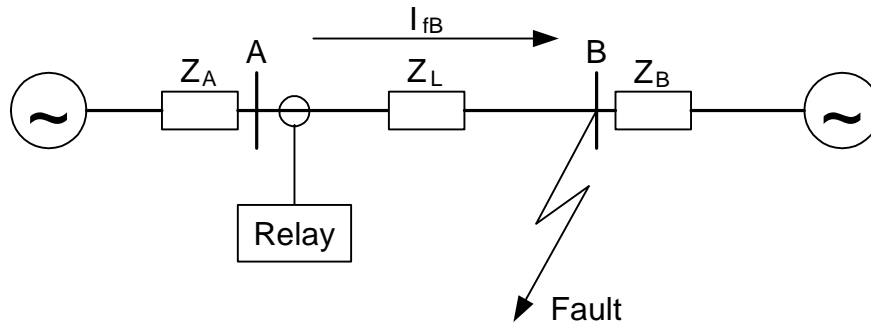

99000474.vsd

Figure 86: Through fault current from A to B:  $I_{fB}$

Then a fault in A has to be applied and the through fault current  $I_{fA}$  has to be calculated (Figure 87). In order to get the maximum through fault current, the minimum value for  $Z_B$  and the maximum value for  $Z_A$  have to be considered.

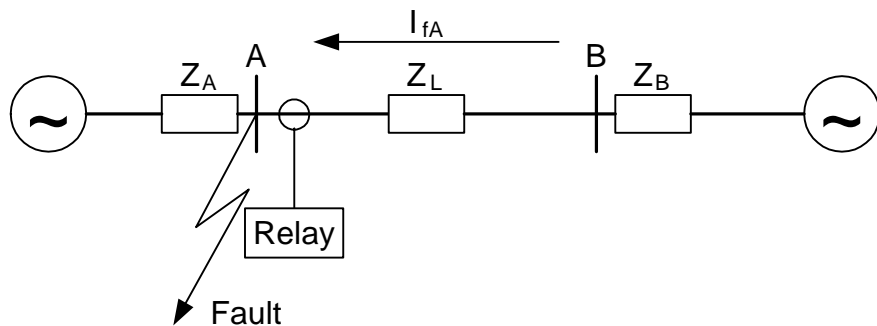

99000475.vsd

Figure 87: Through fault current from B to A:  $I_{fA}$

The relay must not trip for any of the two trough fault currents. Hence the minimum theoretical current setting ( $I_{min}$ ) will be:

$$I_{min} \geq \text{MAX}(I_{fA}, I_{fB})$$

(Equation 186)

A safety margin of 5% for the maximum protection static inaccuracy and a safety margin of 5% for the maximum possible transient overreach have to be introduced. An additional 20% is suggested due to the inaccuracy of the instrument transformers under transient conditions and inaccuracy in the system data.

The minimum primary setting ( $I_s$ ) for the instantaneous phase overcurrent protection is then:

$$I_s \geq 1,3 \cdot I_{min}$$

(Equation 187)

The protection function can be used for the specific application only if this setting value is equal to or less than the maximum fault current that the relay has to clear ( $I_F$  in figure 88).

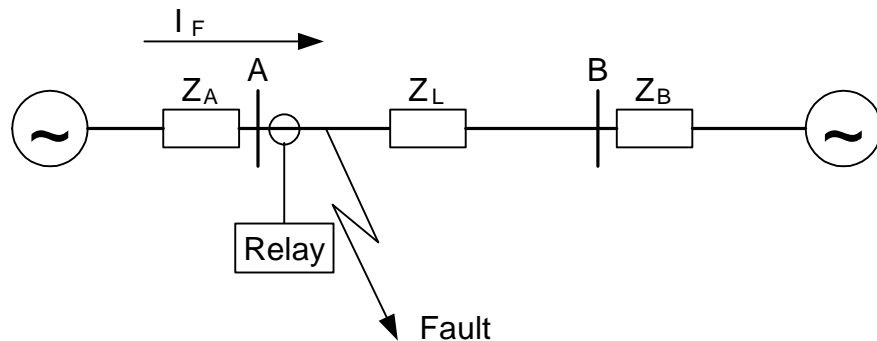

Figure 88: Fault current:  $I_F$

The current transformer secondary setting current ( $I_{SSEC}$ ) is:

$$I_{SSEC} = \frac{I_{SEC}}{I_{PRIM}} \cdot I_s$$

(Equation 188)

Where  $I_{SEC}$  is the secondary rated current of the main CT and  $I_{PRIM}$  is the primary rated current of the main CT.

The relay setting value  $IP_{>>}$  is given in percentage of the secondary base current value,  $I_{1b}$ , associated to the current transformer input I1. The value for  $IP_{>>}$  is given from this formula:

$$IP_{>>} = \frac{I_{SEC}}{I_{1b}} \cdot 100$$

(Equation 189)

This is the value that has to be set in the terminal.

Set this value under the setting menu:

**Settings**  
**Functions**  
**Group n**  
**InstantOC**

#### **Meshed network with parallel line**

In case of parallel lines, the influence of the induced current from the parallel line to the protected line has to be considered. One example is given in figure 89 where the two lines are connected to the same busbars. In this case the influence of the induced fault current from the faulty line (line 1) to the healthy line (line 2) is considered together with the two through fault currents  $I_{fA}$  and  $I_{fB}$  mentioned previously. The maximal influence from the parallel line for the relay in figure 89 will be with a fault at the C point with the C breaker open.

A fault in C has to be applied, and then the maximum current seen from the relay ( $I_M$ ) on the healthy line (this applies for single-phase-to-earth and two-phase-to-earth faults) is calculated.

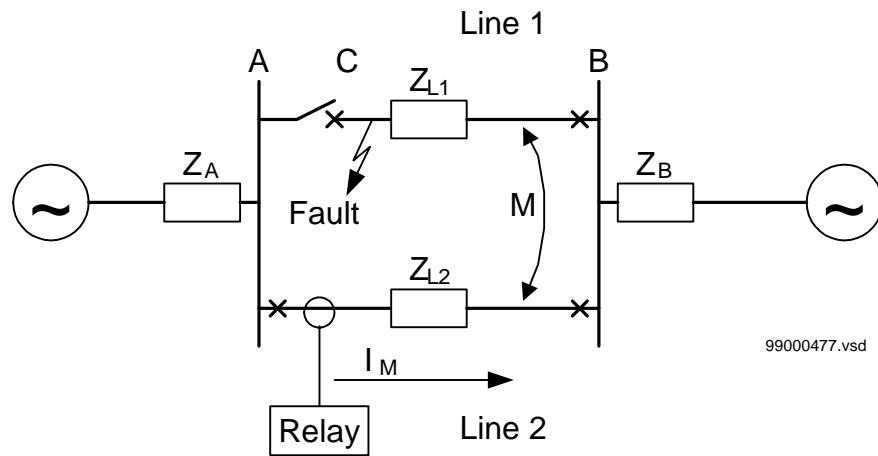

Figure 89: Two parallel lines. Influence from parallel line to the through fault current:  
 $I_M$

The minimum theoretical current setting for the overcurrent protection function ( $I_{min}$ ) will be:

$$I_{min} \geq \text{MAX}(I_{fA}, I_{fB}, I_M)$$

(Equation 190)

Where  $I_{fA}$  and  $I_{fB}$  have been described in the previous paragraph. Considering the safety margins mentioned previously, the minimum setting ( $I_s$ ) for the instantaneous phase overcurrent protection is then:

$$I_s \geq 1,3 \cdot I_{min}$$

(Equation 191)

The protection function can be used for the specific application only if this setting value is equal or less than the maximum phase fault current that the relay has to clear.

The current transformer secondary setting current ( $I_{SSEC}$ ) is:

$$I_{S_{SEC}} = \frac{I_{SEC}}{I_{PRIM}} \cdot I_s$$

(Equation 192)

Where  $I_{SEC}$  is the secondary rated current of the main CT and  $I_{PRIM}$  is the primary secondary rated current of the main CT.

The relay setting value  $IP_{>>}$  is given in percentage of the secondary base current value,  $I_{1b}$ , associated to the current transformer input I1. The value for  $IP_{>>}$  is given from this formula:

$$IP_{>>} = \frac{I_{S_{SEC}}}{I_{1b}} \cdot 100$$

(Equation 193)

This is the value that has to be set in the terminal.

Set this value under the setting menu:

**Settings**  
**Functions**  
**Group n**  
**InstantOC**

**1.4.2****Setting instructions**

The residual overcurrent protection is very sensitive to the change of zero source impedance. Since it must operate only in a selective way, it is necessary to check all system and transient conditions that can cause unwanted operation.

Only detailed network studies can determine the operating conditions under which the highest possible fault current is expected on the line. In most cases, this current appears during single-phase fault conditions. But also examine two-phase-to-earth conditions, since this type of fault can be higher than single-phase to earth fault in some cases.

Also study transients that can cause a high increase of the line current for short times. A typical example is a transmission line with a power transformer at the remote end, which can cause high inrush current when connected to the network and can thus also cause the operation of the built-in, instantaneous, earth-fault protection.

**Meshed network without parallel line**

The following fault calculations have to be done for single-phase-to-earth and two-phase-to-earth faults. With reference to figure 90, apply a fault in B and then calculate the relay through fault residual current  $I_{fB}$ . The calculation should be done using the minimum source impedance values for  $Z_A$  and the maximum source impedance values for  $Z_B$  in order to get the maximum through fault current from A to B. The zero sequence source impedances are of great importance.

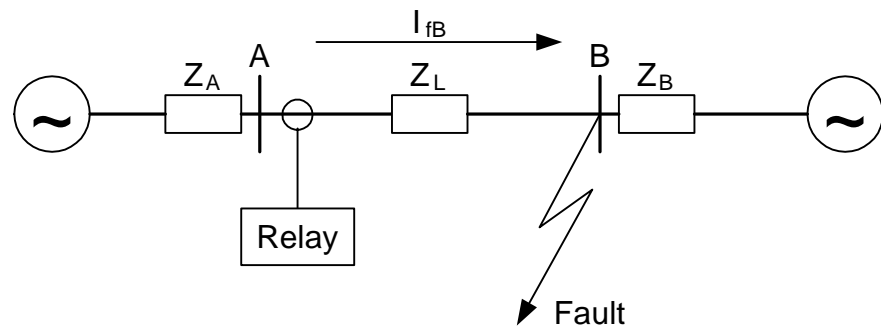

99000474.vsd

Figure 90: Through fault current from A to B:  $I_{fB}$

Then a fault in A has to be applied and the through fault residual current  $I_{fA}$  has to be calculated (Figure 91). In order to get the maximum through fault current, the minimum value for  $Z_B$  and the maximum value for  $Z_A$  have to be considered.

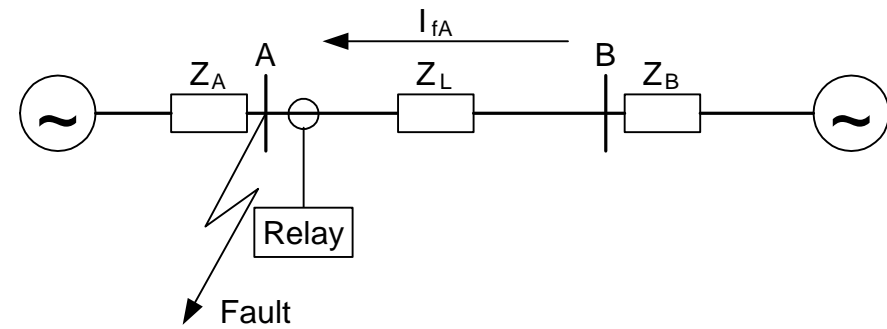

99000475.vsd

Figure 91: Through fault current from B to A:  $I_{fA}$

The relay must not trip for any of the two trough fault currents. Hence the minimum theoretical current setting ( $I_{min}$ ) will be:

$$I_{min} \geq \text{MAX}(I_{fA}, I_{fB})$$

(Equation 194)

A safety margin of 5% for the maximum protection static inaccuracy and a safety margin of 5% for the maximum possible transient overreach have to be introduced. An additional 20% is suggested due to the inaccuracy of the instrument transformers under transient conditions and inaccuracy in the system data.

The minimum setting ( $I_s$ ) for the instantaneous residual overcurrent protection is then:

$$I_s \geq 1,3 \cdot I_{min}$$

(Equation 195)

The protection function can be used for the specific application only if this setting value is equal or less than the maximum fault current that the relay has to clear ( $I_F$  in Figure 92).

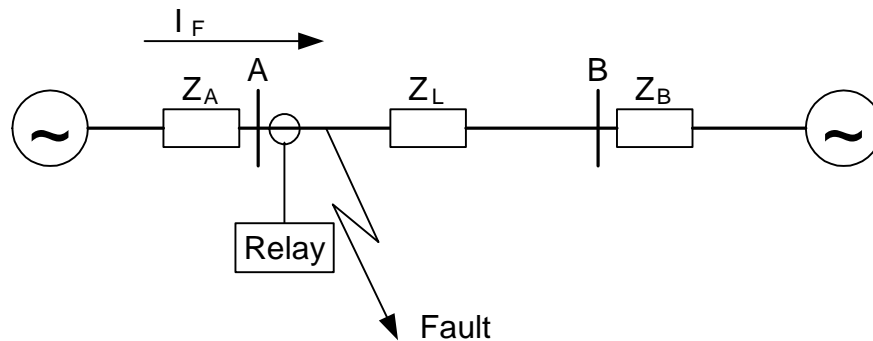

99000476.vsd

Figure 92: Fault current:  $I_F$

The current transformer secondary setting current ( $I_{sSEC}$ ) is:

$$I_{sSEC} = \frac{I_{SEC}}{I_{PRIM}} \cdot I_s$$

(Equation 196)



Set this value under the setting menu:

**Settings**  
**Functions**  
**Group $n$**   
**InstantOC**

Note:  $n=1,2,3$  or  $4$ , depending on which group to set.

**Meshed network with parallel line**

In case of parallel lines, the influence of the induced current from the parallel line to the protected line has to be considered. One example is given in figure 93, where the two lines are connected to the same busbar. In this case the influence of the induced residual fault current from the faulty line (line 1) to the healthy line (line 2) is considered together with the two through fault currents  $I_{fA}$  and  $I_{fB}$  mentioned previously. The maximal influence from the parallel line for the relay in Figure 93 will be with a fault at the C point with the C breaker open.

A fault in C has to be applied, and then the maximum current seen from the relay ( $I_M$ ) on the healthy line (this applies for single-phase-to-earth and two-phase-to-earth faults) is calculated.

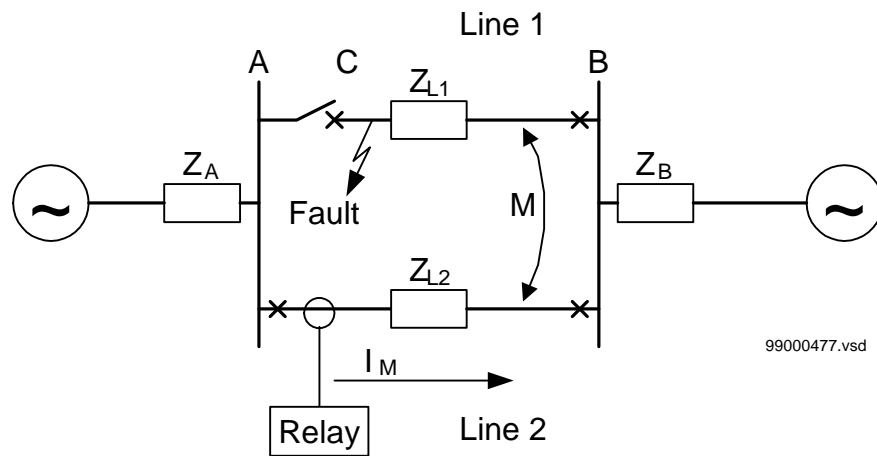

Figure 93: Two parallel lines. Influence from parallel line to the through fault current:  $I_M$ .

The minimum theoretical current setting for the residual overcurrent protection function ( $I_{min}$ ) will be:

$$I_{min} \geq \text{MAX}(I_{fA}, I_{fB}, I_M)$$

(Equation 197)

Where  $I_{fA}$  and  $I_{fB}$  have been described in the previous paragraph. Considering the safety margins mentioned previously, the minimum setting ( $I_s$ ) for the instantaneous phase overcurrent protection is then:

$$I_s \geq 1,3 \cdot I_{min}$$

(Equation 198)

The protection function can be used for the specific application only if this setting value is equal or less than the maximum residual fault current that the relay has to clear.

The current transformer secondary setting current ( $I_{sSEC}$ ) is:

$$I_{sSEC} = \frac{I_{SEC}}{I_{PRIM}} \cdot I_s$$

(Equation 199)

Set this value under the setting menu:

**Settings**  
**Functions**  
**Group $n$**   
**InstantOC**

Note:  $n=1,2,3$  or 4, depending on which group to set.

---

## 2 Time delayed overcurrent protection (TOC)

### 2.1 Application

The time delayed phase overcurrent protection can be used as independent overcurrent protection, particularly for radially fed systems, or as back-up protection to the main distance or line differential protection functions. In the first case the protected zone of the time delayed overcurrent protection reaches upto the next overcurrent protection and works in its zone as back-up protection. The programmable time delay (definite time) of the function allows the time selectivity through an appropriate time grading among the overcurrent relays protecting the system.

Where the function acts as back-up for the main line protection, the trip from the overcurrent protection can be activated when the main protection function is blocked (e.g. by the fuse failure protection) or it can be active all the time.

In some cases, where it could be difficult to achieve a selective trip, the function can be used as a helpful overcurrent signallization for the post-fault analysis.

The time delayed residual overcurrent protection (TOC) which is an earth-fault protection, serves as a built-in local back-up function to the main protection function. In most cases, it is used as a back-up for the earth-fault measuring in distance protection.

The function is intended to be used in solidly earthed systems.

The time delay makes it possible to set the relay to detect high resistance faults and still perform selective trip.

The protection, which is non-directional, is included in some of the REx 5xx terminals. Refer to the ordering information for more details.

### 2.2 Functionality

The current-measuring elements within one of the built-in digital signal processors continuously measure the current in all three phases, and compare them with the IP> set value. A recursive Fourier filter filters the current signals, and a separate trip counter prevents high overreaching of the measuring elements. The logical value of each phase current signal on the output of the digital processor (STIL1, STIL2 and STIL3 respectively) is equal to 1 if the measured phase current exceeds the set value. These signals will instantaneously set their respective output starting signals (TOC--STL1, TOC--STL2, TOC--STL3), if the function is not blocked.

If any of the three phase currents exceeds the set value for a period longer than the set time  $t_P$ , then a three phase trip is generated from the output signal TOC--TRP.

The current-measuring element within one of the built-in digital signal processors continuously measures the residual current (3I0), and compares it with the IN> set value. A recursive Fourier filter filters the current signal, and a separate trip counter prevents high overreaching of the measuring element. The logical value of the signal on the output of the digital signal processor (TOC--STIN) is equal to 1 if the measured residual current exceeds the pre-set value. This signal will instantaneously set the output start signal (TOC--STN), unless the function is blocked (see "Design").

The function trip signal (TOC--TRN) can be delayed 0-60 s.

If the residual current exceeds the set value for a period longer than the set value, then a three phase trip is generated from the output signal TOC--TRN.

## 2.3

### Design

The simplified logic diagram of the time delayed phase overcurrent function is shown in figure 94.

The function is disabled (blocked) if:

- The terminal is in TEST mode (TEST-ACTIVE is high) and the function has been blocked from the HMI (BlockTOC=Yes).
- The input signal TOC--BLOCK is high.

The TOC--BLOCK signal is a blocking signal of the time delayed phase overcurrent function. It prevents the activation of any trip or starting output signal. It can be connected to a binary input of the terminal in order to receive a block command from external devices or can be software connected to other internal functions of the terminal itself in order to receive a block command from internal functions. Through OR gate it can be connected to both binary inputs and internal function outputs. The TOC--BLOCK signal blocks also the time delayed residual overcurrent protection, if this is installed in the same REx 5xx terminal.

When the function is enabled, there is still the possibility to block the output trips only, without affecting the start signals, that will always be active. This can be obtained with the function input TOC--BLKTR. Similarly to the TOC--BLOCK signal, also the time delayed residual overcurrent protection, if present in the terminal, is blocked from TOC-BLKTR.

The duration of each output signal is at least 15 ms. This enables continuous output signals for currents, which go just a little above the set operating value.

The output trip signal TOC--TRP is a three phase trip. Single phase information is available from the starting signals, that are phase segregated.

The TOC--TRIP output signal behaves as general time delayed overcurrent trip when in the REx 5xx terminal also the time delayed residual overcurrent function is implemented; i.e. this signal will be activated in case of any time delayed overcurrent or time delayed residual overcurrent trip. If only the time delayed phase overcurrent function is installed in the terminal, then this signal behaves exactly as the signal TOC--TRP and can be used for signallization.

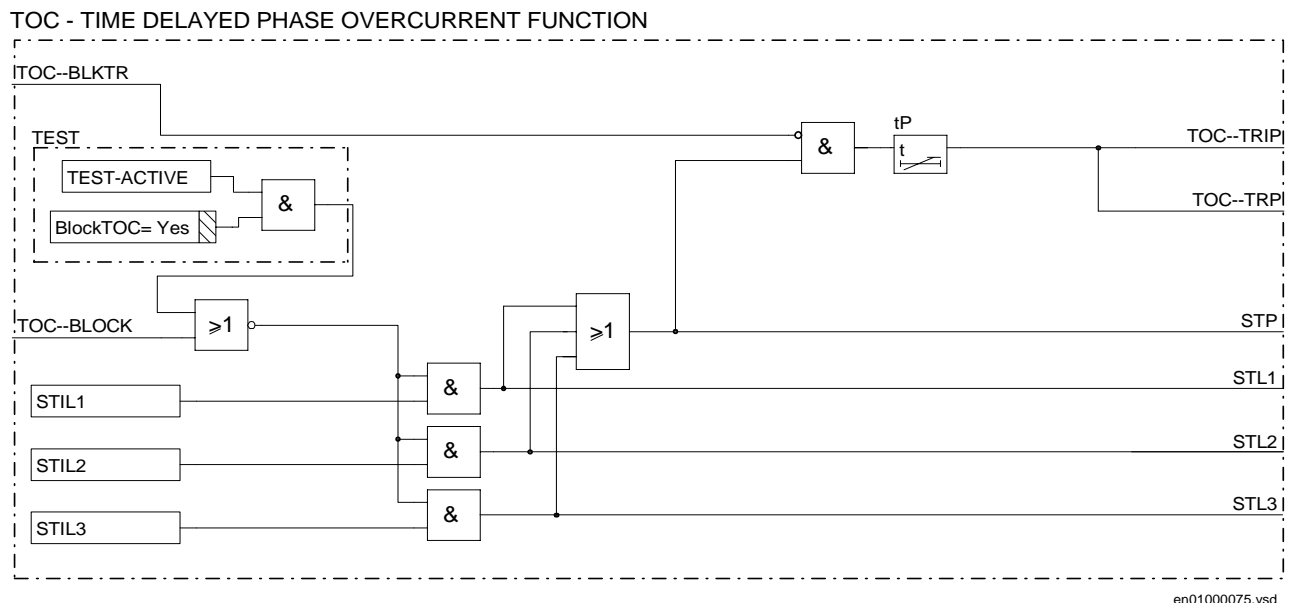

Figure 94: Simplified logic diagram of time delayed phase overcurrent protection

The simplified logic diagram of the time delayed earth-fault protection is shown in figure 95.

The time delayed residual function is disabled if:

- The terminal is in TEST status (TEST-ACTIVE is high) and the function has been blocked from the HMI (BlockTOC=Yes).
- The input signal TOC--BLOCK is high.

The TOC--BLOCK signal is a blocking signal of the earth-fault function. It blocks the whole function and prevents the activation of any trip or starting output signals.

It can be connected to a binary input in order to receive a block command from external devices or it can be configured (software connection) to other internal functions within the terminal itself, in order to receive a block command from internal functions. Through OR gates it can be connected to both binary inputs and internal function outputs.

When the residual overcurrent protection is enabled, there is still a possibility to block the trip output only, without affecting the start signals, which always will be active. The input which provides this function is TOC--BLKTR.

The duration of each output signal is at least 15 ms. This enables continuous output signals for currents, which go just a little beyond the set operating value.

The TOC--TRN signal is related to the residual overcurrent trip.

The TOC--TRIP output signal behaves as general time delayed overcurrent trip when in the REx 5xx terminal also the time delayed phase overcurrent function is implemented. I.e. this signal will be activated in case of delayed residual overcurrent trip or in case of time delayed phase overcurrent trip. If only the residual overcurrent function is implemented in the terminal, then this signal behaves exactly as the signal TOC--TRN and can be used for signalization.

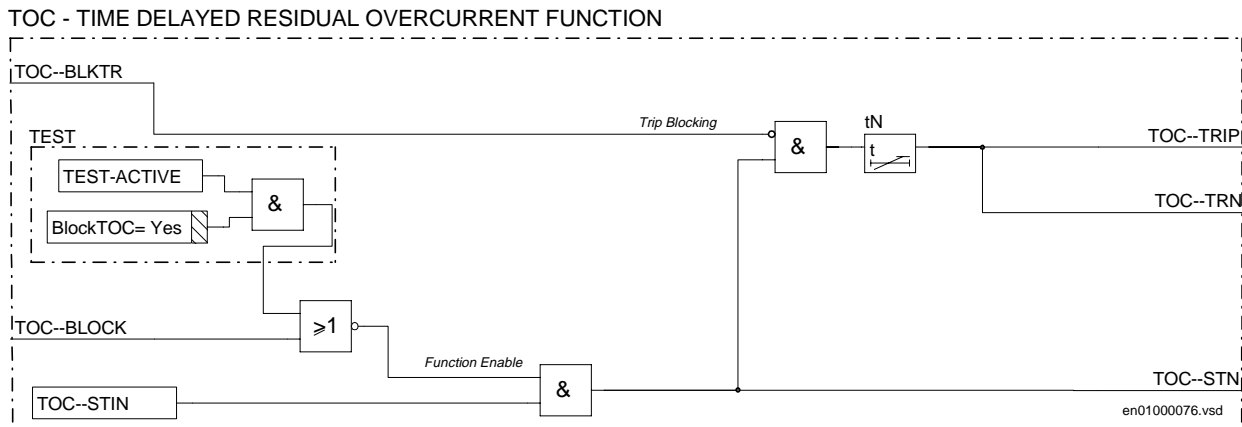

Figure 95: Simplified logic diagram of the TOC-- protection function.

## 2.4

### Calculations

#### 2.4.1

##### Setting instructions

The current setting value must be selected to permit the detection of the lowest short circuit current without having any unwanted tripping or starting of the function under normal load conditions. The following relation has to be considered for the setting of the primary operating current ( $I_s$ ) of the function:

$$1.2 \cdot \frac{I_{Lmax}}{K} < I_s < 0.7 \cdot I_{Fmin}$$

(Equation 200)

Where:

$I_{Lmax}$	is the maximum permissible load current of the protected unit,
$I_{Fmin}$	is the minimum fault current that the relay has to clear. The values 1.2 and 0.7 are safety factors and
$K$	is the reset ratio of the overcurrent function: 0.95.

The settable time delay  $t_P$  allows the time selectivity of the overcurrent function, according to the time grading plan of all the other overcurrent protections in the system. The time setting value should also consider transients that could cause a high increase of the line current for short times. A typical example is a transmission line with a power transformer at the remote end, which can cause high inrush current when energized.

Where the time delayed overcurrent function is used as back-up of impedance protection, normally the time delay is set higher than the time delay of distance zone 2 (or 3) in order to avoid interferences with the impedance measuring system.

##### Setting of operating current $I_P$ >

If  $I_s$  is the primary setting operating value of the function, than the secondary setting current ( $I_{SEC}$ ) is:

$$I_{SEC} = \frac{I_{SEC}}{I_{PRIM}} \cdot I_s$$

(Equation 201)

Where:

$I_{SEC}$  is the secondary rated current of the main CT  
and

$I_{PRIM}$  is the primary rated current of the main CT.

The relay setting value  $IP>$  is given in percentage of the secondary base current value,  $I_{1b}$ , associated to the current transformer input I1. The value for  $IP>$  is given from this formula:

$$IP> = \frac{I_{SEC}}{I_{1b}} \cdot 100$$

(Equation 202)

This is the value that has to be set in the terminal.

Set this value under the setting menu:

**Settings**  
**Functions**  
**Group n**  
**TimeDelayOC**

On the value  $IP>$ .

**Setting of time delay  $tP$**

Set the time delay of the function,  $tP$ , under the setting menu:

**Settings**  
**Functions**  
**Group n**  
**TimeDelayOC**

on the value  $tP$ .



**2.4.2****Setting instructions**

The residual overcurrent protection is very sensitive to the change of zero source impedance. Since it must operate only in a selective way, it is necessary to check all system and transient conditions that can cause unwanted operation.

The settings should be chosen in such a way that it can detect high resistance faults on the protected line and still be selective to other residual time delayed protections in both forward and reverse directions. The time setting value should also consider transients that can cause a high increase of the residual line current for short times.

A typical example is a transmission line with a power transformer at the remote end, which can cause high inrush current when being energised.

In well transposed system, the false earth-fault current is normally lower than 5% of the line current. For non transposed lines a considerably higher false residual current may be found.

In case of extremely short or not fully transposed parallel lines, the false residual current must be measured or calculated when maximum sensitivity is desired. Generally, 80 A is recommended as a minimum primary operation value for the residual overcurrent protection.

General criteria for the primary current setting value of the time delayed residual overcurrent protection is given in the formula below:

$$1.3 \cdot IR_{\max} < I_s < 0.7 \cdot IF_{\min}$$

(Equation 203)

Where:

$IR_{\max}$  is the maximum permissive residual current flowing in the protection unit during normal service conditions and

$IF_{\min}$  is the minimum residual fault current that the relay has to clear.

1.3 and

0.7 are safety factor values.

**Setting of operating current IN>**

If  $I_S$  is the primary setting operating value of the function, then the secondary setting current ( $I_{S_{SEC}}$ ) is:

$$I_{S_{SEC}} = \frac{I_{SEC}}{I_{PRIM}} \cdot I_S$$

(Equation 204)

where  $I_{SEC}$  is the secondary rated current of the main CT and  $I_{PRIM}$  is the primary rated current of the main CT.

The relay setting value IN> is given in percentage of the secondary base current value,  $I_{4b}$ , associated to the current transformer on input I4. The value for IN> is given from the formula:

$$IN> = \frac{I_{S_{SEC}}}{I_{4b}} \cdot 100$$

(Equation 205)

and this is the value that has to be set in the relay.

Set the value under the setting menu:

**Settings**  
**Functions**  
**Group n (n=1-4)**  
**TimeDelayOC**

For the parameter IN>.

**Setting of time delay tN**

Set the time delay of the function, tN, under the setting menu:

**Settings**  
**Functions**  
**Group n (n=1-4)**  
**TimeDelayOC**

---

## 3 Two step time delayed phase overcurrent protection (TOC2)

### 3.1 Application

The time delayed phase overcurrent function is to be used as short-circuit protection in three phase networks operating at 50 or 60 Hz. It is intended to be used either as primary protection or back-up protection for differential functions or impedance measuring functions.

In radial networks it is often sufficient to use phase overcurrent relays as short circuit protection for lines, transformers and other equipment. The current time characteristic should be chosen according to common practice in the network. It is strongly recommended to use the same current time characteristic for all overcurrent relays in the network. This includes overcurrent protection for transformers and other equipment.

There is a possibility to use phase overcurrent protection in meshed systems as short circuit protection. It must however be realized that the setting of a phase overcurrent protection system in meshed networks, can be very complicated and a large number of fault current calculations are needed. There are situations where there is no possibility to have selectivity with a protection system based on overcurrent relays in a meshed system.

The measuring function contains one current measuring element for each phase, each of them with a low set and a high set measuring step. The low set step can have either definite time or inverse time characteristic. The characteristics available are extremely inverse, very inverse, normal inverse or RI inverse. The high set step has definite time delay.

The settings are common for all phases but both the low and high set step can be set On/Off individually and also have individual inputs for blocking.

### 3.2 Functionality

The time delayed overcurrent protection is used as short-circuit protection in power systems, either as the primary protection or as a back-up function for selective differential protection or impedance measuring protection. The protection function comprises of measuring circuits for the three phase currents, each with a low and high current setting. The low current setting has definite or inverse time-delay while the high current setting has only definite time-delay. The measuring circuits share common settings for all phases, however, both the low and high current settings can be blocked or enabled independent of the other setting.

Figure 96 shows a simplified logic diagram for the two step phase overcurrent protection.

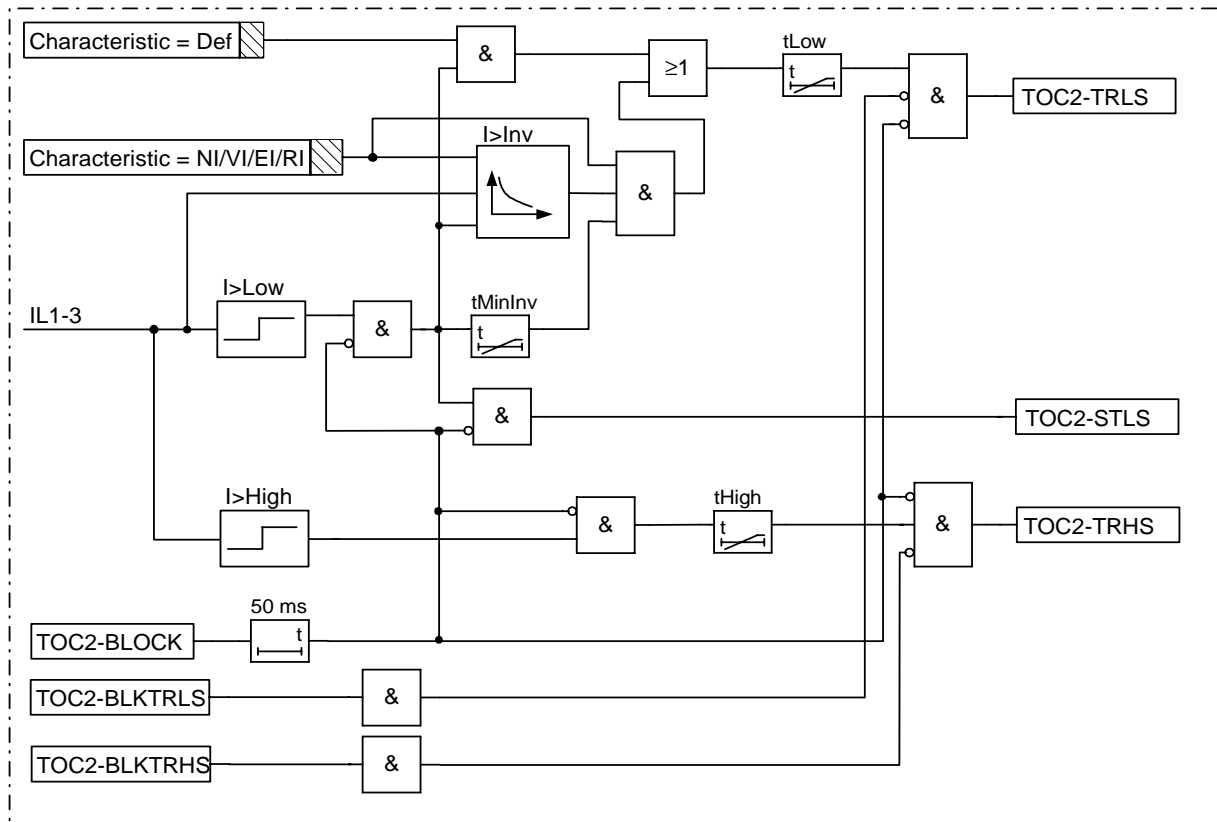

en01000090.vsd

Figure 96: Two step time delayed phase overcurrent protection, simplified logic diagram

### 3.3

### Calculations

#### 3.3.1

#### Setting instructions

The phase overcurrent protection can be used in different applications. In most applications it is required that all short circuits within a protected zone shall be detected and cleared and the fault clearance shall be selective. As the protection can be used in several applications only some examples are discussed.

**Line protection in radial network**

The phase overcurrent protection is suitable to use in radial systems without any fault current infeed from the radial feeders.

The pick up current setting (inverse time relays) or the lowest current step (constant time relays) must be given a current setting so that the highest possible load current does not cause relay operation. Here consideration also has to be taken to the relay reset current, so that a short peak of overcurrent does not cause operation of the relay even when the overcurrent has ceased.

The lowest setting value can be written:

$$I_{pu} \geq 1.2 \cdot \frac{I_{max}}{k}$$

(Equation 206)

Where:

1.2 is a safety factor due to load estimation uncertainty etc.,

k the resetting ratio of the relay (about 0.95) and

$I_{max}$  the maximum load current.

The maximum load current on the line has to be estimated. From operation statistics the load current up to the present situation can be found. Also emergency situations must be considered. The current setting must be valid also for some years ahead.

There is also a demand that all faults, within the zone that the protection shall cover, must be detected by the phase overcurrent relay. The minimum fault current  $I_{scmin}$ , to be detected by the relay, must be calculated. Taking this value as a base, the highest pick up current setting can be written:

$$I_{pu} \leq 0.7 \cdot I_{scmin}$$

(Equation 207)

Where:

0.7 is a safety factor, due to calculation uncertainty and

$I_{scmin}$  the smallest fault current to be detected by the overcurrent protection.

As a summary the pick up current shall be chosen within the interval:

$$1.2 \cdot \frac{I_{max}}{k} \leq I_{pu} \leq 0.7 \cdot I_{scmin}$$

(Equation 208)

The high current function of the overcurrent relay, which only has a short or no delay of the operation, must be given a current setting so that the relay is selective to other relays in the power system. It is desirable to have a rapid tripping of faults within as large portion as possible of the part of the power system to be protected by the relay (primary protected zone). A fault current calculation gives the largest current of faults,  $I_{scmax}$ , at the most remote part of the primary protected zone. Considerations have to be made to the risk of transient overreach, due to a possible DC component of the short circuit current. The lowest current setting of the most rapid stage, of the phase overcurrent relay, can be written:

$$I_{high} \geq 1.2 \cdot k_t \cdot I_{scmax}$$

(Equation 209)

Where:

1.2 is a safety factor, due to calculation uncertainty

$k_t$  is a factor that takes care of the transient overreach due to the DC component of the fault current.  $k_t$  is less than 1.05 if the power system time constant is less than 100 ms.

$I_{scmax}$  is the largest fault current at a fault at the most remote point of the primary protection zone.

The operate times of the phase-overcurrent protection have to be chosen so that the fault time is so short that equipment will not be damaged due to thermal overload, at the same time selectivity is assured. For overcurrent protection, in a radial fed network, the time setting can be chosen in a graphical way. This is mostly used in the case of inverse time overcurrent protections.

#### Line protection in meshed network

The current setting can be made in the same way as for radial networks.

If inverse time characteristics are used with equal current and time setting for all phase current protections in the system the selectivity is assured as long as there are more than two bays carrying fault current to each substation. Sometimes this is however impossible due to the fault current distribution between the different lines.

If definite time characteristic is used the co-ordination between the different phase overcurrent line protections is done by means of current setting.

As the phase overcurrent protection often is used as a back-up protection of lines, where a distance protection is the main protection, relatively long operation times are acceptable for the phase overcurrent protection.

#### Setting characteristics

Following formulas are valid for the inverse time characteristic:

**Table 7: Formulas for the inverse time characteristic**

Characteristic:	Time delay(s):
Normal inverse	$t = \frac{0,14}{I^{0,02} - 1} \cdot k$ (Equation 210)
Very inverse	$t = \frac{13,5}{I - 1} \cdot k$ (Equation 211)
Extremely inverse	$t = \frac{80}{I^2 - 1} \cdot k$ (Equation 212)
RI inverse	$t = \frac{1}{0,339 - \langle(0,236)/I\rangle} \cdot k$ (Equation 213)

Where:

I denotes (measured current)/  $I_{>Inv}$  and

k is a time multiplier with setting range 0,05 - 1,10.

The decisive factors for the setting of inverse time characteristic are the allowable time for disconnection of fault at minimum fault current that the function shall operate for together with selectivity at maximum fault current.

The settings are given in Setting table. Setting of parameters are found in the menu under:

**Settings**

**Functions**

**Group n (n=1-4)**

**InvTDelay**



---

## 4 Two step time delayed directional phase overcurrent protection (TOC3)

### 4.1 Application

The time delayed phase overcurrent function is to be used as short-circuit protection in three phase networks operating at 50 or 60 Hz. It is intended to be used either as primary protection or back-up protection for differential functions or impedance measuring functions.

In radial networks it is often sufficient to use phase overcurrent relays as short circuit protection for lines, transformers and other equipment. The current time characteristic should be chosen according to common practice in the network. It is strongly recommended to use the same current time characteristic for all overcurrent relays in the network. This includes overcurrent protection for transformers and other equipment.

There is a possibility to use phase overcurrent protection in meshed systems, as short circuit protection. It must however be realized that the setting of a phase overcurrent protection system in meshed networks, can be very complicated and a large number of fault current calculations are needed. There are situations where there is no possibility to have selectivity with a protection system based on overcurrent relays in a meshed system.

In some applications the possibility of obtaining selectivity can be improved significantly if a directional phase overcurrent function is used. This can be the case in meshed networks and in radial networks with generation connected remote in the system, thus giving fault current infeed in “reverse” direction.

The measuring function contains one current measuring element for each phase, each of them with a low set and a high set measuring step. The low set step can have either definite time or inverse time characteristic. The characteristics available are extremely inverse, very inverse, normal inverse or RI inverse. The high set step has definite time delay.

The settings are common for all phases but both the low and high set step can be set On/Off individually and also got individual inputs for blocking.

## 4.2 Functionality

### 4.2.1 Theory of operation and design

#### Current measuring element

The current measuring element continuously measures the current in all phases and compares it to the set operating values for the two steps. If the current is above set value the corresponding output signal will be set. If the current is above both the setting  $I > \text{Low}$  and  $I > \text{Inv}$  the inverse time evaluation according to chosen characteristic starts and the INV signal sets after corresponding time. A filter ensures immunity to disturbances and DC-components and minimizes the transient overreach. A simplified block diagram is found in figure 97. The function is true phase segregated. This means that there are identical measuring elements in each phase.

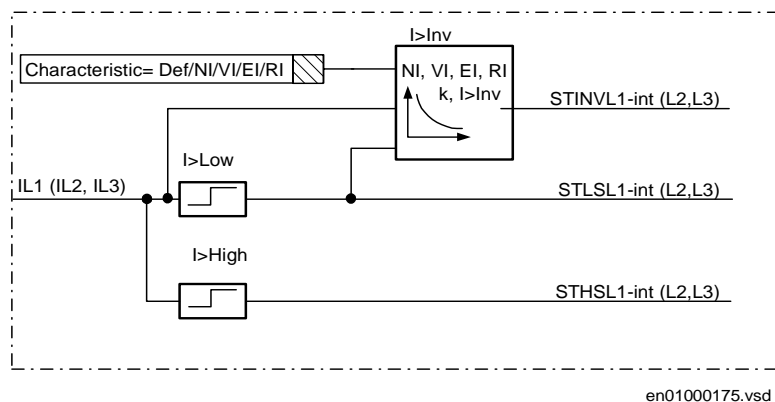

Figure 97: Simplified block diagram for definite and inverse time delayed phase overcurrent function

The inverse time delay can be set for different characteristics by the setting Characteristic = x, the x is chosen from the following:

1. Def (Definite time)
2. NI (Normal inverse)
3. VI (Very inverse)
4. EI (Extremely inverse)
5. RI (Inverse time corresponding to relays of type RI)

With setting Characteristic = Def the signal INV will be set to zero.

The different inverse time characteristics are defined in the “Technical reference manual”.

### **Directional overcurrent function**

The directional overcurrent function uses the information from the current measuring elements as described in "Current measuring element" and the directional impedance measuring element as described for the distance protection function, to create the directional overcurrent function.

### **Directional phase selection**

In order to use correct directional information during all types of faults the function is provided with a simple phase selection. The phase selection is assigned to distinguish between phase to earth faults and phase to phase faults.

The criteria for the two indications that are regarded in the function are:

#### **Phase to earth fault (PE FAULT):**

$$3 \cdot I_0 \geq 0.5 \cdot I_{\text{MinOp}}$$

(Equation 214)

and

$$3 \cdot I_0 \geq \text{INReleasePE} / 100 \cdot I_{\text{phmax}}$$

(Equation 215)

#### **Phase to phase fault (PP FAULT):**

$$3 \cdot I_0 < 0.2 \cdot I_r$$

(Equation 216)

OR

$$3 \cdot I_0 < \text{INBlockPP} / 100 \cdot I_{\text{phmax}}$$

(Equation 217)

If the criteria for PE FAULT are fulfilled the phase to earth directional indications are used and if the criteria for PP FAULT are fulfilled the phase to phase directional indications are used. If all criteria are met, then only the directional indications for phase to phase are released. The aim is to preserve the phase to phase measurement also during two-phase to ground faults with high residual current (at least as long as the criteria allows, see equations above). However, the directional indications will appear also for healthy phases and in the phase to phase case the indications would overlap in an unwanted manner because the overcurrent evaluation is performed per phase only (both forward and reverse can be indicated for one phase, simultaneously). So in order to establish a complete directional phase selection the one and only faulty loop must be singled out. This is done by means of releasing the directional indication with the corresponding overcurrent indications (overcurrent in two phases is required, see figure 98).

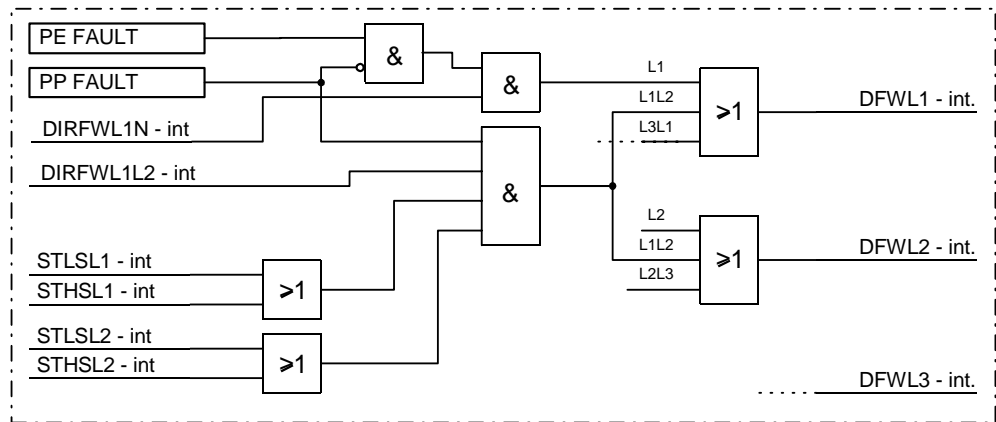

Figure 98: Excerpt from directional phase selection

Consider the case where a reverse fault is cleared and the prefault forward load conditions are retrieved. So, in order not to issue a false trip if the reversal indication is deactivated (or the forward indication becomes active) before the overcurrent indication drops, the reversal of direction is actually held back during 50 ms according to the logic of figure 99. Each phase and each set stage is provided with an individual logic circuit (six circuits in all) to allow operation during simultaneous earth faults (one forward, one reverse).

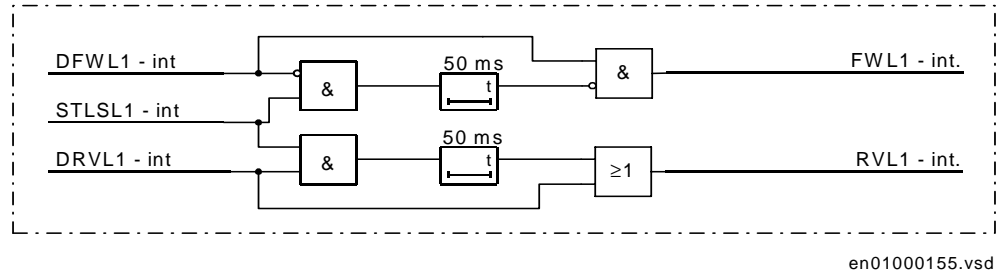

Figure 99: Current reversal logic for one phase and one set step

### General overcurrent operating principles

The low and high set steps can individually be set directional or non-directional. If set in non-directional mode the overcurrent function only uses the signals from the current measuring elements as seen from figure 97. In directional mode there are two modes of operation, forward release and reverse block denoted ForwRelease and RevBlock respectively. The principles of these three modes of operation are illustrated in figure 100, below.

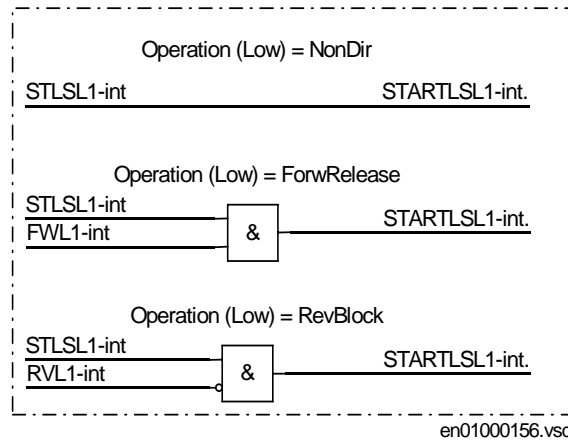

Figure 100: Directional operation modes of TOC3

In forward release operation mode a criteria that indicates that the fault is in forward direction is needed for tripping. Since the directional function needs voltage for the directional check it will not be able to operate when switching in a line against a persistent close-up three phase fault if voltage is measured on the line side of the breaker. A solution to this might be to use the SOTF function for the distance protection, with output TOC3-STND as acceleration signal.

In reverse block operation mode a criteria that indicates that the fault is in reverse direction is used for blocking the function. In this case there is no problem switching in a line against a persistent close-up three phase fault even if voltage is measured on the line side of the breaker since the directional function will not issue any reverse signal.

The general principles of time delay for the two steps of the overcurrent function is displayed in the following figure 101.

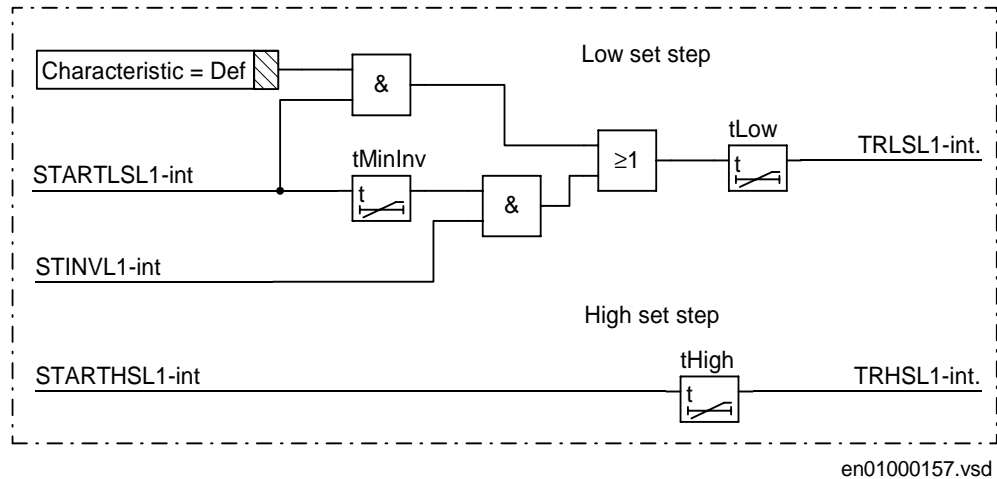

Figure 101: Delayed time operation for low set step and general time delay

General trip signals are derived from the phase segregated starts according to figure 102.

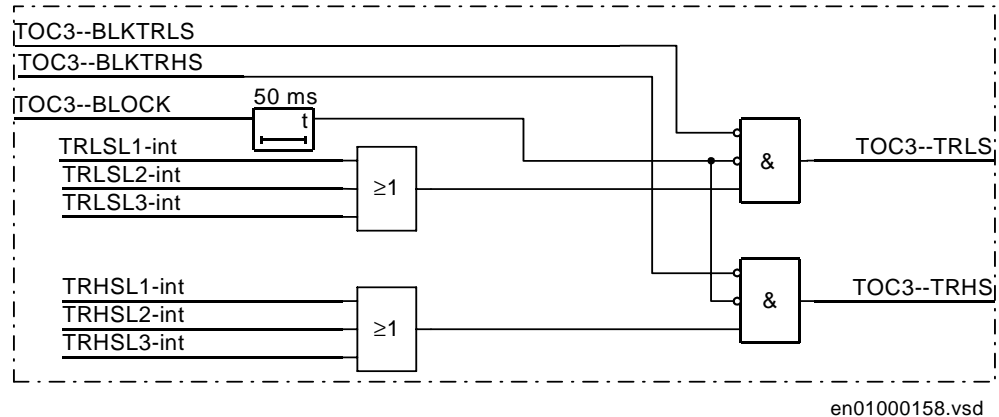

Figure 102: General trip

With setting Characteristic = Def (figure 101) the signal TOC3-TRLS will be active if, at least, one of the phase currents exceeds the set value  $I > \text{Low}$  for the low set step, and if the directional criterion is fulfilled for a longer time than the set delay  $t_{\text{Low}}$ .

With setting Characteristic = NI/VI/EI or RI (figure 101) we have the following: If, at least one of the phase currents exceeds the set value  $I > \text{Low}$ , the timer circuit  $t_{\text{MinInv}}$  is activated together with the inverse time measuring circuit (figure 97) in order to calculate the operating time. The operating time is determined by the magnitude of the current, characteristic chosen, set characteristic current  $I > \text{Inv}$  and time multiplier  $k$ . When both the inverse time and  $t_{\text{MinInv}}$  have elapsed the timer  $t_{\text{Low}}$  will be activated and after its time is elapsed the signal TOC3-TRLS is activated. It must be observed that the time delay of operation, if inverse time characteristics is used, will be the sum of the inverse time delay and the  $t_{\text{Low}}$  setting.

The timer circuit  $t_{\text{MinInv}}$  (figure 101) can be used to achieve a defined minimum operating time at high fault currents. The timer circuit  $t_{\text{Low}}$  can be used for adding an additional time delay to the inverse time characteristic.

The signal TOC3-TRHS will be active if one of the phase currents exceeds the set value  $I > \text{High}$  for a longer time than the set delay  $t_{\text{High}}$  at the same time as TOC--BLKTRSH and TOC--BLOCK are not present.

An external signal connected to TOC3\_BLKTRLS will block tripping from low set step. The step can also be blocked with the setting Operation Low= Off.

An external signal connected to TOC3\_BLKTRHS will block tripping from high set step. The step can also be blocked with the setting Operation High= Off.

An external signal connected to TOC3\_BLOCK will block both low and high set steps.

Figure 103 illustrates how the start signals are formed.

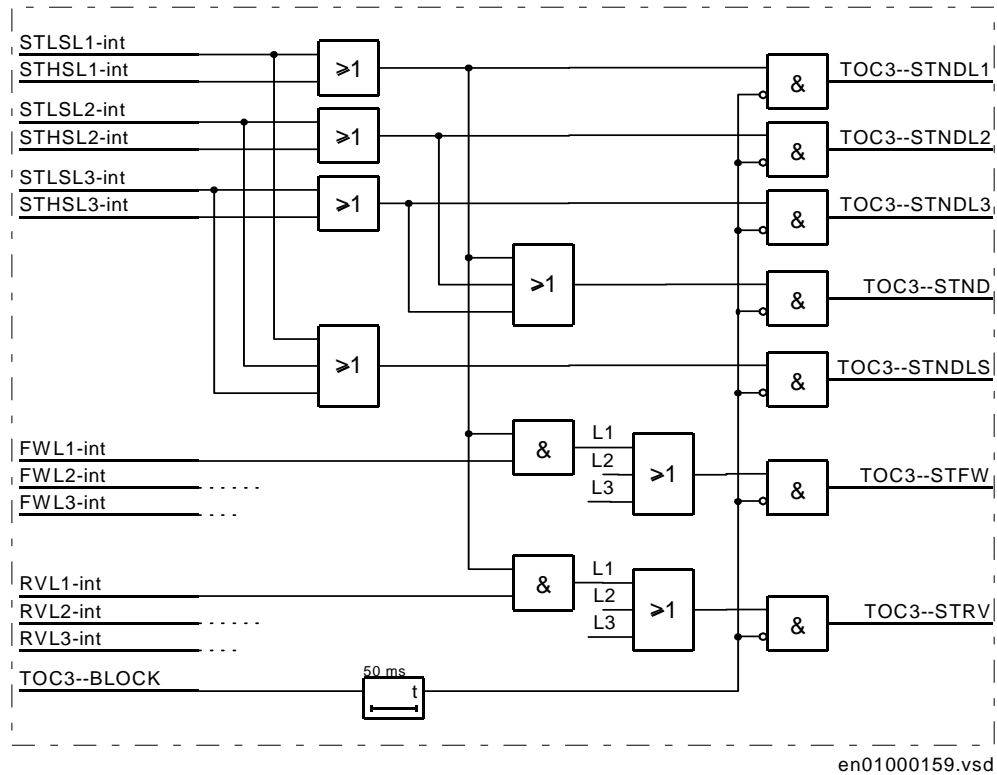

Figure 103: Start signals

As the phase segregated start signals are non directional, and used for indication only, there is no possibility to use a phase segregated transfer trip scheme. A three-phase transfer trip scheme will be applicable using the output TOC3-STFW or TOC3-STRV, keeping in mind the performance expected during simultaneous faults on parallel lines.

## 4.3

### Calculations

#### 4.3.1

#### Setting instructions

The directional phase overcurrent protection can be used in different applications. In most applications it is required that all short circuits within a protected zone shall be detected and cleared and the fault clearance shall be selective. As the protection can be used in several applications only some examples are discussed.



### Line protection in a radial network

The directional phase overcurrent protection is suitable to use in radial systems with generation connected out in the system. In such a network the fault current can be fed both in the forward and reverse direction. Normally the protection will detect and trip faults in the forward direction.

The pick up current setting (inverse time functions) or the lowest current step (constant time functions) must be given a current setting so that the highest possible load current does not cause operation of the function. The reset ratio of the function has to be taken into consideration, so that a short peak of overcurrent does not cause operation of the protection even when the overcurrent has ceased.

The lowest setting value can be written:

$$I_{pu} \geq 1.2 \cdot \frac{I_{max}}{k}$$

(Equation 218)

Where:

1.2 is a safety factor due to load estimation uncertainty etc.,

k the resetting ratio of the relay (about 0.95) and

$I_{max}$  the maximum load current.

The maximum load current on the line has to be estimated. From operation statistics the load current up to the present situation can be found. Also emergency situations must be considered. The current setting must be valid also for some years ahead.

There is also a demand that all faults, within the zone that the protection shall cover, must be detected by the phase overcurrent relay. The minimum fault current  $I_{scmin}$ , to be detected by the relay, must be calculated. Taking this value as a base, the highest pick up current setting can be written:

$$I_{pu} \leq 0.7 \cdot I_{scmin}$$

(Equation 219)

Where:

0.7 is a safety factor, due to calculation uncertainty and

$I_{scmin}$  the smallest fault current to be detected by the overcurrent protection.

As a summary the pick up current shall be chosen within the interval:

$$1.2 \cdot \frac{I_{max}}{k} \leq I_{pu} \leq 0.7 \cdot I_{scmin}$$

(Equation 220)

The high current function of the overcurrent protection, which only has a short or no delay of the operation, must be given a current setting so that the protection is selective to other protections in the power system. It is desirable to have a rapid tripping of faults within as large portion as possible of the part of the power system to be protected by the relay (primary protected zone). A fault current calculation gives the largest current of faults,  $I_{scmax}$ , at the most remote part of the primary protected zone. The risk of transient overreach, due to a possible DC component of the short circuit current has to be taken into consideration. The lowest current setting of the most rapid stage, of the phase overcurrent relay, can be written:

$$I_{high} \geq 1.2 \cdot k_t \cdot I_{scmax}$$

(Equation 221)

Where:

1.2 is a safety factor, due to calculation uncertainty

$k_t$  is a factor that takes care of the transient overreach due to the DC component of the fault current.  $k_t$  is less than 1.05 if the power system time constant is less than 100 ms.

$I_{scmax}$  is the largest fault current at a fault at the most remote point of the primary protection zone.

The operate times of the phase overcurrent relay have to be chosen so that the fault time is so short that equipment will not be damaged due to thermal overload, at the same time selectivity is assured. For overcurrent protection in a radial fed network, the time setting can be chosen in a graphical way. This is mostly used in the case of inverse time overcurrent protection.

#### Line protection in meshed network

The current setting can be made in the same way as for radial networks.

If inverse time characteristics are used with equal current and time setting for all phase current protections in the system the selectivity is assured as long as there are more than two bays carrying fault current to each substation. Sometimes this is however impossible due to the fault current distribution between the different lines.

If definite time characteristic is used the coordination between the different phase overcurrent line protections are done by means of current setting.

As the phase overcurrent protection often is used as a back-up protection of lines, where a distance protection is the main protection, relatively long operation times are acceptable for the phase overcurrent protection.

#### Setting characteristics

The setting parameters and ranges are shown in the setting table.

Following formulas are valid for the inverse time characteristic:

**Table 8: Formulas for the inverse time characteristic**

Characteristic:	Time delay(s):
Normal inverse	$t = \frac{0,14}{I^{0,02} - 1} \cdot k$ (Equation 222)
Very inverse	$t = \frac{13,5}{I - 1} \cdot k$ (Equation 223)
Extremely inverse	$t = \frac{80}{I^2 - 1} \cdot k$ (Equation 224)
RI inverse	$t = \frac{1}{0,339 - \langle(0,236)/I\rangle} \cdot k$ (Equation 225)

Where:

I denotes (measured current)/  $I_{>Inv}$  and

k is a time multiplier with setting range 0,05 - 1,10.

The decisive factors for the setting of inverse time characteristic are the allowable time for disconnection of fault at minimum fault current that the function shall operate for together with selectivity at maximum fault current.

The settings are given in Setting table. Setting of parameters are found in the menu under:

**Settings**

**Functions**

**Group n (n=1-4)**

**DirInvTDelay**

---

## 5 Definite and inverse time-delayed residual overcurrent protection (TEF)

### 5.1 Application

This earth-fault overcurrent protection is intended for solidly earthed networks.

#### Earth-fault overcurrent protection

In case of single-phase earth-faults, the primary fault resistance varies with the network conditions, the type of fault and location of the fault. In many cases, the fault resistance is much higher than the resistance that can be covered by an impedance-measuring distance protections. This can be the case with a phase to earth fault to a tower with large tower footing resistance.

Earth-faults with high fault resistances can be detected by measuring the residual current ( $3I_0$ ).

The inrush current can cause unwanted tripping of the earth-fault overcurrent relay when energizing a directly earthed power transformer. The earth-fault overcurrent protection is therefore provided with second harmonic restraint, which blocks the operation if the residual current ( $3I_0$ ) contains 20% or more of the second harmonic component.

In some cases, it is possible to improve the selectivity by adding a settable minimum operate current ( $I_{Min}$ ) and a minimum operate time ( $t_{Min}$ ) to the inverse characteristic. These functions are included in the earth-fault protection modules.

To minimize the operate time, in case of closing the circuit breaker to a fault, the residual overcurrent protection module is provided with a switch-onto-fault logic, which can be activated at breaker closure. The tripping time will temporarily be reduced to 300 ms.

In order to achieve the most sensitive earth fault protection the non-directional function can be used. As the residual current is normally very small during normal operation the setting value can be set very low. In case of small residual currents, due to high resistance phase to earth faults or serial faults, the residual voltage in the system can be very low. A serial fault can be caused by broken phase conductor(s) with no contact to earth, or pole discrepancy in a circuit breaker or a disconnecter. The most common type of serial fault is pole discrepancy at breaker maneuvers.

As the residual voltage is often very small at high resistance earth faults and serial faults, any directional element can not be used.

The function can have different types of time-current characteristics; definite time delay or different types of inverse time delay. By using the inverse time delay characteristics some degree of selectivity between non-directional residual protection can be achieved.

Directional earth-fault protection is obtained by measuring the residual current and the angle between this current and the zero-sequence voltage ( $3U_0$ ).

It is possible to obtain the polarizing voltage ( $-3U_0$ ) from an open delta winding in the voltage transformer or via summation of the three phase voltages supplied to the terminal.

The  $3I_0$  current lags the polarizing voltage ( $-3U_0$ ) by a phase angle equal to the angle of the zero-sequence source impedance. In solidly earthed networks, this angle is in the range of  $40^\circ$  to nearly  $90^\circ$ . The high value refers to stations with directly earthed transformers with delta winding. To obtain maximum sensitivity at all conditions, the forward measuring element should have a characteristic angle of  $65^\circ$ .

As a general rule, it is easier to obtain selectivity by using directional instead of non-directional earth-fault overcurrent protection, but sufficient polarizing voltage must be available.

It is not possible to measure the distance to the fault by using the zero-sequence components of the current and voltage, because the zero-sequence voltage is a product of the zero-sequence components of current and source impedance. It is possible to obtain selectivity by the use of a directional comparison scheme, which uses communication between the line ends.

If a communication scheme can not be used, the best selectivity is generally obtained by using inverse time delay. All relays, in the network, must have the same type of inverse characteristic. An earth-fault on a line is selectively tripped if the difference between the residual current ( $3I_0$ ) out on the faulted line and the residual current ( $3I_0$ ) out on the other lines gives a time difference of 0.3-0.4 seconds. A logarithmic characteristic is generally the most suitable for this purpose, because the time difference is constant for a given ratio between the currents.

#### **Directional comparison logic function**

In the directional comparison scheme, information of the fault current direction must be transmitted to the other line end. A short operate time enables auto-reclosing after the fault. During a single-phase reclosing cycle, the auto-reclosing device must block the directional comparison earth-fault scheme.

A communication logic block for residual overcurrent protection can be included in the REx 5xx terminal to provide this feature. The function contains circuits for blocking overreach and permissive overreach schemes. See the section “*Communication logic for residual overcurrent protection*”.

Also an additional communication logic block for the communication can be included. It contains logic for the weak-end-infeed and current-reversal functions, which are used only in the permissive overreach scheme. See the section “*Current reversal and weak end infeed logic for residual overcurrent protection*”.

## 5.2 Functionality

### 5.2.1 Theory of operation

#### **Directional earth-fault overcurrent protection**

This protection measures the residual current ( $3I_0$ ) and the residual voltage ( $3U_0$ ). Figure 104 shows the current measuring, time delay and logic circuits (both with and without directional check) of this protection function.

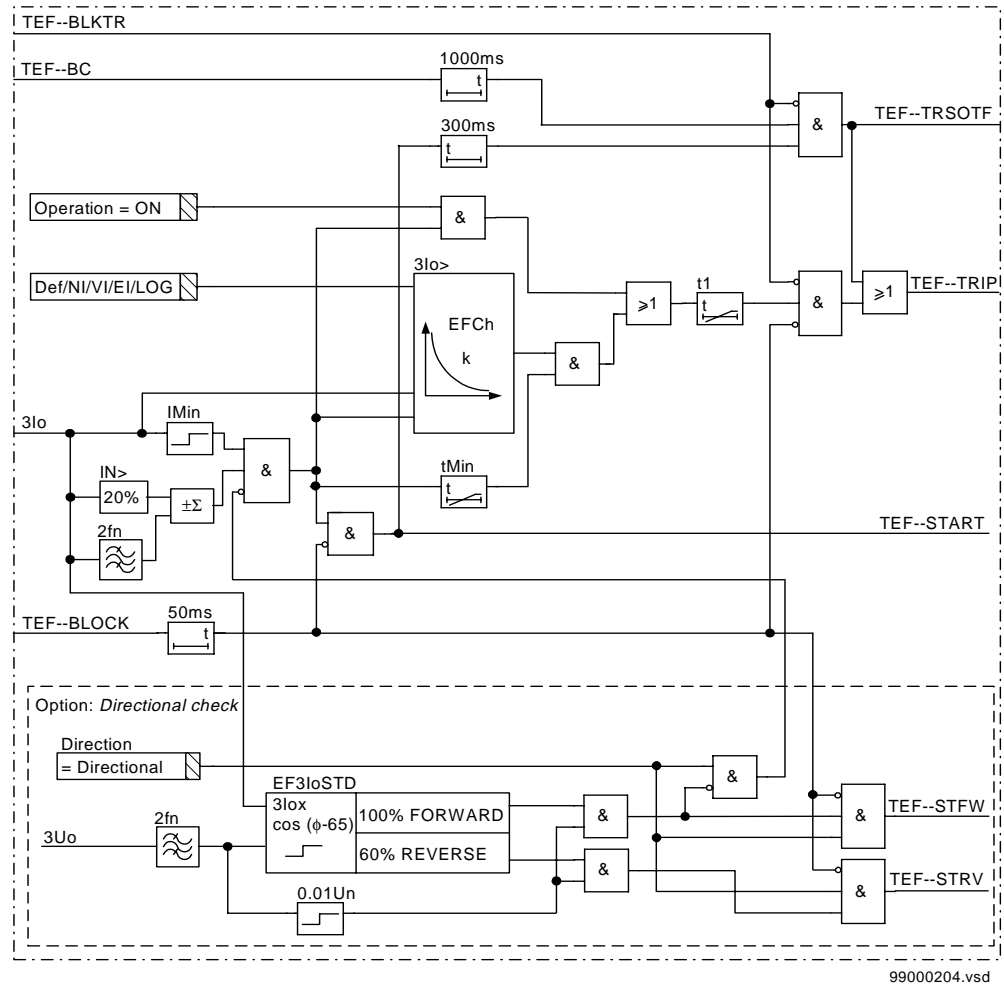

Figure 104: Simplified logic diagram for the residual overcurrent protection

Activate the independent time-delay function by setting *Characteristic*= Def (or inverse time delay according to the setting table). The  $t_1$  timer starts when both the definite/inverse time characteristic and the  $t_{Min}$  timer operate. The  $t_{Min}$  timer starts when the  $3I_0$  current to the relay is equal to or higher than the set operate value for  $I_{Min}$  and the content of the second harmonic in  $3I_0$  is less than 20%.

The inverse time calculation starts when  $3I_0$  is equal to or higher than the set operate value for  $I_{Min}$  and the content of the second harmonic in  $3I_0$  is less than 20%. The inverse time delay is determined by the selection of the characteristic (NI, VI etc.) in the Characteristic setting and the setting of the characteristic  $IN >$  current.



The t1 timer is normally set to zero. Use it to add a constant time to the inverse time delay. Figure 105 shows the effect of the IMin and tMin settings on the inverse characteristic.

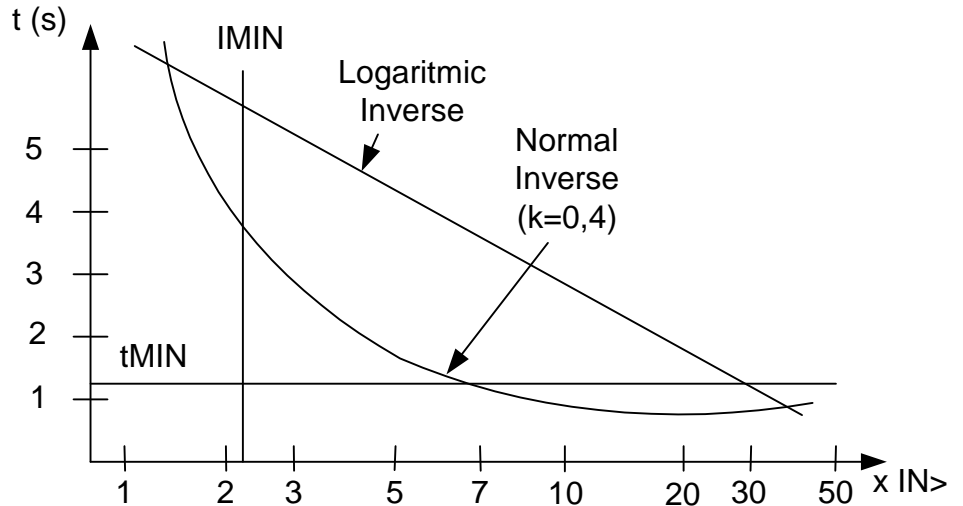

99000105.vsd

Figure 105: Normal inverse and logarithmic inverse time characteristics.

The switch-onto-fault function is used to minimise the operate time in case of pole discrepancy at breaker closing and in case of closing on to a fault. The function is released by activating the TEF--BC binary input. The function is activated for 1 second after the reset of the TEF--BC binary input.

The function is blocked by activating the TEF--BLOCK binary input.

Activating the TEF--BLKTR blocks the definite/inverse delay trip outputs TEF--TRIP and the switch-on-to-fault trip TEF--TRSOTF.

The  $3I_0$  current lags the polarising voltage ( $3U_0$ ) by a phase angle equal to the angle of the zero-sequence source impedance. The forward measuring element operates when:

$$3I_0 \cdot \cos(\varphi - 65^\circ) \geq IN > Dir$$

(Equation 226)

Where:

$\varphi$  is the angle between  $3I_0$  and  $3U_0$  (positive if  $3I_0$  lags  $3U_0$ )

$IN>Dir$  is the set operate value

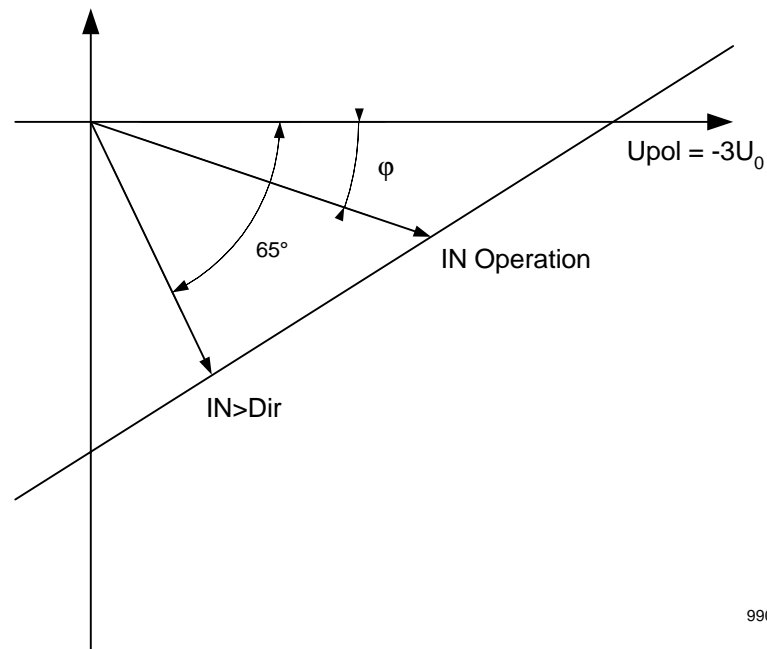

Figure 106: Measuring characteristic of the directional element

The change in operate value is small when the phase angle deviates moderately from  $65^\circ$ . A deviation of  $20^\circ$  increases the operate value by only 6.5%.

The polarising voltage, normally obtained from the broken delta windings of the VTs, can have a high content of harmonics relative to the fundamental frequency when the output voltage is low, particularly when capacitive VTs are used. To secure a correct measurement, the directional function must have an effective bandpass filtering of the voltage. In the module, the filtering secures a correct function for fundamental frequency polarising voltages down to 1% of the rated voltage.

---

In case of an external fault, the capacitive current generated on the line decreases the current to the earth-fault relay situated at the line end towards the fault. So the reverse direction comparator must have an increased sensitivity to secure reliable blocking in case of external faults when a directional comparison or a blocking communication scheme is used. The operate current of the reverse direction measuring element in the module is, as a fixed ratio, set at  $0.6 I_{N> Dir}$ .

## 5.3

### Calculations

#### 5.3.1

##### Setting instructions

To detect high resistive earth-faults, a low operate current is required. On the other hand, a low setting increases the risk for unwanted operation due to imbalance in the network and the current transformer circuits. Set the minimum operate current ( $I_{N> *IMin}$ ) of the earth-fault overcurrent protection higher than the maximum false earth-fault current. If the directional function is chosen, set the start level of the directional function ( $I_{N> Dir}$ ) higher than the maximum false earth-fault current.

The imbalance in the network that causes false earth-fault currents is caused mainly by untransposed or not fully transposed parallel lines with strong zero-sequence mutual coupling. There might also be high imbalance currents for non-transposed single circuit lines if the zero sequence source impedance is low at both line ends. This false earth-fault current is directly proportional to the load current.

In a well-transposed system, the false earth-fault current is normally lower than 5% of the line current.

In case of not fully transposed parallel lines, measure or calculate the false earth-fault current at maximum load.

The choice of time delay characteristics - definite time, normal inverse, very inverse, extremely inverse or logarithmic inverse - depends on the network. To achieve optimum selectivity, use the same type of characteristic for all earth-fault overcurrent protections in the network. This means that in networks already equipped with earth-fault overcurrent relays, the best selectivity is normally achieved by using the same type of characteristic as in the existing relays.

The following formulas for the operate time (in seconds) apply to the characteristic used within the REx 5xx terminal with line protection, see table 9.

**Table 9: Operate time formulas**

Characteristics	Operate time (s)
Normal inverse	$t = \frac{0.14}{I^{0.02} - 1} \cdot k$ (Equation 227)
Very inverse	$t = \frac{13.5}{I - 1} \cdot k$ (Equation 228)
Extremely inverse	$t = \frac{80}{I^2 - 1} \cdot k$ (Equation 229)
Logarithmic inverse	$t = 5.8 - (1.35 \cdot \ln I)$ (Equation 230)

Where:

I is a multiple of set current  $3I_0$

k is a time multiplying factor, settable in the range of 0.05 to 1.10

All inverse time characteristic settings are a compromise between short fault clearing time and selective operation in a large current range. The main determining factors are the maximum allowed fault-clearing time at the maximum fault resistance to be covered and the selectivity at maximum fault current.

Set the minimum operate current (IMin) of the earth-fault overcurrent protection to one to four times the set characteristic quantity (IN>) of the inverse time delay. So an inverse characteristic with a low set IN> set to get a short operate time at minimum fault current can be combined with a higher set IMin minimum operate current, to avoid unwanted operation due to false earth-fault currents.

Set the minimum operate time independent of the inverse time characteristic. Normally, set this time longer than the time delay of distance zone 2 in REx 5xx to avoid interference with the impedance measuring system in case of earth-faults with moderate fault resistance within zone 2.

When a solidly earthed, power transformer is energized, an inrush current normally flows in the neutral-to-earth connection of the transformer. This current is divided among other earthed transformers and lines connected to the same bus, inversely proportional to their zero-sequence impedance. The amplitude and time duration of this current can be sufficiently large to cause the unwanted operation of a sensitive earth-fault overcurrent protection.

The earth-fault overcurrent protection has a built-in second harmonic current stabilization, which prevents unwanted operation if the inrush current has a second harmonic content of 20% or more. This is normally the case. On rare occasions, it may be necessary to increase the setting of the operate value for the residual earth-fault overcurrent protection to avoid unwanted operation due to transformer inrush current.

When single-phase auto-reclosing is used, the minimum time of the inverse time delayed residual overcurrent protection ( $t_{Min}$ ) should be set to be longer than the time from the occurrence of the fault to the reclosing of the breaker at both line terminals. An alternative method is to block the earth fault protection by the autorecloser during the dead time. This avoids unwanted three-phase tripping during a single-phase auto-reclosing cycle controlled by the distance protection.

The polarizing voltage for directional earth-fault overcurrent protection is normally obtained from the broken delta windings of instrument voltage transformers or by internal calculation. The voltage contains a certain amount of harmonics, especially when the protection is connected to CVTs.

Due to the bandpass filtering a polarizing voltage down to 1 percent of the rated voltage will provide correct directional functionality. This is also valid when the protection is connected to CVTs.

The minimum polarizing voltage to the protection ( $U_{min}$ ) is calculated from the formula:

$$U_{min} = I_{Fmin} \cdot Z_{0min} \cdot \frac{U_{sec}}{U_{prim}}$$

(Equation 231)

Where:

$I_{Fmin}$  is the minimum primary operate fault current

$Z_{0min}$  is the minimum zero-sequence impedance seen from the relay

$U_{sec}$ ,  $U_{prim}$  are the rated phase voltages of the broken delta connected CVTs (VTs)

Observe that when a blocking scheme or a permissive scheme with current reversal or weak-end-infeed logic is used,  $I_{Fmin}$  represents the primary operate current of the reverse-looking directional element which is 60% of the forward element.

To even secure operation in unfavorable cases,  $U_{min}$  must be equal to at least 1 volt plus the maximum network frequency false voltage, due to measuring errors in the VT circuits.

If not blocked, the directional comparator operates during the dead time in case of a single-phase auto-reclosure. So the TEF--BLOCK blocking input must be activated during the single-phase auto-reclosing cycle.

---

## 6 Four step residual overcurrent protection (EF4)

### 6.1 Application

In some solidly earthed networks the 4-step earth fault overcurrent protection is used. The function can be used in a similar way as the distance protection. Below is described one example of the normal application of the 4-step earth fault overcurrent protection.

Step 1 has directional function and is set to give instantaneous trip in case of phase to earth faults on the protected line, with large earth fault current. Due to selectivity requirements step 1 can not be set to cover the whole length of the line.

Step 2 has directional function and is set to give a trip with a short delay (~ 0.4 s) for all remote phase to earth faults on the protected line. Step 2 will also serve as main or remote back-up protection for phase to earth faults on the remote busbar.

Step 3 has directional function and is set to give a trip with a medium delay (0.8 - 1.2 s) for phase to earth faults with some fault resistance. Step 3 can also serve as remote back-up protection for phase to earth faults on other lines, out from the remote busbar.

Step 4 has non-directional function and is set to give a trip with a long delay of 1.2 s or more. The current setting is chosen so that high resistive phase to earth faults will be detected and cleared. Also most series faults will be detected and cleared after operation of step 4. To achieve selectivity also for earth faults with small residual current, step 4 can have inverse time characteristic.

The four step earth fault protection can also be used in a communication scheme together with the communication logic for residual overcurrent protection (EFC). Blocking or permissive overreach schemes can be used. One possibility is that step 2 or step 3 is used in an overreach mode. If the overreaching step 2 (3) starts, an acceleration signal is sent to the remote line end. If an acceleration signal is received step 2 (3) will give an instantaneous function.

In case of application on a double circuit line or small infeed of residual current, the additional logic for “Current reversal and weak-end-infeed logic for residual overcurrent protection” (EFCA) should be used in permissive overreaching scheme.

To assure dependable and secure function of the 4-step residual overcurrent protection, extensive network calculations are required.

## 6.2 Functionality

### 6.2.1 Theory of operation

#### Function logic

The 4 step earth-fault overcurrent protection has three current steps with independent time delay and a fourth current step with independent time delay or inverse time characteristics (Normal inverse (NI), Very inverse (VI), Extremely inverse (EI) and one logarithmic inverse characteristic (LOG)).

The formulas in table 10 are valid for the different inverse time characteristics in the four-step earth-fault protection.

**Table 10: Inverse characteristics formulas**

Characteristic:	Time delay (s):
Normal inverse	$t = \frac{0,14}{(I/I_B)^{0,02} - 1} \cdot k$ (Equation 232)
Very inverse	$t = \frac{13,5}{(I/I_B) - 1} \cdot k$ (Equation 233)
Extremely inverse	$t = \frac{80}{(I/I_B)^2 - 1} \cdot k$ (Equation 234)
Logarithmic inverse	$t = 5.8 - (1.35 \cdot \ln(I/I_B))$ (Equation 235)

The simplified logic diagrams in figure 107 to 110 show the circuits for the four overcurrent steps and the directional function. The diagrams also include the logic of the switch-onto-fault function.



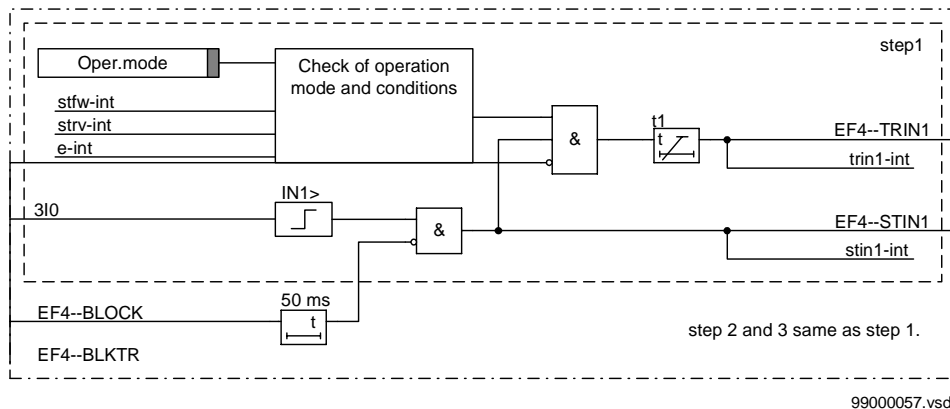

Figure 107: Simplified logic diagram of internal function Step 1. Step 2 and step 3 are the same.

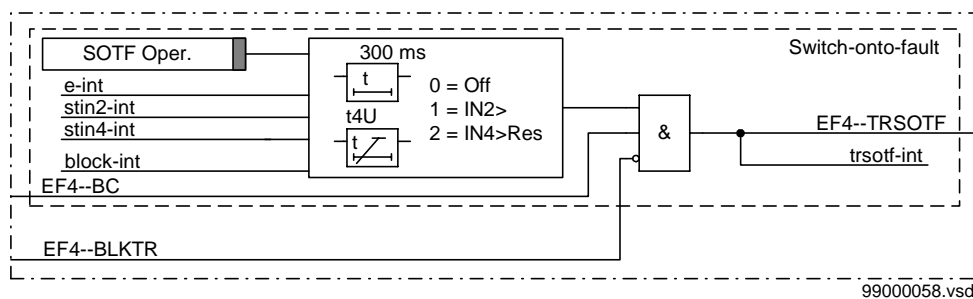

Figure 108: Simlified logic diagram of internal function Switch-onto-fault.

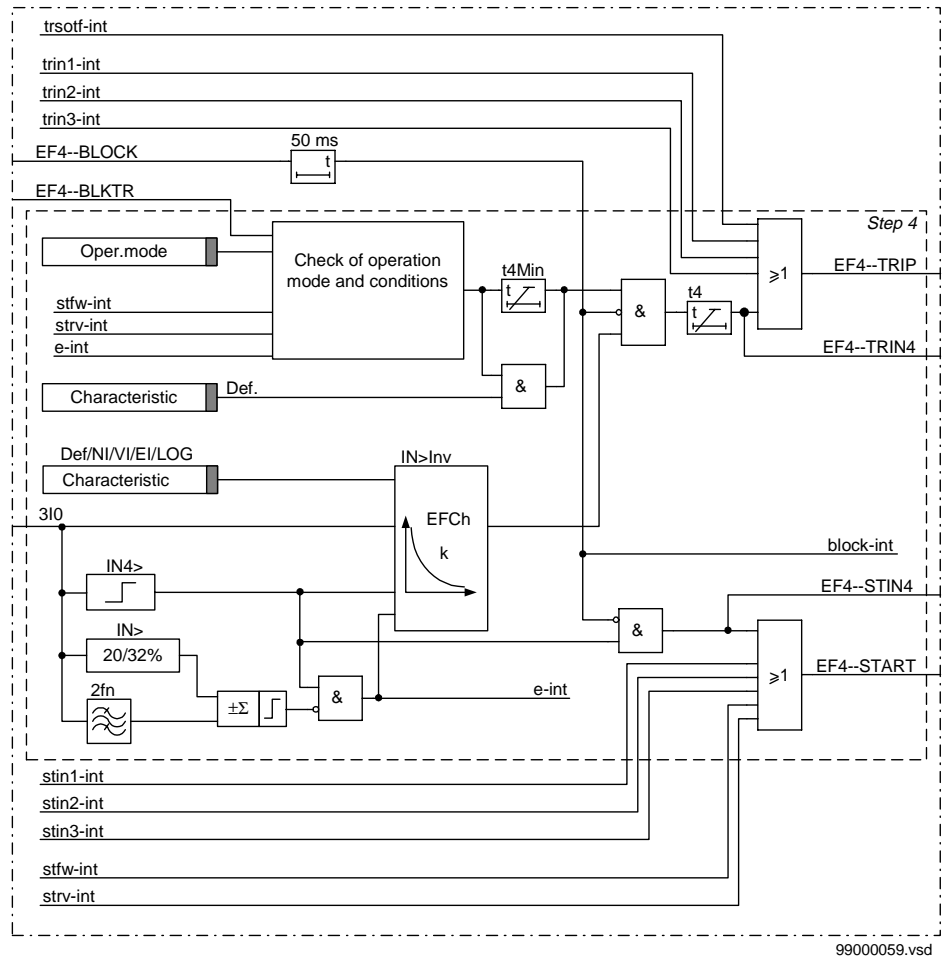
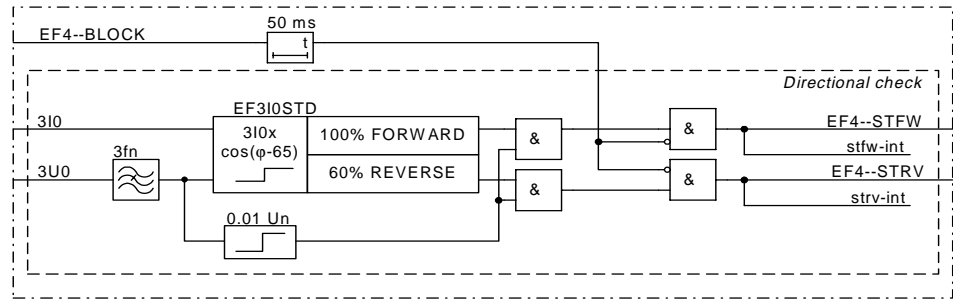

Figure 109: Simplified logic diagram of internal function step 4.



99000060.vsd

Figure 110: Simplified logic diagram of internal function Directional check.

For all four current steps, one of the following operate modes can be selected, independently of the other steps:

- Non-directional overcurrent function without second harmonic restraint, *NonDirNonRestr.*
- Forward directional overcurrent function without second harmonic restraint, *ForwRelease.*
- Non-directional overcurrent function with second harmonic restraint, *Restrained.*
- Forward directional overcurrent function with second harmonic restraint, *ForwRelRestr.*
- Overcurrent function without second harmonic restraint, with blocking from the reverse direction measuring element, *RevBlock.*
- Overcurrent function with second harmonic restraint, with blocking from the reverse direction measuring element, *RevBlRestr.*

### The directional measuring function

The forward direction measuring element (STFW) operates when:

$$3I0 \cdot \cos(\varphi - 65^\circ) \geq IN > Dir$$

(Equation 236)

Where:

$IN > Dir$  = set operate current

---

$\varphi$  = phase angle between the current and the voltage (positive if the current lags the voltage)

The operate current can be set between 5 and 40% of the base current ( $I_b$ ) of the REX 5xx terminal.

The operate current is very little influenced by moderate phase angle differences. A deviation of  $20^\circ$  from the characteristic angle  $65^\circ$  only increases the operate value by 6.5%.

The operate value is practically independent of the magnitude of the polarising voltage in the interval from 0.5 to 100% of nominal value. When the voltage is less than 0.5%, the measuring circuit is blocked.

In special cases when the polarising voltage is too low, current polarising can be used by inserting an external unit which converts the zero sequence current into a voltage.

The polarising voltage is normally obtained from the broken delta winding of the VT's. When the voltage is low, it can have a high content of harmonics - especially third harmonic - relative the basic frequency component. This is specially the case when capacitive VT's are used. To secure correct directional function down to a polarising voltage of 0.5% of rated voltage, the measuring circuit is provided with a filter which has a damping factor of  $>20$  for the third harmonic component of the voltage.

The directional function has two comparators, one operates in the forward direction (STFW) and one operates in the reverse direction (STRV). The operate current of the reverse directional comparator is  $0.6I_{N>Dir}$ , i.e. 40% lower than that of the forward directional. The increased sensitivity is used to compensate for the influence of the capacitive current generated by the faulty line, which in case of an external fault decreases the current fed to the earth-fault protection situated at the line end towards the fault. By increasing the sensitivity, reliable blocking from the reverse directional measuring element is obtained for the directional comparison system.

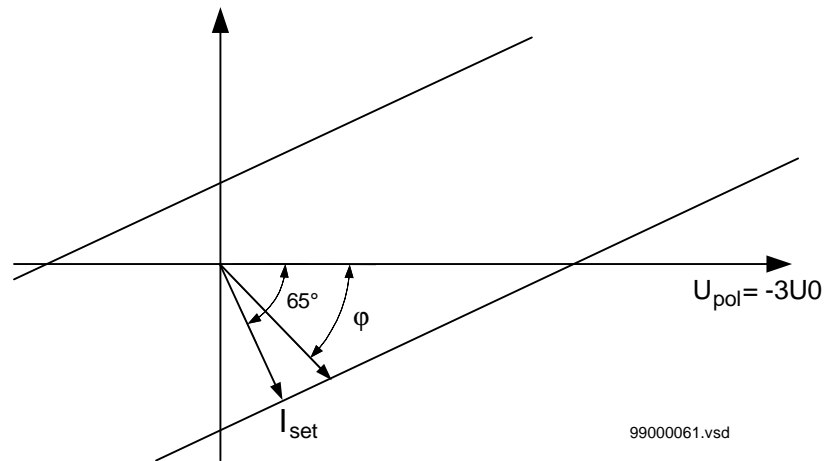

Figure 111: Operate characteristic of the direction measuring element.

#### Definite time overcurrent step 1

When the current exceeds the set operate value for IN1> and no blocking is applied to input EF4-BLOCK, the &-gate operates and the start flag EF4-STIN1 is activated.

When the setting “ForwRelease” is selected, the forward directional element must also operate in order to start the timer t1.

When the setting “RevBlock” is selected, the timer t1 is not activated if the reverse directional element is activated.

When the setting “Restrained” is selected, the timer t1 is not activated if the second harmonic content in 3I0 is higher than the set blocking value (20 or 32%).

#### Definite time overcurrent step 2 and 3

The overcurrent steps 2 and 3 have the same functionality as step 1.

#### Overcurrent step 4

With setting “Characteristic = Definite”, the function of step 4 with current detector IN4> and timer t4 is the same as for overcurrent steps 1 – 3.

When logarithmic inverse time characteristic is selected the inverse time calculation starts when the current exceeds the set operate value of current detector  $I_{N4>}$  (see figure 109). For the NI, VI and EI characteristics the inverse time calculation starts when the current exceeds the set characteristic current ( $I_{N4>Inv}$ ). The inverse time delay is determined by the selection of the characteristic (NI,VI etc.), the setting of the time multiplier (k) and the characteristic current ( $I_{N4>Inv}$ ). The timer  $t_4$  starts when both the inverse timer and the timer  $t_{4Min}$  operate. Hence, the setting  $I_{N4>}$  determines the minimum operate current and the setting  $t_{4Min}$  determines the minimum operate time.

The influence of the setting of minimum operate time and minimum operate time on the inverse time function is shown in figure 112.

Observe that when inverse characteristic NI, VI or EI is selected, the second harmonic restrain is a fixed value=20 %, independent of the setting.

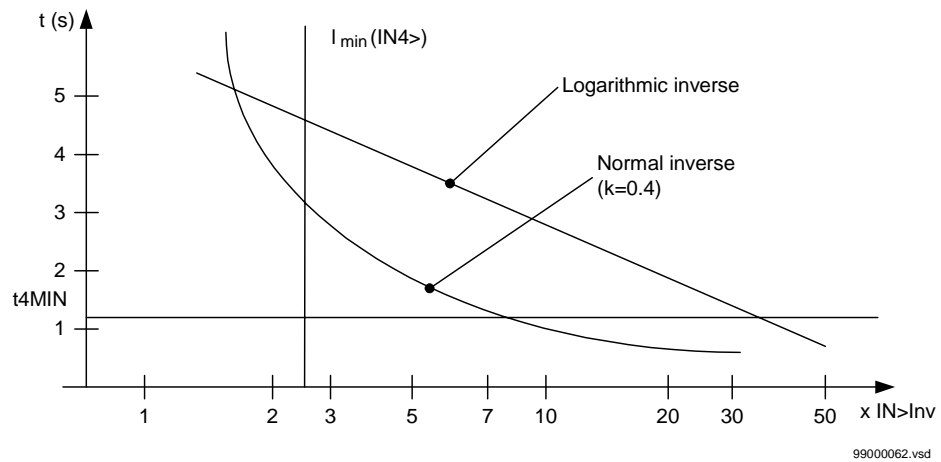

Figure 112: Normal inverse and logarithmic inverse time characteristics.

Timer  $t_{4Min}$  is normally set to zero. It can be used to add a constant time to the inverse time delay.

The functions ForwRel, RevBlock and Restrained are applicable also when inverse time is selected.

To release the switch-onto-fault function, the input EF4--BC is activated when the breaker is closed. The function remains released 5 seconds after reset of the input signal.

When the operation mode SOTF is set to IN2>, the current stage IN2> activates the output EF4--TRSOTF with a fixed time delay of 300 ms. With the setting SOTF = IN4>Res, the current stage IN2> activates the output with a fixed time delay of 300 ms and the current stage IN4>Res activates the output EF4--TRSOTF with a time delay  $t_{4U}$ . Nevertheless, a condition is that the second harmonic content in 3I0 is less than the set blocking value. Both time steps are blocked when input EF4--BLOCK is activated.

When the setting BlkParTransf = On is selected and the second harmonic content in the current 3I0 is higher than the set restrain value 70 ms after the operation of current detector IN4>Res, the &-gate after the timer seals in and gives second harmonic blocking until the current detector resets. The function is used for parallel connected transformers, for which the second harmonic content of the inrush current may become substantially reduced within fractions of a second after breaker closure.

## 6.3

### Calculations

### 6.3.1

#### Settings

##### General

Only detailed network studies can determine the operate conditions under which the highest possible fault current is expected on the line. In most cases, this current appears during single-phase fault conditions. But to examine two-phase-to-earth conditions is also needed, since this type of fault can give larger earth fault current than single-phase to earth fault in some cases.

Also transients, that could cause a high increase of the line current for short times, should be considered. A typical example is a transmission line with a power transformer at the remote end or at a line tap, which can cause high inrush current when connected to the network and can thus also cause operation of the residual overcurrent protection.

As the reach of each step is dependent on the operation conditions, fault calculations for the settings should be done with various switching states in the network.

##### Step 1

The settings for step 1 is described in the following sections. Section "Meshed network without parallel line" on page 230 and section below are valid for both directional and non-directional operation. For non-directional operation, also section "Meshed network non-directional" on page 232 must be considered.

### Meshed network without parallel line

This section describes the setting calculation for Step 1 for both directional and non-directional operation. But when non-directional operation is selected, an additional fault calculation, with a fault applied in A, has to be done. See section "Meshed network non-directional" on page 232.

The following fault calculations have to be done for single-phase-to-earth and two-phase-to-earth faults. With reference to figure 113, apply a fault in B and then calculate the relay through fault residual current  $I_{fB}$ . The calculation should be done using the minimum source impedance values for  $Z_A$  and the maximum source impedance values for  $Z_B$  in order to get the maximum through fault current from A to B. For most protections a network switching state, with one of the lines out from the remote busbar taken out of service, will give the largest residual fault current to the protection.

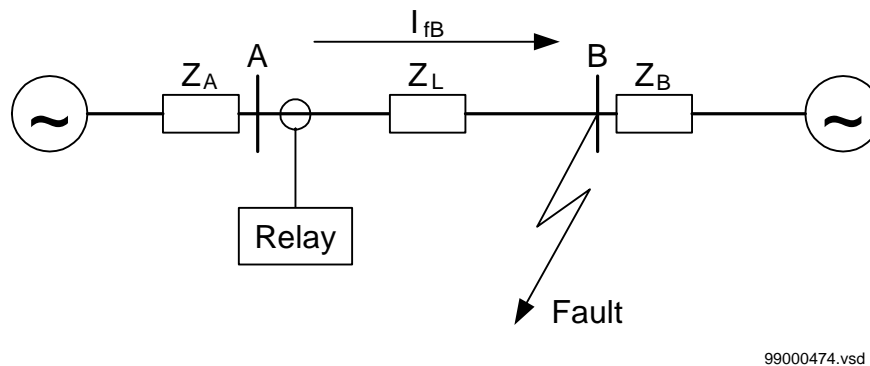

Figure 113: Through fault current from A to B:  $I_{fB}$

The minimum theoretical current setting ( $I_{min}$ ) will be:

$$I_{min} \geq \text{MAX}(I_{fB}) \quad (\text{Equation 237})$$

A safety margin of 5% for the maximum protection static inaccuracy and a safety margin of 5% for the maximum possible transient overreach have to be introduced. An additional 10% is suggested due to the inaccuracy of the instrument transformers during transient conditions and inaccuracy in the system data.

The minimum setting ( $I_s$ ) for the residual overcurrent protection, step 1, is then:

$$I_s \geq 1,2 \cdot I_{fB} \quad (\text{Equation 238})$$



### Meshed network with parallel line

In case of parallel lines, the influence of the induced current from the parallel line to the protected line has to be considered. One example is given in figure 114, where the two lines are connected to the same busbar. In this case the influence of the induced fault current from the faulty line (line 1) to the healthy line (line 2) is considered together with the through fault current  $I_{fB}$  mentioned previously. The maximal influence from the parallel line for the relay in figure 114 will be with a fault at the C point with the breaker C open.

A fault in C has to be applied, and then the maximum current seen from the relay ( $I_M$ ) on the healthy line (this applies for single-phase-to-earth and two-phase-to-earth faults) is calculated. The through fault current  $I_M$  is the sum of the induced fault current from line 1 and the fault current that would occur in line 2 if the mutual impedance  $M$  would be zero. Also in the case with fault at a parallel line, the case with one of the lines out from the remote busbar taken out of service, should be considered.

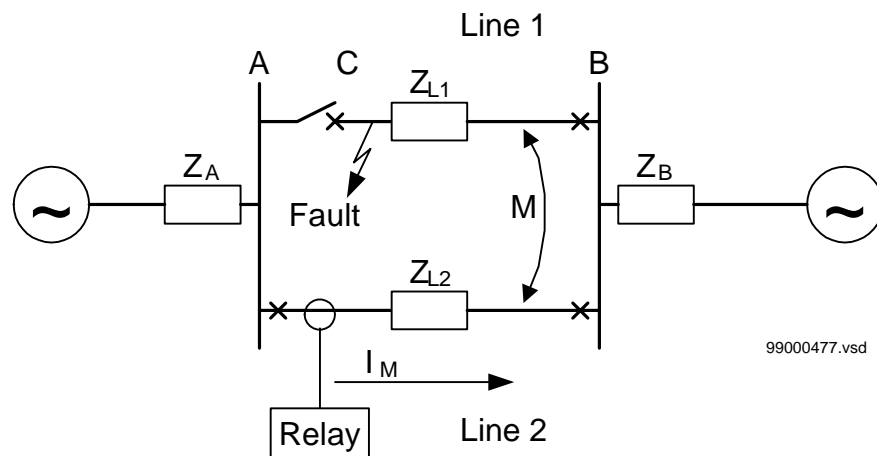

Figure 114: Two parallel lines. Influence from parallel line to the through fault current:  $I_M$

The minimum theoretical current setting for the residual overcurrent protection function ( $I_{min}$ ) will be:

$$I_{min} \geq \text{MAX}(I_{fB}, I_M)$$

(Equation 239)

Where:

$I_{fB}$  has been described in the previous paragraph

Considering the safety margins mentioned previously, the minimum setting ( $I_s$ ) for the protection, step 1, is then:

$$I_s \geq 1,2 \cdot I_{min}$$

(Equation 240)

The protection function can be used for the specific application only if this setting value is equal or less than the maximum residual fault current that the relay has to clear.

### Meshed network non-directional

First do the calculation according to section "Meshed network without parallel line" on page 230.

Then apply a fault in A and calculate the through fault residual current  $I_{fA}$  (Figure 115). In order to get the maximum through fault current, the minimum value for  $Z_B$  and the maximum value for  $Z_A$  have to be considered.

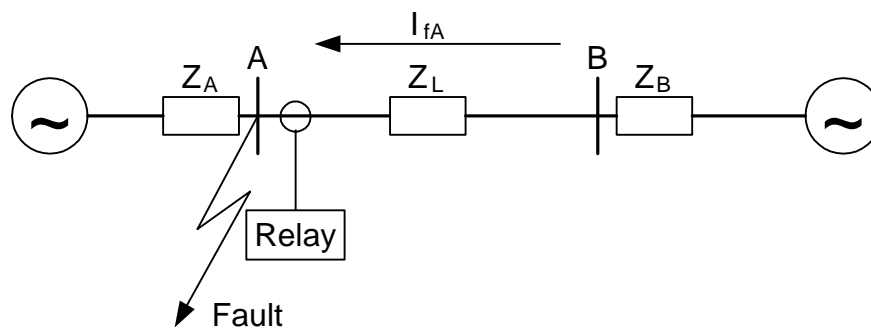

99000475.vsd

Figure 115: Through fault current from B to A:  $I_{fA}$

The minimum theoretical current setting ( $I_{min}$ ) will then be:

$$I_{min} \geq \text{MAX}(I_{fA}, I_{fB})$$

(Equation 241)

A safety margin of 5% for the maximum protection static inaccuracy and a safety margin of 5% for the maximum possible transient overreach have to be introduced. An additional 10% is suggested due to the inaccuracy of the instrument transformers during transient conditions and inaccuracy in the system data.

The minimum setting ( $I_s$ ) for the residual overcurrent protection, step 1, is then:

$$I_s \geq 1,2 \cdot I_{min}$$

(Equation 242)

The protection function can be used for the specific application only if this setting value is equal or less than the maximum fault current that the relay has to clear ( $I_F$  in figure 116)

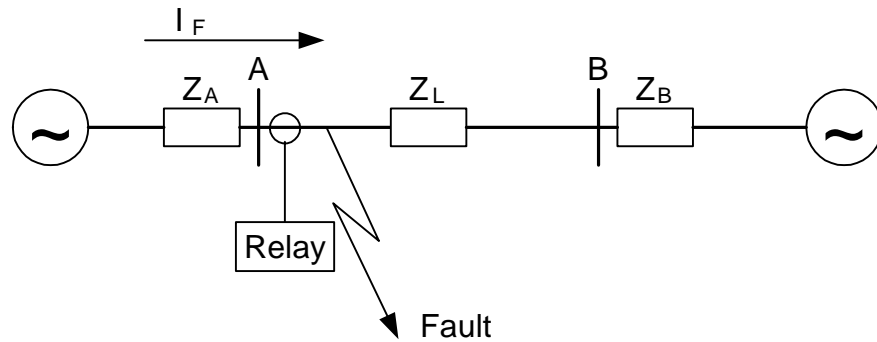

99000476.vsd

Figure 116: Fault current:  $I_F$

For parallel lines, the minimum theoretical current setting for the residual overcurrent protection function ( $I_{min}$ ) will be:

$$I_{min} \geq \text{MAXI} \langle I_{fA}, I_{fB}, I_M \rangle$$

(Equation 243)

Where:

$I_{fA}, I_{fB}$  have been described in the previous paragraphs

### Step 2 and 3

The calculation of the settings for step 2 and 3 differs from step 1. However, the method to calculate the values are the same for step 2 and 3. First it is necessary to apply the faults as in figure 117, one at a time, and measure the residual currents and calculate the settings for step 2. Phase to earth faults out on each line out from the remote busbar, are calculated. In these calculations the circuit breaker at the remote end of the faulted line is open (instantaneous trip).

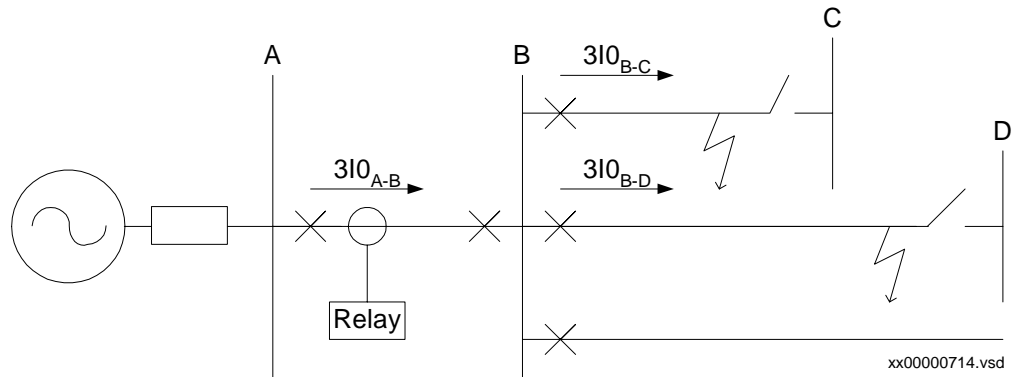

Figure 117: Example of fault cases between stations. Calculation of  $3I0_{min}$  for step 2 (and step 3).

Use the values for step 1 to calculate minimum residual current setting for step 2. Similarly, use the values from step 2 to calculate the settings for step 3.

The minimum current for step 2 is calculated from:

$$3I02_1 = s \cdot a_1 \cdot 3I01_{B-C} \quad (\text{Equation 244})$$

Where:

$3I01_{B-C}$  is the step 1 current setting for the B-C protection

$$3I02_2 = s \cdot a_2 \cdot 3I01_{B-D} \quad (\text{Equation 245})$$

Where:

$3I01_{B-D}$  is the step 1 setting for the B-D protection

Which then gives  $3I0_{min}$  as:

$$3I02_{min} = \max(3I02_1, 3I02_2) \quad (\text{Equation 246})$$

Where:

$s$  is the safety factor (=1.2)

$$a_1 = \frac{3I_{A-B}}{3I_{B-C}} \quad (\text{Equation 247})$$

$$a_2 = \frac{3I_{A-B}}{3I_{B-D}} \quad (\text{Equation 248})$$

The currents to be found in figure 117.

For step 2 there is normally a requirement that faults on the remote busbar shall be detected and cleared. Calculations are done where a phase to earth fault is applied at the remote busbar. In this calculation the zero sequence source impedance, “behind” the relay, shall be minimized. This is normally done by taking one line out of service. The step 2 setting should be chosen according to:

$$3I_{\max} \leq s2 \times \min(3I_{\text{busbar}}) \quad (\text{Equation 249})$$



**Note!**

*The safety factor, s, may be increased if there exists a mutual coupling for the lines from B to C or D.*

Step 2 or step 3 can also be used in communication schemes: Blocking or permissive overreach.

In case of a blocking scheme step 3 can be given reverse direction. This step will be used as blocking criterion. The reverse step 3 must overreach the overreach step 2 in the remote line end.

In case of a permissive overreach scheme it must be assured that the step to be used for sending and accelerated trip, must overreach the line. This can be done as described above for step 2 and 3.

**Step 4, non-directional**

To detect high resistive earth-faults, a low operate current is required. On the other hand, a low setting will increase the risk for unwanted operation due to unbalance in the network and the current transformer circuits. The minimum operate current of the earth-fault overcurrent protection must be set higher than the maximum false earth-fault current.

The unbalance in the network that causes false earth-fault currents is caused mainly by untransposed or not fully transposed single circuit or parallel lines. This false earth-fault current is directly proportional to the load current.

In well transposed systems, the false earth-fault current is normally lower than 5% of the line current.

In case of extremely short or not fully transposed parallel lines, the false earth-fault current must be measured or calculated when maximum sensitivity is desired. Generally, 80 A is recommended as a minimum primary operate value for the earth-fault overcurrent protection.

#### Inverse time delay

To achieve optimum selectivity, the same type of inverse characteristic should be used for all earth-fault overcurrent protections in the network. Therefore, in networks already equipped with earth-fault overcurrent relays, the best selectivity will normally be achieved by using the same type of inverse characteristic as in the existing relays.

The following formulas are valid for the inverse characteristics in the four-step earth-fault protection in REx 5xx:

**Table 11: Inverse characteristics formulas**

Characteristic:	Operate time (s):
Normal inverse	$t = \frac{0,14}{(I/I_B)^{0,02} - 1} \cdot k$ (Equation 250)
Very inverse	$t = \frac{13,5}{(I/I_B) - 1} \cdot k$ (Equation 251)
Extremely inverse	$t = \frac{80}{(I/I_B)^2 - 1} \cdot k$ (Equation 252)
Logarithmic inverse	$t = 5,8 - (1,35 \cdot \ln(I/I_B))$ (Equation 253)

Where:

- I is a multiple of set current  $3I_0 > I_{nv}$
- $I_B$  is the set base current of the terminal
- k is a time multiplying factor, setting range 0.05-1.10.

The determining factors for the inverse characteristic settings are the allowed fault clearing time at the maximum fault resistance to be covered, and the selectivity at maximum fault current.

The minimum operate current  $I_{N4}$  of the inverse current step can be set in the range of one to four times the set characteristic current  $I_{N>Inv}$ . Hence, an inverse characteristic with a low set  $I_{N>}$  to get short operate time at minimum fault current can be combined with a higher set minimum operate current in order to avoid unwanted operation due to false residual currents.

The minimum operate time  $t_{4Min}$  is set independent of the inverse time characteristic. This time is normally set longer than the time delay of impedance zone 2 in the line protections, in order to avoid interference with the impedance measuring system in case of earth-faults with moderate fault resistance within zone 2.

### Directional current function

#### Polarising voltage

The polarising voltage for directional earth-fault protection is normally obtained from the broken delta connected secondary windings of instrument voltage transformers or interposing voltage transformers. The voltage contains a certain amount of harmonics, especially when the protection is connected to CVT's.

Due to the efficient band-pass filtering within REx 5xx, a polarising voltage down to 0.5% of the rated voltage will provide correct directional functioning. This is also valid when the protection is connected to CVT's.

The minimum voltage to the protection ( $U_{min}$ ) is calculated from the formula:

$$U_{min} = I_{F min} \cdot Z_{0 min} \cdot \frac{U_{sec}}{U_{prim}} \quad (\text{Equation 254})$$

Where:

$I_{Fmin}$  is the minimum primary operate current,

- $Z_{0min}$  is the minimum zero-sequence sources impedance at the relay site and
- $U_{sec}$  is the rated secondary phase voltage of the broken delta connected winding of the voltage transformers
- $U_{prim}$  is the rated primary voltage

### Directional current settings

The operate value of the forward direction function ( $IN > Dir$ ) should with some margin be set lower than both:

- The operate current of the most sensitive directional step.
- The lowest set current step which is used as input to the directional comparison logic.

Check according to the formula above that the necessary polarising voltage is obtained for the directional function.

Observe that when the current reversal or weak-end-infeed logic is used,  $I_{fmin}$  represents the primary operate current of the reverse directional element.

To secure operation in unfavorable cases as well,  $U_{min}$  should be equal to at least 0.5 volts plus the maximum network frequency false voltage, due to measuring errors in the VT circuits.

If not blocked, the directional comparator will operate during the dead time in case of a single-phase auto-reclosure. Therefore, the blocking input EF4-BLOCK should be activated during the single-phase auto-reclosing cycle.

### Example of protection scheme

Due to the flexibility of the 4 step earth-fault protection, different protection schemes according to the customers preference can be realised. One established scheme is to use Step 1-3 as directional steps and the inverse time delayed step 4 as a low set, non-directional back-up step. A selectivity plan for the different current steps is presented in figure 118.



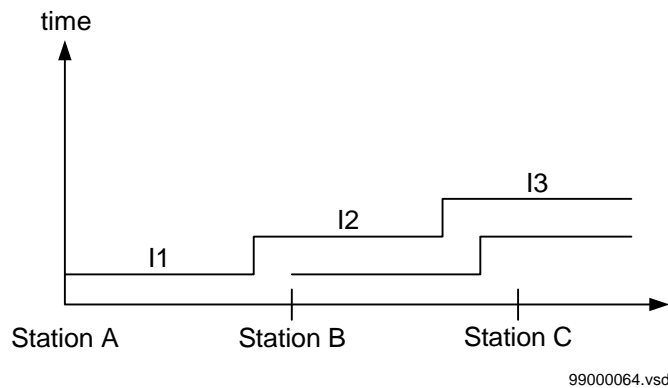

Figure 118: Example of selectivity plan for the directional current steps.

In systems with 3-phase tripping from the distance relays in case of earth-faults, no time delay is normally used for step 1.

Step 2 is set to operate for all earth-faults on the entire line and at the remote end station, even with a certain additional fault resistance. The calculated minimum earth-fault current is multiplied with a safety factor of 0.9 to get the current setting of step 2. The time delay of step 2 is normally set to 0.4 s.

Step 2 shall also be selective to step 2 in the adjacent station, see figure 118. It may, therefore, be necessary to compromise and accept a higher current setting than according to the above for the protection in station A.

Directional current step 3 is set to operate for earth-faults with additional resistance or for the minimum current at which sufficient polarising voltage is obtained. The time delay of step 3 is normally set to 0.8-1.5 s.

The inverse time delayed, non-directional step 4 is in this scheme used as a back-up function which shall trip the line in case of earth-faults with so high additional resistance that the directional steps cannot operate. Step 4 is normally given the same setting for all lines in the network with a time/current characteristic that normally gives selectivity towards the directional steps.

Desirable values of the fault resistances for the different current steps are –  $\sim 15 \Omega$  for  $R_{I2}$ ,  $\sim 25 \Omega$  for  $R_{I3}$  and  $\sim 50 \Omega$  for  $R_{I4}$ . If these values cannot be fulfilled, another protection function should be considered, for example current differential protection.

## 7 Sensitive directional residual overcurrent protection (WEF1)

### 7.1 Application

In networks with high impedance earthing, the phase to earth fault current is significantly smaller than the short circuit currents. Another difficulty is that the magnitude of the phase to earth fault current is almost independent of the fault location in the network.

Directional residual current can be used to detect and give selective trip of phase to earth faults in high impedance earthed networks. The protection uses the residual current component  $3I_0 \cos \varphi$ , where  $\varphi$  is the angle between the residual current and the residual voltage, compensated with a characteristic angle.

In an isolated network, i.e. the network is only coupled to earth via the capacitances between the phase conductors and earth, the residual current always has  $-90^\circ$  phase shift compared to the residual voltage. The characteristic angle is chosen to  $-90^\circ$  in such a network.

In resistance earthed networks or in Petersén coil, with or without a parallel resistor, the active residual current component (in phase with the residual voltage) should be used for the earth fault detection. In such networks the characteristic angle is chosen to  $0^\circ$ . As the amplitude of the residual current is independent of the fault location the selectivity of the earth fault protection is achieved by time selectivity.

When should the sensitive directional residual overcurrent protection be used and when should the sensitive directional residual power protection be used? We have the following facts to consider:

- Sensitive directional residual overcurrent protection gives possibility for better sensitivity
- Sensitive directional residual power protection gives possibility to use inverse time characteristics. This is applicable in large high impedance earthed networks, with large capacitive earth fault current

### 7.2 Functionality

#### Features

- Separate starting indicators
- Separate trip indicator
- Separate direction indicators
- Settable characteristic angle, RCA, between -90 deg. to +90 deg.
- Internal supervision
- Binary input to enable or block the operation
- Independent time delay for trip

### Description of operation

Sensitive directional residual overcurrent protection function (WEF1) has two analog inputs, residual current and residual voltage. The main functionality goal is to measure the residual current component  $3I_0 \cos \varphi$ .

The reference for the directional check is the voltage  $3U_0$ . Depending on the earthing of the network the angle of the voltage  $3U_0$  must be adjusted with the relay characteristic angle, RCA. The reference voltage, see figure 119, is

$$U_{ref} = -3U_0 \cdot e^{j \cdot (RCA)}$$

(Equation 255)

Where:

$-3U_0$  is equal to  $3U_0$  with 180 degrees adjusted

RCA is usually equal to zero in compensated network (Petersén coil) and 90 degree in isolated network.

Precondition for the calculation is the availability of high enough residual voltage and residual current respectively. The sum of  $\varphi$  and RCA (called ANGLE) is used in the protection algorithm, see figure 119.

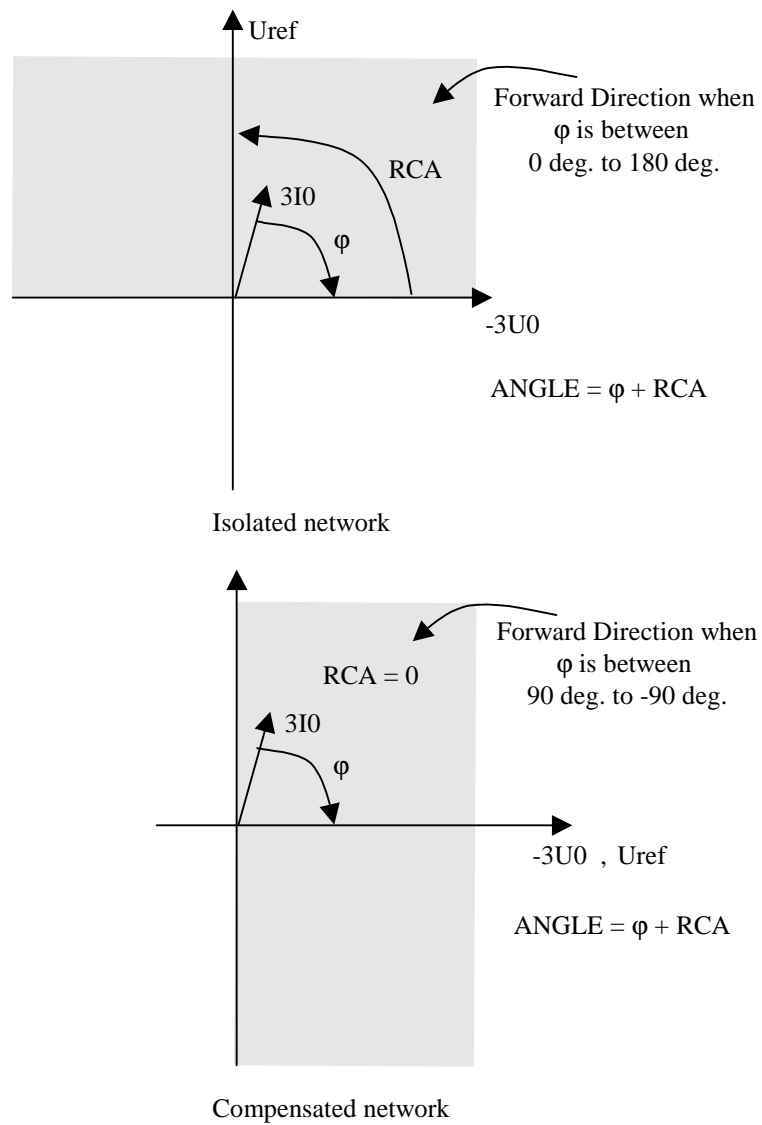

en01000037.vsd

Figure 119: RCA with regard to compensated or isolated network

The compensated angle is used for directional detection and for input of the calculation of the fault current component,  $3I_0 \cos \varphi$ .

**Start conditions**

A start signal from the function is given if both residual voltage, ( $UN>$ ) and residual current component,  $3I_0 \cos \varphi$  ( $IN\cos\Phi>$ ) exceeds the setting values, see figure 120.

### Trip conditions

A trip signal from the function is given if all the following conditions are fulfilled:

- The current component,  $3I_0 \cos \varphi$  ( $IN\cos\Phi>$ ) exceeds the setting value.
- The residual voltage, ( $UN>$ ) exceeds the setting value.
- The fault is detected in the chosen direction (FW = forward or RV = reverse).
- The time delay  $t_{Trip}$  has elapsed.

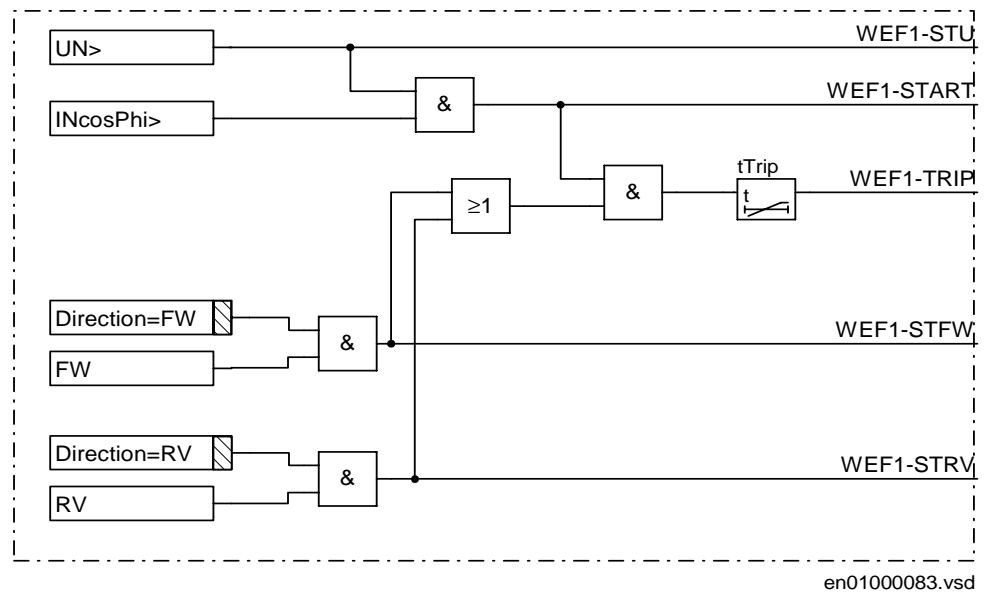

Figure 120: Logic for sensitive directional residual overcurrent protection function (WEF1)

## 8 Sensitive directional residual power protection (WEF2)

### 8.1 Application

In networks with high impedance earthing, the phase to earth fault current is significantly smaller than the short circuit currents. Another difficulty is that the magnitude of the phase to earth fault current is almost independent of the fault location in the network.

Directional residual power can be used to detect and give selective trip of phase to earth faults in high impedance earthed networks. The protection uses the residual power component  $3I_0 3U_0 \cos \varphi$ , where  $\varphi$  is the angle between the residual current and the residual voltage, compensated with a characteristic angle.

In an isolated network, i.e. the network is only coupled to earth via the capacitances between the phase conductors and earth, the residual current always has  $90^\circ$  phase shift compared to the residual voltage. The characteristic angle is chosen to  $-90^\circ$  in such a network.

In resistance earthed networks or in Petersén coil, with or without a parallel resistor, the active residual current component (in phase with the residual voltage) should be used for the earth fault detection. In such networks the characteristic angle is chosen to  $0^\circ$ . As the amplitude of the residual current is independent of the fault location the selectivity of the earth fault protection is achieved by time selectivity.

When should the sensitive directional residual current protection be used and when should the sensitive directional residual power protection be used? We have the following facts to consider:

- Sensitive directional residual overcurrent protection gives possibility for better sensitivity
- Sensitive directional residual power protection gives possibility to use inverse time characteristics. This is applicable in large high impedance earthed networks, with large capacitive earth fault current
- In some power systems a medium size neutral point resistor is used. Such a resistor will give a resistive earth fault current component of about 200 - 400 A at a zero resistive phase to earth fault. In such a system the directional residual power protection gives better possibilities for selectivity enabled by inverse time power characteristics.

### 8.2 Functionality

#### Features

- Separate starting indicators
- Separate trip indicator
- Settable characteristic angle, RCA, between -90 deg. to +90 deg.
- Internal supervision
- Binary input to enable or block the operation
- Independent time delay for trip
- Inverse time function

### Description of operation

Sensitive directional residual power protection function (WEF2) has two analog inputs, residual current and residual voltage. The main functionality goal is to measure the residual power  $3U_0 3I_0 \cos \varphi$ .

The reference for the directional check is the voltage  $3U_0$ . Depending on the earthing of the network the angle of the voltage  $3U_0$  must be adjusted with the relay characteristic angle, RCA. The reference voltage, see figure 121, is

$$U_{ref} = -3U_0 \cdot e^{j \cdot (RCA)}$$

(Equation 256)

Where:

$-3U_0$  is equal to  $3U_0$  with 180 degrees adjusted

RCA is usually equal to zero in compensated network (Petersén coil) and -90 degrees in isolated network.

Precondition for the calculation is the availability of high enough residual voltage and residual current respectively. The sum of  $\varphi$  and RCA (called ANGLE) is used in the protection algorithm, see figure 121.

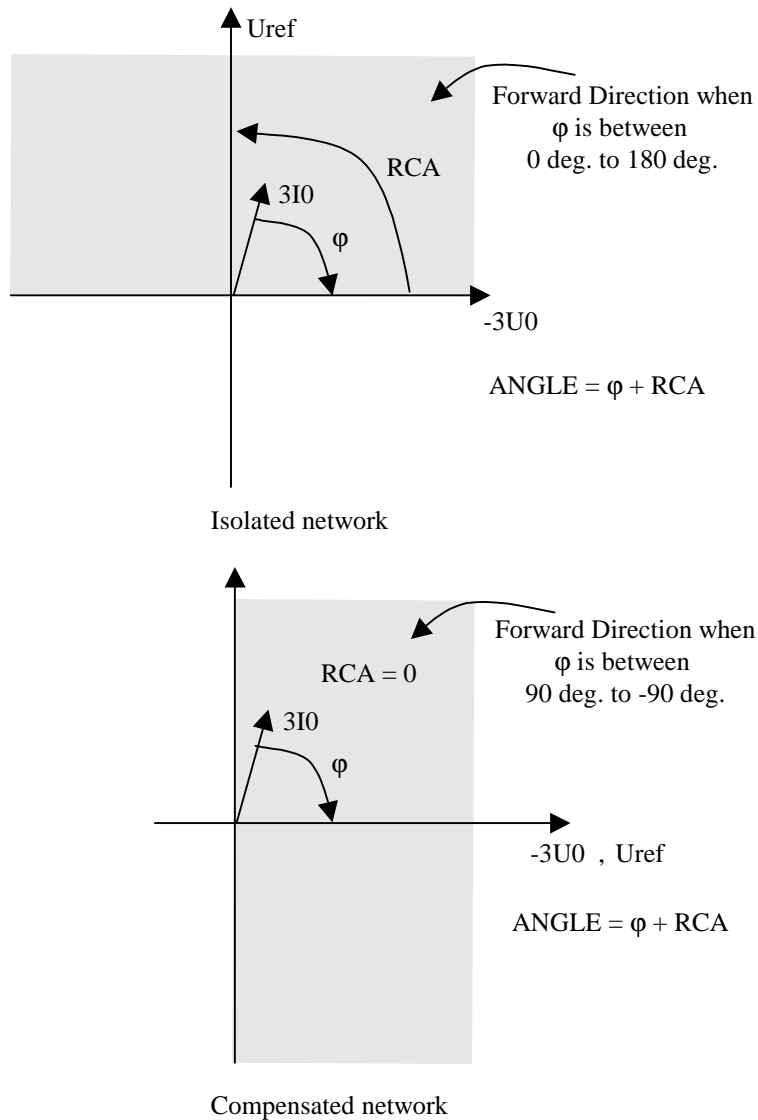

en01000037.vsd

Figure 121: RCA with regard to compensated or isolated network

The compensated angle is used for directional detection and for input of the calculation of the fault power component,  $3U_0 3I_0 \cos \varphi$ .

**Start conditions**



A start signal from the function is given if all the following conditions are fulfilled, see figure 122.

- Residual voltage exceeds the setting value ( $UN >$ )
- Residual current exceeds the setting value ( $IN >$ )
- The measured real power  $3U_0 3I_0 \cos \varphi$  exceeds the setting value ( $SN >$ )

### The inverse function

An inverse time trip function for the Sensitive directional residual power protection is implemented in the algorithm for WEF2.

The inverse time function:

$$T_{inv} = k \cdot S_{ref} / (3U_0 3I_0 \cos \varphi)$$

(Equation 257)

Where:

- |                          |                                    |
|--------------------------|------------------------------------|
| k                        | is k-factor (0.0 - 2.0),           |
| Sref                     | is scaling factor (5.0 - 50.0) and |
| $3U_0 3I_0 \cos \varphi$ | is the measured real power         |

### Trip conditions

A trip signal from the function is given if all the following conditions are fulfilled:

- Residual voltage exceeds the setting value ( $UN >$ )
- Residual current exceeds the setting value ( $IN >$ )
- The measured real power component  $3U_0 3I_0 \cos \varphi$  exceeds the setting value ( $SN >$ )
- The measured real power component  $3U_0 3I_0 \cos \varphi$  is activated until the inverse time  $T_{inv}$  has elapsed.
- The time delay  $t_{Trip}$  has elapsed.
- The fault is detected in the chosen direction (forward or reverse).

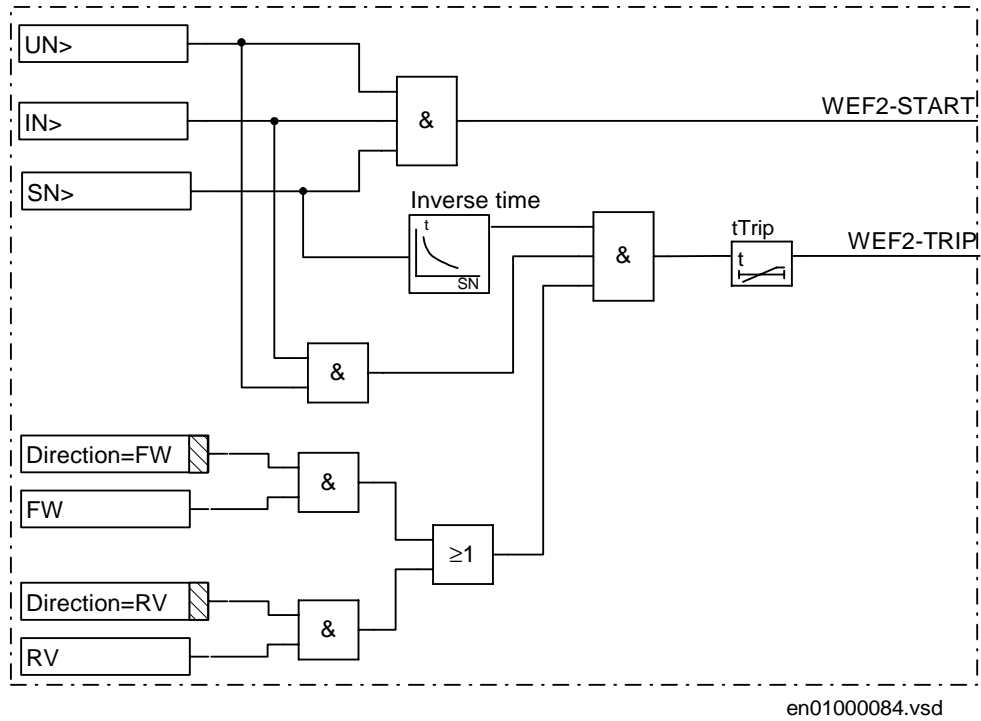

Figure 122: Logic for sensitive directional residual power protection function (WEF2)

### 8.3

#### Calculations

Consider a MV system with a medium size neutral point resistor connected to the neutral of the transformer feeding the system. A phase to earth fault occurs on a line in the system, as shown in figure 123.

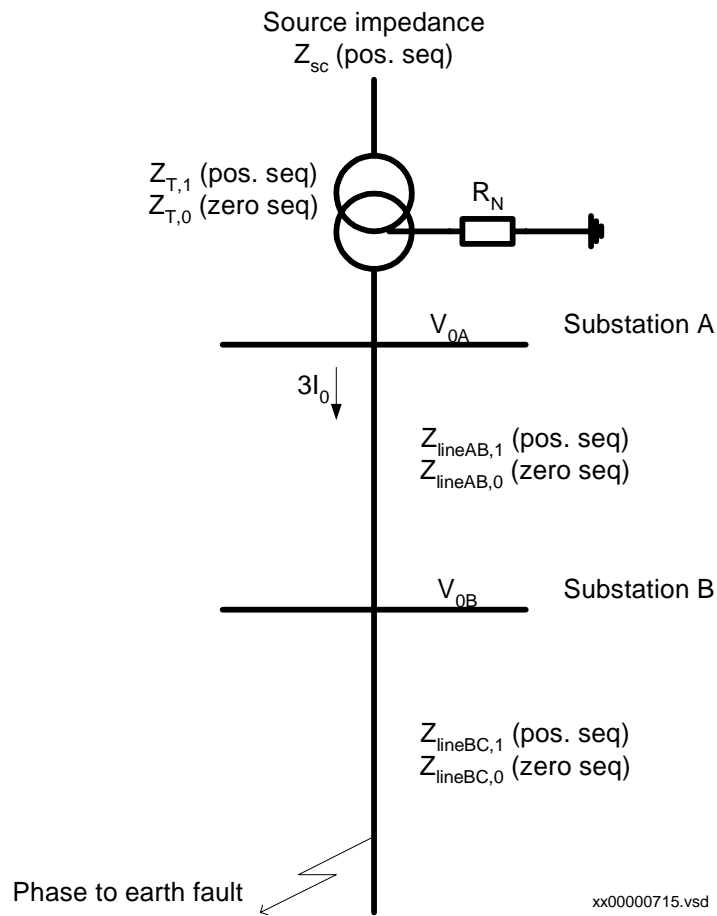

Figure 123: Equivalent of power system for calculation of setting

The residual fault current can be written:

$$3I_0 = \frac{3 \cdot V_{ph}}{2 \cdot Z_1 + Z_0 + 3 \cdot R_f}$$

(Equation 258)

Where:

$V_{ph}$  is the phase voltage in the fault point before the fault

$$Z_1 = Z_{sc} + Z_{T,1} + Z_{lineAB,1} + Z_{lineBC,1}$$

(Equation 259)

is the total positive sequence impedance to the fault point,

$$Z_0 = Z_{T,0} + 3 \cdot R_N - jX_{0tot} + Z_{lineAB,0} + Z_{lineBC,0} \quad (\text{Equation 260})$$

is the total zero sequence impedance to the fault point and  $R_f$  is the fault resistance.

The residual voltage in stations A and B can be written.

$$V_{0A} = 3I_0 \cdot (Z_{T,0} + 3 \cdot R_N) \quad (\text{Equation 261})$$

$$V_{0B} = 3I_0 \cdot (Z_{T,0} + 3 \cdot R_N + Z_{lineAB,0}) \quad (\text{Equation 262})$$

The residual power will be:

$$S_{0A} = 3 \cdot V_{0A} \cdot 3I_0 \quad (\text{Equation 263})$$

$$S_{0B} = 3 \cdot V_{0B} \cdot 3I_0 \quad (\text{Equation 264})$$

The residual power is a complex quantity. The protection will have a maximum sensitivity in the characteristic angle  $\varphi$ . The protection will use the component with the characteristic angle for measurement and as base for the inverse time delay.

$$S_{0A,prot} = 3 \cdot V_{0A} \cdot 3I_0 \cdot \cos \varphi_A \quad (\text{Equation 265})$$

$$S_{0B,prot} = 3 \cdot V_{0B} \cdot 3I_0 \cdot \cos \varphi_A \quad (\text{Equation 266})$$

The time delay for the two protections in A and B will be:

$$t_A = k \cdot \frac{S_{0A,prot}}{S_{ref}} \quad (\text{Equation 267})$$

$$t_B = k \cdot \frac{S_{0B,prot}}{S_{ref}}$$

(Equation 268)

Where:

$k, S_{ref}$  are setting parameters

The network calculation should be used to find the base for setting of the parameters.

---

## 9 Scheme communication logic for residual overcurrent protection (EFC)

### 9.1 Application

This communication logic is intended for residual overcurrent protections.

To achieve fast fault clearing for a fault on the part of the line not covered by the instantaneous zone 1, the directional residual overcurrent protection function can be supported with logic, that uses communication channels.

One communication channel in each direction, which can transmit an on/off signal is required. The performance and security of this function is directly related to the transmission channel speed and security against false or lost signals. So special channels are used for this purpose. When power line carrier is used for communication, these special channels are strongly recommended due to the communication disturbance caused by the primary fault.

In the directional comparison scheme, information of the fault current direction must be transmitted to the other line end.

With directional comparison, an operate time of 50-60 ms, including a channel transmission time of 20 ms, can be achieved. This short operate time enables rapid automatic reclosing function after the fault.

During a single-phase reclosing cycle, the auto-reclosing device must block the directional comparison earth-fault scheme.

The communication logic module for the REx 5xx terminal contains circuits for blocking overreach and permissive overreach schemes. The module also contains logic for the weak-end-infeed and current-reversal functions, which are used only in the permissive overreach scheme.

### 9.2 Functionality

#### 9.2.1 Theory of operation

##### **Directional comparison logic function**

The directional comparison function contains logic for blocking overreach and permissive overreach schemes.

---

The circuits for the permissive overreach scheme contain logic for current reversal and weak-end-infeed functions. These functions are not required for the blocking overreach scheme.

Use the independent or inverse time functions in the directional earth-fault protection module to get back-up tripping in case the communication equipment malfunctions and prevents operation of the directional comparison logic.

Connect the necessary signal from the auto-recloser for blocking of the directional comparison scheme, during a single-phase auto-reclosing cycle, to the EFC--BLOCK input of the directional comparison module.

### **Blocking scheme**

In the blocking overreach scheme, a signal is sent to the other line end if the directional element detects a fault in the reverse direction. When the forward directional element operates, it trips the line after a short time delay if no blocking signal is received from the other line end. The time delay, normally 30-40 ms, depends on the communication transmission time and the chosen safety margin.

One advantage of the blocking scheme is that only one channel (carrier frequency) is needed and the channel can be shared with the impedance-measuring system, if that also works in the blocking mode. The communication signal is also transmitted on a healthy line and no signal attenuation will occur due to the fault.

Blocking schemes are particularly favourable for three-terminal applications if there is no zero-sequence current outfeed from the tapping. The blocking scheme is immune to current reversals because the received carrier signal is maintained long enough to avoid unwanted operation due to current reversal. There is neither any need for weak-end-infeed logic, because the strong end trips for an internal fault when no blocking signal is received from the weak end. But the fault clearing time is generally longer for a blocking scheme than for a permissive one.

If the fault is on the line, the forward direction measuring element operates. If no blocking signal comes from the other line end via the EFC--CR binary input (carrier receive) the EFC--TRIP output is activated after the tCoord set time delay.

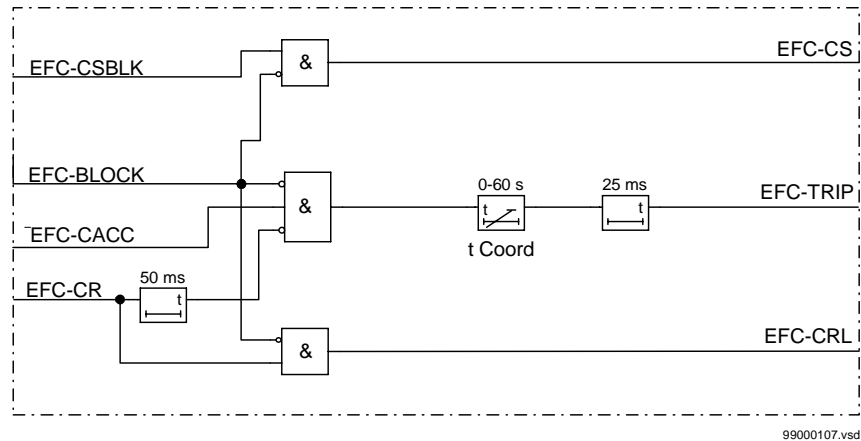

Figure 124: Simplified logic diagram, Scheme type = blocking

### Permissive overreach scheme

In the permissive scheme, the forward directed measuring element sends a permissive signal to the other line end if a fault is detected in the forward direction. The directional element at the other line end must wait for a permissive signal before giving a trip signal. Independent channels (frequencies) must be available for the communication in each direction.

An impedance-measuring relay which works in an underreach permissive mode with one channel in each direction can share the channels with the earth-fault overcurrent protection. If the impedance measuring relay works in the permissive overreach mode, common channels can be used in single-line applications. In case of double lines connected to a common bus at both ends, use common channels only if the ratio  $Z_{1S} / Z_{0S}$  (positive through zero-sequence source impedance) is about equal at both line ends. If the ratio is different, the impedance measuring and the directional earth-fault current system of the healthy line may detect a fault in different directions, which could result in unwanted tripping.

Common channels can not be used when the weak-end-infeed function is used in the distance or earth-fault protection.

In case of an internal fault, the forward directed measuring element operates and sends a permissive signal to the remote end via the EFC--CS output (carrier send). Local tripping is permitted when the forward direction measuring element operates and a permissive signal is received via the EFC--CR binary input (carrier receive).



The total operate-time for the system is the sum of the Pick-up time (of the measuring element) and the Transmission time (of the permissive signal)

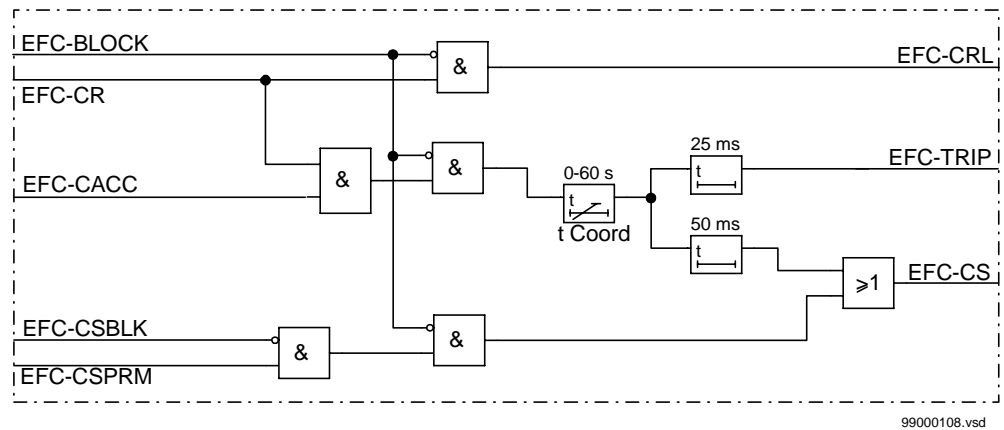

Figure 125: Simplified logic diagram, Scheme type = permissive

## 9.3

### Design

#### Blocking scheme

In the blocking scheme, a signal is sent to the other line end if the directional element in TEF function, connected to the EFC--CSBLK input signal, detects a fault in the reverse direction. When the forward directional element operates, it trips the line after a short time delay if no blocking signal is received from the other line end. The time delay, normally 30-40 ms, depends on the communication transmission time and the chosen safety margin.

#### Permissive overreaching scheme

In the permissive scheme, the forward direction measuring element in TEF function, connected to the EFC--CSPRM input, sends a permissive signal to the other line end if a fault is detected in the forward direction. The directional element at the other line end must wait for a permissive signal before giving a trip signal. Independent channels (frequencies) must be available for the communication in each direction.

## 9.4

### Calculations

#### 9.4.1

##### Setting

The settings are done from the local HMI under the menu:

**Settings**

**Functions**

**Group n (n = 1.4)**

**Earth Fault**

**EFCom**

**Blocking scheme**

In the blocking scheme, set the tCoord timer to the channel transmission time during disturbance conditions. Add a margin of 20-30 ms. Two times the nominal value of the channel transmission time is recommended when a power line carrier is used.

**Permissive communication scheme**

In the permissive communication scheme, the security against unwanted operation caused by spurious carrier receive signals can be increased by delaying the tripping output with the tCoord timer. Set the timer in the range of 0.000 to 60.000 s. In most cases, a time delay of 30 ms is sufficient.

---

## 10 Current reversal and weak end infeed logic for residual overcurrent protection (EFCA)

### 10.1 Application

This additional communication logic is intended for the Communication logic for residual overcurrent protections.

To achieve fast fault clearing for a fault on the part of the line not covered by the instantaneous zone 1, the earth-fault protection functions can be supported with logic, that uses communication channels. REx 5xx terminals have for this reason available a scheme communication logic. Different system conditions require in many cases additional special logic circuits, like current reversal logic and weak-end-infeed logic. Both functions are available within the additional communication logic for earth-fault protection.

#### Current reversal logic

If parallel lines are connected to common buses at both terminals, overreaching permissive communication schemes can trip unselectively due to fault current reversal. This unwanted tripping affects the healthy line when a fault is cleared on the other line. This lack of security can result in a total loss of interconnection between the two buses.

To avoid this type of disturbance, a fault current-reversal logic (transient blocking logic) can be used.

#### Weak end infeed logic

Permissive communication schemes can basically operate only when the protection in the remote terminal can detect the fault. The detection requires a sufficient minimum fault current. The fault current can be too low due to an opened breaker or low short-circuit power of the source. To overcome these conditions, weak end infeed (WEI) echo logic is used.

The fault current can also be initially too low due to the fault current distribution. Here, the fault current increases when the breaker opens in the strong terminal and a sequential tripping is achieved. This requires a detection of the fault by an independent-tripping zone 1. To avoid sequential tripping as described and when zone 1 is not available, weak end infeed tripping logic is used.

## 10.2 Functionality

### 10.2.1 Theory of operation

#### Directional comparison logic function

The directional comparison function contains logic for blocking overreach and permissive overreach schemes.

The circuits for the permissive overreach scheme contain logic for current reversal and weak end infeed functions. These functions are not required for the blocking overreach scheme.

Use the independent or inverse time functions in the directional earth-fault protection module to get back-up tripping in case the communication equipment malfunctions and prevents operation of the directional comparison logic.

Figures 128, 129 and 130 shows the logic circuits.

Connect the necessary signal from the auto-recloser for blocking of the directional comparison scheme, during a single-phase auto-reclosing cycle, to the EFCA-BLOCK input of the directional comparison module.

#### Fault current reversal logic

Figures 126 and 127 show a typical system condition, which can result in a fault current reversal; note that the fault current is reversed in line L2 after the breaker opening. This can cause an unselectiv trip on line L2 if the current reversal logic does not block the permissive overreach scheme in the terminal at B:2.

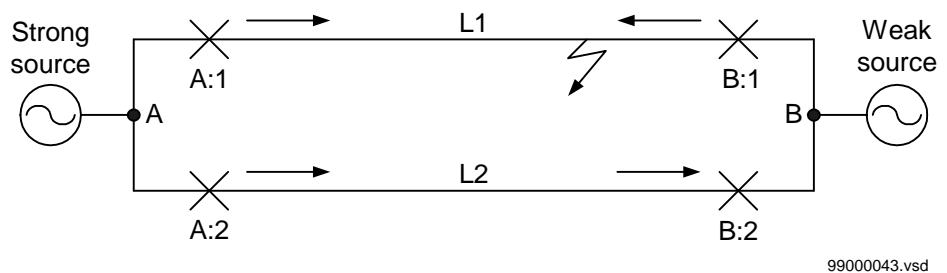

Figure 126: Initial condition

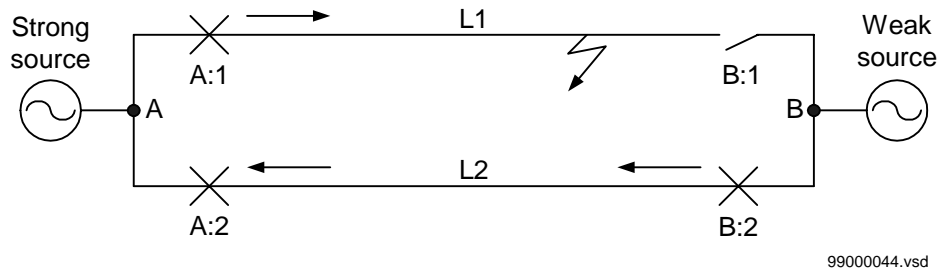

Figure 127: Current distribution after the breaker at B:1 is opened

The fault current reversal logic uses a reverse directed element, connected to EFCA-IRV, which in terminal at B:2 recognises the fault on the L1 line. See Figure 126. When the reverse direction element is activated during the tPickUp time, the EFCA-IRVL signal is activated, see figure 128. The logic is now ready to handle a current reversal without tripping. EFCA-IRVL will be connected to the block input on the permissive overreach scheme.

When breaker in B:1 operate, the fault current is reversed in line L2. The terminal at B:2 recognises now the fault in forward direction. Together with the remaining carrier received signal it will trip the breaker in B:2. To ensure that this does not occur, the permissive overreach function need to be blocked by EFCA-IRVL, until the carrier receive signal is reset.

When the fault current is reversed in line L2, EFCA-IRV is deactivated and EFCA-IRVBLK is activated. The reset of EFCA-IRVL is delayed by the tDelay time, see figure 128. This ensures the reset of the carrier receive EFCA-CR signal in terminal B:2.

In terminal A:2, where the forward direction element was initially activated. This direction element must reset before the carrier send signal is initiated from B:2. The delayed reset of EFCA-IRVL also ensures the carrier send signal from terminal B:2 is held back until the forward direction element is reset in terminal A:2.

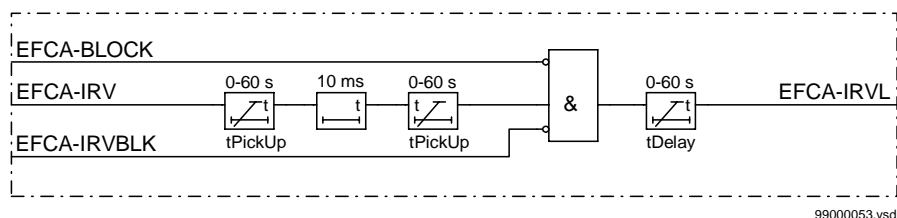

Figure 128: Simplified logic diagram, current reversal

### Weak and infeed logic

Figure 129 shows a typical system condition, which can result in a missing operation; note that there is no fault current from node B. This cause that terminal at B cannot detect the fault and trip the breaker in B. To cope with this situation, a selectable weak end infeed logic is provided for the permissive overreach scheme.

The weak end infeed function can be set to send only an echo signal (WEI=Echo) or an echo signal and a trip signal (WEI=Trip). See figures 130 and 131.

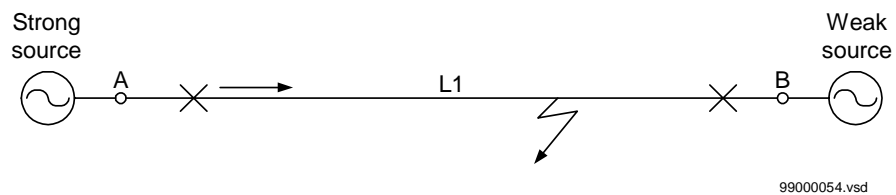

Figure 129: Initial condition

The weak end infeed logic uses normally a reverse and a forward direction element, connected to EFCA-WEIBLK via an OR-gate. See figure 130. If neither the forward nor the reverse directional measuring element is activated during the last 200 ms. The weak-end-infeed logic echoes back the received permissive signal. See figure 130.

If the forward or the reverse directional measuring element is activated during the last 200 ms, the fault current is sufficient for the terminal in B to detect the fault with the earth-fault function that is in operation.

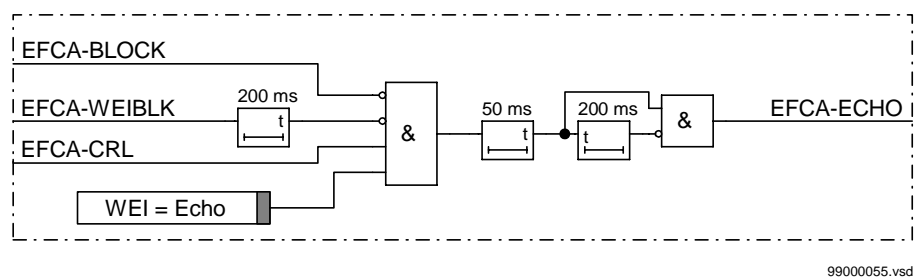

Figure 130: Simplified logic diagram, weak end infeed - echo.

With the Trip setting, the logic sends an echo according to above. Further, it activates the EFCA-TRWEI signal to trip the breaker if the echo conditions are fulfilled and the neutral point voltage is above the set operate value for  $3U_0$ .

The voltage signal that is used to calculate the zero sequence voltage is set in the earth-fault function that is in operation.

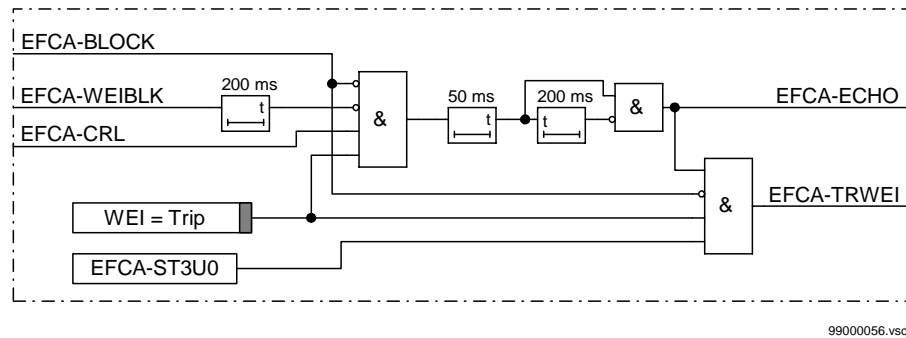

Figure 131: Simplified logic diagram, weak end infeed - Trip.

The weak end infeed echo sent to the strong line end has a maximum duration of 200 ms. When this time period has elapsed, the conditions that enable the echo signal to be sent are set to zero for a time period of 50 ms. This avoids ringing action if the weak end echo is selected for both line ends.

### 10.3

#### Design

The complete EFCA additional logic for the directional residual OC protection is consisting of two parts: Current reversal logic and weak end infeed logic. Each of them has its own setting parameters and possibility for its own configuration.

Figure 132 presents a simplified logic diagram for the current reversal function. The reverse directed signal from the TEF directional residual OC function should be connected to the EFCA-IRV functional input, to start the operation of a logic. The EFCA-IRVL signal will be activated, if the fault has been detected in reverse direction for more than the tPickUp time set on the corresponding timers.

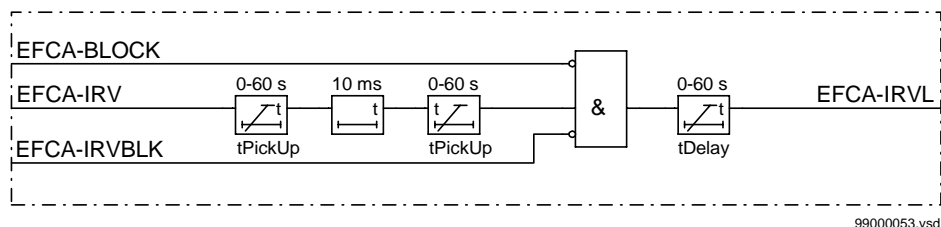

Figure 132: Simplified logic diagram, current reversal

The tDelay timer delays the reset of the output signal, when the current reversal occurs and the fault is detected in the forward direction. This prevents the TEF function to operate unnecessarily during the current reversal conditions.

The weak end infeed function can be set to send only an echo signal (WEI=Echo) or an echo signal and a trip signal (WEI=Trip). The function is released with either of the WEI=Echo or WEI=Trip settings in the menu.

The weak end infeed logic uses normally a reverse and a forward directional element, connected to EFCA-WEIBLK via an OR-gate. The weak-end-infeed logic echoes back the received permissive signal, if neither the forward nor the reverse directional measuring element is activated during the last 200 ms.

With the Trip setting, the logic sends an echo according to above. Further, it activates the EFCA-TRWEI signal to trip the breaker if the echo conditions are fulfilled and the residual voltage is above the set operate value for  $3U_0$ .

## **10.4**

### **Calculations**

#### **10.4.1**

#### **Setting**

The settings are done from the local HMI under the menu:

##### **Settings**

##### **Functions**

##### **Group n (n = 1..4)**

##### **Earth Fault**

##### **ComIRevWeiEF**

#### **Current reversal**

The Current-reversal function is set on and off by setting the parameter CurrRev = On/Off. Time delays shall be set for the timers tPickUp and tDelay.

tPickUp is chosen shorter (<80%) than the breaker opening time, but minimum 20 ms.

tDelay is chosen at a minimum to the sum of protection reset time and the communication reset time. A minimum tDelay setting of 40 ms is recommended.

#### **Weak end infeed**

The weak end infeed can either be set off or to echo or trip by setting the parameter WEI = Off/Echo/Trip. (Echo = Echo, Trip = Echo + Trip). Operate zero sequence voltage for WEI trip is set with  $U_{gr} = xx \% \text{ of } U_b$ .



The zero sequence voltage for a fault at the remote line end and appropriate fault resistance is calculated.

To avoid unwanted trip from the weak end infeed logic (if spurious carrier signals should occur), set the operate value of the broken delta voltage level detector ( $3U_0$ ) higher than the maximum false network frequency residual voltage that can occur during normal service conditions. The recommended minimum setting is two times the false zero-sequence voltage during normal service conditions.

## 11 Thermal overload protection (THOL)

### 11.1 Application

When the load currents exceed the permitted continuous current there is a risk that the conductor or the insulation will be subject to permanent damage due to overheating. Even moderate overloads under long time give appreciable temperature increase. For example, a current of 1.2 times rated load current gives a temperature rise of  $1.2 \times 1.2 = 1.44$  times rated value.

The temperature rise as a function of time for a fixed load is determined by the so called thermal time constant  $\tau$  of the element. Moderate overloads are normally not detected by current or impedance measuring relays. A current thermal overload protection can prevent damage caused by excessive temperature increase due to moderate or heavy current overloads.

Electrical cables which can be loaded up to the permissible load current should be provided with thermal protection. For cables surrounded by air, the thermal time constant  $\tau$  can vary from some few minutes for 10 kV cables with small cross-sectional area to more than one hour for high voltage cables with large cross-sectional area. The shorter time constant valid for cables in air is decisive if some part of the cable is surrounded by air.

For overhead lines and cables placed in the air, the ambient temperature will normally vary considerably. Since the temperature of the element is the sum of the ambient temperature and the temperature rise, the thermal protection for heavily loaded lines should be provided with compensation for the ambient temperature. The heating effect of radiant power from the sun can also be appreciable in some areas.

### 11.2 Functionality

The function includes a memory that is continuously updated with the heat content of the line based on the RMS value of the line current and the ambient temperature. The current used in the function is the phase current having the highest RMS value out of the three phase currents. The function has two settable operating levels for temperature, one intended for alarm and one intended for tripping. For the tripping function a reset hysteresis is included that can be set between 5 and 30°C while for the alarm function it is fixed at 5°C hysteresis.

For the alarm there is an output denoted ALARM which is active as long as the temperature is above alarm level. For the tripping there are two outputs, one denoted TRIP which gives only a 50 ms pulse at operation and one denoted START which is active as long as the temperature is above tripping level.

The function also includes a possibility for ambient temperature compensation through a mA transducer input. The upper and lower value for the input range can be set between -25 and +25 mA and corresponding temperature between -1000 and + 1000°C. If transducer for ambient temperature is not available the function uses a +20°C reference value instead. This value will also be used if a fault is detected in the transducer circuits or mA input module.

### 11.3

#### Calculations

The settings for the THOL function, with exception of the settings for the ambient temperature compensation, can be made on the built-in HMI unit:

##### Settings

##### Functions

##### Group n (n=1...4)

##### ThermOverLoad

The settings can also be made by aids of the SMS or PST setting tools.

For temperature compensation, input No. 1 on the MIM module No.1 is always used (fixed configuration). Necessary settings for the MIM module are On/Off for activation, time intervals for measuring of current, upper and lower value for the current input and temperatures corresponding to max. respectively min. current. These settings can only be made via the SMS or PST setting tools.

To make the correct settings, the following data are required for the protected object:

- Final temperature rise after continuous load with specified load current
- Max. permissible continuous temperature and thermal time constant  $\tau$  of the object
- Max. ambient temperature
- Max. temperature rise due to radiant power from the sun - if significant

The time constant can be found if a curve is available which shows the temperature rise as a function of time for a given load current. At load current  $I_{load}$  and final temperature rise  $T_{fin}$  the following is valid:

Time:	$1 \times \tau$	$2 \times \tau$	$3 \times \tau$	$4 \times \tau$	$5 \times \tau$
Temperature rise <sup>1)</sup> :	63	86	95	98	99
1) in % of $T_{fin}$					

If different values of  $\tau$  are calculated from the curve, select the lowest value of  $\tau$  to obtain the best protection.

The time to function is calculated from the formula:

$$t = \tau \cdot \ln \frac{\left(\frac{I}{I_{\text{base}}}\right)^2 - p^2}{\left(\frac{I}{I_{\text{base}}}\right)^2 - \frac{T_{\text{trip}} - T_{\text{amb}}}{T_{\text{base}}}}$$

(Equation 269)

Where:

$p$  is  $I_p/I_{\text{base}}$

$I_p$  is continuous load current before the current is increased to  $I$   $T_{\text{amb}}$  = ambient temperature. If temperature compensation is not used,  $T_{\text{amb}} = 20^\circ\text{C}$  as fixed value,

$T_{\text{amb}}$  is ambient temperature and

$T_{\text{base}}$  is  $20^\circ\text{C}$  as a fixed value if temperature compensation is not used.

For other parameters: see description in the setting table in the Technical Reference Manual

### Setting example

Assume the following data:

- $I_{1b}$ : 5 A
- Temperature increase of the conductor :  $90^\circ\text{C}$  at continuous load current 4.5 A.
- Max. permissible temperature of the conductor:  $125^\circ\text{C}$
- Time constant  $\tau = 20$  min
- Max. ambient temperature:  $30^\circ\text{C}$
- Max. temperature increase due to radiant power from the sun:  $5^\circ\text{C}$

### Example 1: THOL with no temperature compensation

$$I_{\text{base}} = 4.5 \text{ A} = 4.5/5 \times 100 = 90 \% \text{ of } I_{1b}$$

$$T_{\text{base}} = 90^\circ\text{C}, \tau = 20 \text{ min}$$

---

The thermal function assumes 20°C ambient temperature as a fixed value instead of the actual value 30°C. Also, the 5°C temperature increase due to the sun radiant power is not included in the calculated temperature increase. Hence, the function calculates continuous conductor temperature  $20 + 90 = 110^\circ\text{C}$  at 4.5 A whereas the max. value is  $30 + 90 + 5 = 125^\circ\text{C}$ . Hence the setting should be  $T_{\text{Trip}} = 125 - (125 - 110) = 110^\circ\text{C}$ .

**Example 2: THOL with temperature compensation**

Assume temperature measuring elements with output 4 mA at -20°C and 20 mA at 100°C. Settings of  $I_{\text{base}}$ ,  $T_{\text{base}}$  and  $\tau$  same as above

.MI11-I-Max= 20.00mA MI11-I-MaxValue = +100°C

CMI11-I-Min= 4.00mA MI11-I-MinValue = -20°C

The influence of the ambient temperature is included in the calculated values. The 5°C temperature increase due to the sun radiant power, however, is not included. Hence the setting should be  $T_{\text{trip}} = 125 - 5 = 120^\circ\text{C}$ .

---

## 12 Breaker failure protection (BFP)

### 12.1 Application

This function issues a back-up trip command to trip adjacent circuit breakers in case of a tripping failure of the circuit breaker (CB), and clears the fault as requested by the object protection.

The breaker-failure function is started by a protection trip command, from the line and busbar protection through the breaker-related trip relays. The start can be single-phase or three-phase. Correct fault current clearing or failure is detected by a current check in each phase. The current level can be set at 0,05 to 2 times the rated current.

Retrip of the faulty CB can be done with or without current check. A delay, 0-60 s, can be set for the retrip.

The use of retrip, limits the impact on the power system if the breaker-failure protection function (BFP) is started by mistake during testing or other maintenance work.

A second time step is used for the back-up trip command. It should be connected to trip the adjacent breakers, to clear the busbar section and intertrip the remote end, if so required. The time setting range is 0-60 s.

By using separate timers for each phase, correct operation at evolving faults is ensured.

The timer setting should be selected with a certain margin to allow variation in the normal fault clearing time. The properties of the BFP function allow the use of a small margin.



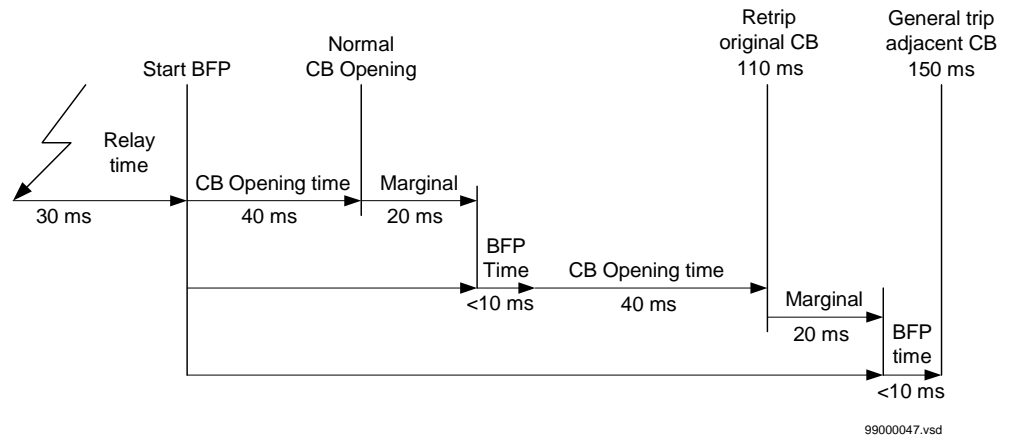

Figure 134: Time sequence

## 12.2

### Functionality

The breaker-failure protection starts on a single-phase or three-phase condition, either from an external protection, or internally from a protection trip signal in the terminal.

The breaker receiving the original protection trip command can be retripped from the BFP. The retrip can be controlled by a current check, or carried out as a direct retrip without any current check. The direct retrip can be used, because the breaker-to-trip has already received a tripping command, and the direct retrip does not cause any unselective tripping.

The use of retrip, limits the extent of unwanted power disconnection in case of an accidental start of the BFP at work in the initiating circuits, with the primary circuit in service and the load above the set current level.

The back-up trip is sent to the adjacent circuit breakers in order to clear the fault and disconnect the failing circuit breaker.



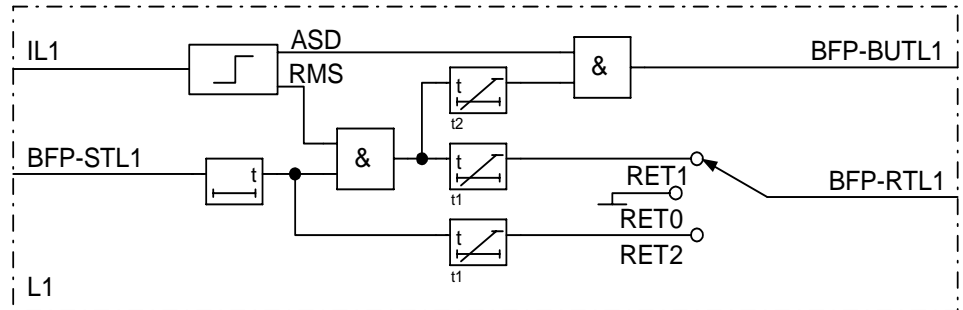

RET0 : No retrip  
 RET1 : Retrip with current check  
 RET2 : Unconditional retrip

Figure 135: Logic diagram of breaker-failure protection, phase L1

**Input and output signals**

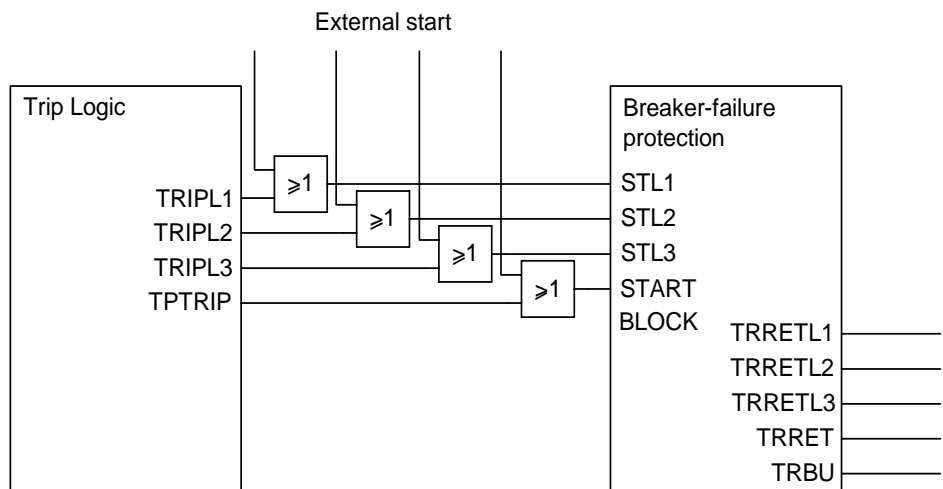

99000049.vsd

Figure 136: Input and output signals

The connectable inputs are connectable by configuration to the binary inputs of the terminal or to other internal functions' outputs. The outputs are connectable by configuration to the binary output relays. "Connectables" and "outputs" can be connected to the free-logic functions of the unit, OR gates, and in that way add connection links

**Start functions**

The breaker-failure protection can be started either internally or externally. The start pulse is sealed-in as long as the current exceeds the preset current level, to prevent a restart of the BFP timers in case of a chattering starting contact. The preset current level may be set to  $(0.05 - 2.0) \cdot I_r$  where  $I_r$  is 1 or 5 A.

**Measuring principles**

The current is filtered through a specially designed high-pass filter to obtain the required suppression of the dc components.

High-pass filtering is performed basically for two reasons, i.e. to remove the:

- dc component caused by saturated current transformers with a decaying current due to de-energizing of the secondary circuit. This is done to achieve a more correct representation of the real current in the line.
- dc component that is a part of the fault current. This is done to achieve a correct base for both ASD and RMS calculations.

The frequency limit of the filter is very close to the service frequency, to obtain a maximum suppression of the above dc components.

The intention of the adaptive signal detection (ASD) concept is to achieve independence from the absolute filtering requirement, when dealing with extremely high fault currents in combination with low preset values. This is obtained by creating a new stabilizing signal to compare the current with.

The ASD works continuously, regardless of if the BFP was started. Its result is however considered only when the BFP has started and the pre-set time has elapsed.

As the current exceeds the previously stabilized sample, it adapts the value of the current and when it does not, it decays. This adaptive behaviour makes it possible to rapidly and securely detect a breaker failure situation after the pre-set time has elapsed. Continuously and in parallel, the RMS value of the post-filtered signal is calculated and compared with a preset current level. As the RMS value decreases below the preset current level, the breaker-failure function is momentarily reset.

At normal operation of the circuit breaker, the stabilizing signal exceeds the post-filtered signal for a consecutive period of maximum 10 ms before it is reset. Resetting occurs before the back-up trip timer  $t_2$  has timed out.

At a breaker failure situation, the post-filtered current exceeds the stabilizing signal, resulting in a trip from the breaker-failure function within 10 ms after the trip timer  $t_2$  has elapsed.

The breaker-failure protection works with all three phases totally separated. But a possibility exists to start all three phases simultaneously. The back-up trip is always three-phase.

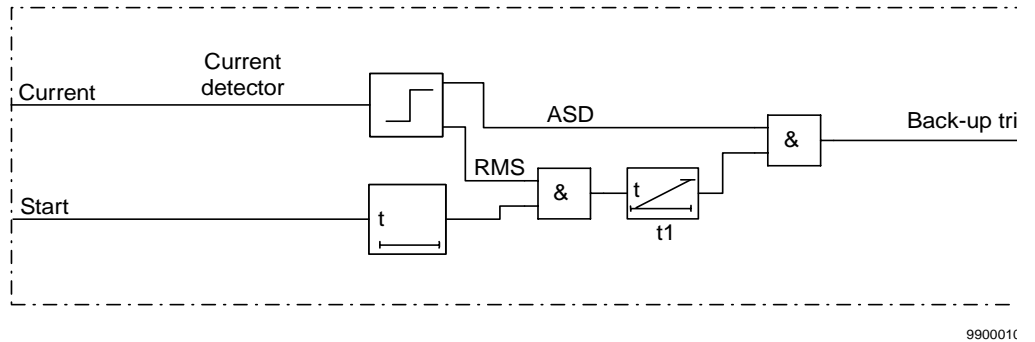

9900010

Figure 137: Breaker-failure protection

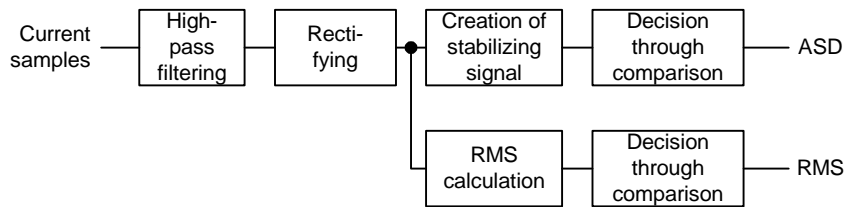

en00000011.vsd

Figure 138: Current detector, ASD and RMS measurement

**Retrip functions**

The retrip function of the original circuit breaker is set at one of three options:

<b>Setting:</b>	<b>The retrip;</b>
Off	function is not executed.
I> check	occurs with a current check.
No I> check	occurs without a current check.

The retrip timer t1 can be set from 0 to 60 s.

A trip pulse,  $tp$ , is generated with a length of 150 ms.

**Back-up trip**

The back-up trip delay timer  $t_2$  can be set between 0 and 60 s.

A trip pulse,  $tp$ , is generated with a length of 150 ms.

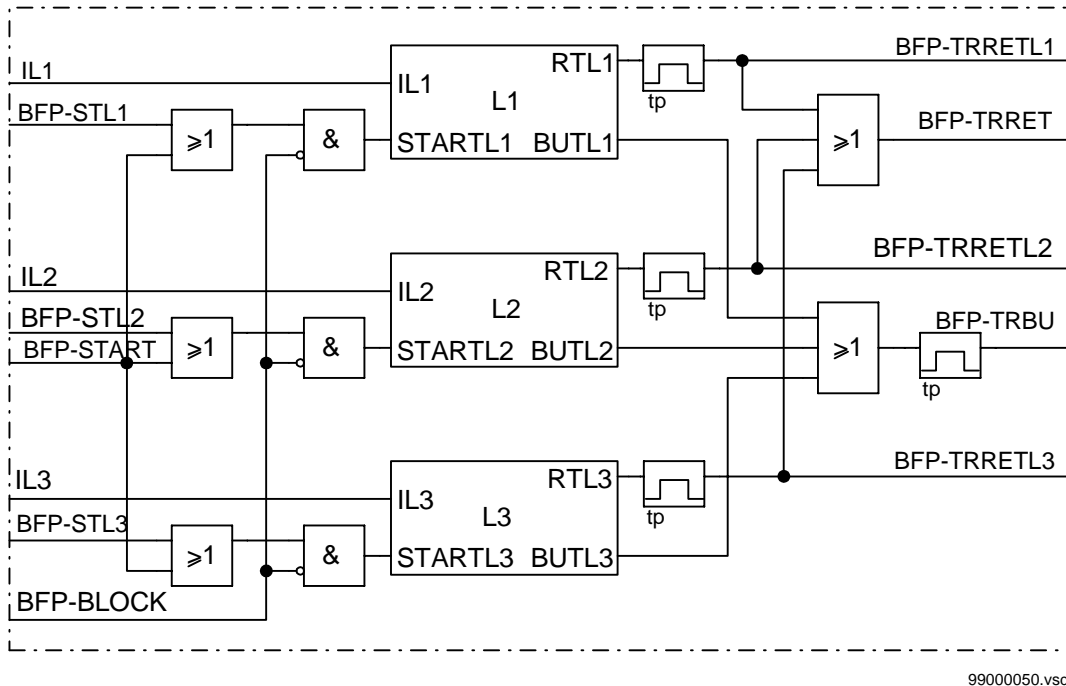

99000050.vsd

Figure 139: Breaker-failure protection

12.3

**Design**

The breaker failure protection is initiated by the trip commands from the protection functions, either internal to the terminal or from external commands through binary inputs. The start can be single-phase or three-phase.

The operating values of the three current measuring elements are settable within a wide setting range. The measuring is stabilised against the dc-transient that can cause unwanted operation at saturated current transformers and correct breaker operation. Time measurement is individual for each phase. Two independent timers are available, T1 for repeated tripping of “own” breaker and T2 which operates trip logic for adjacent breakers.

---

## 12.4 Calculations

### 12.4.1 Setting

#### Human-machine interface (HMI)

The configuration of alternatives or settings to the functions is made on the built-in HMI:

##### Settings

##### Functions

##### Group n

##### Breaker Failure

The breaker-failure protection can be controlled from the human-machine interface (HMI) by an “Operation” parameter, to be set between alternatives Off/On.

When “Operation” is set to Off, the function becomes inoperative.

The configuration of input and output signals to the function is made on the built-in HMI:

##### Configuration

##### Function Inputs

##### Breaker Failure

The inputs and the outputs to and from the breaker-failure protection are presented in the signal list.

##### Fixed values

Trip pulse, tp      150 ms, fixed

The breaker failure protection shall be set by means of a current limit for detection of a breaker failure. The current setting shall be chosen in relation to the protection functions, initiating the breaker failure protection. Normally the current setting should be equal to or lower than the most sensitive setting of a residual overcurrent protection.

If the retrip function is used a time delay before retrip has to be set. In most cases this time delay can be set to zero.

---

The time delay of the back-up trip function shall be chosen so that selectivity is maintained. Consider the following:

$t_1$ : Set retrip time delay

$t_{br}$ : Circuit breaker opening time

BFR reset time

The back-up trip delay  $t_2$  shall be set:

$$t_2 \geq t_1 + t_{br} + \text{margin}$$

(Equation 270)

At the same time it is desired that the back-up trip is done so fast that remote protections will not trip.

---

## 13 Unbalance protection for capacitor banks (TOCC)

### 13.1 Application

Capacitor banks are made up of individual units which are series and parallel connected. Each unit contains a number of series and parallel connected elements. The individual elements in a capacitor can be separately fused.

If one element is damaged, it will be disconnected by its fuse and the rest of the elements can continue to operate. However, the load on the healthy elements will increase. When a certain number of elements are out of service, the load on the remaining elements becomes so high that the remaining elements will quickly be destroyed. The purpose of the unbalance protection is to detect the damage and disconnect the capacitor bank from the network before the healthy units are overloaded.

The protection is connected to a current transformer which measures the current flow between two normally balanced parts of the capacitor battery. Under normal conditions, no fundamental frequency current flows in the interconnection. A low set current stage gives alarm when elements are damaged and current flows in the interconnection. The trip stage is set to disconnect the battery before healthy elements become overloaded and quickly damaged.

Three-phase capacitor banks are often made up of two identical Y-connected groups. The neutral points are then interconnected via a current transformer which feeds the unbalance protection.

### 13.2 Functionality

The current measuring element continuously measures the unbalance current (via analog input I5) and compares it to the set operate value for the two current stages. A recursive Fourier filter ensures immunity to disturbances and harmonic currents. When applied between the neutral points of two identical Y-connected capacitor groups, no false unbalance currents will flow, even for high contents of harmonics in the voltage. The output relay for the low current (alarm) stage operates if the current becomes higher than the set operate value  $I_{Low}$  during a time exceeding the set time delay  $t_{Low}$ . If the current becomes higher than the set operate value  $I_{High}$  during a time exceeding the set delay  $t_{High}$ , the output relay for the high current stage operates.

The input signal TOCC-BLOCK blocks both the low set and the high set function. The stages may also be blocked individually by setting Operation Low = Off respectively Operation High = Off. The setting BlockTOCC = Yes will block the function, during testing.

## 13.3

### Calculations

The settings for the TOCC function can be made on the built-in HMI unit:

#### Settings

##### Functions

##### Group n (n=1...4)

##### CapUnbalance

The settings can also be made by aids of the SMS or PST setting tools.

The current stage I>High is normally set to trip the capacitor battery before any unit is subjected to a voltage increase of 10 % above rated value. The delay tHigh should be set longer than the operate time of the ground fault protection if the primary operate current of stage IHigh is low compared to the ground fault current in the system. The current stage I>Low is normally set to give alarm at 50 % of the set operate current of stage I>High.

The calculation of settings for the unbalance protection function must take into consideration how the capacitor bank is built up and it is often made by aids of a computer program.



# Chapter 6 Voltage

## **About this chapter**

This chapter describes the voltage protection functions.

# **1 Time delayed undervoltage protection (TUV)**

## **1.1 Application**

Undervoltage protection prevents the sensitive elements from running under conditions that could cause their overheating and thus shorten their life expectancy below the economical limits. In many cases, it is a useful tool in circuits for local or remote automation processes in the power system.

## **1.2 Design**

The voltage measuring elements within one of the built-in digital signal processors continuously measure the phase-to-neutral voltages in all three phases. Recursive Fourier filter filters the input voltage signals and a separate trip counter prevents high overreaching or underreaching of the measuring elements.

## **1.3 Calculations**

The parameters for the undervoltage protection are set on the local HMI under the menu:

### **Settings**

#### **Functions**

#### **Group n (n = 1...4)**

#### **TimeDelayUV**

All the voltage conditions in the system where the undervoltage protection performs its functions should be considered. The same also applies to the associated equipment, its voltage and time characteristic.

---

## 2 Time delayed overvoltage protection (TOV)

### 2.1 Application

The application areas of the overvoltage protection functions are different in distribution and transmission networks.

The overvoltage protection is used to protect the equipment and its insulation against overvoltage. In this way it prevents damage to the equipment in the power system and shortening of their life time.

The residual overvoltage protection function is mainly used in distribution networks, primarily as a back-up protection for the residual overcurrent protection in the line feeders. This to secure disconnection of earth-faults.

### 2.2 Functionality

The phase overvoltage protection function continuously measures the three phase voltages and initiates the corresponding output signals if the measured phase voltages exceed the preset value (starting) and remain high longer than the time delay setting on the timers (trip). This function also detects the phases which caused the operation.

The residual overvoltage protection function calculates the residual voltage ( $3U_0$ ) from the measuring three phase voltages and initiates the corresponding output signals if the residual voltage is larger than the preset value (starting) and remains high longer than the time delay setting (trip).

### 2.3 Design

Figure 140 shows a simplified logic diagram of the overvoltage protection function. The time delayed residual overvoltage protection and the time delayed overvoltage protection share some input signals and logical elements. For this reason and for the sake of better overview both the protections are shown in the figure.

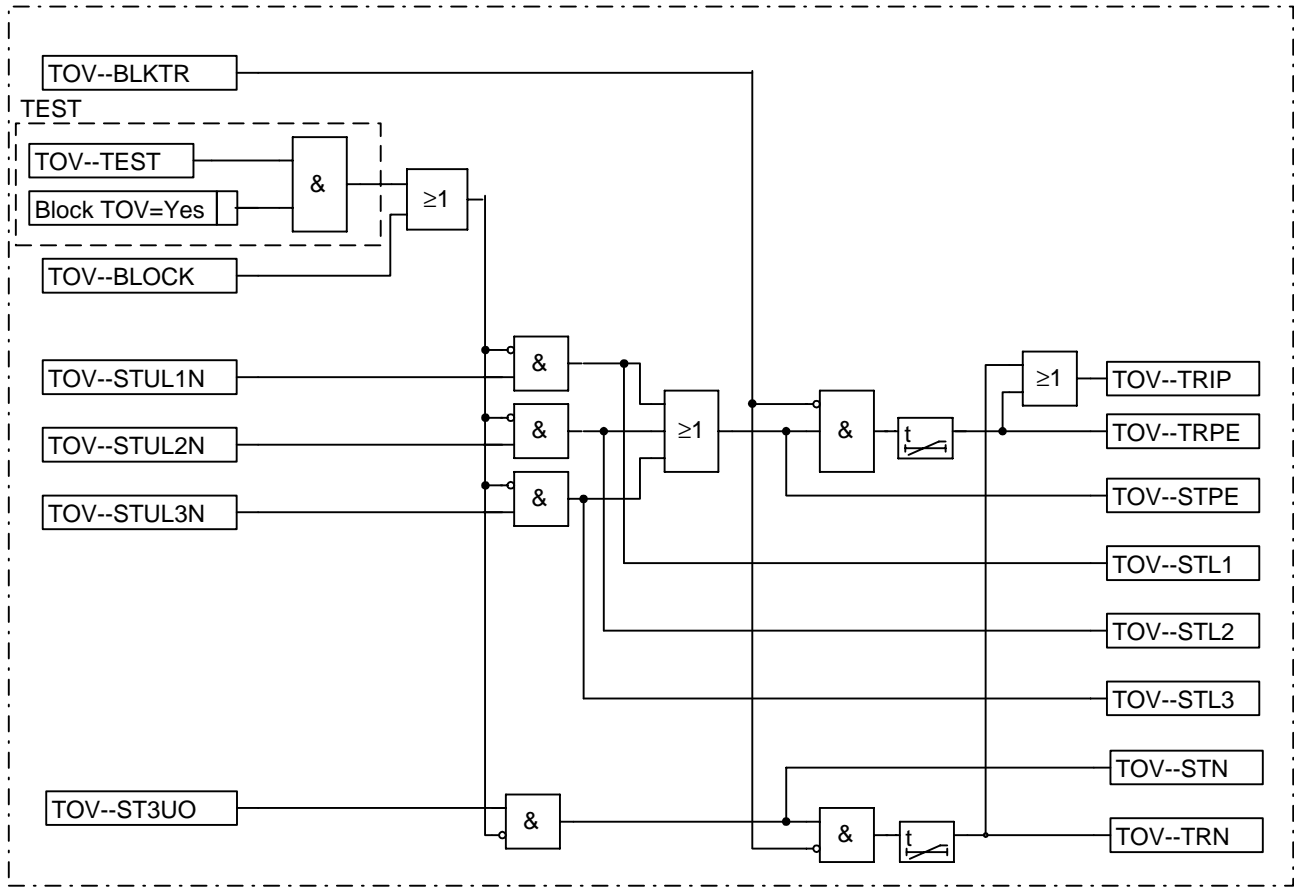

en01000187.vsd

Figure 140: Time delayed overvoltage protection - simplified logic diagram

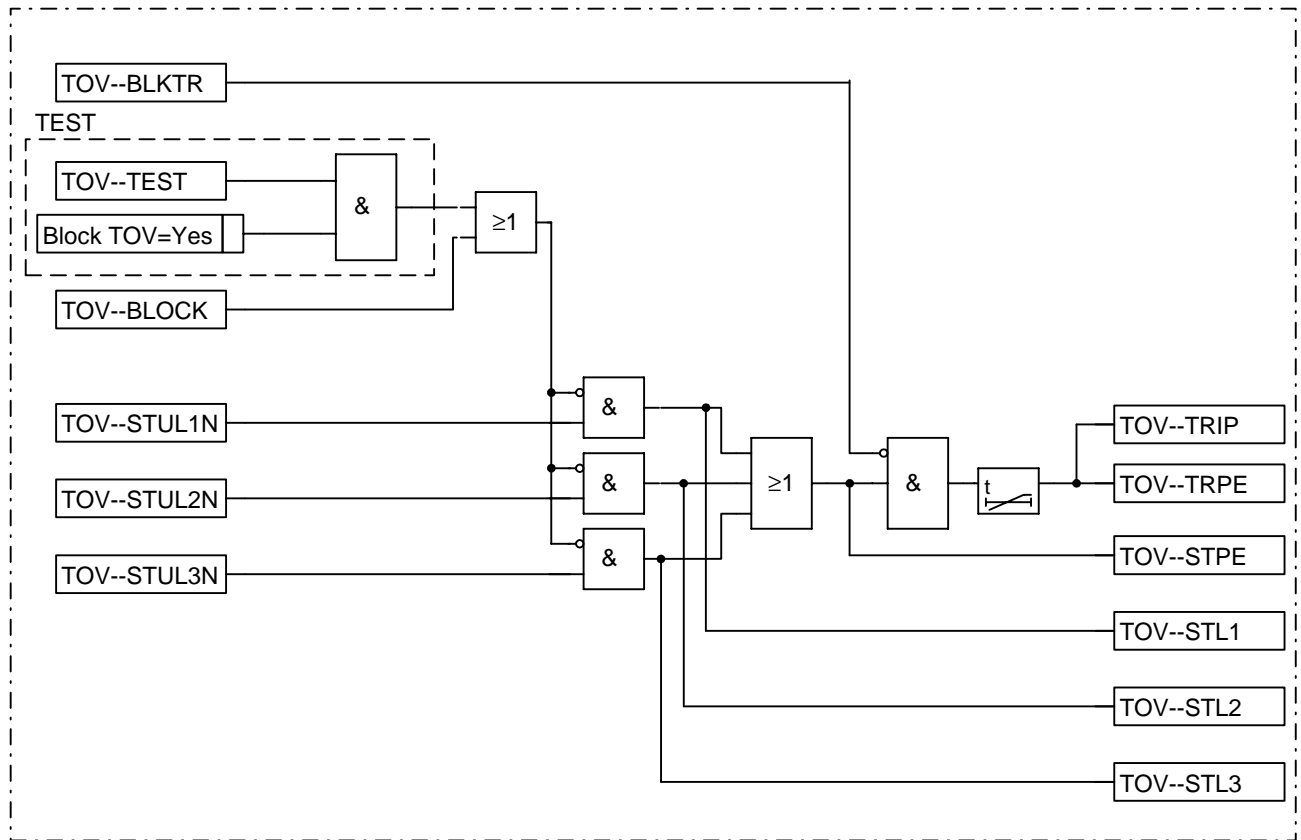

en01000088.vsd

Figure 141: Logic diagram, time delayed overvoltage protection, phase wise

The TOV--TRIP and TOV--TRPE output signals changes from logical 0 to logical 1 if at least one of the logical signals TOV--STUL1N, TOV--STUL2N, TOV--STUL3N remains equal to logical 1 for a time longer than the set value on the corresponding timer. The signal TOV--TRPE will be high, to indicate that the overvoltage protection caused the trip

Any signal connected to the TOV--BLOCK input blocks the operation of the time delayed overvoltage protection. Similarly any signal connected to TOV--BLKTR will block the trip output from the time delayed overvoltage protection.

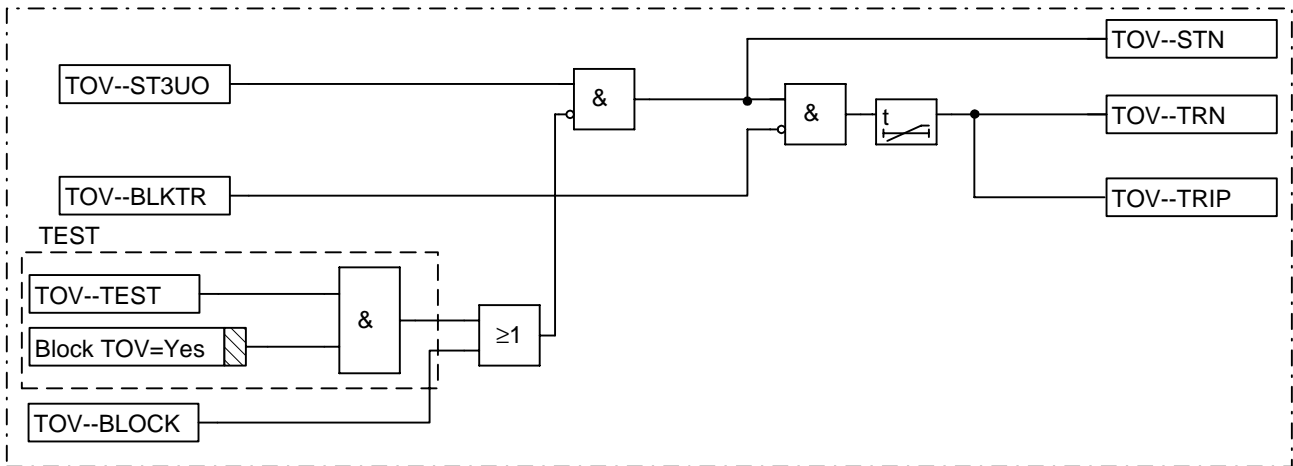

en01000089.vsd

Figure 142: Logic diagram, time delayed overvoltage protection, residual

The TOV--TRIP and TOV--TRN output signal changes from logical 0 to logical 1 if TOV--ST3U0 remains equal to logical 1 for a time longer than the set value on the corresponding timer. The signal TOV--TRN will be high, to indicate that the residual overvoltage protection caused the trip.

Any signal connected to the TOV--BLOCK input blocks the operation of the time delayed residual overvoltage protection. Similarly any signal connected to TOV--BLKTR will block the trip output from the time delayed residual overvoltage protection.

## 2.4

## Calculations

### 2.4.1

### Setting

The time delayed overvoltage protection parameters can be set on the local HMI under the menu:

#### Settings

#### Functions

#### Group n (n = 1...4)

#### TimeDelayOV

All the voltage conditions in the system where the overvoltage protection performs its functions must be considered. The same also applies to the associated equipment, its voltage-time characteristic.

The overvoltage protection should be set higher than the expected maximum system operate voltage that is in a particular part of a network. A safety margin of at least 10% should also be considered due to the inaccuracies in the instrument transformers, calculation methods, and the inaccuracy of the measuring elements in the terminal.

The residual overvoltage protection should be set higher than the expected maximum system operate voltage that is in a particular part of a network. A safety margin of at least 10% should also be considered due to the inaccuracies in the instrument transformers, calculation methods, and the inaccuracy of the measuring elements in the terminal.

## 3 Intercircuit bridging protection (TOVI)

### 3.1 Application

If a conductor in the 50 Hz system comes into contact with the conductor of a 16 2/3 Hz system with higher nominal voltage, the 16 2/3 Hz voltage must quickly be disconnected to avoid damage on the power transformer and other components in the 50 Hz system. The protection is connected to measure the phase-to-earth voltage of the 50 Hz conductor. The operate voltage must, with margin, be set higher than the 16 2/3 Hz voltage injected in the conductor.

### 3.2 Functionality

The voltage measuring element continuously measures the 16 2/3 Hz voltage component from U4 and compares it to the set operate value  $U_{>}$ . A second order band-pass filter (center frequency 16 2/3 Hz) ensures immunity to disturbances and harmonic voltages and reduces the influence of the 50 Hz voltage component with a factor  $> 10$ . The output trip relay operates if the voltage becomes higher than the set operate value  $U_{>}$  under a time exceeding the set definite time delay  $t$ .

An external signal connected to the input TOVI-BLOCK may block the function. It is also possible to block the function during testing, by setting Block TOVI = Yes.

### 3.3 Calculations

The settings for the TOVI function can be made on the built-in HMI unit:

#### Settings

#### Functions

#### Group n (n=1...4)

#### IntCircBridge

The settings can also be made by aids of the SMS or PST setting tools.

The operate voltage must be set higher than the highest 16 2/3 Hz voltage injected in the conductor. A safety margin of at least 10 % in addition to the inaccuracies of the voltage transformer and the measuring function is recommended.



# **Chapter 7 Power system supervision**

## **About this chapter**

This chapter describes the power system supervision functions.

# 1 Broken conductor check (BRC)

## 1.1 Application

Conventional protections can not detect the broken conductor condition. In REx 5xx terminals this detection is achieved through the broken conductor check function (BRC), consisting of continuous current unsymmetry check on the line where the terminal is connected. The detection might also concern possible interruptions in the connecting circuits between the instrument current transformers and the terminal.

## 1.2 Functionality

The current-measuring elements continuously measure the three-phase currents. The current unsymmetry signal STI is set to 1 if :

- Any phase current is lower than 80% of the highest current in the remaining two phases
- The highest phase current is greater than the minimum setting value IP>

If the unsymmetrical detection lasts for a period longer than the set time t, a three phase trip signal BRC--TRIP is emitted.

## 1.3 Design

The simplified logic diagram of the broken conductor check function is shown in figure 143.

The function is disabled (blocked) if:

- The terminal is in TEST status (TEST-ACTIVE is high) and the function has been blocked from the HMI (BlockBRC=Yes)
- The input signal BRC--BLOCK is high

The BRC--BLOCK signal is a blocking signal of the broken conductor check function. It can be connected to a binary input of the terminal in order to receive a block command from external devices or can be software connected to other internal functions of the terminal itself in order to receive a block command from internal functions. Through OR gate it can be connected to both binary inputs and internal function outputs.

The output trip signal BRC--TRIP is a three phase trip. It can be used to command a trip to the circuit breaker or for a signallization.

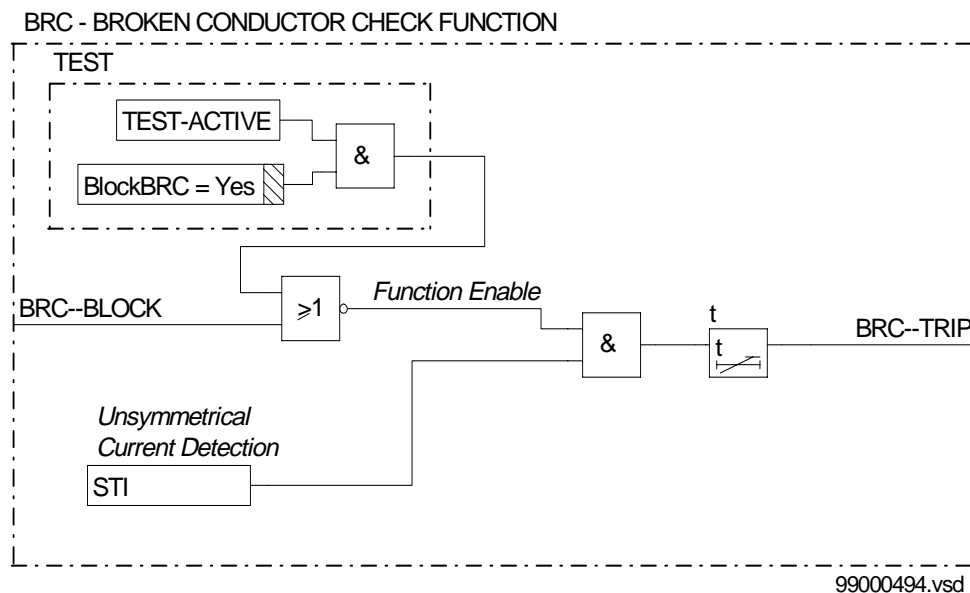

Figure 143: Simplified logic diagram of broken conductor check function

## 1.4

### Calculations

#### 1.4.1

#### Setting instructions

The setting of the operating values for the broken conductor check function occurs under the menu:

##### Settings

##### Functions

##### Group n (n = 1...4)

##### BrokenConduct

The minimum operating current is usually set to about 15% of the rated protected line current.

The time delay must comply with the selectivity planning of the protection in the whole network if the function is used for tripping the circuit breaker. The time delay might be longer if the function is intended for alarming purposes.

For the parameter list and their setting ranges, please see “Setting parameters” in the “Technical reference manual”.

**Setting of the minimum operating current IP>**

If the rated current of the protected line is  $I_L$ , then the primary set value  $I_{S_{PRIM}}$  will be:

$$I_{S_{PRIM}} = 0,15 \cdot I_L$$

(Equation 271)

The secondary setting value  $I_{S_{SEC}}$  is:

$$I_{S_{SEC}} = \frac{I_{SEC}}{I_{PRIM}} \cdot I_{S_{PRIM}}$$

(Equation 272)

Where:

$I_{SEC}$  is the secondary rated current of the main CT and

$I_{PRIM}$  is the primary rated current of the main CT.

The relay setting value IP> is given in percentage of the secondary base current value, I1b, associated to the current transformer input I1. The value for IP> is given from this formula:

$$IP> = \frac{I_{S_{SEC}}}{I_{1b}} \cdot 100$$

(Equation 273)

and this is the value that has to be set in the terminal.

Set this value under the setting menu:

**Settings**  
**Functions**  
**Group n**  
**BrokenConduct**

on the value IP>.



**Note!**

Usually  $I_{PRIM}$  is chosen to be 1.4 times the rated line current ( $I_{PRIM} = 1.4 \cdot I_L$ ) and is set to the relay rated current, equal to the secondary rated current of the main CT ( $I_{1b} = I_{SEC}$ ).

So it is obtained:

$$IP> = \frac{\frac{I_{SEC}}{I_{PRIM}} \cdot I_{SPRIM}}{I_{1b}} \cdot 100$$

(Equation 274)

$$IP> = \left( \frac{\frac{I_{SEC}}{1.4 \cdot I_L} \cdot 0,15 \cdot I_L}{I_{SEC}} \cdot 100 \right) = 10,7 \%$$

(Equation 275)

This is why the default setting for IP> is 10%.

**Setting of time delay t**

Set the time delay of the function, t, under the setting menu:

**Settings**  
**Functions**  
**Group n**  
**BrokenConduct**

on the value t.

## 2 Loss of voltage check (LOV)

### 2.1 Application

The trip of the circuit breaker at a prolonged loss of voltage at all the three phases is normally used in automatic restoration systems to facilitate the system restoration after a major blackout. The loss of voltage check function gives a trip signal only if the voltage in all the three phases is low for more than 7 seconds. If the trip to the circuit breaker is not required, then the function can be used for signallization through an output contact or through the event recording function.

### 2.2 Functionality

The voltage-measuring elements continuously measure the three phase-to-earth voltages, and compare them with the set values. Fourier recursive filter filters the voltage signals.

The logical values of the following signals become equal to 1, if the related phase measured voltage decrease under the pre-set value:

- STUL1N for  $U_{L1N}$  voltage
- STUL2N for  $U_{L2N}$  voltage
- STUL3N for  $U_{L3N}$  voltage

The 150 ms output trip pulse is issued if all the three phase voltages are below the setting value for more than 7s. The function can be blocked from the fuse failure supervision function intervention and when the main circuit breaker is open.

### 2.3 Design

The simplified logic diagram of the loss of voltage check function is shown in figure 144.

The function is disabled (blocked) if:

- The terminal is in TEST status (TEST-ACTIVE is high) and the function has been blocked from the HMI (BlockLOV=Yes)
- The input signal LOV--BLOCK is high

---

The LOV--BLOCK signal is a general purpose blocking signal of the loss of voltage check function. It can be connected to a binary input of the terminal in order to receive a block command from external devices or can be software connected to other internal functions of the terminal itself in order to receive a block command from internal functions. Through an OR gate it can be connected to both binary inputs and internal function outputs.

The function has a particular internal latched enable logic that:

- enables the function (signal latched enable in figure 144 is set to 1) when the line is restored; i.e. at least one of the three voltages is high for more then 3 seconds (signal set enable in figure 144).
- disables the function (signal latched enable in figure is set to 0) if the signal reset enable in figure 144 is set to 1 (reset of latced enable signal).

The latched enable signal is reset (i.e. the function is blocked) if:

- the main circuit breaker is opened. This is achieved by connecting a N.C. contact of the main circuit breaker to a terminal binary input connected to the function input LOV--BC
- the fuse failure supervision function has tripped. This is achieved by connecting the output signal of the fuse failure supervision, FUSE-VTSU, to the function input LOV--VTSU
- not all the three phase voltages are low for more then 10 s (only one or two phase voltages are low).

The output trip signal of the voltage check function is LOV--TRIP.

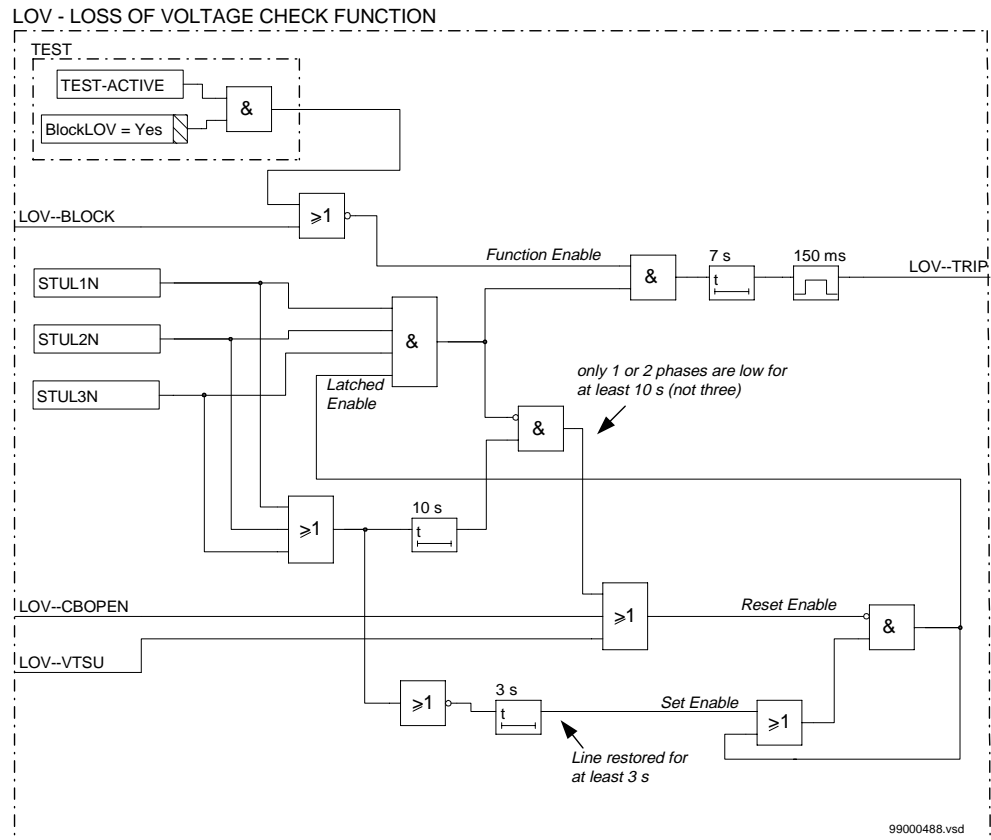

Figure 144: Simplified logic diagram of loss of voltage check protection function

## 2.4

### Calculations

#### 2.4.1

#### Setting instructions

The setting parameters are accessible through the HMI. The parameters for the loss of voltage function are found in the HMI-tree under:



**Settings****Functions****Group 1,2,3 and 4****LossOfVoltage**

For the parameter list and their setting ranges, please see “Setting parameters” in the “Technical reference manual”.

The low voltage primary setting should be lower than the minimum system operating voltage. A reasonable setting will probably be 20-50% of system nominal voltage.

For a primary set value  $U_{S_{PRIM}}$  the secondary setting value  $U_{S_{SEC}}$  is:

$$U_{S_{SEC}} = \frac{U_{SEC}}{U_{PRIM}} \cdot U_{S_{PRIM}}$$

(Equation 276)

Where:

$U_{SEC}$  is the secondary rated voltage of the main VT and

$U_{PRIM}$  is the primary rated voltage of the main VT

The relay setting value  $U_{PE<}$  is given in percentage of the secondary base voltage value,  $U_{1b}$ , associated to the voltage transformer input. The value for  $U_{PE<}$  is given from this formula:

$$U_{PE<} = \frac{U_{S_{SEC}}}{U_{1b}} \cdot 100$$

(Equation 277)

and this is the value that has to be set in the terminal.

## 3 Overload supervision (OVL D)

### 3.1 Application

The overload supervision function sends an alarm signal when the current exceeds the set level for longer than a pre-set time. The operating level of the current measuring element can be set to the maximum, accepted, continuous current. So operators are alerted if the primary system operates in a dangerous overload mode. A typical application is the signalling of the overload of the current transformers connected to the terminal, as they usually can withstand a small current beyond their rated current.

### 3.2 Functionality

The current-measuring elements continuously measure the three phase currents, and compare them with the set values. Fourier's recursive filter filters the current signals.

The logical values of the following signals become equal to 1, if the measured current in any phase exceeds the pre-set value:

- STIL1
- STIL2
- STIL3

If any of the three phase currents exceeds the set value  $I_{P>}$  for a period longer than the delay time  $t$ , then the trip signal OVL D-TRIP is emitted.

### 3.3 Design

The simplified logic diagram of the time delayed phase overload function is shown in figure 145.

The function is disabled (blocked) if:

- The terminal is in TEST status (TEST-ACTIVE is high) and the function has been blocked from the HMI (BlockOVL D=Yes)
- The input signal OVL D-BLOCK is high

The OVLN-BLOCK signal is a blocking signal of the overload supervision function. It can be connected to a binary input of the terminal in order to receive a block command from external devices or can be software connected to other internal functions of the terminal itself in order to receive a block command from internal functions. Through an OR gate it can be connected to both binary inputs and internal function outputs.

The output trip signal OVLN-TRIP is a three-phase trip. It can be used to command a trip to the circuit breaker or for a signallization.

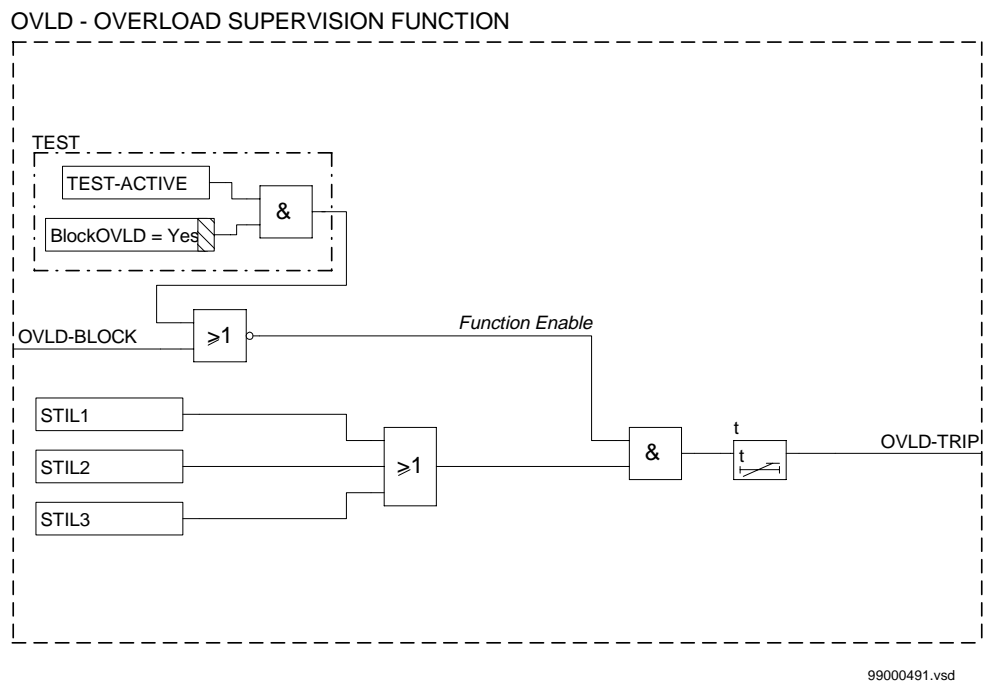

99000491.vsd

Figure 145: Simplified logic diagram of overload supervision function

3.4

Calculations

3.4.1

Setting instructions

The setting parameters are accessible through the HMI. The parameters for the overload supervision function are found in the HMI-tree under:

**Settings****Functions****Group n (n = 1...4)****OverLoad**

The current level set should be above the maximum permissible load current. Consider the accuracy class of the used instrument current transformers and the specified accuracy of the current measuring elements in the REx 5xx terminals.

The corresponding time delay must comply with the selectivity planning of the protection in the whole network, and with the permissible overloading of the conductors, if the function is used for tripping the circuit breaker. The above settings might change to a lower current value and longer time delay if the function serves only for alarming and not for tripping purposes.

**Setting of operating current IP>**

The relay setting value IP> is given in percentage of the secondary base current value,  $I_{1b}$ , associated to the current transformer.

If  $I_{S_{SEC}}$  is the secondary current operating value of the function, then the relay setting value IP> is given from this formula:

$$IP> = \frac{I_{S_{SEC}}}{I_{1b}} \cdot 100$$

(Equation 278)

and this is the value that has to be set in the terminal.

---

## 4 Dead line detection (DLD)

### 4.1 Application

The dead-line detection function (DLD) detects the disconnected phase(s) of a protected object. The output information serves as an input condition for some other measuring functions within the REx 5xx terminals. Typical examples of such functions are:

- Fuse failure supervision function (FUSE)
- Switch-onto-fault function (SOTF)

For this reason, always configure the DLD--START output signal to the corresponding inputs of the above functions.

### 4.2 Design

Figure 146 presents a simplified logic diagram of the function. Phase L1, L2 and L3 currents and voltages are measured by one of the built-in digital signal processors. Logical signals STMILn become logical one, if the measured current in the corresponding phase ( $n = 1..3$ ) decreases under the set operating level.

Logical signals STULnN become logical one, if the measured voltage in the corresponding phase ( $n = 1..3$ ) decreases under the set operating level.

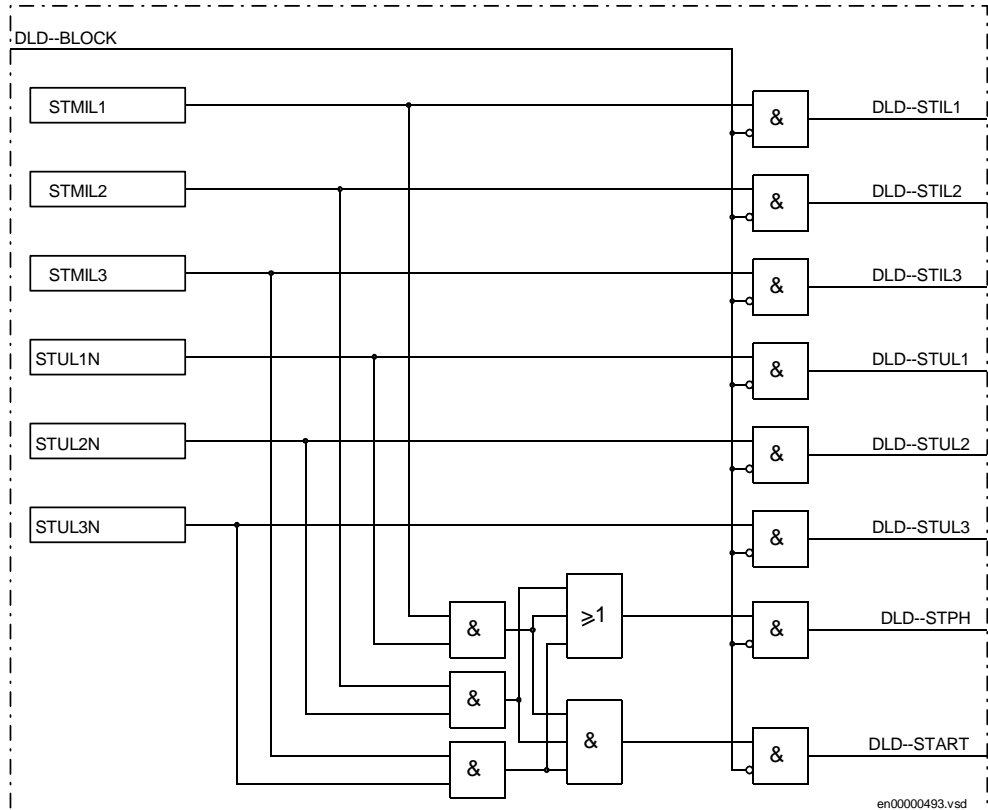

Figure 146: DLD - simplified logic diagram of the dead line detection function

Corresponding phase starting output signals DLD--STIL<sub>n</sub> and DLD--STUL<sub>n</sub> become in this case logical one, if the function is not blocked by the logical one on DLD--BLOCK functional input.

Simultaneous operation of current and voltage measuring elements in one phase is a necessary condition for the determination of a “dead-phase” condition. This condition is presented by the activation of a DLD--STPH output signal.

A complete line is determined as a “dead-line”, when the voltages and the currents in all three phases decrease under the set operate values. A DLD--START output informs about this operating condition.

---

## 4.3 Calculations

### 4.3.1 Setting instructions

The setting parameters are accessible through the HMI. The parameters for the dead line detection function are found in the HMI-tree under:

#### Settings

#### Functions

#### Group n (n=1-4)

#### DeadLineDet

Set the minimum operate voltage  $UP<$  (phase value) with a sufficient margin (at least 15%) under the minimum expected system operate voltage.

Set the minimum operate current with sufficient margin (15 - 20%) under the minimum expected load current. In many cases the minimum load current of a line is close to 0 or even 0. In such cases a setting must be chosen so that signals DLD-STILn are given during normal operation. The operate value must however exceed the maximum charging current of an overhead line, when only one phase is disconnected (mutual coupling to the other phases).





# **Chapter 8 Secondary system supervision**

## **About this chapter**

This chapter describes the secondary system supervision functions.

# 1 Current circuit supervision (CTSU)

## 1.1 Application

The correct operation of a protection depends on correct information about the primary value of currents and voltages. When currents from two independent 3-phase sets of CT's, or CT cores, measuring the same primary currents are available, a reliable current circuit supervision can be arranged by comparing the currents from the two sets. If an error in any CT circuit is detected, the protection functions concerned are to be blocked and an alarm given.

In case of large currents, unequal transient saturation of CT cores with different remanence or different saturation factor may result in differences in the secondary currents from the two CT sets. Unwanted blocking of protection functions during the transient period must be avoided.

The supervision function must be sensitive and have short operate time to prevent unwanted tripping from fast-acting, sensitive numerical protections in case of errors in the current circuits.

Note that the same current input transformer (I5) in REx 5xx is used for the reference current  $I_{ref}$  of the CT supervision, the residual current from the parallel line for the fault locator and, dependent on setting I4 or I5, maybe for the earth-fault protection function. Hence, when the CT supervision function is used, the other functions mentioned can not be used. Also the settings  $Xm0 = 0$  and  $Rm0 = 0$  must be used for the fault locator.

## 1.2 Functionality

The supervision function compares the numerical value of the sum of the three phase currents  $|\Sigma I_{phase}|$  (current inputs I1, I2 and I3) and the numerical value of the residual current  $|I_{ref}|$  (current input I5) from another current transformer set, see figure 147.

The CTSU-FAIL output will be set to a logical one when the following criteria are fulfilled:

- The numerical value of the difference  $|\Sigma I_{phase}| - |I_{ref}|$  is higher than 80% of the numerical value of the sum  $|\Sigma I_{phase}| + |I_{ref}|$ .
- The numerical value of the current  $|\Sigma I_{phase}| - |I_{ref}|$  is equal to or higher than the set operate value  $I_{MinOp}$  (5 - 100% of I1b).
- No phase current has exceeded 1.5 times rated relay current I1b during the last 10 ms
- The current circuit supervision is released by setting Operation = On.



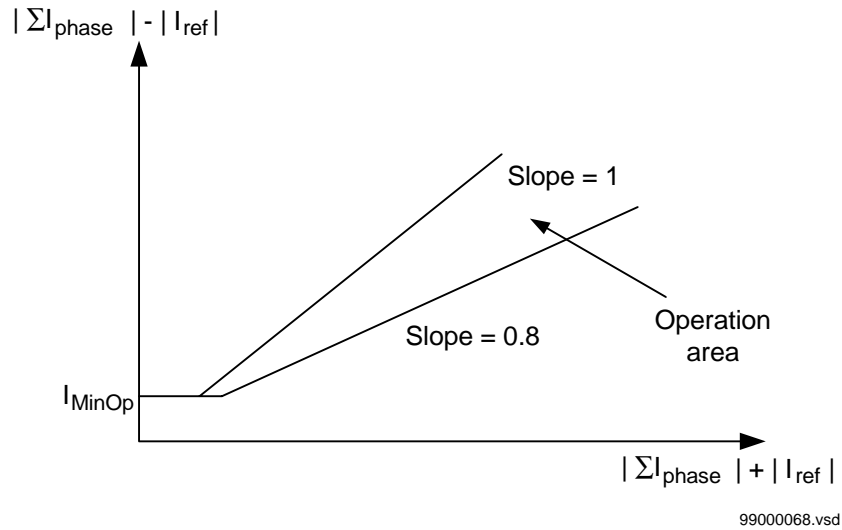

Figure 148: Operate characteristics

Note that due to the formulas for the axis compared,  $|\Sigma I_{\text{phase}}| - |I_{\text{ref}}|$  and  $|\Sigma I_{\text{phase}}| + |I_{\text{ref}}|$  respectively, the slope can not be above 1.

### 1.3

### Calculations

#### 1.3.1

#### Setting instructions

The function is activated by setting Operation = On.

The minimum operate current ( $I_{\text{MinOp}}$ ) should as a minimum be set to twice the residual current in the supervised CT circuits under normal service conditions and rated primary current. The setting range is 5 – 100% of  $I_{1b}$

The CTSU-FAIL and CTSU-ALARM outputs are connected to the blocking input of the actual protection function and output alarm relay respectively via the internal logic programming of the REx 5xx relay.

## 2 Fuse failure supervision (FUSE)

### 2.1 Application

Different protection functions within the REx 5xx protection, control and monitoring terminals operate on the basis of the measured voltage in the relay point. Examples are: distance protection function, undervoltage measuring function and voltage check for the weak infeed logic.

These functions can operate unnecessarily if a fault occurs in the secondary circuits between the voltage instrument transformers and the terminal.

It is possible to use different measures to prevent such unwanted operations. Miniature circuit breakers in the voltage measuring circuits, located as close as possible to the voltage instrument transformers, are one of them. Separate fuse-failure monitoring relays or elements within the protection and monitoring devices are another possibilities. These solutions are combined to get the best possible effect in the fuse failure supervision function (FUSE) of REx 5xx terminals.

The fuse-failure supervision function as built into the REx 5xx terminals can operate on the basis of external binary signals from the miniature circuit breaker or from the line disconnecter. The first case influences the operation of all voltage-dependent functions while the second one does not affect the impedance measuring functions.

The negative sequence detection algorithm, based on the negative-sequence measuring quantities, a high value of voltage  $3 \cdot U_2$  without the presence of the negative-sequence current  $3 \cdot I_2$ , is recommended for terminals used in isolated or high-impedance earthed networks.

The zero sequence detection algorithm, based on the zero sequence measuring quantities, a high value of voltage  $3 \cdot U_0$  without the presence of the residual current  $3 \cdot I_0$ , is recommended for terminals used in directly or low impedance earthed networks.

A criterion based on delta current and delta voltage measurements can be added to the FUSE function in order to detect a three phase fuse failure, which in practice is more associated with voltage transformer switching during station operations.

### 2.2 Functionality

#### Negative sequence

The current and voltage measuring elements within one of the built-in digital signal processors continuously measure the currents and voltages in all three phases and calculate:

- 
- The negative-sequence current  $3I_2$
  - The negative-sequence voltage  $3U_2$

comparing them with their respective set values  $3I_{2<}$  and  $3U_{2>}$  .

Fourier's recursive filter filters the current and voltage signals, and a separate trip counter prevents high overreaching of the measuring elements. The signal STNEG is set to 1, if the negative sequence measured voltage exceeds its set value  $3U_{2>}$  and if the negative sequence measured current does not exceed its pre-set value  $3I_{2<}$ .

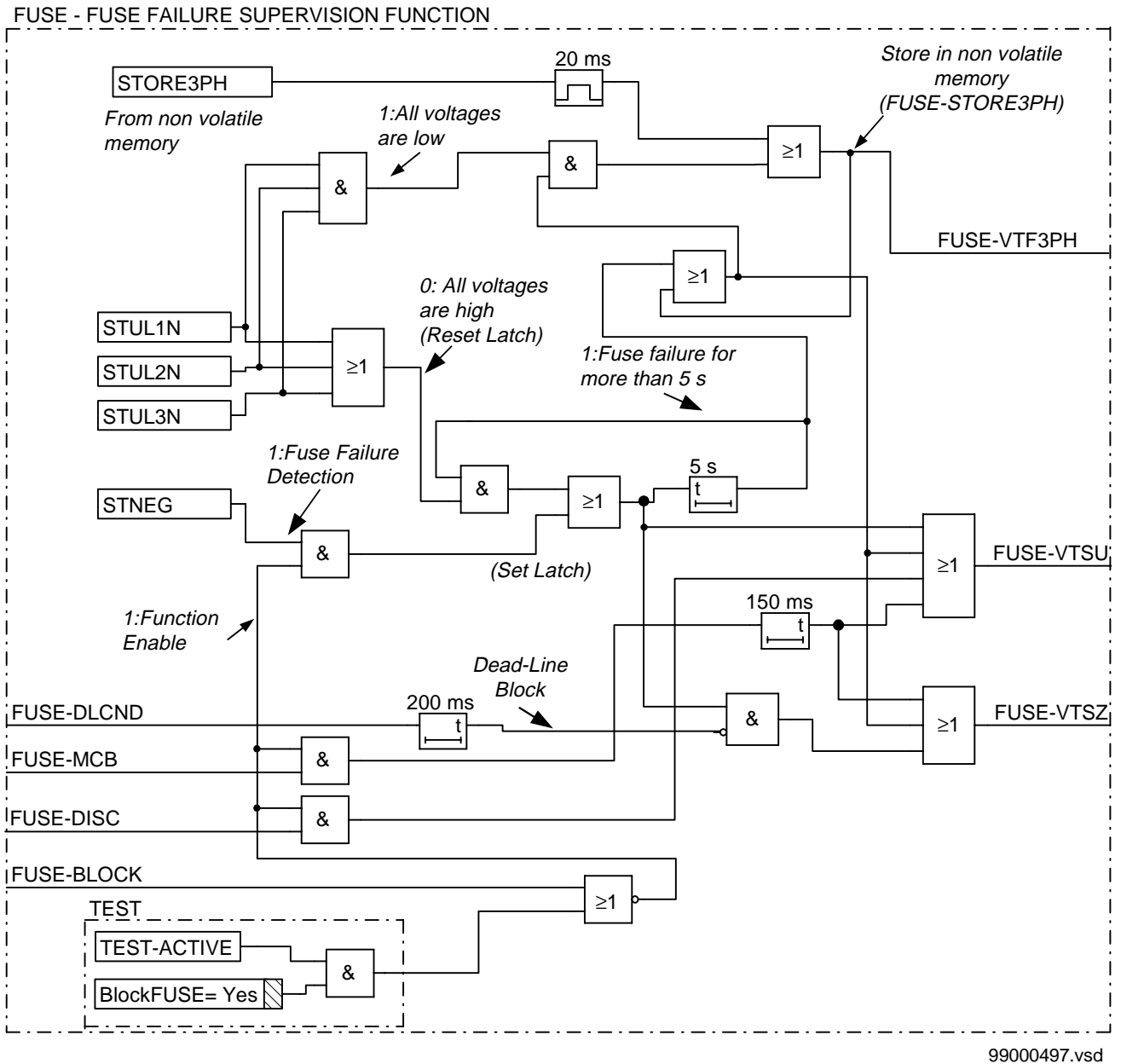

Figure 149: Simplified logic diagram for the fuse failure supervision function, negative sequence based.

**Zero sequence**

The current and voltage measuring elements within one of the built-in digital signal processors continuously measure the currents and voltages in all three phases and calculate:

- The zero-sequence current  $3 \cdot I_0$
- The zero-sequence voltage  $3 \cdot U_0$

comparing them with their respective set values  $3I_{0<}$  and  $3U_{0>}$ .

Fourier's recursive filter filters the current and voltage signals, and a separate trip counter prevents high overreaching of the measuring elements. The signal STZERO is set to 1, if the zero sequence measured voltage exceeds its set value  $3U_{0>}$  and if the zero sequence measured current does not exceed its pre-set value  $3I_{0<}$ .



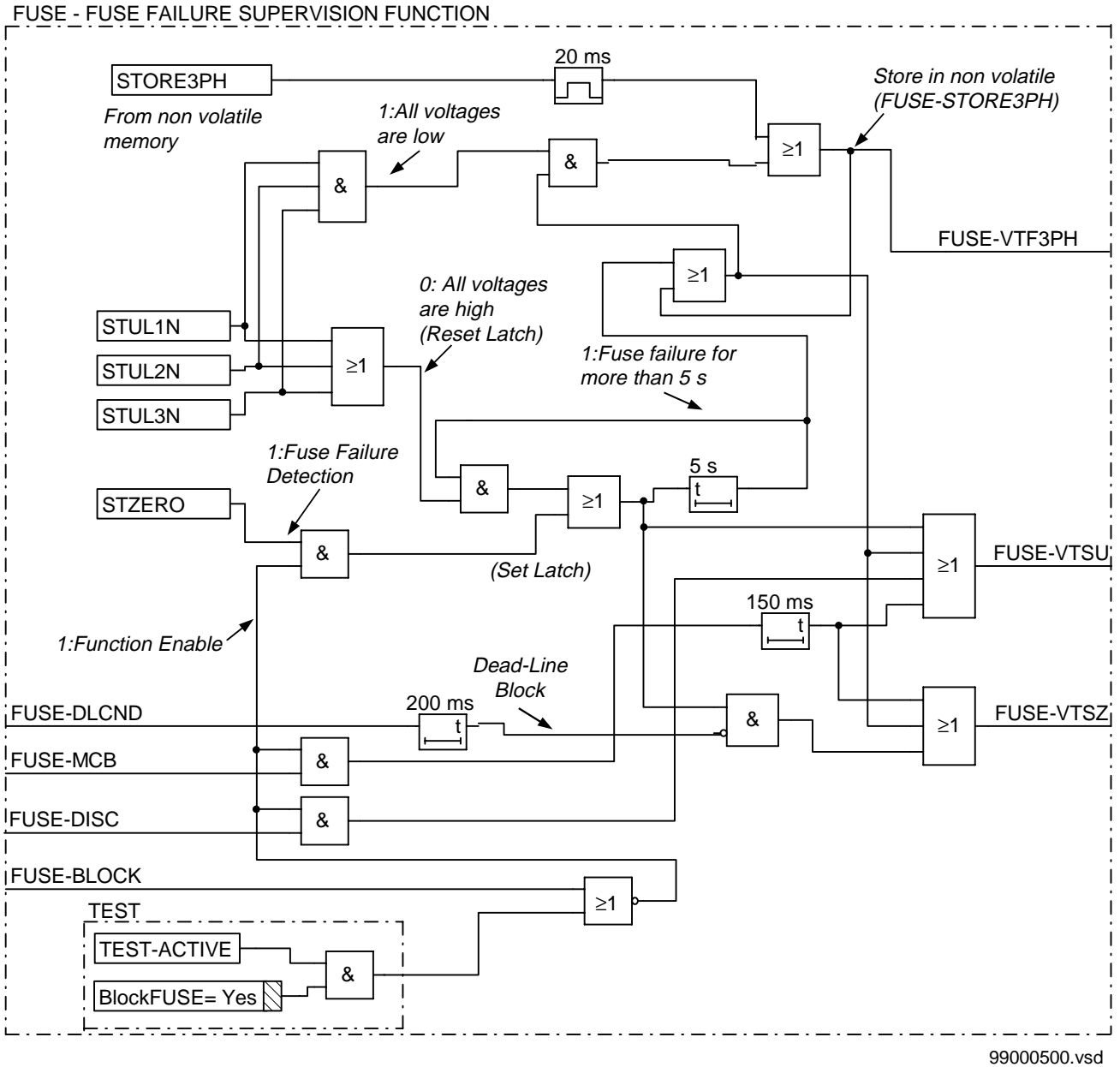

Figure 150: Simplified logic diagram for fuse failure supervisione function, zero se-  
quence based

**du/dt, di/dt**

The current and voltage measuring elements within one of the built-in digital signal processors continuously measure the currents and voltages in all three phases and calculate:

- The change of current  $\Delta I/\Delta t$
- The change of voltage  $\Delta U/\Delta t$

comparing them with their respective set values  $\Delta I<$  and  $\Delta U>$ .

The delta current and delta voltage algorithm, detects a fuse failure if a sufficient negative change in voltage amplitude without a sufficient change in current amplitude is detected in each phase separately. This check is performed if the circuit breaker is closed. Information about the circuit breaker position is brought to the function input CBCLOSED through a binary input of the terminal.

The signal STDUDI is set to 1, if the measured voltage change exceeds its set value  $\Delta U>$  and if the measured current change does not exceed its pre-set value  $\Delta I<$ . If the voltage is low in any phase (STUL1N, STUL2N or STUL3N=1), the STDUDI signal is sealed in.

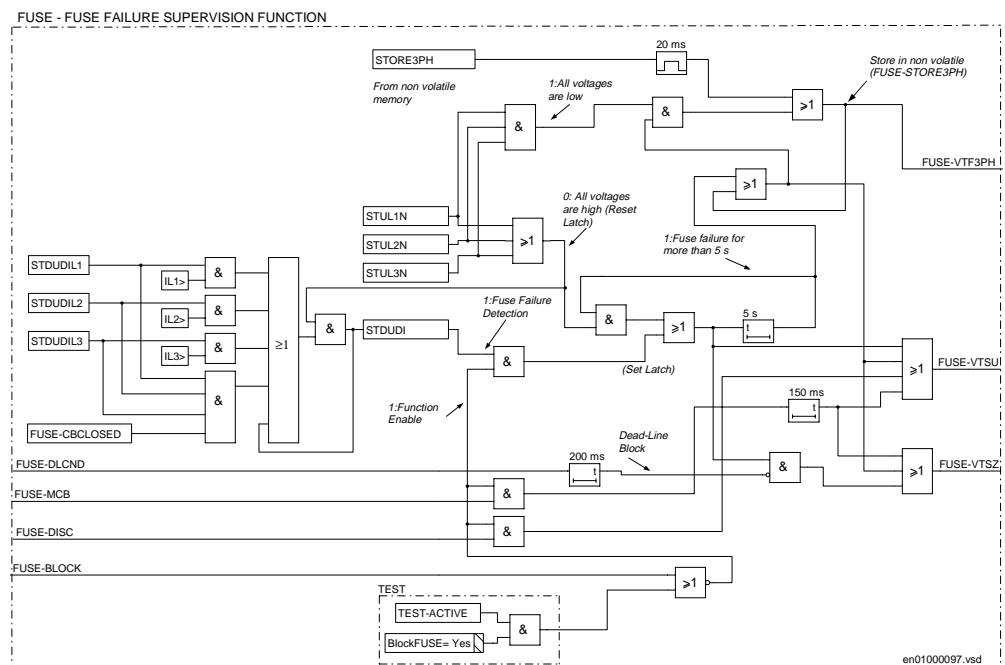

Figure 151: Simplified logic diagram for fuse failure supervision function, du/dt based.

**Logic**

Signals STUL1N, STUL2N and STUL3N are related to phase to earth voltages and become 1 when the respective phase voltage is lower than the set value. The set value ( $U_{<}$ ) is chosen in the dead line detection function, that is always present in the terminal when the fuse failure supervision is present.

The fuse failure supervision function is disabled (blocked) if:

- The terminal is in TEST status (TEST-ACTIVE is high) and the function has been blocked from the HMI (BlockFUSE=Yes)
- The input signal FUSE-BLOCK is high

The FUSE-BLOCK signal is a general purpose blocking signal of the fuse failure supervision function. It can be connected to a binary input of the terminal in order to receive a block command from external devices or can be software connected to other internal functions of the terminal itself in order to receive a block command from internal functions. Through OR gate it can be connected to both binary inputs and internal function outputs.

Function input signal FUSE-MCB is to be connected via a terminal binary input to the N.C. auxiliary contact of the miniature circuit breaker protecting the VT secondary circuit.

Function input signal FUSE-DISC is to be connected via a terminal binary input to the N.C. auxiliary contact of the line disconnector.

The function output FUSE-VTSU can be used for blocking the voltage related measuring functions (undervoltage protection, synchrocheck etc.) except for the impedance protection.

Function output FUSE-VTSZ can be used for blocking the impedance protection function.

The FUSE-MCB signal sets the output signals FUSE-VTSU and FUSE-VTSZ in order to block all the voltage related functions when the MCB is open. The additional drop-off timer of 150 ms prolongs the presence of FUSE-MCB signal to prevent the unwanted operation of voltage dependent function due to non simultaneous closing of the main contacts of the miniature circuit breaker.

The FUSE-DISC signal sets the output signal FUSE-VTSU in order to block the voltage related functions when the line disconnector is open. The impedance protection function is not affected by the position of the line disconnector.

---

The function input signal FUSE-DLCND is related to the dead line condition detection. It has to be connected to the output signal of the dead line condition function DLD-STPH (dead phase condition detected). This signal is activated from the dead line condition function when the voltage and the current in at least one phase are below their respective setting values. It prevents the blocking of the impedance protection by a fuse failure detection during dead line condition (that occurs also during single pole auto-reclosing). The 200 ms drop-off timer prolongs the dead line condition after the line-energization in order to prevent the blocking of the impedance protection for unequal pole closing.

If a fuse failure condition is detected, the signal FUSE-VTSU is turned high, and if there is no dead line condition also FUSE-VTSZ is high. If the fuse failure condition remains for more than five seconds and at least one of the phases has a low phase to earth voltage, then the fuse failure condition is latched.

The output signal FUSE-VTF3PH is high if the fuse failure condition is detected for 5 seconds and all the three measured voltages are low ( $STUL1N = STUL2N = STUL3N = 1$ ).

Fuse failure condition is unlatched when the normal voltage conditions are restored ( $STUL1N = STUL2N = STUL3N = 0$ ).

Fuse failure condition is stored in the non volatile memory of the terminal. In the new start-up procedure the terminal checks the VTF3PH (STORE3PH) value in its non volatile memory and establishes the corresponding starting conditions.

## 2.3

### Calculations

The operating value for the voltage check function (signals STUL1N, STUL2N, STUL3N) is the same as the operating value of the dead line detection function. The setting of the voltage minimum operating value  $U_{<}$  occurs under the submenu:

**Settings****Functions****Group n****DeadLineDet****Negative sequence function**

The negative sequence voltages and currents always exist due to different non-symmetries in the primary system and differences in the current and voltage instrument transformers. The minimum value for the operation of the current and voltage measuring elements must always be set with a safety margin of 10 to 15%, depending on the system operating conditions.

Pay special attention to the dissymmetry of the measuring quantities when the function is used on longer untransposed lines, on multi circuit lines and so on.

**Setting of negative sequence voltage 3U2>**

The relay setting value 3U2> is given in percentage of the secondary base voltage value,  $U_{1b}$ , associated to the voltage transformer input U1. If  $U_{SSEC}$  is the secondary setting value of the relay, then the value for 3U2> is given from equation 279.

$$3U2> = \frac{U_{SSEC}}{U_{1b}} \cdot 100$$

(Equation 279)

Set this value under the setting menu:

**Settings****Functions****Group n****FuseFailure**

on the value 3U2>.

**Setting of negative sequence current 3I2<**

The relay setting value 3I2< is given in percentage of the secondary base current value,  $I_{1b}$ , associated to the current transformer input I1. If  $I_{SSEC}$  is the secondary setting value of the relay, then the value for 3I2< is given from equation 280.

$$3I2< = \frac{IS_{SEC}}{I_{1b}} \cdot 100$$

(Equation 280)

Set this value under the setting menu:

**Settings**  
**Functions**  
**Group n**  
**FuseFailure**

on the value 3I2<.

#### **Zero sequence function**

The zero sequence voltages and currents always exist due to different non-symmetries in the primary system and differences in the current and voltage instrument transformers. The minimum value for the operation of the current and voltage measuring elements must always be set with a safety margin of 10 to 15%, depending on the system operating conditions.

Pay special attention to the dissymmetry of the measuring quantities when the function is used on longer untransposed lines, on multi circuit lines and so on.

#### **Setting of zero sequence voltage 3U0>**

The relay setting value 3U0> is given in percentage of the secondary base voltage value, U1b, associated to the voltage transformer input U1. If U<sub>SSEC</sub> is the secondary setting value of the relay, then the value for 3U0> is given from equation 281.

$$3U0> = \frac{US_{SEC}}{U_{1b}} \cdot 100$$

(Equation 281)

Set this value under the setting menu:

**Settings**  
**Functions**  
**Group n**  
**FuseFailure**

on the value 3U0>.

**Setting of zero sequence current 3I0<**

The relay setting value 3I0< is given in percentage of the secondary base current value, I1b, associated to the current transformer input I1. If  $I_{S_{SEC}}$  is the secondary setting value of the relay, then the value for 3I0< is given from equation 282.

$$3I0< = \frac{I_{S_{SEC}}}{I1b} \cdot 100$$

(Equation 282)

Set this value under the setting menu:

**Settings**  
**Functions**  
**Group n**  
**FuseFailure**

on the value 3I0<.

**Setting of voltage change DU>**

The relay setting value DU> is given in percentage of the secondary base voltage value, U1b, associated to the voltage transformer input U1. If  $U_{S_{SEC}}$  is the secondary setting value of the relay, the value for DU> is given from equation 283.

$$DU> = \frac{U_{S_{SEC}}}{U1b} \cdot 100$$

(Equation 283)

Set this value under the setting menu:

---

**Settings**  
**Functions**  
**Group n**  
**FuseFailure**

on the value DU>.

**Setting of current change DI<**

The relay setting value DI< is given in percentage of the secondary base current value, I1b, associated to the current transformer input I1. If IS<sub>SEC</sub> is the secondary setting value of the relay, the value for DI< is given from equation 284.

$$DI< = \frac{IS_{SEC}}{I1b} \cdot 100$$

(Equation 284)

Set this value under the setting menu:

**Settings**  
**Functions**  
**Group n**  
**FuseFailure**

on the value DI<.



## 3 Voltage transformer supervision (TCT)

### 3.1 Application

If a capacitor element in a capacitive voltage transformer breaks down, that is the element is short circuited or interrupted an unbalance appears. This unbalance occurs as a “false” residual voltage on the capacitive voltage transformer terminals. If the capacitor element is interrupted the corresponding phase voltage will be undefined, and if the capacitor element is short circuited the corresponding phase voltage is increased. This “false” voltage change might affect different functions, such as distance protection, under voltage, overvoltage and voltage check for weak infeed logic.

After a settable time delay, the voltage transformer supervision function activates the TCT\_START signal, if the residual voltage exceeds the set value. This signal can be used as an alarm to the operator that the capacitive voltage transformer is not in a good condition and/or as a blocking signal for certain relays that rely on any phase voltage or the residual voltage.

To ensure that the function is not activated while the protected object is out of operation, it is required that at least one of the phase to phase voltages exceeds 80% of nominal voltage.

Fuse failure supervision is a related function, but is activated only when a secondary voltage totally disappears, i.e. goes to approximately zero. The TCT function can act on smaller residual voltages.

### 3.2 Functionality

#### Abbreviations and definitions

**Table 12: Abbreviations and definitions**

TCT	Voltage transformer supervision
UL1	Phase L1
UPP	Phase-to-phase voltage
STUPP	Start phase-to-phase voltage
UR	Residual voltage
STUR	Start residual voltage

**Description of operation****Algorithm**

The algorithm of the Voltage transformer supervision function is rather straightforward. The phase voltages pass a fourier filter. The magnitude of phase-to-phase voltage, UPP is measured. An indicator signal STUPP will be issued when the magnitude of phase-to-phase voltage passes the set value of nominal phase-to-phase voltage. See figure 152.

Residual voltage pass a frequency adjusted fourier filter. The magnitude of residual voltage, UR is measured. An indicator signal STUR will be issued when the magnitude of residual voltage passes the set value of residual voltage.

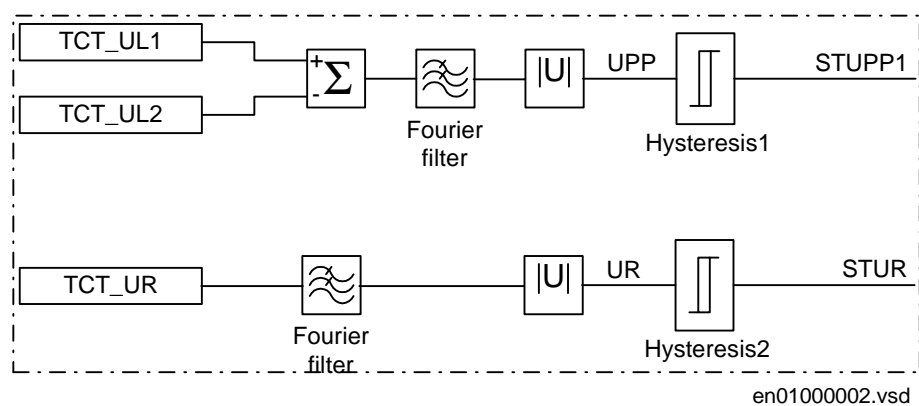

Figure 152: Phase-to-phase voltage and residual voltage measurement

**Logic**

Following modules for the TCT are described:

- Start logic
- Block and VTSU logic

The logic consists of two different functions, one for detection of lower limit phase-to-phase voltage and one for detection of over limit residual voltage.

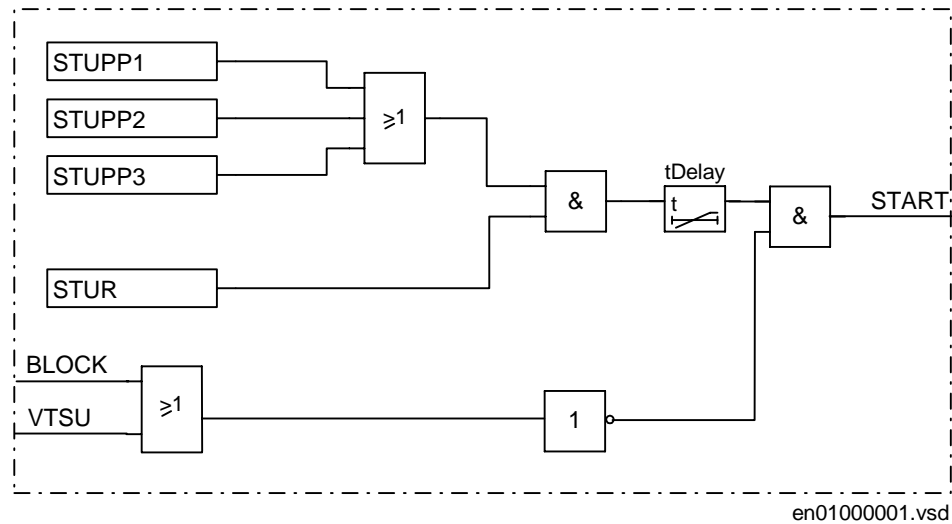

Figure 153: TCT logic

### Start logic

The START signal shall be issued when all the conditions below are fulfilled:

- Residual voltage  $3U_0$  passing the set value for residual voltage limit  $UN>$ . At least one of the phase-to-phase voltage is higher than 80% of the rated voltage phase-to-phase, see figure 153.
- Time delay  $tDelay$  has elapsed.

The START signal shall be reset when at least one of the conditions below is fulfilled:

- Residual voltage is lower than the set value for residual voltage limit  $UN>$ .
- All of the phase-to-phase voltages are lower than 40% of the rated voltage phase to phase.

### Block logic

All binary outputs shall be reset when the input BLOCK or VTSU is set.

Note that the BLOCK or VTSU only blocks outputs. All measuring functions are still executing. Disabling the input BLOCK or VTSU can trip the TCT instantaneously.

## 3.3

## Calculations

There are only two parameters to set for the TCT function: the residual overvoltage limit, and the time delay.

The capacitive voltage transformer is schematically shown in figure 154, the voltage increase in a phase voltage, after the insulation break-down in one capacitor element, is shown in figure 155 and can be calculated as:

$$\Delta V_a = V'_a - V_a = \frac{1}{(n-1)+1} V_A - \frac{1}{n+1} V_A = \frac{1}{n(n+1)} V_A = \frac{1}{n} V_a$$

(Equation 285)

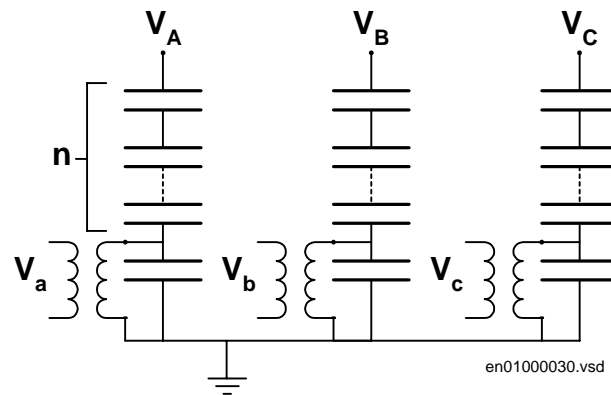
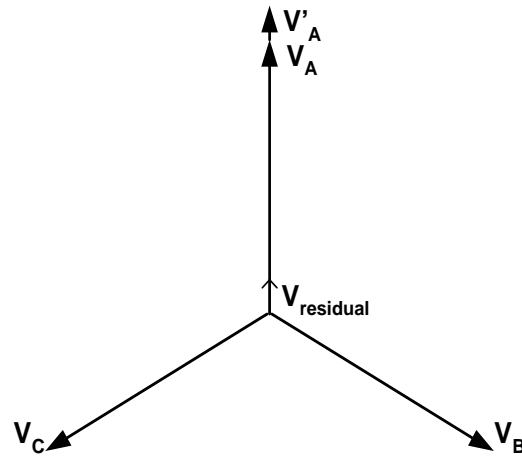

Figure 154: Capacitive voltage transformer

The corresponding vector diagram is shown in figure 155, where also the residual voltage is shown. The residual voltage will be equal to the voltage increase in the phase with the broken capacitor element.



*Figure 155: The residual voltage will be equal to the voltage increase in the phase with the broken capacitor element.*

With a security margin of about 15% the suitable setting for the residual overvoltage limit should be:

$$UN_{>} = 0.85 \cdot 1/n$$

(Equation 286)

Where:

(n+1) is the total number of capacitor elements in one phase of the capacitive voltage transformer, having one element feeding the magnetic voltage transformer.

The time delay is set in such a way that high speed protective functions, not sensitive to the residual voltage caused by the insulation break-down of one capacitor element, are not affected. Sensitive delayed protective functions, that are sensitive to this change in residual voltage could be blocked by this voltage transformer supervision function.



# **Chapter 9 Control**

## **About this chapter**

This chapter describes the control functions.

# 1 Synchrocheck (SYN)

## 1.1 Application

### Synchrocheck, general

The synchrocheck function is used for controlled closing of a circuit in an interconnected network. When used, the function gives an enable signal at satisfied voltage conditions across the breaker to be closed. When there is a parallel circuit established, the frequency is normally the same at the two sides of the open breaker. At power swings, e.g. after a line fault, an oscillating difference can appear. Across the open breaker, there can be a phase angle and a voltage amplitude difference due to voltage drop across the parallel circuit or circuits. The synchro-check function measures the difference between the U-line and the U-bus, regarding voltage (UDiff), phase angle (PhaseDiff), and frequency (FreqDiff). It operates and permits closing of the circuit breaker when the following conditions are simultaneously fulfilled:

- The voltages U-line and U-bus are higher than the set value for UHigh of the base voltage U1b.
- The differences in the voltage and phase angles are smaller than the set values of UDiff and PhaseDiff.
- The difference in frequency is less than the set value of FreqDiff. The bus frequency must also be within a range of +/-5 Hz from the rated frequency.



### Note!

*Phase-phase voltage (100 V or 220 V) can not be connected directly to an individual input voltage transformer. The individual transformer is designed for phase-neutral voltage ( $U_r = 63.5 \text{ V}$  or  $U_r = 127 \text{ V}$ ).*

The function can be used as a condition to be fulfilled before the breaker is closed at manual closing and/or together with the auto-recloser function.



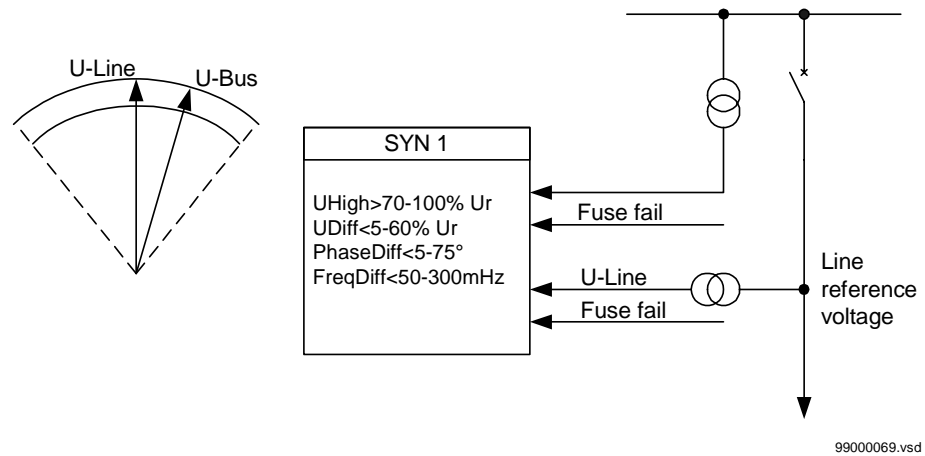

Figure 156: Synchrocheck.

### Synchrocheck, single circuit breaker

The voltage circuits are arranged differently depending on the number of synchrocheck functions that are included in the terminal.

In terminals intended for one bay the U-line voltage reference phase is selected on the human-machine interface (HMI). The reference voltage can be phase-neutral L1, L2, L3 or phase-phase voltage L1-L2, L2-L3, L3-L1. The U-bus voltage must then be connected to the same phase or phases as are chosen on the HMI. Figure 157 shows the voltage connection.

In terminals intended for several bays, all voltage inputs are single phase circuits. The voltage can be selected for single phase or phase-to-phase measurement on the HMI. All voltage inputs must be connected to the same phase or phases.

The circuit breaker can be closed when the conditions for FreqDiff, PhaseDiff, and UDiff are fulfilled with the UHigh condition.

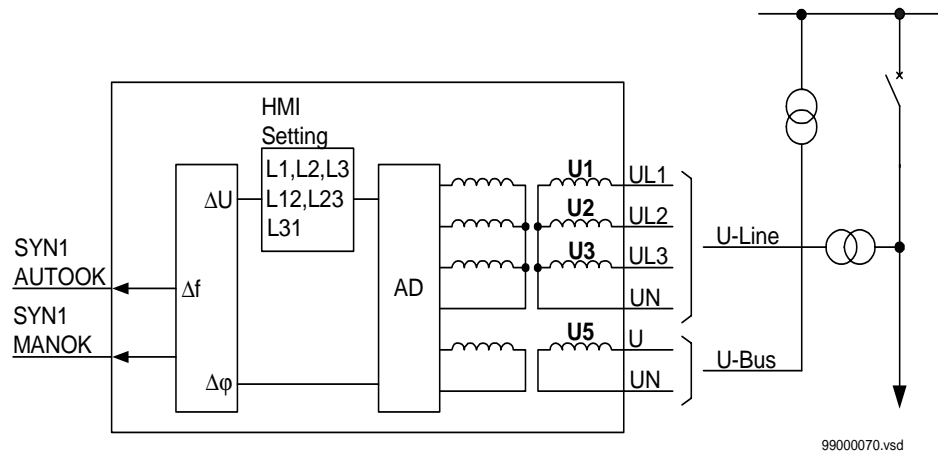

Figure 157: Connection of the synchrocheck function for one bay.

**Energizing check, general**

The energizing check is made when a disconnected line is to be connected to an energized section of a network, see figure 158. The check can also be set to allow energization of the busbar or in both directions.

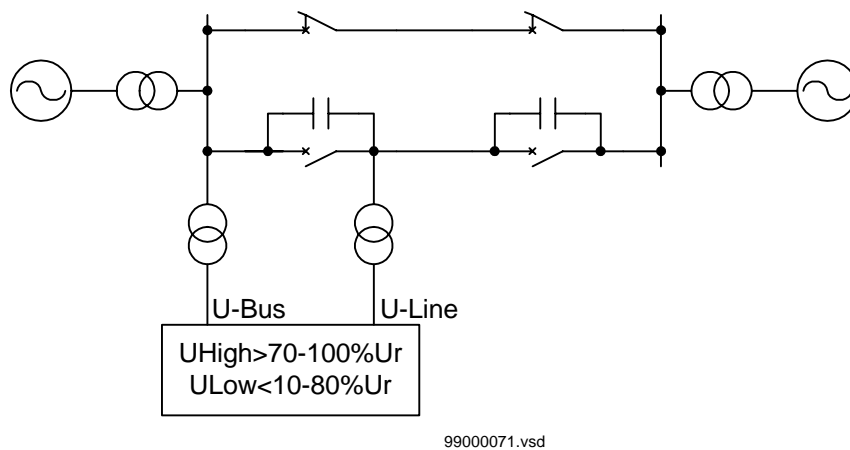

Figure 158: Principle for energizing check.

The voltage level considered to be a non-energized bus or line is set on the HMI. An energizing can occur — depending on:

- the set direction of the energizing function
- the set limit for energized (live - UHigh) condition
- the set limit for non-energized (dead - ULow) condition

The equipment is considered energized if the voltage is above the set value UHigh (e.g. 80% of the base voltage), and non-energized if it is below the set value, ULow (e.g. 30% of the base voltage). The user can set the UHigh condition between 70-100% U1b and the ULow condition between 10-80% U1b.

A disconnected line can have a considerable potential due to, for instance, induction from a line running in parallel, or by being fed via the extinguishing capacitors in the circuit breakers. This voltage can be as high as 30% or more of the rated voltage of the line.

The energizing operation can be set to operate in either direction over the circuit breaker, or it can be permitted to operate in both directions. Use the AutoEnerg and ManEnerg HMI setting to select the energizing operation in:

- Both directions (Both)
- Dead line live bus (DLLB)
- Dead bus live line (DBLL)

The voltage check can also be set Off. A closing impulse is issued to the circuit breaker if one of the U-line or U-bus voltages is High and the other is Low, that is, when only one side is energized. The user can set AutoEnerg and ManEnerg to enable different conditions during automatic and manual closing of the circuit breaker.

In the manual mode it is also possible to allow closing when both sides of the breaker are dead. This is done by setting the parameter ManDBDL = "On" and ManEnerg to "DLLB", "DBLL" or "Both".

#### **Voltage selection, single circuit breaker**

The voltage selection function is used for the synchrocheck and energizing check functions. When the terminal is used in a double bus, the voltage that should be selected depends on the status of the breakers and/or disconnectors. By checking the status of the disconnectors and/or breakers auxiliary contacts, the terminal can select the right voltage for the synchrocheck and energizing check functions. Select the type of voltage selection from the synchrocheck, Uselection, SingleBus or DbleBus on the HMI. When using voltage selection, some extra binary inputs are required.

The configuration of internal signal inputs and outputs may be different for different busbar systems, and the actual configuration for the substation must be done during engineering of the terminal.

**Voltage connection for a single bus and single bay**

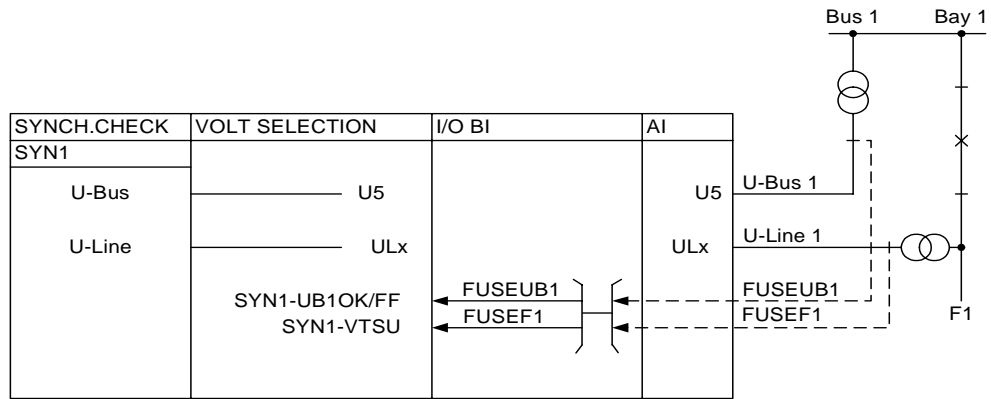

en01000106.vsd

Figure 159: Voltage connection in a single busbar arrangement.

Single bus is selected on the HMI. Figure 159 shows the principle for the connection arrangement. One terminal unit is used for one bay. For the synchrocheck (SYN1) and energizing check function, there is one voltage transformer at each side of the circuit breaker. The voltage transformer circuit connections are straight forward, no special voltage selection is needed.

For the synchrocheck and energizing check, the voltage from Bus 1 (U-Bus 1) is connected to the single phase analogue input (U5) on the terminal unit.

The line voltage (U-line 1) is connected as a three-phase voltage to the analog inputs UL1, UL2, UL3 (ULx).

**Fuse failure and Voltage OK signals, single bus and single bay**

The external fuse-failure signals or signals from a tripped fuse switch/MCB are connected to binary inputs that are configured to inputs of the synchrocheck functions in the terminal. There are two alternative connection possibilities. Inputs named OK must be supplied if the voltage circuit is healthy. Inputs named FF must be supplied if the voltage circuit is faulty.

The SYN1-UB1OK and SYN1-UB1FF inputs are related to the busbar voltage. Configure them to the binary inputs that indicate the status of the external fuse failure of the busbar voltage. The SYN1-VTSU input is related to the line voltage.

The user can use the FUSE-VTSU signal from the built-in optional fuse-failure function as an alternative to the external fuse-failure signals.

In case of a fuse failure, the energizing check (dead line-check) is blocked via the inputs (SYN1-UB1OK/FF or SYN1-VTSU).

**Voltage selection for a double bus and single bay**

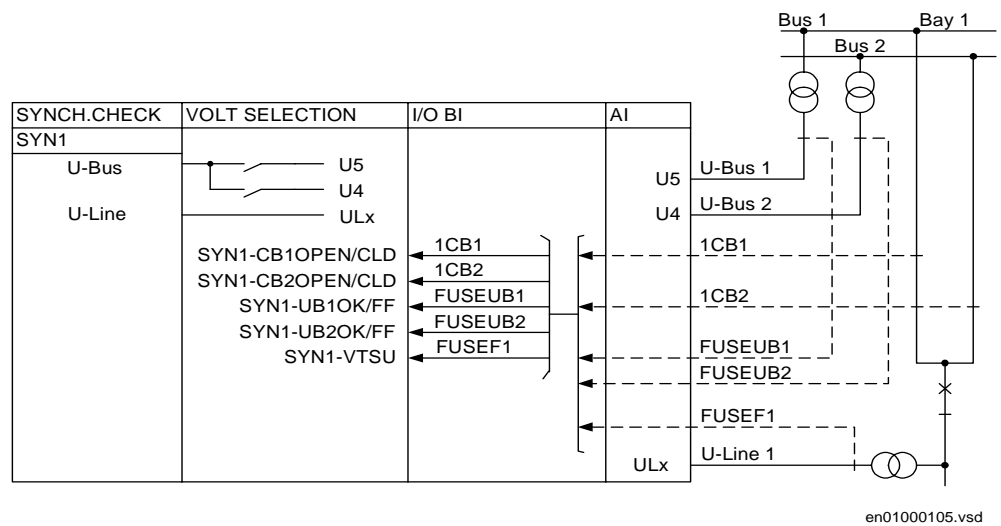

en01000105.vsd

Figure 160: Voltage selection in a double bus arrangement.

Select DbleBus on the HMI. Figure 160 shows the principle for the connection arrangement. One terminal is used for one bay. For the synchrocheck (SYN1) and energizing check function, the voltages on the two busbars are selected by the voltage selection in the terminal unit. The bus voltage from Bus 1 is fed to the U5 analog single-phase input, and the bus voltage from Bus 2 is fed to the U4 analog single-phase input. The line voltage transformers are connected as a three-phase voltage UL1, UL2, UL3 (ULx) to the input U-line 1.

The selection of the bus voltage is made by checking the position of the disconnectors' auxiliary contacts connected via binary inputs of the voltage selection logic inputs, SYN1-CB1OPEN (Disconnector section 1 open), SYN1-CB1CLD (Disconnector section 1 closed) and SYN1-CB2OPEN (Disconnector section 2 open), SYN1-CB2CLD (Disconnector section 2 closed).

**Fuse failure and Voltage OK signals, double bus and single bay**

The external fuse-failure signals or signals from a tripped fuse switch/MCB are connected to binary inputs configured to inputs of the synchro-check functions in the terminal. There are two alternative connection possibilities. Inputs named OK must be supplied if the voltage circuit is healthy. Inputs named FF must be supplied if the voltage circuit is faulty.

The SYN1-UB1(2)OK and SYN1-UB1(2)FF inputs are related to each busbar voltage. The SYN1-VTSU input is related to the line voltage. Configure them to the binary inputs that indicate the status of the external fuse failure of the busbar respectively the line voltage. Only the fuse failure of a selected voltage causes a blocking of the relevant energizing check unit.

The user can use the FUSE-VTSU signal from the built-in optional selectable fuse-failure function as an alternative to the external fuse-failure signals.

In case of a fuse failure, the energizing check (dead line-check) is blocked via the inputs (SYN1-UB1OK/FF, SYN1-UB2OK/FF or SYN1-VTSU).

**Synchrocheck, double circuit breaker**

The voltage circuits are arranged differently depending on the number of synchrocheck functions that are included in the terminal.

In terminals intended for one bay the U-line voltage reference phase is selected on the human-machine interface (HMI). The reference voltage can be phase-neutral L1, L2, L3 or phase-phase L1-L2, L2-L3, L3-L1. The U-bus voltage must then be connected to the same phase or phases as are chosen on the HMI. Figure 161 shows the voltage connection.

In terminals intended for several bays, all voltage inputs are single phase circuits. The voltage can be selected for phase-neutral or phase-to-phase measurement on the HMI. All voltage inputs must be connected to the same phase or phases.

The circuit breaker can be closed when the conditions for FreqDiff, PhaseDiff, and UDiff are fulfilled with the UHigh condition.

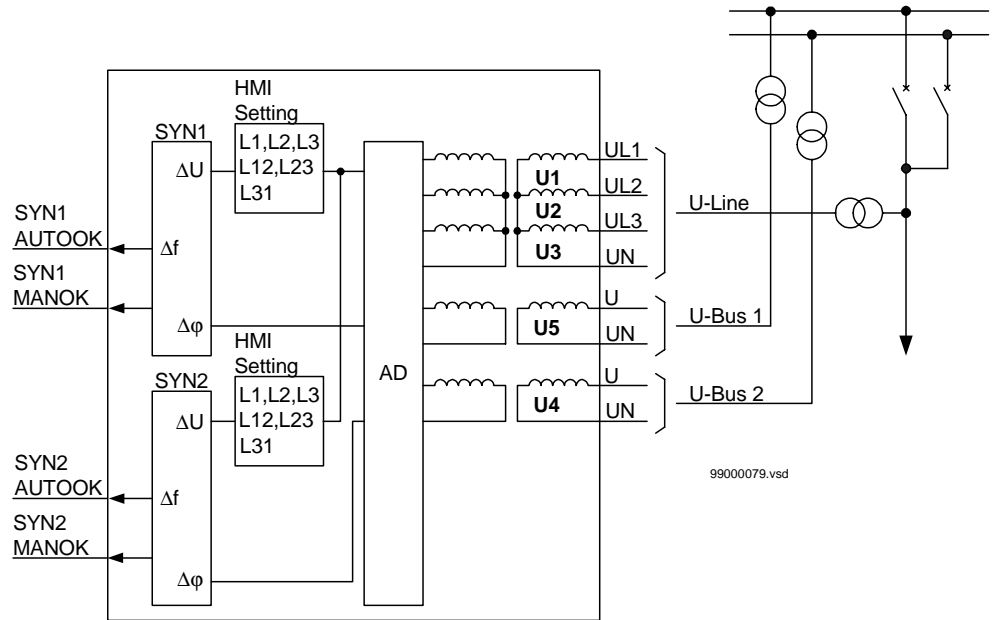
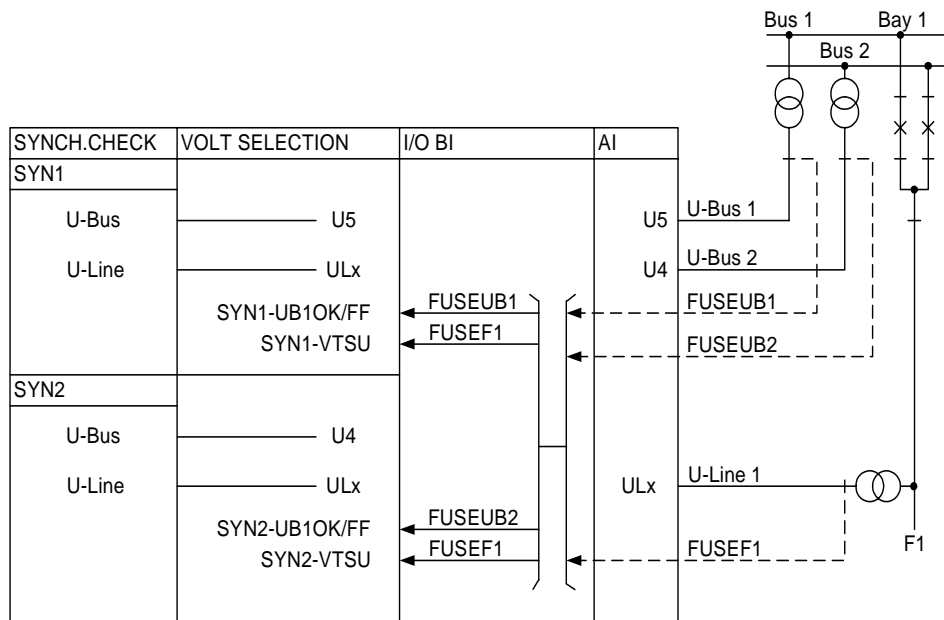

Figure 161: Connection of the synchrocheck function for one bay.

Voltage connection, double circuitbreaker and single bay



en01000116.vsd

Figure 162: Voltage connection in a double breaker arrangement.

The principle for the connection arrangement is shown in figure 162. One terminal is used for the two circuit breakers in one bay. There is one voltage transformer at each side of the circuit breaker, and the voltage transformer circuit connections are straightforward, without any special voltage selection.

For the synchrocheck and energizing check, the voltage from Bus 1 (U-bus 1) is connected to the single-phase analog input (U5) on the terminal and the voltage from Bus 2 (U-bus 2) is connected to the single-phase analog input (U4).

The line voltage transformers are connected as a three-phase voltage to the analogue inputs UL1, UL2, UL3 (ULx).

The synchronism condition is set on the HMI of the terminal, and the voltage is taken from Bus 1 and the Line or from Bus 2 and the Line (U-line 1). This means that the two synchrocheck units are operating without any special voltage selection, but with the same line (U-line 1) voltage.



---

The configuration of internal signals, inputs, and outputs may be different for different busbar systems, and the actual configuration for the substation must be done during engineering of the terminal.

#### **Fuse failure and Voltage OK signals, double circuit breaker and single bay**

The external fuse-failure signals or signals from a tripped fuse switch/MCB are connected to binary inputs configured to inputs of the synchro-check functions in the terminal. There are two alternative connection possibilities. Inputs named OK must be supplied if the voltage circuit is healthy. Inputs named FF must be supplied if the voltage circuit is faulty.

The SYN1(2)-UB1OK and SYN1(2)-UB1FF inputs are related to the busbar voltage. Configure them to the binary inputs that indicate the status of the external fuse failure of the busbar voltage. The SYN1(2)-VTSU input is related to the line voltage from each line.

The user can use the FUSE-VTSU signal from the built-in optional selectable fuse-failure function as an alternative to the external fuse-failure signals.

In case of a fuse failure, the energizing check (dead line check) is blocked via the inputs (SYN1(2)-UB1OK/FF or SYN1(2)-VTSU).

#### **Phasing, general**

The phasing function is used to close a circuit breaker when two asynchronous systems are going to be connected. The breaker close command is issued at the optimum time when conditions across the breaker are satisfied in order to avoid stress on the network and its components.

The systems are defined to be asynchronous when the frequency difference between bus and line is larger than an adjustable parameter. If the frequency difference is less than this threshold value the system is defined to have a parallel circuit and the synchro-check function is used.

The phasing function measures the difference between the U-line and the U-bus. It operates and enables a closing command to the circuit breaker when the calculated closing angle is equal to the measured phase angle and the following conditions are simultaneously fulfilled:

- The voltages U-line and U-bus are higher than the set value for UHigh of the base voltage U1b.
- The difference in the voltage is smaller than the set value of UDiff.
- The difference in frequency is less than the set value of FreqDiffSynch and larger than the set value of FreqDiff. If the frequency is less than FreqDiff the synchrocheck is used. The bus and line frequencies must also be within a range of +/-5 Hz from the rated frequency.
- The frequency rate of change is less than 0.21 Hz/s for both U-bus and U-line.
- The closing angle is less than approx. 60 degrees.

The phasing function compensates for measured slip frequency as well as the circuit breaker closing delay. The phase advance is calculated continuously by the following formula:

$$\text{Closing angle} = 360^\circ \cdot \text{Meas. freq. diff.} \cdot t_{\text{Breaker}}$$

(Equation 287)

Closing angle is the change in angle during breaker closing operate time.

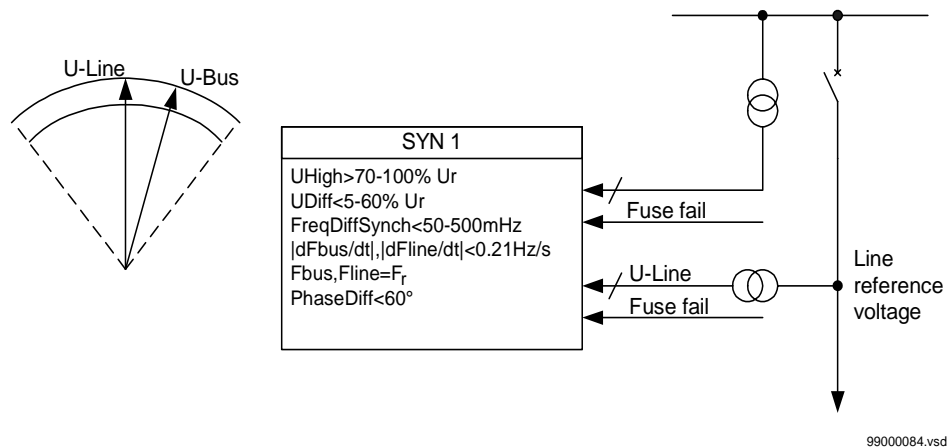

Figure 163: Phasing.

### Phasing, single circuit breaker

The reference voltage can be phase-neutral L1, L2, L3 or phase-phase L1-L2, L2-L3, L3-L1. The U-bus voltage must then be connected to the same phase or phases as are chosen on the HMI. Figure 164 shows the voltage connection.

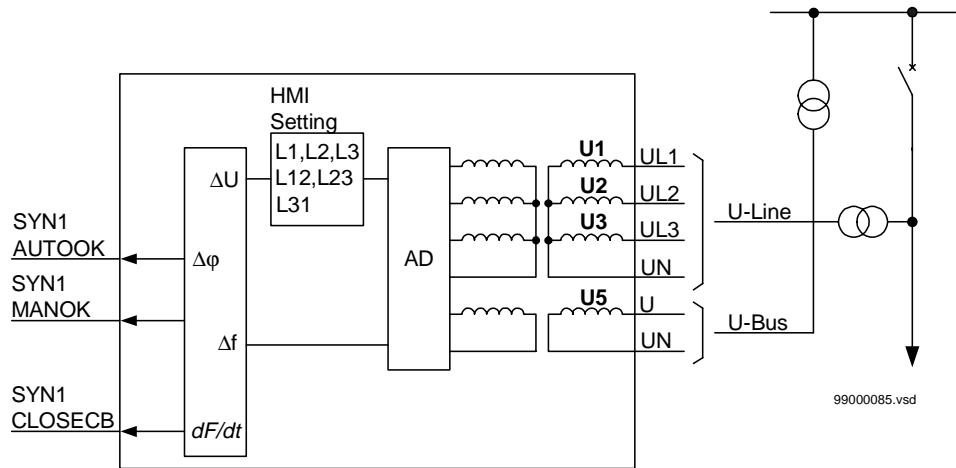
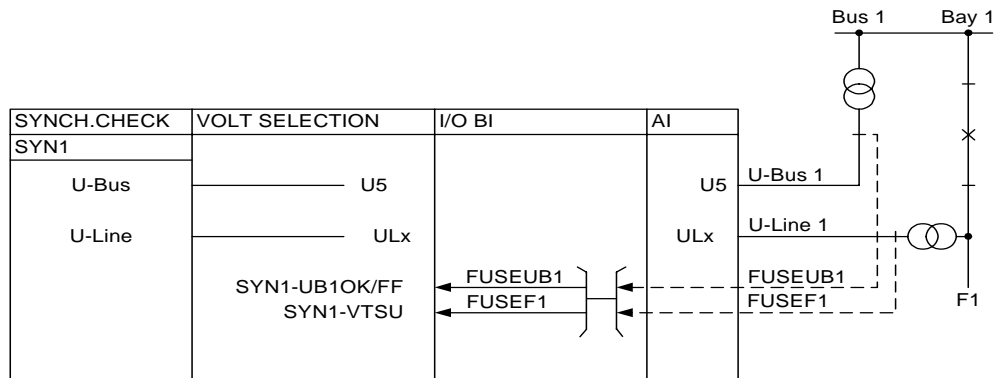

Figure 164: Connection of the phasing and synchrocheck function for one bay.

#### Voltage selection, single circuit breaker

The voltage selection function is used for the phasing and synchronism (SYN1) and energizing check functions. When the terminal is used in a double bus, the voltage that should be selected depends on the positions of the breakers and/or disconnectors. By checking the position of the disconnectors and/or breakers auxiliary contacts, the terminal can select the right voltage for the synchronism and energizing function. Select the type of voltage selection from the Synchro-check, Uselection, SingleBus or DbleBus on the HMI.

The configuration of internal signal inputs and outputs may be different for different busbar systems, and the actual configuration for the substation must be done during engineering of the terminal.

**Voltage selection for a single bus and single bay**

en01000106.vsd

Figure 165: Voltage connection in a single busbar arrangement.

Single bus is selected on the HMI. Figure 165 shows the principle for the connection arrangement. For the phasing, synchrocheck (SYN1) and energizing check function, there is one voltage transformer at each side of the circuit breaker. The voltage transformer circuit connections are straight forward, no special voltage selection is needed.

For the phasing, synchrocheck and energizing check, the voltage from Bus 1 (U-Bus 1) is connected to the single phase analog input (U5) on the terminal.

The line voltage (U-line 1) is connected as a three-phase voltage to the analog inputs UL1, UL2, UL3 (ULx).

**Fuse failure and Voltage OK signals, single bus and single bay**

The external fuse-failure signals or signals from a tripped fuse switch/MCB are connected to binary inputs configured to inputs of the synchrocheck functions in the terminal. There are two alternative connection possibilities. Inputs named OK must be supplied if the voltage circuit is healthy. Inputs named FF must be supplied if the voltage circuit is faulty.

The SYN1-UB1OK and SYN1-UB1FF inputs are related to the busbar voltage. Configure them to the binary inputs that indicate the status of the external fuse failure of the busbar voltage. The SYN1-VTSU input is related to the line voltage.

The user can use the FUSE-VTSU signal from the built-in optional fuse-failure function as an alternative to the external fuse-failure signals.

In case of a fuse failure, the energizing check (dead line check) is blocked via the inputs (SYN1-UB1OK/FF or SYN1-VTSU).

**Voltage selection for a double bus and single bay**

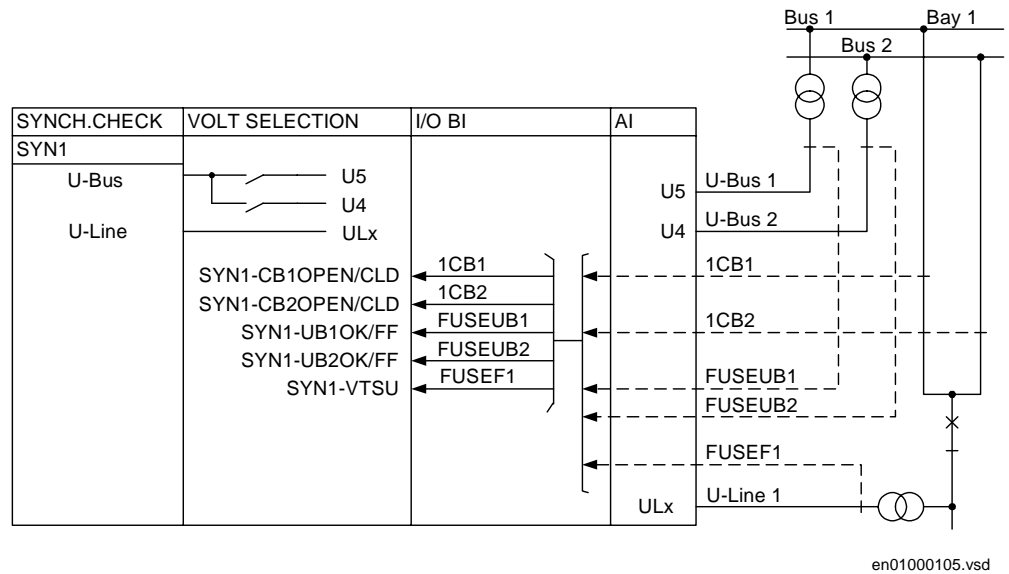

Figure 166: Voltage selection in a double bus arrangement.

Select DbleBus on the HMI. Figure 166 shows the principle for the connection arrangement. For the phasing and synchrocheck (SYN1) and energizing check function, the voltages on the two busbars are selected by the voltage selection in the terminal unit. The bus voltage from Bus 1 is fed to the U5 analog single-phase input, and the bus voltage from Bus 2 is fed to the U4 analog single-phase input. The line voltage transformers are connected as a three-phase voltage UL1, UL2, UL3 (ULx) to the input U-line 1.

The selection of the bus voltage is made by checking the position of the disconnectors' auxiliary contacts connected via binary inputs of the voltage selection logic inputs, SYN1-CB1OPEN (Disconnector section 1 open), SYN1-CB1CLD (Disconnector section 1 closed) and SYN1-CB2OPEN (Disconnector section 2 open), SYN1-CB2CLD (Disconnector section 2 closed).

**Fuse failure and Voltage OK signals, double bus and single bay**

The external fuse-failure signals or signals from a tripped fuse switch/MCB are connected to binary inputs configured to inputs of the synchro-check functions in the terminal. There are two alternative connection possibilities. Inputs named OK must be supplied if the voltage circuit is healthy. Inputs named FF must be supplied if the voltage circuit is faulty.

The SYN1-UB1(2)OK and SYN1-UB1(2)FF inputs are related to each busbar voltage. The SYN1-VTSU input is related to each line voltage. Configure them to the binary inputs that indicate the status of the external fuse failure of the busbar respectively the line voltage. Only the fuse failure of a selected voltage causes a blocking of the relevant energizing check unit.

The user can use the FUSE-VTSU signal from the built-in optional selectable fuse-failure function as an alternative to the external fuse-failure signals.

In case of a fuse failure, the energizing check (dead line check) is blocked via the inputs (SYN1-UB1OK/FF, SYN1-UB2OK/FF or SYN1-VTSU).

**Phasing, double circuit breaker**

The reference voltage can be phase-neutral L1, L2, L3 or phase-phase L1-L2, L2-L3, L3-L1. The U-bus voltage must then be connected to the same phase or phases as are chosen on the HMI. Figure 167 shows the voltage connection.

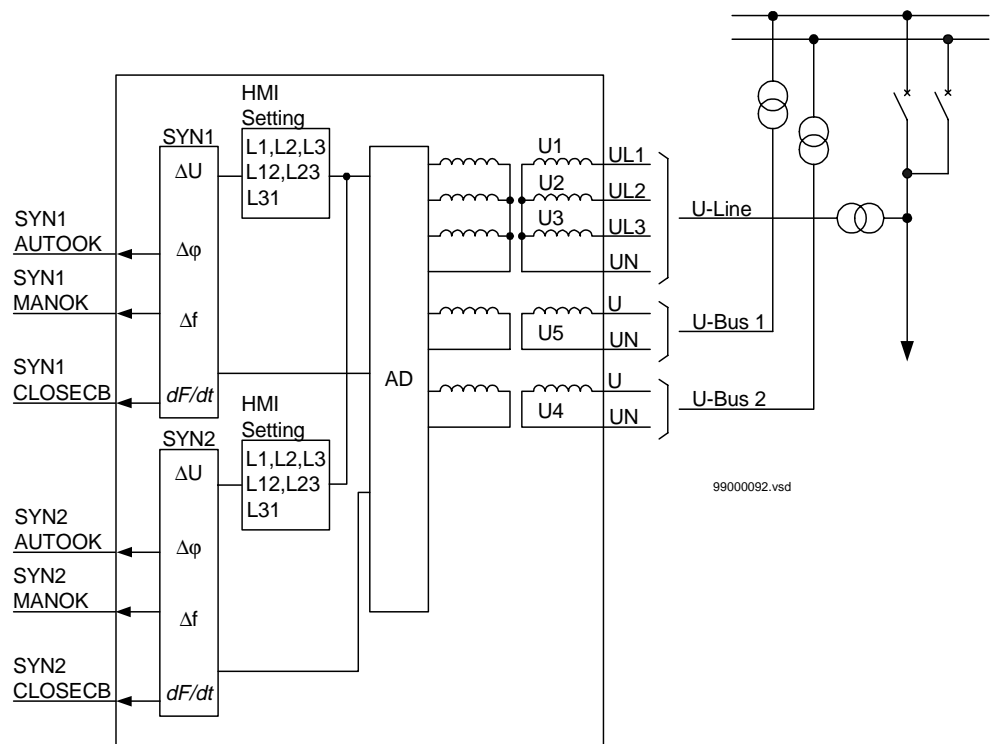

Figure 167: Connection of the phasing and synchrocheck function for one bay.

Voltage connection, double circuit breaker and single bay

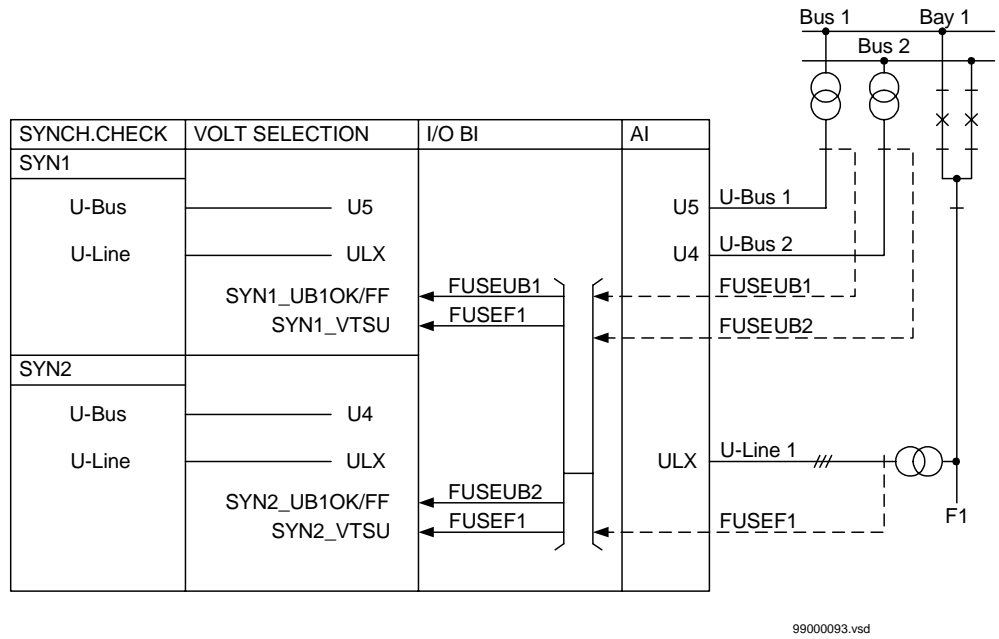

Figure 168: Voltage connection in a double breaker arrangement.

The principle for the connection arrangement is shown in figure 168. One terminal unit is used for the two circuit breakers in one bay. There is one voltage transformer at each side of the circuit breaker, and the voltage transformer circuit connections are straight forward, without any special voltage selection. For the synchrocheck and energizing check, the voltage from Bus 1 (U-bus 1) is connected to the single-phase analog input (U5) on the terminal and the voltage from Bus 2 (U-bus 2) is connected to the single-phase analog input (U4).

The line voltage transformers are connected as a three-phase voltage to the analog inputs UL1, UL2, UL3 (ULx).

The synchronism condition is set on the HMI of the terminal unit, and the voltage is taken from Bus 1 and the Line or from Bus 2 and the Line (U-line 1). This means that the two synchrocheck units are operating without any special voltage selection, but with the same line (U-line 1) voltage.

The configuration of internal signals, inputs, and outputs may be different for different busbar systems, and the actual configuration for the substation must be done during engineering of the terminal.

**Fuse failure and Voltage OK signals, double circuit breaker and single bay**

The external fuse-failure signals or signals from a tripped fuse switch/MCB are connected to binary inputs configured to inputs of the synchro-check functions in the terminal. There are two alternative connection possibilities. Inputs named OK must be supplied if the voltage circuit is healthy. Inputs named FF must be supplied if the voltage circuit is faulty.

The SYN1(2)-UB1OK and SYN1(2)-UB1FF inputs are related to the busbar voltage. Configure them to the binary inputs that indicate the status of the external fuse failure of the busbar voltage. The SYN1(2)-VTSU input is related to the line voltage from each line.

The user can use the FUSE-VTSU signal from the built-in optional selectable fuse-failure function as an alternative to the external fuse-failure signals.

In case of a fuse failure, the energizing check (dead line- check) is blocked via the input (SYN1(2)-UB1OK/FF or SYN1(2)-VTSU).



1.2

Functionality

Single circuit breaker

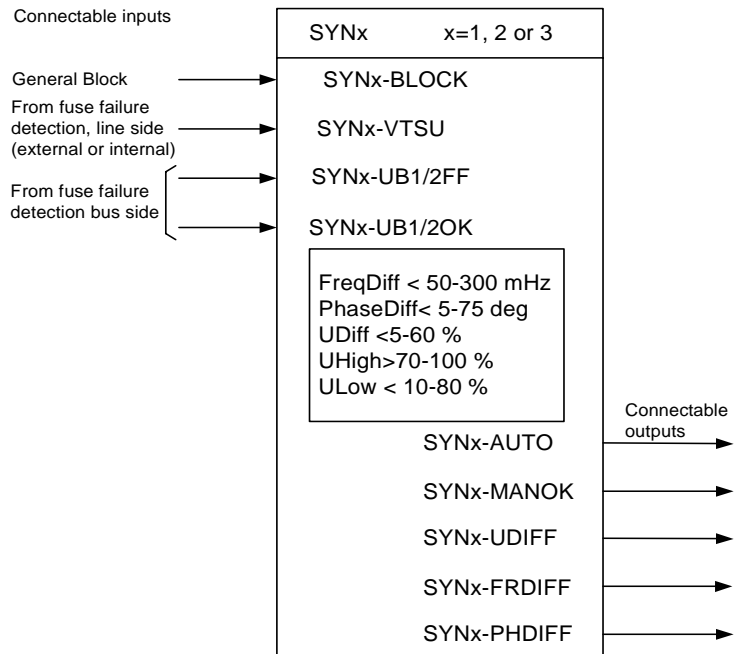

99000074.vsd

Figure 169: Input and output signals.

Synchrocheck

Description of input and output signals for the synchrocheck function.

<b>Input signals</b>	<b>Description</b>
SYNx-BLOCK	General block input from any external condition, that should block the synchrocheck.
SYNx-VTSU	The synchrocheck function cooperates with the FUSE-VTSU connected signal, which is the built-in optional fuse failure detection. It can also be connected to external condition for fuse failure. This is a blocking condition for the energizing function.
SYNx-UB1FF	External fuse failure input from busbar voltage Bus 1 (U5). This signal can come from a tripped fuse switch (MCB) on the secondary side of the voltage transformer. In case of a fuse failure the energizing check is blocked.
SYNx-UB1OK	No external voltage fuse failure (U5). Inverted signal.
SYNx-UB2FF	External fuse failure input from busbar voltage Bus 2 (U4). This signal can come from a tripped fuse switch (MCB) on the secondary side of the voltage transformer. In case of a fuse failure the energizing check is blocked.
SYNx-UB2OK	No external voltage fuse failure (U4). Inverted signal.
<b>Output signals</b>	<b>Description</b>
SYNx-AUTOOK	Synchrocheck/energizing OK. The output signal is high when the synchrocheck conditions set on the HMI are fulfilled. It can also include the energizing condition, if selected. The signal can be used to release the auto-recloser before closing attempt of the circuit breaker. It can also be used as a free signal.
SYNx-MANOK	Same as above but with alternative settings of the direction for energizing to be used during manual closing of the circuit breaker.
SYNx-UDIFF	Difference in voltage is less than the set difference limit.
SYNx-FRDIFF	Difference in frequency is less than the set difference limit.
SYNx-PHDIFF	Difference in phase angle is less than the set difference limit.

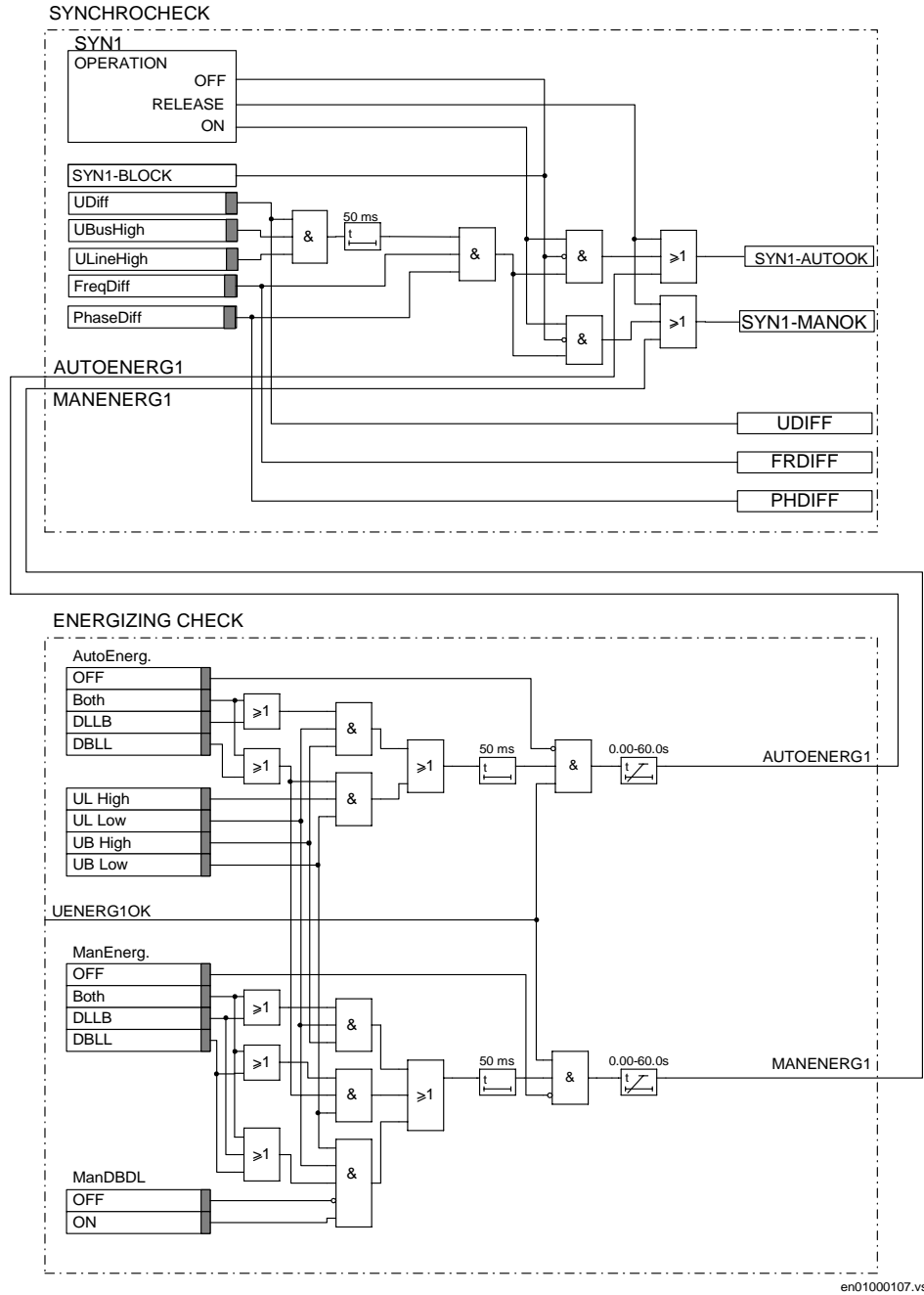

Figure 170: Simplified logic diagram - Synchrocheck and energizing check. The internal signal UENERG1OK refers to the voltage selection logic.



---

<b>Input signal</b>	<b>Description</b>
SYNx-UB1OK	No external voltage fuse failure (U5). Inverted signal.
SYNx-UB2FF	External fuse failure input from busbar voltage Bus 2 (U4). This signal can come from a tripped fuse switch (MCB) on the secondary side of the voltage transformer. In case of fuse failure, the energizing check is blocked.
SYNx-UB2OK	No external voltage fuse failure (U4). Inverted signal.
SYNx-VTSU	Internal fuse failure detection or configured to a binary input indicating external fuse failure of the UL1, UL2, UL3 line-side voltage. Blocks the energizing function.

<b>Output signals</b>	<b>Description</b>
SYNx-VSUB1	Signal for indication of voltage selection from Bus 1 voltage.
SYNx-VSUB2	Signal for indication of voltage selection from Bus 1 voltage.

**Double circuit breaker**

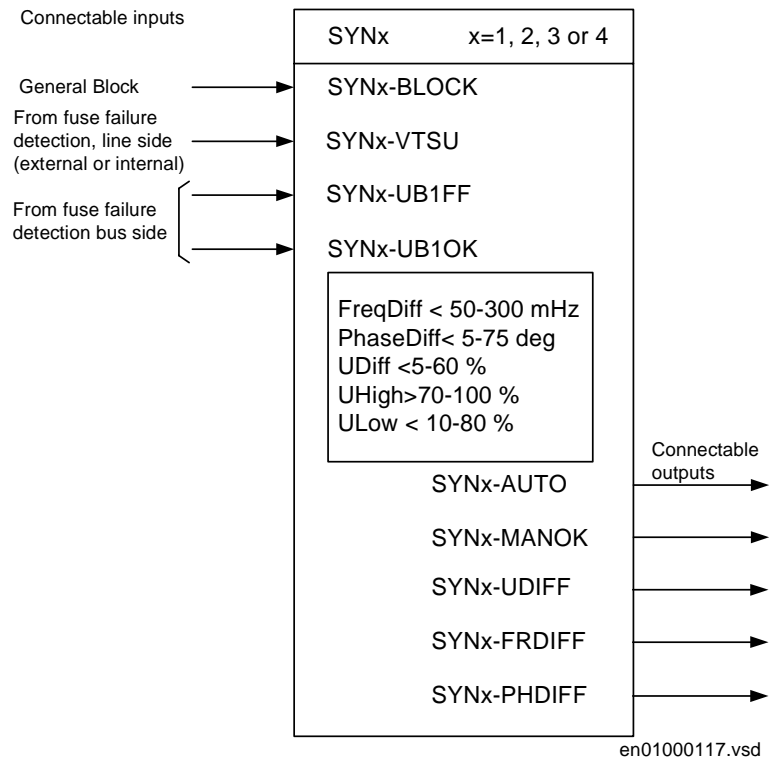

Figure 172: Input and output signals.

**Synchrocheck**

Description of input and output signals for the synchrocheck function.

Input signals	Description
SYNx-BLOCK	General block input from any external condition, that should block the synchrocheck.

---

<b>Input signals</b>	<b>Description</b>
SYNx-VTSU	The synchrocheck function cooperates with the FUSE-VTSU connected signal, which is the built-in optional fuse failure detection. It can also be connected to external condition for fuse failure. This is a blocking condition for the energizing function.
SYNx-UB1FF	External fuse failure input from busbar voltage Bus 1 (U5). This signal can come from a tripped fuse switch (MCB) on the secondary side of the voltage transformer. In case of a fuse failure the energizing check is blocked.
SYNx-UB1OK	No external voltage fuse failure (U5). Inverted signal.

<b>Output signals</b>	<b>Description</b>
SYNx-AUTOOK	Synchrocheck/energizing OK. The output signal is high when the synchrocheck conditions set on the HMI are fulfilled. It can also include the energizing condition, if selected. The signal can be used to release the auto-recloser before closing attempt of the circuit breaker. It can also be used as a free signal.
SYNx-MANOK	Same as above but with alternative settings of the direction for energizing to be used during manual closing of the circuit breaker.
SYNx-UDIFF	Difference in voltage is less than the set difference limit.
SYNx-FRDIFF	Difference in frequency is less than the set difference limit.
SYNx-PHDIFF	Difference in phase angle is less than the set difference limit.

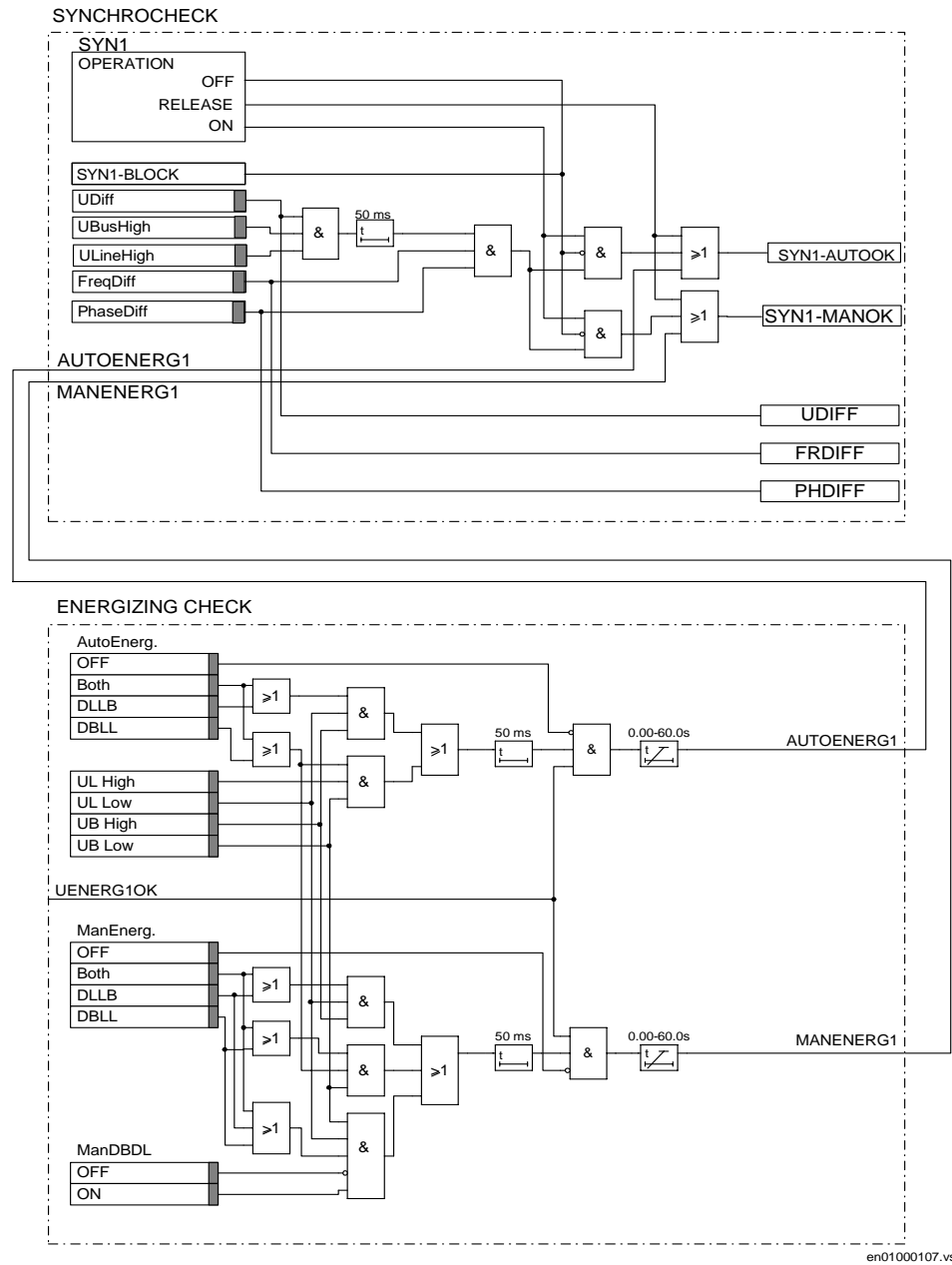

Figure 173: Simplified logic diagram - Synchrocheck and energizing check for one circuit breaker. The internal signal UENERG1OK derives from the external or internal fuse failure inputs SYN1-UB1OK/FF and SYN1-VTSU.



**Phasing and synchrocheck, single circuit breaker**

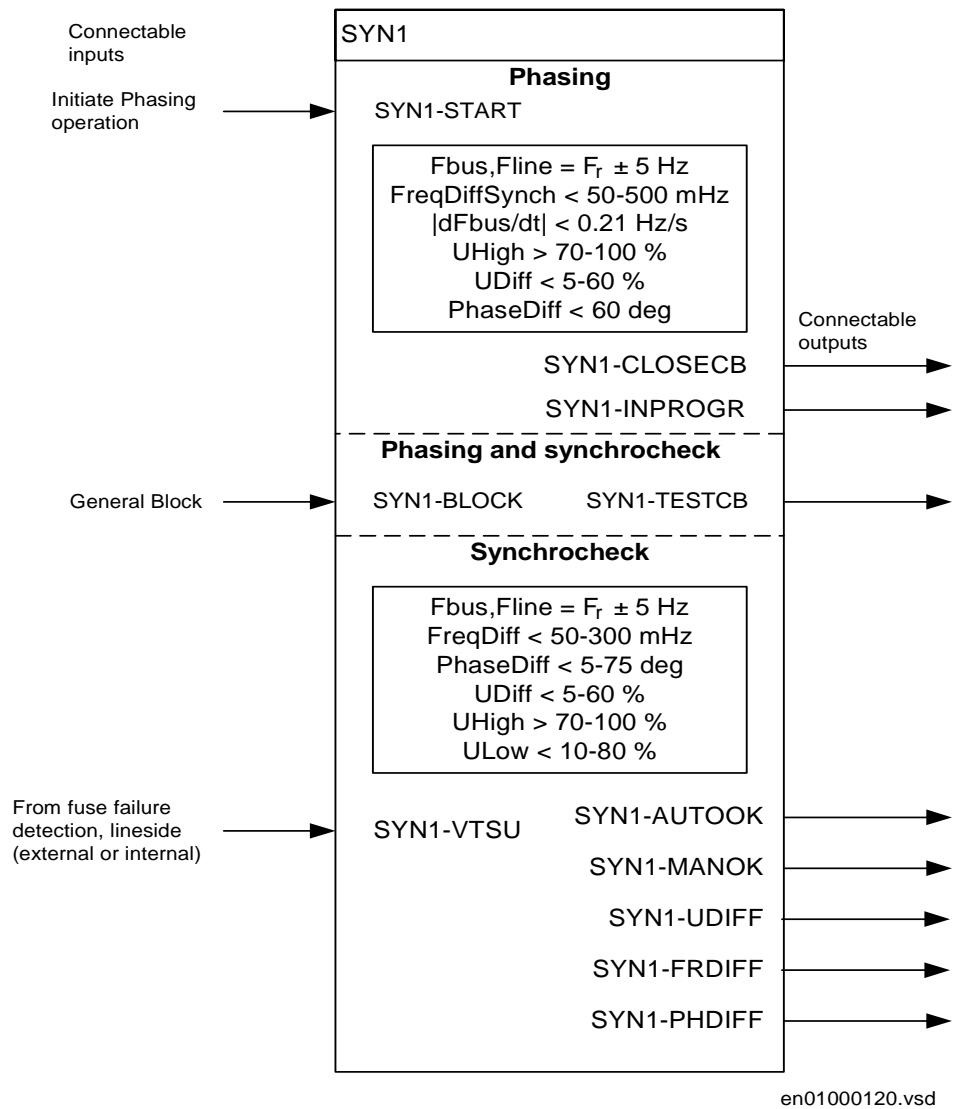

Figure 174: Input and output signals.

**Phasing and synchrocheck**

Description of input and output signals for the phasing and synchrocheck function.

Input signals	Description
SYN1-BLOCK	General block input from any external condition, that should block the phasing and the synchrocheck.
SYN1-VTSU	The SYNC function cooperates with the FUSE-VTSU connected signal, which is the built-in optional fuse failure detection. It can also be connected to external condition for fuse failure. This is a blocking condition for the energizing function
SYN1-START	The signal initiates the phasing operation. When initiated the function continues until the SYN1-CLOSECB pulse is submitted or it is stopped by the SYN1-BLOCK signal. In test mode (SYN1-TESTCB) ends the phasing operation.

Output signals	Description
SYN1-TESTCB	Output when the function is in test mode. In test mode a complete phasing sequence is performed except for closing of the circuit breaker. The output signal SYN1-TESTCB indicates when the SYN1-CLOSECB signal would have been submitted from the phasing function or when the conditions for paralleling are fulfilled, from the synchro-check function
SYN1-CLOSECB	Close breaker command from phasing. Used to the circuit breaker or to be connected to the auto-reclosing function.
SYN1-INPROGR	The signal is high when a phasing operation is in progress, i.e from the moment a SYN1-START is received until the operation is terminated. The operation is terminated when SYN1-CLOSECB or SYN1-TESTCB has been submitted or if a SYN1-BLOCK is received.
SYN1-AUTOOK	Synchrocheck/energizing OK. The output signal is high when the synchro-check conditions set on the HMI are fulfilled. It can also include the energizing condition, if selected. The signal can be used to release the autorecloser before closing attempt of the circuit breaker. It can also be used as a free signal.
SYN1-MANOK	Same as above but with alternative settings of the direction for energizing to be used during manual closing of the circuit breaker.
SYN1-UDIFF	Difference in voltage is less than the set difference limit.
SYN1-FRDIFF	Difference in frequency is less than the set difference limit.
SYN1-PHDIFF	Difference in phase angle is less than the set difference limit.

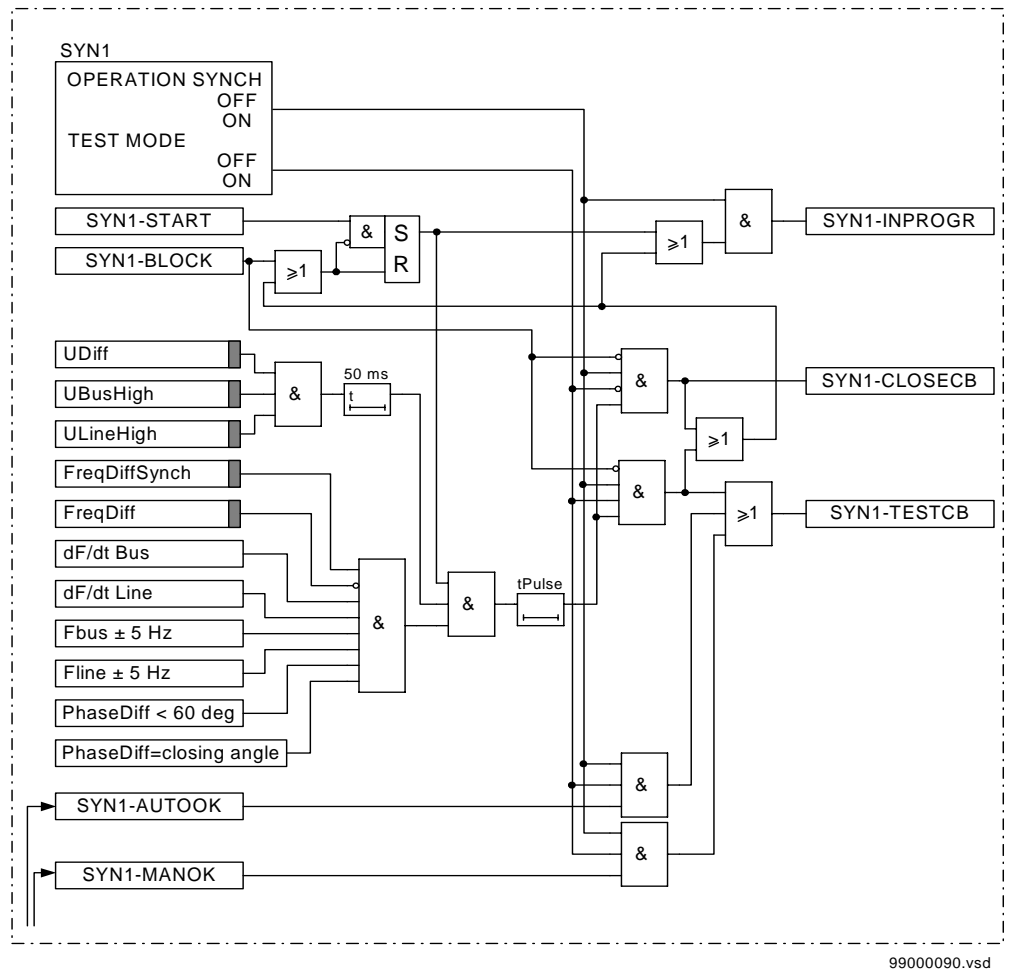

Figure 175: Simplified logic diagram - Phasing. The input signals SYN1-AUTOOK and SYN1-MANOK derive from the synchrocheck and energizing logic.

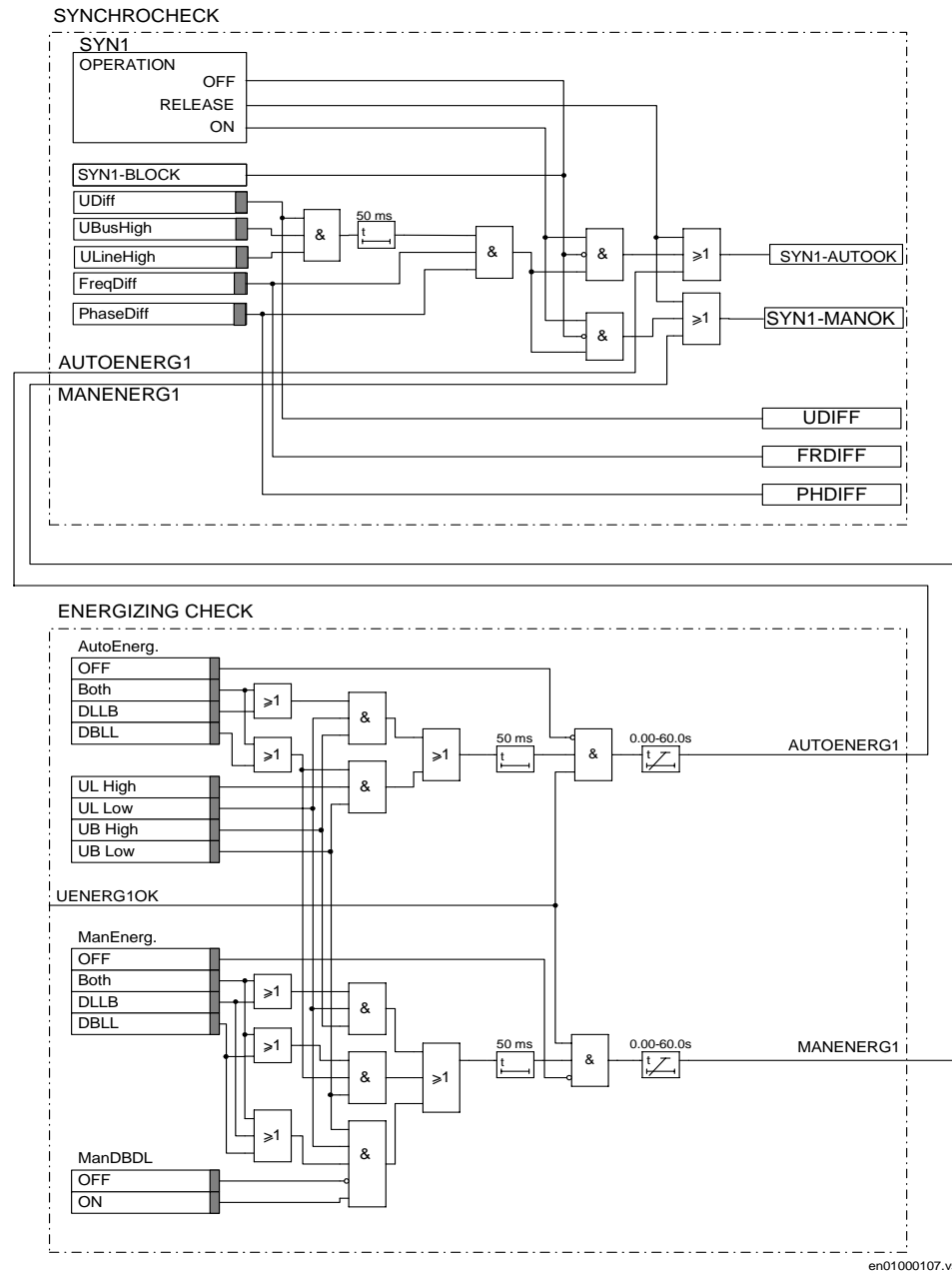
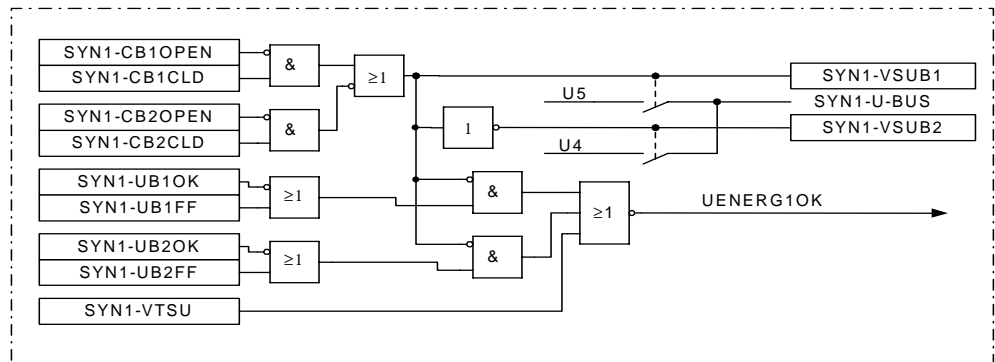

Figure 176: Simplified logic diagram - Synchrocheck and energizing check. The internal signal UENERG1OK refers to the voltage selection logic.

**Voltage selection**



99000089.vsd

Figure 177: Simplified voltage selection logic in a double bus, single breaker arrangement.

Description of the input and output signals shown in the above simplified logic diagrams for voltage selection:

Input signal	Description
SYN1-CB1OPEN	Disconnecter section 1 of Bay 1 open. Connected to the auxiliary contacts of a disconnecter section in a double-bus, single breaker arrangement, to inform the voltage selection about the positions.
SYN1-CB1CLD	Disconnecter section 1 of Bay 1 closed. Connected to the auxiliary contacts of a disconnecter section in a double-bus, single breaker arrangement to inform the voltage selection about the positions.
SYN1-CB2OPEN	Same as above but for disconnecter section 2.
SYN1-CB2CLD	Same as above but for disconnecter section 2.
SYN1-UB1FF	External fuse failure input from busbar voltage Bus 1 (U5). This signal can come from a tripped fuse switch (MCB) on the secondary side of the voltage transformer. In case of a fuse failure, the energizing check is blocked.
SYN1-UB1OK	No external voltage fuse failure (U5). Inverted signal.

---

<b>Input signal</b>	<b>Description</b>
SYN1-UB2FF	External fuse failure input from busbar voltage Bus 2 (U4). This signal can come from a tripped fuse switch (MCB) on the secondary side of the voltage transformer. In case of fuse failure, the energizing check is blocked.
SYN1-UB2OK	No external voltage fuse failure (U4). Inverted signal.
SYN1-VTSU	Internal fuse failure detection or configured to a binary input indicating external fuse failure of the UL1, UL2, UL3 line-side voltage. Blocks the energizing function.

<b>Output signals</b>	<b>Description</b>
SYN1-VSUB1	Signal for indication of voltage selection from Bus 1 voltage.
SYN1-VSUB2	Signal for indication of voltage selection from Bus 1 voltage.

**Phasing and synchrocheck, double circuit breaker**

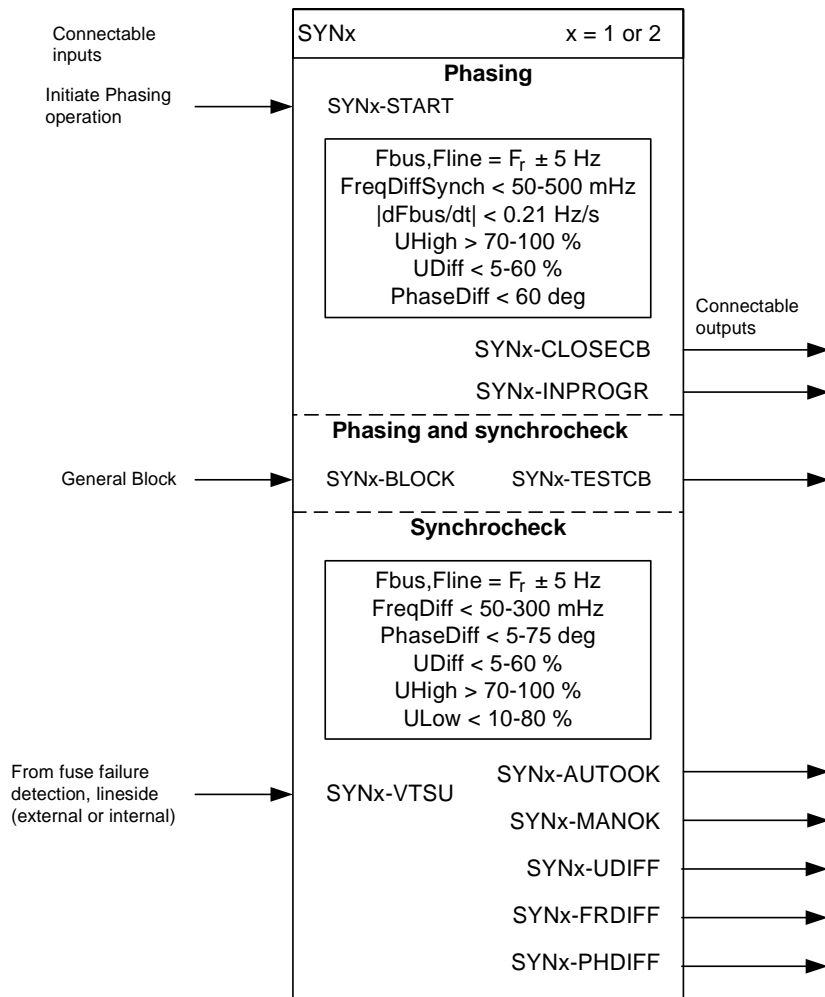

en01000119.vsd

Figure 178: Input and output signals.

**Phasing and synchrocheck**

Description of input and output signals for the phasing and synchrocheck function.

<b>Input signals</b>	<b>Description</b>
SYNx-BLOCK	General block input from any external condition, that should block the phasing and the synchrocheck.
SYNx-VTSU	The SYNC function cooperates with the FUSE-VTSU connected signal, which is the built-in optional fuse failure detection. It can also be connected to external condition for fuse failure. This is a blocking condition for the energizing function.
SYNx-UB1FF	External fuse failure input from busbar voltage Bus 1 (U5). This signal can come from a tripped fuse switch (MCB) on the secondary side of the voltage transformer. In case of a fuse failure the energizing check is blocked.
SYNx-UB1OK	No external voltage fuse failure (U5). Inverted signal.
SYNx-START	The signal initiates the phasing operation. When initiated the function continues until the SYNx-CLOSECB pulse is submitted or it is stopped by the SYNx-BLOCK signal. In test mode SYNx-TESTCB ends the phasing operation.
<b>Output signals</b>	<b>Description</b>
SYNx-TESTCB	Output when the function is in test mode. In test mode a complete phasing sequence is performed except for closing of the circuit breaker. The output signal SYNx-TESTCB indicates when the SYNx-CLOSECB signal would have been submitted from the phasing function or when the conditions for paralleling are fulfilled, from the synchro-check function.
SYNx-CLOSECB	Close breaker command from phasing. Used to control the circuit breaker or to be connected to the auto-reclosing function.
SYNx-INPROGR	The signal is high when a phasing operation is in progress, i.e from the moment a SYNx-START is received until the operation is terminated. The operation is terminated when SYNx-CLOSECB or SYNx-TESTCB has been submitted or if a SYNx-BLOCK is received.
SYNx-AUTOOK	Synchrocheck/energizing OK. The output signal is high when the synchrocheck conditions set on the HMI are fulfilled. It can also include the energizing condition, if selected. The signal can be used to release the autorecloser before closing attempt of the circuit breaker. It can also be used as a free signal.



Output signals	Description
SYNx-MANOK	Same as above but with alternative settings of the direction for energizing to be used during manual closing of the circuit breaker.
SYNx-UDIFF	Difference in voltage is less than the set difference limit.
SYNx-FRDIFF	Difference in frequency is less than the set difference limit.
SYNx-PHDIFF	Difference in phase angle is less than the set difference limit.

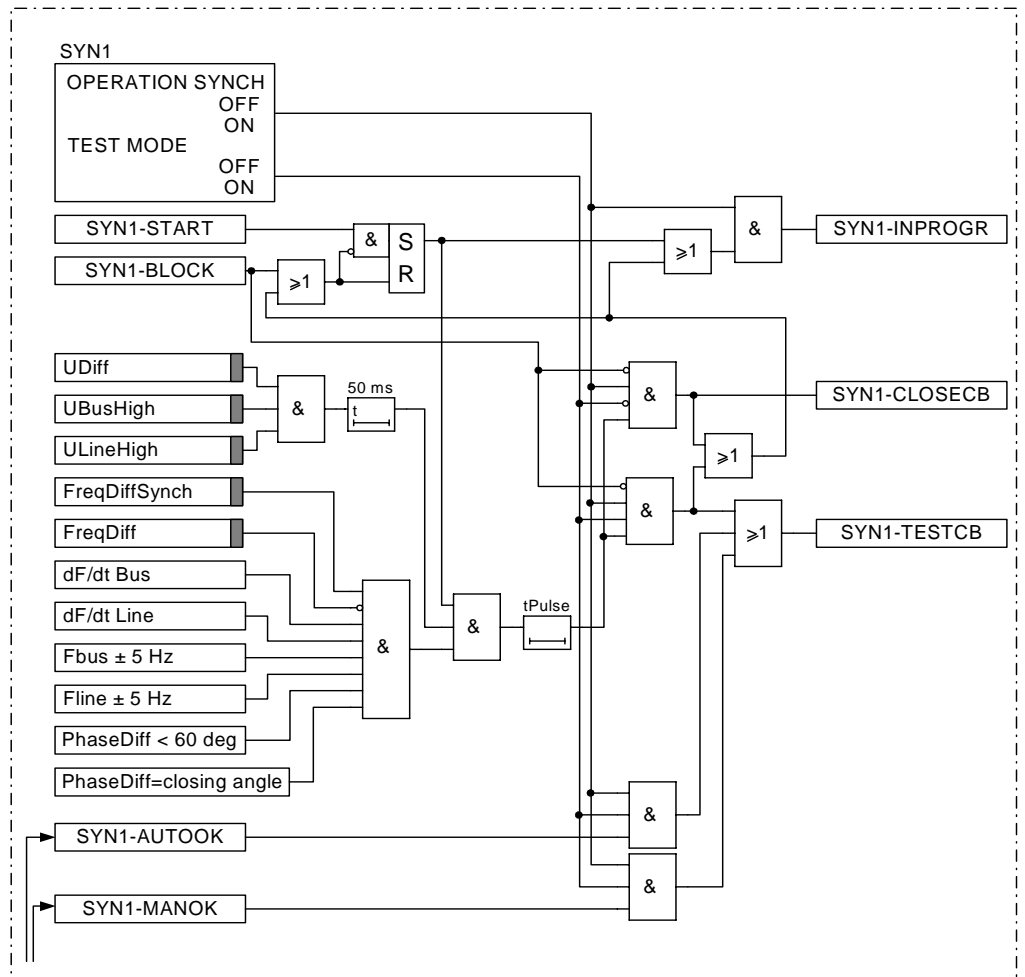

99000090.vsd

Figure 179: Simplified logic diagram - Phasing. The input signals SYN1-AUTOOK and SYN1-MANOK derive from the synchrocheck and energizing logic.

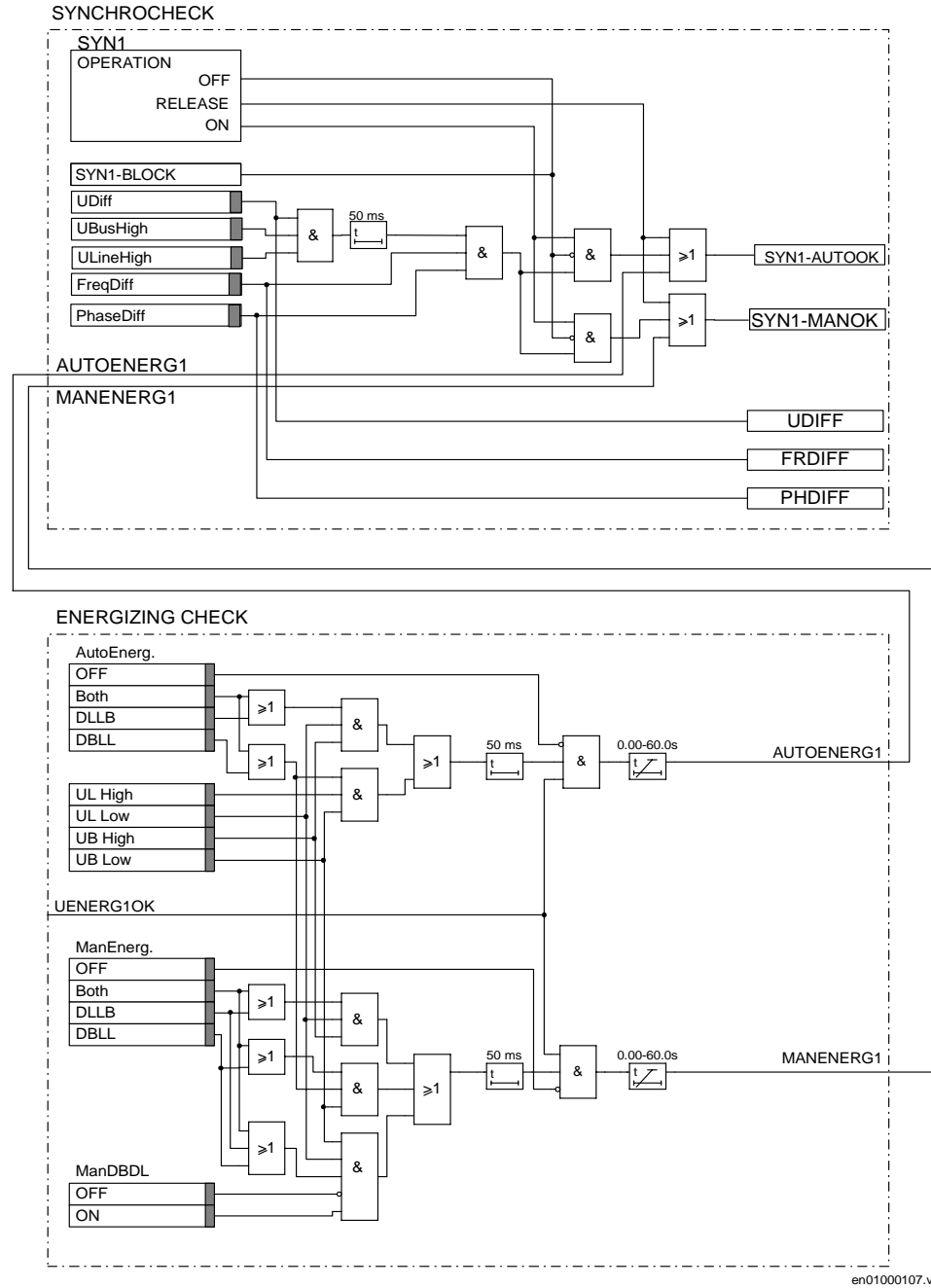

Figure 180: Simplified logic diagram - Synchrocheck and energizing check for one circuit breaker. The internal signal UENERG1OK derives from the external or internal fuse failure inputs SYN1-UB1OK/FF and SYN1-VTSU.

**1.3****Calculations**

The setting parameters are accessible through the HMI. The parameters for the synchrocheck function are found in the HMI tree under:

**Settings****Functions****Group n****SynchroCheck****SynchroCheck n (n=1-3)**

(The number of Synchro Check functions is dependent of the version)

Comments regarding settings.

**Operation**

Off/Release/On

- Off        The synchrocheck function is disabled and the output is low.
- Release    There are fixed, high output signals  $SYN_x-AUTOOK = 1$  and  $SYN_x-MANOK = 1$ .
- On        The function is in service and the output signal depends on the input conditions.

**Input phase**

The measuring phase of the UL1, UL2, UL3 line voltage, which can be of a single-phase (phase-neutral) or two-phases (phase-phase). (Only available in terminals intended for one bay).

**UMeasure**

Selection of single-phase (phase-neutral) or two-phase (phase-phase) measurement. (Only available in terminals intended for several bays).

**PhaseShift**

This setting is used to compensate for a phase shift caused by a line transformer between the two measurement points for UBus and ULine. The set value is added to the measured phase difference. The bus voltage is reference voltage.

**URatio**

The URatio is defined as  $URatio = U_{Bus}/U_{Line}$ . A typical use of the setting is to compensate for the voltage difference caused if one wishes to connect the UBus phase-phase and ULine phase-neutral. The “Input phase”-setting should then be set to phase-phase and the “URatio”-setting to  $\sqrt{3}=1.732$ . This setting scales up the line voltage to equal level with the bus voltage.

**USelection**

Selection of single or double bus voltage-selection logic.

**AutoEnerg and ManEnerg**

Two different settings can be used for automatic and manual closing of the circuit breaker.

Off	The energizing function is disabled
DLLB	The line voltage U-line is low, below (10-80% U1b) and the bus voltage U-bus is high, above (70-100% U1b).
DBLL	The bus voltage U-bus is low, below (10-80% U1b) and the line voltage U-line is high, above (70-100% U1b).
Both	Energizing can be done in both directions, DLLB or DBLL.
tAutoEnerg	The required consecutive time of fulfillment of the energizing condition to achieve SYN1-AUTOOK.
tManEnerg	The required consecutive time of fulfillment of the energizing condition to achieve SYN1-MANOK.

**ManDBDL**

If the parameter is set to “On”, closing is enabled when Both U-Line and U-bus are below ULow and ManEnerg is set to “DLLB”, “DBLL” or “Both”.

The setting parameters are accessible through the HMI. The parameters for the synchrocheck function are found in the HMI tree under:

**Settings****Functions****Group n****SynchroCheck****SynchroCheck n (n=1-4)**

(The number of SynchroCheck settings is dependent of the version)

Comments regarding settings.

**Operation**

Off/Release/On

Off	The synchrocheck function is disabled and the output is low.
Release	There are fixed, high output signals SYN1-AUTOOK = 1 and SYN1-MANOK = 1.
On	The function is in service and the output signal depends on the input conditions.

**Input phase**

The measuring phase of the UL1, UL2, UL3 line voltage, which can be of a single-phase (phase-neutral) or two-phases (phase-phase). (Only available in terminals intended for one bay).

**UMeasure**

Selection of single-phase (phase-neutral) or two-phase (phase-phase) measurement. (Only available in terminals intended for several bays).

**PhaseShift**

This setting is used to compensate for a phase shift caused by a line transformer between the two measurement points for UBus and ULine. The set value is added to the measured phase difference. The bus voltage is reference voltage.

**URatio**

The URatio is defined as  $URatio = UBus / ULine$ . A typical use of the setting is to compensate for the voltage difference caused if one wishes to connect the UBus phase-phase and ULine phase-neutral. The "Input phase"-setting should then be set to phase-phase and the "URatio"-setting to  $\sqrt{3} = 1.732$ . This setting scales up the line voltage to equal level with the bus voltage.

**AutoEnerg and ManEnerg**

Two different settings can be used for automatic and manual closing of the circuit breaker.

Off	The energizing function is disabled.
DLLB	The line voltage U-line is low, below (10-80% U1b) and the bus voltage U-bus is high, above (70-100% U1b).
DBLL	The bus voltage U-bus is low, below (10-80% U1b) and the line voltage U-line is high, above (70-100% U1b).
Both	Energizing can be done in both directions, DLLB or DBLL.
tAutoEnerg	The required consecutive time of fulfillment of the energizing condition to achieve SYN1-AUTOOK.
tManEnerg	The required consecutive time of fulfillment of the energizing condition to achieve SYN1-MANOK.

**ManDBDL**

If the parameter is set to “On”, closing is enabled when Both U-Line and U-bus are below ULow and ManEnerg is set to “DLLB”, “DBLL” or “Both”.

The setting parameters are accessible through the HMI. The parameters for the phasing and synchrocheck function are found in the MMI tree under:

**Settings****Functions****Group n (n=1-4)****SynchroCheck****SynchroCheck1****Operation**

Off	The synchrocheck function is disabled and the output is low.
Release	There are fixed, high output signals SYN1-AUTOOK = 1 and SYN1-MANOK = 1.
On	The synchro-check function is in service and the output signal depends on the input conditions.

**Input phase**

The measuring phase of the UL1, UL2, UL3 line voltage, which can be of a single-phase (phase-neutral) or two-phases (phase-phase).

**PhaseShift**

This setting is used to compensate for a phase shift caused by a line transformer between the two measurement points for UBus and ULine. The set value is added to the measured phase difference. The bus voltage is reference voltage.

**URatio**

The URatio is defined as  $URatio = UBus / ULine$ . A typical use of the setting is to compensate for the voltage difference caused if wished to connect the UBus phase-phase and ULine phase-neutral. The “Input phase”-setting should then be set to phase-phase and the “URatio”-setting to  $\sqrt{3} = 1.732$ . This setting scales up the line voltage to equal level with the bus voltage.

**USelection**

Selection of single or double bus voltage-selection logic.

**AutoEnergy and ManEnergy**

Two different settings can be used for automatic and manual closing of the circuit breaker.

Off	The energizing condition is not used, only the synchro-check.
DLLB	The line voltage U-line is low, below (10-80% U1b) and the bus voltage U-bus is high, above (70-100% U1b).
DBLL	The bus voltage U-bus is low, below (10-80% U1b) and the line voltage U-line is high, above (70-100% U1b).
Both	Energizing can be done in both directions, DLLB or DBLL.
tAutoEnergy	The required consecutive time of fulfillment of the energizing condition to achieve SYN1-AUTOOK.
tManEnergy	The required consecutive time of fulfillment of the energizing condition to achieve SYN1-MANOK.

**ManDBDL**

If the parameter is set to “On”, closing is enabled when Both U-Line and U-bus are below ULow and ManEnergy is set to “DLLB”, “DBLL” or “Both”.

**OperationSynch**

Off	The phasing function is disabled and all outputs are low.
On	The phasing function is in service and the output signals depends on the input conditions.

**ShortPulse**

Off	The closing pulse issued to the circuit breaker will be of length=tPulse.
On	The closing pulse issued to the circuit breaker will be of length=one cycle time in the internal logic.

The setting parameters are accessible through the HMI. The parameters for the synchro-check function are found in the MMI tree under:

**Settings****Functions****Group n (n=1-4)****SynchroCheck****SynchroCheck1 (and 2)****Operation**

Off	The function is disabled and the output is low.
Release	There are fixed, high output signals SYN1-AUTOOK = 1 and SYN1-MANOK = 1.
On	The function is in service and the output signal depends on the input conditions.

**Input phase**

The measuring phase of the UL1, UL2, UL3 line voltage, which can be of a single-phase (phase-neutral) or two-phases (phase-phase).

**PhaseShift**

This setting is used to compensate for a phase shift caused by a power transformer between the two measurement points for UBus and ULine. The set value is added to the measured phase difference. The bus voltage is reference voltage.



**URatio**

The URatio is defined as  $URatio = U_{Bus}/U_{Line}$ . A typical use of the setting is to compensate for the voltage difference if UBus phase-phase and ULine phase-neutral is used. The “Input phase”-setting should then be set to phase-phase and the “URatio”-setting to  $\sqrt{3}=1.732$ . This setting scales up the line voltage to equal level with the bus voltage.

**AutoEnergy and ManEnergy**

Two different settings can be used for automatic and manual closing of the circuit breaker.

Off	The energizing condition is not used only the synchro-check.
DLLB	The line voltage U-line is low, below (10-80% U1b) and the bus voltage U-bus is high, above (70-100% U1b).
DBLL	The bus voltage U-bus is low, below (10-80% U1b) and the line voltage U-line is high, above (70-100% U1b).
Both	Energizing can be done in both directions, DLLB or DBLL.
tAutoEnergy	The required consecutive time of fulfilment of the energizing condition to achieve SYN1-AUTOOK.
tManEnergy	The required consecutive time of fulfilment of the energizing condition to achieve SYN1-MANOK.

**ManDBDL**

If the parameter is set to “On”, closing is enabled when Both U-Line and U-bus are below ULow and ManEnergy is set to “DLLB”, “DBLL” or “Both”.

**OperationSynch**

Off	The phasing function is disabled and all outputs are low.
On	The phasing function is in service and the output signals depends on the input conditions.

**ShortPulse**

Off	The closing pulse issued to the circuit breaker will be of length=tPulse.
On	The closing pulse issued to the circuit breaker will be of length=one cycle time in the internal logic.

---

## 2 Automatic reclosing function (AR)

### 2.1 Application

Automatic reclosing (AR) is a well-established method to restore the service of a power line after a transient line fault. The majority of line faults are flashover arcs, which are transient by nature. When the power line is switched off by operation of line protection and line breakers, the arc de-ionises and recovers voltage withstand at a somewhat variable rate. So a certain line dead time is needed. But then line service can resume by the auto-reclosing of the line breakers. Select the length of the dead time to enable good probability of fault arc de-ionisation and successful reclosing.

For the individual line breakers and auto-reclosing equipment, the Auto-reclose open time (AR open time) expression is used. At simultaneous tripping and reclosing at the two line ends, Auto-reclose open time equals approximately the dead time of the line. Otherwise these two times may differ.

In case of a permanent fault, the line protection trips again at reclosing to clear the fault.

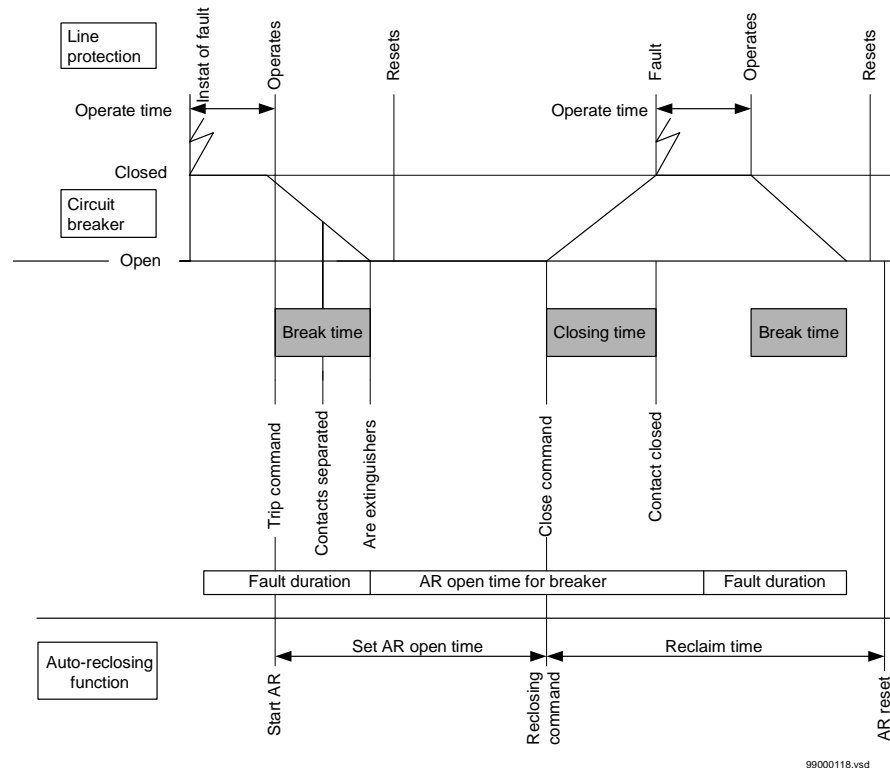

Figure 181: Single-shot auto-reclosing at a permanent fault

In a bay with one circuit breaker only one terminal is normally provided with one AR function.

Single-phase tripping and single-phase reclosing is a way to limit the effect of a single-phase line fault to system operation. Especially at higher voltages, the majority of line faults are of the single-phase type. The method is of particular value to maintain system stability in systems with limited meshing or parallel routing. It requires individual operation of each phase of the breakers, which is common at the higher transmission voltages.

A somewhat longer dead time may be required at single-phase reclosing compared to high-speed three-phase reclosing, due to influence on the fault arc from voltage and current of the non-tripped phases.

There is also a possibility to trip and reclose two of the circuit breaker poles, in case of faults when two out of the three phases are involved and parallel lines are in service. This type of faults is less common compared to single phase to earth faults, but more common than three phase faults.

In order to maximize the availability of the power system there is a possibility to chose single pole tripping and auto-reclosing at single phase faults, two pole tripping and auto-reclosing at faults involving two phases and three pole tripping and auto-reclosing at three phase faults.

During the single pole open time there will be an equivalent “series”-fault in the system. As a consequence there will be a flow of zero sequence current. Therefor the residual current protections must be co-ordinated with the single pole tripping and auto-reclosing.

The reclosing function can be selected to perform single-phase, two-phase and/or three-phase reclosing from six single-shot to multiple-shot reclosing programs. The three-phase auto-reclose open time can be set to give either high-speed auto-reclosing (HSAR) or delayed auto-reclosing (DAR). In the reclosing programs the delayed auto-reclosing (DAR) is always a three pole trip and reclosing, even if the first high-speed reclosing is a single pole action.

## 2.2

### Functionality

The AR function is a logical function built up from logical elements. It operates in conjunction with the trip output signals from the line protection functions, the OK to close output signals from the synchrocheck and energizing check function, and binary input signals (for circuit breaker position/status, or from other external protection functions).

In the AR logic a number of parameters can be set to adjust the auto-reclosing function to the desired requirements. Examples are:

- Number of AR attempts
- AR programs
- Open times for different AR attempts

#### Start and control of the auto-reclosing

The automatic operation of the auto-reclosing function is controlled by the parameter *Operation* and the input signals as described above. When it is on, the AR01-SETON output is high (active). See Function block diagrams.

---

The auto-reclosing function is activated at a protection trip by the AR01-START input signal. At repeated trips, this signal is activated again to make the reclosing program continue.

There are a number of conditions for the start to be accepted and a new cycle started. After these checks, the start signal is latched in and the *Started* state signal is activated. It can be interrupted by certain events.

#### **Extended AR open time, shot 1**

The purpose of this function is to adapt the length of the AR Open time to the possibility of non-simultaneous tripping at the two line ends. If a permissive communication scheme is used and the permissive communication channel (for example, PLC, power-line carrier) is out of service at the fault, there is a risk of sequential non-simultaneous tripping. To ensure a sufficient line dead time, the AR open time is extended by 0.4 s. The input signal AR01-PLCLOST is checked at tripping. See Function block diagrams. Select this function (or not) by setting the Extended t1 parameter to On (or Off).

#### **Long trip signal**

During normal circumstances, the trip command resets quickly due to fault clearing. The user can set a maximum trip pulse duration by tTrip. At a longer trip signal, the AR open dead time is extended by Extend\_t1. If the Extended t1 = Off, a long trip signal interrupts the reclosing sequence in the same way as AR01-INHIBIT.

#### **Reclosing programs**

The reclosing programs can be performed with up to maximum four reclosing attempts (shots), selectable with the NoOfReclosing parameter. The first program is used at pure 3-phase trips of breakers and the other programs are used at 1-, 2- or 3-phase trips of breakers.

#### **3ph**

3-phase reclosing, one to four attempts (NoOfReclosing parameter). The output AR01-P3P is always high (=1).

A trip operation is made as a three-phase trip at all types of fault. The reclosing is as a three-phase reclosing in program 1/2/3ph, described below.

#### **1/2/3ph**

1-phase, 2-phase or 3-phase reclosing in the first shot.

For the example, one-shot reclosing for 1-phase, 2-phase or 3-phase, see Figures in Function block diagrams. Here, the AR function is assumed to be On and Ready. The breaker is closed and the operation gear ready (manoeuvre spring charged etc.). Only the 1-phase and 3-phase cases are described.

AR01-START is received and sealed-in at operation of the line protection. The AR01-READY output is reset (Ready for a new AR cycle).

If AR01-TR2P (2-phase trip) is low and AR01-TR3P (3-phase trip) is:

- low, the timer for 1-phase reclosing open time  $t1$  1Ph is started and the AR01-1PT1 output (auto-reclosing 1-phase, shot 1, in progress) is activated. It can be used to suppress Pole disagreement and Earth-fault protection during the 1-phase open interval.
- high, the timer for 3-phase AR open time,  $t1$ , is started (instead of  $t1$  1Ph) and AR01-T1 is set (auto-reclosing 3-phase, shot 1, in progress). While either  $t1$  1Ph or  $t1$  is running, the output AR01-INPROGR is activated.

Immediately after the start-up of the reclosing and tripping of the breaker, the input (see Function block diagrams) AR01-CBCLOSED is low (possibly also AR01-CBREADY at type OCO). The AR Open-time timer,  $t1$  1Ph or  $t1$ , keeps on running.

At the end of the set AR open time,  $t1$  1Ph or  $t1$ , the respective SPTO or TPTO (single-phase or three-phase AR time-out, see Function block diagrams) is activated and goes on to the output module for further checks and to give a closing command to the circuit breaker.

At any kind of trip, the operation is as already described, program 1/2/3ph. If the first reclosing attempt fails, a 3-phase trip will be issued and 3-phase reclosings can follow, if selected. Maximum three additional attempts can be done (according to the NoOfReclosing parameter).

#### **1/2ph**

1-phase or 2-phase reclosing in the first shot.

At 1-phase or 2-phase trip, the operation is as in above described example, program **1/2/3ph**. If the first reclosing attempt fails, a 3-phase trip will be issued and 3-phase reclosings can follow, if selected. Maximum three additional attempts can be done (according to the NoOfReclosing parameter).

At 3-phase trip, TR2P low and TR3P high, the AR will be blocked and no reclosing takes place.

#### **1ph + 1\*2ph**

1-phase or 2-phase reclosing in the first shot.

At 1-phase trip (TR2P low and TR3P low), the operation is as in above described example, program 1/2/3ph. If the first reclosing attempt fails, a 3-phase trip will be issued and 3-phase reclosings can follow, if selected. Maximum three additional attempts can be done (according to the NoOfReclosing parameter).

At 2-phase trip (TR2P high and TR3P low), the operation is similar as above. But, if the first reclosing attempt fails, a 3-phase trip will be issued and the AR will be blocked. No more attempts take place!

At 3-phase trip, TR2P low and TR3P high, the AR will be blocked and no reclosing takes place.

#### **1/2ph + 1\*3ph**

1-phase, 2-phase or 3-phase reclosing in the first shot.

At 1-phase or 2-phase trip, the operation is as described above. If the first reclosing attempt fails, a 3-phase trip will be issued and 3-phase reclosings can follow, if selected. Maximum three additional attempts can be done (according to the NoOfReclosing parameter).

At 3-phase trip, the operation is similar as above. But, if the first reclosing attempt fails, a 3-phase trip will be issued and the AR will be blocked. No more attempts take place!

#### **1ph + 1\*2/3ph**

1-phase, 2-phase or 3-phase reclosing in the first shot.

At 1-phase trip, the operation is as described above. If the first reclosing attempt fails, a 3-phase trip will be issued and 3-phase reclosings can follow, if selected. Maximum three additional attempts can be done (according to the NoOfReclosing parameter).

At 2-phase or 3-phase trip, the operation is similar as above. But, if the first reclosing attempt fails, a 3-phase trip will be issued and the AR will be blocked. No more attempts take place!

**Table 13: Type of reclosing for different programs**

<b>Program</b>	<b>1st attempt</b>	<b>2-4th attempt</b>
3ph	3ph	3ph
1/2/3ph	1ph	3ph
	2ph	3ph
	3ph	3ph
1/2ph	1ph	3ph

Program	1st attempt	2-4th attempt
	2ph	3ph
	No 3ph reclosing	No 3ph reclosing
1ph + 1*2ph	1ph	3ph
	2ph	No
	No 3ph reclosing	No 3ph reclosing
1/2ph + 1*3ph	1ph	3ph
	2ph	3ph
	3ph	No
1ph + 1*2/3ph	1ph	3ph
	2ph	No
	3ph	No

#### Blocking of a new reclosing cycle

A new start of a reclosing cycle is blocked for the reclaim time after the selected number of reclosing attempts are performed.

#### Reclosing checks and Reclaim timer

An AR open-time time-out signal is received from a program module. At three-phase reclosing, a synchro-check and/or energising check or voltage check can be used. It is possible to use an internal or an external synchro-check function, configured to AR01-SYNC. If a reclosing without check is preferred, configure the input AR01-SYNC to FIXD-ON (set to 1).

Another possibility is to set the output from the internal synchro-check function to a permanently active signal. Set Operation = Release in the synchro-check function. Then AR01-SYNC is configured to SYNx-AUTOOK.

At confirmation from the synchro-check or if the reclosing is of single-phase type, the signal passes on.

At AR01-CBREADY signal of the Close-Open (CO) type, it is checked that this signal is present to allow a reclosing.

The synchrocheck and energizing check must be fulfilled within a certain period of time, tSync. If it does not, or if the other conditions are not fulfilled, the reclosing is interrupted and blocked.



---

The Reclaim-timer defines a period from the issue of a reclosing command, after which the reclosing function is reset. Should a new trip occur within this time, it is treated as a continuation of the first fault. When a closing command is given (Pulse AR), the reclaim timer is started.

There is an AR State Control, see Function block diagrams, to track the actual state in the reclosing sequence.

#### **Pulsing of CB closing command**

The circuit breaker closing command, AR01-CLOSECB, is made as a pulse with a duration, set by the tPulse parameter. For circuit breakers without an anti-pumping function, the closing-pulse-cutting described below can be used. It is selected by means of the CutPulse parameter (set to On). In case of a new trip pulse, the closing pulse will be cut (interrupted). But the minimum length of the closing pulse is always 50 ms.

At the issue of a reclosing command, the associated reclosing operation counter is also incremented. There is a counter for each type of reclosing and one for the total number of reclosings. See Function block diagrams.

#### **Transient fault**

After the reclosing command, the reclaim timer keeps running for the set time. If no tripping occurs within this time, tReclaim, the auto-reclosing function will be reset. The circuit breaker remains closed and the operating gear ready (manoeuvre spring is recharged). AR01-CBCLOSED = 1 and AR01-CBREADY = 1.

After the reclaim time, the AR state control resets to original rest state, with AR01-SETON = 1, AR01-READY = 1 and AR01-P1P = 1 (depending on the selected program). The other AR01 outputs = 0.

#### **Unsuccessful signal**

Normally the signal AR01-UNSUC appears when a new start is received after the last reclosing attempt has been made. See Function block diagrams. It can be programmed to appear at any stage of a reclosing sequence by setting the parameter *UnsucMode* = On. The UNSUC signal is attained after the time tUnsuc.

#### **Permanent fault**

If a new trip takes place after a reclosing attempt and a new AR01-START or AR01-TRSOTF signal appears, the AR01-UNSUC (Reclosing unsuccessful) is activated. The timers for the first reclosing attempt (t1 1Ph, t1 2Ph and t1) cannot be started.

Depending on the PulseCut parameter setting, the closing command may be shortened at the second trip command.

After time-out of the reclaim timer, the auto reclosing function resets, but the circuit breaker remains open (AR01-CBCLOSED = 0, AR01-CBREADY = 1). Thus the reclosing function is not ready for a new reclosing cycle. See Function block diagrams and Sequence examples.

#### **Automatic confirmation of programmed reclosing attempts**

The auto-recloser can be programmed to continue with reclosing attempts two to four (if selected) even if the start signals are not received from the protection functions, but the breaker is still not closed. See figure in Function block diagrams. This is done by setting the parameter *AutoCont* = On and the wait time *tAutoWait* to desired length.

## **2.3**

### **Calculations**

#### **2.3.1**

#### **Configuration and setting**

The signals are configured in the CAP 531 configuration tool.

The parameters for the auto-reclosing function are set through the local HMI at:

**Settings**

**Functions**

**Group n**

**AutoRecloser**

**AutoRecloser n**

#### **Recommendations for input signals**

See figure 182 and the default configuration for examples.

#### **AR01-START**

Should be connected to the protection function trip output which shall start the auto-recloser. It can also be connected to a binary input for start from an external contact. A logical OR gate can be used to multiply the number of start sources.

#### **AR01-ON and AR01-OFF**

May be connected to binary inputs for external control.

**AR01-INHIBIT**

Can be connected to binary inputs, to block the AR from a certain protection, such as a line connected shunt reactor, transfer trip receive or back-up protection or breaker-failure protection.

**AR01-CBCLOSED and AR01-CBREADY**

Must be connected to binary inputs, for pick-up of the breaker signals. If the external signals are of Breaker-not-ready type, uncharged etc., an inverter can be configured before CBREADY.

**AR01-SYNC**

Is connected to the internal synchro-check function if required. It can also be connected to a binary input. If neither internal nor external synchronising or energising check (dead line check) is required, it can be connected to a permanent 1 (high), by connection to FIXD-ON.

**AR01-PLCLOST**

Can be connected to a binary input, when required.

**AR01-TRSOTF**

Can be connected to the internal line protection, distance protection, trip switch-onto-fault.

**AR01-STTHOL**

Start of thermal overload protection signal. Can be connected to OVLD-TRIP to block the AR at overload.

**AR01-TR2P and AR01-TR3P**

Are connected to the function block TRIP or to binary inputs. The protection functions that give two-phase or three-phase trips are supposed to be routed via that function.

**Other**

The other input signals can be connected as required.

**Recommendations for output signals**

See figure 182 and the default configuration for examples.

**AR01-READY**

Can be connected to the Zone extension of a line protection. It can also be used for indication, if required.

**AR01-1PT1 and 2PT1**

1-phase and 2-phase reclosing in progress is used to temporarily block an Earth-fault protection and/or a Pole disagreement function during the 1-phase or 2-phase open intervals.

**AR01-CLOSECB**

Connect to a binary output relay for circuit breaker closing command.

**AR01-P3P**

Prepare 3-phase trip: Connect to TRIP-P3PTR.

**AR01-P1P**

Permit 1-phase trip: Can be connected to a binary output for connection to external protection or trip relays. In case of total loss of auxiliary voltage, the output relay drops and does not allow 1-phase trip. If needed to invert the signal, it can be made by a breaking contact of the output relay.

**Other**

The other output signals can be connected for indication, disturbance recording etc., as required.

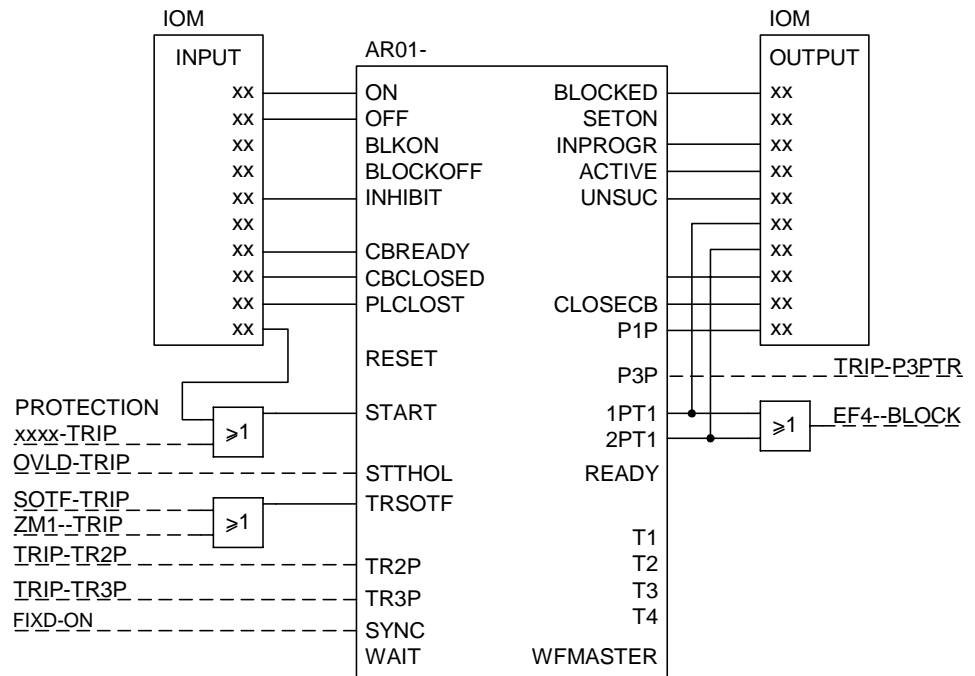

99000097.vsd

Figure 182: Recommendations for I/O-signal connections.

### Recommendations for multi-breaker arrangement

Sequential reclosing at multi-breaker arrangement is achieved by giving the two line breakers different priorities. Refer to figure 183. At single breaker application, *Priority* is set to *No*, and this has no influence on the function. The signal *Started* is sent to the next function module. At double breaker and similar applications, *Priority* is set *High* for the Master terminal and *Priority = Low* for the Slave.

While reclosing is in progress in the master, it issues the signal -WFMMASTER. A reset delay ensures that the -WAIT signal is kept high for the breaker closing time. After an unsuccessful reclosing, it is also maintained by the signal -UNSUC. For the slave terminal, the input signal -WAIT holds back a reclosing operation. A time  $t_{Wait}$  sets a maximum waiting time for the reset of the Wait signal. At time-out, it interrupts the reclosing cycle by a WM-INH, wait for master inhibit, signal.

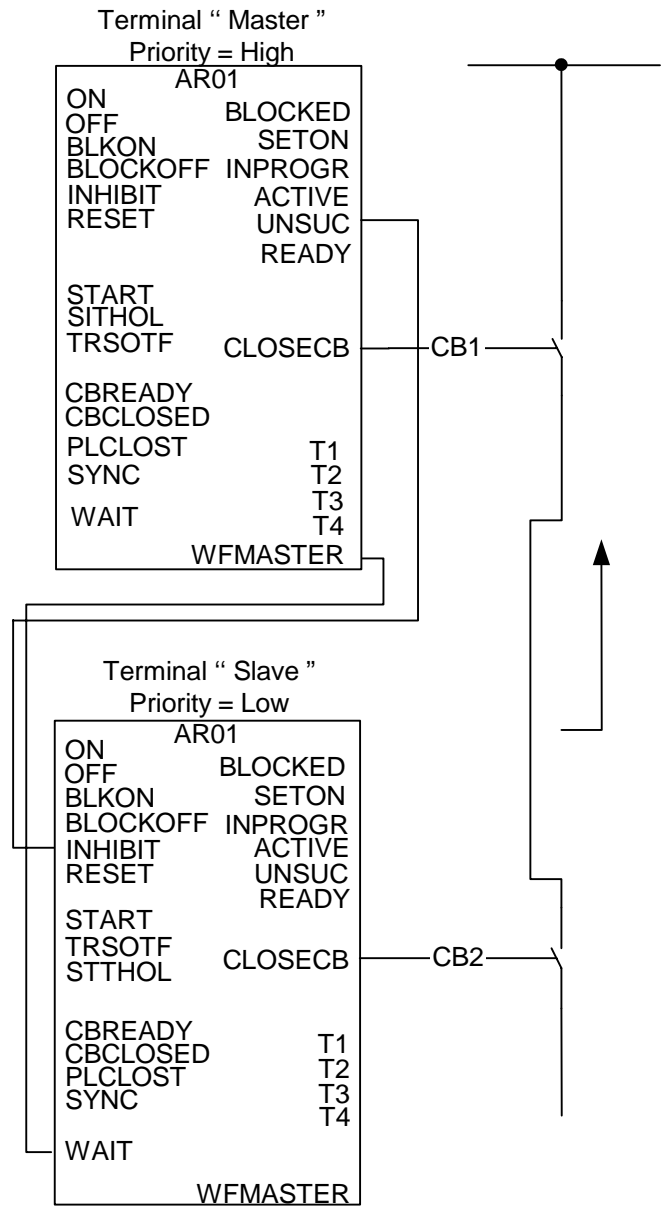

\*) Other input/output signals as in previous singel breaker arrangements

99000120.vsd

Figure 183: Additional input and output signals at multi breaker arrangement

### Settings

Number of reclosing attempts: 1 to 4 attempts can be chosen. In most cases 1 attempt is sufficient as the majority of arcing faults will cease after the first reclosing shot. In power systems with many faults caused by other phenomena than lightning, for example wind, it can be motivated with more than one reclosing attempt.

There are six different possibilities in the selection of reclosing programs. What type of first shot reclosing shall be made, and for which types of faults? In completely meshed power systems it is often acceptable to use three pole auto-reclosing for all fault types, as first shot. In power systems with few parallel paths single pole auto-reclosing should be considered, in order to avoid reclosing in a phase opposition situation. In such systems auto-reclosing should be allowed for single phase faults only. It must be remembered that there will be zero sequence current flow in the power system during the single pole reclosing open time.

If a permissive channel is used between the line ends, and the availability of the communication channel is considered to be low, extended dead time in case of loss of the channel should be used.

Due to the secondary arc at single pole trip and auto-reclosing, the extinguishing time for the arc will be longer than for three pole trip and auto-reclosing. Typical required dead time for single pole trip and reclosing: 800 ms. Typical required dead time for three pole trip and reclosing: 400 ms. Different local phenomena, such as moisture, salt, pollution, etc. can influence the required dead time. Different open time for first auto-reclosing shot can be chosen for single pole ( $t1$  1Ph), two pole ( $t1$  2PH) and three pole ( $t1$ ).

The open time for the three pole delayed auto-reclosing shots can be set individually ( $t2$ ,  $t3$  and  $t4$ ). This setting can in some cases be restricted by national regulations.

In case of reclosing based on synchrocheck a maximum wait time ( $tSync$ ) can be set. If the synchrocheck does not allow reclosing within this set time there will be no autoreclosing. This setting must be matched against the setting of the synchrocheck function. The operate time of the synchrocheck is mainly dependent on the setting angle difference. A typical operation time is about 200 ms. If the system will start to oscillate during the dead time, there can be some time before the synchronising quantities can be accepted for reclosing. This can be checked by means of dynamic simulations. As a base recommendation  $tSync$  can be set to 2.0 s.

The breaker closing pulse length ( $tPulse$ ) can be chosen with some margin longer than the shortest allowed pulse for the breaker (see breaker data).

The  $tReclaim$  setting must be chosen so that all autoreclosing shots can be completed.

---

The setting  $t_{\text{Trip}}$  is used for blocking of autoreclosing in case of long trip duration. This can be the consequence of an unwanted permanent trip signal or a breaker failure.

In case of two or more autoreclosing modules only one shall be chosen as master (priority high). The others should have priority low. In case of one breaker only none priority is chosen.



### 3 Single command (CD)

#### 3.1 Application

The terminals may be provided with a function to receive signals either from a substation automation system or from the local human-machine interface, HMI. That receiving function block has outputs that can be used, for example, to control high voltage apparatuses in switchyards. For local control functions, the local HMI can also be used. Together with the configuration logic circuits, the user can govern pulses or steady output signals for control purposes within the terminal or via binary outputs.

Figure 184 shows an application example of how the user can, in an easy way, connect the command function via the configuration logic circuit to control a high-voltage apparatus. This type of command control is normally performed by a pulse via the binary outputs of the terminal. Figure 184 shows a close operation, but an open operation is performed in a corresponding way without the synchro-check condition.

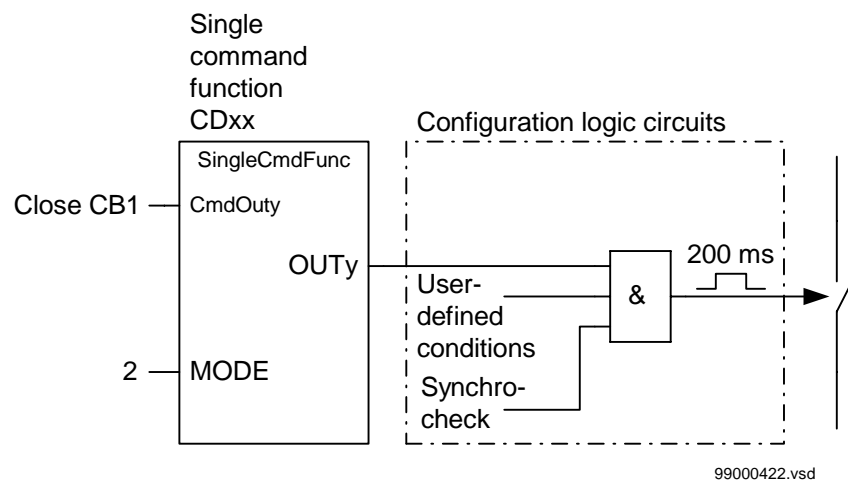

Figure 184: Application example showing a logic diagram for control of a circuit breaker via configuration logic circuits

Figure 185 and figure 186 show other ways to control functions, which require steady On/Off signals. The output can be used to control built-in functions or external equipment.

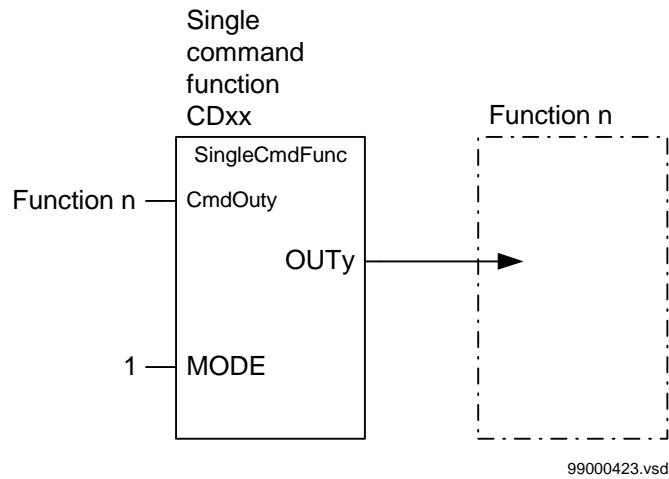

Figure 185: Application example showing a logic diagram for control of built-in functions

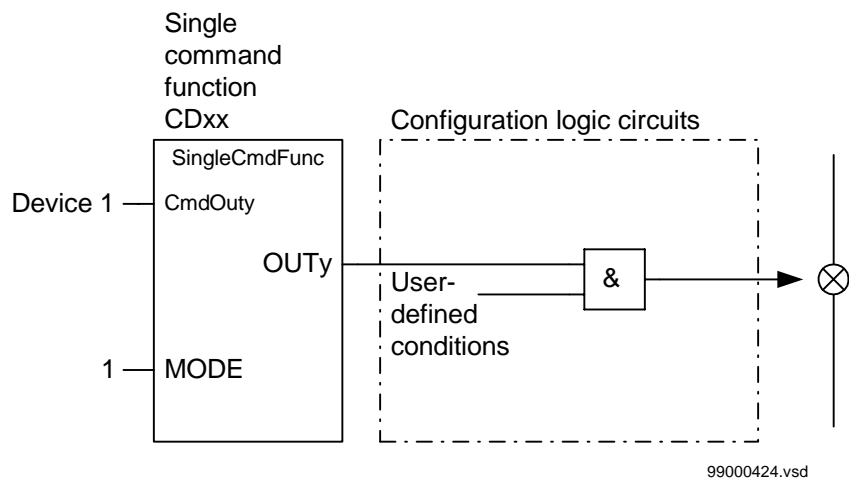

Figure 186: Application example showing a logic diagram for control of external equipment via configuration logic circuits

### 3.2

#### Design

The single command function consists of one function block, CD01 for 16 binary output signals. For REC 561, the single command function consists of eleven function blocks, CD01-CD11 for 16 binary output signals.

---

The output signals can be of the types Off, Steady, or Pulse. The setting is done on the MODE input, common for the whole block, from the CAP 531 configuration tool.

- 0 = Off sets all outputs to 0, independent of the values sent from the station level, that is, the operator station or remote-control gateway.
- 1 = Steady sets the outputs to a steady signal 0 or 1, depending on the values sent from the station level.
- 2 = Pulse gives a pulse with one execution cycle duration, if a value sent from the station level is changed from 0 to 1. That means that the configured logic connected to the command function block may not have a cycle time longer than the execution cycle time for the command function block.

The outputs can be individually controlled from the operator station, remote-control gateway, or from the local HMI. Each output signal can be given a name with a maximum of 13 characters from the CAP 531 configuration tool.

The output signals, here OUT1 to OUT16, are then available for configuration to built-in functions or via the configuration logic circuits to the binary outputs of the terminal.

### 3.3

### Calculations

#### 3.3.1

#### Setting

The setting parameters for the single command function are set from the CAP 531 configuration tool.

Parameters to be set are MODE, common for the whole block, and CmdOuty - including the name for each output signal. The MODE input sets the outputs to be one of the types Off, Steady, or Pulse.

---

## 4 Multiple command (CM)

### 4.1 Application

The terminals may be provided with a function to receive signals either from a substation automation system or from other terminals via the interbay bus. That receiving function block has 16 outputs that can be used, together with the configuration logic circuits, for control purposes within the terminal or via binary outputs. When it is used to communicate with other terminals, these terminals have a corresponding event function block to send the information.

### 4.2 Design

#### General

One multiple command function block CM01 with fast execution time also named *Binary signal interbay communication, high speed* and/or 79 multiple command function blocks CM02-CM80 with slower execution time are available in the REx 5xx terminals as options. For REC 561 the seventy-nine multiple command function blocks CM02-CM80 with slow execution time is included in basic.

The output signals can be of the types Off, Steady, or Pulse. The setting is done on the MODE input, common for the whole block, from the CAP 531 configuration tool.

- 0 = Off sets all outputs to 0, independent of the values sent from the station level, that is, the operator station or remote-control gateway.
- 1 = Steady sets the outputs to a steady signal 0 or 1, depending on the values sent from the station level.
- 2 = Pulse gives a pulse with one execution cycle duration, if a value sent from the station level is changed from 0 to 1. That means that the configured logic connected to the command function blocks may not have a cycle time longer than the execution cycle time for the command function block.

The multiple command function block has 16 outputs combined in one block, which can be controlled from the operator station or from other terminals. One common name for the block, with a maximum of 19 characters, is set from the configuration tool CAP 531.

The output signals, here OUT1 to OUT16, are then available for configuration to built-in functions or via the configuration logic circuits to the binary outputs of the terminal.

### Binary signal interbay communication

The multiple command function block can also be used to receive information over the LON bus from other REx 5xx terminals. The most common use is to transfer interlocking information between different bays. That can be performed by an Event function block as the send block and with a multiple command function block as the receive block. The configuration for the communication between terminals is made by the LON Network Tool.

The MODE input is set to Steady at communication between terminals and then the data are mapped between the terminals.

The command function also has a supervision function, which sets the output VALID to 0 if the block did not receive data within an INTERVAL time, that could be set. This function is applicable only during communication between terminals over the LON bus. The INTERVAL input time is set a little bit longer than the interval time set on the Event function block (see the document Event function). If INTERVAL=0, then VALID will be 1, that is, not applicable.

## 4.3

### Calculations

#### 4.3.1

#### Settings

The setting parameters for the multiple command function are set from the CAP 531 configuration tool.

The multiple command function has a common name setting (CmdOut) for the block. The MODE input sets the outputs to be one of the types Off, Steady, or Pulse. INTERVAL is used for the supervision of the cyclical receiving of data.



# Chapter 10 Logic

## **About this chapter**

This chapter describes the logic functions.

# 1 Trip logic (TR)

## 1.1 Application

All trip signals from the different protection functions shall be routed through the trip logic. In its most simple alternative the logic will only link the trip signal and assure a sufficient duration of the trip signal.

To meet the different single, double, 1 and 1/2 or other multiple circuit breaker arrangements, one or more identical TR function blocks may be provided within a single terminal. The actual number of these TR function blocks that may be included within any given terminal depends on the type of terminal. Therefore, the specific circuit breaker arrangements that can be catered for, or the number of bays of a specific arrangement that can be catered for, depends on the type of terminal.

One TR function block should be used for each breaker, if the line is connected to the substation via more than one breaker. Assume that single pole tripping and auto-reclosing is used for the line. The breaker chosen as master must in that case have single pole tripping, while the slave breaker could have three pole tripping and auto-reclosing. In case of a permanent fault only one of the breakers has to be operated at the second energising of the fault. In case of a transient fault the slave breaker reclosing is made as a three pole reclosing onto the non-faulted line.

The same philosophy can be used for two-pole tripping and auto-reclosing.

## 1.2 Functionality

The minimum duration of a trip output signal from the TR function is 150ms. This is to secure the fault clearance.

The three-pole TR function has a single input through which all trip output signals from the protection functions within the terminal, or from external protection functions via one or more of the terminal's binary inputs, are routed. It has a single trip output for connection to one or more of the terminal's binary outputs, as well as to other functions within the terminal requiring this signal.

In case of multi-breaker arrangement, one TR function block can be used for each breaker, if the breaker functions differ. This can be the case if single pole trip and auto-reclosing is used.



---

## 2 Pole discordance protection (PD)

### 2.1 Application

Circuit breaker pole position discordance can occur on the operation of a breaker with independent operating gears for the three poles. The reason may be an interruption in the trip coil circuits, or a mechanical failure resulting in a stuck breaker pole. A pole discordance can be tolerated for a limited time, for instance during a single-phase trip-auto-reclose cycle.

The pole discordance logic (PD) detects a breaker pole position discrepancy not generated by a single pole reclosing and generates a three phase command trip to the circuit breaker itself.

### 2.2 Functionality

#### 2.2.1 Functionality for contact based pole discordance

The operation of the contact based pole discordance logic is based on checking the position of the circuit breaker through six of its auxiliary contacts: three parallel connected normally open contacts are connected in series with three parallel connected normally closed contacts. This hard-wired logic is very often integrated in the circuit breaker control cabinets and gives a closed signal in case of pole discordance in the circuit breaker. This signal is connected to the PD---POLDISC input of the pole discordance function. If the function is enabled, after a short delay, the activation of this input causes a trip command (PD---TRIP).

Figure 187 shows the typical application connection for the contact based pole discordance function.

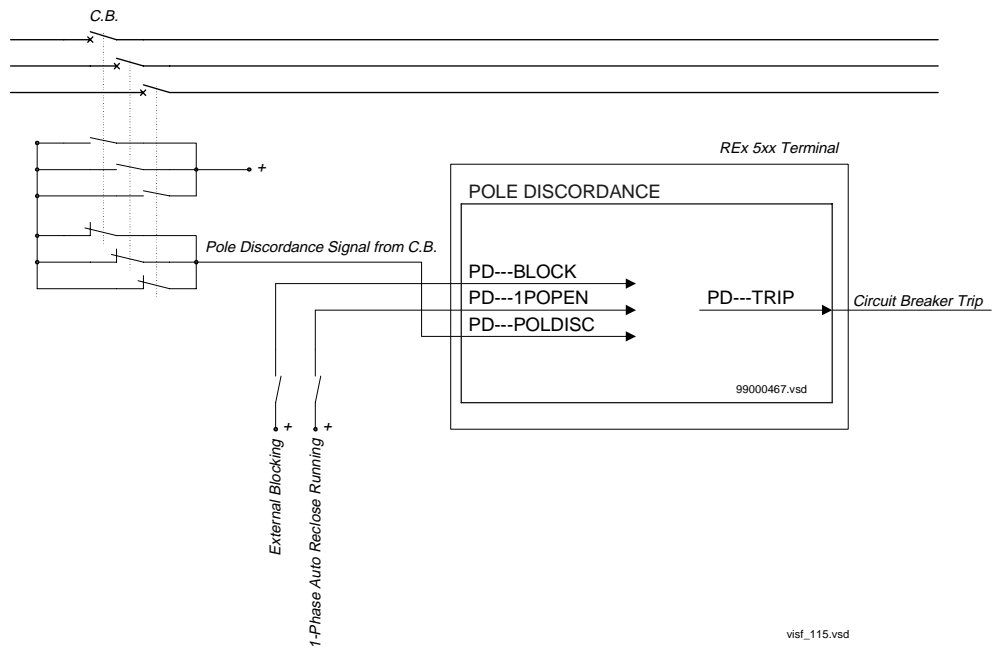

Figure 187: Typical connection diagram for pole discordance function - contact based

### 2.3

#### Design

The simplified logic diagram of the contact based pole discordance logic is shown in figure 188.

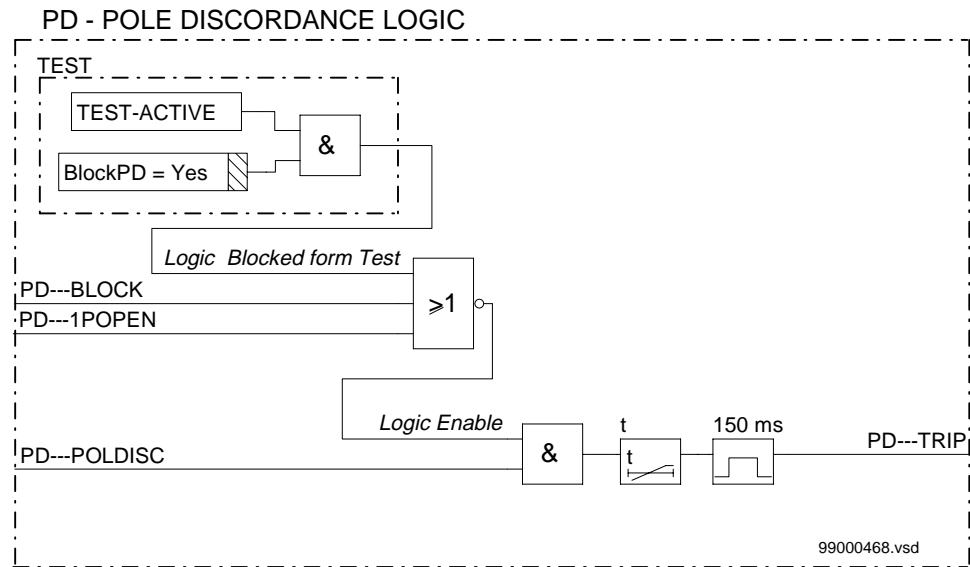

Figure 188: Simplified logic diagram of pole discordance logic - contact based

The pole discordance logic is disabled if:

- The terminal is in TEST status (TEST-ACTIVE is high) and the function has been blocked from the HMI (BlockPD=Yes)
- The input signal PD---BLOCK is high
- The input signal PD---1POPEN is high

The PD---BLOCK signal is a general purpose blocking signal of the pole discordance logic. It can be connected to a binary input of the terminal in order to receive a block command from external devices or can be software connected to other internal functions of the terminal itself in order to receive a block command from internal functions. Through OR gate it can be connected to both binary inputs and internal function outputs.

The PD---1POPEN signal blocks the pole discordance operation when a single phase auto-reclosing cycle is in progress. It can be connected to the output signal AR01-1PT1 if the autoreclosing function is integrated in the terminal; if the auto-reclosing function is an external device, then PD---1POPEN has to be connected to a binary input of the terminal and this binary input is connected to a signalling “1 phase auto-reclosing in progress” from the external auto-reclosing device.

If one or two poles of the circuit breaker have failed to open or to close (pole discordance status), then the function input PD---POLDISC is activated from the pole discordance signal derived from the circuit breaker auxiliary contacts (one NO contact for each phase connected in parallel, and in series with one NC contact for each phase connected in parallel). If the pole discordance function is enabled, a 150 ms trip pulse command (PD---TRIP) is generated, after a settable time interval  $t$  (0-60 s).

## 2.4

### Calculations

#### 2.4.1

#### Setting Instruction

The setting parameters are accessible through the HMI. The parameters for the pole discordance logic are found in the HMI-tree under:

##### Setting

##### Functions

##### Group 1,2,3 and 4

##### PoleDiscord

The parameters and their setting ranges are shown in the appendix.

Comments regarding settings:

Operation:	Pole discordance protection On/Off. Activation or de-activation of the logic.
Time delay , $t$ :	The time delay is not critical because the pole discordance logic operates mainly with load conditions. The time delay should be chosen between 0.5 and 1 s.

---

## 3 High speed binary output logic (HSBO)

### 3.1 Application

The high-speed binary out logic (HSBO--) is included as basic and is used as a supplement to the high-speed protection function (HS--) and the distance protection zone 1 function (ZM1--) in the REx 5xx terminals.

Depending on the terminal type (actually the set of included functions) the following description will be valid entirely or partly.

Together with the high-speed binary out logic, the high-speed (distance) protection and the (main) distance protection zone 1 obtain even shorter operate times since the critical connections to/from binary output/input are established in a more straightforward way than in the case of using the regular I/O-modules.

The high-speed binary out logic also includes trip scheme logic employing the same 'fast' connections. The HSBO trip scheme logic will run in parallel with the regular trip scheme logic configured within the terminal (ZC1P and ZCOM). In fact, information from these two functions will be used in the HSBO function.

### 3.2 Functionality

The operation of the high-speed binary out logic overruns all other logical circuits within the terminal and activates, with minimum time delay, the binary outputs (output relays). The same relays should also be activated by the normal functional outputs of corresponding built-in functions (TRIP function, for example). The reason for this is that the 'fast' (phase segregated) outputs of the HSBO function should bring forward an earlier activation of trip and carrier send signals that are supposed to be continued by the regular functions (TRIP, ZC1P and ZCOM function). For example, the trip signals that are issued by the high-speed protection function through the HSBO function are presented as short pulses (20ms) and therefore they need to be extended (continued). In the general case, this would be provided for by the intervention of the TRIP function.

The operation is dependent upon other functions within the terminal. To achieve correct functionality, it is absolutely necessary that all depending functions are configured correctly, set on and not blocked. With respect to the employed distance protection transfer trip scheme the HSBO function will retrieve the necessary information from the regular communication functions (ZC1P or ZCOM) in order to determine the mode of operation. The HSBO function will support intertrip, permissive under-reach and permissive

---

overreach scheme. There is, however, one exception to the possible use of these schemes. A delayed operation within the communication functions (ZCOM or ZC1P) (i.e.  $t_{Coord} > 0$ ) is not allowed. In this case the trip scheme logic within the HSBO function should be blocked through activating input HSBO-BLKZCTR. Do not use the default value for  $t_{Coord}$  of 50ms.

The main configuration for the function is shown in figure 189 below.

**This configuration is made internally and cannot be altered.**

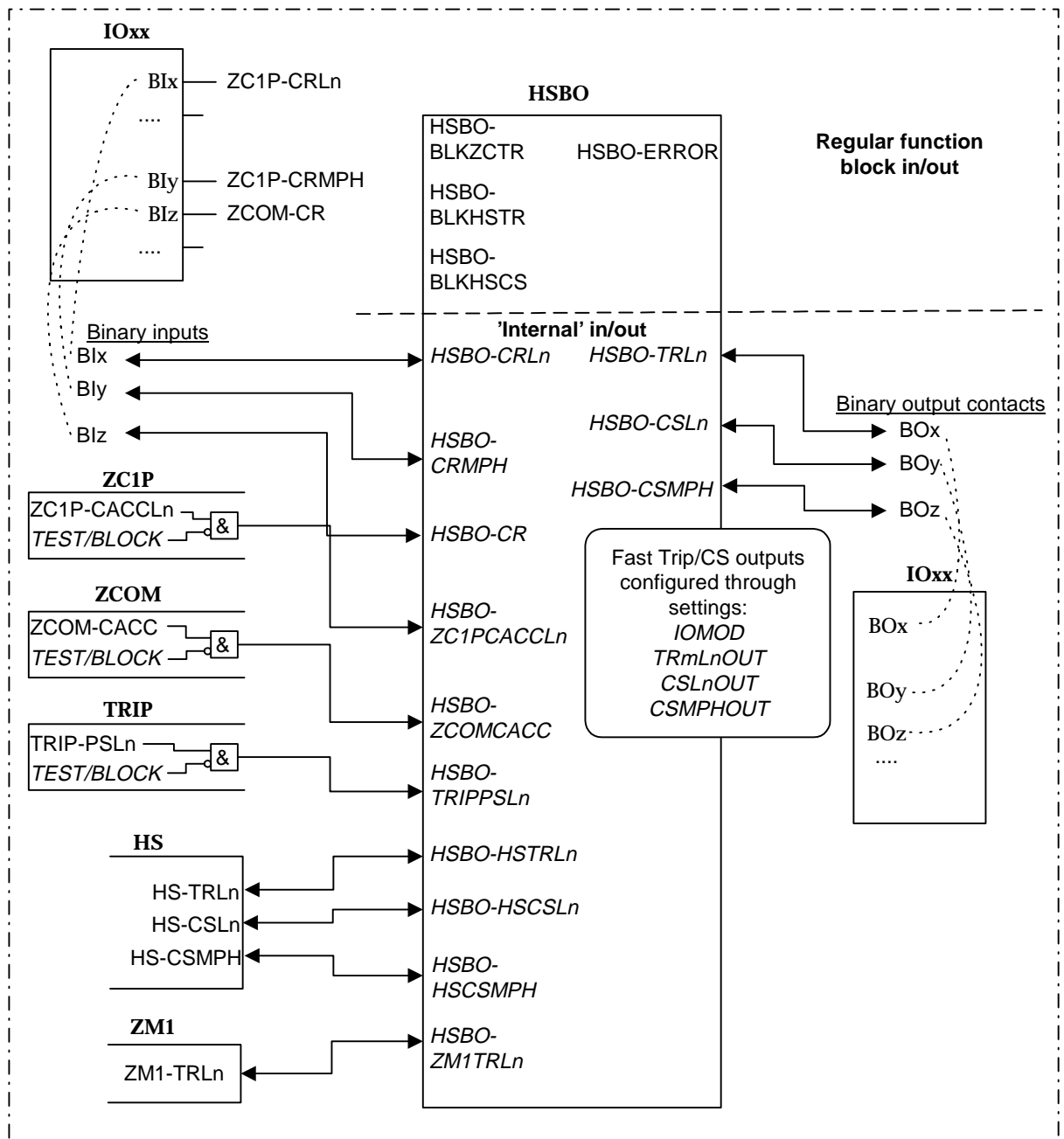

en01000181.vsd

Figure 189: Simplified diagram of the high-speed binary out logic function together with depending functions

---

According to the presented 'internal' configuration input will be brought in from the HS, ZM1, ZC1P, ZCOM and TRIP functions.

In the case of carrier receive signals, the input will be attained directly from binary input overriding the binary I/O-modules. This is obtained by means of looking up and connecting to the input contacts used for the carrier receive inputs of the ZC1P and/or the ZCOM function. This calls for that the carrier receive inputs of the latter functions must be connected **directly to a binary I/O-module**, with nothing in between. In figure 189 this is illustrated with ZC1P-CRLn and ZCOM-CR connected to arbitrary binary in (BIx, BIy,...).

The input signals (HSBO-ZC1PCACCLn, HSBO-ZCOMCACC and HSBO-TRIPPSLn) are connected to the inputs on respective function block. This means that the high-speed binary out logic runs in parallel with those functions. But **it is important** that the functions are **set on** so the signals are received with true values. Otherwise, the logic can malfunction. Note that these signals can be blocked in the function from where they originate.

Similarly, input signals HSBO-HSTRLn, HSBO-CSLn and HSBO-HSCSMPh are connected to the output of the HS function. Input signals HSBO-ZM1TRLn are connected to the output of the ZM1 function.

Shown connections to in and outputs of the other function blocks (ZC1P-, ZCOM-, TRIP-, HS- and ZM1-) can not be reconfigured. They are so called *hard connections* in the software and done during manufacturing.

The output signals (trip and carrier send) must be configured to appropriate binary output contacts during engineering. This is done through configuring the corresponding parameters of the HSBO-function in CAP 531 (IOMOD, TRmLnOUT, CSLnOUT and CSMPhOUT).

It should be noted that trip output from the HSBO-function can be issued either from the HS-function or the ZM1-function, or both in parallel, dependin on terminal type and setting. As specified above the common trip outputs are configured through parameters TRmLnOUT.

The blocking input signals (HSBO-BLKZCTR, -BLKHSTR and -BLK-HSCS) are normal function input signals. The configuration is done with the configuration tool CAP 531 as usual.

The error output signal (HSBO-ERROR) indicates if the present configuration of 'fast' trip and carrier send output does not correspond to actual hardware (binary output cards). The signal can be used for indication or as wanted.



3.3

Design

The internal design of the functional block is shown in figure 190 below.

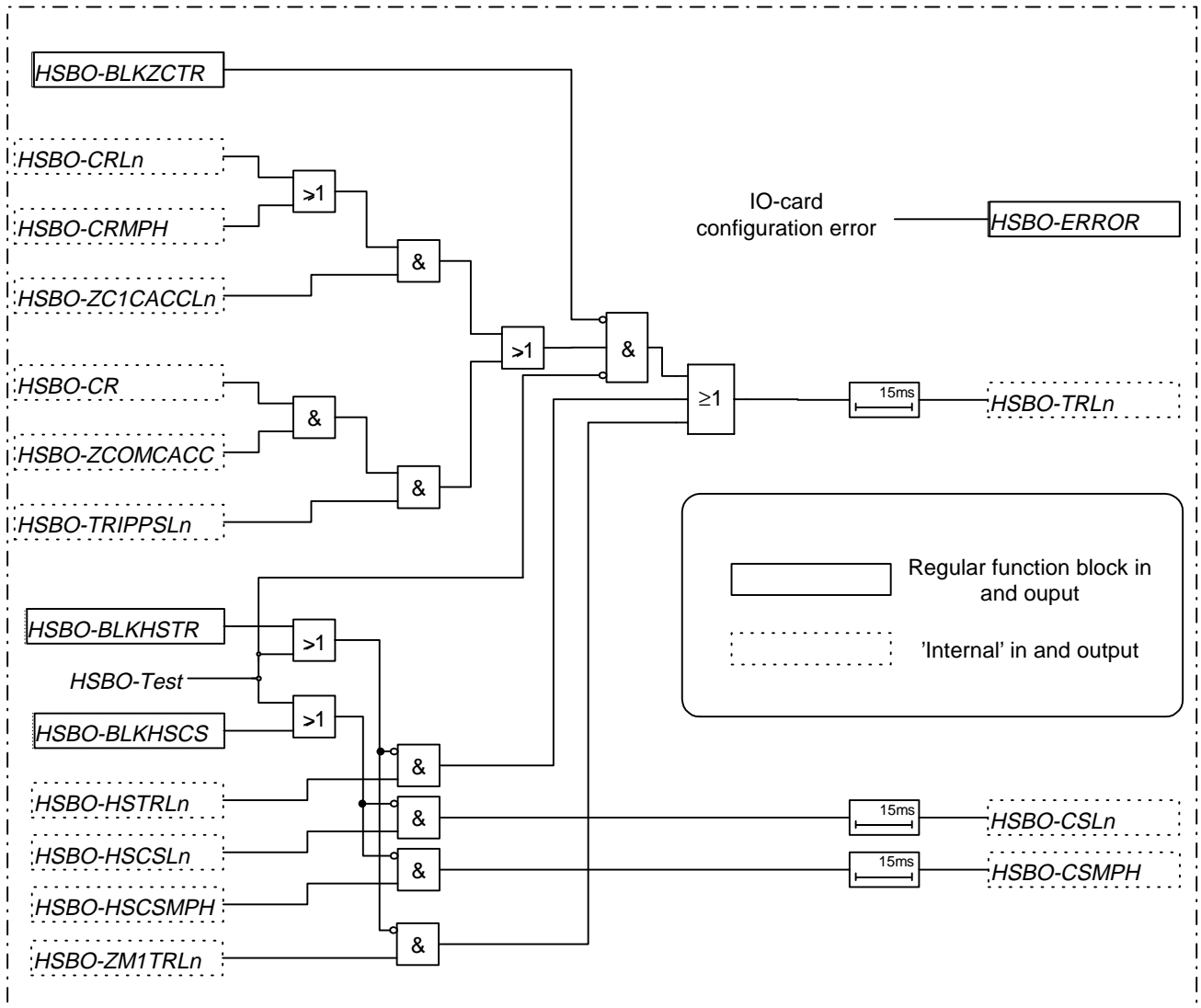

en01000182.vsd

Figure 190: Simplified logic diagram of the function block

Below is a description of the internal input/output signals.

**Input signals:**

HSBO-CRLn	Carrier receive signal, for phase n (n=1..3), connected to the binary input. These inputs use the same signals as the inputs to the communication logic ZC1P-.
HSBO-CRMPH	A carrier receive signal, multi-phase, connected to a binary input. It uses the same signal as the input to the communication logic ZC1P-.
HSBO-ZC1PCACCLn	Carrier acceleration signals, for phase n (n=1..3). They are connected internally to the input of the communication logic ZC1P- and cannot be redirected.
HSBO-CR	A carrier receive signal connected to a binary input, already connected to the corresponding input of the communication logic ZCOM-.
HSBO-ZCOM-CACC	A carrier acceleration signal. Is a hard connection to the input of the communication logic ZCOM-.
HSBO-TRIPPSLn	Phase selection signal, selected phase n (n=1..3). Is a hard connection to the input of the trip function block TRIP-.
HSBO-ZM1TRLn	Trip signal, of phase n (n=1..3). Is a hard connection to the output of the distance protection zone 1 function block ZM1-.
HSBO-HSTRLn	Trip signal, of phase n (n=1..3). Is a hard connection to the output of the high-speed function block HS---
HSBO-HSCSLn	Carrier send signals, of phase n (n=1..3). Is a hard connection to the output of the high-speed function block HS---
HSBO-HSCSMPH	A carrier send signal, multi-phase. Is a hard connection to the output of the high-speed function block HS---

**Configuration parameters**

**Output signals:**

IOMOD	Parameter for selecting the binary out card supposed to transfer the 'fast' outputs of the HSBO function.
TRmLnOUT	Parameter for selecting the specific binary output contact intended for trip signal m of phase n. m is either 1 or 2. Both the 'TR1LnOUT-output' and 'TR2LnOUT-output' carry the same signal, for a possible double-breaker arrangement. It is recommended that these trip outputs are configured to the same contacts as the corresponding regular trip outputs (of the TRIP function). If three-pole trip is required all three trip outputs should be configured to the same contact (i.e. TRxL1OUT=TRxL2OUT=TRxL3OUT). Consider that the trip signals can be issued from the HS function and/or the ZM1 function.
CSLnOUT	Parameter for selecting the specific binary output contact intended for carrier send signal of phase n. Like in the trip output case above, it is recommended that these carrier send outputs are configured to the same contacts as the corresponding regular carrier send outputs (of the ZC1P or ZCOM function).
CSMPHOUT	Parameter for selecting the specific binary output contact intended for the multi-phase carrier send signal. If it is applicable, connect it to the same contact as the regular multi-phase carrier send signal (of the ZC1P function).

Status of the output signals can be viewed on the local HMI under menu:

**ServiceReport**  
**Functions**  
**Impedance**  
**HighSpeedBO**  
**FuncOutputs**

Here, the signals are designated:

HSBO-TRLn  
 HSBO-CSLn  
 HSBO-CSMPH

---

## 4 Communication channel logic (CCHL)

### 4.1 Application

The security of the protection system can be influenced by the performance of communication channels. In many applications spurious signals or absence of signals can cause malfunction of the protection system. One example is when direct intertrip is used where a false signal will cause unwanted tripping.

In order to increase security double communication channels between the line ends can be used. For the combination of two channels the communication channel logic (CCHL) is used. CCHL is intended to be used together with the system protection and control functions. This logic combines the two received signals to one CR signal in the terminal. The logic will accept the two channel signals as simultaneous only if they appear both during a settable time. Further the logic detects faults in the communication channels and blocks or changes the decision mode from two-channel-out-of-two into one-channel-out-of-two.

In case of a “dead” communication channel there is a possibility to have an unblocking function activated. If there is no CR signal, no CGuard signal and no fault signal from the PLC equipment, this can be transferred to a CR signal in the terminal.

### 4.2 Functionality

#### General

CCHL is used together with different sub-functions of a system protection function. It has an independent function block with two independent channels (four independent input channels). Their cooperation with different measuring functions will be determined by means of a terminal configuration tools (CAP 531, for example).

The CCHL logic receives channel received, channel guard received and channel failed signals from both communication channels. The unblocking logic is not incorporated in the logic for the receipt of both channels. To have this output, the actual signals for both channels must be simultaneously received. The logic for the receipt of one-channel-out-of-two is enabled by way of an input signal. Furthermore, the one-channel-out-of-two output can only be given if one of the communications channels has failed, as this logic is supervised by the failure of either channel. When selected, the unblocking logic is incorporated within this one-out-of-two logic.

The CCHL logic incorporates a number of security timers to make absolutely sure that no erroneous outputs are given for spurious channel received signals.

The CCHL logic also provides, for each channel, a communications channel failed output.

### Basic signals from each communication channel

Each communication channel has three basic output signals, which are used as inputs to the logic:

- CR<sub>n</sub> (n is a serial number of communication channel) is an input signal on received carrier signal, see figure 191.
- CRG<sub>n</sub> is a guard signal for the corresponding communication channel. It is normal, that this signal is logical one, when CR<sub>n</sub> is logical zero and vice-versa. The input should be configured to FIXD-OFF, if the CRG<sub>n</sub> signal is not available from the carrier communication equipment.
- COMF<sub>n</sub> is an input signal, which informs on the operation of a self-supervision function within the carrier communication equipment used. The input should be configured to FIXD-OFF, if the signal is not available on the communication equipment.

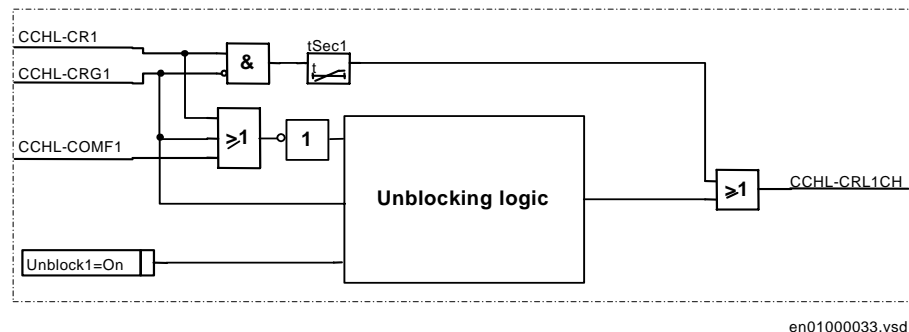

Figure 191: Communication channel logic 1

### Time delayed operation for one only received communication signal

If one communication channel has been detected as faulty (see section ) and the operating mode has been permitted to change from two-of-two to one-of-two, a CCHL-CR appears after a time delay, set on tSec1 timer in case, that the second channel is healthy and the CR<sub>n</sub> signal appears without the presence of a CRG<sub>n</sub> signal.

### Unblocking logic within each separate signal

For an illustration of an unblocking logic within each separate signal, see figure 191. If none of signals CCHL-CR1 and CCHL-CRG1 is present for a time longer than the one set on a tSec1 timer and no CCHL-COMF1 signal has been detected, an unblocking logic for a particular signal channel is permitted to operate. The operation of this logic is additionally conditioned by the Unblockn setting parameter, which must be set to Unblockn = On, if the logic is intended to operate. The logic is practically the same as used together with the communication logic for the line distance protection (ZCOM function). The difference is that the tReSt restart timer and the tSig signal timer are settable.

### Simultaneous presence of two carrier receive signals

For an illustration of a simultaneous presence of two carrier receive signals, see figure 192. If both carrier receive signals (CCHL-CR1 and CCHL-CR2) are present at the same moment and both guard signals go to logical zero, the output signals CCHL-CR goes high after a time delay, which is settable on the security timer TSecC. The most common setting for this timer is 0 ms, because the high enough security is obtained already with serial connection of two communication channels. This mode of operation is also indicated by the appearance of CCHL-CRL2CH output signal.

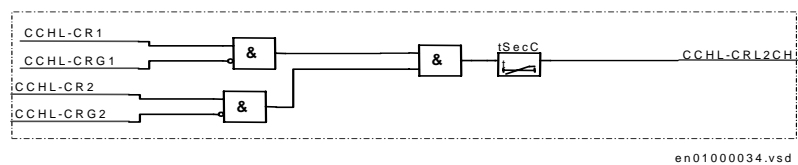

Figure 192: Combination of two communication channels

### Detection of a failed communication channel

For an illustration of a combination of two communication channels, see figure 193. The communication channel is understood as faulty under the following conditions:

- If CR1 and CRG1 signals are present simultaneously for more than 20 ms and no COMF1 signal has been present
- If a COMF1 signal appears on the corresponding functional input
- If non of the three input signals (CR1, CRG1, and COMF1) appears for more than the time delay set on a security timer tSec2.

The logic detects the faulty channel and sets high the corresponding CCHL-CH1FAIL output signal.

In all three cases the logic checks also the CCHL-2TO1OK input signal, which is common to both communication channels. This signal determines whether it is possible to switch the operating mode from two-of-two to one-of-two or not. This means that the user can influence this change by configuring the CCHL-2TO1OK to FIXD-ON (change permitted) or to FIXD-OFF (switch not permitted).

The CCHL-CRL1CH output signal goes high, if a fault has been detected on one communication channel and the second communication channel has operated correctly and transmitted the corresponding carrier signal.

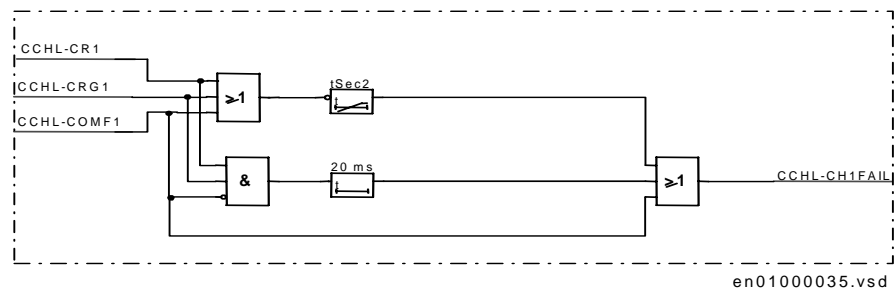

Figure 193: communication channel fail logic.

### 4.3

#### Calculations

There are some time settings to be made:

tSecC: the time for which the signals from both channels must be simultaneous received before a CR signal is given as an output from the logic. In most cases this timer can be set to 0.

tSec1: Security time to ensure definite, and not spurious, receipt of the channel signal. This time delay shall be about the same as the shortest pulse time of the CS signal from the remote line end.

tSec2: Security time following the loss of guard signal before activation of the unblocking logic. The setting shall be longer than the possible time difference between the change of CR and CRG signals. 50 ms is recommended.

---

## 5 Communication channel test logic (CCHT)

### 5.1 Application

Many applications in secondary systems require testing of different functions with confirmed information on successfully completed test. **C**arrier **c**hannel test (CCHT) function serves primarily testing of communication (power line carrier) channels in applications, where continuous monitoring by some other means is not possible due to technical or economical reasons.

The logic initiates sending of some impulse (carrier send signal), which starts the operation of different functions outside the logic, and checks the feedback from the external function. It reports the successful or non-successful response on initiated test. It is also possible to abort the test with some external signal, which overrules all internal process.

It is possible to initiate the logic manually or automatically. Manual starts are possible by means of external push-button, connected to the binary input of a terminal. Automatic starts are possible in long time intervals with their duration dependent on setting of the corresponding timer.

### 5.2 Design

Figure 194 presents a simplified logic diagram for the CCHT function. Logical one on CCHT-BLOCK functional input disables completely the operation of the logic.



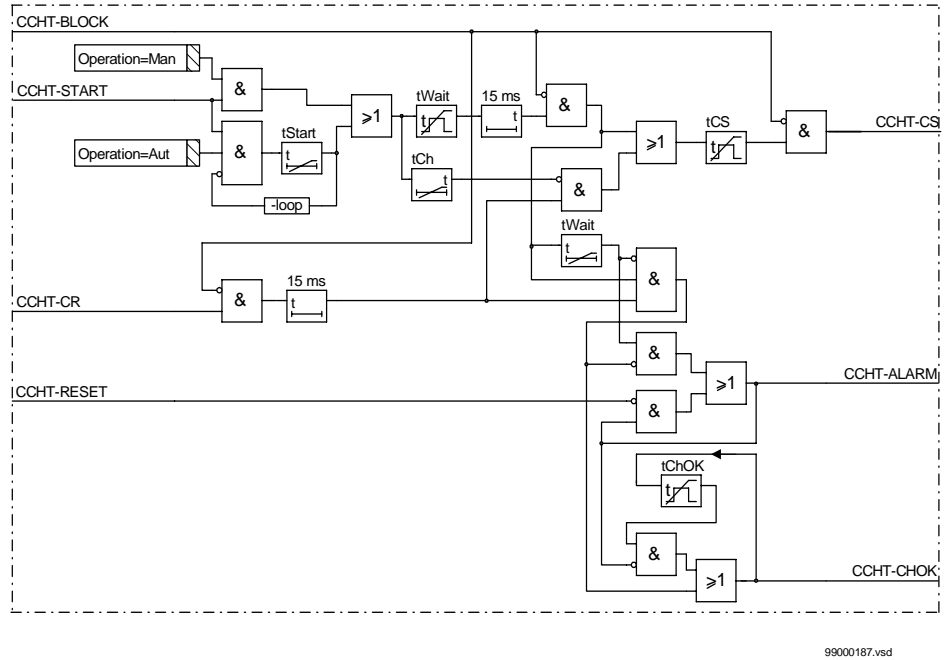

Figure 194: Simplified logic diagram for the CCHT function

### Selection of an operating mode

Selection of an operating mode, which determines the automatic (internal) or manual (external) start is possible by setting the “Operation = Aut” and “Operation = Man” respectively (see figure 194). The automatic starting requires continuous presence of logical one on CCHT-START functional input. Setting of the tStart timer determines the time intervals for the automatic starts logic.

Any presence of the logical one signal on the CCHT-START functional input starts the function, when in manual operating mode.

### Operation at sending end

Manual or automatic start initiates the pulse, which is 15 ms longer than the time set on a tWait timer. This pulse initiates the CCHT-CS functional output signal in duration as set on a tCS pulse timer. The same pulse starts also the time measurement by the tWait timer. The CCHT-ALARM output signal appears, if the CCHT-CR input does not become logical one within the time interval, as set on the tWait timer. The appearance of the CCHT-CR signal is safeguarded by a 15 ms timer, to prevent influence of the disturbances on a communication link.

The appearance of the CCHT-CR signal within the  $t_{Wait}$  time interval activates the CCHT-CHOK output signal. It remains active for the period as set on the timer  $t_{ChOK}$  or until the CCHT-ALARM appears at new start of a CCHT function.

The  $t_{Ch}$  timer, which is delayed on drop-off, prevents ringing of a complete system. It is possible to reset the CCHT-ALARM output signal by activating the CCHT-RESET functional input.

**Operation at receiving end**

Activation of a CCHT-CR functional input activates instantaneously the CCHT-CS functional output, if the timer  $t_{Ch}$  has not been activated or the function has not been blocked by the active CCHT-BLOCK functional input. Duration of the CCHT-CR input signal must be longer than 15 ms to avoid operation at different disturbances on communication link.

---

## 6 Binary signal transfer to remote end (RTC)

### 6.1 Application

The binary signal transfer function is preferably used for sending communication scheme related signals, transfer trip and/or other binary signals required at the remote end. Up to 32 selectable binary send signals, internal or external, and 32 selectable binary receive signals can be transmitted.

Together with the binary signals internal to the terminal, the function is utilising binary inputs and outputs. The function can be provided with various 56/64 kbit/s communication modules for optical fibre or galvanic connection.

The communication can be done via direct galvanic communication line for shorter distances, via dedicated optical fibres up to around 30 km and via a communication network for longer distances.

### 6.2 Design

The function Binary signal transfer to remote end consists of two function blocks, RTC1 and RTC2, each handling 16 inputs (SEND01-16) and 16 outputs (REC01-16). Figure 195 shows the signal diagram for RTC1. This diagram is also valid for RTC2 since the signal inputs and outputs are the same.

A signal applied to an input of one function block, eg. RTC1-SEND01, in one terminal will be transmitted, via a data communication link, to a remote terminal and there appear at the corresponding output of the corresponding function block, that is in the example RTC1-REC01. The transmission takes 10 - 25 ms plus communication link delay. No additional security actions to that included in the communication handling, that is CRC-check, checking length of telegram and addressing, is incorporated.

Both function blocks have an input BLOCK, which is available to block the operation. When the input is energized, all 16 binary input signals of that function block will be sent as zeroes. Incoming signals from remote end are not affected.

An output COMFAIL is also available to announce an alarm when there is a failure in the communication with the remote terminal. The COMFAIL for both function blocks works in parallel so information will appear simultaneously on both function blocks. At COMFAIL all 16 output signal on both function blocks will be set to zero.

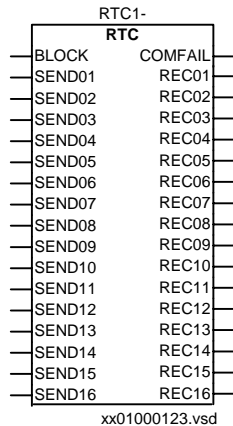

Figure 195: Binary signal transfer to remote end RTC1, signal inputs and outputs

User defined names can be applied to the inputs and outputs. These identities are set from the configuration tool CAP 531.

A service report provides information of the status of all function block outputs as well as inputs. The status can be viewed on the local HMI under:

**ServiceReport**

**I/O**

**RemTermCom1**

**RemTermCom2**

**Remote end data communication**

The “Binary signal transfer to remote end” function uses the same communication functionality and hardware for communication with remote end as used for the line differential function. These items are described in the chapter “Data communication” in the application manual. The settings that has to be made for these items are also described in each chapter respectively.

Status information of the Remote end data communication is available on the local HMI under:

**TerminalReport**

**SelfSuperv**

**RemTermCom**

---

## 7 Event function (EV)

### 7.1 Application

When using a Substation Automation system, events can be spontaneously sent or polled from the terminal to the station level. These events are created from any available signal in the terminal that is connected to the event function block. The event function block can also handle double indication, that is normally used to indicate positions of high-voltage apparatuses. With this event function block, data also can be sent to other terminals over the interbay bus.

### 7.2 Functionality

The events can be created from both internal logical signals and binary input channels. The internal signals are time tagged in the main processing module, while the binary input channels are time tagged directly on each I/O module. The events are produced according to the set event masks. The event masks are treated commonly for both the LON and SPA channels. All events according to the event mask are stored in a buffer, which contains up to 1000 events. If new events appear before the oldest event in the buffer is read, the oldest event is overwritten and an overflow alarm appears.

The outputs from the event function block are formed by the reading of status and events by the station HMI on either every single input or double input. The user-defined name for each input is intended to be used by the station HMI.

Twelve of the event function blocks are executed with fast cyclicality. That means that the time-tagging resolution on the events that are emerging from internal logical signals, created from configurable logic, is the same as the cyclicality of this logic. The time tagging resolution on the events that are emerging from binary input signals have a resolution of 1 ms.

Two special signals for event registration purposes are available in the terminal, *Terminal restarted* and *Event buffer overflow*.

### 7.3 Design

#### General

As basic, 12 event function blocks EV01-EV12 running with a fast cyclicality, are available in REx 5xx. When the function Apparatus control is included in the terminal, additional 32 event function blocks EV13-EV44, running with a slower cyclicality, are available.

---

Each event function block has 16 connectables corresponding to 16 inputs INPUT1 to INPUT16. Every input can be given a name with up to 19 characters from the CAP 531 configuration tool.

The inputs can be used as individual events or can be defined as double indication events.

The inputs can be set individually from the Parameter Setting Tool (PST) under the Mask-Event function as:

- No events
- OnSet, at pick-up of the signal
- OnReset, at drop-out of the signal
- OnChange, at both pick-up and drop-out of the signal

Also an input PrColxx (xx=01-44) is available on the function block to define on which protocol the events shall be sent.

The event function blocks EV01-EV06 have inputs for information numbers and function type, which are used to define the events according to the communication standard IEC 60870-5-103.

#### **Double indication**

Double indications are used to handle a combination of two inputs at a time, for example, one input for the open and one for the close position of a circuit breaker or disconnector. The double indication consists of an odd and an even input number. When the odd input is defined as a double indication, the next even input is considered to be the other input. The odd inputs has a suppression timer to suppress events at 00 states.

To be used as double indications the odd inputs are individually set from the SMS under the Mask-Event function as:

- Double indication
- Double indication with midposition suppression

Here, the settings of the corresponding even inputs have no meaning.

These states of the inputs generate events. The status is read by the station HMI on the status indication for the odd input:

- 00 generates an intermediate event with the read status 0
- 01 generates a close event with the read status 1
- 10 generates an open event with the read status 2
- 11 generates an undefined event with the read status 3

### Communication between terminals

The BOUND and INTERVAL inputs are available on the event function block.

The BOUND input set to 1 means that the output value of the event block is bound to another control terminal on the LON bus. The event function block is then used to send data over the LON bus to other REx 5xx terminals. The most common use is to transfer interlocking information between different bays. That can be performed by an event function block used as a send block and with a Multiple Command function block used as a receive block. The document *Apparatus Control* describes how to transfer the interlocking information. The configuration of the communication between control terminals is made by the LON Network Tool.

The INTERVAL input is applicable only when the BOUND input is set to 1. The INTERVAL is intended to be used for cyclic sending of data to other control terminals via the LON bus with the interval time as set. This cyclic sending of data is used as a backup of the event-driven sending, which always is performed. With cyclic sending of data, the communication can be supervised by a corresponding INTERVAL input on the Multiple Command function block in another control terminal connected to the LON bus. This INTERVAL input time is set a little bit longer than the interval time set on the event function block. With INTERVAL=0, only event-driven sending is performed.

## 7.4

### Calculations

The event reporting can be set from the PST as:

- Use event masks
- Report no events
- Report all events

*Use of event masks* is the normal reporting of events, that is, the events are reported as defined in the database.

An event mask can be set individually for each available signal in the terminal. The setting of the event mask can only be performed from the PST.

All event mask settings are treated commonly for all communication channels of the terminal.

---

*Report no events* means blocking of all events in the terminal.

*Report all events* means that all events, that are set to OnSet/OnReset/OnChange are reported as OnChange, that is, both at set and reset of the signal. For double indications when the suppression time is set, the event ignores the timer and is reported directly. Masked events are still masked.

Parameters to be set for the event function block are:

- T\_SUPRyy including the suppression time for double indications.
- NAMEyy including the name for each input.
- PrColxx including the type of protocol for sending the events.
- INTERVAL used for the cyclic sending of data.
- BOUND telling that the block has connections to other terminals over the LON bus.
- FuncTEVx (for EV01-EV06) including the function type for sending events via IEC 60870-5-103.
- InfoNoyy (for EV01-EV06) including the information number for the events sending via IEC 60870-5-103.

These parameters are set from the CAP 531 configuration tool. When the BOUND parameter is set, the settings of the event masks have no meaning.



---

## 8 Event counter (CN)

### 8.1 Application

The function consists of six counters which are used for storing the number of times each counter has been activated. It is also provided with a common blocking function for all six counters, to be used for example at testing. Every counter can separately be set on or off by a parameter setting.

### 8.2 Functionality

The function block has six inputs for increasing the counter values for each of the six counters respectively. The content of the counters are stepped one step for each positive edge of the input respectively. The maximum count up speed is 10 pulses per second. The maximum counter value is 10 000. For counts above 10 000 the counter will stop at 10 000 and no restart will take place. At power interrupt the counter values are stored.

The function block also has an input BLOCK. At activation of this input all six counters are blocked. The input can for example be used for blocking the counters at testing.

All inputs are configured via configuration tool CAP 531.

#### Reporting

The content of the counters can be read in the local HMI under the menu:

**ServiceReport**  
**Functions**  
**Counters**  
**Count**  
**Counters**

Reset of counters can be performed in the local HMI under the menu:

---

**ServiceReport**  
**Functions**  
**Counters**  
**Count**  
**ClearCounters**

Reading of content and resetting of the counters can also be performed remotely, for example via SPA-communication.

### 8.3

#### **Calculations**

The parameters for the counters, Operation = Off/On, are set in the local HMI under the menu:

**Settings**  
**Functions**  
**Group n**  
**Counters**

or via the PST Parameter Setting Tool.

# Chapter 11 Monitoring

## **About this chapter**

This chapter describes the monitoring functions.

# 1 LED indication function (HL, HLED)

## 1.1 Application

The LED indication module is an additional feature for the REx 500 terminals for protection and control and consists totally of 18 LEDs (Light Emitting Diodes). It is located on the front of the protection and control terminal. The main purpose is, to present on site an immediate visual information on:

- actual signals active (or not active) within the protected bay (terminal).
- alarm signals handled as a simplified alarm system.
- last operation of the terminal. Here we understand the presentation of the signals appeared during the latest start(s) or trip(s) since the previous information has been reset.

The user of this information is the technician in substation or the protection engineer during the testing activities. The protection engineer can also be able to read the status of all LEDs over the SMS in his office as well as to acknowledge/reset them locally or remotely.

## 1.2 Functionality

Each LED indication can be set individually to operate in six different sequences; two as follow type and four as latch type. Two of the latching types are intended to be used as a protection indication system, either in collecting or re-starting mode, with reset functionality. The other two are intended to be used as a signaling system in collecting mode with an acknowledgment functionality.

### Priority

Each LED can show green, yellow or red light, each with its own activation input. If more than one input is activated at the time a priority is used with green as lowest priority and red as the highest.

### Operating modes

#### Collecting mode

LEDs which are used in collecting mode of operation are accumulated continuously until the unit is acknowledged manually. This mode is suitable when the LEDs are used as a simplified alarm system.

---

**Re-starting mode**

In the re-starting mode of operation each new start resets all previous active LEDs and activates only those which appear during one disturbance. Only LEDs defined for re-starting mode with the latched sequence type 6 (LatchedReset-S) will initiate a reset and a restart at a new disturbance. A disturbance is defined to end a settable time after the reset of the activated input signals or when the maximum time limit has been elapsed.

**Acknowledgment/reset****From local HMI**

The active indications can be acknowledged/reset manually. Manual acknowledgment and manual reset have the same meaning and is a common signal for all the operating sequences and LEDs. The function is positive edge triggered, not level triggered. The acknowledgment/reset is performed via the C-button on the Local HMI according to the sequence in figure 196.

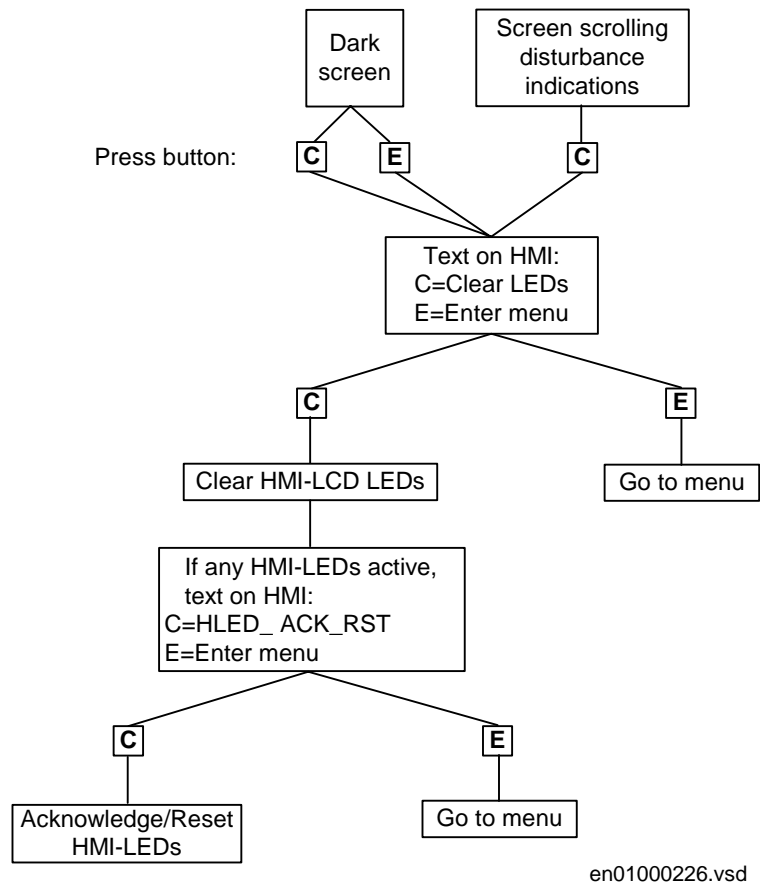

Figure 196: Acknowledgment/reset from local HMI

#### From function input

The active indications can also be acknowledged/reset from an input (ACK\_RST) to the function. This input can for example be configured to a binary input operated from an external push button. The function is positive edge triggered, not level triggered. This means that even if the button is continuously pressed, the acknowledgment/reset only affects indications active at the moment when the button is first pressed.

#### From SMS/SCS

It is also possible to perform the acknowledgment/reset remotely from SMS/SCS. To do that, the function input (ACK\_RST) has to be configured to an output of a command function block (CD or CM). The output from these command function blocks can then be activated from the SMS/SCS.

**Automatic reset**

The automatic reset can only be performed for indications defined for re-starting mode with the latched sequence type 6 (LatchedReset-S). When the automatic reset of the LEDs has been performed, still persisting indications will be indicated with a steady light.

**Operating sequences**

The sequences can be of type Follow or Latched. For the Follow type the LED follow the input signal completely. For the Latched type each LED latches to the corresponding input signal until it is reset.

The figures below show the function of available sequences selectable for each LED separately. For sequence 1 and 2 (Follow type), the acknowledgment/reset function is not applicable. Sequence 3 and 4 (Latched type with acknowledgement) are only working in collecting mode. Sequence 5 is working according to Latched type and collecting mode while sequence 6 is working according to Latched type and re-starting mode. The letters S and F in the sequence names have the meaning S = Steady and F = Flash.

At the activation of the input signal, the indication obtains corresponding color corresponding to the activated input and operates according to the selected sequence diagrams below.

In the sequence diagrams the LEDs have the following characteristics:

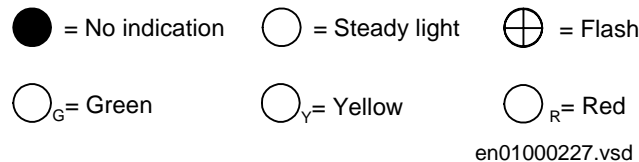

*Figure 197: Symbols used in the sequence diagrams*

**Sequence 1 (Follow-S)**

This sequence follows all the time, with a steady light, the corresponding input signals. It does not react on acknowledgment or reset. Every LED is independent of the other LEDs in its operation.

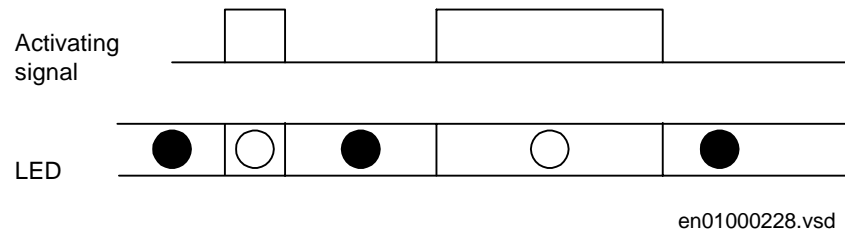

Figure 198: Operating sequence 1 (Follow-S)

If inputs for two or more colors are active at the same time to one LED the priority is as described above. An example of the operation when two colors are activated in parallel is shown in figure 199.

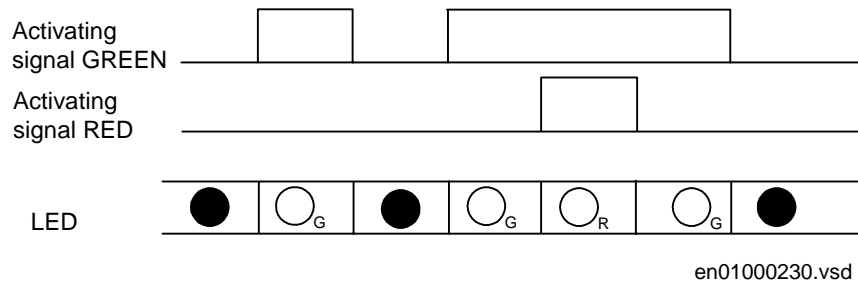

Figure 199: Operating sequence 1, two colors

### Sequence 2 (Follow-F)

This sequence is the same as sequence 1, Follow-S, but the LEDs are flashing instead of showing steady light.

### Sequence 3 (LatchedAck-F-S)

This sequence has a latched function and works in collecting mode. Every LED is independent of the other LEDs in its operation. At the activation of the input signal, the indication starts flashing. After acknowledgment the indication disappears if the signal is not present any more. If the signal is still present after acknowledgment it gets a steady light.



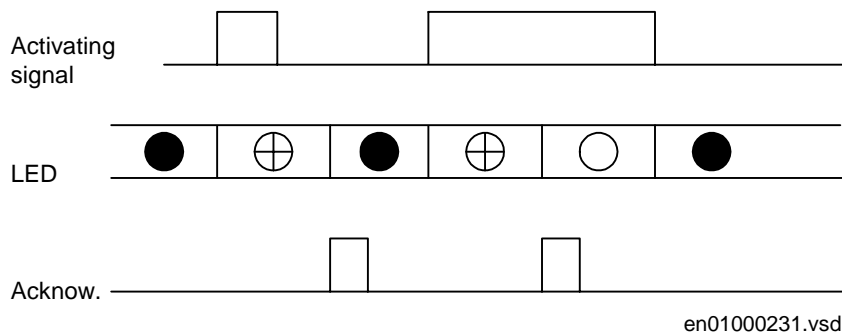

Figure 200: Operating sequence 3 (LatchedAck-F-S)

When an acknowledgment is performed, all indications that appear before the indication with higher priority has been reset, will be acknowledged, independent of if the low priority indication appeared before or after acknowledgment. In figure 201 is shown the sequence when a signal of lower priority becomes activated after acknowledgment has been performed on a higher priority signal. The low priority signal will be shown as acknowledged when the high priority signal resets.

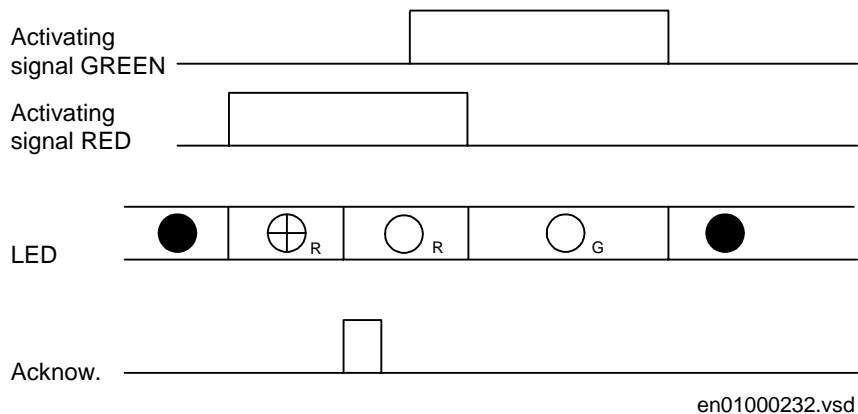

Figure 201: Operating sequence 3, two colors involved

If all three signals are activated the order of priority is still maintained. Acknowledgment of indications with higher priority will acknowledge also low priority indications which are not visible according to figure 202.

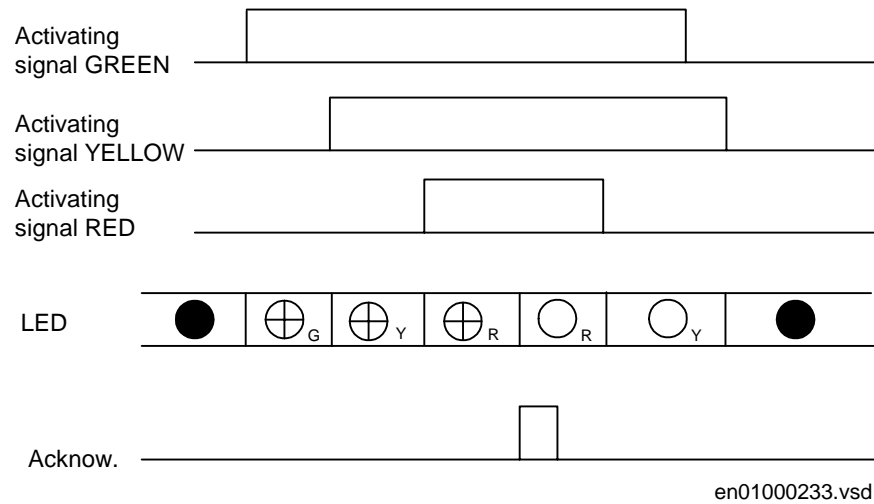

Figure 202: Operating sequence 3, three colors involved, alternative 1

If an indication with higher priority appears after acknowledgment of a lower priority indication the high priority indication will be shown as not acknowledged according to figure 203.

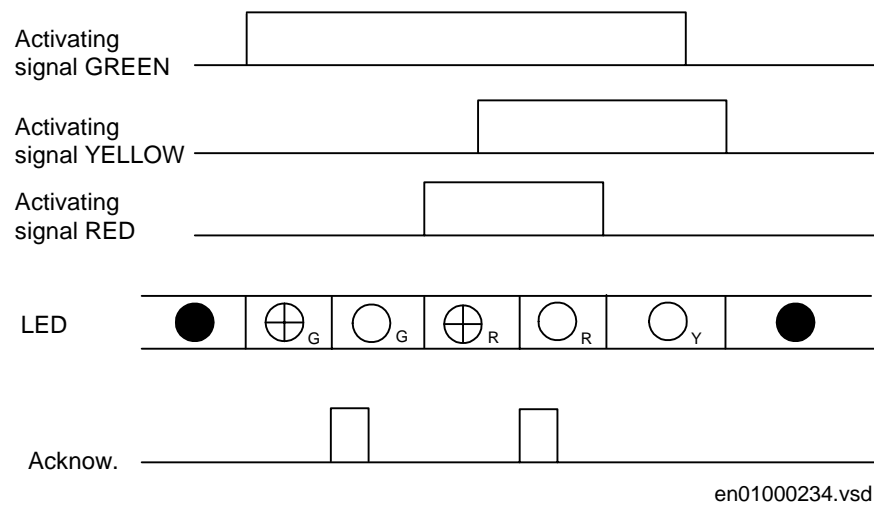

Figure 203: Operating sequence 3, three colors involved, alternative 2

**Sequence 4 (LatchedAck-S-F)**

This sequence has the same functionality as sequence 3, but steady and flashing light have been alternated.

**Sequence 5 (LatchedColl-S)**

This sequence has a latched function and works in collecting mode. At the activation of the input signal, the indication will light up with a steady light. The difference to sequence 3 and 4 is that indications that are still activated will not be affected by the reset i.e. immediately after the positive edge of the reset has been executed a new reading and storing of active signals is performed. Every LED is independent of the other LEDs in its operation.

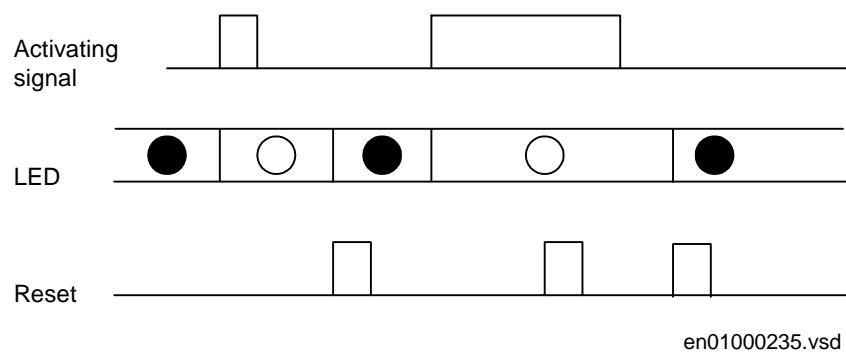

*Figure 204: Operating sequence 5 (LatchedColl-S)*

That means if an indication with higher priority has reset while an indication with lower priority still is active at the time of reset, the LED will change color according to figure 205.

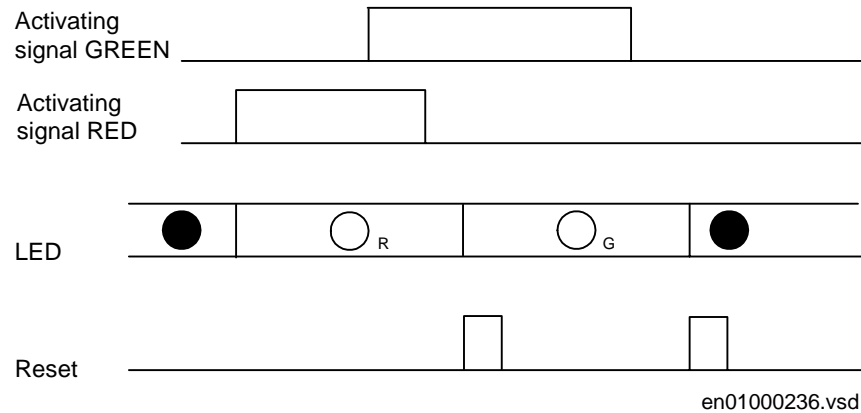

Figure 205: Operating sequence 5, two colors

### Sequence 6 (LatchedReset-S)

In this mode all activated LEDs, which are set to sequence 6 (LatchedReset-S), are automatically reset at a new disturbance when activating any input signal for other LEDs set to sequence 6 (LatchedReset-S). Also in this case indications that are still activated will not be affected by manual reset, i.e. immediately after the positive edge of that the manual reset has been executed a new reading and storing of active signals is performed. LEDs set for sequence 6 are completely independent in its operation of LEDs set for other sequences.

### Definition of a disturbance

A disturbance is defined to last from the first LED set as LatchedReset-S is activated until a settable time,  $t_{Restart}$ , has elapsed after that all activating signals for the LEDs set as LatchedReset-S have reset. However if all activating signals have reset and some signal again becomes active before  $t_{Restart}$  has elapsed, the  $t_{Restart}$  timer does not restart the timing sequence. A new disturbance start will be issued first when all signals have reset after  $t_{Restart}$  has elapsed. A diagram of this functionality is shown in figure 206.

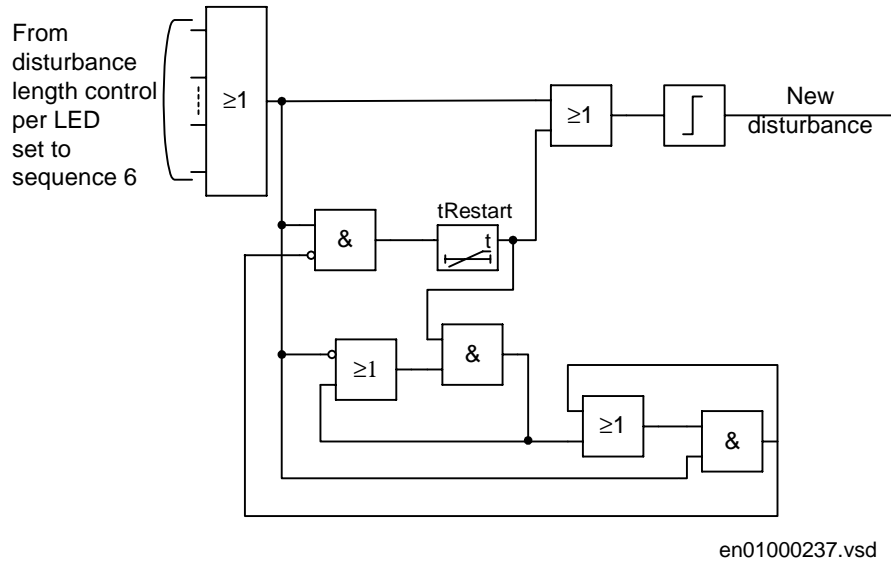

Figure 206: Activation of new disturbance

In order not to have a lock-up of the indications in the case of a persisting signal each LED is provided with a timer, tMax, after which time the influence on the definition of a disturbance of that specific LED is inhibited. This functionality is shown in diagram in figure 207.

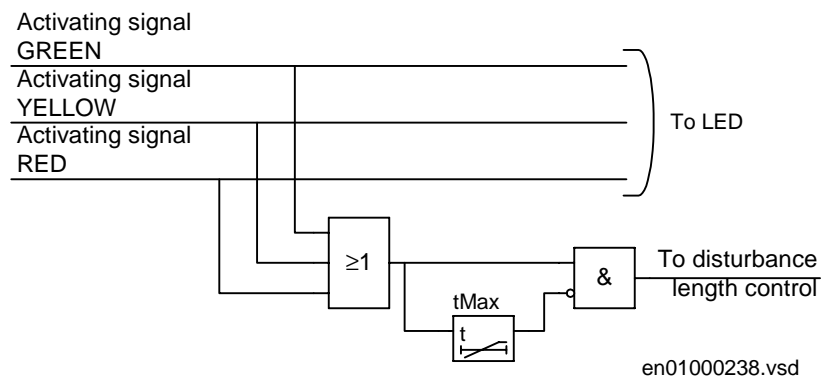
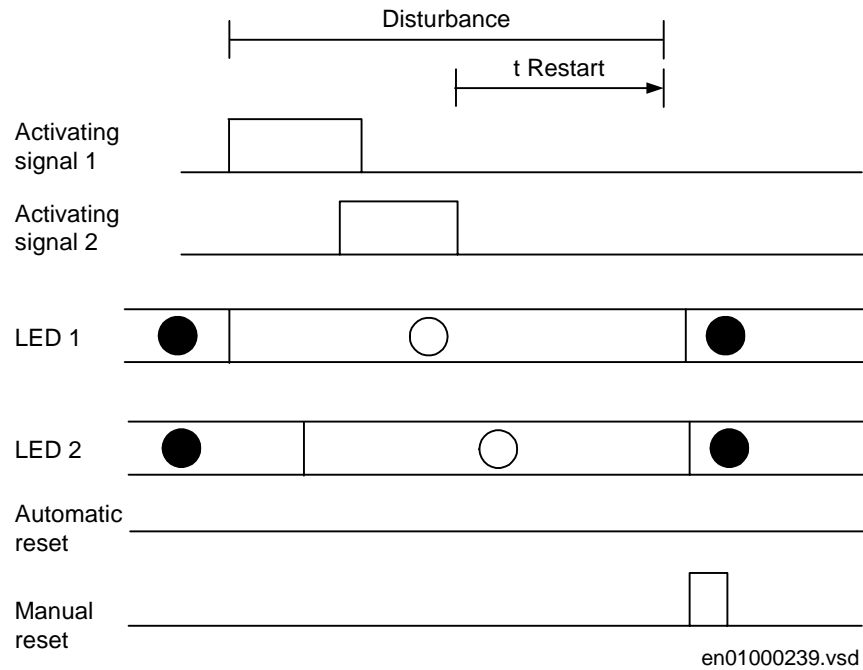

Figure 207: Length control of activating signals

**Timing diagram for sequence 6**

Figure 208 shows the timing diagram for two indications within one disturbance.



*Figure 208: Operating sequence 6 (LatchedReset-S), two indications within same disturbance*

Figure 209 shows the timing diagram for a new indication after  $t_{Restart}$  time has elapsed.

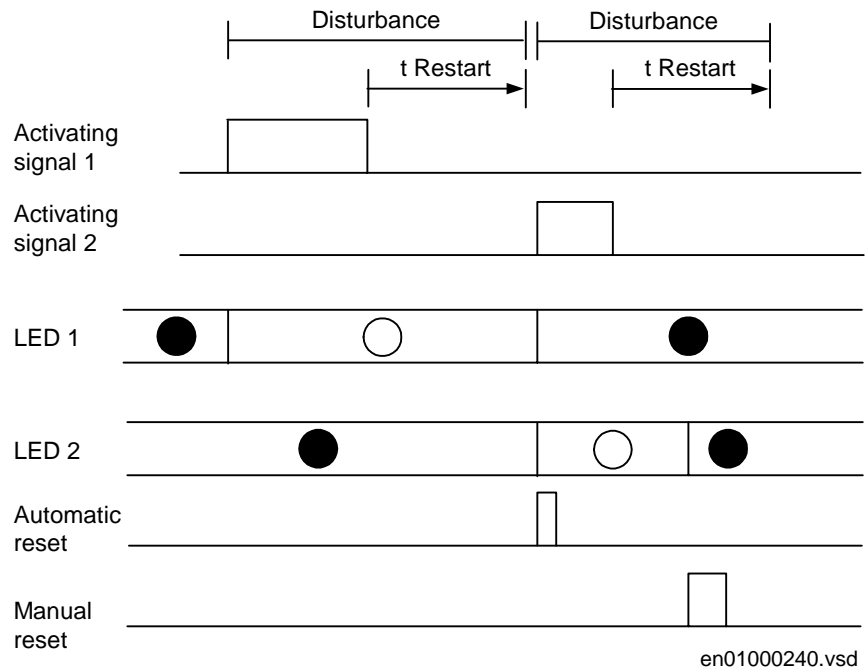

Figure 209: Operating sequence 6 (LatchedReset-S), two different disturbances

Figure 210 shows the timing diagram when a new indication appears after the first one has reset but before  $t_{Restart}$  has elapsed.

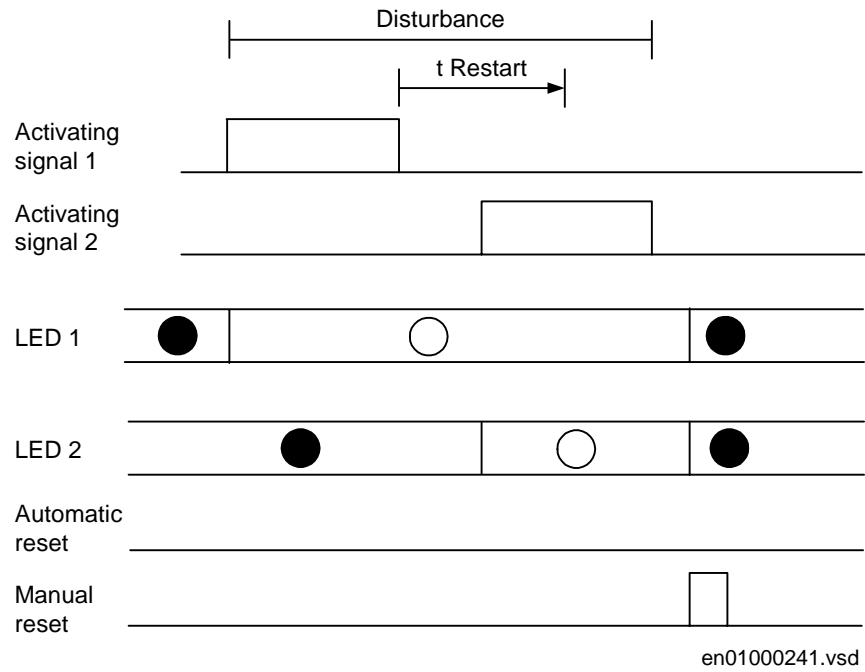

Figure 210: Operating sequence 6 (LatchedReset-S), two indications within same disturbance but with reset of activating signal between

Figure 211 shows the timing diagram for manual reset.



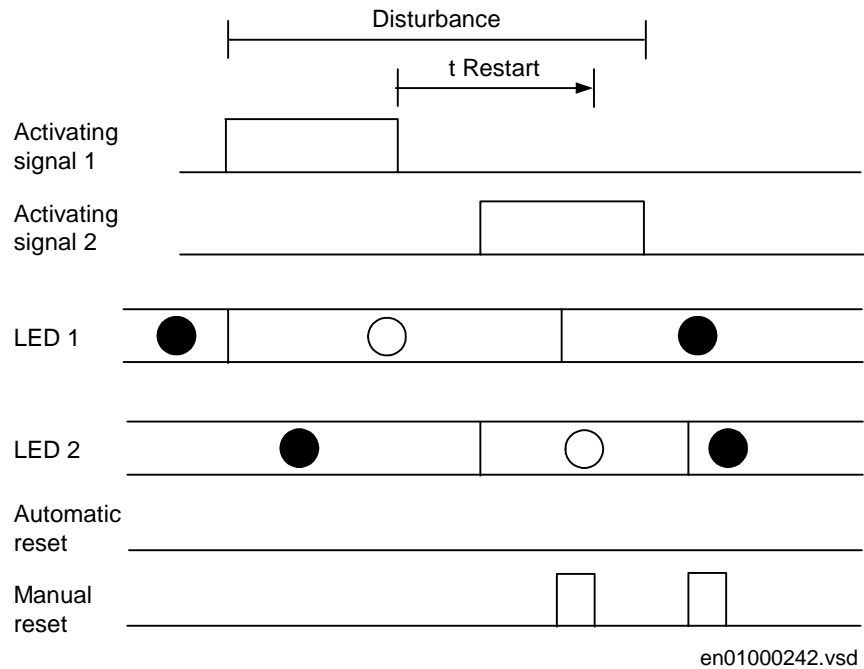

Figure 211: Operating sequence 6 (LatchedReset-S), manual reset

### 1.3

#### Calculations

Settings can be performed from the local HMI in a separate menu-tree or from the PST. Change of settings is restricted by the activation of a local HMI function.

From the local HMI, the parameters can be set via the sub-menu:

**Setting**  
**Functions**  
**Groupx**  
**HMI LED**

---

## 2 Disturbance report (DRP)

### 2.1 Application

Use the disturbance report to provide the network operator with proper information about disturbances in the primary network. Continuous collection of system data and, at occurrence of a fault, storing of a certain amount of pre-fault, fault and post-fault data, contributes to the highest possible quality of electrical supply. The stored data can be used for analysis and decision making to find and eliminate possible system and equipment weaknesses.

The function comprises several sub functions enabling different users to access relevant information in a structured way.

### 2.2 Functionality

The disturbance report is a common name for several facilities to supply the operator with more information about the disturbances in the system. Some of the facilities are basic and some are optional in the different products. For some products not all facilities are available.

The facilities included in the disturbance report are:

- General disturbance information
- Indications
- Event recorder
- Fault locator
- Trip values (phase values)
- Disturbance recorder

The whole disturbance report can contain information for up to 10 disturbances, each with the data coming from all the parts mentioned above, depending on the options installed. All information in the disturbance report is stored in non-volatile flash memories. This implies that no information is lost in case of loss-of-power supply

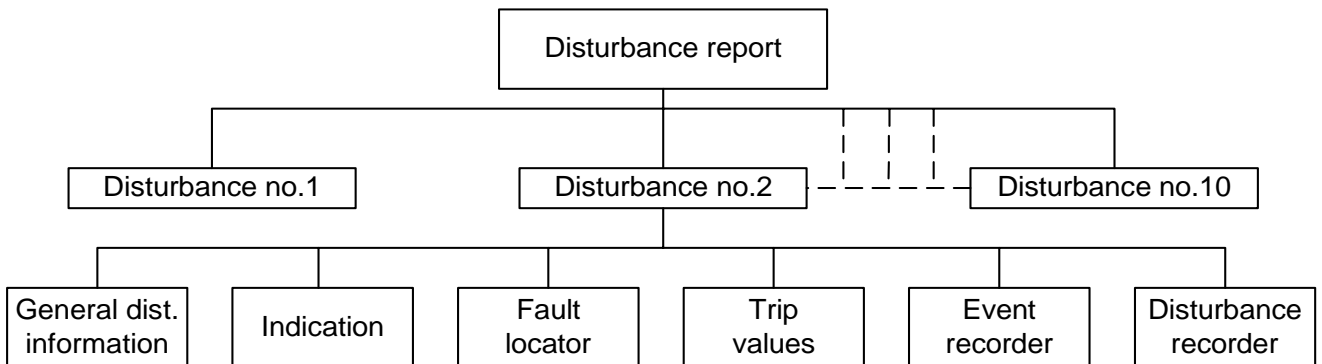

99000311.vsd

Figure 212: Disturbance report structure

Up to 10 disturbances can always be stored. If a new disturbance is to be recorded when the memory is full, the oldest disturbance is over-written by the new one. The nominal memory capacity for the disturbance recorder is measured with 10 analog and 48 binary signals recorded, which means that in the case of long recording times, fewer than 10 disturbances are stored. If fewer analog signals are recorded, a longer total recording time is available. This memory limit does not affect the rest of the disturbance report.

#### Disturbance information

The indications, the fault locator result (when applicable), and the trip values are available on the local HMI. For a complete disturbance report, front communication with a PC or remote communication with SMS is required.

**Disturbance overview** is a summary of all the stored disturbances. The overview is available only on a front-connected PC or via the Station Monitoring System (SMS). The overview contains:

- Disturbance index
- Date and time
- Trip signals
- Trigger signal that activated the recording
- Distance to fault (requires Fault locator)
- Fault loop selected by the Fault locator (requires Fault locator)

**Disturbance Summary** is automatically scrolled on the local human-machine interface (HMI). Here the two latest disturbances (DisturbSummary 1, which is the latest and DisturbSummary 2 which is the second latest) are presented with:

- Date and time
- Selected indications (set with the Indication mask)
- Distance to fault and fault loop selected by the Fault locator

Disturbance data on the HMI is presented at:

### **DisturbReport/Disturbances/Disturbance n (n=1 - 10)**

The date and time of the disturbance, the trigger signal, the indications, the fault locator result and the trip values are available, provided that the corresponding functions are installed.

#### **Indications**

Indications is a list of signals that were activated during the fault time of the disturbance. A part (or all) of these signals are automatically scrolled on the local HMI after a disturbance.

#### **Event recorder**

The event recorder contains an event list with time-tagged events. In the Station Monitoring System, this list is directly connected to a disturbance.

#### **Fault locator**

The fault locator contains information about the distance to the fault and about the measuring loop that was selected for the calculation. After changing the system parameters in the terminal, a recalculation of the distance to the fault can be made in the protection

#### **Trip values**

Trip values includes phasors of currents and voltages before the fault and during the fault

#### **Disturbance recorder**

The disturbance recorder records analog and binary signal data before, during and after the fault.

#### **Recording times**

The disturbance report records information about a disturbance during a settable time-frame. The recording times are valid for the whole disturbance report. The disturbance recorder and the event recorder register disturbance data and events during *tRecording*, the total recording time. Indications are only registered during the fault time.

The total recording time, *tRecording*, of a recorded disturbance is:

$t_{\text{Recording}} = t_{\text{Pre}} + t_{\text{Fault}} + t_{\text{Post}}$  or  $t_{\text{Pre}} + t_{\text{Lim}}$ , depending on which criterion stops the current disturbance recording

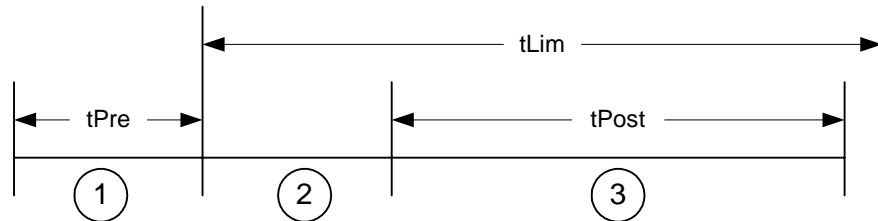

xx00000316.vsd

**Table 14: Definitions**

1	Pre-fault or pre-trigger recording time. The time before the fault including the operate time of the trigger. Use the setting $t_{\text{Pre}}$ to set this time.
2	Fault time of the recording. The fault time cannot be set. It continues as long as any valid trigger condition, binary or analog, persists (unless limited by $t_{\text{Lim}}$ the limit time).
3	Post fault recording time. The time the disturbance recording continues after all activated triggers are reset. Use the setting $t_{\text{Post}}$ to set this time.
$t_{\text{Lim}}$	Limit time. The maximum allowed recording time after the disturbance recording was triggered. The limit time is used to eliminate the consequences of a trigger that does not reset within a reasonable time interval. It limits the maximum recording time of a recording and prevents subsequent overwriting of already stored disturbances. Use the setting $t_{\text{Lim}}$ to set this time.

*Figure 213: The recording times definition***Analog signals**

Up to 10 analog signals (five voltages and five currents from the transformer module) can be selected for recording and triggering if the disturbance recorder function is installed. If fewer than 10 signals are selected, the maximum storing capacity in the flash memories, regarding total recording time are increased.

A user-defined name for each of the signals can be programmed in the terminal.

---

For each of the 10 analog signals, *Operation = On* means that it is recorded by the disturbance recorder. The trigger is independent of the setting of *Operation*, and triggers even if operation is set to *Off*. Both undervoltage and overvoltage can be used as trigger condition. The same applies for the current signals.

The check of the trigger condition is based on peak-to-peak values. When this is found, the absolute average value of these two peak values is calculated. If the average value is above the threshold level for an overvoltage or overcurrent trigger, this trigger is indicated with a greater than (>) sign with the user-defined name.

If the average value is below the set threshold level for an undervoltage or undercurrent trigger, this trigger is indicated with a less than (<) sign with its name. The procedure is separately performed for each channel.

This method of checking the analog start conditions gives a function which is insensitive to DC offset in the signal. The operate time for this start is typically in the range of one cycle, 20 ms for a 50 Hz network.

The analog signals are presented only in the disturbance recording, but they affect the entire disturbance report when being used as triggers.

### **Binary signals**

Up to 48 binary signals can be selected from the signal list, where all available signals are grouped under each function. The 48 signals can be selected from internal logical signals and binary input signals. Each of the 48 signals can be selected as a trigger of the disturbance report. It is also possible to set if the trigger should be activated on a logic 1 or a logic 0. A binary signal can be selected to activate the red LED on the local HMI.

A user-defined name for each of the signals can be programmed in the terminal.

The selected 48 signals are presented in the event list and the disturbance recording. But they affect the whole disturbance report when they are used as triggers.

The indications, that are to be automatically scrolled on the HMI when a disturbance has been recorded are also selected from these 48 signals with the HMI Indication Mask.

### **Trigger signals**

The trigger conditions affect the entire disturbance report. As soon as a trigger condition is fulfilled, a complete disturbance report is recorded. On the other hand, if no trigger condition is fulfilled, there is no disturbance report, no calculation of distance to fault, no indications, and so on. This implies the importance of choosing the right signals as trigger conditions.

---

A trigger can be of type:

- Manual trigger
- Binary-signal trigger
- Analog-signal trigger (over/under function)

#### **Manual trigger**

A disturbance report can be manually triggered from the local HMI, a front-connected PC, or SMS. When the trigger is activated, the manual trigger signal is generated. This feature is especially useful for testing.

Manual trigger from the local HMI is found at:

**DisturbReport**  
**ManualTrig**

#### **Binary trigger**

Any binary signal state (logic one or a logic zero) can be selected to generate a trigger. The binary signal must remain in a steady state for at least 15 ms to be valid.

When a binary signal is selected to generate a trigger from a logic zero, the selected signal will not be listed in the indications list of the disturbance report.

#### **Analog trigger**

All analog signals are available for trigger purposes, no matter if they are recorded in the disturbance recorder or not. But the disturbance recorder function must be installed in the terminal.

#### **Retrigger**

Under certain circumstances the fault condition may reoccur during the postfault recording, for instance by automatic reclosing to a still faulty network. In order to capture the new fault it is possible to allow retriggering during the PostFault recording.

## **2.3**

### **Calculations**

The main part of the settings for the Disturbance Report is found on the local human-machine interface (HMI) at:

### Settings

#### DisturbReport

The settings include:

<b>Operation</b>	Disturbance Report (On/Off)
<b>ReTrig</b>	Re-trigger during post-fault state (On/Off)
<b>SequenceNo</b>	Sequence number (0-255) (normally not necessary to set)
<b>RecordingTimes</b>	Recording times for the Disturbance Report and the event/indication logging, including pre-fault time, post-fault time, and limit time for the entire disturbance
<b>BinarySignals</b>	Selection of binary signals, trigger conditions, HMI indication mask and HMI red LED option
<b>AnalogSignals</b>	Recording mask and trigger conditions
<b>FaultLocator</b>	Distance measurement unit (km/miles/%) km or miles selected under line reference

User-defined names of analog signals can be set at:

### Configuration

#### AnalogInputs

The user-defined names of binary signals can be set at:

### Configuration

#### DisturbReport

##### Input n (n=1-48)

The analog and binary signals appear with their user-defined names.



**Settings during normal conditions****Table 15: How the settings affect different functions in the disturbance report**

HMI Setting menu	Function	Disturbance summary (on HMI)	Disturbance recorder	Indications	Event list (SMS)	Trip values	Fault locator
Operation	Operation (On/Off)	Yes	Yes	Yes	Yes	Yes	Yes
Recording times	Recording times (tPre, tPost, tLim)	No	Yes	No	Yes	No	No
Binary signals	Trigger operation and trigger level	Yes	Yes	Yes	Yes	Yes	Yes
	Indication mask (for automatic scrolling)	Yes	No	No	No	No	No
Analog signals	Operation (On/Off)	No	Yes	No	No	Yes	Yes
	Trigger over/under function	Yes	Yes	Yes	Yes	Yes	Yes
Fault Locator	Fault locator settings (Distance Unit)	No	No	No	No	No	Yes

**Operation**

HMI submenu:

**Settings****DisturbReport****Operation**

Operation can be set to On or Off. If Off is selected, note that no disturbance report is registered, including indications, fault locator, event recorder, and disturbance recorder.

**Operation = Off:**

- Disturbances are not stored.
- LED information (yellow - start, red - trip) is not stored or changed.
- No disturbance summary is scrolled on the local HMI.

**Operation = On:**

- Disturbances are stored, disturbance data can be read from the local HMI and from a front-connected PC or Station Monitoring System (SMS).
- LED information (yellow - start, red - trip) is stored.
- The disturbance summary is automatically scrolled on the local HMI for the two latest registered disturbances, until cleared.

Post re-trigger can be set to On or Off

**Postretrig = On:**

Re-trigger during the set post-fault time is enabled.

**Postretrig = Off:**

Re-trigger during the set post fault time is not accepted.

**Sequence number**

HMI submenu:

**Settings****DisturbReport****SequenceNo**

Normally, this setting option is seldom used. Each disturbance is assigned a number in the disturbance report. The first disturbance each day normally receives *SequenceNo* = 0. The value of *SequenceNo* that can be read in the service report is the number that will be assigned to the next disturbance registered during that day.

In normal use, the sequence number is increased by one for each new disturbance until it is reset to zero each midnight.

**Recording times**

HMI submenu:

---

**Settings****DisturbReport****RecordingTimes**

Under this submenu, the different recording times for the disturbance report are set (the pre-fault time, post-fault time, and limit time). These recording times affect the disturbance recorder and event recorder functions. The total recording time,  $t_{\text{Recording}}$ , of a recorded disturbance is:

$$t_{\text{Recording}} = t_{\text{Pre}} + t_{\text{Fault}} + t_{\text{Post}}, \text{ or } t_{\text{Pre}} + t_{\text{Lim}}, \text{ depending on which criterion stops the current disturbance recording.}$$

**Binary signals**

HMI submenu:

**Configuration****DisturbReport****Input n (n=1-48)**

Up to 48 binary signals can be selected from the signal list, where all available signals are grouped function by function. The 48 signals can be selected among internal logical signals and binary input signals. Each selected signal is registered by the disturbance recorder, event recorder, and indication functions during a recording.

A user-defined name for each of the signals can be entered. This name can comprise up to 13 characters.

HMI submenu:

**Settings****DisturbReport****BinarySignals**

For each of the 48 signals, it is also possible to select if the signal is to be used as a trigger for the start of the disturbance report (*TrigOperation*), and if the trigger should be activated at a logical 1 or 0 level (*TrigLevel*).

---

The indications in the disturbance summary, that are automatically scrolled on the HMI when a disturbance is registered, are also selected from these 48 signals using the indication mask.

### **Analog signals**

HMI submenu:

#### **Settings**

##### **DisturbReport**

##### **AnalogSignals**

This HMI submenu is only available when the disturbance recorder option is installed. For each of the 10 analog signals (five voltages and five currents), *Operation = On* means that it is recorded by the disturbance recorder. If fewer than 10 signals are selected, the maximum storing capacity in the flash memories for total recording time becomes longer.

Both undervoltage and overvoltage can be used as trigger condition. The same applies for the current signals. The trigger is independent of the setting of *Operation* and triggers even if *Operation = Off*.

A user-defined name for each of the signals can be entered. It can consist of up to 13 characters. It is found at:

#### **Configuration**

##### **AnalogInputs**

### **Behaviour during test mode**

When the terminal is set to test mode, the behaviour of the disturbance report can be controlled by the test mode disturbance report settings **Operation** and **DisturbSummary** available on the local HMI under:

#### **Test/Testmode/DisturbReport**

The impact of the settings are according to the following table:

**Table 16: Disturbance report settings**

Operation	Disturb-Summary	Then the results are...
Off	Off	<ul style="list-style-type: none"> <li>Disturbances are not stored.</li> <li>LED information is not displayed on the HMI and not stored.</li> <li>No disturbance summary is scrolled on the HMI.</li> </ul>
Off	On	<ul style="list-style-type: none"> <li>Disturbances are not stored.</li> <li>LED information (yellow - start, red - trip) are displayed on the local HMI but not stored in the terminal.</li> <li>Disturbance summary is scrolled automatically on the local HMI for the two latest recorded disturbances, until cleared.</li> <li>The information is not stored in the terminal.</li> </ul>
On	On or Off	<ul style="list-style-type: none"> <li>The disturbance report works as in normal mode.</li> <li>Disturbances are stored. Data can be read from the local HMI, a front-connected PC, or SMS.- LED information (yellow - start, red - trip) is stored.</li> <li>The disturbance summary is scrolled automatically on the local HMI for the two latest recorded disturbances, until cleared.</li> <li>All disturbance data that is stored during test mode remains in the terminal when changing back to normal mode.</li> </ul>

## 3 Indications

### 3.1 Application

The indications from all the 48 selected binary signals are shown on the local human-machine interface (HMI) and on the Station Monitoring System (SMS) for each recorded disturbance in the disturbance report. The LEDs on the front of the terminal display start and trip indications.

### 3.2 Functionality

The indications shown on the HMI and SMS give an overview of the status of the 48 event signals during the fault. On the HMI, the indications for each recorded disturbance are presented at:

#### **DisturbReport**

##### **Disturbances**

##### **Disturbance n (n=1-10)**

All selected signals can be internally produced signals or emerge from binary input channels.

The indications are registered only during the fault time of a recorded disturbance, as long as any trigger condition is activated. A part or all of these indications can be automatically scrolled on the local HMI after a disturbance is recorded, until acknowledged with the C button on the HMI. They are selected with the indication mask.

The signal name for internal logical signals presented on the screen follows the signal name, which can be found in the signal list in each function description of the “Technical reference manual”. Binary input signals are displayed with their user-defined names.

The LED indications display this information:

#### **Green LED:**

- Steady light            In Service
- Flashing light        Internal fail, the INT--FAIL internal signal is high
- Dark                    No power supply

**Yellow LED:**

- Steady light            A disturbance report is triggered
- Flashing light         The terminal is in test mode or in configuration mode

**Red LED:**

- Steady light            Trig on binary signal with HMI red LED option set
- Flashing light         The terminal is in configuration mode

**3.3****Calculations**

The signals to be displayed as indications are selected in the disturbance report setting. This can be found on the local HMI at:

**Settings****DisturbReport****BinarySignals****Input n (n=1-48)**

## 4 Disturbance recorder

### 4.1 Application

Use the disturbance recorder to achieve a better understanding of the behavior of the power network and related primary and secondary equipment during and after a disturbance. An analysis of the recorded data provides valuable information that can be used to improve existing equipment. This information can also be used when planning for and designing new installations.

The disturbance recording function in the REx 5xx terminals is characterized by great flexibility as far as starting conditions and recording times, and large storage capacity are concerned. Thus, the disturbance recorders are not dependent on the operation of protective functions, and they can record disturbances that were not discovered by protective functions for one reason or another.

The disturbance recording function in the REx 5xx terminals is fully adequate for the recording of disturbances for the protected object.

Use available software tools to retrieve the recordings and the evaluation software RE-VAL to analyze, evaluate and print recordings.

### 4.2 Functionality

Disturbance recording is based on the continuous collection of network data, analog values and binary signals, in a cyclic buffer. The buffer operates according to the FIFO principle, old data will be overwritten as new data arrives when the buffer is full. The size of this buffer is determined by the set pre-fault recording time.

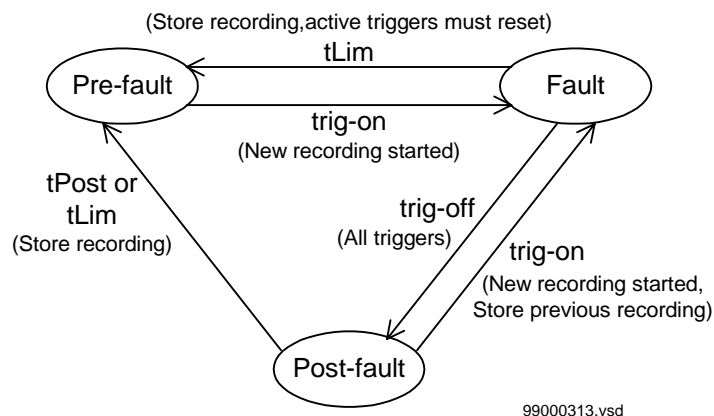



---

Upon detection of a fault condition (triggering), the data storage continues in another part of the memory. The storing goes on as long as the fault condition prevails - plus a certain additional time. The length of this additional part is called the post-fault time and it can be set in the disturbance report. The above mentioned two parts form a disturbance recording. The whole memory acts as a cyclic buffer and when it is full, the oldest recording is overwritten.

A user-defined name for each of the signals can be programmed in the terminal.

### **Recording Capacity**

The recording function can record all analog inputs in the transformer module and up to 48 binary signals. To maximise the use of the memory, the number of analog channels to be recorded is user-selectable by programming and can be set individually for each analog input. The recorded binary signals can be either true binary input signals or internal logical signals created by the functions.

### **Memory capacity**

The maximum number of recordings stored in the memory is 10. So depending on the set recording times and the recording of the enabled number of channels, the memory can contain a minimum of six and a maximum of 10 disturbance recordings comprising of both header part and data part. But the header part for the last 10 recordings is always available.

### **Time tagging**

The terminal has a built-in, real-time clock and calendar. This function is used for time tagging of the recorded disturbances. The time tagging refers to the activation of the trigger that starts the disturbance recording.

### **Signal processing**

The processing of analog signals is handled by a dedicated DSP (digital signal processor). Other functions are implemented in the main CPU. The memory is shared with other functions.

The numerical signals coming from the A/D conversion module in serial form are converted to parallel form in a dedicated DSP. The analog trigger conditions are also checked in the DSP.

A check of the start conditions is performed by searching for a maximum value. This is a positive peak. The function also seeks a minimum value, which is the negative peak.

When this is found, the absolute average value is calculated. If this value is above the set threshold level for the overfunction on the channel in question, an overfunction start on that channel is indicated. The overfunction is indicated with a greater than (>) sign.

Similarly, if the average value is below the set threshold level for underfunction on the channel in question, an underfunction start on that channel is indicated. The underfunction is indicated with a less than (<) sign.

The procedure is separately performed for each channel. This method of checking the analog start conditions gives a function that is insensitive to DC offset in the signal. The operating time for this start is typically in the range of one cycle, 20 ms in a 50 Hz network.

The numerical data, along with the result of the trigger condition evaluation, are transmitted to the main CPU. The main CPU handles these functions:

- Evaluation of the manual start condition
- Evaluation of the binary start condition, both for true binary input signals and for internally created logical signals
- Storage of the numerical values for the analog channels

The numerical data for the analog channels are stored in a cyclic pre-fault buffer in a RAM. When a trigger is activated, the data storage is moved to another area in the RAM, where the data for the fault and the subsequent post-fault period are stored. Thus, a complete disturbance recording comprises the stored data for the pre-fault, fault, and post-fault period.

The RAM area for temporary storage of recorded data is divided into sub-areas, one for each recording. The size of a subarea is governed by the sum of the set pre-fault (tPre) and maximum post-trigger (tLim) time. There is a sufficient memory capacity for at least four consecutive recordings with a maximum number of analog channels recorded and with maximum time settings. Should no such area be free at the time of a new trigger, the oldest recording stored in the RAM is overwritten.

When a recording is completed, a post recording processing occurs.

This post-recording processing comprises:

- Merging the data for analog channels with corresponding data for binary signals stored in an event buffer
- Compression of the data, which is performed without losing any data accuracy
- Storing the compressed data in a non-volatile memory (flash memory)

The recorded disturbance is now ready for retrieval and evaluation. The recording comprises the stored and time-tagged disturbance data along with relevant data from the database for configuration and parameter set-up.

Some parameters in the header of a recording are stored with the recording, and some are retrieved from the parameter database in connection with a disturbance. This means that if a parameter that is retrieved from the parameter database was changed between the time of recording and retrieval, the collected information is not correct in all parts. For this reason, all recordings should be transferred to the Station Monitoring System (SMS) workstation and then deleted in the terminal before any such parameters are changed.

### 4.3

## Design

The recordings can be divided into two parts, the header and the data part. The data part contains the numerical values of recorded analog and binary channels. The header contains clearly written basic information about the disturbance. A part of this information is also used by REVAL to reproduce the analog and binary signals in a correct and user-friendly way. Such information is primary and secondary instrument transformer ratings.

**Table 17: Disturbance header**

Parameter	Parameter data-base	Stored with disturbance
<b>General</b>		
Station, object and ID	x	
Date and time		x
Sequence number		x
CT earthing	x	
Time synchronization source	x	
Collection window parameters tPre, tPost, tLim		x
Prefault phase-to-phase voltage and current RMS values		x
Trig signal and test flag		x
<b>Analog signals</b>		
Signal name	x	
Primary and secondary instrument transformer rating	x	
Undertrig: level and operation	x	
Overtrig: level and operation	x	

Parameter	Parameter data-base	Stored with disturbance
Undertrig status at time of trig		x
Overtrig status at time of trig		x
Instantaneous phase voltage at time of trig		x
Instantaneous phase current at time of trig		x
Phase voltage and phase current before trig (prefault)		x
Phase voltage and phase current after trig (fault)		x
<b>Binary signals</b>		
Signal name		x
Type of contact (trig level)	x	
Trig operation	x	
Signal status at time of trig		x
Trig status at time of trig		x

#### 4.4

#### Calculations

The setting parameters specific for the disturbance recording function are available in the menu tree under:

---

**Settings****DisturbReport****Operation****SequenceNo****RecordingTimes****BinarySignals****AnalogSignals**

The list of parameters in the “Technical reference manual”, explains the meaning of the abbreviations used in connection with setting ranges.

Remember that values of parameters set elsewhere in the menu tree are linked to the information on a recording. Such parameters are, for example, station and object identifiers, CT and PT ratios.

The sequence number of the recordings is a specific parameter for the disturbance recorder and is used to identify the different recordings. By combining the date and the sequence number for a recording, the recording can be uniquely identified. The sequence number is also shown under:

**Settings****DisturbReport****SequenceNo**

The read value on the local human-machine interface (HMI) display is the sequence number that the next recorded disturbance receives. The number is automatically increased by one for each new recording and is reset to zero at each midnight. The sequence number can also be set manually.

---

## 5 Event recorder

### 5.1 Application

When using a front-connected PC or Station Monitoring System (SMS), an event list can be available for each of the recorded disturbances in the disturbance report. Each list can contain up to 150 time-tagged events. These events are logged during the total recording time, which depends on the set recording times (pre-fault, post-fault and limit time) and the actual fault time. During this time, the first 150 events for all the 48 selected binary signals are logged and time tagged. This list is a useful instrument for evaluating a fault and is a complement to the disturbance recorder.

To obtain this event list, the event recorder function (basic in some terminals and optional in others) must be installed.

### 5.2 Functionality

When one of the trig conditions for the disturbance report is activated, the events are collected by the main processing unit, from the 48 selected binary signals. The events can come from both internal logical signals and binary input channels. The internal signals are time tagged in the main processing module, while the binary input channels are time tagged directly on each I/O module. The events are collected during the total recording time, *tRecording*, and they are stored in the disturbance report memory at the end of each recording.

The name of the binary input signal that appears in the event list is the user-defined name that can be programmed in the terminal.

The time tagging of events emerging from internal logical signals and binary input channels has a resolution of 1 ms.

### 5.3 Calculations

The settings of the event recorder consist of the signal selection and the recording times. It is possible to select up to 48 binary signals, either internal signals or signals coming from binary input channels. These signals coincide with the binary signals recorded by the disturbance recorder. The disturbance summary indications that are to scroll automatically on the local human-machine interface (HMI), can only be selected from these 48 event channels.

The signal selection is found at:

---

**Settings****DisturbReport****BinarySignals****Input n (n=1-48)**

Each of the up to 48 event channels can be selected from the signal list, consisting of all available internal logical signals and all binary input channels.

For each of the binary input and output signals, a user-defined name can be programmed at:

**Configuration****I/O****Slotnn-XXXX (ex. Slot15-BOM3)**

## 6 Fault locator (FLOC)

### 6.1 Application

The main objective of line protection and monitoring terminals is fast, selective and reliable operation for faults on a protected line section. Besides this, information on distance to fault is very important for those involved in operation and maintenance. Reliable information on the fault location greatly decreases the downtime of the protected lines and increases the total availability of a power system.

The distance to the fault, which is calculated with a high accuracy, is stored for the last ten recorded disturbances. This information can be read on the HMI or transferred via serial communication within the Station Monitoring System (SMS) or Station Control System (SCS).

The distance to fault can be recalculated for the latest 10 disturbances by using the measuring algorithm for different fault loops or for changed system parameters.

### 6.2 Functionality

#### 6.2.1 Distance-to-fault locator

The distance-to-fault locator (FLOC-) in the REx 5xx terminals is an essential complement to different line protection functions, since it measures and indicates the distance to the fault with great accuracy. Thus, the fault can be quickly located for repairs.

The calculation algorithm considers the effect of load currents, double-end infeed and additional fault resistance.

The function indicates the distance to the fault as a percentage of the line length, in kilometers or miles as selected on the HMI.

The accuracy of measurement depends somewhat on the accuracy of the system parameters as entered into REx 5xx (for example source impedances at both ends of the protected line). If some parameters have actually changed in a significant manner relative to the set values, new values can be entered locally or remotely and a recalculation of the distance to the fault can be ordered. In this way, a more accurate location of the fault can be achieved.

In order to compensate for the influence of the zero-sequence mutual impedance  $Z_{m0}$  on the distance-to-fault calculation in case of faults on double circuit lines, the terminal has a special current transformer input for the residual current from the parallel line.



---

Any start of the disturbance reporting unit also starts the operation of the FLOC- function. The distance to the fault automatically appears on the local HMI, if the fault is also detected by the phase selection elements within the terminal. The currents and voltages before and during the fault are available via SCS/SMS. The terminal saves, in any other case, the pre-fault and fault values of currents and voltages for a particular disturbance. At any time a calculation of the distance to fault for a selected fault loop can be initiated manually.

The information on distance to fault automatically appears on the local HMI for the first fault only, if more than one fault appears within a time shorter than 10 seconds. Automatic reclosing on persistent faults enables this. In such a case the first set of data is more accurate than the second set. The unit also stores the phasors of currents and voltages for the last faults. A calculation can be initiated locally or remotely.

The percentage value is also binary coded, thus the distance to fault value can also be read on binary outputs of the terminal.

Additional information is specified in symbols before the distance-to-fault figure:

- \* A non-compensated model was used for calculation.
- E Error, the fault was found outside the measuring range.
- > The fault is located beyond the line, in forward direction.

Two signs can be combined, for example, \*>.

### 6.3

#### Measuring principle

For transmission lines with voltage sources at both line ends, the effect of double-end infeed and additional fault resistance must be considered when calculating the distance to the fault from the currents and voltages at one line end. If this is not done, the accuracy of the calculated figure will vary with the load flow and the amount of additional fault resistance.

The calculation algorithm used in the distance-to-fault locator in REx 5xx line-protection terminals compensates for the effect of double-end infeed, additional fault resistance and load current.

6.3.1

**Accurate algorithm for measurement of distance to fault**

Figure 214 shows a single-line diagram of a single transmission line, that is fed from both ends with source impedances  $Z_A$  and  $Z_B$ . Assume, that the fault occurs at a distance  $F$  from terminal A on a line with the length  $L$  and impedance  $Z_L$ . The fault resistance is defined as  $R_F$ . A single-line model is used for better clarification of the algorithm.

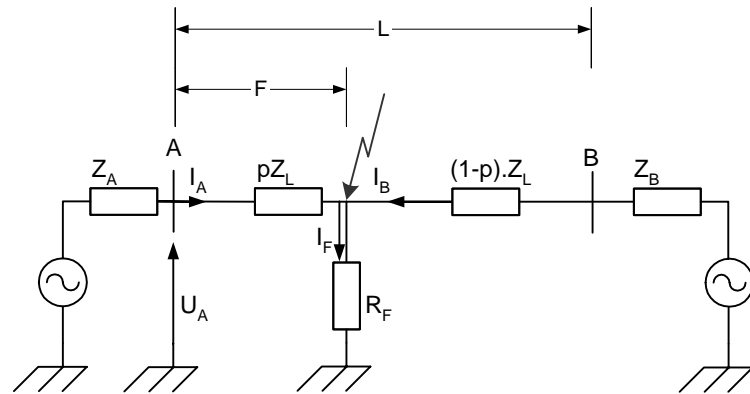

xx01000171.vsd

Figure 214: Fault on transmission line fed from both ends.

From figure 214 it is evident that:

$$U_A = I_A \cdot p \cdot Z_L + I_F \cdot R_F$$

(Equation 288)

Where:

$I_A$  is the line current after the fault, that is, pre-fault current plus current change due to the fault,

$I_F$  is the fault current and

$p$  is a relative distance to the fault

The fault current is expressed in measurable quantities by:

$$I_F = \frac{I_{FA}}{D_A}$$

(Equation 289)

Where:

$I_{FA}$  is the change in current at the point of measurement, terminal A and  
 $D_A$  is a fault current-distribution factor, that is, the ratio between the fault current at line end A and the total fault current.

For a single line, the value is equal to:

$$D_A = \frac{(1-p) \cdot Z_L + Z_B}{Z_A + Z_L + Z_B}$$

(Equation 290)

In case of phase short circuits, the change in the line currents is used directly. For earth faults, the better defined positive-sequence quantities, which eliminate the influence of the zero sequence currents of the network are used.

Thus, the general fault location equation for a single line is:

$$U_A = I_A \cdot p \cdot Z_L + \frac{I_{FA}}{D_A} \cdot R_F$$

(Equation 291)

The expressions for  $U_A$ ,  $I_A$  and  $I_{FA}$  for different types of faults are in table 18 below.**Table 18:**

Fault type:	$U_A$	$I_A$	$I_{FA}$
L1-N	$U_{L1A}$	$I_{L1A} + K_N \times I_{NA}$	$\frac{3}{2} \times \Delta(I_{L1A} - I_{0A})$
L2-N	$U_{L2A}$	$I_{L2A} + K_N \times I_{NA}$	$\frac{3}{2} \times \Delta(I_{L2A} - I_{0A})$
L3-N	$U_{L3A}$	$I_{L3A} + K_N \times I_{NA}$	$\frac{3}{2} \times \Delta(I_{L3A} - I_{0A})$

Fault type:	U <sub>A</sub>	I <sub>A</sub>	I <sub>FA</sub>
L1-L2-L3, L1-L2, L1-L2-N	U <sub>L1A</sub> -U <sub>L2A</sub>	I <sub>L1A</sub> - I <sub>L2A</sub>	ΔI <sub>L1L2A</sub>
L2-L3, L2-L3-N	U <sub>L2A</sub> -U <sub>L3A</sub>	I <sub>L2A</sub> - I <sub>L3A</sub>	ΔI <sub>L2L3A</sub>
L3-L1, L3-L1-N	U <sub>L3A</sub> -U <sub>L1A</sub>	I <sub>L3A</sub> - I <sub>L1A</sub>	ΔI <sub>L3L1A</sub>

The  $K_N$  complex quantity for zero-sequence compensation for the single line is equal to:

$$K_N = \frac{Z_{0L} - Z_{1L}}{3 \cdot Z_{1L}}$$

(Equation 292)

ΔI is the change in current, that is the current after the fault minus the current before the fault.

In the following, the positive sequence impedance for  $Z_A$ ,  $Z_B$  and  $Z_L$  is inserted into the equations, because this is the value used in the algorithm.

For double lines, the fault equation is:

$$U_A = I_A \cdot p \cdot Z_{1L} + \frac{I_{FA}}{D_A} \cdot R_F + I_{0P} \cdot Z_{0M}$$

(Equation 293)

Where:

$I_{0P}$  is a zero sequence current of the parallel line,

$Z_{0M}$  is a mutual zero sequence impedance and

$D_A$  is the distribution factor of the parallel line, which is:

$$D_A = \frac{(1-p) \cdot (Z_A + Z_{AL} + Z_B) + Z_B}{2 \cdot Z_A + Z_L + 2 \cdot Z_B}$$

(Equation 294)

The  $K_N$  compensation factor for the double line becomes:

$$K_N = \frac{Z_{0L} - Z_{1L}}{3 \cdot Z_{1L}} + \frac{Z_{0M}}{3 \cdot Z_{1L}} \cdot \frac{I_{0P}}{I_{0A}}$$

(Equation 295)

From these equations it can be seen, that, if  $Z_{0m} = 0$ , then the general fault location equation for a single line is obtained. Only the distribution factor differs in these two cases.

Because the  $D_A$  distribution factor according to equation 290 or 294 is a function of  $p$ , the general equation 293 can be written in the form:

$$p^2 - p \cdot K_1 + K_2 - K_3 \cdot R_F = 0$$

(Equation 296)

Where:

$$K_1 = \frac{U_A}{I_A \cdot Z_L} + \frac{Z_B}{Z_L + Z_{ADD}} + 1$$

(Equation 297)

$$K_2 = \frac{U_A}{I_A \cdot Z_L} \cdot \left( \frac{Z_B}{Z_L + Z_{ADD}} + 1 \right)$$

(Equation 298)

$$K_3 = \frac{I_{FA}}{I_A \cdot Z_L} \cdot \left( \frac{Z_A + Z_B}{Z_1 + Z_{ADD}} + 1 \right)$$

(Equation 299)

and:

- $Z_{ADD} = Z_A + Z_B$  for parallel lines.
- $I_A$ ,  $I_{FA}$  and  $U_A$  are given in the above table.
- $K_N$  is calculated automatically according to equation 295.
- $Z_A$ ,  $Z_B$ ,  $Z_L$ ,  $Z_{0L}$  and  $Z_{0M}$  are setting parameters.

For a single line,  $ZOM = 0$  and  $ZADD = 0$ . Thus, equation 296 applies to both single and parallel lines.

Equation 296 can be divided into real and imaginary parts:

$$p^2 - p \cdot \text{Re}(K_1) + \text{Re}(K_2) - R_F \cdot \text{Re}(K_3) = 0$$

(Equation 300)

$$-p \cdot \text{Im} \cdot (K_1) + \text{Im} \cdot (K_2) - R_F \cdot \text{Im} \cdot (K_3) = 0$$

(Equation 301)

If the imaginary part of  $K_3$  is not zero,  $R_F$  can be solved according to equation 301, and then inserted to equation 300. According to equation 300, the relative distance to the fault is solved as the root of a quadratic equation.

Equation 300 gives two different values for the relative distance to the fault as a solution. A simplified load compensated algorithm, that gives an unequivocal figure for the relative distance to the fault, is used to establish the value that should be selected.

If the load compensated algorithms according to the above do not give a reliable solution, a less accurate, non-compensated impedance model is used to calculate the relative distance to the fault.

### 6.3.2

#### The non-compensated impedance model

In the non-compensated impedance model,  $I_A$  line current is used instead of  $I_{FA}$  fault current:

$$U_A = p \cdot Z_{1L} \cdot I_A + R_F \cdot I_A$$

(Equation 302)

Where:

$I_A$  is according to table 18.

The accuracy of the distance-to-fault calculation, using the non-compensated impedance model, is influenced by the pre-fault load current. So, this method is only used if the load compensated models do not function and the display indicates whether the non-compensated model was used when calculating the distance to the fault.

## 6.4

### Design

When calculating the distance to fault, pre-fault and fault phasors of currents and voltages are filtered from disturbance data stored in digital sample buffers.

When the disturbance report function is triggered, the fault locator function starts to calculate the frequency of the analogue channel U1. If the calculation fails, a default frequency is read from the database to ensure further execution of the function.

Then the sample for the fault interception is looked for by checking the non-periodic changes. The channel search order is U1, U2, U3, I1, I2, I3, I4, I5 and U5.

If no error sample is found, the trig sample is used as the start sample for the Fourier estimation of the complex values of currents and voltages. The estimation uses samples during one period before the trig sample. In this case the calculated values are used both as pre-fault and fault values.

If an error sample is found the Fourier estimation of the pre-fault values starts 1.5 period before the fault sample. The estimation uses samples during one period. The post-fault values are calculated using the Recursive Least Squares (RLS) method. The calculation starts a few samples after the fault sample and uses samples during  $1/2 - 2$  periods depending on the shape of the signals.

The pre-fault time ( $t_{Pre}$ ) should be at least 0.1 s to ensure enough samples for the estimation of pre-fault trip values.

The phase selectors from the distance protection function provide the necessary information for the selection of the loop to be used for the calculation. The following loops are used for different types of faults:

- for 3 phase faults: loop L1 - L2.
- for 2 phase faults: the loop between the faulted phases.
- for 2 phase to earth faults: the loop between the faulted phases.
- for phase to earth faults: the phase to earth loop.

## 6.5

### Calculations

The system parameters required for the correct operation of a FLOC function are available under:

**Settings**

**Functions**

**Group n (n=1-4)**

**LineReference**

The list of parameters (see the setting parameters in the Technical reference manual) explains the meaning of the abbreviations. Figure 215 also presents these system parameters graphically. Note, that all impedance values relate to their secondary values and to the total length of the protected line. The conversion procedure follows the same rules as for the distance-protection function.

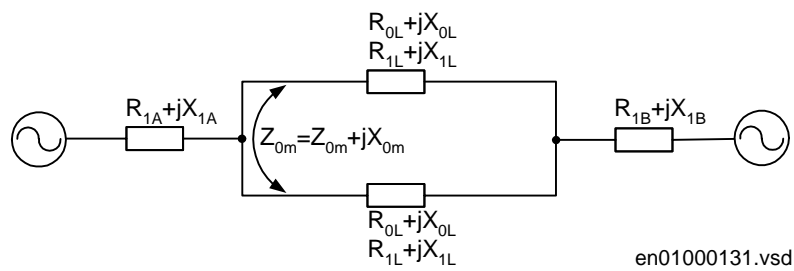

Figure 215: Simplified network configuration with network data, required for settings of the fault location-measuring function.

For a single-circuit line, the figures for mutual zero-sequence impedance ( $X_{0M}$ ,  $R_{0M}$ ) are set at zero.

The source impedance is not constant in the network. However, this has a negligible influence on the accuracy of the distance-to-fault calculation, because only the phase angle of the distribution factor has an influence on the accuracy. The phase angle of the distribution factor is normally very low and practically constant, because it is dominated by the positive-sequence line impedance, which has an angle close to  $90^\circ$ . Always set the source impedance resistance to values other than zero. If the actual values are not known, the values that correspond to the source impedance characteristic angle of  $85^\circ$  give satisfactory results.



---

## 7 Trip value recorder

### 7.1 Application

The main objective of line protection and monitoring terminals is fast, selective and reliable operation for faults on a protected object. Besides this, information on the values of the currents and voltages before and during the fault is valuable to understand the severity of the fault.

The trip value recorder in the REx 5xx series of terminals provides this information on the HMI and via SCS/SMS. The function is an optional software module in the terminal.

The function calculates the pre-fault and fault values of currents and voltages and presents them as phasors with amplitude and argument.

### 7.2 Design

Pre-fault and fault phasors of currents and voltages are filtered from disturbance data stored in digital sample buffers.

When the disturbance report function is triggered, the trip value recorder function starts to calculate the frequency of the analogue channel U1. If the calculation fails, a default frequency is read from database to ensure further execution of the function.

Then the sample for the fault interception is looked for by checking the non-periodic changes. The channel search order is U1, U2, U3, I1, I2, I3, I4, I5 and U5.

If no error sample is found, the trig sample is used as the start sample for the Fourier estimation of the complex values of currents and voltages. The estimation uses samples during one period before the trig sample. In this case the calculated values are used both as pre-fault and fault values.

If an error sample is found the Fourier estimation of the prefault values starts 1.5 period before the fault sample. The estimation uses samples during one period. The postfault values are calculated using the Recursive Least Squares (RLS) method. The calculation starts a few samples after the fault sample and uses samples during  $1/2 - 2$  periods depending on the shape of the signals.

The pre-fault time ( $t_{Pre}$ ) should be at least 0.1 s to ensure enough samples for the estimation of pre-fault trip values.

---

## 7.3

### Calculations

Customer specific names for all the ten analogue inputs (five currents and five voltages) can be entered. Each name can have up to 13 alphanumeric characters. These names are common for all functions within the disturbance report functionality.

The user-defined names for the analogue inputs are set under the menu:

**Configuration**

**AnalogInputs**

**U1 (U2..U5, I1..I5)**

---

## 8 Monitoring of AC analog measurements

### 8.1 Application

Fast, reliable supervision of different analogue quantities is of vital importance during the normal operation of a power system.

Operators in the control centres can, for example:

- Continuously follow active and reactive power flow in the network
- Supervise the busbar voltage and frequency

Different measuring methods are available for different quantities. Current and voltage instrument transformers provide the basic information on measured phase currents and voltages in different points within the power system. At the same time, currents and voltages serve as the input measuring quantities to power and energy meters, protective devices and so on.

Further processing of this information occurs within different control, protection, and monitoring terminals and within the higher hierarchical systems in the secondary power system.

### 8.2 Functionality

The REx 5xx protection, control, and monitoring terminals have as basic the functionality to measure and further process information about up to five input currents and five input voltages. The number of processed alternate measuring quantities depends on the type of terminal and built-in options. Additional information is also available:

- Mean values of measured currents  $I$  in the first three current measuring channels.
- Mean values of measured voltages  $U$  in the first three voltage measuring channels.
- Three-phase active power  $P$  as measured by the first three current and voltage measuring channels.
- Three-phase reactive power  $Q$  as measured by the first three current and voltage measuring channels.
- Three-phase apparent power  $S$  as measured by the first three current and voltage measuring channels.
- Frequency  $f$ .

---

The accuracy of measurement depends on the requirements. Basic accuracy satisfies the operating (information) needs. An additional calibration of measuring channels is necessary and must be ordered separately when the requirements on accuracy of the measurement are higher. Refer to the technical data and ordering particulars for the particular terminal.

The information on measured quantities is then available for the user at different locations:

- Locally by means of the local human-machine interface (HMI) unit.
- Locally by means of a front-connected personal computer (PC).
- Remotely over the LON bus to the station control system (SCS)
- Remotely over the SPA port to the station monitoring system (SMS).

#### **User-defined measuring ranges**

Each measuring channel has an independent measuring range from the others. This allows the users to select the most suitable measuring range for each measuring quantity on each monitored object of the power system. This gives a possibility to optimize the functionality of the power system.

#### **Continuous monitoring of the measured quantity**

Users can continuously monitor the measured quantity in each channel by means of four built-in operating thresholds (figure 216). The monitoring has two different modes of operating:

- Overfunction, when the measured current exceeds the HiWarn or HiAlarm pre-set values.
- Underfunction, when the measured current decreases under the LowWarn or LowAlarm pre-set values.

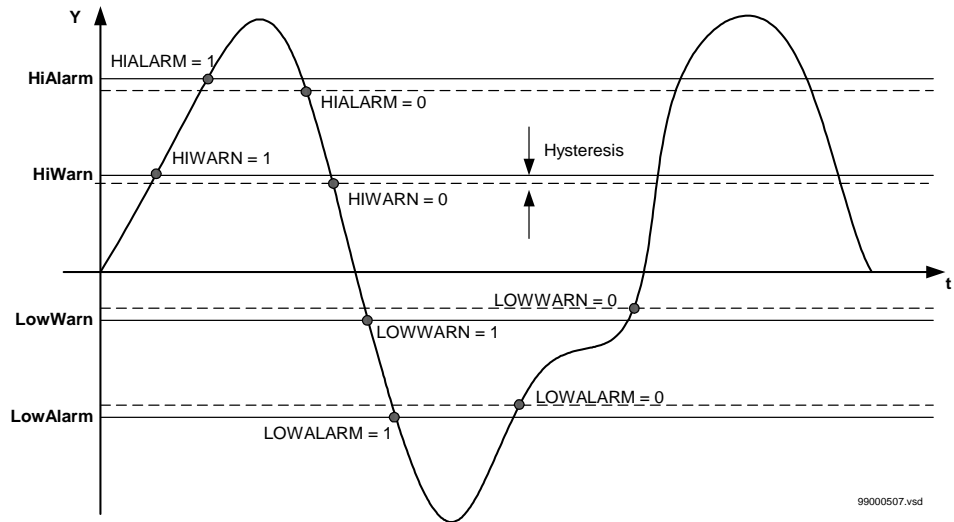

Figure 216: Presentation of the operating limits.

Each operating level has its corresponding functional output signal:

- HIWARN
- HIALARM
- LOWWARN
- LOWALARM

The logical value of the functional output signals changes according to Figure 216.

The user can set the hysteresis, which determines the difference between the operating and reset value at each operating point, in wide range for each measuring channel separately. The hysteresis is common for all operating values within one channel.

### Continuous supervision of the measured quantity

The actual value of the measured quantity is available locally and remotely. The measurement is continuous for each channel separately, but the reporting of the value to the higher levels depends on the selected reporting mode. The following basic reporting modes are available:

- Periodic reporting.
- Periodic reporting with dead-band supervision in parallel.
- Periodic reporting with dead-band supervision in series.
- Dead-band reporting.

Users can select between two types of dead-band supervision:

- Amplitude dead-band supervision (ADBS).
- Integrating dead-band supervision (IDBS).

### Amplitude dead-band supervision

If a measuring value is changed, compared to the last reported value, and the change is larger than the  $\pm \Delta Y$  predefined limits that are set by user, then the measuring channel reports the new value to a higher level, if this is detected by a new measuring sample. This limits the information flow to a minimum necessary. Figure 217 shows an example of periodic reporting with the amplitude dead-band supervision. The picture is simplified: the process is not continuous but the values are evaluated with a time interval of one second from each others.

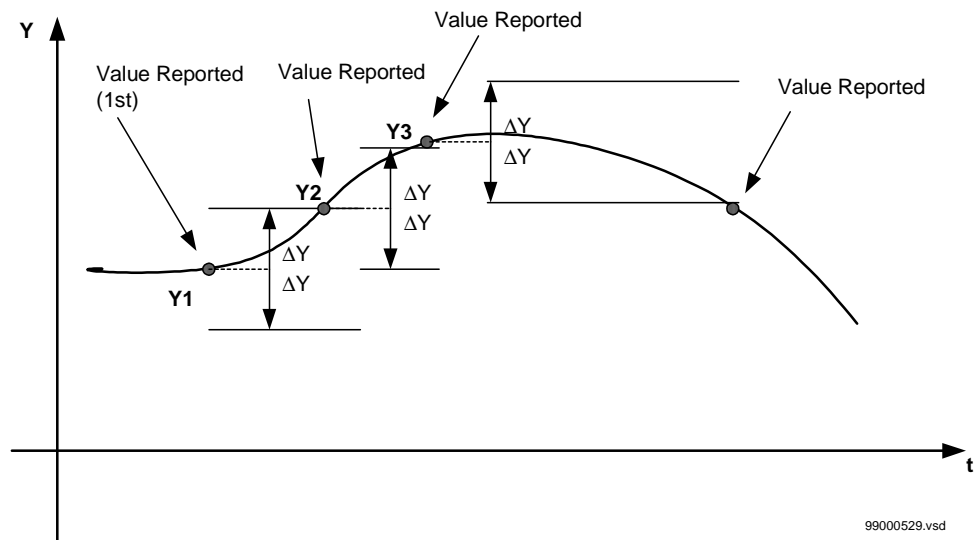
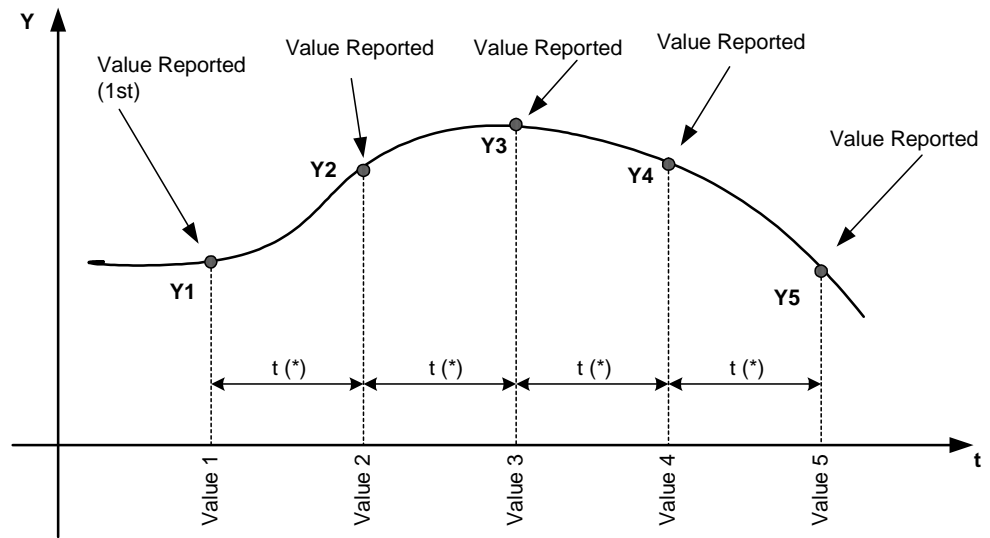

Figure 217: Amplitude dead-band supervision reporting

After the new value is reported, the  $\pm \Delta Y$  limits for dead-band are automatically set around it. The new value is reported only if the measured quantity changes more than defined by the  $\pm \Delta Y$  set limits.





(\*)Set value for t: Replnt

99000528.vsd

Figure 219: Periodic reporting.

#### Periodic reporting with parallel dead-band supervision

The newly measured value is reported:

- After each time interval for the periodic reporting expired or
- When the new value is detected by the dead-band supervision function.

The amplitude dead-band and the integrating dead-band can be selected. The periodic reporting can be set in time intervals between 1 and 3600 seconds.



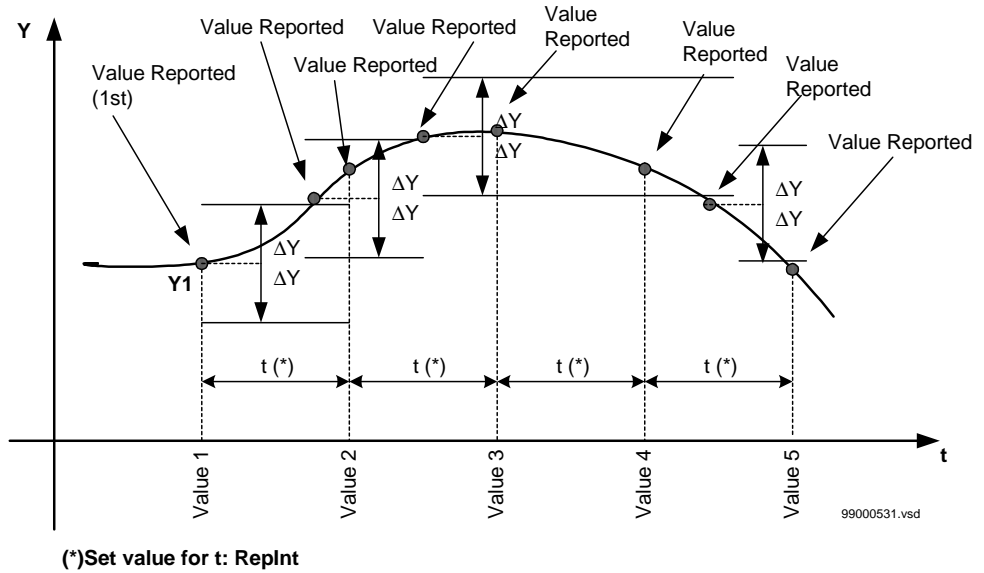
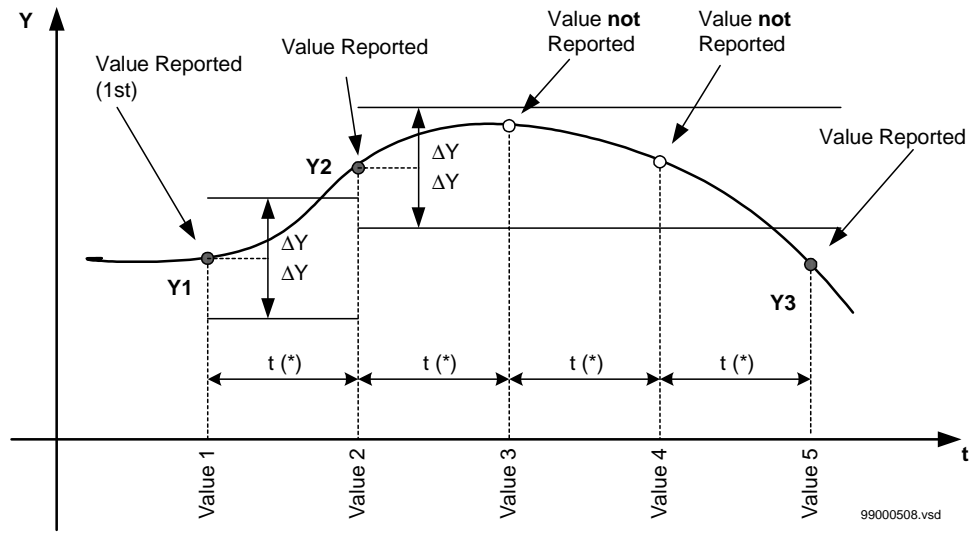

Figure 220: Periodic reporting with amplitude dead-band supervision in parallel.

#### Periodic reporting with serial dead-band supervision

Periodic reporting can operate serially with the dead-band supervision. This means that the new value is reported only if the set time period expired and if the dead-band limit was exceeded during the observed time (figures 221 and 222). The amplitude dead-band and the integrating dead-band can be selected. The periodic reporting can be set in time intervals between 1 and 3600 seconds.



(\*)Set value for t: Replnt

Figure 221: Periodic reporting with amplitude dead-band supervision in series.

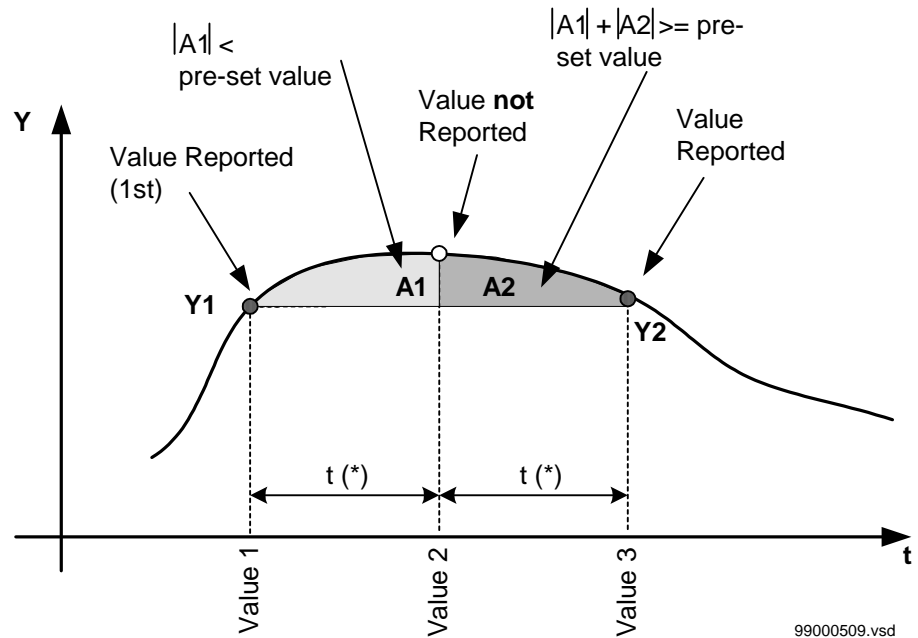

99000509.vsd

(\*)Set value for t: Replnt

Figure 222: Periodic reporting with integrating dead-band supervision in series

### Combination of periodic reportings

The reporting of the new value depends on setting parameters for the dead-band and for the periodic reporting. Table 19 presents the dependence between different settings and the type of reporting for the new value of a measured quantity.

**Table 19: Dependence of reporting on different setting parameters:**

EnDeadB*	EnIDeadB*	EnDeadBP*	Replnt*	Reporting of the new value
Off	Off	Off	0	No measured values is reported.
Off	On	On	t>0	The new measured value is reported only if the time t period expired and if, during this time, the integrating dead-band limits were exceeded (periodic reporting with integrating dead-band supervision in series).
On	Off	On	t>0	The new measured value is reported only if the time t period has expired and if, during this time, the amplitude dead-band limits were exceeded (periodic reporting with amplitude dead-band supervision in series).
On	On	On	t>0	The new measured value is reported only if the time t period expired and if at least one of the dead-band limits were exceeded (periodic reporting with dead-band supervision in series).
Off	On	Off	0	The new measured value is reported only when the integrated dead-band limits are exceeded.
On	Off	Off	0	The new measured value is reported only when the amplitude dead-band limits were exceeded.
On	On	Off	0	The new measured value is reported only if one of the dead-band limits was exceeded.
x	x	Off	t>0	The new measured value is updated at least after the time t period expired. If the dead-band supervision is additionally selected, the updating also occurs when the corresponding dead-band limit was exceeded (periodic reporting with parallel dead-band supervision).
* Please see the setting parameters in the Technical reference manual for further explanation				

---

## 8.3

### Design

The design of the alternating quantities measuring function follows the design of all REx 5xx-series protection, control, and monitoring terminals that have distributed functionality, where the decision levels are placed as closely as possible to the process.

The measuring function uses the same input current and voltage signals as other protection and monitoring functions within the terminals. The number of input current and voltage transformers depends on the type of terminal and options included. The maximum possible configuration comprises five current and five voltage input channels.

Measured input currents and voltages are first filtered in analogue filters and then converted to numerical information by an A/D converter, which operates with a sampling frequency of 2 kHz.

The numerical information on measured currents and voltages continues over a serial link to one of the built-in digital signal processors (DSP). An additional Fourier filter numerically filters the received information, and the DSP calculates the corresponding values for the following quantities:

- Five input measured voltages (U1, U2, U3, U4, U5), RMS values
- Five input measured currents (I1, I2, I3, I4, I5), RMS Values
- Mean RMS value, U, of the three phase-to-phase voltages calculated from the first three phase-to-earth voltages U1, U2 and U3
- Mean RMS value, I, of the first three measured RMS values I1, I2, and I3
- Three-phase active power, P, related to the first three measured currents and voltages (I1, U1, I2, U2, I3, U3)
- Three-phase, reactive power, Q, related to the first three measured currents and voltages (I1, U1, I2, U2, I3, U3)
- Three-phase apparent power, S, related to the first three measured currents and voltages (I1, U1, I2, U2, I3, U3)
- Mean value of frequencies, f, as measured with voltages U1, U2, and U3

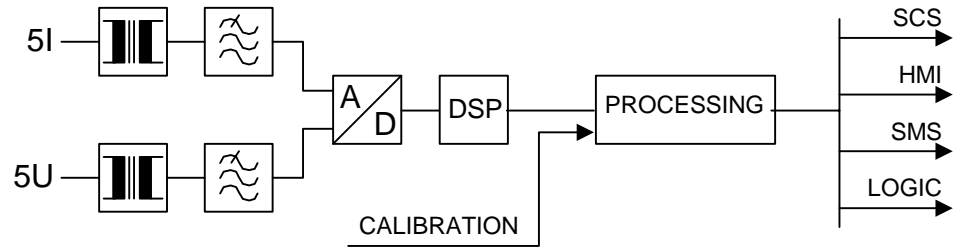

99000510.vsd

Figure 223: Simplified diagram for the function

This information is available to the user for operational purposes.

## 8.4

### Calculations

The basic terminal parameters can be set from the HMI under the submenu:

**Configuration**  
**AnalogInputs**  
**General**  
**fr,CTEarth**

So users can determine the rated parameters for the terminal:

- Rated frequency  $f_r$
- Position of the earthing point of the main CTs (CTEarth), which determines whether the CT earthing point is towards the protected object or the busbar

The other basic terminal parameters, related to any single analog input, can be set under the submenu:

**Configuration**  
**AnalogInputs**  
**U1, U2, U3, U4, U5, I1, I2, I3, I4, I5, U, I, P, Q, S, f**

So the users can determine the base values, the primary CTs and VTs ratios, and the user-defined names for the analog inputs of the terminal.

## Under U1:

- ac voltage base value for analog input U1: U1b
- voltage transformer input U1 nominal primary to secondary scale value: U1Scale
- Name (of up to 13 characters) of the analog input U1: Name

## Under U2:

- ac voltage base value for analog input U2: U2b
- voltage transformer input U2 nominal primary to secondary scale value: U2Scale
- Name (of up to 13 characters) of the analog input U2: Name

## Under U3:

- ac voltage base value for analog input U3: U3b
- voltage transformer input U3 nominal primary to secondary scale value: U3Scale
- Name (of up to 13 characters) of the analog input U3: Name

## Under U4:

- ac voltage base value for analog input U4: U4b
- voltage transformer input U4 nominal primary to secondary scale value: U4Scale
- Name (of up to 13 characters) of the analog input U4: Name

## Under U5:

- ac voltage base value for analog input U5: U5b
- voltage transformer input U5 nominal primary to secondary scale value: U5Scale
- Name (of up to 13 characters) of the analog input U5: Name

## Under I1:

- ac current base value for analog input I1: I1b
- current transformer input I1 nominal primary to secondary scale value: I1Scale
- Name (of up to 13 characters) of the analog input I1: Name

## Under I2:

- 
- ac current base value for analog input I2: I2b
  - current transformer input I2 nominal primary to secondary scale value: I2Scale
  - Name (of up to 13 characters) of the analog input I2: Name

Under I3:

- ac current base value for analog input I3: I3b
- current transformer input I3 nominal primary to secondary scale value: I3Scale
- Name (of up to 13 characters) of the analog input I3: Name

Under I4:

- ac current base value for analog input I4: I4b
- current transformer input I4 nominal primary to secondary scale value: I4Scale
- Name (of up to 13 characters) of the analog input I4: Name

Under I5:

- ac current base value for analog input I5: I5b
- current transformer input I5 nominal primary to secondary scale value: I5Scale
- Name (of up to 13 characters) of the analog input I5: Name

Under U:

- Name (of up to 13 characters) of the average voltage U: Name

Under I:

- Name (of up to 13 characters) of the average current I: Name

Under P:

- Name (of up to 13 characters) of the active power P: Name

Under Q:

- Name (of up to 13 characters) of the reactive power Q: Name



Under S:

- Name (of up to 13 characters) of the apparent power S: Name

Under f:

- Name (of up to 13 characters) of the frequency value f: Name

The names of the first 10 quantities automatically appears in the REVAL evaluation program for each reported disturbance.

The PST Parameter Setting Tool has to be used in order to set all remaining parameters that are related to different alternating measuring quantities.

In the settings menu it is possible to set all monitoring operating values and the hysteresis directly in the basic units of the measured quantities for each channel and for each quantity:

### Settings

#### DisturbReport

#### AnalogSignals

The dead-band limits can be set directly in the corresponding units of the observed quantity for the:

- Amplitude dead-band supervision (ADBS)
- Integrating dead-band supervision (IDBS)

The IDBS area is defined by the following formula:

$$IDBS = \frac{IDeadB}{ReadFreq} = IDeadB \cdot ts$$

(Equation 303)

Where:

---

IDeadB is a set operating value for IDBS in corresponding unit.  
ReadFreq is the reading frequency. It has a constant value of 1Hz.  
 $t_s = 1/\text{ReadFreq}$  is the time between two samples (fixed to 1s).

The setting value for IDBS is IDeadB, and is expressed in the measuring unit of the monitored quantity (kV, A, MW, Mvar, MVA or Hz). The value is reported if the time integral area is greater than the value IDBS.

If a 0.1 Hz variation in the frequency for 10 minutes (600 s) is the event that should cause the reporting of the frequency monitored value, than the set value for IDeadB is 60 Hz.

The hysteresis can be set under the setting Hysteres.

Alarm and warning thresholds have to be set respectively under the settings HiAlarm (LowAlarm) and HiWarn (LowWarn).

See the Technical reference manual for a list of all the setting parameters.



**Note!**

*It is important to set the time for periodic reporting and deadband in an optimized way to minimize the load on the station bus.*

---

## 9 Monitoring of DC analog measurements

### 9.1 Application

Fast, reliable supervision of different analogue quantities is of vital importance during the normal operation of a power system. Operators in the control centres can, for example:

- Continuously follow active and reactive power flow in the network
- Supervise the busbar voltages
- Check the temperature of power transformers, shunt reactors
- Monitor the gas pressure in circuit breakers

Different measuring methods are available for different quantities. Current and voltage instrument transformers provide the basic information on measured phase currents and voltages in different points within the power system. At the same time, currents and voltages serve as the input measuring quantities to power and energy meters.

Different measuring transducers provide information on electrical and non-electrical measuring quantities such as voltage, current, temperature, and pressure. In most cases, the measuring transducers change the values of the measured quantities into the direct current. The current value usually changes within the specified mA range in proportion to the value of the measured quantity.

Further processing of the direct currents obtained on the outputs of different measuring converters occurs within different control, protection, and monitoring terminals and within the higher hierarchical systems in the secondary power system.

### 9.2 Functionality

The REx 5xx control, protection and monitoring terminal have a built-in option to measure and further process information from 6 up to 36 different direct current information from different measuring transducers. Six independent measuring channels are located on each independent mA input module and the REx 5xx terminals can accept from one up to six independent mA input modules, depending on the case size. Refer to the technical data and ordering particulars for the particular terminal.

Information about the measured quantities is then available to the user on different locations:

- Locally by means of the local human-machine-interface (HMI)
- Locally by means of a front-connected personal computer (PC)
- Remotely over the LON bus to the station control system (SCS)
- Remotely over the SPA port to the station monitoring system (SMS)

#### **User-defined measuring ranges**

The measuring range of different direct current measuring channels is settable by the user independent on each other within the range between -25 mA and +25 mA in steps of 0.01 mA. It is only necessary to select the upper operating limit I\_Max higher than the lower one I\_Min.

The measuring channel can have a value of 2 of the whole range I\_Max - I\_Min above the upper limit I\_Max or below the lower limit I\_Min, before an out-of-range error occurs. This means that with a nominal range of 0-10 mA, no out-of-range event will occur with a value between -0.2 mA and 10.2 mA.

User can this way select for each measuring quantity on each monitored object of a power system the most suitable measuring range and this way optimize a complete functionality together with the characteristics of the used measuring transducer.

#### **Continuous monitoring of the measured quantity**

The user can continuously monitor the measured quantity in each channel by means of six built-in operating limits (figure 224). Two of them are defined by the operating range selection: I\_Max as the upper and I\_Min as the lower operating limit. The other four operating limits operate in two different modes:

- Overfunction, when the measured current exceeds the HiWarn or HiAlarm pre-set values
- Underfunction, when the measured current decreases under the LowWarn or Low-Alarm pre-set values

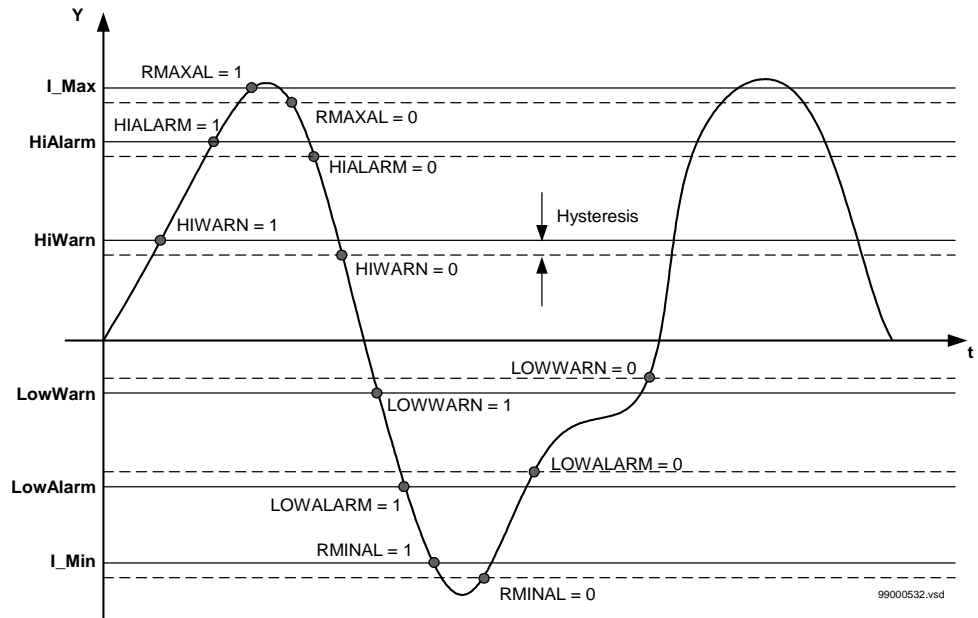

Figure 224: Presentation of the operating limits

Each operating level has its corresponding functional output signal:

- RMAXAL
- HIWARN
- HIALARM
- LOWWARN
- LOWALARM
- RMINAL

The logical value of the functional output signals changes according to figure 224.

The user can set the hysteresis, which determines the difference between the operating and reset value at each operating point, in wide range for each measuring channel separately. The hysteresis is common for all operating values within one channel.

### Continuous supervision of the measured quantity

The actual value of the measured quantity is available locally and remotely. The measurement is continuous for each channel separately, but the reporting of the value to the higher levels (control processor in the unit, HMI and SCS) depends on the selected reporting mode. The following basic reporting modes are available:

- 
- Periodic reporting
  - Periodic reporting with dead-band supervision in parallel
  - Periodic reporting with dead-band supervision in series
  - Dead-band reporting

Users can select between two types of dead-band supervision:

- Amplitude dead-band supervision (ADBS).
- Integrating dead-band supervision (IDBS).

#### **Amplitude dead-band supervision**

If the changed value —compared to the last reported value— is larger than the  $\pm \Delta Y$  predefined limits that are set by users, and if this is detected by a new measuring sample, then the measuring channel reports the new value to a higher level. This limits the information flow to a minimum necessary. Figure 225 shows an example of periodic reporting with the amplitude dead-band supervision.

The picture is simplified: the process is not continuous but the values are evaluated at time intervals depending on the sampling frequency chosen by the user (SampRate setting).

After the new value is reported, the new  $\pm \Delta Y$  limits for dead-band are automatically set around it. The new value is reported only if the measured quantity changes more than defined by the new  $\pm \Delta Y$  set limits.

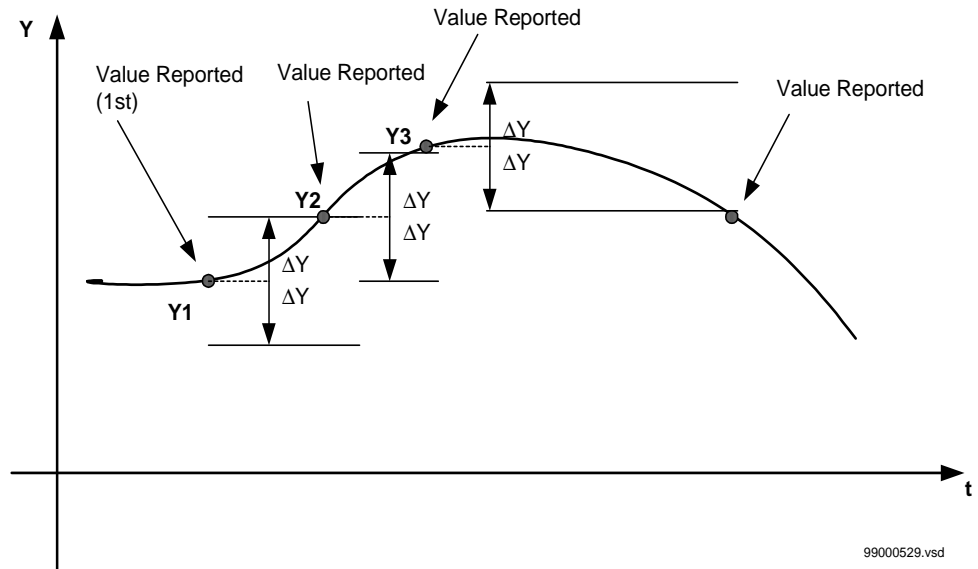

Figure 225: Amplitude dead-band supervision reporting

### Integrating dead-band supervision

The measured value is updated if the time integral of all changes exceeds the pre-set limit (figure 226), where an example of reporting with integrating dead-band supervision is shown. The picture is simplified: the process is not continuous but the values are evaluated at time intervals depending on the sampling frequency chosen by the user (SampRate setting).

The last value reported (Y1 in figure 226) serves as a basic value for further measurement. A difference is calculated between the last reported and the newly measured value during new sample and is multiplied by the time increment (discrete integral). The absolute values of these products are added until the pre-set value is exceeded. This occurs with the value Y2 that is reported and set as a new base for the following measurements (as well as for the values Y3, Y4 and Y5).

The integrating dead-band supervision is particularly suitable for monitoring signals with low variations that can last for relatively long periods.

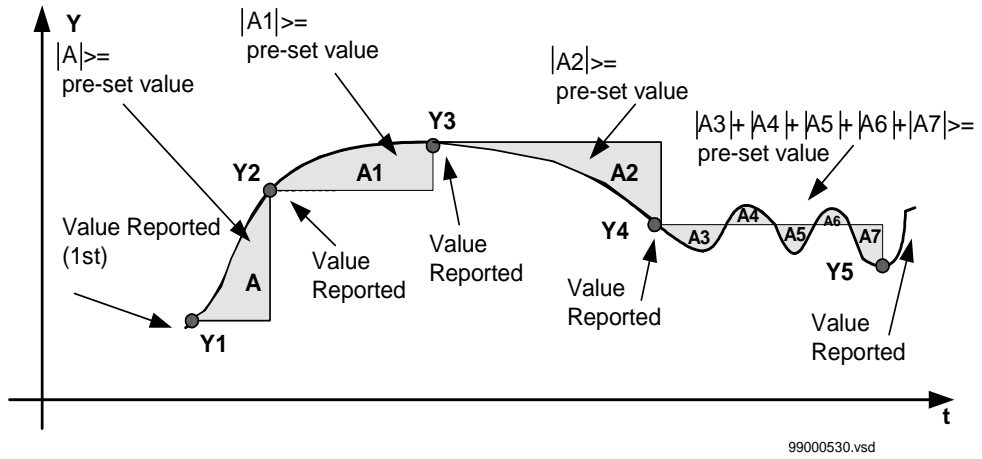

Figure 226: Reporting with integrating dead-band supervision

**Periodic reporting**

The user can select the periodic reporting of measured value in time intervals between 1 and 3600 s (setting RepInt). The measuring channel reports the value even if it has not changed for more than the set limits of amplitude or integrating dead-band supervision (figure 227). To disable periodic reporting, set the reporting time interval to 0 s.

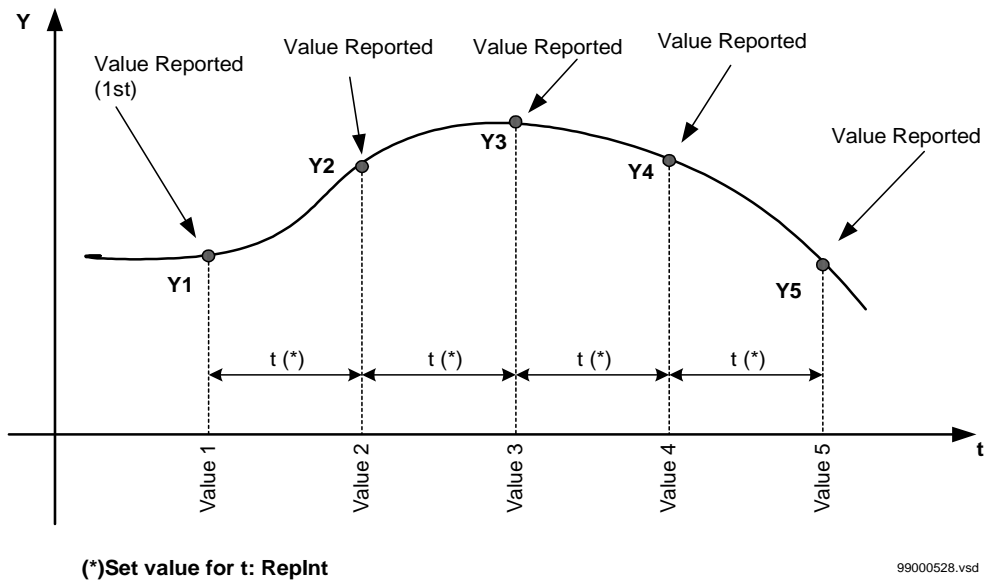

Figure 227: Periodic reporting



**Periodic reporting with parallel dead-band supervision**

The newly measured value is reported:

- After each time interval for the periodic reporting expired, **OR**;
- When the new value is detected by the dead-band supervision function.

The amplitude dead-band and the integrating dead-band can be selected. The periodic reporting can be set in time intervals between 1 and 3600 seconds.

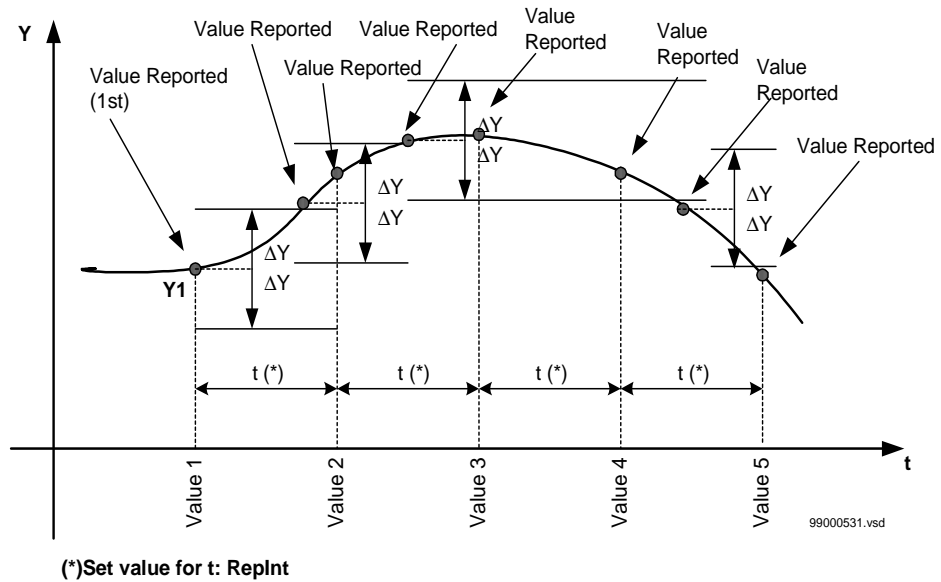
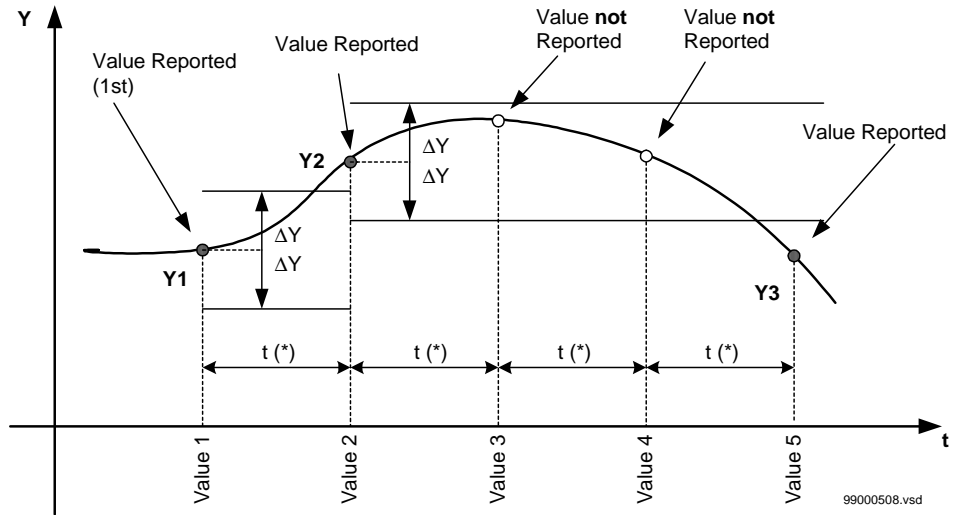

Figure 228: Periodic reporting with amplitude dead-band supervision in parallel.

**Periodic reporting with serial dead-band supervision**

Periodic reporting can operate serially with the dead-band supervision. This means that the new value is reported only if the set time period expired **AND** if the dead-band limit was exceeded during the observed time (figures 229 and 230). The amplitude dead-band and the integrating dead-band can be selected. The periodic reporting can be set in time intervals between 1 and 3600 seconds.



(\*)Set value for t: Replnt

Figure 229: Periodic reporting with amplitude dead-band supervision in series

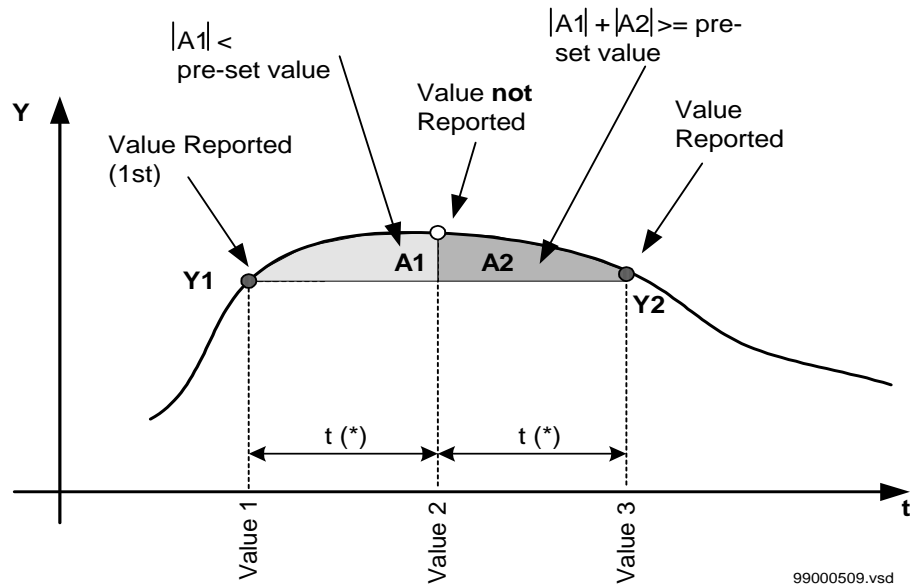

(\*)Set value for t: Replnt

Figure 230: Periodic reporting with integrating dead-band supervision in series

**Combination of periodic reportings**

The reporting of the new value depends on setting parameters for the dead-band and for the periodic reporting. Table 1 presents the dependence between different settings and the type of reporting for the new value of a measured quantity.

**Table 20: Dependence of reporting on different setting parameters:**

EnDeadB *	EnIDeadB *	EnDeadBP *	Replnt *	Reporting of the new value
Off	Off	Off	0	No measured values is reported
Off	On	On	$t > 0$	The new measured value is reported only if the time $t$ period expired and if, during this time, the integrating dead-band limits were exceeded (periodic reporting with integrating dead-band supervision in series)
On	Off	On	$t > 0$	The new measured value is reported only if the time $t$ period has expired and if, during this time, the amplitude dead-band limits were exceeded (periodic reporting with amplitude dead-band supervision in series)
On	On	On	$t > 0$	The new measured value is reported only if the time $t$ period expired and if at least one of the dead-band limits were exceeded (periodic reporting with dead-band supervision in series)
Off	On	Off	0	The new measured value is reported only when the integrated dead-band limits are exceeded
On	Off	Off	0	The new measured value is reported only when the amplitude dead-band limits were exceeded

EnDeadB *	EnIDeadB *	EnDeadBP *	Replnt *	Reporting of the new value
On	On	Off	0	The new measured value is reported only if one of the dead-band limits was exceeded
x	x	Off	t>0	The new measured value is updated at least after the time t period expired. If the dead-band supervision is additionally selected, the updating also occurs when the corresponding dead-band limit was exceeded (periodic reporting with parallel dead-band supervision)
* Please see the setting parameters in the Technical reference manual for further explanation				

### 9.3

#### Design

The design of the mA input modules follows the design of all REx 5xx-series protection, control, and monitoring terminals that have distributed functionality, where the decision levels are placed as closely as possible to the process.

Each independent measuring module contains all necessary circuitry and functionality for measurement of six independent measuring quantities related to the corresponding measured direct currents.

On the accurate input shunt resistor (R), the direct input current (from the measuring converter) is converted into a proportional voltage signal (the voltage drop across the shunt resistor is in proportion to the measured current). Later, the voltage signal is processed within one differential type of measuring channel (figure 231).

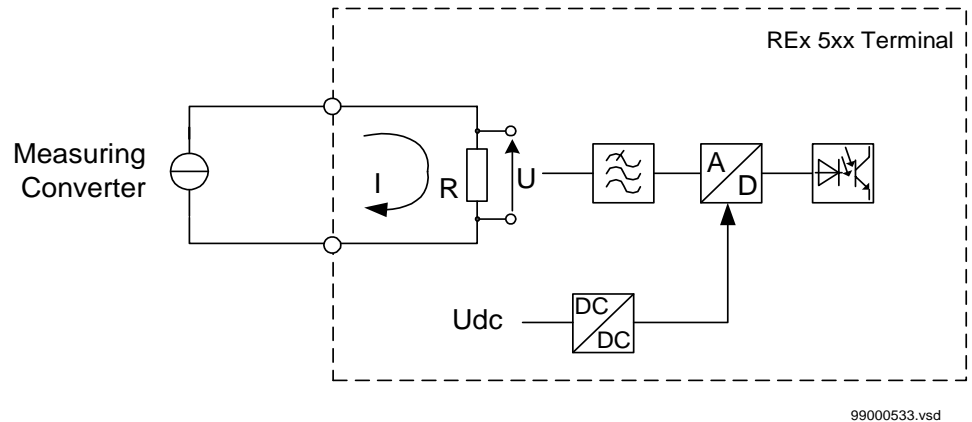

Figure 231: Simplified diagram for the function

The measured voltage is filtered by the low-pass analogue filter before entering the analogue to digital converter (A/D). Users can set the sampling frequency of the A/D converter between 5 Hz and 255 Hz to adapt to different application requirements as best as possible.

The digital information is filtered by the digital low-pass filter with the  $(\sin x/x)^3$  response. The filter notch frequency automatically follows the selected sampling frequency. The relation between the frequency corresponding to the suppression of -3 dB and the filter notch frequency corresponds to the equation:

$$f_{-3dB} = 0,262 \cdot f_{notch}$$

(Equation 304)

Using optocouplers and DC/DC conversion elements that are used separately for each measuring channel, the input circuitry of each measuring channel is galvanically separated from:

- The internal measuring circuits
- The control microprocessor on the board

A microprocessor collects the digitized information from each measuring channel. The microprocessor serves as a communication interface to the main processing module (MPM).

All processing of the measured signal is performed on the module so that only the minimum amount of information is necessary to be transmitted to and from the MPM. The measuring module receives information from the MPM on setting and the command parameters; it reports the measured values and additional information—according to needs and values of different parameters.

Each measuring channel is calibrated very accurately during the production process. The continuous internal zero offset and full-scale calibration during the normal operation is performed by the A/D converter. The calibration covers almost all analogue parts of the A/D conversion, but neglects the shunt resistance.

Each measuring channel has built in a zero-value supervision, which greatly rejects the noise generated by the measuring transducers and other external equipment. The value of the measured input current is reported equal to zero (0) if the measured primary quantity does not exceed +/-0.5% of the maximum measuring range.

The complete measuring module is equipped with advanced self-supervision. Only the outermost analogue circuits cannot be monitored. The A/D converter, optocouplers, digital circuitry, and DC/DC converters, are all supervised on the module. Over the CAN bus, the measuring module sends a message to the MPM for any detected errors on the supervised circuitry.

## 9.4

### Calculations

The PST Parameter Setting Tool has to be used in order to set all the parameters that are related to different DC analogue quantities.

Users can set the 13 character name for each measuring channel.

All the monitoring operating values and the hysteresis can be set directly in the mA of the measured input currents from the measuring transducers.

The measured quantities can be displayed locally and/or remotely according to the corresponding modules that are separately set for each measuring channel by the users (five characters).

The relation between the measured quantity in the power system and the setting range of the direct current measuring channel corresponds to this equation:

$$\text{Value} = \text{ValueMin} + (I - I_{\text{Min}}) \cdot \frac{\text{ValueMax} - \text{ValueMin}}{I_{\text{Max}} - I_{\text{Min}}}$$

(Equation 305)

Where:

I_Min	is the set value for the minimum operating current of a channel in mA.
I_Max	is the set value for the maximum operating current of a channel in mA.
ValueMin	is the value of the primary measuring quantity corresponding to the set value of minimum operating current of a channel, I_Min.
ValueMax	is the value of the primary measuring quantity corresponding to the set value of maximum operating current of a channel, I_Max.
Value	is the actual value of the primary measured quantity.

Figure 232 shows the relationship between the direct mA current I and the actual value of the primary measured quantity, Value.

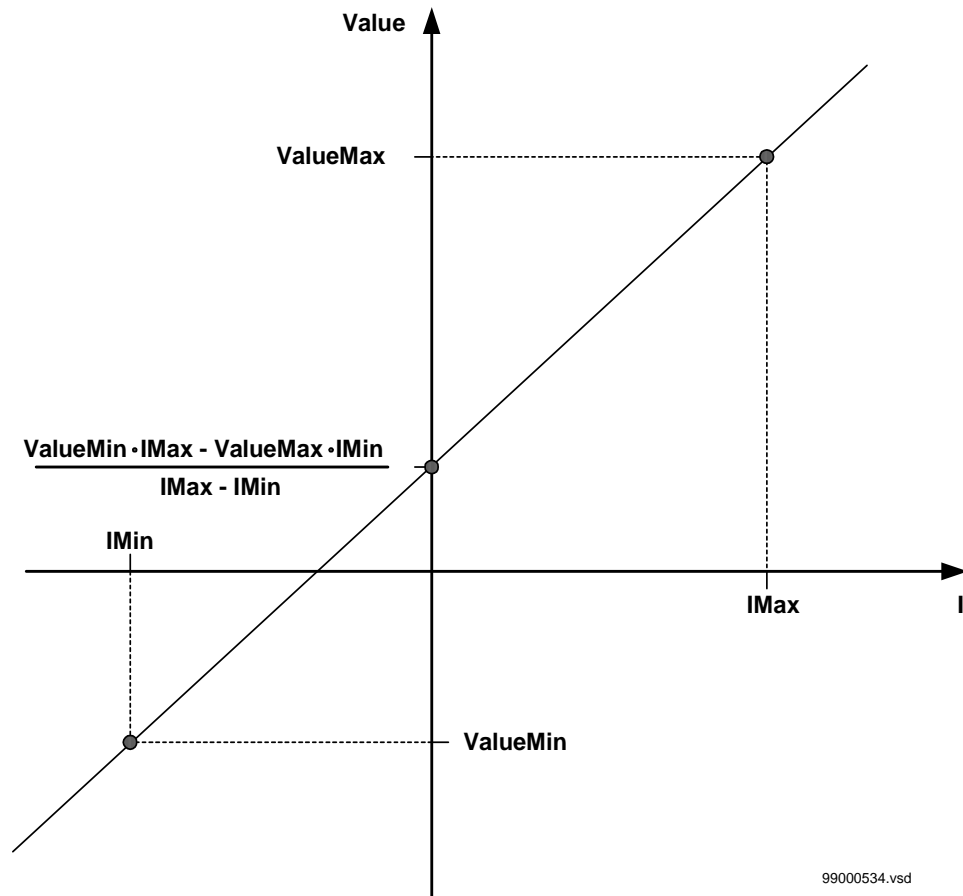

Figure 232: Relationship between the direct current ( $I$ ) and the measured quantity primary value ( $Value$ )

The dead-band limits can be set directly in the mA of the input direct current for:

- Amplitude dead-band supervision ADBS
- Integrating dead-band supervision IDBS

The IDBS area [mAs] is defined by the following equation:

$$IDBS = \frac{I_{DeadB}}{SampRate} = I_{DeadB} \cdot ts$$

(Equation 306)



where:

IDeadB is the set value of the current level for IDBS in mA.

SampRate is the sampling rate (frequency) set value, in Hz.

$t_s = 1/\text{SampRate}$  is the time between two samples in s.

If a 0.1 mA variation in the monitored quantity for 10 minutes (600 s) is the event that should cause the trigger of the IDBS monitoring (reporting of the value because of IDBS threshold operation) and the sampling frequency (SampRate) of the monitored quantity is 5 Hz, then the set value for IDBS (IDeadB) will be 300 mA:

$$\text{IDBS} = 0.1 \cdot 600 = 60[\text{mA s}]$$

(Equation 307)

$$\text{IDeadB} = \text{IDBS} \cdot \text{SampRate} = 60 \cdot 5 = 300[\text{mA}]$$

(Equation 308)

The polarity of connected direct current input signal can be changed by setting the ChSign to On or Off. This way it is possible to compensate by setting the possible wrong connection of the direct current leads between the measuring converter and the input terminals of the REx 5xx series unit.

The setting table lists all setting parameters with additional explanation.



**Note:**

*It is important to set the time for periodic reporting and deadband in an optimized way to minimize the load on the station bus.*



# Chapter 12 Metering

## **About this chapter**

This chapter describes the metering functions.

# 1 Pulse counter logic (PC)

## 1.1 Application

The pulse counter function provides the Substation Automation system with the number of pulses, which have been accumulated in the REx 5xx terminal during a defined period of time, for calculation of, for example, energy values. The pulses are captured on the Binary Input Module (BIM) that is read by the pulse counter function. The number of pulses in the counter is then reported via LON to the station HMI or read via SPA as a service value.

The normal use for this function is the counting of energy pulses for kWh and kvarh in both directions from external energy meters. Up to 12 binary inputs in a REx 5xx can be used for this purpose with a frequency of up to 40 Hz.

## 1.2 Functionality

The registration of pulses is done for positive transitions (0->1) on one of the 16 binary input channels located on the Binary Input Module (BIM). Pulse counter values are read from the station HMI with predefined cyclicity without reset, and an event is created.

The integration time period can be set in the range from 30 seconds to 60 minutes and is synchronised with absolute system time. That means, a cycle time of one minute will generate a pulse counter reading every full minute. Interrogation of additional pulse counter values can be done with a command (intermediate reading) for a single counter. All active counters can also be read by the LON General Interrogation command (GI).

The pulse counter in REx 5xx supports unidirectional incremental counters. That means only positive values are possible. The counter uses a 32 bit format, that is, the reported value is a 32-bit, signed integer with a range 0...+2147483647. The counter is reset at initialisation of the terminal or by turning the pulse counter operation parameter Off/On.

The reported value to station HMI over the LON bus contains Identity, Value, Time, and Pulse Counter Quality. The Pulse Counter Quality consists of:

- Invalid (board hardware error or configuration error)
- Wrapped around
- Blocked
- Adjusted

The transmission of the counter value by SPA can be done as a service value, that is, the value frozen in the last integration cycle is read by the station HMI from the database. The pulse counter function updates the value in the database when an integration cycle is finished and activates the NEW\_VAL signal in the function block. This signal can be connected to an Event function block, be time tagged, and transmitted to the station HMI. This time corresponds to the time when the value was frozen by the function.

1.3

Design

The function can be regarded as a function block with a few inputs and outputs. The inputs are divided into two groups: settings and connectables (configuration). The outputs are divided into three groups: signals (binary), service value for SPA, and an event for LON.

Figure 233 shows the pulse counter function block with connections of the inputs and outputs.

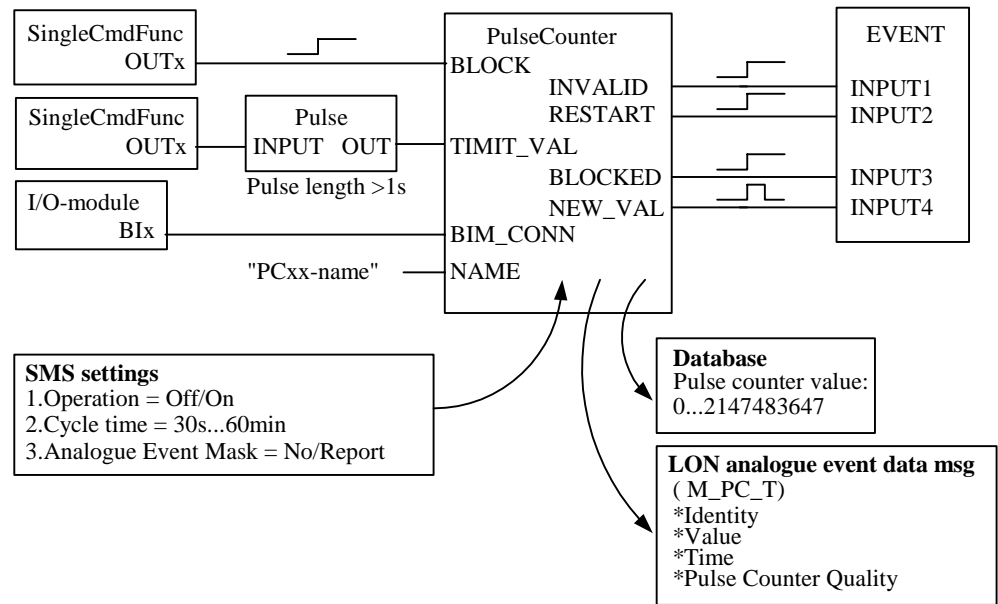

xx00000543.vsd

Figure 233: Overview of the pulse counter function

The BLOCK and TMIT\_VAL inputs can be connected to Single Command blocks, which are intended to be controlled either from the station HMI or/and the local HMI. As long as the BLOCK signal is set, the pulse counter is blocked. The signal connected to TMIT\_VAL performs one additional reading per positive flank. The signal must be a pulse with a length >1 second.

The BIM\_CONN input is connected to the used input of the function block for the Binary Input Module (BIM). If BIM\_CONN is connected to another function block, the INVALID signal is activated to indicate the configuration error.

The NAME input is used for a user-defined name with up to 19 characters.

Each pulse counter function block has four output signals: INVALID, RESTART, BLOCKED, and NEW\_VAL. These signals can be connected to an Event function block for event recording.

The INVALID signal is a steady signal and is set if the Binary Input Module, where the pulse counter input is located, fails or has wrong configuration.

The RESTART signal is a steady signal and is set when the reported value does not comprise a complete integration cycle. That is, in the first message after terminal start-up, in the first message after deblocking, and after the counter has wrapped around during last integration cycle.

The BLOCKED signal is a steady signal and is set when the counter is blocked. There are two reasons why the counter is blocked:

- The BLOCK input is set, or
- The Binary Input Module, where the counter input is situated, is inoperative.

The NEW\_VAL signal is a pulse signal. The signal is set if the counter value was updated since last report.

## 1.4

### Calculations

#### 1.4.1

##### Setting

From the PST Parameter Setting Tool under SETTINGS/PC01-12 (Pulse Counter) in the terminal tree, these parameters can be set individually for each pulse counter:

- Operation = Off/On
- Cycle Time = 30s / 1min / 1min30s / 2min / 2min30s / 3min / 4min / 5min / 6min / 7min30s / 10min / 12min / 15min / 20min / 30min / 60min.

---

Under EVENT MASKS/Analogue events/Pulse Counter in PST, the reporting of the analogue events can be masked:

- Event Mask = No Events/Report Events

The configuration of the inputs and outputs of the pulse counter function block is made by the CAP 531 configuration tool.

On the Binary Input Module, the debounce filter time is fixed set to 5 ms, that is, the counter suppresses pulses with a pulse length less than 5 ms. The input oscillation blocking frequency is preset to 40 Hz. That means that the counter finds the input oscillating if the input frequency is greater than 40 Hz. The oscillation suppression is released at 30 Hz. From the PST under CONFIGURATION/Binary I/O-modules/Oscillation in the terminal tree and from the local HMI, the values for blocking/release of the oscillation can be changed.



**Note!**

*The setting is common for all channels on a Binary Input Module, that is, if changes of the limits are made for inputs not connected to the pulse counter, the setting also influences the inputs on the same board used for pulse counting.*





# **Chapter 13 Data communication**

## **About this chapter**

This chapter describes the data communication and the associated hardware.

# 1 Remote end data communication

## 1.1 Application

### General

The hardware communication modules (or modems) for the Remote end data communication are available in basically three different versions:

- for optical communication
- for short range pilot wire communication
- for galvanic connection to communication equipment according to ITU (former CCITT) and EIA interface standards.

All systems are designed to be able to work at 64 kbit/s. Some of them can also work at North American standard of 56 kbit/s. This is especially pointed out in the description under each module.

If the protection terminal is located at a long distance (>100 m for V.36, X.21 and RS530 and >10m for G.703) from the communication equipment or multiplexer or if the cables run through a noisy area, optical communication should be used to interconnect the protection terminal and the communication equipment. In this case the protection terminal contains module used for optical fibre communication and a suitable optical to electrical converter is installed close to the communication equipment due to the fact that there exists no standard for optical connections to communication equipment. The optical-to-electrical converters that can be used are FOX6Plus (and FOX20) from ABB and 21-15xx or 21-16xx from FIBERDATA. The FOX6Plus together with optical fibre modem supports the G.703 co-directional interfacing and with restrictions for X.21 and V.36. 21-15xx supports V.35 and V.36 while 21-16xx supports X.21, G.703 and RS530 co-directional and contra-directional. For 21-15xx and 21-16xx short range optical fibre modem is needed.

### **NOTE!**



*When using galvanic connection between protection terminal and communication equipment or point to point galvanic connection between two protection terminals it is essential that the cable installation is carefully done. See Installation and commissioning manual for further information.*

Optical connection of multiplexer is only possible if the multiplexer is of type FOX6Plus or FOX20 from ABB. The terminal can then be connected optically to the multiplexer, provided the protection is equipped with the optical fibre modem, not the short range fibre optical modem, and the FOX is equipped with an Optical Terminal Module of type N3BT.

## 1.2

### Design

The Remote end data communication consists of two parts, one software part that handles the message structure, packing different pieces together, activate sending of the messages, unpacking received messages etc, and one hardware part forming the interface against external communication equipments. The hardware part, or built-in modems, can have either galvanic or optical connection. To ensure compatibility with a wide range of communication equipment and media, the terminal is designed to work within the signalling bandwidth of a standard CCITT PCM channel at 64 kbits/s. To enable the use in North American EIA PCM systems working at 56 kbits/s, some of the interfacing modules can be adapted to this bit rate.

The message is based on the HDLC protocol. This is a protocol for the flow management of the information on a data communication link that is widely used. The basic information unit on an HDLC link is a frame. A frame consists of:

- start (or opening) flag
- address and control fields (if included)
- data to be transmitted
- CRC word
- end (or closing) flag.

The start and stop flags are 8 bit each and the Cyclic Redundancy Check (CRC) 16 bits. The data field differs if between a message sent from a slave to a master and a message sent from a master to a slave. The principle design is according to figure 234.

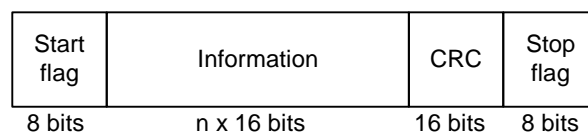

en01000134.vsd

Figure 234: Data message structure

The start and stop flags are the 0111 1110 sequence (7E hexadecimal) defined in HDLC standard. The CRC is designed according to standard CRC16 definition.

The optional address field in the HDLC frame is not used, instead a separate addressing is included in the data field.

The address field is used for checking that the received message originates from the correct equipment. There is always a risk of multiplexers occasionally mixing up the messages. Each terminal is given different terminal numbers. The terminal is then programmed to accept messages only from a specific terminal number.

If the CRC function detects a faulty message, the message is thrown away and not used in the evaluation. No data restoration or retransmission are implemented.

The hardware, consisting of a Data communication module, is placed in an applicable slot in the terminal. To add or remove the module, a reconfiguration of the terminal is done from the graphical configuration tool, CAP 531.

## 2 Optical fibre communication module

### 2.1 Application

#### Optical fibre modem

This module is designed for point to point optical communication, see figure 235, but can also be used for direct optical communication to a multiplexer of type FOX6Plus or FOX20, see figure 236 from ABB, provided it is equipped with an Optical Terminal Module of type N3BT. The FOX6Plus can also be used as an optical to electrical converter supporting the G.703 co-directional interfacing according to ITU (former CCITT), see figure 237. FOX6Plus can also in some cases be used for X.21 and V.36 interface but special attention must be paid to how to connect the signal. Used as an optical to electrical converter the FOX6Plus only supports 64 kbit/s data transmission.

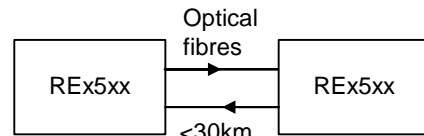

xx00000536.vsd

Figure 235: Dedicated link, optical fibre connection.

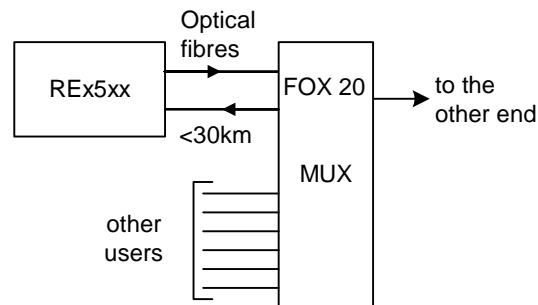

xx00000538.vsd

Figure 236: Multiplexed link, optical fibre connection.

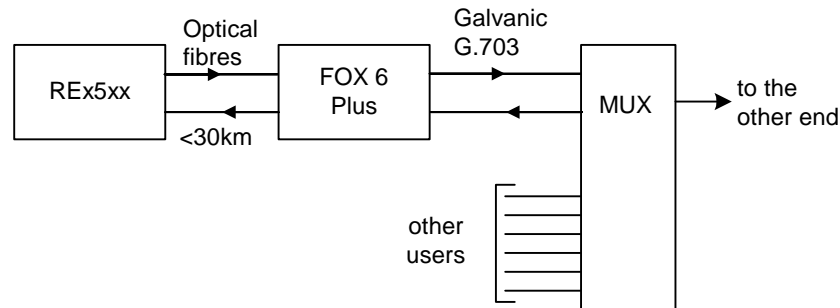

xx00000535.vsd

Figure 237: Multiplexed link, fibre optical-galvanic connection with FOX6Plus

## 2.2

### Design

The optical communication module is designed to work with both 9/125  $\mu\text{m}$  single-mode fibres and 50/125 or 62,5/125  $\mu\text{m}$  multimode fibres at 1300 nm wavelength. The connectors are of type FC-PC (SM) or FC (MM) respectively. Two different levels of optical output power are used to cover distances from 0 to approximately 30 km. The level of optical power is selected with a setting. The attenuation of the fibre is normally approximately 0.8 dB/km for multimode and 0.4 dB/km for single-mode. Additional attenuation due to installation can be estimated to be 0.2 dB/km for multimode and 0.1 dB/km for single-mode fibres. For single-mode fibre and high output power this results in a maximum distance of 32 km.

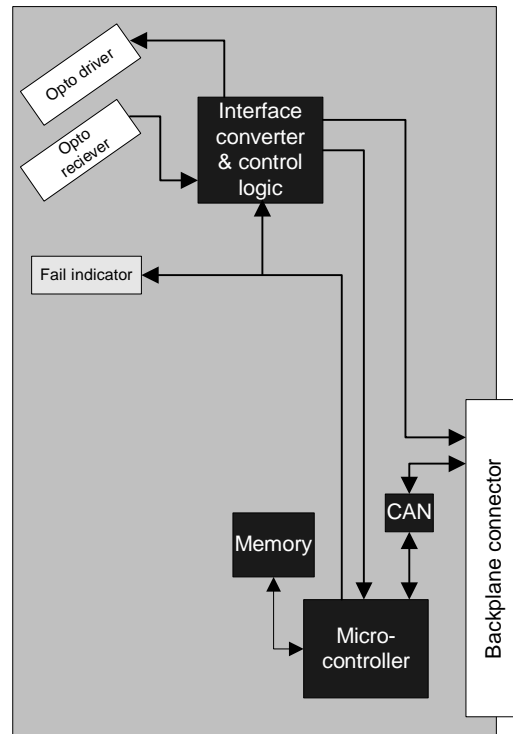

99000224.vsd

Figure 238: Block diagram for the optical communication module.

## 3 Galvanic data communication module

### 3.1 Application

#### Interface modules for V.36, X.21 and RS530

These interface modules are intended for connection to commercially available communication equipments or multiplexers and can be used both with 56 and 64 kbit/s data transmission.

Since the protection communicates continuously, a permanent communication circuit is required. Consequently, the call control and handshaking features specified for some interfacing recommendations are not provided.

Even if the standard claims that the reach for these interfaces are up to 1 km at 64 kbit/s it is not recommended to use that distance for protection purposes where the communication has to be reliable also under primary power system faults. This is due to the low level of the communication signals which gives low margin between signal and noise. If the protection terminal is in the same building as the multiplexing equipment and the environment is relatively free from noise, the protection terminal may be connected directly to the multiplexer via shielded and properly earthed cables with twisted pairs for distances less than 100 m.

Modules are available for the following interface recommendations, specifying the interconnection of the digital equipment to a PCM multiplexer:

- V.35/36 co-directional galvanic interface
- V.35/36 contra-directional galvanic interface
- X.21 galvanic interface
- RS530/422 co-directional galvanic interface
- RS530/422 contra-directional galvanic interface



#### **Note!**

*Due to problems of timing co-directional operation for V.35/36 and RS530 is only recommended to be used for direct back-to-back operation, for example during laboratory testing!*



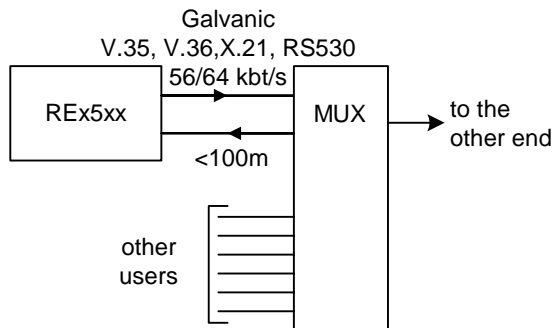

xx0000539.vsd

Figure 239: Multiplexed link, galvanic connection

### 3.2

### Design

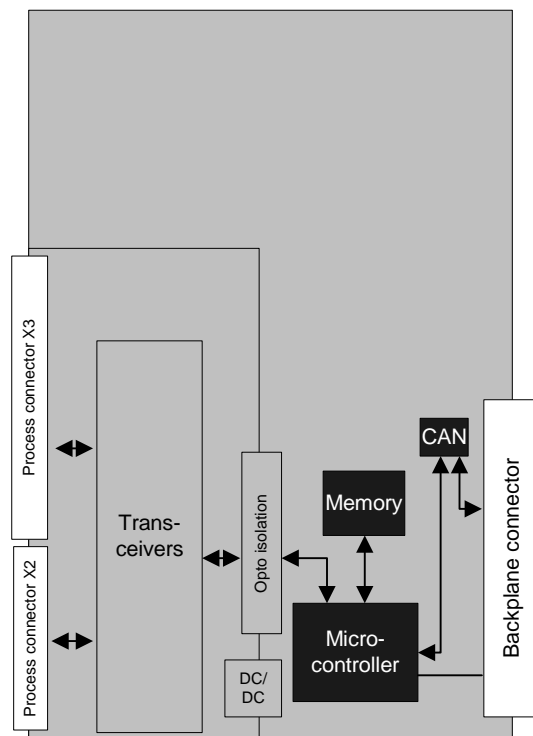

99000519.vsd

Figure 240: Block diagram for the galvanic communication module

## 4 Short range galvanic module

### 4.1 Application

#### Short range galvanic modem

The short range galvanic modem is used for point to point synchronous data transmission at 64 kbit/s at distances up to 4 km. Transmission is performed simultaneously in both directions, full duplex, over four wires in a communication (pilot wire) line according to figure 241.

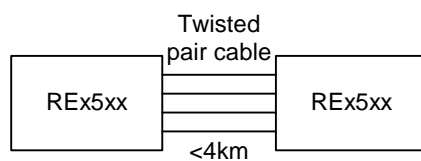

xx00000540.vsd

Figure 241: Dedicated link, short range galvanic modem

Compared to normal data transmission standards, for example V.36, X.21 etc., the short range modem increase the operational security and admits longer distances of transmission. This is achieved by a careful choice of transmission technology, modified M-3 balanced current loop and galvanic isolation between the transmission line and the internal logic of the protection terminal.

The reach will depend on the used cable. Higher capacitance between conductors and higher resistance will reduce the reach. The use of screened cables will increase the capacitance and thereby shorten the reach but this will often be compensated by the reduced noise giving a better operational security. Maximum ranges as a function of cable parameters are given in the diagram in figure 242.

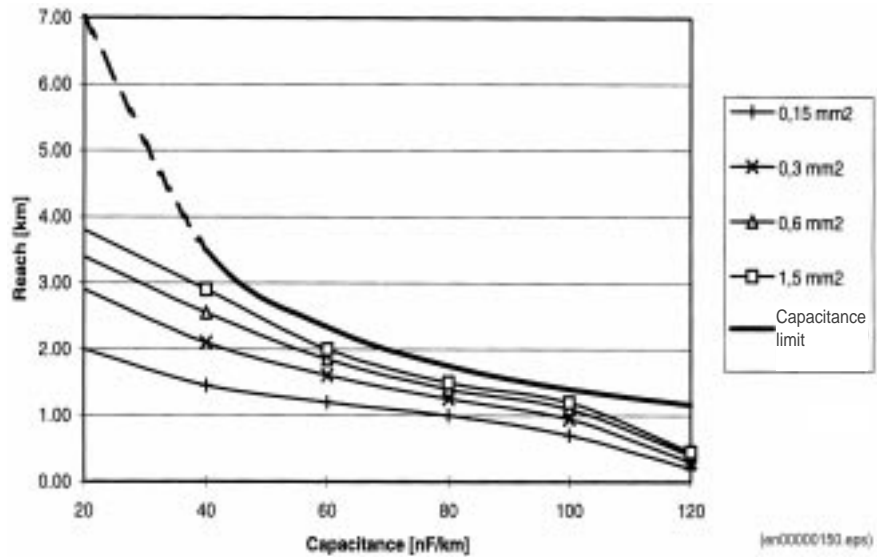

Figure 242: Maximum reach for short range galvanic modem



### Note!

The reaches in the diagram, figure 242, are given for twisted-pair and double-screened cables, one screen for each pair and one common outer screen. For non twisted-pair cables, the reach has to be reduced by 20%. For non pair-screened cables, the reach also has to be reduced by 20%. For non twisted and single screened cables, one common outer screen, the reach will therefor be reduced by 40%.

## 5 Short range optical fibre module

### 5.1 Application

The short range optical fibre modem is used for point to point synchronous 64 kbit/s data transmission at distances up to 5 km, the principle is according to figure 243. It can also be used together with optic fibre transceiver type 21-15xx/16xx from FIBERDATA in order to get an optical link between the protection terminal and a remotely located communication equipment as in figure 244.

21-15xx supports interfaces according to ITU (former CCITT) standards V.35 and V.36 co- and contra-directional. 21-16xx supports interfaces standards X21 and G.703 according to ITU (former CCITT) and RS.530 according to EIA co- and contra-directional.

Transmission is performed simultaneously in both directions, full duplex, over two optical fibres. The fibres shall be of multi mode type, 50/125  $\mu\text{m}$  or 62.5/125  $\mu\text{m}$ .

The short range optical module has ST type connectors.

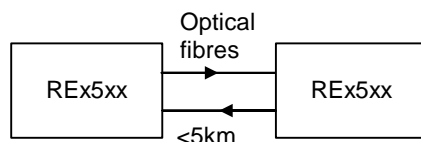

en01000248.vsd

Figure 243: Dedicated link, optical fibre connection

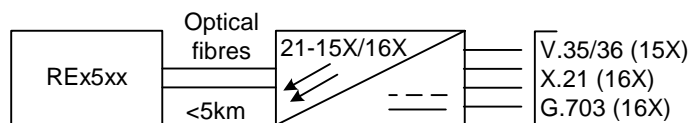

xx00000542vsd

Figure 244: Multiplexed link, short range optical fibre connection

---

The reach will depend on the properties of the used optical fibre. In the optical budget has also to be accounted for losses in splices, connectors and also ageing of the cable. The connection to the protection terminal shall not be accounted for in the optical budget. 15 dB optical budget gives up to 5 km reach under normal conditions.

---

## 6 G.703 module

### 6.1 Application

#### **Interface modules for G.703 co-directional**

This interface module is intended for connection to commercially available communication equipments or multiplexers with G.703 interface. It can only be used with transmission rate of 64 kbit/s. Furthermore it only supports co-directional operation. Contra-directional and centralised clock are not supported.

Even if the standard claims that the reach can be rather long at 64 kbit/s, it is not recommended to use this for protection purposes where the communication has to be reliable also under primary power system faults. This is due to the low level of the communication, signals only 1 V, which gives low margin between signal and noise. If the protection and the communication equipment are located in the same room and the environment is free of noise, the protection terminal may be connected directly to the multiplexer via shielded and properly earthed cables with twisted pairs, same as shown in figure for V.36 etc, for distances up to 10 m.

---

## 7 Carrier module

### 7.1 Application

Use the carrier module with the appropriate galvanic or optical communication sub-module for short range communication of binary signals. Use the optical communication module when connecting a FIBERDATA 21-15X or FIBERDATA 21-16X optical-to-electric modem. The 21-15X model supports V.35 and V.36 standards, and the 21-16X model X.21, RS530 or G.703 standards.

### 7.2 Design

The carrier module is used to connect a communication sub-module to the platform. It adds the CAN-communication and the interface to the rest of the platform. By this the capability to transfer binary signals between for example two distance protection units is added.

The following three types of sub-modules can be added to the carrier module:

- Short range galvanic communication module
- Short range optical communication module
- G.703 communication module

The carrier module senses the type of sub-module via one of the two connectors.

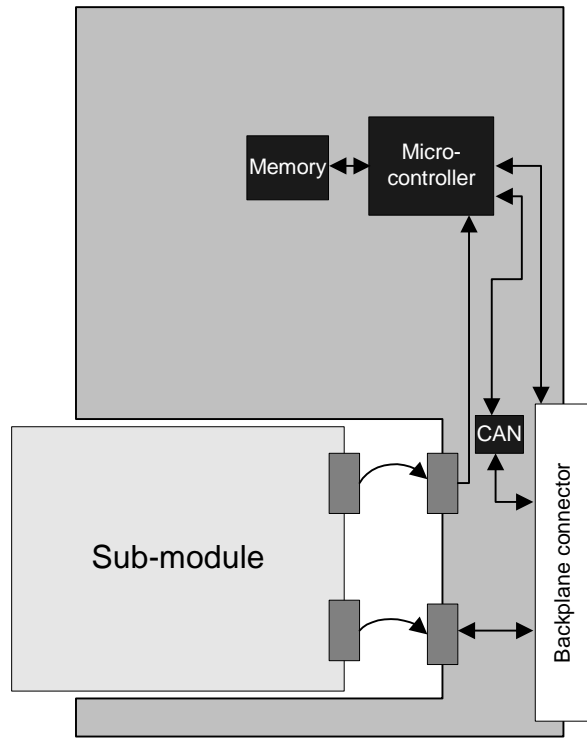

99000520.vsd

Figure 245: Block diagram for the carrier module.



---

## 8 Serial communication

### 8.1 Application

The serial communication can be used for different purposes, which enable better access to the information stored in the terminals. The serial communication is also used for communication directly between terminals (bay-to-bay communication).

The serial communication can be used with a station monitoring system (SMS) or with a substation control system (SCS). Normally, SPA communication is used for SMS and SCS; LON communication is used for SCS. Additionally, LON communication can also be used for SMS 510. SPA communication is also applied when using the front communication port, but for this purpose, no special serial communication function is required in the terminal. Only the software in the PC and a special cable for front connection is needed.

The rear SPA-port can alternatively be set up for IEC 60870-5-103 communication. IEC 60870-5-103 is a standard protocol for protection functions.

## 9 Serial communication, SPA

### 9.1 Application

The SPA communication is mainly used for SMS. It can include different numerical relays/terminals with remote communication possibilities. Connection to a personal computer (PC) can be made directly (if the PC is located in the substation) or by telephone modem through a telephone network with CCITT characteristics.

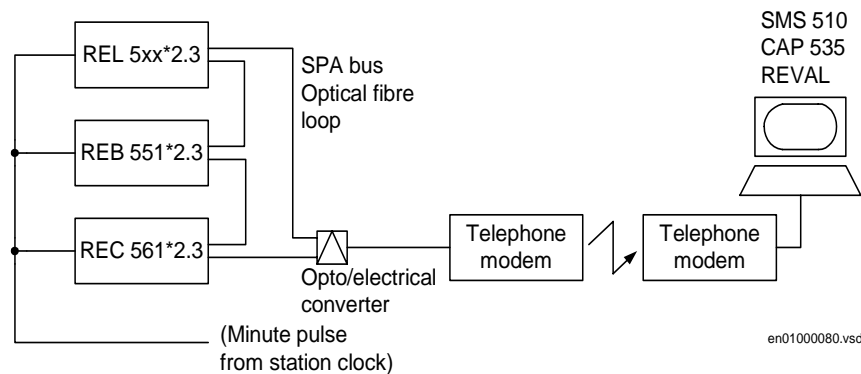

Figure 246: Example of SPA communication structure for a station monitoring system

### 9.2 Functionality

The SPA protocol V2.5 is an ASCII-based protocol for serial communication. The communication is based on a master-slave principle, where the terminal is a slave and the PC is the master. Only one master can be applied on each optic fibre loop. A program is needed in the master computer for interpretation of the SPA-bus codes and for translation of the settings sent to the terminal.

### 9.3 Design

When communicating locally with a Personal Computer (PC) in the station, using the rear SPA port, the only hardware needed for a station monitoring system is:

- Optical fibres
- Opto/electrical converter for the PC
- PC

---

When communicating remotely with a PC using the rear SPA port, the same hardware is needed plus telephone modems.

The software needed in the PC, either local or remote, is:

- CAP 535 (Ver. 1.0 or higher) for configuration and parameter setting
- SMS 510 (Ver 1.0 or higher) for reading of disturbance records, events, distance to fault and trip value settings
- REVAL (Ver 2.0 or higher) for evaluation of the disturbance recorder data

When communicating to a front-connected PC, the only hardware required is the special front-connection cable. The software needed in a front connected PC is:

- CAP 535 (Ver. 1.0 or higher) for configuration and parameter setting
- SMS 510 (Ver 1.0 or higher) for reading of disturbance records, events, distance to fault and trip value settings
- REVAL (Ver 2.0 or higher) is also required if the same PC is used for evaluation of the disturbance recorder data.

## 9.4

### Calculations

The SPA and the IEC use the same rear communication port. To define the protocol to be used, a setting is done on the local HMI under the menu:

#### **Configuration**

##### **TerminalCom**

##### **SPA-IECPort**

When the type of communication protocol is defined, the power to the terminal has to be switched off and on.

The most important settings in the terminal for SPA communication are the slave number and baud rate (communication speed). These settings are absolutely essential for all communication contact to the terminal.

These settings can only be done on the local HMI for rear channel communication at:

---

**Configuration**  
**TerminalCom**  
**SPACOMM**  
**Rear**

and for front connection at:

**Configuration**  
**TerminalCom**  
**SPACOMM**  
**Front**

The slave number can be set to any value from 1 to 899, as long as the slave number is unique within the used SPA loop.

The baud rate, which is the communication speed, can be set to between 300 and 38400 bits/s. The baud rate should be the same for the whole station, although different baud rates in a loop are possible. If different baud rates in the same fibre optical loop are used, consider this when making the communication setup in the communication master, the PC. The maximum baud rate of the front connection is limited to 9600 bit/s.

For local communication, 19200 or 38400 bit/s is the normal setting. If telephone communication is used, the communication speed depends on the quality of the connection and on the type of modem used. But remember that the terminal does not adapt its speed to the actual communication conditions, because the speed is set on the HMI of the terminal.

---

## 10 Serial communication, IEC

### 10.1 Application

The IEC 60870-5-103 communication protocol is mainly used when a protection terminal communicates with a third party control or monitoring system. This system must have a software that can interpret the IEC 60870-5-103 communication messages.

### 10.2 Functionality

The IEC 60870-5-103 is an unbalanced (master-slave) protocol for coded-bit serial communication exchanging information with a control system. In IEC terminology a primary station is a master and a secondary station is a slave. The communication is based on a point to point principle. The master must have a software that can interpret the IEC 60870-5-103 communication messages. For detailed information about IEC 60870-5-103, refer to the IEC60870 standard part 5: Transmission protocols, and to the section 103: Companion standard for the informative interface of protection equipment.

### 10.3 Design

#### General

The protocol implementation in REx 5xx consists of the following functions:

- Event handling
- Report of analog service values (measurands)
- Fault location
- Command handling
  - Autorecloser ON/OFF
  - Teleprotection ON/OFF
  - Protection ON/OFF
  - LED reset
  - Characteristics 1 - 4 (Setting groups)
- File transfer (disturbance files)
- Time synchronization

#### Hardware

When communicating locally with a Personal Computer (PC) or a Remote Terminal Unit (RTU) in the station, using the SPA/IEC port, the only hardware needed is:

- Optical fibres, glass/plastic
- Opto/electrical converter for the PC/RTU
- PC/RTU

### Events

The events created in the terminal available for the IEC 60870-5-103 protocol are based on the event function blocks EV01 - EV06. These function blocks include the function type and the information number for each event input, which can be found in the IEC-document. See also the description of the Event function.

### Measurands

The measurands can be included as type 3.1, 3.2, 3.3, 3.4 and type 9 according to the standard.

### Fault location

The fault location is expressed in reactive ohms. In relation to the line length in reactive ohms, it gives the distance to the fault in percent. The data is available and reported when the fault locator function is included in the terminal.

### Commands

The commands defined in the IEC 60870-5-103 protocol are represented in a dedicated function block. This block has output signals according to the protocol for all available commands.

### File transfer

The file transfer functionality is based on the Disturbance recorder function. The analog and binary signals recorded will be reported to the master. The eight last disturbances, that are recorded, are available for transfer to the master. A file that has been transferred and acknowledged by the master it cannot be transferred again.

The binary signals, that are reported, are those that are connected to the disturbance function blocks DRP1 - DRP3. These function blocks include the function type and the information number for each signal. See also the description of the Disturbance report.

The analog channels, that are reported, are the first four current inputs and the first four voltage inputs.

## 10.4

### Calculations

#### Settings from the local HMI

The SPA and the IEC use the same rear communication port. To define the protocol to be used, a setting is done on the local HMI under the menu:

---

**Configuration**  
**TerminalCom**  
**SPA-IECPort**

When the type of communication protocol is defined, the power to the terminal has to be switched off and on.

The settings for IEC 60870-5-103 communication are the following:

- Individually blocking of commands
- Setting of measurand type
- Setting of main function type and activation of main function type
- Settings for slave number and baud rate (communication speed)
- Command for giving Block of information command

The settings for individually blocking of commands can be found on the local HMI at:

**Configuration**  
**TerminalCom**  
**IECCom**  
**Commands**

Each command has its own blocking setting and the state can be set to OFF or ON. The OFF state corresponds to non-blocked state and ON corresponds to blocked state.

The settings for type of measurand can be found on the local HMI at:

**Configuration**  
**TerminalCom**  
**IECCom**  
**Measurands**

The type of measurands can be set to report standardised types, Type 3.1, Type 3.2, Type 3.3, Type 3.4 or Type 9.

The use of main function type is to facilitate the engineering work of the terminal. The settings for main function type and the activation of main function type can be found on the local HMI at:

---

**Configuration**  
**TerminalCom**  
**IECCom**  
**FunctionType**

The main function type can be set to values according to the standard, this is, between 1 and 255. The value zero is used as default and corresponds to not used.

The setting for activation of main function type can be set to OFF or ON. The OFF state corresponds to non-activated state and ON corresponds to activated state. Upon activated the main function type overrides all other settings for function type within the terminal, that is, function type settings for event function and disturbance recorder function. When set to OFF, function type settings for event function and disturbance recorder function use their own function type settings made on the function blocks for the event function and disturbance recorder respectively. Though for all other functions they use the main function type even when set to OFF.

The settings for communication parameters slave number and baud rate can be found on the local HMI at:

**Configuration**  
**TerminalCom**  
**IECCom**  
**Communication**

The slave number can be set to any value between 0 to 255.

The baud rate, the communication speed, can be set either to 9600 bits/s or 19200 bits/s.

The settings for issuing a block-of-information command can be found on the local HMI at:

**Configuration**  
**TerminalCom**  
**IECCom**  
**BlockOfInfo**

Information command with the value one (1) blocks all information sent to the master and abort any GI procedure or any file transfer in process. Thus issuing the command with the value set to zero (0) will allow information to be polled by the master.



---

The dialogue to operate the output from the BlockOfInformation command function is performed from different state as follows:

1. Selection active; select the:
  - C button, and then the No box activates.
  - Up arrow, and then New: 0 changes to New: 1. The up arrow changes to the down arrow.
  - E button, and then the Yes box activates.
2. Yes box active; select the:
  - C button to cancel the action and return to the BlockOfInfo window.
  - E button to confirm the action and return to the BlockOfInfo window.
  - Right arrow to activate the No box.
3. No box active; select the:
  - C button to cancel the action and return to the BlockOfInfo window.
  - E button to confirm the action and return to the BlockOfInfo window.
  - Left arrow to activate the Yes box.

### **Settings from the CAP 535 tool**

#### **Event**

For each input of the Event function there is a setting for the information number of the connected signal. The information number can be set to any value between 0 and 255. In order to get proper operation of the sequence of events the event masks in the event function shall be set to ON\_CHANGE. For single-command signals, the event mask shall be set to ON\_SET.

In addition there is a setting on each event block for function type. Refer to description of the Main Function type set on the local HMI.

#### **Commands**

As for the commands defined in the protocol there is a dedicated function block with eight output signals. The configuration of these signals are made by using the CAP 531 tool.

To realise the BlockOfInformation command, which is operated from the local HMI, the output BLKINFO on the IEC command function block ICOM has to be connected to an input on an event function block. This input shall have the information number 20 (monitor direction blocked) according to the standard.

**File transfer**

For each input of the Disturbance recorder function there is a setting for the information number of the connected signal. The information number can be set to any value between 0 and 255.

Furthermore there is a setting on each input of the Disturbance recorder function for the function type. Refer to description of Main Function type set on the local HMI.

## 11 Serial communication, LON

### 11.1 Application

An optical network can be used within the Substation Automation system. This enables communication with the terminal through the LON bus from the operator's workplace, from the control center and also from other terminals.

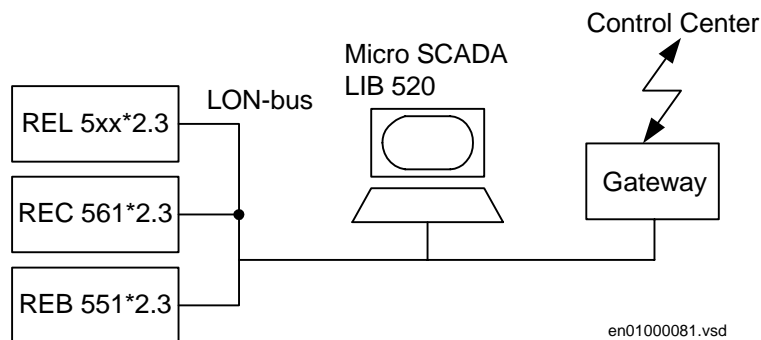

Figure 247: Example of LON communication structure for substation automation

### 11.2 Functionality

The LON protocol is specified in the LonTalkProtocol Specification Version 3 from Echelon Corporation. This protocol is designed for communication in control networks and is a peer-to-peer protocol where all the devices connected to the network can communicate with each other directly. For more information of the bay-to-bay communication, refer to the documents Event function and Multiple command function.

### 11.3 Design

The hardware needed for applying LON communication depends on the application, but one very central unit needed is the LON Star Coupler and optical fibres connecting the star coupler to the terminals. To communicate with the terminals from MicroSCADA, the application library LIB 520 is needed.

The HV/Control and the HV/REx 500 software modules are included in the LIB 520 high-voltage process package, which is a part of the Application Software Library within MicroSCADA applications.

The HV/Control software module is intended to be used for control functions in REx 5xx terminals. This module contains the process picture, dialogues and process database for the control application in the MicroSCADA.

The HV/REx 500 software module is used for setting and monitoring of the terminal via the MicroSCADA screen. At use of this function the PST Parameter Setting Tool (of v1.1 or higher) is required.

## 11.4

### Calculations

Use the LNT, LON Network Tool to set the LON communication. This is a software tool applied as one node on the LON bus. In order to communicate via LON, the terminals need to know which node addresses the other connected terminals have, and which network variable selectors should be used. This is organised by the LNT.

The node address is transferred to the LNT via the local HMI at:

#### Configuration

##### TerminalCom

##### LONComm

##### ServicePinMsg

By setting YES, the node address is sent to the LNT via the LON bus. Or, the LNT can scan the network for new nodes.

The speed of the LON bus is set to the default of 1.25 MHz. This can be changed by the LNT.

If the LON communication from the terminal stops, caused by setting of illegal communication parameters (outside the setting range) or by another disturbance, it is possible to reset the LON port of the terminal. This is performed at the local HMI at:

#### Configuration

##### TerminalCom

##### LONComm

##### LONDefault

By setting YES, the LON communication is reset in the terminal, and the addressing procedure can start from the beginning again.

---

There are a number of session timers which can be set via the local HMI. These settings are only for advanced use and should only be changed after recommendation from ABB Automation Products AB. The time values below are the default settings. The settings can be found at:

**Configuration**

**TerminalCom**

**LONComm**

**SessionTimers**

---

## 12 Serial communication modules (SCM)

### 12.1 SPA/IEC

The serial communication module for SPA/IEC is placed in a slot at the rear part of the main processing module. The serial communication module can have connectors for two plastic fibre cables or two glass fibre cables. The incoming optical fibre is connected to the RX receiver input and the outgoing optical fibre to the TX transmitter output. Pay special attention to the instructions concerning the handling, connection, etc. of the optical fibres.

### 12.2 LON

The serial communication module for LON is placed in a slot at the rear part of the Main processing module. The serial communication module can have connectors for two plastic fibre cables or two glass fibre cables. The incoming optical fibre is connected to the RX receiver input and the outgoing optical fibre to the TX transmitter output. Pay special attention to the instructions concerning the handling, connection, etc. of the optical fibres.

# Chapter 14 Hardware modules

## About this chapter

This chapter describes the different hardware modules.

---

# 1 Platform

## 1.1 General

The REx 5xx platform consists of a case, hardware modules and a set of basic functions.

The closed and partly welded steel case makes it possible to fulfill stringent EMC requirements. Three different sizes of the case are available to fulfill the space requirements of different terminals. The degree of protection is IP 40 according to IEC 529 for cases with the widths 1/2x19" and 3/4x19". For case size 1/1x19" IP 30 applies for the top and bottom part. IP 54 can be obtained for the front area with accessories for flush and semiflush mounting. Mounting kits are available for rack, flush, semiflush or wall mounting.

All connections are made on the rear of the case. Screw compression type terminal blocks are used for electrical connections. Serial communication connections are made by optical fibre connectors type Hewlett Packard (HFBR) for plastic fibres or bayonet type ST for glass fibres

A set of hardware modules are always included in a terminal. Application specific modules are added to create a specific terminal type or family.

The basic functions provide a terminal with basic functionality such as self supervision, I/O-system configurator, real time clock and other functions to support the protection and control system of a terminal.



## 1.2

## Platform configuration

Table 21: Basic, always included, modules

Module	Description
Combined backplane module (CBM)	<p>Carries all internal signals between modules in a terminal. The size of the module depends on the size of the case.</p> <p>1/1x19": 13 slots available for I/O.</p> <p>3/4x19": 8 slots available for I/O.</p> <p>1/2x19": 3 slots available for I/O.</p>
Power supply module (PSM)	<p>Available in two different versions, each including a regulated DC/DC converter that supplies auxiliary voltage to all static circuits.</p> <ul style="list-style-type: none"> <li>• For case size 1/2x19" and 3/4x19" a version with four binary inputs and four binary outputs are used. An internal fail alarm output is also available. PSM output power 20W.</li> <li>• For case size 1/1x19" a version without binary I/O:s and increased output power is used. An internal fail alarm output is available. PSM output power 30W.</li> </ul>
Main processing module (MPM)	<p>Module for overall application control. All information is processed or passed through this module, such as configuration, settings and communication.</p>
Human machine interface (LCD-HMI)	<p>The module consist of LED:s, a LCD, push buttons and an optical connector for a front connected PC</p>

**Table 22: Application specific modules**

Module	Description
Signal processing module (SPM)	Module for protection algorithm processing. Carries up to 12 digital signal processors, performing all measuring functions.
Milliampere input module (MIM)	Analog input module with 6 independent, galvanically separated channels.
Binary input module (BIM)	Module with 16 optically isolated binary inputs
Binary output module (BOM)	Module with 24 single outputs or 12 double-pole command outputs including supervision function
Binary I/O module (IOM)	Module with 8 optically isolated binary inputs, 10 outputs and 2 fast signalling outputs.
Data communication modules (DCMs)	Modules used for digital communication to remote terminal.
Transformer input module (TRM)	Used for galvanic separation of voltage and/or current process signals and the internal circuitry.
A/D conversion module (ADM)	Used for analog to digital conversion of analog process signals galvanically separated by the TRM.
Optical receiver module (ORM)	Used to interface process signals from optical instrument transformers.
Serial communication module (SCM)	Used for SPA/LON/IEC communication
LED module (LED-HMI)	Module with 18 user configurable LEDs for indication purposes

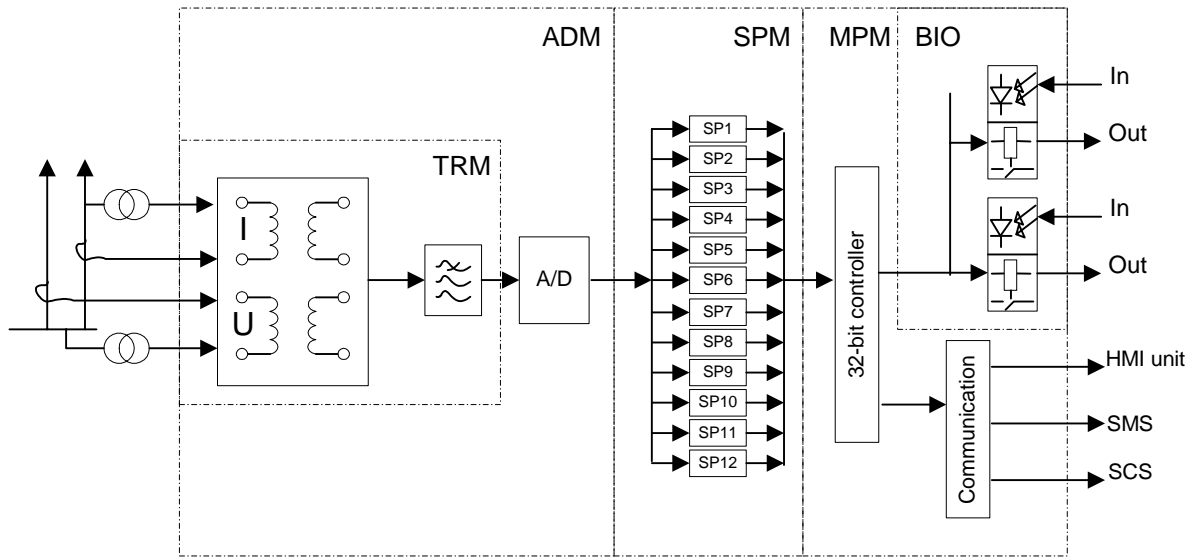

99000522.vsd

Figure 248: Basic block diagram

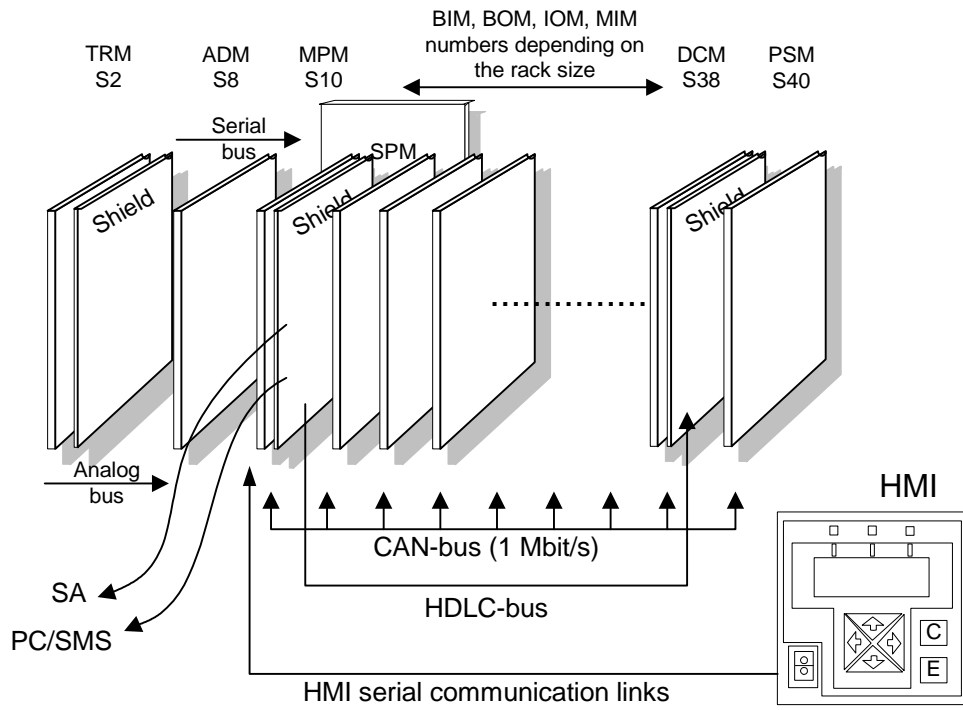

99000526.vsd

Figure 249: Internal hardware structure showing a full width case configuration

1.3 3/4x19" platform

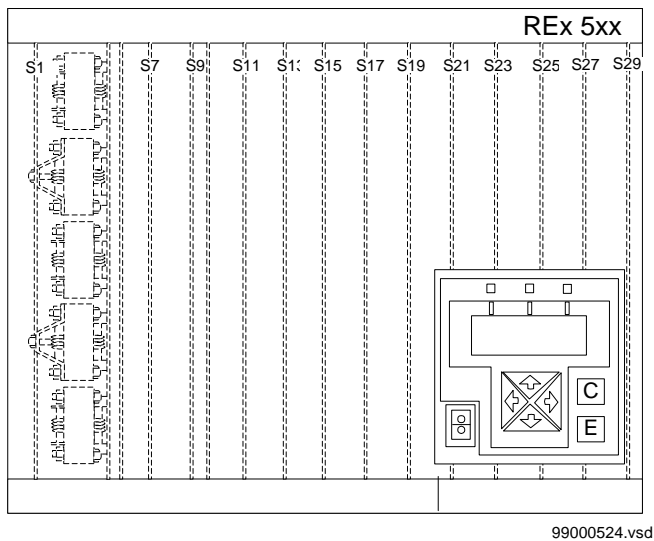

Figure 250: Hardware structure of the 3/4x19" case

1.4 1/2x19" platform

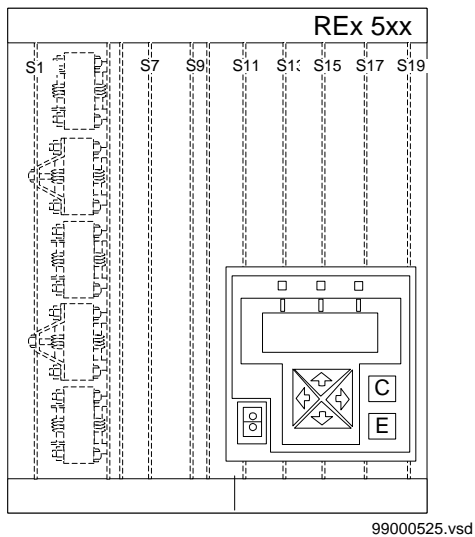

Figure 251: Hardware structure of the 1/2x19" case

## 2 Transformer input module (TRM)

Current and voltage input transformers form an insulating barrier between the external wiring and internal circuits of the terminal. They adapt the values of the measuring quantities to the static circuitry and prevent the disturbances to enter the terminal. Maximum 10 analog input quantities can be connected to the transformer module (TRM). A TRM with maximum number of transformers has:

- Five voltage transformers. The rated voltage is selected at order.
- Five current transformers. The rated currents are selected at order.

The input quantities are the following:

- Three phase currents
- Residual current of the protected line
- Residual current of the parallel circuit (if any) for compensation of the effect of the zero sequence mutual impedance on the fault locator measurement or residual current of the protected line but from a parallel core used for CT circuit supervision function or independent earthfault function.
- Three phase voltages
- Open delta voltage for the protected line (for an optional directional earth-fault protection)
- Phase voltage for an optional synchronism and energizing check.

The actual configuration of the TRM depends on the type of terminal and included functions. See figure 252 and figure 253.

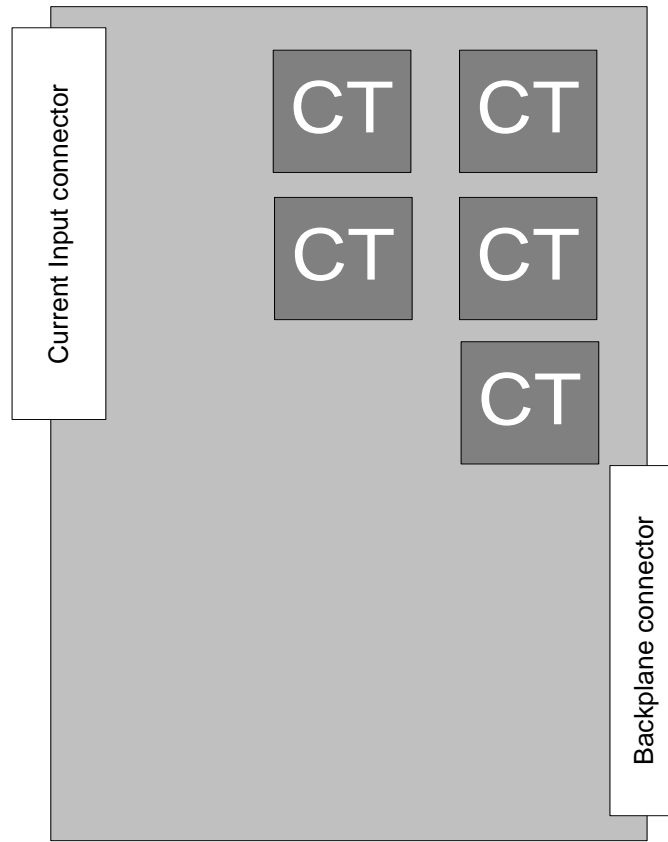

99000560.vsd

Figure 252: Block diagram of the TRM for REL 551, Line differential protection

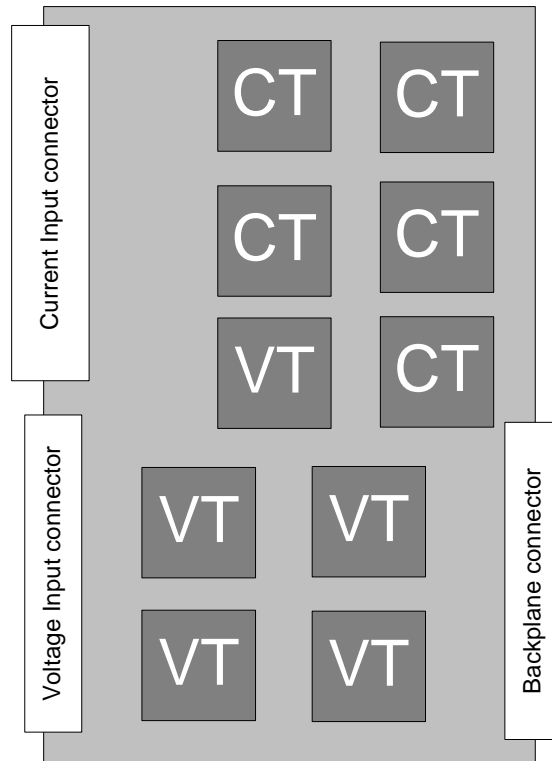

990000511.vsd

Figure 253: Block diagram of the TRM with maximum number of transformers used in most REx 5xx.



---

**3****A/D-conversion module (ADM)**

The incoming signals from the intermediate current transformers are adapted to the electronic voltage level with shunts. To gain dynamic range for the current inputs, two shunts with separate A/D channels are used for each input current. By that a 16-bit dynamic range is obtained with a 12 bits A/D converter.

The next step in the signal flow is the analogue filter of the first order, with a cut-off frequency of 500 Hz. This filter is used to avoid aliasing problems.

The A/D converter has a 12-bit resolution. It samples each input signal (5 voltages and 2x5 currents) with a sampling frequency of 2 kHz.

Before the A/D-converted signals are transmitted to the signal processing module, the signals are band-pass filtered and down-sampled to 1 kHz in a digital signal processor (DSP).

The filter in the DSP is a numerical filter with a cut-off frequency of 250 Hz.

The transmission of data between the A/D-conversion module and the signal processing module is done on a supervised serial link of RS485 type. This transmission is performed once every millisecond and contains information about all incoming analog signals.

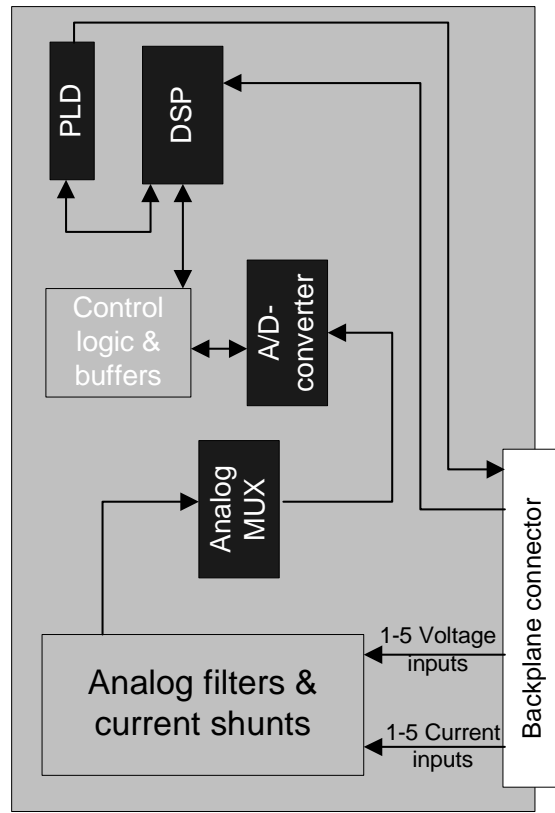

99000512.vsd

*Figure 254: Block diagram for the ADM*

## 4

**Optical receiver module (ORM)**

The optical receiver module (ORM) is used to interface signals from optical instrument transformer platform (OITP) to the terminal. The ORM will replace the conventional analog input modules. Either 50 or 60 Hz signals is handled by the module. Only one of the frequencies must be selected and used for all inputs.

The optical receiver module has four optical input channels that handles data from optical instrument transformer platform (OITP). It converts the OITP data to a format used in the terminal. The received data is processed in different ways depending on the setting of the eight pole dip-switch of the module.

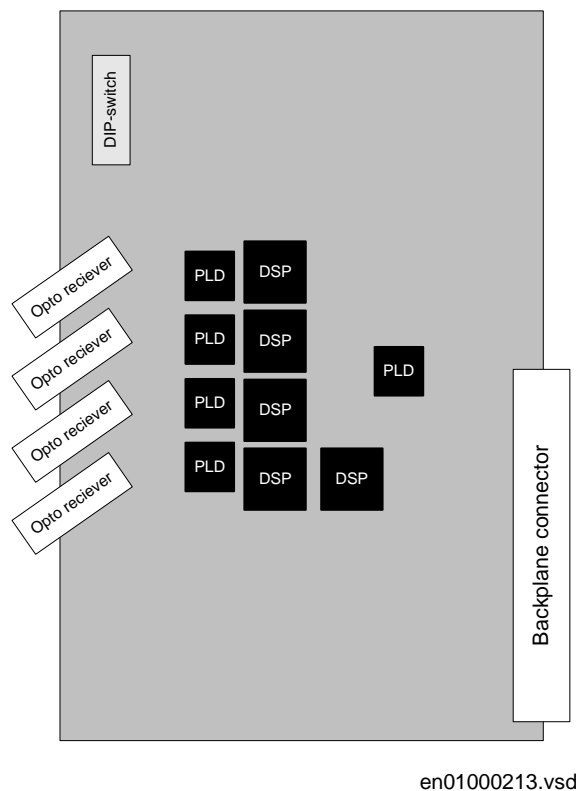

Figure 255: Block diagram for the ORM

---

## 5 Main processing module (MPM)

The terminal is based on a pipelined multi-processor design. The 32-bit main controller receives the result from the Signal processing module every millisecond.

All memory management are also handled by the main controller. The module has 8MB of disc memory and 1MB of code memory. It also has 8MB of dynamic memory.

The controller also serves four serial links: one high-speed CAN bus for Input/Output modules and three serial links for different types of HMI communication.

The main controller makes all decisions, based on the information from the Signal processing module and from the binary inputs. The decisions are sent to the different output modules and to these communication ports:

- Local HMI module including a front-connected PC, if any, for local human-machine communication.
- LON communication port at the rear (option).
- SPA/IEC communication port at the rear (option)

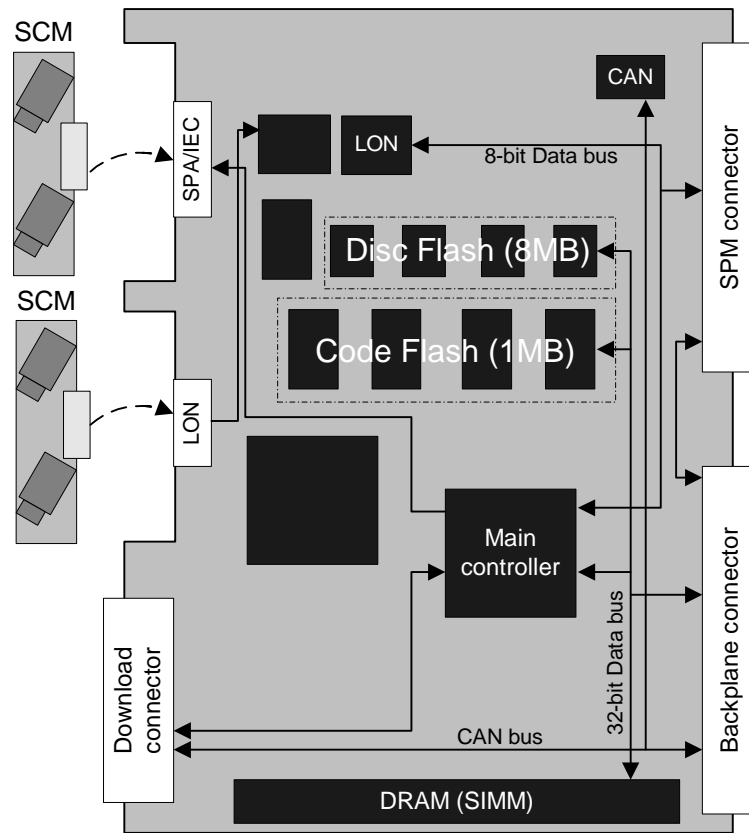

99000513.vsd

Figure 256: Block diagram for the MPM

To allow easy upgrading of software in the field a special connector is used, the Download connector.

## 6 Signal processing module (SPM)

All numerical data is received in all of the up to 12 (16 bits) digital signal processors (DSP). In these DSPs, the main part of the filtering and the calculations take place. The result from the calculations in the DSPs is sent every millisecond on a parallel bus to the (32 bit) main controller on the Main processing module.

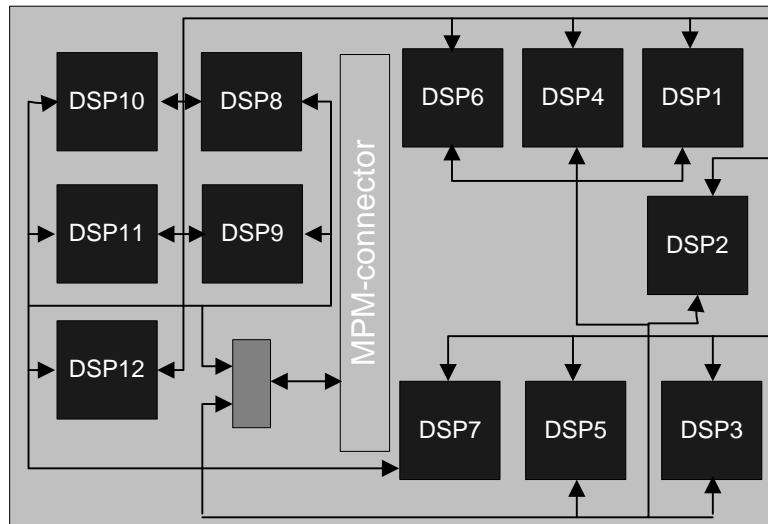

99000514.vsd

Figure 257: Block diagram of the SPM

## 7 Input/Output modules

### 7.1 General

The number of inputs and outputs in a REx 5xx terminal can be selected in a variety of combinations depending on the size of the rack. There is no basic I/O configuration of the terminal. The table below shows the number of available inputs or output modules for the different platform sizes.

Platform size	1/1x19"	3/4x19"	1/2x19"
I/O slots available	13	8	3

A number of signals are available for signalling purposes in the terminal and all are freely programmable. The voltage level of the input/output modules is selectable at order. Available versions are RL 48, 110, or 220 (48/60 V +/-20%, 110/125 V +/-20% or 220/250 V +/-20%). The Binary in/out module and the Binary input module are also available in an RL 24 version (24/30 V +/-20%).

Figure 258 shows the operating characteristics of the binary inputs of the four voltage levels.

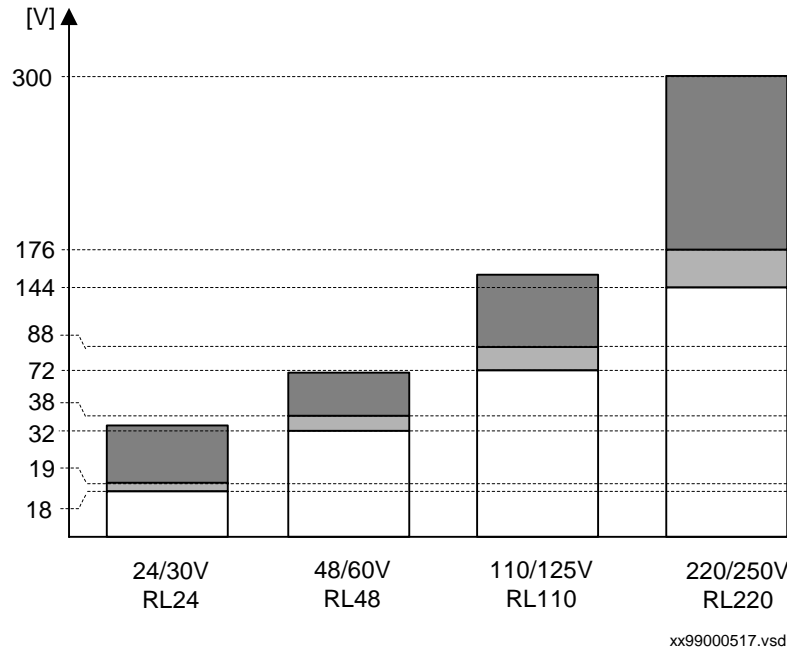





Figure 258: Voltage dependence for the binary inputs

Table 23: Input voltage ranges explained

	Guaranteed operation
	Operation uncertain
	No operation

The I/O modules communicates with the Main Processing Module via the CAN-bus on the backplane.

The design of all binary inputs enables the burn off of the oxide of the relay contact connected to the input, despite the low, steady-state power consumption, which is shown in figure 259.



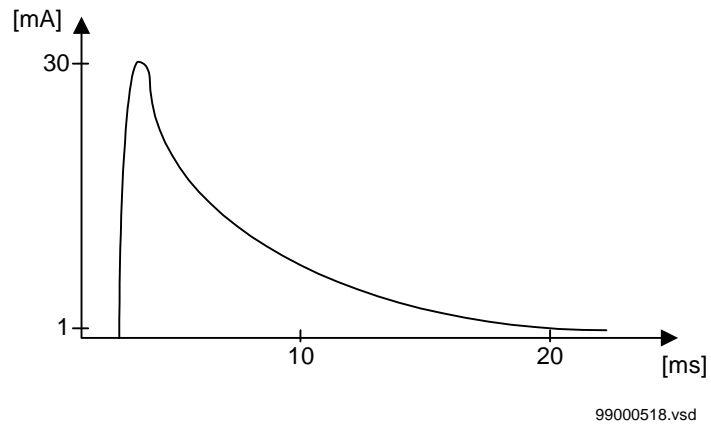
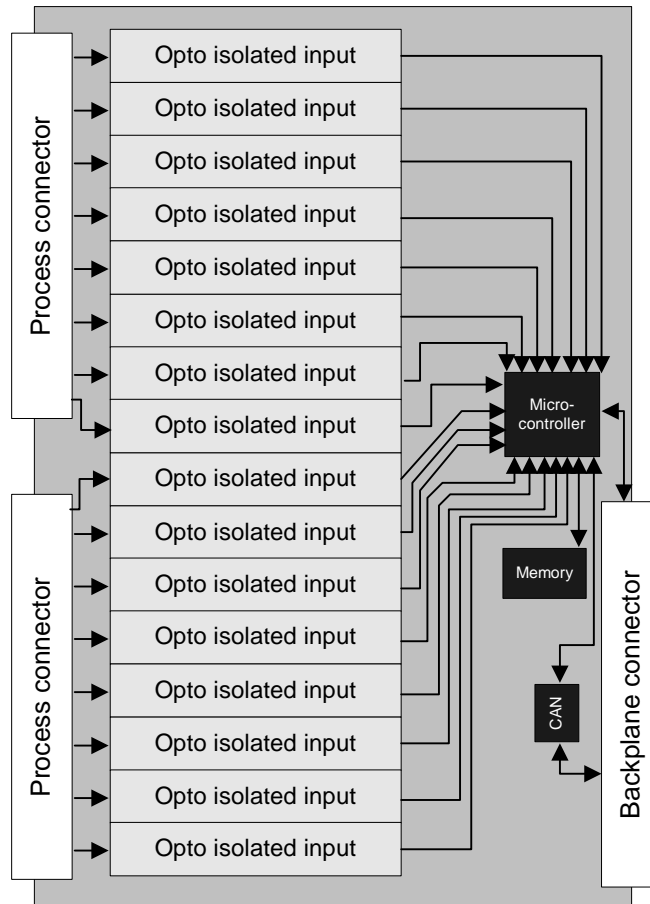

Figure 259: Current through the relay contact

## 7.2

### Binary input module (BIM)

The binary input module contains 16 optically isolated binary inputs. The binary inputs are freely programmable and can be used for the input logical signals to any of the functions. They can also be included in the disturbance recording and event recording functions. This enables the extensive monitoring and evaluation of operation for the terminal and for all associated electrical circuits. The voltage level of the binary input modules can be selected at order.



99000503.vsd

Figure 260: Block diagram of the binary input module

### 7.3

#### Binary output module (BOM)

The Binary output module has 24 single-output relays or 12 command-output relays. They are grouped together as can be seen in figure 261 and 262. All the output relays have contacts with a high switching capacity (trip and signal relays).

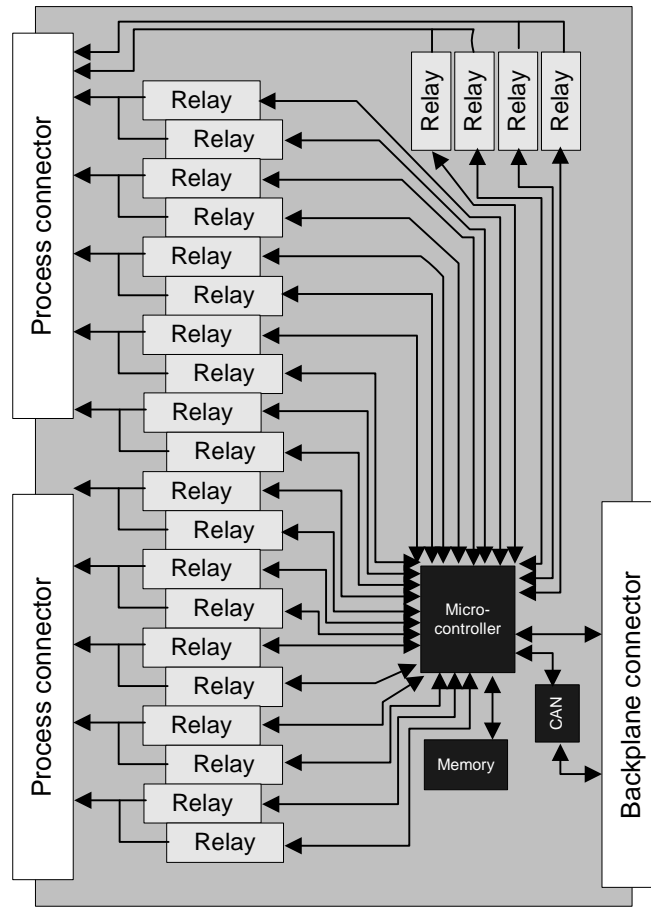

99000505.vsd

Figure 261: Block diagram of the binary output module

Two single output relay contacts can be connected in series (which gives a command output) in order to get a high security at operation of high voltage apparatuses.

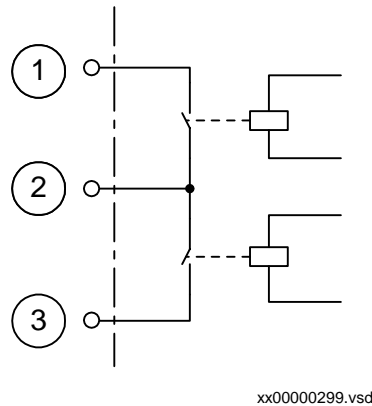

Figure 262: One of twelve binary output groups

The output relays are provided with a supervision function to ensure a high degree of security against unwanted operation. The status of the output circuits is continuously read back and compared with the expected status. If any discrepancy occurs, an error is reported. This function covers:

- interrupt or short circuit in an output relay coil
- failure of an output relay driver.

## 7.4

### Binary I/O module (IOM)

The binary in/out module contains eight optically isolated binary inputs and twelve binary output contacts. Ten of the output relays have contacts with a high-switching capacity (trip and signal relays). The remaining two relays are of reed type and for signalling purpose only. The relays are grouped together as can be seen in the terminal diagram.

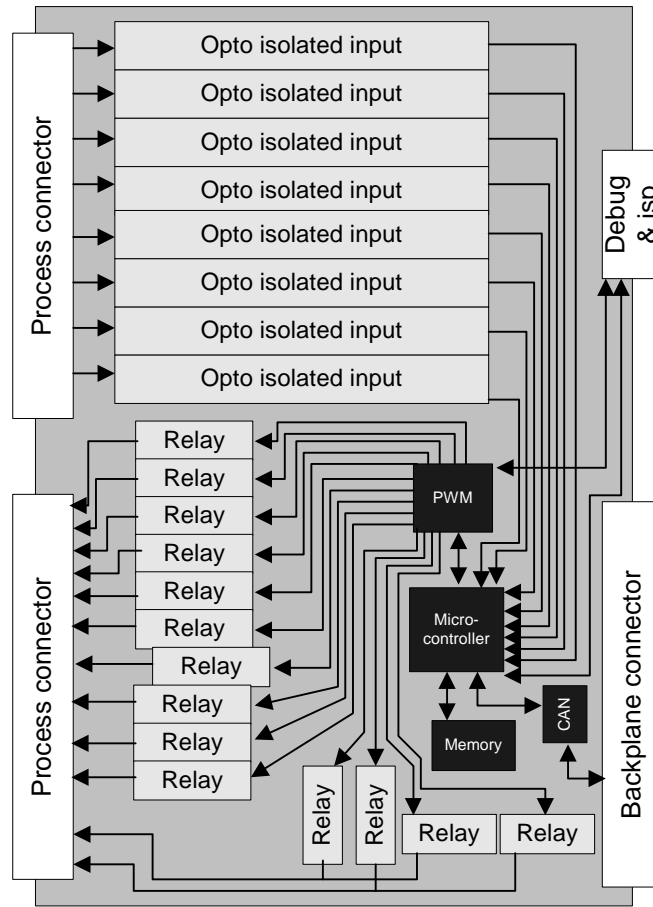

99000502vsd

Figure 263: Block diagram for the binary input/output module

## 8 Power supply module (PSM)

The power supply module (PSM) contains a built-in, self-regulated DC/DC converter that provides full isolation between the terminal and the external battery system. The wide input voltage range of the DC/DC converter converts an input voltage range from 48 to 250V, including a +/-20% tolerance on the EL voltage. The output voltages are +5, +12 and -12 Volt.

The PSM, used in the 1/2x19" and 3/4x19" platforms, has built-in binary I/O with four optically isolated inputs and five outputs. One of the binary outputs is dedicated for internal fail. The PSM can provide power up to 20W.

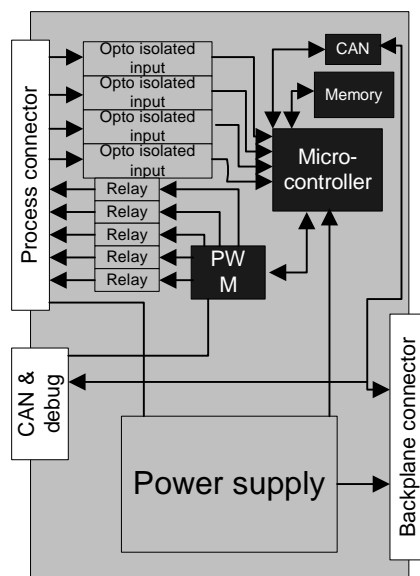

Figure 264: Block diagram for the PSM used in 1/2x19" and 3/4x19" cases.

## 9

**mA input module (MIM)**

The mA input module (MIM) has six independent analog channels with separated protection, filtering, reference, A/D-conversion and optical isolation for each input making them galvanically isolated from each other and from the rest of the module.

The analog inputs measure DC and low frequency currents in range of up to +/- 20mA. The A/D converter has a digital filter with selectable filter frequency. All inputs are calibrated separately and stored in a non-volatile memory and the module will self-calibrate if the temperature should start to drift. This module communicates, like the other I/O- modules, with the Main Processing Module via the CAN-bus.

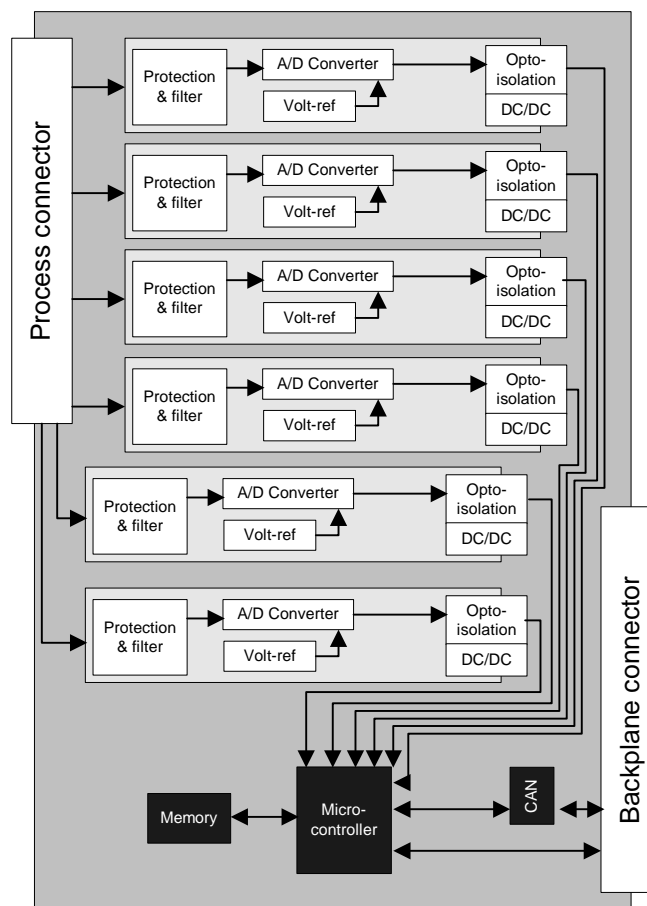

99000504.vsd

Figure 265: Block diagram of the mA input module

## 10

## Human-machine interface (HMI)

The local HMI module consists of three LEDs (red, yellow, and green), an LCD with four lines, each containing 16 characters, six buttons and an optical connector for PC communication.

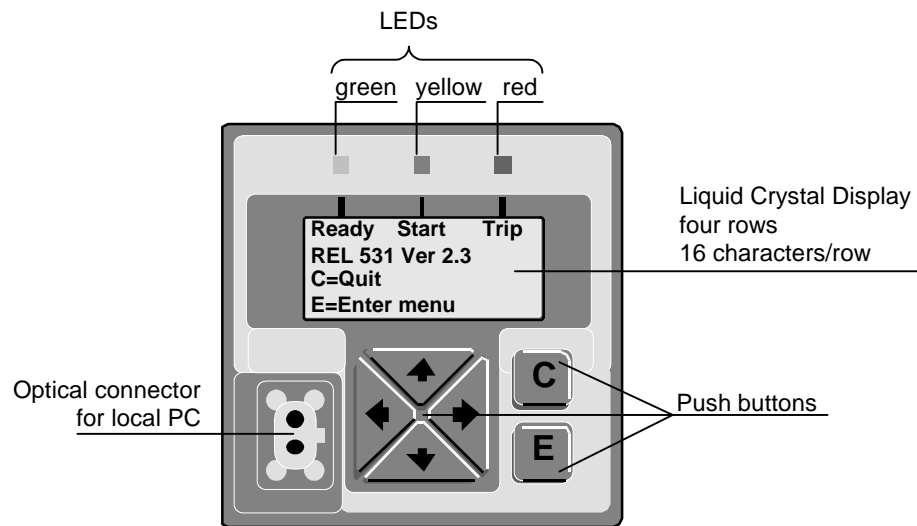

en00000422.vsd

Figure 266: Local HMI

The PC is connected via a special cable, that has a built-in optical to electrical interface. Thus, disturbance-free local serial communication with the personal computer is achieved. Software tools are available from ABB for this communication. A PC greatly simplifies the communication with the terminal. It also gives the user additional functionality which is unavailable on the HMI because of insufficient space. The LEDs on the HMI display this information:



**Table 24: The local HMI LED display**

LED indication	Information
<b>Green:</b>	
Steady	In service
Flashing	Internal failure
Dark	No power supply
<b>Yellow:</b>	
Steady	Disturbance Report triggered
Flashing	Terminal in test mode
<b>Red:</b>	
Steady	Trip command issued from a protection function or disturbance recorder started
Flashing	Blocked

