CATALOG

T&B Fittings

Rigid conduit and fittings

Ordinary and hazardous location solutions



**Thomas & Betts is now ABB
Installation Products, but our long
legacy of quality products and
innovation remains the same. From
connectors that help wire buildings
on Earth to cable ties that help put
machines in space, we continue to
work every day to make, market,
design and sell products that
provide a smarter, safer and more
reliable flow of electricity, from
source to socket.**

Table of contents

004–005	Overview
006–021	Bushings, nipples, locknuts and plugs
022–032	Hubs and bulkhead fittings
033–049	Couplings and accessories
050–055	Stainless steel conduit and fittings
056–064	Straps, spacers and clamps
065–086	Conduit bodies and covers
087–101	Device boxes and covers
102–130	Hazardous location fittings
131–133	Technical information
134–147	Appendix

Overview

The complete product line

Since the turn of the century, ABB has been a recognized leader in electrical fittings. Industry standards such as Chase® nipples and Erickson® couplings were introduced by ABB and are still registered trademarks. This leadership continues. Here's why...



Innovative designs

The real test of product design of electrical fittings lies in two areas: Job-suited installation and life of the job reliability. ABB fittings provide both because we listen. We listen to problems and suggestions from the field. Most of the products in this section result from the good suggestions by knowledgeable electrical people. Many were customer specials to solve particular installation and performance problems. You can benefit from their experience.

Approvals and listings

Electrical raceways require accessory fittings that provide the mechanical strength, ground continuity and environmental integrity of the system. As new raceways have been introduced, ABB engineers have designed fittings that meet the requirements of the National Electrical Code® as well as the listing requirements of the Underwriter's Laboratories and the Canadian Standards Association. You can use ABB fittings with confidence.

High-performance products

Quality and performance result when engineering design skills are combined with the manufacturing technologies required to produce them. The ABB fittings in this section are produced from many materials and by many manufacturing methods, each carefully selected for its end use suitability. This combination gives you the reliable performance you expect from ABB raceway fittings.

Lower installed cost

It is a function of purchase cost, availability, installation advantage and performance. Lower installed cost comes in every carton of ABB raceway fittings.

Note: In the United States, boxes and fittings are not listed or marked for use in Class I Division 2 locations. See NEC® 501.10(B) for the wiring methods allowed in these areas.

NEC and National Electrical Code are registered trademarks of the National Fire Protection Association, Inc.



Overview

DURA-PLATE® finish – corrosion-resistant finish protects fittings in harsh environments



DURA-PLATE corrosion-resistant fittings use an ABB plating process that provides excellent corrosion resistance on threaded steel and malleable iron fittings for use in harsh environments.

DURA-PLATE corrosion-resistant fittings utilize an electro-plating process that ensures a uniform thickness of protective material over the entire part. Conventional hot dip coatings deposit an uncontrolled buildup of material on the part, especially in threaded areas. This excess buildup must be removed to enable mating parts to function.

The process of removing this buildup in the threads in turn damages the coating and compromises the effectiveness of the protection.

An additional drawback of hot dip coating is that the lower ductility of the alloyed interface layer that is formed during the hot dip process can cause spalling if the item is deformed after coating.

In addition to the uniformity of the coating, the distinctive gold color of the plating enables immediate recognition that the part has been prepared for exposure to harsh environments and confirms the extra protection by visual inspection.

DURA-PLATE corrosion-resistant fittings have been subjected to salt spray tests conducted according to ASTM Specification B-117. The results of corrosion-resistant fittings tests, along with galvanized parts, appears in the graph below.

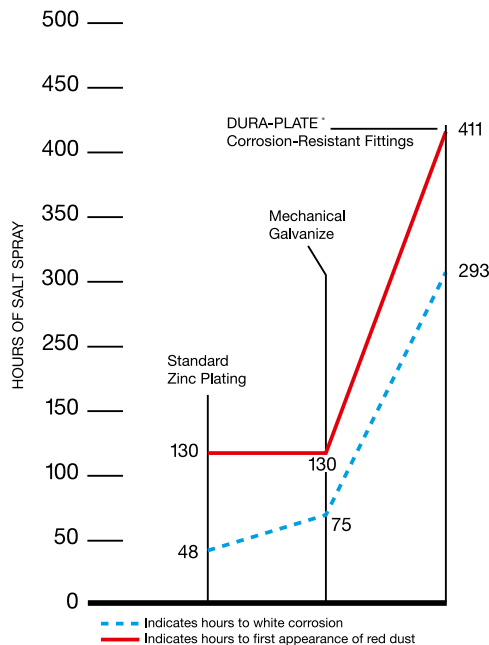

Ordering information

- Add the prefix "040-" to the standard catalog number – for example: a 5332 with DURA-PLATE corrosion-resistant fittings protection would be ordered as "040-5332"
- Check for catalog numbers in stock
- Allow 6–8 weeks for delivery on nonstock items
- Add 30% to price of standard item
- Minimum order is standard package quantity



Bushings, nipples, locknuts and plugs

Locknuts – Now available in stainless steel 316

—
01 140 Series
141AL Series
—
02 106 Series

Application

- To connect externally threaded conduit or connector to a threadless opening in a box or enclosure
- To effectively bond conduit or connector to box or enclosure

Features

- Hardened steel/malleable iron/copper-free aluminum/stainless steel 316 construction
- Tightens without deformation
- Locknuts specially designed to:
 - (i) Provide extended reach for clamping on thin boxes and enclosures
 - (ii) Cut through protective coating on box and enclosure, thereby ensuring ground continuity
 - (iii) Permit tightening from outside
 - (iv) Prevent loosening under vibration
- 106 Series provided with a hardened cone-point screw

Standard material

140 Series and 106 series

- $\frac{3}{8}$ " through 2" steel (hardened)
- 2 $\frac{1}{2}$ " through 6" malleable iron
- All screws steel
- Option: Stainless steel 316 (add suffix "SS6")

141AL Series

- All copper-free aluminum

Standard finish

- All steel and malleable iron locknuts, including electro zinc-plated bonding screws and chromate coated all-aluminum locknut, degreased
- Stainless steel 316 — Polished

Range

- $\frac{3}{8}$ " through 6" conduit (all threads straight pipe NPS) (140 series)
- $\frac{1}{2}$ " through 4" conduit (106 series, 141AL series)
- $\frac{1}{2}$ " through 4" conduit (stainless steel 106 and 140 series)

Listings/compliances

- UL (UL File No. E-23018)
- CSA (catalog numbers 108, 109, 110 and 111, all 140 series except catalog number 140) (LR-2884, LR-4484)
- UL 514B
- CSA C22.2 No. 18
- NEMA FB1
- NFPA 70
- Federal specification replaced by A-A-50553
- Federal standard H-28 (threads)

Case hardened locknuts

Case hardened locknuts make fittings faster and easier to install. Case hardened locknuts do not slip or turn, thereby protecting the biting edge. Case hardened locknuts bite through paint into the enclosure, providing excellent continuity of ground (typical ABB fitting with case hardened locknuts successfully passed minimum fault current of 10,000 amps RMS). Case hardened locknuts, when assembled in the intended manner, will not vibrate loose, thereby ensuring excellent ground continuity.



01



02

Bushings, nipples, locknuts and plugs

Locknuts and bonding locknuts



Stainless steel version coming soon

Available in your choice of steel/ malleable iron, aluminum or stainless steel.

- Steel from ¼" to 2", malleable iron from 2½" to 6"
- Aluminum 3003 from ½" to 6" or type 304 stainless steel from ½" to 2"
- Stainless steel 316 locknuts from ½" to 4"

Locknuts



Cat. no.		Dimensions (in.)				
Steel/M.I.	Alum.	St. Stl. 304	St. Stl. 316	Size (in.)	A	B
139*	-	-	-	¼	¾	9/64
140*	-	-	-	⅜	1 ⁵ / ₁₆	9/64
141**	141AL	141-SST	141SS6	½	1 ⁷ / ₆₄	5/32
142**	142AL	142-SST	142SS6	¾	1 ³ / ₈	3/16
143	143AL	143-SST	143SS6	1	1 ¹¹ / ₁₆	13/64
144	144AL	144-SST	144SS6	1¼	2 ⁵ / ₃₂	13/64
145	145AL	145-SST	145SS6	1½	2½	13/64
146	146AL	146-SST	147SS6	2	3	7/32
147	147AL	-	-	2½	3 ⁹ / ₁₆	13/32
148	148AL	-	148SS6	3	4 ³ / ₁₆	13/32
149	149AL	-	149SS6	3½	4 ¹³ / ₁₆	15/32
150	150AL	-	150SS6	4	5 ⁵ / ₁₆	15/32
151	151AL	-	-	4½	5 ¹⁵ / ₁₆	17/32
152	152AL	-	-	5	6½	17/32
153	153AL	-	-	6	7¾	19/32

Diagram

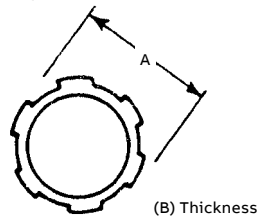

*Hex shape
 **Case hardened locknuts
 Aluminum locknuts comply with federal standard of copper-free aluminum; less than 0.5% copper.
 Available with DURA-PLATE® finish.
 UL File E-23018
 CSA File No. 2884
 Stainless steel 316 version is cULus (file number: E23018)



Stainless steel version coming soon

Ensures positive bonding of conduit to box and prevents loosening due to vibration.

- Steel or malleable iron (steel through 2")
- Stainless steel 316 available from ½" to 4"
- Can be used anywhere an ordinary locknut is installed
- Also can be used for service entrance applications in conformance with code
- Rigid conduit and EMT (thinwall) fittings comply with Federal Specification A-A-50553

Bonding locknuts



Cat. no.		Dimensions (in.)		
Steel/M.I.	St. Stl. 316	Size (in.)	A	B
106 [†]	106SS6	½	1 ³ / ₈	0.125
107 [†]	107SS6	¾	1 ⁵ / ₈	0.140
108	108SS6	1	1 ¹⁵ / ₁₆	0.170
109	109SS6	1¼	2 ⁵ / ₃₂	0.170
110	110SS6	1½	2½	0.170
111	111SS6	2	3	0.187
112 [†]	112SS6	2½	3 ¹³ / ₃₂	0.375
113 [†]	113SS6	3	4 ¹³ / ₁₆	0.375
114 [†]	-	3½	4 ²⁹ / ₃₂	0.438
115 [†]	115SS6	4	5 ⁷ / ₃₂	0.438

Diagram

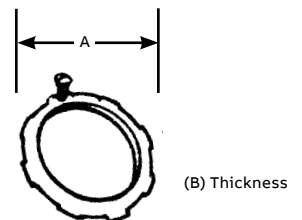

[†] Not CSA certified.
 Available with DURA-PLATE® finish.
 UL File No. E-3060
 CSA File No. 638
 Stainless steel 316 version is cULus (file number: E3060)

Bushings, nipples, locknuts and plugs

Sealing locknuts



Provides positive seal against water and oil.

- For use with rigid and intermediate metal conduits or fittings
- Provides watertight or raintight seal at all enclosures

Sealing locknuts



Cat. no.	Size (in.)	Dimensions (in.)		
		A	B	C
141SL	1/2	1.140	1/8	1/4
142SL	3/4	1.420	5/32	9/32
143SL	1	1.770	11/64	9/32
144SL	1 1/4	2.281	11/64	5/16
145SL	1 1/2	2.598	11/64	9/32
146SL	2	3.175	3/16	7/64

Diagram

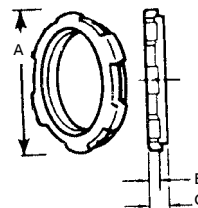

Molded santoprene seal
Color: Blue

Bushings, nipples, locknuts and plugs

Bonding and grounding wedges



Perfect for grounding old work or new.

- Provides grounding without a jumper except in concentric knockouts
- When jumper is required, it fits under set screw in grounding wedge
- Update existing installations to meet code requirements for bonding (NEC® Article 250, Part V) without disconnecting wiring
- For use on new wiring, just loosen bushing, position wedge and tighten bushing and bonding screw

Application

- To effectively bond terminating fitting or conduit to a box or enclosure

Features

- Sizes $\frac{3}{4}$ " through 6" equipped with an additional bonding screw to install bonding jumper where required
- Can be added to an existing installation without disconnecting conductors

Standard material/finish

- $\frac{1}{2}$ " size steel/electro zinc plated
- $\frac{3}{4}$ " through 6" size bronze/tin plated

Range

- $\frac{1}{2}$ " through 6" conduit

Listings/compliances

- UL File #E3060
- CSA File #638
- UL 467
- CSA C22.2 No. 41
- NFPA-70
- Federal Specification A-A-50552

Bonding and grounding wedges



Cat. no.	Size (in.)
3650	$\frac{1}{2}$
3651	$\frac{3}{4}$
3652	1
3653	$1\frac{1}{4}$
3654	$1\frac{1}{2}$
3655	2
3656	$2\frac{1}{2}$
3657	3
3658	$3\frac{1}{2}$
3659	4
3661	5
3662	6

Diagrams

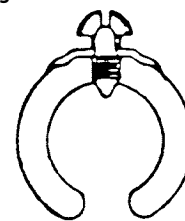

Series 3650

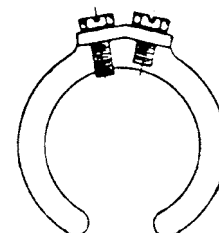

Series 3651

Bushings, nipples, locknuts and plugs

Liquidtight sealing gasket

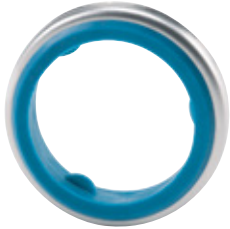

5262 series sealing gasket

Sealing material resists oil, coolants and hydraulic fluids as well as water.

The 5262 series sealing gasket includes a stainless steel retaining ring to prevent elongation of the Santoprene® gasket, ensuring a superior seal.

Application

- When used with an externally threaded connector, provides a tight seal against oil, fumes or moisture at the knockout opening

Features

- Design locks resilient sealing material in steel
- Steel retainer protects seal from extruding out under torque and limits compression to an optimum predetermined value; provides high quality seal
- Resilient material flows and seals rough surfaces
- NEMA 3R, 4, 6 and 13

Standard material

- Retainer: 316 stainless steel
- Sealing material: Santoprene thermoplastic rubber

Range

- ¼" through 4" hub size

Liquidtight sealing gasket



Cat. no.	Conduit size (in.)	Dimensions (in.)		Std. pkg. qty.
		A	B	
5262	½	1.16	0.18	50
5263	¾	1.49	0.19	25
5264	1	1.75	0.19	25
5265	1¼	2.15	0.22	5
5266	1½	2.42	0.23	5
5267	2	2.92	0.23	5
5268	2½	3.44	0.23	5
5269	3	4.08	0.23	5
5270	4	5.29	0.31	5

Diagrams

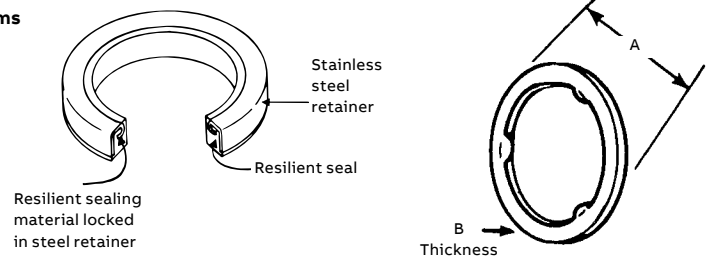

Bushings, nipples, locknuts and plugs

Threaded insulated grounding bushing



Stainless steel version coming soon

Application

- For quick installation of bonding jumper to multiple metal conduits (rigid and IMC)
- Designed to bush conductors and prevent insulation damage

Features

- Ease of installation, lay-in lug design
- Cast malleable iron body designed to lock insulator in place within body, reducing common assembly problem resulting in dislodging of insulator
- Insulator rated for 150 °C/302 °F application
- Look for the unique blue color, ensuring the highest quality fitting

Standard material/finish

- Body: Electro zinc plated
- Lay-in lug: Aluminum/tin plated
- Insulator: Thermoplastic 150 °C/302 °F application with 94V-0 flammability

* Options

- Available in stainless steel 316 (add suffix "SST")
- Body: Stainless steel 316
- Lay-in lug: Stainless steel 316
- Insulator: Thermoplastic 150 °C/302 °F
- Application with 94V-0 flammability
- Finish : Polished

Threaded insulated grounding bushing



Cat. no.	Dimensions (in.)						Wire range (AWG Cu/Al)
	Conduit size (in.)	Bushing dia.	Throat dia.	Lug length	Swing radius	Bushing height	
3870-TB	1/2	1.125	0.560	1.310	1.212	0.657	#14-#4
3861	1/2	1.125	0.560	1.675	1.402	0.657	#8-2/0
3871-TB**	3/4	1.420	0.742	1.310	1.360	0.660	#14-#4
3862	3/4	1.420	0.742	1.675	1.550	0.660	#8-2/0
3872**	1	1.770	0.944	1.310	1.535	0.735	#14-#4
3882	1	1.770	0.944	1.675	1.725	0.735	#8-2/0
3873	1 1/4	2.190	1.242	1.310	1.745	0.735	#14-#4
3883	1 1/4	2.190	1.242	1.675	1.935	0.735	#8-2/0
3874	1 1/2	2.468	1.449	1.310	1.884	0.770	#14-#4
3884	1 1/2	2.468	1.449	1.675	2.074	0.770	#8-2/0
3875	2	3.031	1.860	1.310	2.165	0.770	#14-#4
3889	2	3.031	1.860	1.675	2.355	0.770	#8-2/0
3876	2 1/2	3.516	2.222	1.310	2.408	0.940	#14-#4
3886	2 1/2	3.516	2.222	1.675	2.598	0.940	#8-2/0
3993	2 1/2	3.516	2.222	2.230	2.928	0.940	#6-4/0

Cat. no.	Dimensions (in.)						Wire range (AWG Cu/Al)
	Conduit size (in.)	Bushing dia.	Throat dia.	Lug length	Swing radius	Bushing height	
3877	3	4.234	2.761	1.310	2.767	0.975	#14-#4
3887	3	4.234	2.761	1.675	2.957	0.975	#8-2/0
3994	3	4.234	2.761	2.230	3.287	0.975	#6-4/0
3878	3 1/2	4.781	3.193	1.310	3.040	0.975	#14-#4
3863	3 1/2	4.781	3.193	1.675	3.230	0.975	#8-2/0
3995	3 1/2	4.781	3.193	2.230	3.560	0.975	#6-4/0
3879	4	5.328	3.623	1.310	3.314	0.980	#14-#4
3864	4	5.328	3.623	1.675	3.504	0.980	#8-2/0
3996	4	5.328	3.623	2.230	3.834	0.980	#6-4/0
3880	5	6.328	4.542	1.310	3.814	0.985	#14-#4
3865	5	6.328	4.542	1.675	4.000	0.985	#8-2/0
3998	5	6.328	4.542	2.230	4.334	0.985	#6-4/0
3881	6	7.406	5.458	1.310	4.353	1.200	#14-#4
3866	6	7.406	5.458	1.675	4.543	1.200	#8-2/0
3999	6	7.406	5.458	2.230	4.875	1.200	#6-4/0

Diagram

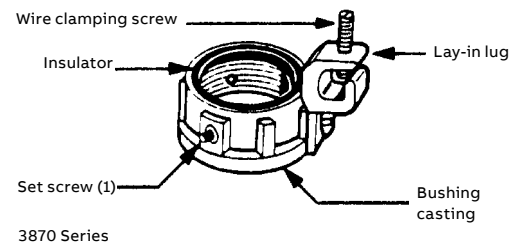

Temperature rating 150 °C
 Meets Coast Guard Regulation CG293
 Available with DURA-PLATE® finish.
 *Available in stainless steel 316.
 +cULus

Bushings, nipples, locknuts and plugs

Blackjack® grounding bushings

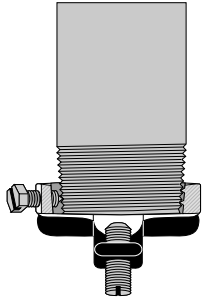

Innovative design makes installation quicker, easier.

The Blackjack grounding bushing never has to be threaded onto a conduit. It is simply placed in position on either a threaded or non-threaded rigid or IMC conduit, with the grounding lug in perfect position to accept the grounding wire – even in tight installations.

It's as simple as one, two, three.



Compare the installation with conventional bushings that must be threaded onto the conduit. In tight areas, you may have to remove the grounding lug, keep up with the loose parts and then reattach the lug. Then you still have to twist and turn the bushing to get the lug in position to accept the grounding wire.

The Blackjack bushing does away with these needless delays for good, making it the ideal grounding bushing – and the only logical choice for small spaces, corners and multiple conduit runs. And, because the grounding lug is an integral part of the bushing, it's designed not to fall off or get lost.

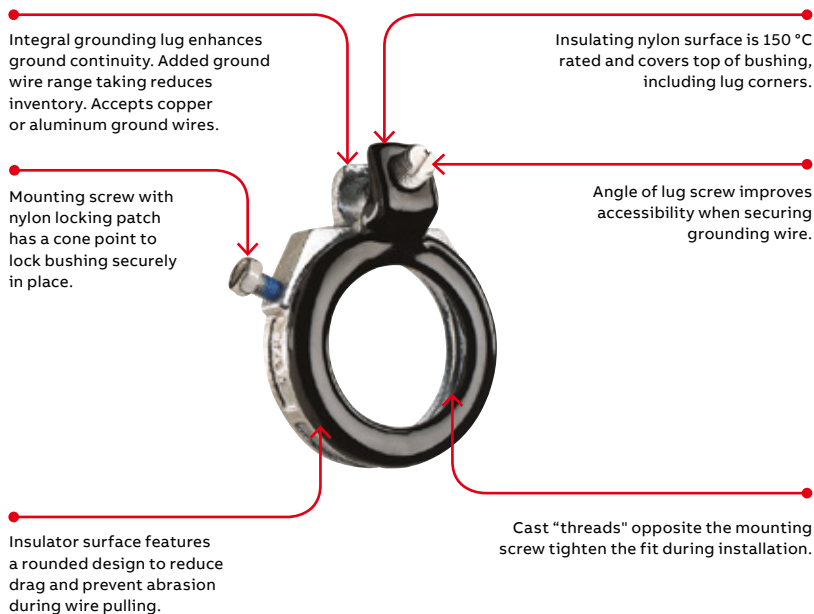

Innovative design improves performance.

The Blackjack bushing provides superior ground continuity.

The design of the Blackjack bushing has an integral, cast-on grounding lug for better ground continuity. This means that the Blackjack bushing stands up to intense loads.

Secure grip forms lasting bond.

The Blackjack bushing's cone-point mounting screw bites securely into both threaded and non-threaded rigid conduits. And the Blackjack bushing's nylon locking patch is designed to prevent the screw from loosening due to vibration.

Reduce inventory.

Because the Blackjack grounding bushing is designed for threaded and non-threaded conduits, and the ground lugs are designed to handle an extended range, the number of parts in inventory is reduced by up to two-thirds without losing any application coverage.

Lug screw:

- #14–#4 AWG: Slotted
- #14–2/0 AWG: Slotted
- #6–4/0 AWG: Internal hex drive

Standard material/finish

- Body: Malleable iron or aluminum
- Mounting screw: (½"–2") Stainless steel, (2½"–6") brass
- Lug screw: Stainless steel
- Finish: Zinc plated

Range

- Conduit: ½" through 6" threaded or threadless rigid/IMC
- Wire range: #14 AWG to 4/0 AWG Cu/Al

Listings/compliances

- UL File #E3060
- CSA File #LR2884
- UL 514B and UL 467
- CSA C22.2 No. 18 and CSA C22.2 No. 41

Bushings, nipples, locknuts and plugs

Blackjack® grounding bushings

Blackjack® grounding bushings



Cat. no.		Dimensions (in.)							Wire range (AWG)
Zinc-plated malleable iron	Aluminum	Conduit size (in.)	ØA max.	ØB Min. throat I.D.	C max.	D max.	E max.		
BG050-14-20	BGA050-14-20	1/2	1.251	0.569	1.181	2.134	0.696	#14-2/0	
BG050-14-4	BGA050-14-4	1/2	1.251	0.569	1.027	1.940	0.696	#14-#4	
BG075-14-20	BGA075-14-20	3/4	1.533	0.772	1.221	2.414	0.696	#14-2/0	
BG075-14-4	BGA075-14-4	3/4	1.533	0.772	1.030	2.168	0.696	#14-#4	
BG100-14-20	BGA100-14-20	1	1.783	0.993	1.181	2.581	0.696	#14-2/0	
BG100-14-4	BGA100-14-4	1	1.783	0.993	1.027	2.368	0.696	#14-#4	
BG125-14-20	BGA125-14-20	1 1/4	2.220	1.319	1.181	2.987	0.759	#14-2/0	
BG150-14-20	BGA150-14-20	1 1/2	2.470	1.553	1.181	3.236	0.696	#14-2/0	
BG200-14-20	BGA200-14-20	2	2.830	2.010	1.181	3.766	0.696	#14-2/0	
BG250-14-20	BGA250-14-20	2 1/2	3.418	2.412	1.181	4.341	0.978	#14-2/0	
BG250-6-40	BGA250-6-40	2 1/2	3.418	2.412	1.524	4.526	0.978	#6-4/0	
BG300-14-20	BGA300-14-20	3	4.042	3.022	1.181	4.966	0.978	#14-2/0	
BG300-6-40	BGA300-6-40	3	4.042	3.022	1.524	5.139	0.978	#6-4/0	
BG350-14-20	BGA350-14-20	3 1/2	4.542	3.491	1.181	5.467	0.978	#14-2/0	
BG350-6-40	BGA350-6-40	3 1/2	4.542	3.491	1.524	5.639	0.978	#6-4/0	
BG400-14-20	BGA400-14-20	4	5.042	3.975	1.181	5.966	0.978	#14-2/0	
BG400-6-40	BGA400-6-40	4	5.042	3.975	1.524	6.139	0.978	#6-4/0	
BG500-14-20	BGA500-14-20	5	6.136	4.991	1.181	7.045	0.978	#14-2/0	
BG500-6-40	BGA500-6-40	5	6.136	4.991	1.524	7.207	0.978	#6-4/0	
BG600-14-20	BGA600-14-20	6	7.199	6.009	1.181	8.087	0.978	#14-2/0	
BG600-6-40	BGA600-6-40	6	7.199	6.009	1.524	8.409	0.978	#6-4/0	

Diagrams

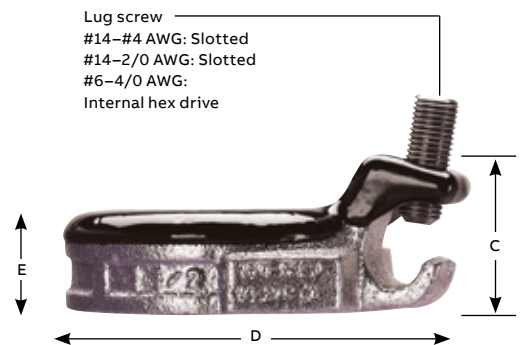
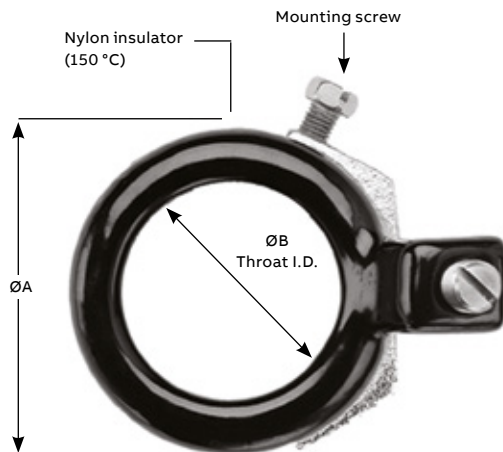

For threaded and threadless rigid and IMC conduit

Suggested specifications: Insulated grounding and bonding bushing (Series BG050-BG600)

Where code requires bonding and grounding of single or multiple metal conduits, or positive bonding and grounding of metal conduit to the box, enclosure or auxiliary gutter, the end of the conduit shall be equipped with an insulated metallic grounding and bonding bushing series BG050-14-20 as manufactured by ABB.

Grounding and bonding bushings used shall be approved for the purpose and

(i) Shall be of malleable iron/steel/aluminum construction adequately protected against corrosion.

(ii) Bushing insulator shall be listed or certified for 150 °C/302 °F application with a flammability rating of 94V-O. Insulator must be positively locked in place.

Bushings, nipples, locknuts and plugs

Insulated throat fittings and metallic bushings



- Meets and surpasses NEC® requirements
- Steel or malleable iron (steel through 1½")
- Exceeds NEC 373-6C requirements for protection of ungrounded connectors at entrance to raceways, pull boxes and junctions
- Recognizable by distinctive trademarked blue insulating liner in throat
- Reduces wire pulling effort by as much as 50%
- Temperature rating of 105 °C
- Look for the unique blue color, ensuring the highest quality fitting

- Locknut-type base improves bonding and resists loosening under vibration.
- Aluminum, steel or malleable iron (steel through 1½")
- Smoothly rounded shoulder covers end of conduit
- Broad flange covers knockout hole
- High ribs for easy tightening with fingers or with wrench
- ½" to 1½" sizes, formed in steel, feature extra-smooth shoulders

Insulated throat fittings

Cat. no.	Dimensions (in.)			
	Steel or M.I.	Alum.	Size (in.)	B
1222	1222AL	½	1 ¹ / ₃₂	²⁹ / ₆₄
1223	1223AL	¾	1 ⁹ / ₃₂	³¹ / ₆₄
1224	1224AL	1	1 ¹⁹ / ₃₂	¹¹ / ₃₂
1225	1225AL	1¼	1 ¹⁵ / ₁₆	²¹ / ₃₂
1226	1226AL	1½	2 ³ / ₁₆	²³ / ₃₂
1227	1227AL	2	2 ¹¹ / ₁₆	⁷ / ₈
1228	1228AL	2½	3 ³ / ₁₆	¹ / ₃₂
1229	1229AL	3	3 ²⁷ / ₃₂	⁵ / ₁₆
1230	1230AL	3½	4 ⁷ / ₁₆	1 ¹ / ₁₆
1231	1231AL	4	4 ⁷ / ₈	1 ³ / ₃₂
1232†	1232AL†	4½	–	–
586	586AL	5	5 ³¹ / ₃₂	1 ⁹ / ₃₂
587	587AL	6	7 ³ / ₁₆	1 ¹¹ / ₃₂

Diagram

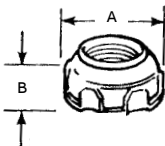

Nylon insulated
metallic bushings

Metallic bushings



Cat. no.	Dimensions (in.)			
	Steel or M.I.	Alum.	Size (in.)	B
122	122AL	½	1 ¹ / ₃₂	¹³ / ₃₂
123	123AL*	¾	1¼	⁷ / ₁₆
124	124AL**	1	1 ⁹ / ₁₆	¹ / ₂
125-TB	125AL	1¼	1 ²⁹ / ₃₂	⁹ / ₁₆
126	126AL	1½	2 ⁵ / ₃₂	¹⁹ / ₃₂
127	127AL	2	2 ²¹ / ₃₂	⁵ / ₈
128	128AL	2½	3 ³ / ₁₆	³ / ₄
129	129AL	3	3 ²⁷ / ₃₂	¹³ / ₁₆
130-TB	130AL	3½	4 ³ / ₈	¹⁵ / ₁₆
131-TB	131AL	4	4 ¹⁵ / ₁₆	1
132-TB	–	4½	5 ⁷ / ₁₆	1 ⁵ / ₆₄
133-TB	133AL	5	6	1 ³ / ₁₆
134-TB	134AL	6	7¼	1¼

Diagram

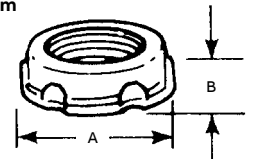

† Not CSA certified
Catalog series 1222 through 1232, 586 and 587 are available in aluminum.
Add suffix AL to cat. no. The aluminum series fittings are not CSA certified.

* Not UL listed or CSA certified
** Not CSA certified
Available with DURA-PLATE® finish.
UL File No. E-23018
CSA File No. 2884

Bushings, nipples, locknuts and plugs

Plastic insulating bushings



- Perfect threads for easy thread-on
- Impact-resistant plastic insulation
- Ribbed for easy, secure gripping
- UL listed 105 °C

Plastic Insulating bushings



Cat. no.	Size (in.)	Dimensions (in.)	
		A	B
222-TB	$\frac{1}{2}$	$1\frac{1}{16}$	$\frac{3}{8}$
223-TB	$\frac{3}{4}$	$1\frac{9}{32}$	$1\frac{13}{32}$
224	1	$1\frac{9}{16}$	$\frac{9}{16}$
225-TB	$1\frac{1}{4}$	$1\frac{29}{32}$	$\frac{9}{16}$
226	$1\frac{1}{2}$	$2\frac{7}{32}$	$\frac{9}{16}$
227	2	$2\frac{25}{32}$	$\frac{5}{8}$
228-TB	$2\frac{1}{2}$	$3\frac{3}{8}$	$\frac{3}{4}$
229-TB	3	$4\frac{1}{16}$	$\frac{3}{4}$
230-TB	$3\frac{1}{2}$	$4\frac{5}{8}$	$\frac{7}{8}$
231	4	$5\frac{1}{8}$	$\frac{7}{8}$
232	$4\frac{1}{2}$	$5\frac{11}{16}$	1
233	5	$6\frac{5}{16}$	1
234	6	$7\frac{7}{16}$	1

Diagram

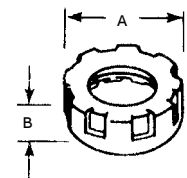

All plastic insulating bushings

Bushings, nipples, locknuts and plugs

Insulating bushings



TRIB-75

For threadless rigid conduit and intermediate metal conduit.

Application

- When assembled to the end of a threadless conduit, provides a well-rounded insulating surface over which conductors may be pulled or on which conductors may bear while in service

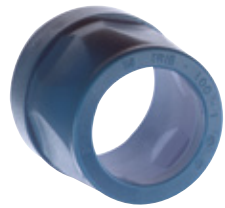

TRIB-100

Features

- Designed to be popped onto conduit end
- Fast, easy installation without screws
- High-impact thermoplastic construction



TRIB-150

Insulating bushings



Cat. no.	Size (in.)	Dimensions (in.)		
		A	B	C
TRIB-50	1/2	19/32	19/32	1 1/16
TRIB-75	3/4	25/32	1 25/64	1 1/4
TRIB-100	1	1	1 1/2	1 9/16
TRIB-125	1 1/4	1 5/16	1 5/8	1 59/64
TRIB-150	1 1/2	1 17/32	1 21/32	2 11/64
TRIB-200	2	1 31/32	1 13/16	2 11/16
TRIB-250	2 1/2	2 23/64	2	3 1/4
TRIB-300	3	2 59/64	2 7/32	3 29/32
TRIB-350	3 1/2	3 3/8	2 5/16	4 29/64
TRIB-400	4	3 27/32	2 13/32	5

Diagram

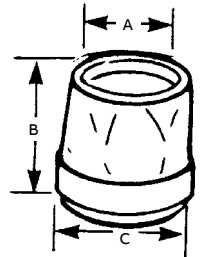

IMC sizes 1/2" through 4"
 UL Rated flame retardant 94V-1
 UL File No. E-13938
 CSA File No. 2884

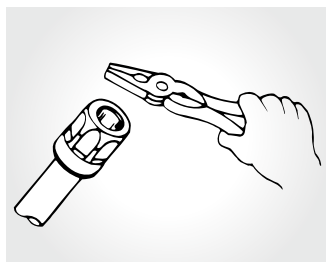

1. Cut conduit end squarely. Remove sharp edges and burrs on inside and outside diameters by reaming or filing.
2. Slip the pop-on bushing over the end of the conduit.
3. Using the flat surface of any standard utility tool such as an electrician's pliers (or a hammer with a block of wood for the larger sizes), strike the bushing on its top surface using a series of light blows until the end of the conduit rests against the bushing throat and conduit stop.

Bushings, nipples, locknuts and plugs

Knockout bushings



3210 Series

Provides smooth, rounded insulation surface for easy wire pulling.

- Quickly snaps into outlet box, switch box or other enclosure left vacant by wiring modifications or maintenance changes
- High-impact polycarbonate, one-piece construction
- Easily installed by hand
- UL listed 105 °C

Application

- To provide smooth, rounded knockout openings in metal boxes or enclosures

Features

- One-piece construction designed to snap in place
- High-impact strength, self extinguishing, non-dripping (per UL 94) polycarbonate construction

Standard material

- Polycarbonate rated for 105 °C (221 °F) application

Standard finish

- As molded

Range

- 0.875" through 2.469" nominal diameter knockout opening (½" through 2" trade size knockouts)
- Wall thickness of box or enclosure:
 - 0.095" max. up to 1" trade size
 - 0.140" max. 1¼" through 2" trade size

Listings/compliances

- UL (UL File No. E-3803)
- CSA (LR-589,LR-4484)
- UL 514B
- CSA C22.2 No. 18
- NFPA 70-1999 (ANSI)

Knockout bushings



Cat. no.	For use in KO size* (in.)	Dimension (in.)	
			B
3210	0.875		0.360
3211	1.109		0.360
3212	1.375		0.360
3213	1.734		0.400
3214	1.984		0.520
3215	2.469		0.520

Diagram



* Per UL and NEMA standards. Refer to knockout plugs table on page 19.
 Oxygen index >28° UL 94V-1
 UL File No. E-3803 CSA File No. 589

Bushings, nipples, locknuts and plugs

Capped bushings and INSULINER® sleeves



- Makes a workman-like seal against grit, plaster and mischief
- Removable with pliers
- ½" through 1¼" sizes in steel
- 1½" and 2" sizes in malleable iron



- Snaps into a regular bushing to make a UL listed insulated bushing
- Converts ordinary bushing to code-approved insulated bushing without disturbing wiring
- For use with standard rigid conduit, EMT (thinwall conduit) or any standard bushed outlet
- Especially suited for use with flexible metallic conduit
- High-dielectric nylon material, rated 105 °C

Capped bushings



Cat. no.	Size (in.)	Dimensions (in.)	
		A	B
1460	½	1⅓ ₃₂	1⅓ ₃₂
1461	¾	1¼	7/16
1462	1	1⅑ ₁₆	½
1463	1¼	1 ²⁹ / ₃₂	9/16
1464	1½	2 ⁵ / ₃₂	1 ⁹ / ₃₂
1465	2	2 ²¹ / ₃₂	5/8

Diagram

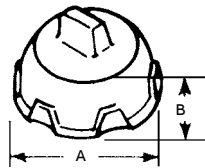

UL File No. E-23018 CSA File No. 2884

INSULINER sleeves



Cat. no.	Size (in.)	Dimensions (in.)	
		A	B
422	½	5/8	0.025
423	¾	11/16	0.025
424	1	7/8	0.025
425	1¼	1	0.030
426	1½	1	0.030
427	2	1⅓ ₈	0.030
428	2½	1¼	0.040
429	3	1½	0.040
430	3½	1 ²⁵ / ₃₂	0.055
431	4	2 ¹ / ₃₂	0.055
433	5	2½	0.070
434	6	2½	0.070

Diagram

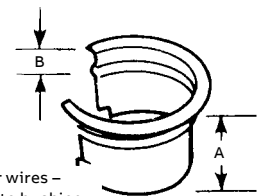

Slip over wires –
insert into bushing
– snaps into place

Oxygen index >28* UL File No. E-23018 CSA File No. 589

Bushings, nipples, locknuts and plugs

Knockout plugs



1451 Series

Made from flame-retardant, non-dripping thermoplastic, UL rated 105 °C.

Application

- To plug unused knockout openings in a box or enclosure

Features

- One-piece construction designed to snap in place
- High impact strength self-extinguishing non-dripping (per UL 94) thermoplastic construction

Standard material

- Thermoplastic rated for 105 °C (221 °F) application

Standard finish

- As molded

Range

- 0.875" through 2.469" nominal diameter
- Knockout opening (½" through 2" trade size knockouts)
- Wall thickness of box or enclosure:
 - 0.095" max. up to 1" trade size
 - 0.140" max. through 2" trade size

Listings/compliances

- UL (UL File No. E13938)
- CSA (LR589)
- UL 514B
- NFPA 70

Knockout plugs



Cat. no.	Size (in.)	Dimension (in.)	
		A	B
1451	½	1.060	0.400
1452	¾	1.300	0.400
1453	1	1.590	0.400
1454	1¼	1.860	0.450
1455	1½	2.240	0.570
1456	2	2.740	0.570

Diagram

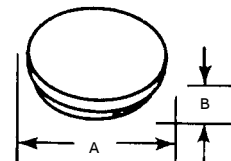

105 °C rated by UL. Made from flame-retardant, non-dripping thermoplastic.

Wall thickness of electrical box .095 max.
Meets Coast Guard Regulation CB293.
UL File No. E-13938 CSA File No. 4484

Bushings, nipples, locknuts and plugs

Push-Penny® plugs and steel pennies



Eliminates need for separate capped bushing or steel penny and bushing.

Application

- To plug open end of conduit or connector in order to prevent ingress of trash, dirt or moisture during construction and remodeling

Features

- Wide range of applications; can be used with rigid metal conduit, intermediate metal conduit, electrical metallic tubing, all connectors and all bushings
- Designed to stand up to normal handling and is functionally unaffected by moisture
- Economically seal out grout and plaster from any fitting or raceway conforming to CSA dimensional tolerances

- Just push into place
- Pressure holds plug fast against internal surface of fitting or raceway
- Made of flexible plastic

Standard material

- Polyethylene

Standard finish

- As molded

Listings/compliances

- CSA (LR2884, LR4484)
- UL 514B
- CSA C22.2 No. 18
- NFPA 70
- NEMA FB1

Push-Penny plugs

Cat. no.	Size (in.)
1470	1/2
1471	3/4
1472	1
1473	1 1/4
1474	1 1/2

Cat. no.	Size (in.)
1475	2
1476*	2 1/2
1477*	3
1478*	3 1/2
1479*	4

*Not CSA Certified.
CSA File No. 2884
UL not applicable.



Steel pennies

Cat. no.	Size (in.)
815-TB	1/2
816	3/4
817	1
818	1 1/4
819	1 1/2
820	2

Cat. no.	Size (in.)
821	2 1/2
822	3
824	3 1/2
823	4

UL not applicable.
CSA File No. 2884

- Made to fit any bushing
- Used under a bushing to seal end of conduit during construction
- Completely salvageable

Bushings, nipples, locknuts and plugs

Chase® nipples



- Bush holes in metal boxes or enclosures
- 3/8" and 1/2" sizes in steel
- 3/4" to 6" sizes in malleable iron
- 1/2" to 4" sizes in copper-free aluminum

Options

- 1/2"–4" sizes in stainless steel 316 (add suffix SST)
- cULus listed

Stainless steel version coming soon



- Nylon insulator offers extra protection
- 3/8" and 1/2" sizes in steel
- 3/4" to 6" sizes in malleable iron
- 1/2" to 6" sizes also available in copper-free aluminum (add AL suffix to cat. no.)
- Look for the unique blue color ensuring the highest quality fitting

Chase nipples



Cat. no.	Size (in.)	Dimensions (in.)	
		A	B
Steel/malleable iron or stainless steel 316*			
841TB	3/8	15/16	7/16
842TB	1/2	1 5/32	11/32
843TB	3/4	1 7/16	17/32
844	1	1 25/32	21/32
845	1 1/4	2 1/32	3/4
846	1 1/2	2 3/8	13/16
847	2	2 15/16	31/32
848	2 1/2	3 9/16	1 1/16
849	3	4 3/8	1 3/16
850	3 1/2	5 1/8	1 5/16
851	4	5 7/8	1 5/16
853	5	6 13/32	1 5/16
854	6	7 3/8	1 3/8
Aluminum			
842AL†	1/2	1 3/16	7/16
843AL	3/4	1 13/32	17/32
844AL†	1	1 21/32	21/32
845AL†	1 1/4	2 1/32	3/4
846AL	1 1/2	2 3/8	13/16
847AL	2	2 15/16	31/32
848AL	2 1/2	3 9/16	1 1/16
849AL	3	4 3/8	1 3/16
850AL	3 1/2	5 1/8	1 5/16
851AL	4	5 7/8	1 5/16

Diagram

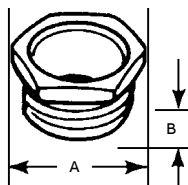

Chase nipples – Nylon-insulated

Cat. no.	Size (in.)	Dimensions (in.)		
		A	B	C
1942	1/2	1 9/64	7/16	19/32
1943	3/4	1 3/8	17/32	23/32
1944	1	1 11/16	21/32	7/8
1945	1 1/4	2 1/32	25/32	1 1/32
1946	1 1/2	2 3/8	13/16	1 3/32
1947	2	2 15/16	31/32	1 11/32
1948	2 1/2	3 9/16	1 1/16	1 7/16
1949	3	4 3/8	1 3/16	1 19/32
1950	3 1/2	5 1/8	1 5/16	1 25/32
1951	4	5 7/8	1 5/16	1 13/16
1953	5	6 3/8	1 5/16	1 13/16
1954	6	7 3/8	1 3/8	1 7/8

Diagram

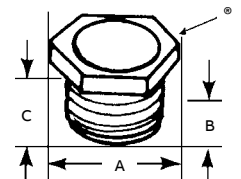

UL File No. E-23018
CSA File No. 2884

*Add suffix SST to catalog number to order stainless steel 316.

† Not UL listed

Available with DURA-PLATE® finish.

UL File No. E-23018

CSA File No. 2884

Stainless steel is cULus listed (file no. E23018)

Hubs and bulkhead fittings

Threaded hubs (Bullet® hubs)

01 370 Series
370AL Series

For threaded rigid metal conduit/IMC/PVC-coated rigid metal conduit.

Application

- To connect threaded metal conduit (ferrous rigid/non-ferrous rigid/PVC coated/or intermediate metal) to a threadless opening in a box or enclosure in outdoor or indoor location exposed to continuous or intermittent moisture
- To positively bond conduit to box or enclosure

Features

- Rugged steel/malleable iron/copper-free aluminum construction
- Tapered internal threads for water-tight/dust-tight union (A)
- Threads relieved to prevent bottoming of conduit, ensuring sound assembly (B)
- Recessed sealing ring at box end; sealing ring captivated (C)
- Hardened steel/malleable iron/copper-free aluminum locknuts designed to provide high-quality ground continuity; extended reach of locknut permits clamping on thin boxes and enclosures (D)
- Insulated throat insulates conductors, prevents abrasion and thinning of conductor insulation, reduces wire pull effort (E)

- Suitable for hazardous location use per following:
 - (i) Class I Division 2, Class II Division 1 & 2, Class III Division 1 & 2 per NEC® 501.10(B), 502.40(A) and (B) and 503.16(A) and (B)
 - (ii) Class II locations & Class III locations per CEC 18-202; 18-252; 18-302; 18-352

National Electrical Code® states that, “Where practical, dissimilar metals in contact anywhere in the system shall be avoided to eliminate the possibility of galvanic action.” The only exceptions, aluminum fittings and enclosures, are permitted to be used with steel conduit.

Joint Industrial Council (JIC) Electrical Standards also forbid dissimilar metals in contact for the same reason and require that the fittings for metal conduit be of malleable iron or ductile iron and have impact strength comparable to that of the conduit.

NEC and National Electrical Code are registered trademarks of the National Fire Protection Association, Inc.

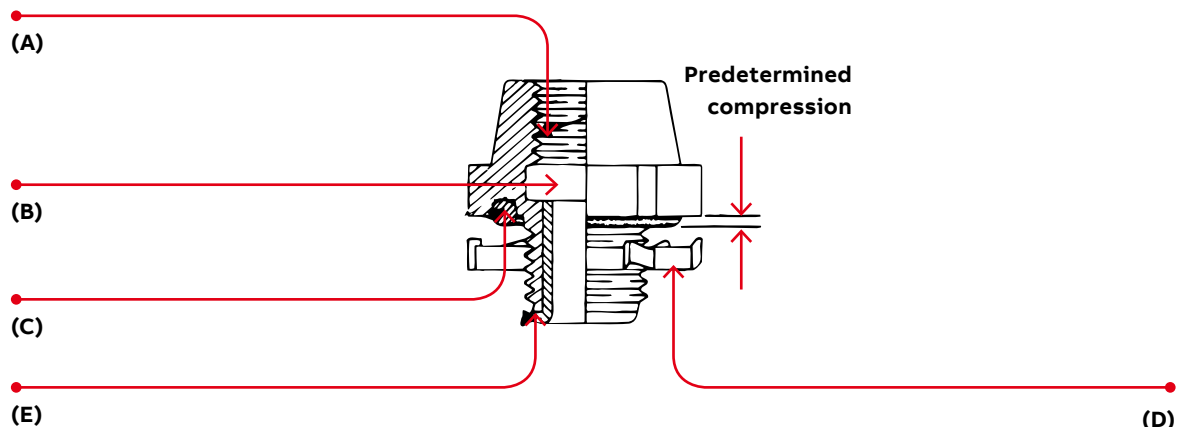

Hubs and bulkhead fittings

Threaded hubs (Bullet® hubs)

Copper-free aluminum

- Copper free aluminum castings for fittings have a maximum of 0.4% copper. The most detrimental effect of higher percentage of copper on aluminum base alloy is its decrease in corrosion resistance.

Range

- 370 Series: ½" through 6" conduit
- 370AL and 401 Series: ½" through 4" conduit
- All hub threads – straight pipe
- All female threads – taper pipe (NPT)

Listing/compliances

- UL (UL File No: E-23018)
- CSA (LR-637, LR-23086)
- UL 514B
- CSA C22.2 No. 18
- NFPA 70
- NEMA FB-1
- JIC EGPI; JIC EMP 1
- Federal Specification A-A-50553
- Federal Standard H-28 (Threads)

Standard material

	370–401 Series	370AL Series
Body:	½"–1" steel 1¼"–6" malleable iron	All copper-free aluminum
Locknut:	½"–2" steel (hardened) 2½"–6" malleable iron	½"–2" steel (hardened) 2½"–4" copper-free aluminum
Screws:	Steel (hardened)	
O-Ring:	Buna N	
Insulator:	Nylon	
Coating:	PVC	

Standard finish

	370–401 Series	370AL Series
Hub:	Electro zinc plated Chromate coated	As cast
Locknuts:	All ferrous locknuts electro zinc plated and chromate coated	
Screws:	All electro zinc plated and chromate coated	

Hubs and bulkhead fittings

Bullet® hubs – steel/malleable iron and aluminum*†



- UL listed rain tight and CSA certified watertight and dust tight
- Available in steel/malleable iron (steel through 1") with nylon-insulated throat – with or without series 106 bonding locknut
- Also available in aluminum without insulated throat
- When used with neoprene O-ring, provides watertight threaded hub on enclosures
- UL Listed 105 °C
- Look for the unique blue color, ensuring the highest quality fitting

Bullet hubs



Cat. no.

Steel/M.I. w/locknut	Alum.**	Steel/M.I. w/bonding locknut	Hub size (in.)	Dimensions (in.)			Max. wall thickness (in.)
				A	B	C	
370	370AL	401	1/2	1 3/8	1 1/4	3/4	5/16
371	371AL	402	3/4	1 5/8	1 1/4	3/4	5/16
372	372AL	403	1	2 3/32	1 3/8	7/8	5/16
373	373AL	404-TB	1 1/8	2 9/16	1 5/8	1	5/16
374	374AL	405	1 1/2	3 3/32	1 5/8	1	5/16
375	375AL	406-TB	2	3 5/8	1 5/8	1	5/16
376	–	407	2 1/2	4 1/8	1 7/8	1 1/8	3/8
377	–	408	3	5	2 1/2	1 1/2	1/2
378	–	409	3 1/2	5 5/16	2 1/2	1 1/2	1/2
379	–	410-TB	4	6 3/16	2 1/2	1 1/2	1/2
381	–	–	5	8	3 3/8	–	1/2
382	–	–	6	9 3/16	3 3/8	–	1/2

* Suitable for hazardous locations use in Class I, Div. 2; Class II, Div. 2; Class III, Div. 1 and 2 where general purpose equipment is specifically permitted per NEC Section 500-2(a).

** Aluminum not available with insulated throat.

† UL listed rain tight and CSA certified watertight and dust tight Available with DURA-PLATE® finish.

UL File No. E-23018

For steel.: CSA File No. 2284

For aluminum.: CSA File No. 0637

Diagram

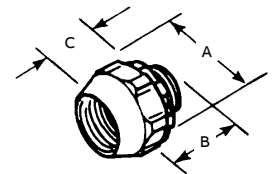

Spacing chart for Bullet hubs

	Center-to-center spacing conduit sizes (in.)												Min. space from center of Bullet hub to wall of box (in.)	KO diameter min. (in.)
	1/2	3/4	1	1 1/4	1 1/2	2	2 1/2	3	3 1/2	4	5	6		
1/2	1 1/16	1 5/8	1 3/4	2 1/8	2 3/8	2 5/8	2 7/8	3 5/16	3 1/2	3 3/8	4 1/8	5 5/16	3/4	7/8
3/4	–	1 3/4	1 7/8	2 1/4	2 1/2	2 3/4	3	3 1/2	3 3/4	4 1/8	4 13/16	5 1/2	7/8	1 1/8
1	–	–	2	2 3/8	2 5/8	2 7/8	3 1/8	3 3/8	3 7/8	4 1/4	4 15/16	5 11/16	1 1/8	1 3/8
1 1/4	–	–	–	2 11/16	2 15/16	3 1/4	3 1/2	4	4 1/4	4 1/2	5 5/16	5 3/4	1 3/8	1 3/4
1 1/2	–	–	–	–	3 1/8	3 1/2	3 3/4	4 1/8	4 3/8	4 3/4	7 1/16	6 3/16	1 5/8	2
2	–	–	–	–	–	3 3/4	4	4 1/2	4 3/4	5	5 3/4	6 1/2	1 7/8	2 1/2
2 1/2	–	–	–	–	–	–	4 1/4	4 3/4	5	5 3/8	6	6 3/4	2 1/8	3
3	–	–	–	–	–	–	–	5 1/8	5 3/8	5 3/4	6 3/8	7 1/8	2 5/8	3 5/8
3 1/2	–	–	–	–	–	–	–	–	5 5/8	6	6 3/4	7 1/2	2 7/8	4 1/8
4	–	–	–	–	–	–	–	–	–	6 1/4	7 1/8	7 7/8	3 1/4	4 5/8
5	–	–	–	–	–	–	–	–	–	–	8	8 3/4	4	5 1/2
6	–	–	–	–	–	–	–	–	–	–	8 3/4	9 1/2	4 3/4	6 1/2

Hubs and bulkhead fittings

T&B® hub



Never before has a single hub fit like this one. Designed for unequalled performance. The innovative engineering of the T&B hub will, quite simply, raise your performance expectations for threaded hubs. Look for the distinctive blue color to ensure the quality of an T&B fitting.

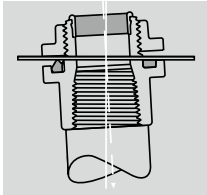

Fig. 1

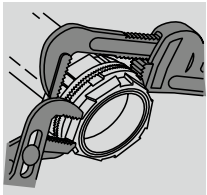

Fig. 2

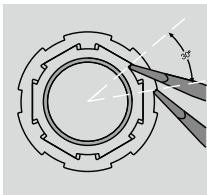
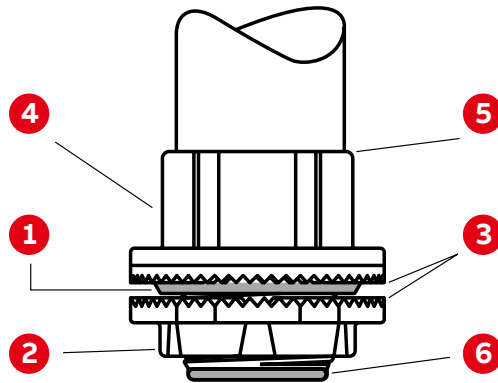

Fig. 3



- 1 Sealing ring and groove with innovative profile outperforms standard O-ring design. Sealing ring is captivated in place before installation and resists buckling or slipping during installation. The seal groove is designed for optimum compression of the sealing ring. The sealing ring is designed to provide a complete 360° seal, even when the conduit is not perpendicular with the enclosure. (See Figure 1)
- 2 Locknut design with peripheral slots and a hexagonal/angled spline spaced every 30° enables easy application of torque with wrench or hammer and screwdriver. (See Figures 2 and 3)
- 3 Sharper and deeper teeth on locknut and body designed for a more penetrating bite for improved bonding to the enclosure.
- 4 Hexagonal/splined body design for fast, easy installation with wrench or hammer and screwdriver.
- 5 Precision machined tapered threads designed to create watertight union.
- 6 Insulated throat molded from 105 °C rated thermoplastic with a flammability rating of 94V-O.

T&B Hub



			A (in.)	B (in.)	C (in.)	D (in.)	E (in.)
	Cat. no.	Trade size (in.)	Dia.			Max. panel thickness	Throat dia.
	H050-TB	1/2	1 7/16	1 9/16	7/8	3/16	19/32
	H075-TB	3/4	1 7/16	1 19/32	29/32	3/16	25/32
	H100-TB	1	2	1 13/16	1 1/4	1/4	1
	H125-TB	1 1/4	2 3/8	1 7/8	1 1/4	1/4	1 5/16
	H150-TB	1 1/2	2 3/4	1 7/8	1 1/4	1/4	1 17/32
	H200-TB	2	3 3/4	1 15/16	1 5/32	1/4	1 31/32
	H250-TB	2 1/2	3 3/4	2 9/16	1 9/16	1/4	2 13/32
	H300-TB	3	4 3/8	2 7/16	1 19/32	1/4	2 31/32
	H350-TB	3 1/2	5	2 23/32	1 5/8	1/4	3 13/32
	H400-TB	4	5 1/2	2 23/32	1 5/8	1/4	3 7/8
	H500-TB	5	6 7/8	3 3/32	1 5/16	1/4	4 15/16
	H600-TB	6	7 1/16	3 5/32	2	5/16	6

Material – Hub and locknut: Zinc or copper-free aluminum
 Insulating throat: Thermoplastic temp. rating – 105 °C
 Flammability rating – 94V-0
 Nitrile (BUNA “N”)
 Sealing ring:
 For aluminum hubs, add suffix A (i.e., H050A). For chrome-plated hubs, add suffix CP (i.e., H050CP). For 316 stainless steel hubs, add suffix GRSST (i.e., H050GRSST).

(1/4" through 2" only.) Meets NEMA sealing requirements for NEMA 3R, 4 and 13 enclosures. CP and SST hubs are also rated NEMA 4X and 12.
 UL listed per NEC® 501.10(B). - CSA certified for hazardous locations Class II Groups E, F, G, Class III
 UL File No. E-23018 CSA File No. 4484
 Chrome-plated hubs (suffix-“CP”) are rated NEMA 4X.

Hubs and bulkhead fittings

T&B® grounding hub



T&B grounding hub

		A (in.)	B (in.)	C (in.)	D (in.)	E (in.)
Diagram	Cat. no.	Trade size (in.)	Dia.	Max. panel thickness	Throat dia.	
	H050GR-TB	1/2	1 7/16	1 9/16	7/8	3/16
	H075GR-TB	3/4	1 7/16	1 19/32	29/32	3/16
	H100GR-TB	1	2	1 13/16	1 1/16	1/4
	H125GR-TB	1 1/4	2 3/8	1 7/8	1 1/16	1/4
	H150GR-TB	1 1/2	2 3/4	1 7/8	1 1/16	1/4
	H200GR-TB	2	3 1/4	1 5/16	1 5/32	1/4
	H250GR-TB	2 1/2	3 3/4	2 9/16	1 9/16	1/4
	H300GR-TB	3	4 3/8	2 7/16	1 19/32	1/4
	H350GR-TB	3 1/2	5	2 23/32	1 5/8	1/4
	H400GR-TB	4	5 1/2	2 23/32	1 5/8	1/4
H500GR-TB	5	6 7/8	3 1/32	1 15/16	1/4	
H600GR-TB	6	7 11/16	3 5/32	2	5/16	6

Material – Hub and locknut: Zinc or copper-free aluminum
 Insulating throat: Thermoplastic temp. rating – 105° C
 Flammability rating – 94V-0
 Sealing ring: Nitrile (BUNA “N”)

For aluminum hubs, add suffix A (i.e., H050A). For chrome-plated hubs, add suffix CP (i.e., H050CP).
 For 316 stainless steel hubs, add suffix GRSST (i.e., H050GRSST). (1/2” through 2” only.) Meets NEMA sealing requirements for NEMA 3R, 4 & 13 enclosures.
 UL listed and CSA certified. CSA certified for hazardous locations Class II and Class III locations.
 UL File No. E-23018
 CSA File No. 4484
 Chrome-plated hubs (suffix-“CP”) are rated NEMA 4X.

T&B hub centerline spacing chart

Conduit trade size (in.)	1/2	3/4	1	1 1/4	1 1/2	2	2 1/2	3	3 1/2	4	5	6
1/2	1 9/16	-	-	-	-	-	-	-	-	-	-	-
3/4	1 43/64	1 25/32	-	-	-	-	-	-	-	-	-	-
1	1 27/32	1 61/64	2 1/8	-	-	-	-	-	-	-	-	-
1 1/4	2 1/32	2 9/64	2 5/16	2 1/2	-	-	-	-	-	-	-	-
1 1/2	2 7/32	2 21/64	2 1/2	2 11/16	2 7/8	-	-	-	-	-	-	-
2	2 15/32	2 37/64	2 3/4	2 5/16	3 1/8	3 3/8	-	-	-	-	-	-
2 1/2	2 23/32	2 53/64	3	3 3/16	3 3/8	3 5/8	3 7/8	-	-	-	-	-
3	3 1/32	3 9/64	3 5/16	3 1/2	3 11/16	3 15/16	4 3/16	4 1/2	-	-	-	-
3 1/2	3 11/32	3 21/64	3 5/8	3 13/16	4	4 1/4	4 3/2	4 13/16	5 1/8	-	-	-
4	3 19/32	3 45/64	3 7/8	4 1/16	4 1/4	4 1/2	4 3/4	5 1/16	5 3/8	5 5/8	-	-
5	4 9/32	3 25/64	4 9/16	4 3/4	4 15/16	5 3/16	5 7/16	5 3/4	6 1/16	6 5/16	7	-
6	4 11/16	4 51/64	4 31/32	5 5/32	5 11/32	5 19/32	5 27/32	6 5/32	6 15/32	6 23/32	7 13/32	7 13/16
Nearest obstruction to center of hub	2 7/32	6 1/64	1 1/8	1 5/16	1 1/2	1 3/4	2	2 5/16	2 5/8	2 7/8	2 9/16	3 31/32

Hubs and bulkhead fittings

T&B® grounding and bonding locknut



Grounding locknut for hubs

T&B grounding and bonding locknut



	Cat. no.	Trade size (in.)	Dia. (in.)	Height (in.)	Ground screw	Max. conductor size (AWG)
Diagram	L050GR-TB	1/2	1 1/2	13/32	#10-32 x 1/4	#10
	L075GR-TB	3/4	1 11/16	13/32	#10-32 x 1/4	#10
	L100GR-TB	1	2	13/32	#10-32 x 1/4	#10
	L125GR-TB	1 1/4	2 3/8	15/32	1/4-20 x 1/4	#10
	L150GR-TB	1 1/2	2 3/4	15/32	1/4-20 x 5/16	#8
	L200GR-TB	2	3 1/4	15/32	1/4-20 x 5/16	#8
	L250GR-TB	2 1/2	3 3/4	11/16	1/4-20 x 5/16	#6
	L300GR-TB	3	4 3/8	23/32	1/4-20 x 5/16	#6
	L350GR-TB	3 1/2	5	23/32	1/4-20 x 5/16	#6
	L400GR-TB	4	5 1/2	23/32	1/4-20 x 5/16	#4
	L500GR-TB	5	6 5/8	23/32	3/8-16 x 3/8	#2
	L600GR-TB	6	7 11/16	23/32	3/8-16 x 3/8	#1

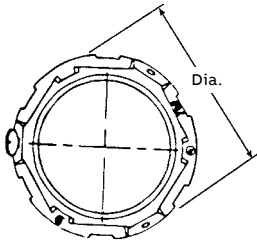

Material – locknut: Zinc or copper-free aluminum UL File No. E-3060
 For aluminum locknuts, add suffix A. (i.e., L050GRA). CSA File No. 4484
 For chrome-plated locknuts, add suffix CP. (i.e., L050CP). For 316 stainless steel locknuts, add suffix SST (1/2" through 2" only.)
 For locknut with lay in-lug, add suffix GRL.

Hubs and bulkhead fittings

Chase® threaded conduit hubs



HT, HTZ

HTGZ

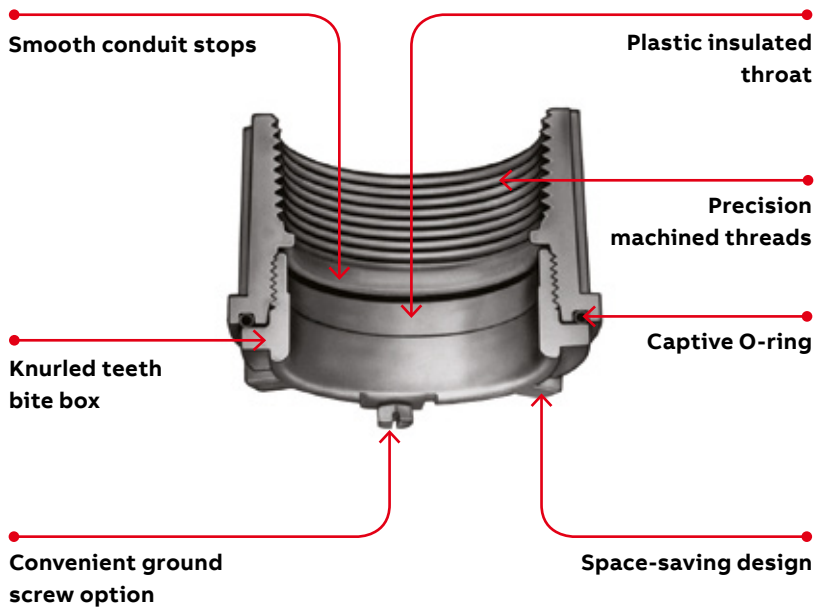

Raintight for rigid or intermediate metal conduit (IMC).

Applications

- A fitting for connecting junction box to junction box, or junction box to the conduit system. The resulting connection maintaining ground continuity is raintight.
- Suitable for use where the system is normally hosed down (NEMA 4) for cleaning.

Features

- Plastic insulated throat, precision cast and machined surfaces permit safer wire pulling.
- Chase design provides maximum space for wiring in the box. Locking nipple sits flush in the enclosure.
- Captive O-ring fits snugly in groove preventing loss and fumbling with parts.
- Knurled inner face of locking nipple provides 360° locking and bites through box wall to ensure grounding.
- Locking nipple has tightening lugs on two planes for easier assembly in hard-to-reach field conditions.
- Grounding hubs have a ground screw located within the enclosure, providing a tamper-proof ground for device.
- Locking nipple design permits replacement of the box without disassembling the installation.

Standard materials

- HTZ Series: Certified die cast zinc alloy ZAMAK 3
- HT Series: Die cast aluminum alloy A360 with less than 0.004% copper content (copper-free)
- O-ring: Buna N
- Insulating sleeves: Plastic

Standard finish

- Aluminum lacquer finish

Listings/compliances

- UL listed
- CSA certified
- Suitable for use in wet locations
- NEMA 4

Hubs and bulkhead fittings

Chase® threaded conduit hubs



HTZ

Chase® hub with insulated throat

Cat. no.	Hub size (in.)	Std. pkg. qty.	Wt. lbs. app. per 100
HTZ1	½	25	26
HTZ2	¾	25	32
HTZ3	1	25	45
HTZ4	1¼	10	58
HTZ5	1½	10	74
HTZ6	2	10	93
HTZ7	2½	5	202
HTZ8	3	2	250
HTZ9*	3½	2	300
HTZ10*	4	2	360

*Made-to-order item. Consult factory for lead time and minimum quantities.



HTGZ

Chase® hub with insulated throat and ground screw

Cat. no.	Hub size (in.)	Std. pkg. qty.	Wt. lbs. app. per 100
HTGZ1	½	25	22
HTGZ2	¾	25	34
HTGZ3	1	25	44
HTGZ4	1¼	10	61
HTGZ5	1½	10	75
HTGZ6	2	10	95
HTGZ7	2½	5	204
HTGZ8	3	2	265
HTGZ9	3½	2	270
HTGZ10	4	2	360

Hubs and bulkhead fittings

Chase® threaded conduit hubs



HT

Chase® aluminum hub with insulated throat

Cat. no.	Hub size (in.)	Std. pkg. qty.	Wt. lbs. app. per 100
HT1	1/2	25	12
HT2	3/4	25	14
HT3	1	25	20
HT4	1 1/4	10	27
HT5	1 1/2	10	32
HT6	2	10	44
HT7	2 1/2	5	85
HT8	3	2	120
HT9	3 1/2	2	138
HT10	4	2	155

HTZ, HTGZ and HT dimensions

Hub size (in.)	Panel width				E (NPT)	F (degrees)	Min. G (in.)	Max. H (in.)	O-ring size J (mm)
	A (in.)	B (in.)	C (in.)	D (in.)					
1/2	1 3/8	1 13/32	1/4	3/16	1/2-14	60	2 1/52	5 9/64	214
3/4	1 3/8	1 21/32	1/4	3/16	3/4-14	60	1 3/32	1 11/64	218
1	1 19/32	1 7/8	1/4	3/16	1-11 1/2	60	1 5/16	1 22/32	222
1 1/4	1 23/32	2 5/16	1/4	1/4	1 1/4-11 1/2	60	1 43/64	1 51/64	225
1 1/2	1 3/4	2 5/8	1/4	1/4	1 1/2-11 1/2	60	1 29/32	2 13/64	227
2	1 25/32	3 5/32	1/4	1/4	2-11 1/2	60	2 3/8	2 21/32	231
2 1/2	2 1/4	2 45/64	3/8	1/4	2 1/2-8	45	2 7/8	3 5/32	236
3	2 21/64	4 5/16	3/8	1/4	3-8	45	3 1/2	3 49/64	241
3 1/2	2 23/64	4 13/16	3/8	1/4	3 1/2-8	45	4	4 7/16	245
4	2 3/8	5 5/16	3/8	1/4	4-8	45	4 1/2	4 63/64	248

Diagrams

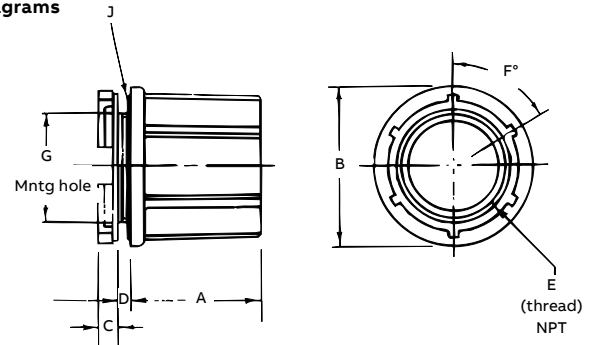

Hubs and bulkhead fittings

ABB bulkhead fittings

ABB bulkhead fittings



Bulkhead fitting	Cat. no.	Trade size (in.)
	H050BHD	1/2
	H075BHD	3/4
	H100BHD	1
	H125BHD	1 1/4
	H150BHD	1 1/2
	H200BHD	2
	H250BHD	2 1/2
	H300BHD	3
	H350BHD	3 1/2
	H400BHD	4
	H500BHD	5
	H600BHD	6

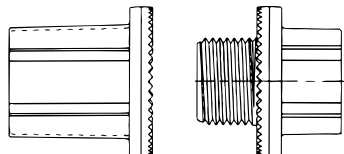

Through-bulkhead fitting

	H050TBF	1/2
	H075TBF	3/4
	H100TBF	1
	H125TBF	1 1/4
	H150TBF	1 1/2
	H200TBF	2

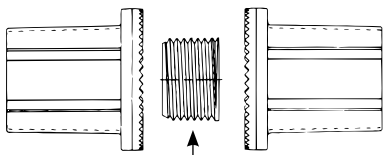

Nipple nut not included

Through-bulkhead hub

	H050TBH	1/2
	H075TBH	3/4
	H100TBH	1
	H125TBH	1 1/4
	H150TBH	1 1/2
	H200TBH	2

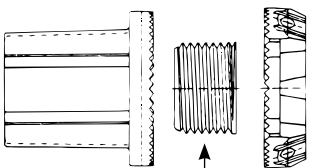

Nipple nut not included

Trade size (in.)	Thread (NPT)	Height (in.)	Diameter (in.)	Across flats (in.)	A (in.)	B (in.)
1/2	1/2-14	1 13/32	1 7/16	1	3/4	1/2
3/4	3/4-14	1 15/32	1 11/16	1 1/4	25/32	17/32
1	1-11 1/2	1 11/16	2	1 17/32	29/32	19/32
1 1/4	1 1/4-11 1/2	1 25/32	2 3/8	1 27/32	29/32	2 1/32
1 1/2	1 1/2-11 1/2	1 13/16	2 3/4	1 1/8	29/32	2 1/32
2	2-11 1/2	1 27/32	3 1/4	2 5/8	1 5/16	2 1/32
2 1/2	2 1/2-8	2 9/32	3 3/4	3 3/8	1 7/32	7/8
3	3-8	2 9/16	4 3/8	3 25/32	1 3/16	29/32
3 1/2	3 1/2-8	2 9/16	5	4 9/32	1 3/8	7/8
4	4-8	2 9/16	5 1/2	4 27/32	1 3/8	7/8
5	5-8	2 23/32	6 5/8	5 29/32	1 15/32	7/8
6	6-8	3	7 1/16	7 1/32	1 1/2	3 1/32

Diagrams

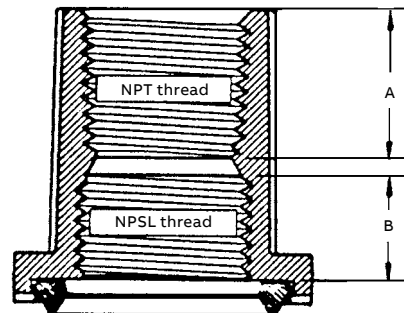
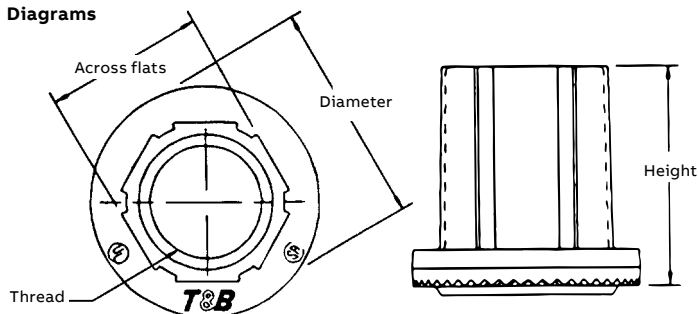

Material – Hub, body and locknut: Zinc or copper-free aluminum
 Insulating throat: Thermoplastic temp. rating – 105 °C
 Flammability rating – 94V-0
 Sealing ring: Nitrile (BUNA "N")

For aluminum bulkheads, add suffix A.
 For chrome-plated bulkheads, add suffix CP.
 Meets NEMA sealing requirements for NEMA 3R, 4 and 13 enclosures.
 UL File No. E-3060
 CSA File No. 4484

Hubs and bulkhead fittings

Offset reducers and capoffs

Offset reducers



Cat. no.	Trade size (in.)	Height	Dia. (Ø)	Dimensions (in.)				
				A	B	C	D	E
H150-TB075ORGR	1½-¾	1 ²¹ / ₃₂	2¾	1 ⁵ / ₁₆	2 ³ / ₃₂	1 ²⁹ / ₃₂	1 ⁹ / ₃₂	1 ¹¹ / ₃₂
H150-TB100ORGR	1 ⁹ / ₃₂ -1	1 ²⁵ / ₃₂	2¾	1¼	2 ³ / ₃₂	1 ²⁹ / ₃₂	1 ⁹ / ₁₆	7 ⁷ / ₃₂
H150-TB125ORGR	1 ⁹ / ₃₂ -1¼	1 ²⁵ / ₃₂	2¾	1¼	2 ³ / ₃₂	1 ²⁹ / ₃₂	1 ⁷ / ₈	1 ¹ / ₃₂
H250-TB200ORGR	2½-2	2 ¹ / ₈	3¾	1¼	1 ⁵ / ₁₆	2 ²⁹ / ₃₂	2 ²¹ / ₃₂	3 ³ / ₃₂

Material – Offset reducer and locknut: Zinc or copper-free aluminum
 Insulating throat: Thermoplastic temp. rating – 105 °C
 Flammability rating – 94V-0
 Nitrile (BUNA “N”)
 Sealing ring:

For aluminum offset reducer, add suffix A.
 For chrome-plated offset reducer, add suffix CP.
 Meets NEMA sealing requirements for NEMA 3R, 4 and 13 enclosures.
 CSA certified for hazardous locations Class II Groups E,F,G. Class III.
 UL File No. E-3060
 CSA File No. 4484

Diagrams

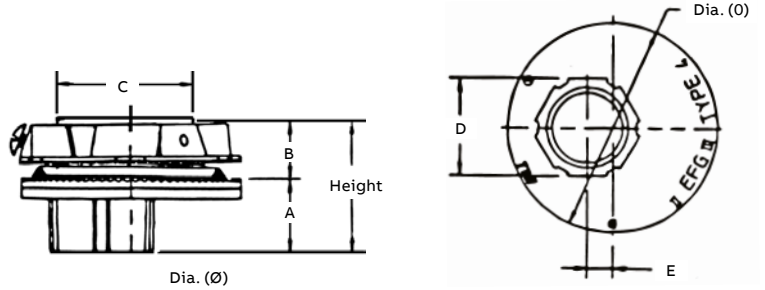

Capoffs



Cat. no.	Trade size (in.)	Height	Diameter	Dimensions (in.)		
				A	B	C
H050CAP	½	1 ¹³ / ₃₂	1 ⁷ / ₁₆	1 ⁹ / ₃₂	2 ⁷ / ₃₂	¾
H075CAP	¾	1 ⁵ / ₃₂	1 ¹¹ / ₁₆	1 ⁹ / ₃₂	1 ¹ / ₁₆	¾
H100CAP	1	1 ¹¹ / ₁₆	2	1 ¹ / ₁₆	1 ³ / ₁₆	¾
H125CAP	1¼	1 ²⁵ / ₃₂	2 ³ / ₈	2 ³ / ₃₂	1 ²¹ / ₃₂	¾
H150CAP	1½	1 ¹³ / ₁₆	2¾	2 ³ / ₃₂	1 ²⁹ / ₃₂	¾
H200CAP	2	1 ²⁷ / ₃₂	3¼	2 ³ / ₃₂	2 ³ / ₈	¾
H250CAP	2½	2 ⁹ / ₃₂	3¾	7 ⁷ / ₈	2 ²⁹ / ₃₂	¾
H300CAP	3	2 ⁹ / ₁₆	4 ³ / ₈	7 ⁷ / ₈	3 ¹ / ₃₂	1 ¹¹ / ₃₂
H350CAP	3½	2 ⁹ / ₁₆	5	2 ⁹ / ₃₂	4 ¹ / ₃₂	1 ¹¹ / ₃₂
H400CAP	4	2 ⁹ / ₁₆	5½	2 ⁹ / ₃₂	4 ¹ / ₂	1 ¹¹ / ₃₂
H500CAP	5	2 ²³ / ₃₂	6 ⁵ / ₈	2 ⁹ / ₃₂	5 ⁹ / ₁₆	1 ¹¹ / ₃₂
H600CAP	6	3	7 ⁵ / ₈	3 ¹ / ₃₂	6 ⁵ / ₈	1 ¹¹ / ₃₂

Material – Capoff and locknut: Zinc or copper-free aluminum
 Insulating throat: Thermoplastic temp. rating – 105 °C
 Flammability rating – 94V-0
 Nitrile (BUNA “N”)
 Sealing ring:

For aluminum capoff, add suffix A.
 For chrome-plated capoff, add suffix CP.
 Meets NEMA sealing requirements for NEMA 3R, 4 and 13 enclosures.
 CSA certified for hazardous locations Class II Groups E,F,G. Class III.
 UL File No. E-3060
 CSA File No. 4484

Diagrams

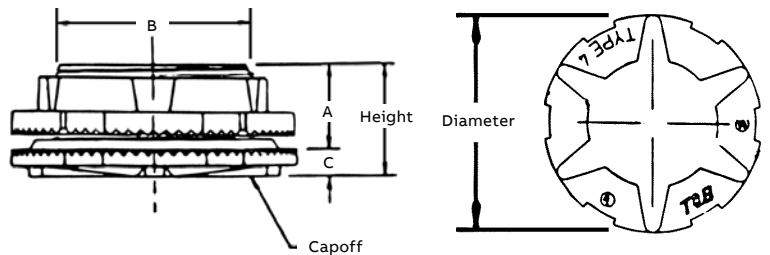

Couplings and accessories

XD expansion/deflection coupling

Watertight, flexible connections support movement and thermal expansion.

Use the ABB XD expansion/deflection coupling to join two conduit runs in applications where movement in any direction is required. The coupling provides a flexible, watertight connection, accommodating axial or parallel movement of up to ¼" and angular movement of up to 30° from normal.

- Ideal for use in bridges, tunnels, interbuilding walkways, docks and piers, wastewater and water treatment facilities and other applications in which conduit runs are subject to movement due to external forces or temperature changes
- Suitable for use indoors, outdoors, direct buried or embedded in concrete
- Watertight, flexible neoprene outer jacket, zinc-plated and acrylic-painted hubs and stainless steel tamperproof straps ensure superior corrosion resistance – ideal for use in harsh environments
- Copper ground mounting plates and grounding bonding jumper both entirely enclosed to safeguard against theft
- Includes an Erickson® type conduit union for faster, easier installation to reduce labor costs
- Durable stainless steel inner sleeve provides a constant, smooth inner diameter in any position to ease wire pulling and protect wire insulation from damage
- NPT threaded hubs fit standard threaded rigid metal conduit
- Can also be used with rigid PVC conduit with the use of standard adapters (not supplied)

Listings/compliances

- UL listed to UL 514B and CSA certified to C22.2 No. 18.3, suitable for wet locations (hub sizes 1"–6")
- Watertight – NEMA 4
- NEC® Article 250.98 and 300.4(A) compliant

Standard materials/finish

- Hub: ductile cast iron, zinc-plated and aluminum acrylic painted
- Inner sleeve: stainless steel
- Internal grounding bonding jumper: flexible copper braid
- Ground mounting plates: copper
- Hub rings: zinc-plated steel
- Outer jacket: molded neoprene (natural black)
- Jacket straps: stainless steel

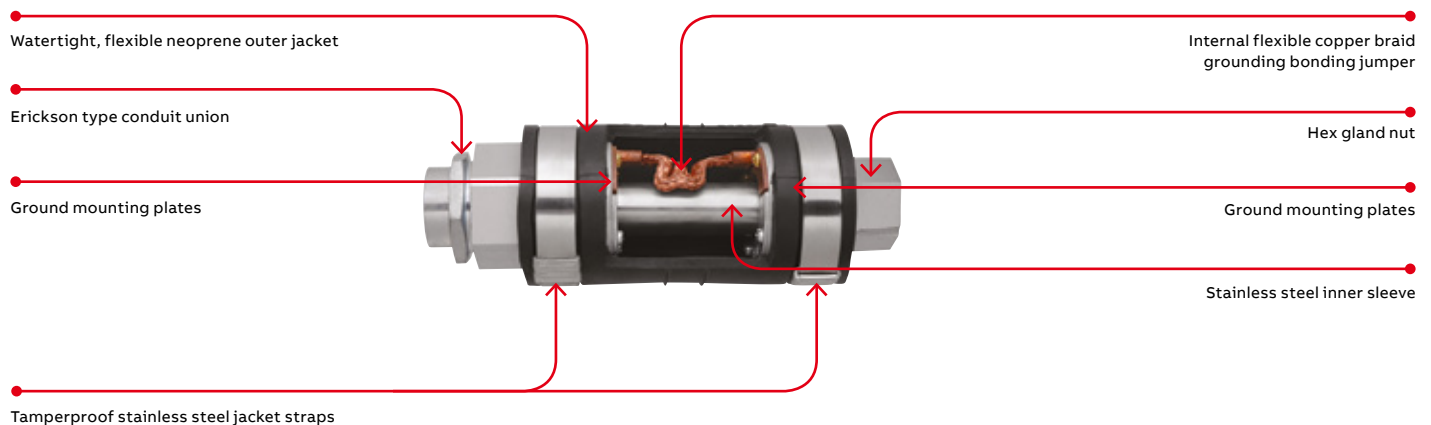

Couplings and accessories

XD expansion/deflection coupling



XD expansion/deflection coupling



Cat. no.	Hub size (in.)	Dimensions (in.)			
		A	B	C	D
XD3-TB	1	9 ¹³ / ₁₆	8 ¹⁵ / ₃₂	6 ⁷ / ₁₆	3 ¹¹ / ₃₂
XD4-TB	1 ¹ / ₄	9 ³ / ₁₆	8 ³ / ₈	6 ⁷ / ₈	3 ⁷ / ₈
XD5-TB	1 ¹ / ₂	9 ¹ / ₄	8 ⁷ / ₃₂	6 ³ / ₄	4 ⁵ / ₃₂
XD6-TB	2	9 ³ / ₄	8 ²¹ / ₃₂	7 ¹ / ₄	4 ¹¹ / ₁₆
XD7-TB	2 ¹ / ₂	11 ³ / ₄	11 ³ / ₈	9 ¹ / ₂	4 ⁷ / ₈
XD8-TB	3	10 ¹ / ₂	9 ²¹ / ₃₂	7 ²¹ / ₃₂	5 ¹⁵ / ₁₆
XD9-TB	3 ¹ / ₂	10 ⁹ / ₁₆	9 ³ / ₄	7 ³ / ₄	6 ⁵ / ₈
XD010-TB	4	13 ³ / ₁₆	11 ²⁷ / ₃₂	8 ⁷ / ₈	7 ⁹ / ₃₂
XD012-TB	5	14	12 ¹⁵ / ₁₆	11	8 ⁹ / ₃₂
XD014-TB	6	14 ⁵ / ₁₆	13 ³ / ₈	11 ¹ / ₂	9 ¹⁹ / ₃₂

Diagram

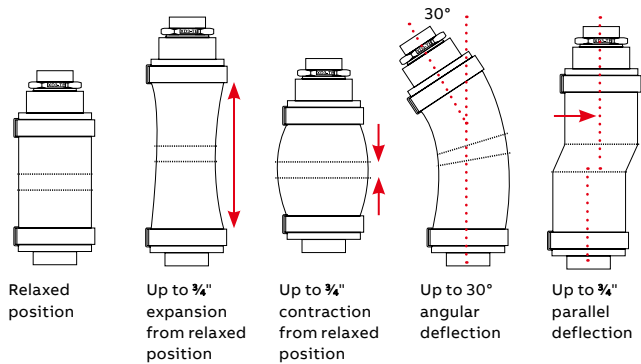
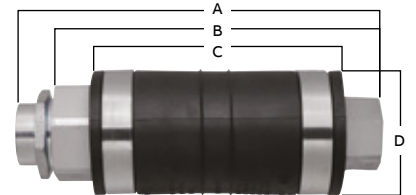

Couplings and accessories

Non-metallic expansion/deflection coupling



Axial expansion from relaxed position



Axial contraction from relaxed position



Parallel deflection



Angular deflection

Innovative design improves safety and saves labor time.

Use the non-metallic expansion/deflection coupling to join two rigid PVC conduit runs in applications requiring movement in any direction at structural joints. It provides a flexible connection, safely accommodating axial or parallel deflection of up to 3/4" and angular deflection of up to 30° from relaxed position.

This coupling meets the requirements of 2014 National Electrical Code (NEC) Article 300.4(H) for use where a raceway crosses a structural joint intended for expansion, contraction or deflection in buildings, bridges, parking garages and similar structures.

- Suitable for use indoors, outdoors, direct burial or embedded in concrete in bridges, piers, parking garages, overhead walkways, hospitals and other buildings
- Flexible neoprene outer jacket with tamper-proof stainless steel straps ensures superior protection and corrosion resistance suitable for wet locations

- Inner sleeve provides a constant, smooth inner diameter in any position to ease wire pulling and prevent wire insulation damage
- Up to five times faster to install than the traditional method
- Up to 5-to-1 SKU reduction
- Can be used with Schedule 40 and Schedule 80 rigid PVC conduit as well as with fiberglass raceways (different adhesive required)
- UV resistant
- Patent pending

Listings/compliances

- cULus listed
- CSA certified to CSA C22.2 No. 85
- 2014 NEC Article 300.4(H) compliant

Materials/finishes

- Coupling ends: smooth gray PVC
- Inner sleeve: smooth gray PVC
- Outer jacket: natural black molded neoprene
- Jacket straps: stainless steel

Non-metallic expansion/deflection coupling



Cat. no.	Trade size (in.)	Dimension A (in.)	Dimension B (in.)*
XD1NM-TB	1/2	7.28	2.40
XD2NM-TB	3/4	7.36	2.66
XD3NM-TB	1	7.66	2.96
XD5NM-TB	1 1/2	8.26	3.60
XD6NM-TB	2	9.14	4.34
XD7NM-TB	2 1/2	10.75	5.15
XD8NM-TB	3	11.36	5.60
XD010NM-TB	4	12.25	7.17

Diagram

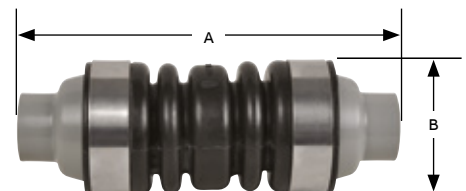

*Add 0.25" to O.D. clearance for strap buckle

Couplings and accessories

XJG conduit expansion coupling



01 Slide the fitting onto the conduit until it stops at the internal sliding bushing. Tighten and you're ready. No parts to reassemble!



02 With a wrench, tighten the gland nut to compress the Teflon packing, creating a raintight seal around the conduit.



03 Thread the next length of conduit into the other end of the fitting and tighten. You're done!

No disassembly required.

Suggested specifications for expansion fittings for rigid steel or intermediate metal conduit

Where raceways require expansion fittings to compensate for thermal expansion and contraction and where expansion fittings and telescoping sections of metal raceway shall be made electrically continuous by bonding jumpers or other means:

- The fitting will be constructed from malleable or ductile iron with exterior and interior zinc plating for corrosion protection.
- The fitting shall be constructed so that disassembly is not required during installation.
- The fitting shall be raintight after installation.

- The fitting shall have an internal bonding jumper constructed of a tinned copper braid, sized to meet UL fault current test requirements and comply with bonding requirements – NEC® Article 250.98.
- External bonding jumper shall not be required to comply with NEC® requirements
- Accepted manufacturers: ABB XJG-TB series

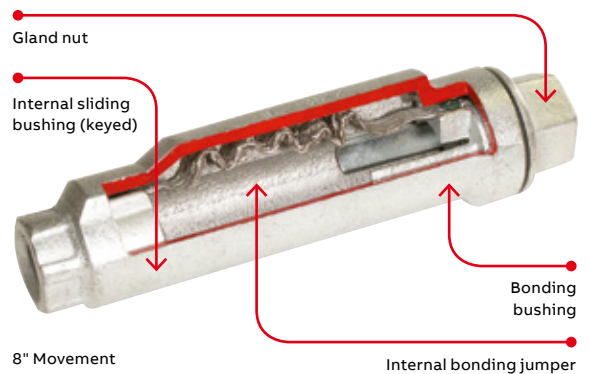

XJG-TB conduit expansion coupling for rigid and intermediate metal conduit

Cat no.	Hub size (in.)	Movement (in.)	Diameter (in.)	A	B	C
				Length (in.)	Height (in.)	
XJG24-TB	¾	4	2.43	10.00	2.75	
XJG28-TB	¾	8	2.43	14.00	2.75	
XJG34-TB	1	4	2.67	10.00	2.99	
XJG38-TB	1	8	2.67	14.00	2.99	
XJG44-TB	1¼	4	3.36	10.56	3.68	
XJG48-TB	1¼	8	3.36	14.56	3.68	
XJG54-TB	1½	4	3.36	10.56	3.68	
XJG58-TB	1½	8	3.36	14.56	3.68	
XJG64-TB	2	4	3.86	11.25	4.18	
XJG68-TB	2	8	3.86	15.25	4.18	
XJG74-TB	2½	4	4.96	12.12	5.25	
XJG78-TB	2½	8	4.96	16.12	5.25	
XJG84-TB	3	4	4.96	12.12	5.25	
XJG88-TB	3	8	4.96	16.12	5.25	
XJG94-TB	3½	4	6.37	12.87	6.75	
XJG98-TB	3½	8	6.37	16.87	6.75	
XJG104-TB	4	4	6.37	12.87	6.75	
XJG108-TB	4	8	6.37	16.87	6.75	
XJG1208-TB	5	8	7.99	18.87	8.56	

Diagram

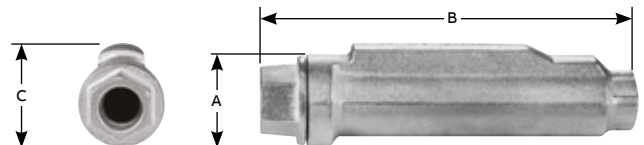

Please consult Technical Services for special orders and availability of products not shown in this list.

Couplings and accessories

XJG-EMT conduit expansion coupling for EMT and threadless connectors/couplings



XJG24-EMT

Features

- Fast and easy installation – no disassembly required
- No external grounding strap needed – internal bonding jumper is protected from tampering and the environment
- Exceeds code requirements for long conduit runs to permit linear movement

Standard materials/finish

- Body: ductile iron, available PVC coated
- Internal bonding jumper: tinned copper braid
- Exterior and interior finish: zinc plating, aluminum acrylic paint
- Packing: PTFE/synthetic fiber material

Listings/compliances

- UL File E23018, Std. 514B, suitable for wet locations
- CSA File LR2884, Std. C22.2 No. 18
- NEC® 250.98

Note: XJG-EMT couplings are not raintight and are for use in dry locations only. They are UL listed for use with aluminum EMT.

XJG-EMT conduit expansion coupling for EMT

Cat no.	Size (in.)	Movement (in.)	Length (in.)	A	B
XJG24-EMT	¾	4	17.39		2.75
XJG28-EMT	¾	8	21.39		2.75
XJG34-EMT	1	4	17.42		2.99
XJG38-EMT	1	8	21.42		2.99
XJG44-EMT	1¼	4	18.27		3.46
XJG48-EMT	1¼	8	22.27		3.46
XJG54-EMT	1½	4	18.69		3.68
XJG58-EMT	1½	8	22.69		3.68
XJG64-EMT	2	4	19.04		4.18
XJG68-EMT	2	8	23.04		4.18
XJG74-EMT	2½	4	23.23		4.52
XJG78-EMT	2½	8	27.23		4.52
XJG84-EMT	3	4	24.09		5.25
XJG88-EMT	3	8	28.09		5.25
XJG94-EMT	3½	4	28.70		6.00
XJG98-EMT	3½	8	28.70		6.00
XJG104-EMT	4	4	29.30		6.75
XJG108-EMT	4	8	29.30		6.75

Diagram

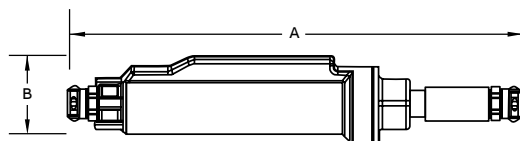

8123 Series



8130 Series



8120 Series

Threadless connectors/couplings

- For threadless rigid metal conduit and intermediate metal conduit

Application

- To connect and effectively bond threadless rigid metal conduit/intermediate metal conduit to a box or enclosure, or to couple ends of threadless conduit

Features

- Steel/malleable iron construction
- Case-hardened ring bites into conduit for high-quality continuity and grip
- Nylon insulator firmly secured in place protects conductors and reduces wire pulling effort by as much as 50%; prevents thread damage in handling
- Case-hardened steel locknut or malleable iron locknut designed to provide a positive bond
- Suitable for concrete-tight application
- Capable of carrying ground fault currents up to 10,000 amps RMS (½" through 1½" size) and 20,000 amps RMS (2" and above sizes) for a duration of three current cycles

Standard material

- Nut, gland: ½" to 1" steel; 1¼" to 4" malleable iron
- Body: all malleable iron
- Ring: steel (case hardened)
- Insulator: nylon
- Locknut: ½" through 2" steel (hardened) 2" through 4" malleable iron

Standard finish

- Electro zinc plated and chromate coated

Range

- 8123 and 8120 Series: ½" through 4" size conduit
- 8130 Series: ½" through 2" size conduit
- All hub threads: straight pipe (NPS)

Listings/compliances

- UL 514B: Federal Specification A-A-50553
- CSA C22.2 No. 18: Federal Standard H-28 (threads)
- NFPA 70: UL (UL File No: E-23018)
- NEMA FB1: CSA (LR-2884, LR-4484)



XJG24-EMT

Couplings and accessories

Threadless connectors/couplings



- Split steel ring with diagonal serrations grips conduit and bites in for positive ground
- Makes a permanent connection
- Eliminates need for cutting a thread on conduit

- Insulation helps ensure continuity of service by protecting the conductor at the critical point – the connector bushing
- Malleable iron construction
- Look for the unique blue color, ensuring the highest quality fitting

Threadless connectors



Diagram	Cat. no.		Conduit size (in.)	Dimensions (in.)		
	Nylon insulated	Non-insulated		A	B	C
	8123	8121	1/2	1 7/32	1 11/16	1/2
	8223	8221	3/4	1 17/32	1 3/4	1/2
	8323	8321	1	1 29/32	2	9/16
	8423	8421	1 1/4	2 3/8	2 7/16	1 1/16
	8523	8521	1 1/2	2 11/16	2 5/8	3/4
	8623	8621	2	3 1/4	2 13/16	27/32
	8723-TB	8721	2 1/2	4 1/8	3 13/16	1 1/8
	8823	8821	3	4 7/8	4	1 7/32
	8853	8851	3 1/2	5 1/2	4 1/8	1 1/8
	8973	8971	4	6 1/32	4 7/8	1 1/8

Available with DURA-PLATE® finish. UL File No. E-23018 CSA File No. 2884



- Just tighten with a wrench to make a UL listed and CSA certified concrete-tight connection

- Eliminates need for conduit threading
- Malleable iron construction

Threadless couplings



Diagram	Cat. no.	Conduit size (in.)	Dimensions (in.)	
			A	B
	8120	1/2	1 9/32	2
	8220	3/4	1 19/32	2 5/16
	8320	1	1 7/8	2 11/16
	8420	1 1/4	2 3/8	2 13/16
	8520	1 1/2	2 5/8	3 5/8
	8620	2	3 1/4	3 13/16
	8720	2 1/2	3 15/16	5 3/8
	8820	3	4 11/16	5 1/2
	8850	3 1/2	5 3/16	5 1/2
	8970	4	5 11/16	5 1/2

Available with DURA-PLATE® finish. UL File No. E-23018 CSA File No. 2884

Couplings and accessories

Threadless short elbows and set-screw connector/coupling



- Ideal for entering enclosure or conduit body at right angles
- Eliminates need to thread conduit

- As with straight couplings, makes a concrete-tight connection
- Malleable iron construction

Threadless short elbows – nylon insulated



Diagram	Cat. no.	Conduit size (in.)	Dimensions (in.)		
			A	B	C
	8130	1/2	1 ¹¹ / ₃₂	1 ¹ / ₂	1/2
	8131	3/4	1 ⁵ / ₈	1 ³ / ₄	9/16
	8132	1	1 ⁷ / ₈	1 ¹⁵ / ₁₆	1 ¹ / ₁₆

Available with DURA-PLATE® finish. UL File No. E-23018 CSA File No. 2884



8125 Series

Set-screw connectors/couplings

- For threadless rigid metal conduit and intermediate metal conduit

Application

- To connect and effectively bond threadless rigid metal conduit or intermediate metal conduit to a box or enclosure or to couple ends of threadless conduit

Features

- Thickwall steel or malleable iron body
- Hardened hex head cup point screw to provide high-quality bond
- Screw captivated, will not vibrate loose
- Nylon-insulated throat meets and exceeds all code requirements for bushing:
 - (i) Prevents thinning of insulation
 - (ii) Reduces installation effort
 - (iii) Prevents first thread damage
- Coupling provided with positive center stop
- Suitable for concrete-tight application
- Capable of carrying ground fault currents up to 10,000 amps RMS (1/2" through 1 1/2" size) and 20,000 amps RMS (2" and above sizes)

Standard material

- Body: 1/2" through 2" steel; 2 1/2" through 4" malleable iron
- Locknut: 1/2" through 2" steel (hardened); 2 1/2" through 4" malleable iron
- Screw: steel (hardened)
- Insulator: nylon

Standard finish

- Electro zinc plated and chromate coated

Listings/compliances

- UL (UL File No: E-23018)
- CSA (LR-2884, LR-4484)
- UL 514B
- CSA C22.2 No. 18
- NFPA 70
- NEMA FB1
- Federal Specification A-A-50553
- Federal Standard H-28 (threads)



8124 Series

Couplings and accessories

Set-screw connector/couplings



- Eliminates the need for conduit threading
- Captive hex head screws tighten down onto conduit for positive holding strength and ground

- Furnished with insulated throats to reduce wire-pulling effort by as much as 50%
- Approved concrete-tight

8125 Series

Insulated set-screw connector



Diagram	Cat. no.	Conduit size (in.)	Dimensions (in.)	
			A	B
	8125	1/2	1 3/8	1 13/32
	8225	3/4	1 1/2	7/16
	8325	1	1 3/16	35/64
	8425	1 1/4	2	5/8
	8525	1 1/2	2 5/16	5/8
	8625-TB	2	2 7/16	1 1/16
	8725-TB	2 1/2	3 3/8	1
	8825	3	3 7/16	1
	8855	3 1/2	3 7/8	1 1/16
	8975	4	4 3/16	1 1/8

Sizes 1/2–2 made of steel. Sizes 2 1/2–4 are malleable iron.

Available with DURA-PLATE® finish.

UL File No. E-23018 CSA File No. 2884



- No need to thread conduit ends when joining rigid conduit

- Captive hex head screws provide positive holding strength and ground continuity
- Approved concrete-tight

8124 Series

Set-screw coupling



Diagram	Cat. no.	Conduit size (in.)	Dimension (in.)
			A
	8124	1/2	2 1/2
	8224	3/4	2 11/16
	8324-TB	1	2 27/32
	8424	1 1/4	3
	8524	1 1/2	3 3/8
	8624	2	3 5/8
	8724	2 1/2	3 7/8
	8824-TB	3	4 1/4
	8854	3 1/2	4 15/16
	8974	4	5 3/8

Sizes 1/2–2 made of steel; sizes 2 1/2–4 are malleable iron.

Available with DURA-PLATE® finish.

UL File No. E-23018 CSA File No. 2884

Couplings and accessories

Elbows

- Smoothly rounded shoulders protect conductor insulation
- Non-insulated
- Malleable iron construction

Bushed elbows

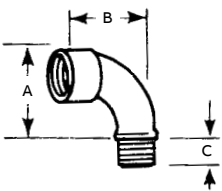
Diagram	Cat. no.	Conduit size (in.)	Dimensions (in.)		
			A	B	C
	460-TB	1/2	1 1/8	1 13/16	5/8
	461TB	3/4	1 1/2	2 1/4	5/8
	462	1	1 13/16	2 11/16	3/4
	463	1 1/4	2 1/4	3 1/8	3/4

Available with DURA-PLATE® finish. U.L. File No. E 23018. CSA File No. 2884

- For non-insulated applications
- Malleable iron construction

Short elbows

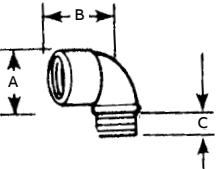
Diagram	Cat. no.	Conduit size (in.)	Dimensions (in.)		
			A	B	C
	4250	1/2	1 5/16	1 1/4	7/16
	4251	3/4	1 17/32	1 5/16	1/2
	4252	1	1 13/16	1 9/16	5/8
	4253	1 1/4	2 9/32	2 1/16	11/16
	4254	1 1/2	2 9/16	2 3/16	11/16
	4255	2	3 3/32	2 9/16	11/16

Available with DURA-PLATE® finish. U.L. File #E-23018 CSA File No. 589

- Integral insulation ensures a smooth bushing in every fitting
- Malleable iron construction

Short elbows – nylon insulated

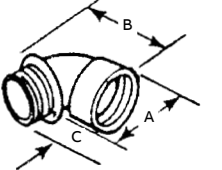
Diagram	Cat. no.	Conduit size (in.)	Dimensions (in.)		
			A	B	C
	4290	1/2	1 7/32	1 1/4	1/2
	4291	3/4	1 7/16	1 5/16	9/16
	4292	1	1 23/32	1 9/16	11/16
	4293	1 1/4	2 7/32	2 1/16	13/16
	4294	1 1/2	2 15/32	2 3/16	13/16
	4295	2	3	2 9/16	13/16

Available with DURA-PLATE® finish. Not UL or CSA.

Couplings and accessories

Nipples

- Die-cast zinc
- 1" long

Conduit nipples

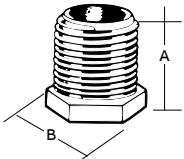
Diagram	Cat. no.	Conduit size (in.)	Dimensions (in.)	
			A	B
	HA-211	$\frac{1}{2}$	1	$\frac{15}{16}$
	HA-212	$\frac{3}{4}$	1	$1\frac{3}{16}$
	HA-213	1	1	$1\frac{7}{16}$

UL File No. E-1275 $\frac{1}{2}$ & $\frac{3}{4}$ only



- Die-cast zinc

Offset nipples

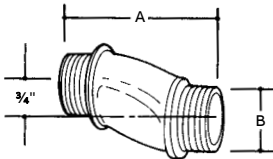
Diagram	Cat. no.	Conduit size (in.)	Dimensions (in.)	
			A	B
	HO-221	$\frac{1}{2}$	2.60	1.00
	HO-222	$\frac{3}{4}$	2.62	1.32
	HO-223	1	2.68	1.51
	HO-224	$1\frac{1}{4}$	2.85	1.85
	HO-225	$1\frac{1}{2}$	2.88	2.08
	HO-226	2	3.19	2.71

$\frac{3}{4}$ offset

UL File No. E-1275

Couplings and accessories

Threaded Erickson® three-piece coupling



674 Series
675AL Series

With an Erickson coupling, a conduit run may be completed when neither conduit can be turned. A conduit run may also be broken without taking down the whole run. Conduit joined with Erickson couplings is rigid and in line and vibration will not loosen the connections. Malleable iron.

For threaded rigid metal conduit and intermediate metal conduit.

Application

- To couple and effectively bond threaded ends of rigid metal conduit/intermediate metal conduit where neither length of conduit can be rotated

Features

- Malleable iron/steel/copper-free aluminum construction
- Free-fitting threads ensure easy assembly
- Permits conduit coupling without rotating either conduit
- Provides rigid in-line coupling with high-quality grounding; will not loosen under vibration
- Suitable for concrete-tight application
- Capable of carrying ground fault currents up to 10,000 amps RMS (½" through 1½" size) and up to 20,000 amps RMS (2" and above) (duration of fault current three cycles) (674 series tested)

Standard material

674 Series

- Bushing and case: malleable iron
- Ring: steel and malleable iron

675AL Series

- Bushing and case: aluminum
- Ring: aluminum

Standard finish

- 674 Series: electro zinc plated and chromate coated
- 675AL Series: degreased

Range

- ⅜" through 6" conduit (malleable iron)
- ½" through 6" conduit (aluminum)
- All straight pipe threads (NPS)

Listings/compliances

- UL 514B
- CSA C22.2 No. 18
- NEMA FB1
- NFPA 70-1999 (ANSI)
- Federal Specification A-A-50553
- Federal Standard H-28 (threads)

Threaded Erickson® three-piece coupling

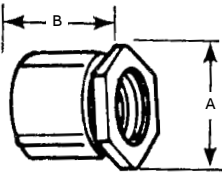

	Steel/M.I. cat. no.	Alum.* cat. no.	Conduit size (in.)	Dimensions (in.)	
				A	B
Diagrams	674	–	⅜	1⅛	1⅞
	675	675AL	½	1 ¹⁵ / ₃₂	1¾
	676	676AL	¾	1 ⁹ / ₁₆	1 ¹³ / ₃₂
	677	677AL	1	1 ²⁹ / ₃₂	1 ⁵ / ₈
	678	678AL	1¼	2 ³ / ₈	1 ¹³ / ₁₆
	679	679AL	1½	2 ⁵ / ₈	1 ³¹ / ₃₂
	680TB	680AL	2	3 ⁷ / ₃₂	2 ⁷ / ₃₂
	681	681AL	2½	3 ³¹ / ₃₂	2 ¹¹ / ₁₆
	682	682AL	3	4 ⁷ / ₁₆	2 ²⁹ / ₃₂
	683	683AL	3½	5	3
	684	684AL	4	5½	3 ³ / ₁₆
	685	685AL	4½	6¼	3 ¹⁵ / ₃₂
	686	686AL	5	6 ²⁵ / ₃₂	3¾
	687	687AL	6	8	4 ¹ / ₃₂

*Copper-free aluminum UL listed and CSA certified concrete-tight.
UL File No. E-23018 CSA File No. 2884

Couplings and accessories

Split couplings



ABB's split coupling is a simple method to join threaded conduits in retrofits or in snug areas. Available in ½" to 6".

- Ideal for retrofit installations or in tight areas
- Fast installation
- Neoprene gasket provides a concrete-tight seal
- Joins threaded conduit even when the conduit can't rotate
- Approved for direct burial

Specifications

- Material: malleable iron
- Gasket: neoprene
- Plating: zinc plated
- Standards: UL Standard 514B, NEMA FB-1

Split couplings

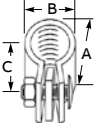

	Cat. no.	Trade size (in.)	Dimensions (in.)			Weight per 100
			A	B	C	
Diagrams	SPCP50	½	2	1¼	1¼	34.4
	SPCP75	¾	2 ⁵ / ₁₆	1½	1¼	39.4
	SPCP100	1	2 ⁹ / ₈	1 ¹³ / ₁₆	1 ⁵ / ₈	60.0
	SPCP125	1¼	3 ¹ / ₁₆	2 ³ / ₁₆	1 ⁵ / ₈	75.0
	SPCP150	1½	3 ⁵ / ₁₆	2 ⁷ / ₁₆	1 ¹⁵ / ₁₆	112.5
½" and ¾" furnished with one screw	SPCP200	2	3 ¹³ / ₁₆	2 ⁷ / ₈	2	112.5
	SPCP250	2½	4 ⁵ / ₈	3 ⁹ / ₁₆	3 ¹ / ₁₆	275.0
	SPCP300	3	5 ⁵ / ₁₆	4 ¹ / ₈	3 ¹ / ₈	300.0
	SPCP350	3½	6 ¹ / ₁₆	4 ¹³ / ₁₆	3¼	425.0
	SPCP400	4	6 ⁹ / ₁₆	5 ³ / ₈	3 ⁷ / ₁₆	500.0
	SPCP500	5	8 ¹ / ₁₆	6 ⁹ / ₁₆	3 ⁷ / ₈	900.0
1" through 6" furnished with two screws	SPCP600	6	9¼	7 ⁵ / ₈	4 ³ / ₁₆	1,300.0

Couplings and accessories

Panel connector extensions and male enlargers

- The ideal solution for applications requiring longer thread length
- Will combine with any fitting with a male thread
- Male thread of panel connector extension is 1" long
- Malleable iron construction

Panel connector extensions



Diagrams	Cat. no.	Conduit size (in.)	Dimensions (in.)		
			A	B	C
	1440	1/2	1 3/4	1 3/32	1 7/8
	1441	3/4	1 3/8	1 11/32	2
	1442	1	1 1/4	1 19/32	1 15/16
	1443	1 1/4	1 1/4	1 15/16	1 5/16

UL File No. E-23018
CSA File No. 2884



- Adapt an outlet hole to the next larger size of conduit
- Built-in bushing covers rough ends of conduit
- Malleable iron construction

Male enlargers*



Diagrams	Cat. no.	Conduit size (in.)	Dimensions (in.)		
			A	B	C
	1245	1/2 to 3/4	1 13/32	1 1/16	1/2
	1246	3/4 to 1	1 11/16	1 1/4	15/32
	1244	1 to 1 1/4	2 1/16	1 11/32	1/2
	1247	1 1/4 to 1 1/2	2 5/16	1 3/8	9/16

* All items shown in this chart are suitable for use in hazardous locations where general purpose equipment is specifically permitted by the NEC; Class I, Div. 2; Class II, Div. 1 & 2; Class III, Div. 1 & 2, NEC 501-4(b); 502-4(a)(b); 503-3(a)(b).
Available with DURA-PLATE® finish.
UL File No. E-23018
CSA File No. 2884

Couplings and accessories

Female reducers

- Adapt any outlet to the next smaller size of conduit
- Hex shoulder for easy wrench tightening
- Malleable iron construction

Female reducers*



Diagrams	Cat. no.	Conduit size (in.)	Dimensions (in.)		
			A	B	C
	1250-TB	$\frac{3}{4}$ to $\frac{1}{2}$	$1\frac{1}{8}$	$\frac{5}{8}$	$\frac{3}{16}$
	1261	1 to $\frac{1}{2}$	$1\frac{7}{16}$	$2\frac{1}{32}$	$\frac{3}{16}$
	1251	1 to $\frac{3}{4}$	$1\frac{3}{8}$	$1\frac{11}{16}$	$\frac{3}{16}$
	1262	$1\frac{1}{4}$ to $\frac{1}{2}$	$1\frac{13}{16}$	$2\frac{3}{32}$	$\frac{3}{16}$
	1263	$1\frac{1}{4}$ to $\frac{3}{4}$	$1\frac{13}{16}$	$2\frac{3}{32}$	$\frac{3}{16}$
	1252	$1\frac{1}{4}$ to 1	$1\frac{3}{4}$	$2\frac{5}{32}$	$7\frac{7}{32}$
	1253	$1\frac{1}{2}$ to $1\frac{1}{4}$	2	$1\frac{3}{16}$	$\frac{1}{4}$
	1254	2 to $1\frac{1}{2}$	$2\frac{3}{8}$	$1\frac{3}{16}$	$9\frac{9}{32}$
	1255	$2\frac{1}{2}$ to 2	3	$1\frac{1}{4}$	$\frac{3}{8}$
	1256	3 to $2\frac{1}{2}$	$3\frac{5}{8}$	$1\frac{1}{2}$	$\frac{1}{2}$
	1257	$3\frac{1}{2}$ to 3	$4\frac{1}{8}$	$1\frac{9}{16}$	$\frac{1}{2}$
	1258	4 to $3\frac{1}{2}$	$4\frac{5}{8}$	$1\frac{9}{16}$	$\frac{1}{2}$

* All items shown in this chart are suitable for use in hazardous locations where general purpose equipment is specifically permitted by the NEC; Class I, Div. 2; Class II, Div. 1 & 2; Class III, Div. 1 & 2, NEC 501-4(b); 502-4(a) (b); 503-3(a) (b).

Available with DURA-PLATE® finish. UL File No. E-23018 CSA File No. 2884

Couplings and accessories

Threaded reducers and reducing washers

- Reduces threaded opening in conduit bodies or any female threaded fitting
- Smooth, built-in bushing completely covers rough ends of conduit
- Malleable iron or steel construction (steel through 606, also 614 and 615)

- Reduce knockout hole in outlet box
- Used in pairs
- Interlock to form a rib that centers washers and conduit in knockout
- Galvanized steel construction

Threaded reducers



Cat. no.	Trade		Dimension (in.)
	Steel or MI	Alum.	
600TB	600ALTB	1/2 to 3/8	9/16
601TB	601ALTB	3/4 to 1/2	9/16
602TB	602ALTB	1 to 1/2	5/8
603TB	603ALTB	1 to 3/4	5/8
604TB	604ALTB	1 1/4 to 1/2	13/16
605TB	605AL	1 1/4 to 3/4	5/8
606TB	606AL	1 1/4 to 1	15/16
607	607AL	1 1/2 to 1/2	13/16
608	608AL	1 1/2 to 3/4	13/16
609	609AL	1 1/2 to 1	15/16
610	610AL	1 1/2 to 1 1/4	3/4
611TB	611AL	2 to 1/2	15/16
612	612AL	2 to 3/4	15/16
613	613AL	2 to 1	15/16
614TB	614AL	2 to 1 1/4	15/16
615TB	615AL	2 to 1 1/2	7/8

Diagram

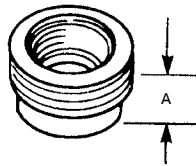

UL File No. E-23018
CSA File No. 2884

Reducing washers



Cat. no.	Trade size (in.)	Dimensions (in.)	
		A	B
3700	3/4 to 3/8	1 3/8	45/64
3701	3/4 to 1/2	1 3/8	7/8
3702	1 to 3/8	1 5/8	45/64
3703	1 to 1/2	1 5/8	7/8
3704	1 to 3/4	1 5/8	1 3/32
3705-TB	1 1/4 to 3/8	2	45/64
3706	1 1/4 to 1/2	2	7/8
3707	1 1/4 to 3/4	2	1 3/32
3708	1 1/4 to 1	2	1 23/64
3709	1 1/2 to 3/8	2 1/4	45/64
3710	1 1/2 to 1/2	2 1/4	7/8
3711	1 1/2 to 3/4	2 1/4	1 3/32
3712	1 1/2 to 1	2 1/4	1 23/64
3713	1 1/2 to 1 1/4	2 1/4	1 23/32
3714	2 to 1/2	2 3/4	7/8
3715-TB	2 to 3/4	2 3/4	1 3/32
3716	2 to 1	2 3/4	1 23/64
3717	2 to 1 1/4	2 3/4	1 23/32
3718	2 to 1 1/2	2 3/4	1 31/32

Diagram

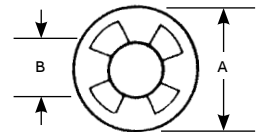

UL File No. E-13938
CSA File No. 2884

Couplings and accessories

Combination couplings, entrance ells and pipe caps

- One-piece fitting couples armored cable or flexible conduit to threaded rigid conduit
- Tite-Bite® wedge holds conduit securely with a double grip
- When used with a Chase® nipple, this fitting will connect flexible conduit to outlet boxes, enabling more wiring space in the box than the usual connector
- UL listed as a grounding means under NEC 350-5
- Malleable iron construction

- Mount flat against wall, eliminating the need to offset conduit
- Designed for a straight pull in either direction
- Smooth surface
- Make it easy to pull heavy wires without damage to insulation
- Made of copper-free aluminum

TITE-BITE combination couplings – Armored cable for threaded rigid



Diagram	Cat. no.	Conduit size (in.)	Dimensions (in.)	
			A	B
	440	1/2	1 5/8	1 27/32
	441	3/4	1 3/4	2 1/8
	442	1	2	2 17/32

UL File No. E-23018
CSA File No. 2884

Entrance ells



Diagram	Cat. no.	Conduit size (in.)	Dimensions (in.)	
			A	C
	1490	1/2	3	1 19/32
	1491	3/4	3 9/16	1 7/8
	1492	1	4 1/4	2 23/64
	1493	1 1/4	5 31/64	2 13/16
	1494	1 1/2	6 1/4	2 7/8
	1495	2	6 3/4	3 9/16

UL File No. E-23018.
CSA File Nos. 2884 and 589

Coming soon

Pipe caps — stainless steel 316

Diagrams	Cat. no.	Trade size (in.)	Weight/100 lbs.	Dimensions (in.)			
				A	B	C	D
	PIPECAP1/2SST	1/2	14	1.00	1.12	1.03	1/2-14 NPT
	PIPECAP3/4SST	3/4	22	1.06	1.37	1.25	3/4-14 NPT
	PIPECAP1SST	1	33	1.25	1.62	1.50	1-11 1/2 NPT
	PIPECAP1 1/4SST	1 1/4	45	1.25	1.99	1.88	1 1/4-11 1/2 NPT
	PIPECAP1 1/2SST	1 1/2	53	1.25	2.24	2.09	1 1/2-11 1/2 NPT
	PIPECAP2SST	2	96	1.31	2.87	2.63	2-11 1/2 NPT
	PIPECAP2 1/2SST	2 1/2	164	1.88	3.37	3.13	2 1/2-8 NPT
	PIPECAP3SST	3	231	2.00	3.99	3.75	3-8 NPT
	PIPECAP4SST	4	445	2.13	5.24	4.88	4-8 NPT

Couplings and accessories

Stainless steel drain adapter and ball valve



In the electrical system of a food and beverage facility and elsewhere, the T&B® Fittings stainless steel drain adapter provides the means to drain accumulated moisture or small debris from stainless steel electrical enclosures for non-threaded connections.

- The drain adapter and ball valve are NSF certified for food and beverage applications
- When the drain adapter is used in conjunction with the ball valve, the assembly offers a UL type 4X rating and is suitable for washdown areas
- The adapter and valve are both constructed of type 316 stainless steel for superior corrosion resistance
- The innovative, compact body design and special-grade silicone gasket make the drain adapter suitable for installation in tight spaces and on curved surfaces

Certifications

- cULus listed type 4X when the ball valve is assembled to the drain adapter
- NSF certified per NSF/ANSI standard 169
- Manufactured with FDA-approved materials

Stainless steel drain adapter and ball valve

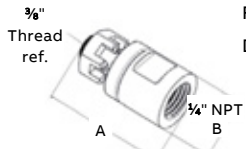
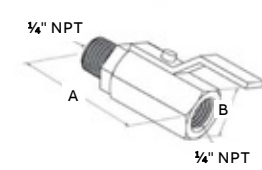
	Cat. no	Description	Trade size (in.)	Dim. (in.)	
				A	B
	FG-DA-3/8	Drain adapter	3/8	1.38	0.75
	DBV-1/4	Ball valve	1/4	2.03	0.75
					

Stainless steel conduit and fittings

Stainless steel conduit



Withstand corrosive environments and meet stringent sanitary requirements.

For corrosion-resistant electrical conduit systems, stainless steel offers value and performance that's hard to match, combining high corrosion, chemical and temperature resistance with strength, durability, ease of installation and low maintenance. Compared to standard galvanized steel conduit in corrosive environments, type 304 stainless steel offers up to five times the lifespan, while type 316 offers up to eight times the lifespan. Because it is very easy to clean and its surface has no pores or cracks to harbor bacteria and other impurities, stainless steel also provides one of the most hygienic surfaces.

- Available in both type 304 and marine-grade type 316 stainless steel
- Features standard NPT threads for easy installation

- Each 10-ft. length of conduit ships with one stainless steel coupling included
- Couplings also sold separately
- Exceeds requirements for washdown applications
- Food- and potable water-safe
- Satisfies plant-cleanliness mandates from HACCP, FDA and various state agencies
- Meets ASTM A-321/SA-312 Standards
- UL®/cUL Listed

Typical applications

- Petrochemical refining/processing
- Water and wastewater treatment
- Food and beverage processing
- Marine and coastal facilities
- Pharmaceutical manufacturing
- Pulp and paper processing
- Other applications in corrosive environments or with strict hygiene requirements

5" and 6" sizes coming soon

Stainless steel rigid conduit



Cat. no.	Trade size (in.)	Weight (lbs./ft.)	Std. pkg. qty. ft.
Type 304 stainless steel conduit with coupling			
COND1/2SS	1/2	0.82	1,500
COND3/4SS	3/4	1.09	1,000
COND1SS	1	1.61	700
COND11/4SS	1 1/4	2.18	350
COND11/2SS	1 1/2	2.63	300
COND2SS	2	3.50	200
COND21/2SS	2 1/2	5.59	120
COND3SS	3	7.27	90
COND4SS	4	10.08	40
COND5SS	5	13.25	40
COND6SS	6	17.65	40

Cat. no.	Trade size (in.)	Weight (lbs./ft.)	Std. pkg. qty. ft.
Type 316 stainless steel conduit with coupling			
COND1/2SST	1/2	0.82	1,500
COND3/4SST	3/4	1.09	1,000
COND1SST	1	1.61	700
COND11/4SST	1 1/4	2.18	350
COND11/2SST	1 1/2	2.63	300
COND2SST	2	3.50	200
COND21/2SST	2 1/2	5.59	120
COND3SST	3	7.27	90
COND4SST	4	10.08	40
COND5SST	5	13.25	40
COND6SST	6	17.65	40

Note: Conduit sold in 10-ft. lengths. Each 10-ft. length ships with one coupling.

Stainless steel conduit and fittings

Stainless steel couplings and nipples

5" and 6" sizes coming soon

Withstand corrosive environments and meet stringent sanitary requirements.



Stainless steel couplings – Type 304

Cat. no.	Trade size (in.)	Weight (lbs./ea.)	Std. pkg. qty.
CPL1/2SS	½	0.22	100
CPL3/4SS	¾	0.28	50
CPL1SS	1	0.39	30
CPL11/4SS	1¼	0.55	25
CPL11/2SS	1½	0.77	25
CPL2SS	2	1.10	20
CPL21/2SS	2½	2.09	12
CPL3SS	3	3.15	16
CPL4SS	4	4.29	10
CPL5SS	5	7.70	4
CPL6SS	6	10.15	4

5" and 6" sizes coming soon



Stainless steel couplings – Type 316

Cat. no.	Trade size (in.)	Weight (lbs./ea.)	Std. pkg. qty.
CPL1/2SST	½	0.17	100
CPL3/4SST	¾	0.29	50
CPL1SST	1	0.34	30
CPL11/4SST	1¼	0.37	25
CPL11/2SST	1½	0.61	25
CPL2SST	2	0.90	20
CPL21/2SST	2½	1.87	12
CPL3SST	3	1.93	16
CPL4SST	4	3.97	10
CPL5SST	5	7.70	4
CPL6SST	6	10.15	4

Stainless steel conduit and fittings

Stainless steel nipples

Withstand corrosive environments and meet stringent sanitary requirements.



Conduit nipples

Type 304 stainless steel	Close	1½"	2"	2½"	3"	3½"
½	CLNPL1/2SS	NPL1/2X11/2SS	NPL1/2X2SS	NPL1/2X21/2SS	NPL1/2X3SS	NPL1/2X31/2SS
¾	CLNPL3/4SS	NPL3/4X11/2SS	NPL3/4X2SS	NPL3/4X21/2SS	NPL3/4X3SS	NPL3/4X31/2SS
1	CLNPL1SS	—	NPL1X2SS	NPL1X21/2SS	NPL1X3SS	NPL1X31/2SS
1¼	CLNPL11/4SS	—	NPL11/4X2SS	NPL11/4X21/2SS	NPL11/4X3SS	NPL11/4X31/2SS
1½	CLNPL11/2SS	—	NPL11/2X2SS	NPL11/2X21/2SS	NPL11/2X3SS	NPL11/2X31/2SS
2	CLNPL2SS	—	—	—	—	NPL2X31/2SS
2½	CLNPL21/2SS	—	—	—	—	—
3	CLNPL3SS	—	—	—	—	—

Type 316 stainless steel	Close	1½"	2"	2½"	3"	3½"
½	CLNPL1/2SST	NPL1/2X11/2SST	NPL1/2X2SST	NPL1/2X21/2SST	NPL1/2X3SST	NPL1/2X31/2SST
¾	CLNPL3/4SST	NPL3/4X11/2SST	NPL3/4X2SST	NPL3/4X21/2SST	NPL3/4X3SST	NPL3/4X31/2SST
1	CLNPL1SST	—	NPL1X2SST	NPL1X21/2SST	NPL1X3SST	NPL1X31/2SST
1¼	CLNPL11/4SST	—	NPL11/4X2SST	NPL11/4X21/2SST	NPL11/4X3SST	NPL11/4X31/2SST
1½	CLNPL11/2SST	—	NPL11/2X2SST	NPL11/2X21/2SST	NPL11/2X3SST	NPL11/2X31/2SST
2	CLNPL2SST	—	—	—	—	NPL2X31/2SST



4"	5"	6"	8"	10"	12"
NPL1/2X4SS	NPL1/2X5SS	NPL1/2X6SS	NPL1/2X8SS	NPL1/2X10SS	NPL1/2X12SS
NPL3/4X4SS	NPL3/4X5SS	NPL3/4X6SS	NPL3/4X8SS	NPL3/4X10SS	NPL3/4X12SS
NPL1X4SS	NPL1X5SS	NPL1X6SS	NPL1X8SS	NPL1X10SS	NPL1X12SS
NPL11/4X4SS	NPL11/4X5SS	NPL11/4X6SS	NPL11/4X8SS	NPL11/4X10SS	NPL11/4X12SS
NPL11/2X4SS	NPL11/2X5SS	NPL11/2X6SS	NPL11/2X8SS	NPL11/2X10SS	NPL11/2X12SS
NPL2X4SS	NPL2X5SS	NPL2X6SS	NPL2X8SS	NPL2X10SS	NPL2X12SS
—	NPL21/2X5SS	NPL21/2X6SS	NPL21/2X8SS	NPL21/2X10SS	NPL21/2X12SS
—	—	—	—	—	NPL3X12SS

4"	5"	6"	8"	10"	12"
NPL1/2X4SST	NPL1/2X5SST	NPL1/2X6SST	NPL1/2X8SST	NPL1/2X10SST	NPL1/2X12SST
NPL3/4X4SST	NPL3/4X5SST	NPL3/4X6SST	NPL3/4X8SST	NPL3/4X10SST	NPL3/4X12SST
NPL1X4SST	NPL1X5SST	NPL1X6SST	NPL1X8SST	NPL1X10SST	NPL1X12SST
NPL11/4X4SST	NPL11/4X5SST	NPL11/4X6SST	NPL11/4X8SST	NPL11/4X10SST	NPL11/4X12SST
NPL11/2X4SST	NPL11/2X5SST	NPL11/2X6SST	NPL11/2X8SST	NPL11/2X10SST	NPL11/2X12SST
NPL2X4SST	NPL2X5SST	NPL2X6SST	NPL2X8SST	NPL2X10SST	NPL2X12SST

Stainless steel conduit and fittings

Stainless steel elbows



Withstand corrosive environments and meet stringent sanitary requirements.

Standard radius elbows 90°

Cat. no.	Trade size (in.)	Radius "R"	Offset "C"	Straight end "D"	Weight (lbs./ea.)	Std. pkg. qty.
Type 304 stainless steel elbows						
ELL1/2SS	½	4	5.50	1.50	0.64	25
ELL3/4SS	¾	4.5	6.00	1.50	0.92	25
ELL1SS	1	5.75	7.63	1.88	1.69	20
ELL11/4SS	1¼	7.25	9.25	2.00	2.66	8
ELL11/2SS	1½	8.25	10.25	2.00	3.67	8
ELL2SS	2	9.5	11.50	2.00	5.31	6
Type 316 stainless steel elbows						
ELL1/2SST	½	4	5.50	1.50	0.64	25
ELL3/4SST	¾	4.5	6.00	1.50	0.92	25
ELL1SST	1	5.75	7.63	1.88	1.69	20
ELL11/4SST	1¼	7.25	9.25	2.00	2.66	8
ELL11/2SST	1½	8.25	10.25	2.00	3.67	8
ELL2SST	2	9.5	11.50	2.00	5.31	6

Diagram

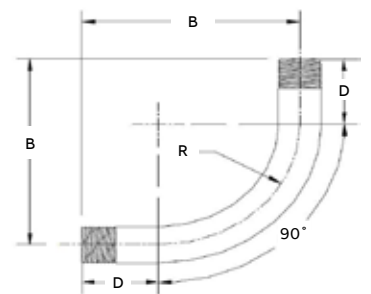

* Minimum

Stainless steel conduit and fittings

Stainless steel elbows



Withstand corrosive environments and meet stringent sanitary requirements.

Standard radius elbows 45°

Cat. no.	Trade size (in.)	Radius "R"	Straight end "D"	Weight (lbs./ea.)	Std. pkg. qty.
Type 304 stainless steel elbows					
ELL1/245SS	½	4	1.50	0.42	25
ELL3/445SS	¾	4.5	1.50	0.61	25
ELL145SS	1	5.75	1.88	1.11	20
ELL11/445SS	1¼	7.25	2.00	1.70	16
ELL11/245SS	1½	8.25	2.00	2.30	16
ELL245SS	2	9.5	2.00	3.10	9
Type 316 stainless steel elbows					
ELL1/245SST	½	4	1.50	0.42	25
ELL3/445SST	¾	4.5	1.50	0.61	25
ELL145SST	1	5.75	1.88	1.11	20
ELL11/445SST	1¼	7.25	2.00	1.70	16
ELL11/245SST	1½	8.25	2.00	2.30	16
ELL245SST	2	9.5	2.00	3.10	9

Diagram

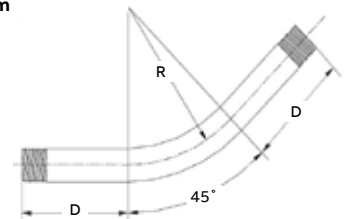

* Minimum

Straps, spacers and clamps

Conduit straps



1275 Series
1276AL Series

For rigid metal conduit and intermediate metal conduit.

Application

- To support and securely fasten rigid metal conduit and intermediate metal to the supporting surface

Features

- Rugged malleable iron/copper-free aluminum construction – snugly fits on the conduit
- Designed to prevent accumulation of moisture and start of corrosion on vertical run of conduit (A)
- Galvanized finish 1275 series
- Copper-free aluminum 1276AL series

Standard material

- 1275 Series: Malleable Iron
- 1276AL Series: All copper-free aluminum

Standard finish

- 1275 Series: electro-galvanized
- 1276AL Series: As cast galvanized

Range

- 1275 Series: 3/8" through 6" conduit
- 1276AL Series: 3/8" through 4" conduit

Listings/compliances

- CSA (LR-2884, LR-4484)
- CSA C22.2 No. 18
- NFPA 70

Diagram

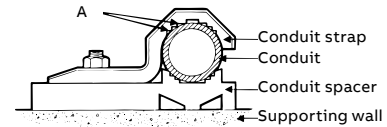

- Designed for snug fit on each size of conduit
- High reinforcing ribs on each side increase strength and reduce weight

- Available in malleable iron with electro-galvanized finish or in copper-free aluminum

Pipe straps – Malleable iron or aluminum



Diagram	Cat. no.		Conduit size (in.)	Dimensions (in.)			Screw size
	Mal. iron	Alum.		A	B	C	
	1275 [†]	1275AL	3/8	1 7/8	1 11/16	3/4	#12
	1276 [†]	1276AL [†]	1/2	2 5/32	2 11/32	1 1/32	1/4"
	1277 [†]	1277AL [†]	3/4	2 9/16	1 11/16	1 1/32	1/4"
	1278 [†]	1278AL [†]	1	3	3/4	1 17/32	1/4"
	1279 [†]	1279AL [†]	1 1/4	3 3/4	1 3/16	1 7/8	5/16"
	1280 [†]	1280AL	1 1/2	4 3/16	1 5/16	2 1/8	3/8"
	1281	1281AL	2	5 3/16	1 1/8	2 17/64	7/16"
	1282*	1282AL	2 1/2	5 15/16	1 1/2	2 3/4	1/2"
	1283*	1283AL	3	6 11/16	1 5/8	3 11/32	1/2"
	1284	1284AL	3 1/2	7 19/32	1 3/4	3 29/32	5/8"
	1285*	1285AL	4	8 5/16	1 7/8	4 13/32	5/8"
	1286	–	4 1/2	9 3/16	1 15/16	4 15/16	5/8"
	1287	–	5	9 15/16	2	5 15/32	5/8"
1288	–	6	11 1/2	2 7/16	6 17/32	5/8"	

*May be used with EMT of same size.

[†] Not snap-on type.

UL not applicable.

CSA File No. 2884

Straps, spacers and clamps

Conduit straps



- Elongated bolt hole makes alignment easy, even when mounting-surface holes are off center
- Snap-on design (except for 3/8" size)
- Rugged steel construction

Pipe straps – Steel



Diagram	Cat. no.	Conduit size (in.)	Dimensions (in.)			Screw size (in.)
			A	B	C	
	1210TB†	3/8	1 ¹⁵ / ₃₂	3/4	1 ¹¹ / ₁₆	1/4
	1211TB	1/2	2	3/4	1 ¹⁵ / ₁₆	1/4
	1212TB	3/4	2 ⁵ / ₁₆	3 ³ / ₄	1	1/4
	1213TB	1	3 ¹³ / ₁₆	3/4	1 ¹⁷ / ₆₄	1/4
	1214TB	1 1/4	2 ³¹ / ₃₂	1 ⁹ / ₁₆	1 ⁹ / ₁₆	3/8
	1215TB	1 1/2	3 ²³ / ₃₂	1 ¹³ / ₁₆	1 ¹³ / ₁₆	3/8
	1216TB	2	4 ⁷ / ₁₆	2 ⁵ / ₁₆	2 ⁵ / ₁₆	3/8

† Not snap-on type.
UL not applicable.
CSA File No. 2884

- PVC coating offers high corrosion resistance
- Designed to fit each size of conduit snugly
- High reinforcing ribs on each side increase strength and reduce weight
- Malleable iron construction

PVC-coated straps for rigid conduit

Diagram	Cat. no.	Conduit size (in.)	Bolt size (in.)	Dimensions (in.)		
				A	B	C
	1275CR	3/8	1/4	1 ⁷ / ₈	1 ¹¹ / ₁₆	3/4
	1276CR	1/2	1/4	2 ⁵ / ₃₂	2 ¹ / ₃₂	1 ¹ / ₃₂
	1277CR	3/4	1/4	2 ⁹ / ₁₆	1 ¹¹ / ₁₆	1 ⁷ / ₃₂
	1278CR	1	1/4	3	3/4	1 ¹⁷ / ₃₂
	1279CR	1 1/4	3/8	3 ³ / ₄	1 ¹³ / ₁₆	1 ⁷ / ₈
	1280CR	1 1/2	3/8	4 ³ / ₁₆	1 ¹⁵ / ₁₆	2 ¹ / ₈
	1281CR	2	1/2	5 ³ / ₁₆	1 ¹ / ₈	2 ¹⁷ / ₆₄

UL not applicable.

Straps, spacers and clamps

Stainless steel pipe straps



Support and securely fasten rigid, IMC and EMT conduit.

- Type 303 stainless steel
- Higher degree of corrosion resistance than traditional zinc-plated or hot-dipped galvanized straps
- One- and two-hole straps for EMT sizes ½" through 2"
- One- and two-hole straps for rigid and IMC sizes ½" through 4"

Type 304 stainless steel pipe straps

Cat. no.	Trade size (in.)	Wt. per 100	Hole dia. (in.)	Std. pkg.
One-hole EMT straps				
TS101-SS	½	2.21	¼	25
TS102-SS	¾	2.49	¼	25
TS103-SS	1	3.31	¼	25
TS104-SS	1¼	3.64	11/16	10
TS105-SS	1½	3.87	11/16	5
TS106-SS	2	4.03	11/16	5
One-hole rigid/IMC straps				
HS100-SS	¾	2.00	9/32	20
HS101-SS	½	2.21	9/32	20
HS102-SS	¾	2.49	9/32	20
HS103-SS	1	3.48	9/32	20
HS104-SS	1¼	3.76	11/32	10
HS105-SS	1½	18.22	13/32	10
HS106-SS	2	19.69	13/32	5
HS107-SS	2½	67.21	15/32	5
HS108-SS	3	76.45	17/32	5
HS110-SS	4	80.18	17/32	5

Cat. no.	Trade size (in.)	Wt. per 100	Hole dia. (in.)	Std. pkg.
Two-hole EMT straps				
TS901-SS	½	2.21	¼	25
TS902-SS	¾	3.31	¼	25
TS903-SS	1	3.87	¼	25
TS904-SS	1¼	7.54	11/16	10
TS905-SS	1½	12.21	11/16	5
TS906-SS	2	18.23	11/16	5
Two-hole rigid/IMC straps				
HS901-SS	½	2.49	9/32	20
HS902-SS	¾	3.64	9/32	20
HS903-SS	1	4.15	9/32	20
HS904-SS	1¼	8.17	11/32	10
HS905-SS	1½	17.50	13/32	10
HS906-SS	2	21.37	13/32	5
HS907-SS	2½	21.54	15/32	5
HS908-SS	3	25.72	17/32	5
HS909-SS	3½	27.27	17/32	5
HS910-SS	4	31.70	17/32	5

Straps, spacers and clamps

Type 316 stainless steel pipe straps



HS101SST



HS110SST



HS901SST



HS910SST

Coming soon

Type 316 stainless steel pipe straps

Cat. no.	Trade size (in.)	Hole dia. (in.)	Wt. per 100 (lbs.)
One-hole rigid/IMC stainless steel 316 straps			
HS101SST	½	0.25	4
HS102SST	¾	0.25	5
HS103SST	1	0.31	8
HS104SST	1¼	0.38	12
HS105SST	1½	0.44	15
HS106SST	2	0.56	24
HS107SST	2½	0.56	43
HS108SST	3	0.56	47
HS110SST	4	0.56	72

Cat. no.	Trade size (in.)	Hole dia. (in.)	Wt. per 100 (lbs.)
Two-hole rigid/IMC stainless steel 316 straps			
HS901SST	½	0.19	2
HS902SST	¾	0.19	3
HS903SST	1	0.25	4
HS904SST	1¼	0.25	6
HS905SST	1½	0.25	9
HS906SST	2	0.38	11
HS907SST	2½	0.38	16
HS908SST	3	0.38	20
HS910SST	4	0.44	29

Straps, spacers and clamps

Beam clamps and supports



- Adjustable design fits a wide range of flange sizes
- Includes bolts
- Steel construction

Adjustable beam clamps

Cat. no.	Description
700TB	Fits flange 2 $\frac{3}{4}$ "–7 $\frac{3}{8}$ "
701	Fits flange 7"–12"
703	Special bolt and (3) nuts

CSA File No. 2884.



- Fits any flange, tapered or straight, up to $\frac{5}{8}$ " thick
- For use with standard rigid conduit, EMT or IMC
- Broad hook holds conduit at any desired angle
- Malleable iron construction

Conduit supports



Cat. no.	Conduit size (in.)
690TB	$\frac{1}{2}$
691TB	$\frac{3}{4}$
692TB	1
693TB	1 $\frac{1}{4}$

CSA File No. 2884



Type 316 stainless steel beam clamps

Cat. no.	Base size (in.)		Jaw opening (in.)	Tapping of base and back holes	Set screw load rating [†]	Torque in inch-lbs.	Std. ctn.
	A	B					
500SS316	1	1 $\frac{1}{4}$	1 $\frac{5}{16}$	$\frac{1}{4}$ –20	250	60	50
502SS316	2	2	1	$\frac{3}{8}$ –16	750	120	50
503SS316	2 $\frac{5}{8}$	2 $\frac{1}{2}$	1	$\frac{1}{2}$ –13	1,250	250	20

Diagrams

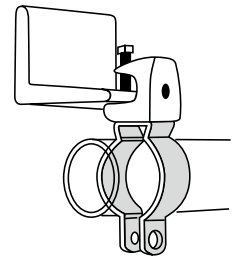
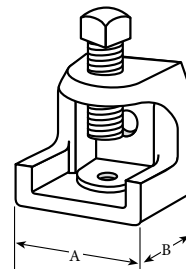

[†]Safety factor of 3.
Load ratings based on bottom hole of beam clamp.
CSA File No. LR-52208.

Straps, spacers and clamps

Beam clamps and supports



Coming soon

PC type — Parallel type 316 stainless steel clamp

Cat. no.	Trade size (in.)	Dimension A (in.)	Dimension B (in.)	Weight/100 (lbs.)
PC3/4SST	¾	2.88	2.53	58
PC1SST	1	3.1	2.53	60

Diagrams

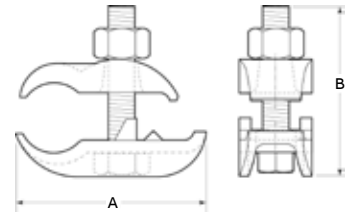

Coming soon

RC Type — Right angle type 316 stainless steel clamp

Cat. no.	Trade size (in.)	Dimension A (in.)			Weight/100 (lbs.)
		A	B	C	
RC1/2SST	½	1.94	1.63	0.19	34
RC3/4SST	¾	2.06	1.63	0.19	35
RC1SST	1	2.56	1.63	0.19	43
RC11/2SST	1½	2.81	1.63	0.19	51
RC11/4SST	1¾	3.31	1.63	0.19	61
RC2SST	2	3.81	1.63	0.19	96
RC21/2SST	2½	4.56	1.75	0.25	125
RC3SST	3	5.19	1.75	0.25	146
RC4SST	4	6.19	1.75	0.25	177

Diagrams

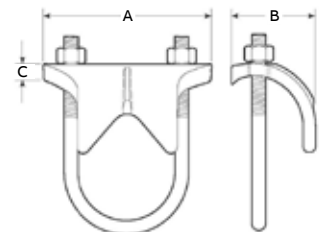

Straps, spacers and clamps

Conduit spacers

—
01 1350

—
02 1351-1354



—
01



—
02

Conduit spacers

For rigid metal conduit, intermediate metal conduit and electrical metallic tubing.

Application

- Provides mounting surface for conduit where installation requires air space between conduit and supporting surface

Features

- Prevents conduit rusting from wall condensation
- Spacers can be stacked one atop the other, facilitating installation and eliminating expensive conduit offsetting (A)
- Designed to cover wide range; marked with accurate size marking for proper positioning (B)
- Electro-zinc plated finish on 1350 Series
- Copper-free aluminum alloy, 1350AL Series

Standard material

- 1350 Series: Malleable iron
- 1350AL Series: Copper-free aluminum

Standard finish

- 1350 Series: Electro-zinc plated
- 1350AL Series: As cast

Range

- ½" through 6" conduit

Listings/compliances

- CSA (LR-2884, LR-4484, LR-4484)
- CSA C22.2 No. 18
- NFPA 70

Diagrams

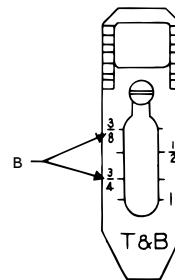
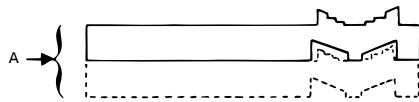

Straps, spacers and clamps

Conduit spacers

- Eliminates the need for costly offset-bending conduit and the possibility of corrosive moisture traps when conduit is mounted directly to a surface!
- Used with ABB conduit straps to provide space between conduit and mounting surface
- Premountable and stackable to eliminate offsetting
- Malleable iron construction with electro-zinc plated finish

Pipe spacers



Diagram	Cat. no.		Conduit size (in.)	Screw size	Dimensions (in.)	
	Mal. iron	Alum.			A	B
	1350	1350AL	1/2, 3/4, 1	#7	3	7/8
	1351	1351AL	1 1/4-1 1/2-2	#12	5	1 3/16
	1352	1352AL	2 1/2-3	#12	9 9/16	1 3/4
	1353	1353AL	3 1/2-4	#14	7 9/16	2
	1354	-	4 1/2-5-6	#16	10 9/16	2 9/16

Conforms to NEC* Sect. 300-5-c. UL not applicable. CSA File Nos. 2884 and 4484.

- Prevents conduit rusting from wall condensation
- Eliminates the need for offset-bending of conduit
- Can be stacked for offsets on wall or into outlet box
- Corrosion-resistant, PVC-coated malleable iron construction

Pipe spacers – PVC coated

Diagram	Cat. no.	Conduit size (in.)	Screw size	Dimensions (in.)	
				A	B
	1350CR	1/2-3/4-1	#7	3	7/8
	1351CR	1 1/4-1 1/2-2	#12	5	3/8

UL not applicable. Conforms to NEC Sect. 300-5-c.

Straps, spacers and clamps

Conduit spacers



- Material: Stainless steel 316

Coming soon

Stainless steel clamp back spacers

Diagrams	Cat. no.	Pipe/rigid conduit size (in.)	Use with cat. no.	Dimensions (in.)						
				A	B	C	D	E	F	G
	CB206-SST	2	HS106SST	3.83	1.40	2.08	2.03	1.19	0.25	0.51
	CB205-SST	1½	HS105SST	3.39	1.26	0.08	1.68	.095	0.25	0.52
	CB204-SST	1¼	HS104SST	3.06	1.14	0.08	1.46	0.83	0.25	0.50
	CB203-SST	1	HS103SST	2.68	1.13	0.08	1.21	0.66	0.25	0.52
	CB202-SST	¾	HS102SST	2.45	1.01	0.08	1.11	0.50	0.25	0.51
	CB201-SST	½	HS101SST	2.20	1.01	0.08	0.93	0.41	0.25	0.54

Conduit bodies and covers

Overview



Application

Conduit bodies are installed in conduit systems to:

- Connect conduit sections
- Act as pull outlets when conductors are being installed
- Provide easy access for splices in branch conductors
- Make 90° bends in conduit runs
- Provide access to conductors for maintenance and future system changes

Features

- Standard features include tapered (NPT) threads and integral bushings to protect wire insulation
- T&B Fittings form 7 bodies and covers are interchangeable with other manufacturers' form 7 bodies and covers
- T&B Fittings form 8 bodies and covers are interchangeable with other manufacturers' Form 8 bodies and covers
- T&B Fittings form 9 bodies and covers are interchangeable with other manufacturers' Form 9 bodies and covers (Mark 9, FM 9)
- T&B Fittings form 7 and form 8 cast iron bodies feature BlueKote® internal coating for easier wire pulling
- Form 9 aluminum sand-cast copper-free aluminum alloy
- T&B Fittings series 35 bodies and covers are interchangeable with other manufacturers' 35/5 series iron and steel bodies and covers
- Form 8 stainless steel conduit bodies are mirror polished with exceptionally smooth hygienic markings, making them easier and faster to clean
- Form 7 sand cast aluminum is made with a special aluminum alloy, providing superior corrosion resistance as cast; no protective coatings needed
- Special sand cast aluminum alloy makes these conduit bodies ideal for use in food and beverage, pharmaceutical, chemical processing and other corrosive environments
- All form 7 and form 8 covers include gaskets

Materials

- Form 7, form 8 and series 35 iron conduit bodies: Sand-cast class 30 gray iron alloy
- Form 9 aluminum: Sand-cast copper-free aluminum alloy
- Stainless steel conduit bodies: Type 316 stainless steel
- Form 7 aluminum: Sand-cast CorroStall™ aluminum alloy
- Covers: Sand-cast gray iron alloy and stamped sheet steel with steel-stainless steel screws
- Stainless steel covers: Stamped type 316 stainless steel with stainless steel screws
- Gaskets: Neoprene
- Aluminum covers: Sand-cast CorroStall aluminum alloy or sheet aluminum with stainless steel screws, aluminum clips and stainless steel and neoprene O-ring washer

Finish

- Form 7, form 8 and series 35 iron conduit bodies: Zinc-plating with aluminum acrylic coating
- Form 7 and form 8 iron bodies: Internal PTFE-based BlueKote coating
- Covers: Gray iron zinc-plating with aluminum acrylic coating, and stamped steel zinc-plating with clear chromate coating; form 7 and form 8 covers include neoprene gasket
- Form 9 aluminum covers: Stamped copper-free aluminum sheet with stainless steel screws
- Stainless steel bodies and covers: Polished
- Aluminum bodies and covers: As cast/natural

Listings/compliances





- UL Standard: 514A, 514B
- Fed. Spec: W-C-586D
- CSA Standard: C22.2 No. 18

Conduit bodies and covers

Quick reference

Conduit bodies quick reference



Shape	Type	Hub size (in.)										See page
		½	¾	1	1¼	1½	2	2½	3	3½	4	
	BlueKote® form 7	LB17	LB27	LB37	LB47	LB57	LB67	LB77	LB87	LB97	LB107	72
	BlueKote form 8*	LB18	LB28	LB38	LB448	LB58	LB68	LB78	LB888	LB98	LB108	77
	Series 35	LB50M	LB75M-TB	LB100M	LB125M	LB150M	LB200M	LB250M	LB300M	LB350M	LB400M	81
	Sand cast aluminum form 7	LB17SA	LB27SA	LB37SA	LB47SA	LB57SA	LB67SA	LB77SA	LB87SA	LB97SA	LB107SA	75
	Sand cast aluminum form 9	LB19SA	LB29SA	LB39SA	LB49SA	LB59SA	LB69SA	LB789SA	LB889SA	LB989SA	LB1089SA	79
	Stainless steel form 8**	LB18SST	LB28SST	LB38SST	LB48SST	LB58SST	LB68SST	LB78SST	LB888SST	-	LB108SST	69
	BlueKote form 7	LU17	LU27	LU37	LU47	LU57	LU67	-	-	-	-	72
	Sand cast aluminum form 7	LU17SA	LU27SA	LU37SA	LU47SA	LU57SA	LU67SA	-	-	-	-	76
	Sand cast aluminum form 9	LU19SA	LU29SA	LU39SA	LU49SA	LU59SA	LU69SA	-	-	-	-	80
	Stainless steel form 8**	LU18SST	LU28SST	LU38SST	LU48SST	LU58SST	LU68SST	-	-	-	-	69
	BlueKote form 7	T17	T27	T37	T47	T57	T67	T77	T87	T97	T107	72
	BlueKote form 8*	T18	T28	T38-TB	T448	T58	T68	T78	T88-TB	-	-	77
	Series 35	T50M	T75M	T100M	T125M	T150M	T200M	T250M	T300M	T350M	T400M	81
	Sand cast aluminum form 7	T17SA	T27SA	T37SA	T47SA	T57SA	T67SA	T77SA	T87SA	T97SA	T107SA	76
	Sand cast aluminum form 9	T19SA	T29SA	T39SA	T49SA	T59SA	T69SA	T789SA	T889SA	T989SA	T1089SA	80
	Stainless steel form 8**	T18SST	T28SST	T38SST	T48SST	T58SST	T68SST	T78SST	T888SST	-	T108SST	69
	BlueKote form 7	C17	C27	C37	C47	C57	C67	C77-TB	C87	-	-	72
	BlueKote form 8*	C18	C28	C38	C448	C58-TB	C68	C78	C88	-	-	77
	Series 35	C50M	C75M-TB	C100M	C125M	C150M	C200M	C250M-TB	C300M	C350M	C400M	82
	Sand cast aluminum form 7	C17SA	C27SA	C37SA	C47SA	C57SA	C67SA	-	-	-	-	75
	Sand cast aluminum form 9	C19SA	C29SA	C39SA	C49SA	C59SA	C69SA	C789SA	C889SA	C989SA	C1089SA	79
	Stainless steel form 8**	C18SST	C28SST	C38SST	C448SST	C58SST	C68SST	-	-	-	-	70
	BlueKote form 7	LL17	LL27	LL37	LL47	LL57	LL67	LL77	LL87	LL97	LL107	73
	BlueKote form 8*	LL18	LL28	LL38	LL448	LL58	LL68	LL78	LL888	-	-	78
	Series 35	LL50M	LL75M	LL100M	LL125M	LL150M	LL200M	LL250M	LL300M	LL350M	LL400M	81
	Sand cast aluminum form 7	LL17SA	LL27SA	LL37SA	LL47SA	LL57SA	LL67SA	-	-	-	-	75
	Sand cast aluminum form 9	LL19SA	LL29SA	LL39SA	LL49SA	LL59SA	LL69SA	LL789SA	LL889SA	LL989SA	LL1089SA	79
	Stainless steel form 8**	LL18SST	LL28SST	LL38SST	LL448SST	LL58SST	LL68SST	-	-	-	-	70

* ½" through 1¼" have (2) mounting holes; 1½" through 4" have (4) mounting holes







** With covers, gaskets and screws

Conduit bodies and covers

Quick reference

Conduit bodies quick reference (continued)



Shape	Type	Hub size (in.)										See page
		½	¾	1	1¼	1½	2	2½	3	3½	4	
	LR BlueKote form 7	LR17	LR27	LR37	LR47	LR57	LR67	LR77	LR87	LR97	LR107	73
	BlueKote form 8*	LR18	LR28	LR38	LR448	LR58	LR68	LR78	LR888	-	-	77
	Series 35	LR50M	LR75M	LR100M	LR125M	LR150M	LR200M	LR250M	LR300M	LR350M-TB	LR400M	81
	Sand cast aluminum form 7	LR17SA	LR27SA	LR37SA	LR47SA	LR57SA	LR67SA	-	-	-	-	75
	Sand cast aluminum form 9	LR19SA	LR29SA	LR39SA	LR49SA	LR59SA	LR69SA	LR789SA	LR889SA	LR989SA	LR1089SA	79
	Stainless steel form 8**	LR18SST	LR28SST	LR38SST	LR448SST	LR58SST	LR68SST	-	-	-	-	70
	L BlueKote form 7	L17-TB	L27-TB	L37-TB	L47-TB	L57-TB	L67-TB	-	-	-	-	73
	TB BlueKote form 7	TB17-TB	TB27	TB37	TB47	TB57	TB67	-	-	-	-	74
	BlueKote form 8*	TB18	TB28	TB38	TB448	TB58	TB68	-	-	-	-	78
	Series 35	TB50M	TB75M	TB100M	TB125M	TB150M	TB200M	-	-	-	-	82
	Sand cast aluminum form 7	TB17SA	TB27SA	TB37SA	TB47SA	TB57SA	TB67SA	-	-	-	-	76
	Sand cast aluminum form 9	TB19SA	TB29SA	TB39SA	TB49SA	TB59SA	TB69SA	-	-	-	-	80
	Stainless steel form 8**	TB18SST	TB28SST	TB38SST	TB448SST	TB58SST	TB68SST	-	-	-	-	69
	X BlueKote form 7	X17	X27	X37	X47	X57	X67	-	-	-	-	74
	BlueKote form 8*	X18	X28	X38	X448	X58	X68	-	-	-	-	78
	Series 35	X50M	X75M	X100M	X125M	X150M	X200M	-	-	-	-	82
	Sand cast aluminum form 7	X17SA	X27SA	X37SA	X47SA	X57SA	X67SA	-	-	-	-	76
	Sand cast aluminum form 9	X19SA	X29SA	X39SA	-	-	-	-	-	-	-	80
	Stainless steel form 8**	X18SST	X28SST	X38SST	X448SST	X58SST	X68SST	-	-	-	-	70
	E BlueKote form 7	E17	E27	E37	-	-	-	-	-	-	-	74
	TA BlueKote form 7	TA17	TA27	TA37	TA47	TA57	TA67	-	-	-	-	73

* ½" through 1¼" have (2) mounting holes; 1½" through 4" have (4) mounting holes

** With covers, gaskets and screws

Conduit bodies and covers

Covers and gaskets

Replacement covers and gaskets

	Shape	Hub size (in.)									
		½	¾	1	1¼	1½	2	2½	3	3½	4
 Stamped	Form 7 steel*	170S	270S	370S	470S	570S	670S	870S	870S	970S	970S
	Form 8 steel*	180	280	380	480	580	680STB	880	880	980	980
	Form 7 aluminum*	170SA	270SA	370SA	470SA	570SA	670SA	870SA	870SA	970SA	970SA
	Form 9 aluminum	190SA**	290SA**	390SA**	490SA**	590SA**	690SA**	889SA	889SA	989SA	989SA
	Series 35	K50S	K75S	K100S	K125S	K125S	K200S	K250S	K250S	K350S	K350S
	Form 8 stainless Steel	180SST	280SST	380SST	480SST	580SST	680SST	-	-	-	-

* Form 7 and Form 8 covers include gasket.

** For Form 9 aluminum cover including gasket, replace suffix SA with GSA (Example : 190GSA)

	Shape	Hub size (in.)									
		½	¾	1	1¼	1½	2	2½	3	3½	4
 Sand cast	Form 7 iron*	170F	270F	370F	470F	570F	670F	870F	870F	970F	970F
	Form 8 iron*	180F	280F	380F	480F	580F	680F	880F	880F	980F	980F
	Form 7 aluminum*	170FSA	270FSA	370FSA	470FSA	570FSA	670FSA	870FSA	870FSA	970FSA	970FSA
	Series 35	K50M	K75M	K100M	K125M	K125M	K200M	K250M	K250M	K350M	K350M

* Form 7 and Form 8 covers include gasket.

	Shape	Hub size (in.)									
		½	¾	1	1¼	1½	2	2½	3	3½	4
 Gasket	Form 7*	GASK571	GASK572	GASK573	GASK574	GASK575	GASK576	GASK578	GASK578	GASK579	GASK579
	Form 8*	GASK581N	GASK582N	GASK583N	GASK584N	GASK585N	GASK586N	GASK588N	GASK588N	GASK589N	GASK589N
	Form 9*	GASK1941	GASK1942	GASK1943	GASK1944	GASK1945	GASK1946	GASK808N	GASK808N	GASK809N	GASK809N
	Series 35	GK50N	GK75N	GK100N	GK125-150N	GK125-150N	GK200N	GK250-300N	GK250-300N	GK350-400N	GK350-400N

* For ordering purposes, please use GASK in the catalog number (Example: GASK 571).

Conduit bodies and covers

Type 316 stainless steel form 8 – Now with smooth hygienic markings

Each conduit outlet body ships complete with gasket, cover and screws.



LU Form 8 conduit bodies with covers



Cat. no.	Hub size (in.)	Dimensions (in.)							Cu. in.
		A	B	C	D	E	F		
LU18SST	1/2	6.210	1.450	3.825	1.125	4.320	3.700	5.5	
LU28SST	3/4	6.981	1.645	4.245	1.500	4.921	4.300	8.5	
LU38SST	1	8.261	1.850	5.050	1.700	5.625	5.000	14.5	
LU48SST	1 1/4	9.923	2.200	5.975	2.200	6.730	5.810	26.5	
LU58SST	1 1/2	11.549	2.813	7.000	2.450	7.938	7.125	45.0	
LU68SST	2	13.989	3.820	8.500	2.900	9.797	9.125	116.5	

Diagrams

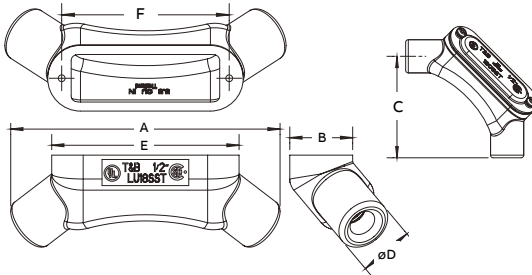

T Form 8 conduit bodies with covers



Cat. no.	Hub size (in.)	Dimensions (in.)							Cu. in.
		A	B	C	D	E	F		
T18SST	1/2	5.820	1.450	2.200	1.150	4.320	3.700	5.5	
T28SST	3/4	6.420	1.645	2.395	1.400	4.921	4.300	9.0	
T38SST	1	7.500	1.850	2.850	1.750	5.625	5.000	13.5	
T48SST	1 1/4	8.738	2.200	2.950	2.200	6.730	5.810	24.0	
T58SST	1 1/2	10.046	2.813	3.867	2.450	7.938	7.125	45.0	
T68SST	2	12.204	3.820	5.070	2.900	9.797	9.125	88.0	
T78SST	2.5	15.659	4.575	6.561	4.250	10.875	-	220	
T888SST	3	15.817	4.575	6.640	4.250	10.875	-	220	
T108SST	4	18.473	5.535	8.037	5.513	13.462	-	420	

Diagrams

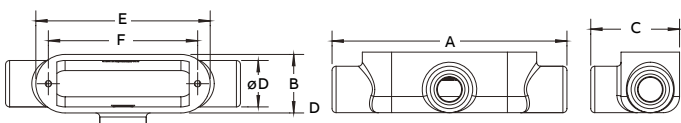

LB Form 8 conduit bodies with covers



Cat. no.	Hub size (in.)	Dimensions (in.)							Cu. in.
		A	B	C	D	E	F		
LB18SST	1/2	5.070	1.450	2.250	1.150	4.320	3.700	5.8	
LB28SST	3/4	5.671	1.645	2.530	1.400	4.921	4.300	8.0	
LB38SST	1	6.563	1.850	2.913	1.750	5.625	5.000	13.0	
LB48SST	1 1/4	7.734	2.200	3.315	2.200	6.730	5.810	23.0	
LB58SST	1 1/2	8.992	2.813	3.800	2.450	7.938	7.125	44.0	
LB68SST	2	11.000	3.820	4.810	2.900	9.797	9.125	88.0	
LB78SST	2 1/2	14.098	6.136	5.000	4.250	10.875	-	220	
LB888SST	3	14.177	6.215	5.000	4.250	10.875	-	220	
LB108SST	4	16.749	7.259	6.313	5.513	13.462	-	420	

Diagrams



TB Form 8 conduit bodies with covers



Cat. no.	Hub size (in.)	Dimensions (in.)							Cu. in.
		A	B	C	D	E	F		
TB18SST	1/2	5.820	1.450	2.250	1.150	4.320	3.700	5.5	
TB28SST	3/4	6.420	1.645	2.530	1.400	4.921	4.300	9.0	
TB38SST	1	7.500	1.850	2.975	1.750	5.625	5.000	13.5	
TB48SST	1 1/4	8.484	2.200	3.319	2.200	6.730	5.810	24.0	
TB58SST	1 1/2	10.046	2.813	3.854	2.450	7.938	7.125	45.0	
TB68SST	2	12.129	3.820	4.810	2.900	9.797	9.125	88.0	

Diagrams

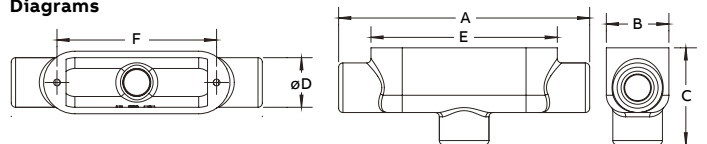

Conduit bodies and covers

Type 316 stainless steel form 8



Coming soon

C Form 8 stainless steel conduit bodies with covers



Cat. no.	Hub size (in.)	Dimensions (in.)						Cu. in.
		A	B	C	D	E		
C18SST	½	5.936	1.5	1.452	1.152	3.28	5.8	
C28SST	¾	6.601	1.780	1.645	1.345	3.925	8.0	
C38SST	1	7.643	1.975	1.850	1.550	4.550	13.0	
C448SST	1¼	8.788	2.315	2.200	1.900	5.290	23.5	
C58SST	1½	9.996	2.800	2.813	2.101	6.500	44.0	
C68SST	2	11.887	3.560	3.820	2.980	8.500	88.0	

Diagrams

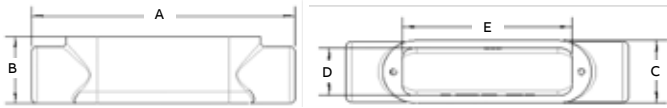

Coming soon

LR Form 8 stainless steel conduit bodies with covers



Cat. no.	Hub size (in.)	Dimensions (in.)						Cu. in.
		A	B	C	D	E		
LR18SST	½	5.137	1.500	2.273	1.152	3.280	5.8	
LR28SST	¾	5.761	1.780	2.4855	1.345	3.925	8.0	
LR38SST	1	6.634	1.975	2.859	1.550	4.550	13.0	
LR448SST	1¼	7.759	2.315	3.229	1.900	5.290	23.5	
LR58SST	1½	8.967	2.800	3.842	2.100	6.500	44.0	
LR68SST	2	10.638	3.560	4.865	2.980	8.500	88.0	

Diagrams

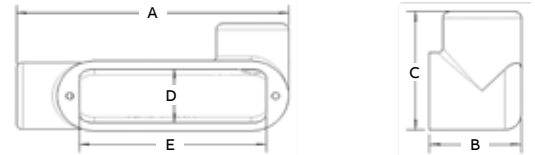

Coming soon

LL Form 8 stainless steel conduit bodies with covers



Cat. no.	Hub size (in.)	Dimensions (in.)						Cu. in.
		A	B	C	D	E		
LL18SST	½	5.087	1.500	2.273	1.152	3.280	5.8	
LL28SST	¾	5.704	1.780	2.4855	1.345	3.925	8.0	
LL38SST	1	6.634	1.975	2.859	1.550	4.550	13.0	
LL448SST	1¼	7.759	2.315	3.229	1.900	5.290	23.5	
LL58SST	1½	8.967	2.800	3.8425	2.100	6.500	44.0	
LL68SST	2	10.843	3.560	4.865	2.980	8.500	88.0	

Diagrams

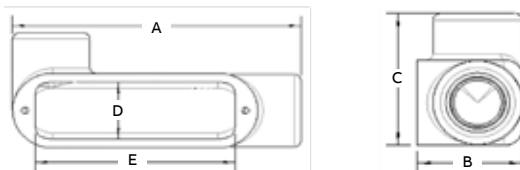

Coming soon

X Form 8 stainless steel conduit bodies with covers



Cat. no.	Hub size (in.)	Dimensions (in.)						Cu. in.
		A	B	C	D	E		
X18SST	½	5.958	1.775	3.094	1.152	3.280	5.5	
X28SST	¾	6.775	2.000	3.455	1.345	3.925	9.0	
X38SST	1	7.643	2.275	3.868	1.500	4.550	13.5	
X448SST	1¼	8.788	2.315	4.258	1.900	5.290	24.0	
X58SST	1½	9.996	2.800	4.871	2.100	6.719	45.0	
X68SST	2	11.887	3.560	5.910	2.980	8.500	88.0	

Diagrams

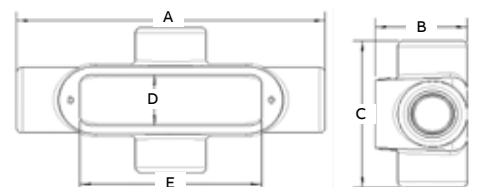

Conduit bodies and covers

Pre-assembled form 7 BlueKote®

Pre-assembled form 7 BlueKote conduit bodies

Form 7 body, gasket and cover – one number. Now you can order a conduit body, gasket and cover, pre-assembled, using one catalog number. ABB's pre-assembled cast conduit bodies help reduce transactions, eliminate the need for additional stocking bins and provide an easy inventory reduction. You'll also have less hassle with managing small parts in the truck or crib. Best of all, you can be absolutely confident that the right parts are in your hands when you need them.

T&B® Fittings conduit bodies and covers feature:

- BlueKote internal finish for faster, easier wire pulling
- Epoxy external finish for superior corrosion resistance
- Tapered NPT threads and integral bushings to protect wire insulation
- Bodies are designed with a flat back for more cubic inch capacity; the flat back also keeps the body more stable during installation, requiring fewer conduit straps
- T&B Fittings form 7 bodies and covers are interchangeable with Crouse-Hinds and Appleton's form 7 bodies and covers

Specifications

- Bodies: Class 30 gray iron alloy
- Covers: Stamped steel with stainless steel screws
- Gaskets: Neoprene
- Finish: Conduit bodies: zinc-plating with acrylic epoxy coating and internal
- PTFE-based BlueKote coating
- Covers: Stamped steel zinc-plating with a clear chromate coating
- Compliances: UL Standard: 514A, 514B Fed. Spec: W-C-586D
- CSA Standard: C22.2 No. 18

Crouse-Hinds is a trademark of Cooper Industries, Inc. Appleton is a trademark of the EGS Electrical Group, a joint venture of Emerson and SPX Corp.

Note: BlueKote is registered for conduit bodies but is not registered for a finish or a coating.

T&B Fittings pre-assembled conduit bodies, gaskets and covers



Cat. no.	Trade size (in.)	Pre-assembled products
C17CG-TB	1/2	C17 body, cover and gasket
C27CG-TB	3/4	C27 body, cover and gasket
C37CG-TB	1	C37 body, cover and gasket
C47CG-TB	1 1/4	C47 body, cover and gasket
C57CG-TB	1 1/2	C57 body, cover and gasket
C67CG-TB	2	C67 body, cover and gasket
LB17CG-TB	1/2	LB17 body, cover and gasket
LB27CG-TB	3/4	LB27 body, cover and gasket
LB37CG-TB	1	LB37 body, cover and gasket
LB47CG-TB	1 1/4	LB47 body, cover and gasket
LB57CG-TB	1 1/2	LB57 body, cover and gasket
LB67CG-TB	2	LB67 body, cover and gasket
LL17CG-TB	1/2	LL17 body, cover and gasket
LL27CG-TB	3/4	LL27 body, cover and gasket
LL37CG-TB	1	LL37 body, cover and gasket
LL47CG-TB	1 1/4	LL47 body, cover and gasket
LL57CG-TB	1 1/2	LL57 body, cover and gasket
LL67CG-TB	2	LL67 body, cover and gasket
LR17CG-TB	1/2	LR17 body, cover and gasket
LR27CG-TB	3/4	LR27 body, cover and gasket
LR37CG-TB	1	LR37 body, cover and gasket
LR47CG-TB	1 1/4	LR47 body, cover and gasket
LR57CG-TB	1 1/2	LR57 body, cover and gasket
LR67CG-TB	2	LR67 body, cover and gasket
T17CG-TB	1/2	T17 body, cover and gasket
T27CG-TB	3/4	T27 body, cover and gasket
T37CG-TB	1	T37 body, cover and gasket
T47CG-TB	1 1/4	T47 body, cover and gasket
T57CG-TB	1 1/2	T57 body, cover and gasket
T67CG-TB	2	T67 body, cover and gasket
TB17CG-TB	1/2	TB17 body, cover and gasket
TB27CG-TB	3/4	TB27 body, cover and gasket
TB37CG-TB	1	TB37 body, cover and gasket
TB47CG-TB	1 1/4	TB47 body, cover and gasket
TB57CG-TB	1 1/2	TB57 body, cover and gasket
TB67CG-TB	2	TB67 body, cover and gasket
X17CG-TB	1/2	X17 body, cover and gasket
X27CG-TB	3/4	X27 body, cover and gasket
X37CG-TB	1	X37 body, cover and gasket
X47CG-TB	1 1/4	X47 body, cover and gasket
X57CG-TB	1 1/2	X57 body, cover and gasket
X67CG-TB	2	X67 body, cover and gasket

For aluminum conduit bodies pre-assembled with covers and gaskets, request Red•Dot® D-PAK® series conduit bodies for rigid and IMC conduit.



Conduit bodies and covers

BlueKote® form 7



BlueKote internal finish reduces the amount of force necessary to pull wires through T&B Form 7 and Form 8 conduit bodies.

LB Form 7 BlueKote conduit bodies



Cat. no.	Hub size (in.)	Dimensions (in.)						Cu. in.
		A	B	C	D	E		
LB17	1/2	4.60	2.20	1.35	.95	3.20	4.0	
LB27	3/4	5.25	2.40	1.65	1.15	3.80	6.6	
LB37	1	6.00	2.65	1.80	1.35	4.55	10.6	
LB47	1 1/4	6.45	3.20	2.20	1.80	5.00	18.8	
LB57	1 1/2	7.25	3.90	2.45	2.05	5.45	26.4	
LB67	2	8.30	4.45	3.10	2.45	6.40	51.0	
LB77	2 1/2	10.55	5.20	4.25	3.60	8.40	102.0	
LB87	3	10.55	5.95	4.25	3.60	8.40	132.0	
LB97	3 1/2	12.85	6.70	5.25	4.55	10.25	210.0	
LB107	4	12.85	7.20	5.25	4.55	10.25	243.0	

Diagrams

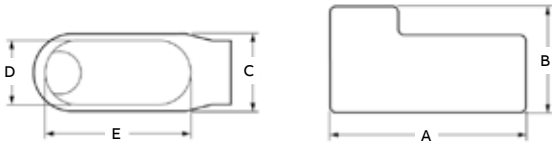

LU Form 7 BlueKote conduit bodies



Cat. no.	Hub size (in.)	Dimensions (in.)						Cu. in.
		A	B	C	D	E		
LU17	1/2	5.54	1.45	2.72	.95	3.20	4.8	
LU27	3/4	6.22	1.70	3.07	1.15	3.80	7.6	
LU37	1	7.34	1.97	3.52	1.35	4.55	13.4	
LU47	1 1/4	8.40	2.47	4.21	1.80	5.00	23.0	
LU57	1 1/2	8.95	2.72	4.44	2.05	5.45	28.3	
LU67	2	10.61	3.43	5.43	2.45	6.40	56.0	

Diagrams

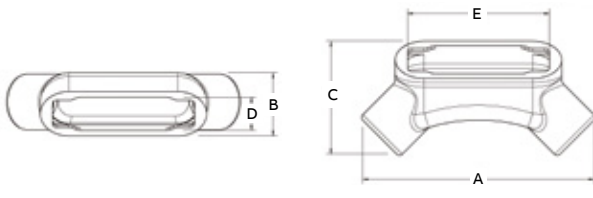

T Form 7 BlueKote conduit bodies



Cat. no.	Hub size (in.)	Dimensions (in.)						Cu. in.
		A	B	C	D	E		
T17	1/2	5.60	1.80	2.35	.95	3.20	6.0	
T27	3/4	6.20	2.00	2.60	1.15	3.80	9.1	
T37	1	7.35	2.30	3.10	1.35	4.55	16.9	
T47	1 1/4	7.30	2.30	3.05	1.80	5.00	19.3	
T57	1 1/2	8.60	2.60	3.80	2.05	5.45	27.5	
T67	2	9.50	3.20	4.25	2.45	6.40	50.0	
T77	2 1/2	12.10	3.65	5.80	3.60	8.40	102.0	
T87	3	12.10	4.40	5.80	3.60	8.40	132.0	
T97	3 1/2	14.65	4.90	7.05	4.55	10.25	210.0	
T107	4	14.65	5.40	7.05	4.55	10.25	243.0	

Diagrams

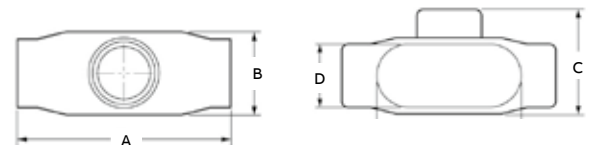

C Form 7 BlueKote conduit bodies



Cat. no.	Hub size (in.)	Dimensions (in.)						Cu. in.
		A	B	C	D	E		
C17	1/2	5.45	1.40	1.45	.95	3.20	4.0	
C27	3/4	6.05	1.60	1.65	1.15	3.80	6.6	
C37	1	6.75	1.90	1.80	1.35	4.55	10.6	
C47	1 1/4	7.30	2.30	2.20	1.80	5.00	18.8	
C57	1 1/2	8.60	2.60	2.45	2.05	5.45	26.4	
C67	2	9.50	3.20	3.05	2.45	6.40	51.0	
C77-TB	2 1/2	12.10	3.65	4.25	3.60	8.40	102.0	
C87	3	12.10	4.40	4.25	3.60	8.40	132.0	

Diagrams

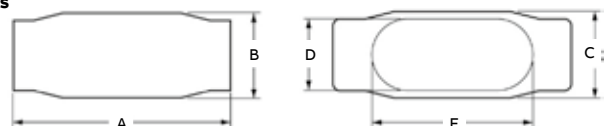

Conduit bodies and covers

BlueKote® form 7



LL Form 7 BlueKote conduit bodies



Cat. no.	Hub size (in.)	Dimensions (in.)						Cu. in.
		A	B	C	D	E		
LL17	1/2	4.60	1.40	1.45	.95	3.20	4.0	
LL27	3/4	5.25	1.60	1.65	1.15	3.80	6.6	
LL37	1	6.00	1.90	2.60	1.35	4.55	10.6	
LL47	1 1/4	6.45	2.30	3.05	1.80	5.00	18.6	
LL57	1 1/2	7.90	2.60	3.80	2.05	5.45	26.4	
LL67	2	8.30	3.20	4.25	2.45	6.40	51.0	
LL77	2 1/2	10.55	3.65	5.80	3.60	8.40	102.0	
LL87	3	10.55	4.40	5.80	3.60	8.40	132.0	
LL97	3 1/2	12.85	4.90	7.03	4.55	10.25	210.0	
LL107	4	12.85	5.40	7.03	4.55	10.25	243.0	

Diagrams

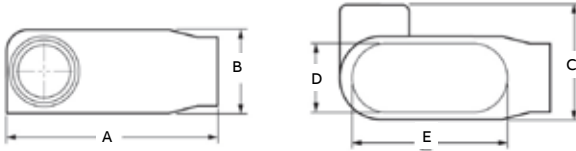

LR Form 7 BlueKote conduit bodies



Cat. no.	Hub size (in.)	Dimensions (in.)						Cu. in.
		A	B	C	D	E		
LR17	1/2	4.60	1.40	1.45	.95	3.20	4.0	
LR27	3/4	5.25	1.60	1.65	1.15	3.80	6.6	
LR37	1	6.00	1.90	2.60	1.35	4.55	10.6	
LR47	1 1/4	6.45	2.30	3.05	1.80	5.00	18.8	
LR57	1 1/2	7.90	2.60	3.80	2.05	5.45	26.4	
LR67	2	8.30	3.20	4.25	2.45	6.40	51.0	
LR77	2 1/2	10.55	3.65	5.80	3.60	8.40	102.0	
LR87	3	10.55	4.40	5.80	3.60	8.40	132.0	
LR97	3 1/2	12.85	4.90	7.03	4.55	10.25	210.0	
LR107	4	12.85	5.40	7.03	4.55	10.25	243.0	

Diagrams

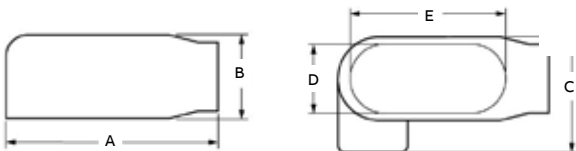

L Form 7 BlueKote conduit bodies



Cat. no.	Hub size (in.)	Dimensions (in.)					
		A	B	C	D	E	
L17-TB	1/2	4.60	1.40	1.45	.95	3.20	
L27-TB	3/4	5.25	1.60	1.65	1.15	3.80	
L37-TB	1	6.00	1.90	2.60	1.35	4.55	
L47-TB	1 1/4	6.45	2.30	3.05	1.80	5.00	
L57-TB	1 1/2	7.90	2.60	3.80	2.05	5.45	
L67-TB	2	8.30	3.20	4.25	2.45	6.40	

Diagrams

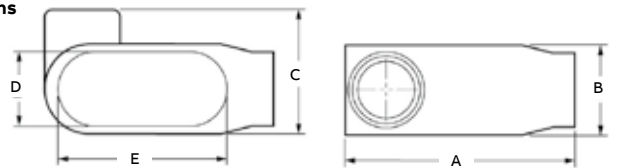

TA Form 7 BlueKote conduit bodies



Cat. no.	Hub size (in.)	Dimensions (in.)						
		A	B	C	D	E	F	G
TA17	1/2	5.57	1.80	2.57	1.62	2.34	3.19	.94
TA27	3/4	6.19	2.00	2.79	1.80	2.58	3.82	1.13
TA37	1	7.35	2.23	3.07	2.29	3.10	4.55	1.35
TA47	1 1/4	7.30	2.32	3.18	2.20	3.06	5.03	1.80
TA57	1 1/2	8.57	2.58	3.89	2.45	3.77	5.44	2.05
TA67	2	9.48	3.20	4.43	3.06	4.26	6.41	2.44

Diagrams

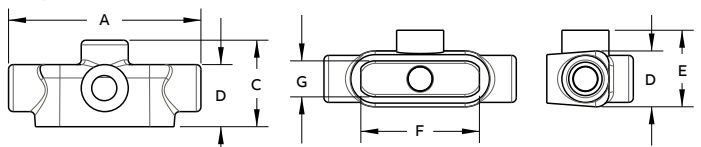

Conduit bodies and covers

BlueKote® form 7



TB Form 7 BlueKote conduit bodies



Cat. no.	Hub size (in.)	Dimensions (in.)					
		A	B	C	D	E	F
TB17-TB	½	5.57	1.77	2.57	1.62	3.19	.94
TB27	¾	6.19	2.00	2.79	1.80	3.82	1.13
TB37	1	7.35	2.28	3.07	2.29	4.63	1.35
TB47	1¼	7.30	2.32	3.18	2.20	5.03	1.80
TB57	1½	8.57	2.58	3.89	2.45	5.44	2.05
TB67	2	9.48	3.20	4.43	3.06	6.41	2.44

Diagrams

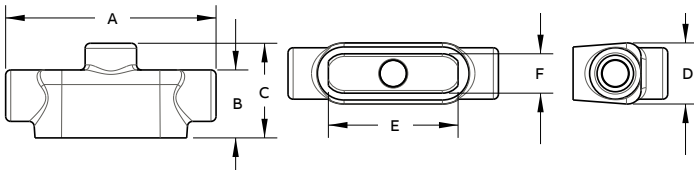

X Form 7 BlueKote conduit bodies



Cat. no.	Hub size (in.)	Dimensions (in.)					
		A	B	C	D	E	Cu. in.
X17	½	5.60	1.80	3.05	.95	3.20	6.0
X27	¾	6.20	2.00	3.30	1.15	3.80	9.1
X37	1	7.35	2.30	3.80	1.35	4.55	16.9
X47	1¼	7.30	2.30	3.85	1.80	5.00	19.3
X57	1½	8.60	2.60	5.05	2.05	5.45	27.5
X67	2	9.50	3.20	5.45	2.45	6.40	52.8

Diagrams

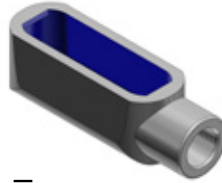
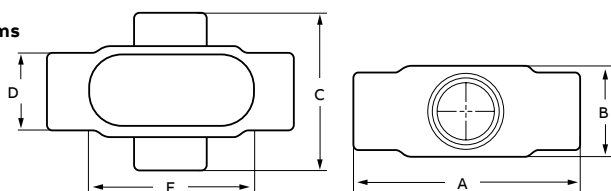

E Form 7 BlueKote conduit bodies



Cat. no.	Hub size (in.)	Dimensions (in.)						Cu. in.
		A	B	C	D	E		
E17	½	4.60	1.40	1.45	.95	3.20	6.0	
E27	¾	5.25	1.60	1.65	1.15	3.80	9.1	
E37	1	6.00	1.90	1.80	1.35	4.55	16.9	

Diagrams

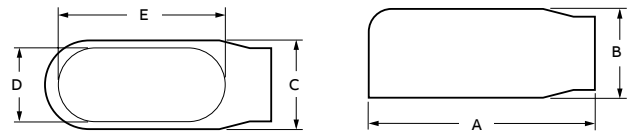

Conduit bodies and covers

Sand cast aluminum form 7



LB Sand cast aluminum form 7 conduit bodies



Cat. no.	Hub size (in.)	Dimensions (in.)					Cu. in.
		A	B	C	D	E	
LB17SA	1/2	4.63	2.19	1.41	1.03	3.19	4.2
LB27SA	3/4	5.25	2.47	1.59	1.22	3.81	6.8
LB37SA	1	6.22	2.88	1.75	1.38	4.56	11.0
LB47SA	1 1/4	6.59	3.34	2.19	1.81	5.03	19.5
LB57SA	1 1/2	6.97	3.59	2.44	2.06	5.44	25.6
LB67SA	2	8.13	4.25	3.06	2.44	6.41	51.2
LB77SA	2 1/2	10.56	5.19	4.25	3.63	8.38	100.4
LB87SA	3	10.66	6.03	4.25	3.63	8.38	126.2
LB97SA	3 1/2	11.06	6.69	5.25	4.44	10.25	219.0
LB107SA	4	12.81	7.72	5.25	4.44	10.25	247.1

Diagrams

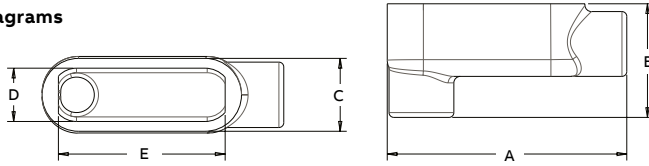

LR Sand cast aluminum form 7 conduit bodies



Cat. no.	Hub size (in.)	Dimensions (in.)					Cu. in.
		A	B	C	D	E	
LR17SA	1/2	4.38	1.41	2.25	1.03	3.19	4.5
LR27SA	3/4	5.31	1.63	2.44	1.19	3.81	7.5
LR37SA	1	6.22	1.88	2.78	1.38	4.56	11.2
LR47SA	1 1/4	6.63	2.31	3.22	1.81	5.03	20.3
LR57SA	1 1/2	6.97	2.56	3.47	2.06	5.44	27.8
LR67SA	2	8.13	3.19	4.13	2.44	6.25	54.0

Diagrams

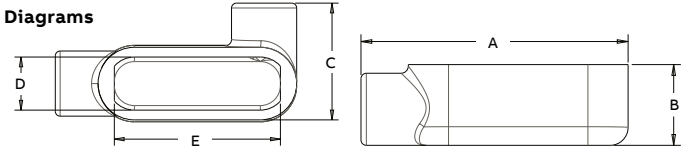

LL Sand cast aluminum form 7 conduit bodies



Cat. no.	Hub size (in.)	Dimensions (in.)					Cu. in.
		A	B	C	D	E	
LL17SA	1/2	4.38	1.41	2.25	1.03	3.19	4.5
LL27SA	3/4	5.31	1.63	2.44	1.19	3.81	7.2
LL37SA	1	6.22	1.88	2.78	1.38	4.56	11.5
LL47SA	1 1/4	6.63	2.31	3.22	1.81	5.03	20.0
LL57SA	1 1/2	6.97	2.56	3.47	2.06	5.44	28.0
LL67SA	2	8.13	3.19	4.13	2.44	6.25	54.2

Diagrams

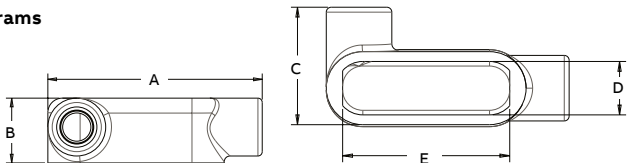

C Sand cast aluminum form 7 conduit bodies



Cat. no.	Hub size (in.)	Dimensions (in.)					Cu. in.
		A	B	C	D	E	
C17SA	1/2	5.44	1.41	1.41	1.00	3.19	4.8
C27SA	3/4	6.16	1.63	1.59	1.22	3.81	7.5
C37SA	1	7.22	1.88	1.75	1.38	4.56	11.8
C47SA	1 1/4	7.63	2.31	2.19	1.91	5.03	19.8
C57SA	1 1/2	8.00	2.56	2.44	2.06	5.44	27.8
C67SA	2	9.16	3.22	3.06	2.44	6.25	53.2

Diagrams

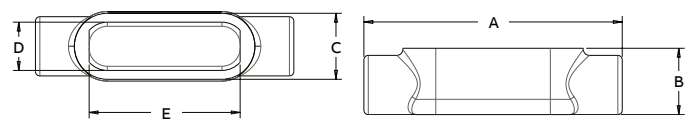

Conduit bodies and covers

Sand cast aluminum form 7



LU® Sand cast aluminum form 7 conduit bodies



Cat. no.	Hub size (in.)	Dimensions (in.)						Cu. in.
		A	B	C	D	E	F	
LU17SA	1/2	5.53	1.50	2.88	1.03	3.19	3.31	5.1
LU27SA	3/4	6.28	1.72	3.22	1.22	3.81	3.75	8.7
LU37SA	1	7.34	1.97	3.78	1.38	4.56	4.41	13.4
LU47SA	1 1/4	8.38	2.47	4.34	1.81	5.03	4.91	23.8
LU57SA	1 1/2	8.97	2.72	4.53	2.06	5.44	5.19	29.6
LU67SA	2	10.78	3.44	5.41	2.44	6.25	6.25	59.4

Diagrams

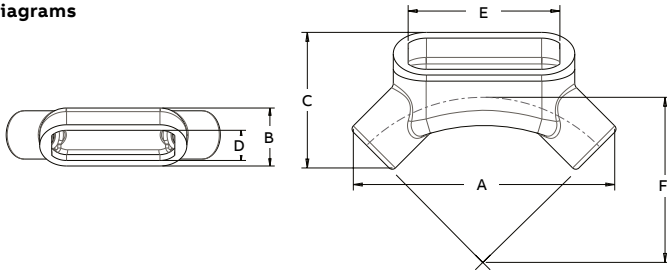

T Sand cast aluminum form 7 conduit bodies



Cat. no.	Hub size (in.)	Dimensions (in.)						Cu. in.
		A	B	C	D	E		
T17SA	1/2	5.44	1.78	2.28	1.03	3.19	5.5	
T27SA	3/4	6.16	2.00	2.59	1.22	3.81	9.1	
T37SA	1	7.22	2.28	3.22	1.38	4.56	15.5	
T47SA	1 1/4	7.63	2.31	3.22	1.81	5.03	20.1	
T57SA	1 1/2	8.00	2.56	3.47	2.06	5.44	27.1	
T67SA	2	9.16	3.19	4.09	2.44	6.41	51.0	
T77SA	2 1/2	12.13	3.63	5.81	3.63	8.38	104.6	
T87SA	3	12.28	4.41	5.91	3.63	8.38	135.2	
T97SA	3 1/2	14.44	4.91	6.94	4.44	10.25	230.0	
T107SA	4	14.50	5.41	6.97	4.44	10.25	260.3	

Diagrams

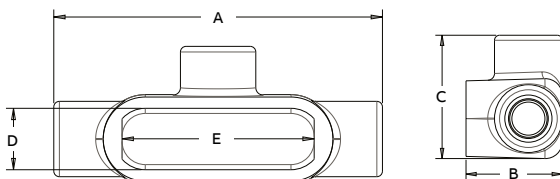

TB Sand cast aluminum form 7 conduit bodies



Cat. no.	Hub size (in.)	Dimensions (in.)						Cu. in.
		A	B	C	D	E		
TB17SA	1/2	5.44	2.59	1.50	1.03	3.19	5.6	
TB27SA	3/4	6.16	2.84	1.66	1.19	3.81	9.0	
TB37SA	1	7.22	3.28	1.78	1.38	4.56	13.1	
TB47SA	1 1/4	7.63	3.34	2.19	1.81	5.03	19.3	
TB57SA	1 1/2	8.00	3.59	2.44	2.06	5.44	25.0	
TB67SA	2	9.16	4.25	3.06	2.44	6.41	51.6	

Diagrams

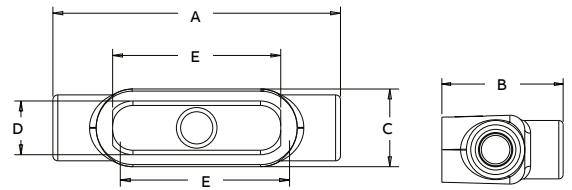

X Sand cast aluminum form 7 conduit bodies



Cat. no.	Hub size (in.)	Dimensions (in.)						Cu. in.
		A	B	C	D	E		
X17SA	1/2	5.44	3.06	1.78	1.03	3.19	5.8	
X27SA	3/4	6.16	3.44	2.00	1.22	3.81	10.3	
X37SA	1	7.22	4.22	2.28	1.38	4.56	16.4	
X47SA	1 1/4	7.63	4.25	2.31	1.81	5.03	21.3	
X57SA	1 1/2	8.00	4.50	2.56	2.06	5.44	28.6	
X67SA	2	9.16	5.16	3.19	2.44	6.41	53.5	

Diagrams

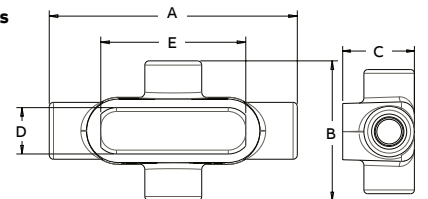

Conduit bodies and covers

BlueKote® form 8

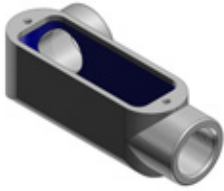

BlueKote internal finish reduces the amount of force necessary to pull wires through T&B Form 7 and Form 8 conduit bodies.

LB Form 8 BlueKote conduit bodies



Cat. no.	Hub size (in.)	Dimensions (in.)						Cu. in.
		A	B	C	D	E		
LB18	1/2	4.94	2.22	1.38	1.00	3.31	4.9	
LB28	3/4	5.56	2.44	1.56	1.19	3.31	8.0	
LB38	1	6.50	2.81	1.75	1.38	4.56	13.0	
LB448	1 1/4	7.53	3.34	2.19	1.75	5.31	23.5	
LB58	1 1/2	9.13	4.03	2.75	2.13	6.50	45.0	
LB68	2	11.00	4.41	3.75	3.00	8.56	88.0	
LB78	2 1/2	13.94	6.13	5.00	4.25	10.88	110.0	
LB888	3	13.94	6.50	5.00	4.25	10.88	110.0	
LB98	3 1/2	16.88	7.56	6.25	5.44	13.44	250.0	
LB108	4	16.88	7.81	6.25	5.44	13.44	250.0	

Diagrams

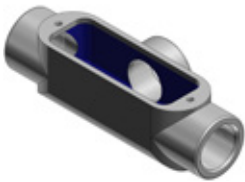
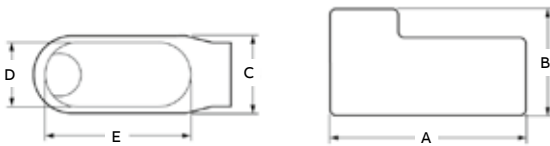

T Form 8 BlueKote conduit bodies



Cat. no.	Hub size (in.)	Dimensions (in.)						Cu. in.
		A	B	C	D	E		
T18	1/2	5.69	7.75	2.16	1.00	3.31	6.0	
T28	3/4	6.28	2.00	2.31	1.19	3.94	9.0	
T38-TB	1	7.31	2.25	2.63	1.38	4.56	15.0	
T448	1 1/4	8.50	2.63	3.16	1.75	5.31	24.0	
T58	1 1/2	10.38	2.78	4.00	2.13	6.50	46.5	
T68	2	12.25	3.56	5.00	3.00	8.56	88.0	
T78	2 1/2	15.63	4.44	6.69	4.25	10.88	110.0	
T88-TB	3	15.63	4.81	6.69	4.25	10.88	110.0	

Diagrams

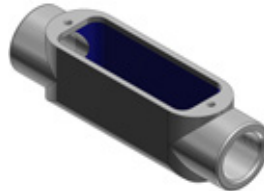
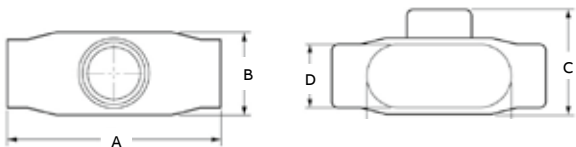

C Form 8 BlueKote conduit bodies



Cat. no.	Hub size (in.)	Dimensions (in.)						Cu. in.
		A	B	C	D	E		
C18	1/2	5.53	1.44	1.38	1.00	3.31	4.9	
C28	3/4	6.28	1.53	1.19	1.19	3.94	8.0	
C38	1	7.31	1.94	1.75	1.38	4.56	13.0	
C448	1 1/4	8.50	2.38	2.19	1.75	5.31	23.5	
C58-TB	1 1/2	10.38	2.78	2.75	2.13	6.50	45.0	
C68	2	12.25	3.56	3.75	3.00	8.56	88.0	
C78	2 1/2	15.63	4.44	5.00	4.25	10.88	110.0	
C88	3	15.63	4.81	5.00	4.25	10.88	110.0	

Diagrams

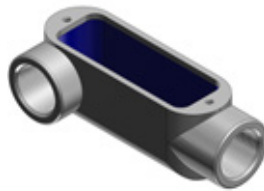
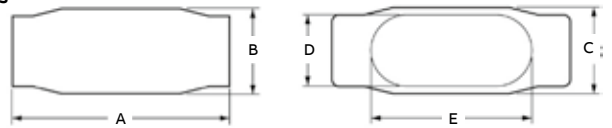

LR Form 8 BlueKote conduit bodies



Cat. no.	Hub size (in.)	Dimensions (in.)						Cu. in.
		A	B	C	D	E		
LR18	1/2	4.94	1.44	2.16	1.00	3.31	4.4	
LR28	3/4	5.56	1.69	2.31	1.19	3.94	8.0	
LR38	1	6.47	1.94	2.63	1.38	4.56	13.0	
LR448	1 1/4	7.53	2.38	3.16	1.75	5.31	23.6	
LR58	1 1/2	9.13	2.78	4.00	2.13	6.50	45.0	
LR68	2	11.00	3.56	5.00	3.00	8.56	88.0	
LR78	2 1/2	13.94	4.44	6.69	4.25	10.88	110.0	
LR888	3	13.94	4.81	6.69	4.25	10.88	110.0	

Diagrams

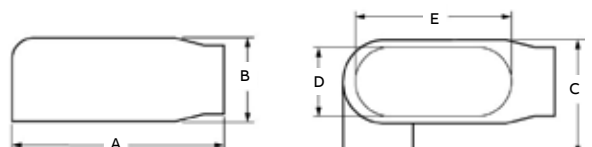

Conduit bodies and covers

BlueKote® form 8



LL Form 8 BlueKote conduit bodies



Cat. no.	Hub size (in.)	Dimensions (in.)						Cu. in.
		A	B	C	D	E		
LL18	½	4.94	1.44	2.13	1.00	3.31	4.9	
LL28	¾	5.56	1.69	2.31	1.19	3.94	8.0	
LL38	1	6.47	1.94	2.63	1.38	4.56	13.0	
LL448	1¼	7.53	2.38	3.16	1.75	5.31	23.5	
LL58	1½	9.13	2.78	4.00	2.13	6.50	45.0	
LL68	2	11.00	3.56	5.00	3.00	8.56	88.0	
LL78	2½	13.94	4.44	6.69	4.25	10.88	110.0	
LL888	3	13.94	4.81	6.69	4.25	10.88	110.0	

Diagrams

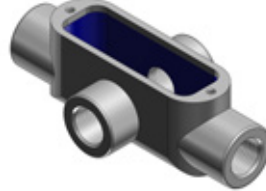
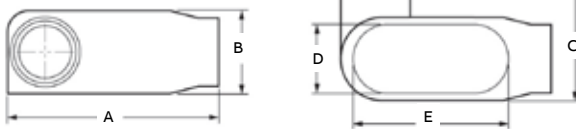

X Form 8 BlueKote conduit bodies



Cat. no.	Hub size (in.)	Dimensions (in.)						Cu. in.
		A	B	C	D	E		
X18	½	5.69	1.75	2.91	1.00	3.31	6.0	
X28	¾	6.28	2.00	3.06	1.38	3.94	9.0	
X38	1	7.31	2.25	3.50	1.38	4.56	15.0	
X448	1¼	8.50	2.63	4.13	1.75	5.31	24.0	
X58	1½	10.38	2.47	5.25	2.13	6.50	46.5	
X68	2	12.25	3.56	6.25	3.00	8.56	88.0	

Diagrams

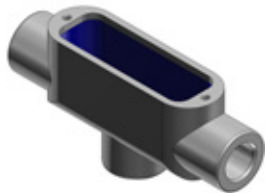
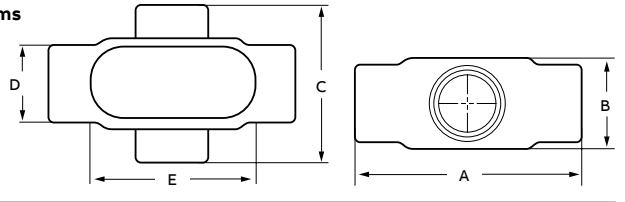

TB Form 8 BlueKote conduit bodies



Cat. no.	Hub size (in.)	Dimensions (in.)						Cu. in.
		A	B	C	D	E		
TB18	½	5.69	2.63	1.38	1.00	3.31	6.0	
TB28	¾	6.28	2.88	1.19	1.19	3.94	9.0	
TB38	1	7.31	3.25	1.75	1.38	4.56	15.0	
TB448	1¼	8.50	3.31	2.19	1.75	5.31	24.0	
TB58	1½	10.38	3.69	2.75	2.13	6.50	46.5	
TB68	2	12.25	4.25	3.75	3.00	8.56	88.0	

Diagrams

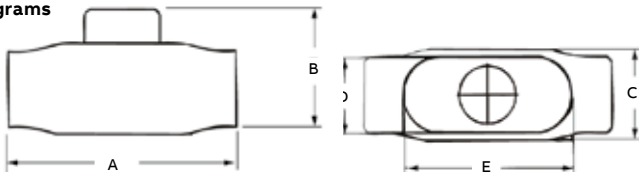

Conduit bodies and covers

Sand cast aluminum form 9



C Sand cast aluminum form 9 conduit bodies



Cat. no.	Hub size (in.)	Dimensions (in.)						Cu. in.
		A	B	C	D	E		
C19SA	½"	5.858	1.5	1.392	1.018	3.307	4.5	
C29SA	¾"	6.48	1.78	1.56	1.186	3.898	7.5	
C39SA	1"	7.578	1.975	1.756	1.382	4.559	11.5	
C49SA	1¼"	8.593	2.315	2.2	1.826	5.197	22.3	
C59SA	1½"	9.238	2.8	2.5	1.788	5.892	34	
C69SA	2"	11.578	3.56	3.189	2.349	8.11	80.0	
C789SA	2½"	15.522	4.575	5.04	4.29	10.827	212	
C889SA	3"	15.68	4.575	5.04	4.29	10.827	216	
C989SA	3½"	18.452	5.535	6.338	5.538	13.438	408	
C1089SA	4"	18.498	5.535	6.339	5.538	13.438	440	

Diagrams

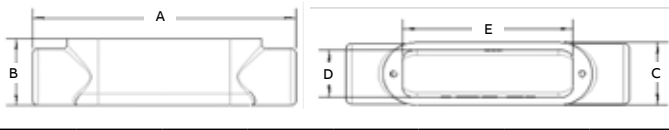

LB Sand cast aluminum form 9 conduit bodies



Cat. no.	Hub size (in.)	Dimensions (in.)						Cu. in.
		A	B	C	D	E		
LB19SA	½"	5.034	2.231	1.392	1.018	3.307	4.5	
LB29SA	¾"	5.64	2.62	1.56	1.186	3.898	7.5	
LB39SA	1"	6.569	2.984	1.756	1.382	4.55	11.5	
LB49SA	1¼"	7.767	3.344	2.2	1.826	5.197	22.3	
LB59SA	1½"	8.209	3.829	2.5	2.1	5.906	34	
LB69SA	2"	10.533	4.605	3.228	2.388	7.941	80.0	
LB789SA	2½"	13.961	6.011	5.04	4.29	10.827	212	
LB889SA	3"	14.04	6.215	5.04	4.29	10.827	216	
LB989SA	3½"	16.751	7.236	6.339	5.576	13.437	408	
LB1089SA	4"	16.774	7.259	6.339	5.573	13.438	440	

Diagrams

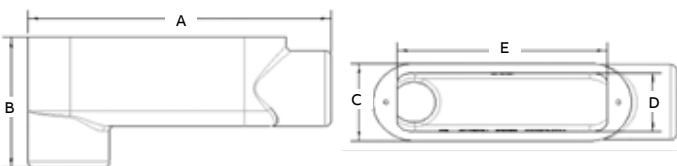

LL Sand cast aluminum form 9 conduit bodies



Cat. no.	Hub size (in.)	Dimensions (in.)						Cu. in.
		A	B	C	D	E		
LL19SA	½"	5.034	1.5	2.213	1.018	3.28	4.5	
LL29SA	¾"	5.64	1.78	2.4	1.186	3.898	7.5	
LL39SA	1"	6.569	1.975	2.765	1.382	4.55	11.5	
LL49SA	1¼"	7.564	2.315	3.229	1.826	5.197	22.3	
LL59SA	1½"	8.591	2.8	3.529	2.126	5.906	34	
LL69SA	2"	10.714	3.56	4.234	2.349	8.11	80.0	
LL789SA	2½"	13.961	4.575	6.601	4.29	10.827	212	
LL889SA	3"	14.04	4.575	6.68	4.29	10.827	216	
LL989SA	3½"	16.563	5.535	8.04	5.577	13.437	408	
LL1089SA	4"	16.774	5.535	8.063	5.577	13.438	440	

Diagrams

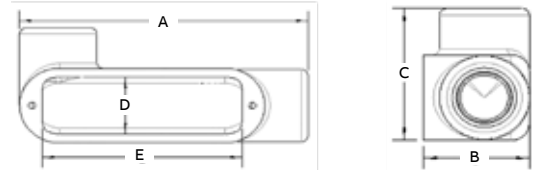

LR Sand cast aluminum form 9 conduit bodies



Cat. no.	Hub size (in.)	Dimensions (in.)						Cu. in.
		A	B	C	D	E		
LR19SA	½"	5.034	1.5	2.213	1.018	3.28	4.5	
LR29SA	¾"	5.64	1.78	2.4	1.186	3.898	7.5	
LR39SA	1"	6.569	1.975	2.765	1.382	4.55	11.5	
LR49SA	1¼"	7.564	2.315	3.229	1.826	5.197	22.3	
LR59SA	1½"	8.591	2.8	3.529	2.126	5.906	34	
LR69SA	2"	10.714	3.56	4.234	2.349	8.11	80.0	
LR789SA	2½"	13.961	4.575	6.601	4.29	10.827	212	
LR889SA	3"	14.04	4.575	6.68	4.29	10.827	216	
LR989SA	3½"	16.563	5.535	8.04	5.577	13.437	408	
LR1089SA	4"	16.774	5.535	8.063	5.577	13.438	440	

Diagrams

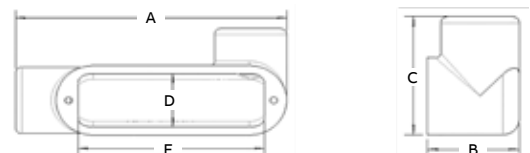

Conduit bodies and covers

Form 9 sand cast aluminum



LU Sand cast aluminum form 9 conduit bodies



Cat. no.	Hub size (in.)	Dimensions (in.)						Cu. in.
		A	B	C	D	E	Radius	
LU19SA	½	6.21	2.701	1.5	1.018	3.28	4.415	5.3
LU29SA	¾	6.97	3.047	1.698	1.186	3.898	4.92	8.0
LU39SA	1	8.276	3.651	2.02	1.445	4.559	6.143	14.0
LU49SA	1¼	9.902	4.266	2.362	1.826	5.29	7.666	30.8
LU59SA	1½	10.256	5.127	2.609	2.126	5.906	8.214	41.0
LU69SA	2	13.968	6.153	3.421	2.815	7.941	8.5	97.0

Diagrams

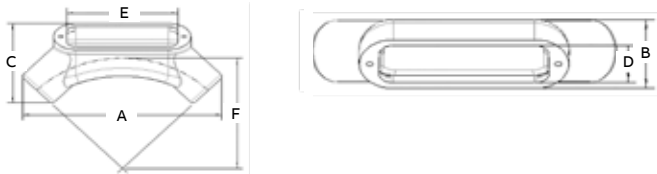

T Sand cast aluminum form 9 conduit bodies



Cat. no.	Hub size (in.)	Dimensions (in.)						Cu. in.
		A	B	C	D	E		
T19SA	½	5.958	1.775	2.393	1.078	3.307	6.3	
T29SA	¾	6.455	2	2.591	1.185	3.925	9.3	
T39SA	1	7.578	2.275	2.765	1.382	4.559	14.0	
T49SA	1¼	8.593	2.315	3.229	1.826	5.197	22.0	
T59SA	1½	9.243	2.8	3.529	2.126	5.906	34.8	
T69SA	2	11.578	3.56	4.234	2.815	8.11	80.5	
T789SA	2½	15.522	4.575	6.601	4.25	10.827	175	
T889SA	3	15.68	4.575	6.68	4.25	10.827	236	
T989SA	3½	18.452	5.535	8.04	5.539	13.437	435	
T1089SA	4	18.498	5.535	8.063	5.539	13.438	450	

Diagrams

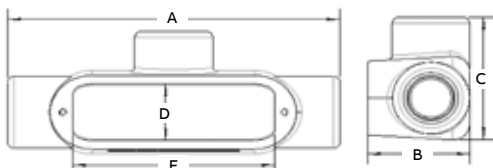

TB Sand cast aluminum form 9 conduit bodies



Cat. no.	Hub size (in.)	Dimensions (in.)						Cu. in.
		A	B	C	D	E		
TB19SA	½	5.958	2.596	1.556	1.018	3.307	6.3	
TB29SA	¾	6.6	2.84	1.715	1.186	3.898	9.3	
TB39SA	1	7.644	3.284	1.756	1.382	4.559	14.0	
TB49SA	1¼	8.788	3.344	2.2	1.826	5.197	22.0	
TB59SA	1½	9.996	3.604	2.5	1.784	5.883	34.8	
TB69SA	2	11.578	4.605	3.189	2.815	8.11	80.5	

Diagrams

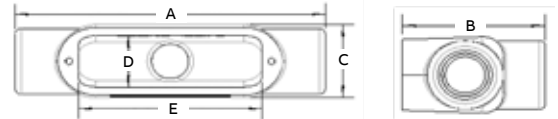

X Sand cast aluminum form 9 conduit bodies



Cat. no.	Hub size (in.)	Dimensions (in.)						Cu. in.
		A	B	C	D	E		
X19SA	½	5.958	1.775	3.094	1.018	3.28	6.3	
X29SA	¾	6.61	2	3.37	1.186	3.898	9.3	
X39SA	1	7.578	2.275	3.774	1.382	4.559	14.0	

Diagrams

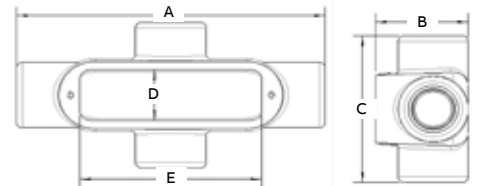

Conduit bodies and covers

Series 35



LB Series 35 conduit bodies



Cat. no.	Hub size (in.)	Dimensions (in.)			Cu. in.
		A	B	C	
LB50M	1/2	4.68	1.34	2.05	4.5
LB75M-TB	3/4	5.37	1.50	2.25	7.5
LB100M	1	6.20	1.80	2.65	12.5
LB125M	1 1/4	8.12	2.60	2.75	32
LB150M	1 1/2	8.12	2.60	2.83	35.3
LB200M	2	10.50	3.12	4.42	73
LB250M	2 1/2	13.60	4.31	5.40	142
LB300M	3	13.87	4.31	5.90	173
LB350M	3 1/2	16.25	5.62	6.90	292
LB400M	4	16.60	5.62	7.21	324

Diagrams

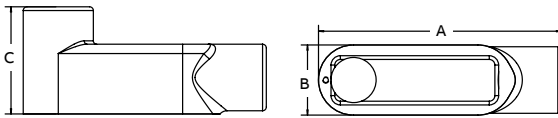

LL Series 35 conduit bodies



Cat. no.	Hub size (in.)	Dimensions (in.)			Cu. in.
		A	B	C	
LL50M	1/2	4.68	2.05	1.37	4.5
LL75M	3/4	5.37	2.25	1.70	7.5
LL100M	1	6.20	2.65	1.90	12.5
LL125M	1 1/4	8.12	2.75	2.75	32
LL150M	1 1/2	8.12	3.50	2.83	33
LL200M	2	10.50	4.12	3.31	68
LL250M	2 1/2	13.60	5.71	3.90	142
LL300M	3	13.87	5.87	4.75	173
LL350M	3 1/2	16.50	7.13	6.81	292
LL400M	4	16.50	7.13	7.19	324

Diagrams

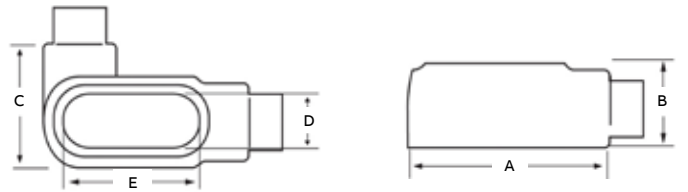

T Series 35 conduit bodies



Cat. no.	Hub size (in.)	Dimensions (in.)			Cu. in.
		A	B	C	
T50M	1/2	5.38	2.05	1.34	6.0
T75M	3/4	6.00	2.25	1.50	9.5
T100M	1	7.05	2.65	1.80	15
T125M	1 1/4	9.00	2.75	2.60	33
T150M	1 1/2	9.00	3.50	2.60	36
T200M	2	11.50	4.12	3.12	76
T250M	2 1/2	15.00	5.71	4.31	142
T300M	3	15.12	5.87	4.31	173
T350M	3 1/2	18.13	6.81	5.19	292
T400M	4	18.13	7.15	5.56	324

Diagrams

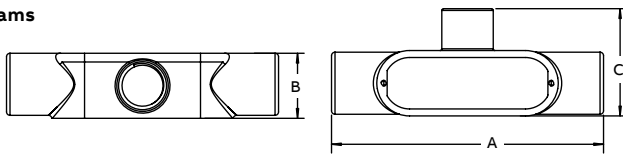

LR Series 35 conduit bodies



Cat. no.	Hub size (in.)	Dimensions (in.)			Cu. in.
		A	B	C	
LR50M	1/2	4.68	2.05	1.37	4.5
LR75M	3/4	5.37	2.25	1.70	7.5
LR100M	1	6.20	2.65	1.90	12.5
LR125M	1 1/4	8.12	2.75	2.75	32
LR150M	1 1/2	8.12	3.50	2.83	35.3
LR200M	2	10.50	4.12	3.31	68
LR250M	2 1/2	13.60	5.71	3.90	142
LR300M	3	13.87	5.87	4.75	173
LR350M-TB	3 1/2	16.25	6.10	5.62	292
LR400M	4	16.25	6.95	5.62	324

Diagrams

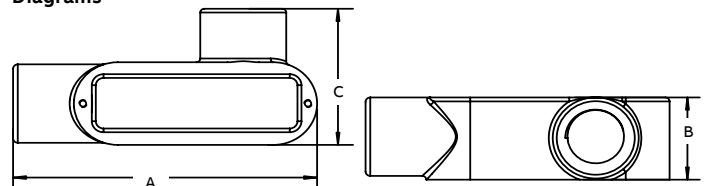

Conduit bodies and covers

Series 35



C Series 35 conduit bodies



Cat. no.	Hub size (in.)	Dimensions (in.)			Cu. in.
		A	B	C	
C50M	1/2	5.38	1.34	1.37	4.5
C75M-TB	3/4	6.00	1.50	1.70	7.5
C100M	1	7.05	1.80	1.90	12.5
C125M	1 1/4	9.00	2.60	2.75	35
C150M	1 1/2	9.00	2.60	2.83	35.3
C200M	2	11.50	3.12	3.31	75
C250M-TB	2 1/2	15.00	4.31	3.90	153
C300M	3	15.12	4.31	4.75	181
C350M	3 1/2	18.13	4.88	5.19	290
C400M	4	18.13	4.88	5.56	320

Diagrams

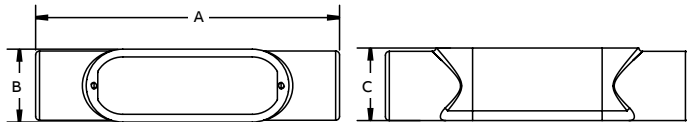

X Series 35 conduit bodies



Cat. no.	Hub size (in.)	Dimensions (in.)			Cu. in.
		A	B	C	
X50M	1/2	5.41	2.79	1.75	36.0
X75M	3/4	6.08	2.93	1.97	76.0
X100M	1	7.1	3.56	2.25	6.0
X125M	1 1/4	9.1	4.43	2.55	9.5
X150M	1 1/2	9.1	4.43	2.75	15.0
X200M	2	11.75	5.4	3.45	33.0

Diagrams

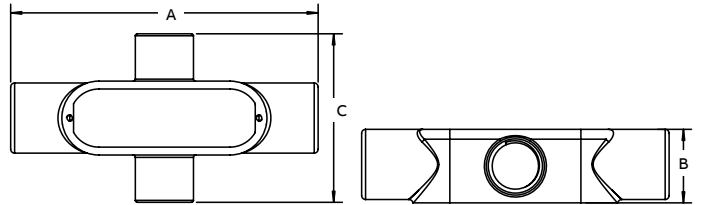

TB Series 35 conduit bodies



Cat. no.	Hub size (in.)	Dimensions (in.)			Cu. in.
		A	B	C	
TB50M	1/2	5.38	1.34	2.05	6
TB75M	3/4	6.00	1.50	2.25	9.5
TB100M	1	7.05	1.80	2.65	15
TB125M	1 1/4	9.00	2.60	2.75	33
TB150M	1 1/2	9.00	2.60	2.83	36
TB200M	2	11.50	3.12	4.42	76

Diagrams

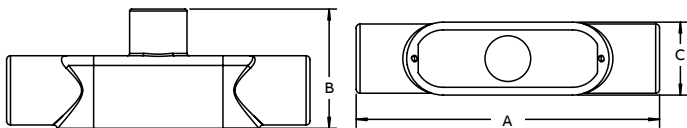

Conduit bodies and covers

Mogul conduit outlet bodies

Application

- Act as pull outlets for conductors that are stiff, due to large size or type of insulation
- Provide the longer openings needed when pulling large conductors
- Prevent sharp bends and kinks in large conductors (protects insulation during installation)
- Provide ample openings for splices and taps
- Provide access to wiring for maintenance and future system changes

Features

- Long openings
- Provision for easy bends
- Tapered tapped hubs with integral bushings
- Stainless steel cover screws
- Covers and gaskets included

Standard materials

- Class 30 gray iron alloy

Standard finishes

- Electrogalvanized and aluminum acrylic paint

Listings/compliances

- UL Standard: 514B
- Fed. Spec.: W-C-586D
- CSA Standard: C22.2 No.18
- UL listed for wet locations

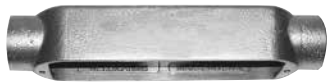

BC mogul series (cover and gasket included)

Note: See NEC® 370-28 (a) (1) and (2) for pull length and bending space requirements applicable to BC, BLB and BUB series moguls.



Diagrams	Cat. no.	Hub size (in.)	Dimensions (in.)					Cu. in.
			A	B	C	D	E	
<p>BC</p>	BC3-TB	1	9.56	1.88	2.25	7.84	6	20.0
	BC4-TB	1¼	9.56	2.31	2.25	7.84	6	25.0
	BC5-TB	1½	13.75	2.56	3	11.45	10	60.0
	BC6-TB	2	13.75	3.31	3	11.45	10	78.0
	BC7-TB	2½	18.38	3.63	4.25	15.61	15	180.0
	BC8-TB	3	18.38	4.38	4.25	15.82	15	225.0
	BC10-TB	4	23.75	5.38	5.25	20.50	20	460.0



BLB mogul series (cover and gasket included)



Diagrams	Cat. no.	Hub size (in.)	Dimensions (in.)					Cu. in.
			A	B	C	D	E	
<p>BLB</p>	BLB3-TB	1	8.66	2.80	2.25	6.92	6	20.0
	BLB4-TB	1¼	8.66	2.70	2.25	6.70	6	25.0
	BLB5-TB	1½	12.58	2.56	3	10.36	10	62.0
	BLB6-TB	2	12.58	4.16	3	10.13	10	78.0
	BLB7-TB	2½	16.94	5.10	4.25	13.89	15	170.0
	BLB8-TB	3	16.94	5.81	4.25	13.59	15	210.0
	BLB9-TB	3½	22.16	6.50	5.25	18.32	20	410.0
	BLB10-TB	4	22.16	7.00	5.25	18.06	20	460.0

Conduit bodies and covers

Mogul conduit outlet bodies



BUB mogul series (cover and gasket included)



Cat. no.	Hub size (in.)	Dimensions (in.)					Cu. in.
		A	B	C	D	E	
Diagrams							
BUB3-TB	1	9.49	2.75	2.25	7.01	6	20.0
BUB4-TB	1¼	9.55	3.21	2.25	6.71	6	25.0
BUB5-TB	1½	16.68	6.67	3	10.47	10	62.0
BUB6-TB	2	13.68	4.28	3	10.20	10	78.0
BUB7-TB	2½	18.30	5.03	4.25	13.97	15	170.0
BUB8-TB	3	18.30	5.67	4.25	13.50	15	210.0
BUB9-TB	3½	23.74	6.72	5.25	18.07	20	385.0
BUB10-TB	4	23.74	7.22	5.25	17.73	20	430.0

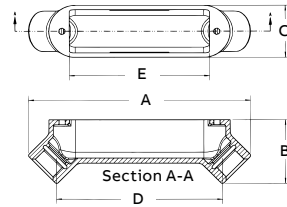

BUB



BT mogul series (cover and gasket included)



Cat. no.	Hub size (in.)	Dimensions (in.)					Cu. in.
		A	B	C	D	E	
Diagrams							
BT3-TB	1	9.56	1.88	3.16	7.84	6	20.0
BT5-TB	1½	13.75	2.56	4.06	11.45	10	62.0
BT6-TB	2	13.75	3.31	4.06	11.45	10	78.0
BT7-TB	2½	18.38	3.63	5.59	15.61	15	180.0
BT8-TB	3	18.38	4.38	5.72	15.82	15	225.0
BT9-TB	3½	23.75	4.88	6.88	20.50	20	410.0
BT10-TB	4	23.75	5.38	6.88	20.50	20	460.0

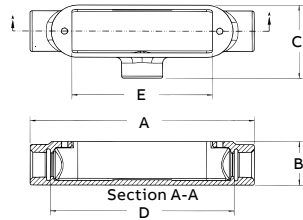

BT



BG mogul series replacement covers



Cat. no.	Hub size (in.)	Dimensions (in.)				
		A	B	C	D	E
Diagrams						
BG48-TB	1-1¼	8.27	6.62	2.77	.67	—
BG68-TB	1½-2	12	10.62	3.60	.82	—
BG88-TB	2½-3	16.22	12.44	4.97	.85	2.75
BG98-TB	3½-4	21.21	16.63	5.96	.87	3.75

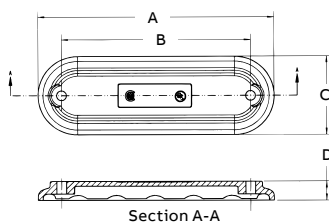

BG

Conduit bodies and covers

Aluminum mogul conduit outlet bodies



MALB



Application

- Raintight junction for bringing electrical service into a location
- Spacious, accessible wiring chamber provides a convenient location to pull conductors and make splices

Features

- Copper-free* aluminum provides increased corrosion resistance
- Precision cast and machined surfaces permit safer wire pulling
- Clean cover edges provide good gasket sealing
- Precision NPT threaded hubs enable trouble-free field installation for rigid and IMC conduit
- Deep slotted stainless steel cover screws for faster installation
- Clear UL, CSA and cubic content markings speed approval by inspectors
- Dome-style cover permits easy wire pulling
- Meets NEC® Article 314.28, 6-1 ratio
- Meets NEMA 3R standards

Standard materials

- Mogul pulling elbows: die cast aluminum alloy A360 with less than 0.004% copper content (copper-free); stainless steel screws
- Gaskets: composition

Standard finish

- Aluminum lacquer finish

Listings/compliances

- UL Listed
- CSA Certified
- Federal Spec. W-C-586
- NEC® Article 314.28

Sample specifications

- Mogul pulling elbows shall be die cast copper-free* aluminum alloy A360. All conduit stops shall be coined and free of rough edges. Mogul pulling elbows shall be finished with aluminum lacquer
- Mogul pulling elbows shall be ABB catalog no. _____

*Less than 0.004% copper content



Conduit bodies and covers

Aluminum mogul conduit outlet bodies



MALB-3 through -6



MALB-7 through -10

Aluminum mogul conduit outlet bodies with covers and gaskets



Cat. no.	Hub size (in.)	Unit qty.	Std. pkg.	Wt. lbs. per 100
MALB-3	1	1	10	174
MALB-4	1¼	2	10	160
MALB-5	1½	1	1	400
MALB-6	2	1	1	375
MALB-7	2½	1	1	1100
MALB-8	3	1	1	1060
MALB-9	3½	1	1	1900
MALB-10	4	1	1	1800



MGKV-4 through -7

Replacement covers and gaskets



Cover cat. no.	Gasket cat. no.	Hub size (in.)	Unit qty.	Std. pkg.	Wt. lbs. per 100
—	MGKV-5	1¼	1	5	4
MALB-56CV	MGKV-5	1½ to 2	1	5	4
MALB-78CV	MGKV-6	2½ to 3	1	5	5
MALB-90CV	MGKV-7	3½ to 4	1	5	5

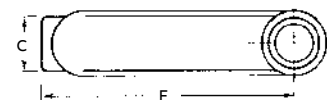
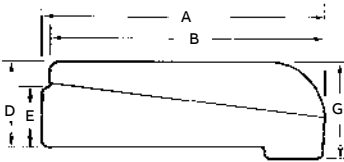

MALB

MALB dimensions

Hub size (in.)	Dimensions (in.)							Cu. in.
	A	B	C	D	E	F	G	
1	9.63	9.06	2.50	2.75	2.06	8.50	3.63	40.0
1¼	9.63	9.06	2.50	2.75	2.06	8.50	3.63	40.0
1½	14.53	14.25	2.75	4.00	2.81	13.00	5.22	128.0
2	14.53	14.25	2.75	4.00	2.81	13.00	5.22	128.0
2½	21.69	21.41	4.50	5.63	4.38	18.00	7.72	398.0
3	21.69	21.41	4.50	5.63	4.38	18.00	7.72	398.0
3½	28.63	28.69	5.50	6.50	5.38	24.00	9.72	766.7
4	28.63	28.69	5.50	6.50	5.38	24.00	9.72	766.7

Device boxes and covers

Cast device boxes

- 01 Dead-end
- 02 Dead-end
- 03 Through-feed

Application

- Accommodate wiring devices
- Act as pull boxes for conductors in a threaded rigid conduit system, including an internal ground screw
- Provide openings to make splices and taps in conductors
- Provide access to conductors for maintenance and future system changes
- Connect conduit sections

Features

- All hubs have NPT threads with a minimum of five full threads and integral bushing
- Internal grounding screw standard on boxes
- Suitable for wet locations when used with gasketed covers
- Available in shallow (FS) or deep (FD) boxes (use FD if device to be enclosed exceeds 1 $\frac{3}{8}$ " in depth)
- Use blank bodies where special arrangements of conduit hubs or entrances are required
- All cover holes are #6–32
- Mounting lugs are standard on all FS and FD boxes
- Easier and faster to clean with exceptionally smooth hygienic markings on stainless steel version

Size range

- Hubs: $\frac{1}{2}$ " to 1" NPT

Materials

- Boxes: class 30 gray iron alloy
- Covers: sand cast aluminum alloy and sheet steel
- Gaskets: neoprene
- Option: Stainless steel 316 – Add suffix “-SST” instead of “-TB”

Finish

- Zinc-plated with aluminum acrylic paint
- Stainless steel 316: Polished

Listings/compliances

- UL 514A (wet locations when used with gasketed covers)
- CSA C22.2 No. 18
- cULus – Stainless steel 316



01



02



03

Device boxes and covers

Single-gang cast device boxes – Now available in stainless steel 316

Stainless steel version coming soon

Shallow single-gang cast device boxes



Cat. no.	Fig.	Hub size (in.)	Dimensions (in.)							Throat dia.	
			A	B	C	D	E	F	G	Min.	Max.
Dead-end											
FS019-TB	A	Blank	2.00	2.75	4.28	—	3.38	4.72	0.88	—	—
FS1-TB	B	½	2.00	2.75	4.28	0.88	2.19	—	—	0.570	0.610
FS2-TB*	B	¾	2.00	2.75	4.28	0.88	2.19	—	—	0.755	0.810
FS3-TB	B	1	2.00	2.75	4.28	0.88	2.19	—	—	0.935	1.035
Through-feed											
FSC1-TB	C	½	2.00	2.75	4.28	0.88	2.19	5.38	—	0.570	0.610
FSC2-TB	C	¾	2.00	2.75	4.28	0.88	2.19	5.38	—	0.755	0.810
FSC3-TB	C	1	2.00	2.75	4.28	0.88	2.19	5.38	—	0.935	1.035

*Available in stainless steel 316, cULus listed. Replace "-TB" with "-SST".

Stainless steel version coming soon

Deep single-gang cast device boxes



Cat. no.	Fig.	Hub size (in.)	Dimensions (in.)							Throat dia.	
			A	B	C	D	E	F	G	Min.	Max.
Dead-end											
FD019-TB	A	Blank	2.81	2.75	4.28	—	3.38	4.72	1.38	—	—
FD1-TB	B	½	2.81	2.75	4.28	0.88	2.19	—	—	0.570	0.610
FD2-TB*	B	¾	2.81	2.75	4.28	0.88	2.19	—	—	0.755	0.810
FD3-TB	B	1	2.81	2.75	4.28	0.88	2.19	—	—	0.935	1.035
Through-feed											
FDC1-TB	C	½	2.81	2.75	4.28	0.88	2.19	5.38	—	0.570	0.610
FDC2-TB*	C	¾	2.81	2.75	4.28	0.88	2.19	5.38	—	0.755	0.810
FDC3-TB*	C	1	2.81	2.75	4.28	0.88	2.19	5.38	—	0.935	1.035

*Available in stainless steel 316, cULus listed. Replace "-TB" with "-SST".

Diagrams

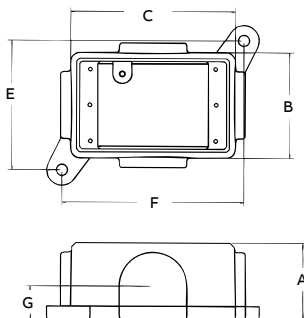

Fig. A dead-end

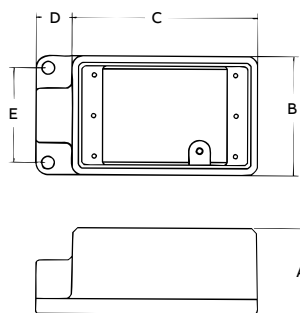

Fig. B dead-end

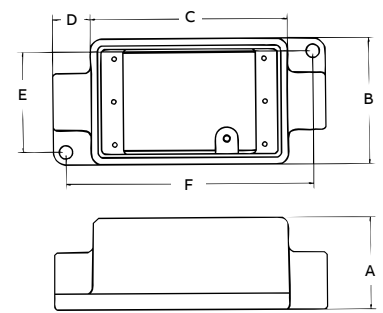

Fig. C through-feed

Device boxes and covers

Double-gang cast device boxes



Fig. A dead-end



Fig. B dead-end



Fig. C through-feed



Fig. D dead-end

Shallow double-gang cast device boxes

Cat. no.	Hub fig.	Hub size (in.)	Dimensions (in.)						Throat dia.	
			A	B	C	D	E	F	Min.	Max.
Dead-end										
FS062-TB	A	Blank	2.00	4.63	4.28	—	4.13	5.50	—	—
FS12-TB	B	1/2	2.00	4.63	4.28	0.88	2.19	—	0.570	0.610
FS22-TB	B	3/4	2.00	4.63	4.28	0.88	2.19	—	0.755	0.810
FS32-TB	B	1	2.00	4.63	4.28	0.88	2.19	—	0.935	1.035
Through-feed										
FSC12-TB	C	1/2	2.00	4.63	4.28	0.88	2.19	5.38	0.570	0.610
FSC222-TB	C	3/4	2.00	4.63	4.28	0.88	2.19	5.38	0.755	0.810
FSC32-TB	C	1	2.00	4.63	4.28	0.88	2.19	5.38	0.935	1.035

Deep double-gang cast device boxes

Stainless steel version coming soon

Cat. no.	Hub fig.	Hub size (in.)	Dimensions (in.)						Throat dia.	
			A	B	C	D	E	F	Min.	Max.
Dead-end										
FDO62-TB	A	Blank	2.81	4.63	4.28	—	4.13	5.50	—	—
FD12-TB	B	1/2	2.81	4.63	4.28	0.88	2.19	—	0.570	0.610
FD22-TB	B	3/4	2.81	4.63	4.28	0.88	2.19	—	0.755	0.810
FD32-TB	B	1	2.81	4.63	4.28	0.88	2.19	—	0.935	1.035
Through-feed										
FDC12-TB	C	1/2	2.81	4.63	4.28	0.88	2.19	5.38	0.570	0.610
FDC222-TB*	C	3/4	2.81	4.63	4.28	0.88	2.19	5.38	0.755	0.810
FDC32-TB*	C	1	2.81	4.63	4.28	0.88	2.19	5.38	0.935	1.035

*Available in stainless steel 316, cULus listed. Replace "-TB" with "-SST".

Double-gang cast device boxes, double hub

Cat. no.	Fig.	Hub size (in.)	Dimensions (in.)						Throat dia.	
			A	B	C	D	E	Min.	Max.	
FSS222-TB	D	3/4	2.00	4.63	4.28	0.88	4.06	0.755	0.810	
FDS222-TB	D	3/4	2.81	4.63	4.28	0.88	4.06	0.755	0.810	

Diagrams

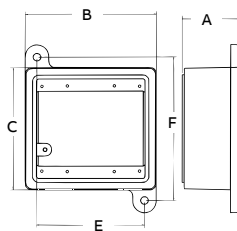

Fig. A dead-end

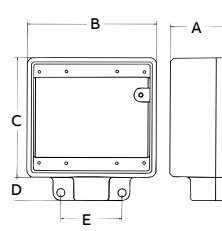

Fig. B dead-end

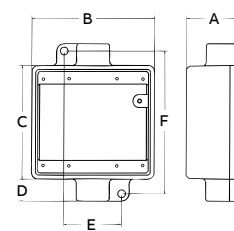

Fig. C through-feed

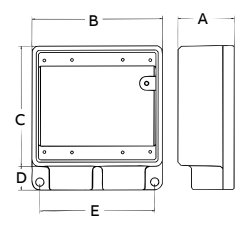

Fig. D dead-end

Device boxes and covers

Covers



DSS100-TB

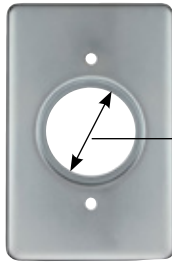

DS21-TB

1.405
dia. hole



DS23-TB



DS32-TB



DS100G-TB

Single-gang covers

Cat. no.	Description
DSS100-TB	Blank, sheet steel
DS21-TB	Round receptacle, sheet steel
DS23-TB	Duplex receptacle, sheet steel
DS32-TB	Single switch, sheet steel
DS100G-TB	Blank, cast aluminum



S1002-TB



S32232-TB

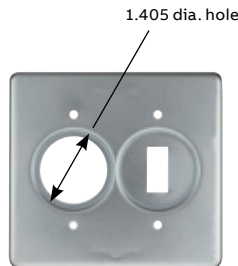

S32212-TB



S232-TB



S322



S1002GSA-TB

Double-gang covers

Cat. no.	Description
S1002-TB	Blank, sheet steel
S32232-TB	2 Receptacle/switch, sheet steel
S32212-TB	Single receptacle/switch, sheet steel
S232-TB	2 Dual receptacle, sheet steel
S322-TB	2 Switch, sheet steel
S1002GSA-TB	Blank, cast aluminum with gasket

Device boxes and covers

Aluminum device boxes

- 01 AFS
- 02 2AFSC
- 03 CWP-G
- 04 CDR

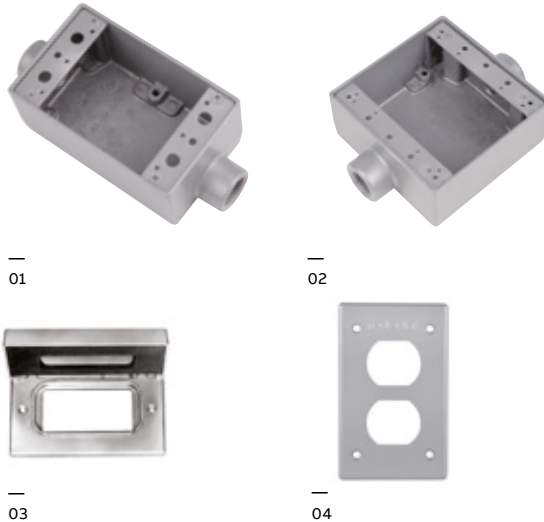

Application

- Industrial-grade FS/FD device boxes and raintight covers protect wiring devices, switches, electronic components and terminal blocks in dry, damp and wet locations
- Spacious, accessible wiring chamber provides a convenient location to maintain or change a system, pull conductors and make splices
- Junction for branch conduits
- Aluminum boxes can be used with steel rigid conduit

Features

- Copper-free* aluminum, stainless steel cover springs and hinge pins provide increased corrosion resistance
- Die-cast construction, boxes with securely fastened mounting plates and industrial designed covers combine to produce a rugged protective enclosure for devices on industrial and OEM applications
- Clean cover edges provide good gasket sealing
- Precision NPT threaded hubs allow trouble-free field installation for rigid or IMC conduit
- Clear UL, CSA and cubic content markings speed approval by inspectors
- Boxes – external hub design provides increased wiring room
- Covers ship complete with gaskets and screws

Standard materials

- Die-cast aluminum alloy A360 with less than 0.004% copper content (copper-free)
- Cover hinge pins and springs: stainless steel

Standard finish

- Aluminum lacquer finish

Listings/compliances

- UL listed
- Boxes CSA certified with factory-installed ground screw **
- Covers CSA certified
- Federal Spec. W-C-586

Sample specifications

- Industrial-grade FS/FD device boxes and covers shall be die-cast copper-free* aluminum alloy A360. All conduit stops shall be coined and free of rough edges. Raintight covers shall have stainless steel springs and hinge pins and be suitable for use in wet locations with cover closed (CFSB, CFST and CFSTF suitable for wet locations). Industrial-grade FS/FD device boxes and covers shall be finished with aluminum lacquer. Industrial-grade FS/FD device boxes and covers shall be ABB catalog no. _____

* Less than 0.004% copper content

** Consult factory for lead time and minimum quantity

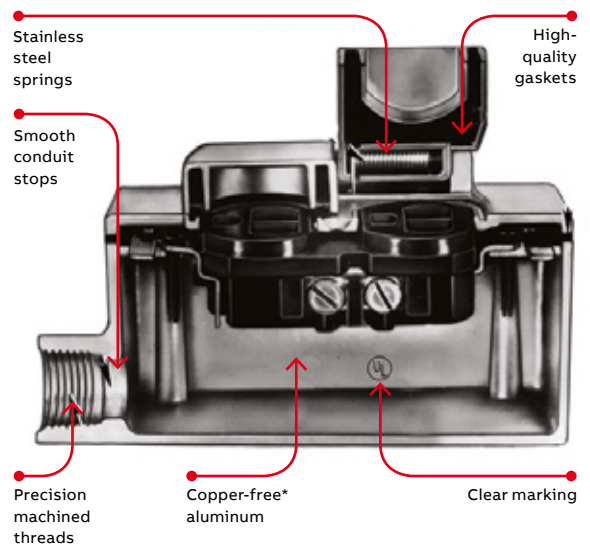

Device boxes and covers

Aluminum device boxes

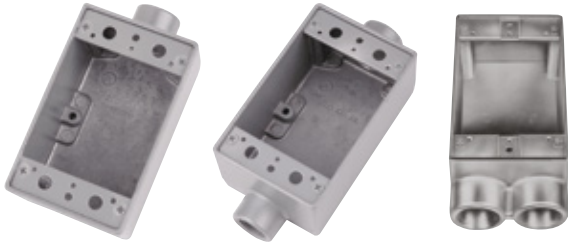

AFS

AFSC

AFSS



AFSCC

ADFS

ADFSC

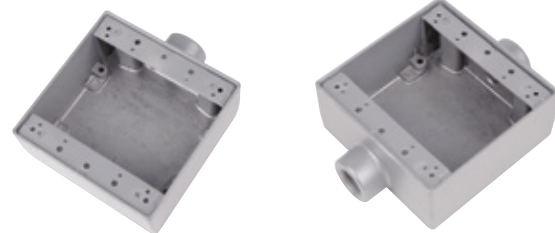

2AFS

2AFSC



2ADFS



FSMG-TB

Single-gang boxes raintight*

Cat. no.	Hub size (in.)	Unit qty.	Std. pkg.	Wt. lbs. per 100
Standard, 1-hole box, dead-end				
AFS-1*	1/2	5	25	68
AFS-2*	3/4	5	25	74
AFS-3*	1	5	25	72
Standard, 2-hole box, through-feed				
AFSC-1*	1/2	5	25	72
AFSC-2*	3/4	5	25	88
AFSC-3*	1	5	25	79
Standard, 2-hole box, dead-end				
AFSS-1*	1/2	5	25	80
AFSS-2*	3/4	5	25	76
Standard, 3-hole box, through-feed				
AFSCC-1*	1/2	5	25	88
AFSCC-2*	3/4	5	25	80
Deep, 1-hole box, dead-end				
ADFS-1*	1/2	—	5	74
ADFS-2*	3/4	—	5	78
ADFS-3*	1	—	5	80
Deep, 2-hole box, through-feed				
ADFSC-1*	1/2	—	5	76
ADFSC-2*	3/4	—	5	90
ADFSC-3*	1	—	5	90

* Rain-tight when used with appropriate ABB covers.

Double-gang boxes raintight*

Cat. no.	Hub size (in.)	Unit qty.	Std. pkg.	Wt. lbs. per 100
Standard, 1-hole box, dead-end				
2AFS-1*	1/2	2	10	115
2AFS-2*	3/4	2	10	95
2AFS-3*	1	2	10	90
Standard, 2-hole box, through-feed				
2AFSC-1*	1/2	2	10	104
2AFSC-2*	3/4	2	10	102
Deep, 1-hole box, dead-end				
2ADFS-1*	1/2	—	3	128
2ADFS-2*	3/4	—	3	143

* Rain-tight when used with appropriate ABB covers.

Multi-gang boxes raintight*

Cat. no.	Hub size (in.)	Unit qty.	Std. pkg.	Wt. lbs. per 100
FSMG-TB	4 Threadless conduit	—	1	242

* Rain-tight when used with appropriate ABB covers and gaskets.

Device boxes and covers

Dimensions and capacity for single-gang boxes

Cat. no.	Hub size (in.)	Dimensions (in.)									Cu. in.
		A	B	C	D	E	F	G	H	J	
AFS-1	1/2	4 ⁹ / ₁₆	2 ¹³ / ₁₆	1 ³ / ₁₆	2 ¹ / ₁₆	1 ¹ / ₈	2 ⁷ / ₈	2 ⁹ / ₁₆	1 ¹⁵ / ₁₆	-	21.6
AFS-2	3/4	4 ⁹ / ₁₆	2 ¹³ / ₁₆	1 ³ / ₁₆	2 ¹ / ₁₆	1 ¹¹ / ₁₆	2 ⁷ / ₈	2 ⁹ / ₁₆	1 ¹⁵ / ₁₆	-	21.6
AFS-3	1	4 ⁹ / ₁₆	2 ¹³ / ₁₆	1 ³ / ₁₆	2 ¹ / ₁₆	1 ¹¹ / ₁₆	2 ⁷ / ₈	2 ⁹ / ₁₆	1 ¹⁵ / ₁₆	-	21.6
AFSC-1	1/2	4 ⁹ / ₁₆	2 ¹³ / ₁₆	1 ³ / ₁₆	2 ¹ / ₁₆	1 ¹ / ₈	2 ⁷ / ₈	2 ⁹ / ₁₆	1 ¹⁵ / ₁₆	-	21.6
AFSC-2	3/4	4 ⁹ / ₁₆	2 ¹³ / ₁₆	1 ³ / ₁₆	2 ¹ / ₁₆	1 ¹¹ / ₁₆	2 ⁷ / ₈	2 ⁹ / ₁₆	1 ¹⁵ / ₁₆	-	21.6
AFSC-3	1	4 ⁹ / ₁₆	2 ¹³ / ₁₆	1 ³ / ₁₆	2 ¹ / ₁₆	1 ¹¹ / ₁₆	2 ⁷ / ₈	2 ⁹ / ₁₆	1 ¹⁵ / ₁₆	-	21.6
AFSS-1	1 1/2	4 ⁹ / ₁₆	2 ¹³ / ₁₆	1 ³ / ₁₆	2 ¹ / ₁₆	1 ³ / ₈	2 ⁷ / ₈	2 ⁹ / ₁₆	1 ¹⁵ / ₁₆	1 1/2	21.6
AFSS-2	3/4	4 ⁹ / ₁₆	2 ¹³ / ₁₆	1 ³ / ₁₆	2 ¹ / ₁₆	1 ³ / ₈	2 ⁷ / ₈	2 ⁹ / ₁₆	1 ¹⁵ / ₁₆	1 1/2	21.6
AFSCC-1	1/2	4 ⁹ / ₁₆	2 ¹³ / ₁₆	1 ³ / ₁₆	2 ¹ / ₁₆	1 ³ / ₈	2 ⁷ / ₈	2 ⁹ / ₁₆	1 ¹⁵ / ₁₆	1 1/2	21.6
AFSCC-2	3/4	4 ⁹ / ₁₆	2 ¹³ / ₁₆	1 ³ / ₁₆	2 ¹ / ₁₆	1 ³ / ₈	2 ⁷ / ₈	2 ⁹ / ₁₆	1 ¹⁵ / ₁₆	1 1/2	21.6

Diagrams

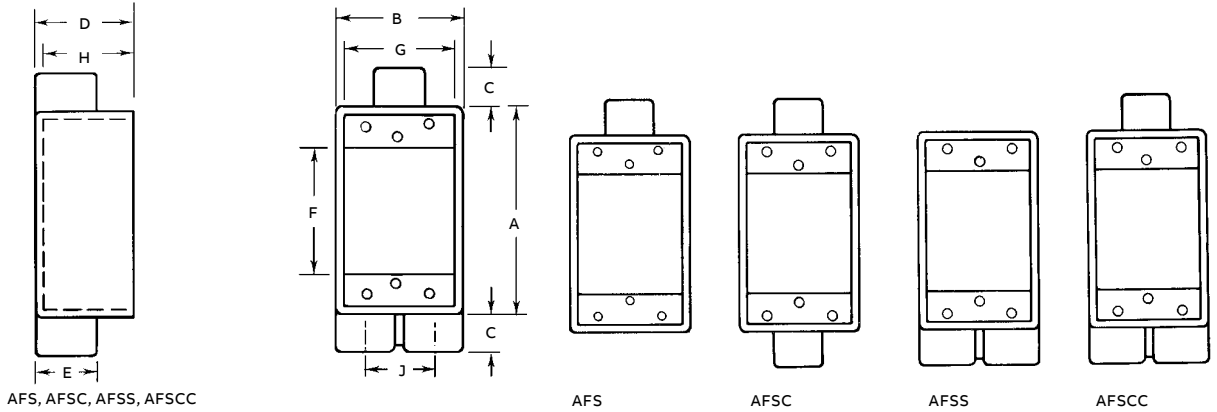

Cat. no.	Hub size (in.)	Dimensions (in.)									Cu. in.
		A	B	C	D	E	F	G	H		
ADFS-1	1/2	4 ⁹ / ₁₆	2 ¹³ / ₁₆	7/8	3 ¹ / ₁₆	1 ¹ / ₈	2 ⁷ / ₈	2 ⁹ / ₁₆	2 ¹⁵ / ₁₆	31.3	
ADFS-2	3/4	4 ⁹ / ₁₆	2 ¹³ / ₁₆	7/8	3 ¹ / ₁₆	1 ¹¹ / ₁₆	2 ⁷ / ₈	2 ⁹ / ₁₆	2 ¹⁵ / ₁₆	31.3	
ADFS-3	1	4 ⁹ / ₁₆	2 ¹³ / ₁₆	7/8	3 ¹ / ₁₆	1 ¹¹ / ₁₆	2 ⁷ / ₈	2 ⁹ / ₁₆	2 ¹⁵ / ₁₆	31.3	
ADFS-1	1 1/2	4 ⁹ / ₁₆	2 ¹³ / ₁₆	7/8	3 ¹ / ₁₆	1 ¹ / ₈	2 ⁷ / ₈	2 ⁹ / ₁₆	2 ¹⁵ / ₁₆	31.3	
ADFS-2	3/4	4 ⁹ / ₁₆	2 ¹³ / ₁₆	7/8	3 ¹ / ₁₆	1 ¹¹ / ₁₆	2 ⁷ / ₈	2 ⁹ / ₁₆	2 ¹⁵ / ₁₆	31.3	
ADFS-3	1	4 ⁹ / ₁₆	2 ¹³ / ₁₆	7/8	3 ¹ / ₁₆	1 ¹¹ / ₁₆	2 ⁷ / ₈	2 ⁹ / ₁₆	2 ¹⁵ / ₁₆	31.3	

Diagrams

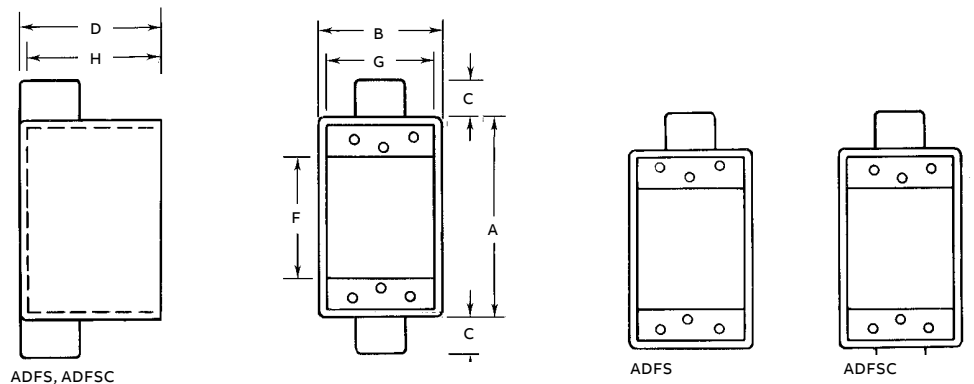

Device boxes and covers

Dimensions and capacity for double-gang boxes

Cat. no.	Hub size (in.)	Dimensions (in.)								
		A	B	C	D	E	F	G	H	Cu. in.
2AFS-1	1/2	4 9/16	4 5/8	1 3/16	2 1/16	1 3/8	2 7/8	4 3/8	1 15/16	36.0
2AFS-2	3/4	4 9/16	4 5/8	1 3/16	2 1/16	1 3/8	2 7/8	4 3/8	1 15/16	36.0
2AFS-3	1	4 9/16	4 5/8	7/8	2 1/16	1 11/16	2 7/8	4 3/8	1 15/16	36.0
2AFSC-1	1/2	4 9/16	4 5/8	1 3/16	2 1/16	1 3/8	2 7/8	4 3/8	1 15/16	36.0
2AFSC-2	3/4	4 9/16	4 5/8	1 3/16	2 1/16	1 3/8	2 7/8	4 3/8	1 15/16	36.0

Diagrams

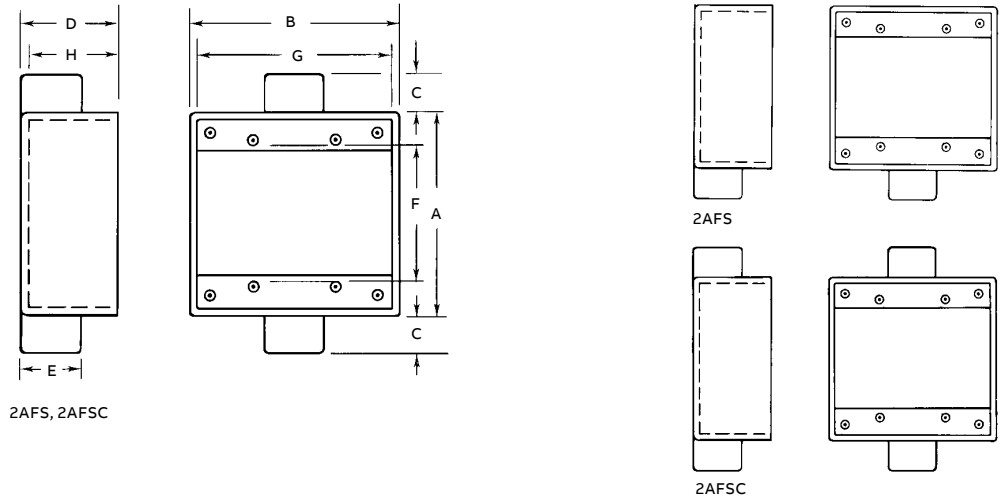

Cat. no.	Hub size (in.)	Dimensions (in.)								
		A	B	C	D	E	F	G	H	Cu. in.
2ADFS-1	1/2	4 9/16	4 5/8	1 3/16	3 3/32	1 3/8	2 7/8	4 3/8	2 31/32	54.0
2ADFS-2	3/4	4 9/16	4 5/8	1 3/16	3 3/32	1 3/8	2 7/8	4 3/8	2 31/32	54.0
2ADFS-3	1	4 9/16	4 5/8	7/8	3 3/32	1 11/16	2 7/8	4 3/8	2 31/32	54.0
2ADFSC-2	3/4	4 9/16	4 5/8	1 3/16	3 3/32	1 3/8	2 7/8	4 3/8	2 31/32	54.0
2ADFSC-3	1	4 9/16	4 5/8	7/8	3 3/32	1 11/16	2 7/8	4 3/8	2 31/32	54.0

Diagrams

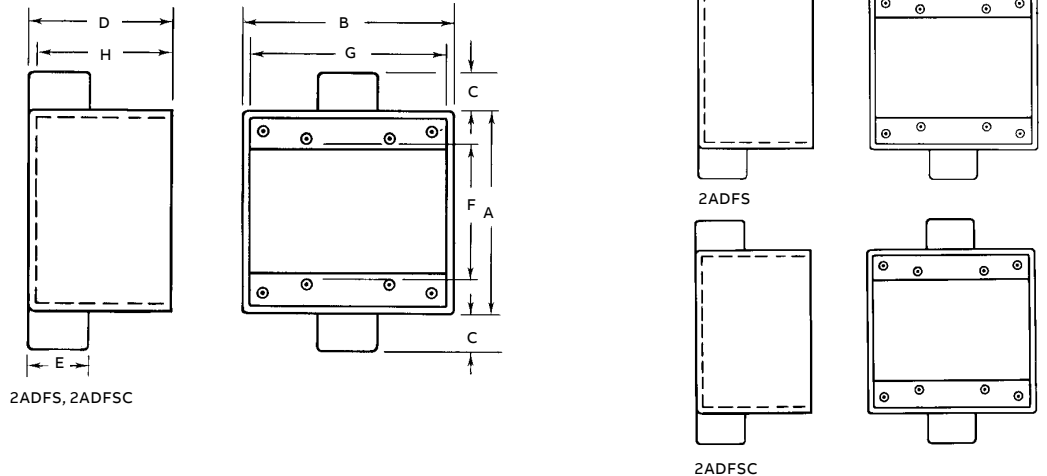

Device boxes and covers

FS/FD CorroStall™ aluminum boxes



- Special aluminum alloy offers the ultimate in corrosion resistance as cast
- No protective coating required to prevent corrosion
- Ideal for use in food and beverage or pharmaceutical washdown areas, chemical processing and other corrosive environments
- Available in single- and double-gang sizes
- Use with standard ABB FS/FD aluminum covers

Material

- Aluminum alloy

Finish

- As cast

—
Single-gang CorroStall boxes



Cat. no.	No. of outlet holes	Hub size (in.)	Std. pkg.
T11-22-FP	5	1/2	25
T14-22-FP	5	3/4	25
T11-FP	3	1/2	25
T14-PL-FP	3	3/4	25
TX11-5-FP	5	1/2	25
TX14-5-FP	5	3/4	25
T14-2-FP	4	3/4	25

Diagrams

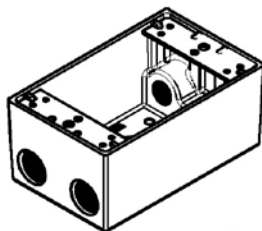
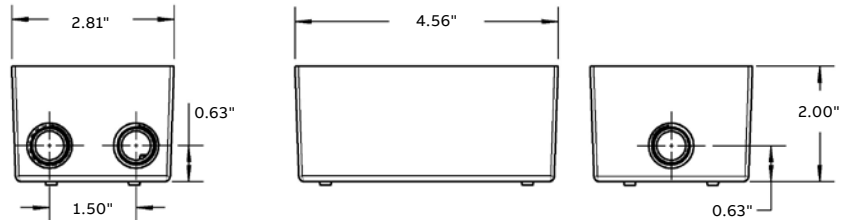

T11-22-FP
T14-22-FP

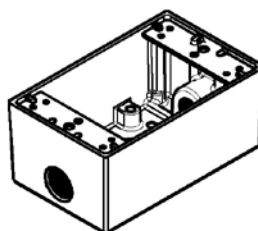

T11-FP
T14-PL-FP

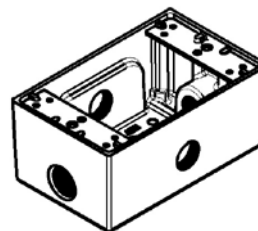

TX11-5-FP
TX14-5-FP

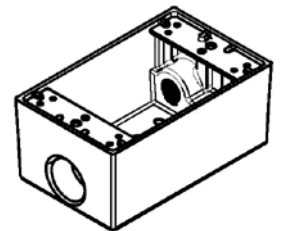

T14-2-FP

Device boxes and covers

FS/FD CorroStall™ aluminum boxes

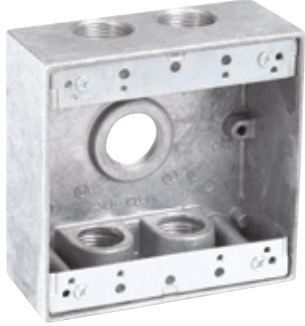

Double-gang CorroStall boxes



Cat. no.	No. of outlet holes	Hub size (in.)	Std. pkg.
LT11-3-FP	5	1/2	10
LT14-3-FP	5	3/4	10
LT11-2-FP	4	1/2	10
LT14-2-FP	4	3/4	10

Diagrams

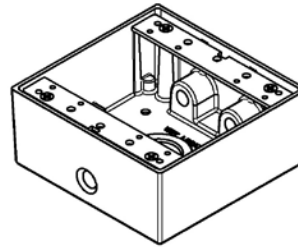
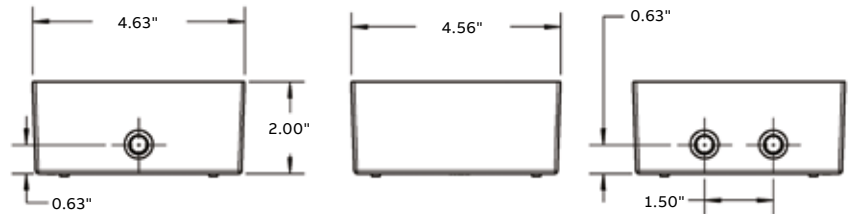

LT11-2-FP
LT14-2-FP

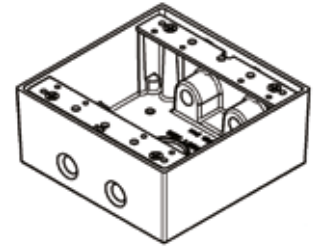

LT11-3-FP
LT14-3-FP

Device boxes and covers

Aluminum single- and double-gang covers



CWPDR



CWPDR-FS



CFSDR



CFSH-G



CWPV-G



CFSR-G



CFSR Series



CFST



CFSTF



CFSB

Single-gang covers — raintight*

Cat. no.	Description	Unit qty.	Std. pkg.	Wt. lbs. per 100
For duplex receptacles, horizontal				
CWPDR*	Duplex receptacle cover with (2) spring doors, device mount	1	25	40
CWPDR-FS*	Box mount	1	25	40
For duplex receptacles, vertical				
CFSDR*	Box mount	1	25	38
For GFCI receptacles, horizontal				
CFSH-G*	Box mount	1	25	40
For GFCI receptacles, vertical				
CWPV-G*	GFCI receptacle cover, 2 ²¹ / ₃₂ " x 1 ¹¹ / ₃₂ " rectangular opening	1	25	40
Device mount				
CFSR-G*	Box mount	1	25	40

*Raintight when used with appropriate ABB boxes and gaskets. Suitable for use in wet locations with cover closed — NEMA 3R.

Cat. no.	Nominal size (in.)	Max. device face dia. (in.)	Unit qty.	Std. pkg.	Wt. lbs. per 100
For single receptacles, vertical (box mount only)					
CFSR-L*	1 ⁹ / ₁₆	1.600	1	25	40
CFSR-S*	1 ³ / ₈	1.395	1	25	40
CFSR-X*	1 ²⁷ / ₃₂	1.865	1	25	40
CFSR-XL*	2 ¹ / ₈	2.145	1	25	40
CFSR-Y*	1 ³ / ₄	1.750	1	25	40

*Raintight when used with appropriate ABB boxes and gaskets. Suitable for use in wet locations with cover closed — NEMA 3R.

Cat. no.	Description	Unit qty.	Std. pkg.	Wt. lbs. per 100
Switch cover				
CFST*	Plunger style, switch cover, box mount NEMA 3R	1	25	40
Switch cover				
CFSTF*	Front lever, switch cover, box mount NEMA 4	1	25	40
Blank cover				
CFSB*	Blank cover, box mount, NEMA 3R	1	25	14

*Raintight when used with appropriate ABB boxes and gaskets. Suitable for use in wet locations with cover closed — NEMA 3R.

Device boxes and covers

Aluminum single- and double-gang covers



CDR



CTS



CR Series



FS-GKV

Single-gang covers

Cat. no.	Description	Unit qty.	Std. pkg.	Wt. lbs. per 100
For duplex receptacles				
CDR	Duplex receptacle cover, box mount	20	100	11
For switches				
CTS	Switch cover, box mount	20	100	14

Cat. no.	Nominal size (in.)	Max. device face dia. (in.)	Unit qty.	Std. pkg.	Wt. lbs. per 100
For single receptacles (box mount only)					
CRL	1 ⁹ / ₁₆	1.600	20	100	12
CRS	1 ³ / ₈	1.395	20	100	12

Cat. no.	Description	Std. pkg.	Wt. lbs. per 100
Gasket			
FS-GKV	Composition gasket	100	2



2CWPR-M



2CWPR-M



2CFSR-M



2CFST



2CFSB

Double-gang covers — raintight*

Cat. no.	Description	Unit qty.	Std. pkg.	Wt. lbs. per 100
For two duplex receptacles				
2CWPR*	Two duplex receptacle cover with (2) spring doors, device mount	1	10	48
For single receptacle				
2CWPR-M*	Single receptacle cover, hole dia. 2 ¹ / ₄ ", device mount	1	10	48
2CFSR-M*	Single receptacle cover, hole dia. 2 ¹ / ₄ ", box mount	1	10	48
For two switches				
2CFST*	Plunger style switch cover, box mount	1	10	26
Blank				
2CFSB*	Blank cover, box mount	10	50	25

*Raintight when used with appropriate ABB boxes, covers and gaskets. Suitable for use in wet locations with cover closed — NEMA 3R.

Device boxes and covers

Aluminum single- and double-gang covers



2CDR



2CTS



2CTDR

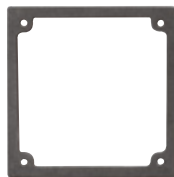

2FS-GKV

Double-gang covers

Cat. no.	Description	Unit qty.	Std. pkg.	Wt. lbs. per 100
For two duplex receptacles				
2CDR	Two duplex receptacle cover, device mount	10	50	24
For two switches				
2CTS	Switch cover, device mount	10	50	24
For switch and duplex receptacles				
2CTDR	Switch and duplex receptacle cover, device mount	10	50	24
Gasket				
2FS-GKV	Composition gasket	—	50	3

Device boxes and covers

Dimensions for single-gang covers

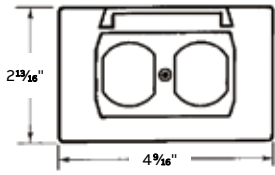

CWPDR

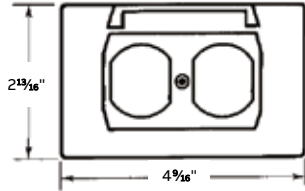

CWPDR-FS

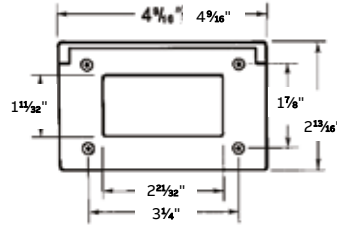

CFSH-G

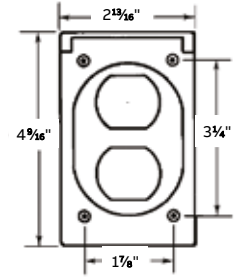

CFSDR

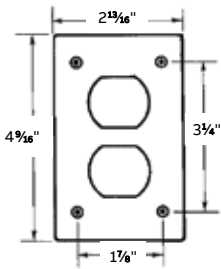

CDR

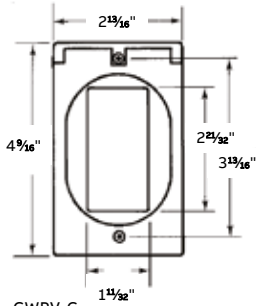

CWPV-G

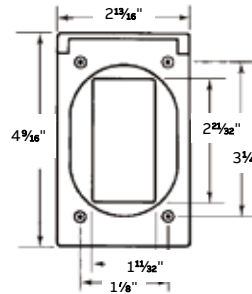

CFSR-G

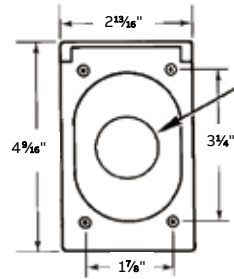

CFSR Series

L=1.60
Dia.
S=1.395
X=1.865
XL=2.145
Y=1.750

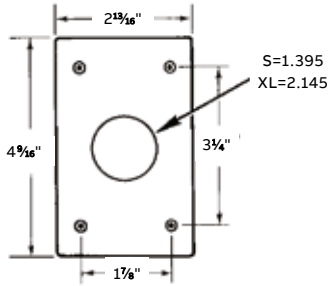

CR Series

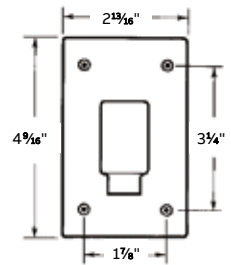

CFST

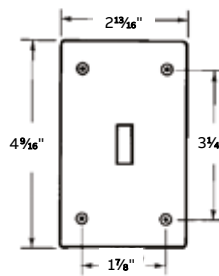

CTS

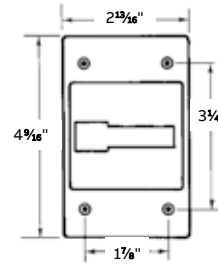

CFSTF

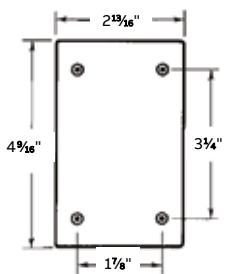

CFSB

Device boxes and covers

Dimensions for double-gang covers

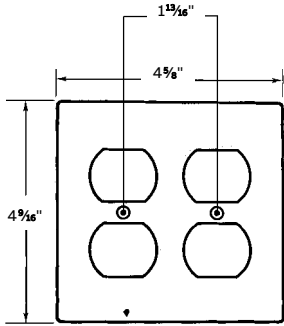

2CDR

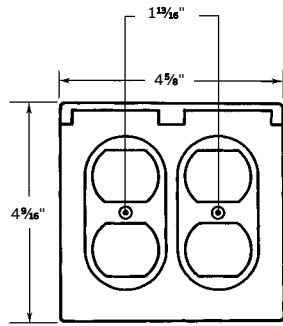

2CWPDR

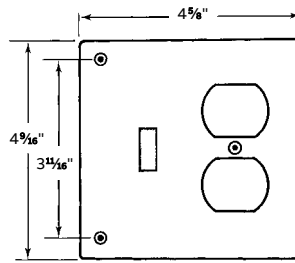

2CTDR

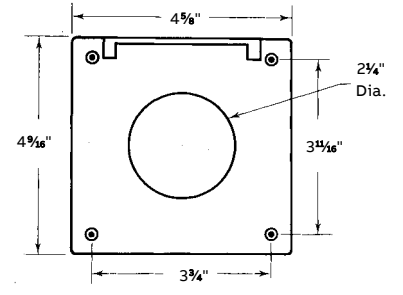

2CFSR-M

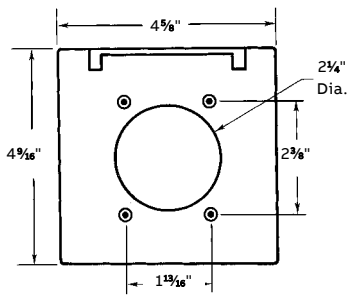

2CWPR-M

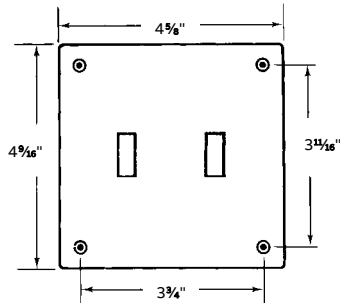

2CTS

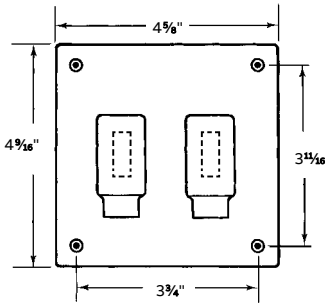

2CFST

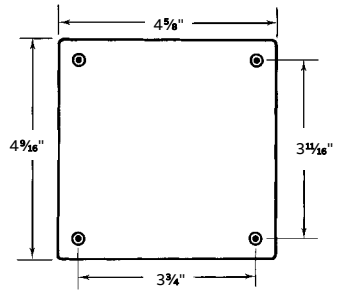

2CFSB

Hazardous location fittings

GUA conduit outlet boxes – Now available in stainless steel 316

Application

GUA boxes can be used for hazardous location conduit runs for the following:

- Allows for mounting of fixture outlets (when used with appropriate covers)
- Provides easy access to wiring
- Provides junction in conduit for wire pulling and splices
- Changes direction in rigid conduit systems
- Attaches two or more pieces of conduit in long runs
- Guards against damage to wires in rigid conduit

Features

- All hubs have a minimum of five full threads and integral bushing
- All boxes are furnished with internal grounding screw
- Cover supplied with O-ring gasket
- Easier and faster to clean with exceptionally smooth hygienic markings on stainless steel 316 version

Size range

- ½" NPT to 2" NPT
- Access opening 2" to 5" diameter



GUA



Cat. no.	Hub size (in.)	Dimensions (in.)			Throat dia. (in.)		Cu. in. capacity
		A	B	C	Min.	Max.	
GUA14-TB	½	1.81	2.50	0.88	0.570	0.610	5.5
GUA16-TB	½	2.00	3.50	0.88	0.570	0.610	13.5
GUA24-TB	¾	2.00	2.50	0.88	0.755	0.810	5.3
GUA26-TB	¾	2.00	3.50	0.88	0.755	0.810	13.3
GUA36-TB	1	2.31	3.50	0.88	0.935	1.035	16.2
GUA47-TB	1¼	2.69	4.38	1.00	1.260	1.360	29
GUA59-TB	1½	3.81	5.75	1.06	1.470	1.590	70

Materials

- Bodies: grade 60-45-10 ductile iron (complies with ASTM standard A536)
- Covers: die-cast aluminum
- Options: Stainless steel 316 body and cover – replace “-TB” with “- SST”*

Finish

- Boxes: zinc-plated with aluminum acrylic paint
- Covers: natural
- Stainless steel 316: polished

Listings/compliances

- UL514A (wet locations when used with gasketed covers)
- UL 1203
- CSA: C22.2 No. 30
- Cl. I, Div. 1 & 2, Groups C, D, Cl. II, Div. 1, Groups E, F, G, Cl. III, Div. 1 & 2
- NEMA 3, 4, 7 CD, 9 EFG
- Explosion-proof
- Dust-ignition-proof
- Raintight
- Wet locations
- cULus (stainless steel 316)



Stainless steel version coming soon

GUAB



Cat. no.	Hub size (in.)	Dimensions (in.)			Throat dia. (in.)		Cu. in. capacity
		A	B	C	Min.	Max.	
GUAB14-TB	½	2.25	2.50	0.88	0.570	0.610	6.9
GUAB16-TB	½	2.00	3.50	0.88	0.570	0.610	13.5
GUAB24-TB	¾	2.50	2.50	0.88	0.755	0.810	7.9
GUAB26-TB*	¾	2.00	3.50	0.88	0.755	0.810	13.5
GUAB36-TB*	1	2.31	3.50	1.00	0.935	1.035	15.4
GUAB47-TB	1¼	2.69	4.38	1.00	1.260	1.360	27.5
GUAB59-TB	1½	3.81	5.75	1.06	1.470	1.590	73.6
GUAB69-TB	2	4.06	5.75	1.06	1.880	2.047	80
GUAB79-TB	2½	4.06	5.75	1.13	2.320	2.380	98

*Available in stainless steel 316, cULus listed.

Diagrams

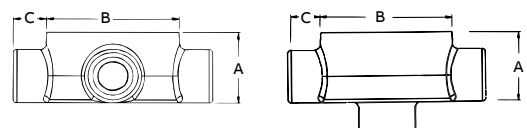

Hazardous location fittings

GUA conduit outlet boxes



—
Stainless steel version
coming soon

—
GUAC



Cat. no.	Hub size (in.)	Dimensions (in.)			Throat dia. (in.)		Cu. in. capacity
		A	B	C	Min.	Max.	
GUAC14-TB	1/2	2.25	2.50	0.88	0.570	0.610	6.8
GUAC16-TB	1/2	2.00	3.50	0.88	0.570	0.610	13.1
GUAC24-TB	3/4	2.00	2.50	0.88	0.755	0.810	5.3
GUAC26-TB*	3/4	2.00	3.50	0.88	0.755	0.810	13.3
GUAC36-TB*	1	2.31	3.50	0.88	0.935	1.035	16.2
GUAC47-TB	1 1/4	2.69	4.38	1.00	1.260	1.360	29.3
GUAC49-TB	1 1/4	3.81	5.75	1.00	1.260	1.360	73.6
GUAC59-TB	1 1/2	3.81	5.75	1.06	1.470	1.590	74
GUAC69-TB	2	4.06	5.75	1.06	1.880	2.047	77.8

*Available in stainless steel 316, cULus listed.



—
GUAD



Cat. no.	Hub size (in.)	Dimensions (in.)			Throat dia. (in.)		Cu. in. capacity
		A	B	C	Min.	Max.	
GUAD14-TB	1/2	1.81	2.50	0.88	0.570	0.610	5.6
GUAD16-TB	1/2	2.00	3.50	0.88	0.570	0.610	12.5
GUAD24-TB	3/4	2.00	2.50	0.88	0.755	0.810	5.2
GUAD26-TB	3/4	2.00	3.50	0.88	0.755	0.810	13.1
GUAD36-TB	1	2.31	3.50	0.88	0.935	1.035	16
GUAD49-TB	1 1/4	3.81	5.75	1.00	1.260	1.360	76



—
Stainless steel version
coming soon

—
GUAL



Cat. no.	Hub size (in.)	Dimensions (in.)			Throat dia. (in.)		Cu. in. capacity
		A	B	C	Min.	Max.	
GUAL14-TB	1/2	2.25	2.50	0.88	0.570	0.610	7.1
GUAL16-TB	1/2	2.00	3.50	0.88	0.570	0.610	13.4
GUAL24-TB	3/4	2.00	2.50	0.88	0.755	0.810	5.3
GUAL26-TB*	3/4	2.00	3.50	0.88	0.755	0.810	13.3
GUAL36-TB*	1	2.31	3.50	0.88	0.935	1.035	16.2
GUAL47-TB	1 1/4	2.69	4.38	1.00	1.260	1.360	30
GUAL49-TB	1 1/4	3.81	5.75	1.00	1.260	1.360	74.5
GUAL59-TB	1 1/2	3.81	5.75	1.06	1.470	1.590	74
GUAL69-TB	2	4.06	5.75	1.06	1.880	2.047	77.8

*Available in stainless steel 316, cULus listed.



—
Stainless steel version
coming soon

—
GUAT



Cat. no.	Hub size (in.)	Dimensions (in.)			Throat dia. (in.)		Cu. in. capacity
		A	B	C	Min.	Max.	
GUAT14-TB	1/2	2.25	2.50	0.88	0.570	0.610	7
GUAT16-TB	1/2	2.00	3.50	0.88	0.570	0.610	13.5
GUAT24-TB	3/4	2.00	2.50	0.88	0.755	0.810	5.3
GUAT26-TB*	3/4	2.00	3.50	0.88	0.755	0.810	13.3
GUAT36-TB*	1	2.31	3.50	1.00	0.935	1.035	15.9
GUAT37-TB	1	2.31	3.50	0.88	0.935	1.035	23.3
GUAT47-TB	1 1/4	2.69	4.38	1.00	1.260	1.360	29.3
GUAT49-TB	1 1/4	3.81	5.75	1.00	1.260	1.360	77.2
GUAT59-TB	1 1/2	3.81	5.75	1.06	1.470	1.590	77.7
GUAT69-TB	2	4.06	5.75	1.06	1.880	2.047	77.8
GUAT79-TB	2 1/2	4.06	5.75	1.06	2.320	2.380	95

*Available in stainless steel 316, cULus listed.

Diagrams

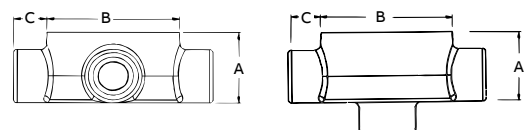

Hazardous location fittings

GUA conduit outlet boxes



GUAM



Cat. no.	Hub size (in.)	Dimensions (in.)			Throat dia. (in.)		Cu. in. capacity
		A	B	C	Min.	Max.	
GUAM14-TB	1/2	1.81	2.50	0.88	0.570	0.610	5.6
GUAM16-TB	1/2	2.00	3.50	0.88	0.570	0.610	12.5
GUAM24-TB	3/4	2.00	2.50	0.88	0.755	0.810	6.2
GUAM26-TB	3/4	2.00	3.50	0.88	0.755	0.810	12.5
GUAM36-TB	1	2.31	3.50	0.88	0.935	1.035	14
GUAM47-TB	1 1/4	2.69	4.38	1.00	1.260	1.360	29.2
GUAM69-TB	2	4.06	5.75	1.06	1.880	2.047	80



GUAW



Cat. no.	Hub size (in.)	Dimensions (in.)			Throat dia. (in.)		Cu. in. capacity
		A	B	C	Min.	Max.	
GUAW14-TB	1/2	1.81	2.50	0.88	0.570	0.610	5.2
GUAW16-TB	1/2	2.00	3.50	0.88	0.570	0.610	13
GUAW24-TB	3/4	2.00	2.50	0.88	0.755	0.810	6.5
GUAW26-TB	3/4	2.00	3.50	0.88	0.755	0.810	13



GUAN



Cat. no.	Hub size (in.)	Dimensions (in.)			Throat dia. (in.)		Cu. in. capacity
		A	B	C	Min.	Max.	
GUAN14-TB	1/2	2.13	2.50	0.88	0.570	0.610	6.8
GUAN16-TB	1/2	2.00	3.50	0.88	0.570	0.610	13.5
GUAN24-TB	3/4	2.31	2.50	0.88	0.755	0.810	7.7
GUAN26-TB	3/4	2.00	3.50	0.88	0.755	0.810	14
GUAN36-TB	1	2.31	3.50	0.88	0.935	1.035	16.9
GUAN47-TB	1 1/4	2.69	4.38	1.00	1.260	1.360	31.5
GUAN59-TB	1 1/2	4.06	5.75	1.06	1.470	1.590	84
GUAN69-TB	2	4.06	5.75	1.06	1.880	2.047	84



Stainless steel version coming soon

GUAX



Cat. no.	Hub size (in.)	Dimensions (in.)			Throat dia. (in.)		Cu. in. capacity
		A	B	C	Min.	Max.	
GUAX14-TB	1/2	1.81	2.50	0.88	0.570	0.610	5.2
GUAX16-TB	1/2	2.00	3.50	0.88	0.570	0.610	13.5
GUAX24-TB	3/4	2.00	2.50	0.88	0.755	0.810	5.3
GUAX26-TB*	3/4	2.00	3.50	0.88	0.755	0.810	13.3
GUAX36-TB*	1	2.31	3.50	1.00	0.935	1.035	16
GUAX37-TB	1	2.31	3.50	.88	0.935	1.035	23.3
GUAX47-TB	1 1/4	2.69	4.38	1.00	1.260	1.360	30
GUAX49-TB	1 1/4	3.81	5.75	1.00	1.260	1.360	72
GUAX59-TB	1 1/2	3.81	5.75	1.06	1.470	1.590	71
GUAX69-TB	2	4.06	5.75	1.06	1.880	2.047	77.8

*Available in stainless steel 316, cULus listed.

Diagrams

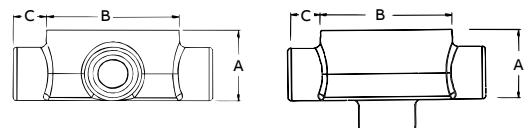

Hazardous location fittings

Aluminum external hubs

—
01 GAX
—
02 GAJU
—
03 GAFX
—
04 GASS

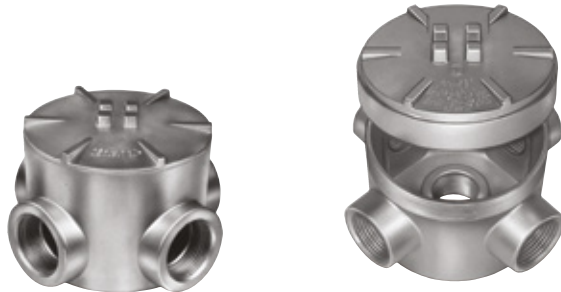

01

02

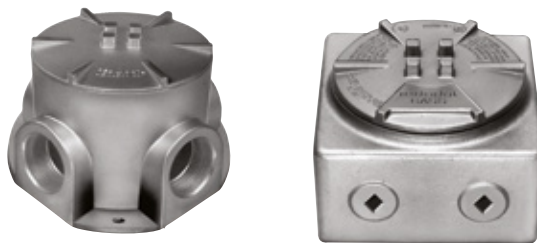

03

04

Application

- Junction for branch conduits in hazardous locations
- Accessible wiring chamber provides a convenient location to maintain or change a system, pull conductors and make splices
- Unique mounting pads and external hub design ideal for installations of OEM devices or instruments

Features

- Copper-free* aluminum provides increased corrosion resistance
- Precision cast and machined surfaces permit safer wire pulling
- Precision NPT threaded hubs enable trouble-free field installation for rigid or IMC conduit
- Die-cast construction and industrial design combine to produce a rugged protective enclosure for devices on industrial and OEM applications
- Clear UL, CSA and cubic content markings speed approval by inspectors

Standard materials

- Die-cast aluminum alloy A360 with less than 0.004% copper content (copper-free)

Standard finish

- Aluminum lacquer finish

Listings/compliances

- UL Listed
- CSA Certified
- Suitable for hazardous locations
- NEMA 4 rated when ordered with O-ring installed
- Federal Spec W-C-586
- Cl.I, Div. 1 & 2, Groups C, D
- Cl.II, Div. 1, Groups E, F, G
- Cl.III, Div. 1 & 2
- Explosion-proof
- Dust-ignition-proof
- Raintight
- Wet locations

Sample specifications

Outlet boxes for hazardous locations shall be die-cast copper-free* aluminum alloy A360 and suitable for use in Class I, Groups C, D, Class II, Groups E, F, G and Class III areas. All conduit stops shall be coined and free of rough edges. Outlet boxes for hazardous locations shall be finished with aluminum lacquer. Outlet boxes shall be ABB catalog no. _____

*Less than 0.004% copper content.

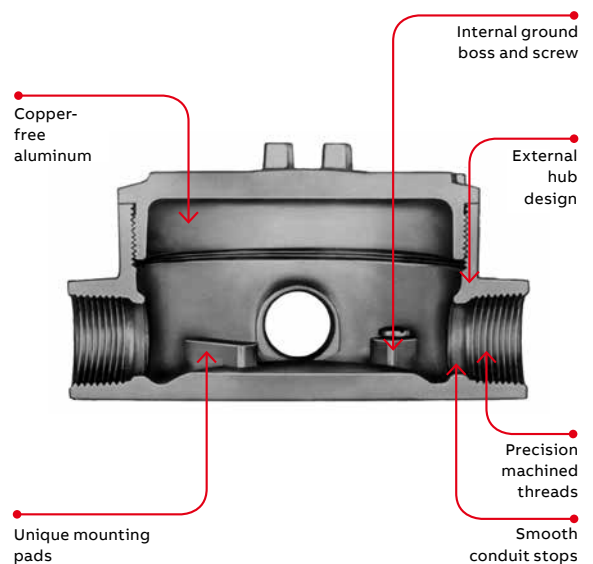

Hazardous location fittings

Aluminum external hubs with installed green ground screw

Through-feed with surface cover



	Cat. no.	Hub size (in.)	Unit qty.	Std. pkg.	Wt. lbs. per 100
	GAC-1•	½	1	5	115
	GAC-2•	¾	1	5	115
	GAC-3•	1	1	5	115

Dead-end with surface cover



	Cat. no.	Hub size (in.)	Unit qty.	Std. pkg.	Wt. lbs. per 100
	GAE-2•	¾	1	5	110

L-style with surface cover



	Cat. no.	Hub size (in.)	Unit qty.	Std. pkg.	Wt. lbs. per 100
	GAL-1	½	1	5	115
	GAL-2•	¾	1	5	115
	GAL-3•	1	1	5	115
	GAL-4•	1¼	1	5	175
	GAL-5•	1½	1	4	247
	GAL-6•	2	1	4	253

LB-style with surface cover



	Cat. no.	Hub size (in.)	Unit qty.	Std. pkg.	Wt. lbs. per 100
	GALB-1•	½	1	5	115
	GALB-2	¾	1	5	115
	GALB-3•	1	1	5	115
	GALB-4•	1¼	1	2	175
	GALB-6•	2	1	4	253

T-style with surface cover



	Cat. no.	Hub size (in.)	Unit qty.	Std. pkg.	Wt. lbs. per 100
	GAT-1•	½	1	5	120
	GAT-2	¾	1	5	120
	GAT-3•	1	1	5	120
	GAT-4	1¼	1	5	180
	GAT-6•	2	1	1	406

• Made-to-order items. Consult factory for lead time and minimum quantities.

Hazardous location fittings

Aluminum external hubs with installed green ground screw

X-style with surface cover



	Cat. no.	Hub size (in.)	Unit qty.	Std. pkg.	Wt. lbs. per 100
	GAX-1†	1/2	1	5	125
	GAX-2†	3/4	1	5	125
	GAX-3†	1	1	5	125
	GAX-5†	1 1/2	1	1	257

X-style with flange and surface cover



	Cat. no.	Hub size (in.)	Unit qty.	Std. pkg.	Wt. lbs. per 100
	GAFX-1†	1/2	1	4	135
	GAFX-2†	3/4	1	4	135

Surface-style cover



	Cat. no.	Cover opening (in.)	Fits boxes (in.)	Std. pkg.	Wt. lbs. per 100
	GAS-123•	3 11/16	1/2, 3/4, 1	1	36
	GAS-4•	3 29/32	1 1/4	1	52
	GAS-56•	5 3/16	1 1/2, 2	1	69

Dome-style cover (Class I, Group D only)



	Cat. no.	Cover opening (in.)	Fits boxes (in.)	Inside height (in.)	Capacity (cu. in.)	Std. pkg.	Wt. lbs. per 100
	GAD-123•	3 11/16	1/2, 3/4, 1	2 5/8	23	1	71

• Made-to-order items. Consult factory for lead time and minimum quantities.

† Suffix-OR: O-ring available for NEMA 4 rating. Consult factory for lead time and price.

Hazardous location fittings

Aluminum external hubs with installed green ground screw, covers and plugs



U-style with canopy cover



Cat. no.	Hub size (in.)	Unit qty.	Std. pkg.	Wt. lbs. per 100
GAJU-2	$\frac{3}{4}$	1	5	130
GAJU-3	1	1	5	130
GAJU-6•	2	1	1	273



Canopy-style cover



Cat. no.	Cover opening (in.)	Fits boxes (in.)	Unit qty.	Std. pkg.	Wt. lbs per 100
GAJ-123•	$3\frac{1}{16}$	$\frac{1}{2}$, $\frac{3}{4}$, 1	1	10	44
GAJ-4•	$3\frac{29}{32}$	$1\frac{1}{4}$	1	5	61
GAJ-56•	$5\frac{3}{16}$	$1\frac{1}{2}$, 2	1	5	78

Hazardous location fittings

Dimensions and capacity for external hubs

EXUN and EXUNL

Hub size (in.)	Dimensions (in.)										Capacity (cu in.)
	A	B	C	D	E	F	G	H	J	K	
1/2	3 ³¹ / ₃₂	3 ¹ / ₈	2 ²¹ / ₃₂	2 ¹ / ₁₆	4	3 ³ / ₈	4 ¹ / ₄	1 ¹ / ₄	1 ⁹ / ₁₆	1 ⁷ / ₆₄	20.3
3/4	3 ³¹ / ₃₂	3 ¹ / ₈	2 ²¹ / ₃₂	2 ¹ / ₁₆	4	3 ³ / ₈	4 ¹ / ₄	1 ¹ / ₄	1 ⁹ / ₁₆	1 ⁷ / ₆₄	20.3
1	3 ³¹ / ₃₂	3 ⁵ / ₁₆	3/4	2 ¹ / ₄	4	3 ⁹ / ₁₆	4 ¹ / ₄	1 ¹ / ₁₆	1 ⁹ / ₁₆	1 ⁷ / ₆₄	20.0

Diagrams

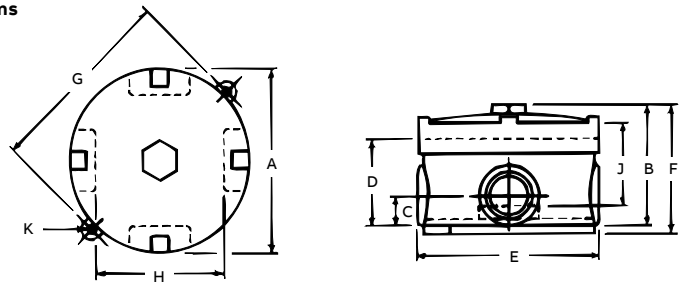

GAC, GAE, GAL, GALB, GAT and GAX

Cover opening	Hub size (in.)	Dimensions (in.)										Capacity (cu in.)	
		A	B	C	D	E	F	G	H	J	K		L
3 ¹¹ / ₁₆	1/2	4	2 ¹ / ₄	2 ¹⁵ / ₁₆	1 ³ / ₈	1 ¹ / ₁₆	1 ¹ / ₁₆	5 ³ / ₁₆	5 ⁹ / ₁₆	4 ³ / ₁₆	3 ⁵ / ₁₆	9/16	18.8
3 ¹¹ / ₁₆	3/4	4	2 ¹ / ₄	2 ¹⁵ / ₁₆	1 ³ / ₈	1 ¹ / ₁₆	1 ¹ / ₁₆	5 ³ / ₁₆	5 ⁹ / ₁₆	4 ³ / ₁₆	3 ⁵ / ₁₆	9/16	18.8
3 ¹¹ / ₁₆	1	4	2 ¹ / ₄	2 ¹⁵ / ₁₆	1 ³ / ₈	1 ³ / ₁₆	2 ⁷ / ₃₂	5 ¹ / ₂	5 ⁹ / ₁₆	4 ³ / ₁₆	3 ⁵ / ₁₆	9/16	18.8
3 ²⁹ / ₃₂	1 ¹ / ₄	4 ⁵ / ₁₆	3	3 ¹¹ / ₁₆	2 ¹ / ₁₆	1 ¹ / ₃₂	7/8	5 ¹¹ / ₁₆	—	4 ⁹ / ₁₆	3 ¹⁵ / ₁₆	5/8	28.0
5 ³ / ₁₆	1 ¹ / ₂	5 ³ / ₄	4 ¹ / ₄	5 ¹ / ₁₆	2 ⁷ / ₈	1 ¹ / ₁₆	7/8	6 ⁵ / ₈	—	6 ⁷ / ₁₆	5 ¹⁵ / ₃₂	1 ³ / ₁₆	69.3
5 ³ / ₁₆	2	5 ³ / ₄	4 ¹ / ₄	5 ¹ / ₁₆	2 ⁷ / ₈	1 ¹ / ₁₆	7/8	6 ⁵ / ₈	—	6 ⁷ / ₁₆	5 ¹⁵ / ₃₂	1 ³ / ₁₆	69.3

Diagrams

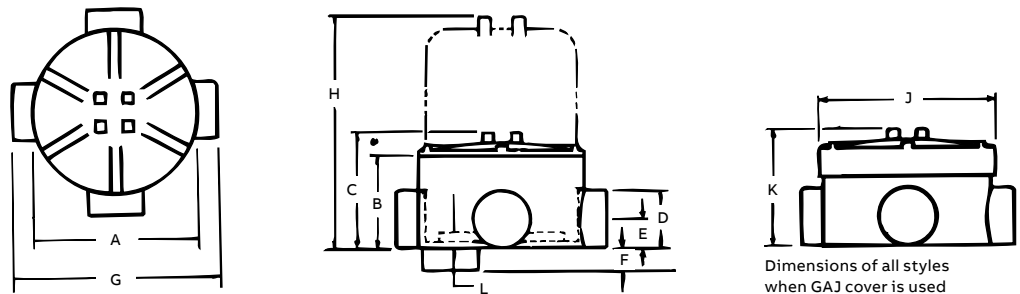

Hazardous location fittings

Dimensions and capacity for external hubs

GAFX

Cover opening	Hub size (in.)	Dimensions (in.)											Capacity (cu in.)
		A	B	C	D	E	F	G	H	L	M		
3 ¹¹ / ₁₆	1/2	4	2 ¹ / ₄	2 ¹⁵ / ₁₆	5 ⁹ / ₁₆	1 ¹ / ₁₆	4 ¹ / ₂	1/4	1 ³ / ₈	9/16	5 ³ / ₁₆	20.0	
3 ¹¹ / ₁₆	3/4	4	2 ¹ / ₄	2 ¹⁵ / ₁₆	5 ⁹ / ₁₆	1 ¹ / ₁₆	4 ¹ / ₂	1/4	1 ³ / ₈	9/16	5 ³ / ₁₆	20.0	
3 ¹¹ / ₁₆	1	4	2 ¹ / ₄	2 ¹⁵ / ₁₆	5 ⁹ / ₁₆	1 ³ / ₁₆	4 ³ / ₄	5/16	1 ⁵ / ₈	9/16	5 ¹ / ₂	19.0	

Diagrams

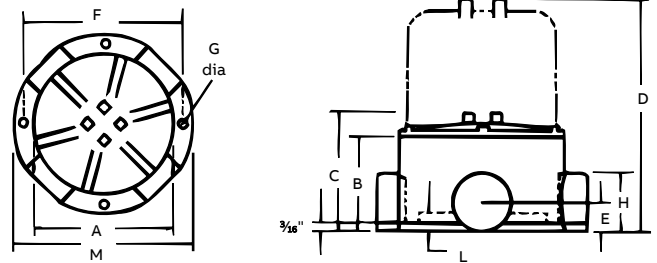

Note: All GAF units supplied as X configuration with proper number of explosion-proof close-up plugs to make C, T or L.

GAJU

Cover opening	Hub size (in.)	Dimensions (in.)								Capacity (cu in.)
		A	D	E	F	G	J	K		
3 ¹¹ / ₁₆	1/2	4	1 ³ / ₁₆	1 ¹ / ₂	3 ¹ / ₃₂	5 ³ / ₁₆	4 ³ / ₁₆	4	23.8	
3 ¹¹ / ₁₆	3/4	4	1 ³ / ₁₆	1 ¹ / ₂	3 ¹ / ₃₂	5 ³ / ₁₆	4 ³ / ₁₆	4	23.8	
3 ¹¹ / ₁₆	1	4	1 ³ / ₁₆	1 ¹ / ₂	3 ¹ / ₃₂	5 ³ / ₁₆	4 ³ / ₁₆	4	23.8	
3 ²⁹ / ₃₂	1 ¹ / ₄	4 ⁵ / ₁₆	2 ¹ / ₁₆	1 ¹ / ₃₂	7/8	5 ¹¹ / ₁₆	4 ³ / ₄	3 ¹⁵ / ₁₆	33.3	
5 ³ / ₁₆	1 ¹ / ₂	5 ³ / ₄	1 ⁷ / ₁₆	2 ¹ / ₁₆	1 ¹ / ₂	6 ⁵ / ₈	6 ⁷ / ₁₆	6 ³ / ₁₆	82.8	
5 ³ / ₁₆	2	5 ³ / ₄	1 ⁷ / ₁₆	2 ¹ / ₁₆	1 ¹ / ₂	6 ⁵ / ₈	6 ⁷ / ₁₆	6 ³ / ₁₆	82.8	

Diagrams

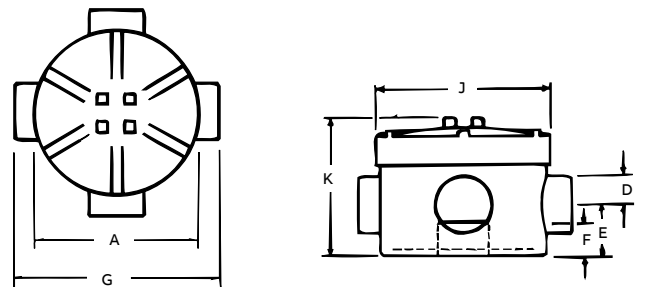

Note: All GA and GAF series boxes are supplied with GAS or GAJ style covers. To order these boxes with GAD dome cover, consult factory.

Hazardous location fittings

EXUN series aluminum internal hubs

—
01 EXUN
—
02 EXUNL



—
01

—
02



Application

- Junction for branch conduits in hazardous locations
- Accessible wiring chamber provides a convenient location to maintain or change a system, pull conductors and make splices
- Internal hub design ideal for installation where space is limited

Features

- Copper-free* aluminum provides increased corrosion resistance
- Precision cast and machined surfaces permit safer wire pulling
- Precision NPT threaded hubs enable trouble-free field installation for rigid or IMC conduit
- Die-cast construction and industrial design combine to produce a rugged protective enclosure for devices on industrial and OEM applications
- Clear UL, CSA and cubic content markings speed approval by inspectors

Standard materials

- Die-cast aluminum alloy A360 with less than 0.004% copper content (copper-free)

Standard finish

- Aluminum lacquer finish

Listings/compliances

- UL Listed
- CSA Certified
- Suitable for hazardous locations
- Federal Spec W-C-586
- Cl.I, Div. 1 & 2, Groups C, D
- Cl.II, Div. 1, Groups E, F, G
- Cl.III, Div. 1 & 2
- NEMA 3, 4, 7 CD, 9 EFG
- Explosion-proof
- Dust-ignition-proof
- Raintight
- Wet locations

Sample specifications

Outlet boxes for hazardous locations shall be die-cast copper-free* aluminum alloy A360 and suitable for use in Class I, Groups C, D, Class II, Groups E, F, G and Class III areas. All conduit stops shall be coined and free of rough edges. Outlet boxes for hazardous locations shall be finished with aluminum lacquer. Outlet boxes shall be ABB catalog no. _____

*Less than 0.004% copper content.

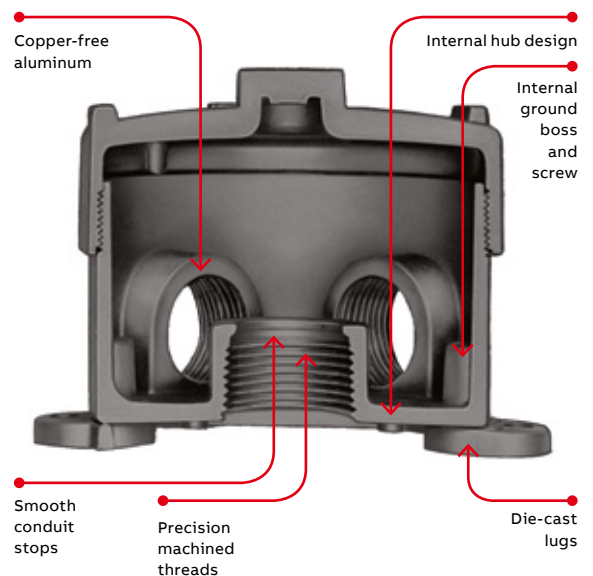

Hazardous location fittings

EXUN series aluminum internal hubs



5-Hole aluminum box



Cat. no.	Hub size (in.)	Description	Unit qty.	Std. pkg.	Wt. lbs. per 100
EXUN-1	$\frac{1}{2}$	(5) Outlets	1	5	140
EXUN-2	$\frac{3}{4}$	With (3) close-up plugs	1	5	140
EXUN-3	1	With (3) close-up plugs	1	5	140



4-Hole aluminum box



Cat. no.	Hub size (in.)	Description	Unit qty.	Std. pkg.	Wt. lbs. per 100
EXUN-11	$\frac{1}{2}$	(4) Outlets	1	5	140
EXUN-22	$\frac{3}{4}$	With (2) close-up plugs	1	5	140

Hazardous location fittings

GASS series aluminum internal hubs

01 GASS



01

Application

- Junction for branch conduits in hazardous locations
- Accessible wiring chamber provides a convenient location to maintain or change a system, pull conductors and make splices

Features

- Copper-free* aluminum alloy provides increased corrosion resistance
- Extra-wide 3¾" opening provides more hand space for easy access to the wiring chamber
- Precision cast and machined surfaces permit safer wire pulling
- Large capacity 31-cu.-in. chamber provides more wiring space
- Precision NPT threaded hubs enable trouble-free field installation for rigid or IMC conduit
- Sand-cast construction and industrial design combine to produce a rugged protective enclosure for devices on industrial and OEM applications
- Clear UL, CSA and cubic content markings speed approval by inspectors
- Hub spacing enables use of EXFU and EXMU unions

Standard materials

- Box — sand-cast aluminum alloy A356. 2-T6
- Cover — die-cast aluminum alloy A360 with less than 0.004% copper content (copper-free)

Standard finish

- Aluminum lacquer finish

Listings/compliances

- UL Listed
- CSA Certified
- NEC
- Cl.I, Div. 1 & 2, Groups C, D
- Cl.II, Div. 1, Groups E, F, G
- Cl.III, Div. 1 & 2
- NEMA 3, 4, 7 CD, 9 EFG
- Explosion-proof
- Dust-ignition-proof
- Raintight
- Wet locations

Sample specifications

Enclosure for hazardous locations. The box shall be cast copper-free* aluminum alloy A356.2-T6. Suitable for use in hazardous locations: Suitable for use in Class I, Groups C, D; Class II, Groups E, F, G; and Class III areas. Enclosures shall be finished with aluminum lacquer. Outlet boxes shall be ABB catalog no. _____

*Less than 0.004% copper content.

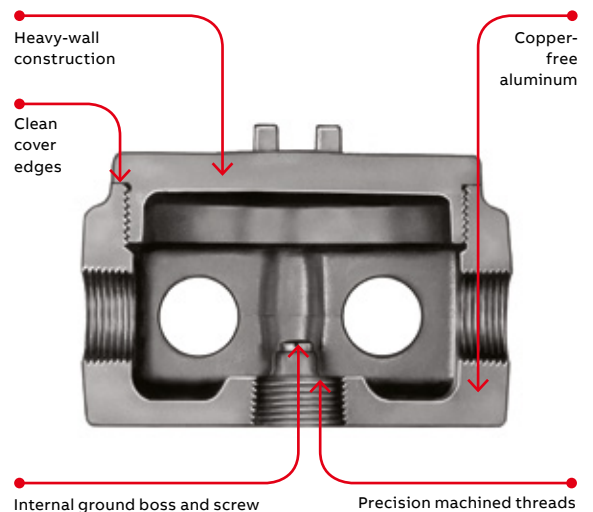

Hazardous location fittings

GASS series aluminum internal hubs

Cover opening (in.)	Hub size (in.)	Dimensions (in.)									Capacity (cu in.)
		A	B	C	D	E	F	G	H	J	
4	1/2	4 5/8	2 3/8	3 3/8	2 3/16	1 3/16	1/2	3/4	4	2 5/8	31
4	3/4	4 5/8	2 3/8	3 3/8	2 3/16	1 3/16	1/2	3/4	4	2 5/8	31
4	1	4 5/8	2 3/8	3 3/8	2 3/16	1 3/16	1/2	3/4	4	2 5/8	31

Diagrams

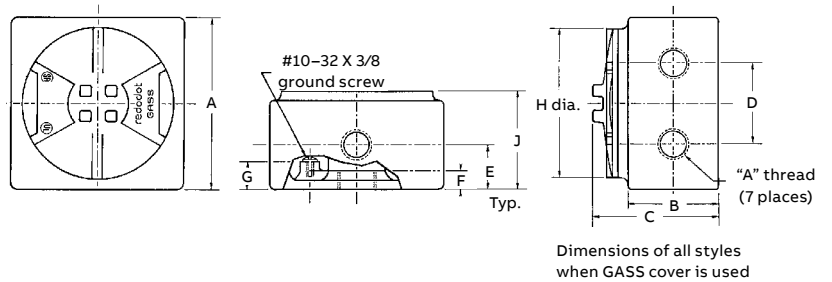

GASS internal hubs with installed green ground screw, cover and plugs



Cat. no.	Hub size (in.)	Unit qty.	Std. pkg.	Wt. lbs. per 100
GASS-1	1/2	1	5	282
GASS-2	3/4	1	5	278
GASS-3	1	1	5	274

Hazardous location fittings

GUP explosion-proof enclosure



Perfect for the petrochemical industry.

ABB has developed an innovative solution ideally suited for gas station contractors and the petrochemical market — the GUP explosion-proof enclosure. The compact design makes gas station pumps an ideal application due to space constraints. Two different configurations are available and the body is constructed of ductile iron for superior strength. Rely on ABB to deliver the best products when safety is a concern.

Features

- Compact design
- O-ring gasket standard for raintight applications
- Supplied with conduit plugs:
 - Three plugs for GUP215-TB
 - Seven plugs for GUP214-TB

Materials

Ductile iron body for superior strength, copper-free cast aluminum (A6) cover and neoprene gasket (O-ring)

Standard finish

- Ductile iron — electrogalvanized and aluminum acrylic paint
- Copper-free aluminum cover — natural

Listings/compliances

- UL 1203 Listed
- CSA Standard C22.2
- Cl. I, Div. 1 & 2, Groups C, D
- Cl. II, Div. 1, Groups E, F, G
- Cl. III, Div. 1 & 2
- NEMA 3, 4, 7 CD, 9 EFG
- Explosion-proof
- Dust-ignition-proof
- Raintight
- Wet locations

GUP explosion-proof enclosure



Cat. no.	Description	Std. pkg. qty.
GUP214-TB	Junction box — (10) hubs (3/4" NPT): (2) in top, (2) in bottom, (1) in each side, (4) in back	1
GUP215-TB	Junction box — (6) hubs (3/4" NPT): (2) in top, (2) in bottom, (1) in each side	1

Diagram

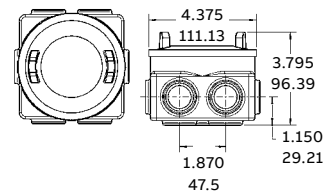

Hazardous location fittings

Aluminum conduit bodies

Application

- Junction for branch conduits
- Accessible wiring chamber provides a convenient location to pull conductors and make splices

Features

- 31 cu. in. capacity
- Copper-free* aluminum provides increased corrosion resistance
- Precision cast and machined surfaces permit safer wire pulling
- Precision NPT threaded hubs enable trouble-free field installation for rigid or IMC conduit
- Deep slotted cover screws for faster installation
- Clear UL, CSA and cubic content markings speed approval by inspectors

Standard materials

- Die-cast aluminum alloy A360 with less than 0.004% copper content (copper-free)
- Standard finish: Aluminum lacquer

Listings/compliances

- UL Listed
- CSA Certified
- Suitable for hazardous locations
- Cl. I, Div. 1 & 2, Groups C, D
- Cl. II, Div. 1, Groups E, F, G
- Cl. III, Div. 1 & 2
- NEMA 3, 4, 7 CD, 9 EFG
- Explosion-proof
- Dust-ignition-proof
- Raintight
- Wet locations

Sample specifications

Conduit fittings for hazardous locations shall be die-cast copper-free* aluminum alloy A360. Suitable for use in hazardous locations: Class I, Groups C, D; Class II, Groups E, F, G and Class III. All conduit stops shall be coined and free of rough edges. Conduit fittings shall be finished with aluminum lacquer. Conduit fittings shall be ABB catalog no. _____

*Less than 0.004% copper content.



—
LB style conduit body — aluminum



Cat. no.	Hub size (in.)	Unit qty.	Std. pkg.	Wt. lbs. per 100
EXLB-1	½	5	76	92
EXLB-2	¾	5	94	115
EXLB-3	1	5	132	172

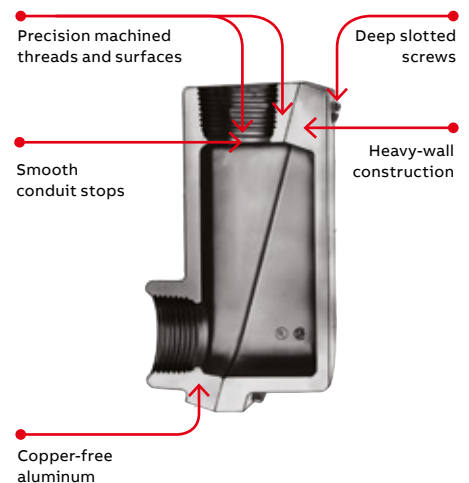

—
T style conduit body — aluminum



Cat. no.	Hub size (in.)	Unit qty.	Std. pkg.	Wt. lbs. per 100
EXT-1	½	5	25	92
EXT-2	¾	5	25	115
EXT-3	1	5	5	172

Hazardous location fittings

OE series iron conduit outlet bodies



Application

OE series are installed in conduit systems within hazardous areas to:

- Protect conductors in threaded rigid conduit
- Act as pulling and splice fittings
- Interconnect lengths of conduit
- Change direction of conduit
- Provide access for maintenance and future system changes

Features

- Tapered threaded hubs for ground continuity
- Smooth integral hub bushings to protect conductor insulation when pulling
- Five different hub arrangements
- Accurately machined body with blind tapped screw holes
- Sizes up to 1"

Standard materials

- Bodies: grade 60-45-10 ductile iron (complies with ASTM standard A536)

Standard finish

- Electrogalvanized and aluminum acrylic paint

Size ranges

- Hub — ½" and ¾"

Listings/compliances

- Cl. I, Div. 1 & 2, Groups C, D
- Cl. II, Div. 1, Groups E, F, G
- Cl. III, Div. 1 & 2
- NEMA 3, 4, 7 CD, 9 EFG
- Explosion-proof
- Dust-ignition-proof
- Raintight
- Wet locations

Cat. no.	Hub size (in.)	Dimensions (in.)						
		A	B	C	D	E	F	
OEC1-TB	½	4.06	1.62	1.90	0.69	0.88	0.63	
OEC2-TB	¾	4.35	1.88	2.19	0.69	0.88	0.76	
OET1-TB	½	4.06	1.62	1.90	0.69	0.88	0.63	
OET2-TB	¾	4.35	1.88	2.19	0.69	0.88	0.76	
OELL1-TB	½	4.06	1.62	1.90	0.69	0.88	0.63	
OELL2-TB	¾	4.35	1.88	2.19	0.69	0.88	0.76	
OELR1-TB	½	4.06	1.62	1.90	0.69	0.88	0.63	
OELR2-TB	¾	4.35	1.88	2.19	0.69	0.88	0.76	
OELB1-TB	½	4.06	1.62	1.90	0.69	0.88	0.63	
OELB2-TB	¾	4.35	1.88	2.19	0.69	0.88	0.76	

Diagrams

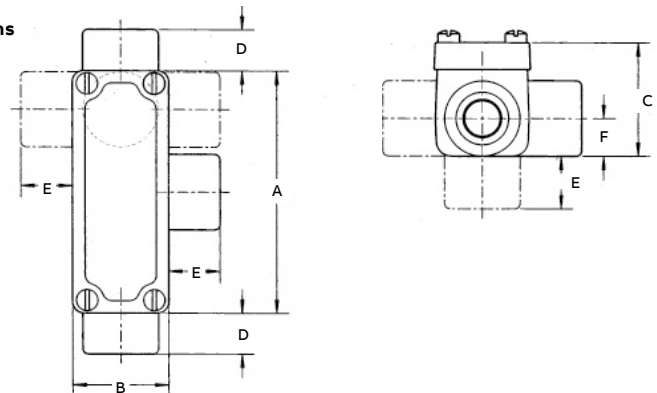

Hazardous location fittings

Capped elbow – female-to-female

Provides maximum volume for bends within a compact overall size

Application

LBY/GYF elbows are installed in conduit systems within hazardous areas to:

- Make 90° bends in conduit systems where space is limited
- Act as pull outlets
- Provide access to conductors for maintenance and future system changes

Features

- Maximum volume for bends within a compact overall size
- Screw-on cover for ease of installation and removal

- Cover opening on an angle, permitting conductors to be pulled straight through either hub
- Tapered threaded hubs and integral bushing for rigid threaded conduit

Standard materials

- LBY ductile iron
- GYF copper free aluminum

Listings/compliances (LBY)

- Cl. I, Div. 1 & 2, Groups C, D
- Cl. II, Div. 1, Groups E, F, G
- Cl. III, Div. 1 & 2
- NEMA 3, 4, 7 CD, 9 EFG
- Explosion-proof
- Dust-ignition-proof
- Raintight
- Wet locations



Capped iron elbow — female to female



Cat. no.	Hub size (in.)	A	B	Throat dim.	
				Min.	Max.
LBY15-TB	1/2	2 ⁹ / ₁₆	2	0.570	0.610
LBY25-TB	3/4	2 ¹³ / ₁₆	2 1/4	0.755	0.810
LBY35-TB	1	3 ³ / ₃₂	2 1/2	0.955	1.035
LBY45-TB	1 1/4	3 3/4	2 ¹⁵ / ₁₆	1.260	1.360
LBY55-TB	1 1/2	4 1/4	3 ³ / ₈	1.470	1.590
LBY65-TB	2	5 1/2	4	1.880	2.047

Diagrams

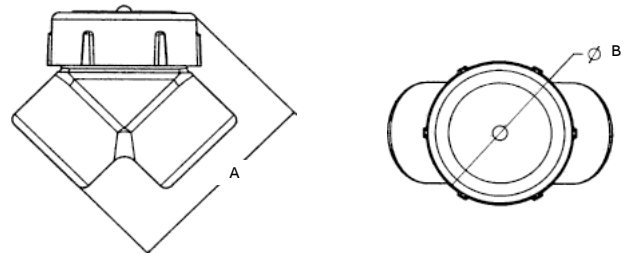

Capped aluminum elbow — female to female



Cat. no.	Hub size (in.)	Unit qty.	Std. pkg.	Wt. lbs. per 100
GYF-1	1/2	10	50	23
GYF-2	3/4	5	25	40
GYF-3	1	5	25	60
GYF-4*	1 1/4	2	10	80
GYF-5	1 1/2	2	10	95

Made-to-order items. Consult factory for lead time and minimum quantities.

Hazardous location fittings

Reducers, plugs and adapters

Application

- RE and REC reducers are used in threaded heavy-wall conduit systems
- RE reduces conduit hubs to a smaller size
- REC connects two different sizes of conduit together or is used to replace a coupling and reducer in an installation
- PLG plugs are used for closing threaded conduit hubs

Features

- All hubs have NPT threads with a minimum of five full threads and integral bushing for preventing damage to wires

Materials

- Machined reducers: steel
- Cast reducers: gray iron or stainless steel 316 (add suffix “-SST” instead of “-TB”)
- Funnel reducers: iron
- Recessed plugs: gray iron or stainless steel 316 (add suffix SST instead of “-TB” for SS option)
- Recessed plugs: copper-free aluminum



—
Stainless steel version coming soon

—
Reducing bushings – Now available in stainless steel 316



Cat. no.*	A male (NPT) (in.)	B female (NPT) (in.)	Cat. no.*	A male (NPT) (in.)	B female (NPT) (in.)
RE21-TB	3/4	1/2	RE73-TB	2 1/2	1
RE31-TB	1	1/2	RE74-TB	2 1/2	1 1/4
RE32-TB	1	3/4	RE75-TB	2 1/2	1 1/2
RE41-TB	1 1/4	1/2	RE76-TB	2 1/2	2
RE42-TB	1 1/4	3/4	RE83-TB	3	1
RE43-TB	1 1/4	1	RE84-TB	3	1 1/4
RE51-TB	1 1/2	1/2	RE85-TB	3	1 1/2
RE52-TB	1 1/2	3/4	RE86-TB	3	2
RE53-TB	1 1/2	1	RE87-TB	3	2 1/2
RE54-TB	1 1/2	1 1/4	RE96-TB	3 1/2	2
RE61-TB	2	1/2	RE97-TB	3 1/2	2 1/2
RE62-TB	2	3/4	RE98-TB	3 1/2	3
RE63-TB	2	1	RE106-TB	4	2
RE64-TB	2	1 1/4	RE107-TB	4	2 1/2
RE65-TB	2	1 1/2	RE108-TB	4	3

*Available in stainless steel 316, cULus listed. Replace “-TB” with “-SST”.

Standard finishes

- Cast: zinc plated with aluminum acrylic paint
- Machined: zinc plated with clear chromate finish
- Stainless steel: polished

Listings/compliances

- UL: 1203
- CSA: C22.2 No.30
- Cl. I, Div. 1 & 2, Groups A, B, C, D
- Cl. II, Div. 1, Groups E, F, G
- Cl. III, Div. 1 & 2
- Explosion-proof
- Dust-ignition-proof
- For hazardous and non-hazardous locations
- Stainless steel 316 versions are cULus



—
REC series reducers



Cat. no.	A (NPT) (in.)	B (NPT) (in.)	C (in.)
REC21-TB	3/4	1/2-14	1 7/8
REC31-TB	1	1/2-14	2
REC32-TB	1	3/4-14	2

Funnel-shaped reducers for hazardous and non-hazardous locations

Diagrams

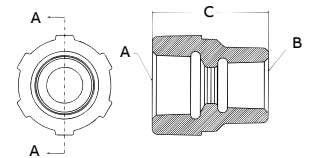

Hazardous location fittings

Reducers, plugs and adapters



—
Stainless steel version
coming soon



—
Recessed plugs – Now available in stainless steel 316



Cat. no.*	Threads (NPT) (in.)
With flush head for hazardous and non-hazardous locations	
PLG1-TB	1/2
PLG2-TB	3/4
PLG3-TB	1
PLG4-TB	1 1/4
PLG5-TB	1 1/2
PLG6-TB	2
PLG7-TB	2 1/2
PLG8-TB	3
PLG9-TB	3 1/2
PLG10-TB	4

*Available in stainless steel 316, cULus listed. Replace "-TB" with "-SST".

—
Aluminum recessed plugs



Cat. no.	Hub size (in.)
With flush head for hazardous and non-hazardous locations	
XPLG-1†	1/2
XPLG-2†	3/4
XPLG-3†	1
XPLG-4*	1 1/4
XPLG-5*	1 1/2
XPLG-6*	2

Made-to-order items. Consult factory for lead time and minimum quantities.

† Not UL listed and not approved for use in hazardous locations.

* UL listed E 34438

Hazardous location fittings

UN series three-piece unions



Application

UNY and UNF unions are installed in threaded thickwall conduit systems:

- UNY – to connect conduit to a conduit fitting, junction box or device enclosure
- UNF – to connect conduit to conduit, or to provide a means for future modification of the conduit system

Standard finishes

- Steel – electrogalvanized with chromate treatment
- Iron alloy, malleable iron – electrogalvanized and aluminum acrylic paint



Listings/compliances

- NEC®/CEC
- Class I, Division 1 & 2, Groups A, B, C, D
Class II, Division 1, Groups E, F, G
Class III
- UNF, UNY ½" – 1"
- UL – Conduit unions for use in cat. nos. UNF/UNY followed by 105, 205, or 305; for use in:
 - Class I, Division 1 & 2, Groups A, B, C, D
Class II, Division 1, Groups E, F, G
Class III
 - UNF, UNY ½", ¾", 1"

- CSA – Conduit unions for use in cat. nos. UNF/UNY followed by 105, 205, 305, 405 or 505; for use in:
 - Class I, Division 1 & 2, Groups B, C, D
Class II, Division 1, Groups E, F, G
Class III
 - UNF, UNY ½", ¾", 1", 1¼", 1½"
- UL – Conduit unions for use in cat. nos. UNF/UNY followed by 405 or 505; for use in:
 - Class I, Division 1 & 2, Groups B, C, D
Class II, Division 1, Groups E, F, G
Class III
 - UNF, UNY 1¼", 1½"
- UL and CSA – Conduit unions for use in cat. nos. UNF/UNY, EL series followed by 605, 905, or 1005; for use in:
 - Class I, Division 1 & 2, Groups C, D
Class II, Division 1, Groups E, F, G
Class III
 - UNF, UNY 2", 2½", 3", 3½", 4"

NEC and National Electrical Code are registered trademarks of the National Fire Protection Association, Inc.

Hazardous location fittings

UN series three-piece unions



UNY male unions



Cat. no.	Trade size (in.)	Overall length (in.)	Overall dia. (in.)
For hazardous and non-hazardous locations			
UNY105-TB	1/2	2 ²⁵ / ₆₄	1 1/2
UNY205-TB	3/4	2 ⁷ / ₁₆	1 ¹³ / ₁₆
UNY305-TB	1	2 ³ / ₄	2
UNY405-TB	1 1/4	3 ¹ / ₁₆	2 ³ / ₄
UNY505-TB	1 1/2	3 ⁵ / ₈	3 ¹ / ₁₆
UNY605-TB	2	3 ¹ / ₂	3 ¹³ / ₁₆
UNY705-TB	2 1/2	4 ¹³ / ₁₆	4 ⁵ / ₁₆
UNY805-TB	3	5 ¹ / ₃₂	5 ¹ / ₁₆
UNY905-TB	3 1/2	5 ¹ / ₂	5 ¹¹ / ₁₆
UNY1005-TB	4	5 ⁵ / ₈	6 ³ / ₁₆

Diagram

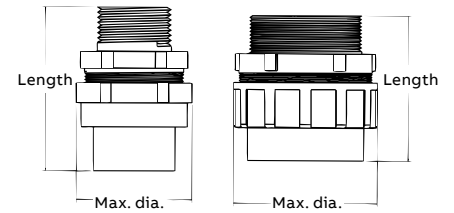

UNF female unions



Cat. no.	Trade size (in.)	Overall length (in.)	Overall dia. (in.)
For hazardous and non-hazardous locations			
UNF105-TB [†]	1/2	1 ⁷ / ₈	1 1/2
UNF205-TB [†]	3/4	2 ¹ / ₈	1 ¹³ / ₁₆
UNF305-TB [†]	1	2 ⁵ / ₃₂	2
UNF405-TB ^{††}	1 1/4	2 ¹ / ₄	2 ³ / ₄
UNF505-TB ^{††}	1 1/2	2 ³ / ₄	3 ¹ / ₁₆
UNF605-TB ^{†††}	2	2 ¹ / ₂	3 ¹³ / ₁₆
UNF705-TB ^{†††}	2 1/2	3 ¹ / ₂	4 ⁵ / ₁₆
UNF805-TB ^{†††}	3	4	5 ¹ / ₁₆
UNF905-TB ^{†††}	3 1/2	4 ⁵ / ₃₂	5 ¹¹ / ₁₆
UNF1005-TB ^{†††}	4	4 ¹ / ₄	6 ³ / ₁₆

Diagram

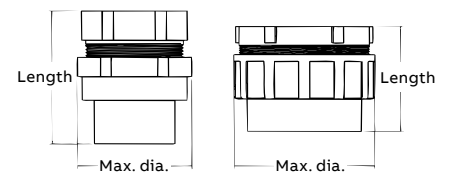

[†] Steel

^{††} Forged steel

^{†††} Malleable iron

Hazardous location fittings

EX series aluminum three-piece unions

Application

- Unions are used as connecting elements between enclosures, fittings or boxes that permit future changes to the system in both hazardous and non-hazardous areas

Features

- Copper-free* aluminum provides increased corrosion resistance
- Precision cast and machined surfaces permit safer wire pulling
- Precision NPT threaded hubs allow trouble-free field installation for rigid or IMC conduit
- Clear UL, CSA and cubic content markings speed approval by inspectors
- Unique concentric ring design ensures critical flame path control

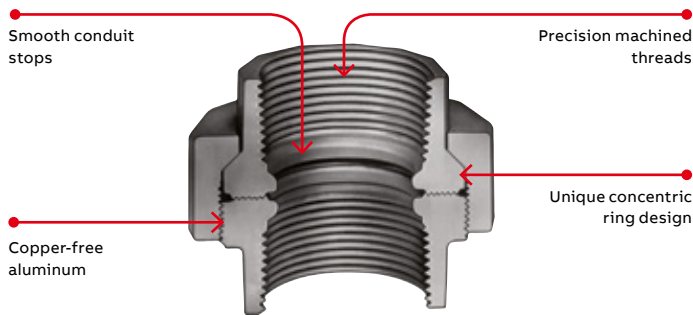

EXFU female-to-female unions



Cat. no.	Hub size (in.)	Unit qty.	Std. pkg.	Wt. lbs. per 100
EXFU-1	1/2	5	25	24
EXFU-2	3/4	5	25	33
EXFU-3	1	5	25	42
EXFU-4	1 1/4	5	25	53
EXFU-5	1 1/2	5	25	68
EXFU-6•	2	2	10	130
EXFU-8•	3	1	5	310
EXFU-9•	3 1/2	1	5	340
EXFU-10•	4	1	1	374

Made-to-order items. Consult factory for lead time and minimum quantities.

Standard materials

- Die-cast aluminum alloy A360 with less than 0.004% copper content (copper-free)
- EXMU nipples are galvanized steel

Standard finish

- Aluminum lacquer finish

Listings/compliances

- UL Listed
- CSA Certified
- Suitable for hazardous locations
- Federal Spec W-C-586
- Cl. I, Div. 1 & 2, Groups C, D
- Cl. II, Div. 1, Groups E, F, G
- Cl. III, Div. 1 & 2
- NEMA 3, 4, 7 CD, 9 EFG
- Explosion-proof
- Dust-ignition-proof
- Raintight
- Wet locations

Sample specifications

Conduit unions for hazardous locations shall be die-cast copper-free* aluminum alloy A360. Suitable for use in hazardous locations: Class I, Groups C, D; Class II, Groups E, F, G and Class III.

All conduit stops shall be coined and free of rough edges. Conduit unions shall be finished with aluminum lacquer. Conduit unions shall be ABB catalog no. _____

*Less than 0.004% copper content.



EXMU male-to-female unions



Cat. no.	Hub size (in.)	Unit qty.	Std. pkg.	Wt. lbs. per 100
EXMU-1	1/2	5	25	24
EXMU-2	3/4	5	25	35
EXMU-3	1	5	25	45

Hazardous location fittings

EYD drain seals



- Cl. I, Div. 1 & 2, Groups A, B, C, D
- Cl. II, Div. 1, Groups E, F, G
- Cl. III, Div. 1 & 2

Application

EYD drain and inspection sealing fittings:

- Restrict the passage of gases, vapors or flames from one portion of the electrical installation to another at atmospheric pressure and normal ambient temperatures
- Limit explosions to the sealed-off enclosure
- Prevent precompression or “pressure piling” in conduit systems
- Drain sealing fittings are installed in vertical conduit runs and at low points in conduit systems to prevent accumulation of condensate above seal

Features

EYD drain sealing fittings include:

- Drain to provide continuous, automatic drainage of condensate
- Large openings with threaded closures to provide easy access to conduit hubs for making dams
- Integral bushings to protect conductor insulation from damage
- Tapered-tapped hubs to ensure ground continuity

Standard materials

- Bodies and drain covers – gray iron alloy and/or ductile iron
- Closure for drain – copper-free aluminum or ductile iron
- Small closure plug – gray iron alloy and/or steel
- Drain – stainless steel
- Removable nipples – steel

Standard finish

- Gray iron alloy and ductile iron – electrogalvanized and aluminum acrylic paint
- Copper-free aluminum – natural
- Stainless steel – natural
- Steel – electrogalvanized

Options

- Copper-free aluminum bodies, nipples and enclosures – see listings

Size ranges

- EYD – ½”–4”

Listings/compliances

- EYD11 – 31-TB
 - Class I, Division 1 & 2, Groups A, B, C, D; Class II, Division 1, Groups E, F, G; Class III
- EYD41 – 101-TB
 - Class I, Division 1 & 2, Groups C, D; Class II, Division 1, Groups E, F, G
 - Class II, Division 2, Groups F, G
 - Class III
- UL Standard: 1203
- CSA Standard: C22.2
- NEMA 3, 4, 7 CD, 9 EFG
- Explosion-proof
- Dust-ignition-proof
- Raintight
- Wet locations

Sealing compound and fibers

- Seal A3 (1-lb. can of sealing compound)
- Fiber X6 (8-oz. fiber packing)
- Seal kit (1-lb. can of sealing compound and 1-oz. fiber packing)

Hazardous location fittings

EYD drain seals and ECD drains/breathers



EYD drain seals



Cat. no.	Hub size (in.)	Dimensions (in.)		
		A	B	Turning radius (in.)
EYD11-TB	1/2	3.81	1.50	1.75
EYD21-TB	3/4	4.08	1.75	1.98
EYD31-TB	1	4.85	2.19	2.19
EYD41-TB	1 1/4	5.00	2.25	1.80
EYD51-TB	1 1/2	5.44	2.44	2.00
EYD61-TB	2	6.25	3.00	2.32
EYD71-TB	2 1/2	7.50	3.50	2.69
EYD81-TB	3	8.50	4.25	3.15
EYD91-TB	3 1/2	9.19	4.75	3.38
EYD101-TB	4	9.75	5.25	3.64

Diagrams

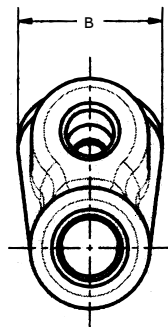

EYD 1/2" - 1"

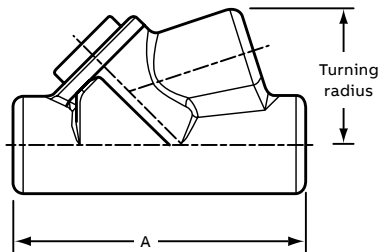

EYD 1/2" - 1"

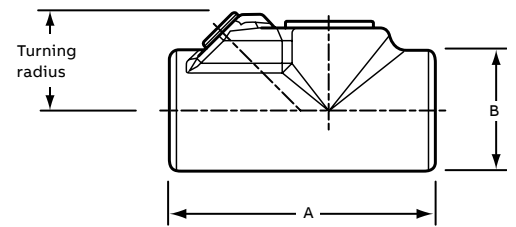

EYD 1 1/4" - 4"



Drains/breathers for hazardous locations

Application

- The ABB universal drain/breather fittings can be used as drains or breathers depending on the installation.
- To use as a drain, the product must be installed in the bottom of the enclosure or the lowest point where an NPT threaded opening exists. It can also be used in a seal fitting or a "T" conduit body. These must be in a lower section of the conduit system. This will enable moisture inside the conduit system to drain out.

- To use as a breather, installation should be done at the top of an enclosure or in upper sections of conduit systems. This will permit air exchange and keep moisture accumulation inside the conduit system to a minimum. ABB recommends the use of at least two devices (one drain and one breather) for maximum efficiency.

Listings/compliances

- Cl. I, Div. 1 & 2, Groups B, C, D
- Cl. II, Div. 1, Groups E, F, G
- Cl. III, Div. 1 & 2

ECD drains/breathers

Cat. no.	Hub size (in.)	Dimensions (in.)	
		A	B
ECD15*	1/2		0.975
ECD384	3/8		0.407
ECD284	1/4		0.327

* NEMA 4X rated.

Hazardous location fittings

EYS sealing fittings – Now available in stainless steel 316



Stainless steel version coming soon

Application

- EYS sealing fittings can be installed in either vertical or horizontal applications
- Seals sections of conduit runs from passage of vapors, flame or gases
- Seals off sections of conduit system during explosion
- Limits precompression or pressure piling in conduit system

Features

- All hubs have a minimum of five full threads, integral bushings to protect conductor insulation from damage and large access openings for easier packing of sealing medium
- Seals are approved to be used with Crouse-Hinds® sealing compound and fiber

Size range

- ½" NPT to 4" NPT

Materials

- Bodies: ductile iron
- Plugs: gray iron
- Nipples: steel, supplied with EYS fittings
- Option: Stainless steel 316 (replace “-TB” with “-SST”)

Finish

- Bodies: zinc-plated with aluminum acrylic paint
- Plugs: zinc-plated with aluminum acrylic paint
- Nipples: zinc-plated
- Stainless steel: polished

Sealing compound and fibers

- Seal A3 (1-lb. can of sealing compound)
- Fiber X6 (8-oz. fiber packing)
- Seal kit (1-lb. can of sealing compound and 1-oz. fiber packing)

Listings/compliances

- UL 1203
- CSA: C22.2 No. 30
- EYS seals are approved to be used with Crouse-Hinds® Chico® A compound and Chico® X fiber
- EYS1-3TB: Cl. I, Div. 1 & 2, Groups A, B, C, D
- EYS4-5TB: Cl. I, Div. 1 & 2, Groups C, D
- EYS11-31TB: Cl. I, Div. 1 & 2, Groups A, B, C, D Cl. II, Div. 1, Groups E, F, G; Cl. III
- EYS41-101TB: Cl. I, Div. 1 & 2, Groups C, D Cl. II, Div. 1, Groups E, F, G; Cl. III
- Explosion-proof
- Dust-ignition-proof
- Stainless steel 316 versions are cULus listed



Diagrams	Cat. no.	Hub size (in.)	Dimensions (in.)			Turning radius (in.)
			A	B	C	
	Vertical only					
	EYS1-TB	½	3.31	1.25	1.50	1.66
	EYS2-TB	¾	3.65	1.50	1.75	1.96
	EYS3-TB	1	4.25	1.75	2.19	2.40
	EYS4-TB	1¼	5.00	2.25	2.45	3.11
	EYS5-TB	1½	5.69	2.45	3.00	3.62
	Horizontal/vertical					
	EYS11-TB	½	3⅝	1¼	–	1⅜ ₃₂
	EYS21-TB*	¾	3 ²¹ / ₃₂	1½	–	1¼
	EYS31-TB*	1	4¼	1¾	–	1 ¹⁹ / ₃₂
	EYS41-TB	1¼	5	2¼	–	1 ¹³ / ₁₆
	EYS51-TB	1½	5 ⁷ / ₁₆	2 ¹ / ₁₆	–	2
	EYS61-TB	2	6¼	3	–	2 ⁵ / ₁₆
	EYS71-TB	2½	7½	3½	–	2 ⁹ / ₁₆
	EYS81-TB	3	8½	4¼	–	3 ³ / ₃₂
	EYS91-TB	3½	9 ³ / ₁₆	4¾	–	3 ³ / ₈
	EYS101-TB	4	9¾	5¼	–	3 ¹⁷ / ₃₂

Crouse-Hinds and Chico are trademarks of Cooper Technologies Company.

*Available in stainless steel 316, cULus listed. Replace “-TB” with “-SST”.

Hazardous location fittings

EYVF and EVHF sealing fittings



EYVF

Application

- Limits flames and/or explosions to area within electrical system where they originate
- Limits pressure piling
- Required by NEC® for conduit systems in hazardous locations 18" from an enclosure housing a heat producing or arcing device; on 2" and larger system that enters an enclosure containing splices; wherever conduit leaves a Class I, Division I area and enters a non-hazardous area

Features

- Copper-free* aluminum provides increased corrosion resistance
- Precision cast and machined surfaces permit safer wire pulling
- Precision NPT threaded hubs enable trouble-free field installation for rigid or IMC conduit
- Large opening provides maximum working room for creating dam and seal pouring to speed up installation
- Compact design permits close construction of parallel conduit runs

Standard materials

- Sealing fittings: die-cast aluminum alloy A360 with less than 0.004% copper content (copper-free)
- Sealing cement
- Fiber: flame-retardant Kaowool Type A fiber

Standard finish

- Aluminum lacquer finish

Listings/compliances

- UL Listed
- CSA Certified
- Suitable for hazardous locations
- Federal Spec W-C-586
- Cl. I, Div. 1 & 2, Groups C, D
- Cl. II, Div. 1, Groups E, F, G
- Cl. III, Div. 1 & 2
- NEMA 3, 4, 7 CD, 9 EFG
- Explosion-proof
- Dust-ignition-proof
- Raintight
- Wet locations

Sample specifications

Sealing fittings for hazardous locations shall be die-cast copper-free* aluminum alloy A360. Suitable for use in hazardous locations: Class I, Groups C, D; Class II, Groups E, F, G and Class III. All conduit stops shall be coined and free of rough edges. Sealing fittings for hazardous locations shall be finished with aluminum lacquer. Sealing fittings shall be ABB catalog no. _____

*Less than 0.004% copper content.



EVHF-1 through -3



EVHF-4 through -9

Vertical sealing fittings



Cat. no.	Hub size (in.)	Unit qty.	Std. pkg.	Wt. lbs. per 100
EYVF-1†	½	5	25	50
EYVF-2†	¾	5	25	54
EYVF-3†	1	5	25	100
EYVF-11	½	10	50	35
EYVF-22	¾	10	50	40
EYVF-33	1	4	20	60

Vertical/horizontal sealing fittings



Cat. no.	Hub size (in.)	Unit qty.	Std. pkg.	Wt. lbs. per 100
EVHF-1	½	10	50	41
EVHF-2	¾	5	25	50
EVHF-3	1	5	25	60
EVHF-4	1¼	4	20	70
EVHF-5	1½	1	5	60
EVHF-6	2	1	1	125
EVHF-7 •	2½	1	1	150
EVHF-9 •	3½	1	1	300

• Made-to-order items. Consult factory for lead time and minimum quantities.

† Packaged with an adequate amount of sealing compound and plugs installed.

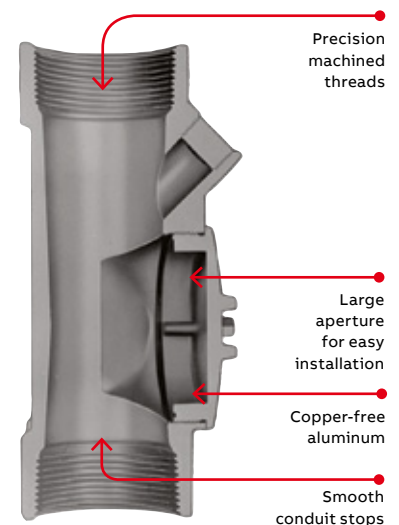

Hazardous location fittings

Preparation of sealing fittings

Applications

ABB T&B® Fittings sealing cement is used for making seals in sealing fittings. The insulation in the conductors sealed in the cement may be approved thermoplastic or rubber, with or without lead covering. The sealing cement should not be used for insulating.

Characteristics

ABB T&B® Fittings sealing cement is not affected by gasoline, alcohol, acetone, ether, naphtha, petroleum, benzol or lacquer solvent.

Preparation

- (1) Use a clean mixing vessel for each batch.
- (2) Thoroughly mix powder before adding water.
- (3) Do not use if temperature is below 40 °F.
- (4) Mix one part water to two parts cement.
- (5) Allow cement to set for 72 hours before use.

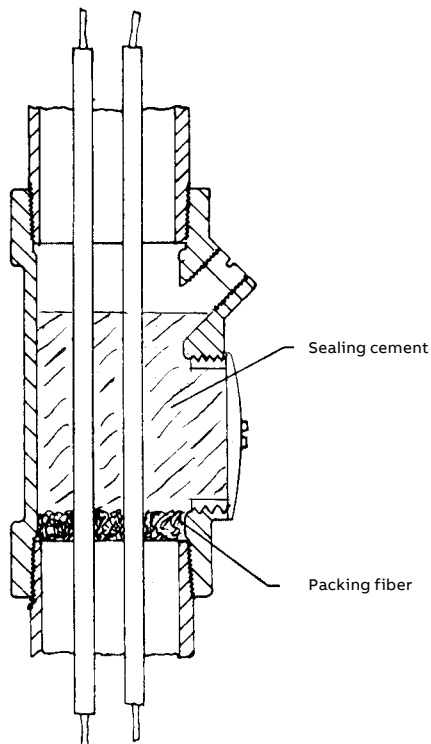

Vertical installation
for EYVF or
EVHF fittings

Standard dams

- (1) Push the conductors away from the filling opening and force them apart so that they do not touch each other or the walls of the fitting or conduit along their length. If the conductors do touch, the sealing cement will not form a closed path between them.
- (2) Force the packing fiber between each conductor and the inside walls. Be sure that the dam is strong enough and tight enough to prevent the considerable weight of the fluid sealing cement from seeping out.

Pouring

- (1) Pour the mixed cement into the fitting slowly so as not to trap air in the seal.
- (2) Replace the close-up plugs to ensure that they engage not less than five full threads.

Cl. I, Div. 1 & 2, Groups C, D

Cl. II, Div. 1, Groups E, F, G

Cl. III, Div. 1 & 2

NEMA 3, 4, 7 CD, 9 EFG

Explosion-proof

Dust-ignition-proof

Raintight

Wet locations

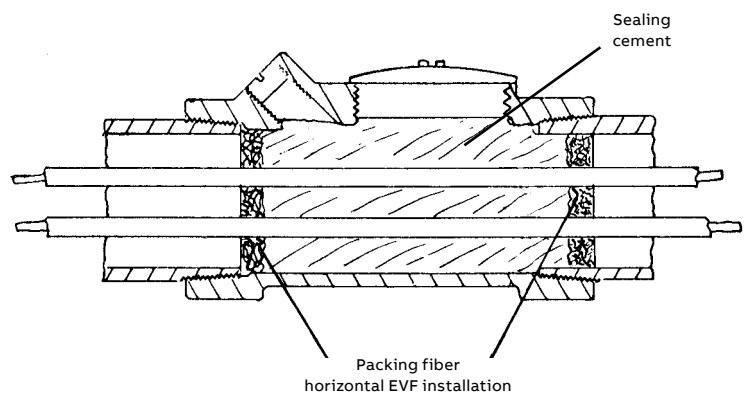

Hazardous location fittings

Sealing cement and fiber for ABB sealing fittings

- Cl. I, Div. 1 & 2, Groups C, D
- Cl. II, Div. 1, Groups E, F, G
- Cl. III, Div. 1 & 2
- Explosion-proof

- Dust-ignition-proof
- Raintight
- Wet locations
- Can be used on T&B EYV, EVH series fittings only



Sealing cement

Cat. no.	Quantity	Volume (cu. in.)	Std. pkg.	Wt. lbs per 100
EXSC-2	3.2 oz.	2.75	25	20
EXSC-8	13 oz.	11.50	15	81
EXSC-16	1 lb., 10 oz.	23.00	10	163



Packing fiber

Cat. no.	Quantity	Std. pkg.	Wt. lbs per 100
EXPF-16	1 lb.	1	112

Approximate amount of cement and fiber required per hub

Cat. no.	Hub size (in.)	Cement quantity (oz.)	Fiber quantity (oz.)
EYVF-11	1/2	2	1/32
EYVF-22	3/4	3	1/16
EYVF-33	1	4	1/8
EVHF-1	1/2	2	1/32
EVHF-2	3/4	2	1/32
EVHF-3	1	4	1/4
EVHF-4	1 1/4	4	1/4
EVHF-5	1 1/2	6	1/2
EVHF-6	2	12	1
EVHF-7	2 1/2	15	1 1/2
EVHF-8	3	40	2
EVHF-9	3 1/2	45	3
EVHF-10	4	50	4

Hazardous location fittings

XP Flex™ explosion-proof flexible couplings

- 01 XPLFL16
- 02 XPLFL110
- 03 XPLFL212

Stainless steel version coming soon

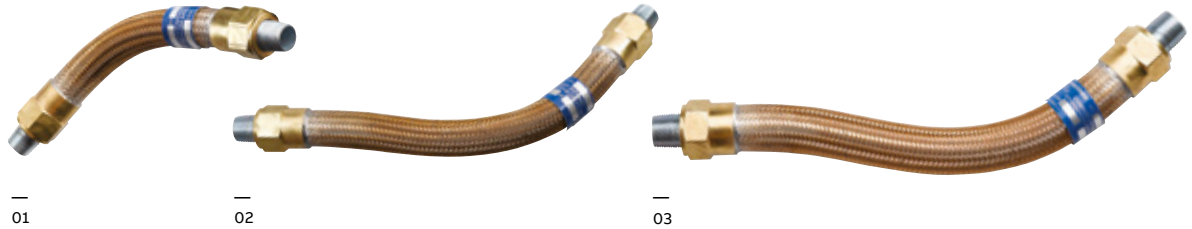

Make flexible connections in hazardous locations. With their flexible design, ABB XP Flex couplings make it easy to achieve tight bends in conduit systems in confined spaces – or to connect stationary equipment to equipment that moves or vibrates. Their explosion-proof and corrosion-resistant construction mean you can use them with confidence in hazardous and wet locations.

Application

- Achieve tight bends in conduit systems in confined spaces
- Connect stationary equipment to equipment that moves or vibrates

Features

- Corrosion resistant – ideal for washdown areas
- Flexible bronze construction with arc-resistant inner sleeve and brass fittings
- Terminated with two threaded female end fittings and male close nipples
- No bonding jumper required

Standard materials

- Flexible bronze construction with arc-resistant inner sleeve
- Brass fittings

Listings/compliances

- UL Listed
- CSA Certified
- Suitable for hazardous locations
- ½" and ¾" hub sizes:
 - Class I, Div. 1 & 2, Groups A, B, C, D
 - Class II, Div. 1, Groups E, F, G
 - Class III
- 1" hub size:
 - Class I, Div. 1 & 2, Groups C, D
 - Class II, Div. 1, Groups E, F, G
 - Class III
- Wet locations
- UL886



Diagrams

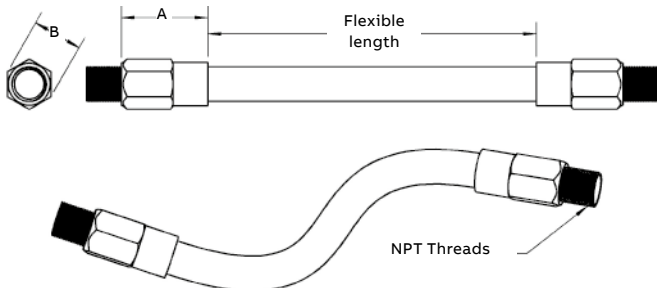

Cat. no.	Hub size (in.)	Flexible length (in.)	Dimensions (in.)	
			A	B
XPLFL16	½	6	1.54	1.44
XPLFL18	½	8	1.54	1.44
XPLFL110	½	10	1.54	1.44
XPLFL112	½	12	1.54	1.44
XPLFL115	½	15	1.54	1.44
XPLFL118	½	18	1.54	1.44
XPLFL124	½	24	1.54	1.44
XPLFL212	¾	12	1.60	1.87
XPLFL215	¾	15	1.60	1.87
XPLFL218	¾	18	1.60	1.87
XPLFL224	¾	24	1.60	1.87
XPLFL236	¾	36	1.60	1.87
XPLFL318	1	18	2.00	2.31

Technical information

UL recommended dimensions and weights of rigid metal conduit

Trade size (in.)	Thds. per in.	I.D. (in.)	O.D. (in.)	Wall thickness (in.)	Min. wt. at 100' length with one coupling attached (lbs.)
¼	18	0.364	0.540	0.088	38.5
⅜	18	0.493	0.675	0.091	51.5
½	14	0.622	0.840	0.109	79.0
¾	14	0.824	1.050	0.113	105.0
1	11½	1.049	1.315	0.133	153.0
1¼	11½	1.380	1.660	0.140	201.0
1½	11½	1.610	1.900	0.145	249.0
2	11½	2.067	2.375	0.154	332.0
2½	8	2.469	2.875	0.203	527.0
3	8	3.068	3.500	0.216	682.6
3½	8	3.548	4.000	0.226	831.0
4	8	4.026	4.500	0.237	972.3
4½	8	4.506	5.000	0.247	1,150.0
5	8	5.047	5.563	0.258	1,313.6
6	8	6.065	6.625	0.280	1,745.3

UL dimensions for intermediate metallic conduit* — type I (10-ft. lengths)

Trade size (in.)	O.D. (in.)		Wall thickness (in.)
	Min.	Max.	
½	0.810	0.820	0.070*
¾	1.024	1.034	0.075*
1	1.285	1.295	0.085*
1¼	1.630	1.645	0.085*
1½	1.875	1.890	0.090*
2	2.352	2.367	0.095*
2½	2.847	2.867	0.130**
3	3.466	3.486	0.130**
3½	3.961	3.981	0.130**
4	4.456	4.476	0.130**

* (+0.015, -0.000)

** (+0.020, -0.000)

† IMC threads are the same as rigid metal conduit threads.

UL dimensions for intermediate metallic conduit — type II (10-ft. lengths)

Trade size (in.)	O.D. (in.)		Wall thickness (in.)
	Min.	Max.	
½	0.825	0.840	0.085*
¾	1.035	1.050	0.085*
1	1.300	1.315	0.108*
1¼	1.645	1.660	0.108*
1½	1.885	1.900	0.108*
2	2.360	2.375	0.108*
2½	2.850	2.875	0.155**
3	3.475	3.500	0.155**
3½	3.975	4.000	0.160**
4	4.475	4.500	0.160**

* (+0.020, -0.000)

** (+0.025, -0.000)

Technical information

UL recommended dimensions and weight of electrical metallic tubing (EMT)

Trade size (in.)	O.D. (in.)	I.D.* (in.)	Wall thickness (in.)	Min. accept. wt. ft. (lbs.)
$\frac{3}{8}$	0.577 ± 0.005	0.493	0.042	0.230
$\frac{1}{2}$	0.706 ± 0.005	0.622	0.042	0.285
$\frac{3}{4}$	0.922 ± 0.005	0.824	0.049	0.435
1	1.163 ± 0.005	1.049	0.057	0.640
1 $\frac{1}{4}$	1.510 ± 0.005	1.380	0.065	0.950
1 $\frac{1}{2}$	1.740 ± 0.005	1.610	0.065	1.100
2	2.197 ± 0.005	2.067	0.065	1.400
2 $\frac{1}{2}$	2.875 ± 0.010	2.731	0.072	2.050
3	3.500 ± 0.015	3.356	0.072	2.500
3 $\frac{1}{2}$	4.000 ± 0.020	3.834	0.083	3.250
4	4.500 ± 0.020	4.334	0.083	3.700

* Not a requirement — included for information only.

Knockout (sliphole) sizes for electrical conduits and connectors

Trade size (in.)	Knockout diameter (in.)		
	Nom.	Min.	Max.
$\frac{1}{4}$	0.575	0.559	0.605
$\frac{3}{8}$	0.718	0.703	0.734
$\frac{1}{2}$	0.875	0.859	0.906
$\frac{3}{4}$	1.109	1.094	1.141
1	1.375	1.359	1.406
1 $\frac{1}{4}$	1.734	1.719	1.766
1 $\frac{1}{2}$	1.984	1.958	2.000
2	2.469	2.433	2.500
2 $\frac{1}{2}$	2.969	2.938	3.000
3	3.594	3.563	3.625
3 $\frac{1}{2}$	4.125	4.063	4.156
4	4.641	4.563	4.672
4 $\frac{1}{2}$	5.109	5.063	5.166
5	5.719	5.625	5.750
6	6.813	6.700	6.844

Sizes $\frac{1}{4}$ " through 1 $\frac{1}{4}$ " are per UL 514.

Sizes $\frac{1}{2}$ " through 6" per proposed revision to NEMA Engineering Bulletin No. 71, Aug. 1976.

UL recommended diameters for flexible metal conduit (greenfield)

Trade size (in.)	Max. O.D. (in.)	O.D. (in.)	
		Min.	Max.
$\frac{5}{16}$	0.510	0.312	0.393
$\frac{3}{8}$	0.610	0.375	0.645
$\frac{1}{2}$	0.920	0.625	0.835
$\frac{3}{4}$	1.105	0.812	—
1	1.380	1.000	—
1 $\frac{1}{4}$	1.630	1.250	—
1 $\frac{1}{2}$	1.950	1.500	—
2	2.450	2.000	—
2 $\frac{1}{2}$	3.060	3.500	—
3	3.560	3.000	—
3 $\frac{1}{2}$	4.060	3.500	—
4	4.560	4.000	—

Technical information

UL recommended diameters for liquid-tight flexible metal conduit

Trade size (in.)	I.D. (in.)		O.D. (in.)	
	Min.	Max.	Min.	Max.
3/8	0.484	0.504	0.690	0.710
1/2	0.622	0.642	0.820	0.840
3/4	0.820	0.840	1.030	1.050
1	1.041	1.066	1.290	1.315
1 1/4	1.380	1.410	1.630	1.660
1 1/2	1.575	1.600	1.865	1.900
2	2.020	2.045	2.340	2.375
2 1/2	2.480	2.505	2.840	2.875
3	3.070	3.100	3.460	3.500
3 1/2	3.500	3.540	3.960	4.000
4	4.000	4.040	4.460	4.500

Diameter of liquid-tight non-metallic flexible conduit

Trade size (in.)	I.D. (in.)		O.D. (in.)	
	Min.	Max.	Mmin.	Max.
3/8	0.485	0.505	0.755	0.775
1/2	0.620	0.640	0.910	0.930
3/4	0.815	0.835	1.150	1.170
1	1.030	1.055	1.415	1.440
1 1/4	1.370	1.395	1.800	1.825
1 1/2	1.585	1.620	2.045	2.080
2	2.045	2.080	2.605	2.640

Appendix

Part number index

Cat. no.	Page	Cat. no.	Page	Cat. no.	Page
106	7	1232AL	14	1283	56
106SS6	7	123AL	14	1283AL	56
107	7	124	14	1284	56
107SS6	7	1244	45	1284AL	56
108	7	1245	45	1285	56
108SS6	7	1246	45	1285AL	56
109	7	1247	45	1286	56
109SS6	7	124AL	14	1287	56
110	7	1250-TB	46	1288	56
110SS6	7	1251	46	128AL	14
111	7	1252	46	129	14
111SS6	7	1253	46	129AL	14
112	7	1254	46	130AL	14
112SS6	7	1255	46	130-TB	14
113	7	1256	46	131AL	14
113SS6	7	1257	46	131-TB	14
114	7	1258	46	132-TB	14
115	7	125AL	14	133AL	14
115SS6	7	125-TB	14	133-TB	14
1210TB	57	126	14	134AL	14
1211TB	57	1261	46	134-TB	14
1212TB	57	1262	46	1350	63
1213TB	57	1263	46	1350AL	63
1214TB	57	126AL	14	1350CR	63
1215TB	57	127	14	1351	63
1216TB	57	1275	56	1351AL	63
122	14	1275AL	56	1351CR	63
1222	14	1275CR	57	1352	63
1222AL	14	1276	56	1352AL	63
1223	14	1276AL	56	1353	63
1223AL	14	1276CR	57	1353AL	63
1224	14	1277	56	1354	63
1224AL	14	1277AL	56	139	7
1225	14	1277CR	57	140	7
1225AL	14	1278	56	141	7
1226	14	1278AL	56	141AL	7
1226AL	14	1278CR	57	141SL	8
1227	14	1279	56	141SS6	7
1227AL	14	1279AL	56	141-SST	7
1228	14	1279CR	57	142	7
1228AL	14	127AL	14	142AL	7
1229	14	128	14	142SL	8
1229AL	14	1280	56	142SS6	7
122AL	14	1280AL	56	142-SST	7
123	14	1280CR	57	143	7
1230	14	1281	56	143AL	7
1230AL	14	1281AL	56	143SL	8
1231	14	1281CR	57	143SS6	7
1231AL	14	1282	56	143-SST	7
1232	14	1282AL	56	144	7

Appendix

Part number index

Cat. no.	Page	Cat. no.	Page	Cat. no.	Page
1440	45	1494	48	280	68
1441	45	1495	48	280F	68
1442	45	149AL	7	280SST	68
1443	45	149SS6	7	290SA	68
144AL	7	150	7	2ADFS-1	92, 94
144SL	8	150AL	7	2ADFS-2	92, 94
144SS6	7	150SS6	7	2ADFS-3	94
144-SST	7	151	7	2ADFSC-2	94
145	7	151AL	7	2ADFSC-3	94
1451	19	152	7	2AFS-1	92, 94
1452	19	152AL	7	2AFS-2	92, 94
1453	19	153	7	2AFS-3	92, 94
1454	19	153AL	7	2AFSC-1	92, 94
1455	19	170F	68	2AFSC-2	92, 94
1456	19	170FSA	68	2CDR	99, 101
145AL	7	170S	68	2CFSB	98, 101
145SL	8	170SA	68	2CFSR-M	98, 101
145SS6	7	180	68	2CFST	98, 101
145-SST	7	180F	68	2CTDR	99, 101
146	7	180SST	68	2CTS	99, 101
1460	18	190SA	68	2CWPDR	98, 101
1461	18	1942	21	2CWPR-M	98, 101
1462	18	1943	21	2FS-GKV	99
1463	18	1944	21	3210	17
1464	18	1945	21	3211	17
1465	18	1946	21	3212	17
146AL	7	1947	21	3213	17
146SL	8	1948	21	3214	17
146-SST	7	1949	21	3215	17
147	7	1950	21	3650	9
1470	20	1951	21	3651	9
1471	20	1953	21	3652	9
1472	20	1954	21	3653	9
1473	20	222-TB	15	3654	9
1474	20	223-TB	15	3655	9
1475	20	224	15	3656	9
1476	20	225-TB	15	3657	9
1477	20	226	15	3658	9
1478	20	227	15	3659	9
1479	20	228-TB	15	3661	9
147AL	7	229-TB	15	3662	9
147SS6	7	230-TB	15	370	24
148	7	231	15	3700	47
148AL	7	232	15	3701	47
148SS6	7	233	15	3702	47
149	7	234	15	3703	47
1490	48	270F	68	3704	47
1491	48	270FSA	68	3705-TB	47
1492	48	270S	68	3706	47
1493	48	270SA	68	3707	47

Appendix

Part number index

Cat. no.	Page	Cat. no.	Page	Cat. no.	Page
3708	47	3879	11	470SA	68
3709	47	3880	11	480	68
370AL	24	3881	11	480F	68
370F	68	3882	11	480SST	68
370FSA	68	3883	11	490SA	68
370S	68	3884	11	500SS316	60
370SA	68	3886	11	502SS316	60
371	24	3887	11	503SS316	60
3710	47	3889	11	5262	10
3711	47	390SA	68	5263	10
3712	47	3993	11	5264	10
3713	47	3994	11	5265	10
3714	47	3995	11	5266	10
3715-TB	47	3996	11	5267	10
3716	47	3998	11	5268	10
3717	47	3999	11	5269	10
3718	47	422	18	5270	10
371AL	24	423	18	570F	68
372	24	424	18	570FSA	68
372AL	24	425	18	570S	68
373	24	4250	41	570SA	68
373AL	24	4251	41	580	68
374	24	4252	41	580F	68
374AL	24	4253	41	580SST	68
375	24	4254	41	586	14
375AL	24	4255	41	586AL	14
376	24	426	18	587	14
377	24	427	18	587AL	14
378	24	428	18	590SA	68
379	24	429	18	600ALTB	47
380	68	4290	41	600TB	47
380F	68	4291	41	601ALTB	47
380SST	68	4292	41	601TB	47
381	24	4293	41	602ALTB	47
382	24	4294	41	602TB	47
3861	11	4295	41	603ALTB	47
3862	11	430	18	603TB	47
3863	11	431	18	604ALTB	47
3864	11	433	18	604TB	47
3865	11	434	18	605AL	47
3866	11	440	48	605TB	47
3870-TB	11	441	48	606AL	47
3871-TB	11	442	48	606TB	47
3872	11	460-TB	41	607	47
3873	11	461TB	41	607AL	47
3874	11	462	41	608	47
3875	11	463	41	608AL	47
3876	11	470F	68	609	47
3877	11	470FSA	68	609AL	47
3878	11	470S	68	610	47

Appendix

Part number index

Cat. no.	Page	Cat. no.	Page	Cat. no.	Page
610AL	47	700TB	60	848AL	21
611AL	47	701	60	849	21
611TB	47	703	60	849AL	21
612	47	8120	38	850	21
612AL	47	8121	38	850AL	21
613	47	8123	38	851	21
613AL	47	8124	40	851AL	21
614AL	47	8125	40	8520	38
614TB	47	8130	39	8521	38
615AL	47	8131	39	8523	38
615TB	47	8132	39	8524	40
670F	68	815-TB	20	8525	40
670FSA	68	816	20	853	21
670S	68	817	20	854	21
670SA	68	818	20	8620	38
674	43	819	20	8621	38
675	43	820	20	8623	38
675AL	43	821	20	8624	40
676	43	822	20	8625-TB	40
676AL	43	8220	38	870F	68
677	43	8221	38	870FSA	68
677AL	43	8223	38	870S	68
678	43	8224	40	870SA	68
678AL	43	8225	40	8720	38
679	43	823	20	8721	38
679AL	43	824	20	8723-TB	38
680AL	43	8320	38	8724	40
680F	68	8321	38	8725-TB	40
680SST	68	8323	38	880	68
680STB	68	8324-TB	40	880F	68
680TB	43	8325	40	8820	38
681	43	841TB	21	8821	38
681AL	43	8420	38	8823	38
682	43	8421	38	8824-TB	40
682AL	43	8423	38	8825	40
683	43	8424	40	8850	38
683AL	43	8425	40	8851	38
684	43	842AL	21	8853	38
684AL	43	842TB	21	8854	40
685	43	843AL	21	8855	40
685AL	43	843TB	21	889SA	68
686	43	844	21	889SA	68
686AL	43	844AL	21	8970	38
687	43	845	21	8971	38
687AL	43	845AL	21	8973	38
690SA	68	846	21	8974	40
690TB	60	846AL	21	8975	40
691TB	60	847	21	970F	68
692TB	60	847AL	21	970FSA	68
693TB	60	848	21	970S	68

Appendix

Part number index

Cat. no.	Page	Cat. no.	Page	Cat. no.	Page
970SA	68	BG88-TB	84	C17	66, 72
980	68	BG98-TB	84	C17CG-TB	71
980F	68	BGA050-14-20	13	C17SA	66, 75
989SA	68	BGA050-14-4	13	C18	66, 77
ADFS-1	92-93	BGA075-14-20	13	C18SST	66, 70
ADFS-2	92-93	BGA075-14-4	13	C19SA	66, 79
ADFS-3	92-93	BGA100-14-20	13	C200M	66, 82
ADFSC-1	92-93	BGA100-14-4	13	C250M-TB	66, 82
ADFSC-2	92-93	BGA125-14-20	13	C27	66, 72
ADFSC-3	92-93	BGA150-14-20	13	C27CG-TB	71
AFS-1	92-93	BGA200-14-20	13	C27SA	66, 75
AFS-2	92-93	BGA250-14-20	13	C28	66, 77
AFS-3	92-93	BGA250-6-40	13	C28SST	66, 70
AFSC-1	92-93	BGA300-14-20	13	C29SA	66, 79
AFSC-2	92-93	BGA300-6-40	13	C300M	66, 82
AFSC-3	92-93	BGA350-14-20	13	C350M	66, 82
AFSCC-1	92-93	BGA350-6-40	13	C37	66, 72
AFSCC-2	92-93	BGA400-14-20	13	C37CG-TB	71
AFSS-1	92-93	BGA400-6-40	13	C37SA	66, 75
AFSS-2	92-93	BGA500-14-20	13	C38	66, 77
BC10-TB	83	BGA500-6-40	13	C38SST	66, 70
BC3-TB	83	BGA600-14-20	13	C39SA	66, 79
BC4-TB	83	BGA600-6-40	13	C400M	66, 82
BC5-TB	83	BLB10-TB	83	C448	66, 77
BC6-TB	83	BLB3-TB	83	C448SST	66, 70
BC7-TB	83	BLB4-TB	83	C47	66, 72
BC8-TB	83	BLB5-TB	83	C47CG-TB	71
BG050-14-20	13	BLB6-TB	83	C47SA	66, 75
BG050-14-4	13	BLB7-TB	83	C49SA	66, 79
BG075-14-20	13	BLB8-TB	83	C50M	66, 82
BG075-14-4	13	BLB9-TB	83	C57	66, 72
BG100-14-20	13	BT10-TB	84	C57CG-TB	71
BG100-14-4	13	BT3-TB	84	C57SA	66, 75
BG125-14-20	13	BT5-TB	84	C58SST	66, 70
BG150-14-20	13	BT6-TB	84	C58-TB	66, 77
BG200-14-20	13	BT7-TB	84	C59SA	66, 79
BG250-14-20	13	BT8-TB	84	C67	66, 72
BG250-6-40	13	BT9-TB	84	C67CG-TB	71
BG300-14-20	13	BUB10-TB	84	C67SA	66, 75
BG300-6-40	13	BUB3-TB	84	C68	66, 77
BG350-14-20	13	BUB4-TB	84	C68SST	66, 70
BG350-6-40	13	BUB5-TB	84	C69SA	66, 79
BG400-14-20	13	BUB6-TB	84	C75M-TB	66, 82
BG400-6-40	13	BUB7-TB	84	C77-TB	66, 72
BG48-TB	84	BUB8-TB	84	C78	66, 77
BG500-14-20	13	BUB9-TB	84	C789SA	66, 79
BG500-6-40	13	C100M	66, 82	C87	66, 72
BG600-14-20	13	C1089SA	66, 79	C88	66, 77
BG600-6-40	13	C125M	66, 82	C889SA	66, 79
BG68-TB	84	C150M	66, 82	C989SA	66, 79

Appendix

Part number index

Cat. no.	Page	Cat. no.	Page	Cat. no.	Page
CB201-SST	64	COND4SST	50	ELL11/245SS	55
CB202-SST	64	COND5SS	50	ELL11/245SST	55
CB203-SST	64	COND5SST	50	ELL11/2SS	54
CB204-SST	64	COND6SS	50	ELL11/2SST	54
CB205-SST	64	COND6SST	50	ELL11/445SS	55
CB206-SST	64	CPL1/2SS	51	ELL11/445SST	55
CDR	98, 100	CPL1/2SST	51	ELL11/4SS	54
CFSB	97, 100	CPL11/2SS	51	ELL11/4SST	54
CFSDR	97, 100	CPL11/2SST	51	ELL145SS	55
CFSH-G	97, 100	CPL11/4SS	51	ELL145SST	55
CFSR	100	CPL11/4SST	51	ELL1SS	54
CFSR-G	97, 100	CPL1SS	51	ELL1SST	54
CFSR-L	97	CPL1SST	51	ELL245SS	55
CFSR-S	97	CPL21/2SS	51	ELL245SST	55
CFSR-X	97	CPL21/2SST	51	ELL2SS	54
CFSR-XL	97	CPL2SS	51	ELL2SST	54
CFSR-Y	97	CPL2SST	51	ELL3/445SS	55
CFST	97, 100	CPL3/4SS	51	ELL3/445SST	55
CFSTF	97, 100	CPL3/4SST	51	ELL3/4SS	54
CLNPL1/2SS	52	CPL3SS	51	ELL3/4SST	54
CLNPL1/2SST	52	CPL3SST	51	EVHF-1	127, 129
CLNPL11/2SS	52	CPL4SS	51	EVHF-10	129
CLNPL11/2SST	52	CPL4SST	51	EVHF-2	127, 129
CLNPL11/4SS	52	CPL5SS	51	EVHF-3	127, 129
CLNPL11/4SST	52	CPL5SST	51	EVHF-4	127, 129
CLNPL1SS	52	CPL6SS	51	EVHF-5	127, 129
CLNPL1SST	52	CPL6SST	51	EVHF-6	127, 129
CLNPL21/2SS	52	CR	100	EVHF-7	127, 129
CLNPL2SS	52	CRL	98	EVHF-8	129
CLNPL2SST	52	CRS	98	EVHF-9	127, 129
CLNPL3/4SS	52	CTS	98, 100	EXFU-1	123
CLNPL3/4SST	52	CWPDR	97, 100	EXFU-10	123
CLNPL3SS	52	CWPDR-FS	97, 100	EXFU-2	123
COND1/2SS	50	CWPDR-G	97, 100	EXFU-3	123
COND1/2SST	50	DBV-1/4	49	EXFU-4	123
COND11/2SS	50	DS100G-TB	90	EXFU-5	123
COND11/2SST	50	DS21-TB	90	EXFU-6	123
COND11/4SS	50	DS23-TB	90	EXFU-8	123
COND11/4SST	50	DS32-TB	90	EXFU-9	123
COND1SS	50	DSS100-TB	90	EXLB-1	116
COND1SST	50	E17	67, 74	EXLB-2	116
COND21/2SS	50	E27	67, 74	EXLB-3	116
COND21/2SST	50	E37	67, 74	EXMU-1	123
COND2SS	50	ECD15	125	EXMU-2	123
COND2SST	50	ECD284	125	EXMU-3	123
COND3/4SS	50	ECD384	125	EXPF-16	129
COND3/4SST	50	ELL1/245SS	55	EXSC-16	129
COND3SS	50	ELL1/245SST	55	EXSC-2	129
COND3SST	50	ELL1/2SS	54	EXSC-8	129
COND4SS	50	ELL1/2SST	54	EXT-1	116

Appendix

Part number index

Cat. no.	Page	Cat. no.	Page	Cat. no.	Page
EXT-2	116	FDC32-TB	89	GASK1943	68
EXT-3	116	FDC3-TB	88	GASK1944	68
EXUN-1	112	FDS222-TB	89	GASK1945	68
EXUN-11	112	FG-DA-3/8	49	GASK1946	68
EXUN-2	112	FS019-TB	88	GASK571	68
EXUN-22	112	FS062-TB	89	GASK572	68
EXUN-3	112	FS12-TB	89	GASK573	68
EYD101-TB	125	FS1-TB	88	GASK574	68
EYD11-TB	125	FS22-TB	89	GASK575	68
EYD21-TB	125	FS2-TB	88	GASK576	68
EYD31-TB	125	FS32-TB	89	GASK578	68
EYD41-TB	125	FS3-TB	88	GASK579	68
EYD51-TB	125	FSC12-TB	89	GASK581N	68
EYD61-TB	125	FSC1-TB	88	GASK582N	68
EYD71-TB	125	FSC222-TB	89	GASK583N	68
EYD81-TB	125	FSC2-TB	88	GASK584N	68
EYD91-TB	125	FSC32-TB	89	GASK585N	68
EYS101-TB	126	FSC3-TB	88	GASK586N	68
EYS11-TB	126	FS-GKV	98	GASK588N	68
EYS1-TB	126	FSMG-TB	92	GASK589N	68
EYS21-TB	126	FSS222-TB	89	GASK808N	68
EYS2-TB	126	GAC-1	106	GASK809N	68
EYS31-TB	126	GAC-2	106	GASS-1	114
EYS3-TB	126	GAC-3	106	GASS-2	114
EYS41-TB	126	GAD-123	107	GASS-3	114
EYS4-TB	126	GAE-2	106	GAT-1	106
EYS51-TB	126	GAFX-1	107	GAT-2	106
EYS5-TB	126	GAFX-2	107	GAT-3	106
EYS61-TB	126	GAJ-123	108	GAT-4	106
EYS71-TB	126	GAJ-4	108	GAT-6	106
EYS81-TB	126	GAJ-56	108	GAX-1	107
EYS91-TB	126	GAJU-2	108	GAX-2	107
EYVF-1	127	GAJU-3	108	GAX-3	107
EYVF-11	127, 129	GAJU-6	108	GAX-5	107
EYVF-2	127	GAL-1	106	GK100N	68
EYVF-22	127, 129	GAL-2	106	GK125-150N	68
EYVF-3	127	GAL-3	106	GK200N	68
EYVF-33	127, 129	GAL-4	106	GK250-300N	68
FD019-TB	88	GAL-5	106	GK350-400N	68
FD062-TB	89	GAL-6	106	GK50N	68
FD12-TB	89	GALB-1	106	GK75N	68
FD1-TB	88	GALB-2	106	GUA14-TB	102
FD22-TB	89	GALB-3	106	GUA16-TB	102
FD2-TB	88	GALB-4	106	GUA24-TB	102
FD32-TB	89	GALB-6	106	GUA26-TB	102
FD3-TB	88	GAS-123	107	GUA36-TB	102
FDC12-TB	89	GAS-4	107	GUA47-TB	102
FDC1-TB	88	GAS-56	107	GUA59-TB	102
FDC222-TB	89	GASK1941	68	GUAB14-TB	102
FDC2-TB	88	GASK1942	68	GUAB16-TB	102

Appendix

Part number index

Cat. no.	Page	Cat. no.	Page	Cat. no.	Page
GUAB24-TB	102	GUAT36-TB	103	H125TBF	31
GUAB26-TB	102	GUAT37-TB	103	H125TBH	31
GUAB36-TB	102	GUAT47-TB	103	H150BHD	31
GUAB47-TB	102	GUAT49-TB	103	H150CAP	32
GUAB59-TB	102	GUAT59-TB	103	H150GR-TB	26
GUAB69-TB	102	GUAT69-TB	103	H150-TB	25
GUAB79-TB	102	GUAT79-TB	103	H150-TB075ORGR	32
GUAC14-TB	103	GUAW14-TB	104	H150-TB100ORGR	32
GUAC16-TB	103	GUAW16-TB	104	H150-TB125ORGR	32
GUAC24-TB	103	GUAW24-TB	104	H150TBF	31
GUAC26-TB	103	GUAW26-TB	104	H150TBH	31
GUAC36-TB	103	GUAX14-TB	104	H200BHD	31
GUAC47-TB	103	GUAX16-TB	104	H200CAP	32
GUAC49-TB	103	GUAX24-TB	104	H200GR-TB	26
GUAC59-TB	103	GUAX26-TB	104	H200-TB	25
GUAC69-TB	103	GUAX36-TB	104	H200TBF	31
GUAD14-TB	103	GUAX37-TB	104	H200TBH	31
GUAD16-TB	103	GUAX47-TB	104	H250BHD	31
GUAD24-TB	103	GUAX49-TB	104	H250CAP	32
GUAD26-TB	103	GUAX59-TB	104	H250GR-TB	26
GUAD36-TB	103	GUAX69-TB	104	H250-TB	25
GUAD49-TB	103	GUP214-TB	115	H250-TB200ORGR	32
QUAL14-TB	103	GUP215-TB	115	H300BHD	31
QUAL16-TB	103	GYF-1	118	H300CAP	32
QUAL24-TB	103	GYF-2	118	H300GR-TB	26
QUAL26-TB	103	GYF-3	118	H300-TB	25
QUAL36-TB	103	GYF-4	118	H350BHD	31
QUAL47-TB	103	GYF-5	118	H350CAP	32
QUAL49-TB	103	H050BHD	31	H350GR-TB	26
QUAL59-TB	103	H050CAP	32	H350-TB	25
QUAL69-TB	103	H050GR-TB	26	H400BHD	31
GUAM14-TB	104	H050-TB	25	H400CAP	32
GUAM16-TB	104	H050TBF	31	H400GR-TB	26
GUAM24-TB	104	H050TBH	31	H400-TB	25
GUAM26-TB	104	H075BHD	31	H500BHD	31
GUAM36-TB	104	H075CAP	32	H500CAP	32
GUAM47-TB	104	H075GR-TB	26	H500GR-TB	26
GUAM69-TB	104	H075-TB	25	H500-TB	25
GUAN14-TB	104	H075TBF	31	H600BHD	31
GUAN16-TB	104	H075TBH	31	H600CAP	32
GUAN24-TB	104	H100BHD	31	H600GR-TB	26
GUAN26-TB	104	H100CAP	32	H600-TB	25
GUAN36-TB	104	H100GR-TB	26	HA-211	42
GUAN47-TB	104	H100-TB	25	HA-212	42
GUAN59-TB	104	H100TBF	31	HA-213	42
GUAN69-TB	104	H100TBH	31	HO-221	42
GUAT14-TB	103	H125BHD	31	HO-222	42
GUAT16-TB	103	H125CAP	32	HO-223	42
GUAT24-TB	103	H125GR-TB	26	HO-224	42
GUAT26-TB	103	H125-TB	25	HO-225	42

Appendix

Part number index

Cat. no.	Page	Cat. no.	Page	Cat. no.	Page
HO-226	42	HTGZ10	29	L67-TB	67, 73
HS100-SS	58	HTGZ2	29	LB100M	66, 81
HS101-SS	58	HTGZ3	29	LB107	66, 72
HS101SST	59	HTGZ4	29	LB107SA	66, 75
HS102-SS	58	HTGZ5	29	LB108	66, 77
HS102SST	59	HTGZ6	29	LB1089SA	66, 79
HS103-SS	58	HTGZ7	29	LB108SST	66, 69
HS103SST	59	HTGZ8	29	LB125M	66, 81
HS104-SS	58	HTGZ9	29	LB150M	66, 81
HS104SST	59	HTZ1	29	LB17	66, 72
HS105-SS	58	HTZ10	29	LB17CG-TB	71
HS105SST	59	HTZ2	29	LB17SA	66, 75
HS106-SS	58	HTZ3	29	LB18	66, 77
HS106SST	59	HTZ4	29	LB18SST	66, 69
HS107-SS	58	HTZ5	29	LB19SA	66, 79
HS107SST	59	HTZ6	29	LB200M	66, 81
HS108-SS	58	HTZ7	29	LB250M	66, 81
HS108SST	59	HTZ8	29	LB27	66, 72
HS110-SS	58	HTZ9	29	LB27CG-TB	71
HS110SST	59	K100M	68	LB27SA	66, 75
HS901-SS	58	K100S	68	LB28	66, 77
HS901SST	59	K125M	68	LB28SST	66, 69
HS902-SS	58	K125S	68	LB29SA	66, 79
HS902SST	59	K200M	68	LB300M	66, 81
HS903-SS	58	K200S	68	LB350M	66, 81
HS903SST	59	K250M	68	LB37	66, 72
HS904-SS	58	K250S	68	LB37CG-TB	71
HS904SST	59	K350M	68	LB37SA	66, 75
HS905-SS	58	K350S	68	LB38	66, 77
HS905SST	59	K50M	68	LB38SST	66, 69
HS906-SS	58	K50S	68	LB39SA	66, 79
HS906SST	59	K75M	68	LB400M	66, 81
HS907-SS	58	K75S	68	LB448	66, 77
HS907SST	59	L050GR-TB	27	LB47	66, 72
HS908-SS	58	L075GR-TB	27	LB47CG-TB	71
HS908SST	59	L100GR-TB	27	LB47SA	66, 75
HS909-SS	58	L125GR-TB	27	LB48SST	66, 69
HS910-SS	58	L150GR-TB	27	LB49SA	66, 79
HS910SST	59	L17-TB	67, 73	LB50M	66, 81
HT1	30	L200GR-TB	27	LB57	66, 72
HT10	30	L250GR-TB	27	LB57CG-TB	71
HT2	30	L27-TB	67, 73	LB57SA	66, 75
HT3	30	L300GR-TB	27	LB58	66, 77
HT4	30	L350GR-TB	27	LB58SST	66, 69
HT5	30	L37-TB	67, 73	LB59SA	66, 79
HT6	30	L400GR-TB	27	LB67	66, 72
HT7	30	L47-TB	67, 73	LB67CG-TB	71
HT8	30	L500GR-TB	27	LB67SA	66, 75
HT9	30	L57-TB	67, 73	LB68	66, 77
HTGZ1	29	L600GR-TB	27	LB68SST	66, 69

Appendix

Part number index

Cat. no.	Page	Cat. no.	Page	Cat. no.	Page
LB69SA	66, 79	LL448	66, 78	LR37CG-TB	71
LB75M-TB	66, 81	LL448SST	66, 70	LR37SA	67, 75
LB77	66, 72	LL47	66, 73	LR38	67, 77
LB77SA	66, 75	LL47CG-TB	71	LR38SST	67, 70
LB78	66, 77	LL47SA	66, 75	LR39SA	67, 79
LB789SA	66, 79	LL49SA	66, 79	LR400M	67, 81
LB78SST	66, 69	LL50M	66, 81	LR448	67, 77
LB87	66, 72	LL57	66, 73	LR448SST	67, 70
LB87SA	66, 75	LL57CG-TB	71	LR47	67, 73
LB888	66, 77	LL57SA	66, 75	LR47CG-TB	71
LB888SST	66, 69	LL58	66, 78	LR47SA	67, 75
LB889SA	66, 79	LL58SST	66, 70	LR49SA	67, 79
LB97	66, 72	LL59SA	66, 79	LR50M	67, 81
LB97SA	66, 75	LL67	66, 73	LR57	67, 73
LB98	66, 77	LL67CG-TB	71	LR57CG-TB	71
LB989SA	66, 79	LL67SA	66, 75	LR57SA	67, 75
LBY15-TB	118	LL68	66, 78	LR58	67, 77
LBY25-TB	118	LL68SST	66, 70	LR58SST	67, 70
LBY35-TB	118	LL69SA	66, 79	LR59SA	67, 79
LBY45-TB	118	LL75M	66, 81	LR67	67, 73
LBY55-TB	118	LL77	66, 73	LR67CG-TB	71
LBY65-TB	118	LL78	66, 78	LR67SA	67, 75
LL100M	66, 81	LL789SA	66, 79	LR68	67, 77
LL107	66, 73	LL87	66, 73	LR68SST	67, 70
LL1089SA	66, 79	LL888	66, 78	LR69SA	67, 79
LL125M	66, 81	LL889SA	66, 79	LR75M	67, 81
LL150M	66, 81	LL97	66, 73	LR77	67, 73
LL17	66, 73	LL989SA	66, 79	LR78	67, 77
LL17CG-TB	71	LR100M	67, 81	LR789SA	67, 79
LL17SA	66, 75	LR107	67, 73	LR87	67, 73
LL18	66, 78	LR1089SA	67, 79	LR888	67, 77
LL18SST	66, 70	LR125M	67, 81	LR889SA	67, 79
LL19SA	66, 79	LR150M	67, 81	LR97	67, 73
LL200M	66, 81	LR17	67, 73	LR989SA	67, 79
LL250M	66, 81	LR17CG-TB	71	LT11-2-FP	96
LL27	66, 73	LR17SA	67, 75	LT11-3-FP	96
LL27CG-TB	71	LR18	67, 77	LT14-2-FP	96
LL27SA	66, 75	LR18SST	67, 70	LT14-3-FP	96
LL28	66, 78	LR19SA	67, 79	LU17	66, 72
LL28SST	66, 70	LR200M	67, 81	LU17SA	66, 76
LL29SA	66, 79	LR250M	67, 81	LU18SST	66, 69
LL300M	66, 81	LR27	67, 73	LU19SA	66, 80
LL350M	66, 81	LR27CG-TB	71	LU27	66, 72
LL37	66, 73	LR27SA	67, 75	LU27SA	66, 76
LL37CG-TB	71	LR28	67, 77	LU28SST	66, 69
LL37SA	66, 75	LR28SST	67, 70	LU29SA	66, 80
LL38	66, 78	LR29SA	67, 79	LU37	66, 72
LL38SST	66, 70	LR300M	67, 81	LU37SA	66, 76
LL39SA	66, 79	LR350M-TB	67, 81	LU38SST	66, 69
LL400M	66, 81	LR37	67, 73	LU39SA	66, 80

Appendix

Part number index

Cat. no.	Page	Cat. no.	Page	Cat. no.	Page
LU47	66, 72	NPL11/2X12SS	53	NPL1X4SS	53
LU47SA	66, 76	NPL11/2X12SST	53	NPL1X4SST	53
LU48SST	66, 69	NPL11/2X21/2SS	52	NPL1X5SS	53
LU49SA	66, 80	NPL11/2X21/2SST	52	NPL1X5SST	53
LU57	66, 72	NPL11/2X2SS	52	NPL1X6SS	53
LU57SA	66, 76	NPL11/2X2SST	52	NPL1X6SST	53
LU58SST	66, 69	NPL11/2X31/2SS	52	NPL1X8SS	53
LU59SA	66, 80	NPL11/2X31/2SST	52	NPL1X8SST	53
LU67	66, 72	NPL11/2X3SS	52	NPL21/2X10SS	53
LU67SA	66, 76	NPL11/2X3SST	52	NPL21/2X12SS	53
LU68SST	66, 69	NPL11/2X4SS	53	NPL21/2X5SS	53
LU69SA	66, 80	NPL11/2X4SST	53	NPL21/2X6SS	53
MALB-10	86	NPL11/2X5SS	53	NPL21/2X8SS	53
MALB-3	86	NPL11/2X5SST	53	NPL2X10SS	53
MALB-4	86	NPL11/2X6SS	53	NPL2X10SST	53
MALB-5	86	NPL11/2X6SST	53	NPL2X12SS	53
MALB-56CV	86	NPL11/2X8SS	53	NPL2X12SST	53
MALB-6	86	NPL11/2X8SST	53	NPL2X31/2SS	52
MALB-7	86	NPL11/4X10SS	53	NPL2X31/2SST	52
MALB-78CV	86	NPL11/4X10SST	53	NPL2X4SS	53
MALB-8	86	NPL11/4X12SS	53	NPL2X4SST	53
MALB-9	86	NPL11/4X12SST	53	NPL2X5SS	53
MALB-90CV	86	NPL11/4X21/2SS	52	NPL2X5SST	53
MGKV-5	86	NPL11/4X21/2SST	52	NPL2X6SS	53
MGKV-6	86	NPL11/4X2SS	52	NPL2X6SST	53
MGKV-7	86	NPL11/4X2SST	52	NPL2X8SS	53
NPL1/2X10SS	53	NPL11/4X31/2SS	52	NPL2X8SST	53
NPL1/2X10SST	53	NPL11/4X31/2SST	52	NPL3/4X10SS	53
NPL1/2X11/2SS	52	NPL11/4X3SS	52	NPL3/4X10SST	53
NPL1/2X11/2SST	52	NPL11/4X3SST	52	NPL3/4X11/2SS	52
NPL1/2X12SS	53	NPL11/4X4SS	53	NPL3/4X11/2SST	52
NPL1/2X12SST	53	NPL11/4X4SST	53	NPL3/4X12SS	53
NPL1/2X21/2SS	52	NPL11/4X5SS	53	NPL3/4X12SST	53
NPL1/2X21/2SST	52	NPL11/4X5SST	53	NPL3/4X21/2SS	52
NPL1/2X2SS	52	NPL11/4X6SS	53	NPL3/4X21/2SST	52
NPL1/2X2SST	52	NPL11/4X6SST	53	NPL3/4X2SS	52
NPL1/2X31/2SS	52	NPL11/4X8SS	53	NPL3/4X2SST	52
NPL1/2X31/2SST	52	NPL11/4X8SST	53	NPL3/4X31/2SS	52
NPL1/2X3SS	52	NPL1X10SS	53	NPL3/4X31/2SST	52
NPL1/2X3SST	52	NPL1X10SST	53	NPL3/4X3SS	52
NPL1/2X4SS	53	NPL1X12SS	53	NPL3/4X3SST	52
NPL1/2X4SST	53	NPL1X12SST	53	NPL3/4X4SS	53
NPL1/2X5SS	53	NPL1X21/2SS	52	NPL3/4X4SST	53
NPL1/2X5SST	53	NPL1X21/2SST	52	NPL3/4X5SS	53
NPL1/2X6SS	53	NPL1X2SS	52	NPL3/4X5SST	53
NPL1/2X6SST	53	NPL1X2SST	52	NPL3/4X6SS	53
NPL1/2X8SS	53	NPL1X31/2SS	52	NPL3/4X6SST	53
NPL1/2X8SST	53	NPL1X31/2SST	52	NPL3/4X8SS	53
NPL11/2X10SS	53	NPL1X3SS	52	NPL3/4X8SST	53
NPL11/2X10SST	53	NPL1X3SST	52	NPL3X12SS	53

Appendix

Part number index

Cat. no.	Page	Cat. no.	Page	Cat. no.	Page
OEC1-TB	117	RE52-TB	119	T14-2-FP	95
OEC2-TB	117	RE53-TB	119	T14-PL-FP	95
OELB1-TB	117	RE54-TB	119	T150M	66, 81
OELB2-TB	117	RE61-TB	119	T17	66, 72
OELL1-TB	117	RE62-TB	119	T17CG-TB	71
OELL2-TB	117	RE63-TB	119	T17SA	66, 76
OELR1-TB	117	RE64-TB	119	T18	66, 77
OELR2-TB	117	RE65-TB	119	T18SST	66, 69
OET1-TB	117	RE73-TB	119	T19SA	66, 80
OET2-TB	117	RE74-TB	119	T200M	66, 81
PC1SST	61	RE75-TB	119	T250M	66, 81
PC3/4SST	61	RE76-TB	119	T27	66, 72
PIPECAP1/2SST	48	RE83-TB	119	T27CG-TB	71
PIPECAP11/2SST	48	RE84-TB	119	T27SA	66, 76
PIPECAP11/4SST	48	RE85-TB	119	T28	66, 77
PIPECAP1SST	48	RE86-TB	119	T28SST	66, 69
PIPECAP21/2SST	48	RE87-TB	119	T29SA	66, 80
PIPECAP2SST	48	RE96-TB	119	T300M	66, 81
PIPECAP3/4SST	48	RE97-TB	119	T350M	66, 81
PIPECAP3SST	48	RE98-TB	119	T37	66, 72
PIPECAP4SST	48	REC21-TB	119	T37CG-TB	71
PLG10-TB	120	REC31-TB	119	T37SA	66, 76
PLG1-TB	120	REC32-TB	119	T38SST	66, 69
PLG2-TB	120	S1002GSA-TB	90	T38-TB	66, 77
PLG3-TB	120	S1002-TB	90	T39SA	66, 80
PLG4-TB	120	S232-TB	90	T400M	66, 81
PLG5-TB	120	S32212-TB	90	T448	66, 77
PLG6-TB	120	S32232-TB	90	T47	66, 72
PLG7-TB	120	S322-TB	90	T47CG-TB	71
PLG8-TB	120	SPCP100	44	T47SA	66, 76
PLG9-TB	120	SPCP125	44	T48SST	66, 69
RC1/2SST	61	SPCP150	44	T49SA	66, 80
RC11/2SST	61	SPCP200	44	T50M	66, 81
RC11/4SST	61	SPCP250	44	T57	66, 72
RC1SST	61	SPCP300	44	T57CG-TB	71
RC21/2SST	61	SPCP350	44	T57SA	66, 76
RC2SST	61	SPCP400	44	T58	66, 77
RC3/4SST	61	SPCP50	44	T58SST	66, 69
RC3SST	61	SPCP500	44	T59SA	66, 80
RC4SST	61	SPCP600	44	T67	66, 72
RE106-TB	119	SPCP75	44	T67CG-TB	71
RE107-TB	119	T100M	66, 81	T67SA	66, 76
RE108-TB	119	T107	66, 72	T68	66, 77
RE21-TB	119	T107SA	66, 76	T68SST	66, 69
RE31-TB	119	T1089SA	66, 80	T69SA	66, 80
RE32-TB	119	T108SST	66, 69	T75M	66, 81
RE41-TB	119	T11-22-FP	95	T77	66, 72
RE42-TB	119	T11-FP	95	T77SA	66, 76
RE43-TB	119	T125M	66, 81	T78	66, 77
RE51-TB	119	T14-22-FP	95	T789SA	66, 80

Appendix

Part number index

Cat. no.	Page	Cat. no.	Page	Cat. no.	Page
T78SST	66, 69	TB67	67, 74	UNY905-TB	122
T87	66, 72	TB67CG-TB	71	X100M	67, 82
T87SA	66, 76	TB67SA	67, 76	X125M	67, 82
T888SST	66, 69	TB68	67, 78	X150M	67, 82
T889SA	66, 80	TB68SST	67, 69	X17	67, 74
T88-TB	66, 77	TB69SA	67, 80	X17CG-TB	71
T97	66, 72	TB75M	67, 82	X17SA	67, 76
T97SA	66, 76	TRIB-100	16	X18	67, 78
T989SA	66, 80	TRIB-125	16	X18SST	67, 70
TA17	67, 73	TRIB-150	16	X19SA	67, 80
TA27	67, 73	TRIB-200	16	X200M	67, 82
TA37	67, 73	TRIB-250	16	X27	67, 74
TA47	67, 73	TRIB-300	16	X27CG-TB	71
TA57	67, 73	TRIB-350	16	X27SA	67, 76
TA67	67, 73	TRIB-400	16	X28	67, 78
TB100M	67, 82	TRIB-50	16	X28SST	67, 70
TB125M	67, 82	TRIB-75	16	X29SA	67, 80
TB150M	67, 82	TS101-SS	58	X37	67, 74
TB17CG-TB	71	TS102-SS	58	X37CG-TB	71
TB17SA	67, 76	TS103-SS	58	X37SA	67, 76
TB17-TB	67, 74	TS104-SS	58	X38	67, 78
TB18	67, 78	TS105-SS	58	X38SST	67, 70
TB18SST	67, 69	TS106-SS	58	X39SA	67, 80
TB19SA	67, 80	TS901-SS	58	X448	67, 78
TB200M	67, 82	TS902-SS	58	X448SST	67, 70
TB27	67, 74	TS903-SS	58	X47	67, 74
TB27CG-TB	71	TS904-SS	58	X47CG-TB	71
TB27SA	67, 76	TS905-SS	58	X47SA	67, 76
TB28	67, 78	TS906-SS	58	X50M	67, 82
TB28SST	67, 69	TX11-5-FP	95	X57	67, 74
TB29SA	67, 80	TX14-5-FP	95	X57CG-TB	71
TB37	67, 74	UNF1005-TB	122	X57SA	67, 76
TB37CG-TB	71	UNF105-TB	122	X58	67, 78
TB37SA	67, 76	UNF205-TB	122	X58SST	67, 70
TB38	67, 78	UNF305-TB	122	X67	67, 74
TB38SST	67, 69	UNF405-TB	122	X67CG-TB	71
TB39SA	67, 80	UNF505-TB	122	X67SA	67, 76
TB448	67, 78	UNF605-TB	122	X68	67, 78
TB47	67, 74	UNF705-TB	122	X68SST	67, 70
TB47CG-TB	71	UNF805-TB	122	X75M	67, 82
TB47SA	67, 76	UNF905-TB	122	XD010NM-TB	35
TB48SST	67, 69	UNY1005-TB	122	XD010-TB	34
TB49SA	67, 80	UNY105-TB	122	XD012-TB	34
TB50M	67, 82	UNY205-TB	122	XD014-TB	34
TB57	67, 74	UNY305-TB	122	XD1NM-TB	35
TB57CG-TB	71	UNY405-TB	122	XD2NM-TB	35
TB57SA	67, 76	UNY505-TB	122	XD3NM-TB	35
TB58	67, 78	UNY605-TB	122	XD3-TB	34
TB58SST	67, 69	UNY705-TB	122	XD4-TB	34
TB59SA	67, 80	UNY805-TB	122	XD5NM-TB	35

Appendix

Part number index

Cat. no.	Page	Cat. no.	Page
XD5-TB	34	XPLFL16	130
XD6NM-TB	35	XPLFL18	130
XD6-TB	34	XPLFL212	130
XD7NM-TB	35	XPLFL215	130
XD7-TB	34	XPLFL218	130
XD8NM-TB	35	XPLFL224	130
XD8-TB	34	XPLFL236	130
XD9-TB	34	XPLFL318	130
XJG104-EMT	37	XPLG-1	120
XJG104-TB	36	XPLG-2	120
XJG108-EMT	37	XPLG-3	120
XJG108-TB	36	XPLG-4	120
XJG1208-TB	36	XPLG-5	120
XJG24-EMT	37	XPLG-6	120
XJG24-TB	36		
XJG28-EMT	37		
XJG28-TB	36		
XJG34-EMT	37		
XJG34-TB	36		
XJG38-EMT	37		
XJG38-TB	36		
XJG44-EMT	37		
XJG44-TB	36		
XJG48-EMT	37		
XJG48-TB	36		
XJG54-EMT	37		
XJG54-TB	36		
XJG58-EMT	37		
XJG58-TB	36		
XJG64-EMT	37		
XJG64-TB	36		
XJG68-EMT	37		
XJG68-TB	36		
XJG74-EMT	37		
XJG74-TB	36		
XJG78-EMT	37		
XJG78-TB	36		
XJG84-EMT	37		
XJG84-TB	36		
XJG88-EMT	37		
XJG88-TB	36		
XJG94-EMT	37		
XJG94-TB	36		
XJG98-EMT	37		
XJG98-TB	36		
XPLFL110	130		
XPLFL112	130		
XPLFL115	130		
XPLFL118	130		
XPLFL124	130		

Additional information

We reserve the right to make technical changes or modify the contents of this document without prior notice. With regard to purchase orders, the agreed particulars shall prevail. ABB Installation Products Inc does not accept any responsibility whatsoever for potential errors or possible lack of information in this document.

We reserve all rights in this document and in the subject matter and illustrations contained therein. Any reproduction, disclosure to third parties or utilization of its contents – in whole or in parts – is forbidden without prior written consent of ABB Installation Products Inc.



—
US

ABB Installation Products Inc.
Electrification business
860 Ridge Lake Blvd.
Memphis, TN 38120
+1 901-252-5000

tnb.abb.com