

Making a self watering container or Earthbox™

A self watering container is a container that has a water reservoir built in. This reservoir waters the plants sometimes for several days. These containers can also contain a fertilizer band to feed the plants for the season. This makes the process of growing almost any flower or vegetable very easy to do and is very productive. Another advantage is it can be placed somewhere where there is no garden such as a deck or patio.



This document will show you step by step how to make your own self watering containers. They are made using plastic storage tubs, 5 gallon buckets, small pots and planters although they can be made of other things as well (plastic garbage pails, laundry pails, Tupperware, Fancy planters, Cat litter pails, Etc. You only need 5 parts the container usually a tub or a bucket, the aeration screen, supports for the aeration screen (paint pails, PVC pipe, another tub cut in half – see below for details), a fill tube, and a mulch cover. I will show you several methods for making these containers so read the whole document and decide which one is correct for you. The focus of this document is to be able to make these containers as cheaply as possible but still be functional. In the next section I will discuss each piece in more detail and show you several options for each component of the design. Unfortunately the following is necessary due to the world that we live in.

Legal disclaimer:

The information presented here is for educational purposes. I or anyone associated with this document can not be held liable for any injuries that might happen using this information. Also anyone associated with this information can not be held responsible for any errors or omissions, or for the results obtained from the use of this information.

The Component parts:

The Container

First we will discuss the container itself. It can be almost anything that has enough room to hold the amount of potting mix for the type of plant that you want to grow. Most people use them for vegetables. The container is divided into two sections the soil chamber and the water reservoir. These two sections are separated by a screen. Also the wall of the container just below the screen has a hole drilled into it so that any excess water that may enter the container will exit the hole and not flood the container. If you look closely in the pictures you will see the overflow holes. Most containers are made from plastic storage tubs or 5 gallon buckets. Below are some pictures of the possibilities.





The aeration screen

The aeration screen separates the soil chamber from the water reservoir. Its purpose is to hold the soil above the water so that oxygen can get to the roots. The also have openings in the screen that allow the soil to come below the water level to wick water to the roots. These are called the wicking chambers. These screens can be made from the center cutout of the lid, another tub cut in half and turned upside down, plastic or acrylic sheets (plexiglass), plastic cutting boards, vinyl window shutters, Etc.



The aeration tube

You can also use a tube (usually a PVC pipe) for the aeration of the roots as opposed to the screen. The tube is just a plastic tube with holes cut into it and then wrapped with breathable landscape fabric to allow air to get to the roots. You must wrap the tube with breathable landscape fabric or else the potting mix will fall into the holes in the tube and be washed out of the container or clog it. You can wrap the tube with the fabric and then hot melt glue the seam with a slight overlap. This tube is then placed in the container with the open ends of the tube protruding out of holes in the container wall to allow the free flow of air to get to the soil. The screen is still used as a separation barrier between the soil chamber and the water reservoir but the only holes in the screen are for the wicking chambers and the fill tube. **Note: the overflow hole is not indicated in the drawing below.**

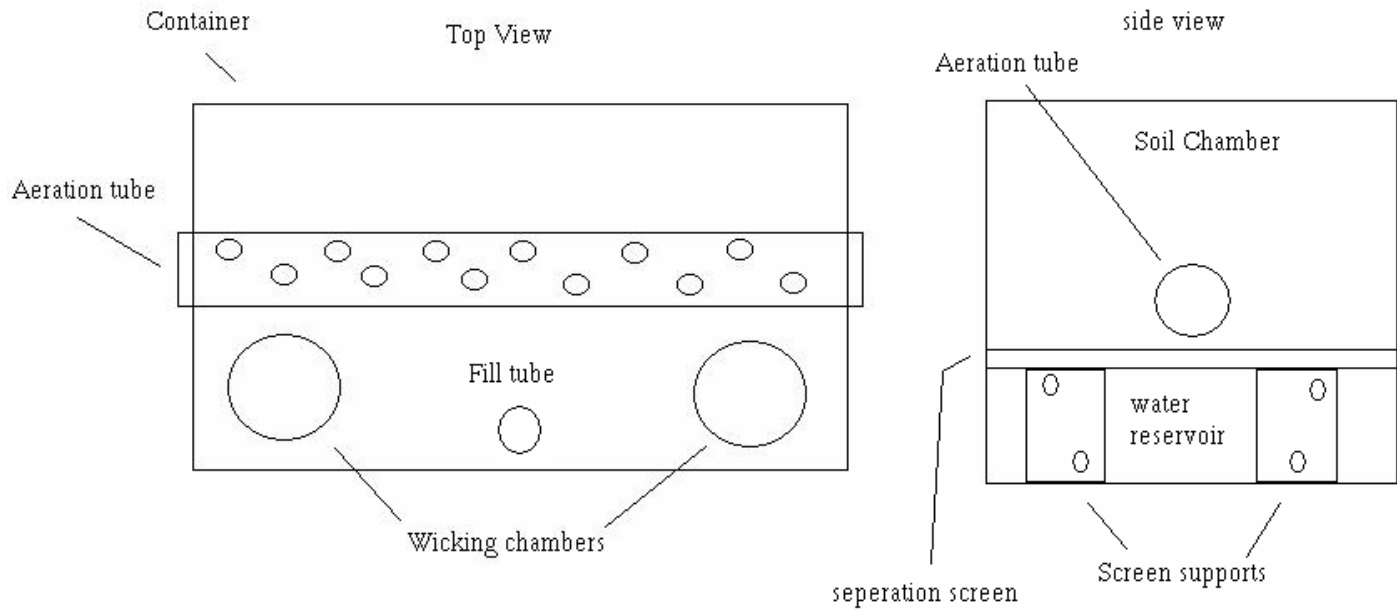

The screen supports:

The screen supports hold up the aeration screen which separates the soil chamber from the water reservoir. The screen also serves to allow oxygen to reach the roots through holes drilled in the screen. The oxygen enters the container through the overflow hole (Note: some people use one overflow hole and some place one on each side of the container) It is important that the supports have a least one hole on the top and the bottom of the support. The top hole is that oxygen can get the roots that are under the support. The bottom hole is so that the water can still enter the wicking chamber when the water level drops to the bottom of the container. The supports can be made out of PVC drain pipe, children's plastic sand pails, plastic paint pails, Tupperware, food containers, baby wipe containers, Etc. The taller the supports the larger the water reservoir and the longer you can go between waterings. The supports are attached to the screen using nylon wire ties.



Note: the center support is for added support you can also use another 4 inch PVC pipe instead of the 1 inch pipe shown.



The fill tube:

The fill tube is made from a 1" PVC pipe 18 inches or so but it depends on the container that you use. Its purpose is to add water to the water reservoir. (Note: the larger the water reservoir capacity the longer you can go between waterings.) The bottom of the tube is either cut on an angle or has several holes in it to allow the water to fill the bottom chamber.



The mulch cover:

The mulch cover serves two purposes first it keeps the soil chamber from losing moisture from the soil surface and second it protects the fertilizer band (discussed later) from getting wet. If the fertilizer gets wet it will add too much fertilizer too quickly into the soil and burn the roots. The mulch cover is made from heavy plastic bags cut to size to fit over the top of the container and held down using the container top rim after the center is cut out for the aeration screen.



The designs:

In this section I will show you several designs that you can make. Remember that you can use almost anything as long as it can perform the job of that part of the design (e.g. cut up an old plastic serving tray or snack tray for an aeration screen) You do not have to use the exact parts that are shown here. You can get creative and see what you come up with.

Design 1 the single tub design:

This design is based on a single Rubbermaid or similar storage tub (18 to 20 gallon size) with an aeration screen separating the soil chamber and the water reservoir. The screen is supported by 5 sections of 4" PVC drain pipe 6 inches long. The screen is made from the center section of the storage tub lid. The lid rim is used to attach the mulch cover. This is the same design used by the Real Earthbox™.

Materials:

The Storage tub	\$3 - \$4 check Wal-Mart, Lowes, and Home Depot
4" PVC drain pipe	\$5 for 10 feet of pipe (enough for 3 to 4 tubs depending on length of supports)
1" PVC pipe	\$2.50 for 10 feet of pipe (enough for 6 tubs plus 2 center supports)
Heavy garbage bag	\$10 per box of 40 at home depot (you probably already have this - 1 bag covers 4 tubs)
Wire Ties	\$1 at the 99cent stores 6 to 8 inches is fine
Price per tub built	about \$6 - \$7 per tub

Tools needed:

- A drill with assorted drill bits
- A pen or pencil
- A razor knife or heavy scissor
- A chop (miter saw) or a hand saw
- A PVC cutting jig if using a hand saw (see cutting PVC at the end of this document)

First cut the middle out of the lid. This will be the aeration screen. See the pictures from the mulch cover section above. I used a sheet rock knife for this. You can also use a heavy scissor which is safer to use. Do not cut the lip (rim of the cover) all the way through it will be used to hold the mulch cover down. Trim the screen so it matched the side of the tub as closely as possible. The screen should fit snugly in the tub.



Cut your hole for the fill tube and the soil wick chambers (see picture below). I place the 4" PVC drain pipe 1 1/2 inches in from each tub wall. Place two lines in each corner 1 1/2 away from each wall and trace around the pipe using a sharpie marker. Cut the holes for the soil wick opening staying a least 1/4 inch away from the line.



Only the 2 front PVC support are to have holes cur for them but you need to mark all four corners of the lid for the 4 supports plus one for the center which could be a pipe from 1" to 4" inches in diameter. All supports need to be clearly marked so that when you drill the holes for the screen you do not drill where the support touches the screen. You will notice in the picture that there is a line drawn from each circle this line correlates with a line drawn on the support (which are also numbered) so that you can line up the 4 equally spaced holes for the wire ties. Before you drill the holes for the screen you need to drill the holes for the wire ties in the screen for all supports. Then you can drill the 1/4 holes for the screen being careful not to drill where you traced the support circles.



Before attaching the supports to the screen take one of the supports hold it against the outside of the container on a level surface and make a line on the center of each wall even with the top of the support. Make sure that all the supports have the holes that they need (see the screen supports above). Then wire tie all supports to the screen using electrical wire ties. Note in the 2nd picture below that a 4" support is placed with a 1" center support for comparison. The 4" support will support more of the screen than a 1" support.

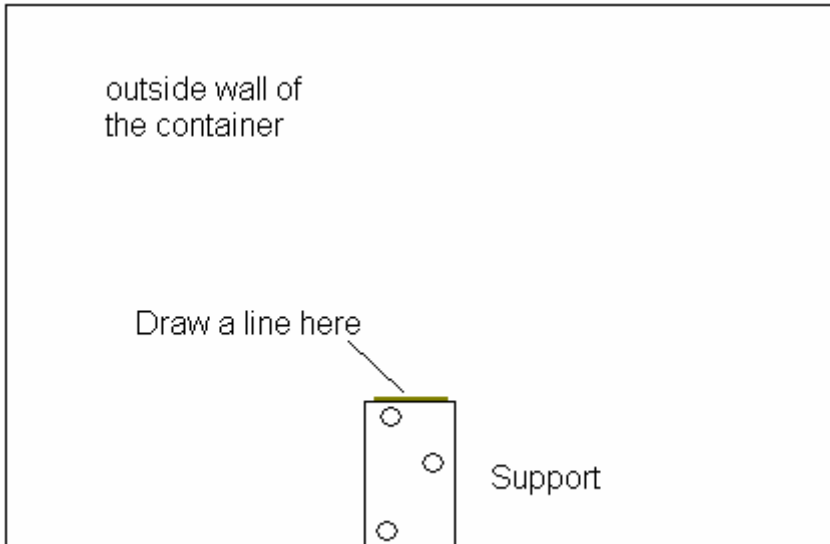



Before inserting the assembled screen assembly into the container drill your $\frac{1}{2}$ overflow hole(s) in the container about $\frac{1}{4}$ inch below the line you drew on the container using the support. Insert the screen assembly and the fill tube. Make sure that everything touches the bottom of the container. You are now ready to add potting mix and plants, add the fertilizer band and the mulch cover. See the setting up the container section for more information.

Design 2 the dual tub design:

This design requires 2 tubs and is slightly more expensive to make due to the extra tub to purchase. The idea here is that the bottom half of one of the tubs becomes the aeration screen and the screen support all in one piece.

Tools needed:

- a pencil or pen
- a drill with a 1/4" or larger bit and a 1-1/2" bit
- a saw (handsaw will work, but a jigsaw makes it much easier)

Materials:

- 2 18-gallon (or similar) tote boxes with lids, such as Rubbermaid. Dark colors are preferable. Also, a box that is somewhat wider is preferable to one that's deeper. (You can also use larger totes, but note that once you fill them with soil, they'll be very hard to move.) The more straight-sided the box, the better.
- 1 5" pond basket (these are plastic planters with perforated sides to allow the free flow of water) any small pail or planter will work as long as the water can get inside. This will be our wicking chamber.
- 1" PVC pipe for a fill tube (a few inches taller than your container – more if you like)



First take you pond basket (or whatever you are using for the wicking chamber) and hold it against one of the containers (Tub) and draw a line all the way around the container. Also mark the other tub using the pond basket on the center of each side of the tub (a reference mark for the overflow hole).



Next Using the tub with the line completely around the tub cut along this line with you saw. Try to cut the line a straight as possible. You may have to touch up the cut edge with a sanding block to get it level so that when you flip it over it sits as level as possible.



Place the tub that you just cut upside down (open side down). Take your wicking chamber container (pond basket) and place in the center of the upside down half tub and trace the outline with a pencil. Cut the circle out allowing a least ½ inch inside the line. This is to allow the lip of the pond basket to support the center of the aeration screen. Drill the holes to wire tie the pond basket to the aeration screen, also drill the air holes for the aeration screen and the hole for the fill tube.



Place the pond basket in the bottom center of the uncut tub. And then place the half cut tub inside the uncut tub open end down on top of the pond basket. Using wire ties attach the pond basket to the aeration screen at this time. Some people find it easier to do this before installing the screen into the tub.





Drill a ½ inch hole through both tubs about ¼ inch below you reference line that you made earlier.



Cut or drill the bottom of your fill tube for water distribution (see the fill tube above) and insert the fill tube in the fill tube hole. You are now ready for planting.



Design 3 dual 5 gallon buckets:

This design is also used with 5 gallon buckets except that the bucket does not get cut but one bucket gets placed in another bucket creating the water reservoir in the space between the buckets. As you can see from the pictures below this design requires 2 buckets, a 16 ounce plastic cup, a fill tube, and a lid which acts as the mulch cover. The upper bucket gets holes cut in the bottom of the bucket for the wicking cup (Note the wicking cup in this design is not supporting any weight so a plastic cup works fine), the air holes, and the hole for the fill tube. The cup must touch the bottom of the lower bucket so the hole must be large enough to permit that. The plastic cup is simply slit down the sides with a razor knife to allow water to enter the cup. The soil must come all the way up to the lid to protect the fertilizer ring around the outer edge of the bucket. You can even tape some plastic over the hole if you wish just be careful not to pinch the stalk of the plant.

Materials:

- 2 – 5 gallon or similar buckets (they must be able to sit in one another with a gap in between them)
- 1 – Bucket lid
- 1 – Fill tube
- 1 – 16 oz. solo plastic drinking cup





Design 4 a small self watering planter:

As I said in the beginning of this document these self watering containers can be made out of almost anything. I was in the dollar store and I purchased the things in the picture below (all for a dollar each) except for the plastic pipe which came from home depot (left over from a plumbing repair). From left to right a plastic serving tray (can be cut to make an aeration screen), A small mesh bucket (a wicking chamber), A plastic plate (a screen), a small bucket (a mini container), and the plastic plumbing pipe in the front can be used for an aeration tube for a mini container. We are going to use the bucket, the plate and the plumbing pipe in this design. The tray and the mesh basket can be used with a large plastic garbage pail or a cat litter bucket.



In this design we are using a plastic plate as the screen to separate the water reservoir from the soil chamber. Although you could have made a small wicking chamber I decided to use a wick to draw moisture from the bottom. The plastic plumbing pipe will be the aeration tube (it still needs to be covered with landscape fabric). The water reservoir can be filled by the overflow hole or you can add a fill tube if desired. This container would be suitable for flowers or possible some herbs on a kitchen window or window box / ledge.



Design 5 a hybrid design:

This design is a mixture of designs one and two but I used aeration tubes instead of the aeration screen. This design may seem more complicated but it is actually less work because you do not have to drill the aeration screen. The only other thing that is new in this design is the fact that the aeration tubes need to be covered in breathable landscape fabric or fiberglass screening to keep the potting mix in the container.

Materials:

The Storage tub	\$3 - \$4 check Wal-Mart, Lowes, and Home Depot
4" PVC drain pipe	\$5 for 10 feet of pipe (enough for 3 to 4 tubs depending on length of supports)
1" PVC pipe	\$2.50 for 10 feet of pipe (enough for 6 tubs plus 2 center supports)
2" PVC pipe	\$3.00 for 10 feet of pipe (enough for 4 tubs)
A play sand pail	\$1 at the dollar store (my kids have 15 of them they wont miss one)
Heavy garbage bag	\$10 per box of 40 at home depot (you probably already have this - 1 bag covers 4 tubs)
Wire Ties	\$1 at the dollar stores 6 to 8 inches is fine
Landscape fabric	\$? I had a roll last for years (you can use fiberglass screening but not metal screening)
Price per tub built	about \$7 - \$8 per tub

Tools needed:

- A drill with assorted drill bits
- A pen or pencil
- A razor knife or heavy scissor
- A chop (miter saw) or a hand saw
- A PVC cutting jig if using a hand saw (see cutting PVC at the end of this document)
- A circle cutter

For this design I will use a play sand bucket for the wicking chamber. To prepare the bucket I drilled a few 3/8 holes into it (drill slowly when drilling this thin plastic or start with a smaller bit and then step up to a larger bit).



The separation screen will be supported by the wicking pail and four 4" PVC drain pipes cut to the same height as the pail. The picture below shows the screen marked for the supports and the wicking pail and the holes that were drilled for the wire ties.

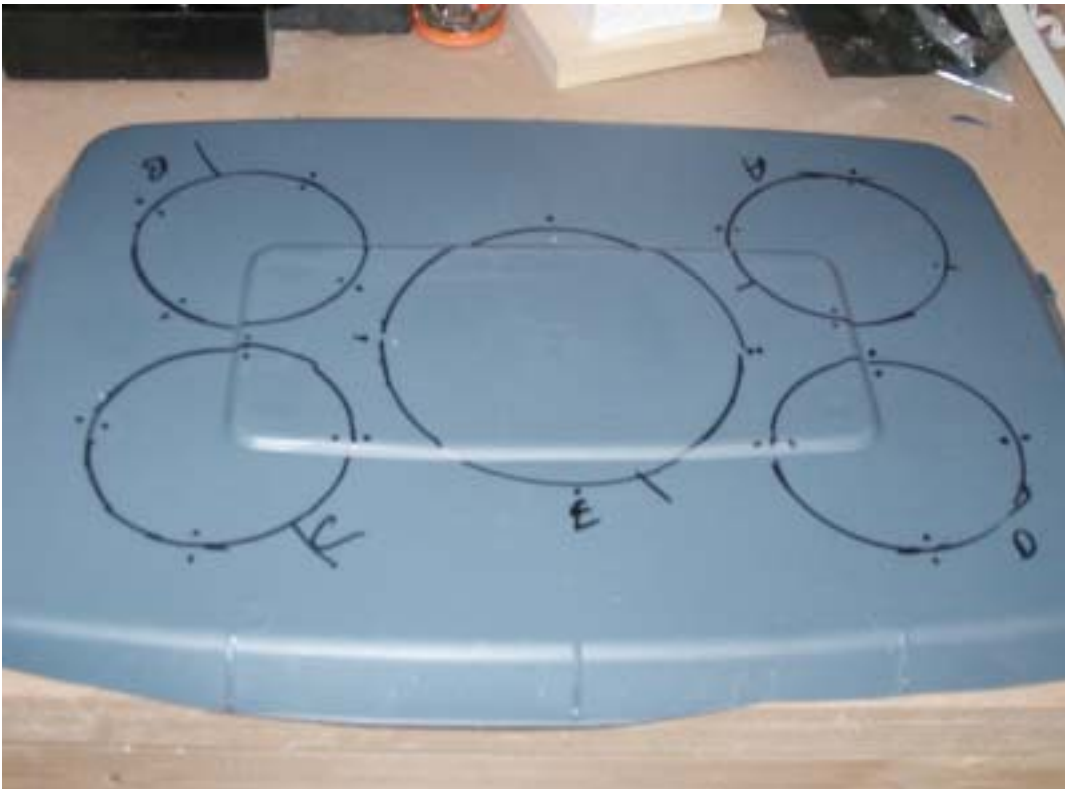

This picture shows one of the PVC drain pipe supports with a wire tie that we will use to attach the supports and the wicking chamber pail to the screen.



The shot below shows the screen with all the holes cut and is ready to have the supports and pail attached to it.



Before you attach the supports to the screen use either one of the supports or the pail to draw a line on the outside of the container to mark the height of the screen on all four sides if desired. This line will be used for reference to drill the overflow hole. Now is a good time to drill the overflow hole or holes $\frac{1}{4}$ inch below the reference line (**Note: the top of the overflow hole will be $\frac{1}{4}$ below the reference line**). I usually drill a $\frac{1}{2}$ inch hole.



The supports and the wicking pail are now attached to the screen.

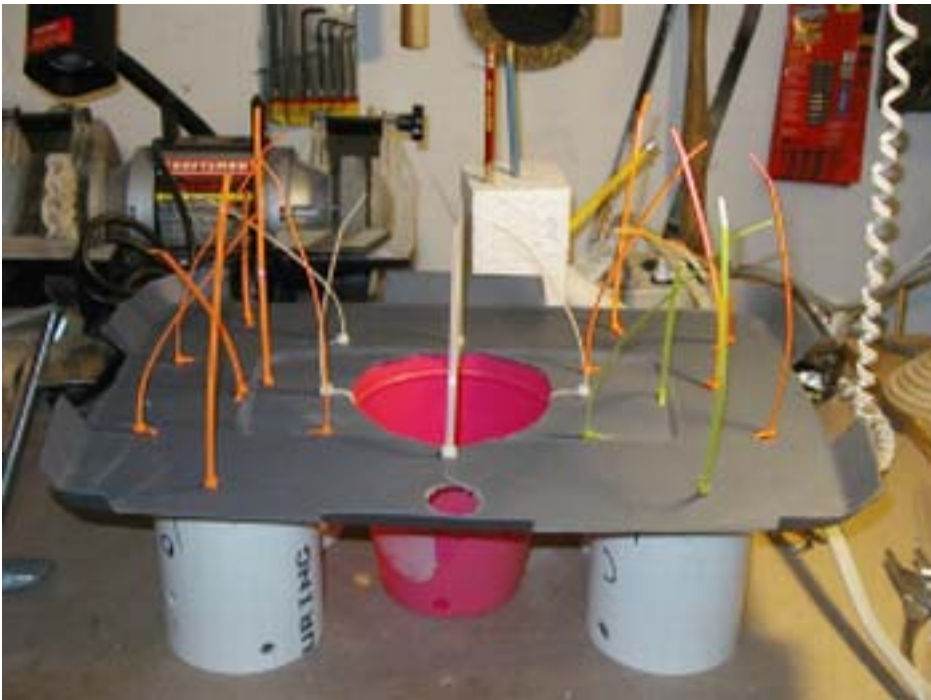

The wire ties are trimmed.



Test fit the screen in the container and trim as needed to allow the screen to follow the contour of the container as closely as possible.



The next step is to drill the holes for the aeration tubes. To drill these holes I used a circle cutter. They are inexpensive and you can find them at Sears, your local home center, and Amazon.com offers several as well. I drilled a test hole from the cover scrap and adjusted to the proper size. I drilled the holes about a third of the way up from the screen to the top of the container and evenly spaced to the either side. Remember to measure the position of your hole so that you can drill the hole for the other end of the aeration tube in the same position on the opposite side of the container. Once I drilled the holes I took a sheet of sand paper rolled into a tube and just touched up the holes to soften any sharp edges.



Here you can see the container from the top showing the aeration tubes. The tube on the left in the picture below is ready for the screen or the breathable landscape fabric to be attached to it. The aeration tube on the right has not yet had the air holes drilled into it yet. I would attach the fabric after pushing the tubes into the holes so as not to rip it off the tube. Once these last few steps are complete the container is ready for planting. You can seal the edges of the screen if you like but it is really not needed.



Extreme designs:

8 foot food grade fresh water tank. (for a boat)



Original water fill for the tank. I placed a "backup" PVC pipe in it to fill the reservoir should something happen to the auto fill.

Top of water tank cut into two pieces. I use these pieces to separate the "soil" from the water reservoir.

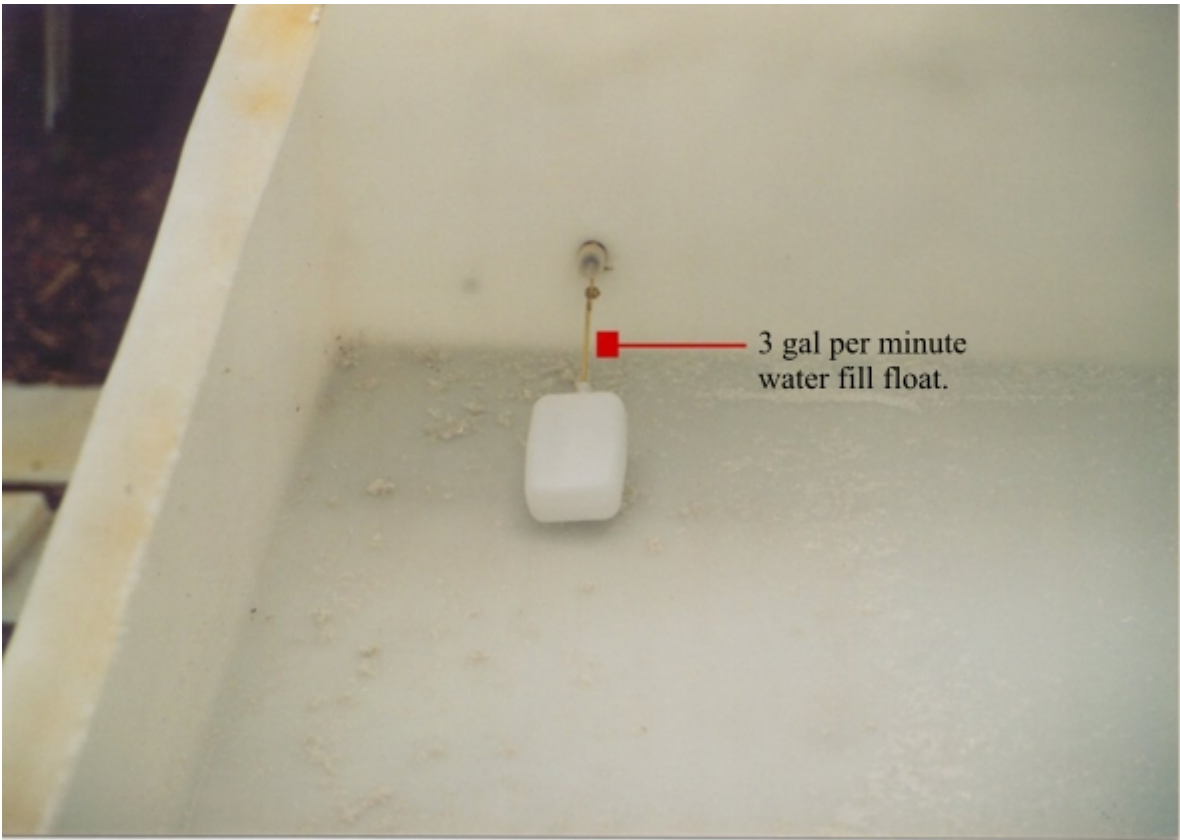

3 gal per minute water fill float.

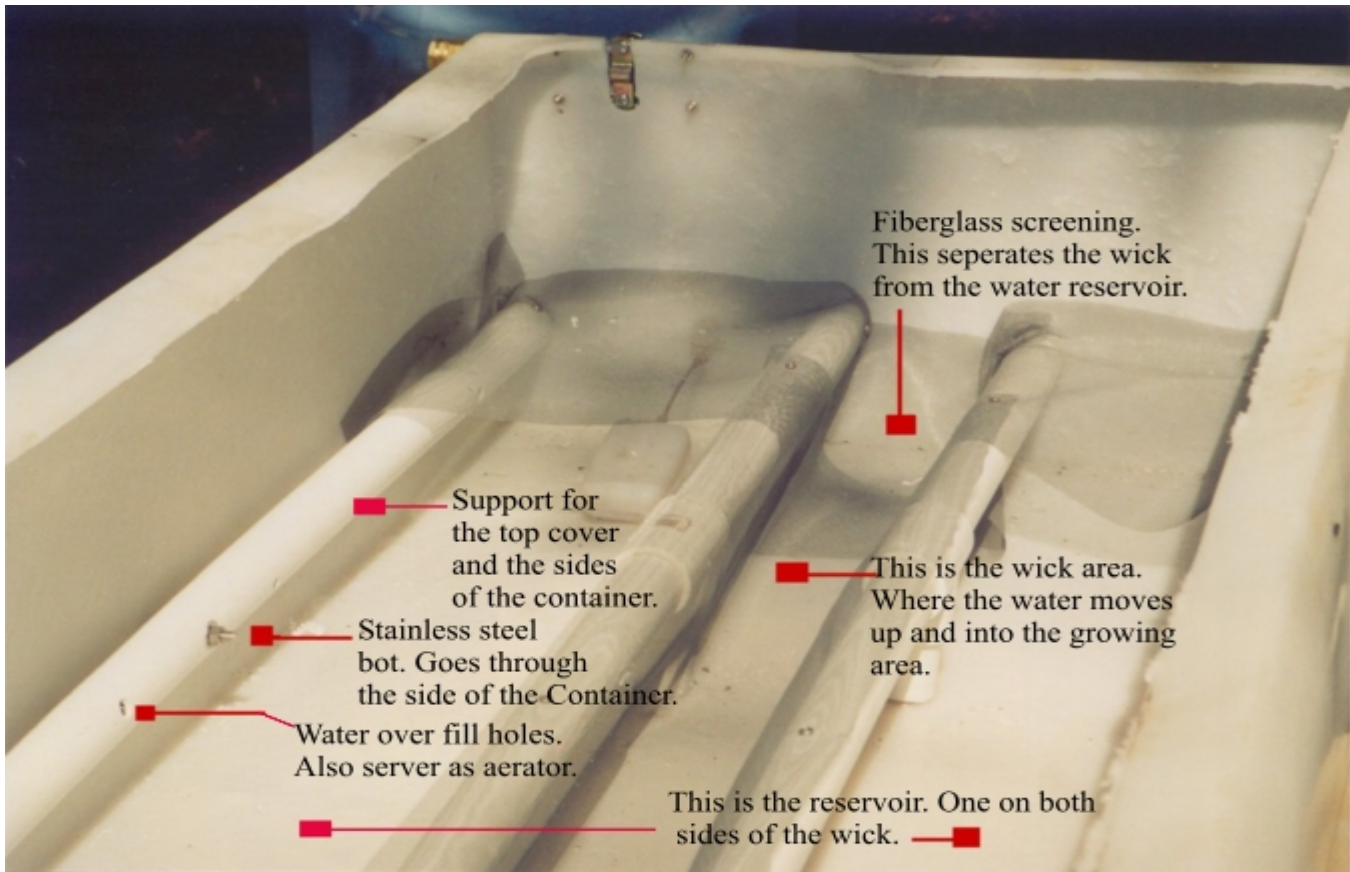

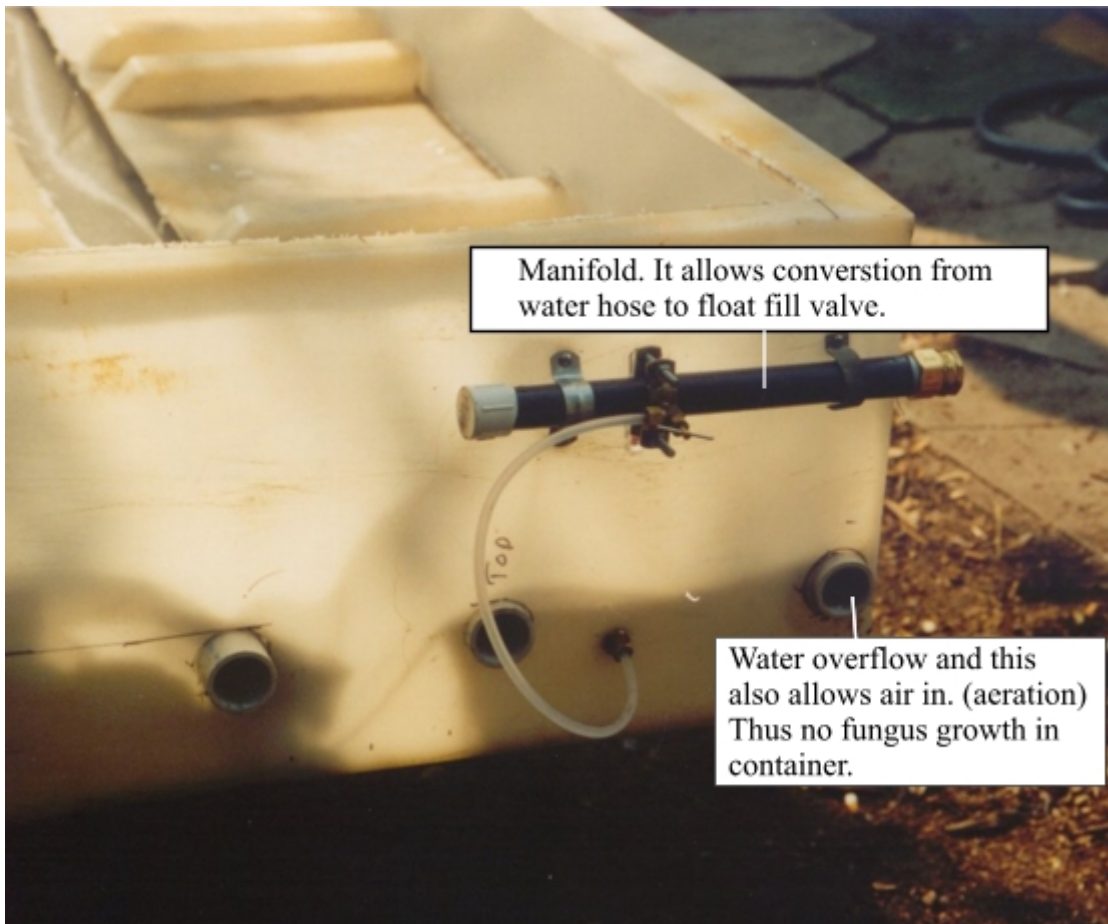
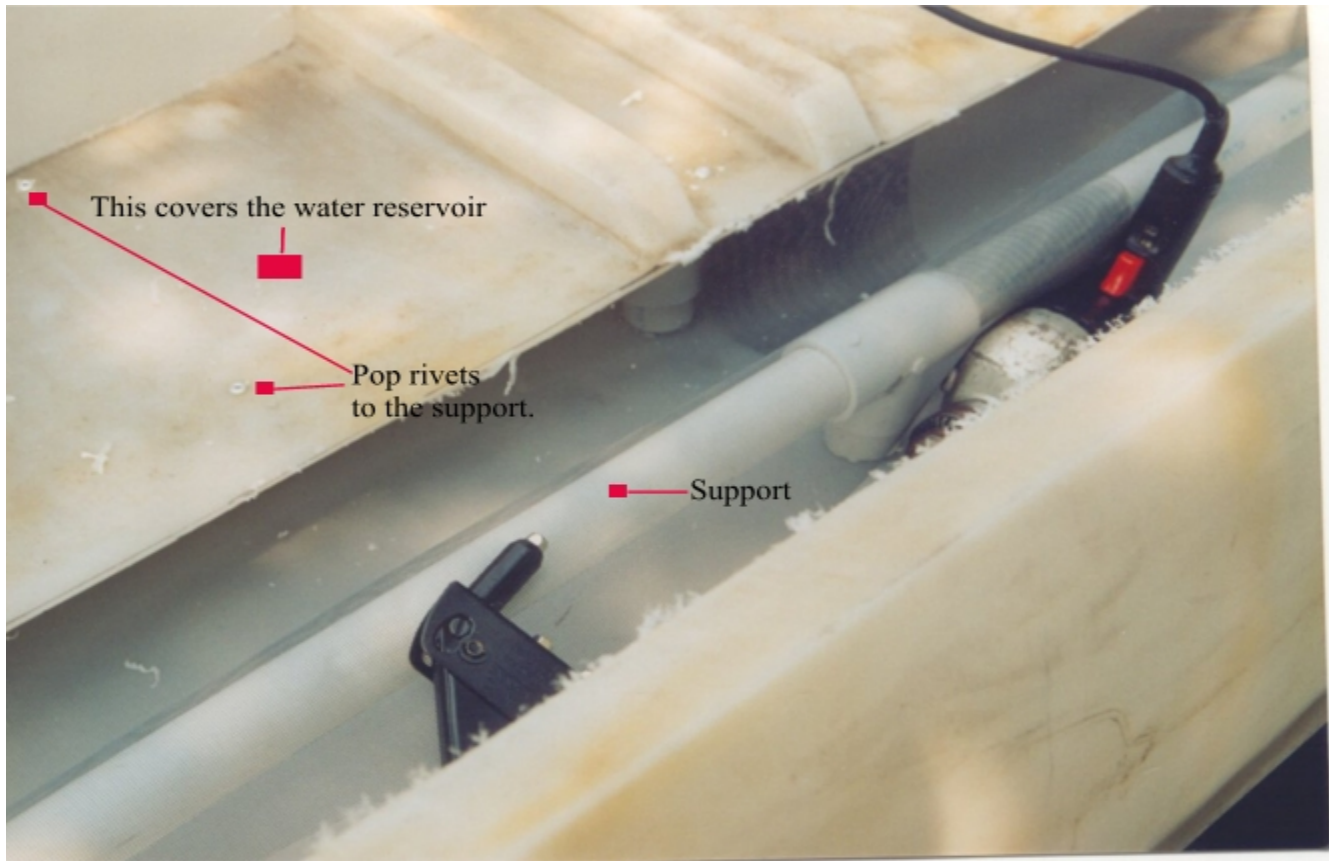

These ideas can be used on any type of container.

Completed Container

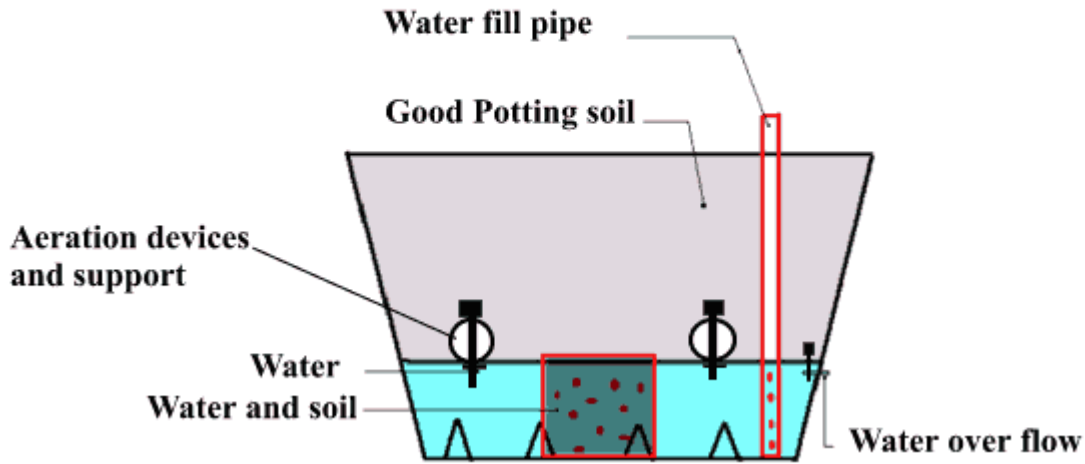

Setting up the container for planting:

1. Place the container where you are going to keep it. Put your container in a sunny spot that gets 6 to 8 hours of sun per day. Once you fill the container they become very heavy and difficult to move so it is best to place it in its final location before you fill it.
2. Get a bucket or other suitable container to moisten the initial potting mix. Make sure that it is moist but not soaking wet. Use this first potting mix to fill the wicking chambers. After you fill the wicking chambers you can pour the potting mix directly into the container and moisten with water. Fill the water reservoir with water through the fill tube until water comes out of the overflow hole.
3. Continue adding moist potting mix on top of the screen until the container is half full. It's OK for some of the mix to fall through the screen. Sprinkle the potting mix with water and gently pat it down, especially above the two wicking chambers you filled first.
4. Fill the container completely to the top with potting mix. Do not leave a space along the sides. Again sprinkle well with water and smooth the soil to the top edges, leaving a slight mound down the center. For tomatoes, mix two cups of dolomite or hydrated lime into the top 3-4 inches of potting mix and re-smooth.
5. Pour two cups of dry fertilizer in a 2" wide stripe directly on top of the potting mix according to the planting guide (see the next section). **DO NOT MIX THE FERTILIZER INTO THE POTTING MIX OR SPREAD IT AROUND.** Simply pour it in a narrow strip on top and gently pat it down. Do not use fertilizer that requires mixing with water, such as Miracle-Gro™ or other "blue water" brands.
6. Place the mulch cover over the container and cut the hole for the fill tube. Pull the mulch cover down over the top of the container and secure with the lid rim or you can wrap a bungee cord around the container to hold the cover. Some people in windy areas also tie two cords completely around the container as extra insurance. **Note: it hot climates you should try to use light colored plastic because dark plastic will heat the soil too much.**
7. Cut 3 inch X pattern in the plastic where the plant needs to go. Dig 2 to 3 inch deep holes into the potting mix (through the cover), just as you would in the ground. Place the plants or seeds in the holes and firm the mix around the roots. Just this one time, "water the plants in" from the top to remove any air spaces from around the roots and put the flaps back around the stems.
8. Your EarthBox has all the fertilizer it needs for one complete growth. Always keep the cover on the keep reservoir full by adding water through the fill tube until it runs out the drain hole. To replant, remove the old cover and dig out the fertilizer stripe. Top it off with potting mix, being sure it is completely wet throughout, and add a new fertilizer strip. Install a new cover and plant again.

Planting Guide:

The storage tubs are not as long as the Earthbox™ so I would take one off the end of the line with a lot of plants (e.g. like corn, string beans, herbs, Strawberries, Etc). Note: the fill tube on the Earthbox™ is in the corner in your container it may be in a different spot but should not affect the plant placement.

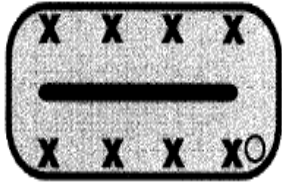

Chard

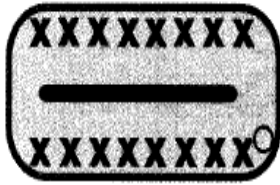

Corn



Artichokes

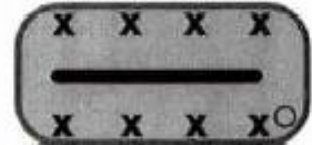

Bell/Hot Peppers

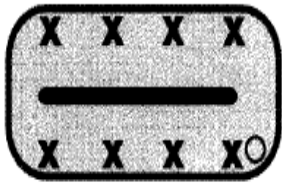

Lettuce

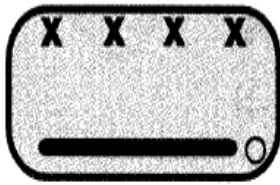

Melons

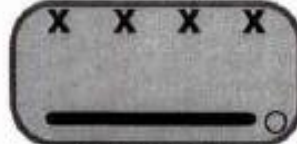

Cucumbers



Eggplant

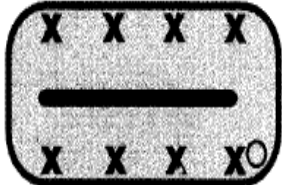

Strawberries



Tomatoes

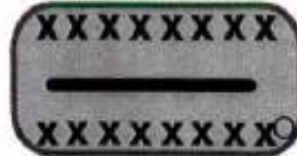

Okra



Onions

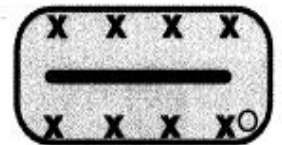

Cabbage

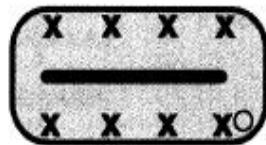

Celery

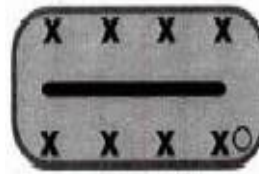

Broccoli/Cauliflower

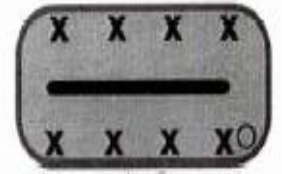

Brussels Sprouts

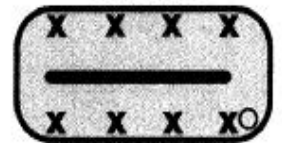

Herbs

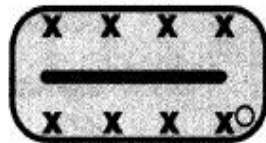

Kohlrabi / Leeks

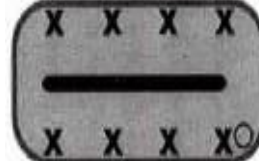

Flowers

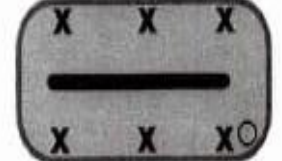

Greens



Spinach

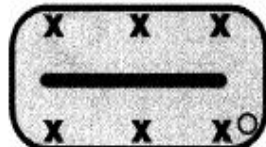

Squash

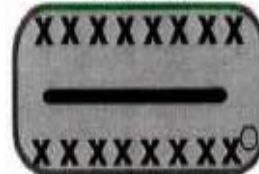

Peas/Beans

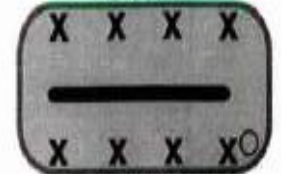

Salad Greens

Questions and answers:

Q - How far from the bottom of the wicking pipe do you drill holes the holes? And how far apart do you space them (or does it matter)?

A - You need a hole at the top and bottom of the wicking chamber PVC pipe. See screen supports at the beginning of this document for more information.

Q - How do you attach the screen support pipes to the screen?

A - I use electrical wire ties to attach the pails to the top. 6" to 8" works great. First drill four small equal spaced holes in the top of the wall of the pail at 90 degree intervals. These ties thread through small holes drilled into the screen.

Q - Can I just use regular garden dirt in these containers?

A - No regular garden dirt will not wick the water properly. You must use potting mix. Also do not use potting soil you need to make sure that it is potting mix.

Q - Can I make my own potting mix?

A - Yes you can the formula is 45% peat moss, 45% compost, 10% perlite, plus 2 cups of hydrated lime or dolomite.

Q - What size hole do you drill for the aeration screen holes?

A - I use ¼ inch holes just like the Earthbox™ however; you can make smaller holes if you wish.

Q - What can I do to keep the soil from getting into the water reservoir (lower) chamber?

A - You can use breathable landscape fabric or fiberglass screen. You can cover the aeration screen with either except over the wicking chamber holes these must remain open so that the soil can wick the moisture to the roots. You can also line the wicking pipe with a screen shaped like a cup. For seasonal gardeners this is not really necessary but for southern region gardeners or long term gardeners this can be done if you wish.

Q - Does the fertilizer band just sit on top of the soil or does get buried or mixed with soil?

A - Choose a fertilizer and plant placement (see the planting guide above). Pour two cups of dry fertilizer in a 2" wide stripe directly on top of the potting mix. **DO NOT MIX THE FERTILIZER INTO THE POTTING MIX OR SPREAD IT AROUND.** Simply pour it in a narrow strip on top and gently pat it down. Do not use fertilizer that requires mixing with water, such as Miracle-Gro™ or other "blue water" brands.

Q - Are the Earthbox™ instructions available online?

A - Yes they are available at <http://www.earthboxresearch.com/> select How it works from the bar at the top and then scroll to the bottom of the page to see the link for the step by step instructions.

How to cut the PVC pipe:

To cut the PVC pipe you can use a regular miter box for anything 2 inches and smaller. You can use either a hack saw or the miter saw. Just take your time especially when first starting the cut.



For cutting the 4" PVC you can use a power miter saw if you have one or use the hand saw with a special miter box design for cutting the larger PVC pipe (see below). Please be extremely careful when using any power tool. When you cut PVC pipe using the miter saw bring the blade down slowly into the PVC pipe. If it does not cut all the way through rotate the pipe slightly to finish the cut. **Important: wear safety glasses when using the saw because PVC can splinter and wait for the blade to stop spinning before you lift it out of the pipe (this prevents the blade from catching the loose cut piece and shattering it or flinging it at your face). Also any pipe that you cut with this saw must be fully supported so that it will not pop up after the cut.**



If you do not want to use a power miter saw you can use a special miter box (see the design below) just like a regular miter box. It made from a small piece of plywood, 4 feet of 2X6 lumber, and a few screws. The most important step is to make sure the saw blade slot is square (90degrees) to the edge of the plywood and that both sides are perfectly straight. Any lumber yard or home center can make the proper cuts for you. Attach 2 of the four 2X6 pieces on one side of the saw blade slot and then align both with a square. Use the saw blade itself to set the gap for attaching to 2 remaining 2X6 pieces. You can also add a small strip of wood or plywood to the edge of the box to catch the table edge when sawing. The saw to use with this it a miter saw. The higher the blade the straight the cut will be.

view from the front

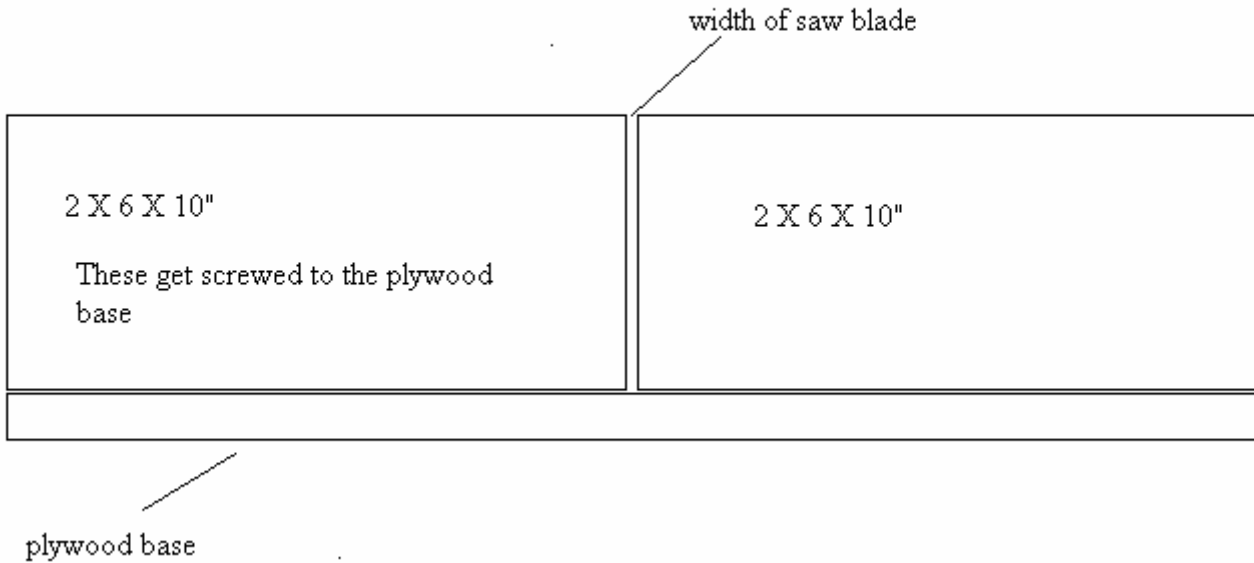

view from the top

