



visual engineering
LIGHTWARE

PRODUCT

L I N E **2020**

MX2
SERIES

visual engineering
LIGHTWARE

lightware.com

18 Gbps Matrix Switchers

with HDMI, DisplayPort or Mixed I/O Configurations



**HDMI 2.0 | DisplayPort 1.2 | 4K UHD @ 60 Hz in 4:4:4
HDR | Dolby Vision | 3D | HDCP 2.2 | HDCP 1.4
Ethernet | RS-232 | USB**



visual engineering
LIGHTWARE

PRODUCT

L I N E **2020**

Table of Contents.....	4
Company.....	6
Lightware Technologies	8
Instantaneous Switching.....	10
Advanced EDID Management.....	10
HDCP Compatibility.....	10
Single Fiber Technology.....	10
Pixel Accurate Reclocking.....	11
Cross Compatibility.....	11
3D Formats Support.....	11
Built-in Cable Compensation.....	11
Advanced Control Options.....	11
4K UHD Support.....	11
Frame Detector and Input Signal Analysis.....	12
Lightware Device Controller.....	12
Configuration Cloning.....	12
Reliability & Redundancy.....	12
RS-232 Over Fiber and TPS.....	13
Advanced Audio Options.....	13
RICOD (Remote Input Control over DDC).....	13
TPS Cable Diagnostics Tool.....	13
Event Manager.....	14
UMX Technology.....	18
Breakaway Audio/Video Switching.....	18
Analog to Digital Conversion.....	18
25G Technologies.....	19
Multilayer Switching.....	19
Advanced Graphical User Interface.....	19
Room Management.....	19
User Access Management.....	19
Cisco Technology.....	20
Advanced Control Pack.....	22
AV Over IP	24
AV Over IP Multimedia System.....	25
UBEX-PRO20-HDMI-F100.....	31
UBEX-PRO20-HDMI-F110.....	31
UBEX Comperation Chart.....	32
UBEX-PRO20-HDMI-R100	34
UBEX-MMU-X200.....	35
VINX-120-HDMI-ENC and VINX-110-HDMI-DEC.....	36
VINX-110AP-HDMI-DEC, VINX-120AP-HDMI-ENC, VINX-120AP-HDMI-ENC-DNT , VINX-210AP-HDMI-ENC.....	37
Standalone Matrix Switchers	39
MX2 Series.....	40
MX2-4x4-HDMI20-CA, MX2-8x4-HDMI20-CA, MX2-8x4-HDMI20-CA.....	44
MX2-8x8-HDMI20-L, MX2-8x8-HDMI20-Audio-L.....	45

MX2-16x16-HDMI20, MX2-24x24-HDMI20, MX2-16x16-HDMI20-Audio, MX2-24x24-HDMI20-Audio.....	46
MX2-16x16-HDMI20-R, MX2-24x24-HDMI20-R, MX2-16x16-HDMI20-Audio-R, MX2-24x24-HDMI20-Audio-R, MX2-32x32-HDMI20-A-R, MX2-48x48-HDMI20-A-R.....	47
MX2-8x8-DH-8DPi-A, MX2-8x8-DH-4DPi-A.....	48
MX2-24x24-DH-12DPi-R, MX2-16x16-DH-8DPi-R, MX2-24x24-DH-12DPi-A-R, MX2-32x32-DH-16DPi-A-R.....	49
MX2-8x8-DH-8DPio-A, MX2-24x24-DH-24DPio-A-R, MX2-48x48-DH-48DPio-A-R.....	50
MX2 Family Comparison Chart.....	52
UMX-HDMI-140, UMX-HDMI-140-Plus.....	53
MMX4x2-HDMI.....	54
MMX4x2-HT200.....	55
MMX6x2-HT220.....	56
MMX6x2-HT210.....	57
MMX6x2-HT200.....	57
MMX8x4-HT420M.....	60
MMX8x4-HT400MC.....	61
MMX8x8-HDMI-4K-A.....	62
MX8x8DVI-HDCP-Pro.....	63
MX8x8HDMI-Pro.....	64
MX4x4DVI-DL, MX6x6DVI-DL, MX8x8DVI-DL.....	64
MX9x9DVI-Slim, MX12x12DVI-Slim and MX16x16DVI-Slim.....	65
MX9x9DVI-Plus, MX12x12DVI-Plus and MX16x16DVI-Plus.....	66

Hybrid Modular Matrix Switchers	67
Frames and Boards Summary.....	68
MX2M Series	70
MX2M Series I/O Cards	72
Matrix Switcher Frames.....	74
MX-CPU2.....	75
MX-RCP16 and MX-RCP32.....	75
Frame Specifications.....	76
Input Boards	78
MX-DVIDL-IB.....	78
MX-3GSDI-IB.....	78
MX-HDMI-3D-IB, -A, -S.....	79
MX-DVI-4K-IB.....	79
MX-4TPS2-4HDMI-IB, -A, -S, -P, -AP, -SP.....	80
MX-TPS-IB, -A, -S.....	81
MX-TPS2-IB-P, -AP, -SP.....	82
MX-DVI-OPT-IB-LC, -NT, -SC, -ST.....	83
MX-DVIDL-OPT-IB-LC, -NT.....	83
MX-HDMI-OPT-IB-LC, -NT, -SC.....	84
Output Boards	85
MX-HDMI-3D-OB, -A, -S.....	85
MX-DVI-4K-OB.....	85
MX-4TPS2-4HDMI-OB, -A, -S, -P, -AP, -SP.....	87

MX-TPS-OB, -A, -S	88	SW4-OPT-TX240RAK	120
MX-TPS2-OB-P,-AP, -SP	89	HDMI-3D-OPT-TX210A and HDMI-3D-OPT-TX210RAK	121
MX-AUDIO-OB-A	90	HDMI-3D-OPT-RX150RA	123
MX-DVIDL-OB	90	DVIDL-OPT-TX200, DVIDL-OPT-RX100	123
MX-DVI-OPT-OB-R, -LC, -ST, -SC, -NT	90	DP-OPT-TX100, DP-OPT-RX100	124
MX-DVIDL-OPT-OB -LC, -NT	91	DP-OPT-TX150, DP-OPT-RX150	124
MX-HDMI-OPT-OB-R-LC, -NT	91	BR-NT	125
Signal Extenders	92	SP2-OPT-LC, -NT, -SC, -ST	125
TPS Extenders	93	Fiber Optic Extenders Comparison Chart	126
■ UMX-TPS-TX140, UMX-TPS-TX140-Plus, UMX-TPS-TX140K	93	Fiber Optic Extension System Comparison Chart	127
UMX-TPS-TX130	94	Accessories	128
UMX-TPS-TX120	94	Mounting Kits	128
WP-UMX-TPS-TX130-US, WP-UMX-TPS-TX130-Plus-US	95	Power Supplies and Accessories	130
WP-UMX-TPS-TX120-US-Black, -White	95	Accessories Compatibility Table	131
HDMI-TPS-RX110AY, HDMI-TPS-RX110AY-Plus	96	OPTJ PowerTray NTD, NTQ, SC	132
■ HDMI-TPS-RX220AK	97	PRC-16-205	133
SW4-TPS-TX240, SW4-TPS-TX240-Plus	98	■ TBX-M210-K	134
DVI-HDCP-TPS-TX97, DVI-HDCP-TPS-RX97	99	25G Hybrid	135
HDMI-TPS-TX97, HDMI-TPS-RX97	99	25G Hybrid Technology	136
DVI-HDCP-TPS-TX95, DVI-HDCP-TPS-RX95	100	25G Configuration	137
■ HDMI-TPS-TX96, HDMI-TPS-RX96	100	25G-FR160x160, 25G-FR120x120 /	
DVI-HDCP-TPS-TX220, DVI-HDCP-TPS-TX210	102	25G-FR160x80, 25G-FR80x160	137
HDMI-TPS-TX220, HDMI-TPS-TX210	102	25G-FR80x80	138
DP-TPS-TX220, DP-TPS-TX210	103	25G-CPUB1	139
TPS-PI-1P1	104	25G-PSU-1600 (1200)	139
WP/FP-HDMI-TPS-TX/RX-97	105	25G Media Layers	140
FP-UMX-TPS-TX120, FP-UMX-TPS-TX130	106	Video Layer with Embedded Audio	140
Interfaces and Distribution Amplifiers	107	25G-FORWARD-AUDIO	140
EDID Manager V4	107	25G-RETURN-AUDIO	140
HDMI-4K Manager	108	25G-ETHERNET	141
HDMI-4K De-embedder	108	25G-USB-HID	141
TBP6-EU-K, TBP6-EU-W	109	25G-IR	141
RAP-B511	110	25G-CEC	141
DA2DVI-DL	111	25G-RS-232	141
DA4-3GSDI	111	25G Input Boards	142
DVISL-, DVIDL-, HDMI-Extender	111	25G-8DVID2-IB series	142
DA2HDMI-4K-Plus-A	112	25G-8HDMI2-IB series	144
DA2HDMI-4K-Plus	112	25G-8TPS2-IB Series	146
Fiber Optical Extenders	113	25G-OPTS2-IB- LC, -SC, -ST, -NT	148
HDMI20-OPTC-TX/RX220-Pro, HDMI20-OPTC-TX/RX220-FOX,		25G-OPTM2-IB- LC, -SC, -ST, -NT	149
HDMI20-OPTC-TX/RX220-NTQ, HDMI20-OPTC-TX/RX220-PCN	114	25G Output Boards	150
HDMI20-OPTJ-TX90, HDMI20-OPTJ-RX90	115	25G-8DVID2-OB Series	150
UMX-OPT-TX150R	116	25G-8HDMI2-OB Series	151
DVI-OPT-TX110, DVI-OPT-RX110	117	25G-8TPS2-OB Series	152
DVI-OPT-TX220-Pro, DVI-OPT-RX220-Pro,		25G-80PTS2-OB- LC, -SC, -ST, -NT	154
DVI-OPT-TX220-ST-Pro, DVI-OPT-RX220-ST-Pro	118	25G-80PTM2-OB- LC, -SC, -ST, -NT	155
HDMI-OPT-TX/RX100, HDMI-OPT-TX/RX100R	119	25G-MX Boards	156
HDMI-OPT-TX100R, HDMI-OPT-RX200R	119		

Company

Lightware Visual Engineering is a leading manufacturer of DVI, HDMI and DisplayPort matrix switchers, signal extenders and accessories for the professional AV market. Our goal is to recognize industry needs and develop performance-rich products of the highest quality by continuously consulting with integrators, rental technicians and design engineers.

Pro-series Matrix Routers. The technology built into our Pro-series DVI matrix routers breaks many standard limitations; allowing 60 meters DVI cable on input, Advanced EDID Management, Pixel Accurate Reclocking, LAN, RS-232, RS-422 control, fiber cable powering and more. All signals from Single-Link to the highest resolution Dual-Link DVI can be managed by Lightware Pro-series routers which deliver the ultimate performance in signal conditioning, retransmission and easy system integration.

Hybrid Modular Design. Lightware's MX series router frames and I/O board family incorporate broad signal compatibility, precise switching, control, troubleshooting and signal measurement. AV professionals can choose various I/O sizes, video signal types and transport media options thanks to our Hybrid Modular Design. The MX series matrix backplanes are capable of switching 12.8 Gigabit per second data rates allowing transportation of HDMI 1.4, 4K UHD, 3D and DisplayPort 1.1 video signals.

25G Hybrid Technology. 25G Hybrid Signal Management introduces a completely new concept to the AV industry. Innovative engineering and design created a uniquely new Multilayer Management technology, which allows managing, switching and extending digital and analog video, audio, Ethernet, and control. Designed to deliver exceptionally high resolution image quality and 24/7 reliability, the 25G Hybrid technology establishes a new standard in the professional AV industry.

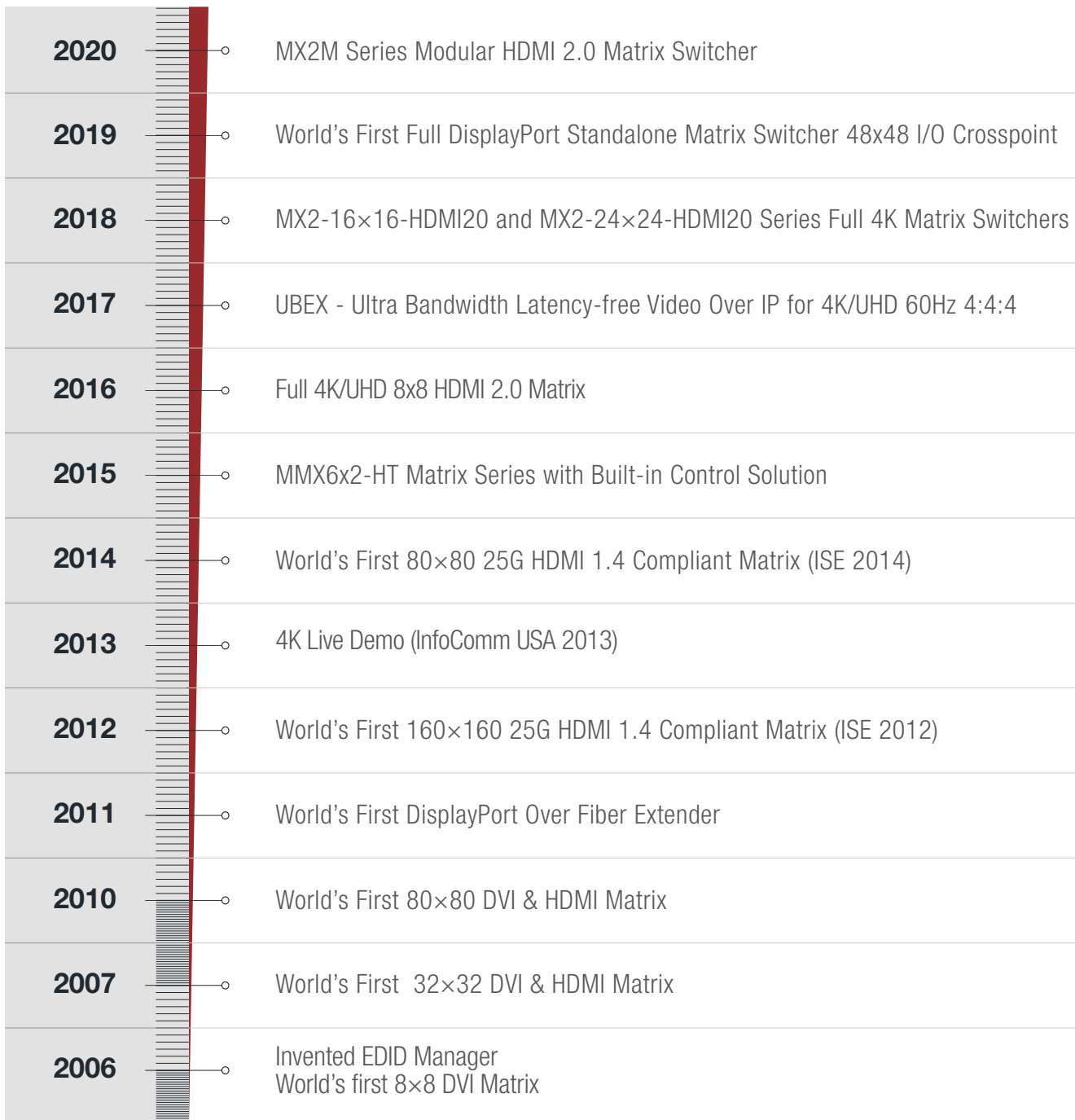

High Fidelity Signal Management. All Lightware products utilize pixel by pixel signal transmission between endpoints. The lack of latency and compression ensures that the signal keep its original quality. This is achieved by employing such proprietary Lightware technologies as Pixel Accurate Reclocking and Single Fiber Technology.

Research and Development. Lightware technology incorporates numerous professional features developed by our R+D centre in Budapest. These features are Lightware's own intellectual property and some have now become industry standards. Lightware products are solely designed, developed and manufactured in Hungary in the European Union.

Trainings and Education. Lightware Visual Engineering organizes educational seminars in our dedicated Lightware Training Center, designed to provide an insight into the specifics, pitfalls and best practices when integrating the major digital video formats. At these events Lightware trainers and engineers respond to questions, and present a deep insight of the digital standards and their application.

Lightware Worldwide. Our products are available in more than 40 countries in Europe, Asia, Australia, Middle East, North America and in Latin America through our offices and distributors. We also find it important to show our latest technologies and products at the finest events of the audiovisual industry worldwide. We are always present at the ISE Forums in the Amsterdam RAI, at the InfoComm shows and at several other events.

Customer Satisfaction Above All. At Lightware we believe in strong direct support service: our engineers spend long service hours at installation premises, if that seems necessary, and never leave any possible problem untreated or unresolved. Nevertheless, owing to the quality assurance and the professional design of our products we have a rather low number of post-sale support calls.

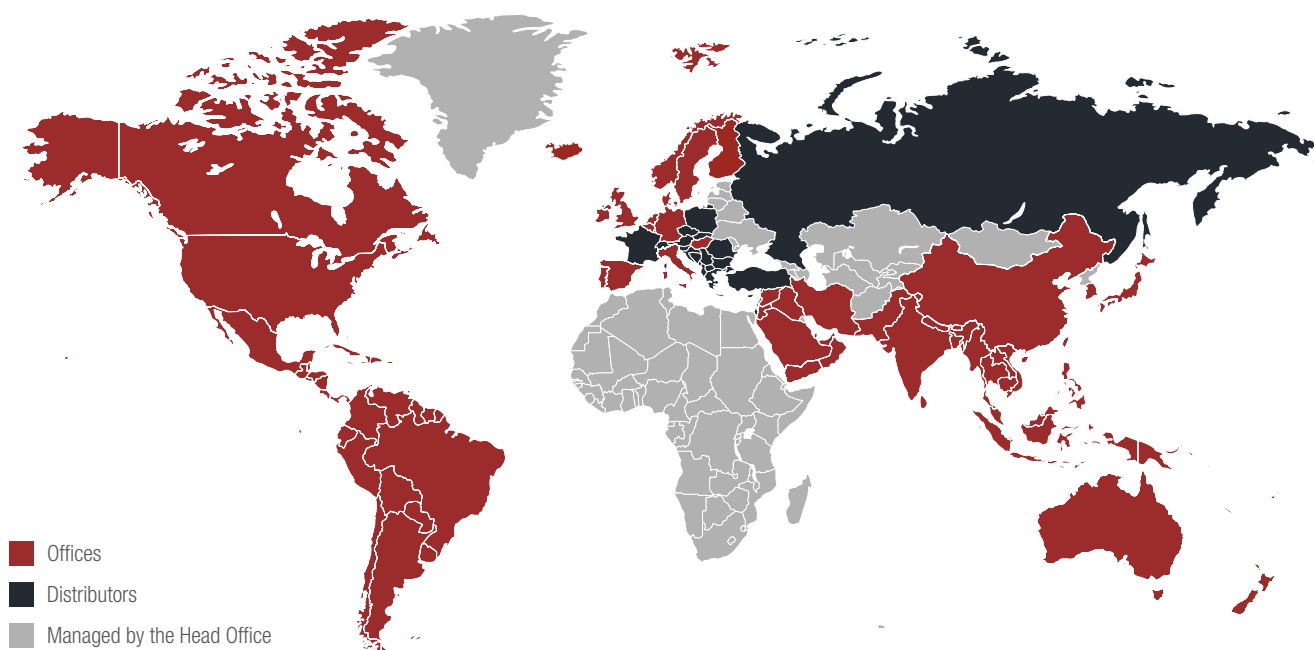

TECHNOLOGIES

Lightware Research and Development



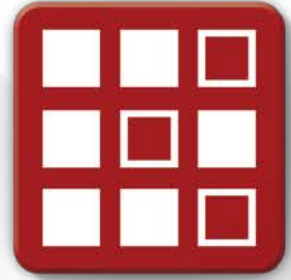

Instantaneous Switching without Signal Latency

All Lightware matrix routers and standalone extenders – even the analog VGA or 3G-SDI Input Boards – add no frame or line period delay to the signal. When a key press or a switch command is sent over any control port the switching is instantaneous. Lightware routers and switchers do not add delay to the switching process and multiple switches can be executed at the same time. Even signals of non-locked sources are switched instantaneously, allowing displays to resynchronize as fast as their internal circuitry allows. The resynchronization time may take between 2 and 50 milliseconds depending on the display or projector type.

Advanced EDID Management

This proprietary Lightware technology stores more than 100 user EDID files and offers numerous factory presets including all standard DVI resolutions. HDMI EDID with various audio channels and codecs are also supported, also analog VESA, non-standard VGA EDID formats and Dual-Link DVI resolutions including requirements of the latest 4K projectors.

With the supplied Lightware Device Controller software application including the Advanced EDID Editor tool users can create their own EDID preset and upload it to any Lightware product or they can modify existing EDID data read from any projector or monitor and send the preset setting file via Email. It supports .bin, .dat and .edid file formats allowing system engineers to generate EDID files for 3rd party manufacturer's AV products.

HDCP Compliance

The Lightware matrix router frames, the majority of I/O boards and other devices are compatible with HDCP encrypted sources and displays. Installing a complex AV system with both HDCP and non-HDCP components is possible, and with our non-blocking architecture HDCP and non-HDCP boards are now compatible within the same chassis.

 A **red screen alert** is shown when protected content is switched to a non-compliant display. Lightware Visual Engineering maintains all HDCP regulations and has developed several functions which help solve HDCP related problems.

 **HDCP key caching** is a method introduced in early 2009, which validates all display keys in an AV system during system boot up and keeps them constantly available for sources. This method eliminates HDCP handshakes at every switching and keeps all sources sending uninterrupted signals. Similarly to fixing an EDID on input ports, the whole video and audio system will be free from black displays, screens blinking from 5 to 8 seconds and dropped signals, which are all too common in many switching and signal distribution products.

 **HDCP enabling/disabling function** turns off HDCP capability on individual input ports while keeping other inputs HDCP compliant. Some computers choose to encrypt their output even when unprotected content is displayed, such as desktop images or presentations. This function forces the source to send an unencrypted signal if the content itself is also unencrypted.

Single Fiber Technology

Single Fiber Technology is one of the main features of our OPT, OPTS, OPTM, OPTJ and OPTC fiber optical extenders. This technology allows sending several signals over one optical fiber core. All the bi-directional communication - necessary for HDCP handshaking or the control commands - is performed via the same fiber core that transmits the video signal, making installation of these extenders easy and cost-effective.





Pixel-Accurate Reclocking

Lightware developed Pixel-Accurate Reclocking and introduced it in the world's first DVI matrix switcher (MX8x8DVI-Pro) in 2006. This technology provides exceptional signal regeneration capability. The circuitry cleans the signal from noise, skew and jitter caused by long cable runs, EMC-incompatible devices and poor quality twisted pair cables and equipment. Automatic skew compensation eliminates intra-pair and inter-pair skew caused by imperfect wire twists and lengths in DVI, HDMI and CAT cables. Pixel-Accurate Reclocking decodes the pixel information from the video content and drives it over the dual PLL circuitry. The regenerated pixel information is re-encoded as a DVI or HDMI signal ensuring the output is stable with sharp digital transitions and accurate timings.

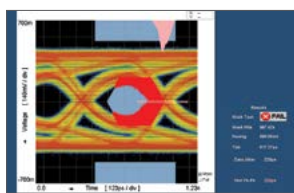

HDMI signal before Pixel Accurate Reclocking

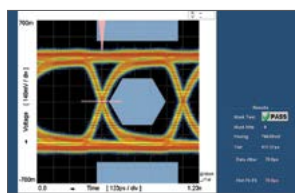

HDMI signal after Pixel Accurate Reclocking



Cross Compatibility

Cross-compatibility is ensured among devices in the Lightware product families. Extender pairs work together in point-to-point standalone applications and also when connected to a matrix router due to Lightware's Hybrid Modular design. This integrated solution simplifies installation and helps reducing system costs as well.



3D Format Support

Lightware provides complex, integrated solutions for the digital age, delivering 3D HDMI. Lightware products enable customers to use 3D technology in every typical professional or household application including Blu-ray players, game consoles, cable, and satellite or broadcast installations.



Built-in Cable Compensation

DVI, HDMI or SDI input ports have built-in cable equalizers in the Modular Matrix Switchers. The cable equalizer can be used in manual or automatic adaptive mode and extends the cable length on inputs as the actual signal format requires. Using a 22AWG high quality DVI or HDMI cable, the inputs are automatically compensated for up to 60 meter cable length at 1080p, WUXGA and 2K computer resolutions at 24bpp. This feature eliminates the need for additional cable extender boxes in the system rack.



Advanced Control Options

Various control options assure that system control, setup, maintenance and troubleshooting tasks are performed easily. A rugged Ethercon connector serves as reliable connection to the LAN, allowing multiple TCP/IP and WEB controls simultaneously in the matrix frames. An RS-232 connector is provided for third-party control systems. Touch-panel controls allow the customization of the system maintaining simplicity in system control and operation. The front panel mini USB connector serves for easy access in rack applications. Lightware Device Controller software enables quick matrix configuration and it includes a built-in Advanced EDID Editor.



4K UHD

The MX and MX2 series Hybrid Modular and the 25G HYBRID matrix switchers support 4K / UHD (30Hz RGB 4:4:4, 60Hz YCbCr 4:2:0) and 1920x1080@120Hz FullHD resolutions. Lightware 4K extenders can be used in point-to-point 4K transmission and can also be connected to

MX series or 25G HYBRID matrix switchers as far end points. Some of our latest matrix switchers and forthcoming extenders already support Full 4K / UHD at 60Hz with 4:4:4 colorspace.

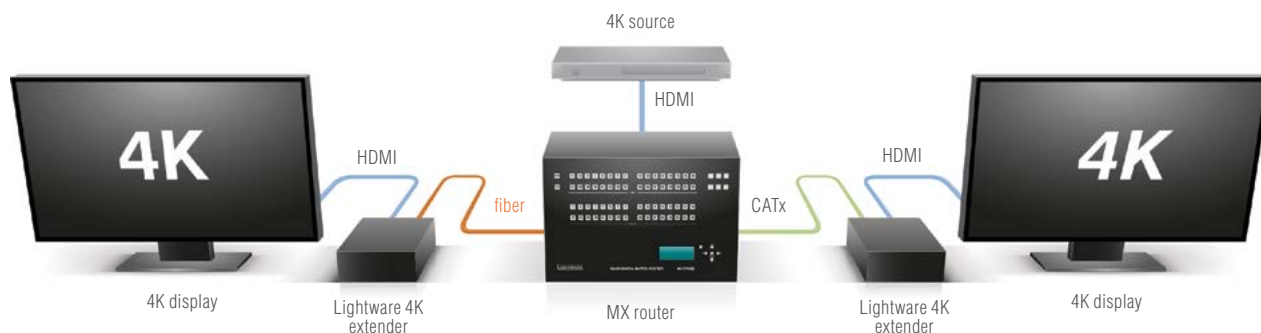



Frame Detector and Input Signal Analysis

Available in Lightware matrix switchers and certain extenders, this function determines the exact video format sent by the source and helps identify many potential issues. The signal analyzer displays detailed information regarding an incoming video and audio signal such as timing, frequencies, scan mode, HDCP encryption, color range, color space and audio sampling rate. In the Frame Detector window the parameters are displayed on an intuitive graphical interface.

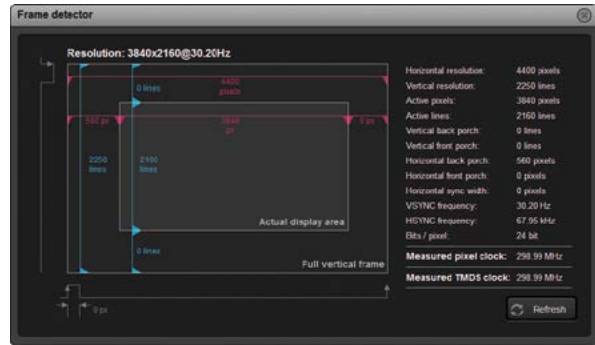

Frame Detector



Lightware Device Controller

The Lightware Device Controller (LDC) application keeps receiving upgrades adding new features and tools. The latest edition of LDC is more intuitive, user friendly, smarter and has a modern interface.

Tile view in LDC presents a new way of matrix handling, the Dynamic Crosspoint Layout allows using it on different screen resolutions and an auto update function is now also integrated. The Lightware Device Controller is available for both Windows and OS X operating systems.

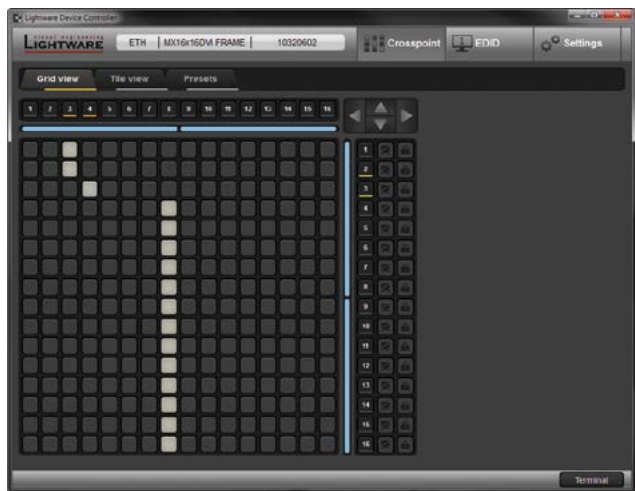

Lightware Device Controller



Configuration Cloning

Configuration Cloning is available as a feature in the Lightware Device Controller software and it eliminates the need to repeatedly configure certain devices in a configuration to have identical (non-factory) settings. If the devices have to be installed in the same type of system multiple times, then it is enough to set up only one device to fit the requirements and then copy those settings to the others, saving time and resources. The cloning process can be performed in two steps: saving the configuration of one device into a backup file and then restoring settings from the backup file in another device.



Reliability and Redundancy

Lightware products are famous for their reliability. The MX-FR9R, MX-FR17R, MX-FR33R, MX-FR65R, MX-FR80R and 25G frames include hot-swappable N+1 redundant Power Supply Units (PSU). These frames were designed for mission critical operations where redundancy is key and high reliability is required. If one of the supplies fail unexpectedly, the remaining PSUs continue to function keeping the AV system continue to operate seamlessly. Our power supplies are all rated to 1,000,000 hours MTBF, their load is set to a maximum of 60% and accept all international AC line voltages from 100 to 240 Volts, with 50 to 60 Hz frequency. PSUs connect to mains cable with a standard IEC connector.





RS-232 Over Fiber and TPS

This control option allows that endpoint devices can be remotely controlled through a single fiber or a twisted pair cable. The central control system can send and receive commands directly to and from the far endpoint devices which have RS-232 control capability. The control commands are delivered on the same fiber or CATx cable which carries the video and audio signal, so extra cabling is not required for RS-232 control. The matrix functions

as a communication hub. The control system needs only one physical LAN or RS-232 connection to the matrix and will be able to communicate with all the endpoint devices directly connected to far end optical or TPS transmitters and receivers.

Using RS-232 command capabilities the central control system can turn on and off a TV which is connected to a TPS or fiber receiver, can select inputs directly on a multi-input TPS or optical transmitter and also be able to communicate with a touch panel connected to a transmitter in a room.

Conference Room Application

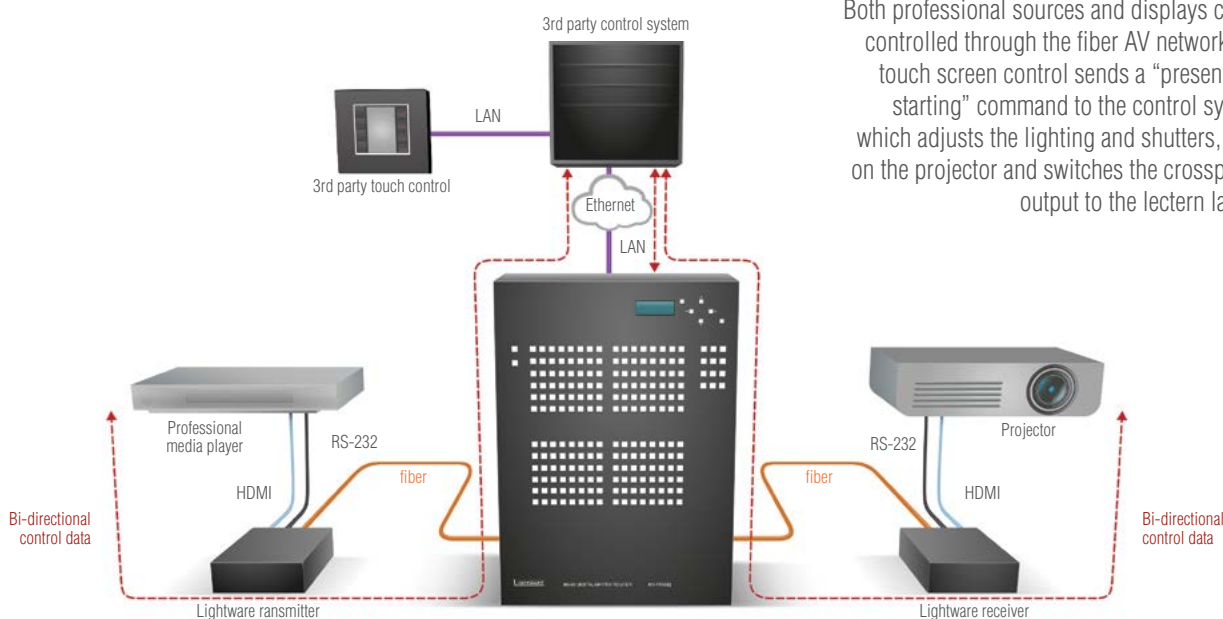

Both professional sources and displays can be controlled through the fiber AV network. The touch screen control sends a “presentation starting” command to the control system, which adjusts the lighting and shutters, turns on the projector and switches the crosspoint’s output to the lectern laptop.



Advanced Audio Options

Lightware extenders and matrix boards support direct analog audio connections to ease system integration. Analog audio ports feature volume, gain, bass and treble controls. These controls help to interface with an audio subsystem or if the ports are connected directly to audio sources or speakers the sound can be directly adjustable.



TPS Cable Diagnostics Tool

The TPS Cable Diagnostics Tool within the LDC software will help you identify potential twisted pair cable issues in your TPS-capable system. It provides a real-time overview of the estimated cable lengths and the quality of the link.

For more information visit Lightware’s dedicated software site at <http://software.lightware.com>



RICOD (Remote Input Control over DDC)

Remote input control over DDC is designed to switch inputs remotely on Lightware signal extenders without any additional control cabling. The RICOD master device can control the RICOD slave device which is connected to its input port. This allows the user to switch between the multiple input ports on the remote transmitter directly from a matrix switcher.

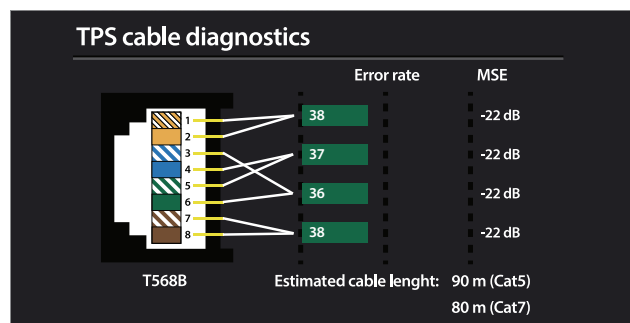

TPS Cable Diagnostics Tool

Who

dimmed the light?
drew the shades?
set the volume?
turned the projector on?



THE BUTLER DID NOT DO IT **EVENT MANAGER DID**

Lightware devices with Event Manager:
all the control you need is already built-in

Event Manager is a **smart, built-in feature** in the Lightware HDBaseT compatible TPS extender family, the MODEX line and in some select matrix switchers like the MMX6x2-HT series units. The feature is available through the freely downloadable **Lightware Device Controller software**.

The Event Manager was developed to handle tasks from the most simple to expert ones, like **controlling** the rolling **shutter**, the air conditioning **system** or the **lights** based on any condition changes on the media ports, such as a new source being connected or removed.

Event Manager application is continuously updated with **additional features** via firmware upgrades: a **delay** can be added between the condition and the action and **more actions** can be triggered **by a single condition change**. With the help of the 'condition count' and 'action test' features, the predefined **settings can be tested** before going live. The system can recognize **infrared** commands which can also be set as conditions, and commands can also be sent via **Ethernet**.

Event Manager saves time, cost and even installation space, which makes Lightware equipment the optimal choice in a number of different configurations. Currently the following Lightware products include Event Manager:

MMX4x2 -HDMI / -HT200	FP-UMX-TPS -TX120 / -TX130
MMX6x2 -HT200 /-210 / -220	UMX-HDMI -140 / -140-Plus
MMX8X4 -HT420M/-HT400MC	UMX-TPS -TX140 / -TX140-Plus
MMX8X8 -HDMI-4K-A	UMX-TPS -TX120 / -TX130
DVI-HDCP-TPS -TX210 / -TX220	HDMI-TPS -RX110AY / -RX110AY-Plus
HDMI-OPTC Series	HDMI-TPS -TX210 / -TX220
WP-UMX-TPS -TX120-US / -130-US	HDMI-3D-OPT -TX210A / -TX210RAK
WP-UMX-TPS -TX120-Plus-US / -130-Plus-US	SW4-TPS -TX240 / -TX240-Plus
TBP6-EU -Series	SW4-TPS -TX240RAK
RAP-B511 -Series	SW4-OPT -TX240RAK

EVENT MANAGER WIZARD

Assigning an action to a condition is quick and easy with the Wizard function of Event Manager. The most typical examples of the currently selectable conditions and actions within the Event Manager Wizard are the following:

Conditions

Video	Signal is detected on a port
Video	Signal is not detected on a port
Audio	Signal is detected on a port
Audio	Signal is not detected on a port
Audio	Signal type changes to PCM
Audio	Signal type changes to Compressed
Audio	Signal type changes to HBR
Audio	Signal type changes to Undefined (no signal)
IR	Infra code recognized
General	OPT/TPS link state changes to Dis-/Connected
CEC	Recognize incoming CEC messages

Actions

Video	Switch input to output
Video	Enable autoselect output
Video	Disable autoselect on output
Ethernet	Send TCP command
Ethernet	Send UDP command
RS-232	Send RS-232 message
EDID	Switch EDID
Audio	Set audio volume
Audio	Mute output
Audio	Unmute output
CEC	Send CEC messages
Audio	Increase/decrease volume

EXAMPLE A

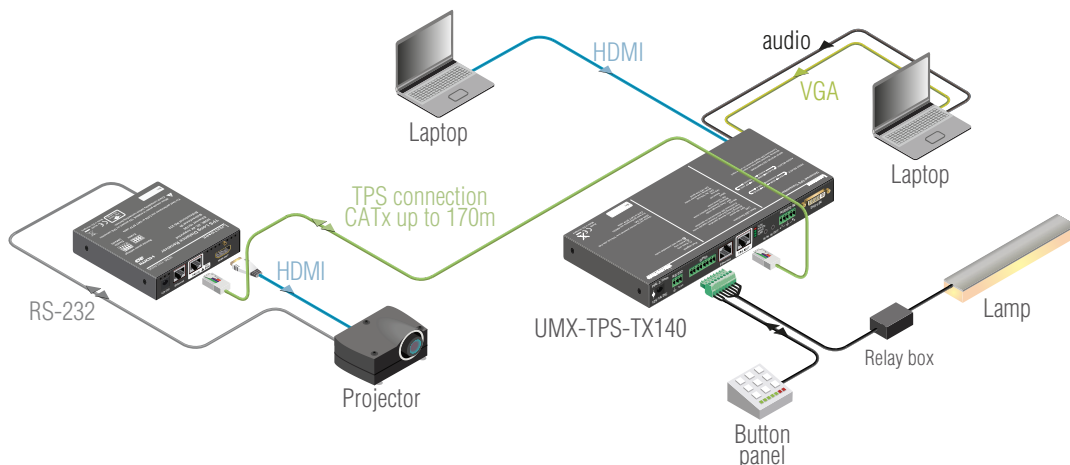

With a button panel connected through the GPIO port, the UMX-TPS-TX140 can be controlled from a remote location; input switching is available even if the transmitter is mounted underdesk. In the example above there are three actions followed by a condition. When an input selector button is pressed on the remote button panel, the selected input port is switched to the output, the projector turns on.

Conditions

Press button panel



Actions



Input select on the TPS transmitter



Switch on the projector using RS-232



Switch off the lamp using the transmitter's GPIO port

EXAMPLE B

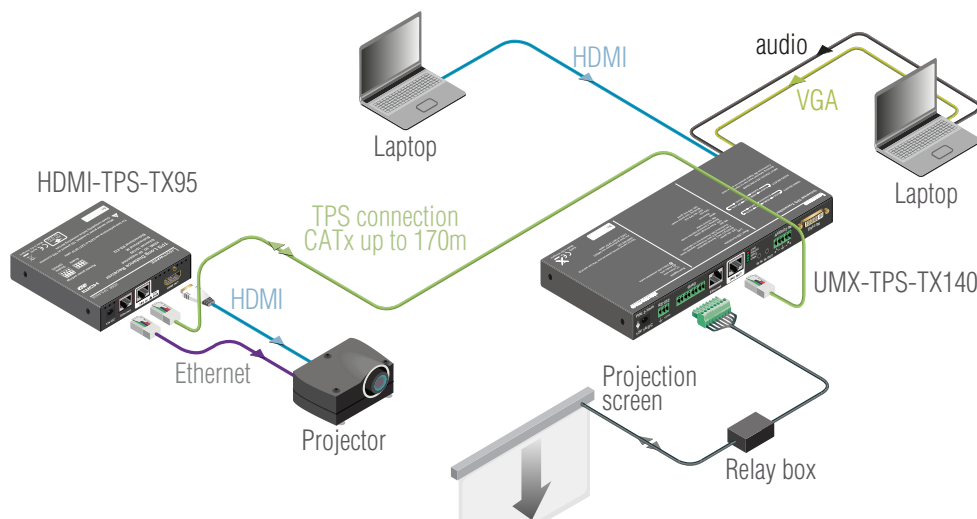

The projector and the rolling screen (via relay box) are connected to the UMX-TPS-TX140. When the user connects a laptop to the HDMI port of the transmitter, then the connected input is selected automatically, the screen goes down and the projector turns on to display the source.

Conditions

Plug HDMI



Actions



Input select on the TPS transmitter



Switch on the projector using TCP/IP



Roll down the projection screen using the transmitter's GPIO port

The Events menu contains separately configurable Events



The Event Wizard makes the setup easy with simple dropdown options

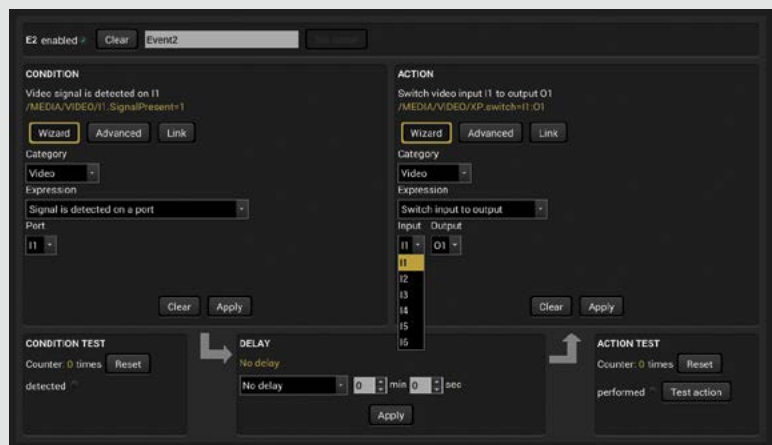

Green lines show which Event is configured and active, the rest stays grey

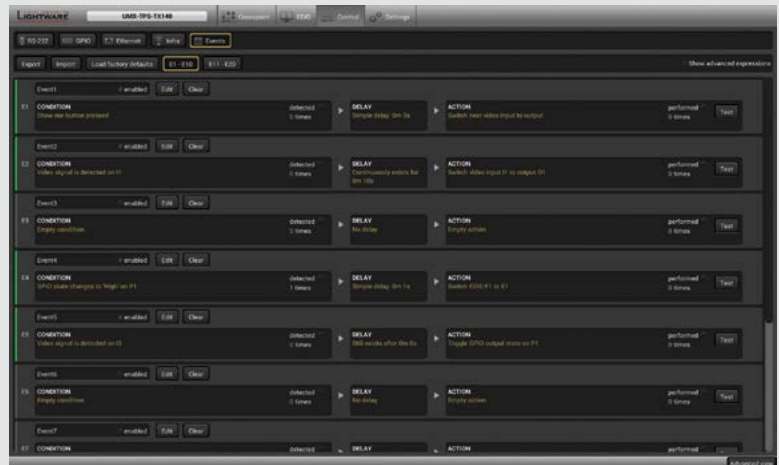

There are many default Expressions available to choose from

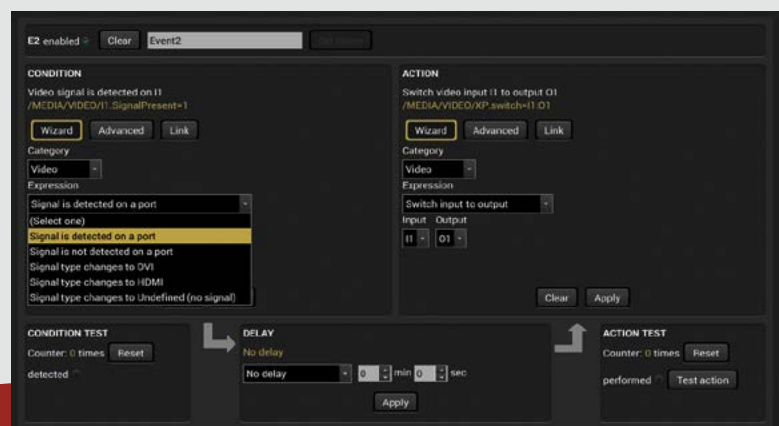

UMX Technology

Lightware developed UMX (Universal Matrix) technology to support various analog and digital video and audio signal formats with several input and output connection possibilities.



Breakaway Audio/Video Switching

The UMX technology provides separate switching of audio and video including de-embedding and embedding from HDMI signals. For instance, de-embedding audio from the incoming HDMI stream, re-embedding at outputs from a different audio source or even routing the audio separately are easily handled. An example of breakaway switching is shown below. Two sources are connected to the UMX Matrix: a laptop with VGA video and analog stereo audio and a Blu-ray player with HDMI video and embedded audio. The AV receiver takes an HDMI signal with video and audio.



Analog to Digital Conversion

The analog video is digitized at the input ports which ensures signal integrity within the whole system. The conversion does not cause any latency as zero frame delay is crucial in certain applications. The UMX technology allows the combination of analog and digital signals in the same system. A VGA video and an analog stereo audio signal can be combined to generate an HDMI signal with embedded audio or the same analog audio can also be embedded into other incoming HDMI signals.

Combining Video and Audio from Different Ports

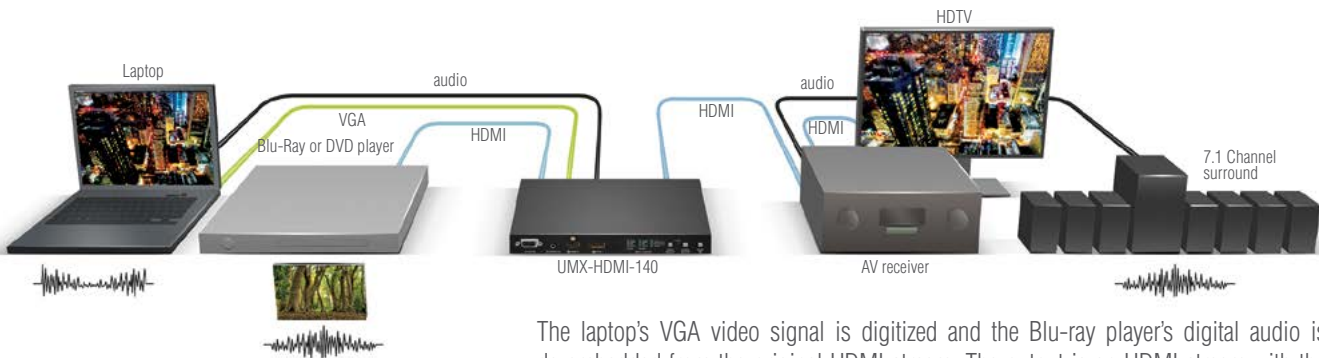

The laptop's VGA video signal is digitized and the Blu-ray player's digital audio is de-embedded from the original HDMI stream. The output is an HDMI stream with the laptop's video and the Blu-ray player's re-embedded audio.

Replacing Audio Content in an HDMI Stream



Blu-ray player's audio signal is de-embedded and the laptop's analog audio is digitized. The output is an HDMI stream with the Blu-ray player's HDMI video and the laptop's digitized embedded audio.

25G HYBRID

signal management

25G Technologies

The unprecedented solutions and methods of the 25G Hybrid family together with other Lightware technologies make this family significantly outstanding and future-proof.



Multilayer Switching

Lightware re-invented the term 'matrix switch'. We do not only handle inputs and outputs, we have added the third dimension of the Media Layers providing the flexibility and freedom of independent signal switching. Inside a 25G Hybrid router there are as many Media Layers as signal types - there are as many individual routers as signal formats being incorporated. The advanced audio functions make this technology even more unique. The 25G Hybrid routers have 3 different audio layers: Embedded Audio, Forward Audio and Return Audio.

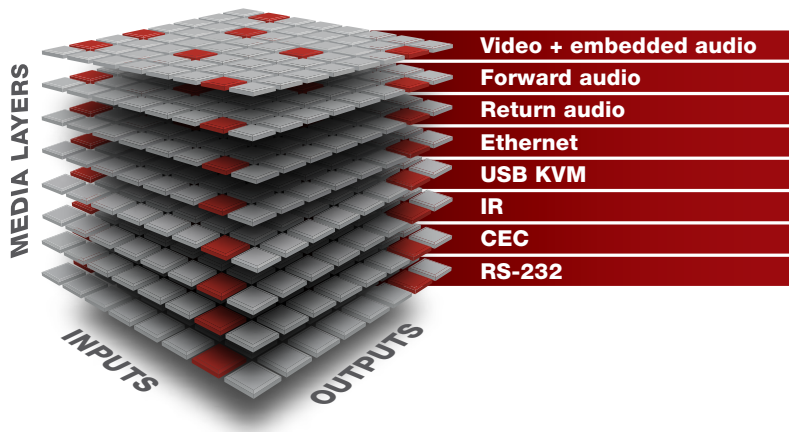

Advanced Graphical User Interface

25G Hybrid matrix switchers have a built-in JAVA-based graphical user interface which eases system control, setup, maintenance and troubleshooting. It is accessible via LAN, RS-232 and the front panel touch screen.

The screenshot above presents the GUI for the 25G routers. The 25G Controller is available for both Apple Macintosh and PC computers as a standalone desktop application.



Room Management

As the maximal 160x160 is a large switching plane, Lightware has introduced Room Management. These smaller virtual matrix switchers called 'rooms' can be programmed with their own sources and destinations, but can also share some resources if required.



User Access Management

For security, a user password can be set to access system control.

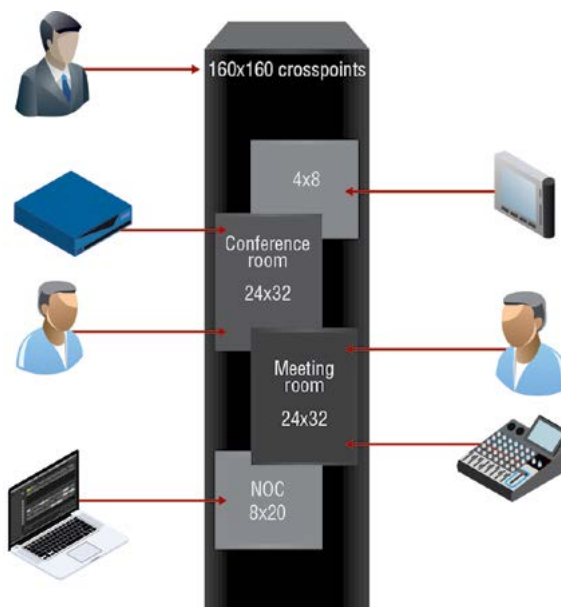

Cisco Technology



Cisco Touch 10 with UMUX-TPS-TX140-Plus

LEVEL UP

Lightware products offer seamless integration with Cisco collaboration systems through their open API software, unlocking the possibility to easily add multiport connection via a Lightware device, a smart extender or a matrix.

This solution expands and enhances the possibilities of Cisco Room Kits in many levels, from adding additional sources through various type of connections to intuitive room control features.

Cisco users can easily control everything that is needed for smooth and effective collaboration, directly from their Cisco Touch10 panel.

To further enhance and deepen this integration, Lightware has developed and released 'Plus' series of smart extender devices with Advanced Control Pack. These products are 'Cisco-friendly' smart extender variants, which carry further extra features helping their integration and use with Cisco rooms. There are also matrix switchers available with upgraded firmware carrying the same Advanced Control Pack features.

- ✓ **Multiport local and remote inputs**
- ✓ **Native Cisco Touch 10 room control**
- ✓ **Easy installation**

The Lightware Advantage in your Cisco Room:

Control integrated Lightware devices natively from a Cisco touch panel

A single smart extender or matrix router can enhance your Cisco configuration with **multiport input** options for remote and local sources

Open API: easy integration of built-in room control including lights, screens, projectors and other elements.

Control connected media devices via **CEC** and **IR**

Advanced Control Devices: 'PLUS' Extenders and Matrix Routers with Event Manager

To further improve services and help the integration process, we have developed and offer new Advanced Control smart TPS extenders and matrix routers with a wide range of control options including support for Cisco password login, CEC and IR controls.



- Support RS-232 protocol for communication and control of third party devices like VC codecs. This allows the Cisco Room Kit login on RS-232–USB connection.
- Support to receive CEC commands for control of displays and Lightware Event Manager to automate room actions
- Support to send CEC commands on HDMI ports for control of other devices
- Support true Infrared messages using HEX codes to control TVs, media players and other devices with IR emitters
- 100 available event slots in 'Plus' extenders



Use our online Cisco Room Configuration Wizard for easy setup

Our freely accessible online Cisco Room Configuration Wizard is easy to use and greatly helps the **integration of Lightware devices by guiding users** through the steps of creating the required configuration file for the selected devices and the room environment.

Currently available products with 'Advanced Control'

Product	Advanced Control Pack
MMX8x4-HT420M	Included
MMX8x4-HT400MC	Included
MMX8x8-HDMI-4K-A	Included
MMX4x2-HT200	Included
MMX4x2-HDMI	Included
UMX-TPS-TX140-Plus	As a new 'Plus' product
UMX-HDMI-140-Plus	As a new 'Plus' product
SW4-TPS-TX240-Plus	As a new 'Plus' product
WP-UMX-TPS-TX130-Plus-US	As a new 'Plus' product
HDMI-TPS-RX110AY-Plus	As a new 'Plus' product

ADVANCED CONTROL PACK



Lightware's unique Advanced Control Pack takes the Cisco Integration to the next level by unlocking further possibilities in controlling and configuration. The enhanced features including CEC command sending and the increased number of programmable tracks within Event Manager along with the RS-232 recognizing capabilities makes the Advance Control Pack a revolutionary solution for corporate environments utilizing the combined strengths of Cisco and Lightware systems.



UMX Series Switcher for VGA, DVI-I, HDMI and DisplayPort

UMX-HDMI-140-Plus **53**
Part No: 9156 0003



4K UHD 4x2 HDMI Matrix Switcher

MMX4x2-HDMI **54**
Part No: 9131 0034



4K UHD 4x2 Matrix Switcher with HDBaseT™ and HDMI

MMX4x2-HT200 **55**
Part No: 9131 0035



HDMI and TPS Matrix Switcher with Special Audio Inputs and Multiport Control Options

MMX8x4-HT420M **60**
Part No: 9131 0042



HDMI Matrix Switcher with Event Manager

MMX8x8-HDMI-4K-A **62**
Part No: 9131 0043



UMX Series TPS Transmitter for VGA, DVI-I, HDMI and DisplayPort

UMX-TPS-TX140-Plus **75**
 Part No: 9154 0059



UMX Series TPS Transmitter for VGA, DVI-I, HDMI, DisplayPort and KVM

UMX-TPS-TX140K **75**
 Part No: 9154 0050



UMX Series TPS Wallplate and Floorplate for VGA and HDMI DisplayPort

WP-UMX-TPS-TX130-Plus-US Black **77**
 Part No: 9154 0071 (Black)
WP-UMX-TPS-TX130-Plus-US White **77**
 Part No: 9154 0072 (White)



TPS Receiver with Relay Modules and Balanced Audio Out

HDMI-TPS-RX110AY-Plus **78**
 Part No: 9154 0021



TPS Receiver with Relay Modules and Balanced Audio Out

HDMI-TPS-RX220AK **79**
 Part No: 9154 0022



TPS Switcher and Transmitter for DisplayPort, HDMI and DVI with Local Monitor Out

SW4-TPS-TX240-Plus **80**
 Part No: 91540065

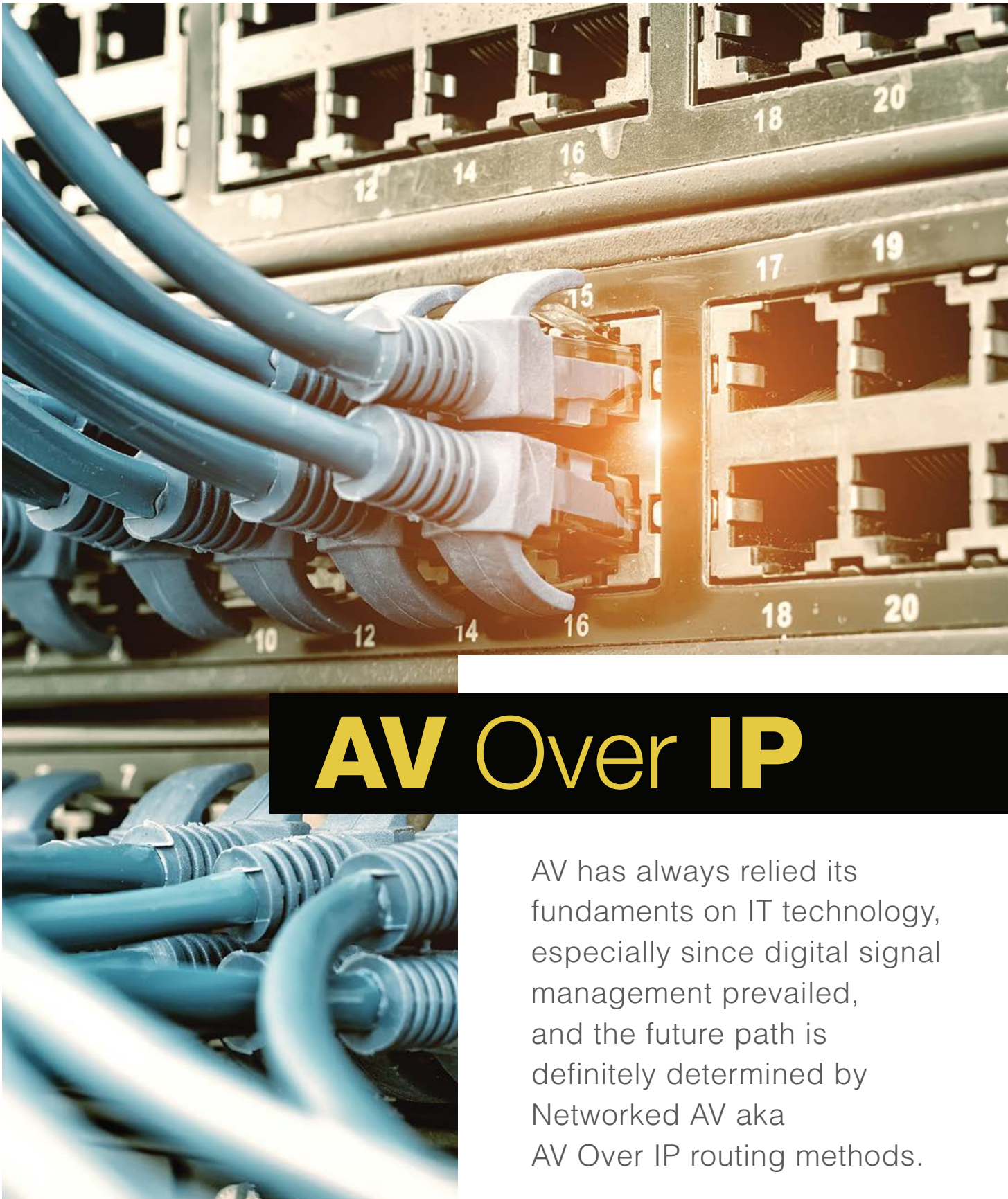

AV Over IP

AV has always relied its fundamentals on IT technology, especially since digital signal management prevailed, and the future path is definitely determined by Networked AV aka AV Over IP routing methods.

UBEX-PRO20-HDMI-F100 / F110

UBEX is a fiber-optical, scaling AV-Over-IP system which allows

uncompressed 4K UHD@60Hz 4:4:4 signal extension with latency-free multistreaming, designed to use in a 10G Ethernet network. UBEX operates with zero frame latency, provides seamless switching and lossless reproduction of source signals of up to 4K60Hz 4:4:4, without artifacts.

Uncompressed 4K60Hz 4:4:4 data transmission, or visually lossless compression at higher data rates. It has standard, 10 Gbps SFP+ optical modules installed, which are field-exchangeable by the user.

UBEX can transfer two video signals over a single 10G link with minimal compression, which requires half the router size compared to the needs of similar, 10G IP based architectures. With a 20G configuration, UBEX can transfer 4K@60Hz 4:4:4 over two links uncompressed.

AV OVER IP MULTIMEDIA SYSTEM

The maximum reachable distance is ranging between 400 m and 80 km, depending on the type of singlemode or multimode SFP+ optical modules installed in the device.

The UBEX design also favors dual-screen applications as a single UBEX device can handle 2x HDMI 2.0 video ports. The UBEX F110 model features balanced audio ports and RS-232 and IR control ports, while the top model UBEX F120 also features USB KVM.



Uncompressed
4K UHD@60Hz 4:4:4



Frame Detector
(Input signal analysis)



Pixel Accurate
Reclocking



Multilayer Signal Routing



Instantaneous Switching
without Signal Latency



Advanced EDID
Management



USB HID (KVM)



Reliability and Redundancy



4K Scaling

The UBEX system offers a great variety of operation and usage modes, providing a future-proof, easily extendable and scalable system.

EXTENDER MODE

In extender mode, two UBEX devices can operate as conventional, high-quality, HDMI 2.0 compatible optical extenders, without applying signal compression and encoding. There are no separate transmitter and receiver UBEX units, the desired operation direction can be selected at boot.

TRANSCIEIVER MODE

UBEX is also capable of transceiver mode, a single unit receiving and transmitting signals simultaneously, this mode can also be selected at boot. One Full 4k video stream can be transmitted while another Full 4k video stream can be received on the same 20G Ethernet link. In a point-to-point extension application, transceiver mode provides a bi-directional video extension. In a virtual matrix configuration (see below) transceiver mode allows a matrix system to reduce the needed number of 10G Ethernet switch ports, as one port can be used as input and output video simultaneously.

VIDEOWALL SUPPORT MODE

UBEX units in receiver mode can be configured to make a videowall with several layouts. The UBEX videowall wizard helps build a videowall configuration in a couple of minutes.

MATRIX MODE

UBEX units can connect to create a complex network, and with the help of a UBEX-MMU-X200 Matrix Management Unit (MMU) it is possible to create a virtual matrix with UBEX units as input and output endpoints, and where a central Ethernet switch acts as crosspoint. Such a virtual matrix can be also extremely asymmetrical, as e.g. it could have only a few (or one) devices on the input side, while an almost unlimited number of output end units.



A background image of a control room with multiple computer workstations, each with multiple monitors displaying various data and maps. The room is dimly lit, with the primary light source being the screens.

UBEX has outstanding built-in features and services providing an unparalleled versatility fitting numerous applications.

UNIQUE ADVANTAGES

BROADCAST QUALITY SCALING BASED ON OMNITEK TECHNOLOGY

The Omnitek Scalable Video Processor within UBEX is a highly configurable set of IP blocks and optional features that together provide a powerful range of tools for multi-video format conversion and image enhancement for a number of ultra-high quality video formats. This scaling technology provides clean, upscaled images when integrating legacy sources with 4K displays, or produces faithful rendering details and integrity of a source when downscaling 4K content to HD displays, with unparalleled processing and clarity.

ULTRA LOW LATENCY

The detectable latency in all configuration modes is sub-frame, consisting of a few lines within a single frame. This is especially remarkable in case of AV-Over-IP, as latency remains so little even is compression is applied to the transferred signal. Of course the smallest latency is achieved when UBEX works without signal compression, which is the default mode of operation in 10G Ethernet networks. To further improve the accuracy and timing of signals, a special, source-locked mode feature has also been developed for UBEX, serving both extender and matrix mode operations.

MULTISTREAMING

The UBEX system is capable of transferring two streams of signals, each up to 4K 60Hz 4:2:2 or any combination of resolutions within the 20G bandwidth without compression.

FRONT PANEL ADJUSTMENTS

It is a great help for people in the field that most of the important settings like EDID can be altered in UBEX without connecting a computer, just by using the front panel jog-dial button and the color LCD screen. For setting further properties and fine-tuning your installation a built-in solid color generator is also provided with selectable resolution to display on the sink.

SEAMLESS SWITCHING

UBEX offers true seamless switching between inputs, without any glitches or black frames appearing between the two sources.

FRAME DETECTOR

This technology inside UBEX provides information about the pixel count, frequencies and also about the measured pixel clock of the full and the actual frame.



VERSATILITY HAS A NEW NAME

The UBEX series provides uncompressed 10G IP switching technology in a rugged chassis, a high-end choice for numerous applications in dynamic environments. UBEX has professional, standard SFP+ field connectors, which can be changed by the user to match the requirements of an actual project.

CONFIGURATION MODES

Using the combination of devices working in transmitter, receiver and transceiver modes, UBEX can perform and improve any function of all traditional AV product classes: extender, splitter, switcher and matrix.

SPLITTER

Using one transmitter and a 10G Ethernet switch, A/V signals can be distributed fast and error-free to a virtually limitless number of receivers and sinks.

EXTENDER

In a point-to-point configuration, UBEX can operate without a central network. Distribute full 4K@60 4:4:4 resolution signals with 1G Ethernet, audio and control signals over IP.

SWITCHER

A single UBEX in receiver mode connected to a 10G Ethernet switch can distribute a huge number of sources to a single screen, where the number of sources is only limited by the number of ports on the Ethernet switch.

MATRIX

By combining UBEX units and a central Ethernet switch a completely scalable matrix system can be created, which can be fully managed by the Matrix Management Unit connected to the same switch. Route video, audio, KVM and control signals from any source to any endpoint.



FEATURE APPLICATIONS



The UBEX series provides the greatest flexibility in a single device, adjustable to be always the right tool for an actual job: from point-to-point extension over an optical network to multi-zone matrix switching: you can be definite that UBEX can handle any task with ease. However, there are some unique UBEX features that make the device especially fitting to the needs of special application areas.

UBEX can operate as a traditional, point-to-point extender pair and transfer signals natively without compression, and can also connect to an Ethernet network, a unique feature most competition products lack. Therefore it can be an excellent choice for rental companies who can easily use both modes of operation as the actual project requires. It is also a rental specific feature that UBEX always remembers the last used setting configuration, so in case of a momentary lapse of electricity it can continue operation where it was left off automatically, as the last used configuration is re-loaded from memory. UBEX features SFP+ modules, which can be swapped to another type of SFP+ modules by the user, by simply removing one and sliding the other into the connector slot. Depending on the SFP+ module and the optical cable used, UBEX can transmit signals to a range between 400 m and 80 km. The on-scene technician can select and install the best fitting SFP+ module for ad hoc installations and perform the change in seconds.

RENTAL AND STAGING

Designing and installing AV equipment on a yacht is a sensitive process. The installed system has to fulfill customer demands and possibly exceed them, it has to be versatile and easily integrable with third party systems, devices and networks. Based upon our previous experience gained in marine AV installations, UBEX was designed to have optimal product properties and features for this purpose. It is particularly well applicable to yacht-like environments, and being an Ethernet-based system, it can cooperate glitch-free with any standard, central Ethernet switch.

MARINE INSTALLATIONS



BUSINESS OFFICE CENTERS

When corporate organizations move into existing office buildings they need solutions to design, install and integrate AV technology into their conference rooms, boardrooms and other spaces to create efficient

ways for company communications in the existing building setting. AN UBEX-based virtual matrix can be created by integrating into an already existing 10 Gbit Ethernet network, where the role of crosspoint will be taken by a standard Ethernet switch. Such a virtual matrix can be extremely asymmetric with any number of input and output endpoints. The UBEX system is flexible and expandable so it is an excellent choice conforming both existing and newly developed office environments, also taking care of the transfer of audio, control and KVM signals.

UBEX is designed to be able to operate conforming data diode network (often also referred to as a unidirectional network) requirements, where data must travel only in one direction to guarantee information safety and security. These networks are common in high security environments including defense, electric power generation facilities, nuclear power stations and similar high security installations. Typically in these configurations two or more networks are connected with changing security classifications. The hardware construction of unidirectional networks only allows data to pass from one side (low side) of a network connection to another (high side), and never the other way around.



SAFETY-CRITICAL SYSTEMS

Visualization of data or concepts in 3D, in order to expose meaning, increase understanding and help, or to actively contribute to designing in engineering all need low latency, high detail visual imaging. Designing an architectural space that needs to be experienced before being built, or sometimes even a mere concept can also be better shared visually, employing virtual and augmented reality and stereographic 3D. The speed, the color accuracy and the low latency video transfer provided by UBEX are key to 3D visualization that can greatly contribute to a wide variety of projects including 2D/3D/4D image analysis, scientific research visualization, 3D animation, 3D object scanning and also macro-photography and video. An UBEX-based medical visualization system can help examine human anatomy and reconstruct it in a real-time 3D environment for use in surgeries, medical education, simulations and trainings.



3D VISUALIZATIONS

Optical AV Over IP Video System for 10G Networks

UBEX-PRO20-HDMI-F100
UBEX-PRO20-HDMI-F110

Part No: 9182 0001
 Part No: 9182 0101



UBEX is an optical scaling extender which allows 4K UHD@60Hz 4:4:4 uncompressed signal extension with latency-free multistreaming. The device is designed to use Video Over IP transmission on a 10G Ethernet network, it has standard, 10 Gbps SFP+ optical modules installed, which are field-exchangeable by the user.

UBEX units can connect to create a complex network with the use of a standard Ethernet switch.

An UBEX-MMU-X200 Matrix Management Unit (MMU) is required to control and supervise a virtual matrix, which can be created by connecting UBEX units as input and output endpoints to an Ethernet switch acting as crosspoint. The MMU device can update the firmware of endpoint UBEX units in a virtual matrix application simultaneously, without limitation for the number of devices in the setup.

One of the prime advantages of such new architecture is scalability: the virtual matrix created can have a virtually infinite number of endpoints, limited only by the number of open ports on the Ethernet switch used. Such a virtual matrix can be also extremely asymmetrical, as e.g. it could have only a few (or one) devices on the input side, while an almost unlimited number of output end units.

Using visually lossless compression, UBEX can extend two Full 4K UHD signals over a single, 10 Gbps Ethernet port. This generates substantial cost saving on the required Ethernet switch side, as with UBEX only half the router size is required compared to the needs of similar, 10 Gbps IP based architectures. For video signals which can be transferred within the 10G speed limit of a single optical fiber, a video signal redundancy feature is available employing the second optical fiber channel.

The UBEX design also favors dual-screen applications: each transmitter and each receiver handles 2x HDMI 2.0 video ports.

UBEX can also be used in a point to point setup as a conventional extender pair between endpoints. It is not required to use an Ethernet switch when point to point extension is required.

The Video Wall Wizard for UBEX features quick video wall installation with bezel adjustment and cropping, includes options for various layouts within the video wall matrix and also allows zones for smart management.

The maximum reachable distance is ranging between 400 m and 80km, depending on the type of singlemode or multimode optical modules installed in the device, and on the signal properties.

Features

- 4K UHD @ 60Hz 4:4:4 Scaler
- Multistreaming technology (multiple video transmission on a single optical link)
- Video Over IP OR Point-to-Point operation modes: UBEX can also work as a conventional extender, no Ethernet switch is required for simple extension
- Versatile operation modes: dual channel 4K transmitter or receiver or transceiver mode: sending and receiving signals simultaneously
- Operation modes can be changed by rebooting and selecting the desired mode
- Field replaceable SFP+ modules: up to Singlemode (SM) 80 km or Multimode (MM) 400 Meters
- Advanced EDID Management
- 10 Gbps on one (or two) fibers OR 20 Gbps on two (or four) fibers
- Virtual Matrix mode with UBEX units connected to a central Ethernet switch serving as crosspoint, supervised and controlled by a UBEX MMU-X200 Matrix Management Unit
- Front panel jog dial push button and color display
- Front panel feedback LEDs
- Internal power supply and front-to-back cooling air trail
- Source Locked - Low Latency Mode: receivers can be set to source-locked mode when the video transmission latency is very low

UBEX-PRO20-HDMI-F110

- Balanced stereo audio connectors
- Optional control speed connectors (RS-232, IR)

UBEX-PRO20-HDMI-F100

Part No: 9182 0001

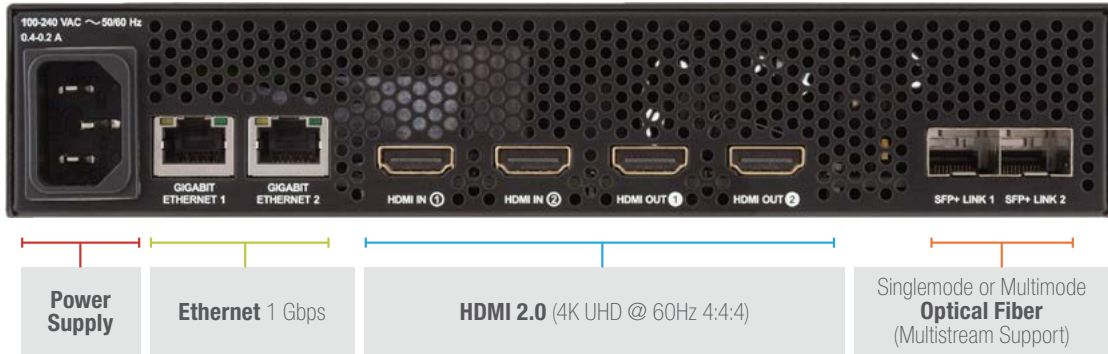

UBEX-PRO20-HDMI-F110

Part No: 9182 0101

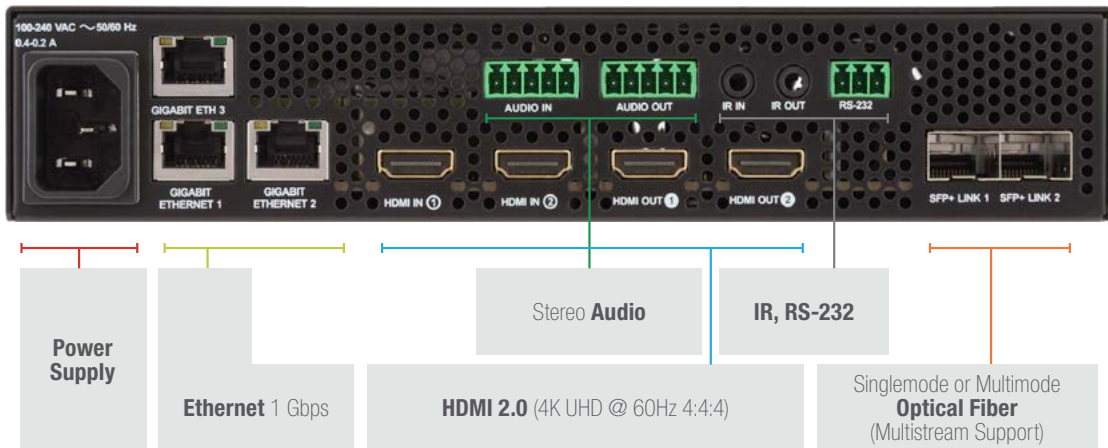

UBEX Comparison Chart:

	UBEX-PRO20-HDMI-F100	UBEX-PRO20-HDMI-F110	
HW features	Link	20G	20G
	Optical	✓	✓
	Type of videos	HDMI 2.0	HDMI 2.0
	Nr. of video inputs	2	2
	Nr. of video outputs	2	2
	USB HID (KVM)	x	x
	Balanced stereo analog audio I/O ports	x	✓
	IR I/O and RS.232 control ports	x	✓
	1 Gbps Ethernet	✓	✓
	Nr. of fibers (W/STANDARD SFP+)	4	4
Nr. of fibers (W/BIDI SFP+)	2	2	
SW features	4K scaling	✓	✓
	Framerate conversion	✓	✓
	4K UHD @ 60Hz 4:4:4	✓	✓
	30 bit deep color support	✓	✓
	Audio embedding and de-embedding	✓	✓
	Advanced edid management	✓	✓
	HDCP 2.2 compliant	✓	✓
Seamless switching	✓	✓	

UBEX lossless video network system
Network Operation Center Application

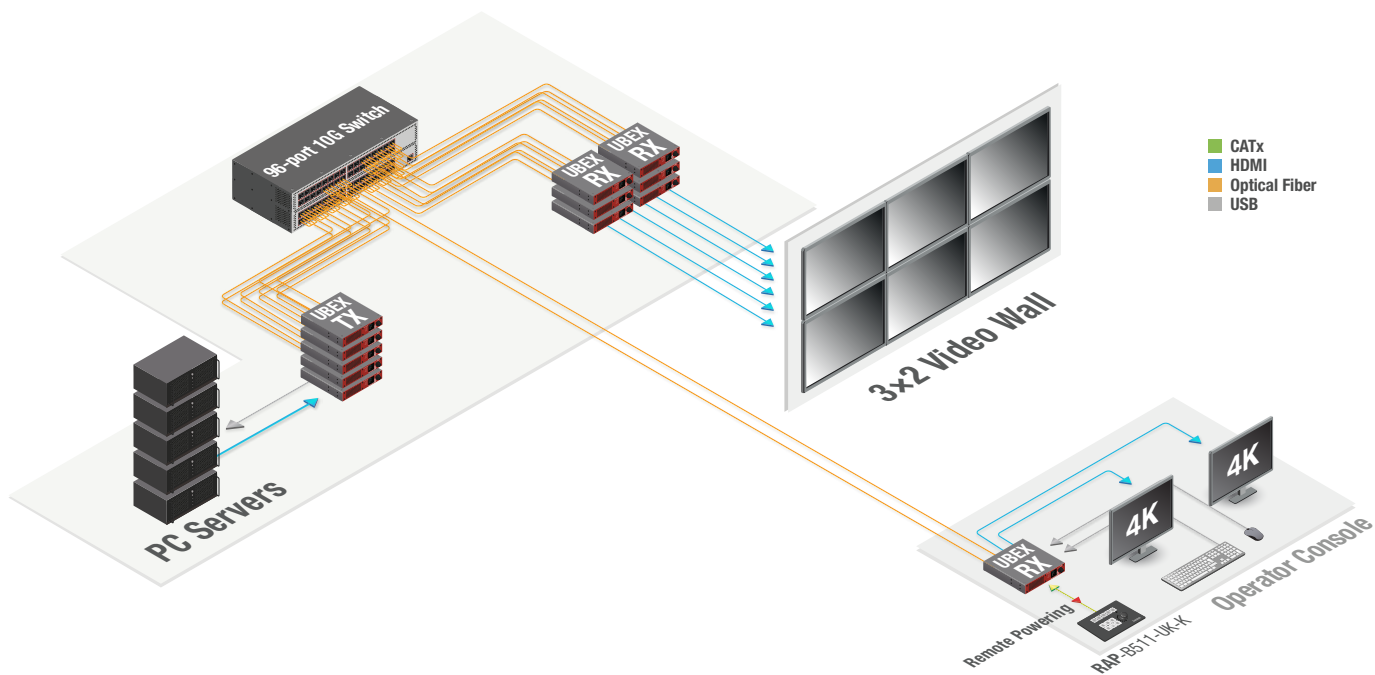

Auditorium Application
UBEX-Pro20-HDMI-F110 20G AVoIP Virtual Matrix System

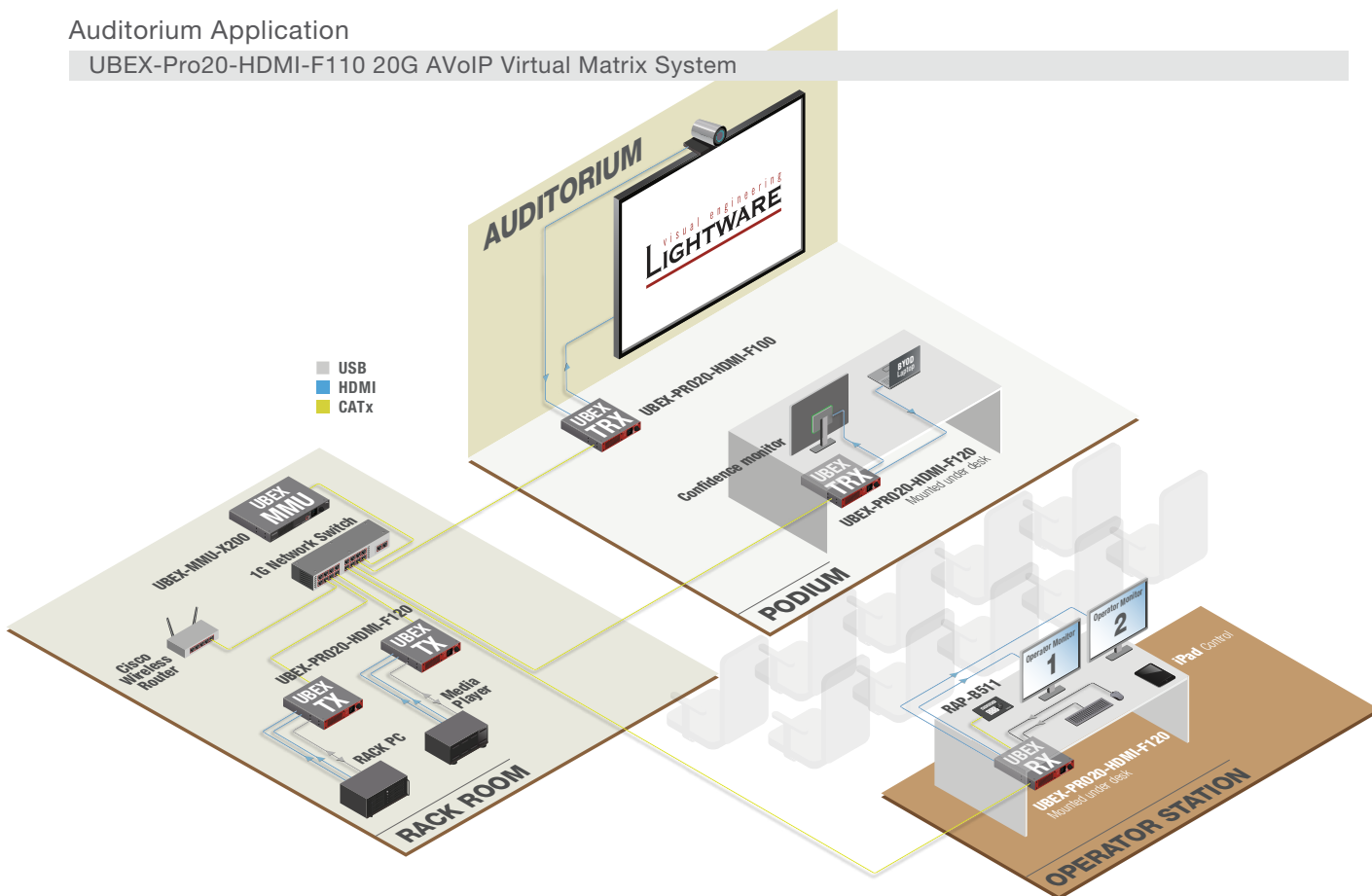



Uncompressed AV-Over-IP Multimedia System for 10G Ethernet Networks

new!

UBEX-PRO20-HDMI-R100

UBEX is a fiber-optical, scaling AV-Over-IP system which allows uncompressed 4K UHD@60Hz 4:4:4 signal extension with latency-free multistreaming, designed to use in a 10G Ethernet network. UBEX operates with zero frame latency, provides seamless switching and lossless reproduction of source signals of up to 4K60Hz 4:4:4, without artifacts. It has standard, 10 Gbps SFP+ optical modules installed. The maximum reachable distance is ranging between 400 m and 80 km, depending on the type of singlemode or multimode SFP+ optical modules installed in the device. The UBEX design also favors dual-screen applications as a single UBEX device can handle 2x HDMI 2.0 video ports.

Features

- 4K UHD @ 60Hz 4:4:4 Scaler
- Multistreaming technology (multiple video transmission on a single optical link)
- Video Over IP or Point-to-Point operation modes: UBEX can also work as a conventional extender, no Ethernet switch is required for simple extension
- Versatile operation modes: dual channel 4K transmitter or receiver or transceiver mode: sending and receiving signals simultaneously
- Virtual Matrix mode with UBEX units connected to a central Ethernet switch
- Front panel jog dial push button, color display and feedback LEDs
- Internal power supply and front-to-back cooling air trail
- Source Locked - Low Latency Mode: receivers can be set to source-locked mode when the video transmission latency is very low

R-TYPE

Rugged – Robust – Rental

The R-type UBEX product variant is specifically designed to withstand the daily wear and tear impacts of dynamic, Rental&Staging type of applications.

The devices shares the features of the standard UBEX-PRO20-HDMI-F100 model, with additional features and changes in build and dimensions.

R-type Features

- Exchangeable cooling air filter inlay
- Reinforced SFP+ module connector, modules can be changed by removing protective top cover
- Standard M10 threads on side and top for safe and secure mounting onto truss assemblies
- Mounting ears and loops for secondary safety clamps
- Various reinforced optical and power connector type options (see below table for details)

UBEX-Pro20-HDMI-R100	Product Name	SFP+ Module Installed	Optical Connector(s)	Ethernet Port for Control	Power Connector
	2xMM-2xDUO	2x10G SFP+ multimode	2x Neutrik OpticalCON DUO	1xNeutrik EtherCON	Neutrik PowerCON True 1
	2xSM-2xDUO	2x10G SFP+ singlemode	2xNeutrik OpticalCON DUO	1xNeutrik EtherCON	
	2xMM-QUAD	2x10G SFP+ multimode	1x Neutrik OpticalCON QUAD	2xNeutrik EtherCON	
	2xSM-QUAD	2x10G SFP+ singlemode	1x Neutrik OpticalCON QUAD	2xNeutrik EtherCON	
	2xSM-BiDi-DUO	2x10G BiDi SFP+ singlemode	1x Neutrik OpticalCON DUO	2xNeutrik EtherCON	



UBEX Matrix Management Unit

UBEX-MMU-X200

Part No: 9181 0004



UBEX-MMU-X200 is a Matrix Management Unit (MMU) for the UBEX AV Over IP optical extender product line. With a standard non-blocking 100G Ethernet switch installed as crosspoint, a virtual matrix can be created with UBEX devices connected to the IP network as input and output endpoints. The virtual matrix established requires to be managed and controlled by the MMU also connected to the Ethernet switch.

The MMU builds and constantly updates a database of the UBEX endpoints connected, displaying a traditional crosspoint view of the virtual matrix in the Lightware Device Controller (LDC) software or the built-in web, also displaying connected, but inactive units.

Users connect and communicate directly with the MMU in matrix mode, and MMU connects to and relays communication to the endpoint UBEX units.

The MMU displays information about endpoints and the overall virtual AV network, backup and restore functions are also provided to save and load the configuration.

The MMU also manages the firmware upgrades of the connected endpoint UBEX devices, it is possible to initiate and update of the

firmware on all UBEX units present in the network. Based on the communication with the UBEX endpoints, the MMU manages and supervises bandwidth use efficiency.

The MMU also serves as an interface for third party control systems and includes Lightware's proprietary Advanced EDID Management technology.

This device has standard one RU size and can be installed in a rack with the help of the rack ears. UBEX-MMU-X200 has an internal power source running on standard 110/220V connected via a standard IEC port to mains.

Features

- Easy access front panel Ethernet and USB ports for device control
- Rear panel RS-232 and Ethernet ports for third party control input
- UBEX network connection: RJ45 1 Gbps Ethernet port or 1 Gbps SFP link module
- Jog-dial push button and color display
- Advanced EDID Management
- IEC standard, 110/220V power inlet port
- Standard, 1 RU size to be installed on rack with supplied rack ears

AV Over IP Scaling Multimedia Extender with USB KVM, RS-232 and IR
VINX-120-HDMI-ENC and **VINX-110-HDMI-DEC**

Part No: 91810002 (ENC), 91810003 (DEC)



VINX-120-HDMI-ENC



VINX-110-HDMI-DEC

VINX-120-HDMI-ENC and VINX-110-HDMI-DEC are LAN based multimedia extender devices transferring HDMI video between endpoints. The VINX encoder and decoder devices connect either via a direct CATx cable connection, or through a Gigabit Ethernet switch in between. The maximum delivery distance can reach to up to 100 m (if connected directly) with minimal latency and employing a quality, proprietary wavelet transform based image compression.

The maximum supported resolution is 3840 x 2160 @ 30Hz with 7.1 audio.

VINX devices support both static and dynamic (DHCP) IP address settings. 100 factory EDID presets and five user EDIDs are stored in the encoder. These units feature embedded web for control.

Front panel DIP switches serve quick manual setting for pairing maximum 15 encoder devices to decoders over the network, a quick and easy installation advantage for digital signage applications. More than 15 units can be paired by software configuration via embedded web page or external controller.

Gap and bezel compensation can be adjusted for video walls. Scaling is available on the decoder side and videos can be freely cropped. With the help of the VINX Video Wall Wizard, the installation of a video wall can be reduced to one tenth of the usual time needed when using similar, third party products.

Feature

- 3840 x 2160 @ 30Hz resolution over a 1 Gigabit network with very low latency
- Audio supports LPCM and Dolby Digital /Dolby Digital Plus/ DTS/ Dolby TrueHD/DTS-HD bit stream
- HDCP compliant
- Local HDMI port for monitoring on the Encoder
- Variable maximum bit rate (10 Mbps ~ 800 Mbps)
- USB KVM and USB 2.0
- LED feedbacks, DIP switches and physical buttons for quick and easy setup and operation
- Embedded web control, direct and networked control via PC
- The device can be controlled via Lightware's proprietary LW3 protocol commands
- Gap and bezel compensation for video wall applications, cropping adjustment capability
- Output video signal scaling to adjust to sink properties

AV Over IP Scaling Multimedia Extender with USB KVM, PoE, RS-232 and IR

VINX-110AP-HDMI-DEC and **VINX-120AP-HDMI-ENC**

Part No: 9181 0010 (DEC), 9181 0008 (ENC)

VINX-120AP-HDMI-ENC-DNT and **VINX-210AP-HDMI-ENC**

Part No: 9181 0011 (DNT), 9181 0009 (ENC)



VINX-110AP-HDMI-DEC

- VINX decoder with analog audio output and PoE remote powering
- The unit can be powered over the CATx cable with PoE from the Ethernet switch
- Analog audio de-embedding

VINX-120AP-HDMI-ENC

- VINX encoder with analog audio and PoE remote powering
- The unit can be powered over the CATx cable with PoE from the Ethernet switch
- Local HDMI output port for monitoring

VINX-120AP-HDMI-ENC-DNT

new!

- VINX encoder with analog audio and PoE remote powering
- The unit can be powered over the CATx cable with PoE from the Ethernet switch
- Dante / AES67 audio output
- Local HDMI output port for monitoring

VINX-210AP-HDMI-ENC

- VINX encoder with HDMI, VGA and analog audio input and PoE remote powering
- The unit can be powered over the CATx cable with PoE from the Ethernet switch
- Autoselect video source or manual selection

Features

- **PoE remote power reception**
- **SFP module slot for optional optical Ethernet connection**
- **Analog audio embedding and de-embedding**
- **Return audio services in unicast mode**
- Max resolution 3840 x 2160 @ 30Hz (on HDMI input) over a 1 Gbps network with HDCP
- LPCM and Dolby Digital / Dolby Digital Plus / DTS / Dolby TruHD / DTS-HD bitstream audio support
- Embedded web control, direct and networked control via PC or mobile device
- Local HDMI port for monitoring (on VINX-120AP-HDMI-ENC)
- Variable maximum bit rate (10 Mbps ~ 800 Mbps)
- USB KVM extension and USB 2.0
- Front panel DIP switches for quick pairing 15 or fewer units OR pair hundreds of units via software control or open API
- Video Wall Wizard: quick, mass adjustment of gap and bezel compensation, cropping and scaling
- Video signal scaling
- IR, RS-232 and USB ports
- Multicast and Unicast operation modes for networked or point-to-point applications
- Virtual Crosspoint View for virtual matrix operation with max 24 units

Overview of VINX Encoder Comparison

	VINX-120-HDMI-ENC	VINX-120AP-HDMI-ENC	VINX-120AP-HDMI-ENC-DNT	VINX-210AP-HDMI-ENC
HDMI input	✓	✓	✓	✓
VGA input	✗	✗	✗	✓
HDMI local output	✓	✓	✓	✗
Analog audio input	✗	✓	✓	✓
Dante / AES67 Audio output	✗	✗	✓	✗
Power	only local DC 5V	local DC or PoE	local DC or PoE	local DC or PoE

Overview of VINX Decoder Comparison

	VINX-110-HDMI-DEC	VINX-110AP-HDMI-DEC
HDMI output	✓	✓
Analog audio output	✗	✓
Power	only local DC 5V	local DC or PoE

visual engineering
LIGHTWARE

R *Rental-Robust-Redundant* **-TYPE**

KEEPS EVENTS ON THE RIGHT TRACK



UBEX-Pro20-HDMI-R100

Uncompressed **AV-Over-IP** Multimedia System
for 10G Ethernet Networks

UBEX

STANDALONE MATRIX SWITCHERS

One-Box Solutions for Dynamically Changing Environments

Standalone matrix switchers do not require any other devices to function, since sources are connected directly to the matrix's input ports, just like the displays to the outputs, making these products a universal solution for dynamically changing environments, such as small board rooms, classrooms or meeting rooms.

Lightware provides standalone matrix switchers in various crosspoint sizes, ranging from 4x4 to 48x48 I/O for a wide range of signals, including VGA, YUV, Digital DVI, HDMI with HDCP, DisplayPort, stereo analog and S/PDIF digital audio streams. Crosspoint switching is done instantly without frame delay or frame latency and can be controlled either by RS-232 / RS-422 port, TCP/IP LAN, via USB connection or through the built-in website.



18 Gbps Matrix Switchers

with **HDMI**, **DisplayPort** or **Mixed I/O** Configurations



The MX2 matrix switcher series includes more than 20 models, including variants with **mixed HDMI** and **DisplayPort I/O ports**. The MX2 series is a **fully HDMI 2.0 compatible matrix** router line, with a maximum resolution of **4K UHD @ 60 Hz in 4:4:4** format, while also supporting **HDR, Dolby Vision, 3D, Dolby TrueHD and DTS-HD Master Audio**. The devices are **HDCP 2.2** and **HDCP 1.4** compliant with cross conversion capabilities, while device control can be achieved **via Ethernet, RS-232** and **USB** ports. The rich feature set of the routers also include **proprietary Lightware services and technologies**.

HDMI 2.0 | DisplayPort 1.2

4K UHD @ 60 Hz in 4:4:4

HDR | Dolby Vision | 3D

HDCP 2.2 | HDCP 1.4

Ethernet | RS-232 | USB

MX2 Variants

with **Various Add-ons** and **Enhancements**

MX2 matrix switchers are available in a great selection of **crosspoint sizes**, with or without analog **audio ports**, and most are also available with **redundant power sources**, paired with **rugged power connectors** and **reinforced control ports**. All models feature a **front panel**, **color LCD screen** with great visibility, and a **jog-dial, multi-function button**, enabling the users to manage most device features and services directly.



Models with Direct Crosspoint Switch Buttons

All crosspoint changing functions are available by using the jog-dial button next to the LCD display, the open API or the web-based control software.

Certain models also come with a full set of **front panel crosspoint buttons**, for easy direct switching in a dynamically changing environment.

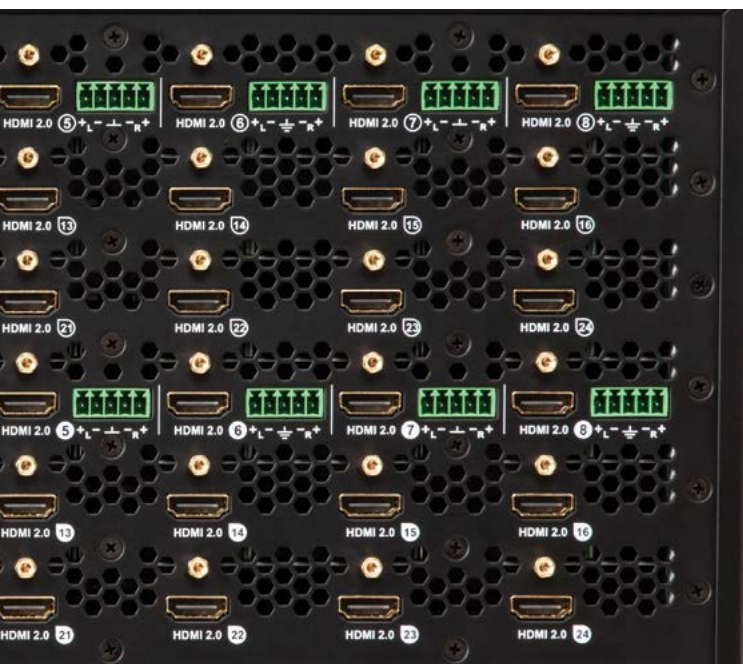

Models with Analog Audio I/O Ports

The models with the **analog audio input and output ports** have **5-pole Phoenix connectors** for audio embedding and de-embedding.

R-*Rental-Robust-Redundant* -TYPE

R-type editions, also marked with an 'R' in their name, feature **two independent power sources with separate mains connectors. The power connector, the RS-232 and Ethernet connectors are all reinforced**, rugged types, especially fitting rental and staging purposes, where wear and tear effects are more regular in everyday use.



Neutrik Ethercon



Neutrik Powercon True1



D-Sub RS-232



Compact MX2 Variants

The MX2-8x8-HDMI20-Audio-L was a breakthrough pioneer product being the **world's first uncompromised HDMI 2.0 compatible matrix router** at the time of its release.

By popular market demand, further product variants have been developed to better serve various target application requirements, in 8x8, 8x4 and 4x4 crosspoint sizes. The features of these compact, one RU high models also include audio embedding and de-embedding.

DH Series Routers

DisplayPort and Mixed HDMI & DisplayPort I/O Ports

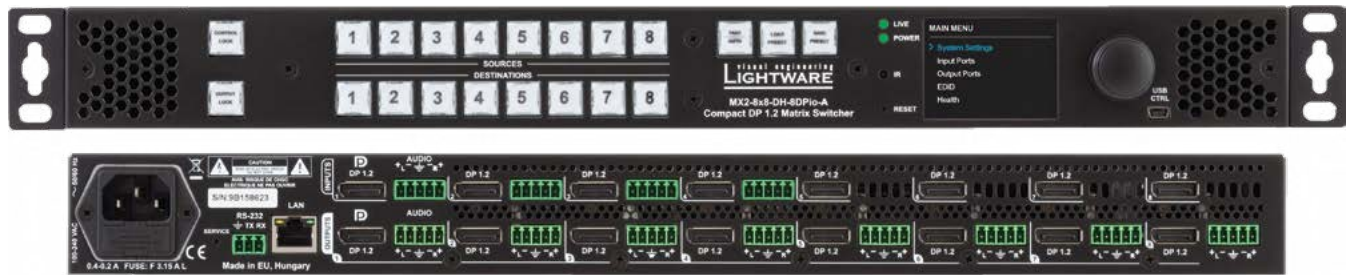

MX2-8x8-DH-8DPio-A

Mixed I/O port Lightware MX2 standalone matrix switcher series support uncompromised 4K UHD resolution at 60Hz with 4:4:4 sampling pattern and allow the connection of DisplayPort 1.2 video sources and sinks directly, without the need of adapters or dongles.

All DisplayPort signals are converted to HDMI 2.0 inside the MX2 series matrix routers, but we have developed features to best provide true DisplayPort support for our customers. One of these features is the **Restart Link Training**: this function allows users to **virtually unplug and re-plug the cables** without actually doing so, in case of missing or bad quality signals. For signals which are not encrypted, DisplayPort **HDCP Management can be turned off**, and HDCP 2.2 or 1.4 compatibility can be set.

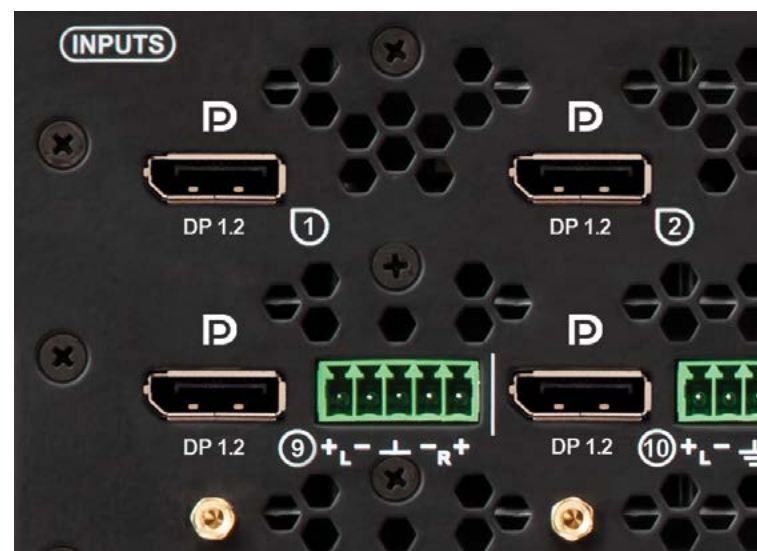

Built-in, Proprietary Lightware Services and Technology

As always, we deliver these matrix switchers also with **proprietary services and technologies built-in** at no extra costs, helping installation and operation.



Analytics and Diagnostics

Cable diagnostics and a **built-in video frame detector** provide feedback about the exact **pixel count** and **clock frequency**.



Open API

Open-source API technology at the core makes these Lightware products **easy to integrate into third party systems**.



Convenient Adjustments and Updates

Device configuration can be adjusted via the **built-in website**, and firmware update is available through Ethernet.

HDMI 2.0 Compatible Full 4K Matrix Switcher

MX2-4x4-HDMI20-CA

Part no: 9131 0061



MX2-8x4-HDMI20-CA

Part no: 9131 0060



MX2-8x8-HDMI20-CA

Part no: 9131 0059



The MX2 matrix switchers' 'CA' variants are HDMI 2.0 compatible, standalone devices that supports uncompromised 4K UHD resolution at 60Hz 4:4:4 and are available in 4x4, 8x4 and 8x8 crosspoint sizes.

Their compact size and silent design make them particularly suitable for offices and meeting rooms and other corporate collaborative environments. These devices are also perfect for home theater enthusiasts who demand the highest quality along with HDMI 2.0 and 4K@60Hz video signals. These standalone products transmit video signals up to 4K at 60Hz in 4:4:4 format, while supporting 3D, Dolby TrueHD and DTS-HD Master Audio. The 2x audio connectors next to the output ports can provide de-embedded audio for amplifiers and audio systems and the output volume is also adjustable.

These matrix switchers support both HDR and Dolby Vision in the HDMI signal.

Highlight features

- 4K @ 60Hz with RGB 4:4:4 colorspace, 18 Gbps data rate
- Supports conversion from 4K UHD@60Hz 4:4:4 to 4K UHD@60 Hz YCbCr 4:2:2
- HDMI 2.0, HDMI 1.x and DVI 1.0 compliant
- HDCP 2.2 and HDCP 1.4 compliant
- Fully non-blocking switching architecture with zero frame delay
- Built-in web control
- RS-232, Ethernet and USB control options
- HDR and Dolby Vision support
- Advanced EDID Management
- Compact and silent design
- LCD and jog dial for front panel control
- Front to back cooling airflow
- Volume control for all audio output ports

HDMI 2.0 Compatible Full 4K Matrix Switcher

MX2-8x8-HDMI20-L

Part no: 9131 0058



MX2-8x8-HDMI20-Audio-L

Part no: 9131 0050



The MX2-8x8-HDMI20-L is an HDMI 2.0 compatible, standalone matrix switcher that supports uncompromised 4K UHD resolution at 60Hz 4:4:4, and its 'Audio-L' version also supports audio signal embedding/de-embedding.

Its compact size, silent design and its crosspoint switching front panel keys make it particularly suitable for live events. This standalone product has 8 HDMI 2.0 inputs and 8 x HDMI 2.0 outputs transmitting up to 4K at 60Hz in 4:4:4 format, while supporting 3D, Dolby TrueHD and DTS-HD Master Audio.

The MX2-8x8-HDMI20-L and MX2-8x8-HDMI20-Audio-L matrix switchers both support HDR and Dolby Vision in the HDMI signal.

Highlight features

- Maximum resolution 4K UHD @60Hz RGB 4:4:4, up to 18 Gbps)
- HDMI 2.0, HDMI 1.4 and DVI 1.0 compliant
- HDR and Dolby Vision support
- HDCP 2.2 and HDCP 1.4 compliant with cross conversion capabilities
- Uncompressed video up to 18 Gbps datarate (600 MHz pixel clock)
- Supports all embedded audio formats (including PCM, Dolby Digital and DTS high bitrate audio)
- Front to back cooling airflow
- Built-in universal power supply
- HDCP enable/disable function on input
- Advanced EDID Management and Pixel Accurate Reclocking
- Front panel LCD menu and buttons for crosspoint control
- Intuitive control software for device configuration
- Device control via Ethernet (TCP/IP), RS-232 and USB
- CEC support (command injection)
- Built-in website for device configuration
- Firmware upgrade through Ethernet
- No signal latency, zero frame delay

HDMI 2.0 Compatible Full 4K Matrix Switcher

MX2-16x16-HDMI20

Part no: 9131 0051

MX2-24x24-HDMI20

Part no: 9131 0055

MX2-16x16-HDMI20-Audio

Part no: 9131 0053

MX2-24x24-HDMI20-Audio

Part no: 9131 0049



MX2-16x16-HDMI20

MX2-24x24-HDMI20-Audio

The MX2 product line offers standalone matrix switchers in 16x16 and 24x24 crosspoint sizes, both supporting uncompromised 4K UHD resolution at 60Hz 4:4:4 signal transfer over HDMI 2.0 connections.

They have an outstanding port density that makes them particularly suitable for rental and fix install applications, as well as for futureproof operation centers. It is a perfect choice for installations where HDMI 2.0 compliant input and output ports are required.

These standalone products have 16 or 24 HDMI 2.0 inputs and 16 or 24 HDMI 2.0 outputs respectively, transmitting up to 4K at 60Hz in 4:4:4 format, while supporting 3D, Dolby TrueHD and DTS HD Master Audio. The 'Audio' marked versions also offer audio embedding/de-embedding features.

Highlight features

- HDMI 2.0, HDMI 1.x and DVI 1.0 compliant
- Supports conversion from 4K UHD at 60Hz 4:4:4 to 4K UHD at 60 Hz YCbCr 4:2:2
- 4K@60Hz with RGB 4:4:4 color space, 18 Gbps bandwidth
- HDCP 2.2 and HDCP 1.4 compliant with cross conversion capabilities
- Fully non-blocking switching architecture with zero frame delay
- Pixel Accurate Reclocking on each input
- Advanced EDID Management
- Built-in website
- RS-232, Ethernet and USB control options
- LCD, push buttons and rotary switch for front panel control
- Front to back cooling airflow
- HDR10 and Dolby Vision support
- Optional redundant power supply with 1:1 redundancy

HDMI 2.0 Compatible Full 4K Matrix Switcher

MX2-16x16-HDMI20-R

Part no: 9131 0052

MX2-24x24-HDMI20-R

Part no: 9131 0056

MX2-16x16-HDMI20-Audio-R

Part no: 9131 0054

MX2-24x24-HDMI20-Audio-R

Part no: 9131 0057

MX2-32x32-HDMI20-A-R

Part no: 9132 0069

MX2-48x48-HDMI20-A-R

Part no: 9131 0065



MX2-16x16-HDMI20-R

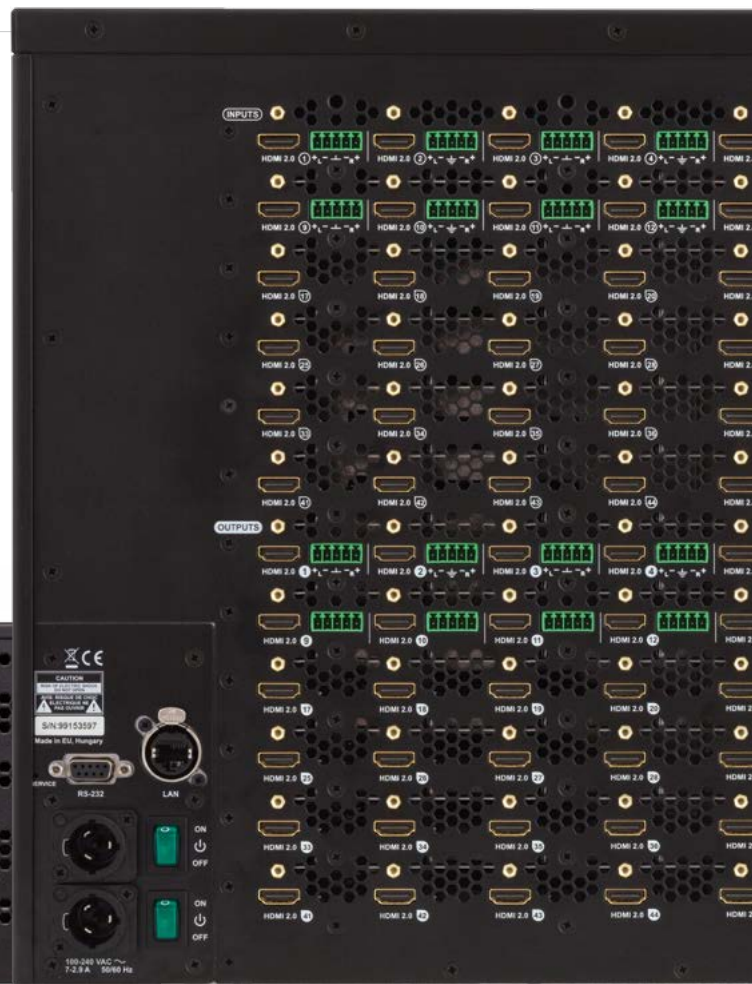

MX2-48x48-HDMI20-A-R

The MX2 standalone matrix switcher series also offers variants with large crosspoint sizes, including 16x16, 24x24, 32x32 and 48x48, all supporting uncompromised 4K UHD resolution at 60Hz with RGB 4:4:4 colorspace. These routers are fully HDMI 2.0 compatible. The switchers have outstanding port density making them particularly suitable for installations where a large number of HDMI 2.0 compliant input and output ports are required.

These standalone product supports 3D, Dolby TrueHD and DTS-HD Master Audio and also HDR 10 and Dolby Vision. Proprietary Lightware technologies like Pixel Accurate Reclocking and Advanced EDID Management are included, and the device can be controlled via the built-in website.

These matrix switcher are R-type versions with dual redundant and reinforced AC mains connectors, rugged RS-232 and Ethernet ports, designed for high operation stress environments.

The audio enhanced variants (marked as Audio-R) allowing embedding audio to, and de-embedding audio from the HDMI stream via dedicated analog audio I/O ports.

Highlight features

- 4K@60Hz with RGB 4:4:4 color space, 18 Gbps bandwidth
- HDMI 2.0, HDMI1.x and DVI 1.0 compliant
- Supports conversion from 4K UHD at 60Hz 4:4:4 to 4K UHD at 60 Hz YCbCr 4:2:2
- HDCP 2.2 and HDCP 1.4 compliant with cross conversion capabilities
- Fully non-blocking switching architecture with zero frame delay
- Pixel Accurate Reclocking on each input
- Advanced EDID Management
- Built-in website, RS-232, Ethernet and USB control options
- LCD, push buttons and rotary switch for front panel control
- Front to back cooling airflow
- HDR and Dolby Vision support
- Analog audio embedding and de-embedding and digital-to-analog conversion of stereo LPCM
- Redundant power supply with rugged AC mains connector and control ports

Full 4K Matrix Switcher with Mixed DisplayPort and HDMI Input and Output Ports

MX2-8x8-DH-8DPi-A

Part no: 9131 0062



MX2-8x8-DH-4DPi-A

Part no: 9131 0066



MX2-8x8-DH-4DPi-A and MX2-8x8-DH-8DPi-A are members of the Lightware MX2 standalone matrix switcher series, supporting uncompromised 4K UHD resolution at 60Hz with RGB 4:4:4 colorspace and feature DisplayPort inputs that allow connecting DisplayPort 1.2 video sources directly, without the need of adapters or dongles.

These devices are fully HDMI 2.0 compatible with DisplayPort input signals transformed to HDMI for signal management. These switchers are particularly suitable for fix-install applications and future-proof operation centers, for installations where HDMI 2.0 compliant input and output ports are required. Both matrices include DisplayPort ports exclusively on the input side.

MX2-8x8-DH-8DPi-A and MX2-8x8-DH-4DPi-A supports 3D, Dolby TrueHD and DTS-HD Master Audio and also HDR10, HDR10+ and Dolby Vision. Proprietary Lightware technologies like Pixel Accurate Reclocking and Advanced EDID Management are included and can be controlled via the built-in website.

These matrix switchers also allow embedding audio to, and de-embedding audio from the signal stream at dedicated analog audio I/O ports. Crosspoint switching functions are available via keys on the front panel.

Highlight features

- DisplayPort 1.2 and HDMI 2.0 compliant
- DisplayPort input signals are converted to HDMI signals via the built-in chipset on each port
- Maximum resolution on HDMI input is 4K@60Hz with 4:4:4 sampling pattern and 8 bit per component
- Maximum resolution on DP input is 4K@60Hz with 4:2:2 sampling pattern and 10 bit per component
- Fully non-blocking switching architecture with zero frame delay
- 18 Gbps bandwidth video crosspoint
- Supports conversion from 4K/UHD at 60Hz 4:4:4 to 4K/UHD at 60 Hz YCbCr 4:2:2 (when HDMI input is used)
- Supports conversion from 4K/UHD at 60Hz 4:4:4 10bit to 4K/UHD at 60 Hz YCbCr 4:2:2 10 bit (when DP input is used)
- HDCP 2.2 and HDCP 1.4 compliant with cross conversion capabilities
- Pixel Accurate Reclocking on each input
- Advanced EDID Management
- Built-in website, RS-232, Ethernet and USB control options
- LCD, push buttons and rotary switch for front panel control
- Front to back cooling airflow
- HDR10, HDR10+ and Dolby Vision support
- Analog audio embedding from and de-embedding to analog audio inputs and outputs for MX2-8x8-DH-8DPi-A

Full 4K Matrix Switcher with Mixed DisplayPort and HDMI Input Ports

MX2-24x24-DH-12DPi-R

Part no: 9131 0067

MX2-16x16-DH-8DPi-A-R

Part no: 9131 0068

MX2-24x24-DH-12DPi-A-R

Part no: 9131 0064

MX2-32x32-DH-16DPi-A-R

Part no: 9131 0070

MX2-48x48-DH-24DPi-A-R

Part no: 9131 0071

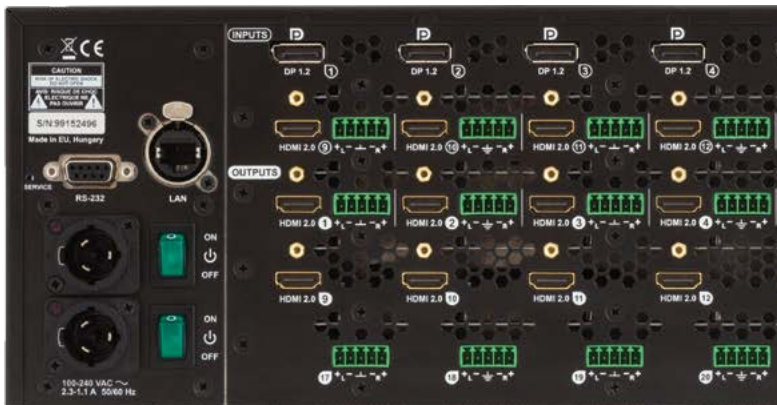

MX2-16x16-DH-8DPi-A-R



MX2-48x48-DH-24DPi-A-R

The MX2 standalone matrix switcher Displayport-compatible variants also offer editions with large crosspoint sizes, including 16x16, 24x24, 32x32 and 48x48, all supporting uncompromised 4K UHD resolution at 60Hz with RGB 4:4:4 colorspace and are fully HDMI 2.0 compatible. The DisplayPort inputs on the MX2 DH series routers allow connecting DisplayPort 1.2 video sources directly, without the need of adapters or dongles.

The switchers have outstanding port density making them particularly suitable for fix-install applications and for future-proof operation centers alike: for installations where a huge number of HDMI 2.0 compliant input and output ports are required. These matrices include DisplayPort ports exclusively on the input side.

All MX2 DH devices support 3D, Dolby TrueHD and DTS-HD Master Audio and also HDR and Dolby Vision. Proprietary Lightware technologies like Pixel Accurate Reclocking and Advanced EDID Management are included and can be controlled via the built-in website.

These 'A-R' marked editions also allow embedding audio to, and de-embedding audio from the signal stream at dedicated analog audio I/O ports, and all of them are R-type models, with a dual redundant power source, with two, independent, rugged power connectors and reinforced RS-232 and Ethernet ports.

Crosspoint switching functions are available via keys on the front panel.

Features

- DisplayPort 1.2 and HDMI 2.0 compliant
- DisplayPort input signals are converted to HDMI signals via the built-in chipset on each port
- Maximum resolution on HDMI input is 4K@60Hz with 4:4:4 sampling pattern and 8 bit per component
- Maximum resolution on DP input is 4K@60Hz with 4:2:2 sampling pattern and 10 bit per component
- Fully non-blocking switching architecture with zero frame delay
- 18 Gbps bandwidth video crosspoint
- Supports conversion from 4K/UHD at 60Hz 4:4:4 to 4K/UHD at 60 Hz YCbCr 4:2:2 (when HDMI input is used)
- Supports conversion from 4K/UHD at 60Hz 4:4:4 10bit to 4K/UHD at 60 Hz YCbCr 4:2:2 10 bit (when DP input is used)
- HDCP 2.2 and HDCP 1.4 compliant with cross conversion capabilities
- Pixel Accurate Reclocking on each input
- Advanced EDID Management
- Built-in website, RS-232, Ethernet and USB control options
- LCD, push buttons and rotary switch for front panel control
- Front to back cooling airflow
- HDR and Dolby Vision support
- Analog audio embedding from and de-embedding to analog audio inputs and outputs
- Power redundancy features and reinforced connectors



Full 4K DisplayPort 1.2 Matrix Switchers

MX2-8x8-DH-8DPio-A

Part no: 9131 0072

MX2-24x24-DH-24DPio-A-R

Part no: 9131 0073

MX2-48x48-DH-48DPio-A-R

Part no: 9131 0074



The MX2 standalone matrix switcher Displayport-compatible variants also offer editions with with Displayport connections on both input and outputs sides and come in various crosspoint sizes of 8x8, 24x24 and 48x48, all supporting uncompromised 4K UHD resolution at 60Hz with RGB 4:4:4 colorspace, are fully HDMI 2.0 compatible and allow connecting DisplayPort 1.2 video sources and displays directly, without the need of adapters or dongles.

These switchers are particularly suitable for fix-install applications and future-proof operation centers, for installations where DisplayPort 1.2 input and output ports are required.

They support 3D, Dolby TrueHD and DTS-HD Master Audio and also HDR10, HDR10+ and Dolby Vision. Proprietary Lightware technologies like Pixel Accurate Reclocking and Advanced EDID Management are included, and the device can be controlled via the built-in website.

These 'A-R' marked editions also allow embedding audio to, and de-embedding audio from the signal stream at dedicated analog audio I/O ports with 5-pole Phoenix type connectors, and all of them are R-type models, with a dual redundant power source, with two, independent, rugged power connectors and reinforced RS-232 and Ethernet ports.

Crosspoint switching functions are available via direct keys on the front panel.

Features

- DisplayPort 1.2 compliant
- DisplayPort input signals are converted to HDMI signals via the built-in chipset on each port
- Maximum resolution on DP input is 4K@60Hz with 4:2:2 sampling pattern and 10 bit per component
- Fully non-blocking switching architecture with zero frame delay
- 18 Gbps bandwidth video crosspoint
- Supports conversion from 4K/UHD at 60Hz 4:4:4 10bit to 4K/UHD at 60 Hz YCbCr 4:2:2 10 bit
- HDCP 2.2 and HDCP 1.4 compliant with cross conversion capabilities
- Pixel Accurate Reclocking on each input
- Advanced EDID Management
- Built-in website, RS-232, Ethernet and USB control options
- LCD, push buttons and rotary switch for front panel control
- Front to back cooling airflow
- HDR10, HDR10+ and Dolby Vision support
- Analog audio embedding from analog audio inputs and de-embedding to audio outputs

WORLD'S **1**st

DisplayPort I/O

Standalone Matrix Switchers



8x8

MX2-8x8-DH-8DPio-A



24x24

MX2-24x24-DH-24DPio-A-R



48x48

MX2-48x48-DH-48DPio-A-R



MX2
SERIES

visual engineering
LIGHTWARE

lightware.com

MX2 Family Comparison Chart

	Product	Inputs			Outputs			Front panel I/O buttons	Front panel LCD menu	Redundant power supply
		HDMI	DP	Audio	HDMI	DP	Audio			
HDMI	MX2-4x4-HDMI20-CA	4x	×	×	4x	×	2x	×	✓	×
	MX2-8x4-HDMI20-CA	8x	×	2x	4x	×	2x	×	✓	×
	MX2-8x8-HDMI20-CA	8x	×	2x	8x	×	2x	×	✓	×
	MX2-8x8-HDMI20-L	8x	×	×	8x	×	×	✓	✓	×
	MX2-8x8-HDMI20-Audio-L	8x	×	8x	8x	×	8x	✓	✓	×
	MX2-16x16-HDMI20	16x	×	×	16x	×	×	✓	✓	×
	MX2-24x24-HDMI20	24x	×	×	24x	×	×	✓	✓	×
	MX2-16x16-HDMI20-Audio	16x	×	4x	16x	×	4xH+4xA	×	✓	×
	MX2-24x24-HDMI20-Audio	24x	×	8x	24x	×	8x	×	✓	×
	MX2-16x16-HDMI20-R	16x	×	×	16x	×	×	✓	✓	✓ (PowerCON)
	MX2-24x24-HDMI20-R	24x	×	×	24x	×	×	✓	✓	✓ (PowerCON)
	MX2-16x16-HDMI20-Audio-R	16x	×	4x	16x	×	4xH+4xA	×	✓	✓ (PowerCON)
	MX2-24x24-HDMI20-Audio-R	24x	×	8x	24x	×	8x	×	✓	✓ (PowerCON)
	MX2-32x32-HDMI20-A-R	32x	×	16xH	32x	×	8xH+8xA	✓	✓	✓ (PowerCON)
MX2-48x48-HDMI20-A-R	48x	×	16xH	48x	×	16xH	✓	✓	✓ (PowerCON)	
MIXED HDMI / DP	MX2-8x8-DH-4DPi-A	4x	4x	×	8x	×	2x	✓	✓	×
	MX2-8x8-DH-8DPi-A	×	8x	4xD	8x	×	4xH	✓	✓	×
	MX2-16x16-DH-8DPi-A-R	8x	8x	8xH	16x	×	4xH+4xA	✓	✓	✓ (PowerCON)
	MX2-24x24-DH-12DPi-A-R	12x	12x	8xH+4xD	24x	×	8xH	✓	✓	✓ (PowerCON)
	MX2-24x24-DH-12DPi-R	12x	12x	×	24x	×	×	✓	✓	✓ (PowerCON)
	MX2-32x32-DH-16DPi-A-R	16x	16x	8xH+4xD	32	×	8xH+8xA	✓	✓	✓ (PowerCON)
MX2-48x48-DH-24DPi-A-R	24x	24x	8xH+8xD	24x	24x	8xH+24xD	✓	✓	✓ (PowerCON)	
DP	MX2-8x8-DH-8DPio-A	×	8x	4xD	×	8x	8xD	✓	✓	×
	MX2-24x24-DH-24DPio-A-R	×	24x	8xD	×	24x	24xD	✓	✓	✓ (PowerCON)
	MX2-48x48-DH-48DPio-A-R	×	48x	16xD	×	48x	48xD	✓	✓	✓ (PowerCON)

H: next to HDMI | D: next to DP | A: independent audio out

Lightware Technology You Can Trust

The new, truly HDMI 2.0 compatible MX2 series matrix routers will help you **save on costs, rack space and installation time, offering Lightware quality and long-time reliability out of the box.** With a **three-year manufacturer's warranty** and probably the best support services in the AV industry MX2 switchers are the excellent choice for AV professionals.

UMX Series Switcher for VGA, DVI-I, HDMI and DisplayPort

UMX-HDMI-140 and UMX-HDMI-140-Plus

Part No: 9156 0001; 9156 0003



UMX-HDMI-140 switches universal 4K video and audio to a HDMI output port. This device was designed for digital and analog video and audio signals: VGA, YPrPb, DVI, HDMI 1.4 and DP 1.1 with analog stereo audio from local inputs or embedded 7.1 HBR audio. The unit can also handle HDCP encryption. Analog signals (both audio and video) are converted into digital format. Using the factory, custom or transparent EDID emulation the user can fix and lock EDID data on each input connector. Advanced EDID Management forces the required resolution from any video source and fixes the output format conforming the system requirements.

The 'Plus' versions of these products include an improved processor and bigger memory which allows the integration of 'Advanced Control' features into the product.

The 'Advanced Control' feature pack includes functions which help to integrate the product with CISCO Rooms and other 3rd party systems, and/or to overcome system automation challenges. In small to mid size systems these automation features can help to dismiss an additional control processor box, thus lowering intergration time and costs.

Port Diagram - UMX-HDMI-140

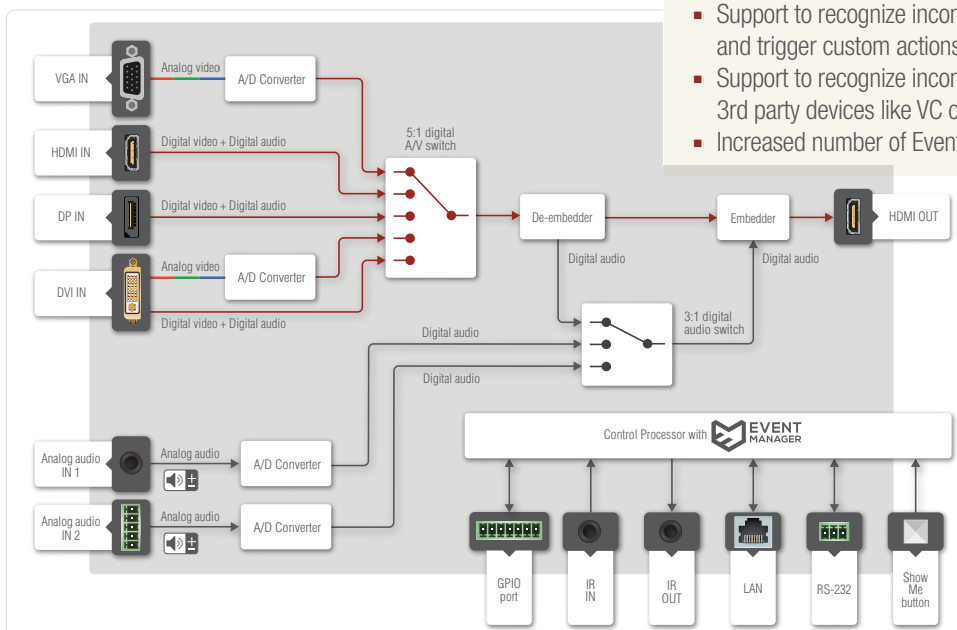

Features:

- 4K/UHD (30Hz RGB 4:4:4, 60Hz YCbCr 4:2:0) and 3D capabilities
- Switches DVI, HDMI, VGA or DisplayPort to a HDMI output port
- Video inputs: VGA, HDMI, DisplayPort, DVI-D and DVI-A
- Audio inputs: Stereo jack in, 5-pole Phoenix connector for balanced audio in
- Stereo jack, 1x5 pole Phoenix
- Embedded 7.1 HBR audio support
- Autoselect mode: video and audio priority modes
- Intuitive Control Software
- GPIO control port
- HDCP compliant
- Audio embedding
- Built-in **Event Manager** feature
- Advanced EDID management
- No signal latency
- Frame detector

Plus Features:

- Support to send raw Infrared messages (Pronto HEX codes) to control TVs, Blurays, etc with connected IR emitters
- Support to send CEC messages to control TVs, Blurays etc which are conencted on HDMI ports
- Support to recognize incoming CEC messages in **Event Manager** and trigger custom actions
- Support to recognize incoming RS-232 messages to integrate with 3rd party devices like VC codecs
- Increased number of Events to 100

4K UHD 4x2 HDMI Matrix Switcher

MMX4x2-HDMI

Part No: 9131 0034

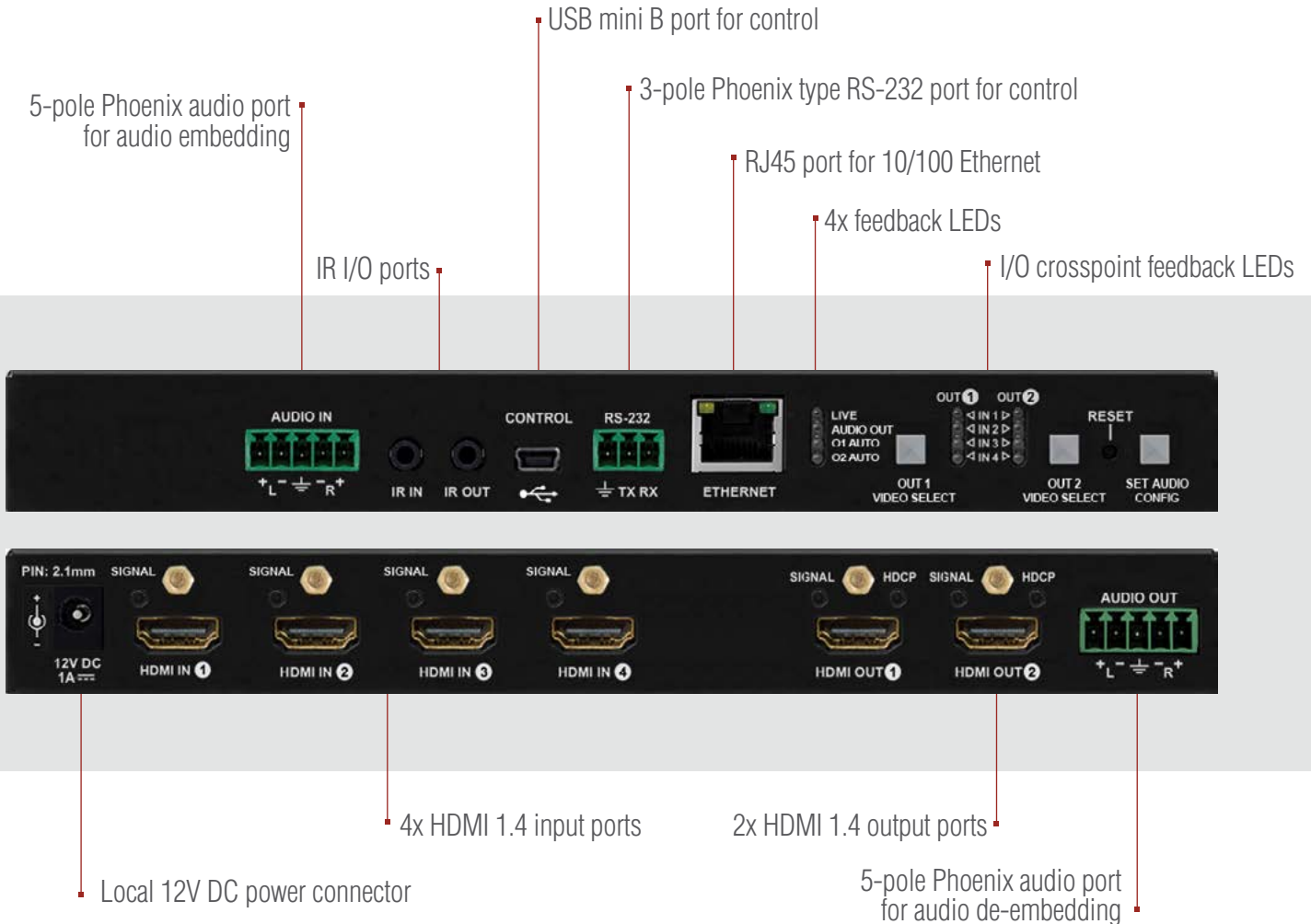

Features:

- 4x2 HDMI matrix switcher
- 4K/UHD (30Hz RGB 4:4:4, 60Hz YCbCr 4:2:0) and 3D capabilities
- Fully HDCP compliant
- Balanced analog audio input and output for embedding and de-embedding audio
- Audio volume and gain control on analog input and output
- **Event Manager**
- RS-232, IR, Ethernet control capabilities
- Compact size

Advanced Pack Features:

- Support to send raw Infrared messages (Pronto HEX codes) to control TVs, Blurays, etc with connected IR emitters
- Support to send CEC messages to control TVs, Blurays etc which are connected on HDMI ports
- Support to recognize incoming CEC messages in Event Manager and trigger custom actions
- Support to recognize incoming RS-232 messages to integrate with 3rd party devices like VC codecs
- Increased number of Events to 100

4K UHD 4x2 Matrix Switcher with HDBaseT™ and HDMI

MMX4x2-HT200

Part No: 9131 0035

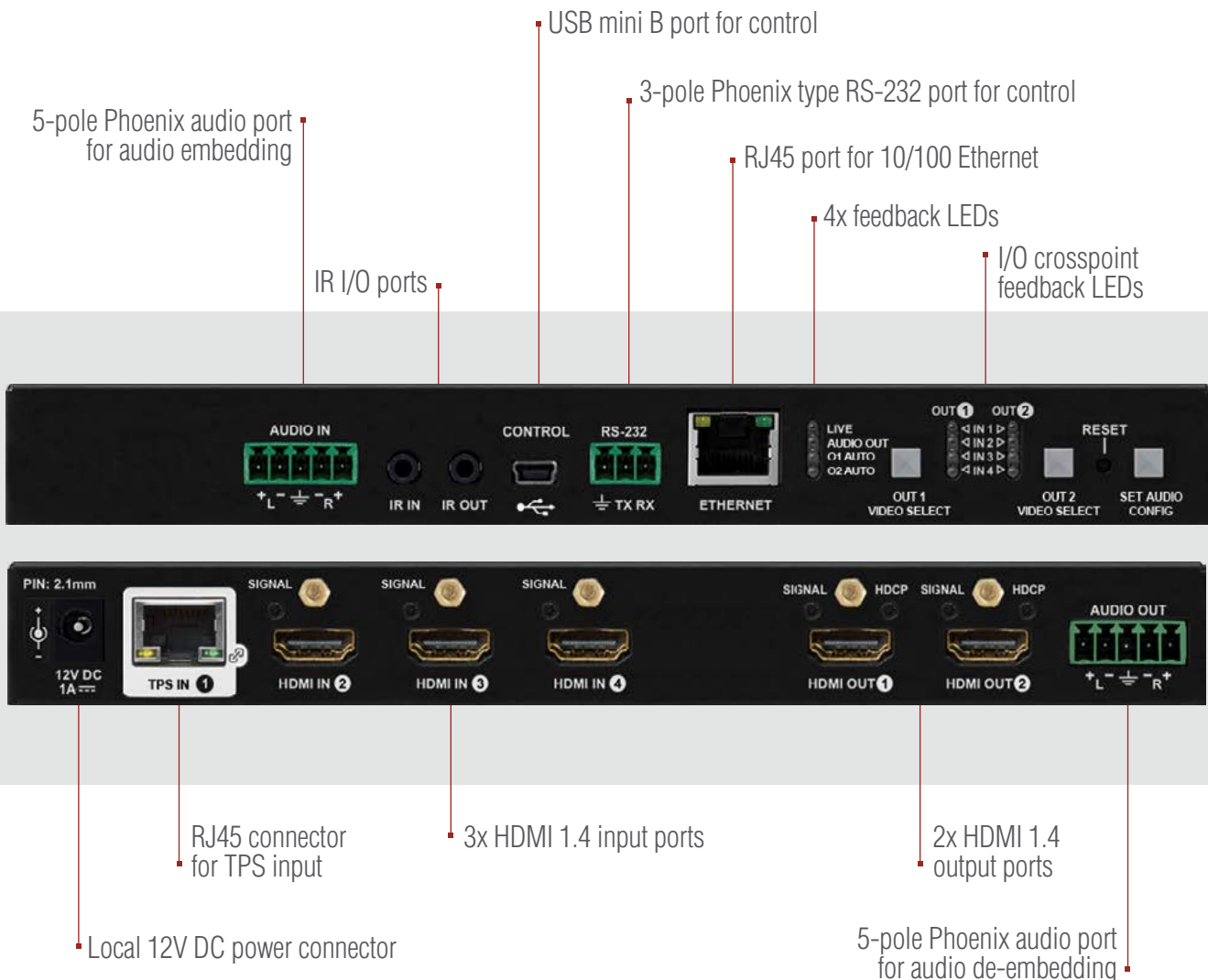

Features:

- 4x2 HDMI matrix switcher, with HDMI and TPS ports
- Up to 170 m transmission distance over TPS*
- 4K/UHD (30Hz RGB 4:4:4, 60Hz YCbCr 4:2:0) and 3D capabilities
- Fully HDCP compliant
- Balanced analog audio input and output for embedding and de-embedding audio
- Audio volume and gain control on analog inputs and outputs
- **Event Manager**
- RS-232, IR, Ethernet control capabilities
- Compact size

* Depends on cable category and quality

Advanced Pack Features:

- Support to send raw Infrared messages (Pronto HEX codes) to control TVs, Blurays, etc with connected IR emitters
- Support to send CEC messages to control TVs, Blurays etc which are connected on HDMI ports
- Support to recognize incoming CEC messages in Event Manager and trigger custom actions
- Support to recognize incoming RS-232 messages to integrate with 3rd party devices like VC codecs
- Increased number of Events to 100

MMX Series 6x2 HDMI TPS Matrix Switcher

MMX6x2-HT220

Part No: 9131 0032



The MMX6x2-HT220 is our solution for a practical standalone matrix switcher specifically designed for meeting room and classroom environments. The compact MMX6x2-HT220 has six video inputs and two video outputs - four HDMI 1.4, two TPS inputs and two independent HDMI outputs, both outputs have mirrored TPS outputs. 4K@30Hz, 3D capabilities and HDCP are fully supported. The device also has four audio connectors for audio insertion and two audio outputs for de-embedding purposes. These features makes this standalone matrix unique on the market. PoE 48V remote powering is available on every TPS ports (both inputs and outputs) for cost effective installations.

Features:

- 6x2 multiport matrix switcher with HDMI and TPS ports
- 4K / UHD (30Hz RGB 4:4:4, 60Hz YCbCr 4:2:0) and 3D capabilities
- 4x HDMI 1.4 input + 2x TPS input
- 2x independent AV output
- Two ports per output: mirrored HDMI + TPS
- PoE (48V) injector on every TPS port (both TPS inputs and outputs)
- Up to 170 m* transmission distance over TPS
- Balanced analog audio inputs and outputs with adjustable volume
- **Event Manager**

*Depends on cable category and quality

Application Diagram:

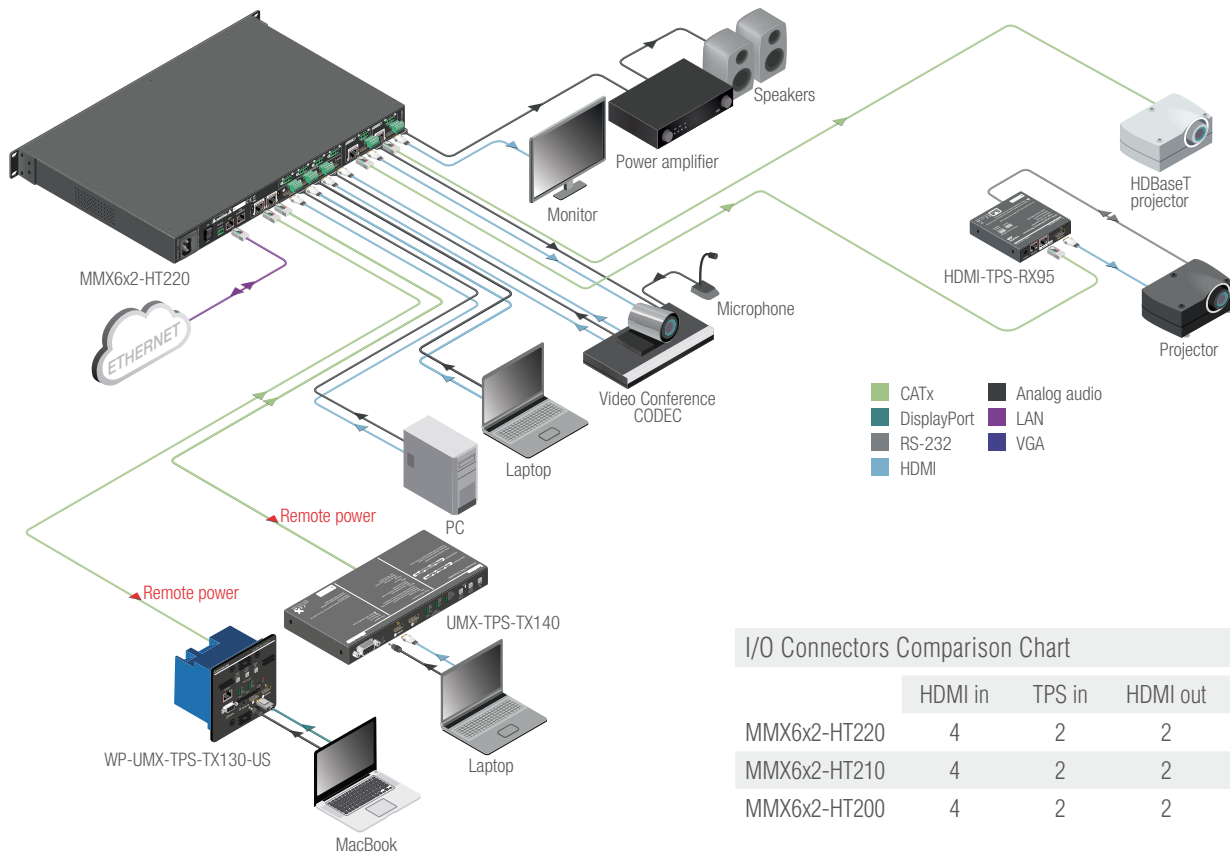

I/O Connectors Comparison Chart

	HDMI in	TPS in	HDMI out	TPS out
MMX6x2-HT220	4	2	2	2
MMX6x2-HT210	4	2	2	1
MMX6x2-HT200	4	2	2	0



MMX6x2-HT220 Rear View

MMX Series 6x2 HDMI TPS Matrix Switcher
MMX6x2-HT210

Part No: 9131 0031



MMX6x2-HT210 is almost fully identical with the MMX6x2-HT220 model and offers all of its functions, but it only has one of its HDMI outputs mirrored as TPS port.

Features:

- 4K / UHD (30Hz RGB 4:4:4, 60Hz YCbCr 4:2:0) and 3D capabilities
- 6 input 2 output video matrix
- 4 HDMI 1.4 and 2 TPS inputs
- 2 independent AV output streams
- Two separate HDMI and one mirrored TPS output ports (the two ports can transmit the same AV content simultaneously)
- Audio insertion and de-embedding options
- Fully HDCP compliant
- PoE (48V) injector on every TPS port (both TPS inputs and outputs)
- RS-232, Ethernet, IR control options
- **Event Manager** support
- Compact one RU chassis

MMX Series 6x2 HDMI TPS Matrix Switcher
MMX6x2-HT200

Part No: 9131 0030



MMX6x2-HT200 is almost fully identical with the MMX6x2-HT220 and MMX6x2-HT210 models and offers all of their functions, but it does not have TPS ports at the output end.

Features:

- 4K / UHD (30Hz RGB 4:4:4, 60Hz YCbCr 4:2:0) and 3D capabilities
- 6 input 2 output video matrix
- 4 HDMI 1.4 and 2 TPS inputs
- 2 independent AV output streams
- Two HDMI outputs
- Audio insertion and de-embedding options
- Fully HDCP compliant
- PoE (48V) injector on every TPS port
- RS-232, Ethernet, IR control options
- **Event Manager** support
- Compact one RU chassis



MMX6x2-HT210 Rear View



MMX6x2-HT200 Rear View

HDBaseT™ and the HDBaseT Alliance logo are trademarks of the HDBaseT Alliance



ALL IN

WE BET IT INCLUDES EVERYTHING FOR A MEETING ROOM



MMX8x4-HT420M HDMI and HDBase™ Matrix Switcher with Event Manager Control Feature, Active Microphone Input, Audio Mixer DSP, Bi-directional Audio and Control Ports

NEW 8x4 Matrix Switchers with

Special Audio Input Block, DSP Mixer and Enhanced Event Manager Control

MMX8x4-HT420M

MMX8x4-HT400MC

Everything you need for a conference room environment

Special Audio Input Block includes input ports for **microphone and line-in**. The **built-in sound mixer DSP** allows for free mixing of the audio signals from the de-embedded HDMI, the microphone or the line-in. The **MIC port can also supply phantom power** to the connected microphone.

Voice Activated Presenter Focus allows the volume of the voice of the speaker to become automatically focused, and the volume of the rest of the sounds to be lowered, as soon as the presenter starts speaking.

The **built-in DSP** provides **audio mixer** services including fader, equalizer, mute, balance and gain.

The unit offers **Ethernet, RS-232, Serial and IR command injection** services allowing to send any control command directly from the LAN connection to remote end points.

The **built-in Event Manager** feature provides **all the necessary control via multiple RS-232, IR, Ethernet, Relay and GPIO ports**.



HDMI and TPS Matrix Switcher with Special Audio Inputs and Multiport Control Options

MMX8x4-HT420M

Part No: 9131 0042



MMX8x4-HT420M

MMX8x4-HT420M is a standalone matrix switcher specifically designed for conference room environments. It has eight video inputs (four HDMI and four TPS) and four video outputs (two HDMI outputs and two TPS outputs). 4K / UHD (30Hz RGB 4:4:4, 60Hz YCbCr 4:2:0), 3D capabilities and HDCP are fully supported.

MMX8x4-HT420M has a dedicated Special Audio Input Block with input ports for microphone and line-in. The built-in sound mixer allows for free mixing of the audio signals from the de-embedded HDMI, the microphone or the line-in. The Special Audio Input block includes a voice activation feature, allowing the volume of the voice of a person speaking into the microphone to be automatically focused, and the volume of the rest of the sounds to be lowered as soon as the presenter starts speaking.

The device also has two balanced 5-pole Phoenix audio connectors at two of the HDMI inputs. The audio signal direction of the port can be changed with the Lightware Device Controller software, so these audio ports can be either input or output ports.

The audio signal presented by the built-in mixer is channeled to one shared, balanced 5-pole Phoenix audio output, including the mixed audio of a selected, de-embedded HDMI audio, the microphone and the Line-in.

PoE 48V remote powering is available on every I/O TPS ports for cost-effective installations.

MMX8x4-HT420M receives and transmits digital video, audio and control to a distance of up to 170m over a single CAT6 cable. Using factory, custom or transparent EDID emulation the user can fix and lock EDID data on each input connector. Advanced EDID Management

forces the required resolution from any video source and fixes the output format to conform to the system requirements. The unit can be controlled via RS-232, Ethernet or USB ports, but it also offers Ethernet, RS-232, Serial and IR command injection capabilities, allowing to send any control command directly from the LAN connection to remote end points.

The built-in **Event Manager** feature provides control via RS-232, IR, Ethernet, Relay and GPIO ports. The MMX8x4-HT420M is compatible with both HDBaseT™ extenders and HDBaseT™ compliant displays.

Plus Features:

- Support to send raw Infrared messages (Pronto HEX codes) to control TVs, Blurays, etc with connected IR emitters
- Support to send CEC messages to control TVs, Blurays etc which are connected on HDMI ports
- Support to recognize incoming CEC messages in **Event Manager** and trigger custom actions
- Support to recognize incoming RS-232 messages to integrate with 3rd party devices like VC codecs
- Increased number of Events to 100

MMX8x4-HT400MC

MMX8x4-HT400MC is a standalone matrix switcher specifically designed for conference room environments.

This device is a cost-effective version of the MMX8x4-HT420M with fewer features and services, and with four HDMI video outputs, lacking the two TPS output ports of the full feature product.

The table lists the available features and services of the two products in comparison:

HDMI and TPS Matrix Switcher with Special Audio Inputs

MMX8x4-HT400MC

Part No: 9131 0041



Features and Services	MMX8x4-HT420M	MMX8x4-HT400MC
4K / UHD (30Hz RGB 4:4:4, 60Hz YCbCr 4:2:0) and 3D capabilities	✓	✓
HDMI input ports	4x	4x
TPS (HDBaseT) input ports	4x	4x
HDMI output ports	2x	4x
TPS (HDBaseT) output ports	2x	✗
Up to 170 m transmission over TPS Long Reach Mode for Full HD signals	✓	✗
Balanced bi-directional analog audio ports	2x	✗
Balanced analog audio input for the built-in mixer	1x	1x
Special Audio Input Block for active microphone and line-in	✓	✓
Built-in sound mixer DSP with volume automation	✓	✓
Ethernet port for device control	1x	1x
Ethernet ports for external device control	2x	✗
Ethernet via TPS	✓	✗
Bi-directional RS-232 ports	2x	2x
Serial/IR ports for display control	2x	2x
IR ports for display control	4x	2x
Relay output ports	4x	✗
GPIO port	6x GPIO + 5V + GND	✗
PoE function to feed remote power to connected devices	✓	✗
Front panel LCD and jog dial button	✓	✓
Event Manager built-in control feature	✓	✓
Dimensions:	442 W (482 with ears) x 300 D x 87.8 H mm	

HDMI Matrix Switcher with Event Manager **MMX8x8-HDMI-4K-A**

Part No: 9131 0043



MMX8x8-HDMI-4K-A is a standalone matrix switcher with eight HDMI video inputs and eight HDMI video outputs. 4K / UHD (30Hz RGB 4:4:4, 60Hz YCbCr 4:2:0), 3D capabilities and HDCP are fully supported.

MMX8x8-HDMI-4K-A has 4+2 balanced, bi-directional, 5-pole Phoenix audio ports for embedding and de-embedding audio.

Using factory, custom or transparent EDID emulation users can fix and lock EDID data on each input connector. Advanced EDID Management forces the required resolution from any video source and fixes the output format to conform to the system requirements.

The unit can be controlled via RS-232, Ethernet or USB ports, but it also offers RS-232, Serial and IR command injection capabilities allowing to send any control command directly to end points.

The built-in Event Manager feature provides control via RS-232 and IR ports.

Features

- 8x8 port HDMI matrix switcher
- 4K / UHD (30Hz RGB 4:4:4, 60Hz YCbCr 4:2:0) and 3D capabilities
- 8x HDMI inputs + 8x HDMI outputs
- 4+2 Balanced, analog, audio ports with user-selectable signal direction
- Front panel control buttons, LCD display and jog dial button
- 1x Ethernet input port for device control
- 2x bi-directional RS-232 ports
- 2x Serial/IR ports for display control
- 2x IR ports for display control
- Event Manager built-in control feature

Plus Features:

- Support to send raw Infrared messages (Pronto HEX codes) to control TVs, Blurays, etc with connected IR emitters
- Support to send CEC messages to control TVs, Blurays etc which are connected on HDMI ports
- Support to recognize incoming CEC messages in **Event Manager** and trigger custom actions
- Support to recognize incoming RS-232 messages to integrate with 3rd party devices like VC codecs
- Increased number of Events to 100

HDCP Compliant Pro Series 8 x 8 DVI Matrix with HDMI

MX8x8DVI-HDCP-Pro

Part No: 9131 0004



MX8x8DVI-HDCP-Pro digital video router is the most advanced DVI router that supports DVI 1.0, HDCP 1.2 and even HDMI.

Features:

- No signal or switching latency
- HDMI 1.3; HDCP 1.1 and DVI 1.0 compliant
- 1920 x 1200 or 2048 x 1080 maximal resolutions
- Frame Detector: Input signal analysis / monitoring
- Signal presence display
- Color space conversion: RGB and YUV per output
- Color range scaling per output, 24/30/36-bit RGB/YCbCr 4:4:4 (deep color)
- Gold plated high grade PCB boards and DVI connectors
- 60 m copper cable compensation on all inputs
- Pixel Accurate Reclocking for both input and output
- Advanced EDID Management
- PCM audio sample rate conversion ½ and ¼ per output - 32-192 kHz Fs sample rate
- Dolby TrueHD and DTS-HD Master Audio
- Full crosspoint configuration saving and reloading as preset (32 presets)

HDCP Compliant Pro Series 8 x 8 HDMI Matrix

MX8x8HDMI-Pro

Part No: 9131 0014



MX8x8HDMI-Pro is full of features and it is a reliable choice for HDMI signal routing. It supports DVI 1.0, HDCP 1.2 and even HDMI 1.3 deep color standards.

Features:

- No signal or switching latency
- HDMI 1.3; HDCP 1.1 and DVI 1.0 compliant
- 1920 x 1200 or 2048 x 1080 maximal resolutions
- Frame Detector: Input signal analysis / monitoring
- Signal presence display, S/PDIF Digital Audio breakout for every output
- Color space conversion: RGB and YUV per output

- Color range scaling per output, 24/30/36-bit RGB/YCbCr 4:4:4 (deep color)
- Gold plated high grade PCB boards and HDMI connectors
- 60 m copper cable compensation on all inputs
- Pixel Accurate Reclocking for both input and output
- Advanced EDID Management
- PCM audio sample rate conversion 1/2 and 1/4 per output - 32-192 kHz Fs sample rate
- Dolby TrueHD and DTS-HD Master Audio
- Full crosspoint configuration saving and reloading as preset (32 presets)
- Control via tRS-232 / RS-422 port, TCP/IP LAN connection or through the built-in website

Dual-Link DVI Switchers

MX4x4DVI-DL, MX6x6DVI-DL, MX8x8DVI-DL

Part No: 9131 0011 (4x4), 9131 0012 (6x6), 9131 0013 (8x8)



MX4x4DVI-DL, MX6x6DVI-DL and MX8x8DVI-DL are Dual-Link DVI crosspoint matrix switchers providing most of the features of the Pro-series modular matrix switchers in a single standalone 4x4, 6x6 or 8x8 design.

Features:

- 4x4/6x6/8x8 I/O size Single and Dual-Link DVI crosspoint matrix switchers
- No signal or switching latency
- 3840 x 2400 pixel maximum resolution (1920 x 1200 in Single-Link mode)

- Front panel buttons control, RS-232 or RS-422 control
- Advanced EDID Management
- TCP/IP LAN control port with built-in WEB access
- Supports 120 Hz - 3D signals
- Full crosspoint configuration saving and reloading as preset (32 presets)
- Outputs supply 500 mA current on DVI +5V pin to power long distance fiber optical transmitters (e.g. DVI-OPT-TX110)
- Available I/O sizes: 8x8, 6x6, 4x4

Slim DVI Matrix Switchers up to 16 x 16

MX9x9DVI-Slim, MX12x12DVI-Slim and MX16x16DVI-Slim

Part No: 9131 0008 (9x9), 9131 0009 (12x12), 9131 0010 (16x16)



MX16x16DVI-Slim

The MX9x9DVI-Slim, MX12x12DVI-Slim and MX16x16DVI-Slim with their 1.2 inch depth are today's smallest and lightest 9x9, 12x12 or 16x16 DVI matrix switchers which provide routing in the most rugged environments.

Features:

- Industry's lightest and most narrow (1.2 inch depth) frame, can even fit behind other rack mounted equipment
- Aluminum alloy body and fan-less design
- No signal or switching latency
- Routing 9x9/12x12/16x16 DVI 1.0 signals
- Routing HDMI 1.3 signals (with embedded audio) without HDCP
- 1920 x 1200 or 2048 x 1080 maximal resolution
- Gold plated PCB boards and connectors
- Web page hosting capabilities
- Front panel buttons control
- Advanced EDID Management
- RS-232 or RS-422 and Ethernet control
- Christie (ex-Vista) Spyder and Barco Encore compatibility
- Full crosspoint configuration saving and reloading as preset (32 presets)
- Available I/O sizes: 9x9, 12x12, 16x16
- +12 dB input cable equalization allows using up to 20 meter long DVI cables
- Outputs supply 500 mA current on DVI +5V pin to power long distance fiber optical transmitters, like DVI-OPT-TX110

Connection Diagram:

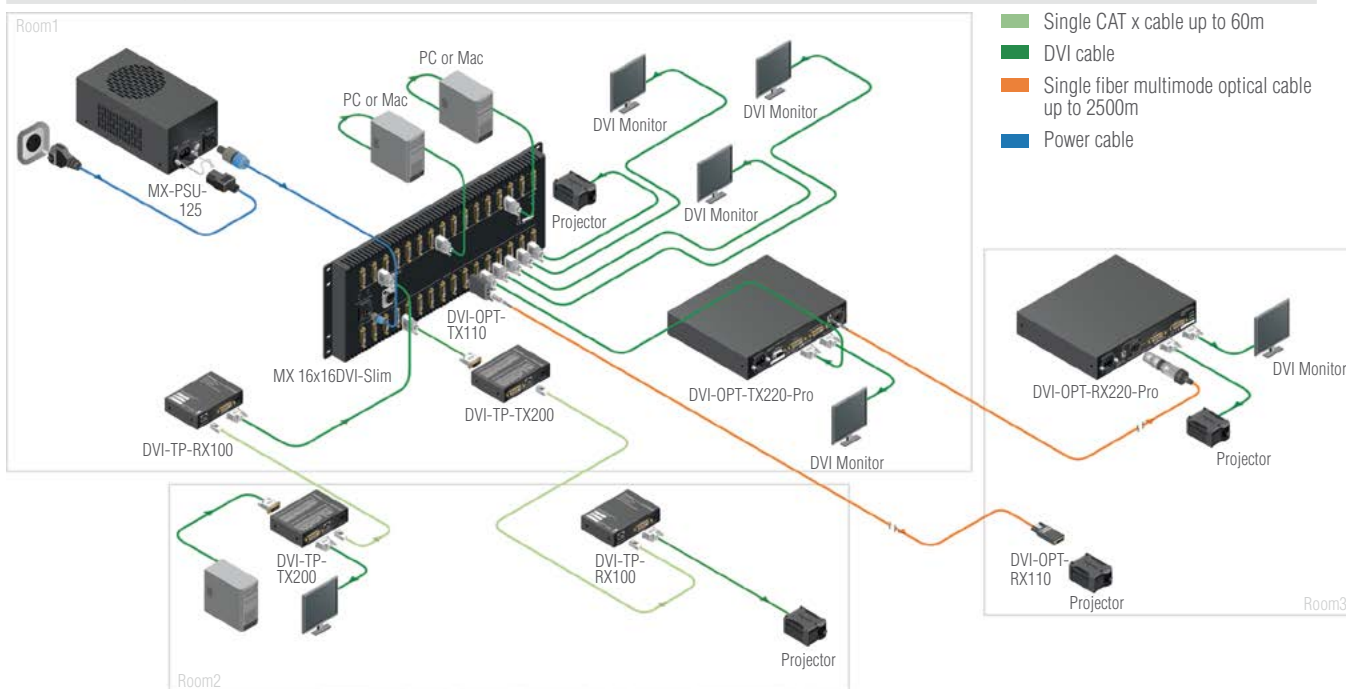

Plus Series DVI Matrix Switchers

MX9x9DVI-Plus, MX12x12DVI-Plus and MX16x16DVI-Plus

Part No: 9131 0005 (9x9), 9131 0006 (12x12), 9131 0007 (16x16)



MX16x16DVI-Plus

The MX9x9DVI-Plus, MX12x12DVI-Plus and MX16x16DVI-Plus cost-effective matrix switchers range from 9 input 9 output, 12 input 12 output to 16 input 16 output. The Plus series switchers are based on the Slim matrix switchers with the added benefits of the integrated power supply insuring reliable performance in the most harshest environments. The 7 inch depth, 4 RU high body and low noise fan design makes it ideal for many space and noise sensitive applications.

Features:

- Integrated power, 7 inch depth, 4 RU height, low noise
- No signal or switching latency
- Routing up to 16x16 DVI 1.0 signals
- Routing HDMI 1.3 signals (with embedded audio) without HDCP
- 1920 x 1200 or 2048 x 1080 maximal resolution
- Gold plated PCB boards and connectors
- Built-in website
- Front panel buttons control
- Advanced EDID Management
- RS-232 or RS-422 and Ethernet control
- Vista Spyder and Barco Encore compatibility
- Full crosspoint configuration saving and reloading as preset (32 presets)
- Built-in power supply
- Available I/O sizes: 9x9, 12x12, 16x16

Connection Diagram:

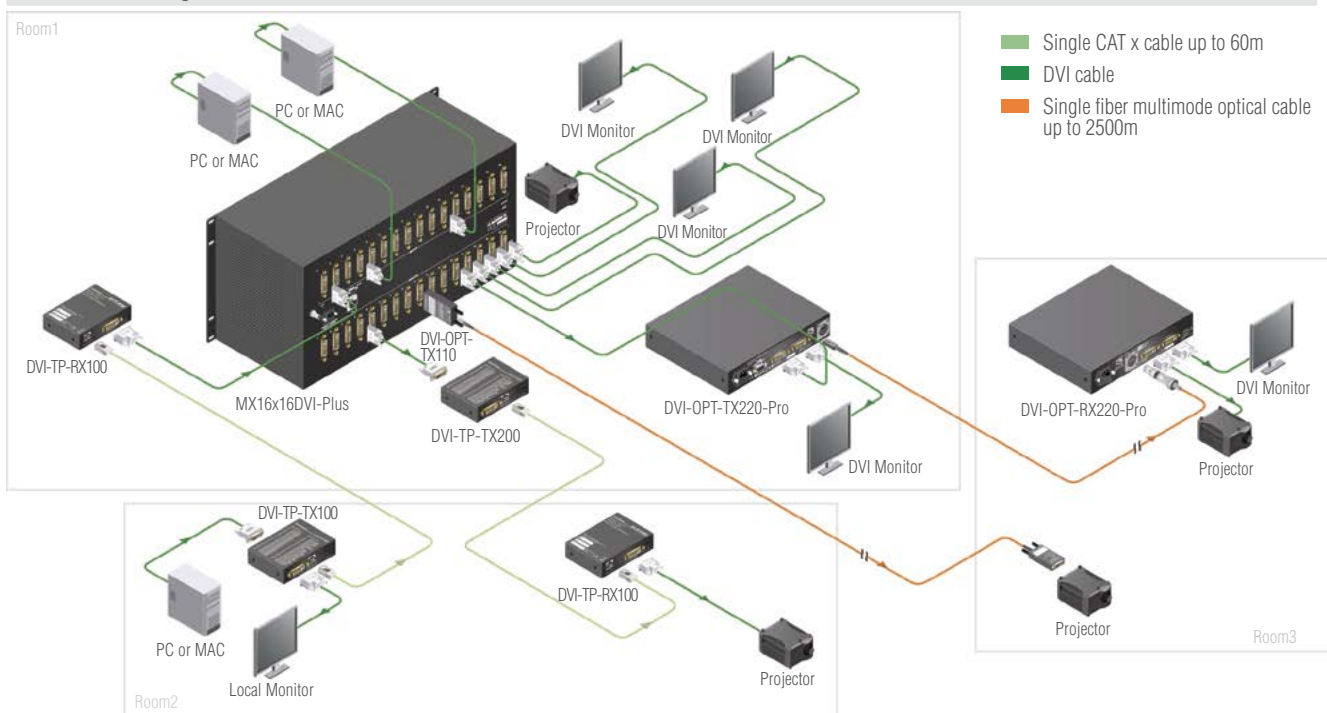

HYBRID MODULAR MATRIX SWITCHERS

The Standard for Variable Matrix Routers

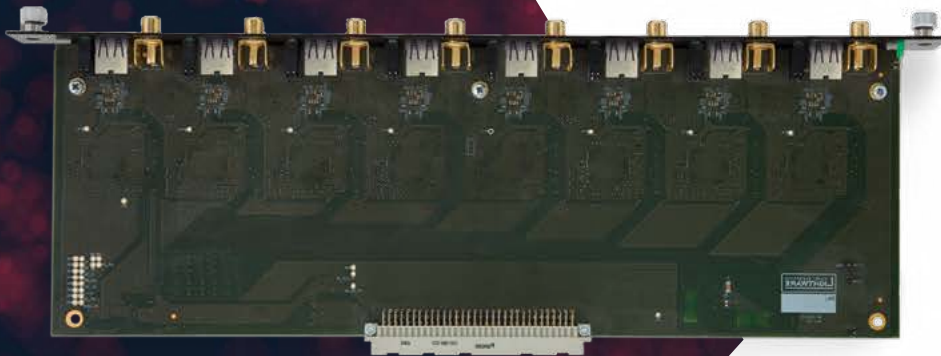

MX2M-Frames	70
▪ MX2M-FR24R Modular 24x24 HDMI 2.0 Matrix Switcher	70
Input Boards	72
▪ MX2M-4HDMI20-IB HDMI 2.0 Input Board	72
▪ MX2M-40PTJ-IB HDMI 2.0 Multimode Fiber Input Board	72
Output Boards	73
▪ MX2M-4HDMI20-OB HDMI 2.0 Output Board	73
▪ MX2M-40PTJ-OB HDMI 2.0 Multimode Fiber Output Board	73
Add-on I/O Boards	73
▪ MX2M-AUX-DANTE-32CH 2 x 16-channel Dante I/O Board	73

MX-Frames	74
▪ MX-CPU2 Processor board for modular matrix frames	75
▪ MX-RCP16 and MXRCP32 Remote control panels for Lightware matrix switchers	75
▪ MX-FR9 9x9 digital crosspoint router frame with built-in control panel and CPU2	76
▪ MX-FR9R 9x9 digital crosspoint router frame with redundant power supplies, built-in control panel and CPU2	76
▪ MX-FR17 17x17 digital crosspoint router frame with built-in control panel and CPU2	76
▪ MX-FR17R 17x17 digital crosspoint router frame with redundant power supplies, built-in control panel and CPU2	76
▪ MX-FR33L 33x33 digital crosspoint router frame with built-in control panel and CPU2	76
▪ MX-FR33R 33x33 digital crosspoint router frame with redundant power supplies, built-in control panel and CPU2	76
▪ MX-FR65R 65x65 digital crosspoint router frame with redundant power supplies, built-in control panel and CPU2	76
▪ MX-FR80R 80x80 digital crosspoint router frame with redundant power supplies, built-in control panel and CPU2	76
Input Boards	78
▪ MX-DVIDL-IB Dual-Link DVI digital only input board with DVI-I connectors	78
▪ MX-3GSDI-IB 3G-SDI input board supporting SDI embedded, S/PDIF and AES/EBU audio	78
▪ MX-HDMI-3D-IB HDMI input board including 4K, 3D and Deep Color	79
▪ MX-HDMI-3D-IB-A HDMI input board including 4K, 3D and Deep Color, with Phoenix connectors	79
▪ MX-HDMI-3D-IB-S HDMI input board including 4K, 3D and Deep Color, with S/PDIF connectors	79
▪ MX-DVI-4K-IB 4K, 3D and DVI Input Board	79
▪ MX-4TPS2-4HDMI-IB TPS-HDMI input board	80
▪ MX-4TPS2-4HDMI-IB-A TPS-HDMI input board with analog audio	80
▪ MX-4TPS2-4HDMI-IB-S TPS-HDMI input board with digital audio	80
▪ MX-4TPS2-4HDMI-IB-P TPS-HDMI input board with PoE	80
▪ MX-4TPS2-4HDMI-IB-AP TPS-HDMI input board with PoE and analog audio	80
▪ MX-4TPS2-4HDMI-IB-SP TPS-HDMI input board with PoE and digital audio	80
▪ MX-TPS-IB TPS input board	81
▪ MX-TPS-IB-A TPS input board with analog audio	81
▪ MX-TPS-IB-S TPS input board with digital audio	81
▪ MX-TPS2-IB-P TPS input board for HDMI, Ethernet, audio and control, with optional PoE	82
▪ MX-TPS2-IB-AP TPS input board for HDMI, Ethernet, audio and control, with optional PoE and analog audio	82
▪ MX-TPS2-IB-SP TPS input board for HDMI, Ethernet, audio and control, with optional PoE and digital audio	82
▪ MX-DVI-OPT-IB-LC Fiber optical input board for Single-Link DVI-D signal extension, with LC connectors	83
▪ MX-DVI-OPT-IB-NT Fiber optical input board for Single-Link DVI-D signal extension, with Neutrik OpticalCON connectors	83
▪ MX-DVI-OPT-IB-SC Fiber optical input board for Single-Link DVI-D signal extension, with SC connectors	83
▪ MX-DVI-OPT-IB-ST Fiber optical input board for Single-Link DVI-D signal extension, with ST connectors	83
▪ MX-DVIDL-OPT-IB-LC Dual-Link DVI fiber optical input board, with LC connectors	83
▪ MX-DVIDL-OPT-IB-NT Dual-Link DVI fiber optical input board, with Neutrik OpticalCON connectors	83
▪ MX-HDMI-OPT-IB-LC HDMI and HDCP compliant fiber optical input board including 4K, 3D, with LC connectors	84
▪ MX-HDMI-OPT-IB-NT HDMI and HDCP compliant fiber optical input board including 4K, 3D, with Neutrik OpticalCON connectors	84
▪ MX-HDMI-OPT-IB-SC HDMI and HDCP compliant fiber optical input board including 4K, 3D, with SC connectors	84

Output Boards	85
■ MX-HDMI-3D-OB	HDMI output board including 4K, 3D and Deep Color 85
■ MX-HDMI-3D-OB-A	HDMI output board including 4K, 3D and Deep Color, with Phoenix connectors 85
■ MX-HDMI-3D-OB-S	HDMI output board including 4K, 3D and Deep Color, with S/PDIF connectors..... 85
■ MX-DVI-4K-OB	4K, 3D and DVI Output Board..... 85
■ MX-4TPS2-4HDMI-OB	TPS and HDMI Output board for Ethernet, audio and Control 87
■ MX-4TPS2-4HDMI-OB-A	TPS and HDMI Output board for Ethernet, audio and Control 87
■ MX-4TPS2-4HDMI-OB-S	TPS and HDMI Output board for Ethernet, audio and Control 87
■ MX-4TPS2-4HDMI-OB-P	TPS and HDMI Output board for Ethernet, audio and Control 87
■ MX-4TPS2-4HDMI-OB-AP	TPS and HDMI Output board for Ethernet, audio and Control 87
■ MX-4TPS2-4HDMI-OB-SP	TPS and HDMI Output board for Ethernet, audio and Control 87
■ MX-TPS-OB	TPS output board for HDMI, Ethernet, audio and control 88
■ MX-TPS-OB-A	TPS output board for HDMI, Ethernet, audio and control with analog audio..... 88
■ MX-TPS-OB-S	TPS output board for HDMI, Ethernet, audio and control with digital audio 88
■ MX-TPS2-OB-P	TPS output board with PoE option 89
■ MX-TPS2-OB-AP	TPS output board with PoE option 89
■ MX-TPS2-OB-SP	TPS output board with PoE option 89
■ MX-AUDIO-OB-A	Analog audio output board..... 90
■ MX-DVIDL-OB	Dual-Link DVI digital only output board with DVI-I connectors..... 90
■ MX-DVI-OPT-OB-R-LC	Fiber optical output board with Pixel Accurate Reclocking, with LC connectors..... 90
■ MX-DVI-OPT-OB-R-NT	Fiber optical output board with Pixel Accurate Reclocking, with Neutrik OpticalCON connectors..... 90
■ MX-DVI-OPT-OB-R-SC	Fiber optical output board with Pixel Accurate Reclocking, with SC connectors..... 90
■ MX-DVI-OPT-OB-R-ST	Fiber optical output board with Pixel Accurate Reclocking, with ST connectors 90
■ MX-DVIDL-OPT-OB-LC	Dual-Link DVI fiber optical output board, with LC connectors..... 91
■ MX-DVIDL-OPT-OB-NT	Dual-Link DVI fiber optical output board, with Neutrik OpticalCON connectors 91
■ MX-HDMI-OPT-OB-R-LC	HDMI optical output board with Pixel Accurate Reclocking including 4K, 3D and Deep Color with LC connectors..... 91
■ MX-HDMI-OPT-OB-R-NT	HDMI optical output board with Pixel Accurate Reclocking including 4K, 3D and Deep Color with NT connectors 91

MX2M

Series **Modular HDMI 2.0** Matrix Switcher **MX2M-FR24R**

Part no: 9112 0045

COMING SOON

Call sales for availability

MX2M-FR24R is a member of the **Lightware MX2 modular matrix switcher series**, supporting uncompromised **4K UHD resolution at 60Hz with 4:4:4** sampling pattern and with downconversion capabilities to 4:2:2, supporting **HDCP 2.3 and 1.x, 3D, Dolby TrueHD and DTS-HD Master Audio**. The non-blocking matrix architecture distributes and switches 24 video signals to 24 outputs, distributed along six 4-port boards respectively per direction.

This versatile and **customizable device is suitable for various types of applications**, the actual application determining the choice of input and output boards to be included in the frame. It is a perfect choice for installations where a huge number of HDMI 2.0 compliant and other types of input and output video ports are required, **including HDMI 2.0, DisplayPort 1.2, CATx extension and compressed AV-Over-IP standards**, as well as extension through fibre.

Besides the six 4-port input and six 4-port output video boards, there are four low speed **installable slots for Dante, ADC and DAC audio input and output boards, GPIO, USB and other connectivity options**.

Control for connected extenders is served **by Ethernet layer**. The Ethernet layer can also be used for IP extension, as well as for command injection for IR and serial control by third party devices.

For operation **safety power redundancy is available**, and PSU drawers are field-exchangeable for ease of maintenance. The device also supports various **IT security standards**.

Features

- Non-blocking matrix architecture to distribute and switch 24 uncompressed 4K@60Hz 4:4:4 input video signals to 24 outputs
- HDCP 1.4 and 2.3 support
- Flexible design with support for hot-swappable I/O boards
- Six slots for 4-port video input boards, six slots for 4-port video output boards and additional four slots for I/O boards audio and GPIO connectors
- Audio layer for independent audio routing of uncompressed (e.g. 7.1 LPCM) and compressed audio
- Audio signals received and extracted by the video I/O boards or via audio I/O boards
- Ethernet layer for IP extension to extenders
- Command injection for IR and serial control of third-party devices
- Interface I/O boards can be placed in video input and output slots
- Front to back cooling
- LCD, jog dial, and push buttons for front panel operation
- Internal power distribution system for video I/O boards with PoE PSE feature and for future high power consumption I/O boards
- Optional AC line redundancy for protection against AC line power outage
- Field replaceable PSU drawers for ease of maintenance
- IT security features e.g. LDAP and AD integration, SSH, HTTPS for control, etc.
- Embedded web and Lightware Device Controller support for control
- Open LW3 control API for integration with third-party controller systems
- Connectivity for breakout boxes that can accommodate additional Interface I/O boards



Event Venue Application

MX2M-FR24 HDMI 2.0 Modular Matrix Switcher with 24x24 Size Matrix Frame

- USB
- HDMI
- CATx
- Optical Fiber
- Analog Audio

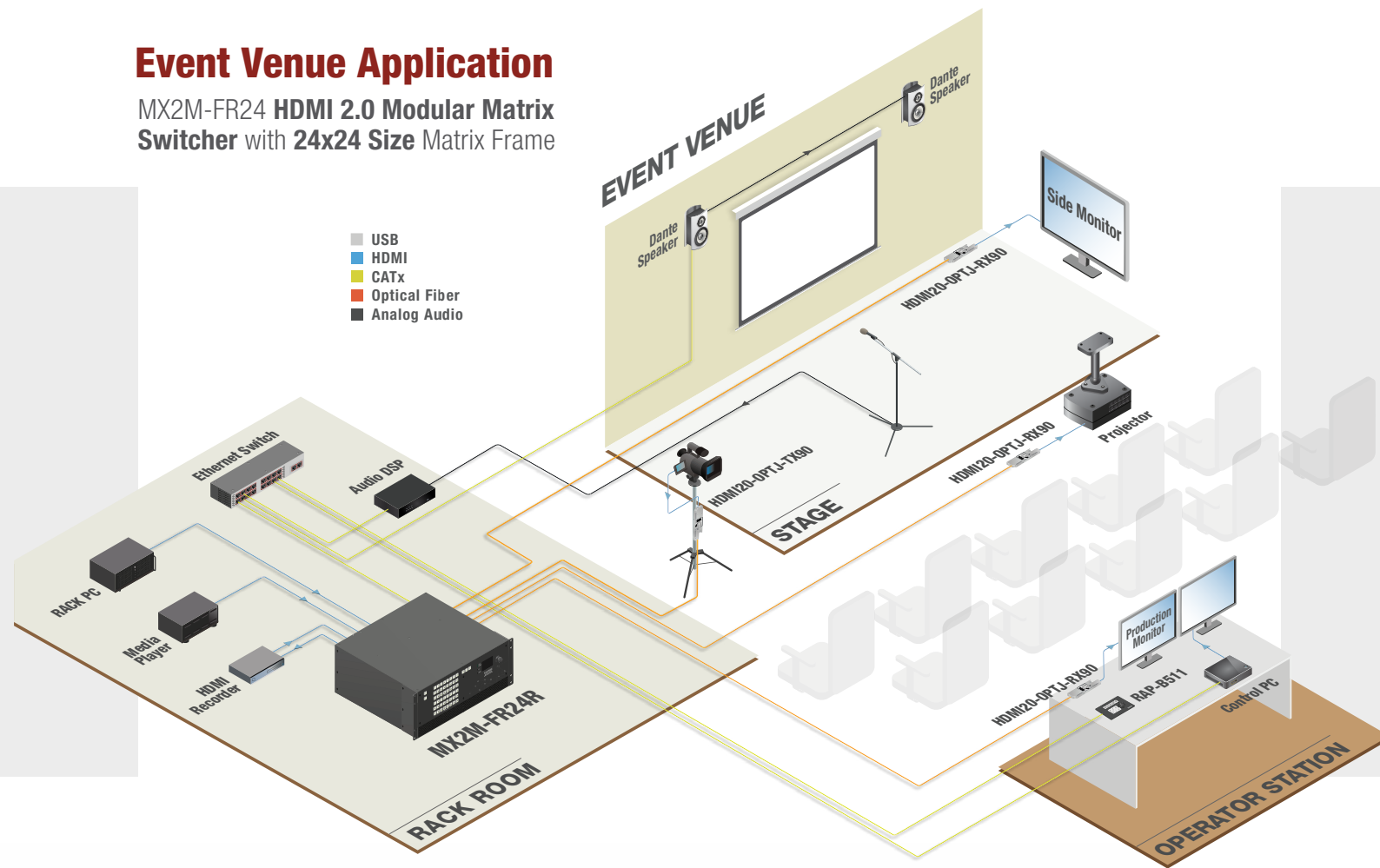

MX2M I/O Cards

S E R I E S for MX2M Modular Matrix switchers

COMING SOON
Call sales for availability 

HDMI 2.0 Input Board

MX2M-4HDMI20-IB Part no: 9112 0045



MX2M-4HDMI20-IB is a HDMI 2.0 compatible input board for the MX2M modular matrix family. The hot-swappable input board has four HDMI connectors of type A, all with flange. All inputs are HDMI 2.0 compliant and can pass HDMI signals with a pixel clock frequency of up to 597 MHz. Advanced professional features of the board include HDCP enable/disable mode, support for signals with high dynamic range or unusual dimensions, EDID management, and Frame detector.

The board extracts the audio from all four incoming HDMI signals to the Audio layer, through which the audio streams can be routed to any of the video or audio output ports.

- HDMI 2.0, HDMI 1.x, and DVI compatible
- Resolutions up to UHD/4k@60Hz 4:4:4
- Uncompressed video up to 18 Gbps
- No signal latency, zero frame delay
- HDCP 2.3 and HDCP 1.4 support
- Support for HDR10, Dolby Vision, HLG
- Deep color support
- 3D signal support
- Hot-swap support
- Advanced EDID management
- DisplayID support for forcing extreme formats (e.g. 7kx1k@60Hz 4:4:4) from the connected source
- CEC support with command injection
- Pass-through and de-embedding of HDMI 2.0 audio including uncompressed (LPCM, DSD), compressed (MPEG 1 L1, MPEG 1 L2, MPEG 1 L3, AC-3, Dolby Digital, Dolby Digital Plus, Dolby Digital EX, Dolby Digital Surround EX, DTS, DTS ES) and compressed HBR (Dolby Atmos, Dolby TrueHD, DTS-HD DA) formats

HDMI 2.0 Multimode Fiber Input Board

MX2M-4OPTJ-IB Part no: 9112 0047



MX2M-4OPTJ-IB is a HDMI 2.0 compatible input board for the MX2M modular matrix family. The hot-swappable input board has four ports with optical SC connectors that can be connected to HDMI2-OPTJ-TX90 extenders. All inputs are HDMI 2.0 compliant and can pass HDMI signals with a pixel clock frequency of up to 597 MHz. Advanced professional features of the board include HDCP enable/disable mode, support for signals with high dynamic range or unusual dimensions, EDID management, and Frame detector.

The board extracts the audio from all four incoming HDMI signals to the Audio layer, through which the audio streams can be routed to any of the video or audio output ports.

- HDMI 2.0, HDMI 1.x, and DVI compatible
- Extension distance of up to 600 meters for 4k@60Hz 4:4:4 signals and 2500 meters for full HD signals
- Resolutions up to UHD/4k@60Hz 4:4:4
- Uncompressed video up to 18 Gbps
- No signal latency, zero frame delay
- HDCP 2.3 and HDCP 1.4 support
- Support for HDR10, Dolby Vision, HLG
- Deep color support
- 3D signal support
- Hot-swap support
- Advanced EDID management
- DisplayID support for forcing extreme formats (e.g. 7kx1k@60Hz 4:4:4) from the connected source
- CEC support with command injection
- Pass-through and de-embedding of HDMI 2.0 audio including uncompressed (LPCM, DSD), compressed (MPEG 1 L1, MPEG 1 L2, MPEG 1 L3, AC-3, Dolby Digital, Dolby Digital Plus, Dolby Digital EX, Dolby Digital Surround EX, DTS, DTS ES) and compressed HBR (Dolby Atmos, Dolby TrueHD, DTS-HD DA) formats

HDMI 2.0 Output Board

MX2M-4HDMI20-OB Part no: 9113 0053



MX2M-4HDMI20-OB is a HDMI 2.0 compliant output board for the MX2M modular matrix family. The hot-swappable output board has four HDMI connectors of type A, all with flange. All outputs are HDMI 2.0 compliant and can pass HDMI signals with a pixel clock frequency of up to 597 MHz. Advanced professional features of the board include HDCP conversion, support for signals with high dynamic range or unusual dimensions, EDID management, and chroma subsampling from 4:4:4 to 4:2:2.

The board can replace the audio in all four routed HDMI signals with compressed or LPCM audio streams from the Audio layer.

- HDMI 2.0, HDMI 1.x, and DVI compliant
- Extension distance of up to 600 meters for 4k@60Hz 4:4:4 signals and 2500 meters for full HD signals
- Resolutions up to UHD/4k@60Hz 4:4:4
- Uncompressed video up to 18 Gbps
- No signal latency, zero frame delay
- HDCP 2.3 and HDCP 1.4 support with cross conversion capabilities
- Support for HDR10, Dolby Vision, HLG
- Deep color support
- Hot-swap support
- 3D signal support
- Advanced EDID management
- DisplayID support
- Chroma sub-sampling from 4:4:4 to 4:2:2
- CEC support with command injection
- Pass-through and of all HDMI 2.0 audio formats
- Embedding of uncompressed (LPCM) and compressed (MPEG 1 L1, MPEG 1 L2, MPEG 1 L3, AC-3, Dolby Digital, Dolby Digital Plus, Dolby Digital EX, Dolby Digital Surround EX, DTS, DTS ES) formats

HDMI 2.0 Multimode Fiber Output Board

MX2M-4OPTJ-OB Part no: 9113 0054



MX2M-4OPTJ-OB is a HDMI 2.0 compliant output board for the MX2M modular matrix family. The hot-swappable output board has four ports with optical SC connectors that can be connected to HDMI20-OPTJ-RX90 extenders. All outputs are HDMI 2.0 compliant and can pass HDMI signals with a pixel clock frequency of up to 597 MHz. Advanced professional features of the board include HDCP conversion, support for signals with high dynamic range or unusual dimensions, EDID management, and chroma subsampling from 4:4:4 to 4:2:2.

The board can replace the audio in all four routed HDMI signals with compressed or LPCM audio streams from the Audio layer.

- HDMI 2.0, HDMI 1.x, and DVI compliant
- Extension distance of up to 600 meters for 4k@60Hz 4:4:4 signals and 2500 meters for full HD signals
- Resolutions up to UHD/4k@60Hz 4:4:4
- Uncompressed video up to 18 Gbps
- No signal latency, zero frame delay
- HDCP 2.3 and HDCP 1.4 support with cross conversion capabilities
- Support for HDR10, Dolby Vision, HLG
- Deep color support
- Hot-swap support
- 3D signal support
- Advanced EDID management
- DisplayID support
- Chroma sub-sampling from 4:4:4 to 4:2:2
- CEC support with command injection
- Pass-through and of all HDMI 2.0 audio formats
- Embedding of uncompressed (LPCM) and compressed (MPEG 1 L1, MPEG 1 L2, MPEG 1 L3, AC-3, Dolby Digital, Dolby Digital Plus, Dolby Digital EX, Dolby Digital Surround EX, DTS, DTS ES) formats

2 x 16-channel Dante I/O Board

MX2M-AUX-DANTE-32CH Part no: 9112 0046



MX2M-AUX-DANTE-32CH is a Dante and AES67 compatible input and output board for the MX2M modular matrix family. The hot-swappable IO board is seen as two distinct Dante devices from the Dante network. Each Dante device can simultaneously send and receive 16 mono audio channels from the Dante network it is connected to via its 1GbE connectors. This makes the board capable of sending and receiving 2 x 16 mono audio channels from the same or different Dante domains with the same or different sampling frequencies.

The received audio is made available to all video and audio outputs over the Audio layer of the matrix as LPCM audio streams. Similarly,

the audio sent to the Dante network can originate from any of the video or audio inputs of the matrix carrying LPCM audio.

The board supports redundant operation mode where the same stream is received or transmitted over a Primary and a Secondary Ethernet connector.

- Dante Audio over IP and AES67 RTP compliant
- Seen as two Dante devices
- Simultaneous transmission and reception of 2 x 16 mono audio channels
- The two Dante devices can be connected to the same or different Dante domains
- Redundant operation with distinct Primary and Secondary 1GbE connectors for each Dante device
- In-built high-quality ASRC for sampling frequency conversion (from 24-192 kHz to 44.1-96 kHz)
- LPCM audio support
- Hot-swap support

Matrix Switcher Frames

The MX series matrix routers are the highest performance, modular expandable DVI and HDMI compliant switchers, available in five different frame sizes.

The built-in sophisticated software and hardware features make these routers the most flexible integrated solution for AV professionals and high-end home theatre applications.



Non-Blocking Topology:

Any input can be tied to any one or more outputs without limitations. One source can be viewed on multiple destinations at the same time. Crosspoint switching is done instantly without frame delay or frame latency. Different frame sizes are available from 9x9 up to 80x80 allowing the building of custom I/O sized matrix switchers.

Hybrid Modular Architecture:

Lightware's Hybrid Modular matrix switchers have various input and output interface boards, which can be mixed in the same frame without limitation. The hybrid architecture allows for routing signals between the boards even if they have different type of interfaces (DVI, HDMI, fiber optical, or CATx twisted pair). A wide range of compatible extender devices is available for all interface boards.

Cross-Platform Signal Routing:

DVI, HDMI, analog VGA, SDI, HD-SDI, 3G-SDI, S/PDIF and analog stereo audio signals are handled in the same frame without routing limitations.

MX Series Frame Features:

- Equipped with MX-CPU2 processor board
- Additional I/O ports accessible on MX-CPU2 processor board
- Dual-Link DVI compatible
(one Dual-Link port uses two Single-Link ports)
- Compatible with all MX- and MXD- I/O boards
- Provide Ethernet and RS-232 extension to the endpoints
- Frame Detector for input signal analysis on any port
- Multiple TCP/IP connection
- Non-blocking topology
- Advanced error handling and logging with time code
- Combine non-HDCP and HDCP capable I/O boards in the same frame
- Advanced EDID Management
- Intuitive control software
- HDCP compliant
- Simultaneous control over several interfaces
- Optional redundant power supplies
- Hybrid Modular and Cross Platform technology
- Full crosspoint configuration save and reload as preset (32 presets)

Control Options:

- Front panel buttons and 4 line LCD menu
- RS-232
- TCP/IP Ethernet (multiple connections)
- Built-in website (multiple access)
- Front panel USB
- Christie (ex-Vista) Spyder and Barco Encore compatible

Processor Board

MX-CPU2

Part No: 9111 0008

MX-CPU2 contains an additional input and output port that fully support DVI and 3D HDMI signals with or without HDCP encryption. The test input and preview output ports turn an existing 16x16 matrix to a 17x17, an existing 32x32 to a 33x33.



Remote Control Panels (RCP)

MX-RCP16 and MX-RCP32

Part No: 9111 0009 (RCP16), 9111 0010 (RCP32)

Features:

- Remote access to matrix switchers
- Setup and programming through Ethernet connection
- 10/100 Ethernet connection
- Programmable Preset and Salvo functions
- 16+16 and 32+32 button versions
- XY control possibility

Lightware MX-RCP16 and MX-RCP32 are remote control panels for controlling Lightware matrix routers remotely through LAN connection. The RCPs can be used just like the front panel buttons on matrix routers to make crosspoint changes, or they can be programmed for special functions like salvo mode or universal device control.

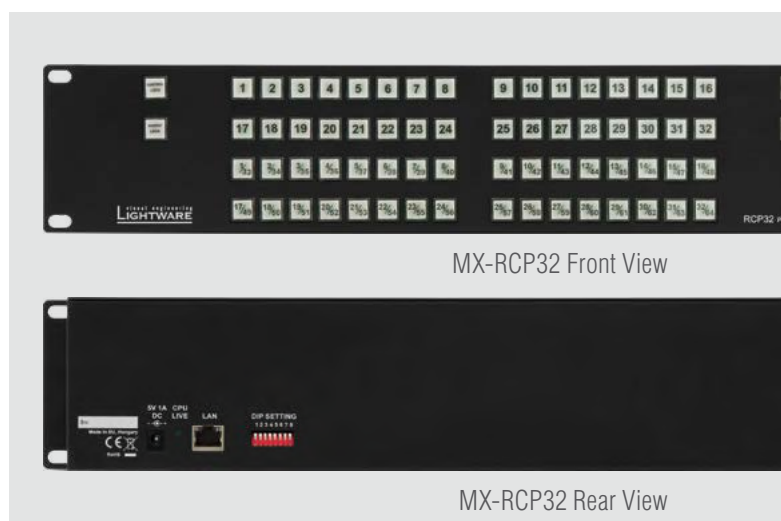

Available MX Frames Sizes and Specifications:

	MX-FR80R	MX-FR65R	MX-FR33R	MX-FR33L	MX-FR17	MX-FR17R	MX-FR9	MX-FR9R
Part number	9111 0006	9111 0005	9111 0004	9111 0003	9111 0002	9111 0020	9111 0001	9111 0019
Equipped with MX-CPU2 processor board	✓	✓	✓	✓	✓	✓	✓	✓
I/O board slots	10 in, 10 out	8 in, 8 out	4 in, 4 out	4 in, 4 out	2 in, 2 out	2 in, 2 out	1 in, 1 out	1 in, 1 out
Additional I/O ports accessible on MX-CPU2	✓	✓	✓	✓	✓	✓	✓	✓
Custom I/O sizes (Crosspoint size)	from 9x9 to 80x80	from 9x9 to 65x65	from 9x9 to 33x33	from 9x9 to 33x33	from 9x9 to 17x17	from 9x9 to 17x17	9x9	9x9
Dual-Link DVI compatible (Dual-Link crosspoint size)	from 4x4 to 40x40	from 4x4 to 32x32	from 4x4 to 16x16	from 4x4 to 16x16	from 4x4 to 8x8	from 4x4 to 8x8	4x4	4x4
Rack height	15U	15U	7U	6U	4U	4U	4U	4U
Redundant high reliability power supplies	✓	✓	✓	✗	✗	✓	✗	✓
Number of power supplies	3	2	2	1	1	1	1	1
Power supply hot swappable	✓	✓	✓	✗	✗	✗	✗	✗
Power consumption ¹	114 W	114 W	27 W	26 W	19 W	19 W	19 W	19 W
Heat dissipation (BTU) ¹	389	389	92	89	65	65	65	65
Cooling (forced convection) 120 mm fans	10	10	4	2	2	2	2	2
Dimensions with rack mounting ears:	482 W x 665 H x 392 D mm	482 W x 665 H x 392 D mm	482 W x 309,5 H x 400 D mm	482 W x 265,5 H x 300 D mm	482 W x 176,5 H x 300 D mm	482 W x 176,5 H x 300 D mm	482 W x 176,5 H x 300 D mm	482 W x 176,5 H x 300 D mm
Dimensions without rack mounting ears:	440 W x 665 H x 392 D mm	440 W x 665 H x 392 D mm	440 W x 309,5 H x 400 D mm	440 W x 265,5 H x 300 D mm	440 W x 176,5 H x 300 D mm	440 W x 176,5 H x 300 D mm	440 W x 176,5 H x 300 D mm	440 W x 176,5 H x 300 D mm
Net weight ²	26,7 kg	25,4 kg	14,0 kg	13,3 kg	12,1 kg	11,3 kg	9,8 kg	11,7 kg

¹ with CPU2 board and without I/O boards

² with CPU2 board, power supplies and without I/O boards

Specifications for All Frames:

Video data rate:	12.8 Gbps
EDID memory:	100 factory preset and 50 user programmable
EDID emulation:	256-Byte Extended EDID v1.3
Front panel buttons:	Yes
Front panel LCD:	Yes, 4 x 20 characters
RS-232:	Selectable (9600, 38400, 57600, 115200) Baud RX, TX (default: 57600)
LAN:	Ethernet 10Base-T or 100Base-TX (Auto-sensing)
WEB:	Built-in website
Temperature:	0°C to +50°C operational, -40°C to +70°C storage
Humidity:	10 to 90% non-condensing
Altitude:	2000 m operational
EMI/EMC compliance:	Yes, EN 55022 Class B
RoHS compliance:	Yes
Warranty:	3 years



MX-FR80R, MX-FR65R



MX-FR33R



MX-FR33L



MX-FR17



MX-FR9



MX-FR17R



MX-FR9R

Available Models, Rear Views

Limitless Variations:

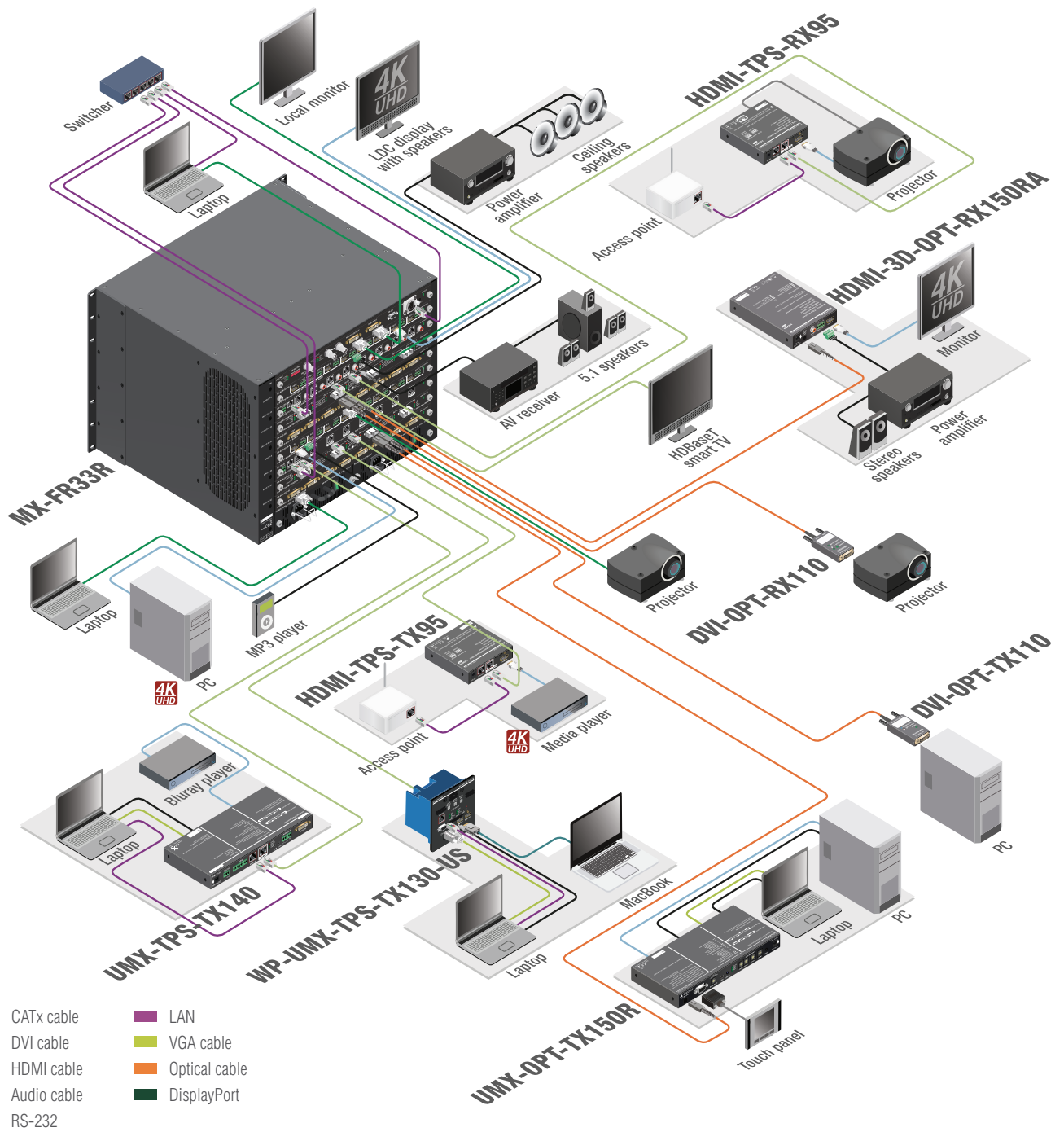

Available Models, Front Views



Dual-Link DVI Input Board

MX-DVIDL-IB

Part No: 9112 0005

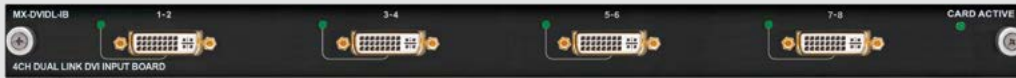

MX-DVIDL-IB is a four-channel Dual-Link DVI Input Board.

Features:

- 4 gold plated DVI connectors
- Pro series Dual-Link DVI input board
- 60 m copper cable equalization - adaptive or manual mode
- Advanced EDID Management
- Designed for high video resolutions of 2560 x 1600 or 4096 x 2400 as well as 100 or 120 Hz 3D signals

3G-SDI-Input Board

MX-3GSDI-IB

Part No: 9112 0010



The MX-3GSDI-IB input board allows 3G-SDI sources to be connected, routed and extended, brings your 3G-SDI sources to an HDMI, DVI routing system.

Features:

- 8 BNC and 8 RCA connectors
- Built-in 8 x SDI to HDMI converter
- Converts SDI, HD-SDI and 3G-SDI to DVI or HDMI
- SDI multichannel audio de-embedding
- Embeds multichannel SDI or external S/PDIF digital audio into the HDMI signal
- Auto-detects input formats
- Input cable equalization
- PLL Reclocking
- Supporting stereo PCM and 5.1 AC3 encoded formats

Port Diagram:

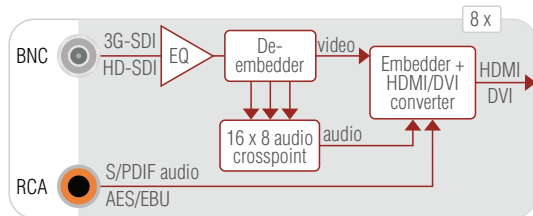

4K, 3D and Deep Color HDMI Input Board

MX-HDMI-3D-IB, -A, -S

Part no: 9112 0007, 9112 0008 (A), 9112 0009 (S)

MX-HDMI-3D-IB provides eight channel HDMI 1.4 extension with 4K resolution, 3D formats and local audio support.

Features:

- 8 HDMI input ports
- HDMI 1.4a; DVI and HDCP compliant
- For advanced audio optional 8 S/PDIF (S) or 8 stereo audio (A) connectors
- 4K / UHD (30Hz RGB 4:4:4, 60Hz YCbCr 4:2:0), 1080p @ 120 Hz, 2560 x 1600, 2048 x 2048, HDCP enable/disable mode, HD video resolutions and all 3D formats are supported
- Advanced EDID Management and Frame Detector
- Pixel Accurate Reclocking
- Dolby TrueHD and DTS-HD Master Audio
- 36-bit deep color support

With Digital S/PDIF Audio Add-On:

MX-HDMI-3D-IB-S

- S/PDIF breakout for every port
- Bi-directional configurable S/PDIF connectors: audio can be de-embedded from the HDMI signals or audio can be embedded (or replaced) to the HDMI signal
- S/PDIF can be sent over ARC back to the source device

With Analog Stereo Audio Add-On:

MX-HDMI-3D-IB-A

- Bi-directional configurable analog stereo port with 5-pole Phoenix connector
- Stereo PCM audio up to 96 kHz can be de-embedded from the HDMI signals
- Digitalized audio (PCM 48 kHz) can be embedded (or replaced) to the HDMI signal
- Volume, gain, balance, bass and treble control
- Phase invert and de-emphasis option

4K, 3D DVI and HDMI Compliant Input Board

MX-DVI-4K-IB

Part no: 9112 0044

MX-DVI-4K-IB provides eight channel HDMI 1.4 extension with 4K resolution and 3D formats.

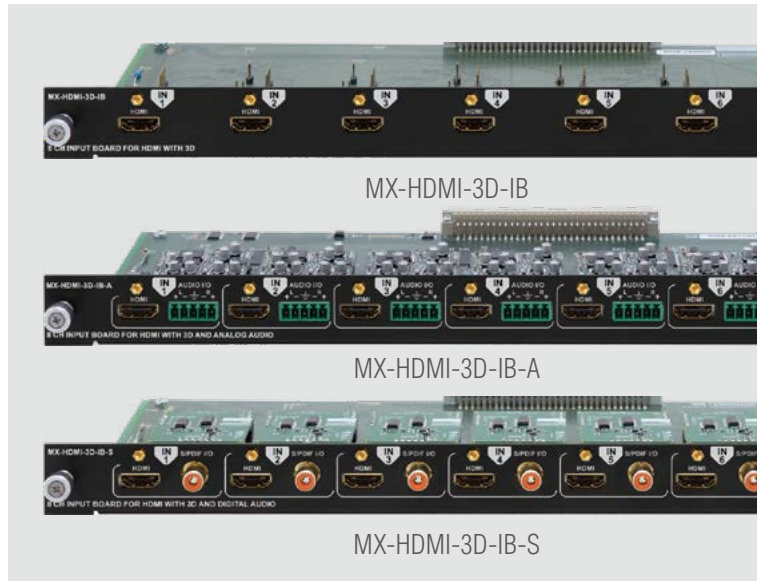

Port Diagrams:

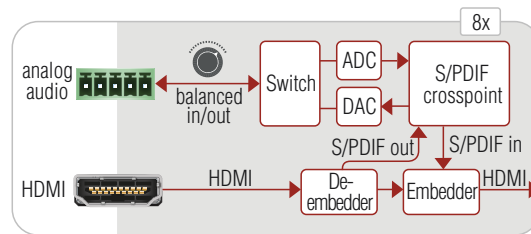

MX-HDMI-3D-IB-A

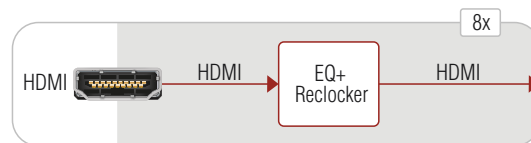

MX-HDMI-3D-IB

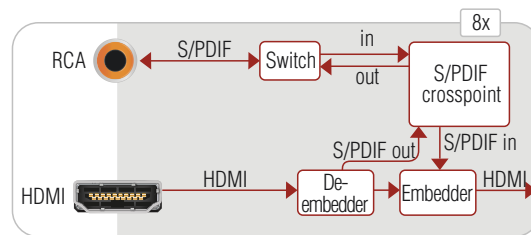

MX-HDMI-3D-IB-S

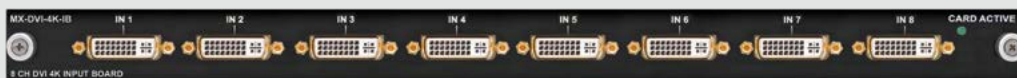

Features:

- 8 DVI input ports
- DVI and HDCP compliant
- 4K / UHD (30Hz RGB 4:4:4, 60Hz YCbCr 4:2:0), 1080p @ 120 Hz, 2560 x 1600, 2048 x 2048, HDCP enable/disable mode, HD video resolutions and all 3D formats are supported
- Advanced EDID Management and Frame Detector
- Pixel Accurate Reclocking
- 36-bit deep color support

TPS and HDMI Input Board for Ethernet, Audio and Control



MX-4TPS2-4HDMI-IB, -A, -S, -P, -AP, -SP

Part no: 9112 0041, 9112 0042 (A), 9112 0043 (S), 9112 0038 (AP), 9112 0039 (SP), 9112 0040 (P)



MX-4TPS2-4HDMI-IB

MX-4TPS2-4HDMI-IB is a mixed input board with four HDMI and four HDBaseT™ single CAT inputs providing HDMI 1.4, audio, Ethernet and RS-232 extension on a single CAT5/6/7 cable up to 120m in HDBaseT™ and 170m distance in Long reach mode.

Features:

- HDMI extension supporting 3D and 4K
- Accepts HDMI + Ethernet + RS-232 over one CAT5/6/7 cable up to 170m distance
- HDMI 1.4; DVI and HDCP compliant with or without HDCP
- 4K / UHD (30Hz RGB 4:4:4, 60Hz YCbCr 4:2:0), 1080p @ 120 Hz, 2560 x 1600, 2048 x 2048,
- 10/100 Ethernet transmission
- Supports all HDMI audio formats
- Pixel Accurate Reclocking
- Advanced EDID Management
- Frame Detector
- Compatible with deep color, Dolby TrueHD and DTS-HD audio

- Remote powering on/off switching
- Volume, gain, balance, bass and treble control
- Phase invert and de-emphasis option

Attention: The built-in PoE injector function requires the supplied PSU-48VP external power source to be connected directly to the board!

Product Name	Audio Add-on	PoE Add-on
MX-4TPS2-4HDMI-IB	none	none
MX-4TPS2-4HDMI-IB-A	analog	none
MX-4TPS2-4HDMI-IB-S	spdif	none
MX-4TPS2-4HDMI-IB-P	none	yes
MX-4TPS2-4HDMI-IB-AP	analog	yes
MX-4TPS2-4HDMI-IB-SP	spdif	yes

With Digital Audio and PoE Add-on



MX-4TPS2-4HDMI-IB-SP

- S/PDIF breakout for every port
- Bi-directional configurable S/PDIF connectors: audio can be de-embedded from the HDMI signals or audio can be embedded (or replaced) into the HDMI signal
- PoE compatible
- 48V remote powering
- Remote powering on/off switching
- Status feedback
- S/PDIF can be sent over ARC back to the source device

Attention: The built-in PoE injector function requires the supplied PSU-48VP external power source to be connected directly to the board!

With PoE Add-on



MX-4TPS2-4HDMI-IB-P

- PoE compatible
- 48V remote powering
- Remote powering on/off switching
- Status feedback

With Analog Audio Add-on



MX-4TPS2-4HDMI-IB-A

- Bi-directional configurable analog stereo ports with 5-pole Phoenix connector
- Stereo PCM audio up to 96 kHz can be de-embedded from the HDMI signals
- Digitalized audio (PCM 48 kHz) can be embedded (or replaced) into the HDMI signal
- Volume, gain, balance, bass and treble control
- Phase invert and de-emphasis option

With Analog Audio and PoE Add-on



MX-4TPS2-4HDMI-IB-AP

- Bi-directional configurable analog stereo ports with 5-pole Phoenix connector
- Stereo PCM audio up to 96 kHz can be de-embedded from the HDMI signals
- Digitalized audio (PCM 48 kHz) can be embedded (or replaced) into the HDMI signal
- PoE compatible
- 48V remote powering

With Digital Audio Add-on



MX-4TPS2-4HDMI-IB-S

- S/PDIF breakout for every port
- Bi-directional configurable S/PDIF connectors: audio can be de-embedded from the HDMI signals or audio can be embedded (or replaced) into the HDMI signal
- S/PDIF can be sent over ARC back to the source device

HDBaseT™ and the HDBaseT Alliance logo are trademarks of the HDBaseT Alliance

TPS Input Board for HDMI, Ethernet, Audio and Control



MX-TPS-IB, -A, -S

Part No: 9112 0027, 9112 0028 (A), 9112 0029 (S),

MX-TPS-IB Input Board is a long distance single CAT HDBaseT™ solution with localized audio embedding and de-embedding points.

Features:

- 8 channel twisted pair input board
- HDMI extension supporting 3D and 4K
- Accepts HDMI + Ethernet + RS-232 over one CAT5/6/7 cable up to 170m distance
- HDMI 1.4; DVI with or without HDCP
- 4K / UHD (30Hz RGB 4:4:4, 60Hz YCbCr 4:2:0), UHD, 2560 x 1600, HD video resolutions and all 3D formats are supported
- 10/100 Ethernet transmission
- Supports all HDMI audio formats
- Compatible with deep color, Dolby TrueHD and DTS-HD audio
- Features PCM audio sample rate conversion
- Pixel Accurate Reclocking, Advanced EDID Management and Frame Detector

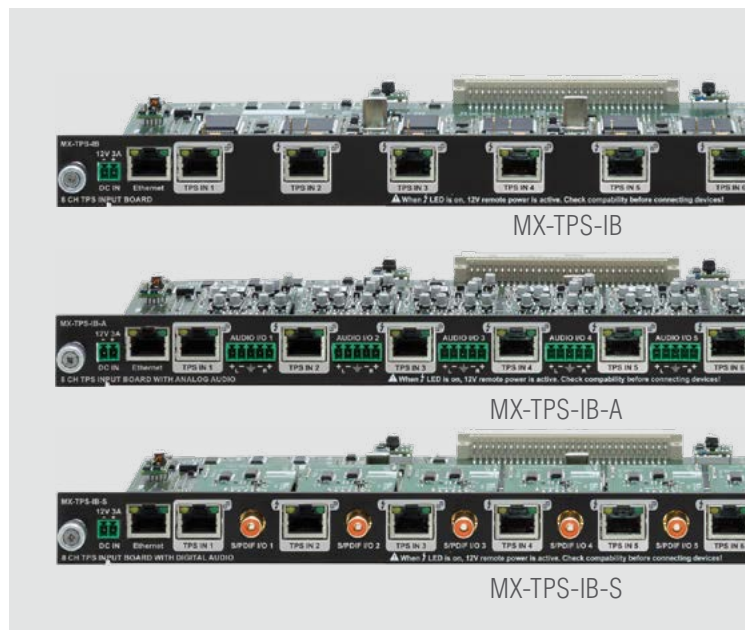

With Digital S/PDIF Audio Add-On

MX-TPS-IB-S

- S/PDIF breakout for every port
- Bi-directional configurable S/PDIF connectors: audio can be de-embedded from the HDMI signals or audio can be embedded (or replaced) to the HDMI signal

With Analog Stereo Audio Add-On

MX-TPS-IB-A

- Bi-directional configurable analog stereo port with 5-pole Phoenix connector
- Stereo PCM audio up to 96 kHz can be de-embedded from the HDMI signals
- Digitalized audio (PCM 48 kHz) can be embedded (or replaced) to the HDMI signal
- Volume, gain, balance, bass and treble control
- Phase invert and de-emphasis option

Port Diagrams:

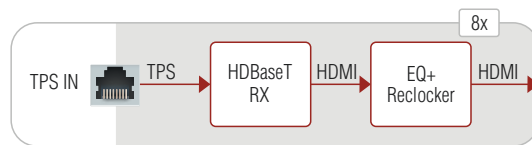

MX-TPS-IB

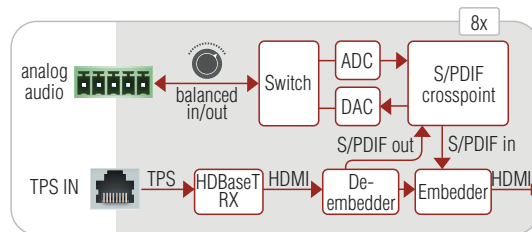

MX-TPS-IB-A

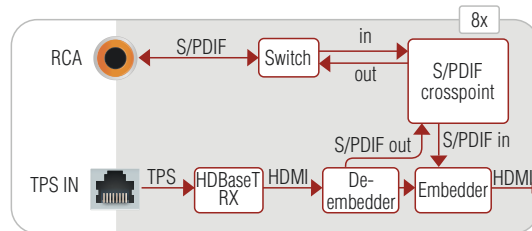

MX-TPS-IB-S

Available Video Patterns:

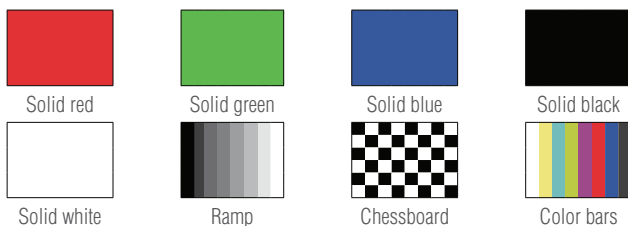

Test Pattern Generator Video Formats:
480p, 576p, 720p, 1080p, 1080p deep color

HDBaseT™ and the HDBaseT Alliance logo are trademarks of the HDBaseT Alliance

Supplied Accessory Required for Remote Powering:



Part No: 9134 0007
Power adaptor with IEC plug.
Power supply for 12V remote powering function.
Universal input: 100-240 V AC, 50-60 Hz.
Output: 12 V DC, 6,67 A.

TPS Input Board with PoE

MX-TPS2-IB-P, -AP, -SP

Part No: 9112 0035 (P), 9112 0036 (AP), 9112 0037 (SP),

MX-TPS2-IB is an eight channel HDMI and single CAT HDBaseT™ Input Board providing HDMI 1.4, audio, Ethernet and RS-232 extension on a single CAT5/6/7 cable up to a 100m in HDBaseT™ and a 170m distance in Long Reach Mode.

Features:

- HDMI extension supporting 3D and 4K
- Accepts HDMI + Ethernet + RS-232 over one CAT5/6/7 cable up to 170m distance
- HDMI 1.4; DVI with or without HDCP
- 4K / UHD (30Hz RGB 4:4:4, 60Hz YCbCr 4:2:0), 2560 x 1600, HD video resolutions and all 3D formats are supported
- 10/100 Ethernet transmission
- Supports all HDMI audio formats
- Digital or analog audio add-on option
- Adjustable analog audio settings
- Integrated PoE power injection option for TPS extenders
- Pixel Accurate Reclocking, Advanced EDID Management and Frame Detector
- Compatible with deep color, Dolby TrueHD and DTS-HD audio
- Features PCM audio sample rate conversion

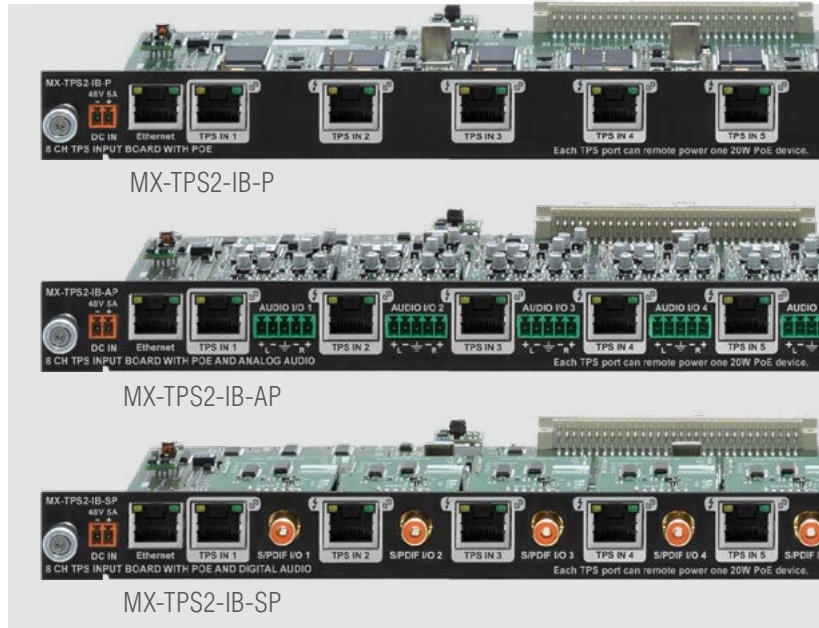

Product Name	Audio Add-on	PoE Add-on
MX-TPS2-IB-P	none	yes
MX-TPS2-IB-AP	analog	yes
MX-TPS2-IB-SP	spdif	yes

With Analog Audio Add-On

MX-TPS2-IB-AP

- Bi-directional configurable analog stereo port with 5-pole Phoenix connector
- Stereo PCM audio up to 96 kHz can be de-embedded from the HDMI signals
- Digitalized audio (PCM 48 kHz) can be embedded (or replaced) to the HDMI signal
- Volume, gain control

With Digital Audio Add-On

MX-TPS2-IB-SP

- S/PDIF breakout for every port
- Bi-directional configurable S/PDIF connectors: audio can be de-embedded from the HDMI signals or audio can be embedded (or replaced) to the HDMI signal
- PoE compatible
- 48V remote powering
- Remote powering on/off switching
- Status feedback

Supplied Accessory Required for the PoE Function



Part No: 9134 0015
Power adaptor with IEC plug. Power supply for PoE 48V remote powering function.
Universal input: 100-240 V AC, 50-60 Hz.
Output: 48 V DC, 5.84 A.

Port Diagrams:

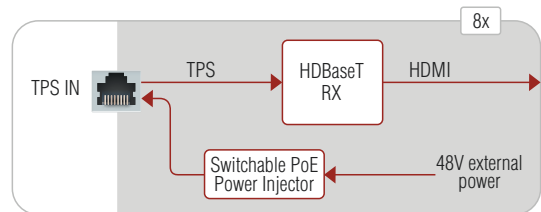

MX-TPS2-IB-P

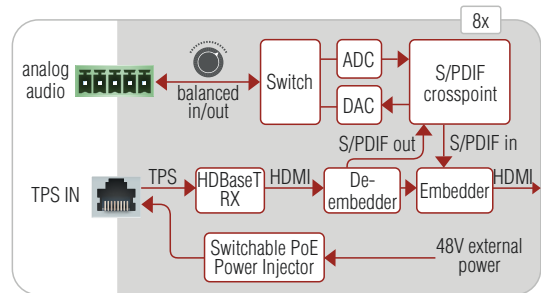

MX-TPS2-IB-AP

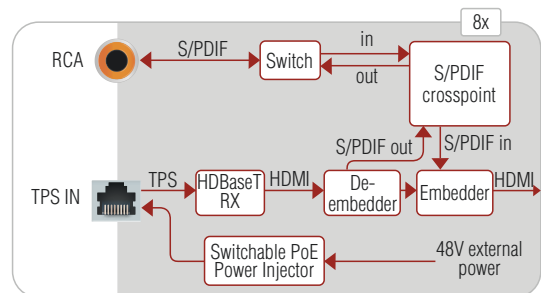

MX-TPS2-IB-SP

Fiber Optical Single-Link DVI Input Board

MX-DVI-OPT-IB -LC, -NT, -SC, -ST

Part no: 9112 0015 (LC), 9112 0016 (ST), 9112 0017 (SC), 9112 0018 (NT)

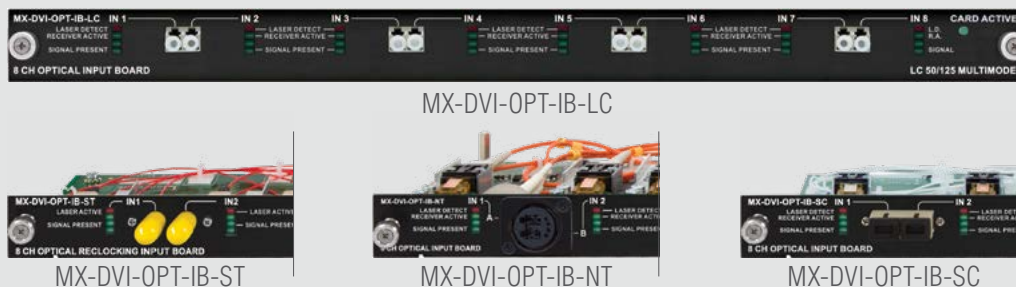

MX-DVI-OPT-IB offers an extremely long, 2500m distance extension over a single Multimode fiber for Single-Link DVI signals on eight channels.

Features:

- 8 x single Multimode fiber input
- Selectable connectors: Neutrik OpticalCON, -LC, -SC, -ST
- Laser detect feedback LED for each input
- No video compression
- Zero frame delay
- Extension distance: up to 2500 m (1600 x 1200 @ 60Hz)
- Incoming signals are converted to DVI-D

Compatible Products:

- Transmitters:
 - DVI-OPT-TX110
 - DVI-OPT-TX220-Pro

Fiber Optical Dual-Link DVI Input Board

MX-DVIDL-OPT-IB-LC, -NT

Part no: 9112 0019 (LC), 9112 0022 (NT)

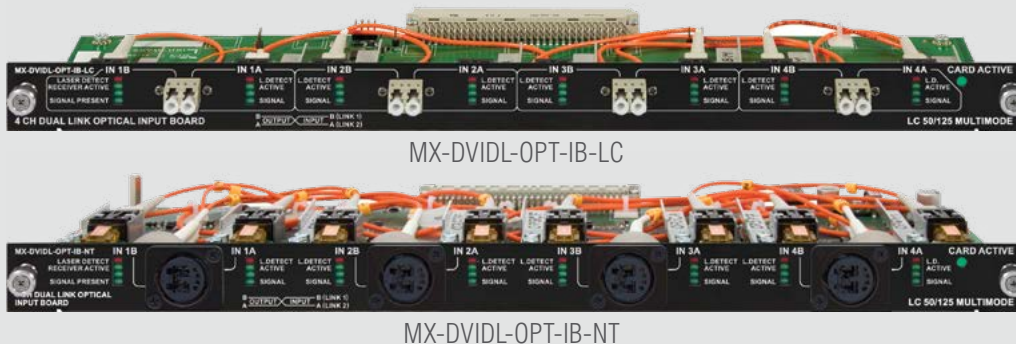

MX-DVIDL-OPT-IB offers an extremely long, 2500m distance extension over a duplex Multimode fiber for Dual-Link DVI signals on four channels.

Features:

- 4 Dual-Link DVI Multimode fiber input
- Selectable connectors: Neutrik OpticalCON, -LC, -ST
- Dual-Link DVI Multimode fiber input for DUAL-Link DVI
- Supports Dual-Link DVI video resolutions and 120 Hz 3D signals

- Selectable connectors: Neutrik OpticalCON, -LC, -ST
- Laser detect feedback LED for each input
- No video compression
- Preserves signal integrity with zero frame delay
- Extension distance: up to 2500 m

Compatible Products:

- Transmitters:
 - DVIDL-OPT-TX200

4K, 3D and Deep Color HDMI Optical Input Board

MX-HDMI-OPT-IB-LC, -NT, -SC

Part no: 9112 0023 (LC), 9112 0025 (SC), 9112 0026 (NT)



MX-HDMI-OPT-IB-NT



MX-HDMI-OPT-IB-SC

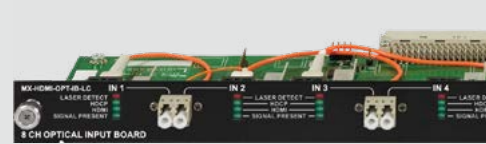

MX-HDMI-OPT-IB-LC

MX-HDMI-OPT-IB offers an extremely long, 2500m distance extension over a single Multimode fiber for HDMI, DVI, VGA signals on 8 channels with 4K resolution and 3D formats support.

Features:

- 8 channels with 4K resolution and 3D format support
- Single Multimode fiber for HDMI, DVI and VGA signals
- Built-in HDMI to fiber converter
- Selectable connectors: Neutrik OpticalCON, -LC, -SC
- 4K x 2K @ 30 Hz, 1080p @ 120 Hz, 2560 x 1600, 2048 x 2048 HD video resolutions and all 3D formats are supported
- Laser detect LED
- No video compression
- Zero frame delay, no latency
- Extension distance: 2500 m (1600 x 1200 @ 60Hz)

Compatible Products:

- Transmitters:
 - DVI-OPT-TX110
 - DVI-OPT-TX220-Pro
 - HDMI-OPT-TX100
 - HDMI-OPT-TX100R
 - HDMI-OPT-TX200R
 - HDMI-3D-OPT-TX210A
 - HDMI-3D-OPT-TX210RAK
 - SW4-OPT-TX240RAK
 - MX-HDMI-OPT-OB-LC
 - MX-HDMI-OPT-OB-SC
 - 25G-MX-HDMI-OPT-OB

4K, 3D and Deep Color HDMI Output Board

MX-HDMI-3D-OB, -A, -S

Part no: 9113 0005, 9113 0006 (A), 9113 0007 (S)

MX-HDMI-3D-OB provides eight channel HDMI 1.4 extension with 4K resolution, 3D and local audio support.

Features:

- 8 HDMI output ports
- HDMI 1.4a; DVI with or without HDCP
- For advanced audio optional 8 S/PDIF (S) or 8 stereo audio (A) connectors
- Available models: analog stereo audio option (MX-HDMI-3D-OB-A) or digital S/PDIF audio option (MX-HDMI-3D-OB-S) or without audio (MX-HDMI-3D-OB)
- 4K / UHD (30Hz RGB 4:4:4, 60Hz YCbCr 4:2:0), 1080p @ 120 Hz, 2560 x 1600, 2048 x 2048 , HD video resolutions and all 3D formats are supported
- Advanced EDID Management and Frame Detector
- Pixel Accurate Reclocking
- HDMI (24 bit RGB) to DVI conversion
- Dolby TrueHD and DTS-HD Master Audio
- 36-bit deep color support

With Digital S/PDIF Audio Add-On:

MX-HDMI-3D-OB-S

- S/PDIF breakout for every port
- Bi-directional configurable S/PDIF connectors: audio can be de-embedded from the HDMI signals or audio can be embedded (or replaced) to the HDMI signal

With Analog Stereo Audio Add-On:

MX-HDMI-3D-OB-A

- Bi-directional configurable analog stereo port with 5-pole Phoenix connector
- Stereo PCM audio up to 96 kHz can be de-embedded from the HDMI signals
- Digitalized audio (PCM 48 kHz) can be embedded (or replaced) to the HDMI signal

4K, 3D DVI and HDMI Compliant Output Board

MX-DVI-4K-OB

Part no: 9113 0052

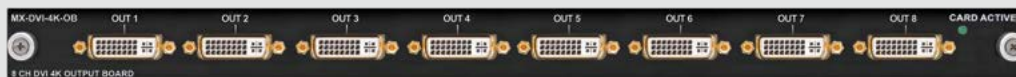

MX-DVI-4K-OB provides eight channel HDMI 1.4 extension with 4K resolution and 3D formats.

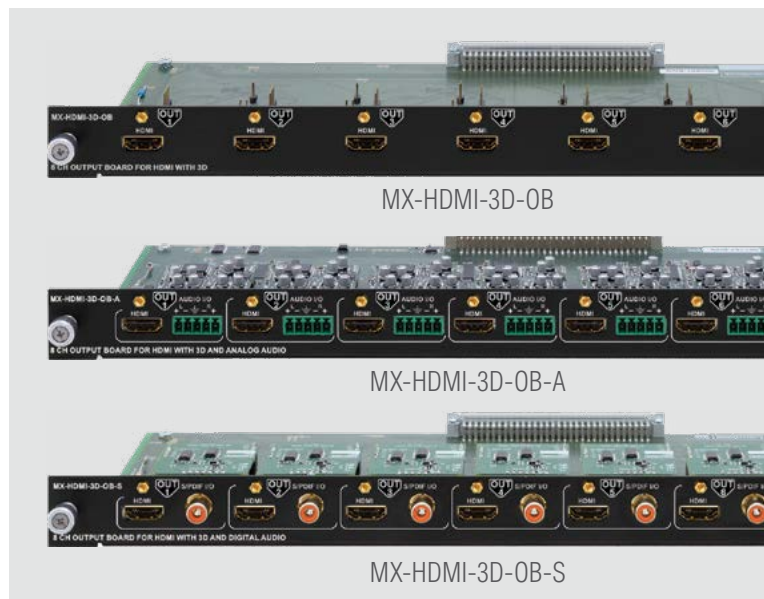

Port Diagrams:

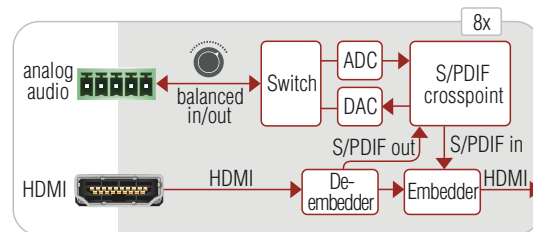

MX-HDMI-3D-OB-A

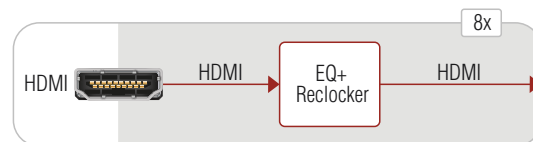

MX-HDMI-3D-OB

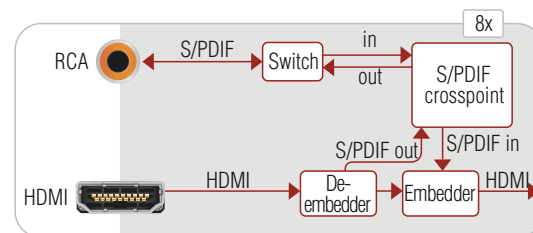

MX-HDMI-3D-OB-S

Features:

- 8 DVI output ports
- DVI with or without HDCP
- 4K / UHD (30Hz RGB 4:4:4, 60Hz YCbCr 4:2:0), 1080p @ 120 Hz, 2560 x 1600, 2048 x 2048 , HD video resolutions and all 3D formats are supported
- Advanced EDID Management and Frame Detector
- Pixel Accurate Reclocking
- 36-bit deep color support

The MX Half & Half Board



THE *WHOLE*
“ IS GREATER
THAN

THE
SUM OF
ITS PARTS.”

Aristotle



MX-4TPS2-4HDMI-IB-AP

visual engineering
LIGHTWARE

lightware.com



TPS and HDMI Output Board for Ethernet, Audio and Control

MX-4TPS2-4HDMI-OB, -A, -S, -P, -AP, -SP

Part no: 9113 0046, 9113 0047 (A), 9113 0048 (S), 9113 0050 (AP), 9113 0051 (SP), 9113 0049 (P)



MX-4TPS2-4HDMI-OB

MX-4TPS2-4HDMI-OB is a mixed output board with four HDMI and four HDBaseT™ single CAT outputs providing HDMI 1.4, audio, Ethernet and RS-232 extension on a single CAT5/6/7 cable up to 120m in HDBaseT™ and 170m distance in Long reach mode.

Features:

- HDMI extension supporting 3D and 4K
- Accepts HDMI + Ethernet + RS-232 over one CAT5/6/7 cable up to 170m distance
- HDMI 1.4; DVI and HDCP compliant with or without HDCP
- 4K / UHD (30Hz RGB 4:4:4, 60Hz YCbCr 4:2:0), 1080p @ 120 Hz, 2560 x 1600, 2048 x 2048,
- 10/100 Ethernet transmission
- Supports all HDMI audio formats
- Pixel Accurate Reclocking
- Advanced EDID Management
- Frame Detector
- Compatible with deep color, Dolby TrueHD and DTS-HD audio

- Remote powering on/off switching
- Volume, gain, balance, bass and treble control
- Phase invert and de-emphasis option

Attention: The built-in PoE injector function requires the supplied PSU-48VP external power source to be connected directly to the board!

Product Name	Audio Add-on	PoE Add-on
MX-4TPS2-4HDMI-OB	none	none
MX-4TPS2-4HDMI-OB-A	analog	none
MX-4TPS2-4HDMI-OB-S	spdif	none
MX-4TPS2-4HDMI-OB-P	none	yes
MX-4TPS2-4HDMI-OB-AP	analog	yes
MX-4TPS2-4HDMI-OB-SP	spdif	yes

With Digital Audio and PoE Add-on



MX-4TPS2-4HDMI-OB-SP

- S/PDIF breakout for every port
- Bi-directional configurable S/PDIF connectors: audio can be de-embedded from the HDMI signals or audio can be embedded (or replaced) into the HDMI signal
- PoE compatible
- 48V remote powering
- Remote powering on/off switching
- Status feedback

Attention: The built-in PoE injector function requires the supplied PSU-48VP external power source to be connected directly to the board!

With PoE Add-on



MX-4TPS2-4HDMI-OB-P

- PoE compatible
- 48V remote powering
- Remote powering on/off switching
- Status feedback

With Analog Audio Add-on



MX-4TPS2-4HDMI-OB-A

- Bi-directional configurable analog stereo ports with 5-pole Phoenix connector
- Stereo PCM audio up to 96 kHz can be de-embedded from the HDMI signals
- Stereo audio (up to PCM 48 kHz) can be embedded (or replaced) into the HDMI signal
- Volume, gain, balance, bass and treble control
- Phase invert and de-emphasis option

With Analog Audio and PoE Add-on



MX-4TPS2-4HDMI-OB-AP

- Bi-directional configurable analog stereo ports with 5-pole Phoenix connector
- Stereo PCM audio up to 96 kHz can be de-embedded from the HDMI signals
- Digitalized audio (PCM 48 kHz) can be embedded (or replaced) into the HDMI signal
- PoE compatible
- 48V remote powering

With Digital Audio Add-on



MX-4TPS2-4HDMI-OB-S

- S/PDIF breakout for every port
- Bi-directional configurable S/PDIF digital audio port with RCA connectors: audio can be de-embedded from the HDMI signals or audio can be embedded (or replaced) into the HDMI signal

HDBaseT™ and the HDBaseT Alliance logo are trademarks of the HDBaseT Alliance

TPS Output Board for HDMI, Ethernet, Audio and Control

MX-TPS-OB, -A, -S

Part No: 9113 0027, 9113 0028 (A), 9113 0029 (S)



MX-TPS-OB Output Board is a long-distance single CAT HDBaseT™ solution with localized audio embedding and de-embedding points.

Features:

- 8 channel twisted pair Output Board
- HDMI extension supporting 3D and 4K
- Accepts HDMI + Ethernet + RS-232 over one CAT5/6/7 cable to up to 170m distance
- HDMI 1.4; DVI and HDCP compliant
- 4K/UHD (30Hz RGB 4:4:4, 60Hz YCbCr 4:2:0), UHD, 2560 x 1600
- Compatible with deep color, Dolby TrueHD and DTS-HD audio
- PCM audio sample rate conversion
- HD video resolutions and all 3D formats are supported
- 10/100 Ethernet transmission
- Supports all HDMI audio formats
- Options for cards with digital or analog audio connectors
- HDCP enable/disable mode, Pixel Accurate Reclocking, Advanced EDID Management and Frame Detector
- 12V Remote powering of compatible devices

Attention: The built-in remote powering injector function requires the supplied PSU-12VP external power source to be connected directly to the board!

With Digital S/PDIF Audio Add-On:

MX-TPS-OB-S

- S/PDIF breakout for every port
- Bi-directional configurable S/PDIF connectors: audio can be de-embedded from the HDMI signals or audio can be embedded (or replaced) to the HDMI signal

With Analog Stereo Audio Add-On:

MX-TPS-OB-A

- Bi-directional configurable analog stereo port with 5-pole Phoenix connector
- Stereo PCM audio up to 96 kHz can be de-embedded from the HDMI signals
- Digitalized audio (PCM 48 kHz) can be embedded (or replaced) to the HDMI signal
- Volume, gain, balance, bass and treble control
- Phase invert and de-emphasis option

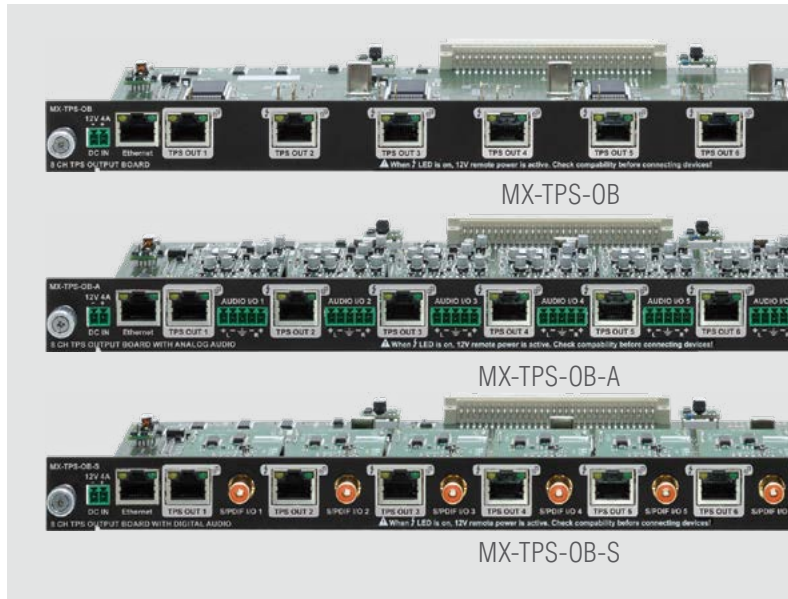

Port Diagrams:

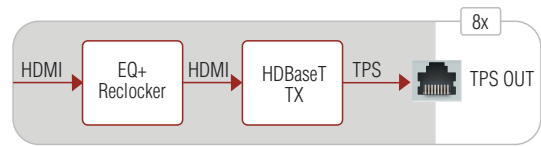

MX-TPS-OB

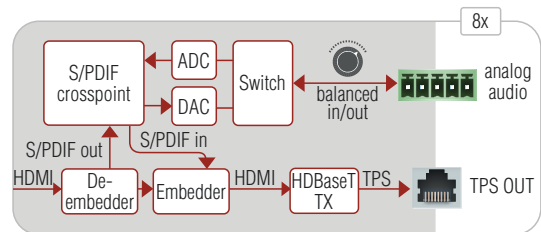

MX-TPS-OB-A

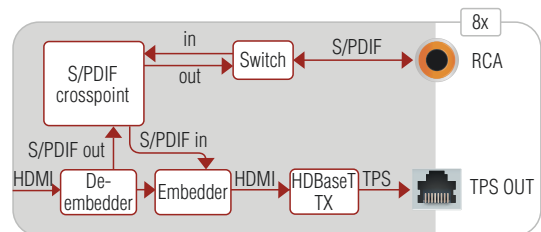

MX-TPS-OB-S

Supplied Accessory Required for Remote Powering:



Part No: 9134 0007
Power adaptor with IEC plug.
Power supply for 12V remote powering function.
Universal input: 100-240 V AC, 50-60 Hz.
Output: 12 V DC, 6,67 A.

Available Video Patterns:

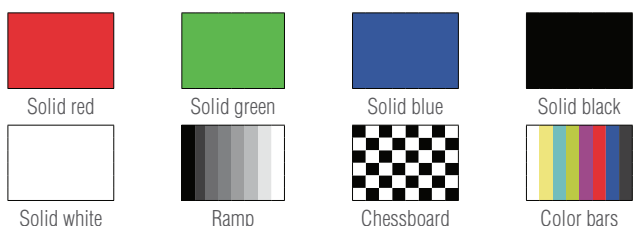

Test Pattern Generator Video Formats:
480p, 576p, 720p, 1080p, 1080p deep color

TPS Output Board with PoE

MX-TPS2-OB-P, -AP, -SP

Part No: 9113 0042 (P), 9113 0043 (AP), 9113 0044 (SP)



MX-TPS2-OB-P



MX-TPS2-OB-AP



MX-TPS2-OB-SP

MX-TPS2-OB-P the 8 channel twisted pair output board provides HDMI 1.4, audio, Ethernet and RS-232 transmission on a single CAT5/6/7 cable up to 100m in HDBaseT™ and 170m distance in Long reach mode.

Features:

- HDMI extension supporting 3D and 4K
- Accepts HDMI + Ethernet + RS-232 over one CAT5/6/7 cable up to 170m distance
- HDMI 1.4 and DVI with or without HDCP
- 4K / UHD (30Hz RGB 4:4:4, 60Hz YCbCr 4:2:0), UHD, 2560 x 1600, HD video resolutions and all 3D formats are supported
- 10/100 Ethernet transmission
- Supports all HDMI audio formats
- Compatible with deep color, Dolby TrueHD and DTS-HD audio
- Features PCM audio sample rate conversion
- Pixel Accurate Reclocking, Advanced EDID Management and Frame Detector
- Integrated PoE power injection option for TPS extenders

Attention: The built-in PoE remote powering function requires the supplied PSU-48VP external power source to be connected directly to the board!

- Digitized audio (PCM 48 kHz) can be embedded (or replaced) to the HDMI signal
- Volume, gain control
- PoE compatible
- 48V remote powering
- Remote powering on/off switching
- Status feedback

With Digital Audio Add-On

MX-TPS2-OB-SP

- S/PDIF breakout for every port
- Bi-directional configurable S/PDIF connectors: audio can be de-embedded from the HDMI signals or audio can be embedded (or replaced) to the HDMI signal
- PoE compatible
- 48V remote powering
- Remote powering on/off switching
- Status feedback

With Analog Audio Add-On

MX-TPS2-OB-AP

- Bi-directional configurable analog stereo port with 5-pole Phoenix connector
- Stereo PCM audio up to 96 kHz can be de-embedded from the HDMI signals

Supplied Accessory Required for the PoE Function



Part No: 9134 0015
 Power adaptor with IEC plug.
 Power supply for PoE 48V remote powering function.
 Universal input: 100-240 V AC, 50-60 Hz.
 Output: 48 V DC, 5.84 A.

Analog Audio Output Board **MX-AUDIO-OB-A**

Part no: 9113 0045



MX-AUDIO-OB-A is an eight-channel analog audio output board to switch audio de-embedded from a video signal to an output port. The board has adjustable audio setting options.

Features:

- Analog audio breakaway switching
- Eight Phoenix (Euroblock) connectors
- Stereo PCM audio up to 96 kHz de-embedded from the HDMI signals
- Volume, balance, bass and treble control
- Phase invert option
- Pre-emphasis option

Dual-Link DVI Output Board **MX-DVIDL-OB**

Part no: 9113 0003

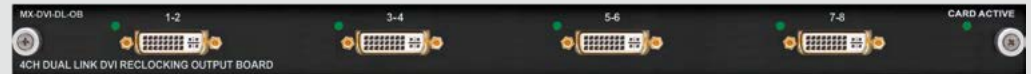

MX-DVIDL-OB is a Dual-Link DVI Output Board supporting four Dual-Link DVI-D connectors.

Features:

- 4 gold plated DVI connectors
- Pro series Dual-Link I/O board
- Advanced EDID Management
- TMD5 Reclocking
- Fiber adapter powering on output
- Supports High Definition computer signals and 120Hz 3D

Fiber Optical Reclocking Single-Link DVI Output Board **MX-DVI-OPT-OB-R-LC, -ST, -SC, -NT**

Part no: 9113 0015 (LC), 9113 0016 (ST), 9113 0017 (SC), 9113 0018 (NT)

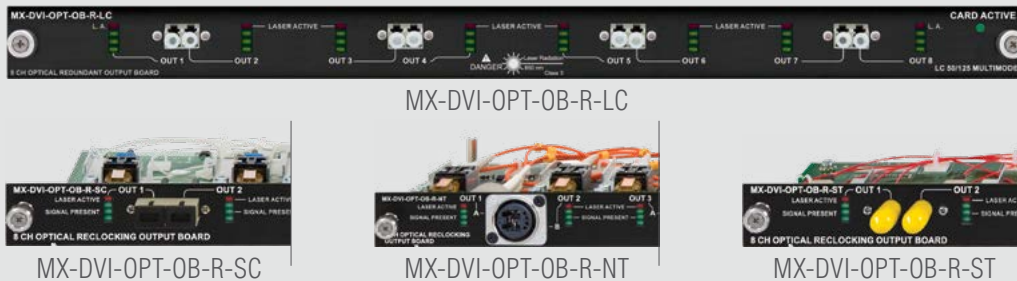

MX-DVI-OPT-OB-R Output Board provides extremely long, 2500m extension and reclocking for DVI-D signals over Multimode fiber on eight channels.

Features:

- 8 Single-Link DVI Multimode fiber output
- DVI Pixel Accurate Reclocking
- Selectable connectors: Neutrik OpticalCON, -LC, -SC, -ST
- No video compression
- Zero frame delay
- Extension distance: 2500 m (1600 x 1200 @ 60Hz)

Fiber Optical Dual-Link DVI Output Board

MX-DVIDL-OPT-OB-LC, -NT

Part no: 9113 0019 (LC), 9113 0022 (NT)



MX-DVIDL-OPT-OB-NT

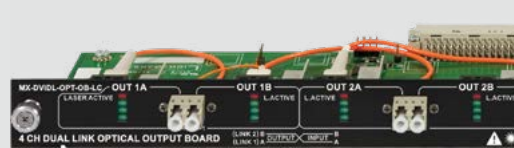

MX-DVIDL-OPT-OB-LC

MX-DVIDL-OPT-OB provides extremely long, 2500m extension over a duplex Multimode fiber for Dual-Link DVI signals on 4 channels.

Features:

- 4 Dual-Link DVI Multimode fiber output
- Selectable connectors: Neutrik OpticalCON, -LC
- Laseractive feedback LED for each output
- No video compression
- Zero frame delay
- Extension distance: up to 2500 m
- Supports 120 Hz 3D signals

4K, 3D and Deep Color HDMI Optical Output Board with Reclocking

MX-HDMI-OPT-OB-R-LC, -NT

Part No: 9113 0030 (LC), 9113 0032 (SC), 9113 0033 (NT),



MX-HDMI-OPT-OB-R-NT

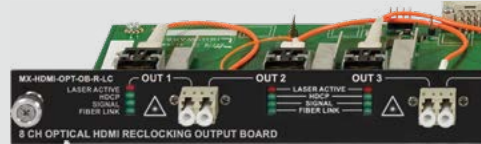

MX-HDMI-OPT-OB-R-LC

MX-HDMI-3D-OB-R is an eight channel Multimode optical Output Board providing HDMI 1.4, audio and RS-232 extension over a single Multimode fiber up to 2500m distance.

Features:

- HDMI 1.4a; DVI and HDCP compliant 8 output matrix board
- Selectable connectors: Neutrik OpticalCON, -LC
- Resolution up to 4096x2048@30Hz and all 3D formats are supported
- Extension distance: 2500 m (up to 1920 x 1200 @ 60Hz), 1100m (4096 x 2048 @ 30Hz)
- Dolby TrueHD and DTS-HD Master Audio
- Advanced EDID Management
- Frame Detector
- Pixel Accurate Reclocking
- One bi-directional RS-232 channel per port

SIGNAL EXTENDERS

Lossless Transmission Solutions



TPS Extenders

Lightware TPS extenders include HDBaseT™ integration with additional Lightware technology enhancements.

Standalone twisted pair extender interfaces are fully compatible with our TPS Matrix Boards and other TPS products.

UMX Series TPS Transmitter for VGA, DVI-I, HDMI, DisplayPort and USB KVM** **HDBT™**
UMX-TPS-TX140, UMX-TPS-TX140-Plus and UMX-TPS-TX140K | **NEW PRODUCT**

Part No: 9154 0008; 9154 0059 (Plus), 9154 0050 (K)

Call sales for availability ☎



UMX-TPS-TX140K

UMX-TPS-TX140 transmits universal 4K video, audio and control up to a 170 m distance* over a single CAT cable. This transmitter was designed for digital and analog video and audio signals: VGA, YPrPb, HDMI 1.4 and DP 1.1 with analog stereo audio from local inputs or embedded 7.1 HBR audio. The unit can also handle HDCP encryption.

The 'Plus' versions of these products include an improved processor and bigger memory which allows the integration of 'Advanced Control' features into the product.

The 'Advanced Control' feature pack includes functions which help to integrate the product with CISCO Rooms and other 3rd party systems, and/or to overcome system automation challenges. In small to mid size systems these automation features can help to dismiss an additional control processor box, thus lowering intergration time and costs.

Features:

- Multiport mini switch extender with local monitoring
- 4K / UHD (30Hz RGB 4:4:4, 60Hz YCbCr 4:2:0) and 3D capabilities
- Extends DVI, HDMI, VGA or DisplayPort + Ethernet + RS-232 +IR over a single CAT5e-CAT7e cable to up to 170 m distance*
- **Event Manager** built-in control application
- **USB KVM (HID) extension****
- **Advanced control feature pack for 3rd party video conference collaboration *****
- Audio and video connectors: DVI-I, HDMI, VGA, DisplayPort, Stereo jack, PHOENIX 1x5-pole

- 10/100 Ethernet transmission
- Bi-directional RS-232 and IR supporting command injection, allowing the sending of any IR or RS-232 control command directly from the LAN connection
- GPIO control port
- HDCP compliant, CEC, EDID transparent
- Local audio embedding
- Advanced EDID Management forces the required resolution from any video source and fixes the output format conforming the system requirements
- Remote (PoE) or local power source
- Standalone or rack-mounted use

* Depends on cable category and quality
 ** UMX-TPS-TX140K only in point-to-point application with HDMI-TPS-RX220AK
 *** UMX-TPS-TX140-Plus and UMX-TPS-TX140K

Plus Features*:**

- Support to send raw Infrared messages (Pronto HEX codes) to control TVs, Blurays, etc with connected IR emitters
- Support to send CEC messages to control TVs, Blurays etc which are conencted on HDMI ports
- Support to recognize incoming CEC messages in **Event Manager** and trigger custom actions
- Support to recognize incoming RS-232 messages to integrate with 3rd party devices like VC codecs
- Increased number of Events to 100

Port Diagram - UMX-TPS-TX140

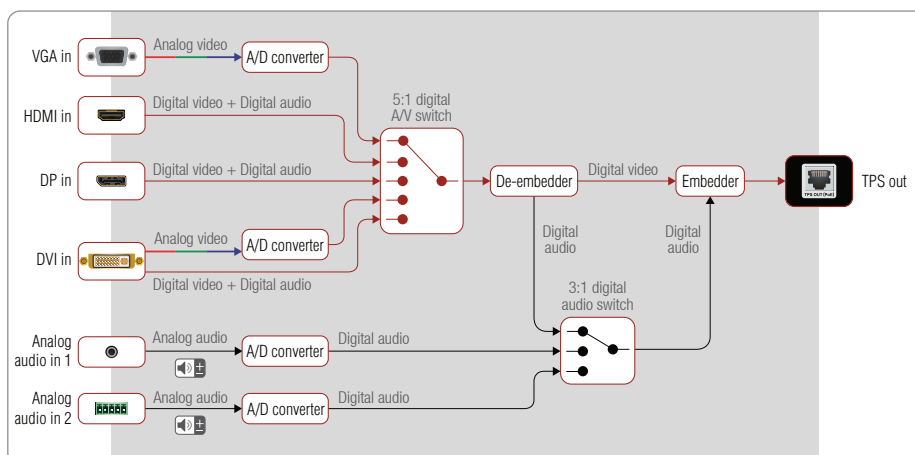

HDBaseT™ and the HDBaseT Alliance logo are trademarks of the HDBaseT Alliance

UMX Series TPS Transmitter for VGA, DVI-I, and HDMI

UMX-TPS-TX130

Part No: 9154 0013



UMX-TPS-TX130 transmits universal 4K video, audio and control up to a 170 m distance over a single CAT cable. This transmitter was designed for digital and analog video and audio signals: DVI, VGA, YPrPb and HDMI 1.4 with analog stereo audio from local input or embedded 7.1 HBR audio. It also handles HDCP encryption.

Features:

- HDBaseT™ compatible TPS transmitter
 - 4K / UHD (30Hz RGB 4:4:4, 60Hz YCbCr 4:2:0) and 3D capabilities
 - Extends DVI, HDMI or VGA + Ethernet + RS-232 + IR over asingle CAT5e-CAT7e cable up to 170 m distance*
 - **Event Manager** built-in control application
 - Audio and video connectors: DVI-I, HDMI, VGA, Stereo jack
 - 10/100 Ethernet transmission
 - Bi-directional RS-232 and IR support command injection, allowing the sending of IR or RS-232 control commands directly from the LAN connection
 - GPIO control port
 - HDCP compliant, CEC, EDID transparent
 - Local audio embedding
 - Advanced EDID Management forces the required resolution from any video source and fixes the output format conforming the system requirements
 - Remote (PoE) or local power source
 - Standalone or rack-mounted use
- *Depends on cable category and quality

UMX Series TPS Transmitter for VGA and HDMI

UMX-TPS-TX120

Part No: 9154 0012



UMX-TPS-TX120 transmits universal 4K video, audio and control up to a 170 m distance over a single CAT cable. This transmitter was designed for digital and analog video and audio signals: VGA, YPrPb and HDMI 1.4 with analog stereo audio from local input or embedded 7.1 HBR audio

Features:

- HDBaseT™ compatible TPS transmitter
 - 4K / UHD (30Hz RGB 4:4:4, 60Hz YCbCr 4:2:0) and 3D capabilities
 - Extends HDMI or VGA + Ethernet + RS-232 + IR over a single CAT5e-CAT7e cable up to 170 m distance*
 - **Event Manager** built-in control application
 - Audio and video connectors: HDMI, VGA, Stereo jack
 - 10/100 Ethernet transmission
 - Bi-directional RS-232 and IR support command injection, allowing the sending of IR or RS-232 control commands directly from the LAN connection
 - HDCP compliant, CEC, EDID transparent
 - Local audio embedding
 - Advanced EDID Management forces the required resolution from any video source and fixes the output format conforming the system requirements
 - Remote (PoE) or local power source
 - Standalone or rack-mounted use
- *Depends on cable category and quality

UMX Series TPS Wallplate and Floorplate for VGA and HDMI DisplayPort

- WP-UMX-TPS-TX130-US** Black Part No: 9154 0009
- WP-UMX-TPS-TX130-US** White Part No: 9154 0040
- WP-UMX-TPS-TX130-Plus-US** Black Part No: 9154 0071
- WP-UMX-TPS-TX130-Plus-US** White Part No: 9154 0072



The WP-UMX-TPS-TX130-US is the flagship model in the Lightware TPS (HDBaseT™ Transmitter) product family. The devices can transmit universal video, audio and control up to a 170 meter distance over a single CAT cable in dynamically changing environments such as small board rooms and classrooms. The extenders were designed to handle digital and analog video and audio signals: VGA, YPrPb, HDMI 1.4 and DP 1.1 with analog stereo audio from local inputs or embedded 7.1 HBR audio.

Features:

- HDBaseT™ compatible TPS transmitter wallplate
- 4K / UHD (30Hz RGB 4:4:4, 60Hz YCbCr 4:2:0) and 3D capabilities
- Extends HDMI, DisplayPort or VGA + Ethernet + RS-232 + IR over a single CAT5e-CAT7e cable to up to 170 m distance*
- **Event Manager** built-in control application
- Advanced EDID Management forces the required resolution from any video source and fixes the output format conforming the system requirements
- Frame detector
- Audio and video connectors: HDMI, VGA, DisplayPort, Stereo jack
- 10/100 Ethernet transmission
- Bi-directional RS-232 and IR, RS-232 supports command injection
- HDCP compliant, CEC, EDID transparent
- Active cooling
- Local audio embedding
- Also available in white colour
- Remote (PoE) or local power source

*Depends on cable category and quality

Plus Features:

- Support to send raw Infrared messages (Pronto HEX codes) to control TVs, Blurays, etc with connected IR emitters
- Support to send CEC messages to control TVs, Blurays etc which are connected on HDMI ports
- Support to recognize incoming CEC messages in **Event Manager** and trigger custom actions
- Support to recognize incoming RS-232 messages to integrate with 3rd party devices like VC codecs
- Increased number of Events to 100

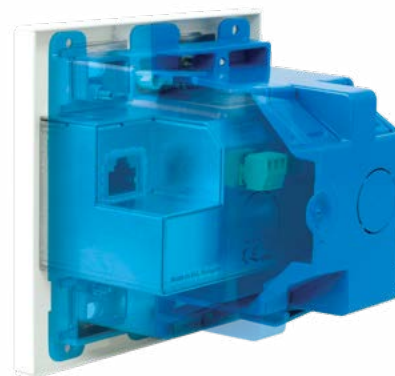

The US type wallplate extenders can come bundled with a matching Carlon box, which is required for the installation. Order it from Lightware and it will arrive to you packaged together with your extender.

UMX Series TPS Wallplate for VGA and HDMI

- WP-UMX-TPS-TX120-US** Black Part No: 9154 0014 (Black)
- WP-UMX-TPS-TX120-US** White Part No: 9154 0041 (White)

The specifications of WP-UMX-TPS-TX120-US Black and White extenders are fully identical with WP-UMX-TPS-TX130-US Black and White extenders, but these models do not have DisplayPort inputs.

HDBaseT™ and the HDBaseT Alliance logo are trademarks of the HDBaseT Alliance



TPS Receiver with Relay Modules and Balanced Audio Out
HDMI-TPS-RX110AY and **HDMI-TPS-RX110AY-Plus** **new!**

Part No: 9154 0021, 9154 0070 (-Plus)

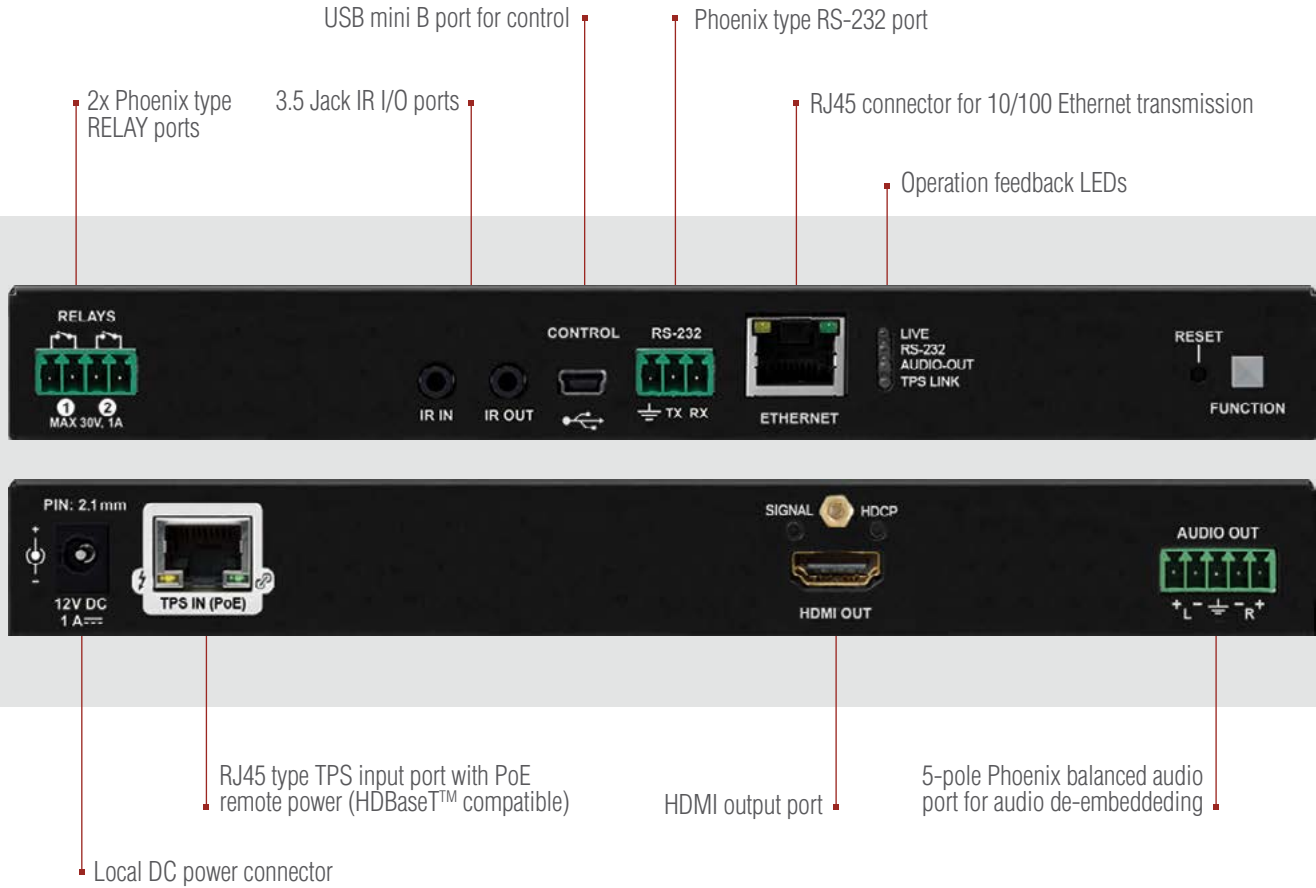

This dual relay capable **HDBase™ compatible TPS receiver** has one **PoE capable TPS input** and one **HDMI output**, and features **audio de-embedding**. The HDMI audio is de-embedded to the balanced audio output via a Phoenix (Euroblock) connector, the audio port has volume control. The unit is **HDCP compliant** and has 4K/UHD and 3D capabilities. The **built-in Event Manager room control** feature provides the necessary control in a less complex application environment. Both the Event Manager feature and the **dual relay module** of the device are configurable via the freely available Lightware Device Controller software. **USB, RS-232, IR (in and out) and Ethernet** ports provide further connection options for control.

Features:

- HDMI 1.4 TPS receiver with audio de-embedding capability
- Up to 170m transmission distance over TPS*
- 4K/UHD (30Hz RGB 4:4:4, 60Hz YCbCr 4:2:0) and 3D capabilities
- Fully HDCP compliant
- Balanced analog audio output for audio de-embedding
- Audio volume and gain control
- 2x Relay modules
- **Event Manager** built-in control application
- Powered by local or PoE remote power
- RS-232, IR, Ethernet extension
- Advanced EDID Management and Frame Detector

*Depends on cable category and quality

Plus Features:

- Support to send raw Infrared messages (Pronto HEX codes) to control TVs, Blurays, etc with connected IR emitters
- Support to send CEC messages to control TVs, Blurays etc which are connected on HDMI ports
- Support to recognize incoming CEC messages in **Event Manager** and trigger custom actions
- Support to recognize incoming RS-232 messages to integrate with 3rd party devices like VC codecs
- Increased number of Events to 100

TPS Receiver with Relay Modules and Balanced Audio Out with USB KVM
HDMI-TPS-RX220AK

Part No: 9154 0022



NEW PRODUCT



Call sales for availability

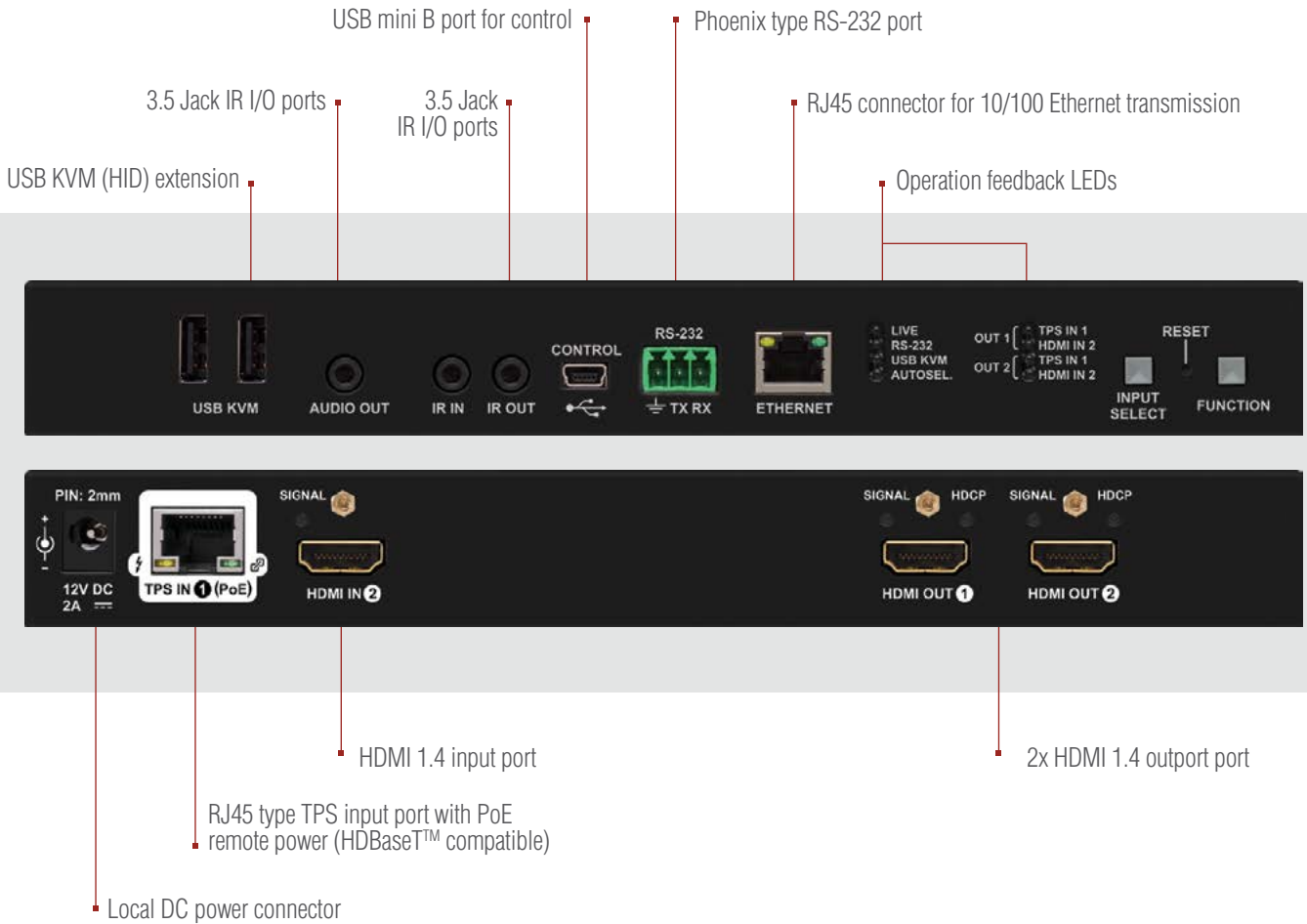

The Lightware HDMI-TPS-RX220AK receiver offers seamless **HDBase™ integration** with additional Lightware product lines and developments, including TPS matrices and 25G boards. The device receives digital video at a **resolution up to 4K**, as well as audio and control up to 170 meters* over a single CAT cable. Furthermore, the device utilizes **control over USB KVM**, and can be remotely **powered over TPS link with PoE** (IEEE 802.3af), a useful array of features to further **simplify the operation** for system integrators and users. UMX-TPS-TX140K only in **point-to-point application** with HDMI-TPS-RX220AK

Features:

- HDMI 1.4 TPS receiver with audio de-embedding capability
- Up to 170m transmission distance over TPS*
- 4K/UHD (30Hz RGB 4:4:4, 60Hz YCbCr 4:2:0) and 3D capabilities
- **USB KVM (HID) extension**
- Fully HDCP compliant
- Balanced analog audio output for audio de-embedding
- Audio volume and gain control
- **Event Manager** built-in control application
- Powered by local or PoE remote power
- RS-232, IR, Ethernet extension
- Advanced EDID Management and Frame Detector

*Depends on cable category and quality

Plus Features:

- Support to send raw Infrared messages (Pronto HEX codes) to control TVs, Blurays, etc with connected IR emitters
- Support to send CEC messages to control TVs, Blurays etc which are connected on HDMI ports
- Support to recognize incoming CEC messages in **Event Manager** and trigger custom actions
- Support to recognize incoming RS-232 messages to integrate with 3rd party devices like VC codecs
- Increased number of Events to 100

TPS Switcher and Transmitter for DisplayPort, HDMI and DVI with Local Monitor Out
SW4-TPS-TX240 and SW4-TPS-TX240-Plus

Part No: 9154 0007, 91540065 (Plus)



SW4-TPS-TX240 is a flagship model in the Lightware TPS (HDBaseT™ Transmitter) product family. The device can transmit universal video, audio and control up to a 170 meter distance over a single CAT cable in dynamically changing environments such as small board rooms and classrooms. The extender was designed to handle HDMI 1.4 and DP 1.1 digital video signals and analog stereo audio from local inputs or HDMI or DP Embedded Audio up to eight Channel PCM or HBR audio.

Features:

- HDBaseT™ compatible mini-switch TPS transmitter for video, audio and control
 - 4K / UHD (30Hz RGB 4:4:4, 60Hz YCbCr 4:2:0) and 3D capabilities
 - Extends DVI, HDMI or DisplayPort + Ethernet + RS-232 + IR over a single CAT5e-CAT7e cable to up to 170 m distance*
 - **Event Manager** built-in control application
 - Local HDMI port for monitoring
 - Advanced EDID Management forces the required resolution from any video source and fixes the output format conforming to the system requirements
 - Audio and video connectors: DVI-D, HDMI (input and output), DisplayPort, Stereo jack
 - 10/100 Ethernet transmission
 - Bi-directional RS-232 and IR supporting command injection
 - GPIO control port
 - HDCP compliant, CEC, EDID transparent
 - Local audio embedding
 - Remote (PoE) or local power source
 - Standalone or rack-mounted use
- *Depends on cable category and quality

Plus Features:

- Support to send raw Infrared messages (Pronto HEX codes) to control TVs, Blurays, etc with connected IR emitters
- Support to send CEC messages to control TVs, Blurays etc which are connected on HDMI ports
- Support to recognize incoming CEC messages in **Event Manager** and trigger custom actions
- Support to recognize incoming RS-232 messages to integrate with 3rd party devices like VC codecs
- Increased number of Events to 100

Standalone Application

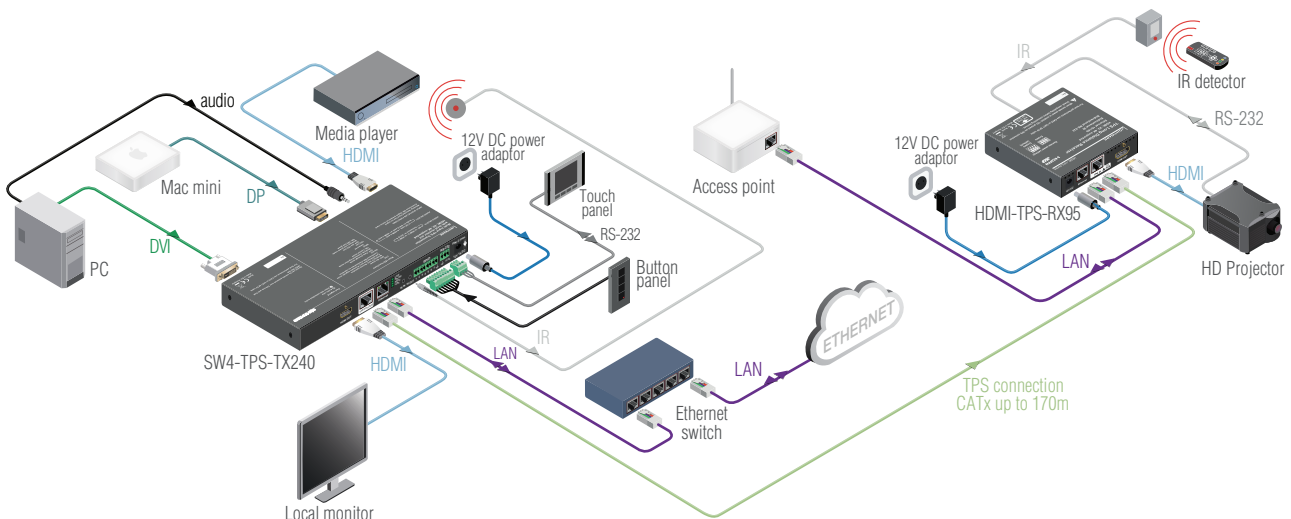

HDBaseT™ and the HDBaseT Alliance logo are trademarks of the HDBaseT Alliance

TPS Extenders for Single CATx Cable with PoE
DVI-HDCP-TPS-TX97 and DVI-HDCP-TPS-RX97

Part No: 9154 0026, 9154 0025



TPS Extenders for Single CATx Cable with PoE
HDMI-TPS-TX97 and HDMI-TPS-RX97

Part No: 9154 0024, 9154 0023

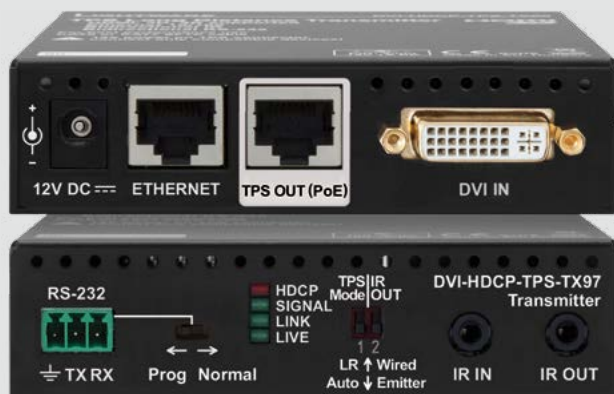

DVI-HDCP-TPS-TX97



HDMI-TPS-TX97

DVI-HDCP-TPS-TX97 and DVI-HDCP-TPS-RX97 twisted pair HDBase™ extenders provide extension of uncompressed 4K/UHD video with embedded audio (up to eight channel PCM or HBR audio) for long distances over a single CATx cable.

Features:

- 4K UHD HDBase™ and PoE compatible DVI TPS extenders
- Single-Link DVI and HDMI extension supporting 4K/UHD (30Hz RGB 4:4:4, 60Hz YCbCr 4:2:0) and 3D capabilities
- Extends Single-Link DVI or HDMI + Ethernet + RS-232 + IR over one CATx cable to up to 170m* transmission distance
- 10/100 Ethernet transmission
- Bi-directional RS-232 and IR
- HDCP compliant, CEC, EDID transparent
- Operation mode switch (Auto or forced Long Reach Mode)
 - The auto operation mode allows the device to detect the far end extender's mode and adopt it.
- IR out mode switch (Wired / Emitter)
- Powered by local or PoE remote power

*Depends on cable category and quality

HDMI-TPS-TX97 and HDMI-TPS-RX97 twisted pair HDBase™ extenders provide extension of uncompressed 4K/UHD video with embedded audio (up to eight channel PCM or HBR audio) for long distances over a single CATx cable.

Features:

- 4K UHD HDBase™ and PoE compatible HDMI TPS extenders
- Single-Link DVI and HDMI extension supporting 4K/UHD (30Hz RGB 4:4:4, 60Hz YCbCr 4:2:0) and 120Hz 3D signals
- Extends Single-Link DVI or HDMI + Ethernet + RS-232 + IR over one CATx cable to up to 170m* transmission distance
- 10/100 Ethernet transmission
- Bi-directional RS-232 and IR
- HDCP compliant, CEC, EDID transparent
- Operation mode switch (Auto or forced Long Reach Mode)
 - The auto operation mode allows the device to detect the far end extender's mode and adopt it.
- IR out mode switch (Wired / Emitter)
- Powered by local or PoE remote power

*Depends on cable category and quality

TPS Extenders for Single CATx Cable
DVI-HDCP-TPS-TX95 and **DVI-HDCP-TPS-RX95**

Part No: 9154 0001, 9154 0002



TPS Extenders for Single CATx Cable
HDMI-TPS-TX96 and **HDMI-TPS-RX96**

Part No: 9154 0067, 9154 0066

new!



DVI-HDCP-TPS-RX95

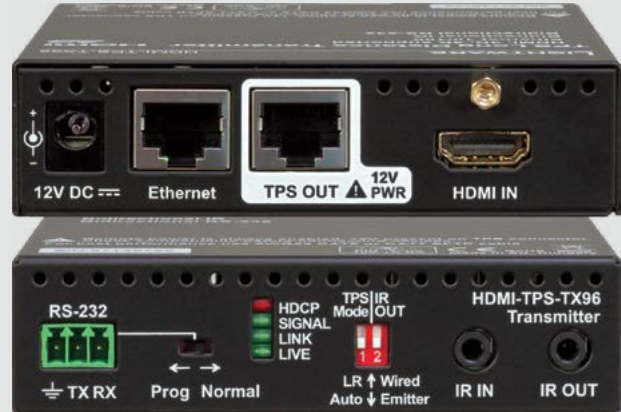

HDMI-TPS-TX96

DVI-HDCP-TPS-TX95 and DVI-HDCP-TPS-RX95 twisted pair HDBaseT™ extenders provide extension of uncompressed Full-HD video for long distances over a single CATx cable.

Features:

- 4K UHD HDBaseT™ compatible DVI TPS extenders
- Single-Link DVI and HDMI extension supporting 4K and 120Hz 3D
- Extends Single-Link DVI or HDMI + Ethernet + RS-232 + IR over one CATx cable up to 170 m distance*
- 10/100 Ethernet transmission
- Bi-directional RS-232 and IR
- HDCP compliant, CEC, EDID transparent
- Operation mode switch (Auto or forced Long Reach Mode)
 - The auto operation mode allows the device to detect the far end extender's mode and adopt it.
- Rack-mounted or standalone use
- Powered by local or 12V remote power

*Depends on cable category and quality

HDMI-TPS-TX96 and HDMI-TPS-RX96 twisted pair HDBaseT™ extenders provide extension of uncompressed 4K/UHD video with embedded audio (up to eight channel PCM or HBR audio) for long distances over a single CATx cable.

Features:

- 4K UHD HDBaseT™ and PoE compatible HDMI TPS extenders
- Single-Link DVI and HDMI extension supporting 4K/UHD (30Hz RGB 4:4:4, 60Hz YCbCr 4:2:0) and 120Hz 3D signals
- Extends Single-Link DVI or HDMI + Ethernet + RS-232 + IR over one CATx cable to up to 170m* transmission distance
- 10/100 Ethernet transmission
- Bi-directional RS-232 and IR
- HDCP compliant, CEC, EDID transparent
- Operation mode switch (Auto or forced Long Reach Mode)
 - The auto operation mode allows the device to detect the far end extender's mode and adopt it.
- IR out mode switch (Wired / Emitter)
- Powered by local or PoE remote power

*Depends on cable category and quality

HDBaseT™ and the HDBaseT Alliance logo are trademarks of the HDBaseT Alliance

NEXT GENERATION

HDMI-TPS-96 SERIES



TPS Extenders for DVI with Local Monitor Out
DVI-HDCP-TPS-TX220 and **DVI-HDCP-TPS-TX210**

Part No: 9154 0010 (220), 9154 0015 (210)



DVI-HDCP-TPS-TX220

The DVI-HDCP-TPS-TX220 is a flagship model in the Lightware TPS (HDBaseT™ Transmitter) product family. The device can transmit universal video, audio and control up to a 170 meter distance over a single CAT cable. The extender was designed to handle DVI, HDMI 1.4 digital video signals and analog stereo audio from local inputs or HDMI Embedded Audio up to eight channel PCM or HBR audio.

Features:

- 4K UHD HDBaseT™ compatible DVI TPS transmitter
 - 4K / UHD (30Hz RGB 4:4:4, 60Hz YCbCr 4:2:0) and 3D capabilities
 - Extends DVI, HDMI 1.4 + Ethernet + RS-232 + IR over a single CAT5e-CAT7e cable up to 170 m distance*
 - **Event Manager** built-in control application
 - Advanced EDID Management can force the required resolution from the input video source and fixes the output format conforming the system requirements.
 - Audio and video connectors: DVI (input), DVI (local output), Stereo jack
 - 10/100 Ethernet transmission
 - Bi-directional RS-232 and IR
 - GPIO control port
 - HDCP compliant, CEC, EDID transparent
 - Local audio embedding
 - Powered by local or PoE remote power
 - Rack-mounted or standalone use
- *Depends on cable category and quality

DVI-HDCP-TPS-TX210 has the same features and capabilities as DVI-HDCP-TPS-TX220, but without GPIO control port and local audio embedding.



DVI-HDCP-TPS-TX210

TPS Extenders for HDMI with Local Monitor Out
HDMI-TPS-TX220 and **HDMI-TPS-TX210**

Part No: 9154 0011 (220), 9154 0017 (210)



HDMI-TPS-TX220

The HDMI-TPS-TX220 is a flagship model in the Lightware TPS (HDBaseT™ Transmitter) product family. The device can transmit universal video, audio and control up to a 170 meter distance over a single CAT. The extender was designed to handle HDMI 1.4 digital video signals and analog stereo audio from local inputs or HDMI Embedded Audio up to 8 Channel PCM or HBR audio. It also handles HDCP encryption. Advanced EDID Management forces the required resolution from any video source and fixes the output format conforming the system requirements. Remote powering is available through the single CAT 5e - CAT 7 cable, but local power supply can also be used. All devices can be mounted on a rack shelf or used standalone. HDMI-TPS-TX220 is compatible with both HDBaseT extenders and matrix switchers.

Features:

- 4K / UHD (30Hz RGB 4:4:4, 60Hz YCbCr 4:2:0) and 3D capabilities
 - Extends HDMI 1.4 + Ethernet + RS-232 + IR over a single CAT5e-CAT7e cable up to 170 m distance*
 - **Event Manager**
 - Audio and video connectors: HDMI (input), HDMI (local output), Stereo jack
 - 10/100 Ethernet transmission
 - Bi-directional RS-232 and IR
 - GPIO control port
 - HDCP compliant, CEC, EDID transparent
 - Local audio embedding
- *Depends on cable category and quality

HDMI-TPS-TX210 has the same features and capabilities as HDMI-TPS-TX220, but without GPIO control port and local audio embedding.



HDMI-TPS-TX210

TPS Extenders for DisplayPort with Local Monitor Out
DP-TPS-TX220 and **DP-TPS-TX210**

Part No: 9154 0018(220), 9154 0019(210)



DP-TPS-TX220



DP-TPS-TX210

The device can transmit universal video, audio and control up to a 170 meter distance over a single CAT. The extender was designed to handle DP1.1 digital video signals and analog stereo audio from local inputs or DP Embedded Audio up to eight channel PCM or HBR audio.

Features:

- 4K UHD HDBaseT™ compatible DisplayPort TPS transmitter
- 4K / UHD (30Hz RGB 4:4:4, 60Hz YCbCr 4:2:0) and 3D capabilities
- Extends DisplayPort1.1 + Ethernet + RS-232 + IR over a single CAT5e-CAT7e cable up to 170 m distance*
- **Event Manager** built-in control application
- Advanced EDID Management can force the required resolution from the input video source and fixes the output format conforming the system requirements.
- Audio and video connectors: DisplayPort (input), HDMI (local output), Stereo jack

- 10/100 Ethernet transmission
 - Bi-directional RS-232 and IR
 - GPIO control port
 - HDCP compliant, CEC, EDID transparent
 - Local audio embedding
 - Powered by local or PoE remote power
 - Rack-mounted or standalone use
- *Depends on cable category and quality

DP-TPS-TX210 has the same features and capabilities as DP-TPS-TX220, but without GPIO control port and local audio embedding.

Standalone Application

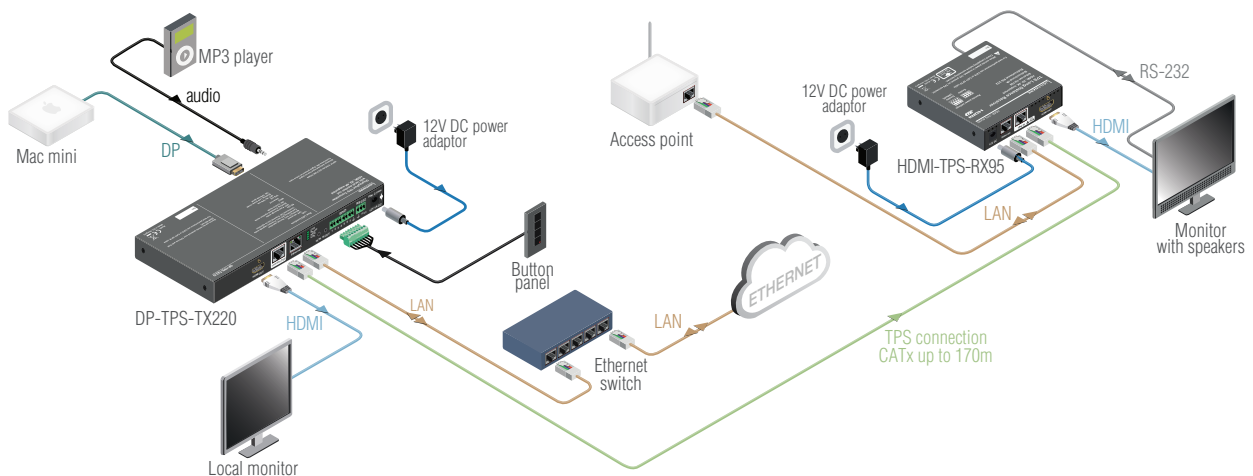

HDBaseT™ and the HDBaseT Alliance logo are trademarks of the HDBaseT Alliance

Single Port Standalone TPS Power Injector TPS-PI-1P1

Part No: 9134 0010



The TPS-PI-1P1 can power a TPS extender placed in the TPS transmission chain, anywhere between the transmitter and the receiver unit. The incoming data stays untouched, the signal quality is unaffected but a 48V DC remote power is added to the signal.

*Remote powering of the 95 series HDMI-TPS and DVI-HDCP-TPS devices is not available by the TPS-PI-1P1 power injector.

Features:

- IEEE802.3at compatible high end remote power injector device
- Single port 48V remote power feed to a TPS endpoint
- Optimized for HDBaseT transmission
- 12V DC power output to feed a local device
- Feeding up to 30W power
- Four front panel feedback LEDs
- Up to 20% increase in reachable extension distance

HDBaseT™ and the HDBaseT Alliance logo are trademarks of the HDBaseT Alliance



Wallplate (WP) and Floorbox (FP) TPS Extenders for Single CATx Cable with PoE
WP-HDMI-TPS-RX97, WP-HDMI-TPS-TX97, FP-HDMI-TPS-RX97, FP-HDMI-TPS-TX97

WP/FP-HDMI-TPS-TX/RX97 series twisted pair HDBaseT™ extenders provide extension of uncompressed 4K/UHD video with embedded audio (up to eight channel PCM or HBR audio) for long distances over a single CATx cable.

Features:

- 4K UHD HDBaseT™ compatible HDMI TPS extender wallplates and floorpanels
- Single-Link DVI and HDMI extension supporting 4K/UHD (30Hz RGB 4:4:4, 60Hz YCbCr 4:2:0) and 120 Hz 3D capabilities
- Extends Single-Link DVI or HDMI + Ethernet + RS-232 + IR over one CATx cable up to 170m* transmission distance over TPS
- 10/100 Ethernet transmission
- Bi-directional RS-232 and IR
- HDCP compliant, CEC, EDID transparent
- Operation mode switch (Auto or forced Long Reach Mode)
 - The auto operation mode allows the device to detect the far end extender's mode and adopt it.
- New design fits standard wall and floor panel boxes while providing optimized cable connect and removal
- Fits in most common standard wall and floor panel boxes

*Depends on cable category and quality

The following table lists additional versions of the same wall and floor panel series. For availability and other information please inquire at your Lightware sales contact.

	Product variants	Part Numbers
Wallplates	WP-HDMI-TPS-RX97-EU	9154 0027
	WP-HDMI-TPS-RX97-US	9154 0029
	WP-HDMI-TPS-RX97-UK	9154 0028
	WP-HDMI-TPS-TX97-EU	9154 0033
	WP-HDMI-TPS-TX97-US	9154 0035
	WP-HDMI-TPS-TX97-UK	9154 0034
Floor panels	FP-HDMI-TPS-RX97-GB3	9154 0031
	FP-HDMI-TPS-RX97-LEGRAND	9154 0032
	FP-HDMI-TPS-RX97-CRFB	9154 0048
	FP-HDMI-TPS-TX97-GB3	9154 0037
	FP-HDMI-TPS-TX97-LEGRAND	9154 0038
	FP-HDMI-TPS-TX97-CRFB	9154 0049

The thoroughly redesigned form factor of the wall and floor panels allows for easier connecting and removing cables in narrow spaces (behind TV sets, under floor panel lids) and reduces cable bending and breaking. The built-in cable tie-down points further ensure stable connection and reduce cable stress.

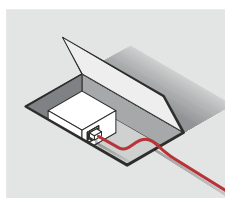
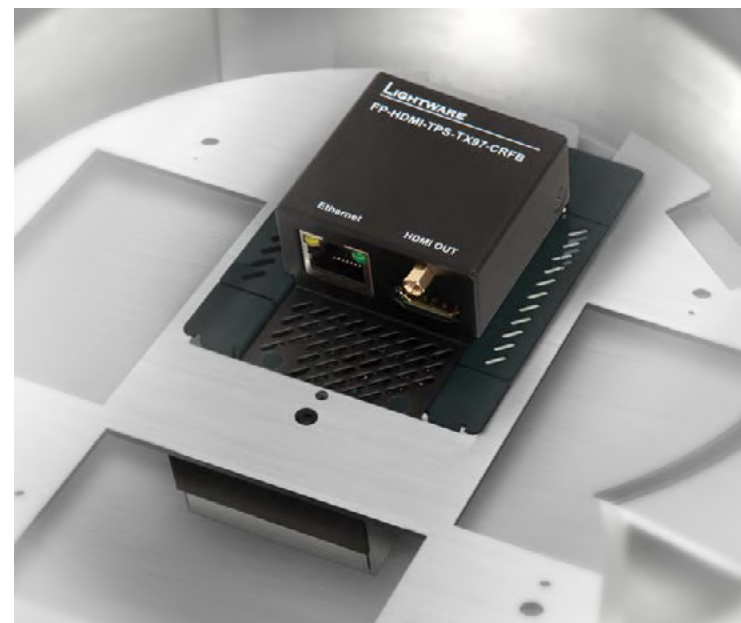

Cable access example with Floorbox extender.

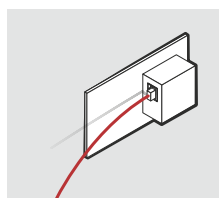

Cable access and orientation example with wallplate extenders.

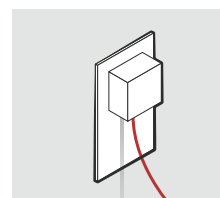

Cable access and orientation example with wallplate extenders.

FP-HDMI-TPS-TX97-CRFB

FP-UMX-TPS-TX120 and FP-UMX-TPS-TX130

Part No: 9154 0055(-TX120), 9154 0047(-TX130)



The FP-UMX-TPS120 and FP-UMX-TPS130 are flagship models in the Lightware TPS (HDBaseT™ Transmitter) product family. The devices can transmit universal video, audio and control up to a 170 meter distance over a single CAT cable in dynamically changing environments such as small board rooms and classrooms. The extenders were designed to handle digital and analog video and audio signals: VGA, YPrPb, HDMI 1.4 and DP 1.1 with analog stereo audio from local inputs or embedded 7.1 HBR audio.

Features:

- HDBaseT™ compatible TPS transmitter wallplate
- 4K / UHD (30Hz RGB 4:4:4, 60Hz YCbCr 4:2:0) and 3D capabilities
- Extends HDMI, DisplayPort* or VGA + Ethernet + RS-232 + IR over a single CAT5e-CAT7e cable to up to 170 m distance**
- Event Manager built-in control application
- Frame detector
- Advanced EDID Management forces the required resolution from any video source and fixes the output format conforming the system requirements
- Audio and video connectors: HDMI, VGA, DisplayPort, Stereo jack
- 10/100 Ethernet transmission
- Bi-directional RS-232 and IR, RS-232 supports command injection
- HDCP compliant, CEC, EDID transparent
- Active cooling
- Local audio embedding
- Also available in white colour
- Remote (PoE) or local power source
 - * FP-UMX-TPS-TX130 only
 - ** Depends on cable category and quality

Compatible Lightware mounting bracket kit

For a list of compatible industry standard floor boxes, please refer to the downloadable [User Manual](#).

FP-UMX-TPS MKM Kit

new!

Part Number:
91340029-KIT01

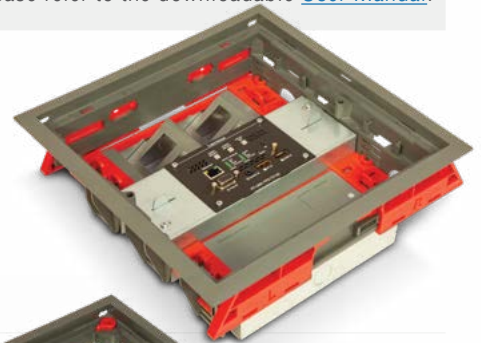

FP-UMX-TPS MKS Kit

new!

Part Number:
91340029-KIT02

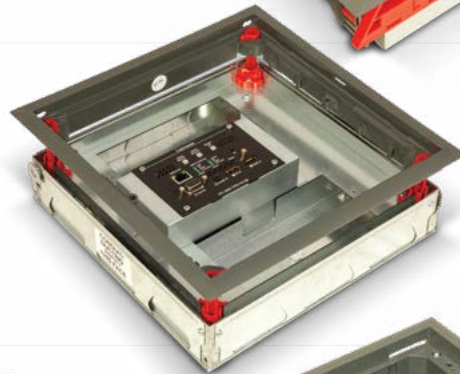

FP-UMX-TPS GES9 Kit

new!

Part Number:
91340029-KIT04



FP-UMX-TPS GES4 Kit

new!

Part Number:
91340029-KIT03



Interfaces and Distribution Amplifiers

Besides the full line of matrix switchers and extenders we also produce interfaces, distribution amplifiers, as well as mounting and other accessories. This is how we make sure you find everything for your desired application in the best Lightware quality under one roof.

HDCP Compliant HDMI and DVI EDID Emulator EDID Manager V4

Part No: 9133 0001

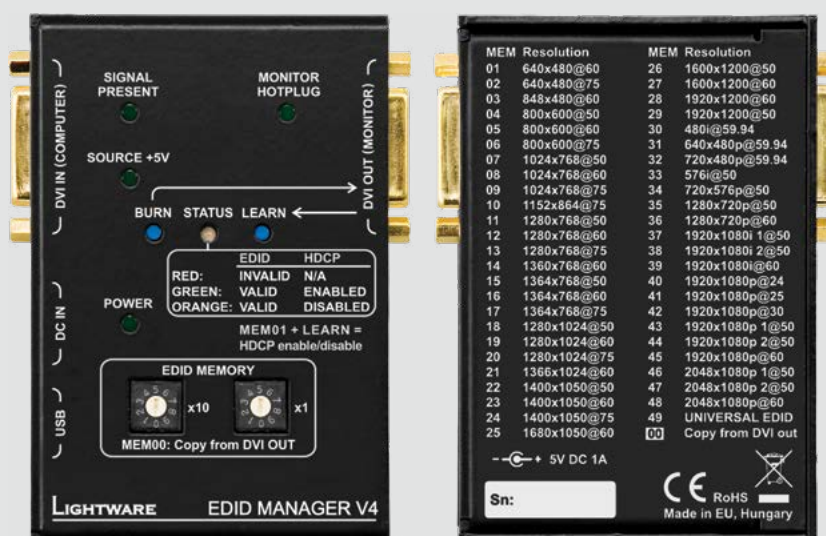

The Lightware EDID Manager V4 is an HDMI/DVI EDID emulator and repeater which can store 79 EDIDs (29 of them user programmable), emulates and keeps a fixed EDID for the source.

Features:

- HDMI/DVI EDID emulator and repeater which emulates and keeps a fixed EDID for the source
- 79 EDID memories 29 of them user programmable
- Up to 60 meters cable loss compensation at input
- Keeps source's HDMI or DVI output continuously active
- HDCP compliancy
- HDCP enable/disable function (to integrate certain laptops into a non-HDCP AV environment)
- Signal detection, source detection and monitor detection LEDs
- USB control
- Free Easy EDID Creator software

Applications:

- Rental and staging
- Post production studios
- Control room
- Digital signage
- Multiroom video
- Conference rooms, collaborative telepresence

4K UHD HDMI Reclocker and EDID Manager **HDMI-4K Manager**

Part No: 9133 0009



4K UHD HDMI Audio De-embedder **HDMI-4K De-embedder**

Part No: 9133 0008



HDMI-4K-Manager is a multifunctional interface with built-in EDID Management and Pixel Accurate Reclocking, supporting DVI and HDMI 1.4 signals with or without HDCP encryption.

Applications:

- Rental and staging
- Medical
- Digital Signage
- Multiroom video
- Conference rooms, collaborative telepresence

Features:

- Multifunctional HDMI interface
- 4K / UHD (30Hz RGB 4:4:4, 60Hz YCbCr 4:2:0) and 3D capabilities
- Multiple powering options over DC plug, USB or HDMI 5V input
- Keeps source's HDMI or DVI output continuously active
- HDCP enable/disable function
- Signal detection, source detection and monitor detection LEDs
- USB control
- Cable loss compensation at Input
- Built-in Advanced EDID Management
- Pixel Accurate Reclocking
- HDCP compliant
- Built-in Video Testpattern Generator
- Deep color support
- Daisy chain support
- Gold-plated connectors

HDMI-4K De-embedder is a multifunctional interface which is capable of audio de-embedding the PCM audio stream. Audio out is a 5-pole Phoenix socket. The unit also features a 3.5 jack output for headphone monitoring.

Applications:

- Rental and staging
- Medical
- Digital Signage
- Multiroom video
- Conference rooms, collaborative telepresence

Features:

- Multifunctional interface for de-embedding the PCM audio stream
- 4K / UHD (30Hz RGB 4:4:4, 60Hz YCbCr 4:2:0) and 3D capabilities
- Multiple powering options over DC plug, USB or HDMI 5V input
- Local audio De-Embedding
- Keeps source's HDMI or DVI output continuously active
- HDCP enable/disable function
- Signal detection, source detection and monitor detection LEDs
- USB control
- Cable loss compensation at Input
- Built-in Advanced EDID Management
- Pixel Accurate Reclocking
- HDCP compliant
- 5-pole Phoenix Balanced Output
- 3.5mm Headphone Output
- Built-in Video Testpattern Generator
- Deep color support
- Daisy chain support
- Free Easy EDID Creator PC software
- Rack mounted or standalone use
- Gold-plated connectors

6x GPIO Trigger Button Panel for Event Manager Room Control

TBP6-EU-K, TBP6-EU-W **new!**

Part No: 9133 0010 (K), 9133 0011 (W)



TBP6 trigger button panel was designed to be used with the Event Manager built-in control feature in select Lightware matrix switcher and extender products.

The button panel can be installed in meeting rooms to perform basic system control actions like input selection, switching the system on/off, increasing or lowering the volume, etc.

This product has a status LED and a backlight, which are fed from the 7th pin of the GPIO connector. The backlight can be switched off, or its intensity can be set to two levels with the help of traditional jumper switches.

Features:

- 6x button panel to trigger events in Event Manager control configurations
- 8-pole Phoenix connector (7x GPIO + GND)
- Mountable to wall
- Status LED and backlight fed from 7th pin on GPIO
- Available in black and white colors

Room Automation Panel
RAP-B511 Series new!



Room Automation Panel (RAP) is an integrated room control interface device for collaboration spaces. RAP features a programmable keypad, a volume knob, and a processor running **Event Manager**, the versatile, proprietary room control application of Lightware.

The stylish unit is available in different sizes and colors fitting EU, US and UK standard electrical boxes and tabletop enclosures. The snap-on front cover is firmly spring-fixed, without the use of screws. Rear panel RS-232, 3x GPIO and 2x RJ45 ports provide connection to controlled devices. The unit is PoE receiver at the first RJ45 connector while the additional RJ45 connector makes cabling flexible, and can supply power to connected PoE receivers, when an optional accessory AC adapter is installed.

Button functions and LED feedback are customizable with the help of our device control software and the provided sticker inlays.

A button press can initiate performing actions in other Lightware products by **Event Manager**, and scheduled tasks can all trigger programmed actions to happen. Room automation panel can send commands to, or set the volume on third party devices as well.



Part Number	Product name	Type	Color
91330012	RAP-B511-EU-K	European 2x60	Black
91330013	RAP-B511-EU-W	European 2x60	White
91330014	RAP-B511-EU-S	European 2x60	Brushed Steel
91330015	RAP-B511-UK-K	English double	Black
91330016	RAP-B511-UK-W	English double	White
91330017	RAP-B511-UK-S	English double	Brushed Steel
91330018	RAP-B511-US-K	USA 2gang	Black
91330019	RAP-B511-US-W	USA 2gang	White
91330020	RAP-B511-US-S	USA 2gang	Brushed Steel

Highlight Features

- Smart Event Manager room control system for collaborative space automation
- Integrated keypad with 11 backlit, programmable buttons
- Rotary knob with a circular line of LED feedback lights to control the volume of Lightware devices, TVs or power amplifiers
- Stylish faceplates with brushed steel, black or white finish
- 2x Ethernet connectivity with PoE reception and transmission
- 1x RS-232 for peripheral device control
- 3x GPIO for motorized screen and shades control
- Real time clock with network time protocol and automatic daylight saving adjustment for **Event Manager** scheduling



Dual-Link DVI Distribution Amplifier

DA2DVI-DL

Part No: 9132 0003



DA2DVI-DL is a single input / 2 output multifunctional Dual- Link DVI distribution amplifier with built-in EDID Management, allowing to create, edit and emulate EDIDs. It distributes signals at the highest resolutions required for military, medical, automotive design and active 3D (60 + 60 Hz) applications.

Features:

- Multifunctional Dual-Link DVI distribution amplifier
- Supports 120 Hz - 3D signals
- Advanced EDID Management
- Quick and easy EDID editing and creation with Advanced EDID Editor software
- Two identical outputs
- Source detection and Monitor detection LED (for DVI-DL OUTPUT1)
- USB connectivity
- Robust metal housing for usage in hard environment
- Locking DC connector
- Rack mountable
- Free Easy EDID Creator software
- Installable on rack or used standalone

SD, HD-SDI and 3G-SDI Distribution Amplifier

DA4-3GSDI

Part No: 9132 0001



Features:

- 3GSDI serial distribution amplifier
- 3G, HD, SD data rates
- Cable lengths:
 - SD-SDI – 400 m
 - HD-SDI – 200 m
 - 3G-SDI – 140 m
- Internal, built-in power supply
- Metal enclosure
- Rack mountable

Single-Link, Dual-Link and HDMI Cable Extenders

DVISL-, DVIDL-, HDMI-, Extender

Part No: 9159 0001 (DVISL), 9159 0002 (HDMI), 9159 0003 (DVIDL)



DVISL-Extender, DVIDL-Extender and HDMI-Extender are matchbox size inline equalizers designed to extend the usable range of high performance DVI, DVI-DL and HDMI signals up to a maximum of 50 m cable length. These extenders are state-of-the- art dynamic equalizers, which perform high speed cable compensation on long DVI and HDMI cables. The amount of equalization is automatically adjusted regardless of the cable length connected. These units provide up to 40 dB of insertion loss correction at 825 Mhz.

Features:

- 50 meter DVI and HDMI cable compensation
- Cable compensation for DDC communication
- Compact sized metal enclosure

4K UHD HDMI Distribution Amplifier with Breakaway Audio

DA2HDMI-4K-Plus-A

Part No: 9132 0006



4K UHD HDMI Distribution Amplifier

DA2HDMI-4K-Plus

Part No: 9132 0007



DA2HDMI-4K-Plus-A is a multifunctional distribution amplifier with audio embedding and de-embedding.

Built-in EDID Management and Pixel Accurate Reclocking, support DVI and HDMI 1.4 signals with or without HDCP encryption. The output signal is reclocked and stabilized using Lightware Pixel Accurate Reclocking technology to remove jitter caused by long cables or poor quality sources.

Applications:

- Rental and staging
- Medical
- Digital Signage
- Multiroom video
- Conference rooms, collaborative telepresence

Features:

- 4K / UHD (30Hz RGB 4:4:4, 60Hz YCbCr 4:2:0) and 3D capabilities
- Local audio Embedding and De-Embedding
- Multiple powering options over DC plug, USB or HDMI 5V input
- Keeps source's HDMI or DVI output continuously active
- HDCP enable/disable function
- Signal detection, source detection and monitor detection LEDs
- USB control
- Cable loss compensation at Input
- Built-in Advanced EDID Management
- Pixel Accurate Reclocking
- HDCP compliant
- 3.5mm Jack input for audio embedding
- 5-pole Phoenix Balanced Output
- 3.5mm Headphone Output for monitoring
- Built-in Video Testpattern Generator
- Deep color support
- Daisy chain support
- Free Easy EDID Creator software
- Installable on rack or used standalone

DA2HDMI-4K-Plus is a multifunctional distribution amplifier with built-in EDID Management and Pixel Accurate Reclocking, supporting DVI and HDMI 1.4 signals with or without HDCP encryption. The output signal is reclocked and stabilized using Lightware Pixel Accurate Reclocking technology to remove jitter caused by long cables or poor quality sources.

Applications:

- Rental and staging
- Medical
- Digital Signage
- Multiroom video
- Conference rooms, collaborative telepresence

Features:

- Multifunctional distribution amplifier
- 4K / UHD (30Hz RGB 4:4:4, 60Hz YCbCr 4:2:0) and 3D capabilities
- Multiple powering options over DC plug, USB or HDMI 5V input
- Keeps source's HDMI or DVI output continuously active
- HDCP enable/disable function
- Signal detection, source detection and monitor detection LEDs
- USB control
- Cable loss compensation at Input
- Built-in Advanced EDID Management
- Pixel Accurate Reclocking
- HDCP compliant
- Built-in Video Testpattern Generator
- Deep color support
- Daisy chain support
- Free Easy EDID Creator software
- Installable on rack or used standalone

Fiber Optical Extenders

Lightware Fiber Optical Extenders are designed to easily overcome large distances. We provide DVI, HDMI, universal video, analog and digital stereo audio and control signal extension over extremely long distances of up to 10 kilometers.

These extenders are available with VGA, DVI, HDMI and DisplayPort connectors in various design, size and finish.





HDMI 2.0 Full 4K Fiber Optical Extenders

HDMI20-OPTC-TX220-Pro, HDMI20-OPTC-RX220-Pro

Part No: 9155 0045 (TX), 9155 0044 (RX)

HDMI20-OPTC-TX220-FOX, HDMI20-OPTC-RX220-FOX

Part No: 9155 0001 (TX), 9155 0002 (RX)

HDMI20-OPTC-TX220-NTQ, HDMI20-OPTC-RX220-NTQ

Part No: 9155 0005 (TX), 9155 0006 (RX)

HDMI20-OPTC-TX220-PCN, HDMI20-OPTC-RX220-PCN

Part No: 9155 0003 (TX), 9155 0004 (RX)



M10 mounting threads on the chassis for truss clamps



HDMI20-OPTC-TX220-Pro

The HDMI20-OPTC-TX/RX220-Pro is a HDMI 2.0 and HDCP 2.2 compatible extender pair for video, RS-232 and Gigabit Ethernet signals, supporting uncompressed 4K UHD resolution at 60Hz 4:4:4. This extender pair is particularly recommended for rental and staging applications, 4K live events, and for future-proof operation centers. The extender can transmit HDMI 2.0 signals with 18Gbps over one multimode fiber to a distance up to 700 meters.

Using the factory, custom or transparent EDID emulation the user can fix and lock EDID data on the HDMI connector. Advanced EDID Management forces the required resolution from any video source and fixes the output format conforming to the system requirements. The unit offers bi-directional and transparent RS-232 transmission and two separate Gigabit Ethernet signals over the fiber connection.

All devices can be mounted on a rack shelf or used standalone, rack ears also serve easy handling and bump protection, mounting threads on top and one of the sides to conform strict installation safety regulations.

The device features Pixel Accurate Reclocking, a Lightware technology to eliminate jitter and skew generated by low quality sources and multiple daisy-chained devices.

Single fiber technology makes these units fully HDMI 2.0 compliant without need of a second fiber cable or copper connections.

Galvanic isolation between source and display helps avoiding ground loops and hum effects. No delay occurs in the signal during optical conversion, the video image is transported without frame latency. This feature is crucial in 3D applications and systems where audio is processed separately.

Lightware's HDMI20-OPTC series supports both HDR10 and Dolby Vision in the HDMI signal at 10 or 12 bit speeds respectively, within its frame bandwidth of 18 Gbps maximum.

Features:

- Resolutions up to 4K@60Hz with RGB 4:4:4 colorspace
- 18 Gbps bandwidth
- HDMI 2.0, HDMI 1.x, DVI 1.0 and HDCP 2.2 compliant
- Splitting of 4K UHD at 60Hz to two output ports with left half and right half of the original video
- HDR and Dolby Vision support
- 36-bit deep color support
- 3D signal compatibility with frame packing, side-by-side and top-bottom formats
- 2x HDMI inputs for main/backup sources with autoswitch
- Supports all HDMI audio formats: Dolby TrueHD and DTS-HD Master Audio
- 2x Gigabit Ethernet (control for both outputs)
- Ethernet and USB control options
- Pixel Accurate Reclocking on each input
- Advanced EDID Management
- Color graphic LCD and jog dial push button for front panel control on TX side
- Lightware Device Controller software control over Ethernet and USB
- Third party control with LW3 protocol over Ethernet or RS-232
- Firmware upgrade with Lightware Device Updater software over Ethernet
- Neutrik OpticalCON, Neutrik PowerCON, Neutrik Quad, or Fiberfox optical connectors
- Breakout LC connector
- Local monitor output on TX side
- Built-in universal power supply
- Mounting thread on top and one of the sides and fixed mounting ears for safe and secure installation
- Handles for rigging and safety wire rope

This extender is also available with Neutrik Quad, Neutrik Powercon True1 and FiberFox optical connectors

TX/RX220-NTQ



TX/RX220-FOX



TX/RX220-PCN



HDMI 2.0 Full 4K Fiber Optical Extenders
HDMI20-OPTJ-TX90 and HDMI20-OPTJ-RX90

Part No: 9157 0002 (TX), 9157 0001 (RX)

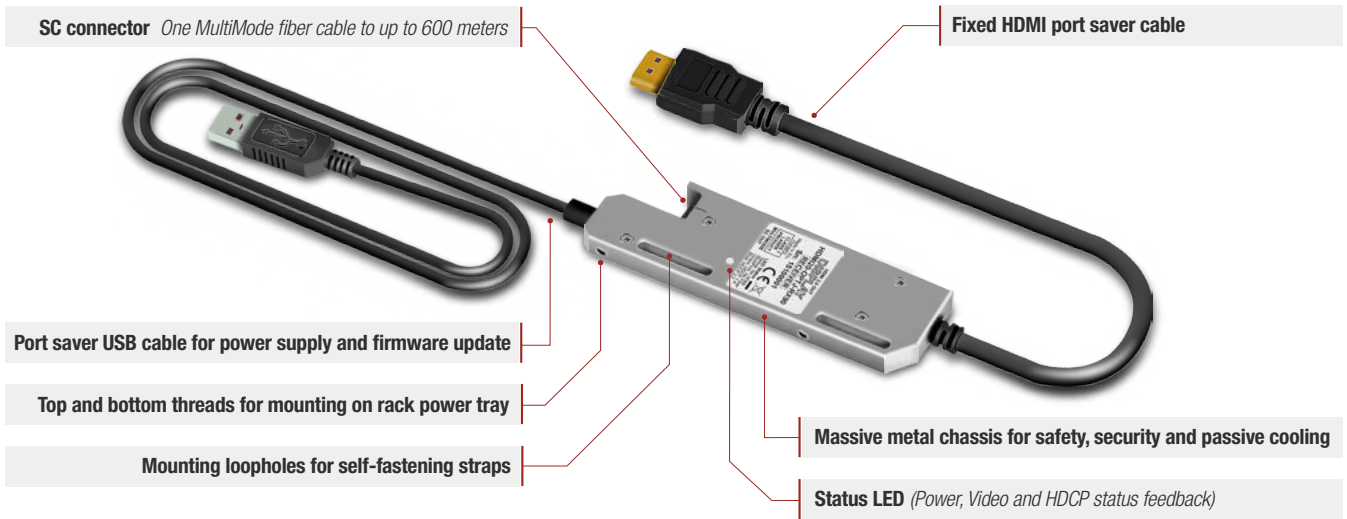

The HDMI20-OPTJ-TX90 and HDMI20-OPTJ-RX90 are HDMI 2.0 compatible optical fiber extenders. These units transfer uncompressed HDMI 2.0 class signals with embedded audio to up to 600 m (1080p60 up to 2500 m) distance, over one MultiMode fiber cable. Embedded HDMI audio signals include Dolby TrueHD and DTS-HD Master Audio.

The maximum resolution is based on the HDMI 2.0 standard: extending uncompressed signals of 4K@60Hz with RGB 4:4:4 colorspace, 36 bit deep color and HDCP 2.2.

These devices have massive, solid aluminum casings, providing excellent cooling, safety, and maximum reliability. There are loops in the chassis for self-fastening straps (commonly known as Velcro straps), to fasten the extender to basically anywhere. The device has an SC optical connector.

Features:

- Resolutions up to 4K@60Hz with RGB 4:4:4 colorspace
- HDMI 2.0, HDMI 1.x and DVI 1.0 compliant
- HDCP 2.2, HDCP 1.4 compliant and CEC, EDID transparent
- 36-bit deep color support
- 3D signal compatibility with frame packing, side-by-side and top-bottom formats
- Zero frame delay: no compression, no latency
- SC connector: one MultiMode fiber cable to up to 600 m distance (1080p60 up to 2500 m)
- HDMI audio formats: Dolby TrueHD and DTS-HD Master Audio
- 5-color Status LED
- Massive metal chassis for safety, security and passive cooling
- Loopholes for mounting with self-fastening straps
- Top and bottom threads for mounting on rack power tray
- Easily replaceable, fixed port saver HDMI and USB 'pigtail' cables
- 3-year warranty (extendable to 5 years)
- Available PowerTray mounting for 16x units with power source for rack installation



HDMI20-OPTJ series front view



OPTJ Powertray with MX2-8x8-HDMI20-Audio-L
 More information on page 108

Combine an MX2-8x8-HDMI20-Audio-L matrix with a fully populated rack tray to create a Full 4K HDMI 2.0 optical matrix.



UMX Series Fiber Optical Transmitter

UMX-OPT-TX150R

Part No: 9151 0020



UMX-OPT-TX150R

UMX-OPT-TX150R is a versatile transmitter which provides long distance connectivity for analog and digital audio and video up to a distance of 2500 m. The extender was designed to handle VGA, DVI-I and HDMI 1.3 signals with analog stereo, 5.1 S/PDIF and 7.1 HDMI embedded audio. Analog video signals are converted into digital formats with digital or digitized analog audio becoming embedded in the video stream. The UMX-OPT-TX150R handles HDCP encryption and includes an HDCP enable/disable setting option.

Features:

- Extends VGA, DVI and HDMI 1.3 signals (YCbCr, RGB formats)
- Accepts analog stereo, 5.1 S/PDIF and even 7.1 HDMI embedded audio signals
- Volume, gain and balance control
- Phase invert and DC filter option
- HDCP compliant, HDCP enable/disable
- Connectors: DVI-I, HDMI and VGA for video, 2 x TRS for analog, 1x RCA for digital audio
- Autoswitch and autosync function for video and audio inputs with priority
- Auto select function for video and audio inputs
- Audio embedding
- Max fiber cable length of 2500 m (using OM3e type fiber)
- All analog signals are converted to digital formats
- Uncompressed video/audio up to 6.75 Gbps
- Input (video & audio) status LEDs
- Bidirectional RS-232 pass through
- Selectable RS-232 baud rates

Standalone Diagram

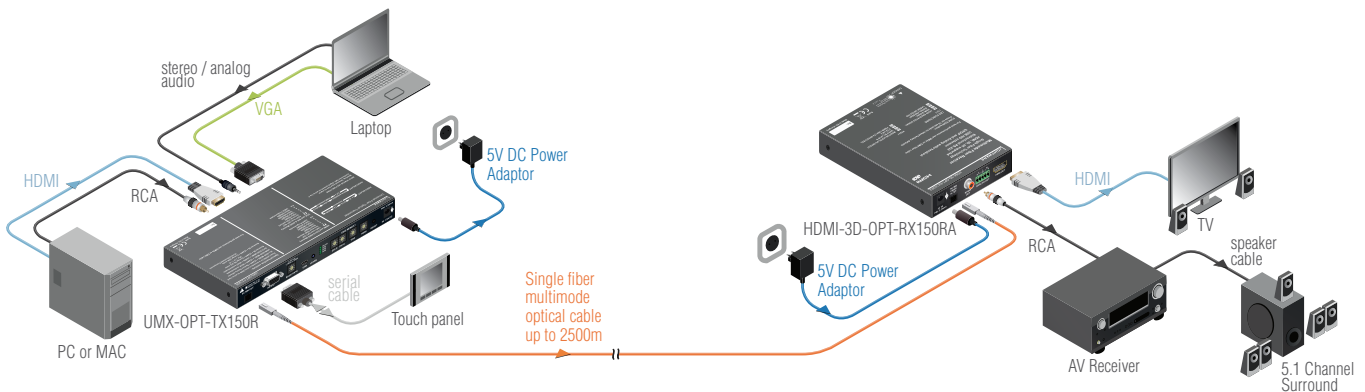

Standalone Diagram

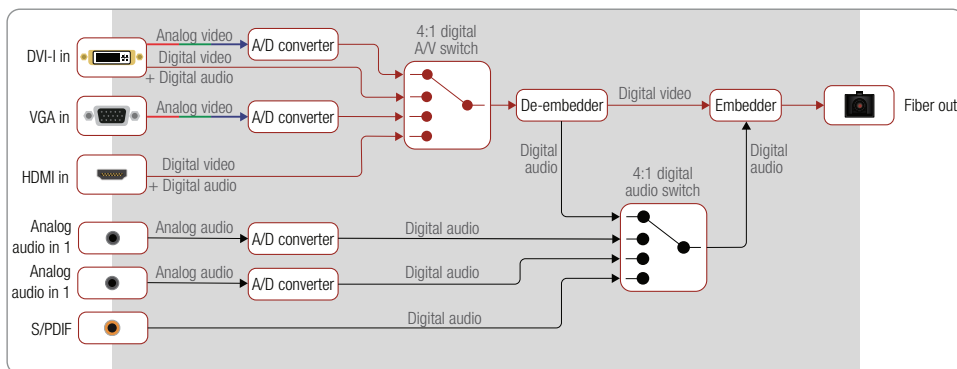

Analog Audio Input

Volume:	-63 .. 0 dB
Gain:	0 .. 24 dB
Balance:	0 .. 100%
Phase invert:	On/Off

Connector-Sized DVI Multimode Fiber Extenders

DVI-OPT-TX110 and **DVI-OPT-RX110**

Part No: 9151 0001 (TX110), 9151 0002 (RX110)



The DVI-OPT-TX110 and DVI-OPT-RX110 pair is a DVI to fiber transmitter / receiver transmitting up to a 2500 m distance. The new, redesigned housing and ports of these units further enhances operation safety and security.

Features:

- DVI Multimode 50/125 fiber extender
- Extends DVI-D signals with Single Fiber Technology
- 1920 x 1200 or 2048 x 1080 maximal resolutions
- Cross compatibility with Lightware fiber devices*
- Plug & Play
- Zero frame delay – no latency
- No compression
- EDID emulation + 1 factory EDID in TX110
- TX Status LEDs: Accurate power detection, EDID state
- RX Status LEDs: Power, laser detect, hotplug detect
- External universal power adaptor for receiver
- Power supplied through DVI connector for transmitter
- DVI connector sized form factor
- Solid Aluminum housing for professional use
- Recessed (slotted) thumbscrews
- Improved ESD protection
- Improved mechanical stability SC connectors
- Secure snap DC plug
- Restorable factory default EDID
- Galvanic isolation against ground loops and humming

*See in compatibility table

Professional Multimode Fiber Extenders

DVI-OPT-TX220-Pro, DVI-OPT-RX220-Pro and DVI-OPT-TX220-ST-Pro, DVI-OPT-RX220-ST-Pro

Part No: 9151 0003 (TX220-Pro), 9151 0004 (RX220-Pro) 9151 0005 (TX220-ST-Pro), 9151 0006 (RX220-ST-Pro)

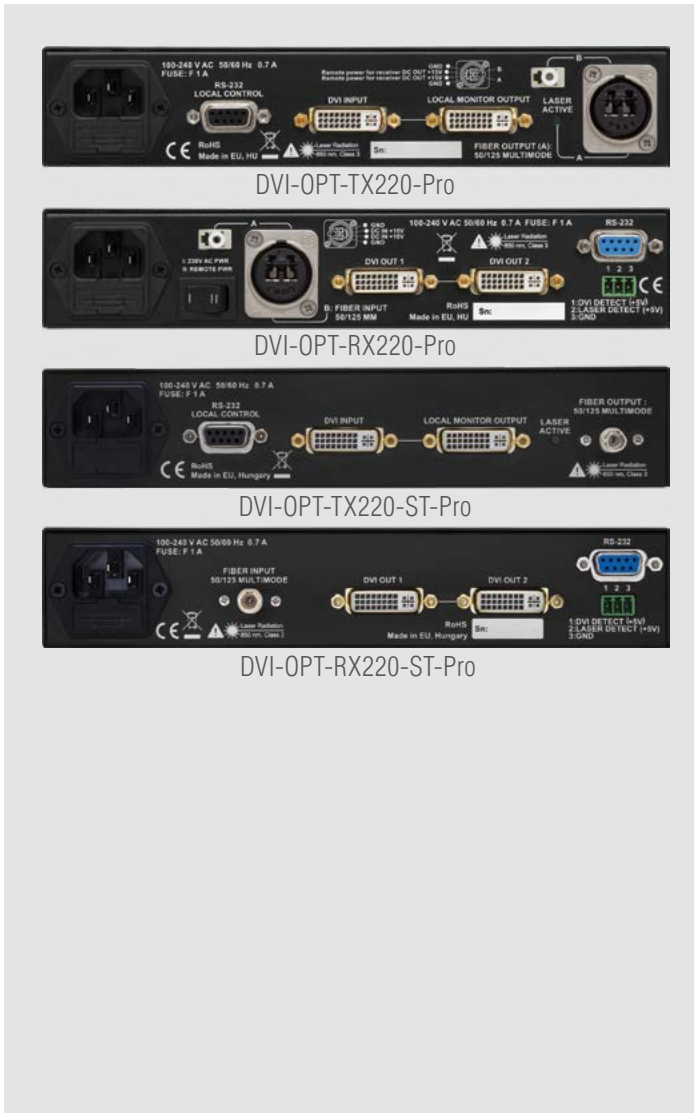

Designed for rental and professional use, the Lightware DVI-OPT 220-Pro series extenders can transmit DVI-D signals over multimode fiber cables up to a 2500 m distance. Using Single Fiber Technology the DVI-D signal is transmitted over one multimode 50/125 fiber core. Sources and display devices are galvanically isolated against ground loops and hum effects. The video image is transported without frame latency and delay in the signal. The Neutrik OpticalCON or ST fiber connectors ensure reliable operation in professional environments. The OpticalCON connectors are rugged, dust proof and reliable and are compatible with standard LC connectors.

Features:

- DVI-D Single Fiber extender
- Extends DVI-D signals with Single Fiber Technology
- 1920 x 1200 or 2048 x 1080 maximal resolutions
- Cross compatibility with any Lightware fiber device*
- Zero frame latency - No delay
- No compression
- Neutrik OpticalCON or ST fiber connectors
- Breakout LC connector for Neutrik B channel (not available in -ST version)
- Advanced EDID Management through front panel LCD menu or serial port (-TX220-Pro)
- Improved DVI signal detection circuit
- Firmware upgrade through serial port
- Status LEDs: source, monitor and laser loss detection
- Local monitor buffered loop output at transmitter
- Pixel Accurate Reclocking (-RX220-Pro)
- Two identical DVI-D outputs at receiver
- Alarm output for fiber and DVI link loss (-RX220-Pro)
- Built-in universal power supply
- Remote power option for receiver (only when using Neutrik 2M-4S75 hybrid fiber cable with 2 fibers + 4 copper wires)
- Improved ESD protection
- Rack, truss or furniture mounting accessories

*See in compatibility table

100 Series HDMI Fiber Optical Extenders
HDMI-OPT-TX/RX100, HDMI-OPT-TX/RX100R

Part No: 9151 0009 (TX100), 9151 0010 (RX100), 9151 0011 (TX100R), 9151 0012 (RX100R),

200 Series HDMI Fiber Optical Extenders
HDMI-OPT-TX200R, HDMI-OPT-RX200R

Part No: 9151 0013 (TX200R), 9151 0014 (RX200R)



HDMI-OPT 100 series devices extend HDMI 1.3, DVI 1.0, HDCP and bi-directional RS-232 (optional add-on in „R” versions) signals over one multimode fiber and transmit the video signal with Embedded Audio up to a 2500 m distance.

Features:

- HDMI Single Fiber optical extenders
- SC fiber optical connectors
- Extends DVI or HDMI signals over one multimode fiber core
- HDMI to DVI conversion (when using DVI monitor)
- 1920 x 1200 or 2048 x 1080 maximal resolutions
- HDCP 1.1 compliant
- Pixel Accurate Reclocking
- Zero frame delay – No signal latency
- No compression
- Cross compatibility with any Lightware fiber device*
- Advanced EDID Management in both transmitter and receiver
- Twist and lock DC power plug
- Several status LEDs: source, display, signal, HDCP and laser detection, EDID validity
- Robust metal housing, rack mountable

*See in compatibility table

HDMI-OPT 200 series have all the features of the 100 series but also include an additional local monitor HDMI output to enable easy monitoring of the outgoing signal on the transmitter, and two identical HDMI outputs through a built-in distribution amplifier on the receiver.

Features:

- HDMI Single Fiber optical extenders with local HDMI monitoring
- SC fiber optical connectors
- Extends DVI or HDMI signals over one multimode fiber core
- HDMI to DVI conversion (when using DVI monitor)
- 1920 x 1200 or 2048 x 1080 maximal resolutions
- RS-232 pass through and remote control over fiber
- HDCP 1.1 compliant
- Pixel Accurate Reclocking
- Zero frame delay – No signal latency
- No compression
- Cross compatibility with any Lightware fiber device*
- Advanced EDID Management in both transmitter and receiver
- Twist and lock DC power plug
- Several status LEDs: source, display, signal, HDCP and laser detection, EDID validity
- Local monitor HDMI output in transmitter
- Two identical HDMI outputs in receiver
- Robust metal housing, rack mountable

*See in compatibility table

4K UHD HDMI and DisplayPort Switcher and Multimode Fiber Transmitter

SW4-OPT-TX240RAK

Part No: 9151 0027

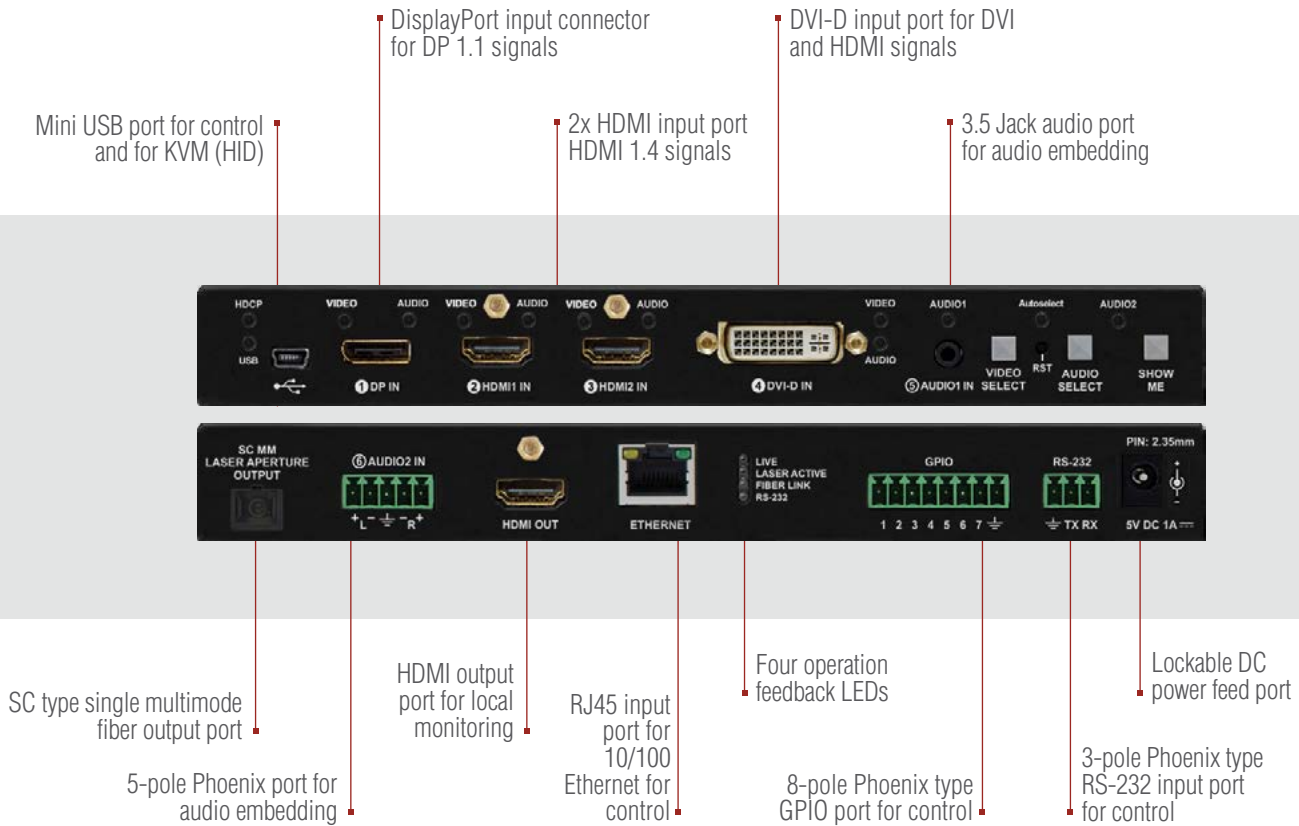

SW4-OPT-TX240RAK extends HDMI 1.4, DVI 1.0, HDCP and bi-directional RS-232 signals over one multimode fiber and transmits video signal with embedded audio to a distance of up to 2500 meters.

Applications:

- Long distance lossless HDMI or DVI signal transmission
- Ground loop isolation
- Professional AV systems, conference rooms
- High End home cinema
- Yacht installations

Features:

- Multimode single fiber transmitter and mini switcher
- 4K/UHD (30Hz RGB 4:4:4, 60Hz YCbCr 4:2:0) and 3D capabilities
- Extends DVI, HDMI or DisplayPort
- Single fiber technology
- **USB KVM (HID) extension**
- Local monitor output
- Analog audio embedding from 3.5mm jack or 5-pole balanced Phoenix ports
- RS-232 pass through and remote control over fiber
- Control via Ethernet, RS-232 or USB
- Pixel Accurate Reclocking
- Zero frame latency, no delay
- No compression
- Cross compatibility with Lightware Fiber devices
- Active status LEDs: signal, HDCP and link detection
- Twist-to-lock DC power plug
- Rack-mountable with optional accessories
- Advanced EDID Management
- GPIO control port
- HDCP compliant
- Built-in **Event Manager** control feature
- CEC



4K UHD HDMI Multimode Single Fiber Extender
HDMI-3D-OPT-TX210A and **HDMI-3D-OPT-TX210RAK**

Part No: 9151 0028 (A), 9151 0030 (RAK)

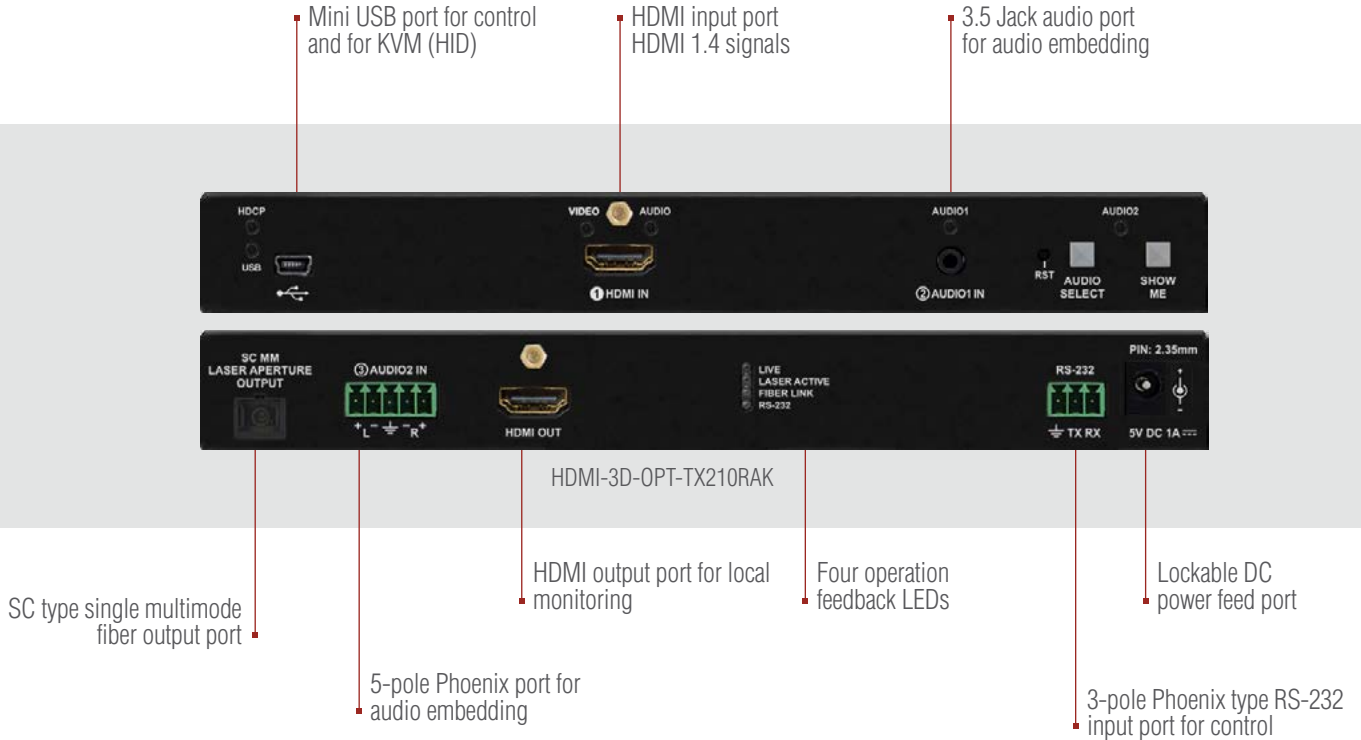

HDMI-3D-OPT-TX210 extends HDMI 1.4, DVI 1.0, HDCP and bi-directional RS-232* signals over one multimode fiber and transmit video signal with embedded audio to a distance of up to 2500 meters.

Applications:

- Rental and staging
- Long distance lossless HDMI or DVI signal transmission
- Ground loop isolation
- Professional AV systems, conference rooms
- High End home cinema
- Yacht installations

Features:

- Multimode single fiber transmitter
- 4K/UHD (30Hz RGB 4:4:4, 60Hz YCbCr 4:2:0) and 3D capabilities
- Multimode single fiber technology
- **USB KVM (HID) extension***
- Extends HDMI 1.4 + Audio + RS-232* over a single multimode fiber
- Local monitor output
- Analog audio embedding from 3.5mm jack or 5-pole balanced Phoenix ports
- RS-232 pass through*
- Control via, RS-232 or USB
- Bi-directional RS-232 extension*
- Pixel Accurate Reclocking
- Zero frame latency, no delay
- No compression
- Cross compatibility with Lightware fiber devices
- Active status LEDs: signal, HDCP and link detection
- Twist-to-lock DC power plug
- Rack-mountable with optional accessories
- Advanced EDID Management
- HDCP compliant
- Built-in **Event Manager** control feature
- CEC

*Only on the TX210RAK version

FAR AWAY, SO CLOSE



EXTEND YOUR SIGNALS TO 2.5 KM



HDMI-3D-OPT-TX210RAK

OPTICAL EXTENDER



4K/UHD



USB/KVM



RS-232



Event Manager



Advanced EDID Manager



Pixel Accurate Reclocking



3D Formats Support



Audio Embedding

4K UHD HDMI, Audio and Control Multimode Fiber Receiver

HDMI-3D-OPT-RX150RA

Part No: 9151 0015

The HDMI-3D-OPT-RX150RA optical receiver provides extension of uncompressed video and audio with optional HDCP encryption and USB HID over one multimode fiber up to a 2500 m distance.

Features:

- HDMI 1.4 + Keyboard + Mouse fiber extender
- Up to 4K x 2K @30Hz or 1080p @60Hz
- HDCP 1.1 compliant extension over one multimode fiber
- 3D compliant
- Audio output: digital S/PDIF and symmetrical analog audio
- Volume, balance, bass and treble control
- Phase invert and de-emphasis option
- **USB KVM (HID) extension**
- Bi-directional RS-232 pass-through
- Uncompressed video/audio up to 9 Gbps
- Single Fiber Technology
- Zero frame latency - No delay
- SC MM fiber connector
- Several status LEDs
- USB control
- Rack mounting options
- Locking DC connector

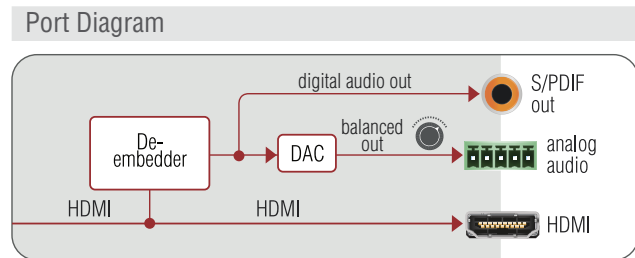

Dual-Link DVI Fiber Extender

DVIDL-OPT-TX200 and DVIDL-OPT-RX100

Part No: 9151 0007 (TX200), 9151 0008 (RX100)

Designed for rental and professional use, the DVIDL-OPT-TX200 and DVIDL-OPT-RX100 extender pair can transmit Dual-Link DVI signals over two multimode fiber cables for up to a 2500 meter distance. Neutrik OpticalCON DUO are compatible with industry standard LC Duplex fiber cables.

Features:

- Extends Dual-Link DVI-D signals over two fibers
- 4096 x 2400 maximal resolution
- Single-Link operation mode with one fiber
- Zero frame latency - No delay
- No compression
- Neutrik OpticalCON fiber connectors
- Advanced EDID Management in transmitter
- USB port for control and firmware upgrade
- Status LEDs: source, signal, monitor and laser loss detection
- Local monitor buffered loop output at transmitter
- TMD5 Reclocking in receiver
- Improved ESD protection
- Rack mounting accessories



DVIDL-OPT-RX100

DVIDL-OPT-TX200

DisplayPort Fiber Optical Extender

DP-OPT-TX100 and DP-OPT-RX100

Part No: 9151 0016 (TX100), 9151 0017 (RX100)



KVM DisplayPort Fiber Optical Extender

DP-OPT-TX150 and DP-OPT-RX150

Part No: 9151 0018 (TX150), 9151 0019 (RX150)

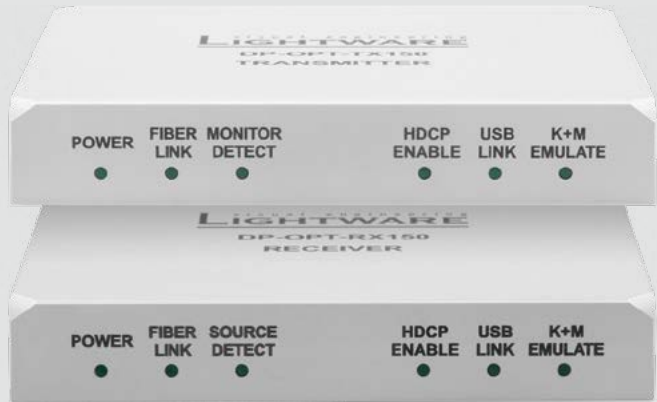

Designed for use in both AV and IT applications, this DisplayPort extender pair provides extension up to 4K / UHD (30Hz RGB 4:4:4, 60Hz YCbCr 4:2:0) resolution on long 1100m distances.

Features:

- DisplayPort 1.1a extension over one multimode fiber
- Dual-mode DP: supports DVI and HDMI adaptors
- 4K / UHD (30Hz RGB 4:4:4, 60Hz YCbCr 4:2:0)
- 10.8 Gbps datarate
- HDCP 1.1 compliant extension over one multimode fiber
- Full support of link training
- Compatible with Apple LED Cinema Display and 30" LCD displays
- Single Fiber Technology

DP-OPT-TX150 and DP-OPT-RX150 devices extend Dual-mode DisplayPort 1.1a high resolution video and Embedded Audio with optional HDCP encryption plus USB HID over one multimode fiber up to 1100 m.

Features:

- DisplayPort 1.1a + Keyboard + Mouse fiber extender
- Plug and Play – no drivers required
- Up to UHD and 4096x2400@30Hz pixel resolution
- HDCP 1.1 compliant extension over one multimode fiber
- Compatible with Apple LED Cinema Display
- Support of the latest Mac laptop and desktop computers with Thunderbolt port

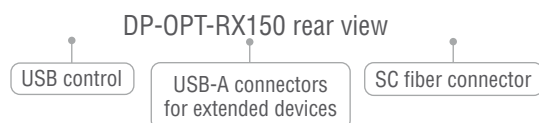
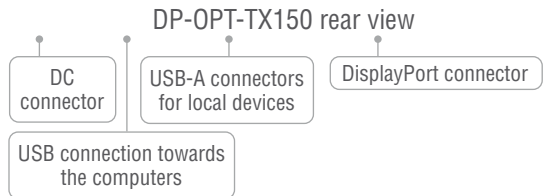

Neutrik OpticalCON Breakout Box

BR-NT

Part No: 9159 0008



Features:

- Distributes one Neutrik connector's fiber A and fiber B channels to two Neutrik connectors
- Passive two-way design, can be used for splitting or combining fibers
- 1/4 rack housing, rack-mountable

Passive Optical Splitters

SP2OPT-LC, SP2OPT-NT, SP2OPT-SC, SP2OPT-ST

Part No: 9159 0004 (LC), 9159 0005 (NT), 9159 0006 (SC), 9159 0007 (ST)

SP2OPT distributes one optical signal to two identical outputs. No power supply is required as the devices have no active electrical parts.

Features:

- Splits fiber signal to 2 destinations
- Selectable connectors: Neutrik OpticalCON, -LC, -SC, -ST
- No power required
- 1/4 rack width, metal enclosure
- Mounting options for rack, furniture or truss
- Two identical outputs



SP2OPT-NT



SP2OPT-LC





SP2OPT-SC



SP2OPT-ST

Transmitters	Receivers	Rack and Desk Mount Unit											MX Boards		
		DP-OPT-RX100	DP-OPT-RX150	DVI-OPT-RX110	DVI-HDCP-OPTM-RX90	DVI-HDCP-OPTS-RX90	DVIDL-OPT-RX100	DVI-OPT-RX220-Pro	HDMI-OPT-RX100	HDMI-OPT-RX100R	HDMI-OPT-RX200R	HDMI-3D-OPT-RX150RA	HDMI20-OPTC-RX220-Pro	HDMI20-OPTJ-RX90	MX-HDMI-OPT-IB
DP-OPT-TX100	DP														
DP-OPT-TX150	DP K														
DVI-OPT-TX110			D			D	D	D	D	D	D			D	D
DVI-HDCP-OPTM-TX90				H											
DVI-HDCP-OPTS-TX90					H										
DVIDL-OPT-TX200			D			D	D	D	D	D	D			D	D
DVI-OPT-TX220-Pro			D			D	D	D	D	D	D			D	D
HDMI-OPT-TX100			D			D	D	H	H	H	H			H	D
HDMI-OPT-TX100R			D			D	D	H	H	H	H			H	D
HDMI-OPT-TX200R			D			D	D	H	H	H	H			H	D
UMX-OPT-TX150R			D			D	D	H	H	H	H			H	D
HDMI-3D-OPT-TX210A			D			D	D	H	H	H	H			H	D
HDMI-3D-OPT-TX210RAK			D			D	D	H	H	H	H	K		H	D
SW4-OPT-TX240RAK			D			D	D	H	H	H	H	K		H	D
HDMI20-OPTC-TX220-Pro												H2 R			
HDMI20-OPTJ-TX90													H2		
MX-HDMI-OPT-OB			D			D	D	H	H	H	H			H	D
MX-DVI-OPT-OB			D			D	D	D	D	D	D			D	D
MX-DVI-OPT-OB-RCLK			D			D	D	D	D	D	D			D	D

 Remote power
 No remote power

H HDMI/DVI transmission
H2 HDMI 2.0
DP DisplayPort

 HDCP compliant
D DVI transmission
 DVI Dual-Link

R RS-232 pass-through
K USB KVM extension
– None of the above

Fiber Optical Extension system Comparison Chart

		Rack and Desk Mount Units											MX Boards			
		DVI-OPT-TX110	DVI-OPT-TX220-Pro	DVI-HDCP-OPTS-TX90	DVI-HDCP-OPTM-TX90	DVIDL-OPT-TX200	HDMI-OPT-TX100	HDMI-OPT-TX100R	HDMI-OPT-TX200R	UMX-OPT-TX150R	HDMI-3D-OPT-TX210A	HDMI-3D-OPT-TX210RAK	SW4-OPT-TX240RAK	MX-DVI-OPT-OB	MX-DVI-OPT-OB-RCLK	MX-HDMI-OPT-OB
Main Features	HDCP and HDMI 1.3a compliant	x	x	x	x	x	✓	✓	✓	✓	✓	✓	✓	x	x	✓
	Pixel Accurate Reclocking	x	x	x	x	x	✓	✓	✓	✓	✓	✓	✓	x	✓	x
EDID	Advanced EDID Management	x	✓	x	x	✓	✓	✓	✓	✓	✓	✓	✓	x	✓	✓
Audio	Analog audio embedding	x	x	x	x	x	x	x	x	✓	✓	✓	✓	x	x	x
	S/PDIF audio embedding	x	x	x	x	x	x	x	x	✓	x	x	x	x	x	x
Input Connectors	HDMI input	x	x	x	x	x	✓	✓	✓	✓	✓	✓	✓	n/a	n/a	n/a
	DVI input	✓	✓	✓	✓	✓	x	x	x	✓	x	x	✓	n/a	n/a	n/a
	DP input	x	x	x	x	x	x	x	x	x	x	x	✓	x	x	x
	VGA input	x	x	x	x	x	x	x	x	✓	x	x	x	x	x	x
	Audio input	x	x	x	x	x	x	x	x	✓	✓	✓	✓	x	x	x
	RS-232	x	x	x	x	x	x	✓	✓	✓	x	✓	✓	n/a	n/a	n/a
Output Connectors	Optical connector	SC	NT,LC	LC	LC	NT,LC	SC	SC	SC	SC	SC	SC	SC	LC,SC,ST	Any	Any
	Local: buffered DVI/HDMI output	x	✓	x	x	✓	x	x	✓	x	✓	✓	✓	x	x	x
Misc	Software control	x	✓	x	x	x	x	✓	✓	✓	✓	✓	✓	✓	✓	✓
	USB KVM	x	x	x	x	x	x	x	x	✓	x	✓	✓	x	x	x

		Rack and Desk Mount Units										MX Boards	
		DVI-OPT-RX110	DVI-OPT-RX220-Pro	DVI-HDCP-OPTS-RX90	DVI-HDCP-OPTM-TX90	DVIDL-OPT-RX100	HDMI-OPT-RX100	HDMI-OPT-RX100R	HDMI-OPT-RX200R	HDMI-3D-OPT-RX150RA	MX-DVI-OPT-IB	MX-HDMI-OPT-IB	
Main Features	HDCP and HDMI 1.3a compliant	x	x	x	x	x	✓	✓	✓	✓	x	✓	
	TMDS Reclocking	x	✓	x	x	✓	✓	✓	✓	✓	x	x	
	Pixel Accurate Reclocking	x	✓	x	x	x	✓	✓	✓	✓	x	x	
Audio	Analog audio de-embedding	x	x	x	x	x	x	x	x	✓	x	x	
	S/PDIF audio de-embedding	x	x	x	x	x	x	x	x	✓	x	x	
Input	Optical connector	SC	NT, LC	LC	LC	NT, LC	SC	SC	SC	SC	Any	Any	
Output Connectors	HDMI output	x	x	x	x	x	✓	✓	✓	✓	n/a	n/a	
	DVI output	✓	✓	✓	✓	✓	x	x	x	x	n/a	n/a	
	Dual buffered output	x	✓	x	x	x	x	x	✓	x	n/a	n/a	
	Audio output	x	x	x	x	x	x	x	x	✓	x	x	
	RS-232	x	x	x	x	x	x	✓	✓	✓	n/a	n/a	
Misc	Software control	x	✓	x	x	x	x	✓	✓	✓	✓	✓	
	USB-KVM	x	x	x	x	x	x	x	x	✓	x	x	

Mounting Accessories



Under-Desk (UD) Mounting Kit Part No: 5240 0275

The UD-kit makes easy to mount a single device on any flat surface (e.g. furniture).

Compatible products:

- DA2DVI-DL
- DP-OPT-TX100
- DP-OPT-RX100
- DVI-TP-TX200
- DVI-TP-TX300
- DVI-TP-RX100
- DVI-TP-TX200DL
- DVI-TP-RX100DL
- DVI-HDCP-TPS-TX95
- DVI-HDCP-TPS-RX95
- DVI-HDCP-TPS-TX97
- DVI-HDCP-TPS-RX97
- DVI-HDCP-TPS-RX97
- DVI-HDCP-TP-TX50
- DVI-HDCP-TP-TX100R
- DVI-HDCP-TP-RX50
- DVI-HDCP-TP-RX100R
- HDMI-OPT-TX100
- HDMI-OPT-TX100R



- HDMI-TP-TX200R
- HDMI-TP-RX100R
- HDMI-TP-RX200R
- HDMI-TP-RX100RA
- HDMI-TPS-TX95
- HDMI-TPS-RX95
- HDMI-TPS-TX97
- HDMI-TPS-RX97
- HDMI-TP-TX200R
- HDMI-TP-RX100
- HDMI-TP-RX100R
- HDMI-TP-RX200R
- HDMI-3D-OPT-RX150RA
- HDMI-TP-TX50
- HDMI-TP-RX50
- HDMI-TP-TX100R
- HDMI-TP-RX100R
- HDMI-TP-TX210
- HDMI-TPS-TX210
- HDMI-TPS-TX220
- HDMI-TPS-RX110AY
- UMX-OPT-TX150R
- UMX-TP-TX100R
- UMX-TPS-TX120
- UMX-TPS-TX130
- UMX-TPS-TX140
- UMX-TPS-TX140-Plus
- UMX-HDMI-140
- UMX-HDMI-140-Plus
- MMX4X2-HT200
- MMX4X2-HDMI
- SW4-TPS-TX240
- SW4-OPT-TX240RAK

Dimensions with rack mounting ears: 131,4 W x 67,6 D x 27,5 H mm
Dimensions without rack mounting ears: 103,4 W x 67,6 D x 27,5 H mm

Under-Desk (UD) Mounting Kit Double Part No: 5240 0276

The UD-kit double makes it easy to mount a single device or multiple devices on any flat surface (e.g. furniture).

Compatible products:

- DA2DVI-DL
- DP-OPT-TX100
- DP-OPT-RX100
- DP-OPT-TX150
- DP-OPT-RX150
- DP-TPS-TX210
- DP-TPS-TX220
- DVI-TP-TX200
- DVI-TP-TX300
- DVI-TP-RX100
- DVI-TP-TX200DL
- DVI-TP-RX100DL
- DVI-HDCP-TP-TX50
- DVI-HDCP-TP-TX100R
- DVI-HDCP-TP-RX50
- DVI-HDCP-TP-RX100R
- DVI-HDCP-TPS-TX210
- DVI-HDCP-TPS-TX220
- DVI-HDCP-TPS-TX95
- DVI-HDCP-TPS-RX95
- DVI-HDCP-TPS-TX97
- DVI-HDCP-TPS-RX97
- HDMI-OPT-TX100
- HDMI-OPT-TX100R



- HDMI-TPS-RX97
- HDMI-TPS-TX210
- HDMI-TPS-TX220
- HDMI-TPS-RX110AY
- UMX-OPT-TX150R
- UMX-TP-TX100R
- UMX-TPS-TX120
- UMX-TPS-TX130
- UMX-TPS-TX140
- UMX-TPS-TX140-Plus
- UMX-HDMI-140
- UMX-HDMI-140-Plus
- MMX4X2-HT200
- MMX4X2-HDMI
- SW4-TPS-TX240
- SW4-OPT-TX240RAK
- HDMI-TPS-RX97
- HDMI-TPS-TX210
- HDMI-TPS-TX220
- HDMI-TPS-RX110AY
- UMX-OPT-TX150R
- UMX-TP-TX100R
- UMX-TPS-TX120
- UMX-TPS-TX130
- UMX-TPS-TX140
- UMX-TPS-TX140-Plus
- UMX-HDMI-140
- UMX-HDMI-140-Plus
- MMX4X2-HT200
- MMX4X2-HDMI
- SW4-TPS-TX240
- SW4-OPT-TX240RAK

Dimensions with mounting ears: 252 W x 67,6 D x 27,5 H mm
Dimensions without mounting ears: 224 W x 67,6 D x 27,5 H mm

Mounting Bracket Part No: 5240 0274

The mounting bracket makes through-furniture and under-desk mounting easy and allows truss mounting with standards clamps. The bracket can be ordered separately.

Compatible products:

- DVI-OPT-TX220-Pro
- DVI-OPT-RX220-Pro
- DVI-OPT-TX220-ST-Pro
- DVI-OPT-RX220-ST-Pro



Mounting Bracket V2 Part No: 5240 0273

Compatible products:

- MODEX frames
- MMX6x2-HT200
- MMX6x2-HT210
- UBEX-PRO20-HDMI-F100 / F110 / F120

Rack Cover Part No: 5240 0272 (half) 5240 0271 (quarter)

Rack shelf false faceplates in 1/4 and 1/2 RU width

Lightware Rack Cover Half is designed for use with Lightware Rack shelf. Rack covers are available in two versions: Quarter with quarter-width enclosure and Half with half rack width enclosure. Both versions provide additional thermal management and complement rack appearance.

Rack cover half dimensions: 221 W x 100 D x 42,2 H mm

Rack cover quarter dimensions: 110 W x 100 D x 42,2 H mm



Rack Shelf Part No: 5540 1179

1U high rack shelf provides mounting holes for fastening two half-rack or four quarter-rack sized units. Pocket sized devices can also be fastened on the self.

Compatible products:

- | | | | |
|------------------------|----------------------|------------------------|----------------------|
| ▪ DA2DVI-DL | ▪ DVI-TP-RX100 | ▪ HDMI-OPT-RX100R | ▪ HDMI-TPS-TX220 |
| ▪ DA2DVI-HDCP-Pro | ▪ DVI-TP-TX200DL | ▪ HDMI-OPT-RX200R | ▪ HDMI-TPS-RX110AY |
| ▪ DA4-3GSDI | ▪ DVI-TP-RX100DL | ▪ HDMI-3D-OPT-RX150RA | ▪ MMX4X2-HT200 |
| ▪ DP-OPT-TX100 | ▪ DVI-HDCP-TP-TX50 | ▪ HDMI-3D-OPT-TX210A | ▪ MMX4X2-HDMI |
| ▪ DP-OPT-RX100 | ▪ DVI-HDCP-TP-TX100R | ▪ HDMI-3D-OPT-TX210RAK | ▪ UMX-OPT-TX150R |
| ▪ DP-OPT-TX150 | ▪ DVI-HDCP-TP-RX50 | ▪ HDMI-TP-TX50 | ▪ UMX-TP-TX100R |
| ▪ DP-OPT-RX150 | ▪ DVI-HDCP-TP-RX100R | ▪ HDMI-TP-RX50 | ▪ UMX-TPS-TX120 |
| ▪ DP-TPS-TX210 | ▪ DVI-HDCP-TPS-TX95 | ▪ HDMI-TP-TX100R | ▪ UMX-TPS-TX130 |
| ▪ DP-TPS-TX220 | ▪ DVI-HDCP-TPS-RX95 | ▪ HDMI-TP-RX100R | ▪ UMX-TPS-TX140 |
| ▪ DVI-HDCP-TPS-TX210 | ▪ DVI-HDCP-TPS-TX97 | ▪ HDMI-TP-RX200R | ▪ UMX-TPS-TX140-Plus |
| ▪ DVI-HDCP-TPS-TX220 | ▪ DVI-HDCP-TPS-RX97 | ▪ HDMI-TP-RX200R | ▪ UMX-HDMI-140 |
| ▪ DVI-OPT-TX220-Pro | ▪ DVIDL-OPT-TX200 | ▪ HDMI-TP-RX100RA | ▪ UMX-HDMI-140-Plus |
| ▪ DVI-OPT-RX220-Pro | ▪ DVIDL-OPT-RX100 | ▪ HDMI-TPS-TX95 | ▪ SW4-TPS-TX240 |
| ▪ DVI-OPT-TX220-ST-Pro | ▪ HDMI-OPT-TX100 | ▪ HDMI-TPS-RX95 | ▪ SW4-OPT-TX240RAK |
| ▪ DVI-OPT-RX220-ST-Pro | ▪ HDMI-OPT-TX100R | ▪ HDMI-TPS-TX97 | |
| ▪ DVI-TP-TX200 | ▪ HDMI-OPT-TX200R | ▪ HDMI-TPS-RX97 | |
| ▪ DVI-TP-TX300 | ▪ HDMI-OPT-RX100 | ▪ HDMI-TPS-TX210 | |

Dimensions with rack mounting ears: 482,6 W x 180 D x 44,25 H mm

Dimensions without rack mounting ears: 445 W x 180 D x 44,25 H mm



Power Supply and Accessories

Rack-Mountable Power Supply Units (PSU)

PSU2x10-200-12V, PSU2x10-200-5V, PSU2x20-400-12V, PSU2x20-400-5V

Part No: 9134 0024;

9134 0023;

9134 0022;

9134 0021



These products have redesigned 2019 hardware featuring the same technical specifications as the previous models.

Power supply is the heart of all electrical devices, the core of any secure and reliable system.

Lightware provides four types of multiple output power supplies. All of them accept 115-230V AC, 47-63Hz housed in a 1U metal rack enclosure for durability and easier mounting. 5V and 12V DC output versions are available with either 10 or 20 separate output connectors, each version is cooled by two fans integrated on the left side of the housing.

These PSUs are designed to power 10 to 20 Lightware products: TP, TPS and OPT extenders, distribution amplifiers and the EDID Manager V4 with 100.000 hours MTBF value. Several protections are built-in against short circuit, overload, over-voltage, and overheating to enhance reliability.

Features:

- Direct 1U rack mount
- Universal full range AC input
- Available with 5V or 12V power outputs
- Available with 10 or 20 output connectors
- 100.000 hours MTBF
- Two cooling fans integrated
- Built-in active PFC function
- High efficiency up to 90% (typical)
- Protections: Short circuit / Overload / Over voltage / Over temperature
- 3 years warranty

Available Cable Types and Compatible Products:

CAB-5V-U16U

Compatible Products:

- EDID Manager V4
- DVISL-Extender
- DVIDL-Extender
- HDMI-Extender
- DA2DVI-HDCP-Pro
- DA2DVI-DL
- DA2HDMI 4K-Plus-A
- DA2HDMI 4K-Plus
- DP-OPT-RX100
- DP-OPT-TX100
- DVIDL-OPT-RX100
- DVIDL-OPT-TX200
- HDMI-OPT-RX100
- HDMI-OPT-TX100
- HDMI-OPT-RX100R
- HDMI-OPT-TX100R
- HDMI-OPT-RX200R
- HDMI-OPT-TX200R
- HDMI-3D-OPT-TX210A
- HDMI-3D-OPT-TX210RAK
- HDMI 4K Manager
- HDMI-4K De-embedder
- UMX-OPT-TX150R
- DVI-TP-RX100
- DVI-TP-RX100DL
- DVI-TP-TX200
- DVI-TP-TX200DL
- DVI-TP-TX300
- SW4-OPT-TX240RAK
- Remote control panels

CAB-5V-U16S

Compatible Products:

- DVI-OPT-RX110
- DVI-OPT-TX110
- DP-OPT-RX150
- DP-OPT-TX150

CAB-5V-U16M

Compatible Products:

- DVI-HDCP-OPTS-RX90
- DVI-HDCP-OPTS-TX90
- DVI-HDCP-OPTM-RX90
- DVI-HDCP-OPTM-TX90

CAB-12V-U16U

Compatible Products:

- BR-TP-COM
- DP-TPS-TX210
- DP-TPS-TX220
- HDMI-TPS-RX95
- HDMI-TPS-TX95
- HDMI-TPS-TX210
- HDMI-TPS-TX220
- HDMI-TPS-TX97
- HDMI-TPS-RX97
- HDMI-TPS-RX110AY
- DVI-HDCP-TPS-TX210
- DVI-HDCP-TPS-TX210
- DVI-HDCP-TP-RX100R
- DVI-HDCP-TP-RX50
- DVI-HDCP-TP-TX100R
- DVI-HDCP-TP-TX50
- DVI-HDCP-TPS-TX97
- DVI-HDCP-TPS-RX97
- HDMI-TP-RX100R
- HDMI-TP-RX100RA
- HDMI-TP-RX200R
- HDMI-TP-RX50
- HDMI-TP-TX100R
- HDMI-TP-TX200R
- HDMI-TP-TX50
- UMX-TP-TX100R
- MMX4x2-HT200
- MMX4x2-HDMI
- SW4-TPS-TX240

Lightware developed several accessories to support mounting in various environments. This compatibility table shows a summary on product compliance with the mounting accessories.

	Product name	Rack shelf	UD-kit double	UD-kit	Mounting bracket
	DA4-3GSDI	✓(4)	✗	✗	✗
	DA2DVI-HDCP-Pro	✓(4)	✗	✗	✗
	DA2DVI-DL	✓(4)	✓(2)	✓(1)	✗
Twisted pair extenders for DVI signal	DVI-TP-TX200	✓(4)	✓(2)	✓(1)	✗
	DVI-TP-TX200DL	✓(4)	✓(2)	✓(1)	✗
	DVI-TP-TX300	✓(4)	✓(2)	✓(1)	✗
	DVI-TP-RX100	✓(4)	✓(2)	✓(1)	✗
	DVI-TP-RX100DL	✓(4)	✓(2)	✓(1)	✗
Twisted pair extenders for HDMI signal	DVI-HDCP-TP-TX50	✓(4)	✓(2)	✓(1)	✗
	DVI-HDCP-TP-TX100R	✓(4)	✓(2)	✓(1)	✗
	DVI-HDCP-TP-RX50	✓(4)	✓(2)	✓(1)	✗
	DVI-HDCP-TP-RX100R	✓(4)	✓(2)	✓(1)	✗
	HDMI-TP-TX50	✓(4)	✓(2)	✓(1)	✗
	HDMI-TP-TX100R	✓(4)	✓(2)	✓(1)	✗
	HDMI-TP-TX200R	✓(4)	✓(2)	✓(1)	✗
	HDMI-TP-RX50	✓(4)	✓(2)	✓(1)	✗
	HDMI-TP-RX100R	✓(4)	✓(2)	(1)	✗
	HDMI-TP-RX100RA	✓(4)	✓(2)	✓(1)	✗
HDMI-TP-RX200R	✓(4)	✓(2)	✓(1)	✗	
Twisted pair extenders for universal signal	UMX-TP-TX100R	✓(2)	✓(1)	✗	✗
TPS extenders for DP signal	DP-TPS-TX210	✓(2)	✓(1)	✗	✗
	DP-TPS-TX220	✓(2)	✓(1)	✗	✗
TPS extenders for DVI signal	DVI-HDCP-TPS-TX97	✓(4)	✓(2)	✓(1)	✗
	DVI-HDCP-TPS-TX97	✓(4)	✓(2)	✓(1)	✗
	DVI-HDCP-TPS-TX95	✓(4)	✓(2)	✓(1)	✗
	DVI-HDCP-TPS-RX95	✓(4)	✓(2)	✓(1)	✗
	DVI-HDCP-TPS-TX210	✓(2)	✓(1)	✗	✗
	DVI-HDCP-TPS-TX220	✓(2)	✓(2)	✗	✗
TPS extenders for HDMI signal	HDMI-TPS-TX97	✓(4)	✓(2)	✓(1)	✗
	HDMI-TPS-RX97	✓(4)	✓(2)	✓(1)	✗
	HDMI-TPS-TX95	✓(4)	✓(2)	✓(1)	✗
	HDMI-TPS-RX95	✓(4)	✓(2)	✓(1)	✗
	HDMI-TPS-TX210	✓(2)	✓(1)	✗	✗
	HDMI-TPS-TX220	✓(2)	✓(1)	✗	✗
	UMX-TPS-TX120	✓(2)	✓(1)	✗	✗
	UMX-TPS-TX130	✓(2)	✓(1)	✗	✗
	UMX-TPS-TX140	✓(2)	✓(1)	✗	✗
	SW4-TPS-TX240	✓(2)	✓(1)	✗	✗
Optical extenders for DVI signal	DVI-OPT-TX110	✗	✗	✗	✗
	DVI-OPT-TX220-Pro	✓(2)	✗	✗	✓(1)
	DVI-OPT-TX220-ST-Pro	✓(2)	✗	✗	✓(1)
	DVI-OPT-RX110	✗	✗	✗	✗
	DVI-OPT-RX220-Pro	✓(2)	✗	✗	✓(1)
	DVI-OPT-RX220-ST-Pro	✓(2)	✗	✗	✓(1)
	DVI-HDCP-OPTS-TX90	✗	✗	✗	✗
	DVI-HDCP-OPTS-RX90	✗	✗	✗	✗
	DVI-HDCP-OPTM-TX90	✗	✗	✗	✗
	DVI-HDCP-OPTM-RX90	✗	✗	✗	✗
	DVIDL-OPT-TX200	✓(4)	✗	✗	✗
	DVIDL-OPT-RX100	✓(4)	✗	✗	✗
	Optical extenders for HDMI signal	HDMI-OPT-TX100	✓(4)	✓(2)	✓(1)
HDMI-OPT-TX100R		✓(4)	✓(2)	✓(1)	✗
HDMI-OPT-TX200R		✓(4)	✓(2)	✓(1)	✗
HDMI-OPT-RX100		✓(4)	✓(2)	✓(1)	✗
HDMI-OPT-RX100R		✓(4)	✓(2)	✓(1)	✗
HDMI-OPT-RX200R		✓(4)	✓(2)	✓(1)	✗
HDMI-3D-OPT-RX150RA		✓(4)	✓(2)	✓(1)	✗
Optical extenders for universal signal	UMX-OPT-TX150R	✓(2)	✓(1)	✗	✗
Optical extenders for DP signal	DP-OPT-TX100	✓(4)	✓(2)	✓(1)	✗
	DP-OPT-RX100	✓(4)	✓(2)	✓(1)	✗
	DP-OPT-TX150	✓(4)	✓(2)	✗	✗
	DP-OPT-RX150	✓(4)	✓(2)	✗	✗

The number after the ✓ sign shows the number of products that can be mounted by the accessory simultaneously. Please note that Lightware's standalone matrix switchers, modular digital matrix frames and remote control panels are delivered with their own rack mounting ears. Interfaces and wallplate extenders are not compatible with any of the accessories listed above.

Rack-mountable PowerTray for up to 16x HDMI20-OPTJ-TX/RX90 Optical Extenders

OPTJ Power Tray NTD, OPTJ Power Tray NTQ, OPTJ Power Tray SC

Part No: 9134 0019 (NTD), 9134 0020 (NTQ), 9134 0018 (SC)

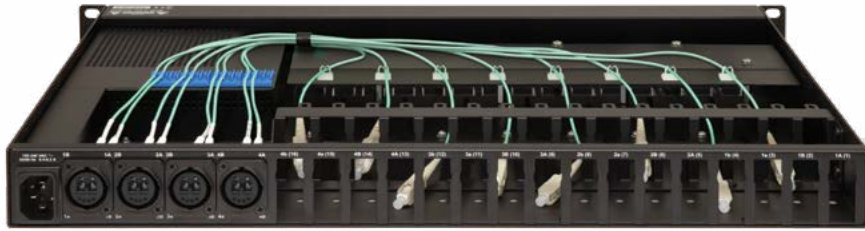

NTD



NTQ

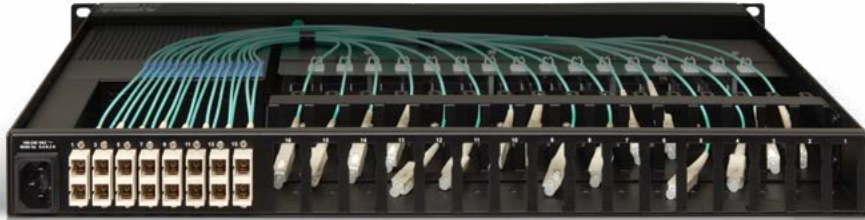

SC

The PowerTray is a 1RU size housing accessory which can enclose up to 16 HDMI20-OPTJ-TX/RX90 units, also providing power source for every installed device. The optical fibers are connected to the four Neutrik OpticalCON Quad or SC connectors, each carrying four signal fibers from four of the extenders. There is also a Neutrik OpticalCON Duo product version available, with two fibers connected to each of the four connectors, but while the SC and the Quad versions can house up to 16 devices, this version can accommodate maximum 8 extenders. The HDMI tail cables of the extenders are accessible directly at the back of the PowerTray.

Features

- 1RU size mounting
- Universal full range AC input with standard C14 socket
- Protections: Short circuit / Overload
- 3 years warranty
- The extender units can be freely added or removed by users, TX and RX units can mix in any combination in the tray
- 4x Neutrik OpticalCON Quad OR 8x SC Duplex OR 4x opticalCON Duo connectors
- Noiseless passive cooling
- Status LED lights on the units are mirrored to the front panel of power tray
- +1 status LED for 5V DC power feedback
- Powering USB port protection: in case a USB port fails the rest of the units keep on working
- Uniquely designed optical and USB cable management
- Optical cables within the power tray are numbered for easy identification and installation

Combine an **MX2-8x8-HDMI20-Audio-L** matrix with a fully populated rack tray to create a **Full 4K HDMI 2.0 optical matrix**.



+16x

HDMI 2.0 optical matrix assembly: by connecting the HDMI connectors outputs of the fully populated PowerTray with the input and output ports of an MX2-8x8-HDMI20-Audio-L matrix a HDMI 2.0 optical matrix system can be created with Full 4K UHD at 60 Hz 4:4:4 maximum resolution.



Powered Rackmount Cage for 16 VINX extenders

PRC-16-205

Part No: 9134 0017



VINX-120-HDMI-ENC



VINX-110-HDMI-DEC

PRC-16-205 is a rack mount cage accessory enclosing up to 16x VINX-120-HDMI-ENC or VINX-110-HDMI-DEC and other, similar size devices in any combination, also providing power source for every installed device. Reliable, safe and secure operation is assured by numerous built-in protections against short circuits and overloads.

Features

- 3RU size rack mount cage
- Universal full range AC input with a standard C14 socket
- Protections: Short circuit and Overload
- Users can easily install and remove VINX devices and mix encoders and decoders in any combination
- VINX units can also be installed in the PRC-16-205 reversed
- Silent front to rear cooling system with temperature control
- Powering port protection: in case a power port fails, the rest of the installed VINX units keep on working
- Powered Rack Cage with built-in power supply for 16 extenders
- Makes installation easy and clean for 16 small extenders in rack
- Multiple mounting options to suit different rack cabling layouts
- Reliable cable management with supplied cable guide rails
- 3 years warranty

Table Box

TBX-M210-K

new!

Part No: 9133 0021

The Table Box (TBX) is a cable pass-through bracket for six AV signal cables, for easy BYOD connection, which also hosts two power outlets. An extender for video signals can be mounted under desk and the cables can be connected, without being visible when not in use.

User can open the lid and pull out the required AV cable to connect to the source device. When not used, the cables can be placed back inside and held by their own weight. The excess cable parts remain hidden by dropping out of sight below the TBX, under the desk.

The installation is quick and easy with the supplied mounting kit.

Features

- 2x multi-region AC connector
- 1x IEC power input on bottom (with locking flange)
- 6x cable holes for cable pass-through
- Soft open and close mechanism
- Desk cut hole size: 179 x 145 (mm)
- Device dimensions : 193 x 184,8 x 163.2 (mm)
- Laser cut metal housing



25G HYBRID

signal management

Video Has Never Travelled So Fast



25G Hybrid by Lightware: Complex Signal Management at Incredible Speed

25G Hybrid is a comprehensive line of digital matrix switchers, transmitters and receivers, which enhances switching with a powerful suite of diagnostic software tools. A true technology for the digital age, delivering a superior user experience.

 MultiLayer Switching for the flexibility and freedom of independent signal switching per Media Layer.

 Advanced audio functions with 3 different audio Layers: Embedded Audio, Forward Audio and Return audio.

 Control signal management including RS-232, Ethernet, KVM and IR.

The data rate of the 25G Hybrid allows transferring and switching all existing standard video formats, establishing a reliable and future-proof platform for all signal management purposes. It is the world's first fully compatible HDMI and DisplayPort matrix switcher that also provides ARC functions, supports 4K resolutions and full 3D formats. 25G Hybrid offers MultiLayer Switching, where signals are handled on eight, separate Media Layers. Inside a 25G Hybrid router there are as many Media Layers as signal types, which are managed by a router each. Media Layers, in a sense, add a third dimension to switching inputs and outputs.



Advanced GUI

25G Hybrid matrix switchers have a built-in front panel touch screen capable of showing the 25G control software with full control options. Unit information, crosspoint setup and switching, EDID Management, User & Room Management, maintenance, troubleshooting and every other tool is available on the front panel display.

The control interface for these routers has been designed to accomplish 3 main principles:

- **Simplicity.** Crosspoint switching has never been easier. By pressing the buttons on the touchscreen interface you can perform multiple switches. The colors and icons are very informative with meaningful details.
- **Seamless control.** Straightforward control interface for all of the inputs and outputs on all 8 Layers.
- **Exceptional diagnostics.** Maintain the strong diagnostic features already provided by present in Lightware architectures, such as Advanced EDID Management, Input Signal Analysis and the Frame Detector.



Room Management

As the maximal crosspoint area in the 25G Hybrid routers is a large switching plane, we have introduced 'Room Management'. All the user-created virtual rooms can be programmed with their own sources and destinations, but can also share some resources if required. If, for example, you want to prohibit an operator in one room from accidentally making switches in another, the maximal crosspoint area can be divided into smaller virtual matrix switchers called 'rooms'.



User Access

For security, a user password can be set to access system control.



Reliability

The components used in this technology are industrial grade and typically designed for the telecom industry. All printed circuit boards are gold plated in order to achieve reliable and stable hardware performance. This technique results in better soldering and contact performance and eliminates corrosion problems caused by salt and humidity in naval military environments.



All boards that contain active electronic components are hot swappable. The front load design makes it easy to replace failed components. All fans and power supplies can also be replaced in a simple movement.



The 25G matrix routers are designed for 24/7 operation and optional redundant CPU and Power supplies can be also added for further reliability.



The 25G CPU stores the settings of all boards and sends backups for the second CPU. If the first CPU fails the second takes over automatically with the same settings. With the redundant power supplies N+1 and N+2 redundancies can be reached.



25G Hybrid Matrix Frame

25G-FR160x160 / 25G-FR144x144 /

25G-FR128x128 / 25G-FR120x120 /

25G-FR160x80 / 25G-FR80x160

Part No: 9121 0001 (FR160x160), 9121 0025 (FR144x144), 9121 0026 (FR128x128)
9121 0002 (FR120x120), 9121 0003 (FR160x80), 9121 0004 (FR80x160)

The 25G-FR160x160 Frame handles up to 160 input and 160 output ports, making this frame one of the largest on the market. This frame manages signals on eight different Layers which creates a three-dimensional signal management structure.

The 25G frames can transmit video signals up to 4K resolution, support all 3D formats, handle forward audio, transmit USB-KVM, Ethernet, bi-directional RS-232/RS-422, IR and CEC signals. The intuitive graphical user interface offers easy and user-friendly control accessing all available features. Advanced EDID Management is included in the frame which is also HDCP compliant.

Changing the configuration is easy and quick, as all boards are hot swappable: the system can work 24/7 without delays. In case of a malfunction, it can easily be fixed without switching the matrix off. Redundant power supplies, CPU boards are also available for this frame for fail safe operation in mission critical applications.

This frame can be configured with 120x120, 128x128, 144x144, 80x160 and 160x80 crosspoints. Software upgrade for these frames is available in case the user wants to raise the capacity up to 160x160.

Features:

- Multilayer signal management – signal switching in 3 dimensions
- 160x160, 120x120, 144x144, 128x128, 80x160, 160x80 video crosspoint versions
- 42 rack units high metal chassis
- Independent switching of audio and video
- USB KVM extension
- Built-in 320 port 100 Mbit Ethernet switch with 1 gigabit uplink
- Dual redundant CPU processor boards for fail safe operation
- Hot swappable components
- RS-232 / RS-422 bidirectional transmission and control
- IR and CEC transmission
- Intuitive GUI interface for easy handling of all functions
- Room Management
- Front panel touch screen
- Advanced error handling and logging with time code
- Combine non-HDCP and HDCP capable I/O boards in the same frame
- TCP/IP Ethernet control (multiple connections)
- Advanced EDID Management
- HDCP compliant
- Redundant power supplies – 24/7 secure operation
- Supports former LW protocols
- Barco Encore and Vista Spyder compatible
- Hybrid Modular technology



25G Hybrid 80x80 Crosspoint Matrix Frame

25G-FR80x80

Part No: 9121 0010

The 25G-FR80x80 frame handles 80 input and 80 output ports and manages the signals on eight different Layers resulting in a three-dimensional switching structure.

The 25G frames can transmit video signals up to 4K resolution, support all 3D formats, handle forward and return audio, transmit USB-KVM, Ethernet, bi-directional RS-232/RS-422, IR and CEC signals. The audio signals of the Forward and Return Audio Layers run through the same crosspoint which allows the user to switch Return Audio Signals to the Forward Audio Layer and vice-versa.

The intuitive graphical user interface offers easy and user-friendly control accessing all available features. Advanced EDID Management is included in the frame which is also HDCP compliant.

Changing the configuration is easy and quick, as each board are hot swappable: the system can work 24/7 without delays. In case of a malfunction, it can easily be fixed without switching the matrix off. Redundant power supplies, CPU boards are also available for this frame for fail safe operation in mission critical applications.

Features:

- Multilayer signal management – signal switching in 3 dimensions
- 80x80 video crosspoints
- 29 rack unit high metal chassis
- Independent switching of audio and video
- Same crosspoint for the Forward and Return audio layers
- USB KVM extension
- Built-in 160 port 100 Mbit Ethernet switch with 1 gigabit uplink
- Dual redundant CPU processor boards for fail safe operation
- Hot swappable components
- RS-232 / RS-422 bidirectional transmission and control
- IR and CEC transmission
- Intuitive GUI interface for easy handling of all functions
- Room Management
- Front panel touch screen
- Advanced error handling and logging with time code
- Combine non-HDCP and HDCP capable I/O boards in the same frame
- TCP/IP Ethernet control (multiple connections)
- Advanced EDID Management
- HDCP compliant
- Redundant power supplies – 24/7 secure operation
- Supports former LW protocols
- Barco Encore and Vista Spyder compatible
- Hybrid Modular technology



Second CPU for Redundancy

25G-CPUB1

Part No: 9121 0005

Features:

- Configuration of all other boards
- Controller connection (LAN, RS-232)
- LW3, LW2 protocol
- Advanced logging
- Redundant – hot swappable

The CPU board, which controls the whole system, can be doubled in the frames. In this case the first CPU is actively operating while the second is a “hot spare”. If the main CPU fails, the second takes over the control instantly and reports the failure of the previous one.



Additional Power Supply for Redundancy

25G-PSU-1600 (1200)

Part No: 9121 0006

Features:

- Up to N+2 redundancy
- 24/7 operation

Power supplies are arranged for N+1 or N+2 redundancy. Depending on the configuration, one or even two power lines can fail while the system remains active. In addition, our approach to power supplies is to ensure that the load never exceeds 60% of their maximum rated output level. These two features will go a long way to providing a robust system capable of 24/7 operation even in the harshest environments.



MEDIA LAYERS

The second step of building a configuration is to find out which Layers the application requires. The Video Layer with the Embedded Audio is always included in the frame by default. If an application requires more Layers you can select from the seven Media Layer options. Selecting the Layers means deciding what type of signals the 25G router will have to handle.



Video Layer with Embedded Audio
included in the frame by default

Features:

- Up to 160 inputs and 160 outputs
- 3D formats supported
- Featured video signals: VGA (input only), Single-Link DVI, Dual-Link DVI, HDMI 1.4, 3G-SDI (input only), DisplayPort 1.1

The Video layer comprises of up to 160 video inputs and 160 video outputs.

The video could be analog VGA, Interlaced Composite Video, DVI, Dual-Link DVI, HDMI 1.4 with 3D, SDI, 3G-SDI and/or DisplayPort 1.1. No matter which video format you input, the pixels will be extended and switched by the 25G Hybrid router. Users can mix various video standards and any input signal can be switched to any output display.

The 25G Hybrid architecture has 3 different audio layers: Embedded Audio, Forward Audio and a Return Audio. The embedded audio lies within the 25G video layer itself, carrying up to 8 high definition audio channels. This audio is always routed with the video and runs from source to display.



Forward Audio Layer
25G-LAYER-FWD-160
25G-LAYER-FWD-80

Part No: 9121 0008 (160), 9121 0016 (80)

Features:

- A fully separate audio channel
- Supports Stereo PCM, 5.1 Dolby Digital, 5.1 DTS and other audio formats

The Forward Audio channel is a second independent S/PDIF audio stream not related to the Embedded Audio. A separate S/PDIF matrix switch manages Stereo PCM, 5.1 Dolby Digital and DTS, and various other formats.

Examples

- You have a set-top box that outputs the HDMI video and audio. The same set-top box outputs the audio with a different language on its S/PDIF audio output. This box is connected to the 25G Hybrid network. Different customers can listen to the same content in different languages in different rooms.
- A media server is connected to the 25G Hybrid network inside the server room along with CD players and other equipment. The LCD displays are located in the demonstration rooms. On a certain display the picture may come from the media server, but the sound from the CD player.



Return Audio Layer
25G-LAYER-RET-80

Part No: 9121 0022

Features:

- A fully separate audio channel routed the opposite way to the Forward Audio Layer
- Supports Stereo PCM, 5.1 Dolby Digital, 5.1 DTS and other audio formats

Return Audio Layer creates the ability to send two different multichannel audio streams, one from source to display and another, a return channel in the opposite direction.

Audio Return Channel (ARC) was introduced by the HDMI 1.4 standard. This S/PDIF signal is sent in the opposite direction to the video signals. Usually displays send ARC to source devices - typically TV sound to audio receivers, or microphone sound from headsets to computers.

Examples

When using microphones in a KVM environment, the operator has an LCD display, 5.1 speakers, Keyboard, Mouse and a microphone. The microphone audio signal from his headset is sent in the opposite direction to the video and the embedded audio.



Ethernet Layer

25G-LAYER-ETH-160
25G-LAYER-ETH-80

Part No: 9121 0015 (160), 9121 0017 (80)

Features:

- 1 Gigabit uplink
- 100 Mbit connection for all matrix I/O ports
- Ethernet extension over TPS cable and OPTS/OPTM fiber
- Layer 2 Ethernet switch

All built-in 100 Mbit Ethernet ports can be used for controlling devices such as projectors and media players or can provide Ethernet access for all connected devices from a 1 Gigabit uplink. Ethernet, as with every other Layer, can be extended over a single fiber or single CAT cable.

25G Hybrid matrix architecture is the world's first fully compatible HDMI 1.4 matrix switcher that provides HEC and ARC functions, supports 4K resolutions and 3D formats.



USB KVM Layer

25G-LAYER-USB-KVM-160
25G-LAYER-USB-KVM-80

Part No: 9121 0014 (160), 9121 0021 (80)

Features:

- 2 USB HID devices per 25G I/O port
- Keyboard combinations for matrix control
- USB HUB can be connected to the outputs (Keyboard, Mouse, Smart Card)
- Point to point connections

With the USB KVM option, users can utilize the 25G Hybrid signal management for KVM matrix purposes. Up to 160 computers can be controlled by up to 160 operators. 25G allows point to point control. This method allows multiple operators to control one single computer or one operator to control multiple computers.



IR Layer

25G-LAYER-IR-160
25G-LAYER-IR-80

Part No: 9121 0011 (160), 9121 0018 (80)

Features:

- Full transparent platform
- Bidirectional transmission
- Point to point, point to multipoint connection and switching

Infrared is commonly used for remote control based applications. This Media Layer helps maintain the structure of the overall AV system. Third party control systems may send IR control commands to endpoints turning them on and off or switching their inputs.



Consumer Electronics Control Layer

25G-LAYER-CEC-160
25G-LAYER-CEC-80

Part No: 9121 0013 (160), 9121 0020 (80)

Features:

- Point to point, point to multipoint connection and switching
- Full transparent platform
- Command injections
- CEC device discovery

Consumer Electronics Control (CEC) is also commonly used for remote control based applications like IR. Third party control systems can also send CEC control commands to endpoints turning them on and off or switching their inputs. CEC was introduced by HDMI standard, and is a bi-directional CEC channel.

We can link sources and destinations via CEC communication while the router itself can initiate its own commands for example: „SYSTEM ON“ or „STANDBY“ commands.



RS-232 & RS-422 Control Layer

25G-LAYER-RS-232-160
25G-LAYER-RS-232-80

Part No: 9121 0012 (160), 9121 0019 (80)

Features:

- Full transparent platform
- Bidirectional transmission
- Configurable baud rates per port (any user specified)
- Input baud rate could be different from output baud rate
- Standards: 9600, 14400, 19200, 38400, 57600, 115200

Full duplex bi-directional, more robust and more reliable than IR, RS- 232 and RS-422 have become the standard control media for professional AV systems. The 25G Hybrid architecture is a fully transparent platform for RS-232 and RS-422 control signals. Ports can be linked together or handled separately, allowing any third-party control systems to be connected.

INPUT AND OUTPUT BOARDS

When we have selected the frame and picked the layers the third step is to populate the matrix with the Input and Output boards.

4K DVI-D Input Board **25G-8DVID2-IB series**

Part No: 9122 0019

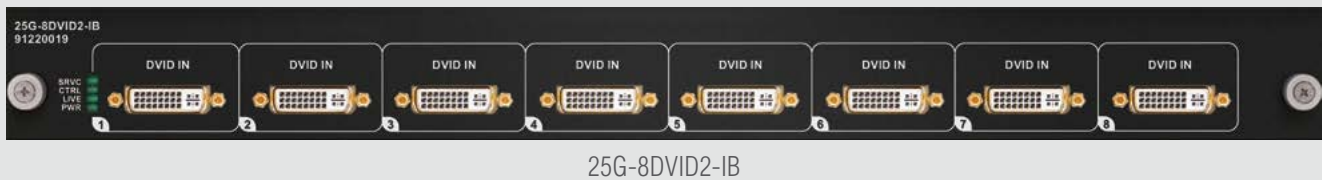

25G-8DVID2-IB

25G-8DVID2-IB provides fully transparent HDMI 1.4 connectivity to the latest high-end digital sources including 3D between the endpoints.

Features:

- HDMI 1.4, DVI and HDCP 1.4 compliant
- 8 DVI-D input connectors
- Resolutions up to 4K / UHD (30Hz RGB or YCbCr 4:4:4)
- 3D signal support
- 36-bit Deep Color support
- Static EDID emulation with EDIDs from the Advanced EDID Management system
- Available video test patterns
- Pass-through of HDMI 1.4 embedded uncompressed LPCM audio and compressed audio (AAC, ATRAC, DTS, DTS ES, DTS-HD, Dolby Digital, Dolby Digital EX, Dolby Digital Plus, Dolby Digital Surround EX, Dolby Digital TrueHD, DST, MPEG1 Layer 1, MPEG1 Layer2, MPEG1 Layer 3, MPEG2, WMA Pro)
- Embedding or de-embedding of two-channel LPCM, Dolby Digital, Dolby Digital EX, Dolby Digital Plus, Dolby Digital Surround EX, DTS, DTS ES
- Pixel Accurate Reclocking
- 30m input cable equalization at 1080p60Hz on all inputs



4K DVI-D Input Board with KVM

25G-8DVID2-K2-IB

Part No: 9122 0058

Additional Features:

- Handles two USB 2.0 HID devices per port
- USB-B connector per port with integrated USB HUB



4K DVI-D Input Board with Digital Audio

25G-8DVID2-A2-IB

Part No: 9122 0048

Additional Features:

- Bi-directional S/PDIF breakout for every port



4K DVI-D Input Board with Analog Audio

25G-8DVID2-A3-IB

Part No: 9122 0047

Additional Features:

- Bi-directional, configurable analog stereo ports with 5-pole Phoenix connector



4K DVI-D Input Board with Digital Audio and KVM

25G-8DVID2-A2K2-IB

Part No: 9122 0059

Additional Features:

- Bi-directional S/PDIF breakout for every port
- USB-B connector per port with integrated USB HUB



4K DVI-D Input Board with Analog Audio and KVM

25G-8DVID2-A3K2-IB

Part No: 9122 0060

Additional Features:

- Bi-directional, configurable analog stereo ports with 5-pole Phoenix connector
- USB-B connector per port with integrated USB HUB

4K HDMI Input Board

25G-8HDMI2-IB

Part No: 9122 0057



25G-8HDMI2-IB provides fully transparent HDMI 1.4 connectivity to the latest high-end digital sources including Audio Return Channel and 3D functions.

Features:

- HDMI 1.4 and HDCP 1.4 compliant
- Resolutions up to 4K / UHD (30Hz RGB or YCbCr 4:4:4)
- 3D signal support
- 36-bit Deep Color support
- Available video test patterns
- Static EDID emulation with EDIDs from the Advanced EDID Management system
- Pass-through of HDMI 1.4 embedded uncompressed LPCM audio and compressed audio (AAC, ATRAC, DTS, DTS ES, DTS-HD, Dolby Digital, Dolby Digital EX, Dolby Digital Plus, Dolby Digital Surround EX, Dolby Digital TrueHD, DST, MPEG1 Layer 1, MPEG1 Layer2, MPEG1 Layer 3, MPEG2, WMA Pro)
- Embedding or de-embedding of 2-channel LPCM, Dolby Digital, Dolby Digital EX, Dolby Digital Plus, Dolby Digital Surround EX, DTS, DTS ES
- Pixel Accurate Reclocking
- 30m input cable equalization at 1080p 60Hz on all inputs
- Audio Return Channel support
- CEC support

HDBaseT™ and the HDBaseT Alliance logo are trademarks of the HDBaseT Alliance



4K HDMI Input Board with KVM

25G 8HDMI2-K2 IB

Part No: 9122 0064

Additional Features:

- Handles two USB 2.0 HID devices per port
- USB-B connector per port with integrated USB HUB



4K HDMI Input Board with Digital Audio

25G-8HDMI2-A2-IB

Part No: 9122 0028

Additional Features:

- S/PDIF breakout for every port



4K HDMI Input Board with Analog Audio

25G-8HDMI2-A3-IB

Part No: 9122 0029

Additional Features:

- Bi-directional, configurable analog stereo ports with 5-pole Phoenix connector



4K HDMI Input Board with Digital Audio and KVM

25G-8HDMI2-A2K2-IB

Part No: 9122 0065

Additional Features:

- Handles two USB 2.0 HID devices per port
- S/PDIF breakout for every port



4K HDMI Input Board with Analog Audio and KVM

25G-8HDMI2-A3K2-IB

Part No: 9122 0066

Additional Features:

- Bi-directional, configurable analog stereo port with 5-pole Phoenix connector
- Handles two USB 2.0 HID devices per port

4K TPS Input Board with PoE Option **25G-8TPS2-IB**

Part No: 9122 0067



Featuring eight HDBaseT™ input ports, this board is compatible with the full range of Lightware TPS extenders and HDBaseT compliant third party transmitters.

Features:

- Resolutions up to 4K / UHD (30Hz RGB or YCbCr 4:4:4)
- Pass-through of 4:2:0 3840x2160@60 Hz video input
- Support for HDMI 1.4 embedded uncompressed LPCM audio or compressed high bitrate audio (LPCM, AC-3, MPEG1 Layer 1, MPEG1 Layer2, MPEG1 Layer 3, MPEG2, AAC, DTS, ATRAC, Dolby Digital+, DTS-HD, Dolby Digital TrueHD, DST, and WMA Pro, Dolby Digital EX, Dolby Digital Surround EX)
- De-embedding of IEC 60958-1 (only stereo LPCM), and IEC 61937 (only AC-3, Dolby Digital Plus, Dolby Digital EX, Dolby Digital Surround EX, DTS, DTS ES)
- Video test pattern generation
- Cable length and link quality estimation
- Frame detector functionality with frame rate, color space, pixel clock rate, and active and total area detection
- HDCP 1.4 support
- Deep color support for up to 36 bpp
- Automatic Ethernet only mode support when an Ethernet only device is connected
- Extension for up to 170 meters over CAT6a or CAT7 depending on the video clock used

HDBaseT™ and the HDBaseT Alliance logo are trademarks of the HDBaseT Alliance

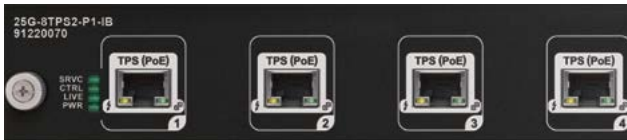

4K TPS Input Board with Remote Powering **25G-8TPS2-P1-IB**

Part No: 9122 0070

Additional Features:

- Remote powering according to IEEE 802.3af-2003 with increased output power



4K TPS Input Board with Digital Audio **25G-8TPS2-A2-IB**

Part No: 9122 0068

Additional Features:

- Bi-directional S/PDIF breakout for every port



4K TPS Input Board with Analog Audio **25G-8TPS2-A3-IB**

Part No: 9122 0069

Additional Features:

- Bi-directional, configurable analog stereo ports with 5-pole Phoenix connector



4K TPS Input Board with Digital Audio and Remote Powering **25G-8TPS2-A2P1-IB**

Part No: 9122 0071

Additional Features:

- Bi-directional S/PDIF breakout for every port
- Remote powering according to IEEE 802.3af-2003 with increased output power



4K TPS Input Board with Analog Audio and Remote Powering **25G-8TPS2-A3P1-IB**

Part No: 9122 0072

Additional Features:

- Bi-directional, configurable analog stereo ports with 5-pole Phoenix connector
- Remote powering according to IEEE 802.3af-2003 with increased output power

4K Singlemode Optical Input Board

25G-8OPTS2-IB- LC, -SC, -ST, -NT

Part No: 9122 0049 (NT), 9122 0050 (LC), 9122 0051 (ST) 9122 0052 (SC)



25G-8OPTS2-IB-LC, -SC, -ST, -NT is a 4K compatible fiber optical input board for the 25G router family and available with a variety of fiber optical connectors LC, SC, ST or Neutrik OpticalCON. These optical boards can extend up to 10.000m distance with singlemode fiber technology. The OPTS technology provides a transparent medium for all existing video, audio and control signal formats according to the 25G multilayer architecture (Video, Audio, Ethernet, USB KVM, RS-232, IR and CEC transmission), and allows the extension from MODEX transmitter units.

Features:

- Up to 10 km extension distance
- Video and audio transmission
- Ethernet, USB KVM, RS-232, IR, CEC transmission
- Extension from MODEX transmitters
- Resolutions up to 4K x 2K @ 30Hz, 2560 x 1440 (WQXGA) @ 60 Hz YCbCr 4:2:2
- Deep color support up to 1920 x 1080 @ 36 bit, 60 Hz

Supported Maximum Resolutions at the Input Board

Resolution	Bit Depth	Color Space
1080p@50/60Hz	24-36 bit	RGB/YUV 4:4:4
1080p@120Hz	24 bit	YUV 4:2:2
3840x2160@24Hz	24 bit	YUV 4:2:2
3840x2160@30Hz	24 bit	YUV 4:2:2
3840x2160@50/60Hz	Not supported	

4K Multimode Optical Input Board

25G-8OPTM2-IB- LC, -SC, -ST, -NT

Part No: 9122 0045 (NT), 9122 0053 (ST), 9122 0054 (LC), 9122 0055 (LC)



25G-8OPTM2-IB-NT



25G-8OPTM2-IB-SC



25G-8OPTM2-IB-LC



25G-8OPTM2-IB-ST

25G-OPTM2-IB-LC, -SC, -ST, -NT is a 4K compatible fiber optical input board for the 25G matrix family and available with a variety of fiber optical connectors LC, SC, ST or Neutrik OpticalCON. These optical boards can extend up to a 300m distance with Multimode fiber technology. The OPTM technology provides a transparent medium for video, audio, Ethernet, USB KVM, RS-232, IR and CEC data according to the 25G multilayer architecture, and allows the extension from MODEX transmitter units.

Features:

- Resolutions up to 4K / UHD (30Hz YCbCr 4:2:2)
- Up to 300m extension distance
- Video and audio transmission
- Ethernet, USB KVM, RS-232, IR, CEC transmission
- Extension from MODEX transmitters
- 3D signal support
- 36-bit Deep Color support for up to 1080p@60 Hz

Supported Maximum Resolutions at the Input Board

Resolution	Bit Depth	Color Space
1080p@50/60Hz	24-36 bit	RGB/YUV 4:4:4
1080p@120Hz	24 bit	YUV 4:2:2
3840x2160@24Hz	24 bit	YUV 4:2:2
3840x2160@30Hz	24 bit	YUV 4:2:2
3840x2160@50/60Hz	Not supported	

4K DVI-D Output Board

25G-8DVID2-OB

Part No: 9123 0013



25G-8DVID2-OB provides fully transparent HDMI 1.4 connectivity to the latest high-end digital sources including 3D between the endpoints.

Features:

- HDMI 1.4, DVI and HDCP 1.4 compliant
- Resolutions up to 4K / UHD (30Hz RGB or YCbCr 4:4:4)
- 3D signal support
- 36-bit Deep Color support
- 30m copper cable compensation
- Submission of EDID information read from the sink to the Advanced EDID Management system
- Available video test patterns
- Pass-through of HDMI 1.4 embedded uncompressed LPCM audio and compressed audio (AAC, ATRAC, DTS, DTS ES, DTS-HD, Dolby Digital, Dolby Digital EX, Dolby Digital Plus, Dolby Digital Surround EX, Dolby Digital TrueHD, DST, MPEG1 Layer 1, MPEG1 Layer2, MPEG1 Layer 3, MPEG2, WMA Pro)
- Embedding or de-embedding of two-channel LPCM, Dolby Digital, Dolby Digital EX, Dolby Digital Plus, Dolby Digital Surround EX, DTS, DTS ES
- Standard compliant output



4K DVI-D Output Board with Digital Audio

25G-8DVID2-A2-OB

Part No: 9123 0034

Additional Features:

- Bi-directional S/PDIF breakout for every port



4K DVI-D Output Board with Analog Audio

25G-8DVID2-A3-OB

Part No: 9123 0033

Additional Features:

- Bi-directional, configurable analog stereo ports with 5-pole Phoenix connector

4K HDMI Output Board

25G-8HDMI2-OB

Part No: 9123 0044



25G-8DVID2-OB provides fully transparent HDMI 1.4 connectivity to the latest high-end digital sources including 3D between the endpoints.

Features:

- HDMI 1.4, DVI and HDCP 1.4 compliant
- Resolutions up to 4K / UHD (30Hz RGB or YCbCr 4:4:4)
- 3D signal support
- 36-bit Deep Color support
- 30m copper cable compensation
- Submission of EDID information read from the sink to the Advanced EDID Management system
- Available video test patterns
- Pass-through of HDMI 1.4 embedded uncompressed LPCM audio and compressed audio (AAC, ATRAC, DTS, DTS ES, DTS-HD, Dolby Digital, Dolby Digital EX, Dolby Digital Plus, Dolby Digital Surround EX, Dolby Digital TrueHD, DST, MPEG1 Layer 1, MPEG1 Layer2, MPEG1 Layer 3, MPEG2, WMA Pro)
- Embedding or de-embedding of two-channel LPCM, Dolby Digital, Dolby Digital EX, Dolby Digital Plus, Dolby Digital Surround EX, DTS, DTS ES
- Standard compliant output



4K HDMI Output Board with Digital Audio

25G-8HDMI2-A2-OB

Part No: 9123 0016

Additional Features:

- Bi-directional S/PDIF breakout for every port



4K HDMI Output Board with Analog Audio

25G-8HDMI2-A3-OB

Part No: 9123 0017

Additional Features:

- Bi-directional, configurable analog stereo ports with 5-pole Phoenix connector

4K TPS Output Board with PoE Option

25G-8TPS2-OB

Part No: 9123 0045



Featuring eight HDBaseT™ output ports, the board is compatible with the full range of Lightware TPS extenders and HDBaseT compliant 3rd party receivers. The HDBaseT technology provides a transparent medium for all video, audio, data and control signals in line with the 25G multilayer architecture and allows for a cost effective extension solution for up to 160 meters.

Features:

- Resolutions up to 4K / UHD (30Hz RGB or YCbCr 4:4:4)
- Pass through of 4:2:0 3840x2160@60 Hz video
- Support for HDMI 1.4 embedded uncompressed LPCM audio or compressed high bitrate audio (LPCM, AC 3, MPEG1 Layer 1, MPEG1 Layer2, MPEG1 Layer 3, MPEG2, AAC, DTS, ATRAC, Dolby Digital+, DTS HD, Dolby Digital TrueHD, DST, and WMA Pro, Dolby Digital EX, Dolby Digital Surround EX)
- De-embedding of IEC 60958 1 (only stereo LPCM), and IEC 61937 (only AC 3, Dolby Digital Plus, Dolby Digital EX, Dolby Digital Surround EX, DTS, DTS ES)
- Video test pattern generation
- Cable length and link quality estimation
- Frame detector functionality with frame rate, color space, pixel clock rate, and active and total area detection
- HDCP 1.4 support
- Deep color support for up to 36 bpp
- Automatic Ethernet only mode support when an Ethernet only device is connected
- Extension for up to 160 meters over CAT6a or CAT7 depending on the video clock used

HDBaseT™ and the HDBaseT Alliance logo are trademarks of the HDBaseT Alliance

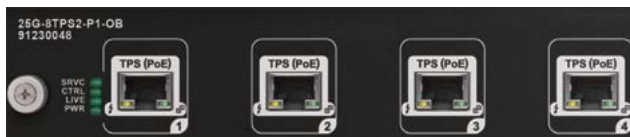

4K TPS Output Board with Remote Powering **25G-8TPS2-P1-OB**

Part No: 9123 0048

Additional Features:

- Remote powering according to IEEE 802.3af-2003 with increased output power



4K TPS Output Board with Digital Audio **25G-8TPS2-A2-OB**

Part No: 9123 0046

Additional Features:

- Bi-directional S/PDIF breakout for every port



4K TPS Output Board with Analog Audio **25G-8TPS2-A3-OB**

Part No: 9123 0047

Additional Features:

- Bi-directional, configurable analog stereo ports with 5-pole Phoenix connector



4K TPS Output Board with Digital Audio and Remote Powering **25G-8TPS2-A2P1-OB**

Part No: 9123 0049

Additional Features:

- Bi-directional S/PDIF breakout for every port
- Remote powering according to IEEE 802.3af-2003 with increased output power



4K TPS Output Board with Analog Audio and Remote Powering **25G-8TPS2-A3P1-OB**

Part No: 9123 0050

Additional Features:

- Bi-directional, configurable analog stereo ports with 5-pole Phoenix connector
- Remote powering according to IEEE 802.3af-2003 with increased output power

4K Singlemode Optical Output Board

25G-80PTS2-OB- LC, -SC, -ST, -NT

Part No: 9123 0035 (NT), 9123 0036 (LC), 9123 0037 (ST), 9123 0038 (SC)



25G-80PTS2-OB-LC, -SC, -ST, -NT is a 4K compatible fiber optical output board for the 25G matrix family available with LC, SC, ST or Neutrik OpticalCON. type fiber optical connectors. These optical boards can extend up to a 10,000m distance using singlemode fiber technology. The OPTS technology provides a transparent medium for video, audio, Ethernet, USB KVM, RS-232, IR and CEC data according to the 25G multilayer architecture and allows the extension to MODEX receiver units.

Features:

- Resolutions up to 4K / UHD (30Hz YCbCr 4:2:2)
- Up to 10km extension distance
- Video and audio transmission
- Ethernet, USB KVM, RS-232, IR, CEC transmission
- Extension to MODEX receivers
- 3D signal support
- 36-bit Deep Color support for up to 1080p60

Supported Maximum Resolutions at the Output Board

Resolution	Bit Depth	Color Space
1080p@50/60Hz	24-36 bit	RGB/YUV 4:4:4
1080p@120Hz	24 bit	YUV 4:2:2
3840x2160@24Hz	24 bit	YUV 4:2:2
3840x2160@30Hz	24 bit	YUV 4:2:2
3840x2160@50/60Hz	Not supported	

4K Compatible Multimode Optical Output Board

25G-8OPTM2-OB- LC, -SC, -ST, -NT

Part No: 9123 0031 (NT), 9123 0041 (SC), 9123 0039 (ST) 9123 0040 (LC)



25G-8OPTM2-OB-LC, -SC, -ST, -NT is a 4K compatible fiber optical output board for the 25G matrix family and available with a variety of fiber optical connectors: LC, SC, ST or Neutrik OpticalCON. These optical boards can extend up to a 300m distance with Multimode fiber technology. The OPTM technology provides a transparent medium for video, audio, Ethernet, USB KVM, RS-232, IR and CEC data according to the 25G multilayer architecture. It also allows extension to MODEX receiver units.

Features:

- Resolutions up to 4K / UHD (30Hz YCbCr 4:2:2)
- Up to 240 m extension distance
- Video and audio transmission
- Ethernet, USB KVM, RS-232, IR, CEC transmission
- Extension to MODEX receivers
- 3D signal support
- 36-bit Deep Color support for up to 1080p@60Hz

Supported Maximum Resolutions at the Output Board

Resolution	Bit Depth	Color Space
1080p@50/60Hz	24-36 bit	RGB/YUV 4:4:4
1080p@120Hz	24 bit	YUV 4:2:2
3840x2160@24Hz	24 bit	YUV 4:2:2
3840x2160@30Hz	24 bit	YUV 4:2:2
3840x2160@50/60Hz	Not supported	

There are six main types of 25G compatible boards available at request, please enquire at a Lightware sales or distributor office. The available 25G MX boards are the following:

25G-MX-3GSDI-IB	25G MX 3GSDI Input Board
25G-MX-DVII-HDCP-IB	25G MX DVII HDCP Input Board
25G-MX-DVI-OPT-IB-LC-NT-SC-ST	25G MX DVI Optical Input Board
25G-MX-HDMI-OPT-IB-LC-NT-SC-ST	25G MX HDMI Optical Input Board
25G-MX-DVI-OPT-OB-LC-SC-ST	25G MX DVI Optical Output Board
25G-MX-HDMI-OPT-OB-LC-NT-SC-ST	25G MX HDMI Optical Output Board

SCALABILITY
Has a New Name

UBEX



Uncompressed Video Over IP

visual engineering
LIGHTWARE

lightware.com/ubex

Lightware Headquarters

Peterdy 15, Budapest H-1071, Hungary

Tel: +36 1 255 3800

sales@lightware.com

| support@lightware.com

| www.lightware.com

Lightware Visual Engineering Australia & New Zealand

Unit 18, Leighton Industrial area, 22 Leighton Place, Hornsby, Sydney, NSW, 2077

Tel : +(02) 9476 8850

| sales.anz@lightware.com

| support.anz@lightware.com

Lightware Visual Engineering Benelux

1218 EB Hilversum, Kerkelmeent 38

Tel: +31 35 631 3295

| sales.nl@lightware.com

| support.nl@lightware.com

Lightware Visual Engineering China

Sailuo No. 1, Room 510, 435 Baizhuan Xili Chao Yang District, Beijing, P. R. China 100124

Tel: +86 010-5712 7558

| sales.china@lightware.com

| support.china@lightware.com

Lightware Deutschland GmbH

Otto Hahn Straße 13b, 85521 Riemerling, Germany

Tel (North): +49 (175) 361 5541

| Tel (South): +49 (0) 171 3232 466

| sales.de@lightware.com

Lightware Visual Engineering Iberia

C/San Bernardo, 107, 28015 Madrid, Spain

Mob: +34 652 99 70 53

| sales.iberia@lightware.com

| support.iberia@lightware.com

Lightware Visual Engineering India

No-1AAC-214, G Floor, East of NGEF Layout, Kasturinagar, Bangalore - 560043, India

Tel: 91 984 5555 4847

| sales.india@lightware.com

| support.india@lightware.com

Lightware Visual Engineering Italy & Malta

Via Mons. Bagnoli, 49 67051 Avezzano (AQ)

Tel: +39 086 345 1738

| italy@lightware.com

| support.italy@lightware.com

Lightware Visual Engineering Latin America

Carrera 83 # 32B-181 Medellin - Colombia South America

Tel: +573 01323 6831

| carlos.otero@lightware.com

Lightware Visual Engineering Middle East

P.O. Box 410595, Techno Point 223, Silicon Oasis, Dubai, UAE

Tel: +971 502449964

| sales.me@lightware.com

| support.me@lightware.com

Lightware Visual Engineering Nordics

c/o Barnö, Frigångsgatan 12, 413 01 Gothenburg, Sweden

Tel: +46 708 409999

| sales.nordics@lightware.com

| support.nordics@lightware.com

Lightware Visual Engineering North America

40 Engelwood Drive Suite C, Lake Orion, MI 48359 USA

| sales.na@lightware.com

| support.na@lightware.com

Lightware Visual Engineering Singapore & Southeast Asia

351 Jalan Besar, Reliance Building, #02-01, Singapore 208988

Tel: +65 6957 3800

| sales.sea@lightware.com

| support.sea@lightware.com

Lightware Visual Engineering UK & Ireland

Dunley Hill Court, Ranmore, Dorking, Surrey, RH5 6SX

Tel: +44(0) 1483 28 13 10

| sales.uk@lightware.com

| support.uk@lightware.com