

## Overview

HP sets the standard for performance and value in the enterprise with the Rack 10000 Series family. This enterprise-class rack cabinet system combines next-generation structural integrity and ease of use capabilities to deliver industry-leading performance. Ideal for onsite assembly of rack mounted ProLiant, Alpha, and Tandem servers, workstations, networking, and StorageWorks products, the 10000 Rack Series of cabinets, complement and protect your customer's investment in technology. Specifically designed to ensure outstanding performance and seamless integration throughout the entire enterprise, the Rack 10000 could easily be the last family of racks that you ever have to buy.

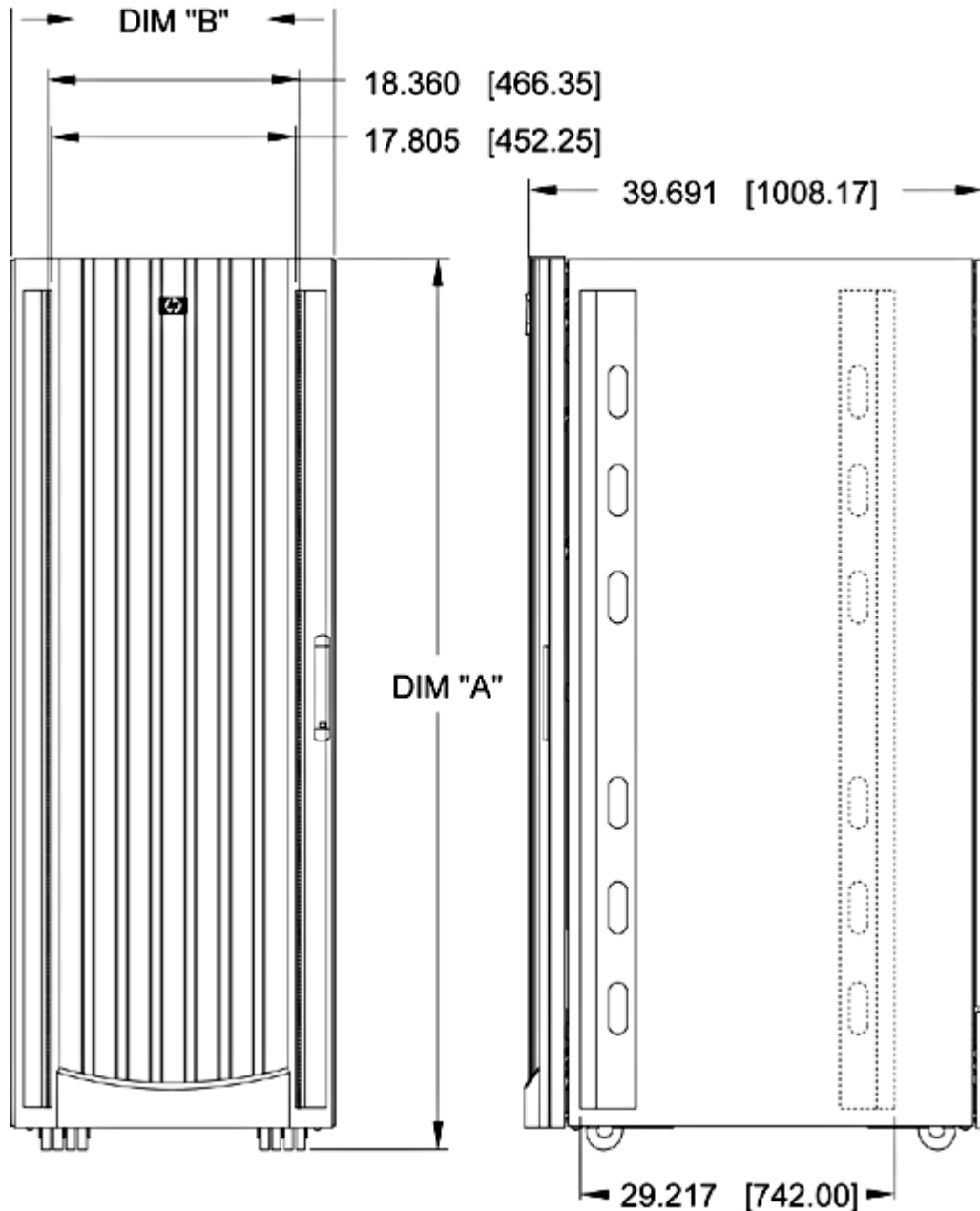

HP Rack 10000 Series - 42U

DIM "A" 78.838 [2002.50]

DIM "B" 24.125 [612.77]

HP Rack 10000 Series - 36U

DIM "A" 68.338 [1735.78]

DIM "B" 24.125 [612.77]

HP Rack 10000 Series - 22U

DIM "A" 43.838 [1113.48]

DIM "B" 24.125 [612.77]

## Overview

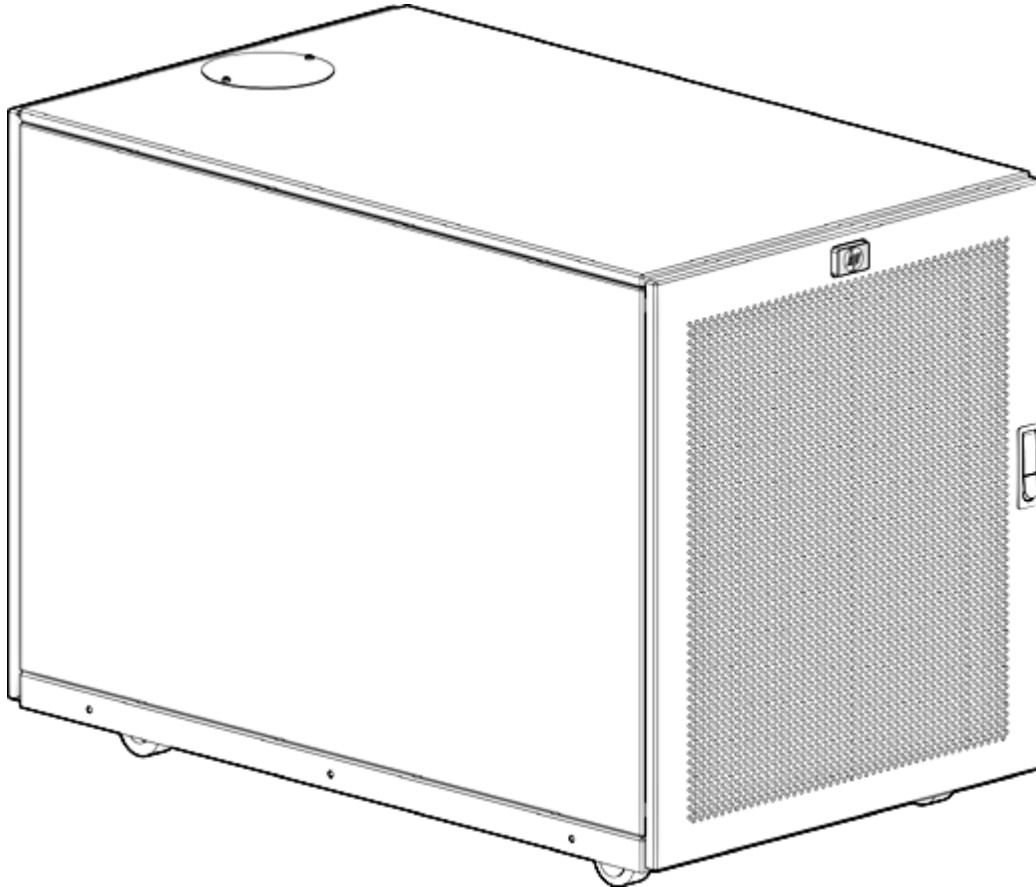

HP S101614, 14U Rack

---

## What's New

- HP Infrastructure Racks 42U (HV and LV) wraps under a single part number all the necessary rack infrastructure products such as the 10000 Series rack, power distribution, switches, keyboard and monitor and other products required for deploying racks in the datacenter, all professionally installed by HP Factory Express.
- Two models are available: (1) Low Voltage and (1) High Voltage.

---

## At a Glance

- Unique frame, rail and door design
- Thermal integrity
- Security provisions
- Flexibility
- Custom expandability
- Powerful 3 year Warranty (3-0-0)
- Static Load capacity up to 2000 lb (10642 dynamic load capacity is also 2000 lb)

### Models

10647 (47U) Rack Cabinet - Pallet	245160-B21
10647 (47U) Rack Cabinet - Crated	245160-B23
10622 (22U) Rack Cabinet - Pallet	245163-B21
10622 (22U) Rack Cabinet - Shock Pallet*	245163-B22
10622 (22U) Rack Cabinet - Crated	245163-B23
S10614 (14U) Rack Cabinet - Shock Pallet	292302-B22
10842 (800 mm wide, 42U) Rack Cabinet - Pallet	257415-B21
<b>NOTE:</b> Server Blade Enclosures must be field integrated into the 10842 racks. Factory integration of Server Blade Enclosures into the 10842 is not supported	
10842 (800 mm wide, 42U) Rack Cabinet - Shock	257415-B22
<b>NOTE:</b> Server Blade Enclosures must be field integrated into the 10842 racks. Factory integration of Server Blade Enclosures into the 10842 is not supported	
10642 (42U) Infrastructure Rack (Low Voltage)*	379006-001
10642 (42U) Infrastructure Rack (High Voltage)*	379005-001

**\*NOTE:** It is mandatory to use a shock pallet when shipping racks with equipment installed.

---

### Standard Features

#### Product Description - 10647, 10642, 10636, 10622 and S10614 models

HP sets the standard for industry standard racks in the enterprise with the HP 10000 Series Rack family and rack options. This enterprise-class rack system combines next-generation structural integrity, rack cooling, cable management and rack security to deliver industry-leading rack performance and value. In addition, HP has a complete line of rack options that will fit your rack and rack management requirements.

The new design of the HP 10000 series racks allows for greater structural integrity, that in turn allow for greater static and dynamic loads, while the perforated front and rear doors allows sufficient air circulation for efficient convection cooling keeping the rack's temperature low even with today's hotter and more dense servers.

Many cable management features have been integrated in the design of the rack that allow for easier and cleaner cable routing within and between the racks. These include a removable panel on the left door at the bottom that facilitates cable routing out of the rear of the rack. Large cable egresses have been built into the rack roof to allow for cabling out the top of the rack. Removable side panels facilitate cabling between connected racks. Locks are standard on all rack doors and side panels.

The 10000 series rack has been designed to accommodate products such as Power Distribution Units (PDUs) or switchboxes in the zero U area on the sides of the rack in order to maximize rack real estate. The 10000 series rack ships standard with split rear doors\*\* to allow full access to rack mounted equipment without blocking rack aisles.

HP offers rack shipments in three ways for most models: on a standard pallet (-B21), on a shock pallet (-B22)\* or crated (-B23). The standard pallet and crated shipping methods can be used to ship only empty racks. The -B21 version ships on a standard wooden pallet with plastic shrink-wrap around the rack. This rack is ordered with the understanding that the component installation will occur on the customer site.

This pallet and rack configuration does not support any component shipping configuration. The -B22 version of the Rack 10000 ships on a shock pallet. The shock pallet is designed to allow the 10000 series racks to be shipped fully loaded and configured with equipment installed in the rack. The shock pallet ensures that the rack is capable of handling the weight of installed equipment during shipment without damaging the rack or the precision components within. When the -B23 version of the 10000 series rack is ordered, it ships enclosed in a wooden crate. This configuration provides more protection for the empty rack for use in air-freight and other rugged transportation modes.

Ideal for rack mounting ProLiant servers, workstations, networking and StorageWorks by HP products, all rack models that comprise the HP 10000 Series ensure outstanding performance and seamless integration throughout the entire enterprise.

\*The S10614 ships only with -B22 Shock Pallet

\*\*Except the S10614

---

#### Product Description - 10842 model

The rack 10842 is a wider version of the 42U 9000 series rack in 31.3 in (800 mm) wide. This added width allows customers almost 8 more inches of room outside of the internal mounting rails for cabling. This rack is ideal used as a networking rack accommodating primarily switching equipment or can be used as a server/storage rack.

---

**Industry Standard Support** All products are 19 inch RETMA standard and will support select third-party equipment  
Extensive evaluation, and testing across all critical platforms

---

### Standard Features

#### Key HP Infrastructure Rack components

- Innovative Breakthroughs**
- The 2 meter form factor of the 42U 10000 Series rack allows the rack to be pushed upright through most standard doorways for easy door clearance. This is an important feature when racks are loaded full of equipment.
  - HP is the only IT rack provider to offer a complete line of options and accessories that are designed to support HP products.
  - HP's reputation for providing the highest quality products throughout the entire enterprise is based on our strategic partnerships, extensive product research, product development and product testing processes.
  - All rack sizes (including the S10614 rack) are configurable at HP CTO (Configure to Order) facilities.

#### HP Infrastructure Rack 42U, Low Voltage

Components included in kit (one each of the following):  
**Infrastructure Rack 42U, Low Voltage:**

- TFT7600 Rackmount Keyboard and Monitor
- Server Console Switch, 0 x 2 x 16 port
- HP Modular Power Distribution Units (mPDU), Low Volt Model, 24A (100-127 VAC) (NA, Japan) (Mounted in 0U space)
- HP Rack 10642 (42U) - Shock Pallet
- HP Rack Light Kit (Neon)
- Blanking Panel Kit
- Rack Coupling Kits
- IP Console Interface Adapter, 8 pack
- IP CAT5 Cable 12', 8 pack

#### HP Infrastructure Rack 42U, High Voltage

Components included in kit (one each of the following except where noted):  
**Infrastructure Rack 42U, High Voltage:**

- TFT7600 Rackmount Keyboard and Monitor
- Server Console Switch, 0 x 2 x 16 port
- Two HP Modular Power Distribution Units (mPDU), High Volt Model, 24A (200-240 VAC) (NA, Japan) (Mounted in 0U space)
- HP Rack 10642 (42U) - Shock Pallet
- HP Rack Light Kit (Neon)
- Blanking Panel Kit
- Rack Coupling Kits
- IP Console Interface Adapter, 8 pack
- IP CAT5 Cable 12', 8 pack

### Standard Features

#### The HP Rack System

All HP rack-mountable products are designed to fit our industry-standard 19-inch wide racks. HP offers several racks to meet your system needs.

Racks and rack-mountable components are typically described using "U" measurements. One "U" is 1.75" (44.45 mm) high.

This sturdy, industrial-strength rack series offers the following features:

- Models - 10647 (600 mm wide, 47U), 10642 (600 mm wide, 42U), 10636 (600 mm wide, 36U), 10622 (600 mm wide, 22U), S10614 (600mm wide, 14U) and 10842 (800 mm wide, 42U)
- Universal - Accommodates all HP equipment (ProLiant, Alpha, StorageWorks, UPS, PDU) in addition to select third party equipment
- Design - Perforated front and back doors which allows for high air flow and cooling up to 65% open; U marking front and sides of rails to ease component installation; increased cable management features
- Loading - The 10642 will accommodate up to 2000 lb. of equipment in a static or dynamic environment. A static environment is one where the rack is positioned into place and the leveling feet are extended prior to equipment being installed. A dynamic environment is one where the rack is shipped on a shock pallet with equipment installed or rolling racks with equipment installed to new locations within the data center.

**NOTE:** Side Panels ship standard on the 10622 and S10614 models only. They are optional for the 10647, 10642, 10636 and 10842 models.

### Product Features

- Unique frame, rail and door design
- Thermal integrity
- Security provisions
- Flexibility
- Custom expandability
- Powerful 3 year Warranty (3-0-0)
- Static Load capacity up to 2000 lb (10642 dynamic load capacity is also 2000 lb)

### HP Rack 10000 Series Key Benefits (Universal Rack)

The HP Rack 10000 Series offers protection, price, performance and quality. The following are a few of the many benefits that come standard:

- **Unique Frame and Rail Design** - enables fast assembly, easy mounting and outstanding structural integrity. Equipment installation effort is dramatically reduced because the vertical mounting system was specifically designed to minimize the time required to install HP products, and can be used with many other non-HP products as well. U markings on the front and sides of rails make it easy to align parts when installing equipment. Cut outs in the rails also allows for cabling between racks.
- **Thermal Integrity** - Front to back natural convection cooling is greatly enhanced by the innovative multi-angled design of the front door. For additional heat removal, an optional roof mounted fan kit can be easily installed.\*
- **Security Provisions** - Front and rear doors are lockable, which provides the necessary level of security to prevent unauthorized entry. Side panels are also lockable\* allowing for your entire rack row to be secure.
- **Flexibility** - Outstanding cable management features make it easy to develop effective solutions and easy to maintain. Cable egresses in the top of the rack allow for ample room for routing cables outside of the rack. The split rear doors\* give ample access to rack mounted equipment without blocking rack rows while the removable panel gives added flexibility for cable routing. Velcro straps are provided in the hardware bag for clean cable bundling within the rack.
- **Loading Capacity** - HP has increased the maximum loading capacity up to 2000 lb.\* Allowing the rack to be completely full of equipment and shipped when using a shock pallet.

**\*NOTE:** Except S10614. The side panels and roof are not removable and cannot be bayed. The S10614 features one back door (not split).

### Low Total Cost of Ownership

Exclusive product options and accessories that optimize rack space utilization

- TFT7210R - 1U Flat panel rack-mount monitor
- 0U and 1U mounting kits for options such as the new Modular Power Distribution Units (mPDU)
- Cost-saving Server Console Switches (KVM) with multiple mounting options
- TFT7600 Rackmount Keyboard and Monitor
- Integrated Keyboard and Drawer
- Highest levels of system management, performance, construction and compatibility

### Investment Protection

- Investment security across all mainstream ProLiant server and storage products.
- Well-designed and crafted options provide unlimited flexibility in growing or adapting the 10000 series of rack cabinets to specific requirements and needs.
- Advanced product integration and quality provides high system reliability

## Product Features

### Simplified Management

- Unique frame and rail design minimizes time necessary to install products in rack cabinet
  - Product selection:
    - 47U @ 2.3 M
    - 42U @ 2.0 M
    - 36U @ 1.7 M
    - 22U @ 1.1 M
    - 14U @ 0.7 M
  - All mainstream ProLiant server and storage products are easily managed with our seamless enterprise integration process
- 

### Industry-leading Breakthroughs

- Exclusive 42U in a two-meter rack cabinet height for easy door clearance
- The only company to provide a complete line of options and accessories that are designed to support HP products
- Special 14U rack designed specifically for remote site deployments.
- 2000 lb dynamic load capacity for the S10642



## Service and Support, HP Care Pack, and Warranty Information

### Service and Support Offerings (HP Care Pack Services)

Three year warranty, parts only (3-0-0).

**NOTE:** Certain restrictions and exclusions apply. Consult the HP Customer Support Center for details.

Care Pack services provide a range of life cycle support options that let you choose the service levels that meet your business requirements, from basic to mission-critical.

A full range of HP Care Pack hardware and software services are available including:

- Installation and start up
- Education courses
- Extended onsite hardware coverage hours from same business day 13 hours, 5 day to 24 hours, 7 days call window with options including 4-hour response or 6-hour Call To Repair
- Comprehensive range of software technical support for Microsoft, Linux, ProLiant Essentials and VMware-based IT solutions helping to deliver high level of application availability. Response times range from 30 mins for critical problems to 2 hours.
- System Management, Performance Services and Mission Critical Support Solution

**NOTE:** For more information on HP Care Pack services, contact any of our worldwide sales offices or resellers or visit our worldwide Web site on the internet at: <http://www.hp.com/hps/carepack>

**NOTE:** For more complete information on HP Services offerings, customers and resellers, please visit us at: <http://www.hp.com/hps>

**NOTE:** Additional information regarding worldwide limited warranty and technical support is available at: <http://h18004.www1.hp.com/products/servers/platforms/warranty/index.html>

**NOTE:** For additional information on Server Services, Rack and Power Options, please visit: <http://h20219.www2.hp.com/services/cache/111072-0-0-225-121.html>

**NOTE:** The information contained herein is subject to change without notice and is provided "as is" without warranty of any kind.

**NOTE:** The warranties for HP products and services are set forth in the express limited warranty statements accompanying such products and services.

**NOTE:** Nothing herein should be construed as constituting an additional warranty. HP shall not be liable for technical or editorial errors or omissions contained herein.

### Rack Options

Several options allow for quick and easy expansion of the HP Rack 10000 Series racks to create a custom solution.

**NOTE:** This is only a sampling of the many HP Rack options available. See the HP rack products Web site for more complete information at <http://www.hp.com/products/rackoptions>. Contact your nearest HP Authorized Reseller or Service Provider for information about ordering HP parts. In the United States, HP can make arrangements to have your rack system installed by qualified Guaranteed Service Providers. This installation service covers the entire hardware installation sequence, from unpacking the components to routing cabling and running a test of the system.

<b>Rack Light Kit</b>	110V/220V Rack Light Kit <b>NOTE:</b> Supports HP Rack 10000 Series only. This neon light kit is mounted on the rack roof and used to provide light to the rear section of the rack.	361589-B21
<b>Plinth Kit</b>	Rack Plinth Kit (Carbon) <b>NOTE:</b> For HP Rack 10000 series only. The Rack Plinth Kit (Carbon) is used to secure the rack to the data center floor to prevent tipping during tremors and earthquakes.	251960-B21
<b>HP Monitored Power Distribution Unit</b>	<b>HP Monitored Power Distribution Unit - Full Rack Version</b> HP 17.3 kVA S2324 Monitored PDU- dual input, 3-phase, 24A (NA/JPN) 370959-D71 HP 8.3 kVA S1324 Monitored PDU- single input, 3-phase, 24A (NA/JPN) 370960-D71 HP 16.6 kVA S2140 Monitored PDU- dual input, 1-phase, 40A (NA/JPN) 370961-D71 HP 8.6 S1140 Monitored PDU- single input, 1-phase, 40A (NA/JPN) 370962-D71 HP 22.1 kVA S2316 Monitored PDU- dual input, 3-phase, 16A (INTL) 370963-B31 HP 11 kVA S 1316 Monitored PDU- single input, 3-phase, 16A (INTL) 370964-B31 HP 14.7 kVA S2132 Monitored PDU- dual input, 1-phase, 32A (INTL) 370965-B31 HP 7.4 kVA S1132 Monitored PDU- single input, 1-phase, 32A (INTL) 370966-B31 <b>HP Monitored Power Distribution Unit - Half Rack Version</b> HP 17.3 kVA S348 Monitored PDU- single input, 3-phase, 60A (NA/JPN) AF916A HP 22 kVA S332 Monitored PDU- single input, 3-phase, 32A (INTL) AF917A	
<b>Coupling Kit</b>	Rack Coupling Kit (Carbon) <b>NOTE:</b> Supported by both the Rack 10000 and Rack 10000 G2 series. Supports 24 in and 600 mm floor tile spacing. The kit is used to join two or more 10000 series racks of the same height together in minutes to create a multi-bay configuration.	248929-B21
<b>9000/10000 Offset Baying Kit</b>	9000/10000 Offset Baying Kit (42U) <b>NOTE:</b> This kit can be used to connect 9000 and 10000 series racks of the same U height together. Kit contents include hardware for connecting racks and a panel to cover the 100mm gap at the rear of the two racks.	248931-B21

### Rack Options

Side Panels	47U Side Panels (set of two) (Graphite Metallic)	255486-B21
	42U Side Panels (set of two) (Graphite Metallic)	246099-B21
	36U Side Panels (set of two) (Graphite Metallic)	246102-B21

**NOTE:** Option kits above are lightweight, locking side panels for the 10647, 10642 and 10636 racks. Side panels are included with the 22U and 14U racks.

Stabilization Kits	Ballast Option Kit	120672-B21
	600mm Stabilizer Option Kit (Graphite)	246107-B21
	800mm Stabilizer Option Kit (Graphite)	255488-B21

**NOTE:** The Ballast Option Kit is designed to provide additional stability and support when used with the Stabilizer Kit. It is typically used when very heavy equipment is routinely installed, removed or accessed within the rack.

**NOTE:** The anti-tip stabilizer kits provide stability and support when equipment is installed, removed or accessed within the rack. The 600mm wide version is to be used with 10622, 10636, and 10642, and 10647 racks. The 800mm wide version is to be used only with the 10842 rack.

Grounding Kit	9000/10000 Grounding Kit	260457-B21
---------------	--------------------------	------------

**NOTE:** The Grounding Option Kit makes it possible to completely integrate grounding in HP racks.

Cable Management	Cable Management "D" Rings Kit (10 pack)	168233-B21
------------------	--	------------

**NOTE:** This kit consists of 10 "D" rings that can be used in addition to the rings that ship standard in the 10000 series and 10000 G2 series racks for cable management.

Blanking Panels (Carbon Graphite)	1U Universal Blanking Panel kit (10 panels)	AF072A
	1U Universal Blanking Panel kit (100 panels)	AF073A

**NOTE:** 0D1 will appear after the above selected part numbers on yours sales order if factory integration is indicated.

**NOTE:** The blanking panels are made from high grade molded plastic, and are designed to be installed without tools. The use of blanking panels is recommended to ensure proper airflow.

Locking Drawer	HP 2U Universal Locking Drawer (WW)	361591-B21
----------------	-------------------------------------	------------

**NOTE:** 0D1 will appear after the above selected part numbers on yours sales order if factory integration is indicated.

**NOTE:** This product mounts on HP 10000 Series and 10000 G2 series racks with sliding rails and is used to store CD's, Instruction manuals, tools, and any other item that is frequently used at the rack. Drawer includes lock.

### Rack Options

Rack Cable Trays	Rack Top Cable Tray, 600W	383982-B21
	Rack Top Cable Tray, 800W	383983-B21
	Rack to Rack Adjustable Cable Tray, Aisle Transfer Bridge	383984-B21

**NOTE:** The Aisle Transfer bridge allows for cabling trays to be connected even across different aisles in the datacenter.

**NOTE:** These kits mount on the top of the 9000 and 10000 Series rack (except the S10614 rack). Kit color is graphite.

Fan Kits	HP Roof Mounted Fan Kit 110V	257413-B21
	HP Roof Mounted Fan Kit 220V	257414-B21

**NOTE:** 0D1 will appear after the above selected part numbers on yours sales order if factory integration is indicated.

Rear Extension Kits	10642 Rear Extension Kit (155mm)	AF058A
---------------------	----------------------------------	--------

**NOTE:** The rear extension kits are compatible with 10000 G2 Series, 10000 Series and the 9000 Series racks. The rear extension kits are compatible with 10000 G2 Series, 10000 Series and the 9000 Series racks.

Fibre Channel Cable Management Kit	FC Cable routing Spool - Box of 12	293357-B21
	Rail-to-Rail FC Cable Routing - All	293358-B21
	Side Rail FC Routing - Box of 6	293359-B21

**NOTE:** This kit mounts on the top of the 9000 and 10000 Series rack (except the S10614 rack) and pulls heated air from the back of the rack out through the top. Kit color is graphite.

This is only a sampling of the many HP Rack options available. See the HP rack products Web site for more complete information at <http://www.hp.com/products/rackoptions>

Contact your nearest HP Authorized Reseller or Service Provider for information about ordering HP parts. In the United States, HP can make arrangements to have your rack system installed by qualified Guaranteed Service Providers. This installation service covers the entire hardware installation sequence, from unpacking the components to routing cabling and running a test of the system.

**NOTE:** Customers interested in AlphaServer ES/DS systems in the HP Rack 10000 Series, for factory-direct or on-site configuration, should consult HP's Custom Systems group.

An order form with pricing is available via PaqFax, HP's fax retrieval service. Dial 1-800-345-1518, select PaqFax, and request Document Number 4552. Installation can also be provided directly by Authorized HP Service Providers.

Service and Support Offerings (HP Care Pack Services)	Hardware Installation (Electronic)	U2871E
---	------------------------------------	--------

## Technical Specifications

### 10647 Rack Physical Characteristics

Dimensions (HxDxW)	<b>Total Cabinet Area</b>	89.96 x 39.691 x 24 in (228.5 x 100.82 x 60.96 cm)
	<b>Shipping</b> (with packaging materials)	95.47 x 48 x 32 in (242.49 x 121.92 x 81.28 cm)
Weight	<b>Operating</b>	245 lb (111 kg)
	<b>Shipping</b>	284 lb (129 kg)
Load	<b>Static</b>	2000 lb (908 kg)
	<b>Dynamic</b>	Do not ship with equipment installed
Color	<b>Doors</b>	Graphite Metallic
	<b>Frame</b>	Carbon

---

### 10642 Rack Physical Characteristics

Dimensions (HxDxW)	<b>Total Cabinet Area</b>	78.7 x 39.691 x 24 in (199.90 x 100.82 x 60.96 cm)
	<b>Shipping</b> (with packaging materials)	86.22 x 48 x 32 in (219 x 121.92 x 81.28 cm)
Weight	<b>Operating</b>	253 lb (114.84 kg)
	<b>Shipping</b>	284 lb (129 kg)
Load	<b>Static</b>	2000 lb (908 kg)
	<b>Dynamic</b>	2000 lb (908 kg)
Color	<b>Doors</b>	Graphite Metallic
	<b>Frame</b>	Carbon

---

### 10636 Rack Physical Characteristics

Dimensions (HxDxW)	<b>Total Cabinet Area</b>	68.6 x 39.691 x 24 in (174.24 x 100.82 x 60.96 cm)
	<b>Shipping</b> (with packaging materials)	75.25 x 48 x 32 in (191.14 x 121.92 x 81.28 cm)
Weight	<b>Operating</b>	220 lb (100 kg)
	<b>Shipping</b>	272 lb (123 kg)
Load	<b>Static</b>	2000 lb (908 kg)
	<b>Dynamic</b>	1520 lb (690 kg)
Color	<b>Doors</b>	Graphite Metallic
	<b>Frame</b>	Carbon

---

## Technical Specifications

### 10622 Rack Physical Characteristics

<b>Dimensions</b> (HxDxW)	<b>Total Cabinet Area</b>	43 x 39.691 x 24 in (109.22 x 100.82 x 60.96 cm)
	<b>Shipping</b> (with packaging materials)	52.25 x 48 x 32 in (132.72 x 121.92 x 81.28 cm)
<b>Weight</b>	<b>Operating</b>	176 lb (79.89 kg)
	<b>Shipping</b>	225 lb (102.13 kg)
<b>Load</b>	<b>Static</b>	2000 lb (908 kg)
	<b>Dynamic</b>	1045 lb (474 kg)
<b>Color</b>	<b>Doors</b>	Graphite Metallic
	<b>Frame</b>	Carbon

### 10842 Rack Physical Characteristics

<b>Dimensions</b> (HxDxW)	<b>Total Cabinet Area</b>	78.7 x 39.691 x 31.5 in (199.90 x 100.82 x 80.01 cm)
	<b>Shipping</b> (with packaging materials)	85 x 48 x 43.5 in (215.9 x 121.92 x 110.49 cm)
<b>Weight</b>	<b>Operating</b>	295 lb (133.8 kg)
	<b>Shipping</b>	335 lb (151.95 kg)
<b>Load</b>	<b>Static</b>	2000 lb (908 kg)
	<b>Dynamic</b>	1000 lb (453 kg)
<b>Color</b>	<b>Doors</b>	Graphite Metallic
	<b>Frame</b>	Carbon

### S10614 Rack Physical Characteristics

<b>Dimensions</b> (HxDxW)	<b>Total Cabinet Area</b>	28.5 x 39.69 x 23.6 in (72.4 x 100 x 60 cm)
	<b>Shipping</b> (with packaging materials)	34 x 44x 30.5 in (86.36 x 111.82 x 77.5 cm)
<b>Weight</b>	<b>Operating</b>	135 lb (61 kg)
	<b>Shipping</b>	190 lb (86.18 kg)
<b>Load</b>	<b>Static</b>	600 lb (270 kg)
	<b>Dynamic</b>	500 lb (227 kg)
<b>Color</b>	<b>Doors</b>	Graphite Metallic
	<b>Frame</b>	Carbon

© Copyright 2006 Hewlett-Packard Development Company, L.P.

The information contained herein is subject to change without notice.

The only warranties for HP products and services are set forth in the express warranty statements accompanying such products and services. Nothing herein should be construed as constituting an additional warranty. HP shall not be liable for technical or editorial errors or omissions contained herein.