



METROPOLITAN TRANSIT AUTHORITY

INVITATION FOR BIDS (IFB)

FOR

PURCHASE AND DELIVERY OF HEAVY DUTY 45-FOOT CLEAN DIESEL COMMUTER BUSES

METRO IFB NO. 4024000045

Bidder's signature on Invitation for Bids (Section III– Forms for Bidding/Proposing/Award) constitutes acceptance of a contract that may result from this Solicitation. Contract award/execution may be made by METRO without discussion.

IMPORTANT – Notice to Bidder

Submit all responses to and questions regarding this solicitation electronically through METRO's Bonfire hub at <https://ridemetro.bonfirehub.com> AND one (1) hardcopy of the bid to the address below.

There is no cost to Contractors to register to submit bids on METRO'S Bonfire hub.

Metropolitan Transit Authority of Harris County, TX
Procurement Division
1900 Main Street
Houston, Texas 77002

Upper Left Corner of Envelope Must Indicate:
Proposer/Contractor Name and Address
Lower Left Corner of Envelope Must Indicate:
Solicitation Number
Due Date
Due Time
Solicitation Title

The Bonfire submission shall take precedence over any discrepancies between the hard copy and the Bonfire submission. Both the electronic (via Bonfire) and hardcopy submittal MUST be received by the deadline specified in the solicitation. A submittal MAY be deemed non-responsive if both the electronic and hardcopy are not received by the deadline specified in this solicitation.

TABLE OF CONTENTS

SECTION I - BIDDING/PROPOSING REQUIREMENTS AND INSTRUCTIONS	1
1 INVITATION FOR BIDS SUMMARY	1
2 INSTRUCTIONS TO BIDDERS.....	3
SECTION II - FORMS FOR BIDDING/PROPOSING	11
1 DISADVANTAGED BUSINESS ENTERPRISES (DBE).....	11
2 BUY AMERICA CERTIFICATE	12
3 CARGO PREFERENCE.....	13
4 DEBARRED, SUSPENDED, OR INELIGIBLE CONTRACTOR'S CERTIFICATION.....	14
5 VEHICLE TESTING CERTIFICATION, 49 CFR PART 665	15
6 FEDERAL MOTOR VEHICLE SAFETY STANDARD (FMVSS).....	16
7 PRE-AWARD AUDIT OF VEHICLES FOR SPECIFICATION AND BUY AMERICA COMPLIANCE	17
8 CERTIFICATION OF RESTRICTIONS ON LOBBYING.....	18
9 AMERICANS WITH DISABILITIES ACT OF 1990 (ADA).....	19
10 MOTOR VEHICLE POLLUTION REQUIREMENTS.....	20
11 BIDDER'S QUESTIONNAIRE	21
12 PRICE BREAKDOWN.....	24
13 REQUEST FOR APPROVAL (RFA FORM).....	25
14 INSTRUCTION FOR USE OF REQUEST FOR APPROVAL (RFA FORM).....	26
15 MANDATORY REQUEST FOR APPROVALS (RFA)	27
SECTION III - FORMS FOR BIDDING/PROPOSING/AWARD	29
1 SOLICITATION, BID AND AWARD FORM	29
2 BID/CONTRACT SCHEDULE OF ITEMS AND PRICES	31
SECTION IV - DELIVERIES OR PERFORMANCE ARTICLES	32
1 DEFINITIONS.....	32
2 PERIOD OF PERFORMANCE.....	32
3 ITEMS PURCHASED, DELIVERY AND COMPENSATION.....	32
4 LIQUIDATED DAMAGES.....	33
5 FORCE MAJEURE.....	34
6 NOTIFICATION OF DELAY	34
7 REQUEST FOR EXTENSION.....	34
8 METRO DELAY OF WORK.....	34
9 PERFORMANCE BOND OR LETTER OF CREDIT.....	34
10 ASSIGNMENT OF VEHICLES	34
11 MATERIALS AND WORKMANSHIP	34
12 CONFORMANCE WITH CONTRACT AND SPECIFICATIONS.....	35
13 REPAIRS AFTER NON-ACCEPTANCE	35
14 DELIVERABLES	35
15 PREPRODUCTION CONFERENCE APPROVALS	35
16 CHANGES OF LAW.....	36
17 TEXAS ETHICS COMMISSION (TEC) ELECTRONIC FILING.....	36
SECTION V - INSPECTION AND ACCEPTANCE ARTICLES.....	37
1 VEHICLE INSPECTION AND ACCEPTANCE	37
2 CONDITIONAL ACCEPTANCE	37
3 FIRST ARTICLE INSPECTION – PRODUCTION (Not Applicable).....	37
4 TESTING OF NEW BUS MODELS.....	37
SECTION VI - CONTRACT ADMINISTRATION DATA ARTICLES	38
1 COMPENSATION.....	38
2 INVOICING AND PAYMENT.....	38
3 CONTRACTOR REPRESENTATIVE.....	38
4 NOTICES	38
SECTION VII - INSURANCE ARTICLES.....	39
1 INSURANCE REQUIREMENT.....	39
2 INDEMNIFICATION AGREEMENT.....	40
SECTION VIII - SMALL BUSINESS PROGRAM ARTICLES.....	42
1 DISADVANTAGED BUSINESS ENTERPRISES	42
SECTION IX - SPECIAL TERMS AND CONDITIONS ARTICLES.....	43
1 DATA RIGHTS	43
2 SOFTWARE.....	43
3 AVAILABILITY OF FUNDS FOR THE NEXT FISCAL YEAR.....	43

SECTION X - GENERAL TERMS AND CONDITIONS ARTICLES	44
1 TITLE.....	44
2 COMPLIANCE WITH LAWS/PERMITS AND LICENSES	44
3 METRO-FURNISHED PROPERTY.....	44
4 WARRANTY.....	44
5 SERVICE LOCATION	44
6 CHANGES.....	44
7 DISPUTES	45
8 TERMINATION FOR CONVENIENCE OF METRO	45
9 TERMINATION FOR DEFAULT	46
10 PATENT INDEMNITY.....	47
11 COVENANT AGAINST CONTINGENT FEES	47
12 DISSEMINATION OF CONTRACT INFORMATION	47
13 CONFIDENTIAL INFORMATION	47
14 USE OF METRO'S NAME IN CONTRACTOR ADVERTISING OR PUBLIC RELATIONS	47
15 ASSIGNMENT.....	47
16 INDEPENDENT CONTRACTOR	47
17 CONTRACTUAL RELATIONSHIPS.....	47
18 CONTRACT ORDER OF PRECEDENCE.....	48
19 SEVERABILITY	48
20 WAIVERS.....	48
21 INTERPRETATION, JURISDICTION AND VENUE	48
22 RIGHTS AND REMEDIES.....	48
23 NOTICE TO METRO OF LABOR DISPUTES	48
24 ETHICAL CONDUCT	48
25 SUSPENSION OF WORK.....	49
26 CONFLICTS OF INTEREST, GRATUITIES	49
27 METRO NON-DISCRIMINATION.....	49
28 CONTRACTOR NON-DISCRIMINATION	49
29 EQUAL OPPORTUNITY FOR VEVRAA PROTECTED VETERANS	49
SECTION XI - FEDERAL REQUIREMENTS ARTICLES	52
1 FEDERAL CHANGES	52
2 OFFICIALS NOT TO BENEFIT	52
3 CONTRACT WORK HOURS AND SAFETY STANDARDS ACT	52
4 TITLE VI OF THE CIVIL RIGHTS ACT OF 1964 OBLIGATIONS	53
5 BUY AMERICA.....	53
6 POST-DELIVERY AUDIT OF VEHICLES FOR SPECIFICATION AND BUY AMERICA COMPLIANCE.....	54
7 FEDERAL MOTOR VEHICLE SAFETY STANDARDS	54
8 MOTOR VEHICLE POLLUTION REQUIREMENTS.....	54
9 ACCESS TO RECORDS.....	54
10 ACCESS REQUIREMENTS FOR INDIVIDUALS WITH DISABILITIES	54
11 ENVIRONMENTAL REQUIREMENTS.....	55
12 RECYCLED PRODUCTS	55
13 FLY AMERICA	55
14 CARGO PREFERENCE--USE OF UNITED STATES-FLAG VESSELS	55
15 RESTRICTIONS ON LOBBYING	56
16 DEBARMENT AND SUSPENSION.....	56
17 NO OBLIGATION BY THE FEDERAL GOVERNMENT	56
18 INCORPORATION OF FEDERAL TRANSIT ADMINISTRATION (FTA) TERMS	56
19 FRAUD AND FALSE OR FRAUDULENT STATEMENTS AND RELATED ACTS	56
20 MAINTENANCE OF RECORDS; ACCESS BY METRO; RIGHT TO AUDIT RECORDS	57
21 VETERANS EMPLOYMENT	57
22 ENTIRE AGREEMENT.....	57
SECTION XII - EXHIBITS	58
1 EXHIBIT "A" MAIN BUS TECHNICAL SPECIFICATIONS AND DRAWINGS	58
2 EXHIBIT "B" CONTRACTOR'S RELEASE.....	285
3 EXHIBIT "C" REQUEST FOR APPROVALS RESPONSES	286
4 EXHIBIT "D" SUPER CIRCULAR.....	287
5 EXHIBIT "E" FEDERAL CERTIFICATES	289

SECTION I - BIDDING/PROPOSING REQUIREMENTS AND INSTRUCTIONS

1 INVITATION FOR BIDS SUMMARY

IFB NO.:4024000045

IFB ISSUE DATE: 12/11/2023

PROJECT NAME: Purchase and Delivery of Heavy Duty 45-Foot Clean Diesel Commuter Buses

ISSUED BY: Metropolitan Transit Authority of Harris County (METRO)

Website: <https://www.ridemetro.org/procurement>

All questions and bid responses to this solicitation must be submitted electronically through METRO’s Bonfire hub at <https://ridemetro.bonfirehub.com>. Registration on METRO’s Bonfire hub is free. Additionally, submit one (1) Original hardcopy delivered in a sealed envelope to the METRO Procurement Office, 1900 Main Street, Houston, Texas 77002. Digital signatures accepted.

CONTRACT ADMINISTRATOR: Kenny Chin
 Senior Contract Administrator
 Procurement Services
 1900 Main Street, 8th Floor
 Houston, Texas 77002
 Email: kenny.chin@ridemetro.org
 Phone: (713) 739-4860

NOTE TO BIDDERS: (1) BIDDERS ARE RESPONSIBLE FOR ALL INFORMATION IN THIS SOLICITATION, HOWEVER, PLEASE PAY PARTICULAR ATTENTION TO INFORMATION SHADED IN GRAY (2) PLEASE BE ADVISED THAT BONFIREHUB.COM HAVE LIMITATION OF DATA THAT CAN BE UPLOADED. PLEASE SEND ALL RFA’s AND SUPPORTING DOCUMENTATION TO andrei.dragomir@ridemetro.org. AND kenny.chin@ridemetro.org ANSWER WILL BE POSTED IN Bonfirehub.com.

BID SUBMISSION/RECEIPT: Sealed bids in original form for work or item(s) described herein will be submitted through METRO’s Bonfire hub at <https://ridemetro.bonfirehub.com> and MUST be received by 2:00 p.m. Central Standard Time (CST) on Wednesday, January 3, 2024. **Additionally, ONE (1) ORIGINAL HARDCOPY:** Deliver in a sealed envelope bearing the name and address of the Bidder and the identification ‘Invitation for Bids’ No. 4024000045 to the METRO Procurement Office, 1900 Main Street, Houston, Texas 77002.

Both the electronic (via Bonfire) and hardcopy submittal MUST be received by the deadline specified in the solicitation. A submittal MAY be deemed non-responsive if both the electronic and hardcopy are not received by the deadline specified in this solicitation.

REQUEST(S) FOR APPROVAL OR DEVIATION: Request(s) for Approval or Deviation are required fifteen (15) calendar days before original bid due date with METRO to respond ten (10) days prior to the due date. (See Instructions to Bidders, paragraph entitled “REQUEST(S) FOR APPROVAL OR DEVIATION “). **Failure to submit the Mandatory RFA’s in Section II will render your bid non-responsive.**

Sunday, December 10, 2023	Ad 1/RFA
Monday, December 11, 2023	Contract Release Date
Thursday, December 14, 2023	Prebid Conference
Thursday, December 14, 2023	RFA Due
Sunday, December 17, 2023	Ad 2
Wednesday, December 20, 2023	Post RFA Responses
Tuesday, December 26, 2023	Post Reconsideration
Wednesday, January 3, 2024	Bid Due
Thursday, January 4, 2024	Bid Open

BID OPENING: Bids will be opened publicly and read aloud at 10 a.m. (CST) on Thursday, January 4, 2024. The opening will be recorded. **Bidders can watch the bid opening live at:**

MS Teams Link: [Join Microsoft Teams Meeting](#)
Dial-In Telephone No.: +1 281-925-7469
Conference ID: 246 022 158 #

After the bid opening and bid evaluation, the apparent lowest bidder will receive an email request from METRO to email its original signed bid in PDF format to kenny.chin@ridemetro.org. The Bidder shall not email the bid prior to receiving the request from METRO.

A PRE-BID BRIEFING will be held at **2 p.m.** (CST) on Thursday, December 14, 2023. (See access information below.) In-person participation is not offered for this briefing.

Meeting ID: 231 784 108 954

Passcode: wgEuqK

[Download Teams](#) | [Join on the web](#)

Or call in (audio only)

[+1 281-925-7469](tel:+12819257469), [1403741574#](tel:+1403741574) United States, Houston

Phone Conference ID: 140 374 157#

RESPONSIBLE BIDDER: Each bidder is cautioned to review and understand the requirements of this solicitation in order to be determined a responsible bidder. (See Section I, Instructions to Bidders, paragraph entitled "BIDDER QUALIFICATIONS/ELIGIBILITY FOR AWARD".)

BID GUARANTEE of not less than 5% of the total bid is required. (See Instructions to Bidders, paragraph entitled "BID SECURITY").

PERFORMANCE BOND: for 5% of the Contract amount required. (See Contract, Article entitled "Performance Bond").

PERFORMANCE/DELIVERY PERIOD: The Contract shall be for delivery of New Buses in accordance with the delivery schedule. (See Contract Article "Period of Performance")

LIQUIDATED DAMAGES: will be assessed as indicated in the Contract Article entitled "Liquidated Damages".

INSURANCE: Each prospective bidder is cautioned to review the Insurance requirements of this Solicitation particularly to understand the criteria and the successful Contractor's responsibilities. (See Contract, Article entitled "Insurance Requirement").

FEDERAL FINANCIAL ASSISTANCE: This procurement is subject to the availability of Federal financial assistance from the Federal Transit Administration (FTA), therefore, all required Federal requirements such as Buy America, Cargo Preference, Debarred, Suspended or Ineligible Contractors, Bus Testing, FMVSS, and Pre-Award and post Delivery Audits for Specification and Buy America Compliance will be included in the resultant Contract (See Section II, forms to be submitted with bid). Failure to submit these will make your bid nonresponsive.

OBLIGATION: This Invitation for Bids does not obligate the Metropolitan Transit Authority to award a contract, or to pay any costs incurred in the preparation or submittal of any bid.

ORGANIZATION OF BID: The Invitation for Bid (IFB) is to be provided as follows:

PRICE BREAKDOWN including all detailed pricing information with particular attention to the unit price breakdown in Section II, subject to detailed METRO review as appropriate.

SMALL BUSINESS CONTRACT GOAL: There is no small business subcontracting goal for this Solicitation.

TYPE OF AWARD: METRO anticipates the award of a Firm Fixed price type contract as a result of this Solicitation.

NOTE: All forms contained in this solicitation may be reproduced if more space is needed due to the number of subcontractors or suppliers to be submitted with the bid or for any other reason.

OBLIGATION: This Invitation for Bids does not obligate the Metropolitan Transit Authority to award a contract or to pay any costs incurred in the preparation or submittal of any bid.

REGISTRATION ON PROCUREMENT WEBSITE: All bidders/proposers **MUST** register on METRO's procurement website at [Ridemetro.org/Supplier Vendor Registration](https://ridemetro.org/SupplierVendorRegistration) to ensure that they receive the latest solicitations and updates via their registered e-mail address.

2 INSTRUCTIONS TO BIDDERS

A. DOCUMENTS

1. A complete hard copy set of bid documents shall be used in preparing a bid. Bids will be accepted from only those bidders listed on METRO'S official Bidder's List at the designated bid opening time. METRO assumes no responsibility for errors or misinterpretations resulting from the use of incomplete sets of documents. After the bid opening, bidders will receive an email request from METRO to email a PDF of their bids to kenny.chin@ridemetro.org. **Do not email bids prior to receiving the request from METRO.**
2. METRO, in making copies of these documents available on the above terms, does so only for the purpose of obtaining bids on the work and does not convey a license or grant for any other use.
3. Each bidder should carefully examine these documents and take such other steps as may be reasonably necessary to ascertain the contract performance requirements. Failure to do so will not relieve Bidders from responsibility for estimating properly the difficulty or cost of successfully performing the Contract. Extra compensation will not be allowed for conditions which are determinable by examining these documents. METRO will assume no responsibility for any understanding or representations concerning conditions made by any of its officers or agents prior to the execution of the Contract, unless included in these documents.
4. Each bidder should visit the site, carefully examine these documents and take such other steps as may be reasonably necessary to ascertain the nature and location of the work. Each bidder shall make themselves aware of local labor availability, means of transportation, local weight restrictions, laws, codes, wage scales, local tax structure, contractor's license and permit requirements, availability of required insurance, and other factors that could affect the work. Failure to do so will not relieve bidders from responsibility for estimating properly the difficulty or cost of successfully performing the work. Extra compensation will not be allowed for conditions which are determinable by examining these documents or the work site.

B. EXPLANATION TO BIDDERS

Any explanation desired by a bidder regarding the meaning or interpretation of the Invitation for Bids, drawings, specifications, etc., must be requested in writing and with sufficient time allowed (**a minimum of fifteen (15) days before date set to receive bids**) for a reply to reach bidders before the submission of their bids. Any interpretation made will be in the form of an amendment to the Invitation for Bids, drawings, specifications, etc., or information letter and will be furnished to all prospective bidders. Receipt of Amendments by the bidder must be acknowledged in the space provided on the Bid or Amendment Form or by letter received by METRO before the time set for opening of bids. Oral explanations or instructions given before the award of the contract will not be binding.

C. BIDDER QUALIFICATIONS/ELIGIBILITY FOR AWARD

1. In order for a bidder to be eligible to be awarded the Contract, the bid must be responsive to the Invitation, show the bidder's technical competency, and METRO must be able to determine that the bidder is responsible to perform the Contract satisfactorily.
2. Responsive bids are those complying with all material aspects of the Solicitation. Bids which do not comply with all the terms and conditions of the Solicitation will be rejected as non-responsive.
3. Responsible bidders as a minimum must:
 - a) Contractor must show evidence of having performed a project of similar size, scope, and complexity.
 - b) Have financial resources adequate to perform the Contract, or ability to obtain such resources as required during the performance of the Contract;
 - c) Be able to comply with the required or proposed delivery or performance schedule, taking into consideration all existing business commitments;
 - d) Have a satisfactory record of current and/or past performance in behalf of METRO and/or other owners, including the areas of scheduling, submittals; record keeping, reporting, qualified supervision, skilled workforce, safety, quality of equipment, materials and workmanship, timely performance, warranties and guarantees;
 - e) Have the necessary technical equipment, material and capability, including qualified supervision and skilled workforce, adequate to perform the Contract, or the ability to obtain such resources as are required during the course of the Contract;

- f) Have a satisfactory record of business integrity and ethics;
 - g) If applicable, have a satisfactory record, as a contractor, of making good-faith efforts to achieve Small Business/Disadvantaged Business Program goals in past METRO projects, as well as providing evidence satisfactory to METRO that the bidder will comply with the Small Business Program/Disadvantaged Business requirements and goals contained herein;
 - h) Certify that it is not on the U.S. General Services Administration's "Lists of Parties Excluded from Federal Procurement or Non-procurement Programs". Signing and submitting the bid is so certifying;
 - i) Be qualified as an established firm regularly engaged in the type of business to provide the items/work required by this Solicitation; and
 - j) Be otherwise qualified and eligible to receive an award under applicable laws and regulations.
4. A bidder may be requested to submit written evidence verifying that they meet the minimum criteria necessary to be determined a responsible bidder. Refusal to provide requested information will result in the bidder being declared non-responsive, and the bid will be rejected.
5. Bids deviating or taking exception to the Solicitation requirements will not be considered.

D. DISQUALIFICATION

METRO reserves the right to disqualify a bid, before or after the bid opening, upon evidence of collusion with intent to defraud or other illegal practices on the part of a bidder.

E. PROTESTS

1. Each protest to the Solicitation documents shall be submitted for resolution to the Chief President Officer of Procurement & Materials. Each such protest shall be in writing and shall be supported by the information set forth in Chapter 12 of METRO's Procurement Manual to enable the protest to be considered. A protest or objection will not be considered if it is insufficiently supported or it is not received within the time limits specified herein.
2. The Chief Procurement Officer must receive the initial protest submission directed to the terms, conditions, or form of a proposed procurement action no later than five (5) calendar days prior to the date established for opening of bids or receipt of proposals.
3. The Chief Procurement Officer must receive the initial protest submission for protests concerning award decisions, including bid evaluations, no later than five (5) days after the interested party knows, or through exercise of reasonable diligence should have known, whichever is earlier, of the grounds for the protest.
4. Each protest will be processed in accordance with METRO's Protest Procedures located in Chapter 12 of METRO's Procurement Manual. A copy of the procedures will be provided to the protester upon written request to METRO's Chief Procurement Officer.
5. A written final determination on any protest will be rendered by METRO's President & Chief Executive Officer and will be provided to the protester as soon as practicable.
6. The protester must exhaust its administrative remedies by pursuing METRO's protest procedures to completion prior to appealing METRO's decision to the FTA.
7. The Federal Transit Administration (FTA) Circular 4220.1F, or any of its successors, paragraph 7L, addresses bid protests. A copy of this paragraph will be provided to the protester upon written request to METRO. Review of a protest by FTA will be limited to a grantee's failure to have or follow its written protest procedures, its failure to review a complaint or protest, or violations of Federal law or regulations. ' An appeal to FTA must be received by the cognizant FTA regional or Headquarters Office within five (5) working days of the date the protester learned or should have learned of an adverse decision by METRO or other basis of appeal to FTA. Violations of a specific Federal law or regulation will be handled by the complaint process stated within that law or regulation. Alleged violations on other grounds are under the jurisdiction of the appropriate State or local administrative or judicial authorities.

F. PREPARATION OF BID

1. A bid shall be submitted on the forms furnished by METRO or re-produced copies of METRO forms; shall be completed in ink or by typewriter and shall be manually or digitally signed. If erasures or other changes appear on the forms, each erasure or change shall be initialed by the person signing the bid. ' Telegraphic or facsimile (fax) bids are not authorized.
2. The Bid Form may provide for submittal of a price or prices for one or more items, which may be lump sum bids, alternative prices, scheduled items resulting in a bid on a unit price, lump sum or a combination thereof. Where the Bid

Form explicitly requires that the bidder bid on all items, failure to do so will disqualify the bid. When submittal of a price on all items is not required, a bidder shall insert the words 'no bid' in the space provided for any item on which no price is submitted.

3. If a bid is from an individual, sole proprietorship, or a bidder operating under a trade name, the bid shall be signed by that individual.
4. A bid by a partnership shall be executed in the partnership name and signed by a partner; the official address of the partnership shall be shown where indicated on the 'Solicitation, Bid and Award' form.
5. A bid by a corporation shall be executed in the corporate name by the president or a vice-president (or other corporate officer accompanied by evidence of authority to sign) and the corporate seal shall be affixed and attested by the corporate secretary or assistant secretary.
6. A bid submitted by a joint venture shall list the names of all joint venturers and the mailing addresses of each and shall be executed by all joint venturers in the same manner as if they were individually submitting bids. The signature portion of the Bid Form shall be altered as appropriate for execution by the joint venture and all joint venturers.
7. All names shall be typed or printed below the signature.
8. The bid shall contain an acknowledgment of receipt of all Amendments to the Solicitation.
9. Communications regarding this Solicitation are to be directed to the address and to the attention of the person shown on the Invitation for Bids form.
10. Unless called for, alternative bids will not be considered.
11. In an effort to promote greater use of recycled and environmentally preferable products and minimize waste, all bids submitted should comply with the following:
 - a) All copies should be printed double-sided.
 - b) All submittals and copies should be printed on recycled paper with a minimum post-consumer content of 30% or on tree-free paper (i.e., paper made from raw materials other than trees, such as kenaf). All bids should note the level of recycled content contained in the paper being used.
 - c) Unless absolutely necessary, all bids and copies should minimize or eliminate the use of non-recyclable or non-reusable materials, such as plastic report covers, plastic dividers, vinyl sleeves and bindings. Three-ringed binders, glued materials, paper clips and staples are acceptable.
 - d) Bids should submit materials in a format that allows for easy removal and recycling of paper materials.
 - e) Bidders are encouraged to use other products that contain recycled content in their bid documents. Such products may include, but not limited to, folders, binders, paper clips, discs, envelopes, boxes, etc. Where appropriate, Proposers may wish to note which products in their proposal are made with recycled materials.
 - f) Unnecessary samples, attachments or documents not specifically asked for should not be submitted with the bid.

G. BID SECURITY

1. Each bid shall be accompanied by Bid Security, drawn payable to the Metropolitan Transit Authority, in the amount required by the Invitation for Bids. The Bid Security shall be a cashier's check, a certified check or a bid bond issued by a surety licensed to do business in Texas, approved for the full amount of bond coverages required on the U.S. Department of the Treasury Circular 570 and by METRO. Failure to furnish the Bid Security in the proper form and amount by the time set for opening of bids will result in rejection of the bid.
2. Bid Security, other than a bid bond, will be returned to:
 - a) Unsuccessful bidders as soon as practicable after the opening of bids, and
 - b) The successful bidder upon execution of such further contractual documents and bonds as may be required by the Contract Documents.
3. If the successful bidder, upon acceptance of its bid by METRO within the period specified therein for acceptance, fails to execute such further contractual documents and furnish such bonds as may be required by the Contract Documents within the time specified in the Contract, will forfeit any Bid Security provided.

H. POSTPONEMENT OF BID OPENING

Notwithstanding the time for opening of bids established in the Invitation for Bids, the bid opening may be postponed solely at METRO's discretion.

I. SUBMISSION OF BIDS

A bid shall be submitted so as to be received no later than the exact time and at the place indicated in the Invitation for Bids and shall be enclosed in a sealed envelope clearly identified as a bid with the project title, Invitation for Bids number and bid opening date and time. The envelope shall identify the name and address of the bidder and shall contain the bid security, if required, and other required documents. Failure to do so may result in a premature opening of, or a failure to open, such bid.

J. LATE BIDS, MODIFICATION OR WITHDRAWAL OF BIDS

1. Any bid or modification of bid received at the METRO office designated in the Invitation for Bids after the exact time specified for receipt will not be considered. Late bids received will be retained unopened and filed with unsuccessful bids in the official contract file.
2. A bid may be withdrawn in person by a bidder or authorized representative, provided their identity is made known and they sign a receipt for the bid, but only if the withdrawal is made prior to the exact time set for opening of bids.
3. Modifications of bids already submitted will be considered if received at the office designated in the Invitation for Bids by the time set for opening of bids.

K. PUBLIC OPENING OF BIDS

Bids will be publicly opened immediately following the time set for opening in the Invitation for Bids. The total bid price(s) will be read aloud for the information of bidders and others interested, who may be present.

L. AWARD OF CONTRACT

1. Award of a Contract, if awarded, will be made to the responsive and responsible bidder offering the lowest **TOTAL BID AMOUNT (Section III, - Bid/Contract Schedule of Items and Prices)** and whose bid conforms to the Solicitation Documents. The lowest price bidder is not guaranteed that it will receive the METRO contract award.
2. METRO reserves the right to reject any and all bids, to waive any informalities in bids received and the right to reject all nonconforming, unbalanced, non-responsive or conditional bids. Discrepancies between words and figures will be resolved in favor of words.
3. Bids containing apparent clerical mistakes such as discrepancy between unit bid price and the price extension or the sum of the extended amounts and the total bid price, or other apparent clerical mistakes, will be resolved by the Contract Administrator in accordance with the Mistake in Bid procedures contained in METRO's Procurement Manual.
4. A written Notice of Award will be issued to the successful bidder upon being selected for award of a contract and execution of any resultant contract.
5. A split award will not be made. Bidders must bid on all items and award will be made based on the total aggregate price.
6. In the event of tie bids, the successful bidder will be determined by drawing of lots at an open meeting with the tie bidders invited to attend.

M. RECEIPT OF SINGLE BID

If only one bid is received in response to the Invitation for Bids, a detailed cost breakdown will be required from the single bidder. An evaluation will be performed of the cost breakdown in order to determine if the price is fair and reasonable.

N. DISCOUNTS

1. No discounts will be considered in the evaluation of bids.
2. Discounts for early payment may be offered in the original bid or on individual invoices submitted under the resulting contract, and discounts offered will be taken by METRO if payment is made within the discount period specified.
3. Discounts that are included in bids become a part of the resulting Contract and are binding on the Contractor. Discounts

offered only on individual invoices will be binding on the Contractor only for the particular invoice on which the discount is offered.

O. CONTRACT BONDS AND INSURANCE

The bidder whose bid is accepted shall, within the time established in the Invitation for Bids, enter into a written Contract with METRO and, if required, furnish Certificates of Insurance and Performance and Payment Bonds in the amounts indicated in the Contract.

P. METRO-FURNISHED PROPERTY

No material, equipment or facilities will be furnished by METRO unless otherwise stated in the Solicitation.

Q. TAXES

METRO is exempt from payment of Federal Excise and Transportation Tax and the Texas Limited Sales, Excise and Use Tax. Contractor's invoice(s) shall not contain assessment for any of those taxes.

R. INSURANCE REQUIREMENTS

The bidder/proposer whose bid is accepted shall, within the time established in the Solicitation, enter into a written Contract with METRO and, if required, furnish Certificates of Insurance in the amounts indicated in the Contract.

S. INSTRUCTIONS FOR CERTIFICATION

1. By signing and submitting a bid, the Bidder is providing the certification set out in the Paragraph entitled "CERTIFICATION REGARDING DEBARMENT, SUSPENSION, INELIGIBILITY AND VOLUNTARY EXCLUSION - LOWER TIER COVERED TRANSACTION.
2. The certification in this instruction to Bidders is a material representation of fact upon which reliance will be placed by METRO to enter into a resultant contract. If it is later determined that the Bidder/Contractor knowingly rendered an erroneous certification, in addition to other remedies available to the Federal Government, METRO may pursue available remedies, including suspension and/or debarment.
3. The bidder shall provide immediate written notice to METRO if at any time the bidder learns that its certification was erroneous when submitted or has become erroneous by reason of changed circumstances.
4. The terms covered transaction, debarred, suspended, ineligible, lower tier covered transaction, participant, person, primary covered transaction, principal, bid and voluntarily excluded, as used herein, have the meanings set out in the Definition and Coverage sections of rules implementing Executive Order 12549. You may contact the person to whom your bid is submitted for assistance in obtaining a copy of this regulation.
5. The bidder agrees by submitting a bid that, should the resulting contract for the proposed covered transactions entered into, it shall not knowingly enter into any subcontract with a firm who is debarred, suspended, declared ineligible, or voluntarily excluded from participation in this covered transaction, unless authorized by METRO.
6. The bidder further agrees by submitting this bid that it will include the instruction titled "Certification Regarding Debarment, Suspension, Ineligibility and Voluntary Exclusion - Lower Tier Covered Transaction," at Paragraph 21 below, without modification, in all solicitations for lower tier covered transactions, expected to equal or exceed \$25,000.00.

T. CERTIFICATION REGARDING DEBARMENT, SUSPENSION, INELIGIBILITY AND VOLUNTARY EXCLUSION - LOWER TIER COVERED TRANSACTION

1. The Bidder certifies, by submission of the bid, that neither it nor its principals is presently debarred, suspended, proposed for debarment, declared ineligible, or voluntarily excluded from participation in this transaction by any Federal department or agency.
2. Where the bidder is unable to certify to any of the statements in this certification, the Bidder shall attach an explanation to the bid being submitted to METRO.

U. REQUEST(S) FOR APPROVAL OR DEVIATION

1. Mandatory Request(s) for Approved equal and request(s) for deviation to the technical specifications or other requirements of the solicitation document shall be submitted to METRO for evaluation at least **fifteen (15) calendar days prior to the original date set for receipt of bids** with METRO to respond ten (10) calendar days prior to the

date set for the receipt of bids.

2. All request(s) for approval shall be submitted on the enclosed RFA form, with all necessary descriptive literature, technical data, or samples to clearly indicate all specifications of the item(s) or deviation(s) proposed to permit evaluation of the request and determine that they meet all requirements of the Solicitation.
3. Individual RFA's shall include all technical data and salient characteristics of the proposed item offered to meet the specification requirement. Such technical data and salient characteristics shall cover as a minimum the installation, operation and design performance of the item offered for approval.
4. Request(s) for Approval may be submitted by e-mail at kenny.chin@ridemetro.org. CAUTION: Telefax or e-mail bids are not authorized.
5. **Failure to submit the Mandatory RFAs in Section II will render your bid non-responsive.**

V. INDEPENDENT PRICE DETERMINATION

By submitting this bid, the bidder certifies that he has not colluded, conspired, connived, or agreed, directly or indirectly, with any bidder or person, to put in a sham bid or to refrain from bidding; and further, that he has not in any manner, directly or indirectly sought by agreement, collusion, communication or conference, with any person, to fix the bid amount herein or any other bidder, or to fix any overhead, profit, or cost element of said bid amount, or that of any other bidder, or to secure any advantage against METRO or any person interested in the proposed Contract.

W. COVENANT AGAINST CONTINGENT FEES

By submitting this bid, the bidder certifies that he has not employed any company or person (other than a full-time, bona fide employee working solely for the bidder) to solicit or secure this Contract, and has not paid or agreed to pay any company or person (other than a full-time, bona fide employee working solely for the bidder) any fee, commission, percentage, or brokerage fee contingent upon or resulting from the award of this Contract; and agrees to furnish information relating to the above, as requested by the Contracting Officer.

X. PROHIBITION ON LOBBYING

No bidder or proposer shall, directly or indirectly, engage in any conduct (other than the submission of the proposal or other prescribed submissions and/or presentations before the Evaluation Committee) to influence any employee of METRO or any member of the Metropolitan Transit Authority Board of Directors or the President and CEO Representative(s) concerning the award of a contract as a result of this Solicitation. Violation of this prohibition may result in disqualification of the proposer from further participation in future METRO solicitations or contracts. **The communication blackout period shall commence from the issue of a solicitation through contract award. The Contract Administrator is the only METRO representative authorized to communicate with firms or their representatives during the blackout period.**

Y. SOLICITATION ORDER OF PRECEDENCE

Notwithstanding the Article of this Solicitation entitled "Contract Order of Precedence," in the event of an inconsistency between provisions of this Solicitation prior to award, the inconsistency shall be resolved by giving precedence in the following order:

1. Solicitation Amendments (if any) with the latest having precedence;
2. Bid/Contract Amount, Items and Prices excluding any specifications or drawings;
3. Instructions to Bidders including Invitation for Bids form;
4. Solicitation, Bid and Award form/Attachments;
5. Technical Specifications/Scope of Service;
6. Contract Articles;
7. Drawings;
8. Any other full-text provision of this Solicitation whether incorporated by reference or otherwise.

Z. APPROVAL OF CONTRACT

If required by the METRO Procurement Manual, award of a Contract evolving from this solicitation shall be contingent upon the prior receipt of written approval from the METRO Board of Directors or the President and CEO

Representative(s). No contractual agreement shall be binding on METRO until this approval has been obtained. It shall be the responsibility of firms responding to this solicitation to monitor Board award decisions. All persons and/or entities responding to this Solicitation hereby acknowledge the contract award requirement enumerated in this Paragraph. Anticipated Board Items are posted on METRO's web site at <http://www.ridemetro.org/Pages/BoardMeetingsAndNotices.aspx>

Public Notice of Solicitation Results

The anticipated METRO Board meeting month for approval of a contract resulting from this solicitation will be forthcoming. It is the responsibility of the bidder to check METRO's website for notices on the specific dates for METRO Board meetings. All bidders of this Solicitation and METRO hereby agree that this provision shall serve as the minimum required action by the bidder toward exercising due diligence in obtaining the results of this Solicitation. The requirement of approval by the METRO Board of Directors or the President and CEO Representative(s) for any particular solicitation is dependent upon several factors. However, all bidders shall be required to check the METRO web site regarding whether or not the solicitation associated with their bid requires approval by the METRO Board of Directors or the President and CEO Representative(s). All persons and/or entities responding to this Solicitation hereby acknowledge the Public Notice of Solicitation Results enumerated in this Paragraph. METRO Board meeting notices are posted on METRO's web site at: <http://www.ridemetro.org/Pages/BoardMeetingsAndNotices.aspx>

AA. METRO-FURNISHED PROPERTY

METRO will furnish equipment and specifically described in the specification.

BB. CONFLICTS DISCLOSURE

Vendors doing business with METRO or seeking to do business with METRO are required to file a completed questionnaire (FORM CIQ) disclosing the vendor's affiliations or business relationship with any Board Member, local government officer (or his or her family member). Form CIQ is available on METRO's web site at <http://www.ridemetro.org/Pages/ConflictsDisclosure.aspx>

CC. SUBMISSION REQUIREMENTS AND PROCEDURES

Submission of the below forms identified as "Contractor Owned" are a condition to be met by the bidders in order to be deemed responsive and must be met as a condition prior to Contract award. Once completed and submitted, these documents will be considered "contractor owned" and will not be incorporated into the Contract. However, they will be made part of the original contract file. Any changes or adjustments to the information on these forms shall be submitted to the Contracting Officer and the Office of Economic Business Opportunity for approval. Once approved, the updated form(s) will be added to the contract file without requiring modification to the contract.

Each bidder must complete, sign and return the following bid forms/Attachments at the times indicated below:

1. Bid Forms

- *a "Disadvantaged Business Enterprise (DBE)"
- *b "Buy America Certificate".
- *c "Cargo Preference Certification"
- *d "Bus Testing Certification"
- *e "Federal Motor Vehicle Safety Standard (FMVSS) Certification of Compliance"
- *f "Pre-Award Audit of Vehicles for Specification and Buy America Compliance"
- *g "Certification of Restrictions on Lobbying"
- *h "Price Breakdown"
- **i "Request for Approval (RFA Form). Provided when required by the paragraph entitled "REQUEST(S) FOR APPROVAL OR DEVIATION".
- *j "Debarment and Suspension form ". Bidder must provide this document with their bid and document must be signed.
- *k "Bidder's Questionnaire". Bidder must provide complete and current information in response to each question. If the bidder is a joint venture, each joint venturer shall prepare and submit a separate form.

*l. "Americans with Disabilities ACT (ADA) Certification of Compliance"

*m "Motor Vehicle Pollution Requirements Certification of Compliance"

2. Bid/Award Forms

*a. "Solicitation, Bid and Award". (must be signed by bidder)

*b. "Bid/Contract Amount, Items and Prices".

**3. When a special license or permit is required by Federal, State or Local law or ordinance, a bidder must be properly licensed prior to bidding and furnish evidence of such with the bid.

* Provide with Bid

** Provide if applicable

SECTION II - FORMS FOR BIDDING/PROPOSING

1 DISADVANTAGED BUSINESS ENTERPRISES (DBE)

I hereby certify that the Bidder has complied with the requirements of 49 CFR 26, Participation by Disadvantaged Business Enterprises in DOT Programs, and it has submitted a goal to Federal Transit Administration and it has not been disapproved.

Signature: _____

Typed Name: _____

Title: _____

Company: _____

Date: _____

2 BUY AMERICA CERTIFICATE

The Bidder/Contractor hereby certifies that it will comply with the requirements of 49 U.S.C. 5323(j)(2)(C), Section 165(b)(3) of the Surface Transportation Act of 1982, as amended, and the regulations of 49 CFR 661.11

Name of Bidder/Contractor: _____

Date of Signing: _____

Signature: _____

Title: _____

OR

The Bidder/Contractor hereby certifies that it cannot comply with the requirements of 49 U.S.C. 5323(j)(2)(C) and Section 165(b)(3) of the Surface Transportation Act of 1982, as amended, but may qualify for an exception to the requirements consistent with 49 U.S.C. 5323(j)(2)(B) or (j)(2)(D), Sections 165(b)(2) or (b)(4) of the Surface Transportation Act, as amended, and the regulations in 49 CFR 661.7.

Name of Bidder/Contractor: _____

Date of Signing: _____

Signature: _____

Title: _____

BUY AMERICA PROOF OF PURCHASE NOTICE – SUPPORTING DOCUMENTS

The bidder/contractor shall provide proof that all required project equipment and products meet the requirements of 49 U.S.C. 5323 (j)(1), and the applicable regulations in 49 CFR Part 661.5, pursuant to purchase by submitting a copy of all Certificate of Origins, along with all digital photos of the data plates showing the place of assembly for each piece of equipment and/or product.

Name of Bidder/Contractor: _____

Date of Signing: _____

Signature: _____

Title: _____

3 CARGO PREFERENCE

Bidder/Contractor agrees to utilize privately owned United States-flag commercial vessels to ship at least 50 percent of the gross tonnage involved (computed separately for dry bulk carriers, dry cargo liners, and tankers), whenever shipping any equipment, material, or commodities pursuant to this Contract, to the extent such vessels are available at fair and reasonable rates for United States-flag commercial vessels.

Bidder/Contractor agrees to furnish within 20 working days following the date of loading for shipments originating within the United States, or within 30 working days following the date of loading for shipments originating outside the United States, a legible copy of a rated, "on-board" commercial ocean bill-of-lading in English for each shipment of cargo described in the paragraph above to the FTA Administrator and to METRO (through the prime contractor in the case of subcontractor bills-of-lading) and to the Division of National Cargo, Office of Market Development, Maritime Administration, Washington, D.C. 20230.

Bidder/Contractor also agrees to insert the substance of the Contract article, entitled "Cargo Preference - Use of United-Flag Ships" in all subcontracts issued pursuant to the Contract.

Signature: _____

Typed Name: _____

Title: _____

Company: _____

Date: _____

4 DEBARRED, SUSPENDED, OR INELIGIBLE CONTRACTOR'S CERTIFICATION

Bidder hereby certifies that its firm is not on the U.S. General Services Administration's 'List of Parties Excluded from Federal Procurement or Non-Procurement Programs' and agrees to comply with the debarment and suspension requirements set forth in the Proposed Contract.

Signature: _____

Typed Name: _____

Title: _____

Company: _____

5 VEHICLE TESTING CERTIFICATION, 49 CFR PART 665

I, _____, representing the _____
(Representative's Name) (Bidder's Name)

_____, do hereby certify that the vehicles offered in response to this solicitation are subject to the 'Vehicle Testing Procedures' set forth in 49 CFR Part 665. Should my firm be the successful bidder and receive award of a Contract, I further certify that the vehicles offered in response to this solicitation have been or will be tested pursuant to 49 CFR Part 665 and that the test results will be furnished to METRO as specified in the Contract.

Representative's Signature

Date

6 FEDERAL MOTOR VEHICLE SAFETY STANDARD (FMVSS)

Bidder hereby certifies that the Vehicles offered in response to this Solicitation will comply with the Federal Motor Vehicle Safety Standards established by the Department of Transportation which are in effect at the time of vehicle manufacture.

Signature: _____

Typed Name: _____

Title: _____

Company: _____

Date: _____

7 PRE-AWARD AUDIT OF VEHICLES FOR SPECIFICATION AND BUY AMERICA COMPLIANCE

Bidder hereby agrees to make available in its office, at all reasonable times, all records and documents pertaining to this solicitation in sufficient detail to permit METRO's Auditor and Quality Control Inspector to perform Pre-award audits of the vehicles offered in response to this Solicitation, for compliance with the specification and Buy America requirements, pursuant to the Federal Transit Administration's Final Rule as published in the Federal Register, dated September 24, 1991.

Signature: _____

Typed Name: _____

Title: _____

Company: _____

Date: _____

8 CERTIFICATION OF RESTRICTIONS ON LOBBYING

The undersigned certifies, to the best of his or her knowledge and belief, that:

- 1) No Federal appropriated funds have been or will be paid, by or on behalf of the undersigned, to any person for influencing or attempting to influence an office or employee of any agency, a Member of Congress, an officer or employee of Congress in connection with the awarding of any Federal contract, the making of any Federal grant, the making of any Federal loan, the entering into of any cooperative agreement, and the extension, continuation, renewal, amendment, or modification of any Federal contract, grant, loan, or cooperative agreement.
- 2) If any funds other than Federal appropriated funds have been paid or will be paid to any person for influencing or attempting to influence an officer or employee of any agency, a Member of Congress, an officer or employee of Congress, or an employee of a Member of Congress in connection with this Federal contract, grant, loan, or cooperative agreement, the undersigned shall complete and submit Standard Form-LLL, "Disclosure Form to Report Lobbying", in accordance with its instructions.
- 3) The undersigned shall require that the language of this certification be included in the award documents for all sub-awards at all tiers (including subcontracts, sub-grants, and contracts under grants, loans, and cooperative agreements) and that all subrecipients shall certify and disclose accordingly.

This certification is a material representation of fact upon which reliance is placed when this transaction was made or entered into. Submission of this certification is a prerequisite for making or entering into this transaction imposed by Section 1352, title 31 U.S. Code. Any person who fails to file the required certification shall be subject to a civil penalty of not less than \$10,000 and not more than \$100,000 for each such failure.

Executed this _____ day of _____, 20__.

Company Name: _____

By: _____
(Signature of Company Official)

(Title of Company Official)

9 AMERICANS WITH DISABILITIES ACT OF 1990 (ADA)

Bidder hereby certifies that the Vehicles offered in response to this Solicitation will comply with the Americans with Disabilities Act of 1990 standards established by the Department of Justice which are in effect at the time of vehicle manufacture.

Signature: _____

Typed Name: _____

Title: _____

Company: _____

Date: _____

10 MOTOR VEHICLE POLLUTION REQUIREMENTS

- A. The horsepower of the vehicle is adequate for the speed, range and terrain in which it will be required to operate and also to meet the demands of all auxiliary power equipment.
- B. All gases and vapors emanating from the crankcase of a start-ignition engine are controlled to minimize their escape into the atmosphere.
- C. Bidder hereby certifies that the Vehicles offered in response to this Solicitation will comply with the Clean Air Act standards established by the United States Environmental Protection Agency which are in effect at the time of vehicle manufacture.

Signature: _____

Typed Name: _____

Title: _____

Company: _____

Date: _____

11 BIDDER'S QUESTIONNAIRE

This questionnaire is an integral part of a bidder's bid, and shall be completed. Failure to provide the required information may cause rejection of your bid. All references and information shall be current and traceable. If the bidder is a joint venture, a separate form shall be prepared by each venturer.

NAME OF BIDDER: _____

PRINCIPAL OFFICE: _____
(Street Address or P. O. Number)

(City) (State) Zip Code

(_____) _____
(Area Code) (Telephone Number)

1. Are you an individual ____, a partnership ____, a corporation ____, or a joint venture ____?
(Check as applicable).

If a partnership, list names and addresses of partners; if a corporation, list names of officers and directors and State of incorporation; if a joint venture, list names and addresses of venturers and, if any venturer is a corporation, partnership or joint venture, list the same information for each such corporation, partnership and joint venturer.

2. How many years has your organization been in business as a contractor under your present business name? _____ years

3. How many people does your firm currently employ?

- A. In Texas _____
- B. Outside Texas _____

4. Of the people employed, what are the job classifications involved and how many people are assigned to each classification?

Job Classification	No. of Employees	Job Classification	No. of Employees
_____	_____	_____	_____
_____	_____	_____	_____
_____	_____	_____	_____
_____	_____	_____	_____
_____	_____	_____	_____
_____	_____	_____	_____
_____	_____	_____	_____
_____	_____	_____	_____

5. What is the total square footage of your company's facilities?

	In Harris County	Outside Harris County
A. Inside Plant Space:	_____ sq ft	_____ sq ft
B. Office Space:	_____ sq ft	_____ sq ft
C. Outside Plant Yard:	_____ sq ft	_____ sq ft
D. Parking Area:	_____ sq ft	_____ sq ft

6. List names of companies and or public bodies, that you have performed similar services for within the last twelve (12) months.

Name of Company/ Public Body	Business Address	Contact Person	Telephone No.

7. List companies and public bodies for which you have current orders for the same or similar type of equipment and services.

Name of Company/ Public Body	Business Address	No. Of Buses	Contact Person	Telephone No.

8. Have you or your organization, or any officer or partner thereof, failed to complete a contract? _____

If so, give details _____

9. Is any litigation pending against your organization? _____

If so, give details _____

10. Name your principal financial institution for financial responsibility reference.

Name of Bank: _____

Street Address: _____

City and State: _____ Telephone: _____

Officer Familiar with Bidder's Account: _____

11. State your firm's annual average receipts over the past 3 fiscal years:

\$ _____

12. Provide upon request a certified financial statement for the bidder's most recently closed fiscal reporting year.

The undersigned certifies that he is legally authorized by the bidder to make the statements and representations contained in this document, and represents and warrants that the foregoing information is true and accurate to the best of his knowledge, and intends that the Metropolitan Transit Authority, Harris County, Texas, rely thereon in evaluating the bidder.

Name of Company: _____

Signature: _____

Title: _____

Date: _____

12 PRICE BREAKDOWN

PRICE BREAKDOWN

Prior to award of a contract, the successful Bidder agrees to furnish a price breakdown as reflected below for the commuter buses offered in accordance with this solicitation. This form is for information purposes only. Evaluation will be based on Section III, Article 2 Bid/Contract Schedule of Items and Prices.

ITEM NO.	<u>DESCRIPTION</u>	<u>PRICE</u>
1.	Engine complete with generator, starter, power steering pump, water pump, oil and water lines, radiator and wiring	\$ _____
2.	Fuel system	\$ _____
3.	All other Electronic Equipment including Route and Destination Signage (Front, side and rear)	\$ _____
4.	Air Conditioning and Heating System	\$ _____
5.	Type of Seating	\$ _____
6.	Wheelchair Lift	\$ _____
7.	Cost included in unit bid price for bus testing pursuant to 49 CFR Part 665, if required	\$ _____
8.	Cost included in unit bid price for warranties pursuant to Exhibit A of this solicitation, if any	\$ _____
9.	Bus body frame with windows, axle, wheels and all other items not listed above	\$ _____
TOTAL: (Should equal unit bid amount for one (1) bus		\$ _____

13 REQUEST FOR APPROVAL (RFA FORM)

(NOTE: See next page for instructions on the use of this form – must be submitted in **Word format**)

SOLICITATION/CONTRACT NO. _____

MANUFACTURER _____ REPRESENTATIVE _____

RFA NO. _____ DATE _____

SECTION _____ PAGE NO. _____ PARAGRAPH NO. _____

MANUFACTURER'S REQUEST:

METRO'S RESPONSE:

APPROVED _____ DENIED _____

APPROVED AS MODIFIED _____

COMMENTS:

APPROVED BY:

DATE

14 INSTRUCTION FOR USE OF REQUEST FOR APPROVAL (RFA FORM)

In order to assure full and prompt response to all requests for approval or exception to the technical specifications, Bidder is required to submit said requests on this form **in Word format**. (Use the Word file posted on the website. Please do not alter the headers on the Word file. Please do not insert tables.) If the Bidder has multiple requests for approval or exception with a particular section of the technical specifications each request shall be individually addressed with the Bidder submitting a form for each request. The lumping of a series of requests together on one form may cause METRO to deny all requests.

1. All of the bidder's RFA forms should be submitted with no more than 1 to 4 Word files. (Do not submit a separate Word file for each RFA form. Use page breaks between RFAs).
2. Support documents for the RFAs should be submitted separately for each RFA and should be clearly labeled with the corresponding RFA number. The RFA support documents can be submitted in Word, Excel or PDF format.

The Bidder shall insert the name of the manufacturer and their representatives in the space provided and note the section, paragraph and page number of METRO's technical specifications for which the request is being made. The Bidder shall sequential number their request using the space provided.

The Bidder shall submit this form and copies of any supporting documentation noted. The Bidder shall submit this form via e-mail as described in the paragraph entitled "REQUEST(S) FOR APPROVAL OR DEVIATION". METRO will not respond to any request for exception or approval that fails to use this form.

Failure to submit the Mandatory RFA's will render your bib non-responsive. All RFA's are due twenty (20) days prior to the bid due date.

15 MANDATORY REQUEST FOR APPROVALS (RFA)

Bidders shall submit the following **Mandatory Request For Approvals (RFA)** fifteen (15) days prior to the published bid due date. **Failure to submit the Mandatory RFA's will render your bid non-responsive.** (All references are to Sections in Exhibit "A")

1	Curb weight and GVWR shall be submitted as a Mandatory Request For Approval (See Section 1.5.2.1 Curb Weight).
2	Complete, scaled, interior layout drawings showing seat positions, hip-to-knee room, foot room, seat height and width dimensions, aisle widths, passenger assists, floor contour, fare box location and all other pertinent interior dimensions including wheelchair maneuverability and free floor space area of the bus proposed for bid shall be submitted as a Request For Approval. (See Sections 1.5.3 Capacity and 2.7 Accessibility Equipment).
3	A detailed description of paint system and procedures to be used shall be submitted as a Mandatory Request For Approval (See Section 2.1.1.2 Finish and Color).
4	A detailed description of all materials and their assembly to be used in the body construction of the bus proposed for bid shall be submitted as a Mandatory Request For Approval (See Section 2.1.2.1 Strength and Fatigue Life).
5	Full information on the anticorrosion treatment and results of the salt spray test performed on bus model to be provided under this technical specification shall be submitted as a Mandatory Request For Approval (See Section 2.1.2.5 Corrosion).
6	A detailed description of the towing methods and devices required for the bus proposed for bid shall be submitted as a Mandatory Request For Approval (See Section 2.1.2.7 Towing).
7	A sample of material to be used as a fire blanket shall be submitted as a Mandatory Request For Approval (See Section 2.1.2.10 Fire Protection).
8	ABC fire extinguisher location shall be submitted as a Mandatory Request For Approval (See Section 2.1.2.11 Fire Extinguisher).
9	Independent third party certification by a recognized engineering firm to certify that roof load bearing, crash test, and exterior body panel criteria have been met for the bus proposed for bid shall be submitted as a Mandatory Request For Approval. Test certifications will include structural diagrams of the bus tested. These diagrams must match exactly, the bus bid by the Contractor (See Section 2.1.2.12 Crashworthiness).
10	Colored samples of all interior materials shall be submitted as a Mandatory Request For Approval (See Section 2.1.4.5 Construction).
11	A sample of the proposed "Take One" holder shall be submitted as a Mandatory Request For Approval (See Section 2.1.4.7 "Take One" Holders).
12	Flooring system and a sample of material shall be submitted as a Mandatory Request For Approval (See Section 2.1.5.2 Strength).
13	Configuration of the battery compartment door, the engine compartment doors, underfloor baggage compartments doors and bike rack location shall be submitted as a Mandatory Request For Approval (Section 2.1.9 Service Compartments and Access Doors).
14	Door system configuration to include door controls, hand rails and door panels shall be submitted as a Mandatory Request For Approval (See Section 2.2.1.1 Controls).
15	Description of roof ventilator system shall be submitted as a Mandatory Request For Approval (See Section 2.2.1.6 Roof Ventilators).
16	Windshield wiper and windshield washer systems shall be submitted as a Mandatory Request For Approval (See Section 2.2.2.1 Windshield Wipers).
17	A detailed description of all exterior lighting of the bus proposed for bid that includes mounting methods and locations (including light dimensions) shall be submitted as a Mandatory Request For Approval (See Section 2.2.3.1 Exterior Lighting).
18	Directional switch location and the exact location and operation of the rear engine door LED "STOP" sign shall be submitted as a Mandatory Request For Approval (See Section 2.2.3.1 Exterior Lighting).
19	Description and function of interior lighting system shall be submitted as a Mandatory Request For Approval (See 2.2.3.3 Passenger Interior Lighting).
20	Design of the operator's dashboard configuration and the accelerator/brake pedal (to include angles) shall be submitted as a Mandatory Request For Approval (See Section 2.2.3.5 Operator Controls).
21	Type of acoustical material to be used in the headlining and the rear bulkhead and rear interior surfaces shall be submitted as a Mandatory Request For Approval (See Section 2.3.1 General Requirements).
22	Model and description of Operator's seat shall be submitted as a Mandatory Request For Approval (See Section 2.3.3 Operator's Seat).
23	Description and sample of floor material and silicone caulking shall be submitted as a Mandatory Request For Approval (See Section 2.3.4 Floor Covering).

24	Test data verifying that criteria have been met for the bus proposed for bid shall be submitted as a Mandatory Request For Approval (See Section 2.5.2.2 Sound Insulation) .
25	Types and method of sun shade installations shall be submitted as a Mandatory Request For Approval (See Section 2.6.1.1 Visors) .
26	Description of outside mirror type and installation for the bus proposed for bid shall be submitted as a Mandatory Request For Approval (See Section 2.6.2.1 Outside Mirrors) .
27	All destination signs, the run number sign and Operator's console mount locations and description/identification of all test methods, parameters and options shall be submitted as a Mandatory Request For Approval (See Section 2.6.4 Exterior Route Information Displays) .
28	Description, function methodology and location of both Next Stop Signs shall be provided as a Mandatory Request For Approval (See Section 2.6.6 Next Stop Sign) .
29	Description and specifications of the wheelchair ramp, its slip resistant qualities, ramp control switch locations, ramp override and overall operation shall be submitted as a Mandatory Request For Approval (See Section 2.7.1 Wheelchair Ramp System) .
30	Description and layout drawings of the wheelchair securement system and mountings, vertical call bell tape switch location, flip seats, passenger amenities and operator's public address system shall be submitted as a Mandatory Request For Approval (See Section 2.7.4 Wheelchair Securement) .
31	Description and specifications of oil lines, fuel lines and high pressure seamless shields shall be submitted as a Mandatory Request For Approval (See Section 3.1.2.2 Service) .
32	Description and specifications of the cooling fan system shall be submitted as a Mandatory Request For Approval (See 3.1.2.4 Electrically Driven Fan System) .
33	Detailed description and performance specifications of engine and transmission propulsion system proposed shall be submitted as a Mandatory Request For Approval (See Section 3.1.3 Power Plant) .
34	Certification that the engine offered complies with the State and Federal Emission Regulations shall be submitted as a Mandatory Request For Approval (See Section 3.1.3.1 Engine Transmission) .
35	Air springs furnished shall be submitted as a Mandatory Request For Approval (See Section 3.3.2.1 Travel) .
36	Turn radius and front and rear swept area dimensions for the bus proposed for bid shall be submitted as a Mandatory Request For Approval (See Section 3.4.2 Turning Radius) .
37	The Steering Column/Wheel shall be submitted as a Mandatory Request For Approval (See Section 3.4.3 Turning Effort) .
38	Description and specifications of wheel bearing seals shall be submitted as a Mandatory Request For Approval (See Section 3.5.1.3 Hubs) .
40	Description of the electrical system proposed shall be submitted as a Mandatory Request For Approval (See Section 3.6.4 Electrical System) .
41	A complete description and functionality of the electrical components being proposed by the bus manufacturer for the bus to be built for METRO shall be submitted as a Mandatory Request For Approval (See Section 3.6.5 Electrical Components) .
42	A complete description of the interior climate control system being proposed by the bus manufacturer for the bus to be built for METRO shall be submitted as a Mandatory Request For Approval (See Section 3.7 Interior Climate Control) .
43	A detailed description of the type of Fire Sensing and Suppression (FSS) equipment of the bus proposed for bid, along with operational information and installation locations, shall be submitted as a Mandatory Request For Approval (See Section 3.9.1 Fire Suppression) .
44	A complete list of scheduled maintenance items for which exceptions to warranty are desired shall be submitted as a Mandatory Request For Approval (See Section 4.1.5 Exception to Warranty) .
45	The contractor shall submit an organizational chart of the service team assigned to Houston, including a description of electric/electronic and HVAC capabilities shall be submitted as a Mandatory Request For Approval (See Section 4.1.11 Contractor's Representative) .

SECTION III - FORMS FOR BIDDING/PROPOSING/AWARD

1 SOLICITATION, BID AND AWARD FORM

METROPOLITAN TRANSIT AUTHORITY OF HARRIS COUNTY TEXAS
INVITATION FOR BIDS

=====

Requisition No. _____

IFB No. _____

Date of Invitation: _____

Contract No. _____

Description of Project: _____

=====

(TO BE COMPLETED BY BIDDER)
 BIDDER/CONTRACTOR NAME AND ADDRESS:
 (Full Name of Firm, Corporation, Partnership, Joint Venturer - Type or Print)

_____ PHONE: () _____

_____ FAX NO: () _____

=====

In compliance with the above referenced Invitation for Bids, the undersigned hereby proposes to furnish all of the resources necessary to complete the above referenced project for the total cost listed in Section 3, Item 2 herein and in accordance with the Contract.

The undersigned agrees that this offer will remain valid for a period of one hundred twenty (120) calendar days after the date of opening of bids. Upon written acceptance of this offer, executed by METRO and mailed or otherwise furnished within the one hundred twenty (120) calendar day bid validity period, the bidder/contractor will within fourteen (14) calendar days (unless a longer period is allowed) after receipt of the award documents, provide required certification of insurance and performance bond with good and sufficient surety.

Any resulting contract will consist of this form and Sections III through XII of the original solicitation.

The resulting contract sets forth the entire agreement between the parties with respect to the subject matter thereof, and supersedes and replaces all proposals, negotiations, representations, and implied obligations. The obligations, liabilities and remedies set forth herein are exclusive and shall operate as limitations on any action brought in connection with this Contract, including an action in tort. The resulting contract is binding upon and shall inure to the benefit of the parties hereto and their successors and permitted assigns, but shall not inure to the benefit of any third party or other person.

CAUTION - Bids shall not be qualified by exceptions to the bidding conditions.

=====

DIRECTIONS FOR SUBMITTING BIDS: Envelopes containing bids, guarantee, or other bid documents shall be sealed, marked, and addressed as follows:

METROPOLITAN TRANSIT AUTHORITY Procurement Division 1900 Main Street, Suite 2021 Houston, Texas 77002	NOTE:	Identify the envelope containing a bid with the Project Title, Invitation for Bid (IB) Number and bid opening date and time; and Company's name and address.
--	-------	--

(TO BE COMPLETED BY BIDDER)
RECEIPT OF BID AMENDMENT(S):
(List number and date of each)

Bidder acknowledges receipt of the following Amendment(s).

OFFER
(TO BE COMPLETED AND SIGNED BY BIDDER)

SIGNATURE OF BIDDER/CONTRACTOR:

ATTEST:

BY: _____
(MUST BE SIGNED BY AUTHORIZED PERSON)

BY: _____

NAME: _____

NAME: _____

TITLE: _____

TITLE: _____

DATE: _____

Note: 1) If Joint Venturer, each party shall provide the above information and sign the offer.
2) Bidder/Contractor's signature constitutes acceptance of a contract that may result from this Solicitation.

=====

ACCEPTANCE AND AWARD
(TO BE COMPLETED AND SIGNED BY METRO)

ALTERATIONS: The following alterations were made in this Contract before it was signed by METRO (Indicate "None" or list alterations)

METRO and the Contractor have executed this Contract and it shall be effective on the ___ day of _____, 20__.

METROPOLITAN TRANSIT AUTHORITY
OF HARRISCOUNTY

Executed for and on behalf of the Metropolitan Transit Authority pursuant to Resolution No. _____ of the Board of Directors or the President and CEO Representative(s) on the ___ day of _____, 20__ and on file in the office of the Assistant Secretary of the Authority.

ATTEST:

BY: _____
Michael Kyme – Chief Procurement Officer

Assistant Secretary

APPROVED:

APPROVED AS TO FORM:

George Fotinos
Chief Financial Officer

Cydonii Fairfax – EVP & General Counsel

APPROVED:

Debbie Sechler – EVP Administration

2 BID/CONTRACT SCHEDULE OF ITEMS AND PRICES

Bidder/Contractor agrees to furnish all resources necessary to supply and deliver FOB Destination the following described vehicles in accordance with the specifications listed in Exhibits "A" through "D " and the attached proposed Contract at the below bid prices.

<u>ITEM NO.</u>	<u>DESCRIPTION</u>	<u>QUANTITY</u>	<u>UNIT</u>	<u>UNIT BID FIXED PRICE</u>	<u>EXTENDED BID FIXED AMOUNT</u>
1.	Heavy Duty 45-Foot Clean Diesel Commuter Buses all delivered Within 12 months of Contract execution. No more than, 12 vehicles delivered per week .	50	EACH	\$ _____	\$ _____
			BASE BID PRICE	\$ _____	\$ _____

OPTION

METRO Board approval shall be required prior to execution of all options. Execution of each option item shall not exceed the maximum listed. Prices for the option buses shall consist of the unit price listed plus the difference in Producer Price Index (PPI) when the option is exercised below.

	Heavy Duty 45-Foot Clean Diesel Commuter Buses all delivered. Option to be exercised Within 24 of Contract execution.	1-50	EACH	\$ _____	\$ _____
--	---	------	------	----------	----------

PROMPT PAYMENT DISCOUNT: The following prompt payment discount(s) are hereby offered for payments made within the period specified after receipt of invoice or acceptance of item(s), whichever is later.

_____ % 10 days _____ % 15 days _____ % _____ days

SECTION IV - DELIVERIES OR PERFORMANCE ARTICLES**1 DEFINITIONS**

- A. "METRO" shall mean Metropolitan Transit Authority of Harris County, Texas.
- B. The term "President & Chief Executive Officer" means the President & Chief Executive Officer of the Metropolitan Transit Authority and the term "the duly authorized representative" means any person specifically authorized to act for the President & Chief Executive Officer. These representatives are authorized to obligate METRO by executing this Contract, and any modification thereto.
- C. The term "Contracting Officer" means the Contract Administrator who has been designated the responsibility, by the METRO Chief Procurement Officer, for overall administration of the Contract, including the execution of contract modifications.
- D. The term "Project Manager" means the technical representative who has been designated as having the responsibility for assessing the Contractor's technical performance and progress; inspecting and periodically reporting on such performance and progress during the stated period of performance, and finally certifying as to the acceptability of the Contractor's work in its entirety or any portion thereof, as required by the Contract documents.
- E. The term "Contract Appeals Committee" means the METRO administrative body designated by the President & Chief Executive Officer to hear a Contractor's appeal submitted under the "Disputes" Article of this Contract.
- F. "Contractor" shall mean the individual, partnership, corporation, organization, or association contracting with METRO to furnish all materials, goods and work defined herein.

2 PERIOD OF PERFORMANCE

The period of performance shall be for two years from the effective date of this Contract or until all of the vehicles have been delivered and accepted by METRO, whichever occurs last, unless otherwise modified.

3 ITEMS PURCHASED, DELIVERY AND COMPENSATION

(Have the PM review this language for the specific vehicles being purchases)

- A. The Contractor shall furnish all necessary resources required to manufacture, supply and have ready a pilot bus for inspection by METRO.
- B. **A pilot bus for a Heavy Duty 45ft clean diesel transit bus shall be built, tested and be 100-percent complete and functional before METRO will issue acceptance and approval to initiate assembly of the remaining buses (production buses) to be delivered under the terms of this Contract.** A pilot bus is not required for the Heavy Duty 45ft clean diesel commuter bus with an electric HVAC system. A full HVAC system test of the Heavy Duty 45ft clean diesel commuter bus with an electric HVAC system will be required in accordance with the technical specification. The Contractor shall provide METRO with all manufacturing and assembly diagrams for the pilot bus no less than 10-business days prior to the start of the pilot bus assembly. At METRO's option, testing can include operation of the pilot buses within METRO's service area for a period not to exceed two (2) weeks. All METRO testing of the pilot buses shall be completed within two (2) weeks. Once complete and approved by METRO, the pilot bus will return to the Manufacturer's facility and remain there to serve as a template for production buses. The Contractor shall schedule the pilot bus production and testing so that it does not alter the delivery schedule specified in Section III, Article 2 Bid/Contract Schedule of Items and Prices. The pilot bus will be placed at the head of the production line and used by production staff to ensure production buses are exact copies of the pilot bus. METRO will pay the Contractor for 95% of the bus unit fixed price listed in Section III, Article 2 Bid/Contract Schedule of Items and Prices, Item No. 1 - Heavy Duty 45ft clean diesel commuter buses after the pilot bus is accepted and the remaining 5% will be paid once the pilot bus is delivered to METRO and final acceptance is completed.
- C. Prior to the start of pilot bus manufacturing or assembly processes, the structure of the proposed bus model shall have undergone appropriate structural testing and/or analysis, including the complete regimen of FTA required Altoona tests. Prior to assembly of the pilot bus, the OEM shall provide the METRO with a completed report of Altoona testing for the proposed bus model along with a plan of corrective action to address deficiencies, breakdowns and other issues identified during Altoona testing. The bus model tested shall match the bus model proposed for procurement, including structure, axles and drive-train. Base model and partial Altoona test reports are acceptable when the combination of these tests adequately represents the proposed bus model.
- D. METRO will issue a Notice to Proceed (NTP) for production of the remaining vehicles after final acceptance of the pilot bus. **If the Contractor starts the bus production line before the pilot bus is accepted by METRO and the NTP issued, those buses will not be accepted by METRO under any circumstance.** Upon receipt of the NTP the Contractor shall furnish all necessary resources required to manufacture, supply and deliver F.O.B. destination, the quantity of buses at the price indicated in accordance with the terms and conditions of this Contract and the Technical Specifications for buses attached hereto as

applicable.

- E. The Contractor shall begin delivery of the remaining buses after receipt of the NTP and complete delivery of all buses according to the time frame specified in Section III, 2 Contract Schedule of Items and Prices. The Contractor shall supply METRO with a delivery schedule for the remaining buses within forty five (45) calendar days of receipt of the NTP.
- F. The Contractor agrees that it shall exert every reasonable effort necessary to deliver all of the buses according to the time frame specified in Section III, 2 Contract Schedule of Items and Prices. The Contractor agrees to notify METRO immediately if, at any time, it appears that all of the buses will not be delivered according to the time frame specified in Section III, 2 Contract Schedule of Items and Prices. Such notification shall include the reasons for any possible delays, steps being taken to remedy any such problems, and a proposed revised delivery schedule, if the Contractor is of the opinion that such a change in delivery is required. Nothing herein shall be interpreted as waiving remedies otherwise available to METRO.
- G. Delivery shall be to the following F.O.B. destination points:

Buses to: METROPOLITAN TRANSIT AUTHORITY
OF HARRIS COUNTY, TEXAS
Attn: Andrei Dragomir
Kashmere Bus Operating Facility
5700 Eastex Freeway
Houston, Texas 77026

Deliveries may be made between the hours of
9:00 a.m. and 3:00 p.m., Monday through Friday.

Final Manuals to: METROPOLITAN TRANSIT AUTHORITY
OF HARRIS COUNTY, TEXAS
Attn: Andrei Dragomir
Kashmere Bus Operating Facility
5700 Eastex Freeway
Houston, Texas 77026

Deliveries may be made between the hours of
9:00 a.m. and 3:00 p.m., Monday through Friday.

- H. The Contractor shall be responsible for all items purchased hereby until delivered at the designated F.O.B. delivery point, and accepted by METRO unless damage results from the negligence of officers, agents, or employees of METRO arising within the scope of their employment. The Contractor shall bear all risks as to rejected items after notice of rejection.
- I. Unless otherwise specified in the Contract Documents, reference to standard specifications of any technical society, organization or association, or to codes of local or state authorities, shall mean the latest standard, code specification, or tentative specification adopted and published and in effect on the Contract date.
- J. Notwithstanding the provision of drawings, technical specifications, or other data by METRO, the Contractor shall have the responsibility of supplying all parts and details required to make each vehicle complete and ready for service even though such details may not be specifically mentioned in the drawings and specifications. In the event of any deviation between the description of the vehicles in the Technical Specifications and other parts of this document the technical specifications shall govern.

4 LIQUIDATED DAMAGES

- A. In the event of delay in the completion of deliveries of vehicles beyond the schedule as provided for according to the time frame specified in Section III, 2 Contract Schedule of Items and Prices, the Contractor shall be liable for liquidated damages in the amount of Seventeen Hundred Dollars (\$1,700.00) per day plus One Hundred and Seventy-two and 81/100 dollars (\$172.81) per day per bus, not including weekends or METRO recognized holidays.
- B. These damages shall be deducted from any monies due, or which may thereafter become due, to the Contractor under this Contract.
- C. The maximum amount of liquidated damages to which the Contractor will be subject is One Million and 00/100 Dollars (\$1,000,000.00). In the event the Contract has not been otherwise terminated, the Contract will be considered terminated for default when accumulated liquidated damages exceed One Million dollars.
- D. The Contractor acknowledges that actual damages likely to result from breach of this section are difficult to estimate on date of this contract and difficult to prove. The parties intend that payment of liquidated damages amount would serve to compensate METRO for any breach by the Contractor of its obligations under this Section and they do not intend for such liquidated damages

to serve as punishment for any such breach by the Contractor.

5 FORCE MAJEURE

- A. To the extent that the Contractor shall be wholly or partially prevented from its performance within the terms specified of any obligation or duty placed on the Contractor by reason of or through riot, acts of war, acts of terrorism, insurrection, by order of court, legislative action, act of God, or specific cause reasonably beyond the parties' control and not attributable to its neglect or nonfeasance, in such event, the time for the performance of such obligation or duty may be suspended until such disability to perform is removed. Determination of force majeure shall rest solely with METRO.
- B. In the event the Contractor seeks to characterize an event as a "Force Majeure Event," the Contractor shall have the obligation to immediately notify METRO at the time the Contractor becomes aware of said force majeure event. Further, the Contractor shall have the obligation to provide METRO with written notice upon the cessation of said Force Majeure event.

6 NOTIFICATION OF DELAY

The Contractor shall notify the Contracting Officer as soon as the Contractor has, or should have, knowledge that an event has occurred which will delay deliveries. Within five (5) days, the Contractor shall confirm such notice in writing furnishing as much detail as is available.

7 REQUEST FOR EXTENSION

The Contractor agrees to supply, as soon as such data are available, any reasonable proofs that are required by the Contracting Officer to make a decision on any request for extension. The Contracting Officer shall examine the request and any documents supplied by the Contractor and shall determine if the Contractor is entitled to an extension and the duration of such extension. The Contracting Officer shall notify the Contractor of his decision in writing. It is expressly understood and agreed that the Contractor shall not be entitled to damages or compensation, and shall not be reimbursed for losses on account of delays resulting from any cause under this Article.

8 METRO DELAY OF WORK

- A. If the performance of all or any part of the work is delayed or interrupted by an act of the Contracting Officer in the administration of this Contract, which act is not expressly or implicitly authorized by this Contract, or by his failure to act within the time specified in this Contract (or within a reasonable time if no time is specified), an adjustment (excluding profit) shall be made for any increase in the cost of performance of this Contract caused by such delay or interruption. However, no adjustment shall be made under this Article for any delay or interruption (i) to the extent that performance would have been delayed or interrupted by any other cause, including the fault or negligence of the Contractor; or (ii) for which an adjustment is provided or excluded under any other provision of this Contract.
- B. No claim under this Article shall be allowed (i) for any costs incurred more than twenty (20) days before the Contractor shall have notified the Contracting Officer in writing of the act or failure to act involved; and (ii) unless the claim, in an amount stated, is asserted in writing as soon as practicable after the termination of such delay or interruption, but not later than the date of final payment under the Contract.

9 PERFORMANCE BOND OR LETTER OF CREDIT

The Contractor shall furnish a Performance Bond or irrevocable Letter of Credit payable in an amount equal to five percent (5%) of the Contract amount. The Performance Bond or Letter of Credit shall remain in effect through delivery, acceptance and final payment of the last vehicle, at which time it will be released back to the Contractor. If a Performance Bond is utilized, the bonding company providing the bond must be approved for the amount of bond on U.S. Department of Treasury Circular C570 and licensed to do business in the State of Texas. If an irrevocable Letter of Credit is utilized it must be issued on a US bank and it must be payable on METRO's first demand. The Performance Bond or Letter of Credit shall be submitted to the Contracting Officer within fourteen (14) calendar days after receipt of a copy of the executed Contract. The Contractor will not be allowed to proceed with production until a properly executed bond or letter of credit is received and accepted by the Contracting Officer.

10 ASSIGNMENT OF VEHICLES

METRO reserves the right to assign all or any portion of the vehicles awarded under this Contract to other grantees of FTA funds in accordance FTA Circular 4220.1F or any of its successors. This assignment, should it occur, shall be to other transit agencies and will be honored by the Contractor. METRO's right of assignment will remain in force until completion of the Contract.

11 MATERIALS AND WORKMANSHIP

The Contractor shall be responsible for all materials and workmanship in the construction of the bus and all accessories used, whether the same are manufactured by the Contractor or purchased from a Supplier. This provision excludes any equipment leased or supplied by METRO, except insofar as such equipment is damaged by the failure of a part or component for which the

Contractor is responsible, or except insofar as the damage to such equipment is caused by the Contractor during the manufacture of the buses.

12 CONFORMANCE WITH CONTRACT AND SPECIFICATIONS

- A. Materials furnished and Work performed by the Contractor shall conform to the requirements of the Specifications, Exhibit "A" and other Contract documents. Notwithstanding the provision of drawings, specifications or other data by METRO, the Contractor shall have the responsibility of supplying all parts and details required to make the buses complete and ready for service even though such details may not be specifically mentioned in the drawings and specifications. Items that are installed by METRO shall not be the responsibility of the Contractor unless they are included in this Contract.
- B. The Contractor shall comply with all applicable federal, state and local regulations. These shall include but not be limited to ADA, as well as state and local accessibility, safety and security requirements. Local regulations are defined as those below the state level. The minivans shall meet all applicable FMVSS and shall accommodate all applicable FMCSR regulations in effect at location of METRO and the date of manufacture. In the event of any conflict between the requirements of these specifications and any applicable legal requirement, the legal requirement shall prevail. Technical requirements that exceed the legal requirements are not considered to conflict.

13 REPAIRS AFTER NON-ACCEPTANCE

- A. The Contractor, or its designated representative, shall perform the repairs after non-acceptance. If the Contractor fails or refuses to begin the repairs within five (5) days, then the Work may be done by METRO's personnel with reimbursement by the Contractor.

B. Repair Performance

1. **Repairs by Contractor.** After non-acceptance of the bus, the Contractor must begin Work within five (5) working days after receiving notification from METRO of failure of acceptance tests. METRO shall make the bus available to complete repairs timely with the Contractor repair schedule.

The Contractor shall provide, at its own expense, all spare parts, tools and space required to complete the repairs. At METRO's option, the Contractor may be required to remove the bus from METRO's property while repairs are being made. If the bus is removed from METRO's property, repair procedures must be diligently pursued by the Contractor's representatives, and the Contractor shall assume risk of loss while the bus is under its control.

2. **Repairs by METRO.** METRO will not take responsibility to correct Defects, except to replace defective parts as instructed by the Contractor.
 - a. **Parts used.** If METRO performs the repairs after non-acceptance of the bus, it shall correct or repair the Defect and any Related Defects using Contractor-specified parts available from its own stock or those supplied by the Contractor specifically for this repair. Reports of all repairs covered by this procedure shall be submitted by METRO to the Contractor for reimbursement or replacement of parts monthly, or at a period to be mutually agreed upon. The Contractor shall provide forms for these reports.
 - b. **Contractor-supplied parts.** If the Contractor supplies parts for repairs being performed by METRO after non-acceptance of the bus, these parts shall be shipped prepaid to METRO.
 - c. **Return of defective components.** The Contractor may request that parts covered by this provision be returned to the manufacturing plant. The total costs for this action shall be paid by the Contractor.
 - d. **Reimbursement for labor.** METRO shall be reimbursed by the Contractor for labor. The amount shall be determined by METRO for a qualified mechanic at a straight time wage rate of \$95.00 per hour, which includes fringe benefits and overhead adjusted for METRO's most recently published rate in effect at the time the Work is performed, plus the cost of towing in the bus, if such action was necessary. These wage and fringe benefits rates shall not exceed the rates in effect in METRO's service garage at the time the Defect correction is made.
 - e. **Reimbursement for parts.** METRO shall be reimbursed by the Contractor for defective parts that must be replaced to correct the Defect. The reimbursement shall include taxes where applicable and fifteen (15) percent handling costs.

14 DELIVERABLES

See Exhibit "A", Appendix 1 for a list of deliverables.

15 PREPRODUCTION CONFERENCE APPROVALS

See Exhibit "A", Appendix 2 for a list of items requiring METRO approval during the Preproduction Conference

16 CHANGES OF LAW

Changes of Law that become effective after the Bid Due Date may result in price changes. If a price adjustment is indicated, either upward or downward, it shall be negotiated between METRO and the Contractor and the final Contract amount will be adjusted upwards or downwards to reflect such changes in Law. Such price adjustment maybe audited, where required.

17 TEXAS ETHICS COMMISSION (TEC) ELECTRONIC FILING

In the event this Contract requires the approval of METRO's Board of Directors or the President and CEO Representative(s), the Contractor shall submit to METRO, after notification that METRO's Board has authorized the Contract and prior to final execution of the Contract, a completed, signed Form 1295 generated by the Texas Ethics Commission's (the "TEC") electronic filing application in accordance with the provisions of Section 2252.908 of the Texas Government Code and the rules promulgated by the TEC (a "Form 1295"). The Contractor hereby confirms and agrees to submit such forms with the TEC through its electronic filing application at: <https://www.ethics.state.tx.us/filinginfo/1295/>

SECTION V - INSPECTION AND ACCEPTANCE ARTICLES**1 VEHICLE INSPECTION AND ACCEPTANCE**

- A. Predelivery inspection and test, for all vehicles excluding the Pilot Buses in Section IV above, shall be performed at the Contractor's plant in accordance with Contract Exhibit "A", Section 6, "Contractor's In-Plant Quality Assurance". METRO's Resident Inspector shall authorize release of each vehicle for delivery upon satisfactory completion of all in-plant inspections and tests. Drivers shall keep a maintenance log enroute for vehicles, which are driven to the destination point. A copy of this log shall be provided to METRO upon delivery.
- B. Within fifteen (15) calendar days after arrival at the destination point the vehicle will undergo METRO post-delivery test as defined in the Technical Specifications. If the vehicle fails these tests, the Contractor shall be notified and the vehicle shall not be accepted until the defects have been corrected.

2 CONDITIONAL ACCEPTANCE

METRO may withhold up to 3 percent of the total cost of each delivered and accepted vehicle to assure correction of early failures and fleet defects. The withheld funds shall be paid in full to the Contractor within thirty (30) days of vehicle acceptance, unless specific defects are found in the vehicle or it is subject to a fleet defect. The defect(s) found shall be described and submitted in writing, including the relevant specification requirement, to the Contractor when identified and within the 30-day withholding period. The withheld funds shall be paid in full to the Contractor upon repair of the vehicle or receipt of a written commitment from the Contractor reflecting a mutual agreement to resolve the identified deficiencies. The withheld funds are not subject to the late payment provisions of this Contract.

3 FIRST ARTICLE INSPECTION – PRODUCTION (Not Applicable)

- A. The purpose of the first article inspection is to confirm that any components, systems, subsystems, major assemblies, subassemblies, products, parts, apparatuses, articles and other materials comply with the Technical Specifications and other Contract documents.
- B. Where required by the Contract documents or requested by METRO, the Contractor shall cause first article inspections to be conducted. A first article inspection may include both a physical configuration inspection and a functional demonstration. First article inspections shall be conducted at the Contractor or Subcontractor's facility. The Contractor shall furnish to METRO prior to each first article inspection a written inspection and demonstration plan for each item for review. METRO's inspectors will attend each first article inspection unless METRO provides a written waiver of its right to attend any such inspection. The results of each first article inspection shall be documented by the Contractor in a format deemed acceptable by METRO, and all documents relating to the inspection shall be forwarded to METRO.

4 TESTING OF NEW BUS MODELS

The Contractor agrees to comply with 49 USC A 5323(c) and FTA's implementing regulation at 49 CFR Part 665 and shall perform the following:

- A. A manufacturer of a new bus model or a bus produced with a major change in components or configuration shall provide a copy of the final test report to the recipient at a point in the procurement process specified by the recipient, which will be prior to the recipient's final acceptance of the first vehicle.
- B. A manufacturer who releases a report under Paragraph 1 above shall provide notice to the operator of the testing facility that the report is available to the public.
- C. If the manufacturer represents that the vehicle was previously tested, the vehicle being sold should have the identical configuration and major components as the vehicle in the test report, which must be provided to the recipient prior to recipient's final acceptance of the first vehicle. If the configuration or components are not identical, the manufacturer shall provide a description of the change and the manufacturer's basis for concluding that it is not a major change requiring additional testing.
- D. If the manufacturer represents that the vehicle is "grandfathered" (has been used in mass transit service in the United States before October 1, 1988, and is currently being produced without a major change in configuration or components), the manufacturer shall provide the name and address of the recipient of such a vehicle and the details of that vehicle's configuration and major components.

SECTION VI - CONTRACT ADMINISTRATION DATA ARTICLES

1 COMPENSATION

- A. The Contractor shall be compensated for the items ordered, installed and accepted at the firm fixed unit prices as provided in the Bid/Contract Amount, Items and Prices of this Contract.
- B. METRO's total obligation for the satisfactory performance of this Contract shall not-to-exceed _____ 00/100 Dollars (\$_____.), less any prompt payment discount earned or set forth below, and in accordance with the payment provisions of this Contract.
- C. METRO Board approval shall be required prior to execution on all options increasing the total contract amount.

2 INVOICING AND PAYMENT

- A. The Contractor shall submit an original invoice and the corresponding certificate of origin, application for Texas title and FMVSS certifications for each bus for payment to the address shown below for the item(s) or service(s) performed, which have been inspected and accepted by METRO:

Kenny Chin, Senior Contract Administrator
 METROPOLITAN TRANSIT AUTHORITY
 1900 Main St. Suite 8133
 Houston, Texas 77002

- B. METRO shall pay the amount due the Contractor under this Contract after presentation with each invoice.
- C. METRO is exempt from payment of Federal Excise and Transportation Tax and Texas Limited Sales, Excise and Use Tax. METRO's Federal Excise Tax Number is 76-79-0020K and METRO's State Tax Exempt Number is 1-74-1998278-4. The Contractor's invoices shall not contain assessment of any of these taxes on materials incorporated into the project.
- D. Payments will be made within thirty (30) calendar days after receipt of a properly prepared invoice, which shall not be issued until the buses are accepted by METRO. Payment shall be considered made when METRO deposits the Contractor's payment in the mail or the date on which an electronic transfer of funds was made. Interest on payments under this Contract shall accrue and be paid only in accordance with Texas Government Code, Title 10, Chapter 2251, which shall be the Contractor's sole remedy under this Article. Discount(s) offered by Contractor for early payment(s), as stipulated below, if any, will be taken by METRO if payment is made within the discount period specified.

_____ % 10 days _____ % 15 days _____ % _____ days

- E. Contractor's final invoice for work performed under this Contract shall be accompanied by a completed copy of the Exhibit entitled "CONTRACTOR'S RELEASE". If this Contract has been assigned, a release of claims is also required of the assignee.

3 CONTRACTOR REPRESENTATIVE

Prior to start of Contract performance, the Contractor shall advise METRO in writing of the primary and alternate representative (including phone number) who will have management responsibility for the total Contract effort to receive and act on technical matters and resolve problems of a contractual nature.

4 NOTICES

All notices to either party by the other shall be delivered personally or sent by U.S. registered or certified mail, postage prepaid, addressed to such party at the following respective addresses for each:

METRO: Kenny Chin, Senior Contract Administrator
 METROPOLITAN TRANSIT AUTHORITY OF HARRIS COUNTY, TEXAS
 1900 Main, Suite, Procurement Department
 Houston, Texas 77002

Contractor: _____

and shall be deemed given on the date so delivered or so deposited in the mail, unless otherwise provided herein. Either party hereto may change the above address by sending written notice of such change of address to the other in the manner provided for above.

SECTION VII - INSURANCE ARTICLES

1 INSURANCE REQUIREMENT

A. The Contractor shall purchase and maintain in effect during the entire period of this contract, including any maintenance period thereof, insurance of the types and with minimum limits of liability as stated below. Such insurance shall protect Contractor from claims which may arise out of or result from Contractor's operations whether such operations are performed by Contractor or by any subcontractor or by anyone for whose acts any of them may be liable.

WORKERS' COMPENSATION INSURANCE providing Statutory Benefits in accordance with the Workers' Compensation Act of the State of Texas and/or any other State or Federal law as may be applicable to the work being performed under this contract. EMPLOYER'S LIABILITY with limits of liability not less than:

- \$1,000,000 Each Accident
- \$1,000,000 Each Employee for Disease
- \$1,000,000 Policy Limit for Disease

Policy shall be endorsed with a waiver of subrogation recognizing the waiver of all rights of subrogation or recovery against METRO as stated in paragraph B. below.

COMMERCIAL GENERAL LIABILITY utilizing Insurance Services Office Form CG 00 01 or its substantial equivalent providing coverage on an "occurrence" basis, including bodily injury, property damage, and products and completed operations with limits no less than:

- \$10,000,000 Each Occurrence
- \$10,000,000 General Aggregate
- \$10,000,000 Products and Completed Operations Liability Aggregate

Policy shall be endorsed to name METRO as Additional Insured as respects Contractor's ongoing and completed operations in performance of this contract.

Policy shall be endorsed with a waiver of subrogation recognizing the waiver of all rights of subrogation or recovery against METRO as stated in paragraph B. below.

Such insurance shall be primary and non-contributing with any other valid and collectible insurance or self-insurance available to METRO. Contractor may alternatively provide General Liability coverage on a "claims-made" basis. If this is the case, Contractor shall maintain such General Liability insurance for not less than five years following completion of services performed under this contract and shall so evidence by Certificate of Insurance each year.

BUSINESS AUTOMOBILE LIABILITY utilizing Insurance Services Office Form CA 00 01 or its substantial equivalent including liability coverage for all autos owned, rented, hired or borrowed by the Contractor, as well as liability coverage for mobile equipment subject to compulsory insurance or financial responsibility laws or other motor vehicle insurance laws with the following minimum limit:

- \$1,000,000 Any One Accident- Combined Single Limit

Policy shall be endorsed to name METRO as Additional Insured as respects Contractor's operations in performance of this contract.

Policy shall be endorsed with a waiver of subrogation recognizing the waiver of all rights of subrogation or recovery against METRO as stated in paragraph B. below.

Such insurance shall be primary and non-contributing with any other valid and collectible insurance or self-insurance available to METRO.

PROPERTY written on an All-Risk form, providing replacement cost coverage for property damage to METRO's owned property in the care, custody, and control of contractor while on contractor's premises, or in transit.

The following provisions apply with respect to all insurance coverages required above:

The insurance coverages required in this section shall not limit the Contractor's liability or limit the indemnification provisions set forth herein.

If the Contractor maintains higher limit than the minimums shown above, METRO requires and shall be entitled to coverage for the higher limits maintained by the Contractor. Any available insurance proceeds in excess of the specific minimum limits of insurance and coverage shall be available to METRO.

The limits of liability as required above may be provided by a single policy of insurance or by a combination of primary, excess or umbrella policies. But in no event shall the total limits of liability available for any one occurrence or accident be less than the amount required above.

All policies of insurance presented as proof of compliance with the above requirements shall be on forms and with insurance companies approved by METRO. All such insurance policies shall be provided by insurance companies having Best's ratings of A- or greater and VI

or greater (A-/VI) as shown in the most current issue of Best's Key Rating Guide. Policies of insurance issued by insurance companies not rated by Best's or having Best's ratings lower than A-VI will not be accepted as complying with the insurance requirements of the contract unless such insurance companies were approved in writing prior to award of contract.

B. Contractor agrees to waive all rights of subrogation or recovery against METRO arising out of any claims for injury(ies) or damages resulting from the work performed by or on behalf of Contractor under this agreement and/or the use of any METRO premises or equipment in the performance of this agreement.

C. Proof of compliance with these insurance requirements shall be furnished to METRO in the form of an original certificate of insurance including the endorsements mentioned in section A. above, or copies of the applicable policy language effecting required coverage signed by an authorized representative or agent of the insurance company(ies), within fourteen (14) days of notice of award of contract and before any work under this contract will be allowed to commence. Certificates will be unacceptable unless they clearly show that all of the above stipulated requirements have been met. Renewal or replacement certificates shall be furnished METRO not less than seven (7) days prior to the expiration or termination date of the applicable policy(ies). Otherwise, METRO may halt all work under this contract upon expiration or other termination of any required coverage, and work will not be allowed to resume until a satisfactory renewal certificate is received.

D. The Certificate Holder shall read as follows on the Certificate of Insurance:

**Metropolitan Transit Authority of Harris County, TX (METRO)
1900 Main St
Houston, TX 77002**

E. Contractor shall require any and all subcontractors performing work under this contract to obtain and maintain the insurance coverage specified in this section. Such insurance shall be endorsed to name METRO and its directors, officers and employees as Additional Insured as respects to subcontractor's operations in performance of this contract. In addition, subcontractor and their respective insurers providing the required insurance coverage will waive all rights of subrogation or recovery against METRO providing such coverage shall be endorsed to recognize this required waiver of subrogation. The insurance limits may be provided through a combination of primary and excess policies, including the umbrella form of policy. In the event a subcontractor is unable to furnish insurance in the limits required under this contract, the Contractor shall endorse the subcontractor as an Additional Insured on its General Liability and Automobile Liability policies and provide METRO a certificate of insurance showing such coverage.

Such insurance will be primary and non-contributing with any other insurance and be in a form and from insurance companies reasonably acceptable to METRO.

Any request to deviate from the stipulated insurance limits required of subcontractor must be approved by METRO and will be based solely on the scope of work to be performed by the subcontractor. Contractor shall obtain and make available for inspection by METRO upon request current certificates of insurance evidencing insurance coverages carried by subcontractor.

2 INDEMNIFICATION AGREEMENT

CONTRACTOR AGREES TO AND SHALL INDEMNIFY AND HOLD HARMLESS METRO, ITS DIRECTORS AND EMPLOYEES FROM AND AGAINST ANY AND ALL CLAIMS, LOSSES, DAMAGES, CAUSES OF ACTION, SUITS AND LIABILITY OF EVERY KIND, INCLUDING ALL EXPENSES OF LITIGATION, COURT COSTS AND ATTORNEY'S FEES, FOR BODILY INJURY, SICKNESS, DISEASE OR DEATH OF ANY PERSON, OR FOR DAMAGES TO ANY PROPERTY, INCLUDING CONSEQUENTIAL DAMAGES OR LOSS OF USE THEREOF, BROUGHT OR RECOVERABLE BY THIRD PARTIES AGAINST METRO, ITS DIRECTORS AND/OR EMPLOYEES AND ARISING OUT OF OR RESULTING FROM ANY NEGLIGENT ACT OR OMISSION BY CONTRACTOR IN THE PERFORMANCE OF THIS CONTRACT. CONTRACTOR AGREES TO PROVIDE ACKNOWLEDGEMENT OF INDEMNIFICATION WITHIN TEN DAYS FROM RECEIPT OF DEMAND FOR INDEMNIFICATION FROM METRO.

THE INDEMNITY PROVIDED FOR IN THIS ARTICLE SHALL HAVE NO APPLICATION TO ANY CLAIM, LOSS OR DAMAGE, CAUSE OF ACTION, SUIT OR LIABILITY BROUGHT OR RECOVERABLE AGAINST METRO, ITS DIRECTORS AND/OR EMPLOYEES TO THE EXTENT THE INJURY, DEATH OR DAMAGE RESULTS SOLELY FROM A GROSS NEGLIGENT ACT OR WILLFUL BEHAVIOR BY METRO.

2 INDEMNIFICATION AGREEMENT

A. CONTRACTOR AGREES TO AND SHALL INDEMNIFY AND HOLD HARMLESS METRO, ITS DIRECTORS AND EMPLOYEES FROM AND AGAINST ANY AND ALL CLAIMS, LOSSES, DAMAGES, CAUSES OF ACTION, SUITS AND LIABILITY OF EVERY KIND, INCLUDING ALL EXPENSES OF LITIGATION, COURT COSTS AND ATTORNEY'S FEES, FOR BODILY INJURY, SICKNESS, DISEASE OR DEATH OF ANY PERSON, OR FOR DAMAGES TO ANY PROPERTY, INCLUDING CONSEQUENTIAL DAMAGES OR LOSS OF USE THEREOF, BROUGHT OR RECOVERABLE BY THIRD PARTIES AGAINST METRO, ITS DIRECTORS AND/OR EMPLOYEES AND ARISING OUT OF OR RESULTING FROM ANY NEGLIGENT ACT OR OMISSION BY CONTRACTOR IN THE PERFORMANCE OF THIS CONTRACT. CONTRACTOR AGREES TO PROVIDE ACKNOWLEDGEMENT OF INDEMNIFICATION WITHIN TEN DAYS FROM RECEIPT OF DEMAND FOR INDEMNIFICATION FROM METRO.

- B. THE INDEMNITY PROVIDED FOR IN THIS ARTICLE SHALL HAVE NO APPLICATION TO ANY CLAIM, LOSS OR DAMAGE, CAUSE OF ACTION, SUIT OR LIABILITY BROUGHT OR RECOVERABLE AGAINST METRO, ITS DIRECTORS AND/OR EMPLOYEES TO THE EXTENT THE INJURY, DEATH OR DAMAGE RESULTS SOLELY FROM A GROSS NEGLIGENT ACT OR WILLFUL BEHAVIOR BY METRO.**

SECTION VIII - SMALL BUSINESS PROGRAM ARTICLES**1 DISADVANTAGED BUSINESS ENTERPRISES**

- A. Policy: It is the policy of the U.S. Department of Transportation and METRO that Disadvantaged Business Enterprises (DBE) as defined in 49 CFR Part 26.49 shall have the maximum opportunity to participate in the performance of contracts financed in whole or in part with Federal funds under this Contract. Consequently the DBE requirements of 49 CFR Part 26 apply to this Contract.
- B. DBE Obligation: The Contractor agrees to ensure that Disadvantaged Business Enterprises as defined in 49 CFR Part 26 have the maximum opportunity to participate in the performance of contracts and subcontracts financed in whole or in part with Federal funds provided under this Contract. In this regard, all Contractors shall take all necessary and reasonable steps in accordance with 49 CFR Part 26 to ensure that Disadvantaged Business Enterprises have the maximum opportunity to compete for and perform contracts. Contractors shall not discriminate on the basis of race, color, national origin, or sex in the award and performance of contracts assisted by the Department of Transportation.

SECTION IX - SPECIAL TERMS AND CONDITIONS ARTICLES**1 DATA RIGHTS**

- A. Proprietary Rights/Rights in Data. The term "subject data" used in this clause means recorded information, whether or not copyrighted, that is delivered or specified to be delivered under the Contract. It includes the proprietary rights of the following:
1. Shop drawings and working drawings
 2. Technical data including manuals or instruction materials, computer or microprocessor software
 3. Patented materials, equipment, devices or processes
 4. License requirements
- B. METRO shall protect proprietary information provided by the Contractor to the fullest extent of the law. The Contractor shall grant a non-exclusive license to allow METRO to utilize such information in order to maintain the vehicles. In the event that the Contractor no longer provides the information METRO has the right to reverse engineer patented parts and software.
- C. METRO reserves a royalty-free, non-exclusive and irrevocable license to reproduce, publish or otherwise use, and to authorize others to use, the following subject data in order to operate or maintain the vehicles: (1) any subject data required to be developed and first produced in the performance of the Contract and specifically paid for as such under the Contract, whether or not a copyright has been obtained; and (2) any rights of copyright to which the Contractor, Subcontractor or Supplier purchases ownership for the purpose of performance of the Contract and specifically paid for as such under the Contract. The Contractor agrees to include the requirements of this clause, modified as necessary to identify the affected parties, in each subcontract and supply order placed under the Contract.
- D. Access to Onboard Operational Data. METRO grants to the Contractor the right to inspect, examine, download, and otherwise obtain any information or data available from components provided by the Contractor, including, but not limited to, any electronic control modules or other data-collection devices, to the extent necessary to enable Contractor to perform reliability maintenance analysis, corrective action and/or other engineering type Work for the bus. This right expressly excludes access to information or data collected on any equipment not provided and installed by the Contractor.

2 SOFTWARE

Upon execution of the Contract, the Contractor shall provide METRO a list of all OEM software comprising proprietary works ("Proprietary Software") for all major vehicle subsystems. From time to time and only upon request, information contained within the listed software may be made available to METRO through the OEM of the vehicle subsystem. The Contractor and OEM are not obligated to provide copies of source code as this is proprietary intellectual property; however, the Contractor is obligated to assist METRO with any technical assistance for the duration of the life of the vehicle.

3 AVAILABILITY OF FUNDS FOR THE NEXT FISCAL YEAR

METRO's obligation for performance of this contract beyond the current fiscal year is contingent upon availability of funds from which payment for contract purposes can be made. No legal liability on the part of METRO for any payment may arise under this contract until funds are made available to the Contracting Officer for performance and until the Contractor receives notice of availability, to be confirmed in writing, by the Contracting Officer. Any option exercised by METRO which will be performed in whole or in part in a subsequent fiscal year is subject to availability of funds and will be governed by the terms of this Article.

SECTION X - GENERAL TERMS AND CONDITIONS ARTICLES**1 TITLE**

Adequate documents for securing title and license plates for the vehicles in Houston, Texas shall be provided to METRO at least thirty (30) calendar days before each vehicle is released for delivery to METRO. Following final acceptance of each vehicle, the Contractor warrants that the title shall pass to METRO free and clear of all liens, mortgages and encumbrances, financing statements, security agreements, claims, and demands of any character.

2 COMPLIANCE WITH LAWS/PERMITS AND LICENSES

The Contractor shall give notices and comply with all Federal, State and Municipal laws, ordinances, rules, regulations and orders of any public authority bearing on the performance of this Contract, including, but not limited to, the laws referred to in this Contract. If the Contractor or METRO observes that this Contract is at variance therewith in any respect, the observing party shall promptly notify the other party in writing, and any necessary changes shall be adjusted by appropriate contract modification. Upon request, the Contractor shall furnish to METRO certificates of compliance with all such laws, ordinances, rules, regulations and orders. The Contractor shall also be responsible for obtaining all necessary permits and licenses required for performance under the Contract.

3 METRO-FURNISHED PROPERTY

- A. METRO shall provide the property specifically described in the Technical Specifications to the Contractor, for use only in connection with this Contract.
- B. Title to METRO-furnished property shall remain with METRO. The Contractor shall maintain adequate property control records of METRO-furnished property in accordance with sound industrial practice.
- C. Unless otherwise provided in this Contract, the Contractor, upon delivery to him of any METRO-furnished property, assumes the risk of, and shall be responsible for, any loss thereof or damage thereto except for reasonable wear and tear, and except to the extent that such property is consumed in the performance of this Contract.
- D. The Contractor shall, upon completion of this Contract, prepare for return or dispose of all METRO-furnished property not consumed in the performance of this Contract or not theretofore delivered to the METRO, as may be directed or authorized by the Contracting Officer or his designee. The net proceeds of any such disposal shall be credited to the Contract price or paid in such other manner as the Contracting Officer or his designee may direct.

4 WARRANTY

The Contractor agrees that the vehicles provided under this Contract shall be covered by the warranty requirements specified in Exhibit "A" and that the rights and remedies provided therein are in addition to and do not limit any rights afforded to METRO by any other provision of this Contract or by laws.

5 SERVICE LOCATION

The Contractor shall have the capability to perform warranty covered repairs on the vehicle engines and transmissions in the Houston metropolitan area. In the event of a fleet defect or if warranty repairs to the basic body structure are required, the Contractor shall follow the repair procedures specified in Contract Exhibit "A". The Contractor shall have sufficient engineering, technical and support personnel to perform warranty and/or retrofit work Monday through Friday between the hours of 8:00 a.m. and 5:00 p.m.

6 CHANGES

- A. The METRO President & Chief Executive Officer or the duly authorized representative may at any time, by written order, and without notice to the sureties, if any, make changes within the general scope of this Contract in any one or more of the following:
 - 1. Drawings, designs or specifications,
 - 2. Method of shipment, or packing
 - 3. Place of delivery,
- B. If any such change causes an increase or decrease in the cost of, or the time required for, performance of any part of this Contract, whether or not changed by the order, the President & Chief Executive Officer or the duly authorized representative shall make an equitable adjustment in the Contract price, the delivery schedule, or both, and shall modify the Contract.

- C. The Contractor must submit any "proposal for adjustment" under this Article within thirty (30) calendar days from the date of receipt of the written order. However, if the President & Chief Executive Officer or the duly authorized representative decides that the facts justify it, the President & Chief Executive Officer or the duly authorized representative may receive and act upon a proposal submitted before final payment of the Contract.
- D. If the Contractor's proposal includes the cost of property made obsolete or excess by the change, the President & Chief Executive Officer or the duly authorized representative shall have the right to prescribe the manner of the disposition of the property.
- E. Failure to agree to any adjustment shall be a dispute under the "Disputes" Article of the Contract. However, nothing in this Article shall excuse the Contractor from proceeding with the Contract as changed.
- F. Except for those changes properly authorized and executed as provided in this Article, the Contractor shall notify the Contracting Officer in writing promptly within fifteen (15) calendar days from the date that the Contractor identifies any METRO conduct (including actions, inactions and written or oral communications) that the Contractor regards as a change to the Contract terms and conditions. This notification shall contain all information available to the Contractor regarding the change. Contractor's failure to provide notification as required herein may jeopardize being compensated for the change if in fact a change has been made

7 DISPUTES

Any dispute concerning a question of fact arising under this Contract which is not disposed of by agreement will be decided by the Contracting Officer, who will reduce his decision to writing and mail or otherwise furnish a copy thereof to the Contractor. The decision of the Contracting Officer will be final unless, within ten (10) calendar days from the date of receipt of such copy, the Contractor mails or otherwise furnishes to the Contracting Officer a written appeal addressed to the METRO Contract Appeals Committee. The Contract Appeals Committee will be designated by the President & Chief Executive Officer and will hear the Contractor's appeal and make a recommendation to the President & Chief Executive Officer for the final decision. In connection with any appeal proceeding under this Article, the Contractor will be afforded an opportunity to be heard and to offer evidence in support of his appeal. The decision of the President & Chief Executive Officer will be final and conclusive with respect to the Contractor's administrative remedies under this Disputes Article. Pending final decision of a dispute hereunder, the Contractor shall proceed diligently with the performance of the Contract and in accordance with the Contracting Officer's decision. This Disputes Article does not preclude consideration of questions of law in connection with decisions provided for above. Nothing in this Contract, however, shall be construed as making final the decision of any administrative official, representative, or committee on a question of law.

8 TERMINATION FOR CONVENIENCE OF METRO

- A. The performance of work under this Contract may be terminated by METRO in accordance with this Article in whole, or from time to time in part, whenever the Contracting Officer shall determine that such termination is in METRO's best interest. Any such termination shall be effected by delivery to the Contractor of a notice of termination specifying the extent to which performance of work under the Contract is terminated, and the date upon which such termination becomes effective.
- B. After receipt of a notice of termination, and except as otherwise directed by the Contracting Officer, the Contractor shall:
 1. Stop work under the Contract on the date and to the extent specified in the notice of termination;
 2. Place no further orders or subcontracts for materials, services, or facilities, except as may be necessary for completion of such portion of the work under the Contract as is not terminated;
 3. Terminate all orders and subcontracts to the extent that they relate to the performance of work terminated by the notice of termination;
 4. Assign METRO in the manner, at the times, and to the extent directed by the Contracting Officer, all of the right, title, and interest of the Contractor under the orders and subcontracts so terminated, in which case METRO shall have the right, in its discretion, to settle or pay any or all claims arising out of the termination of such orders and subcontracts;
 5. Settle all outstanding liabilities and all claims arising out of such termination of orders and subcontracts, with the approval or ratification of the Contracting Officer, to the extent he may require, which approval or ratification shall be final for all the purposes of this Article;
 6. Transfer title to METRO and deliver in the manner at the times and to the extent if any, directed by the Contracting Officer the fabricated or unfabricated parts, work in process, completed work, supplies, and other material produced as part of, or acquired in connection with the performance of, the work terminated, and the completed or partially completed plans, drawings, information and other property which, if the Contract had been completed, would have been required to be furnished to METRO;
 7. Use its best efforts to sell, in the manner, at the times, to the extent, and at the price(s) directed or authorized by the Contracting Officer, any property of the types referred to above, provided, however, that the Contractor shall not be

required to extend credit to any purchaser, and may acquire any such property under the conditions prescribed by and at a price(s) approved by the Contracting Officer, and provided further, that the proceeds of any such transfer or disposition shall be applied in reduction of any payments to be made by METRO to the Contractor under this Contract or shall otherwise be credited to the price or cost of the work covered by this Contract or paid in such other manner as the Contracting Officer may direct;

8. Complete performance of such part of the work as shall not have been terminated by the notice of termination; and take such action as may be necessary, or as the Contracting Officer may direct, for the protection or preservation of the property related to this Contract which is in the possession of the Contractor and in which METRO has or may acquire an interest.
- C. Settlement of claims by the Contractor under this "Termination for Convenience" Article shall be in accordance with the provisions set forth in Federal Acquisition Regulations (FAR) 52.249-2 (c) (d), (e), (f), (g), (h), (i), (j), and (k) except that wherever the word "Government" appears it shall be deleted and the word "METRO" shall be substituted in lieu thereof.

9 TERMINATION FOR DEFAULT

- A. METRO may, subject to paragraphs D and E below, by written notice of default to the Contractor, terminate this Contract in whole or in part if the Contractor fails to make delivery within the time and in the manner specified in this Contract or any extension thereof; or fails to perform any of the other material provisions of this Contract.
- B. METRO's right to terminate this Contract may be exercised if the Contractor does not cure the condition or conditions constituting default within ten (10) calendar days (or such longer period as may be authorized in writing by the Contracting Officer) after receipt of the notice from the Contracting Officer specifying the failure.
- C. If METRO terminates this Contract, it may acquire, under the terms and in the manner the Contracting Officer considers appropriate, item(s) similar to that terminated, and the Contractor will be liable to METRO for any excess costs.
- D. Except for defaults of subcontractors at any tier, the Contractor shall not be liable for any excess costs if the failure to perform the Contract arises from causes beyond the control and without the fault or negligence of the Contractor. Examples of such causes include:
1. Acts of God or of the public enemy,
 2. Acts of METRO in its contractual capacity,
 3. Fires,
 4. Floods,
 5. Epidemics,
 6. Quarantine restrictions,
 7. Strikes,
 8. Unusually severe weather,
 9. Acts of terrorism.

In each instance, the failure to perform must be beyond the control and without the fault or negligence of the Contractor.

- E. If the failure to perform is caused by the default of a subcontractor at any tier, and if the cause of the default is beyond the control of both the Contractor and subcontractor, and without the fault or negligence of either, the Contractor shall not be liable for any excess costs for failure to perform, unless the subcontracted work was obtainable from other sources in sufficient time for the Contractor to meet the required performance schedule.
- F. METRO shall pay the Contract price(s) for completed and accepted item(s). METRO may withhold from these amounts any sum the Contracting Officer determines to be necessary to protect METRO against loss because of outstanding liens or claims of former lien holders.
- G. If, after termination, it is determined that the Contractor was not in default, or that the default was excusable, the rights and obligations of the parties shall be the same as if the termination had been issued for the convenience of METRO.
- H. The rights and remedies of METRO under this Article are in addition to any other rights and remedies provided by law or under this Contract.

10 PATENT INDEMNITY

Except as otherwise provided, the Contractor agrees to indemnify METRO and its officers, agents, and employees against liability, including costs and expenses, for infringement upon any Patent of the United States arising out of the performance of this Contract or out of the use or disposal by or for the account of METRO of supplies or equipment furnished hereunder.

11 COVENANT AGAINST CONTINGENT FEES

The Contractor warrants that no person or selling agency has been employed or retained to solicit or secure this Contract upon an agreement or understanding for a commission, percentage, brokerage, or contingent fee, excepting bona fide employees or bona fide established commercial or selling agencies maintained by the Contractor for the purpose of securing business. For breach or violation of this warranty METRO shall have the right to annul this Contract without liability or in its discretion, to deduct from the Contract price or consideration, or otherwise recover, the full amount of such commission, percentage, brokerage or contingent fee.

12 DISSEMINATION OF CONTRACT INFORMATION

The Contractor shall not publish, permit to be published, or distribute for public consumption, any information, oral or written, concerning the performance of this Contract, without prior written consent of METRO. Two (2) copies of any material proposed to be published or distributed shall be submitted to the METRO through the Contracting Officer.

13 CONFIDENTIAL INFORMATION

All cost estimates and supporting data are considered confidential. Any other reports, information, data, etc., given or prepared or assembled by the Contractor under this Contract which METRO requests in writing to be kept as confidential shall not be made available to any individual or organization by the Contractor without the prior written approval of METRO. These obligations with regard to confidentiality shall be for three (3) years after completion of this Contract but shall not apply to:

1. Information that was in the Contractor's possession prior to this Contract;
2. Information that is or becomes in the public domain; and
3. Information received lawfully from third parties which have no confidentiality obligations in connection with this Contract.

14 USE OF METRO'S NAME IN CONTRACTOR ADVERTISING OR PUBLIC RELATIONS

If the Contractor should desire to use METRO's name, logo or any other material in its advertisement or public relations programs, the Contractor shall receive prior written approval from METRO. Any such information relating to METRO shall be factual and in no way imply that METRO endorses the Contractor's firm, services, or products. The Contractor shall insert the substance of this Article in each subcontract and supply contract or purchase order.

15 ASSIGNMENT

The Contractor's performance under this Contract shall not be assigned except upon written consent of METRO. The Contractor may assign monies due or to become due to him under the Contract and such assignment will be recognized by METRO, if given proper notice thereof, to the extent permitted by law. Assignment of monies will be subjected to proper offsets in favor of METRO and to deductions provided for in the Contract. Money withheld, whether assigned or not, will be subject to being used by METRO for the completion of the work in the event that the Contractor defaults under the Contract. The validity of the assignment and the rights of the assignee against METRO shall be governed by the laws of the State of Texas.

16 INDEPENDENT CONTRACTOR

It is understood and agreed that the Contractor shall be deemed to be an independent contractor in all its operations and activities hereunder; that the employees furnished by the Contractor to perform Work hereunder shall be deemed to be Contractor's employees or independent subcontractors; that Contractor employees shall be responsible for all obligations and reports covering social security, unemployment insurance, income tax, and other reports and deductions required by state or federal law.

17 CONTRACTUAL RELATIONSHIPS

No contractual relationship will be recognized under the Contract other than the contractual relationship between METRO and the Contractor.

18 CONTRACT ORDER OF PRECEDENCE

In the event of an inconsistency between provisions of this Contract, the inconsistency shall be resolved by giving precedence in the following order:

1. Contract Modifications, if any
2. The Contract Articles
3. Request for Approval (RFA Forms)
4. Technical Specifications/Scope of Service
5. Drawings

19 SEVERABILITY

If any provision of this Contract or the application thereof to any person or circumstance, is rendered or declared illegal for any reason and shall be invalid or unenforceable, the remainder of this Contract and the application of such provision to other persons or circumstances shall not be affected thereby but shall be enforced to the greatest extent permitted by applicable law.

20 WAIVERS

- A. Neither METRO's review, approval or acceptance of, nor payment for, the Work required under this Contract shall be construed to operate as a waiver of any rights under this Contract or of any cause of action arising out of the performance of the Contract, and the Contractor shall be and remain liable to METRO in accordance with applicable law and the terms of this Contract for all damages to METRO caused by the Contractor's negligent act, error or omission in the performance of any of the Work furnished under this Contract.
- B. The waiver by METRO of any breach of any term, covenant, condition, or agreement herein contained shall not be deemed to be a waiver of any subsequent breach of the same, or of a breach of any other term, covenant, condition, or agreement herein contained.

21 INTERPRETATION, JURISDICTION AND VENUE

This Contract shall be construed and interpreted solely in accordance with the laws of the State of Texas. Venue of any suit, right or cause of action arising under or in connection with this Contract shall lie exclusively in Harris County, Texas.

22 RIGHTS AND REMEDIES

The rights and remedies of METRO provided for under this Contract are in addition to any rights or remedies provided by law.

23 NOTICE TO METRO OF LABOR DISPUTES

- A. Whenever the Contractor has knowledge that any actual or potential labor dispute is delaying or threatens to delay the timely performance of this Contract, the Contractor shall immediately give notice thereof, including all relevant information with respect thereto, to METRO.
- B. The Contractor agrees to insert the substance of this Article, including this paragraph B, in any subcontract hereunder as to which a labor dispute may delay the timely performance of this Contract; except that each such subcontract shall provide that in the event its timely performance is delayed or threatened by delay by any actual or potential labor dispute, the subcontractor shall immediately notify his next higher tier subcontractor, or the prime contractor, as the case may be, of all relevant information with respect to such dispute.

24 ETHICAL CONDUCT

- A. The METRO Board of Directors has adopted a Code of Ethics governing the conduct of its officers and employees. Contractor agrees it will familiarize itself with this Code of Ethics and that it will not offer, confer or agree to confer any prohibited benefit as consideration for a METRO Board Member's or employee's decision, opinion, recommendation, vote or other exercise of discretion as a public servant or in exchange for the Board Member's or employee's having exercised his official powers or performed his official duties nor will the Contractor participate in any other violation of this Code.
- B. Contractor is required to maintain those records necessary to prove beyond a reasonable doubt Contractor's compliance with METRO Code of Ethics Policy. METRO shall have the right to review for the purpose of determining compliance with Code of Ethics Policy all disbursement records and supporting documents including invoices, payment vouchers, employee expense reports and petty cash records.

- C. Breach of this Article by the Contractor may result in termination of the Contract and exclusion of the Contractor from future contracts with METRO for a period of time determined by the METRO Board.
- D. METRO'S ETHICS AND SAFETY HOTLINE is a reporting system, administered by a third-party vendor, by which employees, Contractors, and others may report concerns or complaints they may have about improper conduct or safety conditions at METRO. Employees and Contractors may report confidentially and anonymously if desired, free of any retaliation. This reporting mechanism satisfies the Federal Transit Administration's Employee Safety Reporting Program Rule requirements (49 CFR 673.23(b), 673.27 (b) and 673.29 (b)). Employees and Contractors may submit a report to the Hotline through one of the following methods: Toll-Free: 1-888-60-REPORT (888-607-37678); Fax: 215-689-3885; Website: www.Lighthouse-services.com/ridemetro; E-Mail: reports@lighthouse-services.com.

25 SUSPENSION OF WORK

- A. METRO may at any time and for any reason within its sole discretion issue a written order to the Contractor suspending, delaying or interrupting all or any part of the Work for a specified period of time.
- B. The Contractor shall comply immediately with any such written order and take all reasonable steps to minimize costs allocable to the Work covered by the suspension during the period of work stoppage. Contractor shall continue the Work that is not included in the suspension and shall continue such ancillary activities as are not suspended. The Contractor shall resume performance of the suspended Work upon expiration of the notice of suspension, or upon direction from METRO.
- C. The Contractor shall be allowed an equitable adjustment in the Contract price (excluding profit) and/or an extension of the Contract time, to the extent that cost or delays are shown by the Contractor to be directly attributable to any suspension. However, no adjustment shall be made under this section for any suspension, delay or interruption due to the fault or negligence of the Contractor, or for which an equitable adjustment is provided for, or excluded under any other term or condition of the Contract. As soon as reasonably possible but no later than forty-five (45) calendar days, or any other period of time agreed to by the parties, after receipt of the written suspension of work notice, the Contractor shall submit to the Contracting Officer a detailed price and schedule Proposal for the suspension, delay or interruption.

26 CONFLICTS OF INTEREST, GRATUITIES

No member, officer, or employee of METRO or of a local public body during his or her tenure, or one year thereafter, shall have any interest, direct or indirect, in this Contract or the proceeds thereof.

27 METRO NON-DISCRIMINATION

METRO shall not discriminate on the basis of race, color, national origin, or sex in the award and performance on any DOT-assisted contract or in the administration of its Program or the requirements of 49 CFR Part 26. METRO shall take all necessary and reasonable steps under 49 CFR Part 26 to ensure nondiscrimination in the award and administration of DOT-assisted contracts. METRO's Program, as required by 49 CFR Part 26 and as approved by DOT, is incorporated by reference in this Contract. Implementation of this program is a legal obligation and failure to carry out its terms shall be treated as a violation of this Contract. Upon notification to METRO of its failure to carry out its approved program, the Department may impose sanctions as provided for under Part 26 and may, in appropriate cases, refer the matter for enforcement under 18 U.S.C. § 1001 and/or the Program Fraud Civil Remedies Act of 1986 (31 U.S.C. § 3801, et seq.).

28 CONTRACTOR NON-DISCRIMINATION

The Contractor or subcontractor(s) shall not discriminate on the basis of race, color, national origin, or sex in the performance of this contract. The Contractor shall carry out applicable requirements of 49 CFR Part 26 in the award and administration of DOT-assisted contracts. Failure by the Contractor to carry out these requirements is a material breach of this Contract, which may result in the termination of this Contract or such other remedy as METRO deems appropriate.

29 EQUAL OPPORTUNITY FOR VEVRAA PROTECTED VETERANS

The definitions set forth in 41 CFR 60-300.2 apply to the terms used throughout this Clause, and they are incorporated herein by reference.

1. The contractor will not discriminate against any employee or applicant for employment because he or she is a disabled veteran, recently separated veteran, active duty wartime or campaign badge veteran, or Armed Forces service medal veteran (hereinafter collectively referred to as "protected veteran(s)") in regard to any position for which the employee or applicant for employment is qualified. The contractor agrees to take affirmative action to employ, advance in employment and otherwise treat qualified individuals without discrimination based on their status as a protected veteran in all employment practices, including the following:
 - i. Recruitment, advertising, and job application procedures.

- ii. Hiring, upgrading, promotion, award of tenure, demotion, transfer, layoff, termination, right of return from layoff and rehiring.
 - iii. Rates of pay or any other form of compensation and changes in compensation.
 - iv. Job assignments, job classifications, organizational structures, position descriptions, lines of progression, and seniority lists.
 - v. Leaves of absence, sick leave, or any other leave.
 - vi. Fringe benefits available by virtue of employment, whether or not administered by the contractor.
 - vii. Selection and financial support for training, including apprenticeship, and on-the-job training under 38 U.S.C. 3687, professional meetings, conferences, and other related activities, and selection for leaves of absence to pursue training.
 - viii. Activities sponsored by the contractor including social or recreational programs.
 - ix. Any other term, condition, or privilege of employment.
2. The contractor agrees to immediately list all employment openings which exist at the time of the execution of this contract and those which occur during the performance of this contract, including those not generated by this contract and including those occurring at an establishment of the contractor other than the one where the contract is being performed, but excluding those of independently operated corporate affiliates, with the appropriate employment service delivery system where the opening occurs. Listing employment openings with the state workforce agency job bank or with the local employment service delivery system where the opening occurs will satisfy the requirement to list jobs with the appropriate employment service delivery system. In order to satisfy the listing requirement described herein, contractors must provide information about the job vacancy in any manner and format permitted by the appropriate employment service delivery system which will allow that system to provide priority referral of veterans protected by VEVRAA for that job vacancy. Providing information on employment openings to a privately run job service or exchange will satisfy the contractor's listing obligation if the privately run job service or exchange provides the information to the appropriate employment service delivery system in any manner and format that the employment service delivery system permits which will allow that system to provide priority referral of protected veterans.
 3. Listing of employment openings with the appropriate employment service delivery system pursuant to this clause shall be made at least concurrently with the use of any other recruitment source or effort and shall involve the normal obligations which attach to the placing of a *bona fide* job order, including the acceptance of referrals of veterans and nonveterans. The listing of employment openings does not require the hiring of any particular job applicants or from any particular group of job applicants, and nothing herein is intended to relieve the contractor from any requirements in Executive orders or regulations regarding nondiscrimination in employment.
 4. Whenever a contractor, other than a state or local governmental contractor, becomes contractually bound to the listing provisions in paragraphs 2 and 3 of this clause, it shall advise the employment service delivery system in each state where it has establishments that: (a) It is a Federal contractor, so that the employment service delivery systems are able to identify them as such; and (b) it desires priority referrals from the state of protected veterans for job openings at all locations within the state. The contractor shall also provide to the employment service delivery system the name and location of each hiring location within the state and the contact information for the contractor official responsible for hiring at each location. The "contractor official" may be a chief hiring official, a Human Resources contact, a senior management contact, or any other manager for the contractor that can verify the information set forth in the job listing and receive priority referrals from employment service delivery systems. In the event that the contractor uses any external job search organizations to assist in its hiring, the contractor shall also provide to the employment service delivery system the contact information for the job search organization(s). The disclosures required by this paragraph shall be made simultaneously with the contractor's first job listing at each employment service delivery system location after the effective date of this final rule. Should any of the information in the disclosures change since it was last reported to the employment service delivery system location, the contractor shall provide updated information simultaneously with its next job listing. As long as the contractor is contractually bound to these provisions and has so advised the employment service delivery system, there is no need to advise the employment service delivery system of subsequent contracts. The contractor may advise the employment service delivery system when it is no longer bound by this contract clause.
 5. The provisions of paragraphs 2 and 3 of this clause do not apply to the listing of employment openings which occur and are filled outside of the 50 states, the District of Columbia, the Commonwealth of Puerto Rico, Guam, the Virgin Islands, American Samoa, the Commonwealth of the Northern Mariana Islands, Wake Island, and the Trust Territories of the Pacific Islands.
 6. As used in this clause: i. *All employment openings* includes all positions except executive and senior management, those positions that will be filled from within the contractor's organization, and positions lasting three days or less. This term includes full-time employment, temporary employment of more than three days' duration, and part-time employment.
 - i. *Executive and senior management* means: (1) Any employee (a) compensated on a salary basis at a rate of not less than

\$455 per week (or \$380 per week, if employed in American Samoa by employers other than the Federal Government), exclusive of board, lodging or other facilities; (b) whose primary duty is management of the enterprise in which the employee is employed or of a customarily recognized department or subdivision thereof; (c) who customarily and regularly directs the work of two or more other employees; and (d) who has the authority to hire or fire other employees or whose suggestions and recommendations as to the hiring, firing, advancement, promotion or any other change of status of other employees are given particular weight; or (2) any employee who owns at least a bona fide 20-percent equity interest in the enterprise in which the employee is employed, regardless of whether the business is a corporate or other type of organization, and who is actively engaged in its management.

- ii. *Positions that will be filled from within the contractor's organization* means employment openings for which no consideration will be given to persons outside the contractor's organization (including any affiliates, subsidiaries, and parent companies) and includes any openings which the contractor proposes to fill from regularly established "recall" lists. The exception does not apply to a particular opening once an employer decides to consider applicants outside of his or her own organization.
7. The contractor agrees to comply with the rules, regulations, and relevant orders of the Secretary of Labor issued pursuant to the Act.
8. In the event of the contractor's noncompliance with the requirements of this clause, actions for noncompliance may be taken in accordance with the rules, regulations, and relevant orders of the Secretary of Labor issued pursuant to the Act.
9. The contractor agrees to post in conspicuous places, available to employees and applicants for employment, notices in a form to be prescribed by the Director, Office of Federal Contract Compliance Programs, provided by or through the contracting officer. Such notices shall state the rights of applicants and employees as well as the contractor's obligation under the law to take affirmative action to employ and advance in employment qualified employees and applicants who are protected veterans. The contractor must ensure that applicants or employees who are disabled veterans are provided the notice in a form that is accessible and understandable to the disabled veteran (e.g., providing Braille or large print versions of the notice, posting the notice for visual accessibility to persons in wheelchairs, providing the notice electronically or on computer disc, or other versions). With respect to employees who do not work at a physical location of the contractor, a contractor will satisfy its posting obligations by posting such notices in an electronic format, provided that the contractor provides computers that can access the electronic posting to such employees, or the contractor has actual knowledge that such employees otherwise are able to access the electronically posted notices. Electronic notices for employees must be posted in a conspicuous location and format on the company's intranet or sent by electronic mail to employees. An electronic posting must be used by the contractor to notify job applicants of their rights if the contractor utilizes an electronic application process. Such electronic applicant notice must be conspicuously stored with, or as part of, the electronic application.
10. The contractor will notify each labor organization or representative of workers with which it has a collective bargaining agreement or other contract understanding that the contractor is bound by the terms of VEVRAA, and is committed to take affirmative action to employ and advance in employment, and shall not discriminate against, protected veterans.
11. The contractor will include the provisions of this clause in every subcontract or purchase order of \$100,000 or more, unless exempted by the rules, regulations, or orders of the Secretary issued pursuant to VEVRAA so that such provisions will be binding upon each subcontractor or vendor. The contractor will take such action with respect to any subcontract or purchase order as the Director, Office of Federal Contract Compliance Programs, may direct to enforce such provisions, including action for noncompliance.
12. The contractor must, in all solicitations or advertisements for employees placed by or on behalf of the contractor, state that all qualified applicants will receive consideration for employment without regard to their protected veteran status.

SECTION XI - FEDERAL REQUIREMENTS ARTICLES**1 FEDERAL CHANGES**

Contractor shall at all times comply with all applicable Federal Transit Administration (FTA) regulations, policies, procedures and directives, including without limitation those listed directly or by reference in the latest FTA Master Agreement or any of its successors between METRO and FTA, as they may be amended or promulgated from time to time during the term of this Contract. Contractor's failure to so comply shall constitute a material breach of this Contract.

2 OFFICIALS NOT TO BENEFIT

- A. No member or delegate to the Congress of the United States shall be admitted to any share or part of this Contract or to any benefit arising therefrom.
- B. No member, officer or employee of METRO, or of any other local public body having jurisdiction over METRO, during his tenure or for one year thereafter, shall have any interest direct or indirect, in the Contract or the proceeds thereof.
- C. The Contractor covenants that he presently has no interest and shall not acquire any interest, direct or indirect, which would conflict in any manner or degree with the performance of the Services required under this Contract. In the event any question of possible conflict should arise, the determination of METRO shall be controlling. The Contractor further covenants that in the performance of this Contract no person having any such interest shall be employed by the Contractor.

3 CONTRACT WORK HOURS AND SAFETY STANDARDS ACT

- A. Overtime Requirements. No Contractor or subcontractor contracting for any part of the Contract Work which may require or involve the employment of laborers or mechanics shall require or permit any such laborer or mechanic in any workweek unless such laborer or mechanic receives compensation at a rate not less than one and one-half times the basic rate of pay for all hours worked in excess of forty hours in such workweek.
- B. Violation; liability for unpaid wages; liquidated damages. In the event of any violation of the clause set forth in paragraph A of this Article on the contractor and any subcontractor responsible therefor shall be liable for the unpaid wages. In addition, such contractor and subcontractor shall be liable to the United States for liquidated damages. Such liquidated damages shall be computed with respect to each individual laborer or mechanic, including watchmen and guards, employed in violation of the clause set forth in paragraph A of this Article, in the sum of \$10 for each calendar day on which such individual was required or permitted to work in excess of the standard workweek of forty hours without payment of the overtime wages required by the clause set forth in paragraph (A) of this Article.
- C. Withholding for unpaid wages and liquidated damages. METRO shall upon its own action or upon written request of an authorized representative of the Department of Labor withhold or cause to be withheld, from any moneys payable on account of work performed by the contractor or subcontractor under any such contract or any other Federal contract with the same prime contractor, or any other Federally-assisted contract subject to the Act, which is held by the same prime contractor, such sums as may be determined to be necessary to satisfy any liabilities of such contractor or subcontractor for unpaid wages and liquidated damages as provided in the clause set forth in paragraph B of this Article.
- D. Subcontracts. The Contractor or subcontractor shall insert in any subcontracts the clauses set forth in this Article and also an Article requiring the subcontractors to include these clauses in any lower tier subcontracts. The prime contractor shall be responsible for compliance by any subcontractor with the clauses set forth in this Article.
- E. Payrolls and basic records. Payrolls and basic records relating thereto shall be maintained by the contractor during the course of the work and preserved for a period of three years thereafter for all laborers and mechanics working at the site of the work (or under the United States Housing Act of 1937, or under the Housing Act of 1949, in the construction or development of the project). Such records shall contain the name, address, and social security number of each such worker, his or her correct classification, hourly rates of wages paid (including rates of contributions or costs anticipated for bona fide fringe benefits or cash equivalents thereof of the types described in section 1 (b)(2)(B) of the Davis-Bacon Act), daily and weekly number of hours worked, deductions made and actual wages paid. Whenever the Secretary of Labor has found under 29 C.F.R. 5.5 (a)(1)(iv) that the wages of any laborer or mechanic include the amount of any costs reasonably anticipated in providing benefits under a plan or program described in section 1(b)(2)(B) of the Davis-Bacon Act, the Contractor shall maintain records which show that the commitment to provide such benefits is enforceable, that the plan or program is financially responsible, and that the plan or program has been communicated in writing to the laborers or mechanics affected, and records which show the cost anticipated or the actual cost incurred in providing such benefits. Contractors employing apprentices or trainees under approved programs shall maintain written evidence of the registration of apprenticeship programs and certification of trainee programs, the registration of the apprentices and trainees, and the ratios and wage rates prescribed in the applicable programs.

4 TITLE VI OF THE CIVIL RIGHTS ACT OF 1964 OBLIGATIONS

During the performance of this Contract, the Contractor, its assignees and successors in interest agrees as follows:

- A. The Contractor shall comply with all requirements of Title VI of the Civil Rights Act of 1964, as amended, 42 U.S.C. § 2000d; 49 U.S.C. § 5332; and Department of Transportation ("DOT") regulations, "Nondiscrimination in Federally-Assisted Programs of the Department of Transportation--Effectuation of Title VI of the Civil Rights Act", 49 C.F.R. Part 21, including any amendments and implementing requirements FTA may issue.
- B. The Contractor, with regard to the Work performed by it during the Contract, shall not discriminate on the grounds of race, color, creed, religion, sex, age, disability or national origin in the selection and retention of subcontractors, including procurement of materials and leases of equipment. The Contractor shall not participate either directly or indirectly in the discrimination prohibited by Section 21.5 of the Regulations, including employment practices when the Contract covers a program set forth in Appendix B of the Regulations.
- C. In all solicitations either by competitive bidding or negotiation made by the Contractor for services to be performed under a subcontract, including procurement of materials or leases of equipment, each potential subcontractor or supplier shall be notified by the Contractor of the Contractor's obligations under this Contract and the regulations relative to nondiscrimination on the grounds of race, color, religion, sex, age, national origin or disability.
- D. The Contractor shall provide all information and reports required by the regulations and directives issued pursuant thereto, and shall permit access to its books, records, accounts, other sources of information, and its facilities as may be determined by METRO or the Federal Transit Administration (FTA) to be pertinent to ascertain compliance with such regulations, orders and instructions. Where any information is required of a Contractor is in the exclusive possession of another who fails or refuses to furnish this information, the Contractor shall so certify to METRO, or FTA, as appropriate, and shall set forth what efforts it has made to obtain the information.
- E. In the event of the Contractor's noncompliance with the nondiscrimination provisions of this Article, METRO will impose such contract sanctions as it or FTA may determine to be appropriate, including, but not limited to:
1. withholding of payments to the Contractor under the Contract, in whole or in part.
 2. cancellation, termination or suspension of the Contract, in whole or in part.
- F. The Contractor shall include the provisions of paragraphs 1 through 7 of this Article in every subcontract, including procurement of materials and leases of equipment, unless exempt by the regulations, or directives issued pursuant thereto. The Contractor shall take such action with respect to any subcontract or procurement as METRO or FTA may direct as a means of enforcing such provisions including sanctions for noncompliance; provided, however, that, in the event a Contractor becomes involved in, or is threatened with, litigation with a subcontractor or supplier as a result of such direction, the Contractor may request METRO to enter into such litigation to protect the interests of METRO, and, in addition, the Contractor may request the United States to enter into such litigation to protect the interests of the United States.
- G. If at any time METRO has reason to believe that the Contractor is in violation of its obligations under these provisions, or has otherwise failed to comply with these provisions, METRO may, in addition to pursuing any other available legal remedy, commence proceedings to impose sanctions on the Contractor. Such sanctions may include, but not be limited to, one or more of the following:
1. The suspension of any payment or part thereof until such time that compliance is demonstrated;
 2. The termination or cancellation of the Contract in whole or in part unless compliance is demonstrated within a reasonable time; and
 3. The denial of the Contractor to participate in any future contracts awarded by METRO.

5 BUY AMERICA

- A. The Contractor agrees to comply with 49 USC 5323(j) and 49 CFR Part 661, which provide that federal funds may not be obligated unless steel, iron and manufactured products used in FTA-funded projects are produced in the United States, unless a waiver has been granted by FTA or the product is subject to a general waiver. General waivers are listed in 49 CFR 661.7. A general public interest waiver from the Buy America requirements applies to microprocessors, computers, microcomputers, software or other such devices, which are used solely for the purpose of processing or storing data. This general waiver does not extend to a product or device that merely contains a microprocessor or microcomputer and is not used solely for the purpose of processing or storing data.

- B. Separate requirements for rolling stock are set out at 49 USC 5323(j)(2)(C) and 49 CFR 661.11. Rolling stock must be manufactured in the United States and must have more than 70-percent domestic content and that final assembly must occur in the U.S.
- C. A Bidder or Proposer must submit to the Agency the appropriate Buy America Certification with all offers on FTA-funded contracts, except those subject to a general waiver. Proposals that are not accompanied by a properly completed Buy America certification are subject to the provisions of 49 CFR 661.13 and may be rejected as nonresponsive.

6 POST-DELIVERY AUDIT OF VEHICLES FOR SPECIFICATION AND BUY AMERICA COMPLIANCE

The Contractor agrees to comply with 49 USC § 5323(l) and FTA's implementing regulation at 49 CFR Part 663 and to submit the following certifications:

- A. The Contractor shall complete and submit a declaration certifying either compliance or noncompliance with Buy America. If the recommended Bidder/Proposer certifies compliance with Buy America, it shall furnish METRO at the time each vehicle is delivered, (1) a list of components and subcomponents used in the assembly and manufacturing of the vehicles; and (2) the location of the final assembly point for the rolling stock, including a description of the activities that will take place at the final assembly point and the cost of final assembly. The list of components and subcomponents that must be furnished is attached hereto as the Contract Exhibit "C", "LIST OF VEHICLE COMPONENTS AND SUBCOMPONENTS", and will be used by METRO's Auditor to perform FTA required post-delivery audit of vehicles for specification and Buy America compliance.
- B. The Contractor shall submit evidence that it will be capable of meeting the bid specifications.
- C. The Contractor shall submit (1) manufacturer's FMVSS self-certification, Federal Motor Vehicle Safety Standards, that the vehicle complies with relevant FMVSS or (2) manufacturer's certified statement that the contracted buses will not be subject to FMVSS regulations.
- D. Further to the above, the Contractor shall make available in its office, at all reasonable times, all records and documents pertaining to this Contract in sufficient detail to permit METRO's Auditor and Resident Inspector to perform a post-delivery audit of the vehicles, for compliance with the Contract specifications and Buy America requirements, pursuant to the Federal Transit Administration's Final Rule as published in the Federal Register.

7 FEDERAL MOTOR VEHICLE SAFETY STANDARDS

The Contractor shall furnish to the Contracting Officer, at time of delivery, a certification of compliance that each vehicle is in compliance with the Federal Motor Vehicle Safety Standards established by the Department of Transportation, which are in effect at time of vehicle manufacture.

8 MOTOR VEHICLE POLLUTION REQUIREMENTS

The Contractor shall provide a certification in writing that:

- A. The horsepower of the vehicle is adequate for the speed, range and terrain in which it will be required to operate and also to meet the demands of all auxiliary power equipment.
- B. All gases and vapors emanating from the crankcase of a start-ignition engine are controlled to minimize their escape into the atmosphere.

9 ACCESS TO RECORDS

- A. The Contractor agrees to maintain all books, records, accounts and reports required under this Contract for a period of not less than three years after the date of termination or expiration of this Contract, except in the event of litigation or settlement of claims arising from the performance of this Contract, in which case Contractor agrees to maintain same until METRO, the FTA Administrator, the Comptroller General or any of their duly authorized representatives have disposed of all such litigation, appeals, claims or exceptions related thereto. Reference 49 CFR 18.39(i)(11).
- B. In accordance with 49 CFR 18.36(i), the Contractor agrees to provide METRO, the FTA Administrator, the Comptroller General of the United States or any of their authorized representatives access to any books, documents, papers and records of the Contractor that are directly pertinent to this Contract for the purposes of making audits, examinations, excerpts and transcriptions. Contractor also agrees, pursuant to 49 CFR 633.17 to provide the FTA Administrator or his authorized representatives including any PMO Contractor access to Contractor's records and construction sites pertaining to a major capital project, defined at 49 USC 5302(a)1, which is receiving federal financial assistance through the programs described at 49 USC 5307, 5309 or 5311.

10 ACCESS REQUIREMENTS FOR INDIVIDUALS WITH DISABILITIES

The Contractor agrees to comply with, and assure that any subcontractor or any other third party contractor under this Contract complies with all applicable requirements regarding Access for Individuals with Disabilities contained in the Americans with Disabilities Act of 1990 (ADA), as amended, 42 U.S.C. § 12101 et seq.; section 504 of the Rehabilitation Act of 1973, as amended, 29 U.S.C. § 794; 49 U.S.C. § 5301(d); and any other applicable Federal regulations, including any amendments thereto.

11 ENVIRONMENTAL REQUIREMENTS

The Contractor and any subcontractor or third party contractor under this Contract shall comply with all applicable environmental requirements and regulations, including any amendments, as follows:

- A. Environmental Protection. The Contractor shall comply with all applicable requirements of the National Environmental Policy Act of 1969, as amended, 42 U.S.C. § 4321 et seq.
- B. Air Quality. The Contractor shall to comply with all applicable standards, orders or regulations issued pursuant to the Clean Air Act, as amended, 42 U.S.C. § 7401 et seq. The Contractor agrees to report each violation to METRO, to FTA and the appropriate EPA Regional Office. The Contractor shall include these requirements in each subcontract exceeding \$100,000 financed in whole or in part with Federal assistance provided by FTA.
- C. Clean Water. The Contractor shall comply with all applicable standards, orders or regulations issued pursuant to the Federal Water Pollution Control Act, as amended, 33 U.S.C. 1251 et seq. The Contractor agrees to report each violation to METRO, to FTA and the appropriate EPA Regional Office. The Contractor shall include these requirements in each subcontract exceeding \$100,000 financed in whole or in part with Federal assistance provided by FTA.
- D. Use of Public Lands. The Contractor shall ensure that no publicly owned land from a park, recreation area, or wildlife or waterfowl refuge of national, state, or local significance as determined by the Federal, state, or local officials having jurisdiction thereof, or any land from a historic site of national, state, or local significance may be used under this Contract unless the FTA makes the specific findings required by 49 U.S.C. § 303.
- E. Historic Preservation. The Contractor shall assist the Federal Government in complying with section 106 of the National Historic Preservation Act, 16 U.S.C. § 470f, involving historic and archaeological preservation.
- F. Mitigation of Adverse Environmental Effects. The Contractor shall take all reasonable steps to minimize adverse environmental effects in accordance with 49 U.S.C. § 5324(b), and all other applicable Federal laws and regulations, specifically the procedures of 23 C.F.R. Part 771 and 49 C.F.R. Part 622.
- G. Energy Conservation. The Contractor shall comply with the mandatory energy efficiency standards and policies within the applicable state energy conservation plans issued in compliance with the Energy Policy and Conservation Act, 42 U.S.C. § 6321 et seq.

12 RECYCLED PRODUCTS

The Contractor agrees to comply with all the requirements of Section 6002 of the Resource Conservation and Recovery Act (RCRA), as amended (42 U.S.C. 6962), including but not limited to the regulatory provisions of 40 CFR Part 247, and Executive Order 12873, as they apply to the procurement of the items designated in Subpart B of 40 CFR Part 247.

13 FLY AMERICA

The Contractor agrees to comply with 49 U.S.C. 40118 (the "Fly America" Act) in accordance with the General Services Administration's regulations at 41 CFR Part 301-10, which provide that recipients and subrecipients of Federal funds and their contractors are required to use U.S. Flag air carriers for U.S. Government-financed international air travel and transportation of their personal effects or property, to the extent such service is available, unless travel by foreign air carrier is a matter of necessity, as defined by the Fly America Act. The Contractor shall submit, if a foreign air carrier was used, an appropriate certification or memorandum adequately explaining why service by a U.S. flag air carrier was not available or why it was necessary to use a foreign air carrier and shall, in any event, provide a certificate of compliance with the Fly America requirements. The Contractor agrees to include the requirements of this section all subcontracts that may involve international air transportation.

14 CARGO PREFERENCE--USE OF UNITED STATES-FLAG VESSELS

The Contractor agrees:

- A. to use privately owned United States-flag commercial vessels to ship at least fifty percent (50%) of the gross tonnage (computed separately for dry bulk carriers, dry cargo liner and tankers) involved, whenever shipping any equipment, materials, or commodities pursuant to the Contract to the extent such vessels are available at fair and reasonable rates of United States-flag commercial vessels;

- B. to furnish within twenty (20) days following the date of loading for shipment originating within the United States or within thirty (30) days following the date of loading, for shipment originating outside the United States, a legible copy of a rated, "on-board" commercial ocean bill-of-lading in English for each shipment of cargo described in Paragraph (1) above to the Division of National Cargo, Office of Market Development, Maritime Administration, Washington, D.C. 20590, and to METRO (through the Contractor in the case of a subcontractor's bill-of-lading); and
- C. to include these requirements in all subcontracts issued pursuant to this Contract when the subcontract may involve the transport of equipment, material or commodities by ocean vessel.

15 RESTRICTIONS ON LOBBYING

Contractors who apply or bid for an award of \$100,000 or more shall file the certification required by 49CFR part 20, "New Restrictions on Lobbying." Each tier certifies to the tier above that it will not and has not used Federal appropriated funds to pay any person or organization for influencing or attempting to influence an officer or employee of any agency, a member of Congress, officer or employee of Congress, or an employee of a member of Congress in connection with obtaining any Federal contract, grant or any other award covered by 31 U.S.C. 1352. Each tier shall also disclose the name of any registrant under the Lobbying Disclosure Act of 1995 who has made lobbying contracts on its behalf with non-Federal funds with respect to that Federal contract, grant or award covered by 31 U.S.C. 1352. Such disclosures are forwarded from tier-to-tier, up to the recipient. See form in Section II, entitled "Certification of Restrictions on Lobbying".

16 DEBARMENT AND SUSPENSION

- A. The Contractor, including any of its officers or holders of a controlling interest, is obligated to inform METRO whether or not it is or has been on any debarred bidders' list maintained by the United States Government. Should the Contractor be included on such a list during performance of this Contract, it shall so inform METRO.
- B. The Contractor and any subcontractor under this Contract shall comply with the certification process under 49 C.F.R. Part 29, "Government Wide Debarment and Suspension (Non-Procurement)", whereby, unless otherwise permitted by law, any person, corporation, partnership or legal entity that is debarred, suspended, or voluntarily excluded by the Federal Government from obtaining federal assistance funds through grants, cooperative agreements or third party contracts may not participate in a federally assisted project.

17 NO OBLIGATION BY THE FEDERAL GOVERNMENT

- A. METRO and the Contractor acknowledge and agree that, notwithstanding any concurrence by the Federal government in or approval of the solicitation or award of the underlying contract, absent the express written consent by the Federal Government, the Federal Government is not a party to this Contract and shall not be subject to any obligations or liabilities to METRO, Contractor, or any other party (whether or not a party to that contract) pertaining to any matter resulting from the underlying contract.
- B. The Contractor agrees to include the above clause in each subcontract financed in whole or in part with Federal assistance provided by FTA. It is further agreed that the clause shall not be modified, except to identify the subcontractor who will be subject to its provisions.

18 INCORPORATION OF FEDERAL TRANSIT ADMINISTRATION (FTA) TERMS

The preceding provisions include, in part, certain Standard Terms and Conditions required by the Department of Transportation (DOT), whether or not expressly set forth in the contract provisions. All contractual provisions required by DOT, as set forth in FTA Circular 4220.1F, or its successors, are hereby incorporated by reference. Anything to the contrary herein notwithstanding, all FTA mandated terms shall be deemed to control in the event of a conflict with other provisions contained in the Agreement. The Contractor shall not perform any act, fail to perform any act, or refuse to comply with any METRO requests, which would cause METRO to be in violation of the FTA terms and conditions.

19 FRAUD AND FALSE OR FRAUDULENT STATEMENTS AND RELATED ACTS

- A. The Contractor acknowledges that the provisions of the Program Fraud Civil Remedies Act of 1986, as amended, 31 U. S. C. § 3801 et seq. And U. S. DOT regulations, "Program Fraud Civil Remedies," 49 C. F. R. Part 31, apply to its actions pertaining to this Project. Upon execution of the underlying contract, the Contractor certifies or affirms the truthfulness and accuracy of any statement it has made, it makes, it may make, or causes to be made, pertaining to the underlying contract or the FTA assisted project for which the Contract Work is being performed. In addition to other penalties that may be applicable, the Contractor further acknowledges that if it makes or causes to be made, a false, fictitious, or fraudulent claim, statement, submission, or certification, the Federal Government reserves the right to impose the penalties of the Program Fraud Civil Remedies Act of 1986 on the Contractor to the extent the Federal Government deems appropriate.
- B. The Contractor also acknowledges that if it makes, or causes to be made, a false, fictitious, or fraudulent claim, statement,

submission, or certification to the Federal Government under a contract connected with a project that is financed in whole or in part with Federal assistance originally awarded by FTA under the authority of 49 U. S. C. § 5307, the Government reserves the right to impose the penalties of 18 U. S. C. § 1001 and 49 U. S. C. § 5307 (n) (1) on the Contractor, to the extent the Federal Government deems appropriate.

- C. The Contractor agrees to include the above two (2) clauses in each subcontract financed in whole or in part with Federal assistance provided by FTA. It is further agreed that the clauses shall not be modified, except to identify the subcontractor who will be subject to the provisions.

20 MAINTENANCE OF RECORDS; ACCESS BY METRO; RIGHT TO AUDIT RECORDS

- A. In accordance with 49 CFR § 18.36(i), 49 CFR § 19.48(d), and 49 USC § 5325(a), provided METRO is the FTA recipient or a sub-grantee of the FTA recipient, the Contractor agrees to provide METRO, FTA, the Comptroller General of the United States, the Secretary of the U.S. Department of Transportation, the State of Texas or any of their duly authorized representatives access to any books, documents, papers and records of the Contractor that are directly pertinent to or relate to this Contract (1) for the purpose of making audits, examinations, excerpts and transcriptions and (2) when conducting an audit and inspection.

1. In the event of a sole source Contract, single Proposal, single responsive Proposal, or competitive negotiated procurement, the Contractor shall maintain and the Contracting Officer, the U.S. Department of Transportation (if applicable) or the representatives thereof shall have the right to examine all books, records, documents and other cost and pricing data related to the Contract price, unless such pricing is based on adequate price competition, established catalog or market prices of commercial items sold in substantial quantities to the public, or prices set by law or regulation, or combinations thereof. Data related to the negotiation or performance of the Contract shall be made available for the purpose of evaluating the accuracy, completeness and currency of the cost or pricing data. The right of examination shall extend to all documents necessary for adequate evaluation of the cost or pricing data, along with the computations and projections used therein, including review of accounting principles and practices that reflect properly all direct and indirect costs anticipated for the performance of the Contract.
2. For Contract modifications or change orders the Contracting Officer, the U.S. Department of Transportation, if applicable, or their representatives shall have the right to examine all books, records, documents and other cost and pricing data related to a Contract modification, unless such pricing is based on adequate price competition, established catalog or market prices of commercial items sold in substantial quantities to the public, or prices set by law or regulation, or combinations thereof. Data related to the negotiation or performance of the Contract modification or change order shall be made available for the purpose of evaluating the accuracy, completeness and currency of the cost or pricing data. The right of examination shall extend to all documents necessary for adequate evaluation of the cost or pricing data, along with the computations and projections used therein, either before or after execution of the Contract modification or change order for the purpose of conducting a cost analysis. If an examination made after execution of the Contract modification or change order reveals inaccurate, incomplete or out-of-date data, the Contracting Officer may renegotiate the Contract modification or change order price adjustment, and METRO shall be entitled to any reductions in the price that would result from the application of accurate, complete or up-to-date data. Lines 2 to end of paragraph are off by one space on the left margin.
3. The requirements of this section are in addition to other audit, inspection and record-keeping provisions specified elsewhere in the Contract documents.

21 VETERANS EMPLOYMENT

Recipients and subrecipients of Federal financial assistance under this chapter shall ensure that contractors working on a capital project funded using such assistance give a hiring preference, to the extent practicable, to veterans (as defined in section 2108 of title 5) who have the requisite skills and abilities to perform the work required under the contract. This subsection shall not be understood, construed or enforced in any manner that would require an employer to give preference to any veteran over any equally qualified applicant who is a member of any racial or ethnic minority, female, an individual with a disability, or former employee.

22 ENTIRE AGREEMENT

This Contract along with the attached exhibits constitutes the entire agreement between the parties and shall supersede all prior offers, negotiations, exceptions and understandings, whether oral or written, between the parties hereto. No modification of this Contract (including any change in the work) shall be binding upon METRO or the Contractor unless evidenced by a written modification issued pursuant to the "Changes Provision" or by other written order modification hereof, as appropriate.

SECTION XII - EXHIBITS

1 EXHIBIT "A" MAIN BUS TECHNICAL SPECIFICATIONS AND DRAWINGS

Table of Contents

Table of Contents..... 58

1.0 GENERAL..... 64

1.1 Scope..... 64

1.2 Definitions..... 64

1.2.1 Alternative 64

1.2.2 Ambient Temperature 64

1.2.3 Analog Signals 64

1.2.4 Audible Discrete Frequency 64

1.2.5 Battery Compartment..... 65

1.2.7 Burst Pressure 65

1.2.8 Classes of Failures..... 65

1.2.9 Capacity (fuel container) 65

1.2.10 Cells 65

1.2.11 Code..... 66

1.2.12 Curb Weight..... 66

1.2.13 dBA 66

1.2.14 Default Configuration Coach 66

1.2.15 Destroyed..... 66

1.2.16 Discrete Signal..... 66

1.2.17 DEF..... 66

1.2.19 Operator's Eye Range..... 66

1.2.20 Fireproof..... 67

1.2.21 Fire Resistant..... 67

1.2.22 Free Floor Space 67

1.2.23 Fusible Material..... 67

1.2.24 GAWR (Gross Axle Weight Rated) 67

1.2.25 Gross Load..... 67

1.2.26 GVW (Gross Vehicle Weight)..... 67

1.2.27 GVWR (Gross Vehicle Weight Rated)..... 68

1.2.28 Hose..... 68

1.2.29 Human Dimensions..... 68

1.2.30 Inverter..... 68

1.2.31 Labeled 68

1.2.32 Leakage 68

1.2.33 Line 68

1.2.34 Local Regulations..... 68

1.2.35 LED..... 69

1.2.36 Maintenance Personnel Skill Levels..... 69

1.2.37 Metallic Hose..... 69

1.2.38 Module 69

1.2.39	Motor (Electric)	69
1.2.40	Operating Pressure	69
1.2.41	Physical Layer	69
1.2.42	Power	70
1.2.43	Power Density	70
1.2.44	Real-Time Clock (RTC)	70
1.2.45	Rupture	70
1.2.46	Seated Load	70
1.2.47	SLW (Seated Load Weight)	70
1.2.48	Serial Data Signals	70
1.2.49	Working Pressure	71
1.2.50	Solid State Alternator	71
1.2.51	Special Tools	71
1.2.52	Specification	71
1.2.53	Standard	71
1.2.54	Standee Line	71
1.2.55	Stress Loops	71
1.2.56	Structure	71
1.2.57	Wheelchair	72
1.2.58	Seated Load	72
1.2.59	SLW (Seated Load Weight)	72
1.2.60	Standard Configuration Coach	72
1.2.61	Standards	72
1.2.62	Standee Line	72
1.2.63	Waterproof	73
1.3	Abbreviations	73
1.3.1	ANSI	73
1.3.2	ASHRAE	73
1.3.3	ASTM	73
1.3.4	AWS	73
1.3.5	BMCS	73
1.3.6	FMVSS	73
1.3.7	JIC	73
1.3.8	MERV	74
1.3.9	SAE	74
1.3.10	SPI	74
1.3.11	UDDS	74
1.3.12	USDHEW	74
1.4	Technical Compartment Information	74
1.4.1	Referenced Publications	75
1.5	Overall Requirements	75
1.5.1	Dimensions	75
1.5.2	Weight	77
1.5.4	Service Life and Maintenance	77
2.0	BODY	79
2.1	General	79
2.1.1	Design	79

<u>2.1.2</u>	<u>Structure</u>	84
<u>2.1.3</u>	<u>Exterior and Applied Panels</u>	90
<u>2.1.4</u>	<u>Interior</u>	91
<u>2.1.5</u>	<u>Floor</u>	98
<u>2.1.6</u>	<u>Kneeling</u>	100
<u>2.1.7</u>	<u>Wheel Housing</u>	100
<u>2.1.8</u>	<u>Passenger Door</u>	101
<u>2.1.9</u>	<u>Service Compartments and Access Doors</u>	102
<u>2.1.10</u>	<u>Steps and Stepwell</u>	105
<u>2.1.11</u>	<u>Bike Rack</u>	106
2.2	<u>Operating Components</u>	106
<u>2.2.1</u>	<u>Door</u>	106
<u>2.2.2</u>	<u>Windshield Wipers and Washers</u>	109
<u>2.2.3</u>	<u>Lighting, Controls, Instruments</u>	110
2.3	<u>Interior Trim</u>	119
<u>2.3.1</u>	<u>General Requirements</u>	119
<u>2.3.2</u>	<u>Passenger Seats</u>	121
<u>2.3.3</u>	<u>Operator's Seat</u>	124
<u>2.3.4</u>	<u>Floor Covering</u>	125
2.4	<u>Windows</u>	126
<u>2.4.1</u>	<u>Operator's Windows</u>	126
<u>2.4.2</u>	<u>Side Windows</u>	127
2.5	<u>Insulation</u>	128
<u>2.5.1</u>	<u>Material</u>	128
<u>2.5.2</u>	<u>Performance</u>	129
2.6	<u>Ancillary Features</u>	130
<u>2.6.1</u>	<u>Operator's Area</u>	130
<u>2.6.2</u>	<u>Mirrors</u>	131
<u>2.6.3</u>	<u>Passenger Assists</u>	132
<u>2.6.4</u>	<u>Exterior Route Information Displays</u>	134
<u>2.6.5</u>	<u>Fare Collection</u>	141
<u>2.6.6</u>	<u>Next Stop Sign</u>	142
2.7	<u>Accessibility Equipment</u>	142
<u>2.7.1</u>	<u>Wheelchair Lift</u>	144
<u>2.7.2</u>	<u>Lift Door</u>	147
<u>2.7.3</u>	<u>Lift Installation</u>	147
<u>2.7.4</u>	<u>Wheelchair Securement</u>	148
<u>2.7.5</u>	<u>Passenger Amenities</u>	149
3.0	<u>CHASSIS</u>	150
3.1	<u>Propulsion System</u>	150
<u>3.1.1</u>	<u>Vehicle Performance</u>	150
<u>3.1.2</u>	<u>Power Plant Mounting and Accessories</u>	152
3.2	<u>Final Drive</u>	164
<u>3.2.1</u>	<u>General Requirements</u>	165
3.3	<u>Suspension</u>	166

3.3.1	General Requirements	166
3.3.2	Spring and Shock Absorbers	167
3.4	Steering	168
3.4.1	Strength	168
3.4.2	Turning Radius	168
Turning Radius		168
3.4.3	Turning Effort	168
3.5	Brakes	170
3.5.1	Service Brake	170
3.6	General Chassis	175
3.6.1	Wheels and Tires	175
3.6.2	Fuel System	175
3.6.3	Bumper System	177
3.6.4	Electrical System	178
3.6.5	Electrical Components	183
3.7	Interior Climate Control	187
3.7.1	Heating and Ventilation System	187
3.7.2	Operator's Heater and Windshield Defroster	188
3.7.3	Air Conditioning System	188
3.7.4	Air Flow	193
3.7.5	Air Intakes	194
3.7.6	Heater Cores	194
3.8	Electronic Communication Equipment	195
3.8.1	Provide and Install	195
3.8.2	Radio Compartment	213
3.9	Fire Suppression System	213
3.9.1	Fire Suppression	213
3.9.2	Fire Detection	214
3.9.3	Tests	214
3.9.4	Design	214
3.9.5	Requirements	214
3.9.6	Requirements of Fire Suppression System (FSS)	215
3.9.7	Fire Suppression Components	216
3.9.8	Tools	218
3.10	System Certifications	218
4.0	WARRANTY AND SPARE PARTS BASIC PROVISION	219
4.1	Warranty Requirements	219
4.1.2	Complete Coach	220
4.1.3	Subsystem and Components	220
4.1.4	Voiding of Warranty	222
4.1.5	Exceptions to Warranty	223
4.1.6	Detection of Defects	223
4.1.7	Fleet Defects	224
4.1.8	Correction of Fleet Defects	224
4.1.9	Voiding of Warranty Provisions	224

4.1.10	<u>Exceptions to Warranty Provisions</u>	225
4.1.11	<u>Contractor’s Representative</u>	225
4.1.12	<u>Repair Procedures</u>	226
4.1.13	<u>Repairs by Contractor</u>	226
4.1.14	<u>Repairs by METRO</u>	227
4.2	<u>Warranty After Replacement or Repairs</u>	229
4.2.1	<u>Failure Analysis</u>	230
4.2.2	<u>Data Processing</u>	230
4.3	<u>Illustrated Parts Catalog Master File</u>	234
4.4	<u>Publications Software</u>	236
4.5	<u>Parts Information</u>	236
4.6	<u>Recommended Spare Parts</u>	237
4.7	<u>Contractor’s Recommendations/Prices</u>	238
4.8	<u>Availability</u>	238
5.0	<u>TRAINING SPECIFICATIONS</u>	239
5.1	<u>Introduction-Training</u>	239
5.2	<u>Maintenance Training</u>	240
5.2.1	<u>Maintenance Training Program Content</u>	241
5.3	<u>Transportation Training</u>	247
5.4	<u>Training Program Aids</u>	248
5.5	<u>Training Facilities</u>	249
5.6	<u>Training Instructors</u>	249
5.7	<u>Supervisor Training</u>	250
5.8	<u>Time Limits</u>	250
5.9	<u>Training Hours Summary</u>	250
6.0	<u>CONTRACTOR'S IN-PLANT QUALITY ASSURANCE</u>	251
6.1	<u>Quality Assurance Organization</u>	251
6.1.1	<u>Control</u>	251
6.1.2	<u>Authority and Responsibility</u>	252
6.2	<u>Quality Assurance Organization Functions</u>	252
6.2.1	<u>Verify Instructions</u>	252
6.2.2	<u>Records Maintenance</u>	252
6.2.3	<u>Corrective Actions</u>	252
6.2.4	<u>Configuration Control</u>	253
6.2.5	<u>Measuring and Testing Facilities</u>	253
6.2.6	<u>Production Tooling as Media of Inspection</u>	253
6.2.7	<u>Equipment Used by Resident Inspectors</u>	253
6.3	<u>Control Of Purchases</u>	254
6.4	<u>Supplier Control</u>	254

<u>6.5</u>	<u>Purchasing Data</u>	254
<u>6.6</u>	<u>Manufacturing Control</u>	254
6.6.1	<u>Completed Items</u>	254
6.6.2	<u>Nonconforming Materials</u>	255
6.6.3	<u>Statistical Techniques</u>	255
6.6.4	<u>Inspection Status</u>	255
<u>6.7</u>	<u>Inspection System</u>	255
6.7.1	<u>Inspection Stations</u>	255
6.7.2	<u>Inspection Personnel</u>	256
6.7.3	<u>Inspection Records</u>	256
6.7.4	<u>Quality Assurance Audits</u>	256
<u>6.8</u>	<u>Resident Inspector</u>	257
<u>6.9</u>	<u>Acceptance Tests</u>	258
6.9.1	<u>Responsibility</u>	258
6.9.2	<u>Pre-Delivery</u>	258
<u>6.10</u>	<u>Chassis Inspection</u>	259
6.10.1	<u>Inspection -- Visual and Measured</u>	259
6.10.2	<u>Total Bus Operation</u>	259
<u>6.11</u>	<u>Post Delivery Tests</u>	259
<u>7.0</u>	<u>MANUALS AND PARTS LISTS</u>	260
<u>7.1</u>	<u>Requirements</u>	260
<u>7.2</u>	<u>Standards And Format Of Manuals</u>	261
<u>7.3</u>	<u>Maintenance Manuals</u>	262
<u>7.4</u>	<u>Operator's Manuals</u>	263
<u>7.5</u>	<u>Parts Manuals</u>	263
<u>7.6</u>	<u>Parts Cross Reference List</u>	263
<u>7.7</u>	<u>Spare Parts</u>	264
<u>7.8</u>	<u>Revisions</u>	265
<u>8.0</u>	<u>ALTOONA BUS TESTING</u>	266
<u>8.1</u>	<u>Bus Testing</u>	266
<u>8.2</u>	<u>Test Standard</u>	266
8.2.1	<u>Replacement Of Selected Subsystems</u>	267
8.2.2	<u>Performance - Top Speed Test</u>	267
8.2.3	<u>Structural Integrity-Strength and Distortion Tests</u>	267
8.2.4	<u>Interior Noise</u>	270
<u>Appendix 1</u>		272
<u>Deliverables</u>		272
<u>Appendix 2</u>		281
<u>Items Requiring METRO Approval During Preproduction Conference</u>		281

SPECIFICATION FOR HEAVY DUTY 45-FOOT CLEAN DIESEL COMMUTER BUSES

1.0 GENERAL

1) 1.1 Scope

These technical specifications define requirements for heavy-duty 45 foot Clean Diesel Commuter Buses that shall be used in local transit service in Houston, Texas. Buses shall have a minimum expected life of twelve (12) years or 500,000 miles, whichever comes first, and are intended for the widest possible spectrum of passengers, including children, adults, the elderly and people with disabilities.

2) 1.2 Definitions

Following are definitions of special terms used in the technical specifications:

1.2.1 Alternative

An alternative specification condition to the default bus configuration. METRO may define alternatives to the default configuration to satisfy local operating requirements. Alternatives for the default configuration will be clearly identified.

1.2.2 Ambient Temperature

The temperature of the surrounding air: For testing purposes, ambient temperature must be between 16 °C (50 °F) and 46 °C (115 °F).

1.2.3 Analog Signals

A continuously variable signal that is solely dependent upon magnitude to express information content.

NOTE: Analog signals are used to represent the state of variable devices such as rheostats, potentiometers, temperature probes, etc.

1.2.4 Audible Discrete Frequency

An audible discrete frequency is determined to exist if the sound power level in any 1/3-octave band exceeds the average of the sound power levels of the two adjacent 1/3-octave bands by 4 decibels (dBA) or more.

1.2.5 Battery Compartment

Low-voltage energy storage, i.e. 12/24 VDC batteries.

1.2.7 Burst Pressure

The highest pressure reached in a container during a burst test.

1.2.8 Classes of Failures

Classes of failures are:

- o Class 1: Physical Safety. A failure that could lead directly to passenger or Operator injury and represents a severe crash situation.
- o Class 2: Road Call. A failure resulting in an en route mechanical interruption of revenue service excluding tires, fare boxes, unsanitary buses, etc., where service is discontinued until the bus is replaced or repaired at the point of failure.
- o Class 3: Bus Change. A failure that requires removal of a bus from service during its assignments. The bus is operable to a rendezvous point with a replacement bus.
- o Class 4: Defect. A failure that does not require removal of the bus from service during its assignments but does degrade bus operation. The failure can be reported by the Operator, Inspector, or Service Attendant.

1.2.9 Capacity (fuel container)

The water volume of a container in gallons (liters).

1.2.10 Cells

Individual components (i.e., battery cells).

1.2.11 Code

A legal requirement.

1.2.12 Curb Weight

Weight of vehicle, including maximum fuel, oil and coolant; and all equipment required for operation and required by this Specification, but without passengers or Operator.

1.2.13 dBA

Decibels with reference to 0.0002 microbar as measured on the "A" scale.

1.2.14 Default Configuration Coach

The coach described if no alternatives are selected. Signing, colors, the destination sign reading list and other information must be provided by METRO.

1.2.15 Destroyed

Physically made permanently unusable.

1.2.16 Discrete Signal

A signal that can take only pre-defined values, usually of a binary 0 or 1 nature where 0 is battery ground potential and 1 is a defined battery positive potential.

1.2.17 DEF

Diesel Exhaust Fluid

1.2.19 Operator's Eye Range

The 95% cutoff eyelipse defined in SAE Recommended Practice J941, except that the height of the eyelipse shall be determined from the seat at its reference height, or H point.

1.2.20 Fireproof

Materials that will not burn or melt at temperatures less than 2,000°F.

1.2.21 Fire Resistant

Materials that have a flame spread index less than 150 as measured in a radiant panel flame test per ASTM-E 162-90.

1.2.22 Free Floor Space

Floor area available to standees, excluding the area under seats, area occupied by feet of seated passengers, the vestibule area forward of the standee line, and any floor space indicated by manufacturer as non-standee areas such as, the floor space "swept" by passenger doors during operation. Floor area of 1.75 sq ft shall be allocated for the feet of each seated passenger that protrudes into the standee area.

1.2.23 Fusible Material

A metal, alloy or other material capable of being melted by heat.

1.2.24 GAWR (Gross Axle Weight Rated)

The maximum total weight as determined by the axle manufacturer, at which the axle can be safely and reliably operated for its intended purpose.

1.2.25 Gross Load

175 lbs for every designed passenger seating position, for the Operator, and for each 1.75 square feet of free floor space.

1.2.26 GVW (Gross Vehicle Weight)

Curb weight plus gross load.

1.2.27 GVWR (Gross Vehicle Weight Rated)

The maximum total weight as determined by the vehicle manufacturer, at which the vehicle can be safely and reliably operated for its intended purpose.

1.2.28 Hose

Flexible line.

1.2.29 Human Dimensions

The human dimensions used in these Technical Specifications are defined in SAE Recommended Practice J833.

1.2.30 Inverter

A module that converts DC to AC.

1.2.31 Labeled

Equipment or materials to which has been attached a label, symbol or other identifying mark of an organization, which is acceptable to the authority having jurisdiction and concerned with product evaluation, which maintains periodic inspection of production labeled equipment or materials, and by whose labeling the manufacturer indicates compliance with appropriate standards or performance in a specified manner.

1.2.32 Leakage

Release of contents through a defect or crack. See Rupture.

1.2.33 Line

All tubes, flexible and hard, that carry fluids.

1.2.34 Local Regulations

Regulations below the state level.

1.2.35 LED

Light Emitting Diode

1.2.36 Maintenance Personnel Skill Levels

Defined below are maintenance personnel skill levels used in the Technical Specifications:

1. 4M: Journeyman or Class A Mechanic
2. 3M: Service Mechanic or Class B Serviceman
3. 2M: Mechanic Helper or Bus Serviceman
4. 1M: Cleaner, Fueller, Oiler, Hostler, or Shifter

In attachments to the Technical Specifications, Metro may relate the skill levels and ratings of mechanics in its operation to the above definitions.

1.2.37 Metallic Hose

A hose whose strength depends primarily on the strength of its metallic parts; it can have metallic liners or covers, or both.

1.2.38 Module

Assembly of individual components.

1.2.39 Motor (Electric)

A device that converts electrical energy into mechanical energy.

1.2.40 Operating Pressure

The varying pressure developed in a container during service.

1.2.41 Physical Layer

The first layer of the seven-layer International Standards Organization (ISO) Open Systems Interconnect (OSI) reference model. This provides the mechanical, electrical, functional and procedural characteristics required to gain access to the transmission medium (e.g., cable) and is responsible for transporting binary information between computerized systems.

1.2.42 Power

Work or energy divided by time.

1.2.43 Power Density

Power divided by mass, volume or area.

1.2.44 Real-Time Clock (RTC)

Computer clock that keeps track of the current time.

1.2.45 Rupture

Sudden and unstable damage propagation in the structural components of the container resulting in a loss of contents. See Leakage.

1.2.46 Seated Load

175 lbs for every designed passenger seating position and for the Operator.

1.2.47 SLW (Seated Load Weight)

Curb weight and seated load.

1.2.48 Serial Data Signals

A current loop based representation of ASCII or alphanumeric data used for transferring information between devices by transmitting a sequence of individual bits in a prearranged order of significance.

NOTE: An example is the communication that takes place between two or more electronic components with the ability to process and store information.

1.2.49 Working Pressure

It is the pressure for which the equipment has been constructed, under normal conditions. Also referred to as the nominal service pressure.

1.2.50 Solid State Alternator

A module that converts high-voltage DC to low-voltage DC (typically 12/24 volt systems).

1.2.51 Special Tools

Tools not normally stocked by METRO.

1.2.52 Specification

A particular or detailed statement, account, or listing of the various elements, materials, dimensions, etc. involved in the manufacturing and construction of a product.

1.2.53 Standard

A firm guideline from a consensus group.

1.2.54 Standee Line

A line marked across the bus aisle to designate the forward area that passengers may not occupy when the bus is moving.

1.2.55 Stress Loops

The “pig-tails” commonly used to absorb flexing in piping.

1.2.56 Structure

The structure shall be defined as the basic body, including floor deck material and installation, load bearing external panels, structural components, axle mounting provisions and suspension beams and attachment points.

1.2.57 Wheelchair

A mobility aid belonging to any class of three- or four-wheeled devices, usable indoors, designed or used by individuals with mobility impairments, whether operated manually or powered. A common wheelchair” is such a device that does not exceed 30 in. in width and 48 in. in length measured 2 in. above the ground, and does not weigh more than 600 lbs when occupied.

1.2.58 Seated Load

One hundred seventy-five (175) pounds for every designed passenger seating position and for the driver.

1.2.59 SLW (Seated Load Weight)

Curb weight and seated load.

1.2.60 Standard Configuration Coach

The bus described by the Technical Specifications. Signing, colors, the destination sign reading list and other information will be provided by METRO.

1.2.61 Standards

Standards referenced in these Technical Specifications are the latest revisions unless otherwise stated.

1.2.62 Standee Line

A two (2) inch line marked in a contrasting color across the bus aisle in line with the driver's barrier to designate the forward area which passengers may not occupy when the bus is moving.

1.2.63 Waterproof

Sealed to prevent moisture damage, impervious to water when submersed.

3) 1.3 Abbreviations

The following is a list of abbreviations used in the Technical Specifications

1.3.1 ANSI

American National Standards Institute

1.3.2 ASHRAE

American Society of Heating, Refrigerating, and Air Conditioning Engineers

1.3.3 ASTM

American Society for Testing and Materials

1.3.4 AWS

American Welding Society

1.3.5 BMCS

Bureau of Motor Carrier Safety

1.3.6 FMVSS

Federal Motor Vehicle Safety Standards

1.3.7 JIC

Joint Industrial Council

1.3.8 MERV
Minimum Efficiency Rating Value

1.3.9 SAE
Society of Automotive Engineers

1.3.10 SPI
Society of the Plastics Industry

1.3.11 UDDS
Urban Dynamometer Driving Schedule

1.3.12 USDHEW
United States Department of Health, Education and Welfare

4) 1.4 Technical Compartment Information

The Contractor shall provide all requested technical information in the English language. The Contractor shall provide a complete preventive maintenance inspection (PMI) format to emulate METRO's PMI format prior to start of the pilot bus. The Contractor shall provide inspection forms on the chassis, power train and air conditioning systems using a 6,000 through 96,000-mile interval. It is METRO's intention to utilize the SAE J1939 or SAE J2496 specification and its Transit Extension to provide for serial data communications and controls between the drive train elements of the vehicle, and separately, the non-drive train elements installed on the vehicle (fare collection, passenger counting, etc.). Wherever there are opportunities to utilize this advanced technology on the vehicle, beyond those

referenced in the text, METRO desires to exercise those opportunities on the vehicle. Refer to SAE J1939 or SAE J2496 for the standards.

1.4.1 Referenced Publications

The documents or portions thereof referenced within this specification shall be considered part of the requirements of the specification. The edition indicated for each referenced document is the current edition, as of the date of the issuance of this specification.

5) 1.5 Overall Requirements

The Contractor shall ensure that the application and installation of major bus subcomponents and systems are compliant with all such subcomponent vendors' requirements and recommendations. Contractor and METRO shall identify subcomponent vendors that shall submit installation/application approval documents with the completion of the pilot bus. Components used in the vehicle shall be of heavy-duty design and proven in transit service.

1.5.1 Dimensions

Physical Size - with the exceptions of exterior mirrors, marker and signal lights, flexible portions of the bumpers, fender skirts and rub rail, the bus shall have the following overall dimensions as Figure 1 bellow.

1.5.1.1 Physical Size

- Length: 45 feet Maximum
- Width: 102 inches, excluding mirrors
- Height: 137 inches, Maximum
- First Step Height: Height of the step above the street shall be no more than 15 +/- 0.5 in. measured at the centerline of the doorway.

FIGURE 1
Commuter Bus Exterior Dimensions

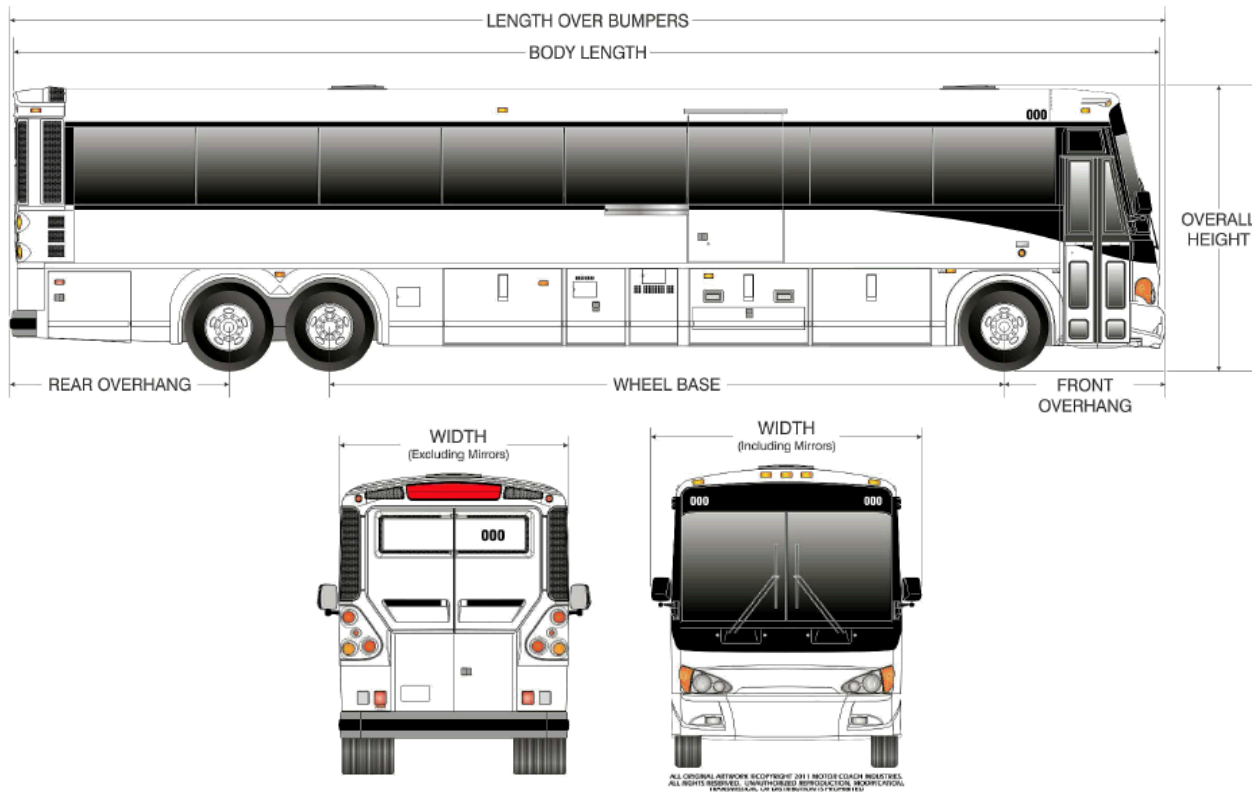

1.5.1.2 Underbody Clearance

The bus shall maintain the minimum clearance dimensions as shown in the minimum road clearance drawing as Figure 2 and defined in SAE Standard J689, regardless of load, up to the gross vehicle weight rating.

- Ramp Clearances: Approach angle shall be no less than 8°. Break over angle shall be no less than 7°. Departure angle shall be no less than 6°.
- Ground Clearance: Ground clearance shall be no less than 10 inches (9 inches at jack pad) except within the axle zone and wheel area.
- Axle Clearance: Axle zone clearance, which is the projected area between tires and wheels on the same axial centerline, shall be no less than 6.5 inches.

FIGURE 2

Commuter Bus Minimum Road Clearance

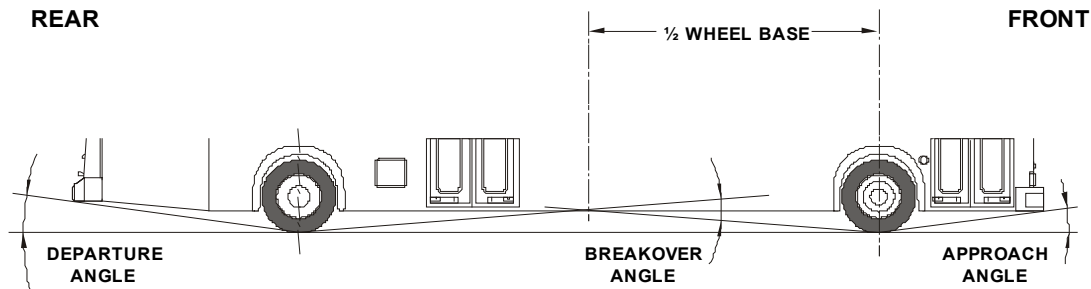
**1.5.2 Weight****1.5.2.1 Curb Weight**

Curb weight and GVWR shall be submitted as a Mandatory Request For Approval (see Section II of the Solicitation, Item 1).

1.5.3 Capacity

Rated capacity of the standard configuration bus shall be no less than fifty-five (55) seated passengers plus the operator with the standard seating arrangement.

SLW and GVWR shall be determined by the seating and standee capacities of the actual arrangement specified.

Complete, scaled, interior layout drawings showing seat positions, hip-to-knee room, foot room, seat height and width dimensions, aisle widths, passenger assists, floor contour, fare box location and all other pertinent interior dimensions including wheelchair maneuverability and free floor space area of the bus proposed for bid shall be submitted as a Mandatory Request For Approval (see Section II of the Solicitation, Item 2).

1.5.4 Service Life and Maintenance

1.5.4.1 Service Life

The bus shall be designed to operate in transit service for at least twelve (12) years or five hundred thousand (500,000) miles.

1.5.4.2 Maintenance and Inspection

Scheduled maintenance or inspections as specified shall require a skill level of 3M or less. Scheduled maintenance tasks shall be related and shall be grouped in maximum mileage intervals. Routine scheduled maintenance, such as filter replacement and adjustments, shall not be required at intervals of less than 6,000 miles, except for routine daily service performed during the fueling operations. Routine daily maintenance shall not include removal and replacement of parts. Higher levels of scheduled maintenance shall occur at even multiples of mileage for lower level tasks.

1.5.4.3 Mean Miles Between Failures (MMBF)

The following are design goals for mean miles between failures by failure class.

- Class 1: Physical Safety. Mean miles shall be greater than one million (1,000,000) miles.
- Class 2: Road Call. Mean miles shall be greater than twenty thousand (20,000) miles.
- Class 3: Bus Change. Mean miles shall be greater than 16,000 miles.
- Class 4: Defect Mean miles shall be greater than 10,000 miles.

1.5.4.4 Accessibility

All systems or components serviced as part of periodic maintenance shall be readily accessible for service and inspection. Removal or physical movement of components unrelated to the specific maintenance and/or repair tasks involved shall be minimized.

Relative accessibility of components, measured in time required to gain access, shall be directly proportional to frequency of maintenance and repair of the components.

1.5.4.5 Interchangeability

Components with identical functions shall be interchangeable to the extent practicable. These components shall include passenger window hardware, interior trim, lamps, lamp lenses and seat assemblies. Components with non-identical functions shall not be, or appear to be, interchangeable.

1.5.4.6 Operating Environment

The bus shall achieve normal operation in the environmental conditions normally occurring in Houston, Texas at temperature ranges of 10°F to 115°F with 5 to 100% humidity and at altitudes up to 3,000 feet above sea level. Speed, gradeability and acceleration performance requirements shall be met at, or corrected to, 77°F, 29.31 inches Hg, dry air per SAE J1995. **The interior climate control system shall perform in accordance with Section 3.7.**

1.5.4.7 Manuals

Maintenance and parts manuals shall be provided that accurately reflect the contents of buses supplied to METRO under this contract. **Manuals shall be provided in accordance with section 7.0 Manuals and Parts Lists, of this specification (Deliverable, See Appendix No.1, Items D51-D62).**

2.0 BODY

6) 2.1 General

2.1.1 Design

The coach shall have a smooth, simple design, primarily derived from bus performance requirements and passenger service criteria meeting all applicable FMVSS requirements, SAE standards and recommended practices. The exterior and body features, including grilles and louvers, shall be shaped to allow complete and easy cleaning by automatic bus washers without snagging washer brushes. Water and dirt shall not be retained in or on any body feature after leaving the washer. Body and windows shall be sealed to prevent leaking of air, dust, or water

under the normal operating conditions and during cleaning in a high-pressure automatic bus washer for the service life of the bus.

2.1.1.1 Materials

Unless otherwise specifically provided, all equipment, material, and articles incorporated in the work covered by this specification are to be new and of the most suitable grade for the purpose intended. Frame and sidewalls shall be corrosion resistant for the life of the bus. Where fiberglass is used, the fiberglass shall be properly cured and samples taken, certified by the Contractor and shall require approval by METRO. If the bus body is manufactured outside of North America, protective coating shall be applied to prevent damage during shipment. The contractor must follow manufacturer's recommendations.

2.1.1.2 Finish and Color

A detailed description of paint system and procedures to be used must be submitted as a Mandatory Request for Approval (see Section II of the Solicitation, Item 3).

METRO's colors shall be applied using a high-solids polyurethane finishing system designed to provide excellent gloss and durability that is formulated to meet commercial vehicle requirements.

Bus exterior decals shall be used for the METRO striping and must be applied in accordance with the manufacturer's recommendations. The METRO stripes shall be UV protected and last at least 5 years.

All exterior surfaces of the bus shall be smooth and free of visible or protruding rivets, fasteners, wrinkles, bubbles, waves, and dents. Structural members behind body panels will not show through the panels. Provisions shall be made to prevent body panel drumming or indentations when components such as lamp assemblies, rub-rails, doors, and windows are fixed to the exterior surface of the body panel.

Exterior surfaces to be painted shall be properly prepared as required by the paint system manufacturer prior to application of paint to assure a proper bond between

the basic surface and successive coats of original paint for the service life of the bus. Drilled holes and cutouts in exterior surfaces shall be made prior to cleaning, priming, and painting to prevent corrosion. The bus shall be completely painted prior to installation of exterior lights, windows, mirrors and other items that are applied to the exterior of the bus. Body filler materials may be used for surface dressing, but not for repair of damaged or improperly fitted panels.

All primer and topcoat film thickness shall be applied and measured in accordance with the pre-determined Paint Manufacturer's Standards. **Mil readings are to be recorded in the Production Verification book for each bus. A copy of the Production Verification book shall be provided with each bus prior to its departure from the bus manufacturer's facility (Deliverable, See Appendix No.1, Item D1).** Paint shall be applied smoothly and evenly with the finished surface free of dirt and the following imperfections:

- Blisters or bubbles appearing in the topcoat film.
- Chips, scratches, or gouges of the surface finish.
- Cracks in the paint film.
- Craters where paint failed to cover due to surface contamination.
- Overspray.
- Peeling.
- Runs or sags from excessive flow and failure to adhere uniformly to the surface.
- Chemical stains and water spots.
- Dry patch due to incorrect mixing of paint activators.
- Buffing swirls.

Painted surfaces shall have a minimum 95 gloss and orange peel in all zones must be between 6 to 7 on the ACT Test Panels Technologies orange peel standard panels.

Wet sanding and polishing is not acceptable for any repairs.

Proper adhesion between the basic surface and successive coats of the original paint shall be measured as per AST D-3359 cross cut method or using an Elcometer adhesion tester as outlined in ASTM D4541-85. Adhesion shall be 300-ft. lbs minimum or meet 4B requirement as per AST D-3359 cross cut method. The bus manufacturer shall supply test samples of the exterior surface for each step of the painting process which may be subject to adhesion testing per ASTM D4541-87 and ASTM D4145-85. ASTM D4541-93 or ASTM D-3359 may be used for inspection testing during assembly of the bus.

All exterior finished surfaces shall be impervious to diesel fuel, and commercial cleaning agents. Finished surfaces shall resist damage by controlled applications of commonly used graffiti-removing chemicals. Paint shall last a minimum of five (5) years with a minimum gloss of 90 as measured in ASTM E97-92, Standard Test Method for Directional Reflectance.

METRO will provide color scheme details and color keys after contract award. Painted colors must match painted samples provided by METRO. At present, the METRO paint scheme includes two (2) paint colors, black and white (see an example of the METRO paint scheme on a 45-ft Coach in the following drawing.).

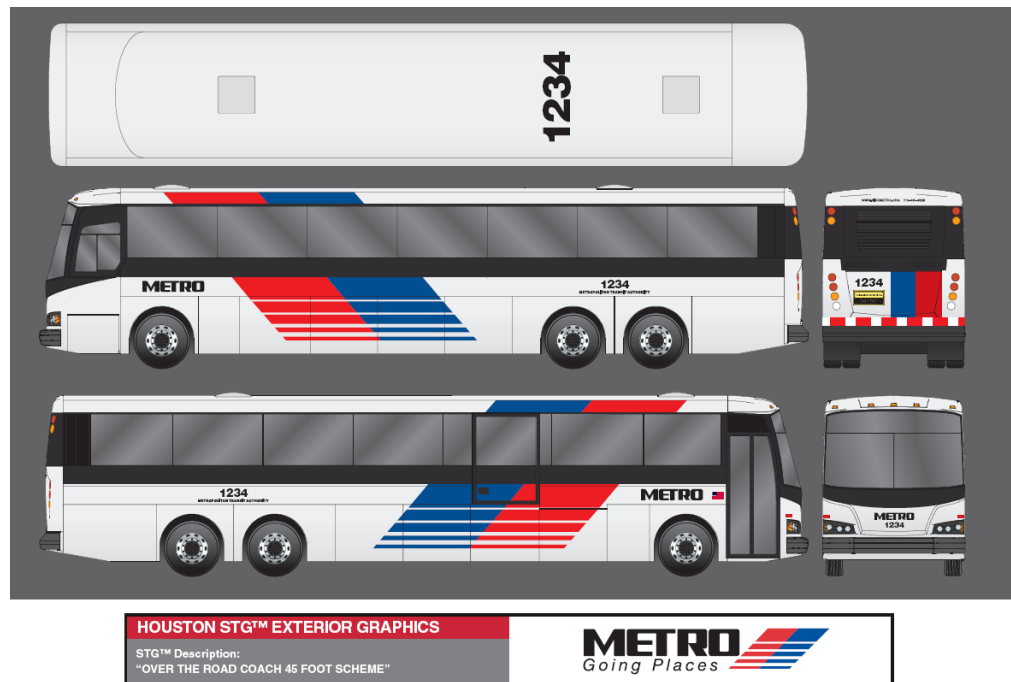

2.1.1.3 Decals, Numbers and Signs

Decals, numbers and other special signs as specified by METRO shall be applied to the inside and outside of the bus. Signs shall be durable and resistant to fading, chipping and peeling. Interior signs may be decals or pressure sensitive. Exterior bus numbers shall be of black retro reflective material. A bus number shall be provided on the inside of the engine door so it will be visible from rear when engine door is open. At least one (1) sign shall be provided in the interior front on each side of the bus to indicate priority seating for the elderly and disabled. An interior bus number shall be provided, centered over top of windshield. A "No Smoking/Eating/Drinking" sign shall also be provided. All interior signs/decals provided shall be in English and in Spanish. A six-inch (6") Red and White reflective warning stripe shall be applied at bottom of the engine door and a sign warning that children may be exiting shall be applied to the rear of the bus. **The exact wording, size, color and location for these and any other signs shall be determined and require approval by METRO during the preproduction conference and during pilot bus construction (See Appendix 2, Preproduction Conference, Item PPC 1).**

2.1.1.4 Pedestrian Safety

Exterior protrusions greater than 1/2 inch and within eighty (80) inches of the ground shall have a radius no less than the amount of the protrusion. The left and right side rear view mirrors and required lights and reflectors are exempt from the protrusion requirement. Grilles, doors, bumpers and other features on the sides and rear of the bus shall be designed to minimize the ability of unauthorized riders to secure footholds or handhold.

2.1.1.5 Passenger Windows

A minimum average of 12,000 square inches of window area, including door windows, shall be required on each side of the standard configuration coach. Section 2.4.2 describes the specific requirements for passenger windows.

2.1.1.6 Passenger Door

One transit style two section bi-part door shall be provided in the right side of the bus for passenger ingress and egress. The door shall be forward of the front wheels and located so that the Operator is able to monitor the collection of fares. Specific requirement for the door are in Section 2.1.8; requirements for operation of door are in Section 2.2.1.

2.1.1.7 Manufacturer's Logos

With the exception of manufacturer's build plate, the contractor shall not affix any logos or vendor's identification to the vehicle.

2.1.2 Structure

2.1.2.1 Strength and Fatigue Life

The structure of the bus shall be designed to withstand the transit service vehicle conditions typical of an urban duty cycle throughout its service life. The structural frame:

- Below the floor line shall be stainless steel series 300 except for primary load carrying members.
- Above the floor line shall be high strength steel alloy or stainless steel.

The structure shall be designed to operate with minimal maintenance throughout the 12-year design operating profile. The design operating profile specified by METRO shall be considered for this purpose. The basic structure shall withstand fatigue damage that is sufficient to cause Class 1 or Class 2 failure.

A detailed description of all materials and their assembly to be used in the body construction of the bus proposed for bid shall be submitted as a Mandatory Request For Approval (see Section II of the Solicitation, Item 4).

The structure shall also withstand impact and inertial loads due to street travel without permanent deformation or damage throughout the vehicle's service life. The inner and outer surfaces are subject to corrosion protection as listed in 2.1.2.5 except for materials inherently corrosion resistant and if inner surfaces are not

exposed to the environment. **Prior to acceptance of the pilot bus, the vehicle must have completed any FTA-required Altoona testing.** Any items that required repeated repairs or replacement must undergo the corrective action with supporting test and analysis. **A report clearly describing and explaining the failures and corrective actions taken to ensure any and all such failures will not occur shall be submitted to METRO prior to acceptance of the pilot bus (Deliverable, See Appendix No.1, Item D2).**

2.1.2.2 Distortion

At GVWR and under static conditions, the bus shall not exhibit deformation or deflection that impairs operation of doors, windows, or other mechanical elements. Static conditions include the vehicle at rest with any one wheel or dual set of wheels on a 6-inch curb or in a 6-inch deep hole.

2.1.2.3 Resonance

All structure, body and panel ending mode frequencies, including vertical, lateral and torsional modes, shall be sufficiently removed from all primary excitation frequencies to minimize audible, visible or sensible resonant vibrations during service.

2.1.2.4 Material

All fasteners used shall be certified as actually being the grade marked on head. They shall be manufactured by a reputable firm who has registered their head markings with Fastener Technology International. **Samples of all head markings to be used shall be submitted and require approval by METRO during the preproduction conference (See Appendix 2, Preproduction Conference, Item PPC 2).** Contractor installed structural fasteners shall be corrosion resistant grade 8 or better (grade 10.9 for metric fasteners) unless it can be shown that Grade 8 is unsuitable for that application.

2.1.2.5 Corrosion

The bus shall resist corrosion from conditions normally experienced in Harris County, Texas. It shall maintain structural integrity and original appearance throughout its service life. Materials exposed to the elements and all joints and connections of dissimilar metals shall be corrosion resistant and shall be protected from galvanic corrosion. Representative samples shall withstand a 500-hour salt spray test in accordance with ASTM Procedure B-117 with no visual or structural detrimental effects to normally visible surfaces, and no significant structural degradation or weight loss of over one percent (1%) for other members or components.

Full information on the anticorrosion treatment and results of the salt spray test performed on bus model to be provided under this technical specification shall be submitted as a Mandatory Request For Approval (see Section II of the Solicitation, Item 5).

The complete information package shall include test evaluations pertaining to all products offered from the basic sub-structure to the paint system top coat, including fasteners.

2.1.2.6 Welding

All welds shall be performed in accordance with recommended practices of SAE HS J1196 and AWS D8.8. This shall include, but not be limited to, accurate measuring equipment, proper joint fit-up, inspection and calibration of welding equipment, frequent inspections by an AWS certified welding inspector, visual reference standards, appropriate weld repair procedures and employee welding certifications. Welds in structural tubing shall not bridge gaps larger than wall thickness of the thinner member.

Structural jigs shall be checked for proper calibration at least annually or all structure getting out of structural jigs must be verified with a GO-NO GO and measurements. **A copy of the bus manufacturer's welding manual for the specified bus shall be submitted and require approval by METRO during the preproduction conference (See Appendix 2, Preproduction Conference, Item PPC 3).**

2.1.2.7 Towing

The towing provisions, when used with a load equalizing sling, shall withstand tension loads up to 1.2 times the curb weight within 20° of the longitudinal axis of the bus without permanent deformation. The coach shall be designed to be lifted from the front of the coach and flat towed from the rear for recovery to a place to where the coach can be lifted and towed from the front of the coach. The front towing provisions shall be permanently attached to the coach structure. The front towing provisions shall permit lifting of the bus, at curb weight, until the front wheels are clear of the ground. In addition to lifting the bus, flat towing in the front is required. All towing devices shall be designed to accommodate METRO's wreckers. Seven (7) sets of flat tow adapters are required.

A detailed description of the towing methods and devices required for the bus proposed for bid shall be submitted as a Mandatory Request For Approval (see Section II of the Solicitation, Item 6).

The bus shall be equipped with sufficient frame strength and designated lift points to allow the vehicle to be lifted from the undercarriage, tires or axles without causing permanent deformation to the frame or structure of the vehicle. The Contractor shall provide tools and lifting devices specifically designed to be used by METRO's existing under lift and universal sling wreckers for towing the buses. The lifting tools shall be designed for lifting and towing the bus from front and rear with the wheels of the end being towed clear of the ground.

The bus shall be equipped with airline quick disconnects (Glad Hands or airline quick disconnects), hard mounted at front and rear of the bus. Quick disconnects shall mate with Bendix P/N 278852 installed on METRO's current wreckers. The coupling shall have a removable filter screen at its mouth opening and will be protected with a dummy coupling tethered to the bus frame. Tether length shall be sufficient to allow dummy coupling to be easily connected, but short enough to preclude the possibility of coupling dragging road surface if left hanging. Quick disconnect couplers shall have a one way check valve between the air supply tank and the quick disconnect to prevent loss of air. The bus shall be equipped with a

front mounted plug connector to operate the stop and turn signal lamps from wrecker when being towed.

2.1.2.8 Jacking

It shall be possible to safely jack up the bus, at curb weight, with a common 5-inch high, 10-ton jack, when a tire or dual set is completely flat and the bus is on a level, hard surface, without crawling under any portion of the bus. Jacking from a single point shall permit raising the bus high enough to remove and reinstall a wheel and tire assembly. Jacking pads located on the axle or suspension near the wheels shall permit easy and safe jacking with the flat tire or dual set on a 6-inch high run-up block not wider than a single tire. Jacking and changing any one (1) tire shall be completed by a 2M serviceman in less than thirty (30) minutes from the time the job is started. The bus shall withstand such jacking at any one or any combination of wheel locations without permanent deformation or damage.

2.1.2.9 Hoisting

The bus axles shall accommodate the lifting pads of a 2-post hoist system. Other pads or the bus structure shall support the bus on jack stands independent of the hoist.

2.1.2.10 Fire Protection

METRO requires that the passenger and engine compartments be separated by a bulkhead(s), which shall be a firewall. This firewall shall preclude or retard propagation of an engine compartment fire into the passenger compartment. Only necessary openings shall be allowed in the firewall and these shall be fire resistant. Piping through the bulkhead shall have copper, brass, or other fire resistant fittings sealed at the firewall. Wiring may pass through the bulkhead only if fire resistant bulkhead connectors or other means are provided to prevent fire propagation through the firewall. Standard fire resistant and UL rated bulkhead connectors are approved and shall also be waterproof. On an exception basis only, wiring which

cannot use a connector may pass through a conduit using fire retarding putty rated to at least 2000°F.

Engine access panels in the firewall shall be fabricated of fire resistant material and secured with fire resistant fasteners. These panels, their fasteners and the firewall shall be constructed and reinforced to minimize warping of the panels during a fire. Use of any part of the bus floor as a firewall is unacceptable. Fire resistant material shall not absorb or be damaged by oil, diesel fuel, water or other fluids present in the engine compartment. The Contractor shall conduct a smoke test on every bus prior to delivery to verify leaks.

A sample of material to be used as a fire blanket shall be submitted as a Mandatory Request for Approval (see Section II of the Solicitation, Item 7).

2.1.2.11 Fire Extinguisher

Contractor shall furnish and install two (each) ten (10) pound rechargeable dry chemical ABC fire extinguishers. The contractor shall install the fire extinguishers under the # 2 LH and RH passenger seats in a mounting box with strap. A metal label shall be attached to the fire extinguisher indicating it has been listed and approved by Underwriters Laboratories or Factory Mutual Laboratories. A gauge to indicate chemical charge shall be provided. Fire extinguisher mounting location shall be clearly identified with a yellow and black decal.

ABC fire extinguishers location shall be submitted as a Mandatory Request for Approval (see Section II of the Solicitation, Item 8).

2.1.2.12 Crashworthiness

The bus shall withstand a 25 mph impact by a 4000-pound automobile at any side, excluding doorways, along either side of the bus with no more than 3 in. of permanent structural deformation at seated passenger hip height. This impact shall not result in sharp edges or protrusions in the bus interior.

Exterior panels below 35 in. from ground level shall withstand a static load of 2000 lbs applied perpendicular to the bus by a pad no larger than 5 sq in. This load shall

not result in deformation that prevents installation of new exterior panels to restore the original appearance of the bus.

Bus body and roof structure shall withstand a static load equal to one hundred fifty percent (150%) of the curb weight, evenly distributed on the roof with no more than a 6-inch reduction in any interior dimension. Windows shall remain in place and shall not open under such a load.

Independent third party certification by a recognized engineering firm to certify that roof load bearing, crash test, and exterior body panel criteria have been met for the bus proposed for bid shall be submitted as a Mandatory Request For Approval (see Section II of the Solicitation, Item 9).

Test certifications will include structural diagrams of the bus tested. These diagrams must match exactly, the bus bid by the bus manufacturer.

2.1.3 Exterior and Applied Panels

2.1.3.1 Strength and Installation

Exterior surface panels shall not be installed or retained with visible rivets or fasteners. Lap joints shall be sealed and installed with the upper panel outside the lower panel to prevent entrance of moisture. All exterior panels above thirty (30) inches shall be fully sealed along all edges to prevent entrance of moisture.

2.1.3.2 Repair and Replacement

Exterior panels below thirty (30) inches shall be repairable or replaceable when fully assembled and painted previously by a 3M mechanic in less than thirty (30) minutes for a section up to five (5) feet long (excluding painting). Exterior panels longer than five (5) feet shall be repairable or replaceable in proportionally longer times. METRO will permit the use of two-section panels on the sides of the bus.

2.1.3.3 Rain Gutters

Gutters shall be provided to minimize water flowing from the roof onto the Operator's side window and passenger doors. When the bus decelerates, drainage onto the main windshield area, operator's side window, or into the door boarding area shall be minimized. Cross sections of the gutters shall be no less than one inch square.

Ends of rain gutters shall be rounded and have a finished appearance. Rain gutters may be built into the roof coves with additional rain gutters over the passenger doors and Operators window.

2.1.3.4 License Plates

Provisions shall be made to mount a standard size U.S. license plate on the rear of the bus. Contractor shall provide for front plate installation. These provisions shall be flush mount or recess the license plate so that it can be cleaned by automatic bus washing equipment without being caught by the brushes. License plate shall be mounted on, or to the left of, the bus center and shall not allow a toehold or handhold for unauthorized riders. The rear license plate shall be illuminated by waterproof led lamps flush or surface mounted as possible. **License plate mounting and location shall be determined and require approval by METRO during the preproduction conference (See Appendix 2, Preproduction Conference, Item PPC 4).**

2.1.4 Interior

2.1.4.1 Headroom

Headroom above the aisle and at the centerline of the aisle seats shall be no less than seventy eight (78) inches over front and rear axles.

2.1.4.2 Operator's Platform and Operator Barrier

The Operator's platform shall be of a height such that, in a seated position, the Operator can see an object located at an elevation of 42 in. above the road surface, 24 in. from the leading edge of the bumper, especially in the right front corner. Notwithstanding this requirement, the platform height shall not position the

Operator such that the Operator's vertical upward view is less than 15°. The above requirement can be met by utilizing a six (6) inch mirror below the curb side mirror. The following figure illustrates a means by which the platform height can be determined, using the critical line of sight.

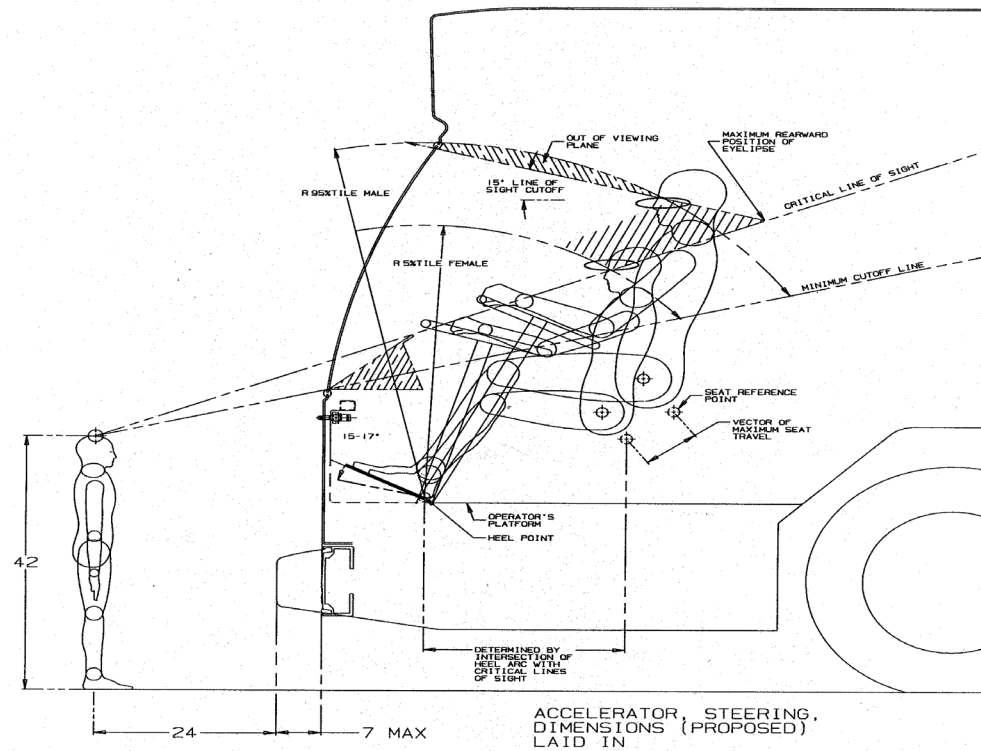

An Operator's barrier or bulkhead between the operator and the left front passenger seat shall be provided for the security of the operator and to limit passenger conversation. This partition shall extend vertically from the ceiling to the floor or wheel well and from the wall to a vertical stanchion located to the right of the Operator's seat.

Operator barrier shall be solidly constructed and be reinforced to prevent drumming. A stainless steel hook and securing straps for the operator's jacket shall be provided on the Operator's barrier.

The layout and mounting of the coat hook and jacket strap used in the Operator's barrier shall be submitted and require approval by METRO during the preproduction conference (See Appendix 2, Preproduction Conference, Item PPC 5).

2.1.4.3 Modesty Panel

Modesty panels constructed of smooth finished, gray melamine shall be provided at the rear of doorway. These dividers shall be mounted on the side wall and shall project toward the aisle no further than the aisle side of the transverse seats. Divider shall extend to within four inches of the floor. The modesty panel and its mounting shall withstand normal kicking, pushing and pulling loads of two hundred (200) pound passengers without permanent visible deformation. **Installation details shall be submitted and require approval by METRO during the preproduction conference (See Appendix 2, Preproduction Conference, Item PPC 6).**

2.1.4.4 Rear Bulkhead

The rear bulkhead paneling shall be contoured to fit the ceiling, side walls and seat backs so that any litter, such as a cigarette package or newspaper, will tend to fall to the floor or seating surface when the bus is on a level surface.

2.1.4.5 Construction

Interior panels may be integral with, or applied to, the basic bus structure. They shall be decorated in accordance with the interior. Use of moldings and small pieces of trim shall be minimized and all parts shall be functional.

Wainscot panels shall be gray melamine and subject to color approval. All trim molding shall be free from burrs and sharp edges. All panels shall be reinforced to prevent drumming. Rear seat riser and bottom of seat track may be stainless steel. Window mullions may be plastic.

The following colors and materials are required:

- Below windows in passenger area;
 - Material: fabric (same properties as seat fabric)
 - Color; match seating material.

- Between windows in passenger area;
 - Material; plastic
 - Color; medium gray.
- Ceiling in passenger area;
 - Material; melamine
 - Color; light gray.
- Operator's area;
 - Material; Fiber Reinforced Plastic
 - Color; dark gray.

Colored samples of all interior materials shall be submitted as a Mandatory Request for Approval (see Section II of the Solicitation, Item 10).

2.1.4.6 Fastening

Interior panels shall be installed to preclude exposed edges or rough surfaces. Panels and fasteners shall not be easily removable by passengers. Interior trim fasteners, where required, shall be rivets or recessed cross-head screws. Interior panels must be fastened securely to prevent panels from hitting our Operator's. Gaps between panels shall not exceed 3/8 inches.

2.1.4.7 Take One Holders

Two (2) molded-one-piece "Take One" pamphlet holders or a four-place schedule holder shall be provided and strategically placed inside the bus interior. The "Take One" holders shall not impede the passenger signal chime operation. Additionally, one (1) 4" X 9" holder shall be supplied. **Exact mounting location shall be submitted and require approval by METRO during the preproduction conference (See Appendix 2, Preproduction Conference, Item PPC 7).** .The four-place schedule holder shall be mounted to the lower aisle facing compartment door of the Operator's barrier.

A sample of the proposed "Take One" holder shall be submitted as a Mandatory Request for Approval (see Section II of the Solicitation, Item 11).

2.1.4.8 Parcel Racks

A minimum 10 module parcel rack without dividers and compartment doors shall be furnished over all two-passenger seating positions except in the wheelchair door area. Retention cords shall run the length of the rack housing except where air conditioning components are housed and except for the first two parcel rack behind the driver partition where compartment doors are required. These compartments will have dividers and locking doors. The parcel rack edge, running along the full length of the aisle, shall incorporate a handhold for use by standees. Passenger headroom measured from the rack end to the top of the seat headrest, shall be a minimum 17 Inches. Interior window post caps shall be ABS, thermo formed plastic, off-white in color to provide a clean finished appearance. The interior of the rack shall be lined with carpet, same material used on seats, covered aluminum to complement the interior. Parcel racks shall be supported by polycarbonate glass filled hangers spaced approximately 40 inches apart. Total capacity shall be a minimum 109 ft.³ to allow for ample storage space for carry-on items.

Passenger service modules mounted on the underside of the parcel rack shall include individually controlled and non-adjustable LED passenger reading lights, an exit signal push button, yellow in color and individual HVAC air distribution outlets. These outlets shall be adjustable from fully closed to full open position.

2.1.4.9 Operator Safety Barrier

The Contractor shall provide a safety barrier solution which is new, generally available, and currently in production and in use in a client environment as proposed.

In accordance with the National Institute for Occupational Safety and Health (NIOSH) requirements Section 5(a)(1) of the OSH Act, the safety barrier shall provide the necessary degree of safety mechanisms and construction to protect the bus operator from generally known standard physical and chemical assaults, reducing potential harm to the bus driver.

The safety barrier shall act as a divider between the bus driver and passenger occupants. The safety barrier shall shield the driver from assault while seated in the operator's area. The safety barrier shall be engineered to withstand high impact.

No portion of the safety barrier partition shall present a hazard or potential injury issue while the bus operator is entering or leaving from the bus operator's area. There shall be no metal and glass sharp marks, snares or protrusions that can potentially cut or scratch a person utilizing or moving near the partitions.

All materials, components of the safety barrier shall meet applicable American National Standards Institute (ANSI) standards. The safety barrier shall not affect the vehicle adherence to ADA or other accessibility standards as pertaining to aisle clearance and conformance to the standardized "Box Test" when in the fully closed position.

The safety barrier shall be easy to operate and easy to maintain. The safety barrier components shall be easily and quickly replaceable during repair and maintenance service. The safety barrier shall take less than 30 minutes to remove and replace.

The safety barrier shall provide unimpeded access past the farebox for movement in and out of the operator seat. The safety barrier shall provide a comfort range for operators within the range from a 5th percentile female to a 95th percentile male.

The safety barrier shall promote good ventilation and air flow. The safety barrier shall produce minimal noise or vibration during normal on-road operation. The safety barrier shall enable access to fare box payment interface or vault door. The safety barrier partition shall be constructed with a sturdy metal frame supporting both upper and lower sections. The metal frame shall be structurally affixed to the vehicle undercarriage, chassis, or body framing. The safety barrier door assembly excluding the glass shall have a flat black finish.

The safety barrier shall allow for a reasonable amount of verbal communication between the bus operator and passengers.

The safety barrier shall be designed with clear and transparent tempered / laminated safety glass meeting AS-2 and ADA requirements with an anti-reflective coating in the upper panel to prevent glare and minimize reflection. The safety barrier partition shall be designed to minimize glare and reflection from outside light sources throughout the day and night. The safety barrier shall not obstruct the rear view of operator to the standee line.

Safety barrier shall be constructed with clear safety glass to facilitate full vision for cameras and to preserve ease of visibility. Safety barrier shall be a solid door that incorporates a sliding two-piece safety glass system. This design allows the driver to adjust the sliding glass into multiple positions, similar to how they would adjust the driver's window.

The safety barrier shall have a scratch resistant coating or other mechanism to minimize scratches on it. Glazing material shall be a minimum of 5/16" (8mm) thickness and be of a tempered / laminated construction. Glazing material shall comply with American National Institute, Standard ANSI/SAE Z26.1-1996 S5.2, FMVSS 571.205 49CFR, and SAE J673 #1 edge standards for automotive glazing. Glazing material shall be properly marked indicating approved for automotive use in accordance with ANSI/SAE Z26.1-1996 S7 and FMVSS 205 S6.2 standards.

A latching system shall be installed to limit noise and vibration when partition door is in closed position. The latching system shall provide a secure method to prevent the safety barrier from swinging open whether it is in the closed or open stowed position.

The safety barrier shall include a stop mechanism to prevent the door from opening more than ninety-five (95) degrees or past the passenger standee line. The door latch shall be commercial grade, easily operated and able to be secured from the interior of the driver compartment. An emergency release system, or approved equal process, shall be present should the standard door latch fail. The Contractor shall provide a sturdy, secure mechanism to support and affix the safety barrier properly within the vehicle to ensure optimal safety and longevity performance of the safety barrier.

In no event, shall the safety barrier design cause the barrier to come loose and potentially fall onto the driver or passengers. All fasteners used on the safety barrier shall be of a safe design to prevent injury to the bus operator or passengers.

The safety barrier hinge shall be of a maintenance-free stainless steel, piano hinge design or approved equal and extend the full vertical height of the door and engineered to withstand a transit bus environment.

2.1.5 Floor

2.1.5.1 Construction

The floor shall be essentially a continuous flat plane, except at the ramp area and at the step up under the front seats. Where the floor meets the walls of the coach, the surface edges shall be blended with a circular section of radius not less than .5 inch and a molding or cover shall prevent debris accumulation between the floor and wall.

Interior flooring shall be flat throughout. The floor is attached to the underframe with adhesive and rivets. Wheel housings may not extend above floor line.

Access openings in the floor shall be sealed to prevent entry of fumes and water into the coach interior. Flooring material shall be flush with the floor and shall be edge-bound with stainless steel to prevent the edges from coming loose. Access openings may be symmetrical if the fasteners are arranged to ensure alignment of the flooring. Fasteners shall be flush with the floor when secured.

Rubber flooring adhesion procedure includes butt cut type edges that are securely bonded to the plywood floor with a waterproof adhesive. Flooring areas which are edge-bound with stainless steel shall include the sidewall on each side, the ramp in the center aisle, the base of rear cross seat, the step up under the number 1 seat, the driver's modesty panel and the RH front passenger's modesty panel.

2.1.5.2 Strength

Alternative flooring material may be utilized to minimize weight, but must meet strength, water protection and anti-rot characteristics of 1/2" 5-ply exterior grade water resistant Douglas fir plywood and shall be warranted for the life of the bus. Flooring must be integral with the basic structure or mounted securely to prevent chafing or horizontal movement.

Flooring system and a sample of material shall be submitted as a Mandatory Request for Approval (see Section II of the Solicitation, Item 12).

Sheet metal screws shall not be used to retain the floor. Torq screws with attached washers are approved. The use of rivets and sealant to secure the floor to the lower frame is approved. All floor fasteners shall be serviceable from one side only. Tapping plates used for the floor fasteners shall be no less than the thickness of a standard nut if fasteners are a primary means of attachment. All floor fasteners shall be secured and protected from corrosion for the service life of the bus. All flooring edges shall be supported underneath by structural members except when using tongue and groove ACQ panels.

The floor deck shall be reinforced as needed to support passenger loads. At GVWR, the floor shall have an elastic deflection of no more than 0.60 inches from the normal plane. The floor shall withstand the application of 2.5 times gross load weight without permanent deformation. With coverings applied, floor shall withstand a static load of at least one hundred fifty (150) pounds applied through the flat end of a .5-inch diameter rod, with 1/32 inch radius, without permanent visible deformation.

2.1.5.3 Sealing

The floor, as assembled, including the sealer, attachments and covering shall be waterproof, non-hygroscopic, stain resistant, resistant to wet and dry rot, resistant to mold growth and impervious to insects.

The gaps at mating edges shall not exceed 1/16" gap and shall be sealed with a sealant.

The floor shall be essentially a flat plane, except at the wheel housings. Where the floor meets the sidewalls of the bus, the surface edges shall be molded to prevent accumulation of dirt and debris. Wheel well design shall prevent debris accumulation between the floor and wheel housings.

2.1.6 Kneeling

The bus shall be equipped with a system, which allows it to kneel the front of the bus. This system shall lower the door floor height at least three (3) inches to assist boarding passengers. A spring-loaded or rocker switch located in the Operator's area, next to door control, shall control the kneeling system. When kneeled, the accelerator and brake interlocks shall be engaged to prevent movement of the bus.

2.1.7 Wheel Housing

2.1.7.1 Construction

All wheel housings shall be constructed of stainless steel. They shall be securely mounted and sealed to the bus body structure. Wheel housings, as installed and trimmed, shall withstand impacts of a 2-inch steel ball with at least 200 foot-pounds of energy without penetration.

2.1.7.2 Clearance

Sufficient clearance and air circulation shall be provided around the tires, wheels, and brakes to preclude overheating when the bus is operating on the design operating profile.

Interference between the tires and any portion of the bus shall not be possible in maneuvers up to the limit of tire adhesion with weights from net to GVWR.

2.1.7.3 Fender Skirts

Fenders designed to minimize water spray from the wheels in wet conditions shall be included in wheel housing design. Fender skirts shall be damage resistant and easily replaceable if they aren't made of a rigid metal part fully integrated to fender.

They shall be flexible if extended beyond the body width. Wheels and tires shall be removable without damaging the fender skirts.

2.1.7.4 Splash Aprons

Splash aprons, composed of .25-inch minimum high impact plastic, composition or rubberized fabric, shall be installed at each wheel and shall extend downward six (6) inches of the bus. Splash aprons shall cover the entire width of the tires. Splash aprons shall be reinforced with metal strips on front and rear along mounting holes and bolted to the bus understructure. Their attachments shall be inherently weaker than the structure to which they are attached. Splash aprons shall not be included in road clearance measurements. Other splash aprons shall be installed where necessary to protect bus equipment.

2.1.8 Passenger Door

2.1.8.1 Materials

Structure of the door, inside and outside trim panels shall be constructed of stainless steel, aluminum or FRP (Fiber Reinforced Plastic). The attachments and any mechanism exposed to the elements shall be durable and corrosion resistant. The door, when fully opened, shall provide a firm support and shall not be damaged if used as an assist by passengers during ingress or egress.

2.1.8.2 Dimensions

The non-symmetrical door will have a clear opening width of a nominal 27 inches up to a height of 44 inches. The clear door opening height will be 84.5 inches. When open, the front door shall leave an opening no less than 75.2 inches in height.

2.1.8.3 Door Glazing

All door glazing shall be 0.250 inch laminated safety glass tinted the same as the windshield. Door glazing shall make up approximately 50% of the surface area of the door.

The upper section, half door height, of door shall be glazed for no less than thirty-eight percent (38%). The lower section of the door shall be glazed for no less than twenty-five percent (25%) of the door opening area of the section. The edge of 6-inch high curb shall be visible to the seated Operator through the closed door when the bus is 12 inches from the curb. Glazing shall be safety glass.

2.1.8.4 Door Projection

Door projection shall not exceed 8 inches out from the side of the coach while in the fully open position and shall not exceed 11.25 inches while going through the opening and closing cycle. The forward front door leaf leading edge shall rest within one inch of the front bumper when fully opened.

2.1.8.5 Door Height Above Pavement

It shall be possible to open and close passenger door when the bus is loaded to GVWR and parked with the tires touching an eight (8) inch high curb on a street sloping toward the curb so that the left side wheels are five (5) inches higher than the right side wheels.

2.1.9 Service Compartments and Access Doors

2.1.9.1 Interior

Destination sign access door shall be secured using aircraft type clamps, quarter turn fasteners or two (2) push type pop out latches. If not hinged at the top, the access door shall be equipped with a safety chain or shielded stainless steel cable to limit travel in the event of clamp malfunction. The safety chain shall be attached to the door panel so that the safety chain cannot be pulled through the door material. The safety chain, shielded stainless steel cable, shall be of sufficient strength to withstand the force exerted from free falling the length of travel.

Access for maintenance and replacement of equipment shall be provided by individual removable panels and doors that appear to be an integral part of the interior. These panels shall be capable of being removed and reinstalled by one

3M mechanic. Removal of fixtures or equipment unrelated to the repair task to gain access shall be minimized.

Access doors shall be hinged. Props shall be used if necessary to hold the doors out of the mechanic's way. Retention of all interior access panels, except the door actuator compartments, shall be with screws. All fasteners that secure access panels shall be captive or non-captive in the cover. Panel fasteners shall be standardized so that minimum amount of tools is required to service all special fasteners within the bus. Access doors for the door actuator compartment shall be a pinned liftable panel secured with hand screws or latches, and shall prevent entry of mechanism lubricant into the bus interior.

Access openings in the floor shall be sealed to prevent entry of fumes and water into the bus interior. Flooring material shall be flush with the floor and shall be edge bound with stainless steel or anodized aluminum to prevent the edges from coming loose. Access openings shall be designed so that the ribs of reinstalled floor shall be properly aligned. Positive screw type mechanical fasteners shall tighten flush with the floor on all access openings.

2.1.9.2 Exterior

Vertically hinged doors shall be used for the engine compartment and for all auxiliary equipment compartments including doors for checking the quantity and adding to the engine coolant, engine lubricant, transmission fluid and the windshield washer reservoir. ~~The upper engine radiator/C.A.C. compartment door shall be vertically/horizontally hinged with a locking latch located behind the engine compartment doors.~~ Access to these compartments shall be from outside the coach. Access openings shall be sized for easy performance of tasks within the compartment including tool operating space. Access doors shall be of rugged construction and shall be capable of withstanding severe abuse throughout the life of the coach. They shall close flush with the body surface. All service/maintenance doors, excluding baggage compartment doors, shall be hinged at the top or on the forward edge and shall be prevented from coming loose or opening during transit service or in coach washing operations. Doors with top hinges shall have props stored behind the door or on the door frame. All access doors (except vertically

hinged access doors) shall be sufficiently retained in the open position by props or counterbalancing, as with baggage compartment doors. Springs and hinges shall be corrosion-resistant and shall last throughout the service life of the coach. Latch handles shall be sized to provide an adequate grip for opening. Large access doors shall hinge up and out of the way or fold flat against the coach body and shall be easily operable by one person. These doors, when opened, shall not restrict access for servicing other components or systems. Retention devices utilized to hold the engine compartment access doors in the open position shall be heavy duty and designed to last the service life of the coach.

The battery compartment shall be designed to prevent the accumulation of debris on top of the batteries, and shall be vented and self-draining. The battery covers (if applicable) shall be fiberglass. The battery tray shall be designed for the batteries that are to be provided. The battery compartment shall be accessible only from outside the bus. All components within the battery compartment and the compartment itself shall be protected from damage and corrosion from the electrolyte. If batteries are to be located within the engine compartment, the batteries shall be insulated from the engine compartment heat. The interior surface of battery compartment door shall be protected to prevent shorting in the event of an accident or if a battery comes loose. Batteries shall be located at least fourteen (14) inches above the road surface (as measured from the ground to the bottom of the batteries). No electrical equipment other than the battery cables shall be located in the battery compartment. The battery tray materials and related parts must be stainless steel.

The coach shall be equipped with an access door to allow removal of the diesel particulate filter (DPF), Selective Catalyst Reduction (SCR) and Decomposition tube.

All exterior equipment compartment doors shall be sealed to prevent entry of water into the compartment during bus washing operations. An engine oil fill door is not required. A defroster door at the front of the bus must provide maintenance access.

2.1.9.3 Underfloor Baggage Compartments

Full width under floor baggage compartments shall be provided between the front and rear axles. Each compartment shall be separated by an aluminum panel except the front and rear bulkheads shall be stainless steel. The compartment doors shall be a two part with the joint at or below the rubrail, fully sealed vertical lift pantograph type. Each door shall include an aluminum frame with an aluminum outer panel. Doors shall be spring counter balanced for ease of operation. All baggage doors shall be equipped with air or electric locks, which when released the brake interlock shall activate. Each baggage door shall have a flush mounted breakaway type latch handle located with a center point approximately 38 inches off the ground.

Each under floor compartment shall be pressurized and illuminated with two LED lamps when the doors are opened. The lamp fixtures shall be sealed to preclude the intrusion of dust and moisture into the fixture. The floor of the baggage compartments shall be corrugated aluminum or polyurethane resin reinforced with fiberglass.

2.1.10 Steps and Stepwell

There shall be no more than 4 steps and no step shall be located between the vestibule and passenger compartment. A ramp shall be provided in this area with the rate of rise not to exceed 1.12 inch per foot with a maximum vertical rise of 9.0 inches.

All step treads shall be of uniform depth no less than 9.8 inches except for the first step which is tapered and a uniform height of no less than 9.5 inches. The plane of the step treads shall be parallel to the plane of the floor except for the first step which is parallel to the entrance door. Treads shall be covered with flooring that shall remain effective in all weather conditions. Color of the tread covering shall match the vestibule flooring. The edge of the vestibule floor shall have no overhang at the step riser. The edge of the vestibule floor and the edge of each of the step treads shall have a bright, contrasting white band, 2 inches wide, the width of the step. This band shall be uniform in width across the entire step and vestibule edge.

Stepwell shall be constructed entirely of stainless steel. The steps shall simultaneously support 300 pound loads evenly distributed over the center half of

each step tread without permanent deformation and with elastic deflection of no more than 0.0625 inches. Each step tread shall support a load of 500 pounds evenly distributed over the center half of the tread without permanent deformation. A minimum 1.0 inch self-adhesive insulation shall be provided behind the stepwell area for added control of interior temperature variances and to minimize road noise.

2.1.11 Bike Rack

The contractor shall supply and install a two position bike rack similar to the one represented in the picture below.



Configuration of the battery compartment door, the engine compartment doors, underfloor baggage compartments doors and bike rack location shall be submitted as a Mandatory Request For Approval (see Section II of the Solicitation, Item 13).

7) 2.2 Operating Components

2.2.1 Door

2.2.1.1 Control

Operation of, and power to, the passenger door shall be controlled by the Operator. Door shall open or close completely approximately 4 seconds from the time of control actuation. A toggle switch on the exterior of the coach shall permit opening of the front door. The switch shall be concealed behind an unmarked flip up cover or hidden under a marker light. The door switch cover shall be spring loaded so as to be held in the closed position and be located rearward of the entrance door.

An air dump valve in the Operator's compartment shall shut off the power to, and/or dump the power from, the front door mechanism to permit manual operation of the front door with the bus shut down. Dump valve shall be accessible from outside of the bus. A master door switch, which is not within reach of the seated Operator, shall close the door, deactivate the door control system, release the interlocks and permit only manual operation of the doors when set in the "OFF" position. All door exhaust valves shall be exhausted to the outside of the bus. Unless the door control handle is accessible from outside the bus, an external toggle switch or button located in a hidden area near the front of the bus shall open or close the front door when the air dump valve is in the "ON" position regardless of the position of the master run switch.

To preclude movement of the bus, an accelerator interlock shall lock the accelerator in the closed position. A brake interlock shall apply the brake system when the door control is activated and bus is stopped. The adjustment device shall be enclosed in a tamper-proof housing, if located inside the bus. A speed sensor system shall be provided to assure that the brake interlock shall not engage and rear door cannot be opened unless bus is traveling less than three (3) MPH.

Passenger hand rail size, strength and knuckle clearance shall meet the requirements defined in Section 2.6.3.1, and shall be located near the opened edge of the door panels and extend from thirty-six (36) inches above the floor to within thirty-six (36) inches of the street surface.

Door system configuration to include door controls, hand rails and door panels shall be submitted as a Mandatory Request for Approval (see Section II of the Solicitation, Item 14).

2.2.1.2 Door Bearings

Doors shall not rattle when in the closed position. Door bearings and other operating components shall have easy replacement capability. All friction points shall have replaceable bearings equipped with lubrication fittings sized for use with a standard American manufactured lube gun or be sealed and permanently lubricated.

2.2.1.3 Closing Force

No more than a twenty (20) pound force shall be imposed on a one (1) inch O.D. diameter pipe struck by a closing door. A maximum force of thirty-five (35) pounds shall be required for a passenger to free himself after having door close upon him.

2.2.1.4 Actuators

The doors shall have, solid-state non-contact proximity switches and shall not require tools to adjust door speed. Actuators and the door mechanism shall be designed to operate without a Class Three (3) failure for 150,000 miles on design operating profile.

2.2.1.5 Emergency Operation

In the event of an emergency, it shall be possible to open the door manually from inside the bus using a force of no more than thirty-five (35) pounds after an unlocking device at door is activated. The unlocking device shall be clearly marked as an emergency-only device and shall require two (2) distinct actions to activate. The door emergency unlocking device shall be accessible from the step well area. When this emergency device is actuated, the door interlock brake system shall apply.

Locked door shall require a force of more than one hundred (100) pounds to open manually. When the locked doors are manually forced to open, damage shall be limited to the bending of minor door linkage with no resulting damage to the doors, engines, or complex mechanism.

2.2.1.6 Roof Ventilators

Two (2) static hatches (Ventilators) shall be provided in the roof of the bus. The ventilator shall be easily opened and closed manually by one (1) person. Ventilator shall cover an opening area no less than four hundred twenty five (425) square inches and shall be capable of being positioned as a scoop with either the leading or trailing edge open no less than 3.25 inches, or with all four (4) edges raised simultaneously to a height no less than 3.25 inches.

Description of roof ventilator system shall be submitted as a Mandatory Request for Approval (see Section II of the Solicitation, Item 15).

An escape hatch shall be incorporated into the roof ventilator. Escape hatch shall be tethered with a plastic coated cable lanyard to prevent its loss if it should become separated from its base structure. Roof ventilators shall be thoroughly sealed to roof panels to prevent water accumulation between vent and roof skin.

2.2.2 Windshield Wipers and Washers

2.2.2.1 Windshield Wipers

The coach shall be equipped with “wet arm” variable speed electric windshield wipers. Each windshield wiper control shall incorporate a park feature as part of its control system. No part of the windshield wiper mechanism shall be damaged by manual manipulation of the wiper arms except for wiper blade replacements or repairs.

The low resistance, long life windshield wipers are to be black in color. The windshield wiper arm shall use replaceable bronze or stainless steel non-replaceable bushing. The windshield wiper idler arm pivot pin must be of sufficient strength to provide useful service life for the life of the bus. No more than ten percent (10%) of the wiper area shall be lost due to windshield wiper lift at sixty (60) mph.

Both wipers shall park along the center edges of the windshield glass. Windshield wiper motor(s) and mechanism shall be easily accessible for repairs and service

and shall be removable as complete unit(s). The windshield wipers shall meet or exceed the requirements of FMVSS 104.

Windshield wiper and windshield washer systems shall be submitted as Mandatory Request for Approval (see Section II of the Solicitation, Item 16).

2.2.2.2 Windshield Washers

The windshield washer system shall deposit washing fluid on the windshield and shall evenly and completely wet the entire wiped area.

Windshield washer fittings and piping shall be simple and durable. Lines shall be secured to fittings in such a way as to prevent the lines from blowing off during operation. Washer hose shall be run through the front panel without the use of any fittings. Lines shall be of sufficient length to allow trimming of the end (if split) without requiring replacement of the line.

The windshield washer system shall have reservoir capacity of at least 3.9 gallons and be easily accessible for filling from the exterior of the bus. Reservoir pumps, lines and fittings shall be corrosion resistant. The reservoir shall allow easy determination of fluid level.

2.2.3 Lighting, Controls, Instruments

2.2.3.1 Exterior Lighting

Exterior marker lights shall comply with part 393, Paragraph 393.12 of the FMCSR and FMVSS 108 and must be provided at the front, rear, and side of bus. All lamp assemblies shall be sealed to prevent entry of moisture or dust in the lamp and shall be light emitting diodes (LED's). Each lamp shall be in a separate fixture and shall be replaceable in less than five (5) minutes by a 2M mechanic. Only domestic manufactured lamps shall be used.

Lights mounted on the rear of the bus shall be seven (7") in diameter except for clearance lights and decal lights. Lamps, lenses and fixtures shall be

interchangeable to the extent practicable. The manufacturer shall try to avoid using lights with plastic sockets. Any light using a metal base shall be installed on a non-conducting pad to eliminate the possibility of electrolysis.

Headlight shall be LED headlights.

All exterior lights shall be LED's, 12 or 24 volts, and shall be mounted in such a manner as to preclude damage from, or removal by, an automatic bus washer. Lamps at the rear of the bus shall be visible from behind when the engine service doors are opened. Side marker lamps shall be mounted above passenger window lines or in belt line, midpoint of the bus and unless flush mounted shall be protected with a metal guard. The marker lights shall be flush mounted LED's. Low profile mounted marker lights are acceptable.

Visible and audible warning shall inform following vehicles or pedestrians of reverse operation. Visible reverse operation warning shall conform to SAE Standard J593. Audible reverse operation warning shall conform to SAE Recommended Practice J994 Type C or D.

Lamps shall be L.E.D type at the front door. Lights shall activate only when the doors open and shall illuminate the street surface to a level of no less than one (1) foot candle for a distance of three (3) feet outward from the lowest step tread edge. The lights must be positioned externally or inside of the door opening and shall be shielded to protect passengers' eyes from glare. Auxiliary front and rear door LED lighting shall be provided to illuminate the wheelchair area and allow the Operators to see the rear door area while pulling from the curb area. Auxiliary emergency flashing lights can be provided in the engine compartment, visible when the engine door is open.

Directional signals shall be provided on the front, side and rear of the bus. Directional signals shall be controlled by water resistant, heavy-duty momentary contact switches mounted on the floor in the Operator's compartment. Foot operated directional control switches shall be so located that they can be easily operated by the operator's left foot. Directional signals shall not be canceled by a service brake application. No direction switches shall be mounted on the steering

column. Side direction lamps shall be located above each front wheel center line or in front of wheel well and shall be protected with a metal guard.

The bus shall be equipped with a bus stop warning system consisting of two (2) additional 7" round LED lamps with yellow lenses, mounted in the rear upper doors below the rear cap with approximately 57 inch spacing between the two lights. These lamps shall be electrically connected to the brake, engine brake and door system and shall activate whenever the brake, engine brake or door system is activated.

Flush-mounted curb lights shall be installed on the right hand curbside of the coach. One light shall be installed in the no.1 baggage bay door, two shall be installed on the wheelchair lift door and one shall be mounted in the right hand rear engine service door.

The curb lights shall illuminate the curbside area the coach when the entrance door is opened, activated through the multiplex outputs.

The lights shall extinguish automatically approximately 10 seconds after closing the entrance door. The curb light in the no. 1 baggage bay door shall extinguish when the baggage bay door is opened.

A detailed description of all exterior lighting of the bus proposed for bid that includes mounting methods and locations (including light dimensions) shall be submitted as a Mandatory Request For Approval (see Section II of the Solicitation, Item 17).

Directional switch location shall be submitted as a Mandatory Request for Approval (see Section II of the Solicitation, Item 18).

2.2.3.2 Service Area Lighting

The engine compartments shall be illuminated by a minimum of four LED light strips controlled by a toggle switch located near the rear start controls in the engine compartment. Service Area lighting shall use "exterior" lights and shall be able to withstand the heat generated within the compartment. The license plate lights and reverse signal lights shall be white LED assemblies.

2.2.3.3 Passenger Interior Lighting

An overhead LED lighting system shall provide general illumination in the passenger compartment and shall be controlled independent of the run switch. The system shall provide no less than fifteen (15) foot candles of illumination on a 1-square foot plane at an angle of 45° centered thirty-three (33) inches above the floor and twenty-four (24) inches in front of the seat back at each seating position except at the rear cross seat where the illumination level equal to seven (7) foot candles is acceptable. LED lighting shall be long-life type. The contractor shall provide a twelve (12) year warranty on all approved interior lighting systems

Description and function of interior lighting system shall be submitted as a Mandatory Request for Approval (see Section II of the Solicitation, Item 19).

Floor surface in the aisle must be illuminated to a level not less than two (2) foot candles. The floor surface in the vestibule shall be illuminated to not less than four (4) foot candles with the front door open and to not less than two (2) foot candles when the front door is closed. LED lighting shall not be installed above the Operator's side window or the front door.

All power supplies shall have an independent in-line fuse or circuit breaker and shall not have a voltage drop greater than 0.2 volts static or dynamic. All lighting assemblies shall be independently grounded to the frame. Lamp fixtures and lenses shall fire retardant capabilities. The fixtures shall be sealed to prevent accumulation of dust and insects but shall be easily opened for cleaning and service. The lenses shall be retained in a closed position and if threaded fasteners are used, they must be captive in the lens and be recessed cross-head type.

Light fixtures shall be sealed from the air conditioning duct system. Lighting fixtures shall be opened to provide access to the air plenum wiring harnesses and terminal strips. The fixture lens covers shall be hinged or easily removable to provide access to lamps and wiring. Power supplies shall be enclosed with fireproof material located at the individual light fixtures. Power supplies shall be inaudible with an operating frequency above 18,000 Hz. Interchangeability of LED lamps, lenses, fixtures and power supplies shall be maximized.

All passenger seats except for center seat of rear cross seat shall have a flush mounted LED light. A minimum of 6 candle power will be provided by each reading light cluster to insure adequate visibility with a button for passenger control. A switch to test the function of the reading lamps shall be provided and be labeled "Test." This switch shall be wired so as to override the function of all passengers reading lamp switches and illuminate all reading lamps when it is moved to the test position.

A minimum of six blue LED aisle lights shall be provided on the underside of the street side passenger seats. These lamps shall be mounted in such a manner so as to prevent passengers from damaging the light's when they are illuminated.

The forward interior light fixture(s) shall be designed to automatically extinguish when the passenger door is closed. When the front passenger door is opened and the interior lights are on, the forward left and right hand interior light fixture shall automatically illuminate. A toggle, or three-position, switch on the Operator's instrument panel shall allow the Operator the option of keeping the forward interior lights on constantly.

A stepwell lighting system shall be wired to illuminate when the front door is opened. The system shall provide no less than 2 foot-candles of illumination of the step treads with the doors open.

Passenger door lighting shall illuminate when the master switch is in RUN and NITE/RUN, except the door lamps, which shall be extinguished when the door are closed. The system shall provide no less than two (2) foot candles of illumination at the entry and exit step treads with the doors open. The lights shall be LED type and shielded to protect passengers' eyes from glare. Light fixtures shall be totally enclosed, splash-proof, flush mount design for ease of cleaning. Doorway lights shall be protected from damage caused by passengers kicking lenses or fixtures.

2.2.3.4 Operator's Lighting

The Operator's area shall be provided with a light to provide general illumination to 1/2 of the steering wheel nearest the Operator at a level of ten (10) to fifteen

(15) foot candles. The light shall be controlled by a switch that is convenient to the Operator.

2.2.3.5 Operator Controls

All switches and controls necessary for the operation of the bus shall be conveniently located in the Operator's area. Switches and controls shall be essentially within the hand reach envelope described in SAE Recommended Practice J287 - Operator Hand Control Reach. Controls shall be located so that boarding passengers cannot easily tamper with control settings.

Design of the operator's dashboard configuration and the accelerator/brake pedal (to include angles) shall be submitted as a Mandatory Request for Approval (see Section II of the Solicitation, Item 20).

Accelerator and brake pedals shall be designed for ankle motion and shall be mounted at the same angle. There shall be enough clear space around pedals to allow an Operator with size 14 shoe sufficient space to rest his shoe on each pedal without interference. Foot surfaces of the pedals shall be faced with wear resistant, nonskid, replaceable material. Controls for engine operation shall be closely grouped within the Operator's compartment and shall include a separate master run switch and start switch or button. The run switch shall be a four (4) position rotary switch with the following functions:

- OFF - All electrical systems off, except power available for stoplights, turn lights, hazard lights, silent alarm, Operator's light, interior lights, horn and communication equipment.
- CL/ID - All electrical systems off, except those listed in OFF and marker lights.
- RUN - All electrical systems and engine on, except the headlights, parking lights and marker lights.
- NITE/RUN - All electrical systems and engine on.

The door control, windshield wiper/washer controls, and run switch shall be in the most convenient Operator locations. They shall be identifiable by shape, touch

and markings. Doors shall be operated by a control at the Operator's left hand. The setting of this control shall be easily determined by position and touch.

All switches and controls shall be high quality and marked with easily read identifiers. All switches shall be rocker or toggle switches with the exception of the four (4) position rotary run switch, and the following switches:

- Horn Button.
- Headlight High Beam (Operator's toe board).
- Instrument Panel Dimmer Switch.
- H.V.A.C. Rotary or Toggle Switch.
- Engine Start Button.
- Turn Signal Push Button Switches (Operator's Toe Board).
- Hazard Lights.

All switches and controls shall be serviceable from the vestibule or front "J" box. Switches, controls and instruments shall be dust and water resistant as described in the bus washing practices.

Required switches and controls are listed below:

- A/C and Heat Climate Control Switch(s).
- Defroster Switches (3 position).
- Diagnostic Light Panel Test Function.
- Emergency Stop Switch (If not part of electronic control).
- Fast Idle Switch.
- Foot Controlled Headlight Dimmer Switch (Waterproof - on angled plate).
- Foot Controlled Turn Signal Switches (Waterproof - on angled plate).
- Forward Dome light Control Switch.
- Hazard Warning Switch (To be oversized and identifiable by touch).
- Horn Button, in steering wheel hub, protected to preclude accumulation of transfer punches in steering wheel hub (no identifier required).
- HVAC Switches.
- Internal-External Speaker Switch.
- Interior Lighting Switch.

- Kneel Switch.
- Master Door Switch.
- Master Run Switch.
- Operator's Area Light Switch.
- Operator's Dash Fan Switch.
- Passenger Chime Switch.
- Engine brake switch (ON/OFF) located in engine compartment.
- Start Button or Switch.
- Switch to check all Exterior LED lighting.
- Wheelchair Lift Master Switch.
- Wiper Switch.

2.2.3.6 Instrumentation

The speedometer, air pressure gauge(s), Diesel Exhaust Fluid gauge on a diesel powered bus and certain indicator lights shall be located on the front cowl immediately ahead of the steering wheel. The steering wheel spokes or rim shall not obstruct the Operator's vision of these instruments when the steering wheel is in the straight-ahead position. Illumination of the instruments shall be simultaneous with the marker lamps and utilize LED lights. Glare or reflection in the windshield, side window, or front door windows from the instruments, indicators, or other controls shall be minimized. Instruments and indicators shall be easily readable in direct sunlight with the gauges having defined warning lines to allow the Operator to quickly spot abnormal operation.

Tell Tale immediately in front of the Operator shall include:

- Air Condition Stop (Yellow).
- Fire (Red).
- Generator Stop (Red).
- Hazard Warning (May be Common with Turn Signal Indicator).
- High Headlamp Beam (Blue).
- Left Turn (Green).
- Low Air (Red).

- Parking Brake Applied (Yellow or red).
- Right Turn (Green).
- Stop Lam (Red).
- Stop Request Lamp (Yellow) (Located to one side, not centered).
- Wheelchair Enabled (Yellow).

All Tell Tale lamps are to utilize LED Lights.

A Tell Tale yellow lamp shall be located on the front left side of the bus to indicate that the IVOMS system is on.

The instrument panel shall include a rotating pointer type speedometer indicating eighty (80) mph and calibrated in maximum increments of five (5) mph. Speedometer shall have a dial deflection of 220° to 270° and forty (40) mph near the top of the dial. It shall be equipped with an odometer with a capacity reading of 999,999 miles. The speedometer shall be sized and accurate in accordance with SAE Recommended Practice J678. The instrument panel shall also include air brake reservoir pressure gauge(s) with indicators for primary and secondary air tanks. The air gauges shall be directly plumbed to the air tanks and shall not be dependent on the electrical system. Voltage indicators to indicate the 24 and 12 volt operating voltage across the bus batteries shall be provided. The instrument panel and wiring shall be easily accessible for service. Wiring shall have sufficient length and be routed to permit service without stretching or chafing the wires.

2.2.3.7 Onboard Diagnostics

Critical systems or components shall be monitored with a built in diagnostic system having visual and audible indicators. The diagnostic indicator lamp panel shall be located in clear sight of the Operator but need not be immediately in front of him. The intensity of indicator lamps shall permit easy determination of on/off status in bright sunlight but shall not cause a distraction or visibility problem at night. All indicators shall have a method of momentarily testing the operation of the lamp. Wherever possible, sensors shall be of the closed circuit type, so that failure of the circuit and/or sensor shall activate the malfunction indicator. An audible alarm

shall sound when certain malfunctions are detected by the diagnostic system. The audible alarm shall be loud enough for the Operator to be aware of its operation.

Required audible alarms are:

- Low Air
- Fire
- Stop Engine

Space shall be provided on the panel for future addition of at least two (2) indicators as the capability of onboard diagnostic systems improves. The steering wheel shall not block the diagnostic panel lights.

8) 2.3 Interior Trim

2.3.1 General Requirements

The interior shall be generally pleasing, simple and modern. It shall be easy to clean and maintain. To the extent practicable, all interior surfaces more than ten (10) inches below the lower edge of the side windows or windshield shall be shaped so that objects placed on them fall to the floor when the bus is parked on a level surface.

Handholds, lights, air vents and other interior fittings shall appear to be integral with the bus interior. There shall be no sharp, abrasive edges and surfaces and no unnecessary hazardous protuberances. All plastic and synthetic materials used inside the bus shall meet the requirements of FMVSS-302, Flammability of Interior Materials.

Trim and attachment details shall be kept simple and unobtrusive. Materials shall be strong enough to resist everyday abuse and vandalism. Interior trim shall be secured to avoid resonant vibrations under normal operational conditions.

Type of acoustical material to be used in the headlining and the rear bulkhead and rear interior surfaces shall be submitted as a Mandatory Request for Approval (see Section II of the Solicitation, Item 21).

2.3.1.1 Trim Panels

Panels shall be easily replaceable, tamper resistant and shall be reinforced as necessary. Interior mullion trim, moldings, and trim strips shall be stainless steel, thermoformed plastic or anodized aluminum. Individual trim panels and parts shall be interchangeable to the extent practicable. Colors and patterns shall be coordinated with the flat black or dark stone gray at the Operator's area of the bus. The lower sidewall interior trim shall be fabric covered aluminum panels, with fabric patterns running horizontally. The fabric covering shall be 85% wool material, commonly used in the transit environment that has anti-bacterial, anti-fungal and anti-stain properties built into the material and an anti-graffiti pattern. Panels shall be sectionalized for ease of repair and joined by aluminum extrusion.

2.3.1.2 Headlining

To meet interior sound levels, the ceiling may be covered with a sound deadening tamper proof material. The acoustic material must comply with the noise requirements in this specification. Headlining shall be supported to prevent buckling, drumming, or flexing and shall be secured without loose edges. Headlining materials shall be treated or insulated to prevent marks due to condensation where panels may be in contact with metal members. Moldings and trim strips, as required to make the edges tamper-proof, shall be stainless steel, vinyl clad aluminum or anodized aluminum, colored to complement the ceiling material. Headlining panels covering operational equipment that is mounted above the ceiling shall be on hinges or mounted with "rivnuts" for ease of service but retained to prevent inadvertent opening.

2.3.1.3 Front End

The entire front end of the bus shall be sealed to prevent debris accumulation behind the dash and to prevent kicking or fouling of wiring and other equipment. The front end shall be free of protrusions that are hazardous to passengers standing or walking in the front of the bus during rapid decelerations. Paneling across the front of the bus and any trim around the Operator's compartment shall be formed metal, fiberglass or plastic material. Formed metal dash panels shall

be painted and finished to exterior quality. Plastic dash panels must be reinforced to prevent cracking, vandal resistant, and replaceable. All colored, painted, and plated parts forward of the Operator's barrier shall be finished with a dull matte surface. Colors of Operator's area, including dash, shall be flat black or dark stone gray. There shall be a closeable locker or box near the Operator's seat where the Operator can stow a purse, lunch box or other personal belongings. **Location and installation of closeable locker or box shall be determined and require approval by METRO during the preproduction conference (See Appendix 2, Preproduction Conference, Item PPC 8).**

2.3.1.4 Rear End

The rear bulkhead and rear interior surfaces may be constructed with a sound deadening, tamper proof material mounted to a solid understructure. Color shall be complimentary to the seat fabric color and design.

2.3.2 Passenger Seats

2.3.2.1 Arrangements

The bus shall have a minimum seating capacity of fifty five (55) passengers and excludes the Operator's position.

The seat frame shall be wall mounted with heavy gauge steel brackets and shall be attached to the coach floor with a heavy duty stainless steel T pedestal. The weight for a standard double seat with wall-bracket and center leg shall be below 100lbs. The seat back shall recline five (5) inches maximum with an infinite number of stops. The reclining seat backs shall be provided with a dress up feature to facilitate coach cleaning. Seat width shall be nominal 39 inches. Aisle shall not be less than 14 inches wide. Seat covering shall be 85% wool material, commonly used in the transit environment that has anti-bacterial, anti-fungal and anti-stain properties built into the material and an anti-graffiti pattern. The contractor shall provide a ½ inch, top layer of foam on seat cushions, less dense than the seat foam padding, to increase passenger comfort. Backrest fabric shall be rugged carpet material. Seat armrest shall be dark gray in color and to be downfolded on the

corridor side. The aisle seats shall be equipped with a grab hold at the top of the seat.

Seat foam padding shall be cold molded polyurethane. Seat upholstery shall utilize zippers or Velcro which allows them be removed from the seat cushions for cleaning/replacement purposes. The contractor shall provide a ½ inch, top layer of foam on seat cushions, less dense than the seat foam padding, to increase passenger comfort. Patterns shall be selected during the pre-production conference.

All materials used on the seat assembly shall meet the flammability and smoke emission requirements of the Federal Motor Vehicle Safety Standard No. 302.

Hip-to-knee room measured from the front of one seat back cushion horizontally across the highest part of the seat cushion to the seat or panel immediately in front, shall be no less than thirty (30) inches. At all seating positions in paired transverse seats immediately behind other seating positions, hip-to-knee room shall be no less than thirty-one (31) inches.

Each transverse seat, except the rear seats, shall accommodate two (2) adult passengers and be equipped with individual non-cushioned inserts. The area between the longitudinal seat backs and the attachment to the bus side walls shall be designed to prevent debris accumulation.

Seat backs shall be shaped to increase this dimension at standing passenger hip height.

2.3.2.2 Dimensions

Seats for the various seating arrangements shall have the dimensions shown in the seating dimensions and standard configuration shown below.

Seating Dimensions and Standard Configuration

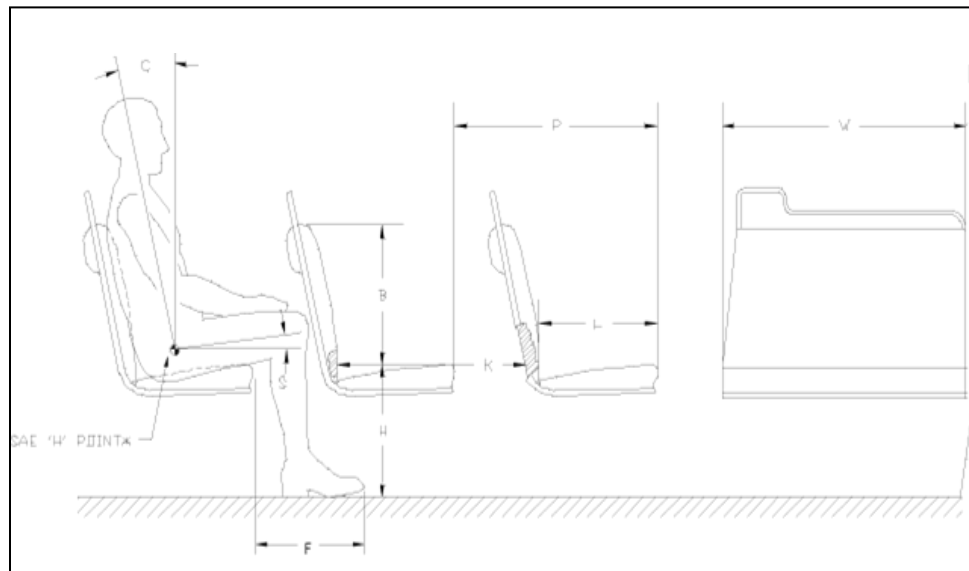

Seat dimensions for the various seating arrangements shall have the dimensions as follows (refer to above figure):

- The width, W, of the two-passenger transverse seat shall be a minimum 39 in.
- The length, L, shall be 17 in., ± 1 in.
- The seat back height, B, shall be a minimum of 26.5 in.
- The seat height, H, shall be 17.5 in., ± 1 in.
- Foot room = F.
- The seat cushion slope, S, shall be between 5 and 11 degrees.
- The seat back slope, C, shall be between 8 and 17 degrees.
- Hip to knee room = K.
- The pitch, P, is shown as reference only.

The rear cross bench seat shall be no less than 17" wide.

2.3.2.3 Structure and Design

The passenger seat frame and its supporting structure shall be constructed and mounted so that space under the seat is as free of obstructions as possible to facilitate cleaning. The underside of the seat and the side wall shall be configured to prevent debris accumulation and the transition from the seat underside to the

bus side wall to the floor cove radius shall be smooth. Trash reflectors are not required.

2.3.3 Operator's Seat

The Operator's seat shall be a heavy-duty black vinyl or synthetic leather material, air suspension type with adjustable headrest, adjustable tilt control for the seat bottom, air slide without pneumatic lumbar support. The Operator's seat shall be designed to accommodate 500 pounds. The Operator's seat shall be ergonomically designed so it will adjust to compensate for different Operator heights and weights. The Operator's seat shall not have arm rests. The seat bottom extender shall provide sufficient travel to allow Operators easier access to the bus pedals. All controls must be clearly marked to define their function and must be conveniently accessible on the right side by the operator from the seated position. A complete instruction sheet, made of laminated material, on the operation of the Operator's seat shall be provided with each bus.

Seat support shall have sufficient dampening capability to preclude bouncing or bottoming/topping out. Fore-and-aft seat travel shall be at least nine (9) inches accomplished by air adjustment. Seat stops shall be supplied to prevent hitting the Operator's barrier.

Operator's seat belt shall be a one piece lap and shoulder (Three-Point) seat belt with a single buckle. Seat belt shall be provided across the driver's lap and diagonally across the driver's chest. Three-point seatbelt must be emergency locking retractor (ELR) in design. Seatbelt webbing shall not be black but shall be a bright orange color. Seat belt shall be stored in automatic retractor. The belt shall be mounted to the seat frame so that the driver may adjust the seat without resetting the seat belt. The seat and seat belt assemblies as installed in the bus shall withstand static horizontal forces as required in FMVSS 207 and 210. The seatbelt assembly shall come equipped with a loud warning device to remind operators to buckle up, the device shall activate when the parking brake is off and the seatbelt is not buckled. The lap belt assembly shall be 72 in. in length with an 8-in. extension. Vertical adjustment travel of seat shall not be less than four (4) inches. Seat cushion bottom and seat back shall have manually controlled

adjustments to provide a comfort range from a 5th percentile female to a 95th percentile male.

Model and description of Operator's seat shall be submitted as a Mandatory Request for Approval (see Section II of the Solicitation, Item 22).

2.3.4 Floor Covering

Description and sample of floor material and silicone caulking shall be submitted as a Mandatory Request for Approval (see Section II of the Solicitation, Item 23)

2.3.4.1 Vestibule

The floor in the vestibule shall be medium gray molted speckles, 3/16 inch thick, non-skid, ribbed, and rubber composition material. The floor covering shall present no tripping hazards. Floor covering ribs shall run transversely in line with the entrance door and longitudinally in line with the aisle and shall be joined smoothly at the fare box/entrance door vestibule. The yellow standee line shall be at least two (2) inches wide and shall extend across the bus aisle in line with the Operator's barrier.

2.3.4.2 Operator's Compartment

The floor in the Operator's compartment shall be a medium-gray with mottled-speckles, 1/8 inch thick, smooth surface heavy duty rubber composition material.

2.3.4.3 Passenger Area

The floor in the passenger area shall be of a non-skid rubber composition material. A one-piece medium gray-mottled speckles center strip shall extend from the rear seat to the standee line (can be broken at steps if necessary). The material shall be 3/16 inch thick in the aisle section and longitudinally ribbed.

The flooring under the seats shall be covered with 1/8 inch thick, medium gray mottled speckles, smooth surface flooring material. The floor covering shall closely fit and extend to the top of the cove.

Floor covering shall be attached continuously to the sub-floor by waterproof adhesives without voids. All seams and interfaces with the wall, wheel wells, etc., shall be covered with trim that will provide a floor that is free of tripping hazards and easy to clean by dry and wet wash with cleaning solutions. Urethane sealant shall be used at seams so no moisture may enter into the flooring material.

Yellow ribbed nosing shall be used at Operators step and platform, exit doors and at the step up to the rear raised floor section, if applicable.

9) 2.4 Windows

2.4.1 Operator's Windows

2.4.1.1 Windshield

The windshield shall permit an Operator's field of view as referenced in SAE Recommended Practice J1050. The windshield shall be designed to minimize external glare as well as reflections from inside the bus when the bus is operated at night with the passenger interior lighting on. Windshield shall be AS-1 laminated safety glass.

The windshield shall be easily replaceable by removing zip locks from the windshield retaining moldings. Zip-locks shall be constructed of low shrinkage material. Seam shall be located at the bottom of windshield. Bonded-in-place windshields shall not be used. The glazing material shall have single density tint

2.4.1.2 Operator's Side Window

The Operator's side window shall open sufficiently to permit the seated Operator to easily adjust the left outside rear view mirror. This window section shall slide rearward in tracks or channels designed to last the service life of the bus. The Operator's window shall be non-locking or provided with an outside release device.

The glazing material shall be single density laminated safety or tempered glass tinted smoke gray to the maximum legal limit.

Driver window glazing shall be a blue hue, allowing 70% LT or greater to pass through the pane. The glazing shall have ¼ inch (6.4 mm) nominal thickness and be laminated heat-treated safety glass. The material shall conform to the requirements of ANSI Z26.1 and the Recommended Practices defined in SAE J673. The glass will comply with AS2 DOT requirements, blocking 99% of the UV and allowing less than 5% of the infrared heat to pass through the pane.

2.4.2 Side Windows

2.4.2.1 Dimensions

Side windows shall extend from the shoulder height of a 5th percentile, seated female passenger to the eye level of a 95th percentile, seated male passenger. The width of vertical mullions between windows including the trim shall be minimized. All side windows shall be replaceable without disturbing adjacent windows.

The side windows shall be a single pane of flush mounted seamless glass

If side windows used as an emergency escape, the release handles shall be positioned so passengers cannot use them as assists when standing. The release mechanisms will be designed with sufficient strength to preclude damage from normally expected abuse.

2.4.2.2 Materials

Side glazing material shall be flat glass, 0.1875 or 0.250-inch nominal thickness. The material shall conform to the requirements of ANSI Standard for Type AS-3 Safety Glazing Materials. Windows on the bus sides shall be between 25 to 28% percent luminous transmittance. Window sashes shall be black anodized or powder coated aluminum.

Templates for window glazing material and exact color and tint density of windows shall be provided with pilot bus (Deliverable, See Appendix No.1, Item D3).

2.4.2.3 Destination Sign Windows

Windows over the front and side destination signs shall be designed to eliminate reflections and fogging to the maximum extent possible. The windows shall not be tinted. Windows over the front and side signs shall be glass and shall not be bonded in place.

2.4.2.4 Water Test

The contractor shall successfully water test each bus at the factory before delivery. At a minimum the test shall consist of a thirty (30) minute saturation, starting with everything on the bus turned off. At the mid-point (15 minutes) everything on the bus shall be turned on and allowed to run for the remaining fifteen (15) minutes. Any leaks detected must be repaired and the complete thirty minute test repeated until no leaks are detected. **Failure of the above described water test will result in non-acceptance of the bus until a successful completion of the water test is performed.**

2.4.2.5 Emergency Exit (Egress) Configuration

There shall be six (6) emergency exit (egress) windows installed on the bus. **Location and installation of emergency exit (egress) windows shall be determined and approved by METRO during the preproduction conference. (See Appendix 2, Preproduction Conference, Item PPC 9).**

10) 2.5 Insulation

2.5.1 Material

2.5.1.1 Properties

All insulation material used between the inner and outer panels shall be fire resistant and completely sealed to minimize entry of moisture and to prevent its retention in sufficient quantities to impair insulation properties. Insulation properties shall be unimpaired by vibration compacting or settling during the life of the bus. The insulation material shall be non-hygroscopic and resistant to fungus and the breeding of insects. Any insulation material used inside the engine compartment shall be fire resistant and shall not absorb or retain oils or water.

2.5.2 Performance

2.5.2.1 Thermal Insulation

The interior of the bus body, including, but not limited to the ceiling and walls, shall be fully insulated against heat and cold and shall provide thermal insulation sufficient to meet the interior temperature requirements stated in this technical specification. The bus body shall be thoroughly sealed so that drafts cannot be felt by the Operator or passengers during normal operation with the passenger doors closed.

2.5.2.2 Sound Insulation

The combination of inner and outer panels and any material used between them shall provide sufficient sound insulation so that a sound source with a level of 80 dBA measured at the outside skin of the bus shall have a sound level of 65 dBA or less at any point inside the bus. These conditions shall prevail when all openings are closed, including doors and windows, and with the engine and accessories switched off.

The bus generated noise level experienced by a passenger at any seat location in the bus shall not exceed 83 dBA and the Operator shall not experience a noise level of more than 75 dBA under the following test conditions.

Test data verifying that criteria have been met for the bus proposed for bid shall be submitted as a Mandatory Request For Approval (see Section II of the Solicitation, Item 24).

The bus shall be empty except for the test equipment and test personnel, not to exceed four (4) persons. All openings shall be closed and all accessories shall be operating during the test. The bus shall accelerate at full throttle from a standstill to forty-five (45) MPH, and back down to zero using a light pressure on brake pedal, on level commercial asphalt or concrete pavement in an area free of large reflecting surfaces within fifty (50) feet of the bus path. During the test, the ambient noise level in the test area shall be at least 10 dBA lower than the bus under test. Instrumentation and other general requirements shall conform to SAE Standard J366. Aside from the above test, any device emitting sound and signal in the interior or on the exterior of the bus shall not be adjustable below 20%.

11) 2.6 Ancillary Features

2.6.1 Operator's Area

2.6.1.1 Visors

Three adjustable rod guided roller shades shall be provided, one at both sides of the windshield and one the Operator's side window. Shades shall be shaped to minimize light leakage between the visor and windshield pillars. Shades shall store out of the way and shall not obstruct air flow from the climate control system or foul other equipment such as the radio handset or the destination sign control. Deployment of the shades shall not restrict vision of the rear view mirrors. Shade adjustments shall be made easily by hand with positive locking and releasing devices. Sun shade construction and materials shall be strong enough to resist breakage during adjustments. Mounting of shade must be accomplished with tapping plates. Shades shall be effective in the Operator's field of view at angles more than 5° above the horizontal and be fully adjustable for all Operators use regardless of Operator's height.

The sun shades shall cover full width of the window and at least one-half (1/2) of the window height and be made of non-reflective gray material.

Type and method of sun shade installation shall be submitted as a Mandatory Request for Approval (see Section II of the Solicitation, Item 25).

Sun shade installation and operation shall be determined and approved by METRO during the preproduction conference with final approval by METRO after delivery of pilot bus, but before start of production of remainder of order (See Appendix 2, Preproduction Conference, Item PPC 10).

2.6.1.2 Exit Signal

A passenger chime signal audible to the operator with a speaker in the operator's area that has volume control that cannot be adjusted below 20% and a separate speaker audible to passengers anywhere inside the bus with volume control that cannot be adjusted below 20% in the passenger area shall be provided. An Operator controlled switch shall de-activate the chime system. The chime system shall activate one "Stop Request" signs, located on the front upper destination sign door visible to all passengers. Passenger exit chime system must be clearly marked and identified.

2.6.1.3 Operators Cup Holder

The contractor shall provide a cup holder for the driver accessible only to the driver.

Placement of cup holder shall be determined and approved by METRO during the preproduction conference with final approval by METRO after delivery of pilot bus, but before start of production of remainder of order (See Appendix 2, Preproduction Conference, Item PPC 11).

2.6.2 Mirrors

Initial placement of interior and exterior mirrors shall be determined and approved by METRO during the preproduction conference with final approval by METRO after delivery of pilot bus, but before start of production of remainder of order (See Appendix 2, Preproduction Conference, Item PPC 12).

2.6.2.1 Outside Mirrors

The bus shall be equipped with corrosion resistant, electric outside rear view mirrors designed for METRO buses. Mirrors shall permit the Operator to view, without vibration, the highway along both sides of the bus, including the rear wheels. The contractor shall install the mirrors per the manufacturer's recommendations. The contractor shall install the street side mirror with sufficient viewing angle between the mirror head and the "A" pillar. Each rear view mirror shall measure at least nine (9) inches by ten (10) inches and have a minimum surface area of ninety (90) square inches.

In addition to the standard rear view mirrors, the bus shall be equipped with a 6" convex mirror incorporated under the rear view mirrors. Mirrors shall be firmly attached to the bus to prevent vibration and loss of adjustment, but not so firmly attached that the bus or its structure is damaged when the mirror is struck in an accident. Mirrors shall retract or fold sufficiently into the bus body, without touching, to allow bus washing operations. Mirrors shall be fully adjustable by the operator without tools.

Description of outside mirror type and installation for the bus proposed for bid shall be submitted as a Mandatory Request for Approval (see Section II of the Solicitation, Item 26).

2.6.2.2 Inside Mirrors

Mirrors shall be provided for the Operator to observe passengers throughout the bus without leaving the operator's seat and without shoulder movement. With a full standee load, including standees in the vestibule, the operator shall be able to observe passengers anywhere in the aisle, rear door area and in the rear seats. Inside mirrors shall not be in the line of sight to the right outside mirror. Mirrors shall be of unit magnification and be ball mounted.

2.6.3 Passenger Assists

2.6.3.1 General Requirements

Passenger assists in the form of full grip, vertical stanchions or handholds shall be provided for the safety of standees and for ingress/egress. Passenger assists shall

be convenient in location, shaped and sized for both the 95th percentile male and the 5th percentile female standee. Excluding those mounted on doors, the assists shall be between 0.85 and 1.5 inches in diameter.

All passenger assists shall permit a full handgrip with no less than 1.5 inches of knuckle clearance around the assist, except the assists mounted on the door panels that shall have no less than one (1) inch of knuckle clearance and the parcel rack hand holds which are not full grip. Any joints in the assist structure shall be underneath supporting brackets and securely clamped to prevent passengers from moving or twisting the assists.

Assists shall withstand a force of three hundred (300) pounds applied over a twelve (12) inch linear dimension in any direction normal to the assist without permanent visible deformation. Brackets, clamps, screw heads and other fasteners used on the passenger assists shall not present a hazard to passengers, and shall be free of rough edges and flush with the surface or surface mounted.

2.6.3.2 Doorway

Doors or the entry area, shall be fitted with yellow powder coated assists no less than .75 inches in width. Assists shall be as far outward as practicable, but shall be no further than six (6) inches from the outside edge of the front door and shall be easily grasped by a 5th-percentile female boarding from street level. Door assists shall be functionally continuous with the horizontal front passenger assist and the vertical assist on the front modesty panel.

2.6.3.3 Vestibule

The aisle side of the Operator's barrier and the modesty panels shall be fitted with vertical passenger assists that are functionally continuous with the overhead assist and that extend to within thirty six (36) inches of the floor. These assists shall have sufficient clearance from the barrier to prevent inadvertent wedging of a passenger's arm.

A horizontal passenger assist shall be located across the front of the bus to minimize the possibility of passengers sustaining injuries on the fare collection device or windshield in the event of a sudden deceleration.

Without restricting the vestibule space, the assist shall provide support for a boarding passenger from the front door through the fare collection procedure. Passengers shall be able to lean against the assist for security while paying fares. The assist shall be no less than thirty six (36) inches above the floor. The assists at the front of the bus shall be arranged to permit a 5th-percentile female passenger to easily reach from the door assist, to the front assist to vertical assists on the Operator's barrier or front modesty panel.

2.6.3.4 Overhead

A continuous, full grip, overhead assist shall be provided except forward of the standee line. This assist shall be convenient to standees anywhere in the bus and shall be located over the center of the aisle seating position of the transverse seats. No more than five (5) percent of the full grip feature shall be lost due to assist supports.

2.6.4 Exterior Route Information Displays

All destination signs, run number sign and Operator's console mount locations and description/identification of all test methods, parameters and options shall be submitted as a Mandatory Request For Approval (see Section II of the Solicitation, Item 27).

2.6.4.1 Front Destination Sign Compartment

The electronic front destination sign shall be a large format type, installed above the windshield. A water-tight compartment shall be arranged to permit interior cleaning of the front sign glass without the removal of the sign. The destination sign compartment shall be sealed to prevent entry of dirt, dust, water and insects during normal operating and cyclone cleaning procedures.

The front destination sign glass shall be ¼" inch thick laminated or solid tempered sheet glass. Glass shall use zip-locks. Glass shall be sized to allow at least one (1) inch clearance around any letters displayed by the sign.

2.6.4.2 Technical Requirements

The following specifications represent minimum standards for new signs that must be met in the performance requirements of this statement of work.

2.6.4.3 System Characteristics

The system shall use nonvolatile read/write programmable memory circuits to store the message listing and program code and have the capability to display at least 8,000 message lines, based upon an average of 12 characters per message line. The system shall have the additional ability to sequentially display multi-line destination messages, but with the route number portion remaining stable in a constant on mode at all times (including display of Public Address Messages).

The system shall incorporate an auto blanking feature that will cause the entire display area to be blank within thirty (30) seconds of the vehicle master power switch being turned off.

The system shall be designed so that the destination signs can display independent messages or the same messages, as chosen by the message programmer during creation of the message listings.

The system shall be capable of displaying all numbers, common symbols and all upper and lower case letters of the alphabet.

The system shall allow two destination messages and one public relations message to be preselected. The operator shall be able to quickly change the preselected message without re-entering the message code. Public relations messages, when selected, shall be capable of being displayed alternately with the regular text and route messages or displayed separately.

The system message programming software shall provide a means of adjusting the length of time the messages are displayed from one second to twenty five seconds duration. The blanking time between messages shall also be adjustable from one second to twenty-five seconds. Each line or blanking time of each message shall be capable of having a different retention time.

Power shall be provided to the sign system components from a circuit breaker at the vehicle's electrical junction box. The power takeoff point at the electrical junction box shall be controlled by the master run switch.

A relay shall be used for the main power and a multiplex output for 5A output power.

2.6.4.4 Operator Control Console

Destinations for the sign system shall be selectable from a switch console located in the Operator's compartment or area that is accessible by 5th percentile female through 95th percentile male Operator. It shall be recess mounted on the destination sign compartment door, located within easy reach of an average size Operator. The sign shall be easily readable in direct sunlight and at night. The console housing shall be sealed to prevent entry of dirt, moisture, dust and insects under normal operation or cyclone cleaning conditions. The control console shall utilize membrane type touch pads. The sign shall be powered by 24 volts independent of the master switch. The ignition signal shall be supplied by the multiplex system. The Operator's control console shall be used to view and update display messages and shall provide the controls and memory for display messages. The console display shall inform the operator on the status of the sign system and, should the display be of liquid crystal type or vacuum fluorescent, be Operator adjustable to maximize display contrast at different viewing angles. The control console shall contain an audio annunciator that beeps to alert the operator to view the display for a message, or beeps indicating that a key is depressed. An external only emergency message capability shall be provided. The enabling mechanism must be of such a nature that it does not automatically allow the emergency message to be displayed without the bus operator's knowledge. The message is to be displayed only by the activation, by the bus operator, either

through the operation of a special switch provided by others or by dialing or inputting the code number assigned to the message. In no case shall the emergency message be inadvertently displayed due to road conditions and/or without the bus operator's knowledge.

2.6.4.5 Programming

The sign system must be reprogrammable on the bus with the use of a memory transfer module, USB key, Wi-Fi and via the J1708/1939 Transit Data Link. Either method of message list programming shall not inhibit the operator from inputting message codes via the control console keypad during normal operation.

A programming software package shall be provided to generate message lists for the destination sign system. The programming software package shall be "Windows" compatible and shall use the capability of a compatible computer with hard disk. The software package shall allow the memory transfer module to be programmed directly from the PC. The programmer shall be designed for ease of deleting and adding messages to the destination sign list.

The programming software shall use techniques that require minimum operator training and that are intended for use by operators that are not trained in complex computer operations. All operator screens shall utilize a pull down menu technique and use non-technical commands. Help shall be available to the operator by pressing the "F1" function key that will cause "help" information to be displayed that is pertinent to the activity occurring at the current cursor location on the screen. A tutorial disk shall be included for operator self training.

The software shall provide capability for custom message writing by selection of pre-programmed standard and/or variable fonts; by creation of a custom font; by varying spacing between characters, words, or other message elements; by allowing creation of graphic displays through picture editing with draw-a-dot-at-a-time capability, with or without text; by selecting preprogrammed graphic sign images; and by allowing use of multiple fonts within the same message line and graphic symbols placed anywhere within the display area.

All computer software required to transfer the electronic sign list into the memory transfer module's non-volatile read/write memory shall be furnished by the Contractor.

The load module from the compatible PC to the vehicle sign controller shall be available in file form for alternate loading of the sign memory by the J-1939-Transit Data Link method of accessing the vehicle controller.

The Sign Controller shall accept, and respond to, all applicable commands of a SAE J-1939 interface in accordance with the protocol section, SAE J-1587.

Applicable commands shall include, but not be limited to, existing Parameter Identification Definitions (PIDs):

- 12)A.192, Multi-section Parameter
- 13)A.194, Transmitter System Diagnostic
- 14)A.195, Diagnostic Data Request/Clear
- 15)A.196, Diagnostic Data/Count Clear Response
- 16)A.243, Component Identification Parameter
- 17)A.256, Request Parameter
- 18)A.257, Cold Restart of Specific Component
- 19)A.258, Warm Restart of Specific Component
- 20)A.259, Component Restart Response
- 21)A.384, Component Specific Request Parameter
- 22)A.501, Signage Message (Change Sign Message Command)
- 23)A.510, Data Link Escape

Communications to change sign messages (A.501) from the SAE J-1939 port shall affect the sign display just as though the command was entered from the operator's manual keypad.

2.6.4.6 Test Compliance:

All components of the sign system shall be compliant with SAE J-1455 environmental standards, with identification of all test methods, parameters and options with the submittal of test criteria.

2.6.4.7 Display Characteristics

The Contractor shall ensure that the signage furnished and installed under the requirements of this contract be compliant, in all respects, with the current guidelines of the ADA.

The signs shall allow for each pixel to be addressed separately for provision of graphics and double stroked letters.

2.6.4.8 Front Sign

The electronic front destination sign shall be installed above the windshield. The destination sign compartment shall be sealed to prevent entry of dirt, dust, water and insects during normal operating and cyclone cleaning procedures.

The front destination sign message shall have the capability of displaying a one line message with a minimum 7.9 inch character height. The front sign shall be readable by a person with 20/40 vision from a distance of one hundred and fifty (150) feet. The sign shall have equal readability at points 65°F on either side of a line perpendicular to the center of the mean plane of the sign display.

The display shall be capable of displaying a three digit route number plus an alphanumeric message, including punctuation characters. When displaying an ADA compliant double stroked route number of "888" and eleven "W" characters, sign shall utilize a minimum of seven (7) rows and greater than eighty (80) columns.

The front destination sign display shall be illuminated with white light emitting diodes (LED's) in all positions.

Access panels and display boards shall be mounted for ease of maintenance and/or replacement, using captive, quarter-turn fasteners. The sign box shall inhibit entry of dirt, dust, water and insects during normal operation or cleaning with a cyclone cleaner. Access shall be provided to clean the inside of destination sign windows and to remove or replace the sign mechanism. It shall not be

necessary to remove the sign assembly to clean either the sign lens or the destination sign cavity window.

2.6.4.9 Side Sign

The side destination sign shall have the capability of displaying on one line a message with a minimum 2.5 inch character height. The side destination message shall be readable by a person with 20/40 vision from a distance of fifty (50) feet. The sign shall have equal readability at points 65°F on either side of a line perpendicular to the center of the mean plane of display and shall be easily read from the sidewalk level by a person of average height standing at a distance 3 or more feet from the side of the bus.

The display shall be capable of displaying a three digit route number plus an alphanumeric message, including punctuation characters. When displaying an ADA compliant double stroked route number of "888" and eleven "W" characters, signs of a matrix type shall utilize seven (7) rows and ninety (90) columns.

The side sign shall be secured in a furnished enclosure, mounted to allow cleaning of the glass in front of the sign.

The sign compartment shall be black and shall enclose all wires and sharp objects to prevent a safety hazard. Access panels and display boards shall be mounted for ease of maintenance and/or replacement, using captive, tamper proof fasteners. The side destination sign display shall be white light emitting diodes (LED's) in all positions.

2.6.4.10 Run Number Sign

A lightweight, serviceable, plastic hinged, illuminated, four-digit run number sign box shall be installed on the right front side of the dashboard. The sign box shall have four (4") inch individually controlled numbers on roller curtains. The run number shall be mounted to permit minimum amount of obstruction to defrosting of windshield and allow maximum operator's view of passengers crossing in close proximity to the front of the bus. Mounting area of dashboard must be reinforced to permit long life without dashboard cracking.

Curtain shall be illuminated with a two (2) candle power, 12 or 24 volt LED lamp behind each curtain and shall be designed to prevent the emission of light streaks between the curtain openings. The curtain shall be spaced from the lamps sufficiently to preclude burning, premature aging, sticking, or charring of the curtain material. Circuit shall be wired to master switch.

The openings in the sign box shall be glazed with cast acrylic sheet transparent plastic material. There shall be knife connectors or Weather-PAC connectors in the wiring below the dashboard and sign.

The exposed leads through the dash shall be a two (2) conductor cable entering the run number box through grommets mounted in the dashboard and sign.

2.6.4.11 Run Number Sign

The rear destination sign message shall have a minimum of three (3) double stroke characters that meet ADA and shall provide a minimum of 6.1 inch character height sign mechanism in all buses. The rear sign shall be capable of displaying numbers. When displaying an ADA compliant double-stroked route number of "888" signs of a matrix type shall utilize seven (7) rows and twenty three (23) columns.

The rear sign shall be sealed in a furnished housing flush mounted on the rear of the bus in a position to be approved by METRO's Project Manager. The housing shall be waterproof and shall operate and not sustain damage at heat soak temperatures, which can, short term, approach 400 degrees, Fahrenheit.

The rear destination sign shall be light emitting diodes (LED) in all positions.

2.6.5 Fare Collection

Space and structural provisions shall be made for installation of a Cubic Western Model 1030 electronic fare collection device as far forward as practical, preferably recessed into the front dash. Location of the fare box shall not restrict traffic in the vestibule and shall allow the Operator to easily reach the coin drop levers and to view the change platform. The fare box shall not restrict access to the Operator's

area nor restrict operation of Operator controls. Fare box location shall permit accessibility to the vault for easy removal. Fare Box location must not interfere with or cause injury to METRO's Operators due to its location and clearances.

The Contractor shall furnish switched 12-volt DC electrical service from the vehicle 12vdc power distribution source to the mounting location of the fare box. This service shall be protected with a 15 amp manual-resetting circuit breaker.

The floor under the fare box shall be reinforced and pre-drilled with appropriately sized and spaced holes as necessary to provide a sturdy mounting platform and to prevent shaking of the fare box.

Fare box installation/location and drawings shall be determined and approved by METRO during the preproduction conference with final approval by METRO after delivery of pilot bus, but before start of production of remainder of order (See Appendix 2, Preproduction Conference, Item PPC 13).

2.6.6 Next Stop Sign

One SAE J-1939 compatible Next Stop Interior Sign at the front of the bus shall be provided. In addition to the Next Stop sign the contractor shall install a visible alarm on the driver's dash to alert the driver when the stop request button has been activated.

Description, function methodology and location of Next Stop Sign shall be provided as a Mandatory Request for Approval (see Section II of the Solicitation, Item 28).

24) 2.7 Accessibility Equipment

As a minimum, all accessibility equipment and vehicle access dimensions shall comply with all applicable standards for accessible vehicles as set forth in the Department of Transportation (DOT) Regulations, Title 49: Transportation; PART 37—TRANSPORTATION SERVICES FOR INDIVIDUALS WITH DISABILITIES (ADA), Subpart D—Acquisition of Accessible Vehicles By Public Entities, §37.71

Purchase or lease of new non-rail vehicles by public entities operating fixed route systems, [56 FR 45621, Sept. 6, 1991, as amended at 76 FR 57936, Sept. 19, 2011] and this specification. This specification includes the Wheelchair or Mobility Aid Envelope.

Complete, scaled, interior layout drawings showing seat positions, hip-to-knee room, foot room, seat height and width dimensions, aisle widths, passenger assists, floor contour, fare box location and all other pertinent interior dimensions including wheelchair maneuverability and free floor space area of the bus proposed for bid shall be submitted as a Mandatory Request For Approval (see Section II of the Solicitation, Item 29).

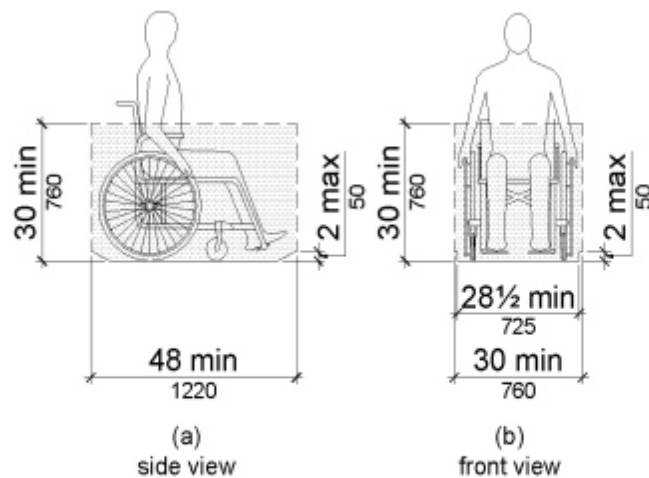

Figure 1
Wheelchair or Mobility Aid Envelope

“The required clear space (envelope) for a wheelchair or mobility aid is a minimum 48 inches long and a minimum 30 inches wide, measured at 2 inches above the floor or platform surface, and extending to a height of 30 inches minimum above the floor or platform surface. The minimum clear width at the floor or platform surface is 28-1/2 inches.”

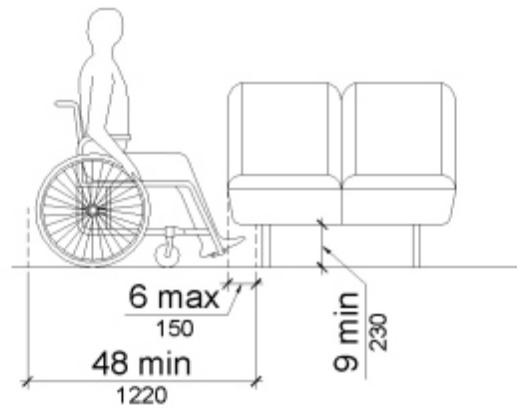

Figure 2
Toe Clearance Under a Fixed Element

“A maximum of 6 inches of toe space of the 48 inches required for a wheelchair or mobility aid may extend under a seat, modesty panel, or other fixed element if there is a minimum of 9 inches of vertical clearance under the element.”

Compliance to this requirement will be determined by successful passage of an actual wheelchair dimensionally compliant to the Mobility Aid Envelope.

2.7.1 Wheelchair Lift

A dedicated access extended travel lift and two forward facing mobility device securement areas to accommodate a maximum 30.0 inches wide mobility device shall be provided. The lift assembly shall comply with all current ADA and FMVSS 403 and 404 requirements. The lift shall be installed below the floor line at the number 2 right-hand luggage bay on the curbside of the coach.

The lift shall be controlled by a dash mounted toggle switch and a rear lift area toggle switch, and operated by up/down switches on a pendant mounted to the lift support bracket inside the number 2 baggage bay. The lift Restraint Belt must be buckled before the lift can be raised or lowered. The safety interlock circuit can be energized to operate the lift only if: the transmission is in neutral, the park brake is applied, engine Fast Idle is ON, the dash-mounted Master Switch is ON, the lift Secondary Switch is ON and the lift restraint belt is buckled.

The wheelchair loading system shall provide safe, comfortable and rapid ingress and egress for applicable passengers from the street level or a curb. When not in use, the lift shall stow in the luggage bay. The lift mechanism shall include a

Threshold Warning device to provide "passenger on platform" information and prevent stowing the lift platform when a passenger is sensed. The outer barrier shall be automatically controlled and shall be such that it cannot be overridden by the loading system operator. A dash mounted indicator light shall be provided and shall be illuminated when the loading system is activated. The interlock shall apply, the bus shall not move and the engine throttle shall be disabled whenever the wheelchair loading system is activated. If the lift door is open or ajar, the interlock shall remain engaged. Brackets, clamps, screw heads and other fasteners used on the passenger assists shall be anodized aluminum or stainless steel and shall be flush with the surface and free of rough edges.

The lift control mounted on the lift structure shall have push button Up / Down switches. The toggle electrical supply switch shall be located in close proximity to the controller. This toggle switch must be turned "ON" prior to the lift operation. All lift control switches shall be permanently labeled. Decals shall not be permitted. The stow guard switch shall be red in color and the Stow / Deploy switch shall be black in color. These switches shall be incorporated in a hand held pendant.

The lift shall include the following specifications:

- Lifting capacity (main platform) 700 pounds
- Vertical travel..... 63" maximum
- Platform width (chair capacity) 30" minimum
- Platform depth (chair capacity) 48" minimum
- Platform side height 1.50" minimum
- Handrail height - two (2) 30" minimum
- Cassette stowed dimension (depth)72.25" total
- Cassette Width & Height 43.5" x 8.375"
- Operating controls 3 pushbutton
- Power source..... Electro- hydraulic
- Voltage 24 volts DC
- Back up system Emergency hand pump
- Construction Steel and aluminum
- Stow level to ground cycle time 12 seconds at 70 degrees (21° C) – no load

- Ground to floor level cycle time 12 seconds at 70 degrees (21° C) – no load
- Hydraulic system fluid capacity 1.0 quart
- Hydraulic system operating pressure 2500 psi minimum

The lift shall be designed to meet the Title 13 California Highway Patrol requirements and Federal Department of Transportation Regulations 49 CFR 38. The lift shall include a hinged platform to bridge the coach floor to the lift platform. Bridge shall be hinged and locked in an upward position to act as a barrier when the lift is in use. Bridge shall also allow the lift passenger to ingress/egress easily from the platform. Lift travel speeds and lift operation shall be adjusted to the lift manufacturer's specifications upon completion of the lift installation into each coach and before coach delivery. The individual handrails shall incorporate a visual aid to insure that they are folded in the proper order.

The lift shall include an emergency system in case of driver operation malfunction. Should an emergency situation occur, the lift operator shall release the pushbutton switch on the controller to immediately stop the lift operation. Loss of electrical power shall also stop the lift operation regardless of switch position. An emergency auxiliary hydraulic hand pump shall be used to complete the lift cycle. The emergency hand pump handles and pump shall be located in an enclosed box at the rear wall of the number 1 right-hand baggage bay to prevent the accumulation of dust and dirt. The pump shall be easily accessible through baggage bay door. The handle shall be stored adjacent to the pump to allow immediate usage.

The contractor shall supply and install alpha-numeric decals on the functional elements of the lift to enhance the ability of the operator to operate the lift.

Description and specifications of the wheelchair lift, its slip resistant qualities, lift control switch locations, lift override and overall operation shall be submitted as a Mandatory Request For Approval (see Section II of the Solicitation, Item 30).

2.7.2 Lift Door

The lift door shall be a single leaf design that operates in a sliding track mounted both above and below the door leaf. The door shall open by sliding to the rear of the coach and shall remain on a horizontal plane throughout the opening and closing process. No pin hinged doors shall be provided. The opening and closing of the lift door shall be aided thru the use of air. The transmission must be in neutral and the parking brake activated for the lift to operate. The accelerator shall be automatically disabled and the fast idle system activated when either the lift master switch is turned "ON" or the lift door is open in order to provide maximum safety and security. These features shall be wired to the lift master switch to allow activation only when the transmission is in neutral. The coach directional (Hazard) lights will also flash on/off. After the lift operation is completed, the lift shall be properly stored and secured, with the access door closed and the lift master switch at the dash in the "OFF" position in order to move the coach.

The lift door shall have a window in line with the other passenger windows and shall not detract from the appearance of the coach. The door latch mechanism shall be located in the lower section of the door so that operators in the 5th percentile female range can operate the lift door.

The lift storage door shall not block the visual observation of the lift assembly while utilizing the manual override mode of the lift. A lift door design consisting of a horizontally hinged lift platform egress door mounted within a vertical motion pantograph baggage door is a preferred design.

2.7.3 Lift Installation

The installation of the lift to the coach structure as well as the installation of the lift door into the sidewall of the coach shall not affect the structural integrity of the coach.

The parcel rack module above the wheelchair lift platform area shall be permanently removed to provide additional headroom. The modified rack shall be professionally finished at all ends.

A Threshold Warning module with a red warning light and acoustic sensor shall be mounted in the ceiling structure above the wheelchair lift entrance doorway.

The heating and air ducts shall be rerouted around the lift area to ensure proper interior air conditioning/heating airflow and distribution.

A passenger chime tape switch shall be mounted on the sidewall at the two (2) wheelchair securement positions.

Each coach shall have adequate information decals installed which details the proper lift operation in both the normal and manual modes of operation.

Lighting for the lift areas shall be designed to exceed Title 13 and ADA and FMVSS 404 standards. Lighting shall be provided to effectively illuminate the lift area. Light shall be wired through the lift master toggle switch on the driver's dash and shall automatically illuminate when this switch is in the "ON" position. The lighting design shall minimize the effect of glare on passengers entering the bus through the wheelchair lift door. During lift operation, the street surface shall be illuminated to a minimum of six candlepower a distance of 3 feet beyond the external dimensions of the lift platform once deployed and lowered. Additional lighting shall be provided to insure illumination of the instruction placard and the manual override pump when it is in use.

2.7.4 Wheelchair Securement

The vehicle shall be equipped with two (2) wheelchair securement areas with a "clear floor space" fifty (50) inches long and thirty (30) inches wide. The length shall be measured from directly in front of the upright seat forward. No more than three (3) inches can extend under the seat in front. The width shall be measured beginning five (5) inches away from the bus wall. These areas will be clearly marked as wheelchair securement areas and bilingual (Spanish/English) signs will request other passengers to make them available for wheelchair use. Securement system shall be compliant with the current guidelines of the ADA, and shall be consistent with the METRO standard installation.

The wheelchair and passenger restraint system shall be a 4 point securement system and shall include belts with hooks to secure each wheelchair and lap belts with shoulder belt for passenger restraint. If automatic locking retractors (ALR) are used the ALR ratchet mechanism shall establish a lock during every inch of

retracted belt to prevent wheelchair movement greater than one (1) inch after the belt is properly attached.

The retractor shall be enclosed by either a plastic boot or die cast housing that has an opening in the back to allow easy access to the locking mechanism. The tongue and buckle shall be designed to be attached with a quick release press type locking device. Each lap belt shall be at least seventy-two (72) inches long and have a shoulder belt. Each wheelchair belt shall be at least seventy-two (72) inches long. In the event of a sudden stop or accident, the shoulder belt shall be equipped with an inertia-locking device that locks when the belt is withdrawn quickly.

A description and layout drawings of the wheelchair securement system and mountings, vertical call bell tape switch location, movable seats, passenger amenities and operator's public address system shall be submitted as a Mandatory Request For Approval (see Section II of the Solicitation, Item 30).

2.7.5 Passenger Amenities

The call bell system on the vehicle must have both a visible "Stop Request" light and audible bell signal (as described in 2.6.1.2 Exit Signal). The wheelchair securement areas shall also be equipped with horizontal call bell tape switches. This call bell must activate the buses call bell system plus a separate light visible to the operator with a double sound distinct from the Stop Requests initiated by switches in non-wheelchair areas. Any device emitting sound and signal in the interior or on the exterior of the bus shall not be adjustable below 20%.

The Contractor shall furnish an operator's public address system complete with a hands-free microphone rated for extreme duty. The amplifier shall have both voice-operated-operation (VOX) microphone input and a line input, configured such that the microphone input shall override simultaneous line input. The Operator shall have a switch, which can route the output of the amplifier to either interior or exterior speakers. Interior speakers shall be furnished to provide clear, balanced audio level announcements to the patrons. A weatherproof exterior speaker shall be furnished at the front door to provide clear announcements to patrons standing at the bus stop. Microphone and speakers shall be of high

quality. The amplifier shall be rated at no less than 30 RMS watts of power and include an automatic gain control, public address system.

A matt black finish gooseneck microphone with a switch to select interior, exterior speakers or all speakers and an amplifier are required.

Priority seating signage/decals shall be provided in compliance with A.D.A. regulations.

3.0 CHASSIS

25) 3.1 Propulsion System

3.1.1 Vehicle Performance

3.1.1.1 Power Requirements

The power propulsion system shall be clean diesel and shall be sized to provide sufficient power to enable the bus to meet the defined acceleration, top speed, and gradeability requirements, and operate all propulsion-driven accessories using actual road test results and computerized vehicle performance data.

3.1.1.2 Top Speed

The bus shall have the top road speed set to 70 mph on a straight, level road at GVWR with all accessories operating when they leave the factory. The bus shall be capable of safely maintaining the vehicle speed according to the recommendations by the tire manufacturer.

NOTE: Values are assumed to be sustained. Manufacturer shall supply METRO with data if there is a variance between peak performance and sustained vehicle performance.

3.1.1.3 Gradeability

Gradeability requirements shall be met on grades with a dry commercial asphalt or concrete pavement at GVWR with all accessories operating. The propulsion system and drive train shall enable the bus to achieve and maintain a speed of 44 mph on a 2½ percent ascending grade and 10 mph on a 16 percent ascending grade continuous.

NOTE: Values are assumed to be sustained. Manufacturer shall supply METRO with data if there is a variance between peak performance and sustained vehicle performance.

3.1.1.4 Acceleration

The acceleration shall meet the requirements below and shall be sufficiently gradual and smooth to prevent throwing standing passengers off-balance. Acceleration measurement shall commence when the accelerator is depressed.

Jerk, the rate of change of acceleration, shall be minimized throughout the acceleration range and shall be no greater than 0.3g/sec.

TABLE 3

Maximum Start Acceleration Times on a Level Surface

Speed (mph)	Maximum time (seconds)
15	5
25	10
35	18
45	30
55	45
Top speed	

- Vehicle weight = GVWR

3.1.1.5 Operating Range

THE OPERATING RANGE OF THE BUS WHEN RUN ON THE “CBD, ARTERIAL AND COMMUTER SEGMENT OF THE DESIGN OPERATING PROFILE” SHALL BE AT LEAST 800 MILES ON A FULL TANK OF FUEL. THE DIESEL EXHAUST FLUID (DEF) OPERATING RANGE OF THE BUS WHEN RUN ON THE “CBD, ARTERIAL AND COMMUTER SEGMENT OF THE DESIGN OPERATING PROFILE” SHALL BE AT LEAST 1600 MILES ON A FULL TANK OF DEF.

3.1.1.6 Fuel Economy (Design Operating Profile)

Test results from the Altoona fuel economy tests or other applicable test procedures shall be provided to METRO for METRO approval prior to acceptance of pilot bus (Deliverable, see Appendix No.1, Item D4). Results shall include vehicle configuration and test environment information. Fuel economy data shall be provided for each design operating profile. The design operating profile is assumed to be defined by the Altoona fuel duty cycle.

3.1.2 Power Plant Mounting and Accessories

3.1.2.1 Mounting

Power plant shall be mounted in the rear of the bus in such a manner that the entire power plant and accessories can be removed as a single unit within four (4) hours. Power plant mounting shall be isolated by means of oil resistant mounts to minimize the transfer of vibration to the body structure and provide a minimum clearance of 0.25 in. Mounts shall control the movement of the power plant so as not to affect performance of belt-driven accessories or cause strain in piping and wiring connections to the power plant.

3.1.2.2 Service

The power plant shall be arranged to provide accessibility for all routine maintenance. No special tools, other than dollies and hoists, shall be required to remove the power plant. Two (2) 4M mechanics shall be able to remove, replace and prepare the engine and transmission assembly for service in less than eight

(8) man-hours. The muffler, exhaust system, air cleaner, air compressor, starter, alternator, radiator, all accessories, and any other component requiring service or replacement, shall be accessible and removable independent of engine and transmission removals.

Engine air cleaner shall be replaceable type, able to provide the maximum filtration surface possible, and be designed for an outside to inside air flow.

The air filter shall be certified by the engine manufacturer as properly sized for the engine provided. The filter canister shall be equipped with an approved restriction indicator. **Location and installation of air filter shall be determined and approved by METRO during the preproduction conference (See Appendix 2, Preproduction Conference, Item PPC 14).** Air inlet shall be designed to draw in ambient air from outside of engine compartment.

An engine oil pressure gauge and coolant temperature gauge shall be provided in the engine compartment. These gauges shall be easily read during service and mounted in an area where they shall not be damaged during minor or major repairs. These gauges can be a digital cluster or individual mechanical gauges. Along with the gauges a J-1939 diagnostic port and a three position regeneration switch shall be provided in the engine compartment. The switch positions should be as follows:

- Position one STOP Regeneration
- Position two AUTO Regeneration
- Position three START Regeneration

All hoses one (1) inch and over shall be clamped with constant tension hose clamps. The Contractor shall torque each clamp to the clamp manufacturer's torque specifications. All cooling system clamps shall be re-torqued after engine reaches operating temperature and after initial road test.

Engine oil and transmission fluid filler caps shall be closed with spring pressure or positive locks. All fluid fill locations shall be properly labeled to help ensure that correct fluid is added. All fillers shall be easily accessible from outside the bus with

standard funnels, pour spouts, and automatic dispensing equipment. All lubricant sumps shall be fitted with magnetic type external, American standard hex head drain plugs of a standard size. Manufacturer's standard dipstick is acceptable, provided length is kept as short as possible.

The engine and transmission shall be equipped with manufacturer's recommended heavy-duty filters to protect the engine and transmission between scheduled filter changes.

All filters (Engine Oil Combination Full Flow and Bypass Filter) shall be disposable type. Fuel and oil lines within the engine compartment shall be composed of flexible hose. All flexible fuel, oil, air and water lines in the engine compartment shall be coded as to the type of fluid carried in the line. The use of ID tags is accepted. Flexible fluid lines shall be short with no sharp bends or turns from fittings. The lines shall be routed or shielded so that failure of a line shall not allow fuel or oil to spray or drain onto any component above the auto ignition temperature of the fluid carried. All hydraulic lines, engine oil and fuel lines shall have the high pressure seamless shields installed.

Flexible lines shall have standard SAE or JIC reusable mandrels and swivel fittings or crimped fittings. Hoses shall be individually supported (tie wraps not allowed) and shall not touch one another or any part of the bus.

Description and specifications of oil lines, fuel lines and high pressure seamless shields shall be submitted as a Mandatory Request for Approval (see Section II of the Solicitation, Item 31).

3.1.2.3 Accessories

Engine driven accessories shall be unit mounted for quick removal and repair. Accessory drive systems shall operate without failure or unscheduled adjustment for 50,000 miles on the design operating profile. There shall be no devices mounted to the engine crankshaft except for pulleys (i.e. no clutch on crankshaft). Accessories shall be driven at speeds sufficient to assure adequate system performance during extended periods of idle operation and low route speed portion

of the design operating profile. The system shall incorporate electrical power to provide 12 volt and 24 volt bus power.

The brushless alternator (cooled by oil or filtered air); air compressor and power steering pump shall be directly driven by the engine. The air compressor shall be gear driven and must be compatible with the engine assembly. Steering shall be a totally separate system. Any exposed belts used on accessory drive systems shall be equipped with belt guards. **Location and style of belt guards for air compressor and alternator or other belt driven equipment shall be determined and approved by METRO during the preproduction conference (See Appendix 2, Preproduction Conference, Item PPC 15).** The alternator shall be capable of providing a positive charge to the electrical system with all systems in operation, at idle.

3.1.2.4 Electrical Fan System

The electrically driven reversible cooling fan system with long life, brushless, sensorless motors that are CAN capable shall demonstrate a mean time between repairs in excess of one hundred fifty thousand (150,000) miles. Electrically driven fan system service tasks shall be minimized and scheduled no more frequently than those of other major mechanical systems. All elements of the fan system shall be easily accessible for service or unit replacement.

Critical points in the fan system shall be fitted with connections so that portable diagnostic equipment may be connected or sensors for an off-board diagnostic system permanently attached to monitor system operation. All electrical cables shall be compatible with the hydraulic, engine oil and fuels.

Electric fans shall be individually and rigidly supported to prevent chafing damage, fatigue failures and tension strain on the radiator assembly. All elements of the fan system shall meet the noise limits defined in the Technical Specification.

The cooling system shall be sized to maintain fluids at safe, continuous operating temperatures during the most severe operations possible with the coach loaded to GVWR and with ambient temperatures up to 110 degrees F (43 C). Sufficient

reserve capacity shall be provided by the cooling system to provide efficient cooling for the coolant and engine charge air in a degraded condition. Radiator(s), complete with charge air cooling circuit shall be provided, mounted above the engine compartment. The charge air cooler and the radiator shall be mounted at least 60 inches (1.50 m) above the road surface. The physical size and heat rejection capacity of the radiator along with the charge air cooling capacity shall be tested and approved by the engine manufacturer for this application. The radiator system shall be easily serviced through the rear doors. The radiator and charge air cooler shall not be stacked in front of one another. Door shall include hinges which hold the doors in the open position.

The charge air cooler (CAC) / radiator assembly shall be primarily of durable corrosion-resistant aluminum construction. Heat exchanger fin spacing shall not exceed 14 fins per inch. Necessary hoses shall be premium, silicone rubber type that are impervious to all coach fluids. All coolant hoses shall be secured with constant tension hose clamps. Fan speed shall be regulated to minimize fan noise. No heat producing components or climate control system components shall be mounted between the engine cooling air intake aperture and the heat exchangers. All cooling system fittings are to be cast iron, brass or copper.

The fan system shall pull outside air through an exterior panel and across the radiator / charge air cooler at a minimum rate approved by the engine manufacturer for maximum cooling efficiency. Belt tension shall be maintained by an automatic belt tensioner to minimize belt slippage and ensure longer belt life. A fan clutch shall control fan operation.

Radiator surge tank shall be made of heavy-duty steel. A sight glass to determine satisfactory engine coolant level shall be provided and shall be accessible by opening the radiator access doors. A spring-loaded radiator cap shall also be provided to safely release pressure or vacuum in the cooling system. An engine alarm system will be included in the engine electronic control. Cooling fan logic shall be controlled electronically through the engine control system. An automatic coolant recovery system will also be provided.

Engine thermostats shall be easily accessible for replacement. The engine cooling system shall be equipped with a properly sized or approved equal cooling system filter with a spin-on, disposable element. The engine coolant shall be extended life. Shutoff valves shall be provided on the coolant filter base which allows filter replacement without coolant loss. Quarter turn valves shall also be provided and installed in the entire cooling system which permits complete shutoff of both lines for the heating and defroster units.

All low points in the water-based cooling system shall be equipped with drain cocks. Air vent lines shall be fitted at high points in the cooling system. Oil and water temperature gauges will be provided in the engine compartment.

Description and specifications of the cooling fan system shall be submitted as a Mandatory Request for Approval (see Section II of the Solicitation, Item 32).

3.1.3 Power Plant

Detailed description and performance specifications of engine and transmission propulsion system proposed shall be submitted as a Mandatory Request for Approval (see Section II of the Solicitation, Item 33).

3.1.3.1 Engine

The bus shall be powered by a clean diesel system with engine brakes. Engine shall meet EPA Emission standards. Engine FEL shall not exceed 0.2 NOx.

The bus shall have return to fast idle and auto shut down options. An auto neutral system (return to neutral) shall be incorporated into the transmission parameters and shall be determined and require approval by METRO during the preproduction conference (See Appendix 2, Preproduction Conference, Item PPC 16).

The engine shall have minimum 11L displacement and provide a minimum of 435 horsepower and 1450 lb.-ft of torque to enable the bus to meet the minimum acceleration, top speed and gradeability requirements specified with optimum fuel

economy. The engine shall meet or exceed the requirements of the standard configuration and performance levels without structural or mechanical modifications.

The engine shall operate in excess of two hundred thousand (200,000) miles on the design operating profile without major failure or significant deterioration. Components of the fuel and control system shall operate for one hundred and fifty thousand (150,000) miles without replacement or major service.

The engine shall meet all requirements of the Technical Specification, as well as State and Federal Regulations.

Certification that the engine offered complies with the State and Federal Emission Regulations shall be submitted as a Mandatory Request for Approval (see Section II of the Solicitation, Item 34).

The Family Emission Limit (FEL) NOx emission level declared by the manufacturer shall be equal to or less than the emission standard.

The engine fast idle device will automatically activate with transmission in the neutral position and parking brake applied. The on/off switch will be located in the engine compartment for mechanic access. Engine electronic controls will be protected from heat, weather, bus washing and engine steam cleaning.

The engine shall be programmed to shut down after 20 minutes of idling when the emergency brake is applied. The clock starts as the bus travel speed drops below 2 miles per hour and can only be overridden by the rear engine run switch located in the engine compartment, or by the re-application of the emergency brake.

The integration of all systems on the vehicle relative to engine idle speed shall be determined and require approval by METRO during the preproduction conference (See Appendix 2, Preproduction Conference, Item PPC 17).

The engine control system shall protect the engine against progressive damage. The system shall monitor conditions critical for safe operation and automatically derate power and/or speed and initiate engine shutdown as needed.

An Automatic Engine Protection/Shutdown Override Feature shall be available to the operator/driver that when constantly depressed and released will delay the engine shutdown or allow the bus to be moved. Override action shall be recorded. This data shall be retrievable by METRO.

The engine shall be equipped with an electric starter, which shall be protected by an interlock that prevents its engagement with the engine running.

The Bus shall be equipped with a progressive engine brake: 1/3 brake applied (2 cylinders) upon release of the accelerator pedal and the remaining 2/3 brake applied in 2 steps, namely 4 cylinders at 4 psi and all 6 cylinders at 7 psi, as a function of brake pedal pressure. Exterior ear yellow lights shall be on upon release of the accelerator pedal until the brake pedal is applied. As brake pedal pressure is increased, the engine brake operates at its full capacity.

The engine brake configuration shall be easily reconfigurable at the METRO Bus Operating Facility locations. The engine brake shall automatically cut-out when the ABS senses a wheel skid.

An engine brake disable switch shall be accessible only in the engine compartment. The engine brake shall be activated when the guard is closed. The engine brake tell-tale ("AUX Brake") which will flash when the engine brake disable switch in the engine compartment is in the ON position. The engine brake tell-tale will be solid ON when the engine brake disable switch is in the OFF position and the engine brake is engaged.

Disabling of the engine brake shall be recorded for METRO data collection.

3.1.3.2 Cooling System

The cooling system shall be part of the electrically driven fan assembly, sized to maintain fluids at safe, continuous operating temperatures during the most severe operations possible with the bus loaded to GVWR and with ambient temperatures up to 115°F. The engine shall be cooled by a water based, pressure type, cooling system that does not permit boiling or coolant loss during the operations described above. Additional cooling shall be required to meet the ambient capability of the retarder operation. Engine thermostats shall be easily accessible for replacement. The engine cooling system shall be equipped with a properly sized water bypass filter with a spin on, disposable element containing no additive package. Shutoff valves shall allow filter replacement without coolant loss. Valves shall permit complete shutoff of both lines for the heating and defroster units.

All low points in the water based cooling system shall be equipped with poppet type drain valves. **The type of poppet drain valve shall be determined and require approval by METRO during the preproduction conference (See Appendix 2, Preproduction Conference, Item PPC 18).** Air vent valves shall be fitted at high points in the cooling system unless it can be demonstrated that the system is self purging.

A tube or two (2) sight glasses to determine satisfactory engine coolant level shall be provided and shall be accessible by opening an access door. A properly sized stainless steel surge tank shall be equipped with a hinged filler cap with a secondary safety lock to preclude the possibility of hot coolant splashing onto service lane personnel during routine service. Low coolant sensor shall be mounted on side of surge tank. A spring loaded, push button type valve or a lever type, to safely release pressure or vacuum in the cooling system shall be provided no more than sixty-six (66) inches above the ground and accessible through the same access door. The automatic pressure release valve shall be a standard automotive radiator cap mounted at top of tank, in an accessible location.

The radiator and charge air cooler shall be of durable corrosion resistant construction and optimized to function with the electrically driven reversible fan system.

The radiator shall be easily accessible for cleaning. Hoses shall be premium, silicone rubber type that is impervious to all bus fluids. All hoses shall be clamped with constant tension hose clamps.

The marine pump assembly shall be mounted in an accessible location and mounted above low point of cooling system. If located in engine compartment, it shall be protected from heat and dirt. Marine pump shall have a high efficiency, long life, brushless and sensorless electric motor and shall have an integrated CAN (SAE J1939 compliant) controller.

No heat producing components shall be mounted between the engine cooling air intake aperture and the radiator. Fans shall be lightweight fiberglass. Radiator and charge air cooler shall have a powder coated steel frame and fan shroud. If air charge cooler is necessary for engine performance, it shall be located elsewhere or be stacked above the radiator. The radiator and charge air cooler shall be designed to withstand thermal fatigue and vibration associated with the installed configuration. The radiator and charge air cooler cores shall be easily cleaned (to include engine side core surface) with standard pressure-washing equipment.

The bus shall be delivered with a fifty-fifty (50-50) mixture of deionized water and ethylene glycol anti-freeze. The coolant shall be charged with an inhibitor package meeting the Maintenance Council recommended practice RP-329. Mix shall contain at least 1200 ppm nitrite. The color of the coolant shall be fuchsia. The coolant shall not contain anti-leak compounds, polystyrene, propylene, chromate, phosphate, or molybdate.

3.1.3.3 Transmission

The bus shall be equipped with a transmission that has a proven record in transit and shall be sufficiently sized to meet the performance requirements of this specification. Cooling provisions shall be sufficient to keep the transmission at safe operating temperatures during the most severe duty cycle. The transmission shall be mounted to allow easy service and replacement.

A large remote mounted, shell and tube, rebuildable heat exchanger shall be provided capable of adequately cooling the transmission.

The transmission shall be a multiple speed, automatic shift with torque converter and electronic controls. Gross input power, gross input torque and rated input speed shall be compatible with the engine. The transmission shall be designed to operate for not less than 300,000 miles on the design operating profile without replacement or major service. The transmission should be easily removable without disturbing the engine and accessible for service.

The electronic controls shall be capable of transmitting and receiving electronic inputs and data from other drive train components and broadcasting that data to other vehicle systems. Communication between electronic drive train components and other vehicle systems shall be made using the communications networks. Electronic controls shall be compatible with either 12- or 24-volt power distribution, provide consistent shift quality and compensate for changing conditions such as variations in vehicle weight and engine power. A brake pedal application of 15 to 20 psi shall be required by the Operator to engage forward or reverse range from the neutral position to prevent sudden acceleration of the bus from a parked position.

The electronically controlled transmission shall have on-board diagnostic capabilities, be able to monitor functions, store and time stamp out-of-parameter conditions in memory, and communicate faults and vital conditions to service personnel. The transmission shall contain built-in protection software to guard against severe damage. The on-board diagnostic system shall trigger a visual alarm to the Operator when the electronic control unit detects a malfunction.

An electronic transmission fluid level monitoring and protection system shall be provided.

An Automatic Neutral Function with Automatic Re-engagement shall be provided. The transmission, when in forward direction, shall automatically shift the transmission to neutral when the vehicle registers zero road speed, engine is idle and service brakes are applied. If the status of any one or more of the three signals

changes, the transmission immediately and automatically resumes forward mode operation. Provision shall be made to have the ability to turn this function off if required.

Transmission shall be Allison Transmission or approved equal.

3.1.3.4 Engine Compartment Gauges

Gauges or cluster indicating engine coolant temperature, and engine oil pressure shall be flush mounted in a common panel located in a conspicuous place in the engine compartment. Voltmeter gauges indicating 24 and 12 volt operating voltages shall be provided in the engine compartment. No gauges shall be directly mounted to the engine or transmission. Gauges shall be water and dust proof, having an accuracy rating within 3 percent of total scale, corrosion and shock resistant casings, and a clear lens. An electrical engine hour meter shall be provided capable of withstanding environmental conditions found in the engine compartment. All gauges shall be shock mounted to preclude damage from vibration, designed for exterior use, and able to withstand conditions found in engine compartment.

3.1.4 Emissions

3.1.4.1 Gas and Smoke

The engine exhaust must conform to all applicable Federal and State emission standards in effect at the time of manufacture.

3.1.4.2 Exhaust Location

Exhaust gases and waste heat shall be discharged at the lower rear left hand side of the bus and shall be directed generally away from the bus body. The contractor shall provide exhaust diffusion. Exhaust piping shall not restrict the underbody clearance defined in Section 1.6.1.2. The exhaust gases shall be discharged in a manner that will not result in the discoloration of the exterior paint. The exhaust compartment must be insulated. **Exhaust routing shall be determined and require approval by METRO during the preproduction conference (See Appendix 2, Preproduction Conference, Item PPC 19).**

3.1.4.3 Exterior Noise

Airborne noise generated by the bus and measured from either side shall not exceed 80 dBA under full power acceleration when operated up to thirty-five (35) mph at curb weight. The bus generated noise at curb idle shall not exceed 65 dBA. If the noise contains an audible discrete frequency, a penalty of five (5) dBA shall be added to the sound level measured. All noise readings shall be taken fifty (50) feet from, and perpendicular to, the centerline of the bus with all accessories operating. Required readings may be achieved through the use of a muffler system or electronic noise attenuation devices.

Instrumentation, test sites, and other general requirements shall be in accordance with SAE Standard J366. The pull away test shall begin with the front bumper even with the microphone. The curb idle test shall be conducted with the rear bumper even with the microphone. **A copy of the test report shall be furnished to METRO prior to acceptance of the pilot bus (Deliverable, See Appendix No.1, Item D5).**

3.1.4.4 Powertrain Audit

The bus manufacturer shall provide engine and transmission manufacturer's audit certification that the power plant is designed and engineered for their bus, shall approve installation in this application and shall provide METRO a copy of this report prior to acceptance of the pilot bus (Deliverable, see Appendix No.1, Item D6). A separate audit shall be conducted on the pilot bus. Manufacturers shall meet the heat transfer and ambient capability of the radiator, trans-cooler, hydraulic coolers, etc. This audit will be corrected to an ambient temperature of 115° Fahrenheit. Particular care shall be taken to assure the system's retarder heat generation is taken into account. This audit shall be performed using a transit cycle test and will be observed by METRO personnel. **Installation Quality Audit (IQA) test results from previous buses identical to bus being built for METRO must be submitted for METRO's approval prior to acceptance of the pilot bus (Deliverable, See Appendix No.1, Item D7).**

26) 3.2 Final Drive

3.2.1 General Requirements

The drive shaft shall be guarded to prevent it from striking the floor of the bus or the ground in the event of a tube or universal joint failure. All axles shall include synthetic oil or grease.

3.2.1.1 Drive Axle

The bus shall be driven by a single heavy duty axle at the rear. The axle shall have a load rating sufficient for the bus loaded to GVWR. The driven axle shall be designed to operate for four (4) years or two hundred thousand (200,000) miles on the design operating profile without repairs. All axles shall include synthetic oil or grease.

Lubricant drain plug shall be the magnetic type, external hex head of a standard size. The axle shall be vented. To reduce likelihood of water entering when the axle is submerged, the vent line shall be a minimum of thirty-two (32) inches above street level and filtered to prevent entrance of foreign material.

3.2.1.2 Front and Tag Axle

The front and tag axles shall be solid beam, non-driving with a load rating sufficient for the bus loaded to GVWR and shall be equipped with unitized grease type wheel bearings and seals. Tag axle shall not be steerable.

All friction points on the front axle shall be equipped with replaceable bushings or inserts and, if needed, lubrication fittings easily accessible from a pit or hoist.

The steering geometry of the outside (frontlock) wheel shall be within 2 deg of true Ackerman up to 50 percent lock measured at the inside (backlock) wheel. The steering geometry shall be within 3 degrees of true Ackerman for the remaining 100 percent lock measured at the inside (backlock) wheel.

The tag axle shall be located behind the drive axle. The tag axle shall have single tires the same size as the tires on the front and drive axles. Tag axle weight shall not exceed 14,000 pounds. With full passenger seating capacity, load on any axle

shall not exceed 22,400 pounds. Combined load capacity weight on the drive and tag axles shall not exceed 36,500 pounds.

27) 3.3 Suspension

3.3.1 General Requirements

The front, drive and tag axles shall be equipped with disc brakes and have a minimum load rating of 13,200-26,600 pounds. The basic suspension system shall last the life of the bus without major overhaul or replacement. Items such as bushings and springs shall be easily and quickly replaceable by a 3M mechanic. All fasteners (bolts, nuts and studs) used in the suspension system shall meet SAE standards. A water and oil proof fastener chart shall be provided, attached to undercarriage, showing locations and torque specifications of all suspension fasteners. **As a general rule all fasteners on the bus required to be torqued shall be identified with torque putty or marked to indicate that proper torque was applied.** A copy of the permanent record of all actual torque values performed during construction of each bus, to include time, date and person performing torqueing, shall be provided to the resident inspector prior to sign-off on each bus **(Deliverable, See Appendix No.1, Item D8)**. As an alternate to bus mounted charts, ten (10) large oil resistant wall charts may be provided.

The front and rear axle suspension shall be pneumatic and equipped with straight side lobe air suspension bellows. Four suspension bellows shall be provided on the drive axle and two suspension bellows on the front axle. The tag axle shall be equipped with two straight side lobe type air springs, 9.5 inch (241 mm) nominal in diameter. Pressure in the tag axle suspension shall be automatically adjusted as required by the load-sharing system. Manual air dump valves for unloading the tag axle air suspension bellows shall also be provided in the engine compartment.

The basic suspension system exclusive of bellows, height control valves, bushings and shock absorbers, shall last the life of the coach without major overhaul or replacement. Four (4) heavy-duty rubber bushed silent block sleeve type radius rods shall be provided at both the front and rear drive axles to control lateral,

longitudinal, and torsional movement. One transverse stabilizing rod shall be provided on front axle for additional support during coach lane changing or turning of corners. The coach shall be equipped with a sway bar designed to reduce body lean and increase bushing life. Items such as bushings and air springs shall be easily and quickly replaceable. Adjustment points shall be minimized and shall not be subject to a loss of adjustment in service. Necessary adjustments shall be easily accomplished without removing or disconnecting the components. The rear suspension shall be capable of raising rear of the bus at least three inches.

3.3.2 Spring and Shock Absorbers

3.3.2.1 Travel

The air suspension system shall permit a minimum wheel travel of 3.5 inches in jounce and three (3) inches in rebound. Elastomeric bumpers shall be provided at the limit of jounce travel. Rebound travel may be limited by elastomeric bumpers or hydraulically within the shock absorbers. Suspensions shall incorporate appropriate devices for automatic height control so that regardless of load, the bus height relative to the centerline of the wheels does not change more than 1.5 inches at any point from the height required in Section 2.1.5.1.

Description of air springs furnished shall be submitted as a Mandatory Request for Approval (see Section II of the Solicitation, Item 35).

3.3.2.2 Damping

Vertical damping of the suspension system shall be accomplished by long life, double acting, hydraulic shock absorbers mounted to the suspension arms or axles and attached to an appropriate location on the chassis. Damping shall be sufficient to control bus motion to four (4) cycles or less after hitting road perturbations. Shock absorbers shall maintain their effectiveness in the Houston environment for at least three years in normal service, and each unit shall be replaceable by a 2M mechanic in less than twenty (20) minutes.

3.3.2.3 Lubrication

All elements of steering, suspension and drive systems requiring grease lubrication shall be provided with grease fittings conforming to SAE Standard J534.

28) 3.4 Steering

3.4.1 Strength

Fatigue life of all steering components shall exceed 500,000 miles. No element of the steering system shall fail before suspension system components when one of the tires strikes a severe road hazard. Inadvertent alterations of steering as a result of striking road hazards are steering failures.

3.4.2 TURNING RADIUS

Outside body corner turning radius for a standard configuration forty five (45) foot long bus shall not exceed 49 ft (outside front axle, TR0).

Turn radius and front and rear swept area dimensions for the bus proposed for bid shall be submitted as a Mandatory Request For Approval (see Section II of the Solicitation, Item 36).

TURNING RADIUS

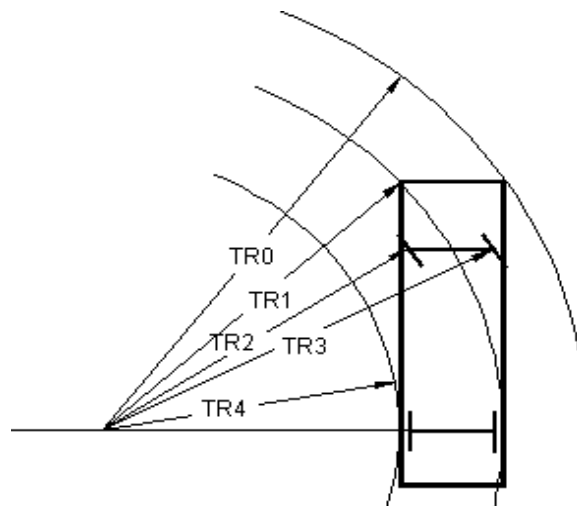

3.4.3 Turning Effort

The steering wheel shall be a minimum of nineteen (19) inches in diameter and shaped for a firm grip with comfort over long periods of time. The steering column shall be equipped with telescoping and tilt features. Steering wheel spokes and wheel thickness shall ensure visibility of the dashboard so that vital instrumentation is clearly visible at center neutral position (within the range of a 95th-percentile male, as described in SAE 1050a, Sections 4.2.2 and 4.2.3). Placement of steering column must be as far forward as possible, but either in line with or behind the instrument cluster. The steering wheel shall be constructed of black non-padded material. The steering wheel shall be made removable with a standard or universal puller.

The Steering Column/Wheel shall be submitted as a Mandatory Request for Approval (see Section II of the Solicitation, Item 37).

Hydraulically assisted power steering shall be provided and adjusted on each bus according to the manufacturer's specifications, including the steering inclination angles. The power steering gear box shall be an integral type with either flexible lines eliminated or the number and length minimized. The properly sized power steering reservoir shall be easily accessible for inspection and service. The power steering reservoir shall be equipped with a filter. Steering torque applied by the Operator to turn 10° shall not exceed ten (10) foot pounds with the front wheels straight ahead.

Steering torque may increase to seventy (70) foot pounds when the wheels are approaching the steering stops. Steering effort shall be measured with the bus at SLW, stopped with the brakes released and the engine at normal idling speed on clean, dry, level, commercial asphalt pavement and the tires inflated to recommended pressure. Power steering failure shall not result in loss of steering control. With the bus in operation, the steering effort shall not exceed fifty-five (55) pounds at the steering wheel rim and perceived free play in the steering system shall not materially increase as a result of power assist failure. Gearing shall require no more than seven (7) turns of the steering wheel lock-to-lock. The bus manufacturer shall test and adjust the power steering system on each bus. The steering geometry of the outside (frontlock) wheel shall be within 2 degrees of true Ackerman up to 50 percent lock measured at the inside (backlock) wheel. The

steering geometry shall be within 3 degrees of true Ackerman for the remaining 100 percent lock measured at the inside (backlock) wheel.

Copies of the power steering test reports shall be forwarded with inspection reports to METRO prior to acceptance of each bus (Deliverable, See Appendix No.1, Item D9).

Caster angle shall be selected to provide a tendency for the return of the front wheels to the straight position with minimal assistance from the Operator. Caster, camber, toe-in and vehicle tracking, front to rear, shall be checked and adjusted on each bus. **Copies of the vehicle alignment reports shall be forwarded with inspection reports to METRO prior to acceptance of each bus (Deliverable, See Appendix No.1, Item D10).**

29) 3.5 Brakes

3.5.1 Service Brake

3.5.1.1 Actuation

Disc air brakes shall be provided on all six (6) wheels, controlled and actuated by a foot treadle valve. Force to activate the brake pedal control shall be an essentially linear function of the bus deceleration rate and shall not exceed ninety (90) pounds at a point seven (7) inches above the heel point of the pedal to achieve maximum emergency braking. The contractor shall provide an Anti-Lock Braking (ABS) system in accordance with the FMVSS standards.

Contractor is to provide Electronic Brake Monitoring (specifically brake stroke) as part of the vehicle air disc braking on-board diagnostic system. The Electronic Brake Monitoring System (EBMS) shall include both parking brake and service brake electronic monitoring utilizing a computer module with appropriate software, brake application pressure sensing via pressure transducer(s), associated cabling communicating the required electronic signals, and optical as well as mechanical sensing at the brake actuator / air disc caliper. The EBMS system shall be designed to detect over-stroke, non-functioning, brake drag and low pad-to-rotor clearance conditions at each vehicle wheel end.

Any wheel-end brake fault condition detected by the EBMS shall be communicated via SAE brake fault codes over the vehicle J-1939 network in real-time. These predefined fault codes shall provide instant warnings to operations and maintenance of critical brake system problems which may affect the safe operation of vehicle.

The system shall specifically employ embedded optical and mechanical sensing at each wheel end which monitors operational conditions for air brake delivery and release, (as well as mechanical conditions inside the caliper that effect lining and pad clearance), and the proper mechanical functionality of air disc calipers at each wheel end position.

The on-board EBMS shall be designed to augment safety and aid maintenance in determining when to perform necessary unscheduled maintenance to mitigate vehicle performance and safety concerns. The EBMS shall additionally provide a log of stored fault codes for later retrieval by maintenance personnel to additionally be utilized by maintenance personnel for vehicle troubleshooting. The system shall also provide additional capability for conducting electronic pre-trip and/or post trip inspection on air disc brake vehicles.

Bus multiplex system and EBMS shall function as follows:

1. Bus multiplex system continuously monitors J1939 for EBMS faults.
2. EBMS broadcasts dragging brake fault via J1939.
3. Bus multiplex monitors active drag fault for 10 seconds.
4. If dragging condition remains active; bus multiplex turns ON dash display "Dragging Brake" text warning with amber field for 30 seconds.
5. If dragging condition remains active; bus multiplex switches display to flashing red field and turns on 4 way flashers for 30 seconds.
6. If dragging condition remains active; bus multiplex cuts throttle over 12 mph (20km) and limits throttle under 12mph (20km) to "limp home".
7. If dragging condition remains active; limited throttle under 12mph (20km) will remain active until vehicle is brought to a stop. Once stopped the interlocks apply and throttle is cut off. Vehicle remains running.

8. Door interlock override switch ON/OFF will reset bus multiplex logic.

9. Switch interlock override switch ON/OFF will allow vehicle to be driven over 12 mph (20km).

3.5.1.2 Friction Material

The friction material shall have an overhaul or replacement life of at least one hundred thousand (100,000) miles when running on the designed operating profile.

The friction material used in the brake system shall be premium material.

3.5.1.3 Hubs

Wheel bearing and hub seals shall not leak or weep lubricant for brake lining life interval when running on the design operating profile. In the event of a seal failure that requires lining to be replaced during the warranty period, the lining and associated labor shall be covered under the warranty provisions.

Description and specifications of wheel bearing seals shall be submitted as a Mandatory Request for Approval (see Section II of the Solicitation, Item 38).

3.5.1.4 Air System

The air system shall operate all accessories with reserve capacity. The engine driven air compressor shall be capable of charging the air system from forty (40) psi to one hundred and twenty (120) psi in less than three (3) minutes while not exceeding the engine's fast idle rated speed. Regardless of the system's air pressure, idle up to the rated engine speed shall be available to the Operator with the transmission in neutral and the parking brake applied.

Air lines, except necessary flexible lines, shall conform to the installation and material requirements of SAE Standard J844-Type 3B for nylon tubing if not subject to temperatures over 200oF. Accessory and other non-critical lines may use Type 3A tubing. Nylon tubing shall be installed in accordance with the following color coding standards:

- o Green Indicates primary brakes and supply
- o Red Indicates secondary brakes
- o Brown Indicates parking brake
- o Yellow Indicates compressor governor signal
- o Grey Indicates accelerator (if used)
- o Black Indicates accessories
- o Blue Indicates suspension

Line supports shall prevent movement, flexing, tension strain, and vibration. Rigid lines shall be supported at no more than five (5) foot intervals. Nylon lines may be grouped and shall be continuously supported every twenty-four (24) inches.

The compressor discharge line between power plant and body mounted equipment shall be flexible convoluted stainless steel line, or flexible Teflon hose with a braided stainless steel jacket. Other lines necessary to maintain system reliability shall be flexible Teflon hose with a braided stainless steel jacket. End fittings shall be standard SAE or JIC brass or steel, flanged, reusable, swivel type fittings.

Flexible hoses shall be as short as practicable and individually supported. They shall not touch one another or any part of the bus except for the supporting grommets. Flexible lines shall be supported at thirty (30) inch intervals or less. Air lines shall be cleaned and blown out before installation and shall be installed so as to minimize air leaks. New buses shall not leak down more than six (6) psi as indicated on the instrument panel mounted air gauges within fifteen (15) minutes from the point of governor cut-off.

All air lines shall be sloped toward a reservoir (where practical) and routed to prevent water traps. Grommets shall protect the air lines at all points where they pass through understructure components.

All air lines to the heating equipment and door controls shall be equipped with an in-line air filter/strainer. Air for the compressor shall be filtered through the main engine air cleaner system. All air reservoirs shall meet the requirements of SAE Standard J10 and shall be equipped with drain valves accessible by maintenance personnel at floor level. Reservoirs shall be sloped toward the drain valve. The air system shall be protected by a pressure relief valve set at one hundred fifty (150) psi and shall be equipped with check valves and pressure protection valves to assure partial operation in case of line failures. All air system valves shall exhaust to the outside of the bus.

An air dryer shall be provided to prevent the accumulation of moisture in the air system. Air dryers shall be vertically mounted with easily replaceable spin on desiccant cartridges. A thermostatically controlled heater element shall be provided with a purge and drain cycle valve equipped to expel moisture below the framework of the bus. **Air Dryer shall be determined and require approval by METRO during the preproduction conference (See Appendix 2, Preproduction Conference, Item PPC 20).**

3.5.1.5 Parking and Emergency Brake

The parking brake shall be spring applied; air released and controlled by an automatic valve that is located in a METRO approved location. The control valve shall be a push to release –pull to apply type similar to BW PP-1 type, and provide a means to apply and release the parking and emergency brake system. This valve will "pop" out and apply the brakes when the pressure in the air system drops below forty (40) PSI. The valve shall stay in if the pressure in the air system is in excess of forty (40) PSI and the parking brake valve is pushed in. A lamp on the instrument panels shall be provided to indicate that the parking brake is on. The air switch for this indicator will be in series with the run switch or a switched ground through the multiplex system. The bus manufacturer may also provide a pop out valve at 40 psi providing this requirement meets the FMVSS 121 requirements. **Location of the parking brake control valve shall be determined and require approval by METRO during the preproduction conference (See Appendix 2, Preproduction Conference, Item PPC 21).**

3.5.1.6 Brake Balance Audit

A Brake Balance Audit shall be conducted by the OEM suppliers of the axles and air system, to check brake balance and brake efficiency. This audit will be corrected to an ambient temperature of at least 100° Fahrenheit and in accordance with the Original Equipment Manufacturer's recommendation. **The Brake Balance Audit shall require approval by METRO prior to acceptance of the pilot bus. The bus manufacturer shall provide all of the necessary braking sequence processes and expected brake life miles prior to acceptance of the pilot bus (Deliverable, See Appendix No.1, Item D11).**

30) 3.6 General Chassis

3.6.1 Wheels and Tires

3.6.1.1 Wheels

Front wheels and tires shall be balanced as an assembly per SAE J1986. Wheels shall be hub piloted, durabrite aluminum tubeless motor city type. Wheels shall have hardened or treated aluminum wheel flanges to reduce rim flange wear. Wheel weights and studs shall be designed for use with aluminum wheels.

A hubometer shall be installed at the right rear wheel on each bus. Hubometer shall read to 999,999 miles and shall not display tenths. The wheel hubs shall be painted black. Wheel-checks, rated at 248°F, shall be installed on all wheel lug nuts.

3.6.1.2 Tires

METRO will furnish eight (8) 315/80R-22.5 load range L tires for these buses through its tire contractor. One spare wheel shall be provided by the contractor per bus. The spare wheel shall be mounted and secured in the baggage compartment. **Spare wheel shall be delivered with each bus. (Deliverable, see Appendix No.1, Item D12).**

3.6.2 Fuel System

3.6.2.1 Fuel Tanks

The fuel tank(s) shall be securely mounted to the bus to prevent movement during the bus maneuvers, but shall be easily removable for cleaning and replacement. The fuel tank(s) shall have a usable minimum capacity of 182 gallons and give the bus an eight hundred (800) mile range. Fuel tank(s) shall be EMCO Wheaton compatible (METRO's current fueling nozzles) and have single point fill. The fuel tank(s) shall be mounted in such a manner to permit the repair and replacement of the fuel pick up and return lines, or cover gasket, or if removable, or the fuel tank neck and gasket without the removal of the fuel tank(s). The fuel tank(s) shall be equipped with an external, hex head brass drain plug(s). The drain plug(s) shall be located at the lowest point of tank(s). The fuel tank shall have a removable inspection plate(s) and removable filler(s) to permit cleaning and inspection. The fuel tank(s) shall be made of aluminum with internal baffles to reduce fuel sloshing regardless of the fuel level. The baffles or fuel pickup location shall assure continuous full power operation on a six percent (6%) upgrade for fifteen (15) minutes starting with no more than twenty five (25) gallons of fuel over the unusable amount in the tank(s). The bus shall operate at idle on a six percent (6%) downgrade for thirty (30) minutes starting with no more than ten (10) gallons of fuel over the unusable amount in the tank(s).

The tank(s) shall be internally braced and externally supported in such a manner as to eliminate the possibility of developing fatigue cracks.

If tank(s) is/are mounted by the steel saddle and strap system, tanks must be insulated from the saddle and strap with non-porous, diesel fuel compatible, hard rubber. No woven fabric strap or webbing will be permitted. If more than one (1) tank is used, the fuel crossovers shall be sized to allow complete filling of all tanks using an fueling system flowing 40 gallons per minute.

The contractor shall provide and install a Diesel Exhaust Fluid (DEF) tank with a minimum capacity of 15 useable gallons. This tank shall be designed specifically for the DEF. DEF tank shall be equipped with an receptacle which is compatible with METRO's current DEF nozzle and have a single point fill with a unique interface which eliminates the risk of cross contamination.

3.6.2.2 Fuel Filler

The fuel filler shall be located on the right side of the bus. The filler cap shall be spring loaded. The fuel filler assembly shall be equipped with a pressure relief vent and level control. A filler whistle shall also be provided. Fuel filler door shall be sized to allow easy attachment and detachment of fuel nozzle.

The filler neck must be equipped with an receptacle to accommodate a nozzle compatible with METRO's current nozzle assembly and have a fill rate of forty (40) gallons per minute of foam free fuel without spitting back or causing the nozzle to shut off before the tank is filled. Any fuel spillage shall be routed to the ground and not on top of tank.

The fuel tank filler neck must be equipped with a poppet valve mounted internally of the fuel filler neck to prevent fuel splash back from the fuel tank.

3.6.3 Bumper System

3.6.3.1 Location

Bumpers shall provide impact protection for the front and rear of the bus up to twenty-four (24) inches above the ground for the front bumper and twenty-six (26") inches for the rear bumper. The bumpers may wrap around the bus to the extent practicable without exceeding allowable bus width.

3.6.3.2 Front Bumper

No part of the bus, including the bumper, shall be damaged as a result of a two (2) mph impact of the bus at curb weight with a fixed, flat barrier perpendicular to the bus' longitudinal centerline. The bumper shall protect the bus from damage as a result of 6.5 mph impacts at any point by the striker defined in FMVSS #215 loaded to four thousand (4,000) pounds parallel to the longitudinal centerline of the bus and 5.5 mph impacts into the corners at a thirty degree (30°) angle to the longitudinal centerline of the bus. The energy absorption system of the bumper shall be independent of every power system of the bus and shall not require service or maintenance in normal operation during the service life of the bus. The flexible

portion of the bumper may increase the overall bus length specified in Section 1.6.1.1 by no more than six (6) inches.

3.6.3.3 Rear Bumper

The rear bumper and its mounting shall provide impact protection to the bus at curb weight from a two (2) mph impact with a fixed, flat barrier perpendicular to the longitudinal centerline of the bus. When using a yard tug with a smooth, flat plate bumper two (2) feet wide contacting the horizontal centerline of the rear bumper, the bumper shall provide protection at speeds up to five (5) mph, over pavement discontinuities up to one (1) inch high, and at accelerations up to two (2) mph/sec.

The rear bumper shall protect the bus when impacted anywhere along its width by the striker defined in FMVSS #215 loaded to four thousand (4000) pounds, at four (4) mph parallel to the longitudinal centerline of the bus or into the corners up to a thirty degree (30°) angle to the longitudinal centerline of the bus. The three part rear bumper and its replaceable bumper extensions shall be shaped to preclude unauthorized riders standing on the bumper and shall wrap around the bus to protect the engine compartment doors and radiator. The bumper extensions shall not hinder service and shall be flared into the bus body with no protrusion or sharp edges. The bumper shall be independent of all power systems of the bus and shall not require service or maintenance in normal operation during the service life of the bus.

3.6.3.4 Bumper Material

Bumper material shall be corrosion resistant. Visible surfaces shall be black. These qualities shall be sustained throughout the service life of the bus.

3.6.4 Electrical System

Description of the electrical system proposed shall be submitted as a Mandatory Request for Approval (see Section II of the Solicitation, Item 39). A complete description and functionality of the electrical components being

proposed by the bus manufacturer for the bus to be built for METRO shall be submitted as a Mandatory Request For Approval (see Section II of the Solicitation, Item 40).

3.6.4.1 General Requirements

The electrical system shall be a programmable, self diagnosing system, designed to provide and distribute power to ensure satisfactory performance of all electrical components. Versatility and future expansion shall be provided for by expandable system architecture. The multiplex system shall be capable of accepting new inputs and outputs through the addition of new modules and/or the utilization of existing spare inputs and outputs. Ten percent of the total number of inputs and outputs, or at least one each for each voltage type utilized (0V, 12V, 24V) at each module location shall be designated as spares.

All like components in the multiplex system shall be modular and interchangeable with self-diagnostic capabilities. The modules shall be easily accessible for troubleshooting electrical failures and performing system maintenance. Multiplex input/output modules shall use solid-state devices to provide extended service life and individual circuit protection.

The system shall supply a nominal twelve (12) or twenty four (24) volts of direct current that it does not present an electrical shock hazard. Electrical power provided for the radio compartment shall be 12 volts DC. Radio shall be wired with both switched and unswitched 20 amps, fused power circuits and separate ground returns. Precautions shall be taken to minimize hazards to service personnel.

The power generating system shall be rated sufficiently higher than the total possible electrical load to maintain the charge on the batteries at all operating conditions including the engine at low idle. All circuits, except for those involved in propulsion system start-up, shall be protected by circuit breakers. Fuses shall be used only where it can be demonstrated that circuit breakers are not practicable and they shall be easily accessible for replacement.

All multiple electrical quick disconnects shall be environmental type and adequate space shall be provided, at the time of installation, for ease of removal. Waterproof electrical connectors shall be used at all locations outside passenger compartment.

Redundant grounds shall be used for all electrical equipment, except where it can be demonstrated that redundant grounds are not feasible or practicable. Each of these areas shall be determined and require approval by METRO during the preproduction conference (See Appendix 2, Preproduction Conference, Item PPC 22). One ground may be the bus body and framing. Grounds shall not be carried through hinges, bolted joints (except those specifically designed as electrical connectors), or power plant mountings. Electrical equipment shall not be located in an environment that will reduce the performance or shorten the life of the component or electrical system. **Wiring located under the bus floor shall be eliminated to the extent practicable and where used, shall be determined and require approval by METRO during the preproduction conference (See Appendix 2, Preproduction Conference, Item PPC 23).** Wiring and electrical equipment necessarily located under the bus shall be insulated from water, heat, corrosion and mechanical damage. **The alternator system load shall be determined and require approval by METRO during the preproduction conference (See Appendix 2, Preproduction Conference, Item PPC 24).** All front to rear electrical harness shall be installed above the window line of the bus.

3.6.4.2 Modular Design

Design of the electrical system shall be modular so that each major component, apparatus panel, or wiring bundle is easily separable with standard hand tools or by means of connectors. Each module, except the main body wiring harness, shall be removable and replaceable in less than sixty (60) minutes by a 3M mechanic. Dielectric grease shall be used in specific areas called for by contractor engineering where non-sealed connections are used. Power plant wiring shall be an independent wiring module. Replacement of the engine compartment wiring module(s) shall not require pulling wires through any bulkhead or removing any

terminals from the wires. **Any wire passing through the rear firewall or upper compartment shelf shall be protected with a waterproof and fireproof connection and shall be determined and require approval by METRO during the preproduction conference (See Appendix 2, Preproduction Conference, Item PPC 25).**

3.6.4.3 Wiring & Terminals

All wiring between major electrical components and terminations, shall have double electrical insulation, be waterproof, and shall meet specification requirements of SAE Recommended Practice J-1292 and J1128-Type SXL or GXL. Except as interrupted by the master battery disconnect switch, battery and starter wiring shall be continuous cables with connections, secured by bolted terminals and shall conform to specification requirements of SAE Standard J1127, Jumbo Type SGT or SGX and SAE Recommended Practice J541-JUL83.

All general purpose wiring shall be made of low smoke cross linked polyethylene insulated wiring. The wiring shall be color coded and clearly numbered with a wiring code at least every six (6) inches. All wiring harnesses over five (5) feet long and containing at least five (5) wires except for the parcel rack and coach ceiling/roof area shall include ten percent (10%), but not less than two (2) spare wires with various sizes, excess wires for spares that are the same size as the largest wire in the harness excluding the battery cables. Wiring harnesses shall not contain wires of different voltages unless all wires within the harness are sized to carry the current and insulated for the highest voltage wire in the harness. No butt splices are allowed on any cables.

Double insulation shall be maintained as close to the terminals as practicable. The requirement for double insulation can be met by HD convoluted plastic loom (electrical tape is not acceptable insulation method). Grommets of elastomeric material shall be provided at points where wiring penetrates metal structure. Wiring supports shall be non-conductive. Wiring harnesses shall be supported with insulated clamps or brackets at least every five (5) feet. Use of stand-alone tie-wraps to support harnesses is not acceptable. All cables or harness shall be shielded that are used for engine electronics, transmission electronics, fare box

electronics and elsewhere consistent with requirements of individual equipment/subsystem manufacturers.

Precautions shall be taken to avoid damage from heat, water, solvents, or chafing. Wiring length shall allow replacement of end terminals twice without pulling, stretching or replacing the wire. Except for those on large wires such as battery cables, terminals shall be crimped to the conductor and the insulator must be soldered only if the wire is not stiffened above the terminal and no flux residue remains on the terminal. Terminals shall be full ring type or interlocking and corrosion resistant. T-splices must be used when it is less than twenty five thousand (25,000) circular mills of copper in cross section, a mechanical clamp is used in addition to solder on the splice, the wire supports no mechanical load in the area of the splice, and the wire is supported to prevent flexing. All terminals outside of passenger compartment must be coated after installation to prevent corrosion.

All harnesses shall contain a protective barrier through the use of convoluted loom, grommets, insulated clamps and a cable tie system.

The bus manufacturer shall provide wiring schematic run sheets and ladder logic sheets prior to production of the pilot and shall provide final as-built drawings prior to production of the 10th bus. The wiring layout and ladder logic shall be determined and require approval by METRO during the preproduction conference (See Appendix 2, Preproduction Conference, Item PPC 26). Schematic runs will be on both computer disks and in book form (Deliverable, See Appendix No.1, Item D13).

3.6.4.4 Junction Boxes

All relays, controllers, flashers, circuit breakers, and other electrical components shall be mounted in easily accessible junction boxes and be clearly identified. The boxes shall be sealed to prevent moisture, including engine compartment cleaning,

from reaching the electrical components and shall prevent fire that may occur inside the box from propagating outside the box. Harris County, Texas, where the buses will operate, experiences very heavy rain and frequent flooding. Electrical components mounted low can be expected to be submerged occasionally. "Sealed to prevent moisture" means water resistant.

The components and circuits in each box shall be identified and their locations recorded on a schematic drawing permanently glued to or printed on the inside of the box cover or door. The drawing shall be protected from oil, grease, fuel and abrasion. If the junction box is located along the left side wall, it shall be replaceable as a unit in less than sixty (60) minutes by a 3M mechanic. A rear start and run control box shall be mounted in an accessible location in the engine compartment. Front mounted "J" boxes shall be located at least twenty-four (24) inches above ground level.

3.6.4.5 Electrical Audit

The bus manufacturer shall perform continuity checks and shall perform an electrical audit in actual operation. This audit will be corrected for an ambient temperature of at least 100° Fahrenheit and in accordance with the Original Equipment Manufacturer's recommendations. **The bus manufacturer shall provide METRO a system total load usage list and maximum generator load limit for the pilot bus which shall require approval by METRO prior to acceptance of the pilot bus (Deliverable, See Appendix No.1, Item D14).**

3.6.5 Electrical Components

3.6.5.1 General Requirements

All electrical components, including switches, relays and circuit breakers shall be heavy duty designs. These components shall be replaceable in less than five (5) minutes by a 3M mechanic. Sockets of plug-in components shall be polarized where required for proper function and the components shall be positively retained. All circuit breakers, with the exception of the head light circuit, which must be an automatic re-setting type, shall be manual reset types. All electric motors shall be

brushless long life type, with a constant duty rating of no less than ten thousand (10,000) hours. Electric motors shall be located for easy replacement and maintenance. A 2,000 hour life rated Operator's dash fan shall be provided.

3.6.5.2 Batteries

Batteries shall be easily accessible for inspection and servicing only from outside the bus (curbside). Batteries shall be Absorbent Glass Material (AGM) group 31 series type, applicable to the mass transit industry. All batteries shall be serialized by engraving, embossing or using a decal for the serial number in the case assembly. Each battery shall have a purchase date no more than 120 days from the date of release, and shall be fully maintained prior to shipment to the METRO. Battery serial number shall be written on the battery case with indelible ink. Positive and negative terminals shall be clearly marked, or the battery terminals and cables shall be arranged to prevent incorrect installation. Battery terminals shall be located for access in less than thirty (30) seconds with jumper cables.

The battery tray shall be stainless steel, shall pull out or swing out easily to properly support the batteries during servicing, filling, inspection and replacement. Pins and rollers shall be made of stainless steel. Use of nylon rollers will not be acceptable. A positive lock shall retain the battery tray in the closed position.

Battery cables shall be flexible and sufficiently long to reach the batteries in extended positions without stretching or pulling any connection and so designed to preclude the possibility of the cables lying on top of the batteries when stored. Battery cables shall be routed so they do not pinch when battery tray is closed. The battery terminals and cable ends shall be color coded with red for the primary positive, black for negative, and another color for any intermediate voltage cables. Voltage regulator, battery switches, etc., shall be mounted in a separate compartment. Voltage regulator shall be shock mounted or hard mounted. Batteries shall have top stud positive and negative terminals.

3.6.5.3 Master Battery Switch

A master battery switch shall be provided near the batteries for completely disconnecting all bus electrical systems except the fire suppression system. The master switch shall be accessible in less than ten (10) seconds for activation. The master switch shall be capable of carrying and interrupting the total circuit load. Opening the master switch with the power plant operating shall not damage any component of the electrical system. The engine ECM must be wired directly to the batteries.

3.6.5.4 Fire Detectors

At least two (2) engineered temperature sensitive sensors shall be provided in the engine compartment mounted under horizontal bulkheads above and downwind of the major heat sources in any area likely to be wetted by leaking flammable fluids. Additional engineered sensors shall be located in other potentially critical areas. The sensors shall detect abnormal temperatures and activate the fire alarm bell and warning light in the Operator's compartment. Sensors must automatically reset to deactivate alarms when the temperature returns to normal. Sensors shall be wired to allow easy diagnosis of failed sensors. These sensors shall be part of the Fire Suppression System as specified in Section 3.9.

3.6.5.5 Radio Noise Suppression

Proper suppression equipment shall be provided in the electrical system to eliminate interference with radio and television transmission and reception, Part 15 of the FCC Rules and Regulations. This equipment shall not cause interference with any electronic system on the bus.

3.6.5.6 Static Strap

Three (3) static ground straps shall be affixed to the bus body surface that has been cleaned to effect maximum conductivity to dissipate a static charge. One (1) of the static straps shall be located forward at the front axle another at the driver axle and the third static strap shall be located at the tag axle.

3.6.5.7 Capacitor Starting System

A Capacitor Starting System, connected in parallel with the batteries, shall be provided to assist with starting the bus. This system shall be isolated from the regular starting system to prevent the capacitors from draining during regular operation or long periods of time. In addition the capacitor system should have the following characteristics:

- Energy storage of 120 kilojoule (kJ) within a specified window of 13-26 volts.
- The capacitor must be of asymmetric, aqueous electrolyte, electromechanical, double layer, nickel carbon design.
- Internal resistance of no more than 0.006 Ohm at 68° F.
- Capacitance rating of no less than 500 F.
- System must be independent of the vehicle's Multiplex controllers and provide for proper operation of capacitors discharge and recharging events.

3.6.5.8 Passenger electrical outlets

The contractor shall provide and install one (1) 110V receptacle and two (2) USB power-ports per seat arrangement. The inverter used to provide power shall have the following minimum characteristics:

Output Power (Watts Cont.)	3600
Output Current (Amps AC Cont.)	30
Input Current (Amps DC Cont.)	Up to 167
Peak Power (Watts)	8000
Peak Output (Amps AC)	100
Motor Starting Rating (hp)	2
Weight (lbs.)	68
Dimensions in. (LxWxH)	13.8x17.1x8
Output Voltage (VAC)	120 +/-3%
Output Frequency	60+/-0.5%
Input Voltage	21-34
Operating Temperature (F)	0-149
Efficiency	Up to 88%
Bypass (Amps AC)	30

In addition the inverter shall have:

- Thermally controlled cooling fan
- GFCI outlet protection
- Remote LED Display Panel
- Automatic electronic short circuit/overload protection
- Automatic over temperature shutdown
- AC output circuit breakers
- Automatic low battery shutdown at 10.5VDC with in-rush delay

31) 3.7 Interior Climate Control

A complete description of the interior climate control system being proposed by the bus manufacturer for the bus to be built for METRO shall be submitted as a Mandatory Request For Approval (see Section II of the Solicitation, Item 41).

3.7.1 Heating and Ventilation System

The heating system shall be of sufficient capacity to maintain an inside temperature of 75 F plus or minus 3 F throughout the bus with an outside ambient temperature of 32 F. The heating pull up test and the heating stabilization test must be performed in accordance to the Recommended Practice for Transit Bus HVAC System Instrumentation and Performance Testing as published by the American Public Transportation Association in their APTA-BT-RP-003-07 Final Draft. The stabilization test shall be recorded as a continuation of the heating pull up test. The heating profile test shall be run at 10 F.

All air entering the passenger compartment shall be filtered. Filters must be re-serviceable type and be located for convenient access for maintenance. Filter must be a washable, reusable type.

The ducting for the heating and ventilating system shall not project into the passenger comfort areas.

The ventilating system shall be so designed that it can be used as a power ventilation system for summer operation. The blowers furnished shall have a low

speed for the heating mode and a high and low speed for the ventilating and air conditioning modes. The heating coils shall be located downstream from the air conditioning coils.

The system control thermostats shall be adjustable with access to this adjustment limited to shop personnel. Heating and air conditioning shall be capable of using different temperature range settings. The adjustable range of the thermostat(s) shall be at least from sixty (62°F) to eighty (82°F) degrees Fahrenheit. **A separate control to vary the temperature by 4°F to 6°F shall be located on the Operators control panel, and location shall be determined and require approval by METRO during the preproduction conference.**

The system run control, four (4) position switch, shall be located in the Operator's compartment providing the operator with "Off", "Vent", "Heat" and "A/C" selection. The location of these controls shall be in a convenient position for the operator.

3.7.2 Operator's Heater and Windshield Defroster

An independent front heater and defroster shall provide heat for the Operator and heated air to defrost the entire windshield and the Operator's side window. A fan or fans shall draw air through a filter and then distribute it through the heater core to the defroster system and/or over the Operator's pedals. Air flow shall be sufficient to reach and completely defrost windshields and side windows. The defroster box shall be constructed of corrosion resistant materials. The windshield shall be fully defogged with two (2) minutes.

All controls shall be within easy reach of the Operator. The fan shall not have less than two (2) speeds.

3.7.3 Air Conditioning System

The air conditioning system and its performance are of paramount importance to METRO. Particular attention should be directed to the high summer temperatures, rainfall, and humidity factors found in Houston, Texas. **The performance of the air conditioning system offered shall be demonstrated to METRO's satisfaction.**

Air conditioning (HVAC) system must operate utilizing power supplied by the main bus engine. The bus temperature control system must be designed for semi-automatic climate control of the air conditioning, heating, and ventilating of the bus as an integrated system. **The HVAC system must be installed according to the installation guidelines of the HVAC system manufacturer. An installation audit and system performance test must be conducted by the HVAC system manufacturer and signed off on by both the HVAC system manufacturer and the bus manufacturer. All identified discrepancies must be satisfactorily addressed to METRO's approval and a copy of the completed document must be presented to METRO before METRO will accept the pilot bus (Deliverable, See Appendix No.1, Item D15).**

With the bus operating at the design operating profile and carrying a number of passengers equal to 150-percent of the seated load, the combined HVAC system must maintain an average passenger compartment temperature within a range of 72°F ±3°F, using 134a refrigerant and a piston type compressor while controlling the relative humidity to a value of 50-percent or less. The combined HVAC system must maintain these conditions while subjected to any outside ambient temperatures within a range of 10° to 110 F and at any ambient relative humidity level in a range from 5 to 100-percent. All circulated air must be filtered.

Using the pilot bus produced for METRO, the performance of the combined HVAC system must be tested at the closed environmental chamber of the test facility of the HVAC system manufacturer in accordance with the Recommended Practice for Transit Bus HVAC System Instrumentation and Performance Testing as published by the American Public Transportation Association in their APTA-BT-RP-003-07 Final Draft. Thermocouples shall be used for all temperature measurements with the exception of the wet bulb temperature readings. **METRO and bus manufacturer personnel must be present and observe and approve all procedures during the time that the pilot bus is present at the test facility.**

Failure of the pilot bus to demonstrate compliance with the requirements of the Recommended Practice for Transit Bus HVAC System Instrumentation and

Performance Testing as published by the American Public Transportation Association in their APTA-BT-RP-003-07 Final Draft will constitute METRO's non-acceptance of the pilot bus. **Bus production cannot begin until test results indicate the HVAC system of the pilot bus is compliant and approved by METRO (Deliverable, See Appendix No.1, Item D16). All production buses must be equipped with a combined HVAC system identical to the compliant system of the pilot bus.**

The air-conditioning capacity of the combined HVAC system must be tested in accordance with all Sections of the APTA document. The air conditioning portion of the HVAC system must be capable of reducing the passenger compartment temperature as defined in the listed APTA test procedure from 110° to 72°F ± 3°F using 134a refrigerant and a piston type compressor in less than 30-minutes after start-up of A/C system. During the cool-down period the refrigerant pressure must not exceed safe high-side pressures. The stabilization test shall be recorded as a continuation of the air conditioning pull-down test. The cooling profile test shall be run with the ambient temperature held to 110°F.

The air conditioner compressor must be belt driven from the bus engine. Design of the compressor must permit its engagement at any engine speed without damage to the compressor or any other components of the bus.

The air conditioning system must employ strategy to prevent hammering, high pitched frequency and vibration in the system.

3.7.3.1 Air Conditioning Dehydrator

Two (2) back seated valves shall be installed at the dryer to facilitate evacuation and charging of the system and to provide easier replacement of the dryer unit.

All A/C Receiver Tanks shall incorporate two (2) sight glasses (one (1) if optimum level is visible in sight glass, not above or below) equipped with floating balls for proper Freon level determination.

The desiccant material that makes up the dehydrator shall not be made of a loose material. The material shall be of a substance, or manufactured in a way that will not allow desiccant material to contaminate the air conditioning system.

3.7.3.2 Air Conditioning Evaporators

- (1) The evaporator(s) will be designed for ease of maintenance, i.e., expansion valve, return air filter, electrical controls, and blower motors.
- (2) The evaporators shall incorporate a design for drainage of condensation, which will be heavy due to the climate conditions found in the Houston area. Design shall insure that under no circumstances can condensation spill into the passenger compartment.
- (3) All evaporator filters shall be designed for ease of installation and removal. The return air filter shall be hydrostatic and shall have a Minimum Efficiency Rating Value (MERV) of 7 per ASHRAE Standard 52.2-1999.
- (4) METRO will not accept the use of roof mounted evaporators.
- (5) Evaporator must incorporate a method to prevent possible slugging of compressor.
- (6) Evaporator coil shall be copper or aluminum to resist corrosion.

3.7.3.3 Air Conditioning Condenser

Condenser coil shall be copper or aluminum to resist corrosion. METRO will not accept the use of roof mounted condensers.

3.7.3.4 Air Conditioning System Controls

The operating control switches for the air conditioning system shall be located in the Operator's compartment operable by a seated Operator in a location that shall be determined and require approval by METRO during the preproduction conference (See Appendix 2, Preproduction Conference, Item PPC 27).

The air conditioning system shall utilize a smart controller which automatically monitors system parameters and makes adjustments to optimize performance. The contractor shall provide the ability to view the AC temperatures and pressures inside the bus. The controller shall be equipped with a read-out to display the current temperatures. The diagnostic software shall be capable of capturing the time and duration of AC operation.

3.7.3.5 Outside Ambient Temperature Lockout Switch

An outside ambient temperature lockout switch shall be installed in the air conditioning system to disengage the air conditioning compressor and make the air conditioning system inoperable when the outside temperature is 55°F or lower.

3.7.3.6 Operator's Evaporator

In addition to the main system evaporator and additional under floor evaporator shall be provided for the operator's area. A separate control shall be provided for the front the operator's area heating and air conditioning, as well as for the main under floor unit. In addition, there shall be a dash mounted fan controlled by a switch on the Operator's console.

3.7.3.7 Parcel Rack Evaporators

The contractor shall provide parcel rack evaporators which will be part of the Parcel Rack HVAC system delivering air to passenger thru individual adjustable vents as identified in paragraph 2.1.4.8 Parcel Racks.

3.7.3.8 Air Conditioning Compressor

The compressor shall be designed to allow its engagement at any speed without damage to the compressor or any other components on the bus. The compressor shall have a minimum useful life of two hundred thousand (200,000) miles on the standard operating profile. A class 3M mechanic shall be able to fully rebuild the compressor in less than six (6) hours. To facilitate service two back seated valves with gauge taps shall be provided at the compressor to allow the compressor to be isolated.

If the air conditioning compressor is belt driven, the belt shall be fully shielded to prevent injury to service personnel. Belt adjustment shall be accomplished by moving the compressor within its mounting bracket using a mechanical system to help the mechanic maintain correct belt alignment when changing belts, belt tension, or compressor.

3.7.4 Air Flow

3.7.4.1 Passenger Area

The cooling mode of the interior climate control system in addition to the individual air distribution outlets shall introduce air into the bus at or near the ceiling height at a rate necessary to attain and maintain cooling parameters identified in paragraph 3.7.3 and shall be based on the standard configuration bus with full standing load. Air flow shall be evenly distributed throughout the bus. The ventilating mode shall provide air at a minimum flow rate of twenty five (25) cubic feet per minute per passenger.

Air flow may be reduced when operating in the heating mode with full standing load. The fans shall not activate until the heating element has warmed sufficiently to assure a 65°F air outlet temperature.

The AC system shall be capable of defogging the interior side windows within 3 minutes.

3.7.4.2 Operator's Area

The bus interior climate control system shall deliver at least two hundred (200) cubic feet per minute of air to the Operator's area when operating in the ventilating and cooling modes. Adjustable nozzles shall permit variable distribution or shut down of the air flow. Air flow in the heating mode shall be reduced proportionally to the reduction of air flow into the passenger area. The windshield defroster unit shall meet the requirements of SAE Recommended Practice J382, Windshield Defrosting Systems Performance Requirements, and shall have the capability of diverting heated air to the Operator's feet and legs. The defroster or interior climate control system shall maintain good visibility through the Operator's side window.

Additional air vents may be added to ensure ample air flow in the Operator area. Defroster air flow shall be sufficient to ensure totally cleared windshield(s) and Operator's side window(s).

3.7.5 Air Intakes

Any outside openings for air intake shall be located to ensure cleanliness of air entering the climate control system, particularly with respect to exhaust emissions from the bus and adjacent traffic. If used all intake openings shall be of a size to allow a minimum of 10% fresh air into the passenger compartment, and baffled to prevent entry of snow, sleet, or water.

Outside air shall be filtered before discharge into the passenger compartment. The filter shall meet the ASHRAE requirement for MERV 7. More efficient air filtration may be provided to maintain efficient heater and/or evaporator operation. Air filters shall be of the reusable type and be easily removable. Moisture drains from air intake openings shall be located so that they will not be subject to clogging from road dirt.

3.7.6 Heater Cores

Heater cores, heat exchangers and piping must be copper or bronze. Aluminum is acceptable for fins. Heat lines shall be copper up to each heater core. All copper lines shall be insulated. Connecting hoses to each heater core shall be silicon hose with constant tension clamps.

3.7.7 Air Purifier

An electronic air cleaner system generating ions of both positive and negative polarities shall be integrated into the interior ductwork of the vehicle. The system will manage average ion concentrations at or above 5000 ions/cc measured from the center aisle (5 feet high). The technology will be designed to suppress dust, treat various odors and minimize the growth of various biological contaminants in the airflow, and shall not be compromised by high humidity levels. The design shall be vibration and thermal shock resistant, with variable dc power management, internal short circuit, over-voltage and automatic fault reset protection. Supplier

must be able to reference at least 3 heavy duty transit fleet vehicle applications in operation for at least two years. Use of chemicals, single polarity ionization, glass bulbs, particulate filters and technologies that do not address gas disassociation are not acceptable.

32) 3.8 Electronic Communication Equipment

3.8.1 Provide and Install

It is METRO's intent that new electronic communication equipment be installed by the bus manufacturer at the factory, such that METRO personnel will only have to "plug in" the following listed equipment once the bus has been delivered to METRO. Failure of the "plugged in" communication equipment to function correctly due to bus manufacturer installation errors will constitute non-acceptance. METRO will supply three (3) complete and correctly functioning sets of "to be plugged in" electronic communication equipment to be shipped from METRO's Kashmere Bus Operating Facility to the bus manufacturer's factory at the bus manufacturer's expense. The three shipped sets of communications equipment will allow the bus manufacturer to test the function of their installed systems at the factory. All antennas are to be mounted on streetside of roof. METRO electronic personnel will be present at the pre-production meeting and when required during the pilot bus construction to assist with any clarifications.

The contractor shall install an emergency alarm switch as per METRO's current configuration. This switch shall be a dedicated circuit direct from the switch to each designated device with no inter-connections.

Electronic communication equipment provided by METRO, "plug in" equipment:

- 1) Farebox
- 2) Vehicular subscriber modem (LTE)
- 3) Current destination sign readings
- 4) Payment card validator

Electronic communication equipment provided by contractor and installed on the bus:

1. GPS equipment and antenna
2. Interconnect box
3. Traffic signal priority emitter
4. Interior sign for displaying the next stop
5. Automatic passenger counter with door sensors
6. Communications radio
7. Communications radio antenna
8. Radio interface
9. Router to support machine to machine application
10. Mobile data terminal
11. Covert microphone
12. Public announcement box
13. Microphone on goose neck
14. Intelligent transportation system PC with antenna
15. Vehicular subscriber modem (LTE) antennas
16. Logon indication light
17. Operator emergency alert button
18. Power Conditioner 12V and 24V

The bus manufacturer shall provide and install the communication equipment listed above. Houston METRO will provide upon request METRO's current bus communication diagrams for reference. (Deliverable, See Appendix No.1, Item D17).

3.8.1.1 Bus Mounted Data Recorders

Each bus shall be supplied with a Data Logger that will function with equipment already installed at the METRO service lanes. Each data logger shall be suitable for mounting on a transit bus and connecting directly to a J1939 connector on the bus. Bus-mounted data recorders shall be programmable by METRO with vehicle number and codes for defining the set of data to be recorded and reported. Three (3) sets of programming software and hardware shall be provided to allow METRO to program or re-program the bus-mounted data recorder units at any time. Bus-mounted data recorders provided shall include a minimum one-year warranty on all parts, including batteries, if applicable. Bus-mounted data recorders shall be programmed to respond to a beacon signal sent from a Receiver Unit and upon receipt of such beacon signal shall transmit via radio frequency the bus number and other defined data to the Receiver Unit. Bus-mounted data recorders shall as a minimum provide the following capability:

- 1) Data always collected and reported:
 - Vehicle Number
 - Vehicle Total Mileage
 - Vehicle Total Engine Hours

- 2) Fault Indicators captured and reported:
 - Fault Codes reported shall include Subsystem ID and Failure Mode Identifier as defined in SAEJ1587 documentation.
 - Record the last 10 unique Active Fault Codes reported with the Date and Time of the beginning and ending of the last occurrence observed.

- 1. Last value observed:
 - The Bus-mounted data recorder shall report the last value observed for 10 items.
 - The user shall be able to define these 10 items using M.I.D. and P.I. D. codes as defined in SAEJ1587 documentation.

Examples	M.I.D.	P.I.D.
-----------------	---------------	---------------

Engine Idle Hours	128	235
Idle Fuel Used	128	346

2. Maximum and minimum value observed in 24 hours:

- The Bus-mounted data recorder shall report the maximum and minimum values observed during the previous 24 hour time period for 10 items defined using M.I.D. and P.I.D. codes.
- The date and time of the minimum and maximum occurrences shall also be reported.
- The user shall be able to define the codes for the items to be reported.

Examples	M.I.D.	P.I.D.
Engine Coolant Temperature	128	110
Engine Oil Pressure	128	100
Engine Oil Temperature	128	175
Transmission Oil Temperature	130	177
Ambient Air Temperature	128	171

3.8.1.2 Standardized Connectors

While the Society of Automotive Engineers does not address the issue of standardized connectors or cables within J1939, MIL-C-24308 Subminiature D Pin and Socket Connectors, that shall be used for device interconnection.

3.8.1.3 General Cabling Requirements

The vehicle operator shall not have access to any exposed wiring. Any length of cable which is exposed to the operator shall be protected by an armored sheath placed over the cable. Grommets of elastomeric material shall be provided at points where wiring penetrates metal structure. All cables shall be supported with insulated clamps at least every five (5) feet. Use of tie-wraps is not acceptable.

3.8.1.4 Backbone Cabling

The front to rear electrical harness run shall be installed above the window line or below the floor of the vehicle.

3.8.1.5 Device Cabling to Device Access Box

Any device which is located beyond a firewall shall have a suitable waterproof and fireproof bulkhead connector installed at the firewall before connecting to the Device Access Box.

All wiring from devices connecting to the Device Access Box shall be made of low smoke cross-linked polyethylene insulated wiring. The wiring shall be shielded, color coded and clearly numbered with a wiring code, and in a common sheath.

Device cables may not exceed a six (6) foot length and shall be terminated in a male connector.

3.8.1.6 Grounding

The electrical point of common connection between all shield grounds, and to the vehicle's ground, shall ONLY be at a single point on the vehicle.

That point shall be within the female connector of the power feed cable inserted into the first Device Access Box. The combined shield grounds shall be connected to the vehicle's power panel ground by a 14 awg, or larger, insulated wire.

Shield grounds shall NOT be connected to each other at any other point; have electrical connection to any J1939 device; or be used to carry electrical power.

The Run and 24-hour power return grounds connected to the female connector of the first Device Access Box shall be connected to the vehicle's power distribution panel ground by separate

3.8.1.7 Video Surveillance System

The Contractor shall provide complete recording video surveillance systems for use aboard buses. Systems are intended to improve patron and operator perception of safety and security through a comprehensive video and sound recording system providing coverage throughout the interior and exterior of the bus at a rate of up to 30 frames per second per camera. Video and sound from the units shall be obtainable by, but not limited to, the following means:

1. Demounting of storage media, flash drive, SD card.
2. Via a Wi-Fi connection. System must be WI-FI ready, capable of connecting and able to transmit/receive data over the facilities network.
3. The system should be able to accept triggered inputs to include emergency alarm signaling.
4. Exterior and interior cameras must be at least HD720 and IP (real time view for operator).

3.8.1.7.1 Deliverables

Complete installed bus video/audio surveillance systems equipped with (Deliverable, See Appendix No.1, Item D18):

- a. Network Video Recording subsystem (NVR).
- b. 9 onboard IP cameras per bus with at least 720P resolution, with built in IR illuminators for low light.
- c. All hardware and cabling necessary to constitute a completed job.
- d. License free software such that video from equipped buses may be viewed from workstations on a network (Minimum 200+ user passwords and 60 user groups). Future software updates shall be free of charge.
- e. Training of METRO personnel in the operating, maintenance and repair, and use of the equipment to include viewing software.
- f. System documentation.
- g. Wiring diagrams showing points of interconnection among system components and points of interface with the bus.

- h. Maintenance documentation that shall include instructions for programming and running diagnostics.
- i. Internal Signage.
- j. One-year on-site Warranty coverage.
- k. Surveillance system has received the designation of the Qualified Anti-Terrorism Technology (QATT) under the Department of Homeland Security's SAFETY Act.

3.8.1.7.2 Scope of Work

Contractor shall engineer, furnish, and install the turnkey systems described within this document and shall furnish all equipment, cabling, hardware, and other materials necessary to provide a completed job.

3.8.1.7.3 Digital Video Recorder (DVR) General Requirements

1. Shall be capable of recording nine (9) simultaneous IP 1080P cameras.
2. Shall support at least nine (9) opto-isolated sensor channels
3. Shall support at least nine (9) channels of audio input.
4. Shall provide capability of monitoring 1708 or 1939 devices.
5. The system should be able to accept triggered inputs to include emergency alarm signaling.

1 Environmental Performance

1. Temperature range (recording) within a range of 25 degrees, F to 130 degrees F.
2. Humidity range to 90-percent, condensing.
3. Shock Resistance: Shall survive up to 20 G-Forces per 11 milliseconds, operating. And shall survive up to 40 G-forces per 22 milliseconds, non-operating.

2 Power Requirements

- a. Shall be operable in a range extending from 9 through 36 volts, DC and the unit operational power draw shall not exceed 2.0 amperes at 24 Volts.
- b. All cables and connectors shall conform to applicable SAE standards.
- c. System shall be tolerant of and insusceptible to voltage spikes, dips, surges and reverse polarity.

3 Emergency Power

- a. Shall include an external power source that can supply the NVR and cameras with power in the event of an unexpected loss of power and shall keep the system running for at least 15 minutes after loss of power.
- b. Power source shall be maintenance-free and have an expected service life of at least five (5) years.

4 Turnoff Delay

Unit shall have the option to remain operating for a predetermined length of time after bus shutdown (Master/ignition switch), up to one hour.

5 Mounting

Shall be mountable in any orientation without detriment to its operation.

6 Troubleshooting and Maintenance

- a. External programming, system diagnostics, transmission of video using software over 802.11, LAN/WAN, cellular networks and Ethernet port shall be standard.
- b. Built-in software shall perform full and continuous system diagnostics and be capable of reporting system failures.

7 Real-time Clock

- a. Shall implement a real-time clock that operates independently of the main power supply and shall have a minimum five (5) year operational lifetime before battery change is required.
- b. Clock intrinsic drift-rate shall not exceed one (1) minute per month.

- c. Clock shall be synchronized through the GPS interface.
- d. Clock shall update, automatically for transitions to and from Daylight Savings Time.

8 GPS

- a. Shall be equipped with a Global Positioning Receiver for purpose of providing vehicle location, speed, and current time-of-day for imbedding in recorded video.
- b. Receiver shall be WAAS-enabled and be of 12 channel parallel capability or greater.

9 Operator Interface

Shall require no operator interface to activate operation, initiate shutdown, maintain the system, service, or program the system, and prepare the system for operation.

10 Processor Control

- 1. NVR shall be controlled using embedded processor(s) in an industrial form factor to assure adequate shock and vibration resistance.
- 2. PC motherboards are not acceptable without a documented mobile rating.

11 Operating System

- a. Shall be of an imbedded type contained within a firmware chip.
- b. Shall be written specifically for NVR operation.
- c. Shall allow the largest available enterprise or security class hard drives to be used.

12 Video Inputs

- a. Shall accommodate ten (10) IP video signals.
- b. Shall support frame rates in the range extending from 1 to 30 fps for all camera inputs.

13 Recording Resolution

- Scalable from VGA (640x480) to at least HD720P (1280x720)
- NVR shall adjust the camera resolution.

14 Audio

- a. Shall support ten (10) channels of digitized synchronous 16-bit audio.
- b. Input frequency range extending from 20 Hz to 8 KHz.

15 Impact Sensor

Unit shall be equipped with a 3-axis accelerometer function, capable of tagging video or sending an alarm notification when the bus exceeds predetermined G-force setting.

16 Data Acquisition and Processing

1. Shall be capable of directly digitizing, combining, compressing, encrypting, and storing IP video, audio sensors and auxiliary sensor signals.
2. Video and audio signals shall be encrypted using digital cryptographic methods that prevent alteration and tampering, restrict access, and detect attempted alteration or tampering. (Authentication)
3. Compressed, encrypted data shall feature H.264 Main-Profile video compression and shall be stored to mobile-rated removable storage media.
4. Shall be transmittable over a wired or wireless network.
5. Shall be TCP/IP addressable – both static and dynamic (DHCP).

17 Sensor Parameters

In addition to accurate current time and date, the NVR shall be capable of acquiring, processing, and appending to image data, up to eight (8) programmable analog vehicle parameters, including, but not limited to:

- a. Run Switch (Master/Ignition)
- b. Vehicle speed
- c. Impact (G-force)
- d. Brake operation
- e. Headlights
- f. Left turn signal

- g. Right turn signal
- h. Event switch
- i. Door actuation
- j. Other analog signals (brake , accelerator pedal)

DVR shall combine the vehicle variables above with the other text data, such as time, date, GPS location, and vehicle identification number.

18 Digital Sensors and Devices

Shall support at least ten SAE-J1939 devices. System shall fully integrate with J1939 CAN-bus, to include support for diagnostic message reporting of video loss per camera, NVR alarm events, 3-axis accelerometer events, hard drive status, system temperature status, bus alarm acknowledgement and roll call acknowledgement.

19 Scripting

1. NVR shall be capable of dynamically changing video and audio settings during operation.
2. Changes to the frame rate or image quality of any camera input shall be changeable based upon time, sensor input, or J-1708/J-1939 input in real time.
3. Frame rates shall be changeable from one frame per second to 30 frames per second for all camera inputs and shall be set at 15 frames per second per camera.
4. Audio shall be controllable based upon input signals. (Gated)
5. Shall be capable of recording multiple differing frame rates and differing levels of image quality per camera, concurrently with enough on-board data storage for a minimum of two thousand (2,000) hours at 30 frames per second per camera plus all audio.

20 Log File

Shall maintain a log file of actions stored on demountable storage media.

1. Time

2. Date of the action
3. Master (run) switch on/off
4. Events start and stop
5. Camera failure
6. Drive errors
7. Other diagnostics

21 SAE Conformance

- a. Shall communicate utilizing the Society of Automotive Engineers (SAE) “Electronic Data Interchange between Microcomputer Systems”.
- b. Shall be compliant with Heavy-Duty Vehicle Applications standards SAE-J-1708 and SAE-J-1587.
- c. Shall be compliant with "Recommended Practice for a Serial Control and Communications Vehicle Network" (SAE-J-1939).
- d. Shall be capable of acquiring data from electronic vehicle systems including engines and transmissions using this data communications standard.
- e. The NVR and all sub-systems shall comply with SAE-J-1455, “Recommended Environmental Practices for Electrical Equipment Design” for vibration and shock isolation, and shall include a shock absorbing mounting kit.

22 Diagnostic Software

1. Shall be capable of interfacing with diagnostic software operated from either a workstation or portable computer for system troubleshooting and configuration purposes.

23 Dash-Mounted LCD Video Monitor Panel

1. Shall be mounted atop dash in a position that will minimize interference with the bus operator’s field of vision.
2. Display dimension minimum, 7”diagonal
3. Shall display exterior right camera and wheel chair door camera upon wheel chair door openings, right/left outside cameras upon activation of directional

signals and reverse camera when the reverse switch is activated on the transmission console.

24 LED Panel

- a) Shall show NVR 'ready' status
- b) Shall provide the status of NVR start-up.
- c) Shall show normal operation.
- d) Shall show events-full status
- e) Shall show camera failure
- f) Shall include an 'event switch' with which the operator can mark files showing significant activities.
- g) **Shall be installed on the left side of the operator control panel in a location that shall be determined and require approval by METRO during the preproduction conference (See Appendix 2, Preproduction Conference, Item PPC 28).**

25 Event Save Switch

1. Shall interface with the vehicle's Silent Alarm Switch to mark and protect data acquired during a Silent Alarm event.
2. When Silent Alarm Switch is pressed, NVR will accelerate to full frame-rate to ensure capture of all pertinent information. Images will be tagged and protected in the interval from 20 seconds prior to activation and for five minutes after Silent Alarm Switch activation.

26 Removable Storage Unit

- a. The removable storage media shall conform to mobile requirements for reliability and durability and also conform to SAE and MILSPEC (STD-810F) shock and vibration standards.
- b. The NVR/drive shall be secured in place by a key lock.
- c. Storage capacity shall be SSD and enough for storage of a minimum of two thousand (2,000) hours at 30 frames per second at 1080P per camera plus all audio.

- d. Disk capacity/storage time shall be field-upgradeable with nominal changes to software and/or hardware.
- e. Shall be capable of withstanding continuous vibration (5 Hz to 500 Hz) and frequent shock pulses of moderate duration (up to 10 milliseconds).
- f. Recorded data shall survive typical traffic accidents as well as collisions up to 40 G-forces.

27 Tamper-Proofing

All recorded data shall be created in a secure encrypted file format using digital cryptographic means which shall restrict access, prevent alteration and tampering and support the detection of attempts to alter or tamper with video images or sensor information.

28 Playback and Long Term Storage

- a. Recorded data shall be viewable in read-only format on a standard PC workstation or PC laptop.
- b. Software shall be supplied for on-site data playback.
- c. Shall be compatible with standard PC-based operating systems such as Windows 7.
- d. Data shall be easily downloadable for long-term storage to high-capacity media such as CD-WR,DVD-RW or USB Drive.

29 Wireless Connectivity

- a. NVR data shall be able of being transferable via a compatible 802.11(x) wireless Ethernet, cellular modem and downloadable to a server via a wireless network.
- b. Transferred or downloaded data shall be reviewable using a workstation that has an installed copy of Vendor's video reviewing software.
- c. The system shall be able of delivering video data and system health status information to the server for review.

30 Video Review Software

Shall allow Review of the data from the NVR's storage media.

31 Playback Windows

- a. Shall allow up to ten simultaneous, synchronized playback windows as thumbnails, with one, two, four, eight, or ten larger windows displayable at one time in a tiled format.
- b. Shall provide a zoom function extending from at least X1 to X8.

32 Vehicle Information Shall Show

- a. Vehicle ID number
- b. Date and time of recorded video
- c. Sensor information
- d. Camera number
- e. Vehicle GPS location
- f. GPS-provided speed information

33 Archiving

Shall support archiving of all video, selected frames, or selected loops of video.

34 Video Image Export

Shall provide for individual video frames or selected loops to be exported in JPEG, BMP, AVI, or TIFF formats.

35 Audio

Shall provide for synchronized ten-channel audio playback with filter options.

36 Time and Date Search

- a. Shall allow searching for specific video indexing on time and date stamps.
- b. Shall allow the user to select the time and date for viewing.
- c. Specific events and incidents shall be selectable

37 Decoding and Authentication

Each video frame shall be decoded and authenticated, dynamically, upon request.

38 Cameras

- a. **The location of nine (9) cameras to be installed in the general locations shown below shall be determined and require approval by METRO during the preproduction conference (See Appendix 2, Preproduction Conference, Item PPC 29).**
- b. Exterior cameras shall be rated IP68 and their housings shall be of such design and construction as to preclude water leakage into bus. Housing shall be rated IK-10 for vandal resistance. Exterior cameras shall have IR illumination with a range of 15m for low light conditions.
- c. Interior cameras shall have IR illumination and true day/night functionality for low light capture. IR illumination range should be 5m. Interior cameras should be rated IP66 for ingress protection and IK-7 for vandal resistance.
- d. **Camera lens selection shall be appropriate to the desired areas of coverage, that is, provide maximum coverage to the area being recorded without sacrificing image quality and shall be determined and require approval by METRO during the preproduction conference with final adjustments made during pilot bus construction. The camera system representative shall be present during the Preproduction conference when camera system setup is being discussed. (See Appendix 2, Preproduction Conference, Item PPC 30).**
- e. Cameras shall be installed in vandal-resistant housings using installation methods and hardware appropriate to ensuring stable, solid operation.
- f. Camera cabling shall be continuous from DVR to camera with no interconnections.

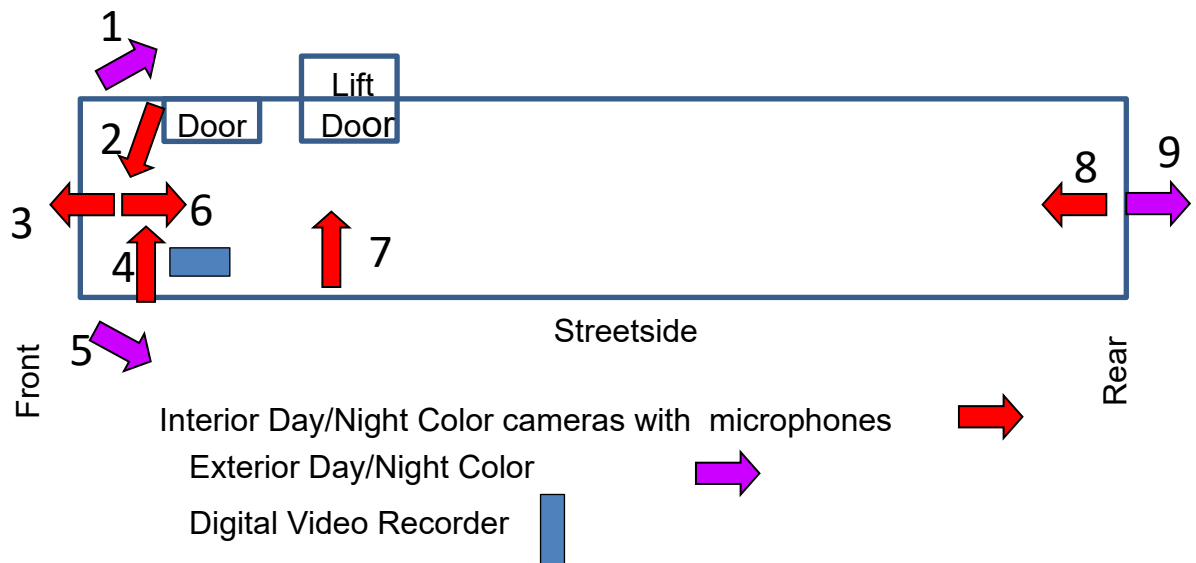

39 Training

- Training shall be provided to METRO personnel, which shall include maintenance procedures, installation and removal procedures, and use of playback and data transfer software.

40 Signage

- **Four (4) signs are required per vehicle in locations that shall be determined and require approval by METRO during the preproduction conference (See Appendix 2, Preproduction Conference, Item PPC 31).**
- Material: Vinyl or plastic with a permanent adhesive backing.
- Lettering size: 7/16"
- Size: 3" X 8"
- Coloring: White background, red lettering
- Wording: Typically – For your safety and security, continuous audio and video monitoring may be occurring on this vehicle.

41 Forensic Acceptance

System video data shall have been accepted as evidence in criminal proceedings and civil proceedings, and have been deemed to have

sufficient forensic integrity to meet authentication and encryption requirements expected by the courts.

42 Installation

Installation shall be performed at the bus manufacturer's plant. Basic system architecture, as referred to in this document, is as follows:

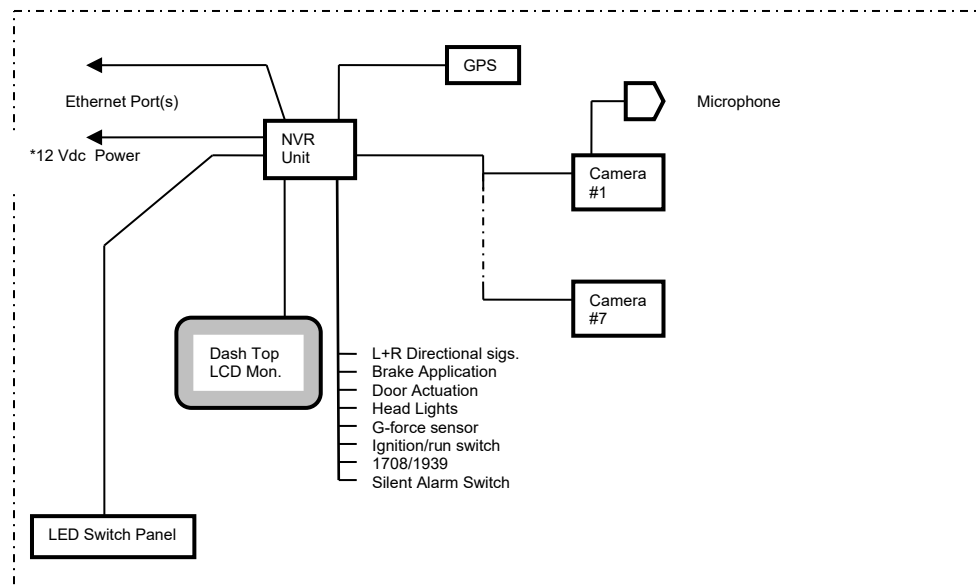

43 Warranty

- Upon notification of a failure, warranty repairs shall be made, on weekdays on METRO's premises, within 24 hours of notification.
- Warranty shall cover all failures and degradation due to equipment failure or deficiencies in installation quality and hardware.

44 Acceptance

- All work and equipment will be inspected and accepted by METRO when it is determined that the conditions of contract have been met and the equipment is completely functional in all applicable modes and functions.
- **Vendor, through bus manufacturer, shall provide certification of each vehicle installed which shall clearly identify equipment installed by model and serial number and shall provide results of proof-of-performance testing witnessed by METRO and the afore-mentioned**

certificate counter-signed before buses are released from factory for delivery (Deliverable, See Appendix No.1, Item D19).

3.8.2 Radio Compartment

3.8.2.1 Compartment

A compartment shall be provided in the first two street side parcel racks to accommodate communications and electronics control equipment.

Power requirements in the compartment are 24VDC Constant, 24VDC Ignition, 12VDC Constant, 12VDC Ignition, Battery Ground, and Chassis Ground. A 30 amp breaker shall be provided for each 12VDC and 24VDC power source in the compartment.

The minimum total volume of radio equipment which shall be accommodated will be 20,400 cubic inches. The absolute dimensions of the container must permit the mounting of internal equipment having minimum vertical dimension 10 inches and minimum horizontal dimension shall be 6 inches and a J-1708B outlet box.

33) 3.9 Fire Suppression System

3.9.1 Fire Suppression

The Contractor shall provide a pre-engineered fire suppression system with detectors. This system shall protect the engine and the battery area in the event of fire or thermal event. The monitoring system shall detect an occurrence and discharge fire retardant in a manner to minimize damage and reduce or eliminate injury to occupants of the bus. The system shall be designed to warn the operator by visual light and audible alarm.

A detailed description of the type of Fire Sensing and Suppression (FSS) equipment of the bus proposed for bid, along with operational information and installation locations, shall be submitted as a Mandatory Request For Approval (see Section II of the Solicitation, Item 42).

3.9.2 Fire Detection

The suppression system shall detect a fire or thermal event and provide warning to the bus operator. The system shall have the capability to detect heat in the engine compartment, battery areas and automatically disconnect the batteries after the orderly shutdown. The system shall warn the operator by visual light and audible alarm and initiate a time delay shutdown of the bus power plant.

Colored control panel lights shall indicate:

- Green - System OK
- Red - Fire Detected

3.9.3 Tests

System components shall have been approved by recognized national testing laboratories such as Factory Mutual, Underwriters, etc. Supporting documentation shall be provided and require approval by METRO during the preproduction conference (See Appendix 2, Preproduction Conference, Item PPC 32) (Deliverable, See Appendix No.1, Item D20).

After installation of the first system in the pilot bus, the Contractor shall demonstrate its ability to operate during a simulated occurrence, prior to acceptance of the pilot bus.

3.9.4 Design

- Recognize a fire in the engine compartment and energy storage areas.
- Suppress the fire at the time of recognition while minimizing damage and preventing injury.
- Alert the bus operator of the occurrence so that proper safety procedures can be initiated.
- Have the ability to automatically shut off the engine, air conditioning/ventilation systems if activated.

3.9.5 Requirements

3.9.5.1 Bill of Materials

Installation drawings, wiring/plumbing schematics, preventative maintenance procedures and parts list are to be provided to METRO in accordance with Section 7.0 Manuals and Parts Lists and 7.1 Requirements (Deliverable, See Appendix No.1, Item D21).

3.9.5.2 Installation of Fire Suppression Systems

The installation drawings, wiring and plumbing schematics, preventative maintenance procedures, parts lists and a picture of each installed component of the system along with descriptive narrative must be integrated into the bus manufacturer's Parts and Maintenance Manuals.

3.9.6 Requirements of Fire Suppression System (FSS)

The FSS system shall have the capability to detect a fire situation, in the engine compartment and energy storage area and initiate a discharge of suppressant agent. The FSS shall have the capability to detect and provide warning to the bus operator.

The FSS shall operate in a manner not to harm bus occupants and shall not restrict emergency exit of the bus.

The FSS suppressant agent shall be 50 LBS of ABC dry chemical discharged out of five brass discharge nozzles, that requires approval by METRO during the preproduction conference and that will allow METRO to receive certified and refilled cylinders from sources located within the Houston Metropolitan area (See Appendix 2, Preproduction Conference, Item PPC 33). In order to minimize damage to the bus structure, wiring and other components (if activated) the agent shall be non-corrosive.

The FSS shall operate effectively as designed during and after exposure to the following environmental conditions:

1. Air temperature minus 20°F to plus 150°F.

2. Humidity 0 to 100 percent.
3. Vibration - normal bus design and engine compartment levels.
4. Shock - normal bus collision design levels.

The FSS shall be capable of detecting fires involving diesel fuel.

The FSS will interface with the bus as follows:

1. Electrical power - operate from the bus batteries as either a 12V or 24V system.
2. Fire warning - if a fire is detected a visual and audible signal shall be immediately provided to warn the operator of a fire situation. The operator display panel shall indicate which detector zone has detected the overheat condition and allow a customized naming protocol for each detection zone.
3. Mounting provisions - components shall be mounted in locations easily accessible for replacement and maintenance.

The FSS shall be designed for reliable operation and ease of maintenance. FSS components shall be reliable so that periodic functional inspection can be done at six month interval. The six month maintenance test of the electronic components shall be done automatically by the control panel and recorded in the bus maintenance history and available for export if necessary for record keeping. The blow out test of the discharge system at the six month interval shall be accomplished by a Schrader valve adapter at the agent cylinder. Testing of FSS functions shall be automatic upon starting the bus and be self diagnostic while in operation. The FSS diagnostics shall alert the operator of a component malfunction.

3.9.7 Fire Suppression Components

3.9.7.1 Fire Detection

Fire detection components shall be set at a temperature to recognize an occurrence in the covered area and shall be set to activate suppressant agent 100° above the normal operating temperature of the area protected by the system.

Programmable Heat Detectors (PHD's) shall be solid state devices that have customizable individual set points which can be set by user/design engineer.

Any fire detection component reaction time shall be no more than .25 seconds from time of reaching set level.

Fire detection components shall be made resistant to damage that may occur from road spray, bus cleaning, road dirt, engine steam cleaning, etc.

3.9.7.2 Extinguisher

Extinguisher shall consist of fast opening valves mounted on the receiver bottles meeting DOT 4BW-350. The receiver bottle shall be filled with an approved suppressant agent incorporating dry nitrogen as a propellant. The agent cylinder shall have a brass guard protecting the gauge that visually indicates internal pressure as well as a pressure sensor integrated, which sends a signal to the control panel to indicate an unpressurized condition. The actuator valve shall be capable of releasing suppression agent at the rate of .8 seconds per pound.

The FSS shall have a manual activator in the operator's area to allow the driver to manually activate the fire suppression if the need arises.

3.9.7.3 Electrical System

Wiring Type: Wiring shall meet all requirements of N.F.P.A. 17 for automatic fire suppression units.

1. Color Coding: Required on all harnesses.
2. Number Coding: All wiring numbered every six (6) inches with numbers that cannot be rubbed off.
3. Connections: All electrical connections/components shall be protected against detrimental environmental influences.

4. Panels and Breakers: Electrical connections/components shall be located away from dirt and water splashed areas. Only manually re-settable circuit breakers shall be used, except where special fuses are required by sensitive equipment.
5. Circuit Diagrams: Circuit diagrams pertaining to each electrical accessory or panel shall be provided on or near each accessory. They shall be plastic laminated diagrams secured to the inside of door panels. **All relays, terminals and electrical accessories shall be numbered on the item and on the diagram These diagrams shall be included in the maintenance manuals (Deliverable, See Appendix No.1, Item D22).**

3.9.7.4 Control Electronics

The control electronics unit shall interface and provide fire warning signals to the bus electrical controls to interrupt fuel and initiate engine shutdown. Electrical power shall be direct from the bus storage battery without passing through a maintenance switch. The circuit shall incorporate an in-line fuse to be located in the bus battery switch compartment.

3.9.8 Tools

The Contractor shall furnish two (2) lists of any special maintenance tools required for maintenance of the system supplied including lists of special diagnostic equipment prior to acceptance of the pilot bus (Deliverable, See Appendix No.1, Item D23).

Maintenance manuals shall describe the specialized tools and diagnostic equipment necessary for system operation with part or model numbers for reference.

3.10 System Certifications

The contractor shall provide the original equipment manufacturer's (OEM) certifications that their system has been designed and engineered to operate in the Houston Texas environment (Deliverable, See Appendix No.1, Item D24).

Each bus system, including subsystems are subject to approval from the OEM. Each system/subsystem document must be signed by the contractor and the OEM supplier and a copy of each shall be delivered to and approved by METRO prior to acceptance of the pilot bus (Deliverable, See Appendix No.1, Item D25).

4.0 WARRANTY AND SPARE PARTS BASIC PROVISION

34) 4.1 Warranty Requirements

Warranties in this document are in addition to any statutory remedies or warranties imposed on the Contractor. Consistent with this requirement, the Contractor shall warrant and guarantee to METRO each complete coach and specific subsystems and components according to the following provisions.

The Contractor shall ensure in its procurement arrangements that the warranty requirements of this Contract are enforceable through and against the Contractor's suppliers, vendors, and subcontractors. Any inconsistency or difference between the warranties extended to METRO by the Contractor and those extended to the Contractor by its suppliers, vendors, and subcontractors, shall be at the risk and expense of the Contractor. Such inconsistency or difference will not excuse the Contractor's full compliance with its obligations under the Contract Documents.

Upon request of METRO, the Contractor promptly shall provide to the Project Manager complete copies of written warranties or guarantees and of documentation of any other arrangement relating to such warranties or guarantees extended by the Contractor's suppliers, sub suppliers, vendors, and subcontractors covering parts, components, and systems utilized in the coach. If any vendor/supplier to the Contractor offers a warranty on a component that is longer or more comprehensive than the required warranties stated. The Contractor shall inform METRO of this additional warranty and pass it through to METRO at no additional cost to METRO.

The Contractor shall ensure that such suppliers, sub suppliers, vendors, and subcontractors satisfactorily perform warranty-related work.

The contractor shall reimburse METRO through check for parts and labor.

4.1.2 Complete Coach

The coach shall be warranted and guaranteed to be free from defects and related defects for two (2) years or 100,000 miles, whichever comes first, beginning on the in service date of each bus. During this warranty period, the coach shall maintain its structural and functional integrity. The warranty shall be based on regular operation of the coach under the operating conditions prevailing in METRO service area.

4.1.3 Subsystem and Components

Specific subsystems and components shall be warranted and guaranteed to be free from defects and related defects for the time or mileages given in the table below and submitted as part of Mandatory Request for Approval (see Section II of the Solicitation, Item 43). Subsystem and Component Warranty begin on the date each bus is placed into revenue service.

Items	Description	Years*	Mileage*
1	Engine and all items supplied by its manufacturers	5	300,000
2	Engine Electronic control system	5	300,000
3	Transmission	5	300,000
4	Drive and non-Drive Axles	2	100,000
5	Suspension	5	300,000
6	Interior lighting	12	500,000
7	Brake System (excluding friction material)	3	150,000
8	Basic Body Structure (excluding primary load carrying structure)	5	300,000
9	Primary Load Carrying Structure and Corrosion Protection	12	500,000
10	Cooling System	3	150,000
11	Heating and Ventilation Units	3	150,000
12	Electric Fan and Power Steering System	3	150,000
13	Wheelchair Ramp System	3	150,000

14	Destination Sign	3	150,000
15	Door System	2	100,000
16	Air System, not limited to Compressor, Dryer, Tanks, Valves	3	150,000
17	Basic Engine Starting System	2	100,000
18	Engine cradle	5	Unlimited

The basic body structure is composed of all components that are welded or riveted together to form the mainframe and body construction. Suspension beams, weldments, and structural members shall be considered as parts of the basic body structure. Bolted-on components and operating hardware are considered add-ons and therefore are not a part of the basic body structure.

Primary load carrying members of the coach structure, including structural elements of the suspension, shall be warranted against corrosion failure and/or fatigue failure for a period of 12 years or 500,000 miles, whichever comes first.

*Whichever Occurs First

4.1.3.1 Warranty Assignment (Delegation)

Should the Bidder desire to delegate warranty responsibility to the Bidder's suppliers, or to others, the Bidder must request warranty delegation authorization as a Request for Approved Equal.

When requesting authorization for warranty delegation, the Bidder must provide the following information and statements in writing (Deliverable, See Appendix No.1, Item D26):

- A. The name and location of each proposed warranty delegate.
- B. A detailed explanation of each proposed delegate's claims procedures.
- C. That the Bidder's warranty delegates will service their respective warranty program according to the terms listed in this contract.

- D. Bidder shall ultimately be responsible for all diagnostic costs and work performed related to warranty repairs that the Bidder directed to their Delegate.
- E. That METRO's due warranty reimbursements will not be negatively impacted by the Bidder's delegation of warranty.
- F. That METRO will be reimbursed all costs incurred in transport of vehicles and/or components.
- G. That METRO shall not be required to expend any monies as a result of the warranty delegation.

Pro-rated or participatory warranties are not acceptable. At any time during the warranty period, the Contractor may delegate his warranty obligations to others, but only on a case-by-case basis when approved in writing by METRO.

Warranty delegations will be acceptable to METRO provided:

- Bidder, during the RFA process, specifically asked to delegate certain warranty or warranties,
- Bidder submits a signed statement that all delegated warranties will be provided in accordance with METRO's specifications. Bidder submits a detailed description of how each delegated warranty will be serviced (description to include required forms, location of warranty repair, parts shipment and return, etc).
- Bidder acknowledges that upon written notice from METRO, any assigned warranty agreement may be revoked, and all liabilities of warranty as specified will become the sole responsibility of Bidder.

4.1.4 Voiding of Warranty

The warranty shall not apply to any part or component of the coach that has failed as a result of misuse, negligence, or accident, or that has been repaired or altered in any way so as to affect adversely its performance or reliability, except insofar as such repairs were in accordance with the Contractor's maintenance manuals and the workmanship was in accordance with recognized standards of the industry.

The warranty on any part or component of the coach shall be void if METRO fails to conduct normal inspections and scheduled preventive maintenance procedures on the same part or component substantially as recommended in the Contractor's maintenance manuals, and such failure by METRO is the sole cause of the part or component failure.

4.1.5 Exceptions to Warranty

The warranty shall not apply to scheduled maintenance items and items furnished by METRO, except insofar as such equipment may be damaged by the failure of a part or component for which the Contractor is responsible.

A complete list of scheduled maintenance items for which exceptions to warranty are desired shall be submitted as a Mandatory Request For Approval (see Section II of the Solicitation, Item 43).

4.1.6 Detection of Defects

If METRO detects a defect within the warranty period, it shall notify the Contractor's representative within a reasonable time after discovery of the defect. Within two (2) working days after receipt of notification, the Contractor's representative shall agree either that the defect is in fact covered by warranty, or reserve judgment until the subsystem or component is inspected by the Contractor's plant. The status of warranty coverage on the subsystem or component shall be mutually resolved between METRO and the Contractor. Work necessary to commence the inspection or repairs, under the provisions of Warranty, Repair Procedures, shall commence within five (5) working days after receipt of notification by the Contractor, unless such time is extended by METRO, and shall be conducted in accordance with Section 4.1.13, Repairs by Contractor.

If METRO and the Contractor are unable to agree whether a defect is covered by the warranty provisions, METRO may direct the Contractor to commence repairs in accordance with the Section 4.1.13, Repairs by Contractor, pending agreement by METRO and Contractor whether the repairs are covered by the warranty provisions. The Contractor shall promptly comply with such a request by METRO.

4.1.7 Fleet Defects

A fleet defect is defined as cumulative failures of any kind in the same components in the same or similar application where such items are covered by the warranty and such failures within the warranty period in at least twenty (20) percent of the vehicles delivered under this contract.

METRO shall have final approval of corrections or changes under these conditions.

4.1.8 Correction of Fleet Defects

The Contractor shall correct a fleet defect under the procedures specified in Section 4.1.12, Repair Procedures.. Within five (5) days of receipt of notification of a fleet defect, unless METRO grants an extension, the Contractor shall provide METRO with a plan, acceptable to METRO, specifying how and when all buses with defects shall be corrected. Said plan is subject to approval by METRO. In addition, after correcting such defects, the Contractor shall promptly undertake and complete a work program, acceptable to METRO, reasonably designed to prevent the occurrence of the same defect in all other coaches and spare parts purchased under this contract. Any proposed changes to a fleet defect work plan or program must be submitted to METRO for its approval. If (a) Contractor does not provide a plan for correction within the time specified above (or as extended by METRO); or (b) a specific declared fleet defect is not fully corrected within the time specified in the plan; or (c) the remainder of the coaches are not corrected in accordance with the Contractor's work program; METRO will assess liquidated damages in accordance with the terms of the contract.

The warranty on parts, components or sub-systems replaced as a result of a fleet defect shall be assigned a new warranty period equal to the original manufacturers or contract part warranty, whichever is longer, effective the replacement date. Any extended warranties shall commence at the conclusion of the new warranty period.

4.1.9 Voiding of Warranty Provisions

The fleet defect provisions shall not apply to coach defects solely caused by noncompliance with the Contractor's recommended normal maintenance practices and procedures or caused solely by abuse of the equipment.

4.1.10 Exceptions to Warranty Provisions

Fleet defect warranty provisions shall not apply to damage that is a result of normal wear and tear in service. The provisions shall not apply to METRO-supplied items.

4.1.11 Contractor's Representative

The Contractor shall, at its own expense, provide qualified factory authorized service personnel at the METRO facilities from the time the first coach is delivered until the warranty period ends. The Contractor's service personnel shall be available twenty-four (24) hours, seven (7) days a week, to assist METRO in the solution of engineering or design problems and perform daily warranty related repairs at METRO's six (6) Bus Operating Facilities that are within the scope of the Technical Specifications and that may arise during the warranty period. Maintenance or repair instructions or suggestions from these representatives affecting warranty shall be in writing and directed to the METRO Project Manager. The Contractor's service personnel shall have authority to accept and approve warranty claims and make timely decisions affecting the repair of defects.

The Contractor shall be responsible for having a suitable service center for its representatives, located within Houston. The facility should have office space with functional communication equipment (telephone, fax and computer capabilities), a parts storage area, and working space for a minimum of two coaches. The service center should be secured in a manner to protect METRO property from theft, vandalism and natural disaster, to the extent possible.

Contractor and contractor's supplier representatives that have warranty responsibilities formally delegated to them, to include senior management responsible for OEM customer service, must attend, in person, at METRO's Kashmere facility, a monthly warranty/service status meeting for the duration of the complete bus warranty period.

The contractor shall submit an organizational chart of the service team assigned to Houston, including a description of electric/electronic and HVAC capabilities shall be submitted as a Mandatory Request For Approval (See Section II of the Solicitation, Item 44)

On a daily basis, Contractor shall supply a record of Contractor's personnel working within METRO property to the METRO supervisor or the superintendent on site and to METRO's Warranty Manager. The record shall contain the following information: Date, contractor personnel Name, and the METRO Vehicle ID number worked on. Contractor shall inform METRO in advance of any modifications proposed on the vehicle during the warranty period (Deliverable, See Appendix No.1, Item D27).

METRO will work the Contractor's representatives as much as possible to minimize the costs and time involved in conducting warranty repairs; however, due to space constraints and labor agreements, METRO cannot guarantee that any Contractor work will be performed on METRO property.

4.1.12 Repair Procedures

The Contractor shall be responsible for all warranty-covered repair work. The Contractor or its designated representative shall secure parts and perform all affected warranty repair work at METRO's six (6) Bus Operating Facilities and at the Contractor's Service Center. . At its discretion, METRO may perform such work if it determines it needs to do so, based on transit service or other requirements. The Contractor shall be responsible, and shall reimburse METRO, for all costs for warranty work performed by METRO personnel by any contractor(s) hired by METRO to perform warranty work, as described in the warranty Section 4.1.14, Repairs by METRO. Form of reimbursement will be made by check.

4.1.13 Repairs by Contractor

When METRO requires the Contractor to perform warranty-covered repairs, the Contractor's representative must begin work necessary to effect repairs in a proper

and timely manner, within two (2) working days after receiving notification of a warranty covered failure from METRO. Whenever the Contractor makes warranty repairs, new parts, subcomponents and subsystems shall be used, unless the repair of original parts is authorized in writing by METRO. METRO will make the buses available to the Contractor to complete warranty covered repairs in a timely manner.

The Contractor shall provide, at its own expense, all spare parts, labor, tools and space required to complete repairs. The Contractor shall reimburse METRO for all warranty related expenses incurred, including labor for driving buses from an in-service breakdown, or towing charges for buses transported from an in-service breakdown or between METRO's facilities and Contractor's service center or the facilities of its subcontractors or suppliers. Form of reimbursement will be made by check. At METRO's option, the Contractor shall repair buses at an offsite location, and not on METRO's property. If the bus is removed from METRO's property, the Contractor's representative shall diligently pursue the acquisition of parts and repair procedures. The schedule and scope of the repairs shall be approved by METRO.

4.1.14 Repairs by METRO

If METRO elects to perform or procure a contractor to perform, the warranty-covered repairs, the following shall apply.

4.1.14.1 Parts Used

METRO may use new parts, subcomponents and subsystems that Contractor shall provide specifically for this repair. Contractor shall stock the majority of parts, including those of its sub-suppliers. All parts shall be stamped or permanently marked with the OEM part number, and serial number if applicable. Warranties on parts used shall begin once the vehicle has been repaired. The OEM warranty will apply to the newly installed part with the manufacturer acknowledging the passed-through warranty.

METRO shall use parts or components available from its own stock only on an emergency basis. Monthly reports, or reports at intervals mutually agreed upon, of all repairs covered by warranty will be submitted by METRO to the Contractor for reimbursement or replacement of parts or components. The Contractor shall provide forms for these reports (Deliverable, See Appendix No.1, Item D28).

4.1.14.2 Contractor-Supplied Parts

The Contractor shall warehouse, at the Contractor's service center in Houston, all necessary parts to support its warranty obligations. The Contractor shall furnish parts for all warranty work, whether the warranty labor is performed by the Contractor or by METRO. Contractor shall deliver prepaid warranty parts for repairs within five (5) calendar days of notification from METRO.

4.1.14.3 Defective Parts Return

The Contractor may request that defective parts or components covered by warranty be returned to the manufacturing plant. The Contractor shall pay the total cost for this action. Materials will be returned in accordance with the Contractor's instructions. Contractor shall provide such instructions to the METRO Project Manager at the beginning of the project.

The Contractor's representative shall meet with a METRO representative on a biweekly basis to determine which parts need to be returned to the manufacturer for evaluation, or which parts may be discarded.

4.1.14.4 Reimbursement for Labor

Contractor shall reimburse METRO for all warranty labor incurred by METRO. The amount shall be determined by multiplying the number of man-hours required to correct the defect by the current top mechanic's or technician's hourly overtime wage rate, which includes fringe benefits, multiplied by the project overhead rate (15% of the wage rate). Additionally, Contractor will be responsible for the cost of towing the coach if such action was necessary and if the coach was in the normal service area.

The wage rate, and therefore, the warranty labor rate, is subject to adjustment each year. The warranty labor rate shall be based on METRO's current technician's wage rate of \$95.00/hour, which includes labor, fringe benefits, and overhead.

In the event METRO deems it necessary to contract out for warranty repairs, the Contractor shall reimburse METRO for the actual cost of the repair, including charges for any warrantable parts, consequential parts or damages, labor, and towing or transportation.

Contractor shall reimburse METRO for warranty claims within forty-five (45) days after each warranty claim has been submitted by METRO. Form of reimbursement will be made by check.

4.1.14.5 Reimbursement for Parts

In the event METRO uses its own parts for warranty repairs, the Contractor shall reimburse METRO for those parts, including all defective parts, components, and consequential parts supporting the warranty repair. The reimbursement shall be at the invoice cost of the parts or components at the time of repair and shall include applicable taxes plus a 15% handling fee.

4.1.14.6 Reimbursement for Towing

The warranty will include the cost of towing the coach or a coach change if either was necessary because of the failure of a warranted part. Towing costs consists of METRO's established contracted tow truck charge including applicable taxes, any parts utilized in the transfer of the coach, any METRO labor expended, plus a 15% handling fee. The cost of a coach change will consist of the actual time spent at the established warranty labor rate.

Contractor shall reimburse METRO for warranty claims within forty-five (45) days after each warranty claim has been submitted by METRO. Form of reimbursement will be made by check.

35) 4.2 Warranty After Replacement or Repairs

The warranty on parts, components or sub-systems replaced as a result of a standard warranty repair shall be assigned a new warranty period equal to the original manufacturers or contract part warranty, whichever is longer, effective the replacement date. Any extended warranties shall commence at the conclusion of the new warranty period.

4.2.1 Failure Analysis

At METRO's request, the Contractor, at its cost, shall conduct a failure analysis of a failed part involved in a fleet defect or that is safety-related or a major component that could affect fleet operation that has been removed from coaches under the terms of the warranty. The analysis shall be documented and compiled into a report. The Failure Analysis Reports shall be delivered to METRO Project Manager within sixty (60) days of the receipt of failed parts.

4.2.2 Data Processing

4.2.2.1 Warranty and Computer Program

To the extent practical as determined by METRO, Contractor shall accept the use of METRO's Maintenance Management System. The current system in place is Trapeze EAM. The Contractor shall accept the use of Trapeze EAM Warranty Conditions, Claims and Payments modules for all tracking and submission of Warranty repairs and/or claims. All systems modifications, parts retrofits, and factory recalls must be documented for integration into warranty software.

4.2.2.2 Warranty Data

The warranty data shall be provided in Microsoft Excel format with the following data elements for Contractor's warranty and manufacturer warranties on all individual components and part(s). METRO will provide Vendor IDs to be used for this data. **At the start of the project Contractor shall provide a complete list of all manufacturers and/or vendors that Contractor will use in building the vehicles (Deliverable, See Appendix No.1, Item D29) and METRO will provide Vendor IDs for use in the following warranty data.**

4.2.2.3 Main Header Information

Warranty name, Vendor ID and name that is contracted to the warranty, and a vendor contract number if there is one.

4.2.2.4 Details of the Warranty Conditions

If the warranty is a Vehicle Class warranty, give the term value, unit of measure and reimbursement type.

If the warranty is system-related, give the term value, unit of measure, reimbursement type, whether the condition is prorated, and whether the warranty term value flows down to underlying attached components of the system.

If the warranty is a component-type of warranty, give the term value, unit of measure, reimbursement type, whether the condition is prorated, and whether the warranty term value flows down to underlying attached components.

If the warranty condition is an item warranty from Contractor or a subcontractor that manufactures parts for Contractor, then please provide the following information: Main header information as described above, Manufacturer part number, Part description, term value, unit of measure, term type, reimbursement type, and whether the condition is prorated.

Data and data processing procedures shall be approved by METRO to ensure compliance with these specifications and compatibility with METRO's data processing methods.

4.2.2.5 Database Information

Contractor shall supply data on the fleet to METRO in an electronic format in order to facilitate its loading into the Trapeze EAM software system. **This section provides layouts and data requirements for the required data elements. Contractor may supply this information in its choice of (Deliverable, See Appendix No.1, Item D30):**

1. Microsoft Excel
2. Microsoft Access
3. Oracle tables
4. Other approved equals

METRO has no preference among the above, but all provided database DVD media must be in the same format. Files will be provided on DVD media using the Contractor's choice of format from the above options. At METRO's discretion, Contractor may transmit these files electronically directly to METRO.

4.2.2.6 Coach Master File

The Contractor shall provide a record for each coach at the time of delivery. This record shall be intended for import into METRO's own database system, shall have no access restrictions, and shall not be indexed. **Contractor may supply a single file, which contains records for multiple coaches (Deliverable, See Appendix No.1, Item D31).**

At a minimum, the following vehicle components shall be serialized and included in the record for the coach:

- A. Engine
- B. Exhaust After-Treatment Device
- C. Alternator
- D. Engine control system
- E. Bus Inverter
- F. Regulator
- G. ECU (Engine Control Unit or Similar)
- H. Radio or GPS system
- I. Destination Sign(s) installed by the vendor.
- J. Air Compressor
- K. Brake Booster
- L. Front Axle
- M. Center Axle
- N. Rear Axle

- O. Differential
- P. Air Conditioner Units
- Q. Wheelchair Ramp
- R. Auxiliary modules
- S. Steering Gear Box

The coach master file shall include at least the following data for all coach and all systems/components listed above:

METRO Equipment Code	CHAR(35)*
Description	CHAR (60)
Manufacturer Name	CHAR(10)**
Manufacturer Part#	CHAR(30)
Model #	CHAR(25)
Serial #	CHAR(30)
Location on Coach or other Equipment	CHAR(5)***
UOM	CHAR(2)*
Next Higher Assembly Code	CHAR (35)(if applicable)

* METRO will provide a coding structure for Contractor to use when creating this equipment master file

** METRO will provide a code and description list of Manufacturer values; Contractor will use the appropriate code from the list in this row

*** METRO will provide a code and description list of Location values; Contractor will use the appropriate code from the list in this row.

Serialized tire “brands” table records will also be provided in the same format as above, but will be provided in a separate file. The locations for tires on each coach are as follows (see** note on above data table):

- A. Left Front
- B. Right Front
- C. Inner Left Rear
- D. Outer Left Rear
- E. Inner Right Rear
- F. Outer Right Rear

36) 4.3 Illustrated Parts Catalog Master File

The Contractor shall provide METRO with the following database information on MPC-compliant DVD media for the Illustrated Parts Manual: The parts catalog data must be provided in Microsoft Excel rows and columns. Rows with data will consist of the following: Section, Graphic Title, Figure #, Item #, (is it item 1, 2, 3, etc. on the graphic), Manufacturer Part Number, Part Description, QTY, and Unit of Measure (Deliverable, See Appendix No.1, Item D32). For example see below.

Section	(14)
Figure #	(14)
Item #	(14)
Manufacturer	CHAR (5)*
Manufacturer Part #	CHAR (30)
Description	CHAR (60)
Quantity	#(14, 4)
UOM	CHAR (3)**
GRAPHIC_TITLE	Coach-1-1-curb side locations

* METRO will provide a code and description list of Manufacturer values. Contractor will use the appropriate code from the list in this row.

** METRO will provide a code and description list of UOM values. Contractor will use the appropriate code from the list in this row.

Example:

Section	2
Fig #	1
Item #	1
Manufacturer	Am Seat
PN	500895
Description	INSTALLATION DRIVER'S BARRIER
Qty	1
UOM	EA
GRAPHIC_TITLE	coach-1-1-curb side locations

Images – Parts catalog images must be provided in TIF format and they must comply with CCITT3 compression level. Image naming will match Graphic Title contained in the record defined above. File name can be provided in a separate row besides the image title.

The Contractor shall provide METRO with the following database information on MPC compliant DVD media for all parts used on the coach.

Manufacturer Name	CHAR (5)
Manufacturer Part #	CHAR (30)

Description	CHAR (60)
Net Price w/freight	NUMBER (14, 2)
UOM	CHAR (2)*
Next Higher Assembly Part #	CHAR (30) (if applicable)

* METRO will provide a code and description list of Manufacturer values. Contractor will use the appropriate code from the list in this row.

** METRO will provide a code and description list of UOM values. Contractor will use the appropriate code from the list in this row.

All warranty repairs done by the coachbuilder at their shop must include a copy of the work performed to document work history by METRO into METRO's SAP system.

37) 4.4 Publications Software

The Contractor shall provide the following on DVD media to METRO (Deliverable, See Appendix No.1, Item D33):

- 1. Drawings in electronic formats such as AutoCAD, TIF, or PDF (only for drawings contained in the Manuals)**
- 2. Maintenance Manuals**
- 3. Parts Manuals**
- 4. Training Manuals**
- 5. Wiring and Air Diagrams**

38) 4.5 Parts Information

The Contractor shall update the parts books (both paper and electronic Excel format) within thirty (30) days of any changes made for the 12 years after the initial production of the METRO coaches described in this request. **The parts books shall have the following indexes sorted in the following order (Deliverable, See Appendix No.1, Item D34):**

1. By part manufacturer's description
2. By coach manufacturer's description
3. By part manufacturer's part number
4. By coach manufacturer's part number
5. By IPC number

The price of all parts shall be included in each index by coach manufacturer's part number. The Contractor shall provide consistent pricing and shall provide a corrected price sheet in Excel format on a DVD media on an annual basis. The detail of the parts books shall be to the level of providing bolt size, lengths and metal grades in addition to cross reference to the part manufacturer or component manufacturer's part number.

In the event there are updated which affect the durability, reliability or safety of spare parts and components supplied as part of this contract, or if there is a running change made during production, the Contractor shall exchange on a one-for-one basis the originally purchased parts with the new updated parts within sixty (60) days of their release.

39) 4.6 Recommended Spare Parts

The Contractor shall submit a recommended spare parts list, after the preproduction meeting (before the pilot bus construction begins), for METRO's use when planning and ordering spare parts and to support METRO's initial start-up for revenue operation (Deliverable, See Appendix No.1, Item D35). The quantities shall be based on the quantity of coaches on order at the time the parts list is generated, and shall be sufficient to cover METRO's reasonable needs for five (5) years.

Spare parts shall be interchangeable with their corresponding part. All spare parts shall be reconfigured to the latest revision during the warranty period. The recommended spare parts list shall take into consideration the potential for certain unused parts and assemblies to "age" and otherwise experience degradation in performance or reliability when installed. All such parts and assemblies should be clearly marked with date of manufacture, ideal storage conditions information, and

shelf life date. This information tag should be clearly visible when the part, container, or assembly is stored.

40) 4.7 Contractor's Recommendations/Prices

The Contractor's recommended spare parts list shall include the following (Deliverable, See Appendix No.1, Item D36):

- A. Grouping by system, and special tool for stocking identification.
- B. Generic name, trade name, description, rating, accuracy, Contractor's part number, original equipment manufacture's (OEM's) name, OEM's part number, drawing references, and correlation with the parts manuals.
- C. Correlation for the recommended quantities with reliability requirements and lead time on the basis of the following classifications:
 - a. Consumable – Parts with an expected life of less than five years.
 - b. Wear – Parts that may be expected to require regular replacement under normal maintenance schedules, such as mechanical parts subject to continuous operation.
 - c. One Shot – Parts that normally require replacement after performing their function one time, such as fuses.
 - d. Long Lead (Three months or greater) – Parts that are not readily available from distributors or manufacturer, such as specially made.
 - e. Exchange Assemblies – Assemblies that will be exchanged with failed units (or units that are not responding as specified) on the supplied equipment and that must be inventoried as complete assemblies.
- D. A cross-reference and indexing system for replacement components common to more than one subsystem (whether vehicle, test equipment, or special tool). Such components shall have only one part number.
- E. Upon request, the original equipment manufacturer name and phone number for non-proprietary items shall be provided.
- F. Identify all proprietary parts.
- G. Current prices for all replacement parts.

41) 4.8 Availability

The Contractor shall guarantee the availability of replacement parts for the coaches for at least a 12-year period after the date of acceptance of the last coach. Spare parts shall be interchangeable with the original equipment and shall be manufactured in accordance with the Quality Assurance Provisions in these Technical Specifications. Contractor shall guarantee delivery of all in stock items within fourteen (14) days. Contractor shall not make exclusive agreements with sub-suppliers that would preclude METRO from purchasing components directly from sub-suppliers. Contractor shall be able to expedite delivery (e.g. overnight delivery) of emergency shipments for 85% of the coach parts.

Spare parts must be available to repair all electronic assemblies, subassemblies, and sub-subassemblies. Special provisions shall be made to supply those components that are not readily available on the commercial market (custom parts, for example). Any custom-made transformers, inductors, programmable components, or other devices containing proprietary firmware, shall be made available to METRO as spare parts. When the original manufacturer is no longer available to supply the spare IC's, the associated proprietary firmware, transformer design specifications, and other relevant detail must be provided to METRO at that time.

METRO will work with the contractor's representative as much as possible to minimize the costs and time involved with conducting warranty repairs, however due to space constraints and labor agreements, METRO cannot guarantee that any contractor work will be performed on METRO property.

5.0 TRAINING SPECIFICATIONS

42) 5.1 Introduction-Training

The Contractor shall provide a METRO approved instruction program for designated Transportation and Maintenance personnel in the proper methods of operating, maintaining and servicing buses provided to METRO by the Contractor. The training program shall be divided into two (2) complete sections, one section for Maintenance personnel and the other section for Transportation personnel.

Sixty (60) days before the scheduled delivery date of the first bus, schedules and lesson plans shall be provided for METRO approval for both the Maintenance and Transportation training programs (Deliverable, See Appendix No.1, Item D37). As part of the lesson plan, the Contractor shall include the names of the instructors. Utilization of vendor presenters is encouraged and supported by METRO. The Contractor is responsible for scheduling and costs of vendor presenters. As part of the training schedule, Contractor shall also inform METRO of any equipment needed to make the presentation, such as audio visual equipment, blackboards, wipe boards, flip charts, overhead or slide projectors.

43) 5.2 Maintenance Training

The Contractor shall provide a complete training and instruction program for METRO's designated mechanics, service personnel and supervisors covering preventative maintenance, trouble shooting and repair of the buses the Contractor will be providing METRO (Deliverable, See Appendix No.1, Item D38). The instruction program shall be in self-contained modules, or subject areas, with each module divided into two (2) phases - a pre-delivery phase and a post-delivery phase. Each module or subject shall be covered at least twice, unless otherwise noted. The pre-delivery training must be completed by the scheduled delivery of the first bus. It is METRO's intent that the post-delivery phase of each module be designed as hands-on trouble shooting on an actual bus. As an example, METRO may mandate thirty-two (32) hours of training for a particular module or subject area which may be divided into sixteen (16) hours of pre-delivery training and sixteen (16) hours of post-delivery training.

Many of the classes will be held during METRO's three (3) shifts of operation. Exact schedules will be negotiated between METRO's training personnel and the Contractor.

METRO will limit the number of personnel in each class to twenty-five (25) or less so that the class size will be manageable.

A maximum of fifty (50) individuals will be scheduled for each module with the exception of the orientation module, which may have as many as two hundred

(200) individuals. Personnel attending each module or class will be designated by METRO with a list of attending individuals available to Contractor. All attendance records will be kept by METRO's Training Division.

The Maintenance training and instruction program shall cover (but not be limited to) the following areas:

1. Orientation
2. Electrical
3. Engine & Fuel System (to include exhaust aftertreatment systems, SCR, DPF maintenance, troubleshoot and diagnostics)
4. Propulsion Control System
5. Air Conditioning
6. Doors
7. Brakes
8. Air System
9. Suspension, Steering, Axles
10. Body
11. Parts
12. Service Instruction (Control System)
13. Lift Equipment
14. Towing
15. Fire Detection – Suppression System
16. Other systems not herein listed but supplied

Contractor shall inform METRO of any special equipment that requires training before the bus is put into revenue service.

5.2.1 Maintenance Training Program Content

5.2.1.1 Orientation Module

5.2.1.2 History of Contractor

5.2.1.3 Advantages and Strong Points of the Bus

5.2.1.4 Visuals of Production System of the Bus**5.2.1.5 Compartment-by-Compartment Tour of the Bus****5.2.1.6 Special Components or Features of the Bus**

The orientation module will consist only of a pre-delivery session with no post-delivery instruction. METRO suggests that the orientation module be limited to three (3) to four (4) hours with one fifteen (15) minute break. The orientation module will be repeated four (4) times.

5.2.1.7 Electrical/Electronics

1. Location of all key electrical components found on the Bus
2. Explanation of the wiring diagram and wiring codes with copies of wiring diagrams given to each attendee.
3. Explanation of the charging system along with basic troubleshooting of the system.
4. Explanation of the Exterior and Interior Lighting system along with basic trouble shooting of the system
5. Explanation of the safety shutdown system, including the warning indicators, along with basic troubleshooting of system
6. Contractor shall provide a module consisting of a minimum of two (2) eight hour days of pre-delivery classroom instruction, followed by a minimum of two (2) eight hour days trouble shooting on a bus. The electrical module will be taught twice.
7. Exhaust After-treatment System

5.2.1.8 Engine and Accessories

1. Explanation of the engine and the location of key components.
2. Explanation of the engine driven accessories.
3. Explanation of the Lube, Air and Cooling Systems.
4. Explanation of Engine Tune-up procedures.
5. Basic trouble-shooting procedures for the engine.
6. Complete explanation of the fuel system.

The emphasis of any engine module should be basic trouble shooting and preventive maintenance procedures. The basic engine course must consist of two (2) eight (8) hour days of pre-delivery classroom instruction and two (2) eight (8) hour days of post-delivery classroom instruction on a bus. The engine course will be taught twice.

5.2.1.9 Propulsion Control System

1. Explanation of the Diesel engine system.
2. Explanation of the electronic control system.
3. Overhaul of the Diesel engine (taught as separate course).

The transmission training course will consist of basic trouble-shooting and preventive maintenance. The course must consist of a minimum of two (2) eight (8) hour day of pre-delivery classroom instruction and two (2) eight (8) hour day of trouble shooting on the bus. The transmission module shall be taught twice.

5.2.1.10 Air Conditioning

1. Explanation of the Air Conditioning system and the location of all key air conditioning components (Handouts Required).
2. Explanation of the Air Conditioning Electrical System.
3. Explanation of the Air Conditioning Compressor along with basic trouble-shooting and preventative maintenance of the air conditioning compressor.
4. Basic trouble-shooting of the air conditioning system.
5. Preventative Maintenance of the air conditioning system.

METRO will require a minimum of two (2) eight (8) hour day of pre-delivery classroom instruction and two (2) eight (8) hour day of post-delivery instruction on the trouble-shooting. The air conditioning module will be taught twice.

5.2.1.11 Door

1. Explanation of the door system and the location of all door components.
2. Explanation of the door electrical system.
3. Proper door adjusting procedures.

4. Basic trouble-shooting of the door system.
5. Rebuilding of the door motors (may be taught as a separate course).

The door module must consist of four (4) hours of pre-delivery classroom instruction and four (4) hours of hands-on post-delivery trouble-shooting. The door module will be taught three (3) times.

5.2.1.12 Brakes

1. Basic brake system repair, including adjustments to brakes (includes disc brake training).
2. Explanation of ABS System.
3. Troubleshooting and repair of ABS System.

The brake module shall consist of eight (8) hours of pre-delivery classroom instruction and eight (8) hours of post-delivery instruction on the brake system on the bus. The brake module will be taught twice.

5.2.1.13 Air System

1. Explanation of the air system with the location of all air system components.
2. Basic trouble-shooting of the air system.
3. Preventive Maintenance of the air system.

The Contractor shall provide an air system module consisting of four (4) hours of pre-delivery classroom instruction and four (4) hours of post-delivery trouble-shooting instruction on a bus. The air system module will be taught twice.

5.2.1.14 Suspension, Steering, Axles

1. Explanation of the suspension system.
2. Basic repairs to the suspension system.
3. Basic trouble-shooting of the suspension system.
4. Explanation of the steering system.
5. Basic trouble-shooting of the steering system.
6. Explanation of the axles.

METRO requires a minimum of four (4) hours of pre-delivery classroom instruction and four (4) hours of post-delivery trouble-shooting instruction on a bus. Suspension, Steering and Axle module will be taught twice.

5.2.1.15 Body

1. Explanation of the body and the attachment method of exterior panels.
2. Basic repair of the exterior panels.

METRO requires that the body module be a minimum of four (4) hours of pre-delivery training and four (4) hours of post-delivery instruction on a bus. The body module will be taught twice.

5.2.1.16 Parts

1. Explanation of the Parts Manual and how it is divided.
2. Explanation of the parts numbering system.
3. Orientation to the bus and components on the bus.
4. Practice in finding parts in the Parts Manual.

METRO requires the parts module to be a minimum of four (4) hours of pre-delivery instruction. No post-delivery instruction will be required. The Parts module will be taught once.

5.2.1.17 Service Instruction

(For Service, Fueling, and Cleaning Personnel)

The Contractor shall provide an Orientation of the bus features, controls and equipment, for safe operation, cleaning and servicing of the bus for METRO's service lane personnel.

- a. Operator Compartment.
- b. Controls and Switches.
- c. Warning Indicators and Gauges.
- d. Seat Adjustment.
- e. Door Control.
- f. Wheelchair Ramp or Lift Operation.
- g. Walk Around Inspection.
- h. Compartment by Compartment Explanation of Service Points.
- i. Mirror Adjustments.
- j. Climate Control System.

This program will be presented once at each garage where buses will be assigned, not to exceed five (5) times of two (2) hours each.

5.2.1.18 Wheelchair Lift Equipment

The Contractor shall provide comprehensive training on this critical system. The training program shall consist of four (4) hours of pre-delivery instruction and four (4) hours of post-delivery instruction. Each class will be taught four (4) times to allow for small class size.

1. Explanation of the Lift System, Mechanisms and Controls.
2. Inspection and Periodic Maintenance of the Lift Mechanism.
3. Trouble shooting of the hydraulic and electrical components.

5.2.1.19 Towing

The Contractor shall provide lifting and towing instruction for METRO's road service personnel consisting of two (2) four-hour classes utilizing METRO's towing equipment and an actual bus. The Contractor will provide any necessary parts or special tools to demonstrate preparation of a bus for safe towing. Example: seals, gaskets.

5.2.1.20 Fire Detection - Suppression System

Contractor shall provide a complete and thorough instructional program for the complete Fire Suppression System. Specific handouts and instructional video shall be supplied by the Contractor for all attendees that will fully describe and pictorially demonstrate all components of the system to the part level. Fundamentals of the system shall be incorporated into this module including basic inspection and troubleshooting procedures. The training shall be presented in two (2) four (4) hour sessions of Pre-Delivery and four (4) four (4) hour sessions of Post-Delivery instruction.

1. Explanation of system components.
2. Electrical Theory of Operation.
3. Preventive maintenance of the system.
4. Troubleshooting and testing of the system.

5.2.1.21 Diesel Propulsion Control System

The Contractor shall provide a complete training program of the Diesel Propulsion Control System. The program shall consist of eight (8) hours of Pre-delivery and eight (8) hours of Post-delivery instructions. Each class shall be presented twice.

1. Explanation of system components.
2. Theory of Operation.
3. Preventive maintenance of the system.
4. Troubleshooting and testing of the system.

44) 5.3 Transportation Training

The Contractor shall provide complete training and instruction for METRO-designated Bus Operator Instructors, Street Supervisors, Safety personnel and Dispatchers. The program shall include, but not be limited to, the following (Deliverable, See Appendix No.1, Item D39):

- Operator Compartment.
- Controls and Switches.
- Instrument Panel

- Warning Indicators and Gauges.
- Seat Adjustment.
- Door Control.
- Walk Around Inspection.
- Compartment-by-Compartment Explanation.
- Mirror Adjustments.
- Climate Control system.
- Driving Instruction.
 - Starting and Stopping
 - Tire area
 - Turns.
 - Braking.
 - Transmission.
 - Backing.
 - Lift Equipment.
 - Controls.
 - Safety.
 - Emergency Procedures.
 - Securing Wheelchairs and Riders.
 - Loading and Unloading.

The Transportation Training Program shall consist of a six (6) hour module on the bus. Each trainee will be given an opportunity to operate the bus with the Contractor's instructor on board. The Contractor shall provide the Transportation Training Program twice.

45) 5.4 Training Program Aids

The contractor shall provide a complete turn key Engine and Transmission assembly module for on hand training purposes. The engine and transmission shall be the same make and model as the proposed bus in the bid.

The Contractor shall provide fifty (50) sets of instructional material or hand-outs for all participants in the Pre-Delivery and Post-Delivery training modules as listed in paragraph 2.0, items B through P. The Orientation program shall be supplied with 200 hand-outs. This instructional material will be kept by the individuals to allow them to retain and remember salient areas of training and instruction modules. METRO will work with the Contractor to help develop this instruction. The contractor shall prepare a PowerPoint presentation as part of the instructional material. The Contractor shall write all instructional material in clear, simple English, keeping in mind that many of the individuals in the training course have minimum literacy skills (6th grade reading level).

The use of slides, view graphs and other visuals is required in the pre-delivery training classes to allow the trainees the opportunity to see the actual location of the components, the size of the components and the physical appearance of the subject (Deliverable, See Appendix No.1, Item D40).

METRO reserves the right to duplicate, at its expense, all films, slides, view graphs, PowerPoints, tapes and handouts for its sole use in follow-up reinforcement training at the option of METRO's Training Division. Unless an Instructor objects in writing, METRO reserves the right to video tape and/or audio tape all Contractor and vendor presentations for its sole use without further costs, obligation or liability to METRO.

46) 5.5 Training Facilities

All training will be conducted at METRO facilities or facilities secured by METRO. The Contractor shall inform METRO in the lesson plans of any special facilities needed. METRO will assist the Contractor in the set up and tear down of training aids and models used in the presentations.

47) 5.6 Training Instructors

All training instructors shall be competent to teach the course area they are instructing. Further, all instructors shall speak English and have a complete understanding of the English language. If the instructor or vendor presenter lacks the skill or knowledge to provide instruction, or cannot communicate with the students, METRO reserves the right to request that the instructor be replaced and the area of training be repeated.

48) 5.7 Supervisor Training

In addition to the in-depth training described above, the Contractor shall provide a series of four (4) short courses of four (4) hours each for Maintenance Supervisors (Deliverable, See Appendix No.1, Item D41). These courses shall be designed to give the Maintenance Supervisors an overview of each system listed in Section III of the Maintenance Training Program Content. The class size will be kept to a manageable number. The courses are intended to allow the supervisors to better understand the bus and how to trouble shoot some of the common problems. METRO will work with the Contractor to develop these supervisory training courses.

49) 5.8 Time Limits

METRO shall not request nor will the Contractor be required to provide more than five hundred and thirty (530) hours of instruction for the initial delivery of buses (to include 80 hours of vendor specific training).

METRO reserves the right to reduce the hours specified where its work force already possesses adequate knowledge of a particular system or specific equipment. In this case, the Contractor will be released from the excess class hours.

50) 5.9 Training Hours Summary

Maintenance	Pre-Delivery	Post-Delivery
Orientation	4 X 4 = 16	n/a
Electrical	2 X 16 = 32	2 X 16 = 32

Engine & Fuel	4 X 16 = 64	4 X 16 = 64
Transmission	2 X 8 = 16	2 X 8 = 16
Air Conditioning	2 X 8 = 16	4 X 8 = 32
Doors	3 X 4 = 12	3 X 4 = 12
Brakes	2 X 8 = 16	2 X 8 = 16
Air System	2 X 4 = 8	2 X 4 = 8
Steering, Suspension, Axles	2 X 4 = 8	2 X 4 = 8
Maintenance Service Instruction		5 X 2 = 10
Fire Detection / Suppression	2 X 4 = 8	4 X 4 = 16
Propulsion Control System	4 X 8 = 32	2 X 40 = 80
TOTAL MAINTENANCE	228 Hours	294 Hours
Transportation	n/a	2 X 6 = 12
Supervisory Orientation	n/a	4 X 4 = 16
TOTAL TRANSPORTATION	n/a	28 Hours
COMBINED TOTALS	228 Hours	322 Hours
GRAND TOTAL		542 Hours

(Deliverable, See Appendix No.1, Item D42)

6.0 CONTRACTOR'S IN-PLANT QUALITY ASSURANCE

51) 6.1 Quality Assurance Organization

The Contractor shall have an established in-plant quality assurance organization specifically and directly responsible to the Contractor's top management.

6.1.1 Control

The vendor's quality assurance organization must be capable of exercising quality control over all bases of production from initiation of design through manufacture and preparation for delivery. The organization must also control the quality of supplied articles.

6.1.2 Authority and Responsibility

The vendor's quality assurance organization must have the authority and responsibility for quality control, inspection, establishment of the quality control systems, acceptance/rejection of materials, and manufactured articles in the production of the transit buses.

52) 6.2 Quality Assurance Organization Functions

The quality assurance organization must include the following minimum functions.

6.2.1 Verify Instructions

The quality assurance organization must verify inspection operation instructions to ascertain that the manufactured product meets all prescribed requirements.

6.2.2 Records Maintenance

The quality assurance organization shall maintain and use records and data essential to the effective operation of its program. These records and data shall be available for review by METRO's Resident Inspectors. Inspection and test records for this procurement shall be available for a minimum of three (3) years after inspections and tests are completed (Deliverable, See Appendix No.1, Item D43).

6.2.3 Corrective Actions

The quality assurance organization shall detect and promptly assure correction of any conditions that may result in the production of defective transit buses. These

conditions may occur in designs, purchases, manufacture, tests, or operations that culminate in defective supplies, series, facilities, technical data, or standards.

The following standards and facilities shall be basic in the quality assurance process.

6.2.4 Configuration Control

The Contractor shall maintain drawings and other documentation that completely describe a qualified bus that meets all of the options and special requirements of this procurement. The quality assurance organization shall verify that each bus is manufactured in accordance with these controlled drawings and documentation.

6.2.5 Measuring and Testing Facilities

The Contractor shall provide and maintain the necessary instruments, other measuring and testing devices for use by the quality assurance organization to verify that the bus conforms to all specification requirements. These devices shall be calibrated at established periods against certified measurement standards that have known valid relationships to national standards.

6.2.6 Production Tooling as Media of Inspection

When production jigs, fixtures, tooling masters, templates, patterns, and other devices are properly used as media of inspection, they shall be certified for accuracy. Certification will require a serial number, or other unique designator. Certification will be performed at formally established intervals and adjusted, replaced, or repaired as required to maintain quality.

6.2.7 Equipment Used by Resident Inspectors

The Contractor's gauges and other measuring and testing devices shall be made available for use by METRO's Resident Inspectors to verify that the buses conform

to all specification requirements. If necessary, the Contractor's personnel shall be made available to operate the devices and to verify their condition and accuracy.

53) 6.3 Control Of Purchases

The Contractor shall maintain quality control of purchases.

54) 6.4 Supplier Control

The Contractor shall require that each supplier maintains a quality control program for the services and supplies that it provides. The Contractor's quality assurance organization shall inspect and test materials provided by suppliers for conformance to specification requirements. Materials that have been inspected, tested, and approved must be identified as acceptable to the point of use in the manufacturing or assembly processes. Controls must be established to prevent the use of nonconforming materials.

55) 6.5 Purchasing Data

The Contractor shall verify that all applicable specification requirements are properly included or referenced in purchase orders of articles to be used on buses (Deliverable, See Appendix No.1, Item D44).

56) 6.6 Manufacturing Control

The Contractor shall ensure that all basic production operations, as well as all manufacturing processes are performed under controlled conditions. Establishment of these controlled conditions shall be based on the documented work instruction, adequate production equipment, and special work environments if necessary.

6.6.1 Completed Items

A system for final inspection and testing of completed buses shall be provided by the quality assurance organization. It shall measure the overall quality of each completed bus.

6.6.2 Nonconforming Materials

METRO's Project Manager and Resident Inspector will monitor the Contractor's system for controlling nonconforming materials. The system shall include procedures for identification, segregation, and disposition.

6.6.3 Statistical Techniques

Statistical analyses, tests, and other quality control procedures shall be used when appropriate in the quality assurance processes.

6.6.4 Inspection Status

A system shall be maintained by the quality assurance organization for identifying the inspection status of components and completed buses. Identification may include cards, tags, or other normal quality control devices.

57) 6.7 Inspection System

The Contractor's Quality Assurance organization will establish, maintain, and periodically audit a fully-documented inspection system. The system must prescribe inception and test of materials, work in progress, and completed articles. As a minimum, it must include the following controls.

6.7.1 Inspection Stations

Inspection stations shall be at the best locations to provide for the work content and characteristics to be inspected. Stations shall provide the facilities and equipment to inspect structural, electrical, hydraulic, and other components and assemblies for compliance with the design requirements.

Stations shall also be at the best location to inspect and test characteristics before they are concealed by subsequent fabrication or assembly operations. These locations shall minimally include underbody structure completion, body framing completion, body prior to paint preparation, water test and insulation installation,

engine installation completion, underbody dress-up and completion, bus prior to final paint touch-up, bus prior to road test, and bus final road test completion.

6.7.2 Inspection Personnel

Sufficient trained inspectors shall be used to ensure that all materials, components, and assemblies are inspected for conformance with the qualified bus design.

6.7.3 Inspection Records

Acceptance, rework, or rejection identification shall be attached to inspected articles. Articles that have been accepted as a result of approved materials review actions shall be identified. Articles that have been reworked to specified drawing configuration shall not require special identification. Articles rejected as unsuitable or scrap shall be plainly marked and controlled to prevent installation on the bus. Articles that become obsolete as a result of engineering changes or other actions shall be controlled to prevent unauthorized assembly or installation. Unusable articles shall be isolated and then scrapped.

Discrepancies noted by the Contractor or METRO's Resident Inspector during assembly shall be entered by the inspection personnel on a record that accompanies the major component, subassembly, or bus from start of assembly through final inspection (Deliverable, See Appendix No.1, Item D45). Actions shall be taken to correct discrepancies or deficiencies in the manufacturing processes, procedures, or other conditions that causes articles to be out of compliance with the requirement of the contract specification. The inspection personnel shall verify the corrective actions and mark the discrepancy record. If discrepancies cannot be corrected by replacing the nonconforming materials, METRO will approve the modification, repair, or method of correction to the extent that the contract specifications are affected.

6.7.4 Quality Assurance Audits

The Contractor's quality assurance organization shall establish and maintain a quality control audit program. Records of this program shall be subject to reviewed by METRO's Project Manager (Deliverable, See Appendix No.1, Item D46).

58) 6.8 Resident Inspector

METRO will be represented at the Contractor's plant by its own Resident Inspectors or Inspectors under contract to METRO or a combination of both. They will monitor the manufacture of buses built under the contract and shall be authorized to approve the pre-delivery acceptance tests to release the buses for delivery. Upon request to the Contractor's quality assurance supervisor, METRO's Resident Inspectors will be provided access to the Contractor's quality assurance supervisor and Contractor's quality assurance files related to this procurement. These files must include drawings, material standards, parts lists, inspection processing and reports, and records of defects.

No less than thirty (30) days prior to the beginning of bus manufacture, the Resident Inspectors will meet with the Contractor's quality assurance manager to review inspection procedures and checklists. The Resident Inspectors may begin monitoring bus construction activities two (2) weeks prior to the start of fabrication.

The Contractor shall provide office space for the Resident Inspectors in close proximity to the final assembly area. This office space shall be equipped with desks, outside and interplant telephones, file cabinet, chairs, and clothing lockers sufficient to accommodate the Resident Inspector staff. Web access will also be provided in the form of Wireless, or LAN hookups. The Contractor is not responsible for supplying a computer work station. Resident and Metro contract inspectors will provide their own communication equipment while in the contractor's facilities. The contractor may provide another form of communication to the inspectors in the form of a pager or 2-way radio.

The presence of these Resident Inspectors in the plant does not relieve the Contractor of its responsibility to meet all of the requirements of this specification.

59) 6.9 Acceptance Tests

6.9.1 Responsibility

Fully-documented tests shall be conducted by the manufacturer on each production bus following manufacture to determine its acceptance to METRO. These acceptance tests shall include pre-delivery inspections and testing by the Contractor and inspection and testing by METRO after the buses have been delivered.

6.9.2 Pre-Delivery

The Contractor shall conduct acceptance tests at its plant on each bus following completion of manufacture and before delivery to METRO. These pre-delivery tests shall include visual and structural inspections, as well as testing the total bus operation. The tests must be conducted on total bus operation. **The tests shall be conducted and documented in accordance with written tests plans. Additional tests may be conducted at the Contractor's discretion to ensure that the completed buses have attained the desired quality and have met the requirements in the Technical Specifications. This additional testing must be recorded on appropriate test forms provided by the Contractor. Pre-delivery tests shall be scheduled and conducted with sufficient notice so that they may be witnessed by the Resident Inspectors, who may accept or reject the results of the tests. The results of pre-delivery tests, and any other test, shall be filed with the assembly inspection records for each bus (Deliverable, See Appendix No.1, Item D47).** The under floor equipment shall be made available for inspection by the Resident Inspectors, using a pit or bus hoist provided by the Contractor. A hoist, scaffold, or elevated platform shall be provided by the Contractor to easily and safely inspect bus roofs. **Delivery of each bus must require written authorization of a METRO Resident Inspector. Authorization forms for the release of each bus for delivery shall be provided by the Contractor. An executed copy of the authorization shall accompany the delivery of each bus (Deliverable, See Appendix No.1, Item D48).** Failure to provide adequate inspection facilities for resident inspectors will result in non-

shipment of buses from the production plant without relief from liquidated damages.

60) 6.10 Chassis Inspection

6.10.1 Inspection -- Visual and Measured

Visual and structured inspections shall be conducted with the bus in a static condition. The purpose of the inspection/testing is to verify overall dimensional weight requirements, verify that required components are included, ready for operating and verify that components and subsystems that are designed to operate with the bus in a static condition are functioning as designed.

6.10.2 Total Bus Operation

Total bus operation shall be evaluated during road tests. The purpose of the road tests is to observe and verify the operation of the bus as a system and to verify the functional operation of the subsystems that can be operated only while the bus is in motion.

Each bus shall be driven for a minimum of fifteen (15) miles during the road tests. **Observed defects shall be recorded on the test forms (Deliverable, See Appendix No.1, Item D49).** The bus shall be retested when defects are corrected and adjustments are made. This process shall continue until defects, or required adjustments, are no longer detected. Results shall meet pass/fail criteria in accordance with this technical specification.

61) 6.11 Post Delivery Tests

METRO will conduct acceptance tests on each delivered bus. These tests will be completed within fifteen (15) days after bus delivery and will be conducted in accordance with Contractor's written tests plans approved by METRO. The purpose of these tests is to identify defects that have become apparent between the time of bus release and delivery to METRO. The post-delivery tests will include visual inspection and bus operation.

Failure of a bus delivered to METRO at Houston, Texas to exactly match the air conditioning performance of the pilot bus will constitute non-acceptance of that bus and no other buses will be accepted by METRO until corrective measures have been taken by the Contractor.

7.0 MANUALS AND PARTS LISTS

62) 7.1 Requirements

The Contractor shall furnish as part of the Contract the manuals and material/parts cross-reference list as indicated below and in accordance with the criteria specified herein **(Deliverable, See Appendix No.1, Item D50):**

Description	No. of Copies
Maintenance Manuals, Destination Signs and Electrical/Air system Schematics	Twenty-Five (25) copies of each
Maintenance on CD-ROM Disc (Indexed, PDF Format (unprotected), Compatible with Acrobat 8.0 and Windows XP.	Five (5) discs
Operating Manuals	One (1) per bus
Parts Manual Indexed, PDF Format (unprotected), Compatible with Acrobat 8.0 and Windows XP.	Twenty-Five (25) copies
Parts on CD-ROM Disc (Indexed, PDF Format (unprotected), Compatible with Acrobat 8.0 and Windows XP.	Five (5) discs
Parts Cross Reference List, Indexed, PDF Format (unprotected), Compatible with Acrobat 8.0 and Windows XP	Five (5) Copies
Parts Cross Reference List on CD-ROM Disc(Indexed, PDF Format,	Five (5) discs

Compatible with Acrobat 3.0 and Windows 3.1	
Recommended Spare Parts List	Five (5) copies

In addition to the requirements listed above, as the documents are developed, the Contractor shall submit one (1) complete set of “AS BUILT” manuals to METRO for review and approval within 30 days of receipt of the pilot bus build and before the production buses starts (Deliverable, See Appendix No.1, Item D51).

A detailed description of the type of Fire Sensing and Suppression (FSS) equipment of the bus proposed for bid, along with operational information and installation locations, shall be submitted as a Mandatory Request For Approval (see Section II of the Solicitation, Item 45). (Deliverable, See Appendix No.1, Item D52).

The bus manufacturer shall provide preliminary wiring schematic run sheets prior to production of the pilot and shall provide final as-built drawings after the delivery of the final coach. The wiring layout shall be determined and require approval by METRO during the preproduction conference. **Schematic runs will be on both computer disks and in book form (See Appendix 2, Preproduction Conference, Item PPC 34) (Deliverable, See Appendix No.1, Item D53).**

METRO reserves the right to reproduce (ex. magnetic media, photo copying, etc.), for its own use, all manuals and lists furnished by the Contractor under this Exhibit.

63) 7.2 Standards And Format Of Manuals

The manuals shall meet the standards and be presented in accordance with the format requirements of this Exhibit. The material in all manuals shall be organized and indexed with a standard numbering system in accordance with an approved Contractor's outline. Each chapter shall cover the same topics. The format of all data contained in each section shall be consistent from section to section. The manuals shall be logically organized with systems and elements considered in

descending order of importance. Care shall be taken that all statements are clear, positive and accurate, with no possibility of an incorrect interpretation. The manuals shall be complete, modern and authentic with no extraneous material such as advertisements or irrelevant information. Manuals shall describe the baseline buses. Additional sections shall be added at end of each manual, detailing the differences in each subgroup delivered.

All maintenance and parts manuals shall be in loose leaf binder form or spiral bound. The page size shall be 8 1/2 X 11 inches and on good quality paper. Folded pages will be permitted where the information cannot be presented clearly on single pages. Pages shall be secured in the binder along the eleven (11) inch page dimension. Required diagrams, illustrations and drawings shall not be loose or in binder pockets. All printed material shall be clearly reproducible by dry copying machines. Halftone illustrations in the Contractor produced material are unacceptable by METRO's Project Manager.

Operator manuals shall be a minimum of 4 1/4 inches wide, 7 inches high and not more than 1 1/4 inch thick. They shall not be bound and the pages therein shall be as large as can be accommodated without damage.

All manuals shall be designed for continuous, long-term service. Binder covers shall be resistant to oil, moisture and wear commensurate with their intended use.

64) 7.3 Maintenance Manuals

Maintenance manuals shall contain complete data required for routine and periodic maintenance of all parts of the bus, including but not limited to the following (Deliverable, See Appendix No.1, Item D54):

1. General operation description.
2. Preventative maintenance, lubrication, and adjustment requirement.
3. Wiring and schematic diagrams and schedules for wire and cable sizes and ratings, plus locations in the bus, of electrical and electronic components, including electronic engine and transmission components.

4. Air and hydraulic system diagrams showing locations in the bus of the air and hydraulic components.
5. Detailed, illustrated procedures for all component change-out, servicing, adjusting, testing, and run-in information.
6. Body and structural information and material specifications for major accident repairs provided at the time of request.

65) 7.4 Operator's Manuals

The operator's manual shall provide information and instructions for all phases of operation of the bus, including but not limited to bus mechanical operation, response to safety alarm systems, lighting system controls, emergency actions, maintenance checks, and turning characteristics of the bus (Deliverable, See Appendix No.1, Item D55).

66) 7.5 Parts Manuals

The parts manuals shall enumerate and describe every component with its related parts including the Contractor's part number. Cutaway and exploded drawings shall be used to permit identification of all parts. The drawings shall contain data arranged so that the part numbers can be readily found and identified in the drawing for each system and subsystem component, assembly, subassembly, or piece part, from an orderly breakdown of the complete bus. They shall be indexed by part number and by part name and shall be sufficiently well illustrated to identify items requiring repair, replacement, and storage for use in the maintenance of buses. Isometric exploded views shall be used to identify each piece part (Deliverable, See Appendix No.1, Item D56).

67) 7.6 Parts Cross Reference List

The Contractor shall furnish a complete Parts Cross Reference List of all parts/components used in the assembly of the bus. This list shall include as a minimum, bus manufacturers part number and part name, and the part number of the original manufacturer of the part or component. The Contractor shall also

furnish templates for each of the bus windows. The Contractor in coordination with METRO's Resident Inspector shall develop the initial parts cross reference list while the pilot bus is in the process of being manufactured in the Contractors assembly line. **Upon completion of the pilot bus the parts cross reference list shall be delivered to METRO along with the pilot bus (Deliverable, See Appendix No.1, Item D57).**

Where the parts ordered by METRO are not received within two working days of the agreed upon time/date and a bus procured under this Contract is out-of-service due to the lack of said ordered parts, then the Contractor shall provide METRO, within eight hours of the customers verbal or written request, the original suppliers' and/or manufacturers' parts numbers, company names, addresses, telephone numbers and contact persons' names for all of the specific parts not received by the customer.

Where the Contractor fails to honor this parts guaranty or parts ordered by METRO are not received within thirty (30) days of the agreed upon delivery date, then the Contractor shall provide to METRO, within seven (7) days of the customer's verbal or written request, the design and manufacturing documentation for those parts manufactured by the Contractor and the original suppliers' and/or manufacturers' parts numbers, company names, addresses, telephone numbers and contact persons' names for all of the specific parts not received by METRO. Contractor's design and manufacturing documentation provided to METRO shall be for its sole use in regard to the buses procured under this Contract and for no other purpose

68) 7.7 Spare Parts

The Contractor shall furnish a recommended spare parts list that includes the OEM's part number, Contractor's part number, description and estimated annual usage for the quantity of buses specified in the contract (Deliverable, See Appendix No.1, Item D58).

Where the parts ordered by METRO are not received within two working days of the agreed upon time/date and a bus procured under this Contract is out-of-service due to the lack of said ordered parts, then the Contractor shall provide METRO, within eight hours of the customers verbal or written request, the original suppliers'

and/or manufacturers' parts numbers, company names, addresses, telephone numbers and contact persons' names for all of the specific parts not received by the customer.

Where the Contractor fails to honor this parts guaranty or parts ordered by METRO are not received within thirty (30) days of the agreed upon delivery date, then the Contractor shall provide to METRO, within seven (7) days of the customer's verbal or written request, the design and manufacturing documentation for those parts manufactured by the Contractor and the original suppliers' and/or manufacturers' parts numbers, company names, addresses, telephone numbers and contact persons' names for all of the specific parts not received by METRO. Contractor's design and manufacturing documentation provided to METRO shall be for its sole use in regard to the buses procured under this Contract and for no other purpose. The Contractor shall guarantee the availability of replacement parts for the buses for at least a twelve (12) year period after date of acceptance of buses. **Routine delivery of spare parts ordered by METRO shall occur within thirty (30) calendar days after confirmation of order placement (Deliverable, See Appendix No.1, Item D59).**

The Contractor shall, with the exception of proprietary parts fabricated exclusively for the bus contractor, give METRO written permission to purchase direct from the manufacture(s) any parts or sub-assemblies used in the manufacturing of buses delivered to METRO in accordance with the contract. **This right shall include all exclusive agreements that the Contractor may have with manufacturers for the exclusive purchase and re-sell of said parts (Deliverable, See Appendix No.1, Item D60).**

69) 7.8 Revisions

Following the publication of each manual required herein, the Contractor shall provide revisions covering any changes, whether required by change of design or procedures or due to error, and these revisions shall be kept current during the warranty period. **Manual revisions shall be furnished to METRO before or coincidental with the arrival of any altered parts or components. Upon expiration of the warranty period, revisions shall be furnished to METRO**

every six (6) months for a period of three (3) years. After the three (3) year period, revisions shall be furnished as they occur until the bus is twelve (12) years old (Deliverable, See Appendix No.1, Item D61).

8.0 ALTOONA BUS TESTING

New bus model (bus) testing must be performed in accordance with 49 CFR Part 665 and FTA's bus testing program at The Pennsylvania Transportation Institute Bus Testing and Research Center, Altoona, Pennsylvania. .This section sets standards that the bus must meet during testing and to describe how each subsystem or component will be tested.

70) 8.1 Bus Testing

The Contractor shall submit its bus for testing to the Altoona Bus Test Center and shall be provide METRO with a copy of the test report for METRO approval prior to acceptance of pilot bus (Deliverable, See Appendix No.1, Item D62).

In the event the bus has been previously tested, a copy of that report shall be furnished to METRO for METRO approval prior to acceptance of pilot bus, provided the report contains sufficient information to show that the bus meets the test criteria specified herein (Deliverable, See Appendix No.1, Item D63).

Any testing performed at Altoona will not be performed on a bus intended for delivery to METRO.

71) 8.2 Test Standard

Each subsystem and component of the bus must meet or exceed the standards specified in METRO's technical specification when tested in accordance with the procedures listed in this exhibit. The Contractor shall make arrangements for a METRO representative to be present at the Altoona Bus Test Center while the test bus is undergoing testing.

8.2.1 Replacement Of Selected Subsystems

The objective of this test is to establish the time required to replace and/or repair selected subsystems.

The test will address components that would be expected to fail or require replacement after 125,000 miles. In addition, any component that fails while the bus is undergoing testing will be added to this list. Components to be included are:

- Transmission
- Batteries

8.2.1.1 Pass/Fail Standard

- Transmission - Remove and replace in less than eight (8) hours using two (2) qualified mechanics.
- Batteries - Connect jumper cables in thirty (30) seconds.

8.2.2 Performance - Top Speed Test

The objective of this test is to determine the top speed capabilities of the bus.

In this test, the bus will be operated at SLW on the skid pad at the Bus Testing Facility. The bus will be accelerated at full throttle from a standstill to a maximum "geared" or "safe" speed as determined by the test driver. The time to 10 MPH increments is measured and recorded using a stopwatch with a lap timer. Time to speed data will be recorded on the test data form and later used to generate speed vs. time plot and gradeability calculations.

8.2.2.1 Pass/Fail Standard

- The bus shall attain a top speed of at least fifty-eight (58) MPH.

8.2.3 Structural Integrity-Strength and Distortion Tests

8.2.3.1 Structural Distortion

The objective of this test is to observe the operation of the bus subsystem when the bus is placed in a longitudinal twist simulating operation over a curb or through a pothole.

With the bus loaded to GVWR, each wheel of the bus will be raised (one at a time) to simulate operation over a curb and the following will be inspected:

- Body
- Windows
- Doors
- Roof Vents
- Special Seating
- Undercarriage
- Engine
- Service Doors
- Escape Hatches
- Steering Mechanism

Each wheel will then be lowered (one at a time) to simulate operation through a pothole and the same items inspected. In each test position, a spray device is passed over the bus to simulate rain.

Pass/Fail Standard:

- The test will not impair operation of items listed above.

8.2.3.2 Static Towing Test

The objective of this test is to determine the characteristics of bus towing mechanisms under static loading conditions.

A heavy-duty wrecker will apply a static tension load equal to 1.2 times the bus curb weight utilizing a manufacturer-approved load-equalizing towing sling. The load will be applied to both the front and rear towing fixtures at an angle of 20° with

the longitudinal axis of the bus, first to one side then to the other in the horizontal plane, and then upward and downward in the vertical plane.

Any permanent deformation or damage to the tow eyes or adjoining structure will be recorded.

Pass/Fail Standard:

- No significant permanent structural deformation shall occur.

8.2.3.3 Dynamic Towing Test

The objective of this test is to verify the integrity of the towing fixtures and determine the feasibility of towing the bus under manufacturer - specified procedures.

This test requires the bus to be towed at curb weight using the specified equipment, and instructions provided by the manufacturer and a heavy-duty wrecker. The bus will be towed for 5 miles at a speed of 20 MPH for each recommended towing configuration. After releasing the bus from the wrecker, the coach will be visually inspected for any structural damage or permanent deformation. All doors, windows and passenger escape mechanisms will be inspected for proper operation.

Pass/Fail Standard:

- No significant permanent structural deformation shall occur.

8.2.3.4 Jacking Test

The objective of this test is to inspect for damage due to the deflated tire, and to determine the feasibility of jacking the coach with a portable hydraulic jack to a height sufficient to replace a deflated tire.

With the bus at curb weight, the tire(s) at one corner of the bus are replaced with deflated tire(s) of the appropriate type. A portable hydraulic floor jack is then positioned in a manner and location specified by the manufacturer and used to

raise the bus to a height sufficient to provide a 3-inch clearance between the floor and an inflated tire. The deflated tire(s) are replaced with the original tire(s) and the jack is lowered. Any structural damage or permanent deformation is recorded on the test data sheet. This procedure is repeated for each corner of the bus.

Pass/Fail Standard:

- No significant permanent structural deformation shall occur.

8.2.3.5 Hoisting Test

The objective of this test is to determine possible damage or deformation caused by the jack stands.

With the bus at curb weight, the front end of the bus is raised to a height sufficient to allow manufacturer-specified placement of jack stands under the axles or jacking pads independent of the hoist system. The bus will be checked for stability on the jack stands and for any damage to the jacking pads or bulkheads. The procedure is repeated for the rear end of the bus. The procedure is then repeated for the front and rear simultaneously.

Pass/Fail Standard:

- No significant permanent structural deformation shall occur.

8.2.4 Interior Noise

The objective of these tests is to measure and record interior noise levels and to check for audible vibration under various operating conditions.

During this series of tests, the interior noise level will be measured at several locations with the bus operating under the following three conditions:

- With the bus stationary, a white noise generating system shall provide a uniform sound pressure level equal to 80 dBA on the left exterior side of the bus. The engine and all accessories will be switched off and all openings, including doors and windows, will be closed.

- The bus accelerating at full throttle from a standing start to forty-five (45) MPH and back to zero (0) on level pavement. All openings will be closed and all accessories will be operating during the test.

All tests will be performed in an area free from extraneous sound-making sources or reflecting surfaces. The ambient sound level, as well as the surrounding weather conditions, will be recorded in the test data.

Pass/Fail Standard:

- With the bus stationary, the interior noise shall be less than 79 dBA.
- With the bus accelerating, the interior noise shall be less than 83 dBA.

Appendix 1

72) Deliverables

The contractor shall submit the following items as indicated.

D1	Mil readings are to be recorded in the Production Verification book for each bus. A copy of the Production Verification book shall be provided with each bus prior to its departure from the bus manufacturer's facility (See Section 2.1.1.2, Finish and Color).
D2	A report clearly describing and explaining the failures and corrective actions taken to ensure any and all such failures will not occur shall be submitted to METRO prior to acceptance of the pilot bus (See Section 2.1.2.1, Strength and Fatigue Life).
D3	Templates for window glazing material and exact color and tint density of windows shall be provided with pilot bus (See Section 2.4.2.2, Materials).
D4	Test results from the Altoona fuel economy tests or other applicable test procedures shall be provided to METRO for METRO approval prior to acceptance of pilot bus (See Section 3.1.1.6, Fuel Economy (Design Operating Profile)).
D5	A copy of the test report shall be furnished to METRO prior to acceptance of the pilot bus (See Section 3.1.4.3, Exterior Noise).
D6	The bus manufacturer shall provide engine and transmission manufacturer's audit certification that the power plant is designed and engineered for their bus, shall approve installation in this application and shall provide METRO a copy of this report prior to acceptance of the pilot bus (See Section 3.1.4.4, Powertrain Audit).
D7	Installation Quality Audit (IQA) test results from previous buses identical to bus being built for METRO must be submitted for METRO's approval prior to acceptance of the pilot bus (See Section 3.1.4.4, Powertrain Audit).

D8	A copy of the permanent record of all actual torque values performed during construction of each bus, to include time, date and person performing torquing, shall be provided to the resident inspector prior to sign-off on each bus. (See Section 3.3.1 General Requirements).
D9	Copies of the power steering test reports shall be forwarded with inspection reports to METRO prior to acceptance of each bus (See Section 3.4.3, Turning Effort).
D10	Copies of the vehicle alignment reports shall be forwarded with inspection reports to METRO prior to acceptance of each bus (See Section 3.4.3, Turning Effort).
D11	The Brake Balance Audit shall require approval by METRO prior to acceptance of the pilot bus. The bus manufacturer shall provide all of the necessary braking sequence processes and expected brake life miles prior to acceptance of the pilot bus (See Section 3.5.1.6, Brake Balance Audit).
D12	Spare wheel mounted with 315/80R-22.5 load range L tire shall be delivered with each bus. (See Section 3.6.1.2, Tires).
D13	The bus manufacturer shall provide wiring schematic run sheets and ladder logic sheets prior to production of the pilot and shall provide final as-built drawings prior to production of the 10 th bus. The wiring layout and ladder logic shall be determined and require approval by METRO during the preproduction conference. Schematic runs will be on both computer disks and in book form (See Section 3.6.4.3, Wiring and Terminals).
D14	The bus manufacturer shall provide METRO a system total load usage list and maximum generator load limit for the pilot bus which shall require approval by METRO prior to acceptance of the pilot bus (See Section 3.6.4.5, Electrical Audit).
D15	The HVAC system must be installed according to the installation guidelines of the HVAC system manufacturer. An installation audit and system performance test must be conducted by the HVAC system manufacturer and signed off on by both the HVAC system manufacturer and the bus manufacturer. All identified discrepancies must be satisfactorily addressed to METRO's approval and a copy of the completed document must be presented to METRO before METRO will accept the pilot bus (See Section 3.7.3, Air Conditioning).

D16	Bus production cannot begin until test results indicate the HVAC system of the pilot bus is compliant and approved by METRO (See Section 3.7.3, Air Conditioning) .
D17	The bus manufacturer shall provide and install the communication equipment listed in the following METRO BUS COMM HARDWARE BLOCK DIAGRAM and METRO BUS COMM BILL OF MATERIALS (BOM) (See Section 3.8.1, Provide and Install) .
D18	Complete installed bus video/audio surveillance systems equipped with: (See Section, 3.8.1.7.1, Deliverables)
D19	Vendor, through bus manufacturer, shall provide certification of each vehicle installed which shall clearly identify equipment installed by model and serial number and shall provide results of proof-of-performance testing witnessed by METRO and the afore-mentioned certificate counter-signed before buses are released from factory for delivery (See Section 3.8.1.7.3, Digital Video Recorder (DCR) General Requirements; 44, Acceptance) .
D20	Supporting documentation shall be provided and require approval by METRO during the preproduction conference (See Section 3.9.3 Tests) .
D21	Installation drawings, wiring/plumbing schematics, preventative maintenance procedures and parts list are to be provided to METRO in accordance with Section 7.0 Manuals and Parts Lists and 7.1 Requirements (See Section 3.9.5.1, Bill of Materials) .
D22	Circuit Diagrams: Circuit diagrams pertaining to each electrical accessory or panel shall be provided on or near each accessory. They shall be plastic laminated diagrams secured to the inside of door panels. All relays, terminals and electrical accessories shall be numbered on the item and on the diagram. These diagrams shall be included in the maintenance manuals (See Section 3.9.7.3, Electrical System) .
D23	The Contractor shall furnish two (2) lists of any special maintenance tools required for maintenance of the system supplied including special diagnostic equipment prior to acceptance of the pilot bus (See Section 3.9.8, Tools) .
D24	The contractor shall provide the original equipment manufacturer's (OEM) certifications that their system has been designed and engineered to operate in the Houston Texas environment (See Section 3.10, System Certifications) .

D25	Each bus system, including subsystems are subject to approval from the OEM. Each system/subsystem document must be signed by the contractor and the OEM supplier and a copy of each shall be delivered to and approved by METRO prior to acceptance of the pilot bus (See Section 3.10, System Certifications) .
D26	When requesting authorization for warranty delegation, the Bidder must provide the following information and statements in writing (See Section 4.1.3.1, Warranty Assignment) :
D27	On a daily basis, Contractor shall supply a record of Contractor's personnel working within METRO property to the METRO supervisor or the superintendent on site and to METRO's Warranty Manager. The record shall contain the following information: Date, contractor personnel Name, and the METRO Vehicle ID number worked on. Contractor shall inform METRO in advance of any modifications proposed on the vehicle during the warranty period (See Section 4.1.11 Contractor's Representative) .
D28	METRO shall use parts or components available from its own stock only on an emergency basis. Monthly reports, or reports at intervals mutually agreed upon, of all repairs covered by warranty will be submitted by METRO to the Contractor for reimbursement or replacement of parts or components. The Contractor shall provide forms for these reports (See Section 4.1.14.1, Parts Used) .
D29	At the start of the project Contractor shall provide a complete list of all manufacturers and/or vendors that Contractor will use in building the vehicles (See Section 4.2.2.2, Warranty Data) .
D30	Contractor shall supply data on the fleet to METRO in an electronic format in order to facilitate its loading into the (SAP) Technologies software system. This section provides layouts and data requirements for the required data elements. Contractor may supply this information in its choice of: (See Section 4.2.2.5, Data Base Information) .
D31	The Contractor shall provide a record for each coach at the time of delivery. This record shall be intended for import into METRO's own database system, shall have no access restrictions, and shall not be indexed. Contractor may supply a single file, which contains records for multiple coaches (Dee Section 4.2.2.6, Coach Master File) .

D32	The Contractor shall provide METRO with the following database information on MPC-compliant DVD media for the Illustrated Parts Manual: The parts catalog data must be provided in Microsoft Excel rows and columns. Rows with data will consist of the following: Section, Graphic Title, Figure #, Item #, (is it item 1, 2, 3, etc. on the graphic), Manufacturer Part Number, Part Description, QTY, and Unit of Measure (See Section 4.3, Illustrated Parts Catalog Master File) .
D33	The Contractor shall provide the following on DVD media to METRO: (See Section 4.4, Publications Software) .
D34	The Contractor shall update the parts books (both paper and electronic Excel format) within thirty (30) days of any changes made for the 12 years after the initial production of the METRO coaches described in this request. The parts books shall have the following indexes sorted in the following order: (See Section 4.5, Parts Information) .
D35	The Contractor shall submit a recommended spare parts list, after the preproduction meeting (before the pilot bus construction begins), for METRO's use when planning and ordering spare parts and to support METRO's initial start-up for revenue operation (See Section 4.6, Recommended Spare Parts).
D36	The Contractor's recommended spare parts list shall include the following (See Section 4.7, Contractor's Recommendations/Prices) :
D37	Sixty (60) days before the scheduled delivery date of the first bus, schedules and lesson plans shall be provided for METRO approval for both the Maintenance and Transportation training programs (See Section 5.1, Introduction - Training) .
D38	The Contractor shall provide a complete training and instruction program for METRO's designated mechanics, service personnel and supervisors covering preventative maintenance, trouble shooting and repair of the buses the Contractor will be providing METRO (See Section 5.2, Maintenance Training) .
D39	The Contractor shall provide complete training and instruction for METRO-designated Bus Operator Instructors, Street Supervisors, Safety personnel and Dispatchers. The program shall include, but not be limited to, the following: (See Section 5.3 Transportation Training) .
D40	The Contractor shall provide fifty (50) sets of instructional material or hand-outs for all participants in the Pre-Delivery and Post-Delivery training modules as

	<p>listed in paragraph 2.0, items B through P. The Orientation program shall be supplied with 200 hand-outs. This instructional material will be kept by the individuals to allow them to retain and remember salient areas of training and instruction modules. METRO will work with the Contractor to help develop this instruction. The contractor shall prepare a PowerPoint presentation as part of the instructional material. The Contractor shall write all instructional material in clear, simple English, keeping in mind that many of the individuals in the training course have minimum literacy skills (6th grade reading level). The use of slides, view graphs and other visuals is required in the pre-delivery training classes to allow the trainees the opportunity to see the actual location of the components, the size of the components and the physical appearance of the subject (See Section 5.4, Training Program Aids).</p>
D41	<p>In addition to the in-depth training described above, the Contractor shall provide a series of four (4) short courses of four (4) hours each for Maintenance Supervisors (See Section 5.7, Supervisor Training).</p>
D42	<p>Training Hours Summary (See Section 5.9, Training Hours Summary).</p>
D43	<p>The quality assurance organization shall maintain and use records and data essential to the effective operation of its program. These records and data shall be available for review by METRO's Resident Inspectors. Inspection and test records for this procurement shall be available for a minimum of three (3) years after inspections and tests are completed (See Section 6.2.2, Records Maintenance).</p>
D44	<p>The Contractor shall verify that all applicable specification requirements are properly included or referenced in purchase orders of articles to be used on buses (See Section 6.5, Purchasing Data).</p>
D45	<p>Discrepancies noted by the Contractor or METRO's Resident Inspector during assembly shall be entered by the inspection personnel on a record that accompanies the major component, subassembly, or bus from start of assembly through final inspection (See Section 6.7.3, Inspection Records).</p>
D46	<p>The Contractor's quality assurance organization shall establish and maintain a quality control audit program. Records of this program shall be subject to reviewed by METRO's Project Manager (See Section 6.7.4, Quality Assurance Audits).</p>

D47	The tests shall be conducted and documented in accordance with written tests plans. Additional tests may be conducted at the Contractor's discretion to ensure that the completed buses have attained the desired quality and have met the requirements in the Technical Specifications. This additional testing must be recorded on appropriate test forms provided by the Contractor. Pre-delivery tests shall be scheduled and conducted with sufficient notice so that they may be witnessed by the Resident Inspectors, who may accept or reject the results of the tests. The results of pre-delivery tests, and any other test, shall be filed with the assembly inspection records for each bus (See Section 6.9.2, Pre-Delivery) .
D48	Delivery of each bus must require written authorization of a METRO Resident Inspector. Authorization forms for the release of each bus for delivery shall be provided by the Contractor. An executed copy of the authorization shall accompany the delivery of each bus (See Section 6.9.2, Pre-Delivery) .
D49	Observed defects shall be recorded on the test forms (See Section 6.10.2, Total Bus Operation) .
D50	The Contractor shall furnish as part of the Contract the manuals and material/parts cross-reference list as indicated below and in accordance with the criteria specified herein (See Section 7.1, Requirements) :
D51	In addition to the requirements listed above, as the documents are developed, the Contractor shall submit one (1) complete set of "AS BUILT" manuals to METRO for review and approval within 30 days of receipt of the pilot bus build and before the production buses starts (See Section 7.1, Requirements) .
D52	A detailed description of the type of Fire Sensing and Suppression (FSS) equipment of the bus proposed for bid, along with operational information and installation locations, shall be submitted as a Mandatory Request For Approval (See Section 7.1, Requirements) .
D53	The bus manufacturer shall provide wiring schematic run sheets prior to production of the pilot and shall provide final as-built drawings prior to production of the 10th bus. The wiring layout shall be determined and require approval by METRO during the preproduction conference. Schematic runs will be on both computer disks and in book form (See Section 7.1, Requirements) .

D54	Maintenance manuals shall contain complete data required for routine and periodic maintenance of all parts of the bus, including but not limited to the following (See Section 7.3, Maintenance Manuals) :
D55	The operator's manual shall provide information and instructions for all phases of operation of the bus, including but not limited to bus mechanical operation, response to safety alarm systems, lighting system controls, emergency actions, maintenance checks, and turning characteristics of the bus (See Section 7.4, Operator's Manuals) .
D56	The parts manuals shall enumerate and describe every component with its related parts including the Contractor's part number. Cutaway and exploded drawings shall be used to permit identification of all parts. The drawings shall contain data arranged so that the part numbers can be readily found and identified in the drawing for each system and subsystem component, assembly, subassembly, or piece part, from an orderly breakdown of the complete bus. They shall be indexed by part number and by part name and shall be sufficiently well illustrated to identify items requiring repair, replacement, and storage for use in the maintenance of buses. Isometric exploded views shall be used to identify each piece part (See Section 7.5, Parts Manuals) .
D57	The Contractor shall furnish a complete Parts Cross Reference List of all parts/components used in the assembly of the bus. This list shall include as a minimum, bus manufacturers part number and part name, and the part number of the original manufacturer of the part or component. The Contractor shall also furnish templates for each of the bus windows. The Contractor in coordination with METRO's Resident Inspector shall develop the initial parts cross reference list while the pilot bus is in the process of being manufactured in the Contractors assembly line. Upon completion of the pilot bus the parts cross reference list shall be delivered to METRO along with the pilot bus (See Section 7.6, Parts Cross Reference List) .
D58	The Contractor shall furnish a recommended spare parts list that includes the OEM's part number, Contractor's part number, description and estimated annual usage for the quantity of buses specified in the contract (See Section 7.7, Spare Parts) .

D59	Routine delivery of spare parts ordered by METRO shall occur within thirty (30) calendar days after confirmation of order placement (See Section 7.7, Spare Parts) .
D60	The Contractor shall, with the exception of proprietary parts fabricated exclusively for the bus contractor, give METRO written permission to purchase direct from the manufacture(s) any parts or sub-assemblies used in the manufacturing of buses delivered to METRO in accordance with the contract. This right shall include all exclusive agreements that the Contractor may have with manufacturers for the exclusive purchase and re-sell of said parts (See Section 7.7, Spare Parts) .
D61	Following the publication of each manual required herein, the Contractor shall provide revisions covering any changes, whether required by change of design or procedures or due to error, and these revisions shall be kept current during the warranty period. Manual revisions shall be furnished to METRO before or coincidental with the arrival of any altered parts or components. Upon expiration of the warranty period, revisions shall be furnished to METRO every six (6) months for a period of three (3) years. After the three (3) year period, revisions shall be furnished as they occur until the bus is twelve (12) years old (See Section 7.8, Revisions) .
D62	The Contractor shall submit its bus for testing to the Altoona Bus Test Center and shall provide METRO with a copy of the test report for METRO approval prior to acceptance of pilot bus (See Section 8.1, Bus Testing) .
D63	In the event the bus has been previously tested, a copy of that report shall be furnished to METRO for METRO approval prior to acceptance of pilot bus, provided the report contains sufficient information to show that the bus meets the test criteria specified herein (See Section 8.1, Bus Testing) .

Appendix 2

73) Items Requiring METRO Approval During Preproduction Conference

PPC 1	The exact wording, size, color and location for these and any other signs shall be determined and require approval by METRO during the preproduction conference and during pilot bus construction (See Section 2.1.1.3 Decals, Numbers and Signs) .
PPC 2	Samples of all head markings to be used shall be submitted and require approval by METRO during the preproduction conference (See Section 2.1.2.4, Material) .
PPC 3	A copy of the bus manufacturer's welding manual for the specified bus shall be submitted and require approval by METRO during the preproduction conference (See Section 2.1.2.6, Welding) .
PPC 4	License plate mounting and location shall be determined and require approval by METRO during the preproduction conference (See Section 2.1.3.4, License Plates) .
PPC 5	The layout and mounting of the coat hook and jacket strap used in the Operator's barrier shall be submitted and require approval by METRO during the preproduction conference (See Section 2.1.4.2, Operator's Platform and Operator Barrier) .
PPC 6	Installation details shall be submitted and require approval by METRO during the preproduction conference (See Section 2.1.4.3, Modesty Panel) .
PPC 7	Exact mounting location shall be submitted and require approval by METRO during the preproduction conference (See Section 2.1.4.7, Take One Holders) .
PPC 8	Location and installation of closeable locker or box and handheld radio holders shall be determined and require approval by METRO during the preproduction conference (See Section 2.3.1.3, Front End) .

PPC 9	Location and installation of emergency exit (egress) windows shall be determined and approved by METRO during the preproduction conference. (See Section 2.4.2.5, Windows)
PPC 10	Sun shade installation and operation shall be determined and approved by METRO during the preproduction conference with final approval by METRO after delivery of pilot bus, but before start of production of remainder of order (See Section 2.6.1.1, Visors) .
PPC 11	Placement of cup holder shall be determined and approved by METRO during the preproduction conference with final approval by METRO after delivery of pilot bus, but before start of production of remainder of order (See Section 2.6.1.3 Cup Holder) .
PPC 12	Initial placement of interior and exterior mirrors shall be determined and approved by METRO during the preproduction conference with final approval by METRO after delivery of pilot bus, but before start of production of remainder of order (See Section 2.6.2, Mirrors) .
PPC 13	Fare box installation/location and drawings shall be determined and approved by METRO during the preproduction conference with final approval by METRO after delivery of pilot bus, but before start of production of remainder of order (See Section 2.6.5, Fare Collection) .
PPC 14	Location and installation of air filter shall be determined and approved by METRO during the preproduction conference (See Section 3.1.2.2, Service) .
PPC 15	Location and style of belt guards for air compressor and alternator or other belt driven equipment shall be determined and approved by METRO during the preproduction conference (See Section 3.1.2.3, Accessories) .
PPC 16	The bus shall have return to fast idle and auto shut down options. An auto neutral system (return to neutral) shall be incorporated into the engine parameters and shall be determined and require approval by METRO during the preproduction conference (See Section 3.1.3.1, Engine Transmission) .
PPC 17	The integration of all systems on the vehicle relative to engine idle speed shall be determined and require approval by METRO during the preproduction conference (See Section 3.1.3.1 Engine) .

PPC 18	The type of poppet drain valve shall be determined and require approval by METRO during the preproduction conference (See Section 3.1.3.2, Cooling System).
PPC 19	Exhaust routing shall be determined and require approval by METRO during the preproduction conference (See Section 3.1.4.2, Exhaust Location).
PPC 20	Air Dryer shall be determined and require approval by METRO during the preproduction conference (See Section 3.5.1.4, Air System).
PPC 21	Location of the parking brake control valve shall be determined and require approval by METRO during the preproduction conference (See Section 3.5.1.5, Parking and Emergency Brake).
PPC 22	Redundant grounds shall be used for all electrical equipment, except where it can be demonstrated that redundant grounds are not feasible or practicable. Each of these areas shall be determined and require approval by METRO during the preproduction conference (See Section 3.6.4.1, General Requirements).
PPC 23	Wiring located under the bus floor shall be eliminated to the extent practicable and where used, shall be determined and require approval by METRO during the preproduction conference (See Section 3.6.4.1, General Requirements).
PPC 24	The alternator system load shall be determined and require approval by METRO during the preproduction conference (See Section 3.6.4.1, General Requirements).
PPC 25	Any wire passing through the rear firewall or upper compartment shelf shall be protected with a waterproof and fireproof connection and shall be determined and require approval by METRO during the preproduction conference (See Section 3.6.4.2, Modular Design).
PPC 26	The bus manufacturer shall provide wiring schematic run sheets and ladder logic sheets prior to production of the pilot and shall provide final as-built drawings prior to production of the 10 th bus. The wiring layout and ladder logic shall be determined and require approval by METRO during the preproduction conference (See Section 3.6.4.3, Wiring and Terminals).
PPC 27	The operating control switches for the air conditioning system shall be located in the Operator's compartment operable by a seated Operator in a location

	that shall be determined and require approval by METRO during the preproduction conference (See Section 3.7.3.4, Air Conditioning System Controls).
PPC 28	Shall be installed on the left side of the operator control panel in a location that shall be determined and require approval by METRO during the preproduction conference (See Section 3.8.1.7.3, Digital Video Recorder (NVR) General Requirements).
PPC 29	The location of nine (9) cameras to be installed in the general locations shown below shall be determined and require approval by METRO during the preproduction conference (See Section 3.8.1.7.3, Digital Video Recorder (NVR) General Requirements).
PPC 30	Camera lens selection shall be appropriate to the desired areas of coverage, that is, provide maximum coverage to the area being recorded without sacrificing image quality and shall be determined and require approval by METRO during the preproduction conference with final adjustments made during pilot bus construction (See Section 3.8.1.7.3, Digital Video Recorder (NVR) General Requirements).
PPC 31	Four (4) signs are required per vehicle in locations that shall be determined and require approval by METRO during the preproduction conference (See Section 3.8.1.7.3, Digital Video Recorder (NVR) General Requirements).
PPC 32	System components shall have been approved by recognized national testing laboratories such as Factory Mutual, Underwriters, etc. Supporting documentation shall be provided and require approval by METRO during the preproduction conference (See Section 3.9.3, Tests)
PPC 33	The FSS suppressant agent shall have an ABC rating that requires approval by METRO during the preproduction conference and that will allow METRO to receive certified and refilled cylinders from sources located within the Houston Metropolitan area (See Section 3.9.6, Requirements of Fire Suppression System (FSS)).
PPC 34	The wiring layout shall be determined and require approval by METRO during the preproduction conference. Schematic runs will be on both computer disks and in book form (See Section 7.1, Requirements)

2 EXHIBIT "B" CONTRACTOR'S RELEASE

Pursuant to the terms of METRO Contract No. _____, as amended, and in consideration of the sum of _____ Dollars (\$ _____), which has been or is to be paid under said Contract to _____ (hereinafter called the Contractor) or its assignees, if any, the Contractor for itself and its subcontractors, upon payment of the said sum by the Metropolitan Transit Authority (hereinafter called METRO), does release and discharge METRO, their officers, agents, and employees, of and from all liabilities, obligations, claims and demand whatsoever under or arising from the said Contract, except specified claims as follows: _____ (IF NONE, SO STATE) _____.

IN WITNESS WHEREOF, this release has been executed this ____ day of _____, 200_.

By:

CERTIFICATE

I, _____, certify that I am _____ (Title) of the firm named as the Contractor in the foregoing release; that _____, who signed said release on behalf of the Contractor and its subcontractors, was the _____ (Title) of said firm; that said release was duly signed for and behalf of said firm; and is within the scope of its powers as so constituted.

(If Corporation, Affix the Corporate (If Corporation, Affix the Corporate Seal)

3 EXHIBIT "C" REQUEST FOR APPROVALS RESPONSES

(To be inserted at Contract award)

The requests for Approvals (RFA's) submitted by prospective bidders and METRO's responses thereto, attached hereto, are hereby incorporated into the Proposed Contract as Exhibit "D".

4 EXHIBIT "D" SUPER CIRCULAR

In addition to other provisions required by the Federal agency or non-Federal entity, all contracts made by the non-Federal entity under the Federal award must contain provisions covering the following, as applicable.

(A) Contracts for more than the simplified acquisition threshold currently set at \$150,000, which is the inflation adjusted amount determined by the Civilian Agency Acquisition Council and the Defense Acquisition Regulations Council (Councils) as authorized by 41 U.S.C. 1908, must address administrative, contractual, or legal remedies in instances where contractors violate or breach contract terms, and provide for such sanctions and penalties as appropriate.

(B) All contracts in excess of \$10,000 must address termination for cause and for convenience by the non-Federal entity including the manner by which it will be effected and the basis for settlement.

(C) Equal Employment Opportunity. Except as otherwise provided under 41 CFR Part 60, all contracts that meet the definition of "federally assisted construction contract" in 41 CFR Part 60-1.3 must include the equal opportunity clause provided under 41 CFR 60-1.4(b), in accordance with Executive Order 11246, "Equal Employment Opportunity" (30 FR 12319, 12935, 3 CFR Part, 1964-1965 Comp., p. 339), as amended by Executive Order 11375, "Amending Executive Order 11246 Relating to Equal Employment Opportunity," and implementing regulations at 41 CFR part 60, "Office of Federal Contract Compliance Programs, Equal Employment Opportunity, Department of Labor."

(D) Davis-Bacon Act, as amended (40 U.S.C. 3141-3148). When required by Federal program legislation, all prime construction contracts in excess of \$2,000 awarded by non-Federal entities must include a provision for compliance with the Davis-Bacon Act (40 U.S.C. 3141-3144, and 3146-3148) as supplemented by Department of Labor regulations (29 CFR Part 5, "Labor Standards Provisions Applicable to Contracts Covering Federally Financed and Assisted Construction"). In accordance with the statute, contractors must be required to pay wages to laborers and mechanics at a rate not less than the prevailing wages specified in a wage determination made by the Secretary of Labor. In addition, contractors must be required to pay wages not less than once a week. The non-Federal entity must place a copy of the current prevailing wage determination issued by the Department of Labor in each solicitation. The decision to award a contract or subcontract must be conditioned upon the acceptance of the wage determination. The non-Federal entity must report all suspected or reported violations to the Federal awarding agency. The contracts must also include a provision for compliance with the Copeland "Anti-Kickback" Act (40 U.S.C. 3145), as supplemented by Department of Labor regulations (29 CFR Part 3, "Contractors and Subcontractors on Public Building or Public Work Financed in Whole or in Part by Loans or Grants from the United States"). The Act provides that each contractor or subrecipient must be prohibited from inducing, by any means, any person employed in the construction, completion, or repair of public work, to give up any part of the compensation to which he or she is otherwise entitled. The non-Federal entity must report all suspected or reported violations to the Federal awarding agency.

(E) Contract Work Hours and Safety Standards Act (40 U.S.C. 3701-3708). Where applicable, all contracts awarded by the non-Federal entity in excess of \$100,000 that involve the employment of mechanics or laborers must include a provision for compliance with 40 U.S.C. 3702 and 3704, as supplemented by Department of Labor regulations (29 CFR Part 5). Under 40 U.S.C. 3702 of the Act, each contractor must be required to compute the wages of every mechanic and laborer on the basis of a standard work week of 40 hours. Work in excess of the standard work week is permissible provided that the worker is compensated at a rate of not less than one and a half times the basic rate of pay for all hours worked in excess of 40 hours in the work week. The requirements of 40 U.S.C. 3704 are applicable to construction work and provide that no laborer or mechanic must be required to work in surroundings or under working conditions which are unsanitary, hazardous or dangerous. These requirements do not apply to the purchases of supplies or materials or articles ordinarily available on the open market, or contracts for transportation or transmission of intelligence.

(F) Rights to Inventions Made Under a Contract or Agreement. If the Federal award meets the definition of "funding agreement" under 37 CFR § 401.2 (a) and the recipient or subrecipient wishes to enter into a contract with a small business firm or nonprofit organization regarding the substitution of parties, assignment or performance of experimental, developmental, or research work under that "funding agreement," the recipient or subrecipient must comply with the requirements of 37 CFR Part 401, "Rights to Inventions Made by Nonprofit Organizations and Small Business Firms Under Government Grants, Contracts and Cooperative Agreements," and any implementing regulations issued by the awarding agency.

(G) Clean Air Act (42 U.S.C. 7401-7671q.) and the Federal Water Pollution Control Act (33 U.S.C. 1251-1387), as amended - Contracts and subgrants of amounts in excess of \$150,000 must contain a provision that requires the non-Federal award to agree to comply with all applicable standards, orders or regulations issued pursuant to the Clean Air Act (42 U.S.C. 7401-7671q) and the Federal Water Pollution Control Act as amended (33 U.S.C. 1251-1387). Violations must be reported to the Federal awarding agency and the Regional Office of the Environmental Protection Agency (EPA).

(H) Debarment and Suspension (Executive Orders 12549 and 12689) - A contract award (see 2 CFR 180.220) must not be made to parties listed on the governmentwide exclusions in the System for Award Management (SAM), in accordance with the OMB guidelines at 2 CFR 180 that implement Executive Orders 12549 (3 CFR part 1986 Comp., p. 189) and 12689 (3 CFR part 1989 Comp., p. 235), "Debarment and Suspension." SAM Exclusions contains the names of parties debarred, suspended, or otherwise excluded by agencies, as well as parties declared ineligible under statutory or regulatory authority other than Executive Order 12549.

(I) Byrd Anti-Lobbying Amendment (31 U.S.C. 1352) - Contractors that apply or bid for an award exceeding \$100,000 must file the required certification. Each tier certifies to the tier above that it will not and has not used Federal appropriated funds to pay any person or

organization for influencing or attempting to influence an officer or employee of any agency, a member of Congress, officer or employee of Congress, or an employee of a member of Congress in connection with obtaining any Federal contract, grant or any other award covered by 31 U.S.C. 1352. Each tier must also disclose any lobbying with non-Federal funds that takes place in connection with obtaining any Federal award. Such disclosures are forwarded from tier to tier up to the non-Federal award.

(J) See § 200.322 Procurement of recovered materials. A non-Federal entity that is a state agency or agency of a political subdivision of a state and its contractors must comply with section 6002 of the Solid Waste Disposal Act, as amended by the Resource Conservation and Recovery Act. The requirements of Section 6002 include procuring only items designated in guidelines of the Environmental Protection Agency (EPA) at 40 C.F.R. Part 247 that contain the highest percentage of recovered materials practicable, consistent with maintaining a satisfactory level of competition, where the purchase price of the item exceeds \$10,000 or the value of the quantity acquired during the preceding fiscal year exceeded \$10,000; procuring solid waste management services in a manner that maximizes energy and resource recovery; and establishing an affirmative procurement program for procurement of recovered materials identified in the EPA guidelines.

(K) Prohibition on contracting for certain Telecommunications and video surveillance services or equipment

1. Definitions. The definitions set forth in 48 C.F.R. 52.204-25(a) shall apply to this Section K.

2. Prohibitions.

a. The Contractor is prohibited from providing to METRO any equipment, system, or service that uses covered telecommunications equipment or services as a substantial or essential component of any system, or as critical technology as part of any system, unless an exception at Paragraph C of this Section applies or the covered telecommunication equipment or services are covered by a waiver described in FAR 4.2104.

b. The Contractor is prohibited from using any equipment, system or services that uses covered telecommunications equipment or services as a substantial or essential component of any system, or as critical technology as part of any system, unless an exception under Paragraph C of this Section applies or the covered telecommunication equipment or services are covered by a waiver described in FAR 4.2104. This prohibition applies to the use of covered telecommunications equipment or services, regardless of whether that use is in performance of work under a federal contract.

3. Exceptions. This Section does not prohibit the Contractor from providing:

- a. A service that connects to the facilities of a third-party, such as backhaul, roaming, or interconnection arrangements; or
- b. Telecommunications equipment that cannot route or redirect user data traffic or permit visibility into any user data or packets that such equipment transmits or otherwise handles.

4. Reporting Requirement.

a. In the event the Contractor identifies covered telecommunications equipment or services used as a substantial or essential component of any system, or as critical technology as part of any system, during contract performance, or the Contractor is notified of such by a subcontractor at any tier or by any other source, the Contractor shall report the information in Paragraph D.2 of this clause to the Contracting Officer, unless elsewhere in this Contract are established procedures for reporting the information.

b. The Contractor shall report the following information pursuant to Paragraph D.1 of this Section :

- i. Within one business day from the date of such identification or notification: The contract number; the order number(s), if applicable; supplier name; supplier unique entity identifier (if known); supplier Commercial and Government Entity (CAGE) code (if known); brand; model number (original equipment manufacturer number, manufacturer part number, or wholesaler number); item description; and any readily available information about mitigation actions undertaken or recommended.
- ii. Within 10 business days of submitting the information in Paragraph D.2.b of this Section by further available information about mitigation actions undertaken or recommended. In addition, the Contractor shall describe the efforts it undertook to prevent use or submission of covered telecommunications equipment or services, and any additional efforts that will be incorporated to prevent future use or submission of covered telecommunications equipment or services.

5. Subcontracts. The Contractor shall insert the substance of this clause, including this Paragraph E and excluding Paragraph B.2 in all subcontracts and other contractual instruments, including subcontracts for the acquisition of commercial items.

(L) Domestic Preferences for Procurements

As appropriate and to the extent consistent with law, the Contractor and all subcontractors shall provide a preference for the purchase, acquisition, or use of goods, products, or materials produced in the United States (including but not limited to iron, aluminum, steel, cement, and other manufactured products). This requirement must be included in all subcontracts.

(M) National Intelligent Transportation Systems Architecture and Standards

The Contractor agrees to conform to the National Intelligent Transportation Systems (ITS) Architecture requirements of 23 U.S.C. § 517(d), unless it obtains an exemption from those requirements, and to follow FTA Notice, "FTA National ITS Architecture Policy on Transit Projects," 66 Fed. Reg. 1455, January 8, 2001, and all other applicable federal guidance.

[78 FR 78608, Dec. 26, 2013, as amended at 79 FR 75888, Dec. 19, 2014]

5 EXHIBIT "E" FEDERAL CERTIFICATES

(To be inserted at Contract award Contract)