

**PFAFF®**

**ACCESSORY  
CATALOGUE  
2021**

**FEATURED ACCESSORIES**

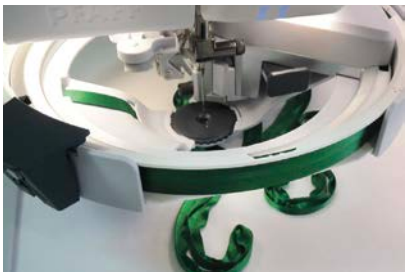

creative™ RIBBON EMBROIDERY  
ATTACHMENT  
821260096



creative™ HAT HOOP  
ATTACHMENT  
821138096



MULTI FUNCTION FOOT  
CONTROL  
821261096

# WELCOME...

...to the world of sewing and a wide range of accessories from PFAFF®.



Your authorized PFAFF® dealer will be happy to advise you and show you the entire range of accessories. You'll also find all the latest news about the PFAFF® accessories on the Internet at [www.pfaff.com](http://www.pfaff.com)



■ ■ ■ PFAFF® SEWING AND EMBROIDERY MACHINES

Code letters/model numbers ..... 4

■ ■ ■ SEWING

Utility Accessories ..... 10

Decorative Accessories ..... 24

■ ■ ■ QUILTING

Quilting Accessories ..... 47

■ ■ ■ EMBROIDERY

Embroidery Collections ..... 68

creative™ Hoops ..... 69

creative™ Accessories ..... 76

■ ■ ■ SERGER/OVERLOCK - DECORATIVE

Decorative Accessories ..... 84

■ ■ ■ SERGER/OVERLOCK - COVERSTITCH

Coverstitch Accessories ..... 96

■ ■ ■ ADDITIONAL

PFAFF Needles ..... 104



# SEWING AND EMBROIDERY MACHINES!



Before you start looking through the pages of PFAFF® accessories, take a quick look at the current line of PFAFF® sewing machines. Comfortable, easy to use, durable quality, a versatile range of sewing features and elegant design – these are all PFAFF® qualities that you have come to know and expect. You can get more detailed information about each machine at your PFAFF® dealer or on the Internet at [www.pfaff.com](http://www.pfaff.com).

L creative icon™  
performance icon™

The top model from PFAFF®!

The *creative icon*™ is the superlative sewing and embroidery machine with features and sewing ease that establish new standards worldwide. It has the largest workspace; connectivity with WiFi and mySewnet™; Integrated Dual feed technology; brightest LED lighting; over 800 stitches and more than 800 built-in embroidery designs and many more innovative and exclusive features.



## NOTE THE CODE LETTERS AND MODEL NUMBER FOR YOUR MACHINE!

### A B C D E F G H J K L

By finding the code letter that represents your machine from the list below, you'll be able to tell which accessories through-out the catalogue are available for your machine. If you have any questions, your PFAFF® dealer will be happy to help you.

*Which presser foot fits your sewing machine? Just check the code!*

A



Machines with 5 mm and 6 mm stitch width,  
without IDT™ system

varimatic™ 6087, 6086, 6085 (6 mm)

\*hobby™ 309, 307, 303, 301 (5,5 mm)

\* These sewing machines have a presser foot holder of 6 mm. Because newer presser feet are produced to fit 8 mm holders, there may be a small gap between the holder and the presser foot attachment. You will need to change the 8 mm presser foot holder when using the newer presser feet.

B



Machines with 5,5 mm stitch width,  
without IDT™ system

hobby™ 1042, 1040, 1032, 1030, 1022, 1020, 1016

C



Machines with 5,5 mm stitch width,  
without IDT™ system

expression™ 2014

tiptronic™ 6112, 6110, 2020, 2010

select™ 2.2, 2.0, 1528, 1526, 1520

hobby™ 4260, 4250, 4240

D



Machines with 5,5 mm and 6 mm stitch width, and IDT™ system

select™ 4.2, 4.0, 3.2, 3.0,

select™ 1548, 1546, 1540, 1538, 1536, 1530 (5,5 mm)

tiptronic™ 6270, 6250, 6232, 6230,

tiptronic™ 6152, 6150, 6122, 6120 (5,5/6 mm)

stretch & jeans™ 6091 (6 mm)

freestyle™ 1527, 1522

E



Machines with 6 mm stitch width, and IDT™ system

creative™ 2124

quilt expression™ 2046, 2044, 2042

expression™ 2036, 2034, 2028, 2026, 2024

classicstyle™ 2029, 2027, 2025, 2023

tiptronic™ 2040, 2030, 2020, 2010

**NOTE THE CODE LETTERS AND MODEL NUMBER FOR YOUR MACHINE!**

**F**



Machines with 9 mm stitch width,  
without IDT™ system  
creative™ 7560

**G**



Machines with 9 mm stitch width, and IDT™ system  
creative™ 2170, 2144, 2140, 2134  
creative™ 7570, 7562, 7550, 7530  
performance™ 2058, 2056, 2054  
quilt expression™ 2048  
expression™ 2038

**H**



Machines with 5,5 mm stitch width,  
without IDT™ system  
hobby™ 1142, 1132, 1122

**J**



Machines with 9 mm stitch width, and IDT™ system  
creative sensation™ pro II  
creative sensation™ pro  
creative sensation™  
creative vision™  
creative performance™  
creative™ 4.5, 4.0, 3.0, 2.0  
performance™ 5.0, 5.2  
quilt expression™ 4.2, 4.0, 720  
expression™ 3.5, 3.2, 3.0, 2.0  
expression™ 150, 710

**K**



Machines with 7 mm stitch width, and IDT™ system  
creative™ 1.5  
quilt ambition™ 2.0, 630  
ambition™ 1.0, 1.5  
ambition™ 610, 620  
ambition essential™  
passport™ 2.0, 3.0

Machines with 6 mm stitch width  
SMARTER BY PFAFF™ 260c, 160s, 140s

**L**



Machines with 9 mm stitch width, and IDT™ system  
creative icon™  
performance icon™

NOTE THE CODE LETTERS AND MODEL NUMBER FOR YOUR MACHINE!









## SEWING

Do you love to sew? Do you enjoy trying new things with your projects? Do you take pride in professional sewing results? Then take a journey through the PFAFF® assortment of accessories that will inspire new ideas and expand the capabilities of your sewing machine. Many beautiful results and special techniques can only be achieved with certain accessories, so don't limit your creativity!

For more information, check our web site regularly at [www.pfaff.com](http://www.pfaff.com) or visit your nearest authorized PFAFF® dealer.







## UTILITY ACCESSORIES

Would you like your handsewn garments to be as perfect as the best ready-to-wear? Then take a look at the wide range of presser feet from PFAFF®. You'll find the right presser foot for every use. They make every sewing job easier... and some jobs are only possible with the help of the right presser foot. Your PFAFF® dealer will be happy to tell you more.

Please note the code numbers for the various PFAFF® sewing machines to instantly see which presser feet are available for your model.

### MULTI FUNCTION FOOT CONTROL



821261096

L creative icon™ performance icon™



Control multiple functions of your machine like thread cut, tie off or reverse without taking your hands off your project.

3 customisable function switches

- 2 side levers
- 1 heel touch button

Five programmable sewing machine functions include:

- Presser foot lift
- Scissors.
- Reverse
- Tie off
- Pattern begin / restart
- Separate needle up / down function
- Extra long 8 foot (2.5m) USB cable to suit various sewing positions
- Ergonomic Design
- Rubberised base for stability



## SEAM GUIDE FOOT FOR IDT™ SYSTEM



820772096

B C D E F G J K L

for IDT™ system



The Seam Guide Foot for IDT™ system guides your stitching perfectly when joining fabrics. The presser foot is designed to help you keep the seam allowance at the same distance from the edge throughout the project. The presser foot has a metal guide at 5/8 inch distance from the center needle position, which is the most used seam allowance when sewing clothes. It has four more markings for various seam allowances.

1. Snap on the Seam Guide Foot for IDT™ system.
2. Engage the IDT™ system.
3. Select a straight stitch.
4. For joining fabrics together; place fabric right sides together.
5. Place the fabric under the presser foot with the metal guide at the edge of the fabric for 5/8 inch seam allowance.
6. Start to sew. The guide will follow the edge of the fabric and the seam will be sewn with the perfect straight seam allowance.
7. Use the 4 other red markings on the presser foot for a narrower seam allowances.

## SEW-ON BUTTON FOOT



820473096

C D E F G J K L



The automatic needle threader cannot be used on Group L machines.

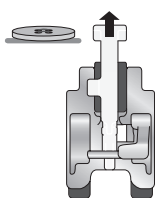
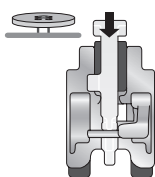

Sewing on buttons can be a tedious job – but not when you use the Sew-on Button Foot! Use it to easily sew 2- or 4-hole buttons of various sizes in place. Just set the stitch width to match the spacing between the holes and your machine does all the work. By including a shaft, you can even sew on buttons with a thread shank, see illustration.

1. Mark on the fabric where you want the button to be placed.
2. Snap on the Sew-on Button Foot.
3. Lower feed dogs.
4. Insert the button between the black metal piece and the presser foot. Make sure that two holes are positioned in the cut-out of the presser foot.
5. Place the fabric under the presser foot. Select button sew-on stitch or zigzag stitch. Lower feed dogs.
6. Select width to match buttonholes. Manually turn the hand wheel to make sure that the needle enters the left hole.
7. Start to sew. The machine will automatically tie off your button if using button sew-on stitch. If using zigzag, sew across button five times.

If you want your button to have a shank, push the plastic piece on the presser foot towards you, placing it between the two holes of the button. When you have finished sewing your button, pull the plastic piece back, remove your button from the presser foot and cut off the threads. Wrap the seam with sewing thread and make a knot.

## ADJUSTABLE GUIDE FOOT FOR IDT™ SYSTEM



820677096

DEFGJKL

for IDT™ system

--	--

The Adjustable Guide Foot for IDT™ system guides your topstitching and decorative stitching perfectly. The presser foot has a “ruler” with an adjustable guide designed so you can place the guide anywhere you want. Place the guide along an already stitched seam or against any edge to give you beautiful topstitching. Use both straight and decorative stitches. It is perfect for channel quilting too.

1. Snap on the Adjustable Guide Foot for IDT™ system.
2. Engage the IDT™ system.
3. Select the stitch of your choice.
4. Set the adjustable grey guide by moving it right or left along the “ruler”.
5. Sew letting the guide follow your seam or edge or marking.

## BUTTONHOLE FOOT



820672096

JKL

--	--

416042001

H

--	--



413170301

J

--	--

68003184

L

--	--

The manual buttonhole foot will sew your buttonhole manually in four steps. (Buttonholes that are to be sewn very small piece of fabric close to a reinforced edge may not always feed optimally with the large Sensomatic Buttonhole Foot. In this case, use the manual buttonhole foot.)

The Sensomatic Buttonhole Foot provides the perfect buttonhole; it will have both sides of the buttonhole sewn in the same direction for a more even result. The buttonhole will be completed automatically.

No matter which machine model you have. A PFAFF® machine will always provide you with a perfect buttonhole. There are different options for the models, refer to the machine code and select the right foot for your machine.

**TIP:** Fabrics that shift or stretch easily should be reinforced with water-soluble, tissue paper or other lightweight stabilizer. Buttonholes are more stable and durable if a gimp thread is inserted while sewing. Linen buttonholes are particularly attractive if you use a heavier-weight thread through a topstitch needle.



*Different fabrics can be sewn together with no problem, thanks to the unique IDT™ system on PFAFF® sewing machines. The fabric layers are fed evenly from top and bottom. Nothing can slip. Learn more about IDT™ system – [www.pfaff.com](http://www.pfaff.com)*





## INVISIBLE ZIPPER FOOT



820474096  
C D E F G J K L

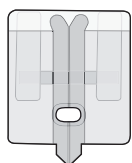

*Garments of the finest fabrics demand perfectly sewn zippers – no problem with the special zipper feet from PFAFF®.*

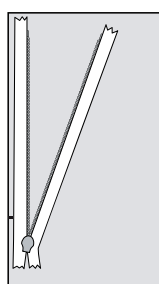

**A**

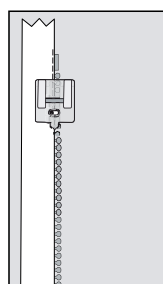

**B**

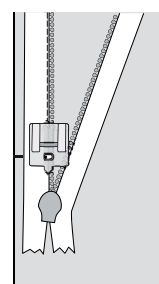

**C**

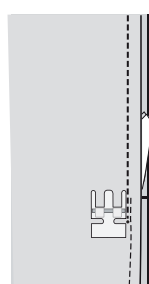

**D**

Invisible zippers are the least noticeable of all zippers. As the name implies, the zipper is hidden in a seam, becoming virtually invisible. This makes it a popular choice for elegant clothing sewn with expensive materials, like evening wear. But it's equally appropriate for skirts, blouses and other everyday clothing items. Invisible zippers (also called concealed zippers) are easily sewn with the PFAFF® Invisible Zipper Foot!

1. Use the marking pen to mark the length of the zipper on the right side of the fabric, on both sides of the opening. The zipper should be at least 2 cm to 3 cm (3/4 to 1 1/4 inch) longer than the opening.
2. Attach the special Invisible Zipper Foot and select a straight stitch, center needle position and stitch length to 2.5 to 3.0 mm.
3. Open the zipper and flatten the coil slightly with your thumb, so that the seam line between the tape and the coil becomes visible. Never iron the zipper.
4. Place the right half of the zipper onto the right side of the opening, with right sides of the zipper and fabric together. The coil should lie directly on the seam line, starting about 1.5 to 2 cm (5/8 to 3/4 inch) below the upper edge of the fabric. Pin in place, if desired. Make sure that the bottom end of the zipper extends 2 cm to 3 cm (3/4 to 1 1/4 inch) beyond the bottom end of the opening. (ill. A)
5. Carefully press the teeth slightly to the right and lower the zipper foot, so that the coil lies in the groove to the right of the needle.
6. Starting at the top, sew the zipper in place, stopping at the previously marked end of the opening. Tie-off the end of the seam. Close the zipper. (ill. B,C)
7. Place the second zipper tape on the left side of the opening, on the right side of the fabric. Make sure that both coils are level.
8. Pin the zipper in place. Open the zipper.
9. Carefully press the teeth slightly to the left and lower the Zipper Foot, so that the coil lies in the groove to the left of the needle.
10. Starting at the top, sew the zipper in place, stopping at the previously marked end of the opening. Tie-off the end of the seam. Close the zipper.
11. Finally, sew the seam below the zipper, starting at the bottom and working up. Attach the standard Zipper Foot so that the presser foot clamp and the foot are to the right of center. Move the needle to the right. (ill. D)
12. Pull the loose bottom end of the zipper toward the seam allowances and stitch as close as possible up to the last stitches of the zipper seams.
13. Press the seam open.

**TIP:** If the zipper is too long, sew over the end of the coil with a straight stitch or a closely spaced zigzag stitch, approx. 2 cm (3/4 inch) below the bottom end of the opening. Cut off the excess zipper and finish the raw edge with a small piece of fabric.

## ZIPPER FOOT FOR IDT™ SYSTEM



The Zipper Foot is the most important zipper tool and will help you stitch the zipper perfectly in place. When attaching any zipper, it is important to sew right next to the edge of the zipper teeth. You can do that with the special Zipper Foot. It can be snapped onto the left or right of the sewing foot ankle, as needed.

**Centered zipper (concealed on both sides):**

1. Overcast the seam allowances. Join the fabric layers, right sides together, with a standard stitch up to the zipper insertion mark.
2. Baste the remainder of the seam closed. Press seam open.
3. Baste the zipper in place, centering the zipper teeth along the basted seam line and with the zipper pull extended beyond the top of the garment edge.
4. Attach the Zipper Foot to your machine.
5. Position edge of Zipper Foot close to teeth of zipper and move the needle to stitch approximately 6 - 10 mm (1/4 - 3/8 inch) away from center seam line. Stitch along both sides and across bottom of zipper with a straight stitch.
6. Remove basting stitches.

820248096

DEGJK\* L

for IDT™ system

K\* except SMARTER BY PFAFF™  
260c, 160s, 140s

--	--

820287096

A

--	--





## ELASTIC FOOT FOR IDT™ SYSTEM



820545096

BCDEFGJKL

for IDT™ system



The automatic needle threader cannot be used on Group L machines.

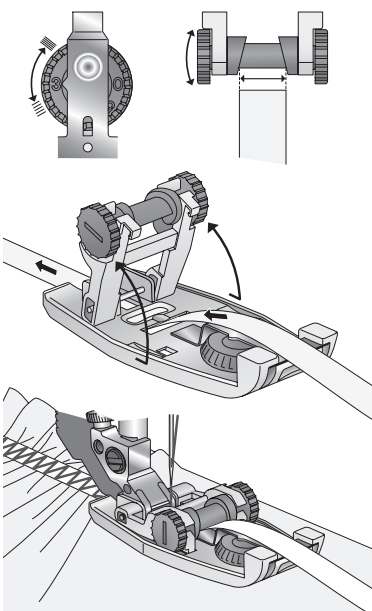

The Elastic Foot simultaneously guides, stretches 6 to 12 mm wide elastic and sews it in place. Use it for active wear, lingerie and other elastic insertion techniques.

1. Set the dark grey numbered dial on the Elastic Foot by aligning the number with the small metal arrow. The higher the number, the more the elastic will be stretched. The stiffness of the elastic will influence the sewing result.
2. Gently push the dark grey roller towards the numbered dial and lift it up.
3. Insert the elastic into the longer slot opening on the base of the presser foot.
4. Turn the roller until the center groove of the roller matches the width of the elastic so that the elastic will guide straight.
5. Bring the roller down on the elastic and click it into place by gently pushing it away from the numbered dial.
6. Snap the Elastic Foot onto the sewing machine. Set the machine for a regular zigzag stitch. Adjust the stitch width according to the width of the elastic and the stitch length according to the quality of the elastic and how much gathering is required.
7. Engage the IDT™ system.
8. Place the fabric under the presser foot and sew. The fabric will gather as the elastic is stretched and sewn in place.





## BIAS BINDER



820245096  
A B C D E F G J K L

--	--



The automatic needle threader cannot be used on Group L machines.

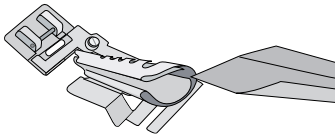

Binding with bias tape is a very easy way to give fabric edges a smooth and neat appearance. You will need unfolded bias tape 24 mm (scant 1") wide.

1. Remove the presser foot. Attach the Bias Binder.
2. Cut the beginning of the bias tape at a diagonal.
3. Feed the tape into the scroll of the binder and pull out to the back.
4. Adjust the binder and/or the needle position so that the needle pierces the fabric approximately 1 - 1.5 mm (1/16 inch) from the folded edge of the bias tape.
5. Stitch about 25 mm (1 inch) along the Bias Tape.
6. Insert the edge of the fabric to be bound between the Bias Tape edges into the slot of the binder. The Bias Tape will enclose the raw edge automatically during sewing.

TIP: Using a zigzag or fancy stitch will give you even more of a decorative effect.

## ROLLED HEM FOOT



820220096  
B C D E F G J K L  
2 mm

--	--

820249096  
B C D E F G J K L  
3 mm, for IDT™ system

--	--

820221096  
B C D E F G J K L  
4 mm, for IDT™ system

--	--

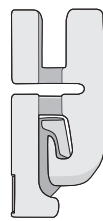

Hemming prevents the edges from fraying and results in a clean, durable edge. With the Rolled Hem Foot, you can hem light to medium weight fabrics for clothing and home decorating items without having to pre-iron the fabric edges.

1. Select a straight stitch, snap on the Rolled Hem Foot and engage IDT™ system (if available on your machine). If needed, press only the beginning of the hem to 2, 3 or 4 mm wide, depending on the size of your foot. Place it flat in the groove under the foot and sew a few stitches. Lower the needle into the fabric to hold it in place. Raise the presser foot and pull the cut edge of the fabric into the scroll of the hemmer. Lower the foot and continue sewing while holding the cut edge up in front of the foot.
2. Do not allow fabric to run under the right half of the presser foot.

TIP: Hem crisp fabrics with a straight stitch. Hem soft fabrics with a zigzag that just encases the mm size of the hem. (Sharply curved areas are not suitable for this type hemmer.)

## BLINDHEM FOOT FOR IDT™ SYSTEM



820256096  
DEGJKL  
for IDT™ system

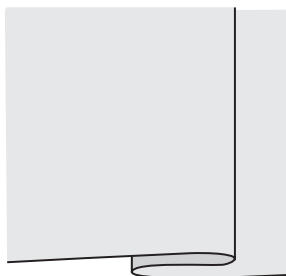

The Blindhem Foot is perfect for sewing invisible hems. Use it to sew the elastic blindhem for an optional finish and you won't need additional finishing on the hem edge. Sewing by hand is no longer necessary.

1. Snap on the Blindhem Foot.
2. Fold the edge in by the hem width.
3. Unfold the hem again so that hem edge protrudes by about 1 cm.
4. Position fabric so red edge guide runs along edge of folded hem.
5. Use the needle position and the width dial to regulate the penetration of the needle in the crease.

**TIP:** If the stitch punctures are visible on the right side of the project, adjust red guide slightly using screw on right side of foot.

## NARROW EDGE FOOT FOR IDT™ SYSTEM



821142096  
BCDEFGJKL  
for IDT™ system

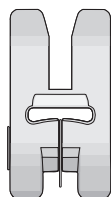

The Narrow Edge Foot is perfect for precision topstitching and joining lace and/or fabric edges together (for example, attaching lace to a finished fabric edge). The metal guide in the center of the foot keeps the two fabrics evenly spaced.

1. Set machine for zigzag or decorative stitch. Needle position will vary according to stitching position desired.
2. For narrow edge topstitching, place the center guide of the presser foot against the fabric edge.
3. Move the needle into the desired left position and topstitch.

**Lace/Edge Joining:** Position lace or finished fabric edges on either side of blade of foot and join together with zigzag or decorative stitch.

**Sewing lace to fabric:** Place the folded/pressed edge of your fabric to the left of the center guide and the finished edge of your lace to the right of the center guide. Both fabric and lace should be placed under the foot, right side up. The center guide will keep the fabrics properly separated to allow for more precise stitching. Choose a zigzag stitch and sew, catching the edge of the fabric and the lace. Adjust the width and length of your zigzag as desired.



## NON-STICK FOOT FOR IDT™ SYSTEM



Due to the special coating on the bottom of this foot, it's perfect for sewing hard-to-feed fabrics, like leather, foam, plastic, imitation leathers and plastic-coated fabrics.

1. Snap on the Non-stick Foot.
2. Select desired stitch and sew.

820664096  
 B C D E F G J K L  
 for IDT™ system

--	--

## ROLLER FOOT

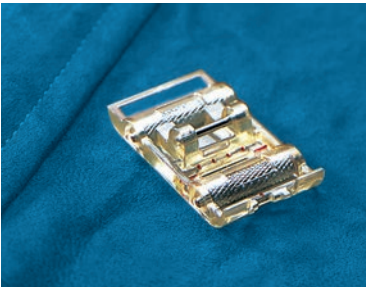

This special presser foot has two metal rollers, making it a good choice for sewing and decorating fabrics that don't feed well, like leather, imitation leather, plastic, foil and similar fabrics. With the Roller Foot, these fabrics are much easier and more convenient to work with. Success is guaranteed!

1. Snap on the Roller Foot.
2. Select desired stitch and sew.

820663096  
 B C D E F G J K L

--	--

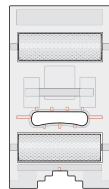

## JOIN AND FOLD EDGING FOOT FOR IDT™ SYSTEM

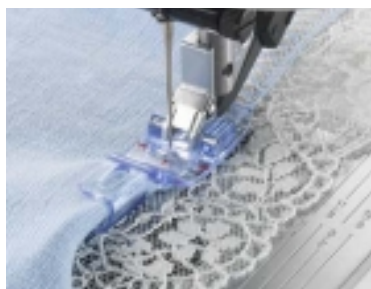

820931096  
D E G J K L



Use the Join and Fold Edging Foot together with different types of edging, such as lace, embroidered edging or varying fabrics and the beautiful PFAFF® 9 mm stitches to create beautiful edgings. Make lingerie in a snap, add lace to create beautiful handkerchiefs or delicate table toppers. This foot will easily guide the edging and the base fabric through the openings in the front of the foot, fold the base fabric and simultaneously sew the edging in place.

1. Thread your machine with regular sewing or decorative thread through the needle and regular sewing thread in the bobbin.
2. Select the stitch you would like to use. For example: the edging could be sewn onto the base fabric using a straight stitch and a 4mm twin needle or a right justified wide decorative stitch.  
**Note:** Decorative stitches that use forward motion work best. (Avoid stitches with too much backward motion.)
3. Fold a ¼" (6mm) hem of base fabric to the wrong side, finger press or iron.
4. Insert the folded edge of base fabric with the right side up into the left fabric guide and the edging (right side up) into the right guide and slide the folded fabric edge and the edging into the foot, prior to attaching the foot onto the sewing machine.
5. Make sure the base fabric and the edging slide easily through the openings.  
**Note:** Lightweight but stable fabrics and edging work best.
6. Snap on the Join and Fold Edging Foot to the sewing machine.
7. Engage IDT™ system.
8. Sew carefully, not too fast. If your machine has a speed control, reduce the sewing speed to easily guide the fabric and edging as you sew. Hold the fabric in your left hand and the edging in your right hand and sew.

## BI-LEVEL TOPSTITCH FOOT FOR IDT™ SYSTEM



820676096  
D E G J K L  
for IDT™ system



The Bi-level Topstitch Foot for IDT™ system guides your topstitching and edge stitching perfectly. The underside of the presser foot is designed to glide along the folded edge, and it will give you beautiful topstitching on your project. Use the Bi-level Topstitch Foot for hemming bulky projects such as waist bands, curtains etc. It will allow you to have the fabric outside the free arm for easier sewing.

1. Snap on the Bi-level Topstitch Foot for IDT™ system.
2. Engage the IDT™ system.
3. select a straight stitch.
4. Use the inner left side of the presser foot to guide the fabric.
5. Adjust the needle position to left to get the topstitching distance you like.



## RIGHT EDGE BI-LEVEL FOOT FOR IDT™ SYSTEM



821007096

D E G J K L

for IDT™ system



The Right Edge bi-level Foot guides your fabric with raised seams easily. The underside of the presser foot is designed to be higher on the right side, allowing it to glide along a folded edge or raised seam. Use the foot with straight stitch for perfect topstitching or edgestitching on pockets, collars, bindings and more or select a decorative stitch for a beautiful finish.

1. Snap on the Right Edge bi-level Foot.
2. Engage the IDT™ system
3. Select a straight stitch or a decorative stitch.
4. Position the fabric under the foot so that the inner right side of the presser foot rides over an already stitched seam or against any edge. (illustr.)
5. Adjust the needle position if necessary for your desired effect.

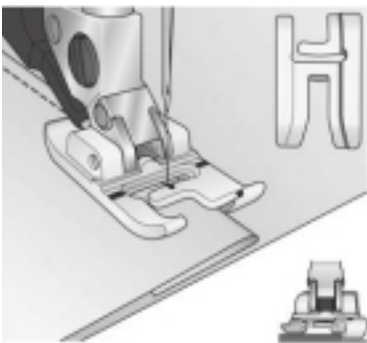

## MAGNETIC SEAM GUIDE



821162096

J K L



This easy to use seam guide simply snaps onto the needle plate on either side of the presser foot to give you accurate seam allowances and straight lines. Use the markings on the needle plate as a guide to help position the magnetic seam guide.

### FREE-MOTION/DARNING FOOT



820243096 A\* C D E F G

A\* except hobby™ 301, 303, 307 & 309

--	--

413039601 J

--	--

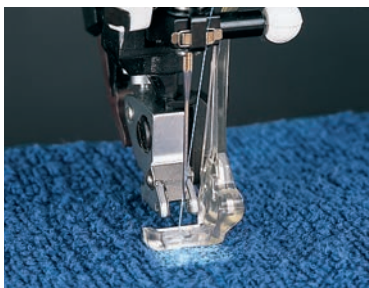

The Free-motion/Darning Foot is perfect for sewing free-motion embroidery or darning.

1. Make sure the needle is at its highest position.
2. Attach the Darning Foot: with your thumb and finger, squeezing the front and back of the foot together. Insert the pin of the Darning Foot as far as it will go into the hole at the back of the presser foot holder.
3. The “C-shaped” Guide should be positioned around the presser bar. The long arm must be behind the needle clamp. Tighten the screw.
4. Lower the feed dogs.
5. If you like, you can hoop the project in a round embroidery hoop for more stability.
6. Select a straight stitch and activate the free-motion function, or put the presser foot in the darning/free-motion position.
7. Pull up the bobbin thread and sew a few stitches to secure. Clip the thread ends close to the project and continue sewing.

TIP: Remember, when sewing with the feed dogs lowered, the stitch length is determined by you. An even, medium-to-fast sewing speed will allow you to sew a more consistent length of straight stitch. Sewing too slowly may cause small knots to appear on the reverse side of your work.

### BOBBINS

No matter if you're sewing, embroidering or experimenting with the creative™ Bobbin Case – you can never own too many Bobbins!



820779096

A C D E F G  
10-pack, blue

--	--



820921096

J  
10-pack, grey

--	--



820905096

J  
Monet bobbins 20-pack

--	--



821037096 J

Monet bobbins 20-pack version 2

--	--



821038096 K

10-pack, clear

--	--

416475801 K

--	--



821147096 L

10-pack, violet

--	--



PRE-WOUND BOBBINS

140000746 J

Box of 144, white

--	--

68008984 J

Box of 144, black

--	--

821192096 L

Pack of 10, white

--	--

821193096 L

Pack of 10, black

--	--







## ■ DECORATIVE ACCESSORIES

Do you know how much potential is hidden within a standard sewing machine? A surprising amount! With the right presser feet you can conjure up the most amazing effects, unique details, and eye-catching accents to make each project you sew uniquely yours. Be inspired by the wide variety of decorative presser feet and the possibilities they offer. Your PFAFF® dealer is a presser foot expert.

Please note the code numbers for the various PFAFF® sewing machines to instantly see which presser feet are available for your model.

## PINTUCK FOOT, 5-GROOVE



You can easily use the classic Pintuck Foot on cotton, light-weight wool or other fine fabrics. Create pintucks to add a nostalgic touch to linens, cushions, blouses or children's clothing.

1. Snap on the Pintuck Foot.
2. Insert a twin needle  
- 5-groove: 2.0 twin needle
3. Thread the twin needle (see manual for threading tips).
4. Using a water-soluble marker, draw a placement line for your first pintuck.
5. Sew your first pintuck. When you start on the second pintuck, allow the first pintuck to run parallel in a groove in the foot. This will produce evenly spaced pintucks.

820226096

B C D E F G J K L



Twin Needle  
620073896: 2 mm



## PINTUCK BLADE

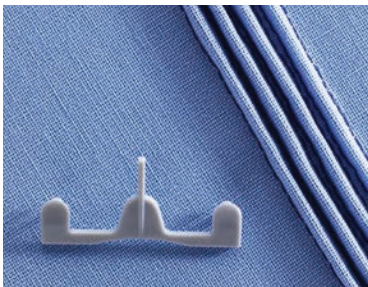

Use the Pintuck Blade to accentuate the tucks. The Pintuck Blade is attached to your machine's needle plate. The fabric is raised by the blade during sewing to make the tucks higher and more visible.

For heavier materials, use the Five-groove Pintuck Foot and the large Pintuck Blade.

1. Attach desired Pintuck Foot to machine.
2. Snap the round knob of the Pintuck Blade into the round hole on the stitch plate with the blade pointing towards the needle. Insert a 1.6 mm - 2.0 mm twin needle into the machine.
3. Draw or create lines on fabric where pintucks are desired. Position the line at the center of the presser foot. Stitch slightly slower than normal, guiding the fabric. The Pintuck Blade will raise the center of the fabric to produce defined pintucks. (Gently pull the fabric taut while sewing the pintucks.)

820678096

J K\* L

K\* except creative™ 1.5

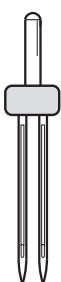
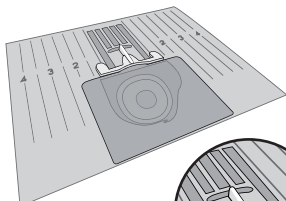

Twin Needle  
620073796: 1,6 mm



620073896: 2 mm





## CIRCULAR ATTACHMENT

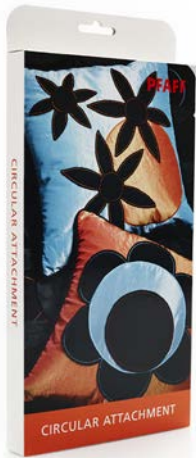

821026096  
J K L



Your Circular Attachment is the perfect tool when you want to make unique embellishments on your sewing projects, garments and quilts. You can sew simple circles, flowers, or parts of circles to create unique borders or graphic patterns. Combine circles in different sizes and create large patterns. Almost all utility or decorative stitches\* can be used when stitching with this attachment so you are free to use your favorite. The possibilities available with the Circular Attachment are as unending as the circles it creates!

\* Stitches with a default stitch width wider than 9 mm, and stitches with backward feeding cannot be used.

### In the package you will find:

- A. Circular Attachment with Size Guide
- B. Pivot Pin
- C. Three different templates: one for sewing circles (1), one for a four-petal flower (2) and one for a six-petal flower (3). The numbers on the templates correspond to the diameter of the circle (in cm)
- D. CD with User Instructions in 11 languages, a tutorial and ideas on how to combine circles using the templates.

With the Circular Attachment, you can sew circles with a diameter measuring from 6 cm up to 26 cm (2½ to 10¼"). The diameters of the circles are printed in both centimeters and inches.

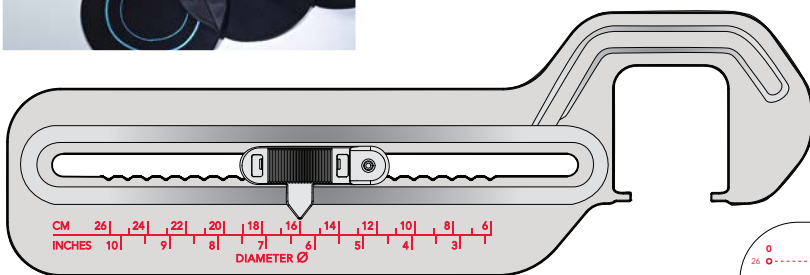

A.



B.

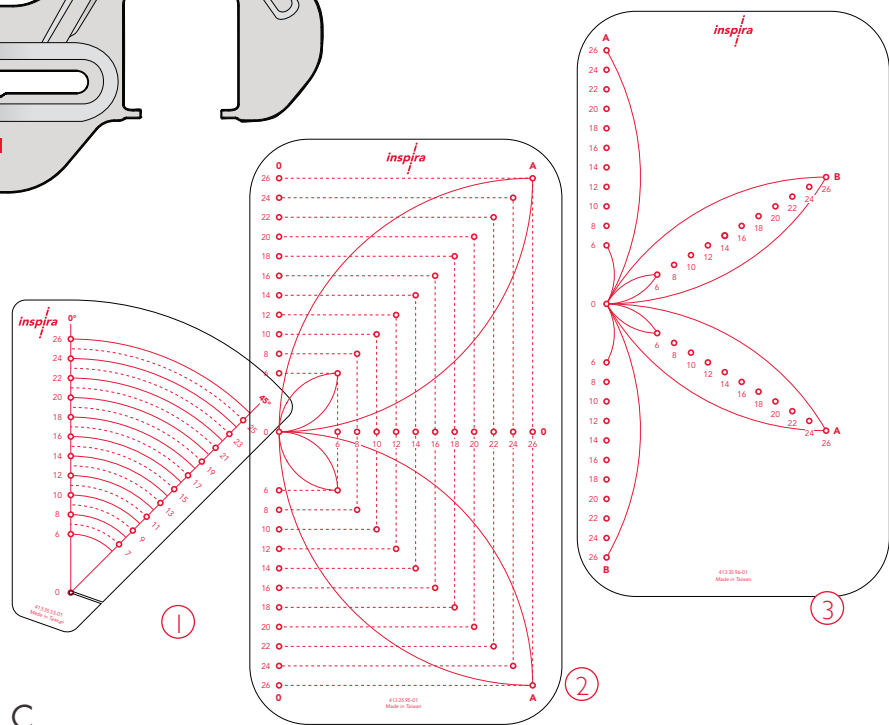

C.



## TIPS AND HINTS

### Extension/Quilter's Table

When using the Circular Attachment, we recommend using an extension/quilter's table. This will give extra support to the fabric and makes it easier to control and guide the fabric. Extension/Quilter's tables are available as extra accessories.

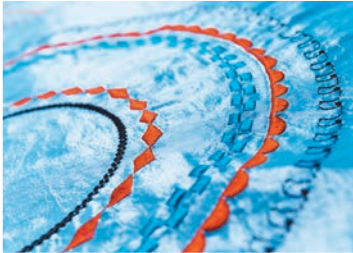

### Stitch Selection

Utility and decorative stitches give wonderful results with this attachment, however, stitches with a default stitch width wider than 9 mm, and stitches with backward feeding cannot be used.

**Tip:** The shorter the stitch, the easier it is to get a nicely joined circle. When about to close the circle, slow down the sewing speed and if necessary, adjust the stitch length to fill the gap.

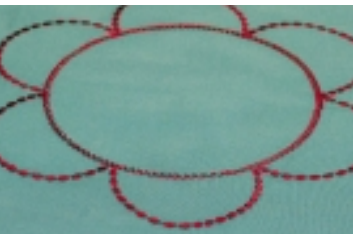

### Appliqués

You can make appliques with the circular attachment. Use fabric that does not fray or make raw edge appliques. You can also simply stitch your applique in place with a straight stitch, cut away the excess fabric, and finish by sewing a satin stitch over the raw edges. When using several layers of fabric, it is even more important to guide the fabric carefully making sure that all the layers feed together equally.

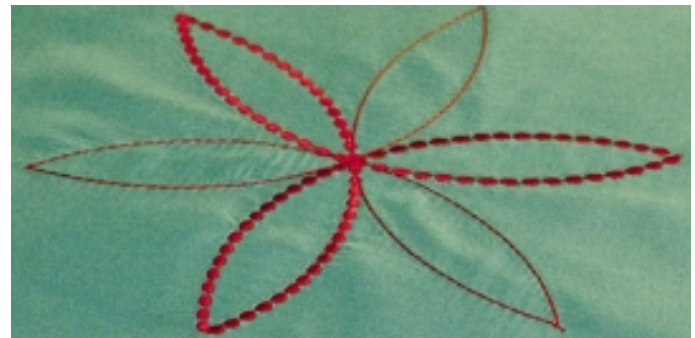
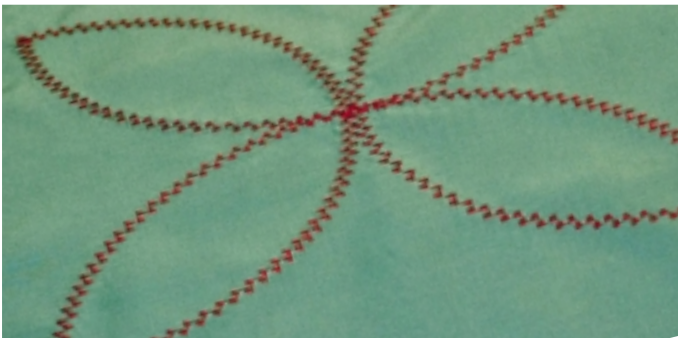

## MULTI-LINE DECORATIVE FOOT

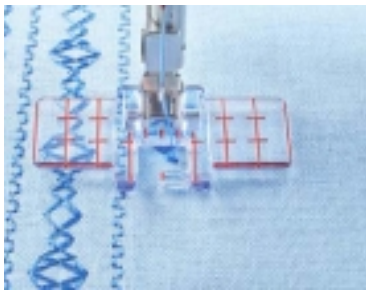

821082096

BCDEFGJKL

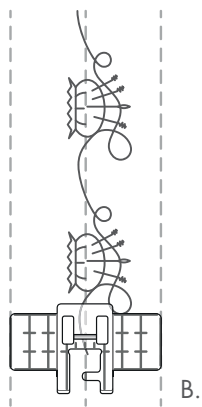
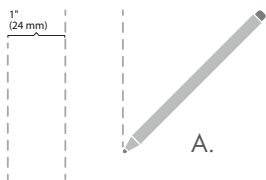

The Multi-line Decorative Foot is designed to help you create parallel rows of decorative stitches that are evenly spaced. The clear view through the foot gives greater visibility and helps to precisely align the rows of stitching. Use the vertical guidelines to evenly space your rows and the horizontal guidelines to match your starting points and accurately turn corners at  $\frac{1}{4}$ " (6mm) or  $\frac{1}{2}$ " (12mm) intervals. The Multi-line Decorative Foot can also be used as a guide when sewing Maxi stitches.

### Decorative Borders

1. Disengage the IDT™ system.
2. Snap on the Multi-line Decorative Foot.
3. Select a decorative stitch.
4. Mark a line on the fabric where the center of the stitching will be.
5. Place Tear-Away stabilizer under the fabric.
6. Place the fabric under the presser foot, aligning the red center mark on the foot with the line on your fabric.
7. Sew the first row of decorative stitching.
8. Choose another decorative stitch or continue on with the same stitch.
9. Move your fabric to the left. Decide the distance you'd like to have between the rows.
10. Use the red horizontal lines to match up the starting point of each row.
11. Sew the new line of stitching using the red vertical lines on the foot as a guide while sewing.
12. Move the fabric and sew another row of decorative stitching to the left of center.
13. Continue with more stitches as desired to create a wider border.
14. Remove the stabilizer.

### Maxi stitches:

1. Disengage the IDT™ system.
2. Snap on the Multi-line Decorative Foot.
3. Select a Maxi stitch.
4. To ensure a straight line of stitching draw a line on the fabric where the center of the stitching will be. Continue to mark one or two lines on each side of the center line. (Illustration A)
5. Place Tear-Away stabilizer under the fabric.
6. Sew carefully, letting the machine control the feeding.
7. Keep the marked lines and the vertical red lines on both sides of the presser foot parallel to each other when sewing. (Illustration B)
8. Remove the stabilizer.



## APPLIQUÉ FOOT



820214096  
B C D E F G J K L

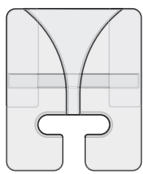

Perfect, narrow and densely satin stitched appliqués can be sewn with an Appliqué Foot. The short toes increase visibility. Use over a strand of crochet cotton to shirr a fabric or to sew a row of twin needle cording. Use the hand-look appliqué stitch to make up fanciful appliqués and create beautiful quilts.

1. Snap on the Appliqué Foot.
2. Select a zigzag stitch.
3. Decrease the stitch length to get a nice, dense satin stitch.
4. Place stabilizer underneath the appliqué area. Stitch over all edges to prevent fraying. Use “needle down” (if available on your machine) for smooth corners and curves.

## PINTUCK FOOT WITH DECORATIVE STITCH GUIDE

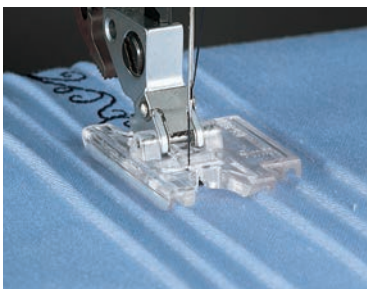

820776096  
F G J K\* L

K\* except creative™ 1.5  
9 mm



With this foot, you can accurately sew pintucks with a spacing of 5 or 11 mm. The same foot allows you to precisely space decorative stitches up to 6 mm or 9 mm wide between the pintucks.

1. Attach the Pintuck Foot with guide. The foot can be attached with the guide pointing to the left or the right.
2. Insert a twin needle.
3. Thread the two needles. Sew one row of pintucks.
4. Place the first pintuck under the groove in the extended guide. Sew a second pintuck. The second pintuck will automatically be spaced to allow a decorative stitch to be sewn in the area between pintucks.
5. Sew all remaining pintucks.

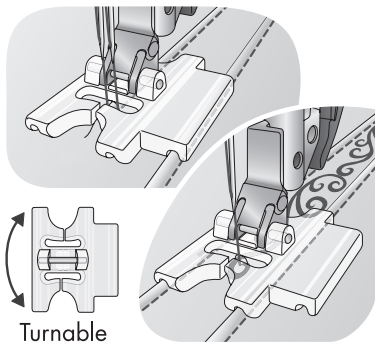

## CANDLEWICKING FOOT FOR IDT™ SYSTEM



The Candlewicking foot has a deep tunnel on the underside of the foot to feed over a built up stitch.

1. Snap on the Candlewicking foot for IDT™ system.
2. Engage the IDT™ system.
3. Select the stitch that you want to sew (either a programmed stitch, a built in stitch or a downloaded stitch.)
4. Sew.

820613096

G\* J K L

G\* except 7530, 7550, 7562,  
7570 and 2054

--	--



## CLEAR OPEN TOE FOOT FOR IDT™ SYSTEM



820916096

D E F G J K L

for IDT™ system

--	--

The Clear Open Toe Foot is perfect for appliqué and other sewing applications requiring an unobstructed view of the sewing area. An extra large opening in the front makes beautiful appliqué quick and easy. The clear view through the foot gives greater visibility and helps to precisely match rows of stitches. A tunnel on the underside of the foot allows your stitches to feed smoothly.

1. Snap on the Clear Open Toe Foot for IDT™ system.
2. Engage the IDT™ system.
3. Choose a decorative stitch or a satin stitch. Use pattern mirror if needed.
4. Guide the stitch along the inner edge of the foot to ensure even seams along the edge.
5. For best results use a marking pen to draw lines for exact guiding of the foot.
6. Sew.

## OPEN-TOE APPLIQUÉ FOOT FOR IDT™ SYSTEM



820215096

D E

6 mm, for IDT™ system

--	--

820213096

F G J K L

9 mm, for IDT™ system

--	--

Perfect for appliqué and other sewing applications requiring an unobstructed view of the sewing area. Produce beautiful appliqué quickly and easily with this foot. Use with a pin-stitch or shell-edging program to achieve an appliqué with the look of hand-sewn overcasting.

1. Cut the pieces to shape without any seam allowance or press under seam allowance of easily materials that fray easily using a template.
2. Iron paper-backed fusible web onto the design. Tear the paper backing away and iron the appliqué fabric onto the base material.
3. Attach the Open-Toe Appliqué Foot for IDT™ system (if available on your machine).
4. Select a stitch and guide the design edge along the inner edge on the right side of the foot to assure even seams along the edge. (Use pattern mirror if needed.) This also hides the straight stitch in the shadow of the seam for a hand-sewn look.



## SEWING STAR FOOT FOR IDT™ SYSTEM



820654096  
D E F G J K L  
for IDT™ system



The Sewing Star Foot is perfect when sewing wide decorative stitches. It gives your fabric the support you need, while giving an open view of the area you are stitching. The Sewing Star Foot prevents the fabric from tunneling and allows you to use the PFAFF® IDT™ system while sewing.

1. Snap on the Sewing Stars Foot w/IDT™ system.
2. Engage the IDT™ system.
3. Select a satin stitch or decorative stitch.
4. Sew as desired.
5. Be sure to use proper stabilizer for your fabric and technique.

## BEADING FOOT, 4 MM & 6 MM

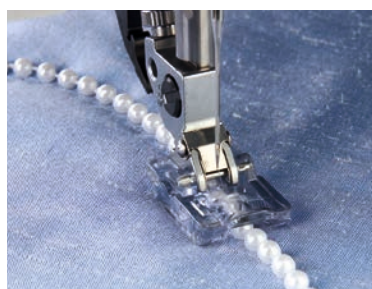

Beading Foot, 4 mm  
820604096  
C D E F G J K L

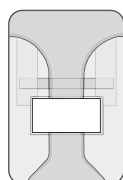

Beading Foot, 6 mm  
820605096  
C D E F G J K\* L  
K\* except SMARTER BY PFAFF™  
260c, 160s, 140s



For that extra touch, highlight any sewing project with strings of pearls or beads. The beads will run smoothly through the groove under the foot while you sew for beautiful results.

1. Snap on the Beading Foot.
2. Thread your machine with invisible thread in the needle and regular sewing thread that matches the fabric in the bobbin.
3. Select one of the following stitches depending on which is available on your machine. Adjust the settings of the stitch according to the size of the beads.
 

For 4 mm beads	Zigzag stitch	length 3.5	width 4.0
	Blindhem stitch	length 1.0	width 4.5
	Beading sitch	length 5.0	width 4.0
For 6 mm beads	Zigzag stitch	length 6.0	width 6.0
	Blindhem stitch	length 1.5	width 6.0
	Beading stitch	length 7.5	width 6.0
4. Lower the needle thread tension to achieve a beautiful stitch.
5. Place stabilizer under the fabric and position both under the foot.
6. Place the bead string under the foot in the groove on the underside of the beading foot. Lower the presser foot.
7. Turn the hand wheel to create manual stitches to set the beads in place.
8. Stitch slowly.

Note: Stitch the bead string to a scrap piece of fabric first to test thread tension, stitch length and stitch width according to the beads and the fabric. Make adjustments as needed.

creative™ BOBBIN CASE



820602096

C D E F G

--	--



820808096

J

--	--

821137096

L

--	--

Create beautiful bobbin work, also called reverse decorative stitch embroidery, with the creative™ Bobbin Case. Depending on the type of decorative thread you are using for your projects, there are different ways of working with the PFAFF® creative™ Bobbin Case.

**For heavy or specialty threads:**

Wind the bobbin with the decorative thread slowly.

Place the bobbin in the PFAFF® creative™ Bobbin Case. For less texture, use finer specialty threads and adjust the bobbin tension screw, if needed, so the thread pulls evenly and has a slight tension. Put the bobbin in the creative™ Bobbin Case and pull the specialty thread into the bobbin tension.

**For heavier yarns and textured specialty threads:**

Wind the bobbin evenly clock-wise by hand. Put the bobbin in the Bobbin Case. For the most textured bobbin work, do not pull the heavy thread or yarn into the bobbin tension, but go directly into the bypass slot. To bring up the bobbin thread, hold the needle thread, and turn the handwheel towards you.

1. Thread the top with regular sewing thread.
2. Use the recommended size needle for your fabric.
3. Snap on the presser foot 2/2A or 8.
4. Place the right side of the fabric facing down and place Tear Away Stabilizer on top.
5. Select stitches where the density is loose. Experiment with the straight stitch, zigzag and decorative stitches. Increase the stitch length for best results.
6. Select slow speed and stitch at an even speed.
7. Increase needle thread tension slightly if needed.



## CHENILLE FOOT FOR IDT™ SYSTEM

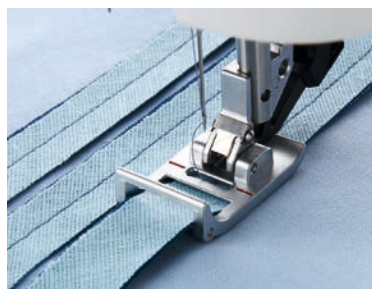

820615096  
 B C D E F G J K L  
 for IDT™ system



The automatic needle threader cannot be used on Group L machines.

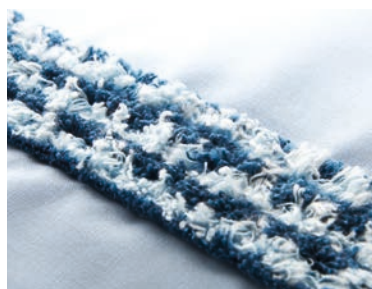

Embellish your project with chenille effects by using the Chenille Foot. This foot will easily guide and stitch layers of chenille strips wherever you want a chenille effect.

1. Thread your machine with regular sewing thread on top and in the bobbin.
2. Select a straight stitch or a zigzag stitch. Use a short stitch length and a narrow stitch width. Another suggestion is three-step zigzag, stitch width set to 1.5.
3. Place the strips in the presser foot as the pictures show. Use three layers of the chenille strips to create a beautiful effect!
4. Snap on the Chenille Foot.
5. Engage IDT™ system.
6. Sew carefully. The Chenille Foot will guide the chenille strips onto the fabric where you want to have the chenille effect with the stitch forming in the middle of the strips. (You might need stabilizer underneath the fabric.)
7. Add more rows of chenille strips in the same way, to complete your project.
8. Rub the strips with a stiff brush to fray.





## GRAND PIPING FOOT FOR IDT™ SYSTEM



820977096

G J K\* L

for IDT™ system

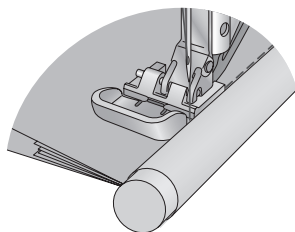
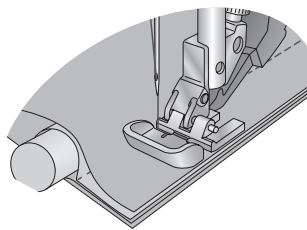
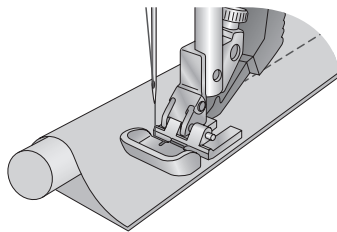
K\* except SMARTER BY PFAFF™  
260c, 160s, 140s

The Grand Piping Foot is perfect for inserting thick home dec piping into seams or wherever you'd like to add a finishing touch! The Grand Piping Foot is used to cover large cords with fabric for specialty piping and insert the piping into seams or edges for a tailored finish. The trim is sewn between the two layers of fabric in one step. You can also create your own piping for a custom finish. This foot can be snapped on to the right or the left of the needle which makes it possible to both create and sew the piping into the seam and to beautifully topstitch along the piping.

**To make piping from your fabric:**

1. Snap on the Grand Piping Foot to the right side of the needle.
2. Engage the IDT™ system.
3. Cut fabric strips on the bias or crosswise grain, wide enough to cover the cording plus seam allowances.
4. Lay the cording on the wrong side of the fabric strip and wrap the fabric over the cord.
5. Place the fabric and cord under the Grand Piping Foot with the cord to the left of the foot.
6. Select a straight stitch, 2.5 mm stitch length. Move the needle position to the left. Sew.
7. Use your new piping in projects following the steps above.

**TIP:** When you sew this piping into a project, adjust the needle position so it stitches one setting closer to the cord, to hide the first stitching.

**To stitch piping into a seam:**

1. Snap on the Grand Piping Foot to the right side of the needle.
2. Engage the IDT™ system.
3. Select a straight stitch, length 2.5.
4. Place the piping on the right side of fabric, matching raw edges. Position under the foot with the piping to the left of the foot.
5. Add a second piece of fabric on top so right sides are together and piping sandwiched between the layers.
6. Position under the Grand Piping Foot with the piping to the left of the foot.
7. Sew.

**Tip:** Clip the seam allowance around curves and at corners to reduce bulk and allow the seams to lay flat.

**Topstitching:**

1. Snap the Grand Piping Foot to the left side of the needle.
2. Engage the IDT™ system.
3. Open the seam and fold so the piping is along the fabric edge. Press.
4. Sew a row of topstitching to the left of the seam line.

## PIPING FOOT



820532096  
A B C D E F G J K L

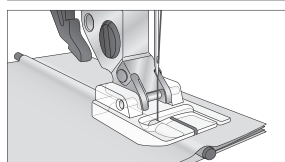
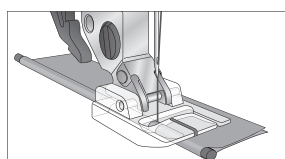
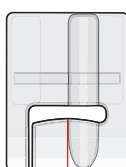

Insert packaged piping into seams and edges for a tailored finish. Cover cord with fabric for specialty piping.

### To stitch piping into a seam:

1. Snap on the Piping Foot.
2. Place piping along the seam line on right side of fabric. Place second piece of fabric on top with right sides together.
3. Put fabric and piping layers under Piping Foot with the piping in the groove on the underside of the foot. Sew with a straight stitch, length 2.5. The groove on the underside of the foot will guide the piping as you sew.

### To make piping from your fabric:

1. Cut bias or crosswise grain strips, wide enough to cover the cording plus seam allowances.
2. Lay the cording on the wrong side of the fabric strip and wrap the fabric over the cord.
3. Place the fabric and cord under the Piping Foot with the cord in the groove on the underside of the foot.
4. Stitch. The groove will guide the cord so the fabric covers evenly.

**TIP:** When you sew this piping into a garment, adjust the needle position so it stitches one setting closer to the cord to cover the first stitching.



## NARROW PIPING FOOT



820918096

A B C D E F G J K L



The Narrow Piping Foot is used to make trim for home dec projects, fashion projects or wherever you'd like to add a finishing touch! It is used to cover 1 mm cords with fabric for specialty piping and insert the piping into seams or edges for a tailored finish. It can also be used with packaged piping. The clear view allows you to see the piping placement and know exactly where you are stitching.

**To stitch piping into a seam:**

1. Snap on the Narrow Piping Foot.
2. Place the piping with the raw edges along the seam line on the right side of fabric. Place second piece of fabric on top with right sides together.
3. Put fabric and piping layers under Piping Foot with the piping in the groove on the underside of the foot.
4. Select a straight stitch, length 2.5. Sew. The groove on the underside of the foot will guide the piping as you sew.

**To make piping from your fabric:**

1. Snap on the Narrow Piping Foot.
2. Cut bias or crosswise grain strips, wide enough to cover the cording plus seam allowances.
3. Lay the cording on the wrong side of the fabric strip and wrap the fabric over the cord.
4. Place the fabric and cord under the Narrow Piping Foot with the cord in the groove on the underside of the foot.
5. Sew using a straight stitch, 2.5 mm stitch length. The groove will guide the cord so the fabric covers it evenly.
6. Use your new piping in projects following the steps above.

**TIP:** When you sew this piping into a project, adjust the needle position so it stitches one setting closer to the cord, to hide the first stitching.





## WELTING FOOT



820530096

A B C D E F G J K\* L

K\* except SMARTER BY PFAFF™  
260c, 160s, 140s

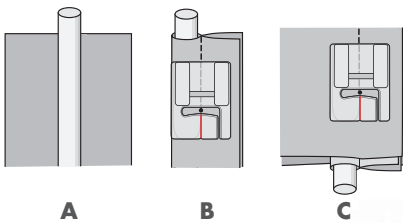
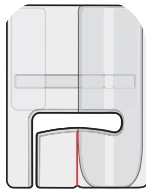

The Welting Foot and the Twin Welting Foot are used to make trim for your home dec projects like pillows, cushions and other home accessories. You can also make trim to cover raw edges on your upholstery, which you can then attach with a staple gun. It's quick and easy to make and insert welt cording. The Welting Foot works the same way as the Piping Foot but is designed for larger sizes of cording. Create your own trim when the color you want isn't available!

1. Cut a bias strip long enough for your cord and wide enough to cover the cord plus seam allowance.
2. Place the cord on the wrong side of the bias fabric strip and wrap it around the cord. (ill. A)
3. Place the fabric and cord under the groove of the foot, and the raw edges to the right. (ill. B)
4. Select center needle straight stitch and stitch length 3.
5. Stitch to cover the cording with the fabric.
6. Trim the seam allowance.
7. To stitch covered welt cord into a seam on your sewing project, place the covered welt cord on the right side of the fabric along the seam line. Place it under the Welting Foot with the welt cord in the groove of the foot. Stitch the welt cord to the fabric. Clip the seam allowance of the welt cord at curves and corners. (ill. C)

*Perfect trims in the colors and materials of your choice – this is a job for the Welting Foot from PFAFF®. The must-have for stylish home decorating.*



## TWIN WELTING FOOT



820531096

A B C D E F G J K\* L

K\* except SMARTER BY PFAFF™  
260c, 160s, 140s



1. Make bias strips long enough to cover the cords and wide enough to wrap around the two cords plus seam allowance.
2. Place the cords on the wrong sides of the bias strip – side to side - and wrap the fabric around the cords. (ill. A)
3. Place the fabric and cord under the presser foot with the right cord under the left groove of the foot, and the raw edges to the right. (ill. B)
4. Adjust to center needle position – straight stitch and stitch length 3.
5. Keep the cords against the fold as you sew.
6. Trim the fabric close to the seam and press seam allowance to the left.
7. Wrap the excess fabric to the center back of the cord.
8. Put the covered cord under the two grooves of the presser foot and sew it onto your sewing project. (ill. C)

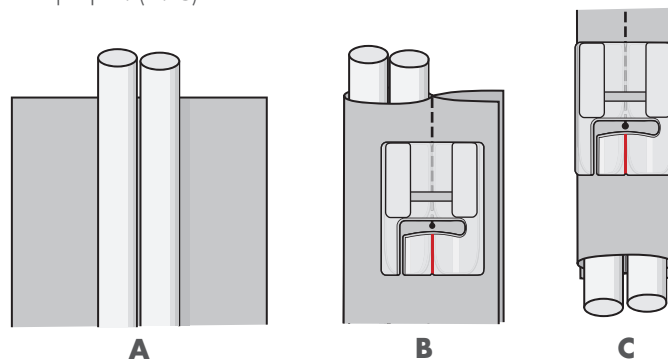

## DECORATIVE TRIM FOOT FOR IDT™ SYSTEM



820614096

B C D E F G J K\* L

K\* except SMARTER BY PFAFF™  
260c, 160s, 140s



The automatic needle threader cannot be used on Group L machines.

Embellish your project with different types of trims by using the Decorative trim Foot. This foot will easily guide the trims through the opening at the front and through the groove under the presser foot.

1. Thread your machine with a regular sewing thread or decorative thread on top and regular sewing thread in the bobbin.
2. Select a straight stitch, zigzag stitch or decorative stitch. Avoid using stitches with side motion and stitches with too much motion forward and back.  
Tip: For the 6 mm wide trims, you can also use a 6 mm twin needle. Select a straight stitch and it will sew at the edges of the trim.
3. Place the trim in the presser foot as the picture shows.
4. Snap on the Decorative Trim Foot.
5. Engage IDT™ system.
6. Sew carefully, not too fast. If your machine has the sew slow function, engage it. (You might need stabilizer underneath the fabric)
7. The best result is achieved if you use flat trims, such as silk, velvet, satin or cotton ribbons.

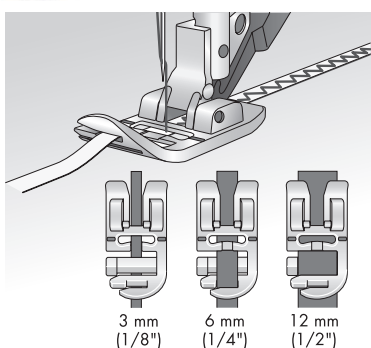

## 7/9 HOLE CORD FOOT FOR IDT™ SYSTEM

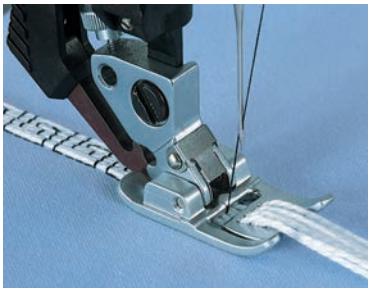

820608096  
B C D E F G J K\* L

for IDT™ system

K\* except SMARTER BY PFAFF™  
260c, 160s, 140s

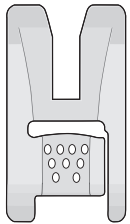

Wonderful decorative embellishments are easy with this special foot. You can sew up to nine different lengths of embroidery floss, pearl cotton or high sheen threads in place with your choice of a decorative or utility stitch.

1. Cut your cords to the desired length. Thread the cords through the holes in the foot from the top to the bottom. Lead the cords under the presser foot and out the back. Leave the thread tails extending about 1 1/2 inches to 2 inches (4 - 5 cm) at the back.
2. Attach the 7/9 Hole Cord Foot.
3. Choose a decorative stitch to sew over the 7 or 9 cords.

TIP: Pearl thread or embroidery twist works well.

## RUFFLER



820885096

J K L



With the ruffler, you can make closely or widely spaced pleats automatically while sewing. This is very useful for ruffles, frills, home decor, etc. The ruffler can be used in three different ways:

1. Folding and securing pleats in fabric.
2. Folding pleats in fabric and securing to a second fabric in one operation.
3. Folding pleats in fabric, attaching lace and securing to another fabric in one operation.

Complete instructions on how to use your ruffler are included when you purchase it from your PFAFF® dealer.



The automatic needle threader cannot be used on Group L machines.

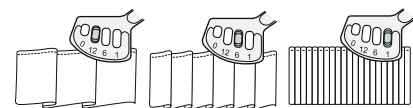
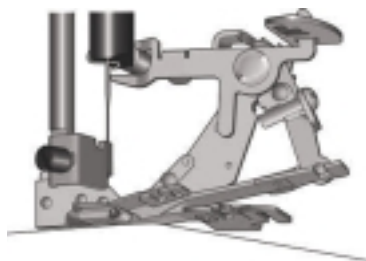
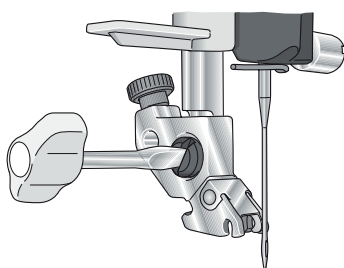





## THREE HOLE YARN FOOT FOR IDT™ SYSTEM



820920096

F G J L

for IDT™ system

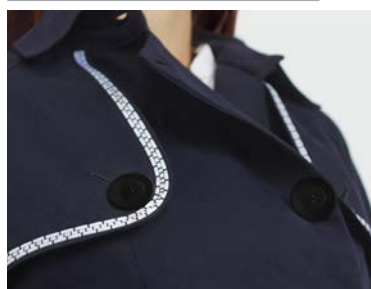

Embellish your project with different types of decorative cords or yarn using beautiful PFAFF® 9 mm stitches and the Three Hole Yarn Foot. This foot will easily guide the cords or yarn through the openings in the front of the foot back through the groove under the presser foot. The decorative cords or yarn will be stitched over creating a beautiful braid embellishment.

1. Thread your machine with a regular sewing thread or decorative thread on top and regular sewing thread in the bobbin.
2. Select a 9 mm decorative stitch.

Note: Decorative stitches that use forward motion work best (Avoid stitches with too much backward motion.)

3. Thread decorative cords or yarn into the holes from the top of the foot, using the Yarn Threader, prior to attaching the foot onto the sewing machine.
4. Make sure the cords or yarn slide easily through the openings. (If the yarn is too thick it will create too much tension and the feeding might be affected.)
5. Snap on the Three Hole Yarn Foot.
6. Engage IDT™ system.
7. Place the threaded cords or yarn under the presser foot with a 5 cm (2") tail.
8. Place a tear away stabilizer underneath the fabric and place your fabric under the presser foot.
9. Sew carefully, not too fast. If your machine has a speed control reduce the sewing speed to easily guide the fabric and yarn as you sew.

## GATHERING FOOT



Metal Foot

820668096

B C D E F G J K L



Gathering is a classic decorative technique. It's easy with this, special foot, which is especially useful for sewing flounces on cushions and curtains or for attaching gathered seams on children's clothing. You can simultaneously stitch and gather two layers of fabric quickly and easily.

1. Set the machine for straight stitch with the needle in far left position.
2. Place fabric to be gathered under the presser foot with cut edge extending slightly to the right of the presser foot. Insert non-gathering fabric fully into slot of foot. Fabrics should be right sides together.
3. Guide fabric, allowing machine to pull bottom fabric freely for uniform gathering.

TIP: Altering stitch length will alter fullness of gathers. A single layer of fabric may also be gathered by placing under foot and adjusting stitch length and tension to desired fullness.



The automatic needle threader cannot be used on Group L machines.

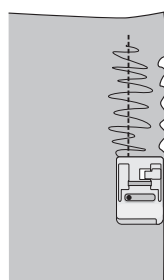
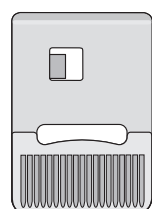

## YARN COUCHING FOOT SET



820912096

J L

except *expression*™ 3.5, 3.2, 3.0,  
2.0, *expression*™ 150



With the PFAFF® Yarn Couching Feet set you can easily create decorative yarn embellishments both when sewing free-motion and embroidering. Two different feet will suit a variety of yarn. A detailed instruction is included with the product.

1. Thread the machine with thread that matches the yarn.
2. Attach the proper yarn guides for your machine to the notches under the handle on the rear side of the machine.
3. Pull out as much yarn as you need from the ball of yarn.
4. Place the yarn in the yarn guides. It is very important that the yarn flows smoothly while you are sewing.
5. Choose Yarn Couching Foot 1 or 2, depending on the size of the yarn. For best result the yarn should fill the hole in the foot and still run easily through it. We recommend using yarn with even thickness.
6. Thread the yarn from above through the hole in the foot using the yarn threader.
7. Snap on the foot to the machine.



## COUCHING/BRAIDING FOOT FOR IDT™ SYSTEM



You can create beautiful trims when you use the Couching/Braiding Foot and your machine's decorative stitches to sew over yarn, cords, narrow satin ribbon, soutache braid, etc.

1. To attach cords, use matching, invisible or decorative embroidery thread.
2. Insert the cording or tape from the front of the foot into the eyelet-type guide and pull it through the front hole, underneath and to the back of the sewing foot.
3. Engage the IDT™ system (if available on your machine).
4. Select stitch, i.e. zigzag, blind hem or decorative. Sew the design by following the premarked design lines. Or, sew random lines and waves for a decorative textured effect.

820607096  
B C D E F G J K L  
for IDT™ system

--	--



The automatic needle threader cannot be used on Group L machines.

TIP: Try several smaller cords and yarns, twist them together to create texture and combine colors.

## FANCY STITCH FOOT FOR IDT™ SYSTEM



Create beautiful embellishments with the Fancy Stitch Foot. This foot has easily visible markings to help you position decorative stitches or borders on your fabric. A special groove on the bottom allows optimal feed of even the most densely stitched patterns.

820253096 

--	--

  
D E  
for IDT™ system

820774096 

--	--

  
G J K L  
for IDT™ system

## creative™ SPOOL STAND



creative™ Spool Stand is an accessory to make it easier to use large spools of decorative thread. The stand is mounted on the top of the sewing machine and includes the actual thread stand, a thread guide and a thread net.

820612096  
C D E F G J  

--	--

*This cushion showcases an explosion of ideas. It was made using the Couching/Braiding Foot from PFAFF®, the Fringe Foot for whimsical fringe effects and also sophisticated decorative stitches, embroidered with the twin needle. Give it a try!*











## ■ ■ ■ QUILTING

Quilting is a passion, as millions of enthusiastic quilters around the world prove. But why is it more fun to quilt with a PFAFF® machine? Maybe it's the intelligent technology of our machines, or the wide range of accessories that go with them, ensuring that every quilt, made by hand, becomes an object of breathtaking beauty and high quality.

For more information, check our web site regularly at [www.pfaff.com](http://www.pfaff.com) or visit your nearest authorized PFAFF® dealer.



## ■ ACCESSORIES

Quilts, cushions, wallhangings – their charm lies in the hand-made appeal. But more and more passionate quilters are discovering the advantages of machine quilting... and for many good reasons. Machine quilting is faster and offers more decorative possibilities. The right presser foot can simplify tricky quilting jobs and guarantee perfect results. At PFAFF® you'll find accessories designed especially to fit the needs of quilters.

Please note the code numbers for the various PFAFF® sewing machines to instantly see which presser feet are available for your model.

## PERFECT FOR EVERY QUILTER: THE QUILTER'S TOOLBOX

The QUILTER'S TOOLBOX is packed with everything you need to sew a beautiful quilt! The 1/4 inch Quilting Foot and the Straight Stitch Plate make it all so easy and professional! Attach the Extension Table for an extra large working area! For fun and decorative free-motion quilting, use the Free-motion Guide Grip and the Free-motion Quilting Foot!

See how much fun quilting can be with the PFAFF® QUILTER'S TOOLBOX!

### Including:

- Quilting Extension Table
- 1/4 inch Quilting Foot
- Straight Stitch Needle Plate
- Special Quilting Needles
- Free-motion Quilt Foot
- Free-motion Guide Grip



820840096  
J

## CREATIVE™ FABRIC FRAME



This unique compact fabric management system allows you to quilt any size of quilt up to a king size or embellish fabric easily using its fabric hoop system. Measuring less than 5 feet x 4 feet this easy to use frame fits easily into customers homes and can be used either sitting or standing. The *creative™* Fabric Frame comes with a large easy to move carriage, cloth leaders and other accessories and is perfect for use with machines such as the *creative performance icon™*.

821177096

JL

## CREATIVE™ FABRIC FRAME STITCH REGULATOR



When used with the *creative™* Fabric Frame, the *creative™* Fabric Frame Stitch Regulator can be used in two ways giving the customer full control over their machine and stitches. Use it in stitch regulation mode for consistent even stitches or switch to constant speed mode and use it to adjust the speed of the sewing machine with a simple push of a button.

821178096

JL

## CREATIVE™ FABRIC FRAME LIGHT



This lighting station is the perfect way to illuminate the *creative™* Fabric Frame with true-color LED lights. The *creative™* Fabric Frame Light is also great for use over a cutting or sewing table making it a truly universal product.



821179096  
US and Canada only



## PERFECT 1/4" FOOT WITH GUIDE FOR IDT™ SYSTEM



821063096  
B C D E G J K L  
for IDT™ system

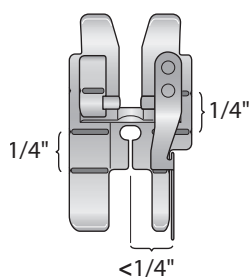
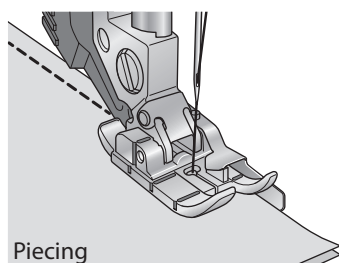
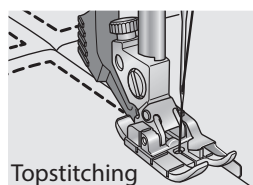

### Piecing:

The Perfect 1/4" Foot is designed to help you achieve a 1/4" (6mm) or scant 1/4" (< 6mm) seam when piecing. The needle hole in the foot is oval shaped allowing you to adjust the needle position. The distance between the center needle position and the guide is less than 1/4" (6mm).

1. Snap-on the Perfect 1/4" Foot. \*
2. Engage the IDT.
3. Select a straight stitch.
  - a. For a 1/4" (6mm) seam; adjust the needle position one or two steps to the left.
  - b. For a scant 1/4" seam; select a centered needle position or one step to the right.
4. Place the fabric pieces right sides together under the presser foot, aligning the edges of the fabric with the guide on the foot.
5. Sew the fabric pieces together guiding the fabric so that the edges touch the guide.
6. Press the seam allowance and measure the block.

Note: Depending on the weight of your fabric and thread it may be necessary to adjust the needle position to achieve your desired seam allowance. Move the needle to the right to decrease the seam allowance and to the left to increase it. You can safely move the needle three steps in either direction but not more.

\* Do not use the Straight stitch plate when using the Perfect 1/4" Foot.

### Topstitching:

The Perfect 1/4" Foot is also wonderful for topstitching. Adjust the needle position and use the guide to place your stitching exactly where you want it on your blocks, garments or home decor projects.

1. Snap-on the Perfect 1/4" Foot.
2. Engage the IDT.
3. Select a straight stitch, triple straight stitch or the mock hand quilting stitch. Adjust the needle position as desired if needed.
4. Place the project under the presser foot so that the guide on the foot runs in the ditch of the seam or along the edge of the fabric. Sew.

Note: Red markings on the Perfect 1/4" Foot help you align the fabric when you start sewing, at corners and at the end of your fabric.

For all machines with manual presser foot lifters: When using any of the optional quilt feet with guides and sewing with the needle set to stop in the down position, it is recommended that the presser foot be lifted only as high as necessary for pivoting. Lifting the foot to the extra high position can cause the needle holder to touch the guide on the presser foot. The foot could become dislodged, causing damage to the needle and or the foot.

## 1/4 INCH QUILTING FOOT FOR IDT™ SYSTEM



820926096

DEGJKL  
for IDT™ system

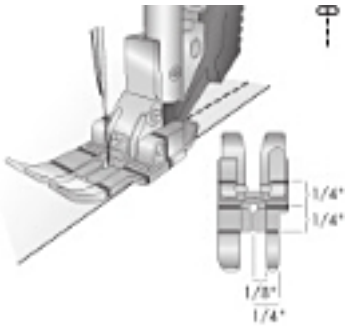

A quilt consists of two layers of fabric with a layer of batting sandwiched between them. Many pieces of fabric can be joined together in continually changing patterns to form the top layer of the quilt. The 1/4 inch Quilting Foot is particularly suitable for joining these pieces of fabric. The clearance between the needle and the outer edge of the foot is 1/4 inch (6.3 mm) and between the needle and the inner edge of the foot 1/8 inch (3.15 mm).

1. Attach the 1/4 inch Quilting Foot.
2. Engage the IDT™ system, if available on your machine.
3. Sew fabric together using straight stitch.
4. When using 1/4 inch seam allowance, guide fabric along outer edge of foot. When using a 1/8 inch seam allowance, guide fabric along inner edge of foot.

## CLEAR 1/4 INCH QUILTING FOOT FOR IDT™ SYSTEM



820883096

DEGJKL  
for IDT™ system

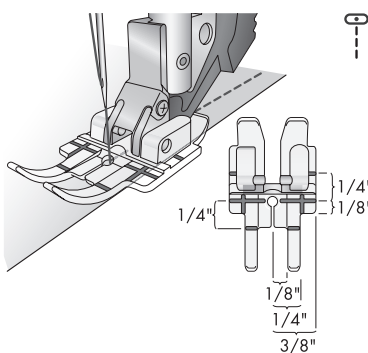

The Clear 1/4 inch Quilting Foot is great for joining pieces of fabric as it gives clear visibility when sewing 1/4, 1/8 and 3/8 inch seams. The red lines on the presser foot mark 1/4 inch pivot points in front of and behind the needle.

1. Place two pieces of fabric right sides together.
2. Select straight stitch, stitch length 2.5.
3. Engage IDT™ system.
4. Place the fabric under the presser foot.
5. When using 1/8 inch seam allowance, guide the fabric along the inner edge of the toe. When using 1/4 inch seam allowance, guide the fabric along the outer edge of the toe. When using 3/8 inch seam allowance, guide the fabric along the outer edge of the foot.
6. To pivot 1/4 inch from the end of the fabric, stop sewing when the fabric edge reaches the first red mark on the foot.

## 1/4 INCH RIGHT GUIDE FOOT FOR IDT™ SYSTEM

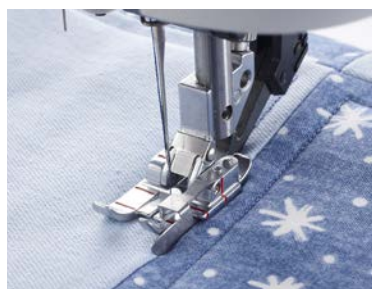

820924096  
B C D E F G J K  
for IDT™ system

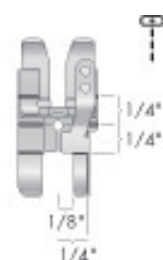

The 1/4 inch Right Guide Foot is designed to help you achieve perfect 1/4 inch seams when piecing. Simply keep the fabric edge next to the guide. The distance between the needle and the right guide is 1/4 inch. The 1/4 inch Right Guide Foot also gives a perfect 1/4 inch topstitch distance from the edge of a block when stitching the blocks, batting and backing together.

### Piecing:

1. Snap on the 1/4 inch Right Guide Foot.
2. Engage the IDT™ system.
3. Select a straight stitch.
4. Place the fabric right sides together under the presser foot with the guide at the edge of the fabric.
5. Sew the blocks together, guiding the edges so that it touches the right guide.

### Topstitching:

1. Snap on the 1/4 inch Right Guide Foot.
2. Engage the IDT™ system.
3. Select a straight stitch, triple straight stitch or the hand-look straight stitch quilting stitch.
4. Place the quilt under the presser foot with the flange guide in the seam ditch or at the edge of the fabric block.
5. Sew around the block and you will get a perfect 1/4 inch distance from every block edge.

Note: With any of the 1/4 inch Right Guide feet for IDT™ system attached to machines with manual presser foot lift we recommend not to lift the presser foot to the extra high position. This can cause the needle holder to touch the guide on the presser feet.

With the needle set to down position we recommend just to lift the presser foot as much as needed for pivoting so that the fabric can be turned freely.

## CLEAR 1/4 INCH RIGHT GUIDE FOOT FOR IDT™ SYSTEM

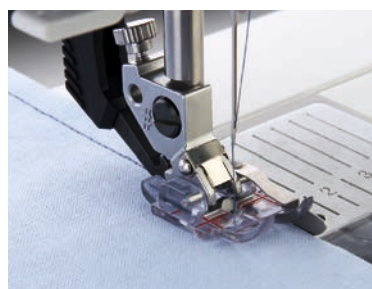

820881096  
D E G J K L  
for IDT™ system

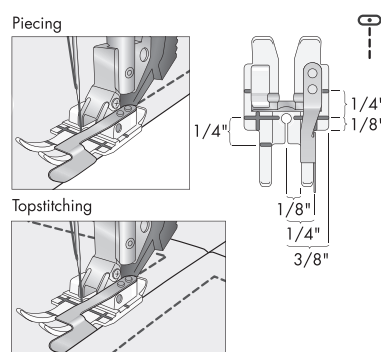

The Clear 1/4 inch Right Guide Foot is designed to help you achieve perfect 1/4 inch pieced seams. Simply guide the fabric edge next to the guide. The clear foot gives great visibility to view when sewing. The distance between the needle and the right guide is 1/4 inch.

### Piecing:

1. Snap on the Clear 1/4 inch Right Guide Foot.
2. Engage the IDT™ system.
3. Select a straight stitch.
4. Place the fabric right sides together under the presser foot with the guide at the edge of the fabric.
5. Sew the blocks together guiding the edges so that it touches the right guide.

### Topstitching:

The Clear Right 1/4 inch Guide Foot also gives a perfect 1/4 inch topstitch distance from the edge of a block when quilting, on your garments or home décor projects.

Refer to instruction for the 1/4 inch Right Guide Foot.

Note: With any of the 1/4 inch Right Guide feet for IDT™ system attached to machines with manual presser foot lift we recommend not to lift the presser foot to the extra high position. This can cause the needle holder to touch the guide on the presser feet.

With the needle set to down position we recommend just to lift the presser foot as much as needed for pivoting so that the fabric can be turned freely.



## STITCH-IN-DITCH FOOT FOR IDT™ SYSTEM

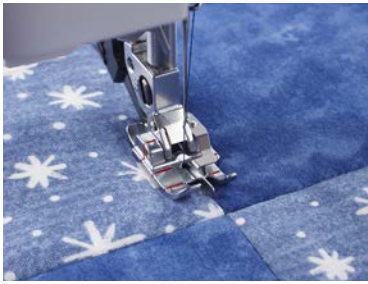

820925096  
B C D E F G J K L  
for IDT™ system

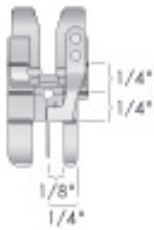

The Stitch-in-Ditch Foot is designed to help you achieve perfect quilting on the top of your quilt. The guide rides smoothly over the seam for perfect stitching “in the ditch”.

1. Attach the Stitch-in-Ditch Foot.
2. Engage the IDT™ system.
3. Select a straight stitch (or another stitch that has a centered needle position like the reinforced straight stitch or the straight stitch hand look quilt stitch).
4. Place the quilt under the presser foot with the guide in the seam (ditch) of the pieced quilt patches.
5. The guide of the presser foot will follow exactly in the center of the pieced seams so you can quilt perfectly.

Note: With any of the Stitch-in-Ditch feet for IDT™ system attached to machines with manual presser foot lift we recommend not to lift the presser foot to the extra high position.

This can cause the needle holder to touch the guide on the presser feet.

With the needle set to down position we recommend just to lift the presser foot as much as needed for pivoting so that the fabric can be turned freely.

## CLEAR STITCH-IN-DITCH FOOT FOR IDT™ SYSTEM



821143096  
D E G J K L  
for IDT™ system

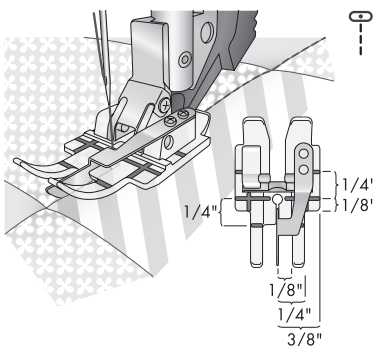

The Clear Stitch-in-Ditch Foot gives excellent visibility and is designed to help you achieve perfect quilting on the top of your quilt. The guide rides smoothly over the seam for perfect stitching “in the ditch”.

1. Attach the Clear Stitch-in-Ditch Foot.
2. Engage the IDT™ system.
3. Select a straight stitch (or another stitch that has a centered needle position like the reinforced straight stitch or the straight stitch hand look quilt stitch).
4. Place the quilt under the presser foot with the guide in the seam (ditch) of the pieced quilt patches.
5. The guide of the presser foot will follow exactly in the center of the pieced seams so you can quilt perfectly.

Note: With any of the Stitch-in-Ditch feet for IDT™ system attached to machines with manual presser foot lift we recommend not to lift the presser foot to the extra high position.

This can cause the needle holder to touch the guide on the presser feet.

With the needle set to down position we recommend just to lift the presser foot as much as needed for pivoting so that the fabric can be turned freely.

## OPEN-TOE FREE-MOTION SPRING



821141096

J L

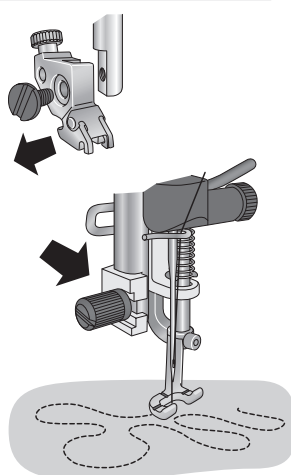

The Open-Toe Free-Motion Spring Foot is excellent for free-motion sewing and quilting. This foot is open in the front for optimum visibility while stitching. The spring action keeps the fabric from lifting with the needle as the stitch is being formed. The fabric is guided manually when free motion sewing or quilting.

1. Disengage the IDT™ system.
2. Loosen the presser foot holder screw completely and remove the holder.
3. Place the Open-Toe Free-Motion Spring Foot around the presser bar and attach it with the screw included in the package. Make sure the metal arm on the foot is placed above the needle clamp.

Hint: Lower the needle a little bit to make it easier to place the guide on the foot in the right position above the needle clamp.

4. Thread your machine.
5. Select a straight stitch or a zigzag stitch (maximum stitch width 5.0).
6. Set your PFAFF® sewing machine to spring foot free-motion setting/ Free-motion position. The feed dogs will drop automatically on some machines. With other machines you need to lower the feed dogs manually. ( Refer to you owner´ s manual).

Note: When the feed dogs are dropped, the fabric is no longer fed by the machine. You must move the fabric.

7. Maintain a consistent speed and move the fabric in a smooth motion. You are creating the length of the stitch as you move the fabric. The red markings on the foot can be used as a guide when stippling or following a design.

## OPEN TOE FREE-MOTION FOOT

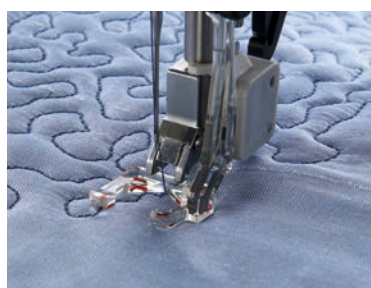

820544096

C D E F G



821140096

J L

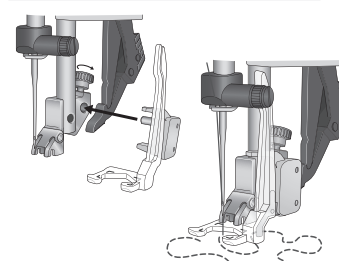

The Open Toe Free-motion Foot is for wonderful free-motion sewing and quilting. This foot has an extra-large opening cut out in the front to give you an optimal view of your free-motion sewing and quilting.

1. Disengage the IDT™ system.
2. Carefully loosen the small silver screw on the back of the presser foot holder until the crosshole is accessible.
3. Squeeze the presser foot gently together and guide the pin of the foot into the crosshole of the presser foot holder as far as it will go. Make sure the clear arm is above the needle clamp.
4. Tighten the silver screw.
5. Lower the Open Toe Free-motion Foot into the free-motion/darning position by either selecting the free-motion icon on the touch screen of your machine or manually setting the presser foot lifter in the free-motion position.
6. Lower the feed dogs.
7. Select a straight stitch or a zigzag stitch.
8. Keeping an even speed, manually move your fabric.

Remember, because the feed dogs are lowered, you must move the fabric manually. For even stitches, move your fabric in a smooth, even motion.

## OPEN TOE FREE-MOTION FOOT



820988096  
K

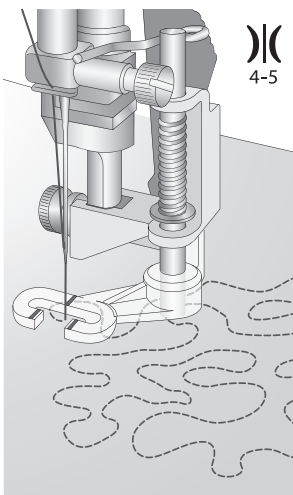

The Open Toe Free-Motion Foot is excellent for wonderful freemotion sewing and quilting. This foot has an extra-large opening cut out in the front to give you an optimal view of your freemotion sewing and quilting. The Open Toe Sensormatic Free-motion foot is used for stippling and free-motion embroidery. The foot allows for greater visibility as the opening in front of the foot gives you an optimal view of your free-motion sewing and quilting. The open front and transparency of the foot with both vertical and horizontal markings, allows you to easily do stippling or follow a design on the fabric.

1. Disengage the IDT™ system.
2. Remove the presser foot holder, and attach the Open Toe Free-Motion Foot to the presser foot holder bar. The pin should be on the needle clamp screw.
3. Press the Open Toe Free- Motion Foot on firmly from behind with your index finder and tighten the screw.
4. Lower the feed dogs.
5. Select a straight stitch.
6. Keeping an even speed, manually move your fabric.

Remember, because the feed dogs are lowered, you must move the fabric manually. For even stitches, move your fabric in a smooth, even motion.

## EDGE GUIDE/QUILTING GUIDE



820251096  
A\* B C D E F G J K L  
A\* except Varimatic 6085, 6086  
and 6087



The guide is especially useful for stitching straight lines when quilting. Use the straight stitch or decorative stitch of your choice for wonderful quilted effects.

1. Loosen the screw at the back of the presser foot ankle just enough to insert the guide in the hole. Secure the guide by tightening the screw.
2. Sew a seam with a stitch of your choice.
3. Place the guide on the seam that you have sewn and sew once more. This will place the seams at the distance that you have chosen.



## FREE-MOTION ECHO QUILTING FOOT

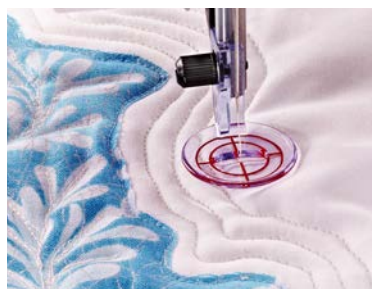

821002096

J L

except *expression*™ 3.5, 3.2, 3.0, 2.0, *expression*™ 150

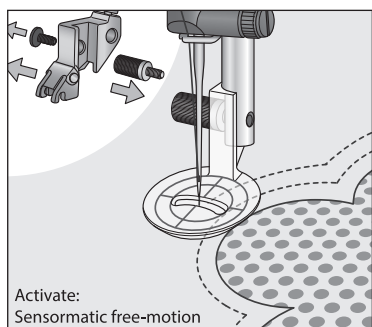

The Free-motion Echo Quilting foot is designed to give you more control when free-motion quilting. The large base ensures good surface contact with the fabric and provides better control of the stitching. The transparent base allows for 360° visibility. Vertical, horizontal and circular markings on the foot make it easy to follow a continuous line quilting pattern or design on the fabric. Sew straight lines or follow patterns with rounded edges in any direction.

1. Disengage the IDT™ system.
2. Loosen the presser foot ankle screw completely and remove the ankle.
3. Fit the Free-motion Echo Quilting foot around the presser bar; attach it with the screw included in the package.
4. Thread your machine.
5. Select a straight stitch.
6. Set your PFAFF® sewing machine to Sensormatic free-motion mode. The feed dogs will drop automatically.  
Note: When the feed dogs are dropped, the fabric is no longer fed by the machine. You must move the fabric.
7. Bring the bobbin thread to the top by taking one stitch. Hold on to both threads and sew a few stitches in place to begin.
8. Maintain a consistent speed and move the fabric in a smooth motion. You are creating the length of the stitch as you move the fabric.
9. Stitch around the quilting motif, appliqué or pattern on the fabric, maintaining a uniform distance to outline the shape.
10. Stitch a second row, maintaining a uniform distance from the first row. Use the red markings on the foot as a guide to keep your spacing even. (illustr. 1)
11. Repeat as many times as you want to create the desired effect.

Note: When sewing in Sensormatic free-motion mode at a low speed the presser foot will raise and lower with each stitch to hold the fabric on the stitch plate while the stitch is being performed. At a higher speed, the presser foot floats over the fabric while sewing.



**NEW!**

## QUILT BINDER



821163096

J\* L

J\* Must be fitted with a compatible Needle Plate - 412964309 (available separately).



This quilt binder attachment is perfect for attaching binding to your quilt projects. The quilt binder has a large opening to accommodate the quilt layers and creates a finished binding size of 1/2". The quilt binder attachment comes with a dedicated presser foot for use with IDT to ensure even feeding through the binder and a perfect result.

The Double Fold 1/2" (12mm) binder will turn a light weight woven fabric strip into a binding and attach it to the project edges all in one step.

To bind edges with the 1/2" (12mm) Quilt Binder, cut a 1 3/4" (45mm) wide strip of light weight woven fabric.

1. Attach the Quilt Foot with guide.
2. Set the machine for straight stitch or hand look quilt stitch.
3. Place the attachment plate on the stitch plate of the machine. Align pin on the back of attachment plate to the top opening on the stitch plate of the machine. Screw the attachment plate in place with one thumb screw.
4. Place the binder on the attachment plate and adjust the binder to line up. Attach the binder in place with the two thumb screws and washers.
5. Measure the length of your project and add at least 6" (15cm).
6. Cut enough 1 3/4" (45mm) strips to equal that number and join the strips together. Cut the end of the strip into a point.
7. Slide the fabric strip into the binder with the wrong side facing you using tweezers.
8. When the fabric is through the end of the binder, hold the folded strip with your left hand and continue to feed it into the binder as shown while the fabric forms a double fold tape.
9. Raise the presser foot and pull the strip under the foot and straight back 2.5" (5-6cm) behind the needle.
10. Slide the fabric to be bound right side up into the slot of the binder. Adjust the stitch position to right or left to reach the desired needle position.

### How to sew a quilt binder corner:

Sew to the edge of the quilt, tie off and then pull the quilt out from binder. Keep the quilt close to the binder when folding the corners. Finger press the folded fabric.

#### Create a mitered corner:

1. Fold and pinch the top mitered corner, pin in place with a long pin. Repeat in the same way on the back of the quilt.
2. To continue sewing the binding, pull the fabric strip back through the binder and at the same time place the quilt back under the presser foot and into the binder again.
3. To insure that the fold is right on both top and back, pull the quilt forward and back again a couple of times.
4. Lower the needle to hold the binding in place and remove the needles. Pull out long thread tails behind the presser foot before start to sew. Backstitch and sew the binder in place. Repeat on the other corners.

#### How to end the binding:

1. Sew the binding all the way around the quilt edges. When the edges off the binding almost meet, cut the excess of fabric in the beginning of binding as illustration.
2. Continue to sew, overlapping the binding one more time. Remove the quilt from the binder and trim excess leaving 1" (2.5) cm tail. Fold back the opening and pin in place. Sew a seam over the folded edge.

Note: See detailed instructions included with the attachment.

## FREE MOTION RULER FOOT



821164096

L  
for quilt expression 720,  
expression 710,



The Free Motion Ruler Foot allows you to create a beautiful style of free motion quilting in conjunction with your ruler templates. The perfectly circular shape allows you to sew a constant ¼" away from the edges of your ruler template. Red markings on the foot indicate the center of the foot, making it easy to line the foot and the ruler up when sewing. Cutouts in the front and side of the foot make it easier to see right up to the needle.

1. Loosen the presser foot ankle screw completely and remove the ankle.
2. Place the Free Motion Ruler Foot around the presser bar; attach it with the screw.
3. Thread your machine
4. Select a straight stitch
5. Set your machine to Free Motion Ruler Foot mode. The feed dogs will drop automatically.

Note: When the feed dogs are dropped, the fabric is no longer fed by the machine. You must move the fabric.

1. Place the fabric under the foot and lower the foot.
2. Bring the bobbin thread to the top by taking one stitch. Hold onto both threads and sew a few stitches in place to begin.
3. Slide the edge of the ruler up to the foot. Place enough pressure on the ruler with your fingertips to gently glide the foot along the edge without the ruler moving.
4. Sew along the edge of the ruler. When near the end, stop the machine, lift the presser foot and slide the ruler into position to continue stitching the design.
5. When changing positions, stop the machine, and simply reposition the ruler and stitch in the direction needed to follow the ruler.

## RULER BASE



821251096

powerquilter™ 1650



The Ruler Base gives extra stability around the needle area to support rulers and other templates while sewing and quilting.

for the creative™ Fabric Frame remove the accessory tray from the machine, and place the machine onto the carriage of the creative Fabric Frame. Attach the Ruler Base around the arm of the machine.

821233096

L  
creative icon™, performance icon™





■ ■ ■ POWERQUILTER FEET

**NEW!**

RULER FOOT



821257096  
powerquilter™ 1600, 1650



The ruler foot has higher sides to give increased stability when using rulers and the cutout in the side of the foot gives better visibility.

TO ATTACH THE RULER FOOT

1. If another presser foot is on the mount, use the 2.5mm hex wrench to loosen the mounting screw far enough that you can slide the foot off of the mount.
2. Slide the Ruler Foot onto the mount. The opening on the side of the foot lines up with the mount's screw hole. Push the Ruler Foot up as far as it will go.
3. Ensure the foot is centered over the hole in the needle plate and that the needle is centered in the foot. Then fully tighten the screw with the 2.5mm hex wrench.

**NEW!**

ECHO FEET SET



821258096  
powerquilter™ 1600, 1650



The Echo Feet Set contains 3 acrylic presser feet with 3/8", 1/2" and 3/4" widths from the needle to the edge of the foot. These perfect for echo quilting round motifs or when using rulers.

TO ATTACH ONE OF THE ECHO FEET

1. If another presser foot is on the mount, use the 2.5mm hex wrench to loosen the mounting screw far enough that you can slide the foot off of the mount.
2. Slide the desired Echo Foot onto the mount. The opening on the side of the foot lines up with the mount's screw hole. Push the Echo Foot up as far as it will go.
3. Ensure the foot is centered over the hole in the needle plate and that the needle is centered in the foot. Then fully tighten the screw with the 2.5mm hex wrench.

**NEW!**

SQUARE FEET SET



821256096  
powerquilter™ 1600, 1650



The Square Feet Set contains 2 acrylic presser feet with 1/4" and 1/2" seam allowances. These feet are designed to help create straight seams when piecing on the quilt frame.

TO ATTACH THE SQUARE FOOT

1. If another presser foot is on the mount, use the 2.5mm hex wrench to loosen the mounting screw far enough that you can slide the foot off of the mount.
2. Slide the chosen foot onto the mount. The opening on the side of the foot lines up with the mount's screw hole. Push the Square Foot up as far as it will go.
3. Ensure the foot is centered over the hole in the needle plate and that the needle is centered in the foot. Then fully tighten the screw with the 2.5mm hex wrench.

**NEW!**

## GLIDE FOOT



821255096

powerquiler™ 1600, 1650

--	--

The Glide Foot's curved shape allows the foot to glide over appliques, embellishments or other dimensional elements.

Perfect for stitching over uneven areas or along the edge of the quilt.

### TO ATTACH THE GLIDE FOOT

1. If another presser foot is on the mount, use the 2.5mm hex wrench to loosen the mounting screw far enough that you can slide the foot off of the mount.
2. Slide the Glide Foot onto the mount. The opening on the side of the foot lines up with the mount's screw hole. Push the Glide Foot up as far as it will go.
3. Ensure the foot is centered over the hole in the needle plate and that the needle is centered in the foot. Then fully tighten the screw with the 2.5mm hex wrench.

## REAR HANDLEBAR AND DISPLAY KIT



821252096

L  
powerquiler™ 1650

--	--

The rear handlebars and display enable you to quilt from the back of the powerquiler™ 1650. Use the laser light with pantographs for edge-to-edge quilting.

## 5' HOOP FRAME



\*Must order all part numbers

850245096a

850245096b

powerquiler™ 1650

--	--

Made of High-quality steel. This is a professional-grade table and frame system for your home quilting studio.

- Innovative hoop technology
- Includes: 1 Deluxe Quilt Clamp, 6 Easy-Grip Quilt Clamps, 3 Large & 3 Small Quilt Clamps
- Accommodates any size quilt
- Easy Release Take-up Bar

## 10' FRAME



Made of High-quality steel. This is a professional-grade table and frame system for your home quilting studio.

- Leader cloths included with frame
- Easy-assembly at 4 foot, 6 foot, 8 foot, or 10 foot allows for length adjustments in different work environments for many years.

\*Must order all part numbers

10 foot: 620150196A / 620150196B / 620150196C / 620150196D10

powerquilter™ 1650

## 12' FRAME



Made of High-quality steel. This is a professional-grade table and frame system for your home quilting studio.

- Leader cloths included with frame
- Easy-assembly at 4 foot, 8 foot, or 12 foot allows for length adjustment in different work environments for many years.

\*Must order all part numbers

620150196A / 620150196B / 620150196C / 620150196D12

powerquilter™ 1650

## TABLE EXTENSION



Expands your work area for an additional 18" of work space. Easy to install, lift the extension up when you need it and fold it down when not needed.

620150696  
powerquilter™ 1600



## EXTENSION TABLE WITH ADJUSTABLE GUIDE



821181096

J

--	--

821136096

L

--	--

Designed and manufactured for PFAFF® machines this extension table attaches to your machine the same way as your accessory box and substantially increases your work area. It is very stable, and because no legs are needed, you have the clearance underneath the extension table for circular items. The Adjustable Guide with ruler has both centimeters and inches to allow you to sew hems, borders and more with perfect accuracy. The ruler printed right on the extension table measures from the needle in both centimeters and inches so you always have the measurements you need right at hand.



## QUILT TABLE



820887096

J

--	--

821263096

L

for creative icon™ performance icon™

--	--

Made of sturdy, smooth Plexiglas. This terrific table substantially increases your work area to accommodate the extra space quilters need. Even very large quilting projects can be handled comfortably.



## EXTENSION TABLE



The sturdy extension table has adjustable legs and allows you to convert the free arm to an extended flat bed to easily support large projects.

821092096

for creative™ 1.5, quilt ambition™ 630, ambition™ 620 and 610



## EXTENSION TABLE



821001096

K\*

K\* except creative™ 1.5,  
quilt ambition™ 630,  
ambition™ 620 and 610,  
passport™ 2.0, SMARTER BY PFAFF™  
260c, 160s, 140s





### EXTENSION TABLE



The sturdy extension table has adjustable legs and allows you to convert the free arm to an extended flat bed to easily support large projects.

821079096  
for SMARTER BY PFAFF™  
260c, 160s, 140s



820492096  
G



### EXTENSION TABLE WITH BAG



Designed for the new *passport*™ 2.0, this extension table has a printed ruler with both centimeters and inches so needed measurements are close at hand. A branded bag for the table is included, which can be attached to the back of the machine cover. The sturdy extension table has adjustable legs and allows you to convert the free arm to an extended flat bed to easily support large projects.

821035096  
*passport*™ 2.0, 3.0





## STRAIGHT STITCH NEEDLE PLATE

The Straight Stitch Needle Plate guarantees even fabric feed at the beginning and end of a seam, while preventing the fabric from being pulled into the needle plate.



Standard Zigzag Needle Plate with Inch Markings  
412964309



Straight Stitch Needle Plate with Inch Markings  
68003080

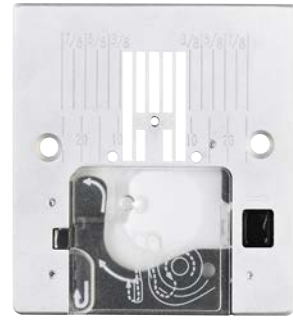

Straight Stitch Needle Plate with Inch Markings  
820999096

quilt ambition™ 2.0 ambition™ 1.5, 1.0 ambition essential

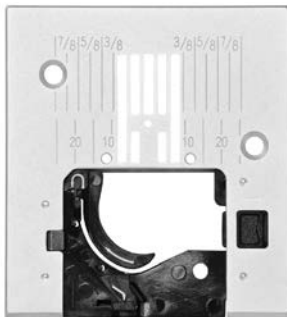

Straight Stitch Needle Plate with Inch Markings

821036096  
passport™ 2.0, 3.0









## ■ ■ ■ EMBROIDERY

The owner of a PFAFF® sewing and embroidery machine has the key to a neverending source of creativity. Embroidery is a popular decoration for fashion, accessories and home decorating items. Colorful, supersized, enchantingly lovely – embroidered by PFAFF® machine with unbelievable quality. Combine your machine with the right accessories, and you'll get professional results every time! It's fun and the new ideas will just keep coming!

For more information, check our web site regularly at [www.pfaff.com](http://www.pfaff.com) or visit your nearest authorized PFAFF® dealer.





## ■ EMBROIDERY COLLECTIONS

An unlimited source of inspiration! Breathtakingly large or delightfully small; flowers or borders, romantic or modern; intricate patterns or clean lines – there is an Embroidery Collection for every taste.

## EMBROIDERY DESIGN COLLECTIONS

Your PFAFF® dealer carries a huge selection of designs in various sizes and for all PFAFF® embroidery machines. Each Embroidery Collection includes a booklet with all the information you'll need to embroider each design.

New Embroidery Collections are added regularly, so check our website at [www.pfaff.com](http://www.pfaff.com) for the latest selection, or visit your local PFAFF® dealer.

## ■ creative™ HOOPS

With the creative™ hoops from PFAFF®, you can expand your embroidery machine's potential and achieve the most professional results. All designs will be perfect, no matter what the size. To guarantee even more embroidery pleasure for, the range of creative™ hoops is constantly being expanded. You can learn more from your PFAFF® dealer.



creative™ GRAND METAL HOOP



821097096

creative icon™, creative sensation™ pro II, creative sensation™ pro, creative sensation™, creative performance™, creative vision™, creative™ 4.5, creative™ 3.0

--	--

creative™ PETITE METAL HOOP 100X100MM



821098096

creative icon™, creative sensation™ pro II, creative sensation™ pro, creative sensation™, creative performance™, creative vision™, creative™ 4.5, creative™ 3.0, creative™ 1.5

--	--

creative™ METAL HOOP 180X130MM

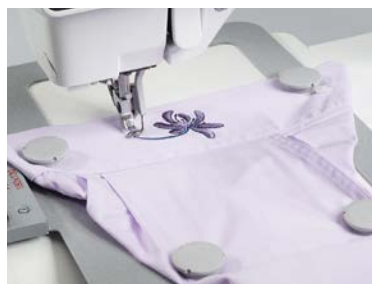

821034096

creative icon™, creative sensation™ pro II, creative sensation™ pro, creative sensation™, creative performance™, creative vision™, creative™ 4.5, 4,0, 3,0, 2,0

--	--

Some fabrics are more difficult to hoop than others or should not be hooped at all, since hooping can damage the fabric. Thick and coarse fabrics can be difficult to hoop but also thin and glossy fabrics. Hooping ready-to-wear garments is difficult or impossible due to seams, narrow areas or buttons/rivets. When using the PFAFF® creative™ Metal Hoops hooping won't be a problem!

When you want to embroider on quilts or other projects where you do not want residuals from stabilizer on the back side, the Metal Hoops are perfect! Embroider without stabilizer. Embroidering several designs after each other or doing endless embroideries is easy, just remove the magnets and move the fabric. Ready to embroider the next design in no time!





creative™ HAT HOOP ACCESSORY  
821138096

J L

--	--

With this accessory, you can monogram caps, hats and other projects. Simply attach the Hat Hoop Accessory to the 180 x 130 mm PFAFF® creative™ Metal Hoop and you can start embroidering letters, logos and other designs from your machine.



Use with Metal Hoop 180 x130 mm, Part #821034096



## SET OF 4 MAGNETS



620132696

--	--

**For**  
METAL HOOP

There is an extra set of four magnets available as an optional accessory. They can be used to fix the fabric more securely to the hoop when not using adhesive stabilizer.



### Safety instructions - magnets

Persons having a pacemaker should not handle magnets. •Keep the magnets away from sensitive electronic equipment, computer disks or credit cards with magnetic slip. •Keep the magnets away from children, swallowing a magnet could cause serious injury. •Be careful not to get pinched between the magnets. •Extreme hot temperatures can affect the magnetism.



creative™ METAL HOOP FABRIC GUIDE SET  
821165096

--	--

These useful guides easily attach onto any metal hoop and act as a barrier to keep the rest of your project out of the way while embroidering. Use the guides with the creative™ Petite Metal Hoop (821098096) to easily embroider on small garments as they hold the excess fabric out of the way.



creative™  
GRAND DREAM HOOP  
820888096

360 x 350 mm

--	--



creative™  
SUPREME HOOP  
68000058

360 x 260 mm

--	--



creative™  
DELUXE HOOP  
412944502

360 x 200 mm

--	--



creative™  
ELITE HOOP  
413116502

260 x 200 mm

--	--



creative™  
GRAND ENDLESS  
HOOP  
820987096

360 x 260 mm

--	--



creative™  
MASTER HOOP  
412968502

240 x 150 mm

--	--



creative™  
GRAND METAL HOOP  
821097096

240 x 150 mm

--	--



creative™  
QUILTERS HOOP  
820940096

200 x 200 mm

--	--



creative™  
GRAND QUILTERS HOOP  
821218096

260 x 260 mm

--	--



creative™  
ENDLESS HOOP II  
820893096  
180 x 100 mm

--	--



creative™  
TEXTURE HOOP  
820919096  
150 x 150 mm

--	--



creative™  
ALL FABRIC HOOP II  
820889096  
150 x 150 mm

--	--



creative™  
120 SQUARE HOOP  
412968202  
120 x 120 mm

--	--



creative™  
PETITE METAL HOOP  
821098096  
100 x 100 mm

--	--



creative™  
PETITE SQUARE HOOP  
821006096  
80 x 80 mm

--	--



creative™  
METAL HOOP  
821034096  
180 x 130 mm

--	--



creative™ HOOP  
9303934044000  
225 x 140 mm

--	--





# EMBROIDERY ■ HOOP / MACHINE COMPATIBILITY CHART



creative icon™

MAX. EMBROIDERY AREA		360 x 350 mm
EMBROIDERY HOOP	FRAME SIZE	
820888096 creative™ GRAND DREAM HOOP	360 x 350 mm	×
68000058 creative™ SUPREME HOOP	360 x 260 mm	×
412944502 creative™ DELUXE HOOP	360 x 200 mm	×
821218096 creative™ GRAND QUILTERS HOOP	260 x 260 mm	×
413116502 creative™ ELITE HOOP	260 x 200 mm	×
820987096 creative™ GRAND ENDLESS HOOP	260 x 150 mm	×
821097096 creative™ GRAND METAL HOOP	240 x 150 mm	×
820940096 creative™ QUILTERS HOOP	200 x 200 mm	×
821034096 creative™ METAL HOOP	180 x 130 mm	×
412968502 creative™ MASTER HOOP	240 x 150 mm	×
820893096 creative™ ENDLESS HOOP	180 x 100 mm	×
820919096 creative™ TEXTURE HOOP	150 x 150 mm	×
820889096 creative™ ALL FABRIC HOOP II	150 x 150 mm	×
412968202 creative™ 120 SQUARE HOOP	120 x 120 mm	×
821098096 creative™ PETITE METAL HOOP	100 x 100 mm	×
821006096 creative™ PETITE SQUARE HOOP	80 X 80 mm	×
9303934044000 creative™ HOOP	225 x 140 mm	

\* When sold with the **large** embroidery unit



## creative™ FELTING EMBROIDERY SET



821068096  
J L for Embroidery machines



With the PFAFF® creative™ Felting Embroidery Set, you can create the most amazing felted embroideries. The effect is created when embroidering without threads but with a special needle that felt fibers together. The effect of the embellishment can be changed dramatically by using different types of fabric/wool.

### Contents

- A. Felting Foot
- B. Felting Bobbin
- C. Felting Needle Plate Cover
- D. Felting Needles (x5)
- E. Screw

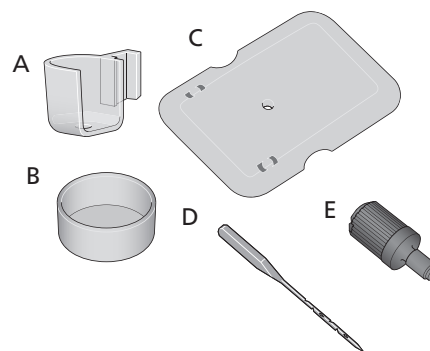

### Fabrics

Just about any fabric can be felted with the creative™ Felting Embroidery Set, however, afterwards some fabrics tend to give a more favorable result when embellished or laundered.

The recommended fabrics are those made from natural fibers, such as wool and wool roving. The best characteristic for fabrics is a napped or textured surface.

A napped surface will adhere to a natural fiber/napped surface/or mixed fiber base.

Avoid synthetics with “wash and wear” type of weaves and finishes that have a smooth surface.

The effect differs from fabric to fabric. Always test on a piece of material before you start.

### Hooping

When embroidering with the felting needles, no threads are used. The fabric is hooped with the right side facing down.

When embroidering free standing designs or when using wool roving, a water soluble stabilizer is needed.







### Felting Techniques

Three designs are available for download from [www.pfaff.com](http://www.pfaff.com). Each design represents a felting technique, Free Standing, Single-Layer and Multi-Layer embroidery. These techniques are explained below.

To download the designs, go to [www.pfaff.com](http://www.pfaff.com).

Find the "creative™ felting embroidery set". Click on the link to download the designs.

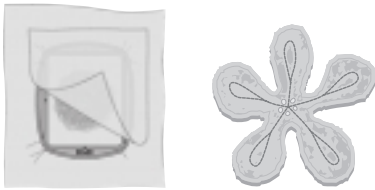

1. FREE STANDING EMBROIDERY

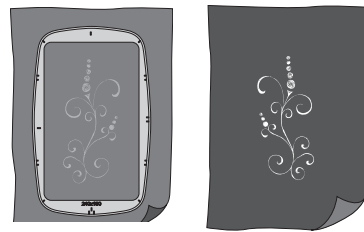

2. SINGLE-LAYER EMBROIDERY

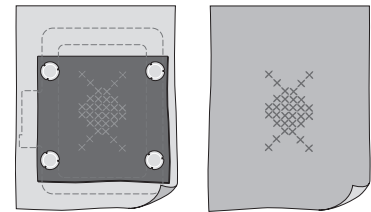

3. MULTI-LAYER EMBROIDERY

## EMBROIDERY/SENSORMATIC FREE-MOTION FOOT



The Sensormatic free-motion foot is used for stippling and free-motion embroidery. The foot allows for greater visibility for both stippling and free-motion embroidery.

When sewing free-motion at a low speed the presser foot will raise and lower with each stitch to hold the fabric on the stitch plate while stitch is being formed. At higher speed, the presser foot floats over the fabric while sewing.

820671096

JL

except expression™ 3.5, 3.2, 3.0, 2.0,  
expression™ 150

--	--

**NEW!**

## CREATIVE™ RIBBON EMBROIDERY ATTACHMENT

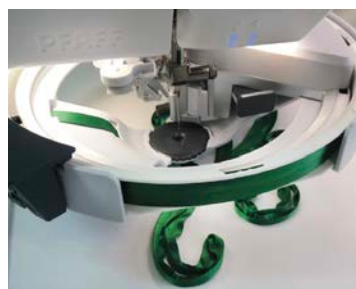

A true innovation in the home embroidery machine. With the optional creative™ ribbon embroidery attachment your creative icon™ will guide and stitch down ribbon in embroidery mode. Adding ribbon to your embroidery designs has never been easier!

- 360° Rotation
- Holds up to 26 feet (8m) of ribbon
- Easily adjusted to work with different ribbon widths.

821260096

creative icon™

--	--



## OPEN TOE SENSORMATIC FREE-MOTION FOOT



820976096

J L

except expression™ 3.5, 3.2, 3.0,  
2.0, expression™ 150



The Open Toe Sensormatic Free-motion foot is used for stippling and free-motion embroidery. The foot allows for greater visibility as the opening in front of the foot gives you an optimal view of your free-motion sewing and quilting. The open front and transparency of the foot with both vertical and horizontal markings, allows you to easily do stippling or follow a design on the fabric.

1. Thread your machine with a thread of your own choice.
2. Make sure the IDT™ system is disengaged.
3. Set your sewing machine in Sensormatic free-motion mode. The feed dogs will drop automatically.
4. Select the stitch you would like to use (straight stitch or zigzag stitch). The stitch length doesn't matter because when the feed dogs are dropped the fabric is no longer fed by the machine. You must feed (move) the fabric.
5. Stitch manually moving the fabric.

Note: When sewing in Sensormatic free-motion mode at a low speed the presser foot will raise and lower with each stitch to hold the fabric on the stitch plate while the stitch is being performed. At a higher speed, the presser foot floats over the fabric while sewing.





## DYNAMIC SPRING FOOT



820991096

J

except quilt expression™ 4.0, expression™ 3.5, 3.2, 3.0, 2.0, expression™ 150

--	--

68003167

L

--	--

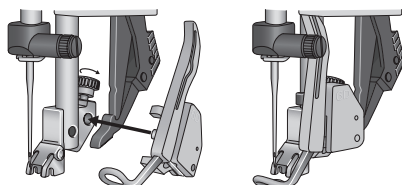

Activate: Dynamic spring foot



The Dynamic Spring Foot is used for embroidery, and free-motion sewing or quilting. The foot is designed to give a great view so you easily can do stippling or follow a design in the fabric. The spring action keeps the fabric from lifting with the needle as the stitch is being formed, giving you more control of your sewing.

1. Disengage the IDT™ system and carefully loosen the small screw on the back of the presser foot holder.
2. Squeeze the Dynamic Spring Foot together. Guide the pin of the foot into the cross-hole of the presser foot holder. The arm of the foot should be placed behind the needle screw.
3. Tighten the screw.
4. Thread your machine.
5. Set the machine in the Dynamic Spring Foot 6D mode. The feed dogs will drop automatically.

### Embroidery

In embroidery the presser foot will move up and down with the needle which gives a more even balance between top and bobbin thread.

### Free-motion

1. Place the quilt under the presser foot.
2. Select a straight stitch and start sewing. You will manually guide your fabric. Your movement will determine the length of the stitch.
3. Move your quilt in a smooth motion, maintaining a consistent speed for even stitches.

## creative™ EMBROIDERY FOOT



820280096

creative™ 2170, 2144, 2140, 2134, 2124

--	--

The embroidery feet are developed especially for use with the embroidery functions of the PFAFF® sewing and embroidery machines. Select the correct foot for your machine.



### creative™ EMBROIDERY CUTWORK NEEDLE KIT



820945096  
E F G J L  
for Embroidery machines  
and creative™ 1.5

--	--

With creative™ Embroidery Cutwork Needle Kit set you can easily create cutwork embroidery. This kit will help you get started!

Contents: INSPIRA™ Cutwork Needles, Multipurpose tool/ Button reed, CD with instruction video, embroidery designs, more tips and inspiration to get you started!

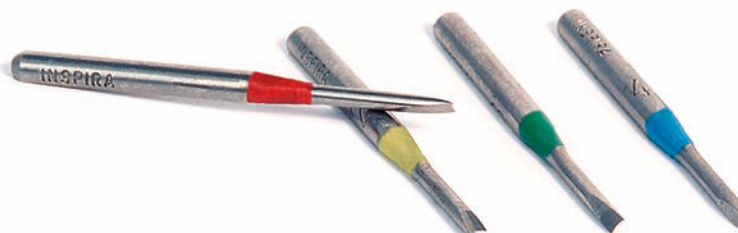

### creative™ EIGHT SPOOL THREAD RACK



821161096  
J L

--	--

Snaps onto top of machine and features pins for up to eight spools of thread. Thread pins are numbered for embroidery color changes.

### creative™ 8 SPOOL THREAD RACK HOLDERS

821171096  
L

--	--

Already own the PFAFF® creative™ Eight Spool Thread Rack and have just bought a creative icon™ then no problem. These holders will allow you to attach the eight spool thread rack to the back of the machine. The increased working height allows you to see the spools of thread even when the lid is open.









# ■■■ SERGER/OVERLOCK

Do you love to sew? Do you enjoy working with all of today's wonderful fabrics and trims? Do you want the results to be as perfect as the best ready-to-wear? Then you need a PFAFF® serger/overlock! It's the ideal complement to your sewing machine. It picks up where your sewing machine stops.

For more information, check our web site regularly at [www.pfaff.com](http://www.pfaff.com) or visit your nearest authorized PFAFF® dealer.

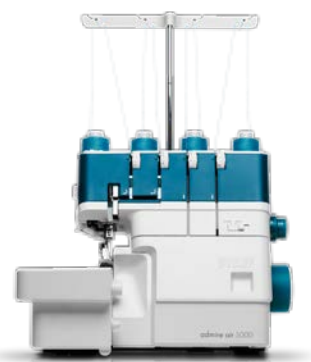

admire™ air 5000



coverlock™ 4.0



coverlock™ 3.0



hobbylock™ 2.5



hobbylock™ 2.0





## CORDED WAVY EDGE FOOT

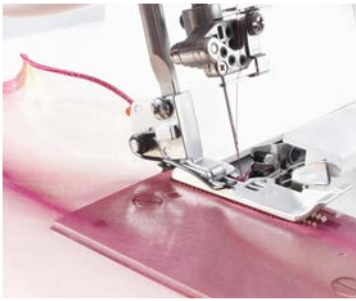

620097296

coverlock™ 4.0 and 3.0  
hobbylock™ 2.5

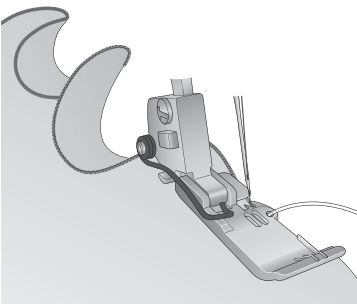
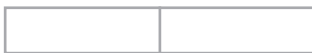

Sewing a decorative wavy edge is easy with the Corded Wavy Edge foot. The curvy, softly ruffled edge is a perfect finish for bridal veils, figure skating costumes, ballet skirts, crafts and more.

Note: For best results, use fabric with stretch. For fabric with no stretch, cut on the bias.

1. Set the machine for a 3-thread rolled edge.
2. Snap on the Corded Wavy Edge foot.
3. Insert a 0.3mm nylon fishing line (or similar) into the opening in the foot. The fishing line will be covered by the rolled edge.
4. Start to sew slowly. Make sure the fishing line is hidden in the rolled edge as you sew.

Tip: \* 40 wt. rayon embroidery threads in a contrasting color in the upper and lower loopers will give a shiny colorful edge.

## YARN APPLICATION FOOT



620117396

hobbylock™ 2.0

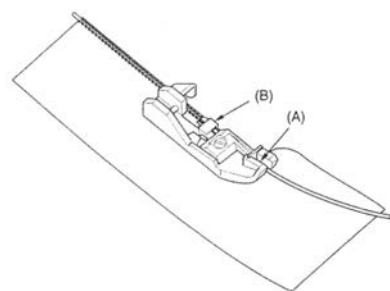

This foot is used for sewing yarns (cords, nylon gut) up to a thickness of 1.0 mm. This produces an undulating or stiffer hem (e.g. on wedding dresses and valance).

### Preparing the machine

- Needle: Right needle
- Stitch type: Two thread lower looper thread wrapped rolled hem or three thread upper looper thread wrapped rolled hem
- Stitch length: 2 mm
- Differential feed lever: Normal position
- Upper knife: Working position

### Sewing

1. Place the fabric under the presser foot.
2. Thread cord (or nylon gut) through slot (A) and under finger (B) of the presser foot.
3. Test sew on a piece of fabric before starting to sew.

## ELASTIC FOOT

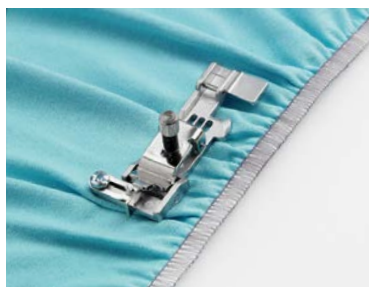

620117896  
coverlock™ 4.0 and 3.0  
hobbylock™ 2.5



The Elastic Foot guides and stretches narrow elastic (1/4-1/2", 6-12 mm) as you sew it to fabric. It is great for sewing for active wear, lingerie and other elastic insertion techniques.

1. Set the overlock machine for the desired stitch.
2. Loosen the screw at the front of the Elastic Foot to release the tension on the roller. Insert the elastic into the foot.
3. Snap on the foot and pull the elastic until it reaches behind the foot.
4. Tighten the tension screw to stretch the elastic.
5. Turn the handwheel to sew the first few stitches to secure the elastic.
6. Place the fabric under the foot and sew both the elastic and the fabric together.
7. Check the stitch and adjust the tension if necessary.

Note: To adjust the stretch of the elastic:

- Turn the tension screw to the right for more stretch.
- Turn the screw to the left for less stretch.
- Be careful not to stretch the fabric while sewing.

## ELASTIC FOOT



620116796  
hobbylock™ 2.0

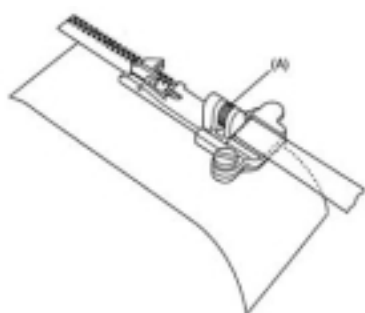

The Elastic Foot guides and stretches narrow elastic (1/4-1/2", 6-12 mm) as you sew it to fabric. It is great for sewing for active wear, lingerie and other elastic insertion techniques.

### Preparing the machine

- Needle: Left or right, or both left and right
- Stitch type: Three-thread overlock or four-thread ultra stretch mock safety stitch
- Stich length: 3-5 mm
- Differential feed lever: Normal position
- Upper knife: Working or non-working position

### Sewing

1. Before attaching the sewing foot to machine, pass the elastic tape through presser foot and adjust stretch with adjusting screw (A).
2. Attach presser foot to machine.
3. Sew 2 - 3 stitches while pulling the elastic tape lightly to the rear of machine.
4. Continue to sew the elastic tape onto the fabric while lightly pulling the end of elastic tape.



## BLINDHEM & LACE FOOT



620117796  
coverlock™ 4.0 and 3.0  
hobbylock™ 2.5



The Blindhem Foot is perfect for sewing invisible hems and for applying lace. The hem is sewn, overcast and trimmed in one step.

### Blind hem:

1. Set the overlock machine for the desired stitch.
2. Snap on the Blindhem Foot.
3. Fold and press the hem in place. Turn the hem back on itself toward the right side of the fabric. Leave ¼" (6mm) of the edge exposed. (See illustration.)
4. Place the hem under the foot with the fold against the guide on the foot.
5. Loosen the guide screw to adjust the guide so that the needle just catches the thread of the fold.
6. Guide the fabric as you sew, making sure the fold of the fabric is always against the guide.
7. Open the fabric and press lightly on the wrong side.
8. Test on a scrap piece of fabric before sewing your project.

### Lace:

1. Set the overlock machine for the desired stitch
2. Snap on the Blindhem Foot.
3. Place the wrong side of the lace to the right side of the fabric.
4. Place under the foot with the fabric extending to the right of the guide. The header of the lace will be against the left side of the guide.
5. Loosen the guide screw to adjust the guide so the needle just catches the header of the lace.
6. Guide the fabric as you sew, making sure the header of the lace is always against the guide.
7. When finished, open the lace flat. Fold the seam allowance to the back of the fabric and press.
8. If using insertion lace, repeat on the other side of the lace.

## BLINDHEM FOOT



620117096  
hobbylock™ 2.0



This foot is for sewing cuffs on knit fabrics, and hemming where seam should not be visible.

### Preparing the machine

- Needle: Right needle
- Stitch type: Three-thread overlock or three-thread flatlock
- Stitch length: 4-5mm
- Differential feed lever: Normal position
- Upper knife: Working position
- 

### Sewing

1. Fold fabric as shown and place it under the presser foot.
2. Loosen screw (A) and adjust edge guide so that needle will penetrate the fabric close to the folded edge.
3. Guide fabric lightly while sewing so that needle will just catch the edge of fold.



## PIPING FOOT



620117596  
coverlock™ 4.0 and 3.0  
hobbylock™ 2.5



The Piping Foot is perfect for inserting packaged piping into seams and on edges for a tailored finish. The trim is sewn between the two layers of fabric in one step. A groove under the foot helps guide the piping. You can also create your own piping for a custom finish. The Piping Foot makes it fast and easy to cover cording with fabric and to insert piping into seams for a professional look!

1. Set the overlock machine for the desired stitch.
2. Snap on the Piping Foot.

### To stitch piping into a seam:

3. Place the piping along the seam line on right side of fabric. Place second piece of fabric on top with right sides together.
4. Put fabric and piping layers under the Piping Foot with the piping in the groove on the underside of the foot.
5. Sew piping into the seam.
6. The groove on the underside of the foot will guide the piping as you sew.

### To make piping from your fabric:

1. Cut bias or crosswise grain strips wide enough to cover the cord plus the seam allowances.
2. Lay the cord on the wrong side of the fabric strip and fold the fabric over the cord.
3. Place the fabric and cord under the Piping Foot with the cord in the groove on the underside of the foot.
4. Sew. The groove will guide the cord as you sew.

## PIPING FOOT



620116996  
hobbylock™ 2.0

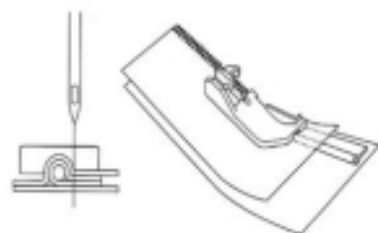

This presser foot is suited for sewing welting between two layers of fabric.

### Preparing the machine

- Needle: Left or both left and right
- Stitch type: Three-thread overlock or four-thread overlock
- Stitch type: 2-5mm
- Differential feed lever: Normal position
- Upper knife: Working position

### Sewing

1. Place fabric with right sides facing.
2. Place cording (piping) in between upper and lower fabrics and insert fabrics under cording foot with cording positioned in groove under foot.
3. Sew while guiding both cording (piping) and fabric.

Note: Cording (piping) using bias tape and cord can also be done with this foot.

## BEADING FOOT



620117496  
coverlock™ 4.0 and 3.0  
hobbylock™ 2.5



The Beading Foot smoothly guides beads and pearls through a channel on the foot for easy application on garments or crafts.

1. Set the overlock machine for the desired stitch.
2. Pull the bead string through the channel on the underside of the foot.
3. Snap the Beading Foot onto the machine.
4. Turn the handwheel to sew the first two stitches to keep the beads in place.
5. Sew pearls onto the edge of fabric, cutting just a little bit of fabric as you sew. Or sew along the fold without cutting.

Note: The needle should penetrate about 5/8" (1.5mm) from the fabric edge.

## BEADING FOOT



620117196  
hobbylock™ 2.0

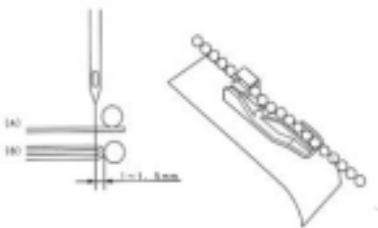

This foot is used for sewing on beads, spangles, etc.

### Preparing the machine

- Needle: Left or right (left is preferable.)
- Stitch type: Three-thread overlock or wrapped edge overlock
- Stitch length: 3-5mm
- Differential feed lever: Normal position
- Upper knife: Working or non-working position

### Sewing

1. Select sewing method (A) or (B), then determine needle position and sew 2 or 3 stitches.
2. Turn hand wheel with hand until needle point is level with fabric surface on its upward stroke. Then insert the end of string of beads into guide on presser foot.
3. Sew 2 - 3 stitches by turning hand wheel with hand.
4. Press beads lightly with left finger while sewing.
5. Sew the last few stitches by turning hand wheel with hand to avoid beads interfering with needle and loopers.



## GATHERING



620117996  
coverlock™ 4.0 and 3.0  
hobbylock™ 2.5



The Gathering Foot is perfect for gathering a single layer of fabric or simultaneously gathering and stitching two layers of fabric. (The bottom fabric layer will be gathered and the top layer remains flat.) Suitable for light and medium weight woven fabrics.

1. Set the overlock machine for the desired stitch.
2. Snap on the Gathering Foot.
3. Insert the bottom fabric layer (fabric to be gathered) between the needle plate and the Gathering Foot all the way up to the cutter, with right side up.
4. Insert the top fabric layer in the opening of the Gathering Foot and even with the bottom layer right side down.
5. Lower the presser foot and sew. Guide the fabric against the fabric guide, letting the bottom layer feed freely to gather.

Tip: To increase the fullness of the gathering:

- Increase the needle thread tension
- Set the differential feed to a higher number
- Adjust the stitch length to a higher number

A single layer of fabric may also be gathered by placing it under foot and adjusting stitch length, differential feed and needle thread tension to desired fullness.

## GATHERING



620116896  
hobbylock™ 2.0

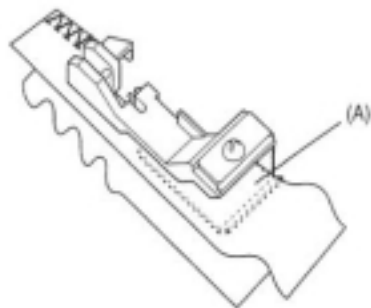

This foot is most suited for gathering when sewing tiered skirts, yokes, cuffs and frills on skirts, etc. This foot is also suited for sewing two fabrics together and gathering the bottom fabric in one operation.

### Preparing the machine

- Needle: Left or right, or both left and right
- Stitch type: Three—thread overlock or four-thread overlock
- Stitch length: 3-5 mm
- Differential feed lever: Gathering position
- Upper knife: Working position

### Sewing

1. Place two layers of fabric on machine with separator plate (A) in between the upper and lower fabrics.
2. Sew 2-3 stitches.
3. Hold and lightly guide upper and lower fabrics separately while sewing.

## LACE FOOT



620117296  
hobbylock™ 2.0

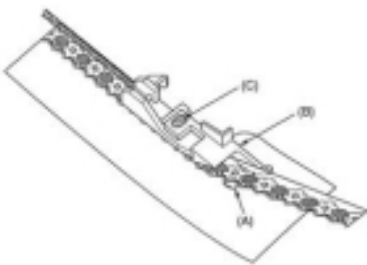

This foot is used for sewing lace or borders together or onto the workpiece.

### Preparing the machine

- Needle: Right needle
- Stitch type: Three-thread overlock or three—thread standard rolled hem
- Stitch length: 1.5 - 3 mm
- Differential feed lever: Normal position
- Upper knife: Working or non-working position

### Sewing

1. Place the fabric under guide finger (A) and lace on top of guide finger (A).
2. If necessary, loosen screw (C) and slide guide plate (B) to the left or right to adjust stitch width.
3. Tighten screw (C).
4. Guide lace along guide plate (B) and sew.

Note: If there is no necessity to cut the fabric edge, place both fabric and lace on top of guide finger (A) . Be sure to disengage the upper knife.

## TAPING FOOT



620117696  
coverlock™ 4.0 and 3.0  
hobbylock™ 2.5



The Taping Foot is used to apply seam tapes to seams to prevent stretching. It is especially good for stabilizing shoulder seams. With this foot you can reinforce and construct seams in one step.

1. Set the overlock machine for the 4-thread overlock.
2. Place the seam tape in the guides on the foot.
3. Adjust the screw to fit the width of the tape.
4. Snap the taping foot onto the machine.
5. Sew the seam.

Note: Works best with ¼" (8mm) seam tape.

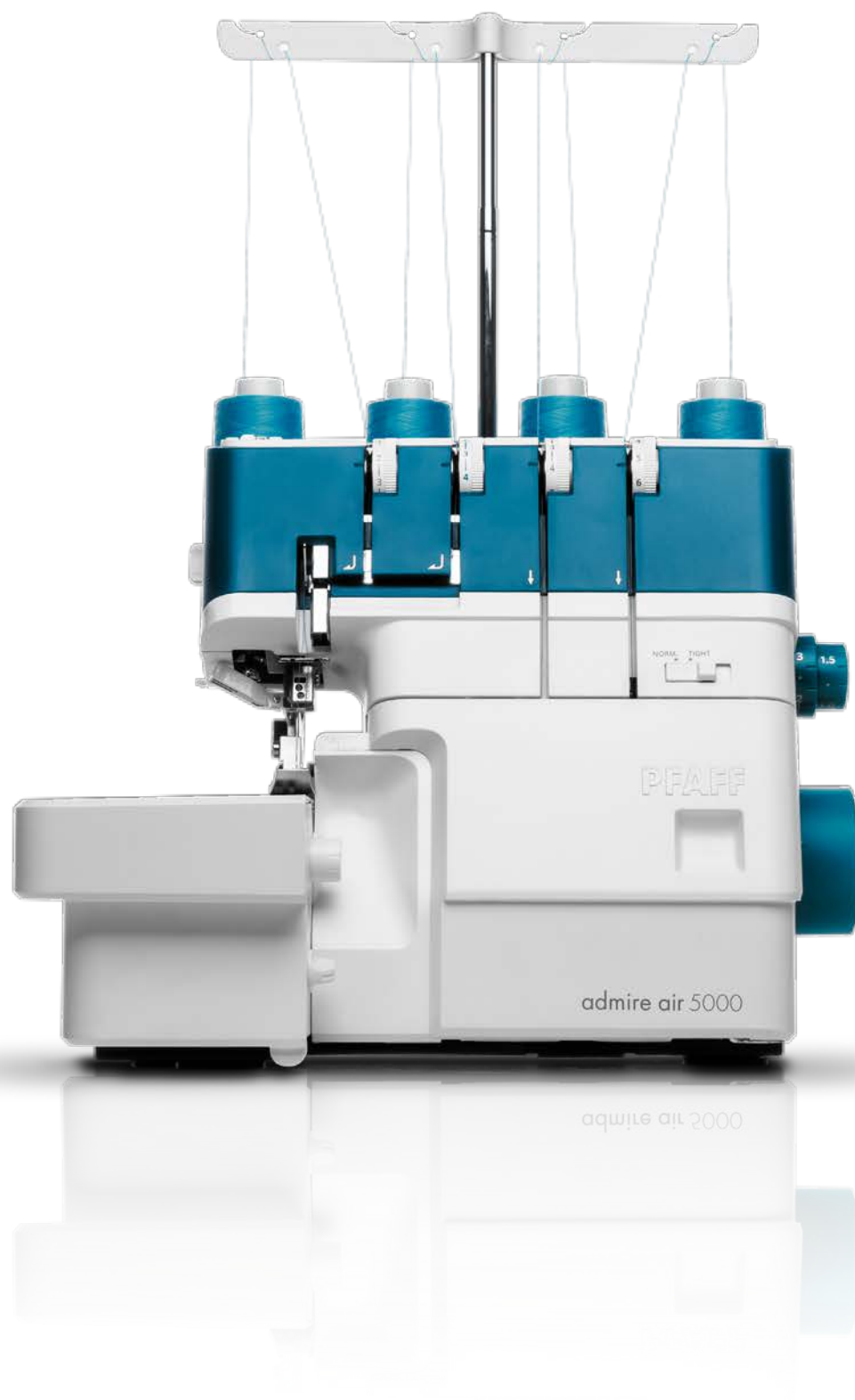



admire™ air 5000  
Embellishment Feet Kit



821221096  
admire™ air 5000

This kit contains 6 accessories, perfect for embellishment, garment sewing, home furnishings and more.

**It Includes:**

- Cording Foot (Type A) For yarn or nylon cord, to secure edges, hems, or create decorative wavy edges
- Cording Foot (Type B) To add cord or seam tape to prevent stretching
- 1/8" Piping Foot For sewing packaged piping into seams and onto edges for a tailored finish
- 3/16" Piping Foot
- Beading Foot & Guide Easily attach strings of beads or pearls to garments

admire™ air 5000  
Utility Feet Kit



821220096  
admire™ air 5000

This kit contains 5 accessories, perfect for utility sewing.

**It Includes:**

- Gathering Attachment Perfect for gathering one layer of fabric on to another
- Blind Hem Foot Creates an invisible hem, trims and overcasts in one step
- Gathering Foot Creates gathers in light to medium weight fabrics
- Elastic Gathering Foot Stretches and sews narrow elastic in place on to the edge of the fabric. Great for active wear, lingerie and other projects
- Cloth Guide For keeping seams straight while sewing and to flatlock seams when knife is lowered

## CLEAR COVERSTITCH FOOT



620096896

coverlock™ 4.0 and 3.0

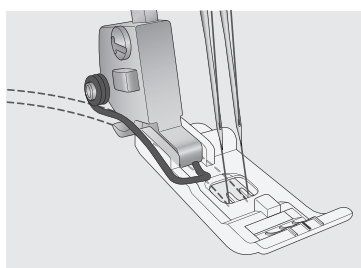

With the Clear Coverstitch foot, you can see your fabric and marked line under the foot as you sew.

1. Set the machine for a Coverstitch or a Chainstitch.
2. With a water soluble marker, draw a line on the fabric to mark the stitching line.
3. Snap on the Clear Coverstitch foot.
4. Use default stitch settings. Adjust if needed.
5. Place the fabric under the presser foot and the needles. Start to sew into the fabric without chaining off first.
6. Use the red center marking on the foot as a guide as you follow a line drawn on the fabric. The Clear Coverstitch foot will give you a great view of the marked line and of your fabric while sewing.

## FLAT TRIM FOOT



620096996

coverlock™ 4.0 and 3.0

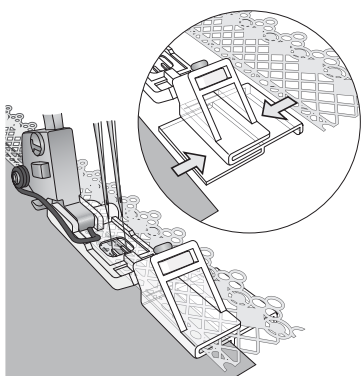

With the Flat Trim foot, you can easily add lace and trims to the top of the fabric with a coverstitch to create beautiful decorative edges and effects.

1. Set the machine for a Coverstitch wide.
2. Snap on the Flat Trim foot.
3. Use default stitch settings. Adjust if needed.
4. Insert the fabric edge into the lower section on the left side of the foot. Slide the fabric under the foot and under the needles.
5. Insert the trim into the upper section on the right side of the foot. Slide the trim toward the back of the foot beyond the needles, leaving a short tail of trim behind the needles. while sewing.  
**Tip:** Use tweezers to slide the fabric and the trim to the correct position under the needles.
6. Lower the needles into the trim and the fabric. Lower the Flat Trim foot
7. As you sew, hold the fabric in your left hand and the trim in your right hand.

**Tip:** If you want a finished fabric edge, press a ¼" (6mm) hem to the right side of the fabric before inserting the fabric into the Flat Trim foot. The lace will cover the fabric raw edge when sewn in place.

## JOIN AND FOLD EDGING FOOT



620097396

coverlock™ 4.0 and 3.0



Use the Join and Fold Edging foot to hem the fabric edge and attach lace at the same time.

1. Set the machine for Coverstitch, wide.
2. Use the default stitch settings. Adjust if needed.
3. Snap on the Join and Fold Edging foot.
4. Slide the raw edge of the fabric right side up, into the fabric guide (illustration 1).
5. Slide the fabric to the back underneath the presser foot and the needles.
6. Insert the lace into the right lace guide and pull a lace tail about 1" (2.5cm) behind the foot (illustration 2). Use tweezers if needed.
7. Lower the presser foot. Hold the fabric in your left hand and the lace in your right hand and start to sew.

Note: Adjust the screw on the guide to adjust the stitch position if needed.

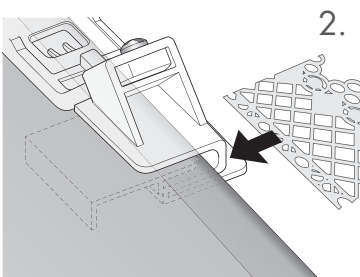
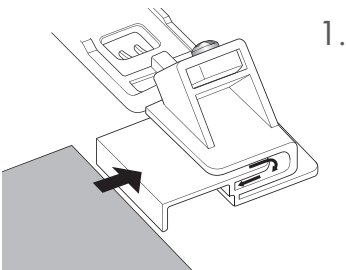



## STRAP AND BELT LOOP FOOT



620097196

coverlock™ 4.0 and 3.0

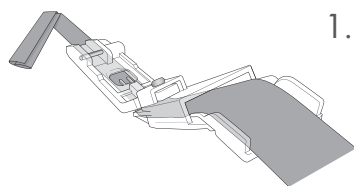

1.

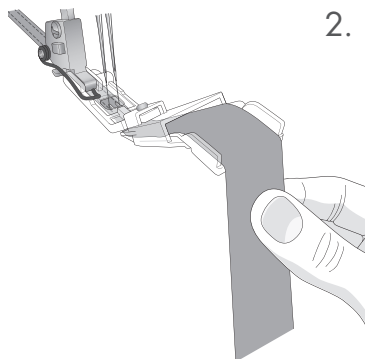

2.

With the Strap and Belt Loop foot, create straps and belt loops easily using a cover stitch. Just put a strip into the foot and the strip is folded automatically and stitched in place.

1. Set the machine for a Coverstitch wide.
2. Use the default stitch settings. Adjust if needed.
3. Cut a strip of fabric, 1" (25mm) wide.
4. Cut the top corner of the strip at a 45 degree angle to form a point.
5. Insert the cut angle into the guide, right side of the fabric facing up. Pull the strip through the slot and under the foot. Extend the tail of the strip behind the foot (Illustration 1). Use a tweezers to feed the strip into the foot if needed.
6. Snap the Strap and Belt Loop foot onto the machine.
7. Slide the strip approximately 2" (5cm) behind the foot.
8. Lower the presser foot. Be sure both raw edges of strip are turned under before stitching. Sew the first few stitches. Stop and clip the needle threads close to the presser foot and continue sewing.
9. For even feeding, hold the fabric strip slightly below the first guide in the front of the foot (Illustration 2).
10. Sew at medium speed. Check the fabric as you sew to ensure proper feeding.

Note: Sew the folded fabric strip without additional fabric underneath to create straps and belt loops or sew the folded strip onto another fabric for decorative effects.

## PIPING FOOT WITH CORDED GUIDE

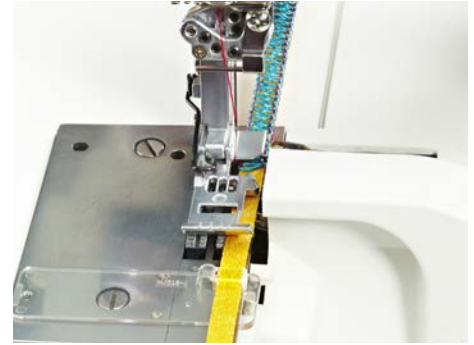
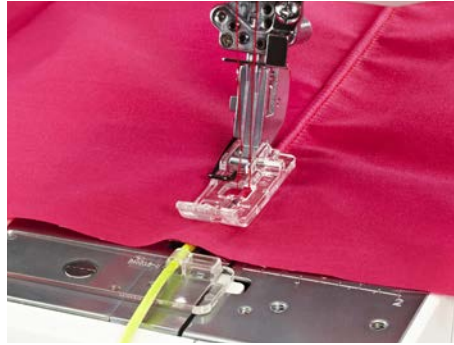

620097096

coverlock™ 4.0 and 3.0



With the Piping foot with Cording guide, you can create piping, corded tucks and decorative trims.



PIPING



CORDED TUCKS



DECORATIVE TRIM

## PIPING

1.

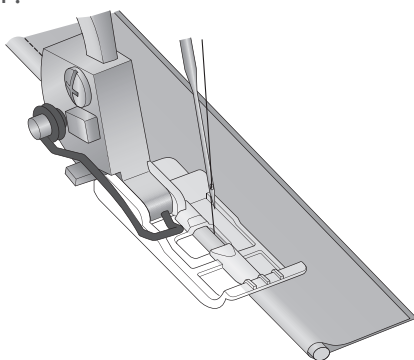

Easily create your own piping:

1. Set the machine for Chainstitch.
2. Use the default stitch settings. Adjust if needed.  
Note: Although the machine recommends needle D, you will use needle E for this technique instead.
3. Snap on the Piping foot. (The cording guide is not used for this technique.)
4. Place the cord in the groove on the bottom of the foot and pull the cord tail behind the foot about 2½" (5cm).  
Note: ¼" - 5/8" (1.5 - 2.0mm) cord can be used.
5. Cut a strip of fabric on the bias, 1" (25mm) wide.
6. Wrap the fabric around the cord in the front of the foot. Slide the fabric under the foot.
7. Lower the presser foot and sew over the cord and fabric (illustration 1). (Hold the cord behind the foot as you begin to sew.)

## CORDED TUCKS

2.

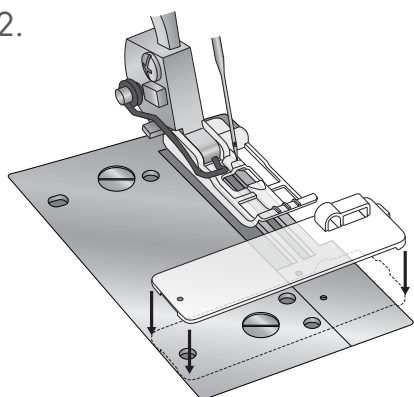

Achieve a trapunto effect when a coverstitch is sewn over a cord in the guide.

1. Set the machine for coverstitch, wide.  
Note: Although the machine recommends needles C and E, you will use needles D and E for this technique instead.
2. Snap on the Piping foot and attach the cording guide as illustrated (illustration 2).
3. Insert the cord into the round hole of the cording guide and position it in the groove on the bottom of the Piping foot.
4. Lay the fabric right side up on top of the cord. Slide it under the foot until it is underneath the needles (illustration 3).
5. Lower the needles into the fabric. Lower the presser foot and start to sew at a medium speed. (Hold the cord behind the foot as you begin to sew.)

3.

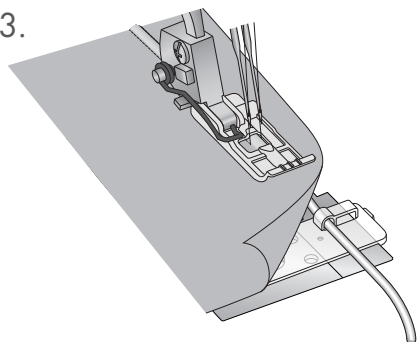

## DECORATIVE TRIM

4.

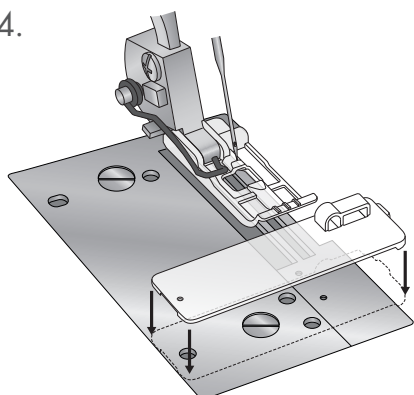

Use decorative thread and ribbons to create special effects and unique trims.

1. Set the machine for 3-thread ornamental fl atlock stitch, wide with decorative thread in the loopers.
2. Snap on the standard presser foot and attach the cording guide as illustrated (illustration 4).
3. Insert a ribbon 1/4" (6mm) wide right side down into the rectangular opening in the guide.
4. Place the ribbon under the presser foot to the right side of the needle, leaving a 2" (5cm) tail behind the foot.
5. The needle should go down into the machine just beyond, not into, the edge of the ribbon (Illustration 5).
6. Sew over the ribbon to make a decorative trim.  
Tip: Make your decorated ribbon long enough to cut it in three pieces, then braid (Illustration 6).

5.

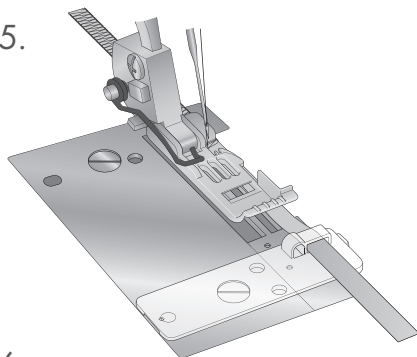

6.











ActivStitch | IDT | mySewnet

performance icon

performance icon™

PFAFF







**NEW!**



UNIVERSAL

821194096 (size 80/12 - 5 pack)

**NEW!**

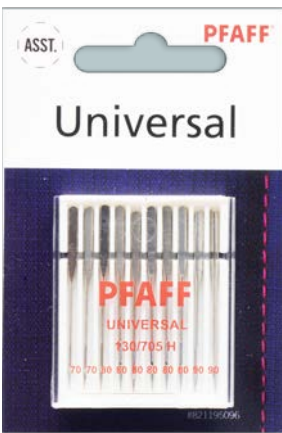

UNIVERSAL ASST

821195096: (ASST - 10 pack)

**NEW!**



TOPSTITCH

821196096: (size 90/14 - 5 pack)

**NEW!**



### EMBROIDERY NEEDLE ASST

821197096: ( ASST - 5 pack)

**NEW!**

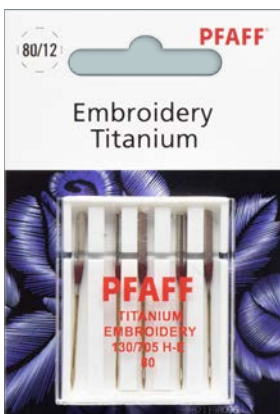

### EMBROIDERY TITANIUM

821198096 (size 80/12 - 5 pack)

**NEW!**

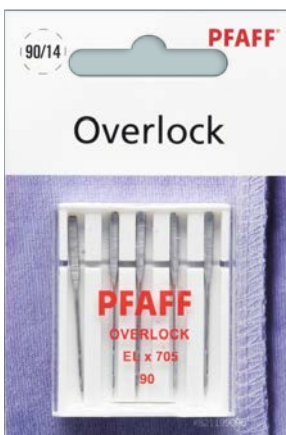

### OVERLOCK NEEDLE

821199096: (size 90/14 - 5 pack)

**NEW!**



LEATHER NEEDLE



821200096: (size 90 - 5 pack)

**NEW!**



QUILTING ASST



821201096: (ASST - 5 pack)

**NEW!**



MICROTEX ASST



821202096 (ASST - 5 pack)



**NEW!**



TWIN 2.5MM

--	--

821203096: (size 80/12 - 1 pack)

**NEW!**



TWIN STRETCH 2.5 MM

--	--

821204096: (size 75/11 -1 pack)

**NEW!**



TWIN STRETCH 4MM

--	--

821205096: (size 75/11 -1 pack)

**NEW!**



### CUTWORK NEEDLES

821206096 (ASST - 4 pack)

**NEW!**



### STRETCH

821199096: (size 90/14 - 5 pack)

**NEW!**

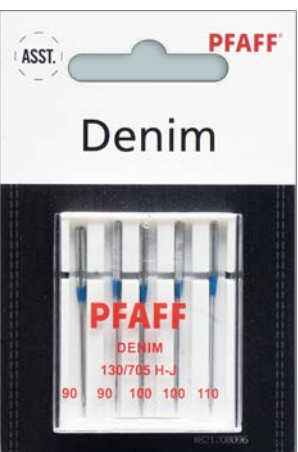

### DENIM ASST NEEDLE

821208096: (ASST - 5 pack)







## WHAT IS THE SECRET TO A PERFECT SEAM?

The fabric is fed from both the top and bottom at the same time with any stitch, no matter the stitch length or width. The result is absolutely no fabric slipping or shifting, which is perfect for quilting. Only PFAFF® machine has the original IDT™ system built right onto the sewing machine!



Fabric feeds evenly  
from both the top and  
bottom.

**IDT**  <sup>TM</sup>

Visit us regularly on the PFAFF® website! [www.pfaff.com](http://www.pfaff.com)

Printed for SVP Sewing Brands LLC, 1714 Heil Quaker Boulevard, LaVergne, TN 37068.

PFAFF is a trademark of KSIN Luxembourg II, S.a.r.l. © 2019 KSIN Luxembourg II, S.a.r.l. All rights reserved.

