

THE AUSTRALIAN MINING REVIEW

PP100007123

MARCH 2020

RRP: \$11.00 (Inclusive of GST)

Incorporating THE AUSTRALIAN OIL & GAS REVIEW

australianminingreview.com.au

A product of Publications & Exhibitions Australia Pty Ltd

**ROY HILL ON
PATH TO FULL
AUTOMATION**

NEWS
p8



**HOW TO SAVE
8M LITRES OF
WATER A YEAR**

TECHNICAL TALK
p90



**INSIDE:
GET THE
SUPERSCOOP
ON TRANSPORT**

OIL AND GAS REVIEW
p1



KING COAL

With support from the Federal Government, Australia's coal industry is headed for a cleaner, more productive future.

FEATURES P19-33



Stoddart are Australia's one-stop supplier of quality food service equipment to high production kitchens, major hotel chains and everyday food outlets

 **STODDART®**

1300 79 1954
www.stoddart.com.au
fse@stoddart.com.au

NEWS

Commodities Snapshot	4
News	6
In The Spotlight	16

FEATURES

Coal in Australia	19
Coal in Australia: Ctrl and Nth Qld	20
Coal in Australia: Saraji	22
Coal in Australia: Sojitz	25
Coal in Australia: Coppabella	30
Carrapateena Mine	34
Eliwana Mine	37
GFG Alliance	39
BHP South Flank	41
GEMCO	44
Minerals and Investment Week	46

MINING LIFESTYLE

Practice Makes Perfect	48
FIF-designed Dongas	50

INDUSTRY FOCUS

Companies Gearing Up	51
Training Providers	59
Labour Hire	60
Dredging Services	61
Cranes and Lifting	62
Aerial Surveying	63
Raiseboring Solutions	64
Hydraulic Systems	71
Drilling Contractors	78
Tailings Dam Management	80
Engineering In Mining	83
Catering and Accommodation	86
Shotcreting Solutions	89

TECHNICAL TALK

Pumps and Dewatering	90
Materials Handling	93
Foundry Services	96
Rockbreaking Solutions	98
Industrial Tyre Solutions	100
Minesite Communications	102

PUBLISHED BY
ABN 28 112 572 433

A product of
Publications & Exhibitions Australia Pty Ltd

GENERAL MANAGER

Trevor Pickett
trevor@australianminingreview.com.au

ASSISTANT GENERAL MANAGER

Biliana Harman
biliana@australianminingreview.com.au

MANAGING EDITOR

Ray Chan
ray@australianminingreview.com.au

JOURNALISTS

Mike Cooper
Michael@australianminingreview.com.au

Linda Smith
Linda@australianminingreview.com.au

PRODUCTION MANAGER

Nikki Weaver
nikki@australianminingreview.com.au

GRAPHIC DESIGNER

Charlotte Lufino
charlotte@australianminingreview.com.au

RESEARCH

Jason Strydom
jason@australianminingreview.com.au

Wayne Dyson

NATIONAL SALES MANAGER

Cal Christelow
Cal@australianminingreview.com.au

DIGITAL SALES CO-ORDINATOR

Chrissy Nurthen
chrissy@australianminingreview.com.au

SALES EXECUTIVES

John Carter, Joshua Dodd, Clare Ford, Donna Orton

PRINTER

Rural Press

CONTACT US

P: (08) 6314 0300

F: (08) 9481 7322

160 Beaufort Street, Perth, WA 6000.

PO Box 8023, Perth BC, WA 6849.

E-mail the editor at editorial@australianminingreview.com.au

For all other emails to staff, the standard convention is, first name (only) @australianminingreview.com.au

The Australian Mining Review is a free publication to all mine sites and mining companies in Australia. Its value is \$11 an issue. (Includes GST, postage and handling).

The copyright is vested in the Proprietors of The Australian Mining Review; neither whole nor any part of this issue may be reproduced without permission.

The views expressed in this publication are not necessarily those of Publications & Exhibitions Australia Pty Ltd and its staff, but are those of the respective author who accepts sole responsibility and liability for them.

NOTICE TO ADVERTISERS:

The Trade Practices Act, 1974 came into force on the 1st October 1974. All advertisers and advertising agents are directed to carefully study the provisions of the Act, which contain strict regulations on advertising.

It can be an offence for anyone to engage, in trade or commerce, in conduct deemed "misleading or deceptive". Specifically s53 of the Act contains prohibitions from doing any of the following in connection with the promotion, by any means, of the supply or use of goods or services:

- (a) falsely represent that goods are of a particular standard, quality, value, grade, composition, style or model or have had a particular history or particular previous use;
- (b) falsely represent that goods are new;
- (c) represent that goods or services have sponsorship, approval, performance characteristics, accessories, uses or benefits they do not have;
- (d) represent that the corporation has a sponsorship, approval or affiliation it does not have;
- (e) make a false or misleading representation with respect to the price of goods or services;
- (f) make a false or misleading representation concerning the need for any goods or services;
- (g) make a false or misleading representation concerning the existence, exclusion or effect of any condition, warranty, guarantee, right or remedy.

PENALTIES:

For an individual — \$10,000 or six months imprisonment
For a corporation — \$50,000. It is not possible for this company to ensure that advertisements published in this newspaper comply with the Act and the responsibility must, therefore, be on the person, company or advertising agency submitting the advertising for publication. In case of doubt, consult your lawyer.



**SAYONA MINING
MANAGING DIRECTOR
BRETT LYNCH**

In The Spotlight p16



**PRACTICE MADE
PERFECT**

Mining Lifestyle p51



WATCH WINNERS

Congratulations to the winners of our February win-a-watch competition:

- **Kylie Stewart**
- **Sean Grainger**

Each of them wins a Hunter Underground Watch from *Miners Watch*.

Improve your crusher's productivity by up to 30% with our new generation upgrades

This is how we make the big difference, the Metso Way.

Now the robustness and reliability of Superior™, Nordberg™ and Symons™ can incorporate the performance that only Metso's modern crushers achieve. Without having to buy a new machine, you can get our new generation crusher upgrades to improve your crusher's safety, performance and maintenance to make you more profitable.

Find out how our new generation of upgrades can make the big difference for your crusher at metso.com/CrusherUpgrades.

#TheMetsoWay



Wollongong
Signarama
The way to grow your business

(02) 4226 4522

wollongong@signarama.com.au
www.minesignsonline.com.au



MINING SIGN SPECIALISTS

SHIPPING AUSTRALIA WIDE - FAST TURNAROUND - QUALITY ASSURANCE - HUGE RANGE OF STOCKED ITEMS - CUSTOM SIGNAGE

- ✓ REFLECTIVE & NON REFLECTIVE SIGNS
- ✓ UNDERGROUND & ABOVE GROUND SIGNS
- ✓ STATUTORY / COMPLIANCE SIGNAGE
- ✓ SAFETY / FIRST AID SIGNS
- ✓ TRAFFIC / PEDESTRIAN CONTROL SIGNS
- ✓ LASER ENGRAVING / ETCHING
- ✓ STREAMERS / DROPPERS / TAGS
- ✓ BARRICADE SIGNS / TAPES & BOLLARDS
- ✓ ALUMINIUM / STEEL FABRICATED SIGNS
- ✓ ILLUMINATED SIGNS



*DIGITAL CATALOGUE AVAILABLE UPON REQUEST

MAJOR COMMODITIES SNAPSHOT

GOLD

\$US/oz

Gold is currently trading at a 7 year high as investors seek a safe haven from uncertainties surrounding the ongoing Covid-19 disruptions.

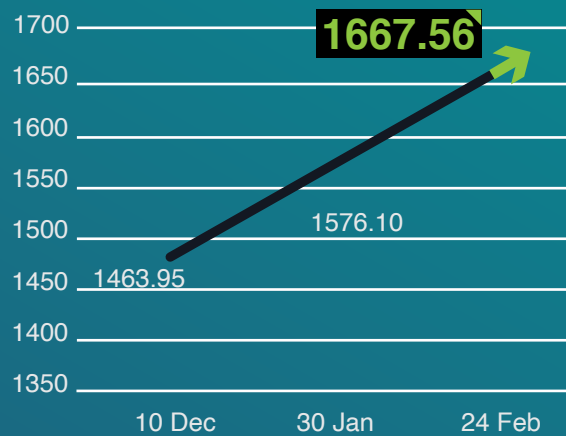

IRON ORE

\$US/t
62% Fe CFR China

Iron ore is feeling the pressure as the Covid-19 bans on movement and shipping begin to bite.



COPPER

\$US/t
LME Price

The effects of the Covid-19 has not been felt as harshly in the copper price as global infrastructure spending has kept prices steady.

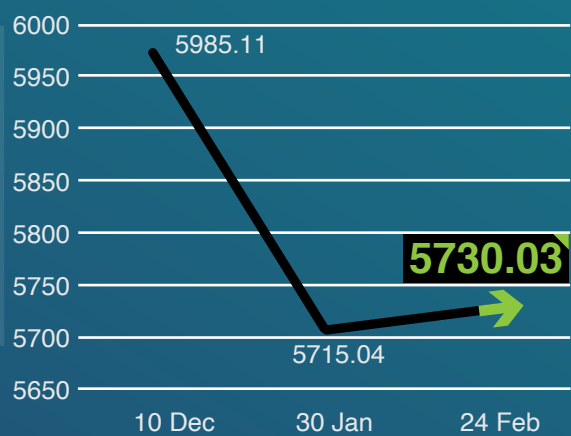

COBALT

\$US/t
LME Price

Cobalt has seen a steady rise as electric car production continues to increase, and will likely continue to do so as batteries move further into the energy equation.



ALUMINIUM

\$US/t
LME Price

Aluminum use is increasingly used as a replacement for other metals and this has seen its value stabilise on the market.



PALLADIUM

\$US/t
LME Price

Trouble in supplies from South Africa has seen a steady rise in palladium prices, though analysts are hedging their bets as to how long the surge will last.

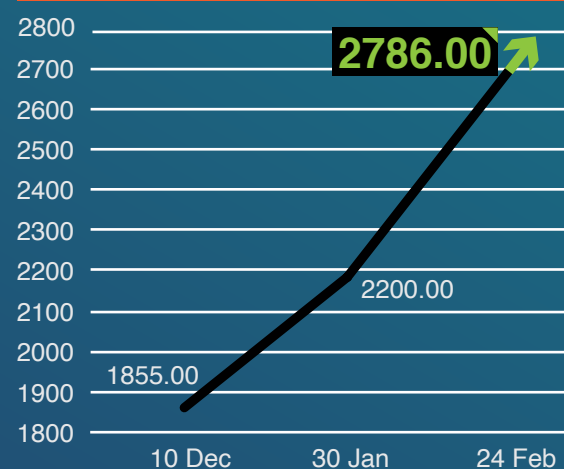

LEAD

\$US/t
LME Price

As China is the largest producer of lead, the tightness in the market is being exasperated by the shipping ban. LME stocks remain their lowest for a decade.



NICKEL

\$US/t
LME Price

With China being a major importer of nickel and its importance in the production of stainless steel, nickel has felt the market shocks from the Covid-19 disruptions.



MINE SAFETY

FIRE PROTECTION

AUSSIE MINE SPEC FIRE PUMPS

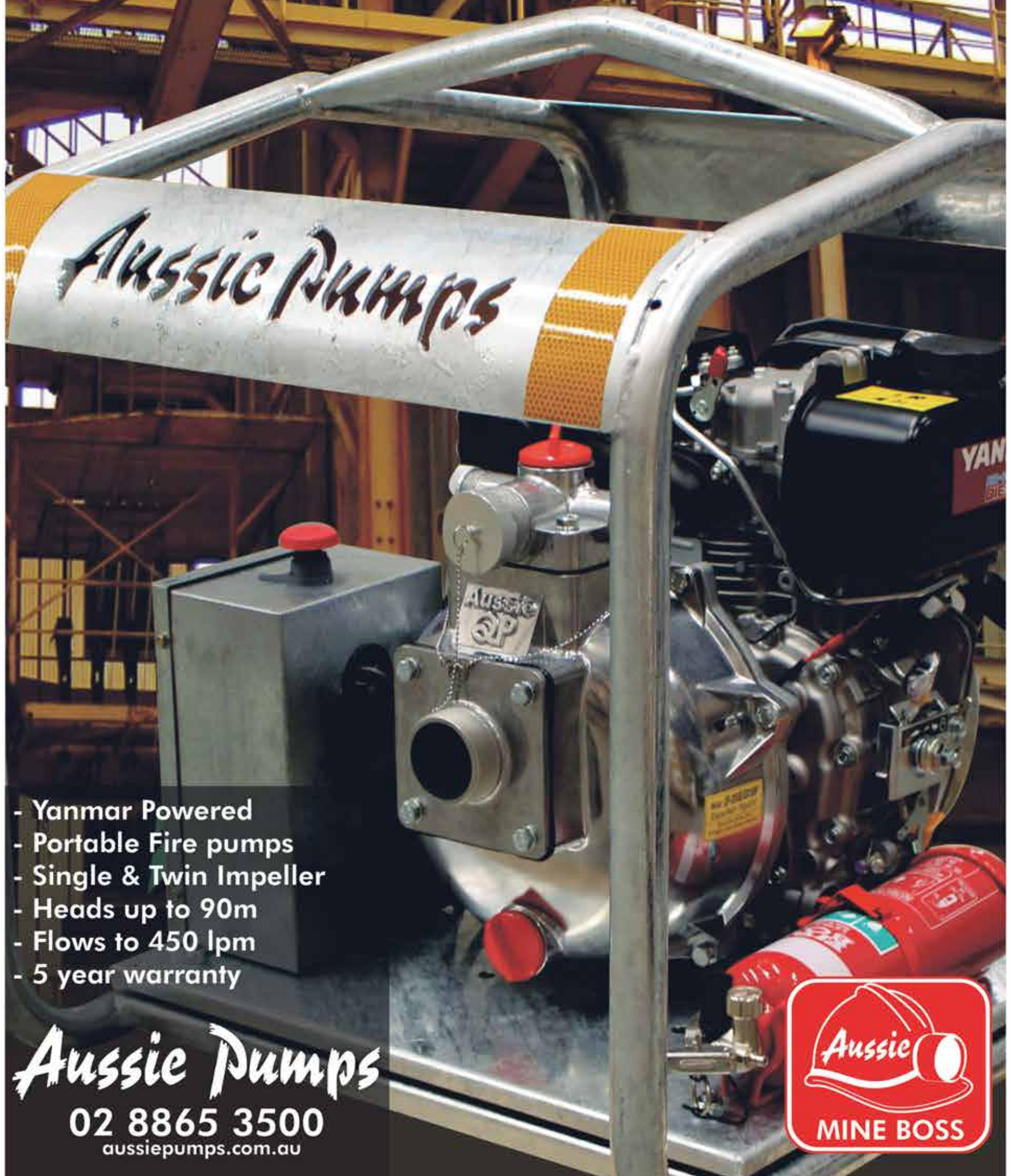

- Yanmar Powered
- Portable Fire pumps
- Single & Twin Impeller
- Heads up to 90m
- Flows to 450 lpm
- 5 year warranty

Aussie Pumps

02 8865 3500
aussiepumps.com.au



Mining giants aid virus recovery

RAY CHAN
NATIONAL

MINING giants Rio Tinto and Fortescue Metals Group have pledged donations to help authorities battle the deadly coronavirus outbreak in China.

FMG will provide \$1 million to the Wuhan Qingshan Charity Federation to support medical efforts at the epicentre of the epidemic.

The funds will be used to convert the WISCO Sports Stadium, owned by long-standing Fortescue customer Wuhan Iron and Steel Co. Ltd, into a 388-bed shelter hospital to treat patients who have been infected by the virus.

Fortescue chief executive officer Elizabeth Gaines said the miner offered its strongest support to the Chinese Government and people, as they worked

with the global community to address the significant challenge.

“The health and safety of the local population in Wuhan is a priority, and we are pleased to provide this donation which will help save lives and contain the spread of the virus,” she said.

“Fortescue has faith in the resilience of the Chinese people and economy, as they continue on their path of urbanisation and development.”

Rio Tinto, meanwhile, has donated US\$1 million to the Chinese Red Cross Foundation to contribute to China’s nationwide medical effort for the outbreak.

The funds will be used by the Red Cross, the Chinese Government’s preferred foreign donor, to support hospital upgrades and the purchase of medical supplies in the areas most affected by the outbreak.

The Foundation regularly contributes to China’s medical aid programs, and has been actively raising funds to strengthen medical resources in the affected areas.

Rio Tinto chief executive officer J-S Jacques said it was deeply concerning to see events unfolding in relation to the coronavirus outbreak.

“Our thoughts are with the people and families impacted,” he said.

“Many of our Chinese partners are playing a vital role on the frontline of containing the outbreak and, as a company with a long-standing partnership with China, we are committed to helping those who need help right now.”

In addition to the donation, Rio Tinto is working with Chinese partners to identify other practical ways Rio Tinto may be able to offer support.

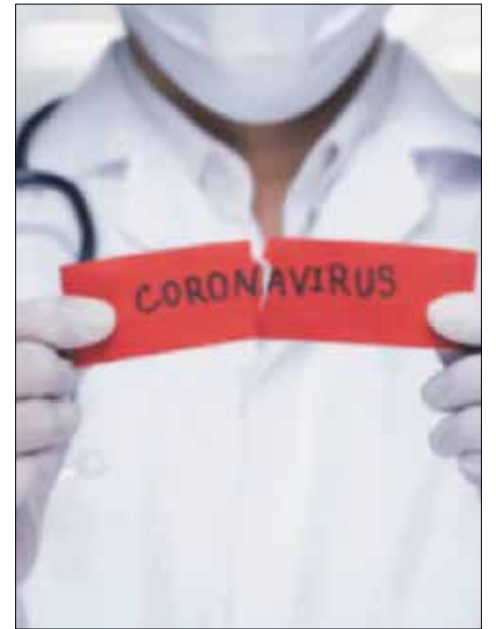

Rio and FMG have donated to the coronavirus cause to help those impacted by the disease.

Gold soars past \$1660

RAY CHAN
INTERNATIONAL

THE price of gold on international spot markets rose above US\$1660/oz in mid-February, marking its highest level since March 2013, in the wake of concerns about weakening fiscal conditions in China as a result of the coronavirus outbreak.

Some analysts believe the price could reach the US\$2000 mark within the next 12 months, as China prepares to pump billions into its financial system to revive its post-outbreak economy.

US investment bank Citi said as the record bull market stretches on, and as the virus impact threatens to slow down global growth, gold could be a way for investors to hedge risks to the downside.

The firm believes market jitters will prompt investors to pile into the so-called safe haven asset, pushing gold prices to the magic \$2000 level.

“Gold should perform as a convex macro asset market hedge, resilient during ongoing risk market rallies but a better hedge during sell-offs and vol spikes,” Citi analyst Ed Morse said.

In the shorter term, Citi lifted its six-to-12 month target on gold to \$1700/oz.

Mr Morse said the bullish activity in gold this year indicates growing investor concern and ongoing uncertainties surrounding the US-China trade war and the upcoming U.S. election.

He said that the economic backdrop was also supportive for gold since it tends to do well in a low interest rate environment as investors look for yield.

Investor sentiment around gold has turned bullish since early 2020, with the price of gold taking off from its US\$1480/oz launchpad at Christmas time 2019.

The price surge came after technology company Apple issued concerns around the impact of the Covid-19 outbreak.

It said it did not expect to meet its revenue guidance for two main factors: a constraint on the worldwide supply of its iPhone due to the slower-than-expected return to work in China, and lessened demand for Apple products in the country.

FMG chairman urges China support

RAY CHAN
NATIONAL

MINING giant Fortescue Metals Group has urged Australia not to over-react to the coronavirus outbreak by allowing fear to trump empathy.

In a joint statement, FMG chairman and mining magnate Andrew Forrest and chief executive officer Elizabeth Gaines said that now was the time to reach out and support the members of the Chinese community and show that the nation stands with them.

“Like so many global epidemics before it – Ebola, SARS or AIDS – we can lose sight of those who are sick or have lost loved ones and those who are helping others or working to contain the harm of the virus,” they said.

“Our hearts go out to all the Chinese Australians affected, especially with increasing reports of this community being the subject of fear-driven racism within our own borders.

“We call for compassion because we have come to know the Chinese people well over the past 30 years and have been regular visitors to their country.

“There are many more similarities between Australians and our Chinese neighbours than differences, and while their political system is different to ours, as a people, they are driven by compassion and desire for a better future for their communities.”

The statement said the level of alarm about the potentially deadly virus was to be expected.

“As Australia’s chief medical officer Brendan Murphy has noted, Australia has been one of the most proactive countries,” it stated.

“This is a global challenge however, and we must take these necessary precautions with compassion and humanity.

“While the worst news may still be ahead of us, China will recover and has demonstrated its commitment to protect its people and the citizens of the world, despite the hard, short-term impact these measures will have on its economy.

“Australia’s relationship with



FMG chairman Andrew Forrest said Australia must stand ready to support China, for the benefit of both countries.

China is multi-layered and complex, however as good friends, neighbours and trading partners, it is pretty simple – the Chinese people deserve our support.”

The statement said Australia had endured terrible bushfires and would take years to recover as it rapidly developed techniques to help mitigate the reoccurrence of fires and devastation of this scale.

“We have been fortunate to receive an enormous outpouring of love and support from around the globe,” it said.

“China is now dealing with its own critical emergency and needs the support and understanding of the international community.

“The most useful thing we can do is assist people who are directly impacted or at risk, including by donating to organisations on the ground that are providing shelter, masks, and medical supplies.”

FMG has donated thousands of face

masks to support health workers in the immediate response and will provide \$1 million to support the conversion of the WISCO Sports Stadium into a 300-bed shelter hospital (see story above).

“We will look for other ways to provide meaningful help, but the little things we can do to support each other are just as important,” Mr Forrest and Ms Gaines said.

“Like going to your local Chinese restaurant or reaching out with a hand and a smile to any Chinese person. It all sends the critical signal that we stand together.

“We are confident the Chinese people will rebound with the resilience they have demonstrated time and again over thousands of years and Fortescue will continue to support China throughout this hardship and beyond.

“Now is the time to remember we are common and unique, the one people on our little planet. We are all vulnerable and we all need each other.”

XTREME DIESEL GENERATORS



3 X Custom 650 kVA Perkins powered units running in Sync for maximum fuel efficiency in the Pilbara

Blue Diamond can customise Diesel Generators to suit any specification, site and project requirements.

All of our customised Diesel Generators are specified using only the highest quality components, including Com Ap, ABB, Schneider.

We also now have a base in Karratha with field mechanical and support.



Denyo

Diesel Generators

Bullet proof Japanese quality using only the best Kubota and Komatsu engines. 11.25% more fuel efficient* than traditional generators. Mobile and compact with strong canopies designed to be moved or truck mounted. Prime power rated to run at 50 degrees 24/7.

* Comparison between 200KVA generators



HONDA

Inverter Generators

Blue Diamond stocks a range of Honda's most popular inverter generators, with models suitable for residential & outdoor users. Legendary Honda quality. Perfect for job sites, camping or domestic use.

2.2 KVA Honda Inverter Petrol Generator

\$2,099

\$1,898



3 KVA Honda Inverter Petrol Generator

\$3,399

\$3,190



7 KVA Honda Inverter Petrol Generator

\$6,669

\$5,999



*Manufacturer's warranty - domestic use

Kubota

Kubota Lowboy GL9000 Mine Spec Diesel Generator

- Custom Steel Roll Cage
- Long Range Bundled Fuel tank
- Panel Cover
- Lockable Battery Isolator
- Fire Extinguisher
- Remote Start Input
- Deep Sea Controller
- Made in Japan customised by Blue Diamond

In stock ready to go!



\$12,650

BLUE DIAMOND
MACHINERY



- Blue Diamond is the authorised national distributor for Denyo Diesel Generators
- A Western Australian, privately owned company
- Full time 24/7 Support from Karratha - Chris Simpson 0439 665 960

1300 998 647

bluedm.com.au

info@bluedm.com.au

Perth: 9 Valentine Street, Kewdale, WA 6105

Karratha: 24/7 Field Support

Melbourne: 1/12 Holcourt Rd, Laverton North, VIC 3023

Mackay: 24/7 Field Support

Prices valid until 29.3.20 or while stocks last.

KPA03.20A/MR

Impressive results for IMDEX

RAY CHAN
INTERNATIONAL

LEADING global mining-tech company IMDEX has delivered its best half-yearly revenue result of \$127.9m, reflecting the strong interest in tech and exploration industries.

The company develops cloud-connected sensors and drilling optimisation products to improve the process of identifying and extracting mineral resources for drilling contractors and resource companies globally.

The figure was up 2pc on the first half of 2019 and comes after seven consecutive halves of growth.

With a solid balance sheet and strong net cash position of \$25.5m, the company issued a fully-franked interim dividend of one cent per share declared, up 25pc on the first half.

IMDEX managing director Bernie Ridgeway said the positive performance was largely driven by increased activity within Asia Pacific, a late Christmas shutdown and growing demand for the company's integrated solutions and cloud-connected technologies, which provided additional value to clients.

"The uplift in earnings reflected an increasing percentage of rental revenue, which yields higher gross margins and our ongoing focus on streamlining operations and managing costs," he said.

"We have delivered seven consecutive halves of growth and a three-year revenue and EBITDA CAGR of 16pc and 27.5pc respectively.

"This highlights the increasing strength of our core business and our ability to outperform market growth."

IMDEX chief operating officer Paul House said the firm's ability to offer leading solutions that delivered clear benefits to all clients in the mining value chain further enhanced the market position.

"We have a robust strategy designed to achieve further growth of our core business, while building more sustainable growth through the addition of our new technologies from FY21 and beyond," he said.

Demand for IMDEX's products continued to increase and the company won mandates for new work based on its ability to provide integrated end-to-end solutions.

IMDEX exercised its option to acquire Flexidrill and its drilling productivity technologies, COREVIBE and MAGHAMMER, in December 2019.

Flexidrill has been renamed IMDEX Technology New Zealand.

IMDEX also continues to have strong support from its METS Ignited partners, Anglo American, Teck Resources and Orica, in the development of the BLASTDOG technology.

Full automation for Roy Hill

RAY CHAN
WA

WA iron ore operator Roy Hill has plotted a path toward full automation.

Leading global mining equipment and services provider Epiroc, in partnership with automation specialist ASI Mining, is set to convert Roy Hill's mixed fleet of 77 haul trucks from manned to autonomous use.

Epiroc/ASI Mining will meet Roy Hill's requirements to deliver a safe, inter-operable solution for its truck fleet.

There is also scope to expand to other mining vehicle types and manufacturers, as well as capability to integrate with existing and future Roy Hill systems.

As part of this project, Epiroc/ASI Mining will work closely with Hitachi/Wencomine on truck conversion and integration of Roy Hill's existing Wenco fleet management system.

Roy Hill CEO Barry Fitzgerald said the company was well-positioned to transition to automation.

"Our teams on site and in our Remote Operations Centre (ROC) in Perth have demonstrated a clear capacity to deliver complex projects, sustainable change and operational excellence with the recent success of the autonomous drill program and fleet optimisation initiatives," he said.

"Now is the right time to bring the combined expertise of Roy Hill, Epiroc, ASI Mining and Wenco together to convert our haul truck fleet.

"Our chairman Gina Rinehart, and our owners Hancock Prospecting, Marubeni, POSCO and China Steel Corporation, have led this project from the start in the interests of staff safety and sustainable productivity.

"Their vision has set us a challenge to



Welcoming the deal were (front) Roy Hill CEO Barry Fitzgerald and Epiroc chairman Ronnie Leten, and (back) Roy Hill chief operating officer Gerhard Veldsman and Epiroc mining and infrastructure senior executive vice-president Helena Hedblom.

seek out partners who have an aligned tenacity and commitment to bring viable autonomous solutions to the table, and I look forward to realising the significant safety and productivity benefits that will come with this shared goal."

Mr Fitzgerald confirmed safety as a key driver of the project.

He also anticipated a range of operational benefits including increased productivity of the fleet.

"Roy Hill's Smart Mine program is driving innovation across our business, and the automation of our haulage fleet is central to delivering safety and production improvements," he said.

"Having delivered major automation projects across the globe, Epiroc and ASI Mining will bring together a highly

credentialled delivery team based in WA who will leverage the knowhow of a worldwide team of experts."

Roy Hill has carefully considered the impact of this project on staff, with reskilling and redeployment plans to assist operators switch to new roles within the business.

"We are committed to an automation journey that creates an environment in which our people can develop new skills critical to the workforce of the future," Mr Fitzgerald said.

The project will see a phased implementation, with testing and production verification of up to eight trucks undertaken in the initial phase prior to the second phase of full fleet expansion from mid-2021.

Resource sector spotlighted

RAY CHAN
WA

A NEW media campaign has begun to highlight the widespread benefits of the WA resources sector to the State economy and local communities.

The Resources Sector Powers WA' campaign will be run across Perth, the South West, Goldfields and the North West by The Chamber of Minerals and Energy of Western Australia (CME) on behalf of the sector.

CME chief executive Paul Everingham said while there was a general understanding that WA is a resources state, there was less recognition about the benefits that brings.

"Most Western Australians are unaware just how significant the sector's impact is on the State, both in an economic and social sense," he said.

"This campaign aims to start a conversation in the community about these benefits, whether it's employment and career opportunities and the royalties and taxes paid to governments that are then invested in infrastructure and services.

"We want to raise awareness of



Part of the digital media campaign.

the contribution the sector makes to local communities, such as sponsoring events, community grants, supporting sporting groups, and rehabilitating the environment.

"The campaign will also try to dispel some myths that working in the resources sector is dirty, dusty and simply FIFO.

"We actually develop some of the world's most cutting-edge technology, so the number of long-term careers available in the sector in the innovation space is growing day by day."

The campaign includes regional television; regional and metropolitan; digital; radio; billboards; and shopper media/outdoor smartlites.

Experience the Progress.



Liebherr R 9100 B – Technology for Your Excellence

- New EVO bucket offers higher productivity without compromising component lifetime
- Perfect match for 50t to 100t trucks
- Continuous improvement with new gen of key components e.g. diesel engine and swing pump
- Operator friendly cab: quieter working environment for efficient work
- First-class accessibility with larger catwalks and new handrails for increased safety.

Liebherr-Australia Pty Ltd | Head Office
1 Dr. Willi Liebherr Drive, Para Hills West
South Australia 5096
P: (08) 8344 0200, F: (08) 8359 4311
www.liebherr.com.au, E: info.las@liebherr.com

LIEBHERR

Palladium price prompts probes

RAY CHAN
NSW

FUELLED by record palladium and rhodium prices, Perth-based explorer Impact Minerals plans to raise funds for new drilling at its Broken Hill project in NSW, targeting high grade palladium and other platinum group metals within its prospects, including Red Hill.

Impact seeks to raise \$2,100,505 (before costs) for Broken Hill via a placement of 233,389,497 ordinary shares to sophisticated and professional investors at nine cents per share.

It follows on from recent findings that a major deposit of high grade nickel-copper-platinum mineralisation has formed in the Broken Hill project bearing similarities to the Junchuan deposit in China, one of the world's largest magmatic sulphide ore bodies.

Impact discovered very high-grade primary nickel-copper-PGM-gold mineralisation along this complex at both the Red Hill Prospect and also the Platinum Springs Prospect.

Exceptional grades were returned from drilling at Red Hill, including a stand out intercept in vein-hosted sulphide of 1.2m at 10.4 g/t platinum, 10.9 g/t gold, 254 g/t (9.5 ounces) palladium, 7.4pc nickel, 1.8pc copper, 19 g/t silver and 0.5pc cobalt.

At the Platinum Springs prospect, drilling returned a very high grade

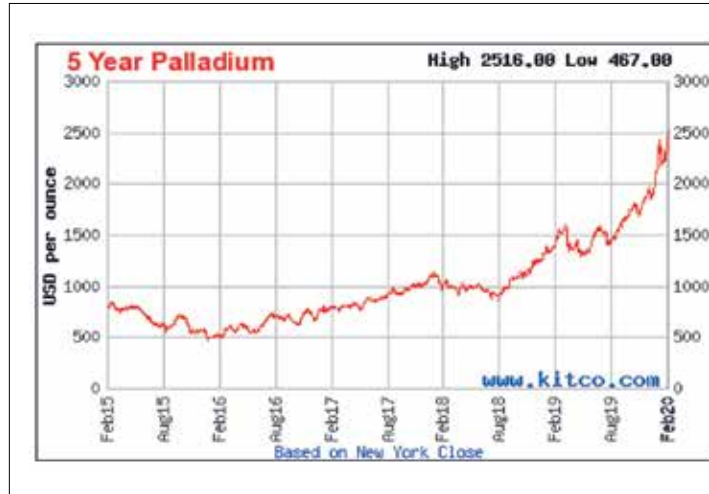

Palladium and rhodium prices have surged.

intercept of magmatic massive sulphide mineralisation, including 0.6m at 11.5g/t platinum, 25.6g/t palladium, 1.4g/t gold, 7.6pc copper, 7.4pc nickel and 44.3g/t silver, 1.3g/t rhodium, 1.7g/t iridium, 2g/t osmium and 0.8g/t ruthenium.

Platinum Springs lies at the southern end of the Moorkai Trend and is the only prospect to have been explored in detail.

However, Impact managing director Mike Jones said the entire 40km long belt had been very poorly explored and many targets remain to be followed up.

Impact will make this exploration a focus for the next quarter and will also continue research into the metallurgical recovery of the PGMs.

Dr Jones said palladium has soared to

record prices of more than US\$2500 per ounce, while rhodium prices "literally exploded" above US\$10,000 an ounce.

"Impact is pleased to now have the funds to aggressively return to exploration at our unique Broken Hill project," he said.

"Our previous drilling at Broken Hill has delivered exceptional grades of all six platinum group metals (palladium, platinum, rhodium, ruthenium, osmium and iridium), not to mention gold, nickel and copper as well," he said.

"We are looking forward to getting the drill bit turning at Red Hill as soon as possible, where we returned drill grades of 1.2m at 254 g/t palladium and 4.6 g/t rhodium - exceptional PGM grades on a world scale.

"The company is also about to commence re-assays of key drill intercepts, for rhodium, which is not routinely assayed for."

Dr Jones said the funds raised would also enable Impact to push forward with follow-up work on its Commonwealth project targets along trend and close to the recent Boda discovery in the copper-gold rich Lachlan Fold Belt.

"It's currently one of the hottest exploration footprints in Australia," he said.

"We will have boots on the ground there shortly to complete soil geochemistry surveys and subsequently ground geophysical surveys to define targets for drilling later in the year."

Golden drill results for Horizon mines

LINDA SMITH
WA

HIGH grade drill results have been announced at the Rose Hill, Gunga West and Golden Ridge gold mining projects in WA.

The sites, near Kalgoorlie and Coolgardie, were acquired by Horizon Minerals under an asset swap with Northern Star resources in September and December last year.

According to Horizon management, Rosehill has produced about 1340oz of gold at 8.3g/t gold from 5000t since 1898.

The drill results came after 12 Reverse Circulation (RC) holes at Rose Hill, which were conducted for the purpose of due diligence.

Significant assays of gold, associated with stock work quartz veining and increased pyrite abundance, were found within a steep dipping, porphyry host rock.

Confirmation of solid gold mineralisation was discovered beneath the pit floor.

Further infill pit drilling is planned in the anticipation that quantities of the shallow ore will be upgraded to a measured category following assessments of the old pit.

RHRC20012 returned 16m at 4.10g/t Au from 93m and confirms the underground potential at Rose Hill.

Mineralisation extends to 300m vertical depth, according to historical drilling results.

Rose Hill lies on the western margin of the Archean Norseman-Menzies Greenstone Belt.



Image: Jeremy Smith.

Barminco has been signed as underground operator for Panoramic Resources' nickel/cobalt project.

Savannah contract for Barminco

LINDA SMITH
NSW

PANORAMIC Resources has signed a letter of intent with Barminco, awarding it preferred underground contractor status.

A subsidiary of Perenti Global Ltd, Barminco is one of the world's largest hard rock underground mining service companies.

Confidence in the long-term potential of the project was supported by a \$32.7m raising in rights issues mid-January.

Barminco will provide a newer mining fleet and is expected to employ the majority of the existing Panoramic underground mining and maintenance workforce.

Its proven expertise and established operating system are expected to improve operational efficiencies and drive production volumes to reach targeted levels.

Barminco chief executive officer Paul Muller said the miner looked forward to working closely with Panoramic Resources in driving the development of the Savannah North orebody safely

and efficiently as it ramped up to full production.

Panoramic has had a full year to date after fighting off a hostile takeover from IGO, hitting the new ore body at Savannah North and employing a new company secretary after the retirement of veteran Trevor Eaton.

Savannah shipped its first shipment of concentrate in February 2019, after reopening in September the previous year.

Barminco hopes to deliver mobilisation and shift to contract mining at Savannah by the end of the March 2020 quarter.



IMPACT ROLLER



Broons has led Impact Roller technology for over 35 years, with benefits to the mining sector:

- Deep Compaction
- Unrivaled Productivity
- Haul Road Construction
- Capping Tailings Dams
- Rock Rubbilisation
- Risk Mitigation
- Tyre Wear Reduction
- Limit Suspension Fatigue
- Operator Comfort
- Reduce Fuel Costs
- Secure Tip Heads
- Low Running Costs

BH-1300 MS
14 Tonne
1300mm Module



Features

- Heavy Duty Linkage
- Gusseted Chassis
- Extra Wear Plates
- Lugged Tyres



BH-1950 MS
18.5 Tonne
1950mm Module

Broons Group (08) 8268 1988 - info@broons.com - www.broons.com

Caterpillar first for Collie

RAY CHAN
WA

LEADING Caterpillar dealer WesTrac is to build a technology training facility in the WA town of Collie focused on providing courses in autonomous operations.

The centre will be the only Caterpillar Autonomous Training Facility in the world apart from Caterpillar's own testing and training ground in Arizona, USA.

The facility will be developed on land owned by Bluewaters Farm Holdings in Collie's Coolangatta Industrial Estate.

The project is supported by a grant through the Collie Futures Fund, awarded to WesTrac by the State Government's Department of Jobs, Tourism, Science and Innovation.

The announcement was made at a ground-turning event in Collie attended by WA Premier Mark McGowan, Regional Development Minister Alannah MacTiernan, Collie-Preston MLA Mick Murray and WesTrac CEO Jarvas Croome.

Mr Croome said the investment includes a new fully autonomous Cat 789D off-highway truck, construction of an autonomous operations zone and training room facilities.

The construction is scheduled to commence at the greenfield site near Collie's Bluewaters Power Station.

Local contractor Piacentini & Son will carry out the earthworks and installation of key infrastructure, with training scheduled to start in May.

"The initial focus will be to provide training in fit-out and maintenance requirements for the conversion and operation of existing Caterpillar haulage vehicles," Mr Croome said.



Turning the sod at the facility were Alannah MacTiernan MLC, WesTrac CEO Jarvas Croome, Mick Murray MLA, Mark McGowan MLA, and Piacentini & Son executive director Kim Piacentini.

"Over time, we anticipate expanding the range of courses on offer to ensure the facility caters for the recognised skills of the future that will be in demand as the resource sector evolves.

"It's an opportunity to position Collie and WA as a world leader in advanced technology and skills development in automation and autonomous operations."

Mr McGowan congratulated WesTrac and Bluewaters Farm Holdings for working with the State Government to get this groundbreaking facility off the ground.

"People will come from all over the world to utilise this facility - the first of its kind in the southern hemisphere and the second worldwide for Caterpillar,"

Mr McGowan said.

"Crucially, we expect clients to spend time in the town as they undertake their training, supporting local businesses and local jobs.

"It will see Collie placed at the forefront of training workers - including local workers in Collie - in new technological skills for large-scale mining operations across the state.

"This is a new industry for Collie and Western Australia that will result in new jobs and training opportunities for local people, while meeting demand from around Australia and overseas."

Mr Croome added that while WesTrac had evaluated a number of potential locations, Collie was the ideal centre for

the training facility.

"The town has a long mining history and an experienced workforce with the potential to help run and develop the training facility over time," he said.

"There's also a vibrant community and plenty of supporting business infrastructure, plus a unique range of natural attractions and easy access to the wider South West region, which adds appeal for Australian and international training participants."

Mr Croome said WesTrac and Caterpillar clients across the Asia Pacific region had shown significant interest in having access to such training and strong demand was expected when the facility commenced operations.

The razor's cutting edge

RAY CHAN
NATIONAL

THE newest release from Bis' innovation pipeline - the cutting edge underground grader named Razor - has sparked strong interest from Australia's mining community within weeks of launching.

Bis, a leading innovator and resources logistics company, confirmed that Whitehaven Coal has already secured a Razor for its operation, with another underground miner taking a further two.

The demand for Bis' newest technology offering follows a successful product launch and customer roadshow across Queensland and NSW in November.

Bis CEO Brad Rogers said the company was delighted in the industry response for Razor.

"I am pleased that two long-term customers of Bis are the first to secure the technology," he said.

"Razor was designed with miners, for miners - offering a step change in efficiency and importantly, operator safety."



The key features of Razor include superior engine power and grader mass that has been optimised to increase tractive effort by more than 30pc.

The key features of Razor include superior engine power and grader mass that has been optimised to increase tractive effort by more than 30pc.

Bis designed the grader with safety front-of-mind, resulting in a modular drivers' cabin which improves ergonomics, and a safer, more reliable, braking system.

"Bis is differentiated in the market by

our range of patented mining solutions," Mr Rogers said.

"We harness the talent and experience of our team and design innovations and invest in new technology which delivers efficiency improvements for our customers.

"We have a pipeline of innovations planned for the sector over the coming 12-18 months.

"We believe the new products and services will add new markets and geographies to our current portfolio - which currently includes 40 operations across Australia and Indonesia."

The release of Razor comes little over a year after Bis unveiled REXX, a revolutionary 20-wheel dump truck to the market, earning the company several innovation awards.

"We're helping to fight cancer with **Australian gold.**"

Gold nanoparticle therapy research offers new hope for the future treatment of cancer. As technology transforms our precious metals, Australian gold is helping to create a healthier world.

Find out more at minerals.org.au

There's more to
Australian Mining



The proof is in the roads

RAY CHAN
SE ASIA

PROOF Engineers has expanded into the South-East Asian market to deliver cutting-edge road condition monitoring techniques and haul road design to help coal mines increase operational efficiencies and improve road safety.

The Australian-based global company has implemented two of its products and programs – the Road Condition Monitor and the Haul Road Development – across three coal mines sites in Kalimantan.

These proven technologies have delivered real-time data on road conditions to help the mines in Kalimantan prioritise maintenance works.

They've also helped the mines manage uncontrolled emissions and improve operational efficiencies.

Proof Engineers specialises in haul road engineering and innovative technology to improve productivity and profitability for the mining and civil industries.

The company's engineering and technologies manager Jordan Handel said after operating successfully in the Australian mining industry in recent years, Proof Engineers has launched into the South-East Asian market.



Proof Engineers has provided recommendations on investing in technology to help build roads that are safer, more sustainable and require less maintenance.

"Indonesian mines are very large operations with high labour demands, and management have welcomed our technology and systems that offer significant opportunities to improve their productivity," he said.

"What Proof Engineers has been able to do is provide recommendations on investing in technology to help them build roads that are safer, more sustainable and require less maintenance."

Mr Handel said the Road Condition

Monitor is an innovative system that collects data in real-time on road conditions and analyses the information to stream it back to the mine site.

The onboard vehicle monitoring system's advanced sensors map out the road quality, which is displayed in colour code, from green signifying good quality of sections of the road, to red highlighting the areas that need urgent maintenance.

Mine site operators that use Proof Engineers' Road Condition Monitor are

given a clear picture of road conditions and use the information it gathers to prioritise road maintenance, increase operational efficiencies and lower the cost per tonne hauled.

Following on from the success of the Monitor at the mine sites, the company implemented its Haul Road Development Program to audit roads.

Mr Handel said mine approach to road maintenance was inconsistent before Proof Engineers implemented its cutting-edge technologies.

"With growing pressure on mines to save costs and improve performance, operators are looking at the efficiency of truck haulage, which accounts for a significant proportion of the total operating costs of a mine," Mr Handel said.

"Our systems have not only helped to increase efficiencies, but they've made the roads safer and taken the guess work out of maintenance."

The biggest challenge the Proof Engineers team overcame was the significant amount of seasonal rain that falls in Kalimantan.

However, having done work in similar climates, its perfected its services to a point where it is now recognised as a proven performer in the mining industry.

Pilbara test for mission on the moon

ROBERT HOBSON
NATIONAL

WA'S Pilbara could be used as a test landscape for remote mining on the moon.

Mining on Earth's satellite and indeed planet Mars using autonomous robots is a pathway to prepare the way for future crewed missions, and potentially even human habitation.

Australia is at the centre of the world's most advanced mining industry innovation, and is looking to take to its know-how out of this world.

According to CSIRO's digital facilities and collections executive director Dave Williams, Australia can bring its geoscience and mining expertise to the table – particularly in the area of remote and automated mining – to prepare the way for crewed missions to the moon, and conceivably to other planets in our solar system.

"There are massive logistical issues around humans going to the moon, such as ensuring adequate supply of water, food, radiation proof shelter, medical support and setting up sustainable life systems," he says.

"That's why an un-crewed mission – with robotics used to explore and test feasibility – is an attractive option in the first instance, because it can potentially do some of the work without people."

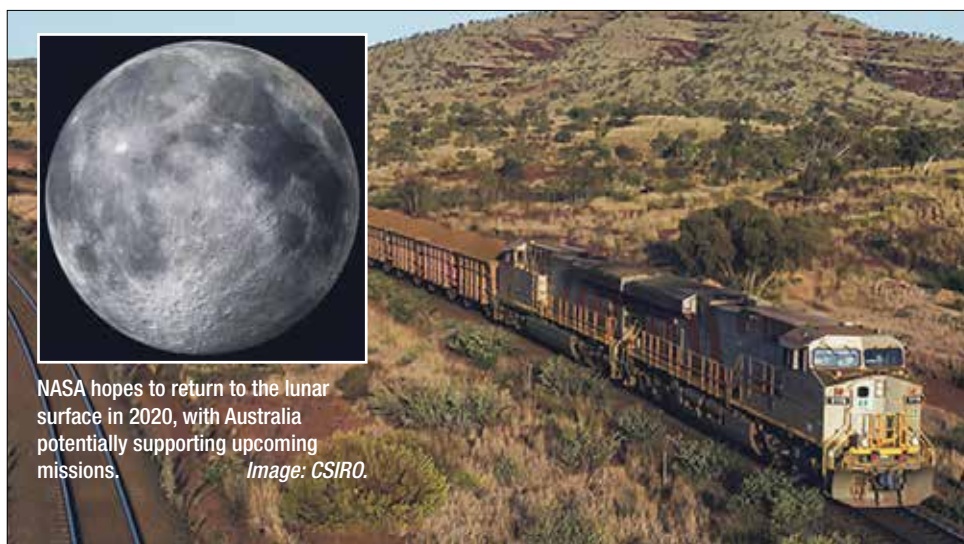

NASA hopes to return to the lunar surface in 2020, with Australia potentially supporting upcoming missions. Image: CSIRO.

Rio Tinto has successfully deployed AutoHaul, establishing the world's largest robot and first automated heavy-haul, long distance rail network.

Pointing to WA as an example, Dr Williams said a lot of the mining activity in the Pilbara is being managed remotely from Perth, and that a system similar to it could be set up to deliver the requisite tools and equipment ahead of a crewed expedition.

"Australia is looking at this, because I believe we are world leaders in remote mining. It isn't saying we have all the answers, but we are definitely ahead of the curve," Dr Williams said.

"There are logistical support areas where we could be, as a country, a player in the global system, and that's one of the challenges space agencies, including our Australian Space Agency, and CSIRO are looking closely at."

Much of the technology at play in remote 'terrestrial' mining operations can be applied to space despite the added challenge that comes with operating in an extra-terrestrial environment, such as lower gravity.

The transition point or 'gateway' solution is the one favoured by NASA,

and the idea behind it is that before sending any humans back to the moon supplies and equipment could be sent ahead, either to the lunar surface or to an orbiting space station. In the future, it can also provide a springboard onto Mars and into the wider solar system.

Dr Williams said this isn't necessarily a negative factor.

"In terms of using the Moon as a base for further exploration, you can see a clear advantage of a transition point in terms of power to payload mass for launch compared to our Earth," he said.

"These, of course, need to be part of a balanced decision across all parameters.

"Just as the lunar rover could be driven on the Moon with less power, and an astronaut can jump up and down with less power, materials are also easier to move with less power. In fact, it might actually be a bonus.

"At the same time, the direct approach to the Moon may be beneficial if you want to get heavy lift equipment

there, dropping it off with no intention of returning it."

So what role would remote mining systems play in this situation? Not everything can be brought from Earth, as more mass means more energy is required to escape Earth's gravity, in addition to whatever support systems will be needed to keep humans alive on the journey.

To minimise the logistical stress placed on an Earth take-off, one approach would be to take enough to get to the Moon and establish the base, with the lunar minerals and resources then being used to the maximum to replenish supplies and for return journeys.

And this is where Australia's remote mining systems experience could play a significant role, by essentially laying the ground work for the development of these resources and managing them remotely from Earth through surface or satellite based sensors, and robotic systems.

Water may already have been discovered at the poles but new deposits are nevertheless important.

"There are a lot of robotics you need for moon based survival and Australia is good at it. And if you are looking to grow crops on the moon at some stage – which we will inevitably try to – the dry agriculture capability of Australia is good as well. We again are the leaders," Dr Williams said.

What makes these ideas worthy of consideration are the advances in data and sensor analysis, which have given unprecedented levels of detail to geoscientists to better characterise resources, and such technology could be applied in a lunar context to determine particular types of mineralisation containing useful materials.

EQUIPMENT READY FOR HIRE

FRECALL
1300 455 195

strategic equipment solutions

- ▶ Water transfer pumpsets
- ▶ Trailer pumpsets
- ▶ Submersible pumpsets
- ▶ Remote start/stop systems
- ▶ Borehole pumpsets
- ▶ Telemetry control systems
- ▶ Trailer mounted water carts
- ▶ Lay flat hose & accessories
- ▶ Layflat deployment systems
- ▶ Dust suppression equipment
- ▶ Sound attenuated pumpsets
- ▶ Water truck fill point kits
- ▶ Silt separation tanks
- ▶ Fuel trailers
- ▶ Stand pipes
- ▶ Fuel cells
- ▶ Generators



PUMPSETS

SOUND
ENCLOSED
PUMPSETS

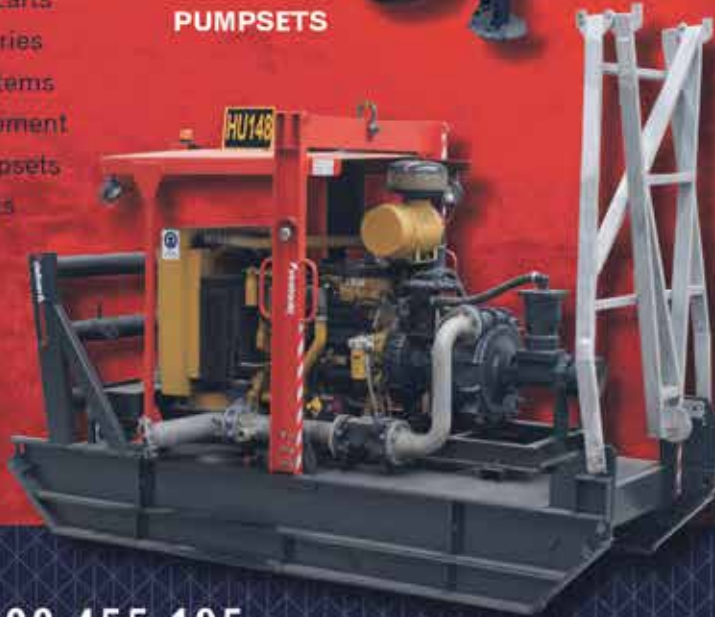

FUEL TANKS

stratquip.com.au

FRECALL 1300 455 195

stratquip
strategic equipment solutions

Unlock Your Mill's Full Potential



Small Footprint > Huge Throughput

StackCell's high performance, two-stage flotation technology greatly improves throughput by lowering residence time compared to conventional cells. This compact powerhouse requires a fraction of the space and can be stacked to accommodate plant expansions.

StackCell's Advantages:

- High-Rate Flotation
- Requires Less Power
- Reduces Capex
- Reduces Foundation Loads

Contact Eriez Flotation Division 1.604.952.2300
or visit EriezFlotation.com

ERIEZ
FLOTATION DIVISION

SAYONA MINING MANAGING DIRECTOR BRETT LYNCH

Australian lithium exploration company Sayona Mining is seeking to add to its suite of lithium projects in WA and Quebec. The company's target customer segment is the lithium-ion battery market, including carmakers. Sayona is currently bidding to acquire the North American Lithium (NAL) mine in Quebec, supported by New York-based investment company Obsidian Global. Mike Cooper spoke with managing director Brett Lynch about its flagship Authier project in Quebec and its ambitions for NAL, WA projects, and the state of play in the lithium market.

Q. Sayona said in a recent market update that it was seeing an upturn or recovery in the lithium market: can you elaborate on this please? Why is this recovery happening?

The ASX-listed lithium sector has had a positive start to 2020 thanks to German automaker BMW's \$600m investment in Australian lithium, Tesla's delivery of Shanghai-made Model 3 cars, China's decision to maintain electric vehicle subsidies, and investments by automakers and others that have highlighted the strength of lithium demand.

For Sayona, our success in securing US investor support follows our recent securing of an agreement with the First Nation Abitibiwinni concerning our flagship Authier Lithium Project in Quebec, Canada.

It also reflects increasing market confidence in the potential for our turnaround strategy at the North American Lithium (NAL) mine, which Sayona is currently bidding for backed by a world-class bid support team.

NAL has a nameplate capacity of 180,000tpa for spodumene and produced 114,000t of the mineral in 2018.

The operation will have the potential to produce battery-grade lithium carbonate following further investment.

Analyst forecasts point to a growing lithium supply deficit emerging this decade and with the continued growth in demand for EVs and energy storage we are very confident in the outlook, particularly given our projects' proximity to North American battery markets.

Q. Sayona is looking to acquire a lithium mine in Quebec. Why is it interested this asset in particular, is it its proximity to its Authier project? Does the new mine acquisition require any new investment or re-equipping?

Sayona has assembled a world-class bid support team for NAL and we are very confident of achieving a successful turnaround.

NAL has an existing concentrator that Sayona aims to feed with spodumene ore from not only NAL but also our Authier project, together with potentially our emerging Viau-Dallaire prospect, putting NAL at the centre of our lithium hub strategy.

Some investment will be required to restart operations, however, this will be minimal considering the C\$400m (A\$444m) previously invested at NAL.

Sayona will be bringing operational expertise combined with engineering, environmental, financial and technical know-how that will be of enormous benefit to NAL.

Importantly, Sayona has the unique advantage of being able to blend ore supplied from the company's Authier project with NAL to achieve a significant improvement in plant performance and



Sayona Mining
MD and CEO
Brett Lynch.



An exploration drilling rig at Sayona's Authier project in Canada.

economics.

Sayona looks forward to continuing our close engagement with key parties and delivering a bid that ensures a successful turnaround.

Q. Sayona has its own lithium project in Authier in Canada, and two exploration projects — one in the Pilbara and another in Canada. How far along are these in terms of development and when are they going into production?

Sayona's flagship Authier project in Quebec is currently progressing through the approvals process, including a new environmental impact statement and ongoing community consultation.

Approval is expected by late 2020, and thanks to support from the Quebec Government for the province's lithium industry, which it has described as a "jewel for Quebec", we are confident of winning approval.

Pending such approval, construction could start as early as 2021 and mining operations in 2022, with the potential to generate new jobs and investment for the local community while also supporting our lithium hub strategy, based around NAL (pending the conclusion of the bid process).

Also in Quebec, the nearby Viau-Dallaire prospect is showing great potential to become a new lithium deposit, being located just 82km south-west of Authier and with mineralisation open in all directions.

In WA, Sayona signed in August 2019 an earn-in agreement with leading lithium

producer Altura Mining to develop Sayona's exploration portfolio in the world-class Pilgangoora lithium district.

Under the agreement, Altura has committed to spending \$1.5m on exploration over three years to earn a 51pc stake. This agreement offers the potential for new lithium discoveries while allowing Sayona to maintain our focus on our more advanced Canadian projects.

Q. What type of lithium product is Sayona going to produce and what will be the target market or markets for this? Is it for electric vehicles, or industrial or household batteries or other uses?

The revised definitive feasibility study (DFS) for Sayona's Authier project, released in November 2019, projected annual average spodumene production of 114,116t, with a life of mine of 13.8 years.

However, a previous study showed the potential for increased value from producing lithium carbonate/hydroxide, both high-value products used in the lithium-ion battery industry.

Given Quebec's proximity to North American battery markets, it is envisaged that the United States will be the target market for the company's production, such as Tesla's gigafactories, helping to power the clean energy revolution in transport and electricity.

Sayona is fully aligned with Quebec's plans to develop a downstream processing industry that capitalises on the strength of battery demand and offers superior returns to stakeholders.

Q. When does Sayona expect to start production of lithium at its minesites and how will it get its product to market?

As indicated above, it is envisaged mining operations could commence at Authier as early as 2022.

However, Sayona could commence production at an earlier date pending the outcome of its bid for the North American Lithium mine.

Q. What is Sayona's forecast for lithium prices in the near term, say the next three years? What demand and supply factors are at play?

The revised DFS for Sayona's Authier project included pricing forecasts from engineers Hatch, which estimated an average spodumene price of US\$693/t for the life of mine.

Q. The company has lined up an investment partner in New York-based investment fund Obsidian Global for its Quebec mine acquisition. Does it have other investors lined up or interested in investing in the company?

Certainly. Sayona is delighted with the support of investors including our new US investors and their confidence in our outlook.

The recent upturn in the lithium sector together with our bid for NAL has attracted significant interest and we welcome new investors seeking to support our strategy of becoming one of Canada's largest lithium miners.

TAKE CONTROL OF YOUR WATER

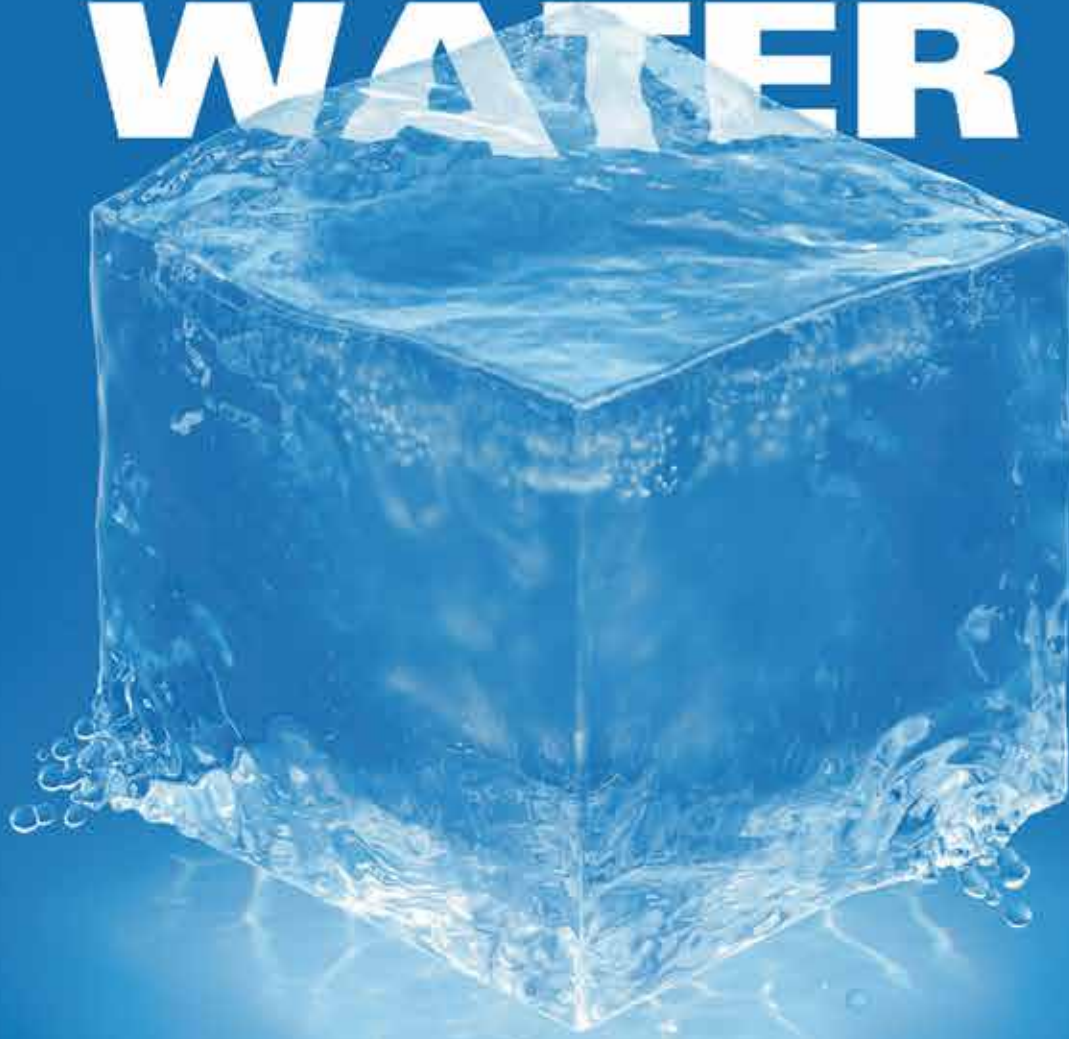

There's nothing worse than an unknown variable and there's nothing more variable than water. Floods, torrential downpours, moving water from A to B – it can very quickly get out of control. That's why the Weir Minerals team works tirelessly with sites to design tailored dewatering solutions. We use our expertise in both process and products to maximise efficiency and help you take control of your water.

Learn more at dewateringsolutions.weir

Copyright © 2019, Weir Minerals Australia Limited. All rights reserved.

WEIR

**DEWATERING
SOLUTIONS**

Minerals
global.weir



**SMITH
BROUGHTON**
AUCTIONEERS

**JOIN US ON-SITE OR ONLINE FOR OUR UPCOMING
TRADITIONAL AUCTIONS. MIDLAND, WESTERN AUSTRALIA**

SALE 802 | 2 APRIL 9AM

COLLECTABLE FLEET & MOTOR VEHICLES



**1987 AIRSTREAM 290 CLASSIC
MOTOR HOME**



1970 FORD SHELBY GT350 FASTBACK



**2014 TOYOTA HILUX KUN26R 4X4
DUAL CAB TRAY BACK UTE**

SALE 803 | 3 APRIL 9AM

ANTIQUES, COLLECTABLES & CURIO COLLECTION



**TJ RICHARDS OF HINDEMARSH ADELAIDE
"KING OF THE ROAD" HORSE DRAWN SULKY**



**FORDSON ROADLESS TRACTION LTD
AGRICULTURAL TRACTOR**



VARIOUS FUEL BOWSERS WITH LIVERY

SALE 801 | 7 APRIL 9AM

**MAJOR AUCTION FEATURING: DUMP TRUCKS, CRAWLER TRACTORS,
WHEEL LOADERS, EXCAVATORS, COMPACTION EQUIPMENT, CRUSHING &
SCREENING, TRUCKS, TRAILERS, AGRICULTURAL EQUIPMENT & MUCH MORE**



**2003 CATERPILLAR 777D OFF
HIGHWAY DUMP TRUCK**



**2010 CATERPILLAR 140M
MOTOR GRADER**



**2018 EVERUN ER28
WHEEL LOADER (UNUSED)**

ALL AUCTIONS ARE GST INCLUSIVE. T&Cs Apply. Inspection available, see website for details. D/L: 8586.

**VIEW FULL AUCTION CATALOGUES & REGISTER ONLINE AT
WWW.SBAUCTION.COM.AU**



Australian coal has grown into an important export industry for the country. For the past decade or two Australian coal has satisfied the rising energy demand of Asia's rising economies. Now, thanks to growing natural gas exports, the supply of energy in Asian markets is starting to outpace demand leading to lower international prices for Australian coal exports. Still, export volumes of Australian coal are expected to hold up against this competition.

Australian coal exporters are rising to the twin challenge of lower cost renewable energy and a changing landscape for international energy markets.

MIKE COOPER

VERSATILE coal has been used by humankind for centuries – as a fuel for power generation, a steelmaking raw material, for smelting, and in the chemical industry – driving economic growth for societies worldwide.

Australia is a major producer of thermal coal and coking coal, the two main types of the fossilised fuel, and its quality is among the world's best.

In Australia, nearly 80pc of coal is produced from open-cut mines, in contrast with the rest of the world where open-cut mining only accounts for 40pc of coal production.

Australia's principal coal producing basins are the Bowen (Queensland) and Sydney (New South Wales) Basins.

Locally important black coal mining operations include Collie in WA, Leigh Creek in South Australia and Fingal and Kimbolton in Tasmania.

Australia's thermal coal mines are mostly located in NSW and shipments are sent from Newcastle to customers all over Asia.

Queensland is the source for most of Australia's coking coal for steel production and its mines ship through four ports – Abbot Point, Hay Point, Gladstone and Brisbane.

In 2019, Australia was estimated to have exported 209mt of thermal coal mostly to countries in Asia, and on top of this it shipped 184mt of coking coal.

Volumes are expected to grow to 216mt and 199mt respectively for thermal coal and coking coal exports in the year 2021, according to the Australian government's Office of the Chief Economist in his report for December 2019.

Asian powerhouses

Over the past decade the powerhouse economies of China and India have become large-scale importers of Australian thermal coal.

This is despite both China and India having large domestic coal industries.

Imports are needed by China, India and increasingly by southeast Asia as their economic growth means their energy demand now outstrips their domestic coal resources.

This situation has made thermal coal shipments from Australia an in-demand fuel for power plants in Asian countries, including lately India.

But the fuel's market share in these countries is starting to be squeezed by the rise of other energy sources.

Some sources such as solar, wind and even wave energy are renewable, and the technology for these is becoming ever cheaper

reducing their cost.

Other energy sources such as natural gas emit less carbon dioxide than coal when consumed and are perceived to have less impact on air quality.

Liquified natural gas (LNG), a super-chilled form of natural gas that is transported on ships, has been taking an increased share of the power generation market globally.

LNG prices are currently sitting at an all-time low in the Asian market at US\$2.5/mmBtu (million British thermal units) with some cargoes sold to India at this level, according to S&P Global Platts, a price reporting agency.

China's extended Lunar New Year holiday and reduced economic output following concerns around the Coronavirus illness has reduced the Asian country's energy demand in February 2020.

Relatively low LNG prices has blunted the competitiveness of Australian thermal coal delivered to ports in Japan and Korea which has been trading in a steady range of around US\$3/mmBtu for the past year.

Energy experts including in the Australian government suggest the scenario of cheap LNG supply is likely to last a while longer, with implications for coal.

According to the Office of the Chief Economist, the "overarching narrative for LNG markets remains unchanged: the long-anticipated overcapacity in LNG markets has arrived, placing downwards pressure on LNG spot prices which remain at multi-year lows".

The Australian government's experts see LNG supply rising for years to come.

"New capacity in the US, Australia and Russia are ramping up operations. Meanwhile, growth in China's LNG imports (the world's second largest importer) has slowed, and imports from Japan and South Korea – the world's largest and third largest LNG importers, respectively – have declined," the Office stated.

Gas emissions

The Australian Coal Association acknowledges that much of Australia's greenhouse gas emissions come from burning black and brown coal for electricity, steel-making and cement manufacture.

The coal industry established the COAL21 initiative, bringing together the coal and electric power industries, unions, federal and state governments, and research organisations.

Supported through a voluntary company levy, the \$1 billion+ commitment supports research, development and demonstration of

low-emissions coal technologies.

To date, the COAL21 Fund has made commitments of more than \$500 million to a number of active and in-development carbon capture and storage research projects.

Coal exporters

Australian coal exporters are rising to the twin challenge of lower cost renewable energy and a changing landscape for international energy markets.

Whitehaven Coal sees a "strong growth outlook across Asia" for its shipments of Australian thermal and coking coal, said the company February 20 in a results presentation for the half-year ended December 2019.

The coal producer bases its business case on three factors in Asian countries, an increase in requirements for electricity and infrastructure and industrial output.

Coal is seen to fuel 50pc of Asia's electricity generation in 2030, down from 62pc in 2017, said Whitehaven Coal citing the International Energy Agency.

But Asia's electricity consumption is forecast to rise to 11.3 thousand terra watt hours in 2023, up from 9.3 thousand TWh in 2017, stated the company presentation.

Whitehaven Coal chief executive Paul Flynn the company expected LNG prices to recover from their current lows.

"Market expectations remain that spot LNG prices are likely to rebound in the medium term as consuming nations, including China, expand their capacity to receive imported LNG and the current LNG development project pipeline is completed and brought onstream," he said.

However, Mr Flynn also cited other factors for having a recent impact on market prices for Australian coal shipped to Asia, including US-China trade friction, and lately the coronavirus issue in China.

"The coronavirus has caused a temporary loss of demand for coal in China, however, the supply of coal in China has also been reduced as a result of the virus," he said.

Therefore, reduced domestic coal production in China has balanced any lost demand.

"During February 2020 the loss of demand in China has been offset by the loss of domestic supply leading to a strengthening of China domestic prices and seaborne coal prices," Mr Flynn said.

He said Whitehaven Coal continues to see strong end-user demand for its high quality Australian thermal coal, and that lower global prices have pushed higher cost coal producers out of the market.

"The globalCOAL Newcastle price [index for Australian thermal coal] levels have seen

'swing' suppliers from Colombia, Canada and the USA withdraw from the market which has led to a rebalancing of the fundamentals, and pricing being well supported in a range around the high US\$60s/t," he said.

Another coal company with mines in Australia, the London-listed Glencore, said technology would help curtail emissions from coal-fired power plants.

"We believe that coal, as a reliable and cost competitive form of energy, will continue to have a role in meeting future energy demand, particularly in developing countries, with Carbon Capture Utilisation and Storage (CCUS) adoption playing an increasingly important role in achieving emissions abatement," it stated.

Government support

Earlier this year, Prime Minister Scott Morrison publicly stood by the Australian coal industry, despite calls from radical climate change activists to ban the export of the commodity.

Fuelled by fires ravaging the country, objectors want exports to be ceased immediately, action expected to cost Australia more than \$52b and jeopardise the jobs of 50,000 people involved in coal mining.

Mr Morrison vowed that climate protesters would not be dictating energy or trade policy, and is sticking with the government's existing plans to reduce carbon emissions by 28pc within a decade.

"We won't embrace reckless targets and abandon our traditional industries that would risk Australian jobs while having no meaningful impact on the global climate," he said in an opinion piece.

"In short, we will continue to act responsibly on climate change, avoiding extreme responses and get the balance right."

Mr Morrison has rejected a suggestion that ramping up renewable energy would have prevented the wide-scale fires.

He said suggesting that increasing Australia's climate targets would have prevented these fires or extreme weather events, in Australia or anywhere else, was "simply false".

In its election platform last year, the Government promised to reduce carbon emissions by 28pc by 2030.

"As part of a global effort, our government will ensure Australia keeps commitments made at the election," Mr Morrison said.

"Australia's carbon emissions are on average 50mt less per year than they were under the previous government. All achieved without a carbon tax."

EXPLORATION IS APLENTY

The Queensland government has fired the starting pistol for a new wave of exploration activity in the state, with the announcement of an extensive land release program for coal and gas projects that has been warmly welcomed by the mining industry.

MIKE COOPER

QUEENSLAND is renowned for its coal mining industry, which generates billions of dollars in revenue and thousands of jobs for Australians.

Now the state's coal mining industry is about to enter a new era of growth, after the Queensland government opened up 7000sq km of land in its Bowen and Surat coal basins to fresh exploration activity for coal and gas.

Mining companies have been invited to stake their claim in the exploration territory to sow the seeds for the next generation of resources projects.

Queensland Member of Parliament for the Mackay constituency, Julieanne Gilbert, said the exploration program could result in significant job opportunities.

"Two areas in the highly prospective Bowen Basin have been earmarked for metallurgical coal – this Basin is already the world's largest exporter of seaborne metallurgical coal in the world," she said.

One of the exploration areas is 40km north-west of Moranbah, comprising 11 blocks covering 35sq km and is prospective for metallurgical coal.

A second area, covering 73sq km in 23 blocks and 60 km north-east of Moranbah, is prospective for thermal and coking coal.

Tenders seeking expressions of interest for the 2020 coal exploration program will open this month and close by May.

Land will be awarded to successful bidders by August this year.

Resources powerhouse

In the two-year period to September 2019, exploration investment in Queensland had risen 27pc, and the government has released a record 64,000sq km for exploration activity in its past three programs.

Queensland Natural Resources, Mines and Energy Minister Anthony Lynham said exploration investment was critical for Queensland to remain a resources powerhouse and to meet the world's demand for resources.

The Queensland Resources Council, which represents coal miners and mining interests



Drilling activity at Batchfire Callide mine.

"For Queensland to remain a resources powerhouse and to meet the world's demand for resources, exploration investment is critical":

in the state, welcomed the land release for exploration.

QRC chief executive Ian Macfarlane said the organisation supported the move.

"A proactive exploration program secures tomorrow's resource industry while supporting jobs, many of which will be in regional Queensland," he said.

Bowen Basin

Most of the state's existing mining for coal is focussed on Queensland's giant Bowen Basin, a 650km long coalfield that covers an area of up to 75,000sq km.

Stretching from Collinsville at its northern tip down to Moura at its southern end, the Bowen Basin coalfield is a hive of activity with around 50 coal mines.

Coal mining started around Collinsville in the 1920s and was joined by mines at Baralaba and Moura in the 1950s, before really taking off in the 1960s with a series of mining towns in Moranbah, Dysart, Middlemount and Blackwater.

Several household name companies mine coal in the Bowen Basin, including Adaro Energy and EMR Capital, Anglo American, Baralaba Coal, Batchfire Callide, BHP in partnership with Mitsubishi and Mitsui, Coronado Global Resources, Glencore, Idemitsu Australia Resources, Jellinbah Group, Peabody Energy, QCoal Group, Sojitz Coal Mining and Yancoal Australia.

They are soon to be joined by India-headquartered company Adani

Australia, currently building a mine in the Galilee coalfield, one step over from the Bowen Basin on its western side, and virtually untouched in terms of coal mining.

Adani Australia has previously stated its first coal exports from its Carmichael mine for thermal coal should emerge in 2021.

Most of the coal mined in the Bowen Basin is coking coal, also known as metallurgical coal, which along with another major Australian export – iron ore – is used to produce steel.

In the past decade, China has emerged as a major consumer of Australian coking coal from the Bowen Basin, joining other industrialised Asian countries such as Japan, Korea, Taiwan and India.

Thermal coal is also exported from some Bowen Basin mines such as Glencore's Rolleston, Idemitsu's Ensham and TerraCom's Blair Athol, formerly operated by Rio Tinto.

Rio Tinto completed its exit from Australian coal in 2018 with the sale of its Kestrel mine to Indonesia's Adaro Energy and private equity manager EMR Capital.

Cook Colliery near Blackwater was put into care and maintenance in December after its owner ASX-listed Bounty Mining went into administration, partly attributing the move to lower international coal prices.

Further south in south-east Queensland, ASX-listed New Hope Group and Yancoal Australia operate some thermal coal mines in Queensland's Surat Basin coalfield that export shipments through Brisbane port.

Rail system

Coal exports in the Bowen coalfield travel on a 2670 km network of railway lines that criss-cross eastern Queensland from mine sites to four major coal ports in the State.

The dedicated rail system for coal exports is called the Central Queensland Coal Network and is owned and operated by Australian company Aurizon.

The system is sub-divided into four rail systems which are essentially supply chains that connect mines in certain parts of the Bowen Basin to Queensland's ports.

The largest of these is the Goonyella system that supports about 20 mines and runs west from Blair Athol to the port of Hay Point and its two coal terminals, BHP's Hay Point dedicated facility and the multi-user Dalrymple Bay terminal.

The Goonyella line also has a northern spur running to North Goonyella, and a southern spur starting at Gregory.

Newlands is another rail system that serves the northern Bowen Basin from North Goonyella up to the northern port of Abbot Point.

Blackwater is the system for around 20 mines in the central Bowen Basin coalfield and runs from Emerald to Gladstone port and its two coal terminals.

The Blackwater system is being extended west into the Galilee Basin to its town of Alpha, the hub of the area's new mining industry.

Hancock Coal has its Alpha thermal coal project in the region, and Waratah Coal, a 100pc owned subsidiary of Clive Palmer's Mineralogy company, has its North Alpha project there.

Moura is the smallest system in the CQC and starts at the Baralaba mine, taking in the Callide coalfield, and terminating in Gladstone.

Brisbane port in the south of the state is served by the West Moreton rail network that carries coal from Queensland's southern Surat coalfield to the port's coal terminal.

Queensland's coal exports – both metallurgical and thermal – had a total value of \$35.9b in the 2019 calendar year, according to the Queensland Treasury.



07 4982 4403

✉ enquiries@mobbs.engineering

🌐 www.mobbs.engineering

📍 Lot 1 Cameron Road Emerald Queensland

ENGINEERING EXCELLENCE IN THE CENTRAL HIGHLANDS

Mobbs Engineering specialise in all types of heavy and light metal fabrication & repairs. With a dedicated design team, extensive workshop and mine compliant mobile equipment, Mobbs Engineering are fully equipped to service all industries across the Central Highlands. Mobbs Engineering also specialise in Industrial Coatings Auditing, Industrial Sandblasting, Soda Blasting & Painting.

With sandblasting booth, spray booth and mobile unit we have your industrial coatings needs covered.



As we are aware some areas in the mining industry can be highly corrosive, in such environments preventative maintenance is a must. Mobbs Engineering offer a complete Structural Coatings Service, from onsite structural coatings auditing to repairs and surface coating. After a comprehensive inspection of your project we supply you with a detailed report identifying all defects along with recommended action required. With mine compliant mobile welding plant and competent people we can repair all defects identified in the report. We can then follow through with sandblasting & painting to meet your surface coating standards.

Due to the quality of work performed by Mobbs Engineering on the previous build we were again engaged for the refurbishment of this Komatsu 785 dump truck. Mobbs Engineering repaired all steel components including the cab, tray, stairs, guards, radiator cowling, platforms & handrails. Any parts that were beyond repair were fabricated new at our workshop, all parts were sandblasted & painted to OEM specs in our blast & paint booths. Our mobile blast & paint trailer allowed us to blast & paint the chassis in situ. All work was completed to a very high standard and delivered on time.

Mobbs Engineering were asked to design and fabricate a QDS Roller Structure Pod for a local underground coal mine. This pod had to accommodate a specific quantity of items without exceeding size restrictions for underground roadways while being safe and user friendly. We successfully designed, drafted, engineered, fabricated and painted a carry pod to meet the customers' specific requirements. Having our own draftsman means we can come to you on short notice and work directly with you on your project resulting in quality drawings to your exact requirements.



EASTWARD HO

Saraji coal mine is ready for the next chapter in its illustrious 40-year history. BMA is pressing ahead with its Saraji East project next to the existing Saraji mine that will unlock 7mtpa of coking coal. An export route through Abbot Point terminal has already been traced for Saraji East which is going through an environmental impact assessment.

BHP is ready to start advancing its Saraji project, now renamed Saraji East.

MIKE COOPER

SARAJI coking coal mine in Queensland's coal-rich Bowen Basin coalfield is ready for the next stage in its development with its Saraji East expansion project.

Purchased by the BHP Mitsubishi Alliance joint venture, a 50:50 joint undertaking between Japanese trading house Mitsubishi and BHP, from Australian coal company New Hope Corporation in July 2008 for the price of \$2.45b, the Saraji (East) coal project marked a new watershed price for coal mining assets in Australia.

New Hope went on to use the money received for its Saraji coal project to fund some coal asset acquisitions including stakes in former Rio Tinto's Hunter Valley coal mine in NSW.

The Saraji project is an undeveloped metallurgical coal resources adjacent to BMA's Saraji mine, 30km north of Dysart in Queensland's Bowen Basin coal field.

The project was estimated to contain a coal resource of 690mt by New Hope.

Included in the purchase price for Saraji was a Mining Lease Application, Exploration Prospecting Consent, and a port user contract for 10mtpa of shipping capacity in Abbot Point coal terminal.

At the time of the deal for Saraji, then BHP coal division president Dave Murray said the asset had the potential to be developed into a large scale, high quality metallurgical coal operation.

"New Saraji could potentially deliver significant synergies due to its proximity to BMA's existing Saraji mine," Mr Murray said.

Advancing project

Fast forward 12 years to the present day, and BHP is ready to start advancing its Saraji project, now renamed Saraji East.

According to documents filed to the Queensland government for the Saraji East project, BHP is proposing to build an underground coal mine for 7mtpa of coking coal with a mine life of 25 to 30 years.

The Saraji East project will also include a new coal handling and preparation plant, and a conveyor system to deliver coal from



Saraji Mine is a multi-seam strip open cut mining operation which produces metallurgical coal for export markets.

the underground mine to the CHPP and product coal to rail loading facilities.

According to the Queensland government, the proposed project would employ up to 1000 construction employees and about 500 operational employees.

Saraji East project has reached the stage of an Environmental Impact Statement in the Queensland government's State planning process.

This means the project still has some regulatory stages to complete before construction can begin.

Queensland government's Environment Department has agreed to an extension to June 2020 for BHP to submit a revised EIS for the Saraji East project, up from the original March deadline.

Other mines under the BMA umbrella are Blackwater, Broadmeadow, Caval Ridge, Daunia, Goonyella Riverside and Peak Downs.

They export their coking coal through BMA's dedicated Hay Point coal terminal at the Queensland port of Hay Point.

Prices, market outlook

BHP stated in its 2019 report that coking coal prices touched a high in the middle

company stated.

The near-term outlook for Australian coking coal prices is slightly bearish, the report stated.

Other coking coal-producing countries around the world such as Russia and the US are increasing their exports of the product.

"In the short term, supply should continue to improve with additional volumes expected from various regions," according to the report.

But, in the years ahead, when the Saraji East project comes online demand is seen as likely to increase for Australian coking coal, stated BHP.

"Over the longer term, emerging markets such as India are expected to support seaborne demand growth," its 2019 annual report stated.

"High-quality metallurgical coals will continue to offer steelmakers value-in-use benefits," the report added.

New mines such as from an expanded Saraji mine in Queensland will be essential in meeting world demand for Australian coking coal in the years ahead.

Safety commitment

A fatality at Saraji on New Year's Eve last year has reinforced BHP's commitment to safety.

According to BHP chairman Ken MacKenzie, the mining giant couldn't determine the definitive cause of a fatality for the first time in 15 years.

This incident, which caused the death of one worker, also contributed to a pay cut for BHP chief executive Andrew Mackenzie.

BHP worked to implement a number of "improvement areas" identified in its incident investigation.

"We believe that a zero fatality workplace is possible and we will do all we can to achieve that outcome," Mr Mackenzie said.

BHP launched a contractor management framework to give all contractors the same access to safety tools and processes as its employees.

BHP has also heightened its effort to create a culture of "chronic unease," which urges everyone to question assumptions around safety.

of 2019 because of supply constraints in Queensland, due to wet weather conditions.

The average realised price for BHP's hard coking coal was US\$199/t in the 2019 financial year, up from US\$194/t in the 2018 FY, said the company report.

"Prices eased from this peak due to weaker demand from India and uncertainties around Chinese imports," the company report stated.

Supply tightness for coking coal, also known as metallurgical coal, have been supportive of market prices and have fed through into earnings for the company.

BHP's Queensland Coal division which includes BMA had underlying earnings before interest and tax expenses of US\$3.1b on revenue of US\$7.6b for the financial year ended June 2019, said BHP in its report.

In its production guidance in its annual report, BHP said its coking coal production is expected to be between 41m and 45mt on an equity share basis.

Production from BHP's Queensland coking coal mines is set to rise in 2020.

"With major wash plant shutdowns at Goonyella, Peak Downs and Caval Ridge planning in the September 2019 quarter, volumes are expected to be larger in the last three quarters of financial year 2020," the

Dream Saraji move for Demi

RAY CHAN

DEMI Keating started out her career in business, tourism and human resources.

Passionate about people, looking for a new challenge, and wanting to pursue her dream of becoming an electrician, she tried her chances at applying for an apprenticeship with BMA, and never looked back.

Now, a mobile maintenance supervisor at BMA's Saraji Mine for Operations Services, she said her apprenticeship was the greatest opportunity she ever took, and one that has taught her many life skills to accomplish personal endeavours.

"After completing my apprenticeship I worked as a high voltage electrician at BMA's Peak Downs Mine, and it was everything I dreamt it would be and more," she said.

"This industry has helped me in so many ways, it's given me the courage to challenge myself – deciding to travel on my own throughout many countries, living and working overseas – and one of my most difficult yet rewarding milestones, trekking to Everest Base Camp in Nepal."

The lessons learned and personal development helped Demi take on new responsibilities, while working at Peak Downs, when she was asked to step up as the supervisor for her crew.

She said it prompted her to take on a new challenge.

"I accepted a position with Operations Services as a maintenance supervisor, and it's given me so many opportunities to work with really incredible people in the process," she said.

"Every day I am still learning something new, and I am extremely passionate about helping people to achieve their goals."

In this capacity, Demi has volunteered for local charity RACQ CQ Rescue and Mine's Rescue, supported community events and encouraged women to enter, and remain, at the coal face.

"This industry has not only allowed me grow into the person I am now, but has assisted me in encouraging others to reach their full potential too," she said.

She said by speaking at career days at local high schools to encourage school leavers to consider a trade as their career, and mentoring apprentices she has been able to support others in their personal and professional life.

"After living my experiences, I am now able to be supportive and guide those around me in approaching the challenges that are thrown their way."



Saraji is in the process of getting soft recovery shackles and soft recovery couplings certified so they can be used in lifting operations.

Kudos for mobile solution

JOSH Leppard, an Overburden Supervisor at BHP Mitsubishi Alliance's Saraji mine, has won plaudits for an alternative mobile equipment transport solution he and his team came up with at the Queensland coal mine.

Leppard was named the 2019 Innovation Award winner at the 2019 Queensland Mining Industry Safety and Health Conference for his and the team's Synthetic Lightweight Couplings (SLC) development.

SLC is a clever alternative to the 110kg combined weight of a pull ring and metal shackles routinely used to pull mobile equipment across the mining industry, according to BMA.

Mr Leppard, who worked on the project for the past six months, is a competitive sailor on his days off and used his knowledge of the marine industry to develop a practical solution to engineer out a manual handling risk.

"Being a yacht racer for many years, we moved away from using metal shackles four or five years ago and now only use synthetic couplings that are made specifically for marine purposes," he said.

"These couplings are lightweight but provide exceptional strength as you would expect to be needed on offshore race yachts."

Mr Leppard and the team worked with the marine coupling manufacturer in New Zealand to "super-size" the technology to suit the mining industry and created Saraji's 'soft couplings'.

The soft couplings weigh around 8kg and are made of Dyneema, one of the world's strongest and most reliable fibres available, BMA said. It is then braided with Technora, which gives it high heat and chemical resistance as well as protecting against chafe – the same product used for bullet proof vests and firefighting clothing.

"We hope that by creating the 'soft couplings' we'll not only reduce the risks associated with heavy lifting and manual handling, but also remove the physical barriers that may prevent some men and women from completing the task," Mr Leppard said.

"I'm really proud that we were able to deliver this for not only Saraji and BMA, but also for the industry."

The team worked with independent testers to verify and strength test the shackles so they could be used on site.

Saraji is in the process of getting soft recovery shackles and soft recovery couplings certified so they can be used in lifting operations which will substitute the existing heavy weight lifting shackles.

The team is also working though and obtaining a 'FRAS' rating so they can be used underground for longwall moves.

Bright minds boosted in the Bowen

RAY CHAN

A NEW technology-focused education partnership has been launched with schools throughout the Bowen Basin, to make sure local children are ready for the jobs of the future.

BMA's Bowen Basin Bright Minds will put technology at the forefront of learning in 18 local schools reaching more than 6000 students.

BMA Asset President James Palmer said the program was developed following community feedback that skills and training in technology-focused areas were critical in making sure people were future fit.

"Our business, like the society in which we live, is changing rapidly," Mr Palmer said.

"We want to make sure that local students have every chance to be a core part of what BMA becomes, and that we are building to a shared future."

The multi-million dollar initiative will see several Bowen Basin schools elevate to become Schools of



BMA's Bowen Basin Bright Minds will put technology at the forefront of learning in 18 local schools reaching more than 6000 students.

Image: BHP

Excellence in Technology, as they embed future-focused learning into their curricula.

The program will boost STEM-related learning for local students from Prep right up to Year 12.

The partnership has been co-designed by BMA, Education Queensland and the 18 participating Bowen Basin schools.

Moranbah State School Principal Anthony Edwards said the program was equipping students across Central Queensland with the skills necessary for their futures.

"This partnership allows us direct access to the funds, expertise and most importantly real life learning

experiences that will ensure that our kids have a life of choice, not a life of chance when they enter the ever changing future workforce," Mr Edwards said.

From professional development in technology for teachers, to programming or equipment for students, the partnership will give local schools the support they need to ride the crest of the fourth industrial revolution wave.

"For us this is much more than making a financial contribution," Mr Palmer said.

"What we do today will determine how Bowen Basin communities are ready for the decades ahead."



Customers can rely on Kelair Pumps Australia to properly repair and maintain their critical flow management equipment either in-house or on-site, regardless of OEM.

Specialists in mine dewatering

NATIONAL

KELAIR Pumps is an Australian-owned and operated company, specialising in industrial pumps and pump packages for the resources industry and industry in general.

Kelair Pumps Australia Qld state manager Myro Bratkovic said an ideal pump for harsh mine dewatering applications would be one that is lightweight, resistant to corrosion, easy to maintain as well as able to pass large solids through the system.

Weight

According to Mr Bratkovic, typical cast iron or other non-metallic diaphragm pumps are very heavy and cumbersome, making them challenging to carry into small access areas.

"In some instances, workers cannot get their underground vehicles close enough to where they need to install the dewatering pump, meaning that they might have to carry the pump 500m or 600m away," he said.

"A '2" cast iron pump can weigh over 60kg, and this can be up to two times heavier than an equivalent sized plastic bodied pump.

"Carrying a heavy item is a major health and safety issue which requires extra human resources to transport and install a pump in a difficult or remote underground location."

Corrosion and maintenance

Plastic bodied ball valve pumps are commonly used in mine sites, and their resistance to corrosion is an added benefit.

However, ball valve design pumps require disassembly in order to carry out any basic maintenance works such as clearing a pump blockage.

"Depending on the geography of the mine site, the pumped solution may be slightly acidic," Mr Bratkovic said.

"Over time, this can corrode the body of a metallic pump, and eventually lead to the pump being inoperable or costly to repair.

"Because of this, a non-metallic casing is ideal for longevity of your dewatering equipment.

"Ball valve designed pumps do not allow for easy access if a blockage in the pump occurs and will need to be disassembled.



The set-up of the Sandpiper 1", 2", and 3" air-operated diaphragm pumps in roll frames is more versatile than other builds and could suit a better range of potential applications.

"Removing the pump from the mine and taking it above ground for repair or maintenance work is a costly procedure, both in terms of personnel as well as operational down time.

"As miners' time is precious and expensive, the less downtime caused by pump maintenance, the better."

Solving this maintenance problem

According to Mr Bratkovic, the Sandpiper HD20F is the next generation in mine dewatering, as it has the advantage of being both a flap-check valve pump as well as having a non-metallic body.

"This design combination is quite unique and has all of the advantages of a Sandpiper metallic flap valve pump, while being free from corrosion," he said.

"The flap-check valves on the Sandpiper HD20F allow access to the pump without having to dismantle the pump.

"There are access ports on the side that are unique to this Sandpiper design and are not found on any other dewatering pump on the global market.

"The benefit of this is that if you have a blockage, you can quickly clear it and put the pump back into service without needing to remove it from the site."

Coping with large solids

The Sandpiper HD20F flap valve design allows the pump to pass large solids through the system, without causing any

damage to the pump.

"The amount that the flap check opens, dictates the size of the solid that can pass through the pump," Mr Bratkovic said.

"In terms of the Sandpiper HD20F which can handle solids of up to 44mm in size. That means that if the solid can pass through the pump's two-inch suction hose, then it can also pass through the pump.

"As well as this, the Sandpiper HD20F has very low air consumption when compared to some of the major brand 2inch plastic pumps.

"Depending on the actual pump duty, comparison testing in the Sandpiper laboratory has shown that the Sandpiper HD20F pump can consume between 25pc to 40pc less compressed air than other brands of pump.

"For big and small users of air powered pumps alike, this is a significant energy saving and an ongoing one."

Proven technology

According to Mr Bratkovic, the Sandpiper HD20F was designed around the existing metallic Sandpiper Heavy Duty HDF2 that has proven technology in terms of its air system, diaphragms and flap valves.

"The original design has been around for a number of years, which means that the longevity of the unit is already there," he said.

"Because of this, you can be sure that the new, plastic bodied HD20F will last longer than the metallic model in corrosive



The Sandpiper HD20F plastic bodied (non-metallic) flap-check valve pump is an ideal pump for harsh mine dewatering applications: one that is lightweight, resistant to corrosion, easy to maintain as well as able to pass large solids through the system.

environments.

"As many of the internal components of the original metallic Sandpiper Heavy Duty Flap Valve Pump are identical to the new HD20F model, so a number of spare parts can also be interchanged if required.

"This is a fantastic advantage for users of the metallic model, who can continue to use spare parts that they have previously purchased."



Custom-built sets of new Sandpiper pumps, housed in frames, offer a creative solution for a tough, portable rig, painted to customers specifications.

Versatility and energy savings

Apart from being well suited to mine dewatering, the Sandpiper HD20F can also be used in other harsh industrial applications.

“An example of this was our recent sale of the HD20F model to pump starch and waste at a manufacturing facility in North Queensland,” Mr Bratkovic said.

“Our client had been using a large number of the older, aluminium bodied Sandpiper SA2 model of the same flap-check design and was needing to begin to replace them due to corrosion.

“Caustic is a main constituent of starch and was slowly corroding away each pump. Many of the customers existing Sandpiper SA2A pumps were around 20 years old.

“We started our investigations on the basis of both corrosion prevention as well as energy savings, by also looking at air consumption and production requirements.

“As Kelair Pumps Australia is the only distributor of Sandpiper pumps in

Australia, we have access to Sandpiper’s fantastic energy consumption calculation program, which helps us calculate the cost of operation based on air consumption.

“We can utilise this program no matter the pump application, and are able to provide our clients with both an energy and dollar saving.

“In the case of the box manufacturing facility, as the pumps are becoming uneconomical to repair, we are changing over their pumps to the HD20F models, giving the client a solution that provided an energy cost saving as well as a pumping solution that would not corrode.

“In addition to these benefits, the client happen to have spare parts from his original pumps and was pleasantly surprised to be able to use these on the new range.”

Custom-made housing

Kelair can customise all pumps into personalised housing and roll or square cages, as required.

This offers higher stability and excellent portability.

Out-of-hours support

The personnel at Kelair Pumps Australia pride themselves on their ability to carry out works around the clock, including working on weekends.

“We operate very much like a small business up here in Mackay, at the Kelair Pumps Australia Queensland division,” Mr Bratkovic said.

“We are a tight-knit family, and we simply get together to organise site works even if required on weekends or after hours.

“Everyone is keen to help out, as we work toward the common goal of solving our clients’ pump problems.

“We look after each other and strive to give our customers the best quality service to get the job done, and done well.”



Lifting lugs can be included on cages/frames to lift them on and off the trucks and onto sites easily and safely.

SANDPIPER EVOLUTION and SIGNATURE series

Engineered to deliver industry leading durability and performance, for even the most severe and demanding mining environments.

Durable and portable pumps suitable for:

- Dewatering
- Fuels and lubricants
- Refining, smelting and milling process
- Water treatment

We know the importance of choosing the right equipment to match your process. With our extensive range of pumps, first class customer service and ongoing comprehensive support, Kelair Pumps are second to none when it comes to your pumping requirements.



Standard Duty Ball Valve Pumps



Heavy Duty Flap Valve Pumps



Heavy Duty Ball Valve Pumps



SludgeMaster™ Air-Powered Trash Pumps



WHEN PUMP KNOWLEDGE MATTERS
Rely on Kelair

Find out more today
1300 789 466
www.kelairpumps.com.au

FULL SPEED AHEAD

Sojitz Coal Mining has worked hard to bring its Gregory and Crinum mines out of care and maintenance this year after they were acquired from BMA in 2018. Both mines have undergone substantial upgrades to increase production. Sojitz is also set to triple production from its Meteor Downs mine a sister to its Minera thermal coal operation which is producing coal at a steady rate.

Excavation being carried out at a trial pit at the Wilton-Fairhill deposit close to the Gregory Crinum mine.

MIKE COOPER

SOJITZ Coal Mining is an Australian subsidiary of Japanese company Sojitz and was established in 2002 as the holding company for its Queensland coal operations.

SCM's span of operations has grown to three Queensland coal mines – Gregory, Minerva and Meteor Downs – and it has been quietly upgrading these.

Sojitz managing director and chief executive Cameron Vorias said the company's plans to develop its Australian coal mines were progressing well despite some hiccups in thermal coal prices.

"Thermal coal prices have been stable but not brilliant," Mr Vorias said.

He said Australian thermal coal prices experienced a difficult market in 2019, when benchmark Australian thermal coal prices endured a steady decline over 2019, falling to US\$65/t free-on-board basis Newcastle at end of the year.

According to the Australian government's Office of the Chief Economist's latest quarterly report, lower prices for competitor power generation fuel liquified natural gas in Asia has undercut demand for Australian thermal coal.

"Weak global demand placed downward pressure on the thermal coal prices in the first eight months of 2019; persistently low spot LNG prices encouraged some coal-to-gas switching – predominately in Europe – dampening demand for thermal coal imports," it stated.

Seaborne prices for Newcastle, Australian thermal coal in the Asian market are expected to recover slightly to US\$70/t FOB in 2020, according to



Production at Minerva mine is running at a rate of 1.5mtpa.

accountancy firm KPMG in its January 2020 coal price forecast.

The forecast is based on submissions from market participants in Australia.

Minerva

Minerva thermal coal mine became Sojitz's first coal mining operation after it purchased a 30pc stake in the mine in 1994 and it started production in 2005.

SCM raised its stake in Minerva to 45pc in 2006, and increased its stake

to 96pc in 2010, after purchasing an additional 51pc equity interest in the joint venture from Australian coal producer Felix Resources.

Korean interests own the remaining 4pc equity interest in Minerva mine.

Minerva is an open-cut coal mine located 45km south of Emerald in Queensland that produces premium thermal coal and some pulverised coal injection coal that is used in steel production.

Minerva mine is relatively steady in

terms of its production, Mr Vorias said.

Production at Minerva mine is running at a rate of 1.5mtpa, he said.

The mine exports its thermal and pulverised injection coal through Gladstone port to customers in Asia following a 400km rail journey.

Gregory and Crinum

SCM bought up BHP-Mitsubishi Alliance's twin Gregory-Crinum operation in central Queensland in early 2019 for just \$100m.

At the time of the deal's announcement in 2018, Mr Vorias said in a statement the purchase aligned with Sojitz's goal of operating a coking coal mine.

"Recommendation of mining operations at Gregory Crinum will deliver significant benefits to all our stakeholders in addition to ensuring security of supply of hard coking coal to our valued customers as well as providing jobs and strengthening the economy for the people in the region and the State of Queensland," Mr Vorias said.

Sojitz has invested heavily in significant upgrade work for Gregory and Crinum.

The work was needed to restart the mines after their production was idled several years ago.

BMA had taken Gregory and Crinum offline in 2015 and 2016, respectively.

Gregory open-cut mine was recently reopened and to date has produced 200,000t of coking coal, Mr Vorias said.

"We have sold 200,000t from Gregory and plan to take production to 2.5mt in 2020.

"Then we are dependent on other plans to further increase volumes," Mr Vorias said.

Crinum underground mine, a sister mine to Gregory, is next in line to restart production in late 2020, he said.

"Crinum mine is being brought on before the end of the year," Mr Vorias said.

Production at Crinum is to change to a bord and pillar mining method under



Sojitz CEO Cameron Vorias.

Sojitz, instead of the longwall method used by BMA.

Meteor Downs

SCM turned Meteor Downs South into a new producing thermal coal mine in 2018 with its 50:50 business partner U&D Mining.

Mr Vorias said the company was

working to expand production at its Meteor Downs South thermal coal mine.

This development requires SCM to undertake some additional rail capacity.

"We are currently in the process of building a train load-out facility which should be ready in June," Mr Vorias said.

Sojitz is planning to triple production at its Meteor Downs mine to about

1.5mtpa from 0.5mtpa currently, all of which is thermal coal.

Meteor Downs produces thermal coal with a relatively low ash content which does not require processing through a coal washery plant, Mr Vorias said.

Sojitz strategy

Sojitz is one of the few Japanese trading companies that is expanding its coal production in Australia after others have decided to limit their presence in the coal space.

Mitsui & Co, for example divested its 10pc interest in the Bengalla coal mine in New South Wales, saying it was no longer investing in thermal coal assets.

"For thermal coal, Mitsui has the corporate strategy to refrain from accumulating new assets while existing assets are under thorough review for divestiture purposes," the company stated.

Another Japanese trading company, Itochu, also said it would not buy any more thermal coal mines after selling its stake in the Rolleston mine in Queensland.

"We recognise that, among other things, our coal-related businesses must be one of the issues which we have to promptly address as its impact on our business and our surrounding stakeholders will be significant, and we therefore hereby commit ourselves, as our policy, to neither develop any coal-fired power generation business nor to acquire any new thermal coal mining interest," the company said stated.

Experienced pipe professionals

NATIONAL

PROFESSIONAL piping company JP Piping Systems has more than 20 years of experience in delivering piping solutions to clients in the construction, mining, industrial and government sectors.

JP Piping Systems has an experienced sales division that services 200 customers ranging from mining companies to construction enterprises.

The firm also handles sales for many government entities including local government organisations, regional councils and some State government departments.

The Mackay-based company has undertaken projects in its home state of Queensland, including a latest project for Japanese coal mining company Sojitz at its Gregory mine.

In this project, JP Piping was responsible for replacing and upgrading pipe systems including for compressed air, fire systems and water reticulation in the Gregory mine's coal handling and processing unit.

The Gregory mine coal processing plant upgrade was completed in January.

The firm has also completed pipeline a project in NSW at Mach Energy's new Mount Pleasant thermal coal mine in the Hunter Valley for Sedgman.

For the Mt Pleasant mine, the company installed small bore piping systems.

JP Piping Systems has installed pipeline systems at more than 25 coal preparation plants, in several



The company has the capacity to undertake highly specialised projects.

ship-loaders and many stacker-reclaimer machines.

In WA, the company worked on the Sino iron ore project for the installation and commissioning of a fire protection system for Wormald.

The firm handles all aspects of the pipeline systems operation for clients from product supply and fabrication, installation right through to maintenance and plant and equipment hire.

Another Australian small bore

piping project for G&S Engineering, also in NSW, was at Dargues gold mine operated by Diversified Minerals.

This project involved putting into the mine poly and galvanised pipe, poly welding and pipe threading, and organising water, slurry and potable water.

In addition to its work installing pipeline products in the mining industry, the company has supplied and handled pipeline systems for the sugar industry and some Australian coal ports.

The company has the capacity to undertake highly specialised projects such as the installation of fire control systems, fuel farms, dust suppression systems and compressed air systems.

JP Piping Systems has also worked on pipeline projects in overseas markets including in Mozambique and in the Solomon Islands.

Also within its capability are supply and installation projects for gas systems.

(CONTINUED OVER)

(CONTINUED FROM PAGE 27)



JP Piping Systems prides itself on its quality workmanship and excellent safety record.

Pneumatics and instrumentation are another speciality for JP Piping Systems.

The company can install poly lines, fire and water lines, flocculent lines, civil works, and water reticulation and pump stations.

Quality products

JP Piping Systems owner Joe Parrotta said only top-quality pipeline products are used by the company in its work.

"We provide a quality service and only use quality products produced to

Australian standards," he said.

The company is able to supply to its customers a wide variety of pipe products in PVC, stainless steel, and metal, depending on the specifications of the job.

Among the products stocked by the company are PVC-U and PVC-C systems, polyethylene electro-fusion fittings, butt-weld fittings, compression fittings and WAGA DI mechanical repair couplers.

There are also other products in its

range such as Cool-Fit pre-insulated systems, polypropylene and PVDF systems, a full range of manual and actuated plastic valves and Signet instrumentation.

In its steel products range are stainless steel press-fit and threaded systems, stainless steel and galvanised roll groove systems, black and galvanised steel systems, instrumentation and air tube systems, manual and actuated metal valves and steel bracketing, clips and fasteners.

The firm is the North Queensland distributor for +GF+ -- one of the world's largest manufacturer of industrial plastic piping systems.

JP Piping Systems prides itself on its quality workmanship and excellent safety record.

Know-how

JP Piping Systems backs up its quality products and service with expert know-how.

The firm has extensive knowledge and skills in mechanical plumbing and well established third party certified HSEQ management systems.

The company's experienced staff are willing and able to answer clients' questions on the best approach to take to planning their pipeline projects.

Questions around the best valve fittings to use, and the best way to connect pipe structures, are some of those answered by the JP Piping Systems team.

According to Mr Parrotta, staff are happy to showcase their in-depth knowledge of pipeline products in advising clients on potential pipeline options.

"We are here to solve clients' piping and pipeline problems," he said.

JP Piping Systems has its own equipment fleet that includes a 22T excavator, backhoe, telehandler with reverse camera, hydro vac trailer and tip truck, hydrostatic testers, butt welders and an electric fusion machine with data logging capacity.

The company has won a clutch of safety awards, including joint winner of the Safety Foremost category in the 2015 Resource Industry Network Chairman's Awards.



PROFESSIONALISM IN PIPING: OVER 23 YEARS EXPERIENCE



Based in Mackay, we are the leading supplier of Quality Poly and Pvc Piping, Fittings, Valves and everything in between, servicing the Mining, Sugar, Government and Construction industries across Australia

JP Piping Systems Pty Ltd undertakes supply and installation projects for:

- Plumbing as Per AS3500
- Gas
- Pneumatics and Instrumentation
- Poly lines
- Fire and Water Lines
- Dust Suppression
- Flocculent Lines
- Fuels and Lube lines and all Small Bore Piping
- Civil Works
- Water Reticulation and Pump Stations



With Safety our number 1 priority, we have completed a wide range of piping, plumbing and mechanical services, Safely, on time and under budget, and delivering quality workmanship. To date we have successfully piped out over 25 Coal Preparation plants in Queensland throughout the Bowen Basin, New South Wales and Western Australia, as well as many Ship Loaders, Stackers/Reclaimers and Pipeline projects. Visit our website below to find out more.



📞 **07 4957 5999**

✉ enquiries@jppipingsystems.com.au

🌐 jppipingsystems.com.au

DRA Global restarts Gregory

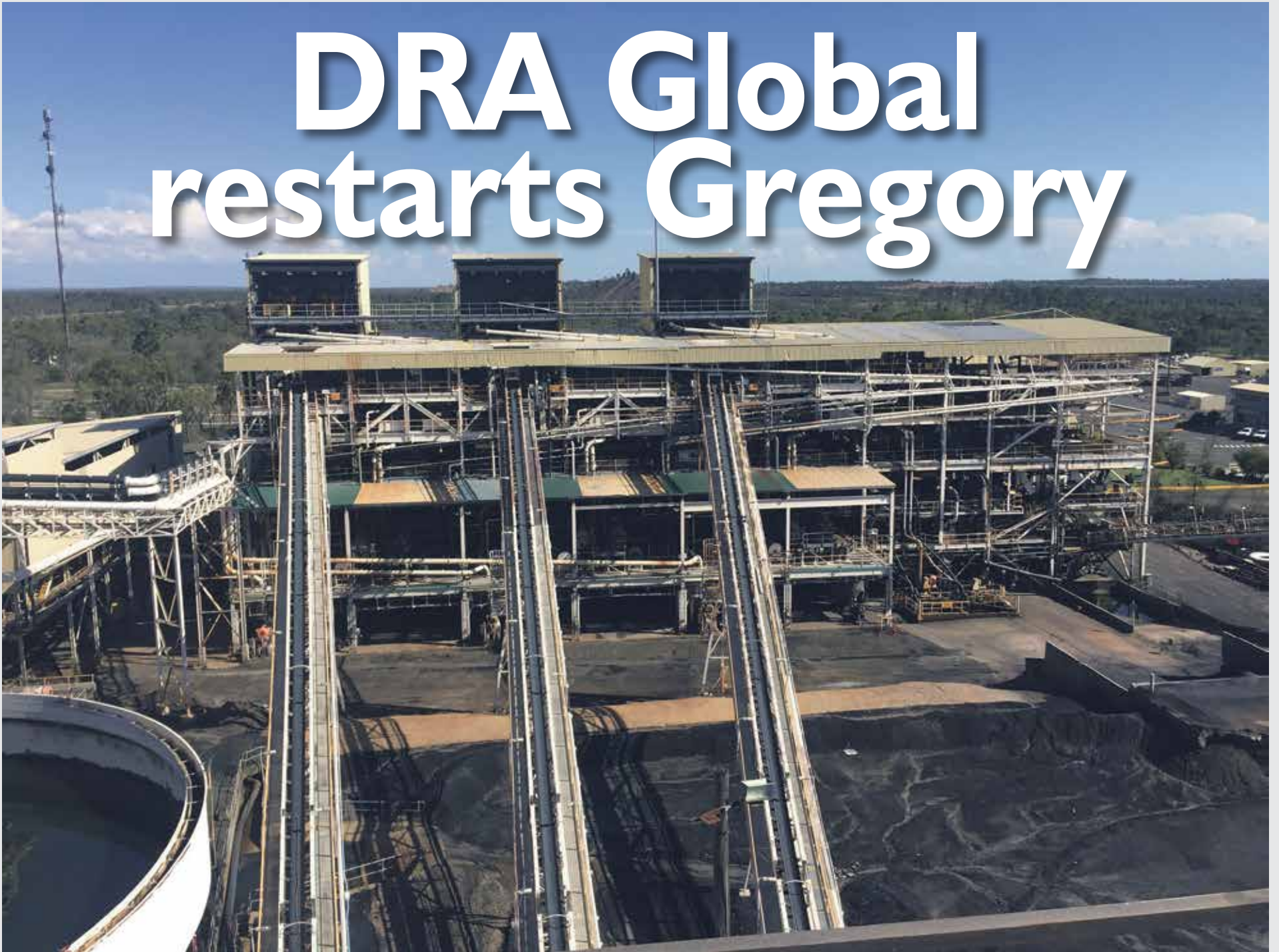

DRA Global has helped refurbish the restarted Gregory mine project for Sojitz.

NATIONAL

DRA Global (DRA) has completed more than 4500 mining engineering projects across the globe, including the major refurbishment in 2019 of Sojitz Coal Mining's recently acquired Gregory Crinum open-cut coking coal mine in Queensland.

An integrated project delivery team from DRA and G&S Engineering (a wholly owned subsidiary of DRA) provided the client a seamless execution model from refurbishment through to operations.

Acquired from BHP in March 2019 for \$100m, Gregory is one of three coal mines in Queensland operated by the Japanese coal marketing and trading company.

The company's other Queensland operations are Minerva and Meteor Downs South, both producing thermal coal for export markets.

The Gregory mine is located 60km northeast of Emerald and has a production capacity of up to 3mtpa and an expected mine life of 20 years.

DRA Project Manager at Gregory Coal, Duncan Cabassi, said the project's aim was to get coal running through the Gregory Coal Handling and Preparation Plant (CHPP) again, after the plant had been in care and maintenance for four years and in urgent need of a full refurbishment to recommence operation.

"A time-challenged overhaul schedule



The Gregory mine has a production capacity of up to 3mtpa and an expected mine life of 20 years.

was put in place as Sojitz committed to first coal delivery in the last quarter of 2019," she said.

"The plant had been in care and maintenance since 2015, exacerbating the challenges to overhaul and restart the facility after being dormant for such a long period of time with full exposure to the elements.

"Major works were required particularly around structures and the electrical installation: the scope of works for Sojitz was quite extensive and involved a comprehensive overhaul of the coal handling and preparation plant."

The refurbishment work ran from the Gregory mine's run-of-mine (ROM) crushing circuit right through to the

train load-out facility, where coal is loaded on to trains and railed from the site to port.

The Gregory coal processing plant has a nameplate capacity of 1200t/h, and produces two types of coal product: a primary product of hard coking coal, and a secondary product of thermal coal.

(CONTINUED OVER)

(CONTINUED FROM PAGE 27)

Extensive experience

The overhaul of the Gregory CHPP was executed from DRA's Brisbane office, drawing on construction experience from G&S Engineering.

The Gregory project was the first integrated coal project between DRA and G&S Engineering in Queensland's Bowen Basin, and consisted of a team of around 135 staff which included white- and blue-collar workers.

G&S' self-delivery capability provided both flexibility and certainty in meeting the schedule.

Included in the workforce were electrical, mechanical and instrumentation trades, supervision, discipline engineers and project management staff.

DRA employs more than 4300 people worldwide, and specialist skills from Perth and Johannesburg were utilised on the Gregory project.

The DRA team mobilised for the Gregory project at the end of March 2019 and work was completed in January 2020.

Due to the amount of refurbishment work, the project was phased to bring modules of the plant online, sequentially, ensuring first coal at the earliest possible timing.

First coal was processed through the plant on 9 October 2019.

As part of the works, new equipment was installed in the Gregory processing plant including double deck reject screens and two new centrifuges.

Key works

The wash plant at Gregory.

A review of previous structural audits and site inspection of the structures identified that significant and critical work was needed to be undertaken by the DRA to get the Gregory CHPP back into fit for purpose operational order.

"Structurally, a lot of rectification work was required on the conveyors within the process plant to get it back to a safe operational state," Mr Cabassi said.

"Mechanically it was normal maintenance. There was a total overhaul of the electrical wiring as it had significant damage from sunlight and wildlife."

About 50pc of the work on the project was in the electrical reticulation as new cabling and instrumentation had to be installed to replace damaged items, he said.

After the electrical, mechanical and structural engineering work was completed, the CHPP had to be thoroughly tested.

DRA performed the commissioning of the

plant whilst refurbishment was ongoing.

The DRA commissioning team worked in parallel to the refurbishment program to progressively bring the CHPP back to life.

"We had to do all of the statutory testing and resurrect the system and processing plant to a compliant state," Mr Cabassi said.

Safety on the project was impeccable with zero recordable injuries and minimal incidents.

The project involved more than 200,000 hours of labour undertaken by the DRA and G&S Engineering team.

DRA senior vice president Michael Carretta said the safety performance on this project was "outstanding and a credit to the entire team from DRA, G&S and Sojitz".

"The work undertaken by the team included high risk activities in a facility over 40 years old requiring significant repairs," he said.

"This result can only be achieved with the right systems and behaviours demonstrated on site."

After refurbishing the Gregory mine's coal processing facility Sojitz is able to further develop the mine site and increase its production at a future date.

Mr Carretta said that the mining sector in Queensland appeared to be going through a growth phase.

"The mining industry is investing for the long term with an increase in sustaining capital projects, major maintenance activities and new developments," he said.

About DRA Global

DRA Global is a diversified global engineering, project delivery and operations management group headquartered in Perth, Australia, with an impressive track record spanning more than three decades.

Known for its collaborative approach and extensive experience in project development and delivery, as well as turnkey operations and maintenance services, DRA Global delivers optimal solutions that are tailored to meet clients' needs.

With expertise in the areas of project development, mining, mineral processing, plant optimisation, operational readiness, systems integration, operations and maintenance and related water, energy, industrial and infrastructure requirements, DRA Global delivers truly comprehensive solutions to the resources sector.

DRA Global employs more than 4500 people and offers flexible engineering and operations management services worldwide through 18 offices.

For more information, contact Christo Visser at christo.visser@draglobal.com, or +61402901555.



Your Total Solutions Partner.

From concept to delivery and ongoing operations and maintenance services.

18 OFFICES
AROUND
THE GLOBE

OVER 3 DECADES
OF
EXPERIENCE

4500 PROJECTS
& STUDIES
GLOBALLY

// draglobal.com // g-s.com.au



MACKEY STEEL

The Coppabella coal mine has been an icon of the North West Queensland community over its 20 years of operations, supporting local industry, and providing jobs. And it's not resting on its laurels, taking its role as regional partner and steward of the land seriously.

PCI coal is mined and shipped to steel industries worldwide.

LINDA SMITH

BUSINESSES around the Mackay region have long thrived on work provided by US company Peabody's Coppabella, and the other mines in the vicinity.

Its strong culture of community engagement and corporate responsibility provides ongoing support to community services, local emergency services, education, safety and environmental management.

Coppabella celebrated its 20th anniversary in 2018.

Peabody Australia president George Schuller said that over its two decades in operation, Coppabella had provided benefits for the Moranbah and Nebo townships and the Mackay region as a whole.

The comments were echoed by Queensland Regional Council director Ian MacFarlane.

"Coppabella has exported coal to Japan, Korea and Taiwan, paying royalties to the State Government which are used to build the schools and hospitals," he said.

"That is good news for every town and community that relies on mining – from Mount Isa to Maroochydore.

"Queensland would be an unimaginably different place without the huge scale of mining investment over the past 25 years.

"The Queensland resources sector now provides one in every six dollars in the Queensland economy, sustains one in eight Queensland jobs, and supports more than 16,400 businesses across the State – all from 0.1 per cent of Queensland's land mass."

The mine lays 140km south-west of the Mackay region close to the Nebo and Moranbah townships.

It is a strong supporter of regional contractors and services and employs 435 workers on site.



Coppabella recently celebrated its 20-year anniversary.

The mine targets local engineering services, mining services, equipment and water treatment and other mine service industries from the region, to complete projects on site and in local workshops.

Benefits from the mines are seen in many markers, including housing provisions for employees and an employment rate that reflects the steady nature of employment provided by the mining industry.

The unemployment rate stays steady at around 1pc while the mining industry, including contractors and service industries, employs nearly 40pc of workers in the region.

This represents around 35,000 people in June 2018.

"The good news is, the resources industry is still creating jobs for people now, and for decades to come," said Mr Macfarlane.

The nearby Moranbah township was built as a home for miners in 1969, and

its symbiotic relationship with the mining companies continues.

The Miners League club is still going strong in the town to this day.

History

Opening on November 6, 1988, Coppabella has shipped more than 65mt of steel-making coal to China, Australia and Japan since reaching full production.

Peabody has a 73pc interest in an unincorporated joint venture that owns the Coppabella and Moorvale mines, and is the world's leading pure-play coal company, producing thermal and metallurgical coal.

Its mines supply power and steel customers in more than 25 countries on six continents.

The surface mine produces Pulverise Coal Injection (PCI) coal, which is used for its heat value and is injected directly into blast furnaces as a supplementary fuel,

which reduces the amount of coke required.

It can also be sold into the thermal coal market.

The open cast mining operation employs conventional processes, using dragline with truck and shovel and hydraulic excavators.

As a steward of the environment, Peabody is committed to following sustainable development practices at Coppabella.

It aims to progressively rehabilitate or reclaim all landscapes disturbed by its mining projects to ensure that post-mine, sound environmental outcomes are achieved.

By continually identifying and managing risks, conservation of the environment is ensured.

Production and geology

The mine includes four pits – Johnson, South, Creek and East.

It lies within the eastern part of the Queensland Bowen basin on the south-western edge of the Carborough syncline.

The south-east section of the deposit has been affected by a cretaceous-aged granodiorite intrusion that has changed the direction of the synclinal flank upwards.

The P&H 4100 electrical shovel is used for pre-stripping operations and removing overburden.

In order to facilitate the process, the overburden is first drilled and blasted.

A Marion 8200 dragline is used on the final pass to coal in the central region.

The exposed coal is mined using hydraulic excavators.

A north-east dipping Permo-Triassic strata encloses the economic coal measures of Fort Cooper and Rangal.

The processed coal is sent to the product stockpile before it is loaded and delivered for export to the Dalrymple Bay Coal terminal.



Scope Equipment Hire offers a full range of pump, pipeline and water management services.



Scope has mine site inducted personnel with pit-dewatering qualifications.

The full scope

NATIONAL

SCOPE Equipment Hire offers specialisation in mine site water management, pump maintenance and dewatering pump hire.

This includes repairing of all pump and engine parts by highly skilled workers, saving costs and extending the life of the equipment.

Its capabilities include its own unique IMS 5012 dredge, site maintenance services and a Mackay-based workshop for offsite repairs.

Scope provides services in dewatering pumps: skid mounted, pontoon-mounted and trailer-mounted.

Pump maintenance

From its fabrication and equipment repair workshop facility based in Mackay, Scope Equipment Hire can reclaim worn pump components to OEM specifications at a fraction of the cost of a new pump.

Scope also refurbishes and rebuilds all centrifugal diesel and electric processing pumps for the wash plants.

Rather than throwing out worn-end-plates and volutes, Scope improves their durability with skilled refurbishment and ceramic coating for extra strength.

Scope's repair services save companies huge amounts in extending the life of pumps and improving the overall pump performance.

An eroded cut water can dramatically reduce pump performance and causes many flow-on negative effects including lowered discharge pressure and flow, increased fuel consumption and reduced production, all leading to higher costs.

Once the part has been built up and ceramic coated a solid, a durable part

is created with up to twice the life and at a far lower cost than a replacement.

Companies can choose to purchase a new volute or let Scope rebuild parts that are sturdier than any new part that can be bought, not to mention having your equipment back on line sooner.

Instead of consigning this cabinet pump with only 3858 hours on it to the scrap yard, Scope took it to its Mackay workshop and performed its magic.

The rusted pump cabinet was removed completely. Scope Equipment Hire modified the old cabinet pump roof, installed a new exhaust system as well as fabricated a new frame to support the new canopy.

A custom designed heavy duty mine spec trailer was built for the pump with brakes fitted in compliance with Queensland road use and mining legislation.

After fabrication all the components were stripped, blast and painted with custom coded high build extreme environment three-layer paint.

The pump wet end was overhauled, the engine was tested and serviced.

The cabinet pump which was turned into a more practical mobile trailer pump was returned to a very happy client for a fraction of the cost of acquiring a brand-new trailer pump.

Meeting safety compliancy and legislation

Scope was contracted to upgrade trailer pumps at Peabody Coppabella after the company was alerted to the fact that most of their trailers may not have been compliant.

Peabody wished to ensure it was fulfilling its responsibility to provide equipment that met legislated specs and was safe for all workers, so Scope was engaged.



A cut water before repairs by Scope .



The same cut water after repair.



A pump skid before a Scope rebuild.



The pump skid after the Scope rebuild.



The roof was modified, and a new exhaust system was installed.



A new frame was fabricated, the roof was modified, and a new exhaust system was installed.



Scope took a cabinet pump destined for the scrap heap.



The rusted cabinet was removed.



A heavy duty mining spec trailer was built for the pump.



Mine compliant brakes were fitted.



The components were blast and painted, pump wet-end overhauled and the engine tested and serviced.

Scope inspected Peabody Coppabella's entire fleet of trailer pumps, upgraded suspensions to make sure it was the correct rating for the weight of the pump-set and upgraded the axles, tyres and rims.

Electric brakes were also installed on all the units.

Scope Equipment was also engaged by BHP to bring its older pump fleet into current site compliance.

This included retro fitting remote start/stop and telemetry eliminating the need for personnel to physically go to the pumpset in order to start/stop the pump.

The new remote-control system ensures site personnel are not put in harm's way when starting or stopping a

pump during inclement weather.

Scope regularly works with major mining companies, such as Peabody, Glencore, BHP and Yancoal to meet their own individual compliance codes.

It provides a reliable service, meeting all requirements provided by the major companies individualised to each site.

Pump hire

Scope Equipment Hire has a fleet of hire pumps ranging from small skid mounted pumps, trailer pumps to large skid and pontoon-mounted high head pit dewatering pumps.

Pumps often experience extreme conditions during the wet season and will need repairing.

Scope can smoothly replace a pump that needs repairing with its own fully maintained hire pump, helping to maintain mining operations.

The client's pump will then be removed to the Mackay workshop for professional repairs.

Scope also has an expert pump team specialising in maintaining equipment for ongoing site-based projects.

Mine site dredging

Scope Equipment Hire recently acquired a portable hydraulic dredge to provide a complete site slurry management plan that ensures mine sites comply with environmental requirements.

Scope uses the state-of-the-art IMS

5012 Dredge, which allows the company to provide dredging services to any mine, regardless of size and scope of the pond.

This dredge is very manoeuvrable in small ponds using the patented paddle wheels as well as having the ability to use on shore anchor points if required.

Scope Equipment Hire prides itself on delivering a high-quality dredging service to clients with up-to-date equipment and the safety of all personnel being paramount.

Contact Scope Equipment Hire today for a consultation.

More information:

Phone: 1800 472 673

Email: enquiries@scopehire.com.au

Website: www.scopehire.com.au



Scope offers fabrication at its workshop.



Scope offer quality dewatering pumps for hire.



The IMS 5012 dredge provides a versatile service, suitable for any site.



SCOPE
EQUIPMENT HIRE

1800 472 673
scopehire.com.au

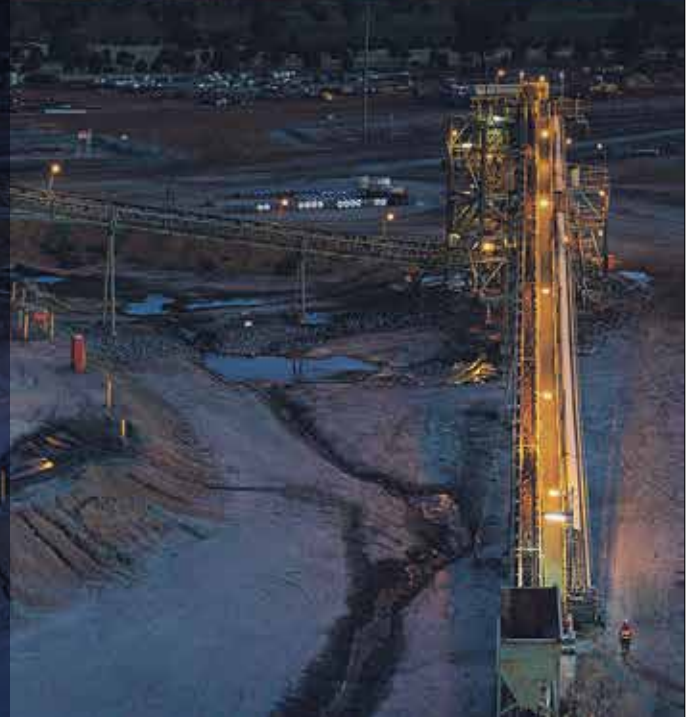

At Scope Equipment Hire, we have over 30+ years of industry experience and specialise in providing fast and cost-effective services such as dewatering solutions, dredging, site maintenance.

Scope Equipment Hire have a fabrication and equipment repair workshop facility based in Mackay servicing our clients in the Bowen and Surat basins. Specialising in pump repairs and rebuilds Scope Equipment can reclaim worn pump components to OEM specifications at a fraction of the cost of a new pump.

We pride ourselves on our workmanship and no matter the size of the project our clients can expect the very best quality and turnaround times.

We also offer high quality mining equipment hire, as well as repair, sell, rent and service LED lighting towers, dewatering pumps, pontoons and more across the Queensland mining, municipal and civil industries.

For on-time, quality and cost-effective services across the Queensland mining, industrial and civil industries, Scope Equipment Hire are your go-to specialists.

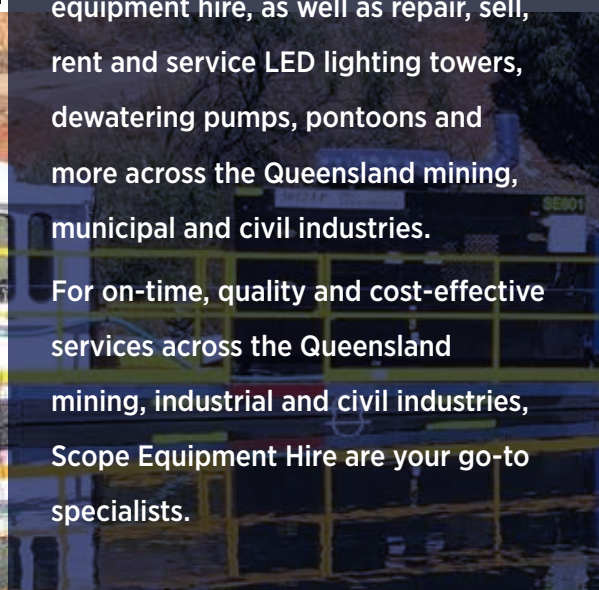

COPPING IT SWEET

South Australia's Carrapateena copper mine is ramping up its forecasts, as it ships out its first concentrate.

Production levels are set to rise at Carrapateena .

LINDA SMITH

PRODUCTION at one of Australia's biggest copper mines is set for a solid rise.

The OZ Minerals-owned Carrapateena already has the potential to produce 65,000t of copper and 67,000oz of gold a year over its expected 20-year lifetime.

The iron-oxide-copper-gold (IOCG) underground mine, located about 160km north of Port Augusta in South Australia, produced its first concentrate at the end of December 2019, targeting 4.25Mtpa throughput rates by end 2020 and 4.7-5Mtpa from 2023.

OZ Minerals chief executive Andrew Cole said the company remained confident in the long-term demand for copper from traditional sources as well as from the rapidly expanding focus on carbon reduction.

"The company is planning to continue its investment in growing Carrapateena," he said.

"2019 was a year of major progress for OZ Minerals," Mr Cole said.

"We will test and optimise the plant in the first half of 2020, leading to gradual throughput and recovery increases which will drive progressively higher output in the second half before turning cash positive in 2021."

The December quarter saw 26,845t of copper produced in the mine, an increase of 23,100t from the previous quarter.

This met the copper guidance for the fifth year in a row.

Low cost energy solutions

In mid-2019, OZ Minerals announced plans to trial a hybrid power station at Carrapateena.

The collaboration project between OZ Minerals and SunSHIFT plans to work with partners to test, trial and pilot new technologies from industry, research institutions, and governments, among others.

Electricity will be generated from a 250 kW



The project is an underground sub-level cave operation with an estimated mine life of 20 years.

solar PV system and 10kW wind turbine generator, and stored in a 250 kW lithium ion battery, integrated with a diesel power plant, demand management technologies and electric light vehicle charging station.

The Carrapateena hybrid electrical project can offer other mines an opportunity to evaluate the commercial value of a wind and solar PV asset at a remote mine site.

Investors may be encouraged by the low cost solution to power generation which could go towards improve the feasibility of mines in the development phase.

NSW-based company SunSHIFT is focussed on exploring developing similar energy solutions for remote mining operations and have experience in installing and operating renewable energy plants at other mining projects.

Production

OZ Minerals acquired the Carrapateena mine from Rudy Gomez and other shareholders in May 2011 after the copper-gold deposit was discovered by Gomez in 2005.

The operation is made up of four exploration licences spread across a 1,070sqkm area in central South Australia.

It is located on Pernatty Station with its supporting infrastructure located within Oaken Hills Station.

Carrapateena geology

The project is an underground sub-level cave operation with an estimated mine life of 20 years.

The copper-gold deposit, hosted in brecciated granite complex, sits under about

500m of un-mineralised rock cover.

The vertical shaped pipe is being mined using sub-level caving with the ore processed to produce copper concentrate.

With a 300m diameter and a vertical depth of 1,000m, the cylindrical-shaped Carrapateena deposit is located within the eastern margin of the Gawler Craton and hosted by the Carrapateena Breccia Complex (CBC), which is overlain by 470m of Stuart Shelf sediments.

The mineralisation at Carrapateena is dominated by coarse-grained disseminated chalcopyrite with common occurrences of sulphide vein-fill and blebs.

The Carrapateena mine is estimated to contain 79Mt of probable ore reserves grading at 1.8pc copper, 0.7g/t of gold and 8.5g/t of silver.

A block caving method involving two 500m-high lifts will be employed at the underground copper and gold mine for ore extraction.

The block cave mine is accessed through two declines, including a main access and a production access decline.

The underground mining project includes two block caves (lifts), a ventilation system delivering 1200m³ of air per second to the mine, access roads, the processing plant and site amenities.

The mine is accessible from the Stuart Highway via a 50km-long access road.

Water supplies for the mining, ore processing and other site activities are supplied from a purposely developed bore field.

Community support

The local community has given strong support to the project from its inception.

A Native Title Mining Agreement is in place with the Kokatha Aboriginal Corporation and is underpinned by a partnering agreement also known as 'Nganampa palyanku kanyintjaku', which translates to 'keeping the future good for all of us'.



GRES is proud to have assisted Oz Minerals on the Carrapateena Northern Wellfield project.

Keeping Carrapateena watered

NATIONAL

GR Engineering Services Limited (GRES) was appointed by OZ Minerals' Carrapateena to execute the detailed design and implementation of the Carrapateena Northern Wellfield project in early 2019, after completion of a Front End Engineering Design (FEED).

The Northern Wellfield was completed in accordance with the budget and schedule and transfers 370 m³/hr of raw water from nine wells and three transfer

stations through a 90km, 400mm diameter high-density polyethylene above ground pipeline network.

The raw water will be used as make up water for the 4.5Mtpa Carrapateena copper gold concentrator plant.

GRES is an ASX-listed process design and engineering company providing fixed price EPC and EPCM project delivery services to the mining and minerals processing industries internationally.

GRES has successfully completed feasibility studies, process and engineering

designs and construction for projects of various scale covering a diverse range of metalliferous and mineral commodities.

The company has delivered mineral processing, hydrometallurgical facilities and infrastructure for a range of clients, both in Australia and internationally.

With extensive experience across a range of commodity types including copper, lithium, graphite, iron ore and nickel the company is equipped to provide solutions for all types of mining projects.

The innovative engineering solutions

developed by GRES enable its clients to confidently move into development with the knowledge that the outcomes from study work will be reproduced in the operation of their projects.

GRES also has a presence in the hydrocarbons industry via its wholly owned subsidiary, Upstream Production Solutions (Upstream).

Upstream is a leading provider of operations, maintenance and well management services to the oil and gas industry in Australia and South East Asia.



Specialists in -

- ◆ Feasibility Studies
- ◆ Engineering and Procurement
- ◆ Construction and Commissioning
- ◆ Project Management
- ◆ Consulting Services
- ◆ Asset Management

📍 www.gres.com.au

Perth +61 8 6272 6000

Brisbane +61 7 3838 8000

GR
GR ENGINEERING SERVICES
ENGINEERING CONSULTANTS AND CONTRACTORS

Finding a better way

SOUTH AUSTRALIA

FINDING a better way is in Ausenco's DNA.

Ausenco responded to the challenge at Carrapateena with an optimised design honed by experience delivering successful copper concentrators globally.

Compared to the pre-feasibility design, Ausenco's design resulted in 30pc less power usage, 50pc footprint reduction and improved operability and maintainability – delivering reduced environmental impact and improved sustainability.

An efficient design

A lean, compact processing plant lowers capital cost and drives efficiency in delivery without compromising operability or maintainability.

Ausenco delivered a plant that reduces the number of people required in operations, with consideration to ready access, data gathering and analytics and general operations.

The result was reduced bulk commodities, and less energy to operate, enhancing both safety and sustainability outcomes.

A smarter process

Ausenco embedded technology into the

Carrapateena design that created a 'thinking' plant.

Using sophisticated instruments and analysis, Ausenco's Advanced Process Control optimises energy use and allows the process team to concentrate on high value activities.

A safer way

Using Ausenco's Safety in Design Protocols, the company minimised the need for interactions between people, mine equipment and vehicles.

Working with joint venture partner Downer, Ausenco considered constructability elements such as lifts; limited working at heights; simplified construction; and traffic management and access control.

A win for community

From the outset, the company created shared value and sustainable benefits for the local, and broader, South Australian community.

Goods and services were procured out of South Australia as a priority.

Local South Australians comprised 30pc of the workforce.

Ausenco's Regional Economic Solutions business unit worked with the Kokotha people, to deliver employment programs that resulted in 11pc of the construction



Ausenco's design minimises interactions between people, mine equipment and vehicles.

labour force being sourced from the local Port Augusta community.

On-the-job training, mentoring and upskilling programs such as rotational

opportunities helped broaden experience and capabilities, and created sustained employment opportunities for local community members.



Finding a better way to produce copper for Oz Minerals.

We know how to optimise your layout, improve capital efficiency, reduce your carbon footprint and improve the lifetime value of your asset.

www.ausenco.com



Carrapateena

50%
Smaller footprint

30%
Less overall installed power

11%
Traditional Owners and broader First Nations Community workforce



ELIWANA ON THE UP

The Fortescue Metals Group (FMG) has committed to taking its iron ore production to another level of almost 200mtpa with its Eliwana project in WA's Pilbara region. FMG has budgeted a mammoth \$1.93b for the project, set to start up in December 2020. Construction has started on the mine and a necessary railway for carting Eliwana's high grade iron ore to port for export to customers in Asia.

WA Premier Mark McGowan, FMG chairman Andrew Forrest and FMG chief executive Elizabeth Gaines, flanked by FMG leadership team members, turn the sod at Eliwana.

MIKE COOPER

ELIWANA is Fortescue Metals Group's (FMG) latest mining project for iron ore in the Pilbara region of WA and is set to start production later in the year.

The mine site will form a new Western production hub for the company.

First ore from Eliwana is expected to flow in December 2020.

According to an FMG statement, the US\$1.275b Eliwana mine and rail project is on schedule and budget with first ore on train due in December 2020.

Site-based work on the project is currently ramping up, and peak construction workforce is expected to be reached in the middle of the year.

The Eliwana project is important as it will enable FMG to sustain production of its premium West Pilbara fines product and provide the company with the flexibility to deliver iron ore with an iron content of 60pc.

The new project is also the next stage in FMG's expansion of its Pilbara operations.

According to FMG chairman Andrew Forrest, Eliwana is the next great step into the Western hub, enhancing the miner's profitability and extending mine life.

He said the project is expected to generate 1900 jobs in its construction phase and another 500 jobs on site in its operational phase.

WA premier Mr Mark McGowan said with around 2400 jobs created in construction and operations, Eliwana will create significant opportunities for Western Australian workers.

WA companies have shared in the award of contract work for the project.

Rail link

In January 2020, the project took a significant

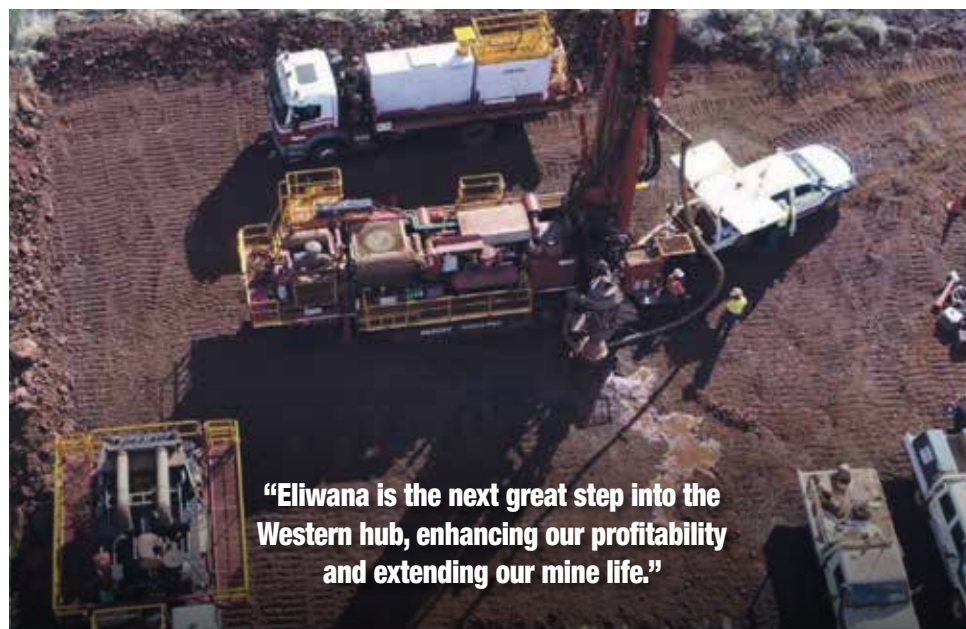

"Eliwana is the next great step into the Western hub, enhancing our profitability and extending our mine life."

Site-based work on the project is currently ramping up, and peak construction workforce is expected to be reached in the middle of the year.

step forward with the WA government awarding a special rail licence for the supporting railway.

The licence allows FMG to build and operate the rail project which is needed to transport Eliwana iron ore to Port Hedland.

The 143km-rail corridor is under construction and will connect Eliwana to FMG's existing Kings iron ore mine at its Solomon production hub in the Pilbara.

The WA government rail license enables the iron ore producer to build and operate the Eliwana rail project for the mine.

A rail fleet of 126 ore wagons and four locomotives has been commissioned for Eliwana.

"The development will utilise the latest technology, autonomous trucks and design efficiency, further cementing Fortescue's world leading use of innovation across its mining operations," FMG said in a ASX company notice.

Investment in the Eliwana project has already reached US\$1.27b, which covers the construction of a 30mtpa iron ore mine, processing plant, and the rail link to Fortescue's existing mines.

Other mines operated by FMG in the Pilbara include Cloudbreak and Christmas Creek which come under the company's Chichester hub.

Production

In a speech delivered at a mining industry event in Perth in February, FMG chief executive Elizabeth Gaines said the Pilbara region of WA was home to three of the world's four largest iron ore producers, which together export 800mtpa of iron ore.

"WA is the largest source of iron ore for China, which in 2019, produced a record 996mt of crude steel as it continues its path of urbanisation and development," Ms Gaines said.

China's crude steel production rose 8.3pc in 2019 compared to the 2018 year, said the company in its January 30 production update.

FMG's production guidance for the 2020 financial year is for its shipments to reach 170m to 175mt, stated the company February in its half-year update.

The iron ore company shipped 88.6mt of its Pilbara product in the six months ended December 2019, which equates to 177mt on an annualised basis.

"Total iron ore stocks at Chinese ports at the end of the [December 2019] quarter were 127mt, representing approximately 42 days offtake, similar to the end of last quarter," FMG said in its latest production update.

Ms Gaines said FMG is deploying innovative technology in its mining operations, and it has trained staff to embrace this new technology.

The company's autonomous vehicle fleet has travelled 39m km and moved 1.1bt of material, she said.

"Every day our autonomous fleet travels a distance equivalent to 3.5 times around Australia's highway one, without drivers at the wheel," Ms Gaines said.

Autonomous technology has contributed to FMG lowering its production costs.

FMG's production cost base for its iron ore operations is forecast to be just US\$12.75-13.25/wet metric tonne, stated a February company presentation.

FMG's average revenue for the September-December 2019 quarter was US\$76/dmt, up 58pc compared with the corresponding 2018 quarter period.

At current market prices, FMG has an operating margin of around US\$63/t.

Iron ore prices are forecast to decline to an average of US\$60/t by 2021, according to the Australian government's Office of the Chief Economist in his report for the December 2019-ended quarter.

Worldwide experts in bulk handling

NATIONAL

HIGHLY-SKILLED German engineering company FAM designs, plans and manufactures bulk handling and minerals processing equipment for the construction, mining and chemicals industries in Australia.

The firm's engineering and equipment solutions are designed to extract, produce, load and store bulk materials across a wide range of applications.

The company's large equipment and machinery includes bucket wheel excavators, spreaders and stackers, conveyor bridges on crawlers and shiploaders and crushing machines.

FAM also produces a variety of reclaimers such as bridge-type, bucket wheel and stacker-reclaimers for moving stockpiled material.

Headquartered in Magdeburg, Germany, FAM is a shortened version of the company's longer German name Magdeburger Förderanlagen und Baumaschinen.

The engineering company has a highly skilled workforce that is proficient in making mining and stockyard systems, and innovative port technologies.

The FAM group of companies has a total of 11 subsidiaries in Germany, Bulgaria, Chile, China, Canada, Singapore, Hungary, India and Australia, as well as representations in South Africa and the US.



An FAM bucket wheel excavator.

Personnel from the FAM group have worked in more than 80 countries worldwide.

In business for 100 years, FAM has incorporated professional experience, engineering knowledge and high-performance project management capabilities into its global solutions.

FAM delivers core systems for bulk handling plants in an array of industrial sectors, including mining, power generation, metallurgy, construction and port handling.

FAM Group also develops bespoke plants for the mining, conveying, processing and handling of minerals, raw materials and goods.

In addition to its manufacturing business, FAM offers a range of other related products and services, building on its experience in customised production processes.

These engineering services include consulting, erection, maintenance and repair, modernisation, training and providing spare parts.

The firm's skilled engineers provide customer-oriented consulting services for any materials handling system worldwide.

FAM's experts can suggest ways of improving the efficiency of bulk handling machines and plants to reduce energy, spare parts, and personnel costs.

Consulting services are also available from FAM to increase the availability of preventive maintenance solutions and improved materials and processes.



The Global Bulk Materials Expert

Bulk materials handling solution for the mining sector

FAM delivers core systems for bulk handling plants in an array of industrial sectors, including mining, power generation, metallurgy, construction and port handling. Our personnel references plants in more than 80 countries worldwide. FAM's portfolio comprises large equipment and individual machines such as:

- Bucket wheel excavators
- Spreaders and stackers
- Conveyor bridges on crawlers
- Full-portal and semi-portal scrapers
- Reclaimers: bridge-type, bucket wheel or stacker
- Ship loaders / unloaders
- Crushers and mills



FAM
Magdeburger Förderanlagen
und Baumaschinen GmbH

Germany
Magdeburg

www.fam.de
sales@fam.de

All Images: GFG Alliance.

WHYALLA TRANSFORMATION

South Australia's Whyalla Steelworks is undergoing a radical remaking as the old industrial plant is revitalised in a \$1b project. The project is funded by Whyalla's owner GFG Alliance and is set to transform the steelworks area. GFG is also building the Cultana Solar Farm to provide cleaner energy to Whyalla.

The entrance to Whyalla steelworks by the river.

MIKE COOPER

WHYALLA Steelworks in South Australia has been an Australian landmark for decades and is now seeing exciting changes with a \$1b investment project.

Renamed Liberty OneSteel by its new owner GFG Alliance, which purchased the plant from Arrium, the company has a radical plan to revitalise the legendary steelworks.

GFG Alliance is spending \$1b to modernise its Whyalla steel plant and double its production capacity from its current 1mtpa over the next three years.

The company has signed contracts to build a new rail and structural heavy section mill expected to produce 1.8mtpa of high quality steel including, new products such as steel slabs, billets, structurals and rail.

Currently, Whyalla produces steel billets which are rolled into long products, and about 65pc is sold to steel rod and bar producers.

The rest is converted to structural steel and rails at Whyalla structural mill.

There is also plans at Whyalla for a modern pulverised injection coal plant, and an expansion of Whyalla's port into a world-scale, multi-user facility.

Whyalla steelworks and its South Australian iron ore mines were acquired by GFG Alliance from Australian company Arrium in September 2017.

Headed by Indian-born Britain-based businessman Sanjeev Gupta, GFG Alliance has been built up over the course of the past 60 years by the Gupta family.

The London-based company's interests span many businesses from mining and energy generation through to metals production and engineering and banking.

GFG Alliance was reluctant to reveal too many details of its transformation programme as it has some important announcements in the pipeline.

"The Whyalla Transformation Program also continues to progress in earnest, with further updates expected to be announced soon," a spokesman for GFG Alliance said.

Sustainability vision



An aerial view of Whyalla Steelworks.

"We are progressing well with our Cultana Solar Farm, and hope to break ground in early 2020."

Behind GFG Alliance's network of businesses is its vision to create a sustainable business model that will work for tomorrow's generations.

"On a planet of limited resources, rising population and cycles of prosperity and recession, we place great emphasis on making our enterprises both resilient and sustainable," the company states on its website.

This approach includes a commitment to using renewable energy sources, and to used recycled metal in its furnaces and mills.

Through its sister company Liberty House Group, GFG Alliance is pursuing two environmental strategies, GREENSTEEL and GREENALUMINIUM.

The GREENSTEEL strategy is for the company to recycle and upcycle its scrap steel products using electric arc furnaces powered by renewable energy.

This marks a shift away from traditional steel-making methods that use steel raw materials in blast furnaces.

Steel produced from scrap material creates a third less carbon dioxide emissions than steel made from iron ore and coking coal, stated the company.

GFG recycles 4mtpa of scrap steel in Britain and Australia, a portion of which is reused by the company after being melted in its electric arc furnaces.

In October 2019, Liberty said it was vesting GFG Alliance's steel assets into a single global company, Liberty Steel Group, including Whyalla.

GREENSTEEL is at the heart of Liberty

Steel Group's strategy with the company exploring new ways of making steel such as hydrogen-based steel production.

Liberty Steel Group has a production capacity of 18mtpa for rolled steel products and employs 30,000 people in 10 countries, making it the eighth largest steel company outside China.

Announcing the creation of Liberty Steel Group at the World Steel Dynamics conference in Rome, Italy, in October 2019, Mr Gupta said he wanted to forge a sustainable pathway for his steel business.

"As a responsible business, the legacy we pass on to future generations is every bit as important as our bottom line," Mr Gupta said.

"We are creating a new force in steel with the size, scale and agility to force a path towards a sustainable future for our steel businesses and the communities in which we operate."

Solar energy

GFG said its project to build a solar farm to harness the energy of the sun for use by the steelworks at Whyalla was making good progress.

"We are progressing well with our Cultana Solar Farm, and hope to break ground in early 2020," the GFG Alliance spokesman said.

Located on the northern outskirts of Whyalla, the Cultana Solar Farm with a generation capacity of 280MW is expected to deliver 600GW of solar-generated electricity to the steelworks and local businesses.

The facility has 780,000 solar panels and covers 1100 hectares, or 550 times the size of the Adelaide Oval, and will offset 492,000tpa of carbon emissions.

GFG Alliance company SIMEC Energy Australia is delivering the \$350m project which is relying heavily on a local workforce.

"We have a strong bias towards employing local people and companies across all our projects and in particular Cultana is expected to generate 350 jobs during construction," the GFG Alliance spokesman said.

SIMEC said on its website that it is committed to upskilling local people to meet the employment requirements of the Cultana solar farm.

Supply chain

For the GREENALUMINIUM strategy, which GFG is pursuing in the UK and Australia, the company is shortening its supply chains, reducing its carbon footprint, and developing a sustainable metals manufacturing sector.

An example of its integrated supply chain is the one feeding coal and iron to its Whyalla steelworks.

SIMEC Mining, a GFG Alliance company, operates iron ore mines in South Australia's Middleback Ranges, 60km from Whyalla, which supply magnetite iron ore to the steelworks.

The mining company also operates the Tahmoor coking coal mine in NSW with its production of 2mtpa, some of which goes to Whyalla.

The alliance also owns the Ardrossan dolomite mine in South Australia that provides dolomite flux to the Whyalla works.

In a January 20 company statement, GFG Alliance announced the creation of a new company within the group, Alvanco Aluminium Group, to consolidate its aluminium-related assets.

The Paris-headquartered Alvanco will oversee GFG Alliance's upstream and downstream aluminium assets from alumina supply to smelters and manufacturing plants.

Alvanco is the standard bearer of GFG Alliance's GREENALUMINIUM sustainable aluminium strategy and has a goal of becoming a carbon neutral enterprise by 2030.

WGA partners Whyalla

NATIONAL

WGA, in a joint venture with Hatch, has been undertaking the engineering design for the Liberty Primary Steel Transformation project at the Whyalla Steelworks in South Australia.

WGA has been providing mechanical, civil, structural, electrical and controls engineering together with geotechnical advice and reporting, showcasing the firm's multidisciplinary approach to delivering complex brownfield projects.

In addition to the transformation project, WGA continues to provide engineering services to Sustaining Capital projects across the steelworks and mining areas.

WGA has been involved in the Whyalla Steelworks for 30 years, having established a permanent office there more than 25 years ago and continues to provide a loyal around-the-clock service whilst actively supporting the local community in Whyalla.

Highlighting its Client Focus value, WGA has shown its ability to react quickly and produce practical solutions that minimise the impact on production.



The exterior view of Whyalla Steelworks.

WGA's extensive experience in Whyalla has meant it has a unique understanding of steelworks and similar heavy industrial-type plants such as NYRSTAR and BHP where it has completed all of the Raise Bore ventilation projects at BHP's Olympic Dam operation in South Australia

over the past 12 years.

After opening an office in Perth in 2012, WGA identified that clients were looking for the same unique skillset it brings to challenging, bespoke, brownfields projects.

This has enabled WGA to secure active projects with Rio Tinto, including

the refurbishment of navigation aids demarking shipping channels into ports.

WGA's specialist skills in demolition, decommissioning and heavy lifting has seen it successfully complete the removal of significant redundant assets for BHP's iron ore operations at Port Hedland, WA.

WGA

WALLBRIDGE GILBERT
AZTEC

- CIVIL
- MARITIME
- ELECTRICAL
- STRUCTURAL
- DEMOLITION
- MECHANICAL
- GEOTECHNICAL
- HEAVY LIFTING
- HYDROGEOLOGY
- PRESSURE VESSELS
- TEMPORARY WORKS
- PROJECT MANAGEMENT

ADELAIDE | DARWIN | MELBOURNE | PERTH | WHYALLA | NEW ZEALAND



All Images: BHP.

A MINE FOR THE FUTURE

The world is waiting in anticipation for BHP to unveil its \$5.3b (US\$3.6b) South Flank iron ore project in Western Australia. The new mine will showcase many of the latest developments and innovations in mining technology. BHP's South Flank project director Simon Thomas gave AMR an update on the vast project's progress and described many of its innovative design features.

Building work in progress at South Flank.

MIKE COOPER

THE South Flank iron ore project currently under construction for BHP in the Pilbara region of WA will be one of the most technologically advanced mines in the world.

Superlatives such as the biggest, longest, latest and greatest are being applied to many aspects of the project which starts production in 2021.

The new mine is incorporating many of the latest developments in mining technology ranging from autonomous mining equipment, digital-connectivity and modular-designed structures.

According to BHP's Project Director for South Flank, Simon Thomas, South Flank is a US\$3.6b project that will fully replace production from the 80mtpa (100 per cent basis) Yandi mine, which is expected to end its economic life in the mid-2020s.

"The first ore from South Flank is targeted for the 2021 calendar year, with the project expected to produce ore for more than 25 years," he said.

The project has a crucial role to play in enhancing the quality of BHP's iron ore products from its Pilbara mines in WA.

"South Flank will enhance the average quality of BHP's WA Iron Ore (WAIO) production and will allow us to benefit from price premiums for higher-quality lump and fines products," Mr Thomas said.

"The iron ore will contribute to an increase in WAIO's average iron grade from 61pc to 62pc, and the overall proportion of lump from 25pc to about 35pc.

"It is expected to have a strip ratio in line with the WAIO average."

Located 130km northwest of Newman, WA, the South Flank mine is close to existing iron ore export infrastructure at BHP's Mining Area C in the Pilbara.

Extra capacity for processing iron ore is being added to the Mining C hub as part of the

South Flank project, Mr Thomas said.

"The South Flank project expands the existing infrastructure at Mining Area C, and involves construction of an 80 mtpa crushing and screening plant, an overland conveyor system, stockyard and train loading facilities, procurement of new mining fleet and substantial mine development and pre-strip work," he said.

Autonomous mining equipment including haul trucks is an integral part of the South Flank project, showcasing the latest advances in mining equipment.

"South Flank will use the Komatsu 930E-5 ultra-class haul trucks, which are made autonomous-ready," Mr Thomas said.

Project progress

Construction work on South Flank is nearly two-thirds complete, and the first large modular structures are starting to be assembled on-site in the Pilbara.

"The project is on schedule and on budget at nearly 60pc complete," Mr Thomas said.

Modern modular construction methods are being used for South Flank.

"South Flank has been designed to allow large, heavy and more complete structural modules to be fabricated and transported to site reducing our exposure to the higher risk construction activities associated with cranes, working at heights and dropped objects," Mr Thomas said.

"Our design incorporates design modification to remove our operators from hazards identified through an extensive safety in design process, and the modular, rotatable nature of many plant components will improve our production efficiency, maintenance safety and productivity."

Large infrastructure components are being delivered to the mine site for assembly from a range of workshops and steel fabrication plants including in Kwinana, WA.

"The first modules for the stacker and

reclaimer recently arrived in Port Hedland, a great milestone. These were locally made on the Kwinana strip," Mr Thomas said.

Contractors are working to bring to the site large, custom-made steel fabricated equipment, such as large stacker and reclaimer machines used to create and move stockpiles of iron ore.

The stacker-reclaimer units and ore conveyors are some of the largest ever made.

Also included in the mine's footprint are primary ore crushing facilities, run-of-mine pads, overland conveyors, ore stockpiling and handling infrastructure, stockyards, train load-out facilities and a processing plant, according to BHP.

WA contractors

WA engineering and steel fabrication companies are sharing in the work to build South Flank, Mr Thomas said.

"About 85 per cent of the project spend will be awarded to companies based in Australia; about 90 per cent of which will go to companies based in Western Australia," he said.

The construction workforce for South Flank totals several thousand people, and in its operating phase the mine will have 600 workers, including many indigenous Australians.

"We have now seen more than 3000 people receive work on South Flank," Mr Thomas said.

"The project will create around 2500 construction jobs, more than 600 ongoing operational roles and generate many opportunities for Western Australian suppliers.

"Over the life of the project we expect more than 9000 people to be engaged in the South Flank work force.

"A total of 346 ongoing operational roles have been filled to date, with nearly half (48pc) of these roles are female and 20pc are Indigenous."



BHP South Flank project director Simon Thomas.

"South Flank is a US\$3.6b project that will fully replace production from the 80mtpa (100 per cent basis) Yandi mine, which is expected to end its economic life in the mid-2020s"

World leader

Australia is the world's largest exporter of iron ore, accounting for 53pc of global seaborne trade, and the nation exported 834mt in the 2019 year, which is expected to grow to 878mt by 2021.

China was the chief destination for Australian iron ore exports with a market share of 81pc, followed by Japan at 8pc, South Korea with 6pc, and Taiwan at 2pc, and the rest of the world on 3pc.

The free-on-board WA price of iron ore with a 62pc iron content was expected to average US\$80/t in the 2019 year, according to the Australian government's Office of the Chief Economist in its report for the December 2019 quarter.

"The iron ore price is forecast to decline to average US\$60/t FOB Australia by 2021, as the seaborne market gradually returns to balance," stated the report.

EnviroMist has dust under control

NATIONAL

AUSTRALIAN company EnviroMist produces custom-made dust suppression systems for the mining industry that safeguard worker safety in a cost-effective way.

Reducing dust levels at mine sites and stockpile areas decreases the health and safety concerns of respirable dust diseases such as silicosis, black lung disease and others whilst reducing cleaning bills and reducing dust related maintenance issues.

The Brisbane-based company's high energy dust suppression systems run at extremely high pressure, up to 21,000kPa, to create a curtain of fine mist that captures and holds dust particles in a dust control zone.

Millions of tiny water droplets are created by EnviroMist's systems, leading to large coverage areas with low water usage when compared to low pressure systems.

The company has invested in research partnerships with Australian universities in order to understand the mechanisms of dust control and to calibrate the size distribution of the water droplets produced by EnviroMist's proprietary systems.

Research has determined that water droplet size plus the probabilistic chance of a water droplet contacting a dust particle is key to reducing overall dust levels in a system.

The firm's proprietary technology is tuned to match water droplet size to the dust particle size.

The size of water droplets produced by EnviroMist's system can be adjusted – from three microns up to 150 microns - to best match the type of dust that is being targeted.

EnviroMist's dust suppression and control systems are custom-made for clients from quality materials using its proprietary product knowledge.

Spray bars are all stainless steel to meet safety requirements and to ensure longevity, while EnviroMist custom machine their own nozzles to meet the pressure and life requirements, with nozzle life lasting for years with little wear.

EnviroMist nozzles never block when fed by a correctly designed and maintained system.

EnviroMist's on-board control systems communicate with plant systems to coordinate system usage with operational requirements in scenarios such as truck dump stations and stockpiling off-feed conveyors.

Skilled engineers from the company can design, manufacture and install dust control systems to suit a client's special requirements.

The company serves many clients in the mining and manufacturing sectors in New South Wales, Queensland and WA.

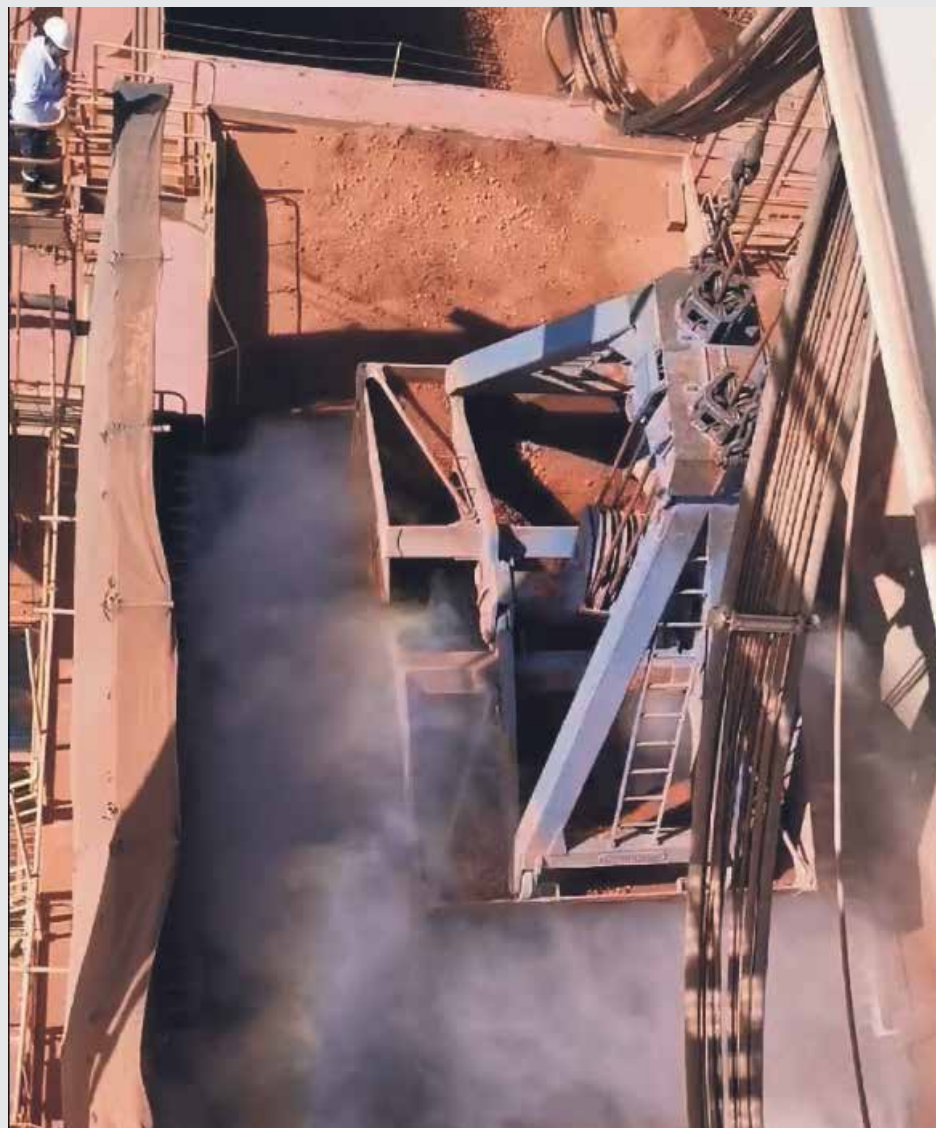

EM spray system in operation during ship-unloading operation



TURN-KEY DUST SUPPRESSION

- Stockpiles & ROM Bins
- Crushers & Conveyors
- Mining Machinery

- Ship Loaders & Unloaders
- Transfer Points & Chutes
- Construction Machinery



Contact Us Today | www.enviro-mist.com.au
info@enviro-mist.com.au | 0408 677 889

MANGANESE MONITOR

Australia's GEMCO has a pivotal role to play in the global market, but as steel production in mega-consumer China stalls, the manganese market stands at a crossroads.

MIKE COOPER

THE Groote Eylandt Mining Company (GEMCO) on Australia's Gulf of Carpentaria has a leading market position on the production cost curve for manganese mining.

The open-cut mining operation is one of the largest and lowest-cost manganese ore producers in the world, according to its operator and 60pc owner South32.

This makes GEMCO an ideal bellwether for assessing the state of the global manganese market.

South32 said in a January production report that it expects its Australian manganese ore production to hit 3.56mwt in the June 2020-ended financial year.

Heavy rainfall slowed throughput at its Australian ore processing facility in September and production fell to 1.77mwt for July-December 2019.

This is down 2pc from 1.81mwt for the corresponding 2018 half year, stated the report.

Total manganese ore production for South32 on an equity share basis was 2.81mt in the July-December 2019 half-year, down 3pc on 2.88mt for the corresponding 2018 half-year.

The company's South African production of manganese ore was 1.03mwt in the six months ended December 2019, down 3pc from 1.07mwt in the corresponding 2018 half year.

Extended maintenance at its Wessels mine in South Africa in late 2019 and South32's reduced use of high-cost trucking affected its ore production in South Africa.

Ore from GEMCO, in which Anglo American has a 40pc stake, is shipped to South32's Tasmania alloy plant for processing into ferro-manganese for use in steelmaking.

Manganese alloy production for the company fell 17pc to 91,000t for the December 2019-ended half year, from 109,000t in the July-December 2018 period.

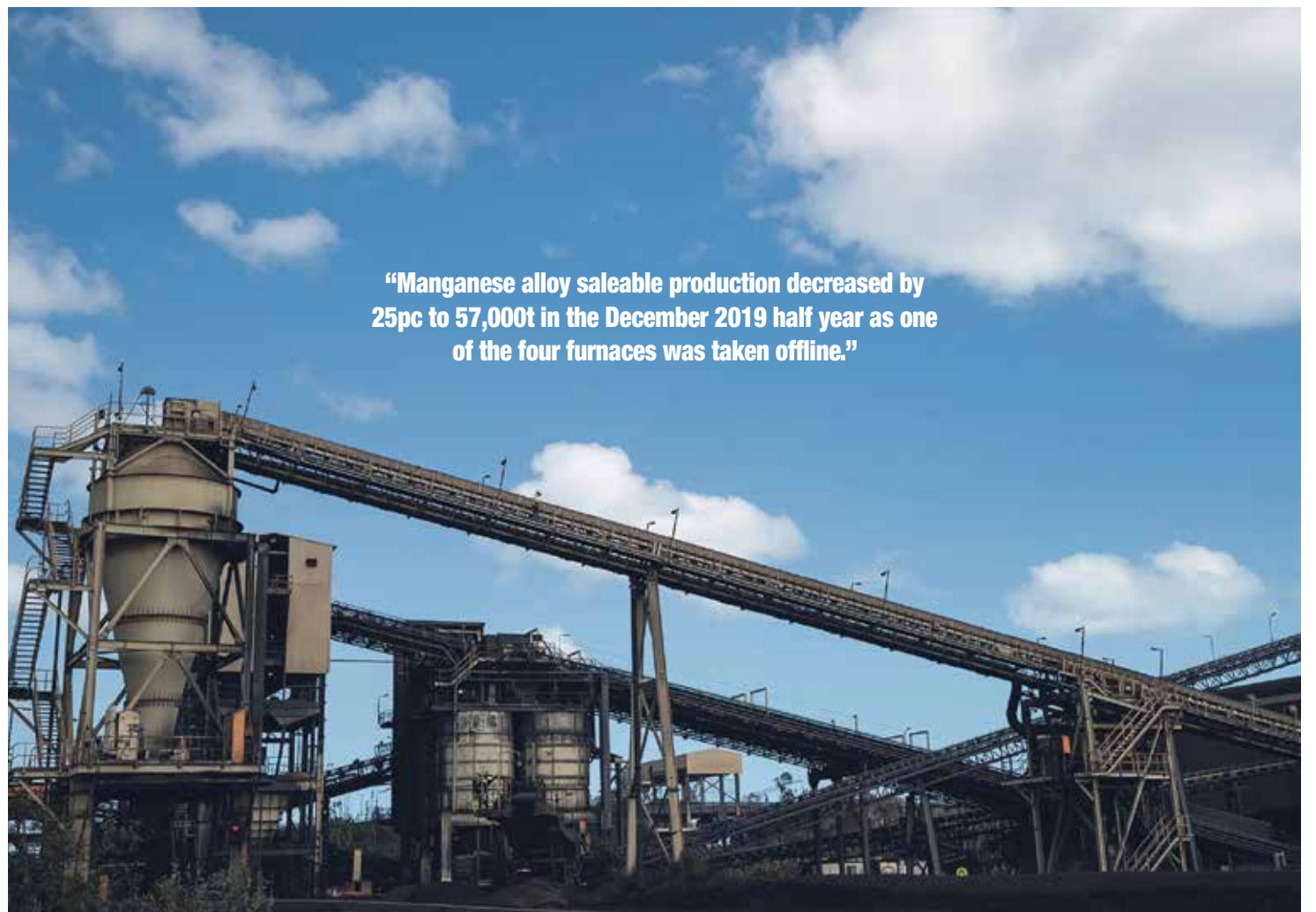

"Manganese alloy saleable production decreased by 25pc to 57,000t in the December 2019 half year as one of the four furnaces was taken offline."

GEMCO is one of the largest and lowest-cost manganese ore producers in the world.

Alloy production at its Australian plant declined in the recent half year following operational issues.

"Manganese alloy saleable production decreased by 25pc to 57,000t in the December 2019 half year as one of the four furnaces was taken offline," stated South32 in its January report.

Market health

The health of the global manganese market is chiefly determined by the state of the steel industry and that of its largest producer, China, which accounts for 50pc of global steel production.

In steel production, manganese is used

as an alloy and deoxidising component.

China's steel production is forecast at 917mt for the 2020 year, and is set to decline to 902mt in 2021, according to Australia's Office of the Chief Economist in its Resources and Energy report for the quarter ended December 2019.

South32 chief development officer Simon Collins highlighted the importance of China's and India's steel production to the manganese market in his speech to the 2019 Diggers and Dealers conference in Kalgoorlie.

Mr Collins also pointed to the increasing trend for China and India to smelt manganese ore which is impacting

the market for manganese alloy.

"Globally, China and India account for approximately 60pc of steel production and have developed significant domestic smelting capacity," he said.

According to the Office of the Chief Economist in its recent report, world steel production is forecast to decline 0.6pc year on year in 2020 to 1.81bt.

"European Union steel output fell in October (for the 10th successive month), as well as in Japan and South Korea.

Growth is also softening in India, and appears to have stalled in the US, though this may be just a temporary downturn," the report stated.

This market trend towards ore and away from alloy has led South32 to review the future of its existing manganese alloy smelters in Australia and South Africa.

In its January 2020 production update, South32 said its review was ongoing and its options for its manganese alloy smelters in

“Globally, China and India account for approximately 60pc of steel production and have developed significant domestic smelting capacity [for manganese].”

Australia and South Africa included sale, closure, or mothballing.

“We have also seen significant new capacity in Malaysia – where there is the advantage of access to cheap power coupled with a favourable location – both to receive raw materials, and to ship to end markets,” Mr Collins said in his Kalgoorlie speech.

Aside from making steel, manganese has a variety of other uses including as an additive in petrol, pigments in the ceramics and glass industries.

Dry-cell electric batteries is another growing demand point for manganese in a dioxide form.

Price volatility

Slowing economic growth in China and the rest of the world as highlighted by recent IMF reports could drag on manganese demand and prices.

Manganese prices have traded in a volatile fashion over the past five years, hitting a low of Yuan 16/t in January 2016, and spiking at Yuan 51/t later that year.

Its current price is around Yuan 32/t (\$6.80/t) on a 37pc quality basis CIF



The open-cut mining operation is one of the largest and lowest-cost manganese ore producers in the world.

Tianjin, China, a major delivery point for the country's steel mills, according to website Trading Economics.

For its Australian manganese ore, South32 realised a market price of US\$4.49/dmt free-on-board (FOB) basis Australia in

the July-December 2019 half year, down 32pc from a realised price of US\$6.59/dmt FOB for the July-December 2018 period.

Realised prices for its South African manganese ore fell 35pc to 3.81/dmt FOB Port Elizabeth in the first half of the 2020

financial year, from US\$5.85/dmt FOB in the first half of the 2019 financial year.

South32's Australian manganese ore product has a 45pc manganese content compared with 40pc for its South African ore product.

I S Systems experts in automation

NATIONAL

PROVIDING tailor-made solutions for industrial automation is a core skillset of Australian electrical engineering firm I S Systems.

I S Systems engineers custom-made electrical automation systems to particular client needs, guaranteeing peak performance and maximised machine productivity.

The firm's three-decade track record includes project work on turnkey greenfield engineering projects right through to complicated machine upgrades.

The NSW-based electrical engineering company has deep specialist knowledge gained through its delivery of practical solutions in process engineering through a broad client base.

Among the engineering project work carried out by I S Systems is process definition, analysis and optimisation, control system design and implementation, AC and DC drive system selection.

In the mining sector, I S Systems has specialised in electrical engineering work for bulk handling and ore processing facilities on mine sites.

The company's core competencies in its mining sector work include



An electrical control system of the kind serviced by I S Systems.

automation and control of material processing plants, automation and drive systems for large materials handling machines such as stackers, reclaimers, shiploaders and conveyors.

I S Systems worked on several upgrades of the electrical and control system of GEMCO's manganese processing plant in the Northern Territory of Australia.

The firm has been the winner of the Pace Zenith Awards in 2007 for the GEMCO Concentrator Siemens S5 to Siemens S7 upgrade.

All of the projects were completed without any loss of production.

I S Systems has a 24/7 contract with GEMCO to provide on-site support for any control system issues that may arise.

I S Systems Pty Limited
AUTOMATION AND CONTROL ENGINEERS

- * Electrical Panel Manufacturing
- * Automation, Drives and SCADA engineering
- * Service, Support and Commissioning
- * Turnkey Projects and Solutions

sales@issystems.com.au
www.issystems.com.au
Ph: +61 (0)2 4964 8548



Perth will host Minerals and Investment Week, to be held from March 18-19 at The Westin, and which will look at the future of the iron ore, steel and mineral sands industries.

The 21st Annual Mineral Sands conference will deliver a comprehensive analysis and insight of the latest updates from industry members.

RAY CHAN

WITH more than half of ASX-listed mineral sands companies showing gains of up to 200pc in recent years, now has never been a better time to invest in commodities like zircon, titanium dioxide and ilmenite.

But does that mean resource investors are putting their hands in their wallets for mineral sands projects more than ever?

Far from it. In fact, a mineral sands investment pitch is more likely to fail than succeed, with an estimated 70-80pc of funding applications rejected.

The reasons for this bearish approach often have little to do with market forces and can be frustratingly simple.

Keep it simple

The mineral sands asset class is complex and not well understood by much of the investment community.

Generally, it doesn't have as much data as its mainstream counterparts, like gold or copper.

It's a more opaque industry and harder to determine price direction.

So even if your investor specialises in resources, he or she may have little knowledge of this particular commodity segment.

That's a problem because it's easier to say 'no' to stocks that aren't familiar.

With that in mind, you'll want to make sure your pitch is seamless and easy to understand.

If most of your revenue comes from a particular part of the product suite, focus your attention on that – i.e. the most material thing for the investor.

If you're a foreign developer, summarise country risks in an easy-to-read fashion.

A simple plan generally gives investors more comfort around things like commissioning risk, than complicated flow sheets.

Allow enough runway

The average time from pitch to cash in any capital raise is typically six months, but within mineral sands, this process can take much longer.

Not only are these projects being told 'no' more – which means they have to work their way through a larger pipeline of prospects – but the due diligence (DD) process tends to be more drawn out than with mainstream commodities.

A key reason for this is a dwindling resource investor pool – meaning that current investors are spreading themselves thinner between more hopefuls.

Ten years ago, resource investors were plentiful.



Clyde Russell.

These days, fee pressure for fund managers means they aren't allocating as many geology specialists as they used to.

Mineral sands specialist investors are even more scarce.

With not as much expertise in the industry – and with less available data – it's taking longer for investors to perform DD.

It might take a non-resource specialist just one day to learn about a gold company, but a week to fully get to grips with a mineral sands project.

Consider private equity

Statistics suggest that there has been more funding from private equity into mineral sands than other commodity segments. Therefore, it may be a stronger avenue for capital raises for those consistently being told 'no' by mainstream investors.

Private equity is generally more willing to take time to learn about and specialise in an industry where they might get an informational advantage.

The downside of private equity is reduced liquidity, but the upside is you are more likely to get an investment partner that can add value.

Use a financial partner

Convincing investors that a pitch is worth the time and effort is often half of the job, regardless of how good the investment opportunity might be.

To this end, a broker or financial partner can make or break your success.

With expertise on writing reports on stock performance and market dynamics, a broker can fill in the gaps of data and educate investors in the most coherent way possible.

On top of this, a stockbroker's reputation can often carry a project through to an investor.

With the company's reputation at stake, investors tend to trust projects brought forward by a broker more than those who skip

the middleperson.

Learn more about what investors are looking for at Informa's forthcoming Mineral Sands Conference, to take place from March 18-19 at the Westin Perth.

The event will be held in conjunction with the Global Iron Ore Conference, at which an impressive line-up of speakers will address issues focusing on growth and development in the iron and steel industries.

Among them will be Reuters columnist Clyde Russell, who is calling on resource companies to make positive change and decarbonise the economy.

Mr Russell said there were rewards for taking steps towards carbon neutrality – and risks for not doing so.

Risks of not taking action

The importance of social license to operate (SLO) appears to have been downplayed in the resources industry – with few, if any, SLO-dedicated staff having senior-executive-level status within a mining organisation, Mr Russell said.

"SLO is one of the top concerns of any mining company, but the person in charge of SLO is rarely one of the top two or three leaders of each company," he said.

The result is that SLO objectives are often stifled by efficiency and financial metrics – usually the main KPIs for a company's biggest heavyweights: its board and C-suite.

Mr Russell says coal companies should continually ask themselves: "Do enough people support what we're doing that allows us continue what we're doing?"

Though often a confronting question, the consequences of not doing this, he says, are far more serious than we might be imagined.

"When you lose community or government support it starts to impact your business in a big way," Mr Russell said.

"People will back you up to a point, but eventually banks will stop investing in you due to the reputational risk of supporting your brand.

"Insurance companies, too, will increasingly deny your applications for fear of upsetting more substantial clients within their portfolio.

"We are already noticing these things start to happen within the coal mining industry.

"If your shareholders want out, yes, there will always be more. But these days most large companies recognise the importance of quality shareholders: i.e. big institutional investors.

"If you get rid of those and they're replaced by hedge funds, speculators, or tax havens, you become a less appealing company and your share price becomes more volatile."

Mr Russell also said a carbon adjustment tax is a very real looming possibility for Australia.

"Eventually everyone may be forced to take care of their scope 3 emissions [emissions created in the beneficiation of their product], but possibly even their scope 2 [transportation] and 1 [direct emissions] as well," he said.

"Companies that are producing dirtier products or through dirtier means (i.e. fossil-fuel powered smelters) are starting to get a penalty – through premiums or involuntary price differentiation."

Rewards of taking action

Those that are seen to be paving the way in decarbonisation can reap a host of benefits, Mr Russell said.

"More and more people are drawing a link between coal and the ongoing bushfire crisis and our sustained period of drought," he said.

"What was once a far-flung scientific discussion, is now becoming people's lived experience.

"If you get out in front of something so central in our society's collective conscience, you are seen as an inspirational leader, someone to follow.

"People will want to invest in you and be associated with your brand. You'll get invited to speak at conferences. All of this no doubt being great exposure."

Decarbonisation projects can be costly, but represent just a tiny dent in profits for some of the biggest market players, Mr Russell said. Plus, they often pay off dividends.

"Ultimately you might actually save money," he said.

"Most mine sites save on diesel power. And if you invest in a mid-size solar array you may be able to power cheaper than diesel over the longer term, whilst becoming carbon neutral.

"If you're publicly seen to be doing that and making genuine change (not just doing lip service), even better."

Mr Russell believes it's now getting to a point where a whole carbon system is probably going to take shape and says that companies can either fight it, or get ahead and have a much easier ride.

Mr Russell said it doesn't actually matter what you believe – it's about what everybody else believes.

"Nobody wants to believe they're causing damage to the environment," he said.

"If you really believed in climate change then you couldn't carry on what you're doing.

"You'd have to offset it in another form. If you declare it's not real, you just keep your money.

"But even if it is all a hoax or a conspiracy theory, that's irrelevant. You'll end up going broke if you think that way."

Make sure you listen to Mr Russell at the Global Iron Ore Conference.



SINGLE REGISTRATION GIVES ACCESS TO BOTH CONFERENCES

MINERAL SANDS

Australia's key meeting place for the mineral sands industry



MINERALS & INVESTMENT WEEK

18 - 19 MARCH 2020 | THE WESTIN PERTH, WA



GLOBAL IRON ORE & STEEL FORECAST CONFERENCE

A new generation of mines, game changing technology,
improved productivity & reduced carbon footprint

Lead Bank Sponsor



Exhibitor





Curtin's School of Mines at Kalgoorlie, WA.



Emeritus Professor Odwyn Jones (OA).

PRACTICE MAKES PERFECT

What do university mining schools need most? Over the past few years increasing attention has been directed to the people employed to teach and mentor students at university engineering schools, with university departments mostly staffed by scientists and graduates with no industry experience.

Emeritus Professor Odwyn Jones (OA) was principal of the WA School of Mines at Kalgoorlie and Dean of Mining and Mineral Technology at WAIT/ Curtin University of Technology for 15 years.

He shares his thoughts with readers of *The Australian Mining Review*.

UNIVERSITIES too often place a premium on engineering applicants having a doctorate with little or no mention of the merit of having some industry experience.

In doing so the teaching becomes too scientific and theoretical with academics unable to relate the subject matter to the realities of the workplace.

To create job-ready graduates, undergraduate programs must include the right balance of education and training.

These issues are most important in mining-related schools, bearing in mind the duty of care borne by managers and supervisors in such a hazardous industry.

This does however raise the very important issue of ensuring a good balance of academic staff in engineering schools which include those with a scientific and research experience and others with a wide-ranging experience of professional engineering practice.

It is the latter that is currently, more often than not, in very short supply at university engineering schools.

This is most disadvantageous in mining-engineering schools because mining, by its very nature, is both a science and an art.

Mining environments, and particularly those underground, require employees to be keenly aware of their surroundings, relying on their senses of hearing, sight and smell to identify likely sources of hazards.

Being sensitive, for example, to the noise of moving ground, the smell of unwanted gases and changes in the fracturing of strata etc., soon become second nature to mineworkers.

Hence the importance of "work integrated learning" to mining undergraduates and the value of having tutors with a broad range of work experience readily available to bring relevance and reality to their teaching, be it mine ventilation, rock mechanics, mine drainage and/or transport, etc.

Professors of professional practice

Recognition of prior learning is common practice these days and usually involves assessing a person's knowledge and skills against a qualification.

Obviously a similar appraisal could be made of a person's holistic knowledge and skills in determining their suitability for university professorial appointments.

Indeed, this is the background to the increasing practice of many overseas university engineering schools to appoint Professors of Practice.

They are professional engineers of some standing and experience who can bring real world experience and skills into the classroom, thereby bringing relevance and application to the study program.

For example at Texas A&M University, the College of Engineering's Professors of Practice teach undergraduate, masters' and doctoral level courses as well as assist in the development of new curricula that reflects cutting-edge industry technology and practice.

They also assist as mentors and research advisors and are useful in identifying research programs of relevance to industry.

Nearer home, La Trobe University claims to be the first Australian-based university employing Professors of Practice at its Business School, integrating them into the routine operation of the school: albeit this is common practice at medical schools where they employ specialists and consultants as Clinical Professors.

Currently, at La Trobe, 11 such Professors of Practice appointments are on two-year contracts, greatly enriching the university's programs with some of them teaching in La Trobe's highly ranked MBA.

Professors of Practice are also greatly valued at Newcastle University's School of Architecture and Built Environment, where rather than having one professor the role was split into six fractional appointments involving internationally renowned architects who participate in all levels of teaching and mentoring.

A recent article by Cecilia Chan of Hong Kong University states that current day students are well advanced in their knowledge of social media and digital technology, and it is important that academics keep up with them and use technology to teach in a way that resonates with them.

Whereas collaboration between academe and industry commonly exist, it is rare for academics to seek industry experience whereby they gain hands-on knowledge and experience of workplaces and the skill sets that employers currently require.

As Ms Chan states, too many academics are inbred products of the university system and hence the reason many universities are seeking to rectify this disconnect by recruiting experienced and distinguished practitioners as "Professors of Practice".

Isn't it also time to follow Ms Chan's suggestion that all academics should be required to return to industry every three to five years as part of their professional development and career advancement?

Requirements for future success

Mining engineers are, more often than not, destined to become future shift bosses, underground supervisors, mine managers and possibly general managers and/or managing directors of mining companies; in other words line-of-command personnel.

All the more reason why the practicalities of mine design, mine development and mineral extraction are integrated into undergraduate teaching.

While the sciences associated with of all aspects of mining are important, the art of mining is also particularly important with emphasis on the soft skills of leadership within a team of experts, good communication with all levels of employees, problem-solving and conflict resolution within a mining context and in all things being a responsible citizen.

To be a good manager, mining engineers' study programs need to cover the entire value chain, which explains why they are sometimes referred to as "jack of all trades and masters of none".

Add to this, the current requirement of mining engineering graduates being well informed on "the Internet of Things" (IoT), and its component parts such as big data, data analytics, sensor technology and the basis of coding etc., and one begins to wonder if the undergraduate mining engineering program needs extending to five years of full time study.

It's also as well to remember that in order to

be a well-rounded mining engineer graduates need to be fully aware of the technologies associated with both surface and underground mining of coal and metalliferous deposits.

Indeed, those intending to obtain a "First Class Managers Certificate of Competency" in WA are required to hold a Bachelor of Engineering in mining, pass an examination in mining law and have at least five years of experience in a mine with at least three years of underground experience and be a person of good character.

Hence the reason why it is vital for every university mining engineering school to have a hard core of teachers who have attained, at the very least, a "First Class Certificate of Competency" or its equivalent.

Indeed, why not make this mandatory for lectureships at mining schools with scientific research experience being desirable and not the other way around?

That apart, as mentioned earlier, serious consideration should be given to full-time academics in university mining schools being required to return to industry every three to five years as part of their professional development and career advancement.

Within this context, the sooner university mining engineering schools in Australia adopt such policies as well as attracting well experienced professional engineers and eminent industry leaders to full-time or fractional appointments as Professors of Practice, the sooner we will return to the forefront of those nations producing graduates capable of leading our minerals industry into the future.

Emeritus Professor Jones is a longstanding member of the Minerals and Energy Research Institute of WA, and played a significant role in developing the Goldfields Mining Expo.

In 2006, he was awarded the Order of Australia Medal as an Officer of the Order for service to the mining industry and the broader Kalgoorlie-Boulder community.

In 2016 he was awarded the Walk of Fame honour as part of the City of Kalgoorlie-Boulder's Australia Day celebrations.

MEET YOUR LOCAL LEGENDS



Benefits of dealing with **Melville Toyota & Rockingham Toyota** your Fleet Specialist



- Educated on Toyota Australia's **future direction** and upcoming products.
- Experience in **tailoring solutions** for all types of Fleet buyers.
- Exceptional customer service.
- Fleet staff continually receive **training in all areas** of Fleet.

- When it comes to **the right advice and expertise**, Toyota's Fleet Specialist Dealers are experts in their field.
- Toyota Fleet Specialist Dealers have **dedicated Fleet staff** with advanced knowledge of vehicles and efficient Fleet planning.
- **Understanding** of the changing Fleet Landscape.

Melville Toyota

Cnr Leach Hwy & North Lake Road,
Melville
08 9317 2333

fleet@melvilletoyota.com.au
melvilletoyota.com.au
DL27343

Rockingham Toyota

75 Dixon Road,
Rockingham
08 9527 5755

fleet@rockinghamtoyota.com.au
rockinghamtoyota.com.au
DL27343

OH WHAT A FEELING

Coveted training award to Barminco

RAY CHAN

PERENTI company Barminco has been named Australia's Large Employer of the Year at the National Australian Training Awards in Brisbane.

Barminco chief executive officer Paul Muller said it was an honour to be win the award, which recognises a company focused on upskilling employees.

"Our vision is to be the world's leading hard rock underground mining service provider, and our people are at the core of that vision," Mr Muller said.

"We are aiming to significantly increase the size of our business in the next five years in what is a highly competitive labour market and our focus is firmly on training and our integrated people strategy.

"It is wonderful to be recognised nationally for our work in this area."

Barminco was established in Coolgardie, WA, 30 years ago with just 30 employees; today it has 3900 employees across 22 projects in eight countries and four continents.

Key elements of Barminco's training strategy are the Barminco Training Centres, the first of which has just opened in its Hazelmere head office in WA, and a second facility being replicated on a larger scale in Botswana that is due to open shortly.

Barminco general manager for

safety and people, Patrick Bourke, said the unique facilities replicated what it was like to be underground.

"There is a focus on operational skills and they utilise technology to offer customised virtual reality scenarios for all the different underground jobs," he said.

"This is a game-changer for us as it ensures new employees go to site with a much better understanding of the underground environment so they are safer and can operate more efficiently.

"Barminco's focus on training people extends to several other programs, including its successful apprenticeship program that has been running for more than 20 years and its unique leadership program designed to provide career progression for employees, a key retention tool to develop and progress staff into management roles."

Mr Bourke said Barminco's rapid growth was down to the people the company employed and therefore investment in their training was essential.

"We are extremely proud of our innovative training programs and it has made an enormous difference to our business," he said.

Barminco was one of three named finalists for the 2019 Australian Training Award – Large Employer of the Year, following a win for the same category at the WA Awards in September.



The new Barminco Training Centre replicates the underground mining environment.



Barminco's apprenticeship program has successfully operated for more than 20 years.

FIFOs design their dongas

RAY CHAN

WHEN it comes to dongas, if you want to know what workers want, ask them.

That's what the WA Mining Club Young Professionals did for its innovative Design a Donga collaboration.

The designs, unveiled at an industry function in November, emphasised privacy, functionality and better telecommunications, and were based on responses from hundreds of FIFO workers on mine sites across WA who

took part in a four-month online survey initiated by the organisation.

While most workers who took part in the survey considered their existing site accommodation was satisfactory, they said it was an important factor in deciding whether to start work or continue working in a FIFO role.

The four design elements considered most important were functionality of storage, better sound-proofing and acoustics, improved telecommunications including WIFI, and increased layout functionality, particularly with ensuite bathrooms.

Young Professionals chairperson Samantha Ware said the design project was innovative and ambitious and the Club was proud to present the results to the wider mining community.

"We have heard from the survey that FIFO workers are generally happy with accommodation on-site," Ms Ware said.

"However, there is a passion for emerging technologies, sustainable building practices and sound proofing."

Grounded Construction Group and Modular WA, the WA Mining Club's Design a Donga partners, used the survey results to produce two designs: a fully refurbished unit and a newly-built one.

The overhauled donga offers a quick, cost-effective approach for companies with established mining camps, while the completed-from-scratch donga improves privacy and comfort for FIFO workers, with features including a concrete base floor, sound-proofing insulation and Gyprock walls, and a focus on comfort

while remaining cost-effective and sustainable.

Grounded Construction Group managing director Paul Natoli said the company was thrilled to be part of such an exciting and creative project.

"The design of the new donga is very much inspired by the feedback we received from hundreds of FIFO workers," he said.

The WA Mining Club established the Young Professionals sub-committee in late 2018 to assist emerging leaders with networking opportunities.

It will continue to engage with students, young professionals and industry leaders through community initiatives and events during 2020.



Some of the designs for the refurbished and newly-built dongas.



The inventory specialists

NATIONAL

GORDON Brothers offers 115 years of expertise and knowledge in the financial advisory and investment business.

It offers a range of options for restructuring, asset remarketing, advisory and capital solutions, specialising in structuring complex, multi-asset transactions.

By incorporating its experience in valuing and selling assets, the company is able to extract the maximum value from plant, machinery and equipment, inventory, real estate, receivables and intellectual property.

It will buy, sell operate and value assets on a standalone and integrated basis.

It works with businesses at all points of the business cycle, whether that means a growth period, transformation, turnaround or strategic consolidation to provide certainty of results.

Gordon Brothers' expertise in assets, plant equipment inventory, receivables, intellectual property and retail is extensive, and it brings an understanding of the Australian market to all sales.

It is one of the few firms in Australia that has the capacity to underwrite major packages, such as the underwriting of the entire Koolyanobbing plant after the mine was purchased from Cliff's by Mineral Resources lock and stock.

Gordon Brothers focuses on the here and



Gordon Brothers specialises in assets and plant inventory.

now when assessing risk.

As contracting is a capital-intensive line of work, it is important that contractors have the ability to mobilise quickly, and access to

the capital that requires is paramount to their success.

The company offers companies assistance with financial flexibility, rental options,

investment propositions and can unlock liquidity for clients by buying and selling underperforming or redundant assets, among many other services.



CONTACT US

☎ 0407 202 179

✉ fhealy@gordonbrothers.com

🌐 australia.gordonbrothers.com



Gordon Brothers

Bringing more than a century of experience to every transaction

Mining asset remarketing

- + Gordon Brothers will assume principal risk on equipment and machinery.
- + We will provide advance funds against a pool of assets identified for realisation.
- + We will give structured guarantees, or tailor the solution to a client's specific needs.

Mining investment solutions

- + Gordon Brothers offers asset-backed financing and credit solutions to our clients to help facilitate transition and transformation.
- + Capital is available for financing, asset acquisitions, leasing or special situations.
- + We have more than A\$1bn of capital available through our strategic partnership with Gordon Brothers Finance Company and independently utilising Gordon Brothers' balance sheet.
- + Our options include debt financing, acquisitions of non-core subsidiaries or orphan assets, and asset sale guarantees.

Automated conveyor belt inspections

NATIONAL

THE use of the Hawk Measurement Systems (HAWK) fiber optic vibration monitoring on conveyors presents operators, planners, engineers and managers a way of automating one of the most dreaded, monotonous and essential ongoing maintenance operations conducted on every mine site around the world: belt inspections.

With all emergent technologies, there can be a lot of questions about the capability and logistics of installing such a system, such as:

Q. Why use this technology?

A. Predictive maintenance is now possible on conveyor idlers.

Q. Where are these made?

A. Proudly designed and manufactured in Melbourne, VIC.

Q. Where does the fiber go?

A. Fiber is run along the return and lifted onto both stringers, then secured to these purlins.

Q. How long does installation take?

A. Varies from site to site but typically installed during scheduled maintenance shutdowns.

Q. Is there anything required in the field?

A. No infield power or communications are required, the fiber cable itself acts as the sensor, the controller is mounted in a



nearby substation.

Q. How many belts can a system handle?

A. Up to 20km of conveyor per system.

Q. How accurate is the system?

A. Identifies idlers to the frames and the side of the conveyor.

Q. Does the roller detect or predict failures?

A. Predict: It is possible to see these

failures two to three weeks ahead of catastrophic failure conditions.

Q. How is information about the belt presented?

A. Daily emailed reports and alarms to SCADA or DCS.

Q. Do you supply everything we need?

A. All materials required for the installation are delivered to site including

cable, hardware, mechanical components, fixings, and optical components.

Q. Who installs the fiber?

A. Installation is provided from a local labour source; HAWK provides installation instruction documentation.

Q. How do we get in contact?

A. Call (03) 9873 4538 or send an email to Fiber@hawk.com.au

Praetorian Fiber Optic Sensing for Conveyor Idler Monitoring

The Praetorian Conveyor Health Monitoring System (CHMS) is a plant & site wide single solution for detecting when critical parts of the idlers are beginning to fail. The early detection warnings allow operators to control down time and avoid catastrophic costly unplanned shutdowns.

HAWK's Praetorian Fiber Optic Sensing detects abnormalities in conveyor idler performance that other technologies cannot.

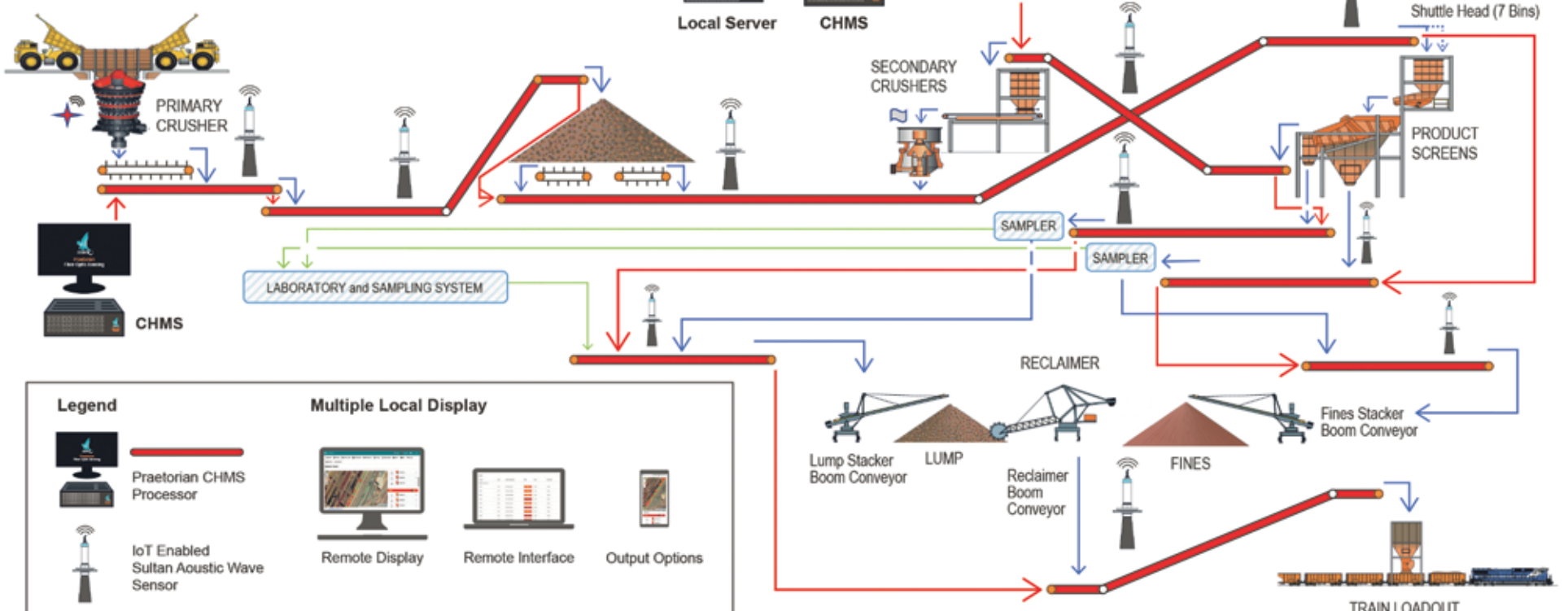

Our ongoing commitment is to develop & provide **industry leading technology** and **cost effective solutions**

Hawk Measurement Systems | fiber@hawk.com.au | www.hawkmeasure.com | T: +61 (0)3 9873 4750

Australian Mines and Services Handbook 2021



The inaugural **Australian Mines and Services Handbook 2021** will be distributed this year and will be an invaluable resource for those who work in the mining industry.

Secure your place in the bible of mining handbooks

The **Australian Mines and Services Handbook 2021** will comprise three sections:

1. Commodities and the Year Ahead
2. Directory of Mines (Divided into states and cross referenced against main commodity)
3. Directory of Services to Mines



Cadia Valley Operations

State:	NSW
Location:	25km South-West of Orange, 33.4580°S, 148.1480°E
Ownership:	100% Newcrest owned
Stock Exchange:	ASX: IGO
Management:	Peter Sharpe - GM Cadia Valley Operations
Mine Status:	Operational
	Care and Maintenance
	Copper and gold discovery in the Cadia Hill Open Pit and Ridge



The haulage transport experts



JD Container Logistics has a fleet of 27 haulage trucks and 12 trailers for container shipments and a range of specialist haulage vehicles.

NATIONAL

JD Container Logistics specialises in handling a wide variety of freight and container traffic, from port-side pickup through to delivery to remote mine sites.

The WA container transport company provides a wide range of services around the container haulage market, including delivery to remote mining sites.

The specialist company has delivered kit to mines in the Pilbara region of WA, including for some major mining companies.

It has also handled and transported fragile equipment such as solar panels on long-distance deliveries in WA.

For one such client, JD Containers delivered 138 trailer loads of equipment over a period of four months, of which 40pc was out-of-gauge, or non-standard loads.

JD Container Logistics organises weekly deliveries of containers up to Pilbara mining sites and is starting to break into the Pilbara freight haulage corridor.

The firm has a fleet of 27 haulage trucks and 12 trailers for container shipments and a range of specialist haulage vehicles.

Its specialist trailers include side-loader trailers, flat-top trailers, tautliner trailers and drop deck trailers.

There is also the option of refrigerated container transport and hazardous cargo transport for clients.

JD Container Logistics is adept at handling unusual-sized loads, so-called out-of-gauge freight, and has expertly handled trailer loads up to 5.8m wide and 4.7m high.

Among the out-of-gauge freight delivered by the firm was one delivery which measured 16m long and weighed 96t.

Solutions-driven

JD Containers Logistics is a solutions-driven business that uses the latest technology to provide transparency and traceability during its container handling process.

The firm works closely with Australian and international shipping companies to coordinate clients' import and export orders.

In addition to its container handling



services, it works with clients to manage their logistics projects.

These specialist project can involve handling large, over-dimensional cargo, and large shipments, or one-off projects that require JD Container Logistics expert advice.

Large container shipments may require substantial coordination including packing and unpacking, collection, storage and quarantine, and delivery.

Customer needs are fully met by the firm in terms of flexibility, transparency, traceability, and care and attention to challenging logistics.

Operating from its base in North Fremantle, WA, JD Container Logistics has a 25-year history.

The company has been providing satisfied clients with wharf cartage and container transport services for this long period of time.

Shipping depots

The WA company has two depots for handling shipping container traffic, one strategically located at North Fremantle, and another at a prime location at Welshpool.

The North Fremantle facility has a concrete hard-standing warehouse with 1000sqm of warehousing space that can be fully utilised for unpacking containers and storage.

JD Container Logistics also maintains its own bonded warehouse facility at its North Fremantle facility.

The facility has direct access to nearby Fremantle port, WA's main import and export hub for the Perth metropolitan area.

At Welshpool, JD Containers Logistics has 750sqm dedicated to quarantine fumigation that is able to handle high volume cargo of all sizes and shapes.

The Fremantle and Welshpool facilities are equipped with state-of-the-art technology for inventory management that is seamlessly integrated into clients' business systems.

This inventory system allows JD Container Logistics to exchange data with its clients and to work efficiently and collaboratively, leading to cost savings.

The company can provide quarantine and bio-security services on-site in North Fremantle and at Welshpool.

The services include fumigation provided by licensed tradespeople, and

quarantine approved premises with on-site bio-security officials.

JD Container Logistics also offers an end-to-end packing and unpacking service to its clients for any containers to ensure all shipping containers are handled with care.

Clients wishing to have their containers loaded for export or unloaded for import can leave this task to the company, which has the capability to carry out these tasks efficiently and with care to ensure safe, damage-free cargo movement through the company's depots.

Cargo destined for packing or unpacking is transported at the company's depot using 20ft/40ft containers, reefer containers, flat rack containers or open top containers.

At its depots, the company uses the very best unloading and loading equipment, with load restraint options such as a 5t rated cord lash.

There is also the option of using 2.5t and 5t rated ratchet and straps, and high-tension rate ThreeD chain and binder systems for transporting container cargo on site.

THE NAME TO REMEMBER IN TRANSPORT & STORAGE

LET US BE YOUR WORKFORCE.

PROJECT AND
NORTH WEST
TRANSPORT
SPECIALISTS



JD Container Logistics provide reliable and cost-effective wharf and container services. Working closely with Australian and international shipping companies, we ensure all imports and exports are co-ordinated to meet our clients' specific needs. We provide end-to-end services from container packing and unpacking to warehousing and distribution and ensure all shipping containers are handled with the utmost care.

JD Container Logistics provides a full one-stop solution for container transport requirements to importers, exporters and freight forwarders. JD Container Logistics operates out of a state-of-the-art facility based at the Fremantle Port operating a large fleet of:

- **Side Loader Trailers** for the delivery of FCL containers to site.
- **Flat-top trailers** for the delivery and collection of LCL cargo.
- **20' and 40' Flush Back Trailers** utilised for live unloads and drop trailer dock deliveries.
- **40' and 20' Skeleton trailers** utilised for the delivery of FCL containers for either live unloads or drop trailer deliveries.
- **B-Double combinations** for both LCL loads and container combination deliveries.
- **Rigid trucks** for the delivery and collection of LCL cargo up to 8 tonne.
- **DG Cargo** – JD Container Logistics have a number of bulk DG licenced drivers whom are fully trained in the transport of DG cargo.
- **45' Tautliner trailers** utilised for the delivery and collection of sensitive cargo.
- **OOG** – JD Container Logistics fleet contains extendable drop-deck trailers which allows for the safe and compliant movement of OOG cargo, including over width and over height flat rack containers.
- **20' ultra-low drop deck trailers** utilised for the delivery of over height containers.
- **Linehaul Capability** – we can save you time and money by consolidating containers bound for the same destination, including long-haul deliveries to remote mine sites in WA's Pilbara region



With JD Container Logistics utilising the above array of transport equipment and capabilities, we can fully handle all your container and LCL transport requirements including:

- Side Loader Transport.
- FCL Container Transport.
- Refrigerated 'Reefer' container transport.
- LCL cargo transport.
- Drop trailer deliveries.
- Hazardous cargo transport including both packaged and bulk DG transport.

JD Container Logistics also offers container storage, bonded warehousing, packing and unpacking, quarantine and project solutions services.



JDCONTAINERLOGISTICS

quotes@jdcontainers.com.au

(08) 9432 6000

www.jdcontainers.com.au



JDCONTAINERLOGISTICS

Corrosive liquid mine pumps

NATIONAL

MANY mines are filled with corrosive liquids that cause wear on equipment.

Australian Pump Industries' new cast 316 stainless steel self-priming centrifugal pump has been introduced to handle corrosive liquids in mining applications.

The new range of mine pumps are close coupled electric drive and feature high efficiencies for both high and low head applications.

The pumps are designed to answer a serious need in mining and chemical industries for cost efficient, ISO9001 quality products capable of handling contaminated and corrosive liquids.

Aussie Pumps product manager, Albie Bester, said that the product was developed for mine tailings and other difficult mine liquids, including light slurries.

"We perceived a major market opportunity for a top-quality stainless-steel pump at a realistic price and built strictly in accordance with our quality culture," he said.

The first pump to be introduced is a 5.5kW 3in pump that delivers a maximum flow of 1100lpm with the added ability to handle solids to 16mm.

Like all of the Aussie GMP range, the pump is self-priming with the ability to draft water from depths of six metres.

The maximum pump head is 40m, making it ideal for high pressure water



The Corrosive liquid mine pump G3TMK-A/ST, when applied to a tanker, is vital for dust suppression on mining sites during dry and windy seasons.

transfer or even machinery wash down.

Power for the machine comes from a 5.5 kW TEFC three-phase, two-pole electric drive motor.

Pump and motor are installed from the factory on a heavy-duty steel base for ease of installation.

Optional stainless steel or hot galvanised

steel bases are available on request.

Mr Bester said the pump's big advantage for miners is its ease of repair in the field and simplicity of operation.

"Even changing the seals is simple," he said.

"The pump is close coupled to the motor with a 316 stainless steel stub shaft.

"Disassembly of the pump body from the motor is a matter of minutes giving access to the pump chamber for clean out or service."

The secret of the pump's excellent self-priming characteristics are the big "shoulders" in the priming tank incorporated in the unit's design.

The high mounted suction port also helps fast self-priming without the need for additional aids like vacuum pumps or compressors.

The pump is available in nickel, aluminium and bronze as well with a semi trash version available in the cast iron configuration.

Seals are heavy duty mechanical style with Nitrile elastomers.

Optional Viton and silicon carbide are also available on request.

The first pumps were sent to Kalgoorlie where they are being used for mine tailings and wash stand applications in high PH level liquids.

Further information including a free mining guide is readily available from Australian Pump Industries or Aussie Pump Distributors throughout Australia or www.aussiepumps.com.au.

Heavy duty trash pump leads way

NATIONAL

AUSTRALIAN Pump Industries (Aussie Pumps) has introduced a new, robust six-inch trash pump.

The heavy duty trash pump, powered by Kubota's 24.8 horsepower (hp) water cooled, three cylinder diesel engine has the ability to produce up to 4200 litres per minute.

Apart from its high flow capability, the big advantage of the Aussie QP60TD/D1105 is its simplicity in design.

Wet prime trash pumps are relatively inexpensive and have less operating costs compared to dry prime pumps.

"Wet priming trash pumps allow portability and independency from a designated power source and the ability to be placed right at the water's edge," Aussie Pumps product manager Brad Farrugia said.

The best conditions for wet priming pumps where the suction lift is less than 8 metres vertically are open pit and sumping applications.

The Aussie QP60TD/D1105 can also be used for bypass pumping when there is sufficient retention time to allow for the pump to prime.

With features such as its big non-clog style impellers, manufactured from high SG cast iron, dirty water pumping and pumping



Ideal for site dewatering in mines and quarries, Aussie's new Kubota powered six inch trash pump can be mounted on a trailer or transported by utility vehicle.

solids in suspension is not an issue.

The hydraulic design of the impeller and volute obtains the best result in flow pressure, while the pump passes solids up to 40mm in diameter.

The pump's six inch inlet and outlet ports allows for easy adaption of camlock or bauer style fittings, while its cleanout port is easily accessed by releasing four toggle style hinged levers.

The pump's face plate can hinge open,

making it easy for operators to clean out the bowl or service the impeller without dismantling the body or pipework.

Left over sediment can be flushed out easily with a readily accessible separate drainage port.

For long, trouble free operation, even in trash laden or muddy liquid applications, an oil bath mechanical seal is provided made of tungsten carbide.

The engine powering the pump set is a three cylinder Kubota D1105 and has a number of features including low oil, high temperature shutdown, plus an emergency stop button.

Aussie Pumps offers a free extended five-year warranty on all its range of poly pumps.

"This is a testament to the product and being powered by a high quality Kubota powered diesel engine ensures the customer has complete piece of mind," Mr Farrugia said.

The Aussie QP60TD/D1105 is mounted on a sturdy skid steel base, has a 60 litre long range fuel tank incorporated into the skid.

The long range fuel tank allows the unit to run up to 10 hours when running at maximum speed.

An integrated centre mounted lifting bar is also supplied.

The unit's compact design, in spite of its high performance characteristics, allows the unit to be easily trailer mounted or transported by utility vehicle when necessary.

More information can be found at Aussie Pumps or authorised distributors throughout Australia.

Foam sweet foam

NATIONAL

WATER shortages and environmental restrictions are increasing the need for mining and quarrying companies to find solutions that reduce water consumption while enabling operations to continue at optimum level.

fine particle specialist Reynolds Soil Technologies (RST) has reported an unprecedented increase in demand for its dust control and water management formulas that require substantially less water to achieve the same, if not better results.

RST has recorded significant increases in supply of its water-saving solutions, including the Hi-Foam formula, every year for the past five years.

RST's Hi-Foam product has been selling in record amounts, as mining companies find ways to improve mining efficiencies and reduce water consumption to lessen the environmental impacts of their operations.

Hi-Foam requires substantially less water and has been found to be more effective at



By using RST's foaming agents, mines are using up to half the amount of water compared to conventional wet spray dust suppression systems.

suppressing dust in the crushing and the bulk material handling processes than traditional water spray dust suppression systems.

Its unique formula was developed by RST in response to increasing demand from mining and quarrying companies for ways to cope with water restrictions while keeping operations running as normal.

The Australian-based, international environmental specialist company develops and manufactures products and solutions for dust suppression, stabilisation and erosion control, and water sediment solutions to assist the mining, construction, civil and agricultural industries.

RST operations and technical director David Handel said increased pressure was being placed on these industries to reduce their environmental impact.

"All companies are required to be a lot more mindful about water consumption to ensure their operations have less of an effect on the environment," he said.

"We are seeing significant demand for products that require less water usage, especially from companies dealing with drought and water shortages.

"By using RST's foaming agents, mines are using up to half the amount of water compared to conventional wet spray dust

suppression systems.

"Using foam stops dust lift-off in the first instance and is both a short and long-term dust prevention method because it binds dust particles, unlike water that dries out and returns surfaces to dust."

But it's not only the mining sector that is becoming increasingly aware of the need to change its processes in order to reduce the impact of its operations and conserve water.

"We are now supplying Hi-Foam as a dust suppression solution to quarry companies throughout Australia who are working with minimum water access to contain hazardous silica dust," Mr Handel said.

Signs make safety a priority

NSW

SAFETY and communications are high priorities for all mining operations.

Signarama Wollongong specialises in providing clear and durable signs, banners, poles and tapes for rugged and remote mine sites in and around the Sydney region.

Well-placed, visible signage is an effective way to ensure a safe working environment for all mine personnel.

Signarama offers high quality, heavy duty products that allow the correct signals and information to be easily identified by mining, construction and other teams as they move around potentially dangerous situations.

Signage is particularly important during shut-downs, maintenance and construction phases, when new staff who need to be familiarised efficiently and quickly with safety instructions, hazardous areas and other dangers may be frequenting the mine site.

All Signarama's display products come in highly visible and durable formats which are suitable for underground and open pit locations at each stage of the operation.

Conveniently located on the Princess Highway, Signarama is a specialist in mining and reflective signage, and also offers a huge range of other related products including building signs, outdoor signs, vehicle signs, digital printing, custom fabrication, illuminated signage and much more.



Signarama offers a complete range of signage for mining operations. Image source: Signarama Wollongong.

Signarama Wollongong also offers a digital catalogue which assists with the process of choosing and ordering the products for immediate production.

Custom signs can be made in the format most suitable to the hazard and location and company experts can provide advice regarding the most appropriate sign designs for the purpose.

Signarama has a standard range of widely used products available including:

- No entry
- First aid

- Fire extinguisher
- Blast area
- Hazard
- High voltage
- Caution
- Drill site
- Give way
- Flammable gas

Signarama is known for a fast and reliable turnaround and quick delivery of the signs needed for any job.

Emergency and unexpected situations can be provided for efficiently with signage materials delivered and installed at the earliest convenience.

For mining companies planning on promoting their brand at conventions or conferences, Signarama also has a wide range of promotional corflutes and banners for display.

The correct safety messages clearly displayed will ensure a safe environment for all onsite personnel at any mine site.

Pump in class of its own

NATIONAL

WHILE the market offers specialised slurry pumps to handle thick and abrasive slurries, as well as submersible and sump pumps for pumping clean water, neither of these options provide an effective solution for pumping dirty mine water.

Weir Minerals took its extensive knowledge of pumping slurries and developed the Warman DWU (Dirty Water Unit) pump, designed to handle both increased suspended solids in dirty water whilst operating at high discharge head pressures.

The introduction of, and subsequent clogging from, suspended solids is one of the most common causes of premature failure in a dewatering pump.

'Upset' conditions during the underground mining process are the general cause of increased suspended solids levels entering the mine's dewatering discharge water.

The Warman DWU pump combats both these challenges head on, transporting the dirty mine water to its designated discharge point via single (140m), multi-stage (480m) portable or permanent pumping solutions.

The challenge of dirty water

'Dirty water' is the name given to water with too high a percentage of suspended solids to be 'clean', but too low of a percentage to be classed as slurry.

Dirty water becomes a problem onsite when the solids concentrate inside a dewatering pump collects around the motor frame, overheating the pump and causing the motor to fail.

The Warman DWU pump is specifically designed to handle dirty water from onsite ponds and open pits with specific gravity (SG) of up to 1.05.

Where a pump built to handle clean water will fail once dirty particles are introduced, the DWU pump will not.

That is because the DWU was designed using Computational Fluid Dynamics (CFD) and utilises Weir Minerals' advanced



A Warman DWU pump installed on site.

material technology, allowing the DWU pump to process the fluid efficiently and minimise pump maintenance in the long run.

Weir Minerals Africa product manager Marnus Koorts said in most circumstances, high-head clean water pumps will fail when they are required to process even a minute amount of particles.

"Once you have greater than 1pc of particles, a site's only other option is to install slurry pumps," he said.

The problem of pumping dirty water with slurry pumps

Slurry pumps are a common answer to the dirty water problem, but this solution is costly and inefficient.

Without a specialised dirty water pump like the Warman DWU, up to three slurry pumps need to be sourced, installed, and maintained just to pump the dirty water as far as a single Warman DWU pump can.

The pump utilises a new high-pressure casing to withstand pressures up to 7000kPa, enabling it to pump operating at maximum speed and achieve a head of 140m at the best efficiency point.

"This results in a lower Total Ownership Cost (TOC) and reduced downtime for



Warman DWU pumps ready for dispatch.

the customer while providing them with increased efficiency and energy savings over using slurry pumps in the same application," Mr Koorts said.

Pumping dirty water with a Warman DWU pump

The Warman DWU pump provides a simple solution to a fluid transfer problem that can quickly affect an entire operation.

By making use of the latest Warman WBH mechanical end design, customers benefit from 90pc common component interchangeability, allowing them to reduce stockholding of spares. In addition, the Warman DWU pump is available with either an electric or diesel motor and can be mounted on either a pontoon, skid, or trailer, which provides sites with the flexibility to move the pump around to where it's needed.

"Pontoon mounting an electric DWU pump allows for series pumping at base level or stage pumping out of an open pit," Mr Koorts said.

"With Weir Minerals' dewatering expertise, we're able to engineer a complete solution that places the suction end of the pumps into the water, while the pump and motor are mounted at an angle above the

water line.

"This keeps the suction end of the pump submerged and eliminates suction problems.

"With a diesel driven pump, we install a vacuum assisted priming system that reprimed the pump when needed. Essentially, customers can set and forget."

The Warman DWU pump provides a flexible dewatering solution to sites: not only in the portability around site, but in the range of fluids the pump is built to handle.

In the nine years the pump has been on the market, Weir Minerals engineers have continued to improve the DWU's capabilities. Although designed to handle dirty water, the Warman DWU pump is also able to process clean water with 78pc efficiency, and the addition of a stainless-steel casing means the DWU pump is now suitable for highly acidic applications (pH >2).

The Warman DWU is the ideal solution for dewatering applications where other pumps fail due to the presence of solid particles.

With its robust design compared to the standard dewatering range, and its higher efficiencies and head compared to conventional slurry pumps, the Warman DWU pump is in a class of its own.



A Pontoon-mounted Warman DWU pump on site.

Best practice worksite training

NATIONAL

VERTICAL Horizonz Australia is a recognised leader in safety and training solutions, providing world class training, advisory, partnership, and development services.

It specialises in delivering solutions to companies' individual requirements, empowering revolutionary change in their people to take responsibility for safety leadership.

Vertical Horizonz prioritises safety.

A specialist team works with each company to provide 'real training that saves lives'.

As subject matter experts, its trainers speak from industry experience, demonstrating workplace best practice and providing practical and contextualised advice.

It understands the everyday challenges faced by employees in all worksites and is well positioned to provide meaningful



Safety first is Vertical Horizonz' objective.

training experiences.

Vertical Horizonz provides services across the mining, civil construction, industrial safety, oil and gas and transport sectors.

In an Australian first, Vertical Horizonz, in cooperation with Contract Resources, designed an extremely advanced training program to ensure the safety of the company's workers.

Contract Resources manager Paul Thew said working in a nitrogen saturated environment was extremely hazardous.

"One false move can literally mean the difference between life and death," he said.

"The solution was completely bespoke and set a new standard for the petrochemical industry internationally."

As a Registered Training Organisation, Vertical Horizonz underpins and assesses

training against nationally recognised qualifications, ensuring the approved Australian quality standards are met.

Located in Brisbane, the company also has the resources, knowledge and experience to deliver quality, culturally appropriate training anywhere across Australia or in the world.

It has a fully flexible approach and can provide training exactly when and where it is needed.

Real TRAINING that SAVES LIVES

SPECIALIST TRAINING IN:

- Certificate II & III Surface Extraction Operations
- Certificate II in Resources and Infrastructure Work Preparation
- Certificate III in Civil Construction Plant Operations

OTHER SPECIALTY AREAS:

- Industrial Safety
- Driving Operations
- High Risk Work Licences

VISIT OUR WEBSITE OR CALL US FOR MORE INFORMATION



P 1800 143 113
E admin@verticalhorizonz.com.au
W www.verticalhorizonz.com.au

VERTICAL HORIZONZ



Safety.Certainty | Australia
STRUCTURED TRAINING SPECIALISTS

Mobile cleaning truck for mines

NATIONAL

WA-BASED company Mine Plus has launched a new service for its mining sector clients in a mobile cleaning service for equipment and workshops.

Available at competitive rates, the company's truck-based mobile cleaning operation provides a cleaning service that can be tailored to individual client needs and which provides the best results.

Mine Plus can visit mine sites to clean earth-moving equipment in readiness for structural inspections, warranty maintenance and service and repair work.

Machinery is cleaned using the mobile truck's hot, high-pressure cleaning system.

Also available from the mobile cleaning operation from Mine Plus is a cleaning service for washpads, workshops and buildings.

The truck has a high quality cleaning capability with two high-pressure hot wash cleaners equipped with 8000litre tanks for continuous operation.

Two operators trained in relevant safety and cleaning standards accompany the mobile cleaning service from Mine Plus.

The new cleaning service is provided alongside Mine Plus's core labour and equipment hire business for mining sector clients.

Mine Plus owner-operator Shane



Mine Plus's mobile machinery wash truck.

Cresswell has 30 years' experience in the mining industry and set up his company in 2011.

The company's experienced staff hire and provide mining sector workers and

qualified trades people for short and long-term assignments in WA.

Mine Plus' expertise covers heavy and light vehicle mechanics, boilermakers, electricians, trades assistants, service

people and drill fitters.

The firm aims to employ the most qualified staff with the best experience and require them to have up-to-date safety qualifications and training.

MINE PLUS LAUNCHES NEW MOBILE CLEANING SERVICE FOR MINE EQUIPMENT



Service tailored to individual needs.

Mine Plus also provide staff and equipment hire services to mining companies.

Mine Plus's truck-based mobile cleaning service is available at competitive rates.

PO BOX 1683
MIDLAND DC WA 6936

Ph: 0403815165
Email: shane@mineplus.com.au

Neumann dredging pioneers

NATIONAL

NEUMANN Contractors has been an industry leader in dredging for the resources industry since the company formed in 1949.

Today, it is still a family-owned business that has more than 70 years' demonstrated industry-leading management, technical and delivery skills over its diverse project portfolio.

Company general manager, Bill Neumann, said that customers benefit from the company's reliability and collaborative approach.

"We are an engaging, reliable contractor who believe in direct and open communication with our clients to deliver professional and friendly service," he said.

"Our primary goal is to ensure projects run smoothly, on time and to the complete satisfaction of our clients."

Neumann's first dredge was developed in the late 1950s for mineral sand recovery, and since then the company has designed and manufactured dredges for a variety of dredging projects in the resources industry.

This has led the company to develop



Neumann built its first dredge in the late 1950s, and since then it has built up its own fleet of dredges and expert operators.

a large, well-maintained dredging fleet of its own with a team of expert dredge operators.

The dredgers have been used for the successful removal of sand, gravels, clays, slimes and weathered rock, and mine tailings.

Mr Neumann said that in harbour and river works, the dredges have proven

their versatility.

"Our dredging experience also makes our dredges highly suited for a variety of material types often encountered in flood prevention and environmental rehabilitation works," he said.

"Our dredging work has been put to the test on a number of occasions.

"We've completed more than 200km of inland channel development and successfully dredged several large-scale projects such as the Ernest Henry mine tailings and the Cadia gold mine tailings."

Neumann Contractors also works across fabrication, industrial coatings and civil contracting.



NEUMANN CONTRACTORS

Over 50 years of contract dredging experience

Phone: +61 7 5589 9746

Email: neumann.contractors@neumann.com.au



**TAILINGS RECOVERY
& FINES RELOCATION**

www.neumanncontractors.com.au

MACA, Liebherr consolidate partnership

NATIONAL

MACA Limited, known for its mine-to-mill solutions particularly in WA, welcomed three new Liebherr R 9200 hydraulic excavators recently at the Ravensthorpe Nickel Mine.

These R 9200s represent the eighth, ninth and 10th purchase of this model excavator for MACA, and the 16th unit Liebherr has sold to MACA since the beginning of the partnership in 2015.

Further equipment is expected for delivery in 2020.

The 16 excavators, ranging from 100t class to 400t class, are used across gold, nickel, lithium and coal mines in WA, Queensland and countries in South America.

The Liebherr and MACA partnership has enjoyed prosperous growth in their few years working together.

Liebherr-Australia sales and marketing executive general manager Tom Juric said the partnership had helped Liebherr-Australia expand its business.

"MACA is an important customer for us as Liebherr diversifies its portfolio into different commodities," he said.

"MACA has been at the leading edge of this diversification.

"The confidence MACA has in our excavators, particularly the R 9200 which have been used in the Kalgoorlie goldfields and for nickel at Ravensthorpe, has bolstered our growth in WA."

Liebherr was also involved in MACA's



One of MACA's 10 Liebherr R 9200 excavators. Image: Liebherr-Australia.

new venture into Queensland coal at the Bluff Coal Project in 2019, purchasing two Liebherr excavators for the site.

"We were excited to be a part of this new opportunity for MACA," Mr Juric said.

"Supporting its east coast venture has strengthened the relationship between our businesses and demonstrated our respective abilities to pursue new opportunities."

MACA executive director Geoff Baker said that working with Liebherr has been

a good business decision.

"Standardising our 200t fleet has allowed us to understand our product better and has made it easier on the business in terms of sourcing parts, training and delivering for our clients," he said

Liebherr has also collaborated with MACA beyond the mine pit.

In 2019 it was a major participant and sponsor in the annual MACA Cancer 200 for the fourth year running.

The 200 km charity bike ride, on the coast of WA, raises funds for cancer research at the Harry Perkins Institute of Medical Research.

"Liebherr has always been willing to support MACA in our community work," Mr Baker said.

"It's the support of distributors like Liebherr which make an impact and allow us to continue raising vital funds for cancer research."

Cranes help recycle waste

WA

KONECRANES will provide two refuse cranes to Avertas Energy, Australia's first energy-from-waste facility in WA.

The order was booked in July 2019, with delivery planned for June 2020.

Energy-from-waste uses post-recycling rubbish to generate clean, baseload power – the minimum amount of electric power needed for an electrical grid at any given time.

The Kwinana facility will divert up to 400,000t of waste a year and generate an estimated 36MW of electricity for the grid, enough to power 50,000 households.

Metallic materials will be recovered and recycled, while other by-products will be reused as construction materials.

Avertas Energy's operations are expected to start by the end of 2021.

Konecranes will provide two fully automated refuse cranes and three grab buckets, with the agreement including commissioning, installation supervision and maintenance services.

The cranes will operate in the refuse pit receiving, mixing, and feeding waste material to and from hoppers.

The two cranes are equipped with several Konecranes smart features that support safety and productivity at the production site, such as sway control, shock load prevention and restricted areas. With Konecranes digital services including TRUCONNECT Remote



An example of a refuse crane.

Monitoring, crane usage and condition can be monitored in real time on the yourKONECRANES customer portal.

In addition, the delivered equipment utilises the DynaReg feature, which recycles power generated by the hoists.

Konecranes offers products and services that support circularity with long-lasting design, easy maintainability and repair with the possibility for modernisation or retrofits to further extend the lifespan.

Konecranes Waste to Energy Industry director Joseph Botros said

the contract was another example of how the investments were making Konecranes the right choice for customers across the globe.

"The combination of our vast experience in the industry, our proven technology and excellent service support were a decisive factor here," he said.

"We also benefited from our great service organisation in the region, which was a must for the customer to ensure reliable performance for the decades to come."

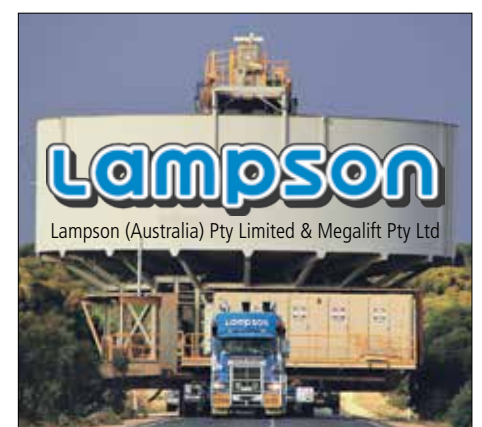

Lampson
Lampson (Australia) Pty Limited & Megalift Pty Ltd

**Lifting and
Transportation
Specialists
for over 30 years**

(02) 4941 0400

info@lampson.com.au | www.lampson.com.au



Bird's-eye view with accuracy

NATIONAL

AERIAL mapping specialist Aerometrex provides high resolution, geo-referenced LiDAR, 2-D Ortho-imagery and 3-D modelling products.

These products help provide its mining industry clients with a detailed understanding of their sites' topography and model ground, vegetation, and infrastructure features.

With cutting-edge technology and self-run aviation operations, the ASX-listed company can offer mining clients an extensive survey coverage in an efficient and cost-effective way.

Aerometrex's high data quality, great accuracy and quick three-day turnaround is ideal for the mining industry.

Aerometrex marketing officer Ravi Mehta said LiDAR and 2-D and 3-D modelling have proven highly useful for various applications across a mine's life cycle from exploration to reclamation.

During the prospecting and exploration phase, mines rely highly upon this data, using it for corridor and exploration mapping as well as engineering surveys, with the advantage of reduced ground surveys and mine site disruptions.

Throughout the development and extraction stages, mines regularly calculate stockpile volumes by measuring changes across Digital Surface Models (DSMs).

One of the products that can be extracted from these high-resolution datasets. These

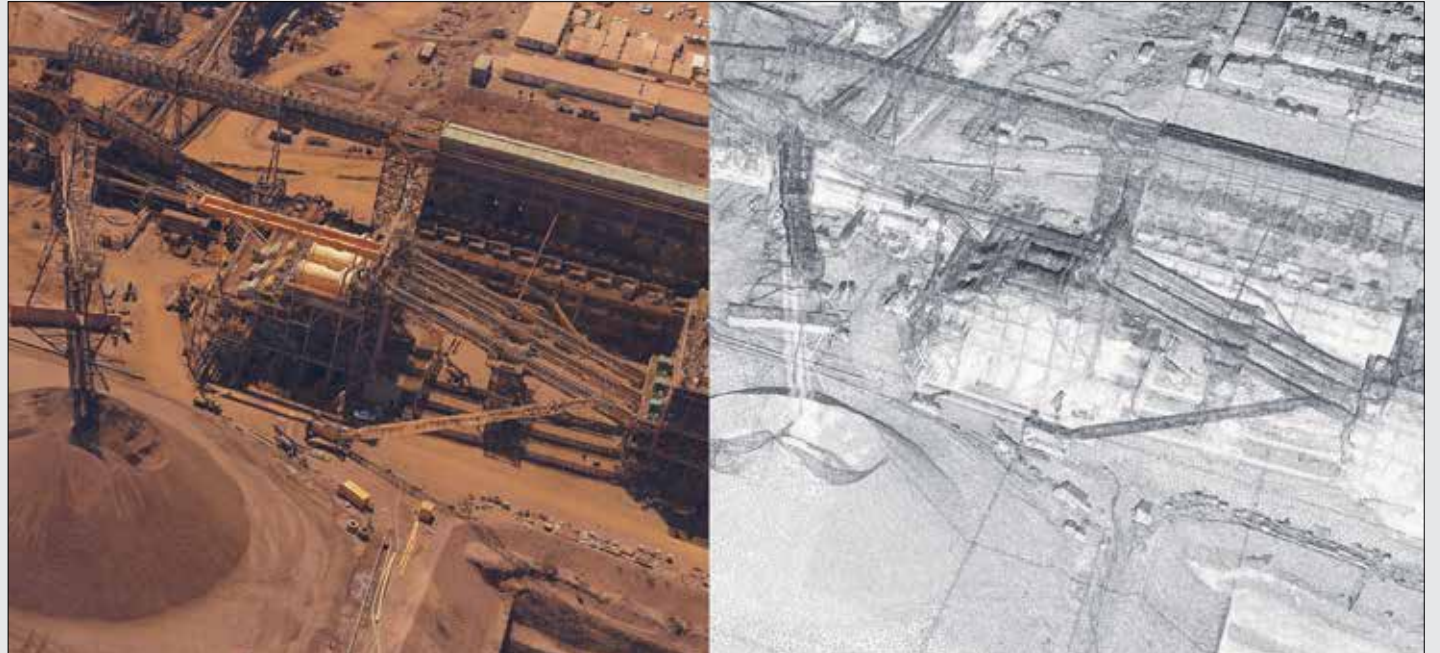

An example of a digital surface model of a mine site.

aerial surveys provide a more accurate volume calculation than what can be achieved by traditional surveying methods and they significantly reduce the health and safety risks associated with having personnel on-site.

For open cut mines, LiDAR as well as 3-D modelling can provide a comprehensive model of an entire site.

Integrated into an interactive viewing platform, engineers, project managers and other stakeholders can immerse themselves into a virtual but accurate and photorealistic representation of their

mining site to communicate complex information in a more accessible way.

Over time, these models show how the mine has expanded, providing an important historical perspective and asset when it comes time for site restoration.

Additionally, environmental monitoring, a critical component for all mine sites, can highly benefit from four-band imagery, which allows for better vegetative assessment and accurate vegetation rehabilitation planning using the near infrared band.

"At Aerometrex, we are proud of

our customer service; our deliverables are driven by client requirements and our production-hardened workforce, with a total of over 770 years' industry experience, take the time to ensure outputs are designed to address client needs," Mr Mehta said.

In addition to LiDAR, 2-D ortho-imagery and 3-D modelling, Aerometrex also provides a subscription-based imagery service known as MetroMap.

More information on all its products and services can be found at www.aerometrex.com.au or by calling (08) 8362 9911.



High Quality ■ Great Accuracy ■ Quick Turnaround ■ Extensive Coverage ■ Cost Efficient

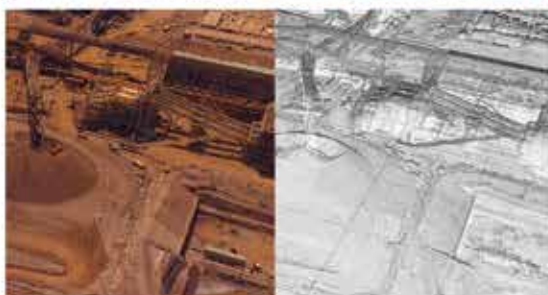
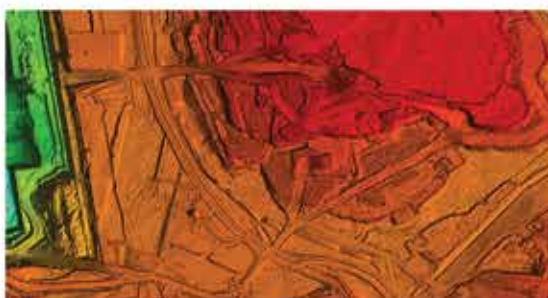

FACILITATING MINE PLANNING THROUGH ACCURATE, ON-DEMAND DATA

High resolution, geo-referenced LiDAR, 2D ortho-imagery and 3D modelling products can help provide mining companies a detailed understanding of their sites' topography and model ground, vegetation, and infrastructure features. These data captures can help reduce mine site disruptions and prove useful for a range of applications across a mine's life cycle from exploration to reclamation.

- Stockpile Volume Calculations
- Comprehensive 3D Modelling
- Corridor & Exploration Mapping
- Engineering Surveys
- Environmental Monitoring
- Vegetative Rehabilitation

Robotic fibrecrete for shaft lining

INTERNATIONAL

SINCE 1990, Mancala Pty Ltd has provided a wide range of unique services and expertise to Australia's mineral and civil construction industries.

Mancala has worked on numerous projects over the years across Australia, Papua New Guinea, Fiji, New Zealand, Indonesia, Botswana and Vietnam, for a variety of gold, coal, and base metal mines, hydro power sites and other projects where safe, innovative, cost-effective solutions are required.

Specialising in design, engineering, construction, excavation and mining services, Mancala provides unique solutions for shaft construction and ancillary services, which have earned the company business from industry giants like BHP Billiton, Glencore, Barrick (Niugini) Ltd, Anglo-coal, Newmont, Newcrest and many others.

Mancala's success has been founded upon providing clients innovative solutions to complex problems which, at the foremost, deliver safe and cost competitive results.

Continuing innovation has recently resulted in the development of a highly automated, robotic fibrecrete shaft lining system.

The shaft liner can apply precise quantities of fibrecrete in shafts from 2.5m to 8m in diameter to depths of 400m and at inclinations up to 35 degrees from vertical.



Mancala provides unique solutions for shaft construction and ancillary services.

The system can be established at a shaft collar, either underground or on surface in a single day and can apply fibrecrete at a rate of 4m³ per hour.

A Citect control system allows precise application control with the required thickness and shaft diameter as an

input control element.

Minimal re-bond and a superior sprayed liner is the result.

Four onboard cameras allow pre and post lining inspections for quality control purposes.

Safety is inherent in the design with the use of automated hose reels failsafe winches, which totally remove the need for manual handling.

For all shaft lining requirements, whether fibrecrete, concrete or steel, contact the specialist – Mancala.

BE AT THE FINGERTIPS OF EVERY MINESITE OPERATOR AUSTRALIA WIDE

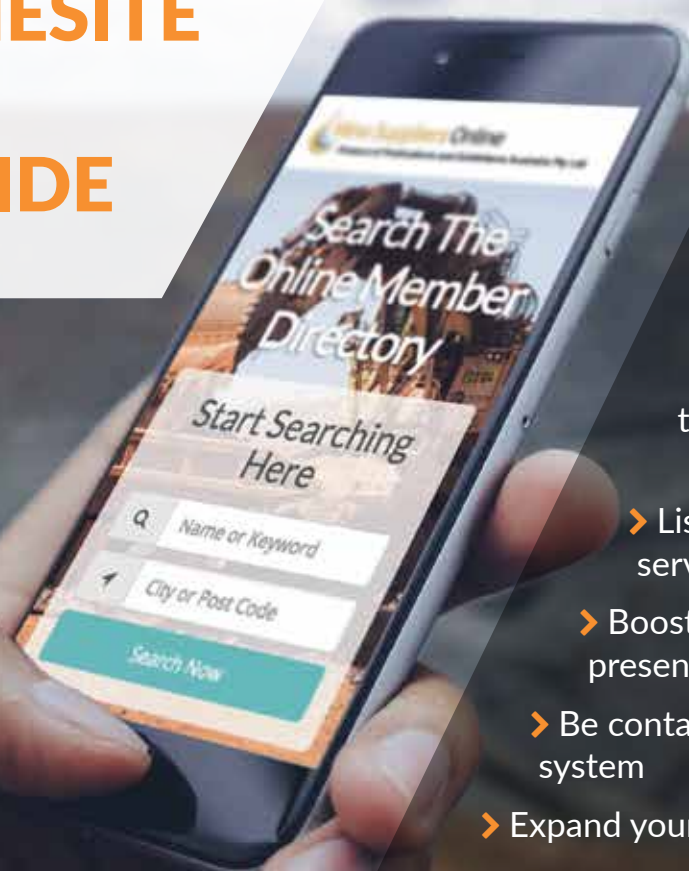

Join **Mine Suppliers Online** and be seen by mine operators all over the country.

Our comprehensive directory is the one stop when looking for services on the go.

- > List your company details, logo and services
- > Boost your own website SEO and expand your presence
- > Be contacted directly via our instant messaging system
- > Expand your online presence

Get a listing today!



☎ (03) 8562 9400
✉ enquiries@mancala.com.au
🌐 mancala.com.au

INNOVATIVE COST EFFECTIVE SOLUTIONS

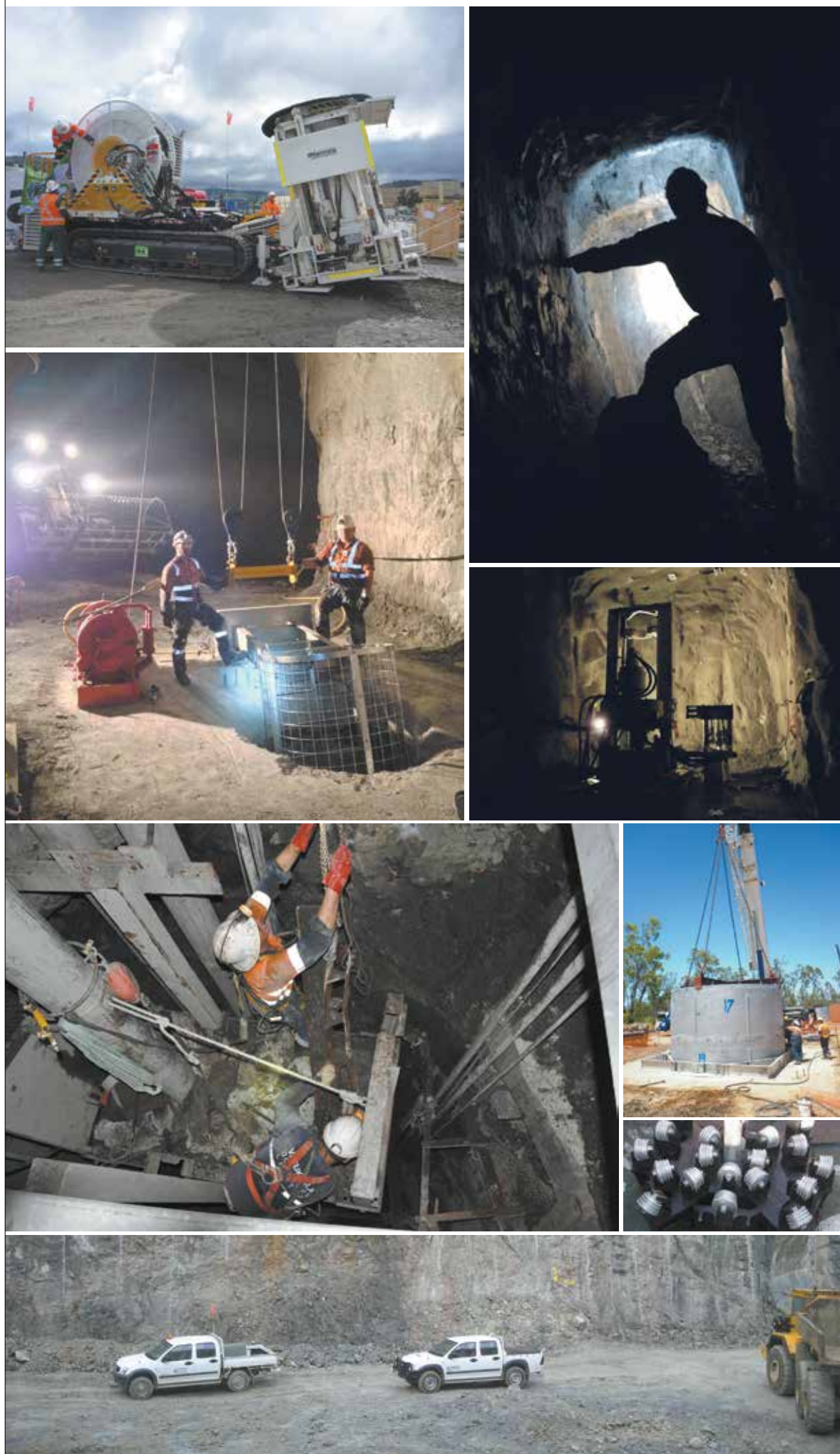

MANCALA ARE EXPERTS IN VERTICAL DEVELOPMENT.

WE SPECIALISE IN:

- **MECHANISED SLOT RISING**
 - It is innovative, safe and highly productive blind box drilling at 1.1 metre diameter
- **CONVENTIONAL RAISE BORING**
 - We can assist with diameters from 200 millimetres to 6 metres
- **COLLARS AND LINERS**
 - We can provide simple collar slabs to 50m deep pre-sinks and fully lined (steel/shotcrete/concrete) shafts
- **FLAME PROOF SYSTEMS FOR RAISE BORING IN UNDERGROUND COAL**
 - We have developed a fully certified and compliant raise bore power pack for use in Australian Coal Mines
- **BORE HOLE HOISTING**
 - We provide supplementary or alternative hoisting capacity depths in excess of 500 metres
- **SHAFT SINKING**
 - Blind or benched, we have the experience and the expertise to mobilise people and equipment
- **SHAFT REHABILITATION**
 - Using our mobile head frames and winches or clients existing infrastructure, we can safely and efficiently repair high value mine assets
- **HORADIAM EXCAVATION**
 - Our method of progressive shaft opening via raise boring and Horadium techniques can be used in the excavation of new shafts and for the construction of large underground coal bins
- **EGRESS SYSTEM**
 - We have installed surface and underground ladders with complete lengths exceeding 300 metres and we can design, fabricate and install winder and Alimak based systems.

International approach to drilling

INTERNATIONAL

MASTER Drilling offers cutting edge, one-stop drilling solutions.

The South African-based company works closely with a flexible support and logistics chain, partnering with clients during every project milestone from exploration to production and capital stages.

Its specialised, adaptive techniques provide companies worldwide with fully mechanised, precision drilling to the mining, infrastructure and energy sectors.

Master Drilling offers services in rock boring, slim drilling and a full range of support services.

It recently launched a new mobile tunnel borer named the MTB, in partnership with Italy-based tunneling experts Seli Technology.

The MTB is an innovative new piece of equipment, focused on convenience, access and safety.

It can operate on a 12-degree incline/decline and has an impressive 30m turning radius.

A major advantage for clients and operators is the ability to be dismantled and brought back to the surface after a project is completed.

The MTB requires a rounded profile side wall to grip and thrust the machine forward and for this reason, uses a starting frame assembled in advance of the next heading to be tunneled.

Once the backup of the MTB has advanced through the starting frame, it can easily be disassembled and moved to the next location where a new heading will begin - this process will then be repeated.

For breakaways, the MTB relies on a starting chamber that will be excavated and made safe by cyclical conventional mechanised drilling, blasting, scaling, loading, supporting and hauling equipment.

The benefits of the new design are numerous.

It allows for simultaneous cutting loading meshing and bolting.

The MTB is capable of steering in all directions during excavation for advanced mobility and it is capable of transportation in vertical shafts.

It fits into standard cage dimensions and low areas with a 2m height restriction.

Master Drilling's leading experts and advisors are able to provide a solution for every operational challenge - be it access, transportation, ventilation or analysis - focusing on the continuous research and development of new techniques and methods.

MAN AND MACHINE

Masters in innovative, cutting-edge drilling solutions

THE MASTERS
Leading global experts in drilling solutions that support our clients' unique needs with our specialised in-house equipment design, manufacturing, training and maintenance capabilities.

ROCK BORING
Our raise boring fleet of 152 rigs is the largest in the world, with our larger diameter rigs we are able to drill 8m diameter holes with depths of up to 1.5 km.

SLIM DRILLING
Master Drilling offers a fleet of specialised drill rigs capable of supplying drilling services across the exploration drilling spectrum.

SUPPORT SERVICES
Our service division additionally undertakes design, engineering, manufacturing, customisation and maintenance support for our drilling activities.

Keen to drill deeper?
Visit us at www.masterdrilling.com

Master Drilling offers services in rock boring, raiseboring, slim drilling and a full range of support services.



The MTB is an innovative new piece of equipment, focused on convenience, access and safety.



RAISEBORE AUSTRALIA

THE RAISEBORE SPECIALISTS

A privately owned company
supplying raiseboring services to the
mining and construction industries.

CONVENTIONAL | DOWN REAMING | UP-HOLE



Our services include:

- A specialist raiseboring company with a core business in conventional, down reaming and up-hole raiseboring
- Our fleet features 15 machines (one of the largest in Australia) with the flexibility to ream raises as small as 0.66 metre diameter up to 6.0 metre diameter and 1,000 metres in depth
- RBA has raisebored 150,000 metres since inception

We provide Directional Drilling of Pilot Holes for Raiseboring using:

- Welnav Directional Drilling Systems
- Micon RVDS Directional Drilling Systems

Raisebore
Australia raisebore.com.au

Rod Bertram *Managing Director*

// m. 0419 856 118 // t. (08) 8358 4444 // e. rod.bertram@raisebore.com.au



Epiroc Easer and Robbins 92R raise boring machines.

Epic Epiroc raise borers

NATIONAL

RAISEBORING equipment specialist Epiroc produces a range of mobile and traditional raiseboring machines.

Examples of these are the Easer L and the Robbins 92R that are able to cope with the most challenging underground mining conditions.

The Easer L model is a mobile raise borer that has high versatility and productivity that is used for medium to large underground drift mining.

Designed to drill opening holes in a block cave, sub-level caving and sub-level stoping mines, the Easer rig can be used for pre-condition holes, paste fill tube and media holes.

The Epiroc Easer L can carry out the three types of raisebore drilling modes being Conventional (or back reaming), Boxhole, and Down reaming in one package without expensive add on modules.

The Easer L machine operates in drift mines from 4.7m x 4.7m to 6 x 6m, and when drilling in conventional mode can drill holes up to 200m.

Epiroc's Easer L model can also drill box holes up to 60m and, has the ability to drill angled holes in any direction with a minimum range of 90-60 degrees.

Robbins 92R

Epiroc's Robbins 92R raise borer is a large capacity drilling rig that can be operated from a workstation and has recently undergone a revamp to increase its safety and productivity features.

The 92R model is the next generation in the Robbins line of raise borers and, is designed with improved features compared to its predecessors the Robbins 91RH & 123 RH introduced a decade ago.



The Robbins 92R borer can easily drill holes ranging from 2.4 to 6m in diameter and its modular format makes for easy transportation allowing for straightforward set up.

Interchangeable parts for the single base model Robbins 92R machine enable quick changeovers for different drilling conditions.

A single power pack is a new design feature of the Robbins 92R, replacing the previous standard of twin power packs.

This has reduced the installed motor power and increased overall efficiency. The powerful 500-kW main electric motor provides the torque and thrust required to penetrate the hardest of rocks.

Epiroc also manufactures and supplies drilling consumables for Raisebore drilling including drill pipe, stabilizers, pilot bits, reamers and cutters.

Recent developments include the capability for inbuilt RFID tags to keep track of usage.



Epiroc has a wide product offering in terms of mining equipment that stretches from drill rigs, loaders and trucks, excavator attachments, rock drilling tools and rock reinforcement items.

Also available from the Australian company are parts and services, including custom-engineering and fluid management solutions, replacement parts and kit and training products such as simulators.

Easer L

- boxholes
- down reaming
- conventional
- no add-ons

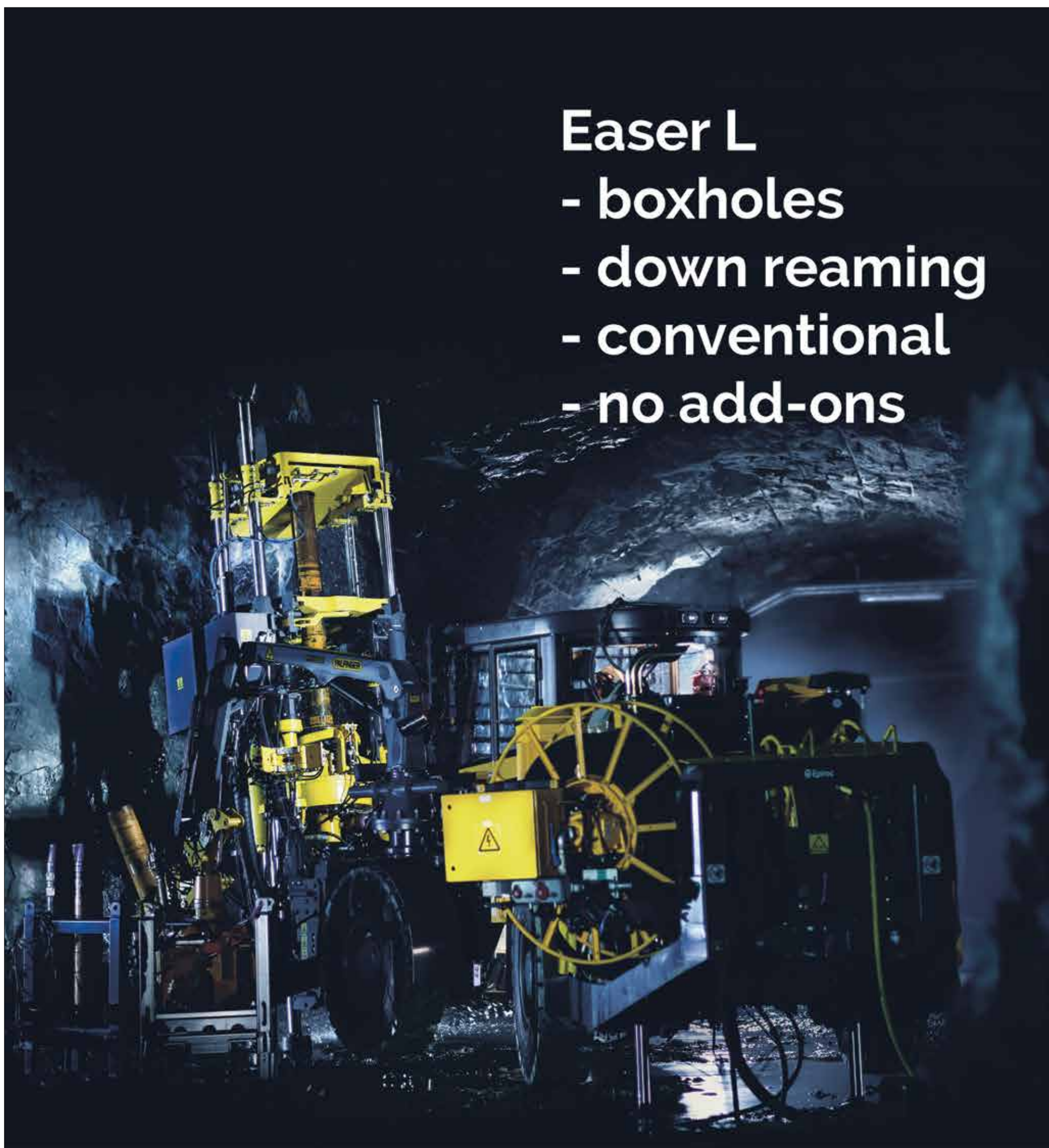

United. Inspired.

Drill 10m holes quickly

Or make conventional holes up to 200 m long, box holes and down reaming up to 60 m long, with a maximum diameter of 750 mm. Easer L has a wide horizontal drill angle, which allows the machine to reach a minimum range of 90-60° in all directions.

Find out more go to epiroc.com



epiroc.com

Committed to quality work

WA

AUSTRALIA'S leading manufacturer of raisebore equipment and a dedicated service centre, Silverise is a WA-owned company that provides quality drilling equipment and services to the global mining community.

With more than 20 years in the business, Silverise is dedicated to supplying its customers with the best components for raisebore, blasthole, waterwell and numerous other drilling applications.

Manufacturing raiseboring drill string consumables and raise boring machinery parts of the highest quality, Silverise specialises in raiseboring drill rods, stabilisers and stems as well as machinery components, including floatboxes, spindle bolts, drive bodies, and various other components.

Manufacturing its own products with in-house engineering, Silverise is able to provide customers with design improvements leading to extended component life and lower operating costs.

The company's services extend to inspecting and repairing of threaded connections, welding and fabrication, specialised fabricating, deep hole drilling and general machining work.

Using non-destructive testing, Silverise can inspect your existing drill string, ascertain repair requirements and provide services accordingly.

The company also provides welding and fabricating services of the highest standards to clients in the mining, gas and oilfields industries.

Silverise is committed to providing nothing but the best quality for its customers.

The impressive catalogue includes rock breakers – it's the WA agent for Indeco rock breakers – raise bore rods, blast hole equipment, water wells, reverse circulation units, large diameter casing, stabilisers, hole openers and rig components.

For more information on any of the Silverise products and services, visit the online catalogue at www.silverise.com.au.

Or call 08 9493 9393, or email: rbybyk@silverise.com.au.



Silverise is dedicated to supplying its customers with the best components for raisebore, blasthole, waterwell and numerous other drilling applications.

SILVERISE

+61 8 9493 9393

rbybyk@silverise.com.au

silverise.com.au

22 Church Road, Maddington WA 6109

Putting Today's
Technology To Work

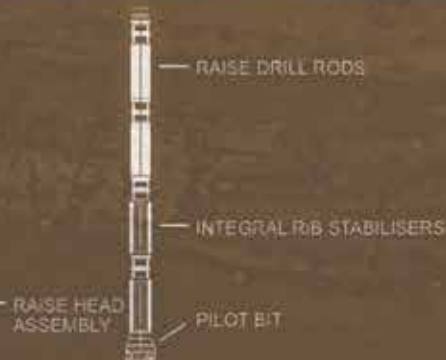

TOP QUALITY DRILLING AND BORING MACHINERY

Silverise provides the global mining industry with top-quality raise bore drill string and machinery components.

Silverise is also proud to be the Western Australian Agent for Indeco Rock Breakers.

Based in Perth, Western Australia, Silverise manufactures and services equipment for use in raise boring, blasthole and waterwell drilling.

Silverise also provides drill rod inspection and repair services incorporating innovative, state of the art technology.

OUR SERVICES

General Machining
Drill String Inspecting
Welding and Fabrication

OUR CATALOGUE

Rock Breakers
Raise Bore Rods
Blast Hole
Water Well
Large Diameter
Reverse Circulation
Large Diameter Casing
Stabilisers
Hole Openers
Rig Components

Please contact us for more information.



Custom-built hydraulic machinery

NATIONAL

ALCARO Industries designs, builds and repairs special purpose hydraulic machinery for the mining industry at its specialist workshops on 16 acres in Bullsbrook on the north eastern edge of Perth, WA with double road train access and storage for equipment.

The company can provide diagnostic services, mobile hydraulic hose and machinery repair, preventative maintenance schedules and equipment modifications and aim to provide customised solutions for its clients.

Alcaro Industries capabilities include hydraulic pumps and motors, piston, vane and gear, and hydraulic directional control valves — monoblock, segmented and proportional.

Specialised filtration equipment can be designed, installed and maintained with annual servicing of systems.

Its services include side and end tipper PTO and hoist systems installations, cylinder and valve repairs and machine diagnostics.

Alcaro has a specialised machine shop, tube and pipe bending and boiler making facility to support client needs which reduces turn-around time for equipment repairs.

The company serves a wide range of clients in the agricultural, mining and industrial hydraulics sectors and has two



The company's engineers can change out redundant products, repair and replace equipment and design or upgrade older equipment according to client needs.

fully equipped mobile hydraulic truck service vehicles to provide ready assistance to clients.

The mobile service vehicles facilitate fast on-site repairs and troubleshooting.

Skilled mobile technicians from Alcaro Industries arrive on-site fully prepared with tools and relevant parts to effect equipment repairs in the shortest of time.

The company's engineers can change out redundant products, repair and replace equipment and design or upgrade older

equipment according to client needs.

An Alcaro specialty is electro/hydraulic design and installation of man cage modifications to telehandlers to AS 1418.1, hydraulic hose burst valves, load holding and crane valves to AS 1418.8 (ISO 8643) and new / modification of old hydraulic systems to computer controlled hydraulic systems.

Alcaro Industries has a range of conveyor belt winding product for hire and sale.

The equipment is fabricated and fitted out at its facility in Bullsbrook.

The conveyer maintenance support equipment includes 7,10,15,25, 40t belt winders, braked tail units, support stands, winches proportional control, flaking guides and turnovers.

The company offers a range of hydraulic machinery and systems for hire or purchase, and standardised products can be customised to meet clients' designs or needs

Alcaro Industries is the new name for Alcaro Hydraulic Services and the group has been operating for more than 20 years.

ALCARO INDUSTRIES



MINING HYDRAULIC SPECIALISTS IN PERTH



For hydraulics, pneumatics and light engineering put your trust in Alcaro Industries.

A WA owned and operated business, **Alcaro Industries** specialises in mining, agricultural and industrial hydraulics. With workshops in Wangara, Muchea and Bullsbrook, as well as the capability to provide fully equipped mobile services, we're able to change out redundant products, repair and replace equipment and design or upgrade old equipment as required.

Whether you're looking for special purpose machine designs and rebuilds or labour and hydraulic power pack hire, we've got you covered. Chat with our Perth professionals to arrange your hydraulic supplies and services today.

Our hydraulics team specialises in:

- Repairs, reconditions and replacements
- Hydraulic pumps
- Hydraulic motors
- Directional problems
- Flow and pressure control valves
- Hydraulic rams
- Machine shop
- Hydraulic hose and fittings
- Barrels
- Piston rods
- Seals
- Steel tube and fitting
- Honed tubing
- Fabrication



ALCARO INDUSTRIES



0428 234 663
sales@alcaro.com.au
www.alcarohydraulics.com.au

The three Rs of filtration

NATIONAL

TRIPLE R Filtration's unique three-in-one Axial Flow Filtration solution for removing even the smallest particles of contaminants from oil and working fluids can save its clients both valuable time and money by providing high reliability, extending component life and preventing equipment breakdowns.

Equipment performance and reliability is a critical function in the mining industry where breakdowns can slow production, escalate costs, and reduce productivity.

Triple R Filtration is the Victoria-based exclusive Australian distributor for Triple R offline and bypass filtration and separation products.

The company's next generation products and solutions are both economical and highly efficient in the removal of the three major contaminants responsible for 80pc of equipment breakdowns related to oil and other working fluids.

These three contaminants are solid particles, sludge, and water.

The presence of these contaminants can damage or drastically reduce the lifespan of cylinders, pumps, valving, gears, bearings and seals in mining equipment.

They can also cause oil to deteriorate at a faster rate, losing the valuable chemical qualities and properties necessary in oil, that provide sound lubrication.

Varnish and other oxidation products from oil such as resins or sludge can cause machinery parts to stick, greatly accelerating

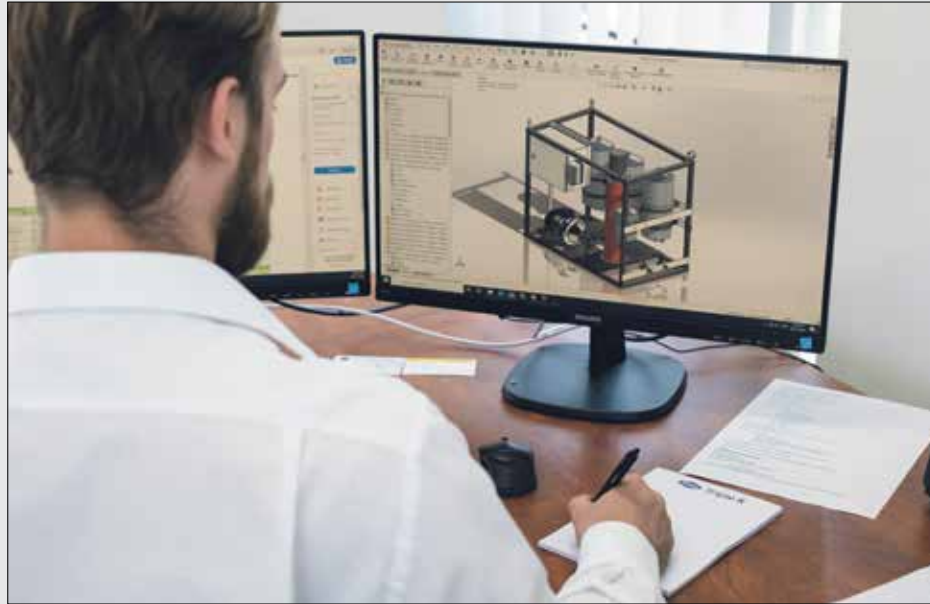

A Triple R employee working on a filter design.

wear and clogging expensive inline filters.

Water can combine with other contaminants in oil such as particles and can accelerate the oxidation process increasing acidity in oil products, leading to equipment failure.

When fitted with Triple R offline or bypass solutions, component life, including cylinder slide time can be extended between two and eight times, oil life increased up to four times, and expensive inline filter life by four times.

Axial flow principle

Triple R is the original worldwide patent

holder for Bypass Oil Cleaning Depth (axial flow) Filters.

They use specially engineered cellulose 3-in-1 filter media to remove solids to less than 2 microns in size, as well as sludge, resins, water and oxidation products.

Triple R, through 40 years continuous research and product application, based on its business experience, is able to offer proven solutions for almost any application, either as a standard off-the-shelf product or customised engineered solution.

Products developed by Triple R use the three-stage 3-in-1 depth filtration system for bypass and offline oil cleaning that are highly effective and can significantly extend

component life, improve equipment reliability, prevent wastage and reduce disposal and associated labour cost.

Triple R's principle of Reduce, Reuse and Recycle can be effective in meeting environmental and social responsibilities.

As a global leader in its field, the company can provide filtration solutions to numerous industries across the Oceania Region that use oil in hydraulic, lubrication systems including companies in the mining sector.

These include mining-related sectors such as bulk materials handling, crushing and screening, haulage, diesel and gas turbine generators, hydrocarbon storage, railway and locomotive, shipping, waste oil treatment and compressors.

In the case of emergency equipment breakdowns, Triple R Filtration offers clients the option of hiring replacement units, including filtration, water removal, vacuum separators, centrifuges and other specialised equipment in order to accelerate the return of equipment to full operating conditions.

Triple R Filtration Australia units are designed and manufactured in Australia, meeting Australian standards and enabling the company to provide custom solutions for its customers.

Customers of Triple R Filtration Australia are well served by a qualified team of client service representatives and engineers, experienced in finding solutions for many different types of oil and lubrication applications.

BENEFITS

- Extend Oil Life up to 40,000 Hours
- Reduced Oil Consumption
- Reduced Waste Oil
- Reduced Disposal Cost
- Extended Full Flow Filter Life
- Increased Productivity
- High Operational Certainty
- Extended Component Life
- Increased Machine Reliability
- Easy to Install and Service

PRODUCTS SUITABLE FOR

- Hydraulic Oil
- Lubricating Oil
- Compressor Oil
- Turbine Oil
- Glycols
- Esters
- Engine Oil
- Diesel Fuel
- Synthetic Oil
- Vacuum Pump Oil
- Heat Transfer Fluids
- Coolants
- Transformer Oil

SOLUTIONS FOR WORKING FLUIDS

- Bypass and Offline Filtration
- Water Separation and Removal
- Oil Separators
- Centrifuges
- Oil Purifiers
- Varnish Removal Systems
- Air Bubble Removers

IMPROVE ENVIRONMENTAL COMPLIANCE & SOCIAL RESPONSIBILITY

REDUCE-REUSE-RECYCLE



Triple R

| OFFLINE | BYPASS OIL CLEANERS | SEPARATORS |
FOR OIL | WORKING FLUID SYSTEMS

EXTREMELY CLEAN OIL AT LOW OPERATING COST
AFFORDABLE SOLUTIONS THAT DRIVE COST OUT AND PRODUCTIVITY UP



Triple R Oil Filters have the remarkable ability to effectively remove the 3 major contaminants that cause 80% of all oil related malfunctions and breakdowns...



UNIQUE CONCEPT

Utilising a massive 114mm of filter media, Triple R bypass micro filters are different to conventional filters.

Using the Axial Flow Principle, with a specially engineered/patented cellulose filter medium that removes solids to >2micron, absorbing water and completely removing resins and oxidation products.

THE IDEAL FILTER

This with just one type of element gives Triple R Offline + Bypass Cleaners the remarkable ability to remove all pollutants. Resulting in extremely clean oil- thanks to our 3 in 1 oil + fluid purification process

- ✓ Removes up to 99% of all solid contaminants.
- ✓ Eliminates damaging sludge, varnish and oxidation products.
- ✓ Reduces water concentration to less than 100 PPM.



(+61) 3 5134 5345 / 3 7019 9351 info@triple-r-filtration.com.au

www.triplerfiltration.com.au



Sealed with quality

NATIONAL

HYDRAULIC Seals Australia is a fully Australian-owned and operated company, specialising in supplying the highest quality hydraulic cylinder seals to meet the demand of the harsh Australian environment.

Located in four convenient locations along the East Coast of Australia (Brisbane, Newcastle, Sydney and Melbourne), HSA is dedicated to providing you with seal engineering solutions across a range of industries, from waste management, food and beverage, construction, to the mining sector.

HSA has access to a range of the highest quality seals from all over the world, from high temperature and self-lubricating polyurethanes to specialised PTFE's (Teflon) and internally lubricated composite guide rings to ensure the seals kits do not compromise on performance.

Customers will get the best products to ensure longer seal life.

Each branch has on-site custom seal



Hydraulic Seals constantly searches the globe for the latest in materials technology, so it is able to offer customers a sealing solution with the ability to exceed the benchmark service life for hydraulic cylinders and suspension struts.

manufacturing capabilities up to 750mm+ in diameter, in a range of materials to cover an enormous spectrum of environments.

Through many years of experience, the company has found that OEM sealing materials can sometimes be outdated or have not been designed with the unique Australian operating conditions in mind.

In the case of large mine shovels and

haul trucks, the common challenge is high operating temperatures and high bearing loads.

In line with Hydraulic Seals' continual-improvement strategies, the company is constantly searching the globe for the latest in materials technology, so it is able to offer customers a sealing solution with the ability to exceed the benchmark service

life for hydraulic cylinders and suspension struts, resulting in reduced downtime and higher productivity of your machinery.

Staff are all highly skilled in seal selection and design and in conjunction with the company's stringent ISO90001 procedures.

Hydraulic Seals strives to get you the correct seal first time, every time.



- **U4150 Polyurethane** – Ultra high temperature (135°C) and compression set Polyurethane
- **CM20** – High Load Composite Guide Rings rated to 200°C
- **HNBR** – Seal Energisers rated to 150°C
- **ATXC-66** – Ultra High Wear and Performance PTFE Seals

Shop online 24/7 at www.HSA.com.au





Leigh Morrison (RYCO Hydraulics) and Dardanio Manuli (Manuli Rubber Industries).

MANULI RUBBER INDUSTRIES AND RYCO COMBINATION TO RESULT IN A NEW MARKET LEADER

3 February 2020 – Manuli Rubber Industries SpA (MRI), headquartered in Milan, and RYCO Hydraulics Pty Ltd (RYCO), headquartered in Melbourne, today jointly announced that MRI has completed the acquisition of a majority shareholding in RYCO. MRI will merge its wholly owned Manuli Hydraulics and Fluiconnecto divisions with RYCO to provide an enhanced product range and full global supply and service offering to customers of both companies. The combined business, with total sales approaching €500 million/\$AUD820 million, will be a leader in the global hydraulic hose and fittings industry, servicing a broad range of market sectors. MRI, founded in 1935, and RYCO founded in 1946, together have over 4,500 employees.

MRI Chief Executive Officer, Dardanio Manuli, said “This transaction captures the full benefit of combining complementary product ranges, engineering and innovation capabilities, a strategically located manufacturing footprint and a truly global market reach. We are excited about the potential benefits and growth opportunities that will result from the best of what both MRI and RYCO bring to the market.”

RYCO Chief Executive Officer, Leigh Morrison, said “Both MRI and RYCO are family owned and run private companies with similar cultures and a shared commitment to remaining agile, responsive and customer-focused. This merger creates benefits greater than either company could achieve alone.”

MRI operates through two divisions: Manuli Hydraulics (design and manufacture) and Fluiconnecto (distribution and service). The Manuli, Fluiconnecto and RYCO, RYCO24•7 brands will be retained, and each company will continue to operate through existing channels to market, with the ability to access both product and distribution synergies.

Leigh Morrison will continue in his role of RYCO CEO and will be invited to join the MRI Board. A new RYCO Board has been constituted with MRI representation.

Details of the transaction were not disclosed. MRI received funding support from Banca Intesa Sanpaolo and Mediobanca. In addition, some consulting services were provided by William Blair & Company. RYCO was advised by Deloitte Financial Advisory.

Hydraulics partner for mining across Australia

NSW

AUSTRALIAN manufacturer Southcott Pty has been involved in hydraulics since 1954, beginning with the design and development of axial piston pumps and motors.

The company is a market leader both as a reliable supplier of quality products, and in servicing diverse industries.

It provides innovative reputable system solutions and is a major force in hydraulics.

Its team of engineers and technicians have an extensive understanding of the hydraulic industry and can provide expert and highly skilled hydraulic system designs, product supply, onsite services, control integration, installation, commissioning, training and technical support.

As a trusted name in hydraulics, Southcott works closely with various industries across Australia, including the mining, agriculture, construction, mobile, industrial, defence and marine sectors.

The company has an extensive product range of hydraulic components available from local and world leading brands.

The Southcott family has been involved in designing and manufacturing of more than 134 years.

Today Southcott is recognised as a manufacturer of hydraulic pumps, motors, valves, manifolds, power units, control systems and Child hose couplings and adaptors.

Southcott manufacturing facilities are fitted with state-of-the-art CNC machinery, impulse and burst testing equipment to



Southcott supports hydraulic service through onsite workshops.

ensure precision and quality production.

It is one of the largest manufacturers of hydraulic hose couplings and adaptors manufactured in Australia.

With four manufacturing facilities, this enables a more systematic approach with

fast reaction time for special orders to meet industry demands.

The company's dynamic culture, combined with a national network of 10 branches, four manufacturing facilities, electronic division and more than 150 distributors nationwide

gives Southcott the leading market advantage.

Southcott prides itself on safety, quality and reliability offering industry leading service that delivers complete hydraulic solutions.





COMPLETE HYDRAULIC SOLUTIONS

Southcott are an Australian supplier and manufacturer of hydraulic components and fluid connectors. With an extensive range of hydraulic components, Gates hydraulic hose, Child & Gates couplings to meet all your requirements.

- ✓ 10 Branches Nationwide
- ✓ 150 Distributors
- ✓ Extensive Product Range
- ✓ MDG41 Hose Assemblies & Kits
- ✓ On-Site Workshop Containers
- ✓ Hydraulic System Design
- ✓ 3D Modelling and F.E.A.

- ✓ Turn-key Hydraulic Systems
- ✓ Electronic Control System & Integration
- ✓ CNC Tube Bending and Assemblies
- ✓ Supply, Install and Commission
- ✓ System Analysis & Auditing
- ✓ Testing, Service and Repairs
- ✓ Custom HIC Manifolds









www.southcott.com.au

Adelaide 08 8228 2411 • Sydney 02 8814 2100

Newcastle 02 4964 2123 • Brisbane 07 3022 3700 • Emerald 07 4988 1800

Mackay 07 4952 4056 • Melbourne 03 8793 6400

Laverton 03 9371 9000 • Perth 08 6216 4600 • Tasmania 03 6427 0908



Complete engineering solutions

WA

ESTABLISHED five years ago, and locally owned and operated, Perth-based OMG Engineering provides complete engineered solutions for mining/exploration, drilling and oil and gas industries.

OMG partners with some of WA's leading drilling companies, providing a range of services from hydraulic cylinder manufacture, rebuild and repair, through to drill rig repairs and custom truck body design and modifications.

Built with in-house engineering and drafting capability, along with more than 30 years of combined industry experience, OMG works with customers across a range of industry.

The company's well-equipped workshop in Welshpool is capable of custom machining and milling to exact customer requirements, from precision machining and turning through to heavy industrial components.

OMG offer turnkey services comprising multiple CNC lathes and milling machines (up to 5m) as well as general machining and milling including tapping, drilling, threading, grinding, gear cutting, part hardening, precision fitting and assembly.

All machining and fitting work is fully production and quality tested.

Since 2017, OMG has become known for its quality truck modifications.



OMG offers complete engineering solutions at its Perth workshop.

It has completed many truck refurbishment projects, helping clients get the most from their on road assets, including custom truck bed mounted fuel transfer tanks, truck bed rebuilds,

bespoke tool boxes, Hiab crane modifications, guards and railings, hydraulic systems, pinch free ladder access systems and tilt tray rebuilds.

Always innovating, in 2018, OMG

Engineering designed and patented (pending) an integrated pinch free truck access ladder system.

The completely pinch and crush-point free ladder is designed to eliminate the types of crush and manual handling injuries that plague other truck ladders and access systems.

Free space around all components meets strict client safety regulations, making the system mine site compliant.

The system includes a unique radial clutch, fully enclosed and suitable for applications (not just ladders) where stored energy, a fall from height or manual handling risks are present.

In early 2020, OMG undertook its largest project to date.

It will modify a Hanjin drill rig (and three ancillary support rigs) to operate effectively on salt lakes in WA's Goldfields region.

Each rig's track base must be modified to exert no more than 2 PSI of pressure on the lake surface.

This will involve modifying existing CAT track base and chains to incorporate custom designed 'paddles', expanding surface area contact with the lake surface and therefore reducing surface pressure.

OMG will rebuild the rigs from the ground up including all fabrication, hydraulics, rod sloop systems, as well as configuring the three support rigs.

'YOUR ONE STOP SHOP' ENGINEERING/FABRICATION SPECIALISTS



FABRICATION
& WELDING



HYDRAULIC CYLINDER
MANUFACTURE & REPAIR



FITTING
& MACHINING



PINCH FREE TRUCK LADDER
ACCESS SYSTEMS



TRUCK REBUILDS &
REFURBISHMENT



PATENTED RADIAL CLUTCH
SYSTEM



Find us on
Facebook @omgengineeringperth

Instagram @omgengineering

info@omgengineering.com.au // +61 4 1264 4045 // www.omgengineering.com.au

Custom Fluidpower provides hydraulic solutions

NATIONAL

HYDRAULIC specialists Custom Fluidpower is skilled in providing superior fluid power solutions for its clients Australia-wide including those in the mining sector.

With 20 years of experience in the hydraulic industry, the Australian company's highly-trained engineers can solve fluid power problems with its tried and tested methods.

Custom Fluidpower has an end-to-end approach to its clients and is involved in each stage of the fluid power solutions process, from system design through to power unit manufacturing, commissioning and training.

The firm is effectively a one-stop provider for supplying high quality hydraulic, pneumatic, filtration, lubrication and electronic products and services for fluid power applications.

The company is capable of designing, assembling, manufacturing



Custom Fluidpower-supplied winding equipment.

and installing fluid power products and services for its clients.

Custom Fluidpower has two manufacturing facilities, and Custom Fluidpower manufactures safe brakes, manifolds and undertakes intricate hydraulic equipment repairs.

The business serves a range of industry clients ranging from the mining and construction industries, materials handling and industrial sectors, transport and marine, and defence and agriculture sectors.

Mining projects

Custom Fluidpower has worked on several key mining-related projects, including the refurbishment of a ship access ladder at an Australian coal terminal.

The company won a recent order from Brevini that was supplying long travel drives for some stacker and reclaimer units built by German engineering firm ThyssenKrupp.

Custom Fluidpower's involvement was to design, construct and test a suitable hydraulic braking system for the stacker and reclaimer units.

This system used one power unit for each machine's 14 calipers, or a total of 42 calipers, and three power units.

Custom Fluidpower's unique power system design has a dual redundancy, SIL 2 system with remote monitoring capability.

Space was at a premium in the stacker and reclaimer units and by using only one power unit per machine the company was able to meet this design issue.

The firm's engineers designed a specific caliper manifold for the project that allowed fresh oil to be used for every braking application.

Used oil was then filtered in the power unit, ready for re-use in the calipers.

The firm's engineers also fitted seven Dana SAC (Brevini) drive gearbox assemblies to each side of the stacker and reclaimer units, a total of 14 gearboxes for each machine.

The gearbox assembly of each stacker and reclaimer machine has one custom-made safe brake caliper, and a single hydraulic unit operates all 14 calipers on one reclaimer or stacker unit.

The brake assemblies operate as a holding brake and an emergency stop brake for each stacker and reclaimer machine.

CUSTOM[®]

fluidpower

INDUSTRIAL BRAKING SOLUTIONS

Designed in Australia for tough mining conditions, Custom Safe Brakes feature:

- Lower operating pressure
- Minimum moving parts
- Stainless steel adjusting screw and pad retainers
- Cartridge style spring pack
- Safety package upgrade kit for existing Calipers



The CSB range features hydraulically released fail-safe disc brakes with a clamping force range from 500N - 250,000N. Self-adjusting options available.

National Strength, Local Service

Masters in pipe products

NATIONAL

PVC pipe fabrication company DEPS has reliably supplied the Australian construction, drilling, excavation, irrigation and mining industries for more than 30 years with its made-to-order products.

DEPS has specialist expertise in manufacturing and threaded bore casings and vertically-slotted drainage pipe at its Victorian facility, and many of its products are custom-made.

The firm can process PVC pipe of any size for threading, slotting or perforation and the company is expert in handling large diameter PVC pipe products.

DEPS machines most of its own casing and screen products on-site using its sophisticated computer lathes to ensure precision and product consistency.

The company has the capability of machine threading PVC pipe with diameters ranging from 15mm up to 300mm.

It can produce different types of threading for PVC pipe products including, flush, collared, tapered, trapezoidal, specially designed taper lock thread, and taper join and snap lock joints for some PVC pipe products.



PVC pipe products supplied to the mining and drilling industries.

The company is able to crate vertically-slotted and horizontally-slotted pipe for drainage purposes.

DEPS business manager Lein Jenkins said the company can process PVC pipe of any size for its clients who include mining companies and ground water specialists.

The firm's PVC pipe products are also

used in the geotechnical and environmental industries and for irrigation.

The company stocks a wide range of branded products in its Victoria warehouse facility including Pipemakers, Iplex and Plascorp made pipes as these suppliers manufacture their products onshore and to unquestionable standards.

DEPS has a wide customer base of clients in Australia and also some overseas clients that prefer to source their PVC pipe products from the company.

Prospective customers are encouraged to contact the company to see how DEPS can assist them in their next project.

► Economic Piping Solutions



On Time, Every Time.



- Large Diameter U/M-PVC & ABS Threaded Casing & Screen
- HDPE Casing & Fittings
- Pumps
- Submersible, Lift, Centrifugal

- Drainage & Stormwater Machine Pipe Slotting/ Slitting/Perforation of any Diameter
- Large Bore CNC Lathe
- Specialty Screens

- National / International Freight
- Steel Core Trays
- PVC Risers
- Stainless Steel Or PVC Vee-Wire



DEPS Aust Pty Ltd
14-16 Gatwick Road
Bayswater North Vic
1300 133 000

HES Winches finds best solution

NATIONAL

SOUTH-EAST Queensland-based company HES Winches Australia specialises in providing quality and leading brand winch solutions to deliver the right winching solution for all industries.

HES Winches was formed in 2012 as a division of HES Group, which was established in 1982.

It also has extensive experience in the design and construction of customised winch products and can engineer and commission winches to meet all specific applications.

This Australian company manufactures and distributes a wide range of winch products including, electric, hydraulic, pneumatic, manual winches, and its own custom-built products are proudly made in Australia.

Recent major custom projects delivered include winch builds for BHP, OK Tedi and Redpath Mining.

The well-known winch business has also successfully negotiated supply and distribution deals with some of the world's leading winch manufacturers to enable its Asia-Pacific customer base to access the best quality products.

HES Winches is the Australian distributor for a number of iconic winch brands such as Pullmaster and Lantec in Canada, Tulsa and DP Winch from the US, Italian-made Dinamic Oil winches and Gebuwin winches from the



Some of HES Winches equipment on a coal mine conveyor system

Netherlands.

The company also markets and distributes its own OzWinch range of AC electric winches.

HES Winches services clients across a range of industries including the oil, gas, energy and mining sectors in the Asia-Pacific region.

After-sales customer service is an important part of HES Winches' service, and the company strives to meet and exceed its customers' expectations.

HES WINCHES AUSTRALIA

CUSTOM WINCH SOLUTIONS | PROFESSIONAL ADVICE | OUTSTANDING SERVICE



HES Winches Australia works with you to develop the most efficient winch solution for your project. Using market leading technology, we supply high quality products for the mining and associated industries that are safe, reliable, practical and meet relevant Australia standards.

Our custom-engineered winch solutions utilise local design, manufacturing and testing facilities whilst complimented by our international manufacturing partners.

Contact us NOW to discuss your winching needs.

1300 946 242

sales@heswinches.com.au

www.heswinches.com.au



Pull+MASTER

dinamic oil

AUSTRALIAN DRILLING INDUSTRY ASSOCIATION

CPH meets civil mining needs



CPH specialises in mining civil works, including road, dam and levee construction, bulk earthworks, top-soil management and environmental rehabilitation.

QLD

CPH Mining & Civil, based in the Bowen Basin, Queensland, partners with big name companies across Australia including BHP, Thiess and Downer Group, offering earthmoving operations and equipment hire, as well as transport services.

Its reliable and exceptional service for all large-scale mining and civil engineering projects is backed by repeat contracts from happy customers.

CPH specialises in mining civil works, including road, dam and levee construction, bulk earthworks, top-soil management and environmental rehabilitation.

CPH Mining and Civil director and founder Colin Riston said that owning all its own equipment means the company can respond quickly to all clients' requests.

"At CPH we ensure that our work meets our clients' expectations," he said.

The philosophy at CPH is to provide the service the client requires, endeavouring to supply the equipment and technical expertise required for any job.

Mr Ritson has grown the company from just two Caterpillars in 2004, working on an urban development project in Sydney, to the massive fleet now available.

A move to the coalfields of the Bowen led to contracts from coal and other mining companies and other major earth moving projects, starting with the first tailing dam raise five years ago.

Projects

Contracted by BMC, CPH performed civil works to enable a pit expansion at South Walker Creek including the construction of 17.5km of roads and associated drainage structures.

It worked on the Goonyella Riverside



The fleet of contracting machines includes scrapers, articulated dump trucks, excavators, dozers and graders.

Mine – GS1 Tailings Dam Raise for BMA, applying its expertise and machinery to construct the tailings dam raise including upstream and downstream embankment raises, a spillway construction and electrical and water treatment works.

For the Goonyella Riverside Mine project, BMA also contracted CPH for the construction of a 2km dividing embankment to an existing dam, including a spillway.

It was also awarded the contract for the complex environmental Blackwater Mine Deep Creek Remediation project.

CPH made modifications to an existing sediment dam, which included removal of silt and sediment; increasing the capacity of the dam, installing a dividing wall; and relocating the spillway.

The contract required the construction of stockpile run-off containment drains, the tailings dam seepage containment levee and creating access roads to newly constructed infrastructure for all mining vehicles.

Transport services

CPH carries a Kenworth T908 prime mover and Drake 2x8 dolly/3x8 float combination that can service the Bowen Basin, Moranbah and beyond, safely hauling loads up to 62t under a single trip permit, or 50t under period permit.

A reliable team of pilot drivers and vehicles are sourced from Moranbah allowing loads up to 4.5m wide.

The service vehicle fleet also includes a Peterbilt 357 and various Isuzu models.

Equipment for hire

CPH offers all machinery as wet hire or dry hire.

It maintains and services an ever-growing fleet of heavy machinery and employs a stable workforce consisting of more than 100 highly trained employees, ensuring that an expert operator is always available for the project, no matter the size or location.

Its operators are all qualified, skilled drivers that ensure the job is done skilfully and safely.

CPH has an emphasis on hassle-free delivery, which makes the company very attractive to clients.

Its versatility and expansive expertise are illustrated by the range of projects it has been involved on.

The fleet

CPH favours leading brand equipment like Caterpillar for its advanced engineering, up to date technology and reliable durability.

Its fleet of scrapers includes the Caterpillar 657E, Caterpillar 637E and G, and Caterpillar 623G.

The Caterpillar 675E motor scraper uses the Cat 3408E engine which provides 311.8kw gross power.

Loaded, its top speed is 50.1km/h and has a heaped capacity of 55.9 m³.

The 657g offer slightly more power with a heaped load capacity of 56m³ and top speed of 53.0 KM/H.

Articulated dump trucks come in the Volvo A40D and A35D and Terex TA400 models.

Hitachi and Caterpillar excavators

The 336 range of Caterpillar excavators use the Cat C9 engine with ACERT Technology Net Flywheel Power that has a maximum digging depth of 820m.

Available for wet or dry hire are also Caterpillar dozers and graders, wheel loader and tyre handlers, Mack, Kenworth and Western Star HR Water trucks and various low-loaders.

CPH Civil and Mining continues to expand and develop its business across the region and Australia.

Customers can be assured that it is open to scoping any earthmoving jobs and will acquire or source the specific machinery necessary for the job.

Its objective is to meet the clients needs and its quality results are an illustration of how it is achieving this goal.



CPH is working with you to move the earth.

CPH is a contractor of choice to Australia's top mining and civil companies.

With a focus on large scale mining projects, CPH has the equipment and manpower to complete all civic jobs

- Mining roads
- Dams
- Levees
- Tailing Rises

Turnkey solutions including earth moving, construction and pump, pipe and spigot installation.



cphmc.com.au

CONTACT

☎ 07 4941 9537

✉ info@cphmc.com.au

📍 25 O'Neill Street, Moranbah QLD 4744



Leader in centrifugal systems

NATIONAL

SOLID bowl centrifuges have emerged as an energy and water efficient technology that can more than match the capacity of belt filter presses for tailings dewatering.

As a leading provider of tailings dewatering technologies, and a presence in Australia for more than 90 years, Alfa Laval provides solid bowl centrifuges to mining companies around Australia and the world.

The company is a world leader in solid-liquid separation, heat transfer and fluid handling.

Its designs focus on enhanced energy efficiency, improved heat recovery, responsible use of natural resources, better water treatment and reduced emissions.

It has committed hefty research and development investment to designing and manufacturing solid bowl centrifugal systems with very large capacity, up to 80 dry tonnes per hour, specifically designed for heavy duties in mining and mineral processing.

In Australia, it has a particular focus on coal, copper, iron ore, gold, nickel and uranium tailings.

Dry tailings can be disposed of alongside coarse rejects using a similar process to overburden.

Alfa Laval dry disposal alleviates the risky and expensive practice of maintaining a tailings dam, which results in the discharge of significant quantities of



Alfa Laval's solid bowl centrifuge, the Alfa Laval P3, is sold worldwide.

toxic tailings into the natural environment if it fails.

Mining companies can also gain additional capacity with solid bowl centrifuge as existing Tailing Storage Facilities (TSF) are reaching capacity and new licenses are harder to come by.

Further advantages of Alfa Laval's efficient solid bowl centrifuges is a reduction of water usage by up to 90pc, as process water can be extracted and re-used.

It will soon be introducing a full-scale skid mounted modular unit for onsite trials and interim solutions for tailings dry disposal.

Alfa Laval's innovative technologies

are dedicated to purifying, refining and recycling material.

In the case of fine coal recovery, next generation solid bowl centrifuges open up significant new revenue streams for customers to extract smaller particles from slurries than ever before.

Working with customers throughout the entire process, the company draws upon its strong R&D commitment as well as its significant inhouse engineering expertise.

It provides commissioning, training, onsite field services, trouble-shooting, process optimisation and major overhauls of centrifuges.

The end-to-end service doesn't stop at

installation.

Over its nearly 100 years working with Australian mining companies, Alfa Laval has developed a strong local support presence, including a fully equipped service centre in Sydney, and field engineers based around Australia to visit even the most remote mining sites.

It also specialises in heating, cooling, waste heat recovery, evaporation, condensation, desalination and zero liquid discharge as well as fine coal recovery and tailings dewatering.

Alfa Laval has a presence in more than 100 countries, 17,000 employees and holds more than 3500 patents worldwide.



Accelerate your tailings dewatering with solid bowl centrifuge technology

Optimising your tailings dewatering processes is a straightforward way to cut operating and investment costs.

Alfa Laval's P3 solid bowl decanter centrifuge has been specifically developed for large scale, heavy duty solid-liquid separation tasks in the mining and mineral industry.

Find out why a growing number of mining companies choose dry centrifuged tailings as an alternative to storing a liquid slurry in a tailings dam.

The Alfa Laval P3 helps boost capacity, reduce tailings volumes, and increase the recovery of water, chemicals and minerals from tailings, including ultra fine solids and slimes. It offers a significantly smaller footprint, lower CAPEX and OPEX than other dewatering technologies.

Contact Alfa Laval Australia for more information on how the P3 decanter centrifuge can help boost your profitability.

www.alfalaval.com.au



www.alfalaval.com



Engineers in solid demand

NATIONAL

ENGINEERS are starting to see an upturn in demand for their skills in Tasmania, which was the only state that did not mirror the broader downturn across Australia (but only marginally)

This is the key finding of the Australian Engineering Vacancies Report – Trends in 2019 that was released in February by Engineers Australia, the leading body representing engineering professionals in Australia.

The regularly updated jobs vacancies report is one of the key services provided by Engineers Australia, and CEO Dr Bronwyn Evans said the report focusses on specific trends in the labour market for engineers.

Civil engineering job vacancies continue to dominate the Australian jobs scene.

“The awarding of major civil infrastructure projects has generated business for associated industries boosting the demand for civil engineers,” Dr Evans said.

NSW is the State with the highest number of advertised engineering vacancies in Australia, but levels have declined over the past year.



EA is the trusted voice of the engineering profession, delivering training, support, accreditation and representation to engineers across the globe.

WA, Queensland and Victoria also recorded high numbers of job vacancies for engineers in Australia, stated the report which analyses job vacancies data for 2019.

For Australia as a whole, however, engineering vacancies across the

economy have been on a downward trend for the 2019 year, stated the report.

“Thankfully, the trends show a recovery for engineering vacancies towards the end of 2019 and this is expected to continue in line with predictions for broader economic recovery,” said Dr Evans.

Engineers Australia provides a wide range of services to business, students, migrants and its members including technical journals, advocacy and statistical data, conferences and training and development activities.

WHERE WILL MEMBERSHIP TAKE YOU?

Fast track your professional development as a member of the largest and most diverse engineering body in Australia. Benefit from opportunities and networks designed to take your career to the next level.

LEAD THE
TEAM



Lead the team and together, we'll advance the profession. We deliver training and support tailored for engineers to help you advance your career. Join for access to exclusive networks with peers and employers.



ENGINEERS AUSTRALIA

BECOME A MEMBER TODAY.
WWW.ENGASU.ORG/JOINTHETEAM

Surge in mining jobs

NATIONAL

AUSTRALIA could be on the cusp of another strong rise in mining employment, and educational organisations such as the Engineering Institute of Technology are responding to this market signal with tailor-made courses.

According to the Australian Mines and Metals Association, there are \$41b of mining projects set to roll off the drawing board over the period 2020-2024.

These extra projects, if realised, could result in a rise of 20,000 jobs over the next five years and push the jobs total in the mining sector to 260,000.

Automation, digital communications and data processing are creating new skill areas that are in demand for mining companies that are seeking to sharpen their competitive edge in the global market.

The Engineering Institute of Technology (EIT) is a pioneering provider of automation and new technology courses in engineering that enable mining industry workers to update their skills in these rapidly-evolving job areas.

EIT's two-year Master of Engineering (Industrial Automation) focusses on skills and knowledge required in the latest developing technologies of instrumentation, process control and



An EIT technician in the computer area.

industrial automation. The degree includes practical guidance from industrial automation experts from around the world.

The qualification is accredited by the Australian government's Tertiary Education Quality and Standards Agency (TEQSA), which regulates and assures

the quality of Australian academic institutions, and is also accredited by professional body Engineers Australia under the Washington Accord.

EIT also delivers an 52708WA Advanced Diploma of Industrial Automation over an 18-month period which has a strong practical focus and is recognised by the International Society of Automation.

This program is also accredited by Engineers Australia under the Dublin Accord.

The course allows students to gain skills in the areas of automation, process control and industrial automation and is deemed suitable for electrical engineers and electricians, energy management consultants, project managers and production managers to name but a few.

The advanced diploma is also suitable for people with technical or trade qualifications who want to make their next career step, or those with substantial relevant experience wanting to formalise their achievements.

Some of EIT's courses are delivered online through live, online tutorials, and utilise remote laboratories, simulation software, and course materials that are accessible through its online Learning Management System.

EIT also has campuses in Melbourne and Perth.

Future proof your career with an industry focused engineering specialist.

We ensure our programs provide you with cutting-edge skills valued by employers globally and remain current with rapidly changing technology and industry developments.

Industry Relevance

Our live online short courses, diplomas and degrees are designed by an international body of industry experts in industrial automation, instrumentation and process control; data communications; electrical, instrumentation and power systems; mechanical engineering and plant design; and civil and structural engineering.

Unique Delivery

Our unique online delivery methodology provides you with access to cutting-edge simulation software alongside remote and virtual laboratories to test concepts and deepen your understanding of program content.

Dedicated Support

Our dedicated learning support officers and small class sizes encourage you to advance your technical knowledge and remain engaged in your studies while forming global networks.

Find out more at
www.eit.edu.au

EIT
Engineering Institute of Technology.

CRICOS Provider Number: 03567C
Higher Education Provider Number: 14008
RTO Provider Number: 51971

LOTUS FILTERS JOINS FORCES WITH EXHAUST EXTRACTION SERVICES IN FAR NORTH QUEENSLAND



Lotus Filters Pty. Ltd. trading as
EXHAUST EXTRACTION SERVICES inc. CAIRNS FILTER SERVICE
ABN: 83 002 694 600

RANGEHOODS • FILTERS
FANS • DUCTING

Phone
4035 3187 | **0408 700 682**

www.lotusfilters.com.au



AFTER many successful years of providing professional mechanical ventilation cleaning services, Lotus Filters has teamed up with Cairns-based Exhaust Extraction Services and Exhaust Extraction Australia in Townsville to expand their geographic coverage in Australia for their valued clients.

Cairns based Exhaust Extraction Services has built a successful business servicing clients across Far North Queensland, in particular focusing on Mining Sector clients and Accommodation Villages throughout Queensland and the Northern Territory and now with the capability to offer these professional services nationally.

Exhaust Extraction Services executive Mike Shipman has joined Lotus Filters as its manager for Far North Queensland. Mike has built up a reputation across the mining sector and with large catering providers who service mine sites as a trusted provider of these specialist services to remote locations.

Lotus Filters provide specialist kitchen exhaust cleaning services to a wide range of businesses that operate restaurants, fast food, fast casual dining venues, catering businesses, pubs and clubs, health sector including aged care, education facilities, hotels and food manufacturing facilities to name just a few.

The business tackles the important task of regularly cleaning extraction systems in kitchens to ensure they operate effectively and as designed. If left untreated these systems can pose a potential fire risk and hygiene hazard.

Lotus Filters and its new business partners will engage with clients to draw up a thorough plan for cleaning their kitchen exhaust systems that in turn provides them peace of mind enabling them to protect their brand and business reputation.

ESSENTIAL TASK



Kitchen exhaust systems carry out an essential task in removing unpleasant aromas and particles from kitchen environments, but they can quickly become dirty and a health hazard.

A build-up of grease and cooking fats in a kitchen exhaust system, or kitchen rangehood and canopy system can increase the risk of a dangerous fire.

All it takes is one small spark or naked flame to ignite accumulated grease and other flammable material in the system and the impact can be significant for the business.

PROFESSIONAL TASK

Cleaning kitchen exhaust systems is a professional task that requires special training and equipment and is subject to government regulation.

As a Lotus Filters customer, clients will be able to make informed decisions on risk management and compliance issues relating to the cleaning of their kitchen exhaust systems.

They will also be able to demonstrate their compliance with regulations on the proper inspection and cleaning of their kitchen exhaust system to landlords, insurers and councils.

And, they will have the reassurance as a Lotus customer that they have a regular and professional cleaning programme for their business.

Lotus Filters is a member of several trade and professional cleaning organisations that exist to raise industry standards and standardise training.

Its memberships include, the Australian Institute of Refrigeration, Air Conditioning and Heating, Fire Protection Association Australia, and the International Kitchen Exhaust Cleaning Association.

Exhaust Extraction Services has more than 30 years of experience in dealing with all aspects of cleaning kitchen exhaust systems for industry and corporate clients and has worked extensively in the mining sector specialising in their ability to service remote locations.

The firm has a customer-centred approach to its work and believes in providing an unparalleled service by up-skilling its staff and in keeping up to date with the latest industry accreditation.

PROFESSIONAL APPROACH

A professional cleaning company like Lotus Filters has years of experience in the field.

It has the operational capability to undertake regular cleaning work in a safe and efficient way with minimal disruption to its clients' business.

Staff at Lotus Filters are trained to high Australian safety standards and receive ongoing training to keep their skills and working methods up to date.

For example, the company has accreditations for undertaking work in confined spaces and at heights, first aid training, and are familiar with various compliance systems and site induction training requirements.

FOR MORE INFORMATION: Visit www.lotusfilters.com.au
email enquiries@lotusfilters.com.au or contact Mike today to discuss your needs on 0408 700 682.



An example of Minesite Furniture products.

Specialists in minesite furniture

NATIONAL

MINING companies seeking to modernise or equip their living and working accommodation to the highest standard for their staff at competitive prices can find a one-stop solution at Perth-based company Minesite Furniture.

It specialises in providing furniture specially suited to the challenging environment of a minesite and which uplifts the living and working conditions of staff members.

Minesite Furniture can offer a bespoke solution to mining companies seeking to equip new accommodation units or for companies looking to upgrade existing facilities to a new level.

The company takes a thorough approach to working with its clients to ensure their requirements for minesite furniture are fully met to their highest satisfaction.

Taking pride in its personalised approach to its clients, the company has knowledgeable experts in the furniture trade who can identify a client's needs and discuss their objectives for a fit-out project.

Minesite Furniture has developed its own, unique approach to serving its customers' needs by applying its Four-Step Camp Upgrade Solution process.

Starting with an outline concept, Minesite Furniture engages with its clients to understand their ideas and goals for their accommodation sites, and to cover every aspect of their furniture needs.

This involves the company's minesite furniture specialists meeting with mining company executives to discuss their furniture needs and desired outcomes for their project.

Once an understanding of client needs is achieved, the company moves on to the design stage and lays out interior designs for accommodation using computer-assisted 3-D software.

When an agreed design is achieved, the furniture specialists deliver on-site the complete furniture package to a mining company's operational area.

Partnerships the company has with freight and logistics companies in Perth mean that Minesite Furniture has some of the lowest transport costs in the business.

Installation of the custom-made

furniture at the mine site by specialised teams completes the four-step process.

With years of experience behind the firm, the company can accommodate the widely different needs of individual clients in terms of the size and scope of a fit-out.

Minesite Furniture staff have an intricate knowledge of the challenges of different minesites and are able to apply furniture solutions that are tried and tested in the field.

Minesite Furniture's product offering covers the full spectrum of minesite furniture needs.

The company's large stock range can cover fit-outs for living accommodation, dining and crib rooms, through to changing room facilities, offices and recreations rooms.

Desks and office chairs, filing cabinets, dining tables and chairs and benches and lounge booths can be chosen from the Minesite Furniture offering to suit a client's business requirements.

There are also items for outdoor use such as utility picnic settings, and plants and trees to complete the styling package for mine site accommodation areas.

The furniture offered by Minesite

Solutions is stylish, durable and high quality and automatically comes with a warranties for up to 10 years.

Minesite Furniture sources its range of furniture from a wide range of suppliers both in Australia and overseas including Europe.

Tailor-made furniture solutions for mining companies have a significant upside, not only financially.

The Minesite Furniture solutions package can boost workforce morale and mental health, and enhance the aesthetic environment contributing to a productive and cheerful atmosphere.

Mining companies know that a pleasant working and living environment for their staff is a major contributing factor to sustaining staff productivity and good health in remote environments.

Buying direct from Minesite Furniture means that companies and clients can save costs by avoiding marked-up prices offered by commercial retailers.

Products supplied by the company come with a lowest price guarantee meaning that Minesite Furniture will beat any published price for similar specification furniture by 5pc.

MINESITE FURNITURE

08 9350 2870

✉ sales@minesitefurniture.com.au

🌐 www.minesitefurniture.com.au

📍 1/9 Pilbara St, Welshpool WA 6106

THE COMPLETE CAMP UPGRADE

IMPROVING LIVING CONDITIONS, MORALE AND THE MENTAL HEALTH OF YOUR WORKFORCE



Minesite Furniture has years of experience in assisting mines of all sizes fit out and update their furniture.

Covering all of your needs from Cribroom and Office through to Lockers and Accommodation you can rely on us for quick supply of high quality furniture which will look

great as well as stand the tests of time and constant use.

As Australia's largest stockist, we can get it to you as soon as you need it and with substantial warranties on all of our products you know that you can rely on all of our products to stand up to the harshest conditions.

CONTACT: BARRY VERMEULEN

Stoddart has the kitchen know-how

NATIONAL

STODDART produces innovative stainless steel and metal products for the architecture, building and food service industries and cater for clients across Australia.

The Queensland-based company's extensive range of quality products provide the finishing touches to many of Australia's most awarded and iconic restaurants, facilities, hotels and buildings.

Stoddart's architectural products include, architectural metalwork, metal fabrication solutions, benching and cabinetry, plumbing fixtures, shelving and storage, outdoor infrastructure and street furniture.

The family-owned company is also at the forefront of the design and manufacture of practical and decorative kitchen equipment and produces both custom-made and standard metal and stainless steel products.

The firm's food service products include items for cooking, countertop, food holding and display, handling and distribution, plumbing fixtures, refrigeration, shelving and storage, and ventilation and exhaust equipment.

Stoddart has three manufacturing brands of its own kitchen equipment – Culinaire, Visualine and Woodson – and two internationally-recognised brands manufactured under licence.

The company's other exclusive brands include Electrolux Professional, Halton, Metro, Simply Stainless, American Range,



Stoddart stainless steel kitchen equipment.

Asado, Adande, Koldtech, Anets, and CookTek.

Stoddart has a state-of-the-art 25,000sqm manufacturing facility at Karawatha in Brisbane, and services clients through its warehouses and sales teams in Adelaide, Melbourne, Perth and Sydney.

All of the company's products are supported by Stoddart's unrivalled team of equipment specialists.

From sales to service, Stoddart staff combine integrity with technical excellence. Stoddart's products are sold nationally through a network of valued distributors.

This network of over 200 retailers and contractors means that all customers receive the right support in their own area.

For more details, or to book a demonstration in any of their fully functional showroom kitchens throughout the country, contact Stoddart on 1300 79 1954 or www.stoddart.com.au

6 VITAL TOOLS TO GROW YOUR BUSINESS

Our Mining Business Development Package has helped businesses like yours, across a range of industries, to form relationships with key decision makers on Australian mine sites.

The 12 Month Package includes:

- Access to our Mines Database (Provides details for Key decision makers across 400 mines)
- Social Media Blast to over 7000 followers across all Publications & Exhibitions platforms
- 12 hard copies of The Australian Mining Review (monthly), including The Australian Oil & Gas Review
- Weekly Mining Report (Carefully researched, real business opportunities)
- Weekly Mines Activity Report (Operational Activity specific to Mine Sites)
- Directory listing on Mine Suppliers Online



Advanced shotcrete services

NATIONAL

REDPATH has been providing full service mining solutions and innovation around the world since 1962.

With a foundation built on global experience, adaptability and exceptional workmanship, Redpath leads the industry with cutting edge innovations in safety and mining practices.

Services including underground construction, shaft sinking, raiseboring, contract mining, mine development, engineering and technical services and a variety of specialty services to the metalliferous and coal mining industries.

Global experience has given Redpath expansive regulatory knowledge, regional expertise and cultural sensitivity.

Redpath utilises advanced shotcrete methods including laser scanning, simulator training, AGI sonar devices, and Lean management principles, while maintaining exceptional safety and production standards for clients.

In Australia alone, Redpath maintains and operates five batch plants, and currently applies more than 15,000m³ of shotcrete every month.

Redpath is highly capable of offering a range of shotcrete services, across all



Redpath uses advanced shotcrete methods in all its operations.

divisions including metalliferous, raisebore and coal operations.

The company is ISO 9001 accredited and a leader in innovation, with the experience and expertise to find the most cost effective and productivity driven packages for all our clients.

Redpath provides a modern fleet with a well-established team of specialised technical

personnel to all its operations.

This approach has enabled it to provide a consistent and supportive role for their clients, accommodating all their underground requirements.

Its technical capability combined with the philosophy of 'consider it done — safely' ensures that each client receives the personnel and equipment necessary to

provide a comprehensive and reliable service across the life of the project.

Redpath has built a solid reputation for conquering tough challenges, and adapting to a variety of environments.

Redpath's employees are the heart of the company's success and it remains through them that the company continues to expand and flourish.



Providing **FULL SERVICE** mining solutions and innovation around the world **SINCE 1962.**

EXPERIENCE

AFRICA | ASIA | AUSTRALIA | EUROPE | NORTH AMERICA | SOUTH AMERICA

- Shaft Sinking
- Mine Development
- Contract Mining
- Raiseboring

- Underground Construction
- Engineering & Technical Services

- Specialty Services
 - Mechanical Excavation
 - Shotcreting & Ground Consolidation



Mining Contractors and Engineers

Consider it done — safely.



redpathmining.com

Saving eight million litres of water a year



The SlurryPro Elite, is a completely flushless seal.

NATIONAL

GLOBAL Pumps' new mechanical seal, the SlurryPro Elite, is a completely flush-less seal that doesn't require any form of seal flush water to stay lubricated.

Based in South Australia, the company supplies mines and industry around the world with innovative pumping technology.

Global Pumps' new seal, the SlurryPro Elite, can be retrofitted into all existing pumps and will eliminate extraneous gland water pumps, water injecting, contaminated water storage and constant management issues.

The addition of the seal will also reduce unplanned downtime of the slurry pumping process on sites.

The secret to the design is explained by Global Pumps' Sales Director Darren Seeley.

"A patented conical design, engineered in Italy, circulates the slurry around the seal, and uses the slurry itself as the cooling mechanism," he said.

"The aim is to eliminate the flow-off effects and band aid solutions being implemented on sites to maintain current sealing methods."

Global Pumps' SlurryPro Elite removes the multiple requirements of leaking glands including the safety aspect of regularly tightening gland packing on live equipment; addition of gland water distribution through the slurry pump; and the need for removing the water further down the process stream.

Eliminate the extras

With the SlurryPro Elite, Global Pumps has removed the undesirable flow-on effects of the slurry process.

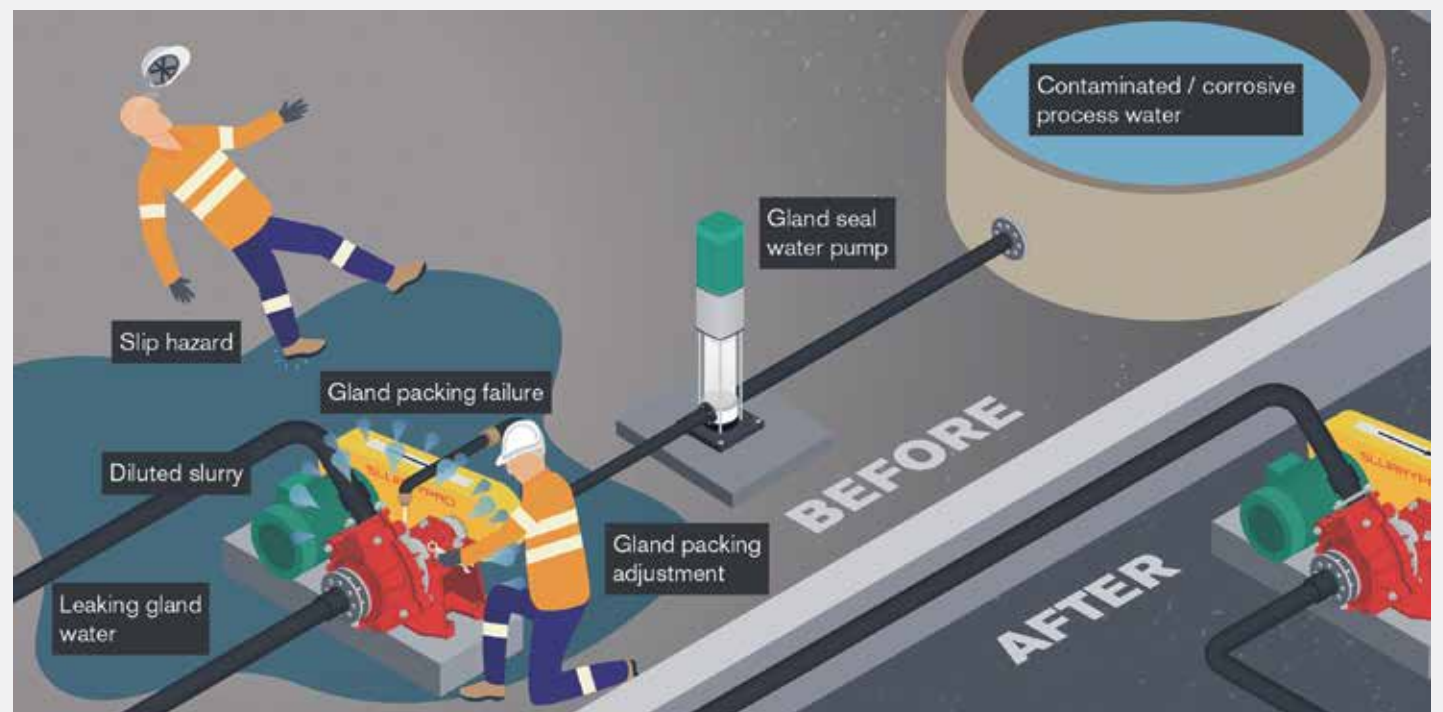

Global Pumps' system eliminates the negative flow on effects of slurry pumping.

In a traditional slurry pump, using either a gland pack or a regular mechanical seal, flushing water needs to be sourced from a dam or reservoir on site or transported and piped from elsewhere.

This separate source of water is injected into the pump and consequently dilutes the slurry.

In some cases, this water also leaks out from the back of the pump, creating an environmental and health and safety hazard. Slurry pumps are typically mounted in a bunded area containing a sump pump which runs to extract the leaking gland water, consuming energy.

Most of the gland water ends up in the slurry stream which must be later removed or evaporated. The SlurryPro Elite seal does

not require an extra source of process water, removing the entire piping infrastructure, clean up and storage process.

Water is the new gold

In current dry conditions, mines have limited access to our precious resource. The injected water that is required to flush the gland packing or traditional mechanical seal needs to be sourced from somewhere.

A lack of regional water has resulted in a competition between mines, farmers and towns for the sparse resources available,

especially in Queensland and NSW.

The search for water is affecting mining around the world, not just Australia, exacerbated by the fact that mining tends to occur in the driest and most extreme landscapes.

Water has become a prime and growing concern for mining companies – it is the new gold. Anglo American Chief Executive Mark Cutifani and Gold Fields' Chief Executive Officer Nick Holland are among those who have expressed concern over water shortages.

"Investors say to us: 'don't talk to us about returns'; they want to know how we're managing water," Mr Holland said.

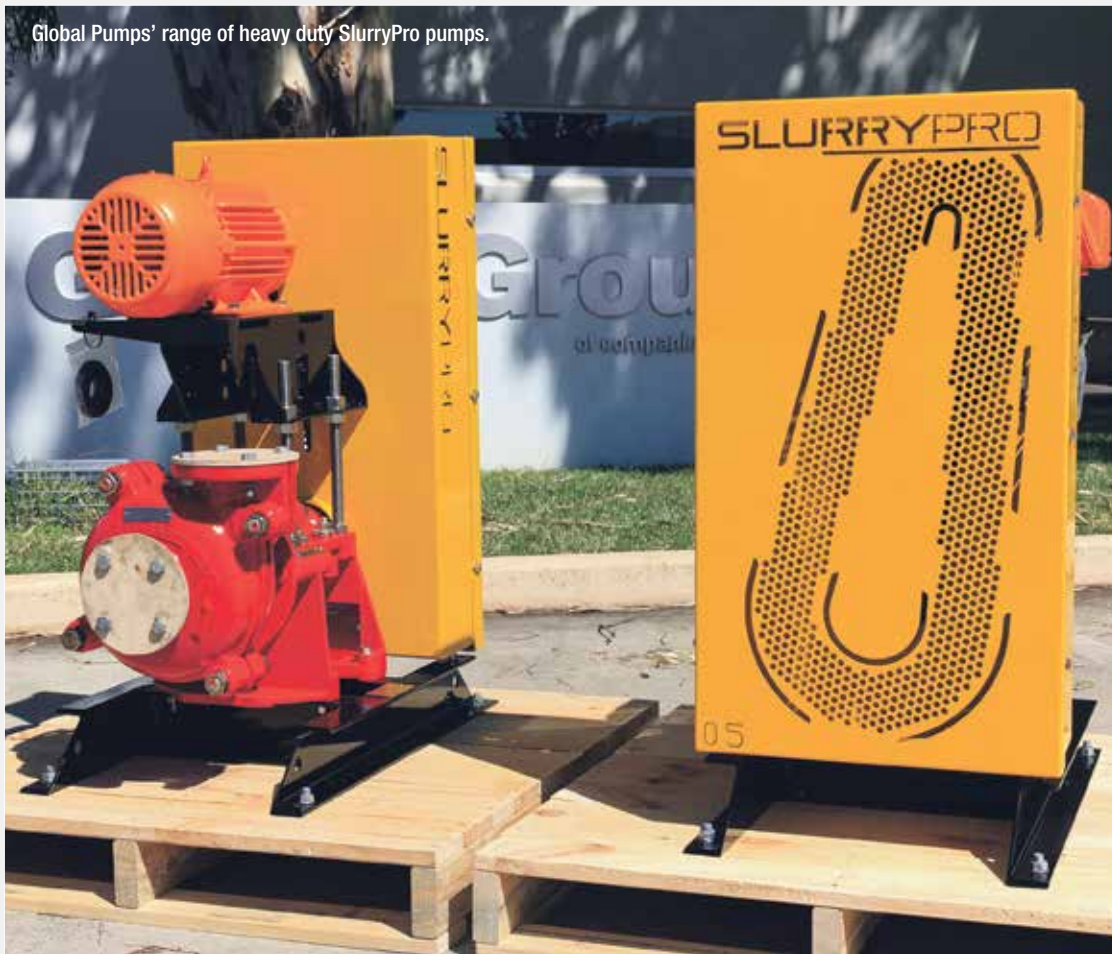

Inside the SlurryPro Elite mechanical seal.

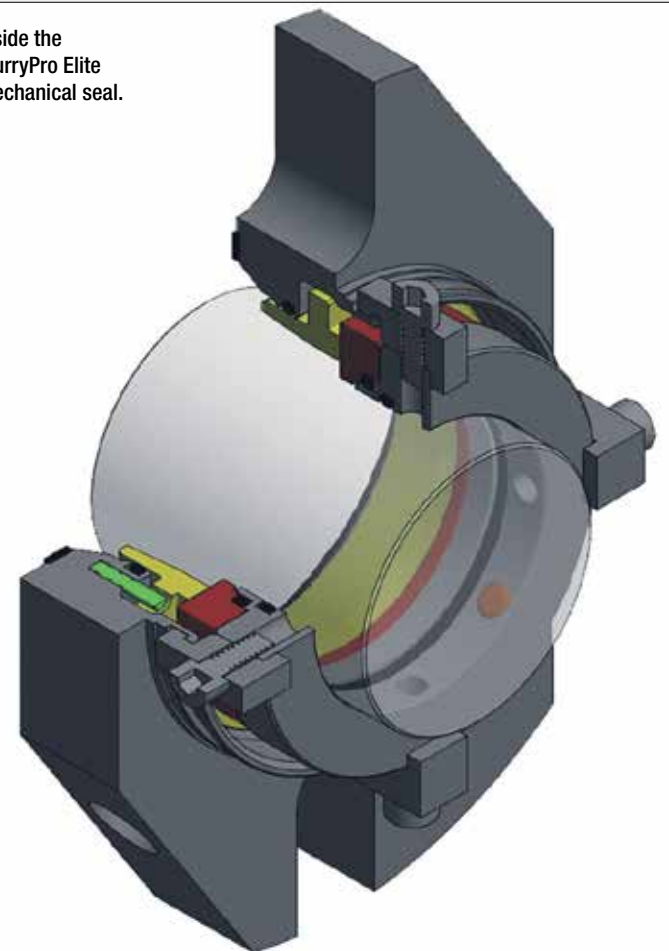

Reassuring investors

Without a SlurryPro Elite seal, a small 3" slurry pump requires a minimum of 15 L of water per hour, equating to 7.884 million litres of water annually and mine sites typically run much larger pumps and multiple of them.

In those quantities, water is one of the greatest constraints to new supplies of mined products across the industry. Installing a SlurryPro Elite can give investors the assurance that water usage in the slurry process will be minimal and will not affect production of the overall mining project.

As the junior mining model begins to look shaky, the introduction of technology that can greatly reduce water consumption is a definite incentive for investment in the project.

Less water, less downtime, smaller footprint

On site, limited access to fresh water not only adds to production and operational expenses but can cause delays in the slurry process - setbacks mitigated with the installation of the SlurryPro Elite.

The water that mines are allocated or can source is often contaminated or of poor quality.

The poor water quality introduces further complications to the pump, affecting the reliability and contributing to pump corrosion.

"Because they are injecting dirty water, miners say that the substandard water quality leads to premature shaft sleeve failure," Mr Seeley said.

With the installation of the new seal into existing pumps, mining operations can immediately experience savings in water, increased safety and reduced maintenance..

Technical talk

The main point of difference for the SlurryPro Elite is the design of the seal faces.

Gland packing is still used in many pumps due to its low initial outlay, however when you factor in the ongoing maintenance, scheduling,

lock out, downtime and loss of production, a repack can become quite expensive.

Mechanical seals result in limited downtime, very low leakage and greatly reduce environmental impact.

They consist of mechanical mating faces that stop the slurry getting out rather than a rope that hugs the shaft tightly.

As opposed to gland packing, users will find fewer bearing failures from leaking fluid, no excessive wear on the shaft sleeve from packing, no continual adjustment and a safer workplace.

Global Pumps' SlurryPro Elite is a mechanical seal with a difference.

The fact that it does not need flushing water has transformed the entire slurry pumping process.

The construction of the conical seal faces is silicone-carbide with diamond coating.

As we know diamond is the hardest material in the world, meaning it has the greatest resistance to abrasion.

Diamond also has an extremely low coefficient of friction and is an exceptional conductor of heat.

To put this into context, its heat transmission is four times faster than copper. That means that, not only does it generate less heat in a dry run scenario, but it can quickly dissipate it.

The combination of the patented conical face design doubled with the properties of the diamond coating result in an innovative seal that requires no extra liquid lubrication beyond what the slurry itself provides.

In summary, the patented conical faces allow greater circulation around seal faces, they increase the misalignment tolerance, produce very high thermal conductivity and a faster disbursement of heat during dry running.

The SlurryPro Elite does not require flush water, has an extended life span and is easily and quickly repaired.

A wise investment

The initial capital outlay will result in dramatic reductions in the site's water usage and environmental footprint.

INVESTMENT OUTLAY

GLAND PACK	SLURRYPRO ELITE SEAL
Three pumps – The Slurry pump, seal water pump & cooling water pump	Slurry pump + Elite seal
Gland packing	
Man-hours to check & tighten gland packing regularly	
Man-hours to repack pumps	
Maintenance on multiple pumps	
Water x11 millions of litres a year	
Transport and piping for water	
Engineers, construction crew, planners and operators for above	

SYSTEM PROCESS

GLAND PACK	SLURRYPRO ELITE SEAL
Slurry runs through pump	Slurry runs through pump
Process water is injected into slurry pump to lubricate gland packing	
Contaminated process water corrodes the pump faster	
The gland packing needs to be tightened regularly	
Pump needs to go offline to repack	
The glands leak	
Leaking water needs a sump pump to remove it	
The bund floor is now wet with leaking gland water	
Water needs to be sourced, transported, piped and pumped from somewhere to inject into the slurry pumps	
A small 3" pump requires 15l of water per minute = 7.884m l of water in a year	

WHY INSTALL A SLURRY PRO ELITE?

Less water: at least 7.884 million litres of water per pump not needed.

Less time pump is offline

Less costs in maintenance

Less costs in infrastructure

Less costs in Pump purchases and maintenance

The installation of the SlurryPro Elite will offer long-term benefits across operations.

Retrofitting to all brands of pumps is part of its value, as the only investment that needs to

be made is the seal itself.

Global Pumps will come on site and discuss how the SlurryPro Elite can make your slurry process safer and easier.

SAVE WATER, SAVE MONEY





Stack the odds in your favour

Replacing wet tailings dams with dry stacking minimises environmental risks.

NATIONAL

HEIGHTENED risks associated with wet tailings dams, as well as cuts to water allocations in mining projects, impelled FLSmidth to seek a solution to dry tailings systems that would be cost efficient for larger mines.

The solution it developed, with a functioning system currently operating in an iron ore project in WA, is economical for mines with a throughput of more than 30,000t of dry stack tailings a day, and can also be applied to mines with lower production levels.

Dry tailing systems cut costs and risk.

The elimination of wet tailings dams and the re-use of process water on the site minimises environmental risks to the community, cuts complexity and helps mining companies attain a social licence to operate.

The FLSmidth solution offers a full dry stacked tailings system which is technologically feasible for large scale operations and provides recovery of 85pc to 95pc of process water.

This is economically competitive with desalination, even for high tonnages.

Water efficiency

Seventy percent of mines operated by the major mining companies are located in countries where water stress is considered a major risk.

The ability to reuse and recycle water in the mining process leads to substantial savings by minimising the amount of make-up water needed for the mining operation.

The total cost to ownership of the mine's lifetime is easier to estimate and the process is cost competitive with the operation of a dry stacking tailings facility.

The dry tailings solution, processing about 10,000t per day of whole tailings, allows the mine to operate with a water make-up ratio of



The modular conveyor can be elongated or reduced to suit production.

0.2m³/t, compared to traditional sand dams that have a ratio of 0.7m³/t.

Fresh water intake has been reduced by more than 70 pc with the FLSmidth tailings system.

Geological advantages

The company has also developed EcoTails, a solution that blends filtered tailings with waste rock in transit, producing a geotechnically stable product branded GeoWaste.

This resulting product is easy to convey and has a high strength when stacked, making it resistant to seismic activity.

The thickened tailings solution uses a high-density thickener which results in 50 to 65pc solids.

This allows water to be recovered in tailings

prior to disposal and enables the recovery of higher volumes of water.

(Much) smaller footprint

The dry stacking system has three main purposes: to reduce water use; to create a much smaller footprint; and to reduce the risk and the environmental damage that is often a by-product of a tailings dam.

The current iron ore operation has an area of 2km x 2km allocated for the tailings.

This area is based on the amount of water provision available to the mine project, and the life of the mine.

An equivalent area for wet tailings would be more than 52 square km, a 92pc reduction in the tailings footprint.

As well as saving water and space, the smaller tailings footprint means improved site rehabilitation potential.

The dry stack layout design has unique elements including the inter-dependence of the stack configuration, the conveyor and stacker design.

This design has many advantages.

The initial and overall footprint is minimised.

Stacker downtime from changeovers is reduced dramatically.

The system sequence improves the aerability of the material by profiling the stack as it layers.

This maximises evaporative drying and the improves density of the stacked tailings lowering stacker and conveyor costs.

The stack can reach up to 90m high, built in three layers.

The first layer reaches 25m, the second 28m and the balance (37m) is used for the last level - all within the 2km x 2km area.

The comparatively tiny footprint is clearly a major advantage over the wet tailings system.

The tracked machine also compresses and compacts the material as it travels across the stack.

The environment of the project, in WA, is predominantly evaporative and the consistently high temperatures facilitates better evaporation and drying of the product, which then settles and stacks better.

Progressive reclamation and rehabilitation to manage dust is also made easier with this system.

The equipment

FLSmidth's system uses advance stacking rather than retreat stacking, which has the advantage of compressing the stacks as it layers.

(CONTINUED OVER)



Stacks fit into a 2km x 2km footprint, layered up to 90m high.



The dry tailings can process 10,000t per day.



(CONTINUED FROM PAGE 93)

All the sections of the conveyor are modular. They are moveable and detachable, which allows the operator to elongate the system as required.

This is useful for times when production levels change such as plant shut-downs.

Two stackers are available, the Compact Spreader and the C-Frame Spreader.

The Compact is the smaller of the two with a capacity of 15,000t per hour.

Its receiving boom reaches up to 50m, with a 50m discharge boom and lift/bench height of up to 20m.

The larger C-Frame has a capacity of 22,000t

per hour, a receiving boom measuring up to 70m, and the discharge boom up to 100m.

The lift/bench height is up to 35m.

BulkExpert mobile stacking technology can be added to the system to ensure a smooth operation, eliminating operator errors and reducing dozer work.

It calculates precise stacking to a reference height with RTK GPS data accuracy to 2cm.

The GPS identifies the discharge point and velocity of the pile build-up, then sends a speed output to the stacker based on the difference of reference height and actual pile height, also taking into account the velocity of the current pile build-up.

A proprietary guidance system tracks the modular system, backed up by a 24-hour support team.

The automatic stacking conveyor will customise the stacked area profile, with GPS ensured stacking height, compensating for incoming volume.

The system also includes 2D real time material discharge measurement and controlled speed reference to the stacker.

Any effects caused by variances in the material flow are removed.

A 3D laser scanner scans the surface, creating a full terrain map.

Adding automation and GPS technology to the system can keep maintenance and servicing issues to a minimum.

The proprietary guidance system tracks the modular system and is backed up by a 24-hour support team.

FLSmidth provides a full range of support for installation, training of operators, re-commissioning, change-out or expansions and parts refurbishment.

These are conducted at the local workshop in Perth and via 24/7 technical support.

The successful design, commissioning and operation of the facility in WA has demonstrated for the company that this is a viable disposal strategy for other mines in similar conditions.

Source: Alex Bozward, FLSmidth.



FLSmidth provides a solution to dry tailings systems that that is cost-efficient for larger miners.



Ensure the correct tailings solution for your requirements

Tailings management is changing. But we know each mine site has unique characteristics so there is no easy, one-size-fits-all solution. That's why you need an experienced partner with a range of tried and tested tailings solutions.

There are obvious benefits from partnering with the only OEM with complete dewatering, material handling technology and co-mingling solutions in-house. It means you get a complete "evaluation partner" when it comes to selecting the right high performance dewatering and transportation solution for your specific location

and requirements. We perform technology trade-off studies to help you implement the most suitable processes and technologies that improve safety, reduce risk and minimise the environmental impact of your operations.

[FLSmith.com/tailings](https://www.flsmith.com/tailings)

WE DISCOVER POTENTIAL

Casting for quality



NATIONAL

CASTINGS Tasmania puts a high premium on the quality of its products, and its commitment to excellence is evident in the company's attention to detail throughout the metals casting process and in its foundry services.

Indeed, foundry services are at the heart of Castings Tasmania's business and the company has invested heavily in new technology such as 3-D scanners and modelling and graphics software to upgrade its processes.

High-technology production methods ensure the Launceston foundry's steel products remain of superior quality in a competitive market.

Castings Tasmania general manager Chris Smart said product quality is an important consideration both for the company and its high-end customers.

"We make high quality castings that people are prepared to pay a premium for," he said.

Castings Tasmania's steel products make their way into many sectors of Australian industry from transportation to mining,

The company has manufactured parts for Australian public transport and has cast rigging gear for dragline excavators.

These steel castings are required to have a high tensile strength and durability.

Quality is maintained right through the metal casting process by the company's technical experts, who carry out extensive metallurgical tests on its steel products during the whole manufacturing process.

Castings Tasmania technical manager Matthew Whittaker said the foundry undertakes a comprehensive range of tests on metal castings prior to and after metal pouring to guard against any potential defects.

"We do a wide range of testwork depending



Some of the Castings Tasmania team.

on the customers' requirements," he said.

"We perform in-house chemical testing with an optical emission spectrometer, in-house ultra-sonics, magnetic particle inspection and dye penetrant testing."

Checks are undertaken both before and after metal is poured into moulds.

Production lines

The metals casting process in the foundry involves a series of intricate steps.

Every step has to be completed to a high standard to ensure the final steel product exactly meets clients' specifications.

Starting with the creation of a pattern or model, through to metal pouring and on to finishing and polishing, the final product has to be flawless.

At the design stage, Castings Tasmania uses state-of-the-art technology.

This includes an Artec Leo 3-D scanner so that foundry staff can quickly build a digital representation of any casting in prototype form.

SOLIDCast software at the foundry simulate different metal pouring scenarios, so that staff and customers can visualise the end product in digital form.

On top of these software process improvements, the company maintains extensive quality checks from the beginning to the end of production.

Prior to its pouring, molten metal is analysed to ensure that the casting has the correct level of strength and grade as required by the customer.

The company operates two different production lines in its foundry workshop.

"We have two areas where we pour castings," Mr Smart said.

There is a fast loop area, an automated production zone for mass-produced steel, and a

jobbing floor which carries out one-off and larger castings.

High quality Tasmanian sand is used as the basis of moulds for metal castings and is tested to ensure it is strong enough to hold several tonnes of metal.

Another locally-sourced material used in the foundry is aluminium, which is used at a Tasmanian smelter and is used in the steel de-oxidisation process.

The foundry has the capacity to melt up to five tonnes of metal at a time, and its largest casting to date has been four and a half tonnes.

The annual melting capacity of the foundry is 3500 dressed mass tonnes.

The foundry will trial new castings to develop a prototype before going into full production.

"If it is a new casting, or if we have never made it before, we have a controls procedure whereby we will make one or two trial castings to make sure they are acceptable to the customer," Mr Smart said.

"Then we will go into full production."

Castings Tasmania's new owner, Recycal Group, provides the majority of the foundry's feedstock from its recycled scrap metal business.

Steel scrap is heated to a temperature of 1600 deg Celsius, before various alloys are added to produce steel with certain characteristics.

"We melt the scrap and then we add whatever we need to get a certain metal specification, such as nickel, high carbon chrome, etc," Mr Smart said.

After the steel is melted to a molten liquid it is ready for pouring and is transferred to one of the two metal casting production areas in the foundry.

"The metal comes out of the furnace in a ladle and is moved on a trolley to either the fast loop or the jobbing area and is then poured into moulds," Mr Smart said.

Once the metal is cast, it is left in its mould for up to 24 hours to allow the product to cool, and the next stage is the after-cast process.

"The casting goes through a shake-out process that takes most of the sand from the casting," Mr Smart said.

"Then it goes through a shot blast to take the last of the sand off it."

A power hammer or oxy-cutting is used to remove the metal casting's feeders that assist when pouring metal into a mould.

The product then goes through a heat treatment stove up to 1100 deg Celsius.

At the finishing stage, the metal casting is put through a quenching process using either air or water.

It is then subjected to welding and grinding, and is painted if required.

Further testing is carried out on metal products post-casting to ensure they meet customer specifications including such tests as magnetic particle checks.

Long history

Castings Tasmania has a long and illustrious history that stretches back to 1833, and the firm has played a role in many chapters of Australia's history, including the two world wars.

This long tradition means the company has many experienced workers, some with decades of service, who can cast almost any type of ferrous metal product.

Fifty-five workers are employed at the foundry in its castings production.



Metal being poured into moulds at the Castings Tasmania foundry.

The foundry is always on the lookout for new applications for its steel products and has had some customer interest from the aquaculture sector.

"We have had some interest from salmon farms in Tasmania for mooring rings that in effect are anchors for fish pens," Mr Whittaker said.

"Historically they have used products from

China or welded steel pipe together.

"Having one single piece cast in Tasmania from 99pc recycled materials has really impressed our customers in terms of its sustainability."

Another alternative market for its metal products in the longer term could be the heavy vehicle market.

The company is also investigating expanding its line of stainless steel products.

Recycal Group, which took over Castings Tasmania in 2019, has invested heavily in new technology for the company including in 3-D modelling and scanners to increase the foundry's production efficiency.

MORE INFORMATION: Castings Tasmania | 03 9873 1133 | chris.smart@castingstasmania.com.au | www.castingstas.com.au

Moving forward with every *Cast*

building Australian industry with state-of-the-art equipment

- ✓ Over 100 years of history
- ✓ Support base in each state
- ✓ Working together to bring you quality on time castings

Quality Australian made steel and iron castings.

03 6343 1570 | www.castingstas.com.au





Breaking new ground

A rotary cutter undertaking profiling work.

NATIONAL

ALTERNATIVES are fast emerging in the mining industry to traditional drilling and blasting methods used to loosen and dislodge rocks in surface and underground operations.

One of these is the Italian-made SIMEX twin header rotary cutting machine, which has many advantages over traditional drill and blast methods.

Twin header rotary cutters are also known as rock grinders, as this aptly describes their use in dislodging and extracting material in quarries and mines.

SIMEX is widely acknowledged to be the market leader in rotary cutting machine technology, which has been specifically developed for the tough conditions of the mining industry.

The cutting machine may also be employed in the construction, demolition, tunnelling and wall profiling industries, making it a versatile tool.

Italy-based SIMEX has been at the forefront of designing and manufacturing highly durable and high performing engineering products to solve specific problems in the mining sector.

The twin header rotary cutter uses special patented technology, with high torque that can bore through the toughest of material.

The product has several other impressive technical features worth mentioning.

Maximum cutting force for the rotary cutting machine varies from 13.5 to 114.5KN, depending on the specific model.

An integrated high displacement hydraulic piston motor in the rotary cutter ensures high torque and high performance is consistently



A SIMEX twin header rotary cutter.

maintained during its deployment.

A filter on the feed line of the rotary cutter prevents impurities from entering the machine's motor system.

Gaskets fitted to the rotary cutter's drums guard against dust while the machine is working in the ground.

The rotary cutter also features double support bearings for each of drums to ensure a longer service life for the machine, as its shaft system transmits only motion and bears no load.

Replaceable anti-wear plates are a low cost in terms of the machine's maintenance.

Dedicated service by authorised dealer network

Brisbane-based firm RDW is the exclusive importer and distributor of SIMEX technology in Australia.

RDW has appointed a dedicated Australian SIMEX dealer network that has ready access

to genuine parts and a wealth of operational knowledge and experience to ensure SIMEX equipment continues to contribute to customers' profitability for their entire working life.

The network includes Walkers Hammers in Victoria, Groundtec in NSW, QLD Rock Breakers (QRB) in QLD and Northern Territory, Total Rockbreaking Solutions (TRS) in WA, RAM Equipment in SA and DLM Machinery in Tasmania.

QRB product specialist Arthur Lewis said the mining machine is inherently adaptable.

"It can operate in all weather conditions and when vibration and shock waves from a blast is not acceptable," he said.

"The SIMEX twin header rotary cutter can also be used under water."

In addition to creating noise emissions and shock waves, drilling and blasting at mine sites can be a time-consuming and costly business for operators.

It can take considerable time to drill the necessary holes at a mine site in preparation for placing explosive charges into them ahead of blasting.

Then it can take additional time to clear a mine site of personnel to allow the blasting operation to proceed safely, and afterwards, once the blasting has occurred and the workforce can return to work.

Furthermore, use of the two-stage traditional mining process can be limited by terrain and topography, weather conditions, and safety considerations in the case of restrictive and difficult to access areas.

Fast set-up

The SIMEX twin headed rotary cutter has a relatively fast set-up time allowing it to be quickly deployed, even in difficult to reach mining locations, and it has many in-built safety features.

The SIMEX rotary cutter can be put to work in underground mining areas with tunnels, and in highwall mining in surface or open-cut mining.

Noise emissions from the rotary cutter are relatively low when compared to other mechanical

mining machines and other methods of extraction, Mr Lewis said.

A twin-headed rotary cutting machine is usually transported using a carrier machine, allowing the equipment to be easily moved around mine sites to different working areas.

There is the option of transporting the rotary cutting machine on carriers ranging from 2.5t to 70t depending on the requirements for the machine.

Significant time savings are possible with the SIMEX twin header rotary cutter.

"The time saving is in set-up and removal from job to job," Mr Lewis said.

In addition, a rotary cutter is suitable for removing smaller quantities of material left behind by traditional mining methods.

In this situation, the costs of drilling and blasting can be prohibitive, relative to the amount of material extracted, or the working area in the mine may be too restrictive to carry out blasting at close quarters.

"In underground and open-cut mines where small quantities of material need to be processed, this can sometimes be when a pocket of material for example coal is left behind after traditional open-cut mining," Mr Lewis said.

The rotary cutter can also tackle tunnelling work and performs well at wall profiling work at building sites or basement digging, allowing the technology to be used in the construction industry.

Another market-leading feature of the SIMEX twin header rotary cutter is that its hydraulic system is fitted with accumulators that act to protect the unit from hydraulic pressures while the unit is in operation.



A SIMEX twin header rotary grinder.

MORE INFORMATION: RDW | 07 37150800 | exc@rdw.com.au | www.rdw.com.au

SIMEX innovations
improve efficiency, safety
and reduce waste



TWIN HEADERS - minimal
vibration and low noise levels

SIMEX at
DDT Expo,
sites G18,
G25 & G26

SIMEX
Dealer Network

NSW

Groundtec Equipment
(02) 9642 2030
groundtec.com.au

WA

Total Rockbreaking Solutions
1300 921 498
totalrockbreaking.com.au

VIC

Walkers Hammers
(03) 9315 3788
walkershammers.com.au

SA

RAM Equipment
1300 726 000
ramequipment.com.au

QLD / NT

QLD Rock Breakers
(07) 3715 0800
rdw.com.au

TAS

DLM Machinery
(03) 6339 1550
dlmmachinery.com.au



The Trelleborg Brawler Soft Ride is changing industry expectations around the use of solid tyres.

Easy rider

NATIONAL

TRELLEBORG Wheel Systems is a leading global supplier of tyres and complete wheels for heavy machinery in the mining, construction and agricultural industries offering specialised solutions to improve operations.

Available throughout Australia, Trelleborg tyres bring efficiencies to mining operations through advanced technology that keeps

machines on-line longer.

Among the most popular products is the Soft Ride series of solid OTR tyres, which uses an exceptional rubber compound that marries the best properties of both solid and pneumatic tyres.

The material is both tough and durable, yet without the rigidity associated with a solid tyre.

It absorbs vibrations and offers a soft comfortable ride.

The innovative tyre technology ensures lower punctures and cuts, lower vibrations for operators and a range of other benefits.

The mining industry, especially underground, presents a range of challenges for heavy machinery.

The ground surface of underground mines can pose hazards for tyres and they must be engineered to handle heavy load, and excessive conditions that are part of the job.

Trelleborg has created a tyre compound is extremely resilient and sturdy and ideal for these conditions.

Downtime is reduced as the usual hazards and damage to tyres do not occur.

Tyres do not need to be repaired or changed as frequently so outlays are lowered, and production is increased thanks to less interrupted operating hours.

For drivers operating machinery over long shifts, the tyres also provide an easy drive which provides health and safety benefits.

The company partners closely with Original Equipment Manufacturers (OEM), ensuring the tyres fit the wheels of the equipment and safety standards are adhered to.

The Brawler has two basic designs: the HPS which can be pressed onto a standard flat-based multi-piece wheel, and the HD which has been moulded onto a steel band.

Both come with a centreplate that is bolted into the Brawler wheel and then onto the piece of equipment.

Installing an HD Brawler tyre is a quick fit as no pressing is required, meaning a quick change and less downtime for the machine.

Tyres can be changed from one machine to the other by swapping the centreplate, providing that both machines have the same original tyre size.

The design of the tyre works in conjunction with the cushion rubber compound to significantly increase deflection and provide greater shock absorption.

The signature elliptical apertures compress into circular apertures.

Combined with the purpose-designed cut resistant tread compound, the result is a solid tyre that is very tough but also not too rigid for comfort.



Anti-vibration construction
Deep tread
Increased footprint
Puncture proof
Damage resistant compound
Elliptical apertures
Maximum value
Maximum uptime
Enhanced safety
Reduced impact

The Soft Ride rubber compound provides operators with an unmatched level of comfort for solid tyres, while the purpose-designed tread compound ensures maximum tyre life.

Tyres for every machine

The Brawler HD range is designed specifically for solid wheel loaders for use in the extreme environment of an underground mine pit.

There are currently six products that meet all the expectations that are required for the heavy load and extreme conditions encountered underground.

Smooth and treaded tyres are both available.

The Brawler HD Smooth features a two-piece patented wheel and disk system that allows tyre and wheel interchangeability by simply changing the disk.

They are manufactured with a robust sidewall and, as with the whole tyre range, are made from Trelleborg's advanced puncture and cut resistant compound.

The HD tyres are available for machines weighing 10,680kg up to 28,320kg used at a speed of up to 25km/hr.

The Brawler range is also offered with a traction finish which includes the elliptical apertures for increased deflection.

The soft ride design reduces vibration, for the benefit of the operator.

For speeds of 10km/h the Brawler traction range is available for machines weighing from 880kg up to 22540kg.

Designed for loaders, dumpers and grader applications, the EMR range of tyres is suitable for open pits and quarries and underground mines, applying maximum protection and durability.

When working on sand rock and gravel, grip is essential, and these tyres are carefully constructed to allow for that.

For the extreme load of a dump truck, these tyres offer premium performance.

The EMR range has a radial all-steel construction and reinforced carcass, for additional strength.

The multi-surface tread pattern allows full grip, and the high shock absorption and reduced vibration or Trelleborg's unique compound delivers a secure and less rigorous ride for the operator.

With a reinforced sidewall rim guard offering increased protection against side impacts, the SK-900 range is engineered for the versatile Skid Steer Loader.

Increased stability and greater surface contact is provided by the flat profile design, and a tread that has equal pull both forwards and in reverse.

The tyres are designed with a flat profile and deep lugs, providing a secure base for all work required.

Brawlers for high-reach machinery

Trelleborg tyres for telehandlers and boom-fits ensure a large footprint for safe use of the extended boom and excellent flotation on soft surfaces.

The wide, flat tread design provides strong stability and the counter-weight required by telehandlers on rough terrain.

Trelleborg also offers the Excavator range, which incorporates extra wide tread, increasing traction and creating advanced stability on the job.

Its Trelleborg T-900 tyres can increase the output and cost efficiency of forklifts and other container handlers used on site and will outlast standard tyres under the same conditions.

For customers with highly demanding requirements including specific treads, Trelleborg offer a customised tyre service.

A representative will meet with the customer and discuss the right tyre for the purpose.

Highly skilled engineering staff will design custom made tyres in any size up to 80ins tall and with a custom traction tread up to 17cm deep.

The Brawler Soft Ride was developed over a two-year period of rigorous research which included field testing at facilities around the globe including Australia, Asia, America and Europe.

Trelleborg used what it calls 'applications expertise' which meant the company spent time listening to customers to deeply understand what they were looking for in a tyre.

The main requirement was a tyre that reduced punctures reducing the amount of time equipment was off-line.

The tyre has re-defined what operators can expect in terms of comfort and what machine owners can expect in terms of equipment longevity from using solid OTR tyres.

Sales Director (Australia) Paul Hansen said that the Brawler Soft Ride's point of

difference is Trelleborg's one-of-a-kind elliptical aperture sidewalls and its specifically engineered 'soft ride' rubber compound.

The Trelleborg tyre starts with an elliptical hole that forms a round hole under load, while the traditional tyre takes a round hole that collapses into an elliptical.

The elliptical hole allows the aperture to perform at its best under load.

Customers get all the advantages associated with durability for a solid tyre with no loss in load index.

The tyre was rigorously field-tested over a two-year period at various facilities around the globe including Australia, Asia, America and Europe.

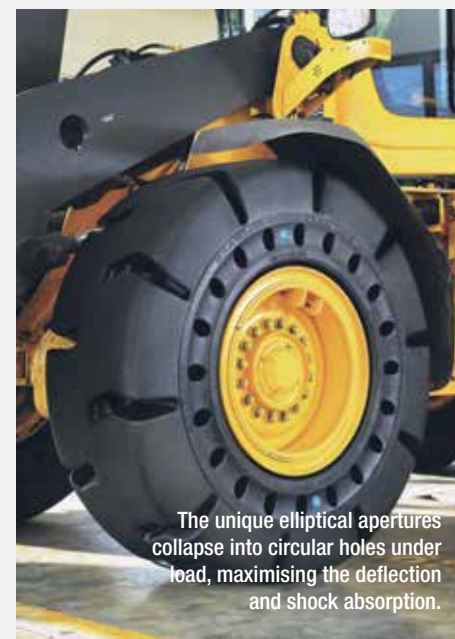

The unique elliptical apertures collapse into circular holes under load, maximising the deflection and shock absorption.

MORE INFORMATION: Trelleborg | 08 9256 6000 | info.tws.@trelleborg.com | www.trelleborg.com

Tough Jobs Soft Ride

BRAWLER SERIES



ANTI VIBRATION
CONSTRUCTION



CUT RESISTANT
COMPOUND



ELLIPTICAL
APERTURES



ULTRA
DEEP TREAD



SOFT
RIDE

Brawler HPS Soft Ride tyres are designed to perform in mining and tough recycling and waste management applications while providing the most comfortable ride within the Trelleborg Brawler range.

The Soft Ride compound combined with Brawler's unique elliptical sidewall apertures delivers higher

shock absorption and reduced vibration ensuring the best possible protection for operators and machines.

Brawler HPS Soft Ride - Delivers the toughness of a traditional solid tyre and a ride comfort equivalent to a filled pneumatic tyre.



www.trelleborg.com/en-au/wheels

A clear vision for Balconi

WA

THANKS to the Balconi Smart Torch Global Live system, video conferencing across long distances has just become a lot easier.

The Smart Torch is a world-first low bandwidth, low cost, portable two-way video conferencing tool for use in extreme and remote locations.

And after two years in development, Balconi Group Telecommunications managing director Con Michael is ready to share his technology with the world.

Mr Michael is highly qualified and experienced in his field and passionate about making video more accessible to remote communities and the resource and mining sector.

He holds a Bachelor of Applied Science, a Bachelor of Engineering, and a Post-Grad Certificate focused in electronics, telecommunications, and telecommunications management.

Working with 100 years of satellite and computing engineering experience, the company has engineered the Smart Torch to achieve its objective, which is to provide clear, unbroken video conferencing using small bandwidth.

Partnering with leading global satellite provider Speedcast, Balconi can provide a global connection using a small system that is either the size of a DVD player or operates like a small laptop with a 30cm screen.

Mr Michael said feedback from industry had been positive and has helped streamline the SmartTorch into its current form.

The complete kit is fully contained in a portable Pelican 1560 Case.

"Video conferencing in the mining industry has transformed the meeting process, allowing face to face meetings from all corners of the globe," Mr Michael said.

"Achieving sufficient internet connectivity is a challenge for all telecommunication officers in remote mines, particularly the junior miners who may not have the budget to achieve the uninterrupted feed that is conducive to a valuable meeting.

"The Smart Torch has been designed to be able to adopt the standards-based system to enable seamless operational integration, and of course an accepted level of cyber security."

The security features comply with international government cyber security standards and deliver a secure and safe communication channel.

It provides a robust system over satellite and provides quality delivery.

A piece of equipment the size of a hand provides a global connection using a tiny amount of bandwidth in proportion to its ground status.

For situations that require a visual explanation, the Smart Torch allows cameras to zoom in on a piece of equipment or work and allow real time vision.

Communicating with an engineer or technician is simple with a small hand-held piece of kit, that can be operated anywhere with minimal bandwidth available, including 4G.

For contracting companies on minesites which may not have access to the company bandwidth, the Balconi SmartTorch allows the use of its own video communication system, operating over 4G or satellite.

Drilling companies or exploration teams will be able to use the two-way video conferencing system to communicate visually in real time.

Any technical issues can be dealt with on the field, reducing downtime and costs significantly.



Con Michael has received multiple awards for his hand-held two-way video.



The Smart Torch can be hand-held or placed on a stand.

Underground mining operations can also slash the budget on interconnectivity with a video system that can operate cable-free.

The SmartTorch is also incredibly useful in offshore conditions, for operational and medical purposes.

Support vessels offshore usually don't have the bandwidth for two-way connectivity and small bandwidths do not work well with conventional video.

"For mechanical questions, verbally describing a problem can be problematic," Mr Michael said.

"The Smart Torch allows a situation to be shown with video rather than taking a photo, sending it off and waiting for a reply.

"If there is a dire situation, a video with a



The Smart Torch is transported in a ruggedised case.

moveable camera will bring massive benefits to both the outcome and the costs involved."

Huge expenses may be incurred in the case of a crew needing to be flown out to vessels, a procedure that can be avoided with the moveable, reliable video camera the Balconi Smart Torch provides.

The two-way video conference system is the first of its kind and will soon be trialled by WACHS (West Australian Country Health System) and NSW Health Service, making technical and medical treatment more accessible to off-shore operators and remote communities across Australia.

Bandwidths

The Balconi enhanced vision algorithms ensure quality video as low as 128Kbps, fully contained in a portable Pelican 1560 case.

It uses a disruptive dynamically adjustable operation algorithm giving the best possible video from a very small bandwidth allowing affordable connectivity access.

This technology allows the modem and the newly designed camera to work smoothly together, providing uninterrupted video access via a small bandwidth.

"If a video freezes when you are talking privately, people put up with it but in a medical situation this cannot happen," Mr Michael said.

"That is why we designed a system that can work with small bandwidths."

Bandwidth is expensive and two-way conferencing using a traditional camera set-up, requires large amounts of bandwidth, making it prohibitive for smaller mining operations, and remote communities.

The Balconi SmartTorch offers two modem kit options, the Cobham Explorer satellite modem or the 3G/4G/LTE Modem Router.

The SmartTorch allows smaller mining projects and any contracting mining operators, drilling companies, or other operators to be connected via video, without cutting into the owner's bandwidth.

In the case of smaller groups, the bandwidth can also be accumulated, allowing multiple stations to timeshare satellite use.

The Balconi Kit contains:

- Smart Torch camera and tripod
- LED lighting with mounts x2
- 12in monitor
- 108W 100-240V/12 PSU
- Pelican 1560 case with wheels
- Cable and accessory pack
- Set up guide and quick start manuals
- 125W Solar Panel Option

Awards

The award-winning technology was recognised at the 2017 AIIA and Australian Government Innovation of the Year iAwards.

Balconi won the categories for National Innovation of the Year, National Community Services, and National Merit Recipient for Mobility Innovation of the Year and were the only multi-awards winner



of the spectacular awards night.

It also won two category awards at 2017 WAITTA INCITE and picked up the 2017 Engineers Australia Award for Most Innovative Engineer.

The Smart Torch can be connected to 3G, 4G, LTE, copper and satellite network connectivity and provides global coverage with satellite modem option.

It offers a secured AES256 encrypted video stream on a standards based video conferencing system (Pexip) and a laptop connection.

The Balconi provides enhanced quality vision for low bandwidths and Balconi dynamic video compression with ancillary equipment connection.

The patented technology ensures reliable operation over satellite and poor cell and copper-based networks.

Balconi developed its Smart Torch to provide a low cost and acceptable video-conferencing system for the United Nations to allow a lightweight two-way video conferencing system its workers could use in countries with poor internet connectivity.

In Australia it is highly suitable for use in mining and remote communities.

Balconi Telecommunications was formed in 1993 as a telecommunications consultancy and niche product design house with extensive experience in the TV broadcast and telecommunications Industries and is the developer of the world-leading Balconi

Telephone and the Balconi Tracker.

The Balconi Smart Torch – Global Live Achievements

- **Curtin University** – Alumni Achievement Awards: Innovation Award 2019
- **Engineers Australia** – Neville Thiele National Award: Outstanding Achievement 2019
- **Engineers Australia Engineering Excellence Awards:** National Winner 2018
- **Engineers Australia Engineering Excellence Awards:** WA Distinction Award 2018
- **WA Innovator of The Year** – Woodside Encouragement Award: Winner 2018
- **WA Innovator of The Year** – Digital Innovation Encouragement Award: Finalist 2018
- **WA Innovator of The Year** – Emerging Innovation: Semi-finalist 2018
- **AIIA iAwards National Innovation of the Year:** Winner 2017
- **AIIA iAwards National Community Services Markets:** Winner 2017
- **AIIA iAwards National Mobility Innovation of the Year:** Merit 2017
- **Engineers Australia Most Innovative Engineer:** Con Michael 2017
- **WAITTA Incite Awards Most Impactful Collaborative Technology:** Winner 2017
- **WAITTA Incite Awards Most Impactful Social Benefit:** Winner 2017

MORE INFORMATION: Balconi | 08 6397 3878 | sales@balconi.com.au | www.balconi.com.au



+61 (08) 6397 3878 | sales@balconi.com.au / support@balconi.com.au | balconi.com.au



VIDEO CONFERENCING WHERE YOU ARE



REAL TIME REMOTE VIDEO

The ultra-portable Smart Torch uses small bandwidth for real time video from the most remote locations.

Use the **Smart Torch** on mines, off-shore and remote communities to keep in touch from wherever you are.



BALCONI MAIN OFFICE
Unit 2, 9 Blackly Row,
Cockburn Central WA 6164





Leverlink®

THINK INNOVATIVE

30
YEARS
EXPERIENCE

- Design and manufacture
- Customisation when required
- Proven in the most hostile environments
- Vertical overhead drive motorbases
- Horizontal drive motorbases
- Vertical up and down motorbases

The mechanical design allows for a quick belt fitting and replacement with a single adjusting screw. This means, safety is increased and the risk of personal injury is minimised.

At Leverlink, we provide high-quality Australian made products and ship them throughout the world. Our reputation has been formed by over three decades of exceptional customer service.

**GET IN TOUCH WITH US
TODAY!**



AUSTRALIAN PIONEERS

IN OEM STORED ENERGY MOTOR
BASES AND DYNAMIC IMPACT BEDS

SALES@LEVERLINK.COM.AU | WESTERN STATES: 08 6165 8892 | EASTERN STATES: 07 3737 2400

leverlink.com.au