

USER MANUAL

IVL™ Carré

IVL™ Pyramide

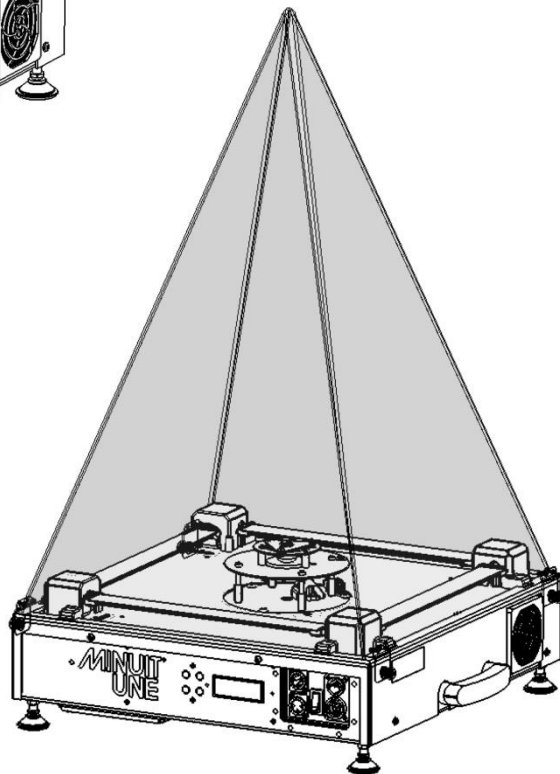
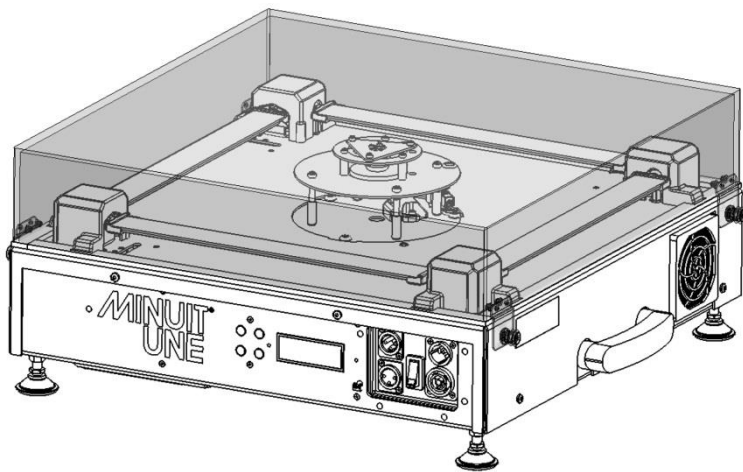

© 2018 ARTEFFECT SAS

All rights reserved. Information subject to change without notice. ARTEFFECT and all affiliated companies disclaim liability for any injury, damage, direct or indirect loss, consequential or economic loss or any other loss occasioned by the use of, inability to use or reliance on the information contained in this document. Minuit Une, IVL LIGHTING, IVL Pyramide and IVL Carré are registered trademarks of ARTEFFECT SAS.

No part of this document may be used for distribution, reproduction, transmission, transcription, storage in a data retrieval system, or translated into any language in any form by any means without the prior written permission of ARTEFFECT. If you are downloading files from our web pages for your personal use, make sure to check for updated versions. ARTEFFECT cannot take any liability whatsoever for downloaded files, as technical data are subject to change without notice.

For France: L'utilisation est réservée à un usage professionnel selon le Décret n° 2012-1303 du 26 novembre 2012 fixant la liste des usages spécifiques autorisés pour les appareils à laser sortant d'une classe supérieure à 2 :

Article 4 bis:

Les usages spécifiques autorisés pour les appareils à laser sortant d'une classe supérieure à 2 sont les usages professionnels suivants:

(...)

9° Spectacle et affichage : Toutes les applications de trajectoire, de visualisation, de projection ou de reproduction d'images en deux ou trois dimensions.

www.minitune.com | 104 avenue de la résistance 93100 Montreuil – FRANCE | 0033 143636590
support@minitune.com

Revision of this manual: B

Content

Content	2
Dimensions	4
IVL Carré and Base Dimensions	4
IVL Pyramide Dimensions	5
Safety Information	6
Vital Precautions.....	7
General Safety Information	7
Laser Safety Information	8
Intended Use	10
Introduction	11
Before using the product	12
Overview	13
Fixture menu and connectors.....	13
Scanner and Mirror Bars.....	14
Bottom View	14
Physical Installation	16
To Place the Product on a Flat Surface	16
To Mount the Product on a Rigging Structure	16
AC Power	17
To Link Fixtures to Power in a Chain.....	17
Control Data Link	18
Tips for a Reliable DMX Data Transmission	18
To Connect the Data Link.....	18
Fixture Menu	19
Effects	20
Vibrant Light, smooth RGB	20
Tilt, Movement and Frost	20
Beam Control	21
Decoration	22
Space coverage	22
Dimmer	22
Colors.....	22
Shutter	22
Service	23
To Clean the Product	23
To Change the PMMA Cover	24
DMX Protocol	25
Specification	28

Dimensions

All dimensions are given in millimetres.

IVL Carré and Base Dimensions

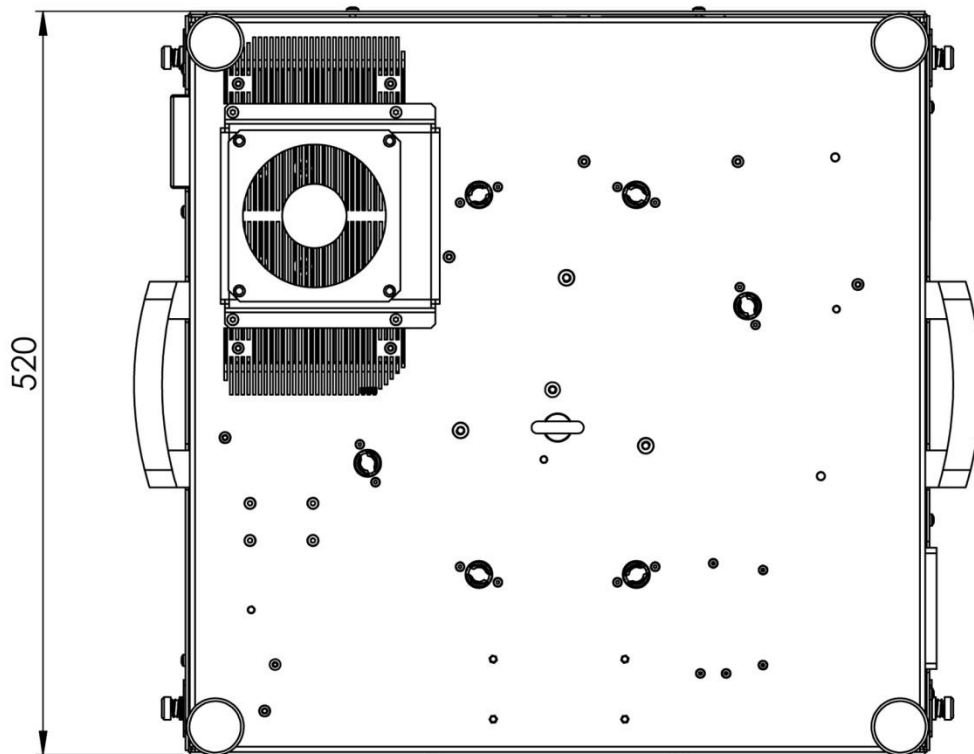
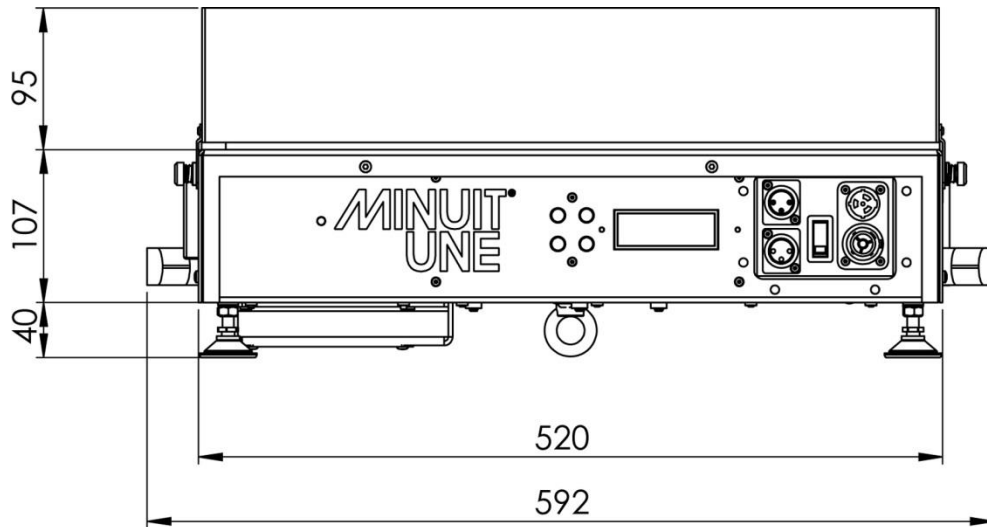

IVL Pyramide Dimensions

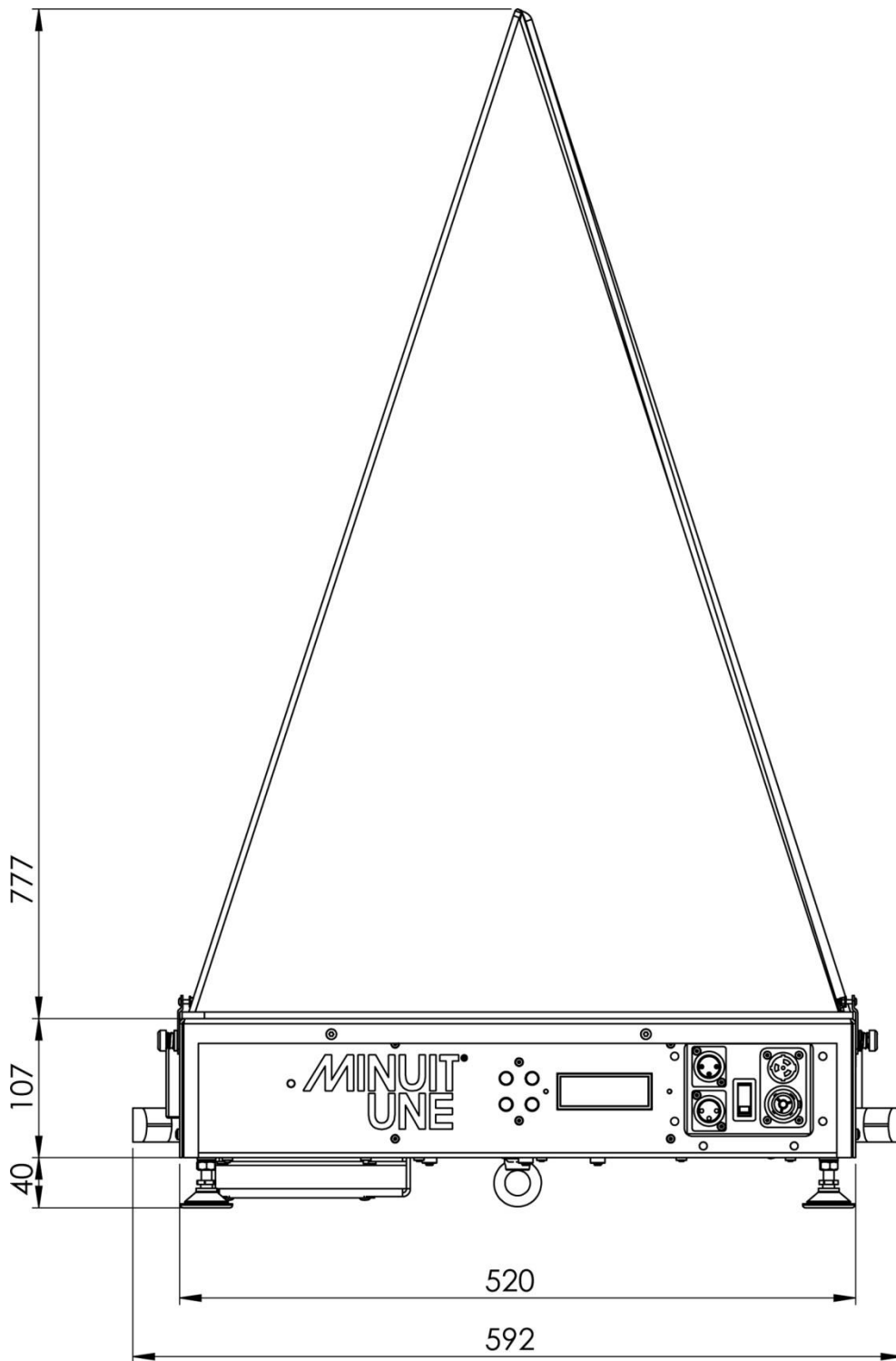

Safety Information

Always follow these instructions and instructions printed on the product or given in the documentation shipped with the product to protect against injury to yourself and damage to the product or other objects.

Risk Levels and Alert Symbols

Safety warnings, safety alert symbols, and signal words in these instructions indicate different risk levels:

DANGER!

DANGER indicates an imminent hazardous situation which, if not avoided, **will result** in death or serious injury.

WARNING!

WARNING indicates a potentially hazardous situation which, if not avoided, **may result** in death or serious injury.

CAUTION!

CAUTION indicates an potentially hazardous situation which, if not avoided, **may result** in minor or moderate injury.

NOTICE

NOTICE explains practices not related to physical injury. No safety alert symbol appears with this signal word.

Vital Precautions



DANGER!

High voltage! Risk of blindness, electric shock and fire.

Read and understand all safety information and operation instructions before you operate or install the product or the system.

Not to observe the safety information or general rules of safety may cause injury, blindness, burn hazards, electric shock, falls and death to yourself and others or damage to equipment.

Use solely and exclusively as described in the instructions.

Always check that the local AC power matches the voltage and frequency range printed on the type label of the product before use.

Always earth the fixture electrically. Only use TN or TT one phase power supplies and a power plug according to IEC 60309-1 or a similar national standard.

Never use the cables for transportation. Never hang the product on its cables.

In case of visible or suspected damage to cables or housings, the product must not be operated any longer. Never attempt to repair any part of the product on your own. Service and repair work is only to be carried out by an authorized ARTEFFECT service center. The user is not allowed to modify the unit or remove protective covers or housings.

Do not bypass or remove any safety feature of the product.

General Safety Information



WARNING!

Humidity, Condensation and Moisture.

Never expose the product to rain or moisture. Do not use the product for 2h when it was exposed to big temperature differences as condensed moisture may damage the product electrically when switched on.

Never expose the product to drip water or water splashes.

Never place an object filled with liquid (e.g. a vase or a bottle filled with liquid) on the product.

Do not bend the power cable directly after the connector. Water could immerse and cause short circuits and damage the connector.



WARNING!

Risk of eye injury through laser radiation.

Laser Radiation!

Avoid exposure to beam. Class 3B laser product according to IEC 60825-1:2014

Do not look at laser devices with magnifiers, telescopes, binoculars or similar optical instruments that may concentrate the light output.



WARNING!

Risk of electric shock and fire.

Socket outlets or external power switches used to supply the product with power must be located near the product and easily accessible to be able to isolate the product from power immediately.

The power cable is equipped with a Neutrik Powercon TRUE1 NAC3FX-W cable connector and bare ends. You can install a suitable power plug on the power cord. Always use a power plug according to IEC 60309-1 or a similar national standard.

Disconnect the product from AC power before moving or doing service work on it.

Refer any service operation not described in this manual to a qualified service technician.

To link several products in one power chain, please observe:

- This fixture has a power consumption of 125W max.
- Always obtain a 1,5 mm² power input cable and 1,5 mm² power throughput cables in Europe.
- Never link more than 10 products in a power chain when using these cables.

Ensure that the airflow around the product is free and unobstructed.

Provide a minimum clearance of 0,3 m (1 in.) around fans and air vents.

No flame source, like a candle light, must be placed on or nearby the product.

This product is intended to be used in temperate climate.

Do not operate the product if the ambient temperature is above 40° C (104° F) or below 0° C (32° F).



WARNING!

Risk of injury and damage through falls.

Always install the product as described in this manual.

Always follow the safety information when suspending the product. Always use a secondary attachment as described in this manual to prevent falls when the primary attachment fails.

Block access area during installation or service of the product due to risk of injury through fall.

Always work from a stable platform.

Laser Safety Information

Important definitions according to IEC 60825-1:2014 :

“Maximum permissible exposure MPE“

Level of laser radiation to which, under normal circumstances, persons may be exposed without suffering adverse effects.

“Nominal ocular hazard distance NOHD”

Distance from the output aperture at which the beam irradiance or radiant exposure equals the appropriate ocular maximum permissible exposure (MPE).

For this product and for an exposition time of $t = 0,25\text{ s}$:

NOHD=

7,2 m Horizontal mode

5,6 m Vertical mode

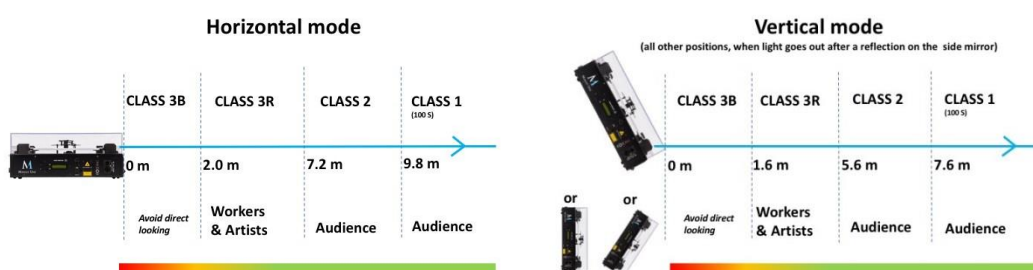

NOTICE

Note that the national and local recommendations, regulations, standards and codes of practice in laser show are different from a country to another. Please contact your provider or Minuit Une’s legal service to know the proper NOHD and the safety procedure in your local area.

WARNING!

This product is intended for professional laser show use only. It must be used and operated by a qualified and trained laser operator.
 The laser is never to be operated if the unit is defective or the cover or seal is damaged.
 Never operate the laser until everybody without safety goggles described as below stays beyond the NOHD.
 The necessary safety goggles in accordance with EN 207:2009 for any persons staying within the NOHD is:
Plastic or Glass: 440-640 D LB3 | LB5

In order to operate the laser, please follow the operating procedure below:

- Enable the interlock by plugging the DMX cable from controller output into the DMX input of the product. The DMX interlock indicator should now light green.
- Turn on the cypher lock by sending the right DMX chain.
- Wait for the scanning motor system to reach 333 Hz.
- The laser safety indicator should now light red.

The product is now ready to be operated by DMX.

The following symbols are used in this manual or on the product to identify important laser safety information:

Hazard Warning Symbol Label



Warning! Visible and / or invisible Laser Radiation can be emitted.

Aperture Label



This label indicates the laser aperture. On this product, the laser aperture is the whole area above the PMMA shape of the product.

Explanatory Label



Avoid exposure to class 3B laser product When light is on, make sure that no one is at a distance below the minimal distance of use, which is the nominal ocular hazard distance (NOHD).

Protective Housing Non-interlocked Label



Avoid eye or skin exposure to direct or scattered radiation.

Before opening any part of the product, disconnect the AC power. Otherwise you may be exposed to a class 4 Laser. MINUIT UNE cannot be held responsible if this instruction is not respected

Incorporated laser: > 2400mW @ 638nm | >2000mW @ 520nm | > 5600mW @ 450nm.

Intended Use

NOTICE

This product is intended for indoor use.

This product is intended to produce lighting effects in a dry environment at an ambient temperature below 40° C (104° F) and above 0° C (32° F).

This product is intended for professional laser show use only. It must be operated by a qualified and trained laser operator.

Always follow the safety information.

Any usage other than described in this manual is not permitted and can damage the product and lead to associated risks such as short-circuit, fire, electric shock, etc. You are not allowed to modify the product. Doing so will void the warranty.

This product fulfils national and international legal requirements.

Introduction

IVL Carré and IVL Pyramide are part of IVL Lighting, a new category of lighting created and patented by Minuit Une.

What is IVL Lighting?

IVL Lighting is the first-ever lighting range specially designed for experience.

IVL lighting by Minuit Une is based on a ground-breaking technology to go further in lighting design.

For the first time ever, create spectacular experiences without heavy logistics:

- Advanced shapes: stunning visual lighting shapes and decors.
- Unique immersive feeling: wide coverage area, calibrated output, enveloping lights covering all the available space.
- Unlimited versatility: infinite effect combinations; constantly renewed style or atmospheres within a show.
- Without a custom programming software: Intuitive programming from any DMX console.
- Without heavy infrastructure: IVL products are a concentrate of technology. Small-sized, light-weighted and robust, they can be hung quickly anywhere and in any direction.

The IVL Lighting is a game-changing lighting product. It creates multidimensional advanced shapes from one source of light. The IVL Lighting covers a wide area by producing 4 directive light plans perpendicular to each other. Each plan is adjustable at a 180° angle to create stunning perspectives when combined together. Each light plan of the IVL Lighting can be divided into 1, 2, 4, 8, 16, 32 or 64 beams. Welcome to a new world of advanced shapes and infinite possibilities!

In a time where crowds ask more and more for exciting experiences, the IVL Lighting's advanced shapes help you create truly immersive designs with their smooth enveloping textures and 3D rendering perception. It is an infinite playground for your creativity. Multiply your creative output using a standard DMX controller.

IVL Carré or IVL Pyramide?

IVL Carré and IVL Pyramide share the same base, only the cover shape changes. One cover is a square shape (for IVL Carré) and the other is a pyramid shape (for IVL Pyramide). According to the chosen cover, the light will spread differently in the space and will create different kinds of advanced shapes.

The two covers are interchangeable and can be purchased solo, meaning you can get one IVL Carré and later on, a Pyramid cover, so a trained service operator can switch from an IVL Carré to an IVL Pyramide or vice-versa. Some technical specifications differ between IVL Carrés and IVL Pyramides such as the weight and the lighting emission results. These covers are made from a unique PMMA material, specifically chosen to increase the decoration output of any design.

- IVL Carrés: the square-shaped cover reinforces the 3D rendering perspectives of IVL Lighting.
- IVL Pyramides: the pyramid-shaped cover reinforces the decoration output of IVL Lighting.

Before using the product

1. Read the “Safety Information” on page 6 before doing anything with the product.
2. Unpack and ensure that there is no transportation damage before using the product. Do not attempt to operate a damaged product.
3. Check that no part shipped with the product is missing. The product is shipped with:
 - A power cable with a Neutrik Powercon TRUE1 connector and bare ends,
 - 2 omega-type clamps quarter-turn fasteners
4. If the product is not going to be hard-wired to a mains supply, install a local power plug (not supplied) on the end of the supplied power cable.
5. Ensure that the voltage and frequency of the power supply match the power requirements of the product.

Note that whenever AC power is applied to the product, it will reset all effects and functions to their home positions. A reset usually takes approximately 8 seconds.

Overview

Fixture menu and connectors

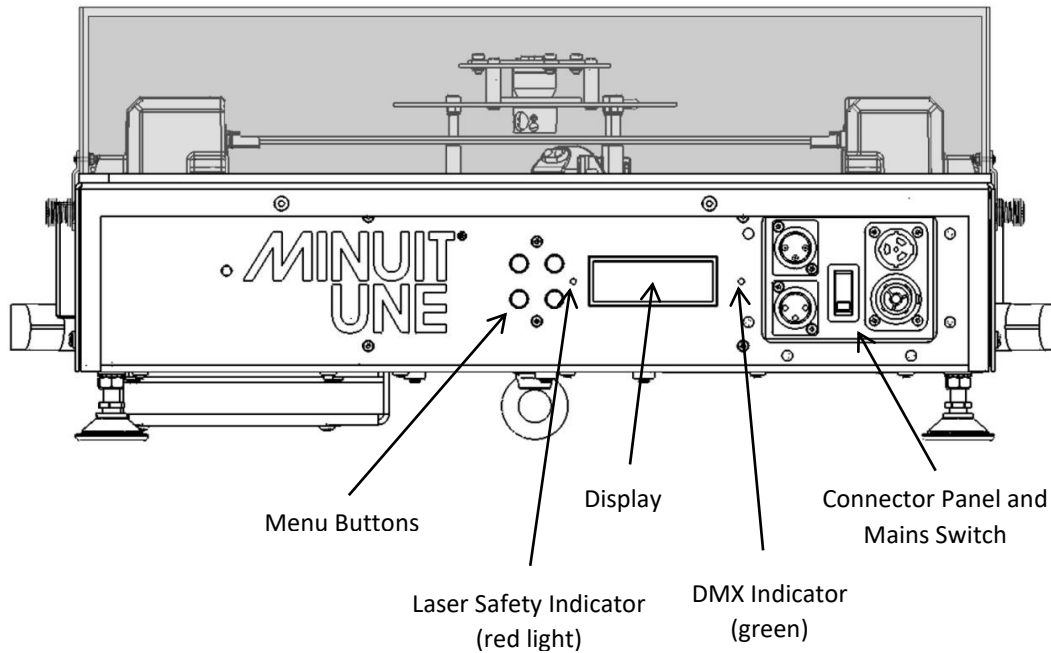

Menu buttons

ENTER	Press to open the main menu. Press to open a sub menu.
ESC	Cancel an action without saving any changes.
+ / -	Select an option or change a value.

Display

The Displays shows fixture and menu information.

Indicator LEDs

Laser safety indicator (red, left from display)	Lights up when the safety bit is OK.
DMX interlock indicator (green, right from display)	Lights up green when a valid DMX signal is detected at the DMX input.

DMX connectors

The product is equipped with 5-pin XLR sockets DMX input and output (through to next fixture).

The pinout of the XLR connectors is:

- pin 1 = shield
- pin 2 = cold (-)
- pin 3 = hot (+).

Pins 4 and 5 in the 5-pin XLR connectors are not used in the fixture but are available for possible additional data signals as required by the DMX512-A standard. Standard pin-out is pin 4 = data 2 cold (-) and pin 5 = data 2 hot (+).

Main Switch

Flip the main switch to power the product or to switch the product off. After powering the product it performs a reset which takes approximately 8 seconds.

Power Connectors

The product is equipped with two Neutrik Powercon TRUE1 connectors for power in and power through. Use only Neutrik Powercon TRUE1 NAC3FX-W cable connectors to connect to power input sockets. Use only Neutrik Powercon TRUE1 NAC3MX-W cable connectors to connect to power throughput sockets.

Scanner and Mirror Bars

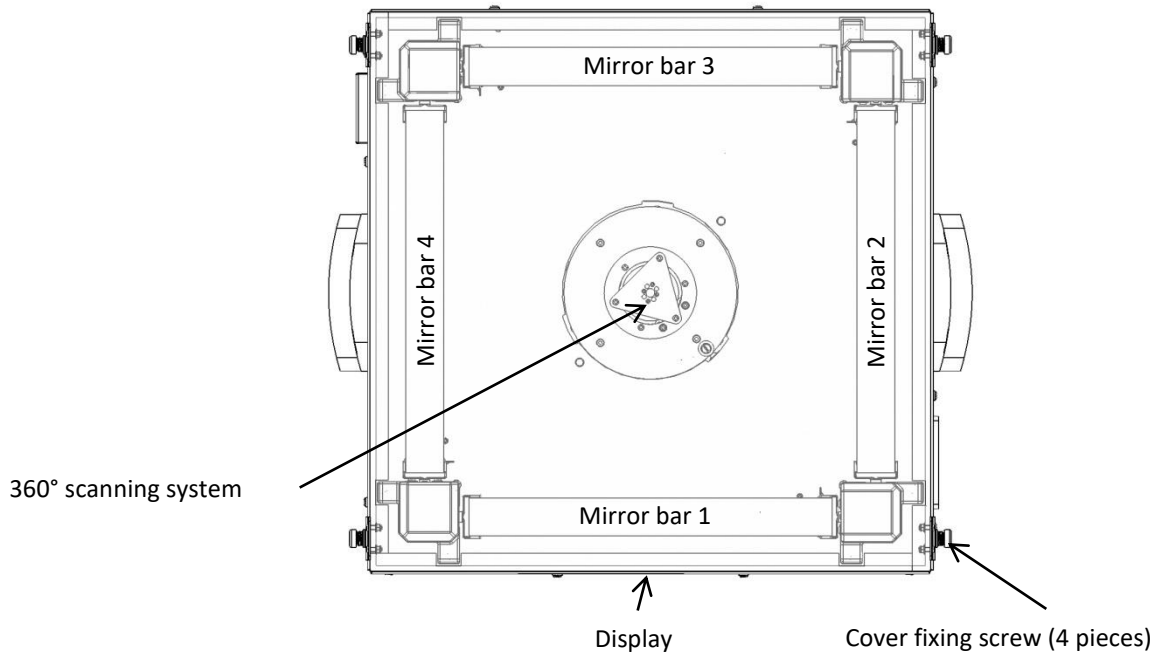

Bottom View

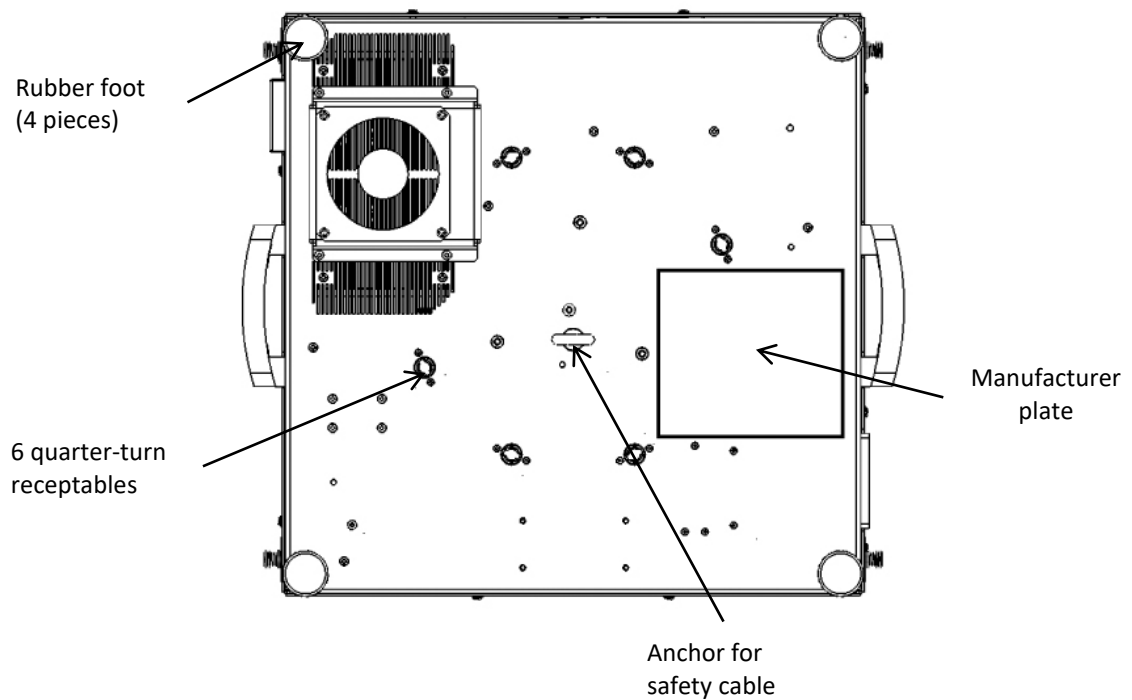

Manufacturer plate

The manufacturer plate is located at the bottom of the product. It contains important information about the type, serial number, power consumption and inherent capability of the laser source used in the product. Please contact your dealer or Minuit Une when a type plate is missing as it has to be present on the product and needs to be replaced.



Quarter-turn Receptables

The product is shipped with two omega-type brackets to which rigging clamps can be attached to the quarter-turn receptables duct using the brackets quarter-turn fasteners.

Anchor for Safety Cable

Secure the product with a safety cable (or other secondary attachment) that is approved for the weight of the product so that the safety cable will hold the fixture if a primary attachment fails.

Loop the safety cable through the anchor for the safety cable on the side of the product (see illustration above) and around a secure anchoring point.

If a safety cable attachment point becomes damaged or deformed, do not suspend the product above ground any more. The anchor needs to be replaced by a qualified service technician.

Rubber Feet

The product is equipped with for damping rubber feet. Check, if all four rubber feet are present and undamaged before placing the product on a flat surface. Replace a missing rubber foot as the product might present a risk of injury when moving during operation.

Physical Installation

WARNING!

Always read the “Safety Information” on page 6 before installing, operating or servicing the product. The installation of this product must be validated by a qualified technician before it is operated. When suspended above ground, the product must be secured with a secondary attachment to prevent injury or damage by falls when the primary attachment fails. If suspended, the rigging structure must be able to bear a static suspended load that is ten times the weight of the product and all installed accessories, especially if the product is installed in a location where it may cause injury or damage if it falls.

To Place the Product on a Flat Surface

The product can be placed on a hard, fixed, flat surface. Ensure that the surface can support at least 10 times the weight of all products and equipment they will support.

Do not place the product on a surface or leave it where it can be moved or fall over. If you install the product in a location where it may cause injury or damage if it falls, secure it as directed below with a securely anchored safety cable that will hold the product if can move and fall.

To Mount the Product on a Rigging Structure

The product can be fastened to a rigging structure in any orientation. The quarter-turn receptacles (see „Overview“ on page 13) allow the clamp brackets to be fastened in parallel, perpendicular or at a 45° angle to the front.

WARNING!

Always use two (2) clamps to fasten the product to the rigging structure. Lock each omega adapter with both quarter-turn fasteners. Fasteners are locked only when turned fully clockwise. When installing the fixture hanging vertically down, you can use an open-type clamp such as a G-clamp. When installing in any other orientation, you must use a closed-type rigging clamp such as half-coupler clamp that completely encircles the truss chord.

The product is supplied with two omega-type brackets to which rigging clamps can be attached. Check that the rigging clamps are undamaged and approved for the product’s weight. Bolt a rigging clamp securely to each bracket. The bolts used must be M12, grade 8.8 steel minimum, and fastened with self-locking nuts.

Align the first clamp bracket with 2 quarter-turn receptacles in the base. Insert the quarter-turn fasteners in the quarter-turn receptacles and turn both lever full 90° to lock them (see illustration on right). Repeat for the second clamp.

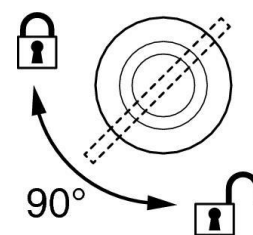

Secure the product against falling when the primary attachment fails with a secondary attachment such as an approved safety cable that is rated for the weight of the product, using the anchor on the side of the product. Do not use any other part of the fixture as a safety cable attachment point.

AC Power



High voltage! Risk of electric shock and fire.

Read the “Safety Information” on page 6 before connecting the product to AC mains power.

Always connect the product directly to AC power.

Use only a Neutrik Powercon TRUE1 NAC3FX-W cable connector to connect the power cable to the power input socket. Use only a Neutrik Powercon TRUE1 NAC3MX-W cable connector to connect the power link cable to the power throughput socket.

For protection from electric shock, the product must be grounded (earthed) electrically. The power distribution circuit must be equipped with a fuse or circuit breaker and ground-fault (earth-fault) protection (RCD).

Socket outlets or external power switches used to supply the product with power must be located near the product and easily accessible so that the product can easily be disconnected from power.

The product can be hard-wired to a building electrical installation if you want to install it permanently, or a power plug (not supplied) that is suitable for the local power outlets can be installed on the power cable.

If you install a power plug on the power cable, install a grounding type (earthed) plug with integral cable grip that is rated minimum 8 A at a suitable voltage for your local power system. Follow the plug manufacturer’s instructions and connect the wires in the power cable as shown in this table:

	Live or L	Neutral or N	Earth, Ground or ⊕
US system	Black	White	Green
EU system	Brown	Blue	Yellow/green

The product has an auto-ranging power supply that accepts AC mains power at 100-240 V at 50/60 Hz. Do not apply AC mains power at any other voltage or frequency to the product.

To Link Fixtures to Power in a Chain

The product has a power consumption of 125 W max. Do not connect products to power in a chain that will exceed the electrical ratings of any cable or connector used in the chain. Connect only the same fixtures into an interconnected chain.

If you wish to connect IVL Carré products to power in a linked chain, you must obtain a 1,5mm² power input cable and 1,5mm² throughput cables in Europe.

Using these gauge cables, you can link maximum 10 IVL Carré by Minuit Une.

Control Data Link

A DMX 512 data link with a ferrite (ref: 742 712 22 S) on it is required to control the product via DMX. The fixture has a 5-pin XLR connector for DMX data input and output.

A single daisy chain can consist of up to 32 devices. The total number of products in one 512-channel DMX universe is limited by the number of DMX channels required by the products. Note that if independent control of a product is required, it must have its own DMX channel range. Products that are required to behave identically can share the same DMX address and channels. To add more products or groups of products when the above limits are reached, add a DMX universe and/or split the daisy-chained link into branches using a powered DMX splitter.

Tips for a Reliable DMX Data Transmission

Use shielded twisted-pair cable designed for RS-485 devices: standard microphone cable cannot transmit control data reliably over long runs. 24 AWG cable is suitable for runs up to 300 meters (1000 ft.). Heavier gauge cable and/or an amplifier is recommended for longer runs.

A valid DMX signal is the safety interlock of the device. Please check, if every DMX cable used in the control data link is in perfect condition if the safety signal (red LED) is switching on and off constantly whereas other products in the control data link are reacting correct on DMX commands.

The pin-out of the connectors is:

- pin 1 = shield
- pin 2 = cold (-)
- pin 3 = hot (+).

Pins 4 and 5 in the 5-pin XLR connectors are not used by the product but are available for possible additional data signals as required by the DMX512-A standard. Standard pin-out is pin 4 = data 2 cold (-) and pin 5 = data 2 hot (+).

To split the link into branches, use an opto-isolated, powered DMX splitter. Terminate the link by installing a termination plug in the output socket of the last product of a DMX data link. The termination plug, which is a male XLR plug with a 120 Ohm, 0.25-watt resistor soldered between pins 2 and 3, “soaks up” the control signal so it does not reflect and cause interference. If a splitter is used, terminate each branch of the link.

To Connect the Data Link

To connect the product to the DMX data link:

1. Connect the DMX data output from the controller to the closest product’s male XLR DMX input connector.
2. Connect the first product’s DMX output to the DMX input of the next product and continue connecting products output to input.
3. Terminate the last product on the link with a DMX termination plug. If the last product in the control data link is an IVL product, you do not need to use a DMX termination plug as a termination resistor is integrated in the electronics board.

Fixture Menu

The IVL Carré and IVL Pyramide support two different DMX Modes. The active DMX Mode (DMX1 / DMX2) is displayed in the display on the front panel of the product.

The DMX address is also displayed. It is indicated by an "A:". "A:001" indicates, that the product is set to DMX start address 1. The recent internal temperature of the product is shown on the display.

To Change the DMX Mode

1. Press ENTER
2. Press ENTER again to open the DMX mode menu.
3. Press + or - to scroll through the DMX modes.
4. Press ENTER to select a DMX mode.
5. Press ESC to cancel the action without changing settings.

To Change the DMX Address

1. Press ENTER.
2. Press +.
3. Press ENTER to open the DMX address menu.
4. Press + or - to scroll to the hundreds digit. Press ENTER to select a digit.
5. Press + or - to scroll through the tens digit. Press ENTER to select a digit.
6. Press + or - to scroll through the ones digit. Press ENTER to select a digit.
7. Press ESC to cancel the action without changing settings.

Temperature and Lifetime Readout

1. Press ESC to call up the main screen.
2. Press – short to display the highest internal temperature since production, the hour counter and the software version.

DMX Channel Value Readout

1. Press ESC to call up the main screen.
2. Press – long to display the values of the DMX start address and the next three DMX channels received by the product.

Effects

The IVL fixture creates four light plans from a laser-based light source split at very high speed by a smart mirror system. A PMMA cover in a specific shape to release a vibrant light with a smooth RGB colour spectrum and enveloping texture.

Each light plane can be played independently with various modes: full plane, beam, frost, décor, projection with a 180° angle.

This is not a laser effect, this is a new category of lighting with unique shapes, unique textures, unique immersive feeling and standard safety.

Vibrant Light, smooth RGB

The super-fast scanning system of the IVL Lighting range (333Hz frequency rate) allows the human eye to see every single nuance of colour: A vibrant and smooth RGB colour spectrum to perfectly complete the best LED's and HALOGEN's chromatic range, with a vivid colour combination, as well as a wide range of pastel colours.

Tilt, Movement and Frost

4 brushless stepper motors control the movement of the 4 mirrors on each side independently (4 separated tilts in the DMX chart). Unlimited immersive positions can be programmed and achieved just by playing with different groups of mirrors from a group of IVL Lightings.

A specific electronically augmented resolution driver allows to achieve a really smooth movement: you can create smooth movement with a really small range (%1) around your immersive advanced shapes.

Each mirror has an angle of position from 0° to 360°, this allows the creation of an infinity of advanced shapes, immersive, decoration and wash effects.

The tilt channels are used to control the angle of the four mirror bars. One side of the mirror is highly reflective while the opposite site is diffusely reflective. DMX values from 0 – 50% (0 – 127) create a single light plan at different angles. DMX values from 51 – 100% (128 – 255) convert the IVL to a diffuse light source.

DMX channels 11 to 18 control single mirror bars as shown below:

DMX channel coarse	DMX channel fine	Mirror bar (see "Scanner and Mirror Bars" on page 14)
11	12	1
13	14	2
15	16	3
17	18	4

Example

- Open immersive position (11% tilt DMX value)
- Eye-capturing position (12.5 % tilt DMX value)
- Close immersive position (14% tilt DMX value)
- Decorative position (15 % tilt DMX value)
- Wash effect position: frost mode (62.5 % tilt DMX value).
- Reset function by optical sensors.

Beam Control

An intelligent electronic software synchronised in real time with the frequency rate of the scanning system allows to cut the light plan into several beams: 1, 2, 4, 8, 16, 32 or 64 beams to create an infinity of effects such as:

- Even more intense advanced shapes,
- Beam looking effects,
- Parallel effects,
- Flower effects,
- And many more.

These beams can be positioned anywhere on the mirrors, either static or in rotation, with control on the size of the beam.

These specifications are converted via DMX consoles as an intuitive gobo system with the following equivalence:

- Gobo type: number of beams
- Gobo size: width of the beam
- Gobo indexation: position of the beam on the mirrors
- Gobo rotation: speed and direction of rotation.

The origin (index = 0°) is located at the upper right side between mirror bars 2 and 3. Increasing the index shifts the origin of the beams counter-clockwise from 0 to 360°:

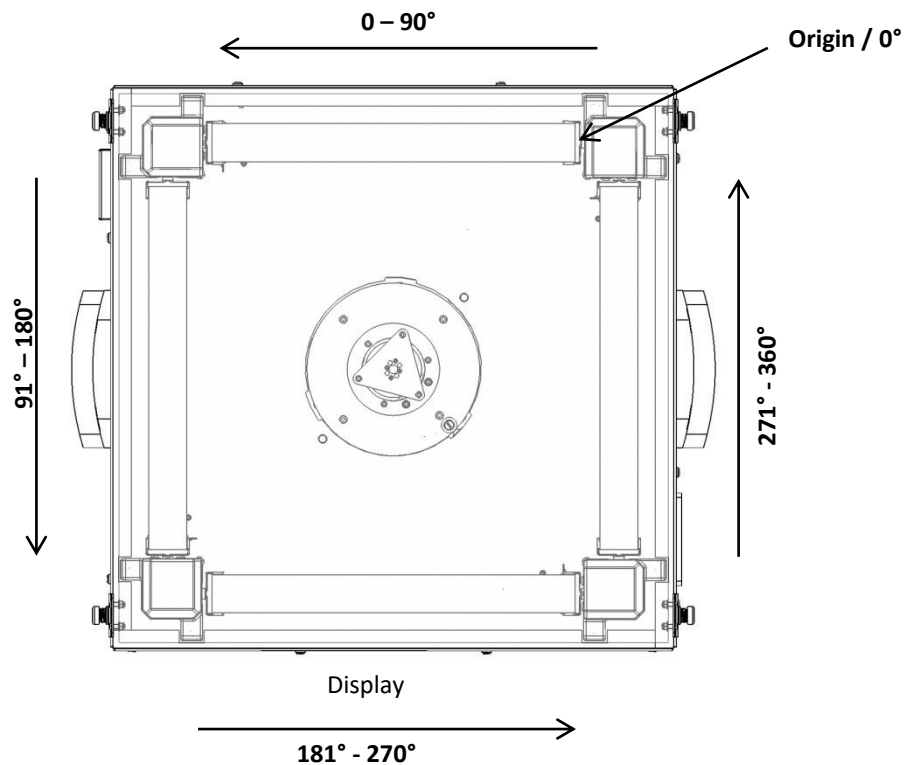

DMX mode 2 gives the creativity to control the beam parameters for the blue, the green and the red source independently.

Decoration

The PMMA material of the cover has the unique property to let the light go through while creating lines of light on it. In fact, the intersection of the 4 light plans with the PMMA cover is visible. It gives you the unique creativity to play either with immersive effects or the decorative effects or both at the same time.

The lines created by the projection of the 4 plans in any venue is an extraordinary way to combine lighting, decoration and mapping all together: your space of creativity is even bigger, as you can enhance the architecture of any place in an absolutely stunning and unique way.

Space coverage

The directivity of the IVL Lighting covers any large indoor area with advanced shapes. The light plan crosses the space thanks to a low divergence: it is important to have the right level of haze in the whole venue to materialize the effect and create a truly amazing experience.

The aperture angle on each mirror is 180°: allowing the 3D rendering perspectives to have no limit of size and the option to fill any indoor space

Dimmer

The dimmer is a full range dimmer from 0 (no light) to 100% (full brightness). The dimmer is controlled via DMX channel 2 in both DMX modes.

Colours

The IVL light source produces red, green and blue light. The red, green and blue portion of the light is controlled via DMX channels 5 (red), 6 (green) and 7 (blue) in both DMX modes.

Shutter

The electronic shutter supports strobe effects from 30 to 1440 bpm via DMX channel 8 in both DMX modes.

Service



High voltage! Risk of electric shock and fire.
Risk of blindness, skin and eye injury! Class 4 laser product
 Read the "Safety Information" on page 6 before connecting the product to AC mains power.
 Always disconnect the product from AC power before cleaning or servicing it to avoid blindness, eye and skin injury.
 Always clean or service the product in a well lit area where there is no risk of injury from falling parts, tools or other materials.

To Clean the Product

Excessive dust, smoke fluid, and particle degrades performance, causes overheating and will damage the product. Damage caused by inadequate cleaning or maintenance is not covered by the product warranty.

The product, and in particular the optics part should be cleaned regularly to obtain maximum performance and brightness.

To clean the cover:

1. Disconnect the product from AC power and allow it to cool for at least 30 min.
2. Remove the PMMA cover (see below).
3. Clean the PMMA cover and the 4 PMMA mirror bars. Clean the PMMA components with a soft wipe and / or standard glass cleaner without alcohol and a lint-free cloth. Do not use products, solvents or abrasive materials for cleaning PMMA.

To clean the fan filter of the side fan:

1. Disconnect the product from AC power and allow it to cool for at least 30 min.
2. Remove the housing of the fan filter and the fan filter.
3. Wash the filter with warm water with a little mild detergent until it is clean.
4. Let the filter dry completely. Do not install a damp filter as moisture damages the fixture.
5. Install the fan filter.

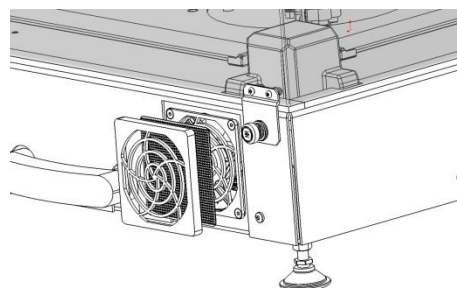

To clean the scanning mirror:

1. Disconnect the product from AC power and allow it to cool for at least 30 min.
2. Remove the PMMA cover (please see „To Change the PMMA Cover“ below).
3. Remove dust from the product with low-pressure dry air and / or a vacuum cleaner.
4. See picture right. Remove the three green marked screws to access the scanning mirror.
5. Clean the central scanning mirror with a soft cotton swab soaked with ethanol or iso alcohol and / or drag a soft lens tissue or microfiber cloth on the mirror. Be careful, the scanning mirror is a high reflective mirror. The coating is very sensitive and can easily be scratched. A scratched scanning mirror is not a warranty issue.

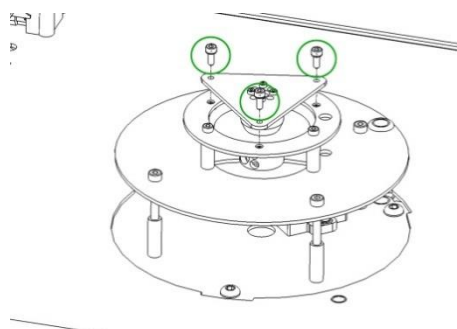

To Change the PMMA Cover

You can change the PMMA cover from IVL Carré to IVL Pyramide and vice versa. To change the PMMA cover:

1. Disconnect the product from AC power and allow it to cool for at least 30 min.
2. See picture on the right. Remove four screws (arrowed). Lift off the PMMA cover (IVL Carré or IVL Pyramide).
3. Place the new PMMA cover (IVL Carré or IVL Pyramide) on the product and close the quick links.

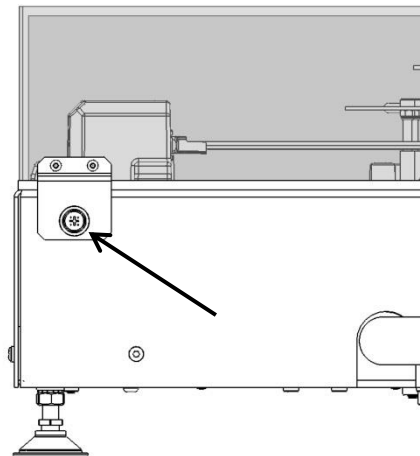

DMX Protocol

Mode / Channel		DMX Value	Percent	Function	Default (%)
1	2				
1	1	0 – 23 24 – 49 50 – 255	0 – 9 10 – 19 20 – 100	Control Off Reset On	75
2	2	0 – 255	0 – 100	Dimmer Close > Open	0
3	3	0 – 255	0 – 100	Blades coarse 0 > 360°	100
4	4	0 – 255	0 – 100	Blades fine	
5	5	0 – 255	0 – 100	Red 0 > Full	100
6	6	0 – 255	0 – 100	Green 0 > Full	100
7	7	0 – 255	0 – 100	Blue 0 > Full	100
8	8	0 – 14 15 – 27 28 – 227 228 – 255	0 – 5 6 – 10 11 – 89 90 – 100	Shutter Open Closed 30 > 1440 bpm Open	0
9	9	0 – 12 13 – 255	0 – 5 5 – 100	Tilt all coarse (disabled in console fixture) Off 0 > 360°	0
10	10	0 – 255	0 – 100	Tilt all fine (disabled in console fixture)	
11	11	0 – 255	0 – 100	Tilt 1 coarse 0 > 360°	0
12	12	0 – 255	0 – 100	Tilt 1 fine	
13	13	0 – 255	0 – 100	Tilt 2 coarse 0 > 360°	0
14	14	0 – 255	0 – 100	Tilt 2 fine	
15	15	0 – 255	0 – 100	Tilt 3 coarse 0 > 360°	0
16	16	0 – 255	0 – 100	Tilt 3 fine	
17	17	0 – 255	0 – 100	Tilt 4 coarse 0 > 360°	0
18	18	0 – 255	0 – 100	Tilt 4 fine	

19		0 – 36 37 – 73 74 – 110 111 – 147 148 – 184 185 – 221 222 – 255	0 – 14 14 – 29 29 – 43 44 – 58 59 – 72 73 – 87 88 – 100	Gobo all 1 Beam 2 Beams 4 Beams 8 Beams 16 Beams 32 Beams 64 Beams	0
20		0 – 255	0 - 100	Index / Offset coarse (inactive for rotation) 0 > 360°	50
21		0 - 255	0 – 100	Index / Offset fine	
22		0 – 12 13 – 122 123 – 133 134 – 242 243 – 255		Rotation No rotation Rotation counter-clockwise fast > slow Stop at current position Rotation clockwise slow > fast No rotation	0
23		0 – 255	0 – 100	Gobo Size all coarse 0 > 360°	0
24		0 – 255	0 – 100	Gobo Size all fine	0
25				Reserved	
	19	0 – 36 37 – 73 74 – 110 111 – 147 148 – 184 185 – 221 222 – 255	0 – 14 14 – 29 29 – 43 44 – 58 59 – 72 73 – 87 88 – 100	Red Gobo 1 Beam 2 Beams 4 Beams 8 Beams 16 Beams 32 Beams 64 Beams	0
	20	0 – 255	0 - 100	Index / Offset Red coarse (not for rotation) 0 > 360°	50
	21			Index / Offset Red fine	
	22	0 – 12 13 – 122 123 – 133 134 – 242 243 – 255		Rotation Red coarse No rotation Rotation counter-clockwise fast > slow Stop at current position Rotation clockwise slow > fast No rotation	0
	23	0 – 255	0 – 100	Rotation Red fine	
	24	0 – 255	0 – 100	Gobo Size Red coarse 0 > 360°	0
	25	0 – 255	0 – 100	Gobo Size Red fine	
	26	0 – 36 37 – 73 74 – 110 111 – 147 148 – 184 185 – 221 222 – 255	0 – 14 14 – 29 29 – 43 44 – 58 59 – 72 73 – 87 88 – 100	Green Gobo 1 Beam 2 Beams 4 Beams 8 Beams 16 Beams 32 Beams 64 Beams	0
	27	0 – 255	0 - 100	Index/Offset Green coarse (not for rotation) 0 > 360°	50

28	0 – 255	0 – 100	Index / Offset Green fine	
29	0 – 12 13 – 122 123 – 133 134 – 242 243 – 255		Rotation Green coarse No rotation Rotation counter-clockwise fast > slow Stop at current position Rotation clockwise slow > fast No rotation	0
30	0 – 255	0 – 100	Rotation Green fine	
31	0 – 255	0 – 100	Gobo Size Green coarse 0 > 360°	0
32	0 – 255	0 – 100	Gobo Size Green fine	
33	0 – 36 37 – 73 74 – 110 111 – 147 148 – 184 185 – 221 222 – 255	0 – 14 14 – 29 29 – 43 44 – 58 59 – 72 73 – 87 88 – 100	Blue Gobo 1 Beam 2 Beams 4 Beams 8 Beams 16 Beams 32 Beams 64 Beams	0
34	0 – 255	0 - 100	Index / Offset Blue coarse (not for rotation) 0 > 360°	50
35			Index / Offset Blue fine	
36	0 – 12 13 – 122 123 – 133 134 – 242 243 – 255		Rotation Blue coarse No rotation Rotation counter-clockwise fast > slow Stop at current position Rotation clockwise slow > fast No rotation	0
37	0 – 255	0 – 100	Rotation Blue fine	
38	0 – 255	0 – 100	Gobo Size Blue coarse 0 > 360°	0
39	0 – 255	0 – 100	Gobo Size Blue fine	
40			Reserved	
41			Reserved	
42			Reserved	
43			Reserved	
44			Reserved	
45			Reserved	

Specification

Measurements and Weight

IVL Pyramide (l x w x h)	594 x 552 x 884 mm ³ , 19 kg
IVL Carré (l x w x h)	594 x 591 x 113 mm ³ , 16 kg

Light Source

Class 3B laser product	Extremely short NOHD
Power embedded inside the housing.....	10 W
Colour.....	Smooth RGB spectrum
4 light plane.....	360°
Beam range	1 to 80°
Frost effect	Diffuse smooth light

Housing / Construction

Housing.....	Aluminium body, black matt
Plastic cover	PMMA
Protection rating	IP20
Transportation.....	Two side handle

Scanning System

Scanning motor	High life brushless DC motor
Constant scanning rate.....	333Hz
Mirror	R>98%
Safeguard	No scanning fail

DMX modes

Mode 1	25 channels
Mode 2	45 channels

Tilt Movement

Motor	4 brushless step to step motors
Mirrors	4 side PMMA mirror
Angle	0° to 360°
Resolution	16 bit

Beam Control

Number of beam	1 to 64
Control.....	Intuitive gobo like system
Gobo type.....	Number of beam
Gobo size	Width of the beam
Gobo indexation	Position of the beam
Gobo rotation.....	Speed and direction of the beam

Power supply

Power supply unit.....	100 to 240 Volts – 50/60Hz
Power	125-Watt max

Cooling system/Thermal

Cooling	Temperature-regulated
Safety.....	Protection against excessive temperatures

Installation

Standard mounting point	Six quarter-turn locking points
.....	Safety cable attachment point

Operating parameters

Positions allowed any
 Maximum ambient temperature 40°C (104°F)
 Minimum ambient temperature 0°C (32°F)

Connections

AC power input/output Neutrik PowerCon True1
 DMX data in/out 5-pin locking XLR

Approvals

Safety (Directive No : 2014/35/UE)
 IEC 60825-1:2014 (EN 60825-1:2014)
 IEC 60825-3:2008 (EN 60825-3:208)
 IEC 60065:2014 (EN 60065:2014)
 EN 62311 : 2008
 EMC (Directive No : 2014/30/UE)
 EN 55103_1:2009/A1:2013
 EN 62311 : 2008
 EN 55103-2 : 2009



	<p>Disposing of this product</p> <p>IVL products are supplied in compliance with Directive 2012/19/EC of the European Parliament and of the Council of the European Union on WEEE (Waste Electrical and Electronic Equipment), where applicable.</p> <p>Help preserve the environment! Ensure that this product is recycled at the end of its life. Your supplier can give details of local arrangements for the disposal of IVL products.</p>
--	---