



2024 Annual Catalog

AUSTIN HEALEY SPRITE & MG MIDGET

SPM-109



STARTERS BY WOSP

pg A39



BRAKE FLUIDS BY DYNOLITE

pg A49



STEERING WHEELS

pg A14





MOSS MOTORS, LTD.

INTO THE FUTURE



For decades, classic British cars have captivated enthusiasts with their timeless elegance and undeniable charm. This didn't happen without a lot of effort by a lot of people.

Restoration, the art of bringing these vintage vehicles back to their former glory, is key of preserving their legacy. And the dedication and attention to detail involved in the restoration process not only upholds the historical significance of these automobiles but also honors the craftsmanship of their original creators, too.

Reliability, a crucial concern for any vehicle, has seen significant advancements in the realm of classic British cars. With technological innovations and the

availability of modern materials and engineering, our beloved classics are being rejuvenated with enhanced performance, safety, and durability without compromising their authentic character. This blend of tradition and innovation enables enthusiasts to enjoy the driving experience of yesteryears with a newfound reliability that we've come to expect today.

Driving a classic British car is more than just a means of transportation; it's an effort to experience motoring elegance. The thrill of gripping the steering wheel that probably isn't power assisted. Listening to the hum of the engine and knowing what the different sounds mean from under the bonnet. Each journey celebrates the craftsmanship, style, and

the sheer joy of driving a timeless motorcar.

The future of classic British cars rests on you. It's your passion and dedication that's preserving these automotive icons, and each one of us here at Moss Motors is grateful of your commitment to maintain not only the cars but also the community that enjoys them. A community intent on passing on the torch of automotive enthusiasm to future generations.

As time marches forward, the legacy of classic British cars shines bright. Embracing the future while honoring the past, our cars remain a timeless symbol of automotive excellence.

Enjoy the ride,

Moss Motors

East & West Locations

Eastern Warehouse

25651 Simpson Rd.
Petersburg, VA 23803
Ph: 800-431-2496

Western Warehouse

440 Rutherford St.
Goleta, CA 93117
Ph: 800-667-7872

Telephone sales availability and showroom hours vary by location and day of the week.

Please visit our website for current hours of operation.



Place a single order of \$1,500 or more and you will automatically receive 10% off regular priced parts for 12 months! You will also be paired with a dedicated Sales Person who will give you personalized service.

Extend your time on the Customer Loyalty Program. While a member of the Loyalty Program, order a total of \$1,000 or more within 12 months and we will extend your 10% discount for an additional year! Only one extension per year is allowed.

For more information, visit MossMotors.com/customer-loyalty

Giftिंग made "easy"



Provide exactly what your favorite British car enthusiast needs when you give a Gift Certificate. Gift Certificates are available in one dollar increments, and shipped USPS 1st Class or UPS Next Day or 2nd Day if you need faster delivery.

Order by phone 800-667-7872 or online MossMotors.com/gift-certificate.



Your Favorite Brands



Working on automobiles is inherently dangerous. Moss Motors, Ltd. is not liable for injury or damage due to incorrect installation or use of their products. All products are sold with the understanding that the safe and proper installation and use of the products is the customer's responsibility. Follow factory workshop manual procedures and instructions, but use current shop safety standards and common sense. Some tasks will require professional advice or services which Moss Motors cannot provide.

OHIO BRUSH WORKS



360-166



360-167

Cleaning Brushes by Ohio Brush Works

The best tools can cost a little more, but with superior performance and longevity, they're often the best value. Ohio Brush Works products are an excellent example; they're handmade in the USA and Germany using only superior-quality American and German materials. Buy the best and have fun cleaning your classic!

6-piece Small Brass Cleaning Brush Set	360-172	\$34.99
Large Brass Cleaning Brush	360-166	26.99
Nylon Cleaning Brush Set	360-167	34.99
Nylon Cleaning Brush with Parts Washer Flow-Thru	360-168	34.99
Nylon Cleaning Brush with Garden Hose Connector	360-169	28.99
3-Piece Interior Detail Brush Set	360-171	30.99

MG Safety Fast Bomber Jacket

This black bomber-style jacket is warm, lightweight, and wind-resistant - making it perfect for early morning drives. Customized for the classic car enthusiast, this jacket sports the classic "Safety Fast" embroidery on the back and a smaller MG octagon on the front.

It features front zippered pockets, soft fleece lining, a rib knit hem and cuffs, and a zip-through cadet collar with chin guard. The jacket has a 100% polyester woven shell bonded to a water-resistant film insert - making it warm and dry no matter the weather. Show it off at your car club meetings or gift it to a fellow enthusiast. Machine washable. Available in sizes Small - 2XL. Get yours today!

Sizing, measured at the chest, in inches:

35-37 (S), 38-40 (M), 41-43 (L), 44-46 (XL), 47-49 (2XL)



Small	009-263	\$89.99
Medium	009-264	89.99
Large	009-265	89.99
Xlarge	009-266	89.99
XXLarge	009-267	89.99



Moss Picnic Blanket

Made of 100% polyester fleece with a water-resistant backing, this plush blanket is perfect for spreading out at a roadside picnic or keeping warm on a long roadtrip. It folds up into a neat parcel via a hook-and-loop closure for compact storage and comes with a handle for easy carrying. Blanket measures 47" x 52" when open.

Moss Picnic Blanket	009-228	\$25.00
---------------------	---------	---------



Polyurethane Valve Cover Bushing Set

Polyurethane bushings are made to be more resistant to abrasion than their traditional rubber counterparts. They have a high tear strength, a low compression set, and hold up against oils and solvents, resulting in a superior service life. With their resistance to compression and wear and tear, these bushings are a solid suppression upgrade for both performance and longevity.

Features:

- Low compression set
- High tear strength
- Resistant to abrasion and dry-rot
- Holds up against oils and solvents

Polyurethane Valve Cover Bushing Set009-164	\$6.99
---	--------



Insulated Mug

Made of stainless steel with a screw-on lid, this travel mug is the perfect way to show off your favorite marque. It's durable and insulated with a 20 oz capacity, laser etched MG Octagon or Austin Healey Script I logo, and a secure slide closure on top.

MG Insulated Mug - 20oz	009-232	\$29.99
Austin Healey Insulated Mug - 20oz	009-234	\$29.99



*See ordering page for details

⚠ WARNING: Cancer and Reproductive Harm. www.P65Warnings.ca.gov





MG Bucket Hat

Stay cool with this Safari-style bucket hat! Made of breathable pre-shrunk 100% cotton fabric, this khaki hat sports the classic MG logo, a wide brim for extra sun-protection, a draw string closure, and snaps on either side - in case you want to change up your look. Perfect for car shows, club meets, or a long drive on a sunny day.

MG Bucket Hat - Khaki 009-262 \$34.99



Blackout Hat

The new Blackout series hats have arrived! Clad in a clean and classic design, these comfort-fit baseball hats will fit in with any automotive occasion, and the black and white stitching match pretty much everything. Black in color, these hats are made of reinforced cotton twill with a 6 panel construction and an adjustable hook and loop closure. Front design features your favorite British classic, with a Union Jack and Moss block logo on the back.

Classic Bugeye 009-171 \$16.00



Union Jack Key Chain

Small and rugged, this new keychain exemplifies the British automotive spirit. Made from a durable and dense alloy, the Union Jack design is showcased uniquely in the rustic casting. The natural wear that comes with time will only make it shine ever brighter. Perfect for any British Classic, you'll be proud to add this to your keys. They also make the perfect gift for a like-minded friend or new club member.

Union Jack Metal Key Chain 009-238 \$7.99



Keep Calm Insulated Lunch Bags

Featuring the phrase "Keep Calm and Lunch on", this insulated lunch bag keeps your food and drinks cool while providing some classic car style. Made from durable 600D polyester, it has an upper and lower zippered compartment which is lined with PEVA for easy clean up.

- The lunch bag dimensions are 9" W x 11" H x 6 1/4" D.

"Keep Calm and Lunch On" - B.C.C. 009-230 \$24.99
 "Keep Calm and Lunch On" - MG 009-231 \$24.99



From **\$769⁹⁹**

Outdoor CarCapsule

This ultimate car parking capsule will protect your vehicle and keep it in showroom condition. The PVC vinyl top cover stands up to heat and cold as well as moisture. Durable material, self-healing coil zippers, and no rusting metal frame make for hassle-free maintenance and long-lasting durability, keeping your car protected from the elements all year round.

The heavy-duty base mat is impervious to oil, gas, and antifreeze while our welded D-rings add extra stability. This storage pod also includes two 12 volts 19 watt fans that provide continuously filtered airflow in all conditions.



See more **CarCapsule Options Online:**





MODERN SOUND FOR YOUR CLASSIC

Vintage Style Radios by RetroSound

RetroSound radios deliver superb sound and the latest audio features without compromising the original style of your dash. We carry a variety of their head units so you can choose the perfect solution for your audio needs.

HEAD UNITS



RetroRadio

The RetroRadio looks like your vehicle's original factory radio while adding all the modern audio features found in your daily driver. Classic push-buttons, replica knobs, and a period-correct bezel or faceplate combine with the radio's display to create a truly authentic look.

Europa

The Europa Radio is designed to replicate the look of the original, complementing the interior style of your classic car while updating audio technology to today's standards. A new Din Kit is included for an easy installation.

Grand Prix

The RetroSound Grand Prix perfectly compliments the interior styling of the 1980s while updating the audio technology to today's standards. A new Din Kit is included for an easy installation.

RetroRadio



Europa





Grand Prix



MOTORS

RetroSound radios are a modular design. Assembly is required. This design allows for a more adjustable fit and to offer different style options. *RetroSound Radios are only compatible with 12V negative grounding vehicles.*

			
	Motor 1B	Motor 2B	Motor 4HD
AM/FM RDS Tuner with 30 Pre-sets	✓	✓	✓
Selectable 12/24 Hour Clock	✓	✓	✓
Selectable Tuner with USA/EU/Japan Frequencies	✓	✓	✓
Clock-Off Feature	✓	✓	✓
Built-in Bluetooth®	✓	✓	✓
Non-Volatile Memory	✓	✓	✓
Front and Rear RCA Low Level Pre-amp Outputs	✗	✓	✓
Subwoofer Output with Variable Crossover	✗	✓	✓
Made for iPod® / iPhone®	✗	✓	✓
USB Port for WMA/MP3 Music Files	✗	1	2
Auxiliary Inputs	1	0	1
Display	White	32,000 Color Display	32,000 Color Display
Power Output	18 watts x 4	25 watts x 4	25 watts x 4
SiriusXM-Ready®	✗	✗	North America Only
Built-in DAB/DAB+ Tuner	✗	✗	✗



Quadraphonic Four-Channel Amp

Features:

- 45 watts x 4 channels continuous power output
- Full range Class D digital circuitry
- Advanced protection circuitry
- Shielded to prevent interference with the radio
- Direct connection compatibility with all RetroSound radios
- Compact size (7 1/4" x 3" x 1 3/4")

230-580 \$219.99



Amplified Subwoofer System

Features:

- 8-inch powered subwoofer system
- Built-in 100 watt Class D digital amplifier
- Built-in continuously variable crossover
- Remote level control
- Speaker level and RCA low-level inputs
- Rugged cast enclosure
- Small footprint (9 1/4" x 2 3/4" x 13 3/4")

230-550

\$199.99



USB/Auxiliary Extension Cables

Black	230-356	\$19.99
Chrome	230-357	\$19.99



SVC N-Series Speakers

Single Voice Coils (SVC) Speakers are a standard configuration single channel speaker for normal installations where speakers are mounted to the left and right of the car, such as doors or dash sides. 4.5" diameter, 2 way, pair.

230-535

\$114.99



Deluxe Surface Mount Speaker Set

Features:

- Multi-purpose surface-mount speaker modules
- Made from rugged ABS plastic
- Can be mounted to any flat surface, including kick panels, doors and rear decks
- Angled design directs sound towards the listener
- Price is per pair

4" x 6"

230-571 \$119.99

6.5" Round

230-575 \$159.99



Surface Mount 2-Way 4" Speakers

Features:

- 4 ohm impedance
- 45 Watts power handling
- Dimensions (each): 4 1/2" x 4 1/2" x 4"

230-565

\$59.99



Hide-Away Antenna

230-556

\$34.99



RetroPod DVC N-Series Speaker

Dual Voice Coils (DVC) Speakers allow for 2 stereo channels (left/right) to be connected to the same single speaker. This means that originality can be maintained on cars where a single speaker was fitted in the center of the dash or rear shelf, providing full stereo sound from a single speaker. These speakers are supplied individually without mesh grilles, to fit existing mountings.

230-505

\$99.99

Shop all Retrosound products online:
MossMotors.com/brands/Retrosound





Seat Kits

Get noticed with great seats! From our rich selection, you can choose to get that “just out of the factory” look with the vinyl kit or upgrade your car’s interior with one of our luxurious leather kits. Made from the best materials, the Sprite and Midget seat kits are patterned exactly like the originals. A great buy, these are sure to enhance your car’s interior. The front seat kits include covers for both front seats.

Note: Cushions, Pads, and Headrest covers available separately



Seat Heater

A little warmth in the right place can really make driving a much more comfortable experience. This therapeutic seat-heater has dual zones and two settings to keep your seat and lower back toasty. Designed to be installed under existing upholstery or seat covers, this kit is suitable for alternator equipped cars. Sold as a set for one seat. Negative ground cars with an alternator only.

Seat Heater Kit 903-251 \$129.99

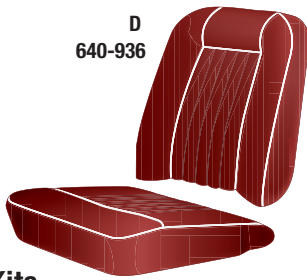

Seat Slides, Foams, Door Seals & Hardware

You'll find a complete listing of all the interior components you need to restore your Sprite or Midget in the Replacement Parts section of this catalog.

Seat Kits

	Black w/White Piping	Black	Red w/ White Piping	Navy w/ Lt. Blue Piping	Navy w/ Navy Piping	Navy	Blue w/ White Piping	Blue w/ Lt. Blue Piping	Autumn Leaf	Price
--	----------------------	-------	---------------------	-------------------------	---------------------	------	----------------------	-------------------------	-------------	-------

(A) Bugeye Sprite, 948 Sprite MkII 1958-62

Vinyl Seat Kit	640-777	640-771	640-778	640-776	640-772 ¹	-	640-773 ¹	640-779	-	\$539.99
Leather Seat Kit	640-781	640-783	640-782	640-784	640-786 ¹	-	-	-	-	799.99

(B) 948 Midget MkI 1961-62

Vinyl Seat Kit	640-700	640-701	640-702	640-703 ¹	640-704	-	640-705 ¹	640-706 ¹	-	\$529.99
Leather Seat Kit	640-710 ¹	640-711	640-712 ¹	640-713 ¹	640-714 ¹	-	-	-	-	799.99

(C) 1098 Sprite MkII & MkIII, Midget MkI & MkII 1963-64

Vinyl Seat Kit	640-720	640-721 ¹	640-722	640-723	640-724 ¹	-	640-725 ¹	640-726 ¹	-	\$559.99
Leather Seat Kit	640-740 ¹	640-741 ¹	640-742	640-743 ¹	640-744	-	-	-	-	799.99

(D) 1098 Sprite MkIII & 1275 MkIV, Midget MkII & MkIII 1965-68

Vinyl Seat Kit	640-935	640-931	640-936	640-932	640-933 ¹	-	640-934 ¹	640-937 ¹	-	\$469.99
Leather Seat Kit	640-965	640-964	640-966	640-963	640-962 ¹	-	-	-	-	719.99

(E) 1275 Sprite MkIV, 1275 Midget MkIII 1969

Vinyl Seat Kit, fixed back	-	640-945 ²	-	-	-	-	-	-	-	\$669.99
Vinyl Seat Kit, reclining back	-	640-950 ²	-	-	-	-	-	-	-	699.99
Leather Seat Kit, fixed back	-	640-800 ²	-	-	-	-	-	-	-	1,599.00

(F) 1275 Sprite MkIV, 1275 Midget MkIII & Midget 1500 1970-on

Vinyl Seat Kit	-	640-960 ²	-	-	-	640-930 ²	-	-	640-980 ²	\$769.99
Leather Seat Kit, fixed back	-	640-805 ²	-	-	-	-	-	-	640-810 ²	1,599.00

¹Special order, allow 6-10 weeks for delivery.

²Headrest covers not included.



*See ordering page for details

WARNING: Cancer and Reproductive Harm. www.P65Warnings.ca.gov



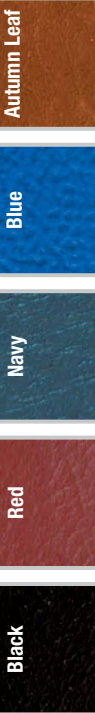
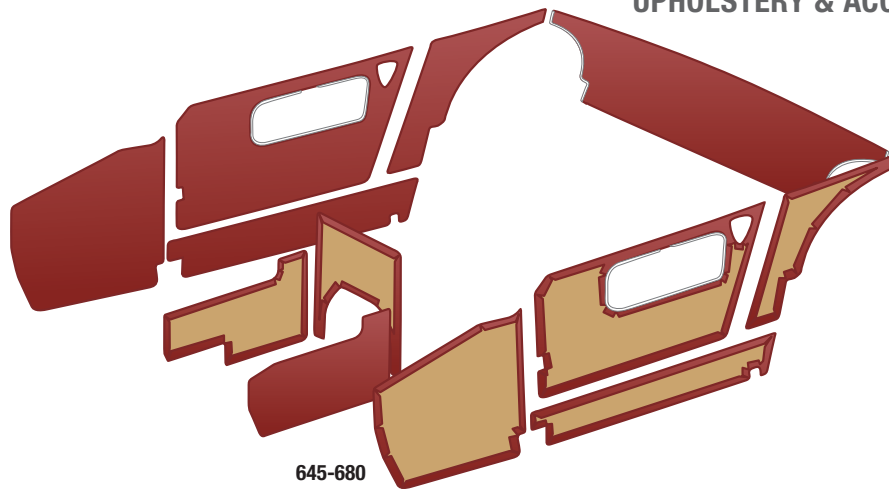
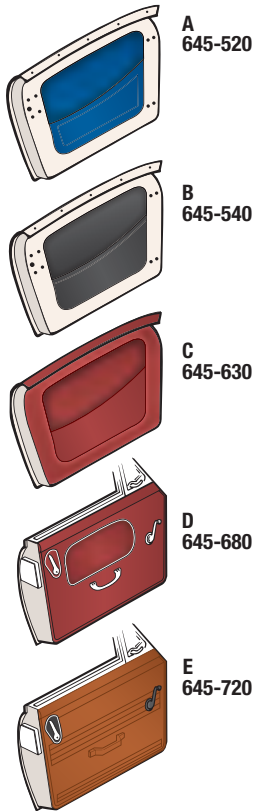

Interior Panel Kits

	Black	Blue	Navy	Red	Price	
(A) Bugeye Sprite; 1958-60	645-500	645-520	645-530	645-510	\$469.99	
(B) 948 Midget MK I, 948 Sprite MK II; 1961-62	645-540	-	-	-	489.99	
(B) 948 Midget MkI, 948 Sprite MkII; 1961-62	-	645-560 ¹	645-565	645-550	489.99	
(C) 1098 Sprite HAN7, Midget GAN2; 1963	645-620	-	-	645-630	569.99	
(D) 1098 Sprite HAN8, Midget GAN3; 1964-66	645-570 ²	645-693 ²	-	645-580 ²	450.00	
	Black w/ Black Piping	Black w/ White Piping	Bright Blue w/ White Piping	Dark Blue w/ White Piping	Red w/ White Piping	Price
(D) 1098 Sprite HAN8, Midget GAN3; 1964-66	-	645-690	645-693	645-692	645-691	450.00
(D) 1275 Sprite HAN9, 1275 Midget GAN4; 1967-69	645-660	645-670	-	-	645-680 ¹	849.99
	Autumn Leaf	Black	Navy	Price		
(E) 1275 Midget GAN5, 1500 Midget GAN6; 1970-80	645-720	645-700	645-710	669.99		

¹Special order, allow 6-10 weeks for delivery.
²With White Piping

Midget Headrest Assemblies and Headrest Covers

These faithfully crafted headrest assemblies and headrest covers offer a perfect solution to the often missing or weather-ruined headrest issue. Offered in both “Eared-type” and “Teardrop-type”, you can select from a variety of factory colors. Sold individually.



Headrest Assembly	Black	Navy	Autumn Leaf	Price
1970-76 “Eared-type” Perforated Headrests	649-100	-	649-130	\$169.99
1970-76 “Eared-type” Non-Perforated Headrests	649-140	649-150	649-170	174.99
1977-80 “Teardrop-type” Non-Perforated Headrests	641-605	641-615 ¹	641-635	169.99

Headrest Covers	Black	Navy	Autumn Leaf	Price
1970-76 “Eared-type” Non-Perforated Headrests	640-200	640-210	640-225	\$79.99
1977-80 “Teardrop-type” Non-Perforated Headrests	640-335	-	640-345	89.99

¹Special order, allow 6-10 weeks for delivery.

Bugeye Rear Deck and Trunk Liner Set

Spruce up your trunk with the Bugeye Rear Deck and Trunk Liner Set. The Bugeye was originally supplied with a rubber mat type of material on the wheel arches, rear deck and vertical panel leading from the floor to the rear deck. In the trunk area was a Hardura mat with grey side panels.

Our trunk liner set includes the trunk floor in black Hardura with fiber board side panels which can be painted in the original grey color. (Use this kit when you order the 1961-63 carpet set which will cover the rear deck area in carpet).

Our deck and trunk liner set includes the trunk liner set, all the pieces to cover the rear deck, wheel arches and the vertical panel between the floor and rear deck in black Hardura. Use this kit when ordering the Bugeye specific carpet set which only covers the floors in carpet.

Trunk Liner Set, Bugeye	242-500	\$169.99
Deck & Trunk Liner Set, Bugeye	242-501	319.99

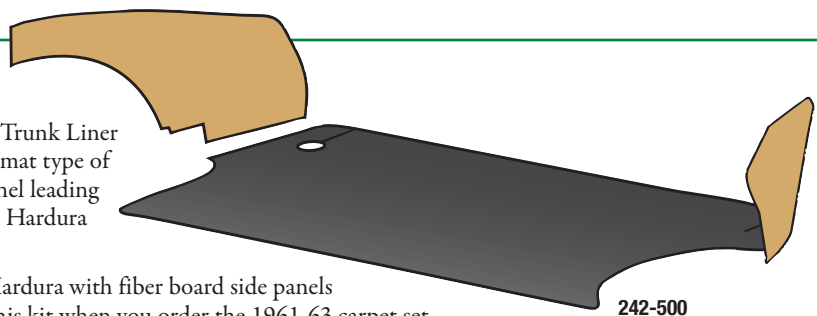



1961-74 Sprite/Midget Trunk Carpet Kit

Upgrade your car's interior with our custom trunk carpet sets. Because the 61-74 Sprite and Midget originally did not come with trunk carpet or mats, we thought it would be great if the Spridget owners had premium upholstery to spruce up their trunk and add that "finished look". Carefully patterned and cut for proper fit and ease of installation, the new trunk carpet for the 61-74 Sprite and Midget is made of high quality cut pile automotive carpet. All carpet sections are finished with heavy padding, bound edges and hardboard panel backing where fitted.

Available in colors to match and complement your interior carpet, these carpet kits are a product of Moss handcrafted upholstery, and include the necessary installation hardware to dress up your trunk. The kit comes with step by step instructions to guide you through a worry free installation. So, adhesive, trim tools, care and time are all you need to create a result you can be proud of. Get a free sample of our material by ordering part number 878-915!

Black	242-588	\$259.99
Red	242-589	259.99
Navy	242-591	259.99
Autumn Leaf	242-592	259.99

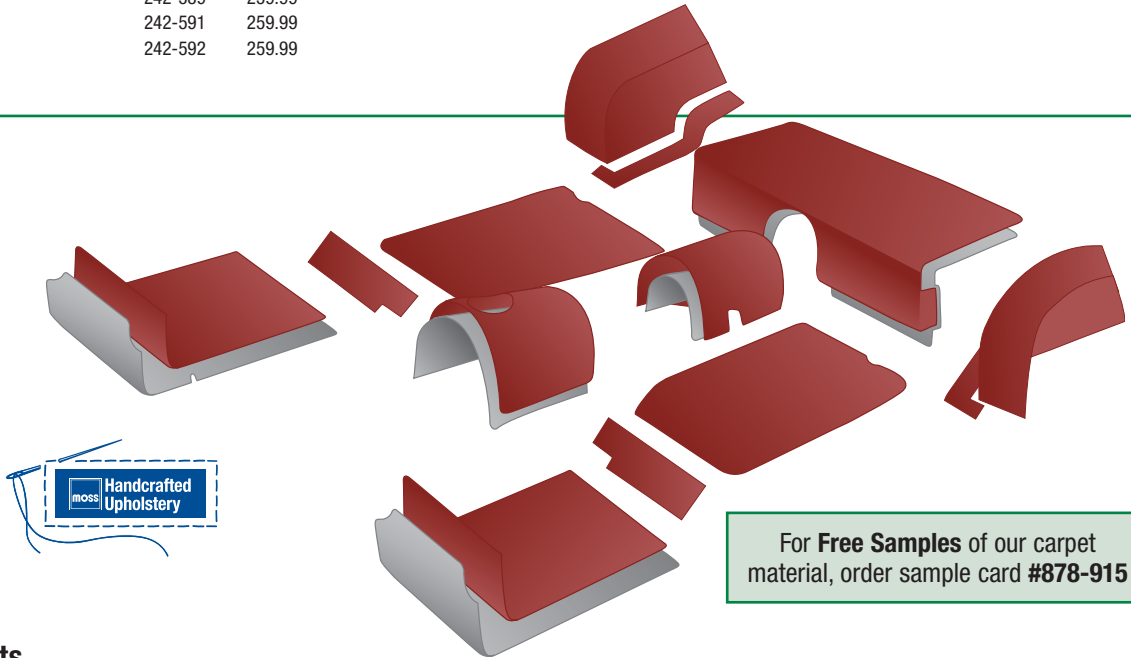

For Free Samples of our carpet material, order sample card #878-915

Carpet Sets

1958-61 (Sprite Mk I) - Covers floors & tunnel

Black	242-531	\$329.99
Red	242-532	329.99
Navy	242-533	329.99
Honey Tan	242-578	329.99

1961-63 (Sprite Mk II, Midget I)

Black	242-541 ¹	\$359.99
Red	242-542 ¹	359.99
Navy	242-543 ¹	359.99

1964-66 (Sprite Mk III, Midget Mk II)

Black	242-551	\$359.99
Red	242-552	359.99

1967-74 (Sprite Mk IV, Midget Mk III)

Black	242-560	\$399.99
Red	242-570	399.99
Autumn Leaf	242-580	399.99
Navy	242-555	399.99

1975-80 (Midget 1500)

Black	242-571	\$399.99
Red	242-572	399.99
Autumn Leaf	242-573	399.99

¹Can be used on Bugeye if you want rear deck and riser covered in carpet.



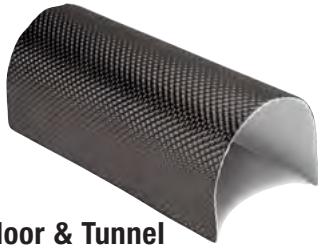

Black Floor & Tunnel Shields by DEI

Block engine and exhaust heat with the new Black Floor & Tunnel Shield by DEI. Backed with a high temperature pressure-sensitive coating, looks great while protecting components from damage. It can withstand up to 1750 F while the adhesive side can hold past 450 F. Constructed with an embossed 10 mil aluminum face bonded to 1/8" composite glass-fiber core, it is very flexible and can easily shape to firewalls, trans-tunnels, floors, and more. Easy to install. Available in two sizes: 48" x 21" and 48" x 42". We highly recommend this heat shield for your car!

Features:

- Proprietary high-temperature black coating
- Wind & water will not affect adhesive
- Minimum clearance required, only 3/16" thick
- Easily shape, trim, peel & stick
- Aggressive self-adhesive backing

48" x 21"	231-975	\$155.99
48" x 42"	231-976	299.99

Heatshield Material

This foil-covered insulation reduces unwanted heat, cold, and sound inside your vehicle when installed under carpets, over the transmission tunnel, and against the firewall. The closed-cell insulating material has a layer of foil on both sides and will not absorb moisture like its jute or cotton counterparts. Lightweight and easily managed, it is sold in 4' x 6' sheets which can be cut to fit.



Heat Shield Material	409-016	\$41.99	OS
Heat Shield Adhesive - 12 fl oz	409-037	28.99	

Sound and Heat Control Insulation

Install on doors, floors, and firewall. This insulation consists of an 80 mil thick butyl rubber-core covered with a 2.4 mil aluminum coating. It deadens body panel vibrations and reduces heat transfer. The kit contains nine 29" x 20" sheets (36 sq ft).



Insulation	409-027	\$159.99	OS
------------	---------	----------	----



Seat Towels

Don't just toss any old towel over your seat to protect your upholstery! This cover is designed specifically for your seats and features the Union Jack in full color or black and white. Made from cotton terrycloth, it's machine washable, and easy to remove and install.

Union Jack	216-590	\$54.99
Checkered & Union Jack	216-592	54.99



Spare Tire Cover

Sturdily constructed from high-quality vinyl, this spare tire cover will not only clean up the look of your trunk, but stand up to pretty much everything you throw at it.

Spare Tire Cover - Black	242-856	\$104.99
--------------------------	---------	----------

Reduce Heat & Noise with HushMat

Custom Sound and Heat Insulation Kits by HushMat

HushMat sound deadening & thermal insulation material leads the automotive industry in performance and ease of installation. Packaged specifically for your Sprite/Midget to provide 100% insulation coverage. No holes in the material - no puzzle pieces to put together - simply apply the HushMat Ultra material, as shown in the Installation Guides. Kits available for your Firewall, Doors, Floorpan, Trunk Floor or Complete Vehicle. Reduce road noise, exhaust noise and insulate your vehicle. Superior performance and adhesion is guaranteed.

Complete Vehicle Kit	409-250	\$619.99
Trunk Kit	409-270	264.99
Floorpan Kit	409-255	369.99 OS
Door Kit	409-265	104.99
Firewall Kit	409-260	154.99

- Complete Kit
- Trunk Kit
- Floor Pan Kit
- Door Kit
- Firewall Kit

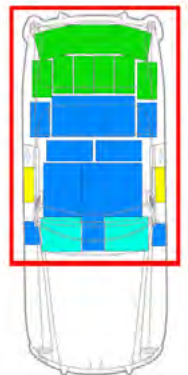

HushMat Ultra and Ultra II Insulation Kits

Easy-to-install butyl damping pads by HushMat reduce road noise and vibration, creating a solid and quieter environment. It will also allow you to stay warmer in the winter and cooler in the summer by reducing thermal transfer by over 40% when compared to other products. The HushMat Ultra II Hoodliner Kit is made from the same material, only slightly thicker for increased insulation. It trims easily with just a standard razor knife or household scissors making installation a snap! Just peel-off and stick. Manufactured only in the United States of America.

HushMat Ultra Door Kit 10 - 12" x 12" sheets	409-009	\$104.99
HushMat Ultra II Hoodliner Kit 6 - 12" x 23" sheets	409-007	\$144.99
HushMat Ultra Interior Kit 8 - 12" x 23" sheets	409-013	\$169.99



Beam's seat belts are made in the USA and exceed federal safety standards. Fire departments and amusement parks trust them, and we at Moss would not offer our customers anything less.



222-054

Vintage Style Seat Belts

Choose a safety measure in the color of your choice! Available in black, grey, red, and tan, our vintage style seat belts have high quality webbing with solid steel, chrome-plated, aircraft-style buckles, and are designed to complement your classic car. The substantial webbing length can be adjusted short or long for safe operation, so you can select the length that best meets your requirements. You can choose a 2-point seat belt that only goes across the lap, or get a 3-point seat belt that has a shoulder strap and goes across the lap and shoulder for added security. These seat belts are bolt-in for easy installation. All required mounting hardware and instructions are included. Sold individually.

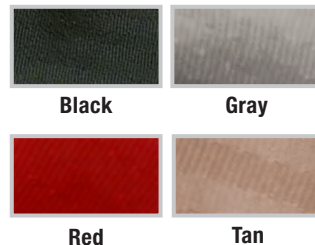

222-058



Hook Mount



Bolt Mount

Bolt Mount

	Black	Gray	Red	Tan	Price
2-Point Belt - Short (20" latch-plate end, 40" latch end)	222-234	222-051	222-053	222-054	\$36.99
2-Point Belt - Long (30" latch-plate end, 44" latch end)	222-235	222-056	222-058	222-059	36.99
3-Point Belt - Short (100" latch-plate end, 20" latch end)	222-204	222-041	222-043	222-044	59.99
3-Point Belt - Long (100" latch-plate end, 30" latch end)	222-205	222-046	222-048	222-049	59.99

Hook Mount

	Black	Gray	Red	Tan	Price
2-Point Belt - Short (20" latch-plate end, 40" latch end)	222-239	222-246	222-247	222-248	\$56.99
2-Point Belt - Long (30" latch-plate end, 44" latch end)	222-236	222-252	222-258	222-259	56.99
3-Point Belt - Short (100" latch-plate end, 20" latch end)	222-209	222-202	222-207	222-217	76.99
3-Point Belt - Long (100" latch-plate end, 30" latch end)	222-206	222-212	222-213	222-214	76.99

RetroBelt®

Seat Belts by RetroBelt

These RetroBelt original equipment-style lap belts come with chrome push-button buckles that feature a starburst design and webbing color-matched to its stitching. Available as a standard belt or with an inertia locking retractor, these meet or exceed Federal Motor Vehicle Safety standards. Priced individually, an economical solution to your seat belt needs.



Standard Seat Belt

These seat belts have alloy steel mounting-hardware for strength and durability. Sold individually.

Standard Seat Belt 222-215 \$34.99



Vintage Competition Belt

Quick release buckle with mounting hardware. Sold individually.

Competition Belt - Tan Buckle Pad 222-211 \$169.99
Competition Belt - Black Buckle Pad 222-221 169.99

Retractable Belts

2-point, 12" - Black 009-133 \$59.99
2-point, 20" - Black 009-134 59.99
2-point, 12" - Tan 009-137 59.99
2-point, 20" - Tan 009-138 59.99

Standard Belts

2-point, Short - Black 009-127 \$34.99
2-point, Long - Black 009-128 34.99
2-point, Short - Tan 009-131 34.99
2-point, Long - Tan 009-132 34.99



3-point Inertia Reel Seat Belt

Strapping on a seat belt should be simple, but replacement inertia reel-belts for pre-1976 Sprites and Midgets had short receivers. If the seat was moved forward, buckling was a struggle. Our new belt has a correctly sized receiver for all drivers. Belts are sold individually and include mounting hardware.

Black 3-point seatbelt 222-216 \$209.99



905-696

Inertia Reel Seat Belt

Angle-sensitive belts are fussy, grabbing even if you're just parked on a hill. Inertia Reel Seat belts grab when pulled rapidly - as they should. We have quality American-made inertia reel seat belts, suitable for Sprites or Midgets. Black with a stalk mounted receiver similar to that originally fitted in 1973 and later cars, and will not fit earlier cars. Includes mounting hardware. Sold individually.

Black Seatbelt 222-025 \$149.99



*See ordering page for details

⚠ WARNING: Cancer and Reproductive Harm. www.P65Warnings.ca.gov





Seat Belt Guide

This clever guide keeps your seat belt strap properly positioned over your shoulder instead of chafing against your neck or slipping down the seat, eliminating twisted and tangled seat belt. It is made of tough but flexible black UV-resistant plastic. Install it by removing your head rest and simply sliding it on for a friction fit, no tools required. The guide can also be modified for snap-on installation if your head rest is frozen. Fits all single-post headrests. Sold by the pair.

Seat Belt Guide 222-198 \$36.99



Direct Replacement Seat Belt Kit

This complete kit includes all the hardware to correctly and safely mount new retractable 3-point seat belts into the 1973-80 MG Midget. This is not a generic kit, or replacement belt, but a properly engineered kit with correct mounting hardware for the car.

1973-80 Midget 222-030 \$299.99
Emblem, MG - Each 905-696 20.99



Shift Knobs

You're not going to throw any random knob on your shifter. Yours will be a natural fit for you and your car. Our gearshift knob is just the right size and feel, and comes topped with a medallion displaying the AH Sprite or MG Midget logo. Get yours in elegant walnut wood or trimmed black leather.

Leather Crested

Midget 234-015 \$39.99
Sprite 234-045 39.99

Wood Crested

Midget 234-010 \$39.99
Sprite 234-040 39.99



234-010



cut-away view

Floor Mats & Trunk Mats



Ultra Plush Embroidered Floor Mat Sets

Step onto comfort with these ultra-dense plush carpet sets with non-slip rubber backing. Custom tailored for a perfect fit, these black mats feature embroidered logo of your favorite classic car. Sold as a pair.

Sprite 240-471 \$219.99
Midget 1961-74 240-481 219.99

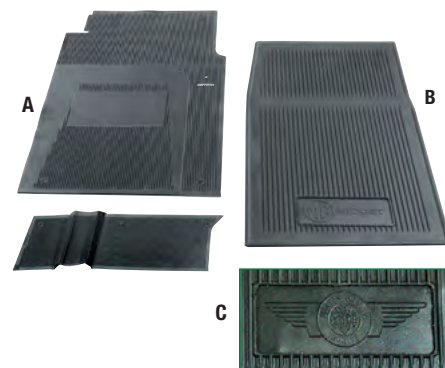

Amco-Style Rubber Floor Mat Sets

Protect your carpets from dirt, wear and fading. If mats get dirty, hose them down and return them to the car. Sold in pairs. Black.

(A) Side Curtain Cars 241-870 \$36.99
(B) Midget MkII-1500 241-860 36.99
(C) Sprite MkII-IV 241-880 36.99



Floor & Tunnel Shield by DEI

Designed to provide the best possible heat protection in areas where high temperatures are present and problematic, the Floor & Tunnel Shield II limits heat transfer on firewalls, transmission tunnels, floor boards, fuel cells and other areas where heat is an issue. It provides excellent light weight thermal protection, acts as a guard against track and road debris, and provides sound deadening.

Constructed with an embossed 10 mil aluminum face bonded to 1/8" composite glass-fiber core and backed with a high temp super strong pressure sensitive backing, it withstands up to 1750 F of direct continuous heat. Its improved multifaceted modern aluminum surface offers improved reflectivity, rigidity and allows for ease of installation. At only 3/16" thick, this product can be shaped and trimmed for a custom fit and is ideal for minimal clearance areas.

10" x 10" 231-904 \$23.79 48" x 21" 231-902 \$119.99
24" x 21" 231-901 59.99 48" x 42" 231-903 235.99

Pricing is subject to change.

Please visit MossMotors.com for current pricing and availability.

INTERIOR



Steering Wheels by Tourist Trophy

Tourist Trophy offers a complete selection of wood and leather steering wheels for most British cars. Made to the highest standards, these use aluminum frames for lightweight strength. With options including wood, leather, spoke style, and several different widths, you can easily personalize the look and feel of your car's interior with these classic steering wheels. Because the wood is unique to every piece, final stain color and grain patterns may vary. Adapter hub sold separately.

Laminated Wood Rimmed Steering Wheels

14" 3-spoke Matte/Drilled	489-070	\$359.99
15" 3-spoke Matte/Drilled	489-060	359.99
14" 3-spoke Matte/Slotted	489-085	359.99
15" 3-spoke Matte/Slotted	489-080	359.99

Leather Rimmed Steering Wheels

14" 3-spoke Black/Drilled	489-040	\$319.99
14" 3-spoke Matte/Drilled	489-030	319.99
15" 3-spoke Matte/Drilled	489-020	319.99
15" 3-spoke Black/Slotted	489-050	319.99

Solid Wood Rimmed Steering Wheels

14" 3-spoke Matte/Drilled	489-095	\$359.99
15" 3-spoke Matte/Drilled	489-090	359.99



489-090
Shown mounted on wheel adapter hub: 905-478



489-060



489-040

Moto-Lita

Moto-Lita Steering Wheels

Moto-Lita steering wheels employ attractive bicolored wood laminations or black leather over aircraft aluminum frames. Adapter hub sold separately.

Accessories

Polished Ring Kit	905-635	\$43.99
-------------------	---------	---------

Leather Rimmed Wheels

13" 3-spoke Polished/Drilled - Flat	905-145	\$489.99
13" 3-spoke Polished/Drilled - Dished	905-075	489.99
14" 3-spoke Polished/Drilled - Flat	499-520	489.99
14" 3-spoke Polished/Drilled - Dished	905-080	489.99
15" 3-spoke Polished/Drilled - Flat	499-500	489.99
15" 3-spoke Polished/Drilled - Dished	905-085	489.99

Wood Rimmed Wheels

13" 3-spoke Polished/Drilled - Flat	499-530	\$489.99
13" 3-spoke Polished/Drilled - Dished	499-585	489.99
14" 3-spoke Polished/Drilled - Flat	499-560	489.99
14" 3-spoke Polished/Drilled - Dished	499-590	489.99
15" 3-spoke Polished/Drilled - Flat	499-540	489.99
15" 3-spoke Polished/Drilled - Dished	499-595	489.99
15" 3-spoke Polished/Teardrop - Flat	499-580	489.99
15" 4-spoke Polished/Solid - Flat	454-245	649.99



499-520



499-580

Shown mounted on wheel adapter hub: 905-468

Billet Horn Push by Tourist Trophy

Engineered specifically for our Tourist Trophy and Moto-Lita Adapter Hubs and machined from aircraft-quality aluminum, you will enjoy the precision feel and crisp appearance of this Billet Aluminum Horn Push Assembly. Comes complete with a 46 mm MG or Austin-Healey emblem.

MG Logo	905-653	\$99.99
Austin-Healey Logo	905-654	99.99



905-653



905-654



454-366



905-648

Complete Wheel Adapter Kits

Includes hub, horn push and emblem.

Midget MkII, III 1964-67	454-366	\$149.99
Midget MkIII 1968-69	905-468	279.99
Midget MkIII 1970-77	905-482	159.99
Midget 1500 1978-79	905-486	159.99
Sprite MkI, II 1958-63	905-346	149.99
Sprite MkIII, IV 1964-67	454-368	149.99
Sprite MkIV 1968-69	905-478	279.99

Horn Push and Emblem Only

With 46 mm Healey Emblem	905-648	\$39.99
With 46 mm MG Emblem	905-646	39.99

Wheelskins

Leather Steering Wheel Cover by Wheelskins



These premium-grade black leather covers are custom tailored to fit your wheel. Simple installation results in a quality factory-fitted appearance. Made in the USA.

Dia: 15"-16"; Grip: 2 3/4"-3 1/8"	223-610	\$84.99
Dia: 16 1/2"-17"; Grip: 2 3/8"	222-310	84.99
Dia: 16 1/2"-17"; Grip: 2 1/2"	222-315	84.99
Dia: 16 1/2"-17 1/2"; Grip: 2 3/4"-3 1/8"	223-620	84.99

Steering Wheel Sun Covers

We all know the pain of a scalding-hot steering wheel, so we created a solution: this heat-resistant steering wheel cover. The combination of quality vinyl and heat reflective materials keep your steering wheel cool to the touch while protecting it from sun damage. The simple slip-over design provides full protection while being compact and malleable for easy storage. Offered in two sizes, Large (17" and smaller wheels) and Small (15" and smaller wheels), and available in black, grey, and tan, this cover is designed to fit with any interior.



The combination of quality vinyl and heat reflective materials keep your steering wheel cool to the touch while protecting it from sun damage. The simple slip-over design provides full protection while being compact and malleable for easy storage. Offered in two sizes, Large (17" and smaller wheels) and Small (15" and smaller wheels), and available in black, grey, and tan, this cover is designed to fit with any interior.

Steering Wheels Up To 18"

Black	009-123	\$59.99
Tan	009-124	59.99
Grey	009-125	59.99

Steering Wheels Up To 17"

Black	009-120	\$59.99
Tan	009-121	59.99
Grey	009-122	59.99



*See ordering page for details

WARNING: Cancer and Reproductive Harm. www.P65Warnings.ca.gov





440-600

440-604

Smiths Classic Digital Gauges

Bring modern technology into your much loved classic car with the brand new Smiths Classic digital gauges. Operating at 12 volts, these digital gauges measure either 100 mm (4 in) or 80 mm (3.15") in diameter, and feature a polished chrome bezel with black gauge face and white lettering. For Negative earth vehicles only.

The tachometer shows a range of 0-7000 rpm, and the speedometer shows a range of 0-140 mph or 0-240 kph with digital odometer/trip readout.

Includes Gauge, Gauge loom (plug for gauge and push button for screen), Gauge fitting bracket and Installation instructions.

Note: If your car does not have an electronic speedo output, our speedo sensor kit (#440-606) will allow gauge installation.

Speedometer		
MPH - 100 mm	440-600	\$459.99
MPH - 80 mm	440-601	459.99
KPH - 100 mm	440-602	459.99
KPH - 80 mm	440-603	459.99
Digital Speed Sensor	440-606	129.99
Tachometer		
100 mm	440-604	\$299.99
80 mm	440-605	299.99



Before

After

LED Dash Bulb

Bright white LED dash bulbs replace and better illuminate your gauges than the standard incandescent bulb (#171000). LEDs burn cooler and last much longer! They are not dimmable and should not be used as turn signal indicators or for the red generator/alternator light on the dash. Sold individually.

Negative Ground	170-972	\$4.99
Negative Ground - Short Profile	170-971	9.99
Positive Ground	170-975	9.99
Positive Ground - Short Profile	170-973	9.99
Wedge Type - Positive or Negative	170-976	3.99
Wedge Type - Positive or Negative - Short Profile	170-977	3.99

Oil Pressure/Water Temperature Gauge

This genuine Smith's combination gauge is a direct replacement for the obsolete originals. Gauge has black face with white lettering and needles, and a 82" capillary tube. Fits Sprite through MkIV, Midget MkI through 1500. Lettering and the scales may differ from the instrument in your car.



Sprite to MkIV, Midget MkI-1500	361-761	\$279.99
---------------------------------	---------	----------



Festoon Style LED Interior Bulb

Our LED festoon style interior bulbs illuminate your interior with bright white light. LEDs are more efficient than standard incandescent bulbs, burning cooler and lasting longer. This bulb replaces the standard festoon style incandescent bulb (#170-010). It is directional, so it must be properly aligned in sockets. Positive and negative ground. Sold individually.

Festoon Style LED Interior Bulb	170-996	\$11.99
---------------------------------	---------	---------

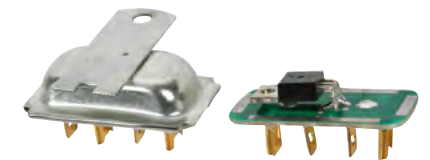

Solid State Voltage Stabilizers

The original Smiths voltage stabilizer is a mechanical device that over time fails for a variety of reasons. We have developed a replacement voltage stabilizer that combines modern electronics inside a vintage style housing.

Negative Ground	131-555	\$18.99
Positive Ground	131-556	18.99



Center Console and Armrest

Similar to the vintage aftermarket consoles made by Amco some years ago, this center console is black grained and has an ABS thermoplastic base with leather covered armrest. A useful large storage compartment is located under the armrest pad, and there's a cup holder in the forward portion.

Center Console & Armrest	453-805	\$174.99
--------------------------	---------	----------



Leather Upholstered

Plain

Center Console

Most existing consoles sit too low to be used as an armrest. Our ergonomic version not only looks great, but the taller height makes it supremely comfortable. Easily installed or removed, it will slip right between the seats of most classic cars where the cushions often provide sufficient grip. (Four small tabs are available for a more permanent installation.) Chose between textured plastic or premium leather. Available in multiple colors to best suit your car. Includes a stainless-steel cup holder and a power outlet for GPS or USB charging. Application specific.



Note: Cup holder opening is 2 3/8" and is suited to cans and standard water or soda bottles. We recommend having the power outlet professionally installed. Instructions not included.

Plain	453-965	\$99.99
Leather Upholstered - Black	453-966	189.99
Leather Upholstered - Red	453-967	189.99
Leather Upholstered - Tan	453-968	189.99
Leather Upholstered - Honey Tan	453-969	189.99

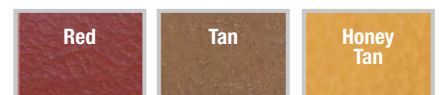

Pricing is subject to change.

Please visit MossMotors.com for current pricing and availability.



1968-80 Dash Pad Cover

Revitalize your old cracked dash top pad with this molded ABS cover. Comes complete with adhesive and instructions.

Dash Pad Cover 453-950 \$144.99 **OS**

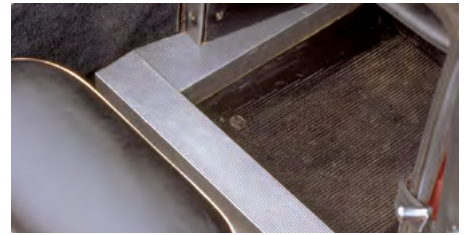

Ribbed Aluminum Trim Plates

Sprite Logo Threshold Plates

Add a custom touch while protecting your door sills from scuffs and scratches. Easy to install. Set of two.

Ribbed Aluminum Frame Cover Plates

Dress up the exposed frame sections in your interior with this four piece set.

Logo Threshold Plates 240-660 \$73.99
For ¼ Elliptic Springs 240-510 139.99



Drink Holder

Add this practical drink holder to your car. With a wide 3¼" diameter opening, it will receive almost any cup and hold it securely. Sturdily constructed and flocked in Charcoal Grey material, it is sure to complement your interior! To use it, just secure it in place by sliding the edge under a floor mat.

Large Drink Holder 100-785 \$39.99



Expandable Cup Holder









Our expandable cup holder mounts nearly anywhere. The arms adjust in or out to hold your container securely. Easily folds up when not in use.

Black 222-090 \$16.99



Key Blanks

Replace your old worn out keys with these new original style keys, or simply use as a spare set. Because original keys are extremely rare to find, we bring you customizable key blanks. These blank ignition keys must be cut locally. Order by the series number of your original locks.

	Crested	Non-Crested	BL
	\$9.99	\$5.49	\$14.99
MRN Series 	163-310	163-510	-
FA Series 	163-320	163-535	-
FS Series 	163-330	163-545	-
FP Series 	163-340	163-550	-
AA Series 	163-370	-	163-375
MG Series 	-	-	163-365
RV Series 	163-380	-	163-355
WS Series 	-	-	163-345
BL Series 	-	-	163-335



Footwell Light Kit

Illuminating the footwell area of your car for entering and exiting makes the transition much safer. Can be wired to any 12V source. Kit includes two lights, wiring and instructions.

Footwell Light Kit 903-651 \$44.99



Three Piece Master Lock Set

Replaces both doors and trunk lock assembly with matching key.

Three Piece Master Lock Set 470-458 \$174.99





OEM Type Top w/Header Rail - Made In England

These are genuine English factory style double-coated vinyl tops, complete with header rail, seal, retainer, and all snaps pre-installed which makes installation a breeze! Although not identical to the factory material, the differences are minor and virtually undetectable. This is as close as you can get to original!

Black Vinyl 242-205 \$1,149.00

Convertible Tops

Includes all necessary snaps and fasteners. Header rail and rear anchor bar are not included.



Fixed Window
Zippered Window

		Stayfast Cloth			Vinyl			
		Black	Tan	Price	Black	Tan	White	Price
Bugeye w/shield studs	✓	242-181 ¹	242-182 ¹	\$999.99	242-180	242-183 ¹	242-184 ¹	\$539.99
Bugeye w/shield rod	✓	242-186	242-187	999.99	242-185	242-188 ¹	242-189 ¹	539.99
1962 on w/Side Curtains	✓	242-191 ¹	242-192 ¹	999.99	242-190	242-193 ¹	242-194 ¹	549.99
1964-66 (winding window)	✓	242-196	242-197 ¹	999.99	242-195	242-198 ¹	242-199 ¹	549.99
1967-69 (8 studs)	✓	242-176	242-177 ¹	999.99	242-175	242-178 ¹	242-179 ¹	549.99
1969-80 (6 studs & velcro)	✓	242-201	-	999.99	-	-	242-204 ¹	539.99
1969-80 (6 studs & velcro)	✓	242-375	242-376 ¹	1,249.00	242-370	242-372 ¹	242-371 ¹	679.99
1969-80 (6 studs)	✓	-	242-202 ¹	999.99	242-200	242-203	-	539.99

¹Special order, allow 6-10 weeks for delivery.

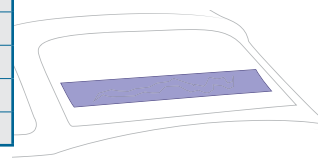

Lamin-X Soft Top Window Repair Strip

Perfect repair solution to keep a cut or crack in the plastic window of your convertible top from getting worse! This 2" x 24" strip of 19 mil clear has 3.5 mils of adhesive that bonds to the clear plastic and creates a strong waterproof seal. This strip is transparent enough that you won't notice it at a distance. Instructions included.

Strip - 2" x 24" 910-475 \$14.79



Side Curtains

Fit your Sprite or Midget with a set of our factory style side curtains, complete with sealing strips, brackets and screws. Just like the original, these side curtains look great while keeping out the wind, the cold and the rain.

Side Curtain Set, Alloy Frame 259-678 \$749.99
 Bracket Set with nuts & bolts 259-675 34.99
 Outer Seal, L/H 282-455 26.99
 Outer Seal, R/H 282-465 26.99
 Screws, side curtain mounting 401-690 11.99

Tonneau Covers

Tonneau covers are the time-tested and approved method of protecting your car's interior. Includes all necessary snaps and fasteners. Stayfast is an acrylic canvas which is flexible over a wide temperature range, while remaining waterproof and resistant to sagging, billowing, shrinking and fading.



	Stayfast Cloth			Vinyl	
	Black	Tan	Price	Black	Price
Bugeye	241-271 ¹	241-272 ¹	\$999.99	241-270	\$439.99
1961-64 w/ Side Curtains	241-281 ¹	241-282 ¹	929.99	241-280	479.99
1967-80 w/o headrests	241-291 ¹	241-292 ¹	999.99	241-285	519.99
1967-80 w/ headrests	241-301 ¹	241-302 ¹	999.99	241-290	519.99
1964-66 (winding window)	241-286 ¹	241-287 ¹	999.99	241-300	519.99

¹Special order, allow 6-10 weeks for delivery.

Pricing is subject to change.
 Please visit MossMotors.com for current pricing and availability.



Features	STORMPROOF	SILVERGUARD PLUS	MOSOM PLUS	TRIGUARD
WATER RESISTANCE	◆◆◆◆	◆◆◆◆	◆◆◆◆	◆◆
BREATHABILITY	◆◆◆◆	◆◆	◆◆	◆◆◆◆
COMPACTNESS	◆◆◆◆	◆◆◆◆	◆◆	◆◆◆◆
UV RESISTANCE	◆◆◆◆	◆◆◆◆	◆◆◆◆	◆◆
HAZARDS	◆◆◆◆	◆◆◆◆	◆◆◆◆	◆◆
SOFTNESS	◆◆◆◆	◆◆◆◆	◆◆◆◆	◆◆◆◆

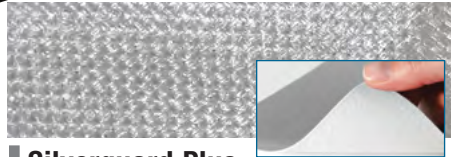

Stormproof

The culmination of over a decade of material engineering, it has only recently been possible to manufacture the microscopic yarns which go into this advanced micro-fiber cover material. Only one textile mill in the world was able to meet the specification – the results are truly a triumph for car cover users! Our Stormproof cover is uncoated and untreated, therefore, even after months or years of use it will retain the same properties. Stormproof has been tested to be the most water-resistant and the most breathable car cover material you can buy. You can't go wrong with Stormproof!

Note: We recommend that you take the cover off after rain or storm and allow the car to dry

Sprite/Midget (not 1500)	237-622	\$279.99
Midget 1500	237-623	279.99

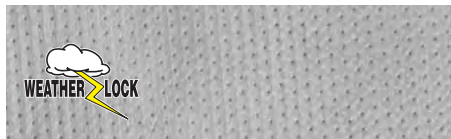

Mosom Plus

Mosom Plus is a four-layer material. The outer two layers are Spunbond Polypropylene, the middle layer is a special micro-porous film and the inside layer is extra soft fabric. The middle layer is an excellent rain barrier, which allows for vapors to pass through. The smooth cotton inner layer provides a delicate blanket for your vehicle, protecting the paint from debris and mild weather. It is a great choice for all-around car cover use, suggested for most conditions except extreme sun, snow or ice. Mosom Plus is a non-woven material, so in the unlikely event a rip occurs in the material, it will not run.

Sprite/Midget (not 1500)	237-460	\$124.99
Midget 1500	237-470	129.99

Please Note: Car covers are not intended for long term outdoor use. Periodically remove the car cover to inspect your vehicle. Not for use on vinyl wrapped vehicles. Liability is limited to the purchase price of the product and we will not be responsible for any other damage.

Silverguard Plus

Silverguard Plus is a 300 Denier polyester material with a reflective, water-resistant coating on the outer layer and a soft, nonabrasive layer on the inside. It is a great choice for areas that get harsh sunlight. It is not suggested for extreme rain, snow or ice. 300 Denier is a strong, heavy weave, which will not rip or tear easily. The silver coating does an excellent job of reflecting sunlight, therefore protecting your top, rubber seals and interior from premature wear. The soft inner layer pampers the most delicate paint finish.

Sprite/Midget (not 1500)	237-461	\$169.99
Midget 1500	237-471	169.99

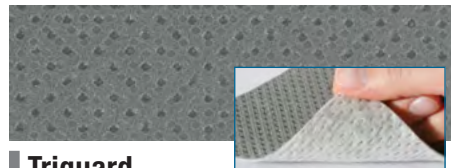

Triguard

This practical and cost effective car-cover has a universal fit and can be used both indoors and outdoors to protect against dust and debris. The medium size will fit vehicles from 13' to 14'.

Triguard Car Cover	236-446	\$64.99
--------------------	---------	---------



Interior Cover

You don't have to raise the top or use your car cover to protect your seats and panels. Slip on an interior cover and protect your interior from sun damage and heat build-up. Saves your interior from cracking and fading.

Sprite/Midget 1969-78	237-815	\$74.99
-----------------------	---------	---------

Car Cover Accessories

Stowage Bag	643-850	\$7.99
Cable Lock	643-855	7.99
Grommet	237-495	1.99



Stainless License Plate Support

Add a touch of sparkle to your ride. Polished stainless steel resists corrosion and brightens up later rubber bumper Midgets.

License Plate Support	451-296	\$48.99
-----------------------	---------	---------



229-730



License Plates

229-735

Display your loyalty with one of our regulation size license plates. Embossed aluminum plates with crisp screen printing.

Union Jack	229-730	\$14.99
MG Octagon	229-735	11.99



Personalized English License Plates

Regulation British plates are identical to those used in England in the '40s, '50s, and early '60s. Semi-sheared raised letters. Nostalgic and attractive, these plates can be personalized with up to seven letters and numbers of your choice. Unpainted.

English License Plate	307-073	\$89.99
-----------------------	---------	---------



*See ordering page for details

⚠ WARNING: Cancer and Reproductive Harm. www.P65Warnings.ca.gov





License Plate Frames

High-quality license plate frames to show off your car's heritage.

Union Jack, Black	222-735	\$51.99
Union Jack, Stainless	222-725	51.99
MG Safety Fast, Stainless	222-776	51.99
Sprite, Stainless	222-880 ¹	51.99
Midget, Black	222-850 ¹	51.99
Morris Garage, Stainless	222-830	51.99
Midget, Stainless	222-875 ¹	51.99

¹Standard mounting hardware included.



470-686

470-687

British Leyland Badges

Accurate reproductions of the two most popular versions of these emblems, the British Leyland badges feature self-adhesive backing for easy installation on the original fender location. In 1972, the cast version was introduced and was typically seen on the left hand fender of LHD cars.

Silkscreened, 1970-71	470-687	\$8.99
Cast, 1972 on	470-686	11.99



Grille Badges

Embellish your grille with these great looking badges. Solid baked enamel finish on a polished stainless steel back.

Note: Each badge requires a badge bar mounting backing plate.

1. Great Britain	408-506	27.49
2. England	408-507	\$27.49
3. U.S.A.	408-527	27.49
4. RAC	408-547	27.49
5. U.S. Coat of Arms	408-529	27.49
6. MG	408-487	27.49
7. Austin Healey	408-457	27.49
Badge Mounting Kit - 3/4" Bar	408-002	9.99
Badge Mounting Kit - 1" Bar	408-001	7.99
Badge Bar Mounting Backing Plate	408-577	11.99



License Plate Mount Badge Holder

A simple and practical way to embellish your car with a couple of badges. This badge holder is designed to mount on the upper or lower license plate mounting screws, and accepts both standard back mount and magnetic badges.

Badge Holder - License Plate Mount	244-105	\$36.99
------------------------------------	---------	---------



408-001



408-002

Badge Bar Badges

Add some flare to the front of your car with a selection of classic badges!

(1) RAC Badge, Chrome	408-695	\$89.99
(2) Cloisonné RAC	408-517	64.99
(3) St. Christopher	408-435	114.99
(4) Brooklands	408-175	74.99
Badge Mounting Kit - 3/4" Bar	408-002	9.99
Badge Mounting Kit - 1" Bar	408-001	7.99



408-001



408-002

Badge Bars and Mounting Hardware

Dress up the front of your classic with these high quality badge bars. Mounting hardware included.

Note: Badge bars do not fit Bugeye or Midget 1500.

Sprite/Midget	451-085	\$96.99
Sprite/Midget w/fog lamp mounts	451-075	164.99
Badge Bar Mounting Backing Plate	408-577	11.99
Badge Mounting Kit - 3/4" Bar	408-002	9.99
Badge Mounting Kit - 1" Bar	408-001	7.99

Pricing is subject to change.

Please visit MossMotors.com for current pricing and availability.

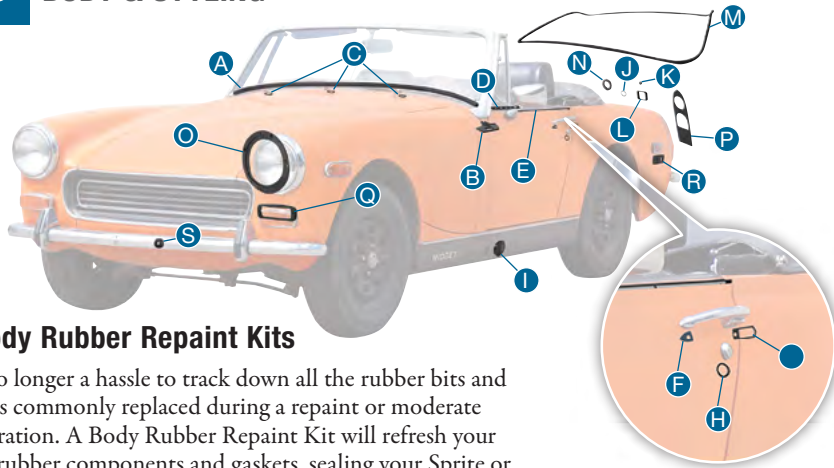

Body Rubber Repaint Kits

It's no longer a hassle to track down all the rubber bits and pieces commonly replaced during a repaint or moderate restoration. A Body Rubber Repaint Kit will refresh your car's rubber components and gaskets, sealing your Sprite or Midget from the elements, and save you time and money.

Start with the base kit, then choose a supplemental kit that corresponds with the year of your Sprite/Midget. This kit will contain additional parts specific to your car. Please check the table for specific content.

Base Kit - Side-Curtain Cars (Except Bugeye)	282-834	\$48.99
Base Kit - Roll-Up Window Cars	282-835	114.99
Supplement Kit - 1961-69	282-836	19.99
Supplement Kit - 1970-74	282-837	51.99
Supplement Kit - 1975-80	282-838	46.99

Body Rubber Kit Contents	
Base Kit - Side Curtain (Except Bugeye)	A, B, C (x2), I, J, K, M, N
Base Kit - Roll-up Windows	A, B, C (x3), D, E, F, G, H, I, J, K, L, M, N
1961-69 Supplemental Kit	O, P, Q, S
1970-74 Supplemental Kit	O, P, Q, R, S
1975-80 Supplemental Kit	I, O, P, R

Ill	Description	QTY
A	Windshield to Body Seal	1
B	Windshield Post Pads	2
C	Wiper Bezel Pads	1
D	Vent Window to Body Pads	2
E	Door Top Seals	2
F	Door Handle Gasket - Small	2
G	Door Handle Gasket - Large	2
H	Door Lock Gasket	2
I	Jack Hole Plug	2
J	Trunk Lock Gasket	1
K	License Lamp Wiring Grommet	2
L	Reverse Lamp Pads	2
M	Trunk Seal	1
N	Gas Filler Neck Grommet	1
O	Headlamp Seals	2
P	Taillamp Gaskets	2
Q	Front Park Lamp Gaskets	2
R	Rear Sidelamp Base Rubber	2
S	Front Bumper Mount Grommets	2

Brooklands Racing Screen

Reproduction of the traditional Brooklands Racing Screen. This accessory spruces up your Classic without taking away the originality. Screen includes a polished aluminum frame, safety glass, and chrome-plated brass mounting-hardware.

Brooklands Screen 224-100 \$199.99

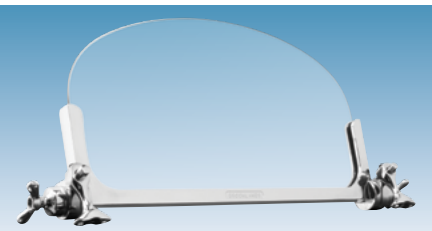

Decal and Plate Kit

Sprite Mkl (pictured)
Includes chassis, valve cover and heater plates. Screen washer reservoir, coil, air filter and wiring harness decals.

Midget 1961-66
Includes chassis and heater plates. Screen washer reservoir, valve cover, trip odometer, and air filter decals.

Midget 1967-69
Includes chassis and heater plates. Screen washer reservoir, valve cover, trip odometer, convertible top, radiator and air filter decals.

Sprite Mkl	410-110	\$41.79
Midget 1961-66	410-190	32.99
Midget 1967-69	410-195	32.99



TOURIST TROPHY®



Chrome Locking Gas Cap with MG Logo by Tourist Trophy

Thwart possible gas thieves and look great in the process! Add some security to your Midget while infusing style with this beautifully chromed gas cap adorned with the MG logo. Using the best materials, this modern day gas cap is long lasting! The outside base is chromed stainless steel while the swiveling MG emblem is cast from Zinc-Aluminum for superb chrome adhesion and shine. This cap has been tested in a mixture of 75% gasoline and 25% methanol to ensure compatibility with all fuels. Supplied with 2 keys.

Midget 1970 On 202-780 \$159.99



Locking Gas Cap

Chrome locking fuel filler cap. Includes two keys. Fits thru 1969.

Locking Gas Cap 202-760 \$54.99



Aston Gas Cap

Stylish, theft proof, and easy to install, the chrome Aston gas cap featuring the quick release function is a great buy! Vented. Fits through 1969.

1962-69 - Chrome 117-462 \$109.99



Warning Labels

These warning labels can help protect your vehicle from people who aren't quite as familiar with classic cars as you are. Traditionally styled, 4" x 1", glossy decals.

Positive Earth	215-010	\$4.29
Silicone Brake Fluid	215-005	4.99





Z-Beam Style H4 E-Coded Headlamp

Get the classic 7" Z-Beam style headlamps for your British sportscar. These quality headlights are e-coded based on EU standards and have an anti-fog coating. Sold individually. H4 60/55w 12v bulb included.

Z-Beam Style H4 Headlamp 162-790 \$45.99



1962-74 Alloy Headlamp Rim

Add a finished look to your headlamps with these lightweight alloy headlamp rims. Sold individually.

Alloy Headlamp Rim 560-211 \$54.99

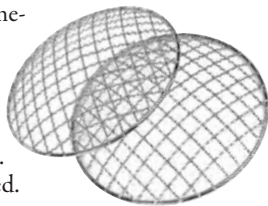

Headlamp Stone Guards

Heavy duty chrome-plated wire mesh stone guards will protect your headlights. May not be street legal. Hardware included.

Stone Guards 222-100 \$18.99



3rd Brake Light Kit

Center-mounted 3rd brake lights reduce accidents, so much so that they have been required on all passenger autos built since 1984. Our older classics, which are equipped with two dim, low mounted brake lights, aren't exactly easy to see. With a little creative wiring, you can mount one of our brilliant accessory 3rd brake light kits and improve the safety of your British classic. The base can be removed for flush mounting.

Chrome Brake Light Kit 116-115 \$114.99

Headlamps



7" Round Halogen Headlamp by WIPAC

This high-quality headlamp comes with replaceable H4 bulbs. Fits all regular 7" headlamp applications. Sold individually.



WIPAC Headlamp, each 162-715 \$64.99
Replacement H4 Bulb 902-998 6.39



P700 Tripod Headlamp Set

The P700, which is a step up from the standard headlamp, features an internal tripod reflector with a round center cap. Our reproductions capture the look and vintage design of these lamps at a much lower price!

P700 Tripod Set 156-878 \$179.99
Replacement Bulb 170-600 7.99



Hella Halogen Headlamp

The Hella Halogen headlamp offers accurate optics and reflector to ensure light is directed where needed. Safe for all vehicles originally equipped with 7" sealed beam headlamps. Sold individually.

Hella Halogen Headlamp, each 902-969 \$84.99
Replacement H4 Bulb 902-998 6.39



Crystal Clear Headlamp

Combine modern looks and improved visibility with the new Crystal Clear Headlamps with halogen H4 bulbs. These lamps are DOT and SAE approved, and deliver a strong focused light. The cast aluminum housing is corrosion resistant, and the lens is vented to prevent fogging. Sold individually.

Crystal Clear Headlamp, each 156-875 \$58.99
Replacement H4 Bulb 902-998 6.39



H4 Style Headlamp LED Conversion Kit

Developed for H4 (Semi-Sealed) style headlamps, the Stella Lux LED conversion represents a technological breakthrough for classic car owners. Lighting levels of 3000 Lumens per bulb mean these can be up to three times brighter than a standard H4 halogen bulb. LEDs emit a bright white 6000K color and deliver vastly improved road presence and visibility for a safe confident driving experience, no matter the conditions. The kit includes a pair of premium quality 25W Lumileds Luxeon Z ES LED H4 light units with a 10,000+ hour lifespan, and low load plug-and-play dual polarity drivers, which works with both positive and negative ground. We also offer this kit with two H4 style WIPAC headlamps. Keep your classic styling and have better lighting; you get the best of both worlds with this easily installed upgrade.

H4 Style LED Conversion Kit	171-250	\$229.99
Conversion Kit with WIPAC Headlamps	171-259	279.99



162-780

Hella 500 Light Kits

Light up the road with Hella 500 Light Kits. The Driving Light kit emits a focused beam for long-range illumination, while the Fog Light kit projects a wide and low illumination perfect for foggy or dusty conditions. Kits include: 2 halogen lamps, 2 H3 12V/55W bulbs, 2 protective stone shields, plug-n-play harness, 1 switch, 1 12V relay, and instructions. Lamp dimensions: 6.8"(h) x 6.4"(w) x 2.6"(d).

Driving Lights	162-780	\$139.99
Fog Lights	162-785	149.99



222-128

222-129

222-126

Competition Headlamp Blanks

Give your classic the racer look with our brand new competition headlamp blanks. Crafted for racing enthusiasts, as many competitions require the removal of the headlights, these blanking plates are designed to fit in place of the original 7" headlamp units. Perfect for racing and off-road use, these lightweight, quality aluminum headlamp blanks are available in two options. Take your pick from a plain brushed aluminum blanking plate or one with a decal simulating a Lucas P700 light!

Another great option is the aluminum competition headlamp intake. It has a big hole in the center to allow cold air to enter the engine bay and provide cooler intake temps. An intake hose can be clamped onto this product and routed closer to the intake filters. Easy to install with no special tools required. Sold individually.

Note: Headlamp intake will require modification to the existing headlamp bucket.

Headlamp Blank	222-128	\$28.99
Headlamp Blank with Decal	222-129	33.99
Headlamp Air Intake	222-126	56.99

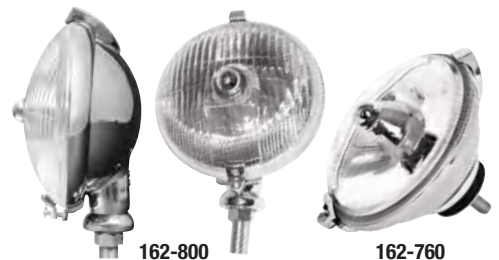

162-800

162-760

Fog and Driving Lamps

Quality reproductions of the classic 5½" Lucas 500 series SLR and SFT lamps as originally fitted on many cars of the 50s and 60s. Lamps are sold individually.

Driving Lamps		
Stem Mount	162-701	\$189.99
Back Mount	162-760	189.99
Fog Lamps		
Stem Mount	162-800	\$189.99
Back Mount	162-770	189.99
Replacement Bulbs		
Driving Lamp Bulb	170-500	\$12.99
Fog Lamp Bulb	170-510	6.99





Chrome Reverse Lamp Rims

The original reverse lamp lenses have never been a thing of beauty. Replace them with the brand new chrome plated brass rims fitted over the original lens to brighten the rear of the car. Available individually, or as a set of two with new lenses and installation screws.

Chrome Rim & Lens, Complete Car Set 164-868 \$59.99

Headlamp Relay Kit

Any British classic can benefit from adding headlamp relays. Your headlights will be significantly brighter, and the life of the lighting switch will be extended considerably with this easy-to-install kit. Relays are especially beneficial (and strongly recommended) if you have fitted halogen headlamps.

Headlamp Relay Kit 117-515 \$36.99

Rear Fog and Reverse Lamps

These matching lamps have polished stainless steel cases, glass lenses and 20W H3 type halogen light bulbs. 4½" wide, 2¼" high. 5/16" mounting hole required. Suitable for mounting below the rear bumper. Check your local regulations to make sure they are legal for street use. Sold individually.

Reverse Lamp, Clear 162-842 \$64.99
Rear Fog Lamp, Red 162-843 64.99

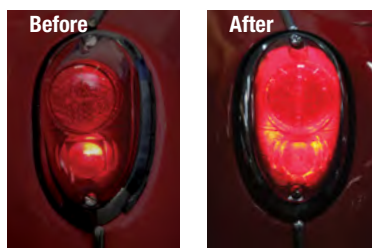

LED Tail Light Kit

By owning classic cars, we make compromises with modern safety in several ways, often with no apparent regret. One risk, however, no one would compromise on: getting hit from behind because our brake lights weren't visible enough. LEDs are a modern technology we can all get behind. Just drill a couple of small holes, and you're all set. And the immediate, intense light LEDs produce transform your brake lights and turn signals from wispy candles to high-powered beams. For negative ground vehicles only.

Note: Requires use of electronic flasher. Part # 141-667 for 2 prong and 141-668 for 3 prong.

Bugeye Sprite 143-810 \$129.99
Electronic Flasher - 2 prong 141-667 26.99
Electronic Flasher - 3 prong 141-668 26.99



Scan code to see LED
INSTALLATION video
MOSSTV



LED Replacement Bulbs

LED Exterior Lighting

We've had our eyes on these for a while now. We couldn't help it, they're so bright! Our LEDs for negative ground vehicles have the advantage of a wide-angle light distribution design. These bulbs fit factory sockets, and can be easily installed. After much searching and testing of different products, we can now say that Moss offers an LED lighting solution that measures up to our high standards.

Our LEDs come in three colors

White, red and amber - to match the color of the lens application. Trust us, you don't want a white light LED behind a red lens. Pink is not the universal color for "stop".

Upgraded Electronic Flasher

If you are upgrading any of your turn signals, you will need to upgrade to an electronic flasher. The LED bulbs draw so little current that they won't trigger a mechanical flasher to blink.

Do I need ballasts with my LED turn signals?

This is not an issue in all Classic British cars. Because of the LEDs low current draw, the tiny amount of current circulating from one side of the car to the other will be enough to let the LEDs on the second side of the car come to life. Blinking turns to hazard lighting and that's not what you want. The fix is simple. The power flowing through the blinker indicator lamp is looking for a ground. We give it one. A ballast resistor is a simple electronic device designed to give the indicator the ground it's looking for without leaving any extra for the opposite LEDs to feed on. You will need one for each side of the car. The application data in the schematic section of this catalog and on our website will tell you if your car needs a pair of ballasts.



170-941 170-956

Ballast Resistor
Spridget 1972-on 170-965 \$17.99

Electronic Flashers
2-Prong - Negative Ground 141-667 \$26.99
3-Prong - Negative Ground 141-668 26.99



170-906 170-920

Industry #	57	89	1157	1156
Replaces Moss #	170-100, 170-250	170-300	170-700	170-800
White	170-906	170-920	170-931	170-946
Amber	170-911	170-921	170-936	170-951
Red	170-916	170-925	170-941	170-956
Price	\$19.99	\$19.99	\$29.99	\$29.99

Pricing is subject to change.
Please visit MossMotors.com for current pricing and availability.

EXTERIOR



Quarter Light Mirror

This popular option can be clamped to a quarter light, windshield frame or roof lip to give better visibility.

Quarter Light Mirror 165-175 \$49.99

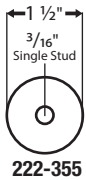

Baby Turbo Mirror

High-quality version of the popular mirror from the 80s, this Baby Turbo mirror looks fresh and gives an updated look. Reversible mount for LH or RH use.

Baby Turbo Mirror 165-350 \$149.99

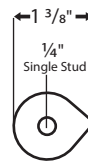

165-400/165-500
165-210/165-300



223-310

Lucas Style Reproduction Mirrors

Flat Fender Mount	223-310	\$56.99
R/H Flat Lens	165-400	42.99
L/H Flat Lens	165-500	42.99
R/H Convex Lens	165-210	42.99
L/H Convex Lens	165-300	42.99

Raydyot Racing Mirrors

Raydyot mirrors were often bolted to racing and performance cars in the '50s and '60s. Their brushed aluminum design was extremely lightweight and strong. Less weight will forever be the aim of speed seekers. The mirror's low mass led to another important advantage: they were stable and vibration-free. Moss has captured not only the distinctive look and character of the original Raydyot mirror, our aluminum reproductions also share the performance advantage of being light and strong. Select mirrors with traditional flat lenses or wide angle convex. Sold individually.

Raydyot Mirror - Flat 222-355 \$54.99
Raydyot Mirror - Convex 222-356 54.99



222-372

Bullet Mirrors

The combination mirror has two base options. Short base is 2 1/4" with bolt holes 1" apart. Long base is 4 7/8" with bolt holes 3 1/2" apart. The oversize lens mirror has a 3" long base with bolt holes that are 1" apart.

Combination Mirror 222-372 \$54.99
Oversize Lens 222-390 64.99

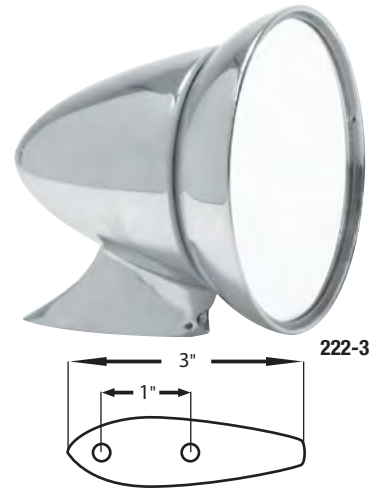

222-390

Luggage Racks



Sprite/Midget Luggage Rack

This stainless steel beauty measures 34 1/2" x 15". Fits all except Bugeye.

Luggage Rack 244-730 \$399.99 OS



Bugeye Luggage Rack

Factory style rear luggage rack. Features strap mounting tabs. Measures 30 1/2" x 16".

Bugeye Luggage Rack 244-720 \$459.99 OS



*See ordering page for details

⚠ WARNING: Cancer and Reproductive Harm. www.P65Warnings.ca.gov





Works Type Bonnet Straps

Bonnet Straps began life as a safety measure for racers but daily drivers loved the look and added them to their sports cars. Our authentic reproductions are sold individually or in pairs, and are a cinch to install.

Tan Leather, Pair	222-728	\$56.99
Tan Leather, Each	222-729	34.99
Black Leather, Pair	222-602	56.99
Black Leather, Each	222-601	34.99



Lucas Style Windtone Horns

A Moss exclusive - our reproduction of the original style Windtone horns is the best available. Originally fitted in many early MGs, Triumphs and Jaguars. Set of two, includes high and low note horns.

Note: Requires bracket #405-800 for easy installation.

Windtone Horns	165-708	\$169.99
Bracket	405-800	54.99

Compact Air Horn Kit

Tired of large, modern vehicles not noticing your classic British sportscar on the highway? This kit fits in a space 5½" x 4½" x 4" and produces deep tones of 115 db at 6 ft. A perfect solution for your compact car. Kit comes with a relay, mounting bolt and nut, and instructions.

Compact Air Horn Kit	545-085	\$62.99
----------------------	---------	---------



Raked Shorty Antenna

Small, powerful, and mere 7 inches tall with a swept back look, our amplified antenna is a major design improvement over an unsightly standard mast or a noisy old power antenna. Comes with a 195" detachable cable, and the mast easily unscrews if you have a car cover without a hole.

7" Amplified	906-185	\$33.99
--------------	---------	---------



386-960 386-971 900-716

Radio Antennas

Upgrade your old antenna with these great replacements!

Electric Retractable Antenna: Our electric antenna kit wires into your radio for fully automatic operation. Requires 13½" depth to mount.

Flush-Fit Antenna: This collapsible antenna locks when down. Requires 11¼" depth to mount.

14" Rubber Antenna: Black. Includes 54" lead cable.

Electric Antenna	386-960	\$149.99
Rubber Antenna	900-716	14.99
Flush-Fit Antenna	386-971	19.99



Twin Air Horns

Our twin tuned air horn set includes two air horns, heavy duty die-cast compressor, air hose, mounting hardware, and installation instructions.

Air Horns	545-080	\$59.99
-----------	---------	---------



Twin Trumpet Horn Kit by Hella

The Twin Trumpet Horn Kit by Hella produces a full harmonious and wide range of sound radiation. Noticeably louder than stock horns, these trumpet horns have been manufactured to the highest standard. This kit includes both high and low note horns, relay, mounting brackets, and instructions.

Twin Trumpet Horn Kit	545-095	\$35.99
-----------------------	---------	---------



Super Tone Horn Kit by Hella

Compact and powerful, a proper horn is more than an accessory: it's a safety measure. Our high quality horn upgrades are simple to install, sound great, and definitely turn heads with their volume!

Super Tone Horn Kit	545-090	\$59.99
---------------------	---------	---------



Pricing is subject to change.
Please visit MossMotors.com for current pricing and availability.



Wire Wheel Balancing Tool Set

The wire wheel balancing tool set is a great buy for any classic car owner. While most auto body shops, garages, and tire centers are equipped to balance the wheels of modern cars, they do not always have the right set of tooling for classics in order to mount the wheel on its true axis and accurately balance center lock wire wheels. When you get your Classic's wheels balanced at these shops, additional weights are put on to make sense of the machine's readings and you end up with incorrectly fitted wheels. Investing in this tool set gives you the freedom to go to any garage and get your wheels balanced properly.

This useful tool set comes with interchangeable parts to accommodate the three most commonly used spindle sizes on dynamic balancing: 36 mm, 38 mm and 40 mm. It also includes two cup sizes to fit 42 mm and 52 mm center lock wheels.

Wire Wheel Balancing Tool Set 386-305 \$649.99

MORE INFO ONLINE



Wire Wheel Conversion Kit

Owners have been converting disc wheels to wire wheels for decades. Our kit makes that conversion a snap!

The kit includes 4 hubs (2 left, 2 right), 4 chrome knockoffs, 16 nuts, 1 hammer and 2 spacers for Bugeye Sprites.

Wire Wheel Conversion Kit 111-425 \$799.99



Wheel Trim Rings

Add an attractive accent to your rims with these polished stainless steel wheel trim rings. Sold in a set of 4. For Rostyle wheels only.

13" Trim Rings - Set of 4 453-048 \$159.99



454-686

Wire Wheels by MWS

Enhance the appearance of your car with this great looking set of chrome wire wheels: an essential part of your Sprite or Midget's styling.

Dia/Width	Spokes	Finish	Unit	Part #	Price
13" x 4"	60	Chrome	Each	454-686	\$549.99
13" x 4"	60	Painted	Each	454-676	399.99



Minilite Style Knockoff Wheels

Designed to replicate the famous racing wheel of the past, this 13" knockoff "Minilite" replica wheel will fit wire wheel hub equipped cars with round rear wheel arches. Please note tire clearance will be tight with some tire sizes.

13" x 5" Bugeye & Round Arch Cars 453-081 \$679.99



453-065

453-066

Minilite Style Sport Wheels

Manufactured using the latest techniques and testing procedures to ensure the highest quality, these wheels carry on the race and rally tradition of the marque.

13" x 5" Sprite/Midget - Silver	453-065	\$239.99
13" x 5" Sprite/Midget - Anthracite	453-066	239.99
Replacement Hub Cap - Metal	455-367	21.99
Replacement Hub Cap - Chrome	456-049	14.99
Lug Nut, Chrome	264-155	3.49
Lug Nut, Stainless Steel	264-156	5.49
Lug Nut, MG Crest	264-465	4.79
A-H Emblem for Center Cap	453-069	3.59
MG Emblem for Center Cap	455-377	4.99



*See ordering page for details

WARNING: Cancer and Reproductive Harm. www.P65Warnings.ca.gov





Inner Tubes and Rim Bands

Designed for use with radial tires. Can be used with bias-ply tires. Features rubber covered valve stems. Rim bands prevent spoke and nipple ends from chafing your inner tubes. All sold individually.

Inner Tubes 145 x 13"	452-736	\$19.99
Rim Bands 13" Rim Band	452-730	\$8.99



Brass Tire Gauge

Solid brass precision gear movement. Push button valve to bleed air to the desired pressure. U.S. and metric scales.

Brass Tire Gauge	225-715	\$29.99
------------------	---------	---------



Valve Stem Caps

Dress up your chrome wheels with a classic touch. These solid brass caps with logos are finished in chrome and utilize an O-ring for a proper seal. Sold as a set of 4.

Union Jack - Non-Locking	101-161	\$13.99
Checkerboard - Non-Locking	101-167	13.99



Embossed Valve Stem Cap Set

Subtle and elegant, these nickel-plated steel valve stem caps feature an MG crest embossed on the top. Sold individually.

MG Valve Stem Caps	215-825	\$11.99
--------------------	---------	---------



Protective Knockoff Wrench

Prevent damage to knockoffs with multi-ply wooden wrenches. Fit all 42 mm conventional British two eared knockoffs.

42 mm Wrench	386-165	\$38.99
--------------	---------	---------



Knockoff Hammers

Useful in multiple applications, these knockoff hammers are available in all types, weights, and sizes.

1 lb Copper/Copper	386-000	\$59.99
2 lb Copper/Copper	386-850	58.99
2 lb Copper/Rawhide	386-110	89.99
2 lb Zinc Alloy	386-020	65.99
4 lb Lead Alloy	386-180	76.99

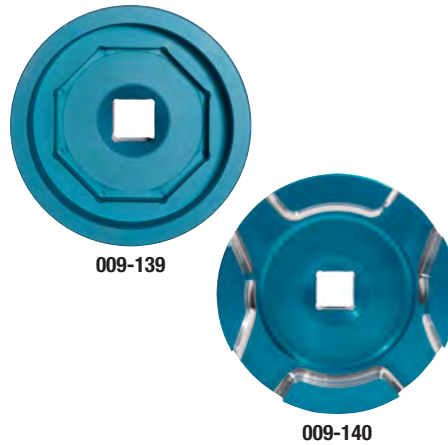

Knockoff Tools

Prevent damage to your knockoffs with these specialty sockets. These sockets allow you to safely tighten or remove knockoffs without a hammer. For use with a 3/4" breaker bar or torque wrench. Available for octagonal or 2 ear knockoffs.

Octagonal	009-139	\$179.99
2-Eared	009-140	179.99



Long Handle Knockoff Wrench

Tighten or remove spinners easily with this long handle wrench.

Octagon Knockoffs	386-120	\$74.99
Eared Knockoffs	386-125	79.99
Fabric Wrench Cover	386-115	22.49

Knockoffs

Choose the original 2-eared style, or the more exotic 3-eared style. Earlier cars have fine 12 threads per inch, later cars use a coarser 8 threads per inch. Our MG crested knockoffs were original equipment on MGT and MGA, but would look great on your Midget.

3-eared Knockoffs

Fine Thread 12 t.p.i. - Left Hand	200-315	\$119.99
Fine Thread 12 t.p.i. - Right Hand	200-325	119.99
Coarse Thread 8 t.p.i. - Left Hand	200-335	139.99
Coarse Thread 8 t.p.i. - Right Hand	200-345	139.99



MG Crested 2-Eared Knockoffs

Fine Thread 12 t.p.i. - Left Hand	200-220	\$69.99
Fine Thread 12 t.p.i. - Right Hand	200-210	69.99
Coarse Thread 8 t.p.i. - Left Hand	200-225	69.99
Coarse Thread 8 t.p.i. - Right Hand	200-215	69.99



Standard 2-Eared Knockoffs

Fine Thread 12 t.p.i. - Left Hand	200-280	\$69.99
Fine Thread 12 t.p.i. - Right Hand	200-290	69.99
Coarse Thread 8 t.p.i. - Left Hand	674-680	69.99
Coarse Thread 8 t.p.i. - Right Hand	674-670	69.99



Wire Wheel Spoke Wrench

With its wide face and long handle, this wrench is perfect for adjusting most spoke nipples without rounding them off.

Spoke Wrench	385-800	\$14.99
--------------	---------	---------



A-Series Performance Tappet Sets

The tappet takes the brunt of the punishment in the engine as it rides on a thin film of oil on the cam lobe. In an effort to offer the engine builder alternatives we carry a range of tested and updated tappets for the 948 to 1275cc engines. Select your application below.

Tested Tappet Sets

These tappets are inspected for dimensional accuracy, and then hardness tested to ensure a hardness of Rc 54-58. The face of the tappet is crowned slightly to ensure rotation and then polished. Finally the tappet is Parkerized for improved oil retention during startup. The lifter set is supplied with installation instructions and assembly lube (#221-565). These processes are time intensive, but result in a tappet that meets all known original specifications.

APT Super Duty Tappet Sets

These tappets have a typical surface hardness above HRC 60 and feature an oil lubrication hole and precision ground face.

Tappet Set, Tested, with Lube	460-604	\$259.99
Tappet Set, Super Duty, APT	460-601	249.99



Super Duty Tappet Sets

Invest in super duty tappets for your Midget 1500. Heat-treated and chilled cast iron with a manganese phosphate break-in coating. Hardness rated at 62-65 HRC. Drilled for oil drainage to reduce operating mass.

Midget 1500	838-306	\$199.99
-------------	---------	----------



Pressure fed oiling to lobes and distributor drive gear

Performance Cams and Oil Pumps

We offer two performance street camshafts ground on new induction hardened steel billets with a finish ground hardness of 56-58 Rc. All cam lobes and the distributor drive gear are drilled for improved oil delivery. Both cams require upgrading to the latest slot type oil pump, which gives improved oil flow. **Both cams incorporate the latest valve timing theory to give the best performance for your driving style.** Choose the Fast Road cam for a smooth idle in your super-charged, city-driven engine. The Road/Rally cam is more suitable for open road driving, but can still be used around town.

Note: For comparison purposes, duration is given at two different lifts. In the UK, 0.0158" cam lift is often used. In the US, cam lift of 0.050" is usually used.

Duration @ .0158" cam lift	Duration @ .050" cam lift	Cam lobe lift	Valve lift gross (1.26 ratio)	Power Band	Part #	Price
257/257°	214/214°	0.270"	0.340"	1500-5500 rpm	114-160	\$599.99
270/270°	224/224°	0.280"	0.353"	1900-5800 rpm	114-165	629.99

Matching Oil Pumps

High Output Slot Drive, 1275	114-039	\$69.99
Standard Slot Drive, 1275	114-034	42.99
Standard Slot Drive, 948-1098	114-040	42.99



114-034



114-039



Adjustable Cam Sprocket Kit

Cam timing adjustment is crucial to performance. This adjustable cam sprocket kit built with unparalleled craftsmanship allows cam timing adjustments to your performance specifications. The kit, which converts your vehicle to a duplex timing chain, includes a heavy-duty adjustable cam sprocket, heavy-duty crank sprocket, a pre-stretched duplex timing chain, seal, locktab and timing cover gasket. Everything you need for a job well done.

948, 1098, 1275	460-386	\$249.99
-----------------	---------	----------



460-059



460-058

Vernier Cam Sprocket Kit

If you're serious about your engine rebuild, this is one upgrade you should be sure to install! Our kit includes the double row chain, crank sprocket, and fully adjustable cam sprocket.



948-1098-1275	460-385	\$184.99
---------------	---------	----------

Billet Tappet Cover Kit

These billet aluminum tappet covers have been meticulously machined to fit your car. They are available either plain or with a machined Union Jack. The kit includes tappet cover, gasket, bushing, cup washer and bolt. Sold individually.

Plain - each	460-058	\$46.99
Union Jack - each	460-059	84.99



*See ordering page for details

⚠ WARNING: Cancer and Reproductive Harm. www.P65Warnings.ca.gov





FREE
SHIPPING
ON ORDERS OVER
\$700

INCREASE!
23 | **25**
horsepower | ft. lbs.
of torque

1275cc Supercharger System

The Moss Motors designed supercharger system uses the same Eaton positive displacement Roots type supercharger found on contemporary applications such as Jaguar and Mercedes Benz. Designed to fit the 1275cc engine, the kit will work with either generator or alternator equipped applications. The

extra loading will reduce the life of generator bearings, so we also offer an alternator upgrade kit. Our engineers designed an intake manifold that provides equal airflow, pressure and fuel mixture to each cylinder. This careful design works with the supercharger to increase torque even at idle. The latest generation Eaton

blower features an internal bypass system that improves operating efficiency and reduces fuel consumption by allowing the boosted mixture to re-circulate under low load conditions, cutting down on drag. The supercharger system is very complete and includes a 4 rib serpentine belt drive system with automatic adjustment. Carburetion is provided by the latest version of the SU HS6 and a K&N air filter is included to make the package complete. A new water pump, NGK spark plugs and very detailed instructions make installation a breeze.

A dramatically linear increase in torque and power produce a driving sensation without the drivability, cooling and fuel consumption problems normally found with traditional performance modifications. A competent mechanic or hobbyist can install the kit in about 8 hours.

Dyno Test Results • 1972 MG Midget

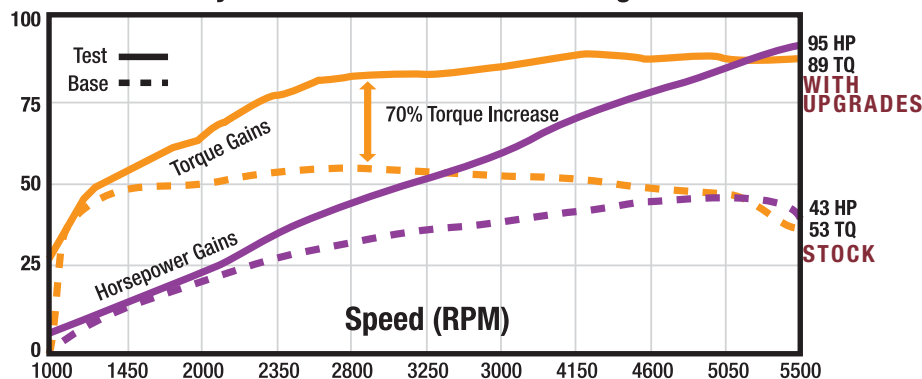

1275cc Supercharger System 150-080 \$5,199.00

Pricing is subject to change.
Please visit MossMotors.com for current pricing and availability.

PERFORMANCE



1962-74 Oil Cooler Installation Kit

A-Series engines were never intended to operate at the speeds and temperatures we experience on American highways. Water may cool the cylinder head and block, but your oil needs cooling as well. Overheated oil leads to increased wear and shorter engine life. Low oil pressure could be a sign of a worn engine, but it also happens when the oil gets too hot. Our bespoke oil cooler fitting kit includes braided stainless lines, all hardware, instructions and correct factory fittings. Combined with our 13 row oil cooler, it's an affordable life insurance policy for your expensive motor.

Stainless Steel Hoses	235-878	\$189.99
Rubber Hoses	235-879	176.99
13 Row Oil Cooler	235-925	69.99



A-Series Rear Oil Seal Conversion Kits

Complete oil seal conversion kits for the A- Series engines. These kits require careful fitting to ensure that the rear cap packing piece is leak tight. The seal rides on the outer flywheel mounting flange and this must be smooth. No drilling or cutting is required and the crank does not have to be removed. Installation does require removal of the flywheel and engine back plate.

948, 1098 w/1.75" Mains	297-665	\$299.99
1098 with 2" Mains	297-660	284.99
1275	297-655	299.99
Repl. Oil Seal - 948, 1098 - 1.75"	297-666	32.99
Repl. Oil Seal - 1098 - 2"	297-661	39.99
Repl. Oil Seal - 1275	297-656	39.99



K&N Performance Oil Filter

K&N Filter technology is the leader for your spin-on oil filter conversion. The resin impregnated filter element traps even the tiniest contaminants and isn't affected by racing fuels. Features include heavy-duty construction with metal end caps, anti-drainback valve, and a 1" safety wire drilled wrench-nut. Give yourself the peace of mind that comes with installing the best filter on the market.



K&N Oil Filter	235-830	\$28.99
----------------	---------	---------



235-875

Spin-On Oil Filter Adapters

Cleaner oil changes will result if you change your engine from the messy original canister filter to a modern spin-on filter. Each kit includes all necessary pieces for installation, filter not included.

Adapter (not 1500)	235-875	\$116.99
Spin-On Filter - Fram	235-880	10.99
Spin-On Filter - Wix	235-855	18.99
Spin-On Filter - K&N	235-830	28.99



Magnetic Oil Drain Plug

Keep metallic particles out of your oil system with a magnetic drain plug.

948-1098-1275	328-282	\$21.99
Midget 1500	328-356	7.99



Oil Catch Can by Mishimoto

A running engine creates blow-by, which is an oil mist that is routed either back to your intake manifold or to the atmosphere under your engine. Not only does that make a mess of the underside of your sports car, it can lead to carbon build-up in your combustion chamber which hampers performance. Trap all that oil for proper disposal by installing an oil catch can between the engine and your intake manifold or the atmosphere. Find more information online.

Oil Catch Can - 16 oz	223-075	\$164.99
-----------------------	---------	----------



Midget 1500 Oil Cooler Installation Kit

This kit allows the fitment of a 13 row oil cooler (not included) on a 1500 Midget. Cooler oil means longer engine life.

1500 Oil Cooler Instl. Kit	235-922 ¹	\$199.99
13 Row Oil Cooler	235-925	69.99

¹May require relocation of air pump hose.



*See ordering page for details

⚠ WARNING: Cancer and Reproductive Harm. www.P65Warnings.ca.gov





Alloy Valve Covers

Give your engine bay an attractive appearance with a brand new alloy rocker cover. This high quality valve cover looks great, and as a bonus will also muffle valve train noise! Available in a variety of finishes.

Note: Remember to fit a new gasket when you replace a rocker cover.

Do not over tighten the rocker cover nuts.

Sprite/Midget 948-1275 - Polished	224-530	\$89.99
Sprite/Midget 948-1275 - Red	224-531	99.99
Sprite/Midget 948-1275 - Blue	224-532	99.99
Midget 1500 - Polished	224-550	94.99
Midget 1500 - Black	224-560	119.99
Replacement Cap	460-145	17.99

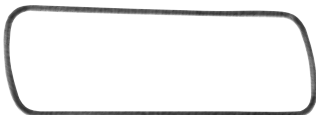

Silicone Valve Cover Gaskets by Gasket Innovations

These premium silicone valve cover gaskets are stronger and more resilient than traditional cork. They will tolerate re-use far better as well, allowing you to remove these covers repeatedly without having to replace your gaskets every time. Two types of gaskets are offered, one for Stock covers, and one for Alloy covers. Select your application below. Instructions included.

Note: Red RTV Sealant is needed for proper installation.

Sprite/Midget w/ Stock Valve Cover	296-006	\$24.99
Sprite/Midget w/ Alloy Valve Cover	296-007	28.99
A-Series Side Cover Gasket - Pair	296-377	30.99
Midget 1500 w/ Stock Valve Cover	694-101	24.99
Midget 1500 w/ Alloy Valve Cover	694-102	32.99
RTV Sealant - Red - 3 oz	221-305	15.99

ARP High Performance Fastener Kits

Trust in top grade 8740 chrome-moly steel with a tensile strength in the range of 200,000 psi. Threads are rolled after heat treat to provide up to 10 times longer fatigue strength. Precision CNC machined to exact specifications.

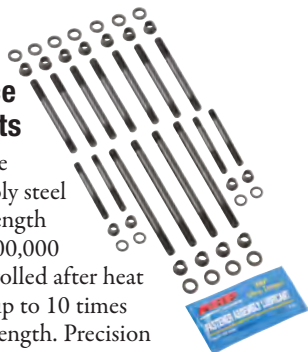

Head Stud Kit 948-1275	322-998	\$199.99
Rod Bolt Kit 1275	322-838	184.99
Main Stud Kit 948-1275	322-888	79.99



Midget 1500 Bushed Rocker Arms

Originally the rocker arms were not bushed and tended to wear quickly. We have had bushed arms made for us by a UK supplier. Ready to be honed, you can purchase these bushed arms individually to fit your rocker shaft, or as a matched set with the rocker shaft. The rocker arms have a tip hardness of 50-52 HRC, as original and should have a clearance of 0.002" after honing.

Arms (8) & Shaft Set	839-138	\$259.99
Odd Numbered Rocker Arms	839-115	17.99
Even Numbered Rocker Arms	839-125	17.99



1275 Alloy Cylinder Head

Light-weight (9 lbs) high strength aluminum alloy cylinder heads run cooler, allow higher compression ratios, and have a greater than 35% increase in flow rate. Includes silicon-bronze valve guides and hardened valve seats. Requires 1275 valves, springs, retainers, and 12 mm spark plugs (use NGK #451-890) not included. Quantities required are in parentheses. These heads do not have air injection ports, and therefore may not be used for street use on cars originally fitted with air pumps.

Alloy Cylinder Head	451-875	\$1,449.00
Head Gasket, Black - Payen	694-527	29.99
Intake Valve (4)	423-190	6.29
Exhaust Valve (4)	423-330	7.99
Valve Spring Set (1)	423-470	32.99
Valve Cotter (16)	460-535	2.29
NGK Spark Plug (4)	451-890	5.39



Valve Cover Thumb Nuts

Beautiful and functional. For A-series engines only, not 1500. Set of two. Can't be used with alloy valve covers.

Chrome Thumb Nuts, pair	460-118	\$15.99
-------------------------	---------	---------



1275 Alloy Crossflow Cylinder Head

Similar to the crossflow head from the '60s, this has an improved design, while using standard valve gear and valve guides. Larger diameter inlet ports (4) and crossflow design overcome the 'A' series engine breathing problems by increasing the inlet manifold air flow by as much as 20%, over an original 5 port head. Aluminum alloy is lighter, runs cooler and allows for higher compression ratios. Designed to fit in cramped engine bays when assembled with Webers, two #378-675 recommended. Bare heads come with silicon-bronze valve guides and hardened valve seats. Assembled heads also have valves and springs installed. Use 10 mm Autolite 4303 spark plugs.

Crossflow Cylinder Head - Assembled	451-808	\$2,199.00
Crossflow Cylinder Head - Bare	451-807	1,899.00



Outside



Inside

Premium Valve Cotters by Good Parts

Now offering your classic car the benefit of high-quality parts manufactured to exact specifications by Good Parts. Replace the worn out and damaged original valve locks with these premium 3/16" valve cotters. Precision engineered. Sold as a pair for 1 valve. 8 pairs required for four-cylinder engines and 12 pairs required six-cylinder engines. Application specific. Made in USA.

Midget 1500 - Pair	831-531	\$9.99
--------------------	---------	--------

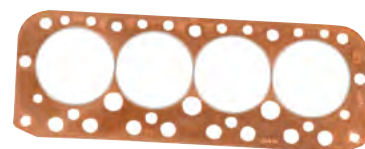

Competition Gaskets

Highly recommended for use with high compression pistons and modified heads, the copper head gasket is made to original British Leyland specifications. The special manifold gasket has enlarged holes to match inlet and exhaust ports on modified cylinder heads.

Head Gasket (1275)	694-555	\$22.99
Manifold Gasket (948-1275)	296-645	13.99

Pricing is subject to change.

Please visit MossMotors.com for current pricing and availability.

PERFORMANCE

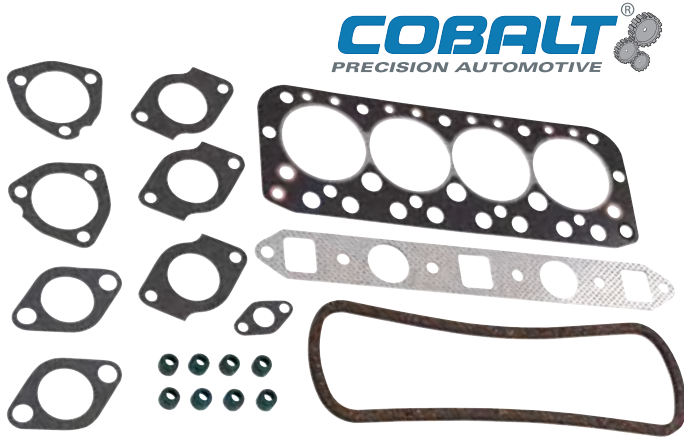

COBALT
PRECISION AUTOMOTIVE

Gaskets by Cobalt

Timely upgrades go a long way in the upkeep of your vehicle, and it is an important aspect of vehicle safety. Switch out your worn-out gaskets with these brand-new Cobalt brand replacement options, offering great quality at a very reasonable price. Built to OEM specifications.

Cylinder Head Gasket Set - Sprite/Midget 1275	296-705	\$39.99
Cylinder Head Gasket Set - Midget 1500	296-735	39.99
Cylinder Head Gasket - Sprite/Midget 948 & 1098	296-750	24.99
Cylinder Head Gasket - Sprite/Midget 1275	296-745	19.99
Cylinder Head Gasket - Midget 1500	296-730	19.99
Lower Engine Gasket Set - Sprite/Midget 948, 1098 (10 CG)	296-760	48.99
Lower Engine Gasket Set - Sprite/Midget 1098	296-710	29.99
Lower Engine Gasket Set - Sprite/Midget 1275	296-715	34.99
Lower Engine Gasket Set - Midget 1500	296-740	26.99



Oil Service Kit

Change your engine oil regularly and avoid sludge build-up using our oil service kit. This application specific kit has everything you need to do an oil change: a filter, seal, drain-plug washer and the right amount of oil for lubrication.

We've selected the Collector's Choice engine oil for your classic car as it contains "pre-ban" ZDDP levels to help prevent premature camshaft lobe wear; additives to help prevent seals from becoming hard and leaking from infrequent use; and antioxidants to combat the effects of humidity during storage which usually leads to moisture and rust in an engine. Regular maintenance activities like an oil change go a long way in the smooth running of the engine.

Offering better value for money, order this kit today!

948-1098 Purolator	225-920	\$56.99	OS
948-1098 Tecalemit, 1275 Cartridge	225-921	57.99	OS
1275 Factory Spin-on Filter	225-922	52.99	OS
Moss Large Spin-on Filter	225-923	56.99	OS
Midget 1500	225-924	62.99	OS

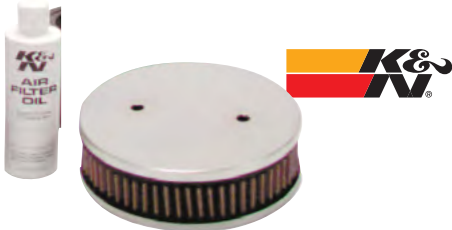

K&N Chrome Air Filters

K&N air filters are designed to be washed and reused for the life of your engine. Have confidence in the K&N ten year/one million mile (non-comp. use) warranty. All sold individually.

Accessories

Filter Recharging Kit	001-130	\$36.99
Filter Cleaning Fluid	231-480	16.99
Filter Oil Bottle (250 mL)	231-490	9.99

Assemblies for Weber DCOE

1 1/4" deep	222-245 ¹	\$146.99
3" deep	222-240 ¹	119.99

Assembly for Weber DGAV

1 1/4" deep	222-366 ¹	\$189.99
-------------	----------------------	----------

Elements for Stock Applications

Sprite/Midget HS2	373-435	\$59.99
-------------------	---------	---------

¹May not be legal on emission controlled vehicles. Check your local laws for compliance.

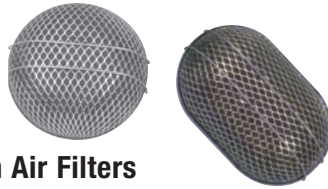

Foam Air Filters

Enjoy these traditional style, washable, performance foam filters.

Round for 1 1/4" SU	223-260 ¹	\$44.99
Oval for Midget 1500	223-280 ¹	44.99
Replacement Foam, Round	37-0890	15.99
Replacement Foam, Oval	37-0893	15.99

¹May not be legal on emission controlled vehicles. Check your local laws for compliance.



Failsafe Thermostat

When most thermostats fail, they close, which will quickly lead to overheating. Avoid the problem by installing this Failsafe Thermostat. It has been designed to stay fully open in the event of a failure.

180° Thermostat	434-205	\$18.99
160° Thermostat	434-206	18.99



Vintage Style Chrome Air Filters

Add some shine to your engine bay. Beautifully plated, ultra-thin design.

Filter for 1 1/4" SUs each	223-100	\$54.99
----------------------------	---------	---------



Thermostat Blanking Sleeve

The thermostat bypass blanking sleeve allows you to remove the thermostat for maximum power and speed, making it advantageous in racing conditions.

Blanking Sleeve	434-135	\$9.99
-----------------	---------	--------



*See ordering page for details

⚠ WARNING: Cancer and Reproductive Harm. www.P65Warnings.ca.gov





Revotec Manual Override Switches

Revotec switches manually control your Revotec Fan Controller. Available as a 3-way rotary switch with On, Off, or Automatic positions or as a 2-way Jaguar-style toggle switch with On or Automatic. Each switch is supplied with a mounting bracket, wiring, decals, and hardware.

3-way Rotary	231-725	\$69.99
2-way Jaguar-Style	231-726	49.99



Electronic Fan Controller by Revotec

Built using the latest technology, components and assembly methods, Revotec's engineering team has developed a robust and reliable electronic fan controller that can be adapted to any electric fan. Engineered to overcome problems associated with capillary-action and clip-on devices, this non-leaking unit is installed in a water hose but will not obstruct coolant flow. Listed sizes refer to the hose I.D. Easy to install, a relay and all necessary fittings are included.

Electric Fan Controller Hose Set		
Hose Set	231-735	\$34.99
Negative Ground		
25 mm	231-740	\$144.99
28 mm	231-742	139.99
32 mm	231-744	139.99
35 mm	231-746	139.99
38 mm	231-748	139.99
Positive Ground		
25 mm	231-741	\$199.99
28 mm	231-743	199.99
32 mm	231-745	199.99
35 mm	231-747	199.99
38 mm	231-749	199.99

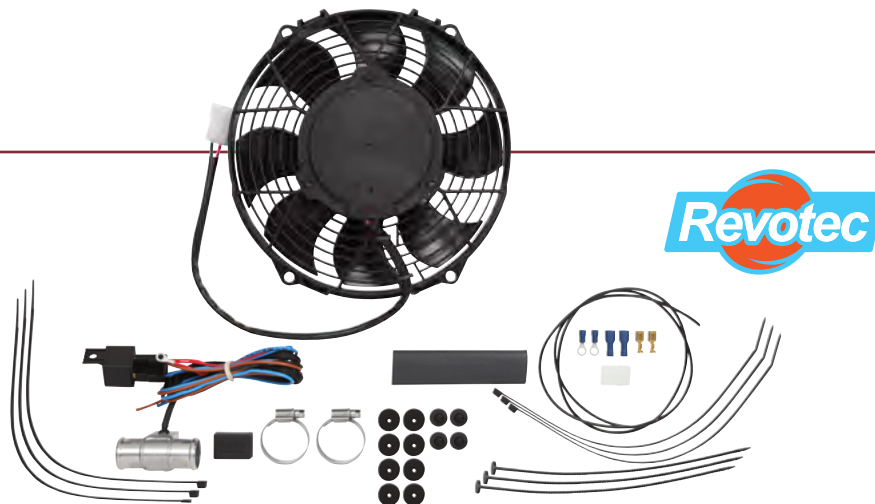

Cooling Fan Kit by Revotec

Designed to replace the standard mechanical fan, the Revotec fan kits reduce noise and engine load while improving power and mpg. The high efficiency fans with adjustable electronic controllers ensure that your car's engine runs at optimum temperature giving the best performance and economy!

The Revotec kits are application specific. While some kits have special 'pull through' ties to hold the fan assembly in place, and foam pads to prevent damage to the radiator core, other kits have bespoke laser-cut, bright passivated brackets which mount directly to the radiator mountings to give a smart appearance, and prevent corrosion.

These kits are available for early Sprite & Midgets with a Vertical Flow radiator, as well as for 1275cc Sprite & Midgets, and for 1500cc Midgets with Cross Flow radiators. Installation is easy with the supplied instructions. Available for both positive and negative earth.

Kit includes:

- 10" Suction fan or 9" Blowing fan as applicable
- 25 mm or 32 mm Revotec Electronic fan controller as applicable
- Fan mounting pull throughs
- Laser cut stainless steel fan mounting brackets
- Earth wire kit
- Bolts and fittings
- Instructions

948-1275 - Vertical Flow - Negative Ground	231-713	\$359.99
948-1275 - Vertical Flow - Positive Ground	231-714	399.99
1275 - Crossflow - Negative Ground	231-715	434.99
1500 - Negative Ground	231-716	434.99

Aluminum Vertical-Flow Radiator

Aluminum radiators are an excellent upgrade for those seeking to prepare their classic car for the rigors of modern traffic conditions. Our aluminum radiator is constructed from high-quality alloys, and has been precision engineered for excellent fitment. It features a brazed aluminum core to optimize heat transfer and provide efficient cooling in the worst of conditions. Application specific.

Features:

- TIG welded construction
- 100% brazed aluminum core
- 18 louvered fins per inch
- Bare weight: 7.8 lbs
- Core area: 14.4" x 11.2"
- Core thickness: 1.91"
- Radiator cap
- Drain plug for easy coolant changes



To AH (c)72033, to MG (c)60440 459-731 \$379.99



SU Competition Double Ended Fuel Pump

Double ended SU pumps have been standard equipment for years on Aston Martins, Bentleys and late model E-Types. Get twice the capacity of a standard type pump with the added confidence of knowing that these units will keep pumping, even if one side fails. Well suited for all high performance engines running SU carbs, as no pressure regulator is required. Will require fabrication of a bracket or use bracket below.

Std. Points Non Polarized	377-036	\$699.99	Bracket, 2 req	377-350	10.79
Solid State Neg. Ground	377-335	699.99	Sleeve, Bracket, 2 req	377-360	2.19



Facet Solid State Fuel Pump

Solid state electric fuel pumps can be used in conjunction with, or in place of, your original pump. Push or pull fuel from a discreet location under the car, through your original pump, or put it in line with a power switch and use it as a backup. Producing 1.5 to 3 psi, it is perfect for SU carburetors. Works on positive or negative ground cars.

Solid State Pump	377-420	\$109.99
Facet Filter	377-424	12.99



SU Solid State Fuel Pump

Solid State electric fuel pumps with modern, reliable electronics eliminate the use of contact breaker points. Now you can have a vintage looking SU fuel pump with peace of mind that only an electric fuel pump can offer. Plus the characteristic ticking is retained.

Positive Ground	377-295	\$339.99
Negative Ground	377-285	339.99



Manual Choke Conversion Kit

Designed in England by Zenith-Stromberg. Easily install this kit with included mounting hardware and detailed instructions.

Midget 1500	386-325 ¹	\$129.99
-------------	----------------------	----------

¹May not be legal on emission controlled vehicles. Check your local laws for compliance.

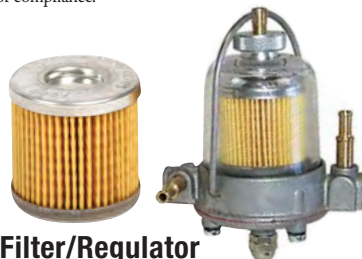

Fuel Filter/Regulator

High quality universal fuel pressure regulator with integral filter comes with 1/4" and 3/16" fittings. Pressure adjustment is 3 psi to 9 psi. Pre-set to 3-3 1/2 psi for SU & ZS carbs. Made in Italy.

Fuel Filter/Regulator	377-435	\$149.99
Replacement Filter	377-436	17.49
Replacement Bowl Gasket	377-437	8.19



Lucas

Universal Fuel Pump Kit by Lucas

The Lucas universal fuel pump kit is an extremely quiet and reliable steel cased sealed unit with zinc plating. It includes attached filter, mounting bracket, push-on fuel pipe unions, two 3.4" lengths of fuel line, and hose clips. This dual polarity 12v electric fuel pump is a replacement for AUA66 and AUA25 (Positive and Negative Earth). Suitable for all single, twin, and triple carburetor installations. A fuel pressure regulator may be required dependent on application/usage.

Technical specs:

- E85/ethanol compatible
- 6.77" Long 2.13" Dia
- 5 amps Current Draw
- Inlet and outlets threaded 1/8" NPT
- 8.5 psi max output

Fuel Pump	377-186	\$119.99
-----------	---------	----------



Ram Pipe Kits

Upgrade your classic's performance with a high-quality ram pipe kit. The short ramp pipe kit is fitted with a screen making it ideal for a street application providing additional performance and an aggressive look under the hood. Sized specifically for SU carbs. Each kit is sold per carb.

1/4" Ram Pipe Kit - H2 & HS2 carbs	372-565	\$94.99
1/2" Ram Pipe Kit - H4, HS4, & HIF4 carbs	372-566	91.99



Racing SU Ram Pipe Sets

A racing tradition, now available in long (3") and short (1 1/4"). Set of two. Check with your salesperson if you are unsure which carburetor you have. For 1/4" carburetors. Sold as a pair.

Short	372-425	\$79.99
Long	372-405	79.99



*See ordering page for details

WARNING: Cancer and Reproductive Harm. www.P65Warnings.ca.gov



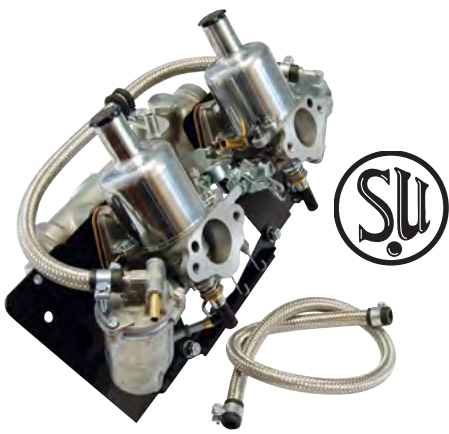

SU HS4 Twin Carburetors

This kit is designed to allow more fuel and air into the engine, while keeping that distinctive period look of a pair of classic SU carburetors. For the best results these carbs require a sports exhaust system. The kit includes all the parts you'll need for installation: manifold, heat shields, carbs, linkages, etc. Air filters not included.

HS4 (1½") Twin Carburetor Kit 114-494 \$2,399.00



New SU Carburetor Sets

Genuine SU carburetors produced in the UK from new and original tooling. Select your application below.

Sprite MkII, Midget MkI	370-708 ¹	\$1,449.00	🏆
Sprite/Midget 1098, 1963-66	370-718	1,899.00	🏆
Sprite/Midget 1275, 1967	370-728	1,799.00	🏆
Sprite/Midget 1275, 1968-69	370-908	1,799.00	🏆
Sprite/Midget 1275, 1969-71	370-928	1,399.00	🏆
Sprite/Midget 1275, 1972-74	370-948	1,799.00	🏆

¹Special order.

Knurled SU Idle Screw Kit

Fine-tune your idle without having to reach for a screwdriver. Made specifically for the SU carburetor, this upgrade is quick and easy.



Knurled SU Idle Screw Kit 372-835 \$18.99

Dashpot Covers for SU Carburetors

Brighten up your engine bay with a set of polished or chrome plated dashpot covers. Fits SU HS4 and HS6. Sold each.



SU HS2 - Silver	117-167	\$39.99
SU HS4/6 - Chrome	374-575	20.99



222-275

Weber Downdraft Carb Kits

The Weber DGV two barrel progressive carburetor has proven to be the most popular replacement for worn out or damaged stock carburetors and gives a good combination of performance and economy on stock engines. Our Weber DGV kits come pre-jetted for the listed applications. Kits include instructions, carburetor(s), manifold/adapters, linkage and air filter(s). Please note that there is no provision for emission connections and some modifications will be required for best operation.

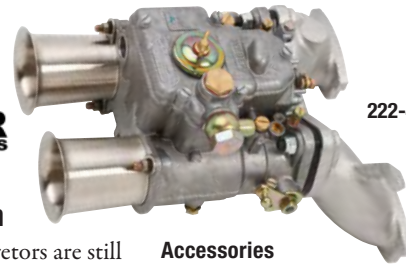

222-480

Weber DCOE Conversion

High performance DCOE carburetors are still the enthusiast's choice to extract maximum power. The kit includes manifold, linkage and carburetor with ram pipes. Our Weber DCOE kits come pre-jetted for the listed applications. However, fine tuning will be necessary. We recommend that tuning be performed by an experienced tuner. Please note that there is no provision for emission connections and some modification will be required for best operation.

SU H-Type 'Superdry' Jet Bearing Kit

The seals used until now have consisted of two small and one large cork seal. There is some evidence which suggests that ethanol may degrade these. A new set of rubber seals and the required new jet bearings have been developed to fix this problem.



SU H-Type, sold individually	370-396	\$129.99
Superdry Seal Kit - Replacement	370-397	16.99

MG Crested Carburetor Caps

Add unique distinction to your engine compartment with these solid brass caps. Your original damper rod must be reused and pressed into the new cap. SU carburetors only.



Dashpot Caps, pair 370-735 \$39.99

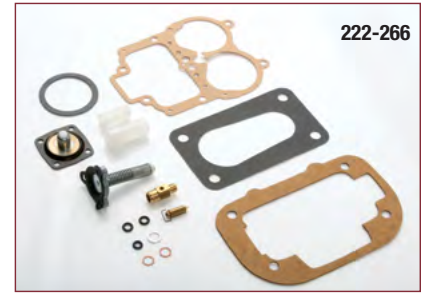

222-266

Sprite/Midget 948-1275	222-275 ¹	\$599.99
Midget 1500 (Water Choke)	222-255 ²	619.99
Midget 1500 (Electric Choke)	222-256 ²	619.99
Midget 1500 (Manual Choke)	222-257 ²	629.99
Chrome Filter Assembly	222-365	39.99
Repl. Element for 222-365	222-364	20.99
K&N Air Filter Assembly	222-366	189.99
Carb Rebuild Kit - w/ Power Valve	222-266	64.99

¹Will not fit Bugeye Sprite with original exhaust manifold. May not be legal on emission controlled vehicles. Check your local laws for compliance.

²May not be legal on emission controlled vehicles. Check your local laws for compliance.

Accessories

K&N Air Filter (1¾" deep)	222-245	\$146.99
K&N Air Filter (3" deep)	222-240	119.99
Stainless Steel Heatshield	865-220	39.99
Sprite/Midget 1275		
Single 45DCOE	222-450 ¹	\$1,199.00
Sprite/Midget 1500		
Single 40DCOE	222-480 ¹	\$999.99
Sprite/Midget 948/1098		
Single 40DCOE	222-440 ¹	\$1,149.00

¹May not be legal on emission-controlled vehicles. Check your local laws for compliance.



Weber DCOE Soft Mount Kit

Vibration wreaks havoc with fuel flow. A Weber DCOE soft mount kit helps dampen these vibrations by isolating the carburetor from the manifold, and improves carburetor efficiency.

DCOE Soft Mount Kit 222-251 \$32.99



Twin SU Stainless Steel Heat Shields

These new mirror finish stainless steel heat shields not only look great, they also redirect some of the heat from the exhaust manifold.

Twin SU S/S Shields HS4 117-180 \$39.99

Pricing is subject to change.

Please visit MossMotors.com for current pricing and availability.

PERFORMANCE



452-016

Stainless Steel Sport Exhaust

This durable stainless steel performance exhaust system was designed specifically for the 1275 Midget using the highest quality materials and workmanship. It uses stock rubber mounts and the stock manifold gasket, which are not included.

Features:

- Header, pipes and muffler shell are constructed from 1.5 mm thick 201 grade stainless steel
- 3-in-1 tubular header has a center primary tube that measures 1 7/8" and outside tubes measuring 1 1/2" which transition to 1 1/8" with the collector being flared to accept 1 7/8" pipe
- Pipes are 1 7/8" in diameter
- Muffler packing is a combination of stainless steel wool and fiberglass, with 409 stainless steel for inner core and perforated tubing

- Classic sports car sound that is throaty under acceleration but never intrusive while cruising
- The entire system weighs about 21 lbs

Sprite-Midget 1275 - Complete System	452-016	\$679.99
Sprite-Midget 1275 - Header	452-017	299.99
Manifold Gasket	296-630	2.29
Mount	614-008	6.99



452-070

Performance Exhaust Headers

These tubular exhaust headers are sourced from the UK and are designed to increase torque in street and vintage race motors. The smaller bore size, long center branch header is optimal for street use where a large bore race header would reduce low end torque making the car no fun to pull away from stop lights. Some hand fitting and port matching may be required. Headers supplied with anti-corrosive protection paint, header should be trial fitted before final paint. The 1500cc header has no provisions for e.g.r. valve or catalytic converter, so is not legal for use on emission controlled cars.

Sprite/Midget 948	452-060	\$439.99
Sprite/Midget 1098/1275	452-065	459.99
Midget 1500	452-070 ¹	569.99

¹Does not fit with ZS manifold. For use with Carb. Conversions



452-030

Stainless Steel Exhaust System by Falcon

Constructed entirely of top-quality stainless steel, ideal system for your car if you live where winter road conditions are harsh. Includes all pipes from the manifold flange back. Clamps, hangers and (when required) catalytic converters not included.

948 to 1098 10CG	452-000	\$329.99	OS
1098 10CC, 1275 (1967)	452-010	349.99	OS
1275 (1968-69)	452-016	679.99	
Midget 1500	452-030	629.99	OS



459-014

Headers by Pace Setter

These tubular exhaust headers are suitable for vintage racing or the sporting enthusiast. The three into one and four into one design gives the best top end power and the large collector can be routed to a custom big bore racing exhaust for track use, or hooked to the stock or sport exhaust using the included adapter. Some hand fitting and port matching may be required. Headers supplied with anti-corrosive protection paint, header should be trial fitted before final paint. The 1500cc header has no provisions for E.G.R. valve or catalytic converter, so it is not legal for use on emission controlled cars.

Sprite/Midget 1275	459-014	\$234.99
Midget 1500	459-017	234.99





Monza Free Flow Mufflers

Mufflers that increase both horsepower and gas mileage by reducing exhaust gas back-pressure. Heavy gauge steel, black with chrome tipped ends. Front down pipe not included.

Sprite/Midget 1275	452-040	\$239.99
Midget 1500	452-050	409.99

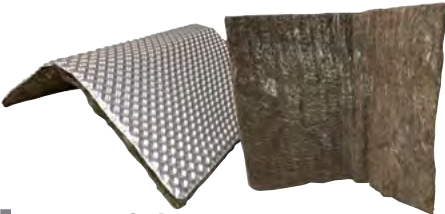

Form-A-Shield by DEI

Made from 10mil aluminum with a 1/4" high temperature basalt insulation, Form-A-Shield can withstand direct temps to +1400 F. Apply Form-A-Shield directly to hot surfaces and mold it easily to exhaust manifolds, pipes, and mufflers. Measures: 21" x 48".

Form-A-Shield	231-905	\$109.99
---------------	---------	----------



Stainless Steel Band Type Exhaust Clamps

We now carry a full range of these band type stainless steel exhaust clamps.

1 1/2" (1.457-1.575")	412-025	\$4.99
1 5/8" (1.575-1.693")	412-026	4.99
1 3/4" (1.693-1.850")	412-027	6.99
1 7/8" (1.850-2.008")	412-029	6.99
2" (2.008-2.165")	412-030	6.99



Stainless Steel U-Bolt Type Exhaust Clamps

These Stainless Steel U-Bolt type exhaust clamps are strong, durable, and best of all, will not rust.

1 1/8"	412-200	\$8.49
1 3/4"	412-201	8.49
1 7/8"	412-202	8.99
2"	412-203	8.99
2 1/8"	412-204	9.99
2 3/8"	412-205	10.49

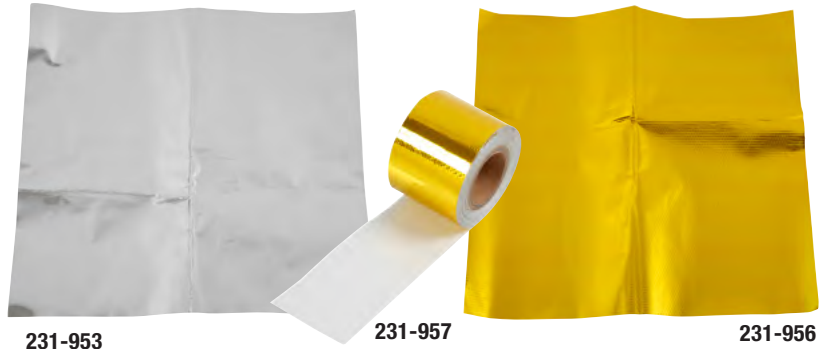

Heat Reflective Sheeting by DEI

Protect against the high-temperature areas of your car with the heat reflective sheets and tape by DEI. The Reflect-A-Gold products are made from a metalized polyamide polymer laminated to a lightweight glass fiber cloth with a high temperature pressure sensitive adhesive, and the Reflect-A-Cool sheet is made from fiberglass and backed with a layer of aluminized reflective foil. Both are great ways to keep interior components cool. The

0.0065" thickness makes them highly effective for covering areas of minimal clearance. While the tape is a suitable for wrapping wires, cables, hoses, or fuel lines etc., the sheets are apt for firewalls, fuel cells, engine compartment, bulk heads, seat bottoms and more. The lightweight products can be easily cut or trimmed and wrapped around parts for an easy installation. Efficiently handle high temperatures at reasonable price.

Features:

- The Reflect-A-Cool Heat Reflective Sheets have a Direct Heat Resistance of 400 F and Radiant Heat Resistance of 2000 F
- The Reflect-A-Gold Heat Reflective Sheet and Tape have Adhesive Heat Resistance of 325 F and Radiant Heat Resistance of 850 F
- Easy to apply, won't lift off
- Moisture and solvent resistant
- Self-adhesive backing to peel off and stick
- Resists UV degradation for long-term performance

Reflect-A-Cool		
12" x 12"	231-953	\$14.39
12" x 24"	231-952	25.99
24" x 24"	231-951	31.49
36" x 48"	231-950	87.99
Reflect-A-Gold		
12" x 12"	231-956	\$24.99
12" x 24"	231-955	43.99
24" x 24"	231-954	82.99
Reflect-A-Gold Tape		
1 1/2" x 15"	231-957	\$43.89
1 1/2" x 30"	231-958	77.89



Header and Manifold Blanket

Reduce under hood temperatures by clipping this flexible heat shield onto your manifold or headers. Designed for use on a V8 engine, the blanket retains exhaust heat, reducing under-hood temperatures and prolonging the life of the rubber engine-parts. The kit has enough material to cover most four cylinder manifolds, with enough left over to protect the starter motor and bulkhead. Two sheets 20" x 24".

Header Manifold Blanket	337-445	\$169.99
-------------------------	---------	----------

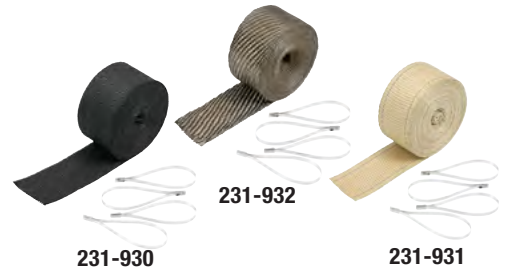

Exhaust Wrap and Tie Kit by DEI

Reduce unwanted and harmful heat under the hood while improving performance with the DEI Pipe Wrap. This kit includes a 25-foot roll of 2-inch wide exhaust wrap that offers a Direct Heat Resistance of 1,800 F, and Radiant Heat Resistance of 2,500 F, as well as four 8-inch stainless-steel locking ties to secure the wrap.

Black	231-930	\$38.69
Tan	231-931	37.49
Titanium	231-932	42.99



Pertronix Ignitor Electronic Ignition



- No external control boxes to mount
- No points to set or change
- Hall effect sensor is impervious to dirt and moisture and retains stock advance curve
- Locate Lucas model number stamped in housing by the vacuum advance
- 30-month manufacturer's warranty

1500
w/Elec. Ign., 45DE4 & 45DM4 222-475 \$219.99

Points Type		
Negative Ground, DM2	222-605 ¹	\$199.99
Positive Ground, DM2	222-615 ¹	224.99
Negative Ground, 25D	222-405	161.99
Positive Ground, 25D	222-555	189.99

¹Not for use with solid core ignition wires.

Pertronix Ignitor II for Mallory Dual Point Distributors

We now carry a Pertronix Ignitor system designed to retrofit Mallory dual point distributors. Retain the longevity of the Mallory distributor while enjoying the ease and accuracy of electronic ignition.

4-Cyl Negative Ground 143-181¹ \$229.99

¹Not for use with solid core ignition wires.



Pertronix Ignition Coils

The Pertronix Ignition Coil isn't called the "Flame-Thrower" for nothing. Matched to the Pertronix Ignitor ignition and with a voltage of 40,000, this coil will deliver a smoother response and better fuel economy, along with enhanced power during acceleration. Ballasted ignition system was used from 1975 on.

Note: These coils require a push-in type coil wire.

Non-ballasted systems - Black	143-265	\$79.99
Non-ballasted systems - Chrome	143-266	84.99
Ballasted systems - Black	143-270	79.99
End Clip for solid core wire	571-037	0.89
Boot for push-in wire end	571-047	1.69



Sports Coil by Intermotor



Intermotor was the original manufacturer of the renowned Sports Coil. Extensive testing has proven the Intermotor Sports Coil to be exceedingly dependable. Allow the 40,000 volt output to provide you with reliable starting power and greater performance at higher rpms. Made in England.



Note: These coils require a push-in type coil wire.

Non-ballasted systems	143-201	\$44.99
Ballasted systems	117-264	44.99
End Clip for solid core wire	571-037	0.89
Boot for push-in wire end	571-047	1.69
Clamp - Chrome	143-255	16.99
Clamp - Stainless Steel	117-265	17.99
Clamp - Zinc Plated	143-256	9.99

Universal Coil Mounting Brackets



Replace missing, bent or corroded coil brackets. Also useful if you are upgrading or relocating the coil.

Chrome	143-255	\$16.99
Stainless Steel	117-265	17.99
Zinc Plated	143-256	9.99



XR700 Electronic Ignition

Replace your troublesome points and condenser with this easily installed kit. FAST (formerly Crane) electronic ignition systems are famous for their reliability. Expect faster starts, cleaner running and better performance at all engine speeds.

For Lucas Points-type Distributors 222-680 \$199.99

Flame Thrower Electronic Distributors by Pertronix



A modern electronic ignition unit already installed in a brand new distributor body. Just swap out your worn out distributor and drop in the Flame Thrower. The drive dog is already installed. Two wire hookup to the coil makes wiring easy and the improved advance curve gives great performance and drivability. The vacuum advance is calibrated for use on carburetors that have ported vacuum, but in many cases will work well with manifold vacuum. The distributor is the 45D style.

4-Cylinder, Neg. Ground	143-116 ¹	\$359.99
4-Cylinder, Pos. Ground	143-125	379.99
4-Cyl. Repl. Cap	143-117	13.99
4-Cyl. Repl. Rotor	143-126	12.29
Repl. Module, Pos. Ground	143-127	156.99
Repl. Module, Neg. Ground	143-118	129.99

¹Not for use with solid core ignition wires.

Race Distributor

This points-type distributor has an advance curve designed for use with long duration race cams. Centrifugal advance only, for the serious racer.



45D Race Distributor	143-165 ¹	\$239.99
Replacement Points	153-915	5.99
Replacement Rotor	151-855	4.49
Premium Rotor	151-865	16.49
Replacement Cap	151-875	14.89

¹May not be legal on emission controlled vehicles. Check your local laws for compliance.

Premium Ignition Rotors

The carbon content in the plastic of most ignition rotors today is way too high and will actually rob your engine of precious spark energy. Don't let your ignition rotor ruin your Sunday drive; replace yours with one that is manufactured correctly.

948-1098-1275 25D	151-805	\$15.99
1500 45D	151-865	16.49





COBALT
PRECISION AUTOMOTIVE

High Performance Plug Wire Sets by Cobalt

Buy Cobalt! These wire sets are made to our specifications using the highest quality materials. These require that a plug-in distributor cap (#163-810) be used in place of the side entry cap.

- 8 mm Silicone Jacket resists high temperatures, fuel and oil
- Compact Silicone Boots with Locking Terminals
- Spiral Magnetic Core to suppress RFI/EMI Interference

948-1098-1275	172-050	\$39.99
Midget 1500	172-040	39.99
Distributor Cap	163-810	11.49



MAGNECOR

Performance Plug Wires

Magnecor competition spark plug cable sets work great on street cars with either conventional or electronic ignition systems. Low resistance, yet also shielded to reduce radio noise interference.

Midget 1500	143-556	\$134.99
-------------	---------	----------

Smiths Voltmeter

Monitor your battery's condition with this 2" illuminated gauge. Easily wired into your car using the included instructions. Also includes bulb holder with bulb for illumination.



Voltmeter	360-975	\$109.99
-----------	---------	----------

Racing Battery Switch

Primarily intended for competition use, this rugged switch can be used on any car. The removable key deters theft. Attached rubber cap keeps dirt and water out when the key is removed. Meets FIA requirements for motor sports.



Racing Battery Switch	145-785	\$29.99
-----------------------	---------	---------



Battery Cut-Off Switches

Simplify servicing and long term auto storage with this battery cut-off switch. A strategically placed remote switch deters theft. A negative post mount switch is quickly accessed.

Remote Switch - 1" shaft	145-770	\$64.99
Remote Switch - 1/2" shaft	145-771	59.99
Negative Post Mount	145-795	7.99



Dummy Voltage Regulator

Alternator conversions are great for power, but leave your engine looking less than authentic. Install a Dummy Voltage Regulator to retain that original look. These appear exactly as the old regulators, but have been bridged with a fuse after having their internals removed. Extra fuse and instructions are included.

Screw Terminal	142-004	\$99.99
Late Style Spade Terminal	142-054	99.99



Steel Battery Tray

Manufactured from high quality steel for a longer life than the original Bakelite/plastic items, which tend to become brittle over time. Finished in a thick black powder coat for added durability and resistance to corrosion or battery acid. No modifications required for installation.

Battery Tray	241-061	\$79.99
--------------	---------	---------

WOSP



High Torque Starters by WOSP Performance

Give your Classic the high torque advantage! Whether you're having problems starting your engines or simply want an upgrade, our selection of high torque starter motors by WOSP perfectly meet your requirements. Manufactured in the UK, these gear reduction starters are powerful, lightweight, and built for performance. Offering increased torque, especially useful on high compression engines, these brand new, application specific starters are direct replacements built to the highest standards to withstand the rigors of all forms of motorsport. Quality and performance, WOSP starters have it all.

Features:

- All units are 100% brand new
- Based on the Denso conventional offset gear reduction design
- High power 1.0 kW and 1.4 kW Denso motors modified to suit each application and individual requirement
- Manufactured with the latest electronic testing equipment to check the performance of every product produced.

Sprite/Midget 948-1275	140-362	\$349.99
Midget 1500	140-363	349.99



Alternator Conversion Kit

Complete kit of all parts and instructions to convert from generator to alternator. Does not have provision for Bugeye tach drive.

A Dummy Voltage Regulator can be installed to retain original look. They appear exactly as the old regulators, but have had their internals removed then bridged with a 50 amp fuse. Extra fuse and instructions are included.

Alternator Conversion Kit	130-068	\$369.99
Dummy Voltage Regulator - Screw Terminal	142-004	99.99
Dummy Voltage Regulator - Lucar Spade Terminal	542-104	99.99
Dummy Voltage Regulator - Late Style Spade Terminal	142-054	99.99

Pricing is subject to change.

Please visit MossMotors.com for current pricing and availability.

PERFORMANCE



5 Speed Conversion Kits

If you plan on driving your classic, installing a 5 speed transmission will make the car much more enjoyable at highway speeds. Using the popular Ford T9 gearbox, the installation is reversible with minimal modifications to the frame or transmission tunnel. Get better fuel economy, less engine wear and easier shifts.

The 5 speed kits come complete with the following components:

- Reconditioned Ford T9 Gearbox
- New Bellhousing (or adaptor plate on 1500cc models)
- Spigot Bushing
- Clutch Plate
- Clutch Plate Cover
- Clutch Release Bearing
- New Clutch Arm Pivot
- New Propshaft
- Chassis Cross Member and Strengtheners
- Speedometer Cable
- Standard Gear Lever

- Gear Lever Gaiter
- All Bolts and Fasteners
- Detailed Instructions

Note: Speedo will need to be recalibrated

Sprite/Midget 948	440-145	\$5,195.00	
Sprite/Midget 1098	440-155	5,195.00	
Sprite/Midget 1275	440-165	5,195.00	
Midget 1500 1975-77	440-175	4,995.00	
Midget 1500 1978-on	440-177	4,995.00	
Replacement Parts			
Shift Knob - 7 mm	041-546	\$44.99	
Clutch Alignment Tool	041-620	3.99	



Alloy Flywheel by Fidanza

Fidanza Performance lightweight aluminum flywheels are designed, engineered and manufactured right here in the USA. These flywheels have been CAD designed/ engineered and precision CNC machined from top quality billet 6061 T6 aluminum to deliver optimum performance and reliability. All flywheels are balanced and thoroughly inspected for quality and fitment.

Fidanza aluminum flywheels deliver:

- Faster throttle response and quicker acceleration
- Additional horsepower to the wheels (reduced parasitic losses)
- Smoother, faster shifting
- Easier braking, better slowing (due to reduced rotational mass)
- Reduced clutch wear and improved efficiency (from better heat dissipation)
- Replaceable friction plate

Sprite/Midget 948	460-505	\$409.99
Sprite/Midget 1275	461-005	409.99
Midget 1500	460-678	439.99



125-822

Tapered Front Wheel Bearing Kit

The standard front hub bearings are angular contact ball bearing type, which works well but does not allow for any adjustment as the bearings wear. Taper bearings provide better support. Our tapered bearing kits includes high quality bearings, seals, spacer ring, split pin and nut and utilizes the standard spacer for a simple installation. The larger bearing has the correct 2mm fillet radius to allow proper fitment on the stub axle and has been specially manufactured to allow the hub to sit in the correct position so the caliper does not interfere with the disc.

We offer two types of tapered front wheel bearing kits. The first (#125-822) is the complete car kit, which consists of all the bearings, seals, spacer rings, shims, split pin, nuts and grease required for both wheels. The other kit (#125-821) consists of the bearings, seals, spacer ring, split pin, nut and grease for a single wheel only and does not include the shims.

Front Wheel Bearing Kit - complete car kit	125-822	\$96.99
Front Wheel Bearing Kit - 1 side	125-821	48.99
Wheel Bearing Shim Set	263-508	13.99

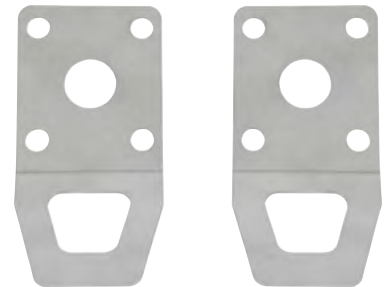

Rear Axle Tie Down Plates - Pair

Attach your trailer tie downs to your classic car with ease! Hooking tie downs to the chassis forces greater loads on the tie downs and could lead to dangerous stretching or breaking. But, by hooking to the axle, your car's suspension is allowed to move naturally. Our rear axle tie down plates do just that by providing an easy-to-reach place to secure your car safely. Add these quality tie-down plates to your cart today! Sold in pairs.

Sprite/Midget ½ Elliptic	267-523	\$54.99
--------------------------	---------	---------





Nylon Axle Straps

These rugged axle straps were engineered to last and are a substantial upgrade over the rubber straps currently on the market. Made from a nylon webbing, they offer some stretch properties, yet provide a tensile strength of over 4,500 lbs Sold in pairs. Metal tubes/sleeves should be reused on vehicles that originally required them.

Sprite/Midget 1958-74	267-611	\$39.99
Midget 1500	267-616	39.99



3/4" Anti Sway Bar

The 3/4" anti sway bar is an excellent compromise for both fast road, and competition use. Increased front sway bar diameter reduces body roll and understeer which in turn gives better handling control.

3/4" Anti Sway Bar, front	264-555	\$194.99
Solid Sway Bar Mounts (Pair)	263-435	89.99
Rubber Mounting Bushing (Individual)	280-915	2.39
Polyurethane Mounting Bushing (Pair)	683-062	23.99
Mounting Strap (Individual)	263-430	1.29



Steering Rack

If you're tired of your Midget wandering across the road, install a new, factory-fresh rack and stop those wandering ways. Give your Midget the crisp steering you crave, our rack bolts right in for that new steering feel all over again.

Midget mid-1973-on	668-000	\$259.99	OS
--------------------	---------	----------	-----------



Front Suspension Lowering Kit

This kit contains special spacers which install between the wishbone/spring pan and the spring seat to lower your front suspension 1/2". Works with all springs. Kit includes spacers and bolts for both sides.

Front Susp. Lowering Kit	264-665	\$25.99
--------------------------	---------	---------

Heavy Duty Front Shock Valve

The higher spring pressure used in this valve is suited for use with heavy duty springs and larger than stock sway bars. Sold each, two required per vehicle.

Heavy Duty Valve	264-027	\$34.99
------------------	---------	---------



Frontline Tube Shock Conversion Kits

The Frontline suspension conversion has been developed in conjunction with specialist suspension engineers to give what is probably the single biggest improvement to the Sprite/Midget's handling. The specially developed telescopic dampers provide progressive damping - as suspension movement increases, the shock absorbers increase resistance - which lever shocks are not able to do.

To maintain front and rear continuity, adjustable AVO shocks are used allowing you to adjust the ride to your personal requirements and driving style.

Front Conversion Kit

1958-80	268-168	\$1,499.00	OS
Replacement Shocks - Pair	268-169	499.99	

Rear Conversion Kits

1958-63	268-171 ¹	\$599.99
1964-74	268-172	599.99
1975-80	268-173	599.99
Replacement Shocks - Pair	268-174	499.99

¹Requires some welding.



Rear Tube Shock Conversion Kits

These kits contain the Spax adjustable gas filled shocks (adjustable from the outside). Includes new lower spring plates that incorporate an angled mounting flange. Installation is easy and instructions are included.

1964-74	264-675	\$649.99
1975-80	264-676	599.99



Rear Tube Shock Conversion Kit by Cobalt

Modern tube shocks provide better ride comfort and handling than the old lever arm style. When was the last time you checked your rear shock fluid? Most people don't, and this leads to premature wear and leaks, which render the shocks worthless. This specially modified set of rear tube shocks which, along with a few simple mounting bolts, give your car a better, maintenance free, ride. Can be installed on Midget 1500; sheet metal shrouding upper mounting must be trimmed.

1964-74 Rear Conversion Kit	268-288	\$299.99
-----------------------------	---------	----------



Roll Bar

Our bolt-in roll bar looks great and causes minimum restriction of cockpit space. They're even designed to fit inside the convertible top. The optional pad is vinyl covered and uses snaps and velcro fasteners to keep it firmly in place. Includes mounting hardware.

1961-69 Roll Bar	453-325	\$799.99	OS
1970-79 Roll Bar	453-326	799.99	OS
Roll Bar Cover	236-000	159.99	

Pricing is subject to change.

Please visit MossMotors.com for current pricing and availability.

PERFORMANCE



Superpro Polyurethane Bushings

An Australian-based company, SuperPro began manufacturing replacement bushings made from polyurethane after they realized that OE rubber couldn't withstand the tough and extreme conditions found in the notorious outback. Rubber has been a traditional material for comfort, but is prone to vulnerabilities and deterioration. Polyurethane bushings ensure the suspension components will retain their desired geometry and last longer than rubber. SuperPro has tuned their bushings to work together on each car as a set. Each location may be stiffer or softer than another location on the same car. This ensures the car as a whole has the absolute best handling possible.

Complete Car Suspension Kit 1964-on	683-137	\$229.99
Front Suspension Complete Kit - 1964-on	683-135	\$119.99
Upper Trunion Bushing Set	683-040	24.99

Rear Suspension Complete Kit - 1964-on	683-136	\$104.99
Front Spring Eye - 1964-on	683-139	65.99
Sway Bar Center Mount Kits 5/16" w/ original strap	683-060	\$22.99
5/8" w/ original strap	683-027	27.99
3/4" w/ original strap	683-062	23.99



Polyurethane Rear Spring Bushing Set

Enjoy increased performance and a prolonged life with the brand new polyurethane bushing set. A consistently top quality product, each bushing in this set has been made with a shore hardness 80 in dark blue. Featuring a unique lip seal, the cross-hatched surface inside the bore of these bushes retains the special polyurethane-safe grease which is included with each set. Manufactured from USA produced urethane. Application specific.

Sprite/Midget 1961-64	680-961	\$76.99
-----------------------	---------	---------



Rear Spring Lowering Kit 1964-80

Easy to install kit lowers the rear of the car by 1 1/4".

Rear Spring Lowering Kit	268-170	\$149.99
--------------------------	---------	----------



Updated Rear Spring Fitting Kit

Replacing the damaged rear leaf springs becomes easy with this new updated rear spring fitting kit. It has all the parts conveniently put together to help you upgrade your leaf springs. The rugged axle straps made from nylon-webbing are a substantial improvement over the rubber straps and offer some stretch properties while providing a tensile strength of over 4,500 pounds! The Prothane bushings and spring pads are designed to be long lasting and quiet, supplied with Teflon grease. These high performance components are much better than original rubber parts. Give your classic car only the best stuff with this premium quality kit!

The updated rear spring fitting kit includes:	Sprite/Midget 948-1275	225-994	\$109.99
• OE length Nylon axle check straps, pair	Midget 1500	225-995	109.99
• Prothane shackle bushings			
• Prothane spring pads			
• 4 U-bolts			
• 8 nuts			



Updated Spring Set

Give your classic car the benefit of good suspension with this updated spring set! A very affordable replacement that lowers your Sprite or Midget by 1". Sold in pairs.

Updated Spring Set	264-608	\$134.99
--------------------	---------	----------

Camber Adjusting A-Arm Bushing Sets

Offset nylon bushings allow for fine tuning of camber. Set of 4. Two sets required.

Camber Adj. Bushings	282-308	\$33.99
----------------------	---------	---------



Prothane Bushings

Superb engineering design details differentiate these from other polyurethane replacement bushings. Grooved bores in some bushings to hold a special Teflon grease (included) make these bushing sets long-lasting and quiet.

Front Suspension Kit includes 4 upper and 8 lower bushings	280-938	\$35.99
5/16" Sway Bar Mount Kit	280-935	9.99
Rear Spring Kit (1/2 elliptic spring cars only)	266-418	72.99



Lowered Rear Springs

Lowered springs are preferred to blocks and long U-bolts because they provide better location of the rear axle. Our 1" lowered springs are perfectly suited to fast road use. The 2" springs are appropriate for the track. Fit chrome-bumpered cars only from 1964-'74.

1964-74 1" Lower	264-685	\$249.99
------------------	---------	----------



*See ordering page for details

⚠ WARNING: Cancer and Reproductive Harm. www.P65Warnings.ca.gov





Cross-Drilled and Slotted Brake Rotors

These cross-drilled & slotted rotors are a performance upgrade option for your Sprite/Midget. Under hard use the brake pad surface emits gasses which cause the pads to plane over the surface of the rotors. The grooves in these rotors channel the gasses away from the braking surface and reduce brake fade, while the cross-drilled holes assist with heat dispersion. The grooves also reduce pad material build-up on the rotor surface and minimize glazing. Sold in a left-hand/right-hand pair.

Disc Wheels	586-601	\$139.99	OS
Wire Wheels	586-602	149.99	

Front Disc Brake Kits

When your Sprite/Midget needs a brake job, ordering one part number and getting everything you need at once makes the job so much simpler.

There are two options available, Stock Replacement and Stage 1 Upgrade. See below for option details.

All Kits Include:

- 2x pad retaining clips
- 2x pad cotter pins

Stock Replacement:

- 2x Stock front rotors
- 1x Classic Gold semi-metallic front pad set

Stage 1 Upgrade:

- 2x Slotted & drilled front rotors
- 1x Classic Gold ceramic front pad set

Stock Replacement - w/ Wire Wheels	182-161	\$63.99	OS
Stock Replacement - w/ Disc Wheels	182-157	69.99	OS
Stage 1 Upgrade - w/ Wire Wheels	182-695	174.99	
Stage 1 Upgrade - w/ Disc Wheels	182-690	179.99	



Cross-Drilled and Slotted Rotors

Get the stopping power you need with a Moss Motors exclusive. Cross-drilled holes lower brake temperatures and reduce rotational mass and out-gassing, while slots allow excess water, dirt and dust to dissipate. Sold as a pair.

Disc Wheels Only	586-600	\$229.99
------------------	---------	----------



Premium Ceramic Brake Pads by Classic Gold

- Withstands high braking temps
- Less fade
- Quicker recovery
- Ultra quiet braking
- Nearly dust free
- Wheels stay cleaner longer
- Anti-squeal compound bonded to brake pad backing plate

Ceramic Pad Set	071-533	\$36.99
-----------------	---------	---------

Semi-Metallic Brake Pads by Classic Gold

- Shorter stopping distances
- Squeal-free
- Less dusting than organic pads
- Asbestos free composition
- Best value - priced right
- Anti-squeal compound bonded to brake pad backing plate

Semi-Metallic Set	071-539	\$23.99
-------------------	---------	---------

High Performance Front Disc Brake Pads

EBC GreenStuff Brake Pads

EBC GreenStuff is a high friction based pad compound designed to improve stopping power on sport cars for street use. The GreenStuff range emits less dust than equivalent semi metallic pads and has been proven in tests to stop a vehicle 20 feet sooner than using stock pads.

Hawk Brake Pads

Designed for the serious street and autocross enthusiast these pads are at home on both the track and street.

Note: due to the increased friction levels, brake rotor life may be decreased.

Greenstuff	585-625	\$76.99
Hawk	585-605	144.99

Pads are fully shimmed, chamfered and slotted for silent braking and feature the EBC brake-in surface coating to accelerate pad bed in after install. GreenStuff pads are designed for spirited street driving. Made in the UK.



585-625



585-605



Rear Disc Brake Kit by Frontline

This kit delivers the ultimate braking for the rear of your Spridget! The kit uses 8" discs with alloy calipers to allow rapid heat dissipation and reduced fade under continued heavy use and eliminates wheel lock under heavy braking. The system has been designed to work in conjunction with any of Frontline's front brake conversions to give the optimum and most balanced braking set-up for your car.

1964-79 w/13" Wheels	586-647	\$2,395.00	
1964-79 w/14" Wheels	586-648	2,195.00	

¹Kits are made to order. Please allow six to ten weeks for delivery.



Brake Servo Kit - Single Line System

If your single-line brakes are working as they should but you'd like the pedal to require less foot pressure, install this servo manufactured to the highest standards. Includes detailed instructions for proper fitment of the servo.

Single Line System Brake Servo	117-312	\$185.99
--------------------------------	---------	----------



Classic Black Stainless Steel Braided Brake Hose Set by Goodridge

Goodridge Classic black brake hose kits feature the finest quality hose, consisting of a PTFE inner with a stainless-steel outer braid. This eliminates the spongy feel under arduous conditions, giving greater brake operation as well as providing superior resistance to abrasion and corrosion. Every brake line made by Goodridge is 100% pressure tested and guaranteed to be leak free and give an improved braking performance. They are also 100% TUV, DOT, ADR and ISO approved and can be used worldwide. Offering reliability, safety, and a brilliant look, buy this braided brake hose set today! Application specific.

Sprite/Midget w/ Drum Brakes 1958-61	182-199	\$84.99
Sprite/Midget w/ Disc Brakes 1962-80	182-249	89.99



Braided Stainless Steel Teflon Brake Hose Sets by Goodridge

These competition-inspired brake hose sets meet all DOT safety standards and are street legal in all 50 states. Each set includes all brake hoses used on your car, with any required retaining nuts and/or copper sealing washers.

With Front Drum Brakes	182-198	\$82.99
With Front Disc Brakes	182-248	74.99



Rubber Brake Hoses by Cobalt

All brake hoses aren't equal. These hoses are a product of many R&D hours devoted to improving quality, safety and performance of these critical brake components. The rubber brake hoses by Cobalt go the extra yard by welding the metal joint end connections for strength and reliability. Other hoses simply press-fit their connections. We stand behind the Cobalt difference.

Front - Disc Brake	180-377	\$13.99
Rear - All	180-897	15.99

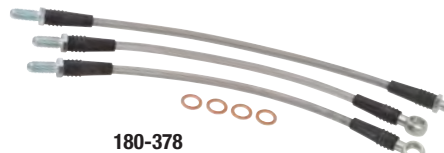

180-378

Stainless Steel Brake Hose Set by Cobalt

Stainless steel brake hoses provide a more direct and consistent brake feel. They won't expand like rubber hoses can. Order this complete set of long-lasting braided steel hoses for your next brake job. DOT approved.

Sprite-Midget (with front and rear drum brakes)	180-358	\$89.99
Sprite-Midget (with front disc brakes)	180-378	89.99



*See ordering page for details

WARNING: Cancer and Reproductive Harm. www.P65Warnings.ca.gov



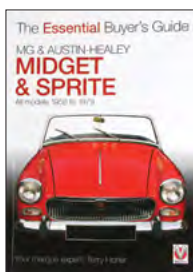

A.

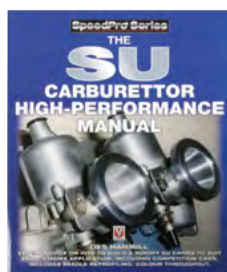

B.

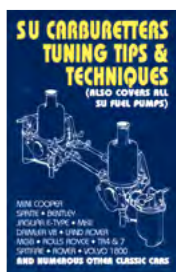

C.

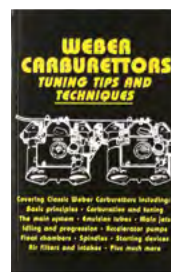

D.



E.

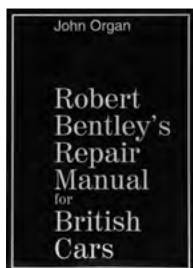

F.



G.

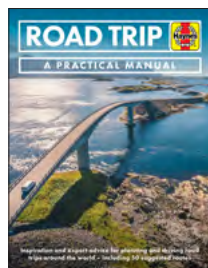

H.



I.



J.

A. Sprite/Midget Essential Buyer's Guide by Terry Horler

This book is the perfect companion for the first-time or even more experienced buyer. All the information is here to help make a clear and balanced decision, to counter the vendor's claims, and even negotiate a better price. The author has bought and sold many MG Midgets & A-H Sprites over the years, and his knowledge and enthusiasm will prove a vital resource for potential buyers. 5½" x 7½", 64 pages, 100 color photos.

Sprite/Midget Essential Buyer's Guide 213-671 \$28.99

B. SU High Performance Manual

Who wouldn't benefit from knowing the secrets that SUs hold? If you are looking to increase your SU repertoire, this is the book for you. Lots of pictures and illustrations. 96 pages.

SU High Performance 211-466 \$32.99

C. SU Tuning Tips & Techniques by G.R. Wade

Use factory information to help you solve all of your standard SU problems.

SU Tips and Techniques 211-345 \$59.99

D. Weber Carburettors: Tuning Tips & Techniques

Benefit from a distillation of many years' experience of working with Weber carbs. Setting the carburetor to suit a particular engine, fault-finding, and the maintenance and repair of older carburetors, are all topics which receive detailed attention. 128 pages with 200 B&W illustrations.

Weber Carbs, Tuning 213-431 \$32.99

E. Lucas Fault Diagnosis

For professional technicians; easily understood by the non-professional. Softbound, 8½" x 11", 46 pages.

Lucas Fault Diagnosis 990-035 \$7.99

F. Robert Bentley's Repair Manual for British Cars

Written in 1970, this book is a wealth of fault-finding and repair references for the British car owner. Covering a wide range of cars from Minis to Cortinas, this book explains how these cars work and guides you how to repair them. Softcover, 7" x 9", 380 pages, 225 B&W photos, and 152 illustrations and diagrams.

Bentley Repair Manual 213-785 \$69.99

G. How to Restore Automotive Interiors

Learn how to bring your car's interior back to life. With nearly 200 pages and 500 color photos, this step-by-step guide walks you through restoring seats, door panels, floor covering and headliners, as well as adding sound dampening and thermal insulation.

Interior Restoration Guide 213-865 \$31.99

H. Road Trip - A Practical Manual

This fascinating guide by Mike Breslin is sure to inspire readers to travel with confidence. Offering a wealth of insight from his experiences around the world, the author talks about everything from packing the right stuff, hiring cars, and doing the proper paperwork, to crossing borders and what to do in times of emergencies. 176 pages, hardback.

Road Trip - A Practical Manual 210-350 \$29.99

I. Original Sprite/Midget Restoration Guide

This looks like a coffee table book and reads like one too - but its easily accessible information is nothing less than what you want. Loaded with original specifications, color schemes and factory options and dates. This book may be written for easy reading and may be readable by anyone - but the serious (or 'soon-to-be serious') enthusiast will recognize how valuable this information is.

Original Sprite/Midget Restoration Guide 211-406 \$49.99

J. Bentley Shop Manual

Robert Bentley manuals contain reprints of the factory workshop manual, plus the owner's manual. Add this complete and authoritative manual to your collection today.

948-1098 212-330 \$129.99
1275 212-340 \$129.99





Original Technical Publication on Portable USB

Get access to the original Heritage publications you need to run and maintain your classic vehicle with these publications! Carefully reproduced from the extensive historical archives in both England and the USA, these technical publications include parts catalogues, service manuals and owner's literature. These are printable (Windows and Android), viewable through the USB or online access (single user license), bookmarked, and searchable with zoom features to see details.

The Original Technical Publications (OTP) product is a portable and secure PDF document solution on a USB stick. With the data locked to the USB device rather than to specific computers, you can use it anywhere and offline too!

Sprite & MG Midget	213-903	\$89.99
Master Collection: Austin Healey		
1953 to 1971	213-910	159.99
Master Collection: MG 1923 to 2005		
(not 1100/1300),	213-908	319.99



The Red Car

Originally published in 1954, The Red Car is a timeless tale that has been translated in several languages. It is the story of Hap Adams, a teenage boy who finds a beat-up MG TC sports car, restores it, and learns the joys of sports cars and driving from the town mechanic, Frenchy Lascelle. The book makes for a wonderful companion for any classic car enthusiast and is the perfect pick to introduce the love of LBCs to a younger audience. Order your copy today!

The Red Car	210-470	\$14.99
-------------	---------	---------

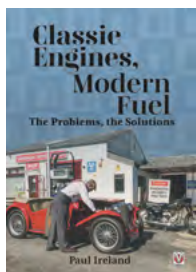

Classic Engines, Modern Fuel - The Problems, the Solutions
210-360 \$24.99



Frogeye Sprite: The Complete Story
210-235 \$54.99

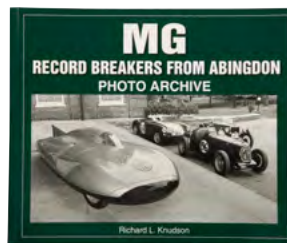

MG Record Breakers from Abingdon
210-245 \$29.99



Never Stop Driving
210-445 \$26.99



Buyers Guide
213-855 \$32.99



Restoring Sprites & Midgets
213-305 \$54.99



Mechanical Ignition Handbook
215-110 \$46.99



Glovebox Workshop Manual
212-480 \$38.99



SU Workshop Manual
211-305 \$59.99



Owner's Manual Reprints

Bugeye Sprite	212-690	\$32.99
Midget MkIII	212-705	22.99
Midget 1975-78	213-310	19.89
Midget 1979-80	213-320	19.89



Factory Workshop Manual Reprints

Bugeye Sprite	212-465	\$59.99
Sprite MkII on/Midget to 74	212-475	64.99
Midget 1500	212-415	79.99



Sprite/Midget 1966-74 - DVD
211-153 \$39.99

SEE MORE BOOKS AT THE MOSS LIBRARY
MossMotors.com/Library



*See ordering page for details

WARNING: Cancer and Reproductive Harm. www.P65Warnings.ca.gov





Professional Car Duster

100% cotton dusting mop is treated with special wax to trap dust. Simply shake it out and it's ready to use again. 20" long. Comes with a protective carrying case.

Professional Duster 231-670 \$23.99



Wire Wheel Brush

If your car has wire wheels, you need this brush! Shaped to get around the spokes without damaging your knuckles, this heavy-duty brush makes light work of cleaning your wire wheels.

Wire Wheel Brush 386-940 \$8.99



Convertible Top Cleaning Brush

Natural horse hair brush is nonabrasive, naturally soft, durable, and exclusively designed to gently remove exterior debris from fabric and vinyl convertible tops.

Horse Hair Cleaning Brush 221-530 \$22.99



Auto Dry Blade

This 11½" water-wand swipes away surface water. The soft silicone contours to your vehicle's shape and glides over any paint surface without scratching the finish. Produces 15% less friction than terrycloth.

Auto Dry Blade 231-674 \$19.99

Detailing Brush by Brush Hero

Say goodbye to grime, muck, and road dust with this detailing brush. Ideal for wheels and the exterior of your car, this original waterpowered car wheel brush meets and exceeds your car washing and surface detailing needs. Crafted from high quality injection molded plastic that doesn't corrode, this long-lasting tool is designed to rotate with continuous strength to provide a lance

Detailing Brush 220-840 \$29.99

rollout of power throughout the brush head. With its slow and steady spin, it offers maximum scrubbing power so not a single spot is missed. No batteries or electricity required, just attach it to your garden hose and you are good to go! Includes 2 brushes.



Connolly Hide Care

This is the same famous "Hide Food," only the name has changed. Apply once a month to keep leather clean, soft and luxurious. Made in England.

Connolly Hide Care 220-210 \$29.99



Renovo Soft Top Care

Clean, waterproof, and revive tired tops safely with water-based Renovo products. The best care you can give to your fabric or vinyl convertible top!

Fabric Top Dry Cleaner	220-260	\$16.99
Water & Stain Proofer, 1 L	220-265	29.99
Water & Stain Proofer, 500 mL	220-280	19.99
Vinyl Top Cleaner, 500 mL	220-285	15.99
Vinyl Top Protector, 500 mL	220-290	15.99
Black Fabric Top Reviver, 1 L	220-250	49.99
Black Fabric Top Reviver, 500 mL	220-270	29.99



Convertible Top Maintenance

The textured surface of a convertible top is challenging to keep clean and protected from the elements. The professional strength of Ragtop products extends the life of your top and keeps it looking new.

Top Cleaner	221-505	\$18.99
Fabric Protectant	221-510	34.99
Vinyl Protectant	221-515	23.99



Simichrome Metal Polish

Highly recommended polishing paste for brass, aluminum, and chrome. Leaves a super shine with a protective film for lasting brightness.

Simichrome 225-350 \$22.99



Pricing is subject to change. Please visit MossMotors.com for current pricing and availability.



HYLOMAR®

MORE INFO ONLINE

Hylomar Sealants and Assembly Adhesives

Hylomar Limited manufactures a wide range of high-performance sealants and adhesives used by some of the leading OEMs in the world. Hylomar products are also widely used and respected in the automotive, aerospace, and industrial aftermarkets.

Hylomar M was originally the Racing Formulation. It is acetone-based, stiffens slightly over time and can be used in place of a gasket between finely machined surfaces. This product comes in a tube and an aerosol.

Hylomar Advanced Formulation (AF) is solvent-free, won't harden and is perfect for use with gaskets on parts that need to be removed regularly for service. AF fills imperfections on mating surfaces, thus forming a seal.

Hylotyte RED is a semi-hardening gasket and jointing compound offering improved gap-filling capabilities. The product is resistant to a wide range of fluids, especially water (including salt water and steam), anti-freeze, and synthetic oils. It forms an instant seal, has a heat-activated curing system and is methylene chloride free.

Hylomar Cleaner removes used Hylomar gasket and jointing compound from disassembled joints. The unique mix of solvents also make it perfect for cleaning and degreasing surfaces prior to use with any of Hylomar's range of adhesives and sealants. It is also very effective at removing uncured anaerobic adhesives, uncured silicone, and uncured epoxy products.

Hylomar M - 80 ml Tube	232-220	\$24.99
Hylomar M - 200 ml Aerosol	232-225	39.99
Hylomar AF - 85 g Tube	232-215	34.99
Hylotyte RED - 40 ml Tube	232-231	16.99
Hylomar Cleaner - 400 ml Aerosol	232-240	18.99

SAE 90 GL4 Gear Oil by Dynolite

Our classic cars require special fluid and oil formulations, in particular, gear oil. Newer GL5 oils have too high of a sulfur content which erodes yellow metals such as bronze or brass, commonly used in British applications. Our cars require a GL4 type oil and this Dynolite Gear Oil is perfect for our classics.



SAE 90 GL4 - 1 Liter	225-306	\$14.99
----------------------	---------	---------

Shock Absorber Oil by Dynolite

Replace the original dirty and degraded fluid with Dynolite Shock Fluid. It is custom formulated specifically for single or double action shock absorbers, in particular Armstrong type lever shock absorbers. Our special formula fluid is fully compatible with original shock fluid and incorporates an anti-foaming agent which maintains damping power even under tough driving conditions. It also repels water and condensation, and prevents corrosion, making it essential for your classic car!



1 Liter	220-306	\$22.99
---------	---------	---------

Transmission Oil

Improve copper-corrosion protection and prolong the life of brass and bronze synchro rings, bushes, and thrust washers. Effective in all manual transmissions.



Trans. Oil (non-OD trans.)	220-145	\$38.99
Trans. Oil (OD trans.)	220-122	38.99

ZDDPlus Engine Oil Additive

MORE INFO ONLINE

After 70+ years of trouble-free, metal to metal engine protection, the E.P.A. is forcing ZDDP (Zinc Dialkyl Dithio Phosphate = Zinc and Phosphorus) out of domestic motor oil. If your engine was designed prior to the 1990s, your non-roller lifters require ZDDP in your motor oil to avoid premature deterioration. Don't let your lifters run metal-to-metal. Add the 4 fluid ounce contents of this ZDDPlus bottle at every 4 to 5 quart oil change. Not for use with catalytic converters.



ZDDPlus, each	220-805	\$16.99
---------------	---------	---------

"Ultra Slick" Engine Assembly Lube

Use "Ultra Slick" during assembly of camshafts, lifters, engine bearings, timing components, valves and guides, and rocker shaft assemblies.



Assembly Lube	221-565	\$13.99
---------------	---------	---------

ZDDP ZPaste Camshaft and Lifter Assembly Lube

ZPaste Camshaft & Lifter Assembly Lube is specifically intended for the special break-in requirements of flat-tappet engines. ZPaste is a proprietary formulation of Zinc Dialkyl DithioPhosphate (ZDDP) types with a Molybdenum Disulfide (MoS2) additive in a new formulation Calcium Sulfonate base. It's extreme adhesion allows it to remain in place on critical engine parts for long periods of time. ZPaste is designed to be used along with ZDDPlus for initial engine break-in. Single use packets are enough paste for a single camshaft installation, paste is designed for use on cam lobes and tappets only.



Collector's Choice Engine Oil

Collector's Choice engine oil is a must for your classic engine. Contains higher zinc and phosphorus levels to help prevent premature camshaft lobe wear, additives to help prevent seals from becoming hard and leaking from infrequent use, and antioxidants to combat the effects of humidity changes during storage that can lead to moisture and even rust in an engine. 12 quarts in a case. Not for use with catalytic converters.



20W-50, quart	220-815	\$12.99
20W-50, case of 12	220-810	146.99 OS
Single Use, 1 Camshaft	220-806	\$24.99



NEW



Brake Fluids by Dynolite

Dynolite Brake Fluids prioritize quality and safety. DOT 4 is a premium polyethylene glycol blend with a minimum dry boiling point of 500 F, exceeding industry standards. It has excellent lubricity, a firm pedal feel, and works well with rubber parts. DOT 5 is a non-hygroscopic, non-corrosive silicone brake fluid, making it ideal for historic vehicles. It maintains a boiling point of 500 F throughout its life and has an operating range of -58 to 500 F. DOT 5 does not mix with glycol fluids, so it is best to convert during a total brake system overhaul.

DOT 4 - 500 mL	220-403	\$9.99
DOT 5 - 1 L	220-413	34.99



Copaslip Anti-Seize Compound

This anti-seize is highly recommended for wire-wheel splines and knockoff threads. The Molybdenum formulation reduces galling and corrosion to improve the life of wire wheels and hubs. Wheel and hub surfaces should be cleaned and re-lubricated at least once per year as part of a regular maintenance program.

3.5 oz Tube	221-406	\$24.99
250 g (8.8 oz) Jar	221-410	37.99



Brake Lube

This grease aids in the assembly of natural and/or synthetic rubber components.

Brake Lube, 5 g	220-443	\$3.49
Brake Lube, 500 g	220-444	23.99



Dynolite Fuel Additives

Dynolite Valve Guard is a high performance, three-in-one formula that combines an efficient octane improver with ethanol corrosion protection and a lead substitute.

Features:

- Prevents valve recession
- Combats adverse effects of ethanol
- Cleans and maintains the fuel system
- Carburettor anti-icing protection
- Add up to 4 octane to unleaded fuel (at maximum over treatment)
- Reduces detonation/engine knock (pinking or pinging)
- Suitable for vehicles requiring leaded or high octane fuel

Dynolite Lead Substitute is a lead replacement fuel additive formulated to protect against valve seat recession under all driving conditions whilst keeping the fuel system clean and protected against corrosive effects of ethanol fuels (E5 & E10).

Valve Guard, 3 in 1 fuel treatment,		
250 mL	220-367	\$14.99
Lead Substitute, 250 mL	220-391	12.99



Water and Gas Don't Mix

MORE INFO ONLINE

If you use modern gas that has Ethanol blended in, and you don't drive your classic very often, the ethanol attracts water in your vented tank which in turn forms rust and sludge, impairing performance. We've got three products to help:

Prevent with PEP Fuel Treatment

PEP fuel treatment is a fuel preservative formulated with antioxidants and de-gumming agents to help fight sludge, resin deposits, and gum from forming in your fuel tank. Modern ethanol-blended gasoline has a shelf life of 30-45 days in a vented tank, PEP fuel treatment increases that to 60 days. PEP fuel treatment should be mixed with the fuel every time you buy gas. Keep a bottle handy in your trunk. An 8 oz bottle treats 80 gallons. If you are storing your vehicle with gasoline in the tank, use 1 oz for every five gallons.

Test with Water Probe Indicator

Using a dip stick that will pass all the way to the bottom of your fuel tank, apply the Indicator to the very tip of the dip stick. Water collects at the very bottom of your tank. The Indicator will turn red to show the exact level of water in your tank.

Emulsify with E-Zorb Treatment

E-Zorb emulsifies the water you've found in the bottom of your fuel tank, and mixes the water and ethanol back into the fuel. The water will pass with the gasoline through your filter and into your engine, finally leaving as steam. E-Zorb should be mixed in the ratio 1 ounce to 20 gallons of gasoline, so one pint bottle of E-Zorb will treat 320 gallons. It will be necessary to agitate the fuel treatment in your tank by rocking your car from side to side and up and down.

PEP Fuel Treatment	220-361	\$13.99
Water Probe Indicator	220-362	12.99
E-Zorb Fuel Treatment	220-355	33.99



Pricing is subject to change.
Please visit MossMotors.com for current pricing and availability.

ACCESSORIES



Stor-N-Start

Stor-N-Start is an additive that prevents deposits from forming in fuel lines and carburetors.

Stor-N-Start 220-375 \$10.49



Dashpot Oil

Specifically designed for both SU and Zenith carbs, this oil will ensure your car's proper performance. 125 mL.

Dashpot Oil 220-225 \$17.99



Fuel Tank Restoration

Step 1: Cleaner

We recommend using this bio-degradable cleaner in conjunction with the etching liquid when planning to seal a fuel tank. 1 gal.

Step 2: Etcher

Use this bio-degradable etcher as a prep to our sealing compound to give maximum adhesion to the sealer. Our tank cleaner should be used first to remove oils or grime. 16 fl oz.

Step 3: Sealing

This sealing compound fluid puts a protective film on the entire inside surface of your fuel tank to prevent rust and eventual fuel line blockage. Tanks should be cleaned with #220-620, then etched with #220-630.

Cleaner	220-620	\$52.99	OS
Etcher	220-630	24.99	
Sealing	220-450	56.99	

Carb Dashpot Oil by Dynolite

Give your dampers and pistons longer life with Dynolite Carb Dashpot Oil. Formulated for SU and Zenith Stromberg Carburetors, this synthetic SAE 20 grade oil contains anti-corrosion and anti-wear additives that provide superior cold and hot temperature performance as well as lubrication.

125 ML 220-226 \$9.99



Supercool by Dynolite

Get better cooling system performance with specially formulated Supercool coolant additive.

- Improves heat transfer properties of your coolant
- Suitable for cast iron, aluminum, copper-brass and bronze cooling systems
- Formulated with a corrosion inhibitor
- Compatible with all water base coolants

Supercool 220-117 \$15.99



WaterWetter

This wetting agent helps the coolant "bond" to metal surfaces, and increases heat transfer. Highly recommended for all climates.

WaterWetter 220-115 \$24.99



Corroseal Rust Converter

Rust. Is there a more deplorable four-letter word? Corroseal is the best way to deal with rust because it is less expensive, less time consuming, and is more environment friendly than sandblasting. Corroseal Rust Converter chemically alters rust (iron oxide) into magnetite, a stable substance, while priming the surface with a high-quality latex metal primer at the same time. Corroseal truly provides one-step corrosion control.

- Water-based rust converter with high-quality latex metal primer
- Non-flammable
- Non-corrosive
- Easy to apply (brush, roll, or spray)
- Easy to clean-up with soap and water

Corroseal Rust Converter 232-205 \$64.99



Spray Paints

These ozone friendly paints come in 12 oz. aerosol cans. Bare metal must be primed to achieve satisfactory results. Ground shipping only.

Engine: Olive Green Engine to 1972	220-580	\$29.99
Engine: Black 1972 on	220-575	19.99
Engine Primer	220-576	19.99
Wheel: Silver-Grey	220-560	29.99
Dash & Wiper: Black Wrinkle	220-570	19.99

Spray Adhesive

Our contact adhesive has a very high heat resistance and bonds firmly to insulation and sound-deadening material, carpet, headliners and many automotive surfaces. Great advantage of this spray is that it goes on as a web rather than a stream for a more complete and consistent coverage. 12 fl oz.

Spray Adhesive 409-037 \$28.99



Castrol Collectable Oil Cans

Classic Castrol oil cans look great in your den or garage.

½ Pint	216-545	\$14.99
1 Pint	216-555	29.99
2 Pint	216-565	34.99



*See ordering page for details

⚠ WARNING: Cancer and Reproductive Harm. www.P65Warnings.ca.gov





384-865

8-Piece Wrench Sets

These quality Whitworth and Standard wrench sets were manufactured from a satin finished chrome vanadium and feature a traditional oiled leather tool roll.

Whitworth Set sizes:

1/8" w, 3/16" w, 1/4" w, 5/16" w, 3/8" w, 7/16" w, 1/2" w, 9/16" w

Standard Set Sizes:

1/4", 5/16", 3/8", 7/16", 1/2", 9/16", 11/16", 3/4"

Whitworth Wrench Set	384-800	\$99.99
Standard Wrench Set	384-805	59.99



MG Tool Roll & Tools

Keep your tool set organized and prepared for those unforeseen roadside repairs with the MG Tool Roll and Tool Set. Made of durable canvas, it has a carefully tailored finish, and sports an embroidered MG logo on the front. Store your roadside tools in perfect order with this 15 pocket canvas-roll. A practical buy, keep this handy accessory in your British car wherever you go!

Specially selected for MG, this tool set includes:

- 7" combination pliers
- Spanners: 3/4", 1 1/16", 5/8", 9/16", 1/2", 7/16"
- Screwdrivers: Posidrive and Slotted
- Spark plug wrench and brush
- Adjustable wrench
- Feeler Gauge Set
- Circuit tester
- Tire Gauge

MG Tool Roll & Tools	384-810	\$159.99
MG Tool Roll	384-811	29.99



Classic Leather Tool Bag

Keep your tools tidy, safe and organized with a brand new classic leather tool bag. A perfect addition to any classic car enthusiast's collection, this beautiful tool bag by Gunson is generously sized, made of heavy duty leather, and features stitched and metal riveted seams. Secured with three buckled straps, it has an adjustable shoulder strap for easy handling. This useful bag measures approximately: 150 mm x 145 mm x 380 mm.

Classic Leather Tool Bag	384-815	\$94.99
--------------------------	---------	---------

Whitworth Drive Sets

Made from high-quality forged materials, King Dick drive sets make for a perfect addition to the tool cabinet of any classic car enthusiast. The drive sets use precision drop forging methods to ensure uniformed steel structure. The sockets are broached to size using exceptional accuracy, then ground and polished before being heat treated for consistent and reliable strength that you can count on! The drive sets are then polished again and stamped for the final touch. The nickel chrome plating ensures maximum resistance to corrosion that also serves to enhance the appearance of the drive set. Check our website for details of each kit.

1/2" - 8 PC	384-860	\$174.99
1/2" - 19 PC	384-865	429.99
3/8" - 9 PC	384-870	176.99



Phillips/Posidriv All-In-One Screw Driver Set by King Dick

Our revolutionary all-in-one screwdriver set features a patented tip design optimized for both Phillips head and Pozidriv patterns. All four screwdrivers are made from hardened and plated high-grade steel, and have soft-feel grips for comfort and control. Take the guesswork out of your British car tasks and save yourself the frustration of stripped screw heads. All four screwdrivers work with PH1-2-3 or PZ1-2-3 and vary only in length.

Phillips/Posidriv	384-850	\$72.99
-------------------	---------	---------



Ignition Wrench Set

High quality ignition wrench set by King Dick. Sizes 0 to 10 BA will handle most fasteners smaller than 1/4" on the car.

Wrench Set	385-000	\$86.99
------------	---------	---------



Pricing is subject to change.
Please visit MossMotors.com for current pricing and availability.

ACCESSORIES

Fuel Sending Unit Tool

This simple socket style tool makes removing the fuel sending unit locking ring from your fuel tank a breeze. It increases efficiency and facilitates your experience, so buy yours today!



MGB/C 65-76 384-985 \$29.99

Snap Installation Tool

Install button snaps easily and without damage.

Snap Tool 386-980 \$4.99



Lift-the-Dot Hand Punch

For professional installers, but this tool would make a fine car club tool box addition. Punches center hole and prong holes for installation of Lift-the-Dot fasteners to make installation of tops and tonneau-covers a cinch.

Lift-the-Dot Hand Punch 226-105 \$89.99

Clutch Alignment Tool

Accurately aligns your clutch disc for easy engine/transmission assembly.

948-1275 387-320 \$3.99
1500 387-330 3.99



Drum Brake Adjusting Wrench

Get a better grip on brake adjusters with our specially designed wrench. It has 1/4" and 5/16" square box end, and a long handle for improved leverage.

Adjusting Wrench 386-160 \$13.99



Grease Gun

A handy tool for all those maintenance tasks.

Grease Gun 386-710 \$36.99



SU Maintenance Tool Sets



SU Jet Wrench

Mixture adjustments on SU H and HS carburetors are much easier with the proper tool. 5/16" W (0.600" nut) fits original carbs. 17 mm (0.669" nut) fits new upgraded carbs.

(A) 5/16" W Wrench 386-400 \$4.39
(B) 17 mm Wrench 386-401 7.99



SU Tool Kit

An assortment of handy tools for the home mechanic. Instructions included. Suitable for all cars with SU carbs. Includes jet wrench (#386-400).

SU Tool Kit 386-300 \$23.99



SU Jet Centering Tool

Jet centering is critical on older fixed needle SU carbs. This simple tool makes it a snap!

Centering Tool 386-500 \$39.99

SU Carb Rebuild DVD

Tune or rebuild SU carbs with this easy-to-follow 2 hour 40 minute video.



SU Rebuild DVD 211-036 \$39.99

Brake Spring Tool

Make an easy work of installing or removing the brake anti-rattle springs with this quality brake spring tool. The 3/8" wide nose end is inserted into the beehive springs. Square holes at ends of the handle are used on the square shank adjuster screws, either 1/4" or 5/16".

Brake Spring Tool 384-980 \$23.99



Scissor Type Ball Joint Separator

This scissor type ball joint separator has a 19 mm jaw capacity and a chemically blackened forged-steel body with thrust bolt.

Scissor Type Ball Joint Separator 386-027 \$34.99



Ball Joint Puller and Separator

These heavy-duty forged tools are the easiest way to split ball and taper joints, such as track rod ends from steering arms.

Puller 386-025 \$54.99
Separator, Scissors Type 386-026 85.99



Steering Wheel Nut Socket

An absolute necessity for removing steering wheel retaining nuts. A worthwhile investment - 2-sided, 1 1/16" and 1 1/2".

Wheel Nut Socket 384-906 \$36.99



Sprite/Midget Rear Axle Hub Nut Wrench

This wrench fits the unique axle nut found on the Sprite and Midget. A standard 1/2" drive socket wrench can then be used to remove and reinstall the nut.

Sprite & Midget 384-959 \$58.99



Bezel Remover Tool Set

The round bezels on most Lucas Switches have two slots, and nobody has the special tool you need to take them off. Using a screwdriver results in a scratched dash and colorful language. These tools have two teeth for the slots in the bezels and are made from hard steel so the teeth will last; critical for this application so you don't mar your bezels. The set includes tools for 3/4" diameter and 1" diameter bezel nuts.

Warning Lights Bezels 384-960 \$37.99



Stromberg Jet Installation Tool

Stromberg jets eventually require replacement, but it's a tricky and tedious job. Our new installation tool takes the guesswork out of correct jet replacement.

Stromberg Jet Installation Tool 386-311 \$109.99



No-Mar Tool Set

Using the right tool for the job is a must if you don't want broken parts or scratched paint. This set of 5 pieces is perfect when you're removing fasteners, trim, or molding, and don't want to damage your paint or those expensive fasteners. No-Mar means the tools won't hurt your car or the parts you're removing. The small price is great insurance, and every tool box is incomplete without this set.



No-Mar Tool Set 231-830 \$23.99

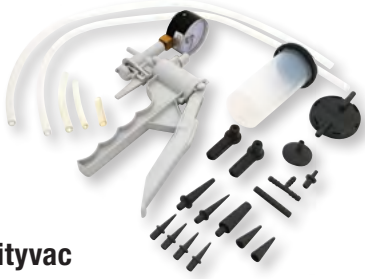

Mityvac

This popular vacuum/pressure pump is perfect for bleeding hydraulic systems. Includes: vacuum/pressure pump, vacuum gauge, 3/4" tubing, automotive and brake bleeding adapter packages, reservoir jar, and a manual with detailed instructions and ideas for additional uses.

Mityvac 386-215 \$89.99



Eezibleed Kit

Kit contains a pressure vessel to hold new fluid, a pipe with interchangeable caps to fit many hydraulic master cylinders, and an air hose to connect to a tire. Instructions included.

Eezibleed Kit 386-860 \$79.99

Gunson's Colortune

A glass topped spark plug allows you to see the color of combustion in your cylinders. Comes with special glass topped spark plug, viewing system for difficult plug locations and complete tuning procedure with trouble shooting guide.



Gunson's Colortune 386-210 \$109.99



One-Man Brake Bleeder

While we obviously advocate for the many stainless steel braking system components available today, they're still no substitute for proper maintenance and fluid renewal. We recommend flushing your vehicle's brake fluid every year. With this kit the hassle factor is no longer a valid excuse.

One-Person Bleeder 37-0104 \$15.69

Lift Pin Tool

This useful tool raises and holds the lift pin on SU carburetors, making air or fuel adjustments easy and safe.

SU Carburetors 384-976 \$26.99



Carburetor Air Flow Meter

An Airflow Meter allows you to quickly tune your engine's carburetion. These precision instruments are designed to measure the airflow directly on the air intake of the carburetor and can be used at low and high rpm on down draft and side draft engines. The sensitivity and accuracy of the Airflow Meter is much greater than any other type of synchro tool or gauge. And the range of indication is very broad on the lower end of the scale to ensure precise adjustment at idle rpm. While a single instrument is sufficient, the use of one per carburetor is advantageous. The airflow of each carburetor can be constantly observed until the tune-up is completed. Made in Germany the BK Model is supplied with an adapter that is ideal for all ram pipes and intake bores of 1 1/4" to 2 1/4" (32 to 55 mm diameter) and provides an easy-to-read indication from 1 to 30 kg/h.

Carburetor Air Flow Meter 375-324 \$99.99



Clickadjust Valve Adjuster

Adjusting tappets has never been easier. Replace the clumsy screwdriver/wrench combination with a single easy-to-use tool. This British tool takes much of the effort out of this necessary job. Turn the handle, click, and tighten. Your clearance is set! Requires a 1/2" drive socket to fit tappet adjustment nut.

Clickadjust 386-205 \$139.99



Brake Piston Resetting Tool

The right tool for the job makes life much easier. The Brake Piston Resetting Tool allows easier installation of brake caliper pistons, seals, and seal retainers.

Brake Piston Resetting Tool 386-285 \$69.99



Circlip Installation Tool

The wheel cylinder circlip is notoriously difficult to install. This easy-to-use tool changes all of that. You can now change wheel cylinders in a snap, while avoiding damage to parts or yourself.

Circlip Installation Tool 386-185 \$33.99



Cooling System Air Purge Tool

Ensuring all the air is purged out of the later cooling systems can be tricky without this handy tool. Tool threads into the filler plug hole and allows easy topping off of the cooling system to ensure all air is evacuated.

1275-1500 384-965 \$58.99



Carburetor Synchronizer

Synchronize airflow between multiple carburetors with this indispensable tool for the serious home mechanic.

Carb Synchronizer 386-200 \$39.99



Pricing is subject to change. Please visit MossMotors.com for current pricing and availability.



Wire Harness Repair Kit

Fast, Secure Connections Made Easy.

Our wiring harness repair kit makes fast, secure wiring connections a snap. Just crimp a bullet to each wire end using the included bullet crimping tool, push bullet ends into the connector sleeve and snap firmly into place with the closing tool for a permanent repair.

The high quality, bullet crimping tool ratchets closed to put a secure hexagonal crimp in bullets. The closing tool presses bullets firmly into both single- and two-wire connectors.

Repair Kit with Tools	161-751	\$249.99
Repair Kit without Tools	161-752	54.99
Bullet Crimp Tool	161-759	139.99
Bullet Closing Tool	161-761	54.99



Tube Bender

Bend fuel and brake lines exactly where you need them to go. This Tube Bender works great for brass, copper, steel and aluminum tubes of the following diameters: 3/16", 1/4", 5/16" and 3/8".

Tube Bender	385-905	\$24.99
-------------	---------	---------



MORE INFO ONLINE

See more Shrink Tube Options by DEI online.

Easy Loom Wiring Kit by DEI

Protect and restore your factory or aftermarket wire harness from abrasion, chemicals and the elements with the Easy Loom Master Wiring Kit. With 5 different diameter easy loom sleeves, shrink tube ends, silicone and electrical tapes, and locking ties, this professional kit includes everything you would need to shield your harnesses.

The high quality components offer a Radiant Heat Resistance of 347 F and Melting Point of 500 F. The looms have self-closing split design with 30% overlap, and the tubes are superior in style and function to plastic tubing. Vouched for by most car manufacturers, buying this kit will go a long way in the upkeep of your classic car.

Kit Includes:

- 1 - 1" x 6' Easy Loom
- 1 - 3/4" x 10' Easy Loom
- 1 - 1/2" x 30' Easy Loom
- 1 - 3/16" x 60' Easy Loom
- 1 - 3/16" x 15' Easy Loom
- 1 - 3/8" x 2' Heat Shrink
- 1 - 1/4" x 1' Heat Shrink
- 1 - 1/2" x 1' Heat Shrink
- 40 - 8" Ties
- 100 - 4" Ties
- 1 - 1" x 12' Silicone Tape
- 1 - Roll of Electrical Tape

Easy Loom Wiring Kit	231-960	\$157.99
----------------------	---------	----------

Protect-A-Wire Sleaving by DEI

Shield your wiring, hoses, and cables from potential burning, cracking, and hardening with the Protect-A-Wire Sleaving by DEI. Offering respite from the damage caused by under hood heat, this wire sleeve can be easily installed by sliding Protect-A-Wire™ over your application. Available in two sizes, this 50 foot roll is especially great for shop use. Choose the one that best meets your requirements: 3/16" or 5/16".

Features:

- Constructed from high temperature resistant glass fiber material
- Can withstand direct heat up to 500 F
- Protects electrical wiring, speedometer cable, hoses & more
- 50 foot bulk spool is great to have on hand for any project

3/16" Diameter		
Black	231-986	\$22.99
Red	231-988	18.99
Blue	231-990	18.99
5/16" Diameter		
Black	231-985	\$55.99
Red	231-987	29.99
Blue	231-989	34.99

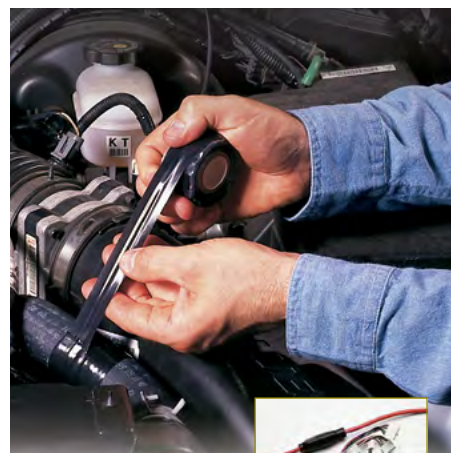

X-Treme Quick Fix Tape

X-Treme tape was developed for the military. Once wrapped around an object, the silicone based tape forms a non-conductive, air/watertight, insulating seal that remains flexible within a range of -60 F to 500 F and has a tensile strength of 600 psi. The tape can be repositioned within two minutes of wrapping and will start to bond immediately upon application. Black roll is 1" wide and 10' long (stretches to 3 times its length).

X-Treme Quick Fix Tape	221-590	\$8.99
------------------------	---------	--------



*See ordering page for details

⚠ WARNING: Cancer and Reproductive Harm. www.P65Warnings.ca.gov





GB40 Lithium Jump Starter by NOCO

This portable lithium-ion battery jump starter pack delivers 1,000 amps (7,000 Joules3S) to jump-start a dead battery in seconds! It features patented safety technology that provides spark-proof connections and reverse polarity protection making it safe and easy for anyone to use. It's a powerful battery booster that doubles as a portable power bank for recharging USB devices, like a smartphone.

Features:

- A lithium battery jump starter rated at 1,000 Amps (7,000 J3S)
- Spark-proof connections and reverse polarity protection
- Recharges USB devices, like smartphones, tablets, and more
- 100 lumen LED flashlight with multiple modes, including SOS
- Jump starts gas engines up to 6 liters, and diesel up to 3 liters
- Provides up to 20 jump starts on a single charge

GB40 Lithium Jump Starter 386-420 \$124.99



On-Board Battery Charger

Every sports car owner who only uses their car part of the year needs one of these, because deep discharge appreciably shortens battery life.

- Attaches permanently to battery tray or fender well
- Molded plastic sealed-case is resistant to water, gasoline, oil, solvents, and acids
- Charges and maintains 12 volt batteries
- Totally automatic. If the battery drops 1 volt, the charger switches on, and when fully charged it switches itself off
- Operates from any regular 110 volt outlet
- Dimensions: 5½" x 3½" x 1½"
- Mounting hardware included

Battery Charger 386-245 \$94.99



MUS 4.3 Battery Test & Charge by CTEK

The MUS 4.3 Test and Charge combines a microprocessor-controlled battery charger with a battery and alternator test function to provide the ultimate in battery testing, charging, and maintenance.

Testing - Three easy to use programs test battery voltage, starting power, and alternator performance to provide a complete picture of battery and vehicle charging system health.

Charging - This charger solves a broad range of battery problems. Its features include a patented automatic desulphation program and a special reconditioning function that can revive deeply discharged and stratified batteries. The patented Float/Pulse maintenance setting makes this charger ideal for long-term battery maintenance.

Features & Technical Info:

- Input 110-120VAC, 50-60Hz, 0.6A max
- Output 14.4V/14.7V/15.8V, 4.3A max
- Fully automatic 'connect and forget' 8 step 12V charging cycle
- 3 voltage test programs
- Battery types: All types of lead-acid batteries, 12V, WET, MF, Ca/Ca, AGM, GEL
- Insulation: IP65 (splash and dust proof)
- Patented float/pulse maintenance for batteries up to 160Ah
- 5 Year Limited Manufacturer Warranty

MUS 4.3 Battery Test & Charge 386-290 \$149.99

Accessories

Silicone Bumper Cover	386-292	\$11.49
Mounting Bracket	386-293	11.49
Comfort Connect Cable	386-294	7.89
8.2 ft Extension Cable	386-295	12.99

Battery Filler

Correct topping up of your battery is ensured with this vintage style battery filler. Simply insert the nozzle into the battery and press down onto the separators. The valve opens and automatically fills the battery cell to the correct level.



Vintage Battery Filler 163-400 \$8.99



MXS 5.0 Battery Charger by CTEK

Get unrivalled charging performance for batteries from 1.2 to 110Ah with the advanced microprocessor controlled MXS 5.0 battery charger. With built-in automatic temperature compensation, it ensures the best charging performance, even in the most extreme conditions. The MXS 5.0 also includes battery diagnosis to establish whether your battery can receive and retain a charge, a patented automatic desulphation program, an AGM (Absorbent Glass Mat) option which maximizes the performance life of most Stop/Start batteries found in modern cars (cars that turn-off when stopped to reduce emissions), and a special mode for reconditioning deeply discharged batteries. The MXS 5.0 includes CTEK's patented float/pulse system, which is certainly the most efficient mode when a battery is connected for long periods.

Features & Technical Info:

- Input 110-120VAC, 50-60Hz, 0.6A max
- Output 14.4V/14.7V/15.8V, 4.3A max
- Fully automatic 'connect and forget' 8 step 12V charging cycle
- Battery types: All types of lead-acid batteries, 12V, WET, MF, Ca/Ca, AGM, GEL
- Insulation: IP65 (splash and dust proof)
- Patented float/pulse maintenance for batteries up to 160Ah
- 5 Year Limited Manufacturer Warranty
- New Feature offered with the MXS 5.0 Charger:
 - Built in charge voltage temperature compensation according to ambient temperature

MXS 5.0 Battery Charge 386-296 \$124.99

Accessories

Silicone Bumper Cover	386-292	\$11.49
Mounting Bracket	386-293	11.49
Comfort Connect Cable	386-294	7.89
8.2 ft Extension Cable	386-295	12.99



Pricing is subject to change.
Please visit MossMotors.com for current pricing and availability.

ACCESSORIES



Keep Calm and Wrench On Work Mat

Stay comfortable as you work on your car with these logo'd work mats. Customized for your British sports car, these work mats are made from closed cell foam, and offer comfort as you sit, kneel, or lay down to work on your car repair projects. Measuring 72" x 24" x 3/16", they are perfectly sized to be kept in your trunk. Made in the USA, these work mats are water and chemical resistant, and they do not stain easily.

Work Mat 217-805 \$45.00



Oberg Tilt Lift

Allows easy adjustment of an engine's lift angle through a full 90° of movement. Adjust with 1/2" ratchet; 2,000 lb capacity with a 3:1 safety load factor. A positive lock ensures the engine stays put. All steel construction and small size.

Oberg Tilt Lift 386-730 \$119.99



Engine Roll Around Stand

If you have a spare engine to store, this stand makes it easy to move and keeps your engine off the ground. Dismantled, the engine stand stores easily until needed. Engine not included.

Fits 948-1275 384-925 \$164.99



214-702



214-700

Classic Logo Kneeling Pads

Stay comfortable as you work on your car using the MG kneeling pads. Customized with an MG logo, these work pads are made from Softek closed cell foam, and offer comfort as you sit or kneel to work on your car repair projects. These lightweight foam cushions can be used on multiple surfaces at home, garden or on the road, and feature a cut-out handle making it easy for you to carry them around. Made in the USA, these work pads are water and chemical-resistant, washable, do not stain easily, and are practically maintenance free. Just wipe away any dirt with a wet tissue or cloth and you're good to go!

MG Octagon Logo	214-700	\$23.99
Austin Healey Script Logo	214-702	23.99



Moss Tinkering Fender Cover

Protect your car's finish from accidental spills, scratches, or small dents while you work on the engine bay. Imprinted with a fun "Tinkering in Progress" text, this fender cover features colorful MG, Triumph, Austin Healey, Jaguar, and MINI logos. It has strong PVC material on one side and a non-slip felt lining on the other. Available in 34" x 21" size, it includes five nylon mesh pockets to hold small tools and hardware. Washable and easy to maintain.

Moss Tinkering Fender Cover 991-020 \$29.00



The Auto Dolly - 8" x 16" Standard Duty

Maneuvering your car is easy with these wide heavy duty rollers. When used as a set, they are able to manage a 6,000 lb capacity.

Standard Duty Dolly 900-163 \$214.99 OS



Oil Spill Mat

Don't let oil stain your garage or driveway. Roll out an absorbent Oil Spill Mat to catch the daily dribbles and engine maintenance spills.

Oil Spill Mat 221-605 \$25.99



*See ordering page for details

⚠ WARNING: Cancer and Reproductive Harm. www.P65Warnings.ca.gov





Trunk Cargo Net

Keep your trunk space cleaner and more organized with the brand new cargo net. It easily attaches to the trunk lid hinges and opens at the top. It is super stretchable to fit small items that often roll around in your trunk, and employs high quality materials to give it durability.

Trunk Cargo Net 900-754 \$12.99



Keep Calm Weekender Bag

Carry a piece of British nostalgia, cheeky humor, and all your travel items with this duffel bag. The "Keep "Calm and Cruise On" tote has a zippered main compartment with a reinforced bottom, a front slip pocket, and expandable top. Its adjustable shoulder strap and the matching handles make carrying more comfortable.

• Size: 22" W x 14" H x 7" D

Keep Calm Weekender Bag 217-830 \$44.99



MG Canvas Duffel Bag

Pack and go with this durable and spacious canvas duffel bag. Created for road trips but destined to be your favorite all-occasion duffel. Its classic design delivers thoughtful features including:

- Synthetic leather accents embossed with the MG wings logo
- A zippered pocket for quick access to items like a wallet or phone
- Side clips for adjustable load carrying capacity
- A trolley sleeve for attaching the duffel to rolling luggage
- Size: 11" H x 20" W x 9½" D

MG Canvas Duffel Bag 217-825 \$79.99



Knit Blankets

Keep the chill away while relaxing at home or during a brisk night drive with this blanket. Made from an 80% cotton blend, the blanket's knit construction feels as soft as a sweater while providing you a substantial buffer against the cold. It measures 50" x 60", weighs 3 ½ pounds, is machine washable, and is made in the USA.

Austin Healey Script	231-315	\$99.99
MG Octagon	231-320	99.99
MG Safety Fast	009-126	99.99
BMC Rosette	231-330	99.99
All British Line Up	009-143	99.99
Union Jack	009-146	99.99
American Flag	009-147	99.99



Moss Collapsible Organizer

Keep your stuff safely arranged with a blue Moss collapsible organizer! Made from a lightweight fabric, this collapsible organizer can be simply unfolded and loaded with items when needed. Durable and easy to use, it has mesh pockets on the inner sides, and stitched piping along the edges. The two compartments offer you plenty of space to fit things neatly and efficiently. The central divider prevents your cargo from sliding. The organizer has rigid base, and stays firm even when empty. The cut out handles on each side make it easy to be lifted and carried around. Featuring the Moss block logo, get this effective organizer for your car, shop, or home!

Collapsible Organizer 217-600 \$15.00



Waterproof Picnic Blankets

Bring a touch of comfort to any roadside picnic with the waterproof picnic blanket. Folded into a parcel, it can be easily stored and transported using its durable handle. When open, this blanket spreads out to 51" x 70". Constructed of gray acrylic with a foam-layer and waterproof PEVA backing, it comes adorned with the MG logo.

MG Logo	231-375	\$34.99
Austin Healey Logo	231-385	34.99



Premium Embroidered Hats

These superbly crafted embroidered hats provide a deep low fit which allows them to stay on at high speed. The adjustable velcro closure ensures a secure, personalized, fit. Offered in a variety of styles and colors, you're certain to find the perfect one to help keep the sun and wind from diminishing your fun!

Features:

- 100% Cotton
- Contoured Sandwich Visor
- Premium Embroidered Designs

A. Tan/Navy - MG Safety Fast	219-933	\$20.00
B. Tan/Navy - Austin Healey Script	219-934	20.00
C. White with Navy Sandwich Visor - MG	219-816	20.00
D. Navy with White Sandwich Visor - MG	219-819	20.00
E. Tan with Green Sandwich Visor - MG	219-817	20.00
F. Black with White Sandwich Visor - MG	219-818	20.00
G. Navy with Red Sandwich Visor - Sprite MkI Half-Jack	219-938	20.00
H. Navy with Red Sandwich Visor - Sprite MkII Half-Jack	219-941	20.00
I. Navy with Red Sandwich Visor - Midget Half-Jack	219-939	20.00
J. Navy/Red - Austin Healey Script	219-834	20.00



Back J



Back A & B

Back G, H, & I



217-520



217-526

Embroidered Coach's Jackets

Add a style statement to your wardrobe with these coach jackets featuring the embroidered logo of your favorite classic car! With contrast poly lining, Raglan sleeves, elastic cuffs, and slash pockets the 3 oz lightweight jacket has a waist toggle pull and dyed-to-match metal snaps in front for easy closure. Made from 100% nylon taffeta, this jacket is water resistant.

MG Octagon Logo

Medium	217-520	\$49.99
Large	217-521	49.99
X Large	217-522	49.99

Austin Healey Script Logo

Medium	217-526	\$49.99
Large	217-527	49.99
X Large	217-528	49.99

Classic Logo Performance Polos

Stay comfortable with our light weight Performance Polos. Moisture-wicking and highly breathable, our polo will keep you dry and cool whether you're out for a drive, at a show, or just working in the garage. This navy-blue polo comes sporting the classic MG Octagon logo. Machine washable.

Austin Healey Script Logo

 Navy - Medium	217-364	\$38.00
Navy - Large	217-365	38.00
Navy - X Large	217-366	38.00
Navy - XX Large	217-367	38.00

MG Octagon Logo

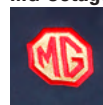
 Navy - Medium	217-360	\$38.00
Navy - Large	217-361	38.00
Navy - X Large	217-362	38.00
Navy - XX Large	217-363	38.00

MG Safety Fast Logo

 Green - Medium	217-275	\$38.00
Green - Large	217-276	38.00
Green - X Large	217-277	38.00
Green - XX Large	217-278	38.00



Classic Logo Scarves

Brave the elements while showing appreciation for your classic car with one of these knit scarves. Made from an 80% cotton blend, their sturdy knit construction offers a feel as soft as a sweater. Machine washable and made in the USA. Each scarf measures 8½" x 80".

MG Octagon	231-340	\$39.99
Austin Healey Script	231-341	39.99



*See ordering page for details

WARNING: Cancer and Reproductive Harm. www.P65Warnings.ca.gov





217-640



217-635

Grey Embroidered Austin Healey Sprite T-Shirts

Get your style on with the brand new Sprite T-shirts! Made using heavy cotton, these t-shirts give a softer feel and comfortable fit for active daily use. They are perfect to wear while you're taking your LBC for a ride, attending your car club meetings or simply enjoying a day out.

Bugeye Sprite

Medium	217-635	\$18.00
Large	217-636	18.00
XLarge	217-637	18.00
XXLarge	217-638	18.00

Austin Healey Sprite

Medium	217-640	\$18.00
Large	217-641	18.00
XLarge	217-642	18.00
XXLarge	217-643	18.00

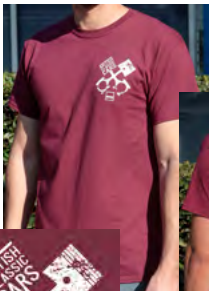

FRONT



British Logo Beanie

Fashioned from 100% soft acrylic, this cuffed beanie has waffle knit construction and features a woven logo of your favorite classic on the front and a Moss block label clipped to the left side of the back.

MG Logo

Dark Green	217-755	\$25.00
Khaki	217-756	25.00

Austin Healey Logo

Red	217-765	\$25.00
Grey	217-766	25.00

Moss Motors Beanie

Smart and casual, the Moss Motors Beanie is made of 100% acrylic knitted fabric in the color steel.

Comfortable and stretchy, it features a woven Moss Motors logo on the front and Moss block label on the back left. One size fits all.



Moss Motors Beanie	217-245	\$25.00
--------------------	---------	---------



BACK

DETAIL



MG Safety Fast Vest

Casual and classic, represent your favorite marque any time of the year with this lightweight, water-resistant vest. Customized for a classic car enthusiast, this vest sports the classic "Safety Fast" embroidery on the back and a smaller MG octagon on the front.

Featuring front zippered pockets, fleece lining for those early morning drives, and a zip-through cadet collar with chin guard, the vest has a 100% polyester woven shell bonded to a water-resistant film insert. Show it off at your car club meetings or gift it to a fellow enthusiast. And the best part is that this outerwear comes at a hard to beat price! Easy to care. Machine washable. Available in sizes Small - 2XL. Get yours today!

Sizing, measured at the chest, in inches:
35-37 (S), 38-40 (M), 41-43 (L), 44-46 (XL), 47-49 (2XL)

Small	217-820	\$69.99
Medium	217-821	69.99
Large	217-822	69.99
X Large	217-823	69.99
XX Large	217-824	69.99



All British Line-Up Hoodie

Medium	009-113	\$40.00
Large	009-114	40.00
X Large	009-115	40.00
XX Large	009-116	40.00
XXX Large	009-117	40.00

Some Assembly Required T-Shirt

Medium	009-108	\$16.00
Large	009-109	16.00
X Large	009-110	16.00
XX Large	009-111	16.00
XXX Large	009-112	16.00

Moss Motors British Classic Cars Apparel

Show your appreciation for British Classic Cars with the latest in our lineup of custom apparel. For the all-around British car fan, our treaded classic design t-shirt and corresponding beanie are sure to turn heads. Our pull-over sweatshirt with front pocket has a back print of the front-angle view of some of the best British cars around (no offense to those we didn't include!). And finally, the complexity of SU carbs with the tagline "Some Assembly Required" is known all too well by those of us who have braved a disassembly and makes for a fun and stylish shirt.

BCC Beanies

Grey	217-750	\$28.00
Red	217-751	28.00
Blue	217-752	28.00

BCC T-Shirt

Medium	217-690	\$16.00
Large	217-691	16.00
X Large	217-692	16.00
XX Large	217-693	16.00
XXX Large	217-694	16.00

Pricing is subject to change.

Please visit MossMotors.com for current pricing and availability.



Shop Aprons

Easily access your tools as you get ready to repair and restore your classic British car. Bearing the logo of your favorite car marque, the navy blue shop apron is available for all Austin Healey fans. Made from 100% cotton, it is machine washable, features 2 deep front pockets for easy tool access, one inch wide adjustable neck strap, and long belts you can comfortably tie around your waist. With stain release technology, this high quality shop apron maintains color and allows stains to be removed easily during laundering without affecting the fabric weight or breathability. So strap it on and work with convenience on your car!

MG Logo	217-200	\$26.99
Austin Healey Logo	217-205	26.99



MG Gunmetal Watch

Show off the MG marque in style with this men's MG watch. The 37mm gunmetal grey alloy case has a matte textured finish, and features a single crown design. Encased inside is a high quality quartz movement for accuracy and longevity, sure to keep you on time for years to come. On the face it features engraved numeric markers and seconds, with black hands with white fill for easy viewing. The strap is a subtle faux alligator in black. With a large MG Octagon logo in red, it's perfect for any MG enthusiast!

MG Gunmetal Watch	231-314	\$89.99
-------------------	---------	---------



MG Octagon 45mm Chronograph Watch

This great looking chronograph style watch has a 45 mm precision machined silver alloy case, sport a mineral glass crystal face, stainless steel bezel and a stainless steel positive clasp band for great looks, easy viewing and durability. It comes packaged in an elegant black tin presentation case for easy gift giving.

Features:

- High quality quartz movement from Japan for accuracy and longevity.
- Fully functional 1/10 second chrono capability up to 60 minutes that provides accurate timing at home or at the track.
- Self-luminous hour markers, hour hand and minute hands with a red second hand for a sporty look and great night-time visibility.
- Logos are raised/embossed and high polished to a jewelry finish for premium good looks.
- Includes a 3 year limited factory warranty. See the enclosed factory warranty papers for specific details and conditions.

MG Octagon	231-311	\$149.99
------------	---------	----------



Insert Before Drive Key Ring

Here's something cool and useful for your car. These "Insert Before Drive" key rings are a fun play on the original "Remove Before Flight" tags often seen on aircraft or their components. These marque specific key rings come with a tag showing off the Moss block and "Insert Before Drive" script on one side, and our classic British marque logos on the other. Get yours with the classic MG Safety Fast logo, Austin Healey Script or Moss Block! And don't forget, Insert Before Drive!

Moss Motors (100 x 20 mm)	217-256	\$4.00
MG (125 x 25 mm)	217-265	6.00
Austin Healey (125 x 25 mm)	217-266	6.00



229-896	229-887	229-888
229-896	915-326	915-327
229-897	229-897	229-898
229-898	915-328	915-328

Engraved Metal Key Fobs

You'll love the sleek beauty of our latest Keychain Fobs. Engraved with your favorite British icon and available in three distinctive styles.

Leather & Bar

Union Jack	229-886	\$15.99
MG Logo	229-896	15.99
Austin Healey Logo	915-326	15.99

Leather & Teardrop

Union Jack	229-887	\$15.99
MG Logo	229-897	15.99
Austin Healey Logo	915-327	15.99

Solid Metal

Union Jack	229-888	\$15.99
MG Logo	229-898	15.99
Austin Healey Logo	915-328	15.99

Tire Drink Holder

Grab attention with a custom tire cup holder for your classic British car. Approximately 4" tall by 3" wide, the rubber tire drink holder has a neoprene liner. This custom koozie keeps your drinks cool and also makes for a great promotional/giveaway item especially when you're hosting a get-together for classic car enthusiasts. Available at an attractive price, get your tire cup holder today!



MG Logo	217-270	\$10.99
---------	---------	---------

Castrol Tin Coffee Cup

Branded with the period Castrol logo this classic style tin mug has an enamel coating in Castrol classic green with white inner. Great for the garage, camping or out at your next car show.

Features:

- Enamel coating
- Chrome polished rim
- Dishwasher safe
- 16 oz capacity



Castrol Coffee Cup	216-570	\$16.99
--------------------	---------	---------





Stainless Steel Cup

Enjoy your favorite drinks in this stackable classic-inspired 16oz cup, made of high-quality stainless steel and featuring your favorite marque logo. Order for yourself or better yet, get some for your friends and share some classic cheer! Does not include a lid, sold individually.

MG Octagon	217-810	\$12.99
Austin Healey Script	217-812	12.99



Classic Logo Wine Glass Set

When raising a toast with friends, share your Austin-Healey passion etched in glass. A set of four wine glasses makes for an amazing gift. Hand wash only.

MG Octagon Wine Glass Set - 4 pc	230-969	\$39.99
----------------------------------	---------	---------



Classic Logo Pint Glass Sets

This set of four pint beer glasses is great for those hot garage days. Your friends will appreciate the pub-like style and ample serving size. Hand wash only.

MG Octagon - 4 pc	230-951	\$36.99
Austin Healey Script - 4 pc	230-953	36.99



214-740

Collapsible Marque Umbrella

Steer clear of rain, wind or the scorching sun with our new umbrellas especially created for British car enthusiasts! Available with the MG or Austin-Healey logos, these 8-panel nylon umbrellas feature a telescopic metal shaft makes lends durability, and the automatic open function allows for an easy one-handed operation. Each umbrella has a rubberized comfort grip, and comes with a matching sleeve and wrist-strap. Keep it in your car and be prepared to have a great time outdoors, no matter the weather!

Features:

- Automatic opening
- Rubberized Comfort Grip
- 16" folded, 44" diameter
- Matching color fabric case with wrist strap

MG Logo	214-740	\$29.99
Austin Healey Logo	214-742	29.99



216-563



216-562



216-558



216-559



216-561

Castrol Enamel Accessories

Bring back some of the classic motoring nostalgia with a variety of enamel accessories featuring the Castrol oil logo. Choose from a range of hardwearing metal backed glass enamel lapel badges, key fobs, fridge magnets or signs and accentuate your favorite places.

Lapel Badge	216-558	\$9.99
Key Fob	216-559	15.99
Magnet - 2½" x 1¼"	216-561	12.29
Sign - 10" x 7"	216-562	63.99
Sign - 15¾" (Round)	216-563	94.99



Logo Bar Stool

Great stools emblazoned with the logo of your favorite car. 30" high with chrome plated legs. The padded 14" diameter seats offer comfort and are covered with easy to clean vinyl.

MG Logo	231-800	\$199.99	OS
Austin Healey Logo	231-810	199.99	OS



214-712



214-710

Classic Logo Flags

Made from 100% woven polyester, these 3' x 5' flags are a great way to show off your appreciation for your MG! These flags are silk screened for precision, feature the MG or Austin Healey logo and are hemmed with header and grommets for a detailed finish. Let these flags wave outdoors or hang them on your walls for a classic touch to your den or garage. Either place, they are sure to look great!

MG Octagon	214-710	\$39.99
Austin Healey Script Logo	214-712	39.99

British Leyland Metal Sign

Bring some classic cheer to your home with the British Leyland metal sign! Made from heavy 20 gauge steel, the 9" x 12" sign boasts digitally printed British Leyland logo in detailed finish. Perfect for indoor or outdoor use, the sturdy metal signs look great wherever you put it. The holes drilled at top and bottom center make it easy to mount. A great way to honor the legacy of this marque, show off your British car loyalty with an British Leyland metal sign!



British Leyland Metal Sign	214-735	\$22.99
----------------------------	---------	---------



Classic Metal Artwork Sign by John Lowerson

Stylize your space with some creative metal signs. Based on the original paintings by artist John Lowerson, these model specific 9" x 12" signs look amazing and are a great way to showcase loyalty to your favorite classic car. Reasonably priced and high in quality, get them for yourself or gift these artistic metal signs to fellow motoring enthusiasts.

Bugeye Sprite 214-461 \$22.99



Parking Only Signs

9" x 12", printed with sublimation for a detailed finish.

MG Logo 215-761 \$22.99
 Sprite Logo 215-971 22.99



Metal Cutout Sign by Ratco

Jazz up your work space, garage, or den with some Classic British Metal Art! Made from mild steel and finished in a black powder coat, these laser-cut metal signs are unique and seriously great to look at! Available in select styles.

British Leyland - 12" 214-822 \$44.99
 MG Octagon - 12" 214-823 44.99
 Austin Healey Wings - 24" 214-829 44.99



Custom British Signs

Add a bit of fun to your garage or den with these new 14" round British car signs. Made from heavy 20-gauge steel, and digitally printed for detailed finish, these metal signs have holes drilled at top and bottom center for easy mounting. Customized for Sprite and Midget enthusiasts, the signs feature illustrations done by our in-house art and graphics department.

- All of our British car signs feature:
- Indoor and outdoor use
- Durable and very detailed finish
- Holes drilled at top and bottom center for easy mounting

MG 214-730 \$31.99
 BMC 214-734 31.99

Factory Dealer Signs

These sturdy factory dealer signs look exactly like the rare originals, and add a bit of motoring nostalgia to your garage or den.

Austin-MG (12" x 48") 214-210 \$49.99 OS
 AH Service (6" x 24") 214-310 36.99
 MG Service (12" x 16") 214-321 25.99

Vintage Metal Signs

Add a bit of nostalgia to your garage or den with classic British metal signs. Made by hand in the USA, these signs are manufactured from 24 gauge steel, and printed using dye-sublimation for a durable and very detailed finish. Take your pick from several vintage designs. All signs measure 12" x 16" except where noted.



MG Service 214-553



British Classics 214-570



Road Racing at Brooklands 214-572

Only \$25.99



See all metal signs online at MossMotors.com



*See ordering page for details

WARNING: Cancer and Reproductive Harm. www.P65Warnings.ca.gov



ORDERING & SHIPPING

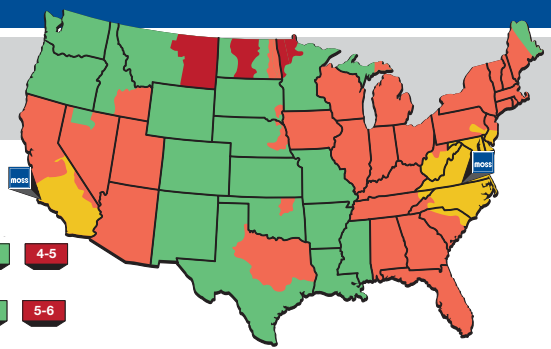

DELIVERY DAYS:

Ground Preferred

1-2 2-3 3-4 4-5

Ground Saver

2-3 3-4 4-5 5-6

AREAS / APPROXIMATE GROUND DELIVERY TIME (In Working Days)

- This map represents approximate working days for Ground Delivery. (As quoted by our carriers, not guaranteed.)
- It also assumes we can ship from the nearest warehouse. Items shipped from an alternate warehouse will take longer.

Shipping, Insurance & Handling Chart US Rates - 48 States (AK*, HI* & PR*)					
Order Total	Ground Saver [†]	Ground Preferred ^{††}	2nd Business Day Air	Next Business Day Air	Canada Air Post ^{**}
\$10.00 to 20.00	\$5.99	\$12.99	\$24.99	\$39.99	\$16.99
20.01 to 50.00	9.99	18.99	34.99	49.99	22.99
50.01 to 75.00	12.99	22.99	43.99	63.99	28.99
75.01 to 100.00	15.99	25.99	49.99	83.99	32.99
100.01 to 150.00	19.99	29.99	59.99	94.99	41.99
150.01 to 200.00	21.99	32.99	69.99	106.99	49.99
200.01 to 300.00	24.99	34.99	79.99	119.99	59.99
300.01 to 500.00	24.99	36.99	94.99	129.99	79.99
500.01 to 700.00	24.99	36.99	106.99	149.99	104.99
700.01 and Up	Free UPS ¹	Free UPS ¹	96.99	139.99	ACTUAL

† Ground Saver (default shipping method) - Ships by most economical method. May add 1-2 days.
 †† Ground Preferred - Ships by UPS and is normally shipped same day if ordered by 3pm local time.

* Alaska, Hawaii and Puerto Rico
 UPS Air - Add \$8 to the 2nd Business Day & Next Business Day Air Rates.
 AK/HI/PR Saver - Subtract \$12 from the 2nd Business Day Air Rates
 (Ships by most economical method and may take longer.)

¹ Free Ground UPS Shipping in the contiguous 48 states. Truck Shipments will be charged a flat \$199 to the 48 Contiguous states and \$279 to Canada.

^{**} Canada Chart Shipping rate is for orders under \$700 and less than 40lbs. Orders under \$700 that are heavier than 40lbs. and orders over \$700 will be charged actual shipping.

SHIPPING

- Shipping is calculated on the regular retail price before any discounts.
- Orders received by 3 p.m. local time are normally shipped same day when shipped by UPS Ground Preferred or UPS Air.
- We will ship by Ground Saver unless an alternate shipping method is specified.
- Alaska, Hawaii, Puerto Rico must choose either AK/HI/PR Saver or UPS Air (see info below shipping chart).

OVERSIZE PARTS FEE

Some items are oversized and are indicated by the oversize parts fee icon. An oversize parts fee (per item) will be applied to your order. This fee will still be charged on free shipping orders. You can find the amount of the fee by visiting MossMotors.com or calling 800-667-7872. The oversize parts fee will not be charged on orders that ship by truck freight.

TRUCK SHIPMENT FEE

- Some parts must be shipped truck freight. Orders shipped to the 48 Contiguous states will be charged a flat \$199. Orders shipped to Canada will be charged a flat rate of \$279.

PO BOX, A.P.O. OR F.P.O.

- A.P.O., F.P.O. and P.O. Box orders are not guaranteed and will be shipped via USPS.

UPS AIR DELIVERY SERVICE (48 STATES)

- Saturday Delivery - Available on UPS Next Day Air and UPS 2nd Day Air orders for an additional \$16.00 and is not available in all areas.
- Orders shipped by air that are over 40 lbs., by weight or dimensions, we reserve the right to charge actual shipping and will notify you in advance.

INTERNATIONAL ORDERS

Orders delivered outside of the USA may take additional time to ship due to additional documentation and payment verification.

- All import costs and fees including duties and taxes are the responsibility of the customer.
- First-time orders and some larger orders may require payment by wire transfer.
- Orders may require a shipping quote and customer approval prior to shipping.
- Customer assumes liability for any disputes or damages when providing their own shipping arrangements.
- Orders are shipped by Air Post when possible. At times, Canada Post may use ground shipping for delivery.
- Shipping charges on orders under \$700 are calculated in the cart during website checkout.
- Orders **under \$700** that are heavier than 40 lbs. (by weight or dimensions) will be charged actual shipping.
- Orders **over \$700** will be charged actual shipping.

See MossMotors.com/ordering-shipping for full details on our ordering and shipping policies

PAYMENT

- We have a \$10 minimum parts order, excluding tax and shipping.
- We accept certified check, money order, and the following credit cards:



WHEN YOUR ORDER ARRIVES

- Please remember to inspect your parts immediately upon receipt of your order.
- Should your order arrive in damaged condition, immediately inform a Moss Motors customer service representative at 1-800-689-9313.
- Claims for damage during shipping must be reported within 3 days of receipt of order.
- Keep original box and packing material.
- If your order was shipped truck freight, note damage on the bill of lading when signing the delivery receipt.
- If there are any other questions about your order, contact customer service within 10 days.

SPECIAL ORDER & DIRECT SHIP PARTS

- Require pre-payment by cashiers check or credit card and may not be cancelled or returned.

BACKORDERS

- Occasionally, we are out of stock on some items, which we will ship to you as soon as available.
- Backorders are shipped free but carry a handling charge of \$3.49 per \$25 of value. (The combined total for original order shipping, and all backorder handling fees, shall never exceed the total shipping charges quoted on the shipping chart on this page.)
- You may request "No Backorders" or cancel backorders at any time prior to shipping.
- We do not backorder to any foreign countries, including Canada.
- Backorders are sent by the most cost effective method, not necessarily the same method as the original order.

WARRANTY - THE LONGEST IN THE BUSINESS!

- All Classic British products are warranted to be free from defects in material and workmanship for 2 years from the date of invoice.
- All superchargers, supercharger components, and supercharger hardware are warranted to be free from defects in material and workmanship for 1 year from date of invoice.
- Moss Motors, Ltd. will, at its discretion, repair or replace any part that fails in service within the warranty period. This warranty does not cover labor, failure of related components, normal wear of brake or clutch components or failure resulting from alteration, misuse, accidental damage, faulty installation, or faulty repair.
- Warranty requests should be submitted to our sales department and must be supported by the original Moss Motors purchase invoice and documentation of the failure.

SALES TAX AND PRICES

- Due to Wayfair Supreme Court Decision we are required to collect sales tax on goods and freight according to each state's law.
- Alabama Simplified Sellers Use Tax:** Moss Motors will collect simplified sellers use tax on taxable transactions delivered into Alabama and the tax will be remitted on the customer's behalf to the Alabama Department of Revenue. Moss Motors program account number is SSU-R010439133
- On the shopping cart checkout page, your sales tax shown will be estimated. Actual sales tax will be calculated at the time of order fulfillment. If your business is tax-exempt, please contact us at (800) 667-7872 to apply your tax exempt status.

RETURNS

See MossMotors.com/returns for full returns policy.

CATALOG ERRORS

Every effort has been made to provide accurate information. We reserve the right to correct typographical errors and will not be held liable for inaccuracy of pricing, descriptions or applications.

TERMS AND CONDITIONS & PRIVACY POLICY

See inside back cover for more information.

 **FREE SHIPPING** Free Ground shipping in the contiguous 48 states. Oversize Parts Fee still applies. Truck shipments will be charged a flat fee of \$199 to the 48 Contiguous states and \$279 to Canada..

 **SAME DAY SHIPPING** Orders received by 3 p.m. local time are normally shipped same day when shipped by UPS Ground Preferred or UPS Air. Does not apply to special orders and some oversized items.

 **OVERSIZE PARTS FEE** Some items are oversized and are indicated by the oversize parts fee icon or an underlined part number. An oversize parts fee (per item) will be applied to your order. This fee will be charged on free shipping orders. You can find the amount of the fee by visiting MossMotors.com or calling 800-667-7872. The oversize parts fee will not be charged on orders that ship by truck freight.

123-456

Pricing is subject to change at any time.

Please visit MossMotors.com for the latest information, current pricing and product availability.

ORDER WORKSHEET

Please Print

Customer No. _____

Name _____

Street _____

City/State _____ Zip _____

Daytime Phone _____ Fax _____

Email _____



Mail To: Moss Motors
440 Rutherford St.
Goleta, CA 93117
Fax To: 805-692-2525

Ship To _____

Street _____

City/State _____ Zip _____

	Part No.	Description	Qty.	Unit Price	Ext. Price
1.					
2.					
3.					
4.					
5.					
6.					
7.					
8.					
9.					
10.					
11.					
12.					
13.					
14.					

Charge My: <input type="checkbox"/> Visa <input type="checkbox"/> Mastercard <input type="checkbox"/> Amex <input type="checkbox"/> Discover	Parts Total
Card Number _____	Sales Tax
Date Card Expires _____	Shipping
Enclosed Is \$ _____	Oversize Fee
For Terms and Conditions & Privacy Policy see inside back cover.	Total

Check YES if you wish to backorder any items not currently stocked. You will not be charged for backordered items until they are shipped.

Yes No

Too many cars is never enough. Need another catalog?

- Austin Healey 100
- Austin Healey 100-6
- Austin Healey 3000
- Austin Healey Sprite
- Triumph TR2, 3, 4 & 4A
- Triumph TR250 & TR6
- Triumph TR7 & TR8
- Triumph Spitfire & GT6
- MG TC, TD & TF
- MGA
- MGB & MGC
- MG Midget
- Jaguar XK120-150, E-Type, Early Sedan, XJ6-12, XJS
- Classic Mini
- Mazda Miata/MX-5

Request one online at MossMotors.com/catalog-request



Sprite / Midget Restoration Parts Catalog

TABLE OF CONTENTS

MANUALS & BOOKS		2
PRODUCTION DATA	Identifying your car	3
TECH. SPECIFICATIONS	Car information	4-5
ENGINE	Engine, 948-1275 Engine, 1500 Engine accessories	6-13 14-16 17
COOLING & HEATING SYSTEM	Radiator, fan, pump & hoses Heaters	18-19 20-21
ENGINE CONTROLS	Control cables	21
FUEL SYSTEM	Carburetors Pumps Tanks	22-24 26 27
EXHAUST / EMISSION CONTROL	Emission control Manifold, pipes, muffler	25 28-33
DRIVELINE	Clutch Gearbox, 948-1275 Gearbox, 1500 Differential & Driveshaft	34-35 36-39 40 41
STEERING	Steering wheels Steering rack assemblies	42 41
SUSPENSION & WHEELS	Front suspension Rear suspension Road wheels	44-45 46 47
BRAKES	Master cylinders Drum brakes Disc brakes Handbrake Pipes, fluid, tools	48 49 50 50 51
BODY PANELS & FITTINGS	Body panels, outer Body panels, inner Windshields Body fittings, Bugeye Body fittings, 1961-'80 Body mouldings, Midget Plugs, grommets, badges, mirrors Door windows / Sidecurtains Bumpers Door fittings	52-53 54 55 56-57 58-60 61 62-63 64-65 66-67 68
ELECTRICAL	Wipers / Washers Headlamps other Lamps Wiring harnesses & wiring fittings Distributors Ignition Battery, Misc. electrical Generator / Alternator Starter	69 70 71-72 73 74-75 76 77 78 79
DASHBOARD	Gauges & Cables Dashboard	79 80-81
SOFT TRIM	Panel kits & Carpets Cockpit fittings Seats Tonneau covers Tops	82 83 84-85 86-87 88-89
TERMS AND CONDITIONS & PRIVACY POLICY		90

About This Catalog

This catalog covers parts for U.S.-specification left hand drive cars. In producing this catalog, our primary goal was to publish a listing of Sprite & Midget parts which was as comprehensive, accurate and informative as possible for the U.S. market. In doing this, we have made every effort to correctly identify and include every part likely to be needed to repair, restore or maintain your car. Although some of the parts listed are not currently available, our Product Development staff is constantly seeking new suppliers and manufacturers of quality reproductions of otherwise obsolete items. The current Moss Motors website (www.mossmotors.com) pricing is always the best indication of availability.

Local laws and regulations relating to pollution, safety and lighting equipment vary considerably from state to state and country to country. Since we distribute parts for these cars on a worldwide basis, we are not in a position to advise what laws are in effect in each locality. We strongly encourage anyone contemplating any modifications to a vehicle intended for street use, to check local regulations before proceeding. We strongly suggest that you save all old stock equipment should reinstallation be necessary at a future date.

NOTE: In the body of this catalog, items with indented descriptions are components of the non-indented kit or assembly above them. When an indented component is "NA", it is still included in the assembly, but not available separately.

Supersession and Rationalization of Parts

Most owners of British cars have, at one time or another, ordered an original "factory" part from an authorized dealer, only to find that the part received was different from the original, although it did work. This is the result of the supersession or rationalization of parts by the factory. Supersessions occur when a part is modified, and the original design or pattern is no longer produced. If old and new parts are interchangeable, even though they may appear slightly different, the old part is superseded by the new part. Rationalization is an attempt by the factory at efficiency in which one new part replaces several original parts, after which the original parts are no longer available.



This "no airplane" symbol indicates that the item(s) may not be shipped by air, and must be shipped by ground.



This truck symbol indicates that the item is shipped by truck freight.

123-456

Underlined part numbers indicate an Oversize Parts Fee will be charged. See mossmotors.com or call for details.

WARNING!

Working on automobiles is inherently dangerous. Moss Motors, Ltd. is not liable for injury or damage due to incorrect installation or use of their products. All products are sold with the understanding that the safe and proper installation and use of the products is the customer's responsibility. Follow factory workshop manual procedures and instructions, but use current shop safety standards and common sense. Some tasks will require professional advice or services which Moss Motors cannot provide.



By special licensing agreement with British Motor Heritage Ltd., Moss Motors, Ltd., is a fully authorized manufacturer and distributor of British sports car spares. With official support from the original manufacturer, we are able to produce a wide range of reproduction spares which meet or exceed the original factory standard of quality. In conjunction with British Motor Heritage, Ltd., Moss Motors is dedicated to the preservation and restoration of British sports cars. The British Motor Heritage, Ltd. and marque trademarks, as well as some exploded view artwork included in this publication, are the property of British Motor Heritage, Ltd., and are reproduced under licensing agreement by Moss Motors, Ltd.



Sprite-Midget Parts Catalog

© Copyright Moss Motors, Ltd. April, 1979
Edition SPM-109 February, 2024
Printed in the USA

All rights reserved. No part of this publication may be reproduced, stored in a retrieval system, or transmitted in any form or by any means, electronic, photocopying, recording, or otherwise without the prior written permission of Moss Motors, Ltd.

Prices subject to change. See MossMotors.com for current pricing.

Toll-Free Orders 1-800-667-7872 | MossMotors.com
Fax 805-692-2525 | Local 805-681-3400

MOSS

Manuals & Books

Factory Workshop Manual Reprints



Bugeye Sprite	212-465	\$59.99
Sprite MkII-on, Midget to '74	212-475	\$64.99
Midget 1500	212-415	\$79.99



Haynes Workshop Manual

Excellent guide to Sprite/Midget tune up and maintenance.

212-380 NA

Glovebox Size Workshop Manual

Though not as complete as the full factory manuals, this clever new manual is packed with information. Tune up data, repair and rebuilding information, dimensions and torque specs are all here in this compact 5-1/2" x 8-1/2" book.

212-480 \$38.99



Bentley Workshop Manual Reprints

Bentley manual reprints are the ultimate shop reference, as they contain both the factory workshop and owners' manuals. The most complete and authoritative manuals available!

948 & 1098	212-330	\$129.99
1275	212-340	\$129.99

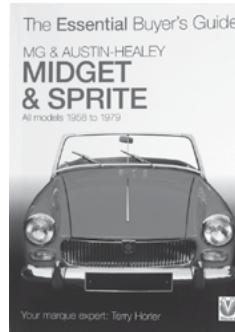

Midget & Sprite Essential Buyer's Guide

This book is the perfect companion for the first-time or even more experienced buyer. All the information is here to help make a clear and balanced decision, to counter the vendor's claims, and even negotiate a better price. The author has bought and sold many MG Midgets & A-H Sprites over the years, and his knowledge and enthusiasm will prove a vital resource for potential buyers. 5.5" x 7.5", 64 pages, 100 color photos.

213-671 \$28.99

Owners' Manual Reprints



Sprite MkI (Bugeye)	212-690	\$32.99
MG Midget 1968-'72	212-705	\$22.99
MG Midget 1975-'78	213-310	\$19.89
MG Midget 1979-'80	213-320	\$19.89

Restoring Sprites & Midgets

by Grahame Bristow

Now you can restore Your Sprite or Midget with the help of this comprehensive and entertaining book. Packed with detailed practical information, photographs, illustrations, and technical specifications. Softbound, 8" x 10-3/4", 210 pages.

213-305 \$54.99



Original Sprite & Midget

This looks like a coffee table book and reads like one too - but its easily accessible information is nothing less than what you want. Loaded with original specifications, color schemes and factory options and dates. This book may be written for easy reading and may be readable by anyone - but the serious (or 'soon-to-be serious') enthusiast will recognize how valuable this information is. Hardbound, approx. 9"x12", 144 pages, over 225 color photographs.

211-406 \$49.99

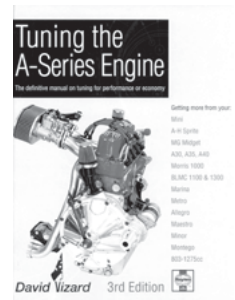
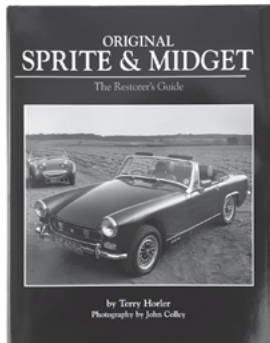

Tuning A Series Engines

by David Vizard

New 3rd Edition. Highly detailed and complete coverage of building and tuning tips. Originally written for the Mini owner, this is a "must-have" for every A-Series Sprite and Midget owner. Hardbound, 8-1/2" x 11", 520 pages.

212-160 NA

Identification Numbers

When ordering parts it is essential to identify your car exactly. Since the changes made by the factory in the course of production have been followed over the years by individual changes made by each owner, it can be extremely difficult in some cases to correctly identify some of the components of your car. To compound the problem, some states title a car by its year of sale rather than the year of its manufacture. In order to make it as easy as possible for you to give us the information we need to supply you with the proper parts, we have found that the common practice of referring to the car series by its engine size ("948, 1098, 1275, & 1500") works quite well and have adopted this system for our listings where possible. Where further detail seemed necessary, we have used the "Mark Series" and "model year" (which should not be confused with the build date). In a few cases, especially in the later cars, we have cited engine and body numbers.

For the sake of simplicity we delete the alpha numeric prefix from the change points in our application. Example G-AN4-72033 is (c)72033. These letters will pinpoint certain production features but will not affect the application of individual parts as listed. Considering the few remaining "original" Sprites and Midgets, this seems to be a rational system that covers most applications.

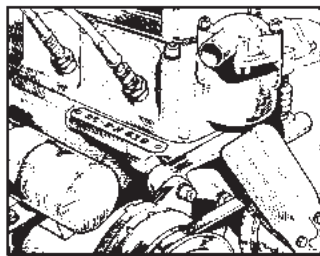

Engine Identification

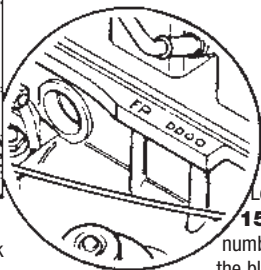

Location of **948, 1098, 1275 engine** number stamped in the block

Location of **1500 engine** number-stamped in the block

Example: **9 CG/ U/ H 12345**

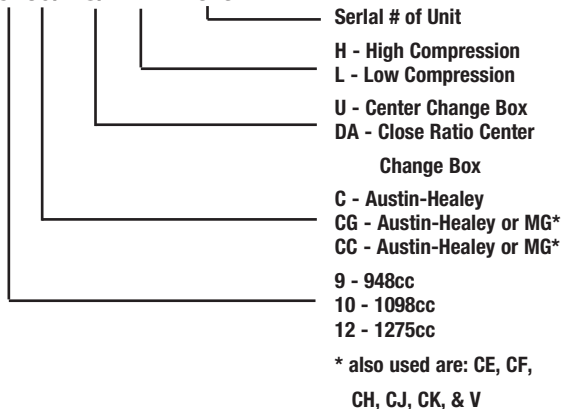

Note: The serial numbers on Sprite and Midget engines do not match the chassis or body numbers.

There are several good published sources of Sprite/Midget production data. Some variation occurs due to inconsistencies in factory record keeping and individual interpretation of available data. Production dates are sometimes confused with model year dates. The factory kept no running totals. The entire Sprite/Midget production came from Abingdon except for 489 Sprites and 476 Midgets which were built at Cowley in 1967. These "Cowley" vehicles may carry an "M" suffix.

Chassis Numbers

The chassis number is stamped on a plate secured to the left-hand inner wheel arch valance under the hood and provides basic information about your car.



Example: **H AN5 L 12345**

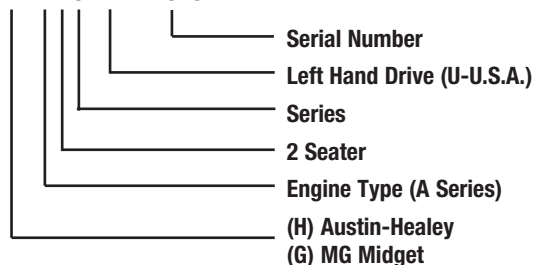

Note: An additional prefix was used from 1970 to indicate the model year.

Production Information (for USA)

Model Year	Build Date	1st Car of model year	Model
	Jun 1961	G-AN1-101	MkI (948)
	Sep 1962	G-AN2-16184	MkII (1098)
	Mar 1964	G-AN3-25788	MkII
1967	Oct 1966	G-AN4-52390	MkIII (1275)
1968	Nov 1967	G-AN4-60441	MkIII
1969	Dec 1968	G-AN4U-66226	MkIII
1970	Sep 1969	G-AN5UA-74886	MkIII
1971	Jun 1970	G-AN5UB-89515	MkIII
1972	May 10, 1971	G-AN5UC-105501	MkIII
1973	Jul 13, 1972	G-AN5UD-123731	MkIII
1974	Aug 23, 1973	G-AN5UE-138801	MkIII
1975	Nov 19, 1974	G-AN6UF-154101	1500
1976	Aug 1975	G-AN6UG-166301G	1500
1977	Dec 14, 1976	G-AN6UH-188001G	1500
1978	Aug 24, 1977	G-AN6UJ-200001G	1500
1979	May 9, 1978	G-AN6UL-212001G	1500
	Dec 7, 1979	G-AN6-229526	last Midget

(There seem to have been no "official" 1980 model year Midgets, although some USA cars are titled as such.)

Sprite

	Mar 31, 1958	H-AN5-501	MkI ("Bugeye")
	Feb 1961	H-AN6-101	MkII (948)
	Sep 1962	H-AN7-24732	MkII (1098)
	Mar 1964	H-AN8-38829	MkIII (1098)
1967	Oct 1966	H-AN9-64735	MkIV (1275)
1968	Nov 1967	H-AN9-72034	MkIV
1969	Dec 1968	H-AN9-77591	MkIV

(Sprite exports were stopped for all foreign markets in early 1969, although production for the home market continued until July 6, 1971.)

Tech. Specs.

BUGEYE SPRITE

948 SPRITE MKII,MIDGET MKI

1098 SPRITE MKII,MIDGET MKI SPRITE MKII,MIDGET MKII

Vehicle Identification	HAN5	HAN6,GAN1	HAN7,GAN2 / HAN8,GAN3
Vehicle Number Location	LH FT FRAME	LH FT FRAME	LH FT FRAME
Engine Number Location	RH FT	RH FT	RH FT
Gearbox Number Location	TOP CASE	TOP CASE	LH CASE
Rear Axle Number Location	LH TUBE	LH TUBE	LH TUBE
Tune Up			
Engine Firing Order	1342	1342	1342
Valve Rocker Clearance	.012 COLD	.012 COLD	.012 COLD
Static Ignition Timing	5 BTDC	4 BTDC	5BTDC
Dynamic Ignition Timing			8BTDC @ 600RPM
Timing Mark Location	BOTTOM TIMING COVER	BOTTOM TIMING COVER	BOTTOM TIMING COVER
Distributor Make/Type	LUCAS DM2	LUCAS DM2P4	LUCAS 25D
Contact Breaker (points) Gap	.014 TO .016	.014 TO .016	.014 TO.016
Rotation of Rotor	COUNTER CLOCKWISE	COUNTERCLOCKWISE	COUNTERCLOCKWISE
Dwell Angle	60	60	60
Ground Polarity	Positive	Positive	Positive
Ignition Coil Make/Type	LUCAS LA 12	LUCAS LA12	LUCAS LA12
Spark Plug Make/Type	CHAMPION N5	CHAMPION N5	CHAMPION N5
Spark Plug Gap	.024 TO .026	.024 TO .026	.024 TO .026
Carburetor Make/Type	SU H1	SU HS2	SU HS2
Carburetor Main Jet	.090	.090	.090
Carburetor Main Jet Needle	GG	V3	GY (HAN7,GAN2), AN (HAN8,GAN3)
Carburetor Piston Spring	NONE	LIGHT BLUE	BLUE
Vehicle & Engine			
Length	11' 5-1/4"	11' 5-5/8"	11' 5-5/8"
Width	4' 5"	4' 5"	4' 6-7/8" [4' 8-1/2" W/WHL]
Height	4' 1-3/4"	4',1-3/4"	4' 1-3/4"
Ground Clearance	5"	5"	5"
Track Front	3' 9-3/4"	3' 9-3/4"	3' 10-5/16"
Track Rear	3' 8-3/4"	3' 8-3/4"	3' 8-3/4" [3' 9-1/4" W/WHL]
Wheelbase	6' 8"	6' 8"	6' 8"
Turning Circle	31' 6"	32' 1-1/2" LH, 31' 2-1/2" RH	32' 1-1/2" LH, 31' 2-1/2" RH
Toe-In	0 TO 1/8"	0 TO 1/8"	0 TO 1/8"
Curb Weight	660 KG	1400 LBS	1466 LBS (HAN7,GAN2), 1490 LBS (HAN8,GAN3)
Original Tire Size	5.20 X13	5.20 X13	5.20 X 13
Original Tire Pressure Front (Cold)	18	18	18
Original Tire Pressure Rear (Cold)	20	20	20
Replacement Tire Size	145 SR 13	145 SR 13	145 SR 13
Engine Type	OHV	OHV	OHV
Engine Displacement	948cc	948 cc	1098 cc
Firing Order	1342	1342	1342
Compression Ratio	8.3:1	9:1	8.9:1
Engine Bore	2.478	2.478	2.543
Engine Stroke	3.00	3.00	3.296
Number of Cylinders	4	4	4
Oil Pressure Idle	10 TO 25	10 TO 25	10 TO 25
Oil Pressure Normal	30 TO 60	30 TO 60	30 TO 60
Ignition Type	POINT	POINT	POINT
Fuel System Type	CARB	CARB	CARB
Fuel Pump Make/Type	AC/SPHINX Y TYPE	AC/SPHINX Y TYPE	AC/SPHINX Y TYPE mechanical (HAN7,GAN2), SU AUF 200 electric (HAN8,GAN3)
Fuel Tank Capacity	7.2	7.2	7.2
Cooling System Capacity	12 PINTS	12 PINTS	12 PINTS
Sump Capacity	7.8 PINTS	7.8 PINTS	7.8 PINTS
Gearbox Capacity, non-overdrive	2.7 PINTS	2.7 PINTS	2.7 PINTS
Gearbox Capacity, overdrive			
Rear Axle Capacity	1-3/4 PINTS	1.8 PINTS	1.8 PINTS

	SPRITE MKIV,MIDGET MKIII	SPRITE MKIV,MIDGET MKIII	1500 MIDGET
Vehicle Identification			
Vehicle Identification	HAN9,GAN4	HAN10,GAN5	GAN6
Vehicle Number Location	LH FT FRAME	LH B PILLAR,LH W/S.	LH B PILLAR,LH W/S
Engine Number Location	RH FT	RH FT	LH REAR
Gearbox Number Location	LH CASE	LH CASE	RH TOP CASE
Rear Axle Number Location	LH TUBE	LH TUBE	LH TUBE
Tune Up			
Engine Firing Order	1342	1342	1342
Valve Rocker Clearance	.012 COLD	.012 COLD	.010
Idle Speed	700 [1000 '68 ON]	1000	700 TO 900
Static Ignition Timing	7 BTDC	7 BTDC	10 BTDC [2 ATDC CALIF.]
Dynamic Ignition Timing	10 BTDC @ 1000RPM	13 BTDC @ 1000	2 ATDC [10 BTDC '78 ON FED.]
Timing Mark Location	BOTTOM TIMING COVER	BOTTOM TIMING COVER	LH TOP
Distributor Make/Type	LUCAS 25D	LUCAS 25D	LUCAS 45DE4
Contact Breaker (points) Gap	.014 TO .016	.014 TO .016	
Rotation of Rotor	COUNTER CLOCKWISE	COUNTER CLOCKWISE	COUNTERCLOCKWISE
Dwell Angle	60	60	
Ground Polarity	Positive thru 1967, Negative from 1968	Negative	Negative
Ignition Coil Make/Type	LUCAS 11C 12 [HA12 '68 ON]	LUCAS HA 12	LUCAS 15C6
Primary Resistance	3 TO 3.4 OHMS	3 TO 3.4 OHMS	1.30 TO 1.45 OHMS
Spark Plug Make/Type	CHAMPION N9Y	CHAMPION N9Y	CHAMPION N12Y
Spark Plug Gap	.024 TO .026	.024 TO .024	.025
Carburetor Make/Type	SU HS 2	SU HS 2	ZENITH-STROMBERG 150CD4
Carburetor Main Jet	.090	.090	.100
Carburetor Main Jet Needle	AN [AAC '68,'69]	AAC [ABC '72 ON]	44A,45Q,45K,45R,BY CARB#
Carburetor Piston Spring	LIGHT BLUE	LIGHT BLUE	BLUE
Vehicle & Engine			
Length	11' 5-5/8"	11' 4-1/2"	11' 9"
Width	4' 6-7/8" [4' 8-1/2" W/WHL]	4' 5-5/8" [4' 8-1/2" W/WHL]	4' 6-7/8" [4FT,8-1/2" W/WHL]
Height	4' 5/8"	4' 1/4"	4' 1/4"
Ground Clearance	5"	5"	3-1/4"
Track Front	3' 10-5/16"	3' 10-9/16" [3FT,10-5/16" W/WHL]	3' 10-9/16" [3' 10-5/16" W/WHL]
Track Rear	3' 8-3/4" [3' 9-1/4" W/WHL]	3' 9" [3FT 9-1/4" W/WHL]	3' 9" [3' 9-1/4" W/WHL]
Wheelbase	6' 8"	6' 8"	6' 8"
Turning Circle	32' 1-1/2" LH, 31' 2-1/2" RH	32' 1-1/2" LH, 31' 2-1/2" RH	32' 1-1/2" LH, 31' 2-1/2" RH
Toe-In	0 TO 1/8"	0 TO 1/8"	0 TO 1/8"
Unladen Weight	1,510 LBS [1,519 '68,'69]		
Curb Weight		1,701 LBS	1,849 LBS
Gross Weight			2,229 LBS
Original Tire Size	5.20X13 [145SR 13 RADIAL]	145SR 13	145 SR-13
Original Tire Pressure Front (Cold)	18 [22 RADIAL]	22	22
Original Tire Pressure Rear (Cold)	20 [24 RADIAL]	24	24
Replacement Tire Size	145SR 13		
Engine Type	OHV	OHV	OHV
Engine Displacement	1275 cc	1275 cc	1493 cc
Firing Order	1342	1342	1342
Compression Ratio	8.8:1	8.8:1 [8.0:1 '72 ON]	9:1 FED TO '77, 7.5:1 CA,FED'78'79
Engine Bore	2.78 IN	2.78IN	2.9
Engine Stroke	3.2 IN	3.2 IN	3.44
Number of Cylinders	4	4	4
Oil Pressure Idle	20	20	20
Oil Pressure Normal	40 TO 70	40 TO 70	40 TO 60
Ignition Type	POINT	POINT	ELECTRONIC
Fuel System Type	CARB	CARB	CARB
Fuel Pump Make/Type	SU AUF 206	SU AUF216	AC DELCO RA1
Fuel Tank Capacity	7.2	7.2 [8.6 '72 ON]	7.5
Cooling System Capacity	12 PINTS [7 PINTS '68 ON]	7 PINTS	11.4 PINTS
Sump Capacity	7.8 PINTS	7.8PINTS	9.6 PINTS
Gearbox Capacity	2.7 PINTS	2.7 PINTS	1.75 PINTS
Rear Axle Capacity	2.1 PINTS	2.1 PINTS	2.1 PINTS

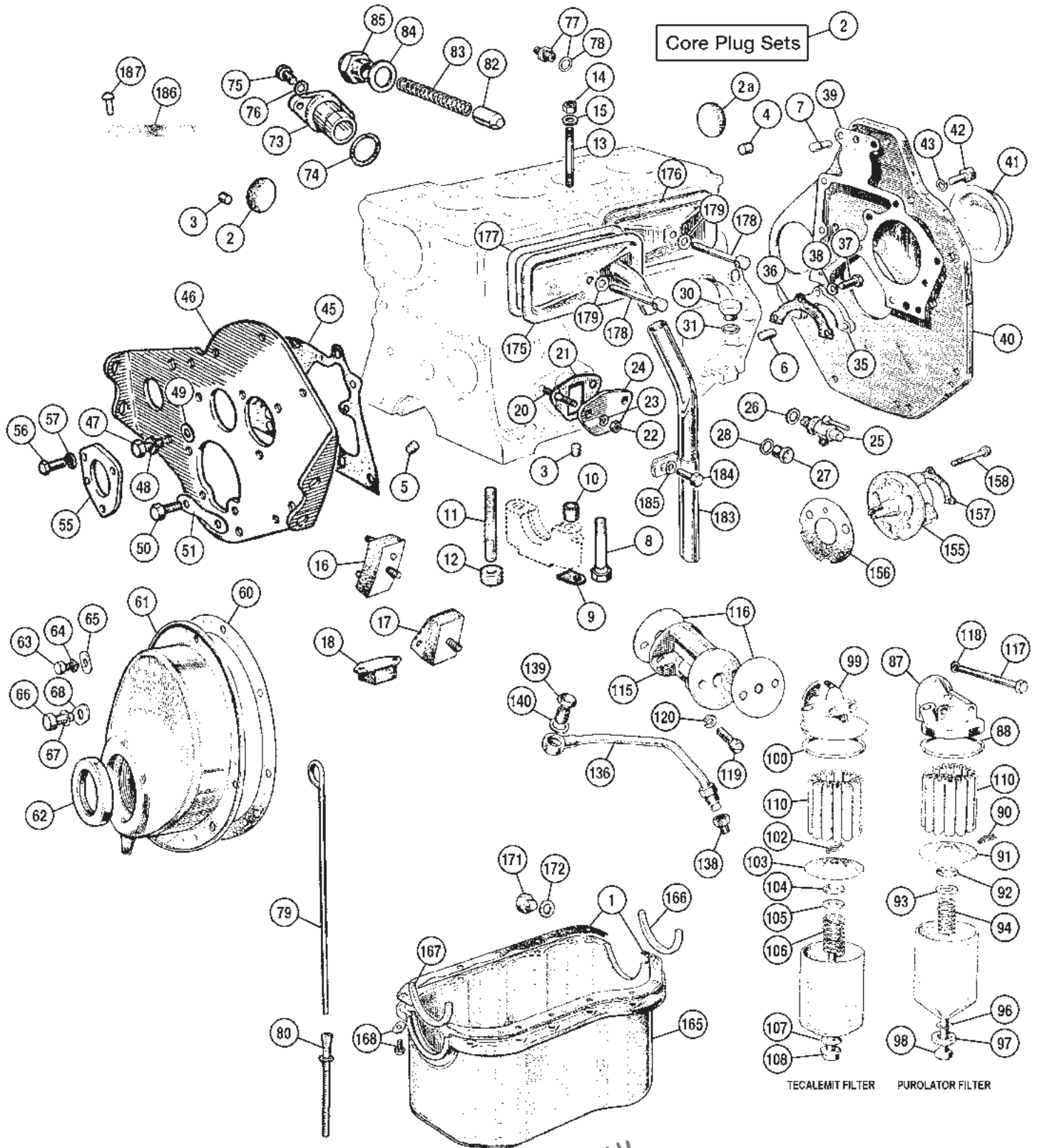

Spin-On Oil Filter Adaptor

This Moss-designed filter head & pipe enables the use of a high capacity and economical spin-on filter.

Spin-on Adaptor	235-875	\$116.99
Filter, K&N	235-830	\$28.99
Filter, Wix	235-855	\$18.99
Filter, Fram	235-880	\$10.99

Engine Bolts and Stud Kits

The head stud kit includes 11 studs. Factory engines used 9, some engines have been modified to use two more. Head studs and main cap studs are rated at 190,000 p.s.i., rod bolts at 180,000 p.s.i. Main bearing cap stud kit replaces original bolts.

948, 1098, 1275 Head Stud Kit	322-998	\$199.99
948, 1098, 1275 Main Bearing Cap Stud Kit	322-888	\$79.99

No.	Part#	Price (Each)	Description	Application	Qty Req.
1	220-580	\$29.99	PAINT, correct olive green (spray can)		1
	296-655	\$6.99	SUMP GASKET (2 pcs.)		1
	296-661	NA	GASKET SET, lower engine, Payen	} 948, early 1098 (10 CG)	1
	296-662	\$16.89	GASKET SET, lower engine*		1
	296-760	\$48.99	GASKET SET, lower engine, Cobalt		1
	296-671	\$89.99	GASKET SET, lower engine, Payen	} late 1098 (10 CC)	1
	296-672	\$15.89	GASKET SET, lower engine*		1
	296-710	\$29.99	GASKET SET, lower engine, Cobalt		1
*Products of various manufacturers supplied.					
2	328-248	\$3.49	CORE PLUG SET, steel	} thru (e)10CC/H3495	1
	328-249	\$18.99	CORE PLUG SET, brass		1
	328-253	\$3.99	CORE PLUG SET, steel		10CC/H3496 on
2a	328-230	\$0.99	CORE PLUG, steel	} thru (e)10CC/H3495	4
	328-231	\$4.99	CORE PLUG, brass		4
	328-235	\$1.09	CORE PLUG, steel	} 10CC/H3496 on	4
	328-236	\$3.99	CORE PLUG, brass		4
3	114-000	NA	PLUG, oil pressure		2
4	114-105	\$6.29	PLUG, oil gallery, 1/2"		4
5	461-300	\$0.69	RESTRICTOR, camshaft oil feed		1
6	325-080	\$1.99	DOWEL, lower		1
7	116-151	NA	DOWEL, upper		1
8	322-890	NA	BOLT, main bearing cap	} 948, 1098 (10CG)	6
9	114-015	\$1.09	LOCK TAB		6
10		NA	COLLAR		6
11		NA	STUD, main bearing cap	} 1098 (10CC)	6
12	021-634	\$0.89	NUT (all metal, self-locking)		6
13	329-715	\$9.99	CYLINDER HEAD STUD, long		4
	329-725	\$6.99	CYLINDER HEAD STUD, short		5
14	310-280	\$0.99	NUT, cylinder head, stock type		9
	114-122	\$3.19	NUT, cylinder head, flanged upgrade replacement		9
15	324-725	\$1.09	WASHER, head stud		9
16	413-160	\$5.59	ENGINE MOUNT, R/H & L/H		2
17	413-170	\$5.99	TRANSMISSION MOUNT, R/H & L/H		2
18	413-180	\$2.49	TRANSMISSION MOUNT, center		1
20	328-670	\$2.29	STUD, fuel pump / blanking plate		2
21	296-220	\$0.69	GASKET, fuel pump / blanking plate		1
22	310-140	\$0.39	NUT		2
23	365-730	\$0.39	WASHER		2
24	460-095	\$9.59	BLANKING PLATE	cars w/electric fuel pump	1
25	470-240	\$29.99	TAP, water drain		1
26	324-671	\$0.99	WASHER, fiber		1
27	328-180	\$15.99	PLUG, drain tap		1
28	324-626	\$0.99	WASHER, plug		1
30	116-153	\$5.99	PLUG, oil primer hole		1
31	116-154	\$1.49	WASHER, copper		1
35		NA	REAR COVER, crankcase		1
36	116-155	\$0.99	GASKET, rear cover		1
37	322-230	\$0.39	BOLT, rear cover to block		3
38	324-020	\$0.20	WASHER, locking		3
39	116-159	\$1.39	GASKET, back plate		1
40		NA	ENGINE PLATE, rear	948	1
		NA	ENGINE PLATE, rear	1098 (10CG)	1
		NA	ENGINE PLATE, rear	1098 (10CC)	1
41		NA	COVER, oil pump		1
42	322-880	\$0.99	BOLT, back plate to block		7
43	365-730	\$0.39	WASHER, locking		7
45	114-004	\$2.19	GASKET, front plate		1
46		NA	ENGINE PLATE, front		1
47	322-040	\$0.59	BOLT, front plate to block		2
48	365-730	\$0.39	WASHER, locking		2
49	365-720	\$0.79	WASHER, plain		2
50	114-032	\$1.49	BOLT, front plate to bearing cap		2
51	114-005	\$5.99	LOCK TAB		1
55	460-475	\$16.99	LOCK PLATE, camshaft		1
56	322-230	\$0.39	BOLT, lock plate to engine plate		3
57	462-385	\$0.39	WASHER, locking		3
60	296-510	\$1.89	GASKET, timing cover		1
61		NA	TIMING COVER	948-1098	1
62	121-500	\$1.99	OIL SEAL, felt	948 to (e)9C-H37646	1
	120-000	\$1.59	OIL SEAL, rubber	from 948 (e)9C-H37647	1
63	320-990	\$1.99	BOLT, timing cover to engine plate		6
64	324-020	\$0.20	WASHER, locking		6
65	324-765	\$0.89	WASHER, oval		6
66	322-880	\$0.99	BOLT, cover to block		4
67	365-730	\$0.39	WASHER, locking		4

No.	Part#	Price (Each)	Description	Application	Qty Req.
68	460-360	\$0.99	WASHER, oval		4
73		NA	HOUSING, distributor		1
74	264-943	\$0.29	O-RING		1
75	322-230	\$0.39	BOLT, housing to block		1
76	462-385	\$0.39	WASHER, locking		1
77	836-566	\$14.29	UNION, oil pressure gauge pipe (incl. washer)		1
78	116-154	\$1.49	WASHER, sealing		1
79		NA	DIPSTICK	948	1
	451-410	NA	DIPSTICK	} 1098	1
80	451-430	\$4.99	DIPSTICK TUBE		1
82	460-155	\$1.99	VALVE, oil pressure release		1
83	329-185	\$2.49	SPRING, oil pressure release		1
84	324-800	\$0.69	WASHER, cap nut		2
85	460-870	\$11.99	CAP NUT		1
87		NA	HEAD, filter, Purolator 948-1098 (10CG)	} Purolator Filters	1
		NA	HEAD, filter, Purolator 1098 (10CC)		1
88	021-467	\$1.79	SEAL, bowl to head		1
90	326-052	NA	CIRCLIP, center bolt retaining		1
91	435-150	\$11.99	PLATE		1
92	435-560	\$0.69	WASHER, felt		1
93	435-570	\$0.89	WASHER, steel		1
94	329-205	NA	SPRING, pressure plate		1
96	021-439	\$1.99	SEAL, center bolt	1	
97	116-152	NA	COLLAR, center bolt	1	
98		NA	BOLT, center	1	
99		NA	HEAD, filter, Tecalemit	} Tecalemit Filter	1
100	435-347	\$2.39	SEALING RING		1
102	466-090	NA	CLIP, retaining		1
103	435-150	\$11.99	PRESSURE PLATE		1
104	435-560	\$0.69	SEALING WASHER, (felt)		1
105	435-565	\$0.39	WASHER, flat		1
106	329-230	\$10.99	SPRING		1
107	460-805	\$1.99	SEAL, lower		1
108		NA	BOLT, center	1	
110	950-540	\$8.99	OIL FILTER, felt, various manufacturers		1
	950-520	\$6.59	OIL FILTER, paper, var. manufacturers		1
115		NA	ADAPTOR, filter head to block	948 to (e)5066	1
		NA	ADAPTOR, filter head to block	948 from (e)5067, 1098	1
116	296-565	\$0.99	GASKET		2
117	116-161	\$2.19	BOLT, filter head	948 to (e)5066	2
	116-160	NA	BOLT, filter head	948 from (e)5067, 1098	2
118	324-040	\$0.39	WASHER, locking		2
119	114-563	\$0.69	BOLT, adaptor to block		2
120	324-040	\$0.39	WASHER, locking		2
136		NA	PIPE, oil filter head to block	948 to (e)5066	1
		NA	PIPE, oil filter head to block	948 from (e)5067, 1098	1
138		NA	ADAPTOR, pipe to oil filter head		1
139	114-045	\$44.99	BOLT, banjo		1
140	324-805	\$2.19	SEAL, copper		2
155	435-630	\$49.99	OIL PUMP, pin drive		1
156	114-059	\$0.99	GASKET, oil pump		1
157	114-056	\$3.09	LOCK TAB, oil pump		1
158	117-004	\$0.99	BOLT, oil pump		3
165		NA	SUMP, oil		1
166	297-645	\$13.99	SUMP SEAL, rear (neoprene)	upgrade from cork	1
	297-646	\$1.19	SUMP SEAL, rear (cork)	} incl. in lower engine gasket set	1
167	297-640	\$8.69	SUMP SEAL, front (cork)		1
168	322-675	\$17.99	FITTING KIT, sump (oval washers, lockwashers, & bolts)		1
171	328-280	\$1.89	PLUG, oil drain, stock type		1
	328-282	\$21.99	PLUG, oil drain, magnetic	(option)	1
172	324-626	\$0.99	WASHER, drain plug		1
175		NA	COVER, side, front, orig. type	948-early 1098 (10CG)	1
	114-022	NA	COVER, side, front, orig. type	late 1098 (10CC)	1
176	460-050	NA	COVER, side, rear, replacement	all (see note)	1
Replacement cover requires bolt, seal and cup washer listed below for replacement cover.					
177	296-370	\$1.99	GASKET, cork, stock type	original covers	2
	296-375	\$3.99	GASKET, rubber	replacement rear cover	1
	296-377	\$30.99	GASKET PAIR, silicone	all	1
178	322-105	\$1.59	BOLT	original covers	2
	320-695	\$0.89	BOLT	replacement rear cover	1
179	324-315	\$0.49	WASHER, fiber	original covers	2
	324-335	\$1.99	SEAL, rubber	} replacement rear cover	1
	324-345	\$1.49	CUP WASHER		1
183		NA	PIPE, vent	} 948-1098 (10CG)	1
184	322-880	\$0.99	BOLT		1
185	365-730	\$0.39	LOCKWASHER		1
186	117-569	\$3.69	ENGINE NUMBER PLATE (blank)		1
187	325-245	\$0.99	RIVET, engine number plate		2



External Engine 1275

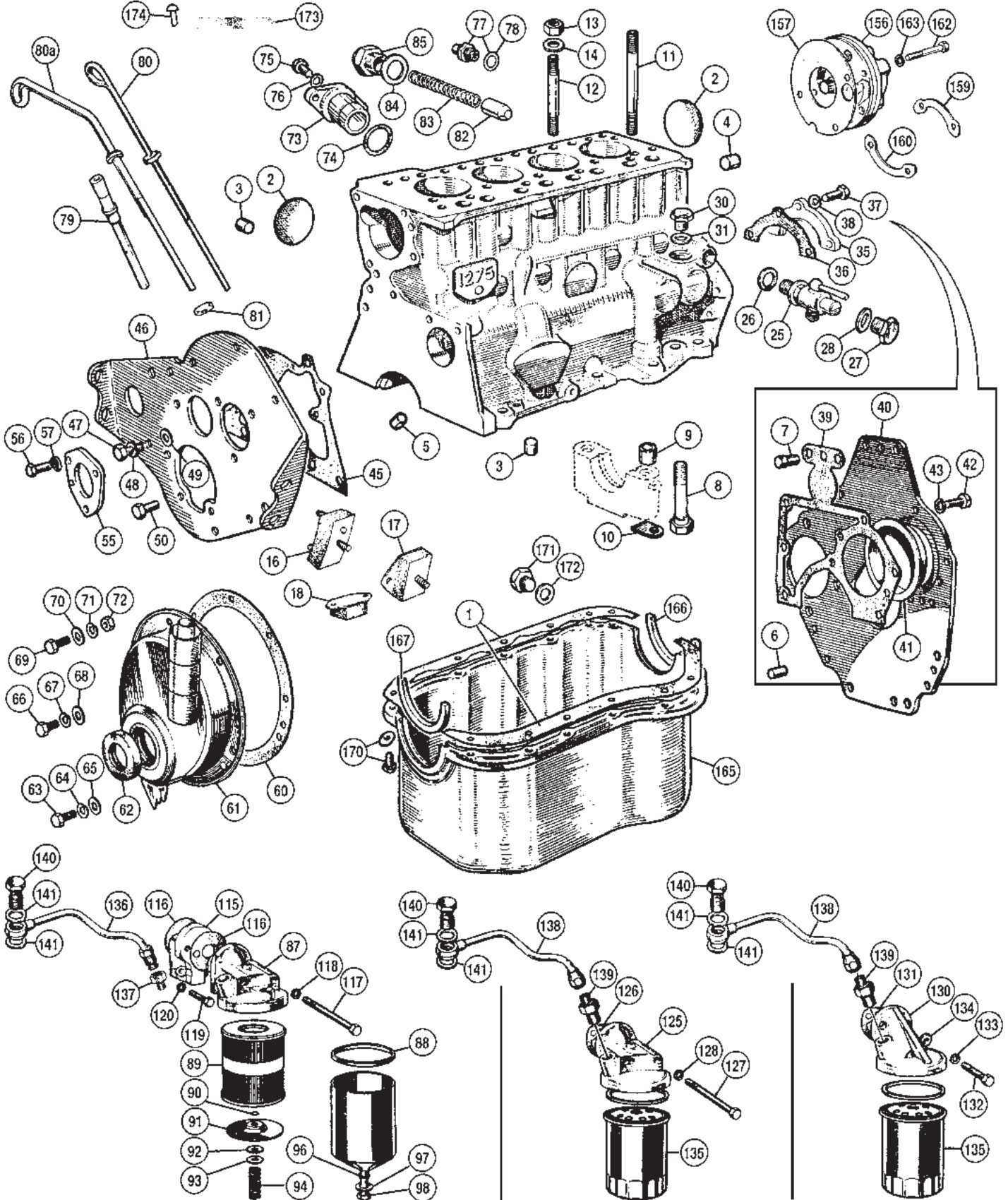

Spin-On Oil Filter Adaptor

This Moss-designed filter head & pipe enables the use of a high capacity and economical spin-on filter.

Spin-on Adaptor	235-875	\$116.99
Filter, K&N	235-830	\$28.99
Filter, Wix	235-855	\$18.99
Filter, Fram	235-880	\$10.99

No.	Part#	Price (Each)	Description	Application	Qty Req.
	220-580	\$29.99	PAINT, correct olive green (spray can)	12CC engines	1
	220-550	\$29.99	PAINT, metallic green (spray can)	12CD engines	1
	220-575	\$19.99	PAINT, black (spray can)	12V engines	1
	220-576	\$19.99	PRIMER, high temp. (use with engine paint)		1
1	296-665	\$3.89	SUMP GASKET (2 pcs.)		1
	296-681	NA	GASKET SET, lower engine, Payen		1
	296-682	\$15.99	GASKET SET, lower engine*		1
			*Products of various manufacturers supplied.		
	296-715	\$34.99	GASKET SET, lower engine, Cobalt		1
2	328-268	\$9.99	CORE PLUG SET		1
3	114-000	NA	PLUG, oil pressure		2
4	114-105	\$6.29	PLUG, oil gallery, 1/2"		4
5	461-300	\$0.69	RESTRICTOR, camshaft oil feed		1
6	325-080	\$1.99	DOWEL, lower		1
7	116-151	NA	DOWEL, upper		1
8		NA	BOLT, main bearing cap	early 12CC, early 12CD	6
	322-895	\$3.99	BOLT, main bearing cap	from late 12CC/CD - on	6
9		NA	COLLAR	early 12CC, early 12CD	6
	114-027	\$10.99	COLLAR	from late 12CC/CD - on	6
10	114-015	\$1.09	LOCK TAB	early 12CC, early 12CD	6
	322-998	\$199.99	HEAD STUD KIT, Uprated ARP		1
11	329-715	\$9.99	CYLINDER HEAD STUD, long		4
12	329-725	\$6.99	CYLINDER HEAD STUD, short		5
13	310-280	\$0.99	NUT, cylinder head, stock type		9
	114-122	\$3.19	NUT, cylinder head, flanged upgrade replacement		9
14	324-725	\$1.09	WASHER, head stud		9
16	413-160	\$5.59	ENGINE MOUNT, R/H & L/H		2
17	413-170	\$5.99	TRANSMISSION MOUNT, R/H & L/H		2
18	413-180	\$2.49	TRANSMISSION MOUNT, center		1
25	470-240	\$29.99	TAP, water drain		1
26	324-671	\$0.99	WASHER, fiber		1
27	328-180	\$15.99	PLUG, drain tap		1
28	324-626	\$0.99	WASHER, plug		1
30	116-153	\$5.99	PLUG, oil primer hole		1
31	116-154	\$1.49	WASHER, copper		1
35		NA	REAR COVER, crankcase		1
36	116-155	\$0.99	GASKET, rear cover		1
37	322-230	\$0.39	BOLT, rear cover to block		3
38	324-020	\$0.20	WASHER, locking		3
39	116-159	\$1.39	GASKET, back plate		1
40	116-156	\$284.99	ENGINE PLATE, rear		1
41	116-157	\$36.99	COVER, oil pump		1
42	322-540	\$0.79	BOLT, back plate to block		7
43	365-730	\$0.39	WASHER, locking		7
45	114-004	\$2.19	GASKET, front plate		1
46		NA	ENGINE PLATE, front		1
47	322-040	\$0.59	BOLT, front plate to block		2
48	365-730	\$0.39	WASHER, locking		2
49	365-720	\$0.79	WASHER, plain		2
50	114-032	\$1.49	BOLT, front plate to bearing cap		2
55	460-475	\$16.99	LOCK PLATE, camshaft		1
56	322-230	\$0.39	BOLT, lock plate to engine plate		3
57	462-385	\$0.39	WASHER, locking		3
60	296-510	\$1.89	GASKET, timing cover		1
61		NA	TIMING COVER		1
62	120-000	\$1.59	OIL SEAL, rubber		1
63	320-990	\$1.99	BOLT, timing cover to engine plate		6
64	324-020	\$0.20	WASHER, locking		6
65	324-590	\$0.19	WASHER, plain		6
66	322-880	\$0.99	BOLT, cover to block		4
67	365-730	\$0.39	WASHER, locking		4
68	460-360	\$0.99	WASHER, plain		4
69	314-265	\$0.59	BOLT, bracket to cover		1
70	324-590	\$0.19	WASHER, plain		1
71	324-020	\$0.20	WASHER, locking		1
72	310-760	\$0.59	NUT		1
73		NA	HOUSING, distributor		1
74	264-943	\$0.29	O-RING		1
75	322-230	\$0.39	BOLT, housing to block		1
76	462-385	\$0.39	WASHER, locking		1
77	836-566	\$14.29	UNION, oil pressure gauge pipe (incl. washer)		1
78	116-154	\$1.49	WASHER, sealing		1
79	451-430	\$4.99	DIPSTICK TUBE		1
80	451-410	NA	DIPSTICK, straight		1
80a	451-420	NA	DIPSTICK, bent (May use 451-410 above)		1
81	031-220	\$2.89	SEAL		1

No.	Part#	Price (Each)	Description	Application	Qty Req.
82	460-155	\$1.99	VALVE, oil pressure release		1
83	329-185	\$2.49	SPRING, oil pressure release		1
84	324-800	\$0.69	WASHER, cap nut		2
85	460-870	\$11.99	CAP NUT		1
	87	NA	HEAD, filter		1
88	021-467	\$1.79	SEAL, bowl to head		1
89	950-540	\$8.99	OIL FILTER, felt, various manufacturers		1
	950-520	\$6.59	OIL FILTER, paper, var. manufacturers		1
90	326-052	NA	CIRCLIP, center bolt retaining		1
91	435-150	\$11.99	PLATE		1
92	435-560	\$0.69	WASHER, felt		1
93	435-570	\$0.89	WASHER, steel		1
94	329-205	NA	SPRING, pressure plate		1
96	021-439	\$1.99	SEAL, center bolt		1
97	116-152	NA	COLLAR, center bolt		1
98		NA	BOLT, center		1
	115	NA	ADAPTOR, filter head to block		1
116	296-565	\$0.99	GASKET		2
117	116-161	\$2.19	BOLT, filter head		2
118	324-040	\$0.39	WASHER, locking		2
119	114-563	\$0.69	BOLT, adaptor to block		2
120	324-040	\$0.39	WASHER, locking		2
	125	NA	OIL FILTER HEAD, original		1
126	296-565	\$0.99	GASKET, filter head to block		1
127	116-161	\$2.19	BOLT, filter head (3 1/2")		2
	116-160	NA	BOLT, filter head (3 1/4")		2
128	324-040	\$0.39	WASHER, locking		2
130	114-063	\$46.99	OIL FILTER HEAD, original		1
131	114-061	\$1.69	GASKET, filter head to block		1
132	116-162	\$1.89	BOLT, filter head to block (1 1/8" long)		2
133	324-040	\$0.39	WASHER, locking		2
134	324-860	\$0.19	WASHER, plain		2
135	950-045	NA	OIL FILTER, spin-on, "Crosland" brand		1
	950-545	\$5.99	OIL FILTER, spin-on, var. manufacturers		1
136		NA	PIPE, oil filter head to block	} Canister filter	1
137		NA	ADAPTOR, pipe to filter head		1
138		NA	PIPE, oil filter head to block	} Spin-on filter	1
139	116-163	NA	ADAPTOR, pipe to filter head, orig.		1
	116-164	NA	ADAPTOR, replacement†		1
	324-740	\$1.69	WASHER, copper, for 116-164†	1	
			†Replacement adaptor 116-164 must use washer 324-740		
140	114-045	\$44.99	BOLT, banjo		1
141	324-805	\$2.19	SEAL, copper		2
156	435-640	\$39.99	OIL PUMP, star drive**	mounts w/ 2 bolts, fits all	1
157	114-059	\$0.99	GASKET, oil pump		1
159	116-150	\$1.39	LOCK TAB, pump upper	} 4 bolt pumps	1
160	114-005	\$5.99	LOCK TAB, pump lower		1
162	114-687	\$0.79	BOLT, oil pump		2/4
163	324-020	\$0.20	WASHER, locking	2 bolt pumps	2
	165	NA	SUMP, oil		1
166	297-645	\$13.99	SUMP SEAL, rear (neoprene)	upgrade from cork	1
	297-646	\$1.19	SUMP SEAL, rear (cork)	} incl. in lower engine gasket set	1
167	297-640	\$8.69	SUMP SEAL, front (cork)		1
170	322-675	\$17.99	FITTING KIT, sump (oval washers, lockwashers, & bolts)		1
171	328-280	\$1.89	PLUG, oil drain, stock type		1
	328-282	\$21.99	PLUG, oil drain, magnetic (option)		1
172	324-626	\$0.99	WASHER, drain plug		1
173	117-569	\$3.69	ENGINE NUMBER PLATE (blank)		1
174	325-245	\$0.99	RIVET, engine number plate		2

**There were two different oil pumps for the 1275cc engine. The 'Concentric' brand pump is fixed in place by four bolts, whereas the 'Hobourn Eaton' pump uses two bolts. On the four bolt pump, a pair of lock tabs are used under the bolt heads, while the two bolt pump simply uses two locking washers.

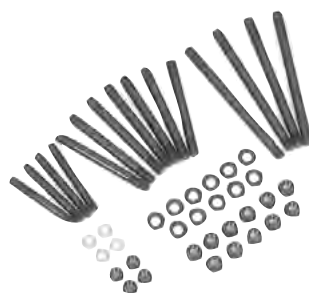

Heavy Duty Bolt and Stud Kits

These premium quality fastener kits are perfect for the racer, road warrior, or anyone who wants added insurance against mechanical failure. The head stud kit includes 11 studs. While factory engines used 9, some engines have been modified to use two more. Head studs and main cap studs are rated at 190,000 p.s.i., rod bolts at 180,000 p.s.i. Main bearing cap stud kit replaces original bolts.

948, 1098, 1275 Head Stud Kit	322-998	\$199.99
948, 1098, 1275 Main Bearing Cap Stud Kit	322-888	\$79.99
1275 Connecting Rod Bolt Kit	322-838	\$184.99



Internal Engine 948 - 1098 - 1275

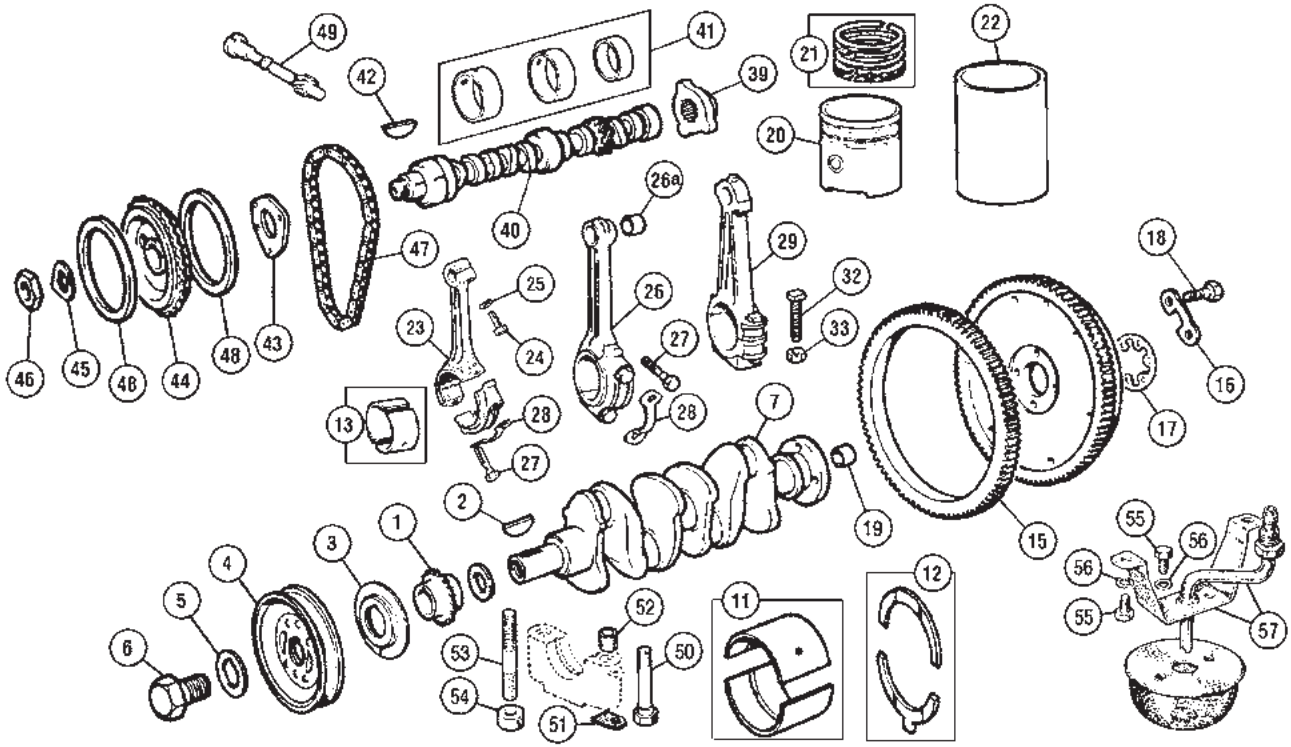

Internal Engine 948 - 1098 - 1275

11925

No.	Part#	Price (Each)	Description	Application	Qty Req.
	328-635	\$38.99	ENGINE LOCKTAB SET	948 & 1098 (10CG)	1
	328-620	\$32.99	ENGINE LOCKTAB SET	1275	1
Locktab sets include all items marked ‡ below.					
1	460-435	\$26.99	CRANK SPROCKET, single	948 - 1098	1
	460-445	\$17.99	CRANK SPROCKET, double	1275	1
2	327-210	\$12.79	KEY		1
3	433-890	\$11.49	OIL THROWER		1
4	460-455	NA	PULLEY (may use 1275 pulley)	948 - 1098	1
	460-465	\$157.99	PULLEY with damper	1275	1
5	460-470‡	\$1.19	WASHER, lock tab		1
6	322-120	\$19.99	BOLT		1
7	451-565	NA	CRANKSHAFT	948	1
	451-570	NA	CRANKSHAFT	1098 (10CG)	1
	451-575	NA	CRANKSHAFT	1098 (10CC)	1
	451-585	NA	CRANKSHAFT	1275	1
11	425-105	\$54.99	MAIN BEARING SET, standard	948, 1.75" crank diameter (orig. 1.192" brg. width) (see note below) Bi-metal	1
	425-110	\$54.99	MAIN BEARING SET, .010"		1
	425-115	\$54.99	MAIN BEARING SET, .020"		1
	425-120	\$54.99	MAIN BEARING SET, .030"		1
	425-125	\$54.99	MAIN BEARING SET, .040"		1
We and our suppliers now have only 1.067" wide bearings for 948 engines, which work fine. Bearings in the original width are no longer available.					
	425-161	\$64.99	MAIN BEARING SET, std., tri-metal	1098(10CG) 1.75" crank diameter 1.067" bearing width	1
	425-166	\$64.99	MAIN BEARING SET, .010", tri-metal		1
	425-171	\$64.99	MAIN BEARING SET, .020", tri-metal		1
	425-176	\$64.99	MAIN BEARING SET, .030", tri-metal		1
	425-181	\$64.99	MAIN BEARING SET, .040", tri-metal		1
	425-160	\$39.99	MAIN BEARING SET, std., bi-metal		1
	425-165	\$39.99	MAIN BEARING SET, .010", bi-metal		1
	425-170	\$39.99	MAIN BEARING SET, .020", bi-metal		1
	425-175	\$39.99	MAIN BEARING SET, .030", bi-metal		1
	425-180	\$39.99	MAIN BEARING SET, .040", bi-metal		1
	425-131	\$79.99	MAIN BEARING SET, std., tri-metal	1098(10CG) & 1275 2.00" crank diameter 0.985" bearing width	1
	425-136	\$79.99	MAIN BEARING SET, .010", tri-metal		1
	425-141	\$79.99	MAIN BEARING SET, .020", tri-metal		1
	425-146	\$79.99	MAIN BEARING SET, .030", tri-metal		1
	425-156	\$79.99	MAIN BEARING SET, .040", tri-metal		1
	425-130	\$42.99	MAIN BEARING SET, std., bi-metal		1
	425-135	\$42.99	MAIN BEARING SET, .010", bi-metal		1
	425-140	\$42.99	MAIN BEARING SET, .020", bi-metal		1
	425-145	\$42.99	MAIN BEARING SET, .030", bi-metal		1
	425-155	\$42.99	MAIN BEARING SET, .040", bi-metal		1
12	425-505	\$10.79	THRUST WASHER SET, standard	948	1
	425-520	\$9.79	THRUST WASHER SET, standard		1
	425-525	NA	THRUST WASHER SET, .003"	1098 (10CG)	1
	425-530	NA	THRUST WASHER SET, .010"		1

No.	Part#	Price (Each)	Description	Application	Qty Req.	
	425-535	\$9.99	THRUST WASHER SET, standard	1098 (10CC) & 1275	1	
	425-540	NA	THRUST WASHER SET, .003"		1	
	114-074	\$18.99	THRUST WASHER SET, .005"		1	
13	425-806	\$74.99	ROD BEARING SET, standard	Tri-metal (copper-lead-tin with babbitt overlay, on steel backing)	1	
	425-811	\$79.99	ROD BEARING SET, .010"		1	
	425-816	\$74.99	ROD BEARING SET, .020"		1	
	425-821	\$79.99	ROD BEARING SET, .030"		1	
	425-805	\$39.99	ROD BEARING SET, standard	Bi-metal (aluminum-tin, on steel backing)	1	
	425-810	\$39.99	ROD BEARING SET, .010"		1	
	425-815	\$39.99	ROD BEARING SET, .020"		1	
	425-820	\$39.99	ROD BEARING SET, .030"		1	
	425-825	\$39.99	ROD BEARING SET, .040"		1	
	425-830	\$39.99	ROD BEARING SET, .060"		1	
15	190-060	\$37.99	RING GEAR		948	1
	190-065	\$21.99	RING GEAR	1098	1	
	190-070	\$26.99	RING GEAR	1275	1	
16	460-405‡	\$1.49	LOCKTAB, flywheel	948 & 1098 (10CG engines)	2	
	460-406	NA	LOCKTAB, flywheel		1098 (10CC engines)	2
	460-415	\$8.49	LOCKTAB, flywheel	1275	1	
18	322-500	\$2.99	BOLT, flywheel	948 & 1098	4	
	322-505	\$3.99	BOLT, flywheel	1275	6	
19	330-475	\$2.99	BUSHING, spigot	948 thru early 12CC (5/8" O.D.)	1	
	330-465	\$12.99	NEEDLE BEARING, spigot		later 1275 (3/4" O.D.)	1
20	420-100	\$279.99	PISTON SET, standard	948 C.R. 8.3:1	1	
	420-105	\$279.99	PISTON SET, .020"		1	
	420-110	\$279.99	PISTON SET, .030"		1	
	420-115	\$279.99	PISTON SET, .040"		1	
	420-120	\$279.99	PISTON SET, .060"		1	
	420-125	\$299.99	PISTON SET, standard		1098 C.R. 8.9:1	1
	420-130	\$299.99	PISTON SET, .020"			1
	420-135	\$299.99	PISTON SET, .030"			1
	420-140	NA	PISTON SET, .040"			1
	420-145	\$299.99	PISTON SET, .060"			1
	420-150	\$369.99	PISTON SET, standard	1275 C. R. 8.8:1 Nüral-AE brand	1	
	420-155	\$369.99	PISTON SET, .020"		1	
	420-161	\$259.99	PISTON SET, .030" (aftermarket)		1	
	420-165	\$369.99	PISTON SET, .040"		1	
	420-170	\$369.99	PISTON SET, .060"		1	
	420-151	\$259.99	PISTON SET, standard		1275 C. R. 8.8:1 aftermarket	1
	420-156	\$259.99	PISTON SET, .020"			1
	420-161	\$259.99	PISTON SET, .030"	1		
	420-166	\$259.99	PISTON SET, .040"	1		
	420-171	\$259.99	PISTON SET, .060"	1		

948 - 1098 - 1275 - Internal Engine

No.	Part#	Price (Each)	Description	Application	Qty Req.
21	421-620	\$92.99	RING SET, standard	948 4-ring(.070" & .125" width)	1
	421-625	\$92.99	RING SET, .020"		1
	421-630	\$92.99	RING SET, .030"		1
	421-635	\$92.99	RING SET, .040"		1
	421-640	NA	RING SET, .060"		1
	421-645	\$114.99	RING SET, standard	948 5-ring (.070" & .125" width)	1
	421-650	\$114.99	RING SET, .020"		1
	421-655	\$114.99	RING SET, .030"		1
	421-660	\$114.99	RING SET, .040"		1
	421-665	\$114.99	RING SET, .060"		1
	421-670	\$82.99	RING SET, standard	1098 4-ring	1
	421-675	\$82.99	RING SET, .020"		1
	421-680	\$82.99	RING SET, .030"		1
	421-685	NA	RING SET, .040"		1
	421-690	\$82.99	RING SET, .060"		1
	421-695	\$89.99	RING SET, standard	1098 5-ring	1
	421-700	\$89.99	RING SET, .020"		1
	421-705	\$89.99	RING SET, .030"		1
	421-710	\$89.99	RING SET, .040"		1
	421-715	\$89.99	RING SET, .060"		1
	421-720	\$82.99	RING SET, standard		1275 4- ring These fit only original factory pistons. 0.0625" compression rings.
	421-725	\$82.99	RING SET, .020"	1	
	421-730	\$82.99	RING SET, .030"	1	
	421-735	\$82.99	RING SET, .040"	1	
	421-740	\$82.99	RING SET, .060"	1	
	421-750	\$69.99	RING SET, standard	1275 3- ring These fit replacement AE pistons #21251. 0.060" compression rings.	1
	421-755	\$69.99	RING SET, .020"		1
	421-760	\$69.99	RING SET, .030"		1
	421-765	\$199.99	RING SET, .040"		1
	421-770	\$69.99	RING SET, .060"		1
22	426-090	\$42.75	CYLINDER LINER	948	4
	426-110	NA	CYLINDER LINER	1098	4
	426-120	\$36.99	CYLINDER LINER	1275	4

Cylinder liners are used to repair damaged bores. Block is bored to accept the liner, liner is pressed into block, trimmed flush with block deck, then bored and honed to fit the piston.

23	837-310	NA	CONNECTING ROD, # 1 & 3	948	2
	837-300	NA	CONNECTING ROD, # 2 & 4		2
24	322-480	\$4.49	BOLT, wrist pin	948	4
25	365-730	\$0.39	LOCKWASHER		4
26	837-350	NA	CONNECTING ROD, # 1 & 3		1098
	837-360	NA	CONNECTING ROD, # 2 & 4	2	
26a	422-085	\$8.99	BUSH SET (4)	948 & 1098	1
27	837-330	\$21.99	BOLT, connecting rod		8
28	837-335‡	\$1.99	LOCK TAB	1275	4
29	837-320	\$239.99	CONNECTING ROD		4
32	837-340	NA	BOLT, connecting rod		8
33	837-345	\$4.59	NUT, connecting rod	1275	8
39	435-670	NA	FLANGE, star drive		1
40	451-442	NA	CAMSHAFT, stock, pin drive	948	1
See "Performance" color pages at the front of this catalog for more camshafts.					
41	NA	NA	CAM BEARING, single	948 (9C engine)	1
Not available. Use cam bearing set 424-980 for 1275, discard extra bearings.					
	424-975	\$17.89	CAM BEARING SET	948 (9CG) & 1098	1
	424-980	\$17.89	CAM BEARING SET	1275	1
42	327-190	\$1.39	KEY, camshaft, stock	948 & 1098	1
	327-005	\$29.99	KEY, camshaft, 2 degree offset		1
	327-015	\$29.99	KEY, camshaft, 3 degree offset		1
	327-025	\$31.99	KEY, camshaft, 4 degree offset		1
	327-035	\$31.99	KEY, camshaft, 5 degree offset		1
43	460-475	\$16.99	PLATE, cam locating		948 & 1098
44	460-525	\$34.99	CAM SPROCKET, single row	1	
This does not use the original tensioner rings.					
	833-430	\$28.99	CAM SPROCKET, double row	1275	1
45	460-550‡	\$1.99	LOCK PLATE	948 & 1098	1
46	311-500	\$10.99	NUT		1
47	460-596	\$44.99	TIMING CHAIN, heavy duty upgrade	948 & 1098 single row chains	1
	460-595	\$7.39	TIMING CHAIN, single row		1
	460-591	\$48.99	TIMING CHAIN, heavy duty upgrade	1275 double row chains	1
	114-077	\$19.99	TIMING CHAIN, orig. manufacturer		1
	460-590	\$10.49	TIMING CHAIN, aftermarket		1
48	460-495	\$2.99	TENSIONER RING	948 & 1098	2
49	460-640	\$89.99	SPINDLE, distributor drive	948, 1098 (10CG)	1
50	322-890	NA	BOLT, main bearing cap		early 12CC, early 12CD
		NA	BOLT, main bearing cap	6	

No.	Part#	Price (Each)	Description	Application	Qty Req.
	322-895	\$3.99	BOLT, main bearing cap	from late 12CC/ CD - on	6
51	114-015‡	\$1.09	LOCK TAB		948, 1098 (10CG)
	114-015‡	\$1.09	LOCK TAB	early 12CC, early 12CD	6
52	NA	NA	COLLAR	948, 1098 (10CG) early 12CC, early 12CD	6
	114-027	\$10.99	COLLAR		from late 12CC/ CD - on
53	NA	NA	STUD, main bearing cap	1098 (10CC)	6
54	021-634	\$0.89	NUT (all metal, self-locking)		6
55	320-990	\$1.99	BOLT, oil pick-up		4
56	462-385	\$0.39	LOCKWASHER		4
57	114-003	\$36.99	OIL SUCTION PIPE & BRACKET	1098, 1275	1

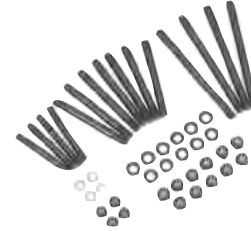

Heavy Duty Bolt and Stud Kits

These premium quality fastener kits are perfect for the racer, road warrior, or anyone who wants added insurance against mechanical failure. The head stud kit includes 11 studs. While factory engines used 9, some engines have been modified to use two more. Head studs and main cap studs are rated at 190,000 p.s.i., rod bolts at 180,000 p.s.i. Main bearing cap stud kit replaces original bolts.

948, 1098, 1275 Head Stud Kit	322-998	\$199.99
948, 1098, 1275 Main Bearing Cap Stud Kit	322-888	\$79.99
1275 Connecting Rod Bolt Kit	322-838	\$184.99

Engine Locktab Sets

Save the hassle of ordering all the separate locktabs on your engine with these sets, which include all locktabs in the listings to the left marked ‡.

948-1098 Locktab Set	328-635	\$38.99
1275 Locktab Set	328-620	\$32.99



Vernier Cam Sprocket Kit

If you are serious about making your engine run "just right", this is one upgrade you should be sure to install. This adjustable cam sprocket enables you to time your cam perfectly to factory specifications, or to change the factory cam timing on seriously modified engines. Kit includes adjustable cam sprocket, duplex crank sprocket, and duplex chain.

460-385	\$184.99
----------------	-----------------

Aluminum Flywheels

Improved throttle response is a main benefit of using this high strength but light weight steel-faced alloy flywheel.

948	460-505	\$409.99
1275	461-005	\$409.99



Speedi-Sleeve

Timing Cover Seal. (use on illustration #4)

When a new seal cannot compensate for excessive damage, this ultra-thin sleeve provides a "new" sealable surface. Instructions and installation tool are included.

520-515	\$69.99
----------------	----------------



Identifying the BMC Engine

The BMC "A" series engine is of venerable lineage. Adapted from the Austin A35 it appeared in the Austin-Healey Sprite as the "948", then went through minor revisions as the "1098". A major revision, the "1275", the strongest engine of the series, appeared in late 1966.

A "950" was cast in the left side of the "948" block. The "1100" (1098) and "1275" had metal tags riveted to the left side of the block just behind the bearer plate. All of these engines had an aluminum tag riveted to the top of the block on the right front. The first number designates the series: 9 = 948cc; 10 = 1098cc; 12 = 1275cc. If the tags have been removed, measuring the piston bore and main cap journals will reveal its origination. The "948" came with a stamped steel backplate and the 1275 is easily identified by its lack of tappet covers.

948	9C, 9CG	1098	10CG 1-3/4" main bearings
1275	12CC, 12CD, 12CE*, 12CF*, 12CG* 12CH*, 12CJ*, 12CK*, 12V (* = not USA)		10CC 2" main bearings

Cylinder Head 948 - 1098 - 1275

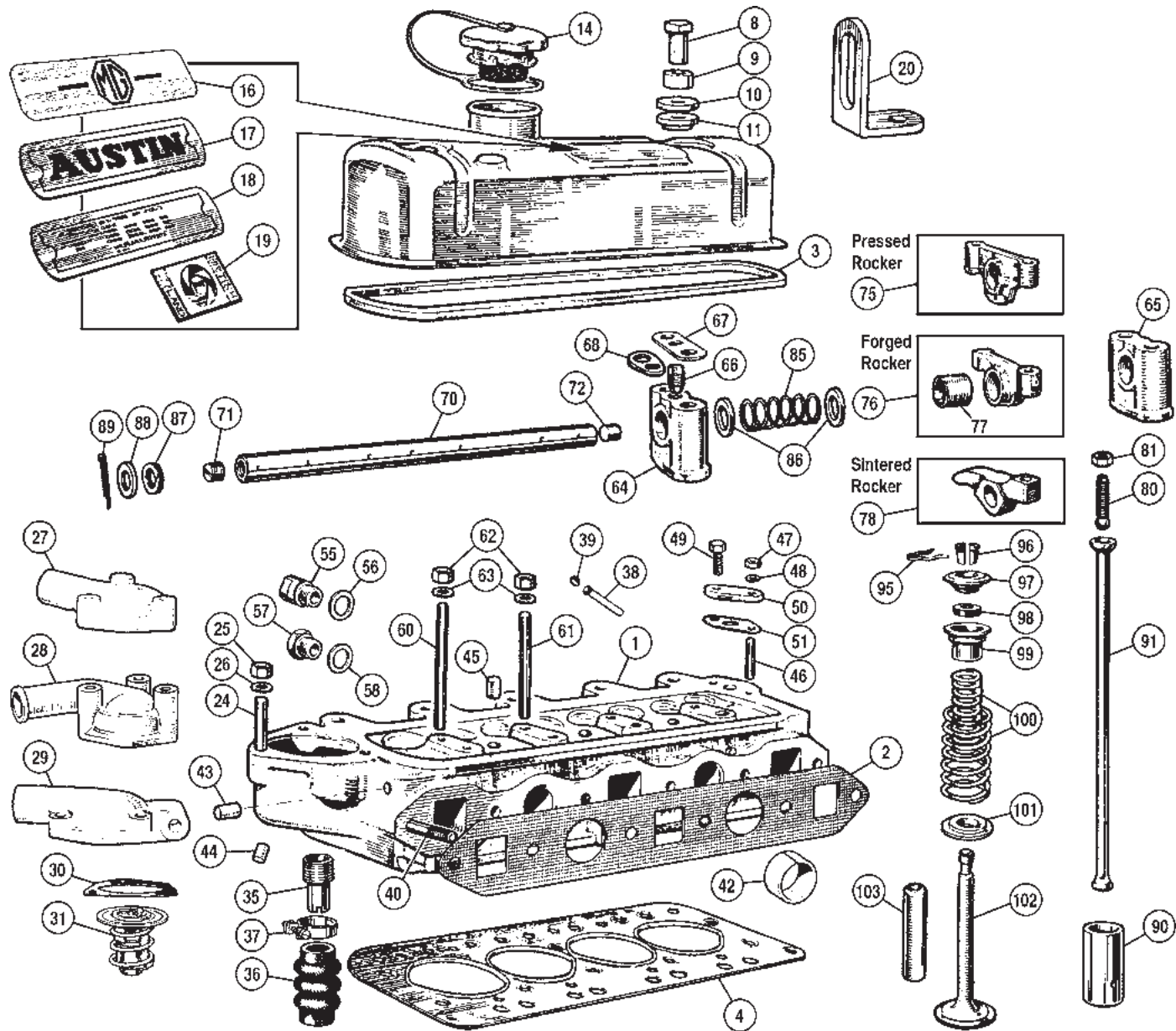

Cylinder Head 948 - 1098 - 1275

11931

No.	Part#	Price (Each)	Description	Application	Qty Req.
1	451-875	\$1,449.00	ALLOY CYLINDER HEAD, new	1275	1
	296-641	NA	HEAD GASKET SET, Payen	948 - 1098	1
	296-642*	\$19.99	HEAD GASKET SET*		1
	296-653	NA	HEAD GASKET SET, Payen (with copper head gasket)		1
	296-651	NA	HEAD GASKET SET, Payen		1
	296-654*	\$37.99	HEAD GASKET SET, w/ copper head gasket*	1275	1
	296-652*	\$15.79	HEAD GASKET SET, w/ composition gasket*		1
	296-705	\$39.99	HEAD GASKET SET, Cobalt brand		1
2	296-630	\$2.29	MANIFOLD GASKET		1
3	296-005	\$1.89	GASKET, valve cover, stock type		1
	296-006	\$24.99	GASKET, valve cover, silicone (not in gasket sets)		1
4	694-536	NA	HEAD GASKET, copper, Payen	948 - 1098	1
	117-120*	\$15.39	HEAD GASKET, upgraded/competition*		1
	694-535*	\$9.99	HEAD GASKET, composition*		1
	296-750	\$24.99	HEAD GASKET, Cobalt brand		1
	694-526	\$32.99	HEAD GASKET, composition, Payen	1275 (not alloy head)	1
	694-525*	\$8.49	HEAD GASKET, composition*		1
	296-745	\$19.99	HEAD GASKET, Cobalt brand		1
	694-527	\$29.99	HEAD GASKET, composition, Payen		1275 alloy head

*Products from various aftermarket manufacturers supplied.

8	460-110	\$2.99	CAP NUT, valve cover		2
9	460-115	\$2.29	SPACER		2
10	460-130	\$0.79	WASHER, cupped		2
11	460-120	\$0.99	BUSH, rubber		2

14	460-100	\$22.99	CAP, metal, w/ cable	948 engines	1
	460-145	\$17.99	CAP, chromed, without cable	all vented applications	1
	460-125	\$5.29	CAP, plastic (non-vented)	1098 (10CG engines)	1
	460-102	\$21.99	CAP, plastic (vented), OE type	1098 (10CC engines & 1275 (12CC, CD, CE)	1
	460-105	\$7.69	CAP, plastic (vented), replacement		1
	460-125	\$5.29	CAP, plastic (non-vented)	1275 CJ eng. (1970-on)	1
16	408-800	\$4.79	VALVE COVER PLATE, MG	aluminum plates	1
17	408-900	\$4.99	VALVE COVER PLATE, Austin		1
18	408-810	\$6.99	VALVE COVER PLATE, patent		1
	458-765	\$0.89	RIVET for aluminum plates		A/R
	215-620	\$2.99	VALVE COVER PLATE, MG	self adhesive mylar	1
	031-232	\$3.49	VALVE COVER PLATE, Austin		1
	215-625	\$2.99	VALVE COVER PLATE, patent		1
19	215-660	\$2.99	STICKER, "British Leyland"		1
20	386-745	\$10.99	LIFTING BRACKET		2
24	328-605	\$1.89	STUD, thermostat housing	for housings #27 & 29	3
	328-606	\$2.09	STUD, thermostat housing	for housing #28	3
25	310-140	\$0.39	NUT		3
26	365-720	\$0.79	WASHER		3
27	460-890	\$26.99	ELBOW, water outlet	948 (flat top)	1
	460-855	\$26.99	ELBOW, water outlet	1098 - 1275 vert. rad.	1
28	460-895	NA	ELBOW, water outlet	1275 cross-flow rad.	1
29	460-885	NA	ELBOW, water outlet	12CD, 12CJ & 12V	1

WARNING: Cancer and Reproductive Harm. www.P65Warnings.ca.gov

948 - 1098 - 1275 Cylinder Head

No.	Part#	Price (Each)	Description	Application	Qty Req.
30	296-380		NA GASKET, thermostat, stock type cork		1
	296-381	\$2.19	GASKET, thermostat, high strength "Klingersil" <small>🔗 MORE INFO ONLINE</small>		1
31	434-180	\$7.99	THERMOSTAT, 160°, hot climates	Will not fit original 948 water elbows. Will fit Moss 460-890.	1
	434-189	\$7.99	THERMOSTAT, 180°, normal		1
	434-195	\$7.99	THERMOSTAT, 195°, cold climates		1
35	434-535	\$17.79	ADAPTOR, bypass (also used on early orig. water pumps)		1/2
36	434-530*	\$5.59	HOSE, bypass (with 2 original type type hose clamps)		1
37	262-200	\$2.99	CLAMP, bypass hose	original band type	2
*These hoses are ribbed as original for easy installation.					
38	NA		AIR INJECTION TUBE	1275	4
39	052-242	\$2.39	PLUG, air injection port (when air injection disabled)		4
40	328-900	\$2.69	STUD, manifold		6
	310-140	\$0.39	NUT, manifold stud, steel	} alternatives	6
	311-540	\$0.79	NUT, manifold stud, brass		6
	324-365	\$1.19	WASHER, inlet manifold		4
42	372-371	\$12.99	FERRULE, inlet manifold locating	{ from 10CG 18628 thru 10CC	2
43	114-000		NA PLUG, oil hole at front of head		1
	114-109	\$13.59	PLUG, water holes, at ends of head	1275	2
44	114-110		NA PLUG, water holes, bottom of head		3
45	114-105	\$6.29	PLUG, oil holes, ends & top of head	(as fitted)	5
46	117-010	\$1.99	STUD, heater valve	} alternative to no. 49	2
47	310-760	\$0.59	NUT		2
48	324-020	\$0.20	LOCKWASHER		2
49	322-230	\$0.39	BOLT	{ (alternative to nos. 46, 47, 48)	2
50	360-215	\$9.99	BLANKING PLATE	when heater not fitted	1
51	296-455	\$1.19	GASKET		1
55	361-065	\$9.49	ADAPTER, temperature gauge	} 1968-'74 (crossflow radiator)	1
56	324-805	\$2.19	WASHER, temp. gauge adapter		1
57	379-362	\$9.59	BLANKING PLUG	} when using late head	1
58	324-145	\$0.39	WASHER, blanking plug	} on pre-1968 car	1
60	329-700	\$5.49	STUD, pedestal & valve cover long (outer)		2
61	328-745	\$1.79	STUD, pedestal, short (inner)	948 - 1098	2
	329-710	\$4.19	STUD, pedestal, short (inner)	1275	2
62	310-290	\$1.19	NUT for pedestal studs		4
63	365-730	\$0.39	LOCKWASHER		4
64	114-136		NA PEDESTAL, tapped	} see note	1
65	114-133		NA PEDESTAL, oil hole		3
Note: Engines through early 1275 production had the front pedestal tapped for the rocker shaft locating screw, and with an oil hole. Later 1275 engines had a tapped pedestal with no oil hole in the second position, with the front pedestal having a drilled oil hole. The "oil hole" pedestals were also used in the two rear positions. Our pedestals are of the later type. To use the tapped pedestal in the front position on early cars, drill a 1/8" hole centered in the dimple on the bottom of the pedestal, into the shaft bore. The "oil hole" pedestals may be used as is in the other positions.					
66	460-270	\$2.69	SCREW, rocker shaft locating		1
67	433-880		NA PLATE, rocker shaft pedestal	see note	4/1
Use one no. 68 (460-280) on front pedestal to retain screw no. 62.					
68	460-280	\$4.79	PLATE, screw retaining		1
70	451-455	\$21.99	SHAFT, rocker arm		1
	114-124	\$37.99	SHAFT, rocker arm, Tuftrided (hardened against wear)		1
71	328-080		NA PLUG, threaded		1
72	328-290	\$15.99	PLUG, pressed in		1
75	NA		ROCKER ARM, pressed †	use no. 76 or 78	8
76	433-840	\$17.29	ROCKER ARM, forged †	{ 1275, replacement for all	8
77	330-495	\$2.29	BUSH	all forged rocker arms	8
Bushes must have oil holes drilled after installation in rocker arm, and must be reamed to fit the rocker shaft.					
78	433-850	\$29.99	ROCKER ARM, sintered, replacement †		8
These sintered rocker arms are slightly porous and are self-lubricating once soaked in oil. They are not bushed. Should be used with Thackery washer No. 88.					
80	433-860	\$12.99	ADJUSTER (28 t.p.i.)	{ early forged & stamped rockers	8
	460-260	\$1.89	ADJUSTER (24 t.p.i.)	{ late forged & sintered rockers	8
81	433-870	\$2.69	NUT, adjuster locking	{ early forged & stamped rockers	8
	310-150	\$0.39	NUT, adjuster locking	{ late forged & sintered rockers	8

† Note: Early 948 had forged rockers (not identical to late 1275 forged rockers), followed by pressed steel rockers into 1275 production. Forged rockers 433-840 were originally supplied on many 1275 engines. Sintered rockers are stock for post-Sprite/Midget A-Series engines produced for other cars.

Toll-Free Orders 1-800-667-7872 | MossMotors.com
Fax 805-692-2525 | Local 805-681-3400

MOSS

No.	Part#	Price (Each)	Description	Application	Qty Req.
85	114-134	\$3.99	SPRING		3
86	379-363	\$1.69	SPACER (at ends of springs)	1275 only	6
87	329-860	\$1.59	WASHER, Thackery	948-1098	2
Use also on 1275 when using sintered rocker arms 433-850.					
88	114-135	\$2.19	WASHER (ends of shaft)		2
89	325-330	\$0.19	COTTER PIN		2
90	460-612	\$64.99	TAPPET SET, AE brand		1
	460-604	\$259.99	TAPPET SET		1
(8 specially selected tappets properly sized, hardened to 54-58 HRC, crowned, etched, & micro-polished, with lube)					
	460-601	\$249.99	TAPPET SET, APT brand		1
(60+ HRC, crowned, phosphated, oil hole. Suitable for high lift cams and higher rpm.)					
	460-608		NA TAPPET SET, lightened, with oil hole		1
(suitable for high lift cams and higher rpm.)					
91	460-625	\$4.99	PUSH ROD	948 - 1098	8
	460-635	\$4.59	PUSH ROD	1275	8
95	326-165		NA SPRING CLIP (not required)	} 948 - 1098	8
96	460-485		NA VALVE COTTER		16
	460-535	\$2.29	VALVE COTTER	1275	16
97	460-552	\$3.79	COLLAR, valve retainer	948-1098	8
	460-556	\$7.39	COLLAR, valve retainer	1275	8
98	297-650	\$0.39	SEAL, valve stem, o-ring	948 - 1098	8
	297-635	\$0.69	SEAL, valve stem, umbrella	1275 intake only	4
	NA		SHROUD	early 948	8
(Shroud not required when using o-ring valve stem seal)					
100	114-106	\$3.19	VALVE SPRING, single	early 948	8
	423-460	\$29.99	VALVE SPRING SET, dual springs	late 948, all 1098	1
	423-470	\$32.99	VALVE SPRING SET	1275	1
101	460-565	\$1.99	CUP	double springs only	8
102	423-195	\$7.29	INTAKE VALVE, 1.094" head dia.*	{ 948 (9C engine) Bugeye	4
	423-175	\$6.99	INTAKE VALVE, 1.156" head dia.*	{ 948 (9CG) & 1098 to 10CG 14877	4
	423-185	\$6.99	INTAKE VALVE, 1.215" head dia.*	{ 1098 from 10CG 14878 & 10CC	4
	423-190	\$6.29	INTAKE VALVE, 1.313" head dia.*	1275	4
	423-320	\$7.99	EXHAUST VALVE, stainless steel, 1.000" head dia.*	} 948 - 1098	4
	423-325		NA EXHAUST VALVE, O/S, 1.098" head dia.*		4
	423-330	\$7.99	EXHAUST VALVE, stainless steel, 1.156" head dia.*	} 1275	4
	423-335	\$26.99	EXHAUST VALVE, stainless steel/stellite tip		4

*Valve head diameters may vary by .005" or more due to manufacturing tolerances.

103	423-286	\$3.49	VALVE GUIDE, intake & exhaust	948 (9C - Bugeye)	8
	423-275	\$2.79	VALVE GUIDE, intake & exhaust	} 948 (9CG) & 1098	8
	423-290	\$13.99	VALVE GUIDE, manganese-bronze		8
	423-285	\$3.39	VALVE GUIDE, intake & exhaust	} 1275	8
	423-295	\$13.99	VALVE GUIDE, manganese-bronze		8

Competition Gaskets

Highly recommended for use with high compression pistons and modified heads, the copper and asbestos head gasket is made to original British Leyland specifications. The special manifold gasket has enlarged holes to match inlet and exhaust ports on modified cylinder heads.



Competition Head Gasket (1275) 694-555 \$22.99
Competition Manifold Gasket (948 - 1275) 296-645 \$13.99

Midget 1500 Engine

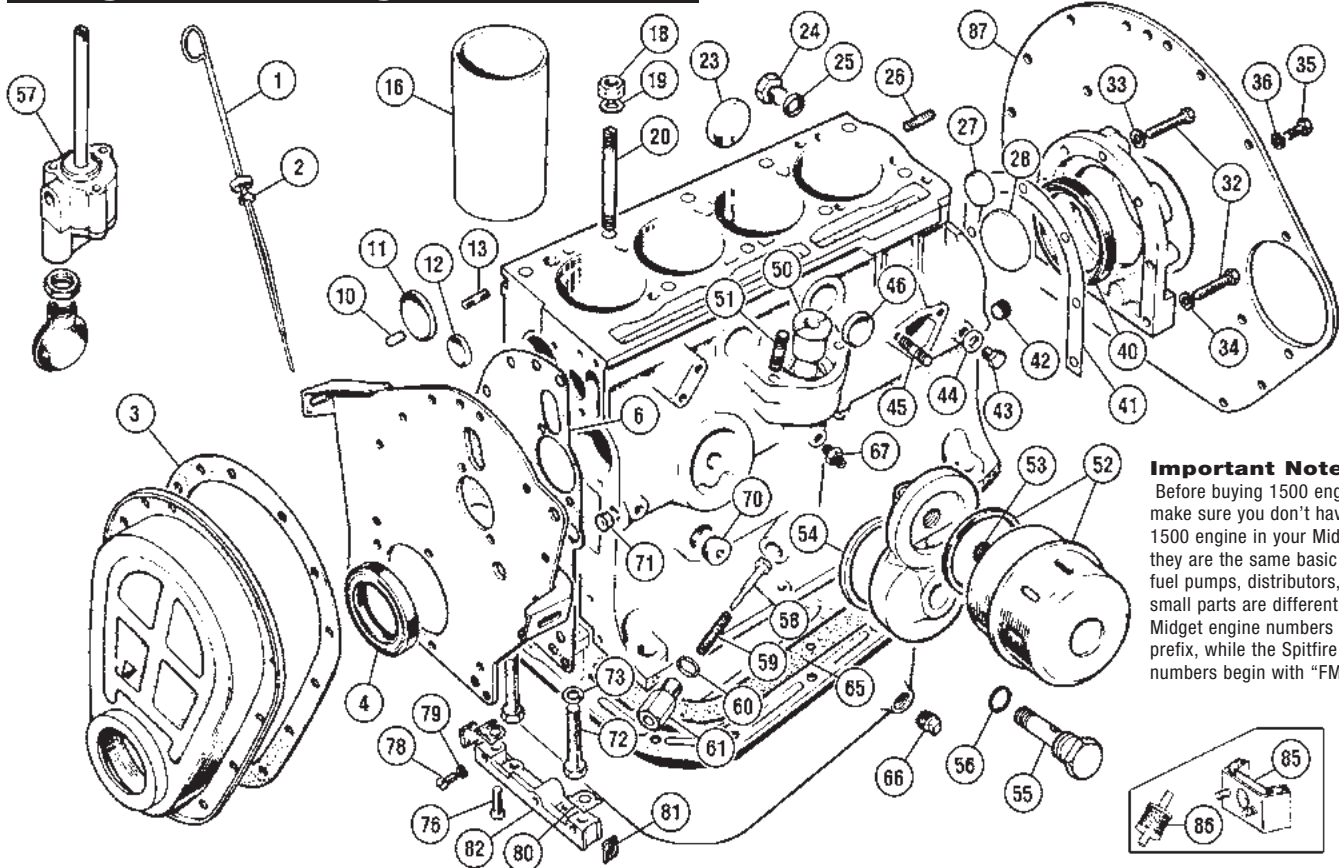

Important Note:
Before buying 1500 engine parts, make sure you don't have a Spitfire 1500 engine in your Midget. While they are the same basic engines, fuel pumps, distributors, and some small parts are different. The real Midget engine numbers have a "FP" prefix, while the Spitfire engine numbers begin with "FM".

External Engine 1500

11933

No.	Part#	Price (Each)	Description	Application	Qty Req.
	694-151	\$35.99	GASKET SET, lower engine, "Payen" brand		1
	694-152	\$7.99	GASKET SET, lower engine (various manufacturers)		1
	296-740	\$26.99	GASKET SET, lower engine, Cobalt brand		1
	694-143	NA	HEAD GASKET SET, "Payen" brand		1
	694-144	\$49.99	HEAD GASKET SET (various manufacturers)		1
	296-735	\$39.99	HEAD GASKET SET, Cobalt brand		1
1	451-205	NA	DIPSTICK		1
2	697-020	\$0.69	SEAL, felt		1
3	697-115	\$1.79	GASKET, timing cover		1
4	520-430	\$4.59	OIL SEAL, timing cover		1
6	695-105	\$1.49	GASKET, front engine plate		1
10	325-215	\$1.19	DOWEL PIN		2
11	328-205	\$1.39	CORE PLUG, steel, large		1
	328-207	\$3.69	CORE PLUG, brass, large		1
12	319-015	\$1.39	CORE PLUG, steel, small		1
	319-016	\$3.69	CORE PLUG, brass, small		1
13	328-654	\$3.29	STUD		1
16	426-130	\$39.99	LINER, cylinder	(requires machining)	4
18	310-045	\$0.79	NUT, head stud		10
19	324-860	\$0.19	WASHER, head stud		10
20	329-615	\$17.99	STUD, cylinder head, short		8
	329-730	\$22.99	STUD, cylinder head, long		2
23	328-205	\$1.39	CORE PLUG		3
24	328-445	\$11.99	PLUG, drain		1
25	324-671	\$0.99	WASHER for plug		1
26	328-900	\$2.69	STUD		3
27	328-215	\$0.99	CORE PLUG, steel, small		1
	328-216	\$3.19	CORE PLUG, brass, small		1
28	328-375	\$1.29	CORE PLUG, steel, large		1
32	320-695	\$0.89	BOLT, seal housing to block		7
33	NA	NA	WASHER, copper		1
34	365-730	\$0.39	LOCKWASHER		6
35	322-040	\$0.59	BOLT		7
36	365-730	\$0.39	LOCKWASHER		7
40	520-320	\$3.49	OIL SEAL, rear		1
41	697-485	\$0.89	GASKET, seal housing to block		1
42	328-245	\$5.69	PLUG, oil gallery, rear		1
43	322-345	\$0.89	PLUG, oil gallery, side		4
44	NA	NA	WASHER, copper		4
45	328-654	\$3.29	STUD, fuel pump mounting		2
46	328-215	\$0.99	CORE PLUG, steel		2

No.	Part#	Price (Each)	Description	Application	Qty Req.
	328-216	\$3.19	CORE PLUG, brass		2
50	836-135	\$129.99	BUSH, distributor/oil pump drive		1
51	328-654	\$3.29	STUD, distributor mounting		2
52	950-525	\$5.99	OIL FILTER, with sealing ring, Classic Gold brand		1
53	833-455	\$7.99	ADAPTOR, oil filter to filter head		1
54	520-400	\$1.09	SEAL, filter head to block		1
55	NA	NA	BOLT, filter head		1
56	466-515	\$0.59	"O" RING		1
57	836-125	\$99.89	OIL PUMP with screen		1
58	836-545	\$7.89	PISTON, oil pressure relief valve		1
59	329-295	\$1.99	SPRING		1
60	315-005	\$1.79	WASHER, copper		1
61	328-065	\$12.99	HOUSING, oil pressure relief valve		1
65	694-160	\$1.69	GASKET, oil pan		1
66	328-340	\$1.79	PLUG, oil drain		1
	328-356	\$7.99	PLUG, oil drain, magnetic	(option)	1
	328-341	\$46.99	DRAIN TAP	(option)	1
67	836-565	\$18.99	ADAPTOR, oil pressure line	thru 1977	1
70	328-425	NA	PLUG		1
71	328-245	\$5.69	PLUG, oil gallery		1
72	266-580	\$2.09	BOLT, main bearing cap		6
73	324-250	\$0.19	LOCKWASHER		6
76	323-015	\$1.89	SCREW		2
78	320-815	\$2.49	SCREW		2
79	365-730	\$0.39	LOCKWASHER		2
80	697-490	\$0.59	GASKET, front sealing block		2
81	697-495	\$1.99	PACKING PIECE, wood		2
82	837-150	\$42.99	SEALING BLOCK, front		1
85	810-120	\$23.99	MOUNT, engine		2
86	810-140	\$2.99	MOUNT, transmission		2
87	832-545	\$109.99	BEARER PLATE, rear	aluminum alloy repl.	1

Core Plug Set

11934

All core plugs for the engine block and cylinder head.

328-278	\$11.99	CORE PLUG SET, steel	1
---------	---------	----------------------	---

Midget 1500 Engine

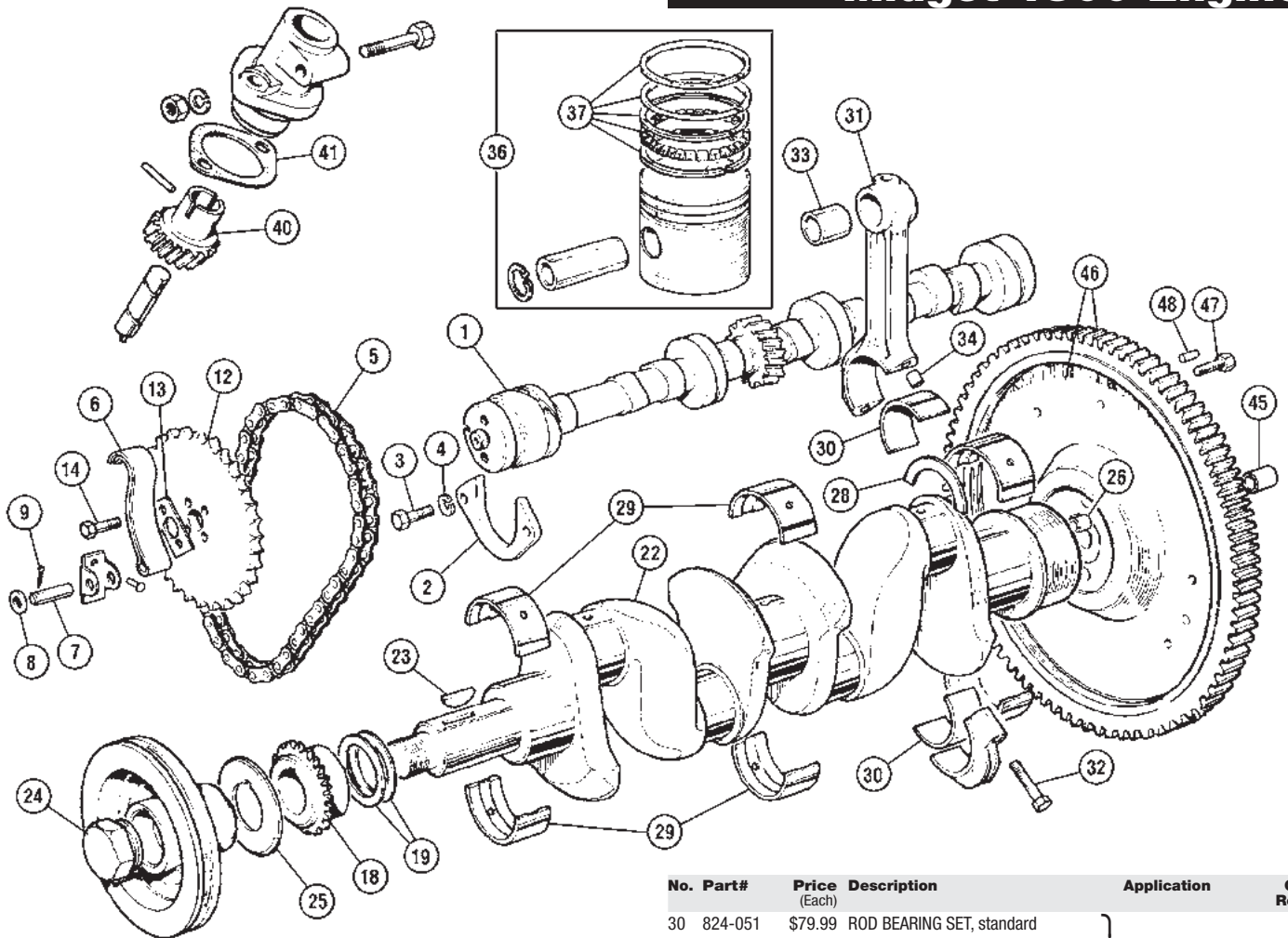

Internal Engine 1500

No.	Part#	Price (Each)	Description	Application	Qty Req.
1	851-330	\$219.99	CAMSHAFT		1
2	838-035	\$31.99	RETAINER, camshaft		1
3	322-540	\$0.79	BOLT for retainer		2
4	365-730	\$0.39	LOCKWASHER		2
5	832-111	\$42.99	TIMING CHAIN, heavy duty upgrade	MORE INFO ONLINE	1
	832-110	\$7.99	TIMING CHAIN		1
6	832-260	\$5.29	TENSIONER, timing chain		1
7	832-265	\$8.99	PIN, tensioner pivot		1
8	324-870	\$0.69	WASHER, plain		1
9	325-475	\$0.29	COTTER PIN		1
12	838-205	\$27.99	SPROCKET, camshaft		1
13	838-025	\$0.89	LOCKPLATE, cam sprocket		1
14	322-395	\$3.29	BOLT, sproket to camshaft		2
18	837-105	\$27.99	SPROCKET, crankshaft		1
19	837-025	\$3.49	SHIM, .004"	A/R	1
	837-035	\$3.49	SHIM, .006"	A/R	1
22	851-350	NA	CRANKSHAFT		1
23	327-220	\$11.99	KEY		1
24	322-910	\$44.99	NUT, crankshaft		1
25	837-055	\$7.99	OIL DEFLECTOR		1
26	325-190	\$3.49	DOWEL, flywheel to crankshaft		1
28	828-030	\$5.99	THRUST WASHER SET, standard		1
	828-035	\$5.99	THRUST WASHER SET, .005"		1
	828-040	\$9.49	THRUST WASHER SET, .015"		1
29	822-041	\$74.99	MAIN BEARING SET, standard	Tri-metal	1
	822-051	\$74.99	MAIN BEARING SET, .010"		1
	822-061	\$74.99	MAIN BEARING SET, .020"		1
	822-071	\$74.99	MAIN BEARING SET, .030"		1
	822-040	\$39.99	MAIN BEARING SET, standard	Bi-metal	1
	822-050	\$39.99	MAIN BEARING SET, .010"		1
	822-060	\$39.99	MAIN BEARING SET, .020"		1
	822-070	\$39.99	MAIN BEARING SET, .030"		1
	822-080	\$39.99	MAIN BEARING SET, .040"		1

Toll-Free Orders 1-800-667-7872 | MossMotors.com
Fax 805-692-2525 | Local 805-681-3400

MOSS

No.	Part#	Price (Each)	Description	Application	Qty Req.
30	824-051	\$79.99	ROD BEARING SET, standard	Tri-metal	1
	824-056	\$79.99	ROD BEARING SET, .010"		1
	824-061	\$79.99	ROD BEARING SET, .020"		1
	824-066	\$79.99	ROD BEARING SET, .030"		1
	824-050	\$42.99	ROD BEARING SET, standard	Bi-metal	1
	824-055	\$42.99	ROD BEARING SET, .010"		1
	824-060	\$42.99	ROD BEARING SET, .020"		1
	824-065	\$42.99	ROD BEARING SET, .030"		1
	824-070	\$42.99	ROD BEARING SET, .040"		1
31	837-730	\$134.99	CONNECTING ROD, new		1
	837-740	\$154.99	CONNECTING ROD, reconditioned		4
32	320-455	\$6.49	BOLT, connecting rod		8
33	829-030	\$2.79	BUSH, wrist pin		4
34	837-745	\$7.95	TUBE, locating		8
36	814-451	\$259.99	PISTON SET, std., aftermarket	9:1 CR, thru 1976 except CA	1
	814-456	\$259.99	PISTON SET, .020", aftermarket		1
	814-461	\$259.99	PISTON SET, .030", aftermarket		1
	814-466	\$259.99	PISTON SET, .040", aftermarket		1
	814-470	\$229.99	PISTON SET, std., aftermarket	7.5:1 CR CA all years Federal 1977-on	1
	814-475	\$229.99	PISTON SET, .020", aftermarket		1
	814-480	\$229.99	PISTON SET, .030", aftermarket		1
	814-485	NA	PISTON SET, .040", aftermarket		1
37	817-650	\$76.99	PISTON RING SET, standard		1
	817-655	\$76.99	PISTON RING SET, .020"		1
	817-660	\$76.99	PISTON RING SET, .030"		1
	817-665	\$76.99	PISTON RING SET, .040"		1
40	836-640	NA	GEAR, oil pump & distributor drive		1
41	697-145	\$2.99	GASKET, .006"		A/R
45	330-510	\$4.29	PILOT BUSHING		1
46	460-678	\$439.99	FLYWHEEL, aluminum		1
	590-030	\$21.99	RING GEAR		1
47	320-790	\$6.69	BOLT, flywheel to crankshaft		4
48	325-340	\$1.59	DOWEL, clutch locating		3

Speedi-Sleeve

Timing Cover Seal. For use on Crank Pulley

When a new seal cannot compensate for excessive damage, this ultra-thin sleeve provides a "new" sealable surface. Instructions and installation tool are included.

520-510 \$69.99



Midget 1500 Cylinder Head

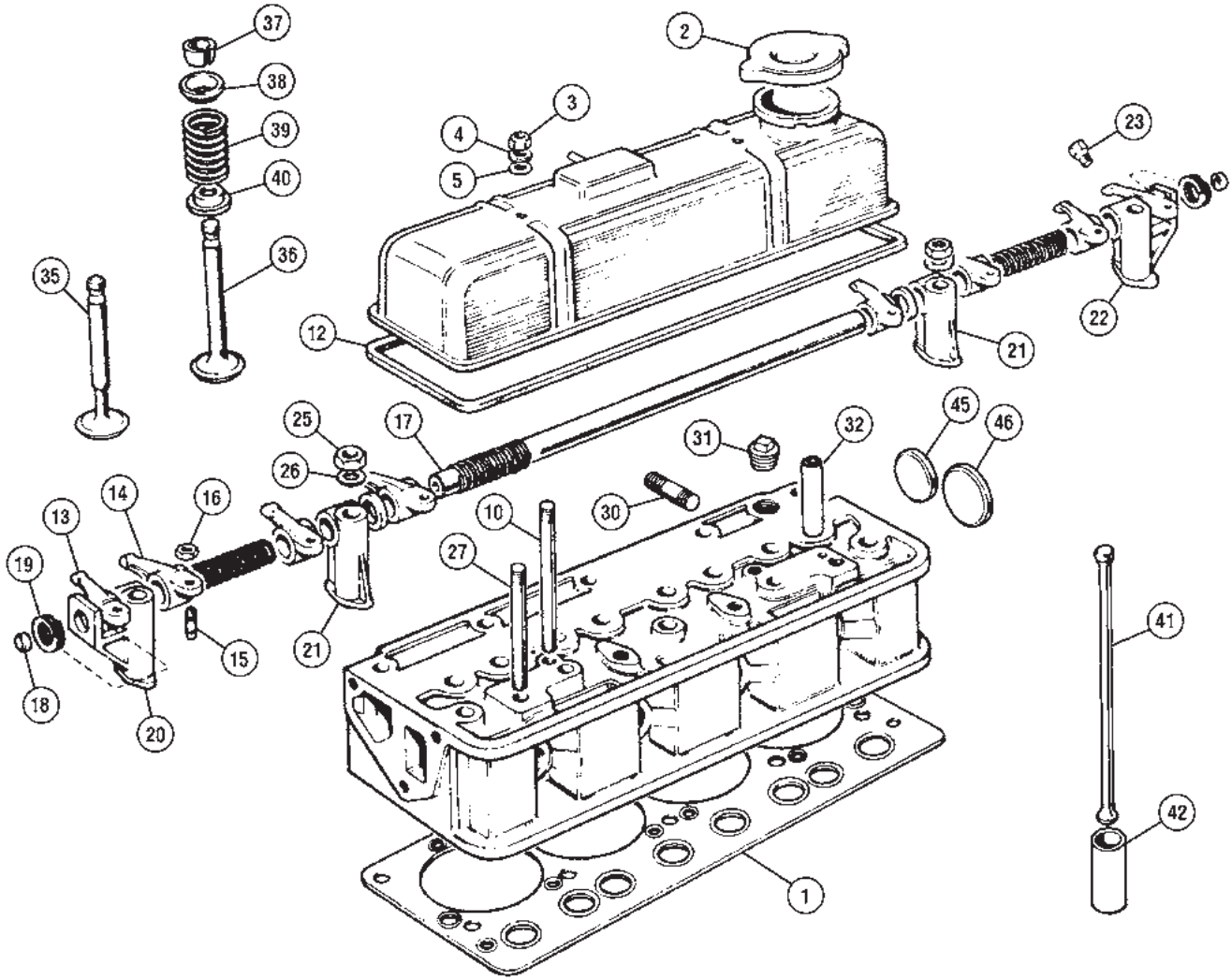

Cylinder Head 1500

11938

No.	Part#	Price (Each)	Description	Application	Qty Req.
	694-143	NA	HEAD GASKET SET, "Payen" brand		1
	694-144	\$49.99	HEAD GASKET SET (various manufacturers)		1
	296-735	\$39.99	HEAD GASKET SET, Cobalt brand		1
1	694-110	\$28.99	HEAD GASKET, "Payen" brand		1
	296-730	\$19.99	HEAD GASKET, Cobalt brand		1
2	834-765	NA	CAP, oil filler		1
	780-126	\$6.39	CAP, oil filler, replacement		1
3	310-105	\$0.49	NUT, valve cover	} thru 1976	2
4	365-720	\$0.79	WASHER, plain		2
5	324-680	\$0.29	WASHER, fiber		2
	072-019	\$4.49	CAP NUT	} from 1977-on	2
	072-020	\$3.49	WASHER		2
	071-092	\$0.89	"O" RING		2
10	328-675	\$4.69	STUD, valve cover (4-1/8" long)	thru 1976	2
	313-020	\$8.49	STUD, valve cover (3-5/16" long)	from 1977-on	2
12	694-100	\$2.89	GASKET, valve cover, stock type		1
	694-101	\$24.99	GASKET, valve cover, silicone		1
13	839-110	\$11.99	ROCKER ARM, stock	} #1,3,5,7	4
	839-115	\$17.99	ROCKER ARM, upgraded		4
14	839-120	\$11.99	ROCKER ARM, stock	} #2,4,6,8	4
	839-125	\$17.99	ROCKER ARM, upgraded		4
Stock rocker arms were not bushed. Upgraded rocker arms are checked for correct hardness and are fitted with bushes which must be honed to 0.002" clearance on the rocker shaft. Instructions are included.					
15	839-030	\$5.99	ADJUSTER, valve		8
	310-150	\$0.39	NUT for adjuster		8
	851-320	\$29.99	ROCKER SHAFT		1
	839-100	\$4.49	END PLUG		2
	329-860	\$1.59	SPRING, front & rear pedestals		2
	831-585	NA	PEDESTAL, front		1
	831-590	NA	PEDESTAL, intermediate		2
	831-595	NA	PEDESTAL, rear		1

No.	Part#	Price (Each)	Description	Application	Qty Req.
23	323-215	\$13.99	SCREW		1
25	310-050	\$0.69	NUT, rocker shaft pedestal		4
26	324-860	\$0.19	WASHER		4
27	328-665	\$6.29	STUD, rocker shaft pedestal		4
30	328-660	\$1.99	STUD, exhaust manifold (1-3/8" long)		2
	328-650	\$4.49	STUD, inlet & exhaust manifolds (1-7/8" long)		6
31	328-340	\$1.79	PLUG, threaded		1
32	830-000	\$2.79	VALVE GUIDE, inlet & exhaust, stock type		8
	830-015	\$13.99	VALVE GUIDE, inlet & exhaust, manganese bronze		8
35	821-250	\$8.99	VALVE, inlet		4
36	821-260	\$8.29	VALVE, exhaust, stainless steel		4
37	831-530	\$1.99	SPLIT COTTER, valve retaining		16
38	821-210	NA	COLLAR, upper, stock		8
	839-150	\$5.49	COLLAR, upper, aluminum alloy	use in sets of 8 only	8
39	821-270	\$31.99	VALVE SPRING SET, double springs		1
40	821-240	NA	COLLAR, lower		8
41	838-530	\$3.79	PUSHROD		8
42	838-306	\$199.99	TAPPET SET, APT brand (60+ HRC heat treated chilled cast iron, with oil hole)		1
	838-300	\$6.99	TAPPET, stock type		8
45	328-215	\$0.99	CORE PLUG, steel, small		1
	328-216	\$3.19	CORE PLUG, brass, small		1
46	328-235	\$1.09	CORE PLUG, steel, large		1
	328-236	\$3.99	CORE PLUG, brass, large		1

Core Plug Set

11934

All core plugs for the engine block and cylinder head.

328-278	\$11.99	CORE PLUG SET, steel	1
---------	---------	----------------------	---



Oberg Tilt Lift

It never fails. No matter what angle you hang an engine from its sling, it will be wrong. Unfortunately, most cars require the engine to be installed in an arc. This chore is hard enough with help, but it's nearly impossible without. Tilt Lift is a product which enables you to remove or install an engine alone. Tilt Lift allows easy adjustment of an engine's lift angle through a full 90 degrees of movement. Adjustment is easy, employing your 1/2" ratchet, and the 2,000 pound capacity – with a 3:1 safety load factor – is more than enough for any modern engine/tranny combination. A positive lock ensures the engine stays put. Tilt Lift's all steel construction ensures durability, and its small size (weighing only

four pounds) makes it perfect for small work areas. The mounting cleats are adaptable to any engine. Reduce the risk of personal injury, or damage to your car with a Tilt Lift.

386-730 \$119.99



"Ultra Slick" Engine Assembly Lube

The most critical time for dangerous wear during an engine's life is during initial start-up. Protect your rebuild (and all of those expensive parts) by using "Ultra Slick" during assembly of camshafts, lifters, engine bearings, timing components, valves & guides and rocker shaft assemblies. It's the best insurance available.

221-565 \$13.99

Hylomar Gasket Dressing

Hylomar "M" was originally the Racing Formulation, is acetone based, stiffens slightly over time and can be used in place of a gasket between finely machined surfaces. Hylomar Advanced Formulation or "AF" is solvent-free, won't harden and is perfect for use with gaskets on parts that need to be removed regularly for service. Both are perfect for shop use, and are ethanol and fuel proof.



Hylomar AF, 85 g tube 232-215 \$34.99
Hylomar M, 80 ml tube 232-220 \$24.99



Engine Paint

The right paint in the right color is the only kind to use on your freshly rebuilt engine. We invested a lot of time and effort to develop the correct shade of olive green for Sprigets. One can is enough to paint a properly prepared engine. (Black is not Moss "Classic Color") Our high temperature primer is specially selected for compatibility with our engine paints.

Dark Olive Green 220-580 \$29.99
Black (1972-'80) 220-575 \$19.99
Primer, high temp. 220-576 \$19.99

Magnetic Drain Plugs

Safeguard your engine! Our magnetic oil drain plug helps protect your engine by collecting metallic particles before they get fed through your oil system. Fits your gearbox, too!

948-1275 328-282 \$21.99
Midget 1500 328-356 \$7.99



1275 Alloy Cylinder Head

Use unleaded fuel with confidence, and increase your engine's efficiency and performance. These light-weight (9 lbs) high strength aluminum alloy cylinder heads run cooler, allow higher compression ratios, and have a greater than 35% increase in flow rate over stock heads. Heads come with silicon-bronze valve guides and hardened valve seats. These require 1275 valves, springs, and retainers. 12 mm spark plugs are required (use part #451-890). All of which must be purchased separately. (Quantities required in parenthesis). These heads do not have air injection ports, and therefore may not be used for street use on cars originally fitted with air pumps.

Alloy Cylinder Head	451-875	\$1,449.00
Intake Valve (4 req.)	423-190	\$6.29
Exhaust Valve (4 req.)	423-335	\$26.99
Valve Spring Set (1 req.)	423-470	\$32.99
Valve Collar (8 req.)	460-556	\$7.39
Valve Cotter (16 req.)	460-535	\$2.29
Spark Plug (4 req.)	451-890	\$5.39

Core Plug Sets

All core plugs for the engine block and cylinder head.

328-248	\$3.49	CORE PLUG SET, steel	} 948 thru (e)10CC/H3495	1
328-249	\$18.99	CORE PLUG SET, brass		1
328-253	\$3.99	CORE PLUG SET, steel	10CC/H3496, 1275	1
328-278	\$11.99	CORE PLUG SET, steel	1500	1

Rocker Assembly Oil Feed Line

Fits Midget 1500. Provide much improved oil flow to your rocker assembly with Triumphtune's external bolt-on braided stainless steel oil line. This is an easily installed improvement that is practical for both stock and modified 1500 engines.

Complete Assembly	821-360	\$89.99
Replacement Bolt	821-375	\$24.39
Replacement Washer	821-365	\$1.29 ea.

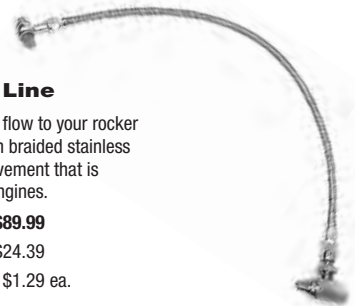

Engine Timing Degree Wheel

To get the best performance from your engine, it's essential to ensure exact camshaft timing. Use our handy plastic degree wheel to check timing when installing a new camshaft.

384-910 \$9.99



Oil Cooler Installation Kit

This kit allows fitment of a 13-row oil cooler on the Midget 1500. Uses stock filter and adaptor. Oil cooler and filter are not included. May require relocation of air pump hose.

Installation Kit	235-922	\$199.99
13-row Cooler	235-925	\$69.99



Toll-Free Orders 1-800-667-7872 | MossMotors.com
Fax 805-692-2525 | Local 805-681-3400



Cooling System - 948, 1098, 1275

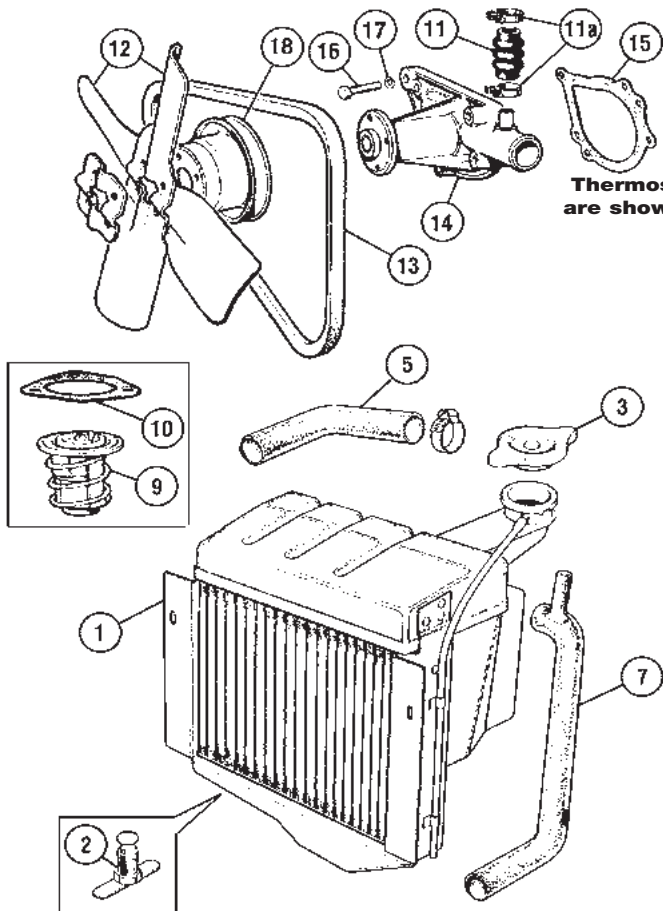

Thermostat housings are shown on page 12

Vertical-Flow System 948-early 1275 (thru 1967)

11949

No.	Part#	Price (Each)	Description	Application	Qty Req.
1	459-730	\$269.99	RADIATOR, vertical-flow	to AH (c)72033, to MG (c)60440	1
	459-731	\$379.99	RADIATOR, vertical-flow, alloy		1
2	660-020	\$12.19	DRAIN TAP		1
3	583-004	\$5.99	CAP		1
5	470-370	\$5.89	HOSE, top	948 & 1098	1
	470-375	\$7.49	HOSE, top	1275 to AH (c)72033 MG (c)60440	1
7	470-380	\$24.99	HOSE, bottom	948 & 1098	1
	470-385	\$17.99	HOSE, bottom	1275 to AH (c)72033 MG (c)60440	1
9	434-180	\$7.99	THERMOSTAT, 160°, hot climates		1
	434-189	\$7.99	THERMOSTAT, 180°, normal		1
	434-195	\$7.99	THERMOSTAT, 195°, cold climates		1
10	296-380	NA	GASKET, thermostat, stock type cork		1
	296-381	\$2.19	GASKET, thermostat, high strength "Klingersil"	MORE INFO ONLINE	1
11	434-530	\$5.59	HOSE, bypass, with original type hose clamps		1
11a	262-200	\$2.99	CLAMP, original band type		2
Check the bypass hose between the cylinder head and the water pump frequently. It is easy to mistake a leaky bypass for a faulty water pump as the leak in both cases will run down the side of the pump. Replace the bypass hose when replacing head gaskets or water pump.					
12	434-550	\$22.99	FAN BLADE, sold individually		2
13	460-990	\$6.49	FAN BELT	948	1
	460-875	\$5.99	FAN BELT	1098 & 1275 thru 1967	1
14	434-540	\$26.99	WATER PUMP (May use later pump for uprated flow)	948 thru 1275 (e)12CD/H1745	1
	434-545	\$27.99	WATER PUMP	1275 from (e)12CD/H1746	1
15	296-620	\$0.99	GASKET, water pump		1
16	322-105	\$1.59	BOLT, long		2
	191-915	\$1.39	BOLT, short		2
17	365-730	\$0.39	LOCKWASHER		4
18	NA		PULLEY, water pump		1

Lining up the various parts that use the radiator mounting bolts as support is easy when a tapered line-up tool is placed through the top holes to support one side while the opposite side is bolted. Install the top bolts first. Do not tighten any of the bolts until all four bolts are in place. The top bolts can be started using a deep well socket on a long extension with a nut in the socket to keep the bolt to the end of the socket. Most Sprites and Midgets have the two lower bolts missing. Get rid of a rattle or two by replacing them.

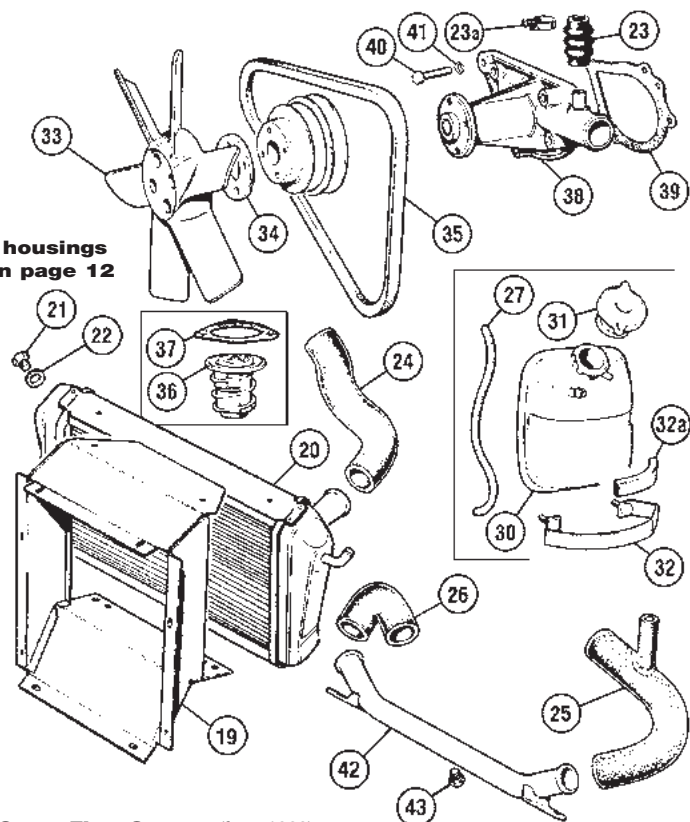

Cross-Flow System (from 1968)

1275 from AH (c)72034 and MG (c)60441

11950

No.	Part#	Price (Each)	Description	Application	Qty Req.
19	459-765	\$299.99	COWL, radiator		1
20	459-735	\$239.99	RADIATOR, cross-flow		1
21	459-760	\$7.69	PLUG		1
22	328-485	NA	WASHER (use 328-486 O-ring to replace washer)		1
	328-486	\$0.69	O-RING (to replace washer)		1
23	434-530	\$5.59	HOSE, bypass, with original type hose clamps		1
23a	262-200	\$2.99	CLAMP, original band type		2
24	470-390	\$5.89	HOSE, top		1
25	470-395	\$15.99	HOSE, lower tube to pump		1
26	470-400	\$2.99	HOSE, radiator to lower tube		1
27	470-345	\$2.39	HOSE, radiator to expansion tank		1
30	459-690	\$94.99	EXPANSION TANK		1
31	459-695	\$4.99	CAP, expansion tank		1
32	459-691	\$23.49	STRAP, expansion tank		1
32a	459-692	\$2.19	PAD, rubber		1
33	434-560	\$46.19	FAN, plastic		1
34	NA		SPACER		1
35	434-600	\$5.99	FAN BELT		1
36	434-180	\$7.99	THERMOSTAT, 160°, hot climates		1
	434-189	\$7.99	THERMOSTAT, 180°, normal		1
	434-195	\$7.99	THERMOSTAT, 195°, cold climates		1
37	296-380	NA	GASKET, thermostat, stock type cork		1
	296-381	\$2.19	GASKET, thermostat, high strength "Klingersil"	MORE INFO ONLINE	1
38	434-545	\$27.99	WATER PUMP		1
39	296-620	\$0.99	GASKET, water pump		1
40	322-105	\$1.59	BOLT, long		2
	191-915	\$1.39	BOLT, short		2
41	365-730	\$0.39	LOCKWASHER		4
42	434-520	\$44.99	PIPE		1
43	319-100	NA	DRAIN PLUG		1

Wire Hose Clamps

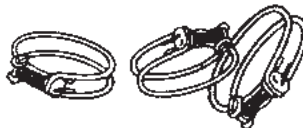

7/16" to 9/16"	326-475	\$2.29
9/16" to 3/4"	635-100	\$3.49
3/4" to 1"	635-101	\$2.39
1" to 1-1/4"	326-410	\$2.89
1-1/4" to 1-7/16"	326-465	\$1.99
1-7/16" to 1-5/8"	326-440	\$2.39
1-11/16" to 1-7/8"	635-102	\$2.49
1-7/8" to 2"	031-724	\$2.19
1-15/16" to 2-1/8"	635-103	\$5.69
2-3/16" to 2-7/16"	326-230	\$3.59
2-7/16" to 2-5/8"	326-460	\$2.69

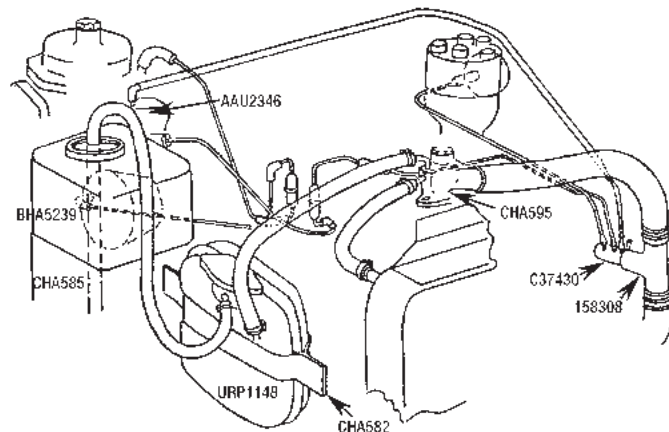
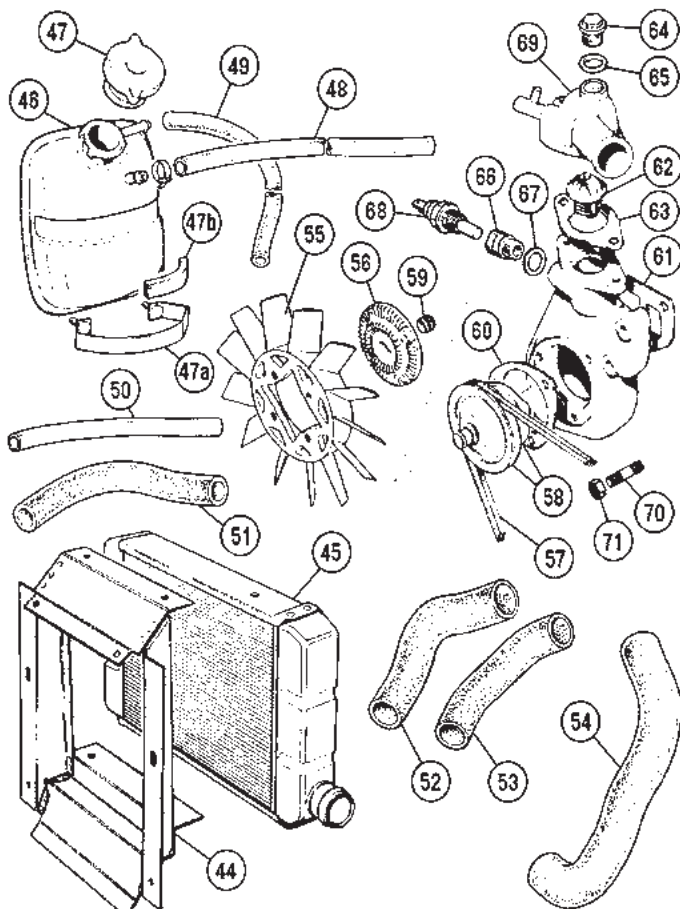

1975 Cooling System Modifications

The following is an extract from the Austin/ MG Technical Service Bulletin 75-A-6 dated August, 1975. **None of the specified parts are currently available.**

Where instance of severe overheating occurs on 1975 MG Midgets, the following modifications should be carried out.

1. Remove and discard the front number plate bracket and plinth assembly. Relocate and mount the front number plate to the center of the bumper, using self-tapping screws.
2. Reposition both horn assemblies by simply bending the mounting bracket upwards and through 90 degrees.
3. Install thermo-vac switch, Part No. C-37430 with 'T' sleeve adaptor, Part no. 158308 in the top radiator hose as shown.
NOTE:- (Remove approximately 1 1/4" from the existing hose to accommodate the 'T' sleeve.)
4. Remove the decell valve from the carburettor and replace with externally vented valve, Part No. AAU-2346.
5. Remove and discard the existing expansion tank and replace with metal type, Part No. URP-1148, using the existing bolts and spacers and new brackets supplied, Part No. CHA-582.
NOTE:- The pressure cap supplied with the metal tank has a double seal, and therefore is not interchangeable with the original cap which should be discarded.
6. Install bracket, Part No. CHA-585 and no-loss bottle, Part No. BHA-5239, utilizing the right-hand upper shock absorber support plate bolts.
7. Remove and discard the thermostat housing and install modified housing, Part No. CHA-595.
8. Connect the vacuum and water hoses as shown in overall illustration.
NOTE:- Vacuum hose will have to be cut to length.
9. Pressure test system for any leaks.
10. Replace temperature gauge assembly, Part No. AAU-2641.
NOTE:- There are many reasons why an engine will overheat, consequently it is essential to establish that no other problem exists, such as cylinder head gaskets, loose cylinder head bolts, incorrect ignition timing or maladjusted fan belt, etc., prior to carrying out the foregoing modifications.

Cross-Flow System - 1500

11952

No.	Part#	Price (Each)	Description	Application	Qty Req.
44	459-775	\$199.99	COWL, radiator		1
45	459-740	\$279.99	RADIATOR	to (c)166303 (1975)	1
	459-745	\$299.99	RADIATOR	from (c)166304 ('76 - on)	1
46	459-750	NA	EXPANSION TANK	to (c)166303 (1975)	1
	459-690	\$94.99	EXPANSION TANK (replacement)	from (c)166304 ('76 - on)	1
47	459-696	\$4.99	CAP, expansion tank		1
47a	459-691	\$23.49	STRAP, expansion tank		1
47b	459-692	\$2.19	PAD, rubber		1
48	470-305	\$3.99	TUBE, to expansion tank	to (c)166303 (1975)	1
	470-345	\$2.39	TUBE, to expansion tank	from (c)166304 ('76 - on)	1
49	470-340	\$3.99	TUBE, exp. tank to spill tank		1
50	470-345	\$2.39	HOSE, thermo. hsg. to radiator	to (c)166303 (1975)	1
51	470-405	\$7.99	HOSE, thermo. hsg. to radiator	from (c)166304 ('76 - on)	1
52	470-410	\$16.99	HOSE, radiator to pump	to (c)166303 (1975)	1
53	470-420	\$8.99	HOSE, radiator to pump	from (c)166304 ('76 - on)	1
54	470-415	\$7.99	HOSE, L/H, to thermo. hsg.		1
55	434-570	\$109.99	FAN		1
56	434-575	\$239.99	FAN CLUTCH		1
57	434-590	\$6.99	FAN BELT		1
58	835-655	\$54.99	WATER PUMP (includes pulley, tolerance ring, & gasket)		1
59	071-239	\$8.99	TOLERANCE RING		1
Must be replaced every time the fan clutch is removed and replaced (incl. w/pump).					
60	697-085	\$0.59	GASKET, water pump to housing		1
61	292-040	\$0.69	GASKET, housing to block		1
62	434-180	\$7.99	THERMOSTAT, 160°		1
	434-189	\$7.99	THERMOSTAT, 180°		1
63	292-101	\$1.79	GASKET, thermostat housing, Klingersil	MORE INFO ONLINE	1
64	328-480	NA	PLUG, thermostat housing	original type	1
	459-760	\$7.69	PLUG, thermostat housing	brass replacement	1
65	328-485	NA	WASHER for plug		1
	328-486	\$0.69	O-RING (to replace washer)		1
66	361-065	\$9.49	ADAPTOR, temp. gauge	thru (c)200000 (1977)	1
67	324-805	\$2.19	WASHER for adaptor	thru (c)200000 (1977)	1
68	071-241	\$8.99	TEMPERATURE SENDER	from (c)200001-on (1978-on)	1
69	363-370	NA	THERMOSTAT HOUSING	to (c)166303 (1975)	1
		NA	THERMOSTAT HOUSING	1976-on	1
70	328-654	\$3.29	STUD, water pump		3
71	310-140	\$0.39	NUT		3

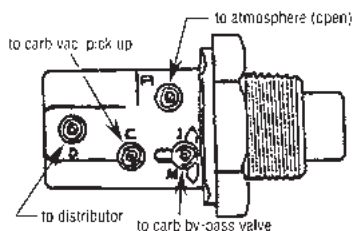

Thermostatic Vacuum Switch

Hayden Electric Fan

Easy to install, these fans may be set up to run in either "pusher" (in front of the radiator) or "puller" (behind the radiator) configuration. The preset temperature control will turn the fan on at 185 F and off at 170 F. This 10" fan is 2-3/4" thick, and requires a clear mounting area of at least 10-5/8" x 11-1/8".



10" Cooling Fan Kit 231-678 \$164.99

Toll-Free Orders 1-800-667-7872 | MossMotors.com
Fax 805-692-2525 | Local 805-681-3400

MOSS

Heaters

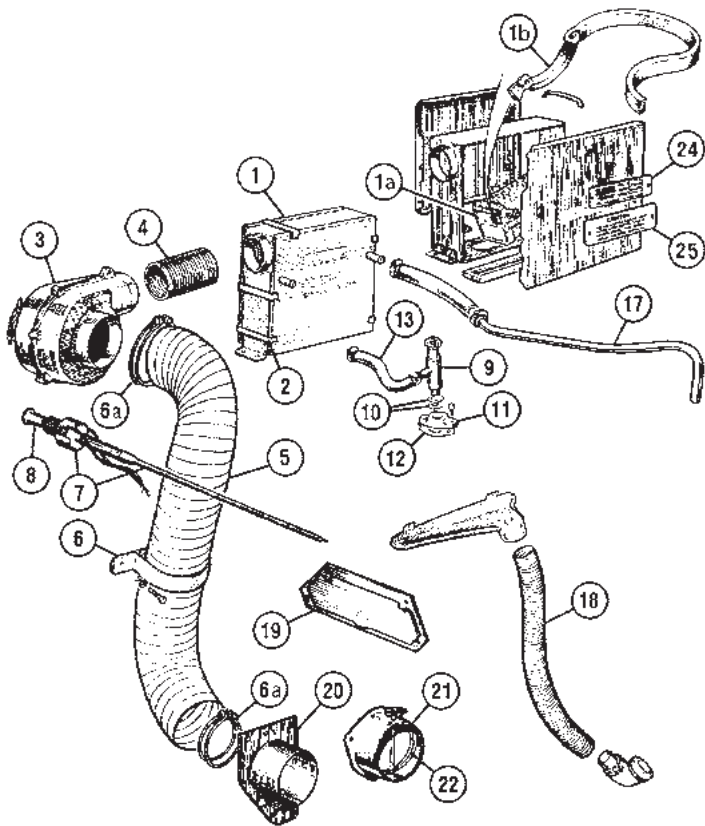

Heater - 948 - 1275 thru Sept. 1970 (GAN5-91406) 11955

No.	Part#	Price (Each)	Description	Application	Qty Req.
1	362-915	\$399.99	HEATER ASSEMBLY	} all through Sept., 1970	1
1a	360-675	\$159.99	RADIATOR, heater		1
1b	363-381	\$2.99	SEAL, foam		1
2	363-025	\$1.79	CLIP, heater box		A/R
3	362-905	NA	BLOWER ASSEMBLY	thru 1967	1
	362-925	NA	BLOWER ASSEMBLY	1968-'70	1
4	363-390	\$7.49	AIR DUCT, fan to heater		1
5	456-130	\$58.99	AIR DUCT, replacement type		1
6	326-220	\$4.79	CLAMP		1
6a	326-255	\$17.99	HOSE CLAMP (wire type replacement)		2
7	331-690	NA	HEATER CONTROL, w/switch	Bugeye	1
	331-695	NA	HEATER CONTROL, w/switch	non-Bugeye thru 1966	1
	331-705	NA	HEATER CONTROL, w/switch	1967	1
	473-070	\$1.79	CABLE STOP		1
8	331-085	\$14.99	KNOB, heater control		1
9	360-400	\$27.99	HEATER VALVE		1
10	324-065	\$1.49	WASHER (may use more than one to align heater valve)		A/R
11	360-415	\$7.69	BASE, heater valve		1
12	296-455	\$1.19	GASKET, heater valve		1
13	363-320	\$14.99	HOSE, heater valve		1
17	635-065	\$52.99	PIPE, heater return		1
18	456-185	\$16.99	HOSE, demister		A/R
19	363-122	\$55.99	DOOR ASS'Y, heater outlet, stainless steel (with screws)		2
20	635-196	\$47.69	INLET FLANGE	Bugeye	1
21	NA		INLET FLANGE	non-Bugeye	1
22	363-415	\$17.99	SEAL, air inlet	non-Bugeye	1
23	408-350	\$6.99	PLATE, "Smiths" (rivetted)	thru 1967	1
	408-355	\$2.79	STICKER, "Smiths" (adhesive)	1968-'70	1
24	408-360	\$5.99	PLATE, "Caution" (rivetted)	thru 1967	1
	408-365	\$4.39	STICKER, "Caution" (adhesive)	1968-'70	1

The "water faucet" heater valve is one of the charming anachronisms of these cars. It's not so charming when it leaks. Part of your regular service routine should include tightening the mounting nuts. If the tap is leaking between the body and the mounting flange, a turn on the tap body should fix it. If not, replacement of the flange and gasket will cure the annoyance for good.

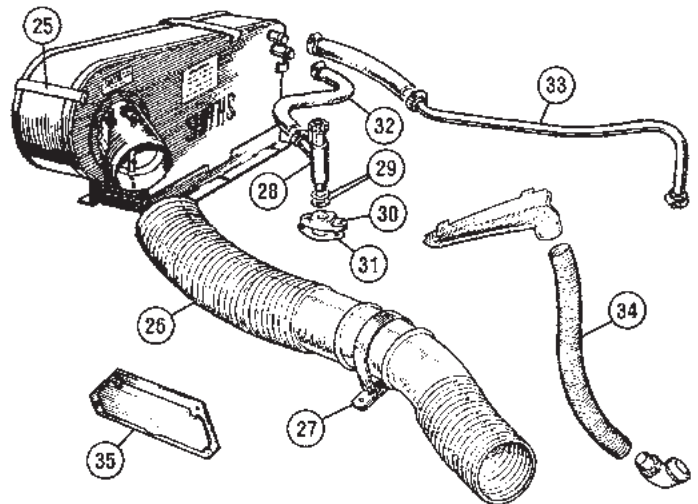

Heater - 1275, Sept. 1970 (GAN5-91407)-'74

11954

No.	Part#	Price (Each)	Description	Application	Qty Req.
	360-705	\$169.99	HEATER CORE ("radiator")		1
25	363-380	\$4.29	CLIP, heater box		A/R
26	456-130	\$58.99	AIR DUCT, replacement type		1
27	326-220	\$4.79	CLAMP		1
28	360-400	\$27.99	HEATER VALVE		1
29	324-065	\$1.49	WASHER		A/R
30	360-415	\$7.69	BASE, heater valve		1
31	296-455	\$1.19	GASKET, heater valve		1
32	363-330	\$22.99	HOSE, heater valve		1
33	635-065	\$52.99	PIPE, heater return		1
34	456-185	\$16.99	HOSE, demister		A/R
35	363-122	\$55.99	DOOR ASS'Y, heater outlet, stainless steel (with screws)		2



Cockpit-controlled Heater Valve

Tired of having to stop and open the hood to turn on your heater valve? Moss comes to the rescue with this cable-operated conversion which allows you to control your heater while seated comfortably in your car. It's a conversion you can easily do yourself. Fits 948, 1098 and 1275 engines.

635-375 \$86.99

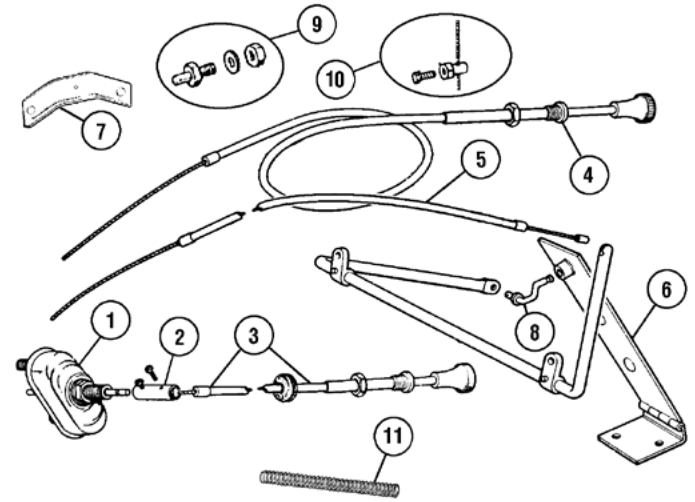
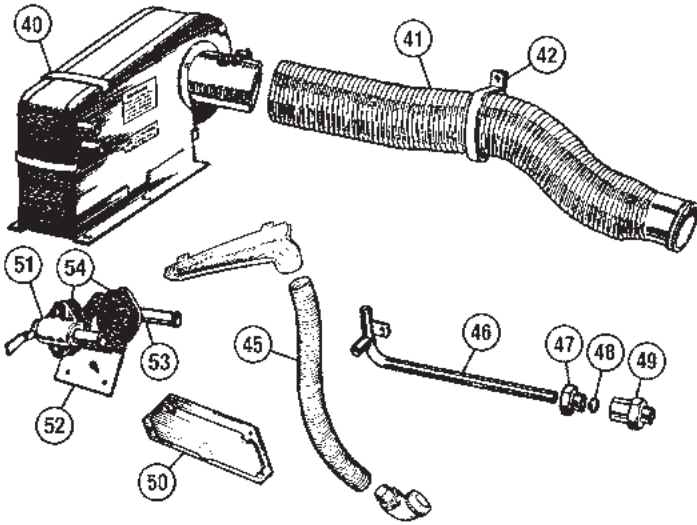

Heater - 1500

11957

No.	Part#	Price (Each)	Description	Application	Qty Req.
	360-705	\$169.99	HEATER CORE ("radiator")		1
40	363-380	\$4.29	CLIP, heater box		A/R
41	456-130	\$58.99	AIR DUCT (replacement type without reduced end)		1
42	326-220	\$4.79	CLAMP		1
45	456-185	\$16.99	HOSE, demister		A/R
46	865-115	\$42.99	PIPE, heater return (mild steel)		1
	635-105	\$69.99	PIPE, heater return (stainless steel)		1
47	635-150	\$3.99	TUBE NUT		1
48	635-160	\$1.59	COMPRESSION FITTING		1
49	635-170	\$14.99	ADAPTOR		1
50	363-122	\$55.99	DOOR ASS'Y, heater outlet, stainless steel (with screws)		2
51	360-425	NA	HEATER VALVE		1
52	360-426	\$15.29	BRACKET, heater valve		1
53	360-427	\$42.39	ELBOW, heater valve		1
54	697-360	\$0.39	GASKET, heater valve		2
	363-340	\$22.99	HOSE, heater valve to heater		1

Engine Controls

11959

No.	Part#	Price (Each)	Description	Application	Qty Req.
1	145-800	\$26.99	SWITCH	948	1
2	161-500	\$12.99	COUPLING (with screws)	948	1
3	331-630	\$25.99	CABLE, starter pull, orig. type	Bugeye	1
	331-710	\$24.99	CABLE, starter pull, replacement	AH MkII, MG MkI	1
4	331-720	\$32.99	CHOKE CABLE, original type	Bugeye	1
	331-080	\$46.99	CHOKE CABLE, repl. w/plain knob	948, 1098, 1275 (1967)	1
	331-240	\$13.79	CHOKE CABLE, "picture knob"	1275 1968	1
	331-645	\$24.99	CHOKE CABLE, "picture knob"	1275, 1970-'74	1
	331-490	\$25.99	CHOKE CABLE, "T-handle" replacement		1
	331-650	\$25.99	CHOKE CABLE	1500 w/o auto choke	1
5	331-006	\$9.99	ACCELERATOR CABLE, Premium	all except 1500	1
	331-731	\$14.99	ACCELERATOR CABLE, Premium	1500 not CA thru (c)188000	1
			Premium cables with low friction liner. MORE INFO ONLINE		
	331-740	NA	ACCELERATOR CABLE	{ 1500 CA only (c)160160 thru 188000	1
	331-750	\$24.99	ACCELERATOR CABLE	1500 from (c)188001 on	1
6	260-340	\$15.69	ACCELERATOR PEDAL, w/ hinge	all except 1500	1
	260-350	NA	ACCELERATOR PEDAL ASS'Y	1500	1
7	372-295	\$14.99	BRACKET, choke cable	Bugeye	1
8	260-345	NA	LINK, accelerator pedal		1
9	375-108	\$2.99	CABLE STOP, accelerator cable		1
10	375-128	\$2.99	CABLE STOP, choke cable		1
11	319-070	\$0.99	SPRING, throttle return	{ 1500 not CA thru (c)188000	1

Carburetors - Bugeye

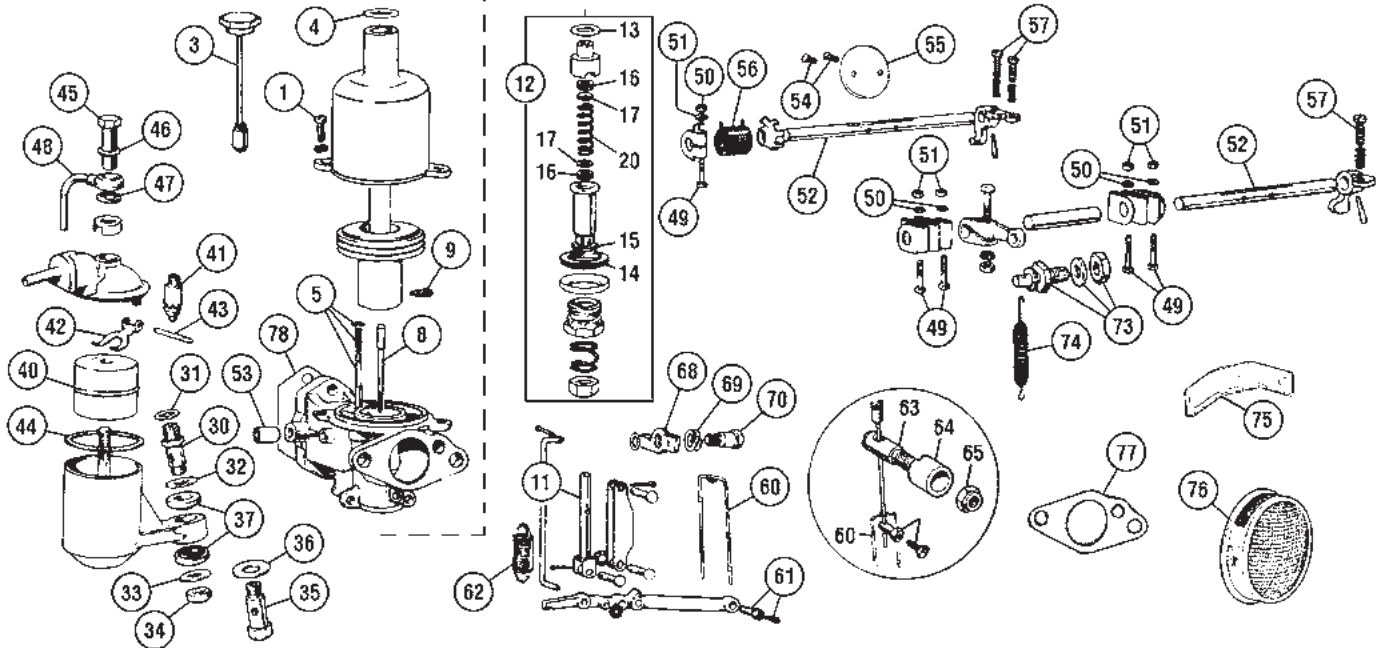

Carburetors - SU H-1 (1 1/8") "Bugeye" only (AUC863) 11960

No.	Part#	Price (Each)	Description	Application	Qty Req.
	375-460	\$189.99	REBUILD KIT, for 2 carburetors	Includes items marked *	1
	375-465*	\$54.99	GASKET KIT for 2 carburetors		1
1	370-290	\$0.89	SCREW, chamber, 2 per carb.		4
3	370-765	\$82.99	CAP & DAMPER, brass		2
	370-750	\$27.99	CAP & DAMPER, plastic replacement		2
4	370-650*	\$0.39	WASHER		2
5	375-048	\$18.99	PIN & SPRING ASS'Y.		2
8	374-095*	\$19.99	JET NEEDLE, standard (GG)		2
	374-055	\$19.99	JET NEEDLE, rich (EB)		2
	374-145	\$19.99	JET NEEDLE, lean (MOW)		2
9	370-180	\$5.49	SCREW, needle locking		2
11	370-760*	\$15.99	JET, .090"		2
12	370-395	\$72.99	JET BEARING KIT (stock type)		2
	370-396	\$129.99	JET BEARING KIT, "Superdry"	MORE INFO ONLINE	2
13	370-250*	\$1.29	WASHER, jet bearing		2
14	295-000*	\$1.19	SEAL, cork		2
15	370-410*	\$1.29	WASHER, bottom jet bearing		2
16	295-200*	\$0.79	JET SEAL, cork		4
	365-420	\$0.89	O-RING, leak-free repl. for 295-200 (not in jet bearing kit)		4
17	370-230*	\$1.79	WASHER, cupped		4
20	370-070	\$2.79	SPRING, jet seal		2
30	372-190	\$13.99	STUD, float bowl to carb.		2
31	372-180	\$1.09	WASHER, fiber	} alternative to #35 & 36	2
32	372-200	\$1.59	WASHER, steel, flat		2
33	372-210	\$1.99	WASHER, steel, flat		2
34	311-230	\$0.69	NUT		2
35	370-080	\$15.99	BOLT, float bowl to carb.	} alternative to #30-34	2
36	370-030	\$5.39	WASHER, steel, cupped		2
37	370-021*	\$1.69	GROMMET, float bowl mount, Viton		4
40	378-050	\$49.99	FLOAT		2
41	373-625*	\$55.99	NEEDLE & SEAT, Viton tip		2
	373-626	\$14.99	NEEDLE & SEAT, Viton tip, aftermarket		2
	386-390	\$18.99	GROSE JET, superior replacement for original style needle & seat		2
42	378-130	\$41.99	LEVER, original cover		2
43	370-060*	\$0.89	PIN, lever		2
44	378-110*	\$1.19	GASKET, float bowl cover		2
45	370-150	\$9.99	BOLT, float bowl cover		2
46	370-130*	\$0.89	WASHER, aluminum		2
47	370-160*	\$1.29	WASHER, fiber		2
48	451-250	\$21.99	OVERFLOW PIPE		2
49	365-610	\$0.99	SCREW, coupling & clamp		5
50	365-620	\$0.79	WASHER		5
51	365-630	\$0.39	NUT		5
52	376-005	\$32.99	THROTTLE SHAFT, standard		2
	376-015	\$32.99	THROTTLE SHAFT, oversize diameter		2
53	330-490	\$3.99	BUSH, throttle shaft		4
54	370-090	\$1.79	SCREW, throttle disc		4
55	378-160	\$19.99	THROTTLE DISC		2
56	370-610	\$16.39	SPRING, front throttle shaft		1

No.	Part#	Price (Each)	Description	Application	Qty Req.
57	370-340	\$1.59	SCREW, idle adjusting		3
60	378-010	\$10.79	STIRRUP		1
61	378-648	\$7.99	PIN ASS'Y., jet lever to stirrup		2
62	370-550	\$3.99	SPRING, choke return		2
63	378-570	\$32.99	PIN, choke control		1
64	378-575	\$20.99	COLLAR, choke control pin		1
65	311-610	\$1.69	NUT		1
66	378-648	\$7.99	CABLE STOP		1
68	378-230	NA	LEVER, fast idle		1
69	370-460	\$0.79	SPRING WASHER		1
70	370-450	\$12.49	BOLT, shouldered		1
73	375-108	\$2.99	PIN ASS'Y., throttle spring		1
74	370-335	\$1.99	SPRING, throttle		1
75	372-295	\$14.99	BRACKET, choke cable		1
76	373-420	\$44.49	AIR FILTER, front, repro. of original		1
	373-425	\$44.49	AIR FILTER, rear, repro. of original		1
77	295-010*	\$1.99	GASKET, filter to carb.		2
78	295-015*	\$0.89	GASKET, carb. to manifold	(gasket set includes 2)	6



SU Carb Rebuild Video

Anyone can tune or rebuild SU carbs with the help of our 2 hour and 40 minute video which uses a combination of sights, sounds and simple conversational dialog to unravel the mysterious SU. A "must" for home mechanics.

DVD 211-036 \$39.99

SU Tool Kit

An assortment of handy tools for the home mechanic. Instructions included. Suitable for all cars with SU carbs.

386-300 \$23.99

Carburetor Synchronizer

Used to synchronize airflow between multiple carbs, this is an indispensable tool for the serious home mechanic.

386-200 \$39.99



SU Jet Wrench

Mixture adjustments on SU carbs (except HIF type) are much easier with the proper tool. 5/16 Whitworth size for original carbs. & replacement H-type, 17 mm for new HS type carbs.

Jet Wrench, 5/16 W (included in SU Tool Kit) 386-400 \$4.39

Jet Wrench, 17 mm 386-401 \$7.99

SU Jet Centering Tool

Jet centering is critical on fixed needle SU carbs. This simple tool makes it a snap.

386-500 \$39.99

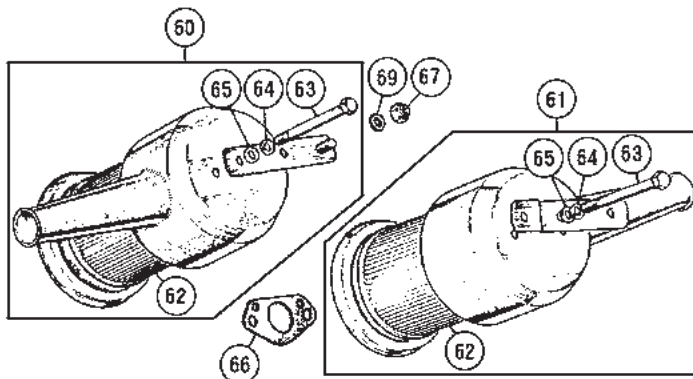
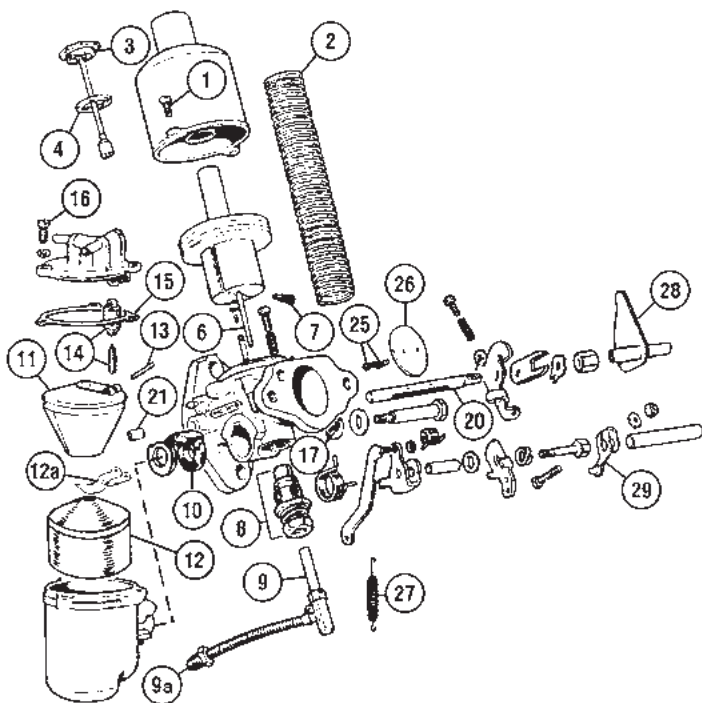

Carburetors - HS-2

11966

No.	Part#	Price (Each)	Description	Application	Qty Req.
New SU Carburetor Sets					
			Carburetor #		
	370-708	\$1,449.00	AUC990F/990R	948 Sprite MkII, Midget MkI	1
			NA AUD73F/73R (use 370-718)	some very early 1098	1
	370-718	\$1,899.00	AUD136F/136R	1098, 1963 - '67•	1
	370-728	\$1,799.00	AUD266F/266R	1275, 1968•	1
	370-908	\$1,799.00	AUD328F/328R	1275, 1969•	1
	370-928	\$1,399.00	AUD404F/404R	1275, 1970 - '71•	1
	370-938		NA AUD502F/502R	1275, early 1972•	1
	370-948	\$1,799.00	AUD549F/549R	1275, 1972 - '74•	1
				•Approximate model year dates	
	375-538†	\$339.99	MASTER REBUILD KIT , 2 carbs 948 thru 1275 (not Bugeye)Ⓢ		1
"Master Rebuild Kit" is a genuine S.U. kit. Includes all parts marked †.					
Jet needles not included.					
	375-450*	\$179.99	REBUILD KIT, for 2 carbs.Ⓢ	948, except Bugeye	1
	375-410*	\$219.99	REBUILD KIT, for 2 carbs.Ⓢ	1098, 1275 AUD136 & 266	1
	375-420*	\$179.99	REBUILD KIT, for 2 carbs.Ⓢ	1275 AUD328 & 404	1
	375-430*	\$189.99	REBUILD KIT, for 2 carbs.Ⓢ	1275 AUD502 & 549	1
* Rebuild kits are genuine SU kits, and include items marked *.					
	375-375**	\$199.99	SERVICE KIT, for 2 carbs Ⓢ	948-1275	1
**Service kit includes jets, needle & seats, and gasket set.					
	375-435†*	\$26.99	GASKET KIT, for 2 carbs. (incl. nos. 4, 15, 41, 42)		1
1	370-290	\$0.89	SCREW, chamber to body, 2 per carb.		4
2	370-530	\$6.29	SPRING, piston return		2
3	370-750	\$27.99	CAP & DAMPER, plastic cap		2
4	370-650†*	\$0.39	WASHER		2
6	374-125	\$19.99	JET NEEDLE, lean (GX)	948 AUC990	2
	374-305*	\$19.99	JET NEEDLE, standard (V3)		2
	374-295	\$19.99	JET NEEDLE, rich (V2)		2
	374-095	\$19.99	JET NEEDLE, lean (GG)	1098/1275 AUD136/266 (original carbs)	2
	374-005*	\$24.99	JET NEEDLE, standard (AN)		2
	374-135	\$19.99	JET NEEDLE, rich (H6)		2
	021-079	\$51.99	JET NEEDLE, spring-loaded (AN)		repl. AUD136/266
	374-355*	\$21.99	JET NEEDLE, spring-loaded (AAC)	1275 AUD328 & 404	2
	374-365*	\$21.99	JET NEEDLE, spring-loaded (ABC)	1275 AUD502 & 549	2
7	370-180	\$5.49	SCREW, needle locking	straight needles	2
			NA SCREW, needle locking	spring-loaded needles	2
8	372-265	\$39.99	JET BEARING KIT	AUC990, AUD136	2
	372-275	\$57.99	JET BEARING KIT	AUD266	2
	372-285	\$62.79	JET BEARING KIT	AUD328,404,502,549	2

No.	Part#	Price (Each)	Description	Application	Qty Req.
9	378-430†*	\$34.99	JET, front		1
	378-440†*	\$34.99	JET, rear		1
9a	378-400	\$0.49	SEAL to float bowl		2
10	378-090	\$7.99	ADAPTOR, front		1
	378-085	\$8.99	ADAPTOR, rear		1
11	378-470	\$17.99	FLOAT (as illustrated with metal hinge tab)		2
12	378-380		NA FLOAT, brass	AUC990	2
12a	370-155		NA LEVER for float #13		2
13	370-060	\$0.89	PIN, float	all	2
14	373-625†*	\$55.99	NEEDLE & SEAT, Viton® tip		2
	373-626	\$14.99	NEEDLE & SEAT, Viton® tip, aftermarket		2
	386-390	\$18.99	GROSE JET, superior replacement for orig. style needle & seat.		2
15	378-360†*	\$1.49	GASKET, float chamber		2
16	370-290	\$0.89	SCREW, 3 per carburetor		6
17	378-070*	\$3.69	WASHER, rubber		2
20	378-370†	\$29.99	THROTTLE SHAFT		2
	378-375	\$29.99	THROTTLE SHAFT, oversize		2
21	330-490†	\$3.99	BUSH, throttle shaft		4
25	370-090†	\$1.79	SCREW, throttle disc		4
26	370-280†	\$19.99	THROTTLE DISC		2
27	370-335	\$1.99	SPRING, choke return		2
	370-320	\$2.19	SPRING, throttle return		1
28	370-121	\$19.99	LEVER, throttle		1
29	371-860	\$4.49	LEVER & PIN, front		1
	371-850	\$4.49	LEVER & PIN, rear		1
60			NA AIR CLEANER ASSEMBLY, front		1
61			NA AIR CLEANER ASSEMBLY, rear		1
62	950-260		NA AIR FILTER ELEMENT, "Crosland" brand		2
	373-435		NA AIR FILTER ELEMENT, "K&N" brand		2
	950-760	\$9.99	AIR FILTER ELEMENT, various manufacturers		2
63	322-175	\$2.99	BOLT, air cleaner to carburetor		4
64	365-730	\$0.39	WASHER, locking		4
65	365-720	\$0.79	WASHER, plain		4
66	295-020†*	\$0.69	GASKET, air cleaner to carb.		2
67	310-290	\$1.19	NUT, nyloc, air cleaner straps		1
69	324-155	\$0.59	WASHER, plain		1



Weber Carburetor Kits

Pick your choice of the traditional high performance side draft DCOE, or the popular DGV downdraft Weber carburetor kits. Please note there is no provision for emission control connections, and re-jetting may be required for best operation. We recommend the tuning be performed by a professional familiar with Weber carburetors.

Single 40DCOE	948, 1098	222-440	\$1,149.00
Single 45DCOE	1275	222-450	\$1,199.00
Single DGV	948, 1098, 1275	222-275	\$599.99

Toll-Free Orders 1-800-667-7872 | MossMotors.com
 Fax 805-692-2525 | Local 805-681-3400



Carburetors - Midget 1500

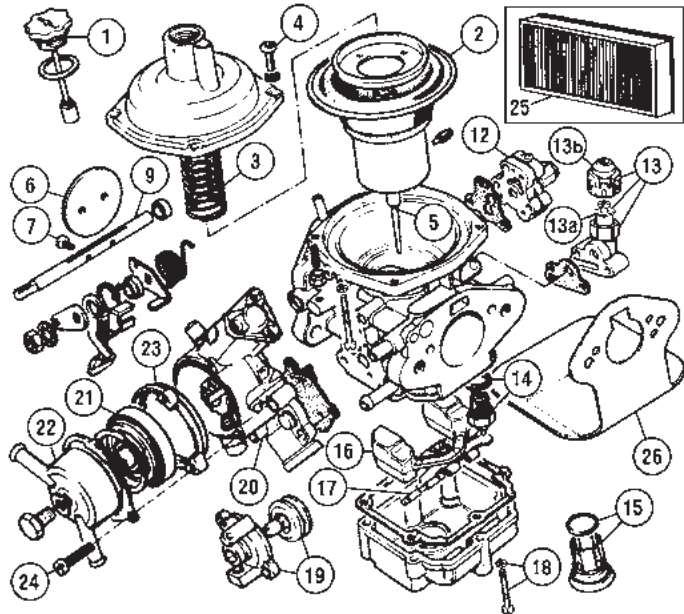

Carburetors - Zenith-Stromberg 150-CD4T

11969

No.	Part#	Price (Each)	Description	Application	Qty Req.
	366-730	NA	CARBURETOR, C3754	Federal, 1975 - '76	1
	366-735	NA	CARBURETOR, C3838	Federal, 1977	1
	366-740	NA	CARBURETOR, C3962	Federal, 1978 on	1
	366-745	NA	CARBURETOR, C3755	California, 1975 - '76	1
	366-750	NA	CARBURETOR, C3863	California, 1977	1
	366-755	NA	CARBURETOR, C3963	California, 1978 on	1
	375-440*	\$69.99	REBUILD KIT		1
includes all items marked * plus all seals and gaskets. Does not include metering needle.					
	375-445	NA	GASKET KIT		1
	295-025	NA	GASKET, carb. to manifold		1
	295-030*	\$0.49	GASKET, air cleaner to carb.		1
1	366-660	\$54.79	CAP & DAMPER	C3754, 3838, 3755, & 3863	1
	366-665	\$52.79	CAP & DAMPER	C3962 & C3963	1
2	366-670*	\$9.49	DIAPHRAGM		1
3	366-675	\$9.99	SPRING, air piston		1
4	365-380	\$1.89	SCREW, cover to body		4
5	374-405	NA	METERING NEEDLE (44A)	C3754 & C3755, fixed	1
	374-415	NA	METERING NEEDLE (44A)	C3838, adjustable	1
	374-425	\$41.99	METERING NEEDLE (45Q)	C3962, adjustable	1
	374-435	\$54.99	METERING NEEDLE (45K)	C3863, adjustable	1
	374-440	\$54.99	METERING NEEDLE (45R)	C3963, adjustable	1
6	366-680	\$21.99	THROTTLE DISC		1
7	366-685	\$3.89	SCREW, disc to shaft		2
9	366-690	\$27.99	THROTTLE SHAFT		1
12	366-695	\$155.99	BYPASS VALVE ASSEMBLY	C3754, 3755, 3863, & 3963	1
	366-700	\$141.99	BYPASS VALVE ASSEMBLY	C3838 & C3962	1
	365-745	\$15.29	DIAPHRAGM KIT, bypass valve		1
13	366-165	\$159.99	REGULATOR, idle air		1
13a	366-215	\$14.99	VALVE BODY, nylon		1
13b	366-245	\$12.49	COVER		1
14	366-705*	\$16.99	NEEDLE & SEAT ASSEMBLY		1
	386-350	\$12.99	GROSE JET, superior replacement for original style needle & seat.		1
15	366-070	\$29.99	PLUG & O-RING, float chamber		1
	365-470*	\$0.79	O-RING, float chamber plug		1
16	365-505	\$65.99	FLOAT ASSEMBLY		1
17	366-080	\$6.99	PIN, float pivot		1
18	366-305	\$4.29	SCREW & WASHER, float chamber, short	C3754, C3838,	2
	366-065	\$5.99	SCREW & WASHER, float chamber, long	C3755, C3863	4
	366-295	\$3.69	SCREW & WASHER, float chamber	C3962, C3963	6
19	366-710	\$149.99	STARTER BOX	C3754	1
20	366-715	\$399.99	HOUSING ASS'Y., auto choke		1
21	366-190	\$149.99	HEAT MASS ASS'Y., auto choke		1
22	366-200	\$42.59	COVER, heat mass		1
23	366-180	\$42.99	INSULATOR		1
24	366-175	\$2.09	SCREW, short		1
	366-185	\$2.69	SCREW, long		2
25	950-710	\$43.99	AIR FILTER ELEMENT, aftermarket		1
See color pages at front of catalog for accessory air filters.					
26	375-480	NA	HEAT SHIELD		1

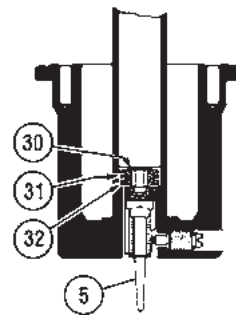

No.	Part#	Price (Each)	Description	Application	Qty Req.
30	365-395	\$1.99	RETAINING CLIP	adjustable needle	1
31	365-420	\$0.89	O-RING		1
32	365-425	\$17.99	SCREW, needle adjusting		1



1500 Manual Choke Conversion Kit

Gain all the advantages of manually controlled choke, while leaving your car's original appearance intact by using this easy to install kit. Designed in England by Zenith-Stromberg engineers, this kit includes all necessary mounting hardware and detailed instructions.

386-325 \$129.99

Amendments to the Clean Air Act make it illegal for anyone to change or alter the emission control system of any automobile in the United States except for cars used exclusively for off-road use.



Zenith-Stromberg Mixture Adjustment Tool

An essential item for owners of 1977 or later cars with a single Zenith-Stromberg carburetors with adjustable metering needles.

386-310 \$11.29

Carburetor Dashpot Oil



Finally take all the guesswork out of what type of oil to use in your dashpots. Specially formulated for all SU and Zenith-Stromberg carburetors, this oil ensures the correct piston movement so critical for correct fuel mixture and optimum performance. You don't have to use engine oil any more. 125 ml supply should last a long time.

220-225 \$17.99



Weber Downdraft Carb Kits

The Weber DGV two barrel progressive carburetor has proven to be the most popular replacement for worn out or damaged stock carburetors and gives a good combination of performance and economy on stock engines. Kits include instructions, carburetor(s), manifold/adapters, linkage and air filter(s). Please note that there is no provision for emission connections and some modifications will be required for best operation. May not be legal on emission controlled vehicles. Check your local laws for compliance.



Midget 1500 (Water Choke)	222-255	\$619.99
Midget 1500 (Electric Choke)	222-256	\$619.99
Midget 1500 (Manual Choke)	222-257	\$629.99

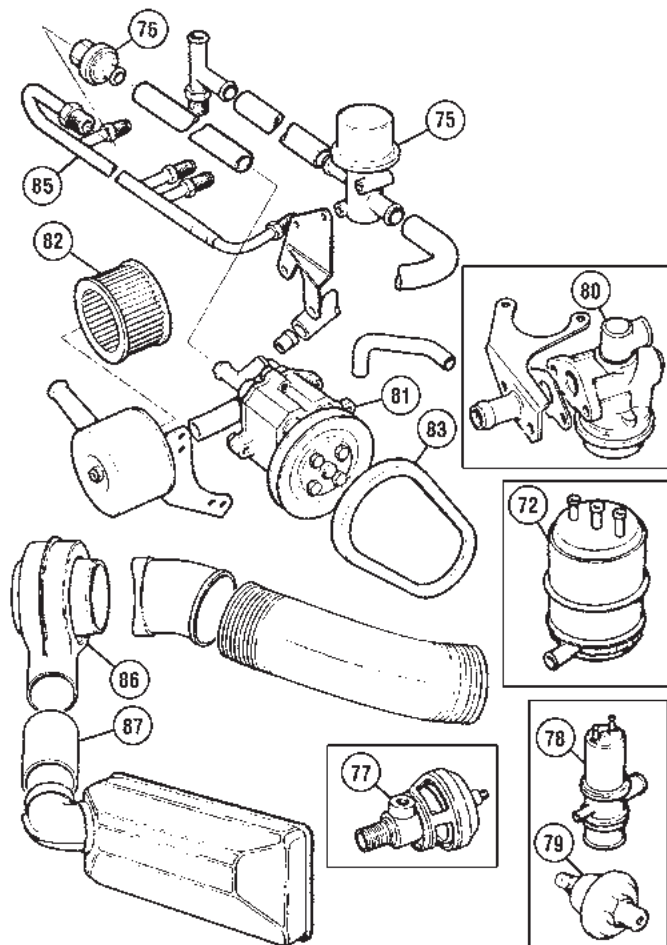

Emission Control

11973

No.	Part#	Price (Each)	Description	Application	Qty Req.
72	367-100	\$74.99	CANISTER, vapor adsorption	1970 on	A/R
	367-105	\$0.79	CAP	(see note below)	1

* Note: Adsorption canisters from (c)74886 thru 105500 had only 2 hose connections on top. These canisters are no longer available, and have been superseded by the later 3-connector canister which we supply. For cars requiring 2-connector canisters, use canister #367-100 with cap #367-105 to seal the connector not used. (Either outer connector may be used.) 1978-'80 used two canisters.

75	366-010	\$109.99	GULP VALVE	1275	1
76	379-470	NA	CHECK VALVE, orig. mfr.	1275 & 1500	1
	367-000	\$19.99	CHECK VALVE, aftermarket		1
77	379-340	NA	E.G.R. VALVE	1500 thru 1976	1
	379-365	NA	E.G.R. VALVE	1500, 1977 on	1
78	367-110	\$87.99	VALVE, anti-run on	1500	1
79	141-715	\$33.99	SWITCH, oil pressure	1500 Fed, CA thru 1977	1
		NA	SWITCH, oil pressure	1500 CA from 1978 on	1
80	379-610	NA	DIVERTER VALVE	1500 thru 1976	1
	379-700	NA	GULP VALVE	1500, 1977-on, CA only	1
81	360-775	NA	AIR PUMP, rebuilt	1275	1
	360-778	NA	AIR PUMP, replacement		1
	379-555	NA	AIR PUMP		1500 thru 1976
	379-565	NA	AIR PUMP	1500, 1977 on	1
82	950-230	NA	FILTER ELEMENT, "Crosland"	1275 & 1500	1
	950-730	\$19.99	FILTER ELEMENT, various mfr.		1
83	434-580	\$5.99	BELT, air pump	1275	1
	379-620	\$7.79	BELT, air pump	1500	1
85	379-630	NA	AIR MANIFOLD	1275	1
	379-640	NA	AIR MANIFOLD	1500, '75 - '76	1
	379-645	NA	AIR INJECTION PIPE	1500, '77 - '80	1
86	373-920	NA	TEMP. COMPENSATOR	1500	1
87	379-660	NA	CONNECTOR		1

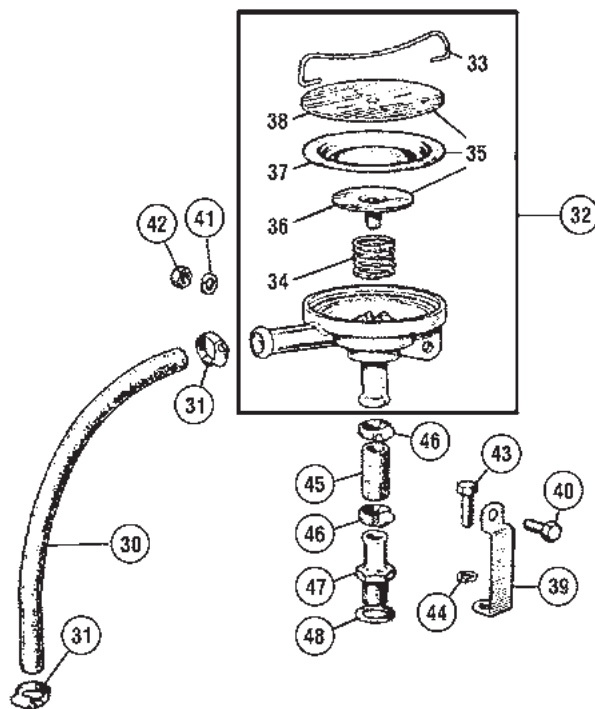

No.	Part#	Price (Each)	Description	Application	Qty Req.
30		NA	HOSE, breather	1098 10CC & 1275 to engine 12CD/DA/H8700	1
31	470-381	\$5.99	CLIP, hose to separator & valve		2
32	360-630	\$66.99	P.C.V. VALVE		1
33		NA	CLIP, cover		1
34		NA	SPRING		1
35		NA	SERVICE KIT, valve		1
36		NA	PLUNGER SUB-ASSEMBLY		1
37	360-635	\$3.99	DIAPHRAGM		1
38		NA	COVER		1
39		NA	SUPPORT BRACKET		1
40	322-230	\$0.39	BOLT, valve to bracket	1	
41	324-020	\$0.20	WASHER, locking	1	
42	310-760	\$0.59	NUT	1	
43	322-645	\$0.49	BOLT, bracket to manifold	1	
44	324-040	\$0.39	WASHER, locking	1	
45		NA	HOSE, valve to adaptor	1	
46	470-381	\$5.99	CLIP, hose to valve & adaptor	2	
47	372-470	\$14.99	ADAPTOR, hose to manifold	1	
48	324-145	\$0.39	WASHER, sealing	1	

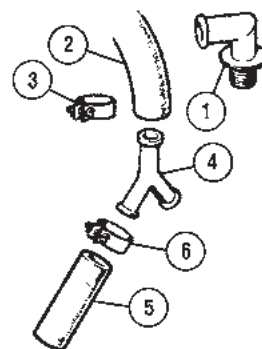

No.	Part#	Price (Each)	Description	Application	Qty Req.
1		NA	ADAPTOR, sensing control	1275 from (e)12CD-DA-H8701	1
2		NA	HOSE, Y-piece to separator		1
3	117-015	\$2.29	HOSE CLAMP		1
4	367-070	\$5.69	"Y" PIECE		1
5		NA	HOSE to carburetor		2
6	326-250	\$1.39	HOSE CLAMP		2

Fuel System

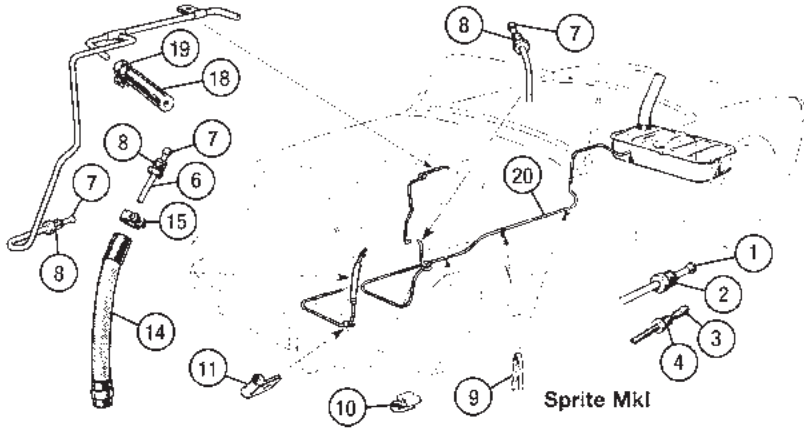

Sprite MkI

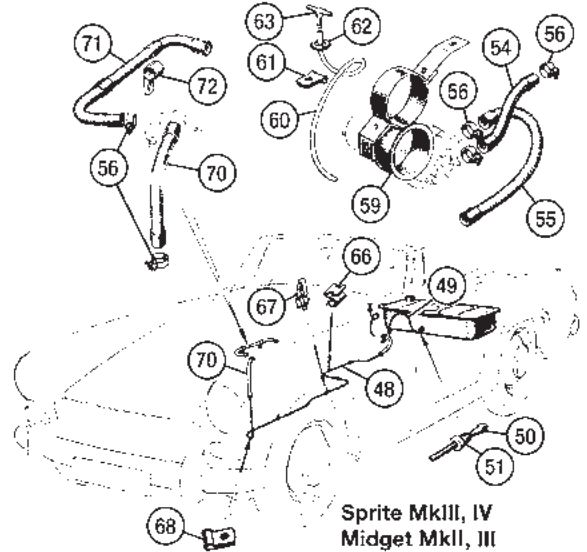

Sprite MkIII, IV
Midget MkII, III

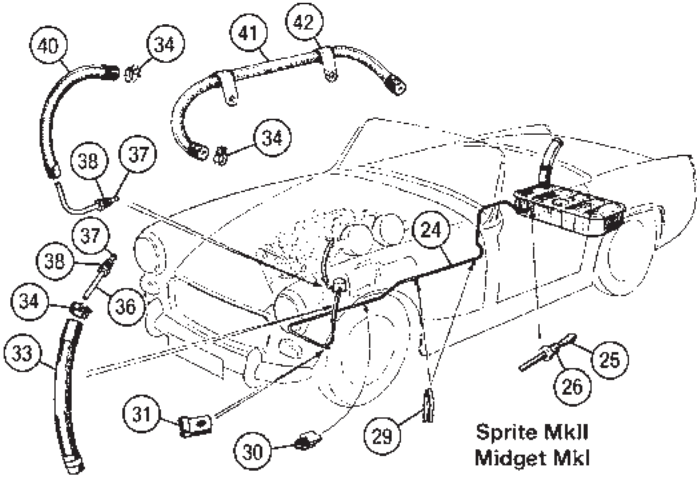

Sprite MkII
Midget MkI

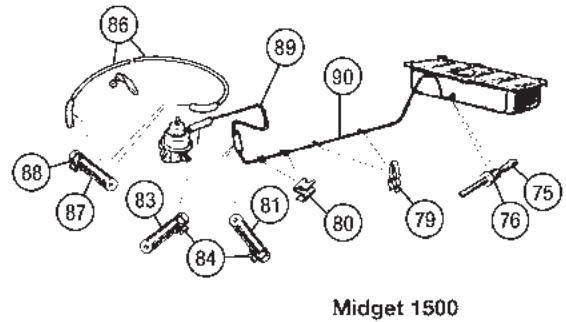

Midget 1500

Fuel System

11974

No.	Part#	Price (Each)	Description	Application	Qty Req.
Sprite MkI ("Bugeye")					
1	376-565	\$0.59	COMPRESSION SLEEVE, pipe to tank	Sprite MkI to (c)41015	1
2	376-575	\$6.89	TUBE NUT, pipe to tank		1
3	376-570	\$6.99	NIPPLE, pipe to tank	Sprite MkI from (c)41016	1
4	376-572	\$10.49	TUBE NUT, pipe to tank		1
6	376-783*	\$31.99	PIPE, hose to pump*		1
7	376-565	\$0.59	COMPRESSION SLEEVE, pipes to pump		2
8	376-575	\$6.89	TUBE NUT, pipes to pump		2
9	582-925	\$1.39	CLIP, fuel pipe to body		2
10	162-356	\$0.99	CLIP, fuel pipe to body		3
11	162-220	\$0.99	CLIP, fuel pipe to engine mount bracket		1
14	376-915	\$10.99	HOSE, pump inlet	Sprite MkI from (c)41016	1
15	117-015	\$2.29	HOSE CLAMP		2
18	379-205	\$0.99	HOSE, pipe to carb		2
19	326-310	\$2.49	HOSE CLAMP		4
20	376-784*	\$79.99	PIPE, tank to pump*	Sprite MkI to (c)41015	1
	376-782*	\$79.99	PIPE, tank to pump*	Sprite MkI from (c)41016	1
Sprite MkII, Midget MkI					
24	376-782*	\$79.99	PIPE, main*		1
25	376-570	\$6.99	NIPPLE, pipe to tank		1
26	376-572	\$10.49	TUBE NUT, pipe to tank		1
29	582-925	\$1.39	CLIP, fuel pipe to body		2
30	162-356	\$0.99	CLIP, fuel pipe to body		3
31	162-220	\$0.99	CLIP, fuel pipe to engine mount bracket		1
33	376-915	\$10.99	HOSE, pump inlet		1
34	117-015	\$2.29	HOSE CLAMP		6
36	376-783*	\$31.99	PIPE, hose to pump*		1
37	376-565	\$0.59	COMPRESSION SLEEVE, pipes to pump		2
38	376-575	\$6.89	TUBE NUT, pipes to pump		2
40	376-885	\$11.99	HOSE, pump to carb		1
41	376-945	\$13.99	HOSE, carb to carb		1
	376-920	\$18.99	HOSE, carb to carb, replacement		1
42	162-355	\$8.49	SUPPORT, hose		2

*Pipes include required Compression Sleeve(s) and Tube Nut(s)

No.	Part#	Price (Each)	Description	Application	Qty Req.
Sprite MkIII, IV; Midget MkII, III					
48	376-786	\$74.99	PIPE, main		1
49	376-781	\$51.99	PIPE, tank to pump		1
50	376-570	\$6.99	NIPPLE, pipe to tank		1
51	376-572	\$10.49	TUBE NUT, pipe to tank		1
54	376-915	\$10.99	HOSE, pump inlet		1
55	376-880	\$9.99	HOSE, pump outlet		1
56	117-015	\$2.29	HOSE CLAMP		8
59	377-360	\$2.19	GROMMET, fuel pump mount		1
60	361-220	\$0.99	VENT LINE, fuel pump	(sold per foot)	2
61	162-210	\$1.39	P-CLIP, vent line		1
62	281-050	\$5.99	GROMMET		1
63			NA T-FITTING		1
66	162-356	\$0.99	CLIP, fuel pipe to body		3
67	582-925	\$1.39	CLIP, fuel pipe to body		2
68	162-220	\$0.99	CLIP, fuel pipe to engine mount bracket		1
70	376-885	\$11.99	HOSE, pipe to carb		1
71	376-945	\$13.99	HOSE, carb to carb		1
	376-920	\$18.99	HOSE, carb to carb, replacement		1
72	162-355	\$8.49	SUPPORT, hose		2
Midget 1500					
75	376-570	\$6.99	NIPPLE, pipe to tank		1
76	376-572	\$10.49	TUBE NUT, pipe to tank		1
79	582-925	\$1.39	CLIP, fuel pipe to body		2
80	162-356	\$0.99	CLIP, fuel pipe to body		2
81	379-210	\$1.89	HOSE, pipe connecting		1
83	379-205	\$0.99	HOSE, pipe to pump		1
84	326-310†	\$2.49	HOSE CLAMP		4
86	589-300		NA PIPE, pump to carb		1
87	379-250	\$1.49	CONNECTOR, pipe to pump & carb		2
88	051-191†	\$2.59	HOSE CLAMP		4
89	376-788	\$27.99	PIPE, flex to pump		1
90	376-787	\$64.99	PIPE, tank to flex		1

†Original 1500 hose clamps were barrel type, and do not fit replacement hoses.

Band type replacement clamps are listed here.

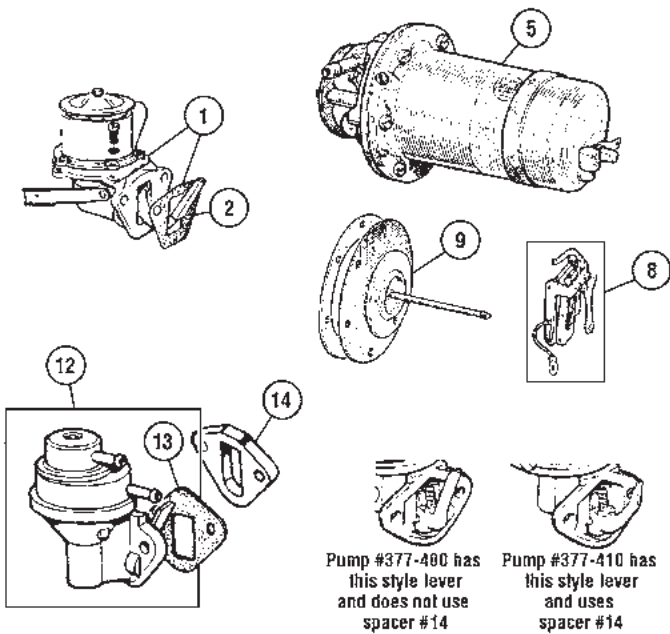

Pump #377-400 has this style lever and does not use spacer #14
 Pump #377-410 has this style lever and uses spacer #14

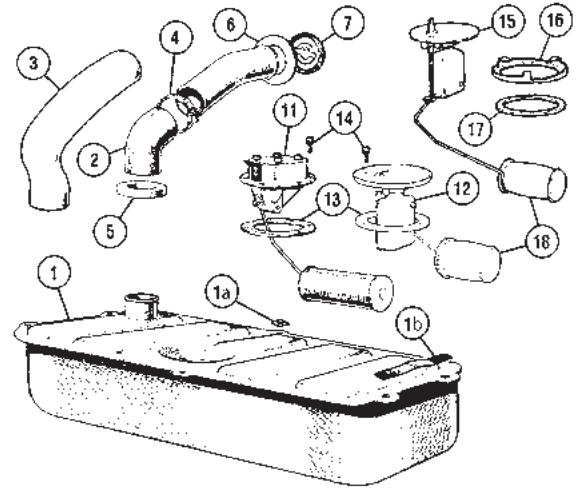

Fuel Pump

11976

No.	Part#	Price (Each)	Description	Application	Qty Req.
1	377-390	\$46.99	FUEL PUMP, mechanical	948, 1098 (10CG)	1
	377-395	NA	REBUILD KIT, fuel pump		1
2	296-220	\$0.69	GASKET, fuel pump		1
5	377-175	\$349.99	FUEL PUMP, original SU	1098 (10CC) & 1275	1
	377-176	\$139.99	FUEL PUMP, plastic replacement		1
8	377-080	\$34.99	POINT SET		1
9	377-130	\$89.99	DIAPHRAGM, 2 3/8" shaft		1
	377-140	\$64.99	DIAPHRAGM, 2 15/16" shaft		1
12	377-400	\$23.99	FUEL PUMP, mechanical, does not use spacer	1500 thru 1977	1
	377-410	\$25.99	FUEL PUMP, mechanical, requires spacer block		1
This pump must be used with the spacer no. 14 below.					
	377-405	NA	REBUILD KIT, fuel pump	all 1500	1
13	697-125	\$0.89	GASKET		1/2
14	377-415	\$15.99	SPACER (used without gaskets)	1500, 1978 on	1

Facet Solid State Electric Fuel Pump

Solid State electronic fuel pumps can be used in conjunction with, or in place of your original pump. This solid state pump will push or pull fuel, from a hidden location under the car, through your original pump. It may be put it in-line with a power switch and used as a backup. Works on positive or negative ground cars.



377-420 \$109.99

Facet Fuel Filter

74 micron filter is recommended for use on the inlet port of the Facet pump above. Filter screws directly into the inlet port.

377-424 \$12.99



Ethanol Resistant Fuel Hose

Gates "Barricade" hose is the lowest permeation multi-fuel compatible hose on the market. Rated for 50 psi at -40 to 257 degrees F, and compatible with all gasoline blends. Sold per inch.

1/4" ID hose 379-214 \$0.69 per inch
 5/16" ID hose 434-451 \$0.69 per inch



Fuel Tank

11975

No.	Part#	Price (Each)	Description	Application	Qty Req.
<u>Underlined part numbers</u> indicate an Oversize Parts Fee will be charged. See mossmotors.com or call for details.					
1	<u>471-189*</u>	\$214.99	FUEL TANK (detachable filler neck)	Bugeye	1
	<u>471-231*</u>	\$199.99	FUEL TANK	non-Bugeye thru 1969	1
	<u>471-241*</u>	\$199.99	FUEL TANK, evaporative loss control	1970 - '71	1
	<u>471-251*</u>	\$199.99	FUEL TANK	1972 on	1
*Classic Gold brand					
1a	280-106	\$1.69	WASHER, rubber, fuel tank mount	thru 1969	2
1b	280-107	\$4.19	STRIP, rubber, fuel tank mount		2
2	282-945	\$24.99	HOSE, filler to tank	thru 1275 (not Bugeye)	1
	282-920	\$37.99	HOSE, filler to tank (as illus)	1500 (as fitted)	1
3	282-946	\$49.99	HOSE, filler to tank (long S-shaped)		1
4	326-460	\$2.69	CLAMP, filler hose		2
5	282-930	\$1.59	SEAL, tank to trunk floor		1
6	280-105	\$4.99	GROMMET, filler neck		1
7	202-750	\$17.99	GAS CAP	thru 1969	1
	202-755	\$18.99	GAS CAP	{ 1970 on, except CA 1500	1
	202-765	\$24.99	GAS CAP	{ CA 1500 (c) 160160 to 166300	1
	202-755	\$18.99	GAS CAP	{ CA 1500 from (c)166301	1
11	361-881	\$39.99	SENDING UNIT (thru 1967) (w/ plastic float no. 18)	{ Bugeye, MG to (c)60459, AH MkII - MkIV to (c)72039	1
12	361-890	\$45.99	SENDING UNIT (1968-'71)	{ MG from (c)60460 105500, AH from HAN9-72040 on	1
13	293-415	\$0.49	GASKET, cork	all through 1971	1
	293-401	\$4.99	GASKET, ethanol-proof (incl. cover gasket for 361-880)		1
14	323-030	\$0.29	SCREW, sending unit to tank		6
15	361-900	\$39.99	SENDING UNIT	MG 1972 on	1
16	360-665	\$1.49	RING, locking		1
17	293-410	\$3.99	RING, sealing, Viton		1
18	360-645	\$8.99	FLOAT, plastic	orig. units 1968-'80 & Moss 361-880	1
	360-646	\$17.99	FLOAT, brass, replacement		1

Locking Gas Cap

Our chrome locking fuel filler caps are similar to originals, but with an important extra feature. With fuel prices as high as they are, a locking gas cap is inexpensive insurance against thieves. Supplied complete with two keys.

202-760 \$54.99

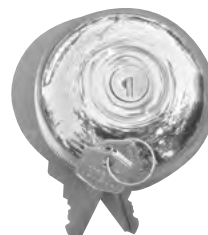

Manifolds and Heatshields 948 - 1098

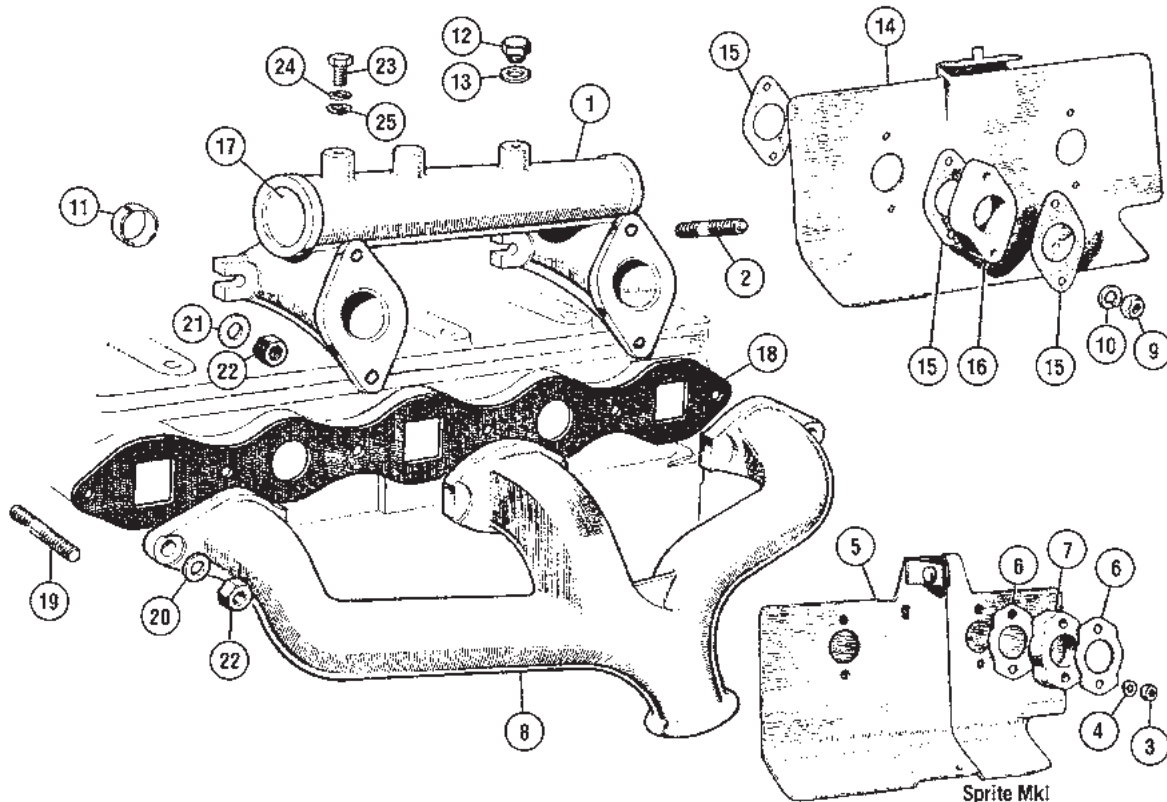

Manifolds and Heatshields 948 - 1098

11981

No.	Part#	Price (Each)	Description	Application	Qty Req.
Sprite MkI (948 9C engine)					
1			NA INLET MANIFOLD, (for 1-1/8" carbs)		1
2	328-766	\$6.29	STUD, carb to manifold		4
3	310-760	\$0.59	NUT		4
4	324-020	\$0.20	WASHER, spring		4
5	444-364	\$78.99	HEAT SHIELD		1
6	295-015	\$0.89	GASKET		6
7			NA SPACER		2
8			NA EXHAUST MANIFOLD		1

Sprite MkII & Midget MkI (948 9CG & 1098 10CG engines)

1	444-363	\$549.99	INLET MANIFOLD, (for 1-1/4" carbs)		1
2	328-767	\$3.79	STUD, carb to manifold		4
8			NA EXHAUST MANIFOLD		1
9	310-070	\$0.39	NUT, thin		4
10	324-860	\$0.19	WASHER, flat		4
11	372-371	\$12.99	RING, locating	from 10CG/DA/H18628	2
12	379-362	\$9.59	PLUG, blanking		1
13	324-145	\$0.39	WASHER, sealing		1
14	372-430	\$29.99	HEAT SHIELD		1
15	294-500	\$0.99	GASKET		6
16	372-375	\$31.99	SPACER		2

Sprite MkIII & Midget MkII (1098 10CC engines)

1	444-363	\$549.99	INLET MANIFOLD, (for 1-1/4" carbs)		1
2	328-767	\$3.79	STUD, carb to manifold		4
8	444-185	\$329.99	EXHAUST MANIFOLD		1
9	310-070	\$0.39	NUT, thin		4
10	324-860	\$0.19	WASHER, flat		4
11	372-371	\$12.99	RING, locating		2
12	379-362	\$9.59	PLUG, blanking		1
13	324-145	\$0.39	WASHER, sealing		1
14	372-430	\$29.99	HEAT SHIELD		1
15	294-500	\$0.99	GASKET		6
16	372-375	\$31.99	SPACER		2

No.	Part#	Price (Each)	Description	Application	Qty Req.
All 948, 1098					
17	319-095	\$1.89	CORE PLUG	to 9CG DAH 3169	2
	444-362	\$1.89	CORE PLUG	from 9CG DAH 3170	2
18	296-630	\$2.29	GASKET, manifold to head		1
19	328-664	\$1.99	STUD, manifolds to head		6
20	365-720	\$0.79	WASHER, flat	for outer studs	2
21	324-365	\$1.19	WASHER, special	for inner studs	4
22	311-540	\$0.79	NUT, brass		6
23	310-489	\$0.19	SCREW		2
24	324-020	\$0.20	WASHER, spring		2
25	324-590	\$0.19	WASHER, flat		2

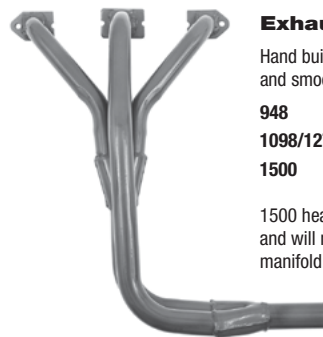

Exhaust Headers

Hand built to obtain maximum power, full bore bends and smooth pipe junctions mark these quality headers.

948	452-060	\$439.99
1098/1275 (illus.)	452-065	\$459.99
1500	452-070	\$569.99

1500 header is for use with carburetor conversions, and will not fit with the stock Zenith-Stromberg intake manifold.

Manifolds and Heatshields 1275 - 1500

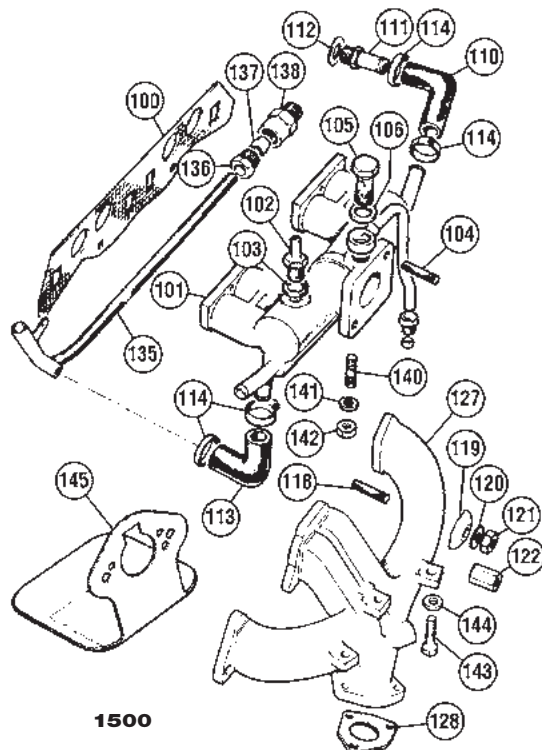
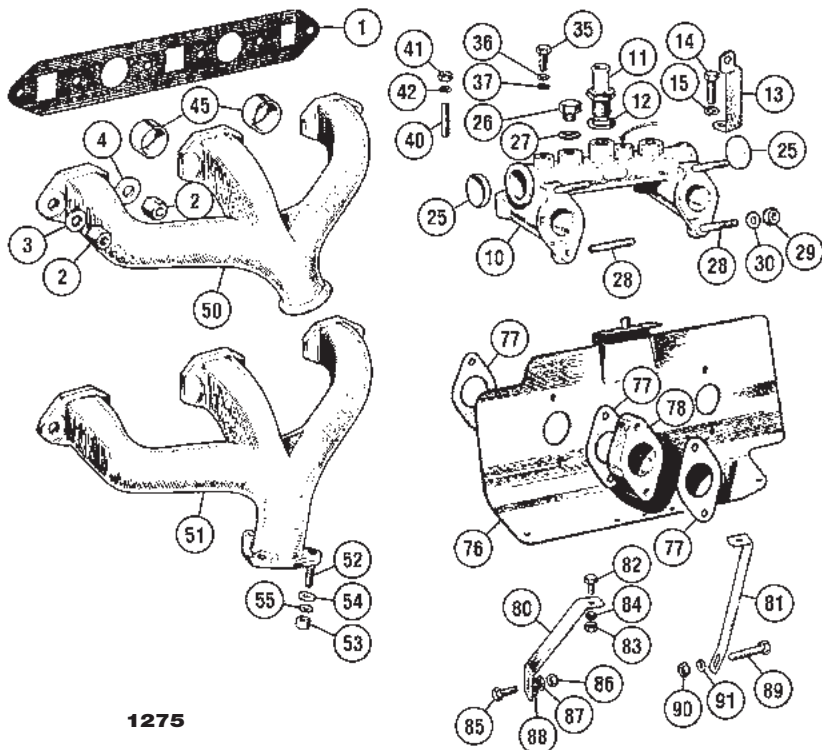

1275

1500

Manifolds & Heatshields, 1275

11983

No.	Part#	Price (Each)	Description	Application	Qty Req.
1	296-630	\$2.29	GASKET, manifolds		1
2	311-540	\$0.79	NUT, brass, manifold to head		6
3	365-720	\$0.79	WASHER, plain, exhaust manifold to head		2
4	324-365	\$1.19	WASHER, manifolds to head		4
10	444-363	\$549.99	MANIFOLD, inlet		1
11	372-470	\$14.99	ADAPTOR, PCV valve		1
12	324-145	\$0.39	WASHER, sealing		1
13			NA BRACKET, PCV valve		1
14	322-645	\$0.49	SCREW, bracket to manifold		1
15	324-020	\$0.20	WASHER, locking		1
25	444-362	\$1.89	CORE PLUG		2
26	379-362	\$9.59	PLUG, threaded		1
27	324-195	\$1.49	WASHER, sealing		1
28	328-767	\$3.79	STUD, carburetor mounting		4
29	310-050	\$0.69	NUT		4
30	324-040	\$0.39	WASHER, locking		4
35	310-489	\$0.19	SCREW, clip to inlet manifold		1
36	324-020	\$0.20	WASHER, locking		1
37	324-590	\$0.19	WASHER, plain		1
40			NA STUD		1
41	310-760	\$0.59	NUT		1
42	324-020	\$0.20	WASHER, locking		1
45	372-371	\$12.99	SLEEVE, inlet manifold to head		2
50	444-185	\$329.99	MANIFOLD, exhaust	clamp type	1
51			NA MANIFOLD, exhaust	flange type	1
52	328-765	\$2.59	STUD, exhaust manifold to down pipe		3
53	311-540	\$0.79	NUT, brass		3
54	324-365	\$1.19	WASHER, plain		3
55	365-730	\$0.39	WASHER, locking		3
76			NA HEATSHIELD, carburetors	up to Dec. 1967	1
	372-430	\$29.99	HEATSHIELD, carburetors	from Dec. 1967	1
77	294-500	\$0.99	GASKET*		6
78	372-375	\$31.99	INSULATING BLOCK		2
80	411-342	\$14.79	BRACKET, heatshield, front		1
81	411-341	\$14.79	BRACKET, heatshield, rear		1
82	322-645	\$0.49	BOLT, bracket to heatshield	} approx. Dec 1967 on	2
83	310-760	\$0.59	NUT		2
84	324-020	\$0.20	WASHER, locking		2
85	314-265	\$0.59	BOLT, bracket to timing cover		1

*Manifold to heatshield, heatshield to insulating block & insulating block to carburetor.

No.	Part#	Price (Each)	Description	Application	Qty Req.
86	310-760	\$0.59	NUT		1
87	324-020	\$0.20	WASHER, locking		1
88	324-590	\$0.19	WASHER, plain	} approx. Dec 1967 on	1
89	322-105	\$1.59	BOLT, bracket to engine back plate		1
90	310-290	\$1.19	NUT, nyloc		1
91	365-720	\$0.79	WASHER, plain		1

Manifolds & Heatshield, 1500

11984

No.	Part#	Price (Each)	Description	Application	Qty Req.
100	694-120	\$13.99	GASKET, manifold, Payen brand		1
101			NA MANIFOLD, inlet	1975-'76	1
			NA MANIFOLD, inlet	1977-'80	1
102			NA ADAPTER		1
103	324-065	\$1.49	WASHER, fiber		1
104	328-660	\$1.99	STUD, carburetor		2
105			NA BOLT, banjo	} 1975-'76	1
106			NA WASHER		2
110	834-550		NA HOSE, manifold to thermo. housing		1
111	379-680	\$9.99	ADAPTOR to thermo. housing		1
112	370-650	\$0.39	WASHER		1
113	834-550		NA HOSE, pipe to manifold	1975-'76	1
	834-555	\$5.29	HOSE, pipe to manifold	1977-'80	1
114	326-250	\$1.39	HOSE CLAMP		4
118	328-650	\$4.49	STUD, manifolds to head (1-7/8")		6
	328-660	\$1.99	STUD, exhaust manifold to head (1-3/8")		2
119	812-025	\$5.79	CLAMP, long		2
	812-010	\$9.99	CLAMP, short		4
120	324-310	\$0.49	WASHER, plain		8
121	310-260	\$1.19	NUT		6
122	310-275	\$4.79	NUT, long		2
127	444-375		NA MANIFOLD, exhaust	1975-'76	1
	444-380		NA MANIFOLD, exhaust	1977-'80	1
128	296-690	\$6.89	GASKET, manifold to pipe		1
135	865-115	\$42.99	PIPE, water pump to inlet manifold rear		1
136	635-150	\$3.99	NUT		1
137	635-160	\$1.59	COMPRESSION SLEEVE		1
138	635-170	\$14.99	ADAPTOR to water pump		1
140	328-997	\$1.99	STUD, inlet to exhaust manifold	} 1975-'76	1
141	365-730	\$0.39	WASHER, locking		1
142	310-140	\$0.39	NUT		2
143			NA BOLT, exhaust to inlet manifold		1
144			NA WASHER, plain		2
145	375-480		NA HEAT SHIELD	1	

Toll-Free Orders 1-800-667-7872 | MossMotors.com
 Fax 805-692-2525 | Local 805-681-3400



Exhaust System 948-1098 (10CG)

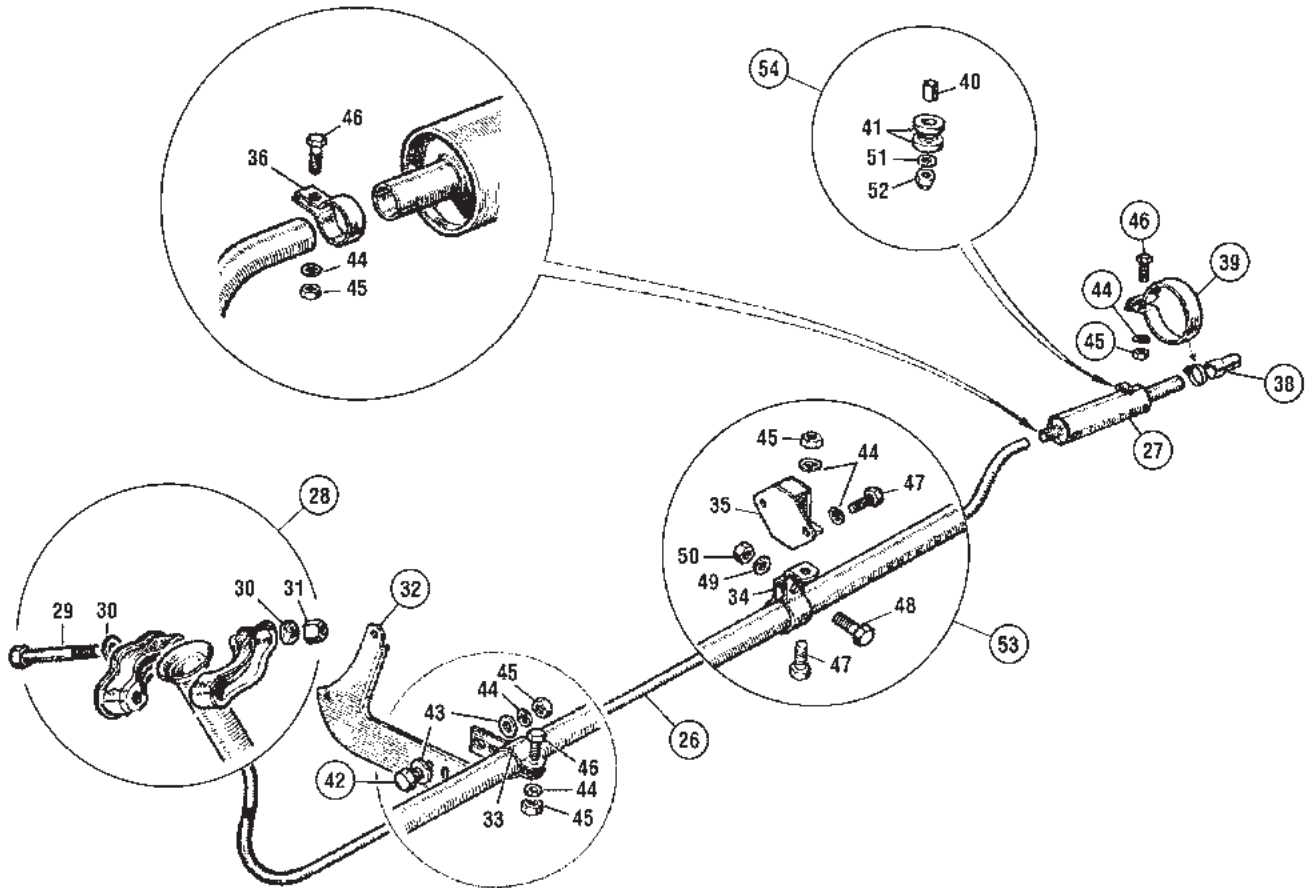

Exhaust System 948-1098 (10CG)

11985

No.	Part#	Price (Each)	Description	Application	Qty Req.
26	<u>444-220</u>	\$139.99	FRONT PIPE, mild steel		1
27	444-250	\$89.99	MUFFLER, mild steel		1
28	444-200	\$6.49	CLAMP ASSEMBLY, pipe to manifold		1
32	444-369	\$84.99	BRACKET, gearbox steady		1
33	444-366	\$10.99	BRACKET, front pipe to steady bracket		1
34	444-367	\$10.99	BRACKET, front pipe support		1
35	614-008	\$6.99	MOUNT, Exhaust		1
36	444-365		NA CLAMP, rear, original type		1
	444-385	\$2.49	CLAMP, rear, replacement 'U' bolt type		1
38	444-401		NA EXTENSION PIPE, (tail pipe)		1
39			NA CLAMP, (for tail pipe extension)		1
40	444-091	\$2.89	SPACER		1
41	444-280	\$1.19	BUSH, rubber		2
42	322-040	\$0.59	BOLT (5/16")		2
43	365-720	\$0.79	WASHER (5/16")		4
44	365-730	\$0.39	WASHER, spring (5/16")		8
45	310-140	\$0.39	NUT (5/16")		8
46	322-290	\$0.89	BOLT (5/16")		3
47	322-880	\$0.99	BOLT (5/16")		3
48	314-265	\$0.59	BOLT (1/4")		1
49	324-020	\$0.20	WASHER, spring (1/4")		1
50	310-760	\$0.59	NUT (1/4")		1
51	324-155	\$0.59	WASHER, flat (5/16")		1
52	311-005	\$1.19	NUT (5/16")		1
53	444-202	\$23.99	MOUNTING KIT, center		1
54	444-201	\$5.79	MOUNTING KIT, rear		1

Underlined part numbers indicate an Oversize Parts Fee will be charged. See mossmotors.com or call for details.

Stainless Steel Exhaust System

Guaranteed to be the last exhaust system you'll need for your car. Constructed entirely of top quality stainless steel with proper fit and great sound. Includes everything you need from the manifold flange back except clamps and hangers.

948 & 10CG engines

452-000

\$329.99



The exhaust system will last longer and won't rattle when installed with the proper hangers and hardware. The front brackets are especially important to the longevity of the clamp joint.

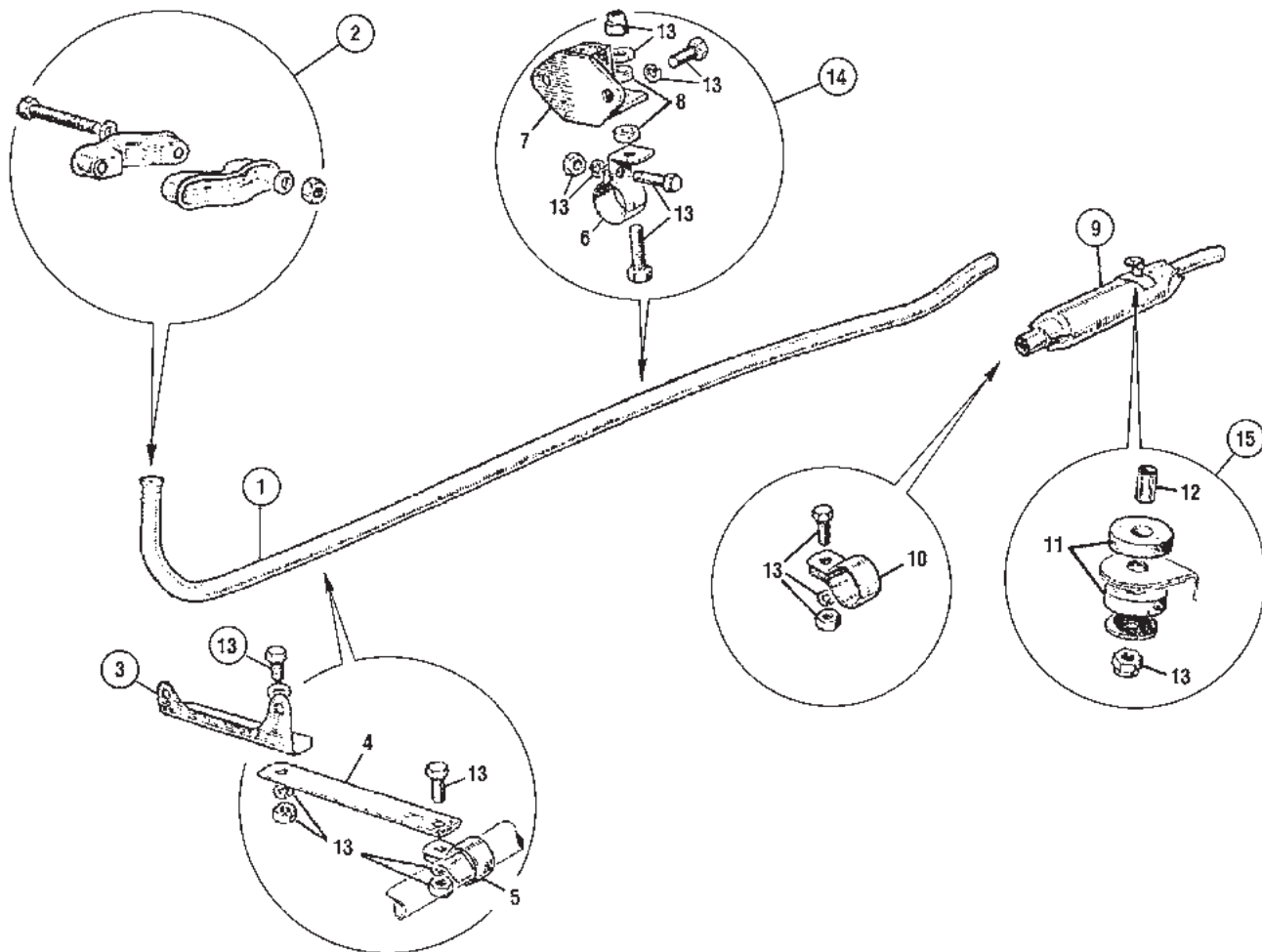

Stainless Steel Exhaust System

Guaranteed to be the last exhaust system you'll need for your car. Constructed entirely of top quality stainless steel with proper fit and great sound. Includes everything you need from the manifold flange back except clamps and hangers.

10CC & early 1275 engines **452-010** **\$349.99**



Exhaust System 1098 (10CC) - 1275

11987

No.	Part#	Price (Each)	Description	Application	Qty Req.
1	<u>444-230</u>	\$119.99	FRONT PIPE, mild steel		1
2	444-210	\$5.39	CLAMP ASSEMBLY, front pipe to manifold		1
3	444-340	\$16.99	BRACKET, gearbox		1
4	444-350	\$6.99	STRAP, front pipe to gearbox		1
5	444-360	\$5.99	CLIP, front pipe to strap		1
6	444-390	\$10.99	CLIP, intermediate		1
7	614-008	\$6.99	MOUNTING, intermediate pipe		1
8	444-090	\$1.49	WASHER/INSULATOR	fits each side of 614-008	2
9	444-260	\$82.99	MUFFLER, mild steel (replacement type with rounded ends)		1
10	411-090	\$14.99	CLIP, front pipe to silencer		1
11	444-280	\$1.19	BUSH, rubber		2
12	444-091	\$2.89	SPACER		1
13	444-208	\$5.49	HARDWARE SET, exhaust mounting (all bolts, nuts and lockwashers for hangers and straps)		1
14	444-203	\$24.99	MOUNTING KIT, center		1
15	444-201	\$5.79	MOUNTING KIT, rear		1

Underlined part numbers indicate an Oversize Parts Fee will be charged. See mossmotors.com or call for details.

The exhaust system will last longer and won't rattle when installed with the proper hangers and hardware. The front brackets are especially important to the longevity of the clamp joint.

Exhaust System 1275 - 1500

1275 1968-1969

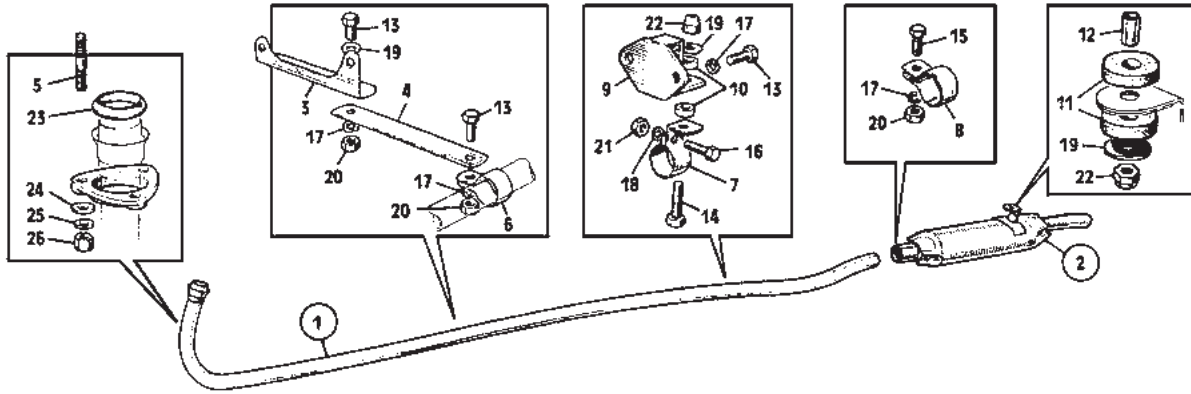

1275 1970-1974

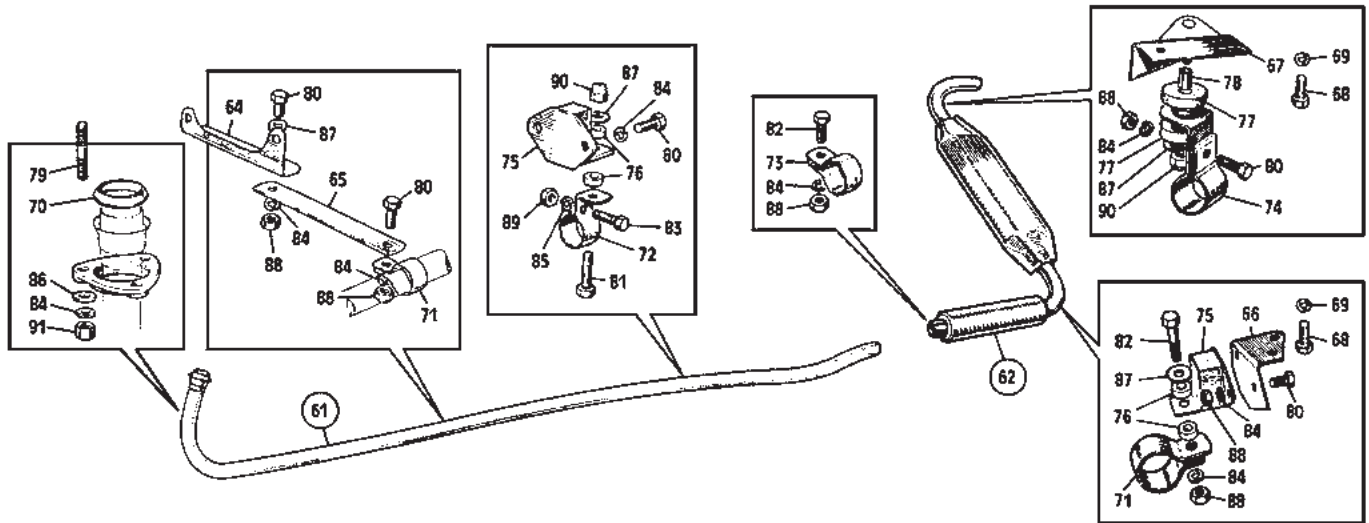

1500 1975-1980

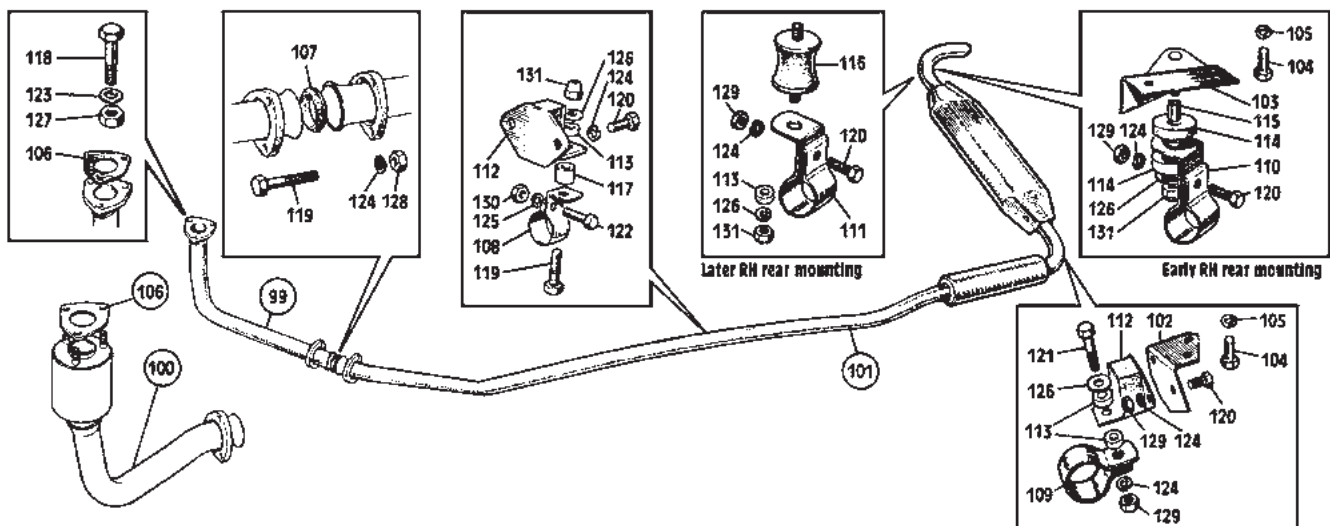

Exhaust System 1275 - 1500

Exhaust System 1275 - 1500

11988

No.	Part#	Price (Each)	Description	Application	Qty Req.
1275 1968-1969					
North American LHD Specification, 1968-1969					
<u>Underlined part numbers</u> indicate an Oversize Parts Fee will be charged. See mossmotors.com or call for details.					
1	<u>444-240</u>	\$79.99	FRONT PIPE, mild steel		1
2	444-260	\$82.99	MUFFLER, mild steel		1
3	444-340	\$16.99	BRACKET, gearbox		1
4	444-350	\$6.99	STRAP, bracket to front pipe		1
5	328-765	\$2.59	STUD, manifold		3
6	444-360	\$5.99	CLAMP, front pipe to strap		1
7	444-390	\$10.99	CLAMP, intermediate mounting		1
8	411-090	\$14.99	CLAMP, system joint		1
9	614-008	\$6.99	MOUNTING, intermediate		1
10	444-090	\$1.49	WASHER, insulation		2
11	444-280	\$1.19	BUSH, rubber		2
12	444-091	\$2.89	DISTANCE TUBE		1
13	322-540	\$0.79	BOLT (5/16" UNF x 7/8")		4
14	191-915	\$1.39	BOLT (5/16" UNF x 1-1/4")		1
15	310-487	\$0.99	BOLT (5/16" UNF x 1-1/2")		1
16	314-265	\$0.59	BOLT (1/4" UNF x 7/8")		1
17	365-720	\$0.79	WASHER, locking (5/16")		5
18	324-020	\$0.20	WASHER, locking (1/4")		1
19	324-155	\$0.59	WASHER, plain (5/16")		3
20	310-140	\$0.39	NUT (5/16" UNF)		3
21	310-760	\$0.59	NUT (1/4" UNF)		1
22	310-290	\$1.19	NUT (5/16" UNF)		2
23	290-510	\$3.99	SEALING RING, front pipe to manifold		1
24	324-365	\$1.19	WASHER, special, manifold stud		3
25	365-730	\$0.39	WASHER, locking (5/16")		3
26	311-540	\$0.79	NUT, brass		3

1275 1970-1974

North American LHD Specification, 1970-1974

This transverse muffler system uses a three stud flanged manifold joint on the front pipe.

Underlined part numbers indicate an Oversize Parts Fee will be charged. See mossmotors.com or call for details.

61	<u>444-240</u>	\$79.99	FRONT PIPE, mild steel		1
62	<u>444-270</u>	\$199.99	MUFFLER ASS'Y & TAILPIPE, mild steel		1
64	444-340	\$16.99	BRACKET, gearbox		1
65	444-350	\$6.99	STRAP, bracket to front pipe		1
66	444-373	\$16.99	BRACKET, LH	thru (c)138800	1
	444-371	\$9.99	BRACKET, LH	from (c)138801 (1974)	1
67	444-374	\$29.99	BRACKET, RH	thru (c)138800	1
	444-372	\$29.99	BRACKET, RH	from (c)138801 (1974)	1
68	322-880	\$0.99	SCREW, brackets to trunk floor		4
69	365-730	\$0.39	WASHER, locking		4
70	290-510	\$3.99	SEALING RING, front pipe to manifold		1
71	444-360	\$5.99	CLAMP, pipe to strap, LH rear mtg.		2
72	444-390	\$10.99	CLAMP, intermediate		1
73	411-090	\$14.99	CLAMP, system joint		1
74	444-400	\$10.99	CLAMP, pipe to RH rear mounting		1
75	614-008	\$6.99	MOUNTING, intermediate LH rear		2
76	444-090	\$1.49	WASHER, insulation		4
77	444-280	\$1.19	BUSH, rubber		2
78	444-091	\$2.89	DISTANCE TUBE		1
79	328-765	\$2.59	STUD, manifold		3
80	322-540	\$0.79	BOLT (5/16" UNF x 7/8")		7
81	191-915	\$1.39	BOLT (5/16" UNF x 1-1/4")		1
82	310-487	\$0.99	BOLT (5/16" UNF x 1-1/2")		2
83	314-265	\$0.59	BOLT (1/4" UNF x 7/8")		1
84	365-730	\$0.39	WASHER, locking (5/16")		12
85	324-020	\$0.20	WASHER, locking (1/4")		1
86	324-365	\$1.19	WASHER, special, manifold stud		3
87	324-155	\$0.59	WASHER, plain (5/16")		4
88	310-140	\$0.39	NUT (5/16" UNF)		7
89	310-760	\$0.59	NUT (1/4" UNF)		1
90	310-290	\$1.19	NUT, nyloc (5/16" UNF)		2
91	311-540	\$0.79	NUT, brass		3

No.	Part#	Price (Each)	Description	Application	Qty Req.
1500 1975-1980					
<u>Underlined part numbers</u> indicate an Oversize Parts Fee will be charged. See mossmotors.com or call for details.					
99	444-290	\$68.79	DOWN PIPE, mild steel	cars w/o Cat. Converter	1
100	444-310	\$329.99	DOWN PIPE, with converter	(not legal in California)	1
101	<u>444-315</u>	\$229.99	PIPE & MUFFLER ASSEMBLY, mild steel		1
			(2-piece assembly slips together)		
102	444-371	\$9.99	BRACKET, LH rear mtg. to trunk floor		1
103	444-372	\$29.99	BRACKET, RH rear mtg. to trunk floor		1
104	322-880	\$0.99	SCREW, bracket to trunk floor		4
105	365-730	\$0.39	WASHER, locking		4
106	296-690	\$6.89	GASKET, manifold to down pipe		1
107	444-130	\$3.69	GASKET, down pipe to rear pipe		1
108	444-390	\$10.99	CLAMP, intermediate mounting		1
109	444-360	\$5.99	CLAMP, pipe to LH rear mounting		1
110	444-400	\$10.99	CLAMP, pipe to RH rear mounting		1
111	310-261	\$10.99	CLAMP, pipe to RH rear mounting		1
112	614-008	\$6.99	MOUNTING, intermediate LH rear		2
113	444-090	\$1.49	WASHER, insulation		3
114	444-280	\$1.19	BUSH, rubber		2
115	444-091	\$2.89	DISTANCE TUBE		1
116	444-080	\$2.49	MOUNTING, RH, clamp to trunk floor		1
117	310-262	\$4.29	SPACER		1
118	322-075	\$1.09	BOLT (3/8" UNF x 1-1/2")		3
119	322-105	\$1.59	BOLT (5/16" UNF x 1-7/8")		4
120	322-540	\$0.79	BOLT (5/16" UNF x 3/4")		5
121	310-487	\$0.99	BOLT (5/16" UNF x 1-1/2")		1
122	314-265	\$0.59	BOLT (1/4" UNF x 7/8")		1
123	324-040	\$0.39	WASHER, locking (3/8")		3
124	365-730	\$0.39	WASHER, locking (5/16")		9
125	324-020	\$0.20	WASHER, locking (1/4")		1
126	324-155	\$0.59	WASHER, plain		3
127	328-651	\$0.99	NUT, special	manifold to down pipe	3
128	311-535	\$9.99	NUT, special	down pipe to exhaust	3
129	310-140	\$0.39	NUT (5/16" UNF)		4
130	310-760	\$0.59	NUT (1/4" UNF)		1
131	310-290	\$1.19	NUT, nyloc, (5/16" UNF)		2



Stainless Steel Exhaust System

This durable stainless steel performance exhaust system was designed specifically for the 1275 Midget using the highest quality materials and workmanship. It uses stock rubber mounts (614-008) and the stock manifold gasket (296-630), which are not included.

Midget 1275 452-016 \$679.99



1500 system illustrated.

Stainless Steel Exhaust System

Guaranteed to be the last exhaust system you'll need for your car. Constructed entirely of top quality stainless steel with proper fit and great sound. Includes everything you need from the manifold flange back except clamps and hangers.

Sprite/Midget mid 1275 ('68-'69 w/flanged headpipe/straight muffler) 452-016 \$679.99

Midget late 1275 ('70-'74 w/flanged headpipe/transverse muffler) 452-025 NA

(Not available. Earlier straight muffler system 452-015 may be used.)

Midget 1500 452-030 \$629.99

Toll-Free Orders 1-800-667-7872 | MossMotors.com
Fax 805-692-2525 | Local 805-681-3400

MOSS

Clutch

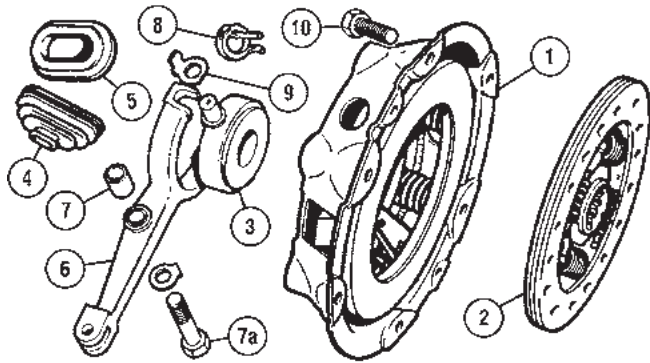

Clutch

11989

No.	Part#	Price (Each)	Description	Application	Qty Req.
948 - 1098 - 1275 Clutch					
	190-963	\$139.99	CLUTCH KIT, Premium aftermarket	948	1
	190-971	\$159.99	CLUTCH KIT, "Powertune"	1098	1
	190-976	\$139.99	CLUTCH KIT, aftermarket		1
	190-980	NA	CLUTCH KIT, AP brand	1275	1
	190-986	\$159.99	CLUTCH KIT, Premium aftermarket		1
1	190-830	NA	PRESSURE PLATE	948	1
	501-025	NA	PRESSURE PLATE, Borg & Beck	1098	1
	190-850	\$189.99	PRESSURE PLATE, AP brand	1275	1
2	190-870	\$79.99	CLUTCH DISC, AP brand	948, 6 1/4"	1
	190-880	\$76.99	CLUTCH DISC, AP brand	1098, 7 1/4"	1
	190-890	\$74.99	CLUTCH DISC, AP brand	1275, 6 1/2"	1
	190-891	NA	CLUTCH DISC, uprated (not in kits)		1
3	190-910	\$27.99	RELEASE BEARING	948	1
	190-915	\$21.99	RELEASE BEARING	1098	1
	190-920	\$28.69	RELEASE BEARING	1275	1
4	461-010	\$3.49	BOOT, clutch lever		1
5	461-870	\$6.99	COVER, dust	948, 1098 & 1275	1
6			NA LEVER, clutch release	948	1
	190-955	\$139.99	LEVER, clutch release	1098 & 1275	1
7	330-435	\$4.99	BUSH	all	1
7a	330-505	\$8.90	BOLT, clutch release fork	all	1
8	190-310	\$1.99	CLIP, release bearing	948	2
9	190-315	\$1.79	CLIP, release bearing	1098 & 1275	2
10	322-040	\$0.59	BOLT, clutch to flywheel	all	6
	324-030	\$0.29	LOCKWASHER for clutch bolt	all	6

NOTE: for early cars fitted with the later ribcase gearbox, use the release bearing appropriate for the engine actually used.



No.	Part#	Price (Each)	Description	Application	Qty Req.
	387-320	\$3.99	CLUTCH ALIGNMENT TOOL	948 - 1275	1
	387-330	\$3.99	CLUTCH ALIGNMENT TOOL	Midget 1500	1

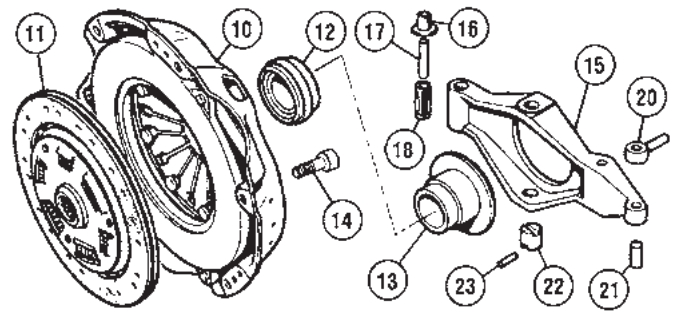

No.	Part#	Price (Each)	Description	Application	Qty Req.
1500 Clutch					
	190-990	\$189.99	CLUTCH KIT, AP brand		1
	190-993	\$149.99	CLUTCH KIT, aftermarket		1
10	190-860	\$139.99	PRESSURE PLATE, AP brand		1
11	190-900	\$89.99	CLUTCH DISC		1
12	190-925	\$34.99	RELEASE BEARING		1
13	190-945	NA	SLEEVE, release bearing		1
14	323-252	\$0.79	SETSCREW, clutch to flywheel (allen head)		6
15	190-950	NA	ARM		1
16	330-445	\$5.99	BUSH, in bell housing		2
17	190-930	\$3.29	RELEASE ARM PIN		1
18	330-455	\$11.69	RELEASE ARM BUSH		1
20	190-935	\$6.99	PUSH ROD		1
21	190-940	\$7.49	PIN, push rod to arm		1
22	328-625	\$18.99	PLUG, sleeve to arm		1
23	329-890	NA	PIN in plug		1



Clutch Hydraulic Kits

Save money and make ordering easy with this kit, which includes all usually replaced clutch hydraulic components: master cylinder, slave cylinder with pushrod, hose, copper washers and required hardware.

Sprite/Midget 1275	180-668	\$53.99
Midget 1500	180-708	\$72.99

Brake fluid and brake service tools are listed in the color section at the front of this catalog.

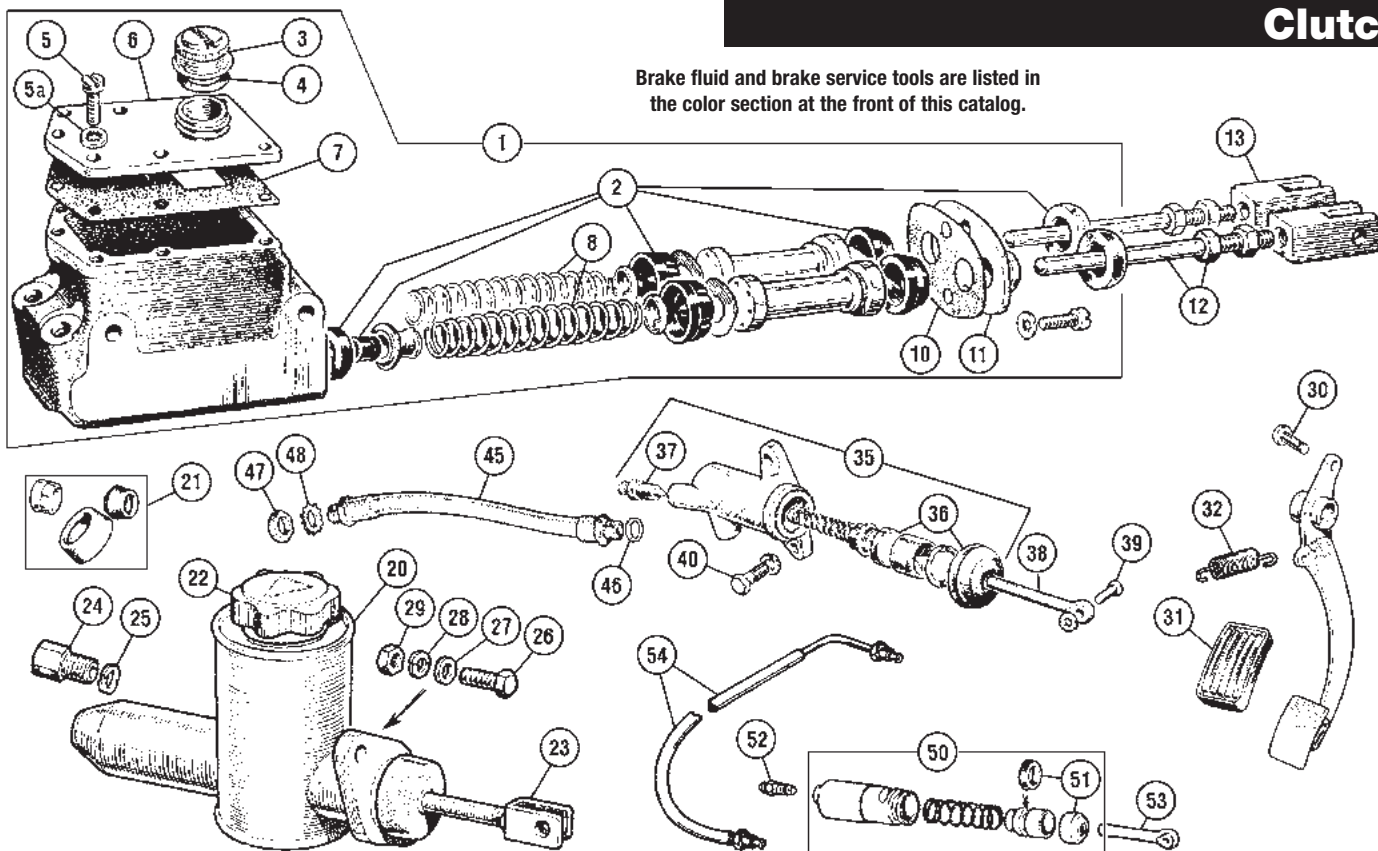

Clutch Hydraulics

11991

No.	Part#	Price (Each)	Description	Application	Qty Req.
1	180-672	\$329.99	MASTER CYLINDER, 7/8", AP Braking	} 948 drum brakes	1
	180-670	\$184.99	MASTER CYLINDER, 7/8", TRW		1
	180-673	\$79.99	MASTER CYLINDER, 7/8", Classic Gold		1
	180-555	\$215.99	MASTER CYLINDER, 3/4", TRW		1
	180-556	\$119.99	MASTER CYLINDER, 3/4", aftermarket		1
2	180-971	\$87.99	REPAIR KIT, 7/8", AP Braking	} 948	1
	180-970	\$11.99	REPAIR KIT, 7/8", aftermarket		1
	180-565	\$12.99	REPAIR KIT, 3/4", aftermarket		1
			These repair kits may include either a replacement type brake cylinder check valve, or the original type rubber cup for the original check valve.		
3	180-210	\$5.29	CAP, plastic replacement	} 948 & 1098	1
	180-211	\$14.99	CAP, metal (as original)		1
4	180-451	\$2.99	WASHER, cap (metal caps)		1
5	323-500	\$0.99	SCREW, front & top covers		9/7
5a	462-385	\$0.39	LOCKWASHER		9/7
6	180-275	\$12.99	COVER	} 948	1
7	180-270	\$1.79	GASKET		1
8	180-030	\$5.99	SPRING	} 1098	2
	181-710	NA	SPRING		2
10	180-020	\$1.49	GASKET	} 948 & 1098	1
11	180-010	NA	PLATE		1
12	180-305	\$12.39	PUSH ROD, drum brakes, 4-1/8" NA PUSH ROD, disc brakes, 3-1/16"		2
13	180-315	\$19.99	FORK	2	
20	180-624	\$229.99	MASTER CYLINDER, metal reservoir	} 1275 & 1500	1
	180-627	\$27.99	MASTER CYLINDER, plastic reservoir		1
21	180-925	\$6.99	REPAIR KIT, cyls. not marked†		1
	180-915	\$7.99	REPAIR KIT, cyls. marked-see illus. showing marks below†		1
22	180-210	\$5.29	CAP (orig. cyls. only)		1
23	180-605	\$28.99	PUSH ROD	1	
24	180-400	\$13.79	ADAPTOR, pipe to master cylinder	1	
25	324-730	\$0.69	WASHER, pipe to master cylinder	1	
26	322-540	\$0.79	BOLT, master cylinder mounting	2	
27	365-720	\$0.79	WASHER	2	
28	365-730	\$0.39	LOCKWASHER	2	
29	310-140	\$0.39	NUT	2	
30	325-150	\$1.29	CLEVIS PIN	all	
31	280-930	\$1.99	PEDAL PAD, brake & clutch	all	
32	180-335	\$2.99	SPRING, pedal return	948 & 1098	

No.	Part#	Price (Each)	Description	Application	Qty Req.
	329-350	\$2.29	SPRING, pedal return	1275 & 1500	2
35	180-655	\$86.99	SLAVE CYLINDER, 7/8" bore, Lockheed	} 948 & 1098	1
	180-657	\$12.99	SLAVE CYLINDER, 7/8" bore, aftermarket		1
	180-665	\$146.99	SLAVE CYLINDER, 1" bore, Lockheed		1
	180-667	\$13.49	SLAVE CYLINDER, 1" bore, aftermarket		1
36	180-935	\$4.99	REPAIR KIT	948 & 1098	1
	180-945	\$5.99	REPAIR KIT	1275	1
37	180-100	\$1.99	BLEEDER SCREW	948 & 1098	1
38	180-200	\$3.59	PUSH ROD, 2-3/8"	948 - 1098	1
	180-595	\$3.99	PUSH ROD, 2-11/16"	1275	1
39	582-590	\$1.19	CLEVIS PIN	} 948-1275	1
40	116-162	\$1.89	BOLT, slave cyl. mounting		2

NOTE: 948 and 1098 cars used a pipe from the master cylinder to the slave cylinder.

These cars did not use a hose in the clutch system.

	588-025	\$49.99	PIPE, master cyl. to slave cyl.	} 948 - 1098	1
	180-606	\$54.99	PIPE, master cylinder to hose		1
45	180-820	\$26.99	HOSE	} 1275	1
	180-821	\$8.99	HOSE, aftermarket		1
	180-823	\$26.99	HOSE, stainless steel braided (includes nut #47)		1
46	324-720	\$0.99	COPPER WASHER	1	
47	311-420	\$1.99	NUT	1	
48	324-180	\$0.49	LOCK WASHER	1	
50	180-705	\$13.49	SLAVE CYLINDER, Classic Gold	} 1500	1
51	180-955	\$9.99	REPAIR KIT		1
52	180-080	\$3.69	BLEEDER SCREW		1
53	190-935	\$6.99	PUSH ROD, 3-1/16"		1
54	180-845	\$28.99	HOSE & PIPE ASS'Y.		1

*Dimensions given are from hole center to end.

†From 1968 to '80, either one of two master cylinders was fitted. One is identified by either of the markings shown below. The other has no such markings. The master cylinder assemblies are interchangeable, but the internal parts are not.

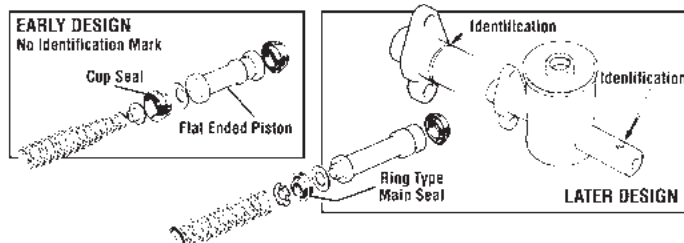

External Gearbox 948-1275

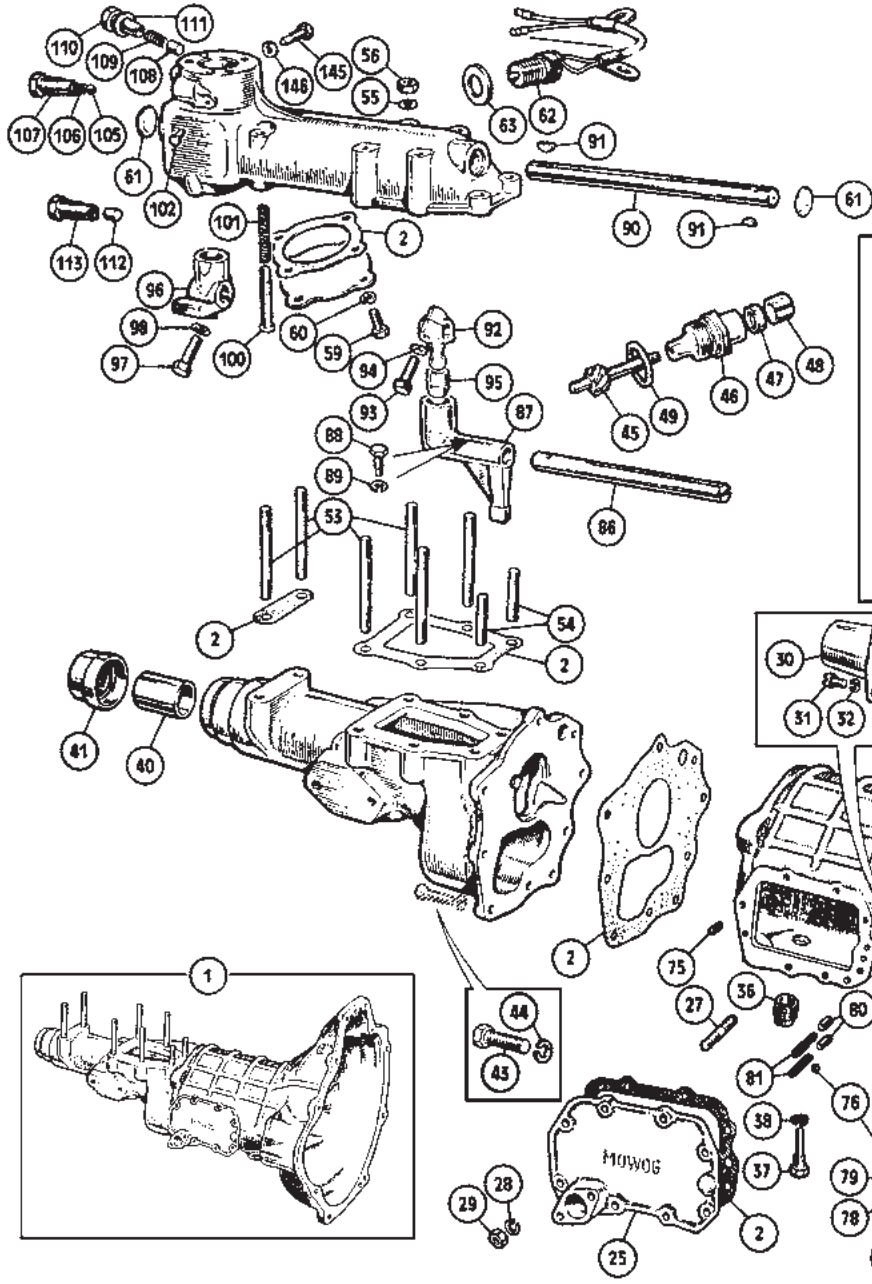
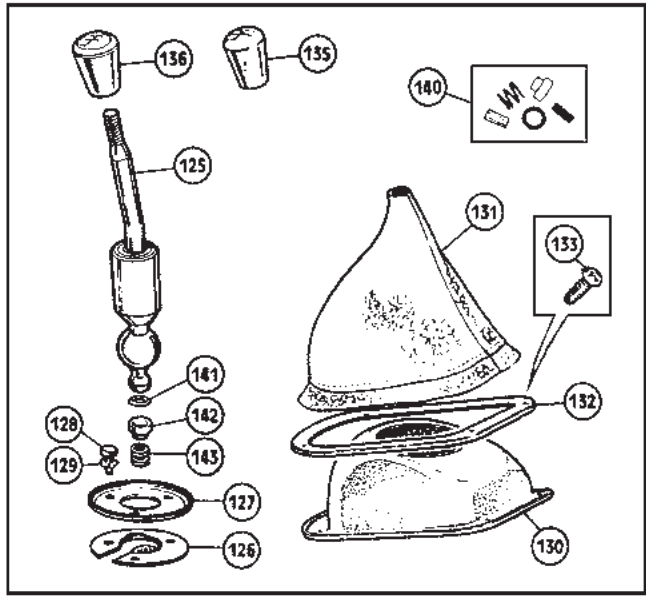
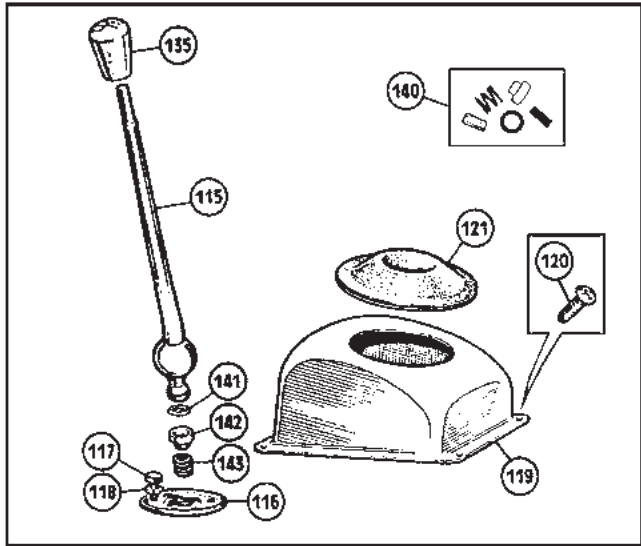

Gasket Set 2

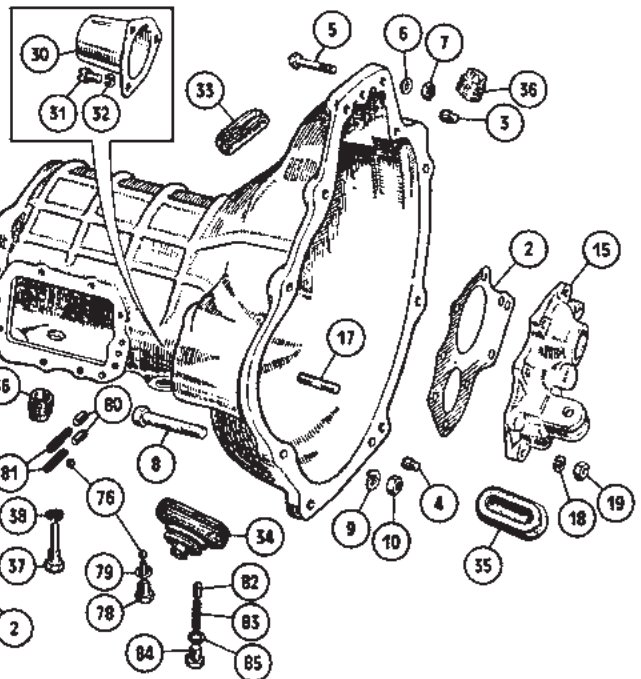
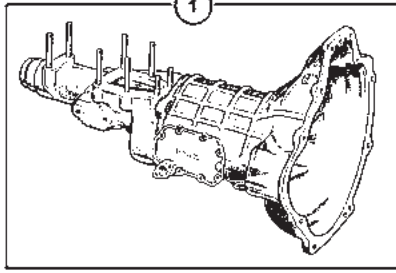
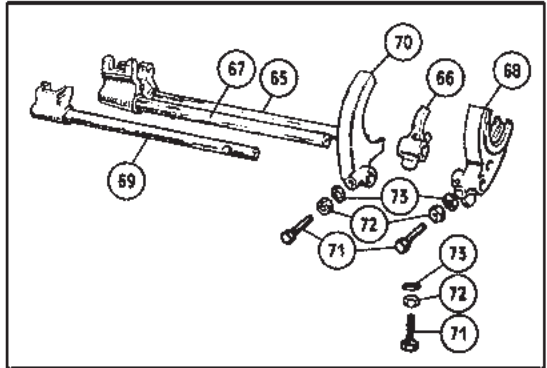

External Gearbox 948-1275

External Gearbox 948-1275

11992

No.	Part#	Price (Each)	Description	Application	Qty Req.
1	427-515	NA	GEARBOX, rebuilt - use 427-520 below	early 1098	1
	427-520	NA	GEARBOX, rebuilt (w/o shifter housing)	late 1098, 1275	1
			(This gearbox will fit all 1098 and 1275 cars)		
		\$600.00	CORE CHARGE FOR 427-520 (see note below)		
Core must be intact, free of cracks, and rebuildable. Input shaft must be stamped 22G229. (If the input shaft is stamped 22G117 this gear box is an early 1098 box and is not an acceptable core.) Do not include shifter housing with core.					
2	297-700	\$5.99	GASKET SET		1
3	325-080	\$1.99	DOWEL, upper	948, 1098	1
3	116-151	NA	DOWEL, upper	1275	1
4	325-080	\$1.99	DOWEL, lower		1
5	320-695	\$0.89	BOLT, gearbox to engine plate	948	8
5	320-070	\$0.99	BOLT, gearbox to engine plate	1098, 1275	8
6	365-730	\$0.39	WASHER, locking		8
7	310-140	\$0.39	NUT		3
8	322-620	\$0.69	BOLT		2
9	324-040	\$0.39	WASHER, locking		2
10	310-050	\$0.69	NUT		2
15		NA	COVER, front	948	1
	461-765	\$289.99	COVER, front, repl., w/ lip type oil seal	} 1098, 1275	1
	461-766	\$6.79	OIL SEAL (replacement) for 461-765		1
17		NA	STUD, cover to gearbox		7
18	324-020	\$0.20	WASHER, locking		7
19	310-760	\$0.59	NUT		7
25		NA	SIDE COVER		1
27		NA	STUD, side cover to gearbox		8
28	324-020	\$0.20	WASHER, locking		8
29	310-760	\$0.59	NUT		8
30	848-760	NA	COVER, starter pinion		1
31	725-070	\$1.99	SCREW, cover to gearbox		3
32	324-020	\$0.20	WASHER, locking		3
33	461-870	\$6.99	COVER, dust		1
34	461-010	\$3.49	BOOT, clutch lever		1
35	461-875	\$3.29	DUST COVER, side		1
36	328-055	\$9.99	PLUG, oil drain/fill		2
	328-056	\$39.99	PLUG, oil drain, magnetic	(optional)	1
37		NA	SCREW, reverse shaft locating		1
38	324-020	\$0.20	WASHER, locking		1
40	330-550	\$10.99	BUSH, rear mainshaft		1
Note: Bush must be reamed or honed to fit yoke spindle after installation.					
41	120-920	\$5.89	OIL SEAL, rear		1
43	314-265	\$0.59	BOLT, rear extension to gearbox		9
44	324-020	\$0.20	WASHER, locking		9
45	461-810	\$209.99	PINION, speedo drive		1
46	461-440	NA	PINION HOUSING		1
47	461-445	\$2.79	OIL SEAL, speedo pinion		1
48	461-460	NA	RING, oil seal retaining		1
49	324-820	\$6.99	SEALING WASHER (copper)	late 1275	1
53		NA	STUD, long		6
54		NA	STUD, short		2
55	365-730	\$0.39	WASHER, locking		8
56	310-140	\$0.39	NUT		8
59	322-170	\$0.49	SCREW, lower cover		4
60	324-020	\$0.20	WASHER, locking		4
61		NA	CORE PLUG, shifter housing		2
62	141-020	\$35.99	SWITCH, reverse lights	1275	1
63	435-567	\$1.69	WASHER, copper	1275	1
65		NA	ROD, reverse selector	948	1
	461-845	NA	ROD, reverse selector	1098, 1275	1
66	461-880	NA	FORK, reverse selector	all	1
67		NA	ROD, 3rd/4th selector	948	1
	461-855	NA	ROD, 3rd/4th selector	1098, 1275	1
68		NA	FORK, 3rd/4th selector	948	1
	461-890	NA	FORK, 3rd/4th selector	1098, 1275	1
69		NA	ROD, 1st/2nd selector	948	1
	461-865	NA	ROD, 1st/2nd selector	1098, 1275	1
70		NA	FORK, 1st/2nd selector	948	1
	461-885	\$72.99	FORK, 1st/2nd selector	1098, 1275	1
71	461-760	\$4.29	SCREW, locating fork on rod		3
72	365-740	\$0.59	NUT, locking		3
73	462-385	\$0.39	WASHER, locking		3
75		NA	PLUNGER, interlock		1
76	329-520	\$0.79	BALL, interlock		2

No.	Part#	Price (Each)	Description	Application	Qty Req.
78		NA	PLUG, interlock ball		1
79	462-465	\$0.49	WASHER, sealing		1
80	462-185	NA	PLUNGER, 1st/2nd & 3rd/4th		2
81	462-460	\$0.89	SPRING, plunger		2
82	462-185	NA	PLUNGER, reverse		1
83	329-240	\$3.49	SPRING, plunger	948, 1098	1
83	462-460	\$0.89	SPRING, plunger	1275	1
84	848-790	NA	PLUG, reverse selector plunger		1
85	462-465	\$0.49	WASHER, sealing		1
86		NA	SHAFT, control	948	1
		NA	SHAFT, control	1098, 1275	1
87		NA	LEVER, control	948	1
		NA	LEVER, control	1098, 1275	1
88	462-550	NA	SCREW, lever to shaft		1
89	324-020	\$0.20	WASHER, locking		1
90		NA	SHAFT, remote control	948	1
		NA	SHAFT, remote control	1098, 1275	1
91	327-200	\$0.59	KEY		2
92		NA	LEVER, selector, front		1
93	322-247	\$0.49	SCREW, pinch		1
94	324-020	\$0.20	WASHER, locking		1
95	461-826	NA	BUSH, front selector lever		1
96		NA	LEVER, selector, rear		1
97		NA	SCREW, pinch		1
98	324-020	\$0.20	WASHER, locking		1
100	441-610	NA	PLUNGER, reverse protection	948 thru 1275 to GAN4-58111	1
		NA	PLUNGER, reverse protection	1275 from GAN4-58112	1
101	329-270	NA	SPRING, plunger	948 thru 1275 to GAN4-58111	1
		NA	SPRING, plunger	1275 from GAN4-58112	1
102	461-720	NA	PIN, plunger locating		1
105	329-520	\$0.79	BALL, reverse selector		1
106	329-240	\$3.49	SPRING, ball		1
107		NA	PLUG, reverse selector ball		1
108	462-440	\$3.49	PLUNGER, control shaft damping		1
109	329-010	\$0.99	SPRING, plunger		1
110	462-445	NA	PLUG, control shaft damper		1
111	324-770	\$1.99	WASHER, copper		1
112	329-520	\$0.79	PLUNGER, reverse detent	} late 1275	1
113	462-490	NA	PLUG, reverse detent plunger		1
115		NA	GEAR LEVER (several variations)	} 948, 1098, & 1275 thru 1969	1
116		NA	COVER, gear lever seat		1
117	322-645	\$0.49	SCREW, cover		3
118	324-020	\$0.20	WASHER, locking	} 1275 1970-74	3
119		NA	COVER, remote housing		1
120	314-200	\$0.59	SCREW, cover to gearbox tunnel		4
121	680-890	\$4.89	GROMMET, gear lever		1
125		NA	GEAR LEVER	} 1275 1970-74	1
126		NA	COVER, gear lever seat		1
127		NA	PLATE		1
128	322-645	\$0.49	SCREW		3
129	324-020	\$0.20	WASHER, locking		3
130		NA	SUPPORT, gear lever boot		1
131	462-780	\$19.99	BOOT, gear lever		1
132		NA	RING, boot & support to gearbox tunnel		1
133	314-045	\$0.39	SCREW, ring to gearbox tunnel		4
135	462-770	NA	SHIFT KNOB (use 462-775)	948	1
135	462-775	\$14.99	SHIFT KNOB	1098, 1275 thru 1971	1
136	462-785	NA	SHIFT KNOB	1275, 1972-74	1
140	462-850	NA	ANTI-RATTLE KIT, shift lever		1
			(Includes nos. 108, 109, 141-143)		
141	290-955	\$0.79	RING		1
142	461-825	NA	BUSH		1
143	329-195	\$5.99	SPRING		1
145	462-550	NA	PEG, gear lever locating		1
146	324-020	\$0.20	WASHER, locking		1

Toll-Free Orders 1-800-667-7872 | MossMotors.com
Fax 805-692-2525 | Local 805-681-3400

MOSS

Internal Gearbox 948-1275

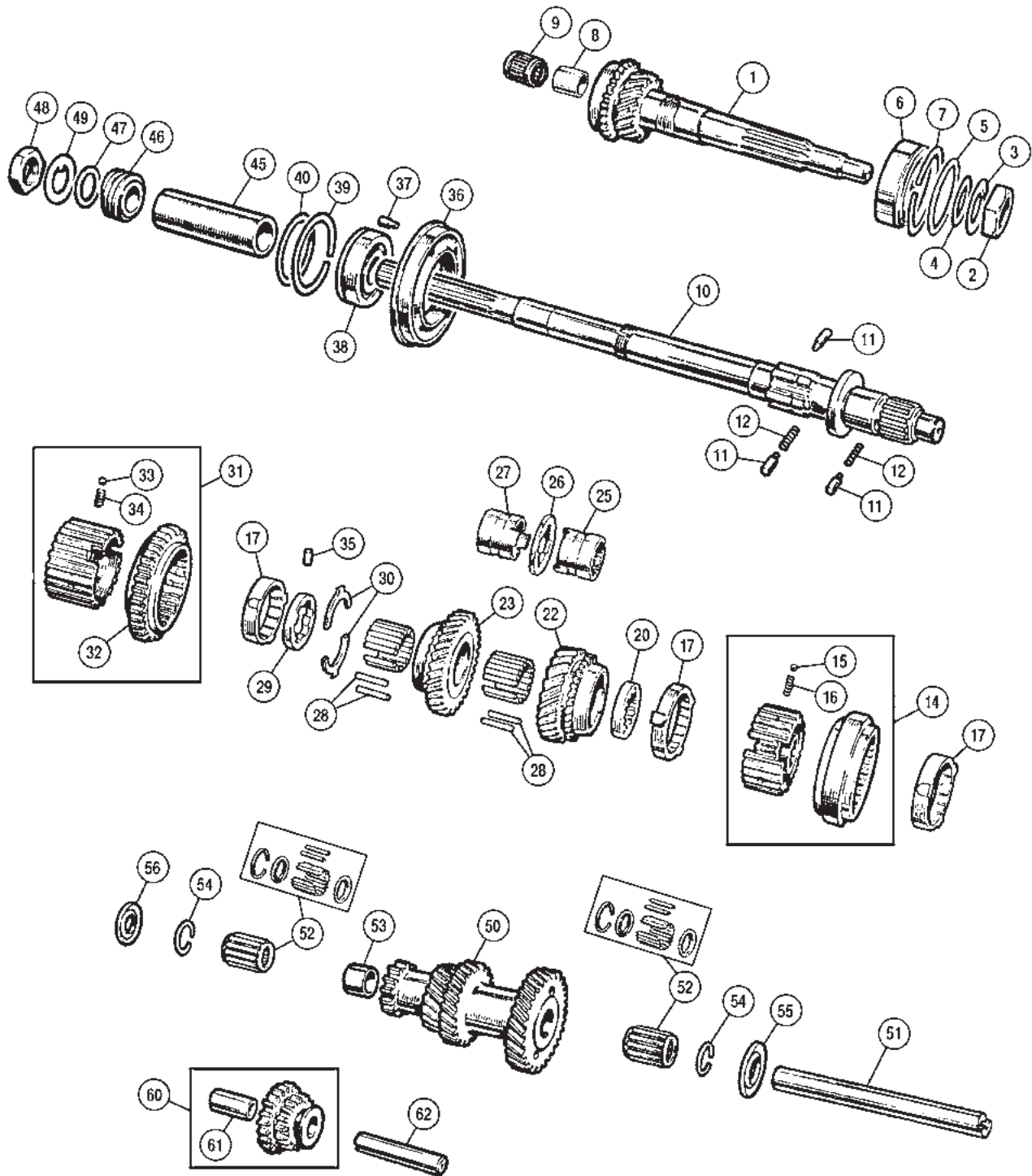

Internal Gearbox 948-1275

Internal Gearbox 948-1275

11993

No.	Part#	Price (Each)	Description	Application	Qty Req.
1			NA INPUT SHAFT (several variations)	948, 1098	1
	461-910	\$299.99	INPUT SHAFT	1275	1
2	311-315	\$0.39	NUT, input shaft		1
3	461-806	\$7.99	LOCK TAB		1
4			NA WASHER, plain		1
5	461-975	\$3.39	SHIM, .004"		A/R
	461-980	\$3.79	SHIM, .006"		A/R
	461-985	\$3.29	SHIM, .010"		A/R
6	127-040	\$31.99	BEARING, input shaft		1
7			NA CIRCLIP, bearing		1
8	330-600	\$7.99	BUSHING, input to mainshaft	9C gearbox	1
9	127-030	\$7.99	BEARING, input shaft to mainshaft	9CG thru 1275	1
10			NA MAINSHAFT (several variations)	948 & 10CC	1
	461-990		NA MAINSHAFT	10CC & 1275	1
11	461-795	\$26.99	PEG		A/R
12	329-215		NA SPRING	948	A/R
			NA SPRING	1098, 1275	3
14			NA SYNCHRO ASS'Y, 3rd/4th (severals)	948, early 1098	1
	461-965		NA SYNCHRO ASSEMBLY, 3rd/4th	10CC from (e)H4642, 1275	1
15	329-600	\$0.49	BALL		3
16			NA SPRING	948	3
	329-305	\$0.99	SPRING	1098, 1275	3
17	461-970	\$24.59	SYNCHRO RING	1098, 1275	3
20			NA THRUST WASHER, front, (0.212"/0.213")	} 9C gearbox	1
			NA THRUST WASHER, front, (0.214"/0.215")		1
			NA THRUST WASHER, front, (0.216"/0.217")		1
			NA THRUST WASHER, front, (0.218"/0.219")		1
			NA COLLAR, locking, front	9CG gearbox	1
			NA COLLAR, locking, front	10CC gearbox	1
			NA COLLAR, locking, front	10CC & 1275	1
22			NA GEAR, 3rd (several variations)	948	1
			NA GEAR, 3rd	10CC, 10CC to (e)H4641	1
	843-050	\$249.99	GEAR, 3rd	10CC from (e)H4642, 1275	1
23			NA GEAR, 2nd	948	1
			NA GEAR, 2nd	10CC, 10CC to (e)H4641	1
	843-040	\$52.99	GEAR, 2nd	10CC from (e)H4642, 1275	1
25	461-785		NA BUSHING, 3rd gear	} 9C gearbox	1
26	461-786	\$17.99	INTERLOCK		1
27	461-775	\$57.99	BUSHING, 2nd gear	} 9CG gearbox	1
28			NA NEEDLE ROLLER (28 per gear)		56
	461-960	\$0.79	NEEDLE ROLLER (26 per gear)	} 1098, 1275	52
29			NA COLLAR, locking, rear		1
30			NA THRUST WASHER, locking collar	9CG gearbox	2
	461-835		NA THRUST WASHER, locking collar	1098, 1275	2
31			NA GEAR ASSEMBLY, 1st (several variations)	948	1
	461-956	\$139.99	GEAR ASSEMBLY, 1st (w/o hub)	10CC, 10CC to (e)H4641	1
	461-950	\$299.99	GEAR ASSEMBLY, 1st	} 10CC from (e)H4642,	1
32	461-945	\$159.99	GEAR, 1st		1275
33	329-600	\$0.49	BALL		3
34			NA SPRING	948	3
	329-305	\$0.99	SPRING	1098, 1275	3
35			NA PLUNGER	1275	1
36			NA HOUSING, mainshaft bearing		1
37	461-370		NA PEG, locating		1
38	127-040	\$31.99	BEARING, mainshaft	948	1
	127-020	\$56.99	BEARING, mainshaft	1098, 1275	1
39			NA CIRCLIP, bearing		1
40	461-975	\$3.39	SHIM, 0.004"		A/R
	461-980	\$3.79	SHIM, 0.006"		A/R
	461-985	\$3.29	SHIM, 0.010"		A/R
45			NA DISTANCE TUBE	948	1
			NA DISTANCE TUBE	1098, 1275	1
46	461-805		NA DRIVE GEAR, speedometer		1
47			NA WASHER, plain		1
48	311-315	\$0.39	NUT, mainshaft		1
49	461-806	\$7.99	LOCK TAB		1
50			NA LAYGEAR (several variations)	948	1
	843-100		NA LAYGEAR (22G76)	10CC, 10CC to (e)H4641	1
	461-905	\$329.99	LAYGEAR (22G232 / 22G1100)	10CC from (e)H4642, 1275	1
51	461-940		NA LAYSHAFT, standard		1
	461-942	\$64.99	LAYSHAFT, premium, hardened to 60-62HRC		1
52	127-010	\$7.99	BEARING, caged, laygear	(replaces early loose rollers)	2
53			NA DISTANCE TUBE		1
54	326-990	\$2.69	CIRCLIP, bearing		2

No.	Part#	Price (Each)	Description	Application	Qty Req.
55	461-915	\$14.99	THRUST WASHER, front		1
56	461-920	\$14.99	THRUST WASHER, rear, 0.123"-0.124"		A/R
	461-925	\$14.99	THRUST WASHER, rear, 0.125"-0.126"		A/R
	461-930	\$14.99	THRUST WASHER, rear, 0.127"-0.128"		A/R
	461-935	\$14.99	THRUST WASHER, rear, 0.130"-0.131"		A/R
	461-937	\$14.99	THRUST WASHER, rear, 0.132"-0.133"		A/R
60			NA GEAR, reverse idler	948	1
	461-896	\$78.99	GEAR, reverse idler	10CC, 10CC to (e)H4641	1
	461-895	\$149.99	GEAR, reverse idler	10CC from (e)H4642, 1275	1
61			NA BUSH, reverse idler gear		1
62	461-900		NA SHAFT, reverse idler		1

Most parts for the 948 "smooth case" transmissions fitted to the Sprite MkI & II and Midget MkI have been unavailable for many years. Synchros for these transmissions are "shrunk-on" to the gears and must be machined to fit; an expensive operation requiring an experienced machinist. Since the ribcase transmissions are less complex and replacement parts are readily available, we recommend the direct replacement of a troublesome smooth case with the ribcase. An added advantage is the more desirable gear ratios fitted to the late units. (The clutch release lever for the ribcase gearbox, #190-955, must be used. However, you must use the release bearing appropriate for the engine installed.) Eliminating excess free play will do wonders for your clutch action. Since for all practical purposes the clutch is not adjustable, each part must be in top condition. New clevis pins and new slave cylinder push rods are recommended. Slave cylinder rods should not have sections welded to them to make them longer. This is an erroneous repair which is done to avoid installing a new release bearing. Occasionally a rod from another car is substituted.



5-Speed Conversion Kits

If you plan on driving your classic, installing a 5 speed transmission will make the car much more enjoyable at highway speeds. Using the popular Ford T9 gearbox, the installation is reversible with minimal modifications to the frame or transmission tunnel. Get better fuel economy, less engine wear and easier shifts. The five speed kits come complete with the following components:

- Reconditioned Ford T9 Gearbox
- New Bellhousing (or adaptor plate on 1500cc models)
- Spigot Bushing
- Clutch Plate
- Clutch Plate Cover
- Clutch Release Bearing
- New Clutch Arm Pivot
- New Propshaft
- Chassis Cross Member and Strengtheners
- Speedometer Cable (Note: Speedo will need to be recalibrated)
- Standard Gear Lever
- Gear Lever Gaiter
- All Bolts and Fasteners
- Detailed Instructions

Sprite/Midget 948	440-145	\$5,195.00
Sprite/Midget 1098	440-155	\$5,195.00
Sprite/Midget 1275	440-165	\$5,195.00
Midget 1500	440-175	\$4,995.00
Clutch Alignment Tool	041-620	\$3.99

Toll-Free Orders 1-800-667-7872 | MossMotors.com
 Fax 805-692-2525 | Local 805-681-3400



Gearbox - 1500 Midget

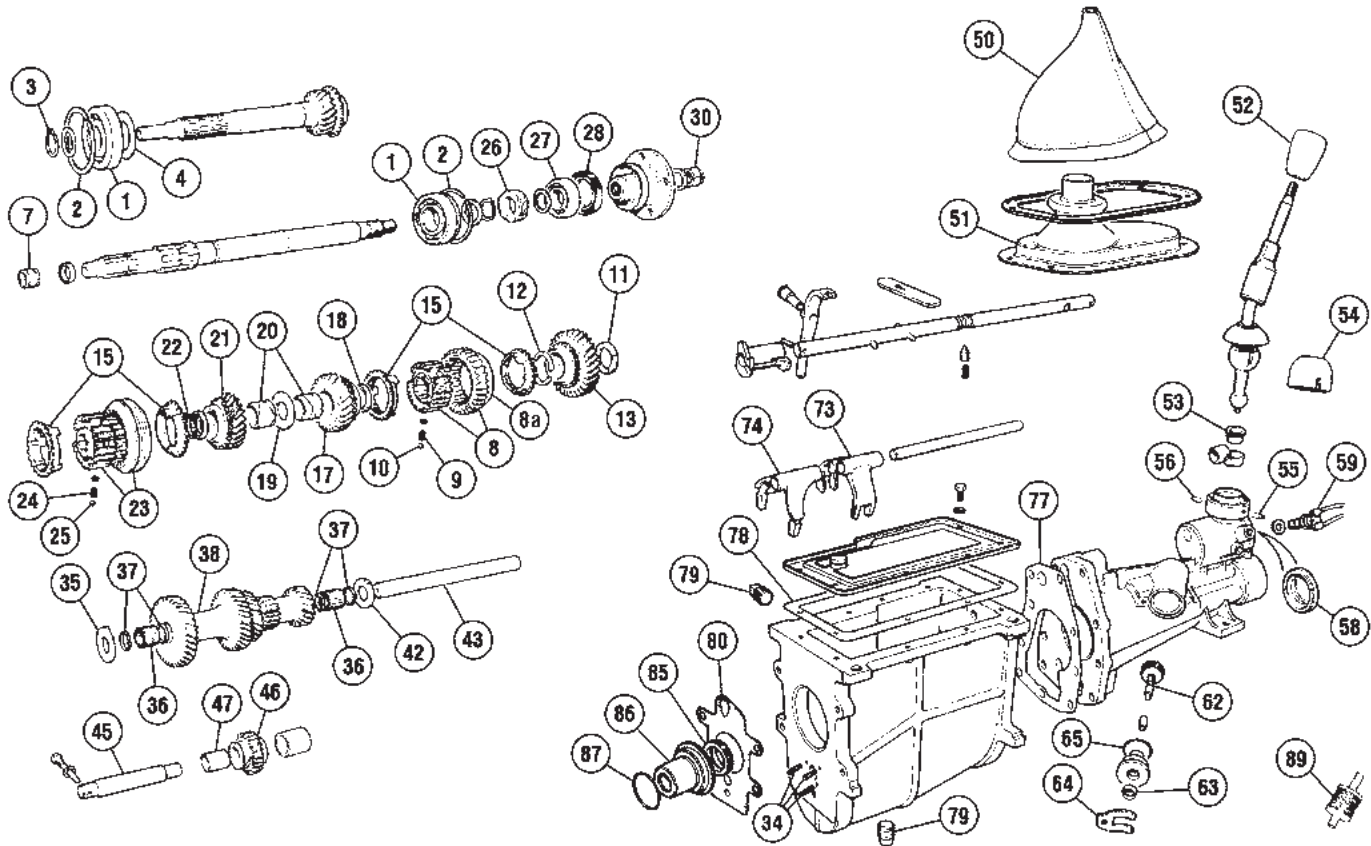

Gearbox - 1500

11995

No.	Part#	Price (Each)	Description	Application	Qty Req.
	693-060	\$4.89	GASKET SET		1
1	071-329	\$16.99	BEARING, input shaft & mainshaft center		2
2	326-745	\$22.99	CIRCLIP, bearing retaining		2
3	326-765	\$1.99	CIRCLIP, input shaft		1
4	848-075	NA	OIL THROWER		1
7	525-190	\$6.99	BEARING, mainshaft spigot		1
8	071-320	NA	SYNCHRO HUB ASS'Y., 1st & 2nd	A - see note below	1
8a	071-342	\$139.99	GEAR, outer	A - see note below	1
	071-321	NA	SYNCHRO HUB ASS'Y., 1st & 2nd	B - see note below	1
9	329-225	\$0.59	SPRING, synchro		3
10	329-510	\$0.89	BALL, synchro		3
11	847-350	NA	THRUST WASHER		1
12	847-475	NA	SPLIT COLLAR, 1st gear		2
13	321-060	\$165.99	1st GEAR		1
15	071-330	\$14.29	SYNCHRO RING		4
17		NA	2nd GEAR		1
18	847-235	NA	THRUST WASHER, 2nd gear		1
19	847-300	NA	THRUST WASHER, .152 - .154"		A/R
	847-310	\$1.59	THRUST WASHER, .156 - .158"		A/R
	847-320	NA	THRUST WASHER, .161 - .163"		A/R
	847-330	NA	THRUST WASHER, .165 - .167"		A/R
	847-340	NA	THRUST WASHER, .169 - .171"		A/R
20	847-290	\$39.99	BUSH, 2nd & 3rd gears		2
21	847-460	\$99.99	3rd GEAR		1
22	326-995	\$1.79	CIRCLIP, mainshaft		1
23	847-410	NA	SYNCHRO HUB ASS'Y., 3rd & 4th		1
24	329-475	\$0.79	SPRING, synchro		3
25	329-510	\$0.89	BALL, synchro		3
26	847-270	\$7.99	GEAR, speedo drive		1
27	525-200	\$14.99	BEARING, mainshaft rear		1
28	520-410	\$2.29	OIL SEAL, rear		1
30	310-485	\$1.89	NUT, mainshaft flange		1
34	847-380	\$1.29	SPRING		3
35	847-230	\$7.89	THRUST WASHER, front		1
36	525-210	\$0.29	NEEDLE ROLLERS		50
37	525-205	NA	RING, roller retaining		4
38	847-240	NA	LAYGEAR (15 teeth on rev. gear)	A - see note below	1
	847-220	NA	LAYGEAR (13 teeth on rev. gear)	B - see note below	1
42	847-250	\$15.99	THRUST WASHER, rear		1
43	071-324	\$32.99	LAYSHAFT		1
45	846-130	NA	SPINDLE, reverse idler		1

No.	Part#	Price (Each)	Description	Application	Qty Req.
46	071-325	\$89.99	REVERSE IDLER GEAR (21 teeth)	A - see note below	1
	071-326	\$119.99	REVERSE IDLER GEAR (17 teeth)	B - see note below	1
47	330-485	NA	BUSH, reverse idler		1
50	681-135	\$24.99	SHIFT BOOT, vinyl		1
51	681-130	NA	SHIFT BOOT, rubber		1
52	847-260	NA	SHIFT KNOB		1
53		NA	BUSH, shift lever	to gearbox #56469	1
	330-580	NA	BUSH, shift lever	from gearbox #56470	1
54	330-585	NA	RETAINER, shift lever		1
55	847-435	\$6.19	PIN, long (L/H side)		1
56	847-430	NA	PIN, short (R/H side)		1
58	848-595	NA	END CAP, shifter housing		1
59	542-410	\$18.99	SWITCH, reverse light		1
62	847-280	\$69.99	PINION, speedo drive	22 teeth, red	1
	847-420	NA	PINION, speedo drive	21 teeth, green	1
	847-285	NA	PINION, speedo drive	20 teeth, orange	1
63	461-445	\$2.79	OIL SEAL, speedo pinion		1
64	072-395	NA	RETAINER, speedo cable		1
65	264-940	\$0.99	"O" RING		1
73	847-390	NA	FORK, 1st & 2nd selector		1
74	847-470	NA	FORK, 3rd & 4th selector		1
77	693-040	\$0.69	GASKET, gearbox to rear extension		1
78	693-050	\$1.49	GASKET, top cover		1
79	328-340	\$1.79	PLUG, drain & filler		2
	328-356	\$7.99	DRAIN PLUG, magnetic	(optional)	1
80	693-030	\$1.39	GASKET, bellhousing to gearbox		1
85	520-240	\$4.99	OIL SEAL, front	when fitted	1
86	848-585	NA	COVER, front		1
87	290-960	\$2.29	O-RING		1
89	810-140	\$2.99	MOUNT, transmission		2

1500 Gearbox Notes

To extend gearbox life, British Leyland designed a modified gear set consisting of a new 1st/2nd synchro hub assembly, laygear, and reverse idler gear. Components with the application "A" above were originally fitted up to gearbox #241363, gears above with the application "B" were originally fitted from gearbox #241364. Over the years, many early gearboxes were fitted with the later gears. To avoid confusion, please count your reverse gear teeth before ordering.

Differential / Driveshaft

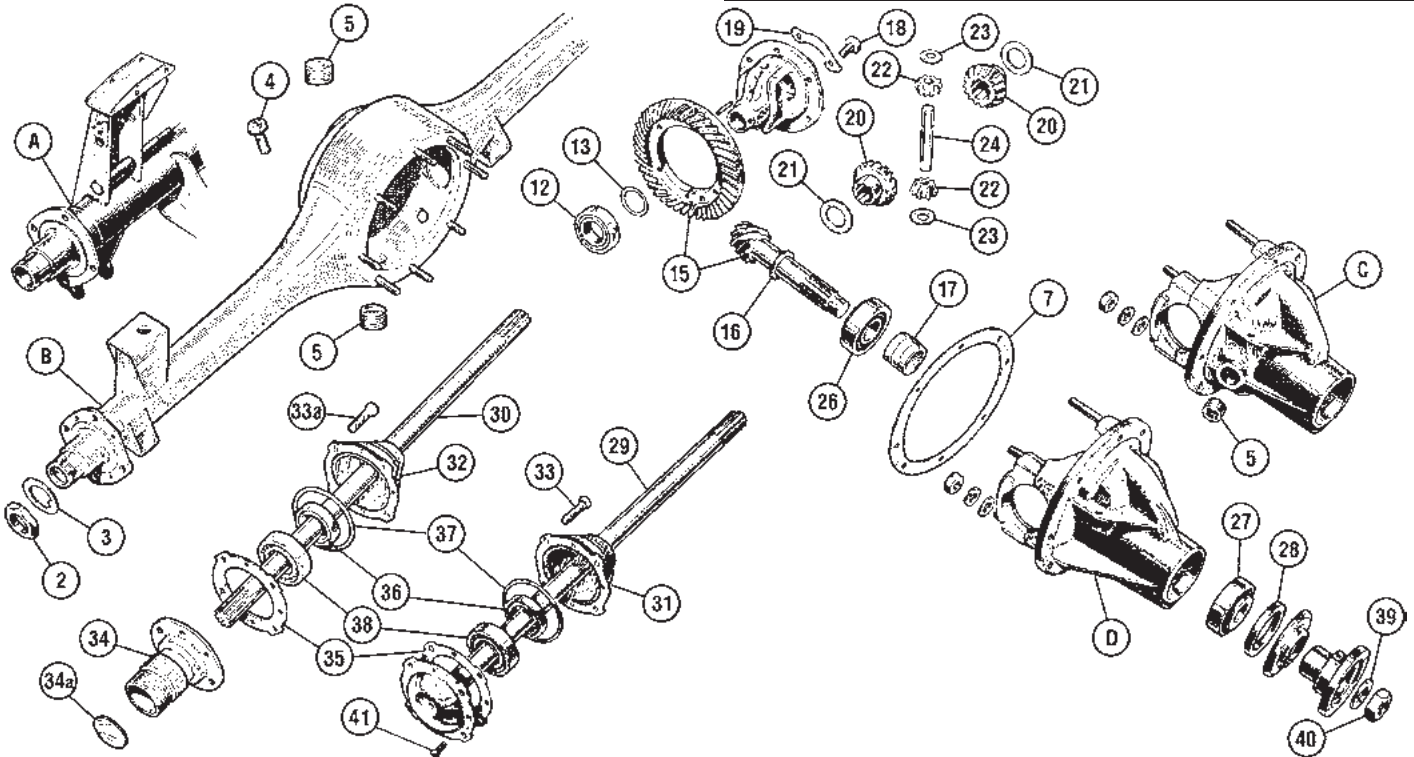

Differential

11996

No.	Part#	Price (Each)	Description	Application	Qty Req.
A		NA	AXLE HOUSING (1/4 elliptic springs)	Sprite Mkl, MklII; Midget Mkl	1
B		NA	AXLE HOUSING (1/2 elliptic springs)	Sprite MklII-on; Midget MklII-1500	1
C		NA	CARRIER HOUSING, 948	Sprite to (c)24731, Midget to (c)16183	1
D		NA	CARRIER HOUSING, 1098 thru 1500	Sprite from (c)24732, Midget from (c)16184	1
2	311-620	\$13.99	NUT, R/H hub (R/H threads)		1
	461-260	\$13.99	NUT, L/H hub (L/H threads)		1
3	265-560	\$2.49	TAB WASHER		2
4	267-040	\$10.79	BREATHER		1
5	319-060	\$3.99	DRAIN/FILLER PLUGS		2
7	294-210	\$1.19	GASKET, differential		1
12	127-300	\$36.99	BEARING, differential		2
13	265-320	\$3.29	SHIM, bearing, .002"		A/R
	265-330	\$3.29	SHIM, bearing, .003"		A/R
	265-340	\$3.49	SHIM, bearing, .004"		A/R
	265-350	\$3.99	SHIM, bearing, .010"		A/R
15		NA	GEAR SET, 4.22:1	housing "C"	1
	265-360	NA	GEAR SET, 4.22:1 (9 x 38 teeth)		1
	265-370	\$749.99	GEAR SET, 3.90:1 (10 x 39 teeth)	housing "D" (will not fit housing "C")	1
	265-375	\$799.99	GEAR SET, 3.73:1 (11 x 41 teeth)		1
	265-265	\$749.99	GEAR SET, 3.55:1		1
16		NA	THRUST WASHER, pinion, from 0.116" to 0.130"		A/R
17		NA	SPACER, solid	housing "C"	1
	265-750	\$14.99	SPACER, collapsible	housing "D"	1
18	320-640	\$3.49	BOLT		6
19	265-255	\$1.69	LOCKTAB		3
20	265-240	NA	DIFFERENTIAL GEAR		2
21	265-250	\$2.99	THRUST WASHER		2
22	265-260	NA	PINION, differential		2
23	265-270	\$8.29	THRUST WASHER, differential pinion		2
24	265-280	\$39.99	PINION AXLE		1
25	265-290	\$1.19	LOCKING PIN, pinion axle		1
26	125-130	\$149.99	BEARING, rear inner pinion	housing "C"	1
	125-150	\$62.99	BEARING, rear inner pinion	housing "D"	1
27	125-805	\$49.99	BEARING, front outer pinion	housing "C"	1
	125-140	\$15.99	BEARING, front outer pinion	housing "D"	1
28	120-800	\$2.39	OIL SEAL	all	1
29	265-300	NA	AXLE SHAFT, disc wheels		2
	265-302	NA	AXLE SHAFT, disc wheels, nitride toughened		2

30	265-310	\$399.99	AXLE SHAFT, wire wheels		2
	265-312	NA	AXLE SHAFT, wire wheels, nitride toughened		2
31	265-210	NA	BEARING HUB, disc wheels		2
32	265-215	NA	BEARING HUB, wire wheels		2
33	265-540	\$4.89	STUD, disc wheels		8
33a	265-550	\$9.99	STUD, wire wheels		8
34	265-220	\$139.99	EXTENSION, R/H, wire wheels, 12 tpi	Sprite MklII, Midget Mkl	1
	265-225	\$139.99	EXTENSION, L/H, wire wheels, 12 tpi		1
	265-230	\$209.99	EXTENSION, R/H, wire wheels, 8 tpi		from Sprite MklII, Midget MklII-1500
	265-235	\$209.99	EXTENSION, L/H, wire wheels, 8 tpi		1
34a	328-260	\$0.99	PLUG, extension	wire wheels	2
	125-830	\$20.99	HUB BEARING KIT, incl. #3, 35, 36, 37, 38		2
35	296-030	\$0.79	GASKET, hub		2
36	120-030	\$2.79	OIL SEAL		2
37	121-410	\$1.59	O-RING		2
38	125-120	\$17.99	BEARING, hub		2
39	324-100	\$0.89	LOCKWASHER		1
40	310-570	\$3.49	NUT		1
41	323-255	\$0.69	SCREW, flange to hub		2

Speedi-Sleeve



Differential pinion seal. (use on differential flange)
When a new seal cannot compensate for excessive damage, this ultra-thin sleeve provides a "new" sealable surface. Instructions and installation tool are included.

520-500 \$62.99

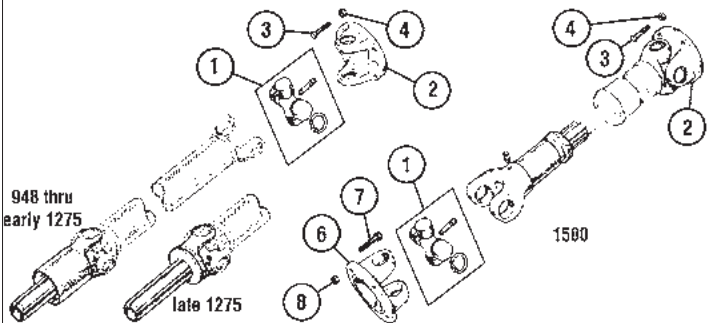

1	268-060	\$26.99	U-JOINT, GKN/Hardy-Spicer	}	2
	268-061	\$12.99	U-JOINT, aftermarket		2
2	268-010	\$29.99	FLANGE to differential	}	1
3	322-310	\$0.99	BOLT to differential flange		4
4	310-290	\$1.19	NUT, nyloc		4
6	674-925	\$37.99	FLANGE to gearbox		1
7	320-395	\$1.49	BOLT to gearbox flange	}	4
8	310-240	\$0.89	NUT, nyloc		4

Toll-Free Orders 1-800-667-7872 | MossMotors.com
Fax 805-692-2525 | Local 805-681-3400



Steering Wheels

Steering Wheels

12001

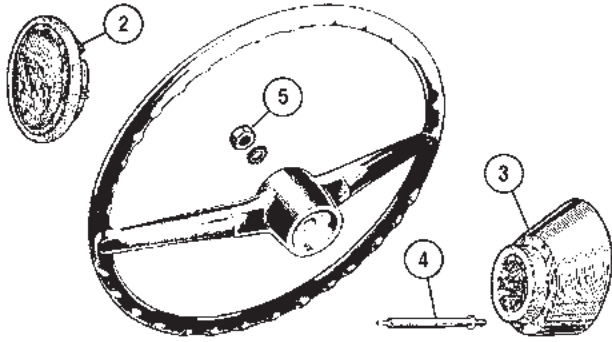

2	408-125	\$44.49	HORN PUSH, Sprite	} Sprite Mkl, MklII; Midget Mkl	1
	408-135	\$49.99	HORN PUSH, Midget (with MG logo)		1
	667-425	\$0.39	CLIP, horn push		2
3	233-215	\$279.99	SURROUND, LHD (includes slip ring)		1
	233-216	NA	SURROUND, RHD (includes slip ring)		1
4	560-430	\$15.99	HORN BRUSH		1
	667-590	\$16.99	SLIP RING	1	
5	263-075	\$5.89	NUT, steering wheel	1	

Slip ring has a plastic base - remove it for this application.

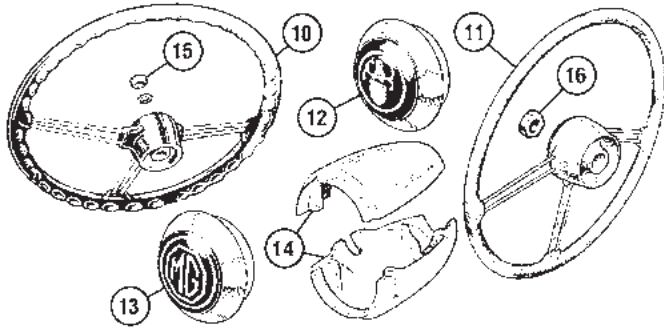

10	453-865	NA	STEERING WHEEL	1964-'67	1
11	453-960	NA	STEERING WHEEL (collapsible column)	1968-'69	1
12	408-155	NA	HORN PUSH	Sprite 1964-'67	1
13	408-145	NA	HORN PUSH	Midget 1964-'67	1
	667-425	\$0.39	CLIP, horn push		3
14	233-205	\$39.99	COWL, steering column	1964-'67	1
15	263-080	\$13.99	NUT (solid column)	1964-'67	1
16	263-085	\$15.89	NUT (collapsible column)	1968-'69	1

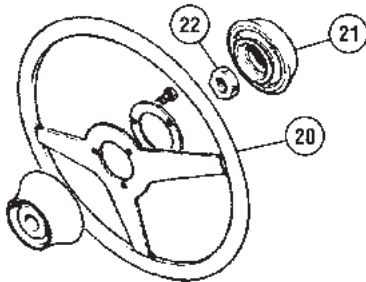

20	263-720*	NA	STEERING WHEEL	Midget from GAN5-135882	1
21	408-275	\$82.99	CENTERPIECE, steering wheel	fits Midget from 1970-on	1
22	263-085	\$15.89	NUT, steering wheel	Midget thru (c)74885	1
	263-785	\$7.99	NUT, steering wheel	Midget from (c)74886-on	1

*This wheel will fit all Midgets from 1970, but does not have cut-outs in the spokes.

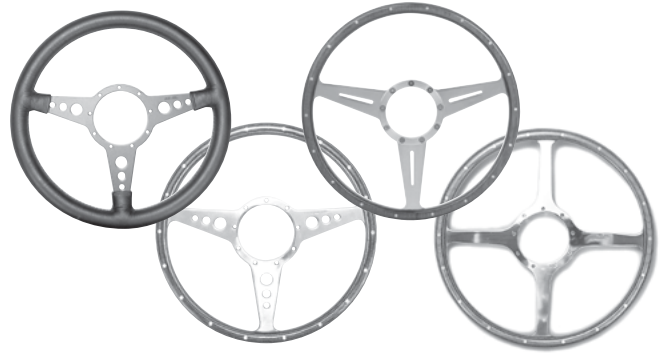

Accessory Steering Wheels

Hand crafted steering wheels employ the finest bicolored wood laminations or smooth leather over aircraft quality aluminum frames. Personalize your car with these classic steering wheels. Simply choose the wheel you want and, then order the correct hub for your car.

Wood Rim Steering Wheels

489-070	14" with 3 Drilled Matte Spokes	\$359.99
489-060	15" with 3 Drilled Matte Spokes	\$359.99
489-080	15" with 3 Slotted Matte Spokes	\$359.99
454-245	15" with 4 Solid Polished Spokes	\$649.99

Leather Rim Steering Wheels

489-040	14" with 3 Drilled Black Spokes	\$319.99
489-030	14" with 3 Drilled Matte Spokes	\$319.99
489-020	15" with 3 Drilled Black Spokes	\$319.99
489-050	15" with 3 Slotted Black Spokes	\$319.99

Adaptor Hubs with Emblems - Sprite

905-346	Sprite Mkl & II - with 46mm enameled emblem	\$149.99
454-368	Sprite MklII, IV thru '67 - with 46mm enameled emblem	\$149.99
905-478	Sprite MklIV 1968-69 - with 46mm enameled emblem	\$279.99

Adaptor Hubs with Emblems - Midget

905-348	Midget Mkl - with 46mm enameled emblem	\$149.99
454-366	Midget MklII, III thru '67 - with 46mm enameled emblem	\$149.99
905-468	Midget MklII, 1968-69 - with 46mm enameled emblem	\$279.99
905-482	Midget 1970-'77 - with 46mm enameled emblem	\$159.99
905-486	Midget 1978-79 - with 46mm enameled emblem	\$159.99



Classic Steering Wheel

A slightly thicker rim than our other classic wooden wheels for a more positive grip (approx. 28mm or 1.1" in diameter). It also features non-glare matte finish spokes and rich solid mahogany wood. This will fit any of our classic steering wheel adaptor hubs.

489-090 \$359.99

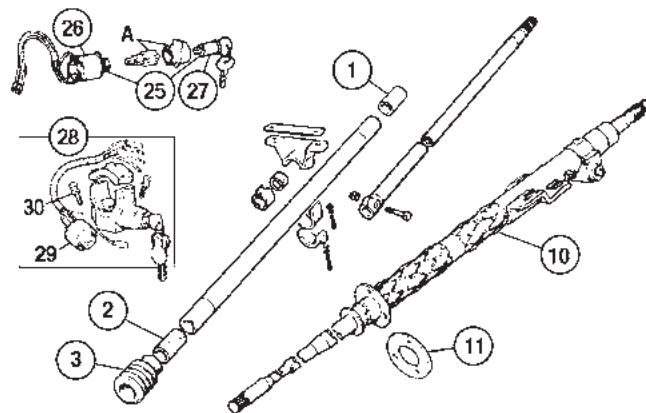
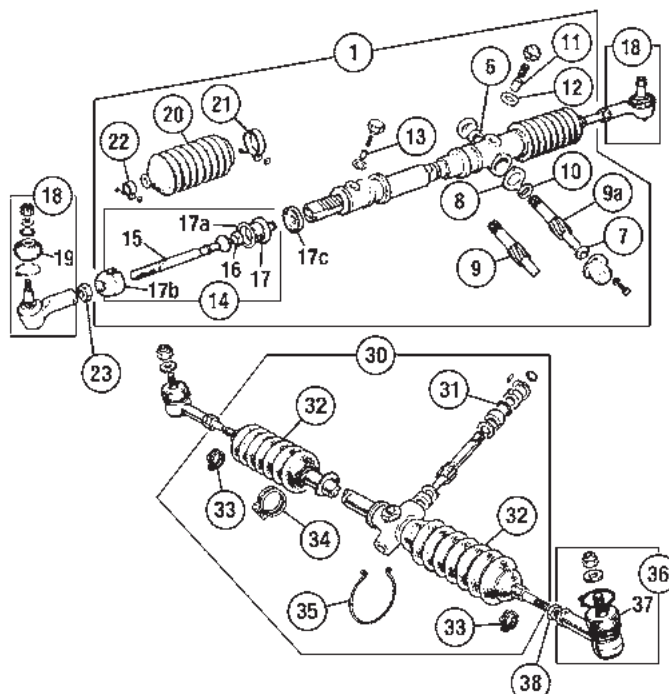

Steering Rack

12003

No.	Part#	Price (Each)	Description	Application	Qty Req.
1	668-001	\$259.99	STEERING RACK ASS'Y. thru approx. 1967	} MG to (c)60440, AH to (c)72033	1
	668-002	\$259.99	STEERING RACK ASS'Y. approx. 1968 - mid '72		} MG from (c)60441 to 114486, AH from (c)72034 on
6	120-040	\$1.49	OIL SEAL, pinion thru approx. 1967	} MG to (c)60440, AH to (c)72033	1
	120-050	NA	OIL SEAL, pinion approx. 1968 - mid '72	} MG from (c)60441 to 114486, AH from (c)72034 on	1
7	260-220	NA	THRUST WASHER, pinion bottom	} all Sprite, Midget to GAN5-114486 (to mid 1972)	1
8	260-230	NA	SHIM, lower pinion bearing, .003"		A/R
	260-240	NA	SHIM, lower pinion bearing, .005"		A/R
	260-250	NA	SHIM, lower pinion bearing, .010"		A/R
9	663-310	NA	STEERING PINION, w/flat on splines		1
9a	663-300	\$52.99	STEERING PINION, w/groove on splines		1
10	663-320	\$0.39	THRUST WASHER, pinion top		1
11	262-190	\$35.99	DAMPER PAD, pinion		1
12	262-120	\$4.99	SHIM, .003"		A/R
	260-270	NA	SHIM, .010"		A/R
13	263-040	\$10.59	DAMPER PAD, secondary		1
14	260-330	NA	TIE ROD ASSEMBLY, inner		2
15	260-280	NA	TIE ROD		2
16	260-290	\$7.69	SOCKET		2
17	262-170	\$24.99	BALL HOUSING, male		2
17a	262-130	\$3.29	SHIM, .003"		A/R
	262-140	\$3.29	SHIM, .005"		A/R
	262-150	\$3.29	SHIM, .010"		A/R
17b	262-160	\$21.99	BALL HOUSING, female		2
17c	262-110	\$10.59	LOCK WASHER		2
18	263-288	\$29.99	TIE ROD END, pair		1
19	262-220	\$2.99	BOOT, tie rod end		2
20	260-325	\$18.99	RACK BOOT SET, replacement, w/ties		1
	260-320	\$10.99	RACK BOOT, orig. type		2
21	263-235	\$3.59	CLAMP, large		2
22	262-200	\$2.99	CLAMP, small		2
23	310-490	\$1.79	JAM NUT, tie rod end		2
30	668-000	\$259.99	STEERING RACK ASSEMBLY, LHD	} MG 1275 from (c)114487 & 1500 (mid '72-on)	1
	668-010	NA	SHIM, .005"		A/R
	668-020	\$0.99	SHIM, .010"	A/R	
32	680-058	\$21.99	RACK BOOT SET, 2 boots (incl. zip ties to replace clamps)		1
	326-475	\$2.29	CLAMP, small		2
34	326-410	\$2.89	CLAMP, large (passenger's side)		1
35	674-870	\$0.59	WIRE TIE (driver's side)		1
36	668-040	\$19.99	TIE ROD END PAIR		1
37	680-060	\$3.79	BOOT, tie rod end		2
38	310-390	\$0.49	JAM NUT, tie rod end		2

Steering Column

12002

No.	Part#	Price (Each)	Description	Application	Qty Req.
1	667-600	\$5.49	BUSH, upper, felt	} non-collapsible steering columns	1
2	263-420	\$2.99	BUSH, lower, felt		1
3	280-880	\$4.99	NA SEAL, steering col. to toe board	Bugeye to (c)7432	1
			SEAL, steering col. to toe board	from (c)7433 thru 1967	1
10			NA STEERING COLUMN, collapsible (several variations)	} from approx. 1968-on	1
11	263-590	\$2.29	SEAL		1
25	263-600*	NA	IGNITION SWITCH ASS'Y.	} MG from (c)60441-74885, AH from HAN9-72034 on	1
26	542-077*	\$23.99	IGNITION SWITCH		1
27	163-500*	\$11.99	LOCK BARREL w/2 keys		1
28	263-610	\$109.99	LOCK & SWITCH ASS'Y (replacement)	} MG from (c)74886 to 154100	1
29	263-655	NA	SWITCH (for orig. ass'ys. only)		1
	263-641	\$79.99	LOCK & SWITCH ASS'Y, Lucas	} Midget 1500, 1975 on	1
	263-640	\$43.99	LOCK & SWITCH ASS'Y, aftermarket		1
	263-691	\$31.99	SWITCH, Lucas		1
	263-690	\$18.49	SWITCH, aftermarket		1
	163-337	\$5.99	KEY BLANK		A/R
30	263-700	\$7.49	SHEAR BOLT (incl. with assemblies)		2

*U.S.-spec column mounted ignition switches are locking-type. Ignition switch #542-077 is similar to the original, but has Lucar spade terminals in place of the wires found on the original switches. To use this replacement switch, three wires approximately 14" long must be attached to the switch with female Lucar connectors (#161-520). To connect the other ends of these wires to your harness, use wire tips, #162-200, and connectors, #162-000. Parts marked "A" in the illustration are no longer available and must be re-used from your old switch assembly.

The most common causes of steering shake are wheel imbalance, tire belt separation, bad shock absorbers and worn wheel bearings. Harder to find problems arise from loose steering rack mounts and out-of-round brake rotors. The most elusive shake is caused by wear in the steering rack itself. This is an unfamiliar problem just coming into its own, due to the age of the affected cars.

The problem manifests itself in localized intermittent shaking in the steering wheel, and is difficult to sort out as most suspension problems end up being felt through the steering wheel. A clue is afforded by determining which parts of the car are shaking as well as the steering wheel. If the cowl or fenders are shaking, the problem lies with suspension parts, not the rack.

There is much you can do to eliminate shake and shimmy not connected with the rack. See that everything is mounted properly and securely as your safety depends on your steering system being in first class operating condition.

Front Suspension

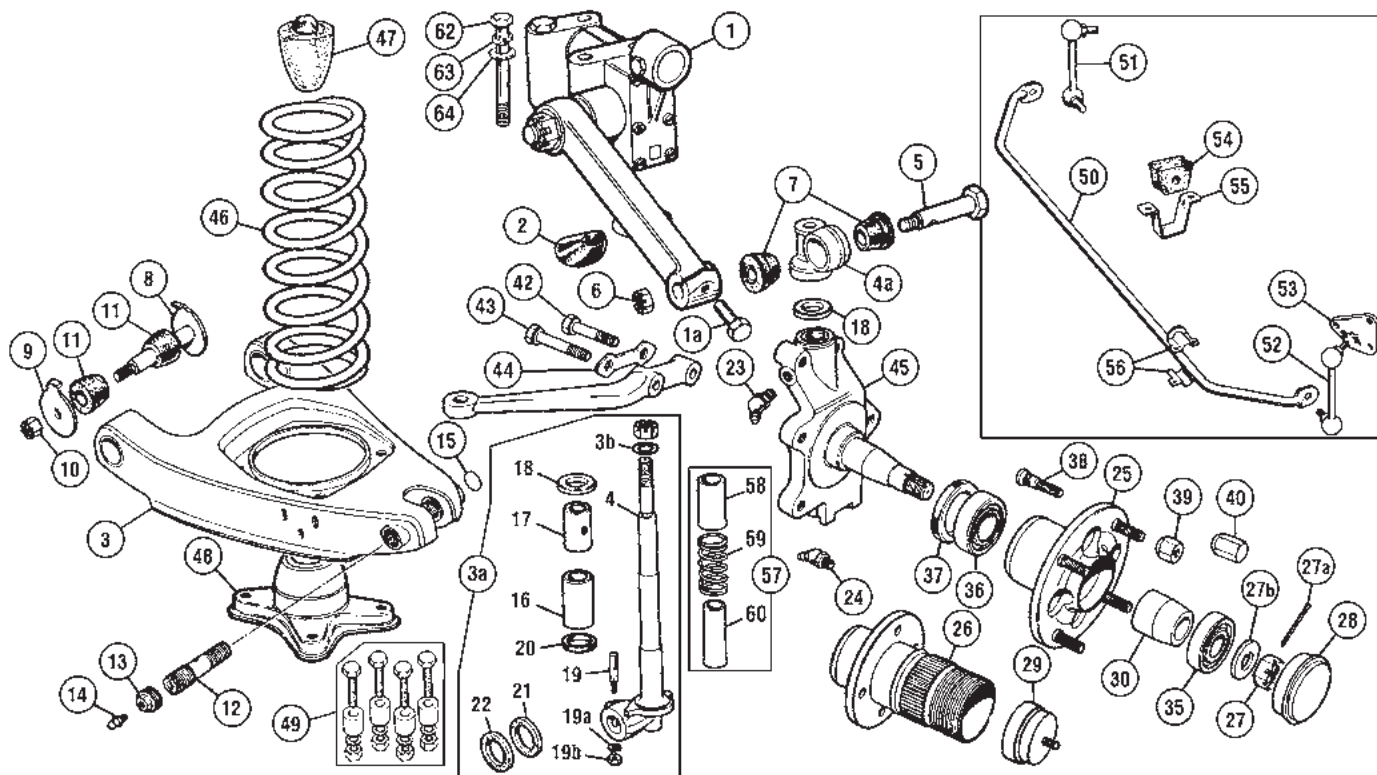

Front Suspension

12004

No.	Part#	Price (Each)	Description	Application	Qty Req.
1	264-000	\$259.99	SHOCK ABSORBER, R/H, new		1
	264-005	\$259.99	SHOCK ABSORBER, L/H, new		1
	264-015	\$199.99	SHOCK ABSORBER, R/H, rebuilt		1
		\$200.00	CORE CHARGE FOR 264-015 SHOCK ABSORBER		
	264-025	\$199.99	SHOCK ABSORBER, L/H, rebuilt		1
		\$200.00	CORE CHARGE FOR 264-025 SHOCK ABSORBER		
1a	322-410	\$1.19	CLAMP BOLT		2
2	264-055	\$1.99	BUFFER, rebound		2
3	264-065	\$399.99	WISHBONE/SPRING PAN (British Motor Heritage part)		2
	264-067	\$174.99	WISHBONE/SPRING PAN, aftermarket, w/ pin no. 12		2
	264-078*	\$279.99	MAJOR SUSPENSION KIT (includes items marked*)		1
3a	264-185*	\$179.99	SWIVEL PIN REPAIR KIT	948 drum brakes	1
	264-195*	\$69.99	FULCRUM PIN REPAIR KIT§		2
	264-088	\$199.99	MAJOR SUSPENSION KIT (includes items marked†)		1
3a	264-205	\$99.99	SWIVEL PIN REPAIR KIT	1098, 1275, 1500 disc brakes	1
	264-195	\$69.99	FULCRUM PIN REPAIR KIT§		2
§ Fulcrum pin repair kits include #5-14, 19-19b, 21-24.					
3b	264-086*†	\$1.19	SHIM, .008"		A/R
4	*	NA	SWIVEL PIN	948	2
	†	NA	SWIVEL PIN	1098, 1275, 1500	2
4a	264-405	\$43.99	TRUNNION		2
5	264-045*†	\$4.99	PIN, upper fulcrum		2
6	311-640*†	\$1.99	NUT		2
	325-330*†	\$0.19	COTTER PIN for nut		2
7	330-520*†	\$2.69	BUSH, top		4
8	264-145*†	\$6.99	BOLT with washer, inner fulcrum		4
9	324-395*†	\$3.19	WASHER, inner fulcrum		4
10	310-240*†	\$0.89	NUT, inner fulcrum bolt		4
11	282-305*†	\$1.79	BUSH, wishbone		8
12	264-075*†	\$16.99	FULCRUM PIN		2
13	328-455*†	\$7.99	PLUG		2
14	328-610*†	\$0.69	GREASE NIPPLE		2
15	328-014*†	\$1.89	PLUG, blanking		2
16	021-184	\$14.99	BUSH, lower‡	948	2
	330-400	\$8.69	BUSH, lower‡	1098, 1275, 1500	2
17	*	NA	BUSH, upper‡	948	2
	330-540	\$9.99	BUSH, upper‡	1098, 1275, 1500	2
18	*†	NA	THRUST WASHER		2

Note: ‡ These bushes must be reamed or honed to fit the swivel pin being installed in the swivel axle. Consult workshop manual for instructions and dimensions.

No.	Part#	Price (Each)	Description	Application	Qty Req.
19	264-445*†	\$3.49	PIN		2
19a	324-010*†	\$0.19	LOCKWASHER		2
19b	310-040*†	\$0.29	NUT		2
20	*†	NA	SEAL		2
21	264-425*†	\$1.39	SEAL, small cork		2
22	264-435*†	\$1.29	SEAL, large cork		2
23	328-505*†	\$1.19	GREASE NIPPLE, top		2
24	328-500*†	\$0.99	GREASE NIPPLE, bottom		2
25		NA	HUB, disc wheel	drum brakes	2
	264-245	\$199.99	HUB, disc wheel	disc brakes	2
26	264-225	\$209.99	HUB, R/H, wire wheels, 12 tpi	Sprite MkII, Midget	1
	264-235	\$209.99	HUB, L/H, wire wheels, 12 tpi		MkI
	264-255	\$179.99	HUB, R/H, wire wheels, 8 tpi	from Sprite MkIII, Midget MkII	1
	264-265	\$179.99	HUB, L/H, wire wheels, 8 tpi		1
27	310-085	\$5.99	NUT		2
27a	325-440	\$0.39	COTTER PIN		2
27b	264-952	\$2.69	WASHER		2
28	264-515	\$6.29	GREASE CAP, disc		2
29	662-030	\$6.49	GREASE CAP, wire		2
30	264-625	\$16.39	BEARING SPACER		2
	125-825	NA	WHEEL BEARING KIT	MORE INFO ONLINE	2
These are "face adjusted" to the correct width (thickness) Kit includes 2 bearings and 1 oil seal.					
35	126-010	NA	BEARING, outer		2
36	126-020	NA	BEARING, inner		2
37	120-910	\$5.49	OIL SEAL		2
See page 45 for important bearing information and alternative bearings.					
38	264-415	\$4.39	STUD, disc wheels	drum brakes	8
	264-095	\$3.89	STUD, disc wheels	disc brakes	8
39	264-215	\$1.39	LUG NUT, plain, disc wheels		8
40	264-155	\$3.49	NUT, chrome for Rostyle wheels		8
	264-156	\$5.49	NUT, stainless steel for Rostyle wheels		8
42	322-077	\$3.69	BOLT, rear		2
43	322-078	\$3.79	BOLT, front		2
44	115-009	\$3.99	LOCKTAB		2
45	264-275	NA	SWIVEL AXLE, R/H	1098, 1275, 1500 disc brakes	1
	264-285	NA	SWIVEL AXLE, L/H		1

Front Suspension

Front Suspension Advice

The front suspension will give good service if kept clean and lubricated. Few cars receive this level of attention, and inspection is impossible without a thorough cleaning. Front end condition should be considered before purchasing a car.

There should be no play in the steering or hub assemblies. Inspect the tie rod ends, hubs and uprights. The front end must be raised. Allow the suspension to hang by placing jack stands on the frame next to the engine or under the rocker panels. Have someone turn the steering wheel from lock to lock while you observe the tie rod ends, which must not have any free play.

Lower king pin bushes and fulcrum pin and wishbone attachments wear out. Grasp the wheel at top and bottom and rock back and forth. (Figure A) Observe any clearance at the king pin and fulcrum pin. If the wheel rocks but there is no "gap" at the fulcrum pin, the hub bearings must be inspected. (Figure B)

All cars eventually need a front end rebuild. The use of new parts is best, as the fulcrum pin often fuses to the wishbone. Few of these parts are reusable.

Severe wear on the lever link is a problem with the single arm shocks. Check by removing the upper link and wiggling the arm back and forth (Figure C). If fluid leaks from the shaft seals, replace the shocks and top bushes.

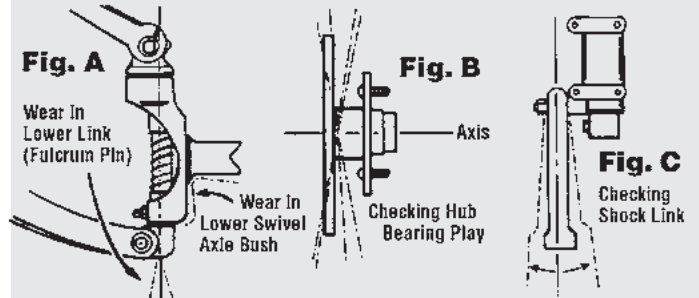

"Stiff steering" can be caused by hardened grease in the lower king pin bushes. Temporary improvement can be made by removing the grease fittings and applying heat to melt out hardened grease. Work the steering from lock to lock while heating. When the joints seem "free", install new fittings and pump grease through the bush. Grease a second time after the joints are cold.

Replacement of the drive shaft is difficult and frustrating as you cannot reach nor see down the tunnel to guide the front flange. Support the front joint with a couple of pieces of cardboard or styrofoam placed across the coupling to hold the flange relatively straight. The spine is then easily mated to the transmission.

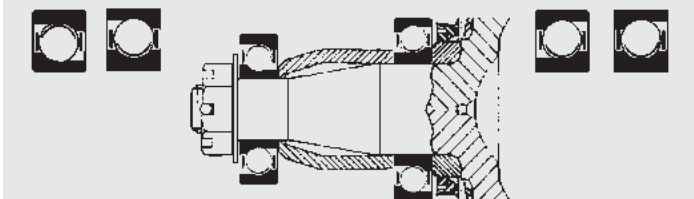

Front Wheel Bearings

Front wheel bearings are thrust bearings; if installed backwards, the hubs may come loose from the axles. Bearings marked "thrust" on the outer race must have this marking face the bearing spacer. Bearings marked "thrust" on the inner races must be installed with the "thrust" marking away from the bearing spacer. Bearings with no "thrust" markings must be installed with the thicker edge of the outer races facing toward the bearing spacer. The illustration above shows the correct orientation of different available bearings. Note the orientation of the thrust (thick) and non-thrust (thin) sides of the bearing races.

Tapered Roller Bearing Set

The standard front hub bearings are angular contact ball bearing type, which works well but does not allow for any adjustment as the bearings wear. Taper bearings provide better support. Our tapered bearing kit includes high quality bearings, seals, shims, split pin and nut and utilizes the standard spacer for a simple installation. The larger bearing has the correct 2mm fillet radius to allow proper fitment on the stub axle and has been specially manufactured to allow the hub to sit in the correct position so the caliper does not interfere with the disc. One kit does both sides.

125-822 \$96.99

Shock Absorber Fluid

Replace the original dirty or degenerated fluid with Dynolite Shock Fluid. It is custom formulated specifically for single or double action shock absorbers, in particular Armstrong type lever shock absorbers and motorbike forks. Our special formula fluid is fully compatible with original shock fluid and incorporates an anti-foaming agent which maintains damping power even under tough driving conditions. It also repels water and condensation, retards internal rust, oxidation, and corrosion.

220-306 \$22.99



No.	Part#	Price (Each)	Description	Application	Qty Req.
46	265-590	\$64.99	SPRING	to HAN8-58380, GAN3-46040	2
	265-610	\$49.99	SPRING		from HAN8-58381 on, GAN3-46041 to GAN6-171477
	265-620	\$64.99	SPRING	GAN6-171478 on	
More spring options are listed in the color section at the front of this catalog.					
47	264-295	\$7.99	SUSPENSION BUFFER		2
48	264-305	\$49.99	SPRING SEAT		2
49	264-665	\$25.99	LOWERING KIT lowers car approx. 1/2"		1
50	264-105	\$164.99	SWAY BAR (anti-roll bar), 9/16"		1
51	264-115	\$21.99	LINK, R/H		1
52	264-125	\$21.99	LINK, L/H		1
53	264-135	\$14.99	BRACKET		2
54	280-920	\$1.69	RUBBER MOUNT for 9/16" sway bar		2
55	263-430	\$1.29	STRAP		2
56	263-778	\$5.99	LOCATOR PAIR with hardware		2
57	264-638	\$28.59	DUST TUBE KIT	drum brakes	2
58	264-315	NA	DUST TUBE, upper	all	2
59	264-655	\$0.99	SPRING, dust tubes	all	2
60	264-635	NA	DUST TUBE, lower	drum brakes	2
	264-645	\$12.99	DUST TUBE, lower	disc brakes	2
62	322-076	\$2.49	BOLT, shock mounting		6
63	324-040	\$0.39	LOCKWASHER		6
64	324-860	\$0.19	WASHER, flat		6



1098-1500 Swivel Axle Assemblies

Rebuild your front suspension the easy way with these swivel axle assemblies. These are also necessary for converting an drum braked car to disc brakes.

Right Hand 264-276 \$379.99
Left Hand 264-286 \$379.99

Front suspension Lowering Kit

This kit contains special spacers which install between the wishbone/spring pan and the spring seat to lower your front suspension one half inch. Works with all springs. Kit includes spacers and bolts for both sides.



264-665 \$25.99

Nylatron Upper Trunnion Bushes

Nylatron bushes firmly locate your front suspension and eliminate unnecessary movement. Standard camber trunnion bushes are a direct replacement for your original bushes. The negative camber bushes are designed primarily for competition purposes and give improved steering and braking control. Sold individually, 4 required per car.

Standard Camber Bushing 264-585 \$28.99
Negative Camber Bushing 264-595 \$34.99

3/4" Sway Bar

The 3/4" sway bar is an excellent compromise for both fast road, and competition use. Increased front sway bar diameter reduces body roll and understeer which in turn gives better handling control.

3/4" Sway bar 264-555 \$194.99
Bushing, rubber (2 req'd.) 280-915 \$2.39
Bushing Pair, polyurethane 683-062 \$23.99
Strap (2 req'd.) 263-430 \$1.29



Solid Sway Bar Mounts

Machined aluminum mounts may be employed for road use, but were primarily designed for competition purposes. Some increase in road noise can be expected. Use with 3/4" bars. Sold as a pair.

263-435 \$89.99

Toll-Free Orders 1-800-667-7872 | MossMotors.com
 Fax 805-692-2525 | Local 805-681-3400



Rear Suspension

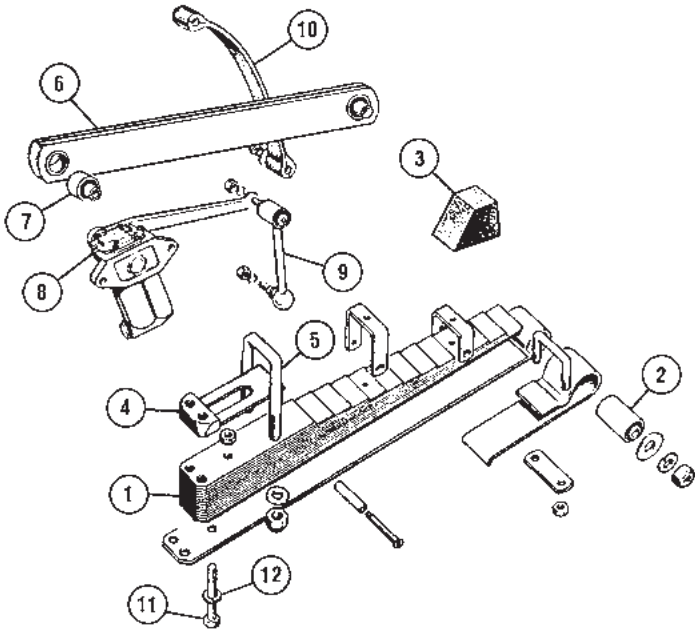

1/4 Elliptic System

12014

No.	Part#	Price (Each)	Description	Application	Qty Req.
1	265-460	NA	SPRING ASSEMBLY, standard	15 leaves	2
	265-630	\$149.99	SPRING ASSEMBLY, heavy duty	10 leaves	2
Will raise ride height 2 to 3 inches. This is the only spring available.					
2	680-960	\$7.99	BUSH, silentbloc (supplied with spring)		2
3	282-220	\$9.99	BUMP RUBBER		2
4	265-600	\$23.99	SPRING PLATE		2
5	265-570	\$46.99	U-BOLT		2
	310-400	\$0.89	NUT, U-bolt		4
6	265-380	\$64.99	RADIUS ARM	} Sprite Mkl & MkII, Midget Mkl	2
7	265-390	\$11.99	BUSH		4
8	265-400	\$229.99	SHOCK ABSORBER, new L/H		1
	265-410	\$229.99	SHOCK ABSORBER, new R/H		1
9	265-420	\$34.99	LINK, shock absorber		2
10	267-610	\$6.99	CHECK STRAP, stock type		2
	267-611	\$39.99	CHECK STRAP PAIR, nylon		1
11	320-315	\$1.99	BOLT, through spring		4
12	324-040	\$0.39	WASHER		4



Safety Knock-Off Wrench

This cleverly designed long handle wrench allows you to tighten or remove octagon "safety" or "eared" spinners without a hammer. Stores easily in the trunk.

"Safety Knockoff" Wrench	386-120	\$74.99
"Eared Knockoff" Wrench	386-125	\$79.99
Fabric Wrench Cover	386-115	\$22.49

Protective Knockoff Wrench

Prevent damage to knock-offs with this multi-ply wooden wrench.

386-165	\$38.99
---------	---------

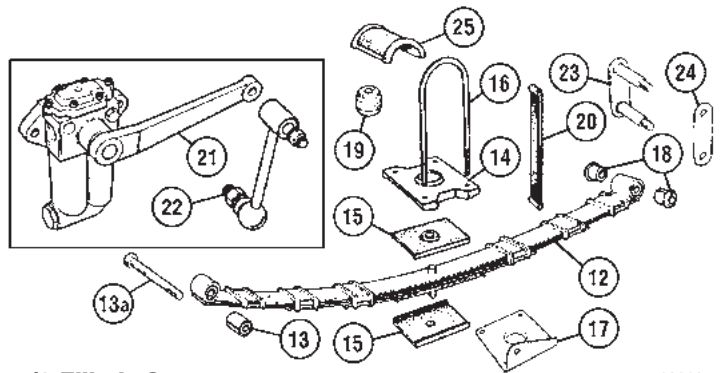

1/2 Elliptic System

12013

No.	Part#	Price (Each)	Description	Application	Qty Req.
12	265-491	\$109.99	SPRING	} MG MkII & MkIII, AH MkIII & MkIV	2
	264-685	\$249.99	SPRING, lowered 1"		2
	264-705	NA	SPRING, lowered 2"		2
	265-500	\$132.99	SPRING	Midget 1500	2
13	266-410	\$4.39	BUSH, silentbloc (supplied with springs)		2
13a	280-903	\$3.99	BOLT, spring attachment		2
14	265-396	\$5.99	PLATE, locating (upper & lower)		4
15	280-900	\$1.39	PAD, seating		4
	280-904	\$26.99	PAD KIT, seating, polyurethane		1
16	265-395	\$2.99	U-BOLT		4
	310-240	\$0.89	NUT, U-bolts		8
17	265-392	\$23.99	BRACKET, R/H		1
	265-393	\$23.99	BRACKET, L/H		1
18	280-905	\$0.99	BUSH, shackle		8
	280-906	\$16.99	BUSH KIT, shackle, polyurethane		2
19	266-530	\$9.39	BUMP RUBBER		2
20	267-610	\$6.99	CHECK STRAP, stock type	} 948 thru 1275	2
	267-611	\$39.99	CHECK STRAP PAIR, nylon		1
	267-615	NA	CHECK STRAP, stock type (use 267-610 as replacement)		2
	267-616	\$39.99	CHECK STRAP PAIR, nylon	Midget 1500	1
21	265-430	\$229.99	SHOCK ABSORBER, new L/H	} Midget from MkII on, Sprite from MkIII on	1
	265-440	\$229.99	SHOCK ABSORBER, new R/H		1
	265-435	\$169.99	SHOCK ABSORBER, rebuilt L/H		1
		\$300.00	CORE CHARGE FOR 265-435		
	265-445	\$169.99	SHOCK ABSORBER, rebuilt R/H		1
		\$300.00	CORE CHARGE FOR 265-445		
22	265-450	\$18.99	LINK, shock absorber		2
23	265-455	\$8.99	SHACKLE PLATE, with pins		2
24	265-465	\$7.99	SHACKLE PLATE		2
25	265-397	\$3.29	SHIM, U-bolts		2

Lowered Rear Leaf Springs

Lowered springs are preferred to blocks and long U-bolts because they provide better location of the rear axle. Our 1" lowered springs are perfectly suited to fast road use. The 2" springs are appropriate for the track. Fit chrome-bumpered cars only from 1964-'74.

1964-'74 Rear Leaf Spring, 1" Lowered	264-685	\$249.99
1964-'74 Rear Leaf Spring, 2" Lowered (Reverse eye)	264-705	NA

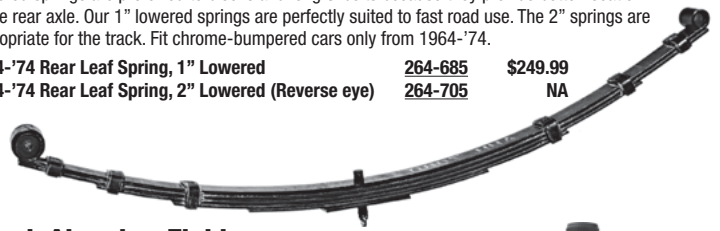

Shock Absorber Fluid

Replace the original dirty or degenerated fluid with Dynolite Shock Fluid. It is custom formulated specifically for single or double action shock absorbers, in particular Armstrong type lever shock absorbers and motorbike forks. Our special formula fluid is fully compatible with original shock fluid and incorporates an anti-foaming agent which maintains damping power even under tough driving conditions.



220-306	\$22.99
---------	---------

Rear Tube Shock Conversion Kit

Fits 1964 to 1974 chrome bumper models. These kits contain the Spax adjustable gas filled shocks (adjustable from the outside), with new lower spring plates that incorporate an angled mounting flange. Installation is easy, and instructions are included.

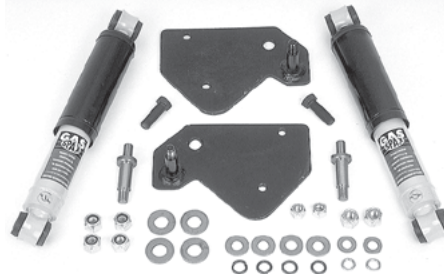

264-675	\$649.99
---------	----------

WARNING: Cancer and Reproductive Harm. www.P65Warnings.ca.gov

Road Wheels & Tools



Bright Trim Ring Set

Deluxe, polished stainless steel trim rings. Our trim rings install in seconds and provide an attractive accent to your Rostyle disc wheels. Sold as a set of 4.

453-048 \$159.99

Inner Tubes and Rim Bands

Top quality heavy-duty tube designed for use with radial tires and have rubber covered valve stems. (Can be used with bias-ply tires.)

We offer high quality vulcanized rubber rim bands to prevent spoke and nipple ends from chafing your inner tubes.

145/155/165 x 13" Inner Tube 452-736 \$19.99

We offer high quality vulcanized rubber rim bands to prevent spoke and nipple ends from chafing your inner tubes.

13" Rim Band 452-730 \$8.99



Bolt-On Sport Wheels

Exact replica of the original Mini-lite wheel is an alternative to steel wheels. Give your British sports car a modern, aggressive look. Wheels bolt on using lug nuts listed below.

13" x 5" Wheel 453-065 \$239.99
 Lugnut, chrome 264-155 \$3.49 ea.
 Lugnut, stainless 264-156 \$5.49 ea.
 Lugnut, "MG" 264-465 \$4.79 ea.

Silver Wheel Paint

The correct shade of silver-grey for your disc or wire wheels.

220-560 \$29.99

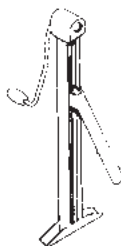

1500 Jack

Original style jack for use on or to complete your show car. (May be used on earlier Sprites & Midgets.)

386-920 \$239.99



Early Type Jack Bag

Styled like the original factory-supplied jack bag made from heavy duty jute-backed vinyl. Complete with straps and buckles. Keeps the jack from banging around, a must for the restored car.

386-930 \$66.99

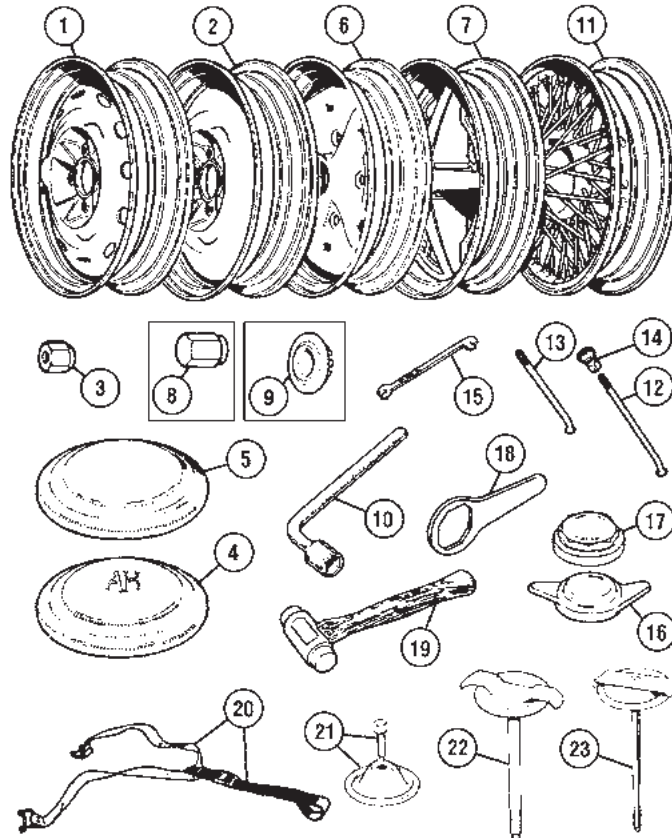

Road Wheels & Tools

12022

No.	Part#	Price (Each)	Description	Application	Qty Req.
1	NA		WHEEL, steel, vented	948	5
2	455-450		WHEEL, steel, non-vented	1098	5
3	264-215	\$1.39	LUG NUT, plain, disc wheels		16
4	200-340	\$94.99	HUBCAP, "AH"	} 948 & 1098	4
5	200-350	\$82.99	HUBCAP, plain, for Midget		4
6	455-455		WHEEL, Rostyle	1275	5
7	455-460		WHEEL, Rostyle	1500	5
8	264-155	\$3.49	NUT, chrome	} 1275 & 1500 Rostyle wheels	16
	264-156	\$5.49	NUT, stainless steel		16
9	462-765	\$11.99	HUBCAP		4
	462-745	\$2.99	MG EMBLEM, hubcap		4
10	386-035		LUG WRENCH	disc wheels	1
11	454-676	\$399.99	WIRE WHEEL, painted	} 13 x 4", 60 spoke	5
12	200-370	\$8.99	SPOKE, long, plain		20
13	200-380	\$8.99	SPOKE, short, plain		40
14	200-050	\$1.19	NIPPLE, plain	Quantities are per wheel	60
	454-686	\$549.99	WIRE WHEEL, chromed	} 13 x 4", 60 spoke	5
	200-390		SPOKE, long, chromed		20
	200-400	\$6.99	SPOKE, short, chromed		40
	200-052	\$2.69	NIPPLE, chromed		60
15	385-800	\$14.99	SPOKE WRENCH	wire wheels	1
16	200-290	\$69.99	KNOCK-OFF, R/H, eared	} Sprite MkII, Midget MkI	2
	200-280	\$69.99	KNOCK-OFF, L/H, eared		2
	674-670	\$69.99	KNOCK-OFF, R/H, eared	} from Sprite MkIII, Midget MkII (8 t.p.i.)	2
	674-680	\$69.99	KNOCK-OFF, L/H, eared		2
17	200-320	\$59.99	KNOCK-OFF, R/H, octagonal	} 12 t.p.i.	2
	200-310	\$59.99	KNOCK-OFF, L/H, octagonal		2
	310-315		NA KNOCK-OFF, R/H, octagonal	} "MG" crested 12 t.p.i.	2
	310-305		NA KNOCK-OFF, L/H, octagonal		2
	462-740	\$69.99	KNOCK-OFF, R/H, octagonal	} 8 t.p.i.	2
	462-730	\$69.99	KNOCK-OFF, L/H, octagonal		2
18	386-030	\$10.99	SPANNER, octagonal knock-offs		1
19	386-000	\$59.99	HAMMER, copper/copper faces, 1 lb.		1
	386-110	\$89.99	HAMMER, copper/rawhide faces, 2 lbs.		1
20	385-950	\$51.99	STRAP SET, spare tire	Bugeye	1
21	386-135		NA CLAMP, spare wheel	std. steel wheels 1961-'67	1
22	386-145		NA CLAMP, spare wheel	Rostyle wheels 1970-'80	1
23	386-155		NA CLAMP, spare wheel	wire wheels 1961-'80	1

Toll-Free Orders 1-800-667-7872 | MossMotors.com
 Fax 805-692-2525 | Local 805-681-3400

MOSS

Brake Hydraulics

Brake fluid and brake service tools are listed in the color section at the front of this catalog.

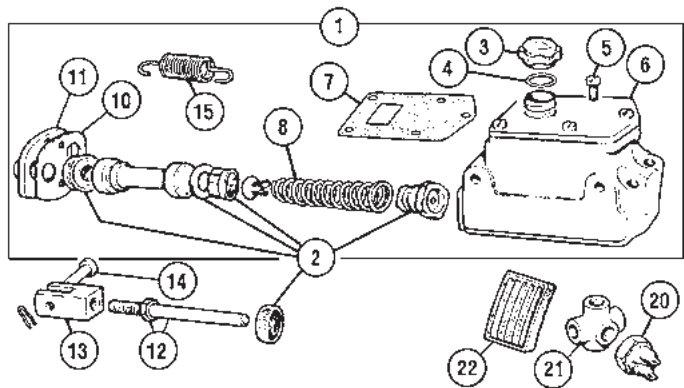

Brake Hydraulics - 948 & 1098

12026

No.	Part#	Price (Each)	Description	Application	Qty Req.
1	180-672	\$329.99	MASTER CYLINDER, 7/8", AP Braking	948 drum brakes	1
	180-670	\$184.99	MASTER CYLINDER, 7/8", TRW		1
	180-673	\$79.99	MASTER CYLINDER, 7/8", Classic Gold		1
	180-555	\$215.99	MASTER CYLINDER, 3/4", TRW		1
	180-556	\$119.99	MASTER CYLINDER, 3/4", aftermarket	1098 front disc brakes	1
2	180-971	\$87.99	REPAIR KIT, 7/8", AP Braking	948	1
	180-970	\$11.99	REPAIR KIT, 7/8", aftermarket		1
	180-565	\$12.99	REPAIR KIT, 3/4", aftermarket		1098
These repair kits may include either a replacement type brake cylinder check valve, or the original type rubber cup for the original check valve.					
3	180-210	\$5.29	CAP, plastic replacement	948 & 1098	1
	180-211	\$14.99	CAP, metal (as original)		1
4	180-451	\$2.99	WASHER, cap (metal cap)		1
5	323-500	\$0.99	SCREW, front & top covers		9/7
6	180-275	\$12.99	COVER		1
7	180-270	\$1.79	GASKET	1	
8	180-030	\$5.99	SPRING	948	2
	181-710	NA	SPRING	1098	2
10	180-020	\$1.49	GASKET	948 & 1098	1
11	180-010	NA	PLATE		1
12	180-305	\$12.39	PUSH ROD, drum brakes, 4-1/8"		2
		NA	PUSH ROD, disc brakes, 3-11/16"		2
13	180-315	\$19.99	FORK		2
14	180-325	\$5.39	CLEVIS PIN	2	
15	180-335	\$2.99	SPRING, pedal return	2	
20	141-700	\$10.99	SWITCH, brake light, screw conn.	Bugeye	1
	542-110	\$9.99	SWITCH, brake light, spade conn.	948, 1098	1
21	180-230	\$46.99	UNION, 4-way plus switch		1
	180-090	\$12.99	UNION, 3-way, rear		1
	322-247	\$0.49	BOLT, union to frame		1
	324-020	\$0.20	LOCKWASHER for bolt		1
22	280-930	\$1.99	PEDAL PAD, brake & clutch		2

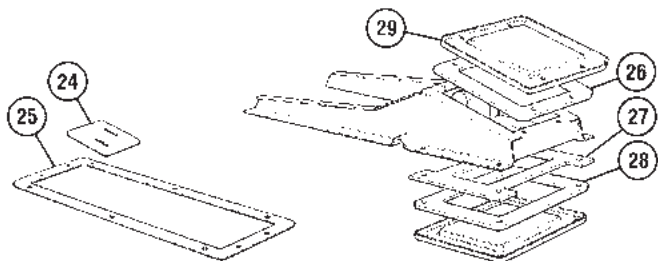

Pedal Box Seals

12028

24	280-085	\$1.49	EXCLUDER, fume & dust	948 & 1098	1
25	280-125	\$2.99	SEAL, pedal box to firewall		1
	280-125	\$2.99	SEAL, pass. side blanking plate		all
26	280-127	\$2.59	SEAL, top cover	1275 & 1500	1
27	280-126	\$3.09	SEAL, pedal box to firewall		1
28	280-128	\$3.99	SEAL, bottom blanking plate		1
29	280-129	\$42.39	TOP COVER		1

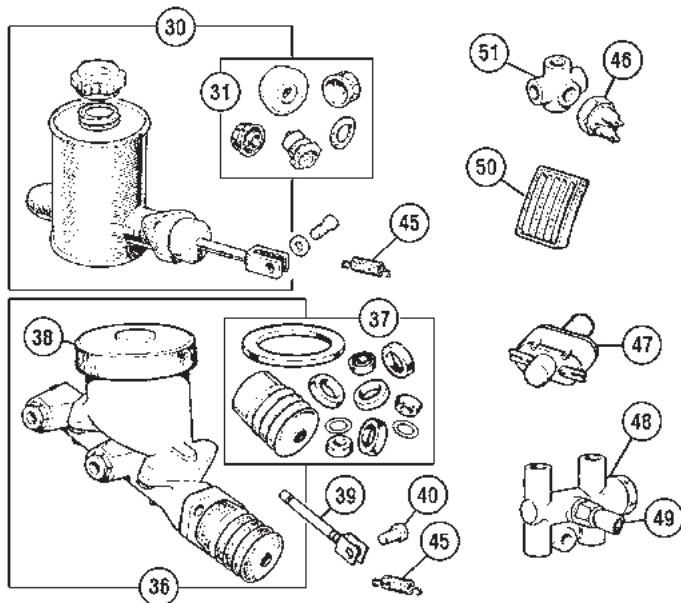

Brake Hydraulics - 1275 & 1500

12027

No.	Part#	Price (Each)	Description	Application	Qty Req.
30	180-584	NA	MASTER CYLINDER, Lockheed (metal reservoir as orig.)	some 1967 cars, single line system	1
	180-585	NA	MASTER CYLINDER, AP Braking (plastic reservoir)		1
	180-586	\$49.99	MASTER CYLINDER, aftermarket		1
31	180-875*	\$6.99	REPAIR KIT, cyls. not marked*	1275 & 1500 dual line system	1
	180-985*	\$7.99	REPAIR KIT, marked cyls.*		1
			*See illustration below. Repair kits fit orig. cyls. only.		
32	180-210	\$5.29	CAP, plastic (orig. cylinders only)		1
36	180-345	\$149.99	MASTER CYLINDER, TRW/Lucas	1275 & 1500 dual line system	1
	180-347	\$44.99	MASTER CYLINDER, aftermarket		1
	180-205*	\$21.99	REPAIR KIT*		1
*Repair Kit fits Lockheed, AP, TRW & Lucas master cylinders only. Disassembly of this master cylinder is very difficult without damage to some internal parts which are not available. We suggest no attempt be made to rebuild these.					
38	180-215	\$18.99	CAP		1
39	181-695	NA	PUSH ROD		1
40	325-135	\$1.59	CLEVIS PIN		1
45	329-350	\$2.29	SPRING, pedal return	1275 & 1500	2
46	542-110	\$9.99	SWITCH, brake light, spade conn.	1275 (1967)	1
47	181-980	\$11.49	SWITCH, brake light	1275 from 1968, 1500	1
	310-070	\$0.39	JAM NUT for switch		1
48	141-710	NA	P.D.W.A. ASS'Y., brass	1275 & 1500 thru 1975	1
	141-720	NA	P.D.W.A. ASS'Y., cast iron	1500 from 1976-on	1
49	542-115	\$69.99	SWITCH for cast iron ass'y.		1
	141-725	\$74.99	SWITCH for brass ass'y.		1
	181-995	\$18.99	REPAIR KIT for original ass'y's. with "O"-ring seals		1
	181-985	\$39.99	REPAIR KIT for original ass'y's. with lip type seals (has new shuttle and replacement o-rings to replace orig. parts)		1
50	280-930	\$1.99	PEDAL PAD, brake & clutch		2
51	180-230	\$46.99	UNION, 4-way plus switch	1275 single line system	1
	180-090	\$12.99	UNION, 3-way, rear		1

Note: 1967 single line systems used either one of two master cylinders. The earlier has no identifying marking. The later has either of the markings shown below. The master cylinder assemblies are interchangeable, but the internal parts are not.

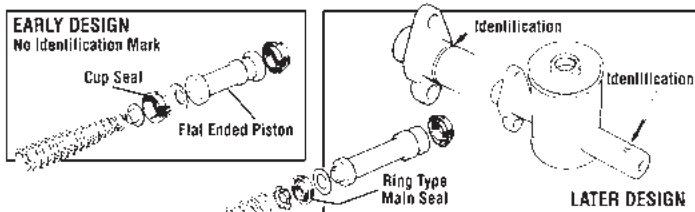

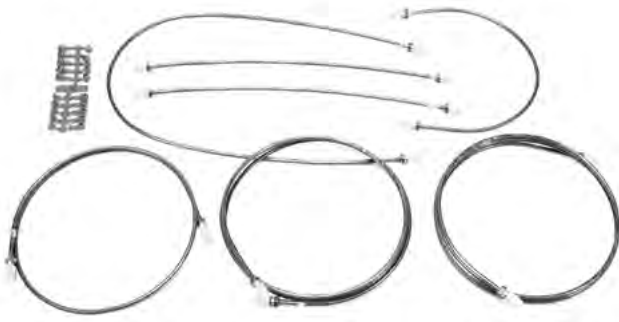

Brake Pipe Sets

Moss brake pipe sets are made in England of high-strength corrosion resistant copper-nickel alloy tubing. Pipes are supplied coiled, but are much easier to bend smoothly and correctly than steel. All pipes come with end fittings and flares, and are individually coded to the instruction sheet so there is no doubt as to where they fit on your car. Note: These pipes have modern universal standard flares which are totally compatible with the original fittings.

184-008	\$274.99	BRAKE PIPE SET	Bugeye
184-018	\$249.99	BRAKE PIPE SET	Sprite MkII, Midget MkI (drum brakes)
184-028	\$219.99	BRAKE PIPE SET	1963-'67 (disc brakes)
184-038	\$239.99	BRAKE PIPE SET	1968-1974
184-048	\$239.99	BRAKE PIPE SET	Midget 1500

Brake Pipe Bending Tool



Smooth bends on small diameter tubing such as brake lines are an important hallmark of quality craftsmanship. Give yourself an edge with our specialty tubing bender which will give you smooth bends in 3/16, 1/4, 5/16, and 3/8 inch tubing.

385-905 \$24.99

Braided Stainless Steel/Teflon Brake Hose Sets

These competition-inspired brake hose sets meet all DOT safety standards and are street legal in all 50 states. Each set includes all brake hoses used on your car, with any required retaining nuts and/or copper sealing washers.

Goodridge brand (England)

Sprite-Midget (with front drum brakes)	182-198	\$82.99
Sprite-Midget (with front disc brakes)	182-248	\$74.99

Cobalt brand (USA)

Sprite-Midget (with front drum brakes)	180-358	\$89.99
Sprite-Midget (with front disc brakes)	180-378	\$89.99



Brake Fluids

Choose the brake fluid your car needs. Genuine Lockheed Brake Fluid is compatible with all British brake systems. Silicone fluid won't harm paint, and doesn't absorb moisture, as do conventional fluids. (If changing from one type to the other, flush your brake system thoroughly with the "new" type of brake fluid.)

Silicone Brake Fluid

220-413 \$34.99

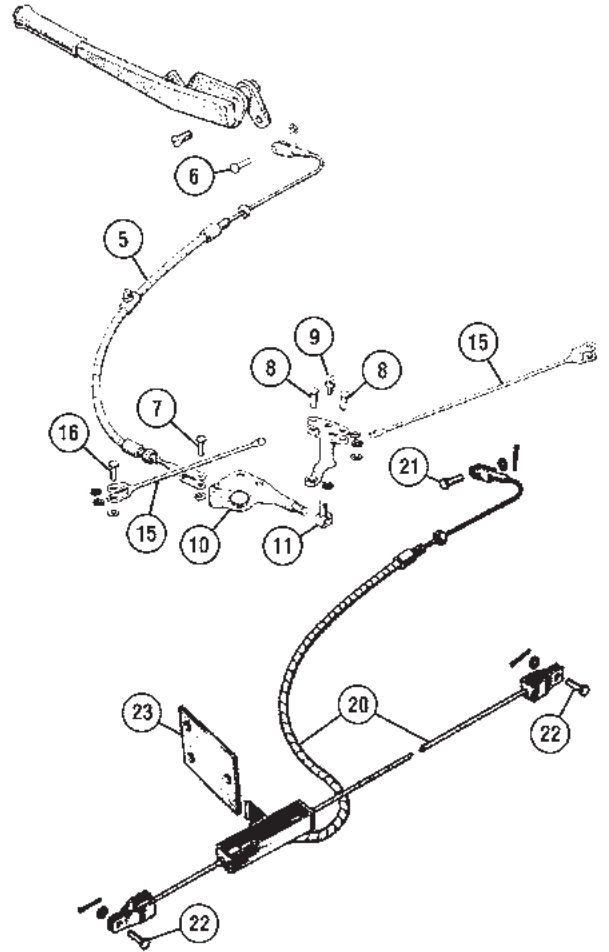

Handbrake

12032

No.	Part#	Price (Each)	Description	Application	Qty Req.
5	331-660	\$28.99	HANDBRAKE CABLE	948 thru 1500 (c)182000	1
6	325-140	\$1.19	CLEVIS PIN, cable to handle		1
7	325-130	\$1.39	CLEVIS PIN, cable to lever		1
8	325-455	\$1.09	CLEVIS PIN, cross-rods to lever		2
9	328-500	\$0.99	GREASE NIPPLE		1
10	331-666	\$86.99	BRACKET, lever support		1
11	182-720	\$12.19	TRUNNION	1	
15	NA		LINK ROD PAIR	Sprite thru HAN6-20792, Midget thru (c)13554	1
	331-668	\$52.99	LINK ROD PAIR (adjustable) (for disc or wire wheels)	Sprite from HAN6-20793, Midget (c)13555 thru 182000	1
16	325-130	\$1.39	CLEVIS PIN, outer ends of rods	(all except 1500)	2
20	331-670	\$33.99	HANDBRAKE CABLE ASSEMBLY, disc wheels	1500 from (c)182001 on	1
	331-680	\$42.99	HANDBRAKE CABLE ASSEMBLY, wire wheels		1
21	325-135	\$1.59	CLEVIS PIN, cable to handle		1
22	325-255	\$1.09	CLEVIS PIN, cable to wheel		2
23	182-345	\$2.19	STRAP, handbrake cable to axle		1

Front Brakes

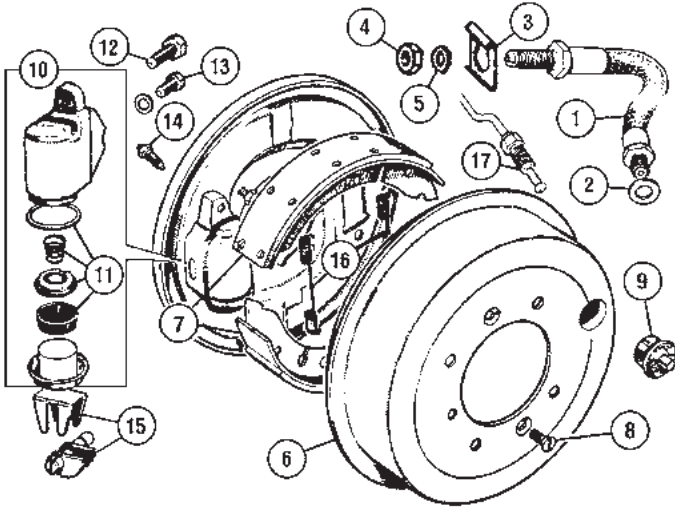

948 Front Brakes

12035

No.	Part#	Price (Each)	Description	Application	Qty Req.
1	180-355	\$32.99	HOSE, front, Delphi-Lockheed		2
	180-356	\$15.99	HOSE, front, aftermarket		2
2	324-730	\$0.69	WASHER, copper		2
3	181-660	\$3.89	LOCKING PLATE		2
4	310-070	\$0.39	JAM NUT		2
5	324-045	\$0.49	LOCKWASHER		2
6	181-885	NA	BRAKE DRUM, front, premium repro.		2
	181-887	\$25.99	BRAKE DRUM, front, Classic Gold		2
7	182-120	\$21.99	BRAKE SHOE SET, front		1
8	323-250	\$0.59	SCREW, front drum to hub		4
9	181-975	\$1.39	PLUG, front & rear drums		4
10	180-640†	\$39.99	WHEEL CYLINDER, R/H front, Delphi-Lockheed		2
	180-641†	\$16.99	WHEEL CYLINDER, R/H front, aftermarket		2
	180-650†	\$39.99	WHEEL CYLINDER, L/H front, Delphi-Lockheed		2
	180-656†	\$16.99	WHEEL CYLINDER, L/H front, aftermarket		2
†All current cylinders use lip type seals. Rebuild kits are not available for these.					
11	180-458	\$79.99	REBUILD KIT, 4 cylinders (orig. cyls. w/cup seals)		1
	180-459	\$19.99	REBUILD KIT, 1 cylinder (orig. cyls. w/cup seals)		4
	180-180	\$1.69	SPRING		4
	180-170	\$2.99	EXPANDER		4
	180-940	\$18.99	CUP & RING		4
12	322-880	\$0.99	BOLT, large		4
13	322-400	\$3.69	BOLT, small		4
14	180-100	\$1.99	BLEEDER, front & rear		4
15	180-105	NA	ADJUSTER & MASK		6
16	182-680	\$5.99	SPRING, shoe return, front		4
17	181-125	NA	PIPE, between ft. wheel cylinders		2

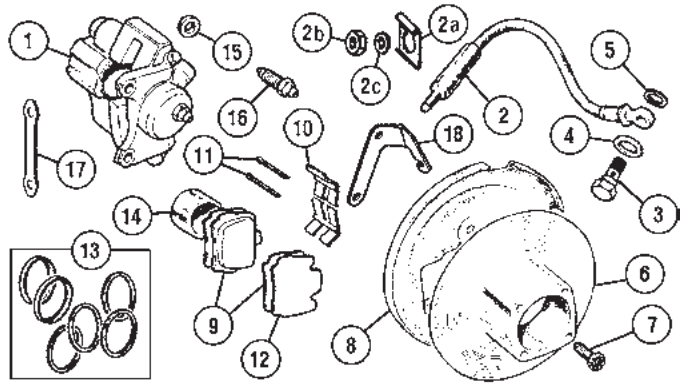

Front Disc Brakes

12034

No.	Part#	Price (Each)	Description	Application	Qty Req.
1	182-718	\$174.99	CALIPER PAIR, new		1
	182-703	\$94.99	CALIPER ASS'Y., new, R/H		1
	182-713	\$94.99	CALIPER ASS'Y., new, L/H		1
2	180-375	\$31.99	HOSE, front disc brake, OE		2
	180-376	\$12.49	HOSE, front disc brake, aftermarket		2
	180-377	\$13.99	HOSE, front disc brake, Cobalt		2
2a	181-660	\$3.89	LOCKING PLATE		2
2b	310-070	\$0.39	JAM NUT		2
2c	324-045	\$0.49	LOCKWASHER		2
3	180-430	\$9.99	BANJO BOLT		2
4	324-720	\$0.99	WASHER, copper, large		2
5	324-730	\$0.69	WASHER, copper, small		2
6	182-155	\$109.99	BRAKE ROTOR, "Brembo" brand	} disc wheels	2
	182-154	\$24.99	BRAKE ROTOR, aftermarket		2
	182-145	NA	BRAKE ROTOR, "Brembo" brand	} wire wheels	2
	182-146	\$17.99	BRAKE ROTOR, aftermarket		2
	586-600	\$229.99	BRAKE ROTOR PAIR, cross-drilled/slotted	disc wheels	1
7	322-435	\$3.89	BOLT, brake rotor		8
8	182-265	\$38.99	DUST COVER, R/H		1
	182-275	\$38.99	DUST COVER, L/H		1
9	071-539	\$23.99	PAD SET, Classic Gold, semi-metallic	} see color section at front of this catalog for details	1
	071-533	\$36.99	PAD SET, Classic Gold, ceramic		1
	585-605	\$144.99	PAD SET, "Hawk"		1
	585-625	\$76.99	PADSET, "Greenstuff"		1
10	181-965	\$2.29	RETAINER		2
11	325-430	\$0.49	COTTER PIN		4
12	181-935	\$2.39	SHIM, anti-squeal		4
	182-890	\$42.99	PISTON & SEAL KIT, for 2 calipers		1
13	182-840	\$9.99	REPAIR KIT, for two calipers		1
14	182-810	\$9.99	CALIPER PISTON, stock type		4
	181-926	\$20.99	CALIPER PISTON, stainless steel		4
15	180-285	\$0.79	SEAL, fluid channel, between caliper halves		2
16	180-100	\$1.99	BLEEDER SCREW		2
17	181-670	\$0.89	TAB WASHER		2
18	181-671	\$17.99	BRACKET, brake hose, R/H		1
	181-672	\$17.99	BRACKET, brake hose, L/H		1

Caliper halves should never be separated. If, for some reason, you have ignored warnings not to do this, this seal is available.



Disc Brake Kits

When your Sprite or Midget needs a brake job, ordering one part number and getting everything you need at once makes the job so much easier.

Stock type

Disc wheels **182-157** **\$69.99**

Wire wheels **182-161** **\$63.99**

Stage 1 (slotted/drilled rotors, ceramic pads)

Disc wheels **182-690** **\$179.99**

Wire wheels **182-695** **\$174.99**



Cross-Drilled & Slotted Brake Rotors

Stop! Cross drilled rotors cool better for reduced brake fade and scrub off water faster in the wet. Special rotational hole pattern. For disc wheel cars. Sold as pairs only.

586-600 **\$229.99**

Rear Brakes

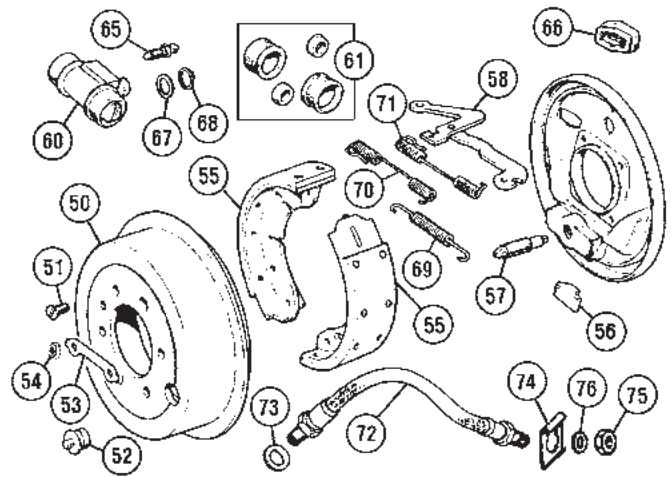
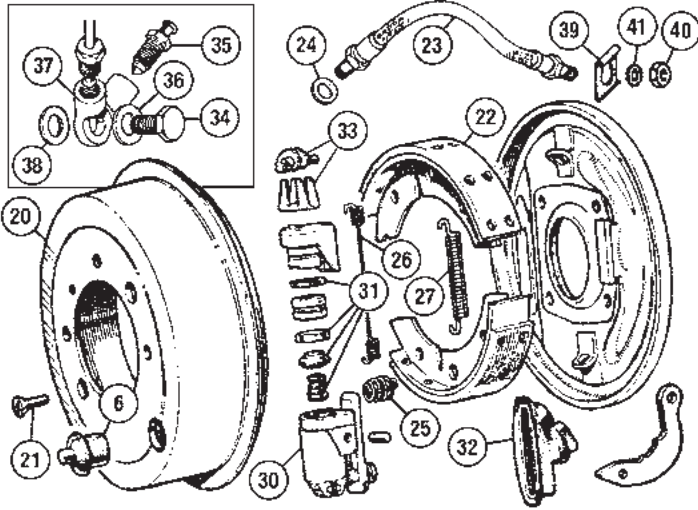

Early 948 Rear Brakes

12038

No.	Part#	Price (Each)	Description	Application	Qty Req.
20	181-885	NA	BRAKE DRUM, rear, premium repro.	Sprite to HAN6-20544, Midget to GAN1-13554	2
	181-887	\$25.99	BRAKE DRUM, rear, Classic Gold		2
21	323-255	\$0.69	SCREW, rear drum to hub		4
22	182-140	\$19.99	BRAKE SHOE SET, rear		1
23	180-895	\$22.99	HOSE, rear		1
	180-896	\$19.99	HOSE, rear, aftermarket		1
	180-897	\$15.99	HOSE, rear, Cobalt		1
24	324-730	\$0.69	WASHER		1
25	181-340	\$1.89	SPRING, shoe steadying		4
26	182-655	\$5.49	SPRING, cylinder end		2
27	182-660	\$4.99	SPRING, abutment end		2
30	181-285*	\$29.99	WHEEL CYLINDER, rear, w/lever		2
31	180-470	\$23.99	REPAIR KIT, for 2 cylinders		1
32	180-950	\$10.99	BOOT (not incl. w/cylinders)		2
33	180-105	NA	ADJUSTER & MASK		6
34	180-130	\$10.99	BANJO BOLT		2
35	180-100	\$1.99	BLEEDER, front & rear		4
36	324-720	\$0.99	WASHER, large copper		2
37	180-460	\$29.99	BANJO FITTING		2
38	324-730	\$0.69	WASHER, small copper		2
39	181-660	\$3.89	LOCKING PLATE	1	
40	310-070	\$0.39	JAM NUT	1	
41	324-045	\$0.49	LOCKWASHER	1	

*Wheel Cylinder 181-285 is Classic Gold brand, and uses a modern lipped ring type seal instead of the original cup seal. Rebuild kits are not available for these wheel cylinders.

Late 948 thru 1500 Rear Brakes

12039

No.	Part#	Price (Each)	Description	Application	Qty Req.	
50	181-885	NA	BRAKE DRUM, rear, premium repro.	7/8" bore, Sprite (c)20545 to 24731, Midget (c)13555 to 16183	2	
	181-887	\$25.99	BRAKE DRUM, rear, Classic Gold		2	
51	323-255	\$0.69	SCREW, drum to hub		4	
52	181-975	\$1.39	PLUG		2	
53	181-915	\$1.49	TAB WASHER		} wire wheels	4
54	310-075	\$0.39	NUT			8
55	115-139	NA	BRAKE SHOE SET, Mintex		1	
	182-175	\$19.99	BRAKE SHOE SET, Classic Gold		1	
	181-906	\$11.99	ADJUSTER KIT (for one side)		2	
56	181-895	NA	ADJUSTER TAPPET		4	
57	181-905	NA	ADJUSTER WEDGE		2	
58	182-676	\$12.79	LEVER ASS'Y., R/H		1	
	182-677	\$11.69	LEVER ASS'Y., L/H		1	
60	180-445	\$84.99	WHEEL CYLINDER, Lockheed		} 1098 & 1275	2
	180-446*	\$16.99	WHL. CYLINDER, aftermarket			2
61	180-480**	\$4.99	REPAIR KIT, aftermarket		} 1500	2
	180-385	\$35.99	WHEEL CYLINDER, 3/4", Lockheed			2
	180-386*	\$10.99	WHEEL CYLINDER, 3/4", aftermarket		2	
	180-406**	\$12.99	REPAIR KIT, AP Braking brand		2	
	180-405**	\$6.79	REPAIR KIT, aftermarket		2	
	180-395	\$35.99	WHEEL CYLINDER, rear, Lockheed	} 1500	2	
	180-396*	\$11.99	WHEEL CYLINDER, rear, aftermarket		2	
	071-526**	\$5.99	REPAIR KIT, aftermarket	2		
65	323-145	\$1.89	BLEED NIPPLE (incl. with wheel cylinders)	2		
66	181-760	\$1.39	BOOT	all	2	
67	180-575	\$7.39	WASHER, cylinder retaining	} original fitment	2	
68	326-945	\$1.79	CIRCLIP		2	
	326-720	\$1.19	"C" CLIP, cylinder retaining	replaces #67 & 68	2	
69	182-665	\$3.59	SPRING, abutment end	2		
70	182-670	\$9.99	SPRING, R/H, cylinder end	1		
71	182-675	\$9.99	SPRING, L/H, cylinder end	1		
72	180-895	\$22.99	HOSE, rear brake	1		
	180-896	\$19.99	HOSE, rear brake, aftermarket	1		
	180-897	\$15.99	HOSE, rear brake, Cobalt	1		
73	324-730	\$0.69	WASHER, copper	1		
74	181-660	\$3.89	LOCKING PLATE	1		
75	310-070	\$0.39	JAM NUT	1		
76	324-045	\$0.49	LOCKWASHER	1		

*No rebuild kits are available for these aftermarket wheel cylinders.

**Rebuild kits fit only original wheel cylinders.



Brake Adjuster Wrench

Get a better grip on your brake adjusters with our specially designed wrench. It has 1/4" and 5/16" square box ends, and a long handle for good leverage.

386-160

\$13.99

Body Panels, Bugeye

Most of our body panels are shipped from overseas, and consequently invariably have some scratches and often minor dents. Panels will likely require alterations to fit your particular car accurately. Please anticipate some clean-up and/or modifications. Test fit body panels before modifying or painting - once altered or painted, they are not returnable.

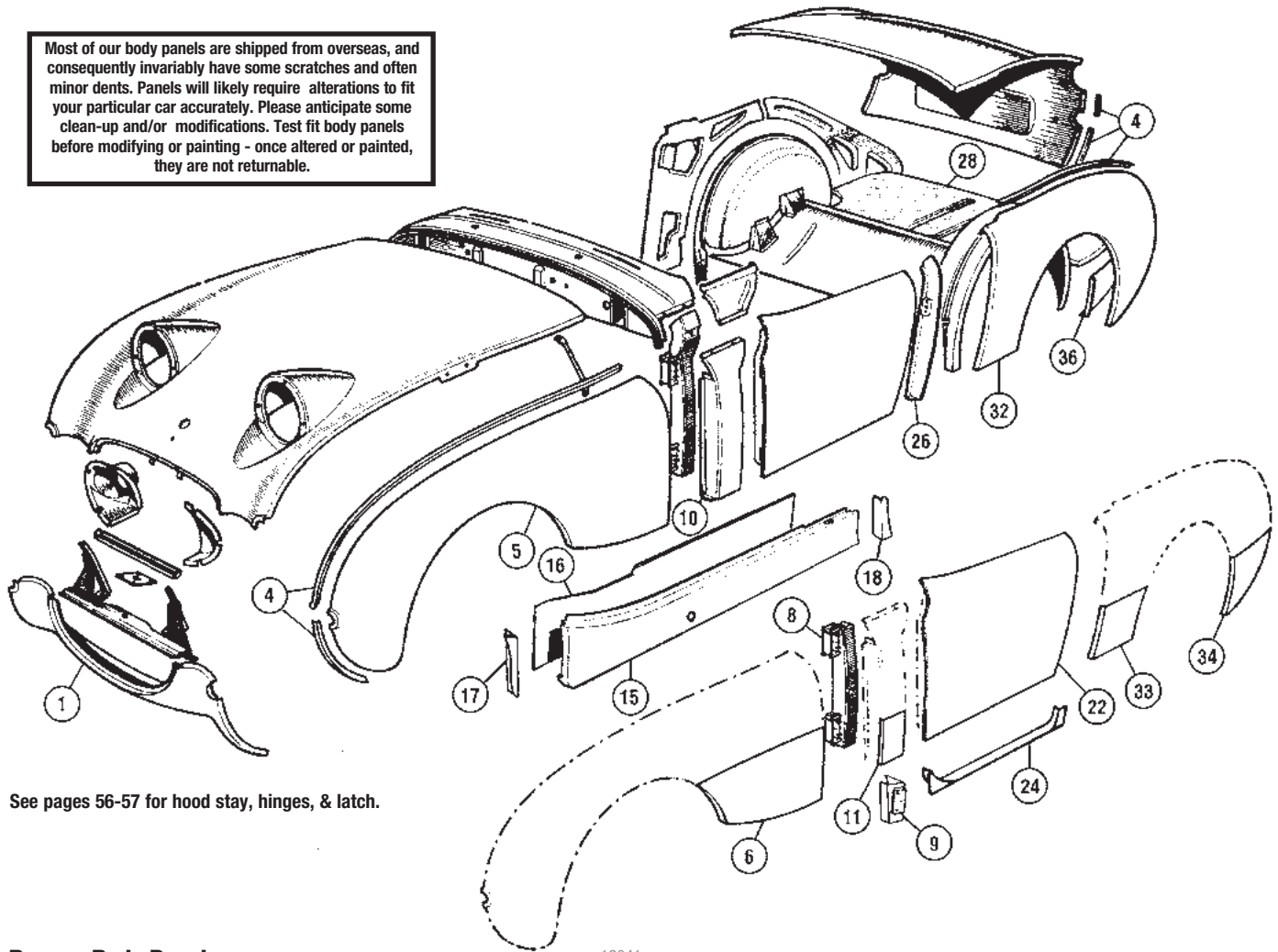

See pages 56-57 for hood stay, hinges, & latch.

Bugeye Body Panels

12041

No.	Part#	Price (Each)	Description	Application	Qty Req.
1	452-110	NA	VALANCE, lower front		1
4	457-990	\$49.99	FENDER BEADING	66" length	A/R
5	455-680	\$999.99	FRONT FENDER, L/H		1
	455-670	NA	FRONT FENDER, R/H		1
6	452-120	\$37.99	REPAIR PANEL, L/H		1
	452-125	\$37.99	REPAIR PANEL, R/H		1
8	452-130	\$49.99	"A" POST, inner, L/H, lower 16"		1
	452-135	\$49.99	"A" POST, inner, R/H, lower 16"		1
9	455-065	\$15.99	HINGE MOUNT, lower, L/H		1
	455-055	\$15.99	HINGE MOUNT, lower, R/H		1
10	452-645	\$54.99	"A" POST, outer skin, L/H	} as illus. w/flange	1
	452-655	\$54.99	"A" POST, outer skin, R/H		1
11	455-280	\$4.69	REPAIR PIECE, lower 7-1/2"		2
15	455-495	\$139.99	OUTER SILL, L/H		1
	455-490	\$139.99	OUTER SILL, R/H		1
16	455-445	\$29.99	INNER SILL, L/H	} late type with 2 holes	1
	455-440	\$29.99	INNER SILL, R/H		1
17	452-150	\$34.99	END CAP, front, L/H	British Motor Heritage	1
	452-310	\$8.89	END CAP, front, L/H	aftermarket	1
	452-155	\$34.99	END CAP, front, R/H	British Motor Heritage	1
	452-300	\$8.89	END CAP, front, R/H	aftermarket	1
18	452-160	\$34.99	END CAP, rear, L/H	British Motor Heritage	1
	452-315	\$12.99	END CAP, rear, L/H	aftermarket	1
	452-165	\$34.99	END CAP, rear, R/H	British Motor Heritage	1
	452-305	\$12.99	END CAP, rear, R/H	aftermarket	1
22	452-170	\$249.99	DOOR SKIN, L/H		1
	452-175	\$249.99	DOOR SKIN, R/H		1
24	452-180	\$49.99	REPAIR PIECE, inner door bottom, L/H		1
	452-185	\$49.99	REPAIR PIECE, inner door bottom, R/H		1
26	455-650	\$76.99	"B" POST FACE, L/H		1
	455-640	\$76.99	"B" POST FACE, R/H		1
28	452-190	\$229.99	TRUNK FLOOR		1

No.	Part#	Price (Each)	Description	Application	Qty Req.
32	455-700	NA	REAR FENDER, L/H		1
	455-690	NA	REAR FENDER, R/H		1
33	452-200	\$21.99	REPAIR PANEL, front, L/H		1
	452-205	\$21.99	REPAIR PANEL, front, R/H		1
34	452-210	\$206.99	REPAIR PANEL, rear, L/H		1
	452-215	\$206.99	REPAIR PANEL, rear, R/H		1
36	452-220	\$34.99	CLOSING PANEL, trunk to fender, L/H		1
	452-225	\$34.99	CLOSING PANEL, trunk to fender, R/H		1

Common Areas of Corrosion

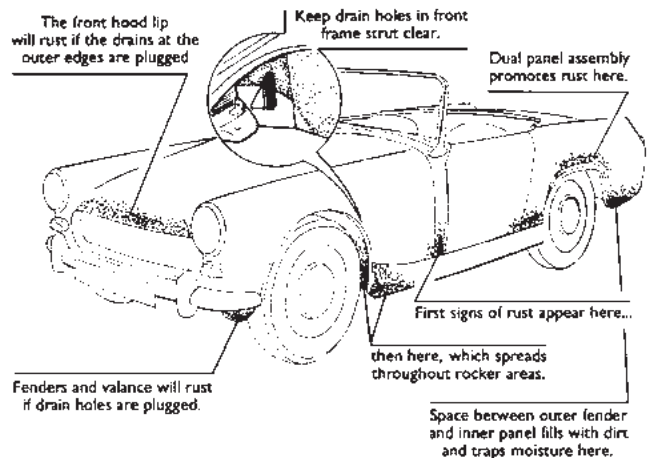

Most of our body panels are shipped from overseas, and consequently invariably have some scratches and often minor dents. Panels will likely require alterations to fit your particular car accurately. Please anticipate some clean-up and/or modifications. Test fit body panels before modifying or painting - once altered or painted, they are not returnable.

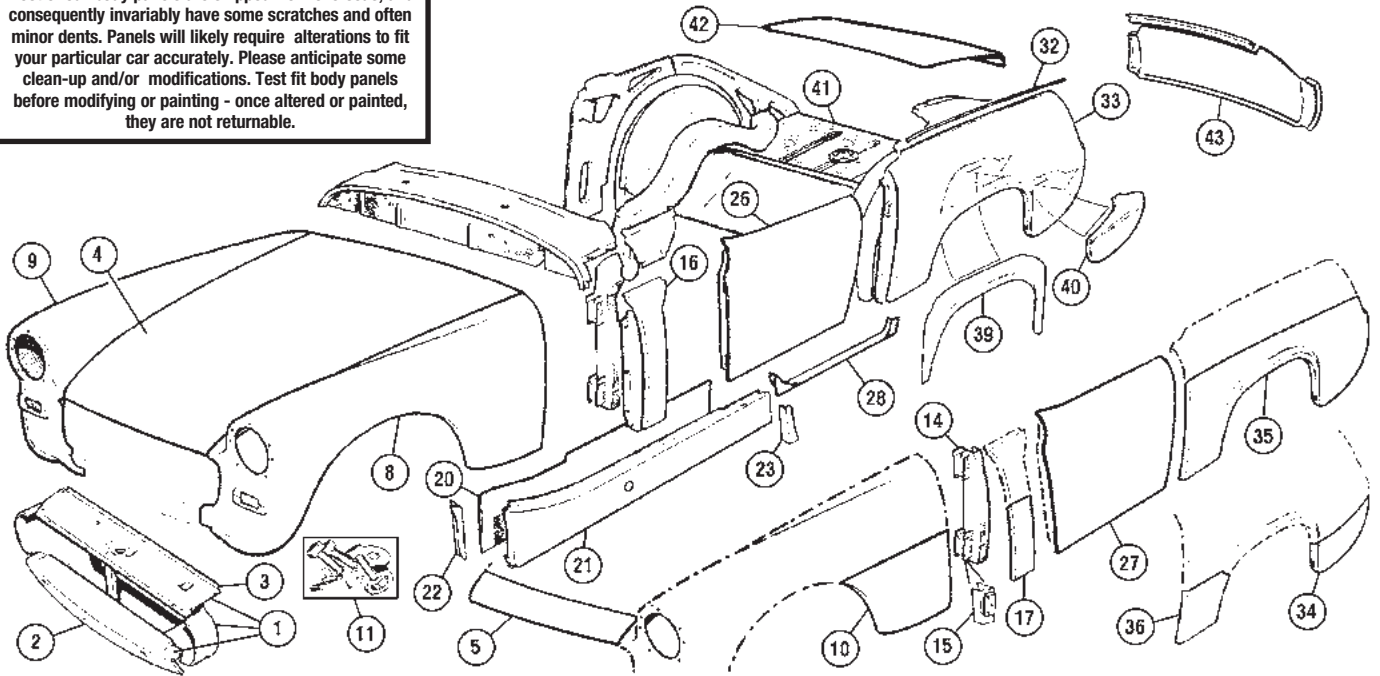

Body Panels (except Bugeye Sprite)

12042

No.	Part#	Price (Each)	Description	Application	Qty Req.
<u>Underlined part numbers</u> indicate an Oversize Parts Fee will be charged. See mossmotors.com or call for details.					
1	455-145	\$589.99	FRONT PANEL ASSEMBLY, BMH*	except 1500	1
	455-155	\$599.99	FRONT PANEL ASSEMBLY, BMH*	1500	1
2	455-190	\$354.99	VALANCE PANEL, front, BMH*	except 1500	1
	452-430	\$229.99	VALANCE PANEL, front	1500	1
3	455-165	\$89.99	HOOD LATCH PANEL	except 1500	1
	455-345	NA	HOOD LATCH PANEL	1500	1
4	455-290	\$1,099.00	HOOD, BMH*	Midget to (c)183739, all Sprite	1
	455-790	\$1,099.00	HOOD, BMH*	Midget from (c)183740	1
5	455-200	NA	REPAIR PANEL, hood "skin"	all	1
	452-240	NA	REPAIR PANEL, inner hood	all	1
8	455-710	\$1,049.00	FRONT FENDER, L/H, BMH*	AH MkII thru 1968,	1
9	455-715	\$1,049.00	FRONT FENDER, R/H, BMH*	MG MkI thru 1968	1
	455-720	\$1,099.00	FRONT FENDER, L/H, BMH*	1275 from '69-'74	1
	455-725	\$1,099.00	FRONT FENDER, R/H, BMH*	1275 from '69-'74	1
	455-730	\$999.99	FRONT FENDER, L/H, BMH*	1500	1
	455-735	\$999.99	FRONT FENDER, R/H, BMH*	1500	1
10	455-265	\$36.99	REPAIR PANEL, L/H	except 1500	1
	455-260	\$36.99	REPAIR PANEL, R/H	except 1500	1
	455-275	\$36.99	REPAIR PANEL, L/H	1500	1
	455-270	\$36.99	REPAIR PANEL, R/H	1500	1
11	322-995	\$12.49	HARDWARE KIT, ft. fender mounting		2
14	452-130	\$49.99	"A" POST ASSEMBLY, L/H	thru 1968 (lower 16")	1
	452-135	\$49.99	"A" POST ASSEMBLY, R/H	16"	1
	455-185	\$49.99	"A" POST ASSEMBLY, L/H	from 1969 on (lower 16")	1
	455-195	\$49.99	"A" POST ASSEMBLY, R/H	from 1969 on (lower 16")	1
15	455-065	\$15.99	TAPPING PLATE ASS'Y., lower, L/H		1
	455-055	\$15.99	TAPPING PLATE ASS'Y., lower, R/H		1
16	452-645	\$54.99	OUTER SKIN, "A" post, L/H	side curtain cars	1
	452-655	\$54.99	OUTER SKIN, "A" post, R/H	side curtain cars	1
	455-665	\$99.99	OUTER SKIN, "A" post, L/H, BMH*	wind-up window cars	1
	455-675	\$99.99	OUTER SKIN, "A" post, R/H, BMH*	wind-up window cars	1
17	455-280	\$4.69	REPAIR PANEL, lower 7-1/2"		2
20	455-445	\$29.99	INNER SILL, L/H	late type with 2 holes	1
	455-440	\$29.99	INNER SILL, R/H	late type with 2 holes	1
21	455-495	\$139.99	OUTER SILL, L/H, 1 jack point	except 1500	1
	455-490	\$139.99	OUTER SILL, R/H, 1 jack point	except 1500	1
	455-025	\$129.99	OUTER SILL, L/H, 2 jack points	1500	1
	455-015	\$129.99	OUTER SILL, R/H, 2 jack points	1500	1
22	452-150	\$34.99	END CAP, front, L/H, BMH*		1
	452-310	\$8.89	END CAP, front, L/H, aftermarket		1
	452-155	\$34.99	END CAP, front, R/H, BMH*		1
	452-300	\$8.89	END CAP, front, R/H, aftermarket		1

No.	Part#	Price (Each)	Description	Application	Qty Req.
23	452-160	\$34.99	END CAP, rear, L/H, BMH*		1
	452-315	\$12.99	END CAP, rear, L/H, aftermarket		1
	452-165	\$34.99	END CAP, rear, R/H, BMH*		1
	452-305	\$12.99	END CAP, rear, R/H, aftermarket		1
26	452-260	\$499.99	DOOR ASSEMBLY, L/H, BMH*	wind-up window cars	1
	452-270	\$499.99	DOOR ASSEMBLY, R/H, BMH*	wind-up window cars	1
27	452-170	\$249.99	DOOR SKIN, L/H	side curtain cars	1
	452-175	\$249.99	DOOR SKIN, R/H	side curtain cars	1
	452-250	\$169.99	DOOR SKIN, L/H, BMH*	wind-up window cars	1
	455-035	\$169.99	DOOR SKIN, R/H, BMH*	wind-up window cars	1
28	452-180	\$49.99	REPAIR PIECE, inner door bottom, L/H	all	1
	452-185	\$49.99	REPAIR PIECE, inner door bottom, R/H		1
32	457-990	\$49.99	FENDER BEADING, 66" length		A/R
33	455-915	\$949.99	REAR FENDER, L/H	Sprite MkII & Midget	1
	455-925	\$949.99	REAR FENDER, R/H	MkI	1
	455-945	NA	REAR FENDER, L/H	Sprite MkIII & Midget	1
	455-955	NA	REAR FENDER, R/H	MkII	1
	455-795	\$649.99	REAR FENDER, L/H, BMH*	1275 square arch to	1
	455-750	\$649.99	REAR FENDER, R/H, BMH*	January 1972	1
	455-765	\$599.99	REAR FENDER, L/H, BMH*	1275 round arch GAN5-	1
	455-760	\$599.99	REAR FENDER, R/H, BMH*	105501 to 123730	1
	455-775	NA	REAR FENDER, L/H	1275 square arch GAN5-	4
	455-770	NA	REAR FENDER, R/H	123730 to 153290	1
	455-785	\$649.99	REAR FENDER, L/H	1500	1
	455-780	\$649.99	REAR FENDER, R/H	1500	1
34	455-705**	\$64.99	REPAIR PANEL, rear of L/H fender	chrome bumper cars	1
	455-695**	\$64.99	REPAIR PANEL, rear of R/H fender	chrome bumper cars	1
35	455-115	\$369.99	REPAIR PANEL, L/H rear wheel arch	square arch only	1
	455-105	\$369.99	REPAIR PANEL, R/H rear wheel arch	square arch only	1
36	455-135	\$42.99	REPAIR PANEL, L/H		1
	455-125	\$42.99	REPAIR PANEL, R/H		1
39	455-095	\$114.99	REPAIR PANEL, L/H inner wheel arch	square arch only	1
	455-085	\$114.99	REPAIR PANEL, R/H inner wheel arch		1
40	455-805**	\$79.99	CLOSING PANEL, trunk to fender, L/H, BMH*		1
	455-815**	\$79.99	CLOSING PANEL, trunk to fender, R/H, BMH*		1
41	452-195	\$349.99	TRUNK FLOOR, BMH*		1
42	455-895	\$549.99	TRUNK LID, BMH		1
43	455-995	\$259.99	REAR APRON PANEL, BMH*	1961-'69	1
	456-505	\$249.99	REAR APRON PANEL, BMH*	1970-'74	1
	455-395	NA	REAR APRON PANEL, BMH*	1500	1

*Parts marked "BMH" are produced by British Motor Heritage.

**Fits thru 1974, but may be modified for rubber bumper cars

Toll-Free Orders 1-800-667-7872 | MossMotors.com
 Fax 805-692-2525 | Local 805-681-3400

MOSS

Inner Body Panels

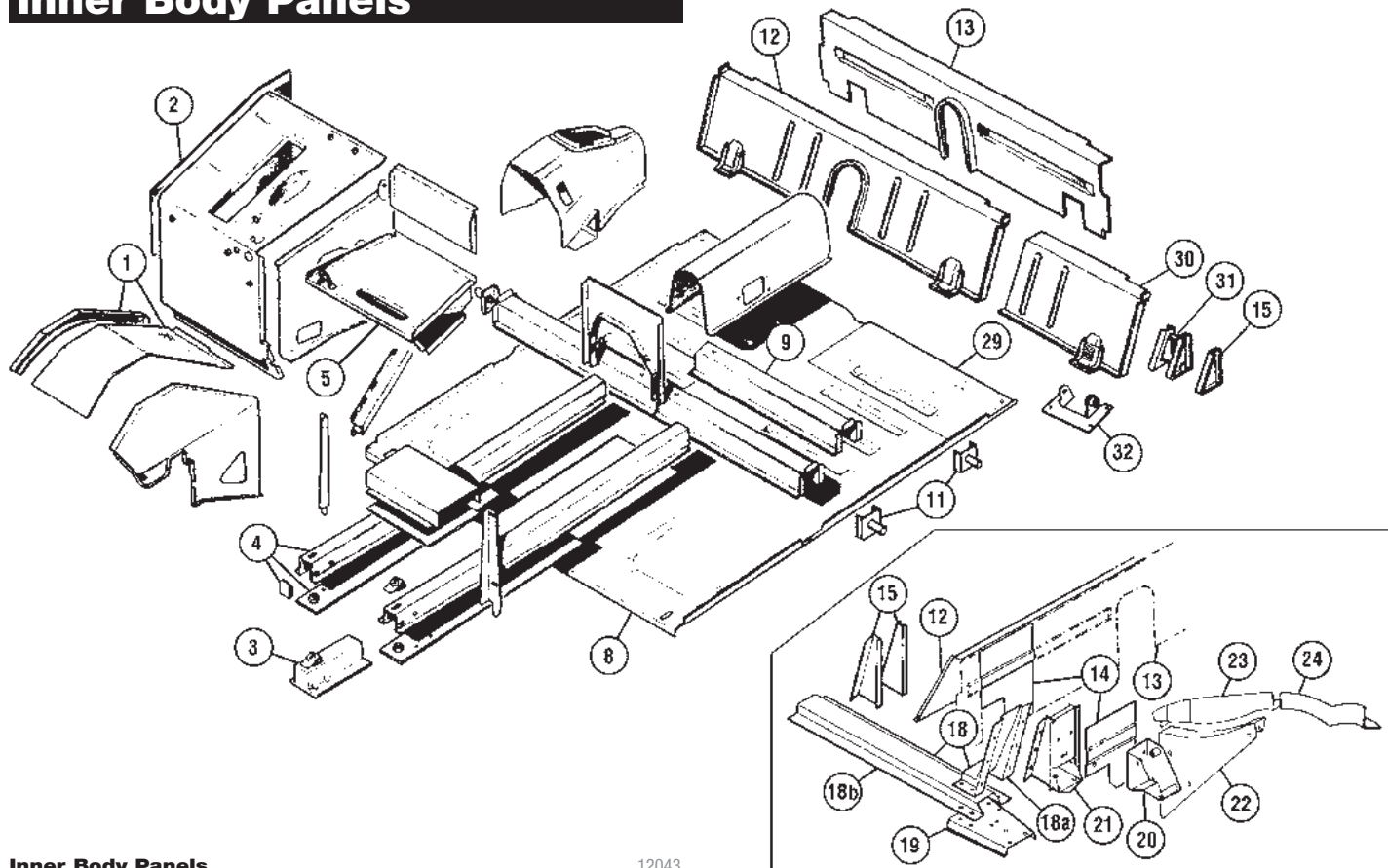

Inner Body Panels

12043

No.	Part#	Price (Each)	Description	Application	Qty Req.
1	455-225	\$59.99	WHEEL ARCH, front, R/H (as illus.)	Bugeye except Bugeye	1
	455-235	\$59.99	WHEEL ARCH, front, L/H (as illus.)		1
	455-245	\$69.99	WHEEL ARCH, front, R/H (as illus.)		1
	455-255	\$61.39	WHEEL ARCH, front, L/H (as illus.)		1
2	455-210	\$72.99	PANEL, outer side of footwell, R/H, BMH**	Bugeye	1
	455-215	\$72.99	PANEL, outer side of footwell, L/H, BMH**		1
3	455-505	\$74.99	FRAME SECTION, front, R/H	Bugeye	1
	455-515	\$74.99	FRAME SECTION, front, L/H		1
4	455-525	\$149.99	FRAME RAIL, complete, R/H, BMH**	all except Bugeye	1
	455-535	\$149.99	FRAME RAIL, complete, L/H, BMH**		1
5	455-236	\$145.99	SHELF, battery & heater, BMH**	1967-'70	1
	455-237	\$145.99	SHELF, battery & heater, BMH**	1971-'80	1
8	455-408	\$589.99	FLOOR PAN, BMH 1500, but fits all (Complete floor, has hole at rear of gearbox for U-joint access.)		1
	455-625	\$229.99	FLOOR PAN REPAIR, R/H*	Sprite Mkl - MkII, Midget Mkl	1
	455-635	\$229.99	FLOOR PAN REPAIR, L/H*		1
	455-410	\$229.99	FLOOR PAN REPAIR, R/H*	Sprite Mk III on,	1
	455-415	\$229.99	FLOOR PAN REPAIR, L/H*	Midget MkII on	1
*Aftermarket parts supplied.					
9	455-005	\$124.99	OUTER CROSS MEMBER SECTION, with jacking point, BMH (approx. 2/5 of total crossmember length)		2
11	455-555	NA	JACKING POINT, rear L/H	1500 from (c)157672	2
	455-845	\$26.49	JACKING POINT, rear R/H		2
12	455-590	\$174.99	BULKHEAD, rear cockpit	Sprite Mkl & Midget Mkl, II	1
	455-645	\$139.99	BULKHEAD, rear cockpit, BMH **	Sprite MkII, Midget MkIII on	1
13	455-565	\$139.99	SHUT PANEL, BMH**		1
14	455-530	\$55.99	REPAIR PIECE, shut panel end		2
15	455-660	\$20.99	REINFORCEMENT PAIR, between # 12 & 13		A/R
18	455-520†	\$149.99	REINFORCEMENT SET, bulkhead/floor	Sprite Mkl, II; Midget Mkl; 1/4 elliptic springs	2
18a	455-975	\$109.99	BRACE		2
18b	455-985	\$49.99	REINFORCEMENT, floor		2
19	455-580	\$59.99	BASE PLATE, spring mount		2
20	455-540	\$57.99	BRACKET, radius arm, R/H		1
	455-550	\$57.99	BRACKET, radius arm, L/H	1	
21	455-500†	\$134.99	SPRING HANGER BOX	Bugeye	2
	455-510	\$134.99	SPRING HANGER BOX	Sprite MkII, Midget Mkl	2
†These parts are designed to be bolted together as sets prior to welding, making proper alignment easier. However, they are not meant to be bolted without being welded.					
22	455-560	\$72.99	SHOCK MOUNTING BRACKET, R/H	Sprite Mkl, II; Midget Mkl	1
	455-566	\$72.99	SHOCK MOUNTING BRACKET, L/H		1

No.	Part#	Price (Each)	Description	Application	Qty Req.
	455-576	\$72.99	SHOCK MOUNTING BRACKET, R/H, BMH**	Sprite Mk III on, Midget MkII on	1
	455-570	\$72.99	SHOCK MOUNTING BRACKET, L/H, BMH**		1
23	455-600	NA	REPAIR PANEL, wheel well, R/H		1
	455-610	NA	REPAIR PANEL, wheel well, L/H		1
24	455-620	NA	REPAIR PANEL, wheel well, R/H		1
	455-630	NA	REPAIR PANEL, wheel well, L/H		1
29	455-465	NA	REPAIR PANEL, rear floor, L/H	Sprite Mkl, II; Midget Mkl	1
	455-475	NA	REPAIR PANEL, rear floor, R/H		1
	455-425	\$26.99	REPAIR PANEL, rear floor, L/H	Sprite Mk III on, Midget MkII on; 1/2 elliptic springs	1
	455-420	\$26.99	REPAIR PANEL, rear floor, R/H		1
30	455-435	\$35.99	BULKHEAD REPAIR PANEL, L/H		1
	455-205	\$35.99	BULKHEAD REPAIR PANEL, R/H		1
31	455-605	\$104.99	SPRING HANGER BOX, BMH**		2
32	455-615	\$29.99	SPRING MOUNTING PLATE		2

**Parts marked "BMH" are produced by British Motor Heritage.

Windshield Sprite MkI & MkII, Midget MkI

No.	Part#	Price (Each)	Description	Application	Qty Req.
1	459-905	\$279.99	WINDSHIELD GLASS	Sprite to (c)5476 Sprite from (c)5477, Midget MkI	1
	459-900	\$219.99	WINDSHIELD GLASS		1
2	282-005	\$32.99	GLAZING RUBBER	Sprite to (c)5476	1
3	282-000	NA	PACKING RUBBER		1
4	680-875	\$27.79	SEAL, windshield to body		1
5	226-600	\$2.99	STUD		9
	226-600	\$2.99	STUD	Sprite from (c)5477, Midget MkI	2
6	310-040	\$0.29	NUT		2
7	281-990	\$84.99	GLAZING RUBBER, with filler strip		1
	282-445	\$13.69	FILLER STRIP, glazing rubber		1
8	680-870	\$11.99	SEAL, windshield to body		1
9	453-935	\$91.99	PILLAR, R/H		1
10	453-940	\$91.99	PILLAR, L/H		1
11	314-270	\$0.69	SCREW, pillar to frame	(original type)	6
12	323-125	\$2.89	SCREW, pillar to body, zinc plated		4
	323-135	\$4.99	SCREW, pillar to body, chromed	(optional)	4
13	324-155	\$0.59	WASHER, flat	rear position only	2
14	365-730	\$0.39	SPRING WASHER		2
15	310-140	\$0.39	NUT		2
16	680-880	\$10.99	PAD SET, pillar to body (pair)		1
17	165-280	\$59.99	MIRROR, interior		1
	472-507	\$1.09	SCREW, mirror		2

Underlined part numbers indicate an Oversize Parts Fee will be charged. See mossmotors.com or call for details.

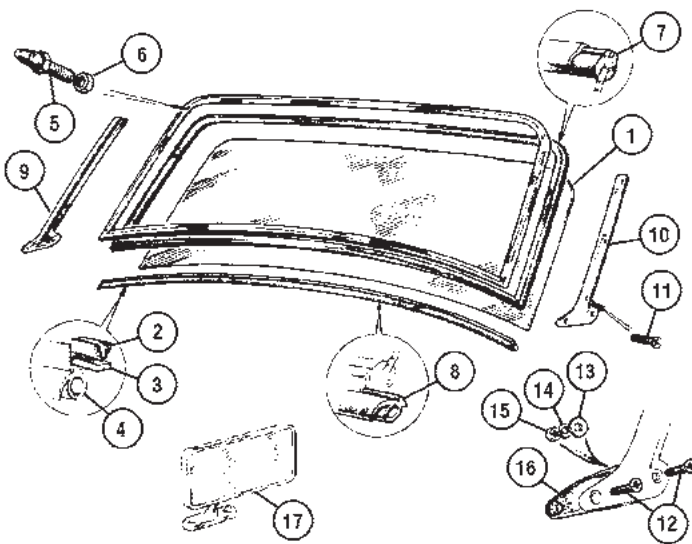

Early Bugeye windshield frames to (c)5476 had 9 Lift-the-Dot studs across the top rail. Later frames had two, one at each corner. The threaded shanks on the later studs were shorter than on the early ones, and care must be used with replacement studs lest they crack the glass. Test fit before installing the glass, and shorten them if need be. Early windshield glass measured 295mm high by 1205mm wide, while the later one measures 287mm high by 1180mm wide.

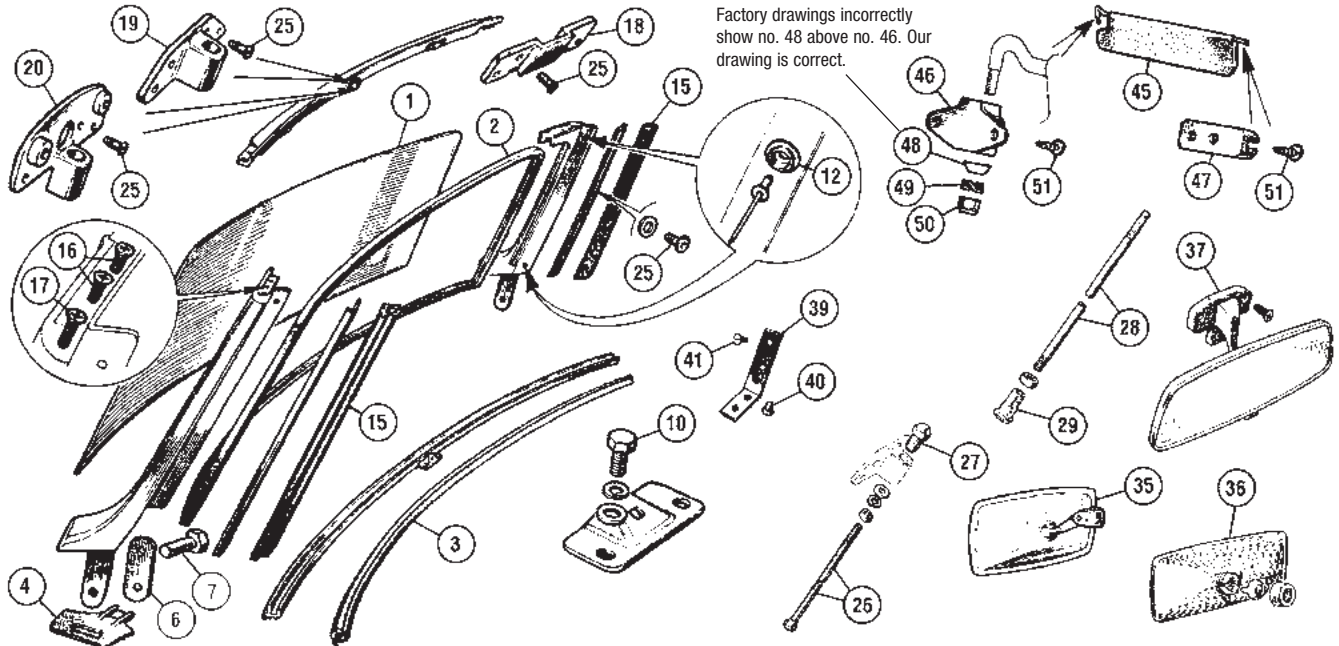

Factory drawings incorrectly show no. 48 above no. 46. Our drawing is correct.

Windshield from Sprite MkIII, Midget MkII on

1	459-915	\$549.99	WINDSHIELD GLASS, Triplex	1967-1969	1
	459-910	\$189.99	WINDSHIELD GLASS		1
2	281-995	\$24.99	GLAZING SEAL	1970-on	1
3	282-025	\$19.99	SEAL, windshield to body		1
4	282-055	\$6.99	SEAL, windshield pillar to body, LH	Midget to (c)63074, Sprite to (c)74461	1
	282-045	\$6.99	SEAL, windshield pillar to body, RH		1
6		NA	SHIM, pillar leg to 'A' post	Midget (c) 63075-75885, Sprite (c)74462-on	1
7	116-162	\$1.89	BOLT, upper		2
	322-615	\$2.99	BOLT, lower	Midget (c)75886-on	1
10	314-275	\$2.69	BOLT, center rod bracket to body		4
12	226-720	\$0.49	STUD, top & tonneau attachment		4
15	282-210	\$7.99	SEAL, pillar to quarter light	thru 1976	1
	282-265	\$6.79	SEAL, pillar to quarter light		1
16	408-056	\$0.59	SCREW, top rail to pillar (inner positions)	1977-'80	1
17	408-057	\$0.39	SCREW, top rail to pillar (outer position)		1
18	472-620	NA	BRACKET, top fastening, satin finish	thru 1976	2
19		NA	BRACKET, center rod, upper		1967-1969
20	472-415	NA	BRACKET, center rod and mirror, upper	1970-on	1
25	325-277	NA	RIVET, brackets & seal retainer		34
26	472-435	\$10.99	CENTER ROD, chrome	1967-1969	1
27	472-635	\$4.99	NUT, domed		1
28	472-445	\$2.99	CENTER ROD, silver painted	1970-on	1
29	472-640	\$1.39	NIPPLE, lower		1
35	165-110	\$44.99	INTERIOR MIRROR, metal	Midget to (c)63074, Sprite to (c)74461	1
36		NA	INTERIOR MIRROR, plastic		Midget (c) 63075-75885, Sprite (c)74462-on
37	165-115	\$42.99	INTERIOR MIRROR	Midget (c)75886-on	1
39	400-620	NA	BRACKET SET, frame corners		1
40	408-056	\$0.59	SCREW, bottom rail to bracket		4
41	408-055	\$0.89	SCREW, pillar to bracket		4
45	233-340	\$29.99	SUN VISOR, R/H	thru 1976	1
	233-350	\$29.99	SUN VISOR, L/H		1
	233-341	\$26.99	SUN VISOR, RH	1977-'80	1
	233-351	\$26.99	SUN VISOR, LH		1
46	233-921	NA	PIVOT BRACKET, sun visor	thru 1976	2
	233-920	\$19.99	PIVOT BRACKET, sun visor		1977-'80
47	233-930	\$1.59	STAY BRACKET, sun visor		2
48	324-175	\$0.69	WASHER, spherical		2
49	324-185	\$0.39	WASHER, Thackery		2
50	310-830	\$0.69	NUT, nylon		2
51	314-280	\$0.99	SCREW, alternative to orig. rivet		8

Toll-Free Orders 1-800-667-7872 | MossMotors.com
Fax 805-692-2525 | Local 805-681-3400



Body Fittings, Bugeye

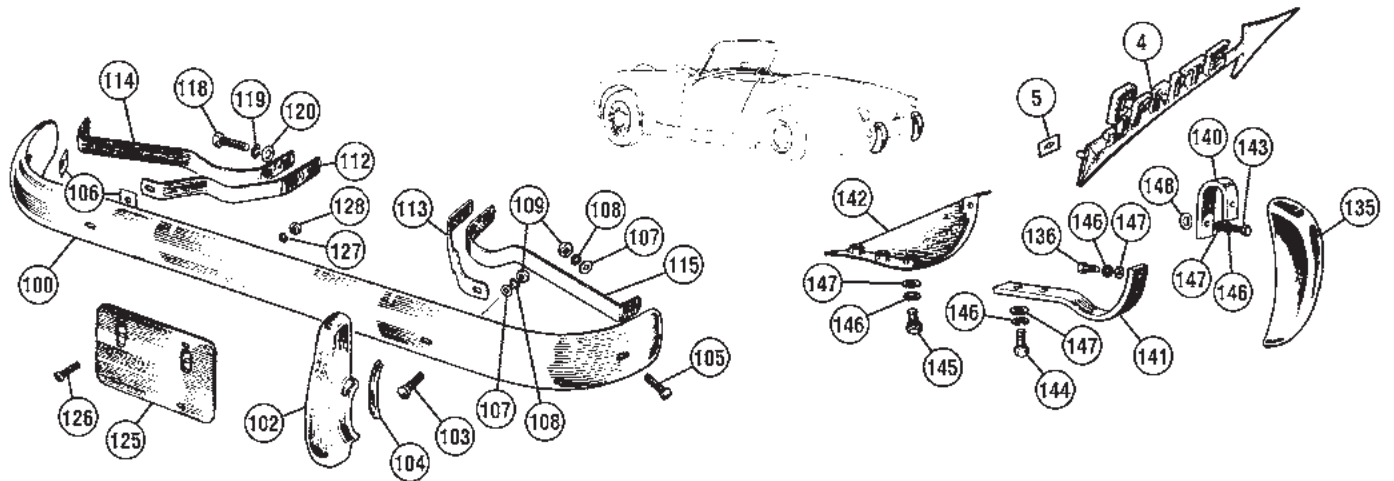
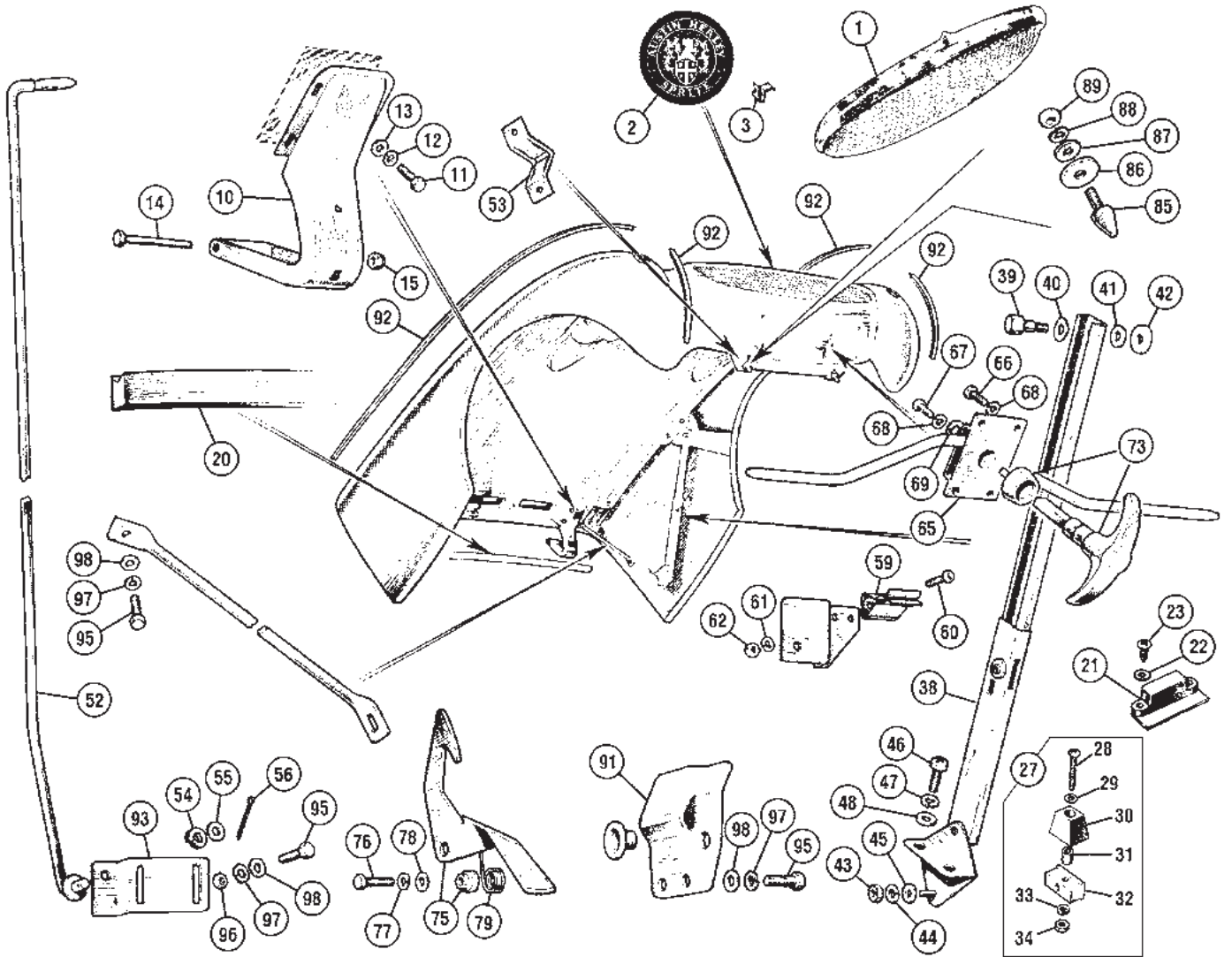



Body Fittings, Bugeye

12046

No.	Part#	Price (Each)	Description	Application	Qty Req.
Grille & Badges					
1	459-770	\$479.99	GRILLE (includes mounting clips)		1
	326-510	\$0.24	CLIP, grille mounting		13
2	031-590	\$44.99	MEDALLION, hood		1
3	326-535	\$0.69	CLIP for medallion		3
4	031-585	\$25.99	BADGE, rear deck, gold color (as original)		1
	031-580	NA	BADGE, rear deck, chromed	(alternative)	1
5	326-665	\$0.49	CLIP for badge		2
Hood Fittings					
10	455-835	\$114.99	HINGE, BMH		2
11	322-645	\$0.49	BOLT		8
12	324-020	\$0.20	LOCKWASHER		8
13	324-590	\$0.19	WASHER		8
14	320-225	\$0.99	BOLT, hinge pin		2
15	311-005	\$1.19	NUT, standard	} alternatives	2
	310-290	\$1.19	NUT, nyloc		2
20	282-105	\$22.99	SEAL, hood rear		1
21	282-110	\$3.99	BUFFER, hood		4
22	315-075	\$0.19	WASHER		8
23	372-950	\$0.49	SCREW		8
27	282-098	\$29.99	BUFFER ASSEMBLY		2
28	314-005	\$1.29	SCREW		2
29	324-990	\$0.39	WASHER		2
30	282-125	\$2.59	BUFFER, wheel arch		2
31	282-126	\$7.49	DISTANCE TUBE		2
32	282-215	\$22.99	SPACER		2
33	324-010	\$0.19	LOCKWASHER		2
34	310-040	\$0.29	NUT		2
38	406-980	\$89.99	STAY, hood		2
39	313-010	\$6.99	BOLT, stay to hood		2
40	365-735	\$0.39	WASHER, anti-rattle		2
41	365-720	\$0.79	WASHER, small		2
42	315-110	\$0.79	WASHER, large		2
43	310-040	\$0.29	NUT		2
44	324-010	\$0.19	LOCKWASHER		2
45	315-085	\$0.29	WASHER		2
46	322-495	\$0.49	SCREW		4
47	324-020	\$0.20	LOCKWASHER		4
48	324-590	\$0.19	WASHER		4
52	406-990	\$44.99	STAY, auxilliary		1
53	NA		CLIP		1
54	315-180	\$0.49	LOCKWASHER		1
55	365-720	\$0.79	WASHER		1
56	325-330	\$0.19	COTTER PIN		1
59	471-130	\$5.29	CLIP		1
60	314-010	\$0.24	SCREW		2
61	324-010	\$0.19	LOCKWASHER		2
62	310-040	\$0.29	NUT		2
65	401-890	\$149.99	LOCK ROD ASS'Y.		1
66	323-005	\$0.39	SCREW		4
67	NA		SCREW		1
68	324-010	\$0.19	LOCKWASHER		5
69	315-085	\$0.29	WASHER		5
73	401-870	\$99.99	HANDLE & ESCUTCHEON		1
75	401-880	\$49.99	SAFETY CATCH & BUSH		1
76	322-247	\$0.49	BOLT		1
77	324-020	\$0.20	LOCKWASHER		1
78	324-590	\$0.19	WASHER		1
79	329-880	\$5.49	SPRING		2
85	282-120	\$11.49	PEG, locating		1
86	NA		WASHER, rubber		2
87	315-095	\$0.49	WASHER		2
88	365-730	\$0.39	LOCKWASHER		2
89	310-140	\$0.39	NUT		2
91	400-650	\$24.99	BRACKET, hood lock, R/H		1
	400-660	\$24.99	BRACKET, hood lock, L/H		1
92	457-990	\$49.99	FENDER BEADING (supplied in straight 66" length)	A/R	1
93	400-665	\$12.99	BRACKET, prop rod	A/R	1
95	322-645	\$0.49	BOLT	A/R	1
96	310-760	\$0.59	NUT	A/R	1
97	324-020	\$0.20	LOCKWASHER	A/R	1
98	324-590	\$0.19	WASHER	A/R	1

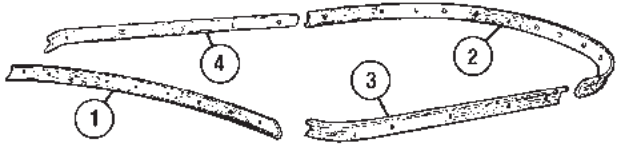
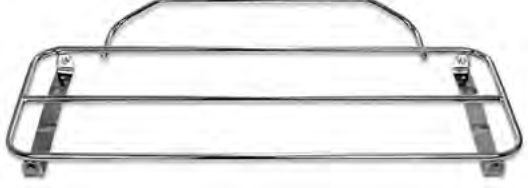
Body Fittings, Bugeye

No.	Part#	Price (Each)	Description	Application	Qty Req.
Front Bumper					
100	400-170	\$649.99	BUMPER BAR, front		1
102	454-010	\$99.99	OVERRIDE		2
103	NA		BOLT, override (for repl. overrides)		2
	322-900	\$2.69	BOLT, override (for orig. overrides)		2
104	400-404	\$0.99	PACKING, override		4
105	322-900	\$2.69	BUMPER BOLT		2
106	400-300	\$1.99	PACKING PIECE		4
107	324-860	\$0.19	WASHER		4
108	324-040	\$0.39	LOCKWASHER		4
109	310-050	\$0.69	NUT		4
112	400-175	\$49.99	BUMPER BRACKET	RH Inner	1
113	400-180	\$49.99	BUMPER BRACKET	LH Inner	1
114	400-185	\$49.99	BUMPER BRACKET	RH Outer	1
115	400-190	\$49.99	BUMPER BRACKET	LH Outer	1
118	322-075	\$1.09	BOLT		4
119	324-040	\$0.39	LOCKWASHER		4
120	324-860	\$0.19	WASHER		4
125	451-285	\$16.99	LICENSE PLATE BACKING		1
126	322-645	\$0.49	SCREW		2
127	324-020	\$0.20	LOCKWASHER		2
128	310-760	\$0.59	NUT		2
Rear Overrides					
135	400-210	\$99.99	OVERRIDE		2
136	322-040	\$0.59	BOLT, override to bracket		4
140	400-220	\$11.99	BRACKET, upper		2
141	400-230	\$21.99	BRACKET, lower		2
142	455-935	\$22.99	BRACKET, inner		2
143	322-540	\$0.79	SCREW, upper		2
144	322-040	\$0.59	SCREW, lower		4
145	313-000	\$0.39	SCREW, locating		2
146	365-730	\$0.39	LOCKWASHER		12
147	365-720	\$0.79	WASHER		12
148	681-300	\$1.19	PAD, rubber		2
					
1	459-940	\$109.99	CAPPING, dash		1
2	459-941	NA	CAPPING, rear cockpit		1
3	459-942	\$109.99	CAPPING, L/H door top		1
4	459-943	\$109.99	CAPPING, R/H door top		1
	459-944	\$9.99	SCREW KIT, cockpit cappings		1
					
Bugeye Luggage Rack					
Increase your cargo carrying capacity with this traditionally styled luggage rack. This rack mounts permanently with the included hardware and rubber mounting strips. Approx. 39" x 18".					
244-720	\$459.99				
					
License Plate Plinth					
For Bugeyes without front bumpers, this is the official factory means of mounting your number plate. (Home market cars had front bumpers as an optional accessory, so this was an important item for those cars.)					
400-625	\$109.99				

Toll-Free Orders 1-800-667-7872 | MossMotors.com
 Fax 805-692-2525 | Local 805-681-3400



Front Body Fittings 1961-'80

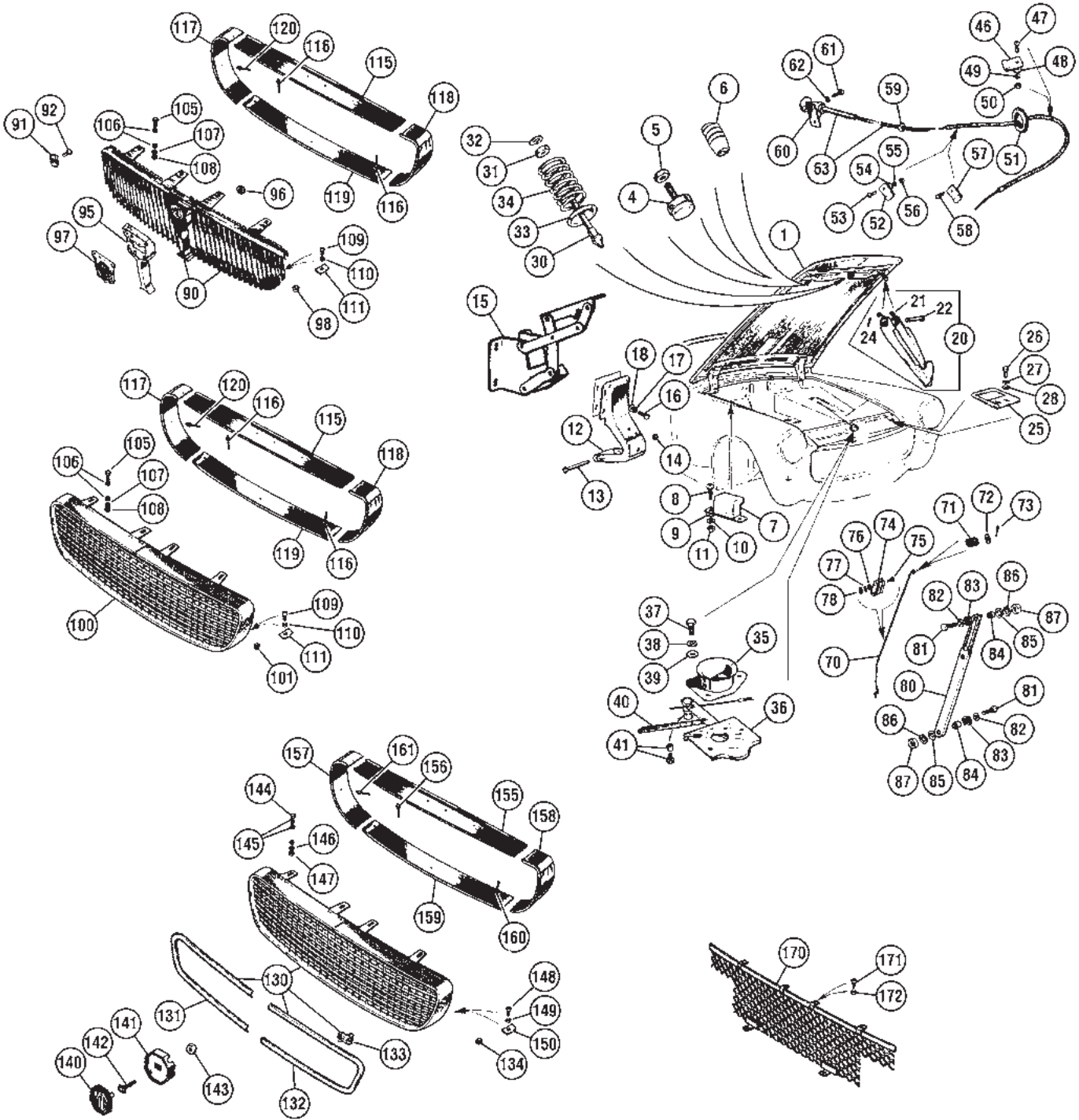

Front Body Fittings 1961-'80

12049

No.	Part#	Price (Each)	Description	Application	Qty Req.
Hood					
1			HOOD ASSEMBLY	See page 53	1
4	282-130	\$2.99	BUFFER, front corner	} Midget to (c)183739, all Sprite	2
5	848-540	\$0.29	NUT, locking		2
6	282-190	\$4.79	BUFFER, front corner	} Midget from (c)183740	2
7	282-115	\$3.99	BUFFER, side		2
8	323-005	\$0.39	SCREW, buffer to fender drainage channel		4
9	315-085	\$0.29	WASHER, plain		4
10	324-010	\$0.19	WASHER, locking		4
11	310-040	\$0.29	NUT		4
12	455-835	\$114.99	HINGE, hood, BMH	} Sprite to (c)77590, Midget to (c)66225	2
13	320-225	\$0.99	BOLT, hinge to bulkhead		2
14	310-105	\$0.49	NUT, nyloc		2

No.	Part#	Price (Each)	Description	Application	Qty Req.
15	455-875	NA	HINGE, hood, R/H	} from Sprite MkIV (c)77591 on, Midget MkIII (c)66226 on	1
	455-885	NA	HINGE, hood, L/H		1
16	322-645	\$0.49	BOLT, hinge to hood		8/4
17	324-020	\$0.20	WASHER, locking		8/4
18	324-590	\$0.19	WASHER, plain		8/4
20	470-640	\$24.99	HOOK ASS'Y, safety catch		1
21	329-325	\$5.29	SPRING, hook return		1
22		NA	CLEVIS PIN		1
24	325-005	\$0.19	SPLIT PIN		1
25	406-020	\$6.39	BRACKET, safety catch		1
26	466-385	\$0.79	SCREW, bracket to landing panel		2

Front Body Fittings 1961-'80

No.	Part#	Price (Each)	Description	Application	Qty Req.
27	324-010	\$0.19	WASHER, locking		2
28	315-085	\$0.29	WASHER, plain		2
30	406-000	\$8.79	PIN		1
31	310-070	\$0.39	NUT, locking pin		1
32	324-040	\$0.39	WASHER, locking		1
33	406-055	\$8.99	THIMBLE, pin (British Motor Heritage part)		1
34	406-060	\$2.99	SPRING, bonnet lock		1
35	406-065	\$14.89	CUP, locating		1
36	406-015	\$109.99	CATCH PLATE		1
37	322-645	\$0.49	SCREW, cup and plate to landing panel		3
38	324-020	\$0.20	WASHER, locking		3
39	324-590	\$0.19	WASHER, plain		3
40	406-035	\$4.99	SPRING, catch return		1
41	406-040	\$1.69	TRUNNION & SCREW, hood release cable		1
46	182-600	\$1.39	CLIP, landing panel		1
47	323-005	\$0.39	SCREW, clip		1
48	315-085	\$0.29	WASHER, plain		1
49	324-010	\$0.19	WASHER, locking		1
50	310-040	\$0.29	NUT		1
51	680-630	\$1.19	GROMMET, mud shield		1
52	182-600	\$1.39	CLIP, LH inner wheel arch	Midget to (c)154100 (1961-'74), all Sprite	1
53	323-005	\$0.39	SCREW, clip to wheel arch		1
54	315-085	\$0.29	WASHER, plain		1
55	324-010	\$0.19	WASHER, locking		1
56	310-040	\$0.29	NUT		1
57	182-600	\$1.39	CLIP, bumper beam	Midget 1500	1
58	323-705	\$0.59	SCREW, clip to bumper beam		1
59	281-050	\$5.99	GROMMET, in LH toe board	Midget to (c)212000 (1961-'78), all Sprite	1
60		NA	BRACKET, footwell side		1
61	314-010	\$0.24	SCREW, footwell side bracket		2
62	324-010	\$0.19	WASHER, locking		2
63	331-700	\$26.99	HOOD RELEASE CABLE, round knob	thru 1977	1
	406-005	\$18.99	HOOD RELEASE CABLE, 'T' handle	1978-on	1
70	406-995	NA	STAY ROD, hood	Midget to (c)89500 (1961-'70), all Sprite	1
71	329-165	NA	SPRING, anti rattle		1
72	365-720	\$0.79	WASHER, plain		1
73	325-330	\$0.19	COTTER PIN		1
74	471-130	\$5.29	CLIP, stay rod stowage		1
75	314-010	\$0.24	SCREW, clip to hood		2
76	315-085	\$0.29	WASHER, plain		2
77	324-010	\$0.19	WASHER, locking		2
78	310-040	\$0.29	NUT		2
80	457-445	\$49.99	TELESCOPIC STAY, hood		1
81	314-265	\$0.59	BOLT	2	
82	324-590	\$0.19	WASHER, plain	Midget from (c)89501(from 1971)	2
83	315-060	\$3.09	WASHER, thackery		2
84	434-370	\$1.09	SPACER		2
85	324-860	\$0.19	WASHER, plain		2
86	324-020	\$0.20	WASHER, locking		2
87	310-760	\$0.59	NUT		2

No.	Part#	Price (Each)	Description	Application	Qty Req.
Grilles					
90	459-790	NA	GRILLE ASSEMBLY	Midget 1961-'69	1
91	326-615	\$1.49	CLIP, slat to frames		76
92	314-280	\$0.99	SCREW, slat to frames		76
95	470-635	\$124.99	PLINTH		1
96	326-530	\$0.29	CLIP, plinth to frames		2
97	201-050	\$21.29	BADGE, 'MG'	1	
98		NA	GROMMET		4
100	459-780	\$419.99	GRILLE ASSEMBLY	Sprite 1961-'69	1
101	472-735	\$0.59	GROMMET		4
105	322-495	\$0.49	SCREW, grille to landing panel	Sprite & Midget 1961-'69	4
106	324-590	\$0.19	WASHER, plain		8
107	324-020	\$0.20	WASHER, locking		4
108	310-760	\$0.59	NUT		4
109	323-705	\$0.59	SCREW, grille to front valance		2
110	315-295	\$0.49	WASHER, plain		2
111	310-355	\$0.39	SPIRE NUT		2
115	459-620	\$41.99	FINISHER, hood edge		1
116	326-285	\$0.99	RIVET, hood & lower finishers		10
117	459-825	\$36.99	FINISHER, grille aperture, RH side		1
118	459-830	\$36.99	FINISHER, grille aperture, LH side		1
119	459-835	\$41.99	FINISHER, grille aperture, lower		1
120	326-285	\$0.99	RIVET, side finishers to fenders	6	
130	459-800	\$519.99	GRILLE ASSEMBLY	Midget 1970-74	1
131		NA	MOULDING, grille, RH		1
132		NA	MOULDING, grille, LH		1
133	455-330	\$0.89	CLIP, moulding to grille		8
134	472-235	NA	GROMMET		4
140	201-060	\$18.99	BADGE, 'MG'		1
141	470-675	NA	PLINTH, badge		1
142		NA	STUD PLATE, plinth to grille		1
143	310-625	\$0.29	NUT		1
144	322-495	\$0.49	SCREW, grille to landing panel		4
145	324-590	\$0.19	WASHER, plain		8
146	324-020	\$0.20	WASHER, locking		4
147	310-760	\$0.59	NUT		4
148	323-705	\$0.59	SCREW, grille to valance		2
149		NA	WASHER, plain		2
150	310-355	\$0.39	SPIRE NUT		2
155	459-620	\$41.99	FINISHER, hood edge		1
156	326-285	\$0.99	RIVET, finisher to hood	6	
157	459-840	\$36.99	FINISHER, grille aperture, RH side	1	
158	459-845	\$36.99	FINISHER, grille aperture, LH side	1	
159	459-850	\$45.99	FINISHER, grille aperture, lower	1	
160	326-285	\$0.99	RIVET, lower finisher to valance	4	
161	326-285	\$0.99	RIVET, side finishers to fenders	6	
170	459-810	\$54.99	GRILLE ASSEMBLY	Midget 1500	1
171	314-070	\$0.59	SCREW, grille mounting		6
172	324-990	\$0.39	WASHER, plain		6

Rear Body Fittings, 1961-'80

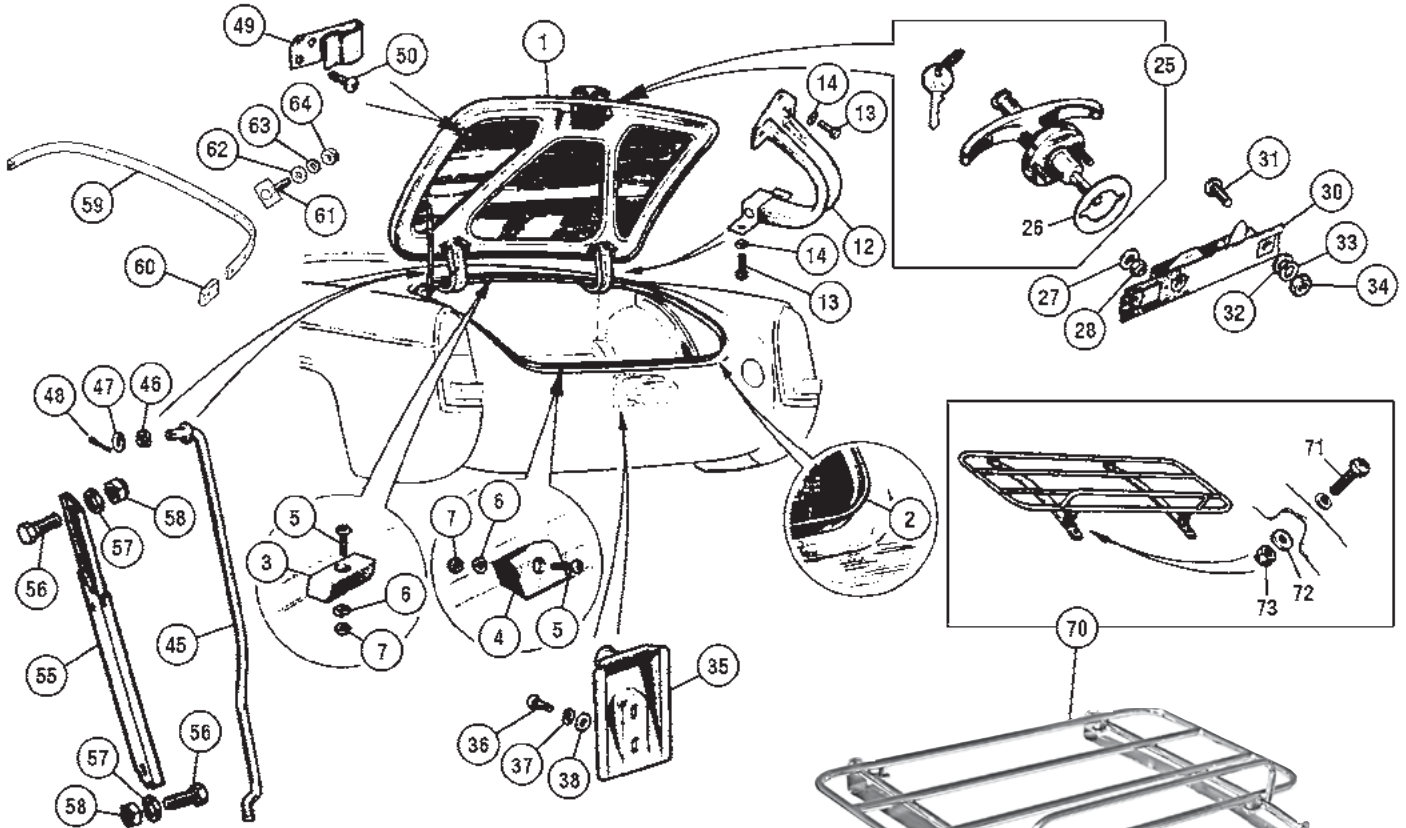

Rear Body Fittings, 1961-'80

12050

No.	Part#	Price (Each)	Description	Application	Qty Req.
1	455-895	\$549.99	TRUNK LID ASSEMBLY, BMH		1
2	282-155	\$14.99	SEAL, trunk lid		1
3	380-335	\$2.99	BUFFER, trunk lid, front		2
4	282-160	\$2.79	BUFFER, trunk lid, rear		2
5	314-290	\$0.49	SCREW, buffer to drainage channel		4
6	315-070	\$0.49	WASHER, locking		4
7	310-625	\$0.29	NUT		4
12	405-425	\$104.99	HINGE, trunk lid, RH, BMH		1
	405-430	\$104.99	HINGE, trunk lid, LH, BMH		1
13	322-645	\$0.49	BOLT, hinge to trunk lid and rear deck		10
14	324-020	\$0.20	WASHER, locking		10
25	470-445	\$94.99	HANDLE AND LOCK, trunk (with two keys)		1
26	402-525	\$0.99	GASKET, fiber		1
27	315-085	\$0.29	WASHER, plain		2
28	159-340	\$0.69	NUT, securing handle to trunk lid		2
30	470-455	\$23.99	LATCH, trunk lid		1
31	322-880	\$0.99	SCREW, latch to trunk lid		2
32	324-590	\$0.19	WASHER, plain		2
33	324-020	\$0.20	WASHER, locking		2
34	310-760	\$0.59	NUT		2
35	407-005	\$34.99	STRIKER PLATE		1
36	323-005	\$0.39	SCREW, striker plate		2
37	324-010	\$0.19	WASHER, locking		2
38	315-085	\$0.29	WASHER, plain		2
45	407-000	NA	STAY ROD, trunk lid		1
46	370-460	\$0.79	WASHER, thackery		1
47	324-590	\$0.19	WASHER, plain	Midget thru (c)89500	1
48	325-330	\$0.19	SPLIT PIN	(to approx. '70), all	1
49	457-475	\$6.99	CLIP, stay rod stowage	Sprite (not Bugeye)	1
50	323-430	\$0.59	SCREW, clip to trunk lid		2
55	407-010	\$42.99	STAY, trunk lid, stock type		1
56	322-645	\$0.49	BOLT, stay	Midget from (c)89501	2
57	324-590	\$0.19	WASHER, plain	(from approx. 1971)	4
58	312-000	\$0.49	NUT, nyloc		2
59	459-855	\$24.99	MOULDING, cockpit		1
60	240-560	\$13.39	FINISHER, R/H		1
	240-565	\$13.39	FINISHER, L/H		1
61	226-660	\$2.19	STUD PLATE, moulding	1275, 1500	9
62	324-990	\$0.39	WASHER, plain		9
63	324-010	\$0.19	LOCKWASHER		9
64	310-040	\$0.29	NUT		9

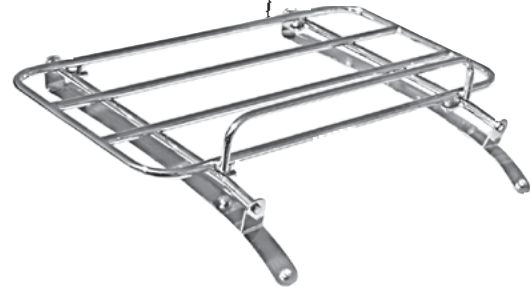

No.	Part#	Price (Each)	Description	Application	Qty Req.
70	244-730	\$399.99	LUGGAGE RACK, stainless steel, optional		1
71	314-295	\$2.99	SCREW, rack mounting		4
72	365-720	\$0.79	WASHER, plain		4
73	310-290	\$1.19	NUT, nyloc		4

Master Lock Set

470-458 \$174.99 MASTER LOCK SET, 3 pieces

(pictured at right)

470-448 \$89.99 LOCK SET, door

(2 door locks with 2 keys)

470-435 \$45.99 LOCK, R/H door with 2 keys

470-440 \$45.99 LOCK, L/H door with 2 keys



Door Lock Fitting Kit

Fits 1964-'80. Fit door locks without using the factory style securing clips, which are not easy to fit and very difficult to remove. These new clips are also designed to prevent the lock from rotating in the door skin.

402-195 \$13.99



Body Mouldings - Midget

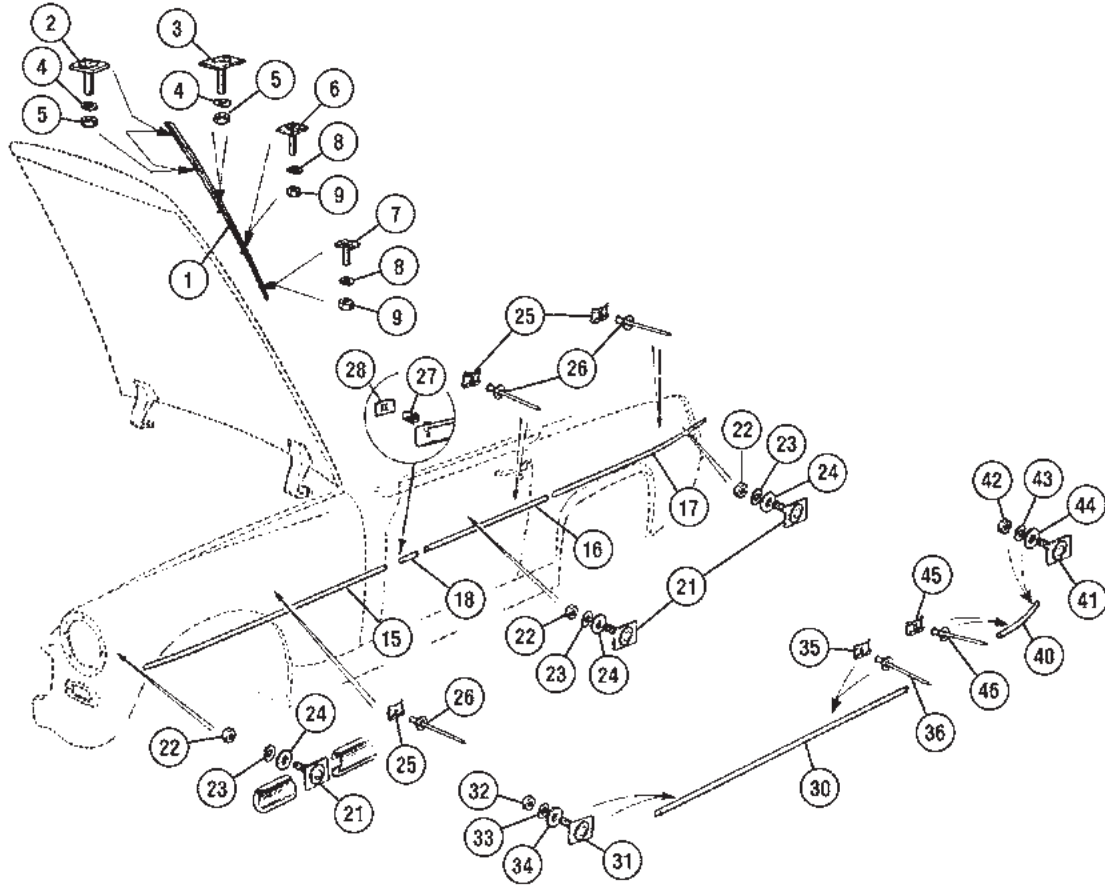

Body Mouldings - Midget

12053

No.	Part#	Price (Each)	Description	Application	Qty Req.	No.	Part#	Price (Each)	Description	Application	Qty Req.
1	459-610	\$172.99	MOULDING, hood	Midget to (c)66225 ('61-approx. '68)	1	30	459-895	\$35.99	MOULDING, sill	Midget from (c)74886 (1970-on)	2
2	326-705	\$4.29	STUD PLATE, front two positions		2	326-618	\$22.99	FITTING KIT, sill mouldings	1		
3	326-075	\$0.99	STUD PLATE, center position		1	31	326-077	\$2.79	STUD PLATE (front end of sill)		2
4	324-010	\$0.19	WASHER, locking, front three positions		3	32	310-040	\$0.29	NUT, stud plate to sill		2
5	310-040	\$0.29	NUT, front three positions		3	33	324-010	\$0.19	WASHER, locking		2
6	326-725	\$4.29	STUD PLATE, second rearmost position		1	34	315-085	\$0.29	WASHER, plain		2
7	326-735	\$3.69	STUD PLATE, rear position		1	35	326-610	\$0.69	CLIP, moulding to sill	14	
8	315-070	\$0.49	WASHER, locking, rear two positions		2	36	326-295	\$0.69	RIVET, clip to sill	14	
9	310-625	\$0.29	NUT, rear two positions		2	40	459-890	\$23.99	MOULDING, rear wing, LH	Midget 1500	1
15	459-868	NA	UPPER SIDE MOULDING SET	Midget to (c)74885 (1961-'69)	1	459-885	\$23.99	MOULDING, rear wing, RH	1		
16	459-860	\$46.99	MOULDING, fender		2	41	326-077	\$2.79	STUD PLATE (rear of fender)		2
17	459-875	\$41.99	MOULDING, door, LH		1	42	310-040	\$0.29	NUT, stud plate to fender		2
18	459-870	\$41.99	MOULDING, door, RH		1	43	324-010	\$0.19	WASHER, locking		2
21	459-880	\$45.99	MOULDING, rear wing		2	44	315-085	\$0.29	WASHER, plain		2
22	459-865	\$24.79	MOULDING, 'A' post		2	45	326-610	\$0.69	CLIP, moulding to fender		6
23	326-608	\$62.99	FITTING KIT, upper side mouldings		1	46	326-295	\$0.69	RIVET, clip to fender		6
24	326-077	\$2.79	STUD PLATE		6						
25	310-115	\$0.24	NUT, stud plate to fender & door		6						
26	324-010	\$0.19	WASHER, locking		6						
27	315-085	\$0.29	WASHER, plain	6							
28	326-610	\$0.69	CLIP	40							
29	326-295	\$0.69	RIVET, clip to fender & door	40							
30	326-665	\$0.49	CLIP, front moulding lug to 'A' post	2							
31	326-510	\$0.24	SPIRE NUT, rear lug to 'A' post	2							

Plugs & Grommets

Plugs & Grommets - Bugeye

12054

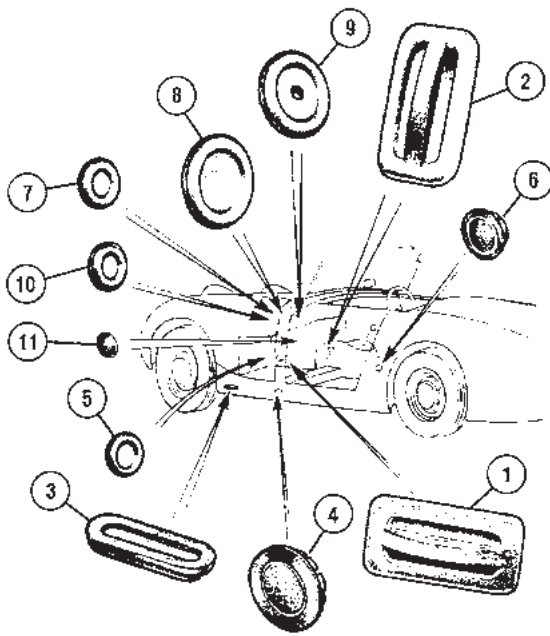

No.	Part#	Price (Each)	Description	Application	Qty Req.
1	680-940	\$2.99	PLUG, RH Toe Box Side	Bugeye	1
2	680-940	\$2.99	PLUG, gearbox filler		1
3	282-235	\$2.19	PLUG, sill & sling point		A/R
4	282-135	\$2.49	PLUG, jack hole		2
5	282-960	\$1.59	PLUG, steering column blanking		1
6	282-150	\$2.49	PLUG, driveshaft inspection		1
7	682-075	\$0.89	PLUG, LH footwell		1
8	NA		PLUG, blanking		1
9	682-205	\$3.89	GROMMET, main wiring harness		1
10	240-515	\$2.99	GROMMET, wiper rack		1
11	282-140	\$1.69	PLUG, hinge holes (in door)		8

Plugs & Grommets - Non-Bugeye

12055

No.	Part#	Price (Each)	Description	Application	Qty Req.
20	280-690	\$1.39	GROMMET, bumper bracket		2
21	282-135	\$2.49	PLUG, jacking point	qty. increased in 1975	2/4
22	280-105	\$4.99	GROMMET, fuel filler tube		1
23	282-385	\$1.49	GROMMET, no. plate lamp harnesses		2
24	282-960	\$1.59	PLUG, steering column hole	passenger's side	1
25	282-395	\$3.29	GROMMET, washer tube		1
	682-480	\$1.59	GROMMET, speedometer cable		1
	282-385	\$1.49	GROMMET, oil pressure pipe	1961-'77	1
	240-515	\$2.99	GROMMET, temp. gauge tube		1
	282-385	\$1.49	GROMMET, heater/air cable		if heater is fitted
26	282-925	\$0.79	PLUG, heater cable hole (5/8")	if heater not fitted	1
	282-385	\$1.49	GROMMET, choke cable through bulkhead		1
	240-515	\$2.99	GROMMET, wiper rack through bulkhead		1
	682-205	\$3.89	GROMMET, main harness in bulkhead		1
	682-480	\$1.59	GROMMET, wiper harness in bulkhead		1
	682-480	\$1.59	GROMMET, dip switch harness in footwell	1961-'69	1
27	282-975	\$1.49	GROMMET, oil cooler hole in mudshield		2
28	NA		PLUG, wheel arch panel		2
29	280-200	\$2.89	GROMMET, front lamp wires		3
	680-630	\$1.19	GROMMET, hood cable in ft. panel		1
	281-050	\$5.99	GROMMET, hood cable, toe board	1961-'78	1
30	282-150	\$2.49	PLUG, propshaft lubricating hole		1
31	282-235	\$2.19	PLUG, front floor pan		2
32	682-075	\$0.89	PLUG, LH footwell side	(if fitted)	2
33	NA		PLUG, slave cyl. access hole	1961-'76	1
			(Not available. Use #34 as replacement.)		
34	680-940	\$2.99	PLUG, gearbox filler hole		1
35	NA		PLUG, demister outlet, footwell side	if heater not fitted	2
36	282-495	\$0.39	PLUG, 'top hat', footwell side		2
37	281-050	\$5.99	GROMMET, fuel pump breather	1961-'74	1
	565-050	\$1.29	GROMMET, fuel pump breather		1
	282-385	\$1.49	GROMMET, fuel tank sender harness		1

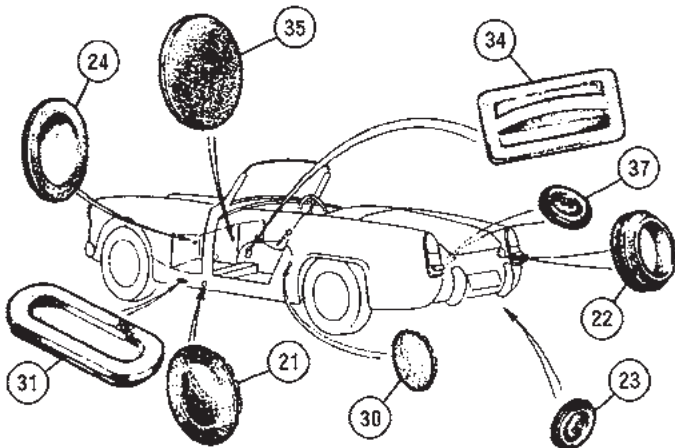
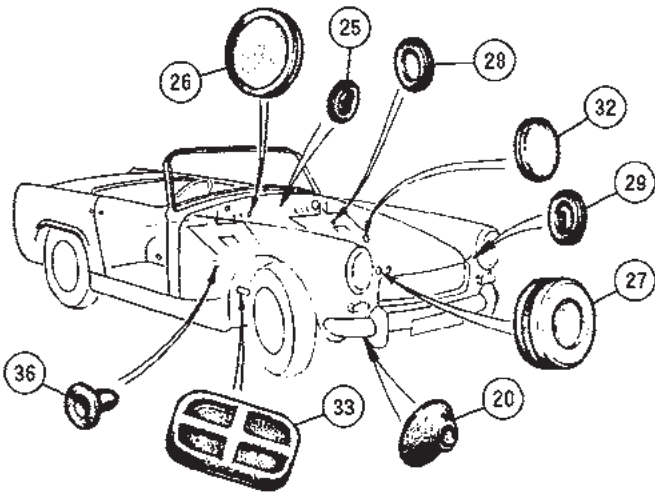

Badges & Mirrors

For Bugeye badges, see pages 56-57

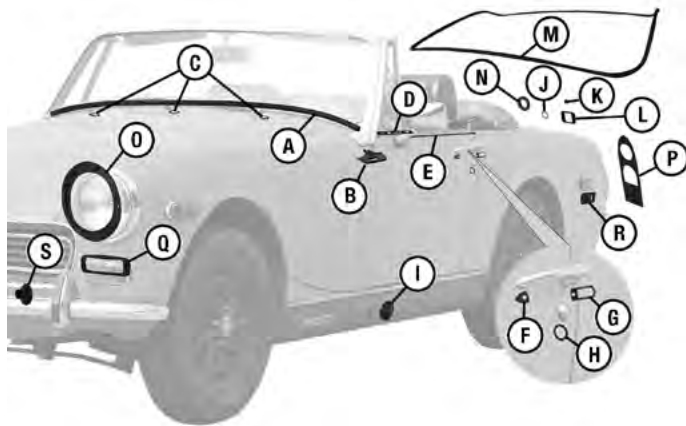
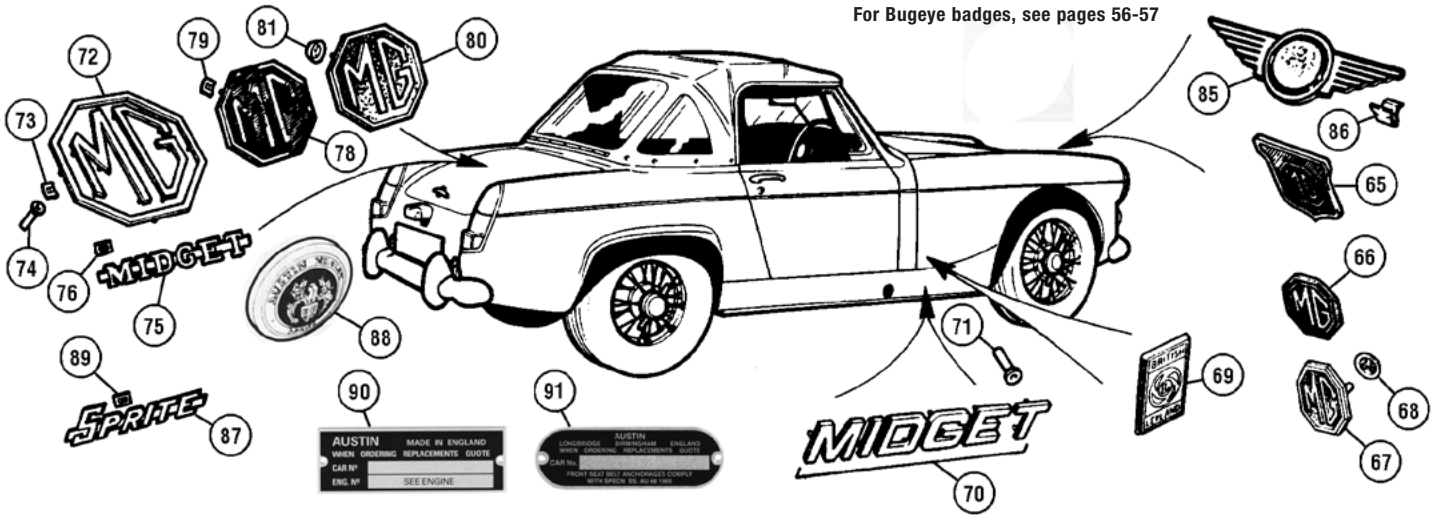

Body Rubber Repair Kits (not Bugeye)

It's no longer a chore to track down all the rubber bits and pieces commonly replaced during a repaint or moderate restoration. Start with the base kit, which contains the pieces common to all years, then add the supplemental kit specific to your year. That's all there is to it. See the accompanying tables for specific content.

Base Rubber Kits:

Sidecurtain cars	282-834	\$48.99
Wind-up window cars	282-835	\$114.99
1961-69 Supplement	282-836	\$19.99
1970-74 Supplement	282-837	\$51.99
1975-80 Supplement	282-838	\$46.99

Illus.	Description	Qty.
A	Windshield Seal	1
B	Windshield Pillar Pad	2
C	Wiper Bezel Pad	2/3
D	Vent Window Seal	2
E	Door Top Seal	2
F	Door Handle Gasket, small	2
G	Door Handle Gasket, large	2
H	Door Lock Gasket	2
I	Jack Hole Plug	2
J	Trunk Lid Handle Gasket	1
K	License Plate Lamp Wire Grommet	2
L	Reverse Lamp Pad	2
M	Trunk Seal	1
N	Filler Neck Grommet	1
O	Headlamp Seals	2
P	Taillamp Gaskets	2
Q	Front Park Lamp Gaskets	2
R	Rear Sidelamp Base Rubber	2
S	Front Bumper Mount Grommets	2

Body Rubber Kit Contents

Base Kit 282-834	A, B, C, I, J, K, M, N
Base Kit 282-835	A, B, C, D, E, F, G, H, I, J, K, L, M, N
1961-69 Supplement	O, P, Q, S
1970-74 Supplement	O, P, Q, R, S
1975-80 Supplement	I, O, P, R

Toll-Free Orders 1-800-667-7872 | MossMotors.com
Fax 805-692-2525 | Local 805-681-3400

MOSS

Midget Badges

12056

No.	Part#	Price (Each)	Description	Application	Qty Req.
65	201-050	\$21.29	GRILLE BADGE, 'MG'	1961-'69	1
66	201-060	\$18.99	GRILLE BADGE, 'MG'	1970-'74	1
67	475-165	\$24.99	BUMPER BADGE, 'MG'	1975-'80	1
68	326-530	\$0.29	CLIP, badge to bumper		2
69	470-687	\$8.99	BADGE, "British Leyland"	1970-'71	2
	470-686	\$11.99	BADGE, "British Leyland"	1972-on	2
70	470-605	\$19.99	SILL LETTER SET, 'Midget'	1970-on	2
71	326-650	\$0.49	CLIP		24
72	470-698	\$28.99	TRUNK BADGE SET, 'MG'	1961-'69	1
73	326-500	\$0.29	SPIRE NUT		13
74	326-650	\$0.49	CLIP, alternative		13
75	470-625	\$13.99	TRUNK BADGE, 'Midget'		1
76	326-510	\$0.24	SPIRE NUT	2	
78	470-665	\$19.99	TRUNK BADGE, plastic, 'MG'	1970-1976 to (c)171430	1
79	326-530	\$0.29	SPIRE NUT		3
80	470-690	\$29.99	TRUNK BADGE, metal, 'MG'	1976 from 171431-on	1
81	326-530	\$0.29	CLIP		3

Sprite Badges

12057

No.	Part#	Price (Each)	Description	Application	Qty Req.
85	031-600	NA	HOOD BADGE, 'Austin Healey Sprite'		1
86	326-535	\$0.69	CLIP		4
87	470-615	\$33.99	TRUNK BADGE, 'Sprite'	Mk2	1
88	408-447	\$29.99	TRUNK BADGE, round	Mk3, 4	1
89	326-510	\$0.24	SPIRE NUT		2
90	408-920	\$6.39	CAR NUMBER PLATE	Sprite 948-1098	1
91	408-925	\$13.29	CAR NUMBER PLATE	Sprite 1275 thru 1969	1

Fender Mirrors

12059

165-400	\$42.99	FENDER MIRROR, R/H flat	1
165-500	\$42.99	FENDER MIRROR, L/H flat	1
165-210	\$42.99	FENDER MIRROR, R/H convex	1
165-300	\$42.99	FENDER MIRROR, L/H convex	1

Door Mirrors

12060

165-170*	\$74.99	DOOR MIRROR, R/H flat, stainless, TEX brand	1
165-135*	\$74.99	DOOR MIRROR, L/H flat, stainless, TEX brand	1
165-195*	\$69.99	DOOR MIRROR, R/H flat, black, TEX brand	1
165-190*	\$69.99	DOOR MIRROR, L/H flat, black, TEX brand	1
165-185**	\$74.99	DOOR MIRROR, R/H convex, stainless, TEX	1
165-180**	\$74.99	DOOR MIRROR, L/H convex, stainless, TEX	1
165-183	\$13.99	MIRROR GLASS only, flat	A/R
165-182	\$13.99	MIRROR GLASS only, convex	A/R
165-630	\$24.99	BASE KIT (chrome plinth), TEX brand	2
165-638	\$12.99	MOUNTING KIT (pad & screws), TEX brand	2

*Base kit 165-630 must be used with these mirrors.

**These mirrors include chrome base kit.

Prices subject to change. See MossMotors.com for current pricing. 63

Door Windows

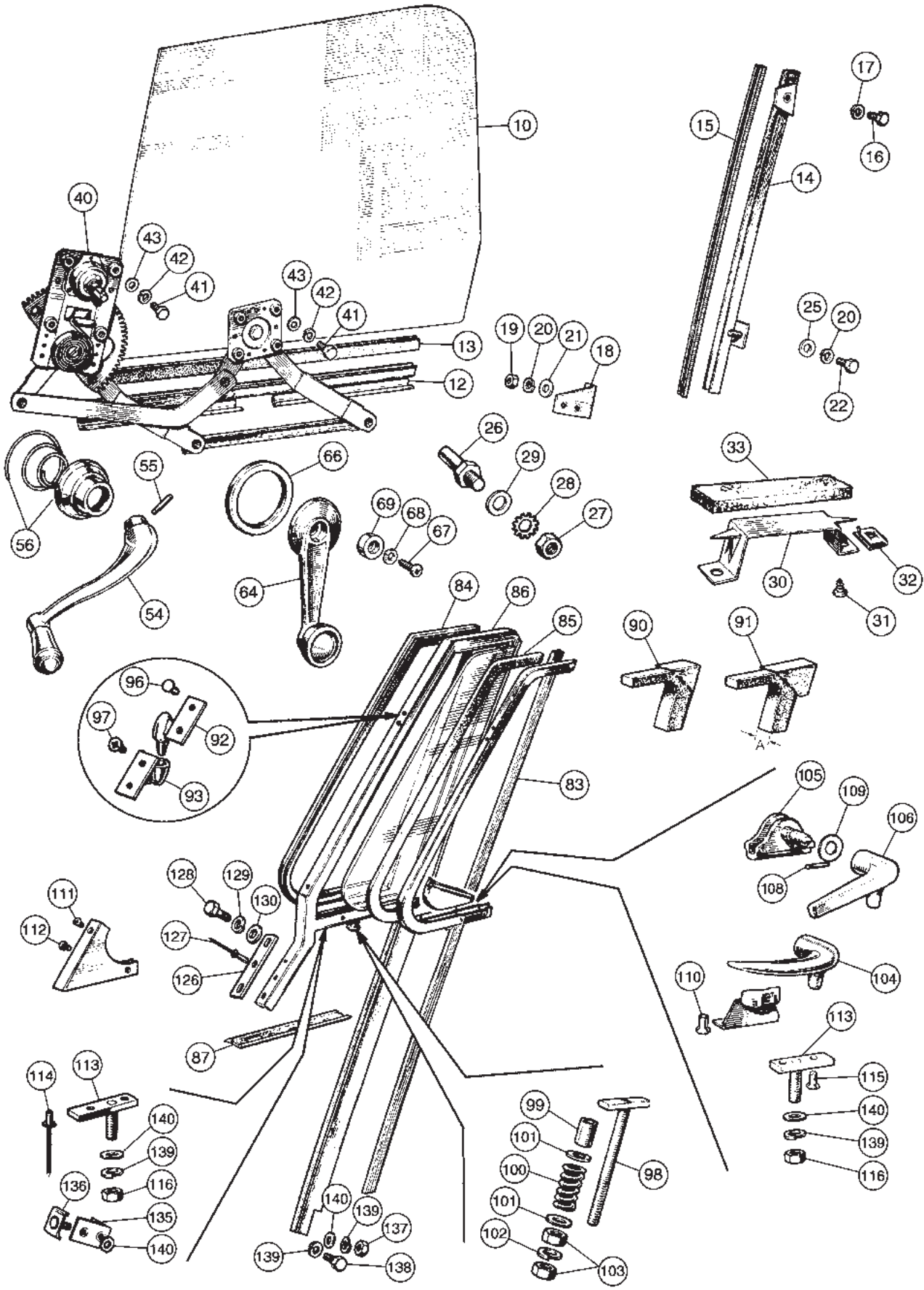

Door Windows

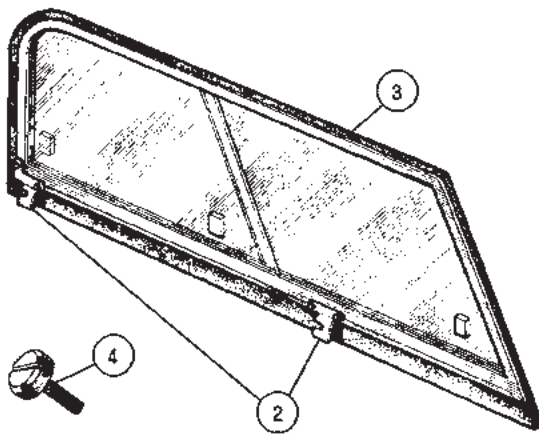

Sidecurtains

12061

No.	Part#	Price (Each)	Description	Application	Qty Req.
	259-678	\$749.99	SIDECURTAIN SET, complete		1
2	259-675	\$34.99	BRACKET SET, with nuts & bolts		1
3	282-455	\$26.99	SEAL, L/H		1
	282-465	\$26.99	SEAL, R/H		1
4		NA	SCREW, sidecurtain retaining	Bugeye thru HAN5-1605	4
	401-690	\$11.99	SCREW, sidecurtain mounting	Bugeye from HAN5-1606, Sprite HAN6-101 thru 24731, Midget thru GAN1-16183	4
	401-700	\$16.99	SCREW, sidecurtain mounting	Sprite from HAN7-24732, Midget from GAN2-16184	4

Our U.K. - made aluminum sidecurtains are close reproductions of the original units fitted to all except the earliest Bugeyes, which used a primitive fabric covered design. Our sidecurtains fit all.

Door Windows

12062

No.	Part#	Price (Each)	Description	Application	Qty Req.
10	459-920	\$129.99	DOOR GLASS, RH		1
	459-925	\$129.99	DOOR GLASS, LH		1
12	407-025	\$35.99	CHANNEL, lower		2
13	680-667	\$3.49	GLAZING STRIP, sold per foot	Cut to 18 3/8" long	A/R
14	407-014	\$39.99	CHANNEL, rear, RH		1
	407-019	\$39.99	CHANNEL, rear, LH		1
15	458-610	\$6.49	GLAZING STRIP, felt and rubber		2
16	322-170	\$0.49	SCREW, channel top to door		2
17	324-020	\$0.20	LOCKWASHER		2
18		NA	BRACKET, channel bottom to door, RH		1
		NA	BRACKET, channel bottom to door, LH		1
19	310-760	\$0.59	NUT, bracket to channel bottom		2
20	324-020	\$0.20	LOCKWASHER		6
21	324-590	\$0.19	WASHER, plain		2
22	322-170	\$0.49	SCREW, bracket to door		4
25	324-590	\$0.19	WASHER, plain		4
27	310-140	\$0.39	NUT, stop to door		2
28	315-300	\$0.59	WASHER, shakeproof		2
29	365-720	\$0.79	WASHER, plain		2
30		NA	STOP, lower		2
31	323-705	\$0.59	SCREW, lower stop to door bottom		4
32		NA	SPIRE NUT		4
33	402-230	\$2.19	FELT PAD, lower stop		2
40	402-295	NA	REGULATOR, window, RH	Midget to (c)60459,	1
	402-290	NA	REGULATOR, window, LH	Sprite to (c)72040	1
	405-535	NA	REGULATOR, window, RH	Midget (c)60460-on,	1
	405-530	NA	REGULATOR, window, LH	Sprite (c)72041-on	1
41	322-170	\$0.49	SCREW, regulator to door		16
42	324-020	\$0.20	WASHER, locking		16
43	324-115	\$0.39	WASHER, plain		16
54	472-110	\$64.99	HANDLE, window regulator	Midget to (c)60459,	2
55	803-230	\$0.99	PIN, handle to regulator	Sprite to (c)72040	2
56	470-600	\$29.99	ESCUTCHEON AND SPRING		2
64	472-520	\$4.99	HANDLE, window, black plastic	Midget (c)60460-on,	2
	472-555	\$15.49	HANDLE, window, chrome (repl.)	Sprite (c)72041-on	2
66	472-515	\$3.29	ESCUTCHEON, handle		2
67	472-535	\$0.89	SCREW, chrome		2
68	324-010	\$0.19	LOCKWASHER	to 1974 approx.	2
69	472-530	\$5.99	ESCUTCHEON, chrome		2

Toll-Free Orders 1-800-667-7872 | MossMotors.com
Fax 805-692-2525 | Local 805-681-3400

MOSS

No.	Part#	Price (Each)	Description	Application	Qty Req.
70	472-495	\$2.99	SCREW, flanged, handle to regulator	1974 on approx	2
80	†	NA	QUARTER LIGHT ASS'Y, RH, chrome (with hooked handle)	to G-AN4-64474; to H-AN9-75702	1
	†	NA	QUARTER LIGHT ASS'Y, LH, chrome (with hooked handle)		1
	†	NA	QUARTER LIGHT ASS'Y, RH, chrome (with straight handle)	G-AN4-64475 to G-AN5-121649; H-AN9-75703 on	1
	†	NA	QUARTER LIGHT ASS'Y, LH, chrome (with straight handle)		1
†These early assemblies are no longer available. The later type below may be used.					
82	407-030	\$499.99	QUARTER LIGHT ASS'Y, RH, stainless steel (w/straight handle)	Midget from (c)121650 (1973-'80)	1
	407-040	\$499.99	QUARTER LIGHT ASS'Y, LH, stainless steel (w/straight handle)		1
83	458-610	\$6.49	GLAZING STRIP, felt and rubber		2
84	282-075	\$12.99	SEAL, quarter light, RH		1
	282-085	\$12.99	SEAL, quarter light, LH		1
85	282-550	\$5.49	GLAZING RUBBER	Cut to 19" long.	2
86	459-930	\$59.99	GLASS, RH		1
	459-935	\$59.99	GLASS, LH		1
87	282-200	\$2.99	SEAL, quarter light to door, RH		1
	282-205	\$2.99	SEAL, quarter light to door, LH		1
90	282-575*	\$6.29	CORNER BLOCK*	chrome ass'y. (1962-68)	2
91	282-595*	\$2.99	CORNER BLOCK A=7/16"		2
	282-065	\$2.39	CORNER BLOCK A=1/2"		2
*These two corner blocks may be interchanged.					
92		NA	TOP PIVOT, upper half, RH	chrome ass'y.	1
93		NA	TOP PIVOT, lower half, RH		1
		NA	TOP PIVOT, upper half, LH	chrome ass'y.	1
		NA	TOP PIVOT, lower half, LH		1
	407-045	\$6.39	TOP PIVOT, upper half, RH	stainless ass'y.	1
	407-050	\$6.39	TOP PIVOT, lower half, RH		1
	407-055	\$6.39	TOP PIVOT, upper half, LH		1
	407-060	\$6.39	TOP PIVOT, lower half, LH		1
	407-065	\$6.39	TOP PIVOT, lower half, LH		1
96	325-085	\$1.99	RIVET, upper pivot half to frame		4
97	314-305	\$1.09	SCREW, lower pivot half to frame		4
98	407-130	NA	BOTTOM PIVOT	chrome ass'y. (use 407-140)	2
	407-140	\$28.99	BOTTOM PIVOT	stainless ass'y.	2
99		NA	DISTANCE TUBE, bottom pivot		2
100	329-850	\$1.79	SPRING, bottom pivot		2
101	324-590	\$0.19	WASHER, plain		4
102	324-020	\$0.20	WASHER, locking		2
103	310-760	\$0.59	NUT		4
104	470-505	NA	LOCKING HANDLE, hooked, RH	Midget to (c)64474, Sprite to (c)75702	1
	470-515	NA	LOCKING HANDLE, hooked, LH		1
105	470-425	NA	BRACKET AND PIVOT		2
	470-430	NA	BRACKET AND PIVOT	G-AN4-64475 on, H-AN9-75703 on	2
106	470-585	\$29.99	LOCKING HANDLE, straight, RH		1
	470-595	\$29.99	LOCKING HANDLE, straight, LH	1	
108	325-470	\$3.19	PIN, handle to pivot		2
109	324-295	\$0.39	WASHER, waved		2
110	325-085	\$1.99	RIVET, bracket to inner frame		4
111	314-300	\$0.89	SCREW, corner finisher to frame, upper		2
112	458-550	\$0.89	SCREW, corner finisher to frame, lower		4
113	407-065	NA	STUD PLATE, quarter light to door		4
114		NA	RIVET, front stud plate to frame		4
115		NA	RIVET, rear stud plate and latch to frame		4
116	312-010	\$3.39	NUT, stud plate to door		4
126		NA	SHIM, front frame foot to door, 1/16" thick		A/R
127		NA	RIVET, shim to front frame foot		2
128	322-540	\$0.79	SCREW, front frame foot to door		4
129	365-730	\$0.39	WASHER, locking		4
130		NA	WASHER, plain		4
135	\$13.79	BRACKET, drop glass channel to door			2
136	407-075	\$1.09	STUD PLATE, bracket to drop glass channel		2
137	310-760	\$0.59	NUT, bracket to drop glass channel		2
138	322-170	\$0.49	BOLT, bracket to door		4
139	324-020	\$0.20	WASHER, locking		10
140	324-590	\$0.19	WASHER, plain		10

Bumpers

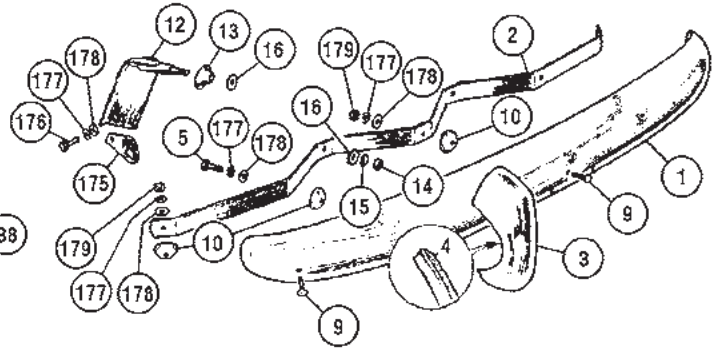
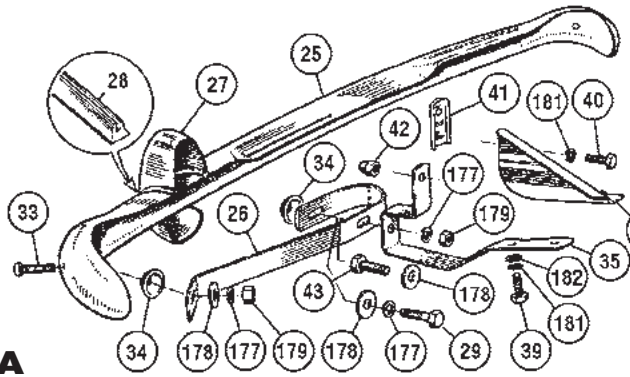

A

All Sprite (except Bugeye), Midget 1961-'69

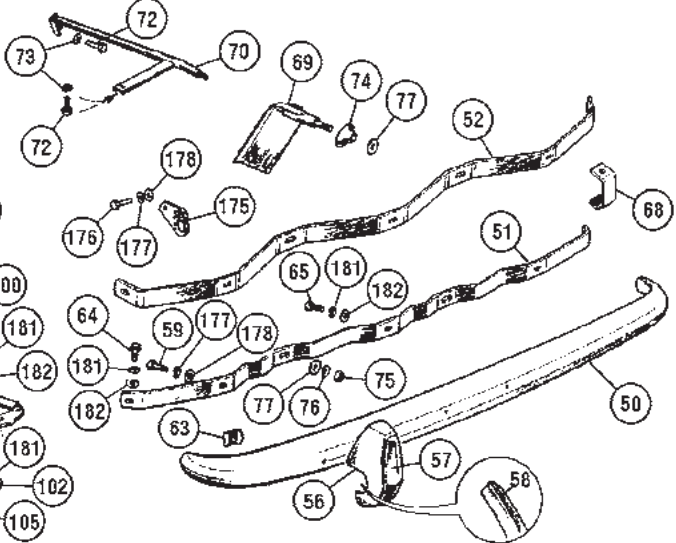
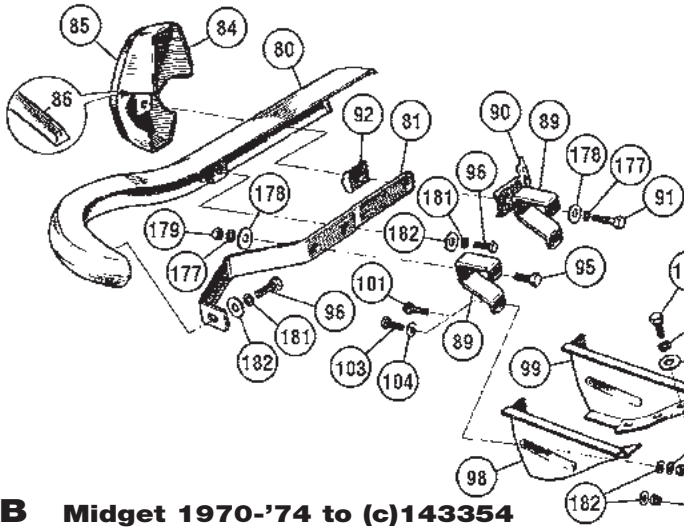

B Midget 1970-'74 to (c)143354

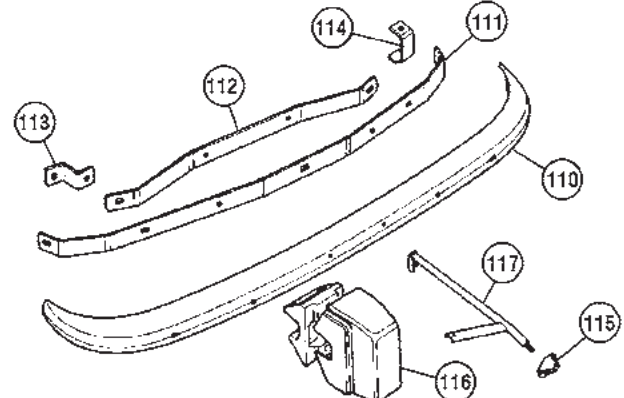
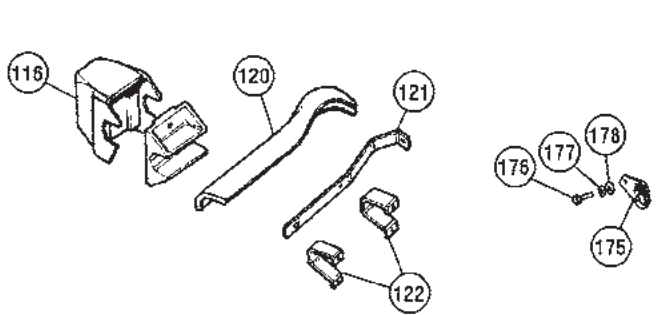

C Midget 1974 from (c)143355

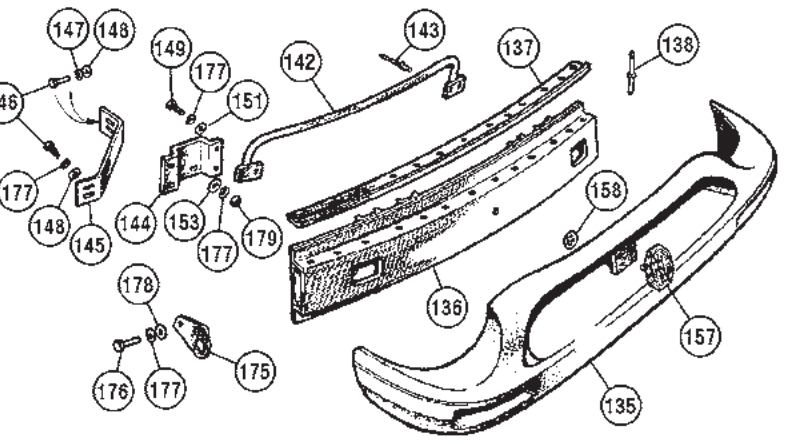
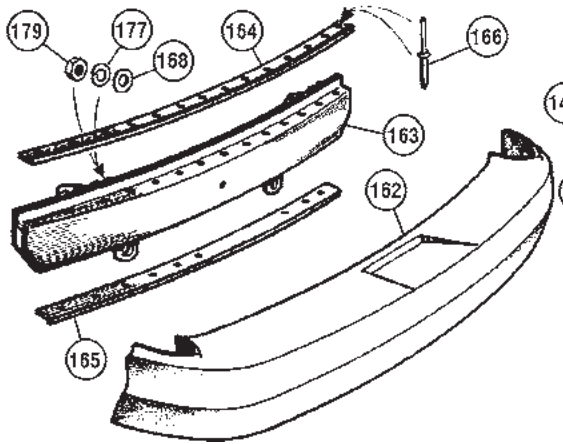

D Midget 1500 1975-'80

Bumpers

12063

No.	Part#	Price (Each)	Description	Application	Qty Req.
A - 948 (except Bugeye), 1098, 1275 to Sprite (c)85286, Midget (c)74885 (1961-'69)					
1	400-240	\$289.99	BUMPER BLADE, front		1
2	400-250	\$89.99	SPRING BAR		1
3	853-110	\$69.99	OVER RIDER		2
4	400-418	\$4.99	PACKING STRIP SET, for 4 over riders		1
5	322-615	\$2.99	BOLT, over rider and blade to spring bar		2
9	322-900	\$2.69	BOLT & NUT, bumper mounting, chrome		3
10	400-315	\$0.99	PACKING PIECE, spring bar to blade		5
12	455-905	\$39.99	BRACKET, bumper to chassis, RH		1
	455-855	\$39.99	BRACKET, bumper to chassis, LH		1
13	280-690	\$1.39	GROMMET, front valance		2
14	472-347	\$0.39	NUT, spring bar to bracket		2
15	322-835	\$0.49	WASHER, locking		2
16	315-120	\$1.29	WASHER, plain		4
25	853-100	\$359.99	BUMPER BAR, rear		1
26	400-260	\$14.99	SPRING BAR		2
27	853-110	\$69.99	OVER RIDER		2
28	400-418	\$4.99	PACKING STRIP SET, for 4 over riders		1
29	322-615	\$2.99	BOLT, over rider and blade to spring bar		2
33	322-900	\$2.69	BOLT & NUT, bumper mounting, chrome		2
34	400-315	\$0.99	PACKING PIECE, spring bar to blade		4
35	400-505	\$19.99	BRACKET, bumper mounting, RH		1
	400-515	\$19.99	BRACKET, bumper mounting, LH		1
38	400-545	\$36.99	SUPPORT, mounting bracket (BMH)		2
39	322-040	\$0.59	BOLT, bracket/support to boot floor		4
40	322-040	\$0.59	BOLT, bracket/support to rear valance		2
41	400-525	\$24.99	FINISHER, chrome, mounting bracket		2
42	402-550	\$3.89	DOME NUT, chrome		2
43	320-285	\$0.69	BOLT, spring bar to bracket		2
B - 1275 Midget from (c)74886 to 143354 (1970-mid'74)					
50	400-270	\$369.99	BUMPER BLADE, front		1
51		NA	SPRING BAR (Not avail.-use #52)	thru 1972	1
52	400-290	\$84.99	SPRING BAR	1973-'74 to (c)143354	1
56	400-310	\$68.99	OVER RIDER		2
57	400-550	\$9.49	RUBBER FACING, over rider		1
58	400-418	\$4.99	PACKING STRIP SET, for 4 over riders		2
59	320-345	\$0.99	BOLT, over rider and blade to spring bar		2
63	400-585	\$2.19	SPACER, bumper blade to spring bar		2
64	322-040	\$0.59	BOLT, outer ends of spring bar to blade		2
65	322-540	\$0.79	BOLT center of spring bar to blade		1
68	400-535	NA	REINFORCEMENT	from (c)123731 (1973+)	2
69	455-905	\$39.99	BRACKET, bumper to chassis, RH	} to (c)138000 (1970-'73)	1
	455-855	\$39.99	BRACKET, bumper to chassis, LH		1
70	400-580	NA	BRACKET, bumper to chassis, RH	} from (c)138801 (1974)	1
	400-590	NA	BRACKET, bumper to chassis, LH		1
72	322-645	\$0.49	BOLT, bracket		4
73	324-020	\$0.20	WASHER, locking		4
74	280-690	\$1.39	GROMMET, front valance		2
75	472-347	\$0.39	NUT, spring bar to bracket		2
76	322-835	\$0.49	WASHER, locking		2
77	315-120	\$1.29	WASHER, plain		4
80	400-320	NA	BUMPER BAR, rear, RH		1
	400-330	NA	BUMPER BAR, rear, LH		1
81	400-340	\$14.99	SPRING BAR		2
84	400-310	\$68.99	OVER RIDER		2
85	400-550	\$9.49	RUBBER FACING, over rider		2
86	400-418	\$4.99	PACKING STRIP SET, for 4 over riders		1
89	400-350	\$11.99	BRACKET, bumper mounting		4
90	400-555	\$69.99	BRACKET, number plate lamp mounting, RH		1
	400-565	\$69.99	BRACKET, number plate lamp mounting, LH		1
91	320-345	\$0.99	BOLT, over rider to mounting bracket		2
92	400-585	\$2.19	SPACER, bumper blade to spring bar		2
95	322-050	\$0.89	BOLT, spring bar to mounting bracket		2
96	322-040	\$0.59	BOLT, bumper blade to spring bar		4
98	400-600	\$24.99	SUPPORT, mounting bracket, outer RH (BMH)*		1
99	400-605	\$29.99	SUPPORT, mounting bracket, inner RH (BMH)*		1
	400-610	\$24.99	SUPPORT, mounting bracket, outer LH (BMH)*		1
	400-615	\$29.99	SUPPORT, mounting bracket, inner LH (BMH)*		1
100	322-040	\$0.59	BOLT, support to trunk floor		12
101	321-708	\$5.29	BOLT & NUT, mounting bracket	} to (c)138000 (1970-'73)	8
102	310-140	\$0.39	NUT		8

*Parts market "BMH" are produced by British Motor Heritage.

Bumpers

No.	Part#	Price (Each)	Description	Application	Qty Req.
103	322-290	\$0.89	BOLT, mounting bracket	from (c)138800	8
104	365-720	\$0.79	WASHER, plain	1974	16
105	310-290	\$1.19	NUT, nylon		8

C - 1275 Midget from (c)143355 to 154100 (mid 1974)

NOTE: Hardware for this application is the same as under illustration B.

110	400-370	NA	FACE BAR, front bumper (may use earlier bumper 400-270)		1
111	400-380	NA	SPRING BRACKET		1
112	400-390	NA	SUPPORT		1
113	400-400	NA	BRACKET		2
114	400-535	NA	REINFORCEMENT		2
115	280-690	\$1.39	GROMMET, front bumper		2
116	400-410	NA	OVERRIDER, R/H, front & rear		2
	400-420	NA	OVERRIDER, L/H, front & rear		2
117	400-580	NA	BRACKET, bumper to chassis, R/H		1
	400-590	NA	BRACKET, bumper to chassis, L/H		1
120	400-430	NA	BUMPER, L/H rear		1
	400-440	NA	BUMPER, R/H rear		1
121	400-450	NA	SPRING BRACKET		2
122	400-460	NA	BRACKET		2

D - Midget 1500 (1975-'80)

135	400-470	NA	BUMPER MOULDING, front		1
136	400-480	NA	ARMATURE, bumper		1
137	400-500	NA	RETAINER, moulding to armature		2
138	326-195	NA	RIVET		26
142	400-490	\$47.99	SUPPORT, upper moulding		1
143		NA	RIVET		4
144		NA	SPRING BRACKET, inner, RH		1
		NA	SPRING BRACKET, inner, LH		1
145	400-570	NA	SPRING BRACKET, outer		2
146		NA	SCREW, outer bracket to body and armature		8
147	324-040	\$0.39	WASHER, locking		8
148	475-155	NA	WASHER, plain		8
149		NA	SCREW, inner spring bracket to armature		8
150	324-040	\$0.39	WASHER, locking		8
151	475-155	NA	WASHER, plain		8
152	324-040	\$0.39	WASHER, locking		4
153	475-155	NA	WASHER, plain		4
157	475-170	\$35.99	BADGE, 'MG', gold on black	some 1975 cars	1
	475-165	\$24.99	BADGE, 'MG', silver on black	from (c)171431	1
	475-175	NA	BADGE, 'MG', silver on bright red	alternative	1
158	326-530	\$0.29	CLIP, push fix, badge to bumper		2
162	400-510	NA	BUMPER MOULDING, rear		1
163	400-520	NA	ARMATURE, bumper		1
164	400-530	NA	RETAINER, moulding to armature, upper		1
165	400-540	NA	RETAINER, moulding to armature, lower		1
166	326-195	NA	RIVET		28
167	324-040	\$0.39	WASHER, locking		4
168	475-155	NA	WASHER, plain		4

Towing Eye / Common Hardware

175	400-575	\$21.99	TOWING EYE	all	2
176	320-285	\$0.69	BOLT, towing eye		4
177	324-040	\$0.39	LOCKWASHER		A/R
178	324-860	\$0.19	WASHER, plain		A/R
179	310-050	\$0.69	NUT		A/R
181	365-730	\$0.39	LOCKWASHER		A/R
182	365-720	\$0.79	WASHER, plain		A/R

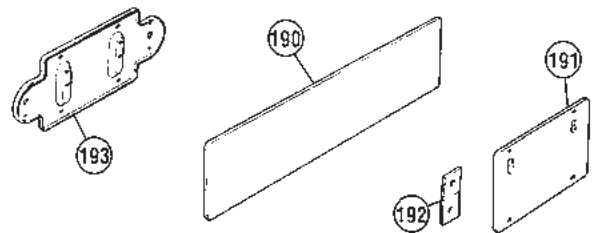

License Plate Supports

190	451-720	\$15.49	SUPPORT, license plate, British style		2
191	451-285	\$16.99	SUPPORT, license plate, for U.S. plates	} 948-1275 ft. & rear, 1500 front	2/1
192	402-560	\$4.49	BRACKET for front support	(all)	2
193	451-295	\$44.99	SUPPORT, license plate, rear, stock	1500	1

Toll-Free Orders 1-800-667-7872 | MossMotors.com
Fax 805-692-2525 | Local 805-681-3400



Door Fittings

Early Doors, 1958-'63

12064

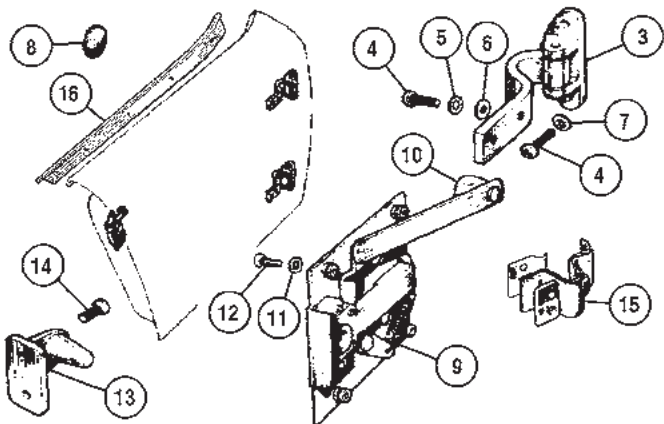

No.	Part#	Price (Each)	Description	Application	Qty Req.
3	471-135	\$159.99	HINGE (British Motor Heritage part)		4
4	322-495	\$0.49	SCREW		20
5	315-300	\$0.59	WASHER, shakeproof		8
6	324-590	\$0.19	FLAT WASHER		8
7	462-385	\$0.39	LOCK WASHER		12
8	282-140	\$1.69	PLUG, rubber	948cc cars only	8
9	402-640	\$34.99	LATCH, R/H		1
9A	402-650	\$34.99	LATCH, L/H		1
10	402-670	\$14.99	KNOB		2
11	324-110	\$0.29	SPRING WASHER		8
12	323-005	\$0.39	SCREW		8
13	470-540	\$12.99	STRIKER		8
14	323-255	\$0.69	SCREW		4
15	NA		CHECK STRAP	(see #60-62 below)	2
16	459-943	\$109.99	DOOR CAPPING, R/H		1
	459-942	\$109.99	DOOR CAPPING, L/H		1

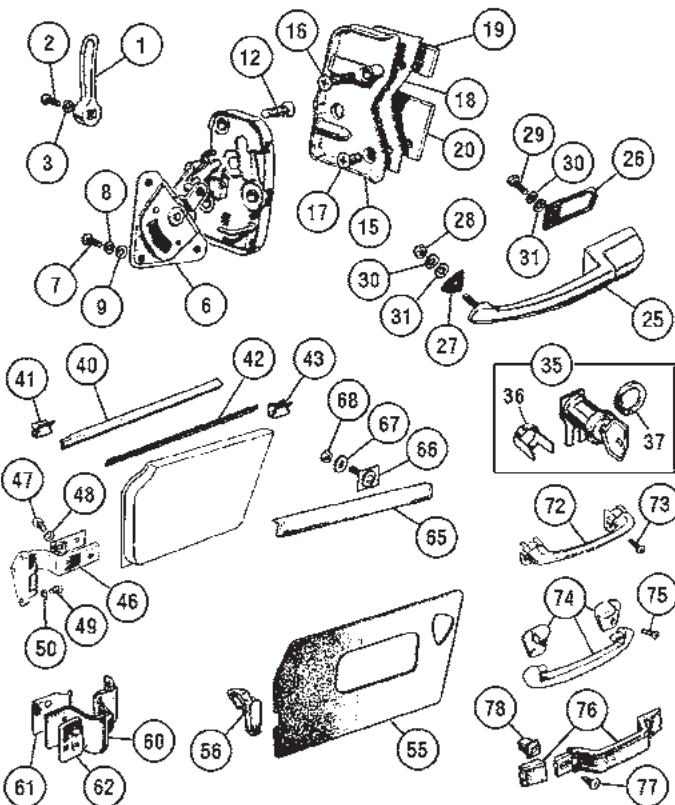

No.	Part#	Price (Each)	Description	Application	Qty Req.
25		NA	EXTERIOR HANDLE ASS'Y	1964-'67	2
	402-660	\$119.99	EXTERIOR HANDLE ASS'Y	1968-on	2
26	401-550	\$0.59	GASKET, handle to door, rear		2
27	401-540	\$0.99	GASKET, handle to door, front		2
28	310-040	\$0.29	NUT, handle to door		2
29	466-385	\$0.79	SCREW, handle to door		2
30	324-010	\$0.19	WASHER, locking		4
31	324-990	\$0.39	WASHER, plain		4
	470-458	\$174.99	MASTER LOCK SET., 3 pieces		1
			Includes 2 door locks, trunk handle & lock; keyed alike, with 2 keys		
	470-448	\$89.99	LOCK SET, door		1
			Includes 2 door locks; keyed alike, with 2 keys		
35	470-435	\$45.99	LOCK, R/H door with 2 keys		1
	470-440	\$45.99	LOCK, L/H door with 2 keys		1
36	401-590	NA	CLIP, lock retaining		2
37	402-170	\$0.99	GASKET, lock to door		2
40	282-175	\$21.99	WEATHER STRIP, door, outer, LH		1
	282-170	\$21.99	WEATHER STRIP, door, outer, RH		1
41	803-400	\$0.59	CLIP, outer weather strip to door		12
42	282-185	\$8.99	WEATHER STRIP, door, inner, LH		1
	282-180	\$8.99	WEATHER STRIP, door, inner, RH		1
43	317-065	\$1.39	CLIP, inner weather strip to door		12
46	471-140	\$154.99	HINGE, door (British Motor Heritage part)		4
47	322-880	\$0.99	SCREW, hinge to door		8
48	315-300	\$0.59	WASHER, shakeproof		8
49	322-495	\$0.49	SCREW, hinge to 'A' post		12
50	462-385	\$0.39	WASHER, shakeproof		12
55			DOOR PANEL, see page 82.		
56	803-420	\$0.99	CLIP, door panel (replacement)		18
60	240-670	\$39.99	CHECK STRAP, red		2
	240-675	\$39.99	CHECK STRAP, black		2
	240-680	\$39.99	CHECK STRAP, blue		2
	240-672	\$39.99	CHECK STRAP, green		2
	240-685	\$39.99	CHECK STRAP, navy		2
	240-690	\$39.99	CHECK STRAP, autumn leaf		2
61	240-805	\$5.29	BRACKET, check strap		2
62	240-815	\$3.99	RETAINER, check strap		2
65	402-700	NA	MOULDING, door top, untrimmed, RH		1
	402-705	NA	MOULDING, door top, untrimmed, LH		1
66	326-075	\$0.99	STUD PLATE, moulding to door top		4
67	315-085	\$0.29	WASHER, plain		4
68	159-340	\$0.69	NUT		4
72	803-440	\$16.99	HANDLE, door pull, chrome*	Midget to (c)60459,	2
73	402-485	\$0.79	SCREW, chrome, handle to door*	Sprite to (c)72040	4
74	472-240	\$5.99	HANDLE, door pull, black†	Midget (c)60460-	2
				105500, Sprite from	
				(c)72041	
75	402-485	\$0.79	SCREW, chrome, handle to door†		4
76	402-450	NA	HANDLE, door pull, autumn leaf		2
	402-455	NA	HANDLE, door pull, ochre		2
	402-453	\$28.99	HANDLE, door pull, black	Midget from	2
	402-490	NA	HANDLE, door pull, navy	(c)105501 (from 1972)	2
77	314-285	\$0.49	SCREW, handle to door		4
78	402-710	NA	CAPTIVE NUT		4

Late Doors, 1964-'80

12065

No.	Part#	Price (Each)	Description	Application	Qty Req.
1	402-685	\$36.99	HANDLE, remote control	Midget to (c)60459,	2
2	323-205	\$2.59	SCREW, handle to remote control	Sprite to (c)72040	2
	402-690	NA	HANDLE, remote control	Midget from (c)60460,	2
			(Use early handle & screw)	Sprite from (c)72041	
	323-005	\$0.39	SCREW, handle to remote control		2
3	324-010	\$0.19	LOCKWASHER		2
6	402-675	NA	REMOTE CONTROL, latch, LH		1
	402-680	NA	REMOTE CONTROL, latch, RH		1
7	323-005	\$0.39	SCREW, remote control to door		6
8	324-010	\$0.19	WASHER, locking		6
9	315-085	\$0.29	WASHER, plain		6
12	323-585	\$0.59	SCREW, latch to door		6
15	401-340	NA	STRIKER PLATE, RH	Midget to (c)60459,	1
	401-320	NA	STRIKER PLATE, LH	Sprite to (c)72040	1
	401-370	NA	STRIKER PLATE, RH	Midget from (c)60460,	1
	401-360	NA	STRIKER PLATE, LH	Sprite from (c)72041	1
16	323-195	\$1.39	SCREW, long, striker plate to 'B' post		2
17	323-280	\$0.89	SCREW, short, striker plate to 'B' post		4
18	402-410	\$1.19	SHIM, striker plate to 'B' post, 0.064"	A/R	
	402-415	\$1.19	SHIM, striker plate to 'B' post, 0.032"	A/R	
19	402-340	\$4.49	TAPPED PLATE, upper (in 'B' post)		2
20	402-420	\$6.29	TAPPED PLATE, lower (in 'B' post)		2

* thru 1967 † from 1968

Wipers & Washers

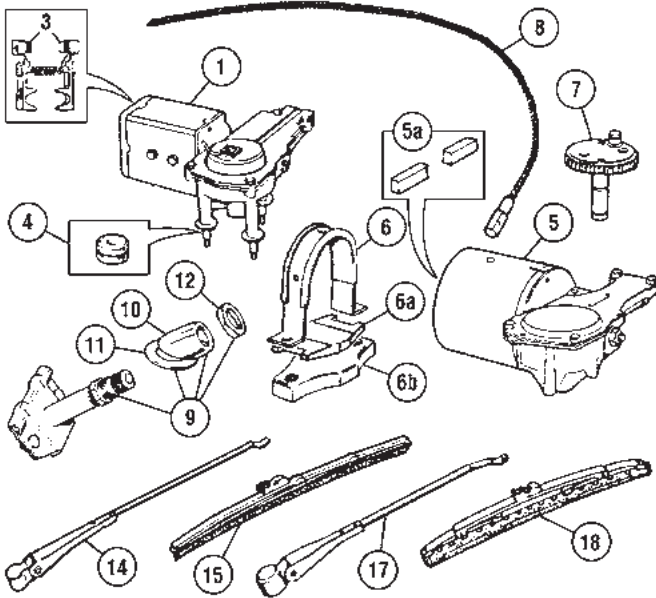

Wipers & Washers, Sprite Mkl-II, Midget Mkl

12066

No.	Part#	Price (Each)	Description	Application	Qty Req.
1	145-510	NA	WIPER MOTOR, less gear #7	replaces original units #75213 & 75387	1
3	554-035	\$22.99	BRUSH BLOCK PAIR (carbon blocks only)		1
4	145-640	\$14.99	MOUNTING KIT (3 grommets, studs, nuts & washers)		1
7	145-320	NA	GEAR & SHAFT		1
8	161-310	\$23.99	CABLE ASS'Y., must be cut to match original length		1
9	145-200	\$42.99	WHEELBOX		2
10	145-290	\$4.89	BEZEL, chrome		2
11	282-820	\$0.79	PAD, bezel		2
12	311-065	\$1.99	NUT		2
14	165-005	\$23.99	WIPER ARM (LHD)		2
15	161-100	\$15.49	WIPER BLADE, 8"		2

Wipers & Washers, Sprite MkIII-IV, Midget MkII-III thru 1967

12067

1	145-510	NA	WIPER MOTOR, less gear #7	replaces units #75452, 75504 & 75801, 1963-'67	1
2	554-030	NA	BRUSH ASSEMBLY		1
3	554-035	\$22.99	BRUSH PAIR (carbon blocks only)		1
4	145-640	\$14.99	MOUNTING KIT (3 grommets, studs, nuts & washers)		1
7	145-535	NA	GEAR & SHAFT	original units #75452 & 75504	1
	560-360	\$119.99	GEAR & SHAFT	replacement unit #75801	1
8	161-310	\$23.99	CABLE ASS'Y., must be cut to match original		1
9	145-217	\$39.99	WHEELBOX		2
10	145-290	\$4.89	BEZEL, chrome		2
11	282-820	\$0.79	PAD, bezel		2
12	145-205	\$2.19	NUT		2
14	165-005	\$23.99	WIPER ARM (LHD)		2
15	161-100	\$15.49	WIPER BLADE, 8"		2

Wipers & Washers, All from 1968 on

12069

5	145-490	\$99.99	WIPER MOTOR, less gear #7	replaces units #75660, 75664 & 75705	1
	145-485	NA	WIPER MOTOR, less gear, Lucas		1
5a	145-590	\$29.99	BRUSH SET		1
6	145-645	\$9.99	STRAP, wiper motor mounting		1
6a	145-660	\$4.29	PAD		1
6b	145-665	NA	PACKING		1
7	145-575	\$49.49	GEAR & SHAFT	twin wipers	1
	145-555	\$21.99	GEAR & SHAFT	triple wipers	1
8	161-310	\$23.99	CABLE ASS'Y., must be cut to match original		1
9	145-150	NA	WHEELBOX	1968 - '74 1/2	2/3
	145-140	NA	WHEELBOX	1974 1/2 on	3
10	145-290	\$4.89	BEZEL, chrome		2/3
11	282-820	\$0.79	PAD, bezel		2/3
12	145-205	\$2.19	NUT		2/3

Toll-Free Orders 1-800-667-7872 | MossMotors.com
Fax 805-692-2525 | Local 805-681-3400

MOSS

17	164-625	NA	WIPER ARM	1968	2
	164-610	\$31.99	WIPER ARM, TEX brand	1969 - '72	2/3
	164-615	\$31.99	WIPER ARM (stainless), TEX brand	1973-'76	3
	164-635	\$34.99	WIPER ARM (black), TEX brand	1977-'80	3
18	165-075	NA	WIPER BLADE	1968	2
	165-055	\$10.99	WIPER BLADE	1969 - '72	2/3
	165-046	\$10.99	WIPER BLADE (stainless)	1973-'76	3
	165-047	\$21.99	WIPER BLADE (black), TEX brand	1977-'80	3
	165-045	\$10.99	WIPER BLADE (black)		3

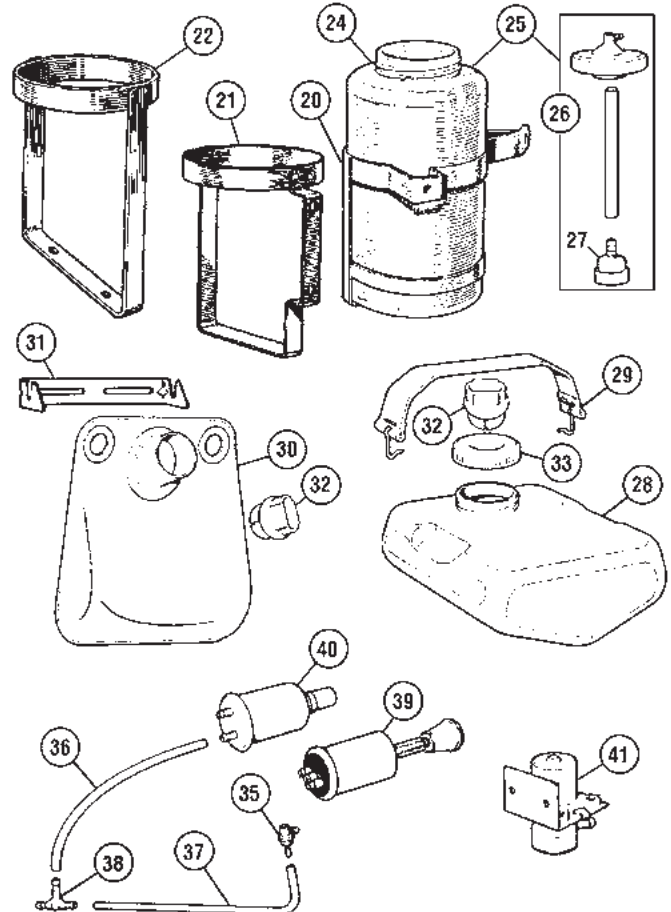

Windshield Washer

12070

No.	Part#	Price (Each)	Description	Application	Qty Req.
20	361-215	\$57.99	BRACKET, washer bottle	Sprite Mkl,II, Midget Mkl	1
21	361-245	\$12.69	BRACKET, washer bottle	from above thru 1967	1
22	361-275	\$15.39	BRACKET, washer bottle	1968-'74	1
24	361-125	\$54.99	CONTAINER (use with #20, 26, 27)	Sprite Mkl,II, Midget Mkl	1
25	361-148	\$18.99	CONTAINER ASS'Y., complete	1098 from '64 & 1275	1
26	361-140	NA	CAP, with tube (included with #25)		1
27	361-145	\$3.19	FOOT VALVE (included with #25 & 26)		1
28	161-125	NA	CONTAINER	1500 to (c)166300	1
29	361-135	NA	STRAP		1
30	361-120	\$34.99	CONTAINER, bag	1500 from (c)166301	1
31	361-270	\$13.69	BRACKET for bag		1
32	361-190	\$1.99	FILLER PLUG	all 1500	1
33	361-150	\$3.99	CAP	1500 to (c)166300	1
35	361-240	\$5.49	JET, chromed	thru 1976	2
	361-260	\$5.49	JET, black	from 1977	2
36	361-210	\$1.09	TUBING, container to pump & pump to 3-way connector*		A/R
37	361-210	\$1.09	TUBING, connector to jets*	thru 1976	A/R
	361-220	\$0.99	TUBING, connector to jets*	1977-on	A/R
*sold per foot					
38	361-235	NA	CONNECTOR, 3-way	thru 1976	1
	115-372	\$1.39	CONNECTOR, 3-way	1977-on	1
39	361-185	NA	PUMP, w/knob	948	1
40	361-160	\$29.99	PUMP, manual (replacement)	1098	1
	361-200	\$8.49	VALVE, in-line	use with pump 361-160	1
41	361-180	\$16.99	PUMP, electric	1275 & 1500	1

Headlamps

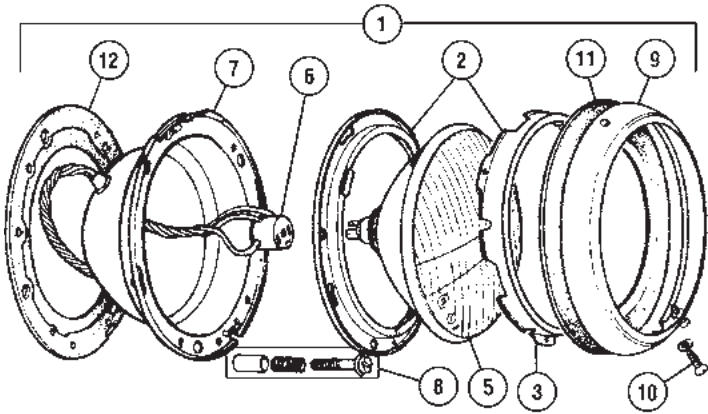

Headlamps - Bugeye to (c)19014

12072

No.	Part#	Price (Each)	Description	Application	Qty Req.
1	168-708	\$129.99	HEADLAMP ASS'Y., sealed beam		2
2	157-300	\$35.99	RING ASS'Y., inner, 2 piece		2
3	156-700	\$14.99	RING, retaining		2
5	171-100	NA	LIGHT UNIT, sealed beam (not in ass'y.)		2
	171-105	\$18.99	LIGHT UNIT, sealed beam, halogen (in ass'y.)		2
6	171-400	\$8.99	PLUG, sealed beam, w/ grommet & pigtail		2
7	144-797	\$25.99	BUCKET (3 adjuster type) without adjusters		2
8	147-015	\$12.99	ADJUSTER SET, for 1 lamp		2
9	164-002	\$27.99	CHROME RIM, outer		2
10	147-000	\$0.99	SCREW		2
	11	280-120	DUST SEAL		2
	12	280-130	GASKET, lamp ass'y., to body		2

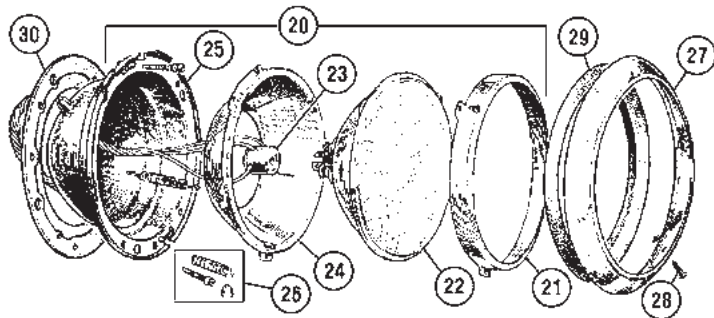

Headlamps - from Bugeye (c)19015 thru 1275

12074

20	144-800	\$114.99	HEADLAMP ASS'Y., sealed beam		2
21	156-700	\$14.99	RING, retaining		2
22	171-100	NA	LIGHT UNIT, sealed beam (not in ass'y.)		2
	171-105	\$18.99	LIGHT UNIT, sealed beam, halogen (in ass'y.)		2
23	171-400	\$8.99	PLUG, sealed beam, w/ grommet & pigtail		2
24	560-215	\$17.99	RIM, inner		2
25	144-807	\$27.99	BUCKET with 2 adjusters		2
26	552-115	\$5.99	ADJUSTER SET, for 1 lamp		2
27	164-000	NA	CHROME RIM, outer, orig. type	} Bugeye	2
	164-002	\$27.99	CHROME RIM, replacement		2
	560-180	\$29.99	CHROME RIM, outer		all except Bugeye
28	147-000	\$0.99	SCREW		2
29	280-120	\$3.69	DUST SEAL	} Bugeye	2
30	280-130	\$2.49	GASKET, lamp ass'y., to body		2
	164-050	\$4.99	GASKET, lamp ass'y., to body	all except Bugeye	2

Your headlamps won't light! Check the ground connector on the passenger side inner fender under the fresh air tube clamp on 948 - 1275 models.

Most lamp problems are caused by bad bulb contacts or corroded grounds. Don't assume major problems until the unit is completely inspected.

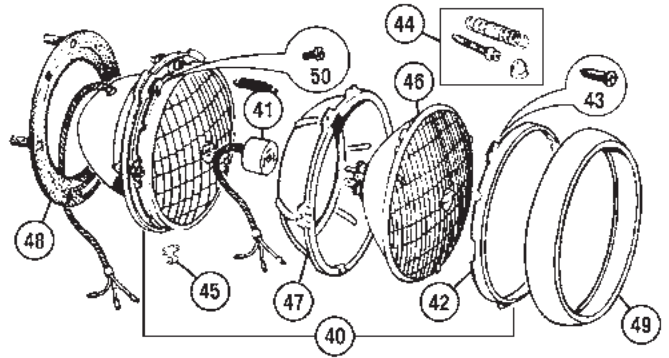

Headlamps - Midget 1500

12071

No.	Part#	Price (Each)	Description	Application	Qty Req.
40	144-810	\$89.99	HEADLAMP ASSEMBLY		2
	169-130	NA	BUCKET ASSEMBLY		2
	144-807	\$27.99	BUCKET, bare		2
41	171-400	\$8.99	PLUG, w/grommet & pigtail		2
42	156-700	\$14.99	RING, retaining		2
43	158-045	\$0.69	SCREW		6
44	552-115	\$5.99	ADJUSTER SET		2
45	560-325	\$2.99	CLIP, rim securing		2
	171-100*	NA	LIGHT UNIT, sealed beam (not in ass'y.)		2
	171-105	\$18.99	LIGHT UNIT, sealed beam, halogen (in ass'y.)		2
47	560-215	\$17.99	RIM, inner		2
48	164-060	\$4.29	GASKET, lamp ass'y., to body		2
49	164-020	\$36.99	RIM, outer (1975-'79)		2
	164-015	\$59.99	RIM, outer, with notch (1980)		2
50	373-960	\$0.20	SCREW, to body		8

*See the Accessories Section at the front of this catalog for alternative headlamps.



Halogen Headlamps

12073

A	162-726	NA	HALOGEN HEADLAMP, Lucas	2
B	902-969	\$84.99	HALOGEN HEADLAMP, Hella	2
C	156-875	\$58.99	HALOGEN HEADLAMP, Crystal Clear	2
	902-998	\$6.39	BULB, H4 halogen	2

See "Exterior" color pages at the front of this catalog for details

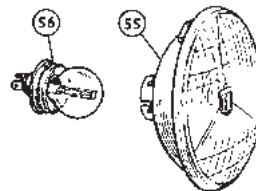

PL Tripod Headlamps

12075

	156-898	NA	PL TRIPOD HEADLAMP SET, two light units with bulbs	} LHD	1
55	163-980	NA	PL LIGHT UNIT		2
56	170-450	\$3.69	BULB		2
	170-675	\$8.49	BULB, quartz halogen replacement		2

*Note: These are reproductions with all of the correct Lucas markings. Tripod headlamps are semi-sealed units with replaceable bulbs, and are not legal for street use where D.O.T. approved headlamps are required.

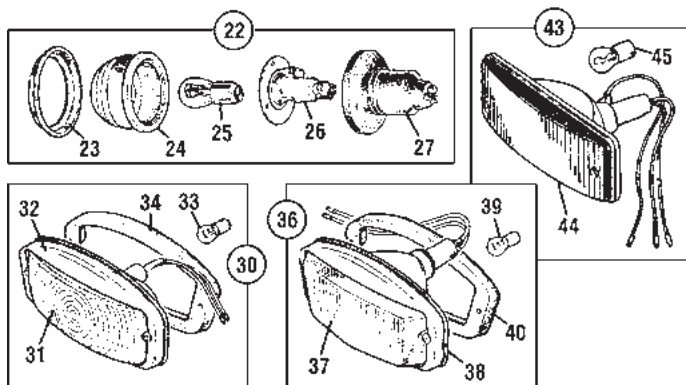

Front Side/Flashers

12076

22	544-050	\$34.99	LAMP ASSEMBLY, side/flasher	} Bugeye	2
23	158-400	\$3.99	RIM, chrome		2
24	560-270	\$7.49	LENS, clear		2
25	170-700	\$0.69	BULB, original type		2
	170-931	\$29.99	BULB, LED, white*		2
26	552-120	\$17.99	SOCKET		2
27	159-600	\$2.69	BODY, rubber		2
30	159-060	NA	LAMP ASSEMBLY, side/flasher, clear lens (use #36 as repl.)	} 1961 - '67	2
	159-065	NA	LAMP ASSEMBLY, side/flasher, amber lens (use #36 as repl.)		2
31	159-048	\$38.99	LENS PAIR, clear (replacement - Euro-spec, glass)	} 1961 - '67	1
	159-075	NA	LENS, amber		2
32	159-050	\$18.99	RIM	} 1961 - '69	2
33	170-700	\$0.69	BULB, original type		2
	170-931	\$29.99	BULB, LED, white*		2
	170-936	\$29.99	BULB, LED, amber*		2
34	159-085	\$2.99	GASKET, lens seating		2
36	159-090	\$74.99	LAMP ASSEMBLY, side/flasher	} Midget 1970-'74	2
37	159-095	\$11.99	LENS, amber		2
38	159-050	\$18.99	RIM		2
	170-700	\$0.69	BULB, original type		2
	170-937	\$39.99	BULB KIT, LED, amber**		2
40	159-085	\$2.99	GASKET, lens seating	2	
43	164-155	NA	LAMP ASSEMBLY, side/flasher, Lucas	} Midget 1500	2
	164-156	NA	LAMP ASSEMBLY, side/flasher, reproduction		2
44	164-815	\$8.49	LENS, amber, with screw & seal		2
	323-035	\$1.39	SCREW, lens to base		2
	164-120	\$1.99	SEAL, lens to base		2
45	170-700	\$0.69	BULB	2	
	170-937	\$39.99	BULB KIT, LED, amber**	2	

** (Bulb Kit includes 1 bulb and 1 ballast)

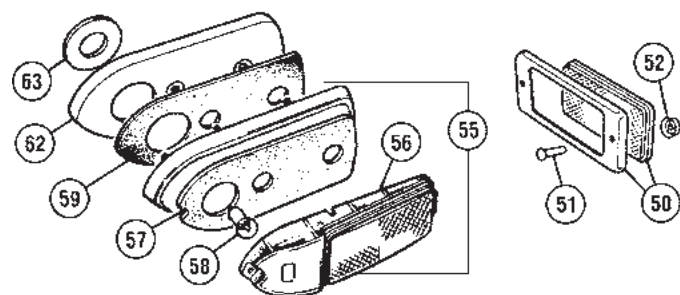

Front Side Markers

12079

50	570-180	\$18.99	REFLECTOR & RIM, front, amber	} 1275, 1968 - '69	2
51	158-230	NA	RIVET, reflector to body		4
52	158-235	NA	PUSH-ON FIX, rivet		4
55	164-846	\$64.99	SIDE MARKER, L/H front	} Midget 1970 on	1
	164-856	\$66.99	SIDE MARKER, R/H front		1
56	164-886	\$29.99	LENS, L/H		1
	164-891	\$29.99	LENS, R/H		1
57	164-910	\$1.49	GASKET, lens seating		2
58	170-250	\$0.99	BULB, original type		2
	170-911	\$25.99	BULB, LED, amber*		2
59	164-915	\$5.79	GASKET, lamp to plinth		2
62		NA	PLINTH, L/H		1
		NA	PLINTH, R/H		1
63	164-130	NA	WASHER, sealing		2

Toll-Free Orders 1-800-667-7872 | MossMotors.com
Fax 805-692-2525 | Local 805-681-3400

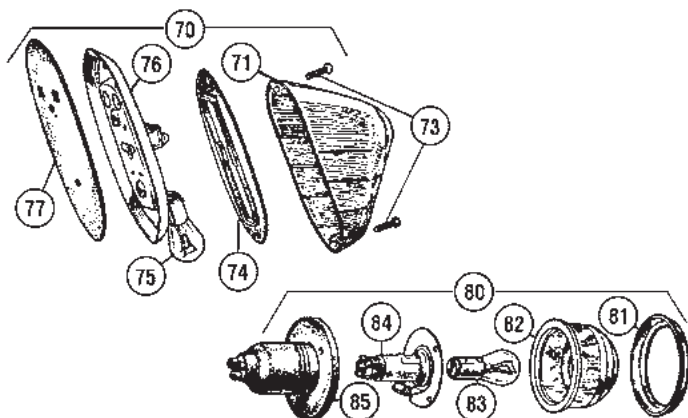

Taillight - Bugeye

12077

No.	Part#	Price (Each)	Description	Application	Qty Req.
70	143-801	\$49.99	TAIL LAMP ASSEMBLY	} Bugeye	2
71	159-200	NA	LENS, Lucas		2
	159-211	\$12.99	LENS, aftermarket		2
73	323-420	\$2.79	SCREW for lens		4
74	159-100	\$2.99	PAD, lens mounting		2
75	170-700	\$0.69	BULB, original type		2
	170-941	\$29.99	BULB, LED, red*		2
76	159-300	\$34.99	BASE ASSEMBLY, chrome		2
77	159-400	\$3.49	PAD, lamp mounting		2
80	144-000	\$31.99	FLASHER LAMP ASSEMBLY		2
81	158-400	\$3.99	RIM, chrome		2
82	164-900	\$7.99	LENS, red		2
83	170-800	\$0.89	BULB, original type		2
	170-956	\$29.99	BULB, LED, red*		2
84	159-900	\$18.49	SOCKET		2
85	159-600	\$2.69	BODY, rubber	2	

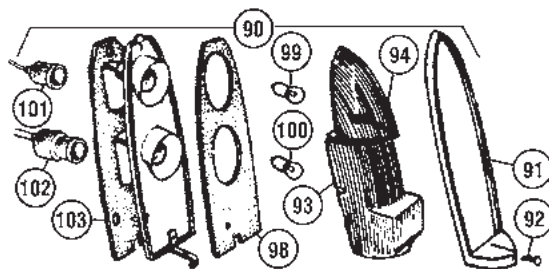

Taillight - 1961-1969

12078

No.	Part#	Price (Each)	Description	Application	Qty Req.
90	144-390	\$99.99	TAIL LAMP ASS'Y., w/red/red lenses	} from Sprite MkII & Midget MkI thru 1969	2
91	164-790	\$17.99	RIM		2
92	323-090	\$1.39	SCREW		2
93	164-820	\$18.99	LENS, stop/tail, original Lucas		2
94	164-830	NA	LENS, flasher, original Lucas		2
	164-725	NA	LENS, flasher, amber (Euro. spec.)		2
98	164-840	\$2.59	PAD, lens seating		2
99	170-800	\$0.89	BULB, original type, flasher		2
	170-951	\$29.99	BULB, LED, flasher, amber*		2
	170-956	\$29.99	BULB, LED, flasher, red*		2
100	170-700	\$0.69	BULB, original type, stop/tail		2
	170-941	\$29.99	BULB, LED, stop/tail, red*		2
101	158-150	\$1.19	GROMMET, flasher wire		2
102	158-160	NA	GROMMET, stop/tail wire	2	
103	164-870	\$1.69	PAD, lamp to car	2	

*Note: For Negative Ground vehicles only. You will want to match LED bulb color with the color of the specific lamp lens to avoid color distortion. Use White for Clear, Amber for Amber, and Red for Red. In some applications there were multiple options, so the appropriate selection must be made based on your vehicle. If you are replacing turn signal bulbs with LEDs you will need to upgrade to an electronic flasher. Flasher part numbers are 141-667 for 2-Prong, or 141-668 for 3-Prong.

Lamps

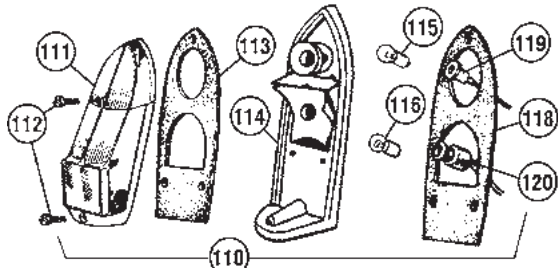

Taillight - Midget 1970 on

12080

No. Part#	Price (Each)	Description	Application	Qty Req.
110 144-395	\$169.99	TAIL LAMP ASSEMBLY, w/ 1 pc. lens	Midget, 1970 on	2
111 164-836	\$62.99	LENS, premium		2
164-735	NA	LENS, quality replacement		2
112 323-035	\$1.39	SCREW, lens to base		4
113 164-883	\$2.19	GASKET, lens seating		2
114 164-785	NA	LAMP BASE, chrome		2
115 170-700	\$0.69	BULB, original type, stop/tail		2
170-941	\$29.99	BULB, LED, stop/tail, red*		2
116 170-800	\$0.89	BULB, flasher		2
170-952	\$39.99	BULB KIT, LED, flasher, amber* (Bulb Kit includes 1 bulb and 1 ballast)		2
118 164-880	\$2.09	GASKET, lamp to car		2
119 158-160	NA	GROMMET, stop/tail wires		2
120 158-150	\$1.19	GROMMET, flasher wire	2	

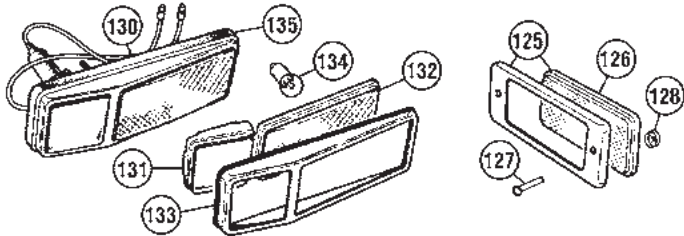

Rear Side Markers

12082

125 144-720	\$13.99	REFLECTOR & RIM, rear, red	1275, 1968 - '69	2
126 164-150	\$11.99	REFLECTOR, red		2
127 158-230	NA	RIVET, reflector to body		4
128 158-235	NA	PUSH-ON FIX, rivet		4
130 164-135	\$179.99	SIDE MARKER ASSEMBLY, rear	Midget, 1970 on	2
131 164-140	NA	LENS, red		2
132 164-150	\$11.99	REFLECTOR, red		2
133 164-145	NA	RIM		2
134 170-250	\$0.99	BULB, original type		2
170-916	\$25.99	BULB, LED, red*		2
135 282-260	\$17.99	BASE, rubber		2

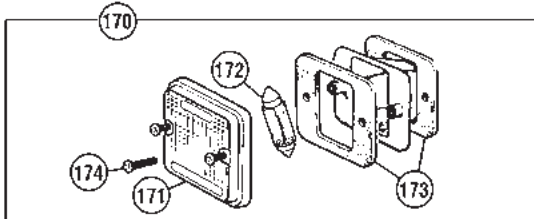

Reverse Lamps

12084

170 144-595	NA	REVERSE LAMP, Lucas**	1275 & 1500	2
144-590	\$26.99	REVERSE LAMP, aftermarket**		2
171 164-861	\$12.99	LENS w/ gasket & screws, Lucas style		2
164-860	\$7.99	LENS w/ gasket, aftermarket		2
172 170-140	\$0.89	BULB		2
173 159-110	\$1.49	PAD, lens & lamp seating		4
174 158-220	\$0.49	SCREW		4

**Screws supplied with lamps must be replaced with no.174 158-220.

Chrome Reverse Lamp Rims

The original reverse lamp lenses have never been a thing of beauty, now that can be changed. These chrome plated brass rims fit over the original lens to brighten the rear of the car. Available individually or as a set of two with new lenses, and installation screws.

Chrome Rim (ea.)	164-862	NA
Chrome Rim & Lens Set	164-868	\$59.99

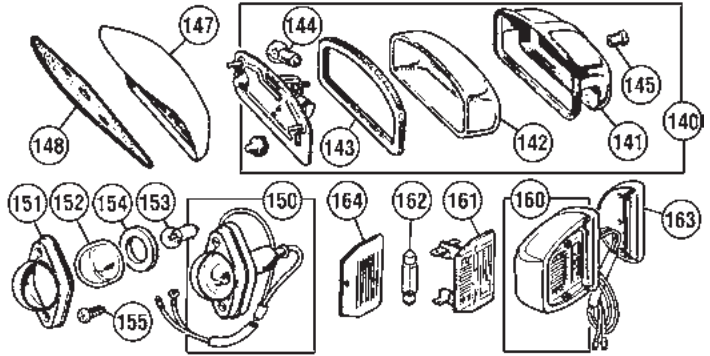

License Lamps

12081

No. Part#	Price (Each)	Description	Application	Qty Req.	
140 144-190	\$89.99	LICENSE PLATE LAMP, "England"	all thru 1969	1	
144-200	\$32.99	LICENSE PLATE LAMP, Classic Gold		1	
141 158-100	\$18.99	COVER, chrome		1	
142 164-100	\$8.99	LENS		1	
143 280-540	\$3.29	SEAL, lens to base		2	
144 170-250	\$0.99	BULB, original type		1	
170-906	\$19.99	BULB, LED, white*		1	
145 158-200	\$2.19	SCREW, cover		1	
147 144-240	\$99.99	PLINTH, lamp mounting		Bugeye	1
148 159-020	\$10.59	GASKET, plinth to body			1
159-025	\$3.09	GASKET, plinth to body		Sprite MkII on, Midget thru 1969	1
150 144-180	\$84.99	LICENSE PLATE LAMP ASS'Y.		Midget 1970 - 74 split rear bumper	2
151 158-510	\$14.99	COVER	2		
152 158-500	\$6.89	LENS	2		
153 170-250	\$0.99	BULB, original type	2		
170-906	\$19.99	BULB, LED, white*	2		
154 158-520	\$2.69	PAD, lens seating	2		
155 159-330	\$1.19	SCREW, lamp mounting	4		
160 144-220	\$29.99	LICENSE LAMP ASS'Y., chrome	Midget 1500 to (c)182000	2	
161 158-915	\$4.49	LENS & BULB HOLDER		2	
162 170-010	\$0.49	BULB, stock type		2	
LLB239LED	\$10.99	BULB, LED replacement*		2	
163 144-225	\$3.99	GROMMET, base	Midget 1500 from (c)182001	2	
144-230	\$26.99	LICENSE LAMP ASS'Y., black		2	
164 158-910	\$4.19	LENS		2	
170-010	\$0.49	BULB, stock type		2	
LLB239LED	\$10.99	BULB, LED replacement*	2		

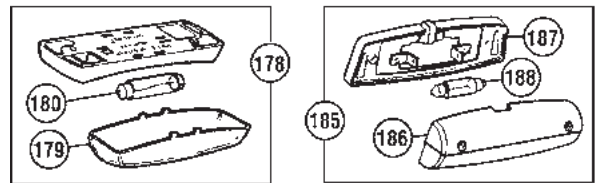

Interior Lamps

12083

178 158-940	\$17.99	TRUNK LAMP, interior	Sprite MkII on, Midget MkII on	1
179 158-945	NA	LENS		1
180 170-010	\$0.49	BULB, stock type		1
LLB239LED	\$10.99	BULB, LED replacement*		1
185 158-920	\$14.99	COURTESY LAMP, fixed		1
186 158-925	\$13.99	LENS & BEZEL		1
187 158-930	NA	PLATE & SWITCH		1
188 170-010	\$0.49	BULB, stock type		1
LLB239LED	\$10.99	BULB, LED replacement*		1
314-280	\$0.99	SCREW, courtesy lamp		2
317-045	\$0.69	FIX NUT for screw		2

*Note: For Negative Ground vehicles only. You will want to match LED bulb color with the color of the specific lamp lens to avoid color distortion. Use White for Clear, Amber for Amber, and Red for Red. In some applications there were multiple options, so the appropriate selection must be made based on your vehicle. If you are replacing turn signal bulbs with LEDs you will need to upgrade to an electronic flasher. Flasher part numbers are 141-667 for 2-Prong, or 141-668 for 3-Prong.

Wiring Harnesses

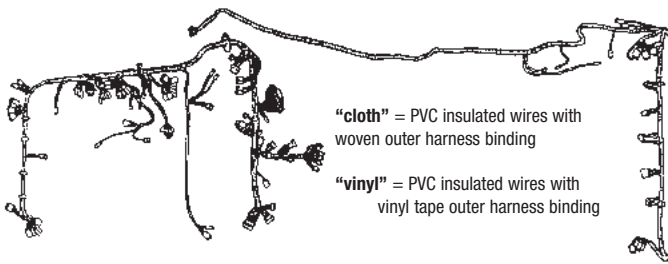

New harnesses have some non-original dash lamp sockets replacing socket no. 14 in the illustration to the right. These use wedge-base bulbs below.

170-150	\$0.89	BULB, wedge base, 3 watt	new wiring harnesses	A/R
170-030	\$0.79	BULB, wedge base, 5 watt	new wiring harnesses	A/R
170-690	\$0.69	BULB, wedge base, 1.2 watt	new wiring harnesses	A/R

Wiring Harnesses

12086

No. Part#	Price (Each)	Description	Application	Qty Req.
356-100*	\$499.90	WIRING HARNESS, cloth	HAN5-501 to 50116 1958 - '61 (Bugeye)	
355-015*	\$499.99	WIRING HARNESS, cloth	HAN6-101 to 24731 1961 - '62 (MkII) 948	
355-025*	\$509.99	WIRING HARNESS, cloth	HAN7-24732 to 38828 1962 - '64 (MkII) 1098	
355-035*	\$629.99	WIRING HARNESS, cloth	HAN8-38829 to 64734 1964 - '67 (MkIII)	
356-805*	\$579.99	WIRING HARNESS, cloth	HAN9-64735 to 70267 (MkIV)	
356-815*	\$599.99	WIRING HARNESS, cloth	HAN9-70268 to 72033 (MkIV)	
356-828*	NA	WIRING HARNESS, cloth	HAN9-72034 to 77590 (MkIV)	
356-830*	\$389.99	MAIN HARNESS, vinyl	HAN9-77591 to 85286 (MkIV)	
356-807*	\$159.99	REAR HARNESS, vinyl		
356-840*	\$499.99	MAIN HARNESS, vinyl	HAN10-85287 on (MkIV)	
356-847*	\$134.99	REAR HARNESS, vinyl		
355-015*	\$499.99	WIRING HARNESS, cloth	HAN1-101 to 16183 1961 - '62 (MkI)	
355-025*	\$509.99	WIRING HARNESS, cloth	HAN2-16184 to 25787 1962 - '64 (MkI)	
355-035*	\$629.99	WIRING HARNESS, cloth	HAN3-25788 to 52389 1964 - '66 (MkII)	
356-805*	\$579.99	WIRING HARNESS, cloth	HAN4-52390 to 58111 (MkIII)	
356-815*	\$599.99	WIRING HARNESS, cloth	HAN4-58112 to 60440 (MkIII)	
356-828*	NA	WIRING HARNESS, cloth	HAN4-60441 to 66225 (MkIII)	
356-830	\$389.99	MAIN HARNESS, vinyl	GAN4-66226 to 74885 (MkIII)	
356-807	\$159.99	REAR HARNESS, vinyl		
356-840	\$499.99	MAIN HARNESS, vinyl	GAN5-74886 to 89514 (MkIII)	
356-847	\$134.99	REAR HARNESS, vinyl		
356-850	\$529.99	MAIN HARNESS, vinyl	GAN5-89515 to 105500 (MkIII)	
356-857	\$174.99	REAR HARNESS, vinyl		
356-860	\$419.99	MAIN HARNESS, vinyl	GAN5-105501 to 112275 (MkIII)	
356-867	\$159.99	REAR HARNESS, vinyl		
356-870	\$569.99	MAIN HARNESS, vinyl	GAN5-112276 to 123730 (MkIII)	
356-877	\$139.99	REAR HARNESS, vinyl		
356-880	\$539.99	MAIN HARNESS, vinyl	GAN5-123731 to 138000 (MkIII)	
356-877	\$139.99	REAR HARNESS, vinyl		
356-890	\$519.99	MAIN HARNESS, vinyl	GAN5-138001 to 154100 (MkIII)	
356-988	\$299.99	DASH HARNESS, vinyl		
356-897	\$129.99	REAR HARNESS, vinyl		
356-900	\$439.99	MAIN HARNESS, vinyl	GAN6-154101 to 159053 (1500)	
356-988	\$299.99	DASH HARNESS, vinyl		
356-907	\$129.99	REAR HARNESS, vinyl		
356-910	\$499.99	MAIN HARNESS, vinyl	GAN6-159054 to 166300 (1500)	
356-988	\$299.99	DASH HARNESS, vinyl		
356-917	\$139.99	REAR HARNESS, vinyl		
356-920	\$499.99	MAIN HARNESS, vinyl	GAN6-166301 to 188000 (Federal)	
356-988	\$299.99	DASH HARNESS, vinyl		
356-917	\$139.99	REAR HARNESS, vinyl		
356-920	\$499.99	MAIN HARNESS, vinyl	GAN6-166301 to 200000 (California)	
356-988	\$299.99	DASH HARNESS, vinyl		
356-917	\$139.99	REAR HARNESS, vinyl		
356-947	\$379.99	MAIN HARNESS, vinyl	GAN6-188001 to 200000 (Federal)	
356-988	\$299.99	DASH HARNESS, vinyl		
356-917	\$139.99	REAR HARNESS, vinyl		

No. Part#	Price (Each)	Description	Application	Qty Req.
356-957	\$379.99	MAIN HARNESS, vinyl	GAN6-200001 on (Federal)	
356-998	\$219.99	DASH HARNESS, vinyl		
356-917	\$139.99	REAR HARNESS, vinyl		
356-967	\$379.99	MAIN HARNESS, vinyl	GAN6-200001 to 212000 (California)	
356-998	\$219.99	DASH HARNESS, vinyl		
356-917	\$139.99	REAR HARNESS, vinyl		
356-977	\$379.99	MAIN HARNESS, vinyl	GAN6-212001 on (California)	
356-998	\$219.99	DASH HARNESS, vinyl		
356-917	\$139.99	REAR HARNESS, vinyl		

These wiring harnesses include main and body-rear harness. All harnesses may not include minor sub-harnesses such as headlight to headlight, horn to horn, dimmer switch, and dash light wires.

Sub-Harnesses

356-825	\$34.99	DIMMER SWITCH HARNESS	Sprite MkI,II, Midget MkI	1
356-835	\$35.99	DIMMER SWITCH HARNESS	Sprite MkIII,IV, Midget MkII,III	1



Wiring Harness Tape

This tape is not self-adhesive. Examine your old harness carefully to see how ends and branches are accomplished.

Blue Harness Tape	162-030	\$13.99
Black Harness Tape	162-025	\$11.99

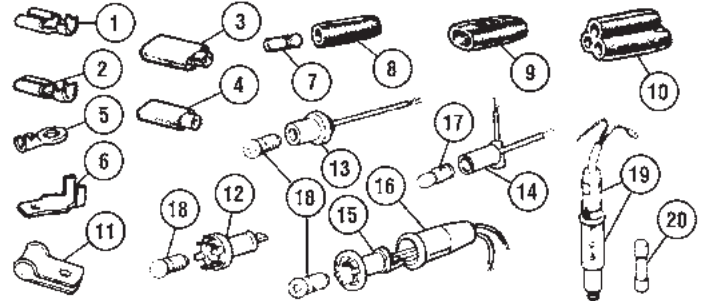

Wiring Fittings

12087

No.	Part#	Price	Description	Application	Qty Req.
1	161-580	\$1.39	CLIP, 35 amp (3/8")		A/R
2	161-520	\$0.59	CLIP, 17.5 amp (1/4")		A/R
3	161-540	\$0.59	INSULATOR, 35 amp clip		A/R
4	161-570	\$0.29	INSULATOR, 17.5 amp clip		A/R
5	161-740	\$0.59	EYELET, 3/16"		A/R
	161-750	NA	EYELET, 1/4"		A/R
	161-760	\$0.59	EYELET, 5/16"		A/R
6	162-205	NA	BLADE, 1/4"		A/R
7	162-200	\$0.49	WIRE NIPPLE		A/R
8	162-000	\$0.79	CONNECTOR, single		A/R
9	161-600	\$0.99	CONNECTOR, double		A/R
10	161-720	\$13.99	CONNECTOR, triple		A/R
11	470-830	\$1.09	CLIP, 1/4" cable dia. 7/32" hole		A/R
	162-210	\$1.39	CLIP, 1/4" cable dia. 9/32" hole		A/R
	162-250	\$1.19	CLIP, 3/8" cable dia. 7/32" hole		A/R
	162-310	\$1.39	CLIP, 5/8" cable dia. 9/32" hole		A/R
12	161-915	\$6.49	BULB HOLDER (orig. type)		A/R
13	158-330	NA	BULB HOLDER (orig. type)		A/R
	158-332	\$14.99	BULB HOLDER, replacement	uses bulb below	A/R
	170-150	\$0.89	BULB for 158-332		A/R
14	158-340	\$6.99	BULB HOLDER (orig. type)		A/R
	158-345	NA	BULB HOLDER, replacement	uses bulb below	A/R
	170-690	\$0.69	BULB for 158-345		A/R
15	158-320	\$8.49	BULB HOLDER (orig. type)		A/R
16	158-360	NA	SLEEVE, bulb holder		A/R
17	170-110	\$0.99	BULB, "eared" base		A/R
18	171-000	\$0.79	BULB, screw base		A/R
19	146-750	\$1.89	FUSE HOLDER, in-line		A/R
20	146-730	\$0.49	FUSE, 10 amp (for in-line holder)		A/R

Distributors - 948-1275

Distributor - 948-1275

12089

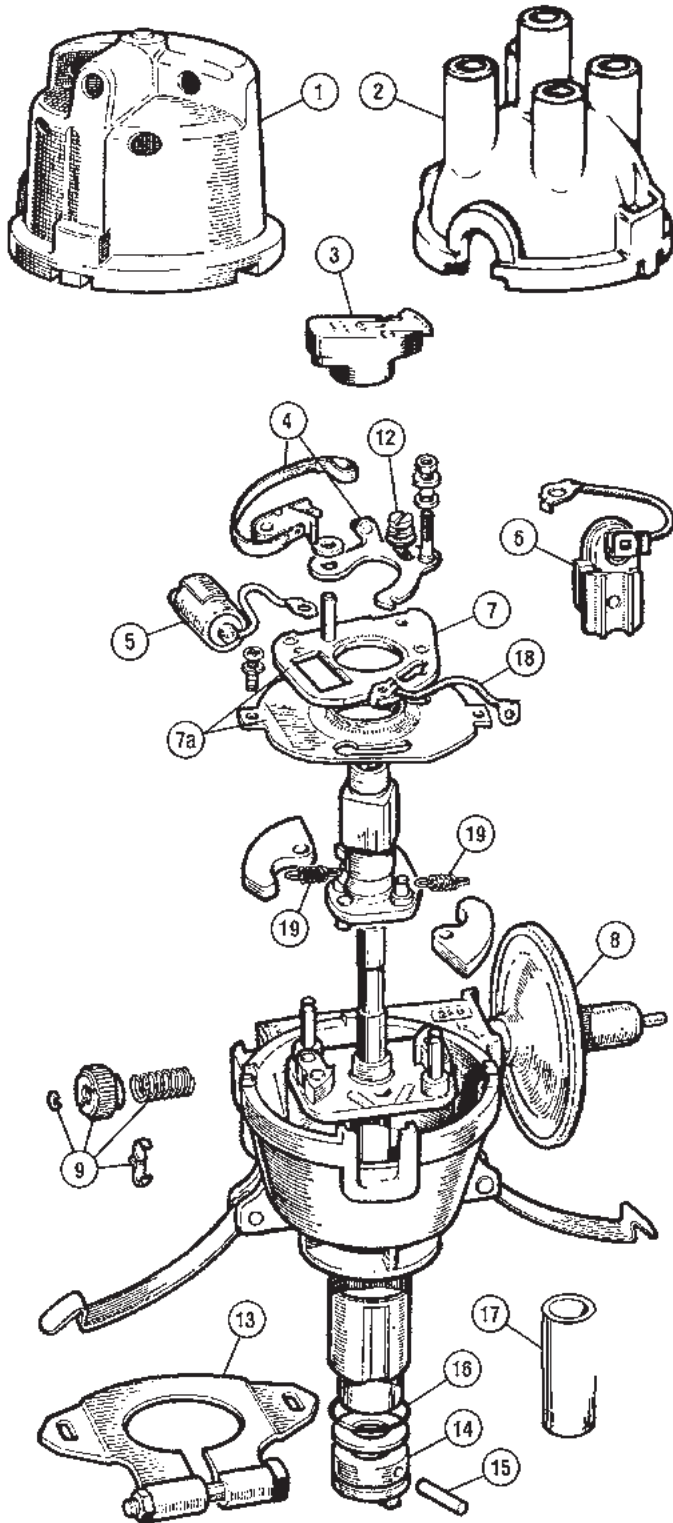

No.	Part#	Price (Each)	Description	Application	Qty Req.
1	163-825	\$36.99	DISTRIBUTOR CAP, side entry, Intermotor brand		1
	163-800	\$14.99	DISTRIBUTOR CAP, side entry, aftermarket		1
2	163-815	NA	DISTRIBUTOR CAP, top entry, Lucas		1
	163-810	\$11.49	DISTRIBUTOR CAP, top entry, aftermarket		1
3	151-805	\$15.99	ROTOR, premium replacement		1
	151-710	\$5.99	ROTOR, Lucas		1
	151-805	\$15.99	ROTOR, Premium aftermarket		1
	151-800	\$4.99	ROTOR, Intermotor		1
	152-220	\$10.99	CONDENSER & POINT SET, Lucas		1
	152-221	\$9.99	CONDENSER & POINT SET, Intermotor brand		1
4	151-720	\$7.99	POINT SET, Lucas		1
	152-225	\$23.99	POINT SET, Premium aftermarket		1
	153-900	\$6.99	POINT SET, aftermarket		1
5	151-730	\$7.99	CONDENSER, Lucas		1
	154-001	\$12.99	CONDENSER, Premium aftermarket		1
6	153-600	\$14.99	TERMINAL & LEAD	DM2P4 models	1
	153-640	\$5.99	TERMINAL & LEAD	25D models	1
7	153-700	\$59.99	BREAKER PLATE (upper)	DM2P4 models	1
7a	551-055	\$54.99	BREAKER PLATE ASS'Y.	25D models	1
8	163-696	\$109.99	VACUUM UNIT	Bugeye distributor #40561	1
	163-697	\$109.99	VACUUM UNIT	948-1098 1961-'62 distributor #40752	1
	163-698	\$109.99	VACUUM UNIT	1098 1963-'66 distributor #40919	1
	163-675	\$109.99	VACUUM UNIT	1275	1
9	163-738	\$17.99	ADJUSTER KIT	DM2P4 models	1
	163-739	\$17.99	ADJUSTER KIT	25D models	1
12		NA	SCREW, points retaining	DM2P4 models	1
	323-245	\$1.09	SCREW, points retaining	25D models	1
13	153-400	\$10.99	CLAMPING PLATE with bolt & nut (replacement)		1
	153-401	\$35.99	CLAMPING PLATE without bolt & nut (OE type)		1
	153-402	\$8.19	BOLT & NUT for clamping plate		1
14	153-300	\$29.99	DRIVING DOG		1
15	539-020	\$0.49	PIN		1
16	163-750	\$0.29	"O" RING	as fitted	1
17	153-500	\$33.99	BUSHING		1
18	153-645	\$2.49	GROUND WIRE (replacement)		1
19	551-010	\$19.99	SPRING SET (universal replacement - set of 5)		1

"Opus"

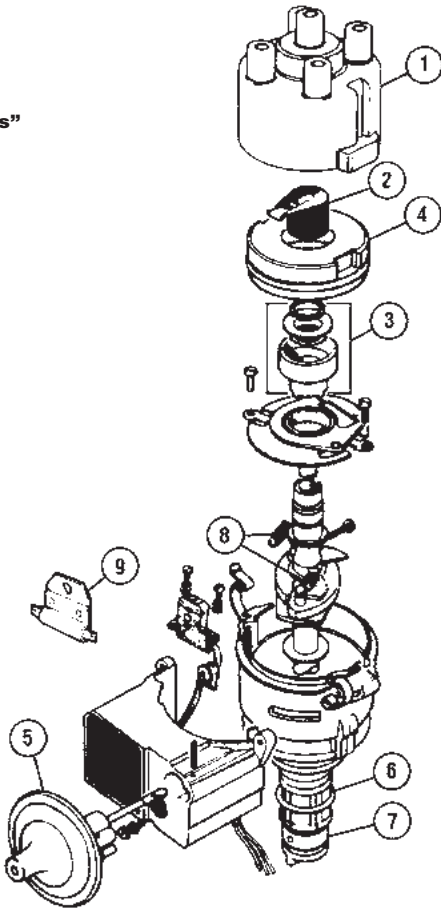

C.E.I.

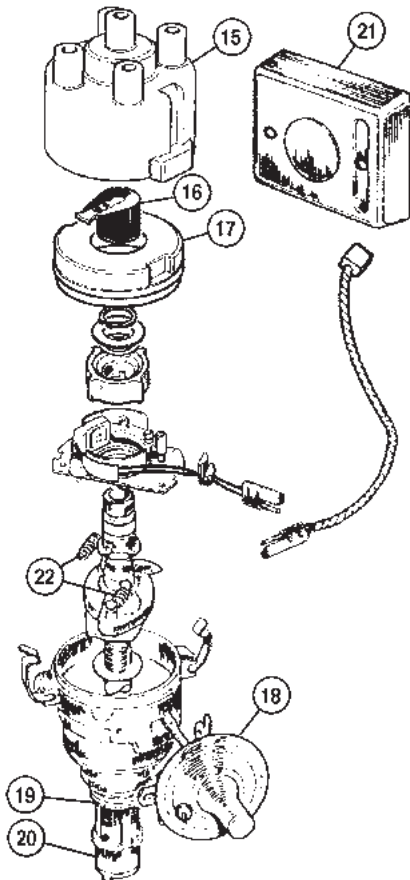

Lucas Electronic Ignition

The original Lucas "Opus" electronic ignition system used through 1979 featured the amplifier module mounted on the distributor body. As this system proved notoriously troublesome and unreliable, all replacements made as of 1980 were of the C.E.I. (Constant Energy Ignition) type, with a remotely mounted amplifier. Needless to say, this has caused much confusion during the intervening years when replacement components have been required. Order parts based on your distributor number.

Model Year	Orig. Opus distributor#	Replacement C.E.I. distributor #
1975	41593	41804
1976 Fed.	41646	41805
1976 CA	41656	41804
1977-79 Fed.	41697	41807
1977-79 CA	41698	41808

Distributors - 1500

12090

No.	Part#	Price (Each)	Description	Application	Qty Req.
Opus System					
1	151-875	\$14.89	CAP, Lucas		1
	151-870	\$13.99	CAP, aftermarket		1
2	151-865	\$16.49	ROTOR ARM, Premium		1
	151-855	\$4.49	ROTOR ARM, Lucas		1
	151-850	NA	ROTOR ARM, aftermarket		1
3	154-050	NA	TIMING ROTOR		1
4	154-030	NA	ANTI-FLASH COVER	Opus distr. #41593 & 41656	1
	154-040	NA	ANTI-FLASH COVER	{ Opus distr. #41646, 41697 & 41698	1
5	142-890	\$119.99	VACUUM UNIT	Opus distr. #41593 & 41656	1
	142-900	\$119.99	VACUUM UNIT	{ Opus distr. #41646, 41697 & 41698	1
6	163-750	\$0.29	O-RING		1
7	153-300	\$29.99	DRIVING DOG		1
	539-020	\$0.49	PIN for driving dog		1
8	551-010	\$19.99	SPRING SET (universal replacement - set of 5)		1
9	131-560	\$29.99	DRIVE RESISTOR		1
C.E.I. System					
15	151-875	\$14.89	CAP, Lucas		1
	151-870	\$13.99	CAP, aftermarket		1
16	151-865	\$16.49	ROTOR ARM, Premium		1
	151-855	\$4.49	ROTOR ARM, Lucas		1
	151-850	NA	ROTOR ARM, aftermarket		1
17	154-040	NA	ANTI-FLASH COVER		1
18	071-691	\$119.99	VACUUM UNIT, reproduction	C.E.I. dist. #41804	1
	071-690	\$119.99	VACUUM UNIT, reproduction	C.E.I. dist. #41805 & 41808	1
	071-692	\$119.99	VACUUM UNIT, reproduction	C.E.I. dist. #41807	1
19	163-750	\$0.29	O-RING		1
20	153-300	\$29.99	DRIVING DOG		1
	539-020	\$0.49	PIN for driving dog		1
21	142-975	NA	AMPLIFIER		1
22	551-010	\$19.99	SPRING SET (universal replacement - set of 5)		1

Ignitor Electronic Ignition

- The solution to your Lucas distributor woes.
 - Completely self contained. Fits inside your original distributor
 - Simple installation. Only two wires to hook up. No permanent modifications involved.
 - No points to set or change.
 - Impervious to dust, moisture, or vibration and retains stock advance curve.
 - Much less affected by distributor shaft wear, firing accuracy to within 1/4°.
- (Distributor not included!)



Points-type distributor (positive ground)	222-555	\$189.99
Points-type distributor (negative ground)	222-405	\$161.99
1500 with Lucas electronic ignition	222-475	\$219.99

Ignition

Intermotor Sports Coils

40,000 volt output gives more reliable starting power, and greater performance at high rpm.

- 948-1275 (non-ballasted system) 143-201 \$44.99
- 1500 (ballasted system) 117-264 \$44.99



Universal Coil Mounting Brackets

Replace missing, bent or corroded coil brackets. Also useful if you are upgrading or relocating the coil.

- Chrome 143-255 \$12.49
- Stainless Steel 117-265 \$17.99
- Zinc Plated 143-256 \$5.49

FAST Electronic Ignition

This electronic conversion (formerly Crane) gives your ignition system a boost- in fact, a 35% increase in energy at the spark plugs. You retain your present distributor and coil, add the electronic module and sensor which replaces your points, condenser and rotor. Easy to install, this electronic conversion gives faster, cleaner running and better performance at all engine speeds. This unit works with both positive and negative ground systems.

- 222-680 \$199.99

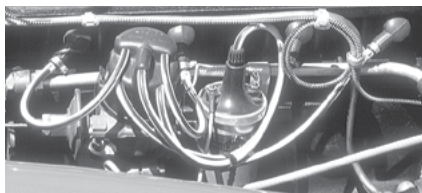

"Bumblebee" Ignition Wire

Its bright yellow and black coloring led to its descriptive nickname. This solid copper core wire is so good it was used for years by factory teams. Sold per foot.

- 571-020 \$8.99 per foot

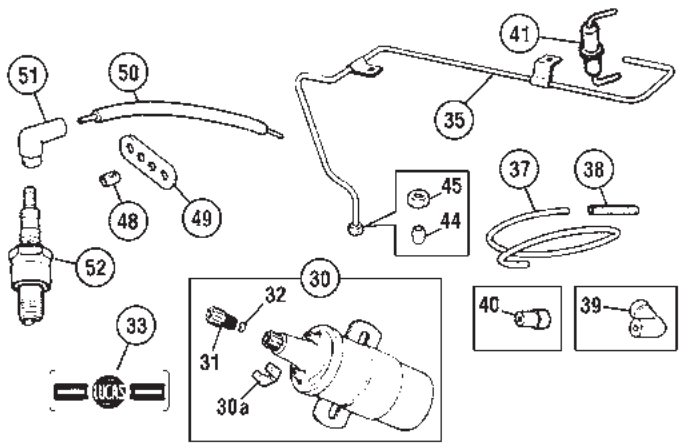

Ignition System

12094

No.	Part#	Price (Each)	Description	Application	Qty Req.
30	543-020	\$42.99	COIL, w/screw connector (illus.)	thru 1967	1
	143-220	\$34.99	COIL, push-in connector, Lucas	} 1275 1968-74	1
	143-221	\$27.99	COIL, push-in connector, aftermarket		1
	143-230	\$34.99	COIL		1500
	143-201	\$44.99	SPORTS COIL, Intermotor brand	not 1500	1
	117-264	\$44.99	SPORTS COIL, Intermotor brand	1500	1
30a	571-045	\$0.39	TERMINAL		A/R
31	152-400	\$2.69	NUT, wire securing	} used and included with coil #543-020	1
32	146-310	\$0.49	WASHER, brass		1
33	36-5019	NA	"LUCAS" COIL DECAL		1
35		NA	VACUUM LINE	948	1
		NA	VACUUM LINE	1098 & 1275	1
37	163-655	\$1.19	VACUUM LINE, plastic, per ft.	1275 & 1500	A/R
38	282-650	\$2.59	CONNECTOR, metal pipe to carb.	1098 & 1275	1
	153-830	\$1.29	CONNECTOR, plastic pipe to carb.	1275 & 1500	1
39	153-840	\$1.09	CONNECTOR		A/R
40		NA	CONNECTOR	1500	1
41	371-855	\$14.99	FUEL TRAP	1500	2
44	163-635	\$0.99	COMPRESSION FITTING		1
45	153-810	\$6.89	NUT		1
48	171-630	\$9.99	WIRE LABEL SET, "1, 2, 3, 4"		1
49	171-550	\$3.29	IGNITION WIRE SEPARATOR		1
50	171-628	\$59.99	IGNITION WIRE SET, side entry cap	} 948, 1098, 1275	1
	171-660	\$41.99	IGNITION WIRE SET, top entry cap		1
	172-050	\$39.99	IGNITION WIRE SET, top entry, "Cobalt"		1
	171-670	\$22.99	IGNITION WIRE SET, stock type	} 1500	1
	143-556	\$134.99	IGNITION WIRE SET, "Magnecore"		1
	172-040	\$39.99	IGNITION WIRE SET, "Cobalt"		1
51	171-620	\$9.99	CLIP, suppressor		all
52	152-120	\$3.69	SPARK PLUG, Champion (std. type)	} 948-1098	4
	152-121	\$3.69	SPARK PLUG, Champion (resistor)		4
	175-080	NA	SPARK PLUG, NGK (std. type)		4
	175-081	\$4.79	SPARK PLUG, NGK (resistor)		4
	152-130	\$3.69	SPARK PLUG, Champion	} 1275	4
	052-627	NA	SPARK PLUG, NGK (std. type)		4
	115-332	\$4.79	SPARK PLUG, NGK (resistor)		4
	860-051	\$3.69	SPARK PLUG, Champion (std. type)	} 1500	4
	860-055	\$3.39	SPARK PLUG, Champion (resistor)		4



Battery Acid Neutralizing Mat

Made from a special acid absorbent material that also neutralizes acids. Cut with scissors to match the shape of any battery or tray.

- 241-025 \$8.49

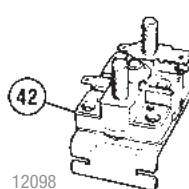
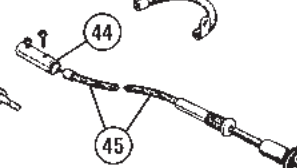
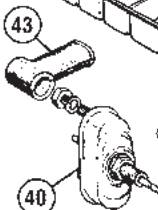
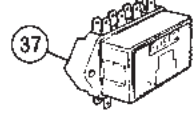
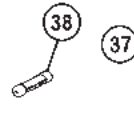
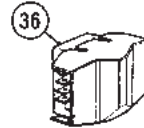
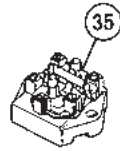
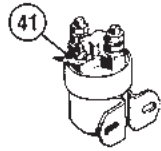
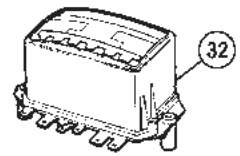
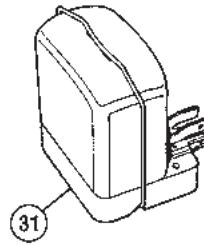
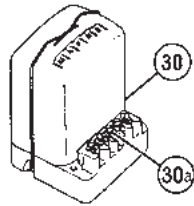
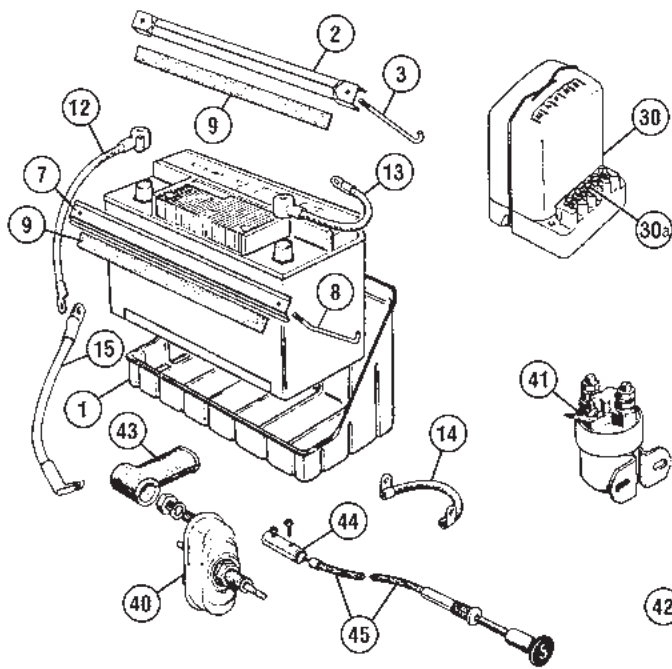

Electrical

12098

No.	Part#	Price (Each)	Description	Application	Qty Req.
1	241-020	\$68.99	LINER, battery tray, 12"x7" battery	thru 1967	1
	241-060	\$29.99	BATTERY TRAY, OE flat type (for 10-1/4" x 5 1/2" battery)	1970-on	1
	241-061	\$79.99	BATTERY TRAY, steel, upgraded		1
2	031-769	\$9.99	BRACKET, battery retaining	948, 1098 & 1275	1
3	407-618	\$4.99	J-BOLT & NUT SET, 4 1/2"	(1967)	1
7	473-185	\$14.99	BRACKET, battery retaining	1275 from 1968 &	1
8	407-608	\$9.99	J-BOLT & NUT SET, 4"	1500	1
9	473-115	\$1.59	PACKING		1
12	332-190	\$33.99	CABLE, battery to switch, repl.	pos. ground cars	1
	NA		CABLE, battery to switch, repl.	neg. ground cars	1
13	736-080	NA	CABLE, battery to body, orig. type	pos. ground cars	1
	736-085	\$53.99	CABLE, battery to body, replacement		1
	736-100	NA	CABLE, battery to body, orig. type		1
	736-105	\$54.99	CABLE, battery to body, replacement		1
14	736-220	\$29.99	GROUND STRAP, engine to body	948, 1098, 1275	1
	332-070	\$34.99	GROUND STRAP, engine to body	1500	1
15	332-170	\$25.99	CABLE, starter switch to starter	948, 1098 & 1275	1
	332-180	NA	CABLE, starter switch to starter	1500	1
30	142-003†	\$86.99	REGULATOR (tested & adjusted)	948 & 1098 screw terminals	1
30a	142-005	\$1.19	SCREW, wire retaining		5
31	542-103†	\$92.99	REGULATOR (tested & adjusted)	1098 & 1275 Lucar terminals	1
32	142-040†	NA	REGULATOR, Lucas	1275	1
	142-045†	\$49.99	REGULATOR, replacement		1
† These regulators are used with generator systems only. Original application change-points are complicated - replace like for like.					
35	162-500	\$12.99	FUSE BOX	Sprite Mkl-II, Midget Mkl	1
36	560-100	\$6.79	FUSE BOX	from above thru 1967	1
37	162-510	\$8.29	FUSE BOX	1968-'80	1
	560-115	\$7.99	COVER for 162-510		1
38	146-700	\$0.69	FUSE 35 amp		A/R
40	145-800	\$26.99	STARTER SWITCH	Sprite Mkl-II, Midget Mkl	1
41	546-020	\$44.99	SOLENOID	from above thru 1967	1
42	546-152	\$18.99	SOLENOID, reproduction	1968-'74	1
	131-506	\$34.99	SOLENOID, Lucas	1500	1
	131-505	\$18.99	SOLENOID, aftermarket		1
43	161-900	\$3.99	BOOT	all	2
44	161-500	\$12.99	COUPLING with screws	used with switch 145-800	1
45	331-630	\$25.99	CABLE, starter pull	Bugeye	1
	331-710	\$24.99	CABLE, starter pull, replacement	Sprite MklII, Midget Mkl	1
46	131-555	\$18.99	VOLTAGE STABILIZER, negative ground	1275, 1500	1

No.	Part#	Price (Each)	Description	Application	Qty Req.
47	141-750	\$9.59	FLASHER, turn signal, screw terminals	948 - 1098, 1275 thru '67	1
	171-300	\$15.99	FLASHER, turn signal, spade terminals		1
48	141-748	\$16.99	FLASHER, turn signal (replacement)	1275 1968 thru 1500	1
	141-655	\$4.89	FLASHER, hazard (replacement)	1275, 1968-'71	1
	141-747	\$15.99	FLASHER, hazard, electronic repl.		1
	141-650	\$4.19	FLASHER, hazard		1
	131-510	\$96.99	RELAY, starter	1275 from '72, 1500 1975 (if fitted)	1
49	181-855	\$29.99	DIODE, handbrake light	1500 from 1978	1

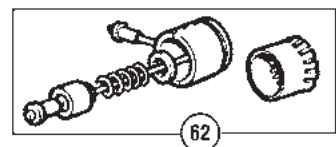
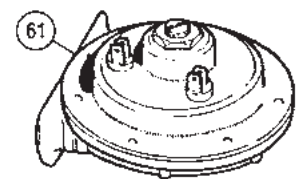
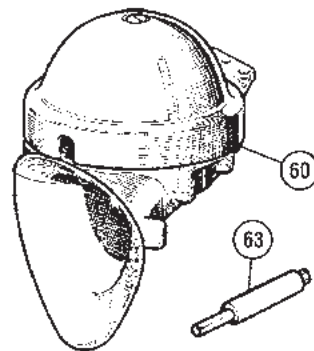

Horns

12099

No.	Part#	Price (Each)	Description	Application	Qty Req.
60	165-700	\$84.99	HORN, Windtone, high note	Bugeye, option	1
	165-800	\$84.99	HORN, Windtone, low note		1
61	545-030	\$53.99	HORN, high note	1098 thru 1500 (option for earlier cars)	1
	545-020	\$53.99	HORN, low note		1
62	263-745	NA	SLIP RING & HORN CONTACT		1
63	560-430	\$15.99	CONTACT, horn push	948	1
	263-750	\$6.99	CONTACT, horn push	1275 as fitted	1

Sprite Mkl-MklII and Midget Mkl standard fitment was single horns of types no longer available. Bugeyes used #60 as options, while later 948cc cars used the 1098-1500 type as options.

Generators are suitable for either negative or positive ground systems providing they are polarized to suit the particular electrical system immediately after fitting. Bolt generator to engine, do not connect the cables to the "D" and "F" terminals, but proceed as follows:

1. Determine which battery terminal is ground.
2. Temporarily connect a length of wire to the battery positive terminal for negative ground systems, or to the negative terminal for positive ground systems.
3. Flick the other end of the wire several times against terminal "F". This serves to repolarize the generator.
4. Remove temporary connection and connect the cables to the "D" and "F" terminals.

Generator & Alternator

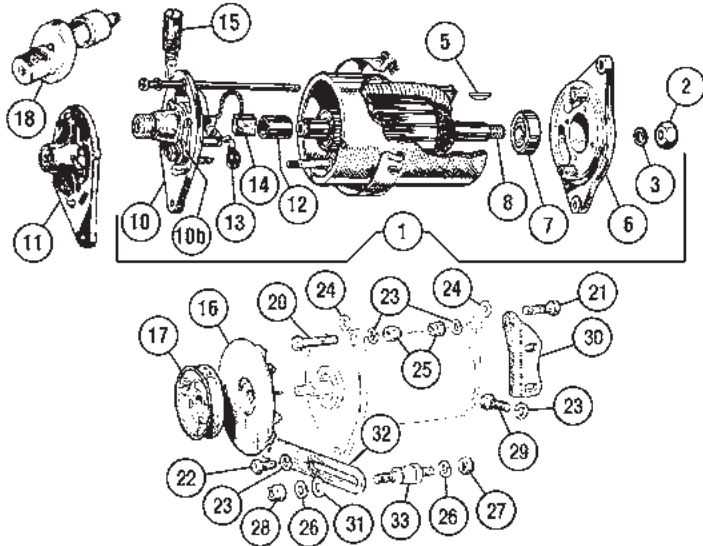

Generator, 1958-'61 (948 cc engines)

12100

No.	Part#	Price (Each)	Description	Application	Qty Req.
1	140-300	\$299.99	GENERATOR, new		1
	140-310	\$229.99	GENERATOR, rebuilt		1
		\$150.00	CORE CHARGE for 140-310		
2	310-310	\$0.59	NUT, armature shaft		1
3	324-050	\$0.20	LOCKWASHER		1
5	327-030	\$0.39	KEY, armature shaft		1
6	147-300	NA	PLATE, drive end		1
7	125-100	\$15.99	BEARING, drive end		1
8	162-600	NA	ARMATURE		1
10	147-500	NA	PLATE, commutator end		1
10b	147-020	\$5.99	INSULATOR, terminal		1
12	147-600	\$8.49	BUSHING, rear		1
13	147-700	NA	SPRING SET, brushes		1
14	147-200	\$2.39	BRUSH SET		1
15	147-900	\$45.99	OILER		1
16	433-670	\$12.99	FAN		1
17	473-130	NA	PULLEY, stock type		1
	473-131	\$129.99	PULLEY, aluminum replacement		1
18	361-870	\$94.99	GEARBOX, tachometer drive		1

Generator, 1962-'71

12101

No.	Part#	Price (Each)	Description	Application	Qty Req.
	140-200	\$149.99	GENERATOR, new, replacement	(no parts available)	1
	540-200	\$199.99	GENERATOR, Lucas, rebuilt		1
		\$300.00	CORE CHARGE for 540-200. Core must be original Lucas		
2	310-310	\$0.59	NUT		1
3	324-250	\$0.19	LOCKWASHER		1
5	327-030	\$0.39	WOODRUFF KEY, for pulley		1
6	147-310	NA	BRACKET, driving end		1
7	125-100	\$15.99	BEARING, driving end		1
8	162-900	\$99.99	ARMATURE		1
11	539-180	NA	BRACKET, commutator end		1
12	147-600	\$8.49	BUSH, commutator end		1
	697-020	\$0.69	OILER (internal, felt)		1
13	549-030	\$31.99	SPRING SET		1
14	147-250	\$2.39	BRUSH SET		1
16	433-670	\$12.99	FAN		1
17	473-130	NA	PULLEY, stock type		1
	473-131	\$129.99	PULLEY, aluminum replacement		1

Generator Mountings

12102

No.	Part#	Price (Each)	Description	Qty Req.
20	322-105	\$1.59	BOLT, front	1
21	191-915	\$1.39	BOLT, rear	1
22	322-510	\$0.39	BOLT	1
23	365-730	\$0.39	LOCKWASHER	5
24	365-720	\$0.79	WASHER, flat	2
25	310-290	\$1.19	NUT, nyloc	2
26	324-040	\$0.39	LOCKWASHER	2
27	310-050	\$0.69	NUT	1
28	310-240	\$0.89	NUT, nyloc	1
29	322-540	\$0.79	BOLT, bracket to block	2
30	460-310	\$31.99	BRACKET	1
31	324-860	\$0.19	WASHER, flat	1
32	460-330	\$11.99	LINK, adjusting (replacement)	1
33	460-320	\$15.59	PILLAR, adjusting link	1

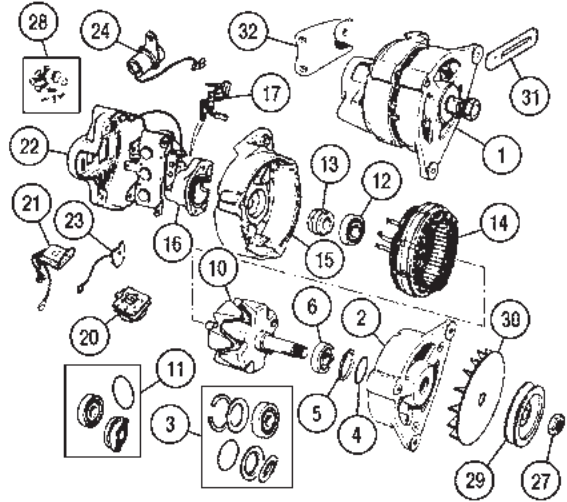

Alternator, 1972-'80

12103

No.	Part#	Price (Each)	Description	Application	Qty Req.
1	130-102	\$129.99	ALTERNATOR, new		1
2		NA	BRACKET, drive end		1
3	125-100	\$15.99	BEARING KIT, drive end		1
4	130-450	NA	O-RING		1
5	130-455	NA	CIRCLIP		1
6	125-100	\$15.99	BEARING, drive end		1
10	130-160	NA	ROTOR ASSEMBLY		1
11	130-180	\$22.99	BEARING SET, slip ring end		1
12		NA	BEARING		1
13	130-215	\$3.89	SLIP RING		1
14	130-190	NA	STATOR		1
15	130-210	NA	BRACKET, slip ring end		1
16	130-230	NA	BRUSH HOUSING ASS'Y.		1
17	130-235	\$3.99	BRUSH SET		1
20	130-250	\$16.99	RECTIFIER	23716	1
	130-260	\$26.99	RECTIFIER	L23804, 23748	1
21	130-280	\$11.99	REGULATOR	23716	1
	130-290	\$37.89	REGULATOR	L23804, 23748	1
22	130-320	\$17.79	COVER		1
23	130-345	NA	SURGE PROTECTOR		1
24	130-350	NA	CAPACITOR		1
27	310-810	\$1.99	NUT		1
28	130-360	NA	SUNDRIES KIT		1
29	130-370	\$29.99	PULLEY	1275 engines	1
	539-090	\$19.99	PULLEY	1500 engines	1
30	130-400	\$15.29	FAN		1
31	460-330	\$11.99	LINK, adjusting	} 1275 engines	1
32	130-115	\$8.99	BRACKET, rear		1

Starter / Gauges & Cables

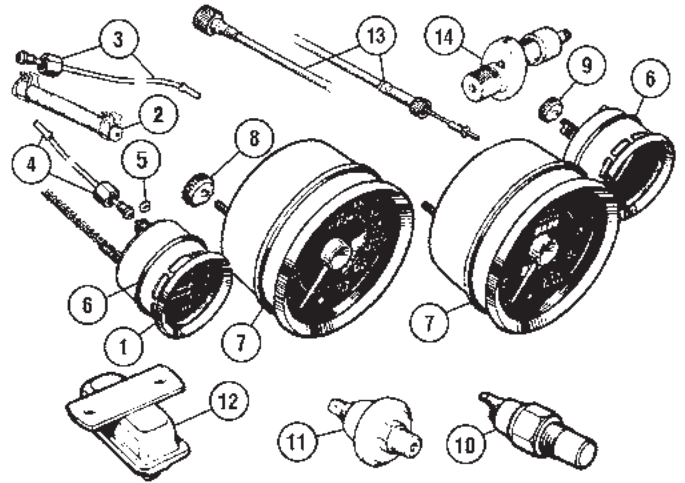
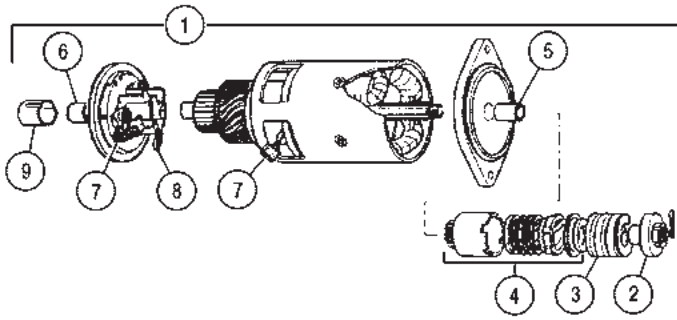

Starter

12104

No.	Part#	Price (Each)	Description	Application	Qty Req.
1	140-400	\$129.99	STARTER, new reproduction		1
	541-540	\$199.99	STARTER, rebuilt, exchange		1
		\$300.00	CORE CHARGE FOR 541-540		
2	150-500	\$29.99	NUT	25022	1
	549-625	NA	CLIP, used in place of nut	25079, 25149	1
		NA	CUP for clip	25079, 25149	1
3	148-200	\$9.59	SPRING, main		1
4	148-800	\$42.99	PINION & BARREL, inner sleeve not included		1
5	148-600	\$4.79	BUSH, driving end	25022	1
	148-610	\$2.49	BUSH, driving end	25079	1
	549-695	NA	BUSH SET (both bushes)	25149	1
6	148-500	\$1.29	BUSH, commutator end	25022	1
	131-325	\$0.89	BUSH, commutator end	25079	1
7	149-000	\$6.99	BRUSH SET (rectangular)	25022, 25079	1
	149-010	\$8.79	BRUSH SET (triangular)	25149	1
8	149-100	NA	SPRING SET, brushes	25022	1
	149-110	NA	SPRING SET, brushes	25079	1
9	149-800	NA	CAP, end shaft	25022	1
10	549-430	\$15.99	SHIM, starter mounting	1500	1

Note: Three different starters were originally fitted: Lucas #25022, 25079, and 25149. All are interchangeable with each other, but differ in some of their internal parts. The starter supplied replaces all three.

Gauges & Cables

12105

No.	Part#	Price (Each)	Description	Application	Qty Req.
1	361-761	\$279.99	COMBINATION GAUGE	replacement type	1
(This replacement gauge is similar to all listed below, but not identical to any - a perfect gauge to use when the "correct" one is not available.)					
	361-760	\$329.99	COMBINATION GAUGE	AH Bugeye only	1
	361-770	NA	COMBINATION GAUGE	AH MkII thru (c)24731	1
	361-780	NA	COMBINATION GAUGE	MG MkI, AH MkII from (c)24732	1
	361-790	\$329.99	COMBINATION GAUGE	MG MkII & III to (c)60440, AH MkIII & IV to (c)72033	1
	361-800	NA	COMBINATION GAUGE	MG MkIII (c)60441 to 105500, AH MkIV (c)72034 on	1
	361-810	\$234.99	COMBINATION GAUGE	MG MkIII (c)105501 to 154100	1
	361-820	NA	COMBINATION GAUGE	MG 1500 thru 1977 (c)154101 to 200000	1
Note: Ensure you have adaptor 361-065 in your cylinder head. Installing the temperature sender bulb without the adaptor will destroy it.					
2	361-765	\$21.99	HOSE, oil pressure, with clamps	948 through 1275	1
3	435-445	\$25.99	PIPE ASS'Y., engine to hose		1
4	435-446	\$41.99	PIPE ASS'Y., hose to gauge		1
	435-475	\$36.99	PIPE ASS'Y. to gauge	1500	1
5	435-516	\$0.39	WASHER, leather, oil pipe to gauge		1
6	280-870	\$0.69	SEALING RING, 2" gauges		A/R
7	280-890	\$1.69	SEALING RING, 4" gauges	USA thru 1967	2
	280-895	\$1.49	SEALING RING, 3-1/2" gauges	USA from 1968 on	2
8	361-035	\$2.99	NUT, speedo & tach retaining		4
9	360-370	\$2.79	NUT, small gauge retaining		2
10	071-241	\$8.99	TRANSMITTER, temp gauge	1500 from (c)200001	1
11	131-585	\$8.99	SWITCH, oil pressure warn. light	1500 except CA	1
	131-595	NA	SWITCH, oil pressure warn. light	1500 CA only	1
12	131-555	\$18.99	VOLTAGE STABILIZER	1275 & 1500	1
13	021-381	\$29.99	SPEEDOMETER CABLE, 54"	948, 1098, 1275 thru '67	1
	331-300	\$15.99	SPEEDOMETER CABLE, 48"	1275 1968-on	1
	331-590	\$18.99	CABLE, gearbox to interval counter	(c)154101- 188000	1
	115-405	\$16.99	CABLE, interval counter to speedo	1975 - '76 except CA	1
	331-600	NA	CABLE, gearbox to 1st interval counter	(c)154101-180000	1
	331-605	NA	CABLE, 1st to 2nd interval counter	1975 - '76 CA only	1
	115-405	\$16.99	CABLE, 2nd interval counter to speedo		1
	331-585	\$26.99	CABLE, gearbox to speedo	(c)1880001 - 200000 1977 except CA	1
	331-590	\$18.99	CABLE, gearbox to interval counter	(c)1880001 - 200000	1
	115-405	\$16.99	CABLE, interval counter to speedo	1977 CA only	1
	331-590	\$18.99	CABLE, gearbox to interval counter	(c)200001 - 212000	1
	331-615	NA	CABLE, interval counter to speedo	1978 CA only	1
	331-595	\$26.99	CABLE, gearbox to speedo	(c)200001 on 1978 on except CA	1
	331-595	\$26.99	CABLE, gearbox to speedo	(c)212001 on 1979 - '80 CA only	1
	732-000	\$18.99	TACHOMETER CABLE	948	1
14	361-870	\$94.99	GEARBOX, tach		1

Note: Ensure you have adaptor 361-065 in your cylinder head. Installing the temperature sender bulb without the adaptor will destroy it.



Hi-Torque Starter

Modern design and reliability make these starters ideal for the "daily driver". Even though they don't look like the originals, have integral solenoids, pre-engaged pinions, and gear reduction drive, they work very well indeed. We have tested these extensively on employee's cars, and heartily recommend them!

948-1275	140-362	\$349.99
1500	140-363	\$349.99

Note: Moss does not stock gauges for Sprites and Midgets other than those listed and priced. Please inquire to:

MO-MA, 1321 2nd St. NW, Albuquerque, NM 87102 (505)766-6661, or

West Valley Instruments, 19314 Van Owen, Reseda, CA 91335 (818)758-9500

Toll-Free Orders 1-800-667-7872 | MossMotors.com
Fax 805-692-2525 | Local 805-681-3400

MOSS

Dashboard

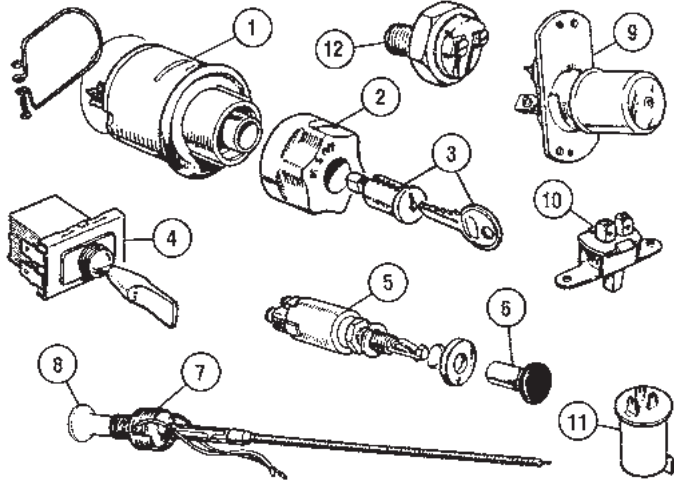
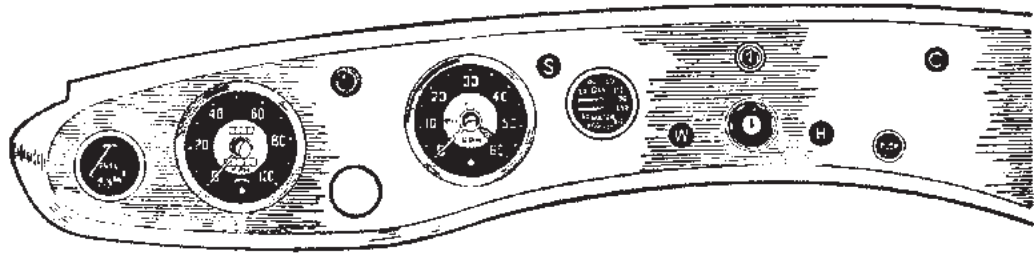

Dashboard - Sprite MkI (Bugeye)

12107

No.	Part#	Price (Each)	Description	Application	Qty Req.
1	140-535	\$106.99	COMBINATION SWITCH. "Classic Gold" reproduction		1
2	140-515	\$18.99	KNOB, light & ignition switch		1
3	163-500	\$11.99	LOCK BARREL, with 2 keys		1
4	141-200	\$25.99	DIRECTIONAL SWITCH		1
5	162-100	\$21.99	WIPER SWITCH (replacement with plain knob)		1
6	331-075	\$12.99	KNOB, wiper switch		1
7	331-690	NA	HEATER CABLE & SWITCH (without knob)		1
8	331-085	\$14.99	KNOB, heater cable		1
9	140-900	\$44.99	SWITCH, high beam		1
	140-906	\$17.99	BRACKET, high beam switch		1
10	140-520	\$56.99	SWITCH, panel lamp		1
11	141-750	\$9.59	FLASHER		1
12	141-700	\$10.99	SWITCH, brake light, screw connectors		1

Note: Starter switch and cable are listed on page 77.

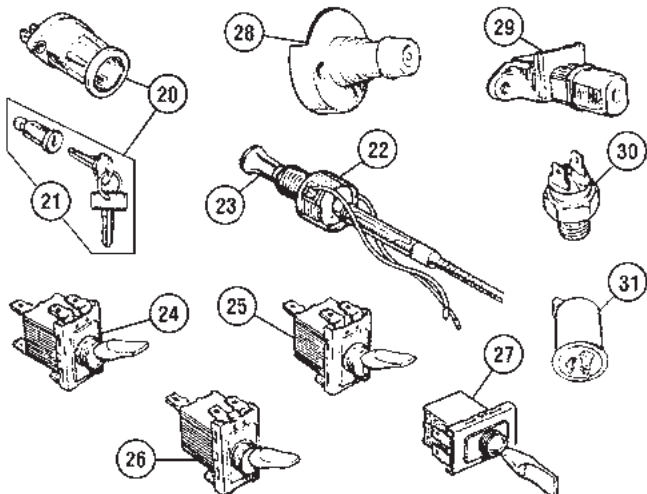
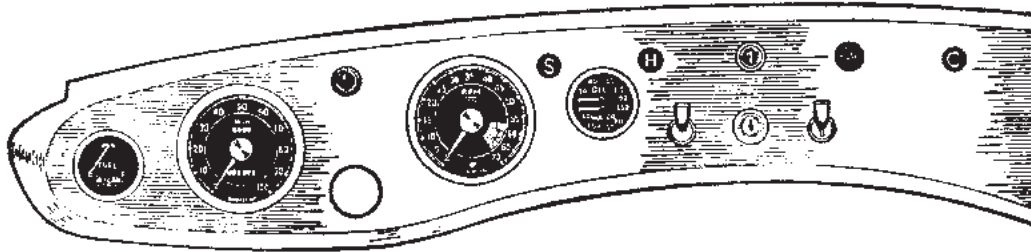

Dashboard - Sprite MkII, Midget MkI

12108

No.	Part#	Price (Each)	Description	Application	Qty Req.
20	169-108	\$42.99	SWITCH, ignition	(spade terminals)	1
21	163-500	\$11.99	BARREL, with 2 keys		1
22	331-695	NA	HEATER SWITCH & CABLE	(without knob)	1
23	331-085	\$14.99	KNOB, heater cable		1
24	141-530	\$13.99	SWITCH, panel lamps		1
25	141-530	\$13.99	WIPER SWITCH		1
26		NA	HEADLAMP SWITCH		1
27	141-200	\$25.99	SWITCH, turn signal		1
28		NA	SWITCH, high beam	(Use #29, 542-130 as replacement)	1
29	542-130	\$28.99	SWITCH, high beam	(replacement)	1
30	542-110	\$9.99	SWITCH, brake light		1
31	141-750	\$9.59	FLASHER UNIT	screw connectors	1

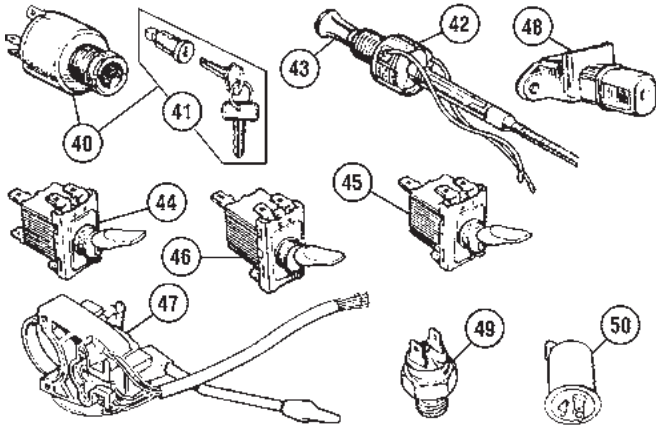
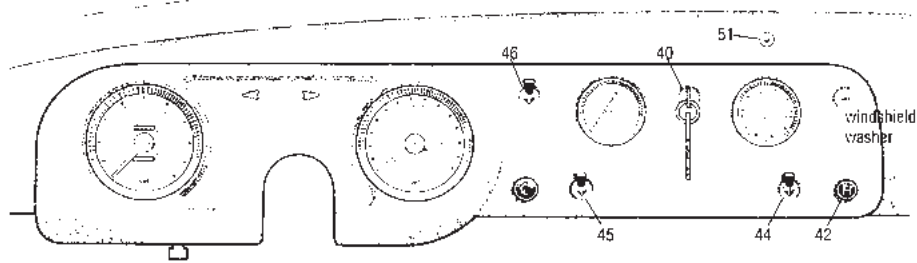

Dashboard - Sprite MkIII-MkIV, Midget MkII-III thru 1967 12109

No.	Part#	Price (Each)	Description	Application	Qty Req.
40	542-070	\$24.99	SWITCH, ignition & starter	Sprite MkIII, Midget MkII	1
41	163-500	\$11.99	BARREL, with 2 keys		1
42	331-695	NA	HEATER SWITCH & CABLE (without knob)	thru 1965	1
	331-705	NA	HEATER SWITCH & CABLE (without knob)	1966 - '67	1
43	331-085	\$14.99	KNOB, heater cable		1
44	141-530	\$13.99	SWITCH, panel lamps		1
45	141-530	\$13.99	WIPER SWITCH		1
46	141-230	\$16.49	HEADLAMP SWITCH		1
47	141-770	\$38.99	SWITCH, turn signal		1
48	542-130	\$28.99	SWITCH, high beam		1
49	542-110	\$9.99	SWITCH, brake light		1
50	171-300	\$15.99	FLASHER UNIT	spade connectors	1
51	142-252	\$5.89	LAMP, oil filter warning (incl. bulb)	replacement type	1

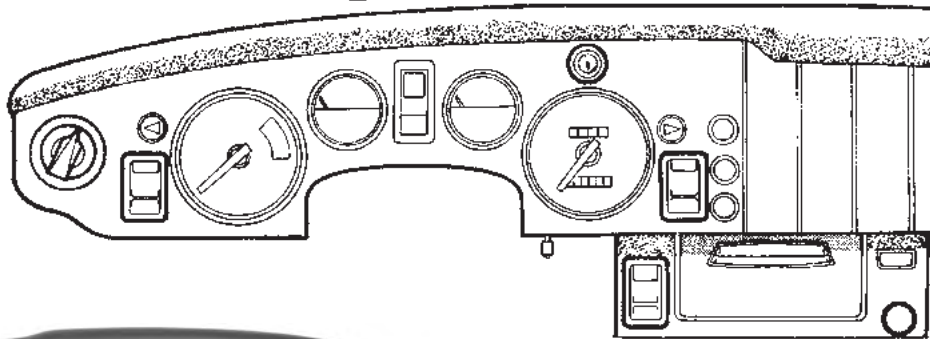

Dashboard - 1275 from 1968 & 1500 12110

60	141-748	\$16.99	FLASHER, turn signal	replacement, w/bracket	1
	141-655	\$4.89	FLASHER, hazard (replacement)	1275, 1968-'71	1
	141-650	\$4.19	FLASHER, hazard	1275 from '72, 1500	1
61	141-260*	\$13.49	SWITCH, headlamp on/off	1275 to (c)123750	1
	141-275	\$13.99	SWITCH, headlamp on/off	1275 from (c)123751-1500	1
62	141-250	\$18.49	SWITCH, heater blower	1275	1
	141-270	\$13.99	SWITCH, heater blower	1500	1
63	140-540	\$31.99	SWITCH, hazard warning, replacement	1275, 1968-'72	1
	141-635	\$13.99	SWITCH, hazard warning	1275 from '73, all 1500	1
64	140-580	NA	SWITCH, panel lamp	1275	1
65	181-980	\$11.49	SWITCH, brake light	1275 & 1500	1
	310-070	\$0.39	JAM NUT for brake switch		1
66	141-825	\$99.99	SWITCH, wiper/washer	1275 thru '73	1
	141-846	\$109.99	SWITCH, wiper/washer	1275, 1500 '74-'77	1
	141-855	\$29.99	SWITCH, wiper/washer	1500 '78 - '79	1
67	141-810	\$48.99	SWITCH, directional, horn, dimmer	1275, 1968-'70	1
	141-830	\$68.99	SWITCH, directional, dimmer	1275, 1971 - '73	1
	141-840	\$39.99	SWITCH, directional, dimmer	1275, 1500, 1974-'77	1
	141-850	\$99.99	SWITCH, directional, horn, dimmer	1500, 1978 - '79	1
	141-851	\$59.99	SWITCH, directional, horn, dimmer, aftermarket		1
67a	141-804	\$29.99	CLAMP & HORN CONTACT	1275, 1500 1971-'77	1
68	141-280	\$17.99	LAMP, brake check & warning	1275	1
	170-160	\$1.19	BULB, brake check lamp		1
69	162-170	NA	SWITCH, fog, accessory	1275	1
70	141-020	\$35.99	SWITCH, reverse lamp	1500	1
	542-410	\$18.99	SWITCH, reverse lamp		1
71	131-620	\$19.99	SWITCH, trunk	1275	1
72	115-391	\$25.99	SWITCH, courtesy light	1971-on	1
	182-410	\$19.99	SWITCH, handbrake	1	
74	146-000	\$41.99	RHEOSTAT, panel lamp (replacement)	1500	1
75	140-630	NA	KNOB	1	
76	453-814	\$469.99	DASHBOARD COVER, padded	cars w/ manual choke	1
	453-817	\$449.99	DASHBOARD COVER, padded	cars w/ auto choke	1

Note: Steering column mounted ignition switches are listed on page 43.

Toll-Free Orders 1-800-667-7872 | MossMotors.com
Fax 805-692-2525 | Local 805-681-3400

MOSS

Interior Products

Restore your Sprite or MG Midget to original specifications with British made reproduction upholstery kits. With duplicated original patterns, vinyls, and even dielectrically welded seams where appropriate, your car will look factory new. Our seat and panel kits are complete and straightforward to install. (For seat kits see page 84). The panel kits include sufficient vinyl to cover your dash panel and cockpit (except 1970-80 kits), new footwell boards, gearbox tunnel boards, inner sill boards, door pocket boards and rear quarter panels.

Bugeye panel kits include plain vinyl for the inside of the doors instead of the original style ribbed rubber, which is not available. Also not available are the door pocket cardboards, metal brackets, and hardware.

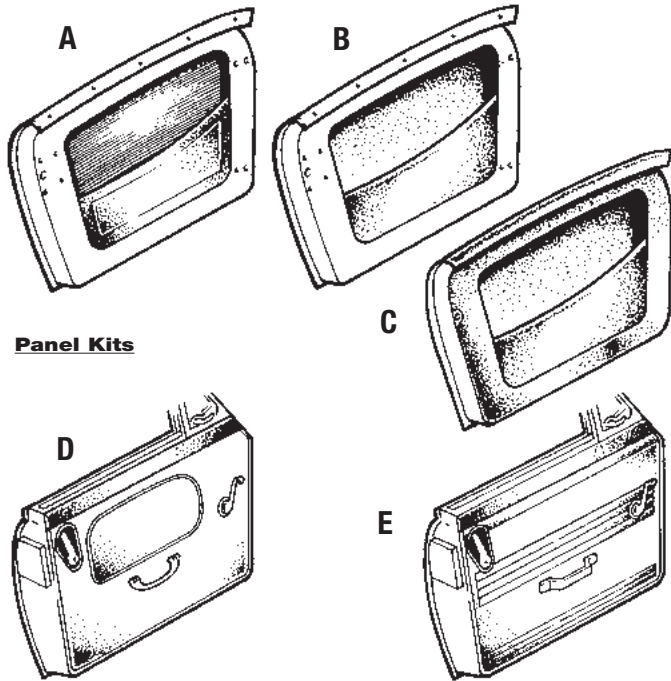

Panel Kits

Panel Kits	approx. model yr.	Black	Red	Blue	Navy	
A Bugeye Sprite	1958-'60	645-500	645-510	645-520	645-530	\$469.99
B 948 Sprite MkII 948 Midget MkI	1961-'62	645-540	645-550	645-560	645-565	\$489.99
C 1098 Sprite HAN7 Midget GAN2	1963	645-620	645-630	-	-	\$569.99
D 1098 Sprite HAN8 Midget GAN3	1964-'66	645-570* * with white piping	645-580*	645-585* (Light Blue)	-	\$450.00

		Black with Black Piping	Black with White Piping	Red with White Piping	
E 1275 Sprite HAN9 1275 Midget GAN4	1967-'69	645-660	645-670	645-680	\$849.99

		Black	Navy	Autumn Leaf	
E 1275 Midget GAN5 1500 Midget GAN6	1970-'80	645-700	645-710	645-720	\$669.99

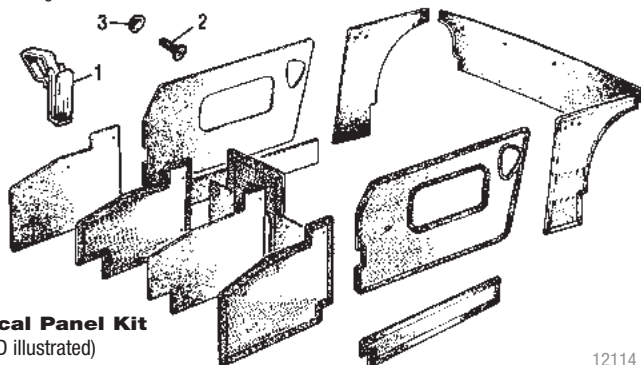

Typical Panel Kit
(style D illustrated)

1	803-420	\$0.99	PANEL CLIP (replacement)	1966-'80	26
2	323-460	\$0.29	PANEL SCREW, chrome		A/R
	323-480	\$0.49	PANEL SCREW, black		A/R
	315-160	\$0.29	CUP WASHER, chrome		A/R
3	323-985	\$0.69	CUP WASHER, black		A/R

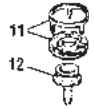
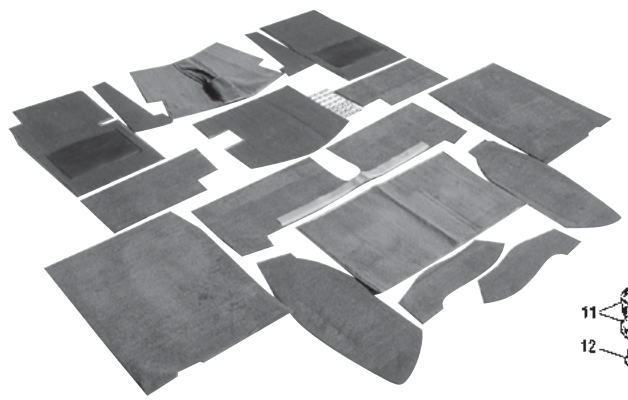

Carpet Sets

12111

No. Part#	Price (Each)	Description	Application	Qty Req.
242-531	\$329.99	CARPET SET, black	Sprite MKI (Bugeye) Floor and tunnel carpet only. May use Sprite MKII carpet for more complete coverage	1
242-532	\$329.99	CARPET SET, red		1
242-533	\$329.99	CARPET SET, navy		1
242-541	\$359.99	CARPET SET, black	Sprite MKII, Midget MKI	1
242-542	\$359.99	CARPET SET, red		1
242-543	\$359.99	CARPET SET, navy		1
242-551	\$359.99	CARPET SET, black	Sprite MKIII, Midget MKII	1
242-552	\$359.99	CARPET SET, red		1
242-553	NA	CARPET SET, blue		1
242-560	\$399.99	CARPET SET, black	Sprite MKIV, Midget MKIII	1
242-570	\$399.99	CARPET SET, red		1
242-580	\$399.99	CARPET SET, autumn leaf		1
242-563	NA	CARPET SET, blue		1
242-555	\$399.99	CARPET SET, navy		1
242-571	\$399.99	CARPET SET, black	Midget 1500	1
242-572	\$399.99	CARPET SET, red		1
242-573	\$399.99	CARPET SET, autumn leaf		1
242-588	\$259.99	TRUNK CARPET SET, black	1961-'74	1
242-589	\$259.99	TRUNK CARPET SET, red		1
242-591	\$259.99	TRUNK CARPET SET, navy		1
242-592	\$259.99	TRUNK CARPET SET, autumn leaf		1
11	226-338	\$2.49	"VELTEX" CARPET RING ASS'Y.	A/R
12	226-800	\$0.99	SNAP & SCREW	A/R

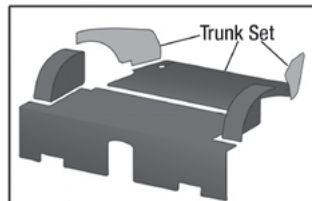

"Original" Set

Bugeye Rear Liner Sets

Dress up the dark chasm behind your seats with a liner set from Moss. "Original" sets include hardura trunk floor covering, two side panels, hardura wheel well covers, and hardura heelboard cover. Trunk sets include trunk floor cover and side panels (use this when installing the Sprite MKII carpet set (which has also carpet heelboard & wheel well covers) in a Bugeye.

"Original" Sets

Black	242-501	\$319.99
Red	242-502	\$319.99
Navy	242-503	\$319.99

Trunk Sets

Black	242-500	\$169.99
Red	242-504	\$169.99
Navy	242-503	\$319.99

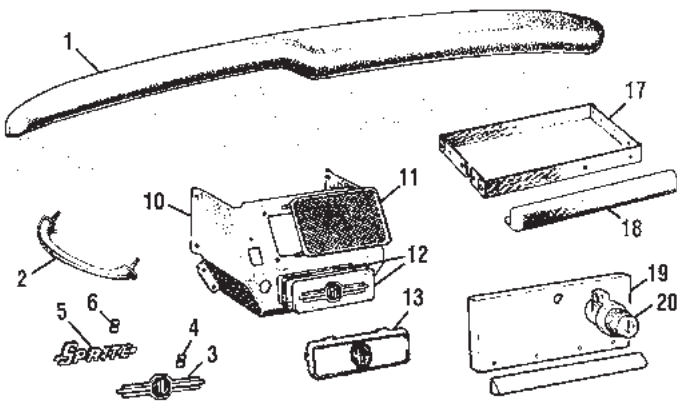

Dashboard Fittings

12115

No.	Part#	Price (Each)	Description	Application	Qty Req.
1	453-950	\$144.99	DASH TOP COVER	1968-'80	1
2	633-690	\$49.99	GRAB HANDLE, dashboard	Sprite MKI, MKII	1
3	472-050	\$16.99	MG BADGE	Midget (as fitted)	1
4	326-520	\$0.29	SPIRE NUT		2
5	470-615	\$33.99	SPIRE BADGE	Sprite MKIII, MKIV	1
6	326-510	\$0.24	SPIRE NUT		2
10	453-810	\$259.99	RADIO CONSOLE	1968-80	1
11	233-835	\$119.99	SPEAKER SCREEN, chrome	1968-74	1
	233-855	NA	SPEAKER SCREEN, black	1975-80 (alt. to above)	1
12	472-078	\$37.99	RADIO BLANKING PLATE SET	1968-76 Midget	1
	472-079	\$49.99	RADIO BLANKING PLATE SET	1968-69 Sprite	1
13	472-035	\$10.89	RADIO BLANKING PLATE	1977-80 Midget	1
17	240-830	NA	PARCEL SHELF	1966-72	1
18	240-840	NA	PAD, parcel shelf		1
19	NA	NA	GLOVE BOX DOOR	1972-80	1
20	234-400	NA	GLOVE BOX LOCK with 2 keys		1

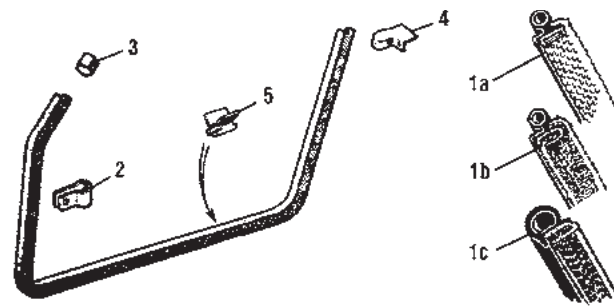

Door Seal & Finishers

12117

No.	Part#	Price (Each)	Description	Application	Qty Req.
1a	249-800*	\$26.99	DOOR SEAL, black woven fabric	orig. type, 1958-'69	4
	249-810*	\$26.99	DOOR SEAL, red woven fabric		4
1b	249-609*	\$26.99	DOOR SEAL, black velour	alt. type, 1958-'69	4
	249-695*	\$26.99	DOOR SEAL, red velour		4
	249-857*	\$26.99	DOOR SEAL, blue velour		4
1c	259-907**	\$6.49	DOOR SEAL, black vinyl	orig. type, 1970-'80	10
2	NA	NA	CLIP, door seal front	Sprite Mkl, II, Midget Mkl	2
3	240-530	\$4.79	CLIP, door seal front end	Sprite from MkIII (1275),	2
4	240-545	\$16.99	FINISHER, L/H rear	Midget from MkII (1275)-on	1
	240-540	\$16.99	FINISHER, R/H rear		1
5	249-795	\$0.59	CLIP, door seal to flange		20

*sold per yard

**sold per foot

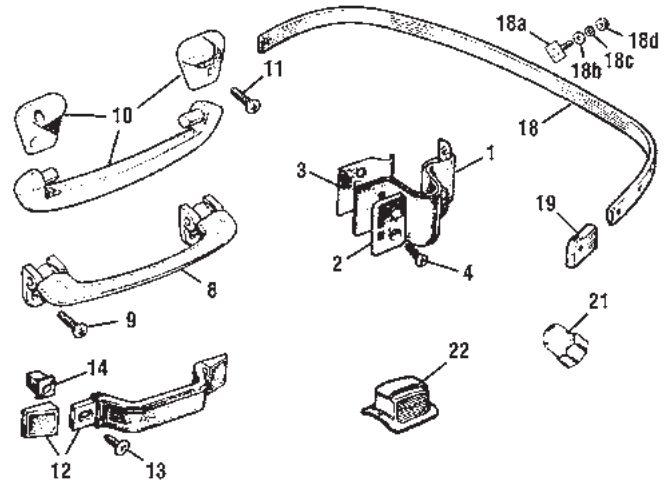

Cockpit Fittings

12116

No.	Part#	Price (Each)	Description	Application	Qty Req.
1	240-675	\$39.99	CHECK STRAP, black		2
	240-670	\$39.99	CHECK STRAP, red		2
	240-680	\$39.99	CHECK STRAP, blue		2
	240-685	\$39.99	CHECK STRAP, navy		2
	240-690	\$39.99	CHECK STRAP, autumn leaf		2
2	240-815	\$3.99	RETAINER, check strap		2
3	240-805	\$5.29	BRACKET, check strap		2
4	314-315	\$0.69	SCREW		4
8	803-440	\$16.99	HANDLE, door pull	Sprite to (c)72040, Midget to (c)60459	2
9	402-485	\$0.79	SCREW, door pull		4
10	472-240	\$5.99	HANDLE, door pull	Sprite from (c)72041, Midget (c)60460 to 105500	2
11	402-485	\$0.79	SCREW, door pull		4
12	402-453	\$28.99	DOOR PULL, black	Midget from (c)105501 (1972-on)	2
	402-450	NA	DOOR PULL, autumn leaf		2
	402-455	NA	DOOR PULL, ochre		2
	402-490	NA	DOOR PULL, navy		2
13	314-285	\$0.49	SCREW, door pull		4
14	402-710	NA	CAPTIVE NUT		4
18	459-855	\$24.99	COCKPIT MOULDING, black vinyl	1967-'80	1
18a	226-660	\$2.19	STUD PLATE, moulding		9
18b	324-990	\$0.39	WASHER, plain		9
18c	324-010	\$0.19	LOCKWASHER		9
18d	310-040	\$0.29	NUT		9
19	240-560	\$13.39	END CAP, chrome R/H		1
	240-565	\$13.39	END CAP, chrome L/H		1
21	402-550	\$3.89	DOME NUT, seat belt mounting	as fitted	4
22	241-015	NA	ASHTRAY ASSEMBLY		1

Rubber Floor Mat Sets

Protect your carpets from damage, while giving your interior added good looks with our heavy duty black ribbed rubber mats. Late mats are embossed with Midget or Sprite logo.

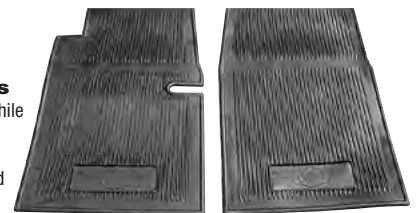

241-870	\$36.99	Sprite/Midget with side curtains (no logo) (Can be used with aluminum frame cover set #240-510)
241-880	\$36.99	Sprite, cars with roll-up windows
241-860	\$36.99	Midget, cars with roll-up windows

Seats

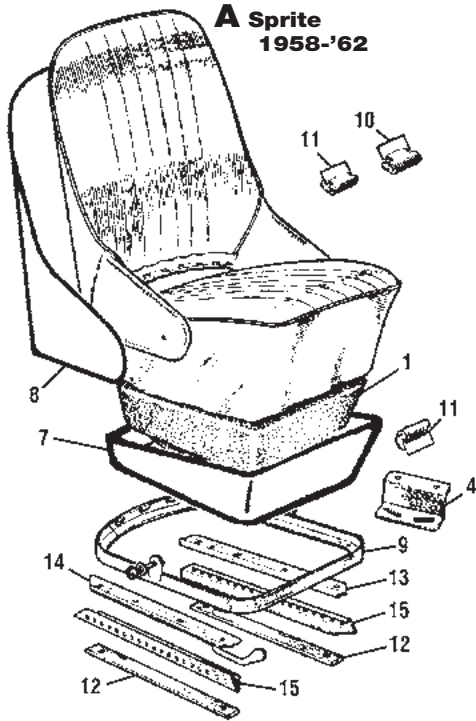

A Sprite
1958-'62

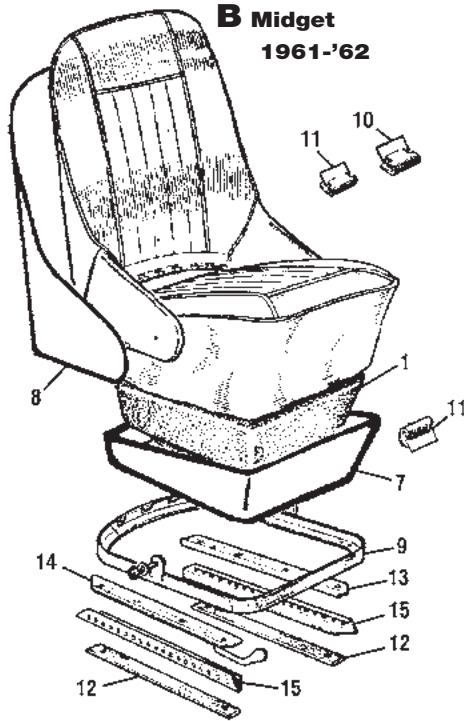

B Midget
1961-'62

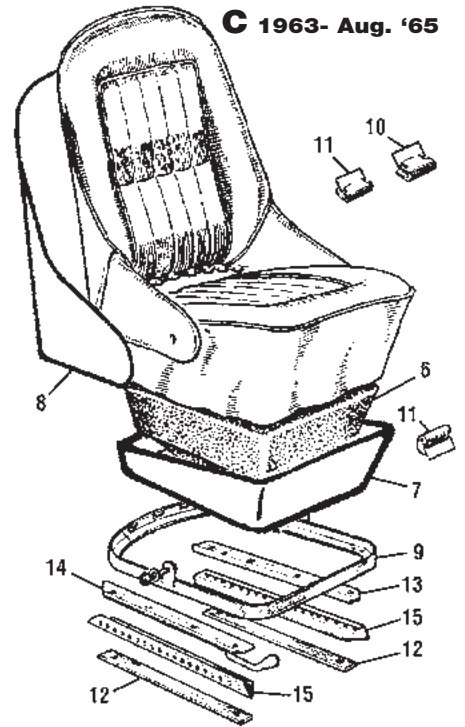

C 1963- Aug. '65

Vinyl Seat Kits

	Black with White Piping	Red with White Piping	Blue with Lt.Blue Piping	
A Bugeye Sprite, 948 Sprite Mk II to HAN7-24731	640-777	640-778	640-779 (Blue) 640-776 (Navy Blue)	\$539.99 \$539.99
B 948 Midget Mk I to GAN1-16183	640-700	640-702	640-706 (Blue)	\$529.99
C 1098 Sprite Mk II & Mk III from HAN7-24732 to HAN8-55372 (approx.) Midget Mk I & Mk II from GAN2-16184 to GAN3-42900 (approx.)	640-720	640-722	640-724 (Navy/Navy) 640-725 (Blue/Wht)	\$559.99 \$559.99
D 1098 Sprite Mk III & 1275 Mk IV from (approx.) HAN8-55373 to HAN9-77590 Midget Mk II from approx. GAN3-42900, Midget Mk III to GAN4-66225	640-935	640-936	640-934 (Blue/White)	\$469.99
E 1275 Sprite Mk IV* from HAN9-77591 to HAN9-85286 (*Headrest covers not included) 1275 Midget Mk III* from GAN4-66226 to GAN4-74885	Black 640-945* (fixed back - USA) 640-950* (reclining back - not USA)			\$669.99 \$699.99
F 1275 Sprite Mk IV* from HAN10-85287 on (*Headrest covers not included) 1275 Midget Mk III & Midget 1500* from GAN5-74886 thru 1500	Black 640-960 640-200 640-335	Autumn Leaf 640-980 640-225 640-345	Navy 640-930 640-210 NA	\$769.99 \$79.99 \$89.99

Leather Seat Kits

	Black / White	Red / White	
A Bugeye Sprite, 948 Sprite Mk II to HAN7-24731	640-781	640-782	\$799.99
B 948 Midget Mk I to GAN1-16183	640-710	640-712	\$799.99
C 1098 Sprite Mk II & Mk III from HAN7-24732 to HAN8-55372 (approx.) Midget Mk I & Mk II from GAN2-16184 to GAN3-42900 (approx.)	640-740	640-742	\$799.99
D 1098 Sprite Mk III & 1275 Mk IV from (approx.) HAN8-55373 to HAN9-77590 Midget Mk II from approx. GAN3-42900, Midget Mk III to GAN4-66225	640-965	640-966	\$719.99
E 1275 Sprite Mk IV* from HAN9-77591 to HAN9-85286 (*Headrest covers not included) 1275 Midget Mk III* from GAN4-66226 to GAN4-74885	Black 640-800	(fixed back)	\$1,599.00
F 1275 Sprite Mk IV* from HAN10-85287 on (*Headrest covers not included) 1275 Midget Mk III & Midget 1500* from GAN5-74886 thru 1500 (not original pleat pattern - has vertical pleats)	Black 640-805	Autumn Leaf 640-810	\$1,599.00

Moss Seat Kits All front seat kits include covers for both front seats. No matter what else you do to your car, one thing which everyone notices is the condition of the seats. Put your seats in tip top condition with a "just as it came from the factory" vinyl kit, or upgrade your car's interior with one of our luxurious leather kits. (Don't forget pads and cushions - we stock a complete selection to properly fill out your new covers, and make your "new" seats as comfortable as can be.) All of the Sprite & Midget seat kits we sell are made of the very best materials, patterned exactly like the originals. **As original from the factory, our leather seat kits have only the seating/wearing surfaces in leather, with the non-wearing surfaces in matching vinyl.**

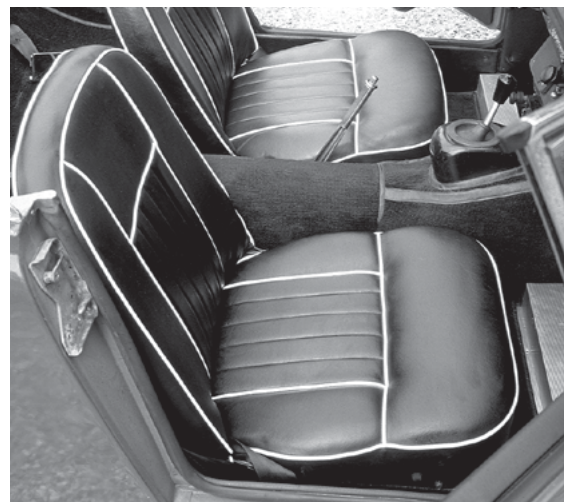

D Aug. 1965-'68

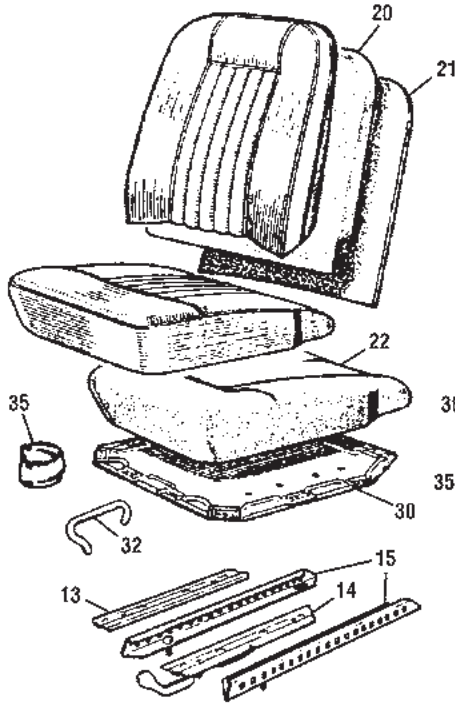

E 1969

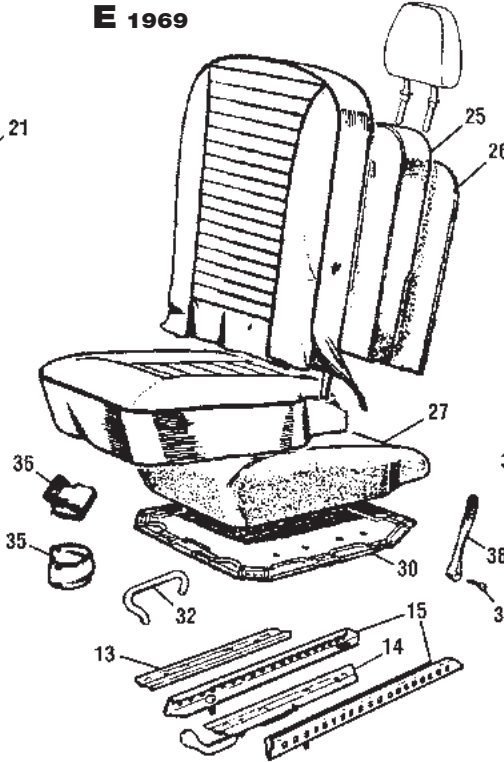

F Midget 1970-'80

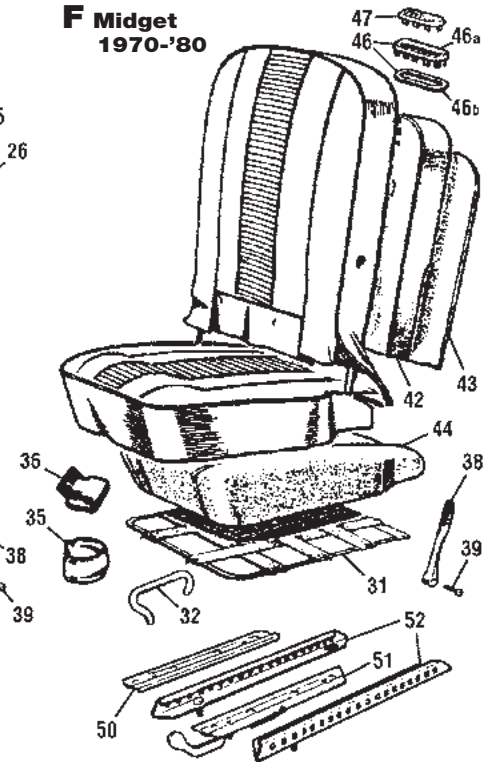

Seat Components

12121

No.	Part#	Price (Each)	Description	Application	Qty Req.
1	640-468	\$199.99	CUSHION & PADDING KIT (foam cushion, plus padding for seat back)	seats "A" & "B"	2
4	640-630	\$29.99	BRACKET, seat mounting	seat "A"	4
These brackets were used instead of seat slides on Bugeye passenger's seat. 948cc Sprite MkII (H-AN6) could be had with the passenger's seat mounted on either these brackets or on slides.					
6	640-478	\$419.99	FOAM CUSHION & PADDING KIT (foam cushion, plus padding for seat back)	seat "C"	2
7	640-570	\$289.99	BASE, steel	seats "A", "B", "C"	2
8	640-575	\$329.99	BACK, steel		2
9	640-640	\$239.99	FRAME		2
10	326-185	\$0.99	CLIP, seat back (large)		20
11	326-155	\$0.29	CLIP, back & cushion covers (small)		56
12	640-605	\$19.99	PACKING STRIP, wood		4
13	640-600	NA	RUNNER, upper, plain	seats "A" thru "E"	2
14	640-585	NA	RUNNER w/lever, R/H		1
	640-595	NA	RUNNER w/lever, L/H		1
15	640-590	\$39.99	RAIL, lower		4
20	641-960	\$76.99	BACK FOAM	seat "D"	2
21	640-545	\$28.99	BACK BOARD		2
22	640-531	\$99.99	CUSHION FOAM		2
25	640-550	\$154.99	BACK FOAM	seat "E"	2
26	640-505	NA	BACK BOARD, adjustable seatback		2
	640-635	NA	BACK BOARD, non-adj. seatback		2
27	640-560	\$149.99	CUSHION FOAM		2
30	281-828	\$29.99	DIAPHRAGM, rubber	seats "D", "E"	2
31	281-858	\$36.99	DIAPHRAGM, web	seat "F"	2
32	325-185	\$0.79	HOOK, diaphragm	seats "D", "E", "F"	20
35	226-645	\$0.89	CLIP, cushion cover		A/R
36	326-185	\$0.99	CLIP, back cover	seats "E", "F"	6
38	409-020	\$24.99	HANDLE, seat back adjusting		2
39	323-205	\$2.59	SCREW, handle		2
42	640-500	\$109.99	BACK FOAM, R/H	seat "F"	1
	640-510	\$109.99	BACK FOAM, L/H		1
43	640-515	\$27.99	BACK BOARD		2
44	640-520	\$99.99	CUSHION FOAM		2
46	409-108	\$3.19	RING ASS'Y, headrest aperture		2
46a	409-100	NA	FINISHING RING		2
46b	409-105	\$1.49	EYELET	2	
47	227-170	\$3.49	PLUG, black (when headrests out) installed on seat kits		2

No.	Part#	Price (Each)	Description	Application	Qty Req.
50	640-600	NA	RUNNER, upper, plain	seat "F", 1970-'71 to approx. (c)105500	2
51	640-585	NA	RUNNER w/lever, R/H		1
	640-595	NA	RUNNER w/lever, L/H		1
52	640-610	\$16.99	RAIL, lower, R/H of ea. seat	seat "F", 1972-'80 from approx. (c)105501	2
	640-620	\$16.99	RAIL, lower, L/H of ea. seat		2
		NA	RUNNER, upper, plain	seat "F", 1972-'80 from approx. (c)105501	2
		NA	RUNNER w/lever, R/H		1
		NA	RUNNER w/lever, L/H		1
	640-615	\$16.99	RAIL, lower, R/H of ea. seat		2
	640-625	\$16.99	RAIL, lower, L/H of ea. seat		2



Midget Headrests

Beautiful reproductions of an often missing or weather-ruined upholstery part. (Sorry - twin-post headrests for 1969 cars are not available.) Sold individually.

	Black	Navy	Ochre	Autumn Leaf	Champagne	
1970-'72 "Eared type" perforated.						
649-100	NA	NA	649-130	NA	\$169.99	
1972-'76 "Eared type" non-perforated						
649-140	649-150	NA	649-170	NA	\$174.99	
1977-'80 "Teardrop type" non-perforated						
641-605	641-615	NA	641-635	NA	\$169.99	

Tonneau Covers



Tonneau Covers

Tonneau covers are the time tested method of protecting your car's interior. Our tonneau covers incorporate the finest materials and workmanship and are supplied complete with hardware (fasteners on car body not included).

Stayfast is an acrylic canvas which is soft and flexible over a wide temperature range, yet is waterproof, and highly resistant to sagging, billowing, shrinking and fading. (These are made to order, so please allow 6 to 10 weeks for delivery.)

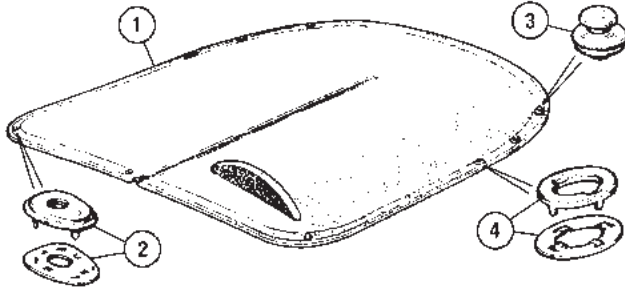

Tonneau Cover, Sprite MK1 ("Bugeye")

12124

No.	Part#	Price (Each)	Description	Application	Qty Req.
1	241-270	\$439.99	TONNEAU COVER, black vinyl		1
	241-271	\$999.99	TONNEAU COVER, black Stayfast		1
	241-272	\$999.99	TONNEAU COVER, tan Stayfast		1
2	226-308	\$1.99	FASTENER, "Lift the Dot"		3
3	227-600	\$11.59	FASTENER, "Tenax" (genuine "Tenax" brand)		4
4	227-408	\$1.29	EYELET		2

Note: Bugeye tonneau covers mount to the chrome retainers behind the rear cockpit rail.

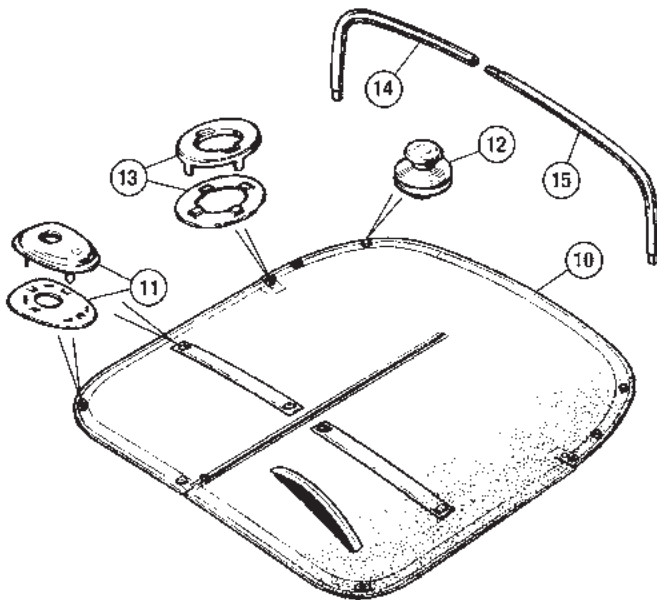

Tonneau Cover, Sprite MKII, Midget MKI (1961-'64)

12126

No.	Part#	Price (Each)	Description	Application	Qty Req.
10	241-280	\$479.99	TONNEAU COVER, black vinyl		1
	241-281	\$929.99	TONNEAU COVER, black Stayfast		1
	241-282	\$929.99	TONNEAU COVER, tan Stayfast		1
11	226-308	\$1.99	FASTENER, "Lift the Dot"		7
12	227-600	\$11.59	FASTENER, "Tenax" (genuine "Tenax" brand)		4
13	227-408	\$1.29	EYELET		2
14	453-605	\$66.99	TONNEAU BAR, R/H		1
15	453-635	\$66.99	TONNEAU BAR, L/H		1

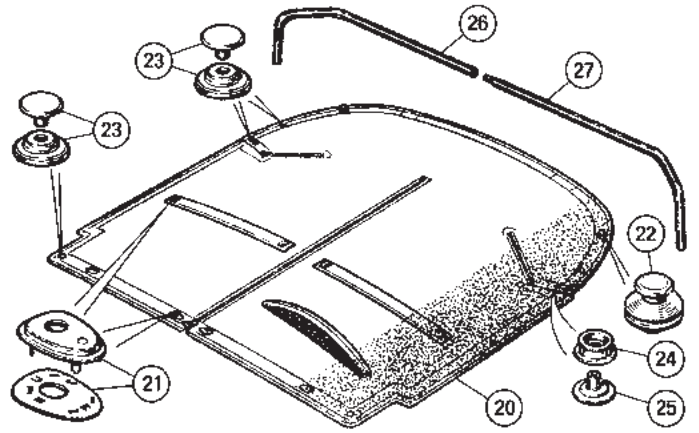

Tonneau Cover, Sprite MKIII, Midget MKII (1964-'66)

12123

No.	Part#	Price (Each)	Description	Application	Qty Req.
20	241-285	\$519.99	TONNEAU COVER, black		1
	241-286	\$999.99	TONNEAU COVER, black Stayfast		1
	241-287	\$999.99	TONNEAU COVER, tan Stayfast		1
21	226-308	\$1.99	FASTENER, "Lift the Dot"		8
22	227-600	\$11.59	FASTENER, "Tenax" (genuine "Tenax" brand)		2
23	227-108	\$0.69	SNAP ASS'Y., female		4
24	226-720	\$0.49	SNAP, male		2
25	226-605	\$0.19	SNAP BASE		2
26	453-910	\$32.99	TONNEAU BAR, R/H		1
27	453-915	\$32.99	TONNEAU BAR, L/H		1

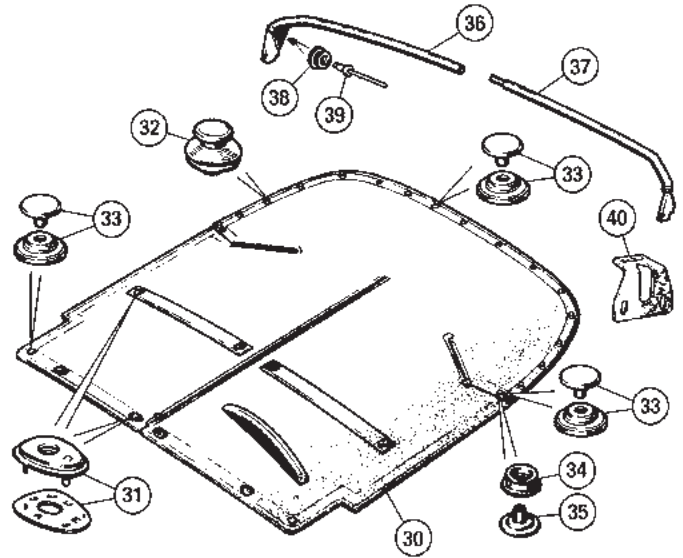

Tonneau Cover, Sprite MKIV, Midget MKIII (1967-'68)

12125

No.	Part#	Price (Each)	Description	Application	Qty Req.
30	241-290	\$519.99	TONNEAU COVER, black vinyl		1
	241-291	\$999.99	TONNEAU COVER, black Stayfast		1
	241-292	\$999.99	TONNEAU COVER, tan Stayfast		1
31	226-308	\$1.99	FASTENER, "Lift the Dot"		8
32	227-600	\$11.59	FASTENER, "Tenax" (genuine "Tenax" brand)		8
33	227-108	\$0.69	SNAP ASS'Y., female		11
34	226-720	\$0.49	SNAP, male		2
35	226-605	\$0.19	SNAP BASE		2
36	453-920	NA	TONNEAU BAR, R/H		1
37	453-925	NA	TONNEAU BAR, L/H		1
38	226-720	\$0.49	SNAP, male		2
39	325-287	\$0.49	RIVET		2
40	402-565	\$35.99	BRACKET, tonneau bar		2

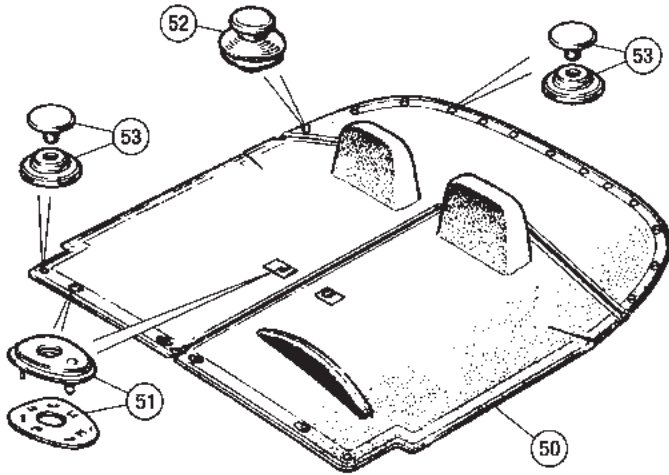

Tonneau Cover, 1969-on

12128

No.	Part#	Price (Each)	Description	Application	Qty Req.
50	241-300	\$519.99	TONNEAU COVER, black vinyl		1
	241-301	\$999.99	TONNEAU COVER, black Stayfast		1
	241-302	\$999.99	TONNEAU COVER, tan Stayfast		1
51	226-308	\$1.99	FASTENER, "Lift the Dot"		6
52	227-600	\$11.59	FASTENER, "Tenax" (genuine "Tenax" brand)		6
53	227-108	\$0.69	SNAP ASS'Y, female		9

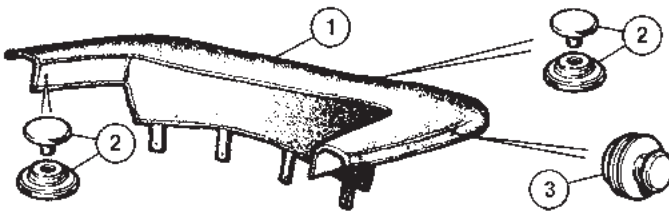

Top Cover

12129

No.	Part#	Price (Each)	Description	Application	Qty Req.
1	241-515	\$299.99	TOP COVER, black	1969-'80	1
2	227-108	\$0.69	SNAP ASS'Y, female		9
3	227-600	\$11.59	TENAX FASTENER (genuine "Tenax" brand)		6

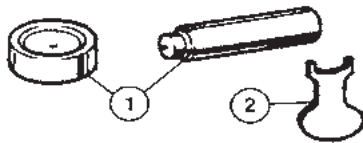

Snap Tool

12131

No.	Part#	Price (Each)	Description	Application	Qty Req.
1	386-980	\$4.99	SNAP FASTENING TOOL		1
2	387-055	\$1.69	FITTING KEY, Tenax fastener		1

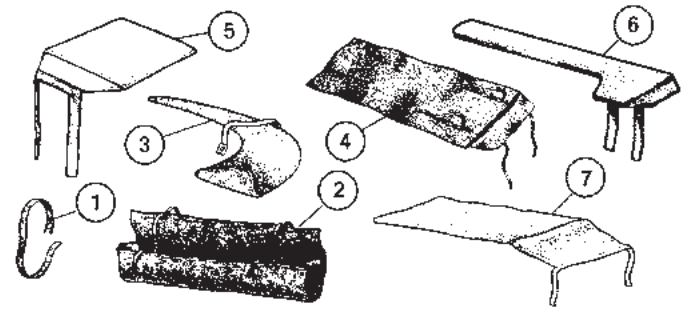

Stowage Bags

12127

No.	Part#	Price (Each)	Description	Application	Qty Req.
1	385-955	\$12.99	STRAP, top stowage, replacement	1958-66	2
2	242-575	NA	TOP STOWAGE BAG	Sprite MkII, Midget MkI	1
3	242-595	NA	TOP FRAME STOWAGE BAG	Sprite MkII-III, Midget MkII	1
4	242-585	\$116.99	SIDE CURTAIN STOWAGE BAG		1
5	242-605	\$54.99	TONNEAU COVER STOWAGE BAG		1
6	242-565	\$43.99	TONNEAU BAR STOWAGE BAG	1967-68	1
7	242-590	NA	TOP COVER STOWAGE BAG	1967-80	1

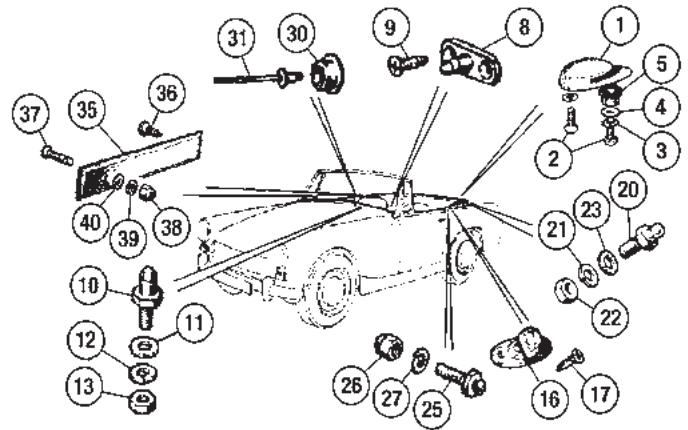

Body Fittings, Tonneau Covers

12130

No.	Part#	Price (Each)	Description	Application	Qty Req.
1	470-747	\$6.99	RETAINER, top & tonneau cover	all through 1966	2
2	323-455	\$0.59	SCREW		4
3	324-010	\$0.19	LOCKWASHER		4
4	324-990	\$0.39	WASHER, plain		2
5	470-757	\$2.99	WASHER, cup		2
8	226-630	\$4.69	STUD, "Lift-the-Dot", rear heelboard	all except Bugeye	4
9	323-460	\$0.29	SCREW		8
10	226-600	\$2.99	STUD, "Lift-the-Dot", dash top	thru 1963 use 3, from 1964 use 4	3/4
11	435-515	\$0.49	WASHER, leather		3/4
12	324-010	\$0.19	LOCKWASHER		3/4
13	310-040	\$0.29	NUT		3/4
16	227-500	\$1.99	TURNBUCKLE	thru 1963	2
17	323-460	\$0.29	SCREW		2
20	227-700	\$2.69	STUD, "Tenax" (3/8" long stud)	most applications	A/R
21	324-010	\$0.19	LOCKWASHER		A/R
22	311-030	\$0.39	NUT		A/R
23	435-515	\$0.49	WASHER, leather	thru 1968	A/R
	324-012	\$0.99	WASHER, chrome	1969-on	6
25	227-010	\$3.19	STUD, "Tenax" (5/8" long stud)	1964-'68	2
26	311-010	\$2.29	DOME NUT, chrome		2
27	324-010	\$0.19	LOCKWASHER	1964-80	2
30	226-720	\$0.49	SNAP, male		A/R
31	325-287	\$0.49	RIVET for snap	A/R	
35	242-215	\$11.99	VELCRO STRIP	1969-'80	2
36	323-460	\$0.29	SCREW, rear		2
37	312-235	\$1.39	SCREW, front		2
38	311-350	\$1.99	DOME NUT		2
39	315-070	\$0.49	LOCKWASHER		2
40	315-075	\$0.19	WASHER		2

Top Fittings / Sidecurtains

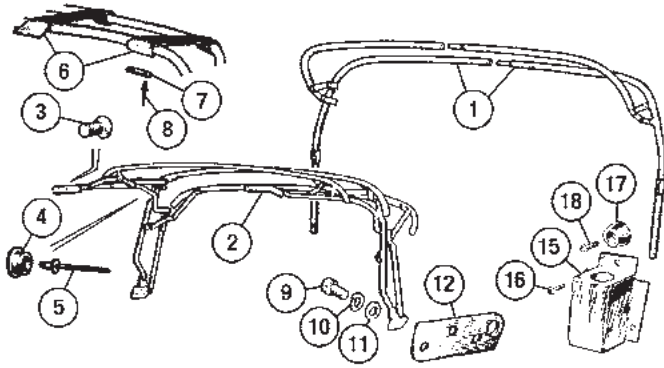

Top Frames

12132

No.	Part#	Price (Each)	Description	Application	Qty Req.
	400-630	\$449.99	TOP FRAME ASSY.	Sprite MkI (Bugeye)	1
1	400-648	\$419.99	TOP FRAME ASSY. (2 piece)	Sprite MkII, Midget MkI	1
	400-658	\$429.99	TOP FRAME ASSY. (2-piece)	Sprite MkIII, Midget MkII	1
2	400-680	\$489.99	TOP FRAME ASSY. (permanent mount)	1967-'80	1
3	323-255	\$0.69	SCREW, frame to header rail		6
4	226-720	\$0.49	MALE SNAP		4
5	325-287	\$0.49	RIVET for snaps		4
6		NA	WEBBING KIT, top frame		1
7	402-545	NA	PLATE, securing webbing		6
8	326-285	\$0.99	RIVET for plates		12
9	322-290	\$0.89	BOLT, top frame to body, short		2
	320-695	\$0.89	BOLT, top frame to body, long		4
10	365-730	\$0.39	LOCKWASHER		6
11	365-720	\$0.79	WASHER, plain		6
12	402-595	\$2.49	PACKING PIECE, top frame to body		2
15	402-555	\$29.99	BRACKET, top frame stowage		2
16	314-070	\$0.59	SCREW		6
17		NA	BUFFER		2
18	314-045	\$0.39	SCREW for buffer		2



Side Curtains

12134

Fit your Sprite or Midget with a set of our factory style side curtains, complete with sealing strips, brackets and screws. Just like the originals, these side curtains look great while keeping out the wind, the cold and the rain.

259-678	\$749.99	Side Curtain Set, Complete	1
259-675	\$34.99	Bracket Set with nuts & bolts	1
282-455	\$26.99	Outer Seal, L/H	1
282-465	\$26.99	Outer Seal, R/H	1

Seals do not fit original side curtains. See page 65 for sidecurtain mounting screws.

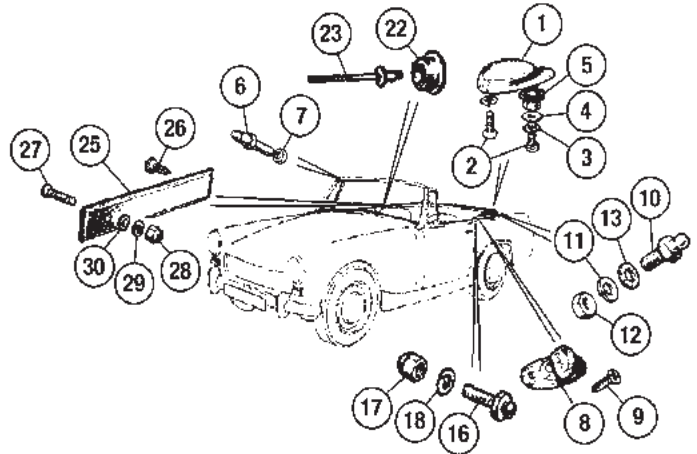

Body Fittings, Tops

12133

No.	Part#	Price (Each)	Description	Application	Qty Req.
1	470-747	\$6.99	RETAINER, top & tonneau cover	all through 1966	2
2	323-455	\$0.59	SCREW		4
3	324-010	\$0.19	LOCKWASHER		4
4	324-990	\$0.39	WASHER, plain		2
5	470-757	\$2.99	WASHER, cup		2
6		NA	STUD, Lift-the-Dot	Bugeye thru (c)5476	9
7	310-040	\$0.29	NUT	Bugeye from (c)5477, Sprite MkII, Midget MkI	2
8	227-500	\$1.99	TURNBUCKLE	thru 1963	2
9	323-600	\$0.39	SCREW		4
10	227-700	\$2.69	STUD, "Tenax" (3/8" long stud)	most applications	A/R
11	324-010	\$0.19	LOCKWASHER		A/R
12	311-030	\$0.39	NUT		A/R
13	435-515	\$0.49	WASHER, leather	thru 1968	A/R
	324-012	\$0.99	WASHER, chrome	1969-on	6
16	227-010	\$3.19	STUD, "Tenax" (5/8" long stud)	1964-'68	2
17	311-010	\$2.29	DOME NUT, chrome		2
18	324-010	\$0.19	LOCKWASHER	1964-80	2
22	226-720	\$0.49	SNAP, male		A/R
23	325-287	\$0.49	RIVET for snap	A/R	
25	242-215	\$11.99	VELCRO STRIP	1969-'80	2
26	323-460	\$0.29	SCREW, rear		2
27	312-235	\$1.39	SCREW, front		2
28	311-350	\$1.99	DOME NUT		2
29	315-070	\$0.49	LOCKWASHER		2
30	315-075	\$0.19	WASHER	2	



Robbins high quality replacement tops duplicate the original tops in almost all respects. Stayfast is an acrylic canvas which is soft and flexible over a wide temperature range, yet is waterproof, and highly resistant to sagging, billowing, shrinking and fading. (Stayfast tops are made to order, so please allow 6 to 10 weeks for delivery.)

Tops are supplied with all snaps and fasteners, but do not include the header rail (except where noted), body hardware or anchor bars.

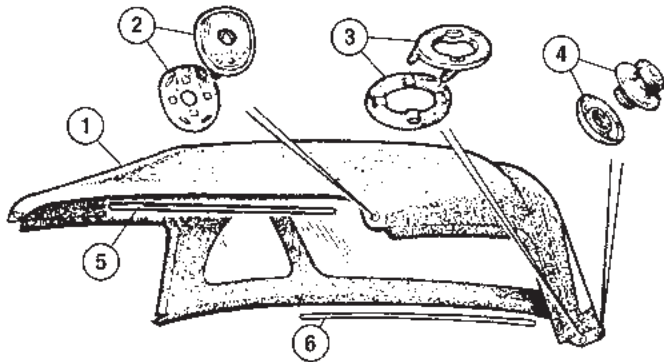

Tops, Sprite Mki, MkII, Midget Mki

12136

No.	Part#	Price (Each)	Description	Application	Qty Req.
1	242-180	\$539.99	TOP, black vinyl	Bugeye, studs on w/s frame thru (c)5476	1
	242-181	\$999.99	TOP, black Stayfast		1
	242-182	\$999.99	TOP, tan Stayfast		1
	242-185	\$539.99	TOP, black vinyl	Bugeye, bar mount from (c)5477	1
	242-186	\$999.99	TOP, black Stayfast		1
	242-187	\$999.99	TOP, tan Stayfast		1
	242-190	\$549.99	TOP, black vinyl	Sprite MkII, Midget Mki	1
	242-191	\$999.99	TOP, black Stayfast		1
	242-192	\$999.99	TOP, tan Stayfast		1
2	226-308	\$1.99	FASTENER, "Lift-the-Dot"	Bugeye thru (c)5476	A/R 9
				Sprite & Midget from above	2
3	227-408	\$1.29	EYELET		2
4	227-600	\$11.59	FASTENER, "Tenax" (genuine "Tenax" brand)		4
5	401-030	\$49.99	BAR, top retaining, front	Bugeye from (c)5477, Sprite MkI, Midget Mki	1
6	401-040	\$36.99	BAR, top retaining, rear		1



OEM Type Top w/ Header Rail - Made In England

These are genuine English factory style double-coated vinyl tops, complete with header rail, seal, and retainer. The rear mounting holes are punched, leaving only the side Tenax studs to be installed for a perfect fit. Although not identical to the factory material, the differences are minor and virtually undetectable. This is as close as you can get to original!

242-205 Black Vinyl \$1,149.00

Toll-Free Orders 1-800-667-7872 | MossMotors.com
Fax 805-692-2525 | Local 805-681-3400



Tops

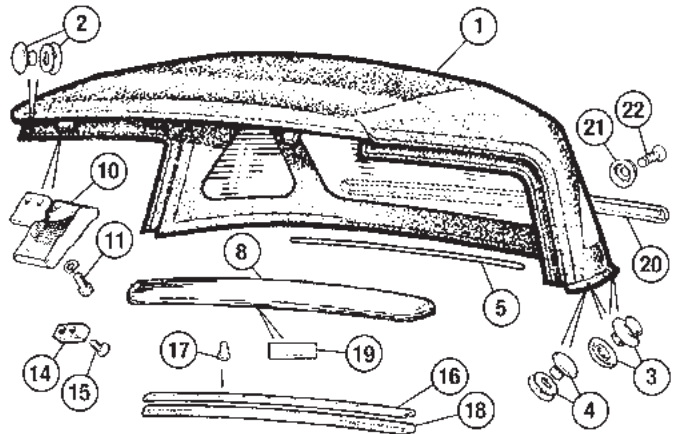

Tops, Sprite MkIII-on, Midget MkII-on (1964-'80)

12135

No.	Part#	Price (Each)	Description	Application	Qty Req.
1	242-195	\$549.99	TOP, black vinyl	Sprite MkIII, Midget MkII	1
	242-196	\$999.99	TOP, black Stayfast		1
	242-197	\$999.99	TOP, tan Stayfast		1
	242-175	\$549.99	TOP, black vinyl	Sprite MkIV, Midget MkIII, 8 Tenax studs 1967-'68	1
	242-176	\$999.99	TOP, black Stayfast		1
	242-177	\$999.99	TOP, tan Stayfast		1
	242-205	\$1,149.00	TOP, black vinyl w/ header rail	Sprite MkIV, Midget MkIII, 1275, Midget 1500, 6 Tenax studs, velcro, 1969 on	1
	242-200	\$539.99	TOP, black vinyl		1
	242-203	\$539.99	TOP, tan vinyl		1
	242-204	\$539.99	TOP, white vinyl		1
	242-201	\$999.99	TOP, black Stayfast		1
	242-202	\$999.99	TOP, tan Stayfast		1
	242-370	\$679.99	TOP, black vinyl, ZW*		1
	242-371	\$679.99	TOP, white vinyl, ZW*		1
	242-372	\$679.99	TOP, tan vinyl, ZW*		1
	242-375	\$1,249.00	TOP, black Stayfast, ZW*		1
	242-376	\$1,249.00	TOP, tan Stayfast, ZW*	1	

*ZW = zippered rear window

2	227-108	\$0.69	SNAP ASSEMBLY, female		A/R
3	227-600	\$11.59	FASTENER, "Tenax" (genuine "Tenax" brand)	Sprite MkIII, Midget MkII 1967-'68	A/R 8
				1969-on	6
4	227-108	\$0.69	SNAP ASSEMBLY, female	Sprite MkIII, Midget MkII	2
5	401-040	\$36.99	BAR, top retaining, rear		1
8	400-695	\$419.99	HEADER RAIL		1
10	406-230	\$79.99	LATCH, header rail		2
11	466-385	\$0.79	BOLT, header rail latches		4
	453-613	\$32.99	TOP SEAL KIT	1964-'80	1
14	406-260	\$1.29	PAD, header rail		2
15	323-635	\$0.34	SCREW		4
16	453-930	\$13.99	RETAINER, header rail seal		1
17	325-288	\$3.49	RIVET SET, 15 pcs., retainer to rail		1
18	453-610	\$9.99	HEADER RAIL SEAL		1
19	408-555	\$3.59	LABEL, header rail	1967-'80	1
20	400-670	\$24.99	RETAINING STRIP		1
21	226-720	\$0.49	SNAP, male		7
22	314-310	\$0.89	SCREW, retaining strip		7



Top Seal Kit

This kit makes it easy for you to replace the header seal which cracks and wears out with time, causing your soft top to leak. The kit includes high quality seal, retainers, and hardware. Includes numbers 14 through 18 shown above.

453-613 \$32.99

STANDARD TERMS AND CONDITIONS OF SALE & LIMITED WARRANTY

Last updated: March 17, 2018

PLEASE READ THE FOLLOWING CAREFULLY. By clicking the button "Agree," or otherwise accessing and using our website, and/or by placing an order with Moss Motors, Ltd. ("Moss," "we," "us" "our"), you acknowledge and represent that you are over 18 and have the legal capacity and authority to enter this Terms and Conditions/Warranty Agreement ("Terms"). These Terms constitute a binding agreement between Moss and you.

1. AGREEMENT TO TERMS AND PRIVACY POLICY

By accessing and continuing to use our Website (<http://mossmotors.com> "Website"), and/or by placing orders with Moss in any other manner, you are agreeing to these Terms including our Privacy Policy ("Privacy Policy", as found immediately following).

2. PRICE

It is Moss' intent that prices in our Catalogues and on our Website are accurate and up to date. However, prices are subject to change without notice. Please inquire about price at the time of purchase.

3. LIMITED WARRANTY

Moss is proud to provide one of the longest warranty in the business. Everything we sell is warranted to be free from defects in material and workmanship for 2 years from the date of invoice, with the exception of all superchargers, supercharger components, and supercharger hardware which carry a 1 year warranty. If the product warranted above fails, within the warranty period, Moss will, at its discretion, repair or replace the product. This warranty does not cover labor, failure of related components, normal wear of brake or clutch components or failure resulting from alteration, misuse, accidental damage, faulty installation, or faulty repair. TO THE FULL EXTENT PERMISSIBLE BY LAW, WE DISCLAIM ALL WARRANTIES, EXPRESS OR IMPLIED, OTHER THAN THOSE EXPRESSLY STATED HEREIN, INCLUDING, BUT NOT LIMITED TO, IMPLIED WARRANTIES OF MERCHANTABILITY AND FITNESS FOR A PARTICULAR PURPOSE. If a product/part fails while under warranty, a warranty request should be submitted to Moss' sales department and must be supported by the original Moss purchase invoice, documentation of the failure and, upon request, return of the defective part.

4. LIMITATIONS OF LIABILITY

It is Moss' intent that the products sold, and services we provide, always function appropriately and no damages result. However, you understood and agree that any damage that may result is expressly limited (A) TO THE MAXIMUM EXTENT PERMITTED BY LAW MOSS, INCLUDING ITS AFFILIATES, EMPLOYEES, OFFICERS, DIRECTORS, CONSULTANTS AND AGENTS, WILL NOT BE LIABLE FOR ANY DIRECT,

INDIRECT, INCIDENTAL OR CONSEQUENTIAL DAMAGE, OR ANY OTHER DAMAGE, LOSS (INCLUDING LOSS OF PROFIT AND LOSS OF DATA), COSTS, EXPENSES AND PAYMENTS, EITHER IN TORT, CONTRACTUAL, OR IN ANY OTHER FORM OF LIABILITY, ARISING FROM, OR IN CONNECTION WITH (I) THE USE OF, OR THE INABILITY TO USE THE WEBSITE; (II) THE FAILURE OF A PRODUCT OR PART SOLD BY MOSS TO YOU; (III) THE INCORRECT INSTALLATION OF A PART/PRODUCT SOLD BY MOSS TO YOU; (IV) ANY FAILURE, ERROR, OR BREAKDOWN IN THE FUNCTION OF THE WEBSITE; AND/OR (V) ANY FAULT, OR ERROR MADE BY OUR STAFF OR ANYONE ACTING ON MOSS' BEHALF; (VI) THE UNAUTHORIZED ACCESS TO OR ALTERATION OF YOUR TRANSMISSIONS OR DATA; OR (VII) STATEMENTS OR CONDUCT OF ANY THIRD PARTY ON THE SERVICE; AND (B) IN NO EVENT SHALL THE AGGREGATE LIABILITY OF MOSS FOR ANY DAMAGES OR LOSSES IN CONNECTION WITH THE SALE OF PART(S)/ PRODUCT(S) EXCEED THE TOTAL AMOUNT OF ANY AMOUNT PAID BY YOU FOR THE PART(S)/ PRODUCT(S).

MOSS MOTORS, LTD. DOES NOT WARRANT THAT ITS WEBSITE OR ANY OF ITS FUNCTIONS, INCLUDING ANY ELECTRONIC COMMUNICATIONS WHICH WE SEND TO YOU, WILL BE UNINTERRUPTED OR ERROR-FREE, THAT DEFECTS WILL BE CORRECTED, OR THAT THIS SITE AND THOSE COMMUNICATIONS, INCLUDING BULLETIN BOARDS, OR THE SERVERS THAT MAKE THESE SERVICES AVAILABLE, ARE FREE OF VIRUSES OR OTHER HARMFUL COMPONENTS. THESE SERVICES ARE MADE AVAILABLE TO YOU ON AN "AS IS" AND "AS AVAILABLE" BASIS AND YOU EXPRESSLY AGREE THAT YOUR USE OF THESE SERVICES IS AT YOUR SOLE RISK.

5. INSTALLATION NOT INCLUDED

Moss is not liable for injury or damage due to incorrect installation or use of their products/parts. All products/parts and are sold with the understanding that the safe and proper installation and use of the products is the customer's responsibility. It is the customer's responsibility to check with their local laws to determine if the product they have purchased from Moss and then installed on their vehicle may or may not be legal. Follow factory workshop manual procedures and instructions, but use current shop safety standards and common sense. Some tasks will require professional advice which Moss does not provide.

6. MODIFICATION OF THESE TERMS

Moss reserves the right, at its discretion, to change these Terms at any time and/or to discontinue any part of the Website. A change to the Terms will be effective (a) ten days following Moss sending a notice to you; or (b) after Moss posts a revised agreement on the Website or in the Catalogue and you subsequently use the Website and/or order a part/product from us.

7. GOVERNING LAW/ VENUE FOR ACTIONS

By ordering parts/products from Moss you agree that (a) all claims arising out of or relating to the transaction will be governed by California Law; (b) all claims arising out of or relating to the transaction shall be brought and litigated exclusively in the Superior Court of the County of Santa Barbara (Anacapa Division), California, USA; and (c) you consent to personal jurisdiction in the previously mentioned court.

8. GENERAL LEGAL TERMS

If any provision, or part of a provision, of these Terms is held to be unenforceable, the rest of the Terms shall remain intact and be construed without the unenforceable such provision, or part of said provision. Moss may provide you with notices, including those regarding changes to the Terms, by email, regular mail, or postings on the Website and in the Catalogue. A waiver of any term or provision of these Terms will be effective only if Moss expressly states in a writing signed by an authorized representative that Moss is waiving that specified term or provision. These Terms and the Privacy Policy represent the complete agreement between you and Moss and supersede all prior agreements and representations related to the subject matter hereof.

PRIVACY POLICY

1. OUR COMMITMENT TO PRIVACY

This notice describes our Privacy Policy. Our privacy policy is designed to advise you about how we collect, use, and protect the personal information you provide. *By using our website or transacting business with us, you consent to the collection and use of your personal information as described in this Privacy Policy.*

2. WHAT INFORMATION IS COLLECTED

(a) **Information You Provide To Us:** We collect any information you enter on our site, or that you give us in any other way. You can choose not to provide certain information, but you may not be able to take advantage of our services and features. (b) **Automatic Information:** When you visit a website, you disclose certain information, such as your Internet Protocol (IP) address and the time of your visit. This site, like many other sites, records this basic information about visits to our site. (c) **"Cookies":** A cookie is a small piece of data that is sent to your browser or mobile device by websites, mobile apps, and advertisements that you access or use. This data is stored on your browser or mobile device and helps website and mobile apps to remember things about you to improve your experience with the website. Most browsers are set up to accept cookies, but you can change your settings to have your browser notify you when you receive a new cookie or to refuse to accept cookies. If you do not wish for cookies to be placed on your computer, most web browsers permit you to prevent that from taking place. However, please keep in mind that these technologies are an important part of how the website works; removing, rejecting or limit-

ing the use of cookies or other similar technologies might affect the availability and functionality of the website. To opt-out of receiving our direct mail or catalogs, you may send us an email at moss.sales@mossmotors.com or call us at 800-689-9313.

3. HOW AND WHEN THE INFORMATION IS USED

The information we collect is used for administering our business activities i.e., collecting your name, mailing address, credit card information, and e-mail address to allow for us to process and fulfill an order you place on our website. Occasionally we may use the information to notify you about changes to our website, new services, or special offers. If you wish to unsubscribe from our email list you may at any time.

4. HOW WE PROTECT YOUR INFORMATION

The privacy and protection of your information is important to us. We do not make any personal information available to third parties without your permission. Your access to some services and content is password protected. We advise that you do not disclose your password to anyone. In addition, we recommend you sign out of password-protected services at the end of your session.

5. WHO HAS ACCESS TO THE INFORMATION

Information about our users is important to us. We will not disclose individually identifiable information to any third party without first receiving that user's permission, except as necessary to fulfill your orders and support our marketing activities including direct mail, e-mail, database cleaning

and maintenance, and analysis. They have access to personal information needed to perform their functions, but may not use it for other purposes. We do not sell, rent or trade our customers' personal information to third parties. We may from time to time contract with third party vendors to provide ads to our customers on our behalf via the Internet or to send direct mail or catalogs to customers whom we think may be interested in our products or services. In order to do so, the vendor may collect anonymous information about your visits to our website using a "cookie". Third-party vendors may then pool the anonymous information that they collect from our website with other sources of information, which may include your name and mailing address, for purposes of determining whether you might be interested in receiving direct mail or a catalog.

6. METHODS WE USE TO PROTECT YOUR INFORMATION

We use security software to protect the confidentiality of your personal information. When you order from us, we offer a secure server. The secure server software (SSL) encrypts all the information you input before it is sent to us. Our system supports up to 128-bit encryption, one of the highest levels available.

7. CHANGES TO PRIVACY POLICY

If our Privacy Policy or procedures change, we will immediately post those changes to our website. Any such changes will be effective immediately upon being posted, unless otherwise stated in the change.

8. EFFECTIVE DATE

This Privacy Policy is effective as of March 17, 2018.

- A**
Accelerator Cable 21
Air Filter
air pump 25
carb. A32, 22-24
Air Horn Kit A25
Alternator 78
conversion A39
Antennae A25
Apparel & Gifts A58-A62
Axle Shafts, rear 41
- B**
Badge Bar & Badges A19
Battery Chargers A55
Bearings
Engine
1500 15
948-1275 10
front axle 44
rear axle 41
Body Panels
Bugeye 52, 54
non-Bugeye 53, 54
Bonnet Straps A25
Books, Manuals, & Videos A45-A46
Brakes A43-A44, 48-51
hoses A44, 50-51
tools A51
Bulb
headlamp 70
instrument 73
tail 71, 72
Bumpers, front & rear 66-67
Bushes, suspension
front A42, 44-45
rear A42, 46
- C**
Cables
accelerator, choke 21
battery/starter 77
speedo, tach 79
Camshafts
1500 15
948-1275 A28, 10
Car Care & Maintenance A53-A57
Car Covers A18
Carburetor Manuals A46
Carburetors
SU A35-A36, 22-23
Weber A35
Zenith-Stromberg 24
Carpet A10, 82
Choke Cable 21
Clutch 34-35
Cockpit Fittings 83
Coil, ignition A38-A39, 76
Condenser, ignition 74
Connecting Rods
1500 15
948-1275 11
Connectors, electrical 73
Conolly Leather Products A47
Cooling System 18-19
Crankshaft
1500 15
948-1275 10
Cup Holders A16
Cylinder Head
948-1275 A31, 12-13
1500 16
- D**
Dash Pad Cover, 1968-80 83
Dashtop Repair Panel A67
Diaphragm
Zenith-Stromberg carb. 24
SU fuel pump 26
Differential 41
Dipstick, engine 6, 8, 14
Distributors A38, 74-75
Door
fittings 68
pillars 52-53
seal 83
skins 52-53
Driving Lamps A22
- E**
E.G.R. Valve 25
Electric Fan Kits A33
Electronic Ignition A38, 74-75
Emission Control 25
Engine Lock Tab Sets 11
Engine Mounts
1500 14
948-1275 7, 9
Engine Performance A28-A42
Exhaust Systems A36, 30-33
- F**
Fan Belts 18-19
Fans, radiator 18-19
Filter
air pump 25
carb. air A35, 22-24
fuel A34
Flasher Unit 77
Floor Mats A13, 83
Floorboards 54
Fog Lamps A22
Front Suspension 44-45
Fuel Pumps A34, 27
Fuel System
Fuse Box / Fuses 77
- G**
Gasket Set
SU carburetor 22-23
Zenith-Stromberg carburetor 24
Gaskets, engine
1500 14, 16
948-1275 6, 8, 12
Gearbox
1500 A40, 40
948-1275 A40, 38-39
Gearshift Knobs A13, 39, 40
Generator 78
Gifts A58-A62
Grille Badges A19
Grilles 59
Grommets 62
- H**
Halfshafts 41
Handbrake 49
Hats A58
Head Rests 87
Headers A36, 30
Headlamps A21, 70
Heaters 20-21
Hinges
door 68
hood 57-58
trunk lid 60
Hood Straps A25
Horns A25, 77
Hub Caps 47
- I**
Ignition System
Inner Tubes A38-A39, 74, 76
A27, 47
- J**
Jack 47
Jack Stowage Bag 46
- K**
Key Blanks A16
Key Fobs A60
Knockoffs A27, 47
hammers A27, 47
- L**
Lamps
license plate 72
dashboard 73
front A21-A23, 70-71
rear A23, 71-73
License Plates A19
frames A19
mounts 57, 67
Lifter
1500 16
948-1275 13
Locking Gas Caps A20
Lowering Springs A42
Luggage Racks A24
- M**
Manifolds 28-29
Mirrors
door & fender A24, 63
windshield 55
Mufflers A36, 30-33
- N**
Needles
SU Carburetor 22-23
Zenith-Stromberg
carburetor 24
Number Plate Mounts 57, 67
- O**
Oil A48
filter
1500 14
948-1275 A30, 7, 9
press./water temp. gauge A15, 79
pump
1500 14
948-1275 7, 9
cooler kit A30
Overrides 56, 66-67
- P**
P.C.V. Valve 25
Paint A50
Panel Kits A9, 82
Patches A61
Pistons
Engine
1500 15
948-1275 10
Rings
1500 15
948-1275 10-11
brake caliper 50
Production Data 3
Pulley
Crankshaft
1500 15
948-1275 10
Pushrods
1500 16
948-1275 13
- R**
Radiators A37, 18-19
Radios A9
Rear Axle 41
Rear Suspension 46
Release Bearing, clutch 34
Ring Gear
1500 15
948-1275 10
Rocker
Arms
1500 A31, 16
948-1275 13
panels 52, 53
Rocker Shaft
1500 16
948-1275 13
Rotor, ignition A41, 74-75
- S**
Seat Components 84-85
Seat Kits/Covers A8, 84-85
Seatbelts A12
Sending Unit, fuel tank 27
Shift Knobs A13, 39, 40
Shock Absorber
front A41, 44
rear A41, 46
Shop Tools & Equipment A51-A55
Signs A62
Slave Cylinder, clutch 35
Sound Deadener A11
Spark Plugs 76
Speedometer Cable 79
Spring, front, coil A42, 44
Spring, rear, leaf A42, 46
Sprockets, timing chain
1500 15
948-1275 A28, 11
Stainless Steel Exhaust A36
Starter Cables 77
Starter 79
Steering Wheels A14, 42
Steering A41, 43
SU Carburetors A35-A36, 22-23
Sun Visors 55
Supercharger A29
Suspension
front A41-A42, 44-45
rear A41-A42, 45
Sway Bar A42
Switches 80-81
Swivel Pin 44
- T**
Tachometer Cable 79
Tappets
1500 16
948-1275 A28, 13
Thermostat A32, 13, 18-19
Tie Rod Ends 43
Timing Chain
1500 15
948-1275 11
Tonneau Covers A17, 86-87
Tools A27, A51-A55
Top Fittings 88
Tops A17, 89
Transmission
1500 40
948-1275 38-39
Trim Rings, wheel A27, 47
- U**
U-Joint, driveshaft 41
Upholstery A8-A10, 82-83
- V**
Vacuum Advance Unit 74-75
Valve
cover plates, 948-1275 12
covers A31
inlet & exhst, 1500 16
inlet & exhst, 948-1275 13
Voltage Regulator 77
- W**
Water Pumps 18-19
Water Temp. & Oil Gauge 80
Weber Carburetors A35
Wheel Cylinders 49
Wheel Tools A27
Wheels
road A26, 47
steering A14, 42
Windows, door 65
Windshield Wipers/Washer 69
Windshield 55
Wire Wheels A26, 47
Wiring Harnesses 73
Wishbones 44

PHONE ORDERS

US 800-667-7872 INTL 805-681-3400

FAX ORDERS

805-692-2525

ONLINE ORDERS

MossMotors.com

CUSTOMER SERVICE

800-689-9313

MOSS



Moss Motors, Ltd.
440 Rutherford Street
Goleta, CA 93117

PRESORTED
STANDARD
U.S. POSTAGE
PAID
MOSS MOTORS,
LTD.

TIMELESS AND TOUGH



WIRE WHEELS

MWS wire wheels are manufactured to a high level of durability for a long life of classic beauty. Chrome finished wheels are first microporous nickel plated for corrosion protection. The spokes and nipples are chrome-plated stainless steel for brightness and longevity. Chrome wire wheels have a two year cosmetic and three year structural warranty.

MWS painted wire wheels are electro coated with primer prior to a silver-gray topcoat which gives the wheel a salt spray resistance of an incredible 840 hours in industry testing. Painted wire wheels have a one year cosmetic and two year structural warranty.

All MWS wheels have silicone sealed nipples at the rim as a water barrier, providing a layer of protection not found on lesser quality wheels.



CHECK OUT THE
MWS WHEELS ON
PAGE A26 >>>

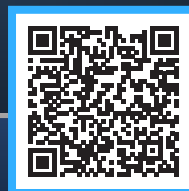

Shop MWS Wheels online at MossMotors.com >>>