

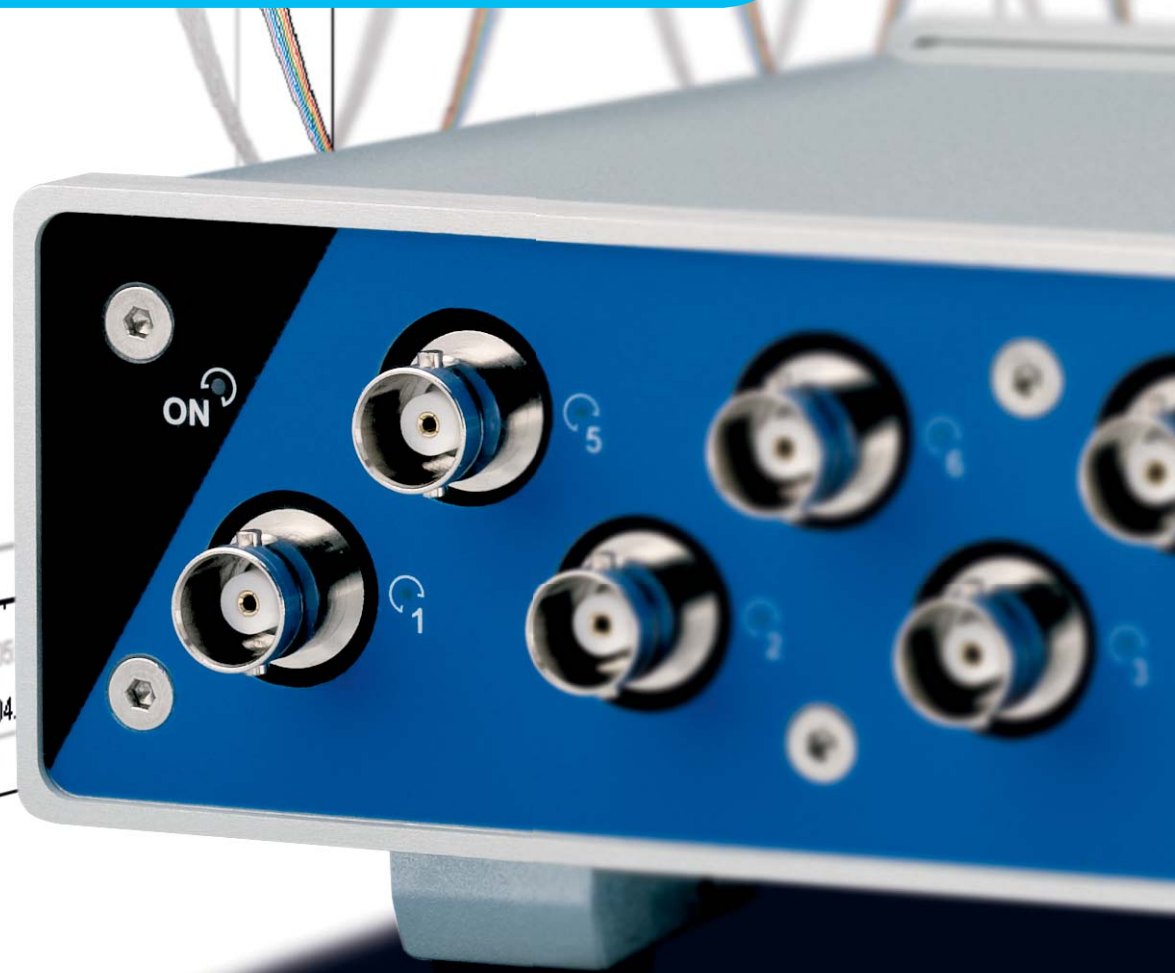

INTERNATIONAL

[www.mpihome.com](http://www.mpihome.com)

# Test and Measurement Solutions



**Vibration Testing**  
**Noise and Vibration Analysis**  
**Data Acquisition**

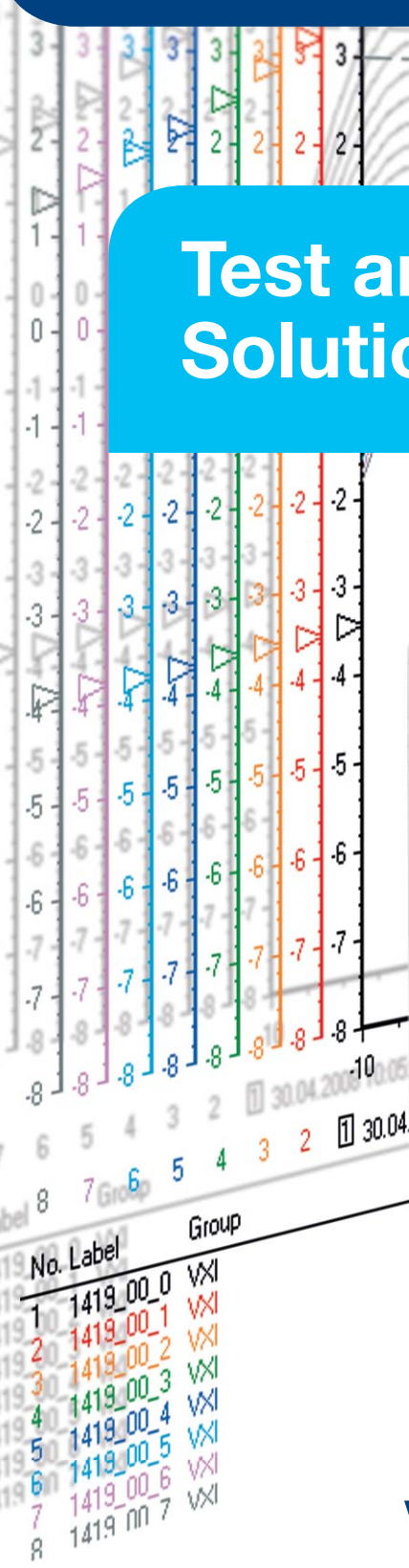

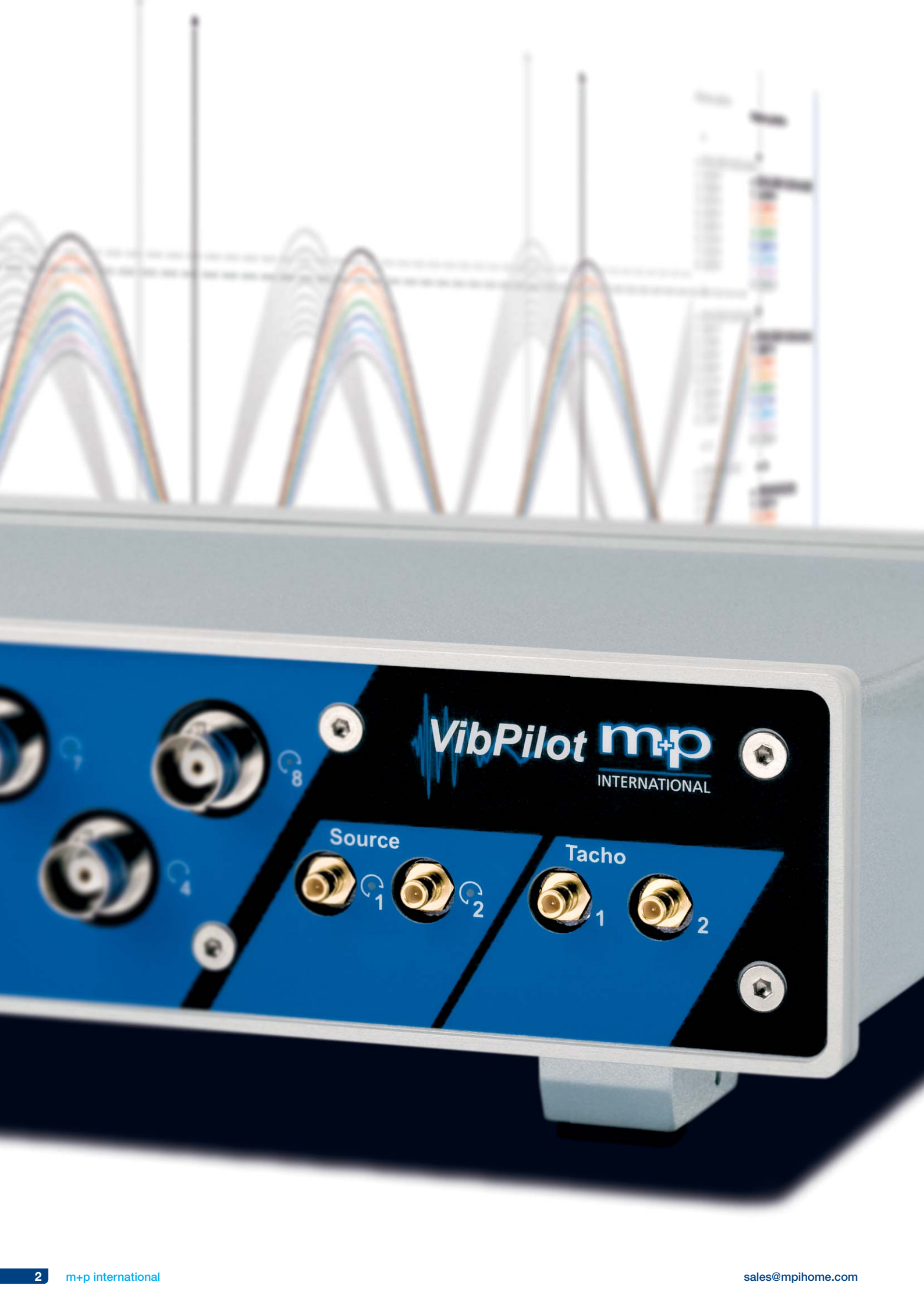

# CONTENTS

<b>OUR PROFILE</b>	4
<b>APPLICATIONS</b>	6
<b>VIBRATION TESTING</b>	8
• Vibration Control	10
• Data Reduction and Throughput to Disc	18
• Multi-Axis Vibration Control	20
• Acoustic Control in Reverberant Chambers	22
• Complete Test Stands	24
• Ordering Information	26
<b>NOISE AND VIBRATION ANALYSIS</b>	28
• Dynamic Signal Analyzers	30
• Structural Acquisition and Analysis	36
• Rotational Dynamics Acquisition and Analysis	40
• Acoustic Analysis	42
• Environmental Vibration Testing	44
• Vehicle Pass-by Noise Testing	46
• Ordering Information	48
<b>DATA ACQUISITION</b>	50
• Continuous Data Acquisition, Signal Analysis and Process Monitoring	52
• Ordering Information	57
<b>TEST STAND ENGINEERING</b>	58
<b>MEASUREMENT HARDWARE</b>	64
• Compact 4/8-Channel Front-End	68
• High-Channel Count Hardware Platform for Standalone and Rack-Mounted Use	72
• Ordering Information	76
<b>THIRD-PARTY MEASUREMENT HARDWARE</b>	78
• National Instruments	78
• VTI Instruments	79
• United Electronic Industries	79
<b>SERVICES AND SUPPORT</b>	80
<b>REFERENCES</b>	82
<b>CONTACT</b>	84



# OUR PROFILE



Photo courtesy of Siemens AG, Germany



m+p international is well-known as a worldwide provider of top-level test and measurement solutions. All the products in this new Product Guide are the result of more than 30 years' expertise and experience in vibration testing, structural analysis, process monitoring and test stand engineering.

By working closely with our customers, we understand their applications from an engineer's point of view and this is apparent in our products. A policy of continuous research and development, which has led to many pioneering solutions, ensures that our products demonstrate superior performance and quality.

Our mission is to offer solutions which perfectly support you in the increasingly challenging test, measurement and analysis tasks you encounter in the field, lab, or production plant. Performance, reliability, longevity, time to market, cost of ownership – these, among others, are important criteria for evaluating the results of your design or production process. We are proud that so many organizations in the automotive, aerospace, electronics and other high-tech industries use our products and trust in m+p international to obtain top quality results.

The Product Guide gives you an excellent overview of our current range. Features, performance and the range of applications are carefully described. New products will be added on a regular basis. If you have any questions or requirements, or simply need advice, please contact us, we'll be happy to help – remember “m+p international listens to customers ...”.



Dr.-Ing. Walter Klie, Managing Director

### Vibration Control

Sophisticated vibration testing procedures are needed to simulate accurately the toughest operating environments. Product designers and test engineers throughout the world count on m+p international's solutions for reliable vibration control, data reduction and acoustic control, from entry-level to high-channel count systems.

### Noise and Vibration Analysis

m+p international provides a family of highly accurate dynamic signal analyzers that can be operational in a matter of minutes to acquire, analyze and report the most complex noise and vibration data requirements in the field and the laboratory.

### Data Acquisition

A specialized engineering team will select, integrate and support the appropriate data acquisition or process monitoring solution to meet the needs of your application. Our fully featured software platform supports a range of USB, Ethernet, LXIbus and VXIbus-based instruments to cover a wide variety of measurement tasks.

### Test Stand Engineering

m+p international has been supplying custom-made solutions for functional test stands across a wide range of industries. Many renowned companies appreciate our broad engineering experience, the reliability and performance of our products, and the close co-operation of our engineers.

# APPLICATIONS



## Automotive

To stay competitive, today's car manufacturers need to produce new or improved models much faster than before. The trend towards mass customization forces engineers to design and develop a large number of vehicle variants while at the same time meeting demands for improved quality, durability, occupant safety, ride comfort and fuel efficiency. m+p international has built strong, longstanding relationships with the automotive industry and its suppliers. We support engineering teams in the following areas:

- Vibration testing on shakers
- Road load simulation
- Dynamic measurements and vibration analysis
- Modal analysis and impact testing
- Rotating machinery diagnostics
- Acoustic analysis and sound quality
- Hand-arm and whole body vibrations
- Strain gauge measurements
- Pass-by noise testing
- High-frequency vibration test stands using piezoelectric shakers
- Customized solutions and test stands



## Aerospace

The high-tech aerospace industry is faced with the challenge of ever-shortening design and development times for products that must be safe, enduring, comfortable and economical and meet stringent environmental demands. Testing is an essential part of the development stage: spacecraft, aircraft wing or satellite tests must be completed successfully and the data stored securely for future use. m+p international has worked closely for many years with aerospace engineering companies throughout the world to assure the highest quality for their products. Our advanced solutions include:

- Dynamic testing and vibration analysis
- Vibration testing on shakers, force limited vibration testing
- Structural and modal testing
- Rotating machinery diagnostics
- Strain gauge measurements
- Acoustic analysis
- Ground vibration testing
- Acoustic control in a reverberant chamber
- Customized solutions and test stands

Photo courtesy of NASA Jet Propulsion Laboratory, USA



## Defence

Defence research and design teams develop systems and components which must be extremely reliable, safe, highly accurate and easy to operate. For armoured vehicles, for example, the performance and quality are crucial, but ride comfort is also an important factor. In some cases the materials to be tested are highly dangerous.

m+p international provides high-quality, state-of-the-art vibration control, noise and vibration measurement and analysis systems for military equipment, where the instrumentation and vehicles often operate under extreme conditions. Tests are performed on individual components and, in the final development stage, on the whole system. We help companies to get this right first time. For special requirements, customized solutions can be provided.



## Electronics

The electronics sector continues to grow rapidly and influences our daily lives to a degree unthinkable just a decade ago. It is vital for manufacturers of devices such as smartphones, laptops, tablets, music players, cameras, camcorders, navigation systems, etc. to develop state-of-the-art, trendy products more and more rapidly.

As electronics products become increasingly more powerful and complex, the functionality must be thoroughly tested before product launch. m+p international matches today's needs for reliable testing in a very limited timeframe by supplying high-performance and user-friendly test and analysis equipment for:

- Vibration testing on a shaker
- Shock and drop testing
- Dynamic testing
- Acoustic analysis and sound quality



Photo courtesy of Fujitsu, Germany

## Energy & Process

m+p international has developed sophisticated, high-precision dynamic measurement products for the energy sector including renewable energy, nuclear and turbomachinery. For wind turbine testing, m+p international provides highly accurate, integrated test, analysis, data storage and reporting capabilities for every stage from design and development to manufacturing and operating. m+p's products help to optimize efficiency and energy output and to minimize expensive downtime and repairs during operation. For monitoring product quality or real-time process monitoring, we supply full-featured, easy-to-operate data acquisition products that deliver precise, repeatable results. Our measurement technology ensures reliable results in the following areas:

- Continuous data acquisition and signal analysis
- Noise and vibration analysis
- Structural testing and modal analysis
- Performance and functional testing
- Multi-axis strain and stress analyses
- Real-time process monitoring
- Vibration testing on a shaker
- Customized solutions and test stands



## Test Houses

Independent test laboratories have to offer a wide range of test functionality in order to satisfy the requirements of many end-user industries, each with their own standards and test specifications. Their customers also demand the highest levels of test safety and reliability to protect their valuable products under test. To provide an efficient service it is also important that once tests are complete reports can be quickly generated to provide proof of testing and any other data required. m+p international is able to offer all these capabilities and has become the industry standard for the world's best known test houses. Our activities include:

- Environmental simulation using vibration and shock testing
- Multichannel FFT data acquisition
- Structural testing and modal analysis
- Rotating machinery diagnostics
- Noise analysis



Photo courtesy of Stirling Dynamics, United Kingdom

## Universities and Research

Universities worldwide benefit from m+p international's innovative test and measurement technology. Our high-quality products for structural dynamics testing, vibration testing and data acquisition are used by leading university engineering and research departments. We have successfully collaborated on many academic projects.



# VIBRATION TESTING





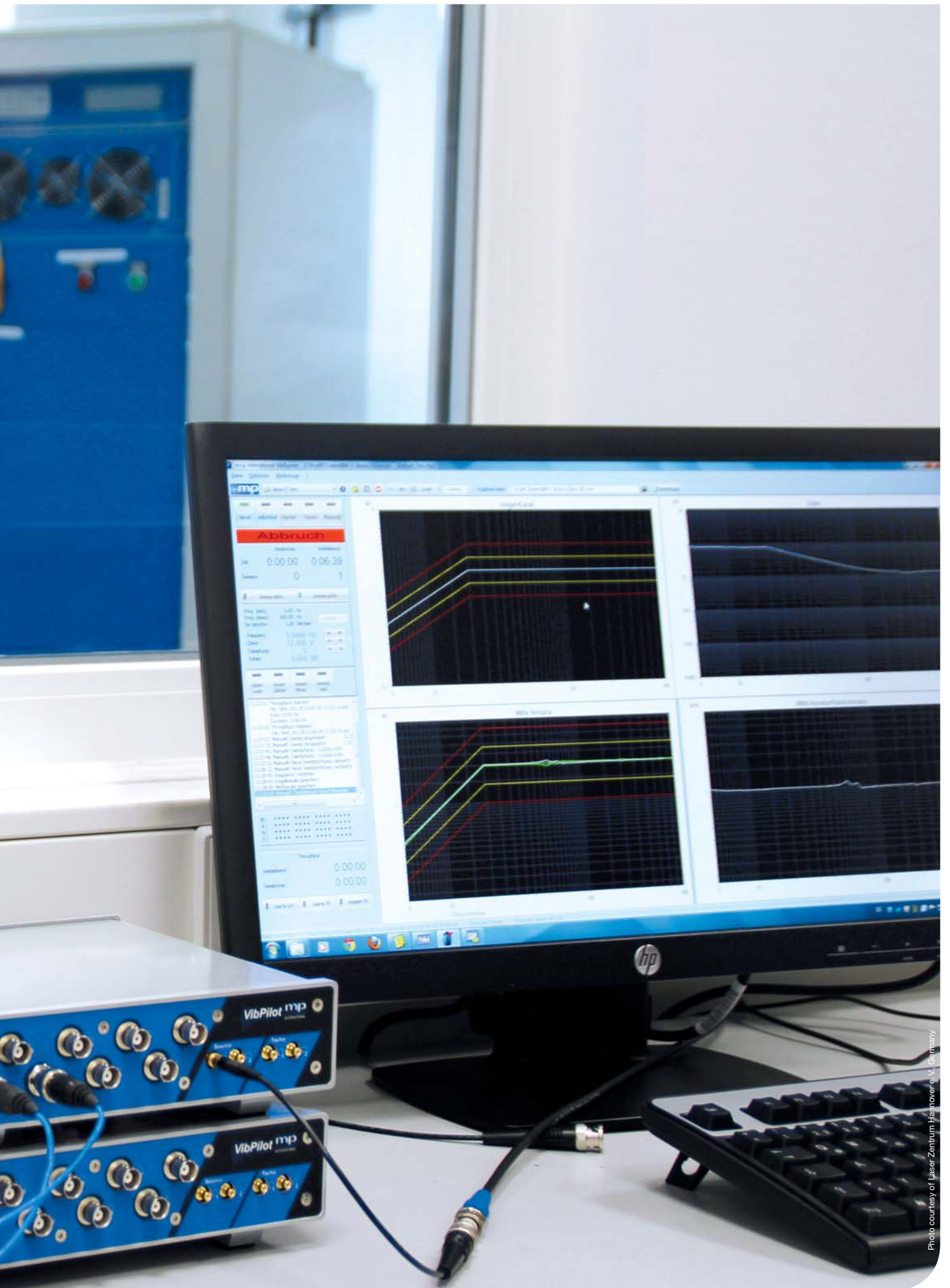

Photo courtesy of Laser Zentrum Hannover e.V., Germany



# Vibration Control





## YOUR BENEFITS

- Full range of excitation modes available from simple ESS random to mixed mode testing, drop table capture and unlimited time data replication to tackle the widest range of applications
- Compliant with all relevant industrial standards (MIL-STD 810, DIN EN 60068, et al.)
- Full test item protection during closed-loop control gives you confidence in the system
- All current Microsoft Windows (32-/64-bit) operating systems supported
- True multi-tasking for maximum test efficiency and safety
- Scalable software and hardware from 4 to 256 channels with the same user interface and the same functionality to simplify upgrading and data sharing
- Time domain displays and data storage for all excitation modes
- Notching for sine and random minimizes over-testing
- Multi-monitor support for rapid monitoring of high channel counts
- Automated and customizable report generation
- Test schedules and external hardware control with digital I/O
- Selectable user interface languages

The m+p VibControl products for advanced vibration and shock testing from four to hundreds of input channels are used by many of the leading environmental test laboratories throughout the world. End users appreciate the simple operation, extensive analysis and reporting functions, and powerful upgrade possibilities, as well as the excellent stability and high quality of the systems.

In cooperation with renowned partners, m+p international provides complete vibration test systems including shaker and accessories as well as combined climatic and vibration test stands.



Detecting unwanted rattles

## Future-Proof Software and Hardware

Thanks to the modular design of software and hardware, m+p VibControl can be configured and expanded at any time to tackle other vibration tasks and higher channel counts. Software upgrades are possible for all test modes, including special post-processing functions, automatic test sequencing, etc.

m+p international regularly adds enhancements to its m+p VibControl software. These software revisions ensure that you always benefit from the latest technology, helping to increase testing efficiency.

Our systems are based on state-of-the-art, high-precision measurement hardware ensuring long-term support and system longevity. What if you want to replace the measurement front-end you have used for many years with the latest hardware technology? No problem, we will equip your m+p vibration controller with the desired measurement hardware without making changes to the familiar user interface.



m+p measurement hardware from 4 to hundreds of input channels

### Common User Interface

All m+p VibControl systems, whatever the channel count, are controlled by the same proven Microsoft Windows-based software. A single interface with the same look and feel means that test specifications can be transferred from engineering to production without change or error and test data can be compared directly between one system and another. Common reporting formats improve communication and data can easily be shared over a network and accessed from anywhere.

This makes intra- and inter-company data sharing simple and straightforward and improves productivity. Since the user interface is common across the whole platform, features typically integrated in high-end systems (e.g. notching in sine and random test mode) are also available for low-channel count system configurations.

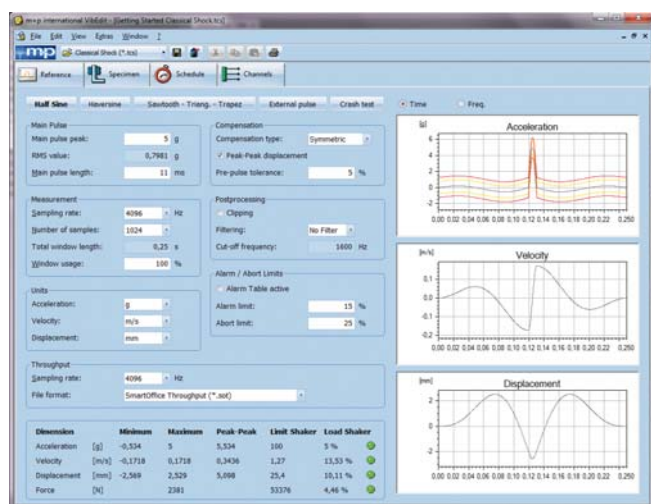

Single interface from four to high-channel count vibration control systems simplifies communication and data sharing

The m+p VibControl solutions for data reduction with/without time history recording to throughput disc and acoustic testing in a reverberant chamber are based on the same user interface and hardware platform as the shaker control systems. Therefore they can be configured for different applications simply by adding software modules, significantly reducing purchase costs and operator training.

### Test Item Protection and Safety

Protecting your valuable unit under test is our top priority. Our software and hardware utilize many safety features to ensure reliable closed-loop vibration control – from pre-test checks to abort checking, notching and controlled shutdown.

The self-check function is an extremely powerful tool for detecting possible set-up problems before your test is started. During closed-loop control the m+p VibControl software performs RMS and line-by-line abort checks, sigma clipping and drive limitation and continuously checks for open channels and overloads. Notching limits the upper vibration level on any number of control or measurement channels, thus minimizing over-testing of the structure. m+p international’s hardware ensures rapid, safe shutdown under any circumstances.

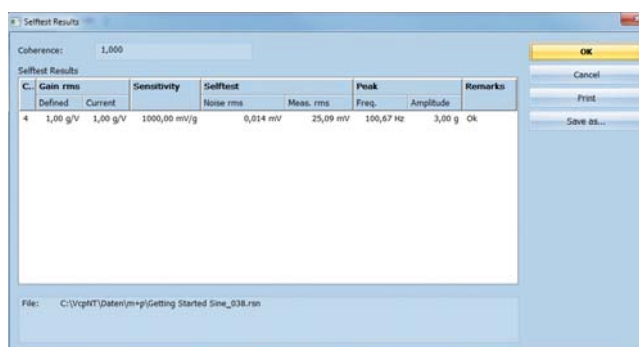

The self-check results indicate that the test was properly configured

### True Multi-Tasking

Since the real-time measurement and control processes are independent of the workstation, you can utilize all the capabilities of the host computer, e.g., generate and print out a test report or set up a new test while the front-end performs the measurement and vibration control tasks.

This multi-tasking concept not only guarantees powerful and time-efficient vibration testing even with time-critical tests but is also an important safety feature, as any unwanted computer command or failure cannot affect the vibration controller.

**“We selected m+p international following the good experience of other Continental Automotive Labs and also because the technical specification of the controller completely matched our needs. I’d also like to commend the very good support we received from them.”**

Christian Tibke, Group Leader Qualification Laboratory at Continental Automotive, Timisoara, Romania



### Automated Functional and Climatic Testing

With the m+p VibUtil module, our vibration controllers offer a versatile tool for automated vibration testing and combined climatic and functional testing. m+p VibUtil easily combines individual vibration tests of identical or different test modes in any complexity of nested loops.

When the system is left unattended, e.g. for an overnight or weekend run, you still remain in control. Test status reports can be sent via email or SMS text message to your mobile phone, enabling you to decide whether to return to work or not within minutes of the test stopping. A protocol file documenting the most important test events is attached to each email.

m+p VibUtil can be easily extended to include eight digital input channels and eight digital output channels which



Always in control: Test status report via SMS text message

provide links to external equipment such as environmental chambers for combined testing. You can also automatically control the power amplifier, i.e., shut it down at the test end and switch it on when a new vibration test is to be started.

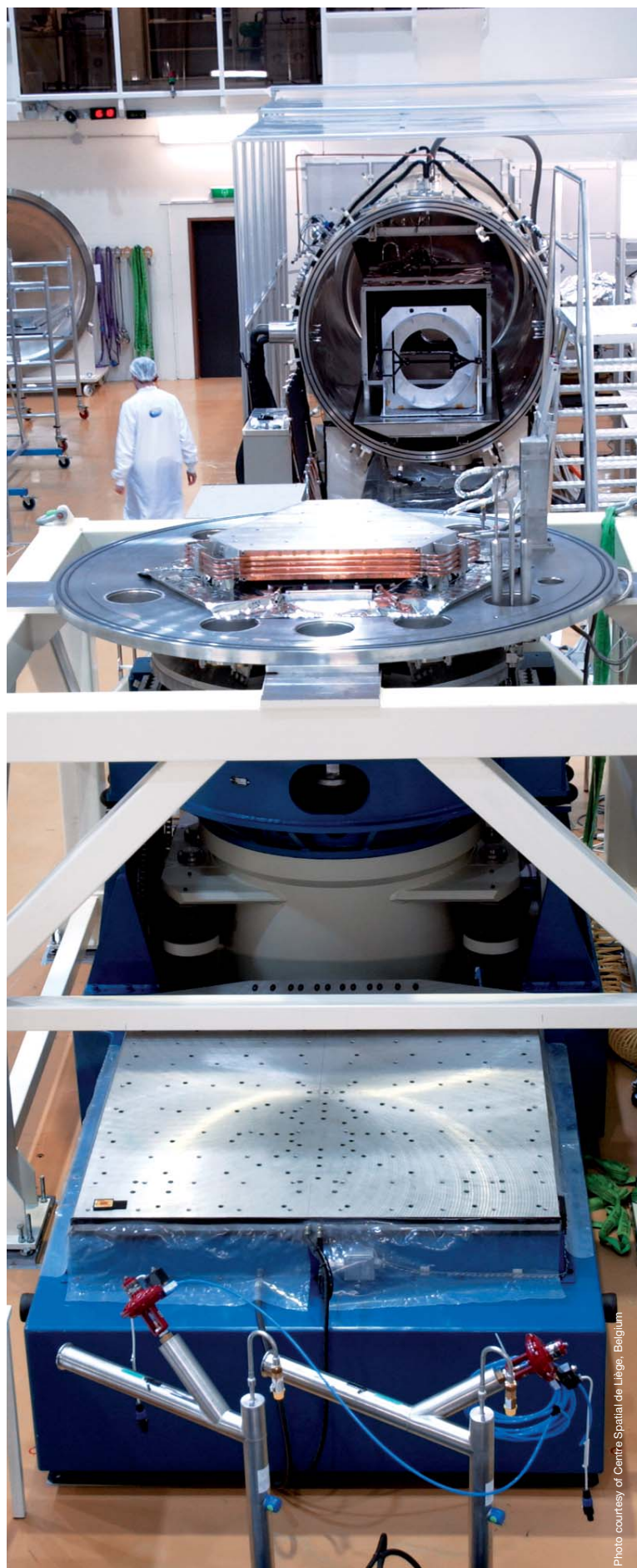

Reliable, high-speed multi-channel vibration controller for spacecraft testing



Setting up a random test

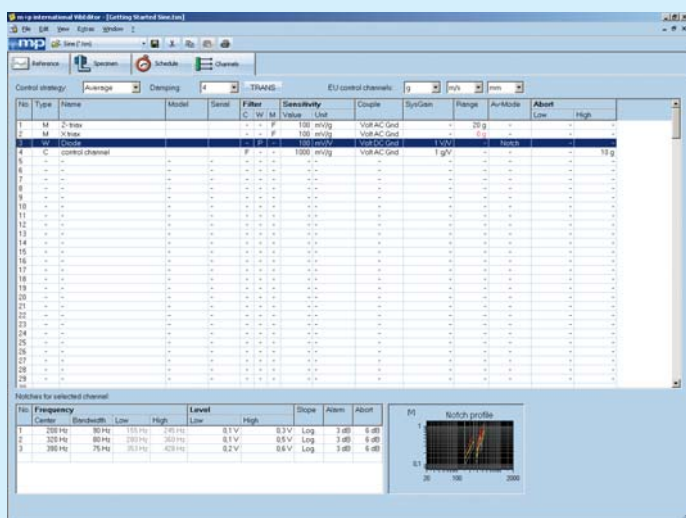

Notching on defined channels to protect against over-testing

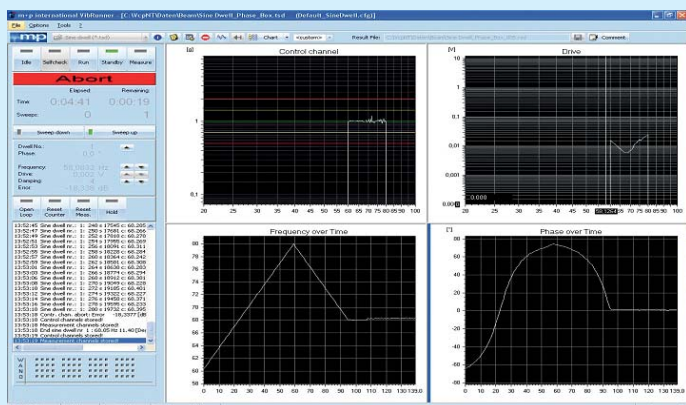

Sine dwell test run with frequency/phase over time charts

### Multi-Screen Support

The highly flexible online display capabilities are expandable, thus making monitoring of high-channel count systems quicker and easier. Operators can open up to 16 online graphics windows on a single monitor to display 64 channels and see all the necessary information at a glance. The function also allows for remote shadow monitoring of the test. This enables customers to observe the channel information on remote PCs without any measurement hardware connected. If you need to observe more than 64 channels, simply use the multi-screen option. A system can be configured with the multi-screen module and a dual or quad graphics card for support of up to four monitors and 256 channels; if required, even more monitors are supported. Channel layouts for each monitor can be set up and stored for quick access.

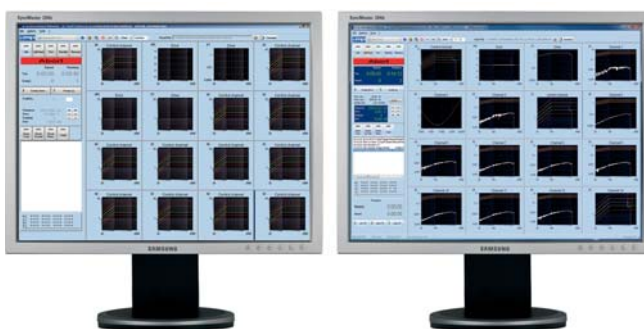

Displaying 32 online graphics windows on two screens

### Remote Client

The m+p VibControl systems can also provide an optional remote client licence which is invaluable to many operators. Often a controller is crowded by engineers trying to view a vibration test during the test run. This is not only a disturbance for operators, it can also lead to mistakes as they might be distracted by questions, requests, etc. However with the remote client, live data can be viewed during an actual test via network or wireless network on a tablet or desktop PC in an entirely different area. The licence allows full m+p VibControl functionality except running the test.

### Excitation Modes

m+p VibControl supports all control modes used in today's vibration testing – everything from simple ESS random to mixed mode gunfire, drop table capture and unlimited time data replication. All tests are fully compliant with ISO, DIN, MIL-STD 810 and many other standards. In sine and random modes, you can designate all input channels as control, watchdog and/or measurement channels. DC signals can be measured and monitored for functional testing in all test modes.



**Random incl. Notching/Force Limiting**

Resolution up to 25,600 lines, selectable in 8 steps. Frequency range up to 12.8 kHz or 40 kHz, hardware dependent. Control strategies: average, maximum or minimum. Frequencies or frequency bands can be defined where limiters take control if the response vibrations exceed a predetermined limit.

**Sine incl. Notching/Force Limiting**

Frequency range up to 20 kHz or 40 kHz, hardware dependent. Measurement filters: RMS, peak, averaged or digital tracking filter. Control on acceleration, velocity, displacement and force.

**Sine Resonance Search & Dwell**

Control criteria: fixed frequency, fixed phase, defined phase, auto phase, peak amplitude.

**Sine Displacement and Velocity Control**

For sine testing starting at very low frequencies, displacement transducers can be used. At a defined frequency, the control changes automatically from a displacement transducer to an accelerometer.

**Shock Classical**

Reference waveforms: half-sine, haversine, sawtooth, triangle, rectangle, trapezoid. Alarm limits as per MIL-STD 810, DIN, GAM-EG 13 and user-defined. Peak-to-peak displacement to guarantee the best shaker performance.

**Shock Response Spectrum (SRS)**

Frequency range up to 20 kHz. Calculation of maximum, positive and negative SRS. Automatic SRS optimization. Wavelets and damped sine components. 1/1-1/24 octave analysis.

**External Pulse**

Import of ASCII data for replication with pulse editor. Synthesis of any pulse form. Kinematic compensation for minimum shaker displacement.

**Sine-on-Random (SoR)**

Up to 10 independently sweeping sine tones are overlaid onto a random background. Sine tones and broadband random signal are generated separately. Gunfire burst simulation.

**Random-on-Random (RoR)**

Up to 25 independently sweeping narrowband random signals are overlaid onto a random background. Each narrowband has its own profile and limits.

**Sine-on-Random-on-Random (SoRoR)**

Sine-on-random is combined with random-on-random.

**Multi-Sine Excitation**

Simultaneously sweeping up to 10 sine tones at different levels across the desired frequency range using different levels and profiles. Also known as “no random option for mixed mode”.

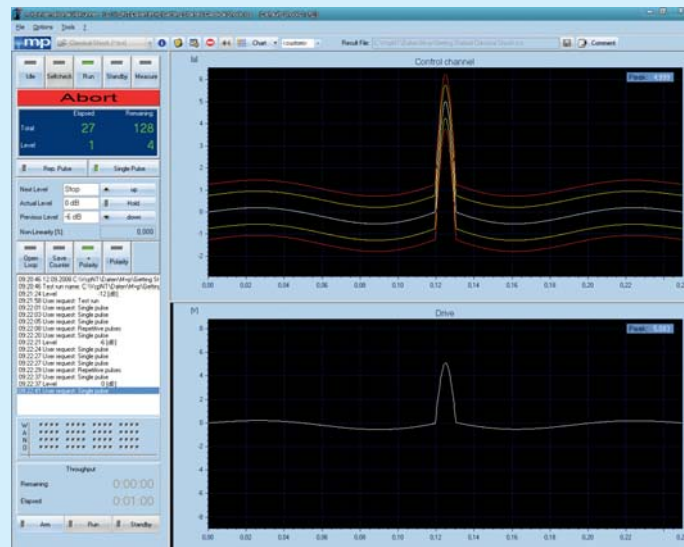

Classical shock test run

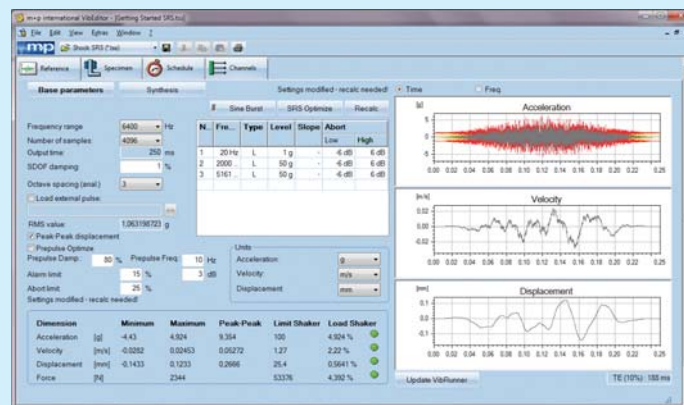

Setting up a shock response spectrum (SRS) test

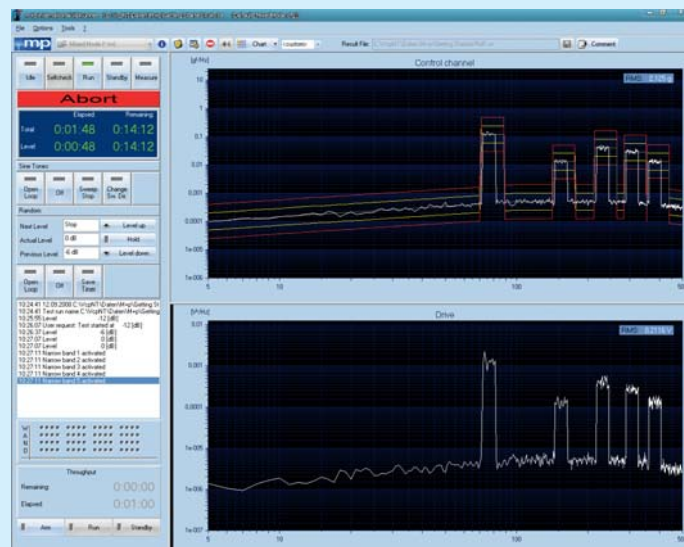

Mixed mode testing: the ultimate in vibration control



Road load simulation provides an easy way to transfer data from the true environment to the test lab for reproduction on the shaker table

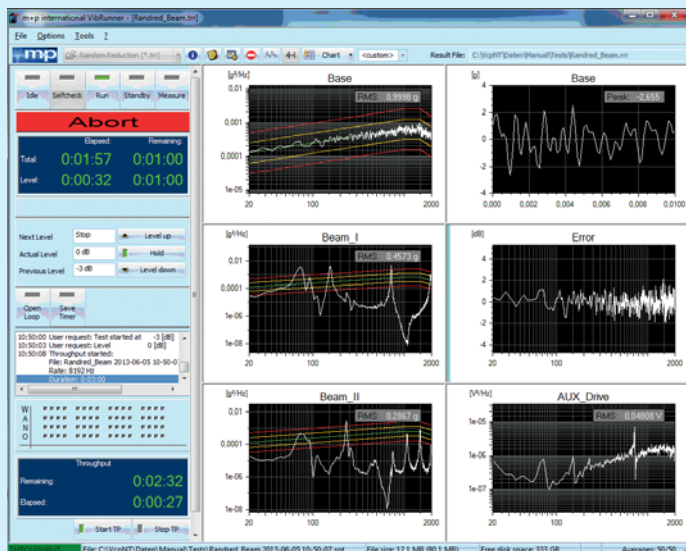

Online random data reduction with throughput to disc recording



Testing engine cooling modules on a long-stroke shaker

**Time Domain Replication (e.g. Road Load Simulation)**

Complete solution for the transfer of data from the true environment to the vibration test lab. Unlimited time data replication. Continuous closed-loop control.

**Time History Recording to Throughput Disc**

For the most critical tests time sample data can be recorded in parallel to control with no reduction in control performance. Complete time domain history is available, recorded with high sample rate. This facility is also available in recorder modes without closed loop control. Post-analysis of the time history data is possible using the Sine and Random Data Reduction modules with the benefit of using the same familiar user interface. Data can be exported for analysis to m+p SO Analyzer package or other advanced analysis systems.

**Data Reduction Modes**

**Random Data Reduction**

Online analysis of measured data or taped random data (PSD averaging). Measured data can be recorded on throughput disc.

**Sine Data Reduction**

Track and online analysis of measured data or taped swept sine data using a COLA signal. Time data can be recorded on a throughput disc.

**Transient Capture**

Capture of transient signals such as drop table or pyroshock pulses with calculation and overlay of SRS or classical shock limits. For applications with high “g” hammer/tap impact. Scope function. Various triggers. Measured data can be recorded on throughput disc.



## Analysis

m+p VibControl's post-testing includes extensive data handling, advanced cursor functions, single and multiple data graphing, peak search, mathematical functions, and transfer function analysis, as well as displaying and printing traces from different sources in a single window.

### Transfer function and transmissibility

Linking the behaviour of control and measurement channels in the test run.

### Mathematical functions

Converting the measured acceleration signal into velocity and displacement, or vice versa (sine and random test mode).

### Automatic peak search

Peak values will be marked automatically in the graphics and listed with their numerical data in a table, single or multiple plots. Q-factor calculation in sine.

### Graphical and numerical measurement and reference data analysis

- Control and response spectra with reference, alarm, abort and notch limits
- Error
- Drive
- FFT amplitude and phase in sine and random
- Coherence in random

### Printouts

- Multiplot: Displaying and printing traces from different test types, several test runs or multiple test specimens in one graphic window.
- Autoplot: Automatically printing a preselected series of graphics.
- Printing a list of preselected test parameters.
- Printing directly to MS Word using a customer-defined template.

## Reporting

The presentation of the test results is as important as a successful test completion. The m+p vibration controllers are perfectly positioned to meet the most demanding requirements. The reports are generated online while running a test or upon test completion. User comments, company logos and graph markers can all be added to create a complete report-ready display. Data and graphics are copied and pasted to standard Microsoft Windows applications such as Word and Excel and can be exported into Universal File Format. The ultimate step in electronic report generation is using the m+p eReporter software package to which the m+p VibControl data can be directly exported.

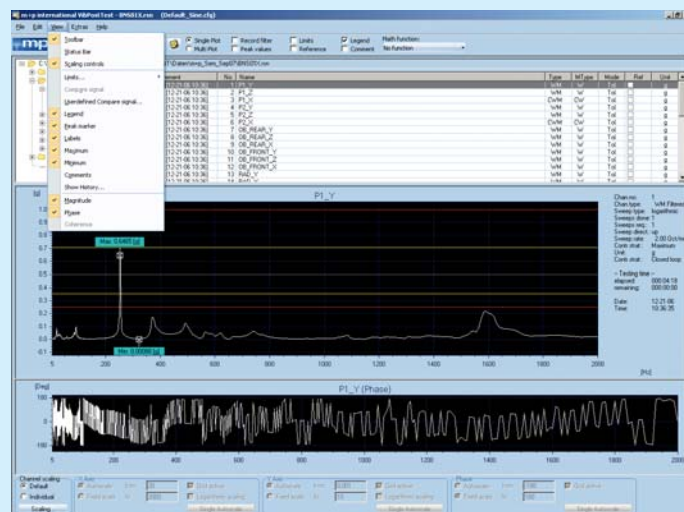

Comprehensive analysis functions

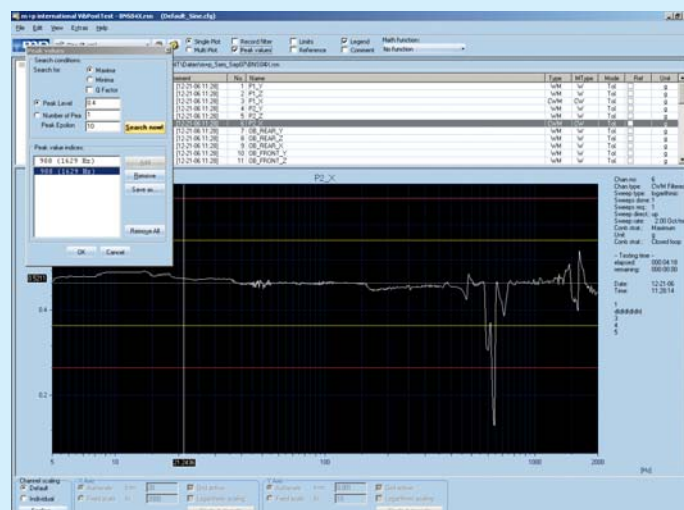

Automatic display of peak values



Multiplot with data from different result files



# Data Reduction and Throughput to Disc

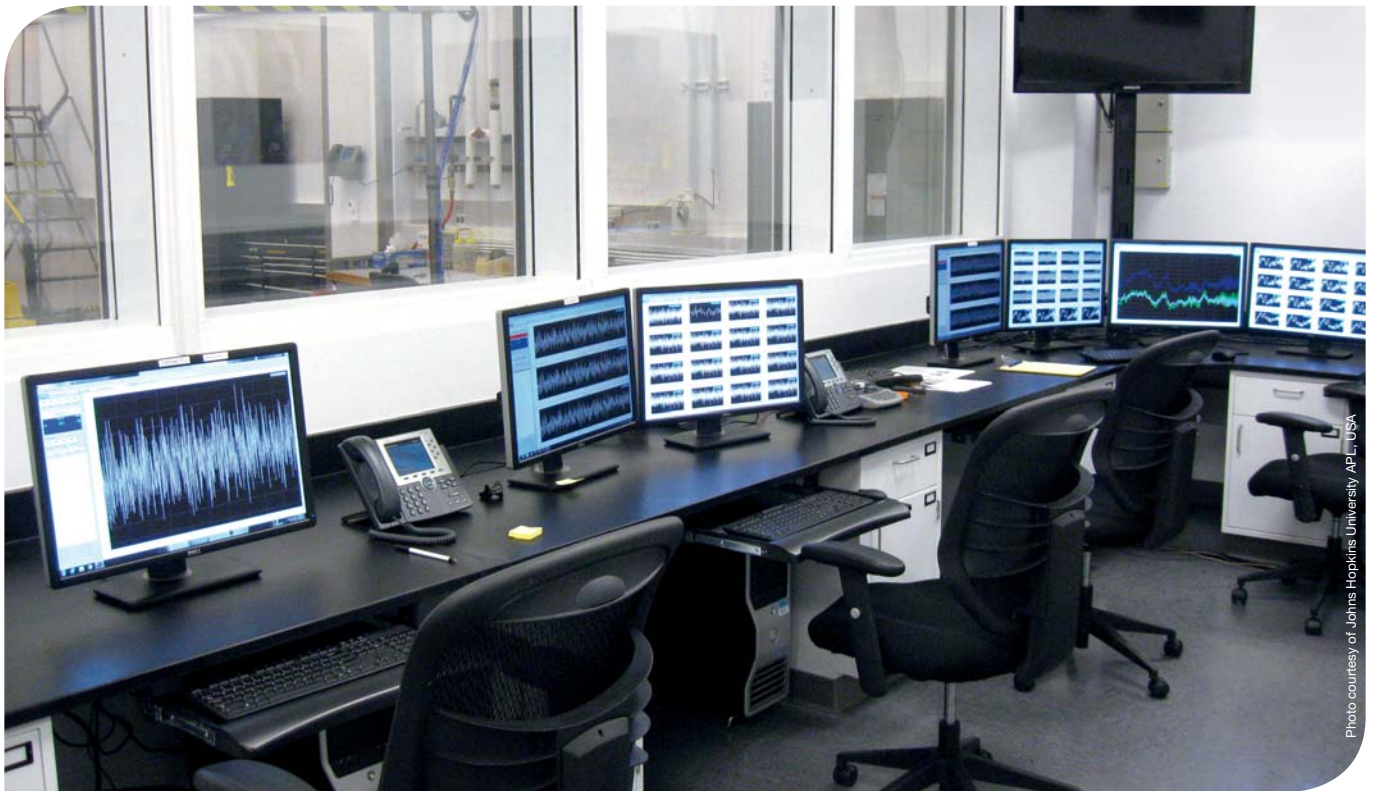

Photo courtesy of Johns Hopkins University, AP, USA

High-channel count data acquisition and vibration control system for large-scale spacecraft testing

## Data Reduction for High-Channel Count Systems

Data reduction systems with or without time history recording are frequently used in critical aerospace testing applications where complete measurements of a high number of channels are required for post-test and possible failure analysis. The m+p VibControl data reduction system configurations are tailored to the specific needs of high-performance measurement applications requiring hundreds or thousands of input channels.

The online analysis and display functions give a fast overview of the test results during the test or when stored data are replayed. Advanced data analysis tools include the m+p SO Analyzer post-processing software for random, sine, shock and acoustic data, providing seamless integration with Microsoft Office products for comprehensive test reporting.

Data formats and data plots of the m+p VibControl data reduction and vibration control systems are the same allowing for a common reporting environment.

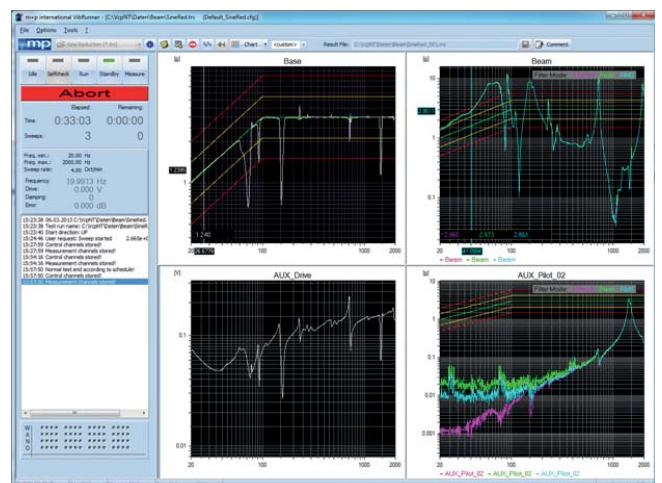

Online data reduction during closed-loop sine vibration test

## YOUR BENEFITS

- Online data reduction for sine/random/transient capture testing
- Fully replaces tape recorder
- Time history recording to throughput disc in parallel with data reduction
- Instant online results
- Common hardware platform and user interface with m+p's vibration control system minimize test costs and maximize test efficiencies
- Scalable hardware from 4 to 1,280 channels
- Post-test tools including file format conversion and data export
- Advanced analysis functions such as FFT calculations and octave analysis using m+p SO Analyzer software
- Common data and plot formats of m+p VibControl data reduction and vibration control systems for transparent test reporting
- Multi-monitor support enables easy online monitoring of high channel counts
- High sample rates for time domain data storage: up to 32,768 Hz for sine and random and 102.4 kHz for transient capture (per channel)

### Gap-Free Time History Recording during Vibration Control

For the most critical tests time history data can be recorded in parallel with vibration control with no reduction in control performance. This facility is also available in recorder modes without closed loop control. The real-time throughput data capture function allows you to record all selected channels continuously in the time domain on the embedded data server ("throughput to disc") irrespective of the channel count and the frequency range utilized. This means that you can always access all the original data for analysis purposes.

One method which is still widely used consists of the time data recording of a vibration test to a second measurement acquisition system in parallel with the usual frequency data recording. This results in additional costs for hardware and more complex system operation. Using m+p international's throughput function simplifies the process and, in addition, you can easily post-process the recorded time data after the test run. The throughput function can be started and stopped independently of the vibration control process. The time data are analyzed using the data reduction software.

*With data reduction, throughput data capture and vibration control running in parallel in one m+p VibControl system, laboratories can reduce their test costs and operator training significantly.*

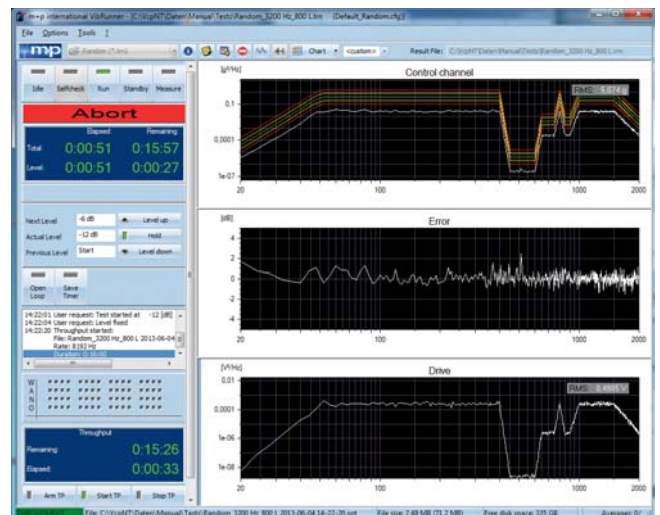

Parallel time data recording and random vibration testing

Time history recording in parallel to multi-channel vibration control for MicroSat satellite testing

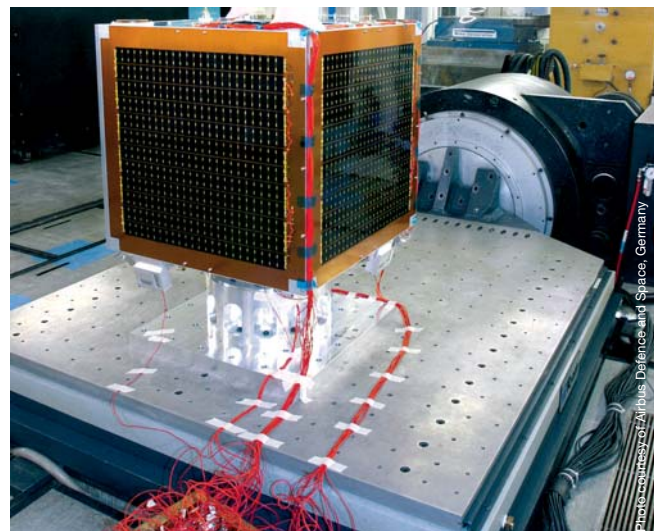



# Multi-Axis Vibration Control



Multi-axis vibration testing



Photo courtesy of German Aerospace Center (DLR), Germany

Multi-axis random testing

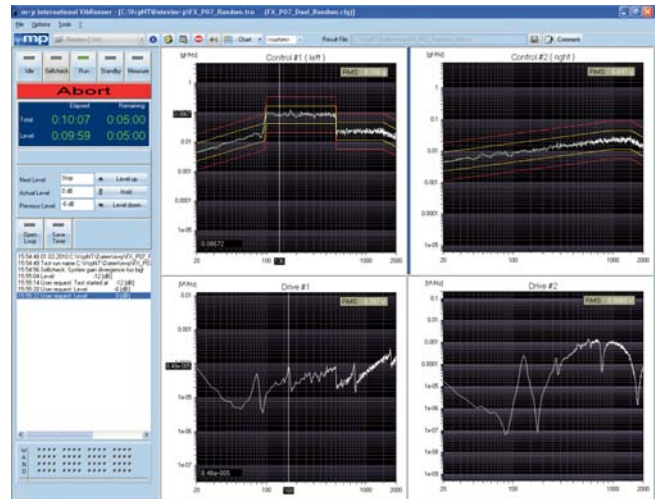



## YOUR BENEFITS

- Test modes: random, sine, shock including SRS, time domain replication (road load simulation)
- Control using unique vibration profiles for each shaker
- Combine multiple vibration profiles and excite all frequencies at the same time using true random
- Reproduce measured time histories at each load input
- True multi-tasking without loss of real-time control increases test efficiencies
- Cross-coupling compensation of dynamic responses from multiple shakers
- Pre-test verification of shaker limits and loop checks for safe testing
- Alarm/abort profile checks to protect from over-testing
- Test sequencing for automated long-term durability testing
- Powerful eReporter analysis tool for browsing, viewing, editing, analyzing and reporting data
- Easy-to-use GUI with familiar Microsoft Windows style
- Up to 16 online graphics windows on a single monitor to display 64 channels
- Seamless import/export of test results into Microsoft Windows applications makes plenty of analysis options available

Simulating the real-world vibration environment for a structure in the laboratory is complex and sometimes requires simultaneous force inputs along several axes. Testing two or more axes in parallel reduces traditional test times considerably and reproduces the true environment more closely than with classical single-axis, single-shaker excitation.

m+p VibControl also provides coupled and uncoupled multi-axis vibration testing in a closed control loop. Test modes include random, sine, shock and time domain replication (road load simulation). Multi-axis motions are characteristic of field environments. The more a vibration test can replicate the field environment, the more realistically it can induce a vibration stress loading equivalent to that experienced by the product in the field. Multi-axis

vibration testing is also known as MIMO (Multiple Input/ Multiple Output) control.

Applications of the m+p VibControl multi-axis controller include vehicle road load simulations for durability tests, testing of large and complicated structures for operational loading as well as earthquake simulation as per IEEE 344. Components (e.g. portable PCs) and sub-assemblies (e.g. in a vehicle) are tested on specially designed shaker tables with motion in several degrees of freedom. For seismic qualification the test specimen is fixed to a multi-axis earthquake shake table. Large structures such as complete automobiles, aircraft, rockets and railroad cars are excited on multiple shakers each directly attached to a load input point. This simulates the real-world vibration environment in a precise and realistic way.

Multi-axis shock testing

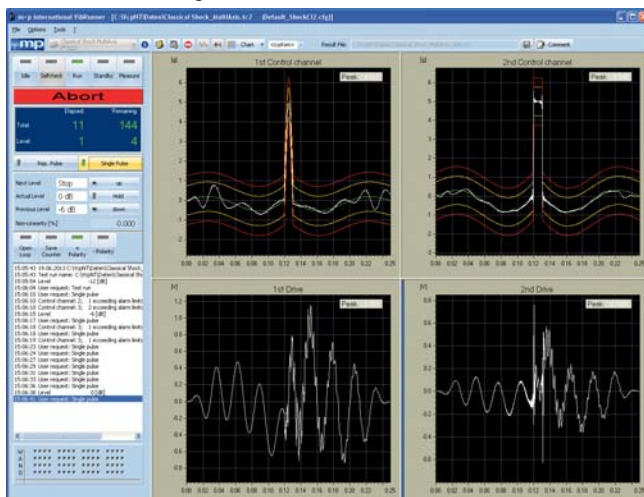

Multi-axis time domain replication testing

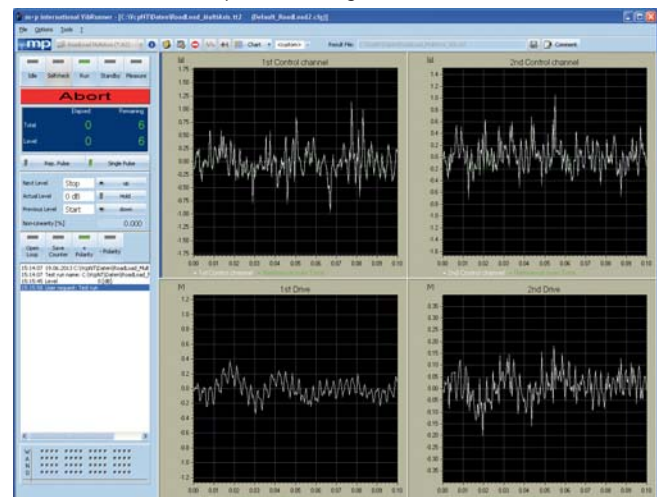

# Acoustic Control in Reverberant Chambers



m+p VibControl also performs acoustic testing in reverberant chambers and direct field environments as well as progressive wave tube testing. It is a fully automatic digital control system, providing fast, accurate and repeatable control of high-level noise to a reference octave band spectrum and the overall sound pressure level (OASPL). The control guarantees a high level of product safety.

The m+p VibControl acoustic control system provides features such as support for up to 50 microphones for control and/or measurement, continuous time domain octave analysis in 1/3 and 1/1 octave bands, a control bandwidth up to 10 kHz with multi-horn control, equalizer tool, calibration tool, automatic microphone drop-out

detection and exclusion from control, extensive octave band and OASPL alarm and abort checks for safe testing as well as comprehensive post-test analysis and reporting functions in 2D and 3D.

In addition to the stored octave spectra, PSD's are calculated and stored for individual measurement channels. They allow monitoring of the mechanical response of the structure to be tested.

Supporting the same Ethernet-based m+p VibRunner hardware, m+p VibControl for acoustic control can be configured as a shaker control system by simply adding software modules.



## YOUR BENEFITS

- 1/1 and 1/3 octave bands usable for control and measurement
- PSD measurements for monitoring mechanical responses during acoustic load
- Protection against open loop/drive runaway
- Easy runtime display configuration
- Display of min, max and average for each octave band over a period of time with a few mouse clicks
- Visual time domain signal verification for each channel
- OASPL over time displays for full test documentation
- Continuous time history recording during test run to stream all raw time data to throughput disc
- Advanced time domain data analysis using m+p SO Analyzer software
- Progressive wave tube testing

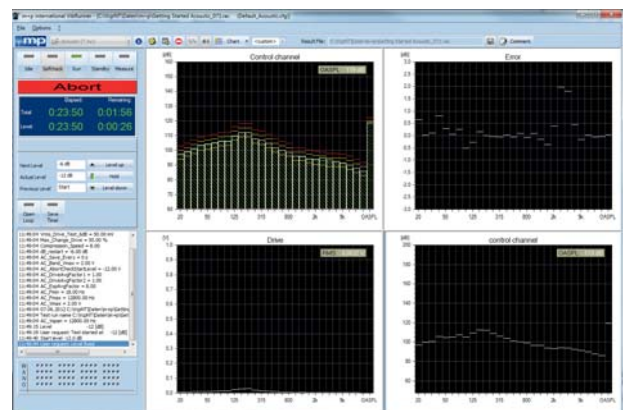

OASPL over time display

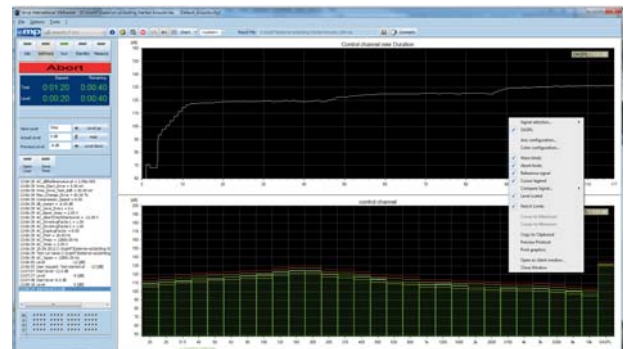

Acoustic control test run

**“The m+p acoustic control system in place at NASA Plum Brook, which can drive all of our reverb chamber’s 36 noise modulators (23 hydraulic type, and 13 electro-pneumatic type), suits our needs very well. I have been relying on the m+p acoustic control system at NASA, and elsewhere, since 2003 and I have always been given attentive and accurate support from the m+p office.”**

Aron Hozman, Vibroacoustic Test Systems Manager at NASA Glenn Research Center, Sandursky, Ohio/USA

# Complete Test Stands

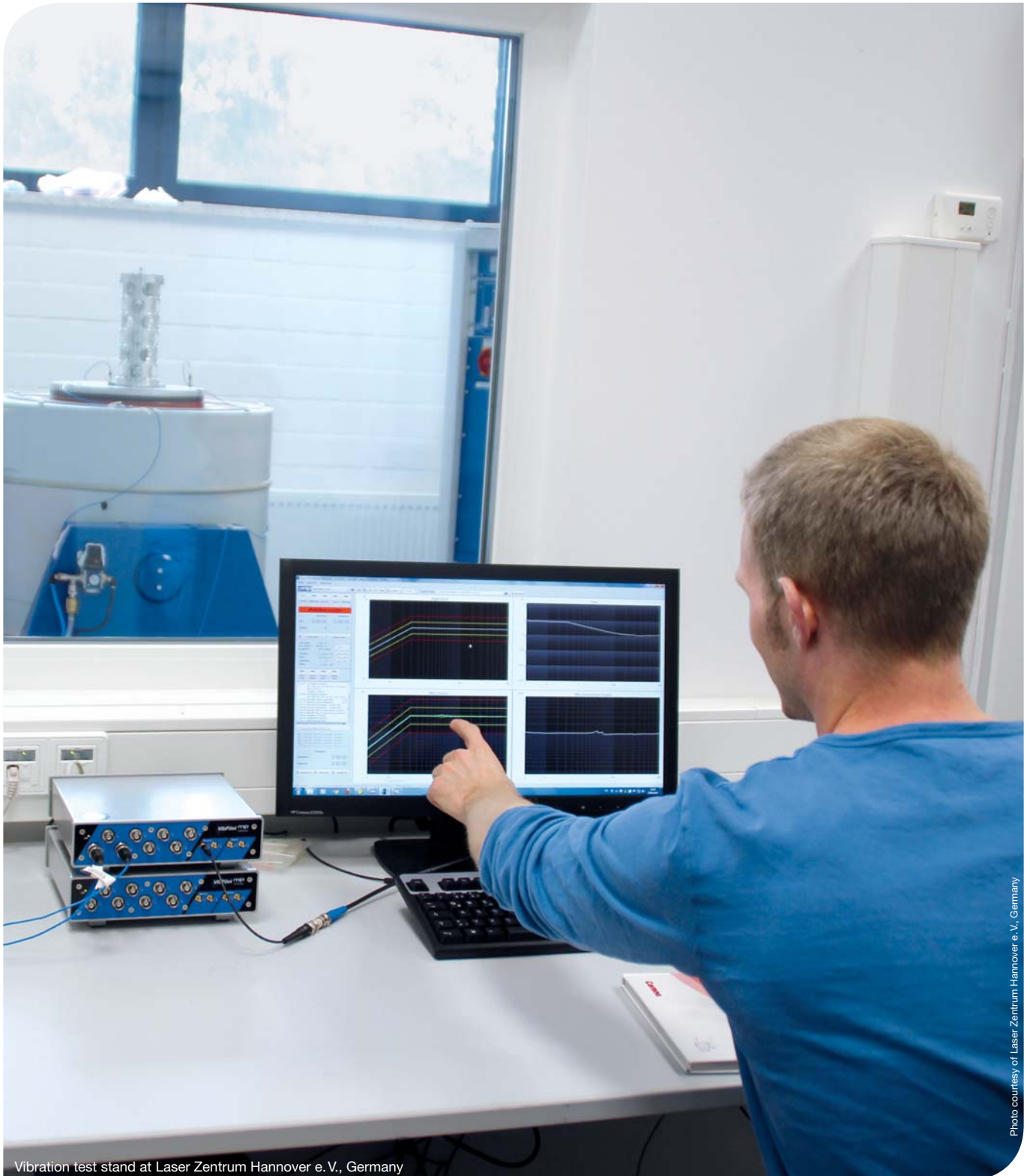

Vibration test stand at Laser Zentrum Hannover e.V., Germany

Photo courtesy of Laser Zentrum Hannover e.V., Germany



If you are looking for a complete vibration test system from one source, m+p international is the place to come. We have enjoyed partnerships with renowned shaker manufacturers for many years and have the experience it takes to provide complete test stands, including the control system, the computer platform, the shaker and accessories such as transducers (e.g. accelerometers), fixtures and

cables. We also calculate, design and manufacture special vibration fixtures.

And if you want to combine functional, climatic and vibration testing, or if you need very special vibration test rigs, m+p international has the necessary experience to provide a complete solution for you.

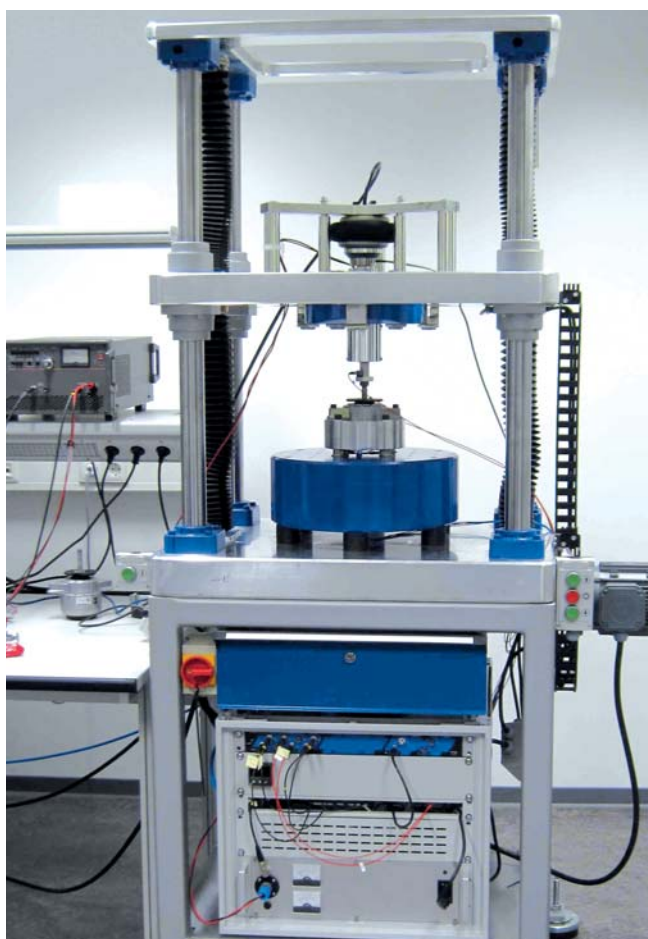

High-frequency vibration test stand using piezoelectric shakers



Combined climatic and vibration testing of car radios

Photo courtesy of Robert Bosch Car Multimedia, Germany

**“m+p always considers customers’ requirements as first priority, doing their best to adapt controllers and design-specific software during co-operation. We also appreciate the quick response and after-sales support.”**

Levin Sun, Component Test Manager at Faurecia Emissions Control Technologies, Shanghai, China

# Ordering Information Vibration Testing

## m+p VibControl Vibration Control and Signal Analysis Software System

<b>VCbase</b>	<b>m+p VibControl Vibration Control and Signal Analysis Basic Software,</b> Advanced Post Processing, up to 16 input channels front-end driver, software licence-to-use. Select any of the VibControl software options below together with the VCbase to build the VibControl system according to your requirements.
---------------	--

## m+p VibControl Server Software Package for High-Channel Count Systems

VC-SER64	VibControl Server license for Vibco systems with embedded controller, support of up to 64 input channels; requires VCbase
VC-SER128	VibControl Server license for Vibco systems with embedded controller, support of up to 128 input channels; requires VCbase
VC-SER256	VibControl Server license for Vibco systems with embedded controller, support of up to 256 input channels; requires VCbase

## m+p VibControl Vibration Control and Signal Analysis Software Options

VC-RAN	Broadband random
VC-SIN	Sine swept & stationary
VC-NOL	Notch/force limiting sine & random; sine force, displacement and velocity control
VC-VNO	Vector notching sine; requires VC-NOL Notch/force limiting sine & random
VC-HFSIN	High frequency sine control; up to 20 or 40 kHz frequency range for drive signal; requires VC-SIN Sine swept & stat.
VC-SRD	Sine resonance search, track & dwell
VC-HCF	High cycle fatigue package; requires VC-SRD Sine resonance search, track & dwell
VC-CLS	Classical shock
VC-EXP	External pulse with RoadLoad Editor (requires VC-CLS or VC-SRS)
VC-SRS	Shock Response Spectrum (SRS) with Shock Synthesis
VC-SOR	Sine-on-Random (SoR); incl. Multi-sine w/wo Random; if combined with RoR: incl. SoRoR
VC-ROR	Random-on-Random (RoR). If combined with SoR: including SoRoR
VC-RANR	Broadband random Data Reduction
VC-SINR	Sine swept & stationary Data Reduction
VC-TRC	Transient Capture with Online SRS Calculation
VC-RLD	RoadLoad – Time Domain Replication
VC-ACS	Acoustic Control Software System; requires VCbase VibControl basic software package
VC-MSIN	Multi-axis Sine control



VC-MRAN	Multi-axis Random control
VC-MRLD	Multi-axis RoadLoad – Time Domain Replication
VC-VUS	VibUtil (test sequencing )
VC-VUA	Advanced VibUtil: supports VibPilot digital I/O channels for connection of chamber/external devices
VC-NOF	NoFrontEnd Licence
VC-MSCRN	Multi-screen support
VC-NXS	B&K Nexus Charge Amplifier control
VC-TRP	Continuous time domain data recording for SIN, RAN, CLS; creates *.SOT files for post test analysis
VC-TRPeRstd	Continuous time domain data recording for SIN, RAN, CLS; incl. SO-eRstd and SO-eTH for post test analysis of *.SOT files
VC-TRPeRpro	Continuous time domain data recording for SIN, RAN, CLS; incl. SO-eRpro and SO-eTH for post test analysis of *.SOT files
VC-CAL	Calibration SW license for VibPilot, VibRunner hardware calibration; Agilent 34401 or 34410 voltmeter needed
VC-8ch+	Add n-times 8 input channel driver to support a total of up to 24/32/40/48/... channels

### m+p SWplus Software Maintenance

<b>SWplus12</b>	m+p SWplus VibControl, SO Analyzer or Coda Software Maintenance Contract for 12 Months including Software and Electronic Literature Update Service and Hotline Support
<b>SWplus24</b>	m+p SWplus VibControl, SO Analyzer or Coda Software Maintenance Contract for 24 Months including Software and Electronic Literature Update Service and Hotline Support
<b>SWplus36</b>	m+p SWplus VibControl, SO Analyzer or Coda Software Maintenance Contract for 36 Months including Software and Electronic Literature Update Service and Hotline Support

# NOISE AND VIBRATION ANALYSIS







# Dynamic Signal Analyzers





## YOUR BENEFITS

- Measurement, analysis and reporting in one application for minimal training and ease of use
- Supports standard hardware for flexible configuration to suit all your projects
- Wide range of applications to satisfy all your NVH needs
- Import 3<sup>rd</sup> party files for analysis and integration of all related data for common reporting
- Customization of macros and online functions to meet your specific requirements
- Mobile, laboratory and network based for optimal access and utilization
- Compatibility with wide range of sensors and signals for future-proofing
- NI hardware support provides only fully supported NVH application solution
- Online and offline processing and data viewers for the clearest picture of your test
- Proven performance and product evolution for long-term reduced cost of ownership

m+p SO Analyzer is a fully integrated solution for dynamic signal measurement, analysis and advanced reporting of all of your noise and vibration, acoustics and general dynamic signal applications. Comprehensive time and frequency analysis is available with both online and offline data processing. Complete with advanced application wizards the system makes light work of gathering data, displaying results, performing specialized analysis and generating customer ready reports – all within one familiar Microsoft Office style user interface.

### Applications

- Data Acquisition with Time and Frequency analysis of all types of dynamic signals and sensors
- Time history recording and post-processing
- Structural Analysis data acquisition including geometry guided impact hammer, shaker drive outputs with random, swept and stepped sine, random and sine burst to drive one or more shakers with full MIMO analysis
- Modal Analysis with Operating Deflection Shape, Circle fit, SDOF and MDOF curve fitters and Modal Model Validation tools
- Ground Vibration Testing with Normal Mode Tuning handling multiple shakers
- Rotational Dynamics with spectral mapping and order tracking with both online and offline analysis tools
- Octave Analysis with real-time fractional octave filters and sound meter functions meeting relevant standards – covering both acoustics and ultrasonics
- Sound Power measurements to IEC standards with ECMA tonality for assessing machine whine components
- Sound Quality analysis for product refinement and diagnostics

- Sound Intensity measurements with acoustic intensity field mapping and sound power analysis
- Vehicle Pass-By Noise measurement system meeting new stringent requirements
- Environmental Vibration testing with full compliance to vibration test standards such as MIL-STD 810 and IEC 60068
  - Independent measurement of additional channels over those available on the vibration controller
  - Random Data Reduction
  - Swept Sine Tracking and Data Reduction
  - Classical Shock Data Reduction with full limit overlays for shakers or drop tables
  - Shock Response Spectrum analysis

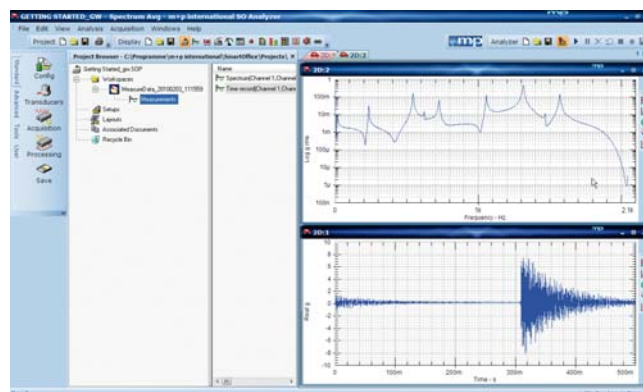

Acquiring dynamic data

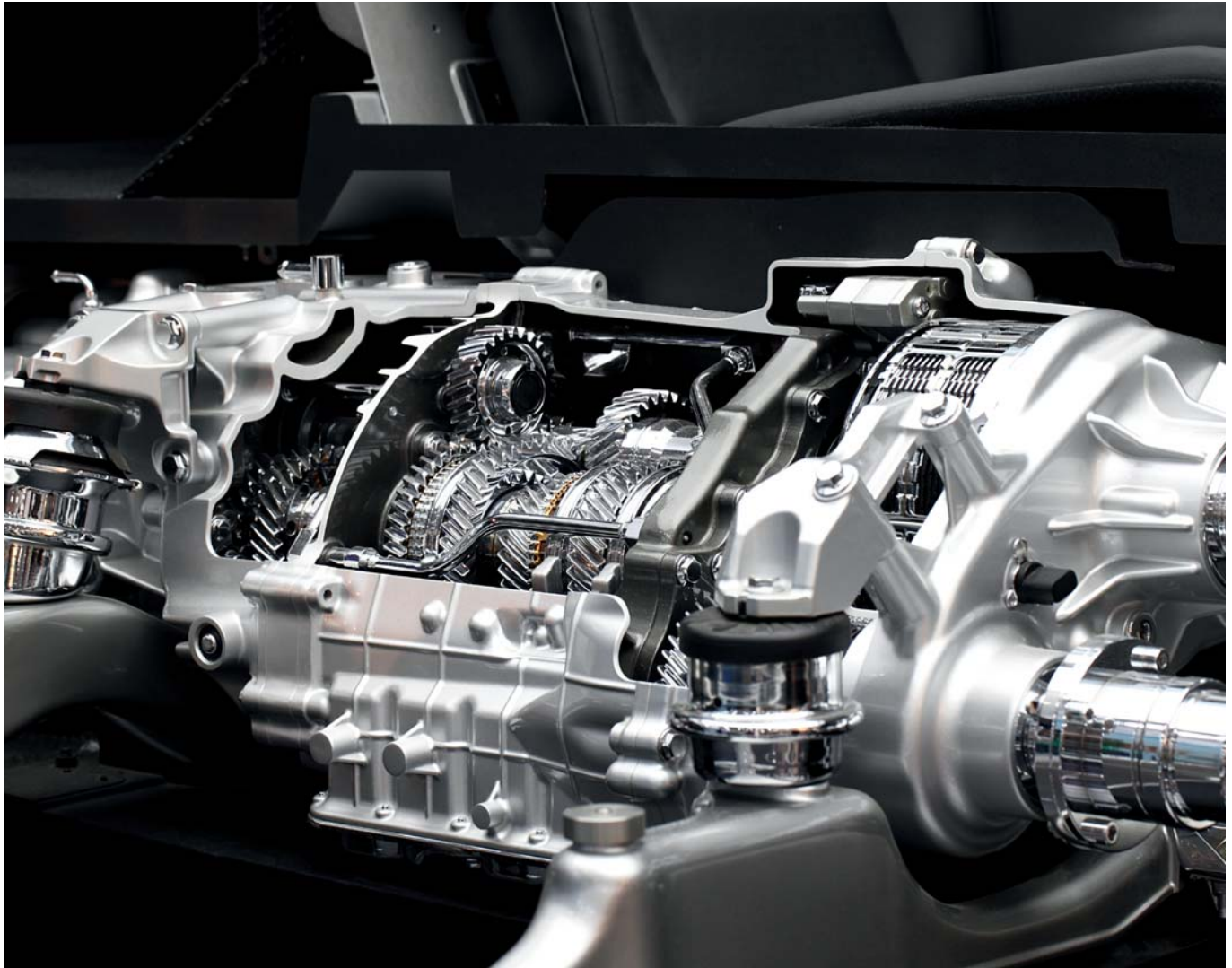

Rotating machinery diagnostics

## Measurements

m+p SO Analyzer systems are available for field and laboratory use from 4 to many hundreds of measurement channels. From gathering simple time history data to narrowband (FFT) spectra, fractional octaves, wavelets, shock response spectra and much more, m+p SO Analyzer can be used with a wide range of instrumentation hardware including our own VibPilot and VibRunner systems, National Instruments (USB, CDAQ, PXI) and VTI Instruments (VXI). Low cost portable USB systems to many hundreds of distributed channels can be configured for maximum system flexibility. Measurement data from all sources are stored in a common format so it is easy to compare and handle results from any measurement source.

Continuous real-time and triggered data acquisition modes are easily set-up by the operator offering a very wide range of sampling frequencies from 32 Hz upwards into the MHz range and with FFT block sizes up to 256 k for the highest frequency resolution. Sampled data is fed to parallel

processing streams so that time history recording, narrowband analysis and octave based analysis can all be done together. A scheduling function even allows repeated measurements at intervals over a long period of data acquisition.

Over 50 standard measurement functions are available from time, spectra and frequency response functions to histograms and statistical results. Instantaneous data blocks can be stored for spectral mapping and averaging methods include ensemble block average, exponential and peak hold modes. Custom online functions can be defined including cross channel calculations and averaging. All common weighting and windowing types are included as is online integration making easy work of deriving velocity and displacement results from acceleration inputs. Single-channel and cross-channel functions are all available for signal correlation and transfer function analysis including full matrix FRF computation for Multiple Input/Multiple Output (MIMO) applications. Additionally user defined online filtering and resampling can be applied when required.



Powerful throughput to disc recording can store raw time history data at very high throughput rates in parallel to normal analysis functions and these recordings can then be used to perform offline post-processing analysis to review field data in more detail or revise analysis settings.

Post-processing of third-party data files is also made easy with flexible data import and export facilities. Stream based binary data files can be used directly as a post-processing data source simulating data direct from an online sampling system.

## Data Display

Chart displays are the key to viewing and analyzing dynamic data and the m+p SO Analyzer 2D, 3D and animation viewers have a wealth of functionality to satisfy any requirement. They are easy to use for new users and offer a wide range of features for experienced practitioners.

Custom layouts can be defined using multiple 2D, 3D and animation viewers and these can be extended over multiple monitors for ease of viewing large number of data channels. Real-time and offline data can be displayed and mixed as required.

- The 2D chart includes simple X/Y chart, bode plot and Nyquist formats with linear, log and dB axes and flexible scaling and zooming modes including chart linking. Dual Y-axis scales allow different data types to be overlaid. Charts can be stacked or tiled or randomly snapped to size for layout flexibility.
- Each 2D chart can handle any number of overlaid traces for comparison, has flexible cursors, labels and markers as well as comprehensive computation of scalar properties and calculation functions such as FFT, Integration etc. for instant data conversions. Over 40 calculation functions are built into the chart and additional tool windows provide features such as trace, trigger, tacho, Least Squared Fit and Upper/Lower limit indicators.
- Multi-2D viewers display 4 or 16 channels for rapid review of many channels in real-time.
- The 3D chart has both waterfall and colour map modes and like the 2D has a built-in calculator for XYZ and order cut calculations direct from the cursor positions.
- The animation viewer is used together with the various structural analysis tools for displaying and comparing mode shapes using wire frame geometry models.
- All chart viewers can be copied for instant paste into a report using a variety of formats including full ActiveX control in MS Office and video clips for reporting mode animation results.
- All data is also available in tabular form for copy and paste exchange with spread sheets etc. Comprehensive header and user Meta-data are included with bulk editing of parameters.

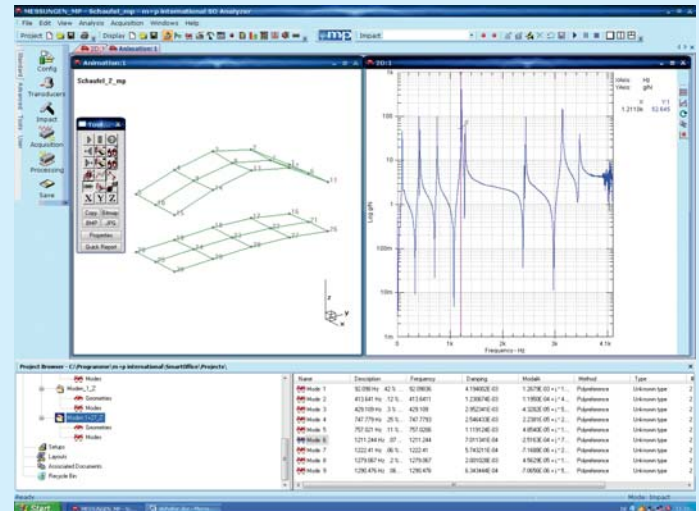

2D and 3D animation viewers

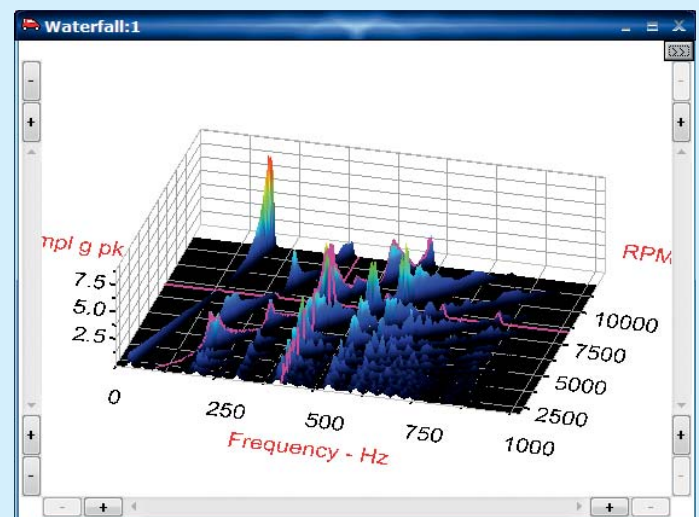

3D spectral map and 2D colour map displays



Structural dynamics testing during a parabolic flight



Acoustic and Human Vibration Analysis

## Data Analysis

Time and frequency analysis are the mainstay of many applications and m+p SO Analyzer's drag/drop data handling makes it quick and easy to get data into charts for investigation. In the time domain stacked charts provide transient and sequence of events analysis or in the frequency domain chart cursors can search for multiple peaks and calculate frequency, amplitude and damping on the fly. Chart legend and markers with over 50 built-in calculations produce report ready results quickly.

m+p SO Analyzer's powerful data browser can handle large numbers of data from multiple measurement runs or saved projects. The data can be sorted, organised and displayed for fast and easy graphical comparisons and for more advanced analysis. An editable engineering units database ensures all data is fully calibrated and derived functions are correctly scaled and identified in ready to report formats. Data can be converted and displayed in any engineering unit at the touch of a button ensuring maximum data integrity during analysis and reporting.

Sequence of event analysis can be performed on large time history recordings which can be handled direct from

file when they are too large to load directly into memory. Many GB of data can be quickly scanned and zoomed across many channels of data making this an ideal tool for reviewing large data files such as recorded by our m+p VibControl system.

The chart based calculator is further augmented with a full array calculator that uses a reverse polish stack to compute cross channel and cross function results using over 50 advanced operators. Equations can be stored as macros for repeated use.

For your own special calculations an online cross-channel calculator can define multiple user functions or a fully embedded Visual Basic programming language can also be used. You can easily create macros and add these to the standard menus for frequently repeated analysis operations. Advanced wizards guide the user through the most complex of applications analysis. These are available to assist with measurement procedures and for post-test analysis to ensure users of all levels of experience can quickly and reliably derive the required results. A wide range of analysis wizards are available:

- Modal Analysis – ODS, SDOF, MDOF, Circle Fit, Geometry creation, Modal Model Validation

***“m+p SO Analyzer's ease of use and flexibility to utilize our National Instruments data acquisition hardware as well as the 8-channel m+p VibPilot allows us to verify product quality prior to shipment with no process delays. Thanks to the excellent pre- and post-sales technical support from m+p we can respond to complex customer demands in a timely manner and continue to expand the system capabilities into modal analysis and FE model validation.”***

Arthur Kohn, President of IVS Industrial Ventilation Systems, Houston, Texas/USA



- Rotational Dynamics – tacho spline fit, RPM mapping, Order tracking, Orbit analysis
- Environmental Test – SRS, Sine Reduction, Classical shock
- Acoustics – Sound Power, Sound Intensity mapping, Transmission loss, pitch and warble
- Pass-by noise testing
- Time/Frequency analysis using Morlet wavelet transforms

**eReporter**

The m+p SO Analyzer eReporter configuration is a very powerful offline data analysis tool for reviewing and exchanging third-party data. Many standard import and export filters are provided and automated links to programs such as Matlab are available. It is now possible to collect all of your dynamic data from any source into one common review, charting and reporting tool with m+p SO Analyzer. In this configuration you continue to enjoy all the post-processing and analysis wizard functionality.

For use across your site the network based license server allows concurrent use by analysts anywhere on your network. This provides flexible and cost effective application deployment in large departments or where data is shared across different departments so the most effective and efficient use of the data can be employed.

**Report Generation**

From a simple copy and paste of a chart into a document to creating automated custom reports m+p SO Analyzer has a wide range of reporting capabilities to suit all needs. Graphical and tabular data can easily be copied to clipboard for instant reports or data exchange with a spreadsheet application making m+p SO Analyzer a great tool for use with all dynamic data reporting requirements.

Microsoft Word templates are used to define “Quick Report” templates for frequently used reports which can be executed immediately from any measurement(s) or chart. The advanced Reporting Wizard includes a comprehensive data base style grouping, select and sort feature to handle large numbers of measurements and also uses templates to define multi-page reports with charts, tables and animations.

Data stored in m+p SO Analyzer contains comprehensive header data which can also be incorporated into report templates as text or tables and automatically filled from the selected measurements.

ActiveX functionality means that documents can be opened with the same chart functionality as available in the full application but without having m+p SO Analyzer installed. A free to download ActiveX viewer is available from our website to activate this feature for your customer.

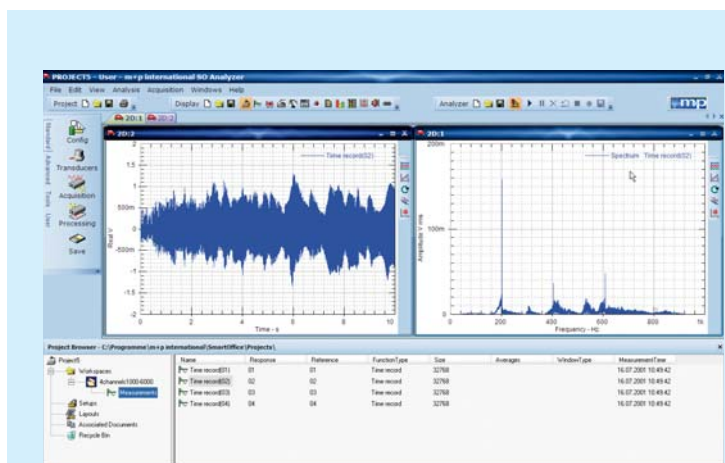
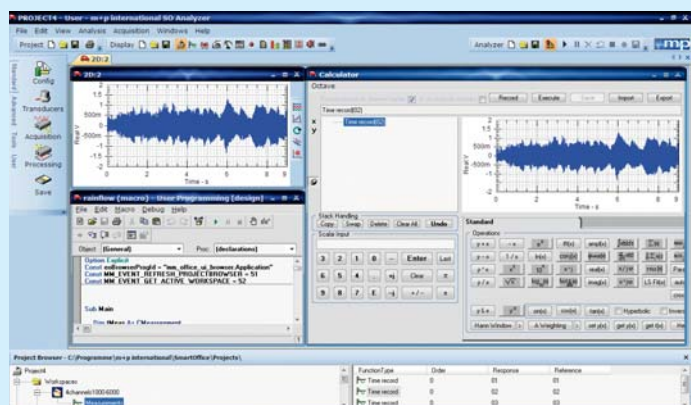
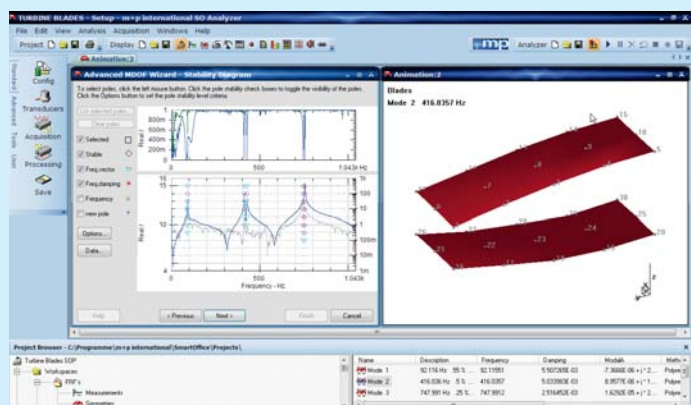

Chart displays for viewing and analyzing dynamic data



eReporter for advanced data management and reporting



Comprehensive data analysis tools

# Structural Acquisition and Analysis



m+p SO Analyzer's structural dynamics package provides a complete set of tools for observing, analyzing and documenting the vibrational behaviour of machines and mechanical structures. Different software modules cover a wide range of techniques including impact testing, shaker measurements (SIMO and MIMO), experimental and operational modal analysis, modes of vibration animation, modal model validation and ground vibration testing.

The standard structural dynamics package includes:

- Impact testing using a modal hammer
- Creation of component-based geometries
- Operating Deflection Shape (ODS) analysis

Optional software modules are available to cover the most demanding and advanced modal analysis applications:

- Single Degree of Freedom (SDOF) analysis
- Multiple Degree of Freedom (MDOF) analysis
- Circle fit wizard to review and validate FRF data and mode shapes
- Operational modal analysis (OMA)
- Modal model validation (MAC, MPD, MPC, MOV, MIF)
- Polyreference Time Domain algorithm (PTD/PolyTime)
- Polyreference Time Domain Plus algorithm (PTD+/Polytime+)
- Polyreference Least-Squares Complex Frequency domain algorithm ( $\rho$ -LSCF/Polyfreq)



## YOUR BENEFITS

- Fully integrated measurement and modal analysis for efficient testing
- Everything you need in one system to eliminate data transfer delays and errors
- Wizard guidance simplifies process for all experience levels
- Advanced Guided Impact Hammer wizard for single operator hands-free operation
- ODS wizard for rapid assessment of vibration shapes
- SDOF wizard for isolated modal parameter extraction
- MDOF analysis using the latest algorithms that handle the widest range of applications
- Modal Model Validation to check modal data and compare with FE shapes and data
- Traditional circle fit analysis and animation viewer for rapid visual data validation
- Integrated signal sources for multi-shaker mode excitation
- MIMO analysis to resolve coincident modes
- Normal Mode Tuning with search and tune using live mode shape animations and MIF

- Multiple Input/Multiple Output (MIMO) analysis including multi-source outputs
- Swept and stepped sine analysis
- Ground vibration testing (GVT) with Normal Mode Tuning (NMT)
- Interface to FEMtools for SDM analysis

## Impact Testing

Our Advanced Guided Impact Hammer wizard assists the user in running an impact test. In a step by step wizard the user is guided to define all acquisition settings which makes it easy to set everything correctly even for inexperienced users. Predefining the points to measure enables a single operator hands-free operation which is especially useful on large structures. Online display of the coherence function, double impact warnings and a predefined customizable layout complete the impact testing capabilities of m+p SO Analyzer.



Modal analysis on a train carriage

## Multiple Degree of Freedom (MDOF) analysis

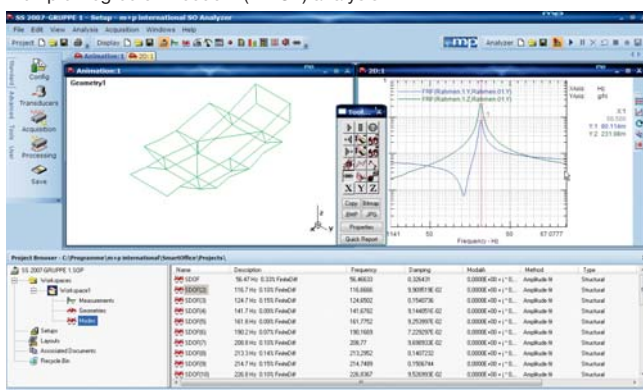

## Measuring and evaluating the vibrational behaviour of a wheel rim





Wind turbine blade testing

Photo courtesy of Narec, United Kingdom

### Shaker Tests

m+p SO Analyzer supports several different source modes (e.g. random, burst, sweep, arbitrary etc.) for shaker excitation. Multiple sources are available as well as open- and closed-loop amplitude control. Random and burst random modes are the methods of choice when broadband excitation e.g. in modal testing is required. They offer the possibility of exciting the structure with uncorrelated signals at different exciter locations using the MIMO capabilities of m+p SO Analyzer. Swept and stepped sine can be used for single- or multi-shaker excitation of larger structures when high input powers are required. A typical application of stepped sine testing in the space and aircraft industry is ground vibration testing also known as normal mode tuning. Arbitrary mode allows the replay of recorded or synthesized excitation time histories.

### Modal Analysis

The experimental modal data are obtained by curve fitting a set of Frequency Response Function (FRF) measurements. Wizards take you through a simple series of steps to complete the acquisition and analysis process and also make intelligent estimates of all analysis options. The

Multiple Degree of Freedom (MDOF) wizard, for example, handles the most sophisticated modal analysis tasks, such as detecting repeated or closely spaced modes.

Industry-proven time and frequency curve fitting algorithms with wizard-guided operation offer ease of use and simplify result interpretation for non-experts. The time domain method is optimized for lightly damped structures and can also be enhanced by the optional PTD+ algorithm to filter spurious modes. The frequency domain algorithm is optimized for more heavily damped structures. All methods include clear stabilization diagrams and synthesized FRFs for optimum analysis. Mean-Phase-Deviation (MPD), Mean-Phase-Correlation (MPC), Mode-Overcomplexity-Value (MOV) and Mode-Indicator-Function (MIF) are additional measures that offer valuable clues to the quality of the extracted modal parameters.

Modal model validation is used for mode comparisons between different tests or between tests and FE analysis results. The Modal Assurance Criterion (MAC) is an effective way to compare the resulting mode shapes and check their agreement.

m+p SO Analyzer also features operational modal analysis based on response signals without the need to measure the





Photo courtesy of NASA, USA

Evaluating the Ares I-X test rocket



Photo courtesy of INSA-Rennes, France

Modal analysis on a parallel robot

excitation. Assuming broadband white-noise excitation this technique can be applied wherever natural excitations are present but excitation forces cannot be measured.

### Ground Vibration Testing

In testing space and aircraft structures ground vibration testing is a common method. In addition to conventional modal tests ground vibration tests are used for further inspection of critical modes. Normal Mode Tuning uses several shakers to force the structure to vibrate in one single mode of vibration. By interactive tuning with online displays of mode shape, MIF etc., the shaker excitation frequency and amplitudes are optimized. The Mode Indicator Function (MIF) indicates when the optimal tuning is reached. Finally a stepped sine measurement is performed using the tuned exciter configuration allowing a detailed investigation of that single mode to be completed.

### Analysis and Animation

The software makes it very simple to create the structure's geometry and calculate modal parameters including mode shape animation.

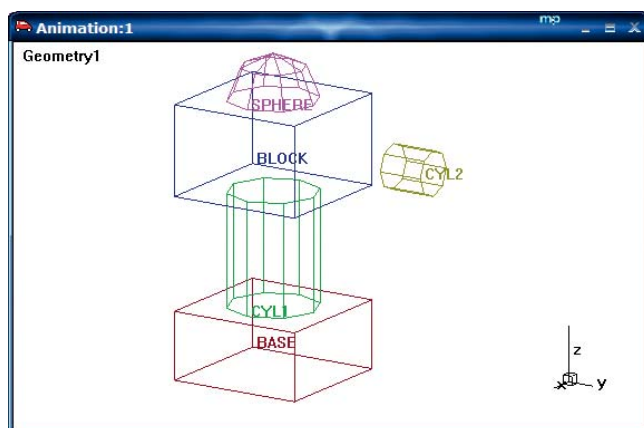

Geometry creation

Normal mode tuning by multi-point sine excitation at a strategic choice of the exciter locations

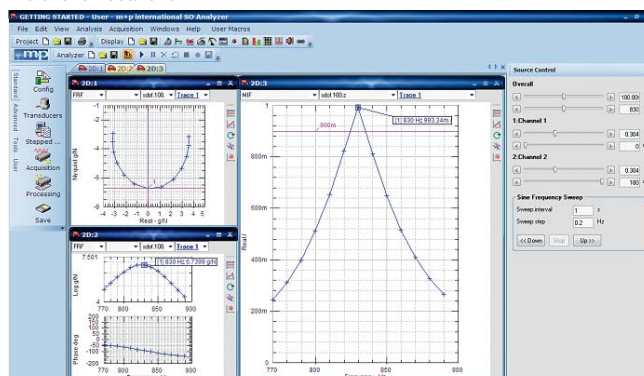

# Rotational Dynamics Acquisition and Analysis

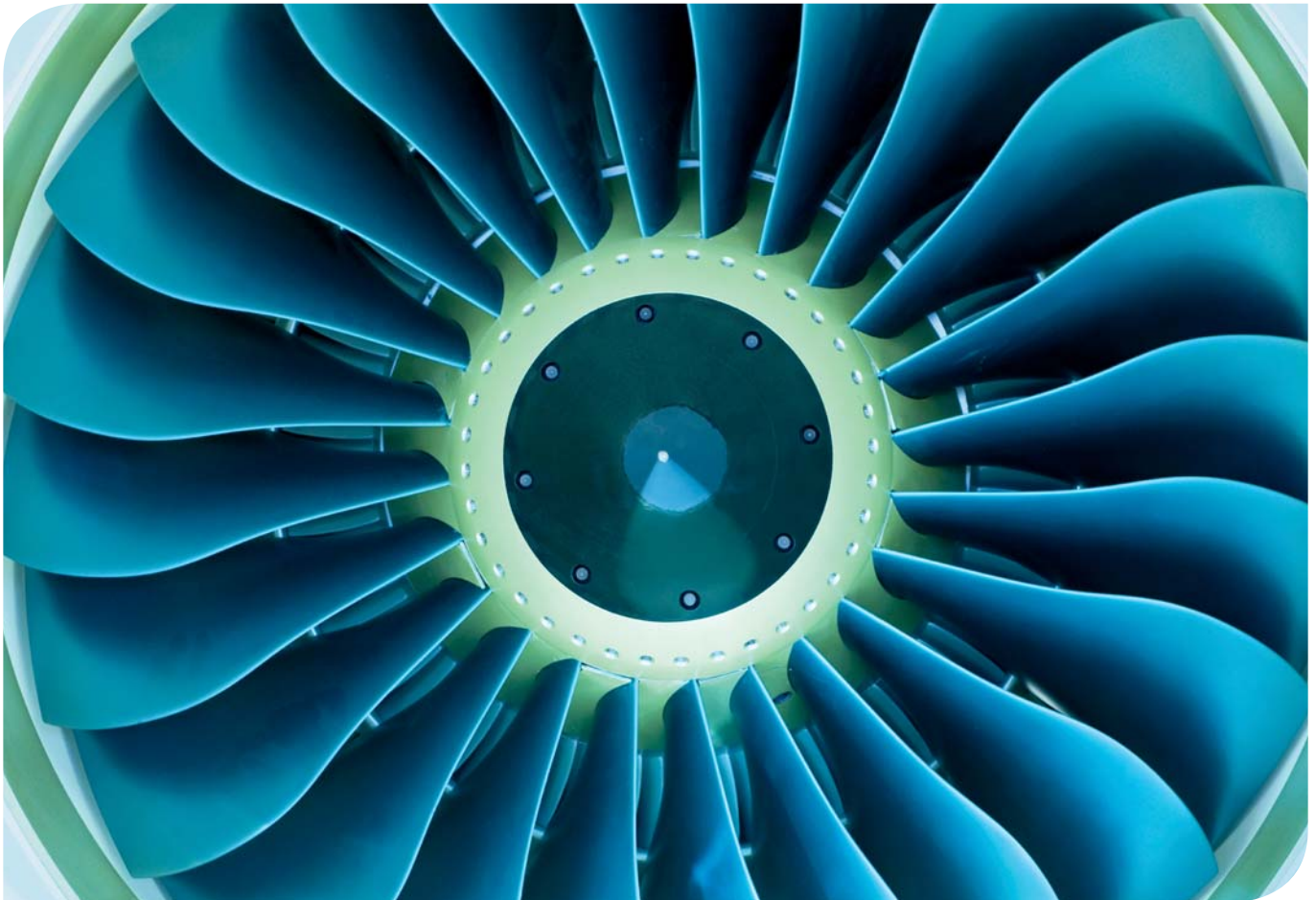

m+p SO Analyzer provides a wide range of data acquisition and analysis tools for capturing and understanding noise and vibration induced in rotating and reciprocating machines by their motion. Fixed and variable speed machines are accommodated as are both structural vibration and condition monitoring diagnostics. Multiple tacho inputs can be processed for accurate speed tracking during analysis. Spectral mapping, order tracking, time history and orbit data analysis are all available.

## Spectral Mapping

A cost effective solution for investigating run-up and run-down vibration uses m+p SO Analyzer's real-time measurement system and the built-in online and offline 3D waterfall and colour map viewer. Time-based capture of spectra can

be augmented using an analog tacho input to provide RPM steps and if a tacho is not available a simple tool will track using a dominant order response from the spectra.

XYZ + order cursors on the 3D chart read off RPM, frequency and amplitude information and the chart calculator computes order and frequency tracks directly from the waterfall data. Rotational and structural resonance components can be easily identified and quantified.

The advanced SO-ROT module is fully synchronized to a tacho input for fixed RPM step analysis at any resolution and the high performance analysis can accommodate the highest rates of change and very high speed machines.

The Throughput to Disc time history recording is extremely useful for post-processing in difficult measurement



## YOUR BENEFITS

- Specialized application wizards integrated with multi-function DSA system
- Ultra-portable systems for field measurements with integrated analysis
- Flexible time, frequency and order domain analysis
- Narrowband and 1/3 octave analysis from vibration and microphone sources
- Analog and digital tacho inputs to suit any available tacho sensor
- Spectral mapping for simple identification of responses
- Order tracking for detailed analysis
- Orbit analysis for bearing and lubrication diagnostics
- RPM and time-based measurements cover all variable and constant speed machines
- Condition monitoring standards supported for an all in one solution
- Balancing and bearing analysis
- Online for speed and offline analysis for handling the most of difficult tasks

conditions where the offline post-processing wizard includes a spline fit tool to overcome noisy tacho signals followed by comprehensive spectrum and order tracking analysis.

### Order Tracking

Tacho signals can be measured on both analog and high speed digital counter inputs with order tracks computed from spectral data or using digital tracking filters for the highest resolution. Any tacho pulse ratios can be used to compute any number of different order numbers in parallel. There are no restrictions on fractional order numbers that can be included so complex engine and gearbox order components are easily identified.

### Orbit Analysis

Online orbits can be displayed and monitored on a standard two-channel orbit diagram chart. For advanced analysis a throughput recording including a tacho or TDC signal can be post-processed using the orbit analysis wizard. This provides averaging, filtering and order based orbit displays with a replay feature for visualising changes over a change in machine speed.

### Condition Monitoring

At the heart of machine condition metrics are acceleration, velocity and displacement measurements which can all be easily derived from a single sensor with time histories of peak, pk-pk and rms values in any engineering unit easily displayed. Flexible pre-filtering of signals easily meets the standard metrics available for different groups of machines.

History and trends can be based on machine speed or, when running at constant speed, with time-based logging providing time history statistics, spectrum analysis and order analysis with both amplitude and phase results.

Balance, bearing condition and performance characteristics can be evaluated meeting the requirements of the numerous standards in this area such as ISO 13373, ISO 7919, ISO 10816, VDI 2056, ISO 2372, NF 90-300/310, BS 4675 or the API acceptance testing series etc.

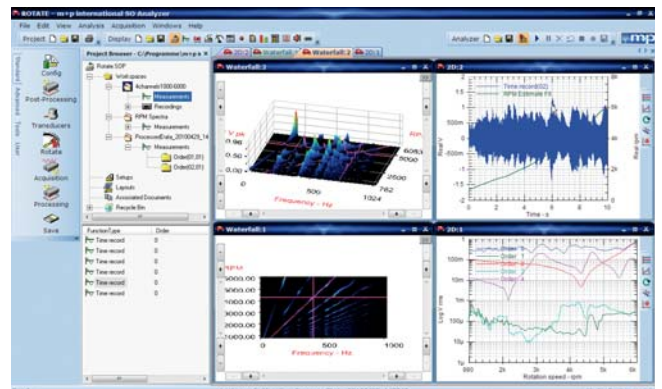

2D and 3D displays of rotational data

Machinery condition monitoring using m+p's rotating machinery software

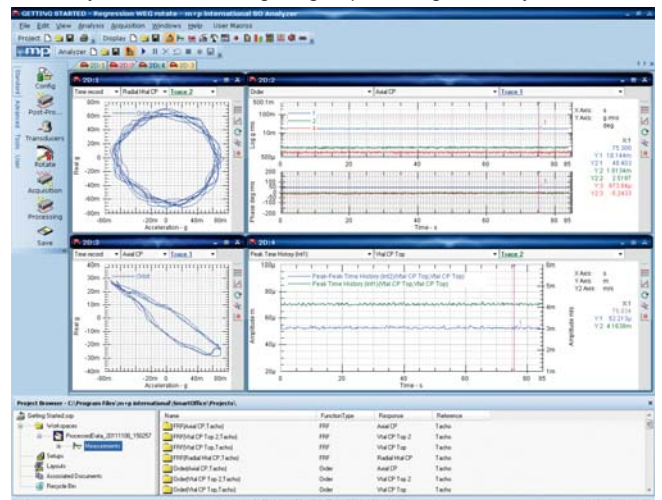

# Acoustic Analysis



Noise is increasingly the subject of new regulations for the protection of human health and safety as well as for improving the environment in general. As well as sound levels, the perceived sound quality of products from washing machines to vehicles is often an important part of the customer buying decision so must be considered during product development. m+p SO Analyzer provides a full range of capability for these applications. Real-time fractional octave filters meet ANSI S1.4 and IEC 61672

type 1 with A/B/C weighting providing fully compliant measurements satisfying all acoustic applications from simple sound pressure, sound power for equipment legislative requirements, intensity mapping to isolate sources, sound quality metrics for product refinement to a full vehicle pass-by noise system for vehicle homologation. All this in parallel with narrowband analysis and time history throughput to disc for fully detailed analysis online and offline post-processing of any data source.

Pitch analysis, an integral part of the sound quality analysis software



## Octave Analysis

Fully compliant with ANSI S1.4 and IEC 61672 type 1 sound meter specifications including A/B/C weighting and 1/1 to 1/24 octave spacing from 10 Hz to 100 kHz on 32 channels or more.

## Sound Meter Functions

With m+p SO Analyzer there is no need for a separate sound level meter as these functions are ready built-in with fast, slow and impulse settings, LEQ, peak hold by band



## YOUR BENEFITS

- One solution for all your sound and vibration applications
- Measurement, analysis and reporting all within one easy-to-learn user interface
- Portable and lab based systems for field and in-house use for maximum utilization
- Traditional 1/3 octave sound meter features plus fractional octaves to cover all needs
- Traditional microphones and intensity probe measurements for flexibility
- Application wizards to guide users of all experience levels through complex procedures
- Sound power procedures for all popular measurement methods with full validity analysis
- Sound power using intensity probe for use within noisy backgrounds
- Sound intensity mapping to identify and visualize noise sources
- Sound quality evaluation to refine your products
- Transmission loss, pitch, warble and tonality to develop your own quality metrics
- Vehicle pass-by noise system satisfying latest and proposed standards – single person operation

or OASPL. Sound pressure histories and trends over long periods can be captured continuously or sampled.

### Sound Intensity

Real-time sound intensity measurements use a standard dual microphone intensity probe calculating real-time pressure, intensity and pressure residual intensity index. This technique is directionally sensitive making it ideal for source localization or background noise cancellation.

### Sound Intensity Mapping

A wire frame 3D model of your equipment under test is used to guide an operator around a sequence of sound intensity measurements. These results are then mapped to the colour coded 3D image for identification of the principal sound sources and their levels.

### Sound Power

All equipment from PC fans to heavy machinery must have published sound power emission levels for environmental regulation. m+p SO Analyzer wizards guide the operator through the maze of requirements in the ISO 374x standards and, using the intensity measurements, the ISO 9614 standards. The latter method has high tolerance to background or reverberation effects so is suitable for use in most on-site environments rather than needing expensive anechoic chambers or field sites. More specialized applications such as wind farm methods like IEC standard 61400-11 and tonality using ECMA-74 are also available.

### Sound Quality

Human perception is critical to improving product competitiveness and sound quality metrics can be used to rank and evaluate different product designs. Based on Zwicker loudness according to ISO-532 and DIN-45631 they include:

- Specific loudness and transient loudness (in terms of sones and bark)
- Loudness and percentile loudness time history
- Articulation index and extended articulation index time history
- Sharpness time history
- Pitch and warble analysis wizards for squeak and rattle analysis
- Statistical analysis of any function, e.g. LSF, L(10), L(50), L(90), L(n)

These functions can be viewed as 2D, 3D charts or as colour maps (spectrograms) for further detailed analysis. Other statistical tools are available for least-squares curve fitting and trend analysis which are useful, for example, in squeak and rattle evaluation.

### Human Vibration

Alongside environmental noise, evaluation of other human factors such as hand-arm vibration from the use of power tools or the evaluation of whole body vibration from riding in vehicles as per the various ISO and BS standards are available. These include C/D/H/K weighting and functions such as VDV (vibration dose value) calculations.

Sound power software includes calculation of the sound transmission loss

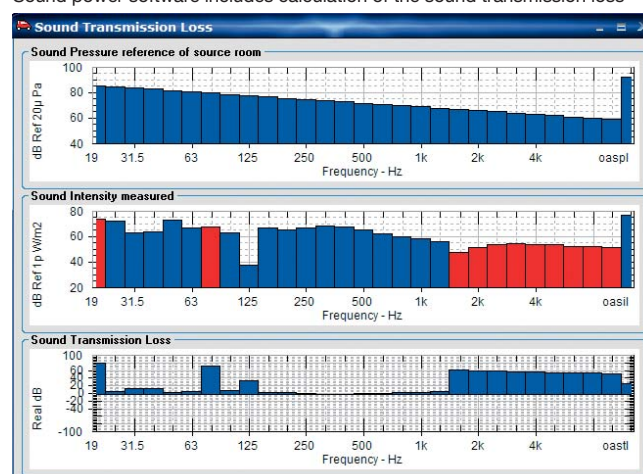

# Environmental Vibration Testing

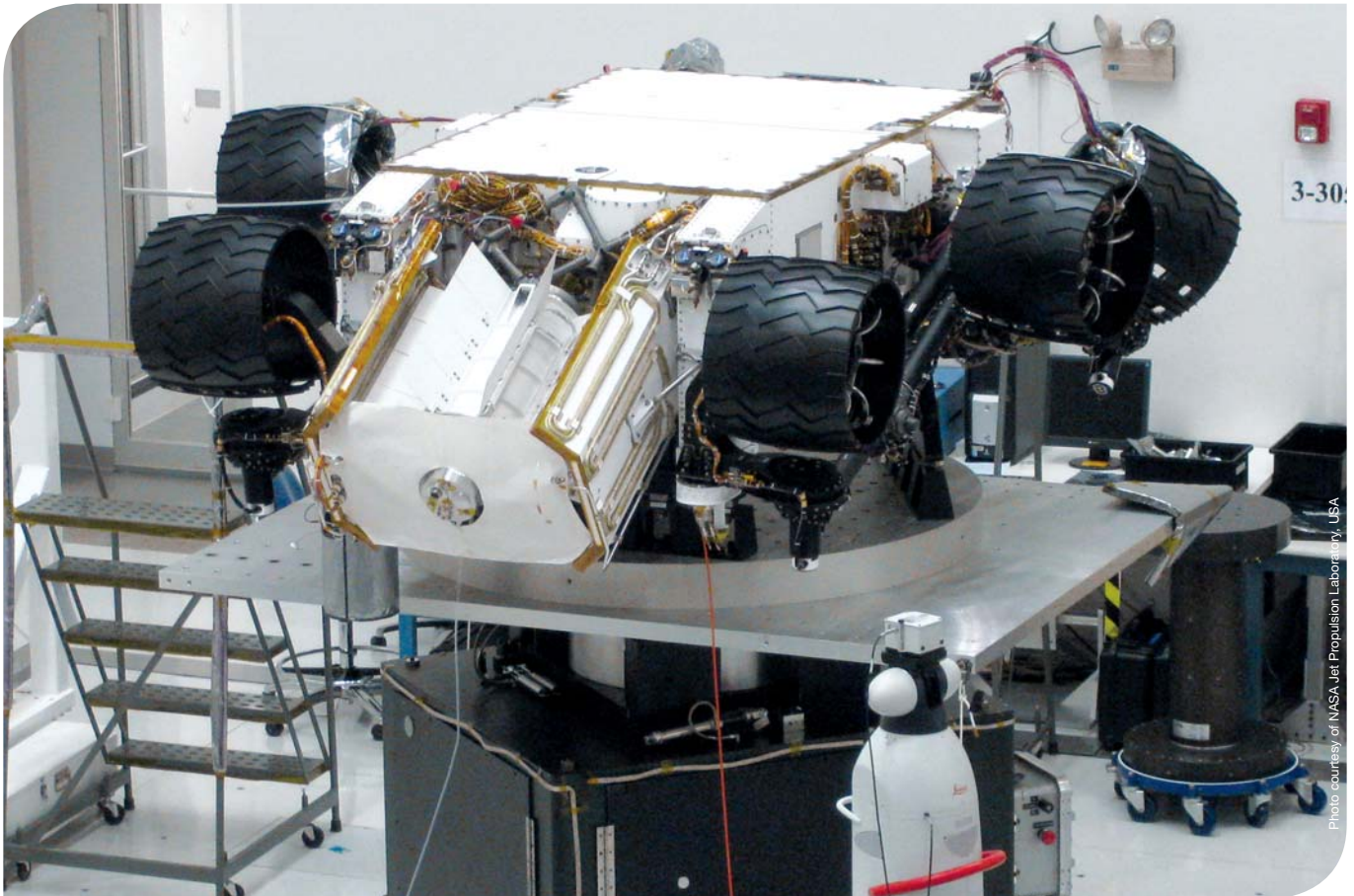

Whether for independent monitoring or just adding additional channels to an existing vibration controller, m+p SO Analyzer provides an ideal solution for measuring vibration and other responses during a shaker test or with shock machines.

## Random Vibration

Power Spectral Density (PSD) data with single or multiple average results can be computed during the vibration test run. m+p SO Analyzer's "scope mode" allows pre-monitoring of the test start-up before averaging starts and averages can be manually reset if required during the process. Transfer functions, coherence and many other functions can be easily included for a more thorough analysis of the test

data. Sampling frequency and windowing can be selected for full compatibility with the vibration controller.

## Swept Sine Vibration

m+p's expertise in vibration control technology has been embedded into m+p SO Analyzer to give accurate and fully compatible swept sine tracking results using the COLA output reference. Sampling, bandwidth and result estimator filters can all be selected to match the controller or indeed used to provide alternative higher resolution results for example. As with all test modes time history recording can be run in parallel for post-processing or detailed sequence of event analysis. Post-processing of both m+p VibControl and m+p SO Analyzer time history recordings provide the



## YOUR BENEFITS

- Independent response channel monitoring for test data security
- Cost effective for addition of large number of monitoring channels
- Fully compatible results with vibration controller so easy to combine data
- Data reduction in all test modes for flexibility and integrity
- Throughput to disc recording at any sample frequency
- Powerful sequence of event analysis on largest of time history files
- Integrated modal analysis for on-the-spot mode shape animation
- Import many types of vibration controller data for integrated reporting
- Built-in m+p VibControl test report templates
- Utilize same hardware as m+p VibControl for improved hardware utilization

opportunity to re-analyze data runs with different settings such as filter bandwidth, etc. as well as doing sequence of event analysis of a premature test abort.

### Classical Shock

For use with shaker tests, drop tables, pneumatic hammers or any other shock machines the classical shock capture wizard enables the full test specification to be entered and overlaid with the measurements. Control and response channels can be independently filtered in real time to avoid out-of-band noise and the result limit overlays are automatically adjusted to best fit the triggered shock waveform. Calculations are also done of pulse duration, peak amplitude, velocity change and within limits so that these data and their pass/fail criteria are displayed for each pulse immediately on capture. Special report templates that handle control and triax response channels automatically make for very rapid report generation.

### Shock Response Spectrum

Online and offline wizards are available to cover all aspects of capturing and reporting SRS data. These can be used with shaker or shock machine testing and include limit overlays for instant test assessment and report generation. As well as real-time low pass filters the online wizard computes the standard maximax results whereas the offline wizard computes all intermediate SRS functions as well as displaying the actual time response waveforms at each frequency for the most detailed of analyses.

### Throughput to Disc Recording and Post-Processing

All test modes allow in-parallel throughput to disc recording so that the raw sample data is available for post-test analysis. This is particularly useful for sequence of event analysis if the vibration test should abort mid-test. Multi-gigabyte file sizes can be easily and quickly reviewed and

zoomed for detailed cross channel analysis. Peak time histories can be computed and kurtosis time history provides a more sensitive identification of transient events in the data. Furthermore all data reduction test modes can be re-run on the recorded data for more detailed analysis using alternative settings.

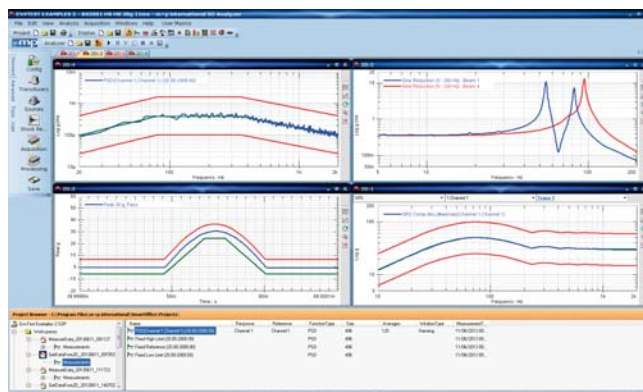

Advanced analysis of shaker test data imported from m+p VibControl system

Shock Response Spectrum testing using an impact hammer



Photo courtesy of German Aerospace Center (DLR), Germany

# Vehicle Pass-by Noise Testing



Photo courtesy of Cooper Tire, USA



## YOUR BENEFITS

- Complete system for vehicle PBN homologation – everything you need in one package
- Unique high-resolution GPS means no need for radar, light trigger or track location sensors for rapid setup
- One person operation from driver's seat with automatic trigger of data runs
- Integrated data base of results and fully compliant reports
- Satisfies requirements of vehicle and tyre measurement standards and procedures
- Built-in calculators, guidance and validation for vehicle types, weight and power requirements
- Detailed 3D waterfall analysis for noise source ranking and identification
- System built from standard m+p SO Analyzer components so can be used for all other N+V applications

Manufacturers have to certify that their vehicles comply with the strict international noise emission standards. Our market-leading pass-by noise testing system based on m+p SO Analyzer uses GPS components for both position and velocity information, thus providing maximum accuracy and repeatability. It allows full operation from within the car by just one person. The portable system frees the user from cumbersome and error-prone manual triggers and radar guns and allows immediate reverse runs and instantaneous pass/fail criteria.

The in-car system can be configured prior to entering the test track, the out-car system simply needs connection to the sound meters and weather station.

A plot of the vehicle track is shown to the driver upon run completion along with vehicle entry and exit speeds and full throttle position, data can be accepted or rejected depending on the values shown. At any time the driver can combine and analyse the results from both the external and internal systems to show full noise, speed, throttle and acceleration data. Noise levels include overall and spectral waterfall maps that can be displayed relative to the microphone and track position.

The portable acquisition system is fully expandable to cover other NVH, modal, rotating machinery and acoustic analysis requirements when not in use for pass-by noise testing.

GPS-based pass-by noise test solution supporting single operator usage

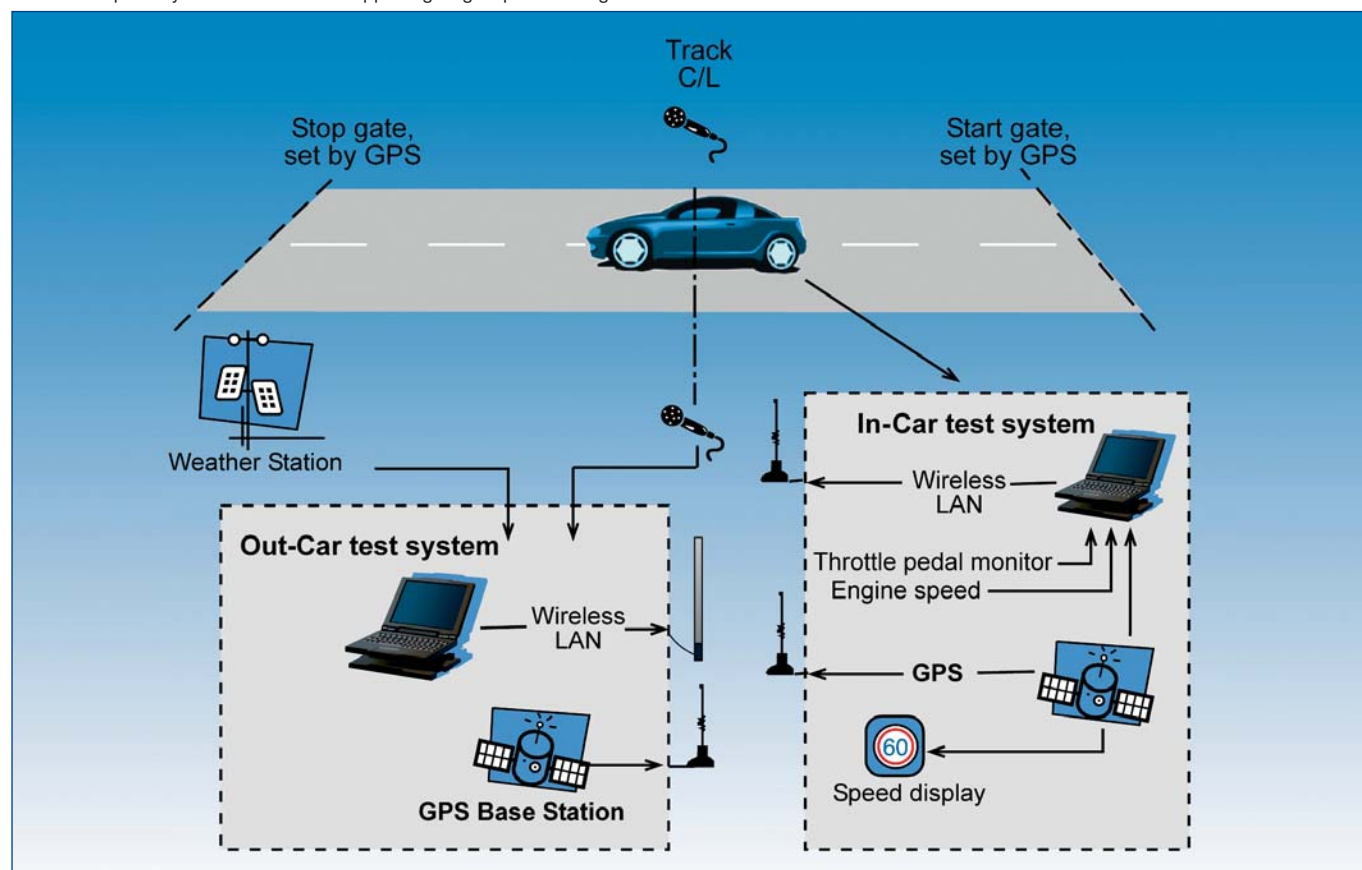

# Ordering Information Noise and Vibration Analysis

## m+p SO Analyzer eReporter Signal Analysis and Reporting Software System

<b>SO-eRstd</b>	<b>SO2001</b>	<b>SO eReporter Standard,</b> 2D, 3D, Import/Export SOT/RPC3/UFF/VibCo (To add Calculator, User Programming, Reporting Wizard, Extended Data Import/Export – see SO-eRpro)
<b>SO-eRpro</b>	<b>SO2002</b>	<b>SO eReporter Pro,</b> SO-eRstd plus Calculator wizard, User Programming & Macros, ActiveX Reporting Wizard, all Data Import/Export Filters (To add Geometry/ODS see SO-eODS)

## m+p SO eReporter Post-Processing add-on applications (Only available with SO-eRstd & SO-eRpro)

SO-eTH	SO1352	DSP Post Processing of time history data; ≤16 channels; SO-8ch+ required for >16 channels (For VibCo includes Random Reduction. To add Sine & Shock Reduction modes see SO-SINR, SO-SC, SO-SRS)
SO-eODS	SO1451	Post Test – Geometry Creation & ODS Animation; channel count unlimited
SO-eMDOF	SO1452	Post Test – Modal Analysis, Circle, SDOF, MDOF & MMV; channel count unlimited
SO-eROT	SO1552	Post Test – Tacho Fit, RPM Mapping & Order Tracking wizards; channel count unlimited
SO-eACOU	SO1652	Post Test – Acoustic, Fractional Octave Analysis (requires SO-eTH)

## m+p SO Analyzer DSA Dynamic Signal Analysis Software Modules

<b>SO-DSAstD</b>	<b>SO2010</b>	<b>SO Analyzer DSA Standard,</b> Real time FFT Acquisition, Analysis & Copy/Paste Reporting, 2D, 3D, Import/Export SOT/RPC3/UFF/VCP up to 16 input channels and one type of front-end drivers supported; specify VibPilot/VibRunner/NI/VXI; TEDS support for front-end; includes SO-eRstd eReporter Standard; for VibCo incl. Random Reduction; to add Sine & Shock Reduction modes see SO-SINR, SO-SC, SO-SRS
<b>SO-DSAprO</b>	<b>SO2011</b>	<b>SO Analyzer DSA Pro,</b> Real Time FFT Acquisition, Analysis & Auto Reporting, 2D, 3D, all Data Import/Export Filters, Time History Recording, Off-line Post Processing of time history files, Calculator, User Programming & Macros, Analog Tacho Inputs with manual spectral mapping, Order cuts using 3D chart up to 16 input channels and one type of front-end drivers supported; specify VibPilot/VibRunner/NI/VXI; TEDS support for front-end; includes SO-eRpro eReporter Pro; for VibCo incl. Random Reduction; to add Sine & Shock Reduction modes see SO-SINR, SO-SC, SO-SRS

## m+p SO Analyzer DSA Dynamic Signal Analysis add-on applications

SO-ACOU	SO2110	Real-Time Acoustic Analyser (fractional octave filters)
SO-8ch+	SO2111	Add n-times 8 input channel driver to support a total of up to 24/32/40/48/... Channels
SO-FED+	SO2112	Additional front-end hardware driver; specify VibPilot/VibRunner/NI/VXI
SO-SI	SO2114	Sound Intensity Measurement; requires dual microphone probe



SO-TL	SO2115	Temperature logging with NI 9211 or NI 9233, supported with any other measurement front-end
<b>m+p SO Analyzer DSA Dynamic Signal Analysis: Structural application add-ons</b>		
SO-ODS	SO2201	Guided Hammer Impact measurement wizard, Geometry creation & ODS Animation
SO-MDOF	SO2202	Modal Analysis pack: Guided Hammer Impact, Geometry Creation & ODS Animation, Circle, SDOF, MDOF pLSCE curve fitters & MMV
SO-MM	SO2203	MIMO Measurement & Analysis Module incl. multi-source outputs (requires SO-MDOF)
SO-PRF	SO2204	Advanced Frequency Domain Curve Fitter pLSCF and optimized pLSCE (requires SO-MDOF)
<b>m+p SO Analyzer DSA Dynamic Signal Analysis: Rotate application add-ons</b>		
SO-ROT	SO2301	Real time Tacho based spectral mapping & Order tracking measurements plus off-line Tacho spline fit, RPM Spectra Mapping & Order tracking wizards.
SO-OA	SO2302	Orbit Analysis Wizard (off-line)
<b>m+p SO Analyzer DSA Dynamic Signal Analysis: Advanced application add-ons</b>		
SO-SSO	SO2401	Stepped Sine online analysis with multiple source control
SO-SINR	SO2402	Sine Reduction analysis with multiple source control
SO-SRS	SO2403	Shock Response Spectra (SRS) analysis with limit overlays (on-line & advanced off-line wizard)
SO-AIM	SO2404	Acoustic Intensity mapping with measurement and 3D colour mapping wizard, requires SO-ACOU + SO-SI
SO-N2216D	SO2405	N2216 driver – Embedded VXI SCSI Disc Throughput Pack
SO-SC	SO2406	Shock Capture with classical shock test limit overlays (Classical Shock Reduction)
SO-PBN	SO2407	Pass-by Noise measurement and analysis wizard
SO-SQ	SO2408	Loudness & Intelligibility analysis (sound quality based on Zwicker loudness) FFT-based or 1/3 Octave with option SO-ACOU
SO-EX1629D	SO2409	EX-1629 Strain Conditioning driver
SO-TADIOD	SO2410	Test automation and digital I/O drivers
SO-NETL	SO2411	SO-NetLic Network Based concurrent licensing server and clients
SO-NETLF	SO2412	SO-NetLic floating (detachable) licensing
SO-SPA	SO2413	Sound Power analysis to ISO 374x including ECMA 74 Tonality (both require SO-ACOU). Additionally with SO-SI includes ISO 9614-2 Sound Power methods and Sound Transmission Loss
SO-GVT	SO2414	GVT test pack with On-Line Normal Mode Tuning and including SO-SINR (SineReduction) + SO-SSO (Stepped Sine)
<b>m+p SWplus Software Maintenance</b>		
<b>SWplus12</b>		m+p SWplus VibControl, SO Analyzer or Coda Software Maintenance Contract for 12 Months including Software and Electronic Literature Update Service and Hotline Support
<b>SWplus24</b>		m+p SWplus VibControl, SO Analyzer or Coda Software Maintenance Contract for 24 Months including Software and Electronic Literature Update Service and Hotline Support
<b>SWplus36</b>		m+p SWplus VibControl, SO Analyzer or Coda Software Maintenance Contract for 36 Months including Software and Electronic Literature Update Service and Hotline Support

# DATA ACQUISITION









# Continuous Data Acquisition, Signal Analysis and Process Monitoring



Photo courtesy of Siemens AG, Germany



## YOUR BENEFITS

- Complete turnkey solution for highest test efficiencies
- For mobile and stationary data acquisition and monitoring
- Scalable from small to high channel counts to match your test requirements
- Select your preferred acquisition hardware from a wide range of supported Ethernet, LXI, VXI and USB instruments
- Sample rates from 1 Hz to 125 kHz
- Client/server architecture enables shared online access to acquired data from several PCs
- Support of all common types of transducers and sensors
- Automatic instrument identification and configuration for fast and easy test set-up
- Full-featured alarm monitoring and event handling increase user confidence and reduce the amount of operator supervision needed
- Different user interface languages supported
- Standalone data acquisition for environments where PCs cannot go

m+p Coda is a full-featured software platform for data acquisition, signal analysis and monitoring. Complete turnkey operation provides quicker time to test by eliminating costly application programming and long learning curves. The extensive built-in features and tools offer a functionality that was previously available only in custom packages. The intuitive GUI facilitates set-up, operation and analysis, thus leading quickly to precise, repeatable results.

### Extensive Application Coverage

Thanks to its modular structure and easy parameterization, m+p Coda is the perfect solution for a wide range of measurement applications in industry and in the laboratory:

- Measurements and data analysis on test stands and test assemblies
- Performance and functional tests of turbo-compressors, gas and steam turbines, jet engines, rocket engines, gearboxes, generators
- Experimental structural testing, multi-axis strain and stress analyses
- Process monitoring in power plants, in refineries, on production lines
- Vibration monitoring during shaker tests
- Condition monitoring
- Standalone data acquisition applications

The acquisition system processes virtually every physical quantity, for example: temperature, voltage, stress, strain, pressure, force, acceleration and frequency. Even high-channel count applications using thousands of channels can be configured within a very short time and are handled safely and efficiently.

Features include measurements with single- and multi-channel strain gauges, real-time strain and stress calculations, limit checking and communication with the load control system.

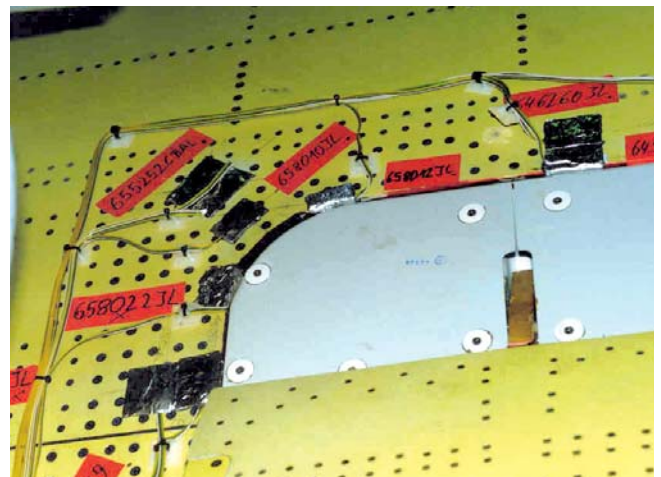

Strain gauge measurements on an aircraft

Performance and functional tests of turbines

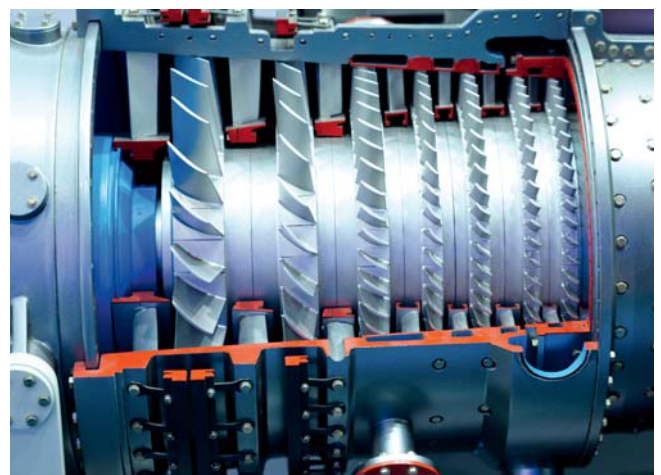

Data Acquisition Units USB/Ethernet/VXI/LXI

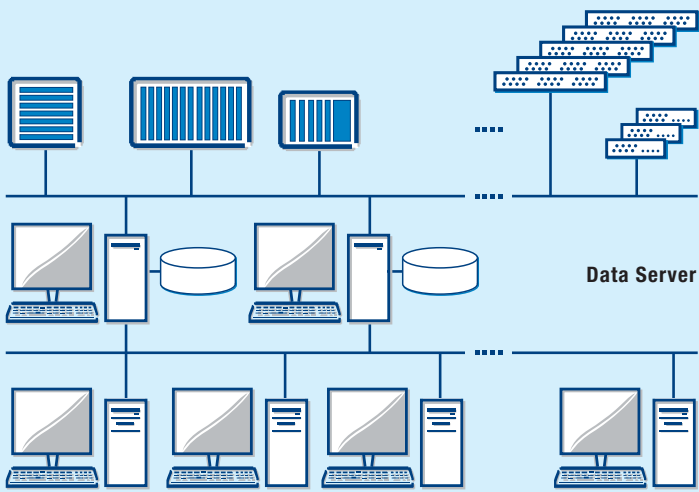

PC Clients: Engineers' Workstations

**Support of Highly Accurate Instrumentation from Established Manufacturers**

For highest system flexibility m+p Coda supports a range of powerful USB, Ethernet, LXIbus and VXIbus-based instruments from m+p international and other manufacturers. These instruments are known for their high performance, measurement accuracy and reliability. Users can select their preferred acquisition hardware for any test size. Other or existing acquisition devices can be easily integrated and communication with subordinate process computers for data transfer is also provided.

**Client/Server System**

The client/server architecture allows several test engineers to have concurrent online access to the acquired data for display and analysis operations. The online server approach also ensures reliable data archival and retrieval with integrated error diagnostics to guard against connection and data access issues.

**Scalable System for Thousands of Channels**

The scalable architecture makes this package ideal for any test size, from tens to thousands of channels. High-channel count systems can be easily configured and are ready to test within a very short time.

**Standalone Data Acquisition**

For standalone applications m+p Coda is used with acquisition hardware running a standard Linux operating system. This eliminates the cost of a dedicated host PC. Just make your acquisition settings in the software and download them via Ethernet. The applications will be deployed on the acquisition hardware and run fully standalone. The data will be stored on SD, SSD or other HDDs supporting large data sets and high throughput rates. Later you can import this data into the m+p Coda software for visualization and post-processing.

**Powerful Data Management**

Configuration data are stored in a central SQL database for maximum flexibility and repeatability. m+p Coda stores and processes the acquired data in its uniform data model. Even different sampling rates for data groups or data acquired asynchronously are permitted. As a rule, the measured raw data are always stored to ensure access to the original data at any time.

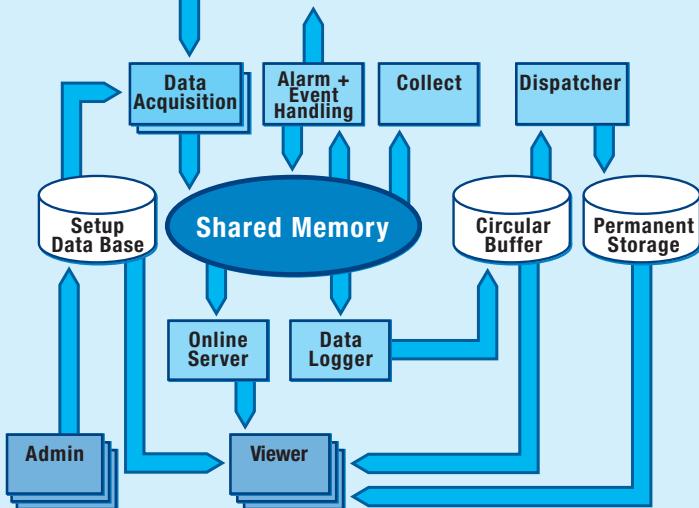
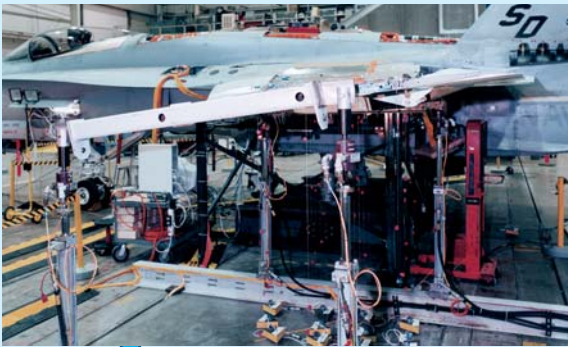



### Automatic Instrument Identification and Channel Configuration

Using a simple mouse-click, the connected measurement hardware is listed and the number of connected channels is identified. A channel configuration wizard, with user-definable default values, is available.

### Measurement Functions

m+p Coda supports 1/4-, 1/2- and full-bridge configurations, rosette type sensors, standard thermocouple types (J, K, T, E, S, R, B, N, and user-definable) as well as voltage and current transducers. During the test run the relative zero point (or reference) of all or selected channels can be acquired at any time. A GPS receiver can also be connected for time and location information.

### Data Storage

Powerful storage functions allow for comprehensive data management and temporary or permanent, preprogrammed or event-controlled data storage for all or selected channel groups.

### Channel Grouping

Acquired data and computed channels can be freely combined in user-definable groups for subsequent analyses.

### Real-Time Alarm Monitoring

Full-featured limit checking and alarm monitoring capability for all active channels. Out-of-limit data is displayed in a separate window and logged.



GPS receiver provides time and location information



Alarm window: Full-featured alarm monitoring allowing the user to see the current status at a glance

**“We found m+p a capable and experienced engineering partner to develop and realize a state-of-the-art measurement system for our turbomachinery test field. They were able to integrate our existing proven and reliable software package for thermodynamic analysis into their Coda solution and to successfully implement our new highly efficient data acquisition and monitoring system.”**

Manfred Praus, Manager of the Metrology and Electrical Assembly Department at Siemens AG, Duisburg, Germany

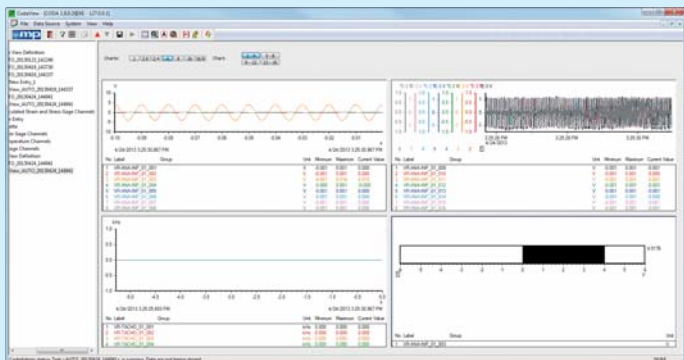

CodaView windows: Displaying the channels in a multitude of ways

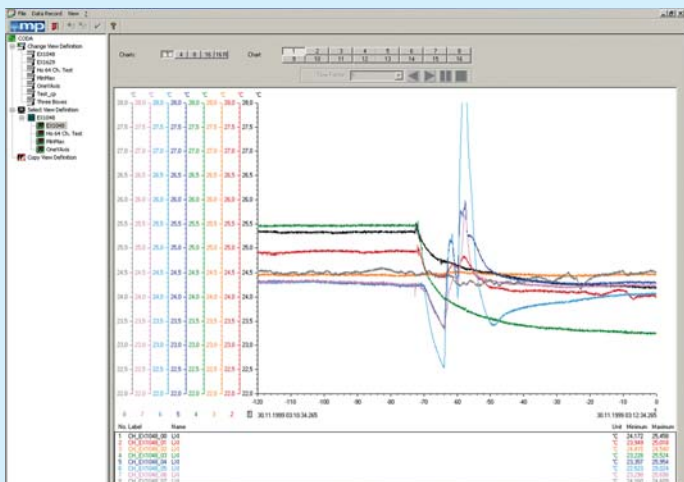

### Comprehensive Visualization

As with the online data analysis, the measured values can be graphically displayed in a y/t- or y/x-diagram, as bar chart, tachometer, waterfall, FFT, PSD or digital numbers by a simple mouse-click. m+p Coda allows the user to design individual graphical interfaces for real-time measurement and visualization.

### Replay Function

This function allows events to be reviewed without affecting the live acquisition process. Adjustable forward/reverse and speed make replay easy. All graphical online functions are available during the data replay.

### Standardized Data Interfaces

m+p Coda has standardized data interfaces which enable easy integration of different measurement devices, acquisition of data coming from process control systems (e. g. via LAN, FireWire, etc.), and synchronization of various data sources.

### Advanced Analysis and Reporting

Convenient analysis tools are included for viewing measured data. The ultimate step is using the m+p eReporter software. It provides test engineers with powerful tools for the most demanding analysis and reporting tasks.

### Data Export

The formatted data of selected or all channels can be easily exported into Excel, ASCII, MATLAB, m+p SO Analyzer or other popular analysis packages.

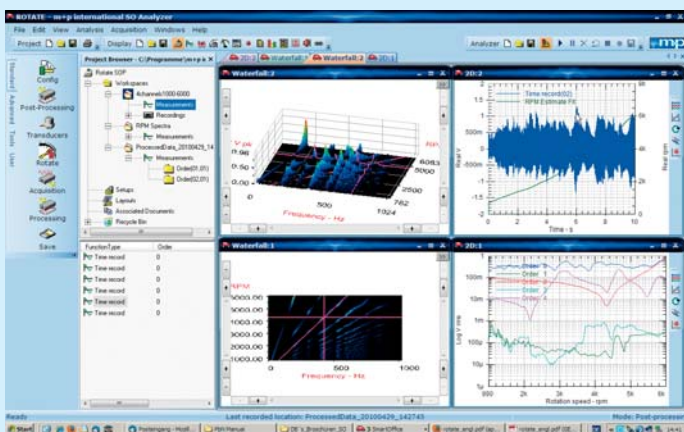

Extensive analysis of acquired data using m+p SO Analyzer



# Ordering Information Data Acquisition

## m+p Coda Continuous Data Acquisition, Signal Analysis & Process Monitoring Software System

<b>CDbase</b>	Coda Basic licence for $\leq 48$ channels, single PC client/server configuration 48 plugged and logical channels, max 10 kHz per channel
---------------	---

## m+p Coda system and channel upgrade

CD-48ch+	Increment licence to upgrade Coda by additional 48 channels
CD-CLNT	Upgrade for existing Coda licence by additional licence for 1 client
CD-DYN	To support $> 10$ kHz per channel
CD-OPC	OPC interface to send data to external systems and get commands from external systems (like save/unsave data)
CD-SA	Interchange configurations and data with the UEI standalone systems UEIPAC600/1200

## m+p Coda application add-ons

CD-Advance	Take snapshots, print test runs, defines calculated channels with Coda Channel Calculator
CD-Export	Export data to Excel, Matlab, ASCII and SOT
CD-FFT	FFT, PSD and waterfall views
CD-Strain	Strain and stress calculations including rosettes
CD-DLL	Add DLL's with customized functions for virtual channels

## m+p SWplus Software Maintenance

<b>SWplus12</b>	m+p SWplus VibControl, SO Analyzer or Coda Software Maintenance Contract for 12 Months including Software and Electronic Literature Update Service and Hotline Support
<b>SWplus24</b>	m+p SWplus VibControl, SO Analyzer or Coda Software Maintenance Contract for 24 Months including Software and Electronic Literature Update Service and Hotline Support
<b>SWplus36</b>	m+p SWplus VibControl, SO Analyzer or Coda Software Maintenance Contract for 36 Months including Software and Electronic Literature Update Service and Hotline Support

# TEST STAND ENGINEERING

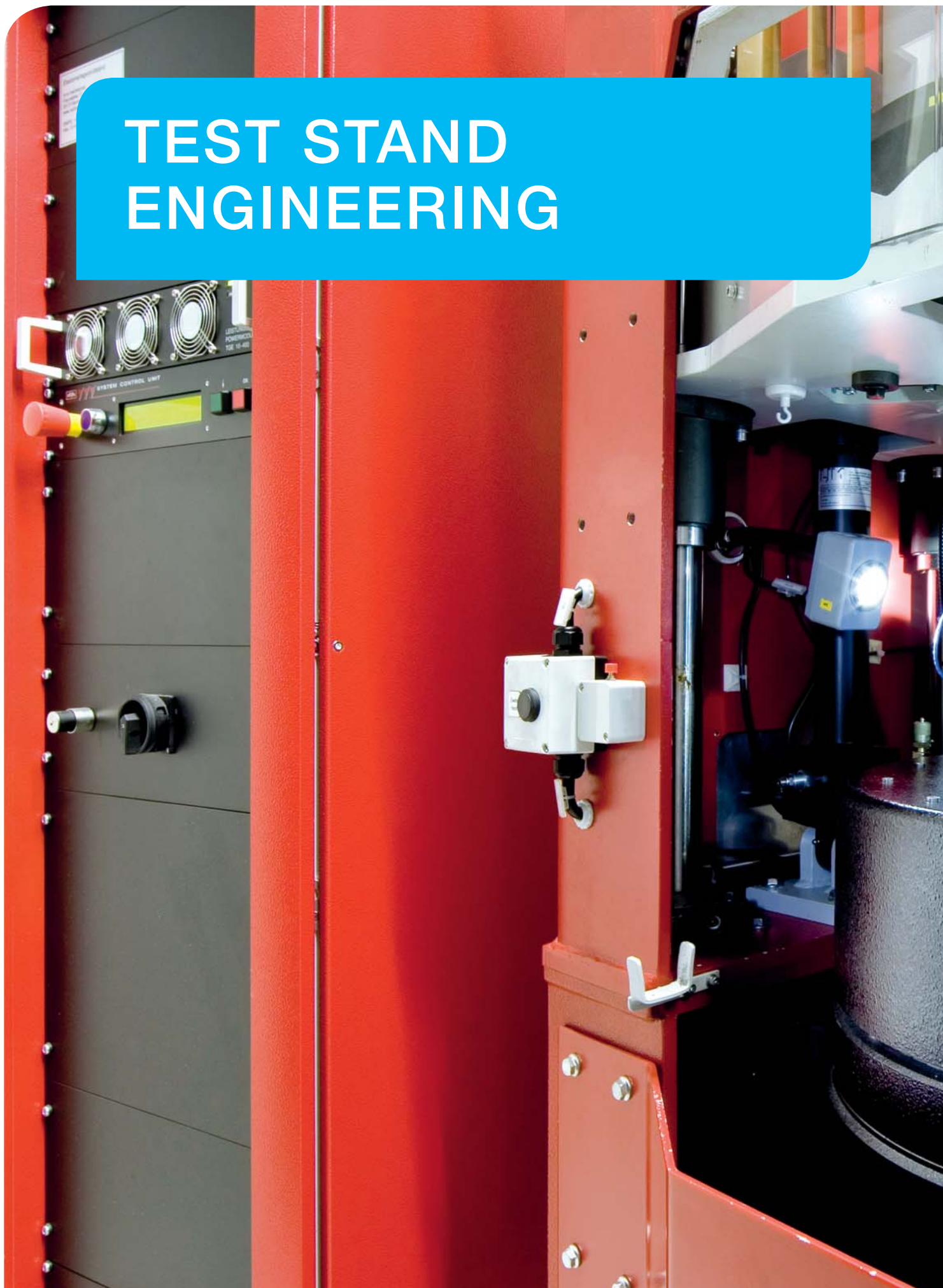



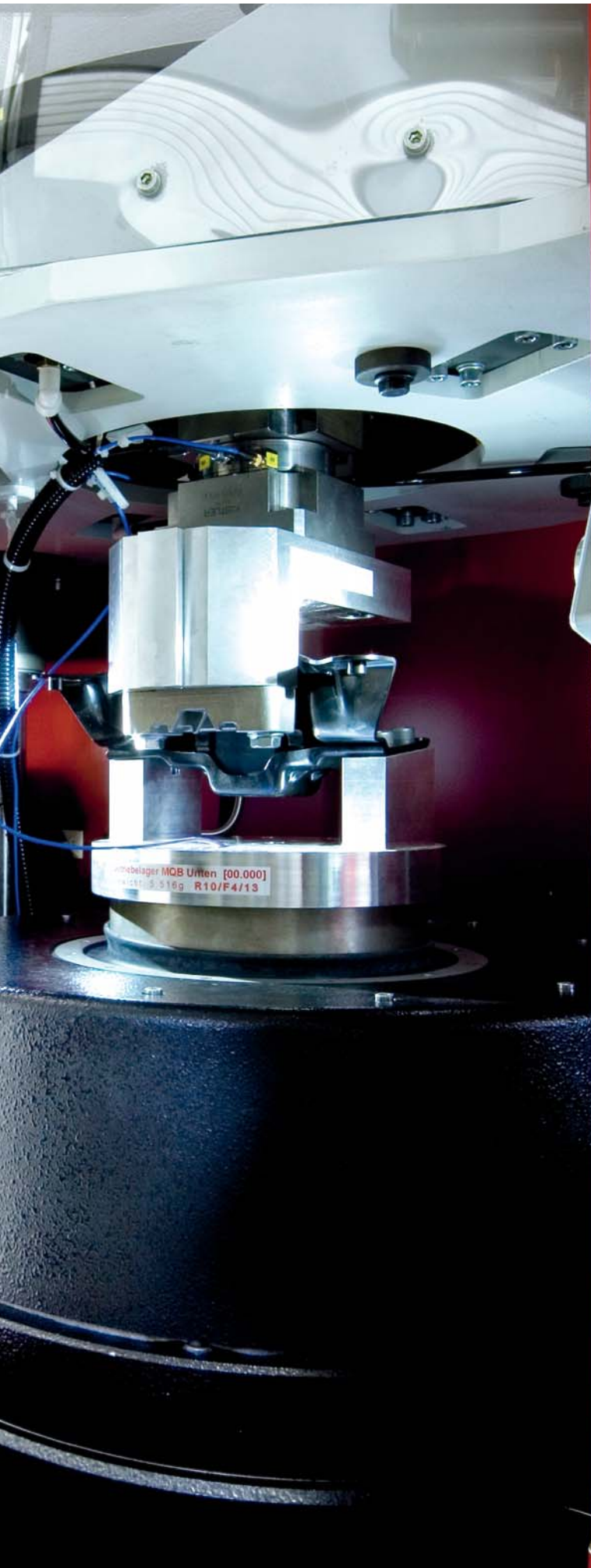

Photo courtesy of Volkswagen AG, Germany





### Solutions Focused on Your Specific Requirements

m+p international has been designing, developing and fabricating customized solutions for functional test stands in key industries for many years. Our engineers apply the latest engineering techniques and a broad range of know-how and experience to create innovative test stand solutions.

A multitude of successfully implemented test stand projects bear witness to our expertise, examples of which include:

#### High-frequency test stand for engine and transmission mounts in vehicle acoustics Volkswagen AG, Wolfsburg, Germany

m+p international developed a high-frequency test stand for Volkswagen to investigate the transmission behaviour of engine and transmission mounts in a frequency range up to 2,000 Hz. The electrodynamic shaker is suspended in a welded test stand frame where it is vibration-isolated. The m+p VibControl system is used for vibration control, data acquisition and analysis in an automatic test operation. Volkswagen commissioned m+p international to plan and build the complete vibration test stand. (left)

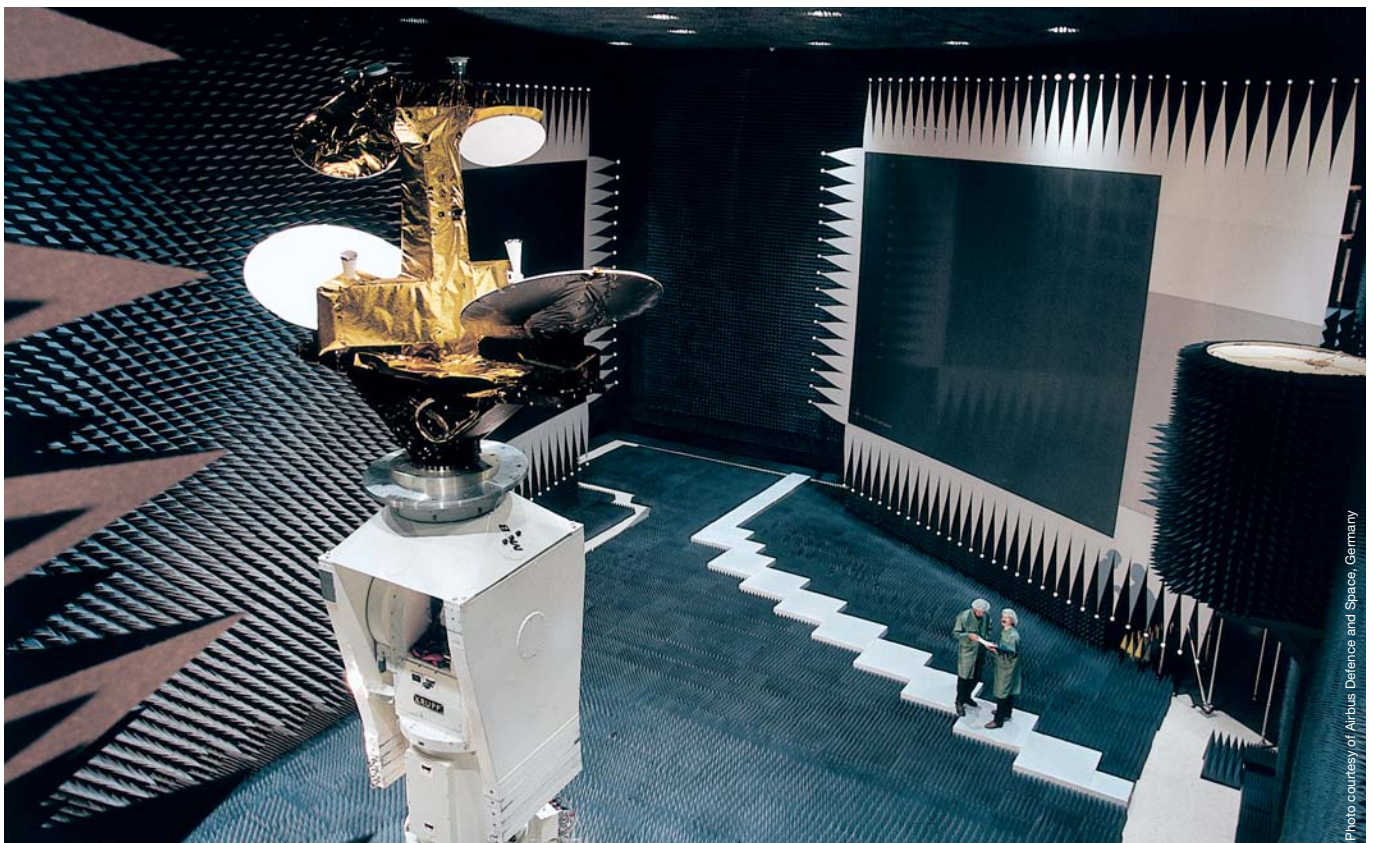



### Test system for airbag electronics

Autoliv, Pontoise, France

Autoliv is a Swedish-American company which develops and manufactures automotive safety systems such as airbags, seatbelts and child restraints. At its location near Paris, two m+p VibControl systems are used to test airbag electronics. The control software replicates the crash pulses and controls the electrodynamic long-stroke shakers. For advanced testing using a higher number of crash detectors on two shakers, the m+p VibControl systems are synchronized. (right)



### Turbomachinery test facility

Siemens AG, Duisburg, Germany

At its turbomachinery test facility in Duisburg, Germany, Siemens has been successfully utilizing a range of m+p Coda systems for continuous data acquisition, data processing and real-time monitoring for several years. They acquire and verify not only the performance data and thermodynamic parameters but also the vibration data of the turbocompressors. A single stationary data acquisition unit acquires up to 168 process signals and 48 vibration signals. A mobile, rugged 96-channel m+p Coda system is used for on-site turbomachinery testing under original process conditions. (right)

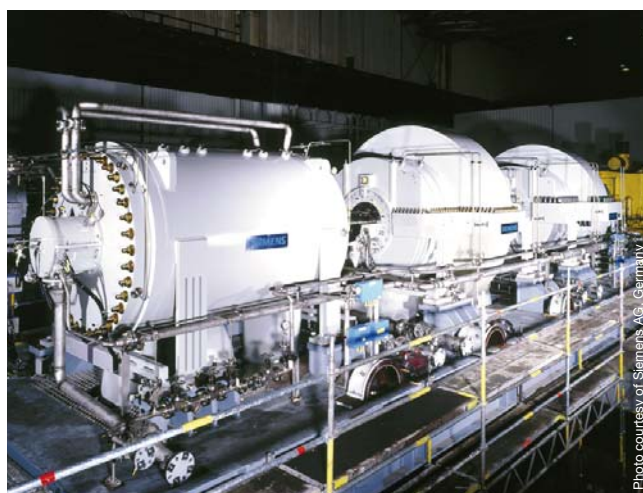

### Antenna measuring range

Airbus Defence and Space, Ottobrunn, Germany

The European space company Airbus Defence and Space developed and built the world's largest antenna measuring range. The antenna measuring range simulates the geostationary satellites' distance of 36,000 kilometres from earth in a 30-metre-long measuring chamber. Airbus Defence and Space, Ottobrunn, Germany awarded m+p international a contract for the required upgrade of the AAMS (Advanced Antenna Measurement System) software. The AAMS system comprises monitoring and control functions for the antenna set-ups, data acquisition, processing, analysis as well as the creation of graphical reports and test logs. (left)

### Evaporative emission testing

INERGY, Brussels, Belgium

Emissions from vehicles do not only come from the exhaust produced by the engine but also evaporate from the rest of the vehicle (mainly the fuel systems). Activated carbon canisters prevent evaporative emissions escaping into the environment from the fuel tank. Our canister conditioning and test systems are used to automatically pre-condition (e.g. purge and load) vehicle canisters. The system meets all EPA/CARB requirements for emission canister conditioning using proven and safe butane/nitrogen procedures. (right)

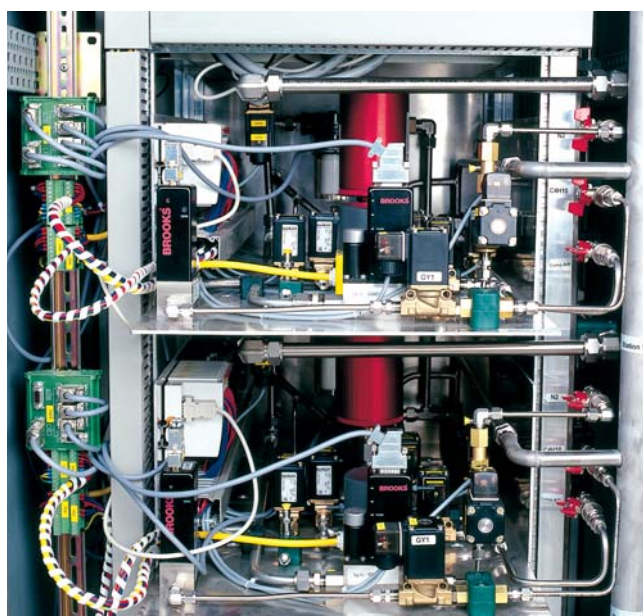

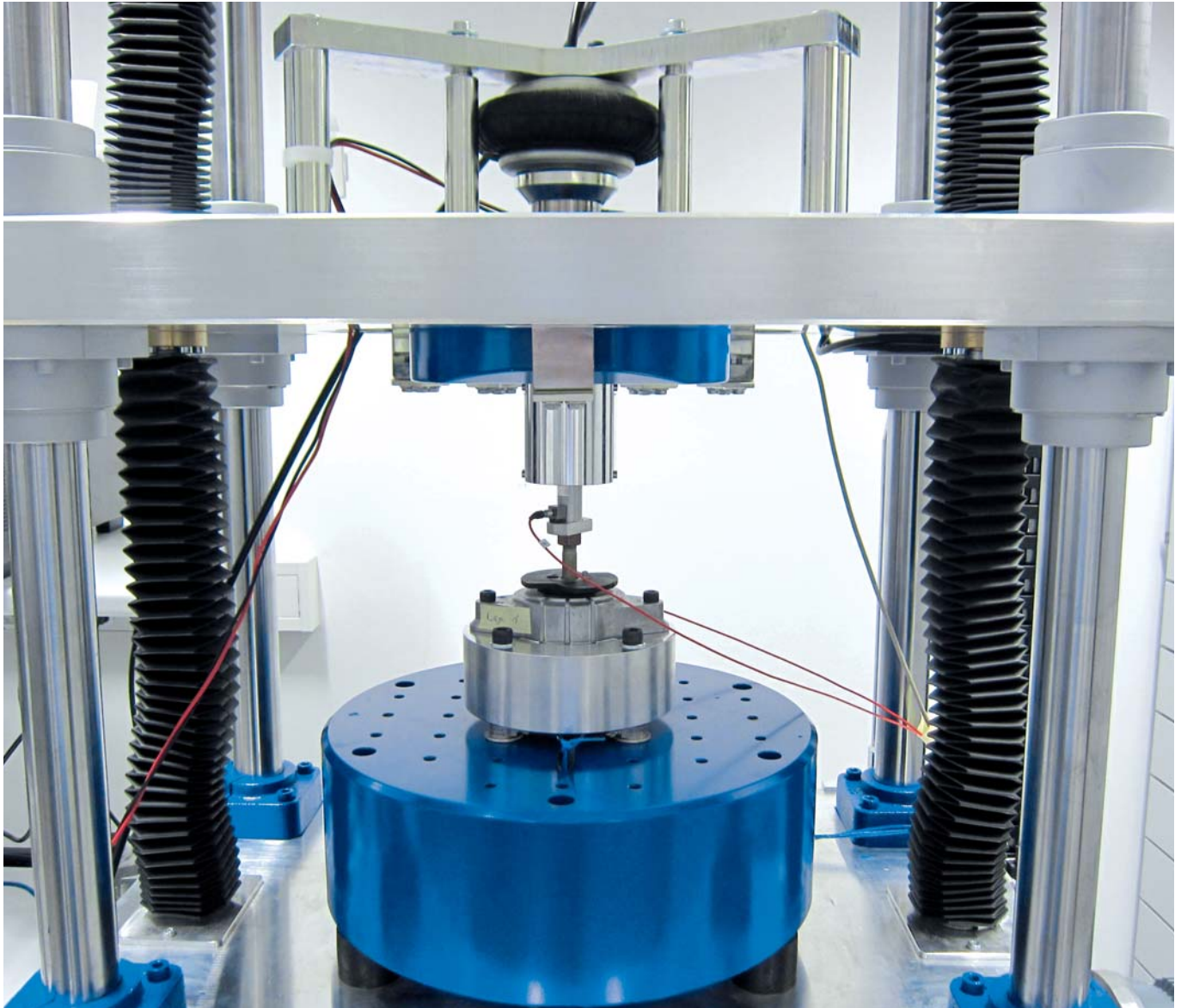

High-frequency vibration test stand

On the previous pages we have demonstrated our activities in the field of custom-made vibration and functional test stands. These test stands are built in close co-operation with our customers in accordance with their requirements and specifications. Often venturing into uncharted technological terrain, these requirements are frequently at the limits of what is technically possible.

Our engineering department responsible for building test stands has the expertise, experience and all resources necessary to design and construct such test stands, as well as verifying their performance. We would be pleased to offer our services for strength and vibration calculations on your components according to your engineering drawings, e.g. for fixtures used for vibration testing. We can also carry out the complete design, construction and calculation for you and provide drawings and CAD data sets for production. And it's no problem if you want the finished

components: the fabrication shops we work with are very reliable and produce high quality work.

The m+p SO Analyzer which is also described in this Product Guide is a high-performance product for the measurement and analysis of mechanical and acoustic vibrational problems. If you have a staff shortage or do not have the required equipment, we can carry out these evaluations for you. We provide the equipment and experienced measurement engineers at your site or wherever you wish. The results are presented in comprehensive reports. If desired, we can help you to evaluate the results and advise on appropriate improvement measures.

We offer our engineering services at a fixed price. You determine the range of services, the time frame and the budget. This provides you with a sound basis for calculating your project costs. Call us and see for yourself!



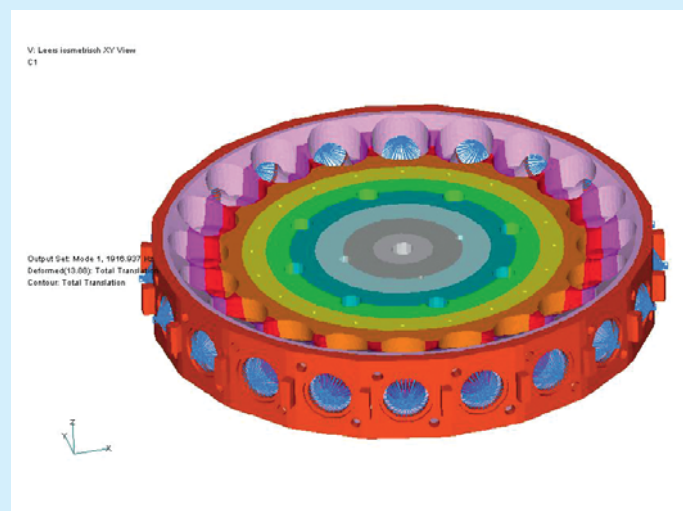

Lamp fixture for vibration testing

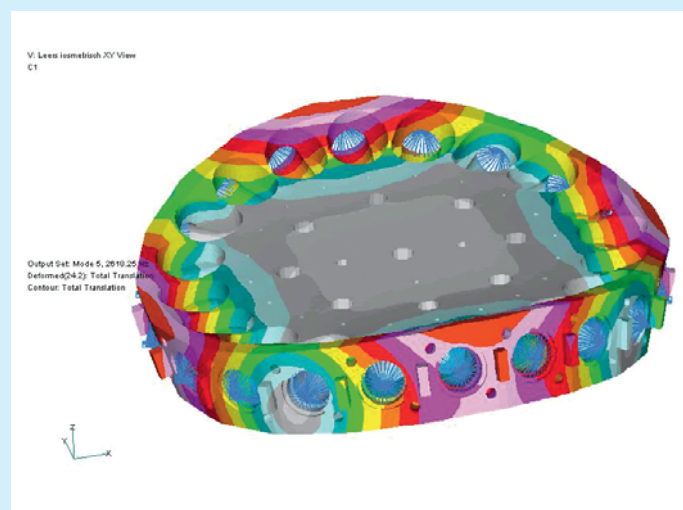
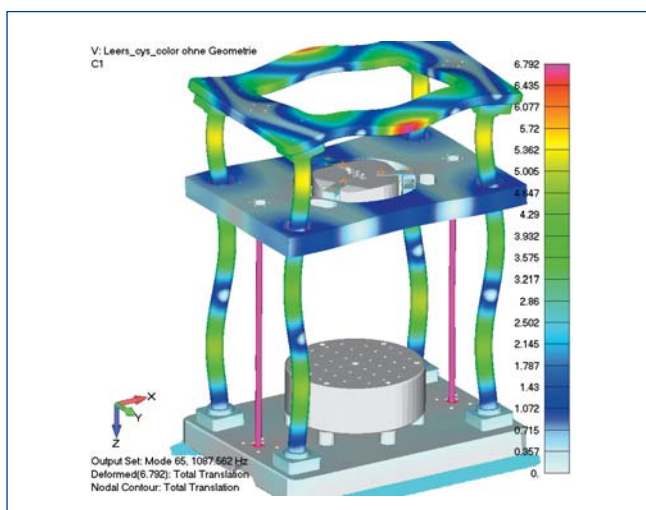

Our engineering services include:

- Design, conception, construction and manufacturing of components, rigs, test stands
- Preparing drawings and CAD data sets for manufacturing
- Vibration and strength calculations (FEM)
- Vibration measurements, analysis and evaluation, modal analysis
- Strain gauge measurements on statically and dynamically stressed components and buildings, plus analysis and evaluation as well as determination of the spatial stress condition
- Advice in metrological problems, evaluation and optimization of components, including damage analysis, especially on welded constructions
- Supply and rental of equipment for vibration and strain gauge measurements including the required measurement analysis and evaluation software

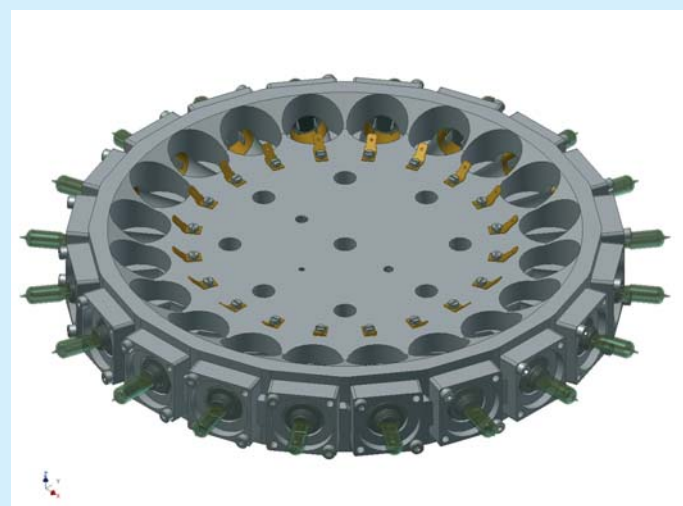

# MEASUREMENT HARDWARE

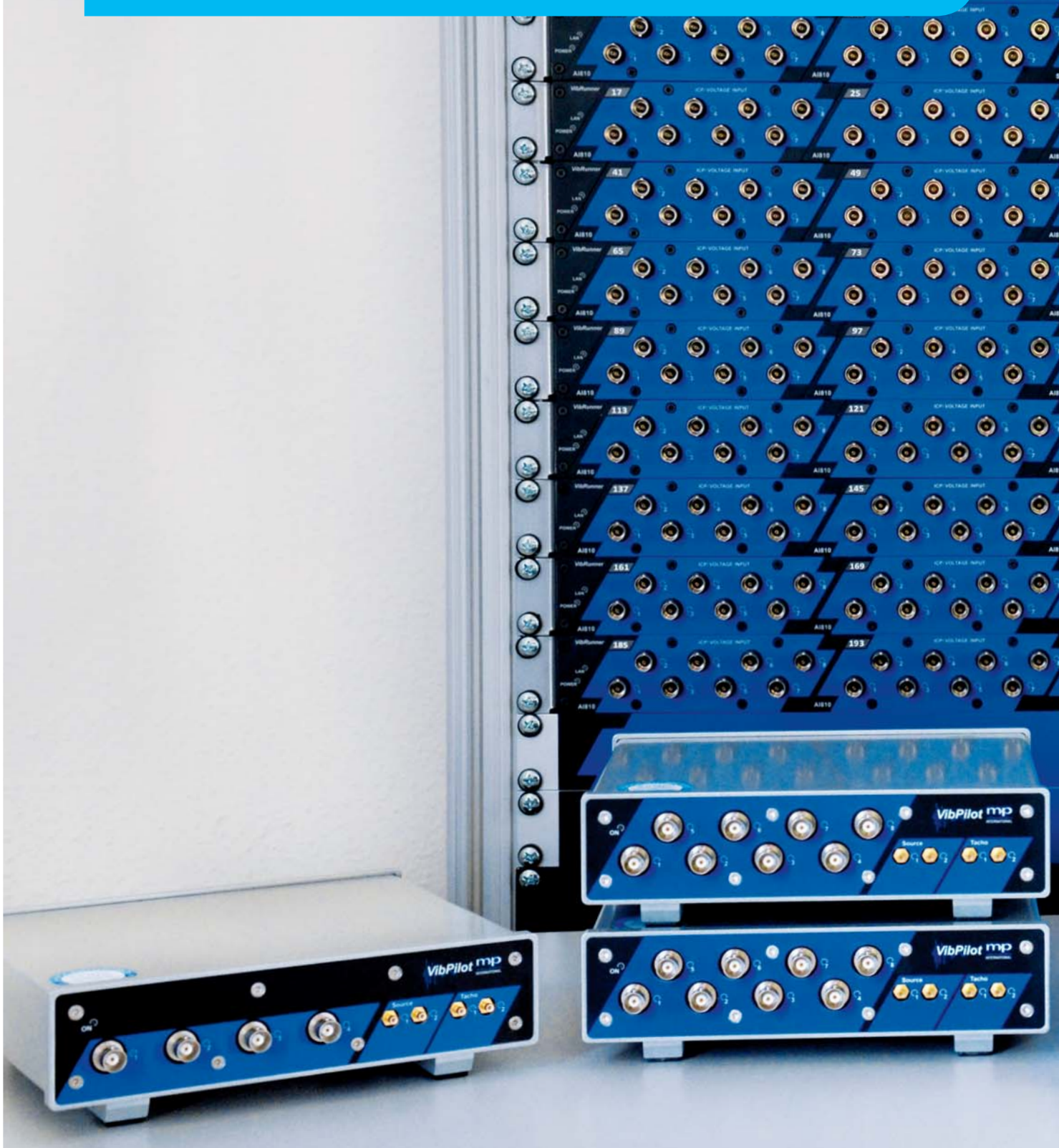





# Precision Instrumentation Purpose-Built to Your Specific Needs

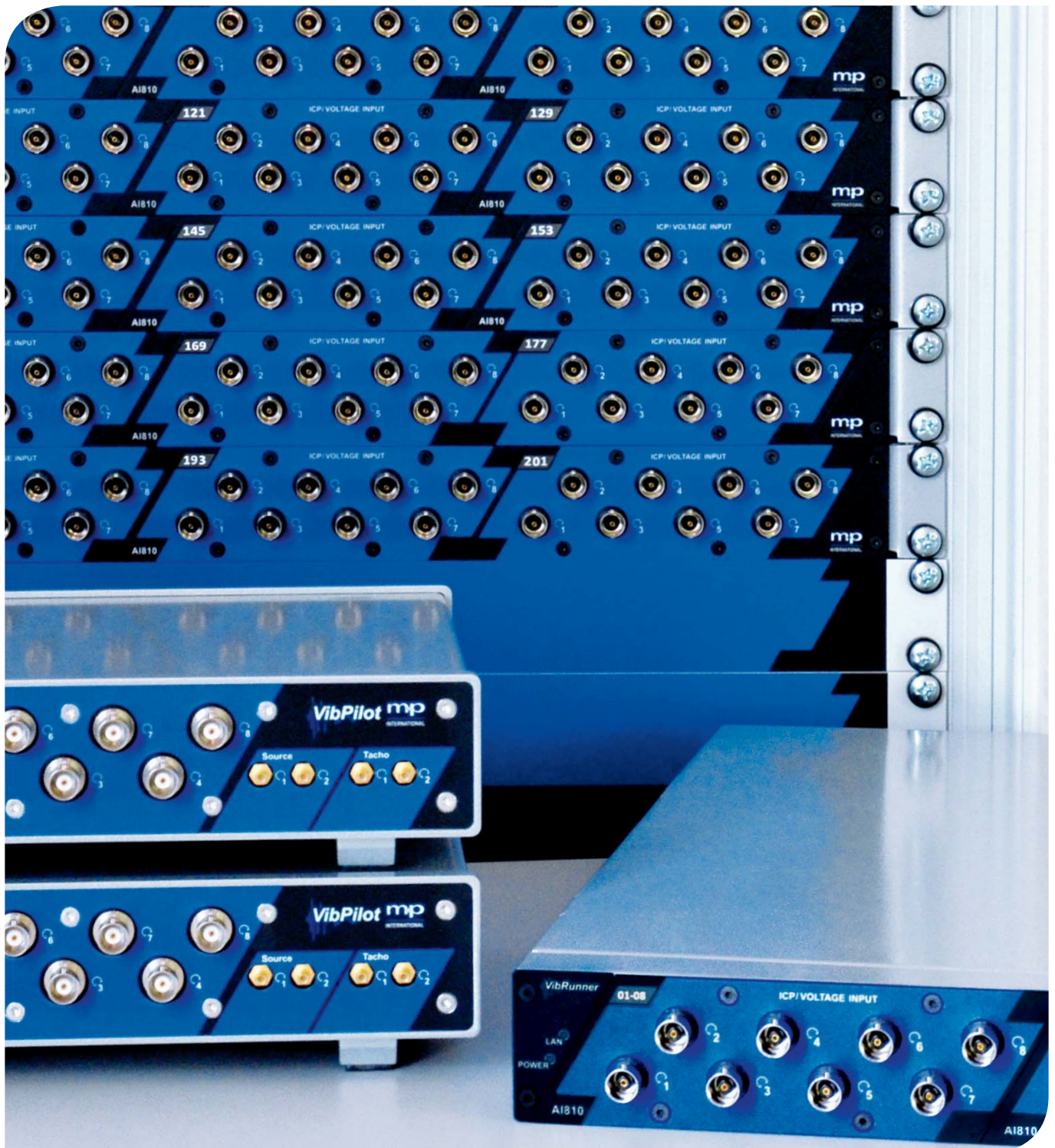



**We tailored our measurement hardware specifically for the requirements of noise and vibration analysis, vibration testing and dynamic data acquisition: m+p VibPilot is a compact 4/8-channel instrument, and the high-channel count m+p VibRunner can be used standalone or mounted into a 19" rack.**

**This allows you to configure your measurement hardware to your specific needs.**

Our solution-oriented approach provides outstanding performance at an excellent price-performance ratio. Measurement hardware from m+p international achieves the highest reliability and system longevity.

Designed to be used with our proven m+p VibControl, m+p SO Analyzer and m+p Coda software solutions, m+p international hardware covers a wide range of applications:

- Vibration testing on electrodynamic and hydraulic shakers
- Multi-axis vibration testing
- Multi-channel vibration data acquisition including data recording and continuous time history recording
- Noise and vibration testing
- Structural testing
- Modal analysis and impact testing
- Rotational dynamics testing
- Data acquisition
- Strain measurements
- Temperature measurements
- Process monitoring
- Acoustic control in a reverberant chamber
- Test stand engineering



High-precision 24-bit D/A converter

**To keep you ahead of your competition, our measurement hardware is designed to put your products at the forefront for performance, durability and quality.**

***“m+p was selected because of the flexibility offered by the modular controllers, intuitive front-end and the excellent support received from m+p over recent years.”***

Richard Thompson, Environmental Test Manager at TÜV SÜD Product Service Ltd, Fareham, UK

# Compact 4/8-Channel Front-End

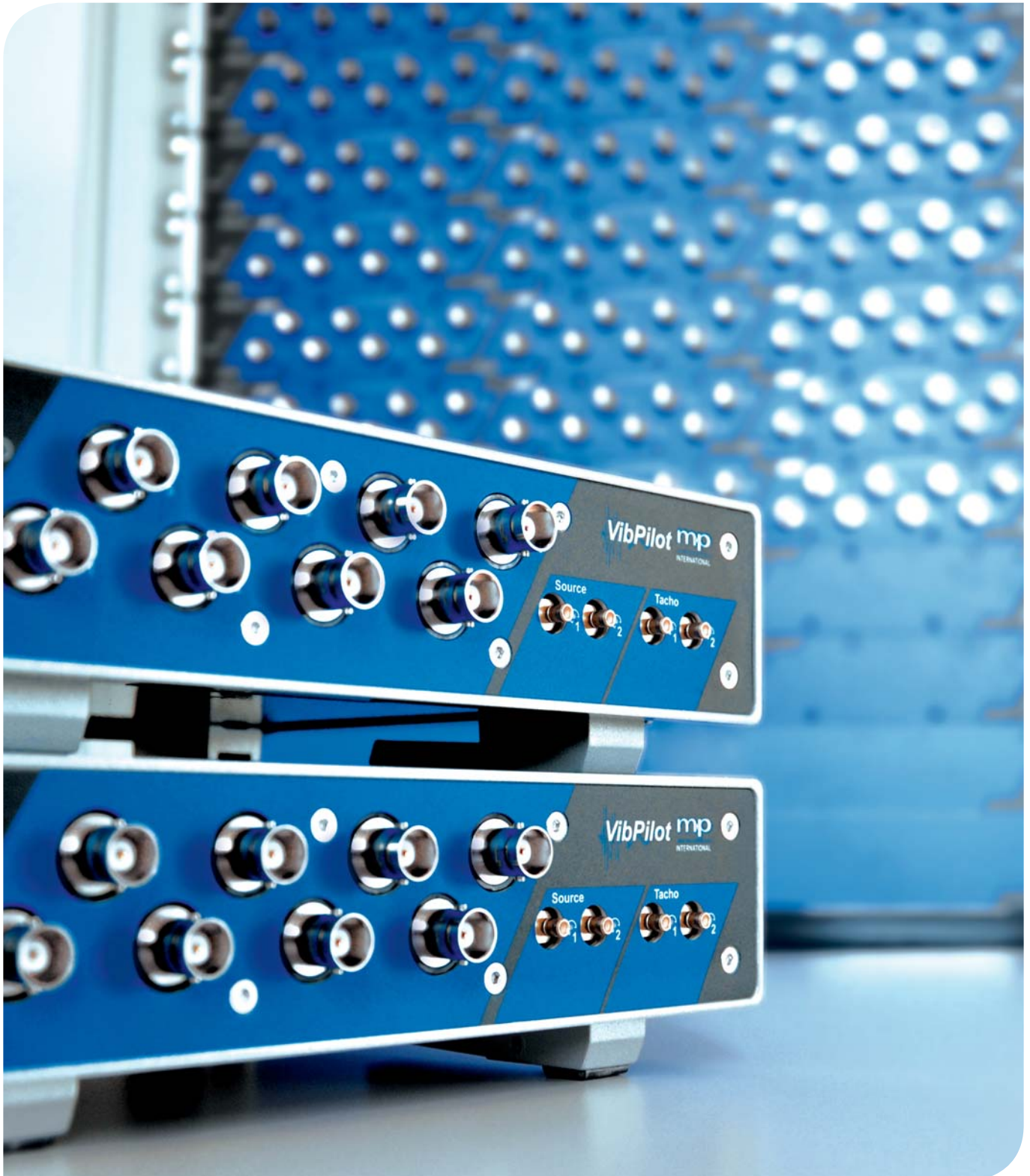



## KEY FEATURES

- 4 or 8 analog input channels – expandable
- 102.4 kHz simultaneous sampling
- ICP® sensor conditioning user selectable on each channel
- TEDS support
- 2 source output channels
- Safety shutdown for source channels
- 2 tachometer inputs
- Digital I/O's for automatic operation, e.g. for shutdown or climatic chamber control
- DSP powered real-time processing
- Synchronization of multiple m+p VibPilot front-ends
- USB 2.0 host interface
- Compact, dust-proof, rugged housing
- Fan-less, noise-free operation
- AC/DC supply floating or grounded, only 20 W power consumption

With the 4/8-channel m+p VibPilot, m+p international sets a new standard for affordable performance in vibration control and dynamic signal analysis. m+p VibPilot is based on the latest generation of IC technology resulting in high-precision measurement ability and impressive real-time performance in signal analysis.

### Operation Indoors and Outdoors

Compact and rugged, m+p VibPilot has a robust look and feel and a clearly arranged front panel with four or eight BNC connectors. Thanks to its dust-proof design you can operate it indoors or outdoors even under harsh conditions. m+p VibPilot provides USB 2.0 connectivity to a host PC or laptop and is operated by either an external AC mains power supply or by a 9 – 36 V DC supply, e.g. for in-car operation. The fan-less, noise-free operation facilitates noise measurements requiring a quiet environment.

### Support of Multiple Front-Ends

To extend input channel capability m+p VibPilot devices can be synchronized via the clock in/clock out circuitry without influencing their excellent measurement performance. This allows you to use additional channels (e.g. 2 x 8 input

channels) or to combine vibration tests and dynamic signal acquisition applications with ease. m+p SO Analyzer for noise and vibration analysis supports up to four m+p VibPilot devices with a total of 32 input channels.

m+p VibPilot. Small in size. Huge in performance.



### Input/Output Channels

Equipped with 24-bit sigma-delta A/D converters with up to 102.4 kHz sampling rate, m+p VibPilot allows for alias-protected measurements in a frequency range up to 40 kHz and with more than 120 dB spurious-free dynamic range. The analog input circuits have advanced sigma-delta converters which offer advantages such as simultaneous sampling by independent A/D converters on each input, reduced noise and improved accuracy due to 64 times oversampling on each input. Both analog and digital filtering are used for full aliasing protection and they provide excellent low-level signal-to-noise performance and differential linearity.

As well as normal differential voltage inputs with AC/DC coupling, signal conditioning for the analog input channels also provides source capabilities for ICP® sensors, including cable break indicators, and an interface for accessing standardized Transducer Electronic Data Sheets (TEDS). TEDS support allows automatic front-end setup based on information stored in the transducer, e.g. sensitivity, calibration and serial number.

Two precision low-noise analog outputs are available together with hardware shutdown circuitry which ramps down the source signals in a controlled manner in case of emergency.



4-channel m+p VibPilot



8-channel m+p VibPilot



**Tacho Inputs**

Two tacho inputs are included with 32-bit high-speed up/down counters for measuring synchronous signals on rotating machines or for use as COLA synch inputs for shaker sine reduction applications.

**Digital Inputs/Outputs**

Eight digital inputs and eight digital outputs enable engineers to directly execute control functions for combined environmental tests (climatic chamber control) or for parallel functional tests of the specimen. Individual tests can be easily combined in any complexity of nested loops.

One input channel serves as safety shutdown triggered by an external event.

**Dynamic Signal Processors**

Two 300 MHz floating-point dynamic signal processors in each m+p VibPilot pre-process the data, thus guaranteeing the high performance and short control cycles.

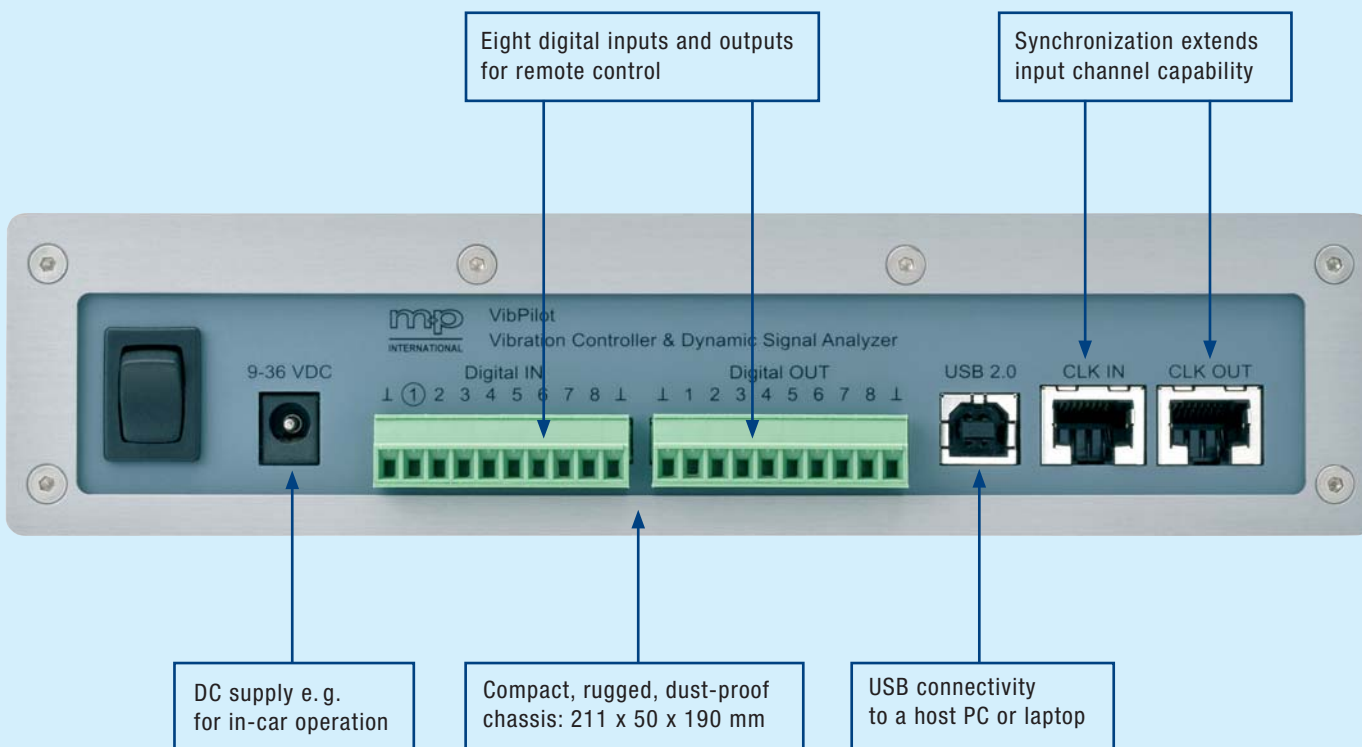

# High-Channel Count Hardware Platform for Standalone and Rack-Mounted Use





## KEY FEATURES

- Standalone desktop instrument or 19" rack-mounted system, 1U high, 3 slots for modules, rugged steel frame
- Silent operation, temperature-controlled fan
- Multi-range AC power supply and DC power supply
- Multiple m+p VibRunner synchronization by means of daisy chain connection and master clock
- Ethernet interface, 1 Gbit/s transfer rate
- DSP powered real-time processing
- 8 – 24 analog input channels per m+p VibRunner, 24-bit, 102.4 kHz max. sampling rate, differential and single-ended measurements, ICP<sup>®</sup> sensor conditioning, TEDS support
- 2 – 12 differential source output channels per m+p VibRunner, 24-bit, safety shutdown
- 2 – 12 tachometer inputs
- 8 digital inputs and 8 digital outputs per m+p VibRunner

m+p VibRunner is our measurement hardware platform for higher channel counts, designed for the specific needs of noise and vibration engineering and general data acquisition such as strain and temperature measurements. This solution-oriented approach provides superb performance at an excellent price-performance ratio.

The hardware platform is ideal for projects such as engine test cells, where high data throughput is important; large structures where distributed inputs reduce sensor cabling; large channel count requirements such as sensitive satellite pre-flight testing; or simply where a wide range of testing needs demand the ultimate flexibility in test system configuration.

### Standalone or Rack Mounted

m+p VibRunner provides maximum modularity. The basic unit is a 19" mainframe that houses up to three front-mounted functional modules. The 1U mainframe can be equipped with feet for use as a standalone desktop instrument or with mounting brackets for 19" rack mounting. m+p VibRunner is completely equipped for standalone operation. It has its own power supply with both multi-range AC and DC inputs. Cooling is performed by a high-quality, silent fan whose speed is temperature-controlled. For sensitive noise measurements the fan can be turned off from the host PC.

### Scalability and Synchronization

For applications requiring a high number of measurement channels, data acquisition over multiple m+p VibRunner

systems will be exactly synchronized. This is made possible by use of a daisy-chain connection which leads from the master frame, accommodating the clock, to all slave mainframes. The daisy-chained configuration means that the m+p VibRunner systems can be placed close to the measuring points and can be synchronized over longer distances. This minimizes costly transducer cabling for measurements of large objects.

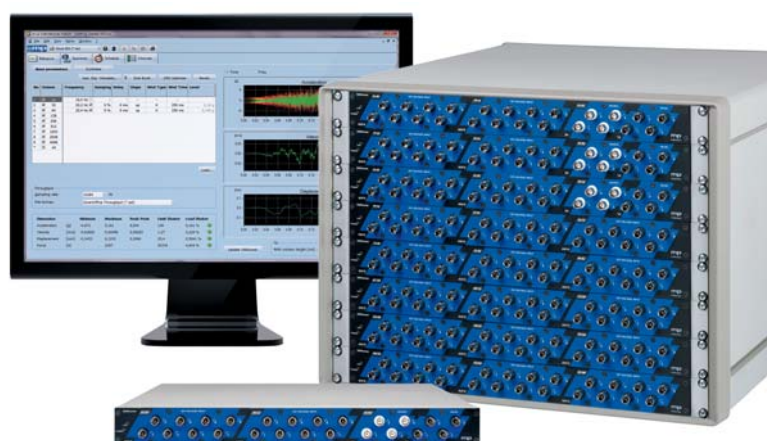

Configure m+p VibRunner to your precise needs.

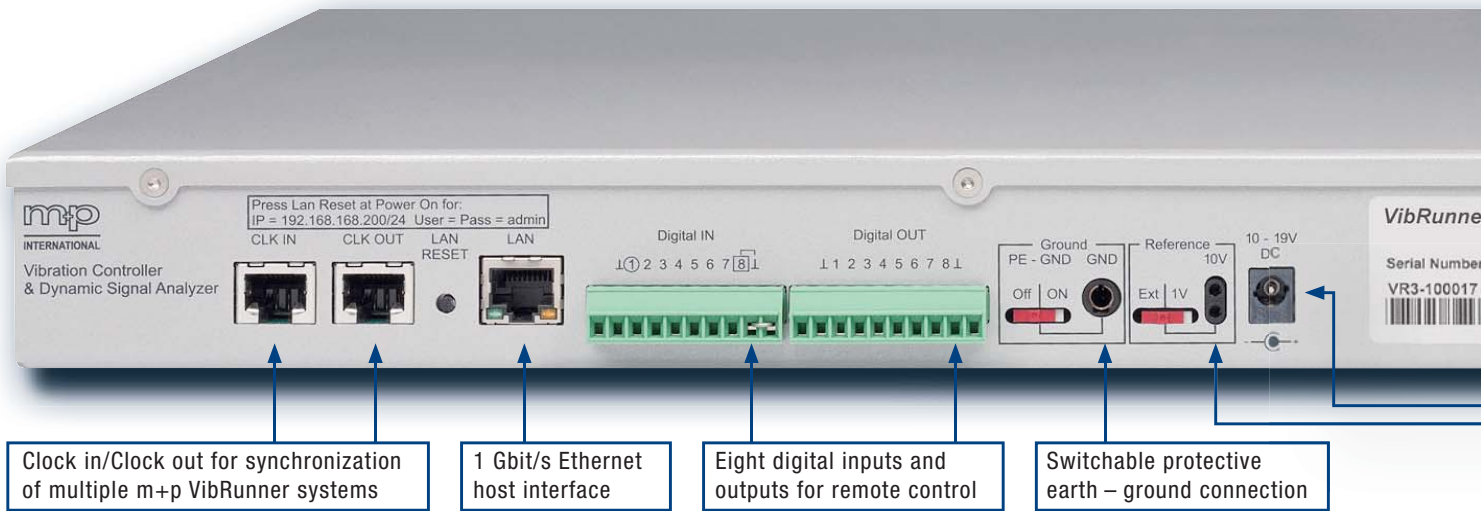

Clock in/Clock out for synchronization of multiple m+p VibRunner systems

1 Gbit/s Ethernet host interface

Eight digital inputs and outputs for remote control

Switchable protective earth – ground connection

**Digital Inputs/Outputs**

Each instrument has a digital interface with 8 inputs and 8 outputs (5 V TTL). These inputs/outputs enable engineers to directly execute control functions for combined environmental tests or for parallel functional tests of the specimen. One input channel serves as safety shutdown triggered by an external event.

**Power of Ethernet**

The 1 Gbit/s Ethernet interface is used for communications with the host PC. To ensure safe and fast communication even when a high number of input channels are utilized, the m+p VibRunner hardware is integrated into its own subnet which is independent of other networks. High channel counts increase the required data rates considerably, but m+p international’s choice of the Ethernet standard means that the host PC system can be configured using common off-the-shelf technology, including very powerful server systems, to cover virtually any requirement.

**Input Channels**

Based on the latest IC technology m+p VibRunner provides high-precision measurement capability and outstanding real-time performance. With 24-bit sigma-delta A/D converters with up to 102.4 kHz sampling rate, it allows for alias-protected measurements in a frequency range up to 40 kHz and more than 120 dB spurious-free dynamic range. The input channels can be switched between single-ended and full differential mode, thus allowing potential-free measurements such as those required on bridge circuits. TEDS (Transducer Electronic Data Sheet) support is a time-saving tool to automatically enter information stored in the transducer, e.g. sensitivity, calibration and serial number. Operators can individually switch the ICP® power supply for every input channel.

**Output Channels**

Additional m+p VibRunner modules provide analog outputs for vibration testing or modal analysis applications requiring a drive signal for the shaker. And here again, m+p VibRunner is optimally tuned to meet the specific requirements: high-precision 24-bit D/A converters are sampled by the master clock in the same way as the A/D converters on each input to ensure the excellent phase stability of the measurements. In case of emergency (for example, at power failure or when the connection to the host PC is lost), the source signal will be ramped down in a controlled manner to avoid damage to the specimen or the test equipment. This automatic, analog shutdown circuitry guarantees the highest safety possible during the test. The m+p VibRunner modules available now cover a wide range of applications in noise and vibration analysis, vibration testing and process monitoring. Other modules (for example, to provide higher sample rates for dynamic measurements, strain gauge measurements or various signal conditioning types) will follow.

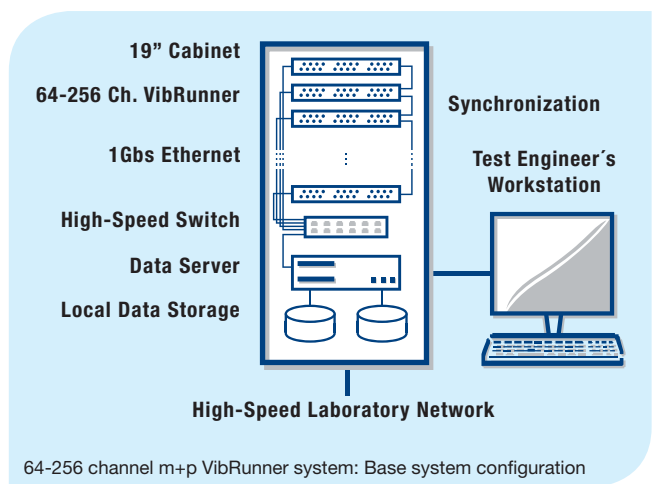





Built-in calibration source for easy calibration

Multi-range AC/DC power supplies

Rugged steel frame

### High-End Solutions for Data Acquisition and Signal Analysis

Based on our powerful software platforms we offer m+p VibRunner hardware configurations tailored to the specific needs of high-performance and multi-channel measurement applications.

The 24-channel m+p VibRunner front-ends with BNC connectors on the front panels and only 1U per front-end are installed in a 19" cabinet to make up a 64-256 channel data acquisition system. Precise synchronization of all front-ends is realized using a daisy-chained master/slave configuration.

For high-speed data processing and continuous data recording (throughput function), a powerful data server is supplied with the data acquisition system. This data server is equipped with two 240 GB solid state discs (SSD) and two 1 TB SATA disc drives to guarantee high-speed recording and fast data access.

If even higher channel counts are required, e.g. for sophisticated aerospace testing applications, several of the 64-256 channel data acquisition systems can be combined. Measurements across all input channels are synchronized for precise amplitude and phase analysis. The measurement systems can be placed close to the measuring points and be synchronized over several hundred metres, thus minimizing transducer cabling and increasing flexibility of the test system configuration.

Independent of how many data acquisition cabinets are used for a test setup, all channels are handled using a transparent and consistent data model. This ensures access to all input channels during setup, online monitoring and post-test analysis, no matter on which hardware unit within the network the channel is located.

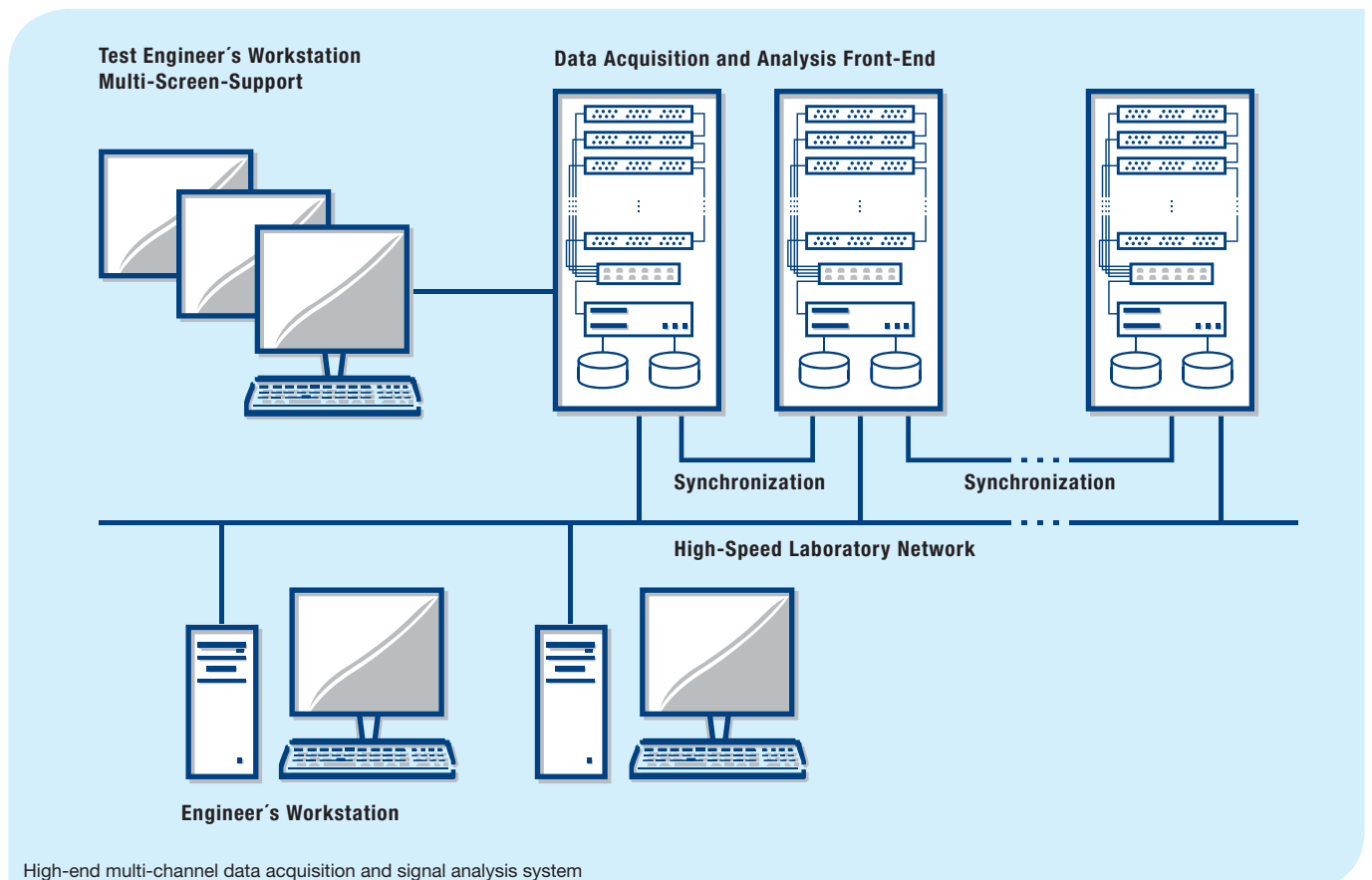

High-end multi-channel data acquisition and signal analysis system

# Ordering Information Measurement Hardware

## m+p VibPilot 2, 4 and 8 Channel Vibration Controller and Dynamic Signal Analyzer Front-End Hardware System

<b>VP2</b>	<b>m+p VibPilot front-end with 2 input channels</b> Volt/ICP/TEDS, 2 output channels, 2 tacho inputs, 8/8 digital input/output, USB 2.0 high speed PC interface, external 100-240 V AC / 9-36 V DC power supply, 1 USB cable 1 m, 2 SMB-BNC adapter cables 0.2 m, calibration certificate, incl. 12 month factory warranty.
VP2-W24	Factory hardware warranty extended to 24 months
VP2-W36	Factory hardware warranty extended to 36 months
<b>VP4</b>	<b>m+p VibPilot front-end with 4 input channels</b> Volt/ICP/TEDS, 2 output channels, 2 tacho inputs, 8/8 digital input/output, USB 2.0 high speed PC interface, external 100-240 V AC / 9-36 V DC power supply, 1 USB cable 1 m, 2 SMB-BNC adapter cables 0.2 m, calibration certificate, incl. 12 month factory warranty.
VP4-W24	Factory hardware warranty extended to 24 months
VP4-W36	Factory hardware warranty extended to 36 months
VP4-UPGRD8	Upgrade of VP4 front-end to VP8 front-end, device return-to-factory
<b>VP8</b>	<b>m+p VibPilot front-end with 8 input channels</b> Volt/ICP/TEDS, 2 output channels, 2 tacho inputs, 8/8 digital input/output, USB 2.0 high speed PC interface, external 100-240 V AC / 9-36 V DC power supply, 1 USB cable 1 m, 2 SMB-BNC adapter cables 0.2 m, calibration certificate, incl. 12 month factory warranty.
VP8-W24	Factory hardware warranty extended to 24 months
VP8-W36	Factory hardware warranty extended to 36 months
	<b>m+p VibPilot Accessories and Services</b>
VP-BAG	VibPilot transport bag
VP-SBA	SMB-BNC Adapter cable, 0,2 m
VP-CAL	Recalibration of VibPilot front-end incl. calibration certificate; on-site or return-to-m+p



## m+p VibRunner Multi-Channel Vibration Controller and Dynamic Signal Analyzer Front-End Hardware System

<b>VRB</b>	<b>m+p VibRunner 3 slot mainframe 8/8 digital input/output, 1 Ethernet TCP/IP IEEE802.3, 100-240 V AC, 10-19V DC, 1 power cable 1.5 m, 1 Ethernet cable 1.5 m, 1 clock-in / 1 clock-out port for multiple device synchronization, 12 months factory warranty.</b>
VRB-W24	Factory hardware warranty extended to 24 months
VRB-W36	Factory hardware warranty extended to 36 months
<b>VRAI8</b>	<b>8 channel, 24 bit, 102.4 kHz analog to digital converter module, Sigma-Delta A/D converter, <math>\pm 10V</math> input range, fully differential/single-ended switchable, AC/DC coupling, ICP power supply 4mA, 24V, TEDS support, 12 months factory warranty, calibration certificate</b>
VRAI8-W24	Factory hardware warranty extended to 24 months
VRAI8-W36	Factory hardware warranty extended to 36 months
<b>VRT2S2</b>	<b>2 channel analog output and 2 channel tachometer input module, analog output 24 bit, 102.4 kHz, <math>\pm 10 V</math>, max. 10 mA, 40 kHz frequency range; tachometer input <math>\pm 10 V</math> input range, differential or single-ended, DC coupling, 32 bit counter resolution, calibration certificate</b>
VRT2S2-W24	Factory hardware warranty extended to 24 months
VRT2S2-W36	Factory hardware warranty extended to 36 months
<b>VRT4S4</b>	<b>4 channel analog output and 4 channel tachometer input module, analog output 24 bit, 102.4 kHz, <math>\pm 10 V</math>, max. 10 mA, 40 kHz frequency range; tachometer input <math>\pm 10 V</math> input range, differential or single-ended, DC coupling, 32 bit counter resolution, calibration certificate</b>
VRT4S4-W24	Factory hardware warranty extended to 24 months
VRT4S4-W36	Factory hardware warranty extended to 36 months
	<b>m+p VibRunner Accessories and Services</b>
VR-BP	Blank Panel for VibRunner, 19", 1U
VR-SW108	Netgear ProSafe GS108E 8 port 1 Gigabit Ethernet switch incl. power supply
VR-SW116	Netgear ProSafe GS 716Tv2 16 port 1 Gigabit Ethernet switch incl. power supply
VR-CAL	Recalibration of VibRunner front-end incl. calibration certificate; on-site or return-to-m+p

# THIRD-PARTY MEASUREMENT HARDWARE

## Wide Variety of Front-End Technology Supported

For highest system flexibility, our software products support not only m+p's own precision instrumentation, but also measurement hardware from other manufacturers, namely National Instruments, VTI Instruments and United Electronic Industries.

Our unique concept allows the user to select his preferred measurement hardware for any test size. He can benefit from our software solutions without having to abandon the measurement hardware he has been successfully working with for many years.

## National Instruments

National Instruments is a global leader in providing test, measurement and embedded systems for engineers and scientists.

m+p international offers fully integrated multi-application NVH software that supports National Instruments acquisition hardware. Compared to a tool-kit approach, m+p SO Analyzer is a complete solution, from taking measurements, to generating reports, and taking care of all the complications of signal processing issues and data interpretation. It is also fully maintained and supported for the long term as well as being quicker to get up and running for your testing projects.

## National Instruments DAQ Hardware for Dynamic Signal Analysis

With National Instruments high-precision data acquisition cards, m+p SO Analyzer is a flexible real-time analyzer for sensor and electrical measurements in the lab or in the field. It integrates seamlessly with a full range of National Instruments USB, Ethernet, Wifi, PCI and PXI modules for analysis, display and reporting.

Signals can be easily acquired from thermocouples, resistance temperature detectors (RTDs), strain gauges, load cells, accelerometers, microphones, and many more, using the appropriate USB module. m+p SO Analyzer supports the NI CompactDAQ USB chassis

providing the plug-and-play simplicity of USB to acquire data from sensors and signals. Available with one, four, and eight slots, NI CompactDAQ USB chassis are designed for small, portable, mixed-measurement systems on the bench or in the field.

The National Instruments PCI data acquisition modules are installed into a PC slot guaranteeing maximum data throughput. For high channel counts requiring tight synchronization PXI hardware is the right solution. The PCI/PXI modules are used for sound and vibration applications, structural tests and strain gauge measurements.



Fully integrated multi-application NVH software supports National Instruments DAQ hardware



## VTI Instruments

Founded in 1990, VTI Instruments delivers instrumentation for electronic signal distribution, acquisition and monitoring. Their headquarters are located in Irvine, California.

m+p international software supports established VXIbus and LXIbus hardware from VTI Instruments.

### VXIbus Instruments

The VXIbus is a proven and well-supported platform for instrumentation systems, with a 25+ year history of success. It has outlived many of the units under test.

The m+p VibControl vibration testing software supports the 8/16-channel VT1432/1435/1436 VXIbus digitizers plus DSP and the VT1434 signal generator accommodated in 4/6/13-slot mainframes. This allows test engineers to benefit fully from the latest m+p VibControl software developments while maintaining existing hardware investment.

The m+p SO Analyzer software for dynamic signal analysis supports 4/6/13-slot VXIbus mainframes housing three, five or twelve digitizers for up to 48, 80 or 192 input channels respectively.

This is what we call “true investment protection”.

## LXIbus Instruments

For thermocouple and voltage measurements, the m+p Coda data acquisition software can be operated with the advanced 48-channel LXIbus-based EX10xxA series instruments. The system accepts all standard thermocouple types including J, K, T, E, S, B, R, N.

m+p Coda supports the LXI-based EX1629 remote strain gauge measurement unit for static and dynamic structural tests, e.g. on aircraft and rail vehicles, and general-purpose data acquisition. It is capable of supporting 1/4, 1/2 and full-bridge configurations as well as rosette-type sensors.



Support of established VXIbus hardware



## United Electronic Industries

United Electronic Industries, based in Massachusetts, USA, provides hardware for the PC/Ethernet data acquisition and control and data logger/recorder markets.

The m+p Coda data acquisition software is used with Ethernet-based I/O chassis from UEI.

### I/O Chassis for Data Acquisition and Logging

Together with the compact and rugged chassis from UEI, m+p Coda data acquisition software is suited to a wide variety of mobile and test bench applications.

United Electronic Industries offers two unique chassis configurations: the very compact 3- or 6-slot cube and the 6- or 12-slot front-loading rack. Larger systems are easily built using multiple cubes. Rack configurations with slot-in cards are also offered. The racks provide two Gigabit Ethernet interfaces and slots for up to 6 or 12 I/O boards, allowing the boards to be quickly and easily installed and removed directly from the front of the rack. m+p Coda enables direct measurement with these boards and

can display the actual and calculated results (e.g. strain, acceleration) online.

A wide variety of I/O boards are available for voltage input, current input, thermocouples, strain gauges, RVDT/LVDT, digital I/O, counter, etc. The boards can be installed in any combination and provide both ICP® signal conditioning and excitation voltage, thus being ideal for signal mixing.

Tests configured on your m+p Coda PC can be run fully standalone without the need for a PC or other network connection – ideal for environments where PCs cannot go.



Rugged Ethernet-based chassis for data acquisition and logging



# SERVICES AND SUPPORT





## Software Updates and Revisions

We protect your investment in the long term – this is part of our product philosophy. Thanks to the modular design of our software products, they can be configured and expanded to meet other test requirements at any time.

m+p international provides customers with regular software updates which offer revised and enhanced software features to increase further the software performance. These updates result primarily from close co-operation with our customers and their valuable feedback. Software revisions keep your software up-to-date with the newest technology and ensure that it is compatible with the latest advances in hardware and operating systems.

## Hardware Warranty and Repair

Measurement hardware from m+p international achieves the highest reliability and system longevity. All functions are thoroughly checked and documented using automatic test procedures before they leave production. The hardware is calibrated and documented with a full calibration certificate.

Our measurement hardware is delivered with a 12-month or optionally 24- or 36-months warranty.

We provide a return-to-m+p repair service, including a guaranteed 24-hours-back-to-operation option. Skilled service engineers use only original spare parts to ensure quality repair work and long service life for the measurement hardware.

Combined with a maintenance contract for the m+p Coda, m+p VibControl or m+p SO Analyzer software products, ownership of a hardware maintenance contract is even more attractive.

## Hotline Support

If you need help, please call our hotline during normal working hours. Our experienced support engineers will

assist you by phone or email. They will check the reported problem and provide the best solution as quickly as possible. Support covers every aspect of our products, from installation of software updates to specific test set-ups and understanding of analysis functions.

## Calibration Services

m+p international offers on-site or return-to-bench commercial re-calibration for all its measurement hardware. Keeping your equipment at peak precision by calibrating it minimizes your testing downtime. Regular calibration of your m+p international systems is not only an investment in quality; it is also a valuable tool to save costs. Errors caused by inaccurate or invalid measurements can become very expensive, e.g., if they necessitate product recalls. The system calibration includes system verification, calibration of all modules and system, system check, cleaning of the filters as well as a calibration certificate.



A2LA accredited ISO/IEC-17025 calibrations are provided by a third party and available on request.

## Rental

If you lack instrumentation for special vibration measurement projects or when your instrumentation is being repaired, we offer short-term rental of our measurement hardware. This allows you to do your testing job at any time using the latest hardware technology.

## Training Classes

Gain valuable know-how in our training and seminar programs. Our practice-oriented training classes for users at different levels cover all aspects from the basics of vibration testing to in-depth expertise on special applications.

# REFERENCES

This list gives some of the companies that chose m+p international to solve their test and measurement tasks.

## Automotive & Suppliers

- Advanced Comfort Systems, France and Spain
- ARDIA, Tunisia
- Autoliv, France and Sweden
- Bosch Automotive, Germany, France, Italy, UK, Spain and China
- Boysen, Germany
- BYD Company, China
- Continental Automotive, Germany, France, Romania and India
- Cooper Tire, USA
- Cummins, China
- Daimler, Germany and USA
- Delphi Automotive, France and UK
- Dongfeng Nissan Passenger Vehicle Co., China
- Faurecia, France, Germany and China
- FAW Group Corp., China
- Ford Motor Company, Turkey and USA
- Honda Research, UK and Germany
- Hyundai Motor Company, South Korea
- Knorr-Bremse, Germany, UK and Italy
- Perkins Engines, UK
- Porsche, Germany
- Pressan, Turkey
- Renault Trucks, France
- Saab, Sweden
- SKF, France
- Toyota, UK
- Tyco Electronics, France and Spain
- Valeo, France and Tunisia
- Volkswagen, Germany
- Volvo, Sweden
- Westfalia, Germany

## Aerospace & Aviation

- Academy of Aerospace Liquid Propulsion Technology (AALPT), China
- Academy of Aerospace Solid Propulsion Technology (AASPT), China
- Airbus Defence and Space, Germany and UK
- Auxitrol, France
- AVIC Aircraft Strength Research Institute, China
- AVIC Beijing Aeronautical Manufacturing Technology Research Institute, China
- BAE Systems, UK
- Boeing, USA
- BUAA, China
- CASA, Spain
- Centre Spatial de Liège, Belgium
- Changhe Aircraft Industries Group, China
- China Academy of Launch Vehicle Technology (CALT), China
- China Academy of Space Technology (CAST), China
- China Electronics Technology Group Corp., China
- COMDEV, UK and Canada
- Dassault Aviation, France
- DLR, Germany
- ECE Zodiac Aerospace, France
- GE Aviation, USA
- Goodrich Engine Control Systems, UK
- Harris, USA
- IABG, Germany
- IAI, Israel
- IAS, France
- INPE, Brazil
- ISRO, India
- Lockheed Martin, UK and USA



- Martin Baker, UK
- Meggit Avionics, UK
- MTU Aero Engines, Germany
- NASA Jet Propulsion Laboratory, USA
- NASA Kennedy Space Center, USA
- Nord-Micro, Germany
- Rafael, Israel
- RAL, UK
- Saab Ericsson Space, Sweden
- Shenyang Engine Design & Research Institute, China
- Snecma (Safran Group), France
- SSTL, UK
- Tesat-Spacecom, Germany
- Ultra Electronics, UK
- ZARM, Germany

#### Telecom/Electrical

- Amphenol-Tuchel, Germany
- Barco, Netherlands and France
- Fujitsu, Germany
- Grass Valley, Netherlands
- Hewlett-Packard, USA
- Hirschmann, Austria
- Johnson Controls, Italy
- Kodak, USA
- L-3 Communications, USA
- Lear Corporation, Italy and Germany
- Motorola, Germany
- Panasonic Electric Works, Germany
- Philips, Belgium
- Texas Instruments, USA

#### Other Industries

- Alstom Nuclear Power, France
- AWE, UK
- Bofors, Sweden
- Danfoss, Denmark
- Doosan Babcock, UK
- Doosan Corporation Mottrol, South Korea
- DuPont, USA
- Korail, South Korea
- PTB, Germany
- Sagem Defense, France
- Siemens, Germany
- Stihl, Germany and Brazil
- Still, Germany
- Swarovski, Austria
- Thales, France, UK and Netherlands
- WEG Euro, Portugal
- Vestas, UK

#### Test Houses

- ADETESTS, France
- Atlas Elektronik, Germany
- Bertrandt, Germany
- Car Synergies, Germany
- CIOP, Poland
- Dayton T. Brown, USA
- Delserro Engineering, USA
- E-Labs, USA
- ELTEC, France
- Environne'Tech, France
- KAIST, South Korea
- Mecano ID, France
- miTechnology, UK
- MIRA, UK
- NTS, USA
- QinetiQ, UK
- RST (Bombardier), Germany
- Rücker, Germany
- SGS, Germany
- Stirling Dynamics, UK
- Telus, Germany
- TRaC Global, UK
- TÜV SÜD, Germany and UK
- Wyle, USA

#### R&D/Education

- Beijing University, China
- Cnam, France
- Cranfield University, UK
- EUPLA, Spain
- Fraunhofer Institut, Germany
- Johns Hopkins University APL, USA
- Kingston University, UK
- Korea Institute of Energy Research, South Korea
- Loughborough University, UK
- MIT, USA
- MSSL, UK
- Nanjing University, China
- Nottingham University, UK
- Purdue University, USA
- Southampton University, UK
- Technische Universität Berlin, Germany
- Technische Universität Braunschweig, Germany
- Technische Universität Darmstadt, Germany
- Technische Universität Hannover, Germany
- Università di Roma, Italy
- University of Alabama, USA
- University of Cincinnati, USA
- Université de St. Etienne, France
- Université de Casablanca, Marocco

## **m+p international**

Founded in Hannover, Germany in 1980, m+p international develops and manufactures test and measurement systems for vibration control, dynamic signal analysis, data acquisition, process monitoring and test stand engineering. Our product reputation and broad experience coupled with valuable user feedback have led to significant market share in numerous key industries worldwide.

The company has its headquarters in Hannover, Germany with sales/marketing subsidiaries in New Jersey (USA), England, France and China, along with representatives and agents in many countries.

Learn more on the full range of m+p international products and services and their applications. Select the m+p literature library on our website: [www.mpihome.com/cms/en/literature-library.html](http://www.mpihome.com/cms/en/literature-library.html)

m+p VibControl, m+p SO Analyzer, m+p Coda, m+p VibPilot and m+p VibRunner are products of m+p international.

All trademarks and registered trademarks are the property of their respective holders.

Specifications subject to change without notice.

## **Germany**

**m+p international**  
**Mess- und Rechnertechnik GmbH**  
Thurnithistraße 2  
30519 Hannover  
Phone: (+49) (0)511 856030  
Fax: (+49) (0)511 8560310  
sales.de@mpihome.com

## **USA**

**m+p international, inc.**  
271 Grove Avenue, Bldg. G  
Verona, NJ 07044-1705  
Phone: (+1) 973 239 3005  
Fax: (+1) 973 239 2858  
sales.na@mpihome.com

## **United Kingdom**

**m+p international (UK) Ltd**  
Mead House  
Bentley, Hants  
GU10 5HY  
Phone: (+44) (0)1420 521222  
Fax: (+44) (0)1420 521223  
sales.uk@mpihome.com

## **France**

**m+p international Sarl**  
5, rue du Chant des Oiseaux  
78360 Montesson  
Phone: (+33) (0)130 157874  
Fax: (+33) (0)139 769627  
sales.fr@mpihome.com

## **China**

**Beijing Representative Office**  
**of m+p international**  
Room 1006, Jin Ma Office  
Building B Seat  
Xue Qing Road No. 38  
Hai Dian District, Beijing  
Phone: (+86) 10 8283 8698  
Fax: (+86) 10 8283 8998  
sales.cn@mpihome.com



**INTERNATIONAL**

*listens to customers ...*

[www.mpihome.com](http://www.mpihome.com)