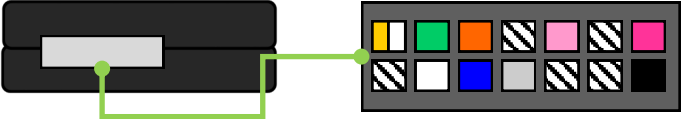

	<h1 style="margin: 0;">UNICAN PLUS</h1> <h2 style="margin: 0;">INSTALLATION MANUAL</h2>	 
---	---	---

**DESCRIPTION**

UNIVERSAL CANBUS adapter for steering wheel commands and services such as ignition, lights, reverse gear and speed pulse. Its compatibility extends to a large number of vehicles, listed in table 1, to the **CLARION - KENWOOD - JVC - ALPINE - PIONEER - SONY** autoradios having wired input remote control on the back of the radio and to the radios listed in table RADIO.

<h3>CABLE WIRES DESCRIPTION</h3>	
----------------------------------	--

CABLE	FUNCTION
	RED POSITIVE POWER SUPPLY
	BLACK NEGATIVE POWER SUPPLY
	GREEN HIGH CAN
	WHITE LOW CAN / K-BUS
	PINK POSITIVE IGNITION OUTPUT
	ORANGE POSITIVE SIDELIGHTS OUTPUT
	GREY ODOMETRIC SIGNAL
	BLUE POSITIVE REVERSE GEAR OUTPUT
	YELLOW/WHITE NEGATIVE HANDBRAKE OUPUT

**ATTENTION!**  
 For the correct working of the module, please connect the following wires: **RED, BLACK** (power feeding) and the **WHITE and GREEN (CAN)** and the radio adapter supplied in the kit, inserting the 4 poles connector into the module harness and the jack into the steering wheel commands input of the radio.  
 For more details about the connection CAN, please consult the **CONNECTION DIAGRAMS**.

**SELF-RECOGNITION AND FUNCTIONS**

The selection of the protocol comes through **SELF-RECOGNITION**. After connections, by inserting the module to the power connector, the unit will manage the synchronization in fews seconds, signalled by **RED quick flashes** of the module's LED.

Once the synchronization is done the LED lights **GREEN FLASHING**.  
 The unit is ready for the RADIO profile selection.

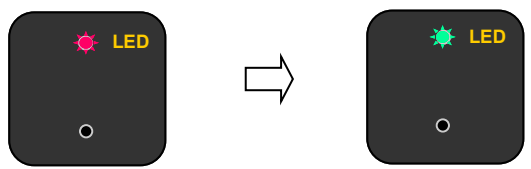

**RADIO PROFILE SETTING**

Now it's necessary now to select the radio protocol needed (see RADIO TABLES).  
 On default the unit offers the first profile available that is the CLARION, the GREEN LED makes one flash.  
 With the attached table select the radio needed so verify how many flashes it must to do the LED related to the radio of interest.  
 If the radio profile we want to set it's the first one, just press SEEK + to confirm the selection, the LED will light on GREEN.  
 To select a different radio press VOLUME + on the steering wheel to increase the number of flashes of the LED or VOLUME - to decrease.  
 Once the radio desired is selected to confirm the choice, press SEEK + on the steering wheel, the LED will light on GREEN as confirmation.

The logic of the flashes of the LED follows this behaviour:  
 LED **GREEN** flash means= units  
 LED **RED** flash means= tens  
 LED **YELLOW** flash means= hundreds

For example 5 GREEN flashes of LED indicate the radio in the 5th position.  
 2 RED flashes of the LED indicate the radio in position 20.  
 1 RED flash of the LED followed by 2 GREEN flashes of the LED indicate the radio in position 12.  
 1 YELLOW flash of the LED, indicates the radio in position 100.

Once the radio of interest is selected to confirm the choice press SEEK + on the steering wheel.  
 The led of the unit will light GREEN

It is also necessary to put the JUMPER JP1 in the correct position for the ALPINE, PIONEER and SONY radios.

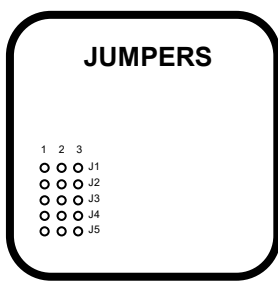

	1 - 2	2 - 3
<b>J1</b>	ALPINE OUTPUT	PIONEER - SONY OUTPUT
<b>J2</b>	GND BRAKE OUTPUT	POSITIVE BRAKE OUTPUT
<b>J3</b>	GND REVERSE OUTPUT	POSITIVE REVERSE OUTPUT
<b>J4</b>	BLAUPUNKT	DO NOT USE
<b>J5</b>	K-BUS HANDLING	CAN-BUS HANDLING

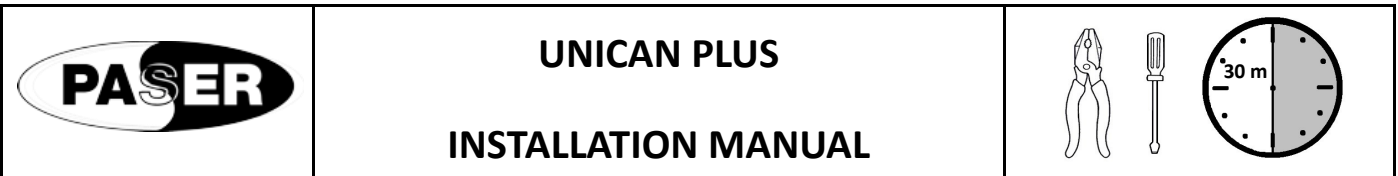

### RADIO PROFILE SETTING

ADAPTERS	RADIO
CBL007UNAL22	ALPINE
CBL007UNBL12	BLAUPUNKT / BLAUPUNKT 2
CBL007UNJV12	CLARION / JVC
CBL007UNPI12	PIONEER / SONY
CBL007UNPN21	PANASONIC

\*Jumper J4 must be inserted just for PHONOCAR VM024 and BLAUPUNKT STANDARD radio, if you use BLAUPUNKT2 (Atlanta110-Madrid210-Toronto410BT-San Francisco310), BLAUPUNKT NEW YORK 800 or if you use IR jumper J4 doesn't be set.

\*Don't insert jumper J1 for SUZUKA, DAYTONA 7000 AUTOSONIK and PHONOCAR VM024 radios.

\*BUENOS AIRES 200 model it is not equipped of the remote wired input so can be controlled only through IRR.

The profile to set it's the same used for Kenwood.

### TROUBLESHOOTING

- **The unit doesn't work and the LED is off.**
- **Check the connections of the power supply.**
- **The unit which is correctly powered, doesn't work and the LED is off.**
- **Check the CANBUS connections.**
- **The unit is connected correctly and the RED LED flashes quickly.**
- **The unit hasn't been synchronized with the CANBUS, contact Paser.**
- **The unit is connected correctly and the RED LED flashes in an irregular way.**
- **Check the CANBUS connections.**
- **The unit is connected correctly and the RED LED is on.**
- **The unit has undertaken the synchronization with the CANBUS but hasn't been able to individuate the vehicle, contact Paser.**
- **The unit is connected correctly but can't handle the K-BUS protocol.**
- **Check that the J5 jumper has been inserted between pins 1 and 2.**
- **The unit is connected correctly, the GREEN LED is on but doesn't control the radio.**
- **Check that the module's PLUG is connected to the radio's REMOTE input or contact Paser.**

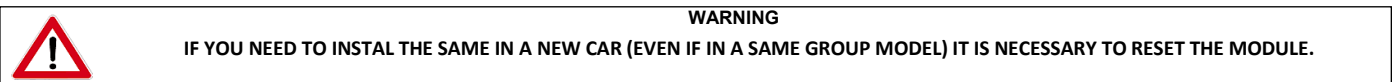

### WARNING

IF YOU NEED TO INSTAL THE SAME IN A NEW CAR (EVEN IF IN A SAME GROUP MODEL) IT IS NECESSARY TO RESET THE MODULE.

### RESET:

1. **WITH THE UNIT POWERED, PRESS AND KEEP PRESSED THE UNICAN BUTTON TILL THE LED SWITCH OFF.**
2. **WITH THE LED SWITCHED OFF RELEASE THE BUTTON, THE RESET IS DONE.**

### TECHNICAL CHARACTERISTICS











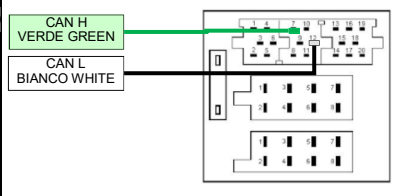

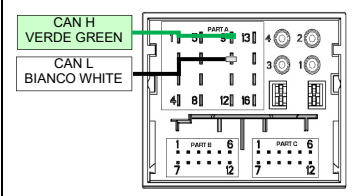

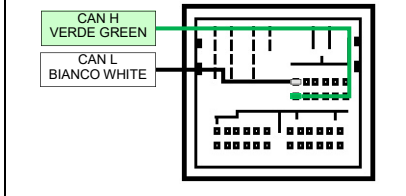



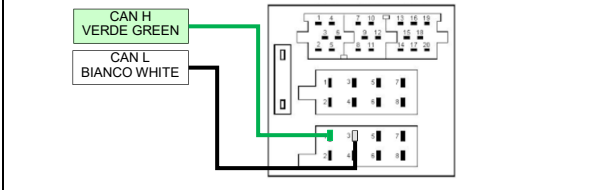



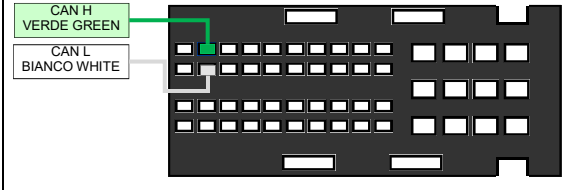

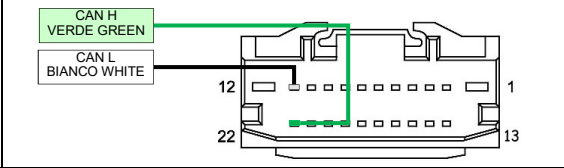

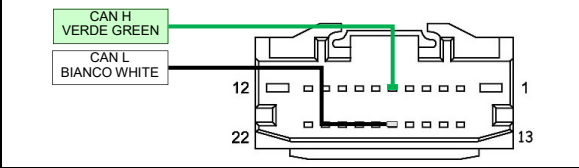

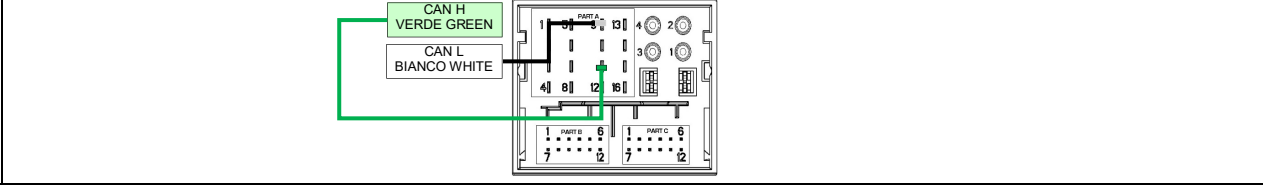

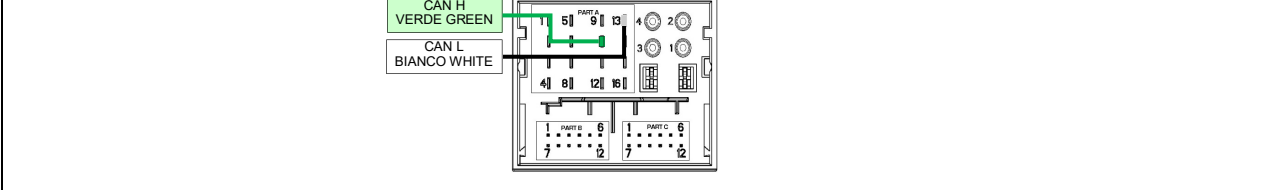
POWER SUPPLY	10/16 VDC
ABSORPTION AT REST	0,001 A
ABSORPTION WHEN WORKING	0,040 A
MAX CHARGE IGNITION OUTPUT	2,000 A
MAX CHARGE SIDELIGHTS / HANDBRAKE / REVERSE GEAR OUTPUT / ODOMETRIC SIGNAL	0,040 A

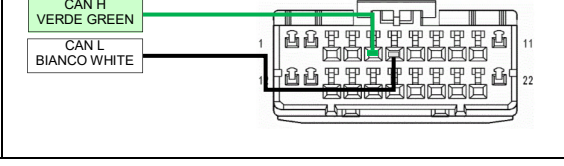

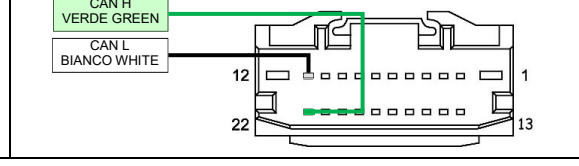

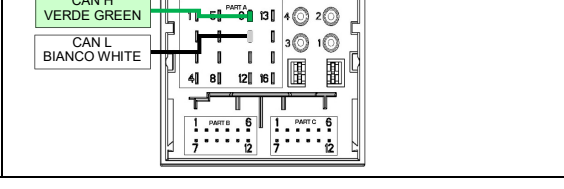

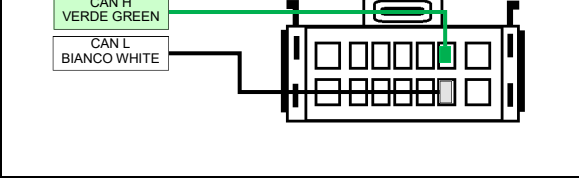

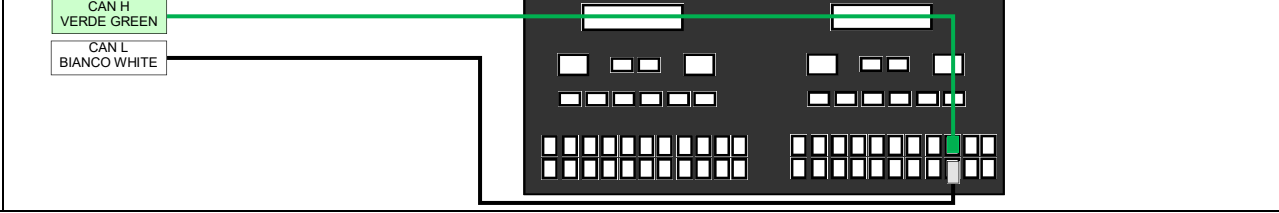



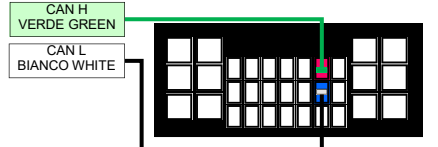

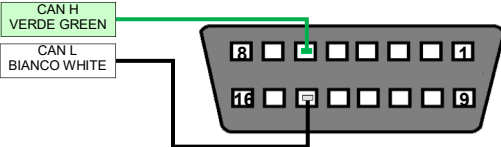
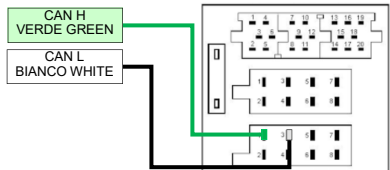

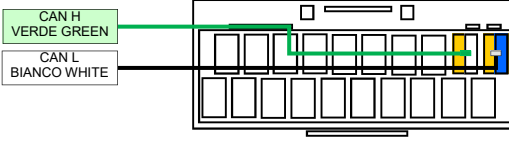

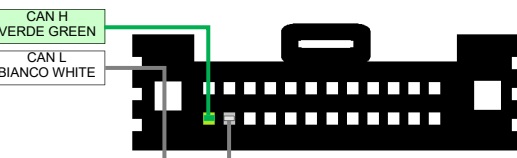



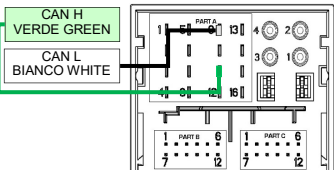

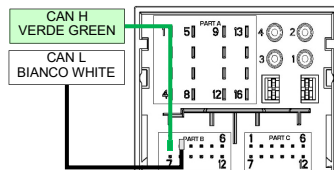
### WARRANTY

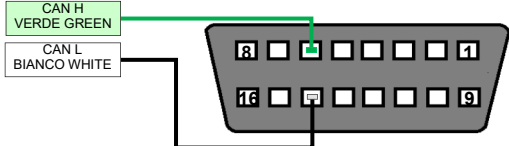

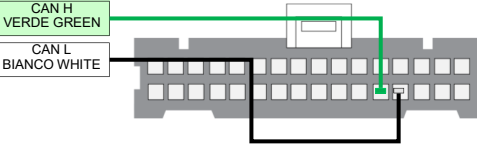



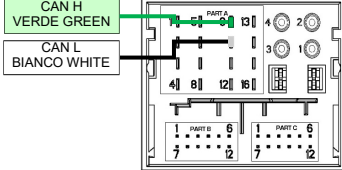

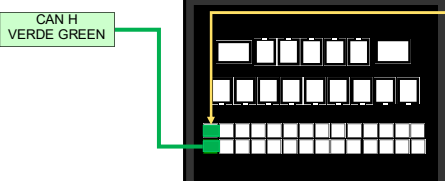

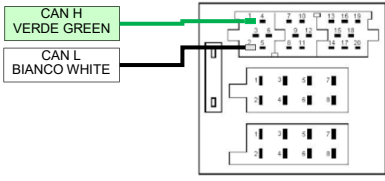

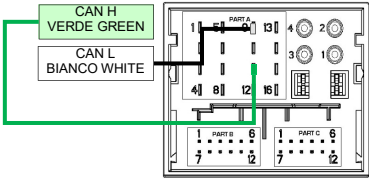

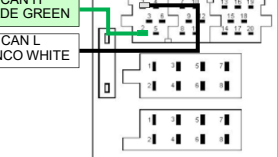

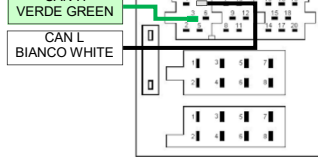

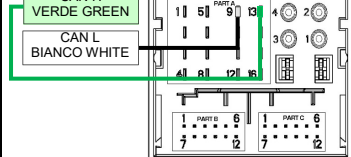

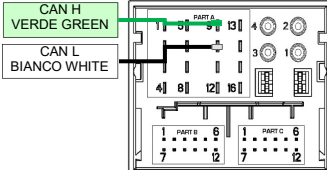

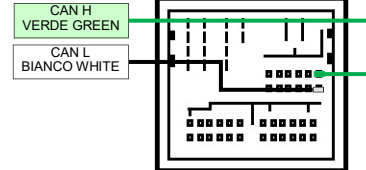

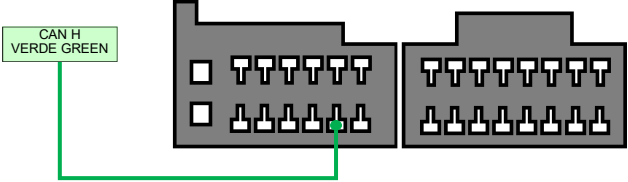

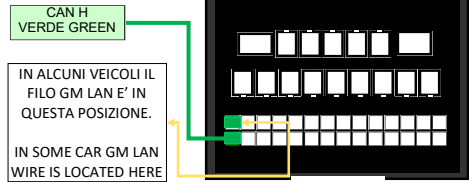
THIS PRODUCT IS COVERED BY TWO-YEAR GUARANTEE FOR ANY MANUFACTURING TROUBLES. THE WARRANTY IS VALID IF ACCOMPANIED BY THE INVOICE OF PURCHASE

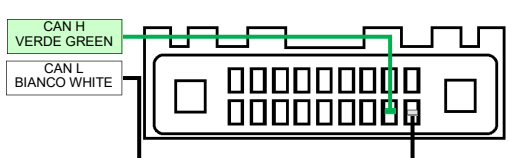
The information in this guide are purely for information purposes, therefore, are subject to change without notice.

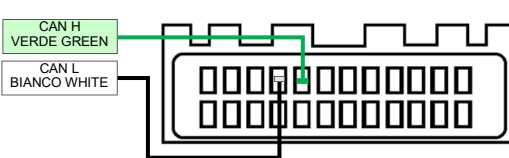
At the time of publication the information is correct and reliable. However Paser can not be held responsible for any consequences resulting from errors or omissions in this manual. Paser reserves the right to improve / change the product or manual without obligation to notify users.

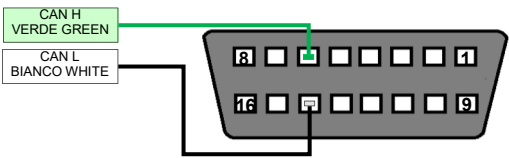
UNICAN	CONNESSIONI (VISTA CONNETTORI USCITA FILI) NON COLLEGARE I CAVI PRESENTI SUL CABLAGGIO NON CITATI NEGLI SCHEMI		CONNECTIONS (WIRES EXIT VIEW) DO NOT CONNECT WIRES PRESENT ON THE HARNESS BUT NOT MENTIONED IN THE DIAGRAMS		
 ISO		 FAKRA 40 WAYS		 FAKRA 52 WAYS	
I CONNETTORI SONO NEL VANO RADIO		CONNECTORS ARE LOCATED IN THE RADIO SLOT			
   		   			
I CONNETTORI SONO NEL VANO RADIO		CONNECTORS ARE LOCATED IN THE RADIO SLOT			
 CALIFORNIA		 FREEMONT			
I CONNETTORI SONO NEL VANO RADIO		CONNECTORS ARE LOCATED IN THE RADIO SLOT			
 FAKRA					
I CONNETTORI SONO NEL VANO RADIO		CONNECTORS ARE LOCATED IN THE RADIO SLOT			
  FAKRA					
I CONNETTORI SONO NEL VANO RADIO		CONNECTORS ARE LOCATED IN THE RADIO SLOT			
 GRAND CHEROKEE COMPASS 300C		 NITRO COMPASS  WRANGLER			
I CONNETTORI SONO NEL VANO RADIO		CONNECTORS ARE LOCATED IN THE RADIO SLOT			
 SMAX - CMAX - FOCUS - KUGA - TOURNEO MONDEO - TRANSIT		 FIESTA 2008			
I CONNETTORI SONO NEL VANO RADIO		CONNECTORS ARE LOCATED IN THE RADIO SLOT			
 TRANSIT 2018					
I CONNETTORI SONO NEL VANO RADIO		CONNECTORS ARE LOCATED IN THE RADIO SLOT			

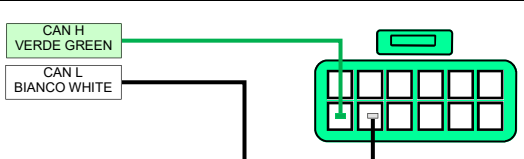
UNICAN	CONNESSIONI (VISTA CONNETTORI USCITA FILI) NON COLLEGARE I CAVI PRESENTI SUL CABLAGGIO NON CITATI NEGLI SCHEMI		CONNECTIONS (WIRES EXIT VIEW) DO NOT CONNECT WIRES PRESENT ON THE HARNESS BUT NOT MENTIONED IN THE DIAGRAMS		
 <b>CRV</b> <b>2013</b>					
I CONNETTORI SONO NEL VANO RADIO		CONNECTORS ARE LOCATED IN THE RADIO SLOT			
 <b>ix20</b> <b>ix40</b>		 <b>ix20</b> <b>ix40</b> <b>OBD</b>			
IL CONNETTORE E' SOTTO IL CRUSCOTTO DIETRO LA PARATIA DI PLASTICA NEI PRESSI DELLO STERZO CONNECTOR IS UNDER THE DASHBOARD NEAR STEERING WHEEL, BACK A PLASTIC COVER		CONNETTORE OBD      OBD CONNECTOR			
<b>IVECO</b>  <b>DAILY</b> <b>2019</b>					
I CONNETTORI SONO NEL VANO RADIO		CONNECTORS ARE LOCATED IN THE RADIO SLOT			
 <b>RANGE ROVER</b> <b>FREELANDER 2</b>		 <b>EVOQUE</b>			
I CONNETTORI SONO NEL VANO RADIO		CONNECTORS ARE LOCATED IN THE RADIO SLOT			
 <b>ISO</b>		 <b>FAKRA</b>		 <b>FAKRA</b> <b>E - SLK</b> <b>OLD</b>	
I CONNETTORI SONO NEL VANO RADIO		CONNECTORS ARE LOCATED IN THE RADIO SLOT			
 <b>SPRINTER</b> <b>2019</b> <b>W907</b>					
I CAVI CANBUS SONO NEL CONNETTORE OBD LATO GUIDA		CANBUS VIRES ARE IN THE OBD PLUG DRIVER SIDE			
 <b>NISSAN</b>		 <b>NISSAN</b>			
IL CONNETTORE E' SOTTO IL CRUSCOTTO DIETRO LA PARATIA DI PLASTICA NEI PRESSI DELLO STERZO CONNECTOR IS UNDER THE DASHBOARD NEAR STEERING WHEEL, BACK A PLASTIC COVER		CONNETTORE OBD      OBD CONNECTOR			
 <b>CANBUS 2</b> <b>WIRES</b>		 <b>CHEVROLET</b> <b>GM LAN</b>	 <p>IN ALCUNI VEICOLI IL FILO GM LAN E' IN QUESTA POSIZIONE. IN SOME CAR GM LAN WIRE IS LOCATED HERE</p>		
I CONNETTORI SONO NEL VANO RADIO		CONNECTORS ARE LOCATED IN THE RADIO SLOT			

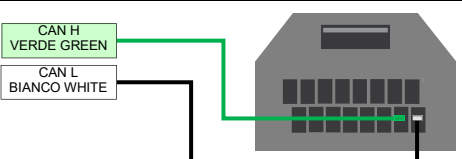
UNICAN		CONNESSIONI (VISTA CONNETTORI USCITA FILI) NON COLLEGARE I CAVI PRESENTI SUL CABLAGGIO NON CITATI NEGLI SCHEMI		CONNECTIONS (WIRES EXIT VIEW) DO NOT CONNECT WIRES PRESENT ON THE HARNESS BUT NOT MENTIONED IN THE DIAGRAMS	
 ISO		 FAKRA			
I CONNETTORI SONO NEL VANO RADIO		CONNECTORS ARE LOCATED IN THE RADIO SLOT			
 ISO 1		 ISO 2		 FAKRA	
I CONNETTORI SONO NEL VANO RADIO		CONNECTORS ARE LOCATED IN THE RADIO SLOT			
 FAKRA 40 WAYS		 FAKRA 52 WAYS			
I CONNETTORI SONO NEL VANO RADIO		CONNECTORS ARE LOCATED IN THE RADIO SLOT			
 93 - 95 2005-2010 GM LAN			 95 2012 GM LAN		
I CONNETTORI SONO NEL VANO RADIO		CONNECTORS ARE LOCATED IN THE RADIO SLOT			
 MOD 1			 MOD 2		
I CONNETTORI SONO NEL VANO RADIO		CONNECTORS ARE LOCATED IN THE RADIO SLOT			
					
		CONNETTORE OBD		OBD CONNECTOR	
 MOD 1			 MOD 2		
I CONNETTORI SONO NEL VANO RADIO		CONNECTORS ARE LOCATED IN THE RADIO SLOT			

Le informazioni riportate in questo manuale e nei suoi allegati sono puramente a scopo informativo pertanto possono subire modifiche senza preavviso. Al momento della pubblicazione le informazioni risultano corrette ed attendibili. Tuttavia Paser non può essere ritenuta responsabile per eventuali conseguenze derivanti da errori, omissioni o incongruenze del presente manuale e dei suoi allegati (ad. es. per l'eventuale mancato recupero di configurazioni audio originali dei veicoli). Paser si riserva il diritto di migliorare/modificare il prodotto o il manuale senza l'obbligo di notificare agli utenti.

Information in this guide and its attachments are for information purposes only, therefore, they are subject to change without notice. At the time of publication the information is correct and reliable. However Paser can not be held responsible for any consequences resulting from errors, omissions or incongruence of this manual (for ex. missed audio configuration back-up of the vehicles). Paser reserves the right to improve / change the product or manual without obligation to notify users.

		<b>UNICAN PLUS</b>			<b>TABELLE RADIO RADIO TABLES</b>		07.1217 REV 2.17 da/from FWP007UNUN209_85_2C	
---	--	--------------------	--	--	---------------------------------------	--	---	--

FUNC.	CLARION	KENWOOD	JVC	ALPINE	PIONEER	PIONEER	SONY PHONOCAR VM040/VM041 Alpine IVE-W560BT IVE-W560BT-R	NON USATO NOT USED
	FILO E IR	FILO E IR	FILO E IR	FILO E IR	IR	FILO	FILO	
FLASH	1	2	3	4	5	6	7	8
1	VOLUME +							
2	VOLUME -							
3	MEM +	SEEK +						
4	MEM -	SEEK -						
5	BAND	FM	BAND +	MEM +	MEM +	MEM +	MEM +	
6	Input_sel	AM	BAND -	MEM -	MEM -	MEM -	MEM -	
7	SRC	SRC	SRC	SRC	SRC	SRC	SRC	
8	MUTE	MUTE	MUTE	MUTE	MUTE	MUTE	MUTE	
9	X	PHONE ANSWER	PHONE ANSWER	PHONE ANSWER	X	PHONE ANSWER	PHONE ANSWER	
10	X	PHONE CLOSE	PHONE CLOSE	PHONE CLOSE	X	PHONE CLOSE	PHONE CLOSE	
11	X	VOICE RECALL	X	X	X	X	X	

FUNC.	QUANTUM	NON USATO NOT USED	PANASONIC 1	NON USATO NOT USED	PHONOCAR VM040 IR ZENEC ZE-MC194	NON USATO NOT USED	BLAUPUNKT	SONY	NON USATO NOT USED	ECLIPSE AVN2227P AVN4429 AVN726EE SOLO SU RICHIESTA/ ONLY ON REQUEST
	FILO E IR		FILO E IR		FILO E IR		FILO E IR	IR		FILO
FLASH	9	10	11	12 / 13	14	15	16	17	18 / 19 / 20 21 / 22	23
1	X	VOLUME +								
2	X	VOLUME -								
3	P +	SEEK +								
4	P -	SEEK -								
5	X		X		UP		MEM+	MEM +		X
6	X		X		DOWN		BAND	MEM -		X
7	X		SRC		SRC		SRC	SRC		SRC
8	X		MUTE		MUTE		MUTE	MUTE		X
9	X		X		X		X	X		X
10	X		X		X		X	X		X

FUNC.	NON USATO NOT USED	ECLIPSE AVN8826 CD8445E CD4525E AVN726EE	PHONOCAR 1 FORYOU CMU128-CM123 VM020-VM021 VM024	PHONOCAR 2 DM736 VM016 MACROM M-DVD4650R	PHONOCAR 3 (1)VM029-VM030 VM031 -VM032 VM036	NON USATO NOT USED	MACROM	NON USATO NOT USED	PHONOCAR 11 VM057
		IR	FILO E IR	FILO E IR	IR		IR		FILO
FLASH	24 / 25	26	27	28	29	30/ 31 / 32	33	34	35
1	VOLUME +								
2	VOLUME -								
3	SEEK +								
4	SEEK -								
5		MEM +	PLAY	PLAY	PLAY		UP		UP
6		MEM -	BAND	BAND	BAND		DOWN		DOWN
7		SRC	SRC	SRC	SRC		MODE		SOURCE
8		MUTE	MUTE	MUTE	MUTE		MUTE		MUTE
9		X	X	X	PHONE ANSWER		X		PHONE ANSWER
10		X	X	X	PHONE CLOSE		X		PHONE CLOSE

	<b>UNICAN PLUS</b>	<b>TABELLE RADIO RADIO TABLES</b>	07.1217 REV 2.17 da/from FWP007UNUN209_85_2C
---	--------------------	---------------------------------------	---

FUNC.	NON USATO NOT USED	ZENEC 1 ZE-MC192 ZE-NC2040 XZENT XT8020	ZENEC 2 ZE-MC192 (SMART-DIAL- REMOTE CON- TROL)	HARDSTONE 1 HS DPM62 HS DPM63	HARDSTONE 2 HS DPM30	HARDSTONE 3 HS DPM31 HS DPM61 FILO E IR PHONOCAR VM017 VM018 FILO E IR VM035	HARDSTONE 4 HS DPM36 HS DPM70	HARDSTONE 5 HS CD1970
		FILO E IR	FILO E IR	FILO E IR	IR	IR	IR	IR
FLASH	36/37/38/39/40	41	42	43	44	45	46	47

1	VOLUME +							
2	VOLUME -							
3	SEEK +		UP	SEEK +				
4	SEEK -		DOWN	SEEK -				
5		OK	UP	>>	BAND	BAND	BAND	BAND
6		DOWN	DOWN	<<	EQ	EQ	EQ	EQ
7		SOURCE	OK/MENU	SOURCE	SOURCE	SOURCE	SOURCE	SOURCE
8		MUTE	STORE	MUTE	MUTE	MUTE	MUTE	MUTE
9		PHONE (OK)	X	X	X	PHONE ANSWER	X	X
10		X	X	X	X	PHONE CLOSE	X	X

FUNC.	NON USATO NOT USED	KENWOOD DT	CLARION BS RCB-165	ALPINE 2 RUE-4912 DVD	ALPINE 3 RUE4912 NAVI	NON USATO NOT USED	ECLIPSE 3 RMC101	HARDSTONE 6 HS DPM7G	NON USATO NOT USED
FLASH		FILO E IR	IR	IR	IR		IR	IR	
	48 / 49	50	51	52	53	54	55	56	57
1		X	VOLUME +	VOLUME +					
2		X	VOLUME -	VOLUME -					
3		UP	MEM +	SEEK +					
4		DOWN	MEM -	SEEK -					
5		X	INPUT SEL	UP	UP		MEM+	UP	
6		X	BAND	DOWN	DOWN		MEM-	DOWN	
7		X	SRC	SRC	SRC		SRC	SRC	
8		X	MUTE	MUTE	X		X	MUTE	
9		X	X	X	X		X	PHONE ANSWER	
10		X	X	X	X		X	PHONE CLOSE	

FUNC.	HARDSTONE7 HS DPM8G PHONOCAR N6205	MACROM2 M-DVD5551R M-DVD6545R	NON USATO NOT USED	BECKER TRAFFIC PRO Solo su richiesta	MACROM3 M-DVD6555R M-DVD6556R PHONOCAR VM041 IR	MACROM4 M-DVD5542R M-DVD5561R M-DVD5562R M-DVD5541R	NON USATO NOT USED	ZENEC 3 ZE-NC520 ZE-NC524
	FILO E IR	IR	60/61/62 63/64/65 66	FILO	FILO E IR	FILO E IR		FILO E IR
FLASH	58	59		67	68	69	70/71/72	73
1	VOLUME +							
2	VOLUME -							
3	SEEK +							
4	SEEK -							
5	UP	PLAY/PAUSA		MODE	UP	PLAY/PAUSE		BAND/STOP
6	DOWN	STOP/BAND		X	DOWN	BAND		DOWN
7	SOURCE	MODE		X	SRC	SRC		SRC
8	MUTE	MUTE		X	MUTE	MUTE		MUTE
9	X	X		X	PHONE ANSWER	PHONE ANSWER		PHONE ANSWER
10	X	X		X	PHONE CLOSE	PHONE CLOSE		PHONE CLOSE

		<b>UNICAN PLUS</b>				<b>TABELLE RADIO RADIO TABLES</b>		07.1217 REV 2.17 da/from FWP007UNUN209_85_2C	
---	--	--------------------	--	--	--	---------------------------------------	--	---	--

FUNC.	NON USATO NOT USED	JVC2	ALPINE4	PIONEER2	PIONEER2	PHONOCAR 4 VM05	NON USATO NOT USED	BLAUPUNKT 2 ATLANTA110 MADRID210 TORONTO410BT SAN FRANCISCO310	BLAUPUNKT NEW YORK 800	
		FILO E IR	FILO E IR	IR	FILO	FILO E IR		FILO E IR	FILO E IR	
FLASH	74	75	76	77	78	79	80/81/82	83	84	
1	VOLUME +									
2	VOLUME -									
3	UP					> (RIC.RADIO)	SEEK +			
4	DOWN					>>  (TRACK +)	SEEK -			
5	SEEK +	SEEK +	SEEK +	SEEK +	PLAY	UP		OK		
6	SEEK -	SEEK -	SEEK -	SEEK -	BAND	DOWN		DOWN		
7	SRC	SRC	SRC	SRC	SRC	SOURCE		SOURCE		
8	MUTE	MUTE	MUTE	MUTE	MUTE	MUTE		MUTE		
9	PHONE ANSWER	PHONE ANSWER	X	PHONE ANSWER	PHONE ANSWER	PHONE ANSWER		PHONE ANSWER		
10	PHONE CLOSE	PHONE CLOSE	X	PHONE CLOSE	PHONE CLOSE	PHONE CLOSE		PHONE CLOSE		

FUNC.	PHONOCAR 5 VM066	TV DAS	NON USATO NOT USED	BLAUPUNKT NEW YORK 800 resistiva	NON USATO NOT USED	PHONOCAR 6 VM037	SONY HW OLD	PIONEER HW OLD	HARDSTONE8 HS-DPM71 HS-DPM64 HS-DPM69	PHONOCAR 7 VM033
	FILO E IR	IR		FILO		FILO E IR	FILO	FILO	FILO E IR	FILO E IR
FLASH	85	86	87/88/89	90	91	92	93	94	95	96
1	VOLUME +									
2	VOLUME -									
3	SEEK +									
4	SEEK -									
5	PLAY/PAUSE	X		X		UP	MEM +	MEM +	>>	UP
6	X	X		X		DOWN	MEM -	MEM -	<<	DOWN
7	SRC	X		SRC or PHONE ANSWER		MODE	SRC	SRC	SOURCE	SRC
8	MUTE	X		MUTE or PHONE CLOSE		MUTE	MUTE	MUTE	MUTE	MUTE
9	PHONE ANSWER	X		PHONE ANSWER or SRC		X	X	X	PHONE ANSWER/BACK	X
10	PHONE CLOSE	X		PHONE CLOSE or MUTE		X	X	X	PHONE CLOSE/ROOT	X

FUNC.	MACROM 5 M-DVD7702 M-DVD7701 M-DVD7602 M-DVD7601	CLARION 2 NX-501E NX-502E NX-503E NX-404E NX-504E	WR9210 RADIO 500	BLACKSTONE BS-ARM11	RADIO JEEP PHONOCAR	RADIO AUDI A4 PHONOCAR
	IR	FILO E IR	FILO	FILO E IR	FILO E IR	FILO E IR
FLASH	97	98	99	100	101	102
1	VOLUME +					
2	VOLUME -					
3	SEEK +	MEM + / SCAN +	SEEK +			
4	SEEK -	MEM - / SCAN -	SEEK -			
5	RIGHT	SCAN +	SOURCE	X	X	X
6	LEFT	SCAN -	MUTE	X	X	X
7	SRC	MUTE	X	SOURCE	SOURCE	SOURCE
8	MUTE / PWR	TA	X	MUTE	MUTE	MUTE
9	AMS/PHONE ANSWER	PHONE ANSWER	X	PHONE ANSWER	PHONE ANSWER	X
10	BAND/PHONE CLOSE	PHONE CLOSE/BAND	X	PHONE CLOSE	PHONE CLOSE	X



			UNICAN PLUS			TABELLE RADIO RADIO TABLES			07.1217 REV 2.17 da/from FWP007UNUN209_85_2C		
FUNC.	PIONEER FILARE OLD2	NON USATO NOT USED	ECLIPSE 4 AVN827GA	PHONOCAR 8 VM08	CONSOLI 1	JVC3	PHNOCAR 9 RENAULT CAPTURE	PHONOCAR 10 VM025 - VM026	NON USATO NOT USED	AUDIOLINK CASKA FOR YOU	*BLAUPUNKT Brisbane 230 Stockholm 370 HARDWARE DEDICATED
	FILO E IR		FILO	FILO E IR	FILO E IR	FILO	FILO E IR	FILO E IR	111 112 113	FILO	FILO RES
FLASH	103	104	105	106	107	108	109	110		114	115
1	VOLUME +										
2	VOLUME -										
3	MEM +		SEEK +								
4	MEM -		SEEK -								
5	SEEK +		SOURCE	SOURCE	UP	BAND +	SOURCE	SOURCE		X	SOURCE
6	SEEK -		MUTE	MUTE	DOWN	BAND -	MUTE	MUTE		X	MUTE
7	SRC		PHONE ANSWER	X	SOURCE	SRC	X	X		SRC	PHONE ANSWER
8	MUTE		VOICE	X	MUTE	MUTE	X	X		MUTE	PHONE CLOSE
9	X		PHONE ANSWER / CLOSE	PHONE ANSWER	PHONE ANSWER	PHONE ANSWER	PHONE ANSWER	X		PHONE ANSWER	X
10	X		PHONE CLOSE	PHONE CLOSE	PHONE CLOSE	PHONE CLOSE	PHONE CLOSE	X		PHONE CLOSE	X

**ATTENZIONE**

IL PROFILO RADIO 23 (ECLIPSE AVN2227P) SI PUO' AVERE PERDENDO I PROFILI RADIO 6 (PIONEER) E 7 (SONY).

IL PROFILO 90 PERMETTE DI VEDERE FINO AD 8 TASTI MA GESTISCE SOLO 6 FUNZIONI SULLA RADIO.

<sup>(1)</sup>LA RADIO PHONOCAR VM029 HA SOLO LE SEGUENTI FUNZIONI: VOLUME-, VOLUME+, SEEK-, SEEK+, MODE E MUTE.

PER IL PROFILO RADIO 105 (ECLIPSE AVN827GA) LE FUNZIONI 7 E 10 SERVONO PER L'APPRENDIMENTO DEI TASTI TELEFONO

IL PROFILO RADIO 108 (JVC3) ATTIVA L'OPZIONE n°22

**CAUTION**

YOU CAN HAVE RADIO PROFILE 23 BUT IT'S LOST RADIO PROFILE 6 (PIONEER) AND PROFILE RADIO 7 (SONY).

IT'S POSSIBLE TO SEE 8 BUTTONS/LEVERS WITH PROFILE 90, BUT YOU CAN TO MANAGE ONLY 6 FUNCTIONS OF THE RADIO.

<sup>(1)</sup>PHONOCAR RADIO VM029 HAS ONLY THE FOLLOWING FUNCTIONS: VOLUME-, VOLUME+, SEEK-, SEEK+, MODE AND MUTE.

PROFILE RADIO 105 (ECLIPSE AVN827GA) FUNCTIONS 7 AND 10 ARE LEARNING KEY TELEPHONE

PROFILE RADIO 108 (JVC 3) ENABLE THE OPTION N° 22

MODELLO RADIO / RADIO MODEL	ADATTATORE RADIO/ RADIO ADAPTER
CLARION, JVC; MACROM M-DVD5542R, M-DVD5561R, M-DVD5562R; BLAUPUNKT NEW YORK 800; PHONOCAR VM033, VM037, VM029, VM057; CONSOLI 1;	CBL007UNJV12
PIONEER; SONY; PHONOCAR VM040 (flashes 7) , VM041 (flashes 7), **VM024, VM025, VM026; *GRUNDIG DELPHI X350BT, DELPHI X440BT; BLAUPUNKT NEW YORK 800 RESISTIVA; WR9210 RADIO 500.	CBL007UNPI12
ALPINE.	CBL007UNAL22
KENWOOD.	CBL007UNKE11
PANASONIC; PHONOCAR FORYOU, CMU128, CM123, VM020, VM021, DM736, VM016, VM017, VM030, VM031, VM032, VM036, VM050, N6205, VM066, VM081; HARDSTONE HS DPM61, HS DPM62, HS DPM63, HS DPM31, HS DPM7G, HS DPM8G, HS DPM71, HS DPM69, HS DPM64; MACROM M-DVD6555R, M-DVD6556R; RADIO JEEP; RADIO AUDI A4.	CBL007UNPN21
BLAUPUNKT; BLAUPUNKT 2 ATLANTA110, MADRID210, TORONTO410BT, SAN FRANCISCO 310.	CBL007UNBL12
*VDO.	CBL007UNVD11
ECLIPSE AVN2227P, AVN4429, AVN726EE. BLAUPUNKT Brisbane 230 Stockholm 370 (USARE SOLO FILO VIOLA ESU KEY1/USE VIOLET ONLY TO KEY1)	CBL007UNEL11
BLACHSTONEBS-ARM11 Radio ad apprendimento resistivo, si deve impostare sulla radio 10kΩ, il cambio sorgente è sul filo blu della radio (MODE-KEY) da collegare con il nostro marrone, il filo rosa della radio (AD-KEY) va collegato con il nostro viola ed il filo nero della radio con il nostro nero. / Radio resistive to learning, to be set on 10k radio, the transmission source is on the blue wire to the radio (MODE-KEY) to be connected with our brown, the pink wire to the radio (AD-KEY) should be connected with our purple and the black wire to the radio with our black.	
* DISPONIBILE SOLO CON HARDWARE DEDICATO / AVAILABLE ONLY WITH DEDICATED HARDWARE	
** TAGLIARE FILO IN POSIZIONE 2 DEL MICROFIT / TO CUT WIRE IN POSITION 2 OF MICROFIT.	

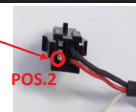



## UNICAN / UNICAN PLUS OPTIONS MANAGEMENT

### OPTIONS MANAGEMENT

The module on default manages some functions. However, sometime, end user prefers other functions instead of those pre-set. For this reason it's available a new procedure allowing to set a series of options. First of all it is important that the unit has synchronized a car canbus protocol. The LED must be GREEN.



Now press 3 times the module button, the LED will flash RED (UNITS), GREEN (TENS) and YELLOW (HUNDREDS) flashing.

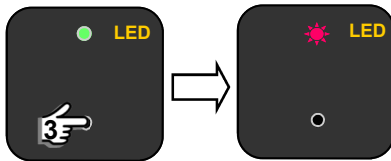

Now turn ignition ON 4 times and the 4th time keep the ignition ON. The LED will flash YELLOW indicating the number of the option, followed by the RED flashes indicating the value of the option.

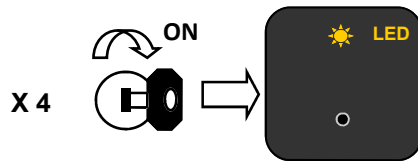

YELLOW flashes represents the number of the option, RED flashes represents the state of the option. To increase the option number please press the button on the module, so if the LED flash 1 time by pressing one time the button it will flash 2 times. If you want to change the default option's state, hold the button pressed until the LED turns off. Once released the button, the unit will flash the option related and the new option state. To exit option management please disconnect and reconnect the module from power. The LED will light GREEN.

OPTION AND FLASH NUMBERS	VALUE OPTION 1 RED FLASHES	VALUE OPTION 2 RED FLASHES
1	SEEK ALWAYS AVAILABLE	SEEK AVAILABLE FOR 10 SEC AFTER A VOLUME PRESS
2	HAND BRAKE AVAILABLE WHEN HANDBRAKE IS ON	ODOMETRIC HANDBRAKE AVAILABLE WHEN THE CAR IS BELOW 3 Km/h SPEED
3	SEEK ALWAYS AVAILABLE	ODOMETRIC SEEK AVAILABLE WHEN THE CAR OVERPASS 3 Km/h SPEED
4	SPEED PULSE FREQUENCY 26000 PULSE PER MILE	SPEED PULSE FREQUENCY 4000 PULSE PER MILE
5	SEEK ALWAYS AVAILABLE	SEEK AVAILABLE IN AUDIO MENU (Mercedes)
6	TELEPHONE BUTTONS ACTIVE (ONLY FOR RADIOS COMPATIBLE)	TELEPHONE BUTTONS NOT ACTIVE (ONLY FOR RADIOS COMPATIBLE)
7	PARKING SENSOR BUZZER SIGNAL DISABLED	PARKING SENSOR BUZZER SIGNAL ENABLED ON HANDBRAKE OUTPUT
8	AMPLI WAKE UP ON	AMPLI WAKE UP OFF
DOGDE JEEP CHRYSLER		
9	RESISTIVE RADIO CODE IMPULSED	RESISTIVE RADIO CODE CONTINUOUS
10	IGNITION INTERRUPTED WHEN KEY IS OFF (ONLY JEEP GRAND CHEROKEE)	IGNITION INTERRUPTED WHEN KEY IS PULLED OUT (ONLY JEEP GRAND CHEROKEE)
11	HAND BRAKE OUTPUT	FIAT BLUE&ME MUTE AVAILABLE ON THE HANDBRAKE OUTPUT
12	SEEK ALWAYS AVAILABLE	SEEK AVAILABLE IN AUDIO MENU (Volkswagen)
13	ANSWER / CLOSE A CALL WITH 2 PHONE BUTTONS	ANSWER / CLOSE A CALL WITH 1 PHONE BUTTON
ONLY FOR ALPINE IXA-W407BT		
14	BACKGEAR OUTPUT	RENAULT DISPLAY WAKE UP
NAVI BACK		
15	HANDBRAKE OUTPUT AVAILABLE WHEN HANDBRAKE ON	GND OUTPUT WHEN CAR REMOTE CONTROL IS OFF
ONLY FOR OPEL ZAFIRA 1C		
16	REVERSE OUTPUT AVAILABLE WHEN REVERSE INSERTED	12V OUTPUT WHEN CAR DOOR OPEN
ONLY FOR OPEL ZAFIRA 1C		
17	REVERSE GEAR OUTPUT	RENAULT DISPLAY WAKE UP
NAVI BACK CARMINAT 2		
18	REVERSE GEAR OUTPUT	RENAULT DISPLAY WAKE UP
NAVI BACK CARMINAT 3		
19	IGNITION OUTPUT SIDELIGHTS OUTPUT	LEFT DIRECTION LIGHT RIGHT DIRECTION LIGHT
MERCEDES ACTROS & AROCS		
20	AMPLI WAKE UP OFF	AMPLI WAKE UP ON
AMPLI VW SKODA		
21	SPEED PULSE SIGNAL DISABLED	SPEED PULSE SIGNAL ENABLED ON HANDBRAKE OUTPUT
(FOR THE CORRECT OPERATION MODE OF THIS OPTION, YOU MUST ALSO ENABLE THE OPTION 7)		
22	VOLUME OUTPUT STANDARD	VOLUME ONE OUTPUT MANAGEMENT
MANAGEMENT VOLUME KENWOOD		
23	AMPLI WAKE UP OFF	AMPLI WAKE UP ON
AMPLI DODGE RAM		
24	IGNITION OUTPUT STANDARD	IGNITION OUTPUT FOR 20 MINUTES, CONNECTING AND DISCONNECTING THE IGNITION WITHIN 3 SECOND
IGNITION ALFA MITO		
25	AMPLI WAKE UP OFF	AMPLI WAKE UP ON
AMPLI FORD F150		
26	BUZZER MANAGEMENT: ALL ACUSTIC SIGNALS RECOVERY	BUZZER MANAGEMENT: PARKING SENSORS SIGNALS RECOVERY <b>ONLY</b>
(FUNCTION RELATED TO THE OPTION 7)		
27	COMMUNICATION TO AVOID KM BLINKING ACTIVE	COMMUNICATION TO AVOID KM BLINKING NOT ACTIVE
FIAT KM BLINKING MANAGEMENT		
28	VOICE RECALL FUNCTION ACTIVE	VOICE RECALL FUNCTION NOT ACTIVE
VOICE RECALL FUNCTION		
29	COMMUNICATION TO AVOID KM BLINKING NOT ACTIVE	COMMUNICATION TO AVOID KM BLINKING ACTIVE
FIAT KM BLINKING MANAGEMENT		

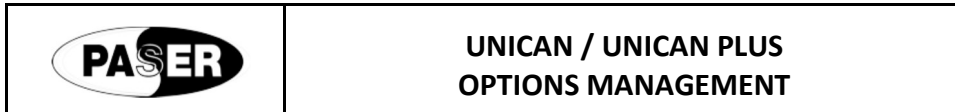

**OPTIONS MANAGEMENT**

The module on default manages some functions. However, sometime, end user prefers other functions instead of those pre-set. For this reason it's available a new procedure allowing to set a series of options. First of all it is important that the unit has synchronized a car canbus protocol. The LED must be GREEN.



Now press 3 times the module button, the LED will flash RED (UNITS), GREEN (TENS) and YELLOW (HUNDREDS) flashing.

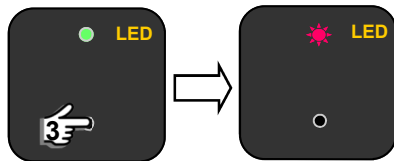

Now turn ignition ON 4 times and the 4th time keep the ignition ON. The LED will flash YELLOW indicating the number of the option, followed by the RED flashes indicating the value of the option.

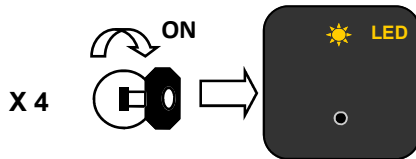

YELLOW flashes represents the number of the option, RED flashes represents the state of the option. To increase the option number please press the button on the module, so if the LED flash 1 time by pressing one time the button it will flash 3 times. If you want to change the default option's state, hold the button pressed until the LED turns off. Once released the button, the unit will flash the option related and the new option state. To exit option management please disconnect and reconnect the module from power. The LED will light GREEN.

OPTION AND FLASH NUMBERS	VALUE OPTION 1 RED FLASHES	VALUE OPTION 2 RED FLASHES
1	SEEK ALWAYS AVAILABLE	SEEK AVAILABLE FOR 10 SEC AFTER A VOLUME PRESS
2	HAND BRAKE AVAILABLE WHEN HANDBRAKE IS ON	ODOMETRIC HANDBRAKE AVAILABLE WHEN THE CAR IS BELOW 3 Km/h SPEED
3	SEEK ALWAYS AVAILABLE	ODOMETRIC SEEK AVAILABLE WHEN THE CAR OVERPASS 3 Km/h SPEED
4	SPEED PULSE FREQUENCY 26000 PULSE PER MILE	SPEED PULSE FREQUENCY 4000 PULSE PER MILE
5	SEEK ALWAYS AVAILABLE	SEEK AVAILABLE IN AUDIO MENU (Mercedes)
6	TELEPHONE BUTTONS ACTIVE (ONLY FOR RADIOS COMPATIBLE)	TELEPHONE BUTTONS NOT ACTIVE (ONLY FOR RADIOS COMPATIBLE)
7	PARKING SENSOR BUZZER SIGNAL DISABLED	PARKING SENSOR BUZZER SIGNAL ENABLED ON HANDBRAKE OUTPUT
8	AMPLI WAKE UP ON	AMPLI WAKE UP OFF
DOGDE JEEP CHRYSLER		
9	RESISTIVE RADIO CODE IMPULSED	RESISTIVE RADIO CODE CONTINUOUS
10	IGNITION INTERRUPTED WHEN KEY IS OFF (ONLY JEEP GRAND CHEROKEE)	IGNITION INTERRUPTED WHEN KEY IS PULLED OUT (ONLY JEEP GRAND CHEROKEE)
11	HAND BRAKE OUTPUT	FIAT BLUE&ME MUTE AVAILABLE ON THE HANDBRAKE OUTPUT
12	SEEK ALWAYS AVAILABLE	SEEK AVAILABLE IN AUDIO MENU (Volkswagen)
13	ANSWER / CLOSE A CALL WITH 2 PHONE BUTTONS	ANSWER / CLOSE A CALL WITH 1 PHONE BUTTON
ONLY FOR ALPINE IXA-W407BT		
14	BACKGEAR OUTPUT	RENAULT DISPLAY WAKE UP
NAVI BACK		
15	HANDBRAKE OUTPUT AVAILABLE WHEN HANDBRAKE ON	GND OUTPUT WHEN CAR REMOTE CONTROL IS OFF
ONLY FOR OPEL ZAFIRA 1C		
16	REVERSE OUTPUT AVAILABLE WHEN REVERSE INSERTED	12V OUTPUT WHEN CAR DOOR OPEN
ONLY FOR OPEL ZAFIRA 1C		
17	REVERSE GEAR OUTPUT	RENAULT DISPLAY WAKE UP
NAVI BACK CARMINAT 2		
18	REVERSE GEAR OUTPUT	RENAULT DISPLAY WAKE UP
NAVI BACK CARMINAT 3		
19	IGNITION OUTPUT SIDELIGHTS OUTPUT	LEFT DIRECTION LIGHT RIGHT DIRECTION LIGHT
MERCEDES ACTROS & AROCS		
20	AMPLI WAKE UP OFF	AMPLI WAKE UP ON
AMPLI VW SKODA		
21	SPEED PULSE SIGNAL DISABLED	SPEED PULSE SIGNAL ENABLED ON HANDBRAKE OUTPUT
(FOR THE CORRECT OPERATION MODE OF THIS OPTION, YOU MUST ALSO ENABLE THE OPTION 7)		
22	VOLUME OUTPUT STANDARD	VOLUME ONE OUTPUT MANAGEMENT
MANAGEMENT VOLUME KENWOOD		
23	AMPLI WAKE UP OFF	AMPLI WAKE UP ON
AMPLI DODGE RAM		
24	IGNITION OUTPUT STANDARD	IGNITION OUTPUT FOR 20 MINUTES, CONNECTING AND DISCONNECTING THE IGNITION WITHIN 3 SECOND
IGNITION ALFA MITO		
25	AMPLI WAKE UP OFF	AMPLI WAKE UP ON
AMPLI FORD F150		
26	BUZZER MANAGEMENT: ALL ACUSTIC SIGNALS RECOVERY	BUZZER MANAGEMENT: PARKING SENSORS SIGNALS RECOVERY <b>ONLY</b>
(FUNCTION RELATED TO THE OPTION 7)		
27	COMMUNICATION TO AVOID KM BLINKING ACTIVE	COMMUNICATION TO AVOID KM BLINKING NOT ACTIVE
FIAT KM BLINKING MANAGEMENT		
28	VOICE RECALL FUNCTION ACTIVE	VOICE RECALL FUNCTION NOT ACTIVE
VOICE RECALL FUNCTION		
29	COMMUNICATION TO AVOID KM BLINKING NOT ACTIVE	COMMUNICATION TO AVOID KM BLINKING ACTIVE
FIAT KM BLINKING MANAGEMENT		