

WASHINGTON OPERATIONS

MTR-7007
NASA CR-144911

(NASA-CR-144911) STRATOSPHERIC MEASUREMENT N76-22636
REQUIREMENTS AND SATELLITE-BORNE REMOTE
SENSING CAPABILITIES. (Mitre Corp.) 223 p HC
\$7.75 CSCI 04A Unclas
G3/43 25301.

Stratospheric Measurement Requirements and Satellite-Borne Remote Sensing Capabilities

J.J. CARMICHAEL
R.G. ELDRIDGE
E.J. FREY
E.J. FRIEDMAN
A.H. GHOVANLOU

FEBRUARY 1976



MITRE

MITRE Technical Report

MTR-7007

NASA CR-144911

Stratospheric Measurement Requirements and Satellite-Borne Remote Sensing Capabilities

J.J. CARMICHAEL

R.G. ELDRIDGE

E.J. FREY

E.J. FRIEDMAN

A.H. GHOVANLOU

FEBRUARY 1976

CONTRACT SPONSOR
CONTRACT NO.
PROJECT NO.
DEPT.

NASA/Langley Research Center
F19628-75-C-0001
819K
W-52

THE
MITRE
CORPORATION
McLEAN, VIRGINIA 22101

This document was prepared for authorized distribution.
It has not been approved for public release

Department Approval: S. Ward

MITRE Project Approval: E. Friedman

EXECUTIVE SUMMARY

Satellite-borne Remote Sensing. The purpose of this planning study is to assess the capabilities of specific NASA remote sensing systems to provide appropriate measurements of stratospheric parameters for potential user needs. The measurement capabilities of specific NASA sensors, the effects of orbital parameters combined with measurement techniques is used to assess the capabilities of the remote sensing systems to perform global monitoring of the stratosphere.

Stratospheric Pollution. There are two general types of pollutants, gaseous and aerosols, which can have detrimental effects on the natural atmosphere. The gaseous pollutants of major concern are chlorine and/or nitrogen oxides which dissociate ozone. More recently, the potential danger from chlorofluoromethanes (Freons) has been added to the list of stratospheric pollutants. Reduction of the ozonosphere can modify the atmospheric temperature structure and allow the transmission of harmful ultraviolet radiation to the Earth's surface (See Section 4.3). Aerosol pollution generally consists of an increase in concentration either by injection of aerosols into the stratosphere or by aerosol formation in-situ. Aerosols scatter, and to a lesser extent absorb, incident solar radiation. As a consequence, an increase in the aerosol population can result in a change in the atmospheric temperature structure thereby altering the Earth's radiation balance and in reduced insolation. These modifications to the atmosphere may

be considered as climatic changes which have socio-economic consequences (See Section 4.4).

The stratospheric constituents and pollutants which have a potential to degrade the ozonosphere or cause other climatic changes are listed in Table I (See Sections 2.0 and 4.0). The concentrations were generally derived from current in-situ measurements; the accuracies are derived from requirements of potential users of the data.

NASA Remote Sensors. NASA/LaRC has a continuing program to develop satellite-borne remote sensors to meet future scientific and regulatory requirements of both governmental and academic communities. This planning study addresses the measurement capabilities of six specific instruments and other devices which can provide supporting data. The six NASA instruments are:

- LACATE (Lower Atmospheric Composition and Temperature Experiment),
- SAM II (Stratospheric Aerosol Measurements),
- CIMATS (Correlation Interferometer for Measurement of Atmospheric Trace Species),
- MAPS II (Monitoring Air Pollution from Satellites),
- VRPM (Visible Radiation Polarization Measurements) and,
- SAGE II (Stratospheric Aerosol and Gas Experiment).

The general measurement technique and type of observations are summarized in Table II (See Section 5.0). In general, those instruments which observe the atmospheric limb of the Earth are capable of measuring the vertical profile of the gas or aerosol, whereas those instruments

TABLE I

STRATOSPHERIC CONSTITUENTS RECOMMENDED FOR MONITORING

<u>CONSTITUENTS</u>	<u>CONCENTRATION*</u>	<u>REQUIRED ACCURACY (%)**</u>
O ₃	6 ppmv	<10
HCl	~1 ppbv	100
Cl	Unknown	100
ClO	Unknown	100
CF ₂ Cl ₂	Unknown	100
CFC1 ₃	Unknown	100
OH	10 ⁻⁴ ppbv	100
CH ₄	1 ppmv	20
O	10 ⁶ /cc	100
NH ₃	Unknown	100
NO	0.1 ppbv	50
NO ₂	~2 ppbv	50
HNO ₃	3 ppbv	30
N ₂ O	0.1 ppmv	5
N ₂ O ₅	Unknown	100
SO ₂	10 ⁻⁶ ug/m ³	100
H ₂ S	10 ⁻⁷ ug/m ³	100
H ₂ O	1 mg/m ^{3***}	100
Aerosols	0.0.-1.0 cm ⁻³	--

*Average Concentration at 20 km.

**100 percent refers to an error band equal to twice the concentration.

***Extremely variable.

TABLE II

REMOTE SENSORS OBSERVATIONAL TECHNIQUES

<u>SENSOR SYSTEM</u>	<u>MEASUREMENT TECHNIQUE</u>	<u>OBSERVABLES</u>
LACATE	Earth's Limb Emission	Temperature Profile, NO ₂ , H ₂ O, CH ₄ , O ₃ , N ₂ O, HNO ₃ and Aero- sol Concentrations.
SAM II	Earth's Limb Extinction	Aerosol Concentra- tion Profiles.
CIMATS	Absorption of Earth's Radiation	Five to seven of the following: NO, NO ₂ , N ₂ O, CO, NH ₃ , CH ₄ , C ₂ H ₄ , C ₂ H ₆ , HCl, HNO ₃ , H ₂ CO, SO ₂ , and CO ₂ .
MAPS II	Absorption of Earth's Radiation	CO ₂ , CO, NO, NO ₂ , NH ₃ , CH ₄ , SO ₂ , H ₂ CO, and Aerosols.
VRPM	Scattered Earth's Radiation	Aerosol Total Burden.
SAGE II	Earth's Limb Extinction	Aerosol vertical profiles, O ₃ , and NO ₂ .

which observe the atmospheric constituents from nadir and near nadir attitudes, measure the total burden of the particular constituent.

User Requirements. The potential users of remotely observed stratospheric data have been discussed in two generic groups; scientific applications and monitoring activities. The scientific user's interests are quite diverse and therefore span all measurable parameters. Conversely, agencies responsible for monitoring the emission of pollutants have specific requirements for timely measurements.

A survey of user requirements was made to evaluate the performance of the proposed instrumentation and to determine the scientific value of the associated data (See Section 4.0). The survey was designed to:

- gather detailed quantitative data requirements as perceived by the various research groups,
- assess the current and future program goals within various offices of the Federal government responsible for monitoring and control of pollution and,
- determine the effects of these pollutants on the stratosphere.

Two areas of major current concern were selected as examples; UV-related effects and climatic effects. In each case, personal contact was made with the institutions and agencies most directly concerned with the problem area. Extensive literature searches were also conducted to augment the list of potential users of NASA data. From the direct contacts, literature sources, and conferences and symposia, the lists of data requirements, such as Table I, were compiled.

Sensing Systems Comparison. Having identified properties of the stratosphere, current measurements, user requirements and anticipated measurement capabilities, an evaluation compared the relative merits of three pairs of remote sensors (See Section 7.0). The first comparison was between two limb viewing instruments, LACATE and SAGE II. However, SAGE II measures the attenuation of solar radiation by the atmospheric limb during occultation, whereas LACATE measures the atmospheric line emission. Although SAGE II has superior vertical resolution, LACATE has greater flexibility, and a higher potential for global observation from a variety of orbits. SAGE II is further limited to twice daily observations--"sunrise" and "sunset".

The next comparison was between two devices designed to observe aerosols. SAM II measures the extinction of solar radiation during "sunrise" and "sunset" at three wavelengths and, because of its small field-of-view, is capable of describing the vertical concentration of aerosols. VRPM measures the scattering properties of the atmosphere viewed from various angles from the nadir. The analysis of the scattered flux with appropriate aerosol size distribution models results in an approximation of the total atmospheric burden of aerosols. The selection of one system over the other is contingent upon the user needs; SAM II provides vertical profiles of aerosol concentrations, whereas VRPM provides an average aerosol size distribution (based on the model selected) and infers the total burden of aerosols.

The final comparison was made between CIMATS and MAPS II. Both instruments are primarily nadir-viewing devices, but CIMATS retains the added capability of operating in a limb scan mode (not considered in this comparison). The expected instrument accuracy of MAPS II appears better than CIMATS, however CIMATS is capable of measuring more species. Both instruments have complex calibration schemes and both require considerable data reduction. When taken in total, CIMATS appears, at this writing, to be the preferred instrument.

Summary of Findings. The generic users' needs survey indicated that both the scientific and regulatory communities have potential requirements for timely, accurate stratospheric observations. Although specific requirements are not available at this time, proposed satellite data can be integrated into current user activities. Some measurements made from balloon and aircraft platforms have accuracies comparable with those expected from satellite remote sensors (See Table I). These accuracies will undoubtedly be sufficient for some years to come, but are limited in spatial and temporal coverage. The requirement for global monitoring of stratospheric constituents can only efficiently be achieved with satellite remote sensors.

Science requirements include the need for vertical profiles and data of fairly high quality. Limb viewing instrumentations appear to satisfy these needs but provide limited temporal sampling for solar occultation when certain orbits are used. As a result, instrumentations of the limb emission type represent the optimum choice.

Orbital considerations emerge as a key element in the applicability of various sensor systems to specific measurement roles (See Section 6.0). Sun-synchronous orbits provide optimum coverage for nadir-viewing, thermal source sensors and limb-viewing emission source sensors. High angle non-Sun-synchronous orbits are preferred for nadir-viewing reflected solar source or limb-viewing solar occultation sensors, if geographical coverage is to be maximized.

The group of sensors reviewed in this study appear in Table II with their measurement characteristics. A number of the suggested constituents (Table I), such as the chlorine compounds, cannot be monitored by the instruments as now envisioned. Presumably, future instrument designs will reflect these latest additions to the set of important stratospheric constituents.

Several other gases have not as yet been selected for measurement (OH, O, N_2O_5 , SO_2 , H_2S , H_2O). Extension of current instrument performance to include these species should receive prime consideration. If future experiments and related model developments confirm their importance, they should be monitored by future spacecraft instrumentation.

TABLE OF CONTENTS

	<u>Page</u>
LIST OF ILLUSTRATIONS	xv
LIST OF TABLES	xvii
1.0 INTRODUCTION	1-1
REFERENCES	1-5
2.0 THE STRATOSPHERE	2-1
2.1 General Properties	2-1
2.2 Relation to Atmosphere	2-5
2.2.1 Constituents	2-7
2.2.2 Transport Phenomena	2-11
2.3 Stratospheric Chemistry	2-12
2.3.1 Ozone Chemistry	2-13
2.3.2 Aerosol Chemistry	2-17
2.4 Mathematical Models	2-26
2.5 Stratospheric Pollutants	2-27
REFERENCES	2-33
3.0 MEASUREMENTS TO DATE	3-1
3.1 General Technique	3-1
3.2 Contact Measurements	3-1
3.2.1 Hygrometers	3-1
3.2.2 Other H ₂ O Contact Sensors	3-2
3.2.3 Electrochemical Measurement of Ozone	3-2
3.2.4 Chemiluminescence Measurement of Gases	3-3
3.2.5 Other NO _x Contact Sensors	3-3
3.2.6 Particulate Techniques	3-4
3.3 Remote Measurements	3-4
3.3.1 LIDAR	3-4
3.3.2 Raman Spectroscopy	3-6
3.3.3 Radiometers	3-7
3.3.4 Spectrometers	3-7
3.3.5 Interferometers	3-9
3.4 Platforms	3-9
3.5 Results and Limitations	3-13
REFERENCES	3-15
4.0 USERS' REQUIREMENTS FOR SATELLITE MEASUREMENTS	4-1
4.1 Approach	4-3

TABLE OF CONTENTS (continued)

	<u>Page</u>
4.1.1 Assumptions	4-5
4.1.2 Organization	4-6
4.2 General Observations on the NASA Relationship with Potential Users	4-7
4.2.1 Uses of Data from Previous Experiments	4-8
4.2.2 User Participation in Mission Development	4-10
4.2.3 Related Factors	4-11
4.3 Influences on the Biosphere	4-12
4.3.1 Introduction	4-12
4.3.1.1 Scope of Study	4-12
4.3.1.2 Methodology	4-15
4.3.2 Study Results	4-17
4.3.2.1 Information Sources	4-17
4.3.2.2 Biophysical Effects of UV	4-18
4.3.2.3 UV Influence on Human Affairs	4-31
4.3.2.4 Organizational Involvement	4-34
4.3.3 Information Flow and Use of Results	4-52
4.3.4 Measurement Requirements	4-54
4.4 Influences on Climate	4-56
4.4.1 Introduction	4-56
4.4.2 Modeling and Studies of Physical Climate	4-57
4.4.2.1 Components of the Climatic System	4-57
4.4.2.2 Radiation Processes	4-58
4.4.2.3 Cloud Processes	4-58
4.4.2.4 Surface Processes	4-59
4.4.2.5 Atmospheric Processes	4-60
4.4.2.6 CIAP Modelers	4-62
4.4.3 Monitoring Program	4-62
4.4.3.1 Background	4-62
4.4.3.2 Current Status	4-64
4.4.3.3 Planned International Programs	4-65
4.4.3.4 Planned Domestic Programs	4-67
4.4.4 Survey of Climate Data Users	4-67
4.4.4.1 Previous Efforts	4-68
4.4.4.2 Criteria Development	4-69
4.4.4.3 User Survey	4-71
4.4.5 User Categories and Their Requirements	4-74
4.4.5.1 Modelers	4-75
4.4.5.2 Physical and Statistical Studies	4-77
4.4.5.3 Monitoring	4-78
4.4.5.4 User Needs Conclusions	4-78
4.5 Specific Measurement Requirements	4-81
4.6 Specific Requirements	4-92

TABLE OF CONTENTS (continued)

	<u>Page</u>
REFERENCES	4-101
5.0 SATELLITE REMOTE SENSING	5-1
5.1 General Features of Remote Sensing in the Stratosphere	5-1
5.1.1 Sensitivity	5-2
5.1.2 Horizontal Resolution	5-4
5.1.3 Vertical Resolution	5-6
5.1.4 Insensitivity to Clouds	5-7
5.1.5 Night Operation	5-8
5.1.6 Measurement Time per Orbit	5-8
5.2 Specific Features of Stratospheric Remote Sensors	5-9
5.2.1 LACATE	5-9
5.2.2 SAM II	5-12
5.2.3 CIMATS	5-13
5.2.4 MAPS II	5-15
5.2.5 VRPM	5-17
5.2.6 SAGE II	5-19
5.2.7 Infrared Heterodyne Radiometer (IHR)	5-21
5.2.8 SERM	5-23
5.2.9 Cloud Scanning Radiometer	5-25
REFERENCES	5-29
6.0 ORBIT INFLUENCES	6-1
6.1 Orbit Parameters	6-2
6.2 Instrument Operation	6-2
6.2.1 Limb - Solar Source (Occultation)	6-5
6.2.2 Reflected Solar Source	6-7
6.2.3 Nadir-Thermal Source	6-12
6.2.4 Limb-Emission Source	6-12
6.3 Coverage Requirements	6-13
7.0 SYSTEM COMPARISONS	7-1
7.1 LACATE vs. SAGE II	7-2
7.2 SAM II vs. VRPM	7-4
7.3 CIMATS vs. MAPS II	7-6
8.0 CONCLUSIONS	8-1
8.1 Current Measurements	8-1
8.2 User Requirements	8-2
8.3 Projected Sensor Systems	8-4
8.3.1 General Characteristics	8-4
8.3.2 Proposed Sensor Systems	8-7

TABLE OF CONTENTS (concluded)

	<u>Page</u>
APPENDIX A: ORBIT CALCULATIONS	A-1
APPENDIX B: CLIMATIC DATA USER SURVEY	B-1
BIBLIOGRAPHY	C-1
DISTRIBUTION LIST	D-1

LIST OF ILLUSTRATIONS

<u>Figure Number</u>		<u>Page</u>
2-1	Sample Temperature Profiles at Tropical and Polar Zones. Troposphere, Stratosphere, Stratopause and Mesosphere Defined in Terms of Vertical Temperature Profiles	2-3
2-2	Average Temperature Contours for March 22, January 15	2-4
2-3	Complete Nitrogen Cycle	2-16
2-4	Chlorine Cycle	2-18
2-5	Stratospheric Pollution Effects	2-32
4-1	User Needs Rationale	4-4
4-2	Primary Influences on Surface UV	4-14
4-3	Basic Research Activity	4-38
4-4	Applications Activity - Animals	4-39
4-5	Applications Activity - Plants	4-40
4-6	Data Utilization and Users	4-55
4-7	The Interdependence of the Major Components of a Climatic Research Program and a Number of Key Questions	4-76
6-1	Experimental Configuration During Solar Occultation Experiment	6-6
6-2	Latitude Coverage of Solar Occultation Instrumentation in Typical Sun-Synchronous Orbits	6-8
6-3	Sampling Characteristics of Solar Occultation Instrumentation in a Non-Sun Synchronous Orbit	6-9

LIST OF ILLUSTRATIONS (concluded)

<u>Figure Number</u>		<u>Page</u>
6-4	Latitudes for Which the Solar Elevation Angle Exceeds 45° as a Function of Season and Time of the Descending Node	6-11

LIST OF TABLES

<u>Table Number</u>		<u>Page</u>
I	Stratospheric Constituents Recommended for Monitoring	v
II	Remote Sensors Observational Techniques	vi
II-1	Minor Atmospheric Constituents	2-9
II-2	Trace Atmospheric Constituents	2-10
II-3	CIAP Program Modelers ⁽⁵⁾	2-28
III-1	Contact Measurements	3-5
III-2	Selected Characteristics of Sensing Platforms	3-10
III-3	Current and Projected Measurement Capability	3-12
IV-1	User Needs Interviews	4-9
IV-2	Human Concern with UV	4-32
IV-3	Federal Departments and Agencies with Major Concern with <u>UV</u>	4-35
IV-4	UV Research Categories	4-41
IV-5	CIAP Program Modelers	4-63
IV-6	Climate Interviews Conducted	4-73
IV-7	General Measurement Requirements of Global Climate Models	4-82
IV-8	General Measurement Requirements for a General Circulation Model	4-83
IV-9	Observations Required for Validation of Climate Models	4-85
IV-10	Data Requirements for FGGE	4-86

LIST OF TABLES (continued)

<u>Table Number</u>		<u>Page</u>
IV-11	Tentative Specification of Global Observation of Gases and Particulates	4-87
IV-12	Aerosol Processes-Summary of Tentative Observational Requirements	4-88
IV-13	Tentative Specification of Long-Term Monitoring Requirements for Radiation Balance Components	4-89
IV-14	Tentative Specification of Global Observation Requirements for Verification of Ocean Models	4-90
IV-15	Trace Gas Measurement Requirements for Climate	4-91
IV-16	The Concentration and Required Measurement Accuracy of Chlorine-Ozone Constituents	4-93
IV-17	The Concentration and Required Measurement Accuracy of NO _x -Ozone Constituents	4-94
IV-18	Chemical Composition of Stratospheric Particles	4-95
IV-19	Gaseous Constituents Influencing Aerosol Formation	4-96
IV-20	Recommended Constituents for a Stratospheric Monitoring Program	4-99
V-1	Properties of Passive Stratospheric Remote Sensors	5-3
V-2	Remote Sensor Systems	5-10
V-3	SERM Instrumentation	5-26
V-4	Development of Scanning Radiometers	5-27
VI-1	Typical Orbit Parameters Utilized in the Analysis	6-3
VI-2	Sensor Requirements on Solar Position During Measurement in Orbit	6-4

LIST OF TABLES (concluded)

<u>Table Number</u>		<u>Page</u>
VII-1	LACATE vs. SAGE II	7-3
VII-2	SAM II vs. VRPM	7-5
VII-3	CIMATS vs. MAPS II	7-7
VIII-1	Current and Projected Measurement Capability	8-3
VIII-2	Science Requirements for Monitoring in the Stratosphere	8-5
VIII-3	Properties of Stratospheric Remote Sensors	8-6
VIII-4	Recommended Constituents for a Stratospheric Monitoring Program	8-8

1.0 INTRODUCTION

The stratosphere, which nominally extends from about 10 to 50 kilometers above the earth's surface, is usually considered devoid of extreme changes in temperature and pressure associated with the phenomena known as weather. Because of the stratosphere's stable temperature structure and lethargic circulation, pollutants introduced into the stratosphere tend to have long residence times. Therefore, the proposal to operate fleets of supersonic transports in the lower stratosphere stimulated considerable concern as to whether the atmosphere could maintain its present characteristics. Such concern also emphasized the importance of understanding the impact of tropospheric pollution sources on the stratosphere.

Scientific inquiries regarding the effect of man's industrial activities on the atmosphere have increased in recent years. The pertinent results of these investigations are summarized in the following reports:

- "Man's Impact on the Global Environment", SCEP, MIT Press, 1970, (1)
- "Inadvertant Climate Modification", SMIC, MIT Press, 1971, (2) and
- "Remote Measurement of Pollution" (RMOP) NASA SP-285, 1971. (3)

With the amassing of inferential, incomplete data by scientists, the concern became public. Congressional concern was manifest by directing the Department of Transportation to mount a Federal scientific program to obtain sufficient knowledge to judge the seriousness of supersonic

transport effluence on the stratosphere and man's environment.

The Department of Transportation's Climatic Impact Assessment Program (CIAP) sponsored the most intensive theoretical and experimental studies of the stratosphere ever undertaken. The scientific results were regularly presented at conferences and their proceedings published. The significant results of the CIAP studies were disseminated as:

- Report of Findings, CIAP, (4) and
- National Academy of Science study based on the CIAP data. (5)

The most important result of the CIAP studies is that a more complete understanding of stratospheric processes was made available for rational decisions. An institutional course of action suggested by the CIAP authors (4) was the development of a global monitoring system. This suggestion, in effect, provides yet another reason for NASA's continuing program of developing satellite-borne remote sensors.

Additional, smaller, studies have been performed of the stratospheric impact of tropospheric emissions of compounds containing chlorine. (6)

The object of this report is to assess the applicability of specific satellite remote sensors to perform stratospheric studies and monitoring based on these concerns. This was accomplished by:

- 1) describing stratospheric processes and current measurement capabilities,
- 2) developing generic requirements of potential users, and
- 3) comparing the capabilities of specific proposed remote sensors to perform global monitoring.

An additional purpose of the report is to perform some initial planning for the use of satellite-borne remote sensors. Current stratospheric characteristics are used to assess the capabilities of specific proposed remote sensors to meet the future requirements of potential users. This planning function is required periodically to assess current plans and to update users' requirements.

REFERENCES

1. "Man's Impact on the Global Environment: Assessment and Recommendations for Action. Critical Environmental Problems (SCEP)." MIT 1970.
2. "Inadvertent Climate Modification. Report of the Study of Man's Impact on Climate (SMIC)." MIT 1971.
3. "Remote Measurement of Pollution," NASA SP-285, 1971.
4. "Report of Findings": "The Effects of Stratospheric Pollution by Aircraft," A. J. Grobecker, et. al., DOT-TST-75-50, December 1974.
5. "Environmental Impact of Stratospheric Flight, Biological and Climatic Effects of Aircraft Emission in the Stratosphere," National Academy of Sciences, 1975.
6. "Fluorocarbons and the Environment: Report of Federal Task Force on Inadvertent Modification of the Stratosphere (IMOS)," Council on Environmental Quality, Federal Council for Science and Technology, June 1975.

PRECEDING PAGE BLANK NOT FILMED

2.0 THE STRATOSPHERE

The purpose of this section is to acquaint the reader with the object of satellite remote sensor measurements--the stratosphere. The temperature regime and circulation are discussed in terms of the general dynamic processes to illustrate the formation of the unperturbed stratosphere. This leads to a summary of the stratospheric constituents and their role in atmospheric chemistry.

The two major reasons for observing or monitoring the stratosphere are to gain a more complete understanding of the subject and to be able to predict changes in the environment. Inadvertent modifications of the stratosphere by pollutants can have far-reaching effects upon man's socio-economic milieu. Therefore, stratospheric chemical processes, both in terms of ozone destruction and aerosol formation, are summarized to provide background for discussions of sensor systems and user requirements.

2.1 General Properties

A series of atmospheric layers may be defined according to the temperature structure. These layers are:

- troposphere,
- stratosphere, and
- mesosphere.

Averaged over reasonably long periods of time, the temperature of the troposphere decreases regularly with altitude. At an elevation that varies systematically with latitude and season, the temperature becomes isothermal. This property defines the tropopause which lies between 8

to 16 km. The stratosphere is the region above the tropopause and below the stratopause. In this region, the temperature is typically constant or increasing with altitude. This increase is reversed at an altitude of about 45 to 50 km--the stratopause. The region above the stratopause is the mesosphere.

The vertical distribution of temperature in the tropical and polar zones is shown in Figure 2-1.⁽¹⁾ The two temperature profiles of Figure 2-1 show substantial differences between polar and tropical regions. An indication of the temperature changes with latitude is illustrated by a series of such profiles. Another way of presenting such data is by the contour lines of zonally averaged temperatures. Figure 2-2^(2,3) shows such contour lines for March 22 and January 15. The dotted lines in these figures are the approximate locations of the averaged tropopause as it changes with latitude. In addition to the latitudinal dependence, the height of the tropopause changes with season and synoptic weather conditions.

The special properties of the stratosphere--its temperature inversion and the resulting slow vertical mixing--are a consequence of the presence of ozone, which is formed rapidly in the upper stratosphere. The formation of ozone occurs at an altitude of 30 to 50 km by the photolysis of molecular oxygen, producing atomic oxygen, which in turn recombines with O_2 to form ozone, O_3 . In the next section, "Relation to Atmosphere", we discuss some of the physical reasons behind the temperature inversions at the tropopause in more detail.

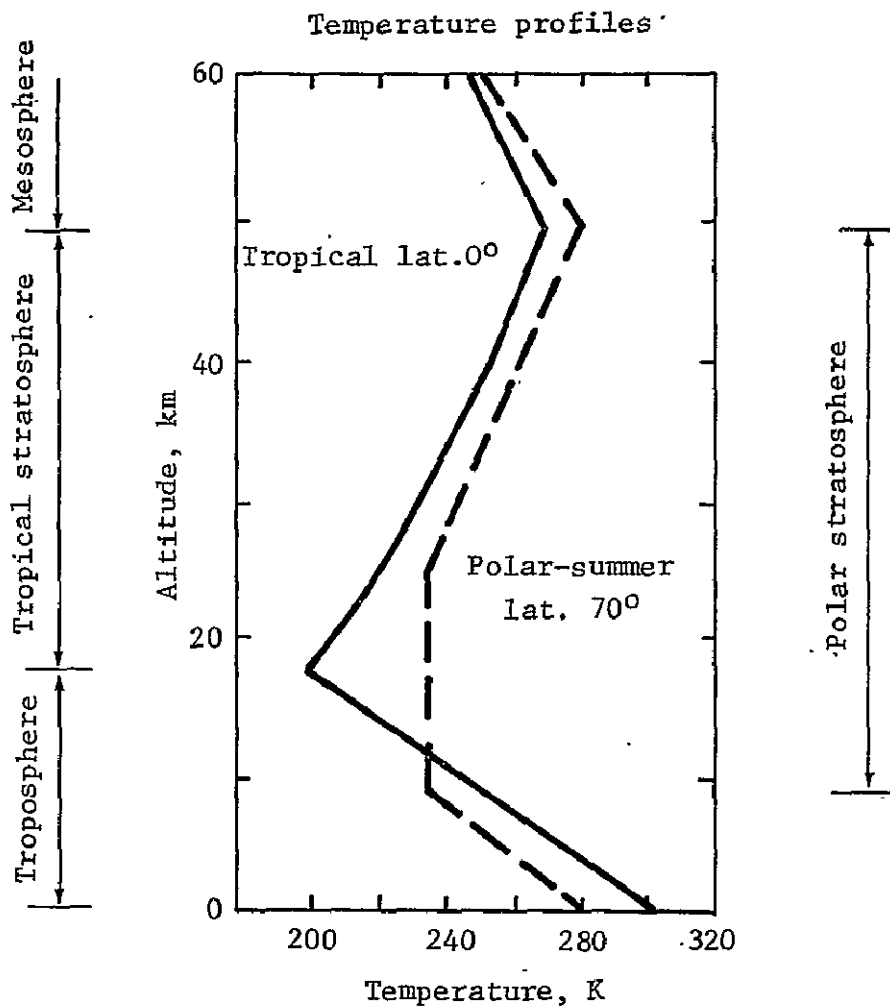

FIGURE 2-1
SAMPLE TEMPERATURE PROFILES AT TROPICAL AND POLAR ZONES.
TROPOSPHERE, STRATOSPHERE, STRATOPAUSE, AND MESOSPHERE
DEFINED IN TERMS OF VERTICAL TEMPERATURE PROFILES.(1)

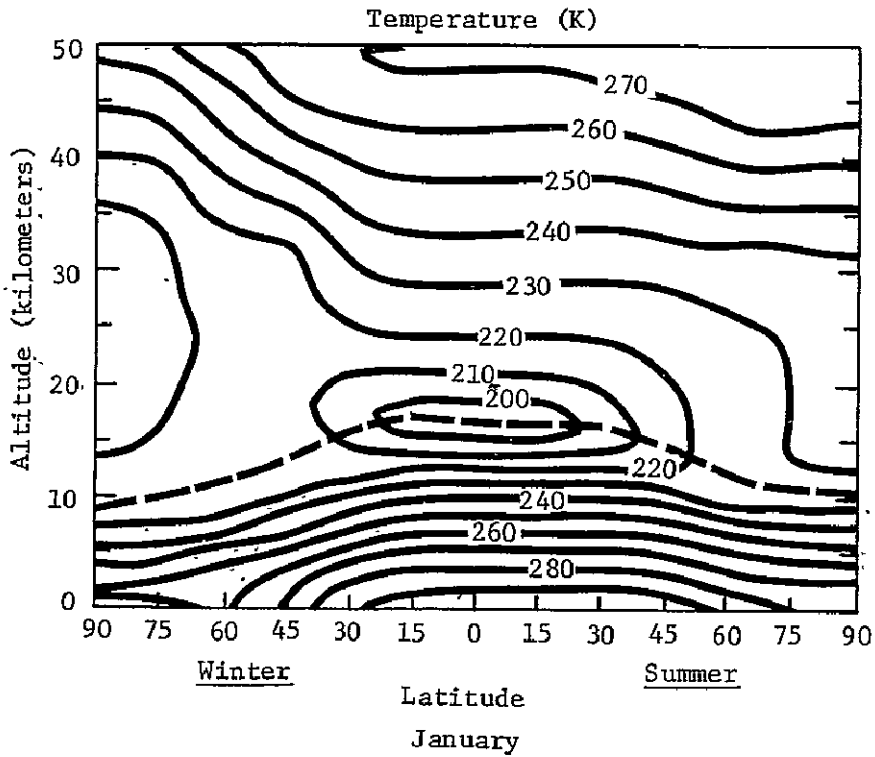
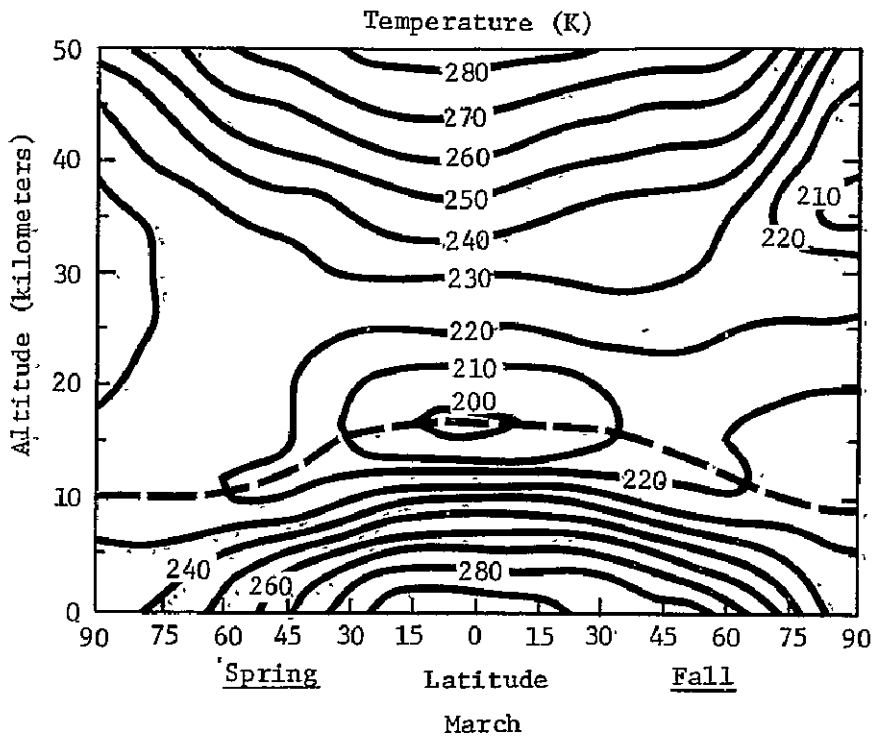

FIGURE 2-2
 AVERAGE TEMPERATURE CONTOURS FOR MARCH 22⁽²⁾, JANUARY 15⁽³⁾.
 DOTTED LINE REPRESENTS LOCATION OF AVERAGE TROPOPAUSE.

2.2 Relation to Atmosphere

The distribution of solar radiation with latitude is the major factor in determining the location of the climatic regions on the Earth's surface. If the incoming solar radiation were exactly balanced by the outgoing terrestrial radiation from that zone, the resulting latitudinal temperature extremes would be greater than those found today. The reason such extremes do not exist is due to heat exchange by the atmosphere and the oceans.

The Earth's atmosphere and the oceans modify the climate by facilitating the transport of energy between regions of extremes on and above the Earth's surface. In what follows we describe, in some detail, the dynamics and causes of the energy redistribution caused by atmospheric motions.

On the average, about 30 percent of the solar radiation entering the top of the atmosphere is either backscattered by the constituents of the atmosphere or reflected by the Earth's surface and clouds. About 50 percent of the incoming radiation heats the ground. The remaining 20 percent of incoming solar radiation is partly absorbed on its path through the atmosphere by the ozone layer, and a variety of atmospheric constituents in the lower troposphere. The one to three percent of this energy, which is absorbed by the ozone layer, provides the major heat input to the upper atmosphere and will be discussed in more detail later in this section.

To understand the consequences of the energy exchange between the Earth and the Sun, let us consider a model atmosphere with uniform temperature, rotating at the same rate as the Earth. If one starts to heat the lower air on the summer side of the Equator, the local temperature will rise and the air column will expand. This process creates a relatively high-pressure belt at the upper levels over the thermal Equator. Next, the north-south pressure gradient will force the equatorial air, at all longitudes, to move toward the low pressure zone, mainly into the winter hemisphere, where vertical contraction has occurred as a result of radiation cooling. The air will then slowly sink over a wide region in the winter hemisphere and return to the Equator at the lower levels. The cycle repeats with a rise of the reheated air in the vicinity of the thermal Equator.

Two members of the Royal Society of London, George Hadley in 1735 and Colin Maclaurin in 1740, first enunciated the above physical explanation for atmospheric circulation. They described a single flow from the tropics to the poles, and predicted a westerly flow in the upper layers and an easterly flow in the lower layers. The Coriolis force-caused by the Earth's rotation-deflects these flows at right angles to their motion. In 1856 William Ferrel, an American meteorologist, in his article appearing in The Nashville Journal of Medicine and Surgery, showed that three cells of the Hadley type, in each hemisphere can account for the important climatological features at the Earth's surface. This picture has been confirmed by many

observational and theoretical studies to provide a good model for the average conditions in the atmosphere.

If heat from the ground were the only source of energy in the atmosphere, the vertical temperature at a given location, would decrease monotonically with altitude. In contrast, the measurement of the vertical temperature profiles show that after passing the tropopause the temperature increases to a height of about 50 km. At this height, the stratopause, the temperature undergoes an inversion and again starts to decrease. The question to be answered is: What causes this temperature increase above the tropopause?

As mentioned earlier, one to three percent of the incoming solar radiation is absorbed by the ozone layer in the stratosphere. The absorbed energy leads to heating of adjacent layers. The model now contains two sources of energy in the atmosphere; one at the surface, and the other at an altitude of about 30 to 50 km. From this simplified picture, it is evident that a temperature inversion should occur at a height between the two sources. The region where the inversion occurs defines the tropopause which lies between 8 to 16 km depending on the season, latitude, and synoptic weather situation.

2.2.1 Constituents

The constituents of the stratosphere may be separated into four categories. These are:

- major chemical constituents,
- minor chemical constituents,

- trace chemical constituents, and
- aerosols.

The major atmospheric constituents are N_2 , O_2 , Ar and CO_2 . The accepted value for nitrogen concentration is 78.08 percent by volume. Recent O_2 measurements show a concentration of 20.95 percent by volume for dry air.⁽⁴⁾ Argon has a stratospheric background concentration of 0.93 percent and carbon dioxide of 0.03 percent at about 20 km.^(5,6)

The minor constituents, such as O_3 , H_2O ; CH_4 , etc., have concentrations of a few parts per million in the stratosphere. Table II-1 summarizes some of the minor constituents at 20 km which are important in stratospheric chemistry and circulation. Table II-2 summarizes some of the important trace constituents, such as NO, H_2O , etc., their concentrations at 20 km, their variability, and their role in stratospheric chemistry.

Besides these chemical constituents, a layer of particles several kilometers thick, exists in the stratosphere. This layer, called the "Junge layer", is located several kilometers above the tropopause. The Junge, or sulfate layer, has a particle density of two to ten times that exhibited above and below this layer. The particle size is predominately in the 0.1 to 1.0 μm radius range. The particle distribution shows a decreasing concentration with increasing size. The particles consist mainly of sulfuric acid solutions and are probably in a supercooled liquid state.

TABLE II-1
MINOR ATMOSPHERIC CONSTITUENTS

Species	Concentration at 20 km	Variability	Importance
O ₃	6 ppmv	Factor of two or more diurnal, season, latitude and height.	UV-shield, radiative heating and cooling of stratosphere.
H ₂ O	3 ppmv	With latitude, season, and altitude.	Radiative balance, clouds, particle formation, O ₃ chemistry.
CH ₄	1 ppmv	Decreases with height above tropopause.	Chemical source of OH. Possible sink of Cl, indicator of tropopause interchange.
H ₂	0.55 ppmv	Increases to a maximum of 0.8 ppmv at 28 km and decreases to 0.4 at 50 km.	O ₃ -chemistry.
N ₂ O	0.1 ppmv	Decreases with altitude, season, and latitude.	Source of stratospheric NO.
CO	0.05 ppmv	May decrease above tropopause, but actual profile and variations are unknown.	Indicator of troposphere-stratosphere exchange. By-product of CH ₄ chemistry.

ORIGINAL PAGE IS
OF POOR QUALITY

TABLE II-2
TRACE ATMOSPHERIC CONSTITUENTS

Species	Concentration at 20 km	Variability	Importance
HNO ₃	3 ppbv	With height, season, latitude and possibly diurnally.	O ₃ -chemistry specifically sink of NO _x , long residence time, therefore, useful as a tracer, and source of nitrate particles
NO ₂	3 ppbv	5 ppbv at altitude >30 km unknown but seems to vary somewhat with altitude	Catalytic reaction with O ₃
NO	0.1 ppbv	Unknown, some variation with altitude	Catalytic reaction with O ₃
OH	10 ⁻⁴ ppbv (estimated)	Unknown - may be related to H ₂)	Ozone chemistry, Aerosol chemistry, methane oxidation which generates CO
HCl	1 ppbv	Unknown	Ozone chemistry, Aerosol chemistry
Cl	10 ⁻⁵ ppbv (estimated)	Unknown	Ozone chemistry
ClO	Unknown	Unknown	Ozone chemistry
CH ₂ O	<2 ppbv	Unknown	May be important in OH budget
O	10 ⁻⁵ ppbv (estimated)	Unknown	Involved in a variety of photochemical reaction
NH ₃	Unknown	Unknown	Particle formation, and involved in HCl chemistry
SO ₂	Unknown	Unknown	Particle formation
<HC>	Unknown	Unknown	OH budget, particle formation

2.2.2 Transport Phenomena

Clouds, rain, and thunderstorms are strong evidence for the considerable vertical motion characteristic of the troposphere. In thunderstorms vertical velocities, which are generally 10 cm/sec in normal latitude cyclones and anticyclones, may reach 10 to 20 meters/sec. In the stratosphere, however, the temperature increases with height providing an equilibrium condition. For this reason, the vertical motions rarely exceed a few centimeters per second and are often much smaller. In other words, an air parcel moves up or down more slowly in the stratosphere than it does in the troposphere. This is not true for horizontal motions in the stratosphere which are significantly more rapid than the vertical motions. Typical horizontal wind velocities in the stratosphere are of the order of 1 to 100 m/sec, whereas vertical velocities are in the range of 10^{-4} to 10^{-1} m/sec.

The overall structure of the wind field in the stratosphere has been investigated and shows a complicated latitudinal and seasonal dependence.^(7,8) In general, there are some correlations between the meridional (N-S) and vertical wind fields at different times of the year.⁽⁹⁾ No correlation seems to exist between the rapid zonal (E-W) circulation and vertical wind data.

In summary, because of the slow vertical mixing, the contaminants which are introduced into the stratosphere at a particular altitude will remain near that altitude for periods as long as several years.⁽¹⁰⁾ This long residence time allows the contaminants to take part actively in the

chemical and radiative processes of the stratosphere. In the case where a contaminant is capable of entering a catalytic process which would lead to the destruction of an important stratospheric constituent such as ozone, the consequences are of great importance and must be thoroughly investigated.

2.3 Stratospheric Chemistry

This section presents an overview of the status of stratospheric chemistry, particularly as it relates to ozone and aerosols. There are a large number of different kinds of reactive chemical species in the stratosphere. Any one of these species can react with a number of others, or be generated by a variety of other reactions in which it does not directly take part.

As related to stratospheric chemistry in general, we may distinguish three types of reactions. These are:

- photochemical reactions,
- homogeneous reactions, and
- heterogeneous reactions.

Photochemical reactions involve the interaction of electromagnetic radiation of varying wavelengths with constituents of the stratosphere. Photochemical interactions are the only known source of ozone production.

Homogeneous reactions are those reactions in which both the reactant species and the products are in a gaseous phase. If in these reactions a "third body" is needed to carry off energy to prevent dissociation of the product, that third body is a gas molecule.

Heterogeneous reactions are those reactions in which a particle, solid or liquid, interacts with gaseous species. The interaction may be catalytic, or the particle itself may take part in the reaction.

In the next two sections, we will discuss the present status of ozone and aerosol chemistry.

2.3.1 Ozone Chemistry

The number of reactions in a pure radiative atmosphere involving ozone are considerable. Originally, only four reactions were considered (Chapman reactions) for quantitative considerations of ozone concentrations. (11) These are:



These two reactions lead to the formation of atomic oxygen and ozone, with M acting as a neutral third body which for all practical purposes is N_2 or O_2 . The formation of atomic oxygen occurs in the Schumann-Runge bands between 1760 and 2030 Å, and below 30 km, primarily at 2100 Å.

The other two reactions which were originally considered to lead to ozone destruction were:

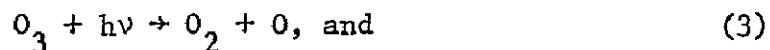

Ozone absorbs UV radiation between 2000 and 3200 Å in the Hartley bands, visible radiation between 4500 and 7000 Å in the Chappuis bands;

and, to a small degree, in the infrared. The simple photochemical Chapman model has two distinct defects. First, it predicts the wrong sense of the variation in the total ozone vertical column with latitude, where the model predicts more ozone in equatorial latitudes than at the poles as a result of total solar UV irradiance. The second defect is that when modelers insert explicit numbers in the Chapman scheme, the computed global ozone production has a tendency to exceed the chemical loss rate due to the Chapman reaction



The loss by transport to the troposphere may be another large factor.

Two reaction schemes have been suggested to account for this discrepancy. One involves water molecules and some of their decomposition products,⁽¹²⁾ and the other involves oxides of nitrogen.^(13,14)

The reaction mechanism involving the water molecules starts with



where $O(^1D)$ is the singlet oxygen and is produced by Hartley dissociation of ozone, that is

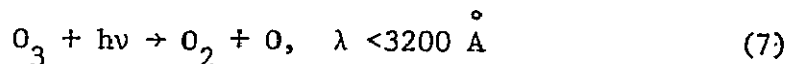

This reaction is then followed by the chain decomposition

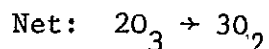

The most recent rate constants for these reactions at 220°K, are 2×10^{-4} cm³/molecule sec and 2×10^{-16} cm³/molecule sec. Using these reaction rates in the available mathematical models, it can be shown that the HO_x reactions are not the dominant ones in the natural ozone balance.

The photochemical reaction scheme which involves the decomposition of ozone by NO_x (NO, NO₂, NO₃, etc.) is presently considered to be dominant in the natural ozone balance. The complete nitrogen cycle which is included in the stratospheric mathematical models, is shown in Figure 2-3. A simple description of the NO_x picture in the stratosphere is essentially as follows. NO is formed in the stratosphere by the reaction



where O(¹D) is produced by Hartley dissociation of ozone, as described above, while N₂O is formed on the ground through biological processes and diffuses upward. Once NO is formed, a photochemical steady state is established between NO and NO₂. The reactions involved are:

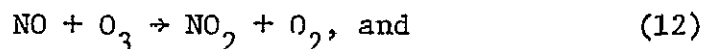

ORIGINAL PAGE IS
OF POOR QUALITY

2-16

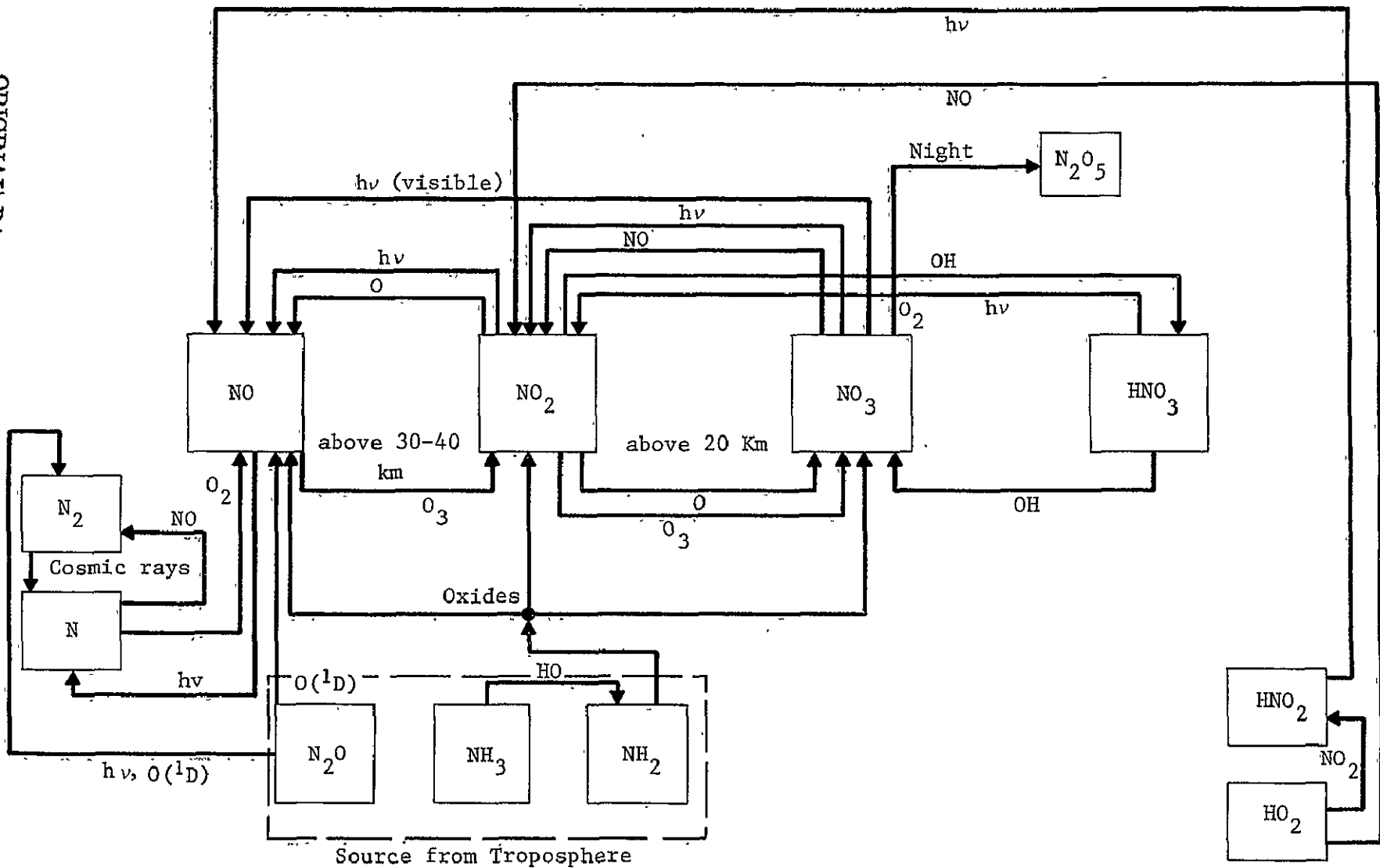
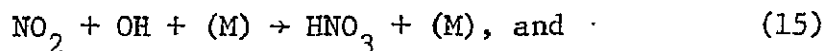
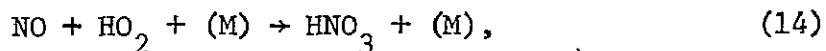

FIGURE 2-3
COMPLETE NITROGEN CYCLE

This results mainly in NO_2 at night and NO in the daytime. This is followed by:



which may possibly proceed through heterogeneous reactions involving ambient sulfate droplets or particles. HNO_2 , and especially HNO_3 , are the only presently known sinks of stratospheric NO_x .

Another chemical compound which has recently been recognized as essential in the stratospheric ozone chemistry is HCl .⁽¹⁵⁾ HCl can produce free chlorine which can, in turn, interact catalytically with the ozone. A simplified diagram shows the interaction mechanisms, Figure 2-4.

The reactions which we described so far are homogeneous and photochemical. Recent investigations indicate that the effects of heterogeneous reactions may be quite significant in the overall stratospheric chemistry.⁽¹⁶⁾ For this reason, further work in this direction is presently being conducted by several groups.

2.3.2 Aerosol Chemistry

The chemical composition of stratospheric aerosols has been the subject of considerable theoretical and experimental investigation during the last few years. Although it is generally agreed that

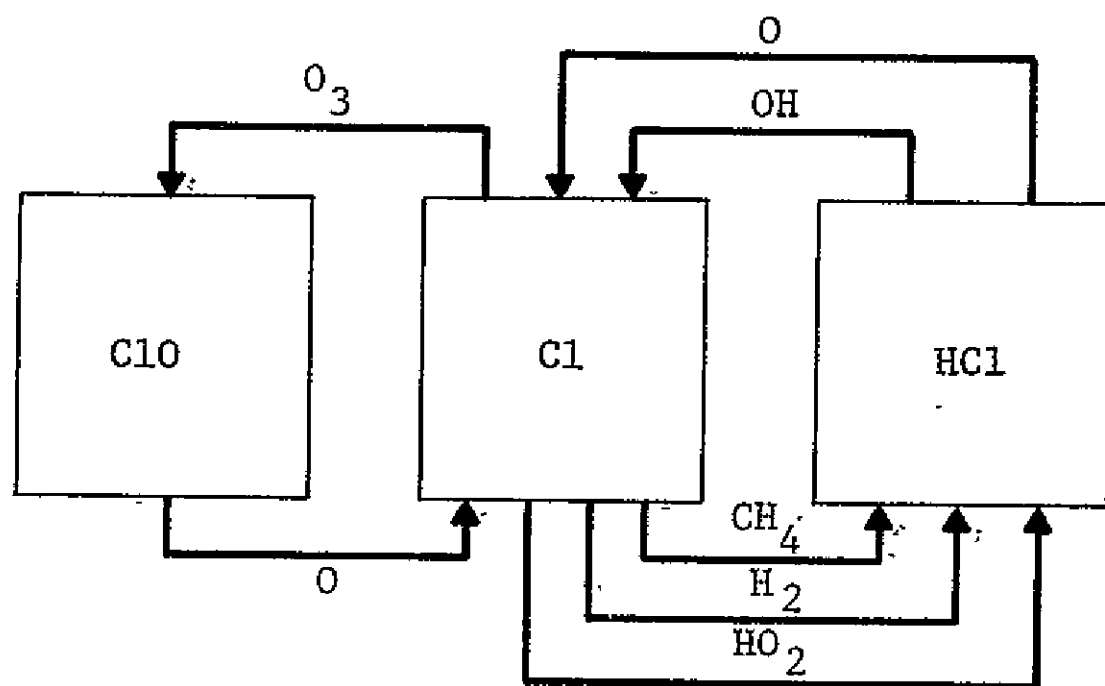
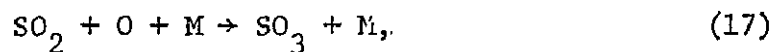

FIGURE 2-4
CHLORINE CYCLE

Aitken nuclei, aerosols less than 0.1 μm radius, are of terrestrial origin, their composition, quoting Junge, is "essentially unknown" (Ellsaesser).⁽¹⁷⁾ Friend⁽¹⁸⁾ has speculated that the Aitken nuclei can be accounted for by the following process: SO_2 is oxidized by O-atoms in a three body reaction-by H_2O -to give SO_3 . This in turn forms H_2SO_4 which can rapidly collect water molecules to form a hydrated embryonic nucleus of sulfuric acid.

Stratospheric aerosols larger than 0.1 μm are generally accepted to be of stratospheric origin. Junge, et al.,⁽¹⁹⁾ found high quantities of sulfur, most likely a sulfate, in the aerosols collected at the 18 to 20 kilometer level, which has become known as the Junge or sulfur layer. Junge postulated that these sulfur aerosols are probably formed by oxidation of H_2S and/or perhaps some SO_2 , both of which are present in the troposphere. The sulfates enter the stratosphere at the Equator where the H_2S and SO_2 are oxidized by ozone or intense ultraviolet radiation. The recent studies of Friend, et al.,⁽²⁰⁾ indicate a more precise process not too unlike that of Junge's hypothesis.

Cadle and Powers⁽²¹⁾ suggested a three-body reaction of SO_2 with atomic oxygen,



where M is the third body in the atmosphere that serves to carry off excess heat. Two other possible chemical systems of interest are:

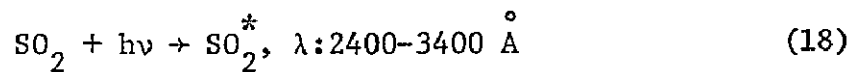

where the asterisk denotes an excited electronic state of the sulfur dioxide; and

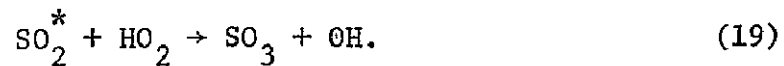

The speculations and observations of many investigators of stratospheric aerosols guided the laboratory study of Friend, et al. (20) They performed a series of experiments to determine the most propitious combination of atmospheric trace gases for the formation and growth of stratospheric aerosols. Their work may be summarized as follows.

Experiments were carried out in a reaction vessel to which was attached both a condensation nuclei counter and a "dust" counter. Provision was made for irradiating gases in the reaction chamber with ultraviolet light. The gases used were air, nitrogen, water vapor, sulfur dioxide, ammonia, and ozone. Each experiment was run for a maximum of five hours unless the desired reaction, the production of condensation nuclei and/or larger aerosols, was generated.

As a result of the experiments of Friend, et al. (20), the following chemical mechanism was proposed for the formation of stratospheric aerosols. Ozone, which is plentiful above the tropopause, is dissociated by ultraviolet radiation

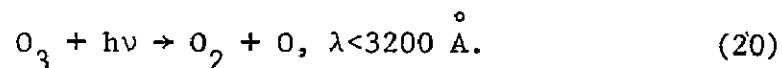

Then

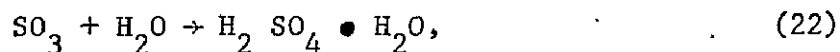
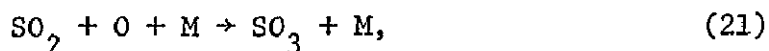

which after $n-1$ steps becomes

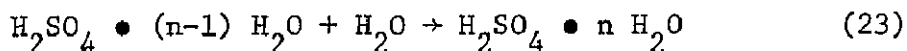

The entity $\text{H}_2\text{SO}_4 \bullet \text{H}_2\text{O}$ is thought of as an embryonic nucleus (acid embryo) which probably is not a cloud condensation nucleus because it may not be capable of growth with the simple addition of water molecules.

It was suggested that these nuclei consist of hydrated sulfuric acid and that photo-oxidation of SO_2 in the lower stratosphere leads to the same type of nuclei found in the natural population of condensation nuclei with $r < 0.1 \mu\text{m}$. Initially, the embryo would be formed quite rapidly following the creation of SO_3 .

The number of water molecules, n , associated with each sulfuric acid molecule is not known but is considered to be greater than ten, i.e., $n > 10$. Coagulation of the acid embryos will produce a size frequency distribution decreasing in concentration with increased sizes and extending to large particles ($r > 0.1 \mu\text{m}$). It should also be noted that the coagulation of the acid embryo with soil minerals and organic particles may alter their properties and make the embryo effective condensation nuclei. The interaction of the sulfuric acid with these

particles may make them more wettable and capable of growth to cloud aerosol sizes.

The introduction of ammonia into an atmosphere of SO_2 , H_2O , and air in the reaction vessel with unfiltered light or ultraviolet light of wavelengths from 2500 to 3200 Å results in the production of a large number of condensation nuclei and larger particles. These particles appear as colorless, hygroscopic crystals, thought to be composed of ammonium sulfate or ammonium bisulfate or both; or possible ammonium persulfate. This reaction occurs at stratospheric as well at room temperatures. The same reaction does not occur in the dark nor with radiation in the 2500 to 4000 Å wavelength band. This observation is interpreted to mean that if the additional compounds of NH_3 and SO_2 [$\text{NH}_3 \bullet \text{SO}_2$ and $(\text{NH}_3)_2 \bullet \text{SO}_2$] were formed they did not lead to ammonium sulfate, and that the addition of NH_3 and SO_2 are not precursors to the formation of ammonium sulfate in the stratosphere.

Therefore, the following chemical reactions were proposed by Friend, et al. (20)

After the formation of the acid embryos, $\text{H}_2\text{SO}_4 \bullet n \text{H}_2\text{O}$, then

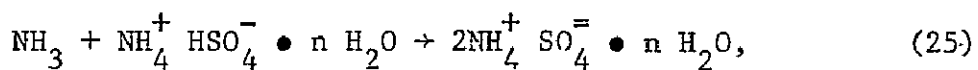
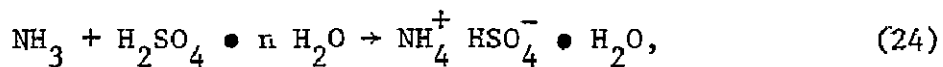

which are embryos of salt solution or salt embryos. They provide the medium in which rapid catalytic oxidation of SO_2 occurs thereby resulting in:

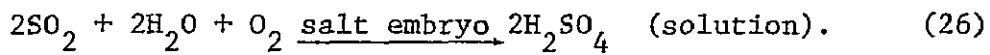

The rate determining step is the oxidation of bisulfite, HSO_3^- to $\text{SO}_4^{=}$ in solution. Ammonium ions "catalyze" the reaction by keeping the pH high so the SO_2 may enter the solution to form HSO_3^- . NH_3 gas is needed to neutralize the acid formed with the salt embryos. This produces NH_4^+ which buffers the solution. The reaction will continue until either NH_3 or SO_2 is depleted. After the NH_3 becomes depleted, continued oxidation overcomes the buffering by NH_4^+ and eventually the low pH prevents further absorption of SO_2 by the particles.

Based on the above rationale, the following model for the formation of stratospheric aerosols was proposed by Friend, et al. (20)

The three main processes are:

- (1) photolysis of O_3 produces O atom which oxidize SO_2 to form acid embryos consisting of sulfuric acid and water,
- (2) the acid embryos are neutralized by NH_3 to form salt embryos, and
- (3) SO_2 forms $\text{SO}_4^{=}$ by rapid catalytic oxidation in the embryonic solution in which NH_4^+ acts as the catalyst.

Growth of the embryos to larger particles continues as long as NH_3 is available to neutralize the acid or as long as SO_2 can be supplied to the particles.

Chemical reactions represented by Equations 20 through 23 produce acid embryos which, through coagulation, form a smooth size

distribution of sulfuric acid-water aerosols ranging from embryo sizes to aerosols with radii greater than $0.1 \mu\text{m}$. This may well be the Aitken or condensation nuclei measured by Junge,⁽²²⁾ and Junge and Manson.⁽²³⁾

The chemical reactions represented by Equations 24 and 25 involving the catalytic oxidation of SO_2 in the presence of NH_3 produces larger particles, i.e., $r > 0.1 \mu\text{m}$; the size and composition of which are determined by the availability of SO_2 , NH_3 , and H_2O . However, H_2O is not considered a limiting constituent because it exists in concentrations several orders of magnitude greater than might be expected for NH_3 or SO_2 .

Specific results of this study may be summarized as follows:

- (1) the quantum yield for homogeneous oxidation of SO_2 when irradiated is less than 1.0×10^{-9} ,
- (2) the addition of NH_3 and SO_2 , if present, are not precursors to the formation of ammonium sulfate in the atmosphere,
- (3) Aitken nuclei are formed by oxidation of SO_2 by O atoms with traces of water vapor present,
- (4) the addition of NH_3 to SO_2 and O atoms results in rapid production of Aitken nuclei and larger particles, probably ammonium sulfate, and
- (5) irradiation of air with water vapor and trace organic gases at wavelengths $< 2500 \text{ \AA}$ produce Aitken nuclei.

The above formulation of Friend, et. al. (20) explains many of the observed optical phenomena and experimental results of aerosol sampling. The exception may be the existence of ammonium persulfate particles proposed by Friend. (24) More complicated chemistry may be required involving such radicals as OH and HO₂. Recently, Harrison and Larson (25) have proposed another scheme involving the homogeneous oxidation by OH and possibly the heterogeneous oxidation by O₃ on sulfate aerosols to produce the observed Junge layer. Oxidation of SO₂ by means of O atoms, NO₃, HO₂ is considered to be too slow.

The Harrison and Larson (25) reaction is a termolecular recombination by the hydroxyl radicals.

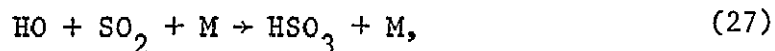

which assumes that an unspecified faster process abstracts the hydrogen, either before or during hydration. Based on transport, diffusion, and process rates, the chemical reaction of Equation 27 predicts a sulfate profile as a function of height above the tropopause such that the peak concentration is approximately equal to that measured and within one kilometer of the measured peak altitude.

The state of our knowledge may be summarized as being able to characterize the stratospheric aerosol size distribution in only a very general manner. The size distribution is based on a few in-situ measurements and theoretical growth concepts. The composition of the aerosols is known only in a general manner, again based on a few in-situ samples - but more detailed possibilities have been suggested from

appropriate laboratory experiments which lead to some consistent speculations.

2.4 Mathematical Models

In order to study the global effects of effluents introduced into the stratosphere, a hierarchy of models has been developed. General properties of these models may be summarized as follows:

(1) Time-dependent or steady state one-dimensional models.

These models have resolution only in the vertical dimension of the atmosphere and include a large number of chemical reactions. The vertical motion is parameterized in terms of one eddy diffusion coefficient. The results of the one-dimensional models may be interpreted as averages with respect to both longitude and latitude.

(2) Time-dependent or steady state two-dimensional models.

These models have vertical and latitudinal resolutions and, compared with the one-dimensional models, include a reduced number of chemical reactions. The two-dimensional motion is facilitated by eddy diffusion coefficients for both vertical and north-south motions. The results of the two-dimensional models may be interpreted as zonal averages at a given latitude.

(3) Time-dependent, three-dimensional models. These models

have limited resolution in the three spherical dimensions of the atmosphere. Such models are able to

consider only a small number of chemical reactions. Components of the smaller scale motions are represented by eddy diffusion terms. These models predict the general circulation of air in the troposphere and stratosphere.

There are two advantages in using one-dimensional models as compared with the two- and three-dimensional models. These are:

- Essentially all the known atmospheric chemical reactions can be included in the model and,
- The description of transport is deliberately kept simple. This allows the eddy diffusion coefficients to be determined empirically from tracers, such as CH_4 . They can then be verified with other tracers, such as N_2O and radioactive debris.

A list of the existing one-dimensional, two-dimensional and three-dimensional models, which have been used in the CIAP program to calculate the global ozone reduction due to NO_x emission, is summarized in Table II-3.

2.5 Stratospheric Pollutants

The contaminants introduced into the stratosphere originate from both man made or natural sources. Whether the contaminants are directly introduced into the stratosphere, or are diffused from the troposphere, two categories of man-made sources should be identified. To the first category belong the supersonic (SST) and subsonic aircrafts, flying

TABLE II-3

CIAP PROGRAM MODELERS

One-Dimensional

Johnston (1971)
Crutzen (1972, 1974)
Chang (1973)
Chang et. al. (1973)
Stewart (1973)
Stewart and Hoffert (1973)
McElroy et. al. (1974)
Witten and Turco (1973, 1974)
Shimazaki and Ogawa (1974)
Hunten (1974)

Two-Dimensional

Hesstvedt (1973, 1974)
Vupputuri (1974)
Widhopf (1974)
Brasseur and Bertin (1974)

Three-Dimensional

Cunnold et. al. (1974)

above the tropopause, and the Shuttle booster. The additional nitrogen oxide which is produced by the aircraft engines increases the rate of catalytic chemical reactions between NO_x and O_3 , and may appreciably diminish the ozone layer which protects the Earth from the UV rays of the sun. In addition to this, the aircraft engine effluents, such as SO_2 and H_2O , may form sulfuric acid particles which alter the heat transfer to and from the Earth and affect the Earth's climate. In the case of the Shuttle, the engine effluent of concern is hydrochloric acid (HCl). Hydrochloric acid acts as a catalyst to NO_x thereby reducing the ozone. This was demonstrated in Section 2.2.1. The aluminum oxide (Al_2O_3) particles emitted by the Shuttle engines play a similar role to produce sulfuric acid particles which affect the radiation balance on the Earth's surface.

The second category of man-made sources are contaminants released in the troposphere and which diffuse into the stratosphere. Chloro- , fluoromethane gases CF_2Cl_2 and CFCl_3 , known as Freon 12 and 11 respectively, are used as propellants in aerosol sprays and as a refrigerant. Freons are themselves chemically inert, and do not react directly with ozone or ordinary oxygen atoms. However, after diffusing into the stratosphere, they absorb short wavelength ultraviolet radiation (1900 to 2250 Å) and each chlorofluoromethane molecule decomposes to release atomic chlorine. Atomic chlorine attacks the ozone through the catalytic chain reaction. More recently it has been suggested that bromine may be considerably more potent in destroying stratospheric

ozone, but so far no bromine carriers, similar to the freons have been found.

The investigation of the natural sources of stratospheric pollutants is in its early stages. In general, volcanos, oceans, plants, industrial and agricultural activities have been suggested as sources of stratospheric contaminations. Preliminary estimates which have been made of the annual emission of HCl, HF, and SO₂ to the stratosphere from volcanic eruptions consider such emissions as nonsignificant. (26) Exceptions, however, are possible for short periods following very intense volcanic activities.

The contaminants which are introduced in the stratosphere by these sources have two consequences:

- (1) reduced ozone concentrations, and
- (2) increased aerosol concentrations.

Since ozone concentration controls the amount of UV-B radiation (290-320 nm) which reaches the surface of the Earth, a reduction in ozone concentration will increase the amount of this radiation, which has been shown to cause skin cancer and other biological effects. The increase in aerosol concentrations (besides increasing the potential for heterogeneous reactions whose effects are not well understood at present) will perturb the radiation balance of the Earth's atmosphere and may lead to climatic changes, affecting sunshine, temperature and precipitation. In addition to these, carbon dioxide and water vapor introduced into the stratosphere by aircraft or space

shuttles may increase the greenhouse effect and lead to stratospheric warming, which would perturb the natural circulation of the stratosphere. In general the interrelationship between pollution sources, and their implications, which are schematically presented in Figure 2-5, belong to two chains. These chains are the UV-chain and the climate chain. (A more complete description is given in Section 4.0).

ORIGINAL PAGE IS
OF POOR QUALITY

2-32

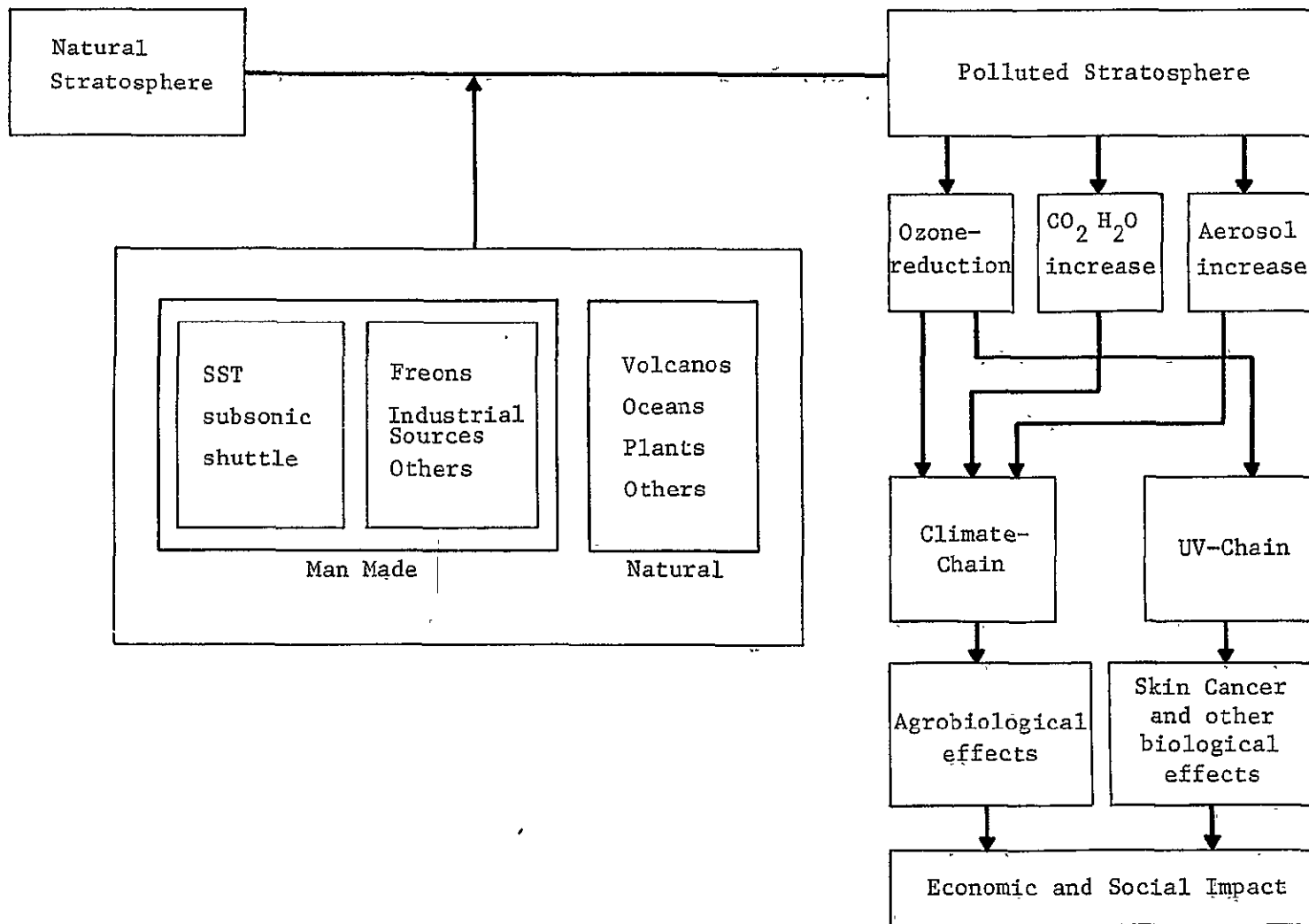

FIGURE 2-5
STRATOSPHERIC POLLUTION EFFECTS

REFERENCES

1. R. E. Newell, Radioactive Contamination of the Vapor Atmosphere, in Progress in Nuclear Energy, Series 12, Health Physics, Vol. 2, p. 538, Pergamon, Oxford, 1969.
2. H. L. Crutcher, 1969, Temperature and Humidity in the Troposphere, World Survey of Climatology, D. R. Rex, ed. Elsevier, Amsterdam-London-New York, pp. 45-83.
3. M. S. Sissenwine, 1969, Standard and Supplemental Atmospheres, World Survey of Climatology, Vol. 4, D. F. Tex, ed. Elsevier, Amsterdam-London-New York, pp. 5-44.
4. L. Machta, and E. Hughes, Atmospheric Oxygenia 1967 to 1970, Science, 168, 582, 1970.
5. A. J. Grobecker, et al. (eds.), Report of Findings: The Effects of Stratospheric Pollution by Aircraft, DOT-TST-75-50, December 1974, p. 6.
6. National Academy of Sciences, Environmental Impact of Stratospheric Flight, 1975, p. 104.
7. E. R. Reiter, Mean and Eddy Motions in the Atmosphere, Monthly Weather Review, 97, 200-204, 1969.
8. S. Teweles, Stratospheric - Mesospheric Circulation, in Research in Geophysics, Vol. 2, edited by H. Odishaw, pp. 509-528, MIT Press, Cambridge, Massachusetts 1964.
9. Reference 5, p. C-59.
10. R. J. Murgatroyd and F. Singleton, Possible Meridional Circulation in the Stratosphere and Mesosphere, Quart. J. Roy. Meteorol. Soc., 87, 125-136, 1961.
11. S. Chapman, Mem. Roy. Meteor. Soc. 3, 103 (1930).
12. B. G. Hunt, The Need For a Modified Photochemical Theory of the Ozonosphere, Journal of Atmospheric Science, 23, 1385-1398, 1966.
13. P. J. Crutzen, Quarter Journal Roy. Met. Soc., 96, 320 (1970).
14. H. S. Johnston, Science 173, 517 (1971).

15. M. J. Molina and F. S. Rowland, Stratospheric Sink for Chlorofluoromethanes: Chlorine Atom - Catalyzed Destruction of Ozone, *Nature* 249 (5460), 810-812, 1974.
16. D. Ehhalt, N. Roper, H. E. Moore, Vertical Profiles of Nitrous Oxide in the Troposphere, *Journal of Geop. Research*, V. 80, p. 1653-1655, 1975.
17. H. Ellsaesser, 1972: The Physics and Chemistry of Stratospheric Aerosols - Panel Discussion. Proceedings of the Second Conference on Climatic Impact Assessment Program, U.S. Department of Transportation, DOT-TSC-73-4.
18. J. P. Friend, 1972: The Physics and Chemistry of Stratospheric Aerosols - Panel Discussion. Proceedings of the Second Conference on Climatic Impact Assessment Program, U.S. Department of Transportation, DOT-TSC-73-4.
19. C. E. Junge, C. W. Changon, and James E. Manson, 1961: Stratospheric Aerosols, *Journal of Atmosphere Science*, 18, 81-108.
20. J. P. Friend, R. Leifer and M. Trichon, 1973: On the Formation of Stratospheric Aerosols, *Journal Atmosphere Science*, 30, 465-479.
21. R. D. Cadle and J. W. Powers, 1966: Some Aspects of Atmospheric Chemical Reactions of Atomic Oxygen, *Tellus*, 18, 176-185.
22. C. E. Junge, 1955: The Size Distribution and Aging of Natural Aerosols as Determined From Electrical and Optical Data of the Atmosphere, *J. Meteor.*, 12, 13-25.
23. C. E. Junge and J. E. Manson, 1961: Stratospheric Aerosol Studies, *J. Geoph. Res.*, 66, 2163-2182.
24. J. P. Friend, 1966: Properties of Stratospheric Aerosols, *Tellus*, 18, 465-473.
25. H. Harrison and T. Larson, 1974: The Oxidation of SO₂ in the Stratosphere, *J. Geoph. Res.*, 79, 3095-3097.
26. R. D. Cadle, Volcanic Emission of Halides and Sulfur Compounds to the Troposphere and Stratosphere, *Journal of Geop. Research*, V. 80, p. 1650-1652.

3.0 MEASUREMENTS TO DATE

3.1 General Techniques

For the purpose of this study, the multitude of stratospheric measurements which have been performed are divided into two generic categories; contact measurements and remote sensing measurements. Within each general category the experiments are segregated into groups which depend upon the chemical, physical or optical technique used.

3.2 Contact Measurements

Within this category are placed all of those experiments which do not utilize remote sensing techniques. It could have been further subdivided into grab-sample and in-situ techniques, but as the intent is to compare the generic category with that of remote sensing, this further distinction has not been made. Historically, contact measurements have formed the bulk of the empirical data collected on stratospheric constituents and processes. They will continue to be used for local or regional measurement programs and to provide calibration for satellite sensor systems now being evolved. The following listing provides a representative cross section of the contact measurements which have been, and are being, made.

3.2.1 Hygrometers

There are two types of hygrometers currently in use for measurements of atmospheric water vapor; the frostpoint hygrometer and the aluminum oxide hygrometer.

Frostpoint hygrometers are used by Mastenbrook of NRL and Sissenwine of AFCRL, among others. A thermoelectric cooler is used to chill

a stainless steel mirror to the dew point, the temperature of which is monitored by a platinum resistance element. The onset of condensation is detected by optical sensors using light reflected from the mirror surface.

The Al_2O_3 hygrometer consists of an aluminum base, aluminum oxide layer, and a porous gold film on top of the oxide. The a-c impedance of this device is dependant upon the amount of adsorbed water. Calibration curves relate the output signal to water vapor concentration. Al_2O_3 hygrometers are used by Hilsenrath of NASA-GSFC and Goodman of ONR/Panametrics.

3.2.2 Other H_2O Contact Sensors

Several other techniques for contact sensing of water vapor have been investigated. ONR has examined the Tritium Water Vapor Sensor which utilizes the measurable release rate of Tritium from a polymer substrate. The rate is proportional to the exchange of hydrogen ions from water vapor with the polymer-bound tritium.

NASA-ARC has investigated a lithium chloride crystal oscillator as a means of determining water vapor concentration. The impedance of the crystal, and thus its frequency of oscillation, is changed by the adsorption of water molecules.

3.2.3 Electrochemical Measurement of Ozone

Most electrochemical techniques utilize variations on the Komhyr cell. This device depends upon the oxidation of potassium iodide by ozone. The reaction produces iodine which, upon conversion to iodide,

produces free electrons. The resulting current is directly proportional to the ozone concentration of the gas sample.

3.2.4 Chemiluminescence Measurement of Gases

These devices depend upon the luminescence induced in dyes such as Rhodamine B by the presence of ozone. The luminescence is proportional to the O_3 concentration and the flow rate of the gas through the sensor. A photomultiplier is used to monitor the light flux from the excited dye. The device is usually coupled with pressure and temperature sensors when used in a rocket-deployed ozonesonde.

A chemiluminescence technique is also used for detection of NO_x . This variation utilizes the reaction between NO and O_3 to produce an excited state of NO_2 and O_2 . The excited state gives up its energy in the form of a photon which is detected by a photomultiplier tube. For NO_2 , a catalytic converter is first employed to reduce NO_2 to NO, and the previous reaction is followed.

3.2.5 Other NO_x Contact Sensors

Other contact techniques have been used for the detection of NO_x . Balloon measurements performed by NASA-GSFC, have used a combination of photoionization and mass spectroscopy to identify NO and NO_2 . A group at the Illinois Institute of Technology Research Institute has used a cryogenic sampler to detect nitrogen oxides as well as CH_4 , CO, and H_2 . The technique is usually coupled with electron spin resonance for laboratory identification of the trace species.

3.2.6 Particulate Techniques

Impact filters continue to be the mainstay of the contact measurements of particles in the atmosphere. They are used to collect particles as small as 0.1 μm in radius. The analysis of the samples may take one of many forms, depending upon the species and the preference of the investigator. Among those used are: gamma radiation, X-ray fluorescence, scanning electron microscopy and neutron activation. For smaller particles, Aitken nuclei detectors are utilized by experimenters, e.g., the University of Wyoming. These devices are modifications of cloud chambers, with particle detection being dependent upon vapor condensation.

Table III-1 summarizes these contact techniques.

3.3 Remote Measurements

All current efforts in remote sensing of atmospheric constituents involve either passive or active optical techniques. Active techniques include LIDAR, for aerosol detection, and Raman spectroscopy for other trace constituents. The passive techniques involve either emission or absorption of radiation by the species of concern. Instruments may be either spectrometers or interferometers. Some representative examples are described below.

3.3.1 LIDAR

Active laser studies of the atmosphere have been made since 1964. Various groups at NASA have made ground-based measurements while Shuster of NCAR has used an air-borne version on the NASA Convair 990.

ORIGINAL PAGE IS
OF POOR QUALITY

TABLE III-1
CONTACT MEASUREMENTS

TECHNIQUE	SPECIES	ABSOLUTE ACCURACY	INTEGRATION TIMES	SENSITIVITY	DYNAMIC RANGE	LIMITATIONS	ADVANTAGES	INVESTIGATORS
Frostpoint Hygrometer	H ₂ O		<1 min.		30 (B)			Mastenbrook-NRL Sissenwine-AFCRL
Aluminum oxide Hygrometer	H ₂ O	±50%	30 sec.	+3°C in dew temperature	30 (B)	Calibration problems		Hilsenrath-GSFC Goodman-ONR
Tritium Sensor	H ₂ O	±10%		0.5 ppb @ 50 mb	20 (A/C)			ONR
LiCl Crystal Oscillator	H ₂ O			1 ppb	20 (A/C)			NASA-ARC
Electro-chemical	O ₃	±10%	90 sec.	2 to 3 ppb	30 (B)	Response time, pump efficiency	Good vert. resolution <25 km	Kroenig-Minn.
Chemilumin- escent	O ₃ , NO _x	+20% ±60%	<1 sec.	10 ppb (0 to 1 ppb)	70 (R) 20 (A/C)	Calibration problems	Fast responses	Hilsenrath-GSFC Popoff-NASA/ARC
Photoion- isation/Mass- Spectroscopy	NO _x				30 (B)			NASA-GSFC
Cryogenic Sampler	NO _x , CH ₄ , CO ₂ , H ₂			1 to 10 ppb	20 (A/C)			IITRI
Impact Filters	Particles ≥0.1 μm	±40%			20 (A/C)	Paper background, air flow varies		Sedlacek-LASL
Aitken nuclei detector	Particles ≥.003 μm	±10%	10 sec.	0.1 to 10 ⁶ nuclei/cc	30 (B)			University of Wyoming

A/C: Airplane
B: Balloon
R: Rocket

All LIDAR systems operate analogously to radar, i.e., a short duration pulse is transmitted and the time for energy to be returned to an associated detector is measured. Some LIDAR experimenters use ruby lasers while others prefer dye lasers, such as Rhodamine 6G. Pulse powers are typically on the order of two joules with pulse widths of between 20 ns and one μ s. Detection is accomplished by means of cooled photomultiplier tubes following suitable collection optics and narrow-band filtering to reduce background noise levels.

Interpretation of the data is dependent upon the supposition of both an isothermal stratosphere and a purely molecular atmosphere. While these assumptions do not, in themselves, introduce sizable errors, the method of normalization is a subject of some controversy. Various investigators have chosen different altitudes for the point of normalization of the data. The fact that the ratio of observed to molecular scattering drops below unity on all of the results would indicate deficiencies in the normalization procedure.

Other sources of error are related to receiver gain variability, deviations from an idealized atmosphere, and identification of different types of aerosols.

3.3.2 Raman Spectroscopy

Related to the LIDAR systems by the requirement for a high powered laser, are the techniques involving Raman spectroscopy. Some results have been reported by Melfi on the Raman detection of NO in the lower troposphere. Other workers such as H. Kidal and R. Byer,

have measured the concentration of CO₂, SO₂, and N₂. While theoretically, the Raman technique offers the advantages of requiring but a single laser wavelength for excitation and unique backscattered frequencies, it is limited, in practice, by its extremely low sensitivity. The scattering cross-section for Raman processes is several orders of magnitude lower than that for Rayleigh scattering.

3.3.3 Radiometers

Radiometers are used to measure the intensity of electromagnetic radiation incident upon a detector. They are, usually, designed to measure over fairly wide spectral regions. This results in relatively simple design criteria but at the price of specificity. Their application to remote sensing is therefore limited, but for the purposes of temperature measurements, they are still widely used. When used in a scanning mode; with the scan perpendicular to the spacecraft heading, the radiometer may produce imagery after suitable processing. This technique is used in the Cloud Imager class of instruments.

3.3.4 Spectrometers

In order to obtain high specificity of atmospheric constituents, greater spectral isolation is required. There are two general classes of spectrometers of interest; non-dispersive and dispersive.

Non-dispersive spectrometers obtain spectral isolation by the simple means of optical filtering. Some instruments utilize narrow-band interference filters to pass the wavelength or wavelengths of interest for detection and subsequent analysis. Other varieties use

a sample of the gas of interest as a filter and perform a correlation between the incident radiation from the scene and that from a reference black body source. Filters may be arranged so as to cover several portions of the spectrum simultaneously, or mounted on a rotating filter wheel which permits sequential viewing of selected spectral regions. Non-dispersive spectrometers are sometimes referred to as spectroradiometers.

Dispersive spectrometers may depend upon either refraction or diffraction of the incident radiation. Refractive spectrometers use prisms of various materials to provide the spectral separation of the received energy. Resolving power is limited in prism instruments and the energy throughput is quite low. Diffraction gratings provide greater resolution but still suffer from the relatively low efficiency imposed by the requirement for narrow slit widths on the entrance and exit apertures.

A variation of the non-dispersive spectrometer was mentioned above in discussing the gas filter correlation techniques. Similar variations of dispersive spectrometers also exist and should be mentioned. While the conventional dispersive instrument scans the spectral components across a single exit slit, several techniques utilize masks in the exit plane to perform either correlation measurements with a known spectra or to simultaneously measure the contributions of the source at several wavelengths.

3.3.5 Interferometers

In order to view a large spectral interval with high resolution, and greater throughput than that provided by spectrometers, many investigators have turned to the interferometer. Most interferometers used for remote sensing are variations on the Michelson instrument, in which the incident radiation is collimated and passed through a beamsplitter in order to obtain separate path lengths which are eventually recombined. One path contains a movable mirror, or other technique to produce a variation in path length with time. Upon recombination, the resultant intensity shows variations due to the phase difference introduced in one path. These variations in intensity, as a function of displacement of the mirror, produce an interferogram. The interferogram contains all the spectral information of the incident radiation. Mathematical techniques, such as Fourier transformations, may be used to extract the spectrum. One current technique, (CIMATS) compares the interferogram directly with one which contains the spectral information on the constituent of interest rather than transform into an optical spectrum.

3.4 Platforms

Stratospheric measurements may be made from balloons, rockets, aircraft, satellites and from the ground. General characteristics of some of the platforms are shown in Table III-2.

Most of the current measurements of the stratosphere have been made from aircraft platforms. These offer a maximum payload, and

TABLE III-2

SELECTED CHARACTERISTICS OF SENSING PLATFORMS

<u>PLATFORM</u>	<u>OPERATING ALTITUDE</u>	<u>OPERATING RANGE</u>	<u>OPERATING TIME</u>	<u>MAX. PAYLOAD CAPABILITY</u>
Airplanes	<23 km	4000 km	5 hrs - 8 hrs	<5000 kg
Balloons	0 to 50 km	4000 km	24 hrs - 30 days	2000 kg
Sounding Rockets	0 to 200 km	5 km - 500 km	minutes (can return by parachute)	200 kg
Earth Satellites	500 to 1000 km	Global	Indefinite	10 kg - 30,000 kg

significant range and durability. Aircraft may also serve as a test bed for satellite instrumentation in the development stages. Coverage may be made nearly global with the development of unmanned instrument packages, such as that developed for the GASP program, to be installed on commercial 747 aircraft flying world wide routes.

Rockets are still used extensively for the measurement of atmospheric state variables such as temperature, pressure and wind profiles. They have an obvious altitude advantage over aircraft and are relatively inexpensive to operate. Rockets may be used to delineate the range of measurement capability which may be required for satellite sensors or to provide corroboration of satellite data.

Balloons provide for larger payloads than rockets with the further advantages of extended operating range and measurement time. They provide accurate vertical profiles up to altitudes of 50 km. Like aircraft platforms, balloons may be used for flight tests of developmental satellite systems.

With the current requirements for global coverage of the stratosphere, there is no platform equal to the satellite. Since the development of the NIMBUS payloads, improved measurements have already been obtained on UV, temperature and ozone. Future NIMBUS systems will measure other trace constituents in the stratosphere on a global scale, for the first time. By the time of NIMBUS G (1978) and subsequent missions, the measurement capability, should be approximately as shown in Table III-3, which also indicates current measurement capability.

TABLE III-3
CURRENT AND PROJECTED MEASUREMENT CAPABILITY

SPECIES	20 km BACKGROUND	ACCURACY		SATELLITE (4)
		REQUIRED	CURRENT	
CO ₂	330 ppmv (1)	0.1% (2)	6% (3)	~10% (C) ~1% (M)
O ₃	6 ppmv (5)	10% (5)	10% (6)	~7% (L)
H ₂ O	3 ppmv (1)	30% (2)	12% (3)	<9% (L)
CO	50 ppbv	20% (2)	5% (7)	<10% (M)(C)
HNO ₃	3 ppbv (5)	30% (5)	30% (8)	<30% (L)
CH ₄	1 ppmv (5)	20% (5)	5% (3)	~4.3% (M) <17% (L) ~10% (C)
N ₂ O	0.1 ppmv (5)	5% (5)	10% (3)	<13% (L) ~10% (C)
NO	0.1 ppbv (5)	50% (5)	35% (8)	~10% (C)
NO ₂	2 ppbv (5)	50% (5)	20% (8)	~6% (M) <30% (L) ~10% (C)

NOTES:

- (1) CIAP summary.
- (2) From Table IV-1.
- (3) Farmer, C. B., Canad. J. Chem., 52, 1554, 1974.
- (4) (C): CIMATS, (L): LACATE, (M): MAPS: all estimated by developers.
- (5) From Tables IV-2 and IV-3.
- (6) Total ozone. Mateer et al., J. Atmos. Sci., 28, 1307, 1971.
- (7) Goldman, et al., J. Geophys. Res., 78, 5273, 1973.
- (8) Fontanella, J., et al., Appl. Opt., 14, 825, 1975.

3.5 Results and Limitations

All of the measurement techniques discussed have their strengths and weaknesses. The in-situ methods are extremely sensitive and accurate but suffer from limited coverage and local contamination problems. Remote sensing techniques offer wide area coverage and relatively long mission lifetimes. Their disadvantages lie in the reduced sensitivity to low concentration levels and the requirements for auxiliary data to invert the integrated path measurements which most utilize. Indeed, the masses of data which must be processed in order to yield the desired information is at least a temporary disadvantage of remote sensing methods. The development of better models and improved data handling techniques is expected to minimize these problems.

BACKGROUND REFERENCES

GENERAL

Instrument Society of America (ISA), "Second Joint Conference on Sensing of Environmental Pollutants," 1973.

Department of Transportation (DOT), TSC-OST-73-4, "Proceedings of the Second Conference on the Climatic Impact Assessment Program," 1973.

DOT-TSC-OST-74-15, Proceedings of the Third Conference on the Climatic Impact Assessment Program, 1974.

H₂O

Goldman, A. et. al., "The vertical distribution of H₂O and CH₄ in the earth's atmosphere," J. Opt. Soc. Amer., 43, 1033, 1953.

Murcray, D. G., et. al., "Distribution of water vapor in the stratosphere as determined from balloon measurements of atmospheric emission spectra in the 24 to 25 μ region," Appl. Opt., 12, 145, 1973.

O₃

Dave, J. V., and C. L. Mateer, "A preliminary study on the possibility of estimating total atmospheric ozone from satellite measurements," J. Atmos. Sci., 24, 414, 1967.

Prabhakara, C., et. al., "Remote sensing of atmospheric ozone using the 9.6 μ band," J. Atmos. Sci., 27, 689, 1970.

NO_x

Farmer, C. B., "Infrared measurements of stratospheric composition," Canad. J. Chem. 52, 1544, 1974.

Goldman, A., et. al., "Identification of the ν_3 NO₂ band in the solar spectrum observed from a balloon-borne spectrometer," Nature, 225, 443, 1970.

LIDAR

Melfi, S. H., "Standard methods for analysis and interpretation of LIDAR data for environmental monitoring," Second Joint Conference on Sensing of Environmental Pollutants, Washington, 1973.

Kildal, H. and R. Byer, "Comparisons of Laser Methods for the Remote Detection of Atmospheric Pollutants," Proc. IEEE, 59, 1644, 1971.

4.0 USERS' REQUIREMENTS FOR SATELLITE MEASUREMENTS

Present concern with the environment in general, and the stratosphere in particular, has focused attention on the manifold ways in which man may inadvertently modify life on Earth. As technology permits man to escape the planet, it also makes possible the injection of waste products which may impact upon the delicate balance of minor constituents in the atmosphere. It is this balance which has allowed life, as we know it, to evolve from simpler forms. The relative fragility of many forms of terrestrial life is well documented in biological studies. Requirements for moisture, temperature and the symbiosis provided by other equally delicate, life forms are relatively stringent. Only man, among the life forms, has the capability of seriously upsetting this balance.

Historically, the ecological price paid for technological progress was considered worth the perceived advantages. Only in the last 10 to 15 years has anyone questioned the price. The complete extinction of certain species, intolerable fouling of lakes and rivers, and smog so pervasive that urban areas must be alerted have contributed to this re-examination of priorities. The above effects may be termed local and reversible. Large-scale concerns, up until now, have centered on the wasteful depletion of natural resources, both living and mineral. Two recent developments have expanded the definition of large-scale effects. The first of these developments is the traversal of the stratosphere by space vehicles and the proposed use of stratospheric altitudes by supersonic transports (SST's) and other aircraft. The effluents produced by

these vehicles will remain in the stratosphere for relatively long periods of time and be available for chemical reactions with the existing constituents. The second development was the realization of the large amounts of fluorocarbons which have been released in the atmosphere and of their potential effects upon the Earth's ozone layer.

Concern of the U.S. Government has been expressed by the funding of studies in each area. The potential pollution of the stratosphere by SST's was studied by the Department of Transportation, under their Climatic Impact Assessment Program (CIAP).⁽¹⁶⁾ The fluorocarbon problem has been examined by the Council on Environmental Quality and the Federal Council for Science and Technology through a Federal Task Force on Inadvertent Modification of the Stratosphere (IMOS).⁽⁵⁾

The global nature of each problem makes it mandatory that any monitoring program be based at least in part upon remote sensing. Neither ground nor aircraft platforms alone can provide the required spatial and temporal coverage. NASA currently has a family of instruments which are designed to measure constituents of the atmosphere from space platforms. It is, therefore, imperative that existing instruments be utilized in the most effective manner in order to provide the greatest benefit to both the direct and secondary users of satellite data. Future sensor development must take the requirements and wishes of the user community into account during the design stage so that subsequent satellite programs may offer improved capabilities and greater utility.

The role of this section is to discuss some general features of NASA interaction with its users and offer the two major examples

(UV and climate) of pressing atmospheric pollution problems which demand of NASA a careful and effective program of development. The examples serve to demonstrate the need for an understanding of the overall physical problem in order to provide effective user support.

As supplementary information, workers active in both fields are identified and their experiment measurement requirements are tabulated both in this section and in Appendix B. Those available specific numerical measurement requirements appear in Section 4.5.

4.1 Approach

The approach to user needs must recognize the synergistic relationship between the user community and the technology community. In the next section the capabilities of the proposed satellite remote measuring instruments will be codified and compared with the requirements of the potential user community. The successful matching of instrument capabilities with user needs results in the identification of users of the observational data. Depending upon the user, modifications of capabilities may be required for the successful melding of instrument capabilities and user requirements.

The rationale used by MITRE is depicted in the accompanying "flow chart" (Figure 4-1). The technological community is on the left; the user community is on the right of the chart. The key activity illustrated is the correlation of the capabilities of technology with the user requirements and the subsequent flow of data. When the observational parameters are agreed upon, the Data Management functions will require

ORIGINAL PAGE IS
OF POOR QUALITY

4-4

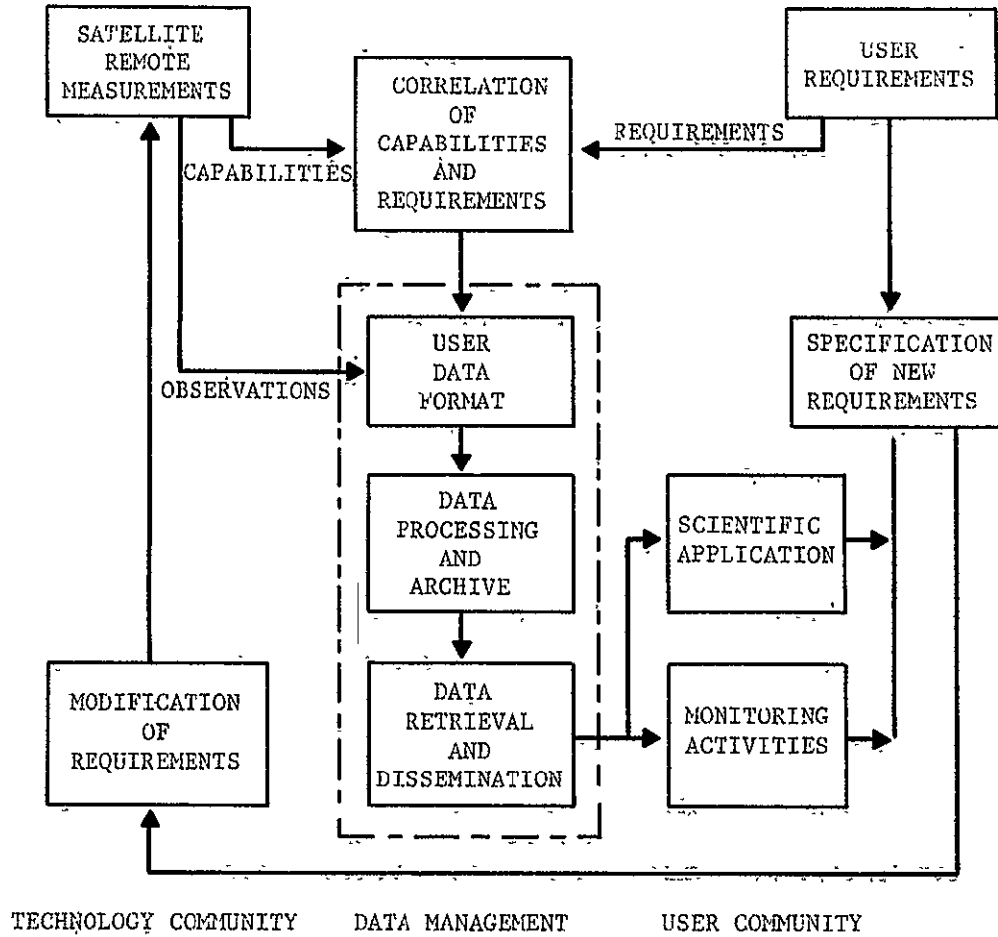

FIGURE 4-1
USER NEEDS RATIONALE

definition. The data should be disseminated in a format which is tailored to meet the user's needs.

The data management functions enclosed in the dashed box are not addressed at this time; only the correlation of capabilities and requirements. However, the successful operation of a satellite remote sensing system will be dependent upon an appropriate data management system in order to provide the users with timely, accurate data.

The users, the recipients of observed data, have been grouped into three major categories, those concerned with scientific studies (stratospheric physics and chemistry, biological research studies, etc.), monitoring activities (for example, regulatory functions and long-term trend analysis), and predictive modeling (particularly in the climate field).

The subsections which follow describe the requirements of some of the organizations and scientists concerned with the application of remotely sensed environmental data. Wherever possible, their general requirements are supplemented by numerical measurement requirements. Finally, the user requirements are summarized in terms of those constituents which predominate in the requirements of the user community.

4.1.1 Assumptions

Any survey of this nature must rest upon certain fundamental assumptions. For the present effort, the following basic assumptions have been made:

- NASA wishes to satisfy as large a user community as can be identified.

- NASA will have a continuing role in the development of sensors for satellite missions and that any Earth-viewing sensors seek to be more than merely experiments. These missions are presumed to provide data which has an identifiable economic benefit.
- Operational control will be vested in another agency, e.g., NOAA.

While most of these assumptions are nearly axiomatic, each has a bearing upon the categorization of potential users.

4.1.2 Organization

The totality of users of satellite data is potentially limitless. In an attempt to reduce the problem to manageable proportions and still provide sufficient detail as to specify user requirements, two specific problems have been addressed. The two topics chosen, the climatic and ultraviolet radiation (UV) changes which may result from alteration of the balance of atmospheric constituents, was defined to a great extent by the current national interest in those two topics. In this way the information obtained can be directly related to any on-going NASA program planning which addresses analysis of these problems. Furthermore, there is an overriding requirement that the development of user requirements, as expressed in Section 4.5, rely upon an understanding of the physical processes being studied by the user. Lastly, structuring the program in this way guarantees a large and current list of workers in each field who can be relied upon for experiment definition and development of measurement requirements. In this section, those scientists interested in the cause and effect of changes in the climate or UV environment are cited directly or in the references which appear at the end of the section.

The evaluation of these example studies includes (in Sections 4.3 and 4.4) descriptions of the research being conducted, workers in the field and, whenever possible, their general requirements for experimental data. Section 4.5 summarizes all of the numerical measurement requirements so as to help set priorities in any upcoming measurement program related to atmospheric constituents.

It should be pointed out that the two topics chosen have some underlying similarities. Namely, both climate and UV and their variability have significant impact on man and other forms of life (with climate having a somewhat more comprehensive set of effects). Furthermore, the changes in both which may result from changes in the atmospheric conditions are ultimately linked. In addition, the climate is affected by a large number of other factors.

In order to separate the two topics as much as possible, the UV study has concentrated on users interested in the effects of such changes on the biosphere, while the climate study has concentrated on those physical processes which may alter the climate.

The following section (4.2) discusses some general observations which relate to NASA's coordination with real or potential users.

4.2 General Observations on the NASA Relationship with Potential Users

In the course of this and other related MITRE studies, a large number of current or potential users of data obtained from NASA experiments were contacted. These contacts and the associated literature reveal a number of interesting features of NASA's approach to dealing with users, their problems and their requirements. Before addressing

the two specific problems of the application of atmospheric measurements to the climate and ultraviolet radiation problems, it is of value to summarize MITRE's opinion as to the success of NASA's methods. More details of the user point of view may be found in the following two sections, particularly 4.4 where specific workers have been contacted. The following table (Table IV-1) indicates those researchers contacted.

4.2.1 Uses of Data from Previous Experiments

A number of those contacted offered the opinion that more consideration should be given to older spacecraft experiments before new missions are flown. In spite of the probability of better data quality, sampling and coverage in proposed experiments, study of older experiments would provide information on:

- The need for further experiment sophistication to support theoretical studies.
- The selection of more appropriate mission parameters (duration, gases monitored, coverage, etc.).
- The development of more complete long-term archives of spacecraft data to be supplemented by new missions.

It is MITRE's view that inclusion of sufficient funds in a program for data reduction and analysis tasks is essential to guaranteeing the long-term interest of the scientific user community and in further guaranteeing its enthusiastic support of a continuing NASA role as a supplier of unique experimental data. It is also evident that the dissemination of the experimental data through the initial (or scientific) users to the monitoring community and on to the general public will both require use of data archives already in existence and encourage a more active support of proposed spacecraft missions.

TABLE IV-1
USER NEEDS INTERVIEWS

AGENCY	BRANCH	INDIVIDUAL	DATE (1975)
DOT	CIAP	Cambridge Conference	February 4-7
EPA	Office of Technical Analysis	Dr. M. Felcher [*]	April 2
ERDA	DBER	Dr. R. Engleman, Mr. T. Gross, Mr. R. Beadle	May 27
	Sandia Laboratory	Dr. F. Hudson	June 19
NASA	User Affairs Office	Dr. J. Posner ^{**}	April 8
NBS	Kinetic Chemistry Group	Dr. D. Garvin	February 9
NOAA	Environmental Satellite Lab	Dr. S. Fritz, Dr. L. Stowe, Dr. M. Weinrab	May 13
	Air Research Lab	Mr. D. Pack	April 17
		Dr. J. Mitchell Dr. L. Machta	May 14 May 27
USDA	Plant Stress Lab	Dr. M. Christiansen	May 16
	Air Sciences Dept.	Mr. R. Miller	May 16

*Now at NASA User Affairs Office.

**Now retired.

4.2.2 User Participation in Mission Development

A number of current and potential users (both institutions and individuals) expressed the view that inclusion of the various levels of users in the program development represents a method for evolving an experiment which is backed by a large contingent of scientists from a wide diversity of fields. Consideration of the difficulty in justifying, in both a scientific and economic sense, the institution of a new spacecraft program, implies the need for the largest number of vocal supporters possible. Those particularly interested in making inputs into the development of new programs were those working at a scientific or technical rather than an administrative level.

The members of the scientific community have considerable concern about the performance of experiments which will help them in their particular field. They are not, however, in MITRE's view, encouraged to participate in the program development until the experiment goals and priorities are well developed. This may account for the feeling of frustration evidenced by several contacts who felt that NASA was not responsive to their needs. Such difficulty can, in MITRE's view, be avoided at least to some degree by guaranteeing that potential users, particularly within other Federal agencies, are well informed about what can and cannot be done from a spacecraft.

As an additional feature, it is clear that coordination of NASA programs from the earliest date possible with the programs of other agencies, particularly those funding related theoretical research, is essential. Such interaction guarantees both the identification of a

vocal user group as well as helping to develop experiments which are responsive to science requirements and issues which can only be viewed from the vantage point of long-term programs (such as those sponsored by NSF at NCAR and other university research groups).

4.2.3 Related Factors

Part and parcel of encouraging the interaction of users and NASA from the conceptual development of a program through its production of a useable product, is the exchange of knowledge which takes place. It is difficult to imagine an effective spacecraft program which ignores either the general or specific scientific features of the desired information. This is merely a statement of the need for information transfer before there can be technological transfer, be it definition of the experiment, interpretation of its results or use of the product by the public.

The sections which follow are merely a microcosm of the approach recommended above. First the scientific aspects of the topic are described both at the cause and effect levels. The general measurement needs are derived from that description and finally a set of numerical measurement requirements are proposed. Other sections of this report address the key issue of the capability of particular sensors to meet these requirements.

As noted earlier, the examples discussed are of particular current interest and were chosen for that reason. Also mentioned was the fact that the two topics are by no means independent. For that reason, a division has been made in the topics so as to present:

- User requirements for studying the effects of change in the UV environment and,
- User requirements for studying the causes of climate changes.

This is a particularly convenient method for it shows the clear distinction in developed user requirements between primary users (in the climate case) who can directly use the spacecraft data and secondary or tertiary users (in the UV-biology case) who must rely upon an intervening group to interpret the spacecraft data and put it into a format which can be used.

In addition, this method results in discussing two problems with well-developed communities of researchers who can present particular measurement requirements which can be used for program development and studies of economic benefits.

4.3 Influences on the Biosphere

4.3.1 Introduction

4.3.1.1 Scope of Study. Provision of useful data from observations of the upper atmosphere is determined by a consideration of atmospheric influences on human activities and on subjects of human interest. The Climatic Impact Assessment Program^(1,2) (CIAP) has examined the cause and effect interactions between human activities and the stratosphere. Because of the wealth of data which this study has produced, this section will focus on the influence of the stratosphere on the biosphere, i.e. the region near earth's surface where life is concentrated.

Most of the solar ultraviolet light (UV) at wavelengths below 300 nm is absorbed by stratospheric ozone before it reaches the troposphere. This absorption limits the amount of UV received by the biosphere and produces the stratospheric heating and temperature inversion, which, by limiting stratosphere-troposphere mixing, maintains the amount of stratospheric ozone at its present levels. The UV energy absorption and the temperature inversion "ceiling" affect the Earth's climate. (6)

UV at the earth's surface is composed of both direct and scattered sunlight. Galactic UV is negligible and artificially generated UV is not found in the upper atmosphere. Changes in surface UV intensity are due to the solar zenith angle and to variations in the solar source intensity and atmospheric transparency. Although both aerosols and clouds affect UV transmission, the primary influence is in the amount of ozone present in the stratosphere. Thus, surface UV involves the relatively simple structure of relations shown in Figure 4-2. Note the absence of rapid stratospheric input mechanisms involving human activity.

Climate is a complex system depending on many factors other than solar radiation and atmospheric transparency. It is a function of albedo, of snow and ice distribution, of global and regional atmospheric and oceanic physical and chemical properties and motions, and of the vegetation and human activity on the surface. Agricultural and grazing practices, e.g. irrigation or replacement of forest by cropland, and industrial activity can change the climate. (7) In turn, climate influences all forms of life, and inorganic materials as well. An attempt to represent climate in a block diagram would require inputs from

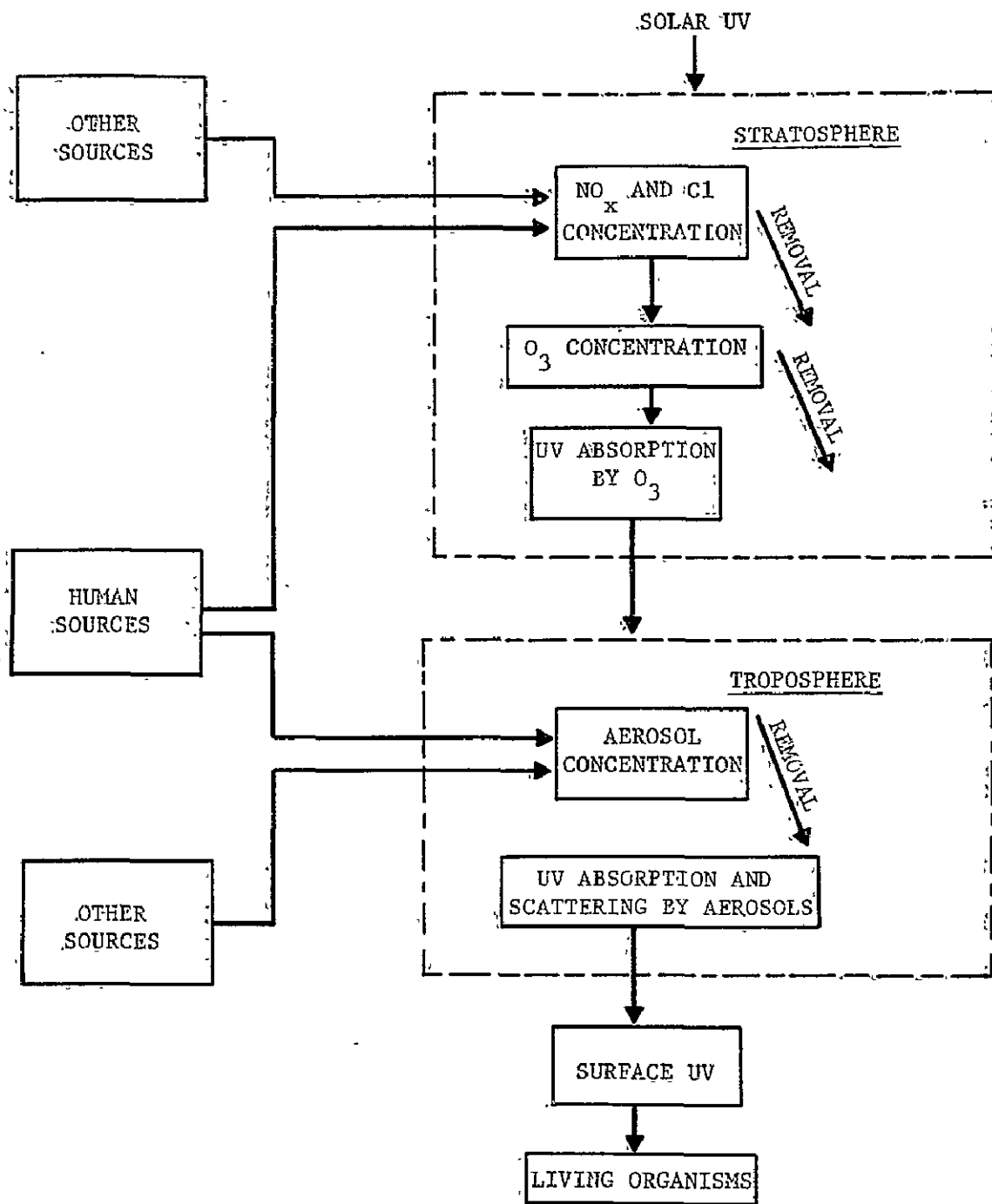

FIGURE 4-2
PRIMARY INFLUENCES ON SURFACE UV

ORIGINAL PAGE IS
OF POOR QUALITY

everywhere and outputs to everywhere, due to the complexity of the set of phenomena collectively called "climate." In such a situation, the numerous feedback relationships make it difficult to determine the precise relationship of any one element to climate and to separate its effects from those of other phenomena.

For this reason, this section concentrates on UV and its relationship to the biosphere. The relative simplicity of the chain of effects producing surface UV makes it easier to isolate its effects compared to the effects of climate. This simplifies the determination of physical phenomena and the functional relationships involved, or organizations concerned, and of the associated data requirements and use. An initial survey of the effects of UV on the biosphere can then serve as a guide to the treatment of the more complicated area of climatic effects. The data utilization, discussed further in the next section, is better understood when one starts with a simple case where fewer organizations are involved.

4.3.1.2 Methodology. A four-step procedure can be used to identify the data requirements and utilization involved in study of UV influences on the biosphere. Similar procedures can serve in the study of UV influence on non-living material. In the case of climatic influence on the biosphere, this study methodology may require modification because of the more complex interactions which must be considered. The procedures follow:

- (1) The first step is identification and tabulation of the important physical and biological effects of UV. The most important information sources are technical journals and publications, and documentation from the CIAP program.

- (2) The second step is identification and tabulation of the related human activities and the people involved. The groups of people and the organizations affected, both governmental and non-governmental, must be established, for in general it is through such organizations that the data requirements originate.
- (3) The third step is classification of the physical/biological phenomena through the human activity concerned, rather than by a biological taxonomy. Such classification follows the end use of the information, and is a natural consequence of the preceding steps, since both information sources and organizations tend to be grouped according to some pattern of end use. As part of the classification, some estimate of the relative importance of the effect to the related human interest or activity is needed. Data utilization is based on the existence of a perceived or assessed problem which is representable by some value scale.
- (4) The final step is identification of the information flow within each category of activity. In the preceding sections, 4.1 and 4.2, concerned with the physics and chemistry of the atmosphere, use was classified as scientific or operational. In the biological fields considered here, research is an obvious use, but the need for operational monitoring for UV purposes is not demonstrated. Should such monitoring be required, it will have to take into account the considerable variation in UV with time, with location, and with local geography, which produces reflection effects.

Until the requirement for operational monitoring is established, the study should focus on data requirements for research purposes. Since the study is concerned with living organisms, the concern is with surface UV, and direct use of satellite observations may not be required. Typical biological research work involves data from many sources, and assessment of these is part of the final step. While UV may have a major and critical effect on some area of activity, the study of that activity need not involve satellite observation at all. Rather the influence of satellite observations may be in establishing the parameters which indicate that a critical situation may occur. The use of these data may be indirect rather than direct.

4.3.2 Study Results

4.3.2.1 Information Sources. At the end of this section are listed a number of basic references for the biological effects of UV. The DOT-CIAP program provides a fundamental source covering all aspects of the problem, including biospheric effects; two of the CIAP conference proceedings are listed, ^(1,2) as well as a report on a specialized CIAP-sponsored conference on cellular and molecular effects of solar UV. ⁽³⁾

CIAP also provided material for some of the surveys carried out and reports issued by such other Federal governmental organizations as the Council on Environmental Quality of the Federal Council for Science and Technology, ⁽⁵⁾ and various panels of The National Academies of Science and Engineering and the National Research Council. ^(4,6) Several of these reports are cited in the list of references.

A number of recent books concerned primarily or incidentally with UV effects on living organisms are also listed. ^(9,10,11,12,13) Those concerned with effects on man deal mostly with cancer and with dermatology, and no additional journal references are added for these well-documented fields.

In recent years an annual volume of survey articles entitled "Photophysiology" has been published. These deal extensively with both visual and UV wavelengths, and because of their survey nature, constitute a valuable source of information.

Two technical journals are of major interest. "Photochemistry and Photobiology" is published by the American Society for Photobiology and contains numerous research results concerned with both UV and visible

light. "Radiation Botany" is concerned with all types of radiation, including nuclear and ultraviolet, on plants.

Literature searches were conducted for MITRE by NASA, by the Department of Agriculture's Current Research Information Service (CRIS), and by the Smithsonian Science Information Exchange. Additional information was obtained by contact with Agricultural Research Service and National Institutes of Health personnel.

4.3.2.2 Biophysical Effects of UV. Photochemistry concerns the effects of radiation, including UV, on matter. Here the interest is in the effects of UV on living matter, and primarily concerned with radiation of wavelengths between 280 and 315 nm, in the "UV-B" region. Radiation at wavelengths below 280 nm is still effectively removed by the atmosphere, even with very reduced levels of stratospheric ozone, and wavelengths longer than 320 nm are relatively unaffected by ozone. Thus variations in stratospheric ozone produce intensity changes mostly in the shorter UV wavelengths penetrating to the surface, and consequently the following discussion relates primarily to UV-B. UV is important enough as a topic to be involved in five out of eight articles, authored in five different countries, appearing in a recent issue of Photochemistry and Photobiology (January 1975).

In general, UV is harmful to living organisms. The production of vitamin D and its use in insect vision are two of the few known beneficial effects. Reactions of the high-energy UV radiation with organic compounds in the cell usually result in products which are not part of

normal cell chemistry. Of the variety of photochemical reactions possible with the complex constituents of living matter, certain important and common effects, involving primarily DNA and proteins, are mentioned here.

Two of the more common photoreactions involving DNA are the dimerization, or linking, of adjacent pyrimidine bases - either in a single strand or cross-connecting the two strands, or the linking of DNA to protein.^(17,18) Other typical reactions may involve hydration of pyrimidine or thymine bases, formation of thymine dimers, and formation of breaks in one or both DNA chains and in protein polypeptide chains.^(19,20)

There are also sensitized photoreactions, in which the first effect of the UV is on another chemical which subsequently transfers its excitation energy to the DNA, with resulting DNA modification, e.g., by dimer formation.⁽¹⁷⁾ These reactions are mentioned to illustrate the variety of reactions possible with the complex chemistry of the living cell. As these reactions occur on or near the surface, UV does not usually penetrate very far through living tissue.

Individual UV photochemical reactions lead to physiological responses which produce complex and synergistic effects and result in varying sensitivities to UV.^(21,22) Without going into detail on this subject, a few reactions are mentioned to provide some idea of the more important responses and of the variety and complexity of these responses.

All cells have repair mechanisms, sometimes of several different types. A universal animal and lower plant mechanism of DNA recovery

is "dark repair," a process taking place in the absence of light, in which the damaged section of a strand is cut loose and then removed (incision and excision) by two enzymes, followed by enzymatic synthesis of a new section from information in the complementary strand and enzymatic sealing of the repair section.

Recombinational repair occurs after damaged DNA strands replicate. After a certain length of time the defects in the newly synthesized DNA may disappear, probably as a result of an exchange with a sister DNA duplex. It is also an enzymatic process. On the other hand, in many cases the defect remains, and the new DNA may be unable to replicate further. This constitutes a one-generation delay in replication. In general, UV tends to inhibit DNA synthesis. (17)

There are also processes of photoreactivation which require the presence of visible or long wavelength UV light to produce an enzymatic splitting of the pyrimidine dimers formed by UV-B. This process is very important in many plants and microorganisms, and occurs in many lower animals, but not in placental mammals. (21,23,25,26)

An important UV photoreaction in plants inhibits a specific step (PS II) in photosynthesis and reduces photosynthetic activity and output. (24,25) Bleaching of chloroplasts is also common.

Sunburn (erythema) and tanning of the human skin by UV stimulation of pigment production are familiar examples of physiological effects. (27) Artificial tanning agents usually contain photosensitive organic compounds. Psoralens, which occur naturally in various plants, such as celery, are photosensitive. After absorption through the skin they can

link to DNA to produce various effects, including DNA synthesis inhibition (which may be used medically in certain conditions, but which is normally undesirable).

Many physiological effects involve multiple factors, such as radiation of different wavelengths,⁽²²⁾ or combination of radiation with various chemical or physical factors such as temperature.⁽²⁸⁾ These factors may be synergistic or act against each other so that the result is a nonlinear function of several variables, including time, rather than being an additive process. Such occurrences are common in any complex system.

After the preceding introduction of photochemical and physiological effects in the cell, subsequent paragraphs consider effects on the entire organism and on systems of organisms. Animals (including man), plants, microbiota and ecological systems are discussed in terms of the influence of UV.

UV cannot penetrate deeply into living tissue because it promptly reacts with the cell material.⁽³⁴⁾ Most mammals have protective inert coverings of hair, fur or surface hide which absorb the UV without damage to the tissue below. Most mammals avoid sunlight unless it must be accepted while grazing, hunting, etc. Man lacks this protective covering, some races lack protective skin pigmentation, and man frequently spends much time in the sunlight during work or leisure activity. Thus, this section is concerned mostly with humans, and, because of the low penetration of UV, mostly with the skin and the eyes.

Erythema from abrupt UV-B exposure is not important in itself since changes in UV levels need not have serious consequences for this avoidable problem. However, UV-B and erythema are both related via long-term effects to skin cancer, and increased levels of UV can have serious results. The medical community has been concerned with the problem for years, and recently it has received additional attention under the CIAP program, the NAS Climatic Impact Committee (NAS-CIC) and Council on Environmental Quality IMOS studies. (5,6) Some major aspects are briefly mentioned here.

Both erythema and skin cancer appear to be produced by, or related to, wavelengths below 320 nm, and especially below 300 nm, although individual sensitivities vary. (9,12,13)

Skin cancer takes two forms. Malignant melanoma, the less common but more virulent and frequently fatal form (median survival time of seven years), has an annual incidence of new cases in white populations varying from 3×10^{-5} in the northern U.S. to 8×10^{-5} in the southwest. The geographic incidence, the location of lesions on sun-exposed areas, and the striking differences in location and frequency according to sex and life habits (e.g., occurrence on women's legs) clearly relate it to sunlight. Frequency among fair skinned people, compared to darker pigmented groups, strongly suggests UV. In humans malignant melanoma commonly arises in pre-existing pigmented moles (nevi), and very rarely on skin unexposed to sunlight. In experimental animals it has been produced by UV in benign, artificially induced, pigmented moles. In

individuals with xeroderma pigmentosum, who lack certain DNA dark-repair mechanisms, it is extremely common - 50 percent incidence by age ten - and usually fatal before maturity. While UV is not the sole cause of malignant melanoma, a relationship seems clear. (6)

Non-melanoma skin cancer is the most common of all cancers in humans and is generally grossly underreported. Incidence statistics for older groups of white males range up to 5×10^{-3} at lower latitudes, and prevalence among whites of all ages may range up to 0.01 according to some recent estimates. The more common basal-cell skin cancer type is rarely fatal, but the less common squamous-cell type may occasionally metastasize and cause death if not treated early. (6)

Evidence clearly links UV to non-melanoma cancer. Squamous cell cancer has been induced in experimental animals by repeated exposures, and in one recent test, by a single exposure of two hours duration and $12 \times 10^4 \text{ Jm}^{-2}$ yield. (29) While rare among heavily pigmented races, it is more common among albinos of such races. Non-melanoma cancer occurs chiefly among lightly pigmented races, especially Celts. Incidence increases with cumulative sunlight exposure, i.e., with increasing age, with lower latitudes, and with outdoor occupations. In one study of basal cell carcinoma, over 90 percent of the lesions appeared on the head and neck, particularly on the face. While generally not fatal, such cancers are disfiguring and expensive, and limit activity because further exposure to sunlight can cause recurrence. Queensland, Australia, combines a light-skinned population with a low latitude and

bright sunlight, and has the highest incidence of skin cancer' in the world. These potential increases in surface UV present a very serious problem to man.

The NAS-CIC study attempted to predict increases in skin cancer which could be expected to result from higher levels of UV, but limitations in the available data and uncertainties in the models made for large uncertainties in the estimates. Using one model, a 50 percent reduction in ozone resulted in increases in various forms of skin cancer ranging from factors of two to ten for melanoma mortality up to factors of 50 or more for overall skin cancer incidence. Clearly numerical predictions on the basis of the then available evidence cannot be very accurate, but it is equally clear that significant increases can be expected to occur with increasing UV dosage.

Admittedly such increases could be offset by avoidance precautions and prompt medical action, but such precautions do not seem, as yet, to have gained wide acceptance, even in Queensland.

There is little evidence currently relating UV to serious ophthalmological problems, although there is some evidence for cataract formation from animal experiments.⁽³⁾ The subject is not discussed further here.

Skin cancer is not limited to man; some light colored animals, lacking melanin, are subject to it. About 90 percent of the slaughterhouse cattle rejections for skin cancer involve "cancer eye," a squamous carcinoma of eyelid or eyeball occurring generally in whitefaced cattle;

but also in sheep, goat, and horses.^(5,30) An infectious condition of farm animals known as pinkeye is exacerbated by UV.

Photosensitization of animals by ingested food, or by drugs or microorganisms, is also possible.⁽³¹⁾ A surprising number of plants produce photosensitization of some sort, including, for example, rye, buckwheat, alfalfa, clover, and various weeds such as St. John's wort, which as "Klamath weed" made some areas totally unsuitable for grazing until it was controlled. UV is often involved in the photosensitization problems. As yet relatively little is known of the nature of the photodynamic agents and processes, nor of the effects on animal tissues of ingestion of irradiated plant matter.

DNA photoreactivating substances have been found in certain marsupial mammal tissues, but it is not clear that they serve this purpose.⁽¹⁷⁾ Very probably they serve other purposes and happen to possess photoreactivating properties.

This study located rather little literature on the effects of UV on other animals. Some reptilians sun themselves to warm their blood, but they are usually well protected, and the topic appears to be not important.

Insects can see in the UV range, but relatively little analysis of the effects of UV-B was found. Insects, however, are quite important to the agricultural and ecological worlds, in both positive and negative ways. The Agricultural Research Service and the Atomic Energy Commission have sponsored some work in this area.⁽³²⁾ To date it appears that many insects are not particularly sensitive to UV, although a few may be

strongly sensitive.⁽⁵⁾ Larval forms may be sensitive, as are the immature forms of most animals but larvae usually are not subjected to light of high intensity.

Trout eggs are easily killed by UV or by artificial visible light to which they are not normally subjected. There are indications that fish populations may vary with solar cycles, which correlate with land vegetation effects, but not enough is known on the subject to assess any problems.⁽³³⁾ Strong hatches of cod and salmon seem to emerge when solar activity is low.⁽²⁾

No references were found relating to effects of UV on other marine animals, such as arthropods, mollusks, echinoderms, etc. Presumably animal eggs and larvae are sensitive to UV if exposed. In summary, the major animal problems determined to exist thus far relate mostly to man and domesticated species.

Studies of effects of UV on higher plants have been supported by the CIAP program and conducted principally at the USDA Agricultural Research Service, Beltsville, MD, and at the Universities of Florida and Utah.⁽²⁾

Plants cannot avoid sunlight and consequently have physiological defense mechanisms, especially photoreactivation.⁽²⁴⁾ The non-linear relationships resulting from synergistic effects and from repair systems make the design of experiments and the interpretation of results difficult.^(6,35) One cannot make very small, and consequently linear, perturbations in a plant experiment as one does with a mathematical problem.

Nature provides her own perturbations, so small artificial perturbations yield undeterminable results unless enormous statistical samples are used.

Thus, the differences resulting from the removal of natural UV-B, which is fairly easily and inexpensively achieved, are not necessarily the negative of those resulting from addition of a like amount of UV-B. Photorepair and synergism imply the need for providing both the correct spectrum of light and correct growing conditions to obtain useful experimental results. This may be difficult and expensive, especially for field tests, whose results frequently differ from those of simpler laboratory tests.

Thus interpretation of results of plant experiments is no easier than predicting the increase in skin cancer corresponding to a certain decrease of stratospheric ozone. This discussion explains the earlier emphasis on synergism and nonlinearity in the section on photophysiological effects. With this caveat, some of the experimental results are summarized.

Occasionally natural mutations produced by UV can be desirable, as in horticulture, where a sport branch of a tree may yield an orchard fruit with desired characteristics, and the individual branch becomes the basis of a whole new variety. The sports with undesirable characteristics are simply pruned away. However, UV is generally harmful and interferes with photosynthesis; in some instances even near-UV and blue light are harmful, while reds and yellows may be beneficial. Removing

UV tends to increase yield and eliminate mutations, most of which are undesirable; adding UV works in the opposite direction.

Sensitivity to UV varies with the type of test and with the variety of plant. Most of the tests were conducted with levels of UV corresponding to a 50 percent reduction in stratospheric ozone. It is unfortunate that earlier work tended to use the easily generated 254 nm wavelength, which does not penetrate to the earth's surface; thus making the results of very limited value.

Current growth chamber tests with enhanced UV-B generally produced significant growth decreases, ranging up to 50 percent in total plant product, and decreases in photosynthesis. Field tests, both with reduced levels of UV-B achieved by filtering and with artificially augmented levels, tended to show smaller changes, sometimes of no statistical significance. Presumably this is due to the photoreactivation effects of the longer wavelengths in sunlight. Field tests did show significant increases in mutations and in plant structure changes attributable to UV-B. A variety of grain and vegetable crops were tested.

While field tests to date seem to indicate that major changes in crop levels would not be anticipated from reductions in ozone, this applies only to the conditions of the tests. When crops are grown in marginal conditions, the combined effects may result in major changes. Thus, in such areas, local results can conceivably be disastrous. Once again, the nonlinearity of the relationships must be stressed. In these circumstances statistical predictions tend to have large uncertainties.

In the long range, if UV levels increase significantly, crops with increased resistance can be expected to take over, and yields may not be reduced. However, the period of change can be troublesome.

No results dealing with forest effects were found, although some experiments have apparently been conducted with woody crops.

All microorganisms and most small organisms tend to be extremely sensitive to UV because they lack protective coverings. UV lamps have long been used germicidally. In the sea, plankton form the base of the life chain. In fresh water, microorganisms provide natural and cultured means of water purification. Unicellular algae are an important component of plant life on land and in water. Algae as symbionts in lichens constitute a major element in arctic tundra, alpine vegetation and other areas.

In addition to their photosynthetic processes, the bluegreen algae and the photosynthetic bacteria together provide a major source of natural nitrogen fixation.^(36,37) (This has been termed "one of the least exploited of the important biological discoveries of modern times.")⁽³⁸⁾ Both algae and bacteria are common in the rice-growing areas of Asia, especially southeast Asia, and rice plants have been grown to maturity with only the nitrogen provided by algae. Overall algal nitrogen fixation, averaged over the entire surface of the earth, including oceans and polar areas, has been estimated at $0.7 \text{ gm m}^{-2} \text{ yr}^{-1}$, or at more than 90 percent of the total nitrogen fixation occurring. Thus, the importance of such organisms as the basis of major ecosystems must be recognized and their vulnerability considered.

Microorganisms make up for their vulnerability by enormous rates of reproduction in favorable conditions. In addition, marine plankton have an avoidance mechanism, for the plankton layer tends to sink several meters during the day to to rise at night. This diurnal motion reduces the sunlight exposure - a few hours of natural sunlight will kill many types of single-celled algae.

Early measurements of penetration of UV into water yielded varying results, and new work in this area is being sponsored by NSF. Clear, fresh or salt water is rather transparent to UV, but turbidity decreases the transmission considerably.

Unfortunately much of the earlier work on UV effects on such life forms was carried out with the readily available 254 nm radiation, and results are not appropriate for UV-B. Recent experiments with CIAP support have confirmed the sensitivity of most microorganisms to UV-B, and also of such larger organisms as aquatic arthropods and flatworms which feed on bacteria and protozoans. (2) The rapid changes in population level which can occur in aquatic ecosystems do make it possible for resistant strains to take over in a short time, provided that they exist. Still, it is clear that increased UV tends to kill the organisms which are the present basis of marine food productions and very important to fresh water purification.

Statistical prediction in this area is as questionable as in skin cancer or higher plant effects. The major cause for concern is that any periods of change of population not be too destructive. An ecosystem

involves interactions between microbiota, plants, insects, and other animals - if all are changing simultaneously it is difficult to predict the eventual mix which will prevail. Forest areas would not appear to be highly sensitive, although no studies have been located. Arctic tundra, on the other hand, may constitute a rather fragile system in which serious consequences could occur if a change in plant and lichen components took some time to stabilize.

Studies of ecosystems take time to accomplish. Potentially important problems may conceivably exist, although the probability of their existence currently appears low.

4.3.2.3 UV Influence on Human Affairs. The preceding sections have identified a number of effects of UV on living organisms and on systems of organizations. This was Step 1 of the methodology set forth in Section 4.3.1.2. The list of phenomena makes it obvious that all humans are affected in some way. Steps 2 and 3 of the methodology examine the types of effects and the human organizations involved, and are followed by consideration of how the flow of information may be related to NASA missions (Step 4).

Table IV-2 lists a few types of effects, classified human interest, generally in a descending order of immediacy or urgency of requirement. Alongside each of the categories of effects is a list of the organized human activities which are involved.

Essentially all of the material on UV effects presented in Section 4.3.2.2 is drawn from research publications. The only "operational"

TABLE IV-2
HUMAN CONCERN WITH UV

<u>NATURE OF UV EFFECT</u>	<u>FIELD OF HUMAN ACTIVITY CONCERNED</u>
1. Direct effects on humans.	Medicine: Cancer, ophthalmology, dermatology.
2. Effects on other organisms used by humans for food, material, etc.	Agriculture, horticulture, forestry, animal husbandry, fish culture and fisheries, veterinary medicine, water purification.
3. Long-term and indirect effects on: systems of organisms, climate, societal problems and stability, etc.	Ecology, conservation practices, regulatory activity.
4. Effects on cultural interests: leisure resources, species preservation, etc.	Ecology, water purification, preservation, environmental planning.

uses of UV known are its use by some insects in vision, the production of vitamin D in humans, and the deliberate exposure of the skin by humans to acquire a fashionable suntan. (Note that this last use tends to be strictly cultural rather than utilitarian, is frequently accompanied by erythema and, if repeated, leads for most skins to more rapid aging, and in some cases to much higher risk of skin cancer.)

Research activity in the effects of UV on living organisms are conveniently classified, for the purposes of this report, as basic or applied. Basic research, as defined here, is concerned with understanding the mechanisms of biological and ecological responses to UV, and may thus be considered to be a branch of photobiology, photophysiology, photochemistry, or ecology.

Applied research, as defined here, is concerned with some of the specific applications listed in Table IV-2. It is aimed at the development of methods of solving specific problems, including the development of plant or animal organisms with desired characteristics. The result of applied research are actual or recommended practice in agriculture, medicine, etc.

The first classification of research activity will then be as basic or applied, with ecology grouped in the applied sector, even though it may include some basic research as well. The applications may then conveniently be classified along plant or animal lines, with ecology spanning the two areas. The applications are similar to those already mentioned in the partial list of Table IV-2, and will be further

detailed, together with the various human organizations concerned, in the next section.

4.3.2.4 Organizational Involvement. Organizations are involved in this work either by conducting the research or by sponsoring it. Basic research is usually done at universities, hospitals, private research foundations, and government laboratories. (Most hospital research tends to be applied, using the definition set forth in the preceding section.) Applications research may also be accomplished by commercial organizations.

Sponsoring organizations generally represent the individuals and groups of people concerned with a problem or an activity, and usually include the Federal Government. Typical nongovernmental organizations are the American Cancer Society, charitable trusts (which essentially represent the people affected), or occupational or industry associations, such as agricultural, forestry, fishermen's, etc. NASA's concern lies more closely with the various Federal organizations involved, with which NASA may have to deal.

A tabulation of the overall research work identified in this review, classified as discussed above, and listed together with organizations involved in the research being conducted, will follow shortly. However, a preliminary table of the Federal executive departments or agencies with a major role in subjects affected by UV is presented first, as Table IV-3. Federal organizations with only minor or peripheral involvement are not mentioned. Table IV-4 follows a set of

TABLE IV-3
FEDERAL DEPARTMENTS AND AGENCIES WITH MAJOR CONCERN WITH UV

4-35

<u>ORGANIZATION</u>	<u>CONCERN</u>
1. <u>Department of Agriculture</u>	
1.1 Animal and Plant Health Inspection Service	Operational - animal inspection
1.2 Packers and Stockyards Administration	Operational - effects on food, animals
1.3 Agricultural Research Service	Research - UV effects on plants, farm animals
1.4 Forest Service	Forestry effects
1.5 Soil Conservation Service	Ecological effects
1.6 Cooperative State Research Service	Research by states on above topics
2. <u>Department of Commerce</u>	
National Oceanic and Atmospheric Administration	
2.1 National Weather Service	*Operational satellite observations
2.2 National Marine Fisheries Service	Effects on marine fisheries
2.3 National Ocean Survey	Oceanic ecological effects
2.4 Environmental Data Service	*Operational data transmission
3. <u>Department of Health, Education, and Welfare</u>	
3.1 Public Health Service	
3.3.1 National Institute of Health	
(i) National Cancer Institute	Human cancer effects
(ii) National Eye Institute	Ophthalmological effects - human
(iii) National Institute of Arthritis, Metabolic, and Digestive Diseases	Dermatological effects - human
(iv) National Institute of Environmental Health	Environmental effects - human
(v) National Institute of General Medical Science	Basic research-cellular and molecular basis of disease

ORIGINAL PAGE IS
OF POOR QUALITY

TABLE IV-3 (Continued)
FEDERAL DEPARTMENTS AND AGENCIES WITH MAJOR CONCERN WITH UV

<u>ORGANIZATION</u>	<u>CONCERN</u>
3. <u>Department of Health, Education, and Welfare (Continued)</u>	
3.1.2 Food and Drug Administration	
(i) Bureau of Radiological Health	Safety standards, exposure effects and control methodology
(ii) Bureau of Drugs	Synergistic photosensitive effects on humans
(iii) Bureau of Foods	Synergistic photosensitive effects on humans
3.2 Health Resources Administration, National Center for Health Statistics	Providing data to researchers
4. <u>Department of Interior</u>	
4.1 National Park Service/U.S. Fish and Wildlife Service	Ecological effects - sport fisheries, game
4.2 Office of Water Resources and Technology	Ecology - water quality
4.3 Office of Land Use and Water Planning	Ecological effects
4.4 Bureau of Land Management	Ecological effects
4.5 Bureau of Reclamation	Ecological effects
5. <u>State Department</u>	
Assistant Secretary for Oceans and International Environmental and Scientific Affairs	International programs-policies, proposals
6. <u>Department of Transportation</u>	
Assistant Secretary for Systems Division and Technology	
Climatic Impact Assessment Program	Overall research

TABLE IV-3 (Concluded)
FEDERAL DEPARTMENTS AND AGENCIES WITH MAJOR CONCERN WITH UV

<u>ORGANIZATION</u>	<u>CONCERN</u>
7. <u>Environmental Protection Agency</u>	Potential regulatory aspects
8. <u>National Academies of Science and Engineering</u>	Advisory aspects
9. <u>Smithsonian Institution</u>	
Radiation Biology Laboratory	Basic research

4-37

ORIGINAL PAGE IS
OF POOR QUALITY

* Only if operational monitoring and reporting becomes involved.

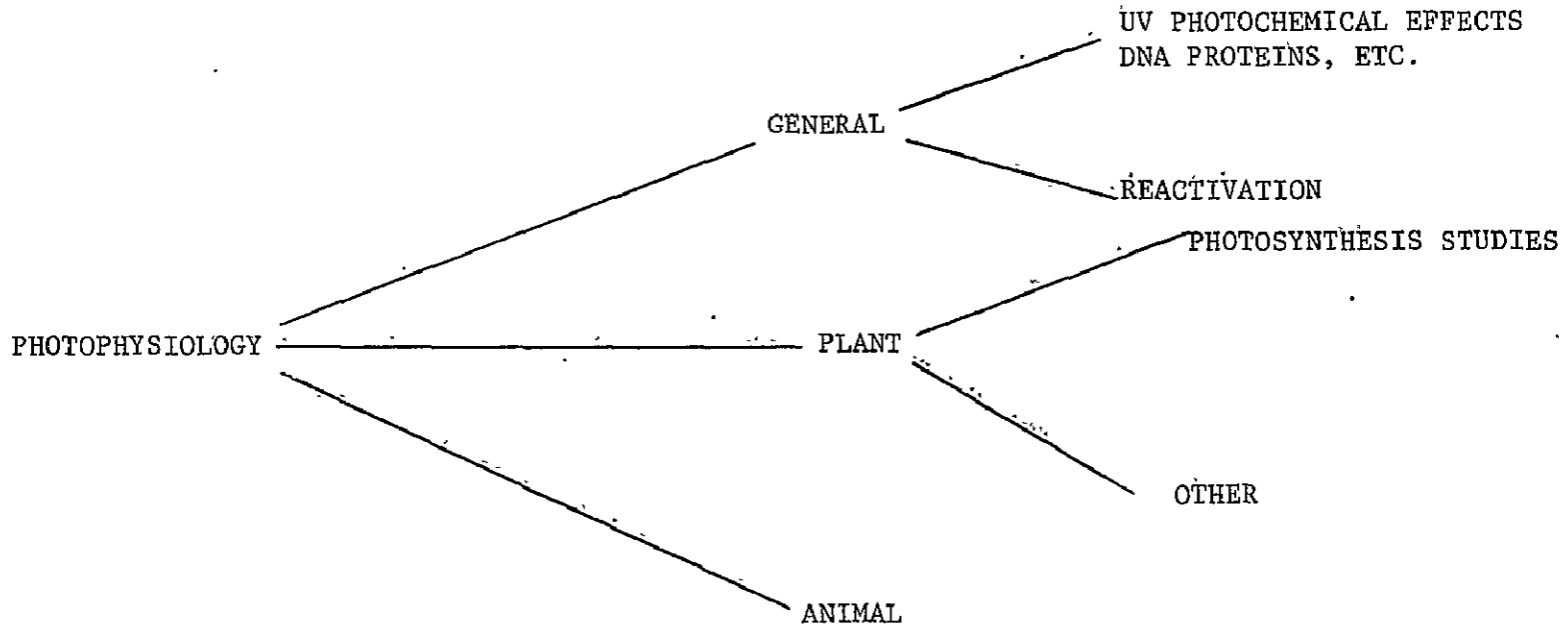

FIGURE 4-3
BASIC RESEARCH ACTIVITY

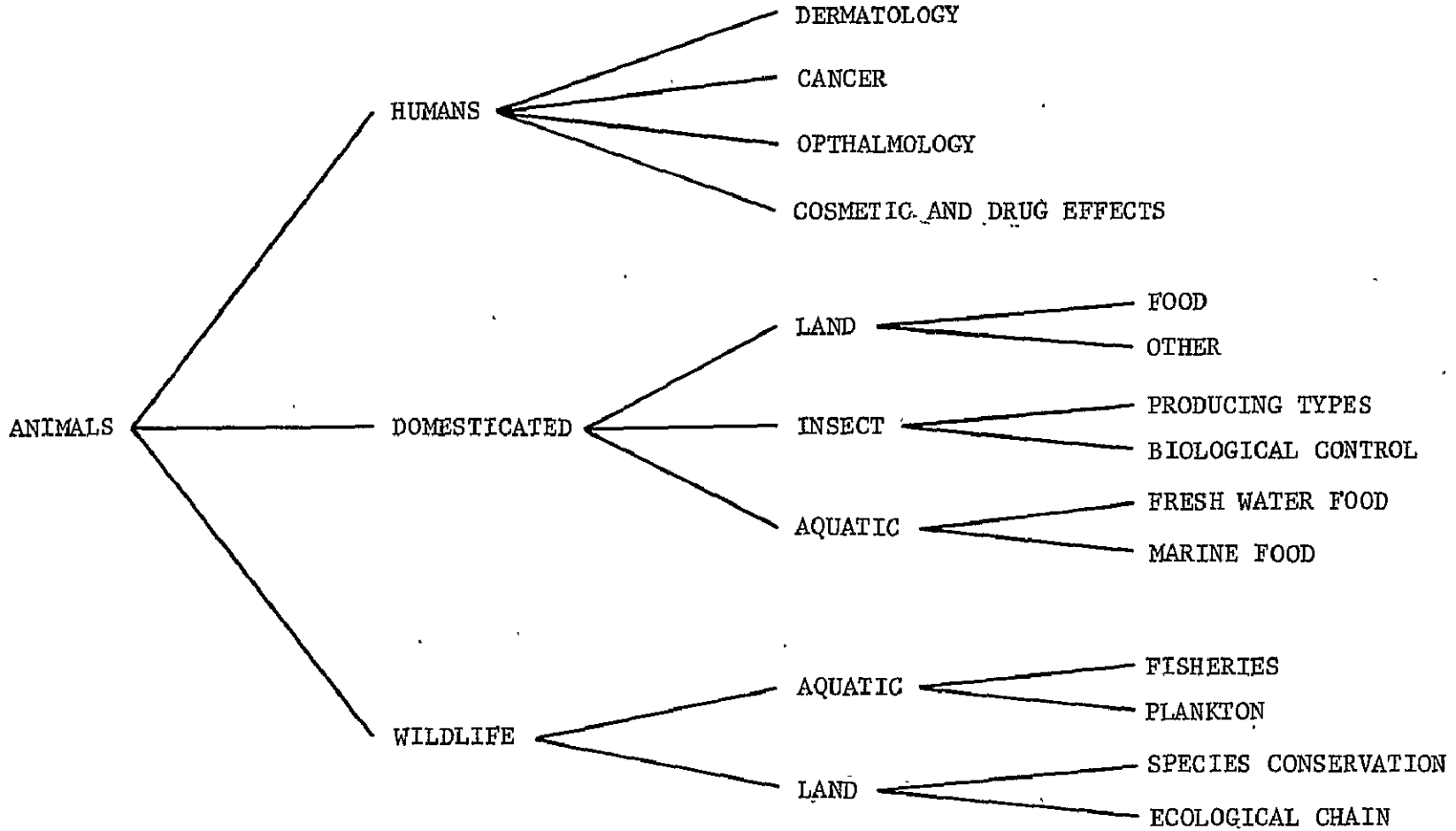

FIGURE 4-4
APPLICATIONS ACTIVITY - ANIMALS

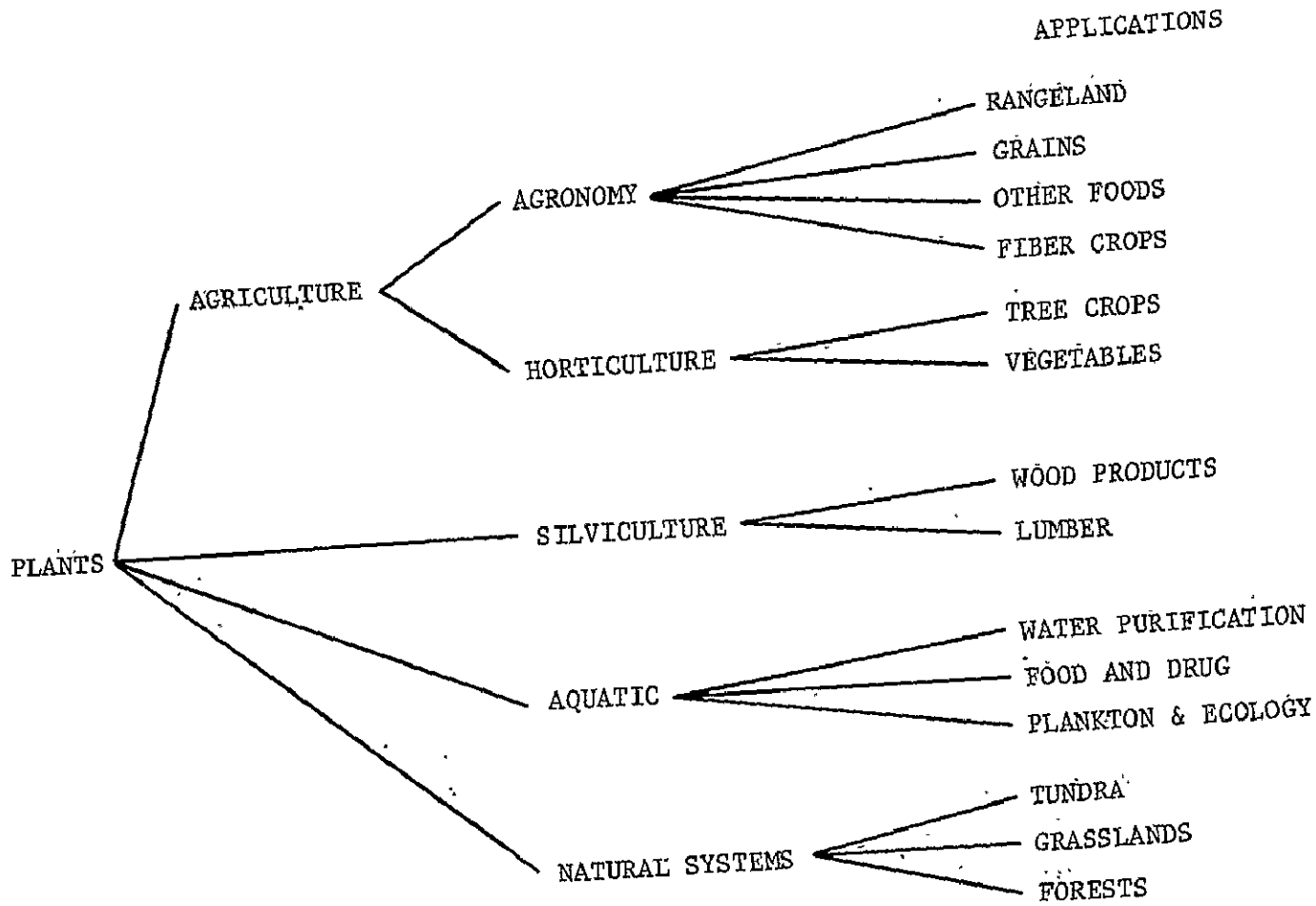

FIGURE 4-5
APPLICATIONS ACTIVITY - PLANTS

TABLE IV-4

UV RESEARCH CATEGORIES

CATEGORY: PLANTS - AQUATIC - PLANKTON

<u>ORGANIZATION</u>	<u>SUBJECT OF WORK</u>	<u>PRINCIPAL INVESTIGATOR</u>	<u>SPONSOR</u>
Stanford U. School of Medicine	UV Sensitization of E. coli	Smith, Kendric, C.	USPHS (HEW)
4-41 Texas Technological University, Dept. of Chemistry	"Photoreactivity of Hydroxy- psoralens and Their Photo- biological Effects in Bacillus Subtilis," Ph. chem. and Ph. biol, 1975	Song, Pill-Soon	USPHS Natl. Cancer Inst., NSF Robert A. Welch, Foundation, Texas Tech. Univ.
U. of California	"Penetration of UV Radiation into Natural Waters"	Smith, R.C.	NSF
U. of Kentucky School of Medicine	Resistance to UV Radiation of Several Fresh Water Eco systems (microorganisms, etc.)	Delabor, C. Calkins, John	DOT
U. of Texas, Dallas	UV Irradiation of Micro- organisms	Jagger, John	USPHS

TABLE IV-4 (continued)

UV RESEARCH CATEGORIES

CATEGORY: PLANTS - AQUATIC - WATER PURIFICATION

<u>ORGANIZATION</u>	<u>SUBJECT OF WORK</u>	<u>PRINCIPAL INVESTIGATOR</u>	<u>SPONSOR</u>
Stanford U. School of Medicine	UV Sensitization of E. Coli	Smith, Kendric C.	USPHS (HEW)
U. of California	"Penetration of UV Radiation into Natural Waters"	Smith, R. C.	NSF
U. of Kentucky School of Medicine	Resistance to UV Radiation of Several Fresh Water Eco-systems - (microorganisms, etc.)	Delabar, C. Calkins, John	DOT
U. of Texas, Dallas	UV Irradiation of Micro-Organisms	Jagger, John	USPHS

TABLE IV-4 (continued)

CATEGORY: PLANTS - AGRICULTURE - HORTICULTURE - TREE CROPS

<u>ORGANIZATION</u>	<u>SUBJECT OF WORK</u>	<u>PRINCIPAL INVESTIGATOR</u>	<u>SPONSOR</u>
U. of Florida	Effects of UV Radiation on Agricultural Productivity	Bartholic, J.M.F. et al.	USDA, Agriculture Research Service
Utah State U. Agriculture Experiment Station	Plant Response to UV	Caldwell, M. M. Salisbury, F. B.	USDA, Agriculture Research Service

4-43

TABLE IV-4 (continued)

UV RESEARCH CATEGORIES

CATEGORY: PLANTS - AGRICULTURE - HORTICULTURE - VEGETABLES

<u>ORGANIZATION</u>	<u>SUBJECT OF WORK</u>	<u>PRINCIPAL INVESTIGATOR</u>	<u>SPONSOR</u>
Colorado State U. Agriculture Experiment Station	"Vegetable Production Problems at High Altitude"	Moore, F. D.	State of Colorado
77-4 Iowa State U. Agriculture Experiment Station	Detection, Evaluation, and Control of Physio- logical Stress in Horticultural Plants (artificial light effects)	Nilsen, K. M.	USDA Coop. State Res. Serv.
U. of Florida	Effects of UV Radiation in Agricultural Productivity	Bartholic; J.M.F. et al.	USDA, Agriculture Research Service
Utah State U: Agriculture Experiment Station	Plant Response to UV	Caldwell, M. M. Salisbury, F. B.	USDA, Agriculture Research Service

TABLE IV-4 (continued)

UV RESEARCH CATEGORIES

CATEGORY: PLANTS - AGRICULTURE - AGRONOMY

<u>ORGANIZATION</u>	<u>SUBJECT OF WORK</u>	<u>PRINCIPAL INVESTIGATOR</u>	<u>SPONSOR</u>
Colorado State U. Agriculture Experiment Station	"Vegetable Production Problems at High Altitude"	Moore, F. D.	State of Colorado
U. of Florida	Effects of UV Radition in Agriculture Productivity	Bartholic, J.M.F. et al.	USDA, Agriculture Research Service
Utah State U. Agriculture Experiment Station	Plants Response to UV	Caldwell, M. M. Salisbury, F. B.	USDA, Agriculture Research Service

TABLE IV-4 (continued)

UV RESEARCH CATEGORIES

CATEGORY: ANIMALS - WILDLIFE - LAND - ECOLOGICAL CHAIN

<u>ORGANIZATION</u>	<u>SUBJECT OF WORK</u>	<u>PRINCIPAL INVESTIGATOR</u>	<u>SPONSOR</u>
U. of Tennessee	UV Acceleration of Mitosis	Carlson, J. Gordon	AEC
97-7 Virginia Poly- technic Institute School of Agriculture	UV-Visible Radiation Effects on Insects	Earp, U. F. Perumpral, J. V.	USDA, Agriculture Research Service

TABLE IV-4 (continued)

UV RESEARCH CATEGORIES

CATEGORY: ANIMALS - WILDLIFE - AQUATIC - PLANKTON

<u>ORGANIZATION</u>	<u>SUBJECT OF WORK</u>	<u>PRINCIPAL INVESTIGATOR</u>	<u>SPONSOR</u>
U. of California	"Penetration of UV Radiation into Natural Waters"	Smith, R. C.	NSF
4-47 U. of Kentucky School of Medicine	Resistance to UV Radiation of Several Fresh Water Ecosystems (microorganisms, etc.)	Delabar, C. Calkins, John	DOT
U. of Texas, Dallas	UV Irradiation of Micro-organisms	Jagger, John	USPHS

TABLE IV-4 (continued)

UV RESEARCH CATEGORIES

CATEGORY: ANIMALS - DOMESTICATED - LAND - FOOD

<u>ORGANIZATION</u>	<u>SUBJECT OF WORK</u>	<u>PRINCIPAL INVESTIGATOR</u>	<u>SPONSOR</u>
U. of Florida	"Epidemiological Index for Skin Cancer" - CIAP Publication	Green, A.E.S., et al.	CIAP - DOT
87-7 U. of Rochester School of Medicine	Relationship of UV to Animal Cataracts	Zigman, Dr. Seymour	USPHS
U. of Texas, Houston	UV Effects on DNA (hamster cells), 1974	MacDonald, Eleanor, J.	USPHS

TABLE IV-4 (continued)

UV RESEARCH CATEGORIES

CATEGORY: ANIMAL - HUMANS - OPHTHALMOLOGY

<u>ORGANIZATION</u>	<u>SUBJECT OF WORK</u>	<u>PRINCIPAL INVESTIGATOR</u>	<u>SPONSOR</u>
U. of Missouri	Lethal Effects of "Daylight" Fluorescent Light on Human Cells in Tissue Culture Medium	Wang, Richard J.	American Cancer Society and USPHS
U. of Rochester School of Medicine	Relationship of UV to Animal Cataracts	Zigman, Dr. Seymour	USPHS

TABLE IV-4 (continued)

UV RESEARCH CATEGORIES

CATEGORY: ANIMALS - HUMANS - DERMATOLOGY

<u>ORGANIZATION</u>	<u>SUBJECT OF WORK</u>	<u>PRINCIPAL INVESTIGATOR</u>	<u>SPONSOR</u>
Texas Technological Univ., Dept. of Chemistry	"Photoreactivity of Hydroxypsoralens and Their Photobiological Effects in Bacillus Subtilis," Ph. chem. and Ph. biol., 1975	Song, Pill-Soon	USPHS NSF, Robert B. Welch Foundation Texas Tech. Univ.
U. of Florida	UV Reaching the Ground, Its Measurement, Erythemal Dose, Climatology of Erythemal Dose	Green, A.E.S. et al.	DOT & CIAP
U. of Missouri	Lethal Effects of "Daylight" Fluorescent Light on Human Cells in Tissue Culture Medium	Wang, Richard J.	American Cancer Society and USPHS
USPHS, FDA	"UV Enhanced Reactivation of Herpes Virus in Human Tumor Cells," (Aug 74)	Lytle, C. D.	Division of Biological Effects

ORIGINAL PAGE IS
OF POOR QUALITY

4-51

TABLE IV-4 (CONCLUDED)

UV RESEARCH CATEGORIES

CATEGORY: ANIMALS - HUMANS - CANCER

<u>ORGANIZATION</u>	<u>SUBJECT OF WORK</u>	<u>PRINCIPAL INVESTIGATOR</u>	<u>SPONSOR</u>
EPA		Benane, S. G.	National Environmental Research Center
Temple Univ. School of Medicine	"Field Measurements of Biologically Effective UV Radiation and Its Relation to Skin Cancer in Man (CIAP-3)	Urback, Frederick Blum, Harold F.	USPHS DOT Thru NOAA
U. of Florida	"Epidemiological Index for Skin Cancer," - CIAP Publication	Green, A.E.S., et al.	CIAP - DOT
U. of Florida	UV Reaching the Ground, Its Measurement, Erythemat Dose, Climatology of Erythemat Dose	Green, A.E.S., et al.	DOT
U. of Missouri	Lethal Effects of "Daylight" Fluorescent Light on Human Cells in Tissue Cultural Medium	Wang, Richard J.	American Cancer Society and USPHS
U. of Texas, Houston	UV Effects on DNA (hamster-cells) (1974)	MacDonald, Eleanor J.	USPHS
U. of Vermont Agriculture Experiment Station	Growth Suppressing Wavelengths Emitted by Fluorescent Lamps	Klein, R. M.	State of Vermont

Figures, 4-3, 4-4 and 4-5 (which list research work in progress), and identifies the sponsoring organizations, including private ones. These tables are not intended nor claimed to be complete, since they were based upon a limited, and selective, sampling of the literature. In particular, numerous organizations active in medical research and in photobiology are not mentioned at all. The intent is rather to indicate the nature of the overall activities by presenting a small representative sample.

4.3.3 Information Flow and Use of Results

Since life is concentrated at or near the Earth's surface, it is subjected only to surface UV, which therefore is the real topic of concern in terms of biological effects. Stratospheric observations are of interest only to predict the surface intensities. Thus, research on biological effects is only at best an indirect user of satellite observations, i.e., these researchers are interested only in the long-term predictions which the atmospheric and climatic models can make on the basis of such observations.

At present the only users of surface UV observations, among the community concerned with biological effects, are research workers. Their use is in statistical correlation of surface UV intensity with the incidence of various biological phenomena, and with the recording, and perhaps modification, of surface UV levels during ongoing experiments. They may also be used for correlative purposes. Thus, there are no operational users of UV data as distinct from research users, nor is

there now any obvious future operational need for stratospheric UV monitoring for biospheric effects.

Operational surface UV monitoring in the future may be a possibility as one part of a system for the early detection of long-term trends in biological effects, such as skin cancer, and their correlation with UV. However, in light of the large and slow variations in surface UV which normally exist, this would probably only be part of a large statistical survey system, i.e., the "operational" use does not present a real-time requirements in the same sense as weather observation.

Note that the research approach used can affect the data requirements very strongly. For example, the attempt to use statistical methods and modeling techniques to correlate UV with skin cancer, requires much data. A few deterministic experiments with mice, on the other hand, prove that UV can create skin cancer. In fact, the two methods are complementary, for the experimental approach provides no basis for prediction of the increase in cancer to be expected from a given increase in surface UV. (On the other hand, even the predictions of the very competent team involved in the NAS study⁽⁶⁾ were subject to all the uncertainties inherent in the modeling process, so the predictions could hardly be called precise.)

Thus, the large classes of people who are undoubtedly concerned with UV may be termed beneficiaries, rather than direct users, of any UV observations. They are users of the applications research work in biological effects, since this research work affects their actual practices. The research workers in biological effects are the users of

surface observations, and of the predictions furnished by climatic modelers. The last group are potential direct users of both satellite and surface measurements.

Examples of the classes, as defined by Figures 4-3 through 4-5, are listed in the subsequent Tables. Figure 4-6 is a block diagram illustrating the relationships between observation data and user classes. An extensive list of references is supplied which indicates the magnitude of the scientific interest in UV-related areas.

4.3.4 Measurement Requirements

It is clear from the material of this section that the predominant interest in the field of UV in the biosphere is in interaction of biological systems with UV. Until recently, little interest had been expressed in the interaction between the UV environment and conditions of the atmosphere. As a result, it appears that this field is dominated by users far removed from the ability to effectively utilize observations which describe the state or variability of those features of the atmosphere which control UV transmission. There is at the same time considerable interest in measurements which will help clarify the physical and chemical processes which control the UV environment. There is an evident gap between those groups of users. That gap can only be filled by scientists interested in the interdisciplinary study of the coupled system of biosphere and atmosphere.

Specific measurement requirements are not clear, particularly because the largest potential group of users is not specifically interested in the physics or chemistry of the atmosphere but rather the

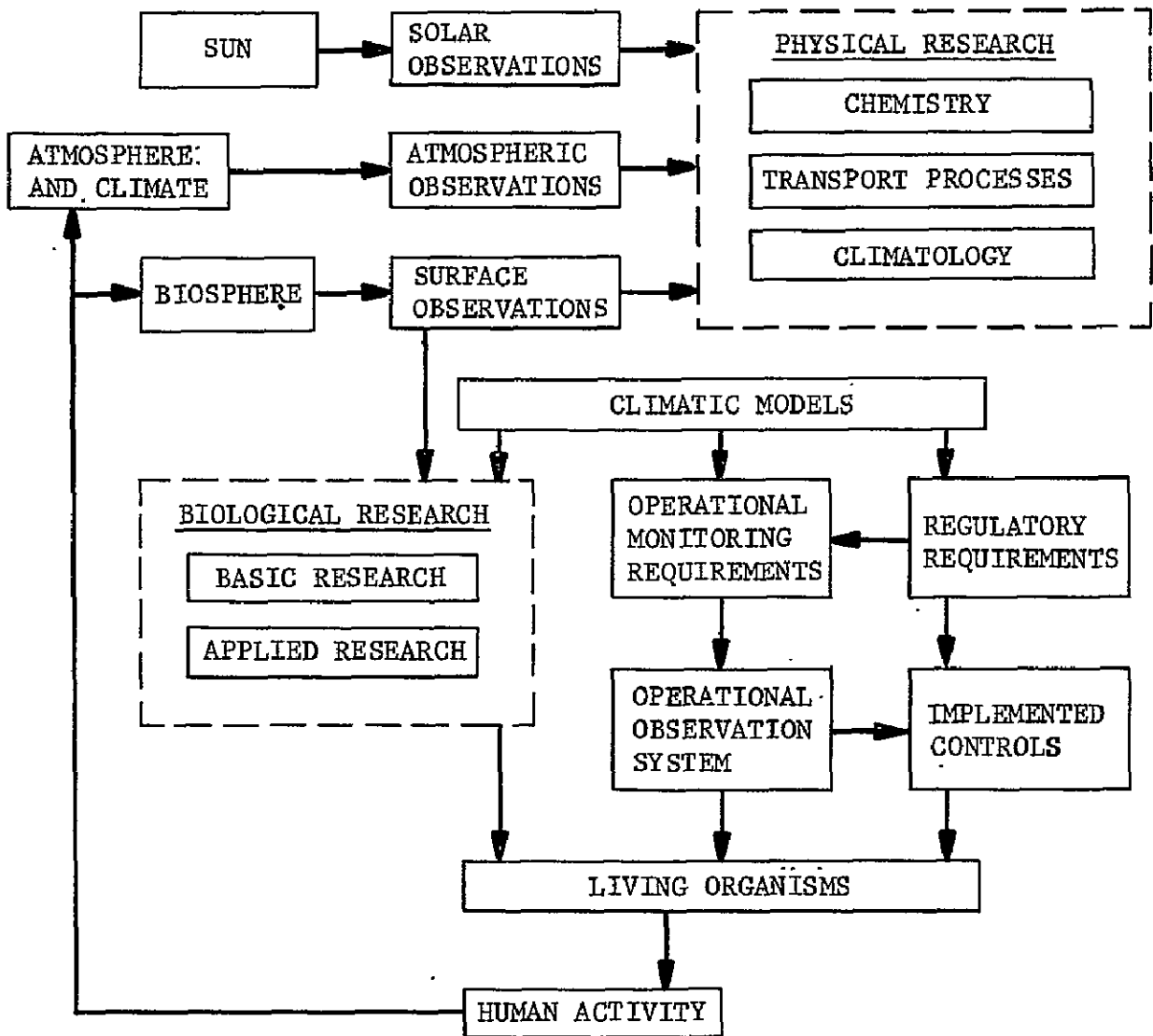

FIGURE 4-6
DATA UTILIZATION AND USERS

reaction of biological systems to changes in their environment. The most effective method for establishing priorities is as suggested in Section 4.5, where the constituents which play a role in determining the UV transmission of the stratosphere are identified as key subjects of an experimental program. However, some general requirements for support in the field can be developed.

First, it is clear that a topic of primary concern is the intensity and wavelength distribution of ultraviolet radiation at the Earth's surface. Inference of this data from spacecraft measurements provides a unique opportunity to supplement the world-wide network of ground stations and provide more comprehensive coverage in space and time.

Secondary studies would include determination of the variability of radiation features, studies of polluting gases on the atmospheric transmission in the UV spectrum and data which relates the UV environment to climate variability.

Clearly, further direct NASA contact with those studying the subject, such as those listed here, will begin the communication cycle so necessary if experiments are to be developed which satisfy these users.

4.4 Influences on Climate

4.4.1 Introduction

Climate effects are much more pervasive than those defined in the previous section for ultraviolet (UV). In the case of UV, the chain of concern is traceable from the stratosphere directly to the well-defined

set of users - both direct and indirect. For climate, the end point of such a consequence chain is much more diffuse. Nearly everyone is concerned, in some degree at least, with climate and the effects of climatic modifications. This interlocking relationships with all human affairs gives climate a more profound influence upon terrestrial life than that attributed to the UV chain.

The above considerations dictate a different approach than that taken in Section 4.3. In this section, the user community will be restricted to the primary users of remotely sensed data, with the tacit understanding that the ultimate users are omnipresent. For purposes of discussing the general areas of climate study, the primary user community will be divided into two categories, modeling (including physical processes) and monitoring. In the more detailed discussion of Section 4.4.4, more specific distinctions will be made. The interests and requirements of each category will be discussed separately, although there is considerable overlap in both interests and activities between the two groups.

4.4.2 Modeling and Studies of Physical Processes

4.4.2.1 Components of the Climatic System. The total system which comprises the Earth's climate is extremely complex and highly inter-related. With the attendant risk of over-simplification, it is usually desirable to separate the system into various components. These components result not only from the different spatial regimes which help to define them, but also, from the differing techniques of observation involved in the description of their characteristic processes.

By considering the processes rather than the spatial location, it will be easier to visualize the interactions and other effects which will be treated in subsequent sections. The major processes to be considered are: radiation, cloud, surface and atmospheric. Each will be defined in this section.

4.4.2.2 Radiation Processes. The most fundamental driving force for Earth's climate is solar irradiance. While the effects of this external energy may be modified by surface and atmospheric effects, it remains the single most important element in the entire climatic system. For purposes of climate modeling, the most useful inputs are the boundary fluxes and the internal sources and sinks of the atmosphere. Solar radiation, in all spectral bands, provides the major input to the system, while scattering and re-radiation provide the primary outputs. All of these parameters are susceptible to measurement from satellite platforms.

4.4.2.3 Cloud Processes. Clouds influence the terrestrial climate in several distinct ways:

- By reflection, absorption and emission of solar and terrestrial radiation;
- By the redistribution of heat and momentum through condensation and evaporative processes; and,
- By the ground-atmosphere coupling provided by precipitation.

The modeling community is interested in the areal and temporal variations in cloud types and coverage. The interactions of radiation, local turbulence, large-scale circulation and microphysical processes need to be investigated.

4.4.2.4 Surface Processes.⁽⁴²⁾ The interaction with the Earth's

land areas produce profound atmospheric effects with climatic implications. One of the more basic aspects is found in the surface albedo, which may range from 0.1 to 0.9 for land areas. Other parameters of interest are the surface topography, land use and distributions of moisture. These directly affect the transfer of momentum and energy from the atmosphere as well as the surface emissivity.

The world's oceans represent the largest component of thermal and mechanical inertia on the Earth's surface. This is due to their high heat capacity and the long time constants found in the oceanic circulation processes. Most of the interactions of the air-sea boundary are determined by the temperature of the sea surface itself. Very little data is available on ocean parameters and their time and space variability. Vertical and horizontal movements of warm and cold water masses impact upon local climate directly and through the air-sea interface, influence atmospheric processes on a much larger scale.

Ice cover, both sea and terrestrial, exerts a large influence upon the Earth's climatic system. Seasonal variations in snow cover and sea ice are extremely large and alter the surface-atmosphere interface as well as the albedo. In the case of sea ice, changes also are produced in the sea surface conditions and in the upper ocean layers. From the hydrological standpoint, ice sheets of Greenland and Antarctica alone, contain 80 percent of the Earth's fresh water supply. Although any changes in these ice sheets occur on time scales of the order of 10^5

years, their presence impacts directly on models of the short-term climatic variability.

4.4.2.5 Atmospheric Processes. (42,50) With the exception of cloud processes, which are described separately, atmospheric processes may be conveniently grouped into the generic headings of gases and aerosols. As examples of the gases of primary concern, carbon dioxide, ozone and freons will be described in this section. In subsequent paragraphs, other species will be described which may impact either directly upon the climate system or upon other gases and aerosols.

Carbon dioxide (CO_2) has a relatively high and spatially constant concentration in the Earth's atmosphere, on the order of 320 ppm. This concentration has been rising with man's increased burning of fossil fuels and is expected to increase another 20 percent by 2000 A.D. The major concern with increasing CO_2 levels is in its ability to absorb infrared radiation and thereby influence the Earth's heat budget and climate. The effects of high levels of CO_2 upon the biosphere is also a matter of increasing concern since some studies have indicated that the ability of the oceans and land plants to take up CO_2 is decreasing as the ambient levels increase.

Ozone has a highly variable concentration in the atmosphere. Section 4.3 has addressed the effects of ozone depletion on the biosphere. There is a climatic effect attributable to ozone as well. It provides the principal mechanism for radiative heating of the stratosphere. This heating results from the absorption, by ozone, of solar radiation, mainly in the ultraviolet region of the spectrum. The stratospheric

heating determines the relative stability as well as the dynamic behavior of the stratosphere and, thus, the interactions with the troposphere where most climatic processes occur. Much more information is required on the natural spatial and temporal variability of ozone in the stratosphere before meaningful predictions can be made on the effects of man-made pollutants.

An example of trace gases which may impact indirectly upon the climatic system is found in the freon family of chemicals. Primary concern with freons is centered in their deleterious effects upon the stratospheric ozone and the subsequent effects of increased UV-B radiation on the biosphere. More recent interest in the photochemical reactions in which freons take part is centered in the potential climatic effects of ozone depletion. The direct impact of ozone absorption on the warming of the stratosphere and troposphere was mentioned above. A recent article⁽⁵⁴⁾ considers the infrared absorption by the chlorofluorocarbons themselves and concludes that this mechanism may enhance the greenhouse effect with a concomitant impact upon the climate chain.

Atmospheric aerosols are the result of both natural and anthropological processes. While aerosols are found in both the troposphere and stratosphere, the sources are thought to be different in most cases. Complex homogeneous and heterogeneous chemical reactions are the source of most aerosols. Some direct injection does occur in both altitude regimes. Volcanic eruptions may increase the background stratospheric aerosol level by as much as a factor of 50 in the case of major eruptions.⁽⁴⁴⁾

These perturbed levels may remain for periods of three to five years. In the case of the troposphere, direct injection is attributable to sea spray and mineral dust particles. Most aerosols, however, in both the troposphere and stratosphere, are the result of gas to particle conversion. Major gases involved in these reactions are SO_2 , NH_3 , NO_2 and hydrocarbons, from either natural or man-made sources. ⁽⁴²⁾ The density and size distribution is a strong function of relative humidity as they depend upon the absorption of water for their growth. The effects of aerosols on the climate are twofold: changes in the radiation budget through their scattering and absorptive properties, and providing condensation nuclei for cloud formation.

4.4.2.6 CIAP Modelers. The CIAP Program identified many modelers of the troposphere and stratosphere. A list of these is given in Table IV-5, in which they have been divided into the various types of models with which they are most closely identified.

4.4.3 Monitoring Programs

4.4.3.1 Background. ⁽⁵⁵⁾ In late 1961 the National Academy of Sciences proposed the establishment of several international programs in atmospheric science. These recommendations were subsequently adopted by the United Nations General Assembly and form the basis for the present international programs administered by the World Meteorological Organization (WMO) in consultation with the International Council of Scientific Unions (ICSU). The first result of these proposals was the creation of the World Weather Watch (WWW) with the required regional weather

TABLE IV-5
CIAP PROGRAM MODELERS (16)

One-Dimensional	Johnston (1971) Crutzen (1972, 1974) Chang (1973) Chang et al., (1973) Stewart (1973) Stewart and Hoffert (1973) McElroy et al., (1974) Witten and Turco (1973, 1974) Shimazaki and Ogawa (1974) Hunten (1974)
Two-Dimensional	Hesstvedt (1973, 1974) Vupputuri (1974) Widhopf (1974) Brasseur and Bertin (1974)
Three Dimensional	Cunnold et al., (1974)

service centers and the necessary telecommunications system to link them together in a world-wide network. In 1967 WMO and ICSU agreed to co-sponsor a Global Atmospheric Research Program (GARP), and created the Joint Organizing Committee (JOC) to define and direct all efforts within the GARP.

The Federal Committee for Meteorological Services and Supporting Systems approved the plan for U.S. participation in GARP in 1970 and assigned planning responsibility to NASA. Goddard Space Flight Center (GSFC) was delegated this responsibility by NASA Headquarters at the same time.

4.4.3.2 Current Status. ^(42,45) Much of the current efforts were originally instituted as weather programs. The variables are similar to those required for climatic monitoring and, thus, may be included in climatological data banks. The Defense Department has been collecting weather and climate data for many years. Examples of these are the , Naval Weather Service Command which operates the Fleet Weather Central, and the Environmental Technical Application Center of the Air Force. In addition to these, are the National Meteorological Center of the National Weather Service and the National Climatic Center of the Environmental Data Service, both of which are parts of the National Oceanic and Atmospheric Administration (NOAA). All of the above data bases are available for climatic studies by such groups as the National Center for Atmospheric Research (NCAR), the Geophysical Fluid Dynamics Laboratory of NOAA and interested universities.

Data from operational satellite systems is being assembled by NOAA's National Environmental Satellite Service (NESS) and will become available to the atmospheric research community. Satellite data will increase in both importance and volume in the years ahead. They will provide man's first global view of the Earth's climate system.

Oceanic data bases exist in a specialized form and have yet to be collated. Individual data exist in the Fleet Weather Central, Scripps Institution of Oceanography, Woods Hole Oceanographic Institution and in the National Marine Fisheries Service. Cryospheric data is being collected by NOAA-NESS and used by the U.S. Geological Survey. Surface-based weather stations around the world are pooling their data through the World Weather Watch program of the WMO.

Within the framework of GARP, several regional observational programs have already been performed. The GARP Atlantic Tropical Experiment (GATE) has had a short data collection phase in 1973 and a three-month long observation period in 1974. The Air-Mass Transformation Experiment (AMTEX) has completed three phases, one each year from 1973-1975. The Polar Experiment (POLEX) has been underway since 1973 and will continue into mid-1978. The Monsoon Experiment (MONEX) has had two collection periods to date, 1973 and 1975. At least one more MONEX is planned for mid-1977. The Complex Atmospheric Energetics Experiment (CAENEX) has been running since 1973 and will continue into early 1976.

4.4.3.3 Planned International Programs. (42,45,55) The major international program planned at this time is the First GARP Global Experiment (FGGE). Scheduled for 1977-1978, this will utilize the

expanded facilities of the World Weather Watch, five geostationary satellites, two polar orbiting satellites, a combination of dedicated ships and carrier balloons, buoys and constant level balloons, and special automatic ground stations. FGGE represents the first major attempt at global coverage for an extended time period. The Global Experiment has four major objectives:

- (1) Obtain better understanding of atmospheric motion for the development of more realistic models for extended range forecasting, general circulation studies and climate.
- (2) Assess the ultimate limit of predictability of weather systems.
- (3) Develop more powerful methods for assimilation of meteorological observations and, in particular, for using non-synchronous data as a basis for predicting the large-scale motion.
- (4) Design an optimum composite meteorological observing system for routine numerical weather prediction of the larger-scale features of the general circulation.

The timing of FGGE is such that both MONEX and POLEX will overlap with the Global Experiment. This will allow a study of model capabilities to simulate the start of the southwest Asian monsoon in the case of MONEX, and increased data coverage in the polar regions with POLEX.

As a result of the Global Experiment, it is felt that most of the requirements for a permanent global monitoring capability will have been identified. Such a monitoring system could become a reality in the 1980's. The U.S. involvement in FGGE will be major. Overall GARP coordination has been assigned to NOAA, preliminary planning for FGGE is the responsibility of NASA, while NSF is responsible for university

support of all GARP-related activities. NASA is also planning and managing the Data Systems Test (DST) for the Global Experiment.

4.4.3.4 Planned Domestic Programs. While FGGE represents a major phase of the United States climatic effort for the next several years, there will continue to be purely domestic programs. NASA has a continuing satellite development program planned through the 1980 time frame. Examples of satellites which will have climatic or meteorological capability are TIROS-N, NIMBUS-G, SEASAT, and SAGE. NASA will continue to develop instruments and platforms for satellite missions while NOAA will assume operational control of monitoring capabilities subsequent to launch.

Also within NOAA, the National Weather Service, the National Ocean Survey, and the Environmental Data Service Centers will be responding to national requirements as well as those generated by international programs.

4.4.4 Survey of Climate Data Users

In order to present an overview of the data requirements of the climatology community, the following material is presented. It is designed to reflect particular uses and categories of users who might be important in a number of areas relating to experiment definition. Any numerical measurement requirements related to this section appear in Section 4.5.

Sources of data for this segment of the study included MITRE's own experience in the field which was obtained during performance of the

Earth Energy Experiment (E³)⁽³⁹⁾ study, a number of interviews with scientists active in the field and a survey of all available current literature which addresses these topics.

The thrust of the effort was to obtain as much information as possible on several aspects concerning the acquisition and utilization of climatological data. Specific topics addressed were:

- Current methods of utilization of data obtained from space;
- Anticipated new methods of utilization of space-derived data;
- Justification of the various measurement requirements as expressed at a number of user meetings and in user-produced documents; and,
- Opinions on the validity of those requirements expressed as well as the experiments proposed.

As can be seen in the various interview summaries, much emphasis is placed on radiation measurements. There are two reasons for this. First, when utilizing spacecraft, the only observables are obtained by interpreting detected radiation in various wavelength bands. In addition, the radiation transport through the Earth-atmosphere-Sun system is a key feature in many of the climate prediction models.

4.4.4.1 Previous Efforts. A number of study groups have addressed the specification of experiments and quantitative measurement requirements. (39,40,41,42,43,44) The selection of these data requirements for climatology research is a particularly difficult problem for a number of reasons. First, the diversity in goals of the various users of the data tend to create different demands on the measurement system. Second, the

general requirement of highly accurate and long-term measurement programs as required for climatological research creates unique and important problems for the instrument designer. Last, and by no means least, the inclusion of satellite remote sensing of the climate requires that considerable compromise be utilized in determining the performance requirements for experiment life, accuracy of the measurements and instrument reliability.

As a result, no set of measurement requirements has yet evolved which clearly defines the optimum experiment. This is, of course, not a unique situation in spacecraft experiments but it does represent a source of difficulty, since a very long experiment might be anticipated in this case. Thus, the initialization of the program will require considerable forethought and planning in order to provide a valuable source of data throughout its implementation.

4.4.4.2 Criteria Development. Several generalized criteria can be developed for the specification of performance criteria in the type of experiment under discussion. This section will discuss the philosophy of such a specification.

First, contact with the interested user community can be used to generally scope the requirements although it often happens that clear agreement on the data quality, or for that matter, the experiments themselves is often a source of controversy. Therefore, it is often only possible to define the range of requirements expressed as well as the intended use of the data so that, if necessary, the selection of criteria can be made on the basis of the value of the data to the

particular user community. As a subgroup of this method is the option of determining the smallest detectible change in the data which can be perceived by the user community. This, for example, could utilize the models which have been developed to determine the smallest perceptible changes in the output as a result of changes or uncertainties in the input data. For an application such as a user archive, that method is less effective since the smallest change of significance is hard to quantify.

Yet another method is to define the minimum improvement in the measurements required to improve currently available data archives. For this purpose, comparison of standards with the data obtained from recent satellite measurements of environmental parameters represents an effective method for defining a worthwhile experiment. Considerable care must be exercised in the use of each of the last two methods for definition of the data already taken or which is required for comparison of model results requires that the data actually measured can be related to those parameters. This is a common problem throughout a measurement program of this type, in that the instrumental factors must be carefully related to the data which is identified as the goal of the work.

These difficulties are further amplified by the long development time which is involved in spacecraft monitoring. In order that an effective program be available in the early 1980's for example, definition of the mission must take place in the near future, possibly before clear measurement requirements can be developed.

It is clear from these considerations that a program must be developed which effectively monitors and integrates ongoing developments in a number of theoretical and instrumental areas so that the resulting experiment is an effective tool. In addition, such a program must be structured so as to reflect the variation in requirements between near-term and long-term goals.

It is also apparent that two general program steps must be undertaken. First, since it is clear what parameters are observable from space, the program should be simply designed to maximize the data quality of these experiments. While this has the inherent advantage of guaranteeing a large number of possible experiments, it is clear that the number may exceed the limits of the program. As a result, decisions will then be required as to the relative importance of the various experiments and the selection of an optimum payload. That decision-making process must be undertaken as soon as possible and must include the program plans for other experiments (either inside or outside of NASA) so that the required data will be provided to the user.

4.4.4.3 User Survey. In order to obtain current measurement requirements, a survey of a number of workers currently active in various aspects of climatology was performed. Their remarks are assembled in the following section in a manner which organizes them by user category (in the case of NCAR) or affiliation (for all others). In doing so, the remarks obtained during different interviews have been integrated to produce a summary of the discussions and conclusions. Each such summary

has in its title those persons who contributed to it, whether in a common meeting or in separate meetings.

Table IV-6 lists the interviews conducted to date. The questions which were utilized during the interviews were derived from the points outlined in Section 4.4.4. The summarized results of the interviews are utilized in Section 4.4.5. The details of the various interviews appear in Appendix B.

The goal of the interviews was to specify more clearly the expressed measurement requirements. For example, the results of a meeting held at NCAR in May 1975,⁽⁴¹⁾ at which a number of modelers expressed their point of view as to experiments that should be performed, have recently been made available by Colorado State University.⁽⁴⁶⁾ Approximately 25 experiments are described, many of which will be difficult to perform from a satellite or which have included within them quantitative measurement requirements which cannot be met by current satellite technology. As a result, any development or evaluation of new concepts of climate measurements or monitoring must be based on a much more realistic set of requirements.

A general philosophical point should be made here. The considerations given above reflect the generally typical decision process required in the definition of any experiment. A unique characteristic here is, however, that the definition of scientific goals can and should be first developed from the advice of each of the interested communities. The related decisions, then, are generated without the influence

TABLE IV-6

CLIMATE INTERVIEWS CONDUCTED

INTERVIEW NO.	AFFILIATION	DATE	INTERVIEWEES
1	NCAR	9- 8-75	R. Dickinson J. Coakley
2	NCAR	9- 8-75	W. Washington
3	NCAR	9- 8-75	T. Sasamori
4	NCAR	9- 8-75	A. Kashahara
5	NCAR	9- 9-75	F. Bretherton
6	NCAR	9- 9-75	D. Baumhefner
7	NCAR	9- 9-75	D. Williamson
8	NCAR	9- 9-75	J. Masterson
9	Colorado State University	9-10-75	T. Vonder Haar
10	University of Arizona	9-11-75	W. Sellers
11	Rand Santa Monica	9-12-75	R. Rapp, L. Gates M. Schlesinger
12	NOAA GFDL	9-22-75	S. Manabe, A. Oort
13	NOAA-NESS	10- 8-75	W. Smith
14	MIT	10-20-75	E. N. Lorenz
15	Harvard University	10-21-75	R. S. Lindzen
16	National Science Foundation	11- 6-75	B. Fogel, J. Geisler

of the instrument/measurement community. Their interaction in the program development occurs as a second but critical step, during which the expressed goals are compared with the probable experiment performance. At that point, the refinement of the goals must begin with the firm knowledge that the users must be willing to accept considerable relaxation of their requirements, due to the unavoidable constraints of reliability, cost and state-of-the-art instrument performance.

Furthermore, the requirements expressed by a community of users must by definition include the limitations imposed by the initial data reduction methodology so that instrument and data analysis uncertainties together do not degrade the data so as to prevent satisfactory quality in the final archive.

4.4.5 User Categories and Their Requirements

An initial study of the various meetings, documents and interviews indicates that the major source of division in establishment of specific goals is derived from the wide diversity of the needs of the user groups involved.

For the purposes of this study, three basic branches of climatology data utilization have been addressed. These are:

- Climate modelers - whose goal is long-term prediction of global atmospheric and oceanic circulation as well as the statistics of variation of climate variables (humidity, pressure, atmospheric and ocean temperature, etc., heat flux and cyclone frequency, path and intensity).
- Atmospheric physicists - whose goal is a clearer understanding of the physical and chemical processes occurring in the atmosphere including the effects of changes in atmospheric constituents and albedo as a result of pollution, land use and other results of man's activity.

Monitoring - for climatology archive development to be used in a variety of applications including statistically-derived predictions, comparison with physical models and direct application to a number of specific problems related to agriculture, energy and resource utilization and oceanography.

It should be clear that improvements in models and validation of their results will rely on the results produced by the last two categories of users. In fact, an overlap in research areas is common. This interaction is summarized in Figure 4-7 which utilized a figure from Reference 44 amended by comments in parenthesis to show categories which relate to this work.

4.4.5.1 Modelers. Within the modeling community, further distinctions can be drawn. There are two major groups engaged in the development of a capability for predicting the time evolution or time-averaged statistics of future climates. As described in the various interviews, the groups include climate modelers who utilize general circulation models and those who have developed global one- or two-dimensional models of climate.

Each of the modeling groups has its own specific requirements (whose relative importance will be discussed below). In addition, both groups share in the general requirements expressed by GARP Publication No. 16⁽⁴²⁾ which states that:

"The observational efforts proposed have been grouped into three categories, namely:

- 1) special studies required to describe the particular processes that are relevant for the modeling,
- 2) observations required to test and validate models as they are being developed and,

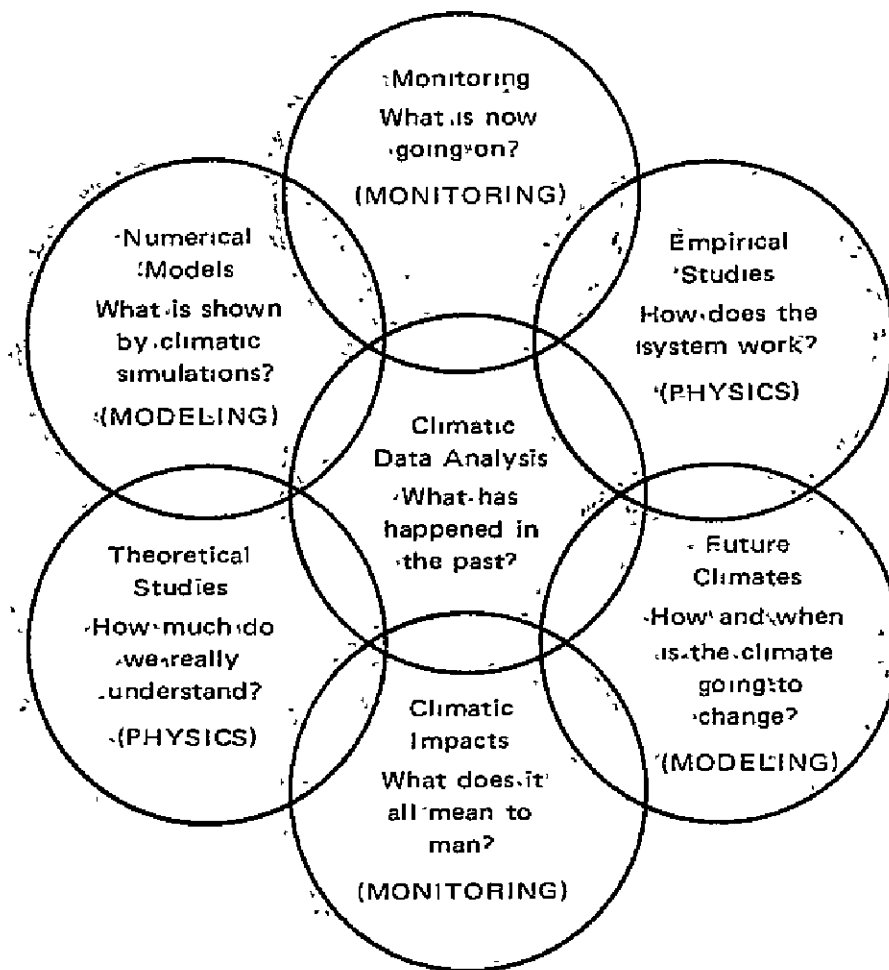

FIGURE 4-7
THE INTERDEPENDENCE OF THE MAJOR COMPONENTS OF A CLIMATIC
RESEARCH PROGRAM AND A NUMBER OF KEY QUESTIONS
 (After Reference 44)

- 3) long-term observation programs and monitoring programs,, required to measure parameters that the models do not predict but which are nevertheless relevant to the climate problem, or variables that are particularly suitable for detecting possible future climatic variations."

The following tables illustrate a summary of general measurement requirements as derived from interviews with modelers as well as documentation which discusses these issues. (41,42,43,45)

Of course, the requirements expressed are by no means unique to any individual worker, but rather represent the requirements of the community as a whole.

4.4.5.2 Physical and Statistical Studies. In order to satisfy the needs of this user group, a slightly different approach must be taken. Two major categories of experiments can be defined which support work of this type. Simply because climate and its variation is the topic of interest, it is clear that long-term and uninterrupted data represents one of the goals. Historically, this data has been provided by a number of individual sensing stations reporting on a periodic basis. The utilization of more advanced techniques, including satellite-based remote observations, will allow the measure of several additional parameters on a global, synoptic basis. Among these data are the solar constant, albedo, long and shortwave fluxes, cloud patterns, trace gases and vertical profiles of temperature and humidity.

In addition to the requirement for long-term data, it is clear that an ideal measurement program would also provide data of high absolute accuracy with a spatial and temporal sampling rate which at least compares

with the typical averaging intervals of climate models, such as 30 day averages and 5° x 5° surface grid (for model validation).

Experiments of this type, which are characterized by the GATE experiment, need not be as long as the monitoring role discussed above nor need they provide the same level of coverage.

In summary, this group will require, for a number of different applications, experiments which range widely in spatial, temporal and radiometric requirements.

4.4.5.3 Monitoring. Clearly, the requirement in this area is to provide reliable, long-term calibrated data which can be used to initialize and carry out a program of observation of features of the climate which are observable from space. As mentioned elsewhere in the report, spacecraft probably should not be expected to perform this role without assistance from the many ground-based observing stations which have been in use for many years and have provided the information available to date. The unique feature of spacecraft which will justify their utilization is their ability to make global observations at a high rate and to measure features not observable from Earth.

As discussed in Section 4.5, the requirements for the types of experiments will include virtually anything which can be observed. While the sampling rate and spatial resolution requirements cannot be clearly stated, the general unavailability of global data sets will guarantee the use of any archive which offers such quality.

4.4.5.4 User Needs Conclusions. Here we will summarize the results of the various sources of information and relate them to the

specific goal of the study. Specific, numerical measurement requirements will be given in Section following 4.6 and Section 8.0. The comments represent MITRE's interpretation of the various user requirements.

- Some of the numerical measurement requirements expressed in a number of user meetings and related documents are merely best informed opinions. To date, little sensitivity analysis has been reported in the modeling community with the exception of solar constant, aerosols, CO₂ and dust particles. Other features, particularly those related to radiation climatology remain to be studied in order that model-specific measurement requirements can be expressed.⁽⁴⁸⁾ While it is not clear how well the various requirements expressed represent what will be found in a detailed analysis, a number of these contacted felt that discrepancies could result. A related result is that it is almost universally felt that a minimum of 3-4 years will be required for the completion of the required sensitivity studies or for the completion of the model development so that such studies can be performed.
- The wide variation in the user goals has guaranteed that no one experiment represents a unique or essential part of the program. This is particularly appropriate in the case of radiation climatology which retains a level of importance which is quite high. While there is scientific interest in an experiment of that type due to pervasive features of radiation in climatology, only the users specifically interested in understanding the role of radiation in the climate feel that this experiment is of unique value. The value of the experiment is most limited in the case of the modelers who face considerable problems with the parameterization of complex systems such as clouds, although the information could be of value in those cases where the model predicts the radiation field and data is needed for validation rather than initialization. However, many other climate features emerge as being utilized as representative of climate and its variability. In fact, for the use of those who study the physical and statistical features of the climate, it is clear that the largest number of experiments possible are required.
- For optimum support of the global climate models, the measurements will have to be long-running but will not require the high absolute radiometric accuracy demanded by the general circulation models. In fact, due to the methods of model

"tuning," trends in the data would be sufficient to be of value to the global models. The use of the data in the service of the GCM's, however, will generally require highly detailed experiments of relatively short duration (approximately one year) which include measurements of a number of interactive features of the climate (temperature and cloudiness, radiation properties and albedo, etc.), on a scale which is at least regional (see Appendix B for detailed comments). These models will also be well served by the short-term experiments of the GARP type which can provide details unavailable from space but which are complemented by spacecraft measurements.

- The proposed NASA radiation climatology experiments (2 SERM instruments aboard near-polar Sun-synchronous TIROS-N) will need to be supplemented with low inclination non-Sun-synchronous instrumentation in order to deal with the sampling and coverage problems.
- Based on the currently available data, the demands of the modeling community on the quality and completeness of the data archive is the highest of any user community.
- The data archive already extracted from spacecraft measurements has been used by only a limited number of scientists mostly in the areas of physical processes and validation of model output. (49) Further exploitation of those older archives could be of value.
- Experiments of the type discussed will have application under any conditions just because they add to the store of information which describes the climate and its variability. However, NASA should not expect the results of any single experiment alone to have a significant impact on the quality of the models currently under development. In fact, it is hard to imagine any single experiment, regardless of length or data quality, heavily impacting the capabilities of the predictive models. The limitations they face at this time go deeper than the quality of the initialization or validation data.
- The current use of radiation climatology, especially that obtained from space, has been to validate the results of model predictions, initialization of particular features of the models, and generation of parametric relationships for model development. The majority of the data appears to have been used for model validation although examples of each type of use can be found.

- The future role of radiation climatology data appears to conform with the three GARP classifications (see Section 3.1) when addressed to the modeling question. Furthermore, interest in the particular features of the radiation climate will continue with much emphasis on the properties of clouds and the parametrization thereof. It should be pointed out the development of the data archive required to serve these users does not necessarily require the use of spacecraft, particularly in those short-term high density experiments discussed earlier and in some cases when the data can be obtained with sufficient spatial and temporal resolution from the ground. (46,47)

4.5 Specific Measurement Requirements

The previous sections have had as their goal the identification of users, their general uses of data and their general measurement requirements if they exist. This section seeks to summarize all that has been learned in this study concerning the specific numerical measurement requirements which must be met in atmospheric observation so as to serve the wide variety of interested users. The data presented in this section includes that data which was obtainable from interested users and MITRE's opinion as to other measurement requirements.

A major source of particular requirements is meetings and conferences held to address these issues. Over the last few years, a number of such conferences and meetings have been held, including the participation of a number of interested organizations, related to the assessment and prediction of climate and its relation to atmospheric properties. As a result of a survey of these conferences, a list of their requirements has been organized into the following tables (IV-7 and IV-8). For completeness, requirements of specific experiments (like the GARP, GATE and FGGE) have been included.

ORIGINAL PAGE IS
OF POOR QUALITY

TABLE IV-7
GENERAL MEASUREMENT REQUIREMENTS OF GLOBAL CLIMATE MODELS

	Radiation Transfer (longwave, shortwave, solar)	Physical Cloud Features (height, type, albedo, global distribution)	Atmospheric Features (temperature, wind, humidity)	Land Features (temperature, albedo)	Trace Constituents (gases, aerosols)	Ocean Features (surface temperature, circulation)	Cryosphere (ice and snow cover)
Duration	In excess of 3 years →						
Time	← Start within 3 to 4 years →						
		Radiation properties needed in future					
Spatial Resolution	Regional of little interest. Global averages required.	Global average. Multiple layer resolution may be required.	Zonal average of 500 mb temperature. Profile desirable of humidity and temperature.	Zonal	Aerosols on a regional scale. Water vapor one year average.	Zonal	Zonal
Temporal Resolution	← Yearly average →						
					Decade average for gases other than water vapor		
Radiometric Resolution	High resolution not required	High resolution not required	Moderate	Trends more important than absolute measurement	Moderate	Desirable	Desirable
Coverage	Global →						
Importance	Desirable but not a complete experiment	Cloud top temperature and albedo highly desirable for model validation	Moderate interest	Moderate	Moderate	Desirable	Desirable
Use	Parameterization	Parameterization	Parameterization	Parameterization	Parameterization sensitivity studies	Parameterization sensitivity studies	Parameterization

4-82

ORIGINAL PAGE IS
OF POOR QUALITY

TABLE IV-8
GENERAL MEASUREMENT REQUIREMENTS FOR A GENERAL CIRCULATION MODEL
(including coupled models)

	Radiation Transfer (longwave, shortwave, solar)	Physical Cloud Features (height, type, albedo, global distribution)	Atmospheric Features (temperature, wind, humidity)	Land Features (temperature, albedo)	Trace Constituents (gases, aerosols)	Ocean Features (surface temperature, circulation)	Cryosphere (ice and snow cover)
Duration	←————— 1 year —————→						
Time	←————— Begin in 3 to 4 years —————→						
Spatial Resolution	Regional with equator-pole variation	Cloud top height and cloud distribution	Profiles	Regional	Regional	Regional	Regional
Temporal Resolution	5 to 15 days	5 days	5 days	5 days	5 to 15 days	5 days	5 to 15 days
Radiometric Resolution	High	High	High	Moderate	Moderate	Moderate-high	Moderate
Coverage	←————— Global —————→						
Importance	Highly desirable	Highly desirable	Desirable, especially winds	Desirable	Low, except ozone	Highly desirable	Desirable, especially ice cover and snow cover
Use	Parameterization validation	Validation	Initialization parameterization validation	Parameterization validation	Parameterization validation	Parameterization validation	Parameterization validation

4-83

Inspection of the tables indicates the considerable detail of the identified measurement requirements. Similar detail cannot be developed in the case of UV effects. However, because of the intimate link between atmospheric properties and the UV environment of the biosphere, the data presented in the tables represents a reasonable set of requirements for monitoring for eventual changes in climate or UV.

The preceding discussion and tables represent an amalgamation of the user requirements from the scientific and monitoring communities as represented by interviews and in the literature. With the present pace of stratospheric investigation, it should not be surprising to find additional species achieving requirement status. Therefore, it is prudent to assess the status periodically.

In addition to the requirements defined above for domestic research requirements, the WMO-ICSU has developed a set of requirements for the GARP. Some of the more pertinent of these are given in the following tables. Tables IV-9 and IV-10 represent the preliminary requirements for model validation and monitoring definition. Tables IV-11 through IV-14 address the tentative measurement requirements for a long-term monitoring program as now envisioned. Results from FGGE and other programs will undoubtedly modify some of these stated requirements. Table IV-15 represents the opinions of experts in climatic effects, while Tables IV-16 thru IV-19 represent MITRE's opinion combined with referenced sources.

In addition to the measurement requirements expressed by the various user meetings, measurement requirements have been developed by evaluating

TABLE IV-9
OBSERVATIONS REQUIRED FOR VALIDATION OF CLIMATE MODELS
(After Reference 42)

VARIABLE	ACCURACY (1σ)		TIME RESOLUTION
	Desired	Useful	
1. Net radiation budget at top of atmosphere (solar and terrestrial)	2 Wm^{-2}	15 Wm^{-2}	5 days
2. Clouds: horizontal distribution, cloud and measure of diurnal variation	5% amount 1°C cloud top temp.		5 days
3.a) Sea surface temperature	0.5°C	1.5°C	5 days
b) Heat content of upper layer (200 m)	1 kcal cm^{-2}	3 kcal cm^{-2}	5 days
4.a) Snow (100 km resolution)	Presence/Absence		5 days
b) Sea ice (50 km resolution)	Presence/Absence		5 days
5. Surface albedo	0.01	0.03	5 days
6.a) Precipitation over land	1 mm/day	3 mm/day	5 days
b) Precipitation over sea*	1 mm/day	4 levels of discrimination	5 days
7. Soil moisture*	10% of local field capacity	2 levels of discrimination	5 days
8. Runoff (river basin)	10%		15-30 days
9. Land surface temperature and relative humidity (over land)	1°C 10%		5 days
10. Ozone Profile (2 km vertical resolution)	0.5 ppm		5 days
11. Wind stress over ocean	0.1 dyne cm^{-2}	0.4 dyne cm^{-2}	5 days

*The tentative specification of useful accuracy for precipitation and soil moisture cannot be used for critical quantitative checking of heat and hydrological budgets, but could be useful for qualitative evaluation.

ORIGINAL PAGE IS
OF POOR QUALITY

TABLE IV-10
DATA REQUIREMENTS FOR FGGE
(After Reference 45)

BASIC PARAMETERS		HORIZONTAL RESOLUTION (km)	VERTICAL RESOLUTION		ACCURACY	FREQUENCY*
			TROPOSPHERE	STRATOSPHERE		
Mid and High Latitudes	Temperature	500	4 Levels	3 Levels	$\pm 1^\circ\text{K}$	1/day
	Wind	500	4 Levels	3 Levels	$\pm 2\text{m/sec}$	1/day
	Relative Humidity	500	2 Degrees of Freedom		$\pm 30\%$	1/day
	Sea-Surface Temperature	500			$\pm 1^\circ\text{K}$	3 day avg.
	Pressure	500			$\pm 0.3\%$	1/day
Tropics**	Wind	500	4 Levels	3 Levels	$\pm 2\text{m/sec}$	1/day
	Temperature	500	4 Levels	3 Levels	$\pm 1^\circ\text{K}$	1/day
	Relative Humidity	500	2 Degrees of Freedom		$\pm 30\%$	1/day
	Sea-Surface Temperature	500			$\pm 1^\circ\text{K}$	3 day avg.

Additional Parameters:

- Cloud, Snow and Ice Cover
- Precipitation Area and Intensity
- Soil Moisture
- Earth Radiation Budget
- Sea Temperature/Currents
- Oceanic Variables in the Upper Mixed Layers
- Aerosols
- Stratospheric Constituents

* 2 Per Day Would Be Highly Desirable for All Parameters Except Sea-Surface Temperature

** Data Requirements for the Tropics are Currently Being Reexamined

TABLE IV-11
TENTATIVE SPECIFICATION OF GLOBAL OBSERVATION OF GASES AND PARTICULATES
(From Reference 42)

Variable	Space Resolution	Time Resolution	Accuracy (1) of Determination	Period	Additional remarks, Observing Technique, Etc.
1. Water vapor	500 km	1 per day	1 per day	FGGE	
2. CO ₂	2 to 4 base-line stations and 10 additional regional stations	15 days	± 0.1 ppm	FGGE-limited number of stations and post-FGGE	Chemical analysis of air sample
3. Ozone distribution	500 km - 2 km vertical resolution	1 day	± 0.5 ppm	FGGE	Backscatter UV spectrophotometry by NIMBUS-G
3a Total Ozone	Existing WMO network	1 day	1 to 5% [†]	FGGE	Ground-based optical measurements (preferably Dobson spectrophotometer)
3b Ozone Profile	10 stations distributed over the globe	1 week	± 1 ppm	FGGE	Ozone sonde profile measurement
4. Tropospheric Aerosols	WMO baseline air-chemistry stations	1 day	5%	FGGE	Aerosol analysis of air sample
5. Atmospheric Turbidity	WMO baseline stations	1 week	1% [†]	FGGE	Need to measure direct and diffuse radiation separately
6. Stratospheric Aerosols	2 to 4 baseline stations	1 day	5%	FGGE	Lidar. Sunlight polarization

† relative accuracy

ORIGINAL PAGE IS
OF POOR QUALITY

4-87

TABLE IV-12
 AEROSOL PROCESSES-SUMMARY OF TENTATIVE OBSERVATIONAL REQUIREMENTS
 (After Reference 42)

I. STUDY OF PROCESSES

a) Radiative effects of aerosols.

Required aerosol parameter for troposphere and stratosphere	Observational require- ment and accuracy
Size distribution	
$\frac{dn}{dr}$ in cm^{-4} STP	5%
Vertical profile of size distribution	5% Required vertical reso- lution generally 0.5 to 1.0 kilometer
Real refractive index of bulk material n	1% over the range $1.0 \geq n < 2$
Imaginary part of the re- fractive index k	10% over the range $0.001 < k < 0.1$
Bulk density δ of aerosol particles, in g cm^{-3}	5% over the range $1.0 \leq \delta < 3.0$
Solubility of aerosol particles and/or growth characteristic with relative humidity	Use of 3 to 4 typical growth curves
For necessary data to calculate energy balance of the atmosphere	
b) Aerosol cloud interaction	Cannot be specified at this time.

II. MONITORING

<u>Variables to be monitored</u>	<u>Space Resolution</u>	<u>Time Resolution</u>	<u>Accuracy</u>
1) Total number concentration 2) Concentration of optically important particles 3) Total mass concentration 4) Concentration of gaseous precursors	about 20 baseline stations distributed over the globe	daily	5%

TABLE IV-13

TENTATIVE SPECIFICATION OF LONG-TERM MONITORING REQUIREMENTS
FOR
RADIATION BALANCE COMPONENTS

(After Reference 42)

VARIABLE	ACCURACY		TIME RESOLUTION
	(DESIRED)	(USEFUL)	
1. Solar irradiance (top of atmosphere) (reproduction accuracy required)	2 WM^{-2}	10 WM^{-2}	$\frac{1}{4}$ - $\frac{1}{2}$ year
2. Net radiation budget (top of atmosphere) solar and terrestrial, 10^4 - 10^5 km^2	2 WM^{-2}	15 WM^{-2}	15 days
3. Clouds		*	*
4. Snow and sea-ice (10^4 km^2)		Presence/Absence	5-15 days
5. Carbon dioxide (2-4 baseline stations, 10 regional stations)		0.1 ppm	15 days
6. Ozone profile (latitudinal distribution, 2 km vertical resolution)		0.5 ppm	10-30 days

* Will be specified as more is learned of the radiative properties of clouds.

TABLE IV-14

TENTATIVE SPECIFICATION OF GLOBAL OBSERVATION REQUIREMENTS
FOR
VERIFICATION OF OCEAN MODELS

QUANTITY	SPACE SCALE*	TIME SCALE	ACCURACY (1σ)		PERIOD
			(DESIRED)	(USEFUL)	
Surface temperature	200 km	5-10 days	0.5°C	1.5°C	FGGE
Heat content upper layer**	200 km	5-10 days	1.0 kcal cm ⁻²	3.0 kcal cm ⁻²	—
Surface stress	200 km	5-10 days	0.1 dyne cm ⁻²	0.4 dynes cm ⁻²	—
Sea level	200 km	5-10 days	2 cm	10 cm	—
Ice cover	200 km	5-10 days	—	—	—

* The space scale is defined as a distance L, where a representative sample for a region LxL is desired. Extra resolution required in special regions.

** Measurements by drifting buoys, ships of opportunity.

TABLE IV 15
TRACE GAS MEASUREMENT REQUIREMENTS FOR CLIMATE

CONSTITUENT	VERTICAL RESOLUTION km	ACCURACY	FREQUENCY	SPATIAL RESOLUTION km	COVERAGE	MEASUREMENTS REQUIRED WITHOUT SPECIFICATION	REMARKS
O ₃	* ₂ (42)	Profile 10% ⁽⁵²⁾ 0.5 ppm ⁽⁴²⁾ Total 1-1.5% ⁽⁴²⁾ 1% ⁽⁵²⁾	1 day average ⁽⁴²⁾ and after volcanoes 30 day average ⁽⁴²⁾ high rate not required ⁽⁴²⁾	100 ⁽⁴²⁾ high resolution not required ⁽⁴²⁾	global ⁽⁴²⁾ (52)		satellite monitoring con- sidered especially appropriate ⁽⁴²⁾
CO ₂	*	0.5 ppm ⁽⁵²⁾			global ⁽⁵²⁾	(16)	not expected from satellite measurements ⁽⁴²⁾ attractive ⁽⁵¹⁾
NO		ppb range ⁽⁵¹⁾ 10 ppb ⁽⁵⁾			lower stratosphere ⁽⁵¹⁾ (8) global ⁽⁸⁾ (52)	(42) (16)	
NO ₂	*	ppb range ⁽⁵¹⁾ 10 ppb ⁽⁵²⁾			lower stratosphere ⁽⁵¹⁾ (8) global ⁽⁸⁾ (52)	(42) (16)	
HNO ₃	*	1 ppb ⁽⁵²⁾			global ⁽⁵²⁾	(42) (16)	
H ₂ O		50 ppb			global ⁽⁵²⁾		
H ₂ O	*	1 ppm ⁽⁵¹⁾ pro- file 0.5 ppm ⁽⁵²⁾ Total 20% ⁽⁵²⁾	sporadically ⁽⁴²⁾	local or region- al ⁽⁴²⁾ latitudinal ⁽⁵¹⁾	lower stratosphere ⁽⁵¹⁾ (8) global ⁽⁸⁾ (52)	(42) (16)	expected from NIMBUS-F and C ⁽⁴²⁾
CO	*	10 ppb ⁽⁵²⁾	sporadically ⁽⁴²⁾		upper stratosphere ⁽⁵¹⁾ global ⁽⁵²⁾	(42) (16)	
Fluorocarbon		<0.001 ppb ⁽⁵²⁾					
H ₂						(42)	
SO ₂		ppb range ⁽⁵¹⁾ 0.5 ppb ⁽⁵²⁾	A.V.E. (42) sporadically ⁽⁴²⁾		lower stratosphere ⁽⁵¹⁾ (8) global ⁽⁸⁾ (52)	(42) (16)	
ClO _x			A.V.E. (42) sporadically ⁽⁴²⁾			(42)	
Particulates		0.01-0.1μ ⁽⁴²⁾	A.V.E. (42)		global ⁽⁵¹⁾ (8) (52) lower stratosphere ⁽⁵¹⁾ (8)		optical properties ⁽⁵¹⁾ distribution ⁽⁸⁾
Aerosols	profiles desired ⁽⁴²⁾		A.V.E. (42)		large as possible in both hemi- spheres ⁽⁴²⁾ global ⁽⁵⁰⁾	(16)	SO ₂ mixing ratio ⁽⁴²⁾ , par- ticle size distribution ⁽⁴²⁾ spacecraft monitoring at- tractive but ground-based preferable ⁽⁴²⁾
H ₂ O	*	50 ppb ⁽⁵²⁾ 5% ⁽⁴²⁾	occasionally ⁽⁴²⁾ sporadically ⁽⁴²⁾			(42)	
NMHC		ppb range ⁽⁵¹⁾			lower stratosphere ⁽⁵¹⁾ (8) global ⁽⁸⁾		
Methane	*	0.2 ppm ⁽⁵²⁾			lower stratosphere ⁽⁵¹⁾ (8) global ⁽⁸⁾ (52)	(42) (16)	
HCl, ClO _x , OH						(16)	

* - simultaneous vertical profiles⁽⁵¹⁾
A.V.E. - after volcanic eruptions

ORIGINAL PAGE IS
OF POOR QUALITY

the constituents which play a major role in the chemistry of the stratosphere. The importance of any one constituent varies somewhat, depending upon the potential user, from absolutely necessary to desirable. An effort has been made to harmonize these requirements and place them in context with the proposed application.

4.6. Specific Requirements

The correlation of user requirements has resulted in the following data criteria. Such data should be capable of:

- (1) relating ozone destruction with stratospheric chlorine concentrations (Table IV-16)
- (2) relating ozone destruction with stratospheric NO_x concentrations (Table IV-17)
- (3) providing input data to aid in the description of stratospheric transport and circulation phenomena (Table IV-15)
- (4) describing the vertical concentration of stratospheric aerosols and aerosol size distributions in the stratosphere (Table IV-18)
- (5) relating gaseous constituents with aerosol formation (Table IV-19).

In order to meet these requirements, the concentration of pertinent stratospheric constituents should be measured. The chlorine-ozone stratospheric constituents are listed in Table IV-16. The concentrations are the accepted values at an altitude of 20 kilometers; the accuracies reflect user requirements derived from Table IV-15 (which provides fully referenced requirements for measurements of climatic effects) or accuracy required to improve current uncertainties in measurements noted in Reference 53 whichever is smaller. Table IV-17 tabulates the same information for the NO_x -ozone regime in the same manner. All of these

TABLE IV-16

THE CONCENTRATION AND REQUIRED MEASUREMENT
ACCURACY OF CHLORINE-OZONE CONSTITUENTS

<u>SPECIES</u>	<u>CONCENTRATION AT 20 km</u>	<u>ESTIMATED REQUIRED ACCURACY</u> *
O ₃	6 ppmv ⁽¹⁶⁾	<10% ⁽⁵²⁾ , (42)
HCl	~ 1 ppbv ⁽⁵³⁾	100%
Cl	Unknown	100%
ClO	Unknown	100%
CF ₂ Cl ₂	Unknown	100%
CFC1 ₃	Unknown	100%
OH	10 ⁻⁴ ppbv (calculated) ⁽¹⁶⁾	100%
CH ₄	1 ppmv ⁽¹⁶⁾	20% ⁽⁵²⁾
O	10 ⁶ /cc (estimated) ⁽¹⁶⁾	100%
NH ₃	Unknown	100%

* 100% corresponds to an error band equal to twice the actual concentration.

TABLE IV-17

THE CONCENTRATION AND REQUIRED MEASUREMENT
ACCURACY OF NO_x-OZONE CONSTITUENTS

<u>SPECIES</u>	<u>CONCENTRATION</u> <u>AT 20 km</u>	<u>ESTIMATED</u> <u>REQUIRED ACCURACY</u> *
O ₃	6 ppmv (16)	<10%(42) (52)
NO	0.1 ppbv (1 ppbv at 30 km) ⁽¹⁶⁾	50%(16)
NO ₂	~2 ppbv (~5 ppbv >30 km) ⁽¹⁶⁾	50%(16)
HNO ₃	3 ppbv ⁽¹⁶⁾	30%(52)
N ₂ O	0.1 ppmv (much less above 25 km) ⁽¹⁶⁾	5%(42)
N ₂ O ₅	Unknown	100%
OH	10 ⁻⁴ ppbv (calculated) ⁽¹⁶⁾	100%
O	10 ⁶ /cc (estimated) ⁽¹⁶⁾	100%

*100% corresponds to an error band equal to twice the actual concentration.

TABLE IV-18

CHEMICAL COMPOSITION OF STRATOSPHERIC PARTICLES⁽⁵⁶⁾

<u>SUBSTANCE</u>	<u>CONCENTRATION IN AIR</u> [†]	<u>CONCENTRATION RANGE</u>	<u>ESTIMATED</u>
	<u>μg/m³</u>	<u>μg/m³</u>	<u>REQUIRED ACCURACY</u>
Sulfate	0.6	0.01 - 4 [*]	100%
Basalt ^{**}	0.05	0 - 0.7	100%
NH ₄ ⁺	0.005	0 - 0.01	100%
Na	0.01	0.001 - 0.05	100%
Cl	0.04	0.002 - 0.09	100%
Br	0.002	0. - 0.003	100%

4-95

[†]At 20 km.^{*}Agung maximum concentration.^{**}Includes Al, Ca, and Mg.

TABLE IV-19
 GASEOUS CONSTITUENTS INFLUENCING
 AEROSOL FORMATION (57)

<u>SPECIES</u>	* <u>CONCENTRATION</u>	<u>ESTIMATED REQUIRED ACCURACY</u>
SO ₂	10 ⁻⁶ μg/m ³	±100%
H ₂ S	10 ⁻⁷ μg/m ³	±100%
CO	4x10 ¹ μg/m ³	100%
H ₂ O	1 mg/m ³ **	±100%
NH ₃	10 ⁻⁶ μg/m ³	±100%

At 20 km.

***Extremely variable.

constituents should be measured simultaneously as a function of altitude. Diurnal and seasonal variations in the concentrations of some of the species is also important in understanding the phenomena of ozone destruction through photo-chemical processes.

The vertical profile of CO₂ and H₂O vapor is basic to describing vertical stratospheric transport and circulation. The mixing ratio of CO₂ is near constant with altitude; it is about 320 ppmv at 20 kilometers, therefore it may be sufficient to measure only the total column burden. Based on the known annual increase in CO₂ concentration, an accuracy of 0.5 percent appears adequate.

Unlike CO₂, the vertical profile of water vapor is subject to considerable variations depending upon intrusions of moist tropospheric air by Hadley cell circulation, volcanic activity, and thunderstorms. Average profiles of water vapor have been generated from limited data. The concentration of water vapor is the order of 3 ppmv at 20 kilometers. In order to meet the needs of potential users, an accuracy of about 15 percent seems appropriate. Infrared radiometers planned for NIMBUS F will provide adequate water vapor mapping on a global scale and periodic vertical profiles.

Measurements of temperature and water vapor as a function of altitude should be measured simultaneously with the stratospheric constituents listed in Tables IV-16 and IV-17. Temperature and water vapor profiles provide clues to vertical atmospheric circulation phenomena which in turn describe the transport of tropospheric gases, such as chlorine, into the stratosphere.

Stratospheric aerosols, depending upon their size, influence the macro-meso- and micro-scale phenomena. On the macro-scale, aerosols influence the global heat budget; on the meso-scale, they provide a source for condensation nuclei, and on the micro-scale, they have a role in the atmospheric chemistry as partial sinks for the absorption of specific species.

The specification of aerosol populations in gross (\pm 5km) altitude regimes over semi-hemispheric (macroscale) areas is quite adequate for most heat budget studies. For some applications, the total burden in the atmospheric column on the synoptic scale is sufficient for insolation and cloud physics studies. However, studies of aerosol formation and chemistry require detailed measurements of the aerosol size distribution as a function of height. Therefore, in general, it is sufficient to measure the gross altitude characteristics of aerosol concentrations in terms of the predominant size. The chemical composition of aerosols at 20 kilometers altitude is listed in Table IV-18.

The major chemical constituents which appear to play a role in aerosol formation are presented in Table IV-19. More than one species of the same element is presented because there is some uncertainty regarding the exact chemical reactions. Table IV-20 summarizes the important species and desired measurement accuracies.

TABLE IV-20

RECOMMENDED CONSTITUENTS FOR A STRATOSPHERIC MONITORING PROGRAM

<u>Constituent</u>	<u>Required Accuracy*</u>	<u>Measurement Proposed By</u>	<u>Estimated Instrument Accuracies</u>
O ₃	<10%	SAGE II, LACATE	7%
HCl	100%		--
Cl	100%		--
ClO	100%		--
CF ₂ Cl ₂	100%		--
CFC1 ₃	100%		--
OH	100%		--
CH ₄	20%	CIMATS, LACATE, MAPS	4%-17%
O	100%		--
NH ₃	100%		--
NO	50%	CIMATS, MAPS	10%
NO ₂	50%	SAGE II, CIMATS, LACATE	6%-30%
HNO ₃	30%	CIMATS	<30%
N ₂ O	5%	CIMATS, LACATE	10%
N ₂ O ₅	100%		--
SO ₂	100%		--
H ₂ S	100%		--
H ₂ O	30%		--
Aerosols	--	VRPM, SAM II, SAGE II, LACATE	--

*100% corresponds to an error band equal to twice the actual concentration

REFERENCES

1. "Proceedings of the Second Conference on the Climatic Impact Assessment Program, November 14-17, 1972," A. J. Broderick (Ed.), Department of Transportation, Report DOT-TSC-OST-73-4.
2. "Proceedings of the Third Conference on the Climatic Impact Assessment Program, February 26 - March 1, 1974," A. J. Broderick and Hard, T. M. (Eds.), Department of Transportation, Report DOT-TSC-OST-74-15.
3. "Cellular and Molecular Effects of Solar UV Radiation," Report on Conference of May 7-8, 1973, at the University of Florida, Gainesville, FL, E. C. Pollard, in *Photochemistry and Photobiology* 20, 3 (1974), pp. 301-308. (Conference sponsored by CIAP)
4. "Biological Impacts of Increased Intensities of Solar Ultraviolet Radiation," National Academy of Sciences, National Academy of Engineering, 1973 (Environmental Study Board, National Research Council).
5. "Fluorocarbons and the Environment," Report of Federal Task Force on Inadvertent Modification of the Stratosphere (IMOS), Council on Environmental Quality, Federal Council for Science and Technology, June 1975.
6. "Environmental Impact of Stratospheric Flight, Biological and Climatic Effects of Aircraft Emission on the Stratosphere," National Academy of Sciences, 1975 (Climatic Impact Comm., NRC, NAS, NAE).
7. "Man's Impact on Climate," W. H. Mathews, W. W. Kellogg and G. D. Robinson (Eds.), 1971, MIT Press, Cambridge, Mass.
8. "Study of Critical Environmental Problems (SCEP)," C. L. Wilson and W. H. Mathews (Eds), 1972, MIT Press, Cambridge, Mass.
9. "Carcinogenesis by Ultraviolet Light," H. F. Blum, Princeton University Press, 1959.
10. "Introduction to Research in Ultraviolet Photobiology," J. Jagger, Prentice-Hall, 1967.
11. "Molecular Photobiology: Inactivation and Recovery," K. C. Smith and P. C. Hanawalt, Academic Press, New York, 1969.
12. "The Biologic Effects of Ultraviolet Radiation with Emphasis on the Skin," F. Urbach (Ed.), Pergamon Press, New York, 1969.

REFERENCES (Continued)

13. "Environment and Cancer: A Collection of Papers," F. Urbach (Ed.), Williams and Wilkins, Baltimore, 1972.
14. "Photophysiology," Volumes I to VIII, inclusive, A. C. Giese (Ed.), Academic Press, New York, 1963 to 1974 (Referenced below simply as "Photophysiology" with the volume number).
15. Journals: Photochemistry and Photobiology
Radiation Botany
16. "Report of Findings: The Effects of Stratospheric Pollution by Aircraft," A. J. Grobecker, S. C. Coroniti, R. H. Cannon, Jr., DOT-TST-75-50, December 1974.
17. "Photochemistry of Nucleic Acids and their Constituents," A. D. Varghese, Photophysiology VII (1972), 267-274.
18. "Denaturation in UV Irradiated DNA," R. O. Rahr, Photophysiology VIII (1973), 231-255.
19. "Chromosome Aberrations Induced by UV Irradiation," Sheldon Wolff, Photophysiology VIII (1973), 189-205.
20. "The Action of Monochromatic UV Light on Proteins," R. B. Setlow, Biochem. Biophys. Acta. 24, 27.
21. "Molecular Photobiology: Inactivation and Recovery," K. C. Smith' and P. C. Hanawalt, Academic Press, New York, 1969.
22. Synergism between different near-UV Wavelengths in the Inactivation of transforming DNA, M. J. Peak et al., Ph. Chem. - Ph. Biol. 21, 2 (1975), 129-131.
23. "Ultraviolet Action and Photoreactivation Algae," Per Haldel and O. Taube, Photophysiology VII (1972), 162-185.
24. "Spectrophotometric Studies of the Mechanism of Photosynthesis," D. C. Fork and J. Amesz, Photophysiology V. (1970), 97-126.
25. "Photoreactivation in Animal Cells," J. S. Cook, Photophysiology V (1970).
26. "Photoreactivation of UV Damage," G. S. Rupert, Photophysiology II (1965).

REFERENCES (Continued)

27. "Mode of Sensitizing Actions of Furocoumarins," L. Musajo and G. Rodighiero, *Photophysiology VII* (1972), 12, 146.
28. "The Effect of Temperature upon Ultraviolet Carcinogenesis," J. A. Bain et al., *Cancer Res.* 3 (1943), 610-612.
29. "Induction of Skin Tumors in Hairless Mice by a Single Exposure to UV Radiation," J. Hsu et al., *Ph. Chem. and Ph. Biol.* 21 (1975), 185-188.
30. "Studies on Bovine Ocular Squamous Carcinoma (Cancer Eye)., XI. Effects of Sunlight," D. G. Anderson and P. E. Skinner, *J. Animal Scr.* 20 (1961), 474-477.
31. "Photoreactivity of Hydroxypsoralens and Their Photobiological Effects in *Bacillus Subtilis*," Pill-Soun Song, *Ph. Chem. and Ph. Biol.* 21, 5 (1975) 317-330.
32. "UV Acceleration of Mitosis," J. G. Carlson, *Ph. Chem. and Ph. Biol.* 20, 1 (1974), 1-7.
33. "Influence of Interannual Climatic Fluctuations on Biological Systems," N. G. Clark et al., *Nature* 256 (1975), 302-305.
34. "Action of UV on Mammalian Cells," R. H. Painter, *Photophysiology V* (1970), 169-190.
35. "Absorption Spectra, Spectrophotometry, and Action Spectra," M. B. Allen, *Photophysiology I* (1964).
36. "Photosynthetic Nitrogen Fixation By Blue-green Algae," M. B. Allen, *Photophysiology VII* (1972), 73-84.
37. "Nitrogen Fixation in Photosynthetic Bacteria," D. L. Keister and D. E. Fleishman, *Photophysiology VIII* (1973), 157-183.
38. "The Population Crisis and the Use of World Resources," S. Mudd, (Ed.), Junk, the Hague, 1974 (p. 478-C.-g. Hedin).
39. H. J. Sheetz and E. Friedman, "Earth Energy Experiment Evaluation," MTR-7008, September 1975.
40. G. E. Sweet, "Requirements for Long-Term Monitoring of Albedo and Earth Emitted Radiation," Langley Research Center, February 1975. (Summary of meeting of experimenters in Chicago, January 1975)

REFERENCES (Continued)

41. T. H. Vonder Haar, "Radiation Budget Program," Presentation to the National Academy of Sciences Ad Hoc Review Panel on Earth Radiation Balance, September 12, 1975.
42. WMO-ICSU, The Physical Basis of Climate and Climate Modeling, GARP Publications, Series No. 16, April 1975.
43. _____, Report of the Ad Hoc Working Group on Extended Cloudiness and the Radiation Budget, Hamburg, June 9-13, 1975.
44. _____, Understanding Climate Change, A Program for Action, National Academy of Sciences, Washington, D.C., 1975.
45. NASA-GSFC, U.S. Plan for Participation in FGGE (First GARP Global Experiment), Greenbelt, MD, August 1, 1975.
46. Correspondence from G. Garrett Campbell (Colorado State University) to Dr. Morris Tepper (NASA), June 17, 1975.
47. Reference 44, pp. 2 and 77.
48. S. Schneider, Statement Before the 2nd Conference on Atmospheric Radiation, Arlington, Virginia, October 1975.
49. J. Ellis, Statement Before the 2nd Conference on Atmospheric Radiation, Arlington, Virginia, October 1975.
50. Weather and Climate Modification; Problems and Progress, Committee on Atmospheric Sciences National Academy of Sciences National Research Council, Washington 1973.
51. Inadvertent Climate Modification - Report of the Study of Man's Impact on Climate (SMIC), MIT, 1971.
52. Remote Measurement of Pollution, NASA SP 285, 1971.
53. Stratospheric Ozone Destruction by Man-Made Chlorofluoromethane; by Ralph J. Cicerone, Richard S. Stolaski and Stacy Walters, Science, Vol. 185, September 1974, p. 1165.
54. Ramanathan, V., Greenhouse Effect Due to Chlorofluorocarbons: Climatic Implications, Science, 190, p. 50, 1975.
55. WMO-ICSU, The First GARP Global Experiment: Objectives and Plans, GARP Publications Series No. 11, Geneva, March 1973.

REFERENCES (Concluded)

56. R. D. Cadle - Personal Communication
57. J. P. Friend et. al., "On the Formation of Stratospheric Aerosols",
J. Atmos. Sci., 30, 465-79, 1973.

5.0 SATELLITE REMOTE SENSING

Remote sensing of the stratosphere from satellites is influenced by several features, including the properties of selected orbit, the characteristics (in both space and time) of the stratosphere and the various instrument properties. In this section, a discussion is presented of the operating principles utilized in the various instruments under consideration. Section 5.1 is devoted to a general discussion of remote sensing techniques, as they might be applied in the stratosphere. A synopsis of each device appears in Section 5.2.

5.1 General Features of Remote Sensing in the Stratosphere

The remote sensors considered in this study, like many other remote sensors, utilize the unique propagation properties of electromagnetic radiation. Since the instruments are passive, the designer is compelled, by engineering and scientific factors, to choose the most appropriate source of the radiation to detect the desired phenomena. The instruments commonly utilize one or more of four radiation sources:

- (1) thermal emission of the earth,
- (2) thermal emission of the atmosphere,
- (3) reflected solar radiation, and
- (4) direct solar radiation.

Methods 1, 3, and 4 rely on the selective absorption by the constituent of interest and a knowledge of the source's radiative characteristics to compute the total number of molecules in the path (usually in units of atmosphere - cm). In case (2), the specific spectral

emission lines of the gases are detected.

Clearly, the viewing direction of the sensor is of significance in the utilization of one of these sources. For example, the down-looking sensor cannot see direct solar radiation. Down-looking (or nadir-looking) and limb-looking instrumentation can utilize the various sources of radiation. This information will be repeated later to indicate into which category each instrument falls:

	<u>Earth Emission</u>	<u>Atmosphere Emission</u>	<u>Reflected Solar</u>	<u>Direct Solar</u>
Nadir	x	x	x	.
Limb		x		x

Note: x indicates ability to perform measurements utilizing the indicated radiation source.

The utilization of the various sources of radiation and instrument orientation, are each associated with a set of compromises, limitations and complexities. A complete discussion of these features is provided along with the advantages of each method for monitoring stratospheric constituents. Table V-1 summarizes the capabilities for the sensors alone, without consideration of data processing techniques.

5.1.1 Sensitivity

Nadir monitoring of the stratosphere is limited in sensitivity by the low concentrations of constituents relative to the troposphere. The result is that measurements will tend to preferentially detect constituents in the troposphere. It is worthwhile to note that the sensitivity of an instrument is ultimately limited by the concentration of

TABLE V-1

PROPERTIES OF PASSIVE STRATOSPHERIC REMOTE SENSORS

	NADIR VIEWING			LIMB VIEWING	
	Earth Emission	Atmospheric Emission	Reflected Solar	Atmospheric Emission	Direct Solar
Sensitivity	poor	poor	fair	good	good
Horizontal Resolution	good	good	good	poor	poor
Vertical Resolution	x	x	x	good	good
Insensitivity to Clouds	poor	fair	poor	good	good
Night Operation	good	good	x	good	x
Measurement Time per Orbit	good	good	fair	good	poor

Note: x indicates that the instrument cannot perform this function.

a. particular constituent within its field of view. Thus, in addition to poor sensitivity, nadir instruments produce data which does not differentiate between tropospheric and stratospheric contributions.

Utilization of thermal emission in a nadir configuration is a particularly ineffective method for monitoring the stratosphere. Using reflected solar radiation is at least twice as good since the radiation must traverse at least two atmospheric paths (when the satellite is on the Earth-Sun line).

Limb-looking instruments have the advantage of viewing through long optical paths of stratospheric constituents because of the spherical geometry involved. This improvement in sensitivity is somewhat offset by the small fields of view and short acquisition and scanning times which place stringent requirements on instrument pointing, spacecraft stability, and data reduction.

5.1.2 Horizontal Resolution

The nadir instruments exhibit superior horizontal resolution because of their orientation. While the field of view of such instruments cannot be small (usually about 0.1 radian) due to requirements for sufficient radiance, the proximity of the Earth can result in resolutions between 10 and 100 kilometers.

A related problem with nadir instruments is that the Earth and/or the atmosphere acts as a source of noise as well as sensed radiation. Non-uniformities in the emissivity or reflectivity of the target will produce amplitude variations in the radiation reaching the receiver even under perfect conditions (uniform target temperature or constant

solar flux). Of course, the target here describes any elements within the field of view, including clouds (which normally cover about 50 percent of the Earth's surface). The sensed radiation amplitude represents the spatial and temporal integrated flux from the various elements of the target. Thus, two reasons emerge for enlarging the field of view:

- (1) to increase the radiance for relatively weak phenomena, and
- (2) to provide more spatial averaging to suppress the associated noise.

These parameters represent a compromise between the need for good spatial resolution and good detection.

Scanning, downward-looking instruments provide a method of increasing the area covered at the expense of added complexity in the instrumentation control and data analysis. The data analysis becomes particularly complex if the scan angles become large, for then the spacecraft - Earth - Sun geometry becomes quite critical. However, by using scanning, good coverage and high resolution can be obtained.

The horizontal spatial resolution of limb-looking instruments is, in general, unequal in the two horizontal dimensions. In one dimension, it is primarily a function of the instrument field of view; in the other dimension, it is a function of the frequency of data acquisition. For example, the more independent data points observed during a "sunrise" or "sunset," the more atmospheric layers can be used in the data analysis. This results in shorter optical path segments which improves the horizontal resolution. Similarly, the horizontal resolution in the

limb emission case is dependent upon the rapidity of vertical scans per satellite ground speed. These relationships apply to instrument viewing along the satellite path or perpendicular to the path. Viewing at intermediate angles will result in a complex combination of both criteria.

5.1.3 Vertical Resolution

Nadir-viewing instruments provide virtually no information on the vertical distribution of pollutants in the stratosphere since they produce an integrated value or total column burden. Furthermore, nadir instruments cannot distinguish between the atmosphere and Earth as radiation sources if both have the same effective temperature. Thus, it is quite common for nadir-viewing instruments to become totally insensitive to pollutants below a particular altitude. Commonly, the atmosphere contributes about 15 percent of the radiance detected, the remainder coming from the ground. While this is not a particular problem in stratospheric monitoring, it is of some concern in other applications.

The limb instruments normally are configured to provide scanning in a vertical mode. Vertical profiles of the atmosphere are obtained by active scanning (up-down) of the Earth's limb. Again, trade-offs must be made. The instrument field of view must be quite small and data interpretation becomes complex since changing the direction of view also changes the path length in the stratosphere. Vertical profiles can also be obtained through an equivalent technique: tracking the sun during an occultation period (sunrise or sunset).

As in the horizontal resolution case, interpretation of limb measurements require special attention. While this approach is complex, it is virtually the only passive way to obtain any information on vertical profiles.

5.1.4 Insensitivity to Clouds

Any instrumentation which relies on propagation of infrared radiation through the atmosphere will be limited by clouds due to their strong absorption characteristics. Nadir instruments are particularly limited since any clouds within the scene prevent surface solar-reflected or earth emitted radiation from reaching the sensor. In both of these cases, the cloud tops become a radiation source which dominates the scene. While this radiance can be used to perform measurements, knowledge of the altitude of the cloud tops and/or their temperature may be necessary for interpretation of the data. If the instrument is designed to utilize atmospheric emission, the cloud top may prove to be a source which eliminates the contribution of tropospheric pollutants to the measurement. However, instruments utilizing reflected solar radiation from clouds and/or the ocean surface in the 1 to 3.5 μm spectral region will provide maximum sensitivity. Radiation in this region is strongly absorbed by ocean water and atmospheric water vapor and CO_2 . Related to the consequences of poor sensitivity in nadir-reflected solar instruments is poor spatial sampling. Clouds and oceans may exclude up to 85 percent of the Earth's atmosphere from observation.

5.1.5 Night Operation

In many monitoring programs it would be attractive to be able to monitor diurnal variations in various locations. Those instruments utilizing thermal emission from the Earth or atmosphere are clearly the only ones which can perform night measurements. This has an important impact in the global coverage which can be achieved.

5.1.6 Measurement Time per Orbit

The qualification of the total measurement time per orbit is presented in Section 6.0 for each of the instruments being considered. Some general features can, however, be described without reference to a specific orbit or instrument.

As noted above, the emission sensitive instruments can operate at any time during an orbit with the possible exception of the limb emission sensor. The presence of the Sun within the field of view usually cannot be tolerated, therefore, data may not be available during that period. Those sensors utilizing the Sun as a direct or reflected source, however, are somewhat restricted in the period of time in which measurements can occur. Instruments utilizing reflected solar radiation usually require that the local zenith angle of the Sun be small enough for adequate radiance as the satellite passes over. While the conditions of adequate radiance may occur for a fraction of the orbit period, quite frequently they will not be met at all. The limb occultation sensors are even more restricted since the Sun must lie in the "sunrise" or "sunset" position when a

measurement is made. This pair of events will occur at least once each orbit but their duration is quite short and thereby limits the measurement period. A related problem is the requirement that the sensor be able to point toward the sunrise or sunset before the event occurs. The position on the horizon at which the event occurs is a function of the orbit and the season.

5.2 Specific Features of Stratospheric Remote Sensors

A survey of a group of candidate remote sensors for the stratosphere follows. In addition, Table V-2 consolidates the specific features of each instrument. These instrument descriptions will be utilized in Sections 6.0 and 7.0 to evaluate the effectiveness of various orbits and the selection of an optimum payload configuration, respectively.

5.2.1 LACATE

Background

The LACATE (Lower Atmospheric Composition and Temperature Experiment) system is a limb radiance sensor which has been proposed for the measurement of vertical profiles of temperature and trace species in the 10-30 km region. A balloon version has demonstrated the concept of limb radiance techniques and a different concept called Limb Radiance Inversion Radiometer (LRIR) is being flown on NIMBUS 6.

Description

The version of LACATE being considered for a satellite mission is called Limb Scanning IR Radiometer (LSIR). It will have the

ORIGINAL PAGE IS
OF POOR QUALITY

TABLE V-2
REMOTE SENSOR SYSTEMS

5-10

OBSERVATION ORIENTATION	MEASUREMENT PHENOMENA	INSTRUMENT	MEASUREMENT TECHNIQUE	SPECIES OBSERVED	OBSERVATIONAL SUPPORT
Earth's Atmospheric Limb	Extinction of Solar Radiation	SAM II	Scattering	Aerosol Concentrations as a function of altitude	Scan Angle Solar Limb Darkening Data
		SAGE II	Scattering and Absorption by Atmosphere	Aerosol, O ₃ , NO ₂ Concentrations as a function of altitude	Solar Limb Darkening Data Scan Angle Temperature and Pressure Profiles
		CIMATS	Absorption of Sunlight by Atmosphere	Five to seven of the following: NO, NO ₂ , N ₂ O, CO, NH ₃ , CH ₄ , C ₂ H ₄ , C ₂ H ₆ , HCl, HNO ₃ , H ₂ CO, SO ₂ , CO ₂	Scan Angle
	Earth's Limb Irradiance	LACATE	Emission	Temperature Profile (15 μm Band) NO ₂ , H ₂ O, CH ₄ , O ₃ , N ₂ O, HNO ₃ Aerosol Concentration (10.8 μm Band)	Sun Angle Scan Angle
Earth and its Atmosphere	Extinction of Earth's Reflected and/or Emitted Radiation	CIMATS	Absorption of Reflected Energy	Five to seven of the following: NO, NO ₂ , N ₂ O, CO, NH ₃ , CH ₄ , C ₂ H ₄ , C ₂ H ₆ , HCl, HNO ₃ , H ₂ CO, SO ₂ , CO ₂	Sun Angle Scan Angle or Nadir
		MAPS	Absorption of Emitted Energy	CO ₂ , CO, NO, NO ₂ , NH ₃ , CH ₄ , SO ₂ , H ₂ CO [Aerosols - Attenuation 0.5 and 0.7 μm]	Nadir Sun Angle Ground Temperature Emission Model
		VRPM	Scattering	Aerosol Total Burden and Distribution	Angle of Observation Sun Angle Model Distributions

capability to scan in both elevation and azimuth and utilize a multi-channel sensor of Hg-Cd-Te detectors cooled by a VM refrigerator. The latter is planned to replace the solid cryogen sublimation cooler of the NIMBUS G configuration.

The sensor head will operate in 10 spectral channels: three in the CO₂ band at 15 μm, and one each in the NO₂ band at 6.2 μm, H₂O band at 6.3 μm, CH₄ band at 7.8 μm, O₃ band at 9.6 μm, an aerosol band at 10.8 μm, the HNO₃ band at 11.3 μm and the N₂O band at 17 μm. Of the three CO₂ channels, two will be relatively broad, 160 cm⁻¹ at the 5 percent transmission points, and the other about 45 cm⁻¹. All three will be used for the temperature profile data. The horizontal field of view of all channels will be 2.5 milliradians (mr). The vertical fields of view will be: 0.38 mr for the O₃ and CO₂ channels, 0.5 mr for HNO₃ and aerosols, and 1.0 mr for NO₂, H₂O, CH₄, and N₂O.

Accuracy of temperature measurements is expected to be on the order of 1.5°K and of constituent concentrations to about 15 percent or less. Vertical resolution of the temperature profile is to be 2.5 km at the point of tangency.

The azimuth scan will allow for +90° pointing from the orbital plane. Vertical scanning is planned to operate in two modes: acquisition from +6° to -5°, and limb-track from +2° to -1°. The vertical scan angles are given with respect to the optical boresight which is 30° below the horizontal.

Since the instrument measures the emission contributed by a horizontal column, the data must be mathematically inverted in order to determine the constituent distribution as a function of height. The temperature profile obtained from the three CO₂ channels is used in this inversion process. The LACATE instrument must be turned so that the sensors do not look directly at the Earth or the Sun.

5.2.2 SAM II

Background

The SAM (Stratospheric Aerosol Measurements) instrumentation has existed in several forms - from a simple hand-held, single wavelength photometer to a three wavelength balloon borne photometer - and finally a one wavelength instrument, called SAM II, configured for the NIMBUS G mission. All versions of SAM observe "sunrise" and "sunset" to measure aerosol concentration as a function of height above the cloud tops by measuring the transmittance of solar radiation through the Earth's limb.

Description

The simple hand-held single wavelength SAM was designed for use by the astronauts on Apollo/Soyuz. It's operating wavelength is 1 μm . It has a photometer with a field of view of the order of one degree and an optically filtered, aiming telescope with a 10° field of view. A SAM photometer with an attached camera is planned for the Apollo/Soyuz space flight. The vertical resolution of measurements, depending upon the data reduction techniques, is on the order of one kilometer. The vertical resolution of the color imagery depends upon the film grain and the "slit width" of the densitometer.

The balloon borne "SAM photometer," consisted of four $14^\circ \times 14^\circ$ horizontally mounted telescopes oriented 90 degrees in azimuth from each other. This instrument was rotated beneath the balloon so that each telescope successively viewed the sun during sunrise and sunset.

The satellite version of SAM employs viewing optics at $1.0 \mu\text{m}$ wavelength. When the sun photometer is extended to additional channels to measure ozone ($\lambda = 0.60 \mu\text{m}$), the experiment is referred to as SAGE, Stratospheric Aerosol and Gas Experiment (See 5.2.6).

5.2.3 CIMATS

Background

CIMATS (Correlation Interferometry for the Measurement of Atmospheric Trace Species) is the proposed extension of techniques developed under the COPE program. COPE (CO Pollution Experiment) has been successfully field-tested and shows promise for the use of correlation interferometry in the quantitative measurement of CO. The COPE instrument has been used, on aircraft and in a ground-based mode, to measure tropospheric column densities.

Description

CIMATS will be designed to operate in two modes: (1) nadir-viewing of reflected solar radiation or thermal radiance from the Earth and its atmosphere, and (2) limb viewing solar radiation through the Earth's atmosphere. Primary emphasis will be placed on the nadir mode. It is anticipated that the instrument will measure five to seven of the following species: NO , NO_2 , N_2O , SO_2 , CO , NH_3 , CH_4 , C_2H_4 , C_2H_6 , HCl , HNO_3 and H_2CO .

An interferometer produces a Fourier transform of the incident radiation spectrum by recombining two portions of the radiation after introducing a time varying path difference in one portion. Upon recombination, the path differences produce alternating reinforcement and cancellation, depending upon the respective phases of the radiation in the two paths. For monochromatic radiation incident upon the interferometer, the result is a sinusoidal oscillation of the detector output. In the more realistic case of polychromatic radiation, the output is a sum of many sinusoidal oscillations and is, in general, a complex waveform.

Separation of the signal of interest is effected in two ways. The incident radiation is spectrally filtered to pass a relatively narrow band centered at the absorption line of interest. Interfering species are separated by means of a weighting function which maximizes the output at the region of interest while minimizing all other effects. The quantitative determination of the column density of the desired pollutant is obtained by performing a correlation with interferograms made with known amounts of the pollutant.

The major advantages of an interferometer system are in its ability to remove the effects of interfering species and its inherent capability to make simultaneous measurements of several species. The latter advantage stems from the particular method of processing. Several weighting functions may be employed on a given interferogram while the correlation technique may be used for several species simultaneously.

The instrument field of view will be 7° without foreoptics and 2° if a telescope is used. Accuracy is expected to be on the order of 10 percent for all gases except SO_2 , which is estimated to be about 30 percent. Spectral resolution is expected to be approximately 0.5 cm^{-1} .

5.2.4 MAPS II

Background

The original MAPS (Monitoring Air Pollution from Satellites) was a single channel, gas correlation filter analyzer used to detect CO or SO_2 . Subsequent design efforts investigated the feasibility of measuring additional species including: CO_2 , NO, NO_2 , SO_2 , NH_3 , HCHO, CH_4 , and aerosols. A version of MAPS was originally scheduled for inclusion on NIMBUS-G, which would have measured four constituents: CO, CH_4 , SO_2 and NH_3 . Recently, the NIMBUS role for MAPS has been deferred.

Description

The principle of the gas filter correlation instrument is based upon non-dispersive optical correlation in which a sample of the pollutant gas to be measured provides a highly specific filter for incident radiation. The instrument channels which measure the constituent gases take a ratio of the incident radiation after it has traversed two cells; one filled with the gas of interest and one evacuated. The exceptions to this operational mode are the aerosol channels. Radiation in each channel is modulated by two tuning fork choppers and imaged upon an array of three detectors contained on a single substrate. As the chopper oscillates, the detector array is exposed to the external radiation passing through the gas filled cell and the evacuated cell. The signal

difference from these two detectors is referred to as ΔV . The signal difference at the second detector is designated $\Delta V'$; and refers to the radiation traversing a gas cell at a partial pressure different from that defining ΔV . Simultaneously, a radiometric channel, unobstructed by either a gas or vacuum cell, is imaged upon the third detector to provide the background brightness temperature at the wavelength interval of interest. The output from this detector is termed, V . ΔV and $\Delta V'$ are each measures of the given pollutant in the atmospheric path. Their ratio $\Delta V/\Delta V'$ serves to eliminate the effects of interfering species, under certain conditions, as well as to minimize the effects of the temperature profile. Another ratio used in the processing of the Gas Filter Correlation (GFC) channels is $\Delta V/V$. This ratio minimizes the effects of water vapor concentration as well as effects of varying ground temperature within the field of view.

Calibration of the instrument, in-flight, has two modes: balance and calibration. In the balance check, the primary mirror is rotated to direct the instrument field of view toward two uniform temperature sources. One source is cold space and the other is the uniform, temperature-controlled instrument cavity. In each case, ΔV should remain a constant. For calibration, small black body sources are provided which simulate a pollutant signal. This check encompasses the entire GFC system, including the gas cells.

MAPS will operate in a nadir-viewing mode with a field of view of 7° . Cross-track scan is limited to $\pm 40^\circ$. Proposed improvements for the future satellite mission (altitude of 958 km) include a 50 km spatial

resolution and a VM cooler. Requirements for auxilliary data include temperature profile, ground temperature and reflectivity, cloud cover, and water vapor.

5.2.5 VRPM

Background

The VRPM (Visible Radiation Polarization Measurement) photometer has been proposed as one means of monitoring aerosols from a satellite platform. VRPM will measure the earth/atmosphere albedo or backscattered flux at several visible wavelengths. The analysis of both the intensity and polarization of the light flux as a function of wavelength allows the description of the general aerosol size distribution and concentration in the total column of the atmosphere. This data can be used to assess sources of pollution, earth heat budget, insolation, and atmospheric circulation and transport processes.

Instrument Description

The VRPM is a multispectral photopolarimeter which uses magneto-optical Faraday rotation as a means of analyzing the polarization of incident light. The VRPM is pointed at a specific ground target and measures the backscattered radiation which is a mixture of both plane polarized and unpolarized light.

The photometer measures the degree of polarization, plane of polarization, and intensity of the backscattered radiation from the atmosphere at three wavelengths. Aerosol properties are inferred, with the aid of models, from mathematical analysis of observed Stokes vectors. The use of magneto-optical modulation techniques, dichroic elements and spectral filtering, results in the optical sensor having

no moving parts. Two Stokes vectors are derived from the measurement of light intensity and the degree of polarization at various viewing angles. The third Stokes vector is obtained from the signal resulting when the Faraday coil is neutral, thus the magnitude measured is a direct function of the plane of polarization of the incident light.

The proposed spectral range of the VRPM is from 4000 Å to 7000 Å with the central wavelengths of each channel at 4575 Å, 6000 Å, and 6925 Å. The spectral width of each channel is to be 150 Å. The optical field of view is three degrees. The plane of polarization will be measured to within one degree whereas the degree of polarization to within five percent. The proposed intensity measurement has an accuracy of one percent over a dynamic range of 1000.

The upwelling diffuse radiation, as seen from a satellite, is measured at known angular positions of the spacecraft and the Sun. The scattering is a function of the index of refraction, size, shape, and distribution of the aerosols. The aerosol parameters may be characterized by the intensity of polarization, the ellipticity, and the orientation of the polarized component by means of Mie scattering principles. However, because the ellipticity is a second order effect, it is commonly deleted in order to simplify the analysis.

The analyses of measured fluxes backscattered from a turbid atmosphere require a determination of the phase matrix. This requires the assumption of an aerosol size distribution with "weighting functions" derived from an empirical formula evolved from in situ observations. The phase matrix is then introduced into radiative

transfer formulations in order to test the predicted flux parameters with those observed. When the parameterization of the phase matrix is such that the predicted and observed flux correspond satisfactorily, the phase matrix parameters are considered similar to those producing the observed fluxes. It is important that the set of parameters be sufficient both in definition and number to inhibit ambiguous results. This problem has been addressed over the years--most recently by Kuriyan, et al (1974) and McKellar (1974).

5.2.6 SAGE II

Background

The SAGE II (Stratospheric Aerosol and Gas Experiment) instrumentation is designed to provide global data over a significant period of time to assess variations in the concentration of stratospheric aerosols and ozone.

Description

The SAGE II instrumentation consists of a pointing telescope subsystem and detector subsystem; the latter is designed to measure the Sun's irradiance through the atmospheric limb of the Earth from a satellite platform. The pointing subsystem will direct the Sun's rays to the detector subsystem with each sunrise and sunset for each orbit of the satellite. The detector subsystem consists of collimating optics, dichroic beam splitters, and interference filters directing the sun's energy to four silicon diode detectors. The solar energy is measured at four wavelengths of approximately 0.38, 0.45, 0.6, and 1.0 μm . The output of the detectors are fed to A/D converters which integrate the solar flux ten times per second to produce the primary measured data.

During each "sunrise" and "sunset" the photometer will measure the solar radiation at four wavelengths. As the spacecraft moves from the Earth's shadow (sunrise) during each orbit, the photometer, locked on to the Sun, scans the Earth's atmosphere from the horizon up, resulting in a measure of atmospheric attenuation as a function of altitude. The sequence is reversed at sunset. Two vertical profiles are made for each orbit of the Earth. The field of view of the photometer is about one arc-minute, so at an orbital altitude of 600 km, the vertical resolution of measurement is less than one km.

After making corrections for solar limb darkening and atmospheric refraction effects, the measured solar flux is converted to intensity versus tangent-height above the Earth. Then the primary data are converted, with the standard inversion techniques to an extinction coefficient versus altitude.

Atmospheric extinction is composed of three primary components: aerosol, Rayleigh, and ozone extinctions; the contribution of each component is dependent upon wavelength. While Rayleigh and Mie (aerosol) scattering are present at all four wavelengths, ozone is the major constituent attenuating solar energy at 0.6 μm because this wavelength is at the peak of the Chappuis absorption band. Therefore, because Rayleigh scattering is quite predictable, the other three wavelengths are used to assess the concentration of aerosols and a primitive size distribution. These data are then used to determine the contribution of aerosol scattering at 0.6 μm leaving the balance of attenuation being caused by ozone. In summary, the four color photometer can

simultaneously assess the aerosol and ozone concentrations twice each orbit on a near global bases approximately every two weeks, assuming a 600 kilometer orbit.

5.2.7 Infrared Heterodyne Radiometer (IHR)

Background

Heterodyne detection has long been used in the radio and microwave regions of the spectrum. With the advent of stable, coherent optical sources, optical heterodyne experiments have been performed by a number of investigators over the past 15 years. As coherent sources have been evolved in the infrared portion of the spectrum, heterodyne techniques have followed (M. C. Teich, 1968).

With current laser research proceeding in the area of tunable lasers, in both the visible and IR regions, it was inevitable that IR heterodyne techniques would be considered for the sensing of pollutant gases in the atmosphere. One of the major problems in remote sensing of pollutants in the atmosphere is the overlap of absorption lines between various gas constituents. This poses a problem of unique identification with conventional instruments which directly measure the absorption spectrum of gases. Higher spectral resolution in conventional spectrometers is obtained at the expense of sensitivity, which is, itself, a limiting factor in instrument design. The Infrared Heterodyne Radiometer (IHR) works with the difference frequency of the source and a laser which acts as a local oscillator (LO). Various choices of LO frequencies and pollutant emission lines can result in a heterodyne intermediate frequency (IF) of anywhere from the kHz to

the GHz region. By proper selection of the LO frequency, spectral resolutions of $<0.01 \text{ cm}^{-1}$ are theoretically obtainable. Furthermore, the response of the detector may be shown to be proportional to the strength of the LO signal, which results in a more than adequate signal-to-noise ratio and sensitivity.

The limitations of the IHR are those imposed by the requirement for coherent signal input and wide-band, high speed detectors in the spectral region of interest. The coherency limitation is not serious for most applications involving large areas or distributed pollutant sources. For those small scale measurements, coherency may be maintained by reducing the detector field of view so that it is filled by the source under investigation. The detector selection is a trade-off between the response time and quantum efficiency.

IHR techniques have been adapted to both active and passive modes of operation. In the active mode, two lasers are used with a slight frequency difference between their emission lines. One of these provides the LO signal and scattered radiation from the other provides the signal channel. The use of the high power lasers required for this technique pose some obvious eye damage hazards and limit its application for atmospheric sensing. The passive techniques involve a low power laser for the LO and heterodyne this with an external signal. The signal may come from thermal emission of a gas, an absorption line from solar occultation, or a fluorescence line stimulated by solar radiation.

Instruments

NASA is currently investigating both modes of infrared heterodyne detection. For the active mode, a pair of CO₂ lasers provide the source energy and LO. The active system is called DARS and may be used in a nadir-viewing system from aircraft for its initial tests. The passive system is called IHR and uses semiconductor lasers in place of the high power CO₂ lasers of DARS. The IHR will be tested on NH₃ and O₃ in two configurations. One will be a nadir-viewing experiment using the thermal radiance of the Earth as a source, and the other will be a ground-based experiment using solar absorption.

Support data requirements include the usual flight path information, temperature and water vapor at flight altitude, ground temperature and water vapor and the atmospheric temperature profile. Photographic records are also required for the nadir experiments to determine the existence and extent of cloud cover.

In the nadir-viewing mode, the IHR will have a 3.95 degree field of view. For solar occultation, a lens is used ahead of the photomixer which reduces the field of view to 0.015 degrees which implies 35 resolution elements across the solar disk.

5.2.8 SERM

Background

The National Environmental Satellite Service of NOAA and the Eppley Laboratory, Inc., jointly proposed and are flying the Earth Radiation Budget (ERB) on NIMBUS F in 1975. Precise ERB observations of net radiation will prove useful to both the operational meteorological community and the dynamic modeling research community. SERM (Solar

and Earth Radiation Monitoring) instrumentation has been proposed for future satellite missions to extend the precise radiation observations for assessing long-term climate changes due to natural or industrial pollution activities.

The SERM instrumentation is designed to provide, for a year or more, data on the Earth's radiation budget on both the global and synoptic scale simultaneously. The incoming solar radiation will be measured in terms of the total incident upon the Earth, the solar constant and the solar ultraviolet irradiance plus the solar visible and near infrared irradiance. The total terrestrial radiation will be measured in the reflected short-wave (visible and near infrared) and the emitted long-wave (far infrared) spectral regions. Both of these measurement techniques are global measurements. The small scale (synoptic) measurements of terrestrial radiation will be made with a narrow field of view sensor in the same spectral regions for reflected and emitted radiances.

Description

The SERM instrumentation utilizes the sensors, optics, mechanical assemblies and circuitry developed for the ERB instrument. The major difference between the ERB and SERM devices is that solar spectral components and the angular distribution of terrestrial radiation will not be measured with SERM. The same calibration equipment and techniques will be used.

SERM will employ four sensors; two thermopiles and two pyroelectric detectors. The thermopiles will measure the total (0.2 to more

than 50 μm) radiation and the reflected (0.2 to 5 μm) Earth fluxes. The field of view of both detectors will be limited to the Earth's disc, about 116° . The thermopiles will be mounted in a temperature controlled cylinder which can be rotated on command behind sun-viewing optics which limit the field of view to about 30° . A filter wheel is used to insert a window which will absorb the solar ultraviolet component so that the ultraviolet radiation may be determined by the difference between fluxes.

The ERB scanning telescope with its two pyroelectric detectors, complete with beam splitting chopper, for both long and shortwave length channels will be used in SERM. The field of view will be modified to about 2° (circular) and will scan from one horizon to above the opposite horizon. The SERM instrument characteristics are shown in Table V-3.

5.2.9 Cloud Scanning Radiometer

The proposed instrument package for a future stratospheric measurement satellite mission may also contain a scanning radiometer which will provide imagery required for the interpretation of the data collected by the nadir sensors. It will permit determination of surface temperatures of the ground, the sea, or cloud tops in the range of 185°K to 330°K . The resultant imagery allows calculation of the percent of cloud cover in the field of view of other on-board sensors.

Background

Various forms of scanning infrared radiometers have been placed on spacecraft from the earliest launches. The evolutionary trend is shown in Table V-4. The primary use of the data obtained from these

TABLE V-3

SERM INSTRUMENTATION

DETECTOR	SPECTRAL INTERVAL	MODE	OPTICS	PURPOSE
Thermopile	0.2-5 μm	Earth Viewing	Suprail-W Fused Silica Window 116 FOV	Total Short-wave Terrestrial Radiation
		Sun Viewing	Suprail-W Fused Silica Window 30 FOV Plus WG-7 Schott Glass Filter	Total Short-wave Solar Radiation Total Short-wave Solar Radiation Minus UV
Thermopile	0.2-50 (+) μm	Earth Viewing	Window less 116 FOV	Total Terrestrial Radiation
		Sun Viewing	Window less 30 FOV Plus WG-7 Schott Glass Filter	Total Solar Radiation Total Solar Radiation minus UV
Pyroelectrics	0.2-5 μm	Earth Viewing	Suprail Fused Silica Window	Scanning Short-wave Radiation
Pyroelectrics	0.2-50 (+) μm	Earth Viewing	Diamond Substrate Filter	Scanning Long-wave Radiation

ORIGINAL PAGE IS
OF POOR QUALITY

5-27

TABLE V-4
DEVELOPMENT OF SCANNING RADIOMETERS

<u>DATE</u>	<u>S/C</u>	<u>NAME</u>	<u>FOV</u>	<u>SCAN RATE</u>
1966	TIROS-2,3,4,7 NIMBUS-2,3	MRIR (Medium Resolution IR Radiometer)	43 mr	8 rpm
1970	NIMBUS-1,2,3	HRIR (Hi-Resolution IR Radiometer)	7.5 mr	45 rpm
1970	NIMBUS-4,5,F,G	THIR (Temperature/Humidity IR Radiometer)	21 mr-Ch.A 7 mr-Ch.B	48 rpm
1972	NOAA-2,3,4	SR (Scanning Radiometer)	2.7 mr-Ch.A 5.6 mr-Ch.B	-----
1972	NOAA-2,3,4	VHRR (Very High Resolution Radiometer)	0.6 mr	400 rpm
----	TIOS-H,I,J TIROS-N	AVHRR (Advanced VHRR)	0.6 mr (4-channels)	-----

instruments has been in meteorology and weather prediction. The trend in instrument design has been toward higher resolution and increased data handling capability. The most recent version will cover four spectral channels.

Description

In its basic form, the scanning radiometer uses a continuously rotating mirror mounted at 45° to the optic axis to provide a scanning field normal to the axis. The instrument is mounted so that the direction of scan is at a right angle to the spacecraft velocity vector. This provides an effective two dimensional field of view, with the scan mirror providing one dimension and the spacecraft motion supplying the other.

The incident radiation is spectrally separated by dichroic beam-splitters before detection. A common arrangement uses a visible channel in the 0.5 to 0.7 μm region and a thermal IR channel in the 10 to 12 μm region. This ensures day-night capability with reflected solar radiation for the former and the Earth's thermal emission for the latter. The detectors operate at ambient or low temperatures, depending upon the sensitivity requirements, with radiation coolers used for the low temperature applications.

Data is stored on-board until the spacecraft is within range of a ground station, then it is data-linked to the ground. At the receiving station, the data is used to drive a facsimile recorder which has its linear motion phased with the spacecraft velocity. The result is a reconstructed image of the Earth as seen by the radiometers.

BACKGROUND REFERENCES

GENERAL

NASA NSSDC/WED-A-R&S 75-01, "1975 Report on Active and Planned Spacecraft and Experiments," January 1975.

LACATE

NASA 1-11-4297, Exhibit A, LaRC, 5/74, "Statement of Work - Lower Atmospheric Composition and Temperature Experiment Hardware for NIMBUS-G."

CIMATS

NASA 1-16-5169, Exhibit A, LaRC, 2/75, "Statement of Work - Advanced Applications Flight Experiment (AAFE) - Correlation Interferometry for Measurements of Atmospheric Trace Species (CIMATS)."

GE N-25229, Space Products Division, General Electric Co., Philadelphia, PA, 10/74, "Correlation Interferometry for the Measurement of Atmospheric Trace Species (CIMATS)."

MAPS

Science Applications, Inc., SAI-73-564-LJ, 6/73, "Monitoring of Air Pollution from Satellites," MAPS.

Henry G. Reichle, Jr., et. al., LaRC, 4/73, "MAPS (Measurement of Air Pollution from Satellites)."

DARS/IHR

M. C. Teich, "Infrared Heterodyne Detection," Proc. IEEE Vol. 56, No. 1, p. 37-46, January 1968.

J. H. McElroy, "Infrared Heterodyne Radiometry" Applied Optics, Vol. 11, No. 7, July 1972.

R. T. Menzies, "Use of CO and CO₂ Lasers to Detect Pollutants in the Atmosphere," Applied Optics, Vol. 10, No. 7, July 1971.

R. K. Seals, Jr., "Analysis of Tunable Laser Heterodyne Radiometry: Remote Sensing of Atmospheric Gases," AIAA Journal, Vol. 12, No. 8, August 1974.

Philip L. Hanst, "Infrared Spectroscopy and Infrared Lasers in Air Pollution Research and Monitoring," Applied Spectroscopy, Vol. 25, No. 2, March-April 1970.

R. K. Seals (private communication) May 22, 1975.

I. Melngalis, "The Use of Lasers in Pollution Monitoring," IEEE Transaction on Geoscience Electronics, Vol. GE-10, No. 1, January 1972.

BACKGROUND REFERENCES (concluded)

DARS/IHR
(concluded)

H. Kildal, "Comparison of Laser Methods for the Remote Detection of Atmospheric Pollutants," Proc. IEEE, Vol. 59, No. 12, December 1971.

CLOUD IMAGER

R. B. Gerding, et. al., "Sensor Development in the Shuttle Era," Proceedings of the SPIE Conference on Scanners and Imagery Systems for Earth Observation, San Diego, CA, August 1974, pp. 136-147.

NASA SP-335, "Advanced Scanners and Imaging Systems for Earth Observations," Chapter 2, 1973.

NASA SP-8078, "Spaceborn Electronic Imaging Systems," June 1971.

SAM

T. J. Pepin, "Remote-Sensing the Stratospheric Aerosols." Second Joint Conference on Sensing of Environmental Pollutants; Instrument Society of America, Pittsburgh, PA, December 1973, pp. 333-336.

VRPM

Radiation Polarization Measurement Experiment-A Technical Description. TRW Systems Group, One Space Park, Redondo Beach, CA, March 23, 1973.

J. G. Kuriyan, D. H. Phillips, and R. C. Wilson; 1974. "Determination of Optical Parameters of Atmospheric Particulates from Ground-Level Polarimeter Measurements." Quart. J. Roy. Meteor. Soc., 100, 665-677.

B. H. J. McKellar, (1974) "What Properties of a Haze is Determined by Light Scattering." Quart. J. Roy. Meteor. Soc., 100, 687-692.

SAGE II

Stratospheric Aerosol and Gas Experiment. Proposal to NASA Hdqrs. for AEM II, July 1974 by Langley Research Center.

E. F. Harrison, R.N. Green, D. R. Brooks, G. F. Lawrence, and M. P. McCormick, 1975. Mission Analysis for Satellite Measurements of Stratospheric Constituents by Solar Occultation. Presented at the AIAA 13th Aerospace Science Meeting, Pasadena, CA, January 20-22, 1975.

6.0 ORBIT INFLUENCES

As in any spacecraft mission, compromises must be performed in the selection of the orbit based on the ideal coverage and available instrumentation. Monitoring of the stratosphere is no exception. Maximum spatial and temporal sampling is required because of the generally scant information on the global distribution and time variance of the various stratospheric constituents. These requirements are discussed in Section 4.0 where a common feature is the requirement for global coverage.

A general set of instrument/orbit criteria has been derived from other sections of the report (primarily Section 4.0 and Tables IV-16 through IV-19) which include requirements for:

- diurnal sampling,
- the largest possible latitude coverage,
- frequent periods when the various types of instrumentation can monitor the same region for corroboration of data quality, and
- seasonal sampling.

This section is devoted to the interplay of the various instruments and possible orbits in order to quantify the sampling characteristics. The discussion will center about two topics:

- (1) properties of the orbit, instrumentation, and resulting coverage of the globe, and
- (2) appropriateness of a set of instrument/orbit

parameters for monitoring a set of significant stratospheric constituents.

Some topics which will be utilized in the evaluation of a monitoring system include properties of the orbit, influences of the solar position as a function of position in the orbit, and season of the year. The influence of mean cloud cover, day/night performance, and the spatial distribution of selected stratospheric constituents will be discussed.

6.1 Orbit Parameters

A number of potential orbits have been considered. For example, a typical sun-synchronous orbit provides morning equatorial crossing and high inclination circular orbits. Typical orbital parameters are found in Table VI-1. Similar parameters are used in the subsequent sections to determine the latitudes over which occultation and nadir measurements can be made, and to identify any operational limitations.

6.2 Instrument Operation

The performance of the remote sensors being considered in this document is greatly influenced by the selection of the spacecraft orbit. The position of the Sun, with respect to the spacecraft for a variety of orbital and seasonal conditions is important in determining global coverage. Table VI-2 compiles the basic requirements for each generic type of sensor system. Each of the four cases depicted in Table VI-2 will be discussed in this section.

TABLE VI-1

TYPICAL ORBIT PARAMETERS UTILIZED IN THE ANALYSIS
 (representing a Sun-synchronous, high inclination, circular orbit).

<u>PROPERTY</u>	<u>VALUE</u>	<u>UNITS</u>
Equatorial Crossing Time	0900	hours
Altitude	958	km
Period	104.3	minutes
Westward displacement per orbit	26.1	° of longitude
Orbits per day	13.8	-
Inclination	99.3	°
Precession Rate	0.986	°/day relative to Earth
	0.0	°/day relative to Sun

TABLE VI-2

SENSOR REQUIREMENTS ON SOLAR POSITION DURING MEASUREMENT IN ORBIT

	Solar Source	Reflected Solar Source	Thermal
Limb (Occultation)	Sun must appear in stratospheric limb	-	Sun must <u>not</u> appear in FOV
Nadir	-	Local elevation angle must be large enough to provide adequate radiance	Sun not required

6.2.1 Limb - Solar Source (Occultation)

Limb instrumentation utilizing the Sun as a radiation source has a large potential for monitoring the stratosphere. The resulting high signal-to-noise ratio and sensitivity are ideal performance criteria. However, instrumentation of this type is limited to a short measurement period per orbit (0.5 - 3 minutes for both the sunrise and sunset) as well as to the location of measurements which are concentrated in relatively narrow latitude bands.

Figure 6-1 illustrates the experiment configuration. The tangent point is some distance from the spacecraft and produces a measurement made through a large segment of the stratosphere. By definition, the tangent point, which moves about 21 km during a given sunrise or sunset, is called the data point.

An important computation is the determination of the latitudes covered (defined by the data points) as a function of the season. Since it takes approximately five days for the spacecraft (with an orbit similar to that in Table VI-1) to repeat coverage of a given ground point, the orbit to orbit variations in latitude can be ignored and the maximum and minimum latitudes computed. For Sun-synchronous orbits, the precession rate of the satellite orbit plane guarantees that a constant angle exists between the plane of the orbit and the Earth-Sun line.

The latitude coverage is defined by determining the tangent point, which is the intercept of the Earth with the satellite-Sun line.

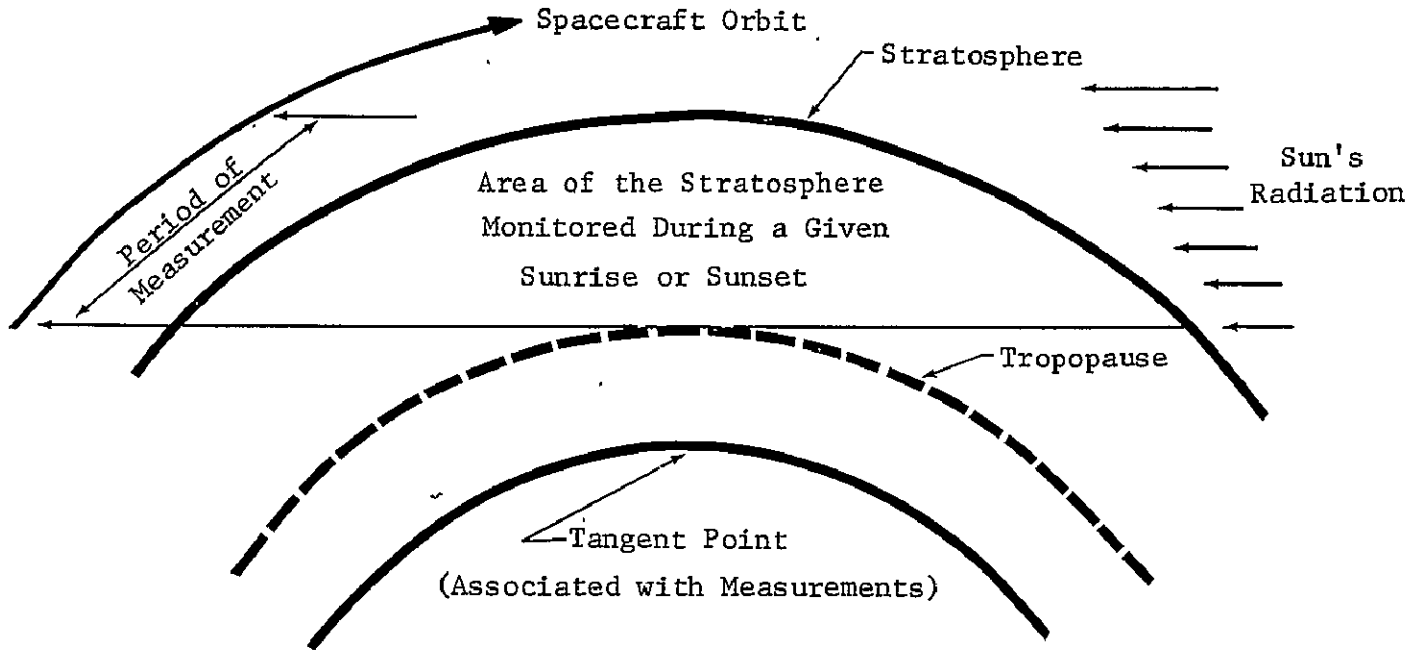

FIGURE 6-1
EXPERIMENTAL CONFIGURATION DURING SOLAR OCCULTATION EXPERIMENT

Calculations of this type have been performed for a variety of Sun-synchronous and other orbits. A typical set of results of the coverage obtained are depicted in Figures 6-2 and 6-3, for Sun-synchronous and non-Sun-synchronous orbits, respectively.

Data of this type make it clear that limb instruments in Sun-synchronous orbits using the Sun as a radiation source have several disadvantages:

- the range of latitude sampled is quite restricted,
- each latitude is seen a maximum of only four times per year (90 days apart),
- the measurement period is quite short (on the order of minutes),
- no diurnal sampling of various latitudes,
- no seasonal sampling of various latitudes, and
- each data point represents the integral of the observed constituent along a substantial path thereby providing limited spatial resolution.

Use of non-Sun-synchronous orbits avoids the first two limitations, thereby more nearly satisfying the requirements for near-global coverage. However, the interpretation of the data, in order to obtain the desired spatial resolution, demands considerable attention.

6.2.2 Reflected Solar Source

Nadir-looking sensors, which rely on reflected solar radiation, are limited in their operation to those areas where the local solar

EFFECT OF TIMING ON LATITUDE COVERAGE

$i = 99.04^\circ$, $h = 900$ km, $t = 1$ yr

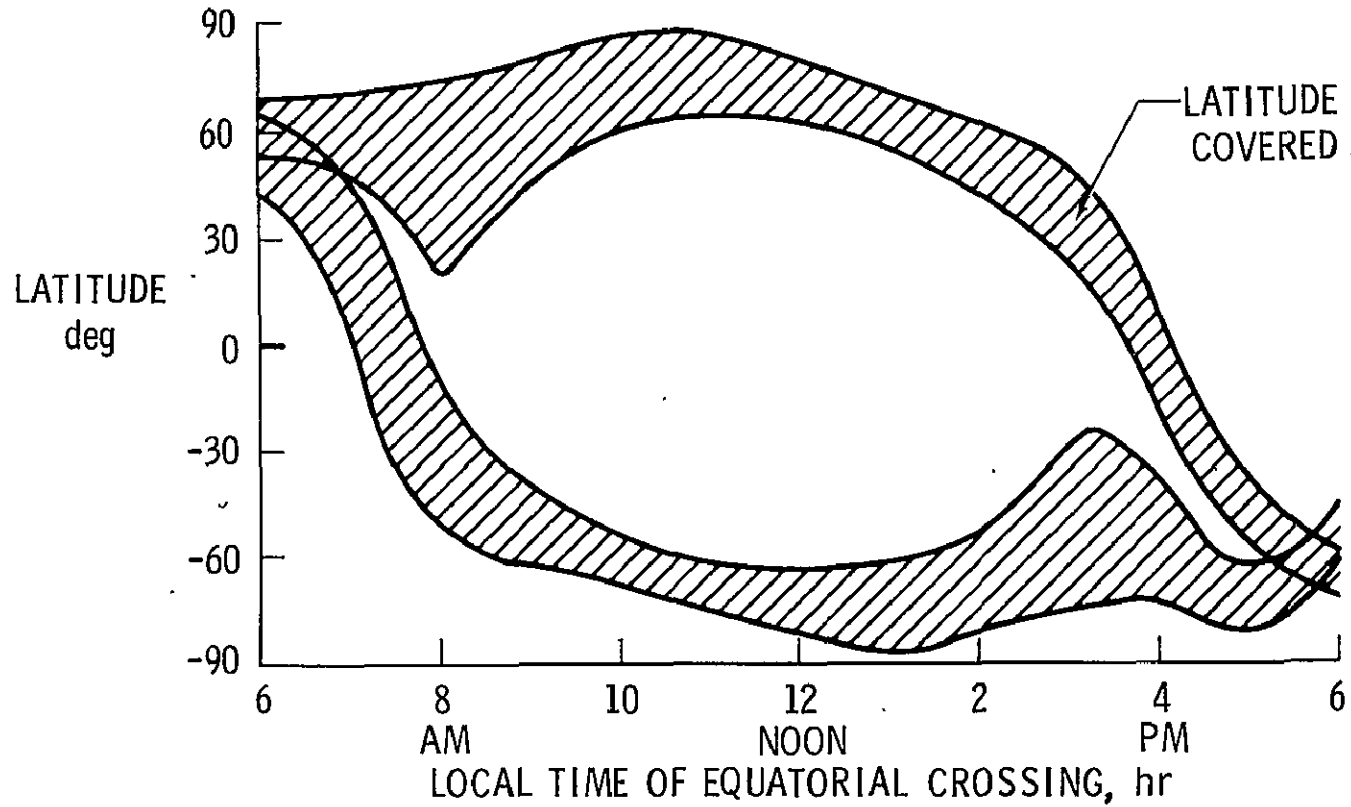

8-9

FIGURE 6-2
LATITUDE COVERAGE OF SOLAR OCCULTATION INSTRUMENTATION IN TYPICAL SUN-SYNCHRONOUS ORBITS
[AFTER G. H. LAWRENCE, PERSONAL COMMUNICATION]

DISTRIBUTION OF MEASUREMENTS DURING A 1 YEAR MISSION

$i = 50^\circ$, $h = 600$ km

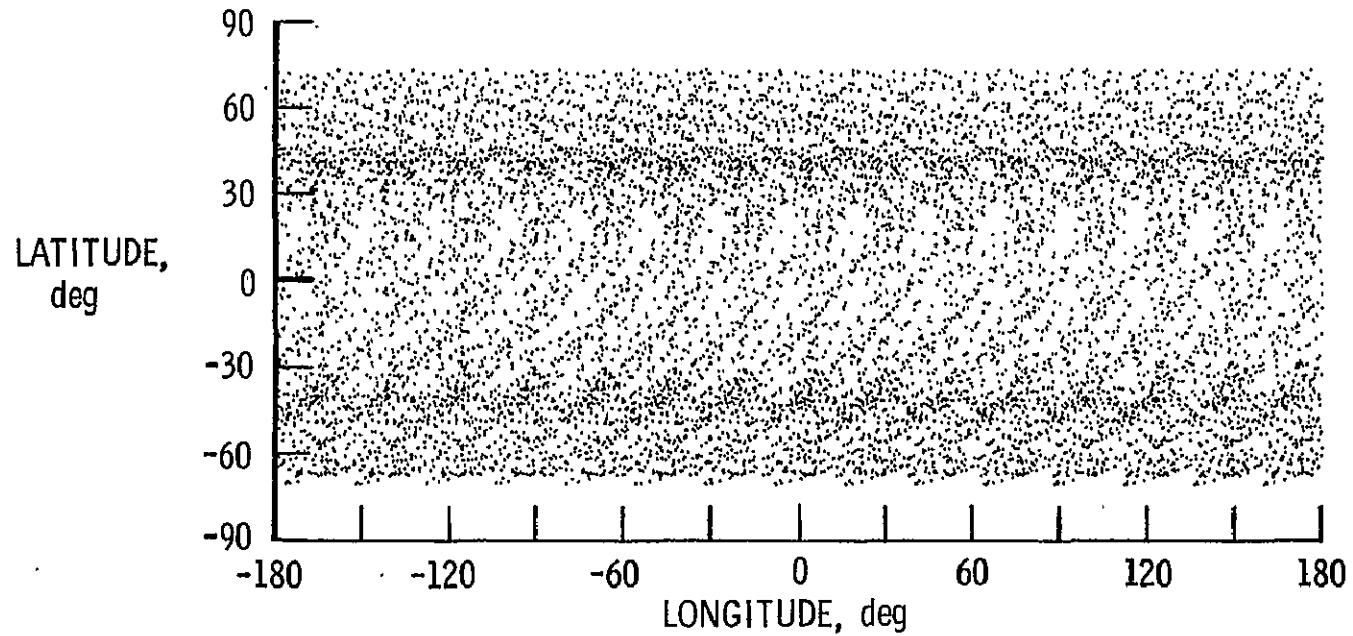

6-9

FIGURE 6-3
SAMPLING CHARACTERISTICS OF SOLAR OCCULTATION INSTRUMENTATION IN A
NON-SUN-SYNCHRONOUS ORBIT. EACH DOT REPRESENTS A DATA POINT.
[AFTER G. H. LAWRENCE, PERSONAL COMMUNICATION]

zenith angle is sufficiently small to provide adequate radiance. Consequently, latitude coverage, as a function of season, is limited. An example of this limitation follows for a nominal solar zenith angle of 45° , the latitudes covered as a function of season of the year and time of the descending node, are illustrated in Figure 6-4 for three equatorial crossing times. As noted in Appendix A, a true polar orbit has been assumed for simplicity.

Clearly, such coverage provides monitoring of the Northern Hemisphere during the summer periods and the Southern Hemisphere between September 21 and March 21. The value of such coverage has yet to be determined, but several points can be made:

- latitude coverage is maximized in each hemisphere only once per year,
- seasonal variations in each hemisphere cannot be monitored,
- the equatorial regions (approximately 10° N to 10° S) can be monitored almost continuously for orbits with descending nodes between 9:30 and noon,
- maximum coverage is obtained for 12:00 noon orbits allowing continuous monitoring for latitudes from 23.5° N to 23.5° S, and
- minimum coverage occurs in the 9 a.m. orbit which has periods in which only the equator can be monitored.

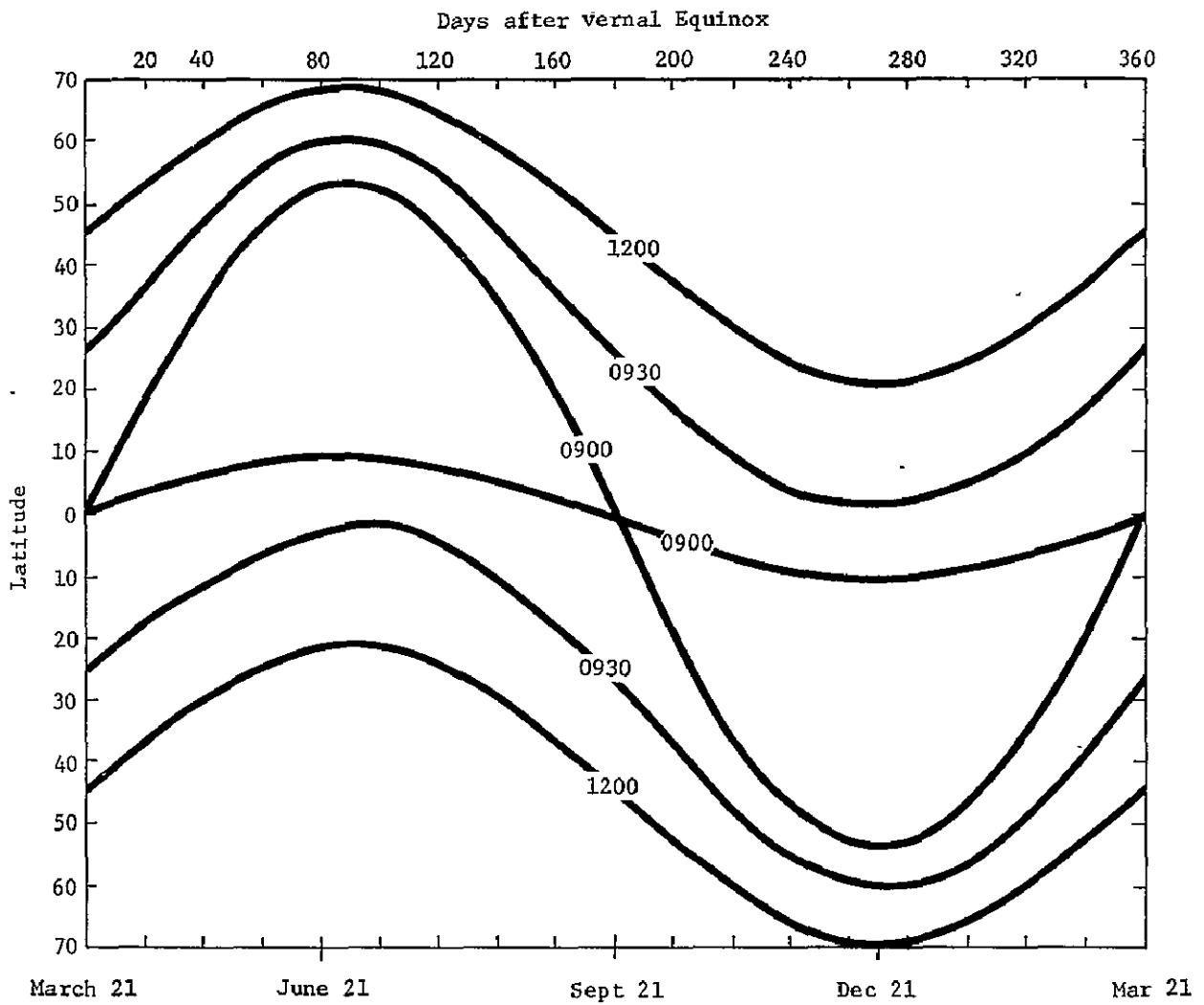

FIGURE 6-4
LATITUDES FOR WHICH THE SOLAR ELEVATION ANGLE EXCEEDS
45° AS A FUNCTION OF SEASON AND TIME OF THE DESCENDING
NODE. AREAS COVERED ARE BOUNDED BY THE APPROPRIATE CURVES

The results indicate that nadir-reflected solar instrumentation has a quite limited geographic coverage under the given conditions. Improved performance can be expected if elevation angles of less than 45° can be used. The selection of a non-Sun-synchronous orbit would improve the coverage to some extent although the dominant feature remains the variation of the Sun's position throughout the year.

The occurrence of cloud cover over the globe, as well as instruments relying upon ocean radiation as a source, also limit sensitivity. As noted in Section 5.1.4, significant limitations in the operation of near-infrared instrumentation can be anticipated under those conditions, thus further reducing the area coverage.

6.2.3 Nadir-Thermal Source

The operation of nadir-thermal emission instrumentation is not influenced by the Sun's position, with the possible exception that specular reflection of sunlight cannot be directly incident on the receiver. In general, nadir-thermal instruments can be expected to provide day/night, global coverage and can provide frequently sampled data utilizing both Sun-synchronous and non-Sun-synchronous orbits.

6.2.4 Limb-Emission Source

As in the case of the nadir-thermal instrumentation, the position of the Sun is only critical for the limb-emission instrument insofar as it does not appear in the field of view of the receiver. Therefore, no significant demands are made on sensor orientation or orbital characteristics. However, the selection of an early morning (6-8 a.m.) Sun-synchronous orbit allows effective diurnal sampling.

6.3 Coverage Requirements

As discussed in some detail in Sections 2.0 and 3.0, many of the constituents of the stratosphere require global observation in order to determine their concentration, seasonal, and latitudinal variations.

These requirements impose several demands on the orbits chosen and, based on the work appearing earlier in this section, one may conclude that no measurement method/orbit combination can satisfy all of the coverage requirements. A review of Section 6.2 reveals that both diurnal and seasonal sampling cannot be provided by either the solar occultation or nadir-reflected solar instrumentation in Sun-synchronous orbits due to their demand on the relative position of the Sun (which, of course, is a seasonal factor). The thermal emission instrumentation (described in Sections 6.2.3 and 6.2.4) are superior in terms of their coverage capability although their sensitivity may be lower.

The conclusion is that, based on the classes of instrumentation identified in Sections 6.2.1 thru 6.2.4, coverage requirements from a Sun-synchronous orbit are met sufficiently well to monitor the detailed temporal and spatial variations of stratospheric constituents only in the cases of nadir thermal and limb-emission instruments. The selection of a non-Sun-synchronous orbit will improve the coverage of the solar occultation class of instruments, but will not provide polar coverage. In order to obtain the temporal sampling rates demanded by some constituents, it may be necessary to use multiple satellite systems.

7.0 SYSTEM COMPARISONS

In making technical evaluations of any sensor system, the most important considerations are obviously, how well the instruments perform the required mission. When the comparison involves instruments which have not been built and the mission concerns targets which have not been selected, or at least universally agreed upon, the comparison methodology must differ from the more concrete cases*. In this section, the instrument pairs selected by NASA will be examined within the orbital constraints given in Section 6.0.

The actual pairing of the systems to be examined represents a mix of approaches between species detection and measurement technique evaluation. In the case of LACATE vs. SAGE II, they are both limb-lookers but one (SAGE II) operates on solar occultation and the other (LACATE) on atmospheric line emission. For SAM II and VRPM, they are each aerosol detectors but one uses solar occultation (SAM II) and the other (VRPM) is a nadir-viewer using reflected solar radiation. The last pair, CIMATS vs. MAPS II is more complex. They are both nadir-viewing, but CIMATS can operate on either reflected solar or thermal radiation in that mode, or function as a limb-viewer. MAPS II has the added capability of measuring aerosol concentrations as well as gaseous constituents.

Each pair of sensors will have the pertinent technical and operational data listed on its own chart (Tables VII-1 thru VII-3). The

* Most of the documentary information available for this comparison was preliminary in nature. Many cited instrument parameters are certain to change before a final design is effected.

last column includes general comments and qualitative observations on each instrument.

The following paragraphs will synopsise the material contained in the charts and make the somewhat qualitative conclusions allowed by the available data and the mission constraints. It should be noted that for different orbits the conclusions could, undoubtedly, be different and, in some cases, completely reversed.

7.1 LACATE vs. SAGE II (Table VII-1)

In terms of species measured, LACATE has an overwhelming advantage over SAGE II. Even though the final selection of parameters may modify the list of species, the flexibility inherent in LACATE gives it a higher rating. The same is true for the second column of Table VII-1 where it is observed that LACATE is operating in the thermal IR region with the advantage of day-night operation. In terms of the field of view (FOV), SAGE II is superior. The narrower FOV implies potentially higher spatial resolution, all other factors being equal. Although the expected instrument accuracies given in column four would indicate an advantage for LACATE, it should be noted that those for SAGE II are within the desired accuracies for the species, as defined by the user's need study. The dynamic range comparison rates a similar comment, both would appear adequate for the mission.

It is in the area of global coverage that SAGE II will be most deficient with a Sun-synchronous orbit. Predicated upon the given orbital parameters, given in Section 6.0, only the polar and high latitude regions will receive coverage, and even they will have but four repeat visits per year.

ORIGINAL PAGE IS
OF POOR QUALITY

TABLE VII-1
LACATE VS SAGE II

SPECIES	METHOD		WAVELENGTH (μm)		FOV (mr) HXV		EXPECTED ABSOLUTE ACCURACY (%)		DESIRED MEASURE- MENT ACCURACY	DYNAMIC RANGE		BACKGROUND RANGE	GENERAL COMMENTS*	
	LACATE	SAGE II	LACATE	SAGE II	LACATE	SAGE II	LACATE	SAGE II	%	LACATE	SAGE II	(density ratio)	LACATE	SAGE II
CO ₂	LE	-	15*	-	2.5 x .38	-	11 2.7*	-	0.5	2000 *500	-	~500	<p style="text-align: center;"><u>COVERAGE</u></p> <p>Complete global, Only Polar and diurnal capability high latitudes, <4 return visits/ year</p> <p style="text-align: center;"><u>SPECIES OBSERVED</u></p> <p>8, plus tempera- 2 to 3 ture profile</p> <p style="text-align: center;"><u>AUXILIARY DATA REQUIRED</u></p> <p>None Temperature & Pressure profiles (for refraction effects) Solar Limb Dark- ening data (for extinction co- efficients)</p> <p style="text-align: center;"><u>SCAN REQUIREMENTS</u></p> <p>Capability for 180° Azimuth +90° azimuth notation each +6° to -5° half-orbit Elevation for <6% Elevation for Limb-track solar acquisition/ lock-on</p> <p>*Based upon 99.3° sun-synchronous orbit</p>	
NO ₂	LE	50	6.2	0.4	2.5 x 1.0	0.5 x 0.5	7	**	50	72	1000	~20		
H ₂ O	LE	-	6.3	-	2.5 x 1.0	-	0.47	-	15	600	-	~1000		
CH ₄	LE	-	7.8	-	2.5 x 1.0	-	0.28	-	20	371	-	~1000		
O ₃	LE	SO	9.6	0.6	2.5 x .38	0.5 x 0.5	4.2	≤5	<10	2857	1000	~100		
N ₂ O	LE	-	17	-	2.5 x 1.0	-	1.5	-	25	286	-	~20		
HNO ₃	LE	-	11.3	-	2.5 x 0.5	-	0.46	-	15	628	-	~200		
Aerosols	LE	S)	10.8	0.3, 0.45, 1.0	2.5 x 0.5	0.5 x 0.5	0.32	<10 †	20	429	1000	~400		
	LE = Limb Emis- sion	SO = Solar Occul- tation	* 3 channels				*narrow band channel	** not known †depends upon size		*narrow band channel				

Based upon species measured, versatility, and adaptability to Sun-synchronous orbits, LACATE is the preferred instrument as compared to SAGE II.

7.2 SAM II vs. VRPM (Table VII-2)

These instruments are the only single species devices being considered for the future stratospheric measurement satellite mission. They each measure aerosols, but by different techniques. SAM II observes the solar disk at sunrise and sunset and measures the extinction, at three wavelengths, caused by aerosols. VRPM measures the degree of polarization, intensity, and polarization angle at three visible wavelengths of the backscattered flux.

The extremely narrow field of view of SAM II gives it the capability of higher vertical resolution than that of the VRPM. Expected instrument accuracies are nearly equal and, thus, provide no basis for ranking. Similarly, due to the observed phenomena, the dynamic range of the VRPM is greater than that postulated for SAM II but the latter is adequate for the anticipated background range.

Based upon the given Sun-synchronous orbit, the coverage for the VRPM is much greater than that of SAM II. SAM II requires 180° slewing each orbit for solar acquisition whereas VRPM can scan across the satellite ground track.

Any selection of these instruments must depend upon the proposed users of the data. If the highest priority is given to knowledge of the aerosol vertical profile, then SAM II is clearly the instrument to

TABLE VII-2
SAM II VS. VRPM

SPECIES	METHOD		WAVELENGTH (μm)		FOV (mr)		EXPECTED INSTRUMENT ACCURACY		DESIRED MEASUREMENT ACCURACY	DYNAMIC RANGE		BACKGROUND RANGE	GENERAL COMMENTS*	
	SAM II	VRPM	SAM II	VRPM	SAM II	VRPM	SAM II	VRPM	%	SAM II	VRPM		SAM II	VRPM
Aerosols	SO	BF	1.0, 0.38, 0.43	0.46, 0.6, 0.69	0.29	52	3.2 × 10 ⁻³ *	1% (for inten- sity	20	429*	1000	~400	<p><u>COVERAGE</u></p> <p>Only Polar and high latitudes, <4 return visits/year</p> <p>Complete global, day operation only</p> <p><u>SCAN REQUIREMENTS</u></p> <p>180° Azimuth rotation each half-orbit; +4.5° elevation</p> <p>+47° along ground track</p> <p>+47° in azimuth</p> <p><u>AUXILIARY DATA REQUIRED</u></p> <p>Solar Limb Darkening data (for extinction coefficients)</p> <p>Solar angle</p>	
	SO = Solar Occula- tion	BF = Back- scatter- ed Flux					* not given - data from SAGE II sources							
													*Based upon 99.3° Sun-synchronous orbit	

7-5

ORIGINAL PAGE IS
OF POOR QUALITY

use. The limited high latitude coverage given by the Sun-synchronous orbit could prove to be an overriding deficiency for some users, but this problem is solvable by choosing a different orbit. If the most desired result of the experiment is a generalization of the aerosol size distribution, then VRPM would be the preferred instrument. The information content of the VRPM data is much greater than that obtained by a simple absorption measurement and has application in a variety of studies. SAM II measurement of limb attenuation provides the vertical distribution of aerosols, while VRPM analysis of backscattered radiation provides an average aerosol distribution of the total atmospheric path (which may be more representative of the troposphere). Subsequent experiments will determine the degree to which ground reflectance and polarization may degrade the data.

7.3 CIMATS vs. MAPS II (Table VII-3)

These two instruments are the only ones proposed for future satellite missions which utilize correlation techniques. CIMATS performs the correlation upon an interferogram while MAPS II uses samples of the gas of interest to obtain a reference signal.

Both instruments are, primarily, nadir viewing devices, but CIMATS retains the added capability of operating in a limb scan mode.* Each may operate in either the solar or thermal regions of the IR spectrum. CIMATS has a smaller instantaneous field of view than MAPS, implying much greater spatial resolution.

*CIMATS will be compared with MAPS II only in its nadir-viewing mode.

TABLE VII-3
CIMATS vs. MAPS II

SPECIES	METHOD		WAVELENGTH (μm)		FOV (mr)		EXPECTED INSTRUMENT ACCURACY		DESIRED MEASUREMENT ACCURACY	DYNAMIC RANGE		BACKGROUND RANGE	GENERAL COMMENTS*	
	CIMATS	MAPS II	CIMATS	MAPS II	CIMATS	MAPS II	CIMATS	MAPS II	%	CIMATS	MAPS II		CIMATS	MAPS II
NO	Nadir view	Gas Filter	5.3	5.3		122	10%		50	N/A	N/A	~20	<u>AUXILIARY DATA REQUIRED</u>	
NO ₂	view of reflected	Correlation	6.1	3.3, 7.6			10%	6%	50			~20	Weighting functions for separation of interfering species; reflectivity, cloud cover, water vapor	
N ₂ O	or Thermal and Solar	NADIR viewing	2.9	-	35 (nadir)		10%	-	25			~20	interferograms of desired species	
SO ₂	Occulation thru Earth		7.3	4.0, 8.6			30%	25%	100%				<u>COMPLEXITIES</u>	
CO	Limb		2.35	2.3, 4.6	2 (Limb)		10%	10%				~20	Extensive processing of collected data	
CO ₂			2.0	1.6, 2.1			10%	1%	0.5			~500	Mechanically complex	
NH ₃	Correlation Interferometer		2.2	3.0, 10.5			10%	7%	100					
CH ₄			2.35	3.3, 7.6			10%	4%	20			~1000		
C ₂ H ₄			3.35	-			10%	-						
C ₂ H ₆			3.35	-			10%	-						
HCl				-					100					
HNO ₃				-					15			~200		
H ₂ CO				3.5										
			5 to 7 gases to be chosen from above list										*Based upon 99.3° sun-synchronous orbit	

ORIGINAL PAGE IS
OF POOR QUALITY

7-7

In terms of expected instrument accuracies, the proposed sensitivity for MAPS II appears better than that of CIMATS. On the other hand, CIMATS is capable of measuring more species than MAPS. It also should be noted that, with the single exception of CO₂, each instrument claims more accuracy than the requirements identified from the user's need section. Dynamic range is apparently not a dominant factor for correlation techniques, as the strength of the radiometric signal is not an important criteria for the data analysis.

Both instruments are self-calibrating by means of cold space viewing ports. MAPS II will also utilize the temperature controlled instrument cavity for a balance check and small black body sources for calibration. In terms of supporting data requirements, both require additional data for analysis. For CIMATS, the selection of the weighting function implies a prior knowledge of the interfering species. MAPS II, on the other hand, requires ground temperatures and reflectivity, water vapor and temperature profiles, and cloud cover data.

Each instrument is comparatively complex in its own way. CIMATS requires two cross correlations of the collected data and MAPS II is extremely mechanically complex. It is this latter deficiency which is most severe for unmanned operation, since the complexities of CIMATS may be handled on the ground, by computers. Therefore, CIMATS, as of now, is the preferred instrument. Subsequent testing may reveal other problems and short-comings with each instrument.

8.0 CONCLUSIONS

All of the data presented in this report may be conveniently organized into three generic areas for summarization:

- Current measurement capability,
- Users' requirements, and
- Projected systems analysis

Each of these areas has been treated in detail above and will be summarized in this section. Where applicable, tabular data have been used to clarify the results.

8.1 Current Measurements

The material generated in Section 3.0 indicates three key conclusions:

- (1) The performance of current remote stratospheric sensors, in some cases, compares quite well with identified measurement requirements. Their ability to measure other species has not been demonstrated. A number of in-situ methods also exist with comparable sensitivity and accuracy but whose measurements are of limited utility, given their spatial and temporal sampling characteristics.
- (2) None of the current, in-situ methods have the capability to satisfy the requirements for global monitoring and the temporal constraints derived from the users needs portion of the study.

(3) Existing, non-remote techniques will continue to play an important role in stratospheric investigations for both corroboration of remotely collected data and in the evolutionary development of future remote sensors.

Table VIII-1 summarizes current remote sensing accuracies for certain constituents and compares these accuracies with anticipated satellite sensor systems.

8.2 User Requirements

Material utilized in the selection of requirements for stratospheric monitoring have been derived from both the user needs survey as well as the detailed investigation of data needed for a better understanding of stratospheric chemistry. In addition, a review of current measurement methods examined the quality of data currently available for a variety of gases of interest. The proposed accuracy requirements reflect improvements, where required, over current limitations.

In many cases no specific requirements have been expressed for spatial or temporal sampling. In view of the generally infrequent and localized nature of current measurements, any satellite monitoring system will represent an improvement in these categories. It is anticipated that the need will exist for global coverage at a rate which provides data on diurnal and seasonal variations as well as longer term trends.

TABLE VIII-1
CURRENT AND PROJECTED MEASUREMENT CAPABILITY

SPECIES	20 km BACKGROUND	ACCURACY		SATELLITE ⁽⁴⁾
		REQUIRED	CURRENT	
CO ₂	330 ppmv ⁽¹⁾	0.1% ⁽²⁾	6% ⁽³⁾	~10% (C) ~1% (M)
O ₃	6 ppmv ⁽⁵⁾	10% ⁽⁵⁾	10% ⁽⁶⁾	~7% (L)
H ₂ O	3 ppmv ⁽¹⁾	30% ⁽²⁾	12% ⁽³⁾	<9% (L)
CO	50 ppbv	20% ⁽²⁾	5% ⁽⁷⁾	~10% (M) (C)
HNO ₃	3 ppbv ⁽⁵⁾	30% ⁽⁵⁾	30% ⁽⁸⁾	<30% (L)
CH ₄	1 ppmv ⁽⁵⁾	20% ⁽⁵⁾	5% ⁽³⁾	~4.3% (M) <17% (L) ~10% (C)
N ₂ O	0.1 ppmv ⁽⁵⁾	5% ⁽⁵⁾	10% ⁽³⁾	<13% (L) ~10% (C)
NO	0.1 ppbv ⁽⁵⁾	50% ⁽⁵⁾	35% ⁽⁸⁾	~10% (C)
NO ₂	2 ppbv ⁽⁵⁾	50% ⁽⁵⁾	20% ⁽⁸⁾	~6% (M) <30% (L) ~10% (C)

NOTES:

- (1) CIAP summary.
- (2) From Table IV-1
- (3) Farmer, C. B., *Canad. J. Chem.*, 52, 1554, 1974.
- (4) (C): CIMATS, (L): LACATE, (M): MAPS: all estimated by developers.
- (5) From Tables IV-2 and IV-3.
- (6) Total ozone. Mateer et al., *J. Atmos. Sci.*, 28, 1307, 1971.
- (7) Goldman, et al., *J. Geophys. Res.*, 78, 5273, 1973.
- (8) Fontanella, J., et al., *Appl. Opt.*, 14, 825, 1975.

The set of requirements is consolidated and presented in Table VIII-2. While this is not intended to be a complete list, it does represent a reasonable set of long-term monitoring goals. As can be seen in Table VIII-2, many of these constituents need only be measured to within a factor of two to provide either improved or initially useful data. As our understanding of the stratosphere matures, various constituents will receive more or less emphasis with respect to sampling and data quality. While this table is presently current, changes should be anticipated, particularly with measurements which exceed the current requirements.

It should be noted that these requirements have been generated independently of any instrument considerations. Therefore, this material represents a set of performance goals for contact or remote sensors placed on airborne, orbiting, or terrestrial platforms. In the case of those species not yet measured, airborne measurements should receive considerable attention in order to establish background levels and to corroborate proposed remote sensing techniques.

8.3 Projected Sensor Systems

8.3.1 General Characteristics

The general features of remote sensors of the stratosphere aboard a satellite platform are described in Table VIII-3. Several key features are to be noted:

- (1) nadir-viewing instrumentation provides superior performance in the areas of horizontal resolution and measurement time per orbit

TABLE VIII-2
SCIENCE REQUIREMENTS FOR MONITORING IN THE STRATOSPHERE

CONSTITUENTS	ACCURACY*	TEMPORAL SAMPLING	SPATIAL SAMPLING	SIGNIFICANCE
O ₃	Vertical profile 10% Total column 1%	Daily	Global on 100 km grid	Key gas of stratosphere
HCl	100%			1 2
Cl	100%			1
ClO	100%	After volcanic activity		1
CF ₂ Cl ₂	100%			1
CFCl ₃	100%			1
OH	100%			1,2
CH ₄	20%			1
O	100%			1,2
NH ₃	100%			1,3
NO	50%			2
NO ₂	50%			2
HNO ₃	30%			2
N ₂ O	5%	Periodically		2
N ₂ O ₅	100%			2
Aerosols		After volcanic activity		
Particles		After volcanic activity		
SO ₂	100%	After volcanic activity		3
H ₂ S	100%			3
H ₂ O	30%	After volcanic activity	Latitude Variations	3

*100% corresponds to an error band equal to twice the actual concentration

- 1- participates in ozone destruction utilizing chlorine
- 2- participates in ozone destruction utilizing NO_x
- 3- participates in aerosol formation

TABLE VIII-3

PROPERTIES OF STRATOSPHERIC REMOTE SENSORS

	NADIR			LIMB	
	Earth Emission	Atmospheric Emission	Reflected Solar	Atmospheric Emission	Direct Solar
Sensitivity	poor	poor	fair	good	good
Horizontal Resolution	good	good	good	fair	fair
Vertical Resolution	x	x	x	good	good
Insensitivity to Clouds	poor	fair	poor	good	good
Night Operation	good	good	x	good	x
Measurement Time per Orbit	good	good	fair	good	poor

Note: x indicates that the instrument cannot perform this function.

- (2) limb-viewing instrumentation provides superior sensitivity, and vertical resolution

In most other areas, the two basic monitoring methods are equally capable. The science requirements include the need for vertical profiles and data of fairly high quality. Limb-viewing instrumentation appear to satisfy these needs but provide limited temporal sampling for solar occultation when certain orbits are used. As a result, instrumentation of the limb emission type represent the optimum choice. In general, this type of instrument has the potential of satisfying scientific requirements for vertical profiles as well as those for spatial and temporal sampling.

Orbital considerations emerge as a key element in the applicability of various sensor systems to specific measurement roles. Sun-synchronous orbits provide optimum coverage for nadir-viewing, thermal source sensors and limb-viewing emission source sensors. High angle non-Sun-synchronous orbits are preferred for nadir-viewing reflected solar source or limb-viewing solar occultation sensors, if geographical coverage is to be maximized.

8.3.2 Proposed Sensor Systems

The group of sensors reviewed in this study appear in Table VIII-4 as they relate to the list of identified measurement requirements. A number of the required constituents, such as the chlorine compounds, cannot be monitored by the instruments as now envisioned. This is a result of the rapid increase in our understanding of the

TABLE VIII-4

RECOMMENDED CONSTITUENTS FOR A STRATOSPHERIC MONITORING PROGRAM

<u>Constituent</u>	<u>Required Accuracy*</u>	<u>Measurement Proposed By</u>	<u>Estimated Instrument Accuracies</u>
O ₃	<10%	SAGE II, LACATE	7%
HCl	100%		--
Cl	100%		--
ClO	100%		--
CF ₂ Cl ₂	100%		--
CFC1 ₃	100%		--
OH	100%		--
CH ₄	20%	CIMATS, LACATE, MAPS	4%-17%
O	100%		--
NH ₃	100%		--
NO	50%	CIMATS, MAPS	10%
NO ₂	50%	SAGE II, CIMATS, LACATE	6%-30%
HNO ₃	30%	CIMATS	<30%
N ₂ O	5%	CIMATS, LACATE	10%
N ₂ O ₅	100%		--
SO ₂	100%		--
H ₂ S	100%		--
H ₂ O	30%		--
Aerosols	--	VRPM, SAM II, SAGE II LACATE	--

*100% corresponds to an error band equal to twice the actual concentration.

stratosphere, and the finite times required for instrument development. Presumably, future instrument designs will reflect these latest additions to the set of important stratospheric constituents.

Several other gases have not as yet been selected for measurement (OH, O, N₂O₅, SO₂, H₂S, H₂O). Extension of current instrument performance to include these species should receive prime consideration. If future experiments and related model developments confirm their importance, they should be included in future spacecraft instrumentation.

APPENDIX A

ORBIT CALCULATIONS

Consider a spherical coordinate system fixed with respect to the terminator and as a simplifying assumption, let the orbit be truly polar and Sun-synchronous (see figure below). Then the position of the terminator is the range of values $180 > \theta > 0$ and $\phi = 0$. The assumption of a truly polar orbit has only a minor effect on the data obtained but simplifies the computations significantly. Since only nominal values for the latitude coverage and solar elevation are required, this approximation is justified. The pole, the associated latitude-longitude grid of the Earth, move as $\theta = 23.5 \sin \mu$, and the orbit such that the nodal crossing time is essentially constant.

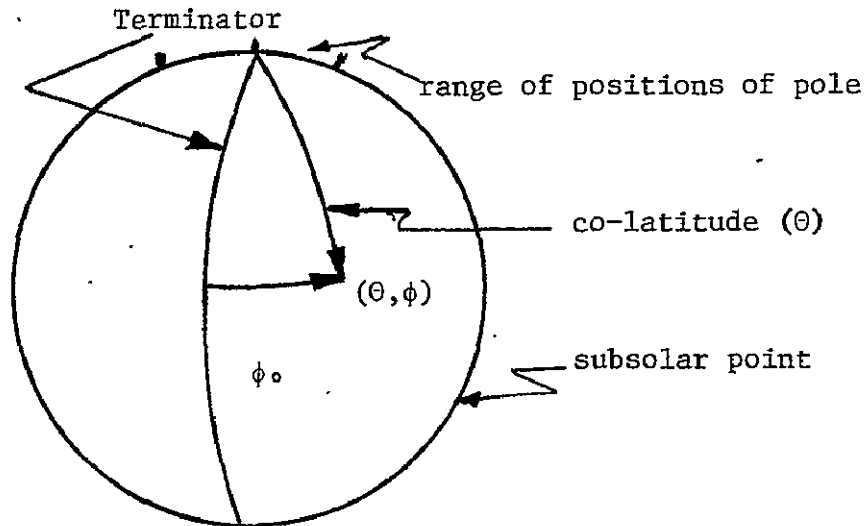

The subsolar point is $\theta' = 90^\circ \phi' = 90^\circ$.

The solar elevation γ along a suborbital track is given by

$$\begin{aligned} \sin \gamma &= \sin \theta \sin 90 \cos(90-\phi) + \cos \theta \cos 90 \\ &= \sin \theta \sin \phi. \end{aligned} \tag{1}$$

On the vernal equinox, θ equals the co-latitude and $\phi_0 = \frac{\text{hour}-6}{6} \times 90$.

Thus for a 9:30 orbit

$$\sin \gamma = \sin \theta \sin 53^\circ$$

Such a calculation also applies to the autumnal equinox. At all other times of the year, the relationship between θ , ϕ and the latitude must be computed.

Application of spherical trigonometry to the problem shows that

$$\sin (\text{latitude}) = \cot \left[\cos^{-1} \left(\cos \phi_0 \cos(\theta - \alpha) \right) \right] \tan \phi_0 \quad (2)$$

$$\alpha = 23.5 \sin N$$

$$\phi_0 = \frac{\text{hour}-6}{6} \times 90$$

and

$$\phi = \cos^{-1} \left[\tan (\theta - \alpha) \cdot \cot \left[\cos^{-1} \left(\cos \phi_0 \cos(\theta - \alpha) \right) \right] \right] \quad (3)$$

Thus Equations 1, 2 and 3 are utilized to compute the solar deviation as a function of latitude and season of the year.

APPENDIX B

CLIMATIC DATA USER SURVEY

The information referenced in Section 4.4.4 and 4.4.5 was obtained during the interviews listed in Table IV-6. The details follow organized by institution and research area as appropriate.

National Center for Atmospheric Research (Boulder, CO)

Climate Modelers (Drs. Dickinson and Coakley)

- Model Characteristics - They are actively developing one- and two-dimension climate models which are relatively simple for computational expediency. Their interest is a prediction of interannual variability of features like mean temperature to within one percent (and relative humidity). Radiation factors such as shortwave and longwave are averaged over the entire globe in order to determine temperatures at the surface and at 500 mb in order to get the mean lapse rate. The model assumes that all surfaces are Lambertian. An important factor is that these models assume radiative equilibrium so that changes in the solar constant are matched by changes in IR emission.
- Data Applications - Two basic uses for measured data can be identified. These are: 1) model inputs and, 2) validation data. In the area of inputs, albedo properties would be particularly useful since the models are quite sensitive to this parameter; Even albedo measurements accurate to ten percent over 10° to 20° zones would be valuable. Properties of the radiative features of clouds would also be useful for parameterization and are generally important (especially cloud-top height and temperature). Globally averaged net radiation measurements, as have been proposed, would be of use if it could be monitored to 0.1 percent over one-year averages. Experiments that would be useful in measurements of this type include: 1) backscattered visible radiation averaged over various sun angles, 2) longwave emission, 3) surface temperature as obtained from microwave radiometry, 4) upper air temperature measured at 500 millibars and, 5) cloud-top temperature and albedo.

Validation applications would include measures of the globally averaged temperature at the ground and 500 mb. In order for this data to serve in a validation role, at least three years

of good data are required (to show interannual variability) with any longer performance welcomed. Currently, cloud archives are used to check the gross scale performance of models. Validation of sea-surface temperatures may require such measurements. It should be pointed out that mean values are particularly important to modelers of this type and as a result, absolute measurements are not essential for model validation or input.

- Assessment - According to these workers, existing archives have interesting features they might be able to use, but it is too early to tell since their model is not developed to the point where they can begin testing it. For example, it is not clear if multi-layer cloud monitoring is required for validation of the results. One to three years may be required for this development. In order to be of value, measurements need to be absolutely accurate to only ten percent, since trends or departures from the mean are more important. In this regard, it is clear that improved ground calibration is required to confirm the remotely sensed measurements. Specification of clouds and cloud properties are of particular interest in this case (relative humidity and/or its profile would also be of value even as a yearly average). Radiation data by itself is insufficient to be of much help. In addition, it demonstrates too much seasonal variation. Long-term averages of trace gases might be of importance. Cloud parameterization and temperature profiles (at least two points) are required for zonal averages. The access to trace gas data would not have a significant impact on their model development. Clearly, they see the need for better definition of user requirements before experiment development and specifically noted the need for improved communication between the user and instrument designer communities. They cite the incompleteness of the proposed experiments which have developed quite a bit without any attention to cloud physics, which they see as important. They also would tend to doubt results from long-term global net radiation measurements, since they expect variations to be smaller than instrument uncertainties.

Global Circulation Modelers (Warren Washington, Takashi Sasamori, Akira Kasahara)

- Model Characteristics - The NCAR GCM is used to perform long-term integrations of weather systems and then to obtain averages (in time) to represent average distribution of properties which are then checked against observed climate averages. Some of the features studied are mean cloudiness and sea-surface temperature. The model has one to two degree spatial resolution and is commonly used to detect interannual seasonal variations for comparison with observations. They

also inspect the results to determine if properties of importance such as the Gulf Stream and Intertropical Zone (ITCZ) are reproduced on an average basis. Current research is concentrating on the causes of climatic change including atmosphere-ocean interactions and the coupling of clouds and average temperature. One aspect receiving attention is improved parameterization, since the physical equations are well developed.

The model currently has a two-level cloud system which predicts monthly average cloudiness. In addition, there is a great sensitivity between the cloudiness and the average global temperature. Initial work in this area shows the vertical currents should also be involved in this relationship.

The current model uses a fixed ocean temperature derived from climatology data which is updated on a monthly basis as the integration proceeds. More realistic ocean-atmosphere interaction models exist (at Geophysical Fluid Dynamics Laboratory of NOAA at Princeton, NJ) but consume large amounts of computer time.

Of course this model, when used for a short-term simulation, is designed to predict weather. Integrations carried out for more than one year of simulations show good stability and simulation. The stability is probably the result of strong filtering (smoothing) in numerical techniques.

- Data Applications - Shortwave, longwave and solar constant measurements as proposed by the various instrumentation groups will only be used for verification, but not as initial inputs to the model except to develop a more realistic albedo field. Information trends and coarse parameterization of these radiometric factors would be of some use also. One-year experiments of radiation budget would also be helpful if the data were good to one percent. Iterative models which utilize data to improve the model calculations could be developed around the data by either modifying the temperature structure or the wind structure within the atmosphere. Higher resolution (spatially temporally or radiometrically) is required for short periods (those less than a year). Also, angular emissivity and reflectivity of surfaces such as cloud tops would be of use. Such experiments help us understand the physics of global circulation models which will, no doubt, help the long-term prediction problem eventually. In addition, ice coverage as commonly determined by microwave radiometry would be a useful added experiment. Also of interest would be any measurements of the liquid water content of clouds,

the temperature, relative humidity or polarization (generally on a scale of about $5^\circ \times 5^\circ$). Tracking wind fields using temperature profiles as a check and input could be implemented. As a related experiment, determination of the temperature profile by inversion of the radiative transport equations could serve as further verification. Humidity and its profile is of less use and trace gases have little value except the ozone distribution, which is currently put in on a monthly mean into the model. Cloud properties are quite important in the model and vertical distribution of the cooling rate is also important.

Other experiments which could be helpful in this area are:

- cloud height and top temperature twice a day on a grid of 200 to 300 km and,
 - wind data in the tropics.
- Assessment - Low resolution data is not particularly useful. Latitude and longitude resolution is required to validate the model. Cloud information might be useful, but would require a method for including it in the model, although there shouldn't be any problem. For climate applications, a long-term crude experiment would suffice while for validation of physical processes finer radiometric and spatial resolution must be provided. Within three years, an atmosphere-ocean interactive model will exist which will define measurement requirements more clearly as well as allow a more complete sensitivity analysis.

Cloud data is also clearly required here, supported by a well developed wind field (also probably observed from satellite). Some data, in the form of the albedo field, is currently utilized as derived from earlier missions, but unless a significant improvement in the data can be anticipated, little is to be gained from new experiments. In addition, the ultimate limits of such modeling have begun to receive some attention.

Clearly these modelers feel that GCM's utilize a more basic set of physical principles and should be supported by any measurement programs in preference to the climate models, which ignore a number of physical processes and thereby have less potential for an eventual understanding on a useful scale.

Numerical Weather Prediction (David Baumhefner, D. Williamson)

- Model Characteristics - Basically GCM models in various forms are used in an experiment to determine the short-term modeling limitations. It has been known for some time that errors in the forecast grow unstable due to errors in the initialization data base, but considerable interest now exists as to why the degradation in predictability occurs so early in the prediction period. Some topics being considered include insufficient initialization data, parameterization error, or incomplete understandings of the physics of the problem.

The tentative conclusion of the study is that there is something rather fundamental which we do not currently understand and which must be resolved before any hope can be had for using GCM models to predict climate with confidence.

- Data Applications - Currently data from NIMBUS and SMS is utilized, but the usefulness of such information (as well as that anticipated from GARP) is limited due to several points:
 - 1) Radiation and cloud properties can be left out of the model without much effect on the results.
 - 2) Errors in satellite data are too large to allow proper implementation into the programs. Particularly important are systematic errors which are common in such data, therefore, suggesting the need for redundant measurements to reduce measurement uncertainty to only random error.
 - 3) Sampling limitations are important, particularly in four-dimensional assimilation schemes where model output and input are compared to reduce errors.
 - 4) Resolution smaller than 5° GCA is required to really assist in this effort.
- Assessment - As noted above, the utility of spacecraft data for this problem is limited by a number of features. It appears that more work must be invested in the areas of the model requiring more attention before a really useful experiment can be defined.

General Comments (Francis Bretherton, John Masterson)

Two points are clear. First, the proposed radiation climatology experiments have clear limitations in their ability to serve the major user groups within NCAR. These limitations have been identified as:

- poor spatial resolution,
- inability to measure true albedo or bidirectional scattering coefficient,
- requirement for composite data on clouds obtained over periods of time which preclude assessment of individual cloud parameters,
- insufficient maturity in NCAR models to define experiment and measurement requirements,
- a significant sampling problem which may, in fact, become more important than individual measurement uncertainties,
- questionable value for the usefulness of long-term experiments designed to measure global net flux even if done to less than one percent. This concern is based on the assumption that variations will be very small and will therefore be difficult to isolate from instrument artifacts and,
- systematic errors are quite common which seriously limit the usefulness of the data.

Second, the large archive of data already obtained from space has not yet been fully utilized. It is true that the data quality is not as high as can be expected from more advanced experiments, but it would be of value to completely explore the importance and utilization of that which is available.

The ability to clearly specify what experiments should be performed will require three to four years of further model development. However, some general recommendations can be made now.

Recommendations for future experiments include:

- Determine the interannual variation in equator to pole net radiation.
- Study the trade-off between orbit lifetime, orbit altitude, spatial resolution and sampling capability.
- Guarantee the quality of the remotely sensed data with the best possible ground truth.
- Try now to begin to identify available workers who will be available for data analysis. This may create problems since the First GARP Global Experiment (FGGE) will be underway and will be demanding attention from much of the atmospheric modeling community. However, the provision of data of this type has the potential to support, in a unique fashion, the work proposed for the FGGE period.
- Consider the use of balloons for monitoring of the radiation budget either alone or in conjunction with the proposed spacecraft experiments as ground truth data.
- Use composite information on clouds to determine their radiation properties recognizing that this method provides only incomplete information.
- Measure on at least a 20° GCA grid.
- Radiation balance over large ocean areas every few months for at least 15 years.
- Monitor sea-surface temperature.

Colorado State University (Tom Vonder Haar)

- Current Data Utilization - Information obtained from earlier experiments on the radiation climatology of the Earth are currently being used by a number of workers including: Murray Mitchell (NOAA), Kirby Hanson (NOAA, Boulder), Mintz (UCLA), Larry Gates (Rand), Warren Washington and others at NCAR.

In addition, a larger list of users exists for the data which is currently being obtained from ERB aboard NIMBUS-F.

Also, it should be clear that any new experiments serve a community larger than just those who are modelers. A number

of interested scientists utilize the data without any specific interest in prediction or modeling, but only a curiosity about statistical or physical relationships between elements of the Earth-atmosphere-ocean system. For those workers, the development of an archive of radiation budget data will provide a source of information obtainable from no other source.

- Recommendations - Any team proposing a spacecraft mission of this type should include an analyst who can identify as large a number of potential users as possible. In recognition of the fact that the SERM instrumentation to be put on TIROS-N is flat plate, any other spacecraft to be launched during that period should also utilize flat plate radiometers in order to allow the most effective intercomparison of the sensors. Sampling limitations and their impact on data utilization must be more completely analyzed. When these studies are performed, recognition should be made of the fact that the modeling community is not the only group which has an interest in the quality of or quantity of data. Specifically, those who study physical processes or statistical correlations between factors involving climate properties and radiation budget data will also find the information useful. As a result, there is considerable justification for guaranteeing that a high-quality and continuously growing archive be established whether the models are prepared to accept the data or not.

University of Arizona (W. Sellers)

- Current Data Utilization - The most recent Seller's climate model requires only solar constant as input. It automatically computes a seasonally adjusted Earth albedo and ocean temperature. For generation of cloudiness, albedo and other variables, physical relationships very similar to those used in GCM models (for coupling interactions and parameterizations) are used. Albedo is assumed to have a lambertian character. This model is based on the hydrological cycle, much like GCM's, and is a first attempt to bridge the gap between statistical/dynamic climate models and the GCM's integrated over long periods of time. The model is started with a known initial solar constant and the various model parameters are adjusted to produce the current surface temperature distribution. Then sensitivity studies are performed.
- Assessment - Sea-ice and sea-surface temperatures are incorporated into the model if provided on a real-time basis. Such information on the oceans could be important since they are the crux of the climate modeling problem, being a very large and long-term heat reservoir. Five degree spatial resolution is required for these features.

Global net flux data is of little use since the changes are likely to be so small as to be indistinguishable from instrument fluctuations. Furthermore, global models assume a radiation balance so that detected deviations are of little value. However, it is clear that any data which can be provided will be used for comparison with model output if available. In this regard, any experiments which are proposed should not be delayed so that a complete data set can be begun and, hopefully, continued without interruption.

Rand Corporation (Drs. Rapp, Gates and Schlesinger)

- Model Characteristics - The model closely resembles the Mintz-Arakawa model and has just two levels. The number of levels does not seem to make a considerable difference in the quality of the simulations. Comparison with the six level models of NCAR and nine level models of Manabe indicate that they do no better in terms of predicting climate, in spite of the fact that this model is quite a bit faster to run. The interest in exercising the model is in establishing interannual variations, which could compare with satellite measurements after a period of about 10 to 15 years. Several tests of the models capabilities have been developed. They include determination of the overall behavior of the model and its correctness, especially in the area of predictability of long-term statistics of climate parameters.
- Assessment - To date much satellite data has been collected and used in an effort to establish the fidelity of the model output. Generally, the predictability can be tested by running the model for 10 Januaries and establishing the interannual variability as it compares with the measured values.

Geophysical Fluid Dynamics Laboratory, NOAA (Drs. Manabe and Oort)

- Model Characteristics - Major emphasis exists within GFDL for the development of an ocean-atmosphere interaction model. It is basically derived from a GCM in which the number of possible wave solutions have been limited so as to produce forecasts of one week to 10 days. In their view, to have an effective climate model, the influences of the ocean must be well understood and included.
- Assessment - Many of the sensitivity tests to be performed with the model have not yet been done. The three uses of data in model development include:

- 1) monitoring,
- 2) calibration of models and,
- 3) input for predictive modeling

In order to verify sea-surface temperature, satellite data is not required. Further, an important feature in initializing the model is determination of the near-surface thermoclines of the ocean which cannot be obtained from space.

In terms of radiation measurements, it was observed that a large archive exists which should and could be better utilized. Additions to that archive could be in the form of short-term high spatial and radiometric resolution, in order to support model development, but would require different features in order to serve the requirements of monitoring.

Experiments of the proposed type appear to be a natural support for the other activities to be carried out during the GARP FGGE. However, it still appears that definition of the radiative properties of clouds remain an area which requires considerable attention.

Global mean averages over one year will be useful if they can be corroborated with other measurements like sea-surface temperature or snow cover.

There is skepticism here over the methods chosen when developing measurement criteria. This is particularly true since little attention has been given to specifying the various requirements for the three main classes of uses above (GARP No. 16 being an exception).

Particular issues which they find important are:

- ocean currents,
- cloudiness prediction models,
- understanding of geostrophic eddys in the ocean and,
- interannual variability in ocean currents.

NOAA-NESS (Dr. W. Smith)

- Assessment - The ERB experiment aboard NIMBUS 6 is supportive to the monitoring community and provides an archive of data for that use only. The SERM instrumentation is designed for long-term monitoring and is not designed to provide bi-directional-scattering coefficients. Planetary trends are of academic interest only. The measurements of real significance are to be made on the regional scale. In terms of measurement priorities, first is radiation monitoring on a regional scale (using the small field of view channels of SERM). Second is the requirement for local data and last is the requirement for global measurements.

The production of regional data from the small field of view data will require a model of the radiance properties of the target before integration.

Radiation measurements are not the most important features of the climate to measure. Features like the sea-surface temperature, ice cover, etc., would be more valuable.

Massachusetts Institute of Technology (E. N. Lorenz)

- Current limitations in numerical weather prediction are basic to the physical processes involved. Particularly, there exists instability in the solutions to the equations of motion and the temporal and spatial scales of motion have nearly constant proportion. The resulting limitation on predictability results in a forecast of less than two weeks (for large-scale patterns) although this capability has not yet been developed.

In terms of experiment requirements, spatial resolution is of key importance and should be as small as possible. Furthermore, the sampling features of the experiment need not be designed to provide daily monitoring of the globe. Due to the stage of development of general circulation models, which have a potential for climate simulation, the recently proposed NASA radiation climatology experiment is premature.

Harvard University (R. S. Lindzen)

- The recently proposed radiation experiment is premature. We do not have enough physics to even know what we want to measure other than the solar radiation. All present models are too crude for this. We would do better by investing model experiment money to have bright graduate students to work into better and more complete physics. Paltridge's recent paper on a new

model based on a minimum entropy change is a bright new approach. This is the kind of thing we need. We are wasting enormous resources and time using global circulation and statistical-dynamic models way beyond their proper capabilities (for climate purposes). He cannot suggest what we should be measuring, because he doesn't know at the moment--come back in three or four years.

Office of Climate Dynamics of NSF (B. Fogel and J. Geisler)

- At this time there is little or no cooperation between this group and those people at NASA working in radiation properties as observed from space. This is mainly a result of the fact that those researchers supported by this office have not expressed a demand for such data.* While this office does not participate in the NCAR support it is clear that both NSF groups together cooperate heavily with NASA only on experiments related to GARP (such as FGGE and GATE).

Such cooperation would be advantageous to both groups, particularly in planning for experiments or monitoring of either long-term or short-term phenomena.

Other Sources

Other personal contacts have been utilized in the study. Some of those with whom we have had regular contact include:

Professor V. Suomi, University of Wisconsin

Professor Fred House, Drexel University

Mr. Harry Press, NASA/Goddard

Mr. Don Hilleary, NOAA/NESS

Dr. Herb Jacobowitz, NOAA/NESS

Dr. Ed Van de Noord, Ball Brothers Research Corporation

*In Geisler's view, the only researcher he is aware of doing such work is Tom Vander Haar of Colorado State University.

Others who had aided our efforts include:

Dr. J. Murray Mitchell, NOAA

Dr. S. Mudrick, AFCRL

Dr. Morris Tepper, NASA Headquarters

Dr. J. Winston, NOAA/NESS

Dr. Walter Orr Roberts, Aspen Institute for Humanistic Studies
Boulder, Colorado

Members of the National Academy of Sciences Ad Hoc Panel to Review
the NASA Earth Energy Budget Program.

Dr. F. Bretherton, NCAR

Dr. J. Gille, NCAR

Dr. J. M. Mitchell, NOAA

Dr. J. Strong, University of Massachusetts

Dr. V. Suomi, University of Wisconsin

Dr. R. S. Lindzen, Harvard University

BIBLIOGRAPHY

Chervin, R., W. L. Gates and S. Schneider, "The Effect of Time Averaging on the Noise Level of Climatological Statistics Generated by Atmospheric General Circulation Models," Journal of the Atmospheric Sciences, Vol. 31, No. 8, p. 2216.

Chylek, P. and J. Coakley, "Analytic Analysis of a Budyko-Type Climate Model," Journal of Atmospheric Sciences, Vol. 32, No. 4, April 1975.

Gleeson, T. A., "On Theoretical Limits of Predictability," Journal of Applied Meteorology, Vol. 6, No. 2, April 1967.

Lahiff, L., "A Low-Latitude Atmosphere-Ocean Climate Model," Journal of Atmospheric Sciences, Vol. 32, No. 4, April 1975.

Manabe, S., K. Bryan and M. Spelman, "A Global Ocean-Atmospheric Climate Model, Part 1, The Atmospheric Circulation," Journal of Physical Oceanography, Vol. 5, No. 1, January 1975.

Pitts, D., W. Reeser and M. Mendlowitz, "Equivalent Blackbody Temperature of the Top of a Severe Storm," Journal of Applied Meteorology, Vol. 14, No. 4, June 1975.

Sellers, W. D., "A Global Climatic Model Based on the Energy Balance of the Earth Atmosphere System," Journal of Applied Meteorology, Vol. 8, June 1969.

Weare, B. C. and F. M. Snell, "A Diffuse Thin Cloud Atmospheric Structure as a Feedback Mechanism in Global Climatic Modeling," Journal of Atmospheric Sciences, Vol. 31, No. 7, October 1974.

_____, "The First GARP Global Experiment," GARP Publications Series No. 11, March 1973.

DISTRIBUTION LIST

D-10

C. A. Zraket

D-11

Sy Blum

D-12

H. Benington

C. C. Grandy

D-15

S. Lewis

W-50

R. Greeley

M. Klein

R. Ouellette

W-51

J. Pfeffer

R. Pikel

W-52

G. Bennington

D. Blake

J. Carmichael (10)

L. Deibel

R. Eldridge (2)

E. Friedman (10)

A. Ghovanlou (5)

L. Goldberg

F. Grover

R. Henderson

A. Johnson

E. Keitz

K. Rebiño

M. Scholl

H. Sheetz

E. Ward (5)

W-53

G. Erskine

V. Wenk

W-54

J. Golden

S. Lubore

W-55

E. Sharp

J. Stone

D-60

A. Roberts

Coauthor and Consultant

Dr. E. J. Frey (5)

W-50 Library (5)

MITRE/Bedford Library

MITRE/Washington Library

Document Control

National Aeronautics and Space
Administration (98)