

NASA CR-170,409

NASA Contractor Report 170409

NASA-CR-170409
19840009105

Airloads Research Study

Volume I: Flight Test Loads Acquisition

M. D. Bartlett, T. F. Feltz, A. D. Olsen, Jr., D. B. Smith, and
P. F. Wildermuth

Contract NAS4-2769
January 1984



NF02562

LIBRARY COPY

FEB 14 1984

LANGLEY RESEARCH CENTER
LIBRARY, NASA
HAMPTON, VIRGINIA

NASA

National Aeronautics and
Space Administration

Airloads Research Study

Volume I: Flight Test Loads Acquisition

M. D. Bartlett, T. F. Feltz, A. D. Olsen, Jr., D. B. Smith, and P. F. Wildermuth
Rockwell International, Los Angeles Division, Los Angeles, California 90009

Prepared for
Ames Research Center
Dryden Flight Research Facility
Edwards, California
under Contract NAS4-2769

1984



National Aeronautics and
Space Administration

Ames Research Center

Dryden Flight Research Facility
Edwards, California 93523

N84-1713[#]

This Page Intentionally Left Blank

TABLE OF CONTENTS

	Page
SUMMARY	1
INTRODUCTION	2
TEST AIRCRAFT DESCRIPTION	3
Configuration	3
Fuselage	3
Wing	5
Nacelle	6
Horizontal Stabilizer	6
Vertical Stabilizer	7
Stability and Control Augmentation System	7
Instrumentation	9
Recording System	10
Data Processing	11
FLIGHT LOAD SURVEY TEST PROGRAM	11
Purpose	11
Test Conditions	12
Loads Data Analysis	13
Flight Loads Results	15
APPENDIX A TABLES AND FIGURES USING ENGINEERING UNITS	37
APPENDIX B DATA TAPE DESCRIPTION	73
APPENDIX C M = 0.85 AND M = 1.20 DATA TAPE DESCRIPTION AND INOPERATIVE PARAMETER LIST	75
APPENDIX D M = 0.85 AND M = 1.20 STEADY YAW DATA TAPE DESCRIPTION AND INOPERATIVE PARAMETER LIST	79
APPENDIX E HIGH q M = 0.85 AND M = 1.20 WINDUP TURN DATA TAPE DESCRIPTION AND INOPERATIVE PARAMETER LIST	83
APPENDIX F M = 0.95 and M = 1.05 DATA TAPE DESCRIPTION AND INOPERATIVE PARAMETERS LIST	87

TABLE OF CONTENTS (Concl)

	Page
APPENDIX G M = 0.70, 0.95, 1.60, AND 2.0 DATA TAPE DESCRIPTION AND INOPERATIVE PARAMETERS LIST	97
APPENDIX H SUPPLEMENTAL DATA	101
APPENDIX I SYMBOLS	108

LIST OF ILLUSTRATIONS

Figure	Title	Page
1	B-1 aircraft.	23
2	Structural breakdown.	24
3	Block diagram, instrumentation system	25
4	Location of strain gages at wing station X_{RS} 354.	26
5	Horizontal tail strain gage location.	27
6	Vertical tail strain gage locations	28
7	Location of strain gages at forward fuselage station, FS 528.5.	29
8	Location of strain gages at aft fuselage station, FS 1337.5	30
9	Location of pressure measurements	31
10	Chordwise locations of pressure orifices on RH movable wing.	32
11	Location of body/fairing/nacelle pressure orifices.	33
12	Digital recording equipment	34
13	A/C-2 flight loads analysis system.	35
A-1	General arrangement - RDT&E A/C-1 and -2.	55
A-2	Fuselage structure diagram (B-1) (-55B)	59
A-3	Wing-structure diagram, outer (-55B).	61
A-4	Structural arrangement - nacelle external compression inlet (RDT&E)	63
A-5	Horizontal stabilizer - STRL arrangement (42-1/2-degree leading edge sweep)	65
A-6	Vertical stabilizer preliminary structure arrangment 55-B configuration.	67
A-7	Location of points for flight loads determination $\Lambda_w = 67.5^\circ$	69
A-8	Initial flight load survey test points $\Lambda_w = 25^\circ$ and 55°	70
A-9	Initial flight load survey test points $\Lambda_w = 67.5^\circ$	71

LIST OF TABLES

Table	Title	Page
I	B-1 Aircraft No. 2 Flight Instrumentation Parameter Summary.	18
II	Planned Flight Loads Data Acquisition Test Conditions . . .	19
III	Block Diagram of Data on Magnetic Computer Tape	20
IV	NASA ARS Flight Data Acquisition	21
A-I	Condition Describing Parameters.	38
A-II	Strain Gage Parameters	40
A-III	Strain Gage Derived Loads.	44
A-IV	Pressure Transducer Parameters	45
A-V	Transducer Derived Pressure Differential Parameters.	50
A-VI	Pressure Transducer Derived Loads.	53
A-VII	Reference Axes for Measured Loads.	54
B-I	Data Tape Description	74
C-I	Data Tape Description	76
C-II	Inoperative Parameters Volume ARSFT2, Files 1-3, M = 0.85. .	77
C-III	Inoperative Parameters Volume ARSFT2, Files 4-6, M = 1.20 .	78
D-I	Data Tape Description.	80
D-II	Inoperative Parameters Volume ARSFT3, File 1, M = 0.85 . . .	81
D-III	Inoperative Parameters Volume ARSFT3, File 2, M = 1.20 . . .	82
E-I	Data Tape Description.	84
E-II	Inoperative Parameters Volume ARSFT4, Files 1-3, M = 0.85. .	85
E-III	Inoperative Parameters Volume ARSFT4, Files 4-7, M = 1.20. .	86
F-I	Data Tape Description.	88
F-II	Inoperative Parameters Volume ARSFT5, Files 1-4, M = 0.95. .	89
F-III	Inoperative Parameters Volume ARSFT5, Files 5-8, M = 0.95. .	90
F-IV	Inoperative Parameters Volume ARSFT5, Files 9-10, M = 1.05 .	91
F-V	Inoperative Parameters Volume ARSFT5, File 11, M = 1.05. . .	92
F-VI	Inoperative Parameters Volume ARSFT5, File 12, M = 1.05. . .	93
F-VII	Inoperative Parameters Volume ARSFT5, File 13, M = 0.99. . .	94
F-VIII	Inoperative Parameters Volume ARSFT5, Files 14-15, M = 0.95.	95
F-IX	Inoperative Parameters Volume ARSFT5, Files 16-17, M = 1.05.	96
G-I	Data Tape Description, Volume ARSFT6 Δ LE = 67.5 Degrees . .	98
G-II	Inoperative Parameters, Volume ARSFT6, Files 1-14	99
G-III	Additional Inoperative Parameters, Volume ARSFT6 Files 11-14 Only	100
H-I	Horizontal Stabilizer Displacement Errata	102
H-II	Weapon Bay Stores Summary	103
H-III	Forward Bay Fuel Tank Inertia Data	104
H-IV	Load Control Equations	105

AIRLOADS RESEARCH STUDY

FLIGHT TEST LOADS DATA ACQUISITION

By M.D. Bartlett, T.F. Feltz, A.D. Olsen, Jr., D.B. Smith, and P.F. Wildermuth
Rockwell International Corporation
Los Angeles, California

SUMMARY

The basic intent of the overall airloads research study (ARS) program is to utilize flight data acquired during B-1 aircraft test flights, to present analyses of these data beyond the scope of Air Force requirements, and to prepare research reports that will add to the technology base for future transport aircraft. Efforts are scheduled as distinct tasks, with separate reports for each task.

Under this task, flight test data are obtained, which include flight condition describing parameters, surface pressures, strain gage outputs, and loads derived from pressure and strain gages. The data are prepared in a format that is compatible with the NASA-DFRC computer.

This report describes the planning for the acquisition of structural loads from the B-1 A/C-2 airloads survey flight test program.

Mr. R. Celniker deserves recognition for his important contributions as program manager during the early part of this study.

INTRODUCTION

The B-1 A/C-2 (figure 1) is being employed in the airloads survey flight test program. This aircraft has undergone extensive ground testing to calibrate the strain gages utilized in the airload survey. A comprehensive wind tunnel test program has been conducted to obtain basic force data and pressure distribution data for both subsonic and supersonic speeds. The aircraft provides a reasonable simulation of a future transport aircraft since it has speed capability in excess of 2.0M and employs a large flexible structure (figure 2).

The airloads data gathered from the flight, ground, and wind tunnel tests can be utilized in the evaluation of recently developed NASA computer programs, such as NASTRAN and FLEXSTAB, to enhance the analytical techniques of predicting aeroelastic response of large flexible aircraft.

The objective of this report is to present the plans for the acquisition of B-1 flight test loads data and to demonstrate the capability to produce a data tape and/or data cards that are compatible with the NASA-DFRC computer.

TEST AIRCRAFT DESCRIPTION

Configuration

The B-1 aircraft was developed to provide low-altitude, high-speed penetration and high-altitude long-range flight. It is a large flexible aircraft with a maximum flight weight in excess of 181,000 kg (400,000 lb). Configuration dimensions and general arrangement are presented in figure A-1.

The aircraft utilizes a blended wing-body concept with variable-sweep wings, a single vertical stabilizer with a three-section (upper, intermediate, and lower) rudder, and horizontal stabilizers which operate independently to provide both pitch and roll control. The variable-sweep (15 to 67.5 degrees) wing, equipped with slats, spoilers (which also function as speed brakes), and flaps, provide the aircraft with a highly versatile operating envelope. Canted vanes, mounted on each side of the forward fuselage, are part of the structural mode control system which reduces structural bending oscillations in the vertical and lateral axes.

The aircraft is powered by four YF101-GE-100 dual-rotor augmented turbofan engines in the 30,000-pound-thrust class. The engines are mounted in twin nacelles below the wing, approximately at the left and right wing-pivot points. For supersonic speeds, an air induction control system varies the internal geometry of the nacelle inlet ducts to maintain the required airflow to the engines for all flight conditions.

Fuel is carried in integral tanks in the fuselage, wing carry-through, and wing outer panels. The fuel system is pressurized and inerted by nitrogen. Fuel transfer sequencing is automatic and provides center-of-gravity control. The aircraft has both in-flight and single-point refueling capabilities.

Fuselage

The fuselage (figure A-2) is constructed primarily of aluminum alloy materials arranged in a semimonocoque, skin-frame-longeron type of construction. Titanium is used in the wing carry-through, nacelle, and tail support structure, and for various other structures where high-load concentrations exist and on the aft fuselage skins where high temperatures and acoustic levels are prevalent. Dielectric materials such as polyimide quartz and fiberglass are used for radomes and antenna covers.

The fuselage structure is fabricated in six major sections and then mated together prior to attaching wings, empennage, landing gears, and nacelles. The

following functional description of each section will provide a better understanding of the overall fuselage and its relationship to most of the aircraft subsystems.

The crew module assembly provides a sealed enclosure with crewmember provisions and is an ejectable unit for emergency escape. The structure is capable of pressurization for a 2,439-meter (8,000 feet) altitude environment and incorporates a clear vision windshield designed to bird-proof requirements, additional crew windows, an entry door, and an emergency exit hatch for ingress and egress. The floor structure supports crew seating and ejection rocket loads. An unpressurized section aft of the crew quarters houses the escape system parachutes and provides support for the stabilizing fins. Two sets of deployable mechanical stabilizing spoilers are hinged in the side panel framework and at the lower forward edge of the module. Structural ties to the forward fuselage are severed by explosive charges for emergency escape.

The forward fuselage section includes the nose radome, forward avionics compartment, in-flight refueling receptacle, nose gear well and support structure, central avionics compartment, a section of the forward fuel tank, doppler radome, environmental control system equipment bay, and the crew entry stairladder structure and mechanism installation. The section also includes many other items of equipment such as antennas and pressure-sensing devices. Left and right structural-mode-control fin surfaces are mounted on this section. Many large and small access doors are provided due to the high density of equipment installations in this assembly.

The forward intermediate section houses the forward and center weapons bays. Major bulkheads located between the two bays and at each end of the bays provide support for the rotary weapons launchers. The aft bulkhead location also forms a part of the wing carry-through section. Large integral fuel tanks are incorporated into the forward intermediate fuselage structure immediately outboard of the weapons bays. A systems-routing tunnel occupies the upper structure area between longerons. Provisions for avionics are incorporated in the side fairing area, consisting of equipment bays, antennas, and radomes. Provisions for external stores pylons, wing sweep actuation components, and flap and slat drive mechanisms are also incorporated in the forward intermediate fuselage section.

The aft intermediate fuselage consists of the main gear well and the aft weapons bay. It incorporates a flight controls mixer compartment and a fuel tank above the main gear well. The gear uplock support structure is located in the mixer compartment. Avionics provisions are made in the compartment between the wheel wells and in the structural compartments outboard of the wheels. Bulkheads at the forward and aft end of the weapons bay support the weapons bay rotary weapons launcher. As in the forward intermediate fuselage,

fuel is stored outboard of the weapons bay. A double support frame for the aft portion of the nacelle extends outboard to the centerline beam of the nacelle. This support is approximately midway between weapons bay bulkheads. The upper centerline longeron and the lower outboard longerons are located and constructed so as to provide a high stiffness-to-weight ratio. The upper centerline longeron extends forward into the wing carry-through section and aft to the vertical stabilizer front spar.

The aft fuselage is a semimonocoque structure and consists of the aft fuel tank area, the dorsal area, the aft avionic bay and the tail cone. The tank area is closed in the forward and aft end by bulkheads. The forward bulkhead separates the aft fuel tank from the aft weapons bay. The aft bulkhead closes the tank and provides mounting support structure for the horizontal tail spindle fitting and the aft avionic bay. The dorsal area is a dry tunnel space which houses flight control cables and hardware and provides for the routing of the electrical conduits.

Wing

The wing consists of the wing pivot, outer wing panel, flaps, slats, and spoilers (figure A-3). The wing pivot consists of the pin, bearings, and inboard and outboard lugs with provisions for attachment to the wing carry-through fuselage section and the wing outer panel.

The wing outer panel consists of a structural box with leading edge slats, trailing edge flaps, and spoilers over the flap leading edge. The outer wing is mounted on pivot bearings whose supporting lugs are mechanically attached to the wing covers. Provisions for integral fuel containment is provided in the outboard wing structural box. Access is provided for sealing, inspection, servicing, and replacement of fuel system components. Control surfaces located on the wing include flaps, slats, and spoilers. The flaps are located aft of the wing rear spar and are mounted on rollers between curved tracks. Flap actuating jack-screws are located in the mid-bay of the flap panels. Segmented leading edge slats are provided. Each segment is supported on tracks mounted on rollers attached to the fixed leading edge structure. Segmented wing spoilers are located aft of the wing rear spar and above the flaps.

Nacelle

The nacelle is constructed of aluminum alloy, titanium alloy, and stainless steel and fiberglass laminates. Structural type is semimonocoque with skins, frames, longerons, and a honeycomb sandwich duct (figure A-4). Each nacelle is fabricated in two major sections, the forward section and the engine compartment.

The forward section consists of the inlet section, duct assembly, ramps, and the center beam. The inlet section consists of the center splitter wedge and the upper and lower leading edges. Portions of the upper and lower leading edges are porous for boundary layer control. The duct assemblies consist of engine air intake ducts supported by frames and stringers and covered with an external skin. In the forward area, the duct wall is covered with aluminum machined skin. The intermediate and aft duct walls are covered with fiberglass honeycomb sandwich. The inboard wall of the duct is made up of a fixed duct and movable ramps, which provide for a variable geometry system for air induction control. The center beam consists of four main longerons, interconnecting shear panels, appropriate frames, and the forward nacelle attach point, and is the primary vertical bending member of the nacelle.

The engine compartment consists of the principal firewall bulkhead, the structure between the two engines, primary engine attach points, and aft nacelle attach points. Large hinged engine-access doors are provided to complete the engine enclosure. Construction is frame, skin, and longeron.

The nacelle is attached to the aircraft at four points. The forward attach point is a single fitting on the top of the centerbeam structure which is connected to the wing pivot pin through a ball joint. The other three attach points are in the engine section in line with the rear engine support. They consist of links, two vertical and one horizontal, which connect the nacelle to the heavy support frame extending from the aft intermediate fuselage.

Horizontal Stabilizer

The horizontal stabilizer (figure A-5) consists of left- and right-hand slab panels attached to a steel spindle projecting out of the aft fuselage stub structure. Both left- and right-hand panels rotate on bearings and are independently controlled in order for the stabilizer to provide pitch and roll control of the aircraft. Each panel consists of a main structural box, leading edge assembly, trailing edge assembly, tip assembly, an aerodynamics chord plane seal at the inboard end, and an air seal around the spindle.

Vertical Stabilizer

The vertical stabilizer consists of the main box structure, leading edge assembly, tip assembly, and trailing edge structure (figure A-6). The main box assembly supports the two upper rudder segments. Routing tunnels are provided in enclosed areas of the main box structure for electrical and cooling lines required to support avionics and antenna equipment located in the tip

and leading edge components. The rudder consists of three segments. The upper two segments are attached to the vertical stabilizer through power hinge fittings and actuated by hydraulic motors located in the horizontal stabilizer actuator fairing. The lower rudder segment is supported by conventional hinge fittings and actuated by linear actuators located between the rudder and aft fuselage structure.

The vertical stabilizer is attached to the aft fuselage principally through a double-shear attachment provided on the horizontal stabilizer spindle fitting. The vertical stabilizer is mechanically attached to the spindle fitting by close-tolerance, high-strength bolts.

Stability and Control Augmentation System

The stability and control augmentation system (SCAS) provides desired damping and maneuver control. The SCAS transforms pilot pitch and lateral stick displacements and aircraft motion about the pitch and roll axes into symmetrical and antisymmetrical horizontal stabilizer displacements. Similarly, the yaw SCAS employs lower rudder displacement for aircraft motion about the yaw axis.

Instrumentation

The B-1 A/C-2 is provided with instrumentation required for (1) flight and ground loads survey program tests; (2) dynamic response tests including flight through atmospheric turbulence, taxi tests, and landing tests; (3) stability and control tests; (4) aircraft performance tests; (5) propulsion and air induction tests; and (6) other subsystem tests. The various elements of the system are shown in block form in figure 3. A total of 1,943 recorded instrumentation parameters are summarized in table I by parameter type and recording system. The instrumentation parameters pertinent to the acquisition of flight measured steady maneuver loads are listed in appendix A, tables A-1, A-II, and A-IV and consist of a total of 479 parameters or channels. Included in appendix A are those parameters which define the flight condition and the pressure measurement and strain gage parameters.

Condition Defining Parameters.- Condition defining parameters are those measured parameters which can be used to analytically predict the airloads and net loads on the aircraft structural components. These consist of "M," "A,"

and "X" parameter numbers listed in table A-I of appendix A and include the following aircraft parameters and movable surface positions:

- Aircraft parameters:

Mach No., altitude, CAS, TAS, total temperature, α , β , θ , ϕ , P, Q, R, \dot{P} , \dot{Q} , \dot{R} , A/C weight, and CG position, total fuel quantity, fuel quantities in each tank and compartment, and vertical and lateral accelerations

- Movable surface positions:

LH and RH wing sweep

LH and RH horizontal stabilizer

Upper-middle and lower rudders

LH and RH spoilers

LH and RH flaps

LH and RH slats

LH and RH mode control vane

Strain Gage Parameters.- The strain gage parameters are those required to determine the net loads on the airframe components. The pertinent airframe loads to be determined are listed in table A-III of appendix A and consist of the following:

- (1) Shear, moment, and torsion at LH and RH wing station X_{RS} 899 cm (354 in.)
- (2) Shear, moment, and torsion at LH and RH horizontal tail station BP 27.3 cm (10.75 in.)
- (3) Shear, moment, and torsion at vertical tail station WL 346.86 cm (136.56 in.)
- (4) Vertical and lateral shears and moments at forward fuselage station FS 1342.4 cm (528.5 in.)
- (5) Vertical and lateral shears and moments and torsion at aft fuselage station FS 3,397.2 cm (1,337.5 in.)

The locations of the points where the loads are to be determined are shown on figure A-7 of appendix A.

The strain gage measurements required for the calculation of the aforementioned loads consist of the "S" parameters listed in table A-II of appendix A. The locations of the strain gages at wing station X_{RS} 899 cm (354 in.), horizontal tail station BP 27.3 cm (10.75 in.), vertical station WL 346.86 cm (136.56 in.), forward fuselage station FS 1,342.4 cm (528.5 in.), and aft fuselage station FS 3,397.2 cm (1,337.5 in.) are shown in figures 4, 5, 6, 7, and 8, respectively.

Pressure Parameters. - Pressures are measured over the movable wing, the wing fairing and nacelle regions, and the midfuselage area, using pressure transducers. The locations of the pressure orifices are shown in figures 9, 10, and 11. Differential pressures between the lower and upper surfaces ($P_l - P_u$) are measured on the movable wing at the span stations noted in figure 9 and at the chord stations noted in figure 10. Pressure measurements over the wing fairing/nacelle and midfuselage areas are local surface static pressures (ΔP). The pertinent pressure measurements consist of the "D" parameters listed in table A-IV of appendix A.

Recording System

The B-1 airborne data acquisition system is a high-performance high-capacity instrumentation data system designed specifically for, and integrated into, the B-1 aircraft. The system provides for magnetic tape recording and telemetry transmission of static or quasi-static data sensor signals in a digital format. In addition, magnetic tape recording of data sensor signals in analog format is provided where frequency response requirements exceed the capability of the digital recording. The equipment is made compatible with aircraft subsystems either directly or through signal interface equipment. Data outputs interface directly with the instrumentation support system, the Rockwell data reduction system, and the AFFTC telemetry receiving station and data handling systems.

Digital Recording. - Digital recording on magnetic tape is the primary means of in-flight data recording. This method provides the channel capacity, frequency response, and accuracy required for the bulk of data. The equipment is modular in design to satisfy individual aircraft data requirements and to provide flexibility and growth capacity. The design employs the concept of a central programmer with remote multiplexing units to reduce the bulk and length of interconnecting wiring. The majority of parameters recorded on the digital system input directly into multiplexer units without the requirement for signal conditioners, thereby reducing equipment required. Signal conditioning is required only for nonstandard parameters, such as alternating currents and voltages, phase-sensitive signals, and dc voltage measurements exceeding a ± 40 millivolt range. A simplified block diagram appears in figure 12.

The digital system will accept, multiplex, and format up to 2,048 data channels (32 multiplexers at 64 channels each) and will sequentially record these channels on magnetic tape with accurate time correlation. The data channels are random-addressable, by the central programmer. The sum of the sampling rates for all channels is 8,192 words-per-second (WPS) per track, or 32,768 WPS for the maximum capacity of four tape tracks. The total word capacity is budgeted to individual channels on the basis of the following standardized rates: 4, 8, 16, 32, 64, 128 or 256 samples-per-second.

Analog Recording.- Analog data recording techniques are used for parameters requiring higher frequency response than can be provided by the digital system. Two methods of frequency multiplexing (FM) are provided. The primary method employs IRIG "A" constant-bandwidth voltage-controlled oscillators with deviation of ± 2 kHz. The second method employs wideband constant bandwidth voltage-controlled oscillators with deviations up to ± 15 kHz for recording data with intelligence frequencies up to 8 kHz.

The primary FM system conforms to IRIG document RCC-106-71 and provides frequency division multiplexing of 21 data channels per tape track through a four-group translation system. Subcarrier oscillators, with translation, conform to the constant bandwidth IRIG channel "A" assignment, with a deviation of ± 2 kHz and a data intelligence frequency of 1 kHz at modulation index of 2.0. Recording of these data is accomplished on the primary data recording system, utilizing 10 tape tracks. This provides for the continuous recording of at least 210 analog parameters with an intelligence of 1000 Hz.

The wide-band analog system conforms to commercial standards (VIDAR) and provides time division multiplexing of seven data channels per tape track. Constant bandwidth subcarrier oscillators with deviations of either ± 8 kHz or ± 16 kHz are utilized to provide data with an intelligence of 4 kHz or 8 kHz. These data are recorded on the third tape recorder, utilizing the total 14 tracks. This provides a total recording capacity of 96 data channels plus two reference channels. A tape speed of 76.2 cm (30 inches) per second is used with start/stop operation.

Data Processing

The primary purpose of the data reduction process is to convert the data recorded in flight to a format suitable for subsequent data analysis. The single source of test data for input to the equipment is the flight data tapes. Processing of the flight tapes is supported by a program data file, stored in system memory, which contains transducer calibration data and software operating and applications programs.

Functional operations required for data analysis include (1) data quick look, (2) editing, and (3) output of data for analysis.

The quick look and data editing operations are usually accomplished simultaneously. These operations consist of processing a small number of preselected data parameters and the presentation of these data, in engineering units, as time history plots for selected portions of the flight or for the total flight. The processing operation selects the data from the flight tape, converts the data to engineering units, and stores the data. Presentation of the data is essentially under the control of an individual analysis engineer or analysis group.

The principal output from the data reduction process is computer-compatible tapes containing flight data which require subsequent large-scale computer analysis. The tapes contain data from the flight tapes for the time periods selected during the data editing process by a single engineering analysis group. Only those parameters identified in specific parameter groups, by engineering discipline, are transcribed to computer tapes.

During this tape generation operation, data are transcribed from the flight tapes for the identified time periods, converted to engineering units, correctly formatted, and recorded on 1.27 cm (1/2 in.) nine-track magnetic tape in proper density, and with record gaps, as required. The transcribed data are time-interpolated to correct for delta time displacements between selected parameters resulting from the sequential data multiplexing process in the airborne digital data acquisition equipment. After completion of the processing, the transcribed tapes are given to the requesting engineering group.

Computer-compatible tapes for Research and Engineering use are in IBM 370 computer tape format for entry into the Rockwell central computer system. This format is 1.27 cm (1/2 in.) nine-track magnetic tape, with a recording density of 1,600 bits per inch (bpi), phase encoded, with variable length data records up to a maximum of 32K bytes per data block.

FLIGHT LOAD SURVEY TEST PROGRAM

Purpose

The flight load survey test program serves several purposes in the structural integrity program:

- (1) Determination and evaluation of loading conditions that produce critical structural load and temperature distribution

(2) Verification of the analytically derived structural loads and temperatures

(3) Definition of possible new critical loading conditions

(4) Structural integrity flight demonstration within the design envelope

A two-phase test program will be performed. The initial phase will be limited to 80 percent of limit design flight loading conditions. Tests will be conducted to identify critical flight load conditions and to demonstrate the structural integrity of the 80-percent limit-load point. Buildup maneuvers will be required to ensure flight safety and permit interpretation and analysis of the measured data.

The final phase will consist of flight tests to the 100-percent limit-load level to demonstrate the structural integrity of the aircraft for operation encompassed by the design envelope.

Test Conditions

The initial phase flight load survey test conditions will consist of performing the following maneuvers in a buildup manner to the 80-percent limit-load or condition level in accordance with MIL-A-8871:

- (1) Steady and abrupt symmetrical pullups
- (2) Steady and abrupt symmetrical pushovers
- (3) Coordinated and uncoordinated rolling pullouts
- (4) Steady and abrupt (dynamic) yaw maneuvers

The 80-percent limit-load or condition level is defined such that the following are not exceeded during the tests:

- (1) Eighty percent of the design limit-load on primary structural components
- (2) Eighty percent of the design limit-load factor for the particular configuration and speed/altitude point

(3) Eighty percent of the design limit dynamic pressure for the particular configuration

The initial phase tests will also include, in general, the following configurational variations:

- (1) Several wing sweep positions (Λ , 15° to 67.5°)
- (2) Several mach numbers (number depends on wing sweep)
- (3) At least two altitudes for significant load conditions
- (4) Buildup load factors for pitch and roll maneuvers
- (5) Buildup rudder deflections for yawing maneuvers
- (6) Design weight cases (as close as practical)

The initial phase flight test points for wing sweep positions, $\Lambda_w = 25^\circ$, 55°, and 67.5° are shown in figures A-8 and A-9.

The final phase load survey test conditions will primarily consist of performing the following maneuvers to the 100-percent design load or condition level:

- (1) Critical initial phase conditions
- (2) Design criteria conditions and conditions at maximum dynamic pressure
- (3) Additional critical conditions defined by the analysis of initial phase test data

It is anticipated that the data of interest for use in the FLEXSTAB aero-elastic analysis will be obtained from the initial-phase flight load survey tests and will provide the most airloads data for variation with mach number and dynamic pressure, as well as load factor. The planned data acquisition test conditions for this airloads research study are shown in table II.

Loads Data Analysis

During flight tests of the B-1 A/C-2, all aircraft parameters (aerodynamic effects, pressures, strains, etc.) are recorded on a magnetic tape while in

flight. During flight tests, selected parameters for test monitoring are telemetered (T/M) to the AFFTC T/M station. Real-time flight test data monitoring at AFFTC is accomplished using the Automated Flight Test Data System (AFTDS), which provides CRT display of selected T/M data. In addition, the AFFTC T/M processor produces strip charts containing time histories of selected condition-describing and load parameters during the entire flight.

After each flight, the strip charts are examined, and various time histories are selected for analysis. The flight tape is then accessed by the External Loads Group obtaining all pertinent flight test parameters for selected time histories. The loads monitor program for pressure data and the loads monitor program for strain gage parameters (figure 13) are used to access the flight tape.

The loads monitor program for pressure data reads the data from the flight tape and prints out the condition describing parameters (mach No., altitude, load factor, etc.) as well as pressure data parameters for the selected time histories. These data are used to select discrete time slices for which detailed load analysis can be made. The selected time slice data are then obtained in punched card form. The pressure data in punched card form are then combined wherever possible to obtain a pressure differential across the wing-body, which is then punched on cards. Table A-V of appendix A contains a list of the points where pressure differentials are obtained. The pressure differential data are then interpolated and integrated over the existing geometry. CRT plots are made of the resulting pressure grid distribution. At this point, the pressure data are corrected and rerun through the previously described system to eliminate bad data points. The corresponding condition inertia loads are then distributed over the grid geometry, using existing weights and inertia programs. Combination of the inertia grid loads and the grid airloads yields a net distributed grid loading over the wing-body. For the ARS, punched cards containing shear, bending moment, and torsion at wing station X_{RS} 899 cm (354 in.) (right-hand wing only) can then be produced for airloads, inertia loads, or net loads (airload + inertia load). Table A-VI of appendix A lists the output points.

The loads monitor program for strain gage parameters performs essentially the same function as does the pressure data loads monitor program; it reads and prints out flight test parameters, in this case condition describing and strain gage parameters. Strain gage data at the same time-slices as selected for the pressure data are then punched on cards for the ARS program. The strain gage data are used to compute the net loads (airloads + inertia) at the instrumented stations on the aircraft. The resultant loads are then punched on cards. Table A-III lists where strain gage derived loads are calculated.

The entire set of punched data (condition describing parameters, pressure data, pressure-derived loads, pressure differential data, strain gage data, and strain gage derived loads) are then formatted to be compatible with the NASA-DFRC CDC CYBER 73-28 computer.

Flight Loads Results

As each phase of the Airloads Research Study is completed, a new appendix will be added to this report (NA-76-562) describing the data tape which will be provided to the NASA. Each appendix will contain a table that will provide the reader with the data tape volume name, mach number, wing sweep, altitude, load factor, and a description of each file of the data tape submitted to NASA.

Each file of each data tape contains one time slice set of data for one mach number and wing sweep. Each data tape file contains the following information:

- (1) Flight condition-describing information (mach No., altitude, wing sweep, etc.) (table A-I)
- (2) Measured static pressure at the locations shown in figures 9, 10, and 11 (table A-IV)
- (3) Strain gage measurements at the locations shown in figures 4 through 8 as well as other pertinent locations on the aircraft (table A-II)
- (4) Differential pressures on the wing-body locations shown in figures 9, 10, and 11 (table A-V)
- (5) Pressure-derived airloads at right-hand wing station X_{RS} 899 cm (354 in.) (table A-VI). (Pressure-derived loads at right-hand wing station X_{RS} 899 cm for the demonstration condition are net loads.)
- (6) Strain-gage-derived net loads at the aircraft component stations listed in table A-III

Some of the flight test parameters were not functioning properly during the second flight of A/C-2 and, therefore, some data are simulated for the demonstration condition. For each succeeding condition, the uncorrected parameter values will be left in the data set, and a table listing the inoperative or malfunctioning parameters will be included.

The NASA has been provided with a demonstration data tape containing one time-slice set of data at one mach number/wing sweep combination containing the information listed in the foregoing and a computer program written for use on the NASA CDC Cyber 73-28 computer to read the data tape. The computer program will only be given to NASA once; the data tape will be given each time a mach/sweep time-slice is given to NASA as a fulfillment of a part of the contract.

The magnetic computer tape is a nine-track, 1,600-bpi magnetic computer tape supplied to Rockwell by NASA. The mach/sweep time-slices are put on the magnetic computer tape using Rockwell's IBM OS/370-168 computer on EBDIC card images with 80 characters per card image. The data are stored on the tape in fixed size blocks of 5,120 bytes per block to be compatible with the requirements of the NASA DFRC CDC Cyber 73-28 computer. Table III shows a block diagram of the data placement on the magnetic computer tape.

The descriptive data (flight conditions, pressure parameter, and strain parameter) were written on the tape using a 40A2 format per 80-character card image. The data values (pressure and strain) were read on the data tape using an E10.2 format.

The computer program provided to NASA to read the data tape using the NASA DFRC CDC Cyber 73-28 computer was written in FORTRAN IV and is provided on punched cards using an EBDIC keypunch machine. The program reads in one block of data at a time (5,120 bytes) from the magnetic computer tape and translates this into a compatible form for use on the Cyber 73-28 computer. The descriptive data are translated into A10-format-type words, and the data values are translated into E10.2-format-type words. The program continues this translation one block at a time until all of the data for one mach/sweep time slice have been translated. The program will then start translating the first block of data of a new mach/sweep or time-slice block, unless the end-of-file indicator is reached.

For data-checking purposes, the program prints out the flight condition description, then a list containing the location, value, and a description of each parameter. A partial listing of the data is found in table IV.

Each line printed out for data checking purposes contains the following information: (Refer to table IV)

- P(I) or S(I) location: The location in the P(I) or S(I) array where the value can be found.

- Values: The value of the parameter in the units listed in the parameter description.
- Parameter Description: A description of each parameter giving the instrumentation identification, units of the parameter, and a description of the parameter.

The computer program and data tape usage on the NASA DFRC CDC Cyber 73-28 computer have been demonstrated and may be used with no changes needed. The computer program can read an expanded list of parameters (up to 800 maximum) with no change to the computer program necessary.

TABLE I.- B-1 AIRCRAFT NO. 2 FLIGHT INSTRUMENTATION PARAMETER SUMMARY

Parameter type	Analog basic	Digital basic	Dual digital-analog	Total
Miscellaneous (M)	14	179	13	180
Accelerations (A)	47	35	23	59
Positions (X)	9	110	9	110
Temperatures (T)	2	66		68
Strain gages (S)	16	524	8	532
Pressures (D)	159	963	128	994
Totals	247	1,877	181	1,943

TABLE II.- PLANNED FLIGHT LOADS DATA ACQUISITION TEST CONDITIONS

Λ W	M	Dynamic Pressure		Pitch Maneuver			Steady Sideslip		Acquisition Sequence
		Low	High	Steady Nz			Low β	High β	
67.5°	0.85	X	X	0.0	1.0	≥ 2.0			Initial
67.5°	1.20	X	X	0.0	1.0	≥ 2.0			
67.5°	1.60	X	X	0.0	1.0	≥ 2.0	X	X	Future (sequence may vary)
67.5°	0.70	X	X	0.0	1.0	≥ 2.0	X	X	
67.5°	0.95	X	X	0.0	1.0	≥ 2.0	X	X	
67.5°	2.20	X	X	0.0	1.0	≥ 2.0	X	X	
55°	0.70	X	X	0.4	1.0	1.6			
55°	0.85	X	X	0.4	1.0	1.6			
55°	0.95	X	X	0.4	1.0	1.6			
25°	0.70	X	X	0.4	1.0	1.6			

X = Data to be acquired.

TABLE III.- BLOCK DIAGRAM OF DATA ON MAGNETIC COMPUTER TAPE

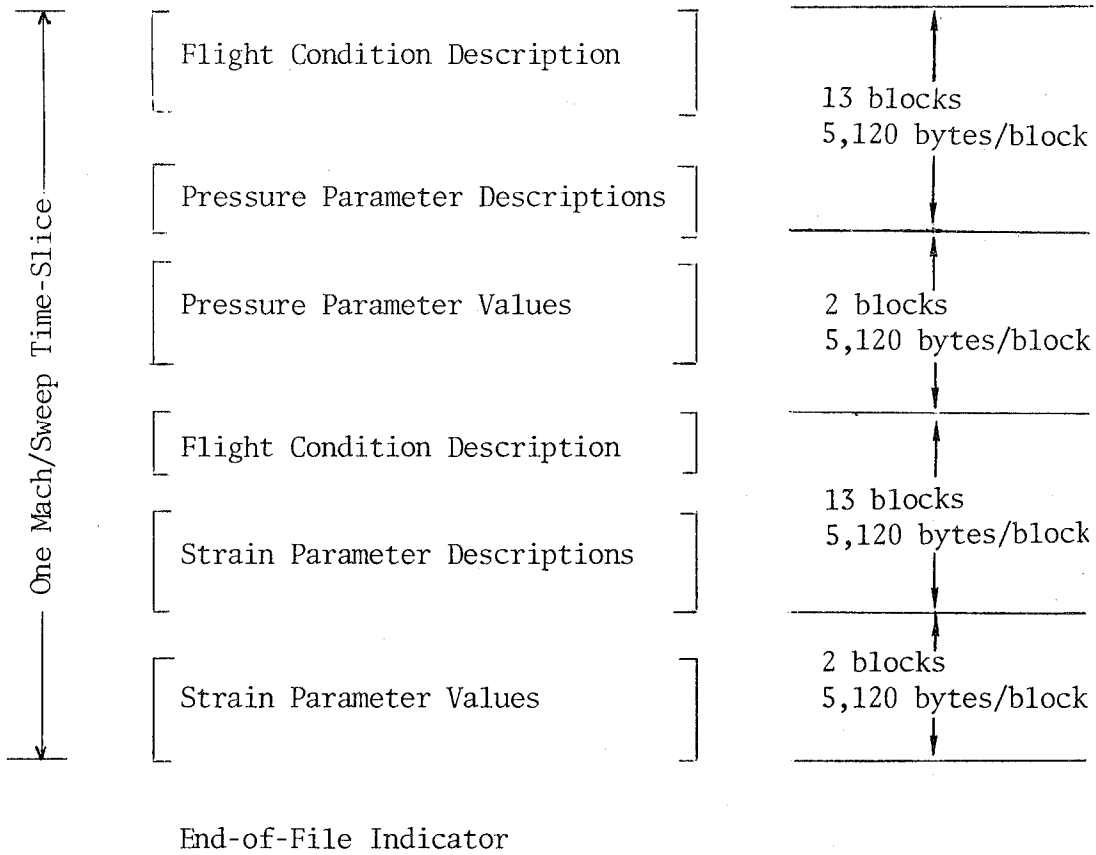

Note: An end-of-file (EOF) indicator is placed after each mach/sweep time slice on the magnetic data tape.

TABLE IV.- NASA ARS FLIGHT DATA ACQUISITION

NASA ARS FLT DATA ACQ **** M=.49 S=25D H=1107M WIND UP TURN

08/06/76

P(I) LOC	VALUES	PRESSURE	PARAMETER	DESCRIPTION	
1	0.	C9001	3 C9001	HRS	1.0 HOUR
2	0.	C9002	4 C9002	MINS	1.0 MINUTES
3	.1875E+02	C9003	5 C9003	SECS	1.0 SECONDS
4	.3046E+03	M1001	6 M1001	KNOTS	1.0 CALIBRATED AIRSPEED-CADC NO. 1
5	.3633E+01	M1002	7 M1002	K FT	1.0 PRESSURE ALTITUDE-CADC NO. 1
6	.4900E+00	M1003	8 M1003		1.0 MACH NO.-CADC NO.1
7	.3301E+03	M1007	9 M1007	KNOTS	1.0 TRUE AIRSPEED-CADC NO. 1
8	.2186E+00	M1012	10 M1012	DEG	1.0 ANGLE OF SIDE SLIP-NOSE BOOM
9	.3809E+01	M1013	11 M1013	DEG	1.0 ANGLE OF ATTACK-NOSE BOOM
10	.3930E+02	M1017	14 M1017	DEG	1.0 ANGLE OF BANK AT CG-GSS NO 1
11	.4371E+01	M1018	15 M1018	DEG	1.0 ANGLE OF PITCH AT CG-GSS NO 1
12	-.1023E+01	M1019	16 M1019	DEG/SEC	1.0 RATE OF ROLL-SCAS CHAN 1A
13	.2325E+01	M1020	17 M1020	DEG/SEC	1.0 RATE OF YAW-SCAS CHAN 1A
14	.3544E+01	M1021	18 M1021	DEG/SEC	1.0 RATE OF PITCH-SCAS CHAN 1A
15	.2271E+02	M1036	19 M1036	K LBS	1.0 FUEL QUANTITY-TANK #1
16	.7802E+01	M1037	20 M1037	K LBS	1.0 FUEL QUANTITY-TANK #2
17	.2901E+01	M1038	21 M1038	K LBS	1.0 FUEL QUANTITY-TANK #3
18	.1860E+02	M1039	22 M1039	K LBS	1.0 FUEL QUANTITY-TANK #4
19	.8202E+01	M1040	23 M1040	K LBS	1.0 FUEL QUANTITY-L MAIN TANK
20	.8502E+01	M1041	24 M1041	K LBS	1.0 FUEL QUANTITY-R MAIN TANK
21	.1100E+01	M1042	25 M1042	K LBS	1.0 FUEL QUANTITY-L WING TANK
22	0.	M1043	26 M1043	K LBS	1.0 FUEL QUANTITY-R WING TANK
23	.6981E+02	M1044	27 M1044	K LBS	1.0 FUEL QUANTITY-TOTAL
24	.1200E+01	M1045	28 M1045	K LBS	1.0 FUEL QUANTITY-L WING COMPT 1
25	.1200E+01	M1046	29 M1046	K LBS	1.0 FUEL QUANTITY-L WING COMPT 2
26	.1200E+01	M1047	30 M1047	K LBS	1.0 FUEL QUANTITY-L WING COMPT 3
27	.1200E+01	M1048	31 M1048	K LBS	1.0 FUEL QUANTITY-L WING COMPT 4
28	.2699E+03	M1049	32 M1049	K LBS	1.0 A/V WEIGHT
29	.2974E+02	M1050	33 M1050	PERCENT	1.0 A/V CENTER OF GRAVITY (CG)
30	.1000E+00	M1527	45 M1527	K LBS	1.0 FUEL QUANTITY-R WING COMPT 1

TABLE IV.- NASA ARS FLIGHT DATA ACQUISITION - Concluded

NASA ARS FLT DATA ACQ **** M=.49 S=250 H=1107R WIND UP TURN

08/06/76

S(I) LOC	VALUE	STRAIN GAGE		PARAMETER		DESCRIPTION
70	.2631E+02	S5225	150	S5225	K LBS	1.0 LH HORIZ STAB ACT #1 LOADS
71	-.9052E+01	S5226	151	S5226	K LBS	1.0 LH HORIZ STAB ACT #2 LOADS
72	-.9796E+01	S5230	152	S5230	K LBS	1.0 RH HORIZ STAB ACT #1 LOADS
73	.4933E+01	S5231	153	S5231	K LBS	1.0 RH HORIZ STAB ACT #2 LOADS
74	.1237E+01	S5245	154	S5245	K LBS	1.0 LWR RUDDER ACT #1 LOAD
75	0.	S5246	155	S5246	KINLBS	1.0 LWR RUDDER ACT #3 LOAD
76	-.1025E-01	S5247	156	S5247	KINLBS	1.0 MID RUDDER ROTARY ACT #2 HM
77	-.3866E-02	S5248	157	S5248	KINLBS	1.0 MID RUDDER ROTARY ACT #4 HM
78	-.7688E-02	S5249	158	S5249	KINLBS	1.0 UPR RUDDER ROTARY ACT #6 HM
79	-.2570E-02	S5250	159	S5250	KINLBS	1.0 UPR RUDDER ROTARY ACT #9 HM
80	.1485E+04	S5306	160	S5306	MICSTR	1000. LH WOP FRONT SPAR SHEAR, XRS 353
81	.1359E+04	S5307	161	S5307	MICSTR	1000. LH WOP FRONT SPAR SHEAR, XRS 356
82	-.1154E+04	S5308	162	S5308	MICSTR	1000. LH WOP UPPER COVER, XRS 354, AXIAL LOC1
83	-.1429E+04	S5309	163	S5309	MICSTR	1000. LH WOP UPPER COVER, XRS 354, AXIAL LOC2
84	-.1412E+04	S5310	164	S5310	MICSTR	1000. LH WOP UPPER COVER, XRS 354, AXIAL LOC3
85	-.1105E+04	S5311	165	S5311	MICSTR	1000. LH WOP UPPER COVER, XRS 354, AXIAL LOC4
86	.1478E+03	S5312	166	S5312	MICSTR	1000. LH WOP UPPER COVER, XRS 354, SHEAR LOC1
87	0.	S5313	167	S5313	MICSTR	1000. LH WOP UPPER COVER, XRS 354, SHEAR LOC2
88	0.	S5314	168	S5314	MICSTR	1000. LH WOP LOWER COVER, XRS 354, AXIAL LOC1
89	0.	S5315	169	S5315	MICSTR	1000. LH WOP LOWER COVER, XRS 354, AXIAL LOC2
90	0.	S5316	170	S5316	MICSTR	1000. LH WOP LOWER COVER, XRS 354, AXIAL LOC3
91	0.	S5317	171	S5317	MICSTR	1000. LH WOP LOWER COVER, XRS 354, AXIAL LOC4
92	.1876E+03	S5318	172	S5318	MICSTR	1000. LH WOP LOWER COVER, XRS 354, SHEAR LOC1
93	0.	S5319	173	S5319	MICSTR	1000. LH WOP LOWER COVER, XRS 354, SHEAR LOC2
94	-.1468E+04	S5320	174	S5320	MICSTR	1000. RH WOP FRONT SPAR SHEAR, XRS 353
95	-.1422E+04	S5321	175	S5321	MICSTR	1000. RH WOP FRONT SPAR SHEAR, XRS 354
96	-.1203E+04	S5322	176	S5322	MICSTR	1000. RH WOP UPPER COVER, XRS 354, AXIAL LOC1
97	-.1466E+04	S5323	177	S5323	MICSTR	1000. RH WOP UPPER COVER, XRS 354, AXIAL LOC2
98	-.1462E+04	S5324	178	S5324	MICSTR	1000. RH WOP UPPER COVER, XRS 354, AXIAL LOC3
99	-.1035E+04	S5325	179	S5325	MICSTR	1000. RH WOP UPPER COVER, XRS 354, AXIAL LOC4
100	-.2047E+03	S5326	180	S5326	MICSTR	1000. RH WOP UPPER COVER, XRS 354, SHEAR LOC1

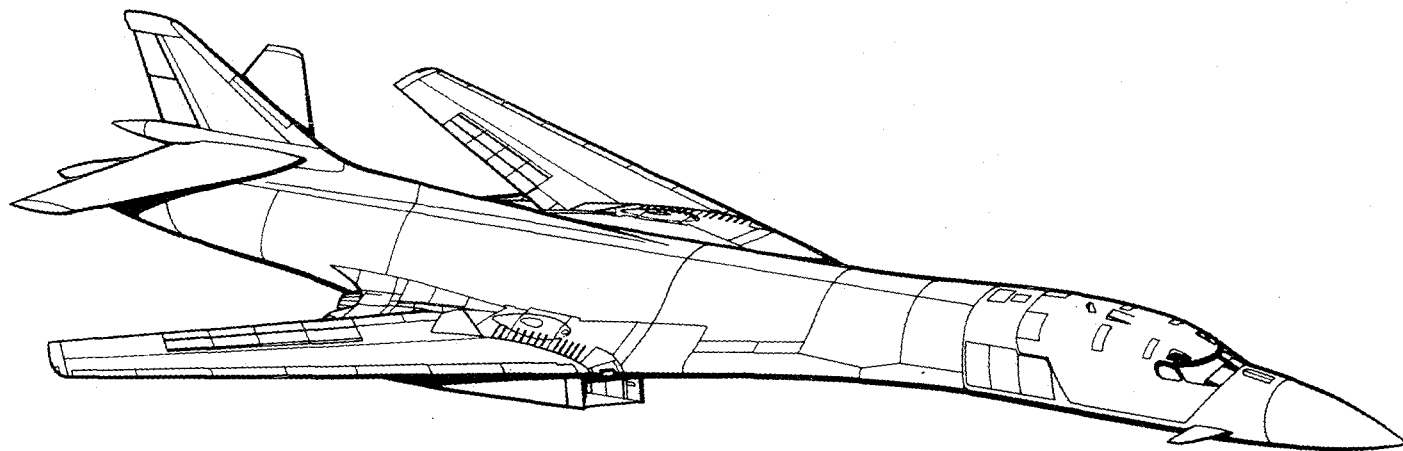

Figure 1.- B-1 aircraft.

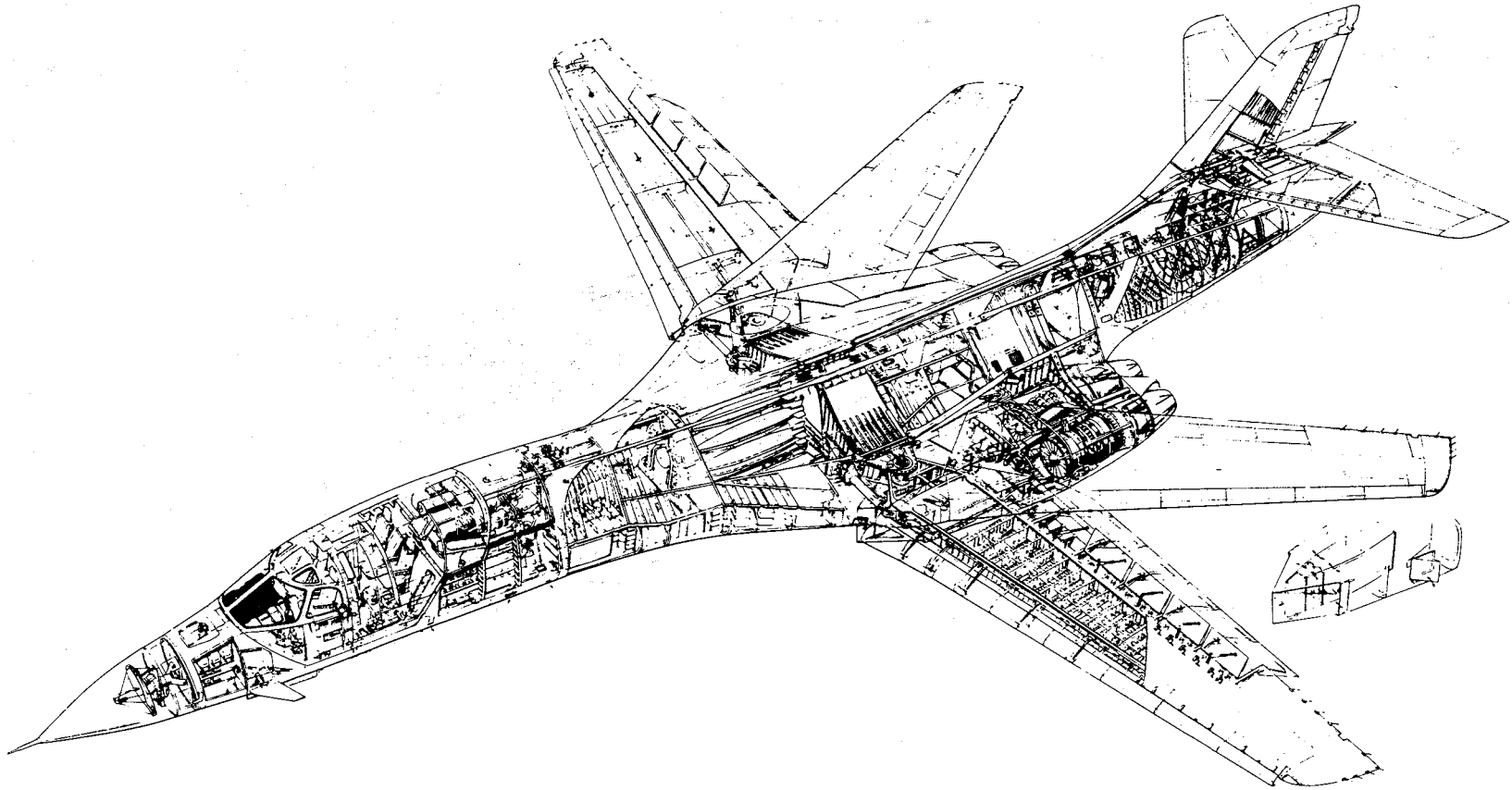

Figure 2.- Structural breakdown.

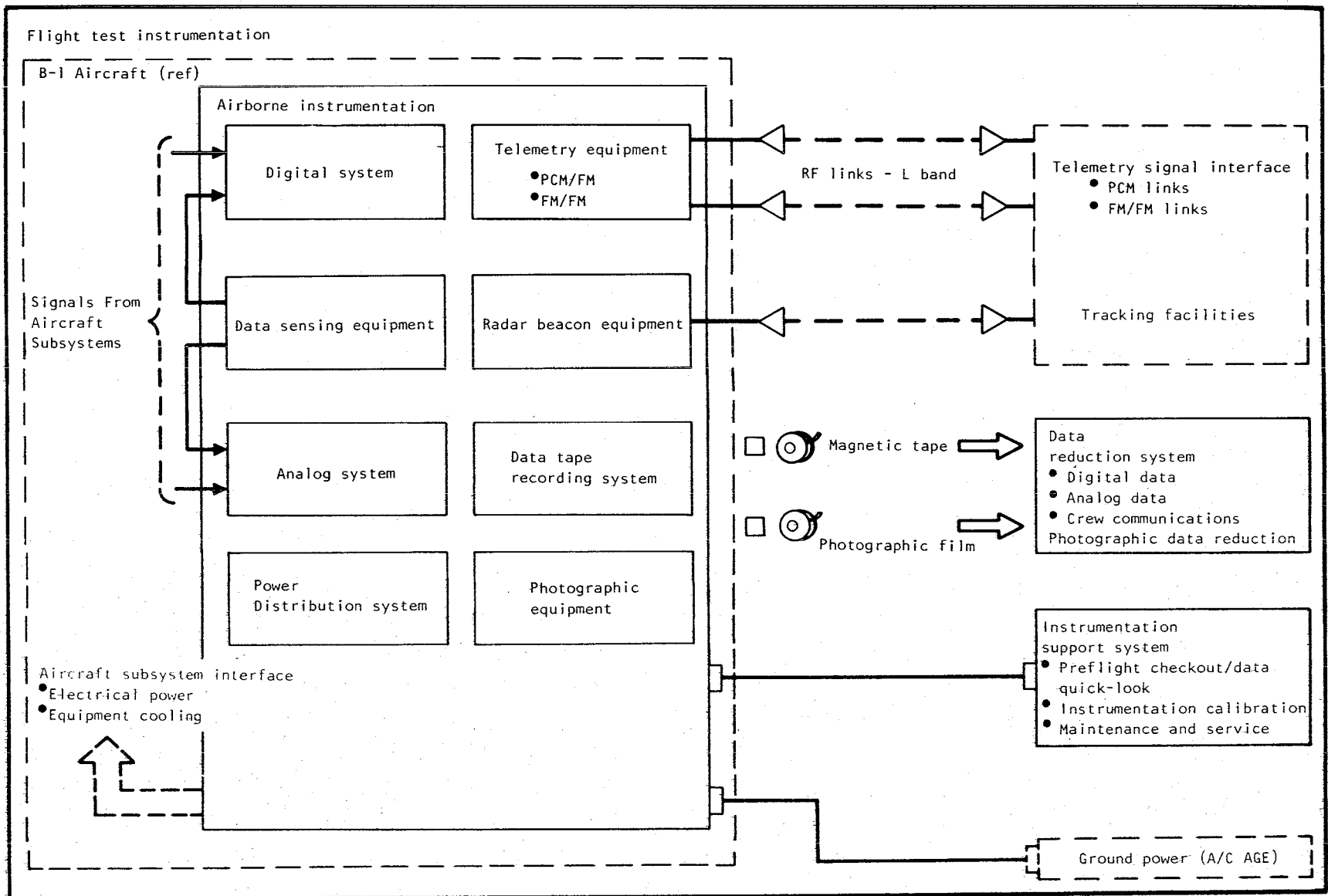

Figure 3.- Block diagram, instrumentation system.

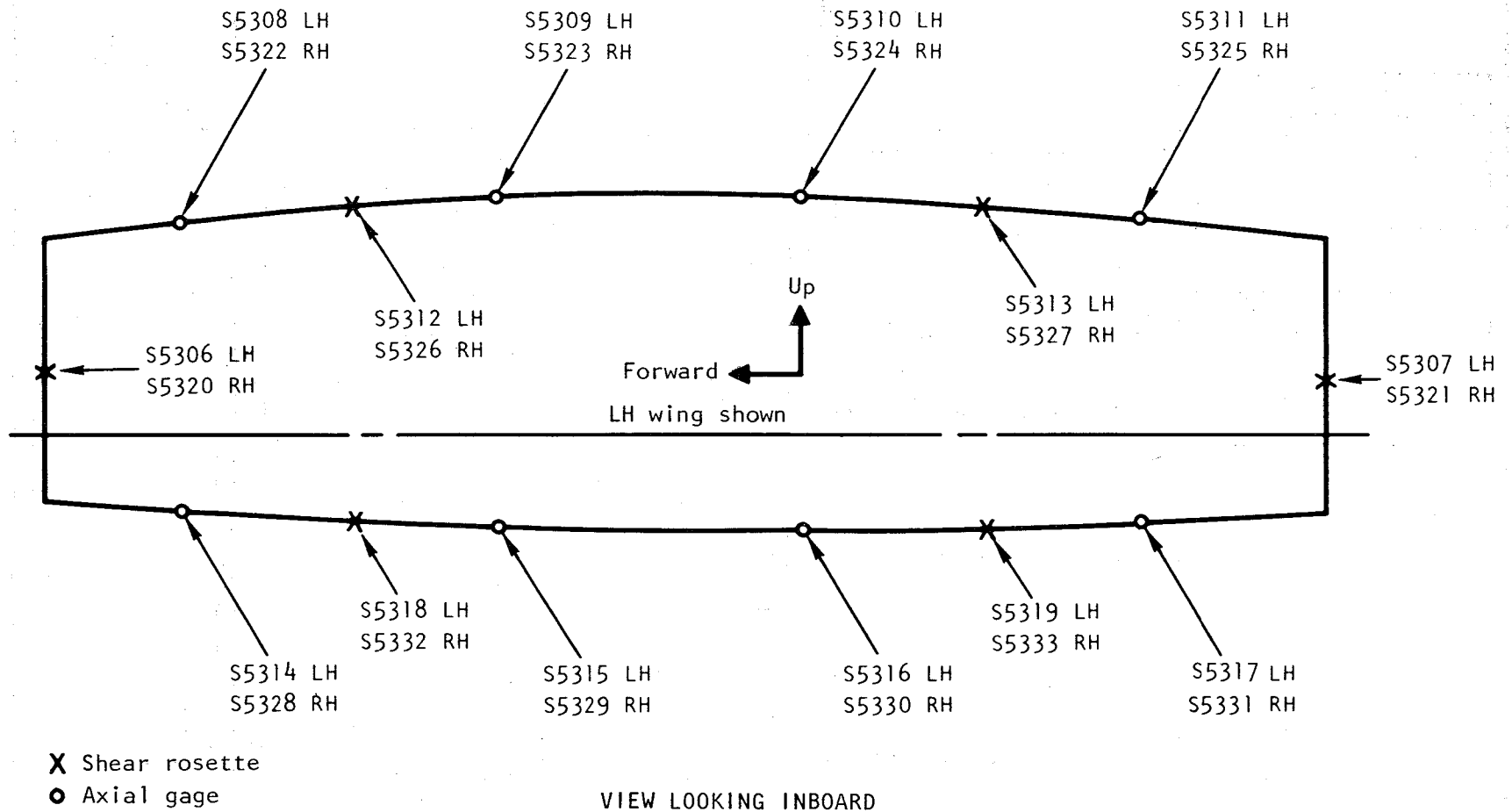
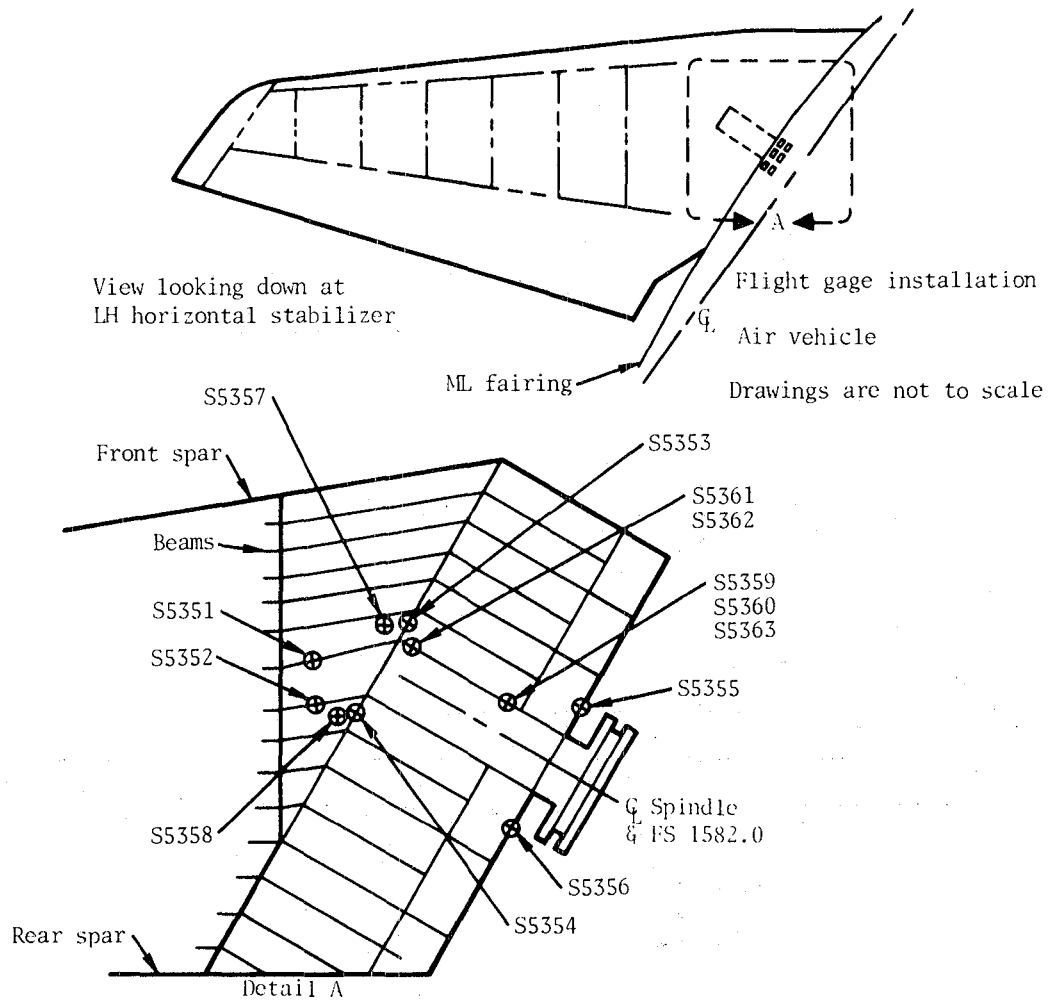

Figure 4.- Location of strain gages at wing station $X_{RS} 354$.



Detail A is typical of the strain gage locations for both the left- and right-hand horizontal stabilizer. Gages S5364-S5376 are right-hand gages, but the respective description is valid.

Gage	Description	Gage
S5351	LH horiz stab fwd interm spar web inbd	S5364
S5352	LH horiz stab aft interm spar web inbd	S5365
S5353	LH horiz stab XHS 47 rib web fwd	S5366
S5354	LH horiz stab XHS 47 rib web aft	S5367
S5355	LH horiz stab root rib web fwd	S5368
S5356	LH horiz stab root rib web aft	S5369
S5357	LH horiz stab upper cover fwd inbd	S5370
S5358	LH horiz stab upper cover aft inbd	S5371
S5359	LH horiz stab spindle ftg upr cap inbd	S5372
S5360	LH horiz stab spindle ftg lwr cap inbd	S5373
S5361	LH horiz stab spindle ftg upr cap outbd	S5374
S5362	LH horiz stab spindle ftg lwr cap outbd	S5375
S5363	LH horiz stab spindle ftg web inbd	S5376

Figure 5.- Horizontal tail strain gage locations.

Drawing is not to scale

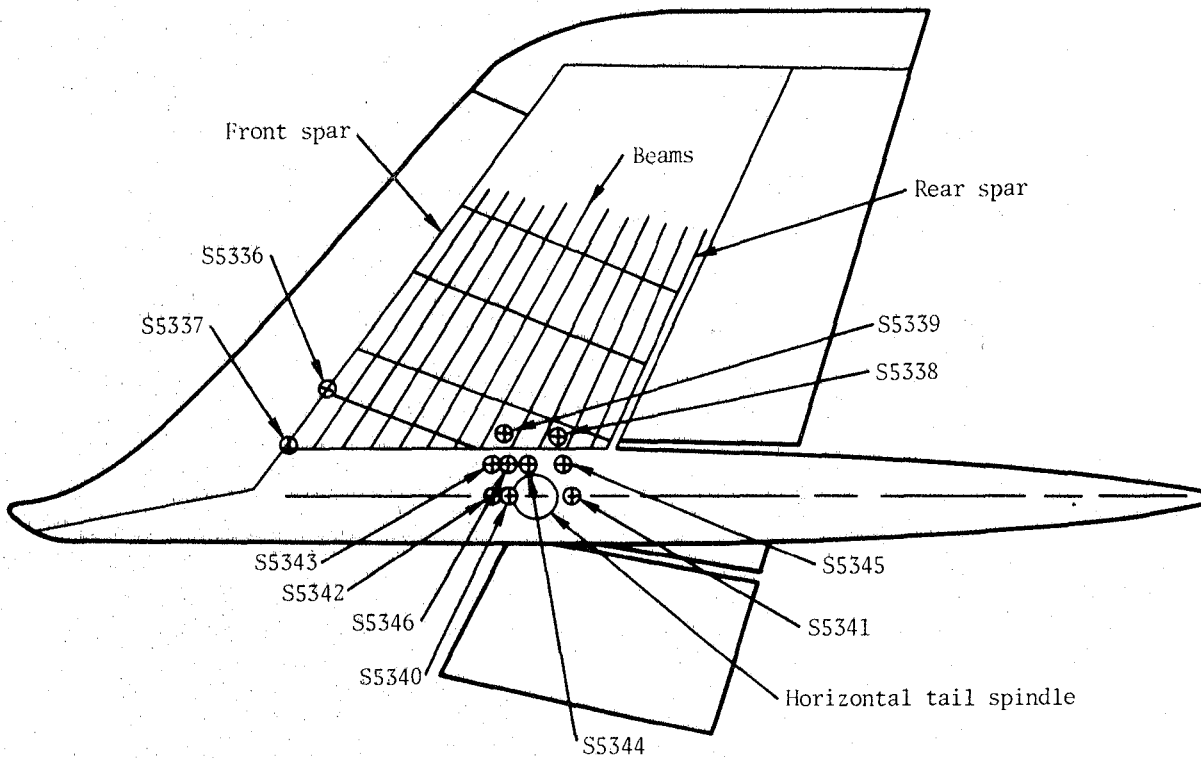

Gage	Description
S5336	Vert stab front spar web lwr
S5337	Vert stab root rib web fwd
S5338	Vert stab RH cover lwr fwd
S5339	Vert stab RH cover lwr aft
S5340	Vert stab attach ftg center web
S5341	Vert stab attach ftg aft web
S5342	Vert stab attach ftg fwd web
S5343	Vert stab attach ftg LH side fwd
S5344	Vert stab attach ftg LH side aft interm
S5345	Vert stab attach ftg LH side aft
S5346	Vert stab attach ftg LH side fwd interm

Figure 6.- Vertical tail strain gage locations.

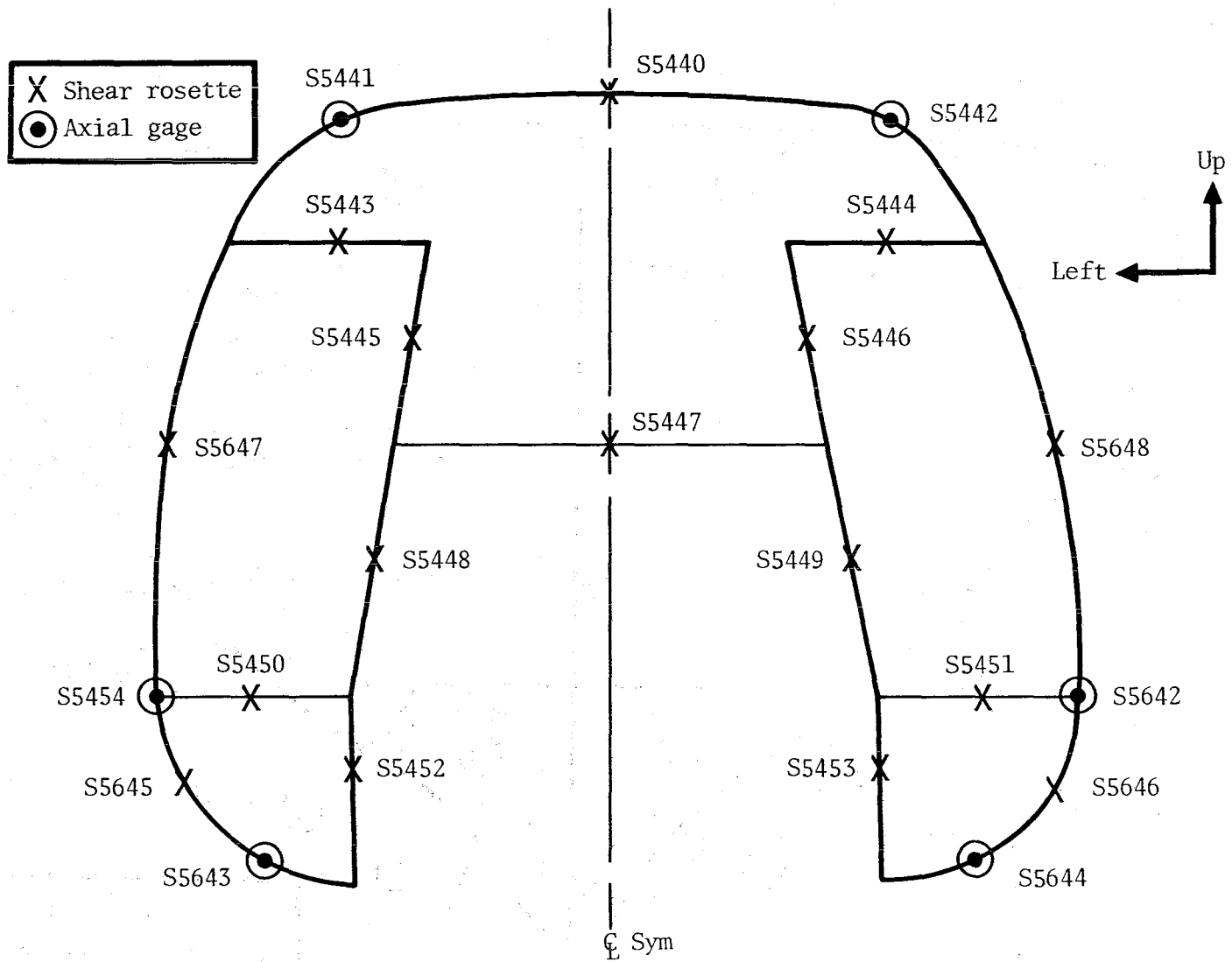

Figure 7.- Location of strain gages at forward fuselage station FS 528.5.

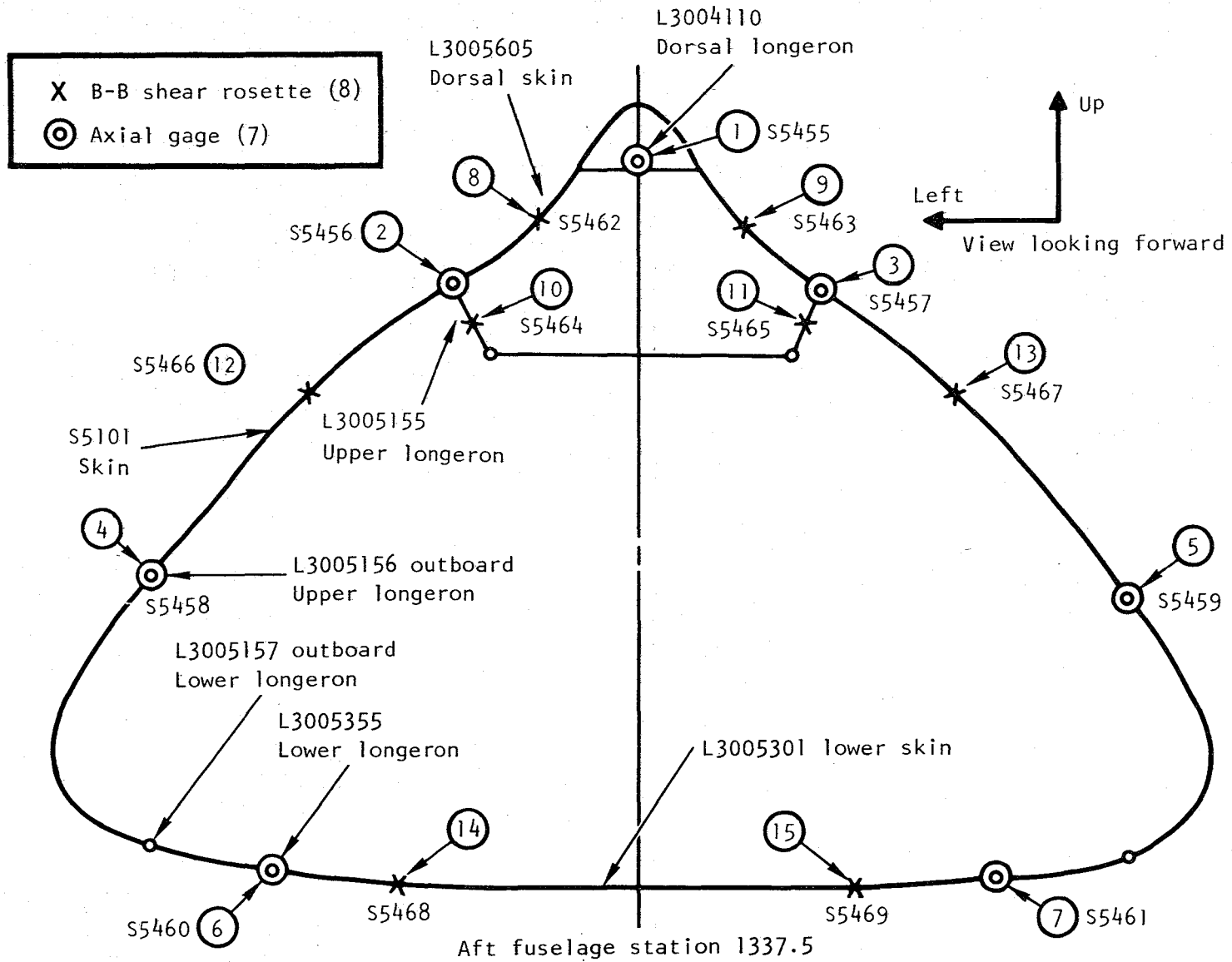
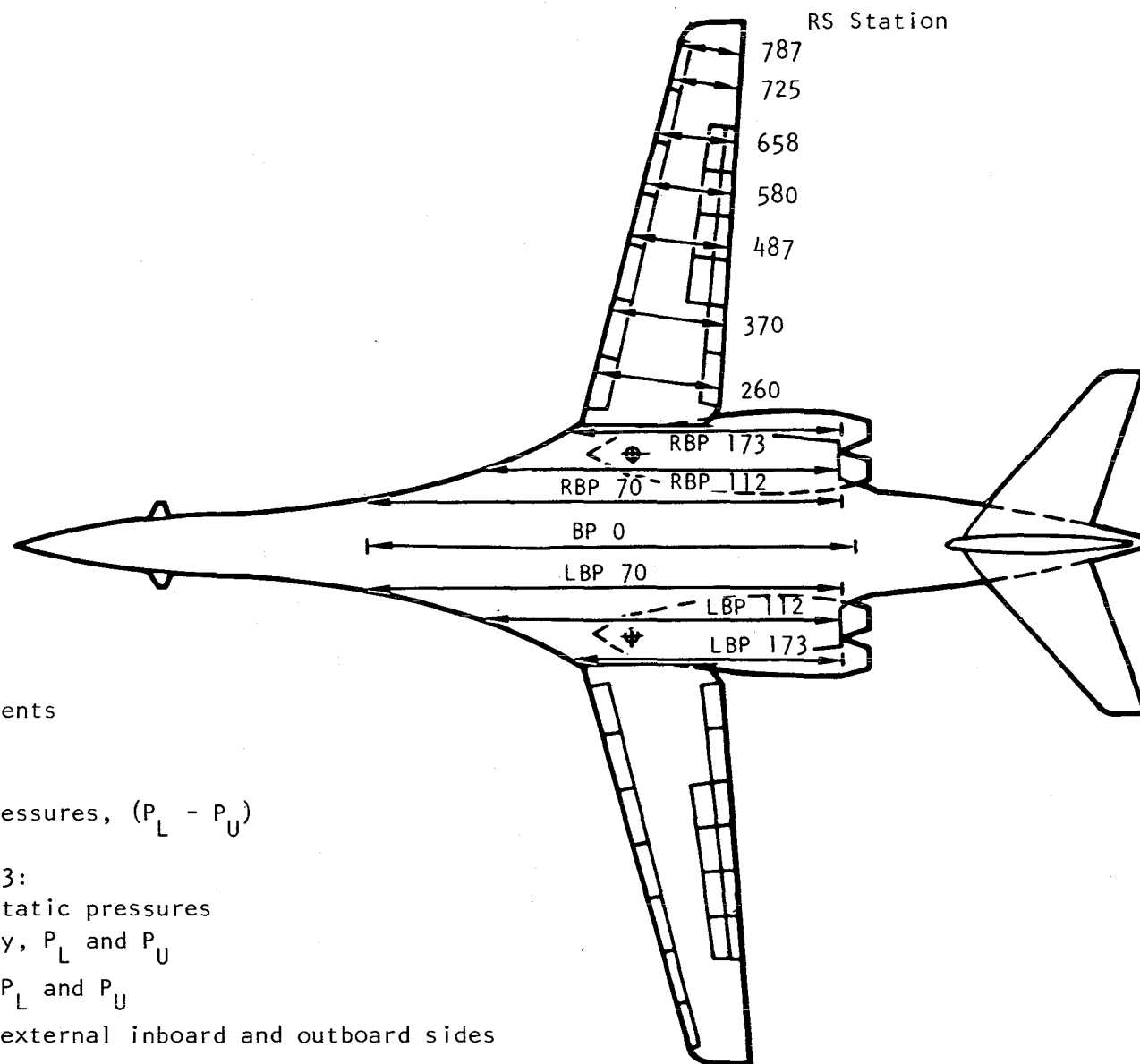

Figure 8.- Location of strain gages at aft fuselage station, FS 1337.5.



Pressure measurements

Outer wing:

Differential Pressures, ($P_L - P_U$)

RBP 173 TO LBP 173:

Local surface static pressures

Fairing and body, P_L and P_U

Both nacelles, P_L and P_U

Right nacelle, external inboard and outboard sides

Figure 9.- Location of pressure measurements.

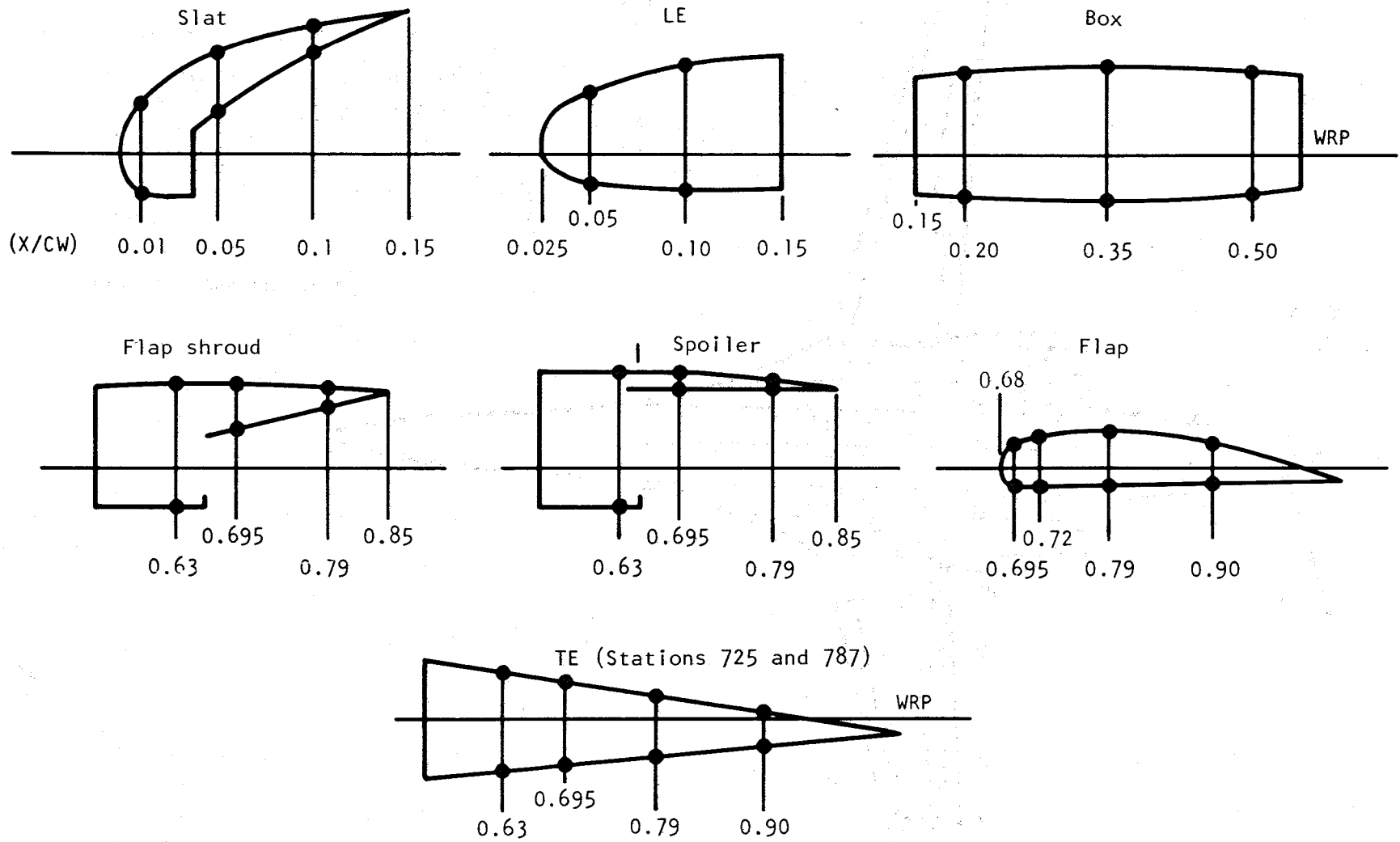

Figure 10.- Chordwise locations of pressure orifices on RH movable wing.

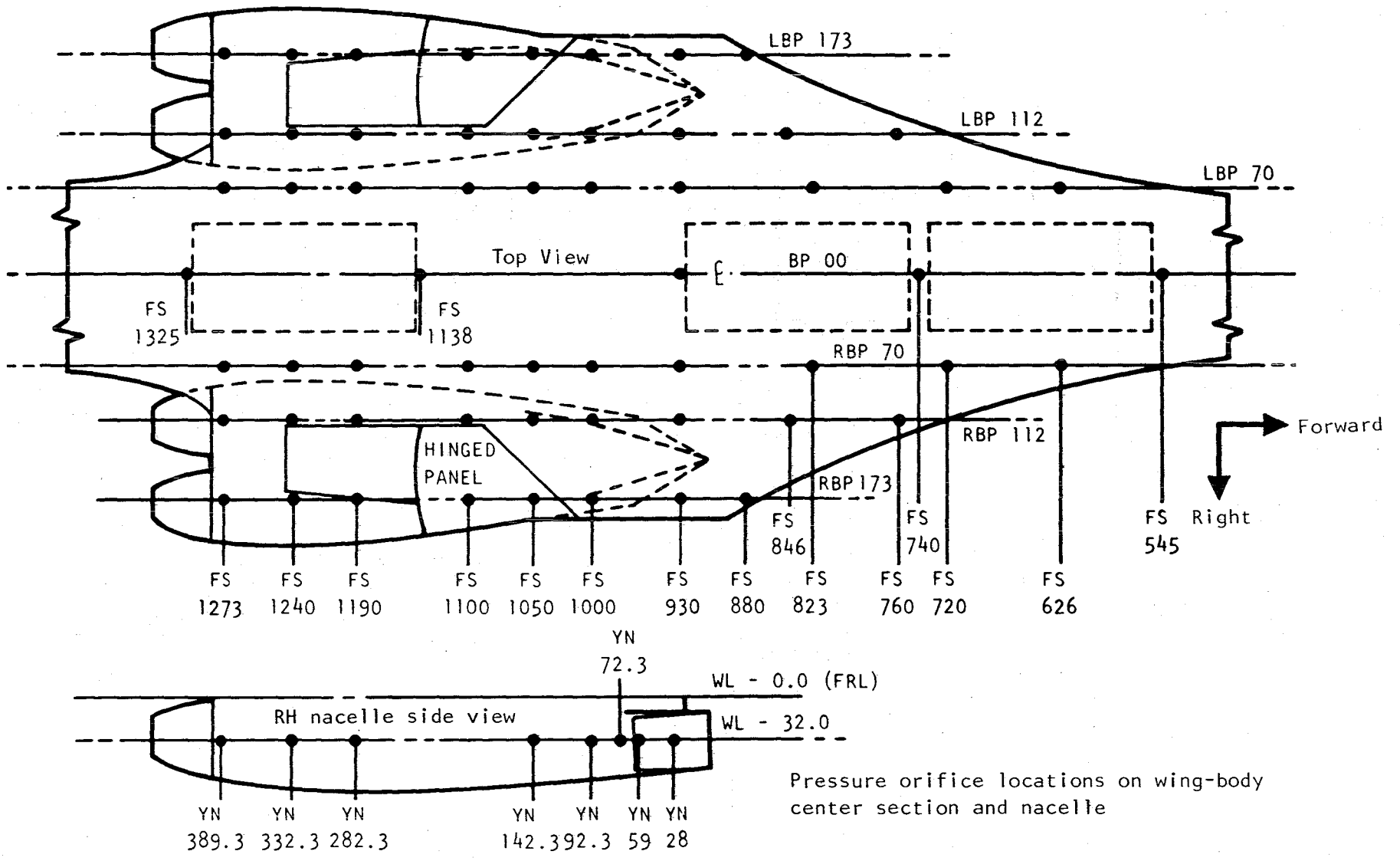

Figure 11.- Location of body/fairing/nacelle pressure orifices.

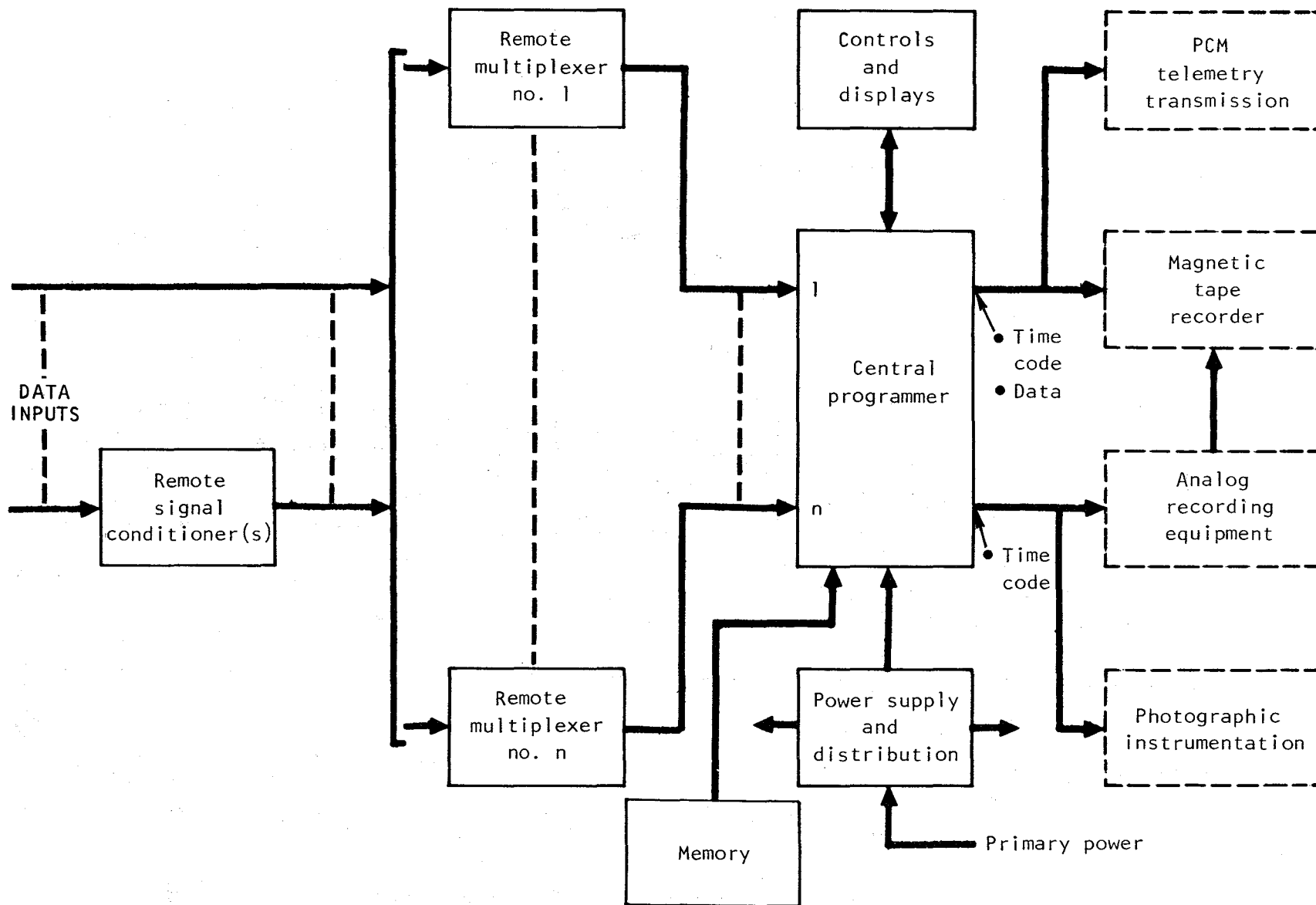

Figure 12.- Digital recording equipment.

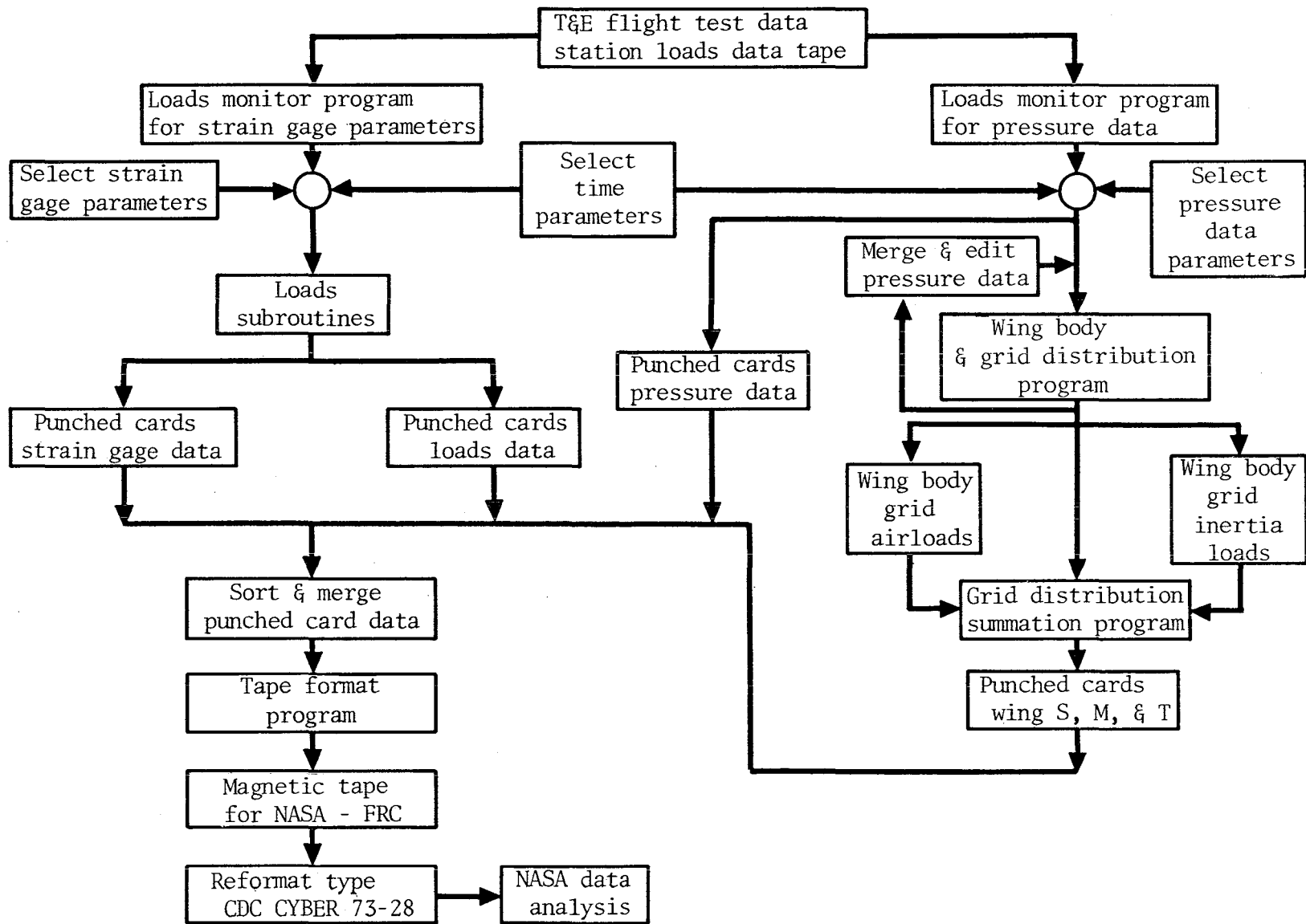

Figure 13.- A/C-2 flight loads analysis system.

This Page Intentionally Left Blank

APPENDIX A

TABLES AND FIGURES USING ENGINEERING UNITS

TABLE A-I.- CONDITION DESCRIBING PARAMETERS

INSTRUMENTATION		
<u>IDENTIFICATION</u>	<u>UNITS</u>	<u>DESCRIPTION</u>
C9001	HRS	FOUR
C9002	MINS	MINUTES
C9003	SECS	SECONDS
M1001	KNOTS	CALIBRATED AIRSPEED-CADC NO. 1
M1002	K FT	PRESSURE ALTITUDE-CADC NO. 1
M1003		MACH NO.-CADC NO.1
M1007	KNOTS	TRUE AIRSPEED-CADC NO. 1
M1012	DEG	ANGLE OF SIDE SLIP-NOSE BOOM
M1013	DEG	ANGLE OF ATTACK-NOSE BOOM
M1017	DEG	ANGLE OF BANK AT CG-GSS NO 1
M1018	DEG	ANGLE OF PITCH AT CG-GSS NO 1
M1019	DEG/SEC	RATE OF ROLL-SCAS CHAN 1A
M1020	DEG/SEC	RATE OF YAW-SCAS CHAN 1A
M1021	DEG/SEC	RATE OF PITCH-SCAS CHAN 1A
M1036	K LBS	FUEL QUANTITY-TANK #1
M1037	K LBS	FUEL QUANTITY-TANK #2
M1038	K LBS	FUEL QUANTITY-TANK #3
M1039	K LBS	FUEL QUANTITY-TANK #4
M1040	K LBS	FUEL QUANTITY-L MAIN TANK
M1041	K LBS	FUEL QUANTITY-R MAIN TANK
M1042	K LBS	FUEL QUANTITY-L WING TANK
M1043	K LBS	FUEL QUANTITY-R WING TANK
M1044	K LBS	FUEL QUANTITY-TOTAL
M1045	K LBS	FUEL QUANTITY-L WING COMPT 1
M1046	K LBS	FUEL QUANTITY-L WING COMPT 2
M1047	K LBS	FUEL QUANTITY-L WING COMPT 3
M1048	K LBS	FUEL QUANTITY-L WING COMPT 4
M1049	K LBS	A/V WEIGHT
M1050	PERCENT	A/V CENTER OF GRAVITY (CG)
M1527	K LBS	FUEL QUANTITY-R WING COMPT 1
M1528	K LBS	FUEL QUANTITY-R WING COMPT 2
M1529	K LBS	FUEL QUANTITY-R WING COMPT 3
M1530	K LBS	FUEL QUANTITY-R WING COMPT 4
A2003	G	VERTICAL ACCEL-CG
A2004	G	LATERAL ACCEL-CG
A2005	G	LONGITUDINAL ACCEL-CG
A2006	G	VERTICAL ACCEL-PILOT SEAT
A2007	G	LATERAL ACCEL-PILOT SEAT
A2012	DE/SEC2	ANGULAR ACCEL- AT CG-PITCH
A2013	DE/SEC2	ANGULAR ACCEL- AT CG-ROLL
A2014	DE/SEC2	ANGULAR ACCEL- AT CG-YAW
A2186	G	VERT ACCEL FSU600 BP 0
A2187	G	LAT. ACCEL FSU600 BP 0
A2191	G	VERT ACCEL RH WING FS AT XRS 786
A2197	G	VERT ACCEL LH WING FS AT XRS 786
A2200	G	VERT ACCEL RH HORIZ STAB TIP
A2201	G	VERT ACCEL LH HORIZ STAB TIP
A2203	G	LAT. ACCEL VERTICAL TAIL TIP
X3004	DEG	LH SPOILER #1
X3005	DEG	LH SPOILER #2
X3006	DEG	LH SPOILER #3
X3007	DEG	LH SPOILER #4
X3008	DEG	RH SPOILER #1
X3009	DEG	RH SPOILER #2
X3010	DEG	RH SPOILER #3
X3011	DEG	RH SPOILER #4
X3510	DEG	LH HORIZ STABILIZER

TABLE A-I.- CONDITION DESCRIBING PARAMETERS - Concluded

INSTRUMENTATION

<u>IDENTIFICATION</u>	<u>UNITS</u>	<u>DESCRIPTION</u>
X3511	DEG	RH HORIZ STABILIZER
X3014	DEG	RUDDER LOWER
X3015	DEG	RUDDER-MIDDLE/UPPER
X3021	DEG	LH FLAP NO. 6
X3023	DEG	RH FLAP NO. 6
X3025	DEG	LH SLAT NO. 7
X3027	DEG	RH SLAT NO. 7
X3028	DEG	LH SMC VANE
X3029	DEG	RH SMC VANE
X3032	DEG	RH WING SWEEP POSITION
X3033	DEG	LH WING SWEEP POSITION
T4001	DEGF	TOTAL TEMPERATURE-CADC NO. 1

TABLE A-II. - STRAIN GAGE PARAMETERS

<u>INSTRUMENTATION IDENTIFICATION</u>	<u>UNITS</u>	<u>DESCRIPTION</u>
S5225	K LBS	LH HORIZ STAB ACT #1 LOADS
S5226	K LBS	LH HORIZ STAB ACT #2 LOADS
S5230	K LBS	RH HORIZ STAB ACT #1 LOADS
S5231	K LBS	RH HORIZ STAB ACT #2 LOADS
S5245	K LBS	LWR RUDDER ACT #1 LOAD
S5246	KINLBS	LWR RUDDER ACT #3 LOAD
S5247	KINLBS	MID RUDDER ROTARY ACT #2 HM
S5248	KINLBS	MID RUDDER ROTARY ACT #4 HM
S5249	KINLBS	UPR RUDDER ROTARY ACT #6 HM
S5250	KINLBS	UPR RUDDER ROTARY ACT #9 HM
S5306	MICSTR	LH WOP FRONT SPAR SHEAR, XRS 353
S5307	MICSTR	LH WOP FRONT SPAR SHEAR, XRS 356
S5308	MICSTR	LH WOP UPPER COVER, XRS 354, AXIAL LOC1
S5309	MICSTR	LH WOP UPPER COVER, XRS 354, AXIAL LOC2
S5310	MICSTR	LH WOP UPPER COVER, XRS 354, AXIAL LOC3
S5311	MICSTR	LH WOP UPPER COVER, XRS 354, AXIAL LOC4
S5312	MICSTR	LH WOP UPPER COVER, XRS 354, SHEAR LOC1
S5313	MICSTR	LH WOP UPPER COVER, XRS 354, SHEAR LOC2
S5314	MICSTR	LH WOP LOWER COVER, XRS 354, AXIAL LOC1
S5315	MICSTR	LH WOP LOWER COVER, XRS 354, AXIAL LOC2
S5316	MICSTR	LH WOP LOWER COVER, XRS 354, AXIAL LOC3
S5317	MICSTR	LH WOP LOWER COVER, XRS 354, AXIAL LOC4
S5318	MICSTR	LH WOP LOWER COVER, XRS 354, SHEAR LOC1
S5319	MICSTR	LH WOP LOWER COVER, XRS 354, SHEAR LOC2
S5320	MICSTR	RH WOP FRONT SPAR SHEAR, XRS 353
S5321	MICSTR	RH WOP FRONT SPAR SHEAR, XRS 354
S5322	MICSTR	RH WOP UPPER COVER, XRS 354, AXIAL LOC1
S5323	MICSTR	RH WOP UPPER COVER, XRS 354, AXIAL LOC2
S5324	MICSTR	RH WOP UPPER COVER, XRS 354, AXIAL LOC3
S5325	MICSTR	RH WOP UPPER COVER, XRS 354, AXIAL LOC4
S5326	MICSTR	RH WOP UPPER COVER, XRS 354, SHEAR LOC1
S5327	MICSTR	RH WOP UPPER COVER, XRS 354, SHEAR LOC1
S5328	MICSTR	RH WOP UPPER COVER, XRS 354, AXIAL LOC1
S5329	MICSTR	RH WOP UPPER COVER, XRS 354, AXIAL LOC2
S5330	MICSTR	RH WOP UPPER COVER, XRS 354, AXIAL LOC3
S5331	MICSTR	RH WOP UPPER COVER, XRS 354, AXIAL LOC4
S5332	MICSTR	RH WOP UPPER COVER, XRS 354, SHEAR LOC1
S5333	MICSTR	RH WOP UPPER COVER, XRS 354, SHEAR LOC2
S5336	MICSTR	VERT STAB FRONT SPAR WEB LWR
S5337	MICSTR	VERT STAB ROOT RIB WEB FWD
S5338	MICSTR	VERT STAB RH COVER LWR FWD
S5339	MICSTR	VERT STAB RH COVER LWR AFT
S5340	MICSTR	VERT STAB ATTACH FTG CENTER WEB

TABLE A-II. - STRAIN GAGE PARAMETERS - Continued

<u>INSTRUMENTATION IDENTIFICATION</u>	<u>UNITS</u>	<u>DESCRIPTION</u>
S5341	MICSTR	VERT STAB ATTACH FTG AFT WEB
S5342	MICSTR	VERT STAB ATTACH FTG FWD WEB
S5343	MICSTR	VERT STAB ATTACH FTG LH SIDE FWD
S5344	MICSTR	VERT STAB ATTACH FTG LH SIDE AFT INTERM
S5345	MICSTR	VERT STAB ATTACH FTG LH SIDE AFT
S5346	MICSTR	VERT STAB ATTACH FTG LH SIDE FWD INTERM
S5351	MICSTR	LH HORIZ STAB FWD INTERM SPAR WEB INBD
S5352	MICSTR	LH HORIZ STAB AFT INTERM SPAR WEB INBD
S5353	MICSTR	LH HORIZ STAB XHS 47 RIB WEB FWD
S5354	MICSTR	LH HORIZ STAB XHS 47 RIB WEB AFT
S5355	MICSTR	LH HORIZ STAB ROOT RIB WEB FWD
S5356	MICSTR	LH HORIZ STAB ROOT RIB WEB AFT
S5357	MICSTR	LH HORIZ STAB UPPER COVER FWD INBD
S5358	MICSTR	LH HORIZ STAB UPPER COVER AFT INBD
S5359	MICSTR	LH HORIZ STAB SPINDLE FTG UPR CAP INBD
S5360	MICSTR	LH HORIZ STAB SPINDLE FTG LWR CAP INBD
S5361	MICSTR	LH HORIZ STAB SPINDLE FTG UPR CAP OUTBD
S5362	MICSTR	LH HORIZ STAB SPINDLE FTG LWR CAP OUTBD
S5363	MICSTR	LH HORIZ STAB SPINDLE FTG WEB INBD
S5364	MICSTR	RH HORIZ STAB FWD INTERM SPAR WEB INBD
S5365	MICSTR	RH HORIZ STAB AFT INTERM SPAR WEB INBD
S5366	MICSTR	RH HORIZ STAB XHS 47 RIB WEB FWD
S5367	MICSTR	RH HORIZ STAB XHS 47 RIB WEB AFT
S5368	MICSTR	RH HORIZ STAB ROOT RIB WEB FWD
S5369	MICSTR	RH HORIZ STAB ROOT RIB WEB AFT
S5370	MICSTR	RH HORIZ STAB UPPER COVER FWD INBD
S5371	MICSTR	RH HORIZ STAB UPPER COVER AFT INBD
S5372	MICSTR	RH HORIZ STAB SPINDLE FTG UPR CAP INBD
S5373	MICSTR	RH HORIZ STAB SPINDLE FTG LWR CAP INBD
S5374	MICSTR	RH HORIZ STAB SPINDLE FTG UPR CAP INBD
S5375	MICSTR	RH HORIZ STAB SPINDLE FTG LWR CAP INBD
S5376	MICSTR	RH HORIZ STAB SPINDLE FTG WEB INBD
S5440	MICSTR	FS 528.5 LOC 1
S5441	MICSTR	FS 528.5 LOC 2
S5442	MICSTR	FS 528.5 LOC 3
S5443	MICSTR	FS 528.5 LOC 4
S5444	MICSTR	FS 528.5 LOC 5
S5445	MICSTR	FS 528.5 LOC 6
S5446	MICSTR	FS 528.5 LOC 7
S5447	MICSTR	FS 528.5 LOC 8
S5448	MICSTR	FS 528.5 LOC 9
S5449	MICSTR	FS 528.5 LOC 10
S5450	MICSTR	FS 528.5 LOC 11

TABLE A-II. - STRAIN GAGE PARAMETERS - Continued

<u>INSTRUMENTATION IDENTIFICATION</u>	<u>UNITS</u>	<u>DESCRIPTION</u>
S5451	MICSTR	FS 528.5 LOC 12
S5452	MICSTR	FS 528.5 LOC 13
S5453	MICSTR	FS 528.5 LOC 14
S5454	MICSTR	FS 528.5 LOC 15
S5455	MICSTR	FS1337.5 LOC 1
S5456	MICSTR	FS1337.5 LOC 2
S5457	MICSTR	FS1337.5 LOC 3
S5458	MICSTR	FS1337.5 LOC 4
S5459	MICSTR	FS1337.5 LOC 5
S5460	MICSTR	FS1337.5 LOC 6
S5461	MICSTR	FS1337.5 LOC 7
S5462	MICSTR	FS1337.5 LOC 8
S5463	MICSTR	FS1337.5 LOC 9
S5464	MICSTR	FS1337.5 LOC 10
S5465	MICSTR	FS1337.5 LOC 11
S5466	MICSTR	FS1337.5 LOC 12
S5467	MICSTR	FS1337.5 LOC 13
S5468	MICSTR	FS1337.5 LOC 14
S5469	MICSTR	FS1337.5 LOC 15
S5470	KINLBS	UPR RUDDER ROTARY ACT # 5 HM
S5471	KINLBS	UPR RUDDER ROTARY ACT # 7 HM
S5472	KINLBS	UPR RUDDER ROTARY ACT # 8 HM
S5473	KINLBS	MID RUDDER ROTARY ACT #1 HM
S5474	KINLBS	MID RUDDER ROTARY ACT #3 HM
S5475	K LBS	LWR RUDDER ACT #2 LOAD
S5476	K LBS	LWR RUDDER ACT #4 LOAD
S5642	MICSTR	FS 528.5
S5643	MICSTR	FS 528.5
S5644	MICSTR	FS 528.5
S5645	MICSTR	FS 528.5
S5646	MICSTR	FS 528.5
S5647	MICSTR	FS 528.5
S5648	MICSTR	FS 528.5
S5160	K LBS	LH SMC VANE FWD ACT LOAD
S5161	K LBS	LH SMC VANE AFT ACT LOAD
S5547	K LBS	LH SMC VANE LOAD LOC 1
S5548	K LBS	LH SMC VANE LOAD LOC 2
S5549	K LBS	LH SMC VANE LOAD LOC 3
S5550	K LBS	RH SMC VANE LOAD LOC 1
S5551	K LBS	RH SMC VANE LOAD LOC 2
S5552	K LBS	RH SMC VANE LOAD LOC 3
S5553	K LBS	RH SMC VANE FWD ACT LOAD
S5554	K LBS	RH SMC VANE AFT ACT LOAD

TABLE A-II. - STRAIN GAGE PARAMETERS - Concluded.

<u>INSTRUMENTATION IDENTIFICATION</u>	<u>UNITS</u>	<u>DESCRIPTION</u>
S5685	MICSTR	FWD SUPPORT,RH NAC, LOC#1
S5686	MICSTR	FWD SUPPORT,RH NAC, LOC#2
S5687	MICSTR	FWD SUPPORT,RH NAC, LOC#3
S5059	K LBS	AFT INBD SUPPORT LOAD-RH NACELLE
S5060	K LBS	AFT OUTBD SUPPORT LOAD-RH NACELLE
S5061	K LBS	AFT SIDE LINK LOAD-RH NACELLE
S5678	MICSTR	FWD SUPPORT,LH NAC,LOC#1
S5679	MICSTR	FWD SUPPORT,LH NAC,LOC#2
S5680	MICSTR	FWD SUPPORT,LH NAC,LOC#3
S5681	MICSTR	FWD SUPPORT,LH NAC,LOC#4
S5682	MICSTR	FWD SUPPORT,LH NAC,LOC#5
S5683	MICSTR	FWD SUPPORT,LH NAC,LOC#6
S5684	MICSTR	FWD SUPPORT,LH NAC,LOC#7
S5053	K LBS	AFT INBD SUPPORT LOAD-LH NAC
S5054	K LBS	AFT OUTBD SUPPORT LOAD-LH NAC
S5055	K LBS	AFT SIDE LINK LOAD-LH NAC
S5689	MICSTR	FWD SUPPORT,RH NAC,LOC#5
S5690	MICSTR	FWD SUPPORT,RH NAC,LOC#6
S5691	MICSTR	FWD SUPPORT,RH NAC,LOC#7
S5688	MICSTR	FWD SUPPORT,RH NAC,LOC#4
S5151	MICSTR	LH WCP UP COVER STA XRS162,LOC#2
S5153	MICSTR	LH WCP LWR COVER STA XRS162 LOC#2
S5155	MICSTR	RH WCP UP COVER STA XRS162 LOC#2
S5157	MICSTR	RH WCP LWR COVER STA XRS162 LOC#2

TABLE A-III. - STRAIN GAGE DERIVED LOADS

<u>INSTRUMENTATION IDENTIFICATION</u>	<u>UNITS</u>	<u>DESCRIPTION</u>
C0501	K LBS	LEFT WING SHEAR AT XRS354
C0502	KIN-LBS	LEFT WING MOMENT AT XRS354
C0503	KIN-LBS	LEFT WING TORQUE AT XRS354
C0504	K LBS	RIGHT WING SHEAR AT XRS354
C0505	KIN-LBS	RIGHT WING MOMENT AT XRS354
C0506	KIN-LBS	RIGHT WING TORQUE AT XRS354
C0507	K LBS	LT. HORIZ. SHEAR AT THE ROOT
C0508	KIN-LBS	LT. HORIZ. MOMENT AT THE ROOT
C0509	KIN-LBS	LT. HORIZ. TORQUE AT THE ROOT
C0510	K LBS	RT. HORIZ. SHEAR AT THE ROOT
C0511	KIN-LBS	RT. HORIZ. MOMENT AT THE ROOT
C0512	KIN-LBS	RT. HORIZ. TORQUE AT THE ROOT
C0513	K LBS	VERT. TAIL SHEAR AT THE ROOT
C0514	KIN-LBS	VERT. TAIL MOMENT AT THE ROOT
C0515	KIN-LBS	VERT. TAIL TORQUE AT THE ROOT
C0516	K LBS	FWD FUS. VERT. SHEAR STA528.5
C0517	KIN-LBS	FWD FUS. BEND. MOMENT STA528.5
C0518	K LBS	FWD FUS. SIDE SHEAR STA528.5
C0519	KIN-LBS	FWD FUS. SIDE MOMENT STA528.5
C0520	K LBS	AFT FUS. VERT. SHEAR STA1337.5
C0521	KIN-LBS	AFT FUS. TORSION STA1337.5
C0522	KIN-LBS	AFT FUS. VERT BENDING STA1337.5
C0523	K LBS	AFT FUS. SIDE SHEAR STA1337.5
C0524	KIN-LBS	AFT FUS. SIDE BENDING STA1337.5

TABLE A-IV.- PRESSURE TRANSDUCER PARAMETERS

INSTRUMENTATION						
<u>IDENTIFICATION</u>	<u>UNITS</u>	<u>DESCRIPTION</u>				
06819	PSI	BP173	FS880	UPPER	LEFT	SIDE
06820	PSI	BP173	FS930	UPPER	LEFT	SIDE
06821	PSI	BP173	FS1000	UPPER	LEFT	SIDE
06822	PSI	BP173	FS1050	UPPER	LEFT	SIDE
06823	PSI	BP173	FS1100	UPPER	LEFT	SIDE
06830	PSI	BP173	FS1190	UPPER	LEFT	SIDE
06831	PSI	BP173	FS1240	UPPER	LEFT	SIDE
06832	PSI	BP173	FS1273	UPPER	LEFT	SIDE
06824	PSI	BP173	FS880	LOWER	LEFT	SIDE
06825	PSI	BP173	FS930	LOWER	LEFT	SIDE
06833	PSI	BP173	FS1000	LOWER	LEFT	SIDE
06834	PSI	BP173	FS1050	LOWER	LEFT	SIDE
06835	PSI	BP173	FS1100	LOWER	LEFT	SIDE
06836	PSI	BP173	FS1190	LOWER	LEFT	SIDE
06837	PSI	BP173	FS1240	LOWER	LEFT	SIDE
06838	PSI	BP173	FS1273	LOWER	LEFT	SIDE
06839	PSI	BP112	FS760	UPPER	LEFT	SIDE
06840	PSI	BP112	FS846	UPPER	LEFT	SIDE
06841	PSI	BP112	FS930	UPPER	LEFT	SIDE
06842	PSI	BP112	FS1000	UPPER	LEFT	SIDE
06843	PSI	BP112	FS1050	UPPER	LEFT	SIDE
06844	PSI	BP112	FS1100	UPPER	LEFT	SIDE
06845	PSI	BP112	FS1190	UPPER	LEFT	SIDE
06846	PSI	BP112	FS1240	UPPER	LEFT	SIDE
06848	PSI	BP112	FS1273	UPPER	LEFT	SIDE
06847	PSI	BP112	FS760	LOWER	LEFT	SIDE
06848	PSI	BP112	FS846	LOWER	LEFT	SIDE
06849	PSI	BP112	FS930	LOWER	LEFT	SIDE
06853	PSI	BP112	FS1000	LOWER	LEFT	SIDE
06854	PSI	BP112	FS1050	LOWER	LEFT	SIDE
06855	PSI	BP112	FS1100	LOWER	LEFT	SIDE
06856	PSI	BP112	FS1190	LOWER	LEFT	SIDE
06857	PSI	BP112	FS1240	LOWER	LEFT	SIDE
06858	PSI	BP112	FS1273	LOWER	LEFT	SIDE
06859	PSI	BP70	FS626	UPPER	LEFT	SIDE
06860	PSI	BP70	FS720	UPPER	LEFT	SIDE
06861	PSI	BP70	FS825	UPPER	LEFT	SIDE
06862	PSI	BP70	FS930	UPPER	LEFT	SIDE
06863	PSI	BP70	FS1000	UPPER	LEFT	SIDE
06864	PSI	BP70	FS1050	UPPER	LEFT	SIDE
06865	PSI	BP70	FS1100	UPPER	LEFT	SIDE
06866	PSI	BP70	FS1190	UPPER	LEFT	SIDE
06867	PSI	BP70	FS1240	UPPER	LEFT	SIDE
06868	PSI	BP70	FS1297	UPPER	LEFT	SIDE
06869	PSI	BP70	FS626	LOWER	LEFT	SIDE
06870	PSI	BP70	FS720	LOWER	LEFT	SIDE
06871	PSI	BP70	FS825	LOWER	LEFT	SIDE
06872	PSI	BP70	FS930	LOWER	LEFT	SIDE
06873	PSI	BP70	FS1000	LOWER	LEFT	SIDE
06874	PSI	BP70	FS1050	LOWER	LEFT	SIDE
06875	PSI	BP70	FS1100	LOWER	LEFT	SIDE
06876	PSI	BP70	FS1190	LOWER	LEFT	SIDE
06877	PSI	BP70	FS1240	LOWER	LEFT	SIDE
06878	PSI	BP70	FS1297	LOWER	LEFT	SIDE
06879	PSI	BPO	FS545	UPPER	CENTERLINE	
06880	PSI	BPO	FS740	UPPER	CENTERLINE	
06881	PSI	BPO	FS930	UPPER	CENTERLINE	

TABLE A-IV.- PRESSURE TRANSDUCER PARAMETERS - Continued

INSTRUMENTATION					
<u>IDENTIFICATION</u>	<u>UNITS</u>	<u>DESCRIPTION</u>			
D6882	PSI	BP0	FS1138	UPPER	CENTERLINE
D6883	PSI	BP0	FS1325	UPPER	CENTERLINE
D6884	PSI	BP0	FS545	LOWER	CENTERLINE
D6885	PSI	BP0	FS740	LOWER	CENTERLINE
D6886	PSI	BP0	FS930	LOWER	CENTERLINE
D6887	PSI	BP0	FS1138	LOWER	CENTERLINE
D6888	PSI	BP0	FS1325	LOWER	CENTERLINE
D6889	PSI	BP70	FS626	UPPER	RIGHT SIDE
D6890	PSI	BP70	FS720	UPPER	RIGHT SIDE
D6891	PSI	BP70	FS825	UPPER	RIGHT SIDE
D6892	PSI	BP70	FS930	UPPER	RIGHT SIDE
D6893	PSI	BP70	FS1000	UPPER	RIGHT SIDE
D6894	PSI	BP70	FS1050	UPPER	RIGHT SIDE
D6895	PSI	BP70	FS1100	UPPER	RIGHT SIDE
D6896	PSI	BP70	FS1190	UPPER	RIGHT SIDE
D6897	PSI	BP70	FS1240	UPPER	RIGHT SIDE
D6898	PSI	BP70	FS1297	UPPER	RIGHT SIDE
D6899	PSI	BP70	FS626	LOWER	RIGHT SIDE
D6900	PSI	BP70	FS720	LOWER	RIGHT SIDE
D6901	PSI	BP70	FS825	LOWER	RIGHT SIDE
D6902	PSI	BP70	FS930	LOWER	RIGHT SIDE
D6903	PSI	BP70	FS1000	LOWER	RIGHT SIDE
D6904	PSI	BP70	FS1050	LOWER	RIGHT SIDE
D6905	PSI	BP70	FS1100	LOWER	RIGHT SIDE
D6906	PSI	BP70	FS1190	LOWER	RIGHT SIDE
D6907	PSI	BP70	FS1240	LOWER	RIGHT SIDE
D6908	PSI	BP70	FS1297	LOWER	RIGHT SIDE
D6909	PSI	BP112	FS760	UPPER	RIGHT SIDE
D6910	PSI	BP112	FS846	UPPER	RIGHT SIDE
D6911	PSI	BP112	FS930	UPPER	RIGHT SIDE
D6912	PSI	BP112	FS1000	UPPER	RIGHT SIDE
D6913	PSI	BP112	FS1050	UPPER	RIGHT SIDE
D6914	PSI	BP112	FS1100	UPPER	RIGHT SIDE
D6915	PSI	BP112	FS1190	UPPER	RIGHT SIDE
D6916	PSI	BP112	FS1240	UPPER	RIGHT SIDE
D6922	PSI	BP112	FS1273	UPPER	RIGHT SIDE
D6917	PSI	BP112	FS760	LOWER	RIGHT SIDE
D6918	PSI	BP112	FS846	LOWER	RIGHT SIDE
D6919	PSI	BP112	FS930	LOWER	RIGHT SIDE
D6923	PSI	BP112	FS1000	LOWER	RIGHT SIDE
D6924	PSI	BP112	FS1050	LOWER	RIGHT SIDE
D6925	PSI	BP112	FS1100	LOWER	RIGHT SIDE
D6926	PSI	BP112	FS1190	LOWER	RIGHT SIDE
D6927	PSI	BP112	FS1240	LOWER	RIGHT SIDE
D6928	PSI	BP112	FS1273	LOWER	RIGHT SIDE
D6929	PSI	BP173	FS880	UPPER	RIGHT SIDE
D6930	PSI	BP173	FS930	UPPER	RIGHT SIDE
D6931	PSI	BP173	FS1000	UPPER	RIGHT SIDE
D6932	PSI	BP173	FS1050	UPPER	RIGHT SIDE
D6933	PSI	BP173	FS1100	UPPER	RIGHT SIDE
D6940	PSI	BP173	FS1190	UPPER	RIGHT SIDE
D6941	PSI	BP173	FS1240	UPPER	RIGHT SIDE
D6942	PSI	BP173	FS1273	UPPER	RIGHT SIDE
D6934	PSI	BP173	FS880	LOWER	RIGHT SIDE
D6935	PSI	BP173	FS930	LOWER	RIGHT SIDE
D6943	PSI	BP173	FS1000	LOWER	RIGHT SIDE
D6944	PSI	BP173	FS1050	LOWER	RIGHT SIDE
D6945	PSI	BP173	FS1100	LOWER	RIGHT SIDE

TABLE A-IV.- PRESSURE TRANSDUCER PARAMETERS - Continued

INSTRUMENTATION					
<u>IDENTIFICATION</u>	<u>UNITS</u>	<u>DESCRIPTION</u>			
D6946	PSI	BP173	FS1190	LOWER	RIGHT SIDE
D6947	PSI	BP173	FS1240	LOWER	RIGHT SIDE
D6948	PSI	BP173	FS1273	LOWER	RIGHT SIDE
D6826	PSI	BP173	FS1000	INNER	LEFT SIDE
D6829	PSI	BP173	FS1000	INNER	LEFT SIDE
D6827	PSI	BP173	FS1050	INNER	LEFT SIDE
D6828	PSI	BP173	FS1100	INNER	LEFT SIDE
D6850	PSI	BP112	FS1000	INNER	LEFT SIDE
D6851	PSI	BP112	FS1000	INNER	LEFT SIDE
D6920	PSI	BP112	FS1000	INNER	RIGHT SIDE
D6921	PSI	BP112	FS1000	INNER	RIGHT SIDE
D6936	PSI	BP173	FS1000	INNER	RIGHT SIDE
D6939	PSI	BP173	FS1000	INNER	RIGHT SIDE
D6937	PSI	BP173	FS1050	INNER	RIGHT SIDE
D6938	PSI	BP173	FS1100	INNER	RIGHT SIDE
D7189	PSI	WL-32	YN23	RH NACELLE	OUTER
D7170	PSI	WL-32	YN59	RH NACELLE	OUTER
D6957	PSI	WL-32	YN72.3	RH NACELLE	OUTER
D6958	PSI	WL-32	YN92.3	RH NACELLE	OUTER
D6959	PSI	WL-32	YN142.3	RH NACELLE	OUTER
D6960	PSI	WL-32	YN282.3	RH NACELLE	OUTER
D6961	PSI	WL-32	YN332.3	RH NACELLE	OUTER
D6962	PSI	WL-32	YN365.3	RH NACELLE	OUTER
D7188	PSI	WL-32	YN28	RH NACELLE	INNER
D7157	PSI	WL-32	YN59	RH NACELLE	INNER
D6950	PSI	WL-32	YN72.3	RH NACELLE	INNER
D6951	PSI	WL-32	YN92.3	RH NACELLE	INNER
D6952	PSI	WL-32	YN142.3	RH NACELLE	INNER
D6953	PSI	WL-32	YN282.3	RH NACELLE	INNER
D6954	PSI	WL-32	YN332.3	RH NACELLE	INNER
D6955	PSI	WL-32	YN365.3	RH NACELLE	INNER
D6963	PSI	XRS260	X/C=.01	SLAT	RIGHT SIDE
D6965	PSI	XRS260	X/C=.05	SLAT	RIGHT SIDE
D6967	PSI	XRS260	X/C=.10	SLAT	RIGHT SIDE
D6964	PSI	XRS260	X/C=.05	WING	RIGHT SIDE
D6966	PSI	XRS260	X/C=.10	WING	RIGHT SIDE
D6968	PSI	XRS260	X/C=.20	WING	RIGHT SIDE
D6969	PSI	XRS260	X/C=.35	WING	RIGHT SIDE
D6970	PSI	XRS260	X/C=.50	WING	RIGHT SIDE
D6971	PSI	XRS260	X/C=.63	WING	RIGHT SIDE
D6972	PSI	XRS260	X/C=.695	WING	RIGHT SIDE
D6975	PSI	XRS260	X/C=.79	WING	RIGHT SIDE
D6973	PSI	XRS260	X/C=.695	FLAP	RIGHT SIDE
D6974	PSI	XRS260	X/C=.72	FLAP	RIGHT SIDE
D6976	PSI	XRS260	X/C=.79	FLAP	RIGHT SIDE
D6977	PSI	XRS260	X/C=.90	FLAP	RIGHT SIDE
D6978	PSI	XRS370	X/C=.01	SLAT	RIGHT SIDE
D6980	PSI	XRS370	X/C=.05	SLAT	RIGHT SIDE
D6982	PSI	XRS370	X/C=.10	SLAT	RIGHT SIDE
D6979	PSI	XRS370	X/C=.05	WING	RIGHT SIDE
D6981	PSI	XRS370	X/C=.10	WING	RIGHT SIDE
D6983	PSI	XRS370	X/C=.20	WING	RIGHT SIDE
D6984	PSI	XRS370	X/C=.35	WING	RIGHT SIDE
D6985	PSI	XRS370	X/C=.50	WING	RIGHT SIDE
D6986	PSI	XRS370	X/C=.63	WING	RIGHT SIDE

TABLE A-IV.- PRESSURE TRANSDUCER PARAMETERS - Continued

INSTRUMENTATION					
<u>IDENTIFICATION</u>	<u>UNITS</u>	<u>DESCRIPTION</u>			
D6987	PSI	XRS370	X/C=.695	WING	RIGHT SIDE
D6990	PSI	XRS370	X/C=.79	WING	RIGHT SIDE
D6988	PSI	XRS370	X/C=.695	FLAP	RIGHT SIDE
D6989	PSI	XRS370	X/C=.72	FLAP	RIGHT SIDE
D6991	PSI	XRS370	X/C=.79	FLAP	RIGHT SIDE
D6992	PSI	XRS370	X/C=.90	FLAP	RIGHT SIDE
D6993	PSI	XRS487	X/C=.01	SLAT	RIGHT SIDE
D6995	PSI	XRS487	X/C=.05	SLAT	RIGHT SIDE
D6997	PSI	XRS487	X/C=.10	SLAT	RIGHT SIDE
D6994	PSI	XRS487	X/C=.05	WING	RIGHT SIDE
D6996	PSI	XRS487	X/C=.10	WING	RIGHT SIDE
D6988	PSI	XRS487	X/C=.20	WING	RIGHT SIDE
D6999	PSI	XRS487	X/C=.35	WING	RIGHT SIDE
D7000	PSI	XRS487	X/C=.50	WING	RIGHT SIDE
D7001	PSI	XRS487	X/C=.63	WING	RIGHT SIDE
D7002	PSI	XRS487	X/C=.695	SPOILER	RIGHT SIDE
D7005	PSI	XRS487	X/C=.79	SPOILER	RIGHT SIDE
D7003	PSI	XRS487	X/C=.695	FLAP	RIGHT SIDE
D7004	PSI	XRS487	X/C=.72	FLAP	RIGHT SIDE
D7006	PSI	XRS487	X/C=.79	FLAP	RIGHT SIDE
D7007	PSI	XRS487	X/C=.90	FLAP	RIGHT SIDE
D7008	PSI	XRS580	X/C=.01	SLAT	RIGHT SIDE
D7010	PSI	XRS580	X/C=.05	SLAT	RIGHT SIDE
D7012	PSI	XRS580	X/C=.10	SLAT	RIGHT SIDE
D7009	PSI	XRS580	X/C=.05	WING	RIGHT SIDE
D7011	PSI	XRS580	X/C=.10	WING	RIGHT SIDE
D7013	PSI	XRS580	X/C=.20	WING	RIGHT SIDE
D7014	PSI	XRS580	X/C=.35	WING	RIGHT SIDE
D7015	PSI	XRS580	X/C=.50	WING	RIGHT SIDE
D7016	PSI	XRS580	X/C=.63	WING	RIGHT SIDE
D7017	PSI	XRS580	X/C=.695	SPOILER	RIGHT SIDE
D7020	PSI	XRS580	X/C=.79	SPOILER	RIGHT SIDE
D7018	PSI	XRS580	X/C=.695	FLAP	RIGHT SIDE
D7019	PSI	XRS580	X/C=.72	FLAP	RIGHT SIDE
D7021	PSI	XRS580	X/C=.79	FLAP	RIGHT SIDE
D7022	PSI	XRS580	X/C=.90	FLAP	RIGHT SIDE
D7023	PSI	XRS658	X/C=.01	SLAT	RIGHT SIDE
D7025	PSI	XRS658	X/C=.05	SLAT	RIGHT SIDE
D7027	PSI	XRS658	X/C=.10	SLAT	RIGHT SIDE
D7024	PSI	XRS658	X/C=.05	WING	RIGHT SIDE
D7026	PSI	XRS658	X/C=.10	WING	RIGHT SIDE
D7028	PSI	XRS658	X/C=.20	WING	RIGHT SIDE
D7029	PSI	XRS658	X/C=.35	WING	RIGHT SIDE
D7030	PSI	XRS658	X/C=.50	WING	RIGHT SIDE
D7031	PSI	XRS658	X/C=.63	WING	RIGHT SIDE
D7032	PSI	XRS658	X/C=.695	SPOILER	RIGHT SIDE
D7035	PSI	XRS658	X/C=.79	SPOILER	RIGHT SIDE
D7033	PSI	XRS658	X/C=.695	FLAP	RIGHT SIDE
D7034	PSI	XRS658	X/C=.72	FLAP	RIGHT SIDE
D7036	PSI	XRS658	X/C=.79	FLAP	RIGHT SIDE
D7037	PSI	XRS658	X/C=.90	FLAP	RIGHT SIDE
D7038	PSI	XRS725	X/C=.01	SLAT	RIGHT SIDE
D7040	PSI	XRS725	X/C=.05	SLAT	RIGHT SIDE
D7042	PSI	XRS725	X/C=.10	SLAT	RIGHT SIDE
D7039	PSI	XRS725	X/C=.05	WING	RIGHT SIDE
D7041	PSI	XRS725	X/C=.10	WING	RIGHT SIDE
D7043	PSI	XRS725	X/C=.20	WING	RIGHT SIDE

TABLE A-IV.- PRESSURE TRANSDUCER PARAMETERS - Concluded

INSTRUMENTATION					
<u>IDENTIFICATION</u>	<u>UNITS</u>	<u>DESCRIPTION</u>			
D7044	PSI	XR5725	X/C=.35	WING	RIGHT SIDE
D7045	PSI	XR5725	X/C=.50	WING	RIGHT SIDE
D7046	PSI	XR5725	X/C=.63	WING	RIGHT SIDE
D7047	PSI	XR5725	X/C=.69	WING	RIGHT SIDE
D7048	PSI	XR5725	X/C=.79	WING	RIGHT SIDE
D7049	PSI	XR5725	X/C=.90	WING	RIGHT SIDE
D7050	PSI	XR5787	X/C=.01	SLAT	RIGHT SIDE
D7052	PSI	XR5787	X/C=.05	SLAT	RIGHT SIDE
D7054	PSI	XR5787	X/C=.10	SLAT	RIGHT SIDE
D7051	PSI	XR5787	X/C=.05	WING	RIGHT SIDE
D7053	PSI	XR5787	X/C=.10	WING	RIGHT SIDE
D7055	PSI	XR5787	X/C=.20	WING	RIGHT SIDE
D7056	PSI	XR5787	X/C=.35	WING	RIGHT SIDE
D7057	PSI	XR5787	X/C=.50	WING	RIGHT SIDE
D7058	PSI	XR5787	X/C=.63	WING	RIGHT SIDE
D7059	PSI	XR5787	X/C=.69	WING	RIGHT SIDE
D7060	PSI	XR5787	X/C=.79	WING	RIGHT SIDE
D7061	PSI	XR5787	X/C=.90	WING	RIGHT SIDE
D7062	PSI	GLST PROBE DIFF ATTACK-FINE			
D7063	PSI	GLST PROBE DIFF ATTACK-COARSE			
D7064	PSI	GLST PROBE DIFF SIDESLIP-FINE			
D7065	PSI	GLST PROBE DIFF SIDESLIP-COARSE			
D7066	PSI	GLST PROBE TOTAL-FINE			
D7067	PSI	GLST PROBE TOTAL-COARSE			
D6001	PSI	REFERENCE #1 - FWD DUCT #1			
D6002	PSI	REFERENCE #2 - AFT DUCT #1			
D6003	PSI	REFERENCE #3 - NOSEBOOM STATIC			
D6004	PSI	REFERENCE #4 - AFT DUCT #3			
D6005	PSI	NCS BOOM TOTAL - CADC #1			
D6006	PSI	NOSE BOOM STATIC - CADC #1			

TABLE A-V.- TRANSDUCER DERIVED PRESSURE
DIFFERENTIAL PARAMETERS

IDENTIFICATION

<u>NO.</u>	<u>UNITS</u>	<u>DESCRIPTION</u>				
C0450	PSID	FS 880	BP 173	BODY	LHS	
C0451	PSID	FS 930	BP 173	BCDY	LHS	
C0452	PSID	FS 1000	BP 173	BODY	LHS	
C0453	PSID	FS 1050	BP 173	H PANEL	LHS	
C0454	PSID	FS 1100	BP 173	H PANEL	LHS	
C0455	PSID	FS 1190	BP 173	FAIRING	LHS	
C0456	PSID	FS 1240	BP 173	NAC-FRG	LHS	
C0457	PSID	FS 1273	BP 173	NACELLE	LHS	
C0458	PSID	FS 760	BP 112	BCDY	LHS	
C0459	PSID	FS 846	BP 112	BCDY	LHS	
C0460	PSID	FS 930	BP 112	BCDY	LHS	
C0461	PSID	FS 1000	BP 112	BCDY	LHS	
C0462	PSID	FS 1050	BP 112	BODY	LHS	
C0463	PSID	FS 1100	BP 112	BODY	LHS	
C0464	PSID	FS 1190	BP 112	NACELLE	LHS	
C0465	PSID	FS 1240	BP 112	NAC-FRG	LHS	
C0466	PSID	FS 1273	BP 112	NACELLE	LHS	
C0467	PSID	FS 626	BP 70	BCDY	LHS	
C0468	PSID	FS 720	BP 70	BCDY	LHS	
C0469	PSID	FS 823	BP 70	BCDY	LHS	
C0470	PSID	FS 930	BP 70	BODY	LHS	
C0471	PSID	FS 1000	BP 70	BODY	LHS	
C0472	PSID	FS 1050	BP 70	BCDY	LHS	
C0473	PSID	FS 1100	BP 70	BODY	LHS	
C0474	PSID	FS 1190	BP 70	BCDY	LHS	
C0475	PSID	FS 1240	BP 70	BCDY	LHS	
C0476	PSID	FS 1273	BP 70	BODY	LHS	
C0477	PSID	FS 545	BP 00	BODY	CL	
C0478	PSID	FS 740	BP 00	BCDY	CL	
C0479	PSID	FS 930	BP 00	BCDY	CL	
C0480	PSID	FS 1138	BP 00	BCDY	CL	
C0481	PSID	FS 1325	BP 00	BODY	CL	
C0482	PSID	FS 626	BP 70	BCDY	RHS	
C0483	PSID	FS 720	BP 70	BCDY	RHS	
C0484	PSID	FS 823	BP 70	BODY	RHS	
C0485	PSID	FS 930	BP 70	BODY	RHS	
C0486	PSID	FS 1000	BP 70	BODY	RHS	
C0487	PSID	FS 1050	BP 70	BODY	RHS	
C0488	PSID	FS 1100	BP 70	BCDY	RHS	
C0489	PSID	FS 1190	BP 70	BODY	RHS	
C0490	PSID	FS 1240	BP 70	BODY	RHS	
C0491	PSID	FS 1273	BP 70	BODY	RHS	
C0492	PSID	FS 760	BP 112	BCDY	RHS	
C0493	PSID	FS 846	BP 112	BCDY	RHS	
C0494	PSID	FS 930	BP 112	BODY	RHS	
C0495	PSID	FS 1000	BP 112	BODY	RHS	
C0496	PSID	FS 1050	BP 112	BODY	RHS	
C0497	PSID	FS 1100	BP 112	BCDY	RHS	
C0498	PSID	FS 1190	BP 112	BCDY	RHS	
C0499	PSID	FS 1240	BP 112	NAC-FRG	RHS	
C0500	PSID	FS 1273	BP 112	NACELLE	RHS	
C0501	PSID	FS 880	BP 173	BCDY	RHS	
C0502	PSID	FS 930	BP 173	BCDY	RHS	
C0503	PSID	FS 1000	BP 173	BODY	RHS	
C0504	PSID	FS 1050	BP 173	H PANEL	RHS	
C0505	PSID	FS 1100	BP 173	H PANEL	RHS	
C0506	PSID	FS 1190	BP 173	FAIRING	RHS	

TABLE A-V.- TRANSDUCER DERIVED PRESSURE
DIFFERENTIAL PARAMETERS - Continued

IDENTIFICATION					
NO.	UNITS				DESCRIPTION
C0507	PSID	FS 1240	BP 173		NAC-FRG RHS
C0508	PSID	FS 1273	BP 173		NACELLE RHS
C0509	PSID	XRS 260	X/C .01		SLAT
C0510	PSID	XRS 260	X/C .05		LE - WING
C0511	PSID	XRS 260	X/C .10		LE - WING
C0512	PSID	XRS 260	X/C .20		BOX - WING
C0513	PSID	XRS 260	X/C .35		BOX - WING
C0514	PSID	XRS 260	X/C .50		BOX - WING
C0515	PSID	XRS 260	X/C .63		FLAP SHROUD-WING
C0516	PSID	XRS 260	X/C .695		FLAP
C0517	PSID	XRS 260	X/C .72		FLAP
C0518	PSID	XRS 260	X/C .79		FLAP
C0519	PSID	XRS 260	X/C .90		FLAP
C0520	PSID	XRS 370	X/C .01		SLAT
C0521	PSID	XRS 370	X/C .05		LE - WING
C0522	PSID	XRS 370	X/C .10		LE - WING
C0523	PSID	XRS 370	X/C .20		BOX - WING
C0524	PSID	XRS 370	X/C .35		BOX - WING
C0525	PSID	XRS 370	X/C .50		BOX - WING
C0526	PSID	XRS 370	X/C .63		FLAP SHROUD-WING
C0527	PSID	XRS 370	X/C .695		FLAP
C0528	PSID	XRS 370	X/C .72		FLAP
C0529	PSID	XRS 370	X/C .79		FLAP
C0530	PSID	XRS 370	X/C .90		FLAP
C0531	PSID	XRS 487	X/C .01		SLAT
C0532	PSID	XRS 487	X/C .05		LE - WING
C0533	PSID	XRS 487	X/C .10		LE - WING
C0534	PSID	XRS 487	X/C .20		BOX - WING
C0535	PSID	XRS 487	X/C .35		BOX - WING
C0536	PSID	XRS 487	X/C .50		BOX - WING
C0537	PSID	XRS 487	X/C .63		FLAP SHROUD-WING
C0538	PSID	XRS 487	X/C .695		FLAP
C0539	PSID	XRS 487	X/C .72		FLAP
C0540	PSID	XRS 487	X/C .79		FLAP
C0541	PSID	XRS 487	X/C .90		FLAP
C0542	PSID	XRS 580	X/C .01		SLAT
C0543	PSID	XRS 580	X/C .05		LE - WING
C0544	PSID	XRS 580	X/C .10		LE - WING
C0545	PSID	XRS 580	X/C .20		BOX - WING
C0546	PSID	XRS 580	X/C .35		BOX - WING
C0547	PSID	XRS 580	X/C .50		BOX - WING
C0548	PSID	XRS 580	X/C .63		FLAP SHROUD-WING
C0549	PSID	XRS 580	X/C .695		FLAP
C0550	PSID	XRS 580	X/C .72		FLAP
C0551	PSID	XRS 580	X/C .79		FLAP
C0552	PSID	XRS 580	X/C .90		FLAP
C0553	PSID	XRS 658	X/C .01		SLAT
C0554	PSID	XRS 658	X/C .05		LE - WING
C0555	PSID	XRS 658	X/C .10		LE - WING
C0556	PSID	XRS 658	X/C .20		BOX - WING
C0557	PSID	XRS 658	X/C .35		BOX - WING
C0558	PSID	XRS 658	X/C .50		BOX - WING
C0559	PSID	XRS 658	X/C .63		FLAP SHROUD-WING
C0560	PSID	XRS 658	X/C .695		FLAP
C0561	PSID	XRS 658	X/C .72		FLAP
C0562	PSID	XRS 658	X/C .79		FLAP
C0563	PSID	XRS 658	X/C .90		FLAP
C0564	PSID	XRS 725	X/C .01		SLAT
C0565	PSID	XRS 725	X/C .05		LE - WING

TABLE A-V.- TRANSDUCER DERIVED PRESSURE
DIFFERENTIAL PARAMETERS - Concluded

IDENTIFICATION		
<u>NO.</u>	<u>UNITS</u>	<u>DESCRIPTION</u>
C0566	PSID	XRS 725 X/C .10 LE - WING
C0567	PSID	XRS 725 X/C .20 BCX - WING
C0568	PSID	XRS 725 X/C .35 BCX - WING
C0569	PSID	XRS 725 X/C .50 BCX - WING
C0570	PSID	XRS 725 X/C .63 FLAP
C0571	PSID	XRS 725 X/C .695 FLAP
C0572	PSID	XRS 725 X/C .79 FLAP
C0573	PSID	XRS 725 X/C .90 FLAP
C0574	PSID	XRS 787 X/C .01 SLAT
C0575	PSID	XRS 787 X/C .05 LE - WING
C0576	PSID	XRS 787 X/C .10 LE - WING
C0577	PSID	XRS 787 X/C .20 BOX - WING
C0578	PSID	XRS 787 X/C .35 BOX - WING
C0579	PSID	XRS 787 X/C .50 BOX - WING
C0580	PSID	XRS 787 X/C .63 FLAP
C0581	PSID	XRS 787 X/C .695 FLAP
C0582	PSID	XRS 787 X/C .79 FLAP
C0583	PSID	XRS 787 X/C .90 FLAP

TABLE A-VI.- PRESSURE TRANSDUCER DERIVED LOADS

IDENTIFICATION		
<u>NO.</u>	<u>UNITS</u>	<u>DESCRIPTION</u>
C0650	K LBS	RIGHT WING SHEAR AT XRS354
C0651	KIN-LBS	RIGHT WING MOMENT AT XRS354
C0652	KIN-LBS	RIGHT WING TORQUE AT XRS354

TABLE A-VII. - REFERENCE AXES FOR MEASURED LOADS

LW, RW (X _{RS} 354 in.)	- V + up and perpendicular to the wing reference plane B + tip up and about an axis perpendicular to the wing load reference line (0.36c line*). T + leading edge up and about the wing load reference line (0.36c line*).
LHT, RHT (B.P. 10.75 in.)	- V + up and perpendicular to the airplane water plane B + tip up and about an axis parallel to the longitudinal axis T + leading edge up and about an axis perpendicular to the plane of symmetry
UVT (W.L. 136.56 in.)	- V + to the right and normal to the plane of symmetry B + tip to the right and about an axis parallel to the longitudinal axis T + leading edge right and about an axis perpendicular to the water plane
FF (F.S. 528.5 in.)	- V + up and normal to the water plane B + nose up and about an axis perpendicular to the plane of symmetry V + to the right and normal to the plane of symmetry B + nose right and about an axis perpendicular to the water plane T + left wing up and about an axis parallel to the longitudinal axis
AF (F.S.1,337.5 in.)	- V + up and normal to the water plane B + aft end up and about an axis perpendicular to the plane of symmetry V + to the right and normal to the plane of symmetry B + aft end right and about an axis perpendicular to the water plane T + left wing up and about an axis parallel to the longitudinal axis

*The wing load reference line passes through the pivot (at X_{RS} 139.515 and Y_{RS} -49.845) and the load reference point (at X_{RS} 354 and Y_{RS} -38.248).

This Page Intentionally Left Blank

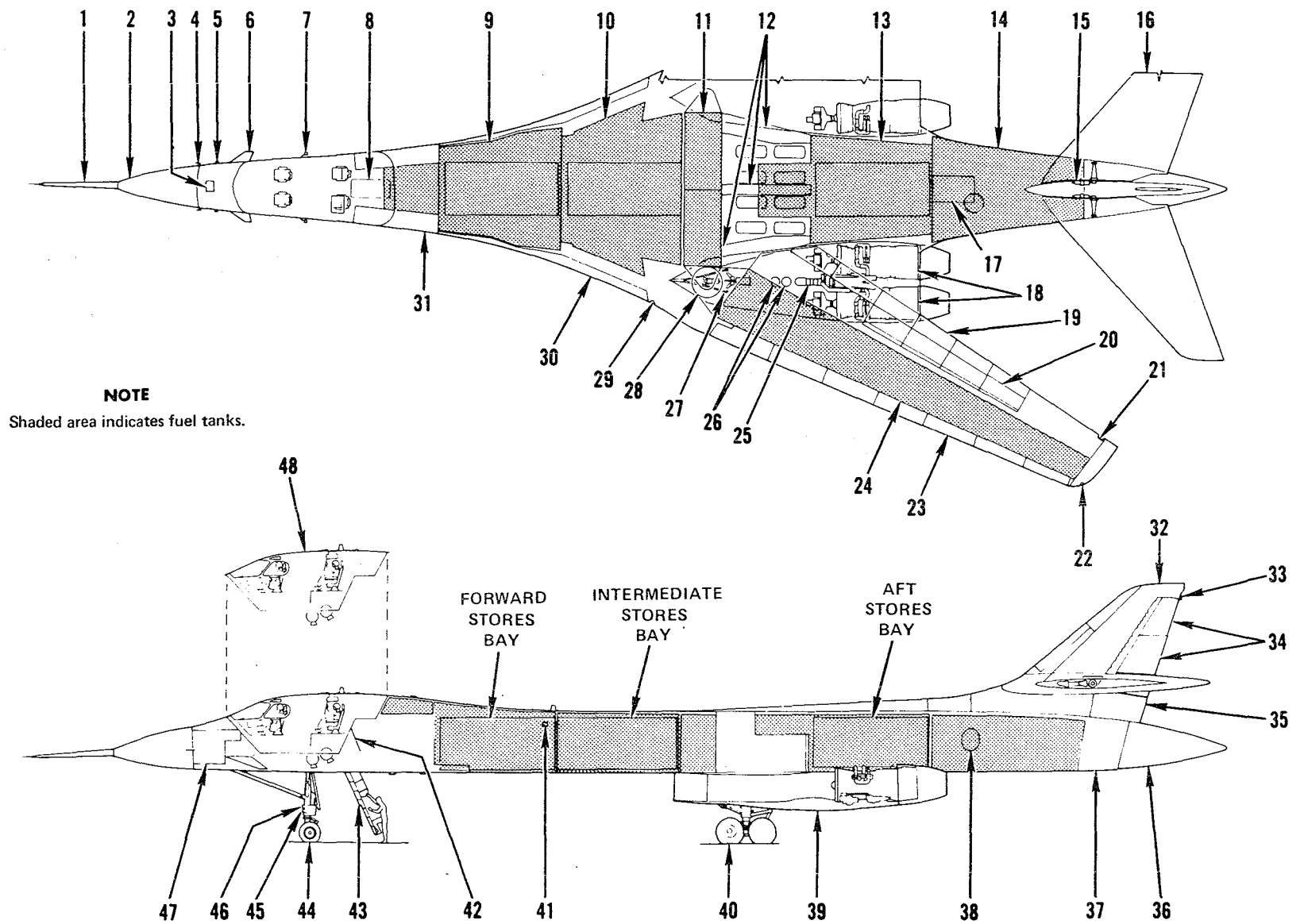

- | | | |
|--|---|--|
| <ol style="list-style-type: none"> 1. PITOT-STATIC BOOM (WITH AOA AND SIDESLIP VANES) 2. FORWARD RADOME 3. AERIAL REFUEL RECEPTACLE 4. PITOT-STATIC PROBE * 5. TOTAL TEMPERATURE PROBE * 6. STRUCTURAL MODE CONTROL SYSTEM VANE * 7. ANGLE-OF-ATTACK VANE * 8. CREW ENTRY WAY 9. FORWARD FUSELAGE FUEL TANK (TANK NO. 1) 10. FORWARD INTERMEDIATE FUSELAGE FUEL TANK (TANK NO. 2) 11. MAIN FUEL TANKS 12. MAIN WHEEL WELL EQUIPMENT (INTERMEDIATE AVIONICS) COMPARTMENT 13. AFT INTERMEDIATE FUSELAGE FUEL TANK (TANK NO. 3) 14. AFT FUSELAGE FUEL TANK (TANK NO. 4) 15. HORIZONTAL STABILIZER ACTUATOR * 16. HORIZONTAL STABILIZER 17. FLIGHT CONTROLS MIXER BAY 18. ENGINES * 19. FLAPS (6) * 20. SPOILERS/SPEED BRAKES (4) * 21. FUEL JETTISON OUTLET * 22. POSITION LIGHT * 23. SLATS (7) * 24. WING FUEL TANK * 25. APU * 26. HYDRAULIC RESERVOIRS * 27. INLET RAMP MECHANISM * 28. WING PIVOT 29. SUPPLEMENTAL POSITION AND ANTICOLLISION LIGHT * 30. WING GLOVE AVIONICS COMPARTMENT * 31. CENTRAL AVIONICS COMPARTMENT 32. VERTICAL STABILIZER 33. TAIL/ANTICOLLISION LIGHT 34. UPPER AND INTERMEDIATE RUDDERS | <ol style="list-style-type: none"> 35. LOWER RUDDER 36. AFT RADOME 37. AFT AVIONICS COMPARTMENT 38. LN₂ DEWAR 39. ENGINE NACELLE * 40. MAIN LANDING GEAR * 41. AERIAL REFUEL/WING INSPECTION LIGHT * 42. ENTRY DOOR 43. ENTRY LADDER 44. NOSE LANDING GEAR 45. LANDING/TAXI LIGHT 46. LANDING LIGHTS (2) | <ol style="list-style-type: none"> 47. FORWARD AVIONICS COMPARTMENT 48. EJECTABLE CREW MODULE 49. FORWARD CREW STATIONS 50. CREW SEAT (4) † 51. ESCAPE HATCH (SEVERABLE) 52. AFT CREW STATIONS 53. CONTROLS FOR ENTRY LADDER, APU, AND MAIN GEAR DOORS 54. SURVIVAL EQUIPMENT 55. SIDE WINDOW (SEVERABLE) * |
|--|---|--|

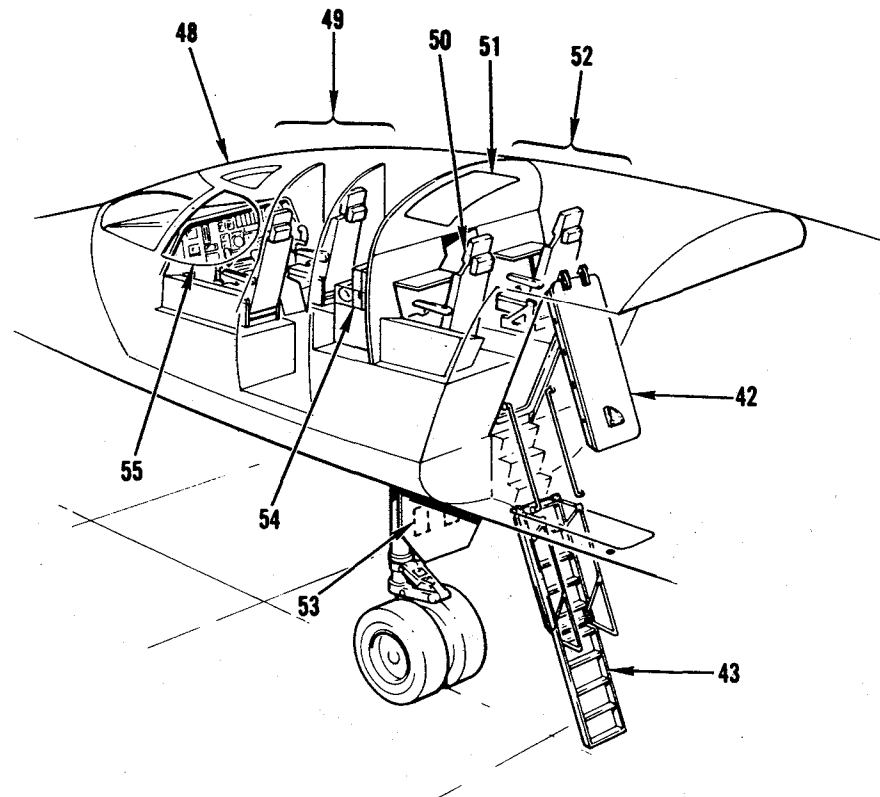

* Both Sides (L and R)
 † Right aft seat temporarily removed

B-1-1-0-4B

Figure A-1. - Concluded.

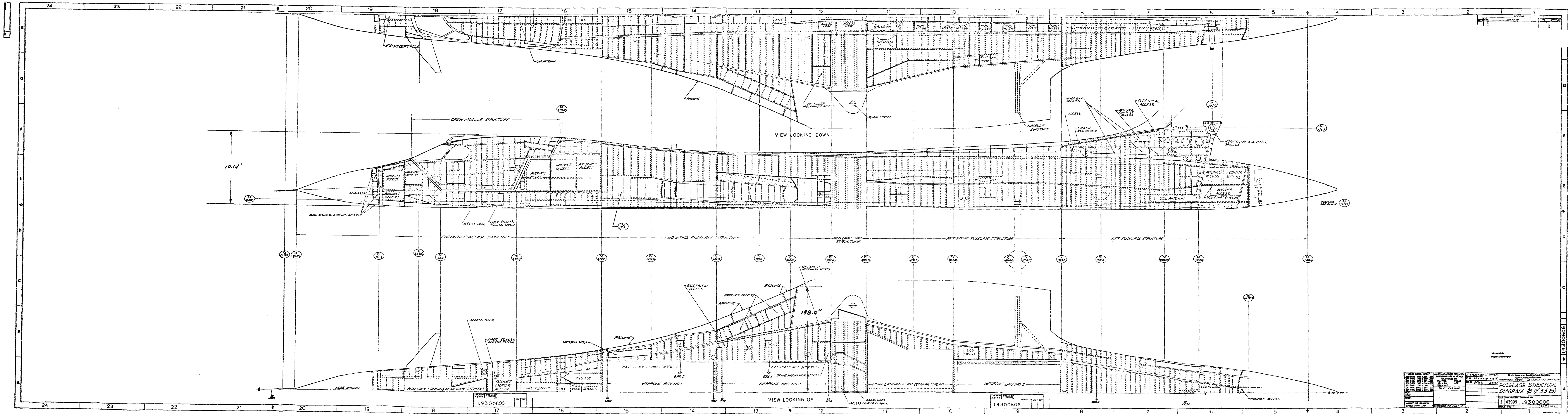
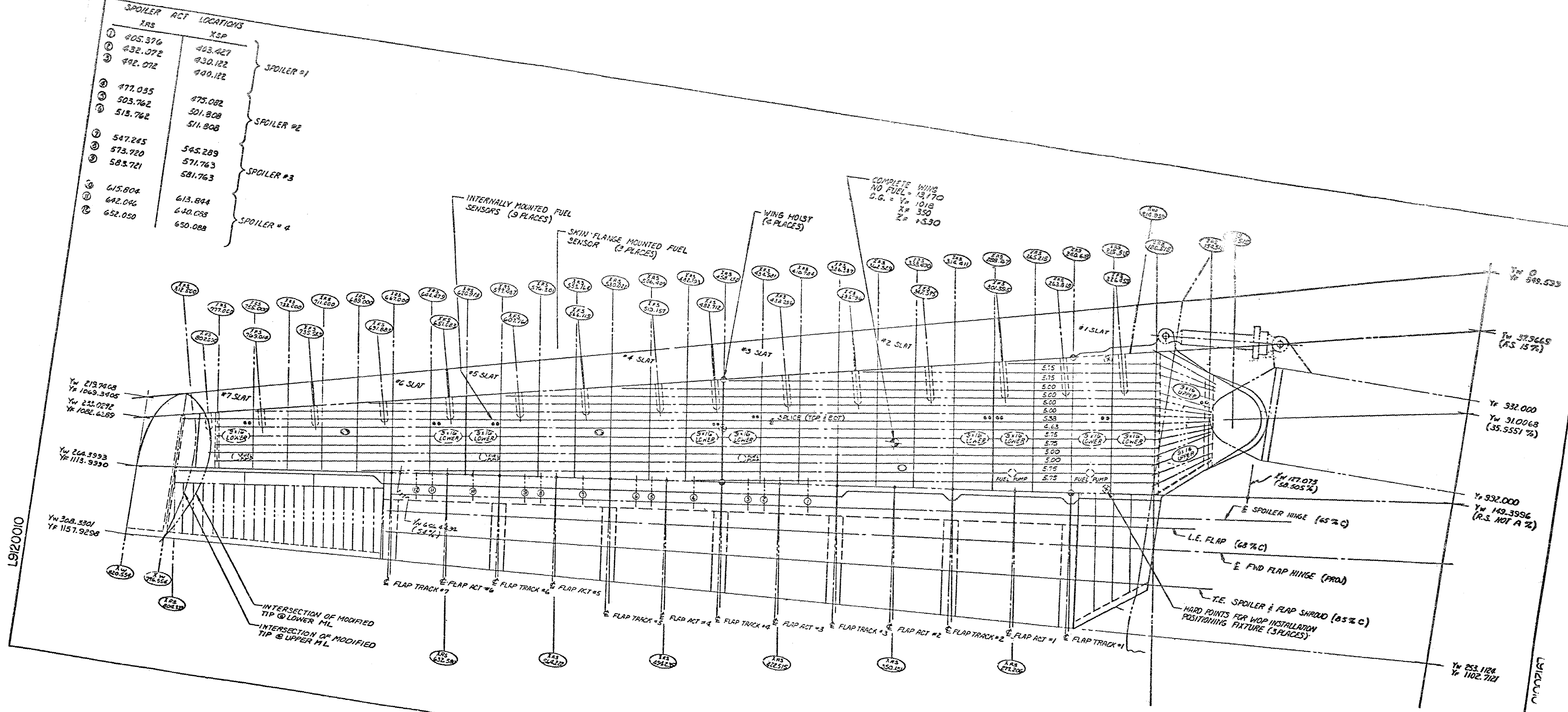

Figure A-2.- Fuselage structure diagram (B-1) (+55B)

This Page Intentionally Left Blank



LOS ANGELES DIVISION		NORTH AMERICAN ROCKWELL CORP.	
INTERNATIONAL AIRPORT-LOS ANGELES, CALIF. 90009		WING-STRUCTURE	
DRAWING NO. 43999		DIAGRAM, OUTER (-55B)	
DRAWING NO. L9120010		SHEET	
DR BY: RUS	SCALE: 1/8" = 1'-0"	REVISIONS:	
CHKD BY: CUBNET		1. REVISED TO SHOW WOP INSTALLATION	
		2. REVISED TO SHOW WOP INSTALLATION	
		3. REVISED TO SHOW WOP INSTALLATION	
		4. REVISED TO SHOW WOP INSTALLATION	
		5. REVISED TO SHOW WOP INSTALLATION	
		6. REVISED TO SHOW WOP INSTALLATION	
		7. REVISED TO SHOW WOP INSTALLATION	
		8. REVISED TO SHOW WOP INSTALLATION	
		9. REVISED TO SHOW WOP INSTALLATION	
		10. REVISED TO SHOW WOP INSTALLATION	

Figure A-3.- Wing-structure diagram, outer (-55B).

This Page Intentionally Left Blank

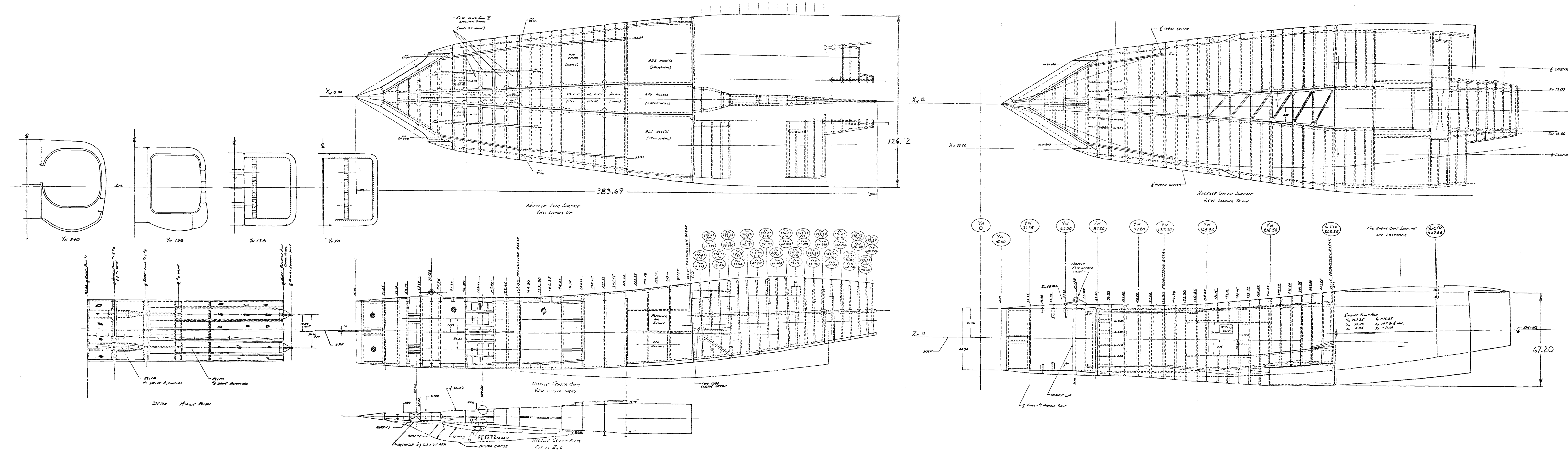

This Page Intentionally Left Blank

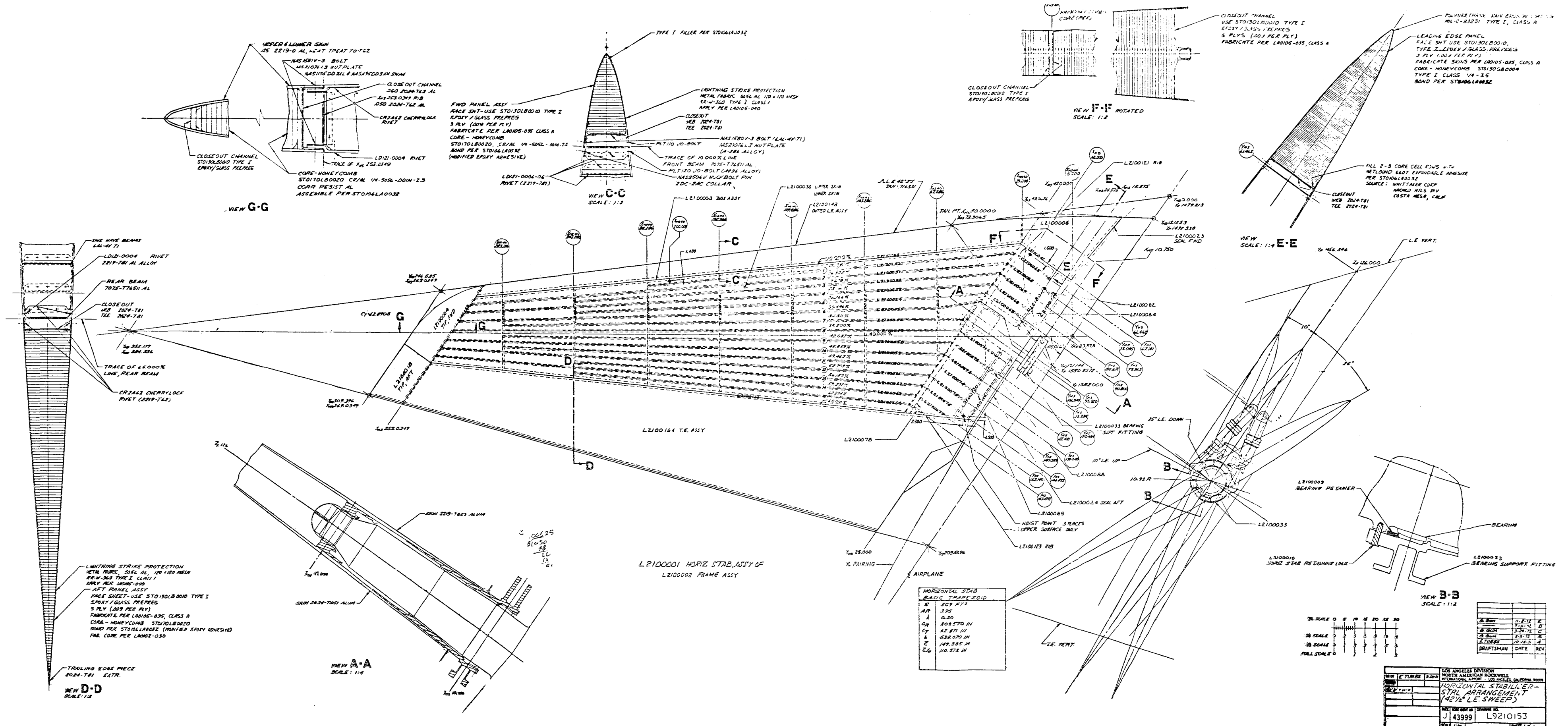

This Page Intentionally Left Blank

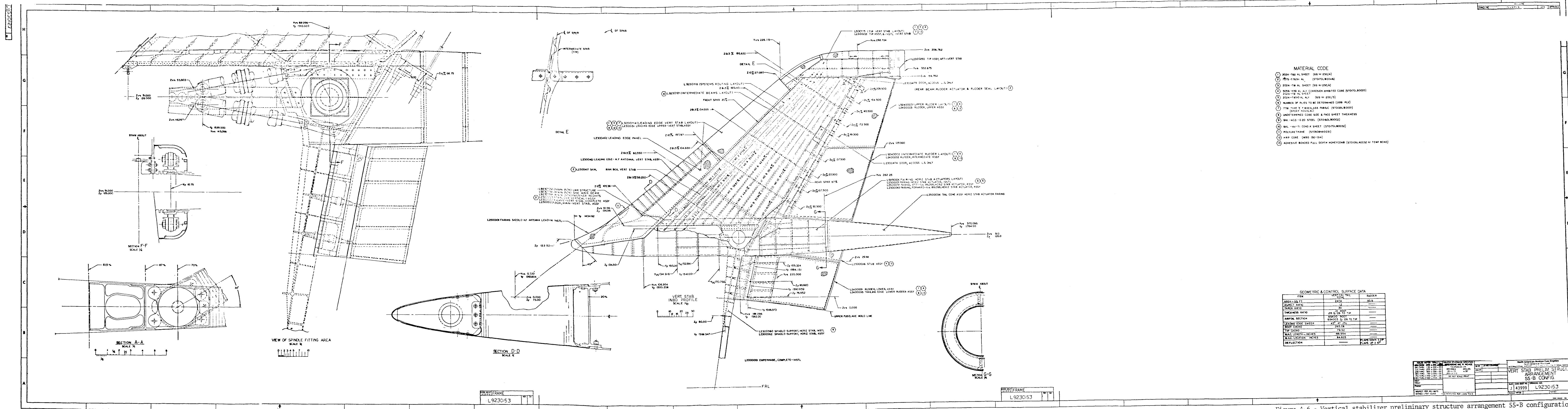

- MATERIAL CODE**
- ① 2024-182 AL SHEET (SQ-A-250/A)
 - ② 2024-17631 AL (STOITOL80048)
 - ③ 2024-TM AL SHEET (SQ-A-250/A)
 - ④ 2024-181 AL SHEET (SQ-A-250/A)
 - ⑤ 2024-1810 AL SHEET (SQ-A-250/A)
 - ⑥ NUMBER OF PILES TO BE DETERMINED (DOOR PLY)
 - ⑦ 7781 FIVE PLY BRASSLESS FABRIC (STOOL8000) (EPGK NOVOLAC)
 - ⑧ UNDETERMINED CORE SIZE & FACE SHEET THICKNESS
 - ⑨ 941-450 -D-20 STEEL (STOOL8002)
 - ⑩ 841-4471 COND A SHEET (STOOL80032)
 - ⑪ POLYURETHANE (STOOL80033)
 - ⑫ HRP CORE (MRO 00-04)
 - ⑬ ADHESIVE BONDED FULL DEPTH HONEYCOMB (STOOL80032 NI TEMP BOND)

GEOMETRIC & CONTROL SURFACE DATA

ITEM	VERTICAL	TAIL	RUDDER
AREA-SQ.FT.	2474	60.6	
ASPECT RATIO	1.4		
TAPER RATIO	30		
THICKNESS RATIO	28.5-26.75	1.5	
FAIRING SECTION	854005 2.06 TO TIP		
LEADING EDGE SWEEP	43° 21' 25"		
ROOT CHORD	263.04		
TIP CHORD	78.52		
MEAN LENGTH-INCHES	44.974		
MEAN LOCATION INCHES	84.825		
DEFLECTION		FLAPS DOWN 1.31°	FLAPS UP 1.0°

REVISIONS

NO.	DATE	BY	CHKD.	DESCRIPTION
1				

North American Aviation, Inc. Engineering

VERT STAB PRELIM STRUC. ARRANGEMENT 55-B CONFIG.

J 43999 L9230153

SCALE: 1/4" = 1'-0"

Figure A-6.- Vertical stabilizer preliminary structure arrangement 55-B configuration.

This Page Intentionally Left Blank

LW, RW - left and right wing at X_{RS} 354.0:

BP \pm 240.672 in. X_{RS} 354.00 in.
 FS 1161.365 in. or Y_{RS} -38.248 in.
 WL 9.075 Z_{RS} 4.370 in.

LHT, RHT - left and right horizontal tail:

BP \pm 10.75 in.
 FS 1582.0 in.
 WL 126.0 in.

UVT - upper vertical tail:

WL 136.56 in.
 FS 1582.0 in.
 BP 0.0 in.

FF - forward fuselage:

FS 528.5 in.
 WL 32.0 in.
 BP 0.0 in.

AF - aft fuselage:

FS 1337.5 in.
 WL 34.0 in.
 BP 0.0 in.

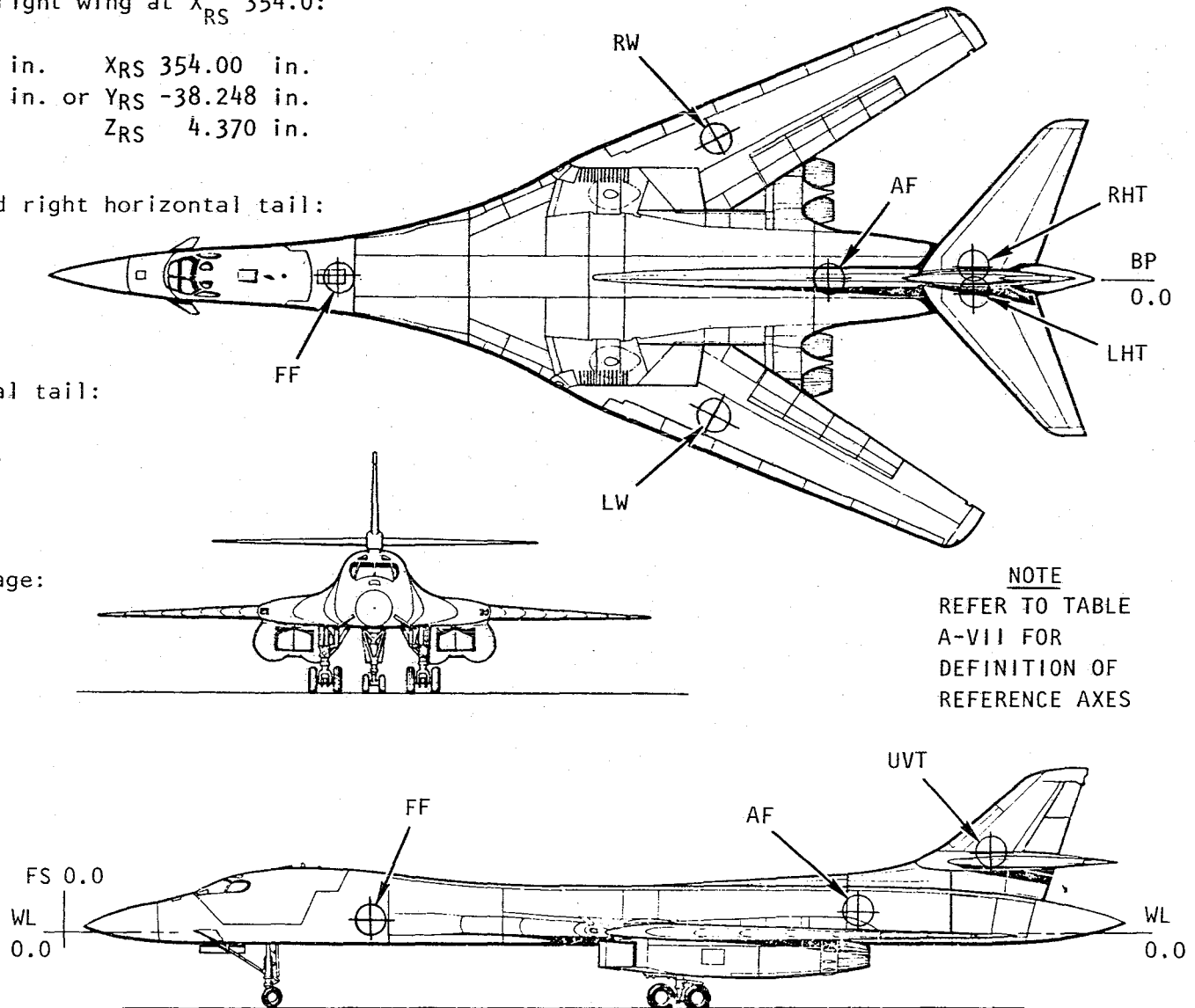

Figure A-7.- Location of points for flight loads determination $\Lambda_w = 67.5^\circ$.

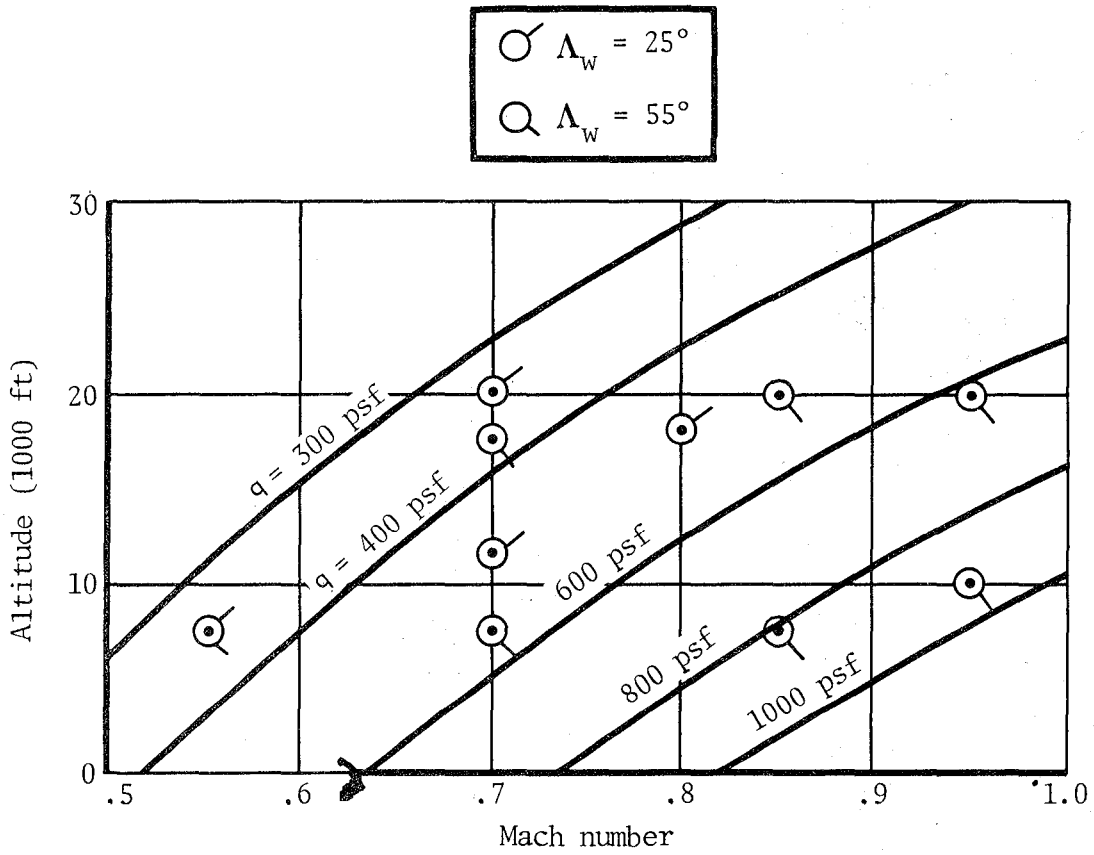

Figure A-8.- Initial flight load survey test points $\Lambda_w = 25^\circ$ and 55° .

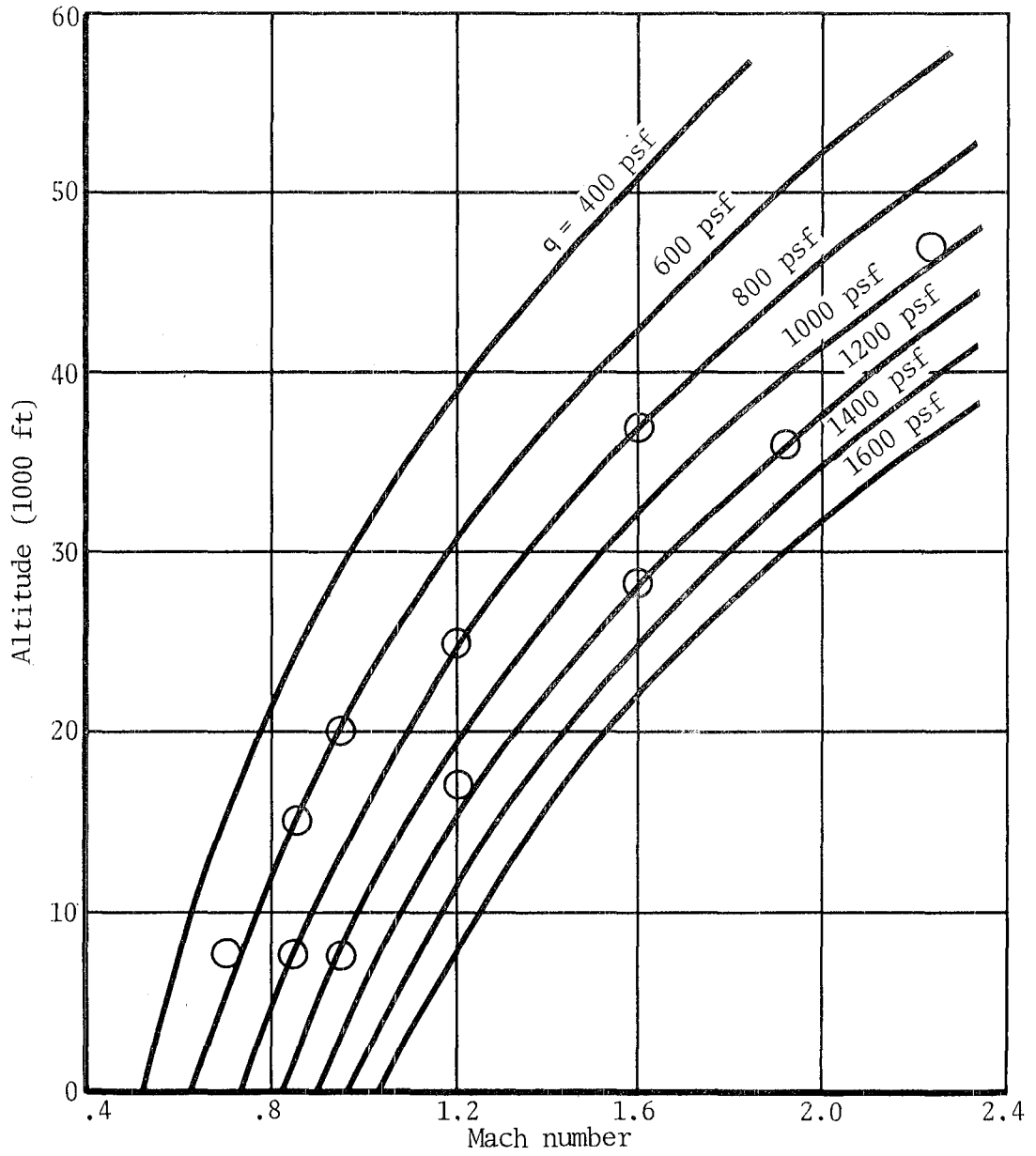

Figure A-9.- Initial flight load survey test points $\Lambda_w = 67.5^\circ$.

This Page Intentionally Left Blank

APPENDIX B

DATA TAPE DESCRIPTION

TABLE B-I.- DATA TAPE DESCRIPTION VOLUME ARSFT1

$$\Lambda_{LE} = 67.5 \text{ Degrees}$$

File No	M	Alt. (ft)	N_z	β (deg)	Description
1	0.49	3633	0.01	0.22	Wind-up turn

APPENDIX C

M = 0.85 and M = 1.20

DATA TAPE DESCRIPTION

AND

INOPERATIVE PARAMETER LIST

TABLE C-I.- DATA TAPE DESCRIPTION VOLUME ARSFT2

$$\Lambda_{LE} = 67.5 \text{ Degrees}$$

File No.	M	Alt (ft)	N _Z	β (deg)	Description
1	0.84	14670	0.19	-0.31	Wind-up turn
2	0.83	14480	0.99	-0.13	Wind-up turn
3	0.84	13050	2.01	-0.22	Wind-up turn
4	1.18	29880	0.00	-0.02	Wind-up turn
5	1.19	28290	1.00	0.00	Wind-up turn
6	1.18	28610	2.60	-0.02	Wind-up turn

TABLE C-II. - INOPERATIVE PARAMETERS VOLUME ARSFT2, FILES 1-3, M = 0.85

Instrumentation Identification	Description
M1045	Fuel Quantity - L Wing Compt 1
M1046	Fuel Quantity - L Wing Compt 2
M1047	Fuel Quantity - L Wing Compt 3
M1048	Fuel Quantity - L Wing Compt 4
M1527	Fuel Quantity - R Wing Compt 1
M1528	Fuel Quantity - R Wing Compt 2
M1529	Fuel Quantity - R Wing Compt 3
M1530	Fuel Quantity - R Wing Compt 4
D6488	BP112 FS1273 Upper Left Side
D6840	BP112 FS846 Upper Left Side
D7015	XRS 580 X/C = 0.50 Wing Right Side
D7028	XRS 658 X/C = 0.20 Wing Right Side
D7029	XRS 658 X/C = 0.35 Wing Right Side
D7052	XRS 787 X/C = 0.05 Slat Right Side
C0516	Fwd Fus Vert Shear
C0517	Fwd Fus Bend Moment
C0518	Fwd Fus Side Shear
C0519	Fwd Fus Side Moment
C0520	Aft Fus Vert Shear
C0521	Aft Fus Torsion
C0522	Aft Fus Vert Bending
C0523	Aft Fus Side Shear
C0524	Aft Fus Side Bending

TABLE C-III. - Inoperative Parameters
VOLUME ARSFT2, FILES 4-6, M=1.20

Instrumentation Identification	Description
M1045	Fuel Quantity - L Wing Compt 1
M1046	Fuel Quantity - L Wing Compt 2
M1047	Fuel Quantity - L Wing Compt 3
M1048	Fuel Quantity - L Wing Compt 4
M1527	Fuel Quantity - R Wing Compt 1
M1528	Fuel Quantity - R Wing Compt 2
M1529	Fuel Quantity - R Wing Compt 3
M1530	Fuel Quantity - R Wing Compt 4
X3006	Left Spoiler #3 Degrees
S5161	Left SMC Vane Aft Act Load
S5318	Left WOP Lower Cover, XRS 354, Shear Loc 1.
S5345	Vert Stab Attach Ftg Left Side Aft
D6820	BP173 FS930 Upper Left Side
D6839	BP112 FS760 Upper Left Side
D6841	BP112 FS930 Upper Left Side
D6849	BP112 FS930 Lower Left Side
D6889	BP70 FS626 Upper Right Side
D6973	XRS260 X/C = 0.695 Flap Right Side
D6974	XRS260 X/C = 0.72 Flap Right Side
D6977	XRS260 X/C = 0.90 Flap Right Side
D6992	XRS370 X/C = 0.90 Flap Right Side
D7015	XRS580 X/C = 0.50 Wing Right Side
D7023	XRS658 X/C = 0.01 Slat Right Side
D7028	XRS658 X/C = 0.20 Wing Right Side
D7029	XRS658 X/C = 0.35 Wing Right Side
D7034	XRS658 X/C = 0.72 Flap Right Side
D7036	XRS658 X/C = 0.79 Flap Right Side
D7038	XRS725 X/C = 0.01 Slat Right Side
D7061	XRS787 X/C = 0.90 Wing Right Side
C0516	Fwd Fus Vert Shear
C0517	Fwd Fus Bend Moment
C0518	Fwd Fus Side Shear
C0519	Fwd Fus Side Moment
C0520	Aft Fus Vert Shear
C0521	Aft Fus Torsion
C0522	Aft Fus Vert Bending
C0523	Aft Fus Side Shear
C0524	Aft Fus Side Bending

APPENDIX D

$M = 0.85$ and $M = 1.20$

STEADY YAW

DATA TAPE DESCRIPTION

AND

INOPERATIVE PARAMETER LIST

TABLE D-I. - DATA TAPE DESCRIPTION VOLUME ARSFT3

$$\Lambda_{LE} = 67.5 \text{ Degrees}$$

File No.	M	Alt (ft)	N_Z	β (deg)	Description
1	0.85	7320	0.97	2.33	Steady Yaw
2	1.20	28380	0.99	2.01	Steady Yaw

TABLE D-II. - INOPERATIVE PARAMETERS, VOLUME ARSFT3, FILE 1, M = 0.85

Instrumentation Identification	Description
A2187	Lat Accel FSU600 BP 0
X3006	L Spoiler 3
S5161	L SMC Vane Aft Act Load
S5318	L WOP Lower Cover, XRS354, Shear Loc 1
S5345	Vert Stabilizer Attach Ftg L Side Aft
S5553	R SMC Vane Fwd Act Load
S5554	R SMC Vane Aft Act Load
D6974	XRS 260 X/C = 0.72 Flap Right Side
D7015	XRS 580 X/C = 0.50 Wing Right Side
D7028	XRS 658 X/C = 0.20 Wing Right Side
D7041	XRS 725 X/C = 0.10 Wing Right Side
D7061	XRS 787 X/C = 0.90 Wing Right Side
D7062	Gust Probe Diff Attack - Fine
D7063	Gust Probe Diff Attack - Coarse
D7064	Gust Probe Diff Sideslip - Fine
D7065	Gust Probe Diff Sideslip - Coarse
D7066	Gust Probe Total - Fine
D7067	Gust Probe Total - Coarse
D7170	WL-32 YN59 R Nacelle Outer
D7189	WL-32 YN23 R Nacelle Outer

TABLE D-III. - INOPERATIVE PARAMETERS, VOLUME ARSFT3, FILE 2, M = 1.20

Instrumentation Identification	Description
X3006	L Spoiler 3
X3010	R Spoiler 3
X3014	Rudder Lower
S5161	L SMC Vane Aft Act Load
S5455	FS1325 Loc 1
D6974	XRS 260 X/C = 0.72 Flap Right Side
D7015	XRS 580 X/C = 0.50 Wing Right Side
D7028	XRS 658 X/C = 0.20 Wing Right Side
D7062	Gust Probe Diff Attack - Fine
D7063	Gust Probe Diff Attack - Coarse
D7064	Gust Probe Diff Sideslip - Fine
D7065	Gust Probe Diff Sideslip - Coarse
D7066	Gust Probe Total - Fine
D7067	Gust Probe Total - Coarse
D7189	WL-32 YN23 R Nacelle Outer

APPENDIX E

HIGH q $M = 0.85$ AND $M = 1.20$

WIND UP TURN

DATA TAPE DESCRIPTION

AND

INOPERATIVE PARAMETER LIST

TABLE E-I.- DATA TAPE DESCRIPTION VOLUME ARSFT4

$$\Lambda_{LE} = 67.5 \text{ Degrees}$$

File No.	M	Alt (ft)	N_z	β (deg)	Description
1	0.83	7572	0.10	-0.07	Wind-up turn
2	0.84	6930	1.00	-0.11	Wind-up turn
3	0.82	6065	2.31	-0.13	Wind-up turn
4	1.14	17430	0.65	0.42	Wind-up turn
5	1.21	19430	1.00	0.42	Wind-up turn
6	1.19	18670	1.68	0.42	Wind-up turn
7	1.17	17710	2.44	0.42	Wind-up turn

TABLE E-II. - INOPERATIVE PARAMETERS VOLUME ARSFT4, FILES 1-3, M=0.85

Instrumentation Identification	Description
A2187	Lat. Accel. FSU600 BPO
D6903	BP70 FS1000 Lower Right Side
D6973	XRS260 X/C=.695 Flap Right Side
D6974	XRS260 X/C=.72 Flap Right Side
D6982	XRS370 X/C=.10 Slat Right Side
D6995	XRS487 X/C=.05 Slat Right Side
D7015	XRS580 X/C=.50 Wing Right Side
D7028	XRS658 X/C=.20 Wing Right Side
D7045	XRS725 X/C=.50 Wing Right Side
D7055	XRS787 X/C=.20 Wing Right Side
D7056	XRS787 X/C=.35 Wing Right Side
D7057	XRS787 X/C=.50 Wing Right Side
D7062	Gust Probe Diff Attack - Fine
D7063	Gust Probe Diff Attack - Coarse
D7064	Gust Probe Diff Sideslip- Fine
D7065	Gust Probe Diff Sideslip- Coarse
D7066	Gust Probe Total - Fine
D7067	Gust Probe Total - Coarse
D7189	WL-32 YN23 RH Nacelle Outer
S5161	LH SMC Vane Aft Act Load
S5318	LH WOP Lower Cover, XRS354, Shear LOCL
S5553	RH SMC Vane Fwd Act Load
S5554	RH SMC Vane Aft Act Load

TABLE E-III. - INOPERATIVE PARAMETERS VOLUME ARSFT4, FILES 4-7, M=1.20

Instrumentation Identification	Description
A2187	Lat. Accel. FSU600 BPO
A2201	Vert. Accel. LH Horiz Stab TIP
D6861	BP70 FS825 Upper Left Side
D6891	BP70 FS825 Upper Right Side
D6973	XRS260 X/C=.695 Flap Right Side
D6974	XRS260 X/C=.72 Flap Right Side
D6977	XRS260 X/C=.90 Flap Right Side
D7015	XRS580 X/C=.50 Wing Right Side
D7028	XRS658 X/C=.20 Wing Right Side
D7062	Gust Probe Diff Attack - Fine
D7063	Gust Probe Diff Attack - Coarse
D7064	Gust Probe Diff Sideslip - Fine
D7065	Gust Probe Diff Sideslip - Coarse
D7066	Gust Probe Total - Fine
D7067	Gust Probe Total - Coarse
S5161	LH SMC Vane Aft Act Load
S5553	RH SMC Vane Fwd Act Load
S5554	RH SMC Vane Aft Act Load
X3006	LH Spoiler #3

APPENDIX F

M=0.95 and M=1.05

DATA TAPE DESCRIPTION
AND
INOPERATIVE PARAMETERS LIST

TABLE F-I.- DATA TAPE DESCRIPTION VOLUME ARSFT5

$$\Lambda_{LE} = 67.5 \text{ Degrees}$$

File No	M	Alt (ft)	N_Z	β (deg)	Description
1	0.93	15000	0.11	-0.20	Wind-up turn
2	0.92	14180	0.96	-0.18	Wind-up turn
3	0.93	13900	1.99	-0.62	Wind-up turn
4	0.93	13450	2.40	-0.55	Wind-up turn
5	0.91	6030	-0.33	0.24	Wind-up turn
6	0.93	5020	1.00	0.37	Wind-up turn
7	0.92	4860	2.05	-0.11	Wind-up turn
8	0.92	5750	3.06	-0.02	Wind-up turn
9	1.05	24960	1.02	-	Lwr rudder test
10	1.05	24920	1.01	-	Lwr rudder test
11	1.04	30690	0.95	-0.07	Lwr rudder test
12	1.05	24910	1.04	-0.07	Lwr rudder test
13	0.99	34910	1.04	0.09	Trim
14	1.10	32130	1.52	0.29	Transonic turn
15	1.06	31840	1.30	0.22	Transonic turn
16	1.05	11470	1.15	-	Trim
17	1.05	11530	0.81	-	Trim

TABLE F-II. - INOPERATIVE PARAMETERS, VOLUME ARSFT5, FILES 1-4, M=0.95

Instrumentation Identification	Description
A2187	Lat. Accel. FSU600 BPO
X3006	LH Spoiler #3
S5161	LH SMC Vane Aft Act Load
S5318	LH WOP Lower Cover, XRS354, Shear Loc 1
S5553	RH SMC Vane Fwd Act Load
S5554	RH SMC Vane Aft Act Load
D6488	BP112 FS1273 Upper Left Side
D6903	BP70 FS1000 Lower Right Side
D6973	XRS260 X/C=.695 Flap Right Side
D6974	XRS260 X/C=.72 Flap Right Side
D6977	XRS260 X/C=.90 Flap Right Side
D7015	XRS580 X/C=.50 Wing Right Side
D7028	XRS658 X/C=.20 Wing Right Side
D7062	Gust Probe Diff Attack - Fine
D7063	Gust Probe Diff Attack - Coarse
D7064	Gust Probe Diff Sideslip - Fine
D7065	Gust Probe Diff Sideslip - Coarse
D7066	Gust Probe Total - Fine
D7067	Gust Probe Total - Coarse

TABLE F-III. - INOPERATIVE PARAMETERS, VOLUME ARSFT5, FILES 5-8, M=0.95

Instrumentation Identification	Description
A2187	Lat. Accel. FS600 BPO
A2200	Vert. Accel. RH Horiz Stab Tip
A2201	Vert. Accel. LH Horiz Stab Tip
D6488	BP112 FS1273 Upper Left Side
D6906	BP70 FS1190 Lower Right Side
D6912	BP112 FS1000 Upper Right Side
D6973	XRS260 X/C=.695 Flap Right Side
D6976	XRS260 X/C=.79 Flap Right Side
D6977	XRS260 X/C=.90 Flap Right Side
D6988	XRS370 X/C=.695 Flap Right Side
D6991	XRS370 X/C=.79 Flap Right Side
D7015	XRS580 X/C=.50 Wing Right Side
D7028	XRS658 X/C=.20 Wing Right Side
D7062	Gust Probe Diff Attack - Fine
D7063	Gust Probe Diff Attack - Coarse
D7064	Gust Probe Diff Sideslip - Fine
D7065	Gust Probe Diff Sideslip - Coarse
D7066	Gust Probe Total - Fine
D7067	Gust Probe Total - Coarse
D7157	WL-32 YN59 RH Nacelle Inner
D7170	WL-32 YN59 RH Nacelle Outer
D7188	WL-32 YN28 RH Nacelle Inner
S5161	LH SMC Vane Aft Act Load
S5553	RH SMC Vane Fwd Act Load
X3028	LH SMC Vane
X3029	RH SMC Vane

TABLE F-IV. - INOPERATIVE PARAMETERS, VOLUME ARSFT5, FILES 9-10, M=1.05

Instrumentation Identification	Description
M1012	Angle of Sideslip - Nose Boom
M1017	Angle of Bank at CG - GSS No. 1
M1018	Angle of Pitch at CG - GSS No. 1
A2187	Lat. Accel FSU600 BP0
S5161	LH SMC Vane Aft Act Load
S5318	LH WOP Cover XRS354 Shear Loc 1
S5553	RH SMC Vane Fwd Act Load
S5554	RH SMC Vane Aft Act Load
D6887	BPo FS1138 Lower Centerline
D6903	BP70 FS1000 Lower Right Side
D6974	XRS260 X/C=.72 Flap Right Side
D6982	XRS370 X/C=.10 Slat Right Side
D7015	XRS580 X/C=.50 Wing Right Side
D7028	XRS658 X/C=.20 Wing Right Side
D7062	Gust Probe Diff Attack - Fine
D7063	Gust Probe Diff Attack - Coarse
D7064	Gust Probe Diff Sideslip - Fine
D7065	Gust Probe Diff Sideslip - Coarse
D7066	Gust Probe Total - Fine
D7067	Gust Probe Total - Coarse
D7170	WL-32 YN59 RH Nacelle Outer
D7189	WL-32 YN23 RH Nacelle Outer

TABLE F-V. - INOPERATIVE PARAMETERS, VOLUME ARSFT5, FILE 11, M=1.05

Instrumentation Identification	Description
A2187	Lat. Accel. FSU600 BPO
S5161	LH SMC Vane Aft Act Load
S5318	LH WOP Lower Cover, XRS354, Shear Loc 1
S5553	RH SMC Vane Fwd Act Load
S5554	RH SMC Vane Aft Act Load
D6903	BP70 FS1000 Lower Right Side
D6971	XRS260 X/C=.63 Wing Right Side
D6974	XRS260 X/C=.72 Flap Right Side
D6977	XRS260 X/C=.90 Flap Right Side
D6995	XRS487 X/C=.05 Slat Right Side
D7015	XRS580 X/C=.50 Wing Right Side
D7028	XRS658 X/C=.20 Wing Right Side
D7055	XRS787 X/C=.20 Wing Right Side
D7056	XRS787 X/C=.35 Wing Right Side
D7057	XRS787 X/C=.50 Wing Right Side
D7062	Gust Probe Diff Attack - Fine
D7063	Gust Probe Diff Attack - Coarse
D7064	Gust Probe Diff Sideslip - Fine
D7065	Gust Probe Diff Sideslip - Coarse
D7066	Gust Probe Total - Fine
D7067	Gust Probe Total - Coarse
D7170	WL-32 YN59 RH Nacelle Outer
D7189	WL-32 YN23 RH Nacelle Outer

TABLE F-VI. - INOPERATIVE PARAMETERS, VOLUME ARSFT5, FILE 12, M=1.05

Instrumentation Identification	Description
A2187	Lat. Accel. FSU600 BPO
D6879	BPO FS545 Upper Centerline
D6903	BP70 FS1000 Lower Right Side
D6973	XRS260 X/C=.695 Flap Right Side
D6974	XRS260 X/C=.72 Flap Right Side
D6982	XRS370 X/C=.10 Slat Right Side
D6977	XRS260 X/C=.90 Flap Right Side
D6995	XRS487 X/C=.05 Slat Right Side
D7015	XRS580 X/C=.50 Wing Right Side
D7028	XRS658 X/C=.20 Wing Right Side
D7045	XRS725 X/C=.50 Wing Right Side
D7055	XRS787 X/C=.20 Wing Right Side
D7056	XRS787 X/C=.35 Wing Right Side
D7057	XRS787 X/C=.50 Wing Right Side
D7062	Gust Probe Diff Attack - Fine
D7063	Gust Probe Diff Attack - Coarse
D7064	Gust Probe Diff Sideslip - Fine
D7065	Gust Probe Diff Sideslip - Coarse
D7066	Gust Probe Total - Fine
D7067	Gust Probe Total - Coarse
D7189	WL-32 YN23 RH Nacelle Outer
S5161	LH SMC Vane Aft Act Load
S5318	LH WOP Lower Cover, XRS354, Shear Loc 1
S5553	RH SMC Vane Fwd Act Load
S5554	RH SMC Vane Aft Act Load

TABLE F-VII. - INOPERATIVE PARAMETERS, VOLUME ARSFT5, FILE 13, M=0.99

Instrumentation Identification	Description
A2187	Lat. Accel. FSU600 BPO
A2197	Vert. Accel. LH Wing FS AT XRS786
A2200	Vert. Accel. RH Horiz Stab Tip
A2201	Vert. Accel. LH Horiz Stab Tip
X3011	RH Spoiler #4
X3028	LH SMC Vane
X3029	RH SMC Vane
S5161	LH SMC Vane Aft Act Load
S5247	Mid Rudder Rotary Act #2 HM
S5248	Mid Rudder Rotary Act #4 HM
S5553	RH SMC Vane Fwd Act Load
D6003	Reference #3 - Nose Boom Static
D6488	BP112 FS1273 Upper Left Side
D6827	BP173 FS1050 Inner Left Side
D6876	BP70 FS1190 Lower Left Side
D6879	BPO FS545 Upper Centerline
D6886	BPO FS930 Lower Centerline
D6937	BP173 FS1050 Inner Right Side
D6976	XRS260 X/C=.79 Flap Right Side
D6977	XRS260 X/C=.90 Flap Right Side
D6991	XRS370 X/C=.79 Flap Right Side
D7015	XRS580 X/C=.50 Wing Right Side
D7028	XRS658 X/C=.20 Wing Right Side
D7062	Gust Probe Diff Attack - Fine
D7063	Gust Probe Diff Attack - Coarse
D7064	Gust Probe Diff Sideslip - Fine
D7065	Gust Probe Diff Sideslip - Coarse
D7066	Gust Probe Total - Fine
D7067	Gust Probe Total - Coarse
D7157	WL-32 YN59 RH Nacelle Inner
D7170	WL-32 YN59 RH Nacelle Outer
D7188	WL-32 YN28 RH Nacelle Inner

TABLE F-VIII. - INOPERATIVE PARAMETERS, VOLUME ARSFT5, FILES 14-15, M=0.95

Instrumentation Identification	Description
A2187	Lat. Accel. FSU600 BPO
A2200	Vert. Accel. RH Horiz Stab Tip
A2201	Vert. Accel. LH Horiz Stab Tip
X3028	LH SMC Vane
X3029	RH SMC Vane
S5161	LH SMC Vane Aft Act Load
S5553	RH SMC Vane Fwd Act Load
D6488	BP112 FS1273 Upper Left Side
D6861	BP70 FS825 Upper Left Side
D6886	BPO FS930 Lower Centerline
D6907	BP70 FS1240 Lower Right Side
D6973	XRS260 X/C=.695 Flap Right Side
D6976	XRS260 X/C=.79 Flap Right Side
D6985	XRS370 X/C=.50 Wing Right Side
D6991	XRS370 X/C=.79 Flap Right Side
D6995	XRS487 X/C=.05 Slat Right Side
D7015	XRS580 X/C=.50 Wing Right Side
D7016	XRS580 X/C=.63 Wing Right Side
D7028	XRS658 X/C=.20 Wing Right Side
D7033	XRS658 X/C=.695 Flap Right Side
D7062	Gust Probe Diff Attack - Fine
D7063	Gust Probe Diff Attack - Coarse
D7064	Gust Probe Diff Sideslip - Fine
D7065	Gust Probe Diff Sideslip - Coarse
D7066	Gust Probe Total - Fine
D7067	Gust Probe Total - Coarse
D7157	WL-32 YN59 RH Nacelle Inner
D7170	WL-32 YN59 RH Nacelle Outer
D7188	WL-32 YN28 RH Nacelle Inner

TABLE F-IX. - INOPERATIVE PARAMETERS, VOLUME ARSFT5, FILES 16-17, M=1.05

Instrumentation Identification	Description
MI012	Angle of Sideslip - Nose Boom
A2187	Lat. Accel. FSU600 BPO
A2200	Vert. Accel. RH Horiz Stab Tip
A2201	Vert. Accel. LH Horiz Stab Tip
X3028	LH SMC Vane
X3029	RH SMC Vane
S5161	LH SMC Vane Aft Act Load
S5553	RH SMC Vane Fwd Act Load
D6488	BP112 FS1273 Upper Left Side
D6861	BP70 FS825 Upper Left Side
D6886	BPO FS930 Lower Centerline
D6888	BPO FS1325 Lower Centerline
D6891	BP70 FS825 Upper Right Side
D6976	XRS260 X/C=.79 Flap Right Side
D6977	XRS260 X/C=.90 Flap Right Side
D6985	XRS370 X/C=.50 Wing Right Side
D6988	XRS370 X/C=.695 Flap Right Side
D6991	XRS370 X/C=.79 Flap Right Side
D6992	XRS370 X/C=.90 Flap Right Side
D7015	XRS580 X/C=.50 Wing Right Side
D7016	XRS580 X/C=.63 Wing Right Side
D7028	XRS658 X/C=.20 Wing Right Side
D7033	XRS658 X/C=.695 Flap Right Side
D7061	XRS787 X/C=.90 Wing Right Side
D7062	Gust Probe Diff Attack - Fine
D7063	Gust Probe Diff Attack - Coarse
D7064	Gust Probe Diff Sideslip - Fine
D7065	Gust Probe Diff Sideslip - Coarse
D7066	Gust Probe Total - Fine
D7067	Gust Probe Total - Coarse
D7157	WL-32 YN59 RH Nacelle Inner
D7170	WL-32 YN59 RH Nacelle Outer
D7188	WL-32 YN28 RH Nacelle Inner

APPENDIX G

M = 0.70, 0.95, 1.60 and 2.0

DATA TAPE DESCRIPTION

AND

INOPERATIVE PARAMETERS LIST

TABLE G-I.- DATA TAPE DESCRIPTION VOLUME ARSFT6

$$\Lambda_{LE} = 67.5 \text{ Degrees}$$

File no.	M	Alt (ft)	n_z	β (deg)	Description
1	0.69	7,045	1.05	-0.33	Trim
2	0.69	7,087	0.96	3.94	Stead yaw
3	1.59	39,510	1.53	-0.04	Wind-up turn
4	1.60	37,440	1.02	-0.04	Trim
5	1.59	38,470	0.16	-0.04	Sym. push-down
6	0.68	7,050	0.99	-0.22	Trim
7	0.68	6,650	1.45	-0.73	Wind-up turn
8	0.66	7,152	0.38	-0.41	Sym. push-down
9	1.59	38,060	0.97	0.64	Steady yaw left
10	1.61	37,770	1.03	-0.70	Steady yaw right
11	2.10	49,590	0.99	0.26	Trim
12	1.91	48,210	1.43	0.24	Wind-up turn
13	0.92	6,715	0.97	0.31	Trim
14	0.92	6,735	1.02	2.88	Steady yaw

TABLE G-II.- INOPERATIVE PARAMETERS, VOLUME ARSFT6 FILES 1-14

Parameter	Description
D7015	XRS 580. x/c = .50 Wing Right Side
D7062	Gust probe diff attack fine
D7063	Gust probe diff attack coarse
D7064	Gust probe diff sideslip fine
D7065	Gust probe diff sideslip coarse
D7066	Gust probe total fine
D7067	Gust probe total coarse
S5322*	RH WOP upper cover XRS354, LOC1

*Inoperative on Files 1 and 2 only

TABLE G-III.- ADDITIONAL INOPERATIVE PARAMETERS,
VOLUME ARSFT6 FILES 11-14 ONLY

Parameter	Description
A2187	LHT accel FSU600 BPO
A2201	Vert accel LH horiz stab tip
D6861	BP 70 FS825 upper left side
D6891	BP 70 FS825 upper right side
D6946	BP173 FS1190 lower right side
D6947	BP173 FS1240 lower right side
D6948	BP173 FS1273 lower right side
D6960	WL-32 YN 282.3 RH nacelle outer
D6961	WL-32 YN 332.3 RH nacelle outer
D6962	WL-32 YN 365.3 RH nacelle outer
D6976	XRS 260 x/c = .79 flap left side
D6985	XRS 370 x/c = .50 wing left side
D6991	XRS 370 x/c = .79 flap left side
D7028	XRS 658 x/c = .20 wing left side
D7061	XRS 787 x/c = .90 wing left side
D7157	WL-32 YN 59 RH nacelle inner
S5161	LH SMC vane aft act load
S5553	RH SMC vane fwd act load
S5323	RH WOP upper cover XRS354, axial LOC2

APPENDIX H

SUPPLEMENTAL DATA

HORIZONTAL STABILIZER DISPLACEMENT ERRATA

The flight test loads data tapes volumes ARSFT2 through ARSFT5 list the horizontal stabilizer displacement values from parameter numbers X3012 and X3013, which should be replaced by values from parameters numbers X3510 and X3511. The correct values from parameters X3510 and X3511 are presented in table H-I. Volume ARSFT6 has the correct values on the tape.

WEAPON BAY STORES SUMMARY

A summary of the store loadings in the forward and middle weapon bays is presented in table H-II for each of the tape file numbers of tape volumes ARSFT1 through ARSFT6. Inertia data for the forward bay fuel tank is presented in table H-III.

COMPONENT LOAD CALIBRATION EQUATIONS

The load calibration equations including the applicable zero loads at the load reference points on the wing, horizontal stabilizer, and vertical stabilizer are presented on pages 105 through 109 for all of the file nos. on tape volume ARSFT2 through ARSFT6.

TABLE H-I.- HORIZONTAL STABILIZER DISPLACEMENT ERRATA

Volume name	File no.	Correct values	
		$\delta_{H_{LH}}$ X3510 (deg)	$\delta_{H_{RH}}$ X3511 (deg)
ARSFT2	1	2.78	3.64
	2	-7.89	-5.52
	3	-9.68	-7.70
	4	6.88	5.26
	5	0.80	-0.35
	6	-4.44	-6.22
ARSFT3	1	4.43	-2.59
	2	3.75	-3.05
ARSFT4	1	3.95	3.52
	2	1.21	0.97
	3	-0.77	-2.29
	4	2.79	2.39
	5	0.83	0.18
	6	-1.46	-2.23
	7	-3.24	-4.55

Volume name	File no.	Correct values	
		$\delta_{H_{LH}}$ X3510 (deg)	$\delta_{H_{RH}}$ X3511 (deg)
ARSFT5	1	4.43	3.68
	2	1.21	0.24
	3	-3.37	-2.79
	4	-4.06	-4.16
	5	5.93	5.09
	6	1.57	1.43
	7	-1.89	-1.24
	8	-3.72	-3.14
	9	-0.80	-0.60
	10	-0.05	-0.75
	11	-0.02	-0.61
	12	-0.39	-0.89
	13	-1.66	-2.63
	14	-2.39	-1.46
	15	-1.99	-0.86
	16	1.69	0.98
	17	2.30	2.44

TABLE H-II.- WEAPONS BAY STORES SUMMARY

Volume name	File nos.	Fwd bay	Mid bay
ARSFT1	1	4 B-43	-
ARSFT2	1-3 4-6	4 B-43 28 MK-82	- -
ARSFT3	1 2	28 MK-82 4 B-43	- -
ARSFT4	1-3 4-7	27 MK-82 28 MK-82	- -
ARSFT5	1-4 5-8 9-10 11 12 13 14-15 16-17	27 MK-82 28 MK-82 27 MK-82 27 MK-82 27 MK-82 28 MK-82 *Fuel Tank *Fuel Tank	- 8 SRAM 7 SRAM 7 SRAM - 8 SRAM 8 SRAM -
ARSFT6	1-2 3-5 6-8 9-10 11-12 13-14	4 B-43 28 MK-82 27 MK-82 28 MK-82 *Fuel Tank *Fuel Tank	- - - - 8 SRAM -

*See fuel tank inertia data in Table H-III

TABLE H-III.- FORWARD BAY FUEL TANK INERTIAL DATA

1. Forward bay fuel tank empty:

Wt = 6921 lb	I_{x_0}	= 5,940,000 lb-in ²
X = FS 641.1	I_{y_0}	= 22,749,000 lb-in ²
Y = BP 0.0	I_{z_0}	= 23,929,000 lb-in ²
Z = WL 52.30	I_{xz_0}	= 0

2. Forward bay fuel only:

a. For ARSFT5 Files 14 and 15 and ARSFT6 Files 11 and 12, the forward bay tank is empty.

b. For ARSFT5 Files 16 and 17 and ARSFT6 Files 13 and 14:

Fuel Wt = 18,500 lb	I_{x_0}	= 12,186,000 lb-in ²
X = FS 642.50	I_{y_0}	= 48,342,000 lb-in ²
Y = BP 0.0	I_{z_0}	= 49,219,000 lb-in ²
Z = WL 30.77	I_{xz_0}	= 0.0

TABLE H-IV - LOAD CALIBRATION EQUATIONS

LEFT WING

For all file nos. on tape volumes ARSFT2 through ARSFT6

Increment loads at strain gage calibration point: Point located at
 $X_{RS} = 354$, $Y_{RS} = -37.221$, $Z_{RS} = 4.37$

$$\Delta SZL = 0.024123(S5306) + 0.0264974(S5307) - 0.0183685(S5308) - 0.004126(S5311)$$

$$\Delta MXL = -2.5482(S5308) - 12.0850(S5309) + 6.6162(S5310) - 7.1045(S5311)$$

$$\Delta MYL = 0.084914(S5306) - 1.829686(S5307) + 1.927062(S5312) + 1.603028(S5318)$$

Net loads at load reference point: Point located at $X_{RS} = 354$, $Y_{RS} = -38.248$,
 $Z_{RS} = 4.35$

$$SZL = \Delta SZL - 6286$$

$$MXL = \Delta MXL - 1122627$$

$$MYL = \Delta MYL + \Delta SZL \left[0.053979 \left(\frac{\Delta MXL}{\Delta SZL} \right) - 1.017 \right] + 76200$$

RIGHT WING

Incremental loads at strain gage calibration point: For file nos. 1, 2,
 and 3 on tape volume ARSFT2

$$\Delta SLR = -0.0247504(S5320) - 0.0256368(S5321) - 0.0149506(S5322) - 0.0066101(S5325)$$

$$\Delta MXR = -2.1484(S5322) - 2.7100(S5323) - 6.3965(S5324) - 2.3926(S5325)$$

$$\Delta MYR = -0.875618(S5320) + 1.829976(S5321) - 2.650604(S5326) - 0.899140(S5332)$$

For file nos. 4, 5, and 6 on tape volume ARSFT2, file nos. 1 and 2 on
 tape volume ARSFT3, all file nos. on tape volume ARSFT4, all file nos.
 on tape volume ARSFT5 and file nos. 3 through 10 on tape volume ARSFT6

$$\Delta SZR = -0.0243896(S5320) - 0.0257162(S5321) - 0.016423(S5322) - 0.0052994(S5325)$$

TABLE H-IV - LOAD CALIBRATION EQUATIONS - Continued

$$\Delta MXR = -2.4902(S5322) - 3.4424(S5323) - 4.6387(S5324) - 3.1982(S5325)$$

$$\Delta MYR = -0.875618(S5320) + 1.829976(S5321) - 2.650604(S5326) - 0.899140(S5332)$$

For file nos. 1 and 2 on tape volume ARSFT6

$$\Delta SZR = -0.0254518(S5320) - 0.0257338(S5321) - 0.0153656(S5323) - 0.0012314(S5325)$$

$$\Delta MXR = -2.8320(S5323) - 10.1563(S5324) + 0.8789(S5325)$$

$$\Delta MYR = -0.875618(S5320) + 1.829976(S5321) - 2.650604(S5326) - 0.899140(S5332)$$

For file nos. 11 through 14 on tape volume ARSFT6

$$\Delta SZR = -0.0243896(S5320) - 0.0257162(S5321) - 0.016423(S5322) - 0.0052994(S5325)$$

$$\Delta MXR = -2.1729(S5322) - 10.8398(S5324) - 0.2686(S5325)$$

$$\Delta MYR = -0.875618(S5320) + 1.829976(S5321) - 2.650604(S5326) - 0.89914(S5332)$$

Net loads at loads reference point: For all file nos. on tape ARSFT2 through ARSFT6

$$SZR = \Delta SZR - 6286$$

$$MXR = \Delta MXR - 1122627$$

$$MYR = \Delta MYR + \Delta SZL \left[0.053979 \left(\frac{\Delta MXR}{\Delta SZR} \right) - 1.017 \right] + 76200$$

LEFT HORIZONTAL STABILIZER

Net loads at load reference point: For all file nos. on tape volumes ARSFT2 through ARSFT6

$$SZLHT = 0.00211152(S5351) + 0.018505(S5352) + 0.0071405(S5353) - 0.01234192(S5354) - 0.01506134(S5355) + 0.00668762(S5356) - 1687$$

TABLE H-IV - LOAD CALIBRATION EQUATIONS - Concluded

$$\text{MXLHT} = 0.897034(S5353) - 0.829194(S5354) - 2.632813(S5357) + 0.015625(S5358) - 149889$$

$$\text{MYLHT} = -0.78537(S5351) - 0.001862(S5352) - 0.827728(S5353) + 0.471252(S5354) - 0.83319(S5355) - 0.316776(S5356) + 89724$$

RIGHT HORIZONTAL STABILIZER LOAD CALIBRATION EQUATIONS

Net loads at load reference point: For all file nos. on tape volumes ARSFT2 through ARSFT6

$$\text{SZRHT} = -0.00406922(S5364) - 0.01390656(S5365) - 0.00628906(S5366) + 0.02511444(S5367) + 0.02005676(S5368) - 0.0061966(S5369) - 1687$$

$$\text{MXRHT} = -0.65918(S5366) + 1.117188(S5367) - 1.042969(S5370) - 1.695313(S5371) - 149889$$

$$\text{MYRHT} = 1.238678(S5364) + 0.277282(S5365) + 0.528962(S5366) - 0.948974(S5367) + 0.69809(S5368) + 0.25037(S5369) + 89724$$

VERTICAL STABILIZER

Net loads at load reference point: For all file nos. on tape volumes ARSFT2 through ARSFT6

$$\text{SYVT} = -0.0834229(S5336) - 0.022652(S5337) - 0.0221417(S5338) - 0.013031(S5339) + 0.0045066(S5341) + 0.0097473(S5342)$$

$$\text{MXVT} = 0.11847(S5337) - 1.83783(S5338) - 0.3195(S5339) + 0.092864(S5342)$$

$$\text{VTMZ} = -1.947247(S5336) - 1.005658(S5341) - 0.1452026(S5342) + 0.230454(S5343) - 0.46198(S5345)$$

APPENDIX I

SYMBOLS

$b/2$	wing reference semispan	in.
BP, FS, WL	butt plane, fuselage station, and waterline, respectively	in.
\bar{c}	mean aerodynamic chord	in.
CAS, TAS	calibrated and true airspeed, respectively	knots
FF, AF	forward and aft fuselage, respectively	
LE, TE	leading and trailing edge, respectively	
LHT, RHT	left and right horizontal tail, respectively	
LW, RW	left and right wing, respectively	
M	Mach number	
N_z	vertical load factor	g
P	rolling velocity, + left wing up	deg/sec
\dot{p}	rolling acceleration, + left wing up	deg/sec ²
q	dynamic pressure	psf
Q	pitching velocity, + nose up	deg/sec
\dot{Q}	pitching acceleration, + nose up	deg/sec ²
R	yawing velocity, + nose right	deg/sec
\dot{R}	yawing acceleration, + nose right	deg/sec ²
SYVT, MXVT, MZVT	vertical tail shear, bending moment, and torsion, respectively	lb, in-lb, in-lb

SZL, MXL, MYL	left wing shear, bending moment, and torsion, respectively	lb,in-lb,in-lb
SZR, MXR, MYR	right wing shear, bending moment, and torsion, respectively	lb,in-lb,in-lb
SZLHT, MXLHT, MYLHT	left horizontal tail shear, bending moment, and torsion, respectively	lb,in-lb,in-lb
SZRHT, MXRHT, MYRHT	right horizontal tail shear, bending moment, and torsion, respectively	lb,in-lb,in-lb
UVT	upper vertical tail	
V, B, T	generalized shear, bending moment, and torsion, respectively	lb,in-lb,in-lb
WRP	wing reference plane	
x/c	nondimensional chordwise location	
X _F , Y _F , Z _F	local fuselage coordinate system	in.
X _{FS} , Y _{FS} , Z _{FS}	local front spar coordinate system	in.
X _{HS} , Y _{HS} , Z _{HS}	local horizontal stabilizer coordinate system	in.
X _N , Y _N , Z _N	local nacelle coordinate system	in.
X _{RS} , Y _{RS} , Z _{RS}	local rear spar coordinate system	in.
X _{VS} , Y _{VS} , Z _{VS}	local vertical stabilizer coordinate system	in.
X _W , Y _W , Z _W	local wing coordinate system	in.

α	angle of attack, + nose up	deg
β	angle of sideslip, + nose left	deg
δ_H	horizontal tail deflection, + leading edge up	deg
θ	pitch angle, + nose up	deg
ϕ	bank angle, + left wing up	deg
Λ_w	wing leading edge sweep angle	deg

1. Report No. NASA CR-170409		2. Government Accession No.		3. Recipient's Catalog No.	
4. Title and Subtitle AIRLOADS RESEARCH STUDY VOLUME I: FLIGHT TEST LOADS ACQUISITION				5. Report Date January 1984	
				6. Performing Organization Code	
7. Author(s) M. D. Bartlett, T. F. Feltz, A. D. Olsen Jr., D. B. Smith, and P. F. Wildermuth				8. Performing Organization Report No. NA-76-562	
				10. Work Unit No.	
9. Performing Organization Name and Address Rockwell International Los Angeles Division Los Angeles, California 90009				11. Contract or Grant No. NAS4-2769	
				13. Type of Report and Period Covered Contractor Report -- Final	
12. Sponsoring Agency Name and Address National Aeronautics and Space Administration Washington, D.C. 20546				14. Sponsoring Agency Code RTOP 505-33-54	
15. Supplementary Notes NASA Technical Monitor: Robert L. Sims, Ames Research Center, Dryden Flight Research Facility, Edwards, CA 93523. Microfiche supplement is attached. "Volume II: Airlord Coefficients Derived From Wind Tunnel Data" is published as NASA CR-170410.					
16. Abstract <p>This report describes the acquisition of B-1 aircraft flight loads data for use in subsequent tasks of the Airloads Research Study. The basic intent of the overall program is to utilize data acquired during B-1 aircraft tests, analyze these data beyond the scope of Air Force requirements, and prepare research reports that will add to the technology base for future large flexible aircraft.</p> <p>Flight test data obtained during the airloads survey program included condition-describing parameters, surface pressures, strain gage outputs, and loads derived from pressure and strain gauges. Descriptions of the instrumentation, data processing, and flight load survey program are included. Data from windup-turn and steady yaw maneuvers cover a Mach number range from 0.7 to 2.0 for a wing sweep position of 67.5°.</p>					
17. Key Words (Suggested by Author(s)) B-1 airplane Flight loads Static aeroelasticity			18. Distribution Statement Unclassified-Unlimited STAR category 05		
19. Security Classif. (of this report) Unclassified		20. Security Classif. (of this page) Unclassified		21. No. of Pages 116	22. Price* A06/E05

*For sale by the National Technical Information Service, Springfield, Virginia 22161.

End of Document