

## **General Disclaimer**

### **One or more of the Following Statements may affect this Document**

- This document has been reproduced from the best copy furnished by the organizational source. It is being released in the interest of making available as much information as possible.
- This document may contain data, which exceeds the sheet parameters. It was furnished in this condition by the organizational source and is the best copy available.
- This document may contain tone-on-tone or color graphs, charts and/or pictures, which have been reproduced in black and white.
- This document is paginated as submitted by the original source.
- Portions of this document are not fully legible due to the historical nature of some of the material. However, it is the best reproduction available from the original submission.

Thermal-Stress Analysis For A Wood Composite Blade

by

(NASA-CR-173394) THERMAL STRESS ANALYSIS  
FOR A WOOD COMPOSITE BLADE Report, 5 Dec.  
1982 - 4 Apr. 1984 (Toledo Univ.) 117 p  
HC A06/MF A01

N84-21903

CSSL 20K

Unclass  
G3/39 18938

Kuan-Chen Fu, Ph.D., P.E.  
Professor of Civil Engineering  
University of Toledo  
Toledo, Ohio 43606

and

Awad Harb, M.S.  
Graduate Student  
Department of Civil Engineering  
University of Toledo  
Toledo, Ohio 43606



Under the Support of

NASA Lewis Research Center  
Grant No. Nag 3-373  
Duration: December 5, 1982 to April 4, 1984  
Principal Investigator: Dr. Fu  
NASA Technical Officers: Mr. T. L. Sullivan & Dr. D. A. Spera

## THERMAL-STRESS ANALYSIS FOR A WOOD COMPOSITE BLADE

### Introduction

Since 1977, NASA Lewis Research Center has been pursuing the development of low cost rotor blade technology for large horizontal axis wind turbine. Laminated wood manufactured by bonding together 1/10" to 1/8" thick sheets, or plys, with epoxy is a particularly attractive candidate material for a rotor blade since the raw material has high specific strength, high specific stiffness and low cost. This led to the manufacturing of eight laminated wood blades in 1980. They were installed as Mod-OA wind turbine at three different locations; Kahuku Point, Hawaii, Culebra, Puerto Rico, and Block Island, Rhode Island. Mod-OA turbines have 125' diameter rotors and generate 200 Kilo-Watts each when in operation. Their performances were closely monitored. In 1981, a crack was found in Blade No. 1012 located in Block Island, which occurred in the leading edge extending along the entire blade. The cause of the crack was unknown, but thermal-stress induced by the sun was suspected to be one of the main reasons. Therefore, the investigation has been persuaded along this line.

The analysis of thermal-stress of the blade induced by solar insolation consists of two phases. The first phase is to find the temperature distribution throughout the blade, a heat conduction problem. The second phase is to determine the thermal-stress distribution of the blade caused by the temperature distribution found in the first phase, a thermal-stress analysis problem. Since wood is an orthotropic material in the senses of heat conduction and stress-strain relationships, these characteristics must be included in the analyses of both phases.

## Phase I: Heat Conduction Analysis

### A. The Blade and the Assumed Environment

Blade No. 1012 is 700 inches long with maximum chord width of 62.4 inches, see Fig. 1 for its overall dimensions. Airfoil standard section NACA 230 [1], is used. The thickness to chord ratio of the blade is varied from 31.75 at station 150 to 7.5 at station 732.

In the determination of temperature distribution throughout the blade, it is reasonable to assume that a two-dimensional heat conduction analysis of a typical blade section is adequate, because the blade is basically a slender body. In addition, the thermal conductivity of wood in longitudinal direction of the blade, which is parallel to the grain, is two to three times higher than those in transversal directions. As a result, the temperature gradient in longitudinal direction is far smaller than those in transversal directions. This again indicates that a two-dimensional analysis is adequate.

The section at station 126 is arbitrarily selected as a typical section for analysis. The thickness to chord ratio at this station is 30.4, which is close to those of the sections in the neighborhood of station 300, the main body of the blade, see Fig. 2. In the nose portion, called D-spar, 3" thick laminated rotary veneers of Douglas Fir is used. In the tail portion, 3/4" thick honeycomb paper core is installed to provide stiffness and light-weight. Pieces of sawn Douglas Fir are used for stringers. On the surface, the blade is covered with a layer of 1/8" thick Birch Plywood.

Two parked positions of the blade are considered; one keeps the section in horizontal position, the other, vertical. Technically speaking, the difference between these two positions is that the heat flux input zones are different as

shown in Fig. 3 and 4. The heat flux input zone is defined as the portion of boundary surface of the blade exposed to the sun. The solar insolation is estimated at  $363 \text{ BTU/ft}^2\text{-hr}$  [2]. The absorbtivity of the blade surface is estimated at 0.9, which is not only on the safe side for the purpose of stress analysis but also has a good reason: after a long period of exposure, the blade surface is usually dirty and full of bug remains, which often drastically increase the surface absorbtivity. Thus, the heat flux input,  $q_r$ , for the heat flux input zone is

$$q_r = 363 \times 0.9 = 326 \text{ BTU/ft}^2\text{-hr} .$$

The ambient temperature,  $T_\infty$ , is assumed to be  $90^\circ\text{F}$ , typical temperature for a hot summer morning in Block Island. Further, the air is assumed to be still, and the convective heat transfer coefficient,  $h$ , for the blade surface is assumed to be  $5 \text{ BTU/ft}^2\text{-hr.}^\circ\text{F}$  .

In description of wood properties, three mutually perpendicular axes, longitudinal, radial and tangential, need to be used. The longitudinal axis,  $L$ , is parallel to the grain; the radial axis,  $R$ , is normal to the growth rings; and the tangential axis,  $T$ , is perpendicular to the grain but tangent to the growth rings. The thermal conductivities of the wood in  $L$ ,  $T$  and  $R$  directions [9] are listed in Table 1, note that a small difference of 10% is assumed between  $k_T$  and  $k_R$  to account for possible physical differential between these two directions. Since rotary veneer is used in blade construction, the axes  $L$ ,  $T$ , and  $R$  correspond to principal material axes  $\xi$ ,  $\zeta$  and  $\eta$  respectively. The material axes will be used in next section.

The thermal conductivity of honeycomb paper core may be estimated by using the average value for paper and air, which is  $0.013 \text{ BTU/hr.ft.}^\circ\text{F}$  .

Table 1. Thermal Conductivity of Wood

Wood	$k_L$	$k_T$	$k_R$
Douglas Fir	0.172 BTU/hr.ft. °F	0.068 BTU/hr.ft. °F	0.075 BTU/hr.ft. °F
Birch	0.211	0.084	0.093

### B. Governing Partial Differential Equation

Because of the configurational complexity of the blade section and the orthotropic property of heat conduction of the wood composite, finite element method with variational approach is chosen as the method of solution. This method may also be called as a numerical method in solving partial differential equations. For an element of an orthotropic material, the controlling partial differential equations may be derived in the following outlines.

$$\text{Heat flux input} - \text{Heat flux output} = \text{Heat retention in body} \quad (1)$$

Referring to Figure 5, let 'f' be the heat flux and 'k', the thermal conductivity, their directions along axes y, z,  $\zeta$  and n are indicated by subscripts. 'T' represents the temperature, 'C<sub>p</sub>', specific heat and 'ρ', the density of wood. Thus, Equation (1) may be expressed as

$$\begin{aligned} f_y|_y dx dz + f_z|_z dx dy - [f_y|_{y+\Delta y} dx dz] - [f_z|_{z+\Delta z} dx dy] \\ = \rho dx dy dz C_p \frac{\partial T}{\partial t} \end{aligned} \quad (2)$$

Applying Taylor's Series and simplifying, Equation (2) becomes,

$$\frac{\partial}{\partial y}(-f_y) + \frac{\partial}{\partial z}(-f_z) = \rho C_p \frac{\partial T}{\partial t} \quad (3)$$

Since the principal axes of the material,  $\zeta$ , and  $\eta$ , are in general at an angle,  $\beta$ , with global axes  $y$  and  $z$  as shown in Fig. 5, the following transformation may be used,

$$\begin{bmatrix} f_y \\ f_z \end{bmatrix} = \begin{bmatrix} \cos \beta & -\sin \beta \\ \sin \beta & \cos \beta \end{bmatrix} \begin{bmatrix} f_\zeta \\ f_\eta \end{bmatrix} = \begin{bmatrix} \cos \beta & -\sin \beta \\ \sin \beta & \cos \beta \end{bmatrix} \begin{bmatrix} -k_\zeta \frac{\partial T}{\partial \zeta} \\ -k_\eta \frac{\partial T}{\partial \eta} \end{bmatrix}$$

Using chain rule;

$$\begin{bmatrix} \frac{\partial T}{\partial \zeta} \\ \frac{\partial T}{\partial \eta} \end{bmatrix} = \begin{bmatrix} \frac{\partial y}{\partial \zeta} & \frac{\partial z}{\partial \zeta} \\ \frac{\partial y}{\partial \eta} & \frac{\partial z}{\partial \eta} \end{bmatrix} \begin{bmatrix} \frac{\partial T}{\partial y} \\ \frac{\partial T}{\partial z} \end{bmatrix} = \begin{bmatrix} \cos \beta & \sin \beta \\ -\sin \beta & \cos \beta \end{bmatrix} \begin{bmatrix} \frac{\partial T}{\partial y} \\ \frac{\partial T}{\partial z} \end{bmatrix}$$

we have,

$$\begin{bmatrix} f_y \\ f_z \end{bmatrix} = \begin{bmatrix} \cos \beta & -\sin \beta \\ \sin \beta & \cos \beta \end{bmatrix} \begin{bmatrix} -k_\zeta & 0 \\ 0 & -k_\eta \end{bmatrix} \begin{bmatrix} \cos \beta & \sin \beta \\ -\sin \beta & \cos \beta \end{bmatrix} \begin{bmatrix} \frac{\partial T}{\partial y} \\ \frac{\partial T}{\partial z} \end{bmatrix} \quad (4)$$

Substitute (4) into (3), we obtain:

$$\begin{aligned} & (k_z \cos^2 \beta + k_\eta \sin^2 \beta) \frac{\partial^2 T}{\partial y^2} + (k_z - k_\eta) \sin 2\beta \frac{\partial^2 T}{\partial y \partial z} \\ & + (k_z \sin^2 \beta + k_\eta \cos^2 \beta) \frac{\partial^2 T}{\partial z^2} = \rho C_p \frac{\partial T}{\partial t} \end{aligned} \quad (5)$$

Equation (5) is the governing partial differential Equation for the heat conduction analysis of the blade.

The boundary conditions around the surface of the blade are:

(a) prescribed heat flux,  $q_r$ , in the heat flux input zone, namely,

$$q_r = 326 \text{ BTU/ft}^2 \text{ hr} \cdot \quad (5a)$$

(b) convective heat transfer loss,  $q_c$ , for the entire boundary surface of the blade,

$$q_c = h(T_s - T_\infty) \quad (5b)$$

where  $T_s$  is the surface temperature of the blade, a variable.

### C. Calculus of Variation

For a given problem with a governing differential equation and boundary conditions, the task of the variational formulation is to find the unknown function 'F' for the differential equation, which extremizes or makes stationary a functional 'I' subject to the same boundary conditions of the problem.



where,

$$I = \int_0^L F(x, \tilde{T}(x), \tilde{T}'(x)) dx \quad (6)$$

$\tilde{T}(x)$ , is a weak variation of  $T(x)$ , namely

$$\tilde{T}(x) = T(x) + \epsilon \eta(x) \quad (7)$$

$\epsilon$  is an error term of a small magnitude,  $\eta(x)$  is an error function which vanishes at its boundaries.

From the calculus of variation [3], when 'I' is extremized respect to 'T' and the error term  $\epsilon$  is made to approach zero, the Euler-Lagrange Equation is formed, namely

$$\frac{\partial F}{\partial T} - \frac{d}{dx} \frac{\partial F}{\partial T'} = 0 \quad (8)$$

In other words, the functional 'I' is extremized or made stationary when the Euler-Lagrange equation and its boundary conditions are satisfied. Therefore, the task of seeking solution,  $T(x)$ , for the governing partial differential Equation (5) becomes a numerically simpler problem, that is, finding first the 'F' in such a way that its Euler-Lagrange equation is identical to the governing differential equation. Next, the Functional 'I' is formed. Then the finite element method is used to find an approximate temperature profile which extremizes the functional and satisfies the boundary conditions. The temperature profile so obtained is the solution to the heat conduction problem in question.

For the governing differential equation, (5), the function 'F' may be formed as follows:

$$F = \frac{1}{2} [(k_{\zeta} \cos^2 \beta + k_{\eta} \sin^2 \beta) \left(\frac{\partial T}{\partial y}\right)^2 + (k_{\zeta} \sin^2 \beta + k_{\eta} \cos^2 \beta) \left(\frac{\partial T}{\partial z}\right)^2 + (k_{\zeta} - k_{\eta}) \sin 2\beta \left(\frac{\partial T}{\partial y}\right) \left(\frac{\partial T}{\partial z}\right) + 2\rho C_p \frac{\partial T}{\partial t} T] \quad (9)$$

Thus, the functional which contains the Function 'F' as described in Equation (9) and the corresponding function for boundary conditions (5a) and (5b), is

$$I = \int_V F dV + \int_S [q_r T + \frac{1}{2} h (T - T_{\infty})^2] ds \quad (10)$$

#### D. Finite Element Method - Variational Approach

The cross section of the blade at station 126 is selected as the typical section for temperature profile determination. Triangular elements are used. The blade consists of 3 different kind of materials, Douglas Fir, Birch plywood and honeycomb paper core. It was divided into 75 regions, see Fig. 6. Each region was further divided into proper numbers of columns and rows. See Table 2. Then the triangular finite element mesh is generated automatically [4]. The results of regions 12 and 54 are shown in Fig. 7 as a typical example.

Table 2.

Region	Row	Column	Region	Row	Column	Region	Row	Column
1	2	2	26	2	7	51	3	3
2	2	5	27	2	5	52	3	9
3	2	7	28	2	3	53	3	9
4	2	7	29	2	3	54	3	9
5	2	5	30	2	3	55	3	9
6	2	3	31	2	3	56	3	3
7	2	3	32	2	5	57	3	3
8	2	3	33	2	7	58	3	2
9	2	3	34	2	7	59	3	2
10	2	9	35	2	5	60	3	3
11	2	9	36	2	2	61	3	3
12	2	9	37	2	2	62	3	3
13	2	9	38	3	2	63	3	3
14	2	3	39	3	5	64	3	3
15	2	3	40	3	7	65	3	5
16	2	3	41	3	7	66	3	7
17	2	3	42	3	5	67	3	7
18	2	5	43	3	3	68	3	5
19	2	7	44	3	3	69	3	2
20	2	7	45	3	3	70	2	2
21	2	5	46	3	3	71	5	3
22	2	2	47	3	3	72	3	3
23	2	2	48	3	2	73	3	2
24	2	5	49	3	2	74	5	3
25	2	7	50	3	3	75	2	10

To describe the finite element method, a typical element as shown in Fig. 8 is chosen. An approximate temperature profile,  $T(y,z)$ , can be constructed by using shape functions  $N_i$ ,  $N_j$  and  $N_k$  to linearly interpolate among the nodal temperatures  $T_i$ ,  $T_j$  and  $T_k$ , the values of which are to be determined.  $T(y,z)$  is described as:

$$T(y,z) = N_i T_i + N_j T_j + N_k T_k \quad (11)$$

where

$$N_i = \frac{1}{2A} [a_i + b_i y + c_i z]$$

$$N_j = \frac{1}{2A} [a_j + b_j y + c_j z] \quad (11a)$$

$$N_k = \frac{1}{2A} [a_k + b_k y + c_k z]$$

$$A = \frac{1}{2} \begin{vmatrix} 1 & Y_i & Z_i \\ 1 & Y_j & Z_j \\ 1 & Y_k & Z_k \end{vmatrix} \quad (11b)$$

and

$$\begin{aligned} a_i &= Y_j Z_k - Y_k Z_j, & a_j &= Y_k Z_i - Z_k Y_i, & a_k &= Y_i Z_j - Y_j Z_i \\ b_i &= Z_i - Z_k, & b_j &= Z_k - Z_i, & b_k &= Z_i - Z_j \\ c_i &= Y_k - Y_j, & c_j &= Y_i - Y_k, & c_k &= Y_j - Y_i \end{aligned} \quad (11c)$$

Substitute  $T(y,z)$  into Equation (10), and partial differentiate 'I' with respect to unknown nodal temperatures. Then, set them equal to zero. The result is a set of equations:

$$[C] \frac{\partial \{T\}}{\partial t} + [K] \{T\} = [P] \quad (12)$$

where

$$[C] = \sum_{e=1}^n [C_e], \quad [K] = \sum_{e=1}^n [K_e], \quad [P] = \sum_{e=1}^n [P_e]$$

and

$$[C_e] = \frac{\rho C_p A}{12} \begin{bmatrix} 2 & 1 & 1 \\ 1 & 2 & 1 \\ 1 & 1 & 2 \end{bmatrix},$$

$$[P_e] = (-q_r + h T_\infty) * \left[ \frac{L_{ij}}{2} \begin{bmatrix} 1 \\ 1 \\ 0 \end{bmatrix} \quad \text{or} \quad \frac{L_{jk}}{2} \begin{bmatrix} 0 \\ 1 \\ 1 \end{bmatrix} \quad \text{or} \quad \frac{L_{ki}}{2} \begin{bmatrix} 1 \\ 0 \\ 1 \end{bmatrix} \right]$$

$$[K_e] = \frac{k_\zeta \cos^2 \beta + k_\eta \sin^2 \beta}{4A} \begin{bmatrix} b_i b_i & b_i b_j & b_i b_k \\ b_j b_i & b_j b_j & b_j b_k \\ b_k b_i & b_k b_j & b_k b_k \end{bmatrix} + \frac{k_\zeta \sin^2 \beta + k_\eta \cos^2 \beta}{4A}$$

$$\begin{bmatrix} c_i c_i & c_i c_j & c_i c_k \\ c_j c_i & c_j c_j & c_j c_k \\ c_k c_i & c_k c_j & c_k c_k \end{bmatrix} + \frac{(k_\zeta - k_\eta) \sin 2\beta}{4A} \begin{bmatrix} b_i c_i & b_i c_j & b_i c_k \\ b_j c_i & b_j c_j & b_j c_k \\ b_k c_i & b_k c_j & b_k c_k \end{bmatrix}$$

$$+ \frac{h L_{ij}}{6} \begin{bmatrix} 2 & 1 & 0 \\ 1 & 2 & 0 \\ 0 & 0 & 0 \end{bmatrix} \quad \text{or} \quad + \frac{h L_{jk}}{6} \begin{bmatrix} 0 & 0 & 0 \\ 0 & 2 & 1 \\ 0 & 1 & 2 \end{bmatrix} \quad \text{or} \quad + \frac{h L_{ki}}{6} \begin{bmatrix} 2 & 0 & 1 \\ 0 & 0 & 0 \\ 1 & 0 & 2 \end{bmatrix}$$

Note that  $n$  is the total number of elements of the blade.  $[C]$  is the capacitance matrix,  $[P]$ , the heat flux matrix and  $[K]$ , the conductance matrix of the entire blade.  $[P_e]$  and  $[K_e]$  contain 'or' in their expressions. The purpose is to accommodate the elements with one edge or two edges on the boundary of the blade. For example, if edge  $j-k$  is on the boundary, the term which contains  $L_{jk}$  is maintained and the other two are deleted. For a non-boundary element,  $L_{ij}$ ,  $L_{jk}$  and  $L_{ki}$  are assumed a value of zero. Thus, the last term of  $[K_e]$  is deleted and  $[P_e]$  is dropped off for that element.

Equation (12) describes the heat conduction problem in transient state. When it reaches the steady state, the rate of change of temperature respect to time vanishes, i.e.,

$$\frac{\partial \{T\}}{\partial t} = 0$$

Equation (12) becomes,

$$[K] \{T\} = [P] \quad (13)$$

Equation (13) describes the heat conduction problem in steady state.

#### E. Heat Conduction in Steady State

Two steady-state Heat Conduction Analyses are made on the University NAS 6650 computer system. The first analysis is performed when the blade section is placed in horizontal position, the second, in vertical position. The sun is assumed to shine vertically on the top of the blade, which defines the heat flux input zone as shown in Fig. 3 or 4. So only the element with an edge on the top side has heat flux input ' $q_r$ ' entering the element thru that edge. The temperatures on all nodal points were obtained. Only the temperatures of the exterior nodes are plotted in Fig. 9 and 10. Temperatures of interior nodes are shown representively on typical sections in Fig. 11.

Observing Fig. 9 and 10, one finds that both of the sunny side surfaces reach a high temperature of 155°F and the opposite sides are on or slightly above 90°F. The identicalness of the results and that the low temperature is so close to the ambient temperature offer strong assurances that the analysis is correct. Further, Fig. 11 shows a smooth transition from high temperature side to low temperature side in all sections. They again indicate that the results are quite reasonable and hence reliable.

#### F. Heat Conduction in Transient State

It is important to determine the length of sunshine time required for the blade to reach the steady-state temperature. If the length of time required is not more than the sunshine hours of a day in the summer, the steady-state temperature may be used as the critical temperature distribution for analysis. Otherwise, temperature distribution at the end of sunshine hours of a day should be used.

In time domain, a linear interpolation model is used, see Fig. 12. The unknown temperature field  $\{T\}$ , spanning from one time to another separated by a time step  $\Delta t$ , may be expressed as

$$\{T\} = N_i \{T_i\} + N_j \{T_j\} \quad (14)$$

where  $N_i$  and  $N_j$  are shape functions, namely,

$$N_i = 1 - \frac{t}{\Delta t} \quad \frac{\partial N_i}{\partial t} = \frac{-1}{\Delta t}$$

hence,

$$N_j = \frac{t}{\Delta t} \quad \frac{\partial N_j}{\partial t} = \frac{1}{\Delta t}$$

substitute Equation (14) into Equation (12) and apply Galerkin's method [5], two integral matrix equations are produced, they are,

$$\int_0^{\Delta t} N_i ([C] \frac{d\{\tau\}}{dt} + [K]\{\tau\} - \{P\}) dt = 0 \quad (15a)$$

$$\int_0^{\Delta t} N_j ([C] \frac{d\{\tau\}}{dt} + [K]\{\tau\} - \{P\}) dt = 0 \quad (15b)$$

The time derivative of Equation (14) is,

$$\frac{d\{\tau\}}{dt} = \frac{dN_i}{dt} \{\tau_i\} + \frac{dN_j}{dt} \{\tau_j\} = -\frac{1}{\Delta t} \{\tau_i\} + \frac{1}{\Delta t} \{\tau_j\} \quad (16)$$

Substitute Equations (14) and (16) into Equation (15a), we have,

$$\int_0^{\Delta t} (1 - \frac{t}{\Delta t}) (\frac{[C]}{\Delta t} \{\tau_j\} - \frac{[C]}{\Delta t} \{\tau_i\} + \frac{t[K]}{\Delta t} \{\tau_j\} + (1 - \frac{t}{\Delta t}) [K] \{\tau_j\} - \{P_i\}) dt = 0$$

After integration, it yields,

$$(\frac{[C]}{2} + \frac{\Delta t}{6} [K]) \{\tau_j\} = (\frac{[C]}{2} - \frac{\Delta t}{3} [K]) \{\tau_i\} + \frac{\Delta t}{2} [P_i] \quad (17)$$

The constants in parentheses are weighting factors, which may be modified to improve the stability of the numerical solution process. Based on Donea's suggestion [6], Equation (17) is modified to the following form.

$$(\frac{[C]}{2} + \frac{\Delta t}{3} [K]) \{\tau_j\} = (\frac{[C]}{2} - \frac{\Delta t}{6} [K]) \{\tau_i\} + \frac{\Delta t}{2} [P_i] \quad (18)$$

Equation (18) is the equation of solution in time domain.



The initial temperature of the blade is assumed to be uniform and same as the ambient temperature, 90°F, namely,

$$\{T_i\} = \{T_0\}_{t=0} = \{90^\circ\}$$

then, an iterative process is commenced to determine the temperature at the next time step  $t + \Delta t$ , namely  $\{T_j\}$ , by using Equation (18). This process is repeated until the maximum difference between  $\{T_j\}$  and  $\{T_i\}$  is smaller than a predetermined small quantity. In this analysis, 500 second is chosen as  $\Delta t$  and good results are obtained as shown in Figs. 13 and 14.

Observing Figs. 13 and 14 and the computer results, numerical instability is experienced in the first hour, but thereafter, stability is restored and steady-state condition is reached. They indicate that the length of sunshine time required for the blade to reach the steady-state temperature is in the neighborhood of 4 hours. Obviously, this is possible. Thus, steady-state temperature distribution of the blade is used as the input of Phase II, finite element thermal-stress analysis.

## PHASE II. THERMAL-STRESS ANALYSIS

### A. Plane-Strain Thermoelastic Problem

From the previous discussions, it has been stated that the blade is a slender body, its length is large compared with its maximum cross-sectional dimension. The thermal input along the blade axis is close to uniform, namely, the blade temperature is independent of the axial coordinate. Under these conditions, the use of the concept of plain strain not only provides a good solution [7], but also greatly reduces the computational effort, because it decreases a three-dimensional problem to a two-dimensional one.

If the orthogonal axes system  $\zeta$ ,  $\eta$  and  $\xi$  are used, the fundamental assumptions for a plane-strain thermoelastic problem are:

$$\mu_{\xi} = 0, \quad \mu_{\zeta} = \mu_{\zeta}(\zeta, \eta), \quad \mu_{\eta} = \mu_{\eta}(\zeta, \eta) \quad (19)$$

The corresponding strain components have the form:

$$\begin{aligned} \epsilon_{\xi} = \epsilon_{\xi\zeta} = \epsilon_{\xi\eta} = 0 \\ \epsilon_{\zeta\zeta} = \epsilon_{\zeta\zeta}(\zeta, \eta), \quad \epsilon_{\eta\eta} = \epsilon_{\eta\eta}(\zeta, \eta), \quad \epsilon_{\zeta\eta} = \epsilon_{\zeta\eta}(\zeta, \eta) \end{aligned} \quad (20)$$

The stress field is related to the strain field by the elastic constants of modulus of elasticity and Poisson's ratios. As stated before, wood is an orthotropic material, the modulus of elasticity of wood in longitudinal direction (parallel to grain) have in general, a significant difference with those in radial or tangential direction, some twenty times as large [9].

To account for the possible difference in radial and tangential directions, a 10% difference is again maintained in this computation. For plywood, an average value is taken. They are listed in Table 3.

Table 3.

	Douglas Fir	Birch	Birch Plywood
$E_L$	$1.95 \times 10^6$ psi	$2.10 \times 10^6$ psi	$1.38 \times 10^6$ psi
$E_T$	$0.098 \times 10^6$ psi	$0.105 \times 10^6$	$0.77 \times 10^6$
$E_R$	$0.133 \times 10^6$ psi	$0.164 \times 10^6$	$0.164 \times 10^6$
$G_{TR}$	$0.014 \times 10^6$ psi	$0.036 \times 10^6$	$0.076 \times 10^6$

The Poisson's ratios ' $\nu$ ' and the thermal expansion coefficients,  $\alpha$ , of wood are also different significantly in the major axis directions. They [9] are listed in Table 4.

Table 4.

	Douglas Fir	Birch	Birch Plywood
$\alpha_L$	$2.1 \times 10^{-6}/^\circ\text{F}$	$2.1 \times 10^{-6}/^\circ\text{F}$	$14.57 \times 10^{-6}$
$\alpha_T$	$34.9 \times 10^{-6}/^\circ\text{F}$	$39.52 \times 10^{-6}/^\circ\text{F}$	$27.05 \times 10^{-6}$
$\alpha_R$	$25.9 \times 10^{-6}/^\circ\text{F}$	$30.38 \times 10^{-6}/^\circ\text{F}$	$30.38 \times 10^{-6}$
$\nu_{LR}$	0.292	0.426	0.433
$\nu_{LT}$	0.449	0.451	0.308
$\nu_{RT}$	0.390	0.697	0.476
$\nu_{TR}$	0.287	0.447	0.440
$\nu_{RL}$	0.020	0.033	0.255
$\nu_{TL}$	0.022	0.023	0.166

## B. Formulation of Potential Energy

In Phase I, the heat conduction portion of the problem, a governing partial differential equation needs to be established first, then, the finite element method in Variational approach is employed as a numerical procedure to obtain its solution. Now, for the problem of finding the thermal-stresses due to a temperature distribution, no controlling differential equation can be found. Thus, a conceptually different technique must be used to determine directly the displacement field,  $\{f\}$ , without going through the intermediate step of establishing the differential equation. Once  $\{f\}$  is found, the stress field  $\{\sigma\}$  can be determined accordingly.

First, with an assumed displacement field and under the influence of temperature rises at various locations, the total potential energy, P.E., may be expressed as

$$P.E. = \int_V \left( \frac{1}{2} [\epsilon]^T [E] [\epsilon] - [\epsilon]^T [E] [\alpha T] \right) dv \quad (21)$$

where  $V$  represents the total volume of the blade. In a two-dimensional case, it may be replaced by the multiplication of thickness and cross-sectional area, i.e.,  $t * A$ .

Let  $v$  and  $w$  be the displacements of a point in  $\zeta$  and  $\eta$  directions, we may express  $[\epsilon]$  in terms of the displacement field  $\{f\}$  as follows:

$$\{\epsilon\} = [\partial] \{f\}$$

where  $\{\epsilon\} = \begin{bmatrix} \epsilon_{\zeta} \\ \epsilon_{\eta} \\ \gamma_{\zeta\eta} \end{bmatrix}$ ,  $[\partial] = \begin{bmatrix} \frac{\partial}{\partial \zeta} & 0 \\ 0 & \frac{\partial}{\partial \eta} \\ \frac{\partial}{\partial \eta} & \frac{\partial}{\partial \zeta} \end{bmatrix}$ ,  $\{f\} = \begin{bmatrix} v \\ w \end{bmatrix}$

Further, the strain components of a point,  $\{\epsilon\}$ , may be expressed in terms of nodal displacements  $\{D\}$ . For demonstration purpose, a triangular element as shown in Fig. 15 and the aforementioned shape functions,  $[N]$ , are again used, the strain field,  $\{\epsilon\}$ , may be expressed as:

$$\{\epsilon\} = [\partial] [N] \{D\},$$

or

$$\{\epsilon\} = [B] \{D\} \quad (22)$$

where

$$[B] = [\partial] [N]$$

$$[N] = \begin{bmatrix} N_i & 0 & N_j & 0 & N_k & 0 \\ 0 & N_i & 0 & N_j & 0 & N_k \end{bmatrix}$$

$$\{D\} = \begin{bmatrix} v_i & w_i & v_j & w_j & v_k & w_k \end{bmatrix}^T$$

$$N_i = \frac{1}{2A} [a_i + b_i \zeta + c_i \eta]$$

$$N_j = \frac{1}{2A} [a_j + b_j \zeta + c_j \eta]$$

$$N_k = \frac{1}{2A} [a_k + b_k \zeta + c_k \eta]$$

Note that  $A$ ,  $a_i$ ,  $a_j$  and  $a_k$  have been described in (11b) and (11c).

Expanding  $\{D\}$  to cover all the nodal displacements in the entire blade section and substituting Equation (22) into Equation (21), one obtains:

$$P.E. = \frac{1}{2} [D]^T \left\{ \int [B]^T [E] [B] dv \right\} [D] - [D]^T \int [B]^T [E] [\alpha T] dv \quad (23)$$

Equation (23) expresses the total potential energy of the blade section in finite element formulation.

### C. Finite Element Method--Minimum Potential Energy Approach

Recall that the total potential energy, P.E., is formed based on an assumed displacement field  $\{f\}$ , for each element. These fields are then expressed in terms of unknown nodal displacements by using shape functions. Although admissible fields are chosen, the compatibility conditions are therefore satisfied within the elements and at the nodes, yet the equilibrium conditions remain to be determined.

It is known that among all admissible configurations of a conservative system, those that satisfy the equations of equilibrium make the potential energy stationary with respect to small variations of displacement. If the stationary condition is a minimum, the equilibrium state is stable. Thus, the equilibrium conditions may be sought through the minimization of the total potential energy P.E., namely,

$$\frac{\partial \text{P.E.}}{\partial D} = 0 \quad (24)$$

$$\text{or,} \quad \left( \sum_1^m \int_v [B]^T [E] [B] dv \right) \{D\} = \sum_1^m \int_v [B]^T [E] [\alpha T] dv \quad (25)$$

where  $v$  is the volume of an element.

Equation (25) may be written in the following simplified form:

$$[K] [D] = [P] \quad (26)$$

where  $[K]$  is the total stiffness of the blade and  $[k]$  is the stiffness of each element,  $[p_e]$  is the thermal load produced at nodal points in a given temperature field and  $[E]$ , Matrix of modulus of elasticity;

$$[K] = \sum_1^m [k]$$

$$[k] = \int [B]^T [E] [B] dv \quad (27)$$

$$[P] = \sum_1^m [p_e]$$

$$[p_e] = \int_V [B]^T [E] [\alpha t] dv$$

Equation (26) is the finite element formulation of the blade section if isotropic material is used. But the wood composite is an orthotropic material, the matrices of modulus of elasticity  $[E]$  in Equation (25), need to be modified accordingly as to be described in the following sections.

#### D. The Treatment of Orthotropic Property

For an orthotropic material such as wood [8] and in the case of plain strain, the normal strain-stress relationships apply:

$$\epsilon_z = \frac{1}{E_z} \sigma_z - \frac{\nu_{zn}}{E_n} \sigma_n - \frac{\nu_{z\xi}}{E_\xi} \sigma_\xi \quad (28)$$

$$\epsilon_n = -\frac{\nu_{nz}}{E_z} \sigma_z + \frac{1}{E_n} \sigma_n - \frac{\nu_{n\xi}}{E_\xi} \sigma_\xi$$

also

$$\epsilon_\xi = -\frac{\nu_{\xi z}}{E_z} \sigma_z - \frac{\nu_{\xi n}}{E_n} \sigma_n + \frac{1}{E_\xi} \sigma_\xi = 0$$

Thus

$$\sigma_\xi = \frac{E_\xi}{E_z} \nu_{\xi z} \sigma_z + \frac{E_\xi}{E_n} \nu_{\xi n} \sigma_n \quad (29)$$

Note that  $\nu_{zn}$  denotes the strain in the  $z$  direction due to strain in the  $n$  direction.

Substitution of Equation (29) into (28) produces:

$$\epsilon_{\zeta} = \frac{1}{E_{\zeta}} (1 - \nu_{\zeta\xi} \nu_{\xi\zeta}) \sigma_{\zeta} - \frac{1}{E_{\eta}} (\nu_{\zeta\eta} + \nu_{\zeta\xi} \nu_{\xi\eta}) \sigma_{\eta} \quad (30)$$

$$\epsilon_{\eta} = \frac{-1}{E_{\zeta}} (\nu_{\eta\zeta} + \nu_{\eta\xi} \nu_{\xi\zeta}) \sigma_{\zeta} + \frac{1}{E_{\eta}} (1 - \nu_{\eta\xi} \nu_{\xi\eta}) \sigma_{\eta}$$

Solving the above equations, one finds:

$$\sigma_{\zeta} = (aE_{\zeta}\epsilon_{\zeta} + bE_{\zeta}\epsilon_{\eta}) / (ad - bc)$$

$$\sigma_{\eta} = (cE_{\eta}\epsilon_{\zeta} + dE_{\eta}\epsilon_{\eta}) / (ad - bc) \quad (31)$$

$$\tau_{\zeta\eta} = G_{\zeta\eta} \gamma_{\zeta\eta}$$

where,

$$a = 1 - \nu_{\eta\xi} \nu_{\xi\eta}$$

$$b = \nu_{\zeta\eta} + \nu_{\zeta\xi} \nu_{\xi\eta}$$

$$c = \nu_{\eta\zeta} + \nu_{\eta\xi} \nu_{\xi\zeta}$$

$$d = 1 - \nu_{\zeta\xi} \nu_{\xi\zeta}$$

or, the stress-strain relationships may be described in a matrix form as

$$\{\sigma\} = [E_m] \{\epsilon\} \quad (32)$$

where

$$[E_m] = \frac{1}{ad - bc} \begin{bmatrix} a E_{\zeta} & b E_{\zeta} & 0 \\ c E_{\eta} & d E_{\eta} & 0 \\ 0 & 0 & (ad - bc)G_{\zeta\eta} \end{bmatrix} \quad (33)$$

From the Maxwell-Betti's Reciprocal theorem,

$$cE_{\eta} = bE_{\zeta},$$

or,

$$\frac{E_{\eta}}{E_{\zeta}} = \frac{b}{c},$$

so the matrix of modulus of elasticity remains symmetrical for wood.



Equation (33) gives the matrix  $[E_m]$  for plane strain in an orthotropic material, where  $\zeta$ ,  $\eta$  and  $\xi$  are principal directions of orthotropy.

The elasticity constants of wood,  $\nu$ ,  $E$ ,  $\alpha$  and  $G$ , have been described in Tables 3 and 4. In view of the blade construction, wood property axis T corresponds to axis  $\zeta$  in this section, R to  $\eta$  and L to  $\xi$ .

#### E. Element Axes to Structural Axes

Because of the blade curvature, the principal axes of material at one point in the blade section have in general, a different orientation with respect to the structural axes than those at another point. A typical orientation of laminated wood has been shown in Fig. 5, where  $\zeta$ ,  $\eta$  and  $\xi$  are the principal axes of material and local axes of the element, while  $y$ ,  $z$  and  $x$  are the structural axes and the axes of the blade section. The transformation from material axes to structural axes is necessary for all elements in order to unify them in the framework of structural axes. This transformation process may be described as follows:

$T_{ms}$  = Transformation from structural axes to material axes

then,

$$\{ \epsilon_m \} = [T_{ms}] \{ \epsilon_s \} \quad (34)$$

where subscript m and s represent material axes and structures axes, and

$$[T_{ms}] = \begin{bmatrix} \cos^2 \beta & \sin^2 \beta & \sin \beta \cos \beta \\ \sin^2 \beta & \cos^2 \beta & -\sin \beta \cos \beta \\ -2 \sin \beta \cos \beta & 2 \sin \beta \cos \beta & \cos^2 \beta - \sin^2 \beta \end{bmatrix}$$

In addition, the stress transformation from material axes to structural axes is

$$\{\sigma_s\} = [T_{ms}]^T \{\sigma_m\} \quad (35)$$

A proper stress-strain transformation may then be obtained by first stating the stress-strain relationships in material axes, namely,

$$\{\sigma_m\} = [E_m] \{\epsilon_m\} \quad (36)$$

where  $[E_m]$  has been described in Equation (33). Substitution of Equation (34) and (36) into (35) gives:

$$\{\sigma_s\} = [T_{ms}]^T [E_m] [T_{ms}] \{\epsilon_s\}$$

or

$$\{\sigma_s\} = [E_s] \{\epsilon_s\} \quad (37)$$

where

$$[E_s] = [T_{ms}]^T [E_m] [T_{ms}]$$

$[E_s]$  is the matrix of modulus of elasticity for orthotropic material, of which the material axes  $\xi$  and  $\eta$  are oriented at  $\beta$  angle with respect to principal axes  $y$  and  $z$ , and material axis  $\xi$  coincides with structural axis  $x$ . This matrix is used in place of  $[E]$  in Equation (25) for the determination of the stiffness of each element,  $[k]$ , and thermal load matrix of each element,  $[P_e]$ . Then, proper combinations of  $[k]$  and  $[P_e]$  respectively for all elements render  $[K]$  and  $[P]$  as described in Equations (25) to (27). Finally, the equation (26) is solved and the displacements of all nodal points  $[D]$  are determined. When the displacement field is found, the stresses at each element can be computed accordingly. Thus, the determination of thermal-stress distribution on the wood blade is accomplished.

## F. Thermal Stresses

Corresponding to the two steady-state Heat Conduction analyses made in Phase I, two thermal-stress analyses are run on the University computer. The stresses are all computed in material axes  $\zeta$  and  $\eta$  as shown in Fig. 5. Only the stresses of elements in the surface layer are plotted. For example, Fig. 16 shows the stresses in  $\zeta$  direction when the blade section is in horizontal position, and Fig. 17 shows the same type of stresses when the blade section is in vertical position.

Observing Fig. 16 and 17, one finds that the high temperature sides of the blades, stresses of same magnitude are induced. This offers an independent check on the correctness of the computations. The sense of the stresses on the high temperature side is tensile, this is largely due to the special characteristics of the blade construction. As described before, in D-spar a thin layer of 1/8" Birch plywood wraps around 3" of laminated Douglas Fir. The thermal expansion coefficient in tangential direction of Douglas Fir is about 23% higher than that of Birch plywood. When the temperature rises, the thin layer of Birch plywood is 'stretched' by the expanding Douglas Fir. Thus, tensile stresses are produced on the exterior surface of the blade. This computational phenomenon agrees to the rationality of engineering. Furthermore, in view of the smooth transition from high stress area to low stress area; in Fig. 16 the stresses on the tail portion varies when the interior materials changed from Douglas Fir to honeycomb paper core; and the approximately symmetrical stress distribution on Fig. 17 for an approximately symmetrical blade geometry and thermal loadings; one can conclude, short of experimental verification, that the analysis offers a set of results with high believability.

## Conclusion Remarks

### A. Pre-run Program Testings

For the purpose of increasing the reliability of the finite element analyses, both the heat conduction analysis computer programs and the thermal-stress analysis computer programs have undergone several testings before using on the analysis of the blade. These testings consist of solving smaller but similar engineering problems with either theoretical solutions or solutions given by other authors. Nearly identical results have been obtained in all testings.

### B. Finer-Mesh Testing

After the thermal-stress analysis has been performed on the blade, for a finite element model of 388 elements, the analysis is repeated on a finer-mesh model of 688 elements. For the finer-mesh model, the stresses in  $\zeta$  direction of the surface layer elements are shown in Fig. 18. A comparison of Fig. 16 to Fig. 18 shows that the stresses of the former are converging to the corresponding stresses of the later. This is considered to be a good convergence test for finite element analysis.

### C. Engineering Judgement

The final results of steady-state temperature distribution and the thermal-stress distribution as shown in Figs. 6, 7, 16 and 17 are agreeable to engineering rationality as stated in section E of Phase I and section F of Phase II.

#### D. The Cause of Cracking

The allowable stresses in principal directions of Birch plywood [9] are listed in Table 5. A comparison reveals that the maximum blade thermal-stress, which occurs in  $\zeta$  direction, is far lower than the allowable stress in the corresponding direction,  $\sigma_T$ . Although the transient thermal-stress analysis is not performed due to time limitation of the research project, yet it is believed that they should not exceed the allowable stress level for a prolonged period, since the sun is a mild heat source.

Table 5

Allowable Stresses for Birch Plywood		
	Compressive	Tensile
$\sigma_L$	5,770 psi	13,640 psi
$\sigma_T$	3,370	7,280
$\sigma_R$	970	920

#### E. Conclusion

In conclusion, the cause of cracking of the blade is not due to thermal stresses induced by the sun. Investigation of other causes, such as poor manufacturing, needs to be made. In addition to the elimination of thermal stress as a possible reason of blade cracking, the research brings forth a method and a practical example of thermal-stress analysis for an engineering body of orthotropic materials, which will find many applications in the Engineering Community.

### Acknowledgement

The work was supported by NASA Grant NAG3-373. The encouragement received from Mr. Darrell H. Baldwin, Manager of Wind Energy Project Office and Dr. David A. Spera, Chief engineer of the same Office is highly appreciated by the senior author. Acknowledgement is due to Mr. Timothy Sullivan, Research engineer of the same office, for providing constant guidance throughout the project.

## References

- [1] Abbot, I. H., vonDoenhoff, A. E., Stivers, Jr., "Summary of Airfoil Data" NACA TR-824, 1945.
- [2] Cinquemani, V., Owenby, J. R. and Baldwin, R. G., "Input Data for Solar Systems," U. S. Department of Energy, Nov. 1978, Reprinted March, 1980.
- [3] Mikhlin, S. G., "Variational Methods in Mathematical Physics Macmillan Company, N.Y.
- [4] Collins, R. J., "Bandwidth Reduction by Automatic Renumbering," International Journal for Numerical Methods in Engineering," 1973, Vol. 6, pp. 345-356.
- [5] Szabo, B. and G. C. Lee, "Derivation of Stiffness Equations for Problems in Elasticity by Galerkin's Method," International Journal for Numerical Methods on Engineering, 1., No. 3, 1969, pp. 301-310.
- [6] Donea, J., "On the Accuracy of Finite Element Solution to the Transient Heat-Conduction Equation,," International Journal for Numerical Methods in Engineering, Vol. 8, No. 1, 1974, pp. 103-110.
- [7] Boley and Weiner, "Theory of Thermal Stresses," pp. 103-107.
- [8] Lekhnitskii, S. G., Theory of Elasticity of an Anisotropic Body, Translation from Russian by P. Fern, Holden-Day, San Francisco, 1963.
- [9] Forest Service, U.S. Department of Agriculture, "Wood Handbook: Wood as an Engineering Material," Revised August, 1974, U.S. Government Printing Office, Washington, D.C.

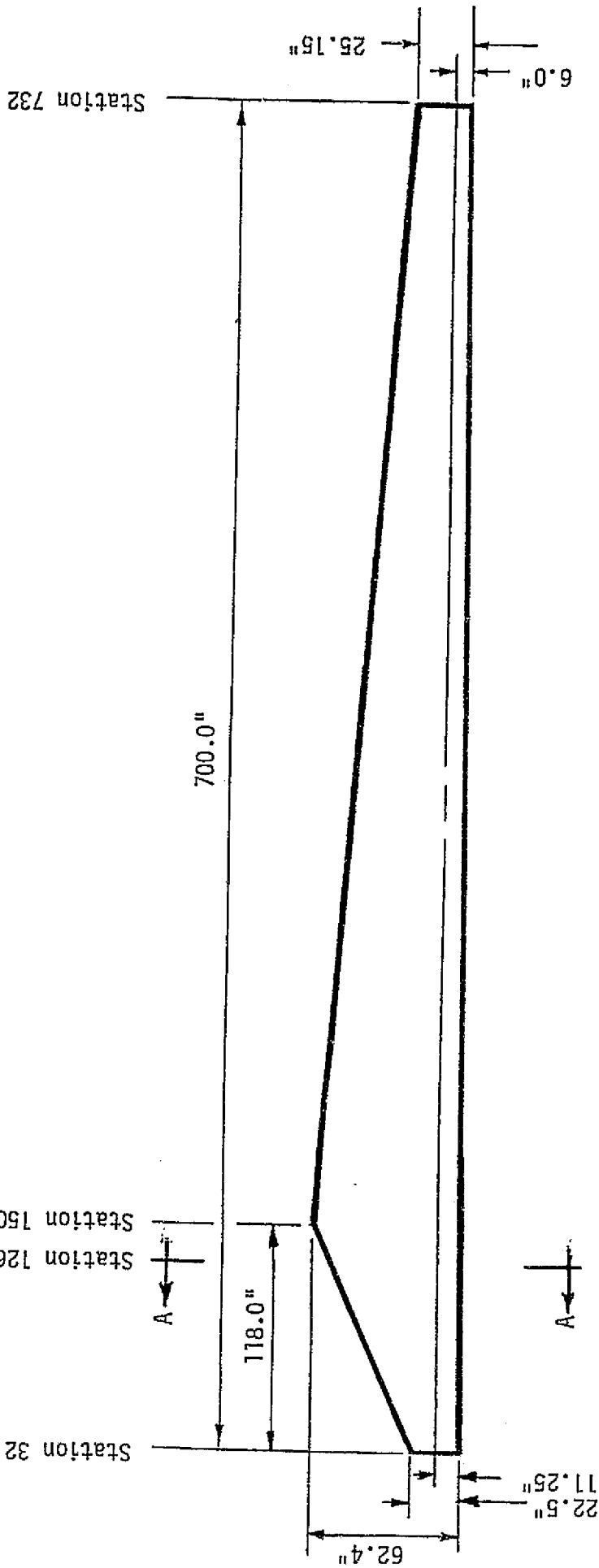

ORIGINAL PAGE IS  
OF POOR QUALITY

Figure 1

Scale: 1:80



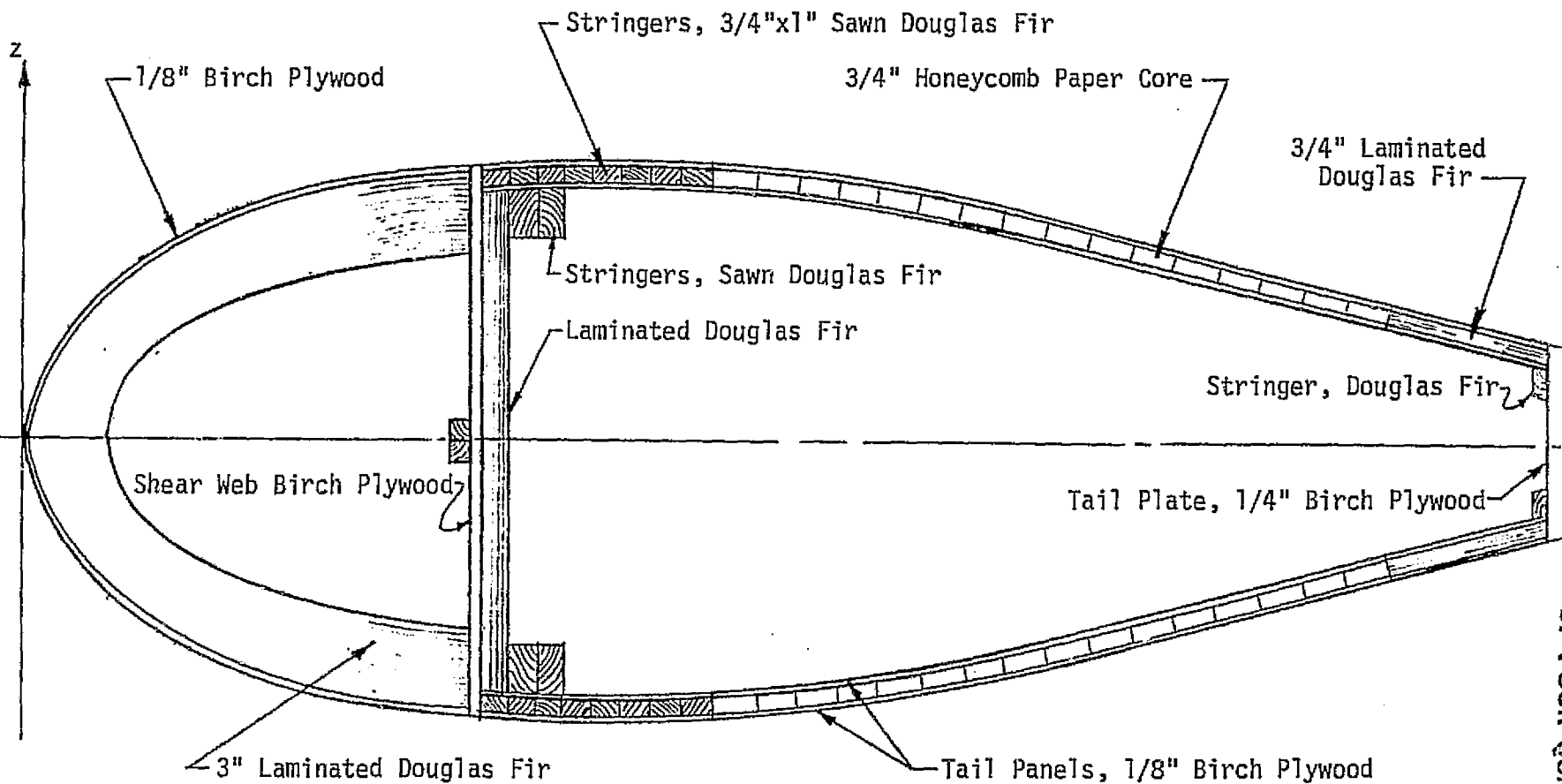

Figure 2. Section A-A at Station 126

Scale: 1:6

ORIGINAL PAGE IS  
OF POOR QUALITY

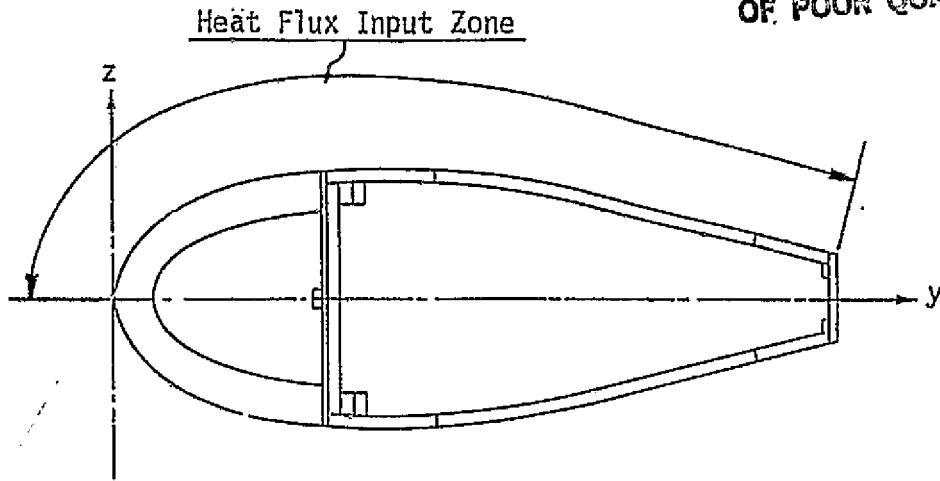

Figure 3

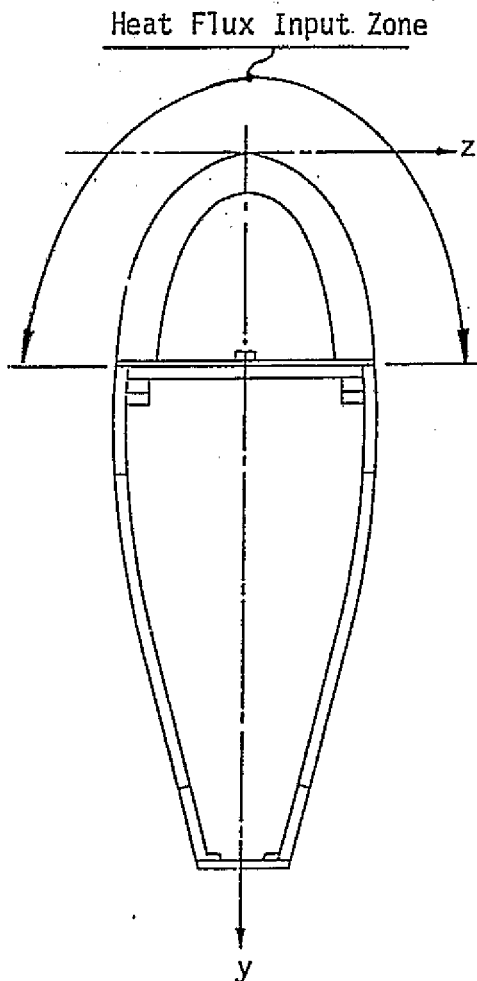

Figure 4

ORIGINAL PAGE IS  
OF POOR QUALITY

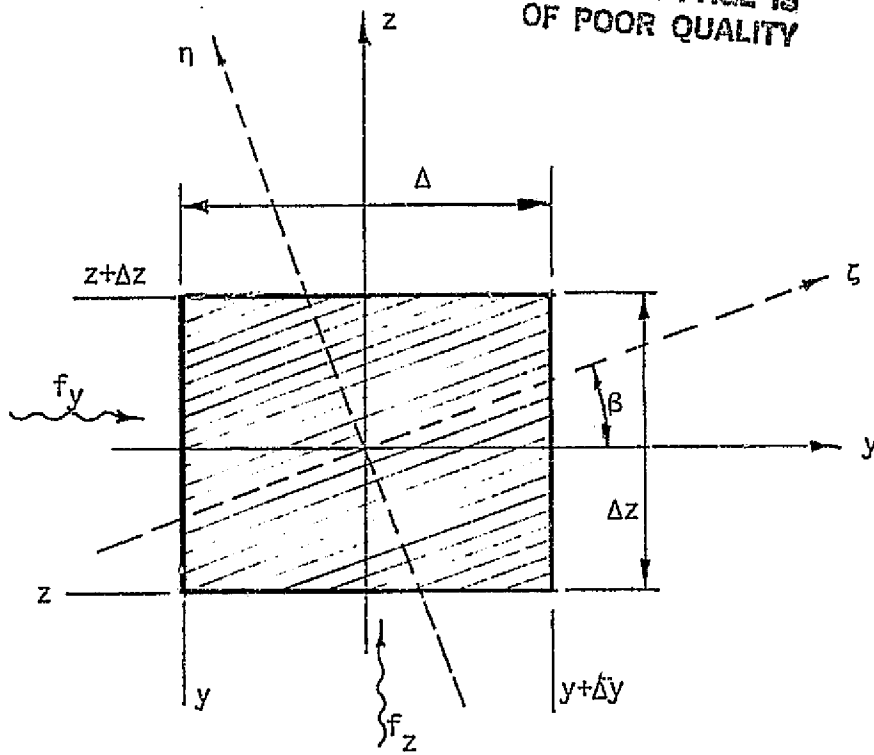

Figure 5

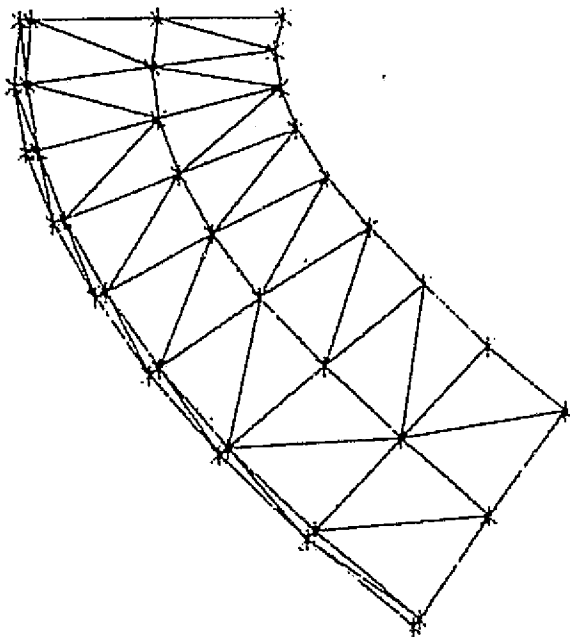

Figure 7

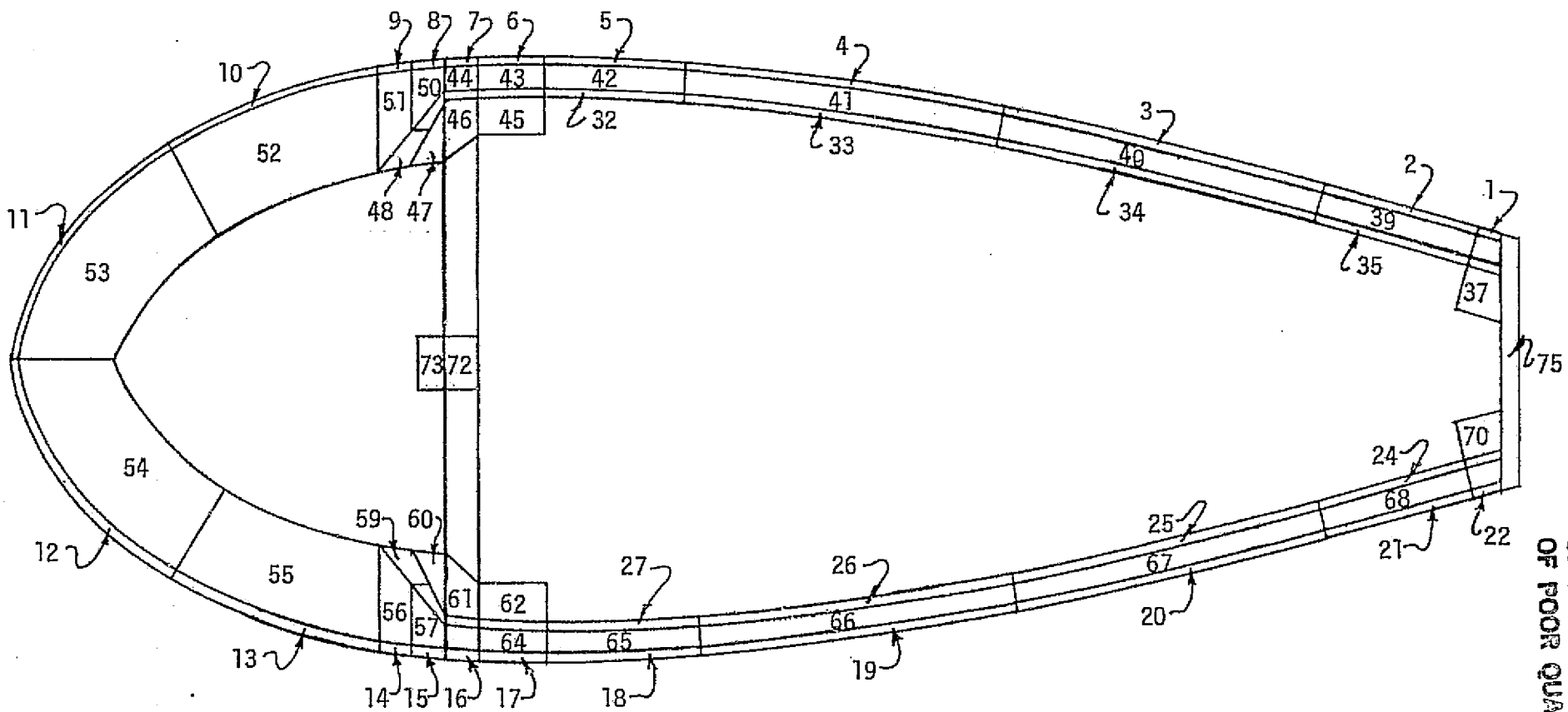
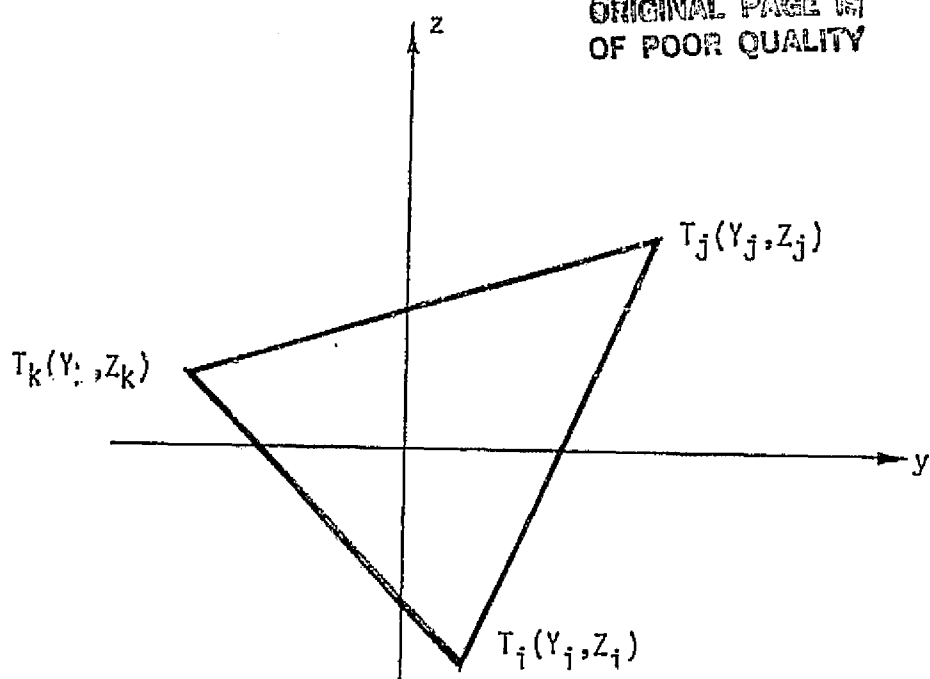
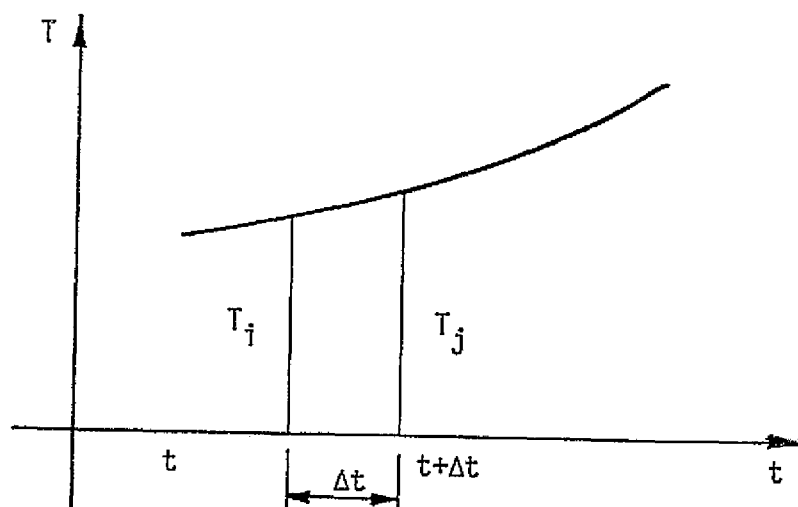

Figure 6. Regions for Mesh Generation

ORIGINAL PAGE IS  
OF POOR QUALITY

ORIGINAL PAGE IS  
OF POOR QUALITYFigure 8Figure 12

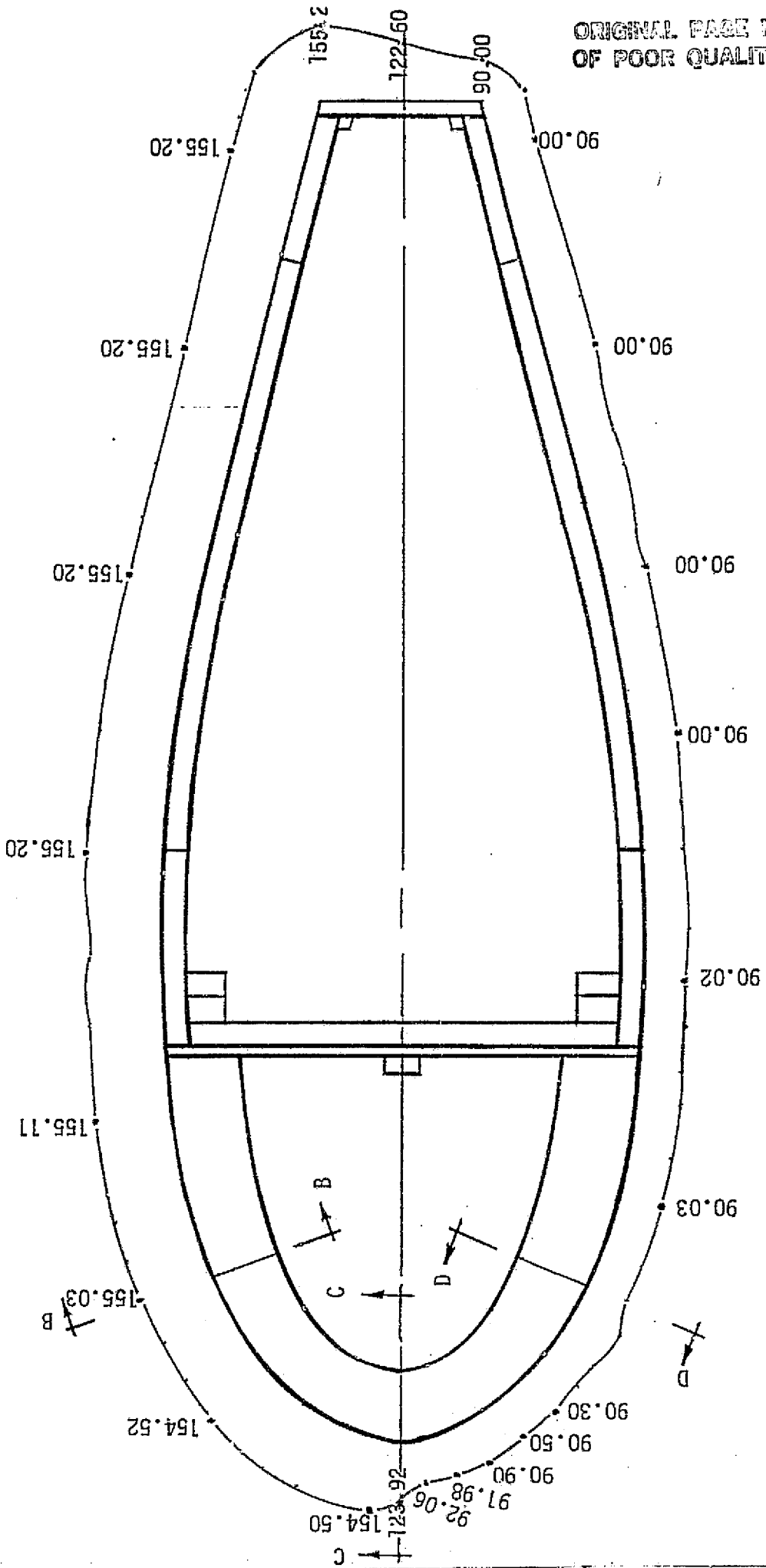
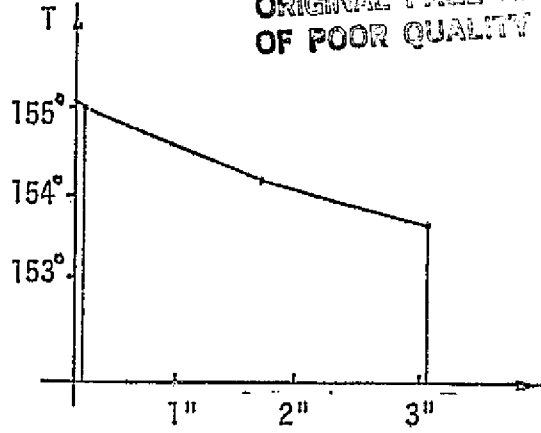

Figure 9. Temperature Distribution of Exterior Elements,  
Blade Section in Horizontal Position



ORIGINAL PAGE IS  
OF POOR QUALITY



Section B-B

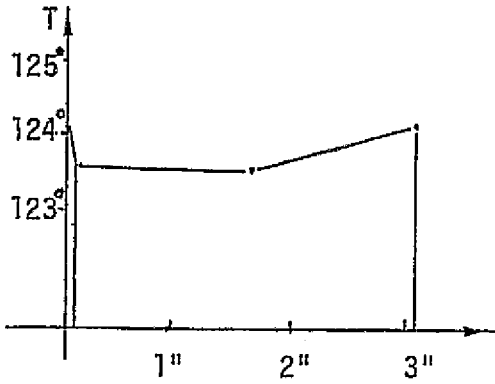

Section C-C

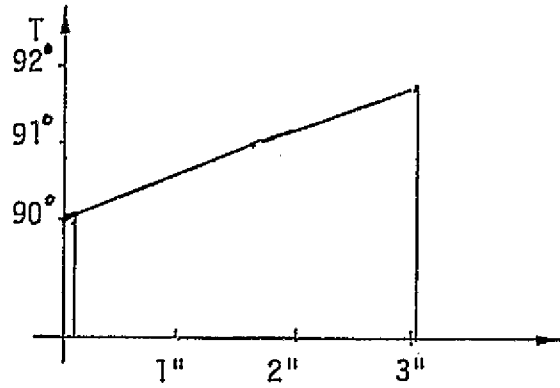

Section D-D

Figure 11. Temperature Profiles

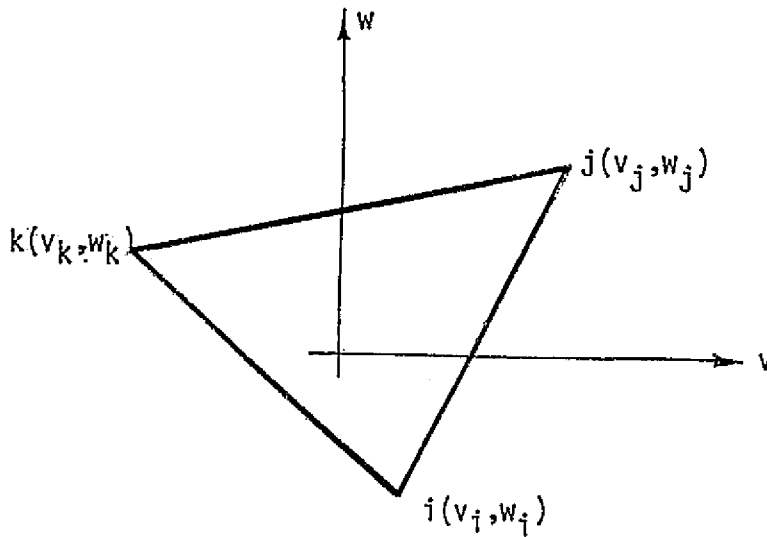

Figure 15



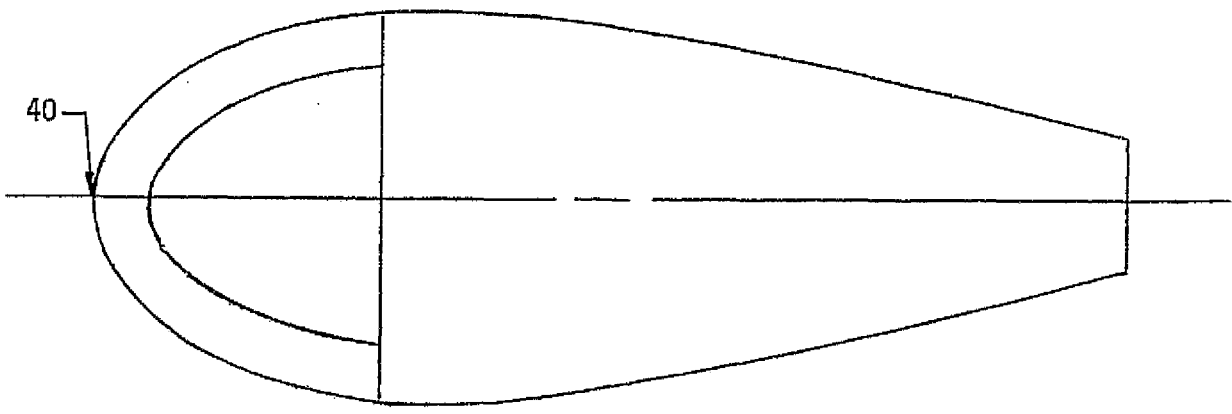
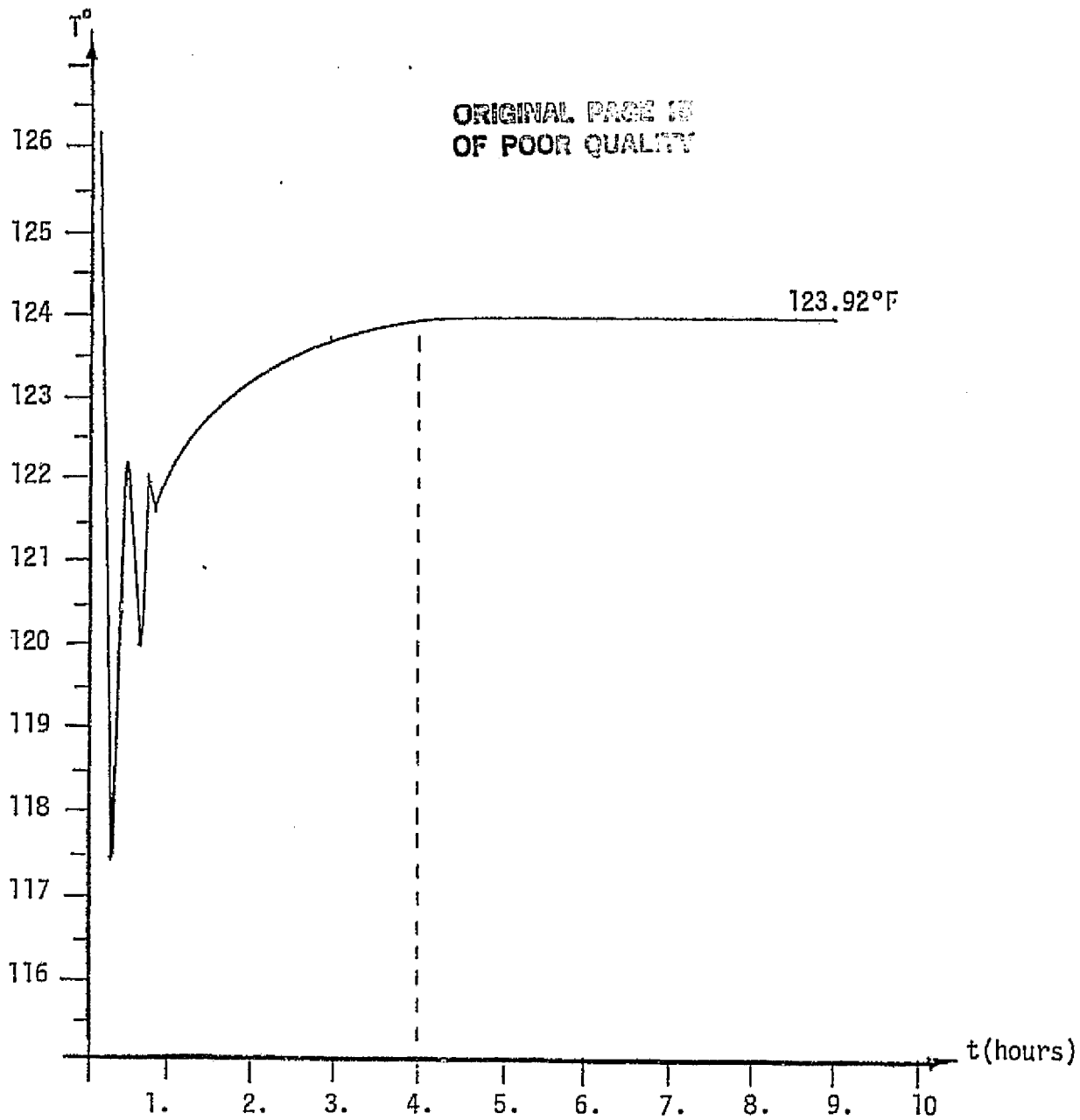

Figure 13. Temperature History at Node 40

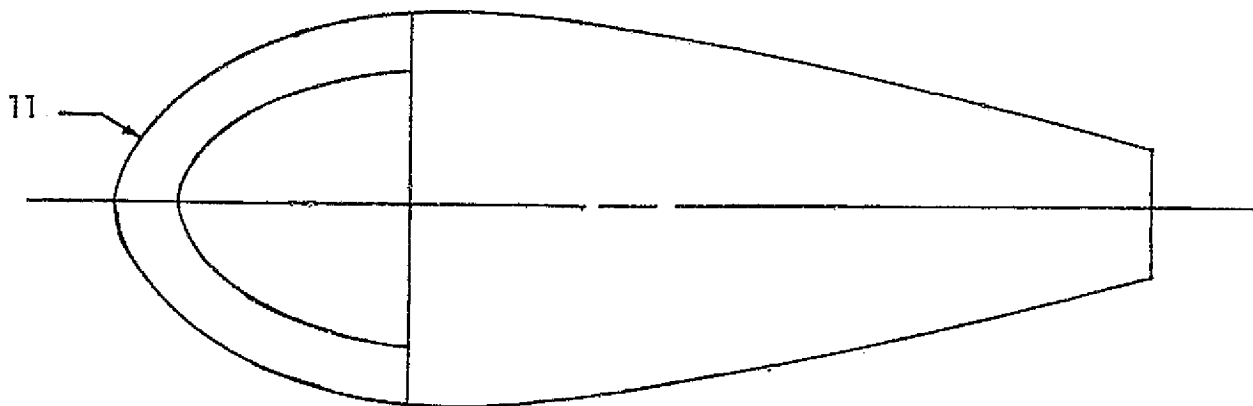
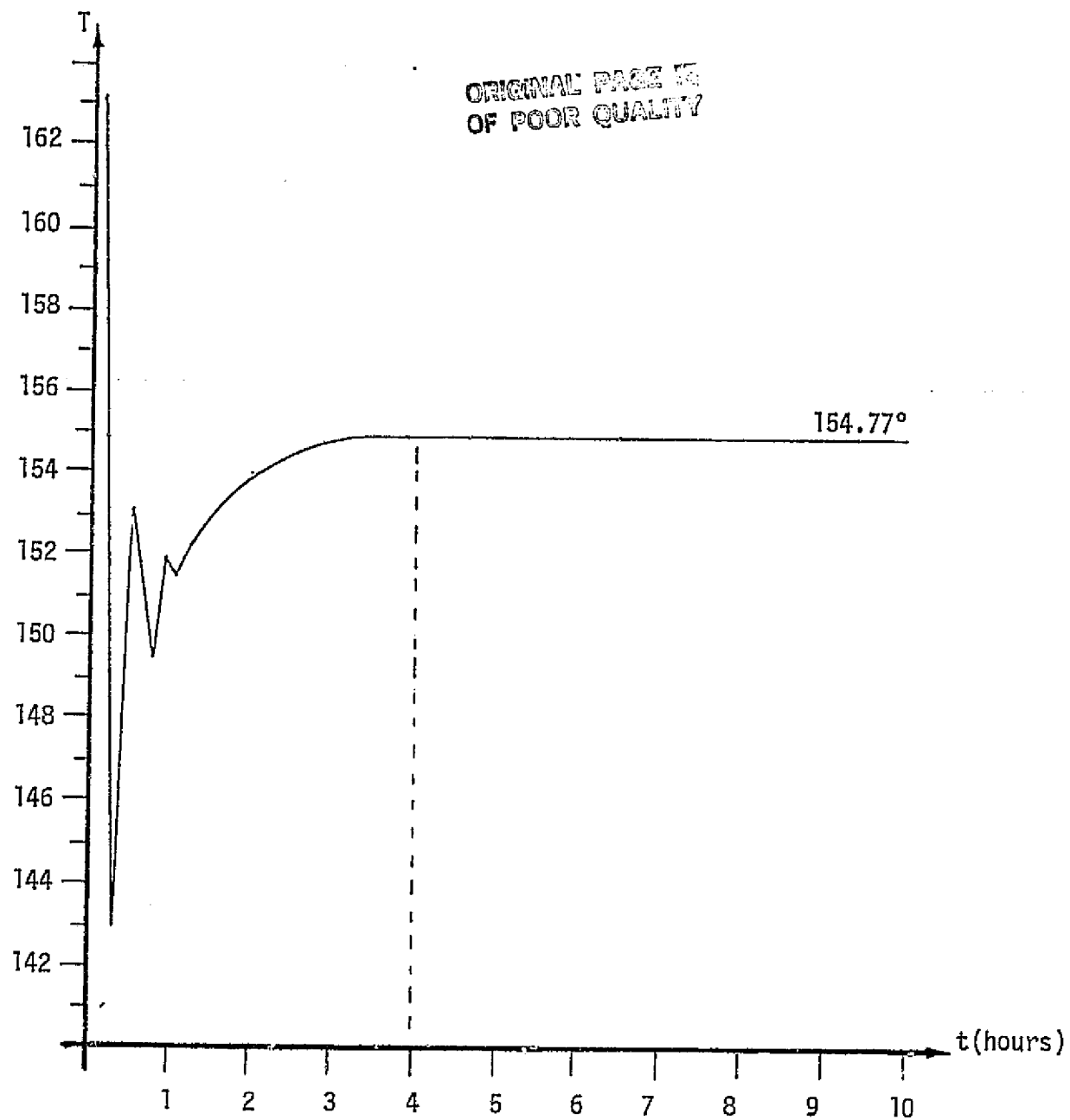

Figure 14. Temperature History at Node 11

ORIGINAL PAGE IS  
OF POOR QUALITY

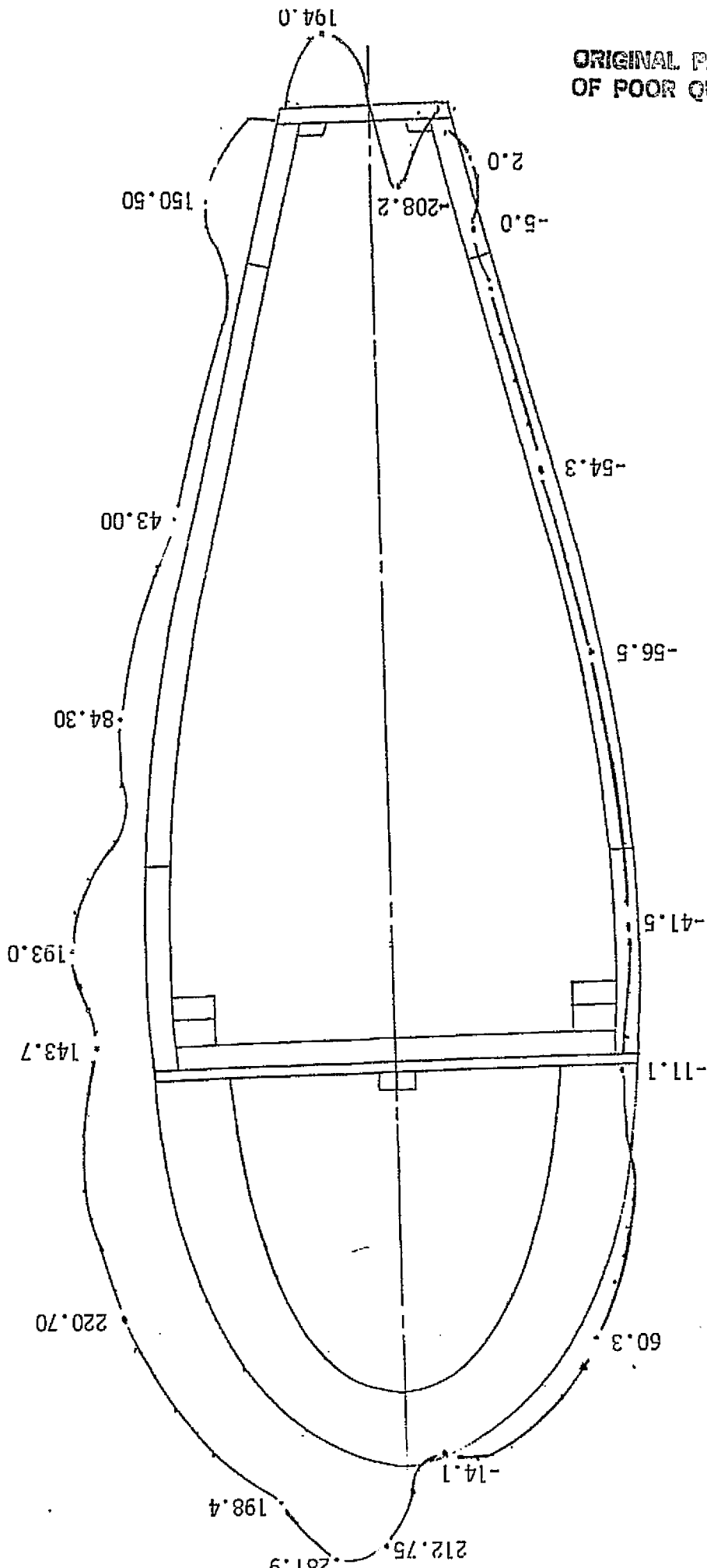

Figure 16. Thermal Stress in z Direction  
Blade Section in Horizontal Position

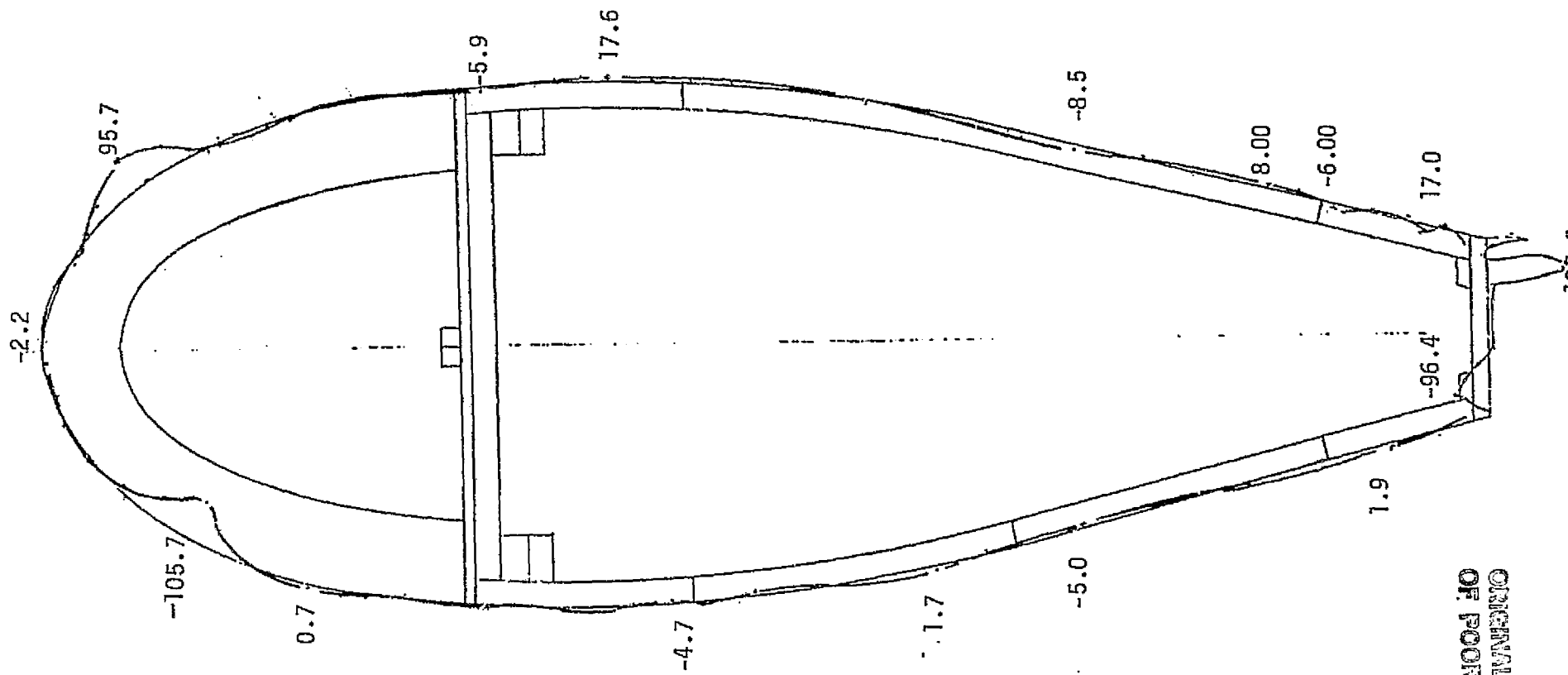

Figure 16a. Thermal Stresses in  $\eta$  Direction,  
Blade Section in Horizontal Position

ORIGINAL PAGE IS  
 OF POOR QUALITY

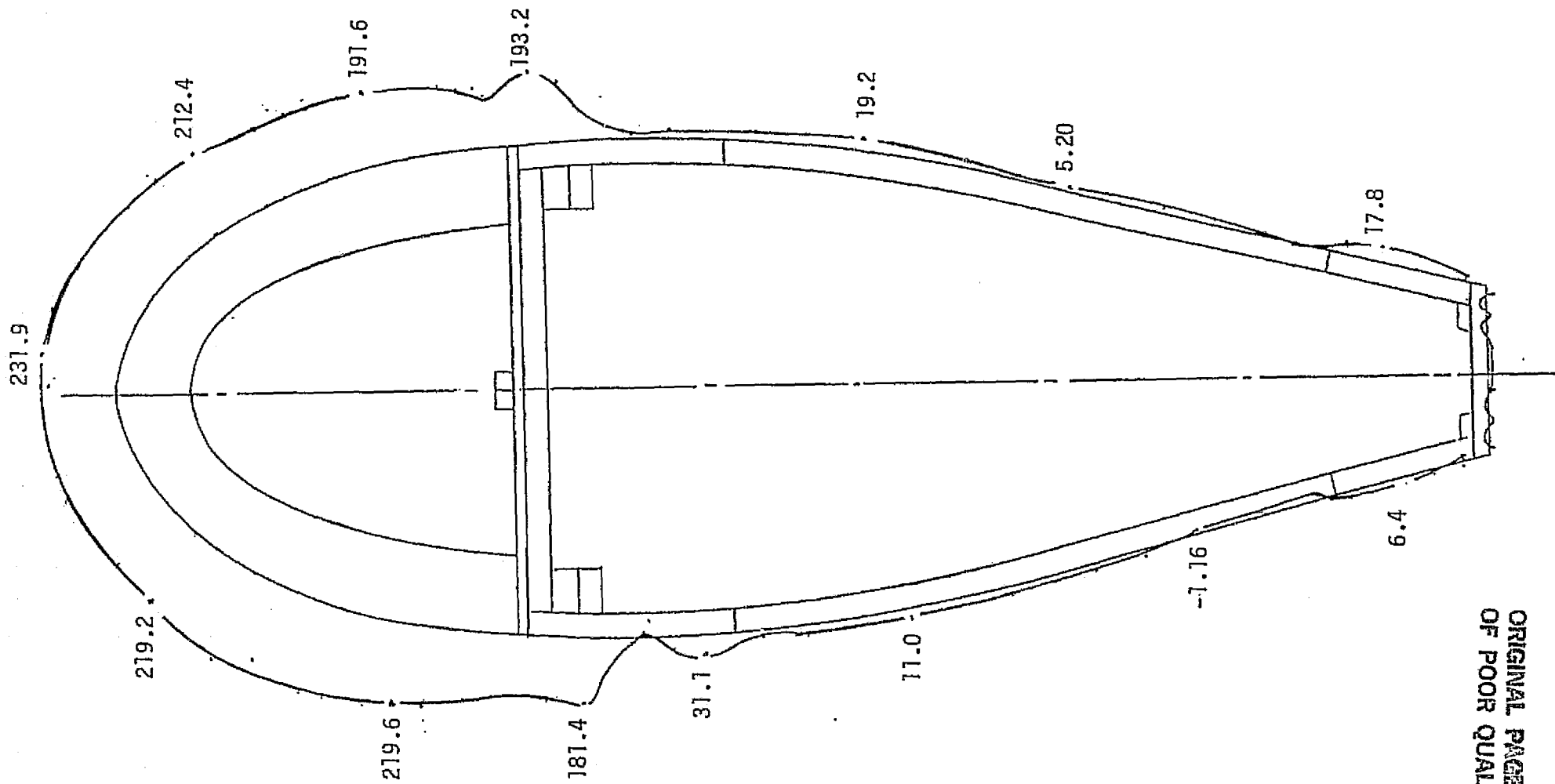

Figure 17. Thermal Stresses in z Direction,  
Blade Section in Vertical Position

ORIGINAL PAGE IS  
OF POOR QUALITY

ORIGINAL PAGE IS  
OF POOR QUALITY

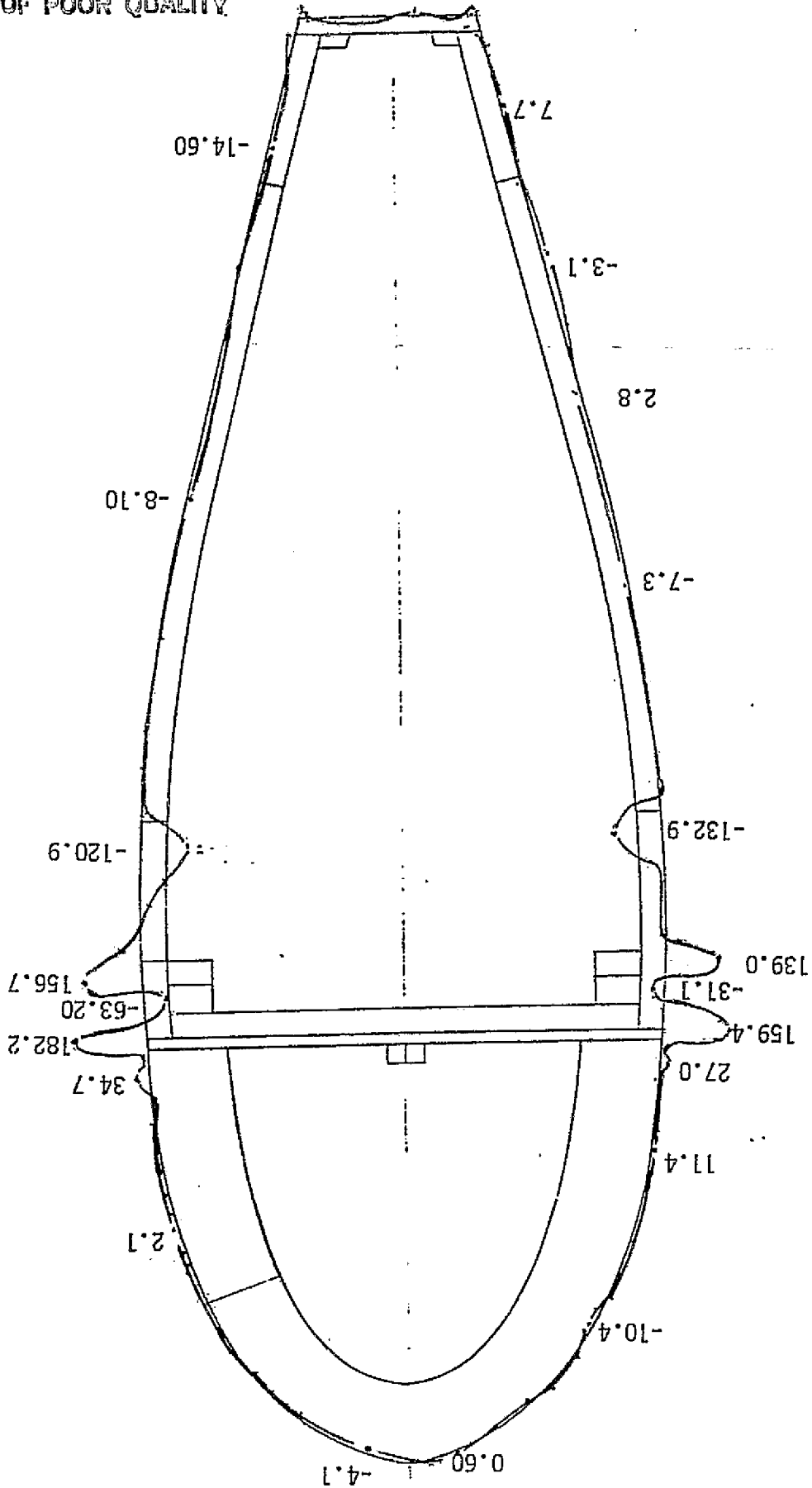

Figure 17a. Thermal Stresses in  $\eta$  Direction,  
Blade Section in Vertical Position

ORIGINAL PAGE IS  
OF POOR QUALITY

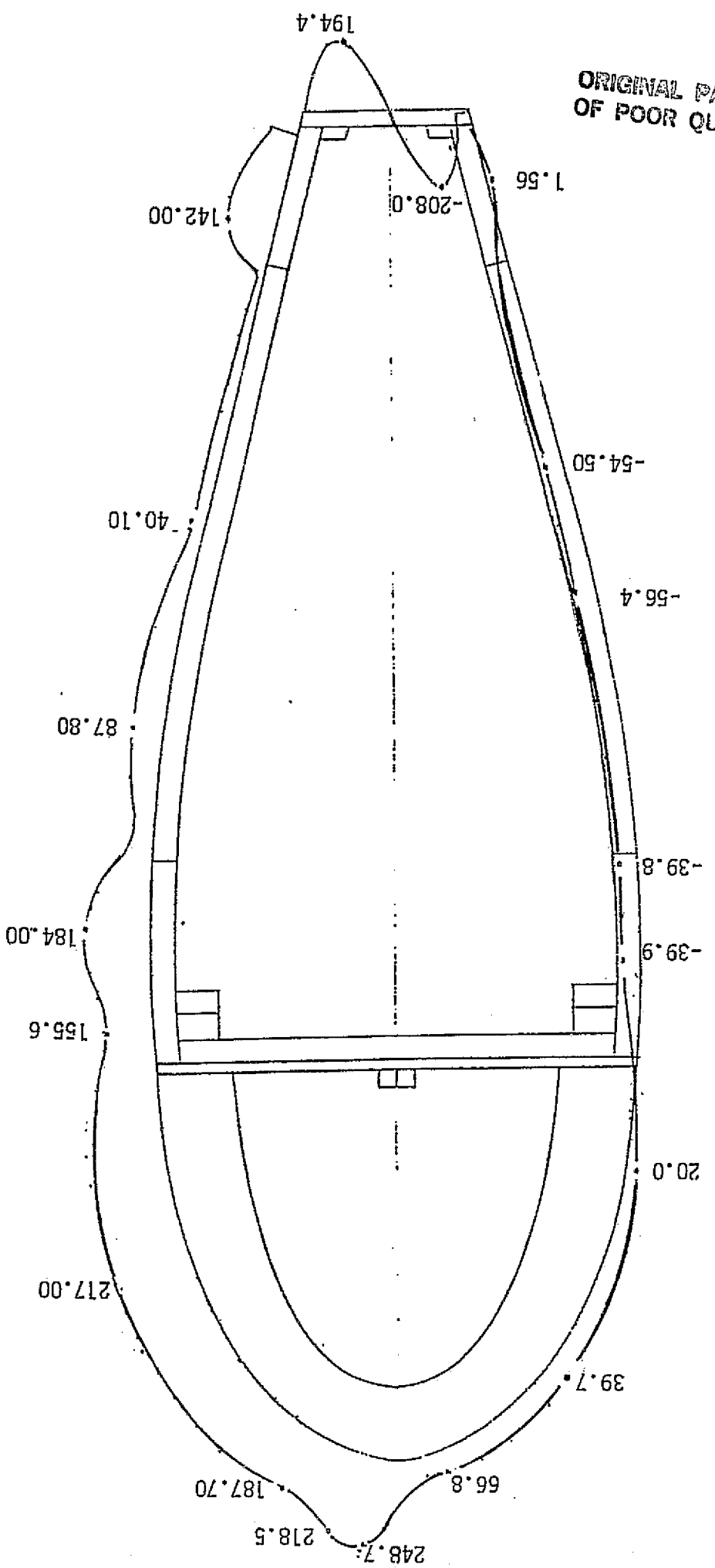

Figure 18. Finer-Mesh Analysis--Thermal Stresses in z Direction,  
Blade Section in Horizontal Position

## Appendix

### Computer Programs and Output Examples

(A) Grid Generation Program for Triangular Element	A1
(B) Bandwidth Reduction Program	A6
(C) Steady State Heat Conduction Program - Heat 1	A10
(D) Transcient State Heat Conduction Program - Heat 2	A22
(E) Changes on Grid Generation Program, Program (A), from Triangular Element to Rectangular Element	A37
(F) Changes on Bandwidth Reduction Program, Program (B), from Triangular Element to Rectangular Element	A39
(G) Transfer Program - Preparing Output Data from Programs (A) and (C) in the Form of Input Data of SAP IV	A42
(H) SAP IV Program for Thermal Stress Analysis when the Blade Section is in Horizontal Position - Rectangular Elements	A45
(I) Transformation of Stresses in Structural Axes of SAP IV to Stresses in Material Axes	A65
(J) Output Example 1: Temperature Distribution when the Blade Section is in Horizontal Position	A66
(K) Output Example 2: Thermal Stresses of Elements Along Boundary When the Blade Section is in Horizontal Position	A69



```

C|<====>
C|
C|          THIS PROGRAM GENERATES THE GRIDS FOR ANY GIVEN
C|          REGION
C|          TRAINGULAR FINITE ELEMENT
C|
C|<====>
C
C

```

```

DIMENSION NOO(2500,6),IRR(500)
DIMENSION XP(500),YP(500),XRG(9),YRG(9),N(8),NDN(8),XC(21,21),
1JT(74,4),ICOMP(4,4),NN(21,21),NNRB(74,4,21),XE(3000),YE(3000),
INE(3000),NR(4),LB(3),TITLE(10),IIRO(90),IICO(90),
2NOU(3000),NOUK(3000),YC(21,21)
REAL N
DATA NBW/0/,NB/0/,NEL/0/
DATA ICOMP/-1,1,1,-1,1,-1,-1,1,1,-1,-1,1,-1,1,1,-1/
DATA IN/5/,IO/6/
DATA IP /11/

```

```

C<====>
C
C          FINITE ELEMENT GRID GENERATION PROGRAM
C
C<====>
C

```

```

C TITLE=AN IDENTIFICATION STATEMENT
C INRG=THE NUMBER OF REGIONS ORIGINALLY DEFINED
C (CAN SPECIFY A MAX OF 20 REGIONS)
C INBP=THE NUMBER OF BOUNDARY POINTS OR GLOBAL POINTS ORIGINALLY DEF
C (MUST HAVE 8 IN EACH REGION)
C IPCH=0 IF ELEMENT DATA IS NOT TO BE PUNCHED
C IPCH=1 IF ELEMENT DATA IS TO BE PUNCHED
C XP(I)=THE X COORDINATE OF EACH OF THE ORIGINAL BOUNDARY POINTS
C YP(I)=THE Y COORDINATE OF EACH OF THE ORIGINAL BOUNDARY POINTS
C NRG=THE REGION NUMBER
C JT(NRG,J)=THE REGION CONNECTIVITY DATA
C NROWS=THE NUMBER OF ROWS OF NODES IN A REGION
C NCOL=THE NUMBER OF COLUMNS OF NODES IN A REGION
C (CAN SPECIFY A MAX OF 21 ROWS AND 21 COLUMNS IN A GIVEN REGION)
C NDN(I)=THE GLOBAL NODE NUMBERS ORIGINALLY DEFINED IN A GIVEN REGIO
C
C
C

```

```

100 FORMAT(10A4)
101 FORMAT(3I3)
102 FORMAT(8F6.2)
103 FORMAT(5I3,2A4)
1113 FORMAT(1X,5I10)
104 FORMAT(////1X,10A4//1X,18HGLOBAL COORDINATES //1X,
130HNUMBER X COORD Y COORD )
105 FORMAT(2X,I3,7X,F7.4,5X,F7.4)
106 FORMAT(//1X,17HCONNECTIVITY DATA/1X,41HREGION SIDE 1 2
1 3 4 )
107 FORMAT(2X,I3,14X,4(I2,5X))

```

```

108 FORMAT(11I3)
109 FORMAT(///1X,12H*** REGION ,I3,6H ***//10X,I2,5H ROWS,10X,I2
1,8H COLUMNS//10X,21HBOUNDARY NODE NUMBERS,10X,8I5)
110 FORMAT(//1X,19HREGION NODE NUMBERS/)
111 FORMAT(1X,20I5)
112 FORMAT(//5X,17HNEL NODE NUMBERS,9X,4HX(1),8X,4HY(1),8X,4HX(2),8X,
14HY(2),8X,4HX(3),8X,4HY(3) )
113 FORMAT(1X,5I5,3X,6F12.4)
114 FORMAT(4I4,6F14.5)
115 FORMAT(///1X,21HBANDWIDTH QUANTITY IS,I4,22H CALCULATED IN ELEMENT
1,I4)
READ(IN,100) TITLE
C READ(IN,129)NRA,SEL,RMO,RA,RMI,SHR
129 FORMAT(I3,5F10.5)
DO 400 IIM=1,1
NEL=0
NB=0
READ(IN,101) INRG,INBP,IPCH
WRITE(IO,116) INRG,INBP,IPCH
116 FORMAT(1X,3I3)
READ(IN,102) (XP(I),I=1,INBP)
WRITE(IO,102) (XP(I),I=1,INBP)
READ(IN,102) (YP(I),I=1,INBP)
WRITE(IO,102) (YP(I),I=1,INBP)
DO 1 I=1,INRG
READ(IN,103) NRG,(JT(NRG,J),J=1,4) ,IRR(I)
WRITE(IO,117) NRG,(JT(NRG,J),J=1,4),IRR(I)
117 FORMAT(//,1X,5I3,2A4)
1 CONTINUE
C WRITE(IO,104) TITLE
IF(IIM.EQ.2)GO TO 401
WRITE(IP,100)TITLE
C WRITE(IP,129)NRA,SEL,RMO,RA,RMI,SHR
401 WRITE(IO,105) (I,XP(I),YP(I),I=1,INBP)
C%% WRITE(IO,106)
DO 2 I=1,INRG
C%% WRITE(IO,107) I,(JT(I,J),J=1,4)
2 CONTINUE
C
C*****
C
C LOOP ON THE REGIONS IN ORDER TO GENERATE THE ELEMENTS
C
C*****
C
DO 22 KK=1,INRG
READ(IN,108) NRG,IIRO(KK),IICO(KK),(NDN(I),I=1,8)
WRITE(IO,109) NRG, IIRO(KK),IICO(KK),(NDN(I),I=1,8)
NROWS=IIRO(KK)
NCOL=IICO(KK)
C
C GENERATION OF THE ELEMENT NODAL COORDINATES
C
DO 3 I=1,8

```

ORIGINAL PAGE IS  
OF POOR QUALITY

```
II=NDN(I)
XRG(I)=XP(II)
3 YRG(I)=YP(II)
XRG(9)=XRG(1)
YRG(9)=YRG(1)
TR=NROWS-1
DETA=2.0/TR
TR=NCOL-1
DSI=2.0/TR
DO 4 I=1,NROWS
TR=I-1
ETA=1.0-TR*DETA
DO 4 J=1,NCOL
TR=J-1
SI=-1.0+TR*DSI
N(1)=-.25*(1.0-SI)*(1.0-ETA)*(SI+ETA+1.0)
N(2)=.50*(1.0-SI**2)*(1.0-ETA)
N(3)=.25*(1.0+SI)*(1.0-ETA)*(SI-ETA-1.0)
N(4)=.50*(1.0+SI)*(1.0-ETA**2)
N(5)=.25*(1.0+SI)*(1.0+ETA)*(SI+ETA-1.0)
N(6)=.50*(1.0-SI**2)*(1.0+ETA)
N(7)=.25*(1.0-SI)*(1.0+ETA)*(ETA-SI-1.0)
N(8)=.50*(1.0-SI)*(1.0-ETA**2)
XC(I,J)=0.0
YC(I,J)=0.0
DO 4 K=1,8
XC(I,J)=XC(I,J)+XRG(K)*N(K)
YC(I,J)=YC(I,J)+YRG(K)*N(K)
4 CONTINUE
```

```
C
C GENERATION OF THE REGION NODE NUMBERS
C
```

```
KN1=1
KS1=1
KN2=NROWS
KS2=NCOL
DO 11 I=1,4
NRT=JT(NRG,I)
IF(NRT.EQ.0.OR.NRT.GT.NRG) GO TO 11
DO 5 J=1,4
5 IF(JT(NRT,J).EQ.NRG) NRTS=J
K=NCOL
IF(I.EQ.2.OR.I.EQ.4) K=NROWS
JL=1
JK=ICOMP(I,NRTS)
IF(JK.EQ.-1) JL=K
DO 10 J=1,K
GO TO (6,7,8,9),I
6 NN(NROWS,J)=NNRB(NRT,NRTS,JL)
C WRITE(6,7000)NN(NROWS,J)
KN2=NROWS-1
GO TO 10
7 NN(J,NCOL)=NNRB(NRT,NRTS,JL)
C WRITE(6,7001)NN(J,NCOL)
```

ORIGINAL PAGE IS  
OF POOR QUALITY

```

7000  FORMAT(// ' STATION 2 ' , I9/)
7001  FORMAT(// ' STATION 1 ' , I9/)
7002  FORMAT(// ' STATION 3 ' , I9/)
7003  FORMAT(// ' STATION 4 ' , I9/)
      KS2=NCOL-1
      GO TO 10
      8 NN(1,J)=NNRB(NRT,NRTS,JL)
C     WRITE(6,7004)NRT,NRTS,JL
7004  FORMAT(// ' NRT=' ,I9/ ' NRTS = ' ,I9/ ' JL = ' ,I9)
C     WRITE(6,7002)NN(1,J)
      KN1=2
      GO TO 10
      9 NN(J,1)=NNRB(NRT,NRTS,JL)
C     WRITE(6,7003)NN(J,1)
      KS1=2
      10 JL=JL+JK
      11 CONTINUE
      IF(KN1.GT.KN2) GO TO 16
      IF(KS1.GT.KS2) GO TO 16
      DO 12 I=KN1,KN2
      DO 12 J=KS1,KS2
      NB=NB+1
C     WRITE(IO,777)NB
      12 NN(I,J)=NB
777  FORMAT(//// ' NB = ' ,I6)
C
C     STORAGE OF THE BOUNDARY NODE NUMBERS
C
      DO 13 I=1,NCOL
      NNRB(NRG,1,I)=NN(NROWS,I)
      13 NNRB(NRG,3,I)=NN(1,I)
      DO 14 I=1,NROWS
      NNRB(NRG,2,I)=NN(I,NCOL)
      14 NNRB(NRG,4,I)=NN(I,1)
C
C     OUTPUT OF THE REGION NODE NUMBERS
C
      WRITE(IO,110)
      DO 15 I=1,NROWS
      WRITE(IO,111) (NN(I,J),J=1,NCOL)
      15 CONTINUE
C
C     DIVISION INTO TRIANGULAR ELEMENTS
C
      16 CONTINUE
      WRITE(IO,112)
      K=1
      DO 17 I=1,NROWS
      DO 17 J=1,NCOL
      XE(K)=XC(I,J)
      YE(K)=YC(I,J)
      NE(K)=NN(I,J)
      17 K=K+1
      L=NROWS-1

```

ORIGINAL PAGE IS  
OF POOR QUALITY

```

DO 21 I=1,L
DO 21 J=2,NCOL
DIAG1=SQRT((XC(I,J)-XC(I+1,J-1))**2+(YC(I,J)-YC(I+1,J-1))**2)
DIAG2=SQRT((XC(I+1,J)-XC(I,J-1))**2+(YC(I+1,J)-YC(I,J-1))**2)
NR(1)=NCOL*I+J-1
NR(2)=NCOL*I+J
NR(3)=NCOL*(I-1)+J
NR(4)=NCOL*(I-1)+J-1
DO 21 IJ=1,2
NEL=NEL+1
IF((DIAG1/DIAG2).GT.1.02) GO TO 18
J1=NR(1)
J2=NR(IJ+1)
J3=NR(IJ+2)
GO TO 19
18 J1=NR(IJ)
J2=NR(IJ+1)
J3=NR(4)
19 LB(1)=IABS(NE(J1)-NE(J2))+1
LB(2)=IABS(NE(J2)-NE(J3))+1
LB(3)=IABS(NE(J1)-NE(J3))+1
DO 20 IK=1,3
IF(LB(IK).LE.NBW) GO TO 20
NBW=LB(IK)
NELBW=NEL
20 CONTINUE
IF( KK . NE . 46 ) GO TO 888
C WRITE(6,666) J3 , NE(J3)
666 FORMAT(///// ' J3 = ',I9, ' NE(J3) = ' , I9 )
888 CONTINUE
WRITE(IO,113) KK,NEL,NE(J1),NE(J2),NE(J3),XE(J1),YE(J1),XE(J2),
1 YE(J2),XE(J3),YE(J3)
IF(IPCH.EQ.0) GO TO 21
WRITE(IP,114) NEL,NE(J1),NE(J2),NE(J3),XE(J1),YE(J1),XE(J2),YE(J2)
1,XE(J3),YE(J3)
NOO(NEL,1)=KK
NOO(NEL,2)=NEL
NOO(NEL,3)=NE(J1)
NOO(NEL,4)=NE(J2)
NOO(NEL,5)=NE(J3)
NOO(NEL,6)=IRR(KK)
21 CONTINUE
22 CONTINUE
WRITE(IO,115) NBW,NELBW
DO 95 IB=1,1000
95 NOU(IB)=0
C%% WRITE(IO,35)
35 FORMAT(///,10X,'***** BOUNDARY NODE NUMBERS *****')
40 FORMAT(22I3)
DO 30 I=1,INRG
C%% WRITE(IO,34)I,IIRO(I),IICO(I)
34 FORMAT(/3X,'REGION',I2,3X,I2,1X,'ROWS',3X,I2,1X,'COLUMNS')
DO 30 II=1,4
NRT=JT(I,II)

```

ORIGINAL PAGE #  
OF POOR QUALITY

```

IF(NRT.GT.0)GO TO 30
K=IICO(I)
IF(II.EQ.2.OR.II.EQ.4)K=IIRO(I)
C%% WRITE(IO,33)II,(NNRB(I,II,III),III=1,K)
33 FORMAT(1X,'SIDE',I2,/,3X,15I4)
DO 90 III=1,K
NII=NNRB(I,II,III)
90 NOU(NII)=1
30 CONTINUE
IKK=1
DO 91 IB=1,700
IF(NOU(IB).EQ.0)GO TO 91
NOUK(IKK)=IB
IKK=IKK+1
91 CONTINUE
IKK=IKK-1
WRITE(IP,94)IKK
94 FORMAT(/50X,I4,46X)
WRITE(IP,92)(NOUK(I),I=1,IKK)
C%% WRITE(IO,93)(NOUK(I),I=1,IKK)
92 FORMAT(20I5)
93 FORMAT(15I4)
DO 333 I=1,NEL
WRITE(IP,575)( NOO(I,J),J=1,6)
WRITE(15,575)( NOO(I,J),J=1,6)
C%% WRITE(IO,575)( NOO(I,J),J=1,6)
333 CONTINUE
575 FORMAT(5I5,A4)
576 FORMAT(10X,5I10,10X,A10)
400 CONTINUE
STOP
END

/**
/**=====c!
/** B A N D W I D T H R E D U C T I O N P R O G R A M c!
/**=====c!
/**=====c!
/**=====c!
C
COMMON/AAA/ NOO(2500,6),NTT(80)
COMMON/BBB/ X(3,2000),Y(3,2000),NBO(1000),TITLE(10)
COMMON/CCC/ NODES,LEMENTS,JT(12000),MEMJT(24000),JMEM(3000),
$JNT(3000),IDIFF,MINMAX
DATA IN/11/,IO/6/,IP/12/

C
READ (IN,100)TITLE
WRITE(IP,100)TITLE
100 FORMAT(10A4)
122 FORMAT(I3,5F10.5)
J =1
JJ=0
150 READ(IN,17)(JT(3000*(I-1)+J),I=1,3),(X(I,J),Y(I,J),I=1,3)
JT(9000+J)=0

```

```

NODES=MAXO(JT(J),JT(3000+J),JT(6000+J),JJ)
JJ=NODES
IF(JT(3000+J).EQ.0)GO TO 152
J=J+1
GO TO 150
152 LMENTS=J-1
    NODES=JJ
    12  FORMAT(//,5X,15HNUMBER OF NODES,I4,15X,
1'NUMBER OF ELEMENTS ',I4,/)
        WRITE(IO,105)TITLE
105  FORMAT(//,1X,20A4,/)
        WRITE(IO,12)NODES,LMENTS
        WRITE(IO,13)
13   FORMAT(//,3X,18HNEL JT1 JT2 JT3,10X,4HX(1),8X,
$4HY(1),8X,4HX(2),8X,4HY(2),8X,4HX(3),8X,4HY(3))
17   FORMAT(4X,3I4,6F14.5)
        DO 10 J=1,LMENTS
C    WRITE(IO,11)J,(JT(3000*(I-1)+J),I=1,3),(X(I,J),Y(I,J),I=1,3)
11   FORMAT(1X,4I5,3X,6F12.4)
10   CONTINUE
        READ(IN,300)IBO
300  FORMAT(50X,I4,46X)
        READ(IN,301)(NBO(I),I=1,IBO)
        WRITE(IO,302)
        DO 333 I=1,LMENTS
        READ (IN,444)(NOO(I,J),J=1,6)
333  CONTINUE
C    WRITE(IO,303)(NBO(I),I=1,IBO)
302  FORMAT(//,' *** BOUNDARY NUMBERS ***')
        CALL SETUP
        NTBAN=IDIFF+1
        WRITE(IO,202)NTBAN
202  FORMAT(//,2X,25HTHE ORIGINAL BANDWIDTH IS,I4,/)
        CALL OPTNUM
        IF(IDIFF.LE.MINMAX)GO TO 115
        MIBAN=MINMAX+1
        WRITE(IO,198)
198  FORMAT(1H1///,1X,5(3HOLD,3X,3HNEW,7X),/,1X,
$5(4HNODE,2X,4HNODE,6X))
        WRITE(IO,200)(J,JNT(J),J=1,NODES)
        WRITE(7,200)(J,JNT(J),J=1,NODES)
200  FORMAT(5(I5,1X,I5,5X))
        WRITE(IO,13)
        DO 180 J=1,LMENTS
        DO 555 II=1,3
        III=II+2
555  NOO(J,III)=JNT(JT(3000*(II-1)+J))
C
180  CONTINUE
C    WRITE(IO,11)J,(JNT(JT(3000*(I-1)+J)),I=1,3),
C    $(X(I,J),Y(I,J),I=1,3)
        WRITE(IO,201)MIBAN
201  FORMAT(//,2X,'THE NEW BANDWIDTH IS',I3,/)
        WRITE(IP,310)NODES,LMENTS,MIBAN

```

ORIGINAL PAGE IS  
OF POOR QUALITY

```

DO 181 J=1,LMENTS
181 WRITE(IP,18)J,(JNT(JT(3000*(I-1)+J)),I=1,3),(X(I,J),
$Y(I,J),I=1,3)
18 FORMAT(4I5,6F10.4)
WRITE(IO,302)
WRITE(IP,300)IBO
WRITE(IP,301)(JNT(NBO(I)),I=1,IBO)
C WRITE(IO,303)(JNT(NBO(I)),I=1,IBO)
303 FORMAT(15I4)
GO TO 117
115 CONTINUE
WRITE(IO,101)
117 CONTINUE
101 FORMAT(///,2X,'THE ORIGINAL BANDWIDTH IS MINIMUM')
WRITE(IP,310)NODES,LMENTS,NTBAN
310 FORMAT(3I5)
DO 190 J=1,LMENTS
190 WRITE(IP,18)J,(JT(3000*(I-1)+J),I=1,3),
1(X(I,J),Y(I,J),I=1,3)
WRITE(IP,300)IBO
WRITE(IP,301)(NBO(I),I=1,IBO)
301 FORMAT(20I5)
C-----c!
444 FORMAT(5I5,A4)
LLL = NOO(1,6)
C
LOL=0
MMM=0
NNN=1
DO 666 II=1,LMENTS
IF ( LLL.EQ.NOO(II,6) )GO TO 1888
NNN=NNN-1
LOL=LOL+NNN
MMM=MMM+1
NTT(MMM)=LOL
C WRITE(IO,888) NNN,NTT(MMM)
LLL=NOO(II,6)
NNN=1
1888 CONTINUE
C WRITE(IO,777)NNN,(NOO(II,J),J=1,6),(X(I,II),Y(I,II),I=1,3)
IF (II. NE . LMENTS) GO TO 1889
LOL=LOL+NNN
MMM=MMM+1
NTT(MMM)=LOL
C WRITE(IO,888) NNN,NTT(MMM)
1889 NNN=NNN+1
666 CONTINUE
C
777 FORMAT(4X,6I6,4X,A8,6F12.5)
888 FORMAT(//', NUMBER OF ELEMENTS IN THIS REGION =' ,2I10/)
400 CONTINUE
C
C-----
C-----

```



ORIGINAL PAGE IS  
OF POOR QUALITY

STOP  
END  
SUBROUTINE OPTNUM

C  
DIMENSION NEWJT(3000),JOINT(3000)  
COMMON/AAA/ NOO(1500,6),NTT(80)  
COMMON/BBB/ X(3,2000),Y(3,2000),NBO(1000),TITLE(10)  
COMMON/CCC/ NODES,LMENTS, JT(12000),MEMJT(24000),JMEM(3000),  
\$JNT(3000),IDIFF,MINMAX  
MINMAX=IDIFF  
DO 60 IK=1,NODES  
DO 20 J =1,NODES  
JOINT(J)=0  
20 NEWJT(J)=0  
MAX=0  
I=1  
NEWJT(I)=IK  
JOINT(IK)=1  
K=1  
30 K4=JMEM(NEWJT(I))  
IF(K4.EQ.0)GO TO 45  
JSUB=(NEWJT(I)-1)\*8  
DO 40 JJ=1,K4  
K5=MEMJT(JSUB+JJ)  
IF(JOINT(K5).GT.0)GO TO 40  
K=K+1  
NEWJT(K)=K5  
JOINT(K5)=K  
NDIFF=IABS(I-K)  
IF(NDIFF.GE.MINMAX) GO TO 60  
IF(NDIFF.GT.MAX)MAX=NDIFF  
40 CONTINUE  
IF(K.EQ.NODES) GO TO 50  
45 I=I+1  
GO TO 30  
50 MINMAX=MAX  
DO 55 J=1,NODES  
55 JNT(J)=JOINT(J)  
60 CONTINUE  
RETURN  
END  
SUBROUTINE SETUP  
COMMON/AAA/ NOO(1500,6),NTT(80)  
COMMON/BBB/ X(3,2000),Y(3,2000),NBO(1000),TITLE(10)  
COMMON/CCC/ NODES,LMENTS, JT(12000),MEMJT(24000),JMEM(3000),  
\$JNT(3000),IDIFF,MINMAX  
IDIFF=0  
DO 15 J=1,NODES  
15 JMEM(J)=0  
DO 60 J=1,LMENTS  
DO 50 I=1,4  
JNTI=JT(3000\*(I-1)+J)  
IF(JNTI.EQ.0) GO TO 60  
JSUB=(JNTI-1)\*8





ORIGINAL PAGE IS  
OF POOR QUALITY

```
C
C      NE : TOTAL NUMBER OF ELEMENTS
C
C..IN:12 .....MAIN LOOP .....
      T(1)=10.
      T(2)=10.
      T(3)=10.
      DO 180 I=1,NE
      H(I)=0.001D0
      ISIDEH(I,1)=0
      ISIDEH(I,2)=0
180   CONTINUE
      DO 178 JJ=1,90
      N=2*JJ
      ISIDEH(N,1)=2
      ISIDEH(N,2)=0
      H(N)=5.D0
178   CONTINUE
C
C      BIRCH LOOP.....
C
      DO 1001 J=1,280
      KZETA(J)=.0924
      KETA(J)=.0836
1001  CONTINUE
C
C      DOUGLAS FIR LOOP .....
C
      DO 1002 J=281, 302
      KZETA(J)=.0754
      KETA(J)=.06820
1002  CONTINUE
      DO 1010 J=351,638
      KZETA(J)=.0754
      KETA(J)=.0682
1010  CONTINUE
      DO 1015 J=687,752
      KZETA(J)=.0754
      KETA(J)=.0682
1015  CONTINUE
C
C      PAPER LOOP.....
C
      DO 1020 J=303,350
      KZETA(J)=.011161
      KETA(J)=.011161
1020  CONTINUE
      DO 1111 J =639,686
      KZETA(J)=.011161
      KETA(J)=.011161
1111  CONTINUE
C
C      LOOP ON THE REGIONS.....
C
```

ORIGINAL PAGE IS  
OF POOR QUALITY

DO 7 KK=1,NE

IF(KK.GE.1.AND.KK.LE.22) BETA(KK)=-.2618  
IF(KK.GE.23.AND.KK.LE.34) BETA(KK)=-.15707  
IF(KK.GE.35.AND.KK.LE.58) BETA(KK)=0.0  
IF(KK.GE.59.AND.KK.LE.66) BETA(KK)=.38394  
IF(KK.GE.67.AND.KK.LE.74) BETA(KK)=.17452  
IF(KK.GE.75.AND.KK.LE.82) BETA(KK)=1.22164  
IF(KK.GE.83.AND.KK.LE.90) BETA(KK)=.69808  
IF(KK.GE.91.AND.KK.LE.98) BETA(KK)=2.4433  
IF(KK.GE.99.AND.KK.LE.106) BETA(KK)=1.91972  
IF(KK.GE.107.AND.KK.LE.114) BETA(KK)=2.9668  
IF(KK.GE.115.AND.KK.LE.122) BETA(KK)=2.7574  
IF(KK.GE.123.AND.KK.LE.146) BETA(KK)=3.14136  
IF(KK.GE.147.AND.KK.LE.158) BETA(KK)=3.29843  
IF(KK.GE.159.AND.KK.LE.202) BETA(KK)=3.40314  
IF(KK.GE.203.AND.KK.LE.214) BETA(KK)=3.29843  
IF(KK.GE.215.AND.KK.LE.230) BETA(KK)=3.14136  
IF(KK.GE.231.AND.KK.LE.246) BETA(KK)=0.0  
IF(KK.GE.247.AND.KK.LE.258) BETA(KK)=-.15707  
IF(KK.GE.259.AND.KK.LE.326) BETA(KK)=-.2618  
IF(KK.GE.327.AND.KK.LE.350) BETA(KK)=-.15707  
IF(KK.GE.351.AND.KK.LE.430) BETA(KK)=0.0  
IF(KK.GE.431.AND.KK.LE.438) BETA(KK)=.38394  
IF(KK.GE.439.AND.KK.LE.446) BETA(KK)=.17452  
IF(KK.GE.447.AND.KK.LE.454) BETA(KK)=.38394  
IF(KK.GE.455.AND.KK.LE.462) BETA(KK)=.17452  
IF(KK.GE.463.AND.KK.LE.470) BETA(KK)=1.2216  
IF(KK.GE.471.AND.KK.LE.478) BETA(KK)=.69808  
IF(KK.GE.479.AND.KK.LE.486) BETA(KK)=1.2216  
IF(KK.GE.487.AND.KK.LE.494) BETA(KK)=.69808  
IF(KK.GE.495.AND.KK.LE.502) BETA(KK)=2.4433  
IF(KK.GE.503.AND.KK.LE.510) BETA(KK)=1.91972  
IF(KK.GE.511.AND.KK.LE.518) BETA(KK)=2.4433  
IF(KK.GE.519.AND.KK.LE.526) BETA(KK)=1.91972  
IF(KK.GE.527.AND.KK.LE.534) BETA(KK)=2.9668  
IF(KK.GE.535.AND.KK.LE.542) BETA(KK)=2.7574  
IF(KK.GE.543.AND.KK.LE.550) BETA(KK)=2.9668  
IF(KK.GE.551.AND.KK.LE.558) BETA(KK)=2.7574  
IF(KK.GE.559.AND.KK.LE.638) BETA(KK)=3.14136  
IF(KK.GE.639.AND.KK.LE.662) BETA(KK)=3.29843  
IF(KK.GE.663.AND.KK.LE.708) BETA(KK)=3.40314  
IF(KK.GE.709.AND.KK.LE.752) BETA(KK)=0.0

READ(IN,1) NEL,NS,X(1),Y(1),X(2),Y(2),X(3),Y(3)

WRITE(6,121) NEL,NS,X(1),Y(1),X(2),Y(2),X(3),Y(3),BETA(KK)

C WRITE(7,122) NEL,NS,X(1),Y(1),X(2),Y(2),X(3),Y(3),BETA(KK)

121 FORMAT(4I5,7F10.4)

122 FORMAT(4I4,7F8.4)

C

C DIMENSION IN FEET...

X1=X(1)

X2=X(2)

X3=X(3)

Y1=Y(1)

```

      Y2=Y(2)
      Y3=Y(3)
C
      X ( 1 )= X(1) /12.0D0
      X ( 2 )= X(2) /12.0D0
      X ( 3 )= X(3) /12.0D0
      Y ( 1 )= Y(1) /12.0D0
      Y ( 2 )= Y(2) /12.0D0
      Y ( 3 )= Y(3) /12.0D0
C
      T1=T(1)
      T2=T(2)
      T3=T(3)
1107  FORMAT(1H1,///20X
      * , ' T(1) T(2) T(3) '
      * , ' ISIDE(1) ISIDE(2) ' )
1108  FORMAT(' ',20X
      * , ' ----- '
      * , ' ----- ' )
C      WRITE(IO,11)T, ISIDEH(KK,1), ISIDEH(KK,2)
C
C
C
C      TOLD(NS(1))=T(1)
C      TOLD(NS(2))=T(2)
C      TOLD(NS(3))=T(3)
C      H : CONVECTION COEFFICIENT
C      WRITE(6,5152)KK,NS(1),NS(2),NS(3),TOLD(NS(1)),TOLD(NS(2)),
C      1 TOLD(NS(3)), H(KK), (ISIDE(JJ),JJ=1,2),
C      1 X1,Y1,X2,Y2,X3,Y3,NOT(KK,1),NOT(KK,6)
5152  FORMAT(' ',4I5,3F10.3,F5.0,2I2,6F8.4,I5,A8)
C
      T(1)=T1
      T(2)=T2
      T(3)=T3
C
C ECHO THE INPUT.....
C      WRITE(IO,23) NEL,NS,X(1),Y(1),X(2),Y(2),X(3),Y(3)
C      * , HH,RHO,CP, ISIDE,T
23  FORMAT(1H0,I5,1X,3I5,2X,6(1X,F8.4),2X,2F5.0,F6.3,2X,2I3,
      * 2X,3F6.0)
C      CALCULATION OF THE CONDUCTION MATRIX
C
C      NPT (NE,3) : ARRAY STORES THE NODE NUMBERS FOR EACH ELEMENT
      NPT(KK,1) = NS(1)
      NPT(KK,2) = NS(2)
      NPT(KK,3) = NS(3)
      R(NS(1)) = X(1)
      R(NS(2)) = X(2)
      R(NS(3)) = X(3)
      Z(NS(1)) =Y(1)
      Z(NS(2)) =Y(2)
      Z(NS(3)) =Y(3)
      AREA(KK)=(X(2)*Y(3)-X(2)*Y(1)+X(3)*Y(1)-X(3)*Y(2)

```



```

666      FORMAT(' NODE NO.',7X,'TEMPERATURE IN DEGREE F',/)
        WRITE(6,787)(I,F(I,1),I=1,NP)
787      FORMAT( 2X,I5,10X,F15.8)
        WRITE(7,777)(F(I,1),I=1,NP)
777      FORMAT(9F8.4)
C
C
        STOP
        END
        SUBROUTINE FORMTK (NE,NP,NBW)
C.....*****
C..... FORM BANDED THERMAL CONDUCTANCE MATRIX
C
        IMPLICIT REAL*4(A-H,O-Z)
        REAL*8 KZETA,KETA,RHOCP,BETA
        REAL*8 BI,BJ,BK,CI,CJ,CK,COF,CON1,CON2,CON3
        REAL*8 RBAR,CON,LG,RCTL,ELKT(3,3),THSTF(482,35)
        REAL*8 A00,A11,A22,B00,B11,B22,C00,THCAP(482,35)
        REAL*8 Z(482),R(482),AREAE(752),X(3),Y(3),DDT,TIME,ATIM,P
        COMMON/CONVEN/H(752),ISIDEH(752,2)
C
        COMMON / SOLID / Z,R,AREAE,THSTF
1      ,THCAP,NPT(752,3)
        REAL*8  ZZ(482,35),F,B,FF,EF
        COMMON / SOLVEQ / F(482,1),EF(752)
        COMMON /CONT/ KZETA(752),KETA(752),RHOCP(752),BETA(752)
C
C
C..... INITIALIZE GLOBAL THERMAL STIFFNESS MATRIX
        .IN=5
        IO=6
        DO 120 J=1,NBW
        DO 110 I=1,NP
            THSTF(I,J) = 0.D0
110     CONTINUE
120     CONTINUE
C
C
130     NBAND = 0
        DO 899 J=1,NE
C         WRITE(6,788)KZETA(J),KETA(J),BETA(J)
788     FORMAT(3X,3F20.9)
899     CONTINUE
C
C         WRITE(6,7776)
7776    FORMAT(' CONDUCTION MATRIX ELEMENTS ARE ',/)
        DO 230 N=1,NE
C<<<<<<<<<<<<<<<<<<<<<<<<<<<<<<<<<<<<<<<<<<<<<<<<<<<<<<<<<<<<<<<<<<<<<<<<<<<
C
        II = NPT(N,1)
        JJ = NPT(N,2)
        KK = NPT(N,3)
        BI = Z(JJ)-Z(KK)

```



ORIGINAL PAGE IS  
OF POOR QUALITY

```

BJ = Z(KK)-Z(II)
BK = Z(II)-Z(JJ)
CI = R(KK)-R(JJ)
CJ = R(II)-R(KK)
CK = R(JJ)-R(II)
X(1) =R(II)
X(2) =R(JJ)
X(3) =R(KK)
Y(1) =Z(II)
Y(2) =Z(JJ)
Y(3) =Z(KK)
C WRITE(6,555)X(1),X(2),X(3),Y(1),Y(2),Y(3)
555 FORMAT(2X,6F12.6)
ALPHA=BETA(N)
C CON1=(KZETA(N)*(COS(BETA(N))))**2+KETA(N)*(SIN(BETA(N))))**2)
C 1/(4.*AREAE(N))
C CON2=(KZETA(N)-KETA(N))*SIN(2.*BETA(N))/(4.*AREAE(N))
C CON3=(KZETA(N)*(SIN(BETA(N))))**2+KETA(N)*(COS(BETA(N))))**2)
C 1/(4.*AREAE(N))
CON1=(KZETA(N)*(COS(ALPHA))))**2+KETA(N)*(SIN(ALPHA))))**2)
1/(4.*AREAE(N))
CON2=(KZETA(N)-KETA(N))*SIN(2.*ALPHA)/(4.*AREAE(N))
CON3=(KZETA(N)*(SIN(ALPHA))))**2+KETA(N)*(COS(ALPHA))))**2)
1/(4.*AREAE(N))
C
C WRITE(6,7999)CON1,CON2,CON3,AREAE(N)
7999 FORMAT(2X,3F10.3,2X,F10.7)
ELKT(1,1) = (BI**2)*CON1+(CI**2)*CON3+(BI*CI)*CON2
ELKT(1,2) = (BI*BJ)*CON1+(CI*CJ)*CON3+(BI*CJ)*CON2
ELKT(1,3) = (BI*BK)*CON1+(CI*CK)*CON3+(BI*CK)*CON2
ELKT(2,1) = (BI*BJ)*CON1+(CJ*CI)*CON3+(BJ*CI)*CON2
ELKT(2,2) = (BJ**2)*CON1+(CJ**2)*CON3+(BJ*CJ)*CON2
ELKT(2,3) = (BJ*BK)*CON1+(CJ*CK)*CON3+(BJ*CK)*CON2
ELKT(3,1) = (BK*BI)*CON1+(CK*CI)*CON3+(BK*CI)*CON2
ELKT(3,2) = (BK*BJ)*CON1+(CK*CJ)*CON3+(BK*CJ)*CON2
ELKT(3,3) = (BK**2)*CON1+(CK**2)*CON3+(BK*CK)*CON2
WRITE(6,*)N,H(N),( ISIDEH(N,J1),J1=1,2)
DO 10 IQ=1,2
C WRITE(6,7805)N,( ISIDEH(N,J1),J1=1,2)
7805 FORMAT(' SIDE EXPOSED ',3I10)
IF ( ISIDEH(N,IQ) . LE . 0 ) GO TO 240
JQ = ISIDEH (N,IQ)
C WRITE(10,12) JQ,N
12 FORMAT(1H0,' INSIDE',I3,3X,' OF ELEMENT',I5)
KQ = JQ +1
IF ( JQ.EQ . 3) KQ=1
LG = DSQRT((X(KQ)-X(JQ))**2+(Y(KQ)-Y(JQ))**2)
HL =H(N)*LG/6.
WRITE(6,*) N,H(N),LG,HL
IF(JQ.EQ.1) GO TO 20
IF(JQ.EQ.2) GO TO 30
IF(JQ.EQ.3) GO TO 40
GO TO 10
20 ELKT(1,1)= ELKT(1,1)+HL * 2.

```

ORIGINAL PAGE IS  
OF POOR QUALITY

```
ELKT(2,2)= ELKT(2,2)+HL * 2.
ELKT(1,2)= ELKT(1,2)+HL
ELKT(2,1)=ELKT(2,1)+HL
GO TO 10

C
30 ELKT(2,2)= ELKT(2,2)+HL*2.
ELKT(3,3)= ELKT(3,3)+HL*2.
ELKT(2,3)= ELKT(2,3)+HL
ELKT(3,2)=ELKT(3,2)+HL
GO TO 10

C
40 ELKT(1,1)= ELKT(1,1)+HL * 2.
ELKT(3,3)= ELKT(3,3)+HL * 2.
ELKT(1,3)= ELKT(1,3)+HL
ELKT(3,1)=ELKT(3,1)+HL
10 CONTINUE

C
C WRITE(10,2000)N,II, JJ, KK, X(1), Y(1), X(2), Y(2), X(3), Y(3), CONDTY(N),
C 1AREAE(N), RBAR, CON, ELKT(1,1), ELKT(1,2), ELKT(1,3), ELKT(2,2),
C 2ELKT(2,3), ELKT(3,3)
2000 FORMAT(1H0,4I5,8G11.4, /21X,8G11.4)
C-----c!
C STORE IN GLOBAL MATRIX c!
C-----c!
240 CONTINUE
C WRITE( IO,266)N,X(1),Y(1),X(2),Y(2),X(3),Y(3),AREAE(N),NBAND
266 FORMAT(1H0,I5,6(1X,F8.4),2X,D14.7,2X,I5)
C WRITE(6,277)N,(( ELKT(I,J),J=1,3),I=1,3)
277 FORMAT(' ',I5/ 3(3F25.6/))
DO 220 LL=1,3
I=NPT(N,LL)
DO 210 MM=1,3
J=NPT(N,MM)-1+18
THSTF(I,J) =THSTF(I,J)+ELKT(LL,MM)
C WRITE(6,7543)I,J,II,JH,NPT(N,J),NPT(N,I)
7543 FORMAT(' ',6I8, '*****')
IF (J.GT.NBAND) NBAND=J
210 CONTINUE
220 CONTINUE
230 CONTINUE
C WRITE(6,5050)((THSTF(I,J),J=1,NBW),I=15,20)
5050 FORMAT(7G11.5)
C
C WRITE (6,200) NBAND
200 FORMAT(1H0,' NBAND= ',I5)
C
C..... END OF PROGRAM
C
C
RETURN
END
SUBROUTINE FORMTF(NE,NP,NBW)
C
C FORM THERMAL FORCE VECTOR
```

ORIGINAL PAGE IS  
OF POOR QUALITY

```
C
C
C
REAL*8 ELF(3),LG,RCTL,COF,THCAP(482,35),THSTF(482,35)
REAL*8 Z(482),R(482),AREAE(752),X(3),Y(3),DDT
COMMON/CONVEN/H(752),ISIDEH(752,3)
C
COMMON / SOLID / Z,R,AREAE,THSTF
1 ,THCAP,NPT(752,3)
REAL*8 ZZ(482,35),F,EF,B,ELF1,ELF2,ELF3,FF,HLL
COMMON / SOLVEQ / F(482,1),EF(752)
REAL *8 KZETA,KETA,RHOCP,BETA
COMMON /CONT/ KZETA(752),KETA(752),RHOCP(752),BETA(752)
REAL *8 QR(752),HL(752)
C
DATA PI/3.14159265D0/
      IO=6
      TINF = 0.D0
C
C
C
FOR EACH ELEMENT ,FORM THERMAL FORCE VECTOR
C
      WRITE(6,9999)
9999   FORMAT(' FORCE VECTORS ARE ',/)
      DO 110 I=1,NE
      EF(I) = 0.D0
      QR(I)=0.0
110    CONTINUE
      DO 1070 J=1,45
      N=2*J
      QR(N)=326.0
1070   CONTINUE
      DO 230 N=1,NE
      ELF(1)=0.D0
      ELF(2)=0.D0
      ELF(3)=0.D0
      II=NPT(N,1)
      JJ=NPT(N,2)
      KK=NPT(N,3)
      CI = R(KK)-R(JJ)
      CJ = R(II)-R(KK)
      CK = R(JJ)-R(II)
      X(1)=R(II)
      X(2)=R(JJ)
      X(3)=R(KK)
      Y(1)=Z(II)
      Y(2)=Z(JJ)
      Y(3)=Z(KK)
      DO 10 IQ=1,2
      IF(ISIDEH(N,IQ).LE.0)GO TO 240
      JQ=ISIDEH (N,IQ)
      KQ=JQ+1
      IF(JQ.EQ.3) KQ=1
      LG=DSQRT((X(KQ)-X(JQ))**2+ (Y(KQ)-Y(JQ))**2)
C
      WRITE(6,999)LG
```

```

999      FORMAT(2X,F10.5)
        HL(N)=QR(N)+H(N)*TINF
        IF ( JQ.EQ.1)GO TO 20
        IF ( JQ.EQ.2)GO TO 30
        IF (JQ .EQ.3)GO TO 40
        GO TO 240
20      ELF(1) =HL(N)*LG*.5+ELF(1)
        ELF(2) =HL(N)*LG*.5+ELF(2)
        GO TO 10
30      ELF(2) =HL(N)*LG*.5+ELF(2)
        ELF(3) =HL(N)*LG*.5+ELF(3)
        GO TO 10
40      ELF(1) =HL(N)*LG*.5+ELF(1)
        ELF(3) =HL(N)*LG*.5+ELF(3)
10      CONTINUE
C
240     EF(II)= EF(II)+ELF(1)
        EF(JJ)=EF(JJ) +ELF(2)
        EF(KK)=EF(KK) +ELF(3)
707    FORMAT(' ',2I8,5F15.5)
C      IF(EF(II).EQ.0) GO TO 50
C      IF(EF(JJ).EQ.0) GO TO 50
C      IF(EF(KK).EQ.0) GO TO 50
C      GOTO 230
C50    WRITE(6,1999)N,II,JJ,KK,EF(II),EF(JJ),EF(KK)
1999   FORMAT(1H0,4I6,2X,3F10.4)
230    CONTINUE
C      WRITE(IO,2000)(EF(I),I=1,NP)
2000   FORMAT(2X,F10.4)
C      WRITE(IO,1000)
1000   FORMAT(1H0,' LEAVING FORMTF          IN TDHEAT ...1B')
        RETURN
        END
SUBROUTINE ASSMBL (NP,NBW,ZZ)
C..... ASSEMBLE MATRICES FOR RECURRENCE FORMULAS
      REAL *8 Z(482),R(482),AREAE(752)
      REAL*8 DDT,DT,THSTF(482,35),THCAP(482,35)
      COMMON/CONVEN/H(752),ISIDEH(752,2)
C
      COMMON / SOLID / Z,R,AREAE,THSTF
1      ,THCAP,NPT(752,3)
      REAL*8 ZZ(482,35),F,EF,B,FF(15,1)
      COMMON / SOLVEQ / F(482,1),EF(752)
      REAL *8 KZETA,KETA,RHOCP,BETA
      COMMON /CONT/ KZETA(752),KETA(752),RHOCP(752),BETA(752)

      DO 150 I=1,NP
C
C..... COEFFICIENT MATRIX
C
      DO 110 J=1,NBW
        ZZ(I,J) = THSTF(I,J)
110    CONTINUE
C      WRITE(6,2000) (ZZ(I,J),J=12,26)

```

ORIGINAL PAGE IS  
OF POOR QUALITY

```
2000 FORMAT(' ',6E9.5)
C
G..... THERMAL LOAD VECTOR
C
      F(I,1) = EF(I)
C
      150 CONTINUE
C      WRITE(6,1313)(F(I,1),I=1,NP)
1313  FORMAT(' ',G11.5)
      1001 FORMAT (1H ,I3,11G11.5)
C
C..... END OF PROGRAM
C
      RETURN
      END
```



ORIGINAL PAGE IS  
OF POOR QUALITY

```
WRITE(IO,1102) NP,NE,NBW
C.....
  1 FORMAT(4I5,6F10.4) .
  2 FORMAT(3I5)
  3 FORMAT(10A4)
  4 FORMAT(1H1,///1X,10A4)
1102 FORMAT(1X,3I6)
C
C.....
C
C OUTPUT OF TITLE AND DATA HEADINGS
C-----
  44 FORMAT(1H1,///1X,20A4//1X,5HKXX =,F7.1,10X,5HKYY =,F7.1/1X,
    121HCONVECTION COEFF(1) =,F7.1,3X,21HCONVECTION COEFF(2) =,F7.1/,
    21X,15HFLUID TEMP(1) =,F7.1,3X,15HFLUID TEMP(2) =,F7.1//,1X,
    317HNEL  NODE NUMBER,6X,4HX(1),6X,4HY(1),6X,4HX(2),6X,4HY(2),
    46X,4HX(3),6X,4HY(3) )
C*****
C ASSEMBLY OF THE GLOBAL STIFFNESS MATRIX AND GLOBAL FORCE MATRIX
C*****
C
C INPUT AND ECHO PRINT OF ELEMENT DATA
C
C.....
C      WRITE(6,604)
  604  FORMAT(1H1,////)
C      WRITE(6,304)
  304  FORMAT('  T(1)      T(2)      T(3)
    1  ISIDE(1) ISIDE(2)  '/')
  1061 FORMAT(6F10.3,2I10)
    11  FORMAT(' ',3F10.3,2I10)
C      WRITE(6,1107)
C      WRITE(6,1108)
C
C      NE : TOTAL NUMBER OF ELEMENTS
C
C..IN:12 .....MAIN LOOP .....
      T(1)=10.
      T(2)=10.
      T(3)=10.
      DO 180 I=1,NE
        H(I)=0.0D0
        ISIDEH(I,1)=0
        ISIDEH(I,2)=0
180    CONTINUE
      DO 178 JJ=1,90
        N=2*JJ
        ISIDEH(N,1)=2
        ISIDEH(N,2)=0
        H(N)=5.D0
178    CONTINUE
C
C      BIRCH LOOP.....
C
```

```
DO 1001 J=1,280
KZETA(J)=.0924
KETA(J)=.0836
RHOCP(J)=10.94246
1001 CONTINUE
C
C DOUGLAS FIR LOOP .....
C
DO 1002 J=281, 302
KZETA(J)=.0754
KETA(J)=.0682
RHOCP(J)=8.5488
1002 CONTINUE
DO 1010 J=351,638
KZETA(J)=.0754
KETA(J)=.0682
RHOCP(J)=8.5488
1010 CONTINUE
DO 1015 J=687,752
KZETA(J)=.0754
KETA(J)=.0682
RHOCP(J)=8.5488
1015 CONTINUE
C
C PAPER LOOP.....
C
DO 1020 J=303,350
KZETA(J)=.011161
KETA(J)=.011161
RHOCP(J)=8.1357
1020 CONTINUE
DO 1111 J =639,686
KZETA(J)=.011161
KETA(J)=.011161
RHOCP(J)=8.1357
1111 CONTINUE
C
C LOOP ON THE REGIONS.....
C
DO 7 KK=1,NE
IF(KK.GE.1.AND.KK.LE.22) BETA(KK)=-.2618
IF(KK.GE.23.AND.KK.LE.34) BETA(KK)=-.15707
IF(KK.GE.35.AND.KK.LE.58) BETA(KK)=0.0
IF(KK.GE.59.AND.KK.LE.66) BETA(KK)=.38394
IF(KK.GE.67.AND.KK.LE.74) BETA(KK)=.17452
IF(KK.GE.75.AND.KK.LE.82) BETA(KK)=1.22164
IF(KK.GE.83.AND.KK.LE.90) BETA(KK)=.69808
IF(KK.GE.91.AND.KK.LE.98) BETA(KK)=2.4433
IF(KK.GE.99.AND.KK.LE.106) BETA(KK)=1.91972
IF(KK.GE.107.AND.KK.LE.114) BETA(KK)=2.9668
IF(KK.GE.115.AND.KK.LE.122) BETA(KK)=2.7574
IF(KK.GE.123.AND.KK.LE.146) BETA(KK)=3.14136
IF(KK.GE.147.AND.KK.LE.158) BETA(KK)=3.29843
IF(KK.GE.159.AND.KK.LE.202) BETA(KK)=3.40314
```



ORIGINAL PAGE IS  
OF POOR QUALITY

```

IF(KK.GE.203.AND.KK.LE.214) BETA(KK)=3.29843
IF(KK.GE.215.AND.KK.LE.230) BETA(KK)=3.14136
IF(KK.GE.231.AND.KK.LE.246) BETA(KK)=0.0
IF(KK.GE.247.AND.KK.LE.258) BETA(KK)=-.15707
IF(KK.GE.259.AND.KK.LE.326) BETA(KK)=-.2618
IF(KK.GE.327.AND.KK.LE.350) BETA(KK)=-.15707
IF(KK.GE.351.AND.KK.LE.430) BETA(KK)=0.0
IF(KK.GE.431.AND.KK.LE.438) BETA(KK)=.38394
IF(KK.GE.439.AND.KK.LE.446) BETA(KK)=.17452
IF(KK.GE.447.AND.KK.LE.454) BETA(KK)=.38394
IF(KK.GE.455.AND.KK.LE.462) BETA(KK)=.17452
IF(KK.GE.463.AND.KK.LE.470) BETA(KK)=1.2216
IF(KK.GE.471.AND.KK.LE.478) BETA(KK)=.69808
IF(KK.GE.479.AND.KK.LE.486) BETA(KK)=1.2216
IF(KK.GE.487.AND.KK.LE.494) BETA(KK)=.69808
IF(KK.GE.495.AND.KK.LE.502) BETA(KK)=2.4433
IF(KK.GE.503.AND.KK.LE.510) BETA(KK)=1.91972
IF(KK.GE.511.AND.KK.LE.518) BETA(KK)=2.4433
IF(KK.GE.519.AND.KK.LE.526) BETA(KK)=1.91972
IF(KK.GE.527.AND.KK.LE.534) BETA(KK)=2.9668
IF(KK.GE.535.AND.KK.LE.542) BETA(KK)=2.7574
IF(KK.GE.543.AND.KK.LE.550) BETA(KK)=2.9668
IF(KK.GE.551.AND.KK.LE.558) BETA(KK)=2.7574
IF(KK.GE.559.AND.KK.LE.638) BETA(KK)=3.14136
IF(KK.GE.639.AND.KK.LE.662) BETA(KK)=3.29843
IF(KK.GE.663.AND.KK.LE.708) BETA(KK)=3.40314
IF(KK.GE.709.AND.KK.LE.752) BETA(KK)=0.0

```

```

READ(IN,1) NEL,NS,X(1),Y(1),X(2),Y(2),X(3),Y(3)

```

```

C WRITE(6,121) NEL,NS,X(1),Y(1),X(2),Y(2),X(3),Y(3),BETA(KK)
121 FORMAT(4I5,7F10.4)

```

```

C DIMENSION IN FEET...

```

```

X1=X(1)
X2=X(2)
X3=X(3)
Y1=Y(1)
Y2=Y(2)
Y3=Y(3)

```

```

C X ( 1 )= X(1) /12.0D0
X ( 2 )= X(2) /12.0D0
X ( 3 )= X(3) /12.0D0
Y ( 1 )= Y(1) /12.0D0
Y ( 2 )= Y(2) /12.0D0
Y ( 3 )= Y(3) /12.0D0

```

```

C T1=T(1)
T2=T(2)
T3=T(3)

```

```

1107 FORMAT(1H1,///20X
* , ' T(1) T(2) T(3) '
* , ' ISIDE(1) ISIDE(2) ' )
1108 FORMAT(' ',20X

```

```

* , '-----'
* , '-----')
C      WRITE(IO,11)T,ISIDEH(KK,1),ISIDEH(KK,2)
C
C
C
C      TOLD(NS(1))=T(1)
      TOLD(NS(2))=T(2)
      TOLD(NS(3))=T(3)
C      H : CONVECTION COEFFICIENT
C      WRITE(6,5152)KK,NS(1),NS(2),NS(3),TOLD(NS(1)),TOLD(NS(2)),
C      1 TOLD(NS(3)), H(KK),(ISIDE(JJ),JJ=1,2),
C      1 X1,Y1,X2,Y2,X3,Y3,NOT(KK,1),NOT(KK,6)
5152  FORMAT(' ',4I5,3F10.3,F5.0,2I2,6F8.4,I5,A8)
C
      T(1)=T1
      T(2)=T2
      T(3)=T3
C
C      ECHO THE INPUT.....
C      WRITE(IO,23) NEL,NS,X(1),Y(1),X(2),Y(2),X(3),Y(3)
C      * , HH,RHO,CP,ISIDE,T
23  FORMAT(1H0,I5,1X,3I5,2X,6(1X,F8.4),2X,2F5.0,F6.3,2X,2I3,
* 2X,3F6.0)
C      CALCULATION OF THE CONDUCTION MATRIX
C
C      NPT (NE,3) : ARRAY STORES THE NODE NUMBERS FOR EACH ELEMENT
      NPT(KK,1) = NS(1)
      NPT(KK,2) = NS(2)
      NPT(KK,3) = NS(3)
      R(NS(1)) = X(1)
      R(NS(2)) = X(2)
      R(NS(3)) = X(3)
      Z(NS(1)) =Y(1)
      Z(NS(2)) =Y(2)
      Z(NS(3)) =Y(3)
      AREAE(KK)=(X(2)*Y(3)-X(2)*Y(1)+X(3)*Y(1)-X(3)*Y(2)
1 + X(1)*Y(2)-X(1)*Y(3))/2.0
C-----c!-----c!
C-----c!-----c!
C      WRITE(6,266)KK,X(1),Y(1),X(2),Y(2),X(3),Y(3),AREAE(KK)
266  FORMAT(1H0,I5,6(1X,F8.4, ),2X,D14.7)
C      WRITE(6,319)KK,(T(I),I=1,3)
319  FORMAT(' ELEMENT NO. ',I8,3F12.4)
7    CONTINUE
C.....END OF THE DO LOOP .....c!
C      WRITE(6,264)(I,TOLD(I),I=1,NP)
264  FORMAT(1H0,I5,E14.5,2X,I5,E14.5,2X,I5,E14.5,2X,I5,E14.5
* ,2X,I5,E14.5,2X,I5,E14.5)
C
C      ADD EXTERNALLY APPL. CONC. NODAL FORCES VECTOR TO EF VECTOR
      ID1=0
      INK=0
202  READ(IN,203) NODNUM,CFV

```



```

MAX(I+1)=DABS(F(I)-TOLD(I))
CF WRITE(6,1211)MAX(I+1)
1211 FORMAT(2X,F15.6)
      IF(MAX(I+1).LT.MAX(I))GOTO 1515
      IF(MAX(I+1).GT.MAX(I))FAXM=MAX(I+1)
      IF(FAXM.GT.STT)GTST=FAXM
      STT=GTST
1515 CONTINUE
C WRITE(6,1222)GTST
CF GTST IS THE STOPPING CRITERION. ITERATION STOPS WHEN DIFF. BETW
CF T(NEW) AND T(OLD) IS LESS THAN 0.3 DEGREE
1222 FORMAT(/,2X,F10.5)
      IF(GTST.LT.0.3)GOTO 1200
      DO 2000 I=1,NP
      TOLD(I)=F(I)
2000 CONTINUE
3000 CONTINUE
1200 DO 3011 IJP = 1,483
      WRITE(7,666)IJP
666 FORMAT(//,' TEMPRATUE DISTRIBUTION AT POINT ',I5,/)
C WRITE(7,777)(I,TIME(I),FIJ(IJP,I), I =1,65)
777 FORMAT(I5,2F10.4)
3011 CONTINUE
C
C
C200 STOP
      END
      SUBROUTINE FORMTK (NE,NP,NBW,TIME,ITER)

```

C\*\*\*\*\*

C..... FORM BANDED THERMAL CONDUCTANCE MATRIX

```

C
      IMPLICIT REAL*4(A-H,O-Z)
      REAL*8 KZETA,KETA,RHOCP,BETA
      REAL*8 BI,BJ,BK,CI,CJ,CK,COF,CON1,CON2,CON3
      REAL*8 RBAR,CON,IG,RCTL,ELKT(3,3),THSTF(483,18)
      REAL*8 A00,A11,A22,B00,B11,B22,C00,THCAP(483,18),TOLD(483)
      REAL*8 Z(483),R(483),AREAE(752),X(3),Y(3),DDT,TIME,ATIM,P
      COMMON/CONVEN/H(752),ISIDEH(752,2)

```

```

C
      COMMON / SOLID / Z,R,AREAE,THSTF
1 ,THCAP,NPT(752,3),TOLD
      REAL*8 ZZ(483,18),F,B,FF,EF
      COMMON / SOLVEQ / F(483),EF(752),ZZ
      COMMON /CONT/ KZETA(752),KETA(752),RHOCP(752),BETA(752)

```

```

C
C
C
C..... INITIALIZE GLOBAL THERMAL STIFFNESS MATRIX

```

```

      IN=5
      IO=6
      DO 120 J=1,NBW
      DO 110 I=1,NP
      THSTF(I,J) = 0.DO
110 CONTINUE

```



ORIGINAL PAGE IS  
OF POOR QUALITY

```
IF ( JQ.EQ . 3) KQ=1
LG = DSQRT((X(KQ)-X(JQ))**2+(Y(KQ)-Y(JQ))**2)
HL =H(N)*LG/6.
IF(JQ.EQ.1) GO TO 20
IF(JQ.EQ.2) GO TO 30
IF(JQ.EQ.3) GO TO 40
GO TO 10
20 ELKT(1,1)= ELKT(1,1)+HL * 2.
   ELKT(2,2)= ELKT(2,2)+HL * 2.
   ELKT(1,2)= ELKT(1,2)+HL
   GO TO 10
C
30 ELKT(2,2)= ELKT(2,2)+HL*2.
   ELKT(3,3)= ELKT(3,3)+HL*2.
   ELKT(2,3)= ELKT(2,3)+HL
   GO TO 10
C
40 ELKT(1,1)= ELKT(1,1)+HL * 2.
   ELKT(3,3)= ELKT(3,3)+HL * 2.
   ELKT(1,3)= ELKT(1,3)+HL
10 CONTINUE
C
C WRITE(IO,2000)N,II,JJ,KK,X(1),Y(1),X(2),Y(2),X(3),Y(3),CONDTY(N),
C 1AREAE(N),RBAR,CON,ELKT(1,1),ELKT(1,2),ELKT(1,3),ELKT(2,2),
C 2ELKT(2,3),ELKT(3,3)
2000 FORMAT(1H0,4I5,8G11.4,/21X,8G11.4)
C-----c!
C STORE IN GLOBAL MATRIX c!
C-----c!
240 CONTINUE
C WRITE( IO,266)N,X(1),Y(1),X(2),Y(2),X(3),Y(3),AREAE(N),NBAND
266 FORMAT(1H0,I5,6(1X,F8.4),2X,D14.7,2X,I5)
C WRITE(6,277)N,(( ELKT(I,J),J=1,3),I=1,3)
277 FORMAT(' ',I5/ 3(3F25.6/))
DO 220 LL=1,3
DO 210 MM=1,3
IF(MM.LT.LL) GOTO 210
I=NPT(N,LL)
J=IABS(NPT(N,MM)-I)+1
IF(NPT(N,MM).LT.NPT(N,LL)) I=NPT(N,MM)
THSTF(I,J) =THSTF(I,J)+ELKT(LL,MM)
C WRITE(6,7543)I,J,II,JH,NPT(N,J),NPT(N,I)
7543 FORMAT(' ',6I8, '*****')
IF (J.GT.NBAND) NBAND=J
210 CONTINUE
220 CONTINUE
230 CONTINUE
C WRITE(6,5050)((THSTF(I,J),J=1,NBW),I=15,20)
5050 FORMAT(7G11.5)
C
C WRITE (6,200) NBAND
200 FORMAT(1H0,' NBAND= ',I5)
C
C..... END OF PROGRAM
```

ORIGINAL PAGE IS  
OF POOR QUALITY

```
C
C
C      RETURN
C      END
C
C..... FORM BANDED CAPACITANCE MATRIX FOR A DEFORMING F.E. MESH
C
C      SUBROUTINE FORMTC (NE,NP,NBW)
C
C      REAL*8 Z(483),R(483),AREAE(752),X(3),Y(3),DDT
C      REAL * 8 CON ,ELCAP(3,3),THCAP(483,18),TOLD(483),THSTF(483,18)
C      1 ,THSTF1(747,17)
C      COMMON/CONVEN/H(752),SIDEH(752,2)
C
C      COMMON / SOLID / Z,R,AREAE,THSTF
C      1 ,THCAP,NPT(752,3),TOLD
C      REAL*8 ZZ(483,18),F,EF,B,COF,FF,KZETA,KETA
C      COMMON / SOLVEQ / F(483),EF(752),ZZ
C      DIMENSION FF(15,1)
C      COMMON /CONT/ KZETA(752),KETA(752),RHOC(752),BETA(752)
C
C
C      REAL * 8 R1,R2,R3,R4,R5,R6
C
C..... INITIALIZE GLOBAL THERMAL CAPACITANCE MATRIX
C
C      IO=6
C      J9=0
C      DO 120 J=1,NBW
C      DO 110 I=1,NP
C      THCAP(I,J) = 0.DO
C 110 CONTINUE
C 120 CONTINUE
C
C
C      WRITE(6,8880)
C 8880 FORMAT(' CAPACITANCE MATRIX ELEMENTS ARE ',/)
C 200 DO 230 N=1,NE
C
C..... FOR EACH ELEMENT, FOR THERMAL CAPACITANCE MATRIX
C
C      II = NPT(N,1)
C      JJ = NPT(N,2)
C      KK = NPT(N,3)
C      CON=RHOC(N)*AREAE(N)/12.
C      ELCAP(1,1)=2.*CON
C      ELCAP(1,2)=1.*CON
C      ELCAP(1,3)=1.*CON
C      ELCAP(2,2)=2.*CON
C      ELCAP(2,3)=1.*CON
C      ELCAP(3,3)=2.*CON
C
C
C
C      WRITE(IO,2000)N,II,JJ,KK,R(II),Z(II),R(JJ),Z(JJ),R(KK),Z(KK),
```

```

C      1 RHOCP(N),AREAE(N),CON,ELCAP(1,1),ELCAP(1,2),ELCAP(1,3),
C      2      ELCAP(2,2),ELCAP(2,3),ELCAP(3,3)
2000  FORMAT(1H0,4I5,9G11.4/21X,6G11.4)
C
C..... STORE IN GLOBAL MATRIX
      DO 220 I=1,3
      DO 210 J=1,3
      IF(J.LT.I) GOTO 210
      II=NPT(N,I)
      JJ=IABS(NPT(N,J)-II)+1
      IF (NPT(N,J).LT.NPT(N,I)) II=NF(N,J)
      THCAP(II,JJ) = THCAP(II,JJ)+ELCAP(I,J)
210   CONTINUE
220   CONTINUE
C
C      WRITE(6,277)N,(( ELCAP(I,J),J=1,3),I=1,3)
277  FORMAT(' ',I5/ 3(3F25.6/))
230  CONTINUE
C
C      WRITE(IO,4000)(THCAP(I,J),J=1,NBW)
4000  FORMAT(1H0,'THCAP',10G11.4/6X,10G11.4/6X,10G11.4/6X,10G11.4)
C      WRITE(IO,1000)
1000  FORMAT(1H0,'LEAVING FORMTC      IN TDHEAT ..1B ')
264   FORMAT(1H0,I5,E14.5,2X,I5,E14.5,2X,I5,E14.5,2X,I5,E14.5
* ,2X,I5,E14.5,2X,I5,E14.5)
C
C..... END OF PROGRAM
C
      RETURN
      END
      SUBROUTINE FORMTF(NE,NP,NBW)
C
C      FORM THERMAL FORCE VECTOR
C
C
C
C      REAL*8 ELF(3),LG,RCTL,COF,THCAP(483,18),THSTF(483,18)
      REAL*8 Z(483),R(483),AREAE(752),X(3),Y(3),DDT,TOLD(483)
      COMMON/CONVEN/H(752),ISIDEH(752,2)
C
C      COMMON / SOLID / Z,R,AREAE,THSTF
1      ,THCAP,NPT(752,3),TOLD
      REAL*8  ZZ(483,18),F,EF,B,ELF1,ELF2,ELF3,FF,HLL
      COMMON / SOLVEQ / F(483),EF(752),ZZ
      REAL *8 KZETA,KETA,RHOCP,BETA
      COMMON /CONT/ KZETA(752),KETA(752),RHOCP(752),BETA(752)
      REAL *8 QR(752),HL(752)
      DATA W/ .6666666666D0/
      IO=6
      TINF =10.D0
C
C
C      FOR EACH ELEMENT ,FORM THERMAL FORCE VECTOR
C

```



ORIGINAL PAGE IS  
OF POOR QUALITY

```

C      WRITE(6,9999)
9999   FORMAT(' FORCE VECTORS ARE ',/)
      DO 110 I=1,NE
      EF(I) = 0.DO
      QR(I)=0.0
110    CONTINUE
      DO 1070 J=1,45
      N=2*J
      QR(N)=326.0
1070   CONTINUE
      DO 230 N=1,NE
      ELF(1)=0.DO
      ELF(2)=0.DO
      ELF(3)=0.DO
      II=NPT(N,1)
      JJ=NPT(N,2)
      KK=NPT(N,3)
      CI = R(KK)-R(JJ)
      CJ = R(II)-R(KK)
      CK = R(JJ)-R(II)
      BI=Z(JJ)-Z(KK)
      BJ=Z(KK)-Z(II)
      BK=Z(II)-Z(JJ)
      X(1)=R(II)
      X(2)=R(JJ)
      X(3)=R(KK)
      Y(1)=Z(II)
      Y(2)=Z(JJ)
      Y(3)=Z(KK)
      ALPHA=BETA(N)
      CON2=(KZETA(N)-KETA(N))*SIN(2.*ALPHA)/(4.*AREAE(N))
      ELF1=CON2*(BI*CI*TOLD(II)+BI*CJ*TOLD(JJ)+BI*CK*TOLD(KK))
      ELF2=CON2*(BJ*CI*TOLD(II)+BJ*CJ*TOLD(JJ)+BJ*CK*TOLD(KK))
      ELF3=CON2*(BK*CI*TOLD(II)+BK*CJ*TOLD(JJ)+BK*CK*TOLD(KK))
      ELF(1)=-W*ELF1
      ELF(2)=-W*ELF2
      ELF(3)=-W*ELF3
      DO 10 IQ=1,2
      IF(ISIDEH(N,IQ).LE.0)GO TO 240
      JQ=ISIDEH (N,IQ)
      KQ=JQ+1
      IF(JQ.EQ.3) KQ=1
      LG=DSQRT((X(KQ)-X(JQ))**2+ (Y(KQ)-Y(JQ))**2)
C      WRITE(6,999)LG
999    FORMAT(2X,F10.5)
      HL(N)=QR(N)+H(N)*TINF
      IF ( JQ.EQ.1)GO TO 20
      IF ( JQ.EQ.2)GO TO 30
      IF (JQ .EQ.3)GO TO 40
      GO TO 240
20     ELF(1) =HL(N)*LG*.5+ELF(1)
      ELF(2) =HL(N)*LG*.5+ELF(2)
      GO TO 10
30     ELF(2) =HL(N)*LG*.5+ELF(2)

```

ORIGINAL PAGE IS  
OF POOR QUALITY

```

      ELF(3) =HL(N)*LG*.5+ELF(3)
      GO TO 10
40    ELF(1) =HL(N)*LG*.5+ELF(1)
      ELF(3) =HL(N)*LG*.5+ELF(3)
10    CONTINUE
C
240   EF(II)= EF(II)+ELF(1)
      EF(JJ)=EF(JJ) +ELF(2)
      EF(KK)=EF(KK) +ELF(3)
707   FORMAT(' ',2I8,5F15.5)
C     IF(EF(II).EQ.0) GO TO 50
C     IF(EF(JJ).EQ.0) GO TO 50
C     IF(EF(KK).EQ.0) GO TO 50
C     GOTO 230
C50   WRITE(6,1999)N,II,JJ,KK,EF(II),EF(JJ),EF(KK)
1999   FORMAT(1H0,4I6,2X,3F10.4)
230   CONTINUE
C     WRITE(IO,2000)(EF(I),I=1,NP)
2000   FORMAT(2X,F10.4)
C     WRITE(IO,1000)
1000   FORMAT(1H0,' LEAVING FORMTF      IN TDHEAT ...1B')
      RETURN
      END
      SUBROUTINE ASSMBL (NP,NBW,DDT,ITER)
C..... ASSEMBLE MATRICES FOR RECURRENCE FORMULAS
      REAL*8 Z(483),R(483),AREAE(752),THSTF(483,18),THCAP(483,18)
1     ,THSTF1(747,17)
      REAL*8 ZZ(483,18),F,EF,B,ZO(747,17),FF(15,1),TOLD(483)
      COMMON/CONVEN/H(752),ISIDEH(752,2)
C
      COMMON / SOLID / Z,R,AREAE,THSTF
1     ,THCAP,NPT(752,3),TOLD
      COMMON / SOLVEQ / F(483),EF(752),ZZ
      COMMON /CONT/ KZETA(752),KETA(752),RHOC(752),BETA(752)
C
      WEIGHTING FACTORS FOR GALERKIN ANALYSIS.....
C
      DATA W1,W2,W3,W4/ 0.3333333333333333D0 ,
1     0.5000000000000000D0 ,
2     -0.16666666666666667D0 ,
3     0.5000000000000000D0 /
C
      IO=6
      DT = DDT
C     WRITE (IO,1000) W1,W2,W3,W4,DT
1000   FORMAT (1H0,'ASSEMBLE      IN TDHEAT ....1'//,5E15.8/' ZZ
1     COL 1 TO 6 '/')
C
6567   FORMAT(' ',I5,6F12.6)
3000   FORMAT(1H0,'THSTF',10G11.4/6X,10G11.4/6X,10G11.4/6X,10G11.4/)
4000   FORMAT(1H0,'THCAP',10G11.4/6X,10G11.4/6X,10G11.4/6X,10G11.4/)
C
      DO 150 I=1,NP
C

```

```

C..... COEFFICIENT MATRIX
C
      DO 110 J=1,NBW
      ZZ(I,J) = W1*(THSTF(I,J))+W2*(THCAP(I,J))/DT
110 CONTINUE
C      WRITE(IO,2000) (ZZ(I,J),J=1,NBW)
2000  FORMAT(' ',8E15.6)
C
C..... THERMAL LOAD VECTOR
C
      F(I) = EF(I)/2.DO
C
      IF (I.EQ.1) GO TO 130
      JST = I+1-NBW
      IF (JST.LT.1) JST=1
      JEND = I-1
C      WRITE (6,1000) I,JST,JEND
C
      DO 120 J=JST,JEND
      II = I+1-J
C-----C!-----
C
      F(I) =F(I)+(W3*(THSTF(J,II))+W4*(THCAP(J,II))
1 /DT)* (TOLD(J))
C      WRITE (6,1000) I,J,II,THSTF(J,II),THCAP(J,II),TOLD(J),F(I)
120 CONTINUE
C
130 JST = I
      JEND = I-1+NBW
      IF (JEND.GT.NP) JEND=NP
C      WRITE (6,1000) JST,JEND
      DO 140 J=JST,JEND
      JJ = J-I+1
      F(I) =F(I)+(W3*(THSTF(I,JJ))+W4*(THCAP(I,JJ))
1 /DT)* (TOLD(J))
C      WRITE (6,1000) I,J,JJ,THSTF(I,JJ),THCAP(I,JJ),TOLD(J),F(I)
140 CONTINUE
C      WRITE (6,1000) I,JST,JEND,F(I)
C      WRITE (6,1001) I,(ZZ(I,J),J=1,NBW),F(I),TOLD(I)
150 CONTINUE
1001 FORMAT (1H ,I3,6G11.5)
C
C..... END OF PROGRAM
C
      RETURN
      END
      SUBROUTINE SOLVE(NP,NBW)
C
C      SOLUTION OF EQUATIONS BY GAUSS ELIMINATION
C      NP=NO. OF NODAL POINTS NBW=BANDWIDTH
C      =NO. OF UNKNOWN
C      =NO. OF EQUATIONS
C
      REAL*8 ZZ(483,18),F,EF,B,P,EXTRA

```

```

COMMON/SOLVEQ/F(483),EF(752),ZZ
IO=6
C   WRITE(6,1002)
1002  FORMAT('  IN SOLVE   ZZ(I,J)  COL 1 TO 4  '/')
100   DO 130 I=1,NP
C     WRITE(IO,1001)I,(ZZ(I,J),J=1,4),F(I)
1001  FORMAT(' ',I5,5E15.5)
C     REDUCE THE STIFFNESS MATRIX.....
C
      DO 120 J=2,NBW
      II=I+J-1
      IF(ZZ(I,J).EQ.0.0) GO TO 120
      P= ZZ(I,J)/ZZ(I,1)
      JJ=0
      DO 110 K=J,NBW
      JJ=JJ+1
      IF(ZZ(I,K).NE.0.0DO) ZZ(II,JJ)=ZZ(II,JJ)-P*ZZ(I,K)
C
      IF(DABS(ZZ(II,JJ)).LT. 1.E-20)ZZ(II,JJ)=0.0DO
110   CONTINUE
      ZZ(I,J) =P
C
      REDUCE LOAD VECTOR
C
      F(II) = F(II)-P*F(I)
C
120   CONTINUE
      F(I) = F(I)/ZZ(I,1)
C
C     WRITE(IO,1000)I,ZZ(I,J),J=1,NBW),F(I)
1000  FORMAT(1H0,'SOLVE',I3/4(5E15.8/))
130   CONTINUE
C
C.....BACK SUBSTITUTION
C
200   N=NP
210   N=N-1
      IF(N.EQ.0) GO TO 300
      II=N
      DO 220 J=2,NBW
      II=II+1
      IF ( ZZ(N,J).NE.0.0) F(N)=F(N)-ZZ(N,J)*F(II)
220   CONTINUE
      GO TO 210
C
C .....SOLUTION VECTOR STORED IN   F   ARRAY
C
300   RETURN
      END

```

ORIGINAL PAGE IS  
OF POOR QUALITY

```

C
C THE GRID PROGRAM IS MODIFIED TO GENERATE RECTANGULAR ELEMENTS.
C THE CHANGES ARE AS FOLLOW:
C
CH THE DIMENSION OF NOO(2500,6) IS CHANGED TO NOO(2500,7)
CH THE DIMENSION OF NR(3) IS CHANGED TO NR(4)
CH THE DIMENSION OF IS CHANGED TO LB(3) TO LB(6)
C
C DIVISION INTO RECTANGULAR ELEMENTS
C
K=1
DO 17 I=1,NROWS
DO 17 J=1,NCOL
XE(K)=XC(I,J)
YE(K)=YC(I,J)
NE(K)=NN(I,J)
17 K=K+1
L=NROWS-1
DO 21 I=1,L
DO 21 J=2,NCOL
CH DIAG1=SQRT((XC(I,J)-XC(I+1,J-1))**2+(YC(I,J)-YC(I+1,J-1))**2)
CH DIAG2=SQRT((XC(I+1,J)-XC(I,J-1))**2+(YC(I+1,J)-YC(I,J-1))**2)
NR(1)=NCOL*I+J-1
NR(2)=NCOL*I+J
NR(3)=NCOL*(I-1)+J
NR(4)=NCOL*(I-1)+J-1
CH DO 21 IJ=1,2
NEL=NEL+1
CH IF((DIAG1/DIAG2).GT.1.02) GO TO 18
J1=NR(1)
J2=NR(2)
J3=NR(3)
J4 = NR(4)
CH GO TO 19
CH 18 J1=NR(IJ)
CH J2=NR(IJ+1)
CH J3=NR(4)
CH LB(3),LB(5) AND LB(6) ARE ADDED
LB(1)=IABS(NE(J1)-NE(J2))+1
LB(2)=IABS(NE(J1)-NE(J3))+1
LB(3)=IABS(NE(J1)-NE(J4))+1
LB(4)=IABS(NE(J2)-NE(J3))+1
LB(5)=IABS(NE(J2)-NE(J4))+1
LB(6)=IABS(NE(J3)-NE(J4))+1
DO 20 IK=1,6
IF(LB(IK).LE.NBW) GO TO 20
NBW=LB(IK)
NELBW=NEL
20 CONTINUE
IF( KK . NE . 46 ) GO TO 888
C WRITE(6,666) J3 , NE(J3)
666 FORMAT(///// ' J3 = ',I9,' NE(J3) = ' , I9 )
888 CONTINUE
WRITE(IO,113) KK,NEL,NE(J1),NE(J2),NE(J3),NE(J4),XE(J1),YE(J1),

```

ORIGINAL PAGE IS  
OF POOR QUALITY

```
1 XE(J2),YE(J2),XE(J3),YE(J3),XE(J4),YE(J4)
  IF(IPCH.EQ.0) GO TO 21
  WRITE(IP,114) NEL,NE(J1),NE(J2),NE(J3),NE(J4),XE(J1),YE(J1),XE(J2)
1, YE(J2),XE(J3),YE(J3),XE(J4),YE(J4)
CH NOO(NEL,6) IS ADDED
   NOO(NEL,1)=KK
   NOO(NEL,2)=NEL
   NOO(NEL,3)=NE(J1)
   NOO(NEL,4)=NE(J2)
   NOO(NEL,5)=NE(J3)
   NOO(NEL,6)=NE(J4)
   NOO(NEL,7)=IRR(KK)
21 CONTINUE
22 CONTINUE
```

ORIGINAL PAGE IS  
OF POOR QUALITY

```

CH THE DIMENSION OF NOO, X, I, OR Y IS INCREASED BY 1
C
COMMON/AAA/ NOO(2500,7),NTT(80)
COMMON/BBB/ X(4,2000),Y(4,2000),NBO(1000),TITLE(10)
COMMON/CCC/ NODES,LMENTS,JT(12000),MEMJT(24000),JMEM(3000),
$JNT(3000),IDIFF,MINMAX
DATA IN/11/,IO/6/,IP/12/
C
READ (IN,100)TITLE
WRITE(IP,100)TITLE
100 FORMAT(10A4)
122 FORMAT(I3,5F10.5)
J =1
JJ=0
CH I IS CHANGED FROM 3 TO 4
150 READ(IN,17)(JT(3000*(I-1)+J),I=1,4),(X(I,J),Y(I,J),I=1,4)
CH JT(9000+J)=0
C WRITE(IO,17)(JT(3000*(I-1)+J),I=1,4),(X(I,J),Y(I,J),I=1,4)
NODES=MAX0(JT(J),JT(3000+J),JT(6000+J),JT(9000+J),JJ)
JJ=NODES
IF(JT(3000+J).EQ.0)GO TO 152
J=J+1
GO TO 150
152 LMENTS=J-1
NODES=JJ
12 FORMAT(//,5X,15HNUMBER OF NODES,I4,15X,
1'NUMBER OF ELEMENTS ',I4,/)
WRITE(IO,105)TITLE
105 FORMAT(//,1X,20A4,/)
C WRITE(IO,12)NODES,LMENTS
C WRITE(IO,13)
C3 FORMAT(//,3X,18HNEL JT1 JT2 JT3,10X,4HX(1),8X,
C $4HY(1),8X,4HX(2),8X,4HY(2),8X,4HX(3),8X,4H (3))
17 FORMAT(4X,4I4,8F10.5)
DO 10 J=1,LMENTS
WRITE(IO,11)J,(JT(3000*(I-1)+J),I=1,4),(X(I,J),Y(I,J),I=1,4)
11 FORMAT(1X,5I5,3X,8F12.4)
10 CONTINUE
READ(IN,300)IBO
300 FORMAT(50X,I4,46X)
READ(IN,301)(NBO(I),I=1,IBO)
C WRITE(IO,302)
DO 333 I=1,LMENTS
READ (IN,444)(NOO(I,J),J=1,7)
333 CONTINUE
C WRITE(IO,303)(NBO(I),I=1,IBO)
302 FORMAT(//,' **** BOUNDARY NUMBERS ****')
CALL SETUP
NTBAN=IDIFF+1
WRITE(IO,202)NTBAN
202 FORMAT(//,2X,25HTHE ORIGINAL BANDWIDTH IS,I4,/)
CALL OPTNUM
IF(IDIFF.LE.MINMAX)GO TO 115
MIBAN=MINMAX+1

```

ORIGINAL PAGE IS  
OF POOR QUALITY

```

WRITE(IO,198)
198  FORMAT(1H1///,1X,5(3HOLD,3X,3HNEW,7X),/,1X,
      $5(4HNODE,2X,4HNODE,6X))
      WRITE(7,200)(J,JNT(J),J=1,NODES)
200  FORMAT(5(I5,1X,I5,5X))
C    WRITE(IO,13)
      DO 180 J=1,LMENTS
      DO 555 II=1,4
      III=II+2
555  NOO(J,III)=JNT(JT(3000*(II-1)+J))
C
180  CONTINUE
C    WRITE(IO,11)J,(JNT(JT(3000*(I-1)+J)),I=1,4),
C    $(X(I,J),Y(I,J),I=1,4)
      WRITE(IO,201)MIBAN
201  FORMAT(/,2X,'THE NEW BANDWIDTH IS',I3,/)
C    WRITE(IP,310)NODES,LMENTS,MIBAN
C    DO 181 J=1,LMENTS
C81  WRITE(IP,18)J,(JNT(JT(3000*(I-1)+J)),I=1,4),(X(I,J),
C    $Y(I,J),I=1,4)
C8  FORMAT(5I5,8F10.4)
C    WRITE(IO,302)
C    WRITE(IP,300)IBO
C    WRITE(IP,301)(JNT(NBO(I)),I=1,IBO)
C    WRITE(IO,303)(JNT(NBO(I)),I=1,IBO)
303  FORMAT(15I4)
      GO TO 117
115  CONTINUE
      WRITE(IO,101)
117  CONTINUE
101  FORMAT(/,2X,'THE ORIGINAL BANDWIDTH IS MINIMUM')
      WRITE(IP,310)NODES,LMENTS,NTBAN
310  FORMAT(3I5)
C    DO 190 J=1,LMENTS
C190 WRITE(IP,18)J,(JT(3000*(I-1)+J),I=1,4),
C    1(X(I,J),Y(I,J),I=1,4)
C    WRITE(IP,300)IBO
C    WRITE(IP,301)(NBO(I),I=1,IBO)
301  FORMAT(20I5)
C-----c!
444  FORMAT(6I5,A4)
      LLL = NOO(1,7)
C
      LOL=0
      MMM=0
      NNN=1
      DO 666 II=1,LMENTS
      IF ( LLL.EQ.NOO(II,7) )GO TO 1888
      NNN=NNN-1
      LOL=LOL+NNN
      MMM=MMM+1
      NTT(MMM)=LOL
C    WRITE(IO,888) NNN,NTT(MMM)
      LLL=NOO(II,7)

```



ORIGINAL PAGE IS  
OF POOR QUALITY

```
      NNN=1
1888 CONTINUE
      WRITE(10,777)NNN,(NOO(II,J),J=1,7),(X(I,II),Y(I,II),I=1,4)
C      WRITE(7,1012)NOO(II,2),NOO(II,6)
      WRITE(7,199) (NOO(II,J),J=2,6),(X(I,II),Y(I,II),I=1,4)
      IF (II. NE . LMENTS) GO TO 1889
      LOL=LOL+NNN
      MMM=MMM+1
      NTT(MMM)=LOL
C      WRITE(10,888) NNN,NTT(MMM)
1889 NNN=NNN+1
666 CONTINUE
C
C1012 FORMAT(15,A5,I5,A5,I5,A5,I5,A5,I5,A5,I5,A5,I5,A5)
777 FORMAT(2X,7I5,1X,A8,8F10.5)
199 FORMAT(5I4,8F7.4)
888 FORMAT(//' NUMBER OF ELEMENTS IN THIS REGION =' ,2I10/)
400 CONTINUE
C
C-----
C-----
      STOP
      END
```

ORIGINAL PAGE IS  
OF POOR QUALITY

```

C
C   T R A S F E R   P R O G R A M
C
      DIMENSION X(482),Y(482),T(482),BETA(376),PROB(3,7),ALFA(3,3),
1      BI(150),TA(482),TG(482)
      INTEGER NM,I,J,K, II,IE(376,5),III,IT,MID(376),IG(482),IS(482)
      CHARACTER*3  TIPE(376),PT(150)
C      DOUBLE PRECISION  PROB,ALFA,BETA
      DATA PROB /770000.0,97500.0,1000.0,
1      164000.0,132600.0,1500.0,
1      1380000.0,1950000.0,3000.0,
1      0.440,0.287,0.40,
1      0.166,0.022,0.02,
1      0.255,0.02,0.02,
1      76000.0,14000.0,500.0/
      DATA ALFA /0.00002705,0.00003490,0.00000005,
1      0.00003038,0.0000259,0.00000005,
1      0.00001457,0.0000021,0.00000005/
C      DATA BIRT/'BIRT'/,BIRL/'BIRL'/, FI/' FI'/,PAP /'PAP'/
      DO 3 I = 1,3
C      WRITE(7,55) (PROB(I,J), J = 1,7)
C      WRITE(7,44) (ALFA(I,J), J =1,3)
3      CONTINUE
55      FORMAT(3F10.1,3F10.8,F10.1)
44      FORMAT(3F10.8)
      PI = 3.1415927
      TI = 70.0
C
      DO 5 I = 1,389
      IF(I.LE.140)TIPE(I) ='BIR'
      IF((I.GE.141).AND.(I.LE.151)) TIPE(I) ='FIR'
      IF((I.GE.152).AND.(I.LE.175)) TIPE(I) ='PAP'
      IF((I.GE.176).AND.(I.LE.319)) TIPE(I) ='FIR'
      IF((I.GE.320).AND.(I.LE.343)) TIPE(I) ='PAP'
      IF((I.GE.344).AND.(I.LE.376)) TIPE(I) ='FIR'
C      IF((I.GE.377).AND.(I.LE.389)) TIPE(I) ='BIR'
5      CONTINUE
      DO 51 KK = 1,389
      IF(KK.GE.1.AND.KK.LE.11) BETA(KK)=-.2618
      IF(KK.GE.12.AND.KK.LE.17) BETA(KK)=-.15707
      IF(KK.GE.18.AND.KK.LE.29) BETA(KK)=0.0
      IF(KK.GE.30.AND.KK.LE.33) BETA(KK)=.38394
      IF(KK.GE.34.AND.KK.LE.37) BETA(KK)=.17452
      IF(KK.GE.38.AND.KK.LE.41) BETA(KK)=1.22164
      IF(KK.GE.42.AND.KK.LE.45) BETA(KK)=.69808
      IF(KK.GE.46.AND.KK.LE.49) BETA(KK)=2.4433
      IF(KK.GE.50.AND.KK.LE.53) BETA(KK)=1.91972
      IF(KK.GE. 54.AND.KK.LE.57) BETA(KK)=2.9668
      IF(KK.GE. 58.AND.KK.LE.61) BETA(KK)=2.7574
      IF(KK.GE. 62.AND.KK.LE.73) BETA(KK)=3.14136
      IF(KK.GE. 74.AND.KK.LE.79) BETA(KK)=3.29843
      IF(KK.GE. 80.AND.KK.LE.101) BETA(KK)=3.40314
      IF(KK.GE.102.AND.KK.LE.107) BETA(KK)=3.29843
      IF(KK.GE.108.AND.KK.LE.115) BETA(KK)=3.14136

```

ORIGINAL PAGE IS  
OF POOR QUALITY

```

IF(KK.GE.116.AND.KK.LE.123) BETA(KK)=0.0
IF(KK.GE.124.AND.KK.LE.129) BETA(KK)=-.15707
IF(KK.GE.130.AND.KK.LE.163) BETA(KK)=-.2618
IF(KK.GE.164.AND.KK.LE.175) BETA(KK)=-.15707
IF(KK.GE.176.AND.KK.LE.215) BETA(KK)=0.0
IF(KK.GE.216.AND.KK.LE.219) BETA(KK)=.38394
IF(KK.GE.220.AND.KK.LE.223) BETA(KK)=.17452
IF(KK.GE.224.AND.KK.LE.227) BETA(KK)=.38394
IF(KK.GE.228.AND.KK.LE.231) BETA(KK)=.17452
IF(KK.GE.232.AND.KK.LE.235) BETA(KK)=1.2216
IF(KK.GE.236.AND.KK.LE.239) BETA(KK)=.69808
IF(KK.GE.240.AND.KK.LE.243) BETA(KK)=1.2216
IF(KK.GE.244.AND.KK.LE.247) BETA(KK)=.69808
IF(KK.GE.248.AND.KK.LE.251) BETA(KK)=2.4433
IF(KK.GE.252.AND.KK.LE.255) BETA(KK)=1.91972
IF(KK.GE.256.AND.KK.LE.259) BETA(KK)=2.4433
IF(KK.GE.260.AND.KK.LE.263) BETA(KK)=1.91972
IF(KK.GE.264.AND.KK.LE.267) BETA(KK)=2.9668
IF(KK.GE.268.AND.KK.LE.271) BETA(KK)=2.7574
IF(KK.GE.272.AND.KK.LE.275) BETA(KK)=2.9668
IF(KK.GE.276.AND.KK.LE.279) BETA(KK)=2.7574
IF(KK.GE.280.AND.KK.LE.319) BETA(KK)=3.14136
IF(KK.GE.320.AND.KK.LE.331) BETA(KK)=3.29843
IF(KK.GE.332.AND.KK.LE.354) BETA(KK)=3.40314
IF(KK.GE.355.AND.KK.LE.376) BETA(KK)=0.0
C IF(KK.GE.377.AND.KK.LE.389) BETA(KK)=1.57079
51 CONTINUE
    READ(5,200)(IG(I),I=1,482)
C    WRITE(6,200)(IG(I),I=1,482)
    READ(5,200)(IS(I),I=1,482)
C    WRITE(6,200)(IS(I),I=1,482)
200  FORMAT(5(6X,I5,5X))
    DO 10 L = 1,376
        READ(5,777) NM,I,J,K,N,X(I),Y(I),X(J),Y(J),X(K),Y(K),X(N),Y(N)
C        WRITE(6,777) NM,I,J,K,N,X(I),Y(I),X(J),Y(J),X(K),Y(K),X(N),Y(N)
            IE(L,1) = NM
            IE(L,2) = I
            IE(L,3) = J
            IE(L,4) = K
            IE(L,5) = N
10    CONTINUE
777  FORMAT(5I4,8F7.4)
    READ(5,666) (T(I), I = 1,482)
C    WRITE(6,666) (T(I), I = 1,482)
    DO 12 I = 1,482
12    TG(IG(I))=T(IS(I))
666  FORMAT(9F8.4)
    MID(1) =1
    DO 50 I = 2,376
        IF((TIPE(I).NE.TIPE(I-1)).OR.(BETA(I).NE.BETA(I-1)))GO TO 25
            MID(I) = MID(I-1)
            GO TO 50
25    MID(I) = MID(I-1) + 1
50    CONTINUE

```

ORIGINAL PAGE IS  
OF POOR QUALITY

```
      IT = 0
      DO 70 I = 1,376
      IF(MID(I).GE.IT) GO TO 15
15      IT = MID(I)
          BI(IT) = BETA(I)
          PT(IT) = TIPE(I)
          WRITE(6,16)I, TIPE(I), BETA(I), IT
C      WRITE(6,66) IT,PT(IT)
70      CONTINUE
16      FORMAT(I5,5X,A4,F10.4, I5)
          DO 30 I = 1,482
              TA(I) = 90.0 + TG(I)
          WRITE(7,555) I,X(I),Y(I),TA(I)
30      CONTINUE
555     FORMAT(I5,40X,2F10.4,5X,F10.4)
          DO 80 I=1,IT
C      WRITE(6,66) I, PT(I)
          BII = BI(I)*180.0/PI
          WRITE(7,11) I,BII
          IF(PT(I).EQ.'BIR') GO TO 7
          IF(PT(I).EQ.'FIR') GO TO 17
          IF(PT(I).EQ.'PAP') GO TO 27
7      WRITE(7,22) TI,(PROB(1,J), J=1,7)
          WRITE(7,33) (ALFA(1,J), J =1,3)
          GO TO 80
17     WRITE(7,22) TI,(PROB(2,J), J=1,7)
          WRITE(7,33) (ALFA(2,J), J =1,3)
          GO TO 80
27     WRITE(7,22) TI,(PROB(3,J), J=1,7)
          WRITE(7,33) (ALFA(3,J), J =1,3)
80     CONTINUE
66     FORMAT(I5,5X,A4)
11     FORMAT(I5,25X,F10.4)
22     FORMAT(4F10.1,3F10.8,F10.1)
33     FORMAT(3F10.8)
          TH=1.000
          N= 4
          TR = 70.00
C      M =1
          DO 40 I =1,376
          WRITE(7,444) (IE(I,J),J=1,5),MID(I),TR, N, TH
40     CONTINUE
444     FORMAT(6I5,F10.4,10X,I5,5X,F10.4)
          STOP
          END
```

ORIGINAL PAGE IS  
OF POOR QUALITY

```
//UOFT1230 JOB (UT,  
// 06250065,2,,V)  
//STEP1 EXEC SAPIV  
//FT06F001 DD SYSOUT=V,OUTLIM=1000000  
//GO.SYSIN DD *
```

THERMAL STRESSES IN THE BLADE USING PLANE STRAIN APPROACH

496	1	1						
1	-1		-1	-1	-1	4.3519	13.0728	147.8842
2						3.8200	12.5000	144.3767
3						3.2448	14.0923	150.2360
4						2.6075	13.3675	147.7226
5						5.0275	13.6888	150.4952
6						4.0394	14.8344	152.0367
7						3.4319	11.9703	139.9296
8						2.1273	12.6598	144.3721
9						2.1441	15.1056	154.4340
10						1.4000	14.2300	154.0150
11						3.0588	15.9725	154.7096
12						0.8266	13.3456	153.5614
13						5.8469	14.3478	152.3099
14						4.9911	15.5936	153.2852
15						4.1441	16.8306	154.9098
16						3.1875	11.4838	134.7187
17						1.8044	11.9694	139.7209
18						0.4237	12.4525	152.5827
19						2.0344	15.2103	154.7712
20						1.2800	14.3200	154.5201
21						2.9625	16.0887	154.9232
22						0.6994	13.4178	154.2866
23						4.0644	16.9553	155.0355
24						0.2925	12.5037	153.5707
25						6.8100	15.0500	153.5261
26						6.1000	16.3700	154.1107
27						5.4000	17.6800	155.0395
28						5.3400	17.8100	155.1139
29						3.0869	11.0403	129.1960
30						1.6386	11.2961	133.0223
31						0.1916	11.5506	150.4510
32						0.0594	11.5778	154.5046
33						7.2091	15.3441	153.9100
34						6.5538	16.6739	154.3554
35						5.9059	18.0200	155.0804
36						5.8544	18.1544	155.1307
37						3.1300	10.6400	124.1252
38						1.6300	10.6400	123.5315
39						0.1300	10.6400	123.5111
40						0.0000	10.6400	123.9204
41						7.8038	15.6287	154.2687
42						7.2100	16.9706	154.5677
43						6.6213	18.3550	155.1068
44						6.5775	18.4925	155.1460
45						3.0397	10.2559	119.1247
46						1.5559	10.0748	115.2346
47						0.0772	9.8925	97.1668

48  
49  
50  
51  
52  
53  
54  
55  
56  
57  
58  
59  
60  
61  
62  
63  
64  
65  
66  
67  
68  
69  
70  
71  
72  
73  
74  
75  
76  
77  
78  
79  
80  
81  
82  
83  
84  
85  
86  
87  
88  
89  
90  
91  
92  
93  
94  
95  
96  
97  
98  
99  
100  
101

ORIGINAL PAGE IS  
OF POOR QUALITY

-0.0594	9.8781	92.0556
8.5941	15.9040	154.5623
8.0688	17.2601	154.7453
7.5459	18.6850	155.1289
7.5094	18.8243	155.1588
3.0913	9.8112	113.2342
1.6412	9.4569	108.1028
0.2013	9.1000	93.2964
0.0625	9.0725	91.9792
9.5800	16.1700	154.7605
9.1300	17.5425	154.8743
8.6800	19.0100	155.1474
8.6500	19.1500	155.1694
3.2847	9.3059	107.4809
1.8859	8.7861	102.8803
0.5022	8.2625	91.9885
0.3656	8.2231	91.1432
10.7616	16.4266	154.8534
10.3938	17.8177	154.9407
10.0234	19.3300	155.1605
9.9994	19.4693	155.1775
3.6200	8.7400	102.4331
2.2900	8.0625	98.9507
0.9800	7.3800	91.4340
0.8500	7.3300	90.8650
12.1388	16.6737	154.8177
11.8600	18.0856	154.9131
11.5763	19.6450	155.1579
11.5575	19.7825	155.1759
4.0972	8.1134	98.3440
2.8534	7.2861	95.8928
1.6347	6.4525	90.9115
1.5156	6.3931	90.5528
13.7116	16.9116	154.5817
13.5288	18.3464	154.7357
13.3384	19.9550	155.1338
13.3244	20.0894	155.1635
4.7163	7.4263	95.3039
3.5763	6.4569	93.6887
2.4663	5.4800	90.5535
2.3625	5.4125	90.3444
15.4800	17.1400	153.8904
15.4000	18.6000	154.2581
15.3100	20.2600	155.0557
15.3000	20.3900	155.1067
5.4772	6.6784	93.2149
4.4584	5.5748	92.1772
3.4747	4.4625	90.3037
3.3906	4.3881	90.1936
16.3600	17.2000	153.0317
16.6300	17.7400	152.9341
15.8000	17.8000	153.7650
15.8025	18.9350	154.2794
15.8000	20.2600	155.0328

ORIGINAL PAGE IS  
OF POOR QUALITY

102	15.8000	20.3900	155.0989
103	6.3800	5.8700	91.8505
104	5.5000	4.6400	91.1968
105	4.6600	3.4000	90.1492
106	4.6000	3.3200	90.0924
107	16.8200	17.2300	152.0987
108	16.9700	18.0400	152.8914
109	17.0800	18.8300	153.7508
110	16.8200	18.2800	153.2712
111	16.3800	18.3600	153.6377
112	16.3400	19.2200	154.3084
113	16.3000	20.2600	155.0112
114	16.3000	20.3900	155.0851
115	6.7350	5.5134	91.4067
116	5.9581	4.2261	90.8833
117	5.2137	2.9275	90.1065
118	5.1578	2.6425	90.0704
119	17.2200	17.2200	150.9112
120	17.2200	18.3000	153.1369
121	17.2200	19.3400	154.2458
122	16.7600	19.0000	154.0092
123	17.2200	19.4600	154.3388
124	16.7600	19.5750	154.4896
125	16.7600	20.2600	154.9978
126	16.7600	20.3900	155.0772
127	7.2900	5.1663	90.9979
128	6.6150	3.8294	90.6383
129	5.9650	2.4800	90.0829
130	5.9137	2.3900	90.0547
131	17.8400	17.5400	151.4541
132	17.9050	18.4900	153.2845
133	17.2200	15.6538	144.1907
134	17.8725	15.7737	144.6731
135	17.9700	19.3600	154.2331
136	17.9700	19.5000	154.3391
137	17.2200	19.8400	154.6544
138	17.9700	19.8750	154.6646
139	17.2200	20.2600	154.9879
140	17.2200	20.3900	155.0715
141	8.0450	4.8284	90.6712
142	7.4706	3.4498	90.4450
143	6.9137	2.0575	90.0612
144	6.8678	1.9625	90.0401
145	18.4700	17.8600	152.5973
146	18.4700	18.6700	153.6167
147	18.4700	15.8938	145.1270
148	18.4700	19.3600	154.2830
149	17.2200	14.1600	138.0302
150	17.9050	14.1600	138.0316
151	18.4700	14.1600	138.0318
152	18.4700	19.5400	154.4113
153	18.4700	19.9100	154.7148
154	17.9700	20.2600	154.9807
155	18.4700	20.2600	154.9871

156		17.9700	20.3900	155.0665
157		9.0000	4.5000	90.4415
158		8.5250	3.0875	90.3062
159		8.0600	1.6600	90.0439
160		8.0200	1.5600	90.0285
161		19.4700	17.8700	153.7898
162		19.4700	18.6550	154.0946
163		19.4700	19.3700	154.5283
164		19.4700	19.5200	154.6021
165		17.2200	12.7388	132.1555
166		17.9375	12.6987	132.0249
167		18.4700	12.6587	131.8744
168		19.4700	19.8925	154.8245
169		19.4700	20.2600	155.0414
170		18.4700	20.3900	155.0680
171		19.4700	20.3900	155.1040
172		10.1550	4.1809	90.3129
173		9.7781	2.7423	90.2227
174		9.4038	1.2875	90.0314
175		9.3703	1.1825	90.0198
176		20.4700	17.8800	154.1075
177		20.4700	18.6400	154.3112
178		20.4700	19.3800	154.7841
179		20.4700	19.5100	154.8236
180		20.4700	19.8800	154.9594
181		17.2200	11.3900	126.2683
182		17.9700	11.3900	126.7595
183		18.4700	11.3900	126.8414
184		20.4700	20.2600	155.0976
185		20.4700	20.3900	155.1358
186		11.5100	3.8713	90.2962
187		11.2300	2.4144	90.2166
188		10.9450	0.9400	90.0313
189		10.9187	0.8300	90.0196
190		21.7062	19.3500	155.1174
191		21.7012	19.4887	155.1178
192		21.7181	19.8631	155.1418
193		21.7325	20.2350	155.1785
194		17.2200	10.6400	124.3878
195		17.9700	10.6400	124.4096
196		16.4700	10.6400	124.3720
197		16.4700	11.3900	125.3677
198		18.4700	10.6400	124.4140
199		21.7387	20.3550	155.1893
200		13.0650	3.5709	90.4361
201		12.8806	2.1036	90.3264
202		12.6838	0.6175	90.0457
203		12.6653	0.5025	90.0261
204		22.9400	19.3000	155.1814
205		22.9400	19.4400	155.1815
206		22.9675	19.8175	155.1866
207		22.9900	20.1800	155.1946
208		23.0000	20.3000	155.1970
209		17.2200	9.8500	122.3997

ORIGINAL PAGE IS  
OF POOR QUALITY



ORIGINAL PAGE IS  
OF POOR QUALITY

210	17.9700	9.8500	121.9564
211	16.4700	9.8500	123.2855
212	18.4700	9.8500	121.8808
213	14.8200	3.2800	90.9077
214	14.7300	1.8100	90.6688
215	14.6200	0.3200	90.1157
216	14.6100	0.2000	90.0768
217	24.1712	19.2300	155.1958
218	24.1862	19.3637	155.1959
219	24.2181	19.7431	155.1970
220	24.2425	20.0950	155.1988
221	24.2537	20.2250	155.1994
222	17.2200	8.1750	115.1947
223	17.9400	8.2131	115.3302
224	18.4700	8.2537	115.4882
225	15.2600	2.7000	91.1052
226	15.2650	1.4925	90.7231
227	16.0200	3.2000	91.7380
228	16.3000	2.6500	91.8801
229	15.2600	0.2800	90.1457
230	15.2400	0.1500	90.0878
231	25.4000	19.1400	155.1987
232	25.4400	19.2600	155.1988
233	25.4700	19.6400	155.1991
234	25.4900	19.9800	155.1997
235	25.5000	20.1300	155.1999
236	17.2200	6.5000	108.2843
237	17.9100	6.4975	108.2734
238	18.4700	6.5000	108.2838
239	15.9800	2.1000	91.3425
240	15.9400	1.1600	90.7478
241	16.6000	2.1200	91.7607
242	15.9000	0.2300	90.1710
243	16.6000	3.1600	92.6067
244	16.7350	2.3650	92.1014
245	16.8800	1.5800	91.3814
246	15.8800	0.1000	90.1029
247	27.4722	18.9144	155.1998
248	27.5022	19.0455	155.1998
249	27.5397	19.4275	155.1999
250	27.5722	19.7844	155.2000
251	27.5855	19.8989	155.2000
252	17.2200	4.8250	101.3809
253	17.8800	4.7031	100.8879
254	18.4700	4.5887	100.4528
255	16.6000	1.5100	91.2262
256	16.5800	0.8375	90.6678
257	16.5600	0.2000	90.1982
258	16.5500	0.0700	90.1203
259	17.2200	3.1500	94.2286
260	17.2200	2.1000	92.0724
261	17.2200	1.0500	90.9383
262	17.2200	0.9300	90.8391
263	29.5188	18.6544	155.2000

264		29.5422	18.7922	155.2000
265		29.5856	19.1733	155.2000
266		29.6289	19.5444	155.2000
267		29.6455	19.6355	155.2000
268	ORIGINAL PAGE IS	17.8500	2.8300	93.6769
269	OF POOR QUALITY	18.4700	2.5200	92.5586
270		17.2200	0.5200	90.4926
271		17.2200	0.1700	90.2098
272		17.2200	0.0500	90.1317
273		17.9100	1.9350	91.9496
274		17.9700	1.0300	90.9540
275		17.9700	0.9100	90.8619
276		17.9700	0.5200	90.5194
277		31.5400	18.3600	155.2000
278		31.5600	18.5000	155.2000
279		31.6075	18.8775	155.2000
280		31.6600	19.2600	155.2000
281		31.6800	19.3400	155.2000
282		18.4700	1.7800	91.6346
283		19.4700	2.5400	91.3945
284		19.4700	1.7900	91.1279
285		17.9700	0.1600	90.2209
286		17.9700	0.0300	90.1343
287		18.4700	1.0200	90.8996
288		18.4700	0.9000	90.8143
289		18.4700	0.5200	90.5006
290		18.4700	0.1400	90.2044
291		33.5355	18.0311	155.2000
292		33.5555	18.1689	155.2000
293		33.6055	18.5400	155.2000
294		33.6655	18.9311	155.2000
295		33.6888	19.0122	155.2000
296		19.4700	1.0300	90.6696
297		20.4700	2.5600	91.1005
298		20.4700	1.8000	90.9125
299		20.4700	1.0400	90.4442
300		18.4700	0.0200	90.1300
301		19.4700	0.9000	90.6054
302		19.4350	0.5150	90.3788
303		19.4100	0.1400	90.1577
304		19.4100	0.0200	90.0994
305		35.5055	17.6678	155.2000
306		35.5289	17.7989	155.2000
307		35.5797	18.1608	155.2000
308		35.6455	18.5578	155.2000
309		35.6722	18.6522	155.2000
310		20.4700	0.9100	90.3968
311		21.2187	1.0387	90.1452
312		21.2175	0.9162	90.1430
313		20.4700	0.5200	90.2397
314		20.4900	0.1500	90.0937
315		20.4700	0.0400	90.0601
316		37.4500	17.2700	155.2000
317		37.4800	17.3900	155.2000

318		37.5299	17.7400	155.2000
319		37.6000	18.1400	155.2000
320		37.6300	18.2600	155.2000
321	ORIGINAL PAGE IS OF POOR QUALITY	21.2100	0.5300	90.1030
322		22.2900	1.0800	90.0357
323		22.2900	0.9600	90.0355
324		22.2850	0.5800	90.0275
325		21.2175	0.1538	90.0439
326		21.2100	0.0375	90.0284
327		37.8422	17.2166	155.2000
328		37.8555	17.3455	155.2000
329		37.8680	17.7036	155.2000
330		37.8988	18.1066	155.2000
331	37.9122	18.2377	155.2000	
332	22.2900	0.2000	90.0110	
333	23.6837	1.1637	90.0063	
334	23.6875	1.0413	90.0062	
335	23.6950	0.6700	90.0048	
336	23.7075	0.2887	90.0019	
337	22.2900	0.0800	90.0062	
338	38.8589	16.9933	155.2000	
339	38.8622	17.1289	155.2000	
340	38.8555	17.4911	155.2000	
341	38.8655	17.8933	155.2000	
342	38.8689	18.0311	155.2000	
343	23.7100	0.1675	90.0010	
344	25.4000	1.2900	90.0013	
345	25.4100	1.1600	90.0013	
346	25.4400	0.8000	90.0009	
347	25.4700	0.4200	90.0002	
348	25.4700	0.3000	90.0001	
349	40.5000	16.6000	155.2000	
350	40.5000	16.7400	155.2000	
351	40.4925	17.1025	155.2000	
352	40.5000	17.5000	155.2000	
353	40.5000	17.6400	155.2000	
354	27.3933	1.5367	90.0002	
355	27.4111	1.4111	90.0002	
356	27.4577	1.0478	90.0001	
357	27.5011	0.6711	90.0000	
358	27.5155	0.5456	90.0000	
359	42.7655	16.0367	155.2000	
360	42.7689	16.1789	155.2000	
361	42.7788	16.5378	155.2000	
362	42.8022	16.9267	155.2000	
363	42.8055	17.0644	155.2000	
364	29.3733	1.8133	90.0000	
365	29.3978	1.6911	90.0000	
366	29.4577	1.3244	90.0000	
367	29.5111	0.9511	90.0000	
368	29.5355	0.8222	90.0000	
369	45.6555	15.3033	155.2000	
370	45.6689	15.4456	155.2000	
371	45.7147	15.7970	155.2000	

C - 2

ORIGINAL PAGE IS  
OF POOR QUALITY

372	45.7722	16.1733	155.2000
373	45.7855	16.3044	155.2000
374	31.3400	2.1200	90.0000
375	31.3700	2.0000	90.0000
376	31.4409	1.6300	90.0000
377	31.5000	1.2600	90.0000
378	31.5300	1.1300	90.0000
379	49.1700	14.4000	155.2000
380	49.2000	14.5400	155.2000
381	49.2999	14.8800	155.2000
382	49.4100	15.2400	155.2000
383	49.4400	15.3600	155.2000
384	33.2933	2.4567	90.0000
385	33.3277	2.3378	90.0000
386	33.4044	1.9644	90.0000
387	33.4677	1.5978	90.0000
388	33.4989	1.4689	90.0000
389	50.4525	14.0200	155.2000
390	50.5025	14.1600	155.2000
391	50.6056	14.5037	155.2000
392	50.7162	14.8625	155.2000
393	50.7450	14.9675	155.2000
394	35.2333	2.8233	90.0000
395	35.2711	2.7044	90.0000
396	35.3511	2.3278	90.0000
397	35.4144	1.9644	90.0000
398	35.4422	1.8389	90.0000
399	51.7400	13.6400	155.2000
400	51.3000	13.7800	155.2000
401	51.9075	14.1250	155.2000
402	52.0200	14.4800	155.2000
403	52.0500	14.5800	155.2000
404	37.1600	3.2200	90.0000
405	37.2000	3.1000	90.0000
406	37.2800	2.7200	90.0000
407	37.3400	2.3600	90.0000
408	37.3600	2.2400	90.0000
409	53.0325	13.2600	155.2000
410	53.0925	13.4000	155.2000
411	53.2056	13.7437	155.2000
412	53.3212	14.0925	155.2000
413	53.3550	14.1975	155.2000
414	39.1844	3.6967	90.0000
415	39.2222	3.5822	90.0000
416	39.3083	3.1958	90.0000
417	39.3811	2.8344	90.0000
418	39.4156	2.7244	90.0000
419	54.3300	12.8800	155.2000
420	54.3800	13.0200	155.2000
421	54.5000	13.3600	155.2000
422	54.6200	13.7000	155.2000
423	54.6600	13.8200	155.2000
424	41.2044	4.1933	90.0000
425	41.2422	4.0822	90.0000

ORIGINAL PAGE IS  
OF POOR QUALITY

426	41.3333	3.6933	90.0000
427	41.4178	3.3344	90.0000
428	41.4622	3.2278	90.0000
429	55.0600	12.6600	155.2000
430	55.0600	12.8300	155.2000
431	54.1000	12.1600	155.2000
432	55.0600	11.8600	155.2000
433	55.0600	13.2100	155.2000
434	55.0600	13.5800	155.2000
435	55.0600	13.7000	155.2000
436	43.2200	4.7100	90.0000
437	43.2600	4.6000	90.0000
438	43.3549	4.2125	90.0000
439	43.4500	3.8600	90.0000
440	43.5000	3.7500	90.0000
441	45.2311	5.2467	90.0000
442	45.2755	5.1355	90.0000
443	45.3733	4.7533	90.0000
444	45.4777	4.4111	90.0000
445	45.5289	4.2911	90.0000
446	47.2377	5.8033	90.0000
447	47.2888	5.6889	90.0000
448	47.3883	5.3158	90.0000
449	47.5011	4.9878	90.0000
450	47.5488	4.8511	90.0000
451	49.2400	6.3800	90.0000
452	49.3000	6.2600	90.0000
453	49.4000	5.9000	90.0000
454	49.5200	5.5900	90.0000
455	49.5600	5.4300	90.0000
456	50.5250	6.7750	90.0000
457	50.5550	6.6475	90.0000
458	50.6637	6.2981	90.0000
459	50.7825	5.9812	90.0000
460	50.8250	5.6675	90.0000
461	51.8000	7.1800	90.0000
462	51.8200	7.0500	90.0000
463	51.9350	6.7075	90.0000
464	52.0500	6.3800	90.0000
465	52.1000	6.0200	90.0000
466	53.0650	7.5950	90.0000
467	53.0950	7.4675	90.0000
468	53.2137	7.1281	90.0000
469	53.3225	6.7863	90.0000
470	53.3850	6.4875	90.0000
471	54.3200	8.0200	90.0000
472	54.3800	7.9000	90.0000
473	54.5000	7.5600	90.0000
474	54.6000	7.2000	90.0000
475	54.6800	7.0700	90.0000
476	55.0600	8.2600	90.0000
477	55.0600	8.1400	90.0000
478	55.0600	9.0500	90.0000
479	54.0800	8.7400	90.0000

ORIGINAL PAGE IS  
OF POOR QUALITY

480					55.0600	7.7300	90.0000
481					55.0600	7.3400	90.0000
482					55.0600	7.2000	90.0000
483					55.0600	10.455	122.6000
484					55.3100	13.700	155.2000
485					55.3100	13.640	155.2000
486					55.3100	13.210	155.2000
487					55.3100	12.830	155.2000
488					55.3100	12.660	155.2000
489					55.3100	11.860	155.2000
490					55.3100	10.455	122.6000
491					55.3100	9.0500	90.0000
492					55.3100	8.2600	90.0000
493					55.3100	8.1400	90.0000
494					55.3100	7.7300	90.0000
495					55.3100	7.3400	90.0000
496					55.3100	7.2000	90.0000
4	388	45	1	1	2		
1						-15.0000	
	70.0	770000.0	164000.0	1380000.00	.4400000000	.166000010.25500000	76000.0
0.000027050.000030380.00001457							
2						-8.9994	
	70.0	770000.0	164000.0	1380000.00	.4400000000	.166000010.25500000	76000.0
0.000027050.000030380.00001457							
3						0.0000	
	70.0	770000.0	164000.0	1380000.00	.4400000000	.166000010.25500000	76000.0
0.000027050.000030380.00001457							
4						21.9981	
	70.0	770000.0	164000.0	1380000.00	.4400000000	.166000010.25500000	76000.0
0.000027050.000030380.00001457							
5						9.9993	
	70.0	770000.0	164000.0	1380000.00	.4400000000	.166000010.25500000	76000.0
0.000027050.000030380.00001457							
6						69.9948	
	70.0	770000.0	164000.0	1380000.00	.4400000000	.166000010.25500000	76000.0
0.000027050.000030380.00001457							
7						39.9970	
	70.0	770000.0	164000.0	1380000.00	.4400000000	.166000010.25500000	76000.0
0.000027050.000030380.00001457							
8						139.9907	
	70.0	770000.0	164000.0	1380000.00	.4400000000	.166000010.25500000	76000.0
0.000027050.000030380.00001457							
9						109.9917	
	70.0	770000.0	164000.0	1380000.00	.4400000000	.166000010.25500000	76000.0
0.000027050.000030380.00001457							
10						169.9851	
	70.0	770000.0	164000.0	1380000.00	.4400000000	.166000010.25500000	76000.0
0.000027050.000030380.00001457							
11						157.9873	
	70.0	770000.0	164000.0	1380000.00	.4400000000	.166000010.25500000	76000.0
0.000027050.000030380.00001457							
12						179.9866	
	70.0	770000.0	164000.0	1380000.00	.4400000000	.166000010.25500000	76000.0
0.000027050.000030380.00001457							

ORIGINAL PAGE IS  
OF POOR QUALITY

13			188.9861		
70.0	770000.0	164000.0	1380000.00.440000000.166000010.25500000	76000.0	
0.000027050.000030380.00001457					
14			194.9855		
70.0	770000.0	164000.0	1380000.00.440000000.166000010.25500000	76000.0	
0.000027050.000030380.00001457					
15			188.9861		
70.0	770000.0	164000.0	1380000.00.440000000.166000010.25500000	76000.0	
0.000027050.000030380.00001457					
16			179.9866		
70.0	770000.0	164000.0	1380000.00.440000000.166000010.25500000	76000.0	
0.000027050.000030380.00001457					
17			0.0000		
70.0	770000.0	164000.0	1380000.00.440000000.166000010.25500000	76000.0	
0.000027050.000030380.00001457					
18			-8.9994		
70.0	770000.0	164000.0	1380000.00.440000000.166000010.25500000	76000.0	
0.000027050.000030380.00001457					
19			-15.0000		
70.0	770000.0	164000.0	1380000.00.440000000.166000010.25500000	76000.0	
0.000027050.000030380.00001457					
20			-15.0000		
70.0	97500.0	132600.0	1950000.00.287000000.022000000.02000000	14000.0	
0.000034900.000025900.00000210					
21			-15.0000		
70.0	1000.0	1500.0	3000.00.399999980.020000000.02000000	500.0	
0.000000500.000000500.00000050					
22			-8.9994		
70.0	1000.0	1500.0	3000.00.399999980.020000000.02000000	500.0	
0.000000500.000000500.00000050					
23			0.0000		
70.0	97500.0	132600.0	1950000.00.287000000.022000000.02000000	14000.0	
0.000034900.000025900.00000210					
24			21.9981		
70.0	97500.0	132600.0	1950000.00.287000000.022000000.02000000	14000.0	
0.000034900.000025900.00000210					
25			9.9993		
70.0	97500.0	132600.0	1950000.00.287000000.022000000.02000000	14000.0	
0.000034900.000025900.00000210					
26			21.9981		
70.0	97500.0	132600.0	1950000.00.287000000.022000000.02000000	14000.0	
0.000034900.000025900.00000210					
27			9.9993		
70.0	97500.0	132600.0	1950000.00.287000000.022000000.02000000	14000.0	
0.000034900.000025900.00000210					
28			69.9925		
70.0	97500.0	132600.0	1950000.00.287000000.022000000.02000000	14000.0	
0.000034900.000025900.00000210					
29			39.9970		
70.0	97500.0	132600.0	1950000.00.287000000.022000000.02000000	14000.0	
0.000034900.000025900.00000210					
30			69.9925		
70.0	97500.0	132600.0	1950000.00.287000000.022000000.02000000	14000.0	
0.000034900.000025900.00000210					

ORIGINAL PAGE IS  
OF POOR QUALITY

31				39.9970			
	70.0	97500.0	132600.0	1950000.00	.287000000	.022000000	.02000000 14000.0
	0.000034900	.000025900	.00000210				
32				139.9907			
	70.0	97500.0	132600.0	1950000.00	.287000000	.022000000	.02000000 14000.0
	0.000034900	.000025900	.00000210				
33				109.9917			
	70.0	97500.0	132600.0	1950000.00	.287000000	.022000000	.02000000 14000.0
	0.000034900	.000025900	.00000210				
34				139.9907			
	70.0	97500.0	132600.0	1950000.00	.287000000	.022000000	.02000000 14000.0
	0.000034900	.000025900	.00000210				
35				109.9917			
	70.0	97500.0	132600.0	1950000.00	.287000000	.022000000	.02000000 14000.0
	0.000034900	.000025900	.00000210				
36				169.9851			
	70.0	97500.0	132600.0	1950000.00	.287000000	.022000000	.02000000 14000.0
	0.000034900	.000025900	.00000210				
37				157.9873			
	70.0	97500.0	132600.0	1950000.00	.287000000	.022000000	.02000000 14000.0
	0.000034900	.000025900	.00000210				
38				169.9851			
	70.0	97500.0	132600.0	1950000.00	.287000000	.022000000	.02000000 14000.0
	0.000034900	.000025900	.00000210				
39				157.9873			
	70.0	97500.0	132600.0	1950000.00	.287000000	.022000000	.02000000 14000.0
	0.000034900	.000025900	.00000210				
40				179.9866			
	70.0	97500.0	132600.0	1950000.00	.287000000	.022000000	.02000000 14000.0
	0.000034900	.000025900	.00000210				
41				188.9861			
	70.0	1000.0	1500.0	3000.00	.399999980	.020000000	.02000000 500.0
	0.000000500	.000000500	.00000050				
42				194.9855			
	70.0	1000.0	1500.0	3000.00	.399999980	.020000000	.02000000 500.0
	0.000000500	.000000500	.00000050				
43				194.9855			
	70.0	97500.0	132600.0	1950000.00	.287000000	.022000000	.02000000 14000.0
	0.000034900	.000025900	.00000210				
44				0.0000			
	70.0	97500.0	132600.0	1950000.00	.287000000	.022000000	.02000000 14000.0
	0.000034900	.000025900	.00000210				
45				90.0000			
	70.0	770000.0	164000.0	1380000.00	.440000000	.166000010	.25500000 76000.0
	0.000027050	.000030380	.00001457				
	1.00						

1	422	434	435	423	1	70.0000	4	1.0000
2	382	392	393	383	1	70.0000	4	1.0000
3	392	402	403	393	1	70.0000	4	1.0000
4	402	412	413	403	1	70.0000	4	1.0000
5	412	422	423	413	1	70.0000	4	1.0000



ORIGINAL PAGE IS  
OF POOR QUALITY

6	319	330	331	320	1	70.0000	4	1.0000
7	330	341	342	331	1	70.0000	4	1.0000
8	341	352	353	342	1	70.0000	4	1.0000
9	352	362	363	353	1	70.0000	4	1.0000
10	362	372	373	363	1	70.0000	4	1.0000
11	372	382	383	373	1	70.0000	4	1.0000
12	234	250	251	235	2	70.0000	4	1.0000
13	250	266	267	251	2	70.0000	4	1.0000
14	266	280	281	267	2	70.0000	4	1.0000
15	280	294	295	281	2	70.0000	4	1.0000
16	294	308	309	295	2	70.0000	4	1.0000
17	308	319	320	309	2	70.0000	4	1.0000
18	184	193	199	185	3	70.0000	4	1.0000
19	193	207	208	199	3	70.0000	4	1.0000
20	207	220	221	208	3	70.0000	4	1.0000
21	220	234	235	221	3	70.0000	4	1.0000
22	155	169	171	170	3	70.0000	4	1.0000
23	169	184	185	171	3	70.0000	4	1.0000
24	139	154	156	140	3	70.0000	4	1.0000
25	154	155	170	156	3	70.0000	4	1.0000
26	113	125	126	114	3	70.0000	4	1.0000
27	125	139	140	126	3	70.0000	4	1.0000
28	91	101	102	92	3	70.0000	4	1.0000
29	101	113	114	102	3	70.0000	4	1.0000
30	27	35	36	28	4	70.0000	4	1.0000
31	35	43	44	36	4	70.0000	4	1.0000
32	43	51	52	44	4	70.0000	4	1.0000
33	51	59	60	52	4	70.0000	4	1.0000
34	59	67	68	60	5	70.0000	4	1.0000
35	67	75	76	68	5	70.0000	4	1.0000
36	75	83	84	76	5	70.0000	4	1.0000
37	83	91	92	84	5	70.0000	4	1.0000
38	39	31	32	40	6	70.0000	4	1.0000
39	31	18	24	32	6	70.0000	4	1.0000
40	18	12	22	24	6	70.0000	4	1.0000
41	12	10	20	22	6	70.0000	4	1.0000
42	10	9	19	20	7	70.0000	4	1.0000
43	9	11	21	19	7	70.0000	4	1.0000
44	11	15	23	21	7	70.0000	4	1.0000
45	15	27	28	23	7	70.0000	4	1.0000
46	105	95	96	106	8	70.0000	4	1.0000
47	95	87	88	96	8	70.0000	4	1.0000
48	87	79	80	88	8	70.0000	4	1.0000
49	79	71	72	80	8	70.0000	4	1.0000
50	71	63	64	72	9	70.0000	4	1.0000
51	63	55	56	64	9	70.0000	4	1.0000
52	55	47	48	56	9	70.0000	4	1.0000
53	47	39	40	48	9	70.0000	4	1.0000
54	215	202	203	216	10	70.0000	4	1.0000
55	202	188	189	203	10	70.0000	4	1.0000
56	188	174	175	189	10	70.0000	4	1.0000
57	174	159	160	175	10	70.0000	4	1.0000
58	159	143	144	160	11	70.0000	4	1.0000
59	143	129	130	144	11	70.0000	4	1.0000

ORIGINAL PAGE IS  
OF POOR QUALITY

60	129	117	118	130	11	70.0000	4	1.0000
61	117	105	106	118	11	70.0000	4	1.0000
62	242	229	230	246	12	70.0000	4	1.0000
63	229	215	216	230	12	70.0000	4	1.0000
64	271	257	258	272	12	70.0000	4	1.0000
65	257	242	246	258	12	70.0000	4	1.0000
66	290	285	286	300	12	70.0000	4	1.0000
67	285	271	272	286	12	70.0000	4	1.0000
68	314	303	304	315	12	70.0000	4	1.0000
69	303	290	300	304	12	70.0000	4	1.0000
70	347	336	343	348	12	70.0000	4	1.0000
71	336	332	337	343	12	70.0000	4	1.0000
72	332	325	326	337	12	70.0000	4	1.0000
73	325	314	315	326	12	70.0000	4	1.0000
74	407	397	398	408	13	70.0000	4	1.0000
75	397	387	388	398	13	70.0000	4	1.0000
76	387	377	378	388	13	70.0000	4	1.0000
77	377	367	368	378	13	70.0000	4	1.0000
78	367	357	358	368	13	70.0000	4	1.0000
79	357	347	348	358	13	70.0000	4	1.0000
80	454	449	450	455	14	70.0000	4	1.0000
81	449	444	445	450	14	70.0000	4	1.0000
82	444	439	440	445	14	70.0000	4	1.0000
83	439	427	428	440	14	70.0000	4	1.0000
84	427	417	418	428	14	70.0000	4	1.0000
85	417	407	408	418	14	70.0000	4	1.0000
86	474	469	470	475	14	70.0000	4	1.0000
87	469	464	465	470	14	70.0000	4	1.0000
88	464	459	460	465	14	70.0000	4	1.0000
89	459	454	455	460	14	70.0000	4	1.0000
90	481	474	475	482	14	70.0000	4	1.0000
91	476	471	472	477	14	70.0000	4	1.0000
92	471	466	467	472	14	70.0000	4	1.0000
93	466	461	462	467	14	70.0000	4	1.0000
94	461	456	457	462	14	70.0000	4	1.0000
95	456	451	452	457	14	70.0000	4	1.0000
96	451	446	447	452	14	70.0000	4	1.0000
97	446	441	442	447	14	70.0000	4	1.0000
98	441	436	437	442	14	70.0000	4	1.0000
99	436	424	425	437	14	70.0000	4	1.0000
100	424	414	415	425	14	70.0000	4	1.0000
101	414	404	405	415	14	70.0000	4	1.0000
102	404	394	395	405	15	70.0000	4	1.0000
103	394	384	385	395	15	70.0000	4	1.0000
104	384	374	375	385	15	70.0000	4	1.0000
105	374	364	365	375	15	70.0000	4	1.0000
106	364	354	355	365	15	70.0000	4	1.0000
107	354	344	345	355	15	70.0000	4	1.0000
108	344	333	334	345	16	70.0000	4	1.0000
109	333	322	323	334	16	70.0000	4	1.0000
110	322	311	312	323	16	70.0000	4	1.0000
111	311	299	310	312	16	70.0000	4	1.0000
112	299	296	301	310	16	70.0000	4	1.0000
113	296	287	288	301	16	70.0000	4	1.0000

ORIGINAL PAGE IS  
OF POOR QUALITY

114	287	274	275	288	16	70.0000	4	1.0000
115	274	261	262	275	16	70.0000	4	1.0000
116	121	135	136	123	17	70.0000	4	1.0000
117	135	148	152	136	17	70.0000	4	1.0000
118	148	163	164	152	17	70.0000	4	1.0000
119	163	178	179	164	17	70.0000	4	1.0000
120	178	190	191	179	17	70.0000	4	1.0000
121	190	204	205	191	17	70.0000	4	1.0000
122	204	217	218	205	17	70.0000	4	1.0000
123	217	231	232	218	17	70.0000	4	1.0000
124	231	247	248	232	18	70.0000	4	1.0000
125	247	263	264	248	18	70.0000	4	1.0000
126	263	277	278	264	18	70.0000	4	1.0000
127	277	291	292	278	18	70.0000	4	1.0000
128	291	305	306	292	18	70.0000	4	1.0000
129	305	316	317	306	18	70.0000	4	1.0000
130	316	327	328	317	19	70.0000	4	1.0000
131	327	338	339	328	19	70.0000	4	1.0000
132	338	349	350	339	19	70.0000	4	1.0000
133	349	359	360	350	19	70.0000	4	1.0000
134	359	369	370	360	19	70.0000	4	1.0000
135	369	379	380	370	19	70.0000	4	1.0000
136	379	389	390	380	19	70.0000	4	1.0000
137	389	399	400	390	19	70.0000	4	1.0000
138	399	409	410	400	19	70.0000	4	1.0000
139	409	419	420	410	19	70.0000	4	1.0000
140	419	429	430	420	19	70.0000	4	1.0000
141	431	432	429	419	20	70.0000	4	1.0000
142	421	433	434	422	20	70.0000	4	1.0000
143	420	430	433	421	20	70.0000	4	1.0000
144	381	391	392	382	20	70.0000	4	1.0000
145	391	401	402	392	20	70.0000	4	1.0000
146	401	411	412	402	20	70.0000	4	1.0000
147	411	421	422	412	20	70.0000	4	1.0000
148	380	390	391	381	20	70.0000	4	1.0000
149	390	400	401	391	20	70.0000	4	1.0000
150	400	410	411	401	20	70.0000	4	1.0000
151	410	420	421	411	20	70.0000	4	1.0000
152	318	329	330	319	21	70.0000	4	1.0000
153	329	340	341	330	21	70.0000	4	1.0000
154	340	351	352	341	21	70.0000	4	1.0000
155	351	361	362	352	21	70.0000	4	1.0000
156	361	371	372	362	21	70.0000	4	1.0000
157	371	381	382	372	21	70.0000	4	1.0000
158	317	328	329	318	21	70.0000	4	1.0000
159	328	339	340	329	21	70.0000	4	1.0000
160	339	350	351	340	21	70.0000	4	1.0000
161	350	360	361	351	21	70.0000	4	1.0000
162	360	370	371	361	21	70.0000	4	1.0000
163	370	380	381	371	21	70.0000	4	1.0000
164	233	249	250	234	22	70.0000	4	1.0000
165	249	265	266	250	22	70.0000	4	1.0000
166	265	279	280	266	22	70.0000	4	1.0000
167	279	293	294	280	22	70.0000	4	1.0000

ORIGINAL PAGE IS  
OF POOR QUALITY

168	293	307	308	294	22	70.0000	4	1.0000
169	307	318	319	308	22	70.0000	4	1.0000
170	232	248	249	233	22	70.0000	4	1.0000
171	248	264	265	249	22	70.0000	4	1.0000
172	264	278	279	265	22	70.0000	4	1.0000
173	278	292	293	279	22	70.0000	4	1.0000
174	292	306	307	293	22	70.0000	4	1.0000
175	306	317	318	307	22	70.0000	4	1.0000
176	180	192	193	184	23	70.0000	4	1.0000
177	192	206	207	193	23	70.0000	4	1.0000
178	206	219	220	207	23	70.0000	4	1.0000
179	219	233	234	220	23	70.0000	4	1.0000
180	179	191	192	180	23	70.0000	4	1.0000
181	191	205	206	192	23	70.0000	4	1.0000
182	205	218	219	206	23	70.0000	4	1.0000
183	218	232	233	219	23	70.0000	4	1.0000
184	153	168	169	155	23	70.0000	4	1.0000
185	168	180	184	169	23	70.0000	4	1.0000
186	152	164	168	153	23	70.0000	4	1.0000
187	164	179	180	168	23	70.0000	4	1.0000
188	137	138	154	139	23	70.0000	4	1.0000
189	138	153	155	154	23	70.0000	4	1.0000
190	123	136	138	137	23	70.0000	4	1.0000
191	136	152	153	138	23	70.0000	4	1.0000
192	146	162	163	148	23	70.0000	4	1.0000
193	162	177	178	163	23	70.0000	4	1.0000
194	145	161	162	146	23	70.0000	4	1.0000
195	161	176	177	162	23	70.0000	4	1.0000
196	120	132	135	121	23	70.0000	4	1.0000
197	132	146	148	135	23	70.0000	4	1.0000
198	119	131	132	120	23	70.0000	4	1.0000
199	131	145	146	132	23	70.0000	4	1.0000
200	98	108	109	110	23	70.0000	4	1.0000
201	108	120	121	109	23	70.0000	4	1.0000
202	97	107	108	98	23	70.0000	4	1.0000
203	107	119	120	108	23	70.0000	4	1.0000
204	99	98	110	111	23	70.0000	4	1.0000
205	89	97	98	99	23	70.0000	4	1.0000
206	122	109	121	123	23	70.0000	4	1.0000
207	111	110	109	122	23	70.0000	4	1.0000
208	112	124	125	113	23	70.0000	4	1.0000
209	124	137	139	125	23	70.0000	4	1.0000
210	111	122	124	112	23	70.0000	4	1.0000
211	122	123	137	124	23	70.0000	4	1.0000
212	90	100	101	91	23	70.0000	4	1.0000
213	100	112	113	101	23	70.0000	4	1.0000
214	89	99	100	90	23	70.0000	4	1.0000
215	99	111	112	100	23	70.0000	4	1.0000
216	26	34	35	27	24	70.0000	4	1.0000
217	34	42	43	35	24	70.0000	4	1.0000
218	42	50	51	43	24	70.0000	4	1.0000
219	50	58	59	51	24	70.0000	4	1.0000
220	58	66	67	59	25	70.0000	4	1.0000
221	66	74	75	67	25	70.0000	4	1.0000

ORIGINAL PAGE IS  
OF POOR QUALITY

222	74	82	83	75	25	70.0000	4	1.0000
223	82	90	91	83	25	70.0000	4	1.0000
224	25	33	34	26	26	70.0000	4	1.0000
225	33	41	42	34	26	70.0000	4	1.0000
226	41	49	50	42	26	70.0000	4	1.0000
227	49	57	58	50	26	70.0000	4	1.0000
228	57	65	66	58	27	70.0000	4	1.0000
229	65	73	74	66	27	70.0000	4	1.0000
230	73	81	82	74	27	70.0000	4	1.0000
231	81	89	90	82	27	70.0000	4	1.0000
232	38	30	31	39	28	70.0000	4	1.0000
233	30	17	18	31	28	70.0000	4	1.0000
234	17	8	12	18	28	70.0000	4	1.0000
235	8	4	10	12	28	70.0000	4	1.0000
236	4	3	9	10	29	70.0000	4	1.0000
237	3	6	11	9	29	70.0000	4	1.0000
238	6	14	15	11	29	70.0000	4	1.0000
239	14	26	27	15	29	70.0000	4	1.0000
240	37	29	30	38	30	70.0000	4	1.0000
241	29	16	17	30	30	70.0000	4	1.0000
242	16	7	8	17	30	70.0000	4	1.0000
243	7	2	4	8	30	70.0000	4	1.0000
244	2	1	3	4	31	70.0000	4	1.0000
245	1	5	6	3	31	70.0000	4	1.0000
246	5	13	14	6	31	70.0000	4	1.0000
247	13	25	26	14	31	70.0000	4	1.0000
248	104	94	95	105	32	70.0000	4	1.0000
249	94	86	87	95	32	70.0000	4	1.0000
250	86	78	79	87	32	70.0000	4	1.0000
251	78	70	71	79	32	70.0000	4	1.0000
252	70	62	63	71	33	70.0000	4	1.0000
253	62	54	55	63	33	70.0000	4	1.0000
254	54	46	47	55	33	70.0000	4	1.0000
255	46	38	39	47	33	70.0000	4	1.0000
256	103	93	94	104	34	70.0000	4	1.0000
257	93	85	86	94	34	70.0000	4	1.0000
258	85	77	78	86	34	70.0000	4	1.0000
259	77	69	70	78	34	70.0000	4	1.0000
260	69	61	62	70	35	70.0000	4	1.0000
261	61	53	54	62	35	70.0000	4	1.0000
262	53	45	46	54	35	70.0000	4	1.0000
263	45	37	38	46	35	70.0000	4	1.0000
264	214	201	202	215	36	70.0000	4	1.0000
265	201	187	188	202	36	70.0000	4	1.0000
266	187	173	174	188	36	70.0000	4	1.0000
267	173	158	159	174	36	70.0000	4	1.0000
268	158	142	143	159	37	70.0000	4	1.0000
269	142	128	129	143	37	70.0000	4	1.0000
270	128	116	117	129	37	70.0000	4	1.0000
271	116	104	105	117	37	70.0000	4	1.0000
272	213	200	201	214	38	70.0000	4	1.0000
273	200	186	187	201	38	70.0000	4	1.0000
274	186	172	173	187	38	70.0000	4	1.0000
275	172	157	158	173	38	70.0000	4	1.0000

ORIGINAL PAGE IS  
OF POOR QUALITY

276	157	141	142	158	39	70.0000	4	1.0000
277	141	127	128	142	39	70.0000	4	1.0000
278	127	115	116	128	39	70.0000	4	1.0000
279	115	103	104	116	39	70.0000	4	1.0000
280	240	226	229	242	40	70.0000	4	1.0000
281	226	214	215	229	40	70.0000	4	1.0000
282	239	225	226	240	40	70.0000	4	1.0000
283	225	213	214	226	40	70.0000	4	1.0000
284	228	225	239	241	40	70.0000	4	1.0000
285	227	213	225	228	40	70.0000	4	1.0000
286	245	255	262	261	40	70.0000	4	1.0000
287	241	239	255	245	40	70.0000	4	1.0000
288	270	256	257	271	40	70.0000	4	1.0000
289	256	240	242	257	40	70.0000	4	1.0000
290	262	255	256	270	40	70.0000	4	1.0000
291	255	239	240	256	40	70.0000	4	1.0000
292	260	244	245	261	40	70.0000	4	1.0000
293	244	228	241	245	40	70.0000	4	1.0000
294	259	243	244	260	40	70.0000	4	1.0000
295	243	227	228	244	40	70.0000	4	1.0000
296	282	273	274	287	40	70.0000	4	1.0000
297	273	260	261	274	40	70.0000	4	1.0000
298	269	268	273	282	40	70.0000	4	1.0000
299	268	259	260	273	40	70.0000	4	1.0000
300	298	284	296	299	40	70.0000	4	1.0000
301	284	282	287	296	40	70.0000	4	1.0000
302	297	283	284	298	40	70.0000	4	1.0000
303	283	269	282	284	40	70.0000	4	1.0000
304	289	276	285	290	40	70.0000	4	1.0000
305	276	270	271	285	40	70.0000	4	1.0000
306	288	275	276	289	40	70.0000	4	1.0000
307	275	262	270	276	40	70.0000	4	1.0000
308	313	302	303	314	40	70.0000	4	1.0000
309	302	289	290	303	40	70.0000	4	1.0000
310	310	301	302	313	40	70.0000	4	1.0000
311	301	288	289	302	40	70.0000	4	1.0000
312	346	335	336	347	40	70.0000	4	1.0000
313	335	324	332	336	40	70.0000	4	1.0000
314	324	321	325	332	40	70.0000	4	1.0000
315	321	313	314	325	40	70.0000	4	1.0000
316	345	334	335	346	40	70.0000	4	1.0000
317	334	323	324	335	40	70.0000	4	1.0000
318	323	312	321	324	40	70.0000	4	1.0000
319	312	310	313	321	40	70.0000	4	1.0000
320	406	396	397	407	41	70.0000	4	1.0000
321	396	386	387	397	41	70.0000	4	1.0000
322	386	376	377	387	41	70.0000	4	1.0000
323	376	366	367	377	41	70.0000	4	1.0000
324	366	356	357	367	41	70.0000	4	1.0000
325	356	346	347	357	41	70.0000	4	1.0000
326	405	395	396	406	41	70.0000	4	1.0000
327	395	385	386	396	41	70.0000	4	1.0000
328	385	375	376	386	41	70.0000	4	1.0000
329	375	365	366	376	41	70.0000	4	1.0000

ORIGINAL PAGE IS  
OF POOR QUALITY

330	365	355	356	366	41	70.0000	4	1.0000
331	355	345	346	356	41	70.0000	4	1.0000
332	453	448	449	454	42	70.0000	4	1.0000
333	448	443	444	449	42	70.0000	4	1.0000
334	443	438	439	444	42	70.0000	4	1.0000
335	438	426	427	439	42	70.0000	4	1.0000
336	426	416	417	427	42	70.0000	4	1.0000
337	416	406	407	417	42	70.0000	4	1.0000
338	452	447	448	453	42	70.0000	4	1.0000
339	447	442	443	448	42	70.0000	4	1.0000
340	442	437	438	443	42	70.0000	4	1.0000
341	437	425	426	438	42	70.0000	4	1.0000
342	425	415	416	426	42	70.0000	4	1.0000
343	415	405	406	416	42	70.0000	4	1.0000
344	473	468	469	474	43	70.0000	4	1.0000
345	468	463	464	469	43	70.0000	4	1.0000
346	463	458	459	464	43	70.0000	4	1.0000
347	458	453	454	459	43	70.0000	4	1.0000
348	472	467	468	473	43	70.0000	4	1.0000
349	467	462	463	468	43	70.0000	4	1.0000
350	462	457	458	463	43	70.0000	4	1.0000
351	457	452	453	458	43	70.0000	4	1.0000
352	480	473	474	481	43	70.0000	4	1.0000
353	477	472	473	480	43	70.0000	4	1.0000
354	478	479	471	476	43	70.0000	4	1.0000
355	222	223	210	209	44	70.0000	4	1.0000
356	223	224	212	210	44	70.0000	4	1.0000
357	236	237	223	222	44	70.0000	4	1.0000
358	237	238	224	223	44	70.0000	4	1.0000
359	252	253	237	236	44	70.0000	4	1.0000
360	253	254	238	237	44	70.0000	4	1.0000
361	259	268	253	252	44	70.0000	4	1.0000
362	268	269	254	253	44	70.0000	4	1.0000
363	194	195	182	181	44	70.0000	4	1.0000
364	195	198	183	182	44	70.0000	4	1.0000
365	209	210	195	194	44	70.0000	4	1.0000
366	210	212	198	195	44	70.0000	4	1.0000
367	196	194	181	197	44	70.0000	4	1.0000
368	211	209	194	196	44	70.0000	4	1.0000
369	133	134	131	119	44	70.0000	4	1.0000
370	134	147	145	131	44	70.0000	4	1.0000
371	149	150	134	133	44	70.0000	4	1.0000
372	150	151	147	134	44	70.0000	4	1.0000
373	165	166	150	149	44	70.0000	4	1.0000
374	166	167	151	150	44	70.0000	4	1.0000
375	181	182	166	165	44	70.0000	4	1.0000
376	182	183	167	166	44	70.0000	4	1.0000
377	434	485	484	435	45	70.0000	4	1.0000
378	433	486	485	434	45	70.0000	4	1.0000
379	430	487	486	433	45	70.0000	4	1.0000
380	429	488	487	430	45	70.0000	4	1.0000
381	432	489	488	429	45	70.0000	4	1.0000
382	483	490	489	432	45	70.0000	4	1.0000
383	478	491	490	483	45	70.0000	4	1.0000

384	476	492	491	478	45	70.0000	4	1.0000
385	477	493	492	476	45	70.0000	4	1.0000
386	480	494	493	477	45	70.0000	4	1.0000
387	481	495	494	480	45	70.0000	4	1.0000
388	482	496	495	481	45	70.0000	4	1.0000

1.0

/\*  
//



```

C
C RADIAL-TANGENTIAL STRESS PROGRAM
C
  DIMENSION SZETA(90),SEATA(90),SZT(90),BETA(90)
  REAL S11, S22, S12, AA, BB
  INTEGER NN, NEL
  DO 20 KK = 1,90
  IF(KK.GE.1.AND.KK.LE.11) BETA(KK)=-.2618
  IF(KK.GE.12.AND.KK.LE.17) BETA(KK)=-.15707
  IF(KK.GE.18.AND.KK.LE.29) BETA(KK)=0.0
  IF(KK.GE.30.AND.KK.LE.33) BETA(KK)=.38394
  IF(KK.GE.34.AND.KK.LE.37) BETA(KK)=.17452
  IF(KK.GE.38.AND.KK.LE.41) BETA(KK)=1.22164
  IF(KK.GE.42.AND.KK.LE.45) BETA(KK)=.69808
  IF(KK.GE.46.AND.KK.LE.49) BETA(KK)=2.4433
  IF(KK.GE.50.AND.KK.LE.53) BETA(KK)=1.91972
  IF(KK.GE.54.AND.KK.LE.57) BETA(KK)=2.9668
  IF(KK.GE.58.AND.KK.LE.61) BETA(KK)=2.7574
  IF(KK.GE.62.AND.KK.LE.73) BETA(KK)=3.14136
  IF(KK.GE.74.AND.KK.LE.79) BETA(KK)=3.29843
  IF(KK.GE.80.AND.KK.LE.90) BETA(KK)=3.40314
20 CONTINUE
  READ(5,11)NN
11  FORMAT(I5)
  WRITE(6,15)
15  FORMAT(/,10X,3HNEL,9X,6HS-ZETA,9X,6HS-EATA,9X,10HTUE-ZET-ET,/)
  DO 10 I=1,NN
  READ(5,22) NEL,S11, S22, S12
  AA=(S11+S22)/2
  BB= (S11-S22)/2
  SZETA(NEL)=AA+BB*COS(2*BETA(NEL))+S12*SIN(2*BETA(NEL))
  SEATA(NEL)=AA-BB*COS(2*BETA(NEL))-S12*SIN(2*BETA(NEL))
  SZT(NEL) =-BB*SIN(2*BETA(NEL))+S12*COS(2*BETA(NEL))
  WRITE(6,33)NEL,SZETA(NEL),SEATA(NEL),SZT(NEL)
10  CONTINUE
22  FORMAT(I5,3E15.5)
33  FORMAT(5X,I5,5X,3F15.3,/)
  STOP
  END

```

TEMPERATURE IN DEGREE F

NODE NO.	TEMP.	NODE NO.	TEMP.	NODE NO.	TEMP.	NODE NO.	TEMP.
1	64.771	2	64.015	3	64.434	4	64.520
5	64.923	6	63.561	7	54.372	8	57.723
9	64.710	10	60.236	11	64.287	12	65.035
13	62.583	14	49.721	15	44.719	16	49.930
17	54.377	18	64.910	19	62.037	20	57.884
21	63.571	22	65.114	23	60.451	24	43.022
25	39.196	26	65.039	27	63.285	28	64.111
29	60.495	30	64.505	31	65.080	32	65.131
33	33.511	34	33.532	35	34.125	36	64.355
37	62.310	38	63.526	39	63.910	40	33.920
41	65.107	42	65.146	43	7.167	44	25.235
45	29.125	46	64.568	47	64.269	48	2.056
49	65.129	50	65.159	51	3.296	52	18.103
53	23.234	54	64.745	55	64.562	56	1.979
57	65.147	58	65.169	59	1.989	60	1.143
61	12.880	62	17.481	63	64.874	64	64.760
65	65.161	66	65.177	67	1.434	68	0.865
69	8.951	70	12.433	71	64.941	72	64.853
73	65.158	74	65.176	75	0.911	76	0.553
77	5.893	78	8.344	79	64.913	80	64.818
81	65.134	82	65.163	83	0.554	84	0.344
85	3.689	86	5.304	87	64.736	88	64.582
89	65.056	90	65.107	91	64.258	92	0.304
93	0.194	94	2.177	95	3.215	96	63.890
97	65.033	98	65.099	99	64.279	100	63.765
101	0.149	102	1.197	103	0.092	104	1.851
105	63.032	106	65.011	107	65.085	108	64.308
109	63.638	110	62.934	111	0.107	112	0.883
113	1.407	114	0.070	115	62.099	116	64.998
117	65.077	118	64.490	119	64.009	120	63.271
121	62.891	122	0.083	123	0.638	124	0.998
125	0.055	126	60.911	127	64.988	128	65.071
129	64.654	130	64.339	131	63.751	132	64.246
133	63.137	134	0.061	135	0.445	136	0.671
137	0.040	138	61.454	139	54.191	140	54.673
141	64.981	142	65.067	143	64.665	144	64.339
145	64.233	146	63.285	147	0.044	148	0.306
149	0.441	150	0.029	151	62.597	152	55.127
153	48.030	154	48.032	155	48.032	156	64.987
157	65.068	158	64.715	159	64.411	160	64.283
161	63.617	162	0.031	163	0.223	164	0.313
165	0.020	166	63.790	167	64.095	168	42.156
169	42.025	170	41.874	171	65.041	172	65.104
173	64.824	174	64.602	175	64.528	176	0.031
177	0.217	178	0.296	179	0.020	180	64.107
181	64.311	182	64.784	183	36.268	184	36.760
185	36.841	186	65.098	187	65.136	188	64.959

189	64.824	190	0.046	191	0.326	192	0.436
193	0.026	194	65.117	195	65.118	196	34.388
197	34.372	198	35.368	199	34.410	200	34.414
201	65.179	202	65.189	203	65.142	204	0.116
205	0.669	206	0.908	207	0.077	208	65.181
209	65.182	210	65.187	211	32.400	212	33.285
213	31.956	214	31.881	215	65.195	216	65.197
217	0.146	218	0.723	219	1.105	220	1.738
221	0.088	222	65.196	223	65.196	224	65.197
225	65.199	226	25.195	227	25.330	228	25.488
229	65.199	230	0.171	231	0.103	232	0.748
233	1.343	234	1.880	235	2.607	236	65.199
237	65.199	238	65.199	239	65.200	240	65.200
241	18.284	242	18.273	243	18.284	244	0.198
245	0.120	246	0.668	247	1.226	248	1.761
249	2.101	250	4.229	251	65.200	252	65.200
253	65.200	254	65.200	255	65.200	256	11.381
257	10.888	258	10.453	259	0.210	260	0.493
261	0.132	262	0.839	263	1.381	264	2.072
265	3.677	266	65.200	267	65.200	268	65.200
269	65.200	270	65.200	271	2.559	272	0.221
273	0.519	274	0.862	275	0.134	276	0.954
277	0.938	278	1.950	279	65.200	280	65.200
281	65.200	282	65.200	283	65.200	284	1.635
285	1.394	286	0.204	287	0.501	288	0.814
289	0.900	290	0.130	291	65.200	292	65.200
293	65.200	294	65.200	295	65.200	296	1.128
297	1.100	298	0.158	299	0.379	300	0.670
301	0.605	302	0.099	303	65.200	304	65.200
305	65.200	306	65.200	307	65.200	308	0.913
309	0.094	310	0.060	311	0.240	312	0.444
313	0.397	314	65.200	315	65.200	316	65.200
317	65.200	318	65.200	319	0.044	320	0.028
321	0.103	322	0.143	323	0.145	324	65.200
325	65.200	326	65.200	327	65.200	328	65.200
329	0.011	330	0.028	331	0.006	332	0.036
333	0.035	334	65.200	335	65.200	336	65.200
337	65.200	338	65.200	339	0.002	340	0.005
341	0.001	342	0.006	343	0.006	344	65.200
345	65.200	346	65.200	347	65.200	348	65.200
349	0.000	350	0.001	351	0.001	352	0.000
353	0.001	354	65.200	355	65.200	356	65.200
357	65.200	358	65.200	359	0.000	360	0.000
361	0.000	362	0.000	363	-0.000	364	65.200
365	65.200	366	65.200	367	65.200	368	65.200
369	0.000	370	0.000	371	0.000	372	0.000
373	0.000	374	65.200	375	65.200	376	65.200
377	65.200	378	65.200	379	-0.000	380	0.000
381	0.000	382	0.000	383	-0.000	384	65.200
385	65.200	386	65.200	387	65.200	388	65.200
389	0.000	390	0.000	391	0.000	392	0.000
393	0.000	394	65.200	395	65.200	396	65.200
397	65.200	398	65.200	399	-0.000	400	0.000
401	0.000	402	0.000	403	-0.000	404	65.200

405	65.200	406	65.200	407	65.200	408	65.200
409	0.000	410	0.000	411	0.000	412	0.000
413	0.000	414	65.200	415	65.200	416	65.200
417	65.200	418	65.200	419	-0.000	420	0.000
421	0.000	422	0.000	423	-0.000	424	65.200
425	65.200	426	65.200	427	65.200	428	65.200
429	65.200	430	0.000	431	0.000	432	0.000
433	0.000	434	0.000	435	65.200	436	-0.000
437	0.000	438	0.000	439	0.000	440	-0.000
441	0.000	442	0.000	443	0.000	444	0.000
445	0.000	446	-0.000	447	-0.000	448	0.000
449	0.000	450	-0.000	451	0.000	452	0.000
453	0.000	454	0.000	455	0.000	456	0.000
457	-0.000	458	0.000	459	0.000	460	0.000
461	0.000	462	0.000	463	0.000	464	0.000
465	0.000	466	0.000	467	-0.000	468	0.000
469	0.000	470	0.000	471	0.000	472	0.000
473	0.000	474	0.000	475	0.000	476	0.000
477	0.000	478	0.000	479	0.000	480	0.000
481	0.000	482	0.000				

	$\sigma_{\xi}$	$\sigma_{\eta}$	$\tau_{\xi\eta}$
NEL	S-ZETA	S-EATA	TUE-ZET-ET
1	72.753	-25.031	0.097
2	128.730	21.610	-10.909
3	150.471	17.487	-3.885
4	134.717	7.048	-3.030
5	103.118	-6.019	-6.335
6	42.985	1.648	1.088
7	43.985	8.558	0.592
8	40.778	4.444	0.450
9	36.630	-2.692	0.738
10	34.134	-8.519	-4.441
11	30.389	-9.585	6.986
12	58.134	-24.751	-12.546
13	71.830	-7.608	4.800
14	84.303	-0.846	1.810
15	85.364	4.561	-1.291
16	74.380	5.382	-0.979
17	57.161	0.881	-0.938
18	182.210	6.823	-4.466
19	193.090	13.623	-6.950
20	184.950	17.615	-4.893
21	138.810	5.602	2.921
22	141.180	-6.364	3.446
23	159.040	-0.724	8.298
24	159.540	-1.576	-4.006
25	143.690	-5.850	-3.097
26	181.040	-1.726	-2.301
27	175.540	1.292	-2.021
28	206.120	-2.201	-0.493
29	196.080	-0.605	-2.915
30	219.495	2.378	8.540
31	220.655	3.084	3.971
32	219.076	0.208	-4.697
33	218.126	-1.217	-8.853
34	220.024	-0.417	2.685
35	219.586	1.129	3.916
36	219.361	0.641	0.488
37	216.837	-0.101	-3.518
38	212.754	62.153	24.500
39	281.875	95.675	-25.342
40	228.291	42.228	-19.808
41	198.368	4.434	-18.915
42	196.845	-7.460	11.578
43	205.437	1.011	6.168
44	211.376	0.407	-3.798
45	218.019	-1.705	-8.118
46	54.648	-2.145	-4.063
47	60.289	-0.573	-6.099

ORIGINAL PAGE IS  
OF POOR QUALITY

48	64.369	0.498	-9.703
49	70.544	2.808	-12.586
50	71.693	-12.204	-2.760
51	44.375	-42.569	-23.700
52	-14.116	-79.770	-49.946
53	21.449	-105.675	-27.785
54	-0.499	-1.587	-1.159
55	-9.181	-0.671	-2.958
56	18.219	0.743	-0.578
57	25.410	0.581	0.050
58	34.978	1.825	-0.734
59	40.194	1.519	-1.884
60	39.774	1.679	-5.518
61	32.715	-3.919	-8.640
62	-9.067	-1.591	1.703
63	-6.920	-3.156	1.557
64	-13.227	-0.119	0.270
65	-11.307	-0.518	1.700
66	-9.902	2.126	-1.099
67	-11.378	0.579	-2.753
68	-33.096	-5.307	3.648
69	-15.536	1.261	2.706
70	-36.337	6.309	-2.919
71	-40.329	0.062	-1.569
72	-44.515	-2.928	-0.573
73	-47.240	-4.734	-0.251
74	-55.141	0.136	-3.032
75	-55.361	-1.528	-1.849
76	-56.541	-0.846	-0.927
77	-58.733	0.498	-0.432
78	-62.359	1.659	0.193
79	-67.046	-0.531	5.309
80	-32.720	-6.246	-3.719
81	-38.555	-5.031	0.494
82	-44.718	-3.183	0.305
83	-50.290	-0.961	0.029
84	-54.344	2.025	0.268
85	-56.160	4.501	1.446
86	1.913	2.701	-3.104
87	1.889	1.905	-0.896
88	1.010	1.776	0.904
89	-5.577	0.805	3.054
90	1.411	-4.648	-8.905