

NASA-TM-108725

NASA-TM-108, 725

**NASA**

(NASA-TM-108725) TECHNOLOGY FOR  
SPACE STATION EVOLUTION. VOLUME 2:  
DATA MANAGEMENT  
SYSTEM/ENVIRONMENTAL CONTROL AND  
LIFE SUPPORT SYSTEMS (NASA) 544 p

N93-27704  
--THRU--  
N93-27725  
Unclas

63/18 0163593

NASA-TM-108725 19930018515

**Technology For  
Space Station Evolution—  
Proceedings**

**Office of Aeronautics and Space Technology**

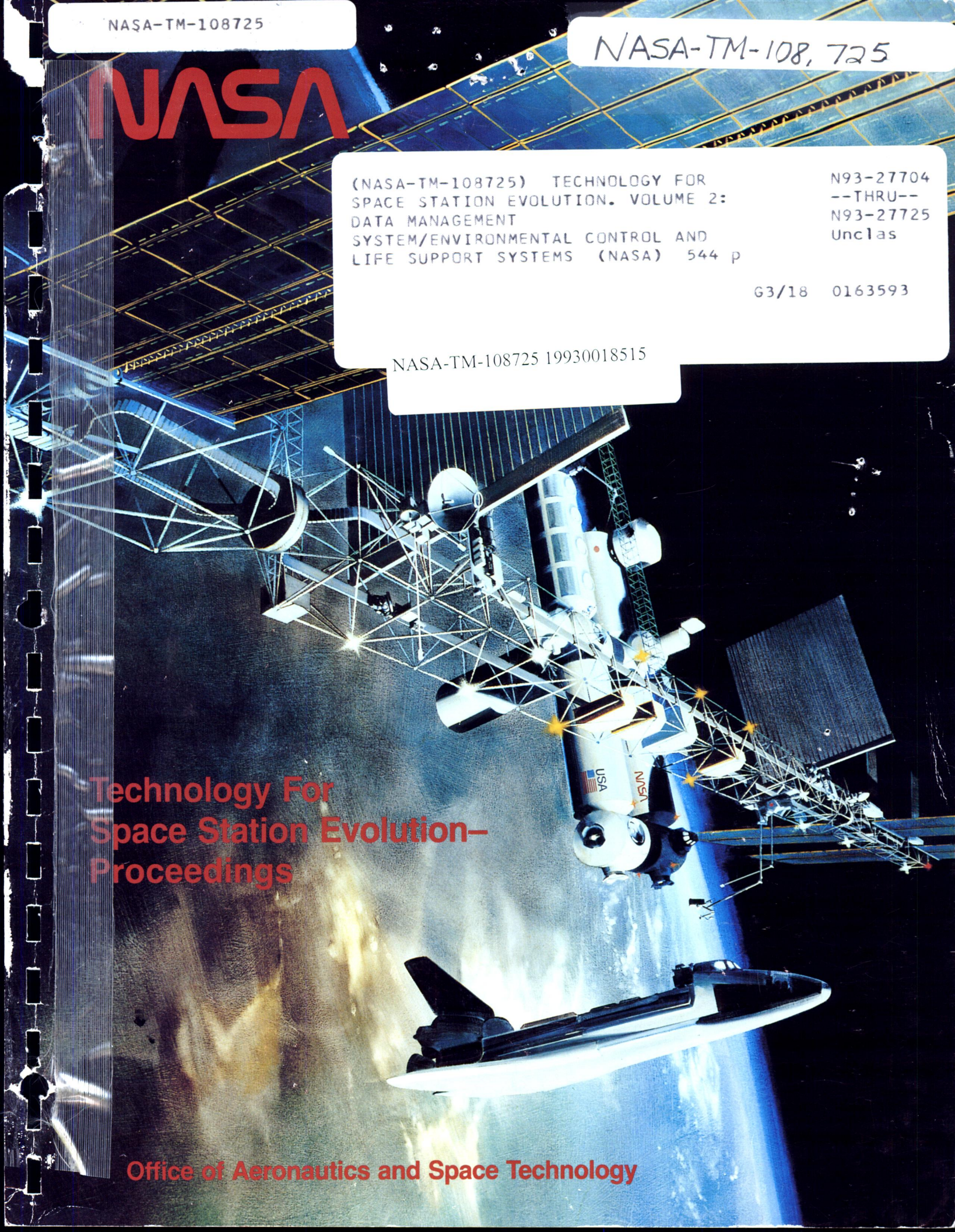

FOREWORD

ORIGINAL CONTAINS  
COLOR ILLUSTRATIONS

Space Station *Freedom*, now under development, is a manned low Earth orbit facility which will become part of the space infrastructure. Starting in the mid 1990s, *Freedom* will support a wide range of activities, including scientific research, technology development, commercial ventures and, eventually, serve as a transportation node for space exploration. While the initial facility will not be capable of meeting all requirements, the space station will evolve over time as requirements and on-board activities mature and change. The space station design, therefore, allows for evolution to:

- expand capability,
- increase efficiency, and
- add new functions.

It is anticipated that many of the evolutionary changes will be accomplished through on-orbit replacement of systems, subsystems, and components as technology advances. Therefore, technology development is critical to ensure the continuing operation and expansion of the facility.

The Office of Aeronautics, Exploration and Technology (OAET) has sponsored development of many of the technologies that are now part of Space Station *Freedom*'s baseline design. Evolutionary and operational aspects of *Freedom* continue to be an important thrust of OAET's Research and Technology (R&T) efforts.

This workshop has been an important step in our understanding of the space station's baseline systems, the evolutionary scenarios including the station's role in space exploration, and the technologies that will be necessary to meet evolutionary and growth requirements.

It is anticipated that application of the information acquired through the workshop will lead to further technology development efforts to benefit *Freedom* and will lead to continued collaboration between the Space Station *Freedom* Program and the technology development community.

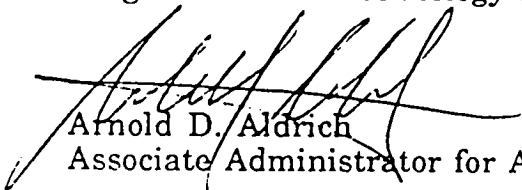
  
Arnold D. Aldrich  
Associate Administrator for Aeronautics, Exploration and Technology

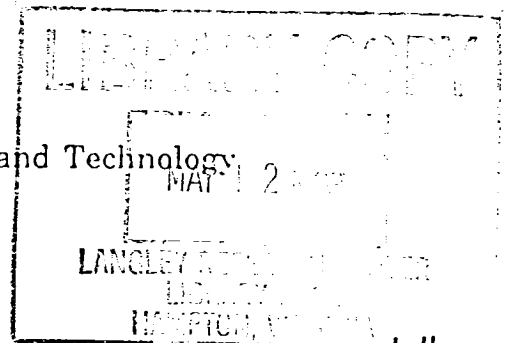

N 93-27704#

N 93-27725#

## CLARIFICATION

Since the workshop was conducted in January of 1990, there have been some organizational changes throughout the agency. The Office of Aeronautics and Space Technology (OAST) has been reorganized to include the former Office of Exploration and is now called the Office of Aeronautics, Exploration, and Technology (OAET). Also, the Human Exploration Initiative (HEI) has been expanded and renamed the Space Exploration Initiative (SEI). Some of the materials in these proceedings were prepared after the workshop, and, therefore, references to new organizational entities and new programs may be found in certain sections.

TECHNOLOGY FOR SPACE STATION EVOLUTION - A WORKSHOP  
Technology Disciplines (DMS - ECLSS)

VOLUME II

Foreword	i
Contents	iii
Introduction to Volume II	1
<u>Data Management System</u>	
Level III Subsystem Presentation:	
Technology for Space Station Evolution - The Data Management System - Dr. L. Abbott, JSC	5-1
Invited Presentations:	
Space Station Freedom Software Support Environment - Susan Voigt, LaRC	39-2
Validated Fault Tolerant Architectures for Space Station - Jaynarayan Lala - Charles Stark Draper Laboratory	75-3
A Fault Tolerant RISC Microprocessor for Spacecraft Applications - Constantin Timoc, Spaceborne, Inc., and Harry Benz, LaRC	103-omit
High Rate Science Data Handling - Richard C. Masline, JPL	111-4
Optical Disk Technology Spaceflight Optical Disk Recorder - Pam Rinsland, LaRC	129-5
Electronic Neural Networks - Dr. Anil Thakoor, JPL	141-6
Space Station Displays and Controls Technology Evolution - Greg C. Blackburn, JSC	167-7
Embedded Multiprocessor Technology for VHSIC Insertion - Paul J. Hayes, LaRC	177-8
Data Management Standards in Computer-Aided Acquisition and Logistic Support (CALS) - David Jefferson, NIST	197-9
Automatic Management of Parallel and Distributed System Resources - Dr. Stephen Lundstrom, PARSA/Stanford University, Dr. Jerry Yan, ARC, and Tin Fook Ngai, Stanford University	227-10
Onboard System Health Assessment - Tom Barry, JSC, and Harry Cunningham, Lockheed	249-11
An Overview of Microelectronics and Computer Technology Corporation (MCC) and Its Research - Dr. Stephen Lundstrom, MCC/Stanford University	285-12
<u>Environmental Control and Life Support System</u>	
Level III Subsystem Presentation:	
Environmental Control and Life Support System, Charles Ray and Alan Adams, MSFC	317-13
Invited Presentations:	
Environmental Control and Life Support System Evolution - Paul Wieland, MSFC	343-14
Technologies for ECLSS Evolution - Bryce L. Diamant, McDonnell Douglas Space Systems	367-15

Alternative Processes for Water Reclamation and Solid Waste Processing in a Physical/Chemical Bioregenerative Life Support System - Tom D. Rogers, Space Research Center, Texas A&M University	495 -16
Increased Fire and Toxic Contaminant Detection Responsivity by Use of Distributed, Aspirating Sensors - Wallace W. Youngblood, Wyle Laboratories	517 -17
The ECLSS Advanced Automation Project Evolution and Technology Assessment - Brandon S. Dewberry, MSFC, and James Ray Carnes, Boeing AI Center	543 -18
MSFC ECLSS Technology Activities - Paul Wieland, MSFC	567 -19
JSC ECLSS R&T Program Overview - A. F. Behrend, JSC	599 -20

## INTRODUCTION

NASA's Office of Aeronautics and Space Technology (OAST) conducted a workshop on technology for space station evolution January 16-19, 1990, in Dallas, Texas. The purpose of this workshop was to collect and clarify Space Station *Freedom* technology requirements for evolution and to describe technologies that can potentially fill those requirements. OAST will use the output of the workshop as input for planning a technology program to serve the needs of space station evolution. The main product of the workshop is a set of program plans and descriptions for individual technology areas. These plans are the cumulative recommendations of the more than 300 participants, which included researchers, technologists, and managers from aerospace industries, universities, and government organizations.

The identification of the technology areas to be included, as well as the development of the program plans, was initiated by assigning NASA chairmen to the eleven technology disciplines under consideration. The disciplines are as follows:

- Attitude Control and Stabilization (ACS)
- Communications and Tracking (C&T)
- Data Management System (DMS)
- Environmental Control and Life Support Systems (ECLSS)
- Extravehicular Activity/Manned Systems (EVA/MANSYS)
- Fluid Management System (FMS)
- Power System (POWER)
- Propulsion (PROP)
- Robotics (ROBOTICS)
- Structures/Materials (STRUCT)
- Thermal Control System (THERM)

Each chairman worked with a panel of experts involved in research and development in the particular discipline. The chairmen, with the assistance of their panels, were responsible for selecting invited presentations, identifying and inviting Space Station *Freedom* Level III subsystem managers, and focusing the discussion of the participants. In each discipline session, presentations describing status of the current programs were made by the Level III subsystem managers and by OAST program managers. After invited presentations by leading industry, university, and NASA researchers, the sessions were devoted to identifying technology requirements and to planning programs for development of the identified technology areas. Particular attention was given to the potential requirements of the Human Exploration Initiative (HEI). The combined inputs of the participants in each session were incorporated into a package including an

overall discipline summary, recommendations and issues, and proposed development plans for specific technology areas within the discipline. These technology discipline summary packages were later supplemented by the chairmen and their panels to include the impact of varied funding levels on the maturity of the selected technologies. OAST will review the program plans and recommended funding levels based on available funding and overall NASA priorities and incorporate them into a new OAST initiative advocacy package for space station evolution technology.

These proceedings are organized into an Executive Summary and Overview and five volumes containing the Technology Discipline Presentations.

Volume II consists of the technology discipline sections for the Data Management System and the Environmental Control and Life Support Systems. For each technology discipline in this volume, there is a Level 3 subsystem description, along with the invited papers for that discipline.

**Data Management System**  
**Level III**  
**Subsystem Presentation**



# TECHNOLOGY FOR SPACE STATION EVOLUTION —

## THE DATA MANAGEMENT SYSTEM

JANUARY 16, 1990  
DALLAS, TEXAS

N 9 3 - 2 7 7 0 5

51-82  
163594

5

PRECEDING PAGE BLANK NOT FILMED

*14*  
JANUARY 16, 1990

## Space Station DMS Summary Schedule

11/1/89

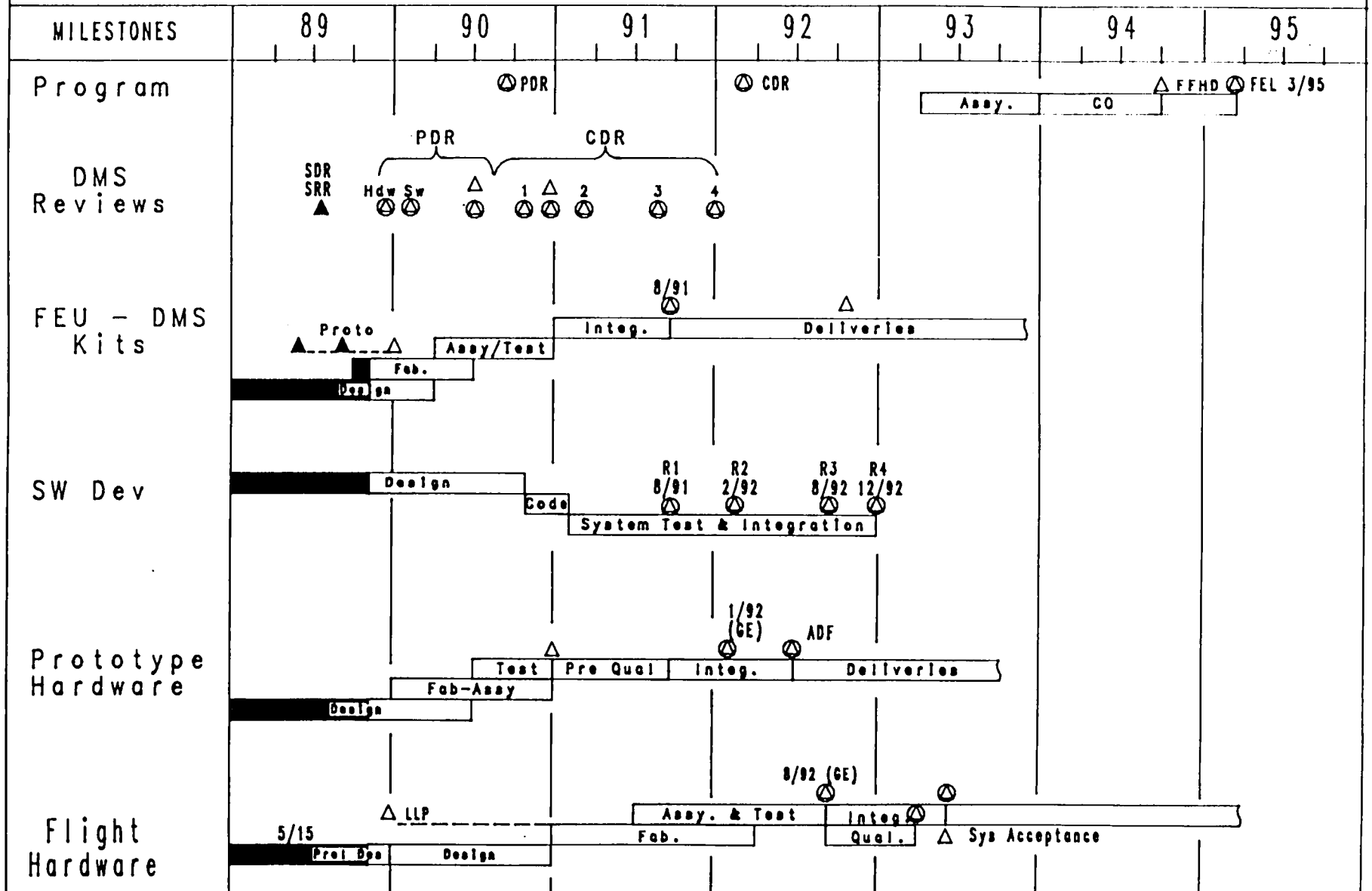

9

**DMS ARCHITECTURE AND IMPLEMENTATION APPROACH**

# ON-ORBIT ARCHITECTURE

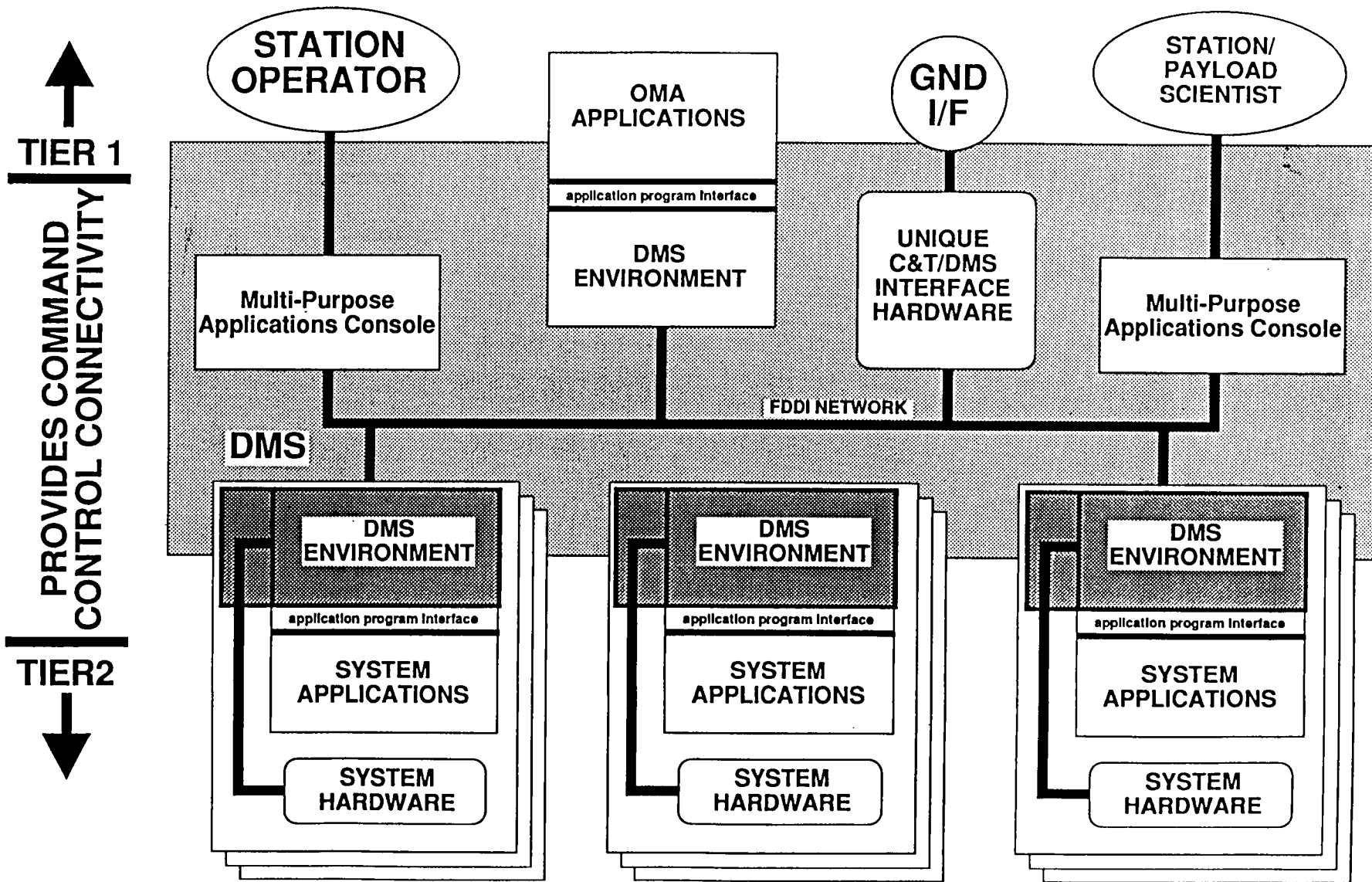

# DMS GENERIC ARCHITECTURE (AC)

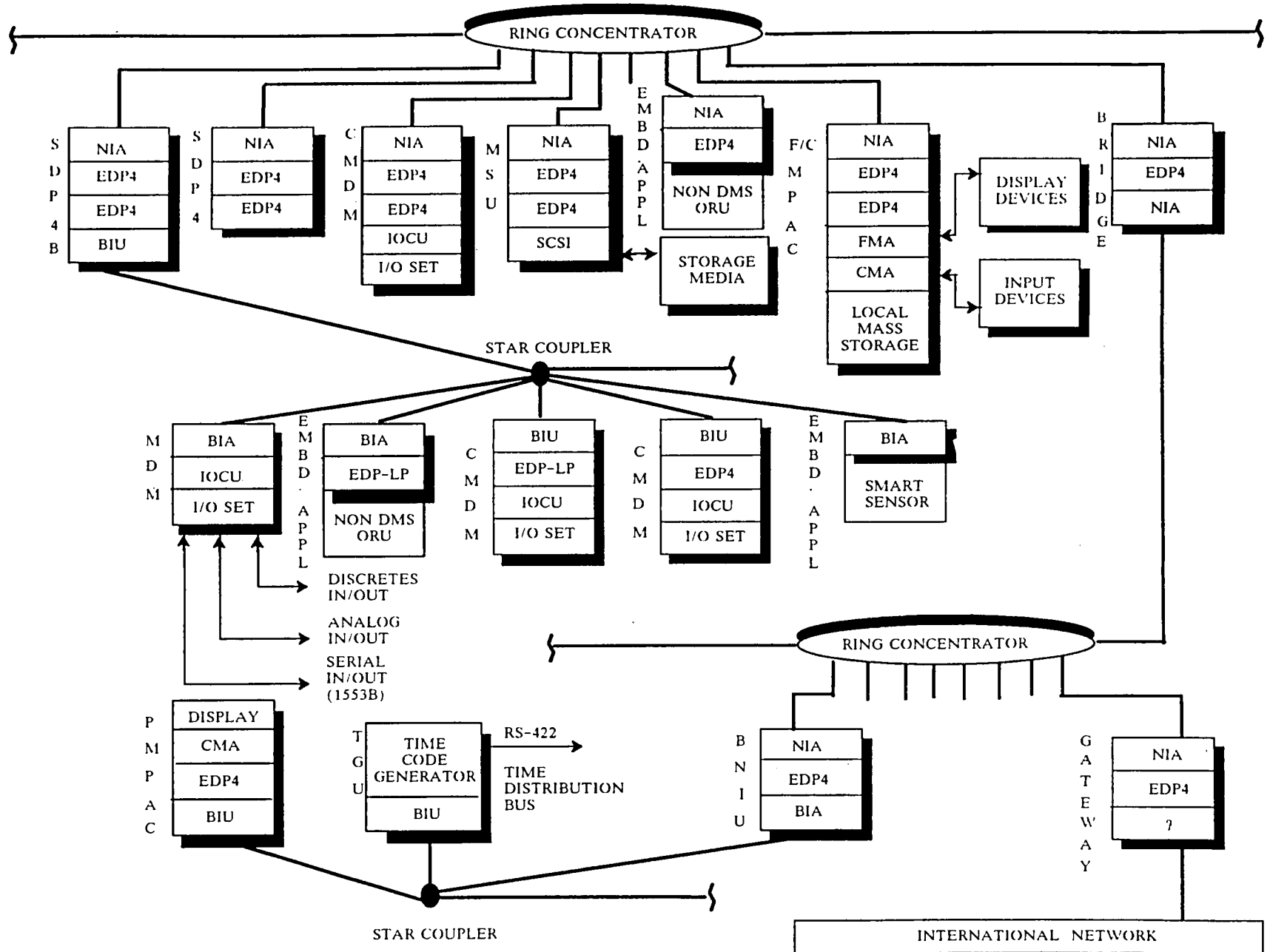

6

# DMS GENERIC ARCHITECTURE (PMC)

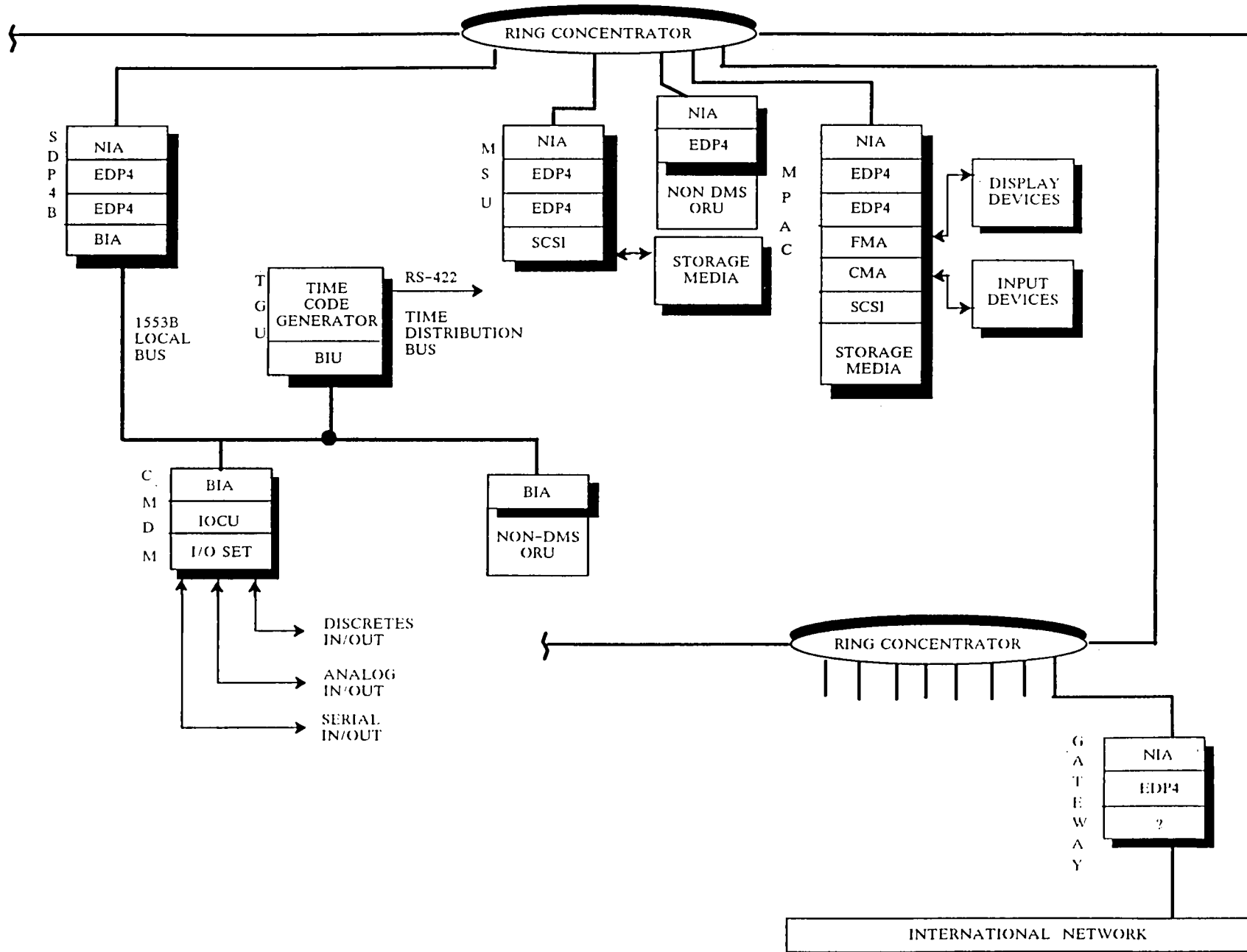

10

## DMS BUILDING BLOCKS

### NOMENCLATURE / CHARACTERISTICS

### DESCRIPTION

- EMBEDDED DATA PROCESSOR

**EDP4** (STANDARD)

- 4 MEGABYTES MEMORY
- 4 MIPS PROCESSING
- 28 WATTS POWER CONSUMPTION

- EMBEDDED DATA PROCESSOR

**NIA** (STANDARD)

- 100 MBPS DATA RATE
- 25 WATTS POWER CONSUMPTION

- INPUT OUTPUT CONTROL UNIT

**IOCU**

- STANDARD CARD FOR MDM
- POWER CONSUMPTION  
- 7 + WATTS

- SINGLE CARD GENERAL PURPOSE COMPUTER WHICH PROVIDES THE PROCESSING FUNCTION FOR ALL SPACE STATION FREEDOM HARDWARE CONFIGURATION ITEMS REQUIRING A PROCESSING CAPABILITY.

- SINGLE CARD WHICH PROVIDES THE FUNCTIONAL AND PHYSICAL CONNECTION TO THE DMS FDDI (FIBER DISTRIBUTED DATA INTERFACE) OPTICAL NETWORK AND TO THE TGDS (TIME GENERATION AND DISTRIBUTION SYSTEM)

- STANDARD CARD FOR MDM WHICH PROVIDES PROCESSING CAPABILITY AND CONTROL FUNCTIONS FOR MDM I/O

## DMS ARCHITECTURAL COMPONENTS

### NOMENCLATURE / CHARACTERISTICS

### DESCRIPTION

- STANDARD DATA PROCESSOR

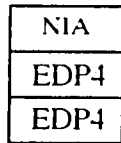

SDP 4

- PWR CONSUMPTION ~ 104W
- INTERFACE TO NETWORK
- 4 MEGABYTES MEMORY
- 4 MIPS PROCESSING SPEED
- SOFTWARE SUPPORTED
  - OS/RTE
  - NOS
  - USE
  - DCS
  - DMS SM
  - OMA
  - APPLICATIONS

- GENERAL PURPOSE COMPUTER WHICH PROVIDE DATA PROCESSING RESOURCES TO SUPPORT CONTROL AND MANAGEMENT OF INTEGRATED STATION FUNCTIONS AND COMMAND AND CONTROL FUNCTIONS REQUIRED BY SYSTEMS, ELEMENTS, AND PAYLOADS.
- PROVIDES INTERFACE TO DMS GLOBAL NETWORKS



## DMS ARCHITECTURAL COMPONENTS

### NOMENCLATURE / CHARACTERISTICS

### DESCRIPTION

- FIXED OR CUPOLA MULTIPURPOSE APPLICATION CONSOLE (MPAC)

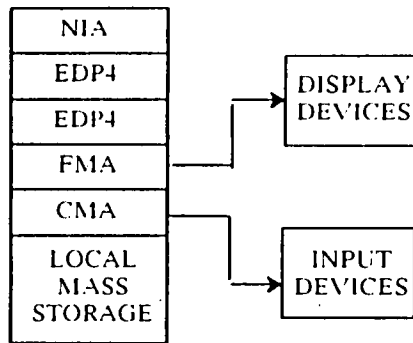

#### FMPAC OR CMPAC

- FMPAC POWER CONSUMPTION 1638 WATTS
- CMPAC POWER CONSUMPTION 969 WATTS
- FMA (FIXED MPAC ADAPTOR) DRIVES DISPLAYS
- CMA (COMMON MPAC ADAPTOR) DRIVES INPUT DEVICES
- SUPPORTS LOCAL MASS STORAGE 30 MBYTES FIXED, 1.4 MBYTES REMOVABLE
- SOFTWARE SUPPORTED
  - SAME AS SDPR
  - PLUS?

- PROVIDES ELECTRONIC INTERFACE BETWEEN APPLICATION PROGRAMS AND ONBOARD OPERATORS. USED FOR OPERATIONAL CONTROL AND MONITORING, TRAINING, TESTING, CAUTION & WARNING ANNUNCIATION AND CREW SERVICES.
- SUPPORTS VISUAL AND LOGICAL ASPECTS OF HUMAN COMPUTER INTERFACE USING USE SOFTWARE.

## DMS ARCHITECTURAL COMPONENTS

### NOMENCLATURE / CHARACTERISTICS

- MULTIPLEXER/DEMULTIPLIER (MDM)

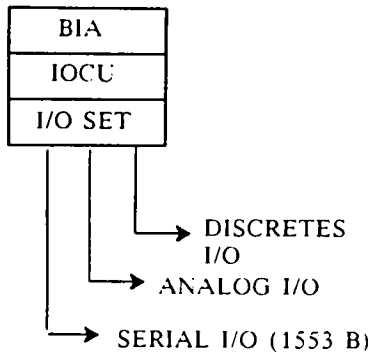

#### MDM

- PROVIDES CHASSIS WITH STANDARD BACKPLANE INTO WHICH I/O SETS CAN BE PLUGGED TO PERFORM REQUIRED TASKS
- 10 STANDARD CARDS ARE CURRENTLY DEFINED.
- POWER CONSUMPTION:
  - IOCU CARD - 7 WATTS
  - TEMP/PRESS/ANALOG - 4 WATTS
  - ANALOG INPUTS (32) - 2 WATTS
  - ANALOG OUTPUTS (4) - 2 WATTS
  - ANALOG OUTPUTS (16) - 4 WATTS
  - 5V DISCRETE INPUTS - 1 WATT
  - 5V DISCRETE OUTPUTS - 3 WATTS
  - SOLENOID DRIVER - TBD
  - SERIAL I/O - TBD
  - MIL STD 1553B BCU - TBD
- CAN ALSO ACCEPT USER CARDS THAT SATISFY STANDARD BACKPLANE INTERFACE
- SOFTWARE SUPPORTED - NONE

### DESCRIPTION

- PROVIDES INTERFACE TO SENSOR AND EFFECTORS.
- COLLECTS, REFORMATS TO DIGITAL WORDS, MULTIPLEXES AND TRANSMITS SENSOR DATA.
- RECEIVES COMMAND WORDS, DEMULTIPLEXES. ISSUES COMMANDS

## DMS ARCHITECTURAL COMPONENTS

### NOMENCLATURE / CHARACTERISTICS

### DESCRIPTION

- MASS STORAGE UNIT (MSU)

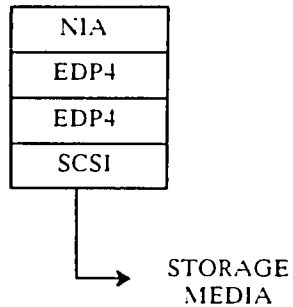

- PROVIDES INTERFACE TO MAIN DMS NETWORK VIA NIA AND EDP4
- LOCAL PROCESSING CAPABILITY IN EDP4
- ALSO PROVIDES SCSI (SMALL COMPUTER SYSTEMS INTERFACE) TO STORAGE MEDIA WITH MODULAR DESIGN TO ALLOW EASY UPGRADE
- CURRENT STORAGE MEDIA IS 250 MBYTES HARD DISK
- POWER CONSUMPTION IS  $\approx$  104 WATTS FOR MSU PLUS - TBD WATTS FOR STORAGE MEDIA
- SOFTWARE SUPPORTED
  - OS/RTE
  - NOS
  - DCS
  - APPLICATIONS

- PROVIDES MASS STORAGE FOR CORE AND PAYLOAD USES
- UTILIZES DIRECT ACCESS, NONVOLATILE MAGNETIC DISK MEMORY
- PROVIDES THE PROCESSING, INSTRUCTIONS, MEMORY AND I/O CAPABILITIES TO RECEIVE INPUT INFORMATION, MANIPULATE THE INFORMATION UNDER INTERNAL STORED PROGRAMS AND PROCESS THE DATA FOR STORAGE

## DMS ARCHITECTURAL COMPONENTS

### NOMENCLATURE / CHARACTERISTICS

### DESCRIPTION

• EMBEDDED APPLICATIONS

NIA
EDP4
NON DMS ORU

- PROVIDES CONNECTIVITY TO 100 MBPS NETWORK
- DMS PART OF POWER CONSUMPTION = 53 WATTS
- SOFTWARE  
-SUBSET OF NOS

- PROVIDES STANDARD FUNCTIONAL AND PHYSICAL INTERFACE BETWEEN THE DMS 100 MBPS OPTICAL NETWORK AND A NON DMS PROCESSOR.

BIA
SMART SENSOR

- PROVIDES CONNECTIVITY TO 10 MBPS LOCAL BUS - LAYERS 1 AND 2 ONLY
- DMS PART OF POWER CONSUMPTION - 4 WATTS
- SOFTWARE - NONE

- PROVIDES PHYSICAL LAYER (LAYER 1) AND MEDIUM ACCESS CONTROL SUBLAYER (PARTIAL LAYER 2) PROTOCOLS BETWEEN DMS 10 MBPS LOCAL BUS AND AN INTELLEGET HARDWARE APPLICATION.

• GATEWAY (GW)

NIA
EDP4
?

- CONNECTS 100 MBPS OPTICAL NETWORK WITH NON DMS NETWORK.
- U.S. PORTION OF POWER CONSUMPTION - 80 WATTS
- RECEIVES & DISTRIBUTES TIME INFORMATION TO NON DMS NETWORK

- THE GATEWAY PROVIDES CONNECTIVITY BETWEEN A DMS OPTICAL NETWORK AND A NON DMS NETWORK. GW TERMINATES U.S. PROTOCOLS AT ISO/OSI LAYER 2 AND PROVIDES A STANDARD LAYER 3 INTERFACE. NON-U.S. DMS CARDS MUST INTERFACE AT LAYER 3.
- IT MAY BE POSSIBLE TO UTILIZE THE DMS BNIU TO PROVIDE THIS FUNCTION IF SUFFICIENT AGREEMENTS CAN BE REACHED WITH THE INTERNATIONAL PARTNERS

## DMS ARCHITECTURAL COMPONENTS

### NOMENCLATURE / CHARACTERISTICS

### DESCRIPTION

- TIME GENERATION UNIT (TGU)

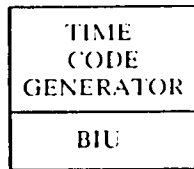

- CCCSDS SEGMENTED CODE
- ACCURATE TO + 10 MICROS
- POWER CONSUMPTION - 30 WATTS

- THE TIME GENERATION UNIT IS THE PRECISION TIME AND FREQUENCY SOURCE FOR ALL SPACE STATION FREEDOM SYSTEMS AND PAYLOADS. CONVERSION TO A CONTINUOUS UNSEGMENTED CODE PROVIDED BY DMS AT DESIGNATED PROCESSORS. TWO TGU'S AND THE TDB CONSTITUTE TGDS.

- RING CONCENTRATOR

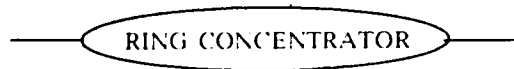

- EIGHT ATTACHMENT PORTS
- OPTICAL SIGNAL REGENERATION
- POWER CONSUMPTION - 7 WATTS

- THE RING CONCENTRATOR PROVIDES THE CONNECTIVITY FOR ALL NIU'S INTERFACING TO THE DMS OPTICAL NETWORKS. THE RC PROVIDES SWITCHING MECHANISM TO CONNECT OR BYPASS AN ORU.

- PATCH PANEL

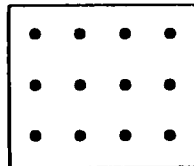

- PASSIVE DEVICE
- MANUAL OPERATION
- PROVIDES 192 PORTS
  - 32 OF WHICH PROVIDE DATA AND CONTROL FLOW TO THE C & T SIGNAL PROCESSOR (SP) (8 PORTS EACH SP, SPARE DUPLEXED FOR REDUNDANCY)

- THE PATCH PANEL PROVIDES CAPABILITY FOR MANUAL SELECTION OF CONNECTIVITY FOR THE HIGH RATE FIBER OPTIC LINKS. THE PANEL IS TRANSPARENT TO BOTH THE DIRECTION AND THE FORMAT OF THE DATA.

# DMS SUMMARY

BASELINE CONTENT	REBASELINE																																																							
	PMC	AC																																																						
<p><b>Distributed Architecture</b></p> <p><b>Distributed Processing at Local Bus Level</b></p> <p><b>Two Types of Local Bus Capability</b></p> <p><b>Separate Payload and Core Networks</b></p> <p><b>New Tech Displays</b></p> <p><b>8 High Rate P/L Link (0 – 100 MBPS)</b></p> <p><b>HARDWARE QTY:</b></p> <table style="width: 100%; border: none;"> <tr><td style="width: 60%;">SDP</td><td style="width: 10%; text-align: center;">–</td><td style="width: 30%; text-align: right;">29</td></tr> <tr><td>EDP</td><td style="text-align: center;">–</td><td style="text-align: right;">216</td></tr> <tr><td>MDM – C</td><td style="text-align: center;">–</td><td style="text-align: right;">12</td></tr> <tr><td>MDM</td><td style="text-align: center;">–</td><td style="text-align: right;">117</td></tr> <tr><td>Bridge</td><td style="text-align: center;">–</td><td style="text-align: right;">3</td></tr> <tr><td>RC</td><td style="text-align: center;">–</td><td style="text-align: right;">42</td></tr> </table>	SDP	–	29	EDP	–	216	MDM – C	–	12	MDM	–	117	Bridge	–	3	RC	–	42	<p><b>More Centralized Architecture</b></p> <p><b>Limited Processing at Local Bus Level</b></p> <p><b>One Local Bus Type</b></p> <p><b>Payload &amp; Core Networks Shared</b></p> <p><b>Use Existing Display Technology</b></p> <p><b>3 High Rate Links (0 – 100 MBPS) ZOE Recording for Core Data</b></p> <p><b>HARDWARE QTY:</b></p> <table style="width: 100%; border: none;"> <tr><td style="width: 60%;">SDP</td><td style="width: 10%; text-align: center;">–</td><td style="width: 30%; text-align: right;">16</td></tr> <tr><td>EDP</td><td style="text-align: center;">–</td><td style="text-align: right;">0</td></tr> <tr><td>MDM – C</td><td style="text-align: center;">–</td><td style="text-align: right;">59</td></tr> <tr><td>MDM</td><td style="text-align: center;">–</td><td style="text-align: right;">0</td></tr> <tr><td>Bridge</td><td style="text-align: center;">–</td><td style="text-align: right;">0</td></tr> <tr><td>RC</td><td style="text-align: center;">–</td><td style="text-align: right;">18</td></tr> </table>	SDP	–	16	EDP	–	0	MDM – C	–	59	MDM	–	0	Bridge	–	0	RC	–	18	<p><b>More Distributed Architecture</b></p> <p><b>Increased Processing Capability at Local Bus Level</b></p> <p><b>Add High Performance Local Bus</b></p> <p><b>Separate Payload and Core Bus</b></p> <p><b>Upgrade Displays</b></p> <p><b>8 (0 – 100 MBPS)</b></p> <p><b>HARDWARE QTY:</b></p> <table style="width: 100%; border: none;"> <tr><td style="width: 60%;">SDP</td><td style="width: 10%; text-align: center;">–</td><td style="width: 30%; text-align: right;">28</td></tr> <tr><td>EDP</td><td style="text-align: center;">–</td><td style="text-align: right;">0</td></tr> <tr><td>MDM – C</td><td style="text-align: center;">–</td><td style="text-align: right;">87</td></tr> <tr><td>MDM</td><td style="text-align: center;">–</td><td style="text-align: right;">81</td></tr> <tr><td>Bridge</td><td style="text-align: center;">–</td><td style="text-align: right;">3</td></tr> <tr><td>RC</td><td style="text-align: center;">–</td><td style="text-align: right;">44</td></tr> </table>	SDP	–	28	EDP	–	0	MDM – C	–	87	MDM	–	81	Bridge	–	3	RC	–	44
SDP	–	29																																																						
EDP	–	216																																																						
MDM – C	–	12																																																						
MDM	–	117																																																						
Bridge	–	3																																																						
RC	–	42																																																						
SDP	–	16																																																						
EDP	–	0																																																						
MDM – C	–	59																																																						
MDM	–	0																																																						
Bridge	–	0																																																						
RC	–	18																																																						
SDP	–	28																																																						
EDP	–	0																																																						
MDM – C	–	87																																																						
MDM	–	81																																																						
Bridge	–	3																																																						
RC	–	44																																																						

18

# DMS SOFTWARE SERVICES ARCHITECTURE

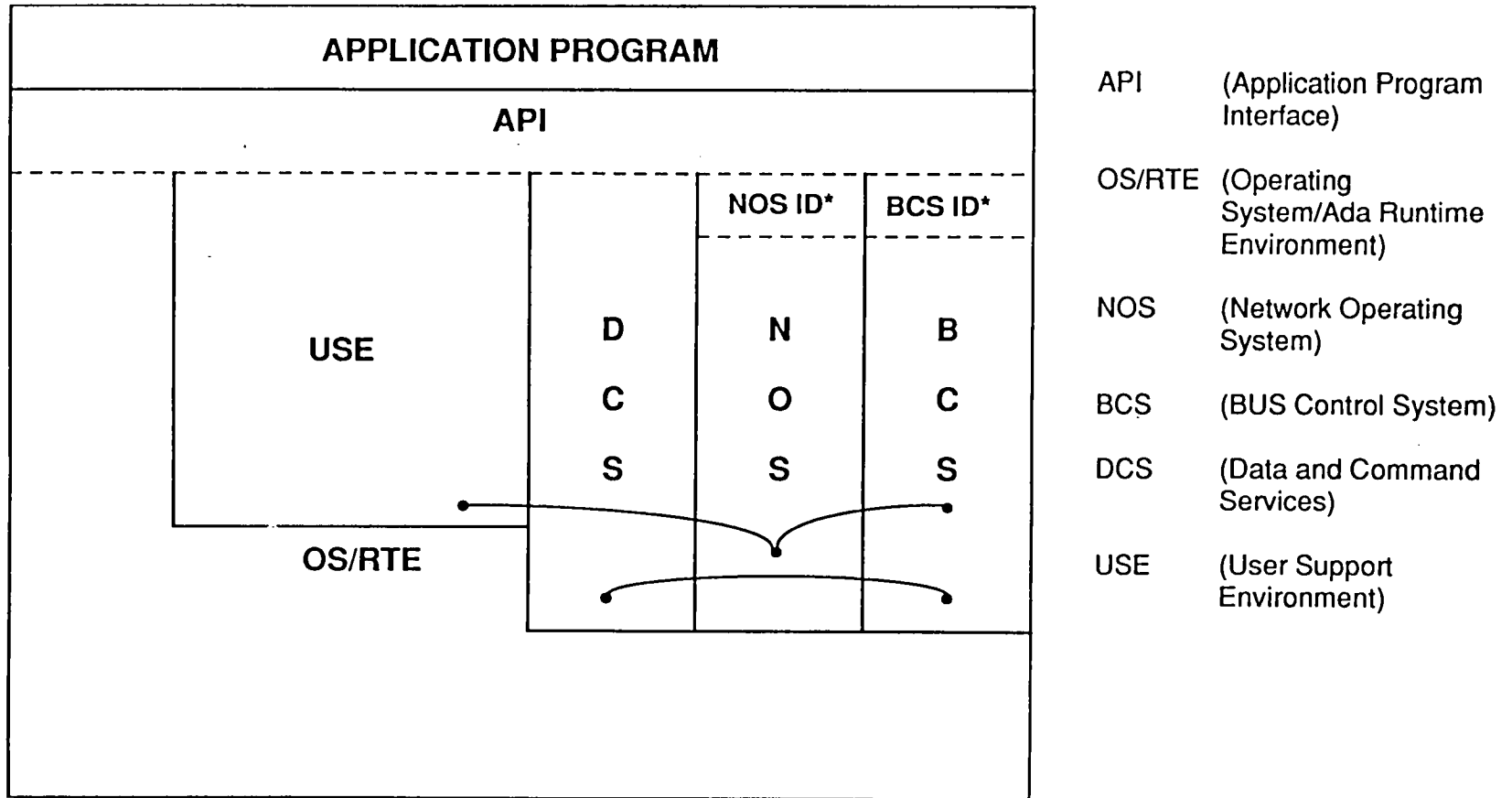

\*Interface Exposed to Embedded NIU or BIU in Non DMS Processor

## DMS SOFTWARE SERVICES

### NOMENCLATURE / CHARACTERISTICS

- OPERATING SYSTEM/ADA RUNTIME ENVIRONMENT

OS/RTE

- TWO PERFORMANCE CATEGORIES
  - PROCESS CONTROL
  - INFORMATION PROCESSING
- FUNCTIONS
  - INITIALIZATION
  - PROCESS MANAGEMENT
  - MEMORY MANAGEMENT
  - PROCESS COMMUNICATION
  - TIME SERVICE
  - INPUT/OUTPUT MANAGEMENT
  - FILE MANAGEMENT
  - ADA RUNTIME ENVIRONMENT EXTENSIONS
  - PRIVACY AND SECURITY
  - MONITOR SERVICES
  - FDIR AND RM FOR PROCESSORS AND I/O

### DESCRIPTION

- PROVIDES MANAGEMENT, ALLOCATION, AND DEALLOCATION OF THE CPU, MEMORY, SYSTEM CLOCK, AND I/O DEVICE PROCESSING RESOURCES AND PROVIDES NETWORK TRANSPARENT INTERFACES FOR APPLICATION TO APPLICATION COMMUNICATIONS.



DMS SOFTWARE SERVICES (CONT)

NOMENCLATURE / CHARACTERISTICS

DESCRIPTION

- NETWORK OPERATING SYSTEM

NOS

- MESSAGING SERVICES
  - CONNECTION ORIENTED
  - CONNECTIONLESS
  - BROADCAST
  - MULTICAST
  - POINT TO POINT
- SUPPORTS
  - PRIORITIZATION
  - TIME TAGGING
  - GRADE OF SERVICE
  - SECURITY & PRIVACY
  - NETWORK MANAGEMENT
  - FDIR

- PROVIDES NETWORK COMMUNICATION FUNCTIONS FOR SYSTEMS, ELEMENTS, AND PAYLOADS PERFORMING ALL OF THE FUNCTIONS REQUIRED FOR TRANSPARENT TRANSMISSION OF USER DATA ACCROSS THE DMS NETWORK. SERVICES PROVIDED ARE LISTED IN TABLE 3.4.1.1.2.-1 OF SSP 30261, PART 3, REV D DRAFT.

## DMS SOFTWARE SERVICES (CONT)

### NOMENCLATURE / CHARACTERISTICS

### DESCRIPTION

- NOMENCLATURE/FUNCTION

DCS

- SENSOR DATA PROCESSING
- DATA AND COMMAND DISTRIBUTION
- DATA DICTIONARY
- ARCHIVE MANAGEMENT
- CHECKPOINT MANAGEMENT
- STRUCTURED FILE SERVICE
- PRIVACY AND SECURITY
- DATA REDUNDANCY SERVICES
- INSTRUMENTATION SERVICES
- LOCAL PROCESS CONTROL

- PROVIDES DATA HANDLING SERVICES WHICH ARE COMMON ACROSS MULTIPLE SYSTEMS AND ELEMENTS

USE

- SOFTWARE SUPPORT FOR MPAC I/O DEVICE
- STATIC & DYNAMIC DISPLAYS
- WINDOWED VIDEO IMAGES DISPLAYS
- WINDOWED C&W DISPLAYS
- PROCEDURAL, ENGLISH-LIKE USER INTERFACE LANGUAGE (UIL)
- REMOTE TERMINAL SERVICE
- ACCESS AUTHORIZATION

- THE DMS USE PROVIDES THE ONBOARD RUNTIME ENVIRONMENT SERVICES WHICH ARE A SUBSET OF THE DEVELOPMENT TOOLS AND RUNTIME ENVIRONMENT DEFINED FOR THE SSIS HCI (HUMAN COMPUTER INTERFACE) SERVICES FOR GROUND AND ONBOARD.

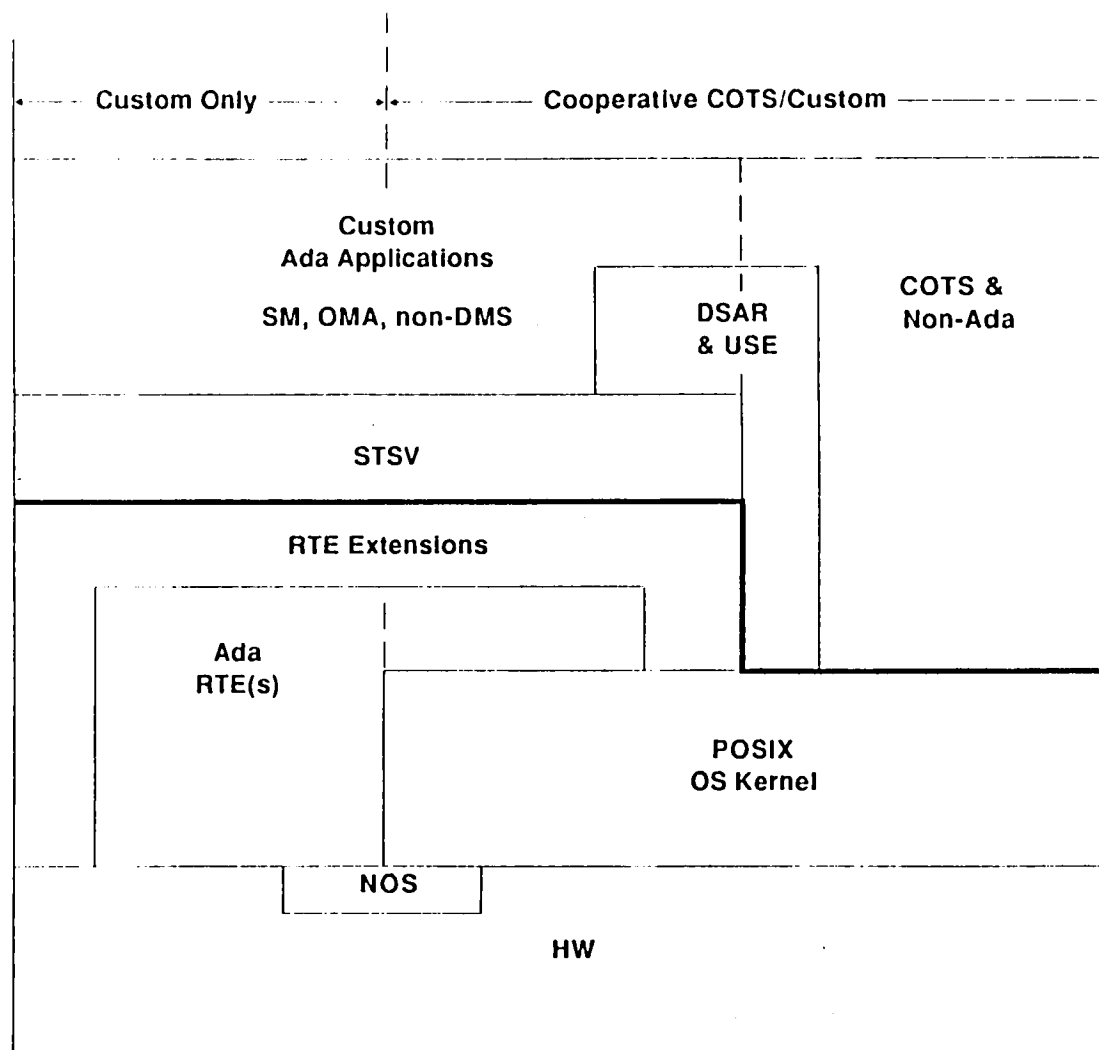

DMS Software Layering

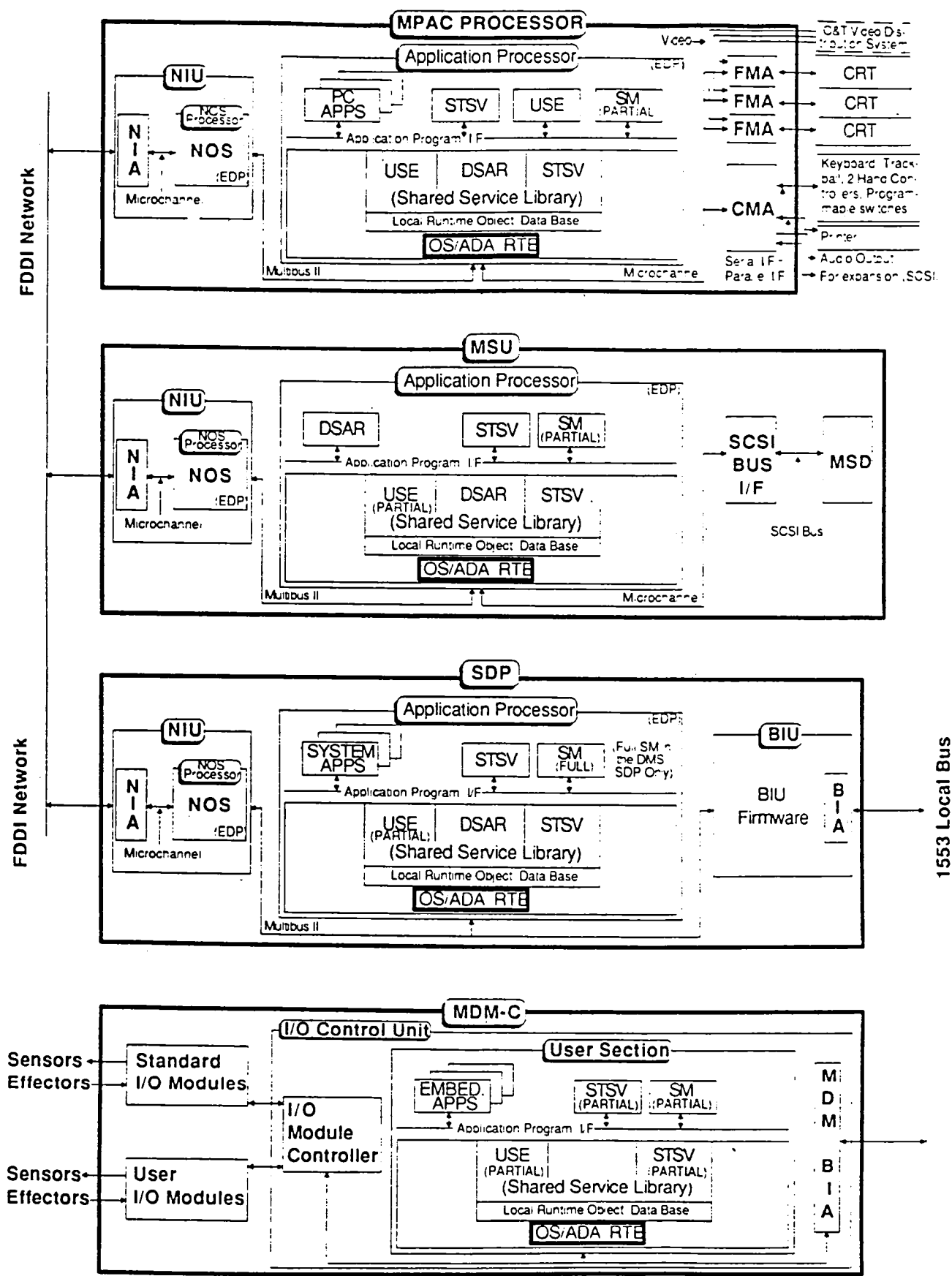
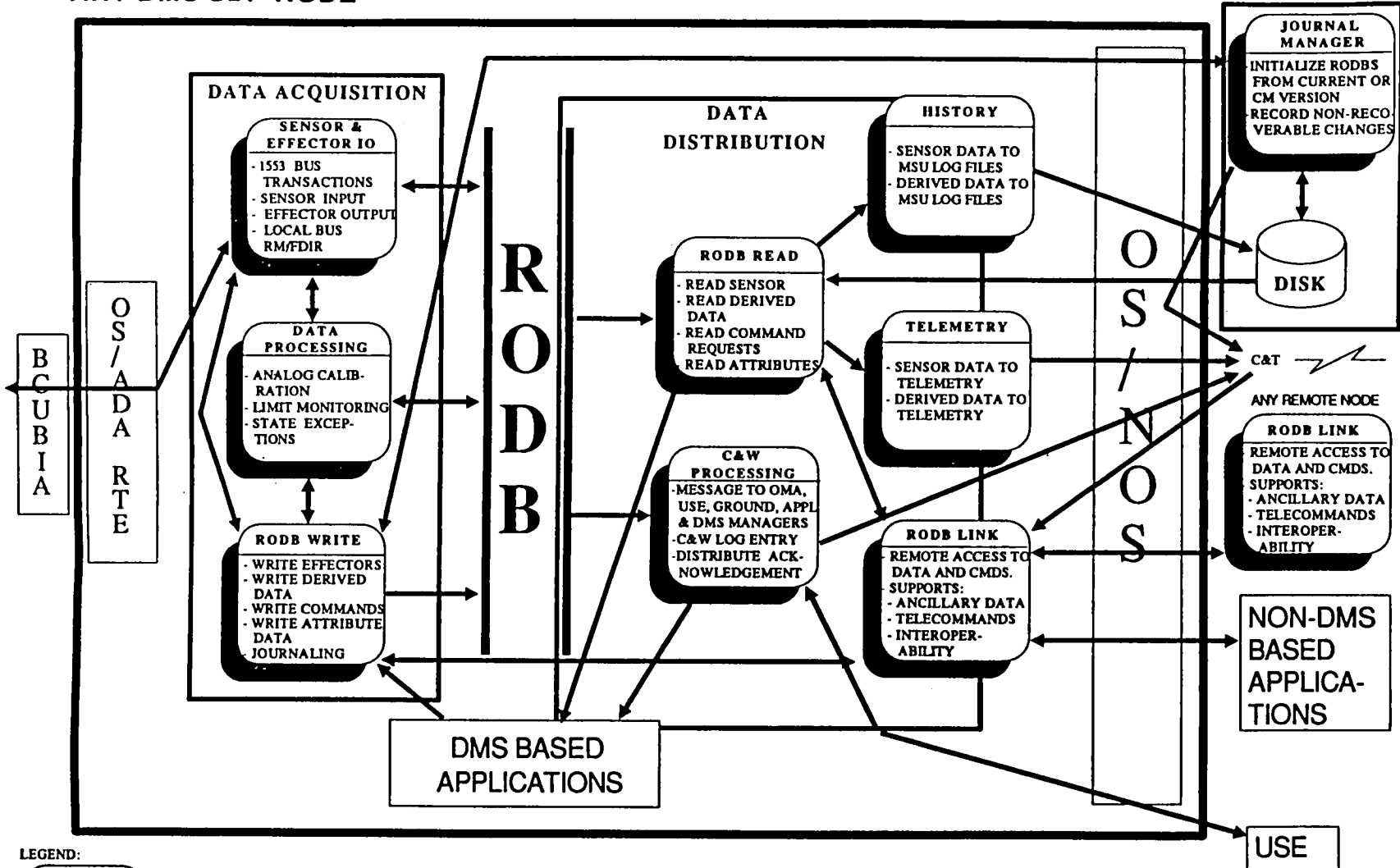

FIGURE 4.0-2. DMS Architecture Model

ANY DMS SDP NODE

MSU



25

LEGEND:



DMS STANDARD SERVICES FUNCTIONAL FLOW DIAGRAM

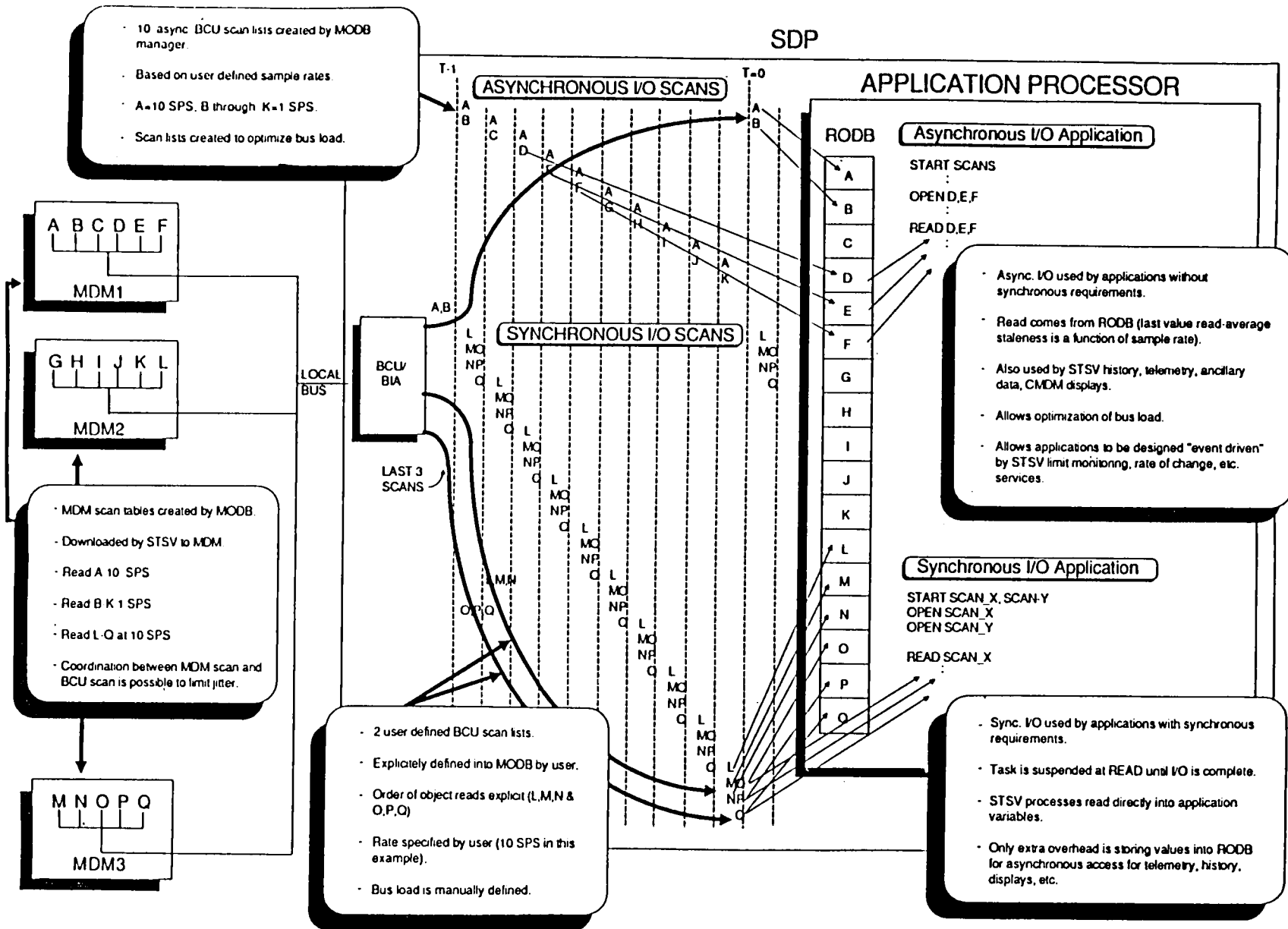

- 10 async BCU scan lists created by MOOB manager.
- Based on user defined sample rates
- A=10 SPS, B through K=1 SPS.
- Scan lists created to optimize bus load.

- MDM scan tables created by MOOB.
- Downloaded by STSV to MDM
- Read A 10 SPS
- Read B K 1 SPS
- Read L Q at 10 SPS
- Coordination between MDM scan and BCU scan is possible to limit jitter.

- 2 user defined BCU scan lists.
- Explicitly defined into MOOB by user.
- Order of object reads explicit (L,M,N & O,P,Q)
- Rate specified by user (10 SPS in this example).
- Bus load is manually defined.

- Async. I/O used by applications without synchronous requirements.
- Read comes from RODB (last value read-average staleness is a function of sample rate).
- Also used by STSV history, telemetry, ancillary data, CMM displays.
- Allows optimization of bus load.
- Allows applications to be designed "event driven" by STSV limit monitoring, rate of change, etc. services.

- Sync. I/O used by applications with synchronous requirements.
- Task is suspended at READ until I/O is complete.
- STSV processes read directly into application variables.
- Only extra overhead is storing values into RODB for asynchronous access for telemetry, history, displays, etc.

SYNCHRONOUS AND ASYNCHRONOUS I/O STANDARD SERVICES SCENARIO

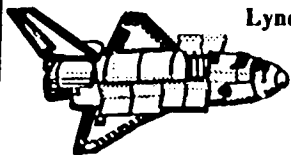

NASA  
Lyndon B. Johnson Space Center

SPACECRAFT  
SOFTWARE  
DIVISION

## OVERVIEW OF THE RUNTIME OBJECT DATABASE

# GENERAL COMMAND AND CONTROL DATA FLOW MODE - CHAOS

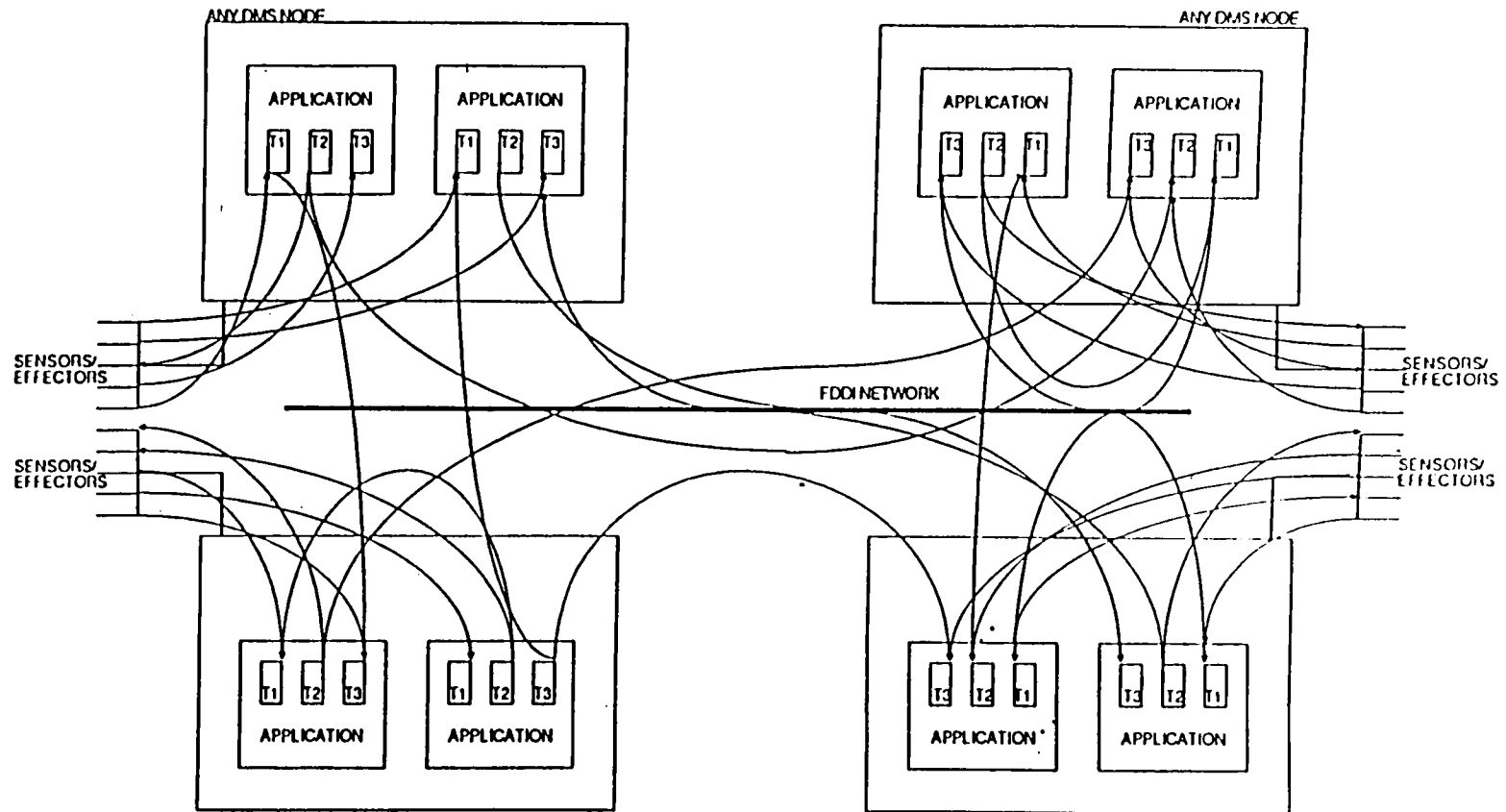

28

COMMAND AND CONTROL WITHOUT RODB/MODB CONCEPT WOULD MEAN:

- IPC MECHANISM FOR TASK TO TASK COMMUNICATION (PRIVATE ICDs FOR ABOVE LINES)
- NO COMMON, SYSTEM-WIDE APPROACH TO COMMAND AND CONTROL FROM OMA, DISPLAYS, GROUND
- NO COMMON, SYSTEM-WIDE APPROACH TO COMPLEXITIES OF COMMUNICATIONS
- MANUAL OVERRIDE (FROM MPAC OR GROUND) IS A NIGHTMARE OF ICD RESOLUTIONS
- IT&V WOULD BE A NIGHTMARE OF PRIVATE IPC VERIFICATION
- NO DRIVING FORCE BEHIND COMMON DATA REPRESENTATION



# RODB COMMAND AND CONTROL DATA FLOW MODEL - ORDER

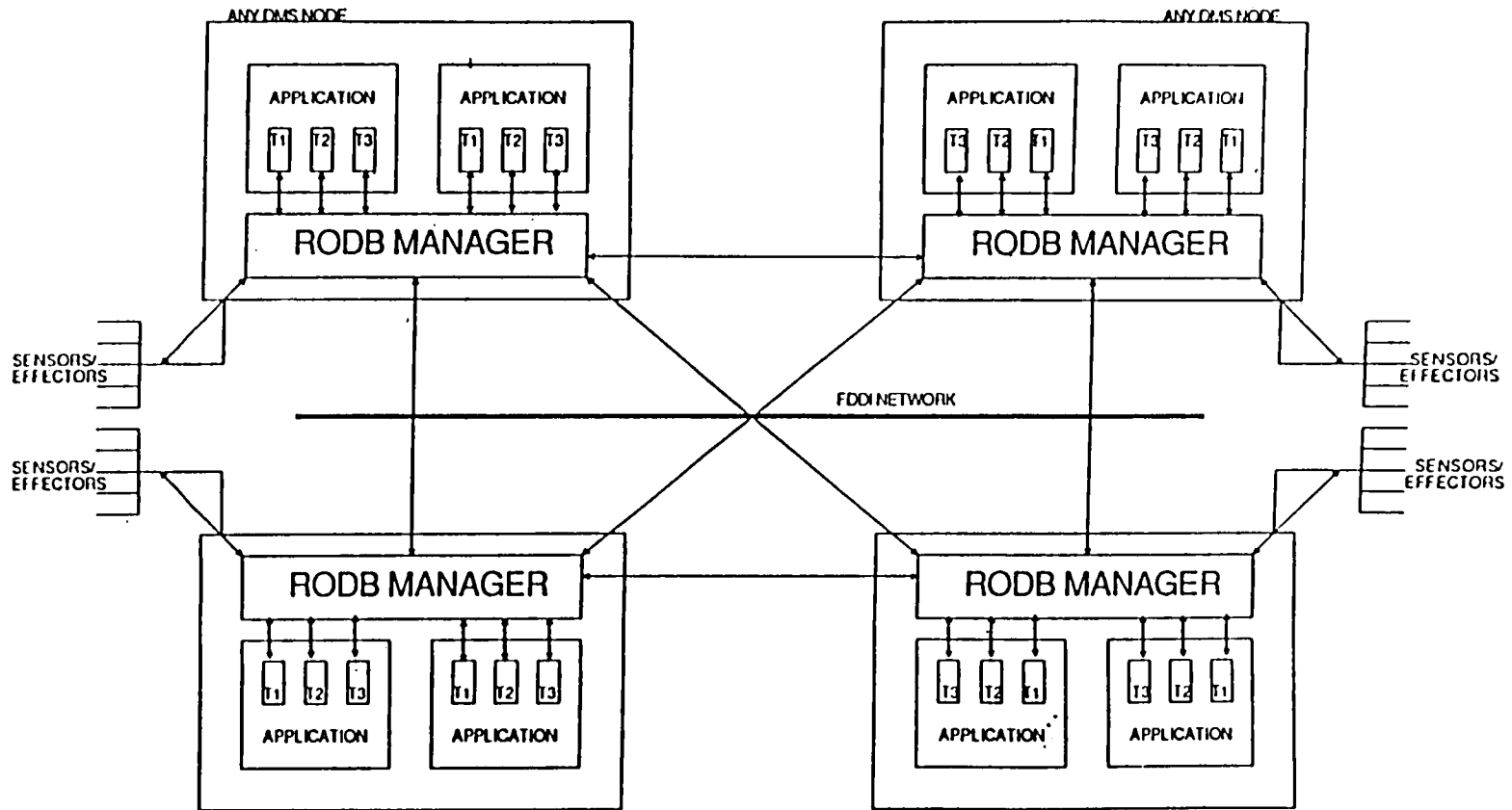

## COMMAND AND CONTROL WITH RODB/MODB CONCEPT WOULD MEAN:

- ONE DMS ENGINEERED, SYSTEM-WIDE APPROACH TO COMMAND AND CONTROL
- EFFECTIVE, CONSISTENT USE OF COMMUNICATION SERVICES BY ALL APPLICATIONS
- MODB/RODB IS LIKE AN AUTOMATED ICD FOR THE WHOLE SYSTEM
- EFFECTIVE ENVIRONMENT FOR CREW COMMAND AND CONTROL DISPLAYS FOR NORMAL OPERATIONS AS WELL AS TROUBLE SHOOTING & MANUAL OVERRIDE
- EFFECTIVE ENVIRONMENT FOR IT&V OF FLIGHT HARDWARE AND SOFTWARE
- COMMON DATA REPRESENTATIONS ACROSS ALL APPLICATIONS

---

## Definitions

- RODB
  - Isolates applications from the effects of data request changes resulting from:
    - Crew user interface
    - Space/ground telemetry/command
  - Provides standard services to applications for sensor/effector related processing
  - Requires applications to make data global for visibility
  - Runtime online data base
  - Contains directory, dictionary, and current values of objects
  - Contains a subset of the data in the MODB

# THE RODB AS THREE KINDS OF INFORMATION

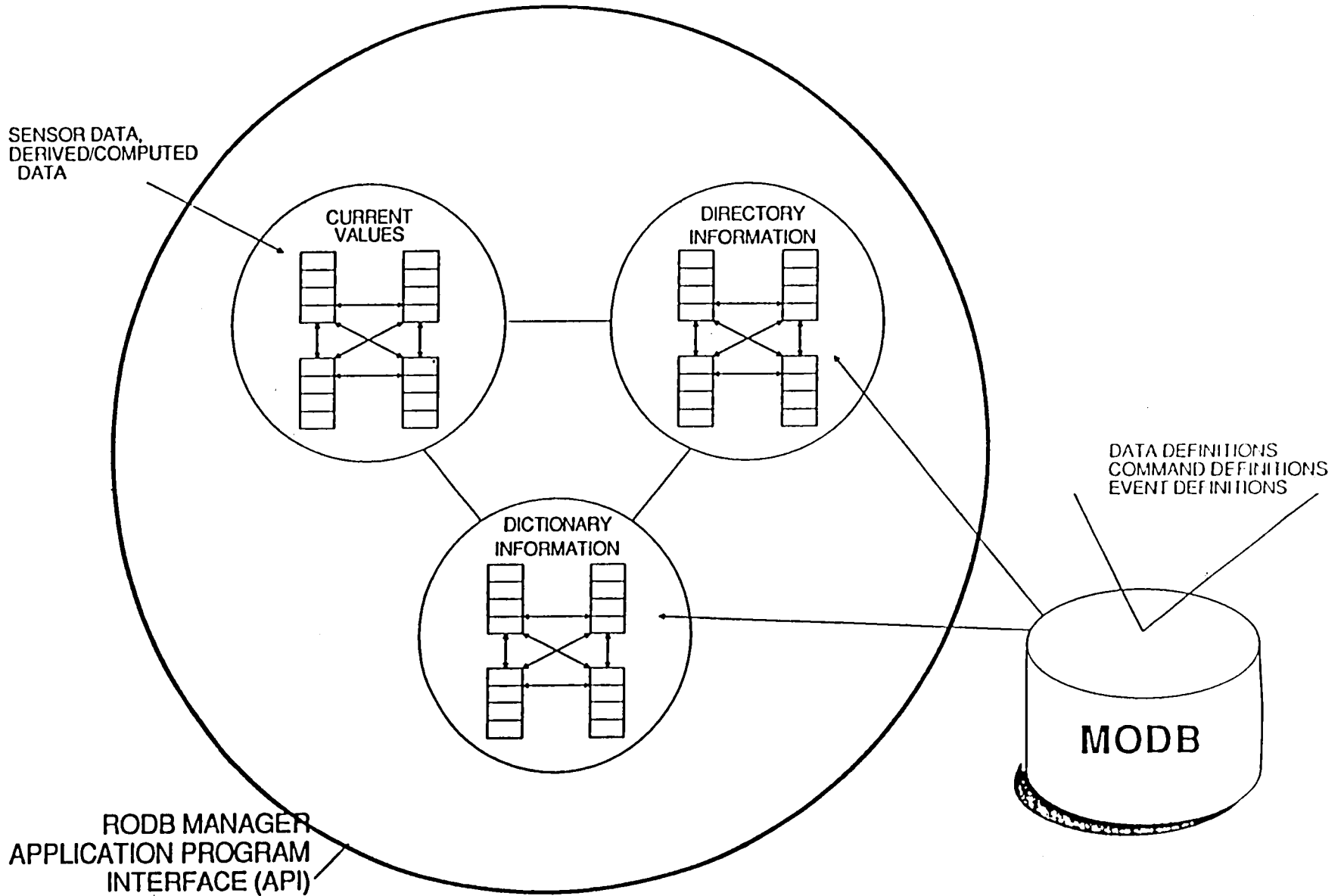

◆ Three parts:

1. Description of the object (at a position in the hierarchy)

2. Attributes of the object:

→ Descriptions

→ Names

→ Constraints

→ RODB and MODB information

3. Actions on the object:

→ Descriptions

→ Names

→ Parameters

→ Completion codes

→ Timeouts

# General RODB Model

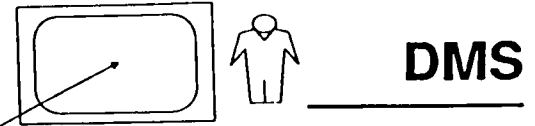

DMS

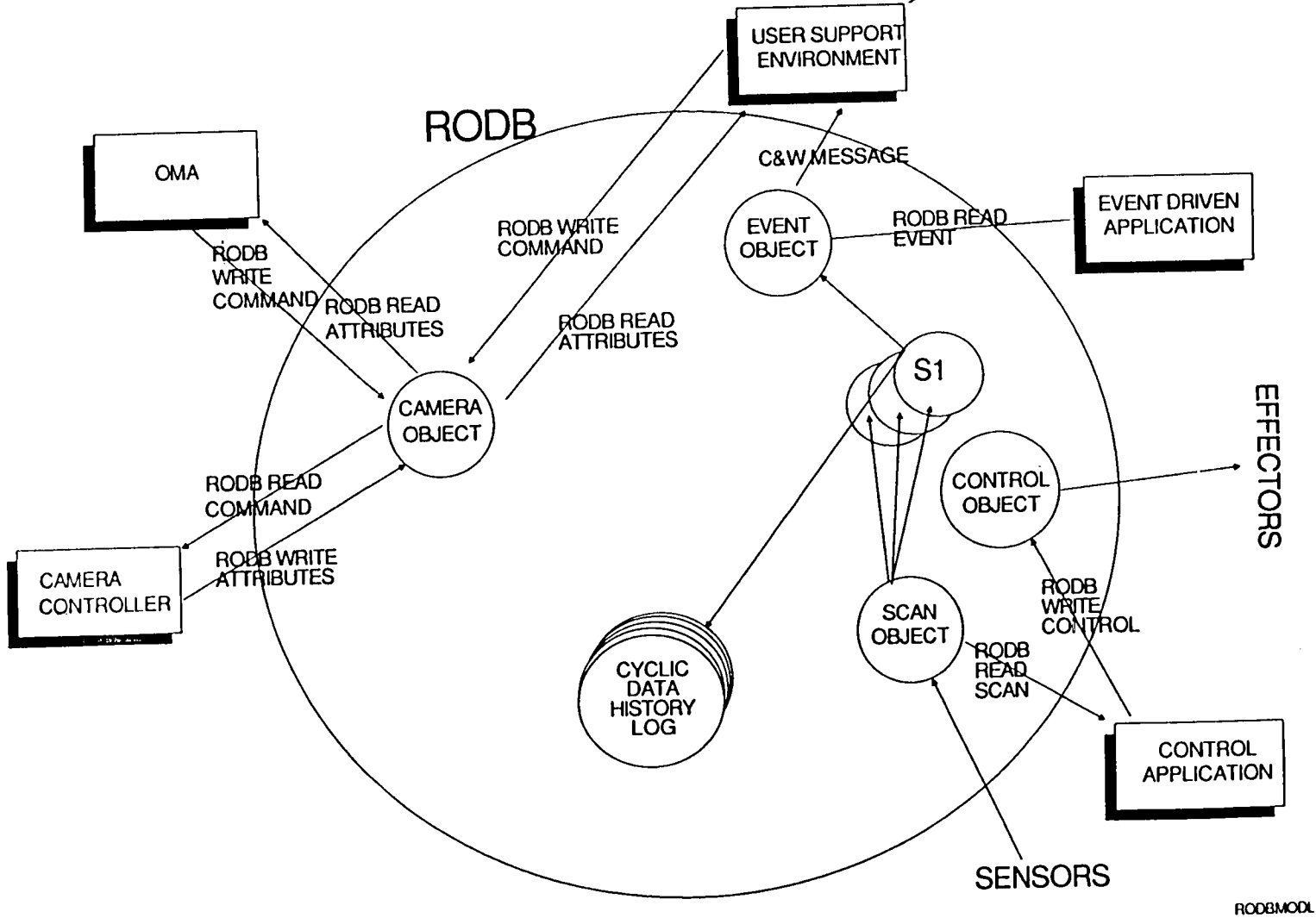

33

# RODB NODE MODEL

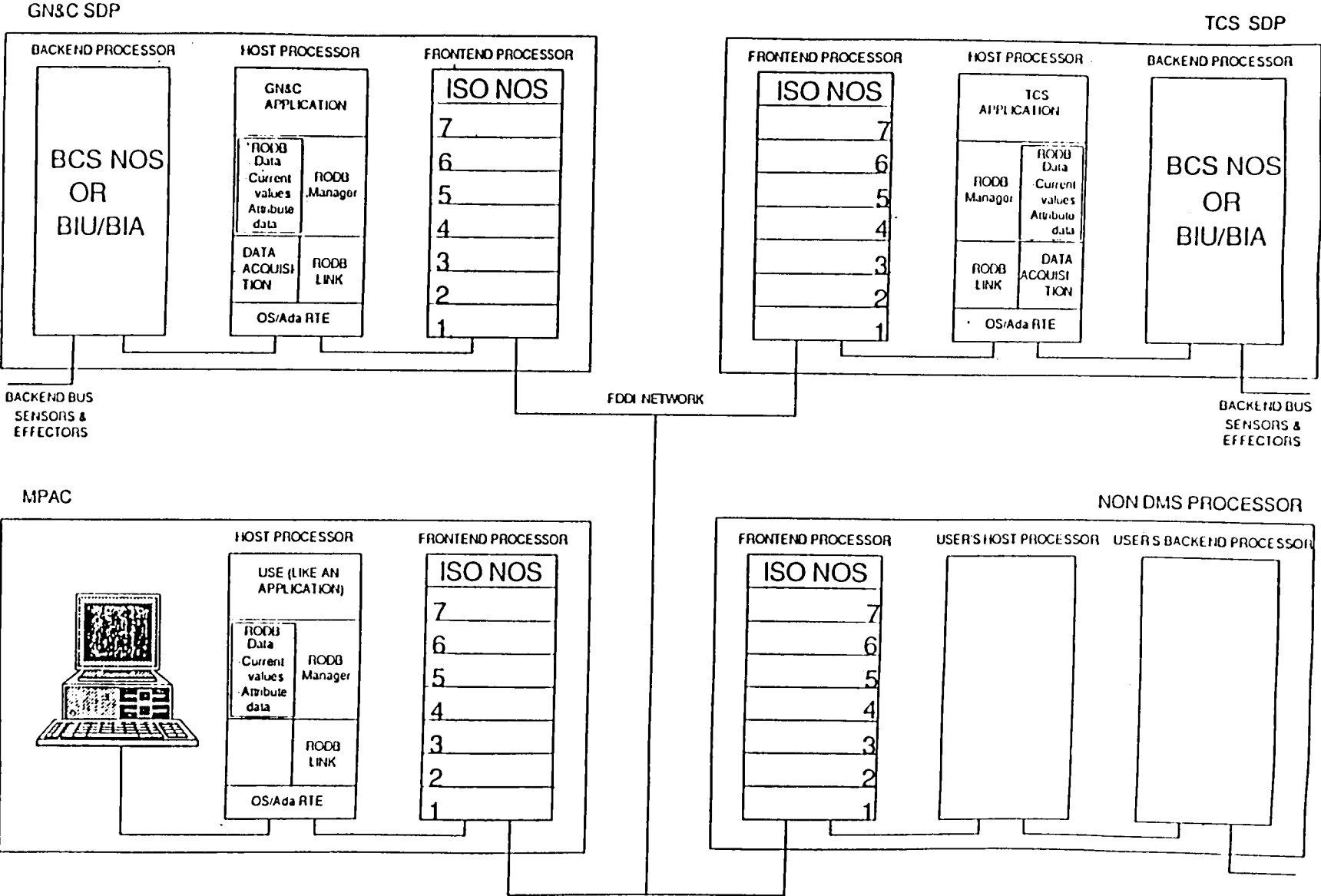

# COMMAND & CONTROL HIERACHY

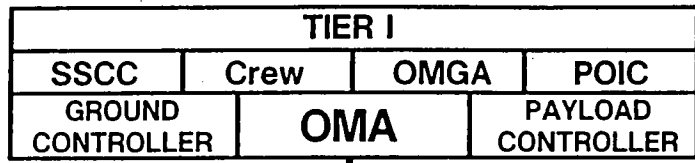

**Tier I**

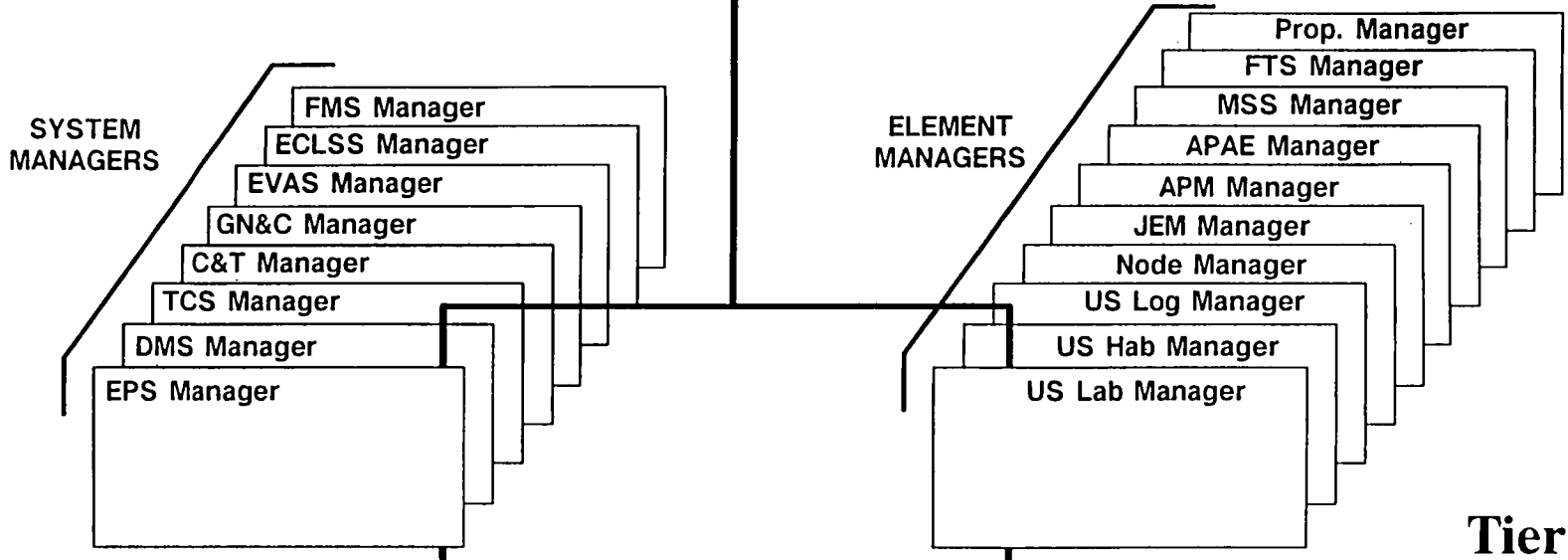

**Tier II**

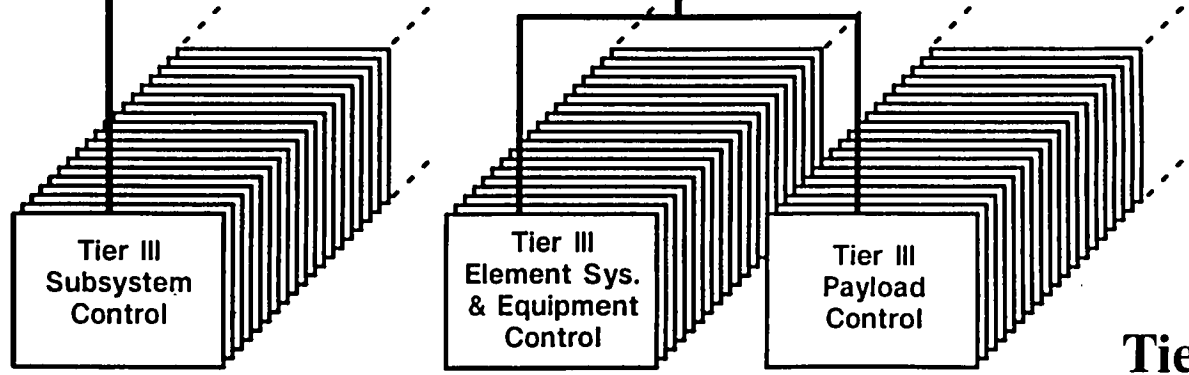

**Tier III**

Johnson Space Center

Space Station Projects Office  
Avionics Office

35



# Data Management System

## Invited Presentations

om 17

PRECEDING PAGE BLANK NOT FILMED

37  
INTERNATIONAL



# SPACE STATION FREEDOM SOFTWARE SUPPORT ENVIRONMENT

JANUARY 17, 1990

SUSAN J. VOIGT  
IN-SPACE TECHNOLOGY OFFICE  
SPACE STATION FREEDOM OFFICE  
NASA LANGLEY RESEARCH CENTER

*52-61*  
N 93-27706

*38*  
PERIODICALLY REPRODUCED

39

PRECEDING PAGE BLANK NOT FILMED

## CONTENTS

**This presentation discusses the Space Station Freedom Software Support Environment. After a brief overview of the SSE, the implementation approach and the current and planned functionality are described. The implications and future potential of this common environment for software development and sustaining engineering are also discussed.**

# **CONTENTS**

## **o OVERVIEW OF SSE**

- WHAT IS THE SSE?**
- WHY IS IT NEEDED?**
- WHO ARE THE USERS?**

## **o IMPLEMENTATION APPROACH**

- SCHEDULE**
- ARCHITECTURE**

## **o SSE FUNCTIONALITY**

## **o IMPLICATIONS AND FUTURE POTENTIAL**

## WHAT IS THE SSE?

The Software Support Environment (SSE) is a common software environment for all developers of Space Station Freedom Program (SSFP) "operational software". It consists of software tools, procedures, standards, hardware specifications, and user support services including continuing maintenance and upgrade of the SSE, user help desks, training material and documentation.

The SSE System is an environment consisting of computer hardware, communications networks, the SSE and other elements forming an integrated support system for SSFP software developers.

The SSE provides a common set of tools and methods across all the SSFP facilities involved in software life cycle management, including the Software Production Facilities (SPFs) at the four Work Package Centers and Kennedy Space Center, the SSFP integration facilities (to be established) and the SSE Development Facility (SSEDF).

"Operational software" is currently defined by the SSFP as ALL flight and ground software that either 1) interfaces with on-orbit elements in real time, or 2) is critical to the mission, such as all control center, test and certification software including associated models and simulations, or 3) SSE software.

## **WHAT IS THE SSE?**

- **SSE PROVIDES THE COMMON ENVIRONMENT TO BE USED FOR THE LIFE CYCLE MANAGEMENT OF ALL SSFP OPERATIONAL SOFTWARE.**
  
- **SSE IS A COLLECTION OF:**
  - **TOOLS (SOFTWARE)**
  - **RULES (POLICIES, STANDARDS, PROCEDURES, SOFTWARE PRODUCTION HARDWARE SPECS)**
  - **SERVICES (DELIVERY OF OI'S, USER SUPPORT, TRAINING, DOCUMENTATION)**
  
- **THE SSE SUPPORTS ALL SSFP FACILITIES INVOLVED IN SOFTWARE LIFE CYCLE MANAGEMENT. THESE FACILITIES INCLUDE:**
  - **WORK PACKAGE AND KSC SOFTWARE PRODUCTION FACILITIES**
  - **SSFP INTEGRATION FACILITIES**
  - **THE SSE DEVELOPMENT FACILITY**

## SSE Supports Program Standards

Since the SSE is the common environment for all SSFP software developers, it provides the mechanisms to enforce program-wide software policies and standards. High-level SSFP software policies are set forth in the Level A Software Management Policies, dated November 11, 1986. Elaboration and expansion on these policies are provided in the Level II Software Policies Document currently in under final review prior to becoming a formally baselined Program document. The SSE will be used to support and enforce use of these policies and standards. Current standards include Ada as the standard programming language, a Common User Interface (CUI) definition, standard content formats for software documentation, and a common software verification approach.

# **SSE SUPPORTS PROGRAM STANDARDS**

**THE SSE SUPPORTS AND PROVIDES MECHANISMS  
TO ENFORCE PROGRAM-WIDE SOFTWARE POLICIES  
AND STANDARDS, SUCH AS**

- **STANDARD PROGRAMMING LANGUAGE (ADA)**
- **COMMON USER INTERFACE STANDARDS**
- **SOFTWARE DOCUMENTATION STANDARDS**
- **COMMON SOFTWARE VERIFICATION APPROACH**

## SSE System Context

The SSE System consists of a collection of SSE System Elements in a wide area network (WAN). Each SSE System Element consists of a host platform and a collection of workstations running the SSE software. Each element has several external interfaces which may include SSFP operational facilities, Data Management System (DMS) simulation facilities and ground systems, SSE users (connected either directly or through a communications network), TMIS (the Program Technical and Management Information System) and other software production facilities.



# SSE SYSTEM CONTEXT

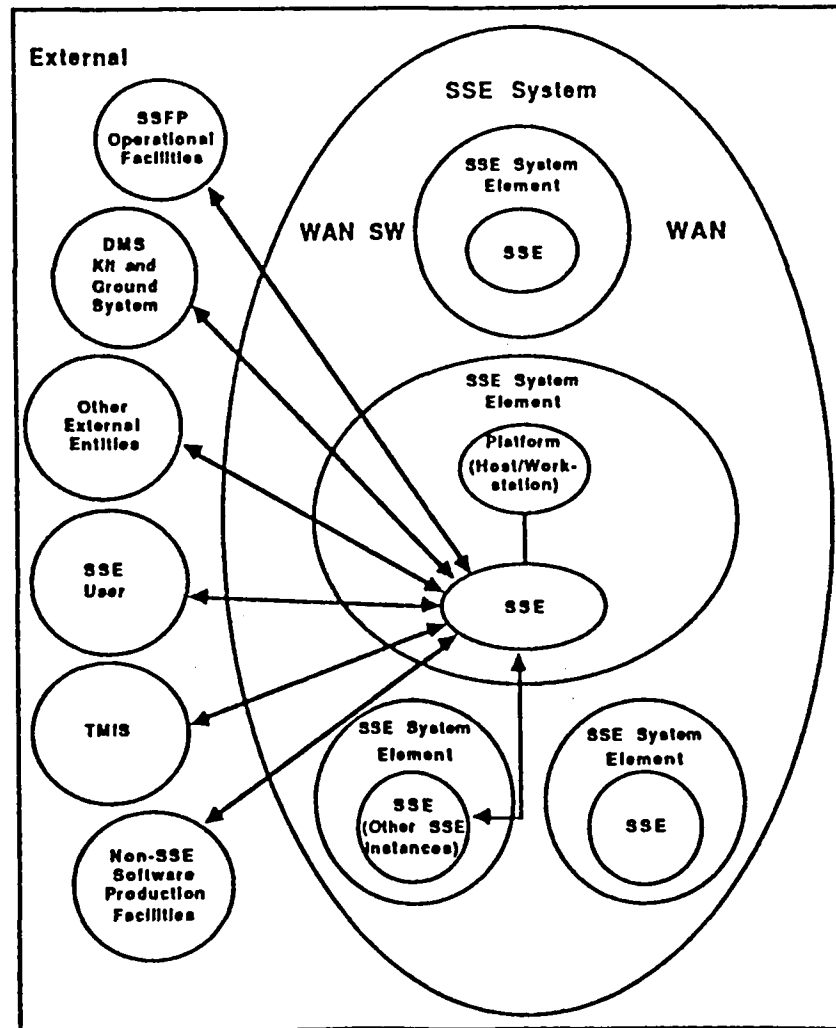

## SSE Hosts and Workstations

Two computer systems are currently supported as SSE host computer architectures: Architecture A is the DEC VAX family with VMS operating system and Architecture B is the larger IBM mainframes with VM. The SSE Development Facility has one of each: a DEC VAX 8820 and an IBM 3090.

There are three workstation types currently approved as SSE workstations: IBM PC/AT Compatible (PS/2 Model 60 running DOS and AT compatible personal computers), Apollo DN 3000 running the DOMAIN operating system, and Macintosh II workstation with Finder as the operating system. Currently, consideration is being given to adding the IBM PS/2 Model 80 as another workstation since the software tools available for this and the Apollo are very similar.

# **SSE HOSTS AND WORKSTATIONS**

- o **SSE HOST COMPUTER ARCHITECTURES AT DF.**
  - DEC VAX 8820 WITH VMS OPERATING SYSTEM
  - IBM 3090 WITH VM
  
- o **SSE WORKSTATION TYPES.**
  - IBM PS / 2 MODEL 60 AND AT COMPATIBLES
  - APOLLO DN 3000
  - MACINTOSH II
  
- o **ADDITIONAL WORKSTATION, IBM PS / 2 MODEL 80 (80386), UNDER CONSIDERATION.**

## Why does SSF need the SSE?

Software is a high risk area for the Space Station Freedom Program in terms of both safety and cost. The quantity of software developed for this program is expected to far exceed that required for previous space programs including the Shuttle Orbiter. Since there are so many different organizations developing software for the SSFP and they are distributed geographically as well, the potential for problems in the integration and testing phase of the development can be alleviated through the use of common tools and standards provided by the SSE.

Through the common environment used by developers of SSFP software, the life cycle costs can be contained in both the development phase by reducing duplicative efforts and especially in the sustaining engineering phase, when the wide use of a common environment will provide a greater base of skilled support personnel.

The SSE will also provide the means to quickly disseminate improved software tools and to increase software quality as technology improvements emerge.

## **WHY DOES SPACE STATION FREEDOM NEED THE SSE?**

- o **SOFTWARE IS HIGH RISK FOR THE SSFP IN TERMS OF BOTH SAFETY AND COST.**
  - **LARGE AMOUNT OF SOFTWARE TO BE DEVELOPED.**
  - **INTEGRATION AND TESTING ARE MAJOR ISSUES.**
  
- o **SSE PROVIDES A MEANS TO CONTROL SSFP SOFTWARE LIFE CYCLE COSTS.**
  - **A SINGLE COMMON IMPLEMENTATION APPROACH.**
  - **A CONSOLIDATION OF SKILLS FOR SUSTAINING ENGINEERING.**
  
- o **SSE PROVIDES THE MEANS TO CONTROL SSFP SOFTWARE QUALITY THROUGH COMMON PROGRAM-WIDE STANDARDS AND TOOLS.**

## Who are the SSE Users?

The SSE user community consists of all persons involved in the life cycle management of SSFP software. This includes software project managers, requirements analysts, software designers, software developers, testers, quality managers, and software configuration control managers. Most of the users will be Work Package contractors. Other SSE users will come from NASA SSFP organizations, Kennedy Space Center and ground support contractors, Space Station Freedom users, and international partners in the SSFP.

The Software Support Environment User's Working Group (SSEUWG) provides the forum for SSE user information exchange and input to the SSE Project. The SSEUWG has representatives from the NASA Centers and organizations involved in the SSFP, the Work Package contractors, the international partners, and potential SSF customers. Meetings are held approximately quarterly. For more information, contact the SSEUWG Chair, Susan Voigt at NASA Langley.

## **WHO ARE THE SSE USERS?**

- **SSE USER COMMUNITY ARE DEVELOPERS, TESTERS AND CONFIGURATION MANAGERS OF SSFP SOFTWARE.**
  
- **MAJORITY OF USERS ARE WORK PACKAGE CONTRACTORS.**
  
- **OTHER SSE USERS WILL INCLUDE:**
  - **NASA SSFP ORGANIZATIONS**
  - **KSC AND NON-PRIME CONTRACTORS**
  - **SPACE STATION FREEDOM USERS**
  - **INTERNATIONAL PARTNERS (STANDARD)**
  
- **SSEUWG IS THE USER FORUM FOR USER INFORMATION EXCHANGE AND INPUT TO THE SSE PROJECT.**

## SSE Implementation Approach

The SSE is being developed by Lockheed Missiles and Space Company, Inc. (LMSC) under contract to NASA. The development team is located in Houston, TX near the NASA Johnson Space Center. Subcontractors with LMSC are PRC, SAIC and Ford Aerospace. The six-year contract started on July 10, 1987.

The SSE is being developed incrementally. The first SSE system was delivered to the Government, called the Interim SSE, on September 10, 1987. Operational Increments (OIs) have been delivered periodically to increase the functionality of the SSE. The SSEDf has been recently upgraded to OI 3.2. This system will be delivered to the user Software Production Facilities (SPFs) beginning in mid-February. Future OIs are planned for release about every 5 months.



## **SSE IMPLEMENTATION APPROACH**

- o SINGLE CONTRACTOR FOR SSE DEVELOPMENT.**
  
- o CONTACT AWARDED TO LOCKHEED MISSILES AND SPACE COMPANY, INC., HOUSTON, TX.**
  - CONTRACT START DATE (CSD) - JULY 10, 1987.**
  
- o INCREMENTAL DEVELOPMENT.**
  - INTERIM SSE SYSTEM (OPERATIONAL INCREMENT 1.0) DELIVERED SEPTEMBER 10, 1987.**
  - CURRENTLY SSE SYSTEM AT OI 3.2.**
  - FUTURE OI'S TO BE DELIVERED EVERY 5 MONTHS.**

## Status and Challenges

The SSE Project Schedule has undergone some replanning in the last year. The original plan called for completion of the SDR in mid 1988, but achieving a requirements specification that was satisfactory to the user community and the SSFP took considerably longer than expected. Subsequent review points have also slipped. The original approach called for a replacement system at OI 4.0, but under the revised plan, the interim SSE system is gradually being refined and will transition to the new SSE architecture by OI 7.0. Meanwhile, the five SPFs have been installed and are operational at Work Package contractor sites. These contractors have software reviews (PDRs and CDRs) that require support from the SSE, and these are also depicted on the schedule.



# STATUS AND CHALLENGES

## SSE PROJECT SCHEDULE

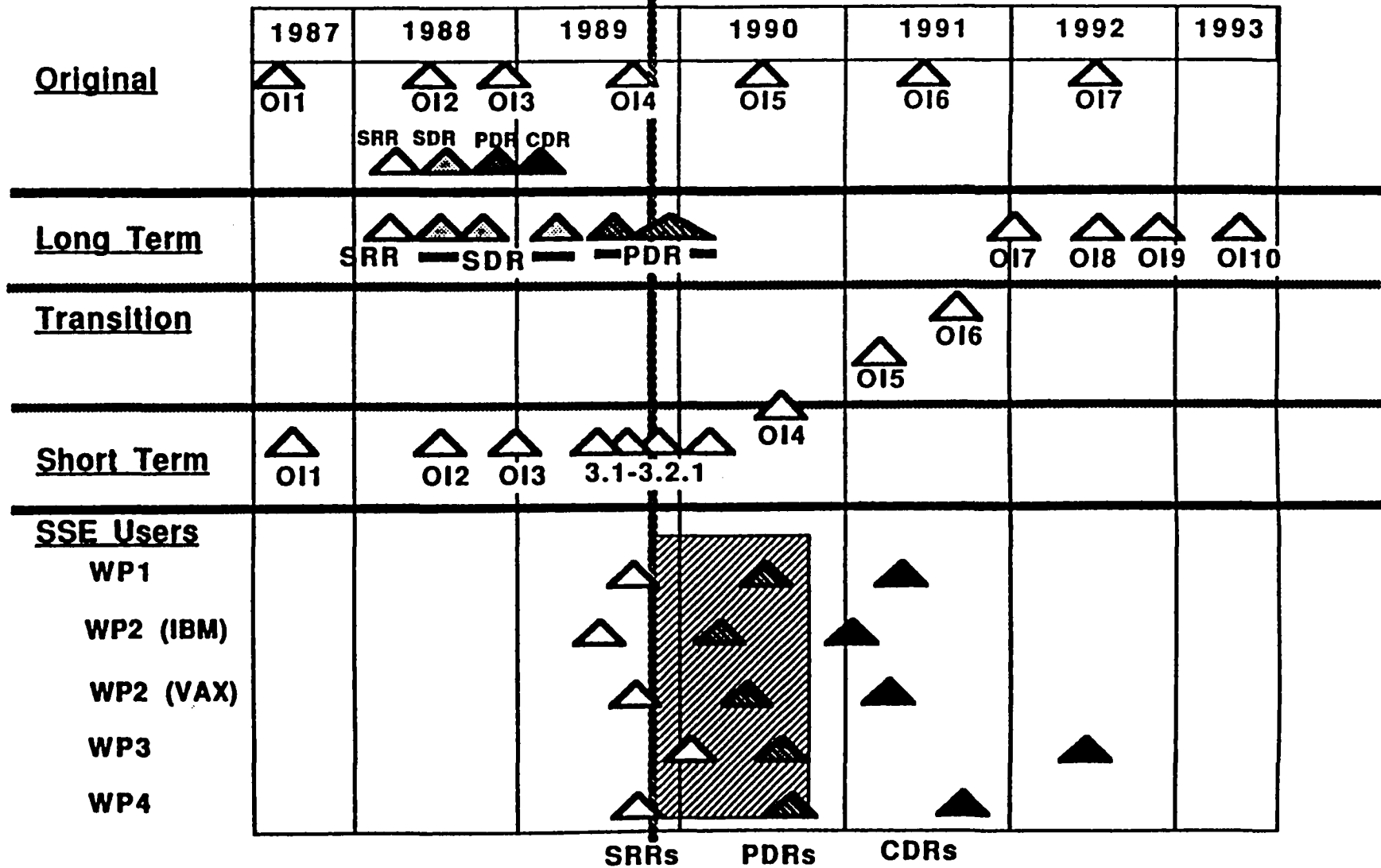

## SSE Implementation Status

Software Production Facilities (SPFs) are installed at five Work Package contractor sites: Work Package 1 - Boeing, Huntsville, AL; Work Package 2 - McDonnell Douglas, Huntington Beach, CA and IBM, Houston, TX; Work Package 3 - General Electric, King of Prussia, PA; and Work Package 4 - Rocketdyne, Canoga Park, CA. An additional SPF is planned for support at Kennedy Space Center at Harris Corporation, Rockledge, FL.

The SSE Operational Increment (version) 3.1 is installed on the five operational SPFs. OI 3.2 has already been installed at the SSEDf and will be installed in the SPFs beginning in February. The next OI will be OI 4.0, ready for installation in the fall 1990.

## SSE IMPLEMENTATION STATUS

- o **SOFTWARE PRODUCTION FACILITIES AT 5 SSFP CONTRACTOR SITES.**
  - **ROCKETDYNE - CANOGA PARK, CA.**
  - **McDONNELL DOUGLAS - HUNTINGTON BEACH, CA.**
  - **BOEING - HUNTSVILLE, AL.**
  - **IBM - HOUSTON, TX.**
  - **GENERAL ELECTRIC - KING OF PRUSSIA, PA.**
  
- o **SSE SOFTWARE PRODUCTION FACILITY PLANNED FOR HARRIS CORPORATION, ROCKLEDGE, FL.**
  
- o **SSE CAPABILITIES IN PLACE.**
  - **OI 3.1 IS INSTALLED AT THE 5 SPFs.**
  - **OI 3.2 INSTALLATION WILL BEGIN AT SPFs IN FEBRUARY 1990.**
  - **OI 4.0 SCHEDULED FOR FALL 1990.**

## SSE Architecture

The architecture for the eventual SSE is a layered one, with very well defined interfaces between the layers, so that it can evolve over the 30 year life time of the Space Station Freedom. The Common User Interface layer is the external view the user will have. It will be based on industry standards such as X-windows and OSF/MOTIF. the software tools that support the users are called "environment applications" and these may be commercial off the shelf (COTS) products or specially tailored tools and procedures. Below that layer is the Process/Object Management layer which contains the mechanisms to provide life cycle support for both software development processes and the objects (specs, designs, code, test procedures, test data, etc.). The lowest layer is the host and workstation platform operating systems on which the SSE system must run.



# SSE ARCHITECTURE

## SSE ARCHITECTURAL MODEL (LONG-TERM)

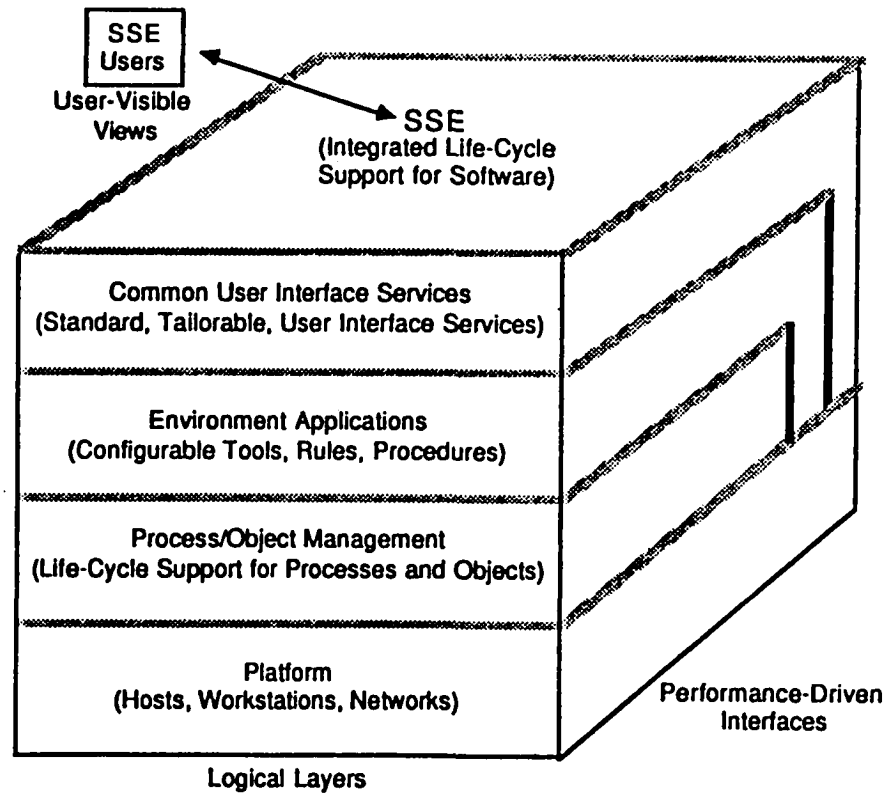

----- = SSE Standard Interface  
————— = No Interface Across Line

## SSE Transition Plan

The SSE Project replan includes a transition phase during which the SSE will evolve from the current collection of proprietary and COTS software to a target architecture which contains the four layers of the final architecture, but also permits "non-conforming environmental applications" which are COTS that require direct user interface and cannot be handled through the common user interface services. The SSE Architectural Design Document (contract document requirements list item number 58) describes the architecture in more detail.





# SSE TRANSITION PLAN

## SSE SOFTWARE ARCHITECTURE

CURRENT SSE

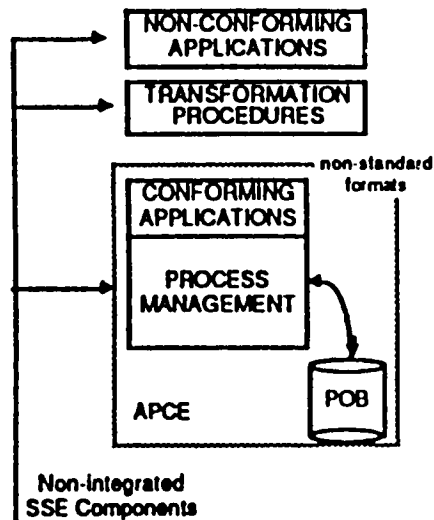

SSE TARGET ARCHITECTURE

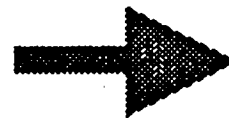
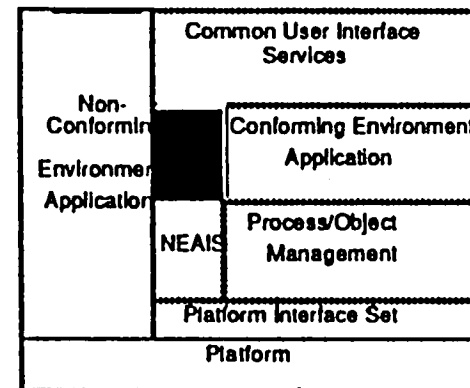

63

- o DURING THE TRANSITION PERIOD SPANNING FROM OI 4 THROUGH OI 6 THE CURRENT SSE WILL EVOLVE FROM A COLLECTION OF PROPRIETARY AND COTS SOFTWARE CAPABILITIES TO THE NEAR TERM GOAL ARCHITECTURE DEFINED IN THE SSE ARCHITECTURAL DESIGN DOCUMENT (DRLI 58)

## SSE Transition Plan/Cube Model OI 5.0

**This is a detail from the SSE Architectural Design document showing the elements of SSE OI 5.0, with several non-conforming tools, many of which reside on the SSE workstations, and some conforming applications/tools which are being developed specifically by the SSE Project. Major elements of the Process Object Manager will also be complete by OI 5.0.**



# SSE TRANSITION PLAN

## CUBE MODEL OF THE SSE OI 5.0

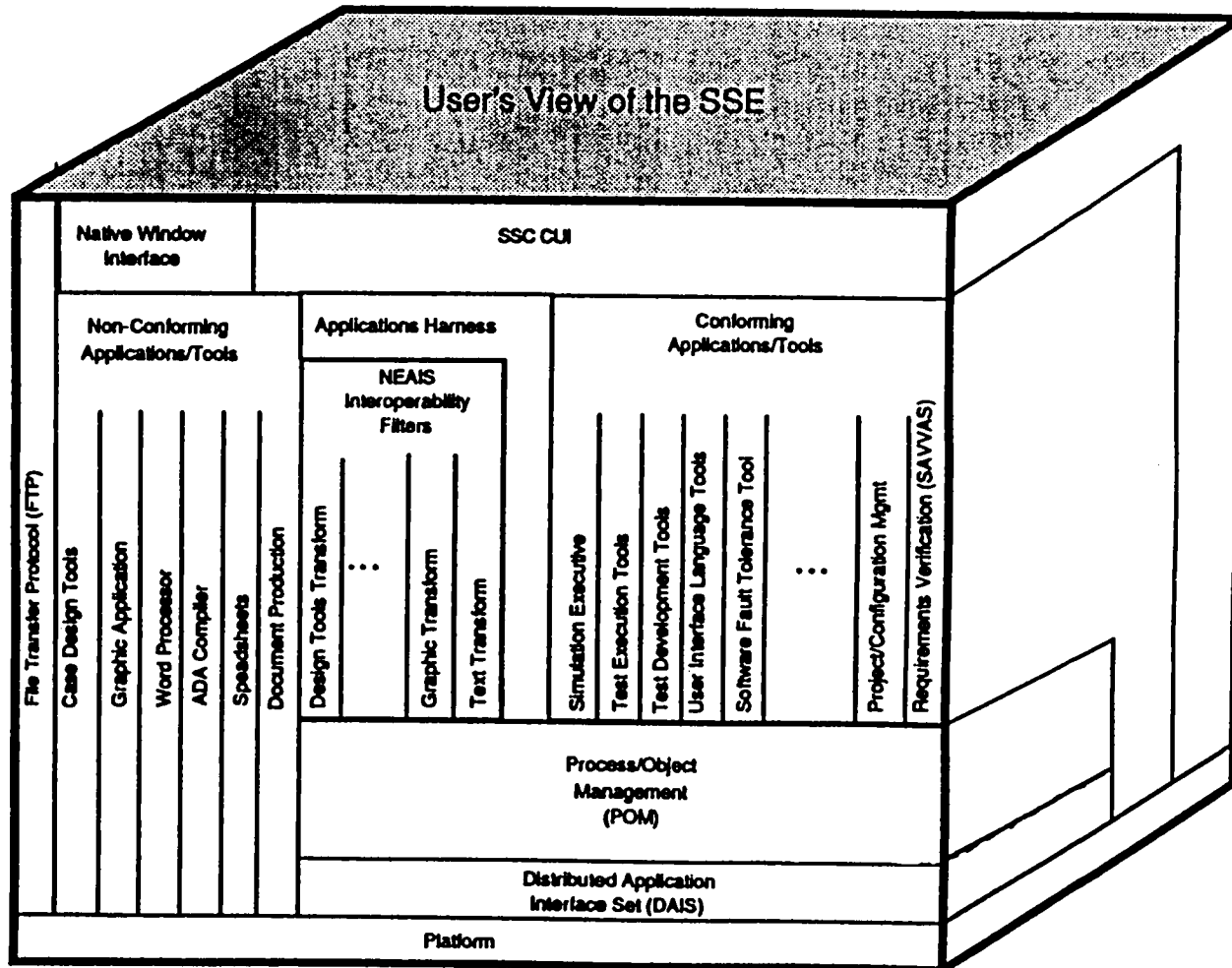

## SSE Functionality

The SSE provides support for software development in Ada. If the SSFP authorizes additional standard languages, the SSE will be expanded to support them as well.

The SSE Ruleset provides the software standards, guidelines, and procedures to support software acquisition, integration, verification and maintenance. It provides support to enforce the software policies and standards established by the SSFP.

The SSE Toolset provides the tools necessary to acquire, integrate and deliver SSFP operational software during all life cycle phases. The tools encompass the following functional areas: SSE process management; software management support; software production; flight software integration, test and verification; data reconfiguration, training, and library (object) management. The SSE also provides services such as delivery and configuration management of the SSE software itself, user support, training, and documentation.

## **SSE FUNCTIONALITY**

- o SSE SUPPORTS SOFTWARE DEVELOPED IN ADA.**
- o SSE RULESET PROVIDES SOFTWARE STANDARDS, GUIDELINES AND PROCEDURES.**
- o SSE TOOLSET PROVIDES ALL SOFTWARE TOOLS NECESSARY TO ACQUIRE, INTEGRATE AND DELIVER SSFP OPERATIONAL SOFTWARE. SSE TOOLS ENCOMPASS THE FOLLOWING FUNCTIONAL AREAS:**
  - SSE PROCESS MANAGEMENT**
  - SOFTWARE MANAGEMENT SUPPORT**
  - SOFTWARE PRODUCTION**
  - FLIGHT SOFTWARE INTEGRATION, TEST AND VERIFICATION**
  - DATA RECONFIGURATION**
  - TRAINING**
  - LIBRARY (OBJECT) MANAGEMENT**
- o SSE SERVICES ENABLE SSE USAGE FOR SSFP.**

## SSE Requirements Specification

The SSE functional and detailed requirements have been documented in the project documents DRLI 16 and 72. This chart indicates the various categories of requirements and how they are organized in the SSE Requirements Specification Document (DRLI 72) Some requirements specifically support user activities and others are computer process support requirements.



# SSE REQUIREMENTS SPECIFICATION

## SSE REQUIREMENTS ORGANIZATION

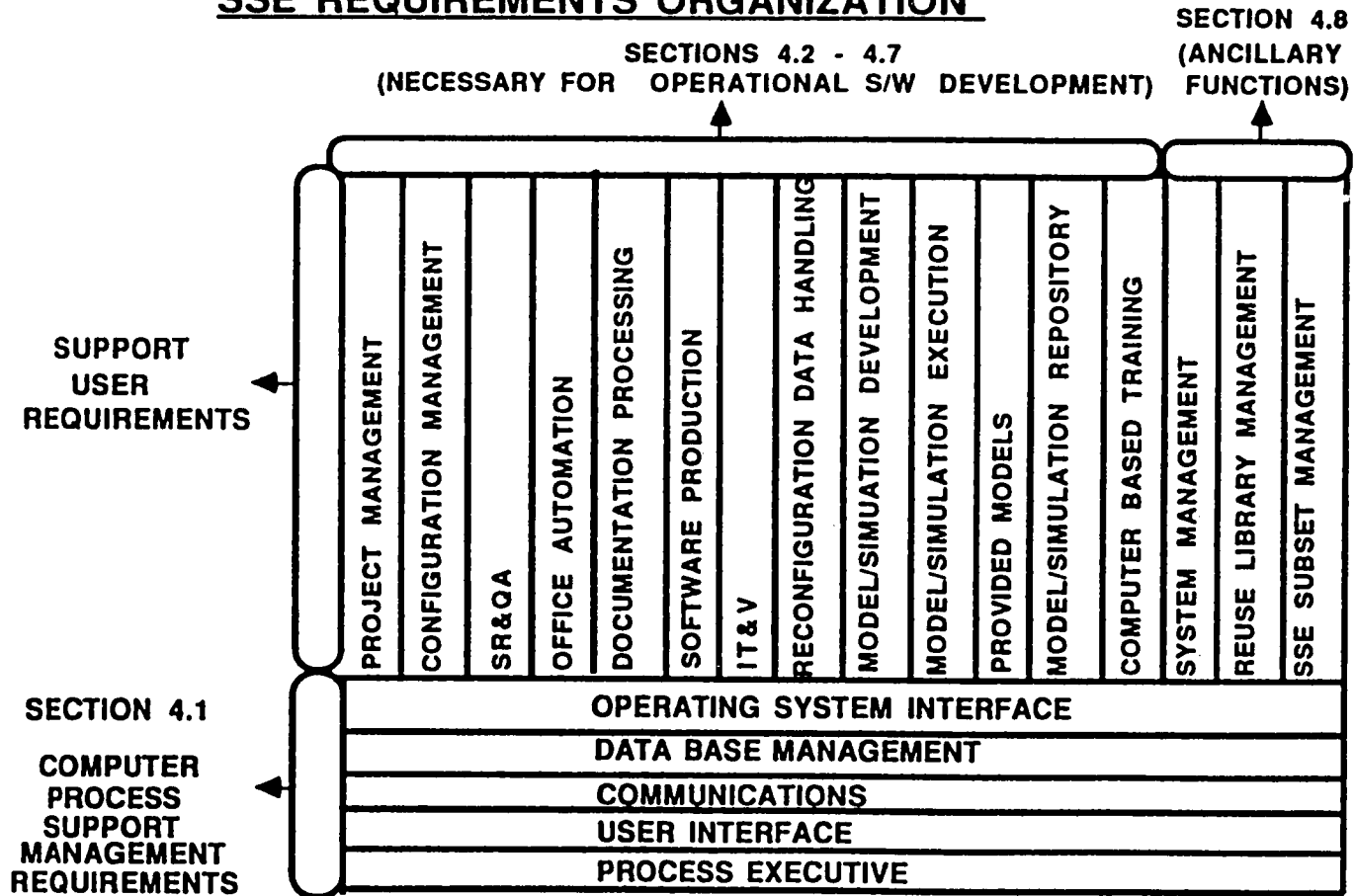

## SSE Project Overview/Functional Capabilities

The allocation of the requirements to the SSE architecture is depicted in this diagram which shows various elements in the SSE design and the categories of tools or functional areas contained in each. The SSE architectural design has evolved so that the terms "Framework" and "Test and Tools Harness" have been replaced. The process management element is now part of the Process/Object Management layer, and the tools are called environment applications. The functional capability of the harness is embodied in the interface between the common user interface and the environment applications layers.





# SSE PROJECT OVERVIEW

## SSE Functional Capabilities

<p><u>Framework</u></p>	<p>Process Management Element</p> <table border="1" style="width: 100%;"> <tr> <td data-bbox="552 375 804 630"> <p><b>Executive</b></p> <ul style="list-style-type: none"> <li>- SW Integ. &amp; Test Mgmt</li> <li>- Test &amp; Integ Control</li> <li>- Interface Between Applications And Comm Element</li> <li>- SR &amp; QA Enforcement Control</li> <li>- Project Management Initiation and Control</li> </ul> </td> <td data-bbox="814 375 982 630"> <p>DBM</p> </td> <td data-bbox="993 375 1192 630"> <p>Config. Control</p> <ul style="list-style-type: none"> <li>- Release and Delivery Control</li> </ul> </td> <td colspan="3" data-bbox="1413 345 1686 654" style="border: 1px dashed black;"> <p>Software Management Support Element</p> <ul style="list-style-type: none"> <li>- Configuration Management</li> </ul> </td> </tr> </table>						<p><b>Executive</b></p> <ul style="list-style-type: none"> <li>- SW Integ. &amp; Test Mgmt</li> <li>- Test &amp; Integ Control</li> <li>- Interface Between Applications And Comm Element</li> <li>- SR &amp; QA Enforcement Control</li> <li>- Project Management Initiation and Control</li> </ul>	<p>DBM</p>	<p>Config. Control</p> <ul style="list-style-type: none"> <li>- Release and Delivery Control</li> </ul>	<p>Software Management Support Element</p> <ul style="list-style-type: none"> <li>- Configuration Management</li> </ul>			<p><u>SSE Management</u></p> <ul style="list-style-type: none"> <li>- Library Mgmt.</li> <li>- Resource Requirements Gathering</li> <li>- Performance Monitoring</li> <li>- Production Facility Generation</li> <li>- Project Generation</li> <li>- SSE System Management</li> <li>- Non-BSE Input</li> <li>- Qualification</li> </ul>
<p><b>Executive</b></p> <ul style="list-style-type: none"> <li>- SW Integ. &amp; Test Mgmt</li> <li>- Test &amp; Integ Control</li> <li>- Interface Between Applications And Comm Element</li> <li>- SR &amp; QA Enforcement Control</li> <li>- Project Management Initiation and Control</li> </ul>	<p>DBM</p>	<p>Config. Control</p> <ul style="list-style-type: none"> <li>- Release and Delivery Control</li> </ul>	<p>Software Management Support Element</p> <ul style="list-style-type: none"> <li>- Configuration Management</li> </ul>										
<p>Test and Tools Harness</p>													
<p><u>Tools</u></p>	<p>SW Mgmt Support Element</p> <ul style="list-style-type: none"> <li>- Document Processing</li> <li>- Office Automation</li> <li>- SR &amp; QA</li> <li>- Project Mgmt. (Budgeting, Scheduling, &amp; Lessons Learned)</li> </ul>	<p>SW Production Element</p> <ul style="list-style-type: none"> <li>- Requirements Definition (Document Testing)</li> <li>- Preliminary Design, Detailed Design &amp; Implementation</li> <li>- TCI Verification, Simulation, Standards Compliance</li> <li>- Static &amp; Dynamic Analyzers</li> <li>- Software Initiation</li> </ul>	<p>Data Reconfiguration Element</p> <ul style="list-style-type: none"> <li>- Data Processing</li> </ul>	<p>Modeling, Sim, &amp; SW Checkout Element</p> <ul style="list-style-type: none"> <li>- Test Component Generator</li> <li>- Test Data Analyzer</li> <li>- Internal Standards Compliance</li> <li>- Simulators</li> </ul>	<p>Training Element</p> <ul style="list-style-type: none"> <li>- Development of Training Materials</li> </ul>	<p>Other</p>							
<p><u>System</u></p>	<p>Process Management Element</p> <div style="border: 1px solid black; width: 100px; height: 100px; margin: 20px auto; text-align: center; padding: 5px;"> <p>Comms</p> </div>												

## Implications and Future Potential

In the near term, the SSE Project will need to focus its resources on providing support to the most critical needs of the Space Station Freedom development teams. With each OI, the SSE will transition more towards the long term architecture. As the Process Object manager evolves, a more object-oriented approach will be enabled, and the layered architecture will have better defined interfaces. The well-defined interface layers will permit changes within any of the layers without a cascading impact on the entire system.

The primary benefits of the SSE will probably not be evident until the Space Station Freedom is in orbit and the program reaches a sustaining engineering and growth status. Then the disciplined software approach enabled by the SSE will make the continued operation and expansion of the software much more tractable.

The layered architecture of the SSE also provides great potential for migrating new software technologies to the SSE, such as improved requirements analysis tools, expert system design aids, elaborate reuse library support, and formal verification.

## **IMPLICATIONS AND FUTURE POTENTIAL**

- o NEAR TERM - SSE PROJECT WILL FOCUS ON SUPPORTING WORK PACKAGE CONTRACTOR DEVELOPMENT EFFORTS**
- o EVOLUTION TO SSE LAYERED ARCHITECTURE PROVIDES GOOD BASIS FOR CONTINUED GROWTH AND IMPROVEMENT OF SSE CAPABILITIES.**
- o SUSTAINING ENGINEERING OF SSFP SOFTWARE USING THE SSE RULES AND TOOLS WILL BE MORE TRACTABLE AND COST EFFECTIVE THAN UNDISCIPLINED DEVELOPMENT AND SUPPORT.**
- o NEW SOFTWARE TECHNOLOGIES CAN MIGRATE TO THE SSE, SUCH AS IMPROVED REQUIREMENTS ANALYSIS TOOLS, EXPERT SYSTEM DESIGN AIDS, ELABORATE REUSE LIBRARY SUPPORT AND FORMAL VERIFICATION.**

# VALIDATED FAULT TOLERANT ARCHITECTURES FOR SPACE STATION

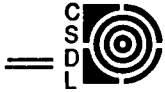

by  
Jaynarayan H. Lala

Presented at  
The Workshop on Technology  
for  
Space Station Evolution  
Dallas--Fort Worth, Texas

January 17, 1990

The Charles Stark Draper Laboratory, Inc.  
Cambridge, Massachusetts 02139

PRECEDING PAGE BLANK NOT FILMED

75

PAGE 74 INTENTIONALLY BLANK

93-27  
N 93-27707

163596

53-82

# OUTLINE



- **Fault Tolerance Approach**
- **Advanced Information Processing System (AIPS)**
- **Fault Tolerant Parallel Processor (FTPP)**



## **BASELINE DESIGN AND VALIDATION PROCESS**

---

- **Baseline processor and network architectures for space station rely on a combination of computer self-tests and diagnostics and additional diagnostics by the crew to:**
  - **detect and isolate in-orbit failures of computers, networks and their interfaces to sensors and subsystems**
  - **reconfigure, repair and revalidate the system following each component failure**
- **Design and validation of distributed fault tolerant architectures is accomplished by extensive testing of ad hoc designs which have been put together using subjective criteria**

## NEED FOR VALIDATED FAULT TOLERANT ARCHITECTURES



- **A validated fault tolerant computer system architecture is required that can autonomously:**
  - **monitor its own status**
  - **monitor the status of sensors and subsystems with which it interfaces**
  - **detect and isolate faults in computers, networks, sensors and subsystems**
  - **reconfigure the resources in realtime to continue to perform all the critical functions without manual (crew) intervention for reconfiguration and revalidation**
  
- **As Space Station evolves to support advanced missions, its computer system architecture must also extend to support:**
  - **mixed redundancy**
  - **function migration**
  - **reliable communication between physically distributed computers of different redundancy levels**

## **DRAPER APPROACH TO FAULT TOLERANT COMPUTER DESIGN**



- **Draper lab has designed fault tolerant computers which possess the following attributes:**
  - **validatable**
  - **Byzantine resilient**
  - **very low fault tolerance overheads**
  - **fault tolerance and redundancy management are transparent to user**



## BYZANTINE FAULTS DEFINITION



- **A Byzantine fault is an arbitrary behavior on part of a hardware component, a software module or a logical entity**
- **A particularly malicious manifestation of a byzantine fault is a "lying fault"**

## BYZANTINE RESILIENCE - MOTIVATION



### Design Example:

- **Highly reliable digital control**
- **$10e-9$  per hour maximum system loss probability**
- **$10e-4$  per hour channel failure rate (typical)**



## BYZANTINE RESILIENCE - MOTIVATION

---

### Approach 1:

- Enumerate each possible failure mode and provide a fault tolerance technique for each
- Uncovered failure probability must be less than  $< 10e-5$

### Problems:

- Must demonstrate that fewer than 1 in 100,000 failures can cause loss of control
- Difficult validation problem
- Difficult reliability analysis problem

# BYZANTINE RESILIENCE - MOTIVATION



**Strange failure mode: Failure on A's transmit bus causes B, C, and D to diverge**

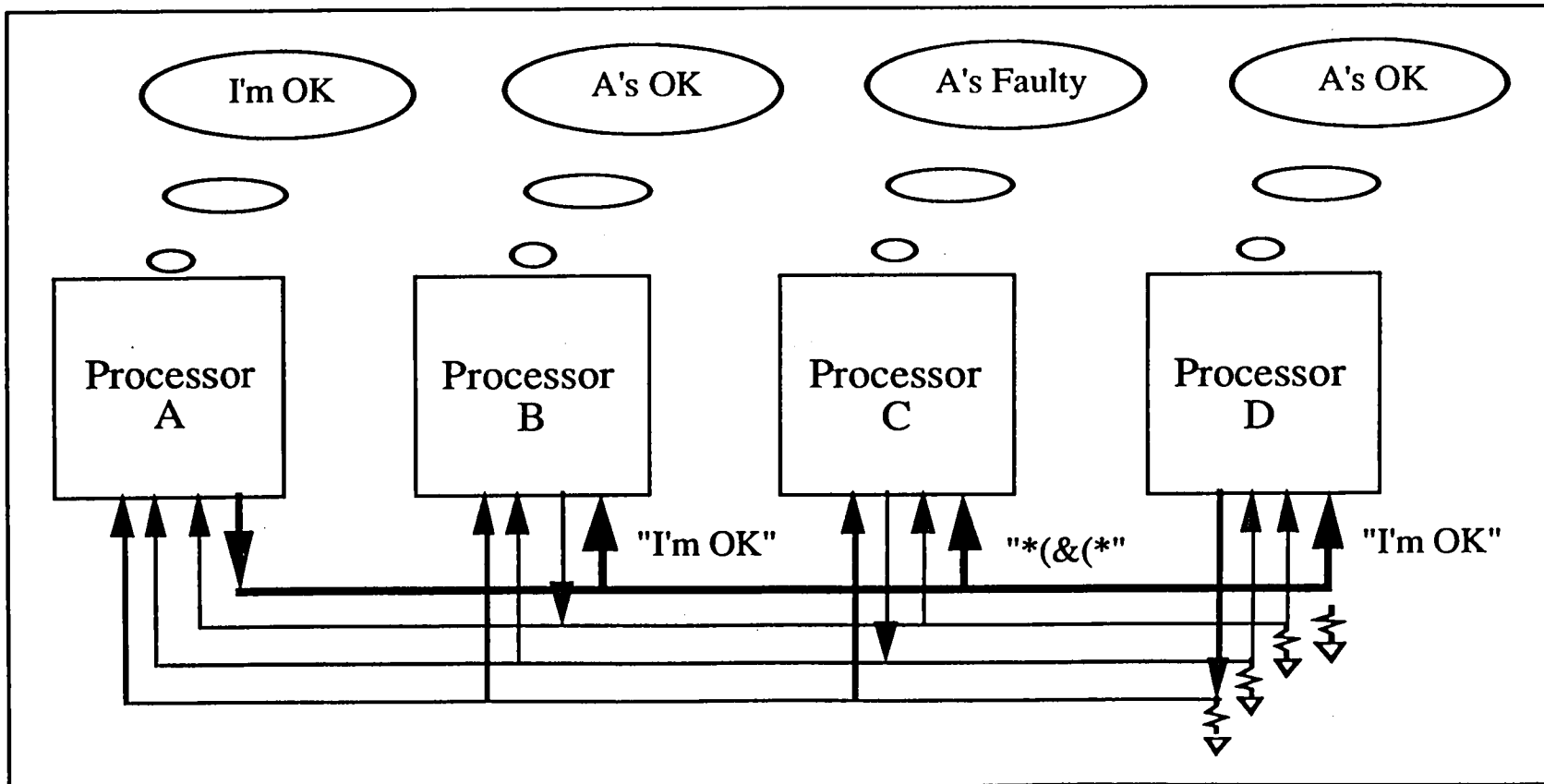

## BYZANTINE RESILIENCE - MOTIVATION

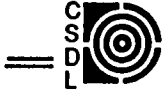

### Examples of strange failure modes:

- In-flight failure of YC-14 flight control computer
- Promiscuous network node failure
- FTP inconsistent vote errors
- FTP power supply-induced error

## BYZANTINE RESILIENCE



### Approach 2:

- Make no guesses about likely failure modes
- Tolerate arbitrary failure behavior:  
"Byzantine Resilience"

### Advantages:

- Theoretical requirements for Byzantine Resilience well-known and unambiguous
- Easier validation and analysis problem
- Higher reliability than other approaches

## BYZANTINE RESILIENCE - REQUIREMENTS



**Theoretically correct implementation of Byzantine Resilience requires:**

- **Bitwise comparison of results emanating from redundant sites of equivalent state complexity**
- **$3f+1$  fault containment regions (FCRs)**
- **$2f+1$  inter-FCR connectivity**
- **$f+1$  round inter-FCR protocol**
- **FCR synchrony**

# BYZANTINE RESILIENCE -REQUIREMENTS



## 1-Byzantine Resilient processing site:

- 4 identical FCRs
- fully connected
- 2-round interactive consistency protocol
- synchronous

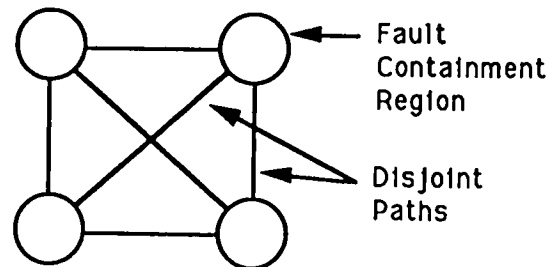



## ADVANCED INFORMATION PROCESSING SYSTEM



### Objective

**Develop an objective knowledgebase and demonstrate system building blocks which will allow achievement of validated fault tolerant distributed computer system architectures for a broad range of advanced aerospace applications.**

### Accomplishments

**Demonstrated major attributes of the AIPS architecture using the engineering model:**

- **Validatability**
- **Distributed computation**
- **Mixed redundancy**
- **Fault tolerance (processors, networks, interfaces)**
- **Damage tolerance**
- **Graceful degradation**
- **Expandability**
- **Transparency of fault tolerance to applications programmer**
- **Low fault tolerance overhead**

## ADVANCED INFORMATION PROCESSING SYSTEM



### Accomplishments

Produced an analytical and empirical knowledgebase for the validation of the AIPS architecture and building blocks:

- Architecture design rules and guidelines
- Analytical reliability and availability models
- Analytical performance models
- Empirical reliability data
- Empirical performance data
- Analytical cost models

Completed the distributed engineering model for the demonstration of the AIPS attributes and for test & evaluation; Demonstrated the following building blocks:

- 3 triplex FTPs
- 1 simplex processor
- triplex intercomputer network
- mesh I/O network
- System Services software (85,000 lines of Ada Code)

# AIPS BUILDING BLOCKS: HARDWARE



## FAULT TOLERANT PROCESSORS

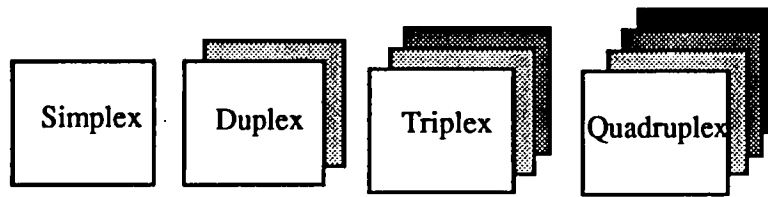

## INTERCONNECTION NETWORKS

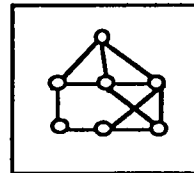

MESH

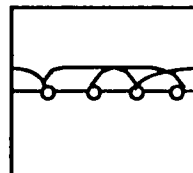

BRAIDED MESH

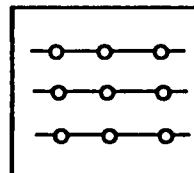

REDUNDANT BUSES

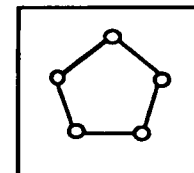

RING

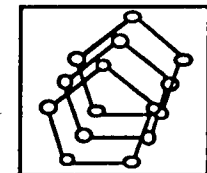

REDUNDANT RINGS

## INTERFACES

**IOS** Input/Output Interfaces

**ICIS** Inter-Computer Interface Sequencer

## AIPS BUILDING BLOCKS: SOFTWARE



### **LOCAL SYSTEM SERVICES:**

- Ada Real Time Operating System**
- FTP Redundancy Management**
- Local Time Management**

### **INPUT/OUTPUT (I/O) SYSTEM SERVICES:**

- I/O User Communications**
- I/O Redundancy Management**

### **INTERCOMPUTER (IC) SYSTEM SERVICES:**

- Ada Distributed Synchronous Communications**
- IC User Communications**
- IC Redundancy Management**

### **SYSTEM MANAGER:**

- Function Allocation & Migration**
- System Redundancy Management**
- Global Time Management**

# AIPS ENGINEERING MODEL CONFIGURATION

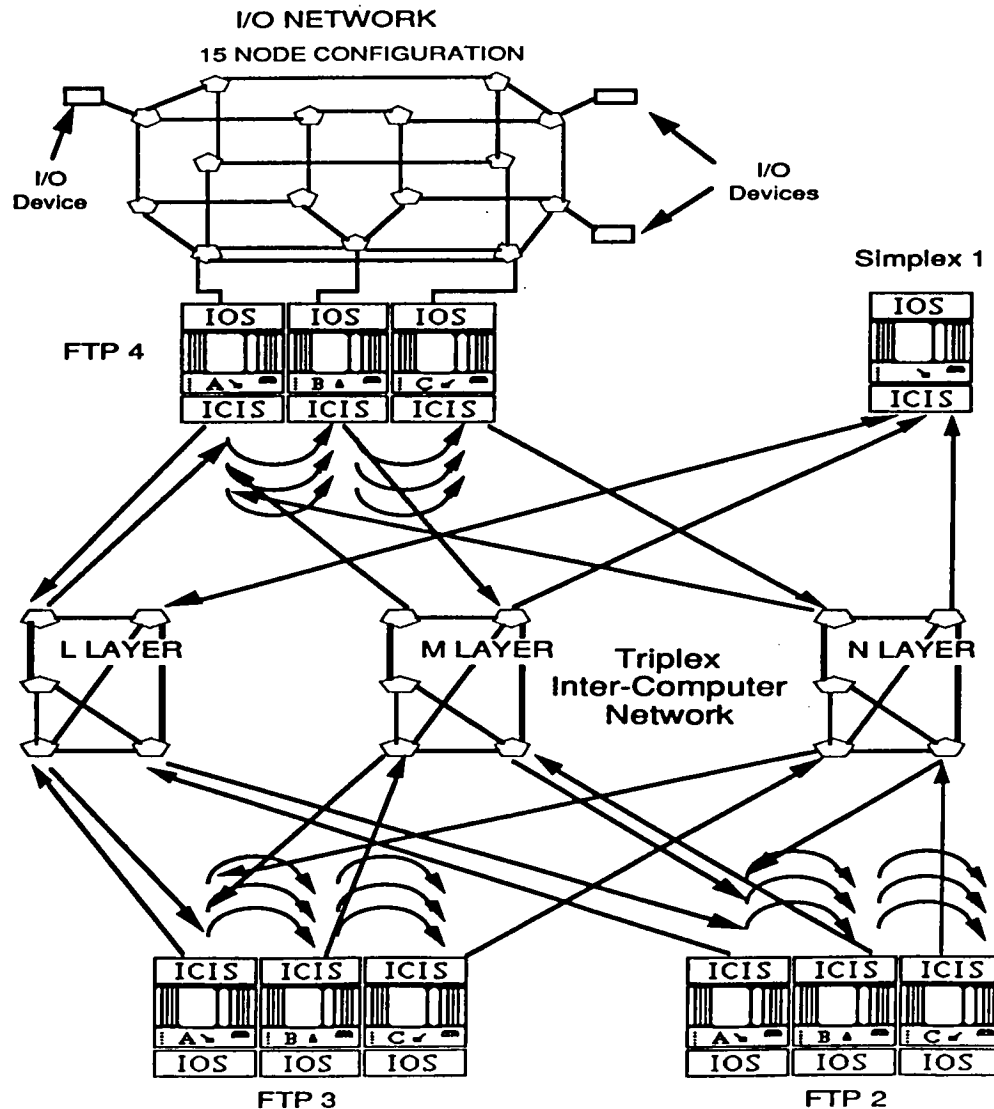

# AIPS ENGINEERING MODEL



Triplex FTP  
(Site 2)



Triplex FTP  
(Site 3)



Triplex FTP  
(Site 4)

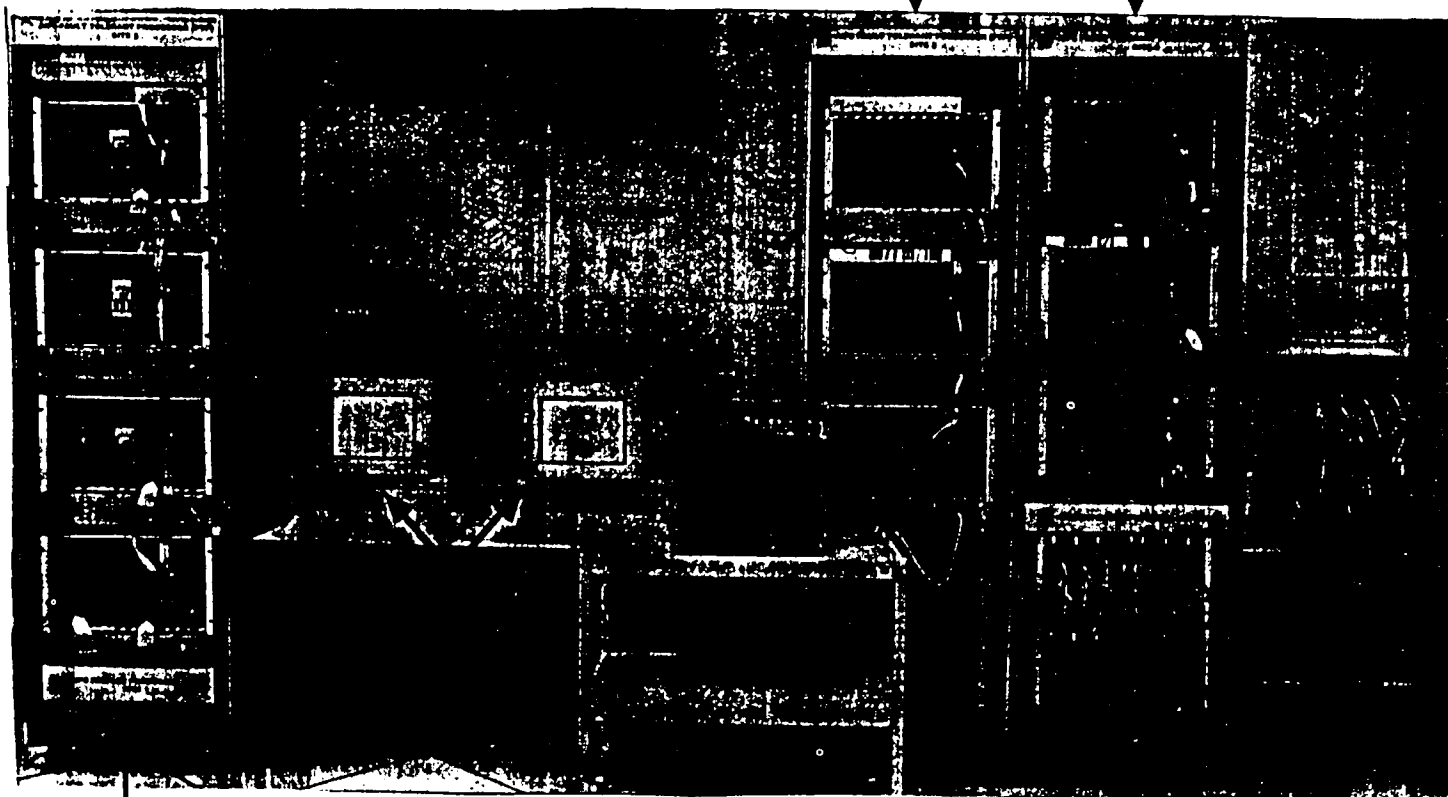

Simplex Processor  
(Site 1)

Triplex IC Network



# TRIPLEX FTP CHARACTERISTICS

## AIPS FAULT TOLERANT PROCESSOR

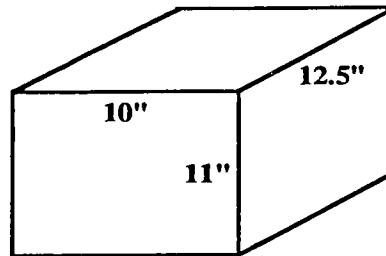

**SIZE: 0.8 CUBIT FEET**

**WEIGHT: 50 lbs**

**POWER: 42 watts**

**THROUGHPUT: 20 MIPS**

**MEMORY: 4 MBYTES**

**RELIABILITY:  $10^6$ -  $10^7$  hrs MTBCF**

**PROB. OF FAILURE:  $10^{-6}$  to  $10^{-7}$  per hour**

**REDUNDANCY: Triplex (Expandable to quad)**

**FAULT TOLERANCE: Fail-Operational, Fail-Safe**

**MODULARITY: Highly Modular**

**EXPANDABILITY: Network of FTPs**

**PROGRAMMING LANGUAGE: Ada**



# ADVANCED LAUNCH SYSTEM AVIONICS BLOCK DIAGRAM

DUPLEX FTP

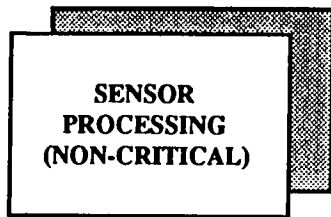

QUAD FTFS

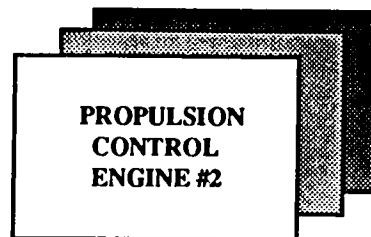
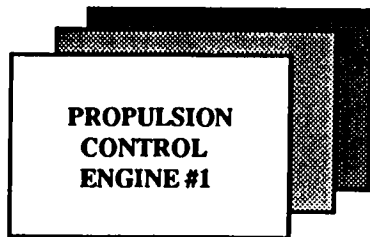
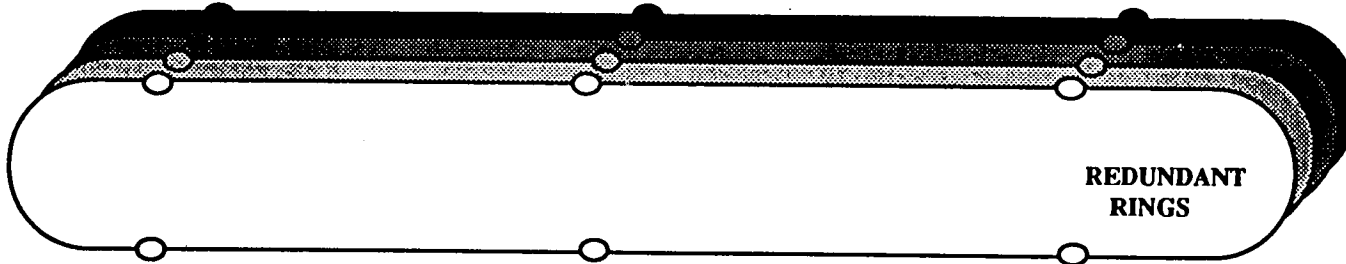
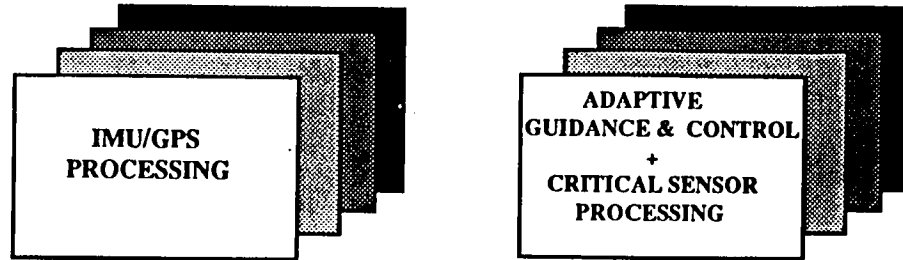

...

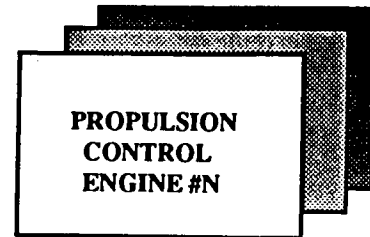

TRIPLEX FTFS



## FAULT TOLERANT PARALLEL PROCESSOR OBJECTIVES

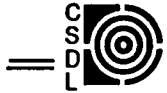

- **Develop concepts applicable to high reliability parallel processing**
- **Demonstrate key concepts via proof of concept**
- **Make FTPP available to NASA/DoD community**

## ATTRIBUTES



- **Message-passing parallel computer**
- **Messages serve both intercomputer communication and fault tolerant purposes**
- **Efficient hardware implementation of fault tolerance-specific functions**

## ATTRIBUTES (CONT.)



- **Highly reconfigurable**
  - **Trades redundancy for throughput in real time**
  - **Allows variety of redundancy management modes**
- **Supports dissimilar processing sites**
- **Supports off-the-shelf components**
- **Programmable in C, ADA, or Assembler**

# FTPP POC CONFIGURATION

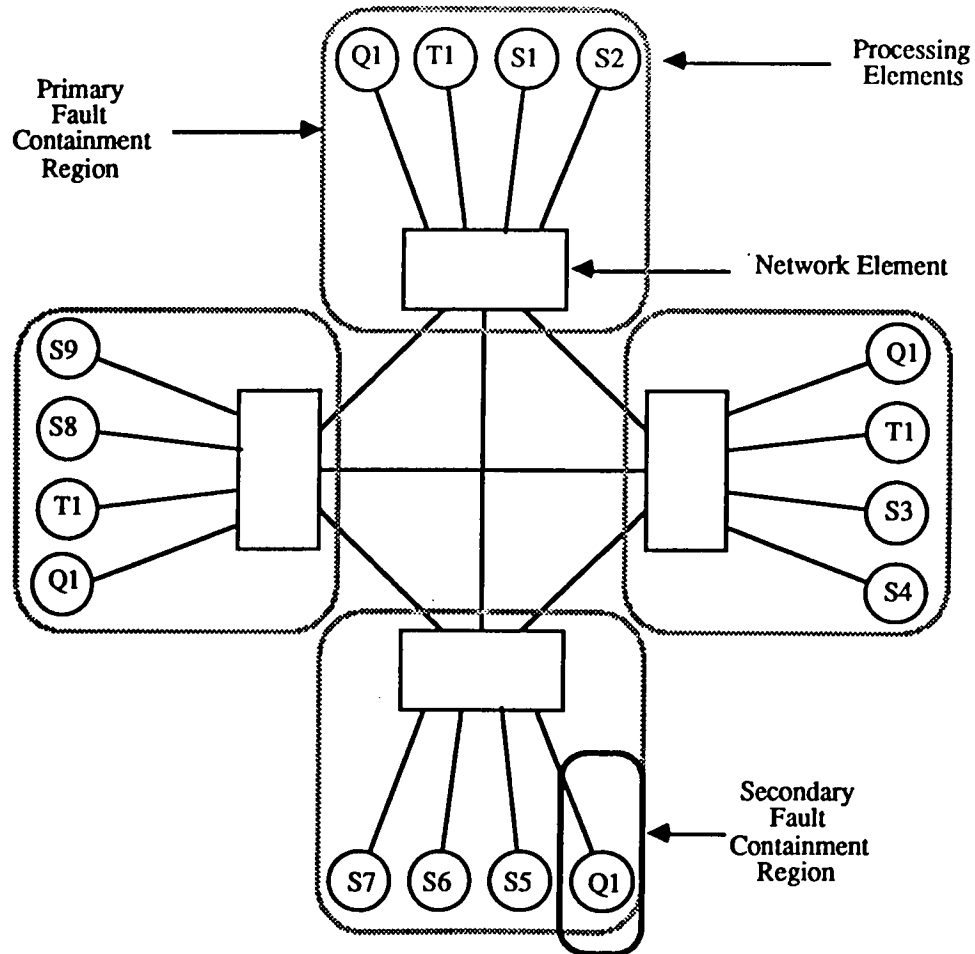

# 192-PE FTTP

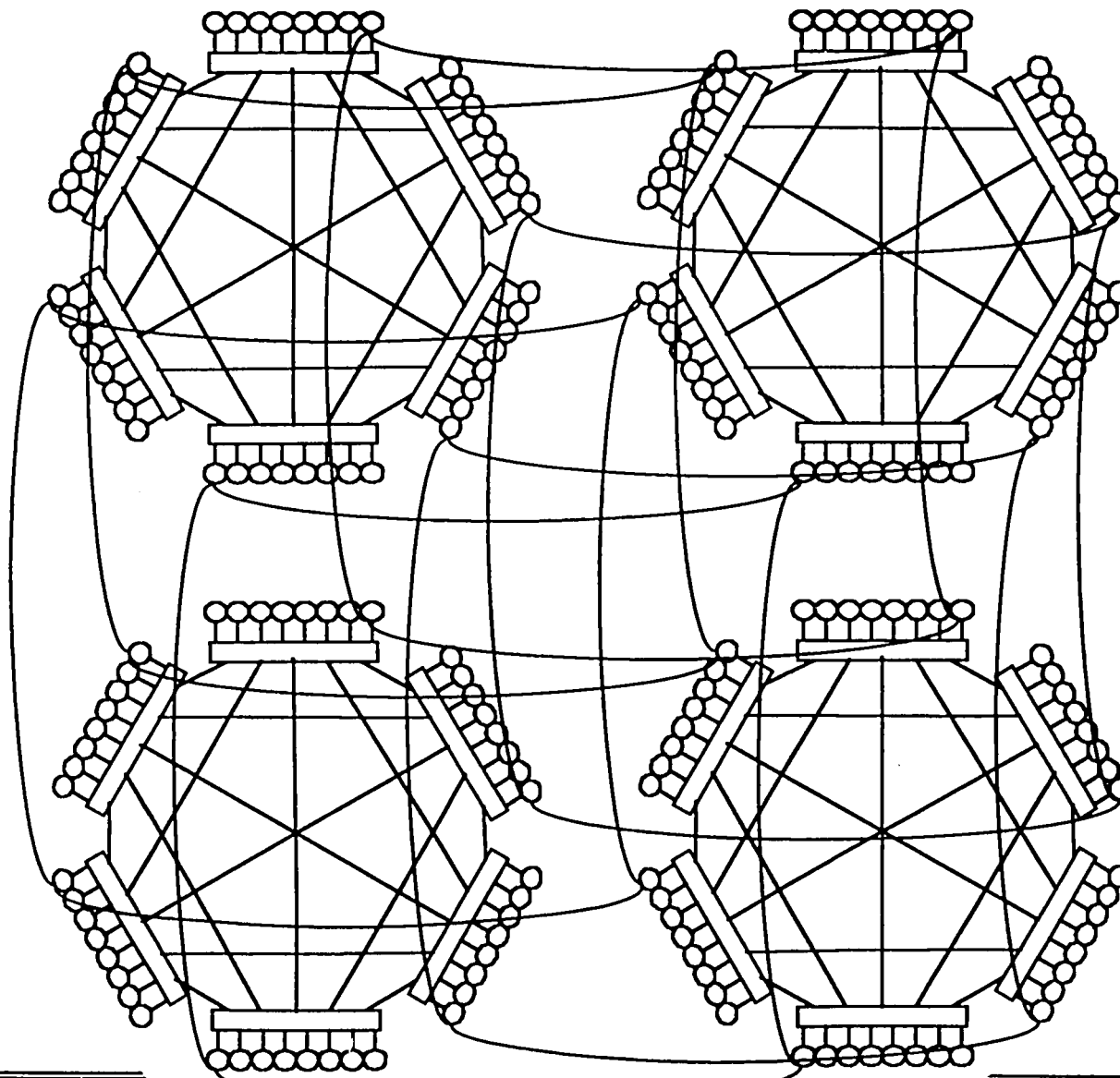

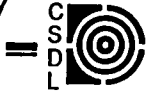

# FTPP POC

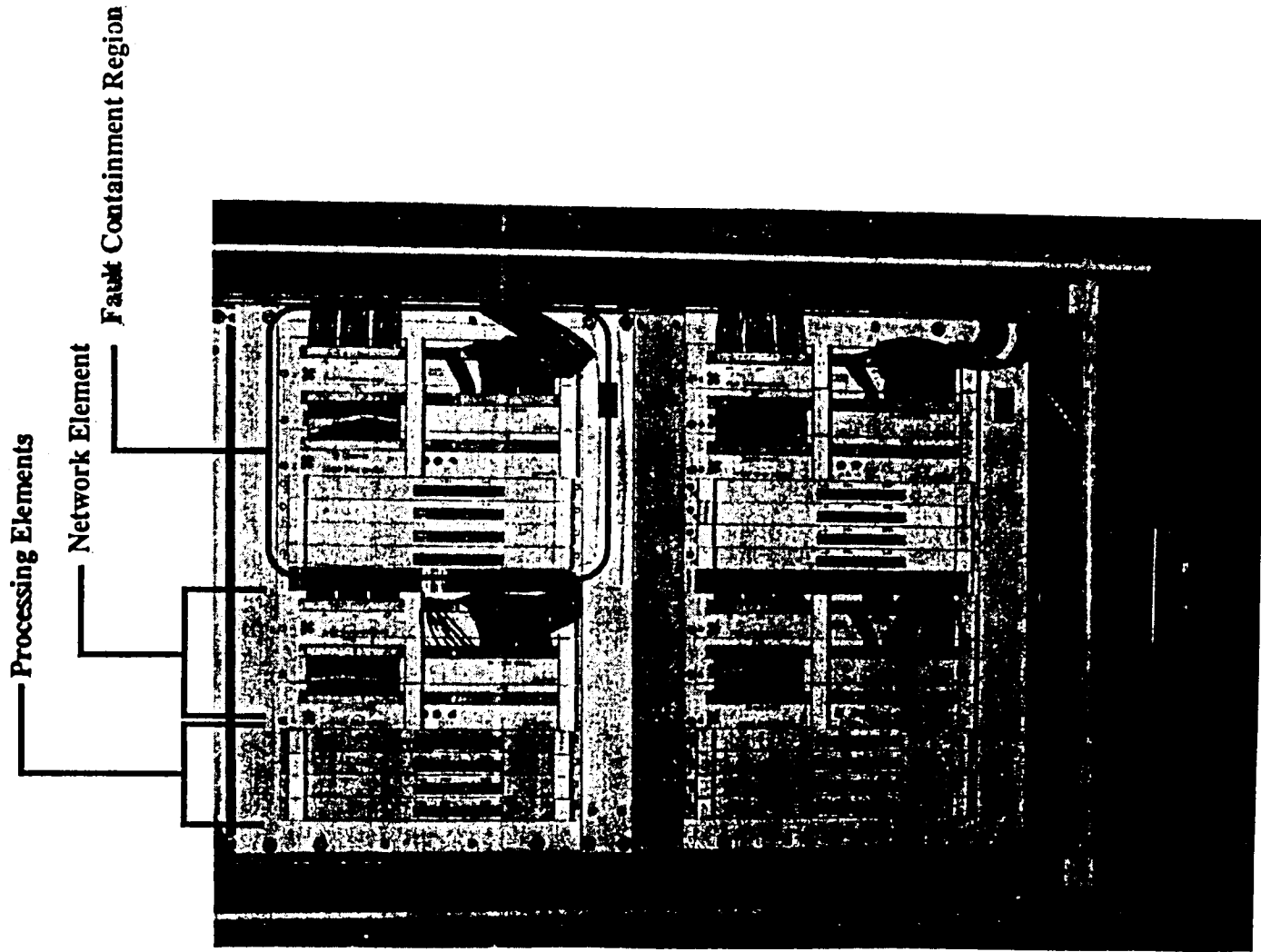

A FAULT-TOLERANT RISC MICROPROCESSOR  
FOR SPACECRAFT APPLICATIONS

CONSTANTIN TIMOC  
SPACEBORNE INC.

HARRY BENZ  
NASA/LaRC

N93-27708

163691

54-60

103

103  
INTERNATIONALLY MARKETED

PRECEDING PAGE BLANK NOT FILMED

# REDUCED INSTRUCTION SET COMPUTER

## CONTROL UNIT

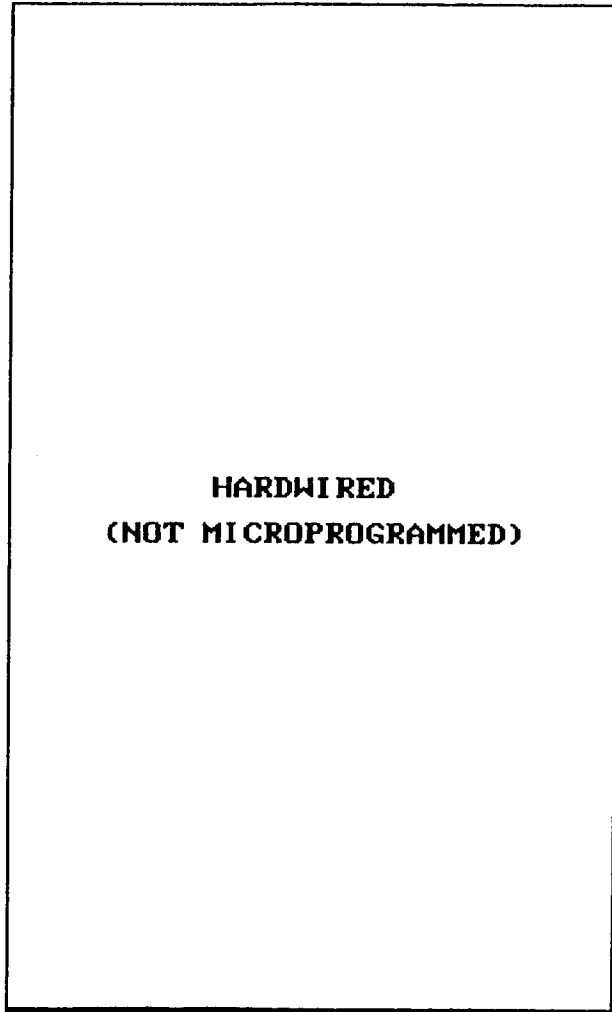

## DATA AND ADDRESS UNIT

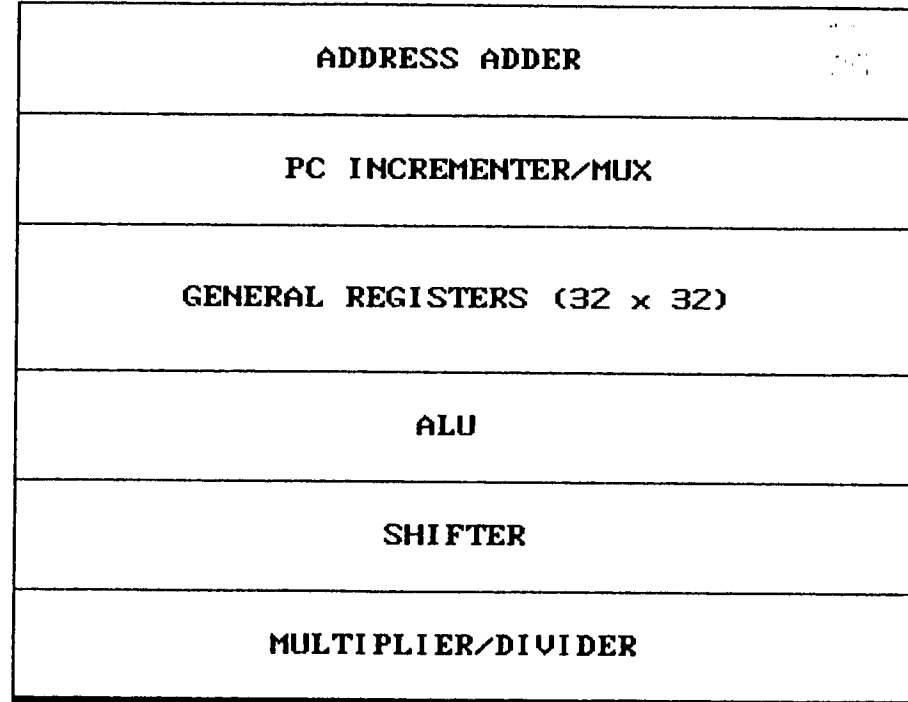

## INTERRUPT UNIT

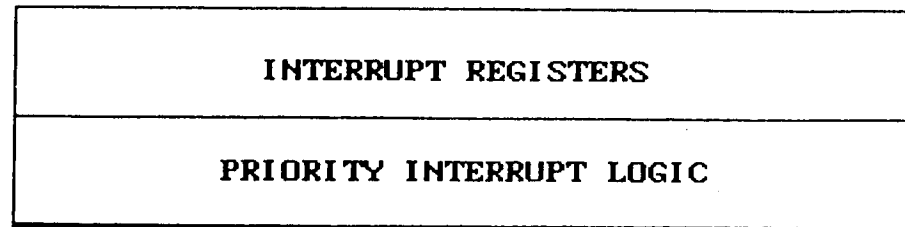



# FAULT TOLERANT REGISTERS

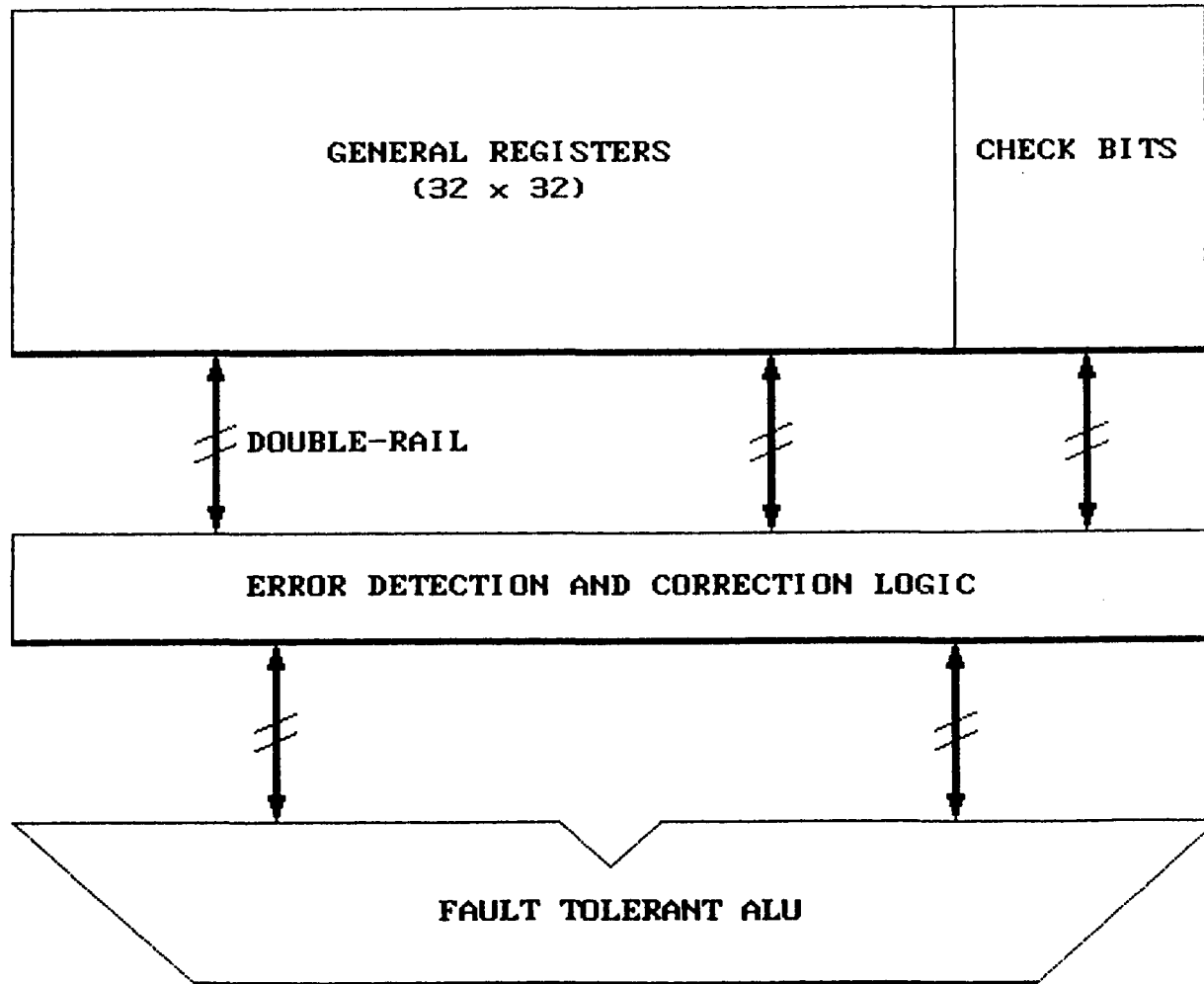

# FAULT TOLERANT ALU

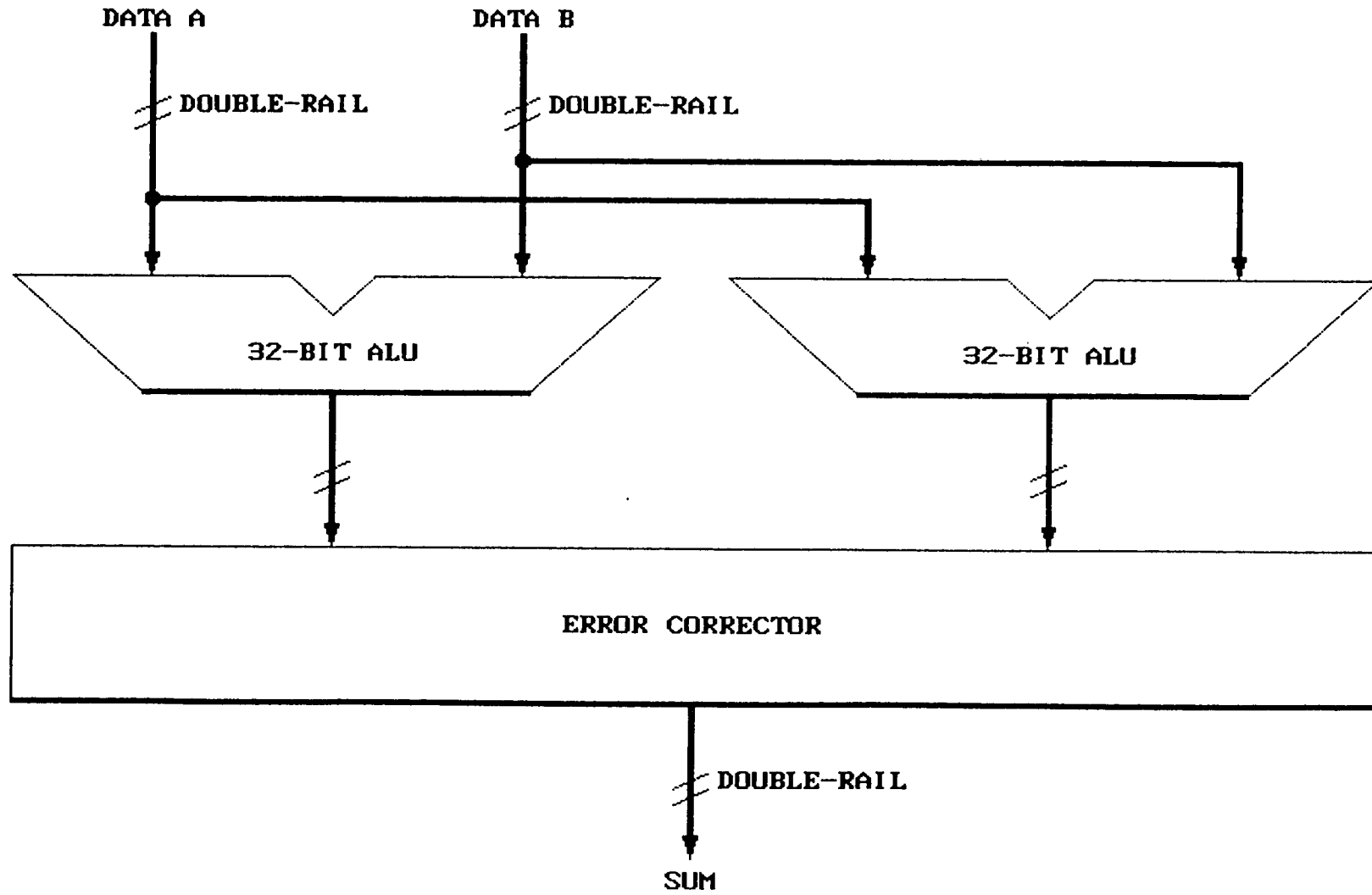

# DOUBLE RAIL CMOS LOGIC

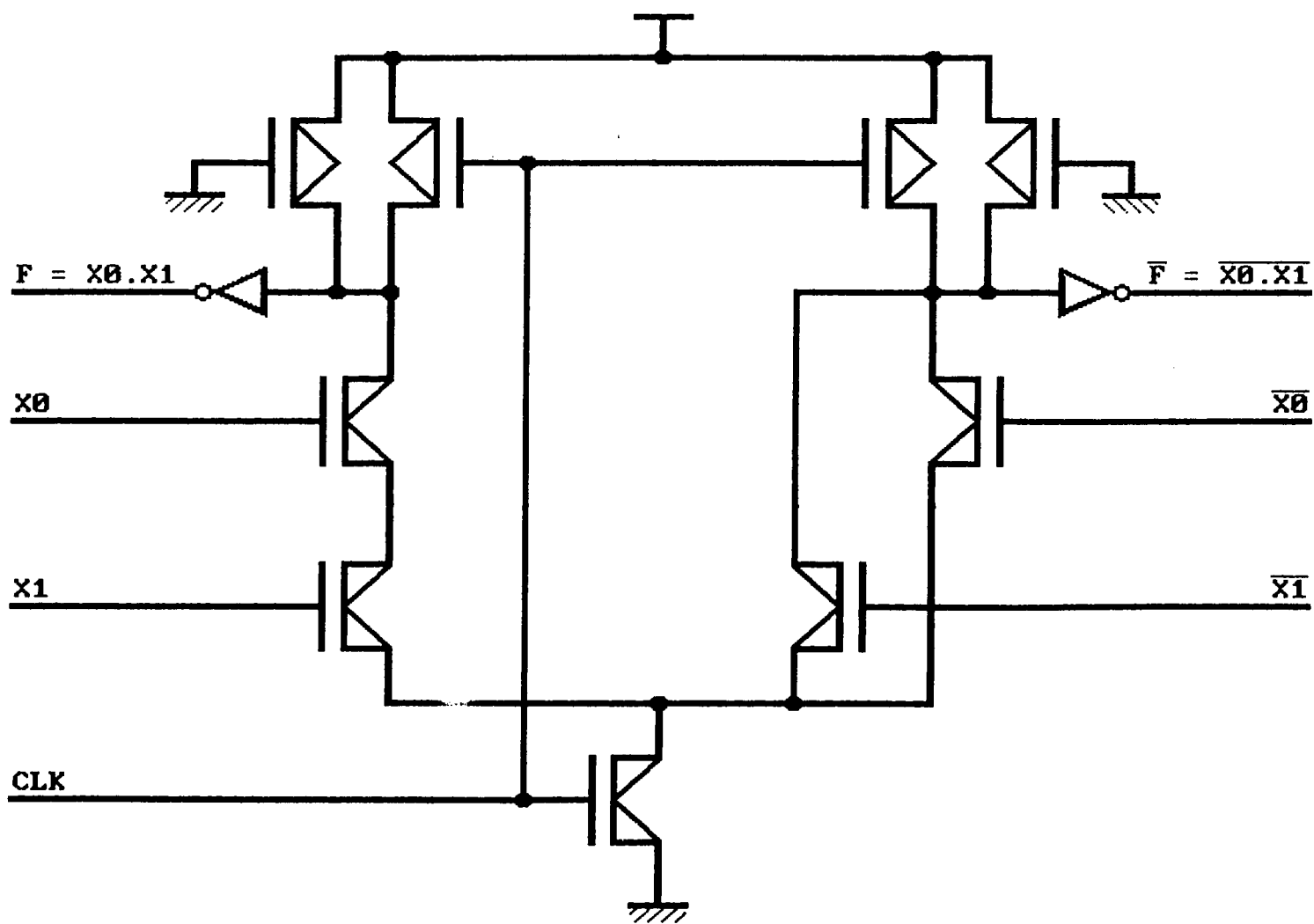

# DOUBLE RAIL CMOS LOGIC (GOOD CIRCUIT)

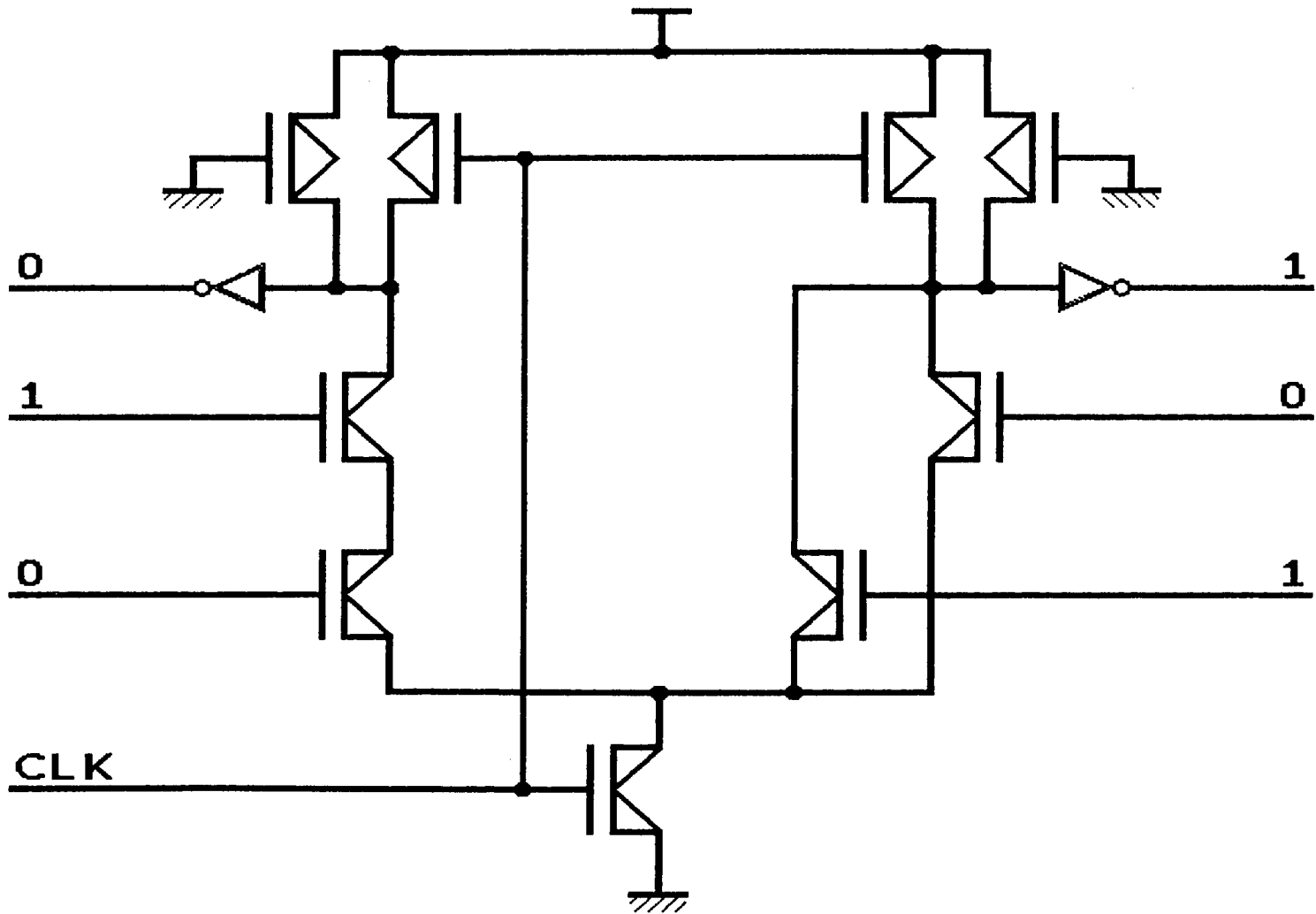

# DOUBLE RAIL CMOS LOGIC (TRANSISTOR STUCK-ON)

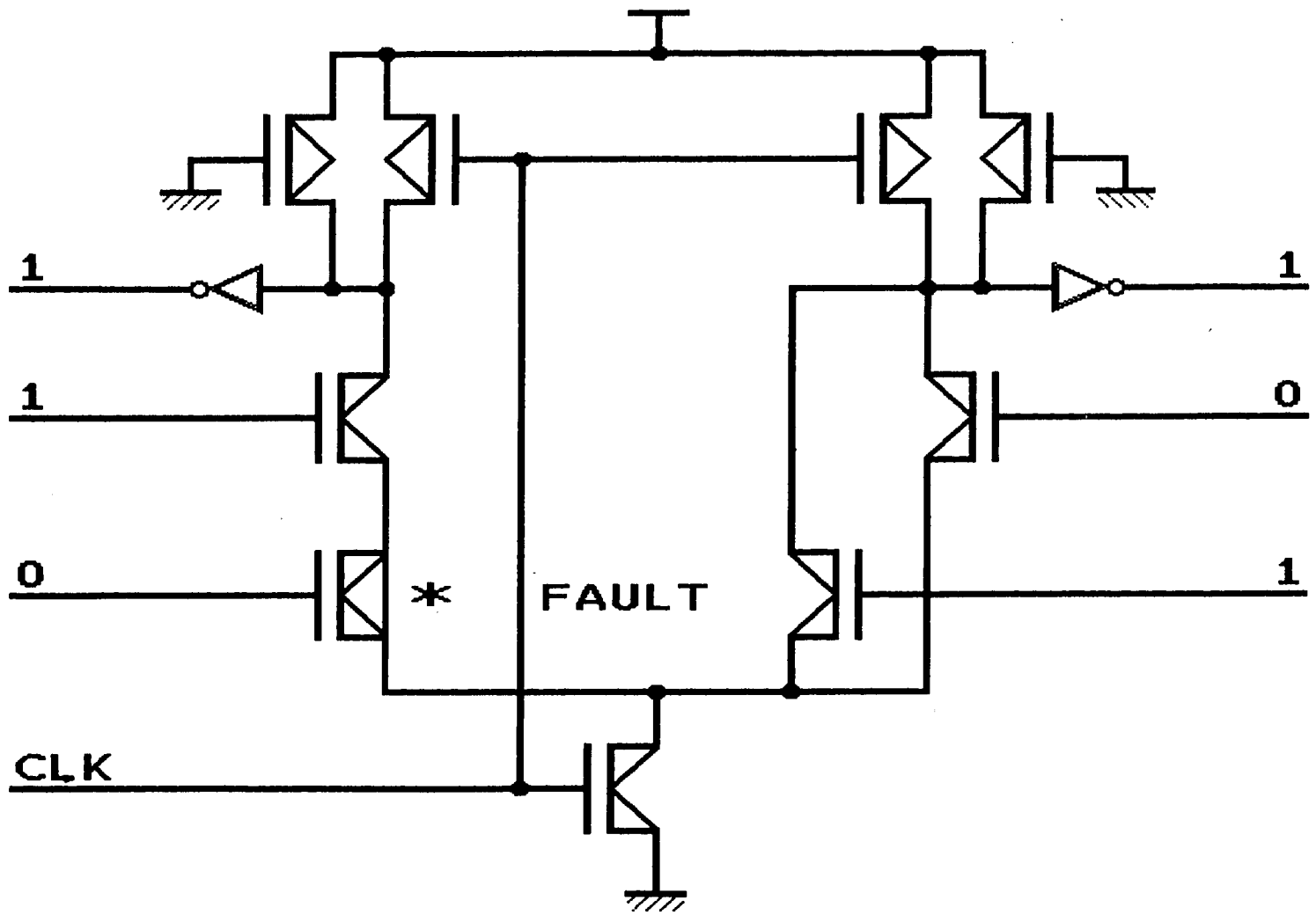

# DOUBLE RAIL CMOS LOGIC (TRANSISTOR STUCK-OFF)

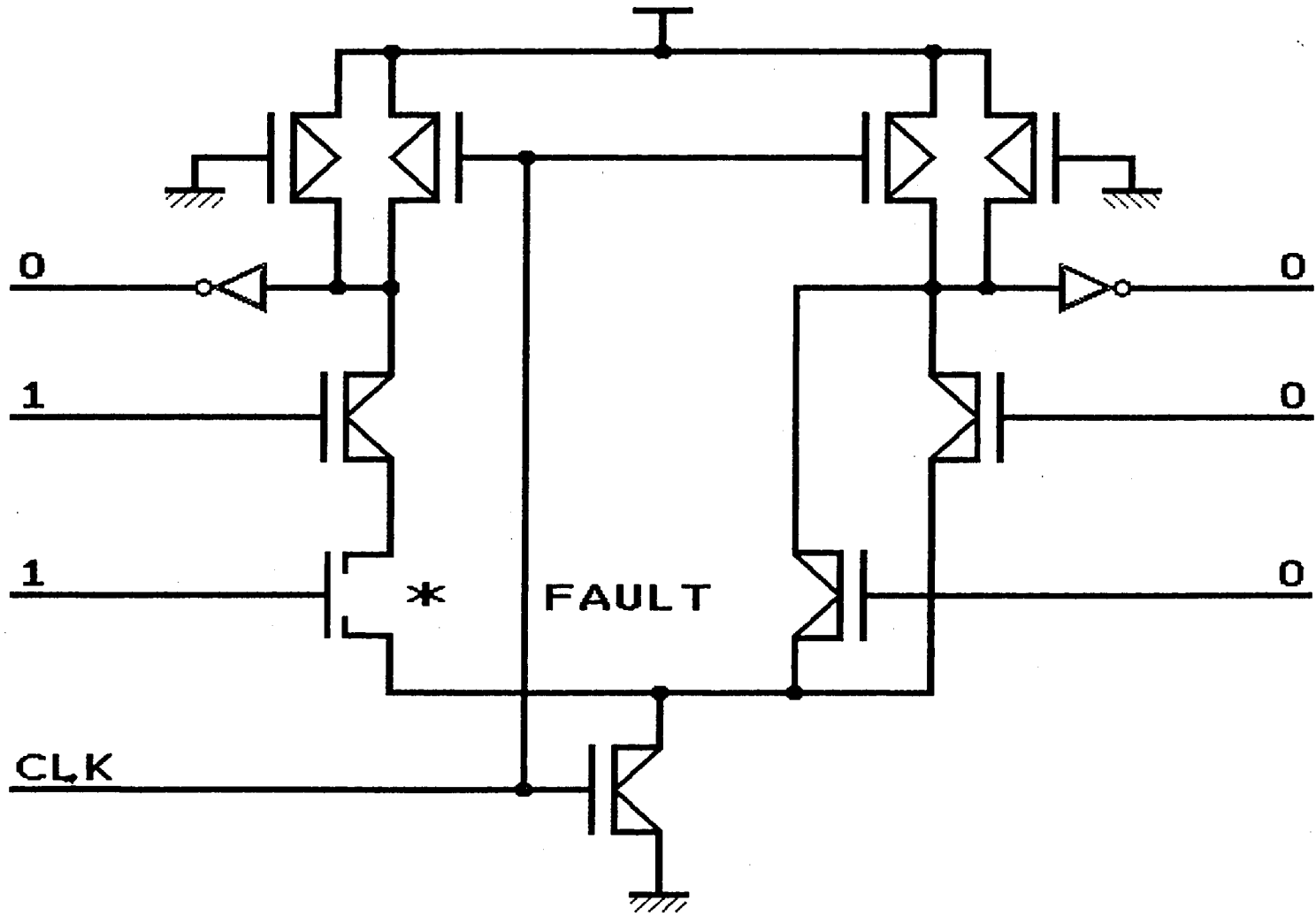

# High Rate Science Data Handling

**JPL**

Richard Masline  
January 16, 1990

N93-27709

55-82  
163597

# **JPL HIGH RATE SCIENCE DATA HANDLING**

- Performed under the auspices (and funding) of the PE&A office.
- Documented in "Data Handling Options for Space Station Freedom Program Office", JPL Document No. JPL D-6746, dated September 19, 1989.
- **Methodology**
  - Identify User Requirements
  - Establish Baseline SSF capability
  - Evaluate experiments' requirements
  - Identify shortfalls
  - Locate new and emerging technologies that may address problems
  - Develop a system architecture that addresses the problems



**JPL**

**SCIENCE NEEDS**

**VERSUS**

**TECHNOLOGY**

# JPL HIGH RATE SCIENCE DATA HANDLING

## SCIENCE NEEDS VS. TECHNOLOGY

### • Experiment Needs

- 2K X 2K by 8 bit @ 1000 frames/sec (Fps)  
Mass Transport
- 1K X 500K by 5 bit @ 1000 Fps  
Thermophysical Measurements
- 3K X 1K by 4 bit @ 2000 Fps  
Microgravity Combustion
- 5K X 5K by 8 bit @ 1000 Fps  
Crystallization of Spheres
- 200K X 266K by 4 bit @ 6000 Fps  
Pool boiling
- 10K X 10K by 8 bit @ 1,000,000 Fps  
Containerless Processing  
SCRAM

Plus a whole host of other rates

### • SSF Provisions

- NTSC - 256K X 256K at 30 Fps  
Broadcast quality  
512K X 512K at 30 Fps  
Studio quality
- HDTV - Approximately 1K X 1K at 30 Fps  
Broadcast quality  
1K X 1K at 60 Fps  
Studio quality
- Best ruggedized display 2K X 2K at 72 Fps

### • Are the needs achievable?

Yes, by Film:

The comparison of film resolution to pixel resolution of a CCD is very difficult. After discussions with scientists at Kodak, I developed an understanding that the boundaries of film resolution are best represented by an ellipse on this chart. Variables such as light source, temperature, handling, time, processing, backing, grain size, etc. affect the results.

If one were to go by line pair resolution figures, then 16MM might be considered to produce a resolution of 26K X 20K. This is not a realistic calculation. Reality is much less than that, but published comparisons have not been found.

### • Are there solutions if we are not going to fly film in SSF?

Yes, work is progressing toward fast, large, digital CCD focal planes:

- Kodak is producing a 2K X 2K focal plane based on their megapixel camera, which their scientists believe can be developed to a 1000 Fps camera.
- Ford Aerospace has a 4K X 4K focal plane which could be developed to run at 1000 Fps.
- Q-Dot has test units designed to run at 1000 Fps, which they plan to evolve into 10,000 Fps.

# SCIENCE NEEDS VRS TECHNOLOGY

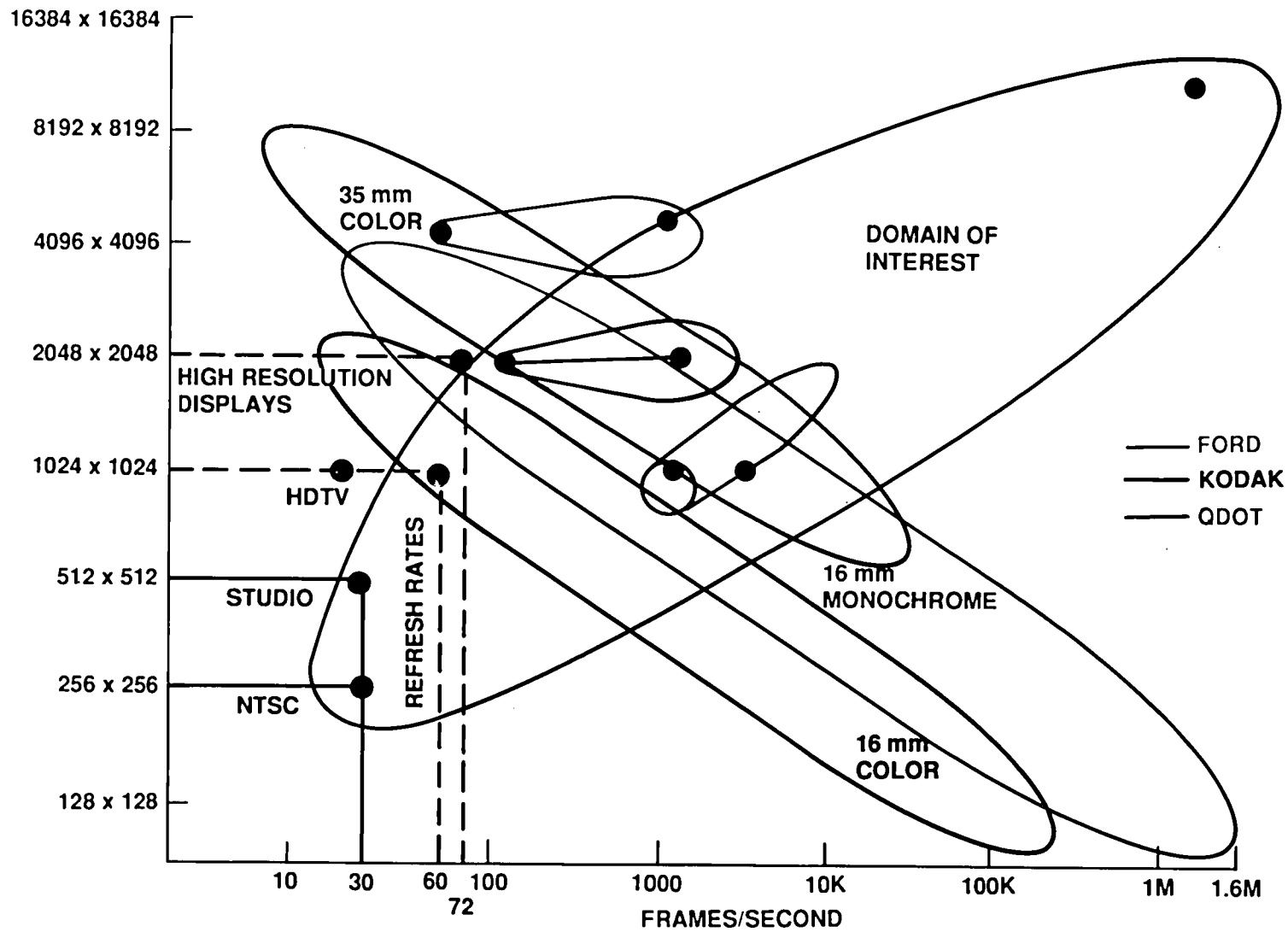

**JPL**

# TECHNOLOGY ASSESSMENT

PRECEDING PAGE BLANK NOT FILMED

117

110  
INTERNATIONAL UNIT

# JPL HIGH RATE SCIENCE DATA HANDLING TECHNOLOGY ASSESSMENT

This chart has no vertical axis. The only axis is the horizontal one, which is calibrated in bits per second on a logarithmic scale. The bits per second is the input or output rate of the devices under consideration.

- There are listed various camera configurations on the left which address the needs on the previous chart.
- The fastest commercially available camera, 192 X 240 @ 2000 Fps, is from Spin Physics.
- The rates of output of these cameras far exceed the Spin Physics camera system.
- They exceed the capability of FDDI and TDRSS by even larger margins.

- What can be done to close this gap?
  - Transport the data - Fiber technology  
1 Gigabit and greater
  - Process the data  
MCNC - Blitzen chip - 10 GByte/sec I/O  
AMT - DAP 620+ - 1.6 GByte/sec I/O
  - Record the data  
1.9 GByte/sec ingest rate
  - Downlink the data  
1-5 Gbit downlinks can be built  
Airborne receipt can be done
  - Optical holographic memories

# TECHNOLOGY ASSESSMENT



119

10K x 10K AT 1M FPS  
BY 8 BITS

OPTICAL HOLOGRAPHIC  
MEMORIES

UNISYS  
DOWNLINK

RECORDERS  
RAM IN 6.25 in.<sup>2</sup>

HOECHST-CELANESE

BY 24 BITS  
2K x 2K AT 1000 FPS  
BY 8 BITS

BY 32 BITS  
1.3K x 1K AT 1000 FPS  
BY 8BITS

1K x 1K AT 1000 FPS  
BY 8 BITS

BLITZEN BY MCNC

AT&T  
ULTRA  
SCS

192 x 240 AT 2000 FPS  
BY 8 BITS

- PROCESSING SWITCHING DOMAIN
- FIBER TECHNOLOGY
- STATED EXPERIMENTAL DOMAIN

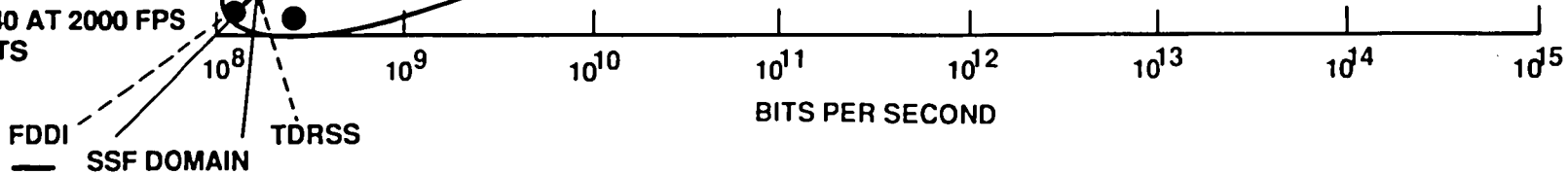

**JPL**

# CONCEPTUAL ARCHITECTURE

PRECEDING PAGE BLANK NOT FILMED

121

PAGE 120 INTENTIONALLY BLANK

# JPL HIGH RATE SCIENCE DATA HANDLING

## CONCEPTUAL ARCHITECTURE

- **Begin with SSF baseline**
  - Experiment
  - DMS
  - C&T
  
- **Add:**
  1. A control structure. This could reside within the DMS, but we did not wish to alter the DMS.
  2. Camera to view the experiment
  3. Processors
    - Camera head
    - Router or switch
    - Image analysis
  4. Network (may include the router in 3)
  5. Recorders
  6. Random store - Holographic memory or parallel disk
  7. Direct downlink



# Conceptual Architecture

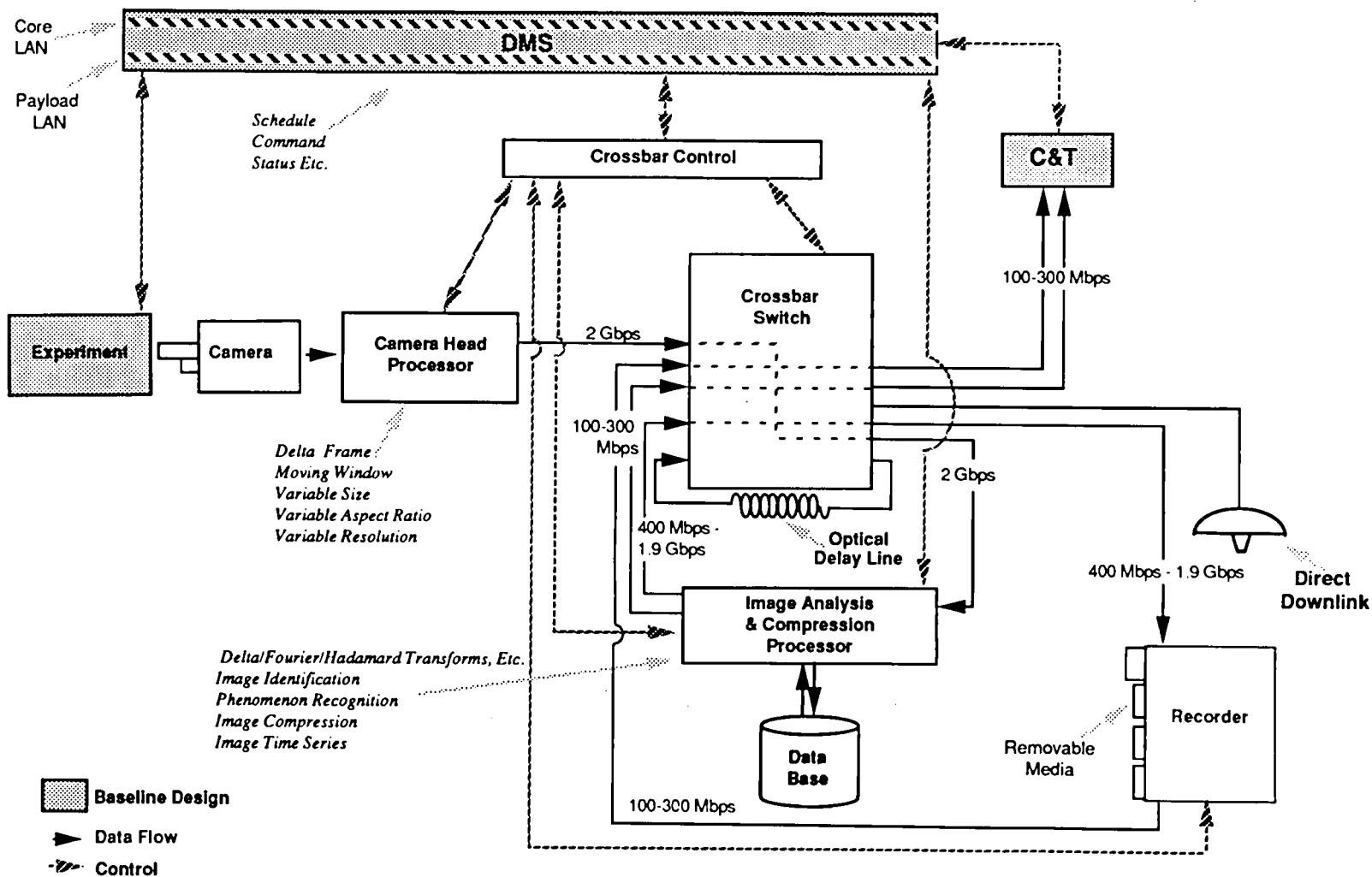

**JPL**

# DIRECT DOWNLINK CONCEPT

PRECEDING PAGE BLANK NOT FILMED

125

FORM 104

INTENTIONALLY BLANK

# ANTENNA PLACEMENT

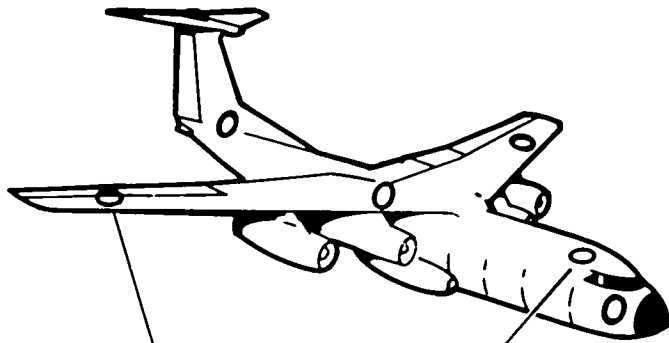

PHASED ARRAY  
OF ANTENNAS

ON AIRCRAFT

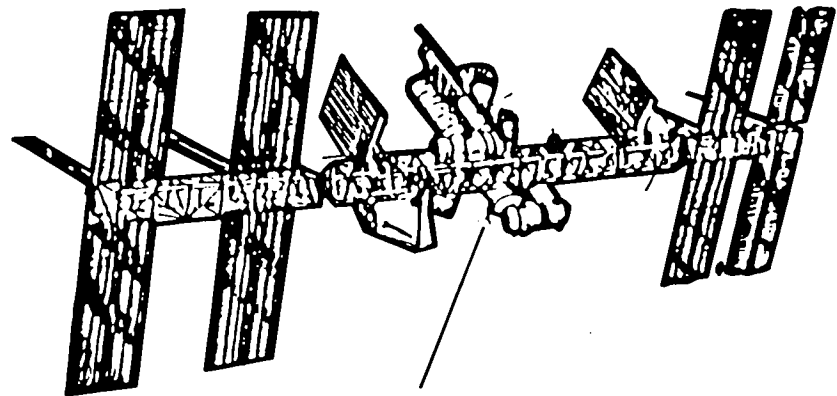

ARRAY OF  
FIVE ANTENNAS

ON SPACE STATION

# CONCEPTUAL FLY-UNDER

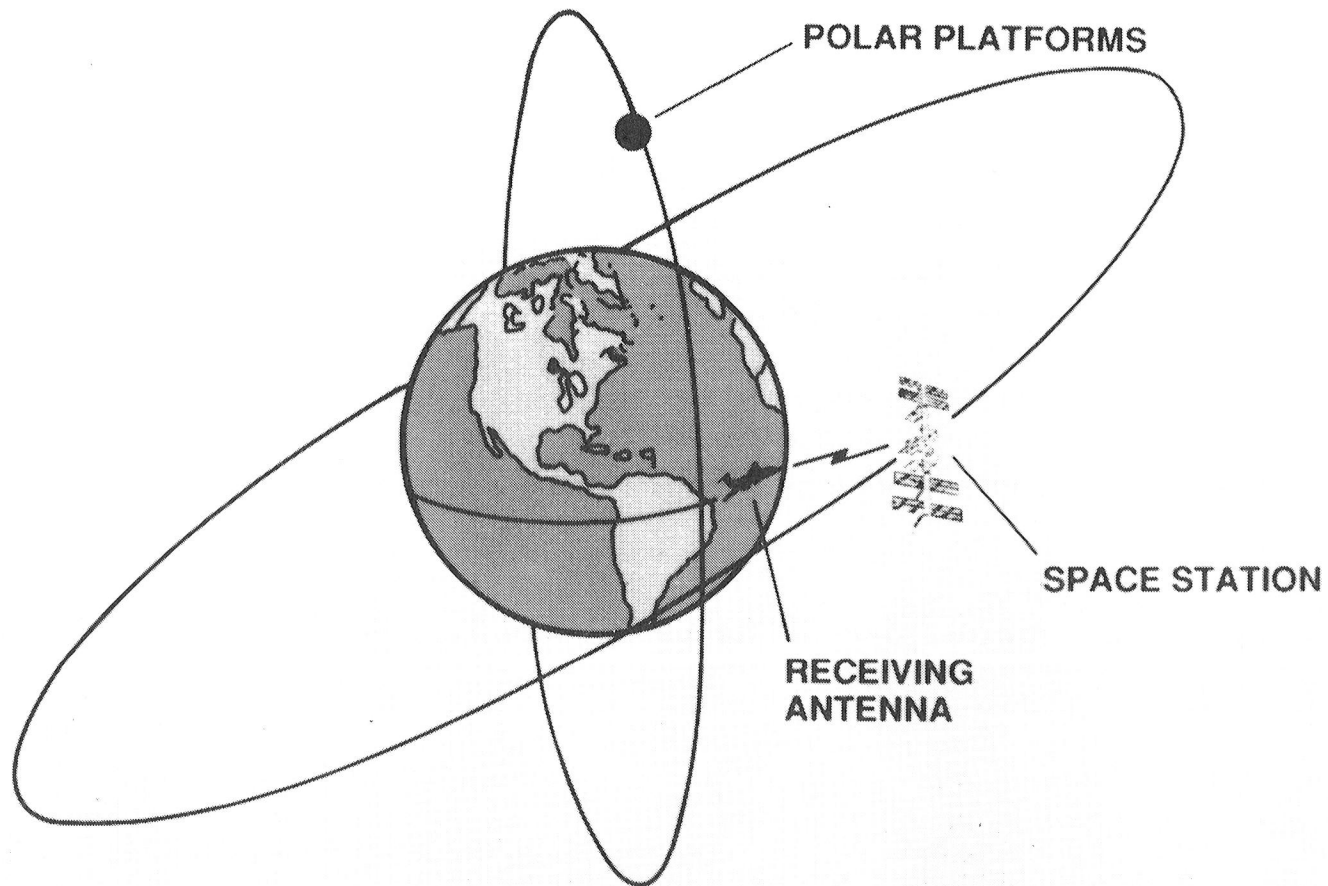

# **JPL HIGH RATE SCIENCE DATA HANDLING**

## **CONCLUSIONS**

- **Science needs will exceed capacity of existing or planned systems to transmit to earth.**
- **Capability to generate image data will continue to exceed capacity to transmit to earth.**
- **The need for mechanisms to capture, route, process, manage, analyze and store High Rate Data are common to many experiments.**
- **Technology for these mechanisms can be made available.**
- **The scientist must actively participate in the development.**
- **The system must be easily adaptable to changes in requirements and technology.**

NASA  
LaRC



# TECHNOLOGY FOR SPACE STATION EVOLUTION

# OPTICAL DISK TECHNOLOGY

SPACEFLIGHT OPTICAL DISK RECORDER

# SODR

**PAMELA RINSLAND**

NASA LANGLEY RESEARCH CENTER

January 16, 1990

SPACEFLIGHT OPTICAL DISK RECORDER

129

N93-27710

163598  
P. 10

56-82

A NASA program to develop a high performance (high rate, high capacity) rewriteable optical disk recorder focused on use aboard unmanned polar orbiting platforms is underway at Langley Research Center. An expandable system concept is proposed consisting of multiple drive modules and a modular controller. System goals are 160 gigabyte capacity at up to 1.2 gigabits per second, concurrent I/O, varying data rates, and five year operating life in orbit. Drive performance goals are 10 gigabyte capacity, 300 megabit/second transfer rate,  $10^{-10}$  corrected BER and 250 millisecond access time.

Although development is currently focused on Eos polar orbiting platforms, the SODR is an enabling capability for many future missions, such as Space Shuttle and Space Station Freedom payloads, Mars Rover, and polar and geostationary orbiting platforms. A possible Space Station application for SODR is that of a dedicated resource to store the high speed optical data recorded and transmitted from microgravity science experiments. Surveys conducted for a workshop sponsored by NASA-Lewis in May 1988 show that a minimally configured SODR can meet the requirements of many of the investigators.

### **3.1--SPACEFLIGHT OPTICAL DISK RECORDER (SODR)**

#### **OBJECTIVE**

Develop and demonstrate components and subsystems required to provide high-performance (high rate, high capacity) random file access storage systems based on erasable optical disk technology for future spaceflight missions. This includes development of magneto-optic disk media, diode laser array, write/read/erase electro-optic head, disk drive unit, and system controller.

#### **DESCRIPTION**

Key technologies that form the basis for the system are 14-inch magneto-optic media, 9-element diode laser arrays, multi-track electro-optic head, and versatile system controller. The areal density (bit/area) of optical media, is projected to be eight to twenty times that of magnetic media. The SODR goal is 10 gigabit per disk. The use of a diode array and supporting electro-optic head to write, read, and erase eight simultaneous data tracks on each surface provides high data rate. The per head goal is 150 megabits/sec or 300 megabit/drive. The concept is a dual-sided disk, two heads, and supporting electronics into a disk drive package. An associated modular controller is to be developed to produce a configurable, expandable system which can provide up to one gigabit/sec rates and 1.2 terabit capacities.

#### **NASA RATIONALE AND BENEFIT**

High performance random file access storage is an enhancing and enabling capability. The current program focus is application aboard Polar Orbiting Platforms in support of the Earth Observing System. High performance optical recording has potential payoff to many major NASA programs including the Space Transportation System, Space Station, including GEO and Polar Platforms, Space Science and Exploration (e.g., Mars Rover and Lunar Base). There are potential benefits to DoD space programs, ground based Government and commercial programs, and the establishment of national leadership in critical technology areas.

#### **STATUS / ACCOMPLISHMENTS**

Feasibility was demonstrated in the lab in 1988. This year the SODR program has developed a new laser structure, delivered improved lasers with 100 hour burn in, completed preliminary environmental testing of aluminum and glass media with glass selected as the new baseline, continued characterization and enhancement of the breadboard drive redefined goals of a drive brassboard reflecting DoD participation, established requirements and initiated breadboard controller design.

Technical Contact: Tom Shull, LaRC, (804)864-1874 (FTS 928-1874)



The SODR program is sponsored by NASA's Office of Aeronautics and Space Technology and managed by Langley Research Center. The objective is to develop and demonstrate the technology, components and subsystems needed to achieve rewriteable optical disk mass storage systems for space flight applications. The fundamental elements associated with this development include the following: a) 14 inch dual-sided magneto-optic (MO) media, b) independently addressable 10-element solid state laser diode arrays, c) an eight data track electro-optic (EO) head and d) electronic and mechanical drive subsystems.

Media studies have addressed the MO performance and suitability of glass versus aluminum substrates for harsh environments. Tests included vibration, thermal cycling and outgassing. A blank glass disk survived 62 G rms random vibration. Results indicate that glass is the preferred substrate from both a performance and cost viewpoint.

Laser development is focused on longevity and yield improvements. This includes fine tuning of the laser structure and process refinement. Conversion to a new growth technique is being considered. Techniques are being studied to stabilize the lasing frequency that can shift due to optical feedback and aging.

The current spot geometry and spacing on the 14 inch disk support a capacity of 5 gigabytes per side. The disk is formatted in a continuous spiral consisting of preformatted permanent pilot track that contains the radius (track number) identification data. This enables closed loop recording and playback that cannot be achieved with a concentric ring pattern. The permanent pilot track lies in the center of a data band of eight rewriteable tracks 1.4  $\mu\text{m}$  apart. There is a 2.1  $\mu\text{m}$  guard band between data bands to accommodate the laser's 0.7  $\mu\text{m}$  spot diameter.

# KEY TECHNOLOGIES



PERMANENT PILOT TRACK  
EIGHT DATA TRACKS

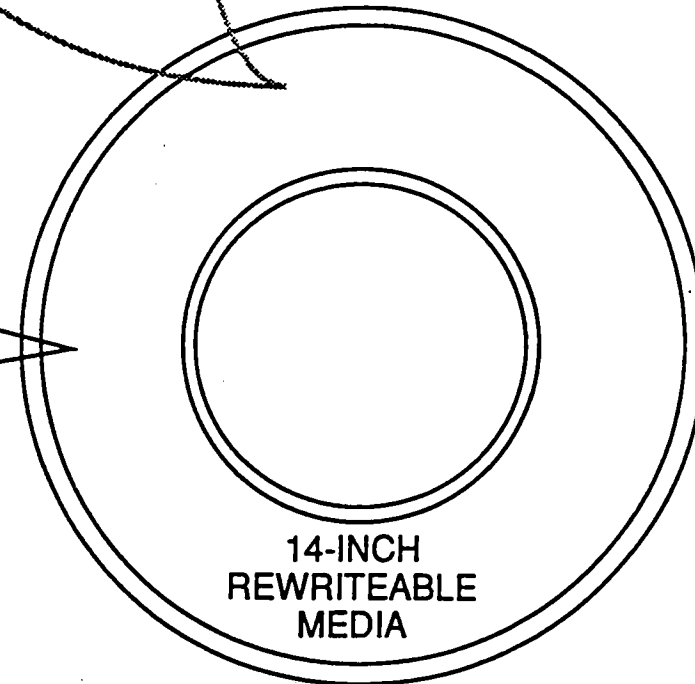
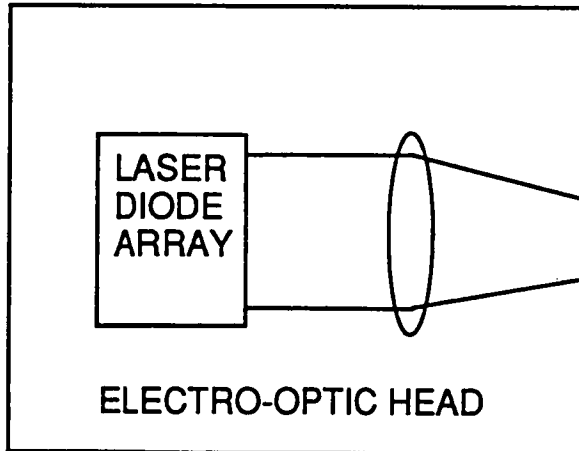
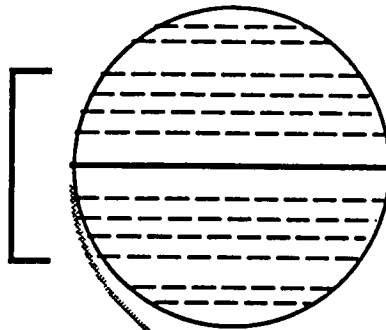

SPACEFLIGHT OPTICAL DISK RECORDER

Each SODR drive contains one 14" dual sided storage disk. The concept of a storage module refers to two drives mounted with counter rotating disks for angular momentum compensation. One disk surface and its associated hardware are referred to as a device (two devices per drive). In the current design the device is the minimum functional unit. The minimum deliverable physical unit is a drive. The physical device contains the media and its supporting mechanisms. This includes the optical heads, rotating disks, photodetectors, and the support subsystems (mechanical, optical and electronic) needed to read or write information on the media. The goal for each drive is 10 Gigabytes of data capacity and 300 Mbps data throughput.

Drive specific functions required to transfer data from the user to the medium will be performed within the storage module. These include sector mapping, data encoding, error detection and correction (EDAC), buffering, overhead formatting, and command interpretations (seek, read, write and erase).

The physical characteristics of the projected flight drive (dual device and device controller) are as follows:

	DEVICE	CONTROLLER
SIZE:	3/4 FT	1/4 FT
WEIGHT:	45 LBS	15 LBS
POWER: Write 150	50 W	50 W
Write 300	70 W	100 W
Read 150	75 W	50 W
Read 300	130 W	100 W
Erase 300	70 W	0 W
ANGULAR MOMENTUM:	1 FT-LB-S	
OVERALL DIMENSIONS:	15.3" x 6.5" x 17.9"	

# DISK DRIVE

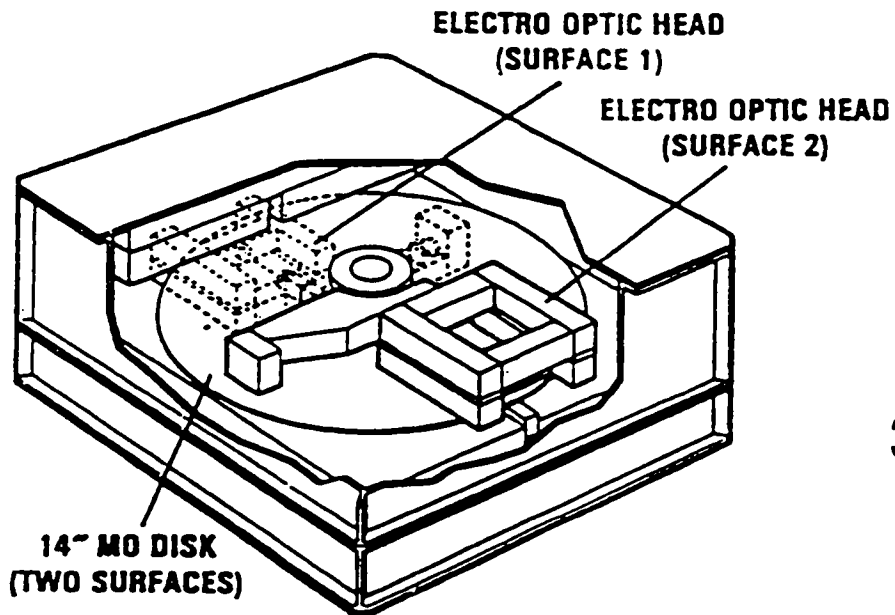

## PERFORMANCE GOALS

10 GIGABYTE CAPACITY  
300 MEGABIT PER SECOND  
250 MILLISECOND ACCESS

The SODR is an expandable modular system which consists of a modular SODR Controller and multiple storage modules. Current plans are to design and build the SODR Controller at LaRC and to obtain the storage module design and development through outside sources. The SODR can be modularly configured to provide up to 1.8 gigabits per second data transfer rate and up to 160 gigabyte capacity.

The primary functional requirements of the SODR Controller are flexibility, high data rate, high capacity, simultaneous I/O through multiple ports, random access to files, and high reliability. Flexibility will be provided by the system's modularity that allows the system to be configured to meet different application requirements. Random access to data is an inherent feature in disk storage systems. This feature will be provided by the controller in the form of random access to files. The primary goals for system reliability include up to  $10^{-12}$  corrected BER and a minimum of two to five years operating life in orbit.

The SODR Controller will perform standard data transfer functions such as directory management, resource allocation and scheduling that remove the user from the physical details of the storage modules. There are differences between the SODR Controller and other high performance controllers. The SODR Controller also provides higher and variable data transfer rates, contains a greater number of modules (more than eight), and supports dynamic reconfiguration, fault tolerance, adaptable file management philosophy and reprogrammable system algorithms. Also, the command and data ports are separated to achieve the desired reconfigurability and data throughput.

# SYSTEM CONCEPT

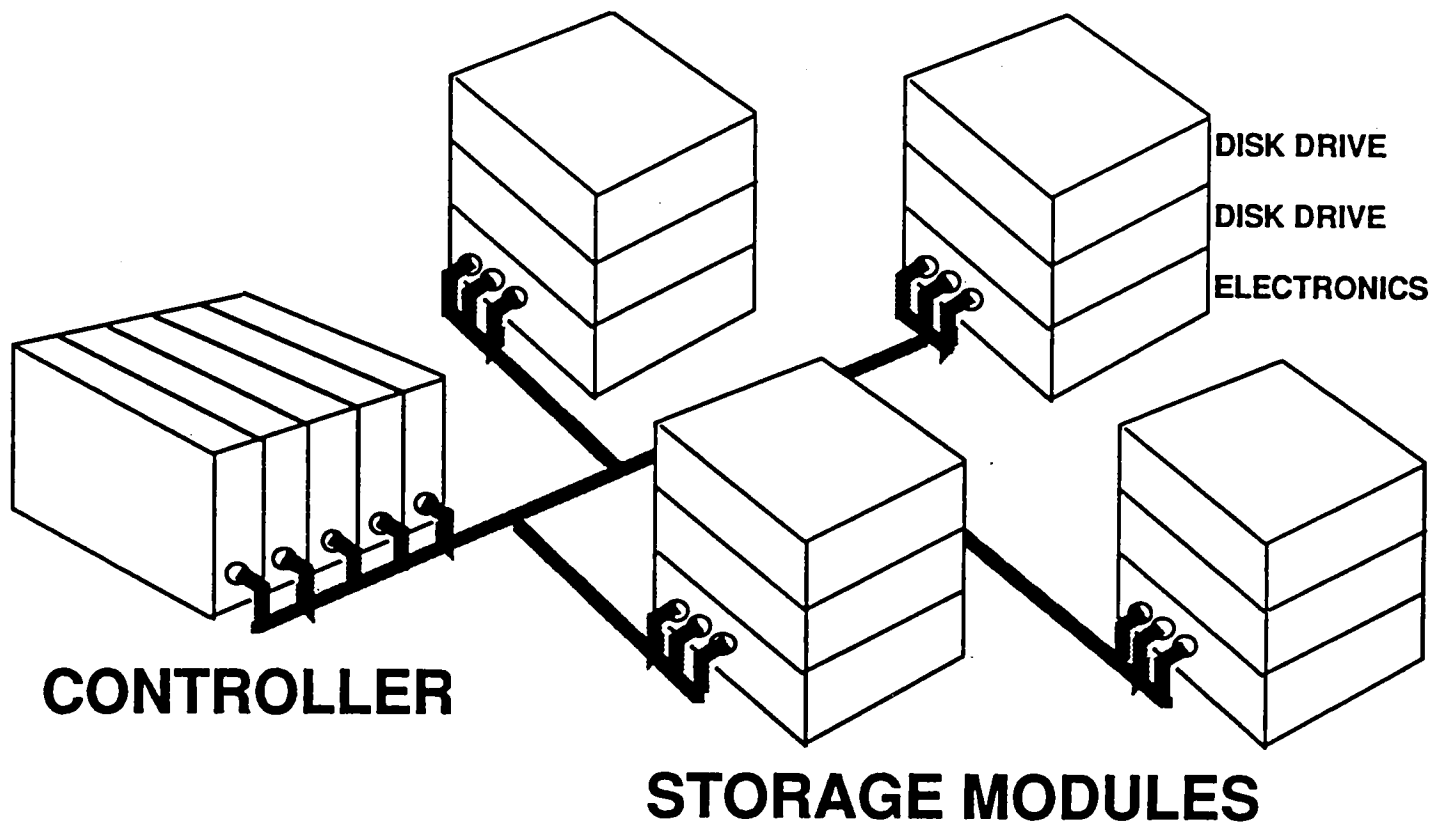



# CONCLUSION

- TECHNOLOGIES FOR FLIGHT OPTICAL DISK RECORDER HAVE BEEN DEMONSTRATED
- BENEFITS TO SPACE STATION IN RELIABILITY, VERSATILITY, AND CAPABILITY
- PROGRAM SCHEDULE CAN BE MET WITH APPROPRIATE FUNDING

# ELECTRONIC NEURAL NETWORKS

ANIL THAKOOR

## JPL

CENTER FOR SPACE MICROELECTRONICS TECHNOLOGY  
JET PROPULSION LABORATORY  
CALIFORNIA INSTITUTE OF TECHNOLOGY  
PASADENA, CALIFORNIA

57-63  
163599  
N93-28711

141

PRECEDING PAGE BLANK NOT FILMED

~~INTENTIONALLY BLANK~~



# ELECTRONIC NEURAL NETWORKS

JET PROPULSION LABORATORY

## BACKGROUND

- NEURAL NETWORKS OFFER A TOTALLY NEW APPROACH TO INFORMATION PROCESSING THAT IS ROBUST, FAULT-TOLERANT, AND FAST.
- MODELS OF NEURAL NETWORKS ARE BASED ON HIGHLY PARALLEL AND DISTRIBUTIVE ARCHITECTURES.
- JPL IS DEVELOPING ELECTRONIC IMPLEMENTATIONS OF ARTIFICIAL NEURAL NETWORKS TO EXPLOIT THEIR EMERGENT PROPERTIES FOR "INTELLIGENT" KNOWLEDGE ENGINEERING APPLICATIONS.
- IN AN ELECTRONIC EMBODIMENT, "NEURONS" ARE REPRESENTED BY THRESHOLD AMPLIFIERS, AND "SYNAPSES" BY RESISTORS. INFORMATION IS STORED IN THE VARYING STRENGTHS OF SYNAPTIC CONNECTIONS.
- ELECTRONIC IMPLEMENTATIONS OF APPLICATION – SPECIFIC HIGH SPEED NEUROPROCESSORS FOR:
  - ASSOCIATIVE RECONSTRUCTION
  - CARTOGRAPHIC ANALYSIS
  - RESOURCE ALLOCATION
  - GLOBAL OPTIMIZATION
  - AUTONOMOUS CONTROL

# INTRODUCTION

- **ARTIFICIAL NEURAL NETWORKS :**
  - **MASSIVELY PARALLEL ARCHITECTURES INSPIRED BY THE NATURE'S APPROACH TO INTELLIGENT INFORMATION PROCESSING**
- **KEY QUESTIONS :**
  - **WHAT GOOD ARE THEY ?**
  - **CAN THEY DO SOMETHING UNIQUE FOR SPACE STATION ?**
  - **WHEN WILL THEY DELIVER ?**

# NUMBERS !

- A HUMAN BRAIN HAS OVER  $10^{10}$  NEURONS AND  $10^{14}$  SYNAPSES.
- HARDWARE IMPLEMENTATIONS TODAY ARE AT ABOUT  $10^3$  NEURONS AND  $10^5$  SYNAPSES.

**BUT** • THE BRAIN IS NOT FULLY CONNECTED !

- THE CURRENT ARTIFICIAL NEURAL NETWORKS ARE ALREADY PROVING THEMSELVES EXTREMELY USEFUL.
- NEURAL NETWORKS ARE NOT GENERAL PURPOSE COMPUTERS. THEY ARE SPECIAL-PURPOSE HIGH PERFORMANCE CO-PROCESSORS.

**JPL**

# NEURAL NETWORK

**BASIC COMPONENTS:**

**NEURONS**

**SYNAPSES**

**ELECTRONIC IMPLEMENTATION:**

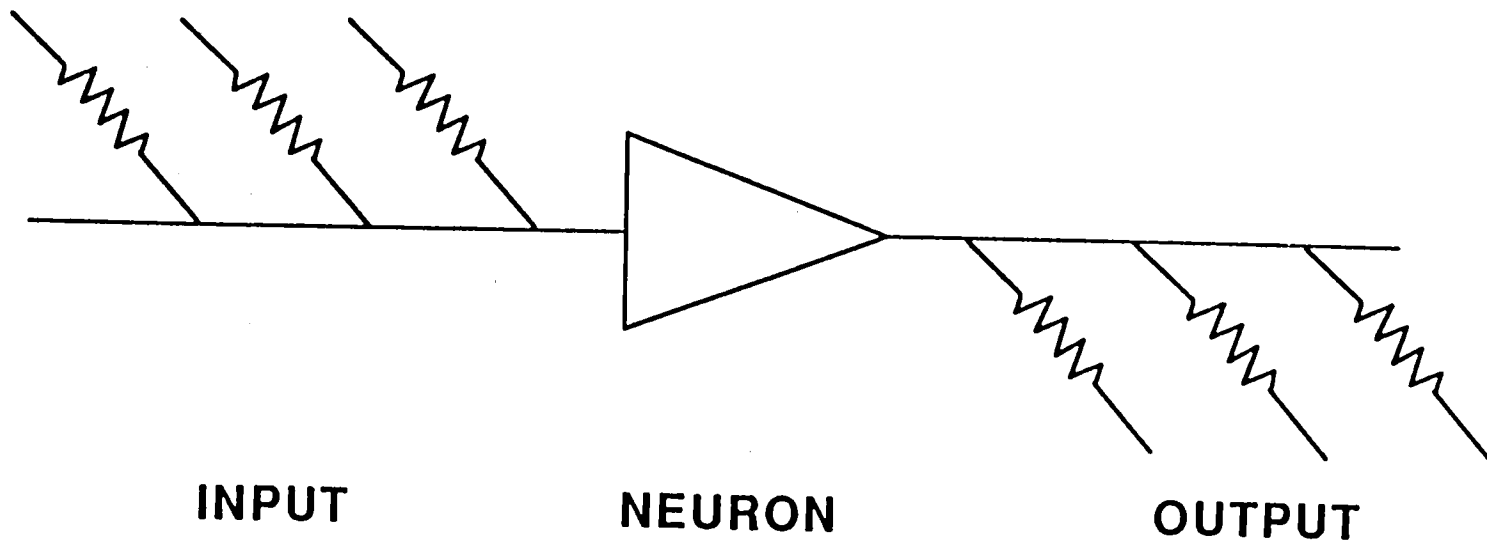

# ELECTRONIC NEURAL NETWORKS

JET PROPULSION LABORATORY

## NEURAL NETWORK ARCHITECTURES

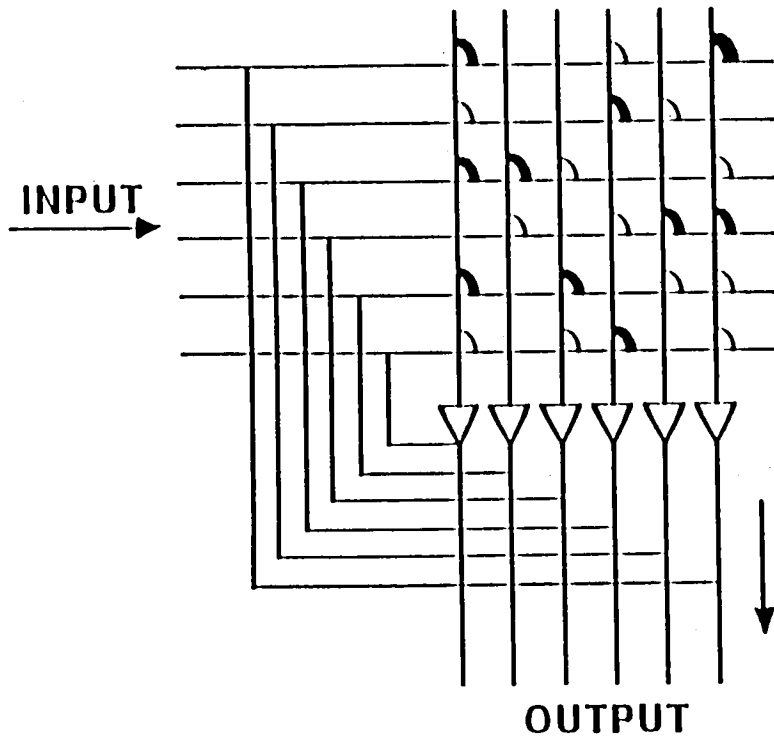

FEEDBACK NETWORK

$$\dot{C}_i \frac{du_i}{dt} = \sum T_{ij} V_j - \frac{u_i}{R_i} + I_i$$

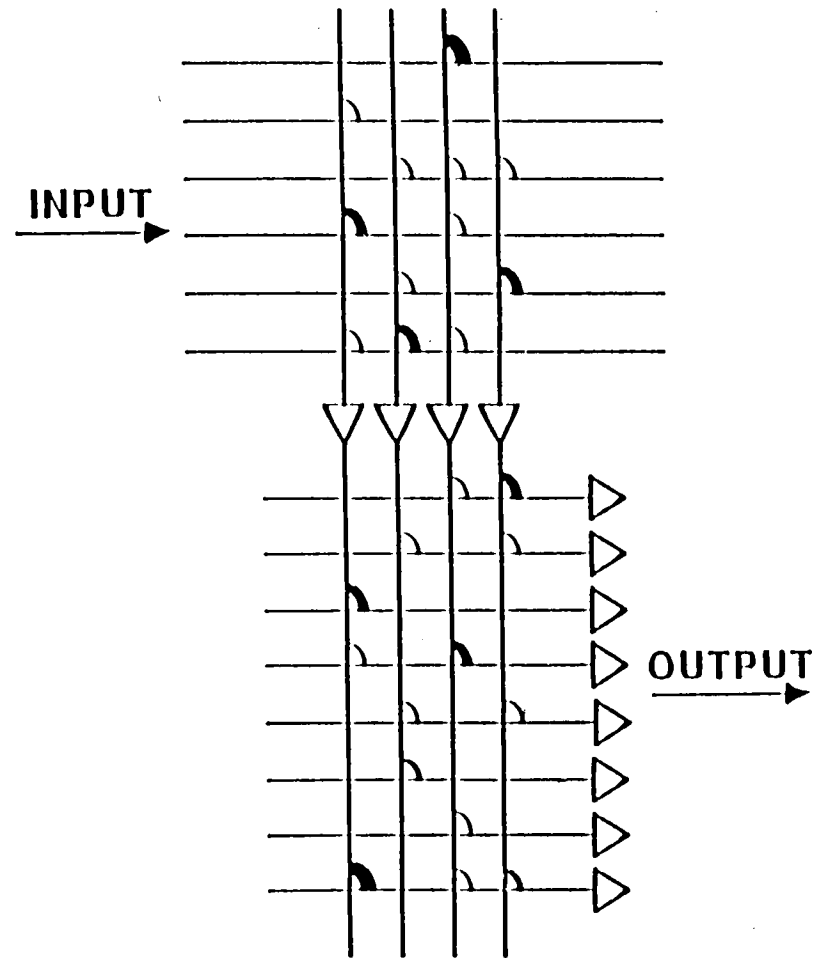

FEEDFORWARD, LAYERED

# ELECTRONIC IMPLEMENTATIONS

- JPL'S APPROACH HAS BEEN:
  - TO DEVELOP NEURAL NET "BUILDING BLOCKS" FOR MODULAR HARDWARE
  - TO VERIFY DESIGN OF NEUROCIRCUITS IN SIMULATION
  - TO TAILOR "NEUROPROCESSORS" FOR SELECTED APPLICATIONS
- TECHNOLOGIES:
  - VLSI: CMOS, BIPOLAR, AND EEPROM (FLOATING GATE)
  - THIN FILM: AMORPHOUS SEMICONDUCTORS, ELECTROCHROMIC MATERIALS, AND CHEMICAL MICROSWITCHES
  - HYBRID: VLSI/THIN FILM, SINGLE/MULTI-CHIP, WAFER-LEVEL INTEGRATION

# VLSI/THIN FILM HYBRID HARDWARE FOR NEUROCOMPUTING

1024 CAPACITOR-REFRESH,  
ANALOG SYNAPSE CHIP

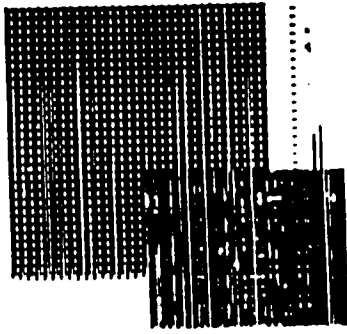

17-NEURON ARRAY CHIP

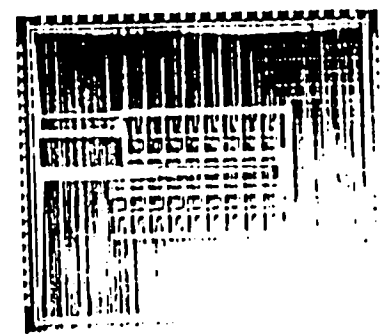

A NEURO-PROCESSOR

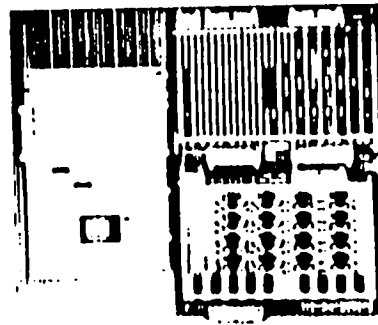

HIGH DENSITY,  
THIN FILM SYNAPTIC ARRAY

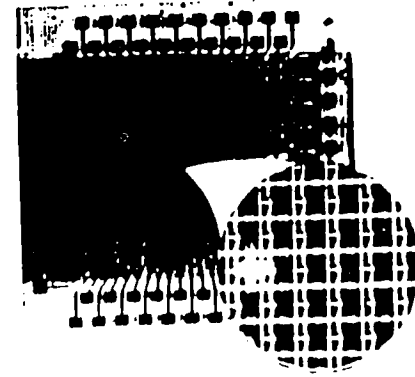

32 x 32 BINARY SYNAPSE CHIP

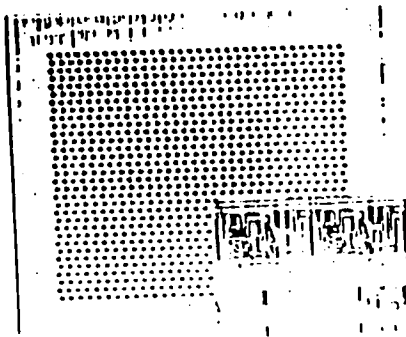

A NEURAL-DIGITAL HYBRID  
COMPUTER SYSTEM

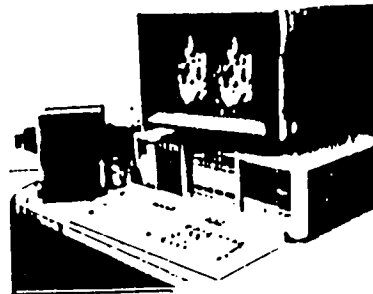

# ELECTRONIC NEURAL NETWORKS

JET PROPULSION LABORATORY

CASCADABLE, PROGRAMMABLE, 32 x 32 SYNAPTIC CMOS CHIP

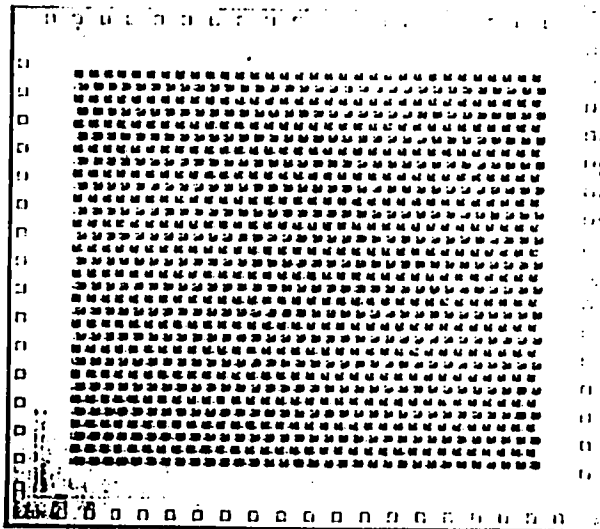

- A BUILDING BLOCK FOR VLSI NEURAL NET HARDWARE
- PROVIDES OVER  $10^9$  ANALOG OPERATIONS/SEC
- POTENTIAL APPLICATIONS:
  - MULTI SENSOR DATA FUSION
  - ASSOCIATIVE RECONSTRUCTION
  - PATTERN RECOGNITION

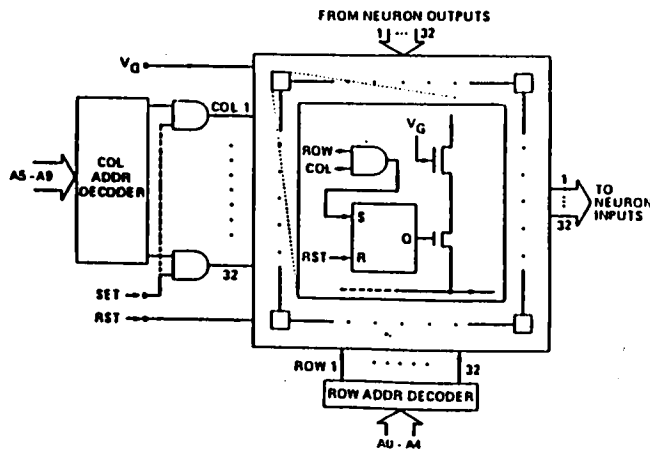



# COMPUTATION WITH ANALOG PARALLEL PROCESSING

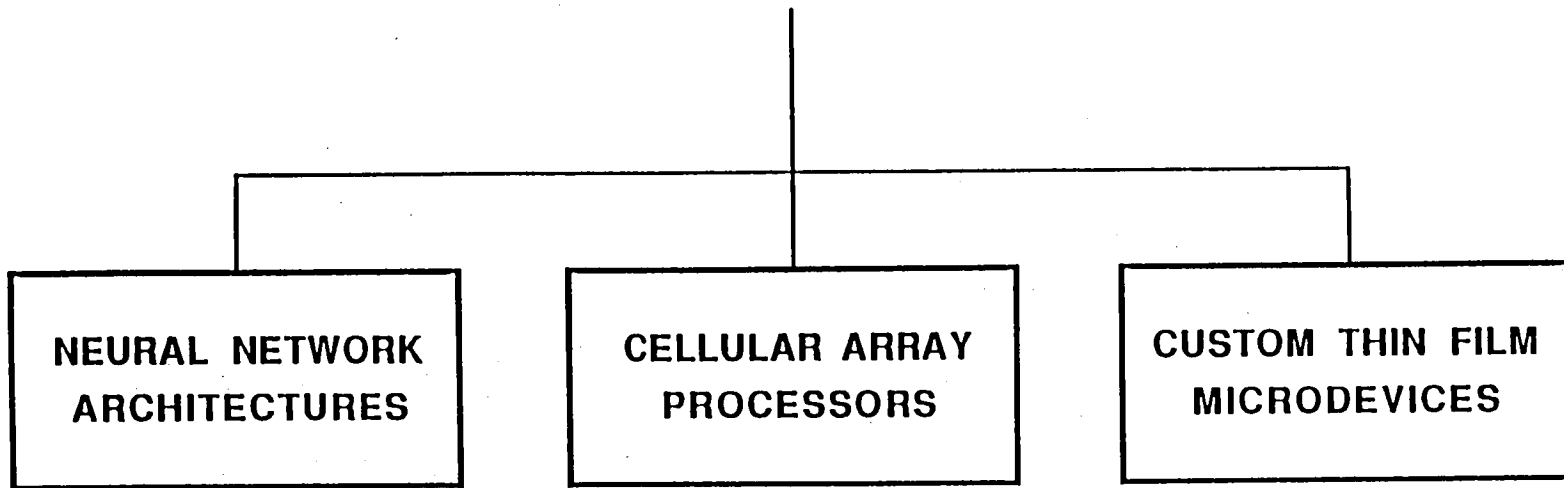

- ASSOCIATIVE MEMORY
- AUTONOMOUS CONTROL
- GLOBAL OPTIMIZATION
- CARTOGRAPHIC ANALYSIS

- PATH PLANNING
- RESOURCE ALLOCATION

- HIGH-DENSITY INTERCONNECTIONS
- NON-VOLATILE ANALOG MEMORIES

# FEATURES OF NEUROPROCESSORS

- APPLICATION-SPECIFIC ARCHITECTURES
- FINE-GRAIN, MASSIVELY PARALLEL, ANALOG, ASYNCHRONOUS PROCESSING
- EXTREMELY HIGH SPEED : TERRA-OPS RANGE
- INHERENT FAULT-TOLERANCE
- UNIQUE CAPABILITIES TO "LEARN" FROM EXPERIENCE AND SELF-ORGANIZE
- TRULY ENABLING NATURE, COMPLEMENTING THE ABILITIES OF HIGH SPEED DIGITAL MACHINES

# APPLICATIONS OF NEUROPROCESSORS

- AUTOMATION AND ROBOTICS
- ON-BOARD, REAL-TIME , GLOBAL OPTIMIZATION
  - ALLOCATION AND MANAGEMENT OF RESOURCES
- AUTONOMOUS, SCHEDULING, SEQUENCING, AND EVENT-DRIVEN MISSION REPLANNING
- SCIENCE DATA ANALYSIS AND MANAGEMENT
  - PATTERN RECOGNITION, CLASSIFICATION
  - MODELING OF LARGE SYSTEMS
  - CODING, DECODING, ASSOCIATIVE RECONSTRUCTION FROM CORRUPT DATA

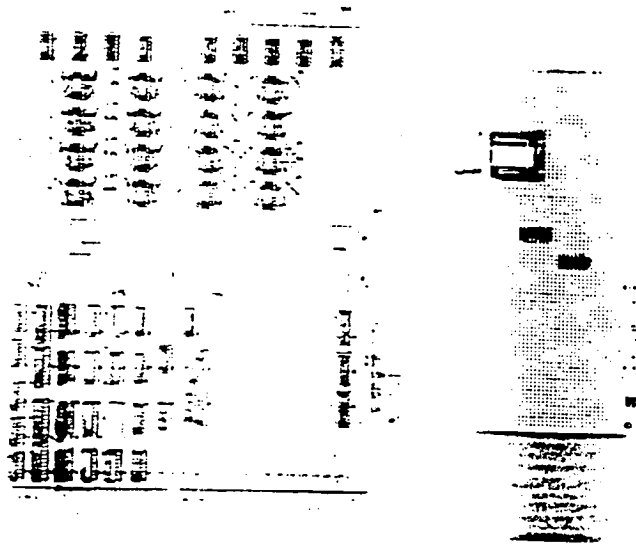

Computer hardware

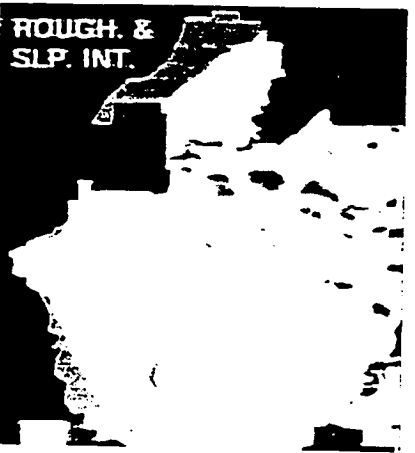
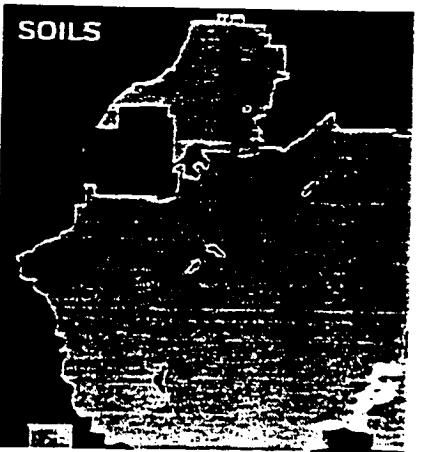
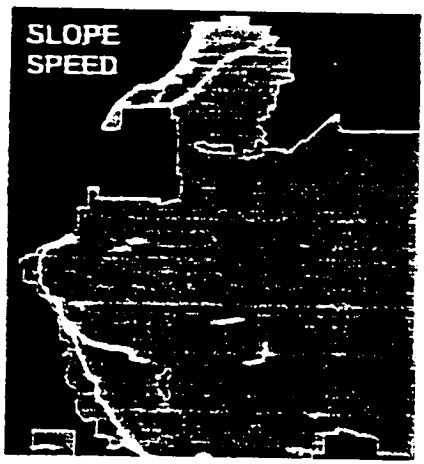

Neural network classification results. Each color denotes a particular decision or classification for a pixel. e.g., green = "GO", yellow = "GO SLOW", orange = "GO VERY SLOW", and red = "NO GO".

A set of four maps showing the results of a neural network classification of a particular area. Each color represents a particular decision or classification for a pixel.

ORIGINAL PAGE IS OF POOR QUALITY

**JPL** NEURAL NETWORK HARDWARE FOR  
TERRAIN TRAFFICABILITY DETERMINATION

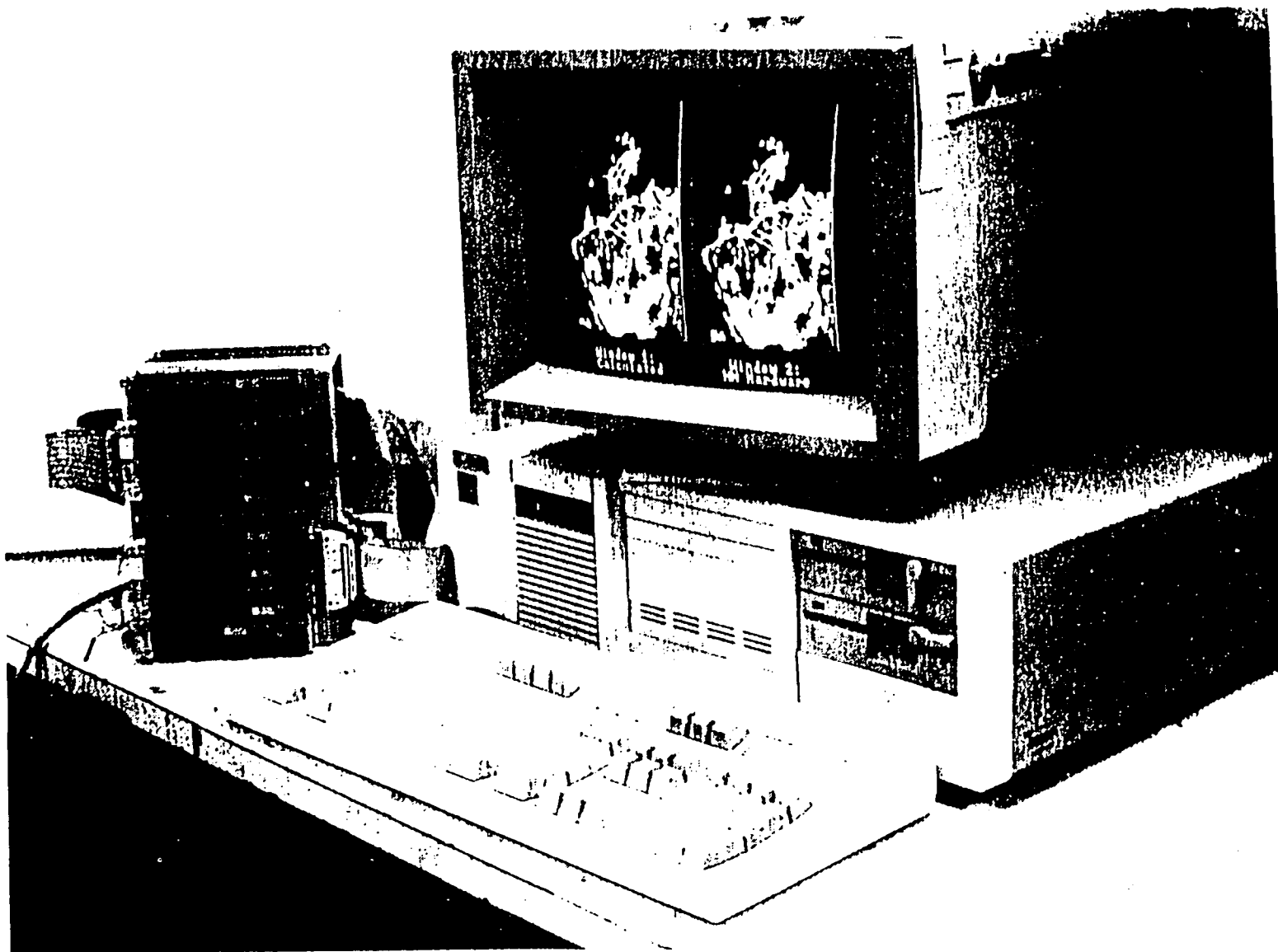

# A DEDICATED PROCESSOR FOR PATH PLANNING

## PATH COMPUTATION

- MASSIVELY PARALLEL, ANALOG, ASYNCHRONOUS PROCESSING
- ACCEPTABLE SOLUTION IN REAL TIME, THAN THE BEST SOLUTION AFTER A LONG TIME
- ORDERS OF MAGNITUDE SPEED IMPROVEMENT, PARTICULARLY FOR "WHAT IF" EXPERIMENTS

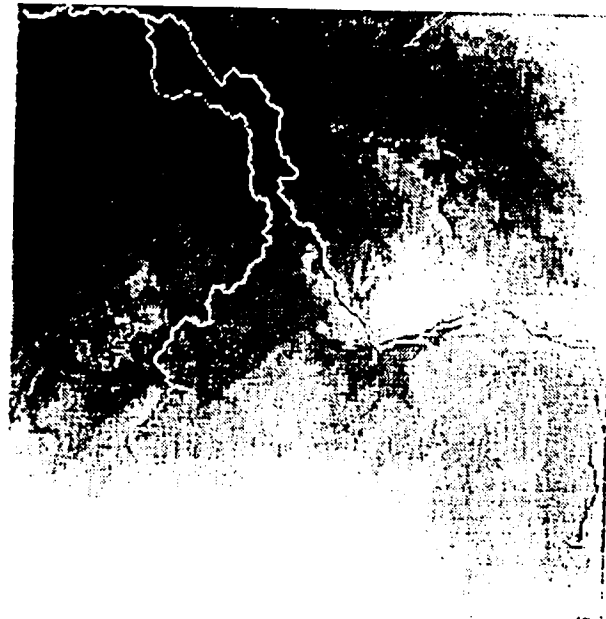

# HARDWARE DETAIL FOR SIGNAL SORTER AND MAP SEPARATES APPLICATIONS

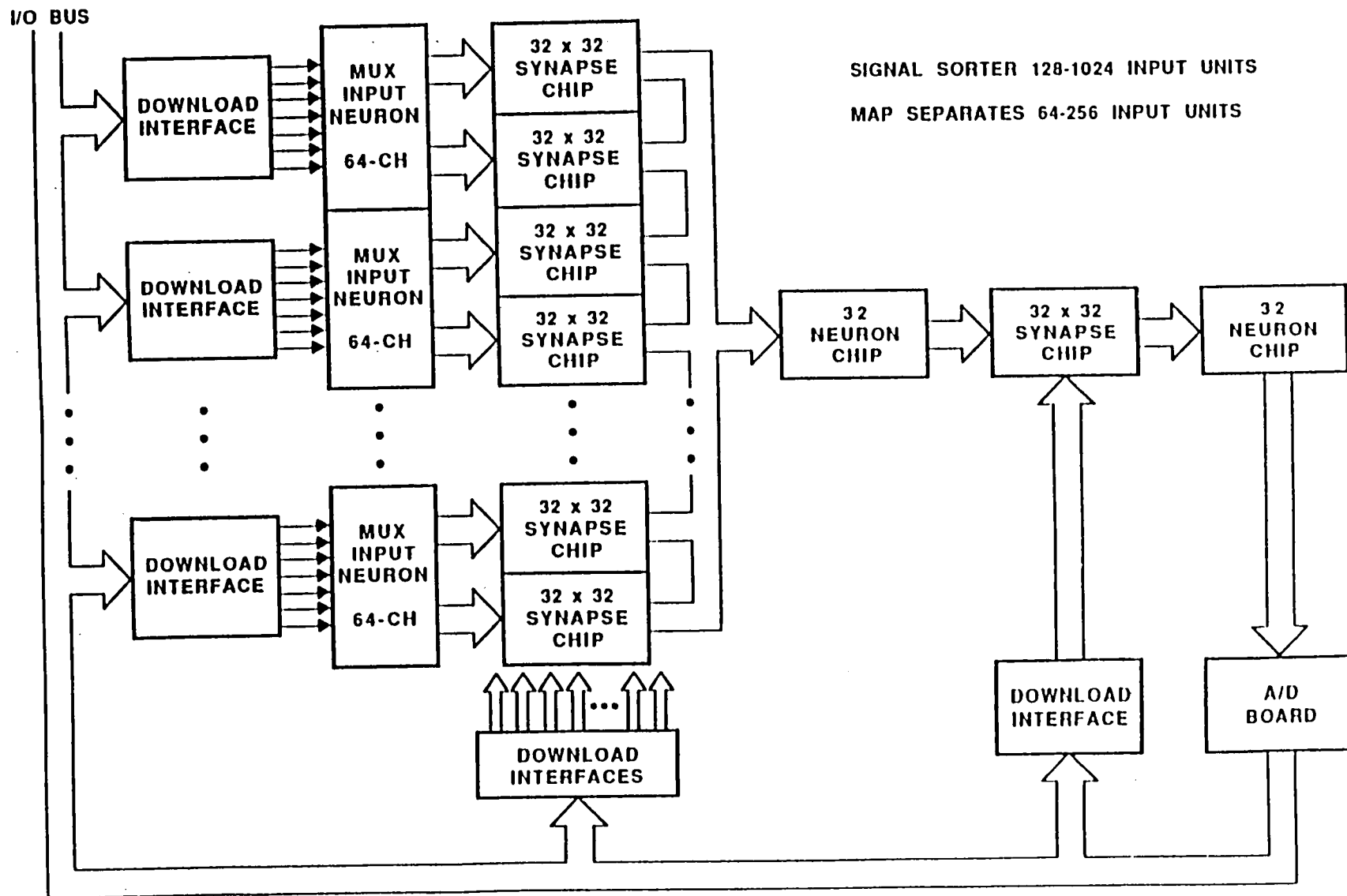

# JPL NEURAL NETWORK SYSTEM INTERFACE

157

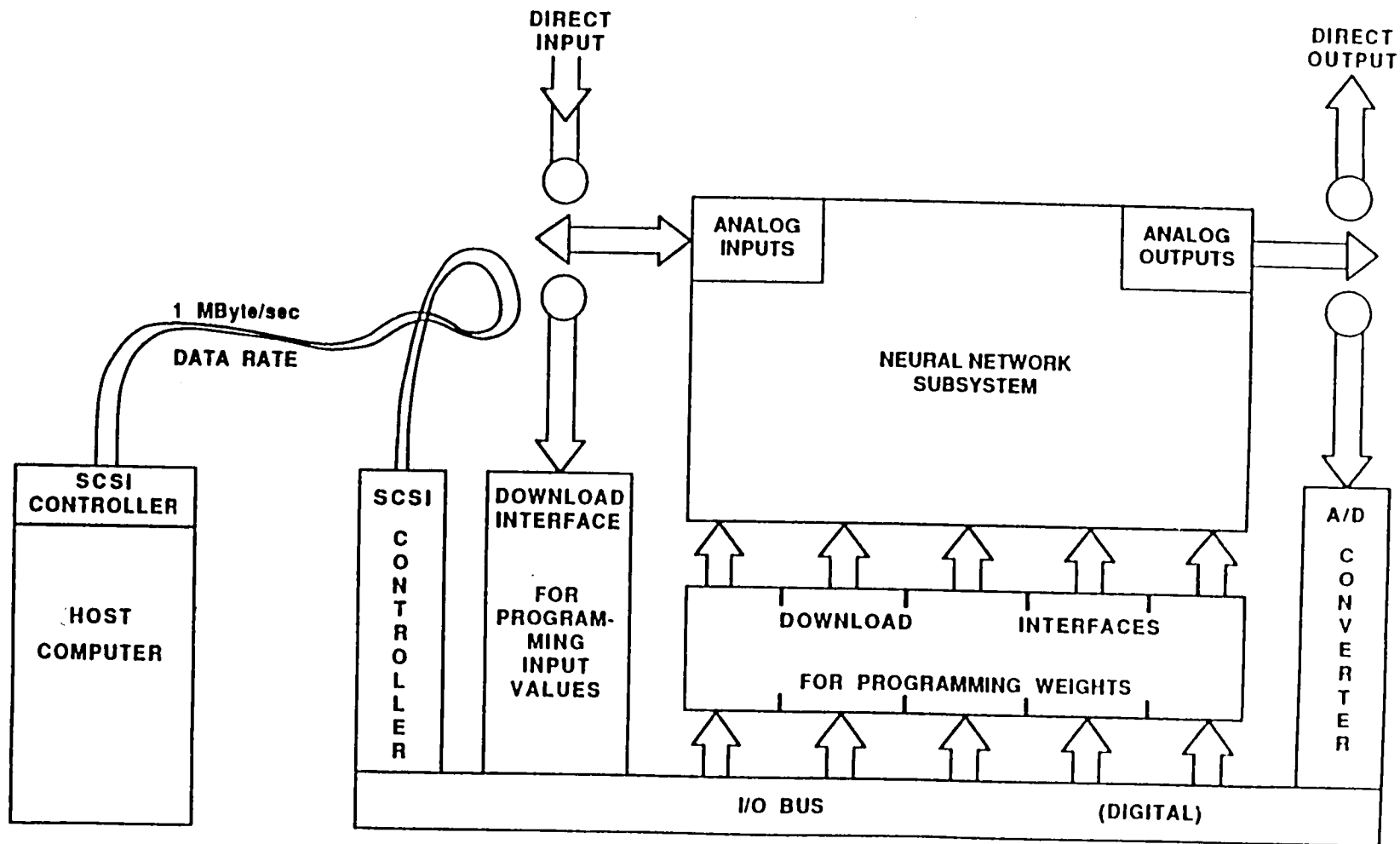



**JPL**

# ELECTRONIC NEURAL NETWORKS RAPID HARDWARE PROTOTYPING OF NEURAL PROCESSORS FOR "REAL" PROBLEMS

## THE PROBLEMS

- MAP KNOWLEDGE BASE APPLICATIONS REQUIRING LARGE AMOUNTS OF DATA AND HIGH SPEED PROCESSING
  - CROSS-COUNTRY MOBILITY DETERMINATION: A MULTIDIMENSIONAL EUCLIDEAN DISTANCE MINIMIZATION PROBLEM
  - GENERATION OF MAP SEPARATES: AN IMAGE SEGMENTATION PROBLEM
  - DETERMINATION OF "BEST" PATH: A ROUTING PROBLEM

## THE SOLUTION

- DEDICATED NEUROPROCESSORS IMPLEMENTING NEURAL ALGORITHMS FOR SOLVING THESE PROBLEMS
- THESE NEUROPROCESSORS WILL BE INTERFACED WITH A PORTABLE ASAS WORK STATION (PAWS) FOR USER EVALUATION AT THE CENTER FOR SIGNALS WARFARE (CSW)

# JPL NEURAL NETS FOR ROBOTIC CONTROL

LAYERED, FEED-FORWARD NETS WITH ABILITIES TO 'LEARN' FROM 'EXPERIENCE'

159

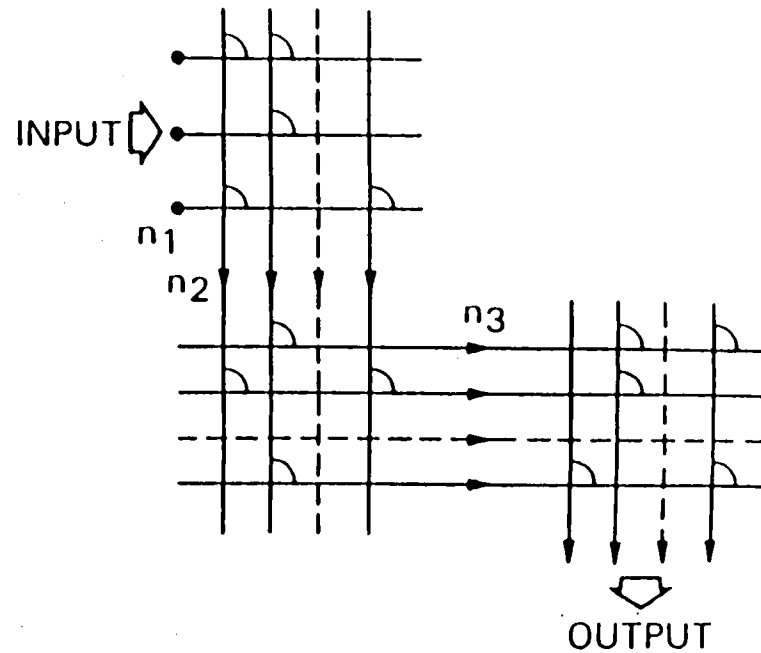
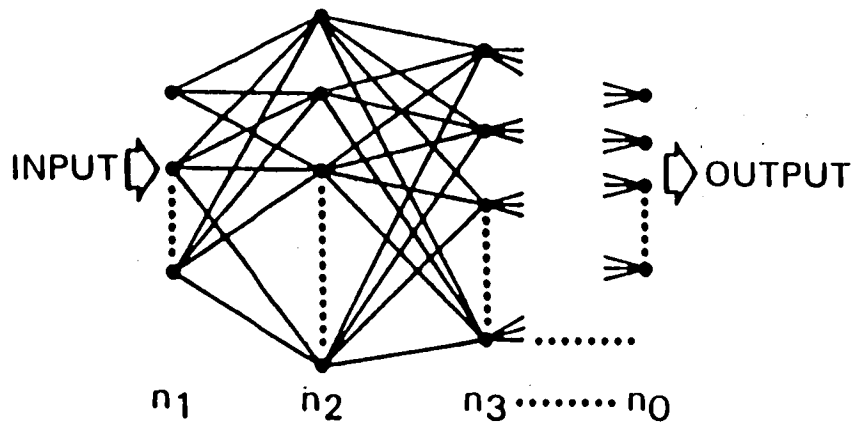

- LEARNING ALGORITHM: ERROR BACK PROPAGATION
- 'KNOWLEDGE' IS ACCUMULATED IN THE ANALOG SYNAPTIC WEIGHTS

# ERROR BACKPROPAGATION ALGORITHM FOR LEARNING

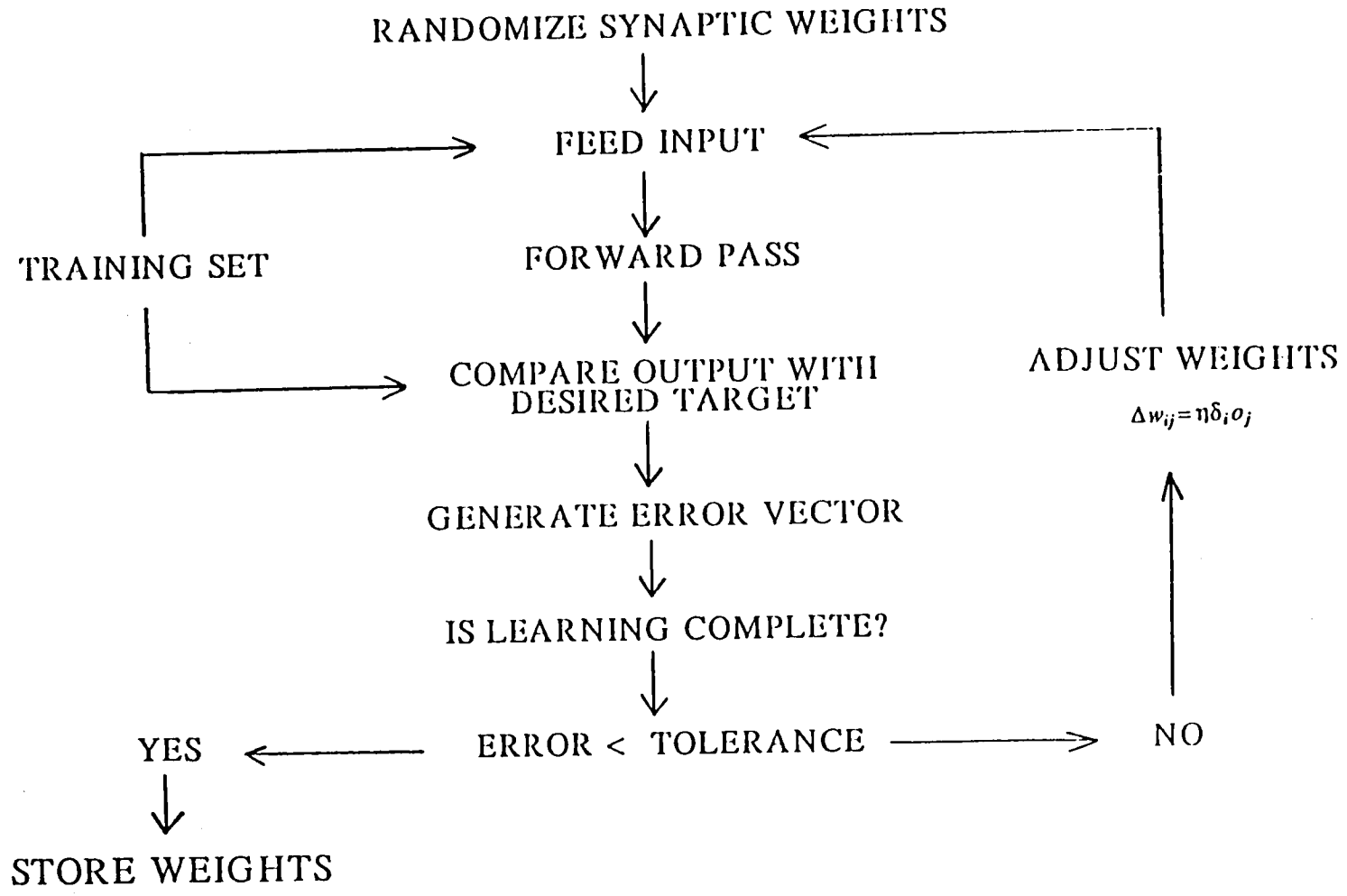

# JPL RESOURCE ALLOCATION MATRIX

TARGET

R  
E  
S  
O  
U  
R  
C  
E

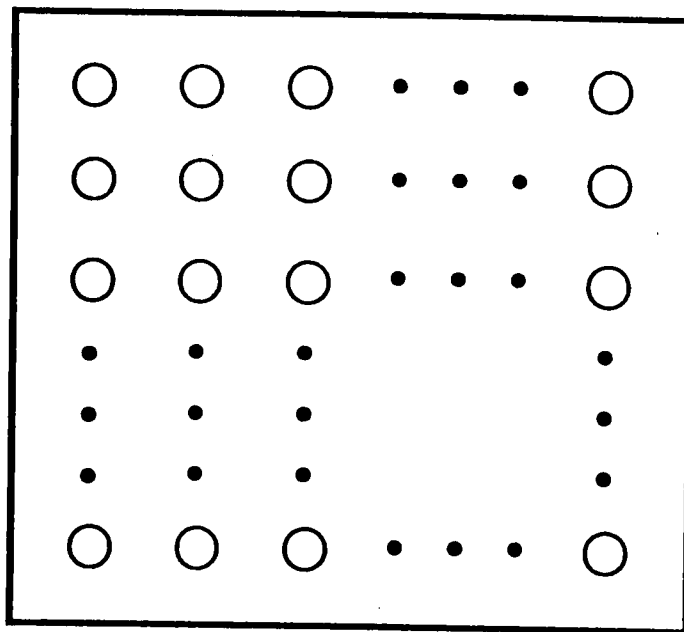

**JPL**

# RESOURCE ALLOCATION PROCESSOR SIMULATION

01/01	01/01	01/02	01/01	01/04	01/01	
2	9	4	4	3	2	01/02
1	9	9	2	3	9	01/01
5	6	4	3	4	2	01/03
8	6	8	4	5	3	01/01
3	4	5	1	9	9	01/02
9	2	3	5	9	9	01/01
08/10						

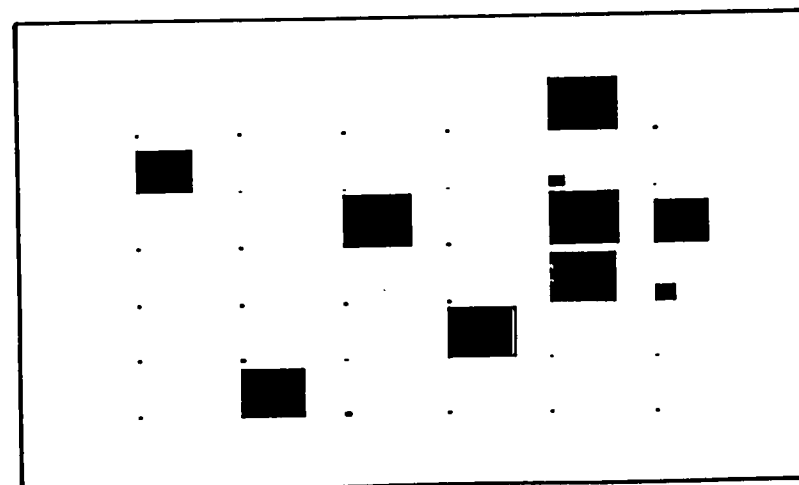
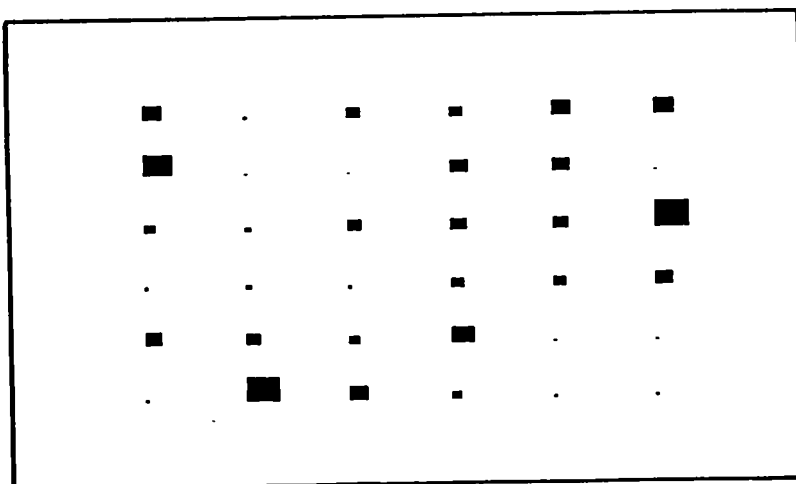
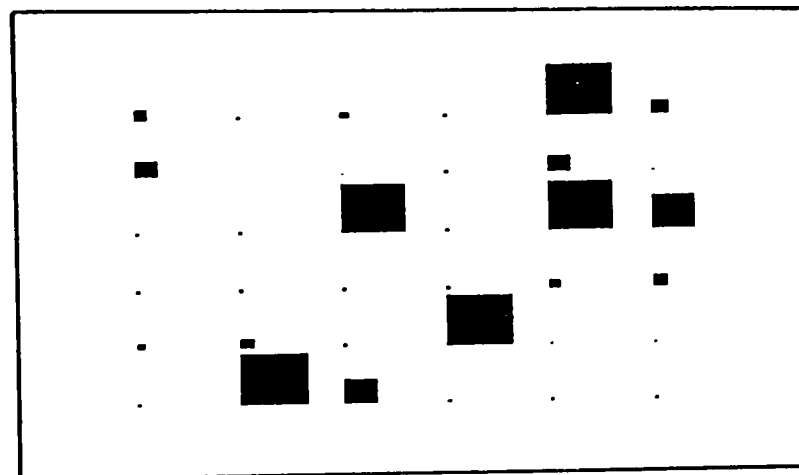

# GLOBAL OPTIMIZATION NEUROPROCESSOR

- RESOURCE ALLOCATION
- DYNAMIC ASSIGNMENT
- MESSAGE ROUTING
- TARGET-WEAPON PAIRING
- LOAD BALANCING
- MULTI-TARGET TRACKING
- SEQUENCING / SCHEDULING
- REAL TIME, ADAPTIVE MISSION RE-PLANNING

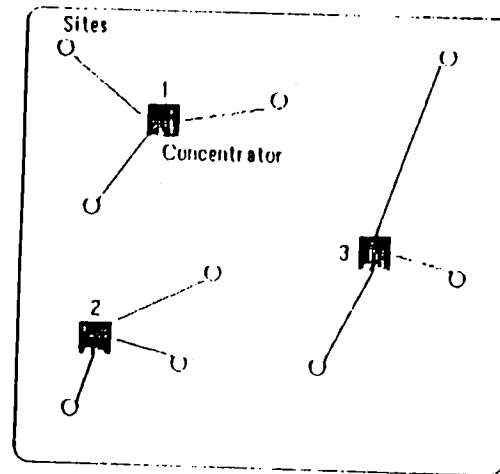

NINE SITES  
3 CONCENTRATORS

ALLOT 3 SITES TO EACH  
CONCENTRATOR TO ACHIEVE  
MINIMUM OVERALL COST

- NEUROPROCESSING APPROACH OFFERS OVER 4 ORDERS OF MAGNITUDE SPEED ENHANCEMENT OVER THE CONVENTIONAL COMPUTING TECHNIQUES.
- ARBITRARY MULTIPLE TO MULTIPLE ASSIGNMENTS ARE POSSIBLE, WHICH ARE NOT EASILY ACCOMPLISHED BY CONVENTIONAL TECHNIQUES.

# ELECTRONIC NEURAL NETWORKS

JET PROPULSION LABORATORY

PROGRAMMABLE, NONVOLATILE, HIGH-DENSITY, THIN FILM  
SYNAPTIC ARRAY FOR INFORMATION STORAGE

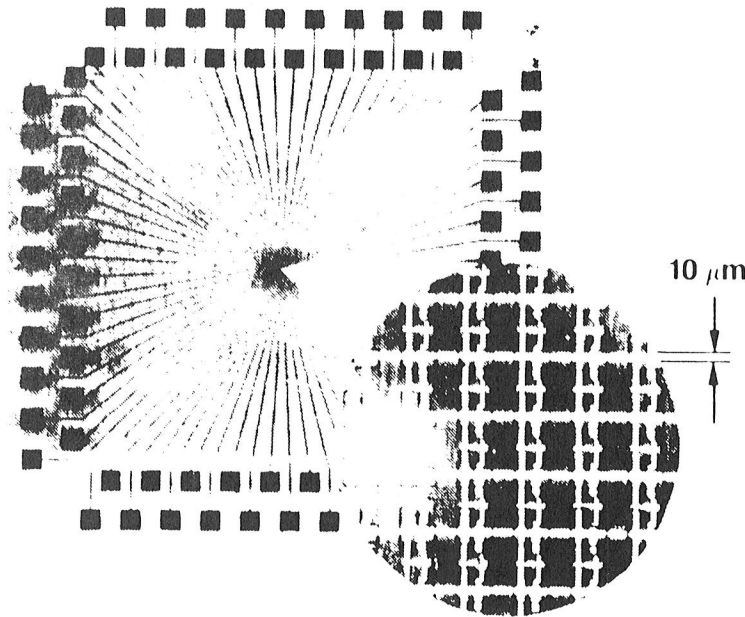

- POTENTIAL FOR HIGH DENSITY APPROACHING  $10^9$  BITS/CM<sup>2</sup>
- FAULT-TOLERANCE
- ASSOCIATIVE, CONTENT-ADDRESSABLE RECALL
- NO MOVING PARTS
- STORAGE IN "PASSIVE," RAD-HARD INTERCONNECTIONS

# ELECTRICALLY PROGRAMMABLE READ ONLY THIN-FILM SYNAPTIC ARRAY

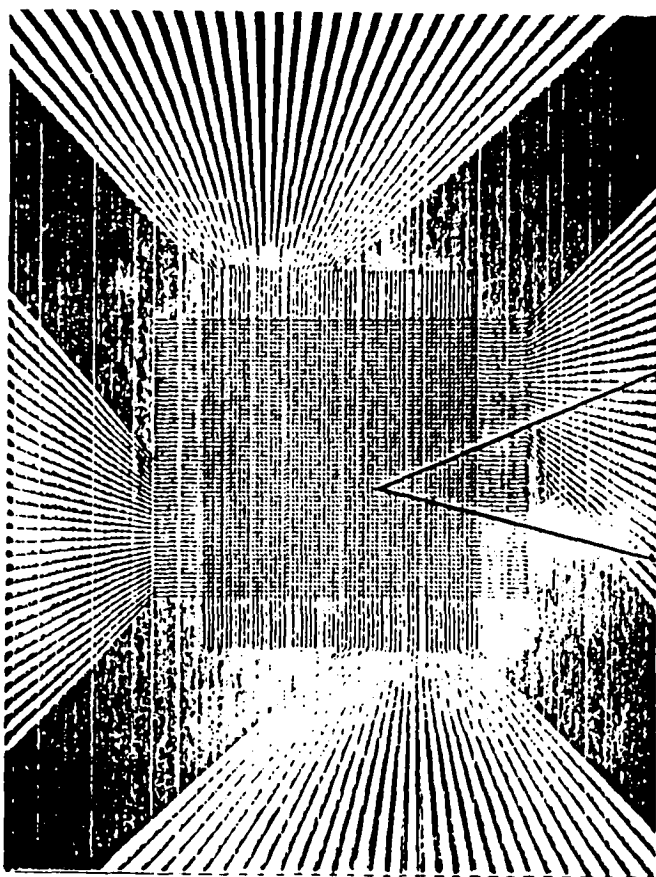

A 62 x 62 SYNAPSE TEST ARRAY WITH  
4- $\mu$ m FEATURE SIZE

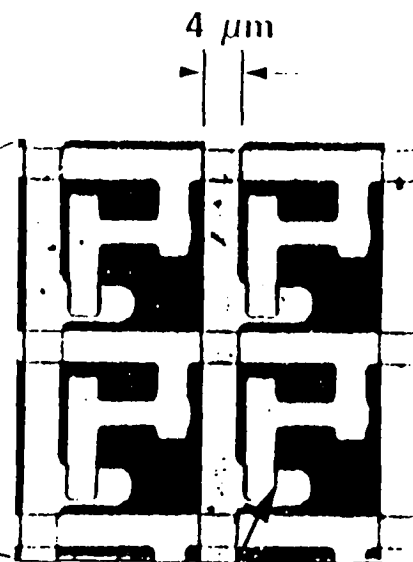

a-Si:H MICROSCHITCH  
AND RESISTOR SANDWICHED  
BETWEEN METAL ELECTRODES



## CONCLUSIONS

- THE FIELD OF NEUROPROCESSING HAS SIGNIFICANTLY ADVANCED IN RECENT YEARS. INVESTMENTS OF DOD AND NASA ARE RESULTING IN THE DEVELOPMENT OF APPLICATION-SPECIFIC, HIGH PERFORMANCE, MODULAR NEUROPROCESSORS.
- SUCH NEUROPROCESSORS OFFER TOTALLY NEW CAPABILITIES, COMPUTATIONAL BREAKTHROUGHS, AND ORDERS OF MAGNITUDE PERFORMANCE ENHANCEMENT WHERE CONVENTIONAL PROCESSING METHODS CHOKES.
- DOD IS MOVING AHEAD IN THE DIRECTION OF HARDWARE PROTOTYPING OF DEPLOYABLE NEUROPROCESSORS FOR COMPLEX PROBLEMS IN BATTLEFIELD MANAGEMENT AND TACTICAL FUSION OF INTELLIGENCE, ETC.
- *TIME IS RIGHT FOR NASA TO TAKE ADVANTAGE OF THIS POWERFUL TECHNOLOGY. TAILORED NEUROPROCESSORS WILL BE IDEALLY SUITED TO SATISFY NASA'S UNIQUE AND GROWING DEMANDS IN COMPUTATION AND DATA MANAGEMENT WITH THE EVOLUTIONARY DEVELOPMENT OF SPACE STATION.*



<b>TECHNOLOGY FOR SPACE STATION EVOLUTION - A WORKSHOP</b>  <b>DATA MANAGEMENT SYSTEM</b>	<b>SYSTEMS DEVELOPMENT &amp; SIMULATION DIVISION</b>	
	<b>EF2/G. C. BLACKBURN</b>	<b>JANUARY 1990</b>

# SPACE STATION DISPLAYS AND CONTROLS TECHNOLOGY EVOLUTION

**GREG C. BLACKBURN**  
**SYSTEMS DEVELOPMENT MANAGER**  
**FOR**  
**SPACE STATION DMS DISPLAYS & CONTROLS**  
**(713) 483-1517**

167

N938-27718  
 163600  
 58-18



Johnson Space Center-Houston, Texas

TECHNOLOGY FOR SPACE STATION EVOLUTION - A WORKSHOP  DATA MANAGEMENT SYSTEM SPACE STATION DISPLAYS & CONTROLS TECHNOLOGY EVOLUTION	SYSTEMS DEVELOPMENT & SIMULATION DIVISION	
	EF2/G. C. BLACKBURN	JANUARY 1990

- **A HISTORICAL PERSPECTIVE**
- **MAJOR DEVELOPMENT OBJECTIVES**
- **CURRENT DEVELOPMENT ACTIVITIES**
- **KEY TECHNOLOGY AREAS**
- **TECHNOLOGY EVOLUTION ISSUES**



Johnson Space Center-Houston, Texas

TECHNOLOGY FOR SPACE STATION EVOLUTION - A WORKSHOP  DATA MANAGEMENT SYSTEM SPACE STATION DISPLAYS & CONTROLS TECHNOLOGY EVOLUTION	SYSTEMS DEVELOPMENT & SIMULATION DIVISION	
	EF2/G. C. BLACKBURN	JANUARY 1990

• **A HISTORICAL PERSPECTIVE**

- **DEDICATED DISPLAYS & CONTROLS (D&C) IN PAST PROGRAMS**
  - **ORBITER HAS OVER 1,200 DEDICATED SWITCHES**
  - **MULTIFUNCTIONAL D&C HAS BEEN LIMITED**
- **LIMITED ONBOARD DATA PROCESSING**
- **MUCH OF DATA RECORDED OR TELEMETERED TO THE GROUND FOR PROCESSING**
- **EXTENSIVE GROUND MONITORING OF ALL SYSTEMS**
- **OPTIMIZATION OF PROGRAM OBJECTIVES**
  - **CREW INTERFACE CONSIDERED SECONDARY**



TECHNOLOGY FOR SPACE  
STATION EVOLUTION - A WORKSHOP

DATA MANAGEMENT SYSTEM  
SPACE STATION DISPLAYS & CONTROLS  
TECHNOLOGY EVOLUTION

SYSTEMS DEVELOPMENT & SIMULATION DIVISION

EF2/G. C. BLACKBURN

JANUARY 1990

• **MAJOR DEVELOPMENT OBJECTIVES**

- **LOWER COSTS, IMPROVE MAINTENANCE/RELIABILITY**
- **MINIMIZE PARTS/SKILL OBSOLENCE**
- **MINIMIZE POWER, WEIGHT, VOLUME CONSUMPTION**
- **PROVIDE A DESIGN WHICH ALLOWS FOR INFUSION OF NEW TECHNOLOGY**
- **REDUCE CREW'S OVERALL WORKLOAD**
- **MAXIMIZE FLIGHT SAFETY AND CREW EFFICIENCY**
- **PROVIDE A SOFTWARE RECONFIGURABLE INTERFACE**
- **MINIMIZE THE USE OF PAPER ON-ORBIT**



<b>TECHNOLOGY FOR SPACE STATION EVOLUTION - A WORKSHOP</b>  <b>DATA MANAGEMENT SYSTEM SPACE STATION DISPLAYS &amp; CONTROLS TECHNOLOGY EVOLUTION</b>	<b>SYSTEMS DEVELOPMENT &amp; SIMULATION DIVISION</b>	
	<b>EF2/G. C. BLACKBURN</b>	<b>JANUARY 1990</b>

• **CURRENT DEVELOPMENT ACTIVITIES**

- **DISTRIBUTED SYSTEM ARCHITECTURE**
- **CREW COMMAND AND CONTROL INTERFACE VIA  
MULTIPURPOSE WORKSTATIONS**
  - **MULTIPLE MULTIFUNCTION DISPLAY DEVICES**
  - **KEYBOARD**
  - **CURSOR CONTROL DEVICE**
  - **PROGRAMMABLE SWITCHES**
  - **HAND CONTROLLERS**



Johnson Space Center-Houston, Texas

TECHNOLOGY FOR SPACE STATION EVOLUTION - A WORKSHOP  DATA MANAGEMENT SYSTEM SPACE STATION DISPLAYS & CONTROLS TECHNOLOGY EVOLUTION	SYSTEMS DEVELOPMENT & SIMULATION DIVISION	
	EF2/G. C. BLACKBURN	JANUARY 1990

**• KEY TECHNOLOGY AREAS**

- COLOR FLAT PANEL TECHNOLOGY
  - COLOR ACTIVE MATRIX LIQUID CRYSTAL DISPLAYS
  - LARGE COLOR PLASMA DISPLAYS
- ADVANCED PROCESSORS
  - LATER GENERATION GENERAL PURPOSE PROCESSORS
  - ADVANCED GRAPHICS PROCESSORS
  - HIGHER DENSITY MEMORIES



Johnson Space Center-Houston, Texas

TECHNOLOGY FOR SPACE STATION EVOLUTION - A WORKSHOP  DATA MANAGEMENT SYSTEM SPACE STATION DISPLAYS & CONTROLS TECHNOLOGY EVOLUTION	SYSTEMS DEVELOPMENT & SIMULATION DIVISION	
	EF2/G. C. BLACKBURN	JANUARY 1990

• **KEY TECHNOLOGY AREAS (CONTINUED)**

- **NEW AND IMPROVED CREW I/O DEVICES**
  - **VOICE RECOGNITION**
  - **VOICE SYNTHESIS**
  - **ADVANCED CURSOR CONTROL**
- **ADVANCED MANIPULATOR/ROBOTIC CONTROL**
  - **HAND CONTROLLER TECHNOLOGY**
- **IMPROVED CREW INTERFACE SOFTWARE**
  - **NEW CREW INTERFACE TECHNIQUES**
  - **USE OF AI/EXPERT SYSTEMS**





TECNOLOGY FOR SPACE STATION EVOLUTION - A WORKSHOP  DATA MANAGEMENT SYSTEM SPACE STATION DISPLAYS & CONTROLS TECHNOLOGY EVOLUTION	SYSTEMS DEVELOPMENT & SIMULATION DIVISION	
	EF2/G. C. BLACKBURN	JANUARY 1990

**• TECHNOLOGY EVOLUTION ISSUES**

- MATURITY OF COLOR FLAT PANEL TECHNOLOGY
- NO SPACEFLIGHT EXPERIENCE WITH ADVANCED INTERACTIVE MULTIPURPOSE SOFTWARE SYSTEMS
  - DEFINITION OF DISPLAY FORMATS
  - DEFINITION OF GRAPHIC OBJECTS
  - EFFICIENT NAVIGATION THROUGH A HIGH NUMBER OF DIFFERENT FORMATS
  - ELIMINATION OF DEDICATED SYSTEM D&C PANELS



Johnson Space Center-Houston, Texas

TECHNOLOGY FOR SPACE STATION EVOLUTION - A WORKSHOP  DATA MANAGEMENT SYSTEM SPACE STATION DISPLAYS & CONTROLS TECHNOLOGY EVOLUTION	SYSTEMS DEVELOPMENT & SIMULATION DIVISION	
	EF2/G. C. BLACKBURN	JANUARY 1990

• **TECHNOLOGY EVOLUTION ISSUES (CONTINUED)**

- **MATURITY AND UTILIZATION OF AI/EXPERT SYSTEM TECHNOLOGY IN A SPACECRAFT**
- **CREW ACCEPTANCE OF A WORKSTATION INPUT VIA VOICE COMMAND**
- **DANGER OF MAKING CREW BORED (MACHINE MINDERS)**
- **LATER INCORPORATION OF NEW TECHNOLOGY**
  - **DIFFICULTY IN UPGRADING AN EXISTING OPERATIONAL NASA SPACECRAFT**
  - **ON-ORBIT CHECK-OUT/VERIFICATION**

**EMBEDDED MULTIPROCESSOR  
TECHNOLOGY FOR  
VHSIC INSERTION**

**Presented at  
Technology for Space Station Evolution  
- A Workshop**

**January 16-19, 1990**

**Paul J. Hayes  
NASA Langley Research Center  
(804) 864-1491**

**N93-27713**

*163601*

*59-60*

PRECEDING PAGE BLANK NOT FILMED

177

~~PAGE~~ 170 INTENTIONALLY BLANK

**VHSIC  
SPACEBORNE  
MULTIPROCESSING**

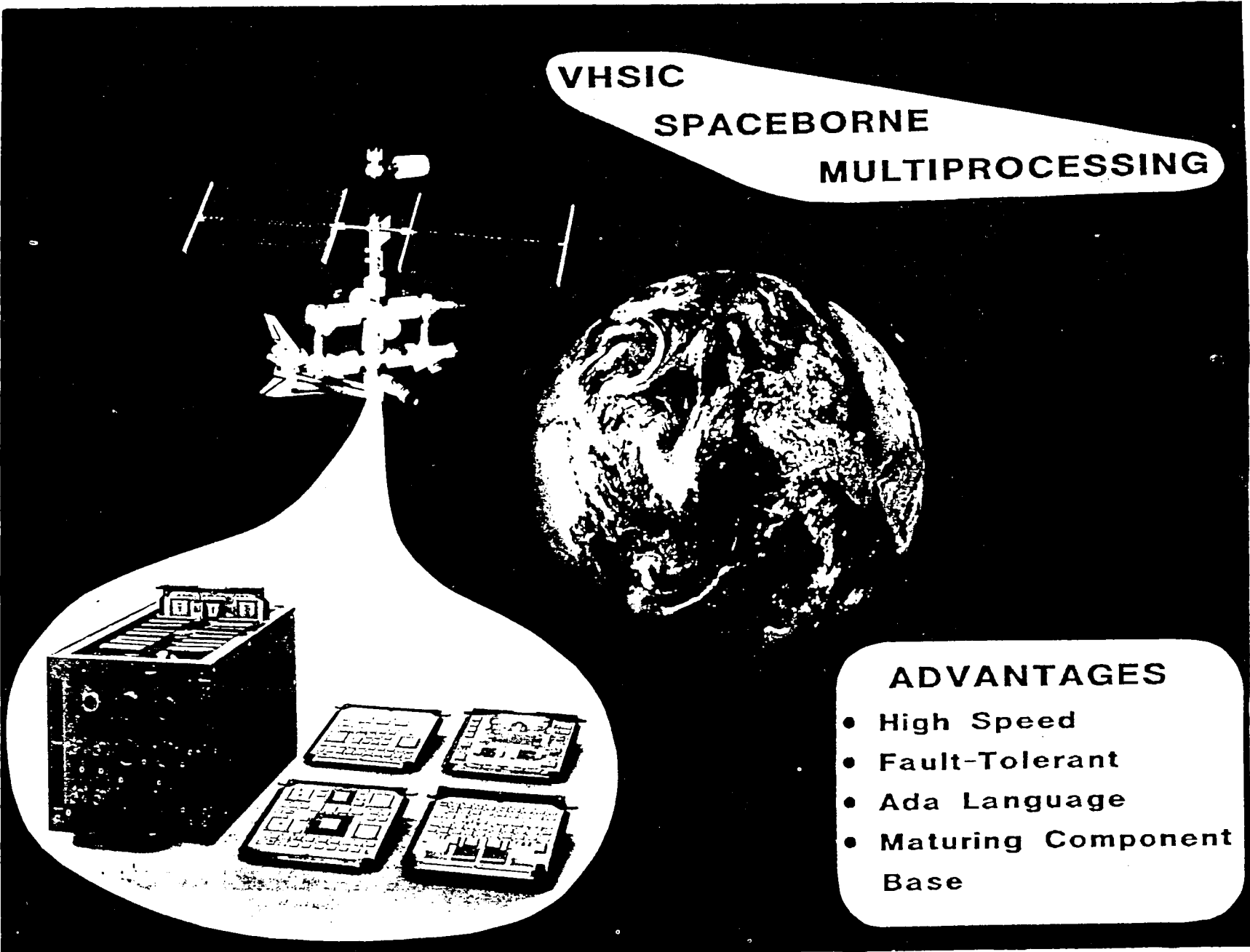

- ADVANTAGES**
- High Speed
  - Fault-Tolerant
  - Ada Language
  - Maturing Component Base

# **NASA MULTIPROCESSOR TECHNOLOGY**

## **OBJECTIVE**

**Develop multiprocessor system technology providing user-selectable fault tolerance, increased throughput, and ease of application representation for concurrent operation.**

## **APPROACH**

**Develop graph management mapping theory for proper performance, model multiprocessor performance, and demonstrate performance in selected hardware systems.**

# MULTIPROCESSING TECHNOLOGY

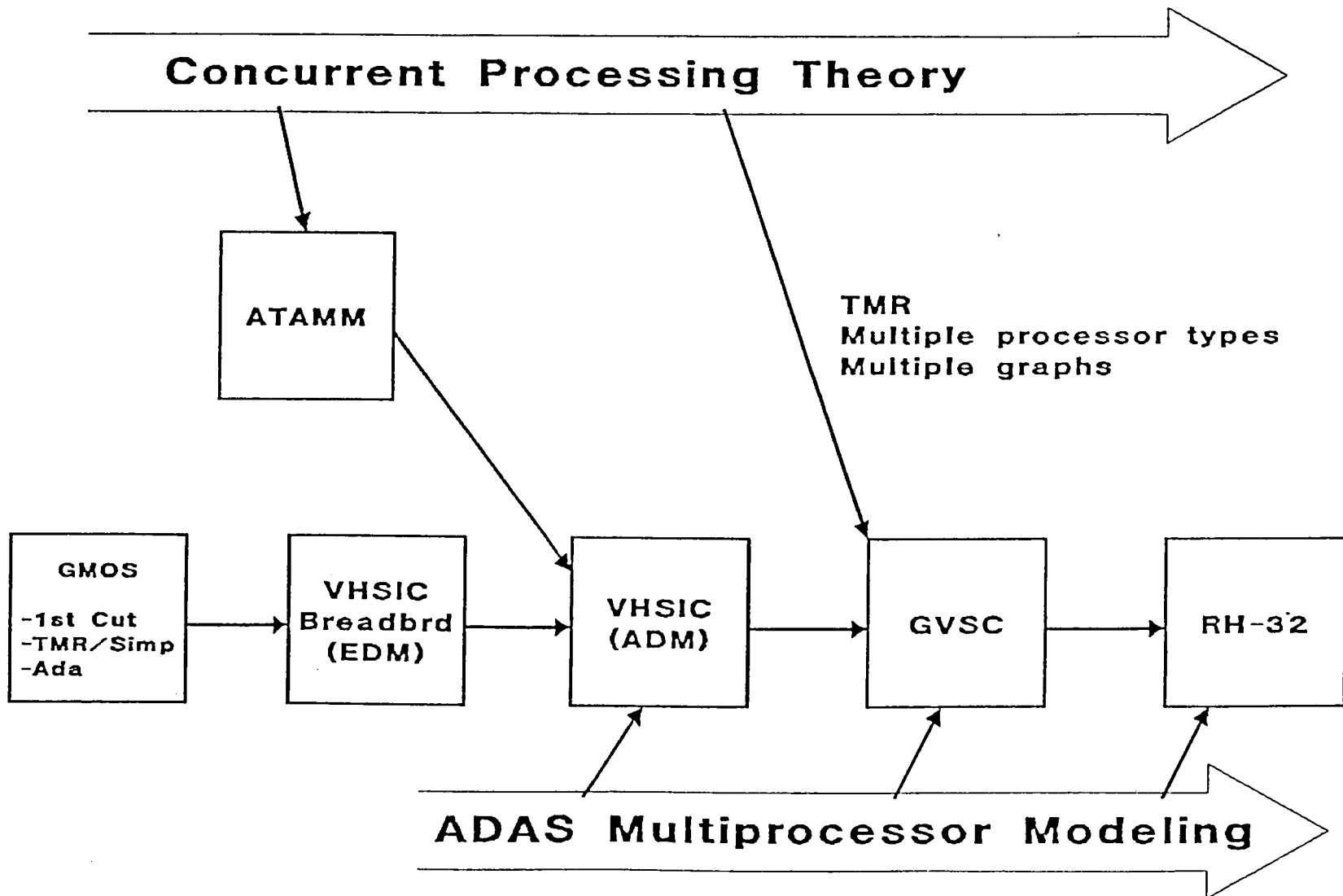

# Graph Management Operating System (GMOS)

181

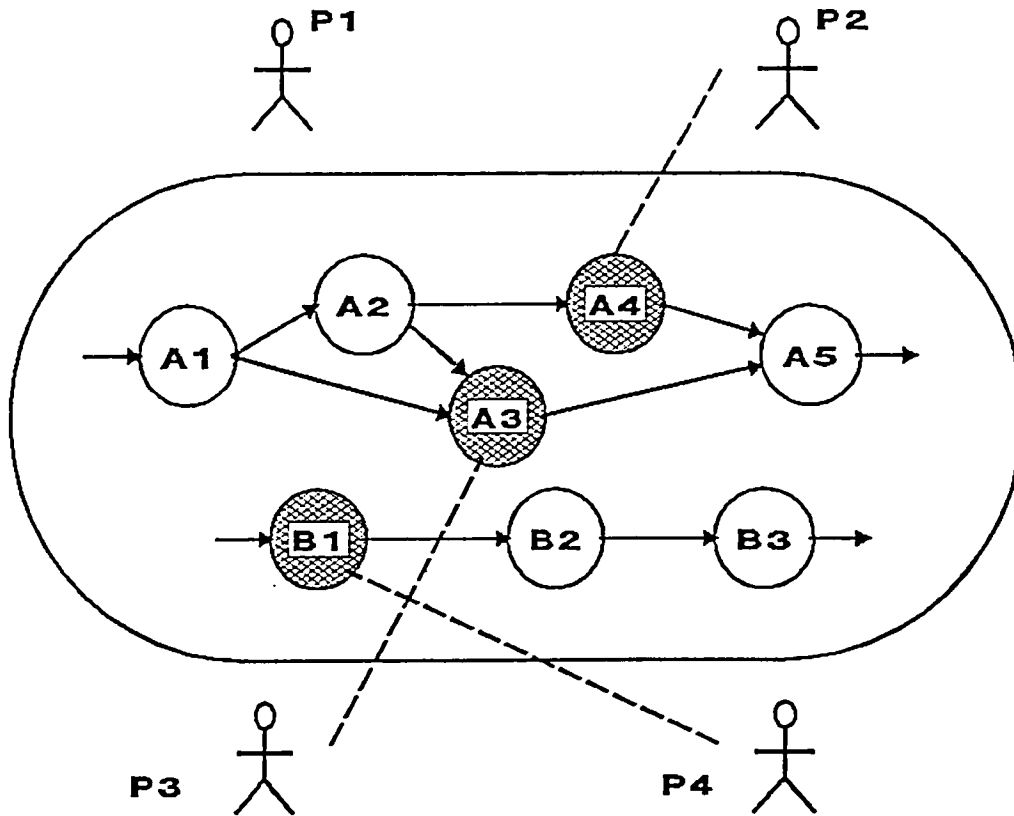

**Processor Assignment  
for Node Execution**

## Features

- o Distributed O/S and Nodes
- o Real-Time Node Assignment
- o Application Graph
- o Node-Selectable Fault Tolerance
- o Ada
- o VHSIC 1750A

# **GMOS FUNCTIONAL FEATURES**

- **EXECUTES DIRECTED GRAPH - SINGLE GRAPH  
- MULTIPLE GRAPH**
- **GRAPH NODE CRITICALITY - TMR OR SIMPLEX**
- **GRAPH NODE SCHEDULING**
  - A) DATA DRIVEN - EVENT FLAG  
- SEMAPHORE (MULTIPLE EVENTS)  
- AND/OR LOGIC**
  - B) DEMAND DRIVEN - PERIODIC TIMER  
- ONE-SHOT TIMER**
- **BACKUP NODE ALLOCATION**
- **FAULTY PROCESSOR EXCLUSION, SELF TEST, REBOOT**



## **ALGORITHM TO ARCHITECTURE MAPPING MODEL (ATAMM)**

- **A strategy for the real-time assignment of the nodes of a data-driven algorithm graph to parallel processors**
- **Based on Petri-Net marked graph theory**
- **Aimed at large-grain graph applications**
- **Provides:**
  - **deadlock-free performance**
  - **optimum time performance**
  - **operating system rules**
  - **performance prediction**

# ALGORITHM MARKED GRAPH (AMG) FOR 7-NODE EXAMPLE GRAPH

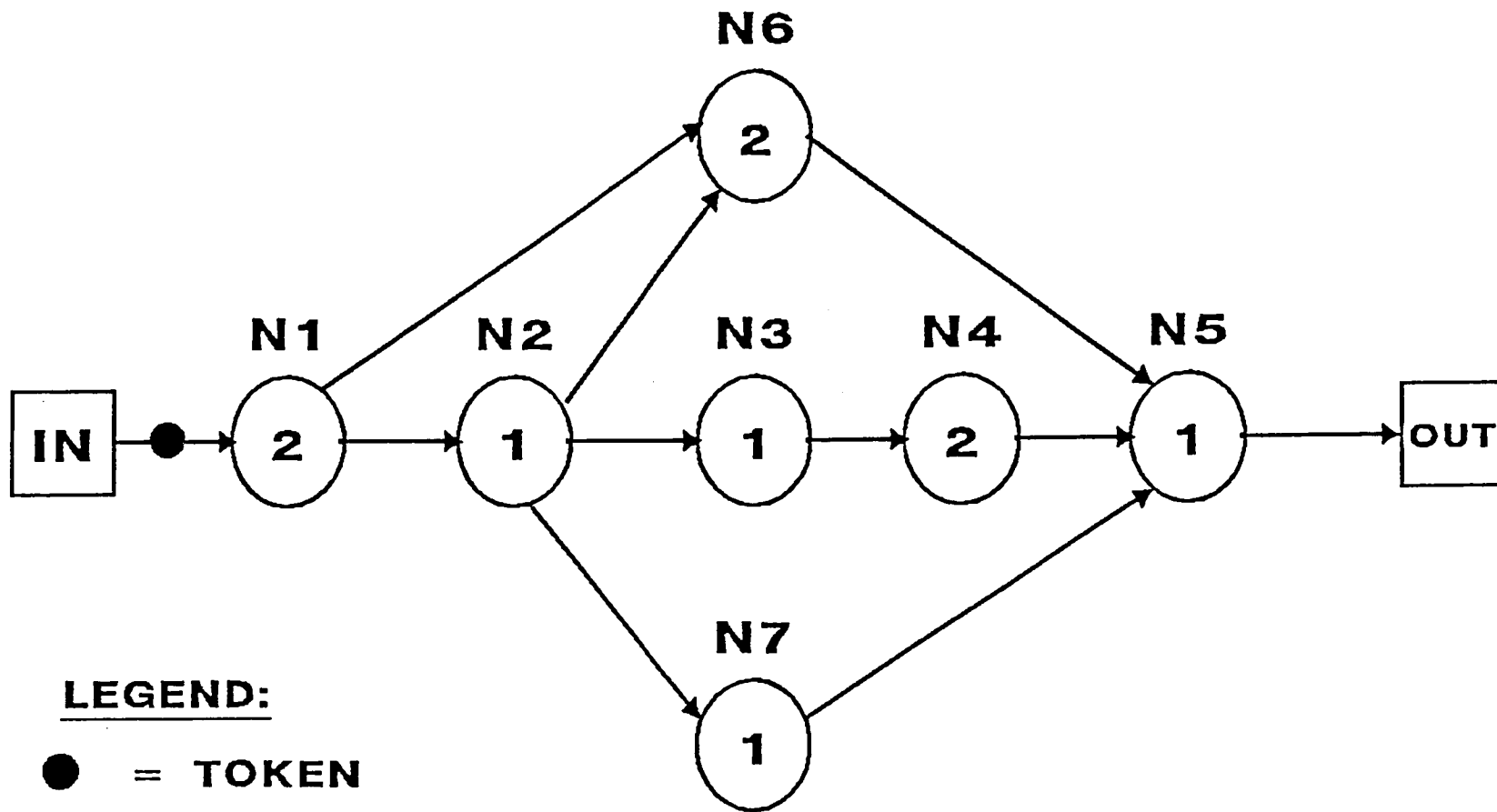

**LEGEND:**

● = TOKEN

**Name**

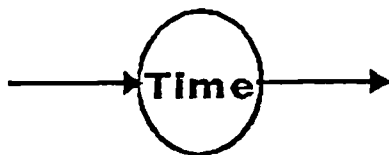

# NODE MARKED GRAPH (NMG) FOR DATA HANDLING

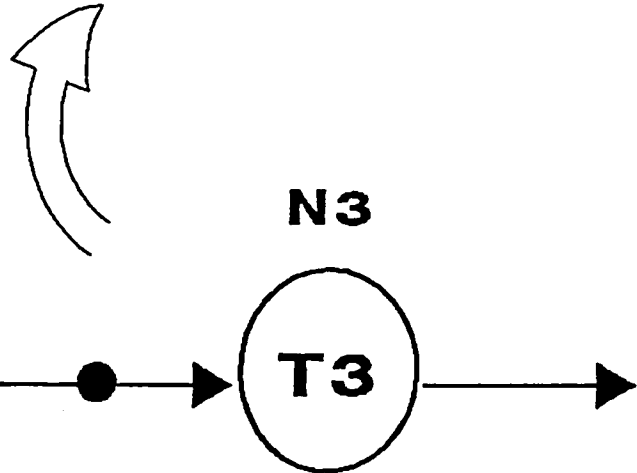
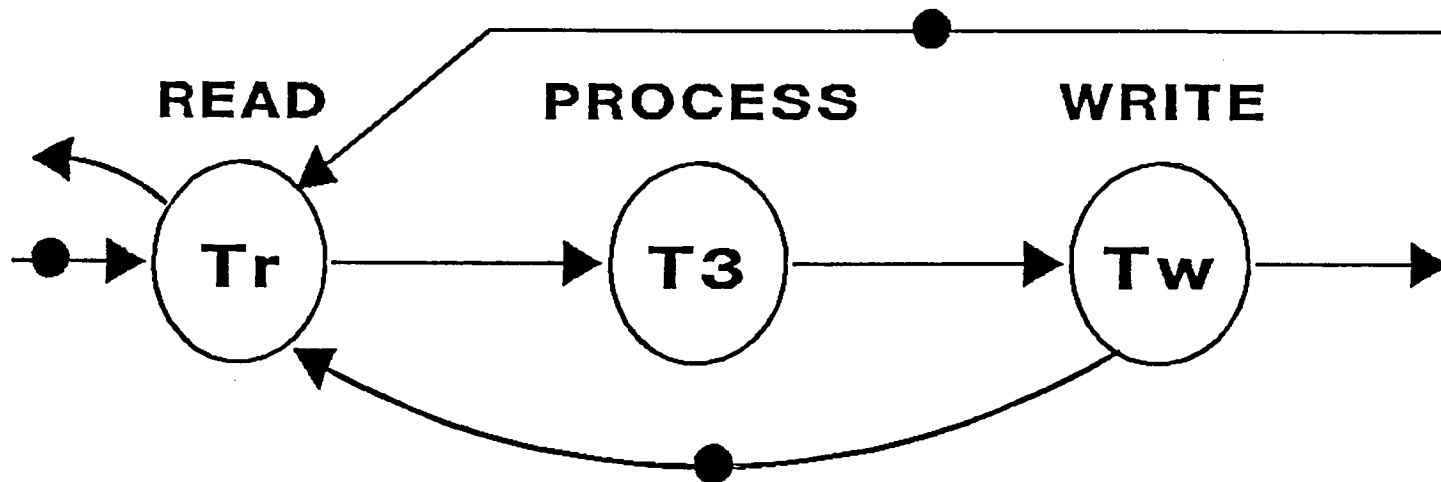

# GRAPH FOR ANALYSIS

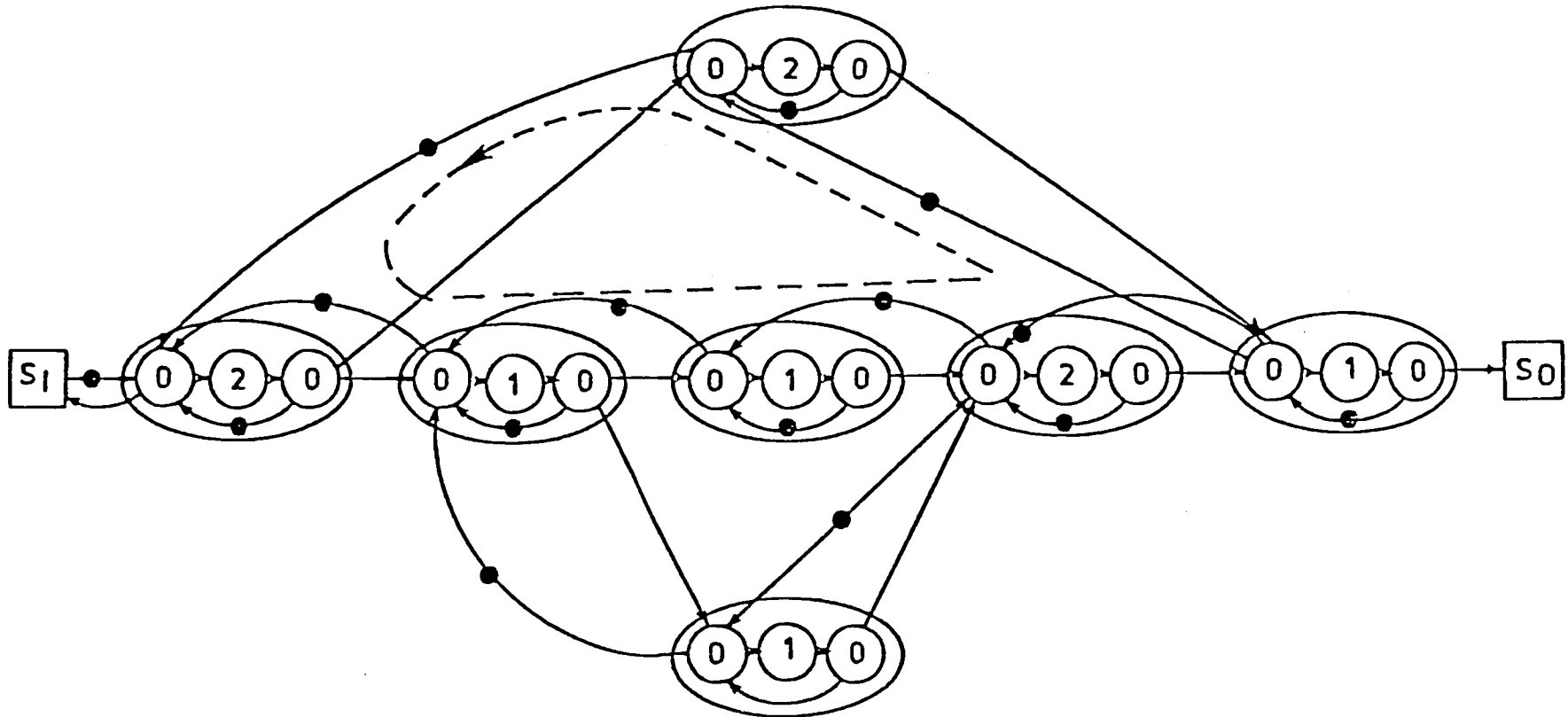

186

TBO = TIME BETWEEN SUCCESSIVE OUTPUTS

TBO<sub>M</sub> = MINIMUM VALUE FOR TBO

$$= \text{MAX (TIME/NO. TOKENS)}_i = 6/2 = 3$$

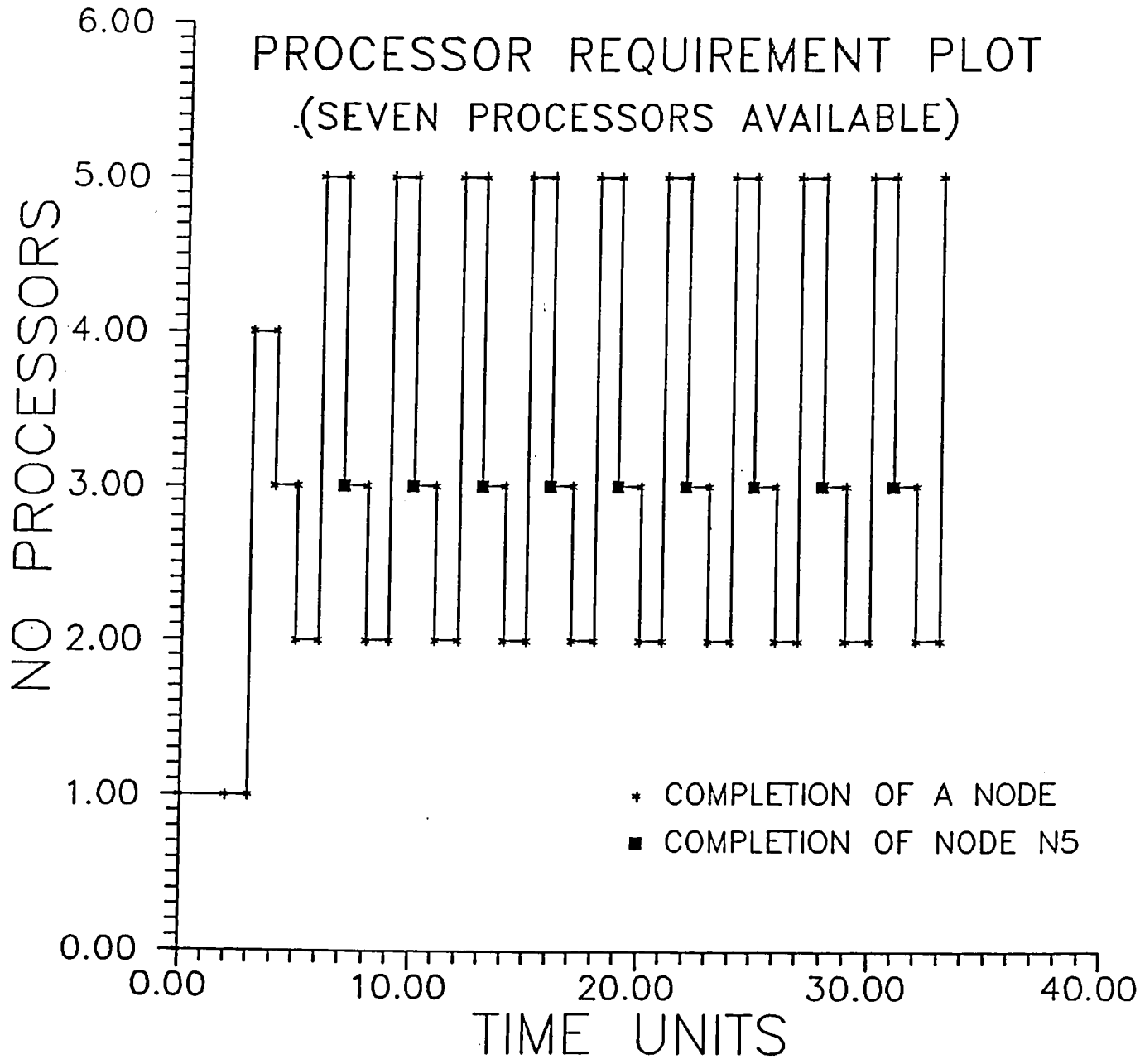

# PROCESSOR REQUIREMENT PLOTS

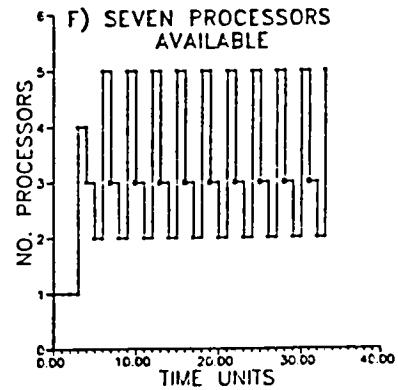
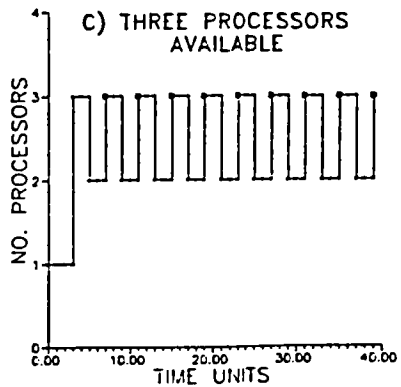
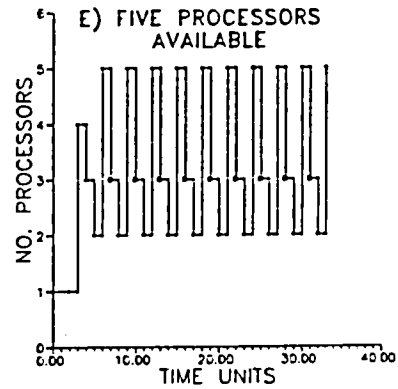
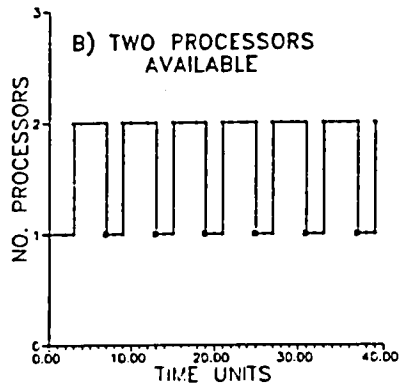
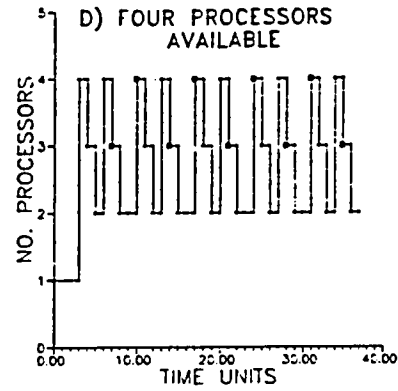
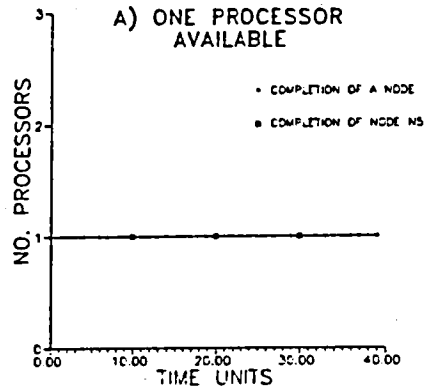

# PERFORMANCE MARGIN

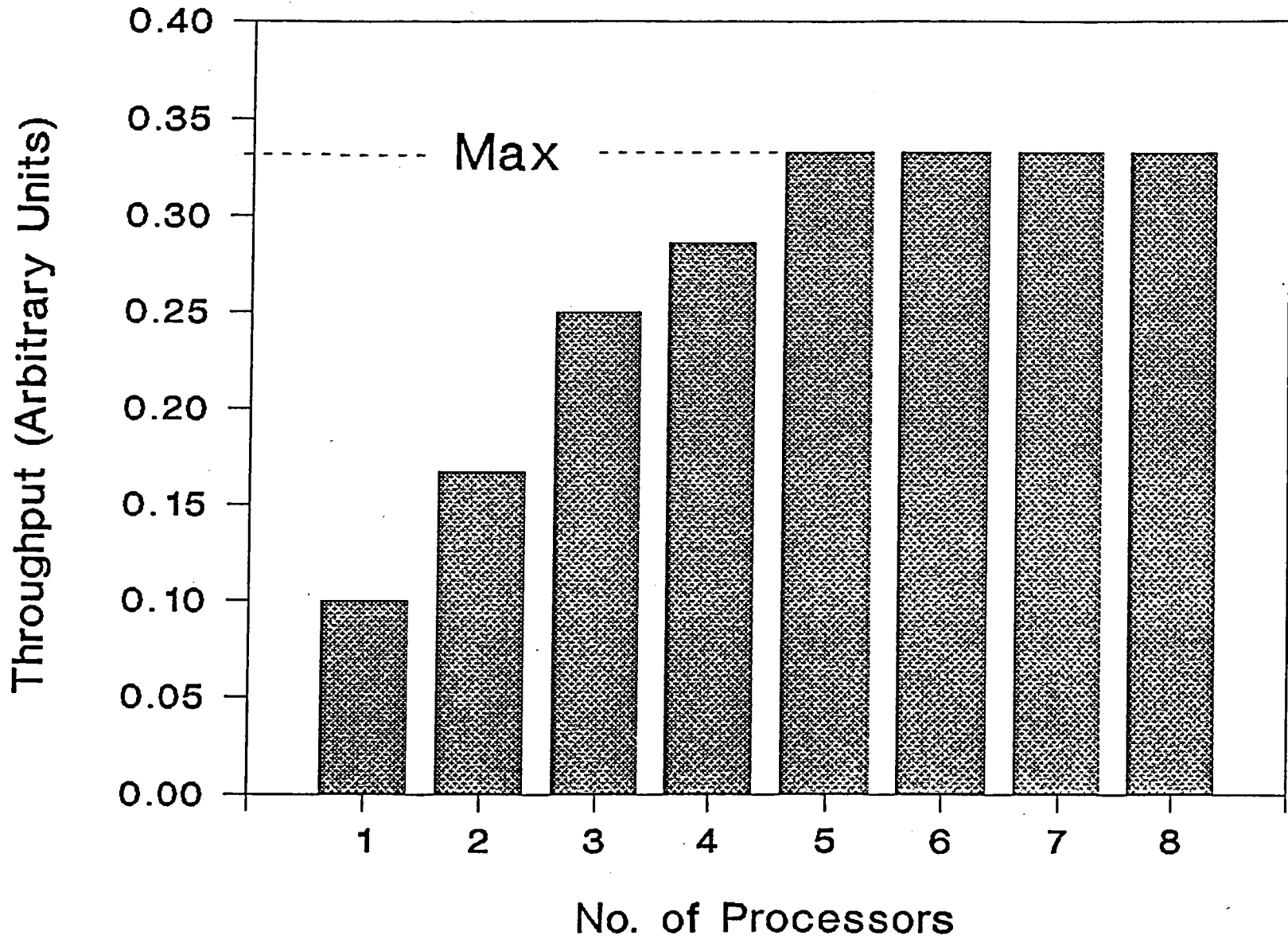

# NORMALIZED THROUGHPUT VERSUS NUMBER OF PROCESSORS

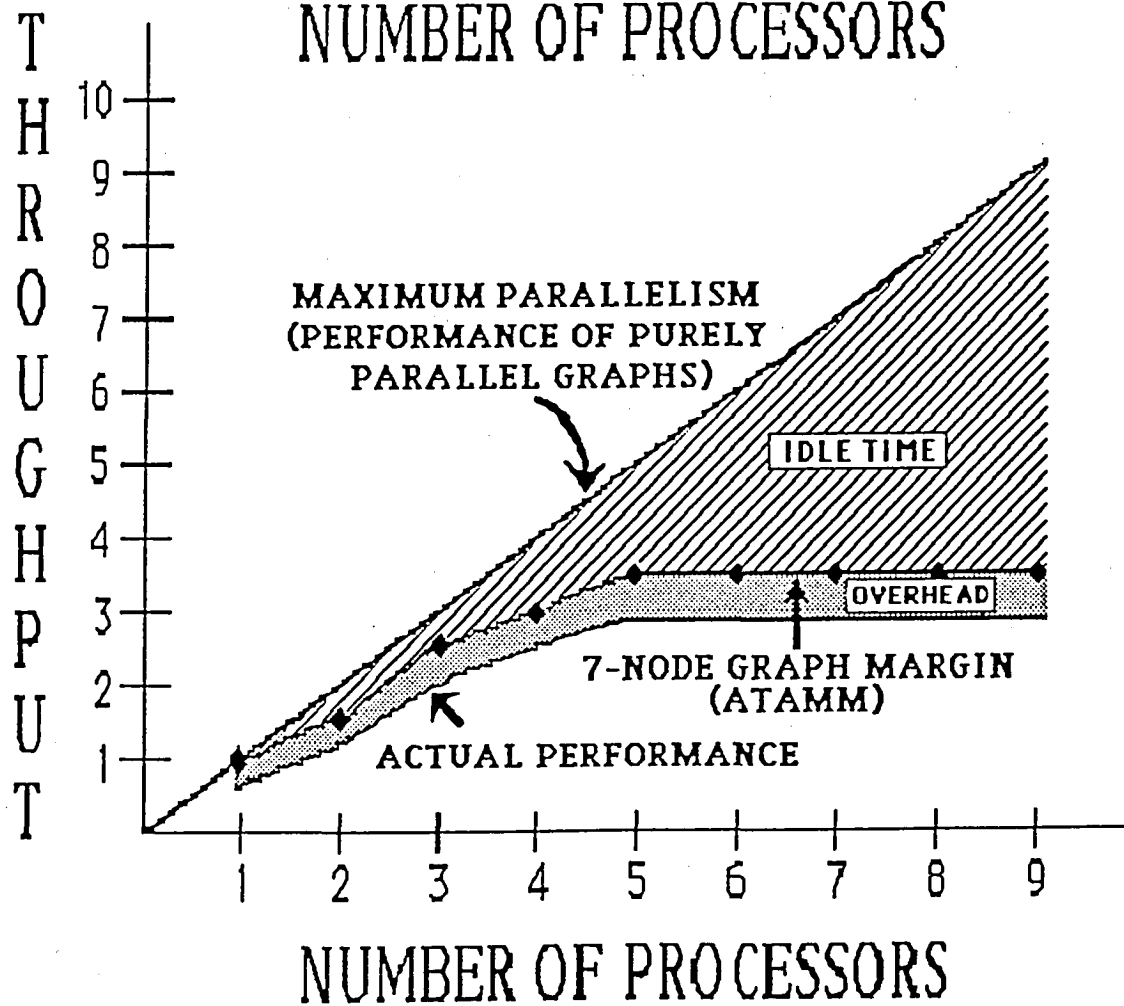



## **ATAMM PROVIDES A NEW CAPABILITY SET**

- o Mathematically proven lock-free performance**
- o Operating system rules to manage the assignment of graph nodes to processors**
- o Prediction of graph's performance bounds**
  - Maximum data rate**
  - Maximum number of processors**
  - Dependency of data rate on number of processors**

# ATAMM DEVELOPMENT/DEMO PLANS

STATUS	FEATURE	DEMO
Initial ATAMM	<ul style="list-style-type: none"> <li>o Single graphs</li> <li>o Simplex</li> <li>o Identical processors (HW &amp; SW)</li> </ul>	ADM
Current Update	<ul style="list-style-type: none"> <li>o Triple Modular Redundant (TMR)</li> <li>o Graph optimization for specific no. processors</li> </ul>	
Future Features	<ul style="list-style-type: none"> <li>o Multiple graphs</li> <li>o Multiple iterations of the same graph</li> <li>o Multiple processor types</li> <li>o Variable node-latency times</li> </ul>	GVSC and/or RH-32

## **MAJOR RESEARCH THRUST FOR FY90**

- o Implement ATAMM Rules into KOS**
  - Simpler operating system than previous GMOS**
  - Use Westinghouse Directed Graph Tool**
  - Use 1553B to provide data I/O and monitor graph status**
  - Improved version of Ada compiler**
  - 2.5 MIPS VHSIC ADM 1750A processor**
  
- o Demo/Evaluate with Ada Algorithms**
  - Test Algorithm (Scan-to-scan track correlation for SDIO)**
  - Time-simulated graphs**
  - Simplex/TMR**
  - Fault injection and continued processing**

# MULTIPROCESSOR INTERFACE DIAGRAM

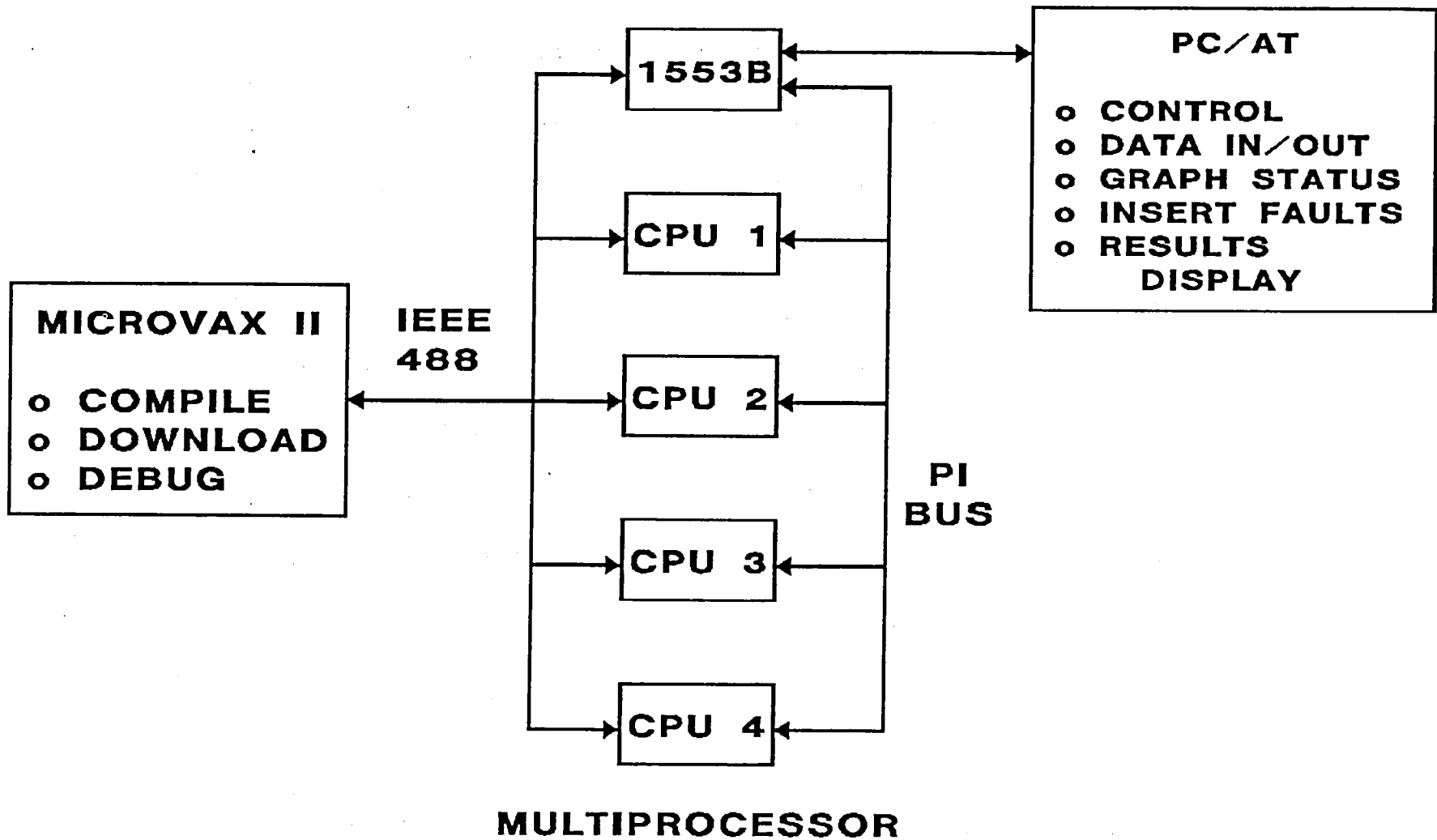

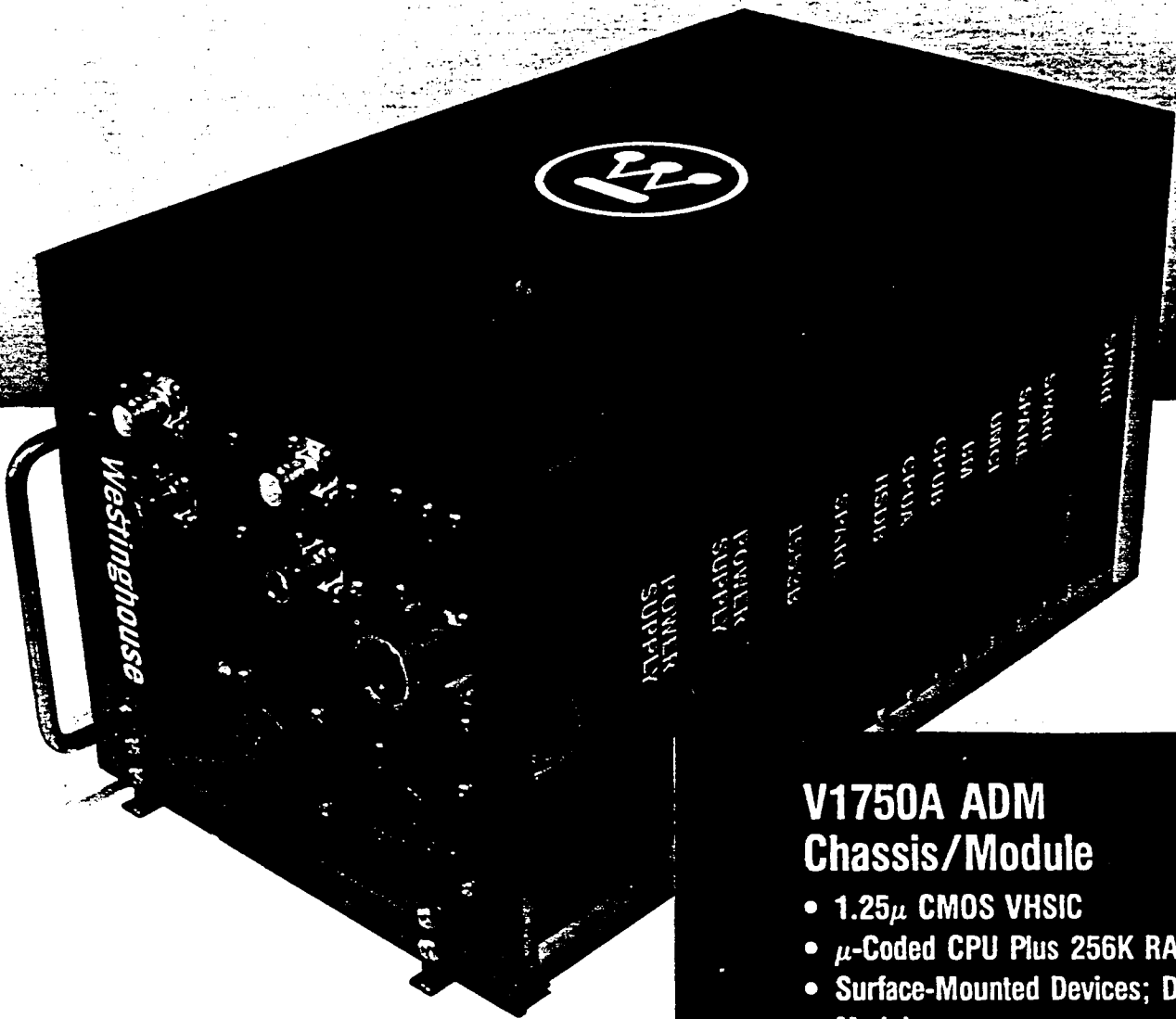

## V1750A ADM Chassis/Module

- 1.25 $\mu$  CMOS VHSIC
- $\mu$ -Coded CPU Plus 256K RAM
- Surface-Mounted Devices; Dual Board Module
- 5.88 x 6.44 Inches (SEM-E)

ORIGINAL PAGE IS  
OF POOR QUALITY

# MAJOR PROGRAM MILESTONES

	FY
<b>1) Integrate/Demo ATAMM and SDIO Algorithm on Avionics Advanced Development Model (ADM)</b>	<b>90</b>
<b>2) Adapt/Demo ATAMM-Based OS on GVSC</b>	<b>91</b>
<b>3) Expand ATAMM Capability and Adapt/Demo on RH-32</b>	<b>94</b>

**DATA MANAGEMENT STANDARDS IN  
COMPUTER-AIDED ACQUISITION AND  
LOGISTIC SUPPORT (CALs)**

**David K. Jefferson  
National Institute of Standards and Technology  
301-975-3262**

197

N 93 27 214

163602

510-82

### Basic Thrusts of CALS

CALS is intended to reduce cost, increase quality, and improve timeliness of weapon system acquisition and support by greatly improving the flow of technical information. This improvement will be realized by substituting an integrated digital environment, encompassing the total weapon system life cycle, for the current islands of automation linked by paper. The current prime targets for CALS are CAD/CAM data, such as engineering drawings; technical manuals, including text and illustrations; and logistic support data, such as tabular data about failure rates.



## **BASIC THRUSTS OF CALS**

**Reduce cost, increase quality, and improve timeliness of weapon system acquisition and support through standards for information technology**

**The current targets are**

- design and manufacturing**
- technical manuals**
- logistic support**

## CALS Phased Development

CALS is concerned with two phases of development: the current Phase I, which provides standards for data interchange; and the future Phase II, which will provide standards for a shared Integrated Weapon System Database (IWSDB). Phase I standards are based on national and international standards; CALS has developed specific subsets or other guidance for the following:

- o the Initial Graphics Exchange Specification (IGES) for product data,
- o the Standard Generalized Markup Language (SGML) for documents,
- o CCITT Group 4 for compressed raster graphics,
- o Computer Graphics Metafile (CGM) for vector graphics, and
- o the Government Open Systems Interconnection Profile (GOSIP) for data communications.

This presentation will be primarily concerned with the Phase II standards which are now being developed.

# CALS Phased Development

(Today)  
Islands of Automation  
Paper Flow

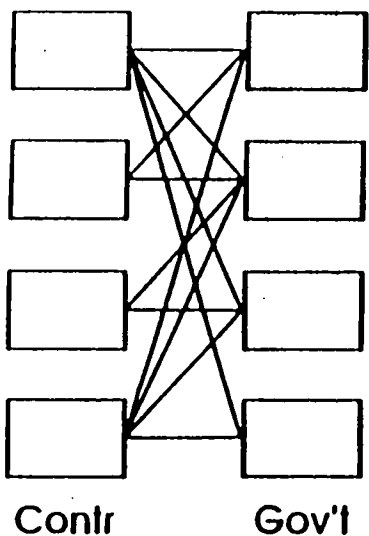

Phase I  
(1988 - 92)  
Interfaced Systems  
Digital Flow

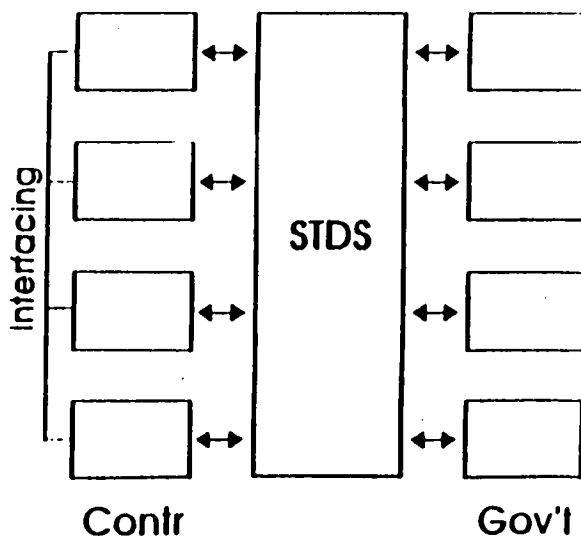

Phase II  
(1991 - 95)  
Integrated Systems  
Shared Data Base

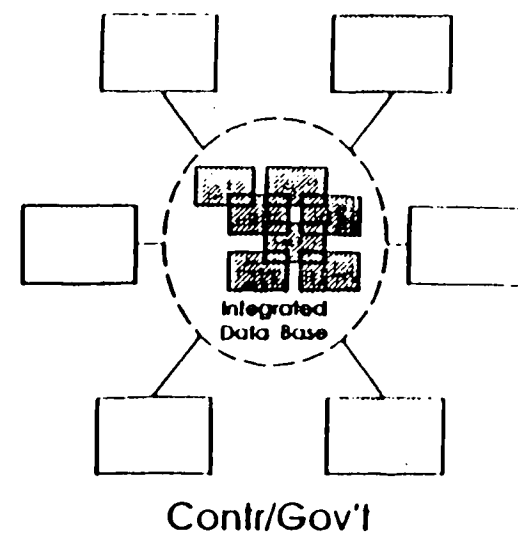

## Industrial Environment - Phase II

The IWSDB will provide a means for efficient, accurate, and timely sharing of technical information among the government, the prime contractor, and subcontractors. The primary means of information delivery to the government will be a contractor-supplied information service, rather than millions of pages of paper. This will save money and time in information development, review, and maintenance. Clearly data integrity and security are critical to the operation of the IWSDB.

# INDUSTRIAL ENVIRONMENT-Phase II

## INTEGRATED WEAPON SYSTEM DATABASE (IWSDb)

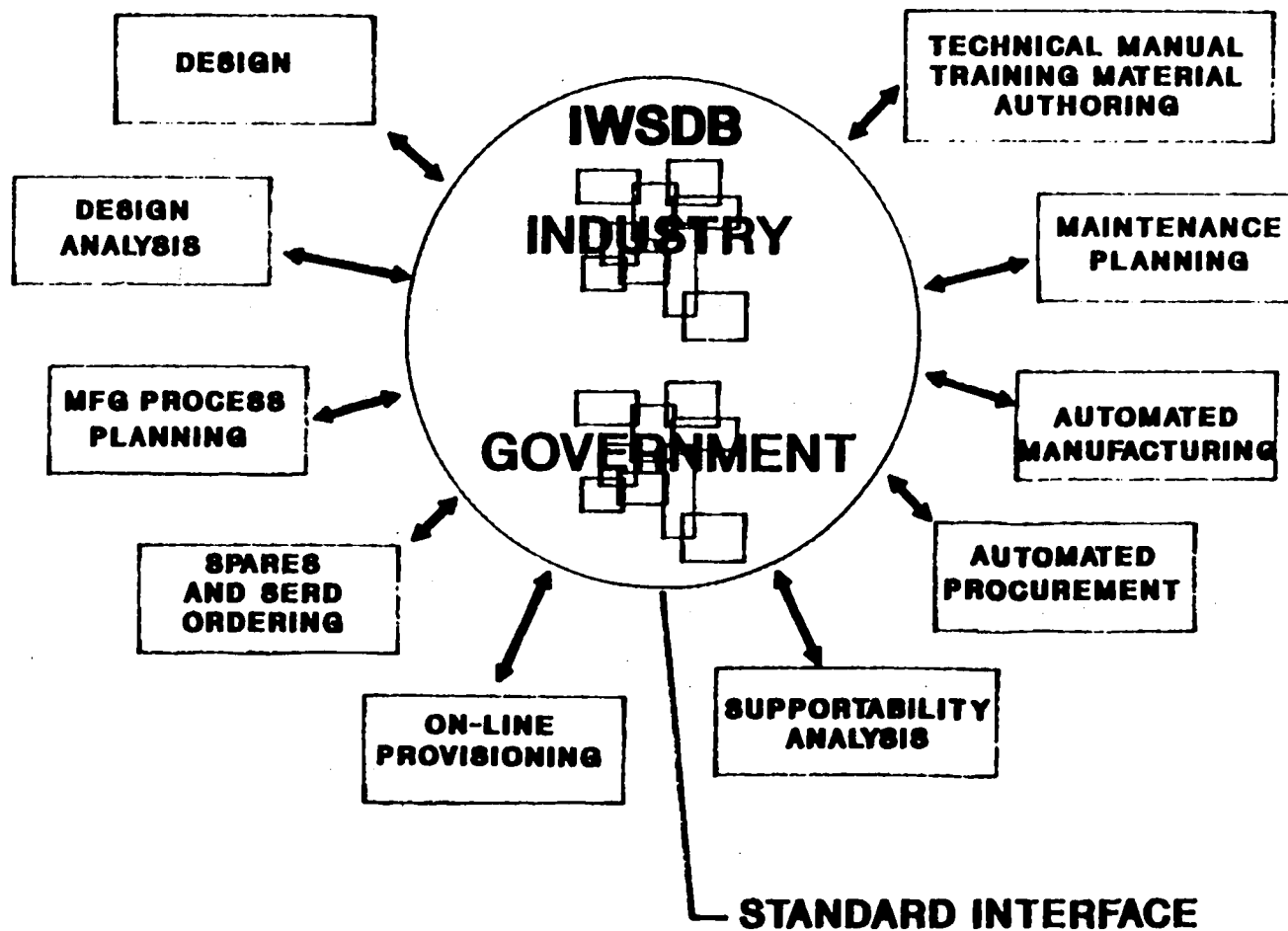

## Standards

CALS is concerned with three types of standards: functional standards, such as those in military standards that describe DoD business processes; data content standards, which describe the structure and integrity rules of the data that supports those business processes; and technical standards, based on national and international standards for information technology. Technical standards provide the basis for open, non-proprietary systems only if:

- o standards are developed through consensus and supported by products from a large number of vendors, and
- o products are tested and certified by a standard procedure which provides evidence of reasonable quality.

Standards are frequently quite complex and may therefore require tailoring to a particular set of users. Very complex sets of standards, such as those of Open Systems Interconnection (OSI) may require the development of integrated profiles, or compatible tailored subsets, as in GOSIP and the Applications Portability Profile (APP).

# STANDARDS

## Three types:

- **Functional (shared business rules)**  
    **example: high-cost items must be reviewed manually**
- **Data content (shared vocabulary)**  
    **example: high-cost is greater than \$100,000**
- **Technical (shared processing)**  
    **example: the Structured Query Language is used for table manipulation**

## Requirements for effectiveness

- **Development through consensus**
- **Testing and certification**
- **Tailoring to users**
- **Integration of compatible standards**

## SQL

SQL became the international and national standard for relational database management systems in October, 1986. That standard specifies a standard cursor-based interface for calling to SQL modules from a number of standard programming languages. A 1989 extension specifies a standard means of embedding SQL statements within a program for a number of standard programming languages. Application system portability is therefore possible. SQL does not yet specify an interactive interface, so ad hoc queries may or may not be portable. SQL has been widely implemented and is being significantly enhanced, as will be described later. NIST has developed an SQL test suite, which has been widely used by SQL vendors; a NIST test service will begin in April, 1990.



# SQL

**ISO/ANSI STANDARD: OCTOBER 1986**

**FEDERAL INFORMATION PROCESSING STANDARD: AUGUST 1987**

**PROVIDES PORTABILITY OF DATABASE DATA DEFINITION AND DATABASE APPLICATION PROGRAMS VIA STANDARDIZED DATA DEFINITION LANGUAGE (DDL), DATA MANIPULATION LANGUAGE (DML), AND BINDINGS TO STANDARD PROGRAMMING LANGUAGES COBOL, FORTRAN, AND PASCAL.**

## **EXTENSIONS**

- **ADDENDUM1 FOR ENHANCED INTEGRITY CONSTRAINTS: 1989**
- **EMBEDDED SQL FOR ADA, COBOL, FORTRAN, PASCAL: 1989**

## SQL2

Two major enhancements to SQL are under development: SQL2 and SQL3. Both include the current SQL. SQL2 is currently expected to become an international and national standard in 1992. SQL2 is quite stable and has achieved very strong vendor support. It provides a standard language for dynamic creation and modification of schema elements as well as an "information schema" which could be used to obtain information about the structure of a database.

# **SQL2**

**ISO/ANSI STANDARD: FALL 1992**

**FEDERAL INFORMATION PROCESSING STANDARD: 1993**

**PROVIDE UPWARD COMPATIBLE ENHANCEMENTS TO SQL.**

**SCHEMA MANIPULATION LANGUAGE FOR DYNAMIC  
CREATION AND MODIFICATION OF SCHEMA ELEMENTS.**

**"INFORMATION SCHEMA" FOR RUN-TIME ACCESS TO  
SCHEMA INFORMATION**

## SQL2 (continued)

SQL2 also provides dynamic SQL, which could be used to formulate ad hoc queries. Functional enhancements include:

- o outer join to specify how null fields should be interpreted when joining tables,
- o integrity enhancement through the automatic propagation (i.e., cascade) of the results of updates and deletes,
- o standard types for date and time,
- o data type casting (i.e., type conversion), and
- o the ability to construct and use temporary tables.

## **SQL2 (continued)**

**DYNAMIC SQL FOR RUN-TIME CREATION OF SQL STATEMENTS. VERY IMPORTANT FOR THIRD-PARTY SOFTWARE DEVELOPERS BUILDING FOURTH GENERATION TOOLS OVER AN SQL DATABASE.**

**FUNCTIONAL ENHANCEMENTS SUCH AS: OUTER JOIN, UPDATE AND DELETE CASCADE, DOMAINS, DATE AND TIME, CASE EXPRESSION, DATA TYPE CASTING, STRING OPERATIONS, TEMPORARY TABLES, AND GENERAL RELAXATION OF PREVIOUS LANGUAGE RESTRICTIONS.**

**NATIONAL CHARACTER STRINGS FOR THE INTERNATIONAL MARKET.**

### SQL3

SQL3 is much less well-defined than SQL2. It is likely to provide support for object-oriented databases, and could therefore support applications such as CAD/CAM. External procedure calls and user-defined data types would provide the basic capabilities for extending the relational model.

# SQL3

**ISO/ANSI STANDARD: 1995**

**FEDERAL INFORMATION PROCESSING STANDARD: 1996**

**WILL PROVIDE UPWARD COMPATIBLE ENHANCEMENTS TO THE SQL STANDARDS TO SUPPORT DATA ADMINISTRATION, KNOWLEDGE-BASE SYSTEMS, AND OBJECT-ORIENTED DATABASE, AS WELL AS INTEGRATION WITH GRAPHICS STANDARDS AND EXPERT SYSTEMS.**

**EXTERNAL PROCEDURE CALLS FOR INTEGRATION WITH EXTERNAL SYSTEMS.**

**USER-DEFINED DATA TYPES, INCLUDING OPERATIONS, TO SUPPORT OBJECT-ORIENTED DATABASES.**

### SQL3 (continued)

Generalization and specialization hierarchies would help support object-oriented databases. SQL3 may also provide support for data administration, including integration with the Information Resource Dictionary System (IRDS) standard to be described later. Asynchronous processing would enable a user to initiate and monitor a number of parallel operations, which would be extremely valuable in dealing with lengthy queries to many different remote databases.



## **SQL3 (continued)**

**GENERALIZATION AND SPECIALIZATION HIERARCHIES TO  
SUPPORT EXPANDED SCHEMA DEFINITION.**

**DATA ADMINISTRATION TOOLS AND BETTER INTEGRATION  
WITH IRDS STANDARDS.**

**ASYNCHRONOUS PROCESSING.**

**RECURSIVE QUERY EXPRESSIONS TO BETTER SUPPORT  
BILL-OF-MATERIALS APPLICATIONS.**

## Information Resource Dictionary System (IRDS)

The IRDS can be considered to be a value-added database of metadata; access control and such configuration management features as version control and the use of variations provide the added value. The IRDS may be used to manage metadata describing such information resources such as programs and hardware, as well as data structures. The IRDS national standard currently specifies two interfaces: a "panel interface" that specifies functionality, and a "command language" that also specifies a concrete syntax.

# **INFORMATION RESOURCE DICTIONARY SYSTEM (IRDS)**

**ANSI STANDARD: 1988**

**FEDERAL INFORMATION PROCESSING STANDARD: 1989**

**MANAGES A POTENTIALLY LARGE VOLUME OF COMPLEX  
METADATA TO FACILITATE PLANNING, DESIGN, AND  
DOCUMENTATION FOR IRM.**

**ACCESS CONTROL OF METADATA.**

**CONFIGURATION MANAGEMENT OF METADATA.**

## Information Resource Dictionary System (IRDS) (continued)

The IRDS is based on entities (i.e., nouns representing objects or concepts), relationships (i.e., verbs representing associations among entities), and attributes (i.e., adjectives representing properties of entities or adverbs representing properties of relationships). A key feature of the IRDS is extensibility, i.e., the ability to define new types of metadata. For example, a new entity type called "screen" could be defined; it could "display" certain data elements and "receive" other input data elements. Communication between an IRDS and other IRDSs, database management systems, Computer-Aided Systems Engineering (CASE) tools, and other software will be enhanced by the addition of the Services Interface, for transferring small chunks of metadata, such as the attributes of a data element; and the Export/Import File Format, for transferring large chunks, such as complete schemas. In particular, the Export/Import File Format could be used to ensure the consistency of definition among a set of IRDSs.

# **INFORMATION RESOURCE DICTIONARY SYSTEM (IRDS) (continued)**

**STANDARD SET OF ENTITIES, ATTRIBUTES, AND  
RELATIONSHIPS (SUCH AS PROGRAM, RECORD, AND  
ELEMENT) FOR IRM MODELING.**

**EXTENSIBILITY TO SUPPLEMENT OR MODIFY THAT  
STANDARD SET TO ACCOMMODATE ORGANIZATIONAL  
TERMINOLOGY OR SPECIAL REQUIREMENTS.**

**DICTIONARY WILL BE ACTIVE WITH ADDITION OF IRDS  
SERVICES INTERFACE: 1990**

**DICTIONARIES WILL COMMUNICATE VIA EXPORT/IMPORT  
FILE FORMAT: 1990**

## IRDS Functionality

Examples of IRDS functionality include:

- o a planned module to enforce data element naming conventions,
- o metadata needed to drive a variety of graphically oriented CASE tools,
- o a report on the effects of change, as, for example, what records, programs, etc. could be affected by a change in the size of the ZIP code,
- o maintenance of a database architecture providing separate but interrelated definitions of the users' logical views of data, the physical representations of that data, and the consolidated enterprise view of that data, and
- o maintenance of the data content rules that provide data integrity and conformance to the business rules.

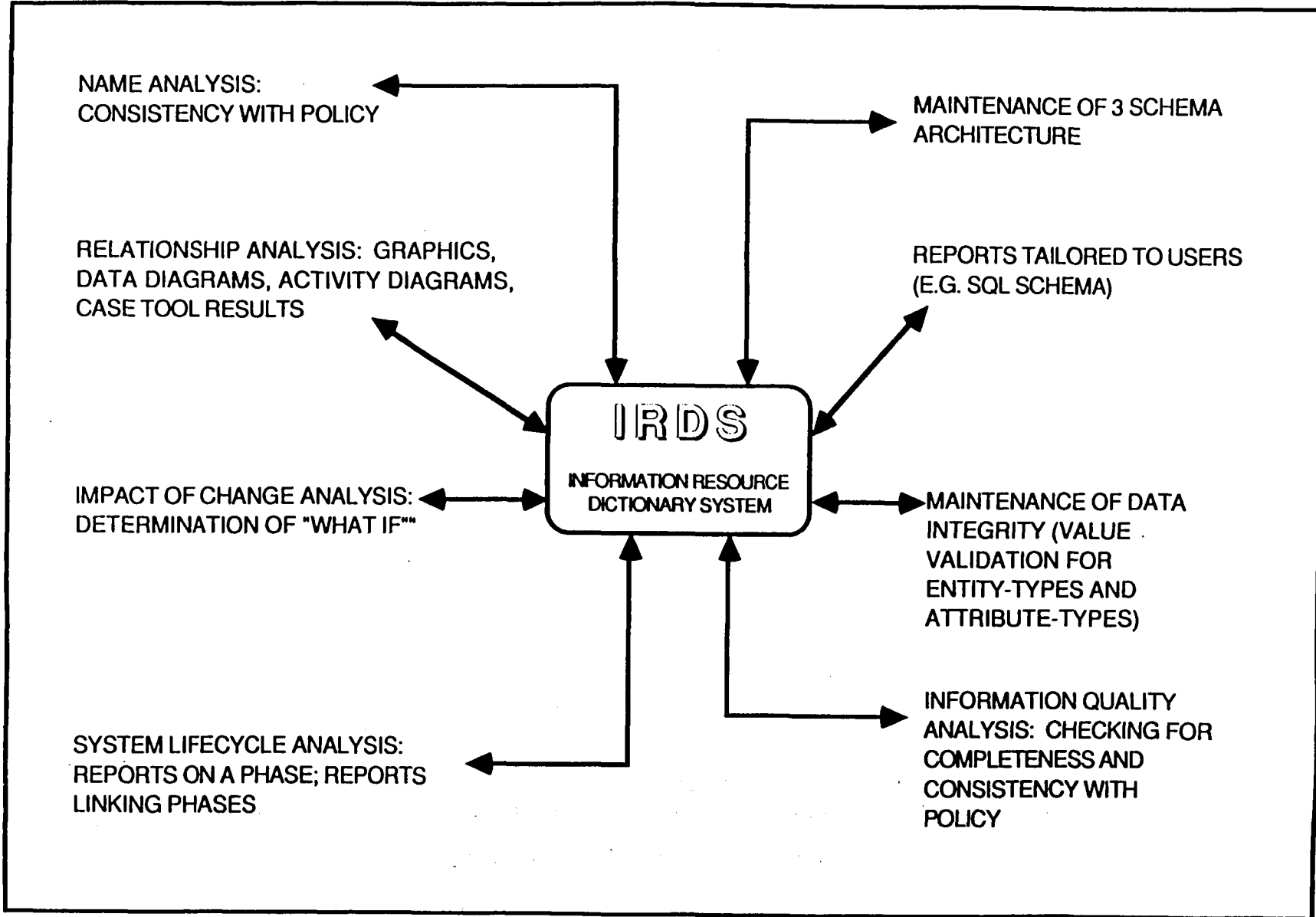

### Future CASE/IRDS Relationship

In the future, the IRDS will provide a common source of metadata that can be used to link various CASE tools together.



# FUTURE CASE/IRDS RELATIONSHIP

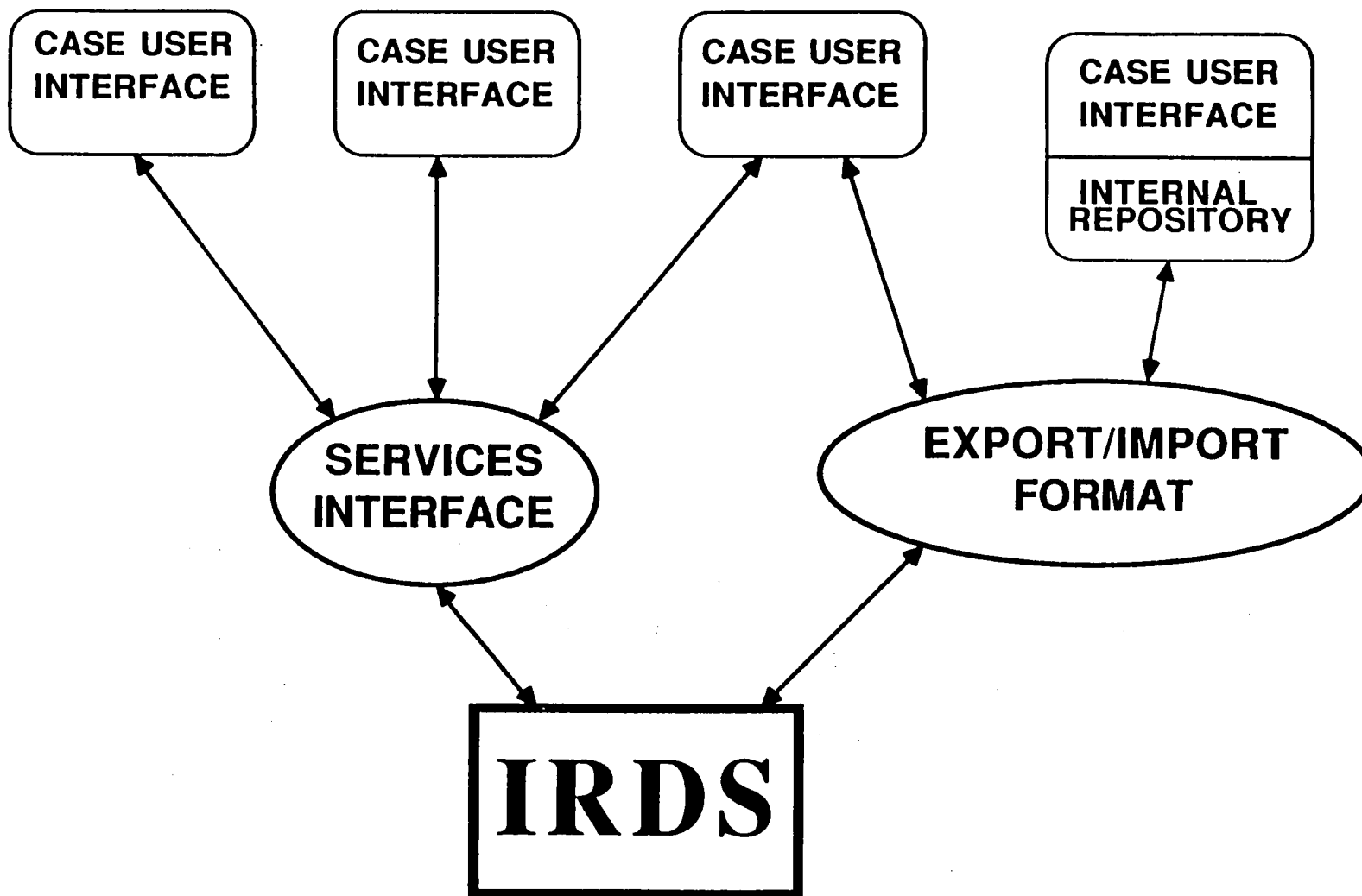

### Remote Database Access (RDA)

The final database standard is Remote Database Access (RDA), which is expected to be an international and national standard in 1992. RDA will provide a standard means for sending an SQL statement to a specific remote site and receiving results and status. RDA provides only a basic capability for distributed database. It does not provide for transparent access to a data directory, nor for the decomposition of complex queries and updates, nor for the control of concurrent updates at multiple sites, nor for the recomposition of results of complex queries.

# **REMOTE DATABASE ACCESS (RDA)**

**ISO/ANSI STANDARD: 1992**

**FEDERAL INFORMATION PROCESSING STANDARD: 1992**

**WILL PROVIDE PROTOCOLS FOR REMOTE ACCESS TO  
DATABASES DISTRIBUTED OVER A COMMUNICATIONS  
NETWORK.**

**ASSOCIATION PROTOCOLS USING OPEN SYSTEMS  
INTERCONNECTION (OSI) STANDARDS.**

**REMOTE ACCESS ONLY - DOES NOT PROVIDE DISTRIBUTED  
ACCESS OR CONCURRENCY CONTROL. ONLY A FIRST STEP  
TOWARD TRUE DISTRIBUTED DATABASE.**

# Automatic Management of Parallel and Distributed System Resources

- NASA Ames Research Center (Dr. Jerry Yan)
- Stanford University (Tin Fook Ngai)

**Dr. Stephen F. Lundstrom**

**Consultant**

**PARSA**

**(415) 723-0140**

**Consulting Associate Professor, Electrical Engineering  
Computer Systems Laboratory  
Stanford University**

N93-27715

163603

511-62

## Program Focus

(at NASA Ames Research Center)

- Parallel Processing is not confined to any one level of the software hierarchy — from applications to operating systems and machines
  - Applications must be formulated with sufficient inherent parallelism to exploit the underlying parallel architecture  
The focus in the area of parallel applications is:
    - Scalable, highly parallel symbolic applications
    - Application development environment
  - The mapping of hardware resources to the application must be able to respond to dynamic load variations and faults on the system. The focus in the area of intelligent management of multiprocessing systems is:
    - High performance and integrity
    - Highly adaptive
  - For space applications, the parallel hardware has to be subject to low weight, power and volume constraints. The focus in the performance evaluation of parallel architectures is:
    - Standardized benchmarks
    - Simulation and prediction tools for parallel systems

## Program Focus

---

- **Parallel Applications**
  - Scalable, highly parallel symbolic applications
  - Application development environment
- **Intelligent Management of Multiprocessing Systems**
  - High performance and integrity
  - Highly adaptive
- **Performance Evaluation of Parallel Architectures**
  - Standardized benchmarks
  - Simulation and prediction tools for parallel systems

## This is how our project fits together

- We are currently working on "parallelizing" three applications (at NASA Ames Research Center)
  - KATE — A Frame-based reasoning system monitoring the subsystem of the shuttle launch system
  - CLiPS — A C-based production system shell
  - Space Station Workloads — We are looking at the possibilities to model part of the OMA
- We are also working on resource management strategies for multiprocessors
  - "Post-Game" Analysis — Static, rule-based module assignment system
  - "Mid-Game" Analysis — Dynamic load-balancing system on hypercube type architectures
- Modeling
  - Axe — we can simulate parallel program execution of MultiComputers and Token-ring based distributed systems
  - BDL — We can model/specify parallel program behavior
- We can also "visualize" how the program executed and in turn, discover bottlenecks due to software and hardware architectural characteristics. (contact Dr. Jerry Yan at NASA Ames Research Center to request a short demonstration video tape.)

# Intelligent Systems Technology Branch

## Software/Workload Models

Model program behavior based on "abstract" or "partial" spec.s

Incremental refinement if necessary

## Concurrent Applications

CLIPS | Space Station Workloads | KATE

Automatic parallelization

Parallelization from requirements spec.

Object-oriented implementation

## Hardware Models: Concurrent Execution on Multiprocessor Systems

Space Station DMS

Token-Rings and GRIDs

Fault Injection Capabilities

## Intelligent Operations

### Compile-time Analysis

Heuristic Static (Initial) Resource Mapping

### Run-time Management

Distributed System Monitoring  
Dynamic Load Balancing / Remapping  
Automated Fault Management

Instrumentation —  
Performance Visualization

**NASA**  
Ames Research Center

Parallel Systems Research



Stanford University - Computer Systems Lab.

Dynamic Concurrent Program and Its Resource Allocation

Our research (at Stanford University) has been primarily focused on dynamic concurrent programs that create networks of communicating sequential processes during their course of execution. These networks of processes are defined dynamically. Run-time variables include the number and type of processes to be spawned and how these processes communicate. The number of available processors is another run-time variable. Once a network is created, these run-time variables remain unchanged.

The resource allocation problem is how to assign the concurrent processes to available processors and how to schedule them for fast program execution. This problem is known to be a difficult and tedious one. The objective of our research is to investigate automatic means to this resource allocation problem.

# Dynamic Concurrent Programs

create networks of communicating sequential processes

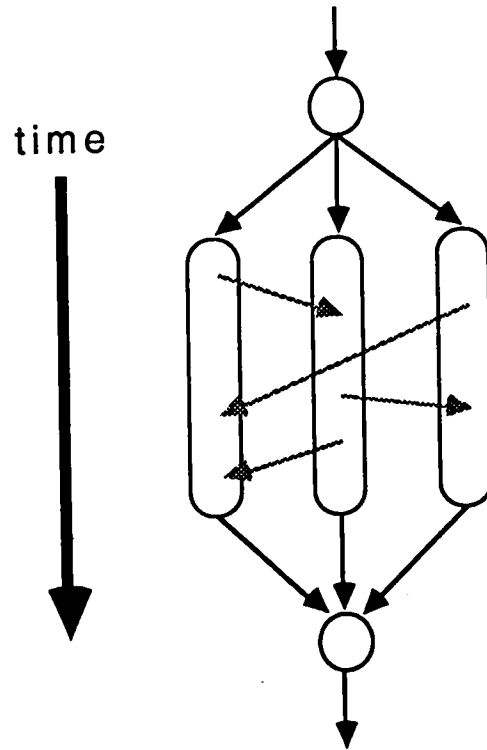

run-time variables:

1. # processes
2. process types
3. inter-process communications
4. # available processors

**Resource Allocation:**

- Assign processes to avail. processors
- Schedule process execution

Compiler-Directed System Approach

We believe that both program-specific information and system information should be fully utilized in order to achieve good resource allocation. Our approach to automatic resource allocation is to extract program-specific information during compile-time and to do resource allocation based on these information and other run-time scheduling parameters during run-time. During compile-time, the compiler also modifies the program by inserting in run-time calls to the run-time resource management system. During program execution, when a network of concurrent processes is about to be created, a scheduler somewhere in the system is called, and all relevant run-time scheduling parameters are gathered and passed to it. The scheduler then allocates the available processors and invoke their resident local schedulers to schedule and execute the assigned processes. We call this approach the compiler-directed system approach. (Note that the resource allocation in this approach is distributed and substantial overlapping of scheduling activities with useful computation is possible.)

# Compiler-Directed System Approach

## Compile time

- compile scheduling parameters.
- insert run-time scheduling routines

## Run time

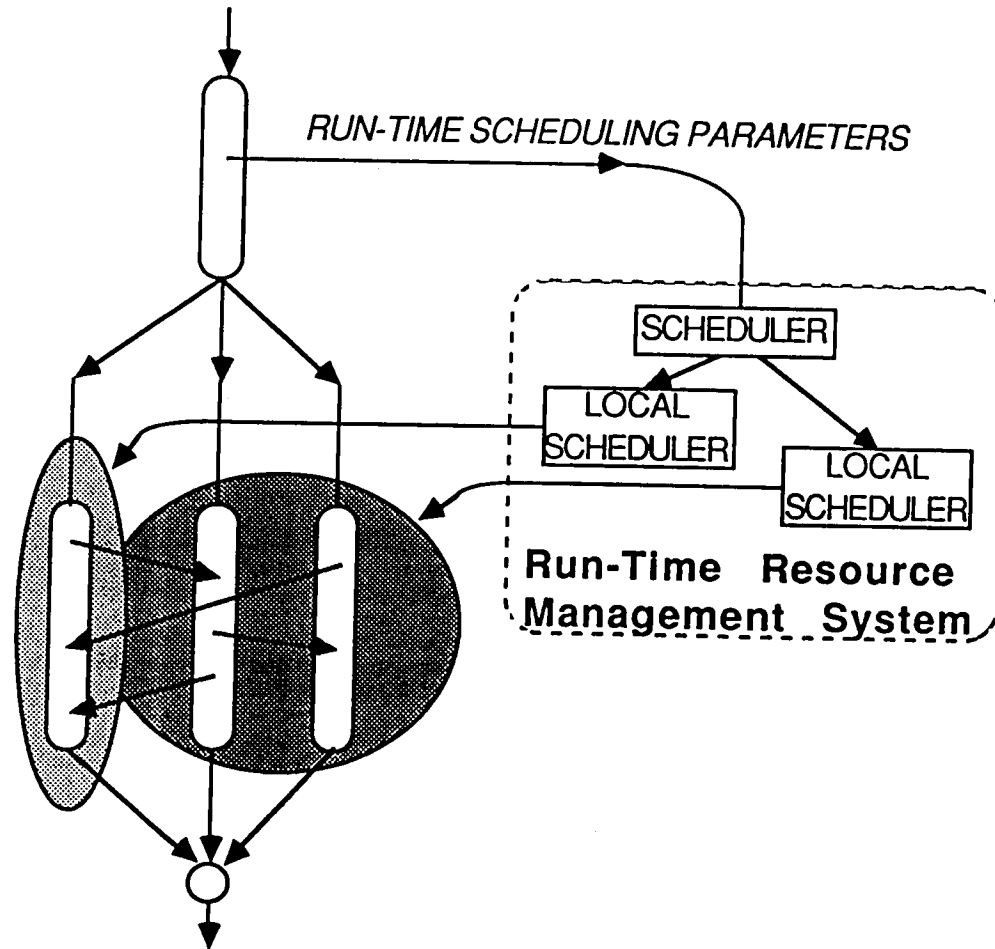

Stanford University - Computer Systems Lab.

Test Case 1 - Lattice Gaseous Cellular Automata

Experiments were performed on hypercube simulator. System load balancing, a common system technique, which distributes the processes evenly across all available processors is used as our reference of comparison. Results obtained from commonly-adopted manual placement strategies are also compared. This test case was chosen because an ideal partitioning onto parallel resources is known. The results for the automatic, dynamic resource management technique are shown both with and without the scheduling overhead (relating to the cases where the scheduling of the dynamically spawned tasks can be done in parallel with other work, or not.)

# Lattice Gaseous Cellular Automata (LGCA)

## *Problem Instance:*

- fhp: Simulation of 256x256 point cells for 100 time steps

## *Program Description:*

- Point-space is partitioned into 64 (8x8) macro-cells.
- Program spawns off 64 concurrent processes, one for each macro cell.
- The master process dispatches and assembles data implicitly.

(ideal allocation of resources is known for this case)

**Stanford University - Computer Systems Lab.**

**Test Case 1 - Lattice Gaseous Cellular Automata**

When the application 'lattice gaseous cellular automata' was run on full hypercubes of 4, 8 and 16 nodes, automatic scheduling performs nearly as well as the best manual placement (block placement), and obviously better than scattering manual placement (+ 8-38%) and system load balancing (+ 15-36%). Even when scheduling overhead is included, automatic scheduling is better than system load balancing (+ 8-15%).

# Lattice Gaseous Cellular Automata (LGCA)

Comparison of Automatic Scheduling on hypercubes  
with Load Balancing & Manual Methods

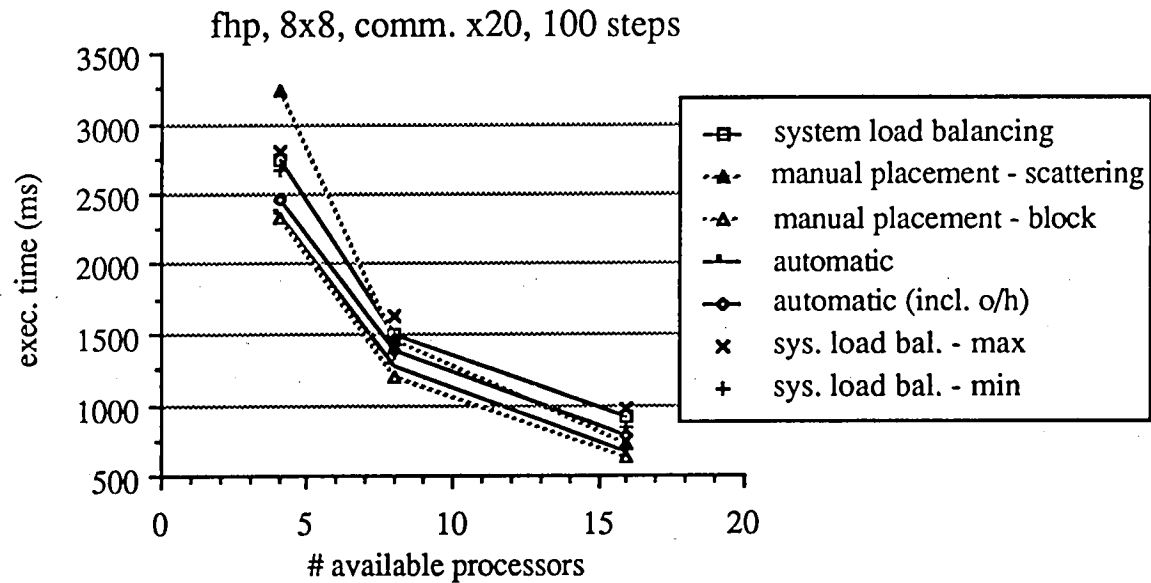



Test Case 1 - Lattice Gaseous Cellular Automata

We believe that dynamic allocation of resources is important both in cases where the application is dynamic and in cases where the resources available in the system change dynamically. Our automatic, run-time resource allocation adapts well to changing system environments. When one node in a full hypercube is unavailable for allocation, automatic scheduling performs better than system load balancing (+ 14-28% w/o overhead, + 5-24% including overhead). Please note that automatic scheduling uses only 13 nodes when there are 15 available nodes.

# Lattice Gaseous Cellular Automata (LGCA)

Comparison of Automatic Scheduling on hypercube with one failed node with Load Balancing

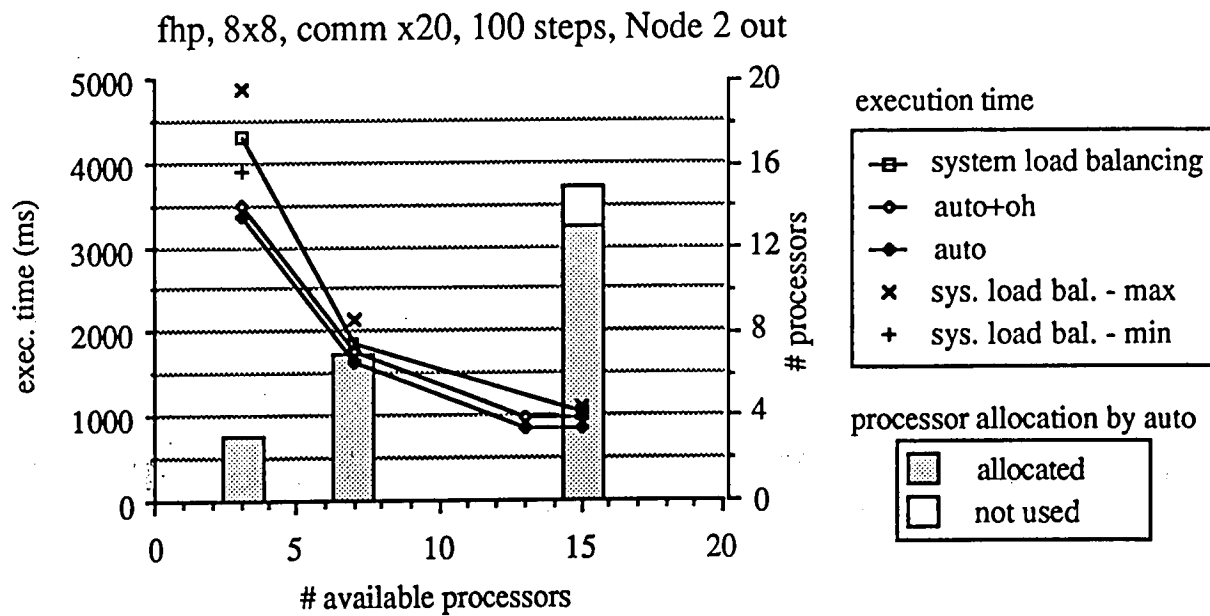

Stanford University - Computer Systems Lab.

**Test Case 2 - Sparse Matrix Cholesky Factorization**

A portion of a sparse matrix multiplication problem is shown here as a testcase. This testcase is chosen because the number of parallel processes spawned is directly related to the input parameters and are not known until execution is in progress. Experiments were performed on hypercube simulator and results were compared with that by system load balancing. Two problem sets were tried - one related to finite element structures in aircraft design (can24) and one related to power system networks (494bps).

## Sparse Matrix Cholesky Factorization

### *Problem Instances:*

1. can24: finite element structures in aircraft design (24 columns, 96 non-zeros)
2. 494bps: power system networks (494 columns, 1080 non-zeros)

### *Program Description:*

- Program spawns off a concurrent process for each column.
- Each process sends and receives according to the cholesky structure

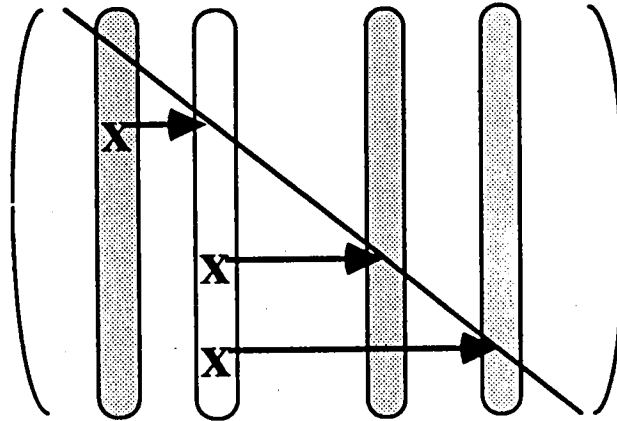

Test Case 2 - Sparse Matrix Cholesky Factorization

For the problem 'can24', automatic scheduling performs better than system load balancing when the number of available nodes is no more than 16 (+ 6-30%). System load balancing appears better (~20%) when 32 nodes are available. However, automatic scheduling allocates **at most 9 nodes** even when there are more nodes available. As a result, in the 32 processor case, the automatic scheduling method, which is using 9 nodes, is only slightly slower than system load balancing which is using 32 processors. The amount of scheduling overhead for this small problem is negligibly small.

# Sparse Matrix Cholesky Factorization - can24 example

## Comparison of Automatic Scheduling on hypercube with Load Balancing

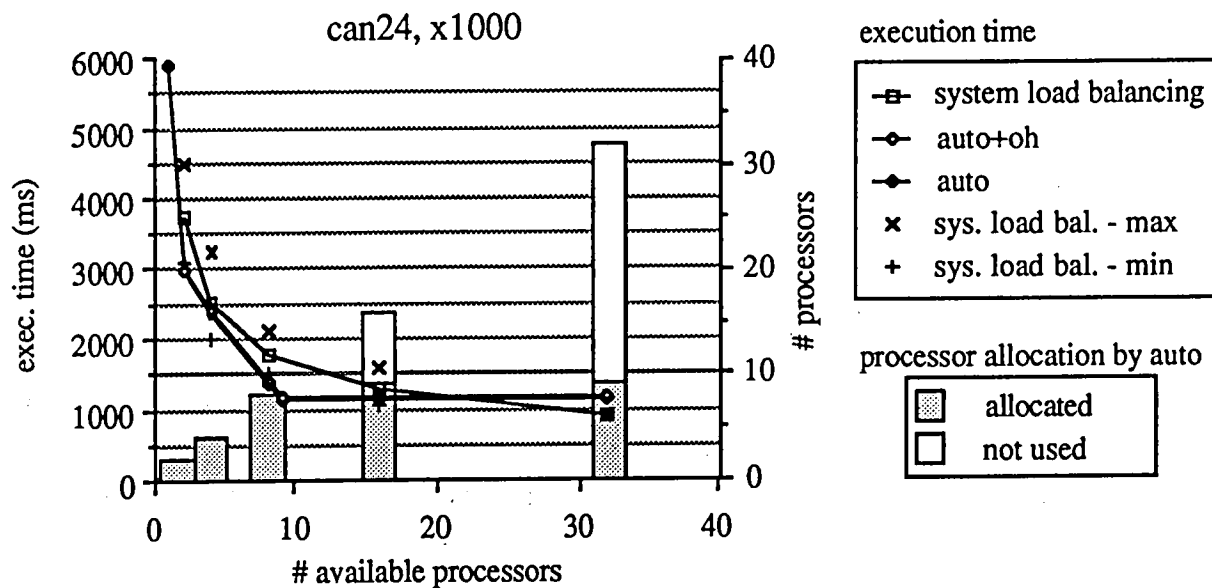

Test Case 2 - Sparse Matrix Cholesky Factorization

For the larger problem '494bps', the performance of automatic scheduling is significantly better than that of system load balancing (+ 36-120% w/o overhead, + 17-95% including overhead). When a full hypercube of 32 nodes is available, automatic scheduling allocates only 25 nodes while the load balancing method is using all 32 nodes.

# Sparse Matrix Cholesky Factorization - 494bps example

## Comparison of Automatic Scheduling on hypercube with Load Balancing

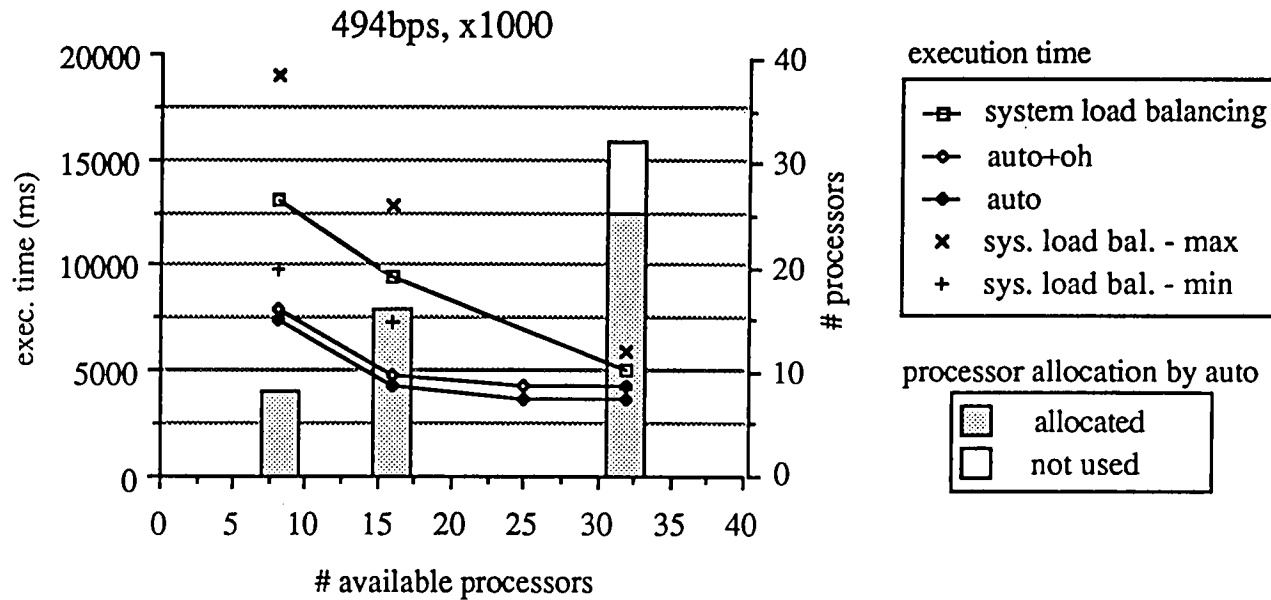



# ONBOARD SYSTEM HEALTH ASSESSMENT

TOM BARRY/ JSC

HARRY CUNNINGHAM  
LOCKHEED ESC  
HOUSTON, TEXAS

PRECEDING PAGE BLANK NOT FILMED

249

INTERNATIONAL BUREAU

512-18

163604

N 93-27716

OUTLINE

BACKGROUND

SCOPE

PURPOSE

CHALLENGES/ISSUES

WHAT DO WE NEED?

DEFINITION OF PROBLEM

HOW DO WE GET THERE?

RECOMMENDATIONS

PRECEDING PAGE BLANK NOT FILMED

251

250  
MICROFILMED

**SLIDE 1**

**SUCCESS OF THE SPACE STATION PROGRAM WILL BE MEASURED BY HOW WELL IT ADDRESSES THE BASIC REQUIREMENTS FOR:**

- 1) MAINTAINING THE ORBITING SPACE STATION FREEDOM FULLY OPERATIONAL FOR ITS PROJECTED LIFE OF THIRTY YEARS**
- 2) THE COST-EFFECTIVE EXECUTION OF THE OVERALL SPACE STATION PROGRAM.**

**THE DEGREE OF SUCCESS WILL DEPEND ON HOW EFFICIENTLY WE ALLOCATE, USE, AND MAINTAIN ONORBIT SYSTEMS AND RESOURCES AND HOW SUCCESSFULLY WE AVOID WASTE OF RESOURCES, TIME, AND DOLLARS. WE CAN'T RISK HAVING COMPLEX ONBOARD SYSTEMS IN AN UNCERTAIN STATE OF HEALTH AT ANY TIME THEY MAY BE NEEDED. NEITHER CAN WE AFFORD TO PROVIDE TWENTY FOUR HOUR PER DAY GROUND BASED SURVEILLANCE OF THE HEALTH OF ONBOARD SYSTEMS FOR THIRTY YEARS. THE ACCUMULATED DOLLAR COST FOR MAINTENANCE OF THE NECESSARY SPECIALIZED GROUND BASED FACILITIES AND STAFF FOR THE THIRTY YEARS WOULD BE ENORMOUS.**

**THE ONLY SOLUTION IS A PROPER BALANCE OF THOROUGH AND COMPLETE ONBOARD TESTING CAPABILITIES WITH SUPPORTING GROUND BASED MONITORING RESOURCES AND ACTIVITIES. THE EFFICIENCY AND EFFECTIVENESS OF THOSE CAPABILITIES AND THAT GROUND BASED SUPPORT WILL DETERMINE THE SUCCESS OF THE OVERALL SPACE STATION PROGRAM .**

**SLIDE 1**

**BACKGROUND**

**BASIC REQUIREMENTS OF THE SPACE STATION FREEDOM (SSF)**

- EXPECTED 30 YEAR CONTINUOUS ONORBIT OPERATION OF SYSTEMS
  
- EFFICIENT ONORBIT UTILIZATION OF SYSTEMS
  - SYSTEM FUNCTIONS MUST BE AVAILABLE FOR USE WHEN NEEDED
  
  - EFFICIENT ALLOCATION AND USE OF RESOURCES IS MANDATORY
  
- EFFICIENT BALANCE BETWEEN ONBOARD AND GROUND MONITORING CAPABILITIES

**SLIDE 2**

ONBOARD SYSTEM HEALTH ASSESSMENT MUST PROVIDE COMPLETE AND THOROUGH TESTING CAPABILITIES ALONG WITH EFFECTIVE ASSOCIATED REDUNDANCY/FAULT MANAGEMENT. THESE CAPABILITIES MUST BE SUPPLIED FOR ALL FUNCTIONS AND INTEGRATED COMBINATIONS, FROM THE ORU LEVEL TO THE ULTIMATE OVERALL MULTI-SYSTEM END-TO-END SSF CONFIGURATION. THE CAPABILITIES WILL BE SOME COMBINATION OF AUTOMATED REDUNDANCY AND STRING RECONFIGURATION MANAGEMENT, BUILT IN TEST/BUILT IN TEST EQUIPMENT (BIT/BITE) AND DIAGNOSTICS, ALONG WITH A VARIETY OF SPECIALIZED ON ORBIT END-TO- END TESTS. CREW/GROUND MANAGEMENT OF THESE CAPABILITIES AND PERFORMANCES MUST BE DIRECTED TO ENSURE THAT ALL ONBOARD SYSTEMS, THEIR CAPABILITIES AND RESOURCES ARE AVAILABLE AND PROPERLY FUNCTIONAL WHEN THEY ARE NEEDED. THAT MANAGEMENT MUST BE WITH RECOGNITION OF THE FOLLOWING BASIC CONSTRAINTS:

- 1) HEALTH ASSESSMENT ACTIVITIES MUST NOT CONFLICT OR OTHERWISE INTERFERE WITH CRITICAL FUNCTIONS
- 2) THEY MUST BE DESIGNED TO AVOID UNREASONABLE DEMANDS FOR CREW PARTICIPATION.
- 3) THE SYSTEMS AND THEIR ASSESSMENT CAPABILITIES MUST BE DESIGNED FOR THE EASY ACCOMMODATION OF ADDITIONS AND MODIFICATIONS TO THE SSF SYSTEMS AND CONFIGURATION(S).

**SLIDE 2**

**WHAT IS ONBOARD SYSTEM HEALTH ASSESSMENT?**

• **SCOPE**

- REDUNDANCY MANAGEMENT AND STRING RECONFIGURATION
- BIT/BITE/DIAGNOSTICS
- END-TO-END ONORBIT CHECKOUT
- CREW/GROUND MANAGEMENT

• **PURPOSE**

**ENSURE THAT EACH ONBOARD SYSTEM IS AVAILABLE AND FUNCTIONS PROPERLY WHEN NEEDED**

**SLIDE 3**

**THE CHALLENGE : TO KEEP ALL ONBOARD SYSTEMS OPERATIONAL FOR THE FULL TERM OF THE PROJECTED THIRTY YEAR LIFETIME SUBJECT TO THE FOLLOWING UNIQUE AND UNUSUAL CONDITIONS AND CONSTRAINTS:**

- (1) THE INITIAL FULL ASSEMBLY OF THE SPACE STATION FREEDOM (SSF) WILL ONLY OCCUR ONORBIT AND WILL PROVIDE THE FIRST OPPORTUNITY TO CONDUCT AN END-TO-END TEST OF ITS FULLY INTEGRATED COMPLEX OF SYSTEMS OR TO TEST ITS SYSTEMS IN THE REAL OPERATIONAL AND FLIGHT ENVIRONMENT. ALL SUBSEQUENT REPLACEMENTS, ADDITIONS AND UPGRADES MUST ALSO OCCUR ONLY ONORBIT. THERE WILL BE NO "BACK TO THE GROUND " FOR CONFIRMATION OF THEIR PROPER INCORPORATION OR THAT THEY FUNCTION PROPERLY. THAT CAN ONLY BE BY WAY OF ONBOARD TESTING**
- (2) THE CREW MUST BE CONTINUALLY ASSURED THAT EVERYTHING IS FUNCTIONING PROPERLY AND THAT ALL SYSTEM RESOURCES ARE OR WILL BE AVAILABLE WHEN NEEDED. OTHERWISE, THEY WILL BE SUBJECT TO WORRY ABOUT THE STATUS OF THEIR EQUIPMENT WHICH WILL IMPACT THEIR EFFICIENCY.**
- (3) ONORBIT HEALTH ASSESSMENT MUST BE ACCOMPLISHED WITH MINIMAL IMPACT ON NORMAL OPERATIONS, ONLY REASONABLE DEMAND FOR CREW PARTICIPATION AND WITHOUT INTERFERENCE TO CRITICAL FUNCTIONS OR IMPORTANT ONGOING ACTIVITIES.**
- (4) A THIRTY YEAR LIFE OF GROWTH AND CHANGE MUST BE ANTICIPATED. THAT GROWTH WILL INCLUDE UPGRADES AND ADDITIONS TO INCREASE EFFICIENCY, CAPACITY AND SCOPE OF CAPABILITIES. PROVEN NEW TECHNOLOGY WILL BE INCORPORATED INTO THE SSF AS IT BECOMES AVAILABLE.**

**SLIDE 3**

**CHALLENGES AND ISSUES**

ACCOMPLISHING, WITH MINIMAL IMPACT ON NORMAL OPERATIONS AN REASONABLE DEMANDS FOR CREW PARTICIPATION, THE FOLLOWING:

- MAINTAIN ONBOARD SYSTEMS OPERATIONAL FOR 30-YEAR SSF LIFETIME
- NO RETURN TO GROUND FOR MAINTENANCE OR OVERHAUL
- REPLACEMENTS, ADDITIONS, AND UPGRADES ONORBIT ONLY
- ONBOARD CAPABILITY TO ASSURE CREW THAT SYSTEMS ARE FUNCTIONING PROPERLY AND SYSTEM RESOURCES ARE AVAILABLE AS NEEDED
- ACCOMMODATE CONTINUED SYSTEM GROWTH AND FREQUENT CHANGES IN STATION CONFIGURATION AND SOFTWARE



**SLIDE 4**

**THE PROBLEM OF ARRIVING AT THE NECESSARY LEVEL OF HEALTH ASSESSMENT CAPABILITY IS MULTI-FACETED. THE FOLLOWING ARE SOME OF THE PROGRAMMATIC ISSUES.**

- (1) CURRENT FUNDING AND SCHEDULE CONSTRAINTS PREVENT EARLY IMPLEMENTATION AND USE OF THE "IDEAL SSF ONBOARD HEALTH ASSESSMENT SYSTEM". SOME CAPABILITIES REQUIRED FOR THAT "IDEAL" SYSTEM ARE BEING DEFERRED TO GROUND MONITORING WHILE OTHERS ARE CURRENTLY CONSIDERED ONLY POTENTIALS FOR GROWTH.**
- (2) R/D OF APPLICABLE TECHNOLOGIES IS FOCUSED ON PROBLEMS SIGNIFICANTLY DIFFERENT FROM THOSE OF THE SSF. THEY GENERALLY FAIL TO RECOGNIZE PROPERTIES THAT ARE UNIQUE TO THE SSF PROGRAM, SUCH AS ITS THIRTY YEAR STAY IN ORBIT WITHOUT RETURN TO EARTH, ITS COMMITMENT TO TECHNOLOGICAL GROWTH AND ITS CHANGEABLE TIME CRITICALITY.**
- (3) THERE HAS BEEN AND STILL IS, THE PROBLEM OF GETTING EXPERTISE OF OTHER NASA RESEARCH CENTERS TO BEAR ON THE THE FULLY INTEGRATED MULTI-SYSTEM SSF HEALTH ASSESSMENT PROBLEM. TO THIS POINT THEIR TENDENCY HAS BEEN TO FOCUS ONLY ON WORK PACKAGE OR SYSTEM RESPONSIBILITIES.**

## SLIDE 4

### DEFINITION OF PROBLEM

#### PROGRAMMATICS

- CURRENT FUNDING/SCHEDULE CONSTRAINTS PREVENT DESIGN/DEVELOPMENT OF AN IDEAL SYSTEM.
  - CURRENT SSF ONBOARD SYSTEM HEALTH ASSESSMENT IS LIMITED, (LESS THAN IDEAL).
  - SOME CAPABILITIES HAVE BEEN DEFERRED TO GROUND MONITORING.
- TECHNOLOGY DEVELOPMENT - IS ISOLATED FROM REAL WORLD SYSTEM LIMITATIONS AND IS NOT FOCUSED ON THIS PROBLEM.
- UNIQUE PROBLEM - ie 30 YEARS OF OPERATION WITH REPAIR SHOP LOCATED THOUSANDS OF MILES AWAY.
- DIFFICULTY IN GETTING EXPERTISE OF OTHER NASA RESEARCH CENTERS TO BEAR ON THE PROBLEM.

**SLIDE 5**

UNDER THE CURRENT SSF DEVELOPMENT PLAN THE ONBOARD HEALTH ASSESSMENT REQUIREMENTS WILL DEPEND ON THE STATE OF SSF DEVELOPMENT. THE REQUIRED ASSESSMENT CAPABILITIES WILL GROW FROM BARE MINIMUM FOR PMC (PERMANENTLY MANNED CONFIGURATION) TO THOSE FOR A SUBSTANTIAL SYSTEM WITH A FAIR AMOUNT OF AUTOMATION AT AC (ASSEMBLY COMPLETE). FROM AC FORWARD ( MATURITY AND GROWTH), THE REQUIREMENT WILL BE TO GROW ONBOARD HEALTH ASSESSMENT CAPABILITIES IN SCOPE EFFICIENCY AND AUTOMATION, ADOPTING NEW APPLICABLE TECHNOLOGY AS IT BECOMES AVAILABLE. THE DIFFERENCES IN THE REQUIREMENTS FOR THE THREE STATES OF DEVELOPMENT ARE SIGNIFICANT AND DESERVE DEEPER CONSIDERATION. LET'S LOOK AT EACH IN TURN.

NOTE: THE DIFFERENCES BETWEEN PMC AND AC ARE MADE OBVIOUS IN THE REQUIREMENTS DOCUMENT JSC 31000. ITS STATEMENTS OF REQUIREMENTS ARE ACCOMPANIED BY DESIGNATIONS AS TO WHETHER THEY ARE TO BE ENFORCED AT PMC OR AC.

**SLIDE 5**

**SSF HEALTH ASSESSMENT REQUIREMENTS**

- REQUIREMENTS DIFFER DEPENDING ON STATE OF SSF DEVELOPMENT
  - SOME REQUIREMENTS HAVE BEEN DEFERRED FROM PMC (PERMANENTLY MANNED CONFIGURATION) TO AC (ASSEMBLY COMPLETE)
  - MANUAL/GROUND FOR PMC
  - AUTOMATIC/ONBOARD WITH GROUND SUPPORT FOR AC
  
- STATES OF SSF DEVELOPMENT
  - PMC
  - AC
  - MATURITY/GROWTH

**SLIDE 6**

UNDER THE CURRENT SSF DEVELOPMENT PLAN, AT PMC ONLY A BARE MINIMUM OF ONBOARD HEALTH ASSESSMENT ASSOCIATED CAPABILITIES WILL BE AVAILABLE. THE ONLY ASSOCIATED AUTOMATION IS THE FAULT DETECTION, ISOLATION AND RECOVERY (FDIR) PROVIDED FOR CRITICALITY 1 ( CREW SAFETY CRITICAL) FUNCTIONS. FOR THOSE, THE FDIR IS TO THE ORU LEVEL AND REDUNDANCY SWITCHOVERS ARE AUTOMATIC. ASIDE FROM THAT, THE ONLY ONBOARD ACTIVITIES ASSOCIATED WITH HEALTH ASSESSMENT AND MAINTENANCE IS THE ACQUISITION OF DIAGNOSTIC DATA, THEIR TRANSFER TO THE GROUND FOR ANALYSIS AND ASSESSMENT AND CREW INITIATED CORRECTIVE ACTIONS DIRECTED FROM THE GROUND. THE PRIMARY CONTROL FOR THOSE ACTIVITIES IS FROM THE GROUND BASED OPERATIONS MANAGEMENT GROUND APPLICATION (OMGA) WITH CREW SUPPORT. THE DATA ACQUIRED ONBOARD AND ISSUED TO THE GROUND ARE DIAGNOSTIC DATA DERIVED FROM INSTALLED BIT/BITE ALONG WITH DMS, REDUNDANCY AND CONFIGURATION STATUS DATA. THE OUTSTANDING FEATURE OF THIS METHODOLOGY IS THE GROUND BASED TIER 1 CONTROL.

## SLIDE 6

### PMC

- MINIMAL REQUIREMENTS
  - FAULT DETECTION/ISOLATION TO ORU FOR CRITICALITY 1 FUNCTIONS ONLY
  - AUTOMATED RM FOR CRITICALITY 1 (SAFETY CRITICALS) ONLY
- PRIMARY CONTROL FROM GROUND (OMGA) WITH CREW SUPPORT
  - ASSOCIATED CREW ACTIVITY IN RESPONSE TO GROUND DIRECTION
- METHODOLOGY
  - DIAGNOSTICS COLLECTED ONORBIT VIA BIT/BITE AND TRANSMITTED TO GROUND FOR ANALYSIS AND FAULT DIAGNOSIS (JSC 31000 Par. 3.1.19.3)
  - CREW/GROUND DIRECTED RECONFIGURATIONS TO REDUNDANT FUNCTIONS (NOT AUTOMATIC) (JSC 31000 Par. 3.1.8.7.1)
  - CONFIGURATION AND REDUNDANCY STATUS DATA ARE SENT TO THE GROUND (SIGNIFICANT OMA FUNCTIONALITY DEFERRED TO OMGA FOR PMC)

**SLIDE 7**

AT AC THE PRIMARY (TIER 1) CONTROL SHIFTS FROM THE OMGA TO THE ONORBIT OMA (OPERATIONS MANAGEMENT APPLICATION), WITH OMGA AND CREW IN SUPPORTING ROLES. SYSTEM AND INTRA-SYSTEM CONTROL WILL BE BY LOWER TIER (SYSTEM) MANAGEMENT. ALSO AT AC, THERE WILL BE THE CAPABILITY FOR FAULT DETECTION/ISOLATION TO THE ORU LEVEL, WITH REDUNDANCY AND AUTOMATED REDUNDANCY MANAGEMENT EXPANDED TO COVER ALL SAFETY AND MISSION CRITICAL FUNCTIONS. THE INITIAL AC HEALTH MONITORING AND MAINTENANCE CAPABILITIES WILL BE THOSE FOR SATISFACTION OF BASELINE OPERATIONAL SSF REQUIREMENTS. THEY WILL INCLUDE FULLY AUTOMATED FDIR FOR HIGH LEVELS OF CRITICALITY (CREW SAFETY AND MISSION) AND BIT/BITE CAPABLE OF FAULT DETECTION/ISOLATION TO THE ORU/ORU INTERFACE LEVEL. DMS WILL BE PROVIDED WITH AUTOMATED FDIR AND RM AND CONFIGURATION STATUS MONITORING AND LOGGING WILL BE AUTOMATED. PRIOR TO THIS, DMS ONLY SUPPLIED DIAGNOSTICS, STATUS AND CONFIGURATION DATA. THESE WILL BE THE PROPERTIES AND FEATURES OF THE BASELINE OPERATIONAL SSF HEALTH ASSESSMENT SYSTEM.

**SLIDE 7**

**AC**

- **SATISFIES BASELINE OPERATIONAL REQUIREMENTS**
  - **FAULT DETECTION/ISOLATION TO THE ORU/ORU'S INTERFACING SYSTEM / SOFTWARE (JSC 31000 PAR. 3.1.8.3.1)**
  - **EXPANDED REDUNDANCY AND AUTOMATED RM FOR SAFETY AND MISSION CRITICAL FUNCTIONS - EXPANDED ROLE OF BIT/BITE (INTRA/INTER-SYSTEM TESTING)**
- **PRIMARY GLOBAL CONTROL IS OMS (OMA) WITH OMGA/CREW SUPPORT**
  - **LOWER TIER CONTROL FOR INTER/INTRA SYSTEM**
- **METHODOLOGY**
  - **AUTOMATED FDIR FOR HIGH LEVELS OF CRITICALITY**
  - **BIT/BITE FOR FAULT DETECTION/ISOLATION TO ORU/ORU INTERFACE**
  - **CAPABILITY FOR ON-DEMAND AUTOMATED STATUS CHECKS**
  - **DMS PROVIDED WITH AUTOMATED FDIR (JSC 31000, PAR. 3.3.2.6.2)**
  - **AUTOMATED CONFIGURATION/RM STATUS MONITORING/LOGGING**



SLIDE 6/7

### SUMMARY OF THE DIFFERENCES

Reference Par. (page(s))	PMC Requirement	AC Requirement
3.1.5.4 (3-10/11)	Onboard/ground operations sequencing override capability	Design for autonomous operations for a TBD period with sequencing override capability
3.1.8.3.5 (3-17)	automatic FDIR for criticality 1 only RM/RM status to crew/ground	automatic RM with status to ground, crew and other automated applications
3.1.8.7.2 (3-25)	automatic RM reconfiguration for safety criticals only - others are manual (crew/ground)	Onorbit automation for elimination of need for realtime continuous monitoring by SSMB ground personnel
3.1.24.2.2 (3-86/87)	overall control by OMGA with crew support	control by OMA with crew/ground support
3.1.24.3.4.8 (3-9)	Primary recovery mode for station wide functional failures is manual/ground process with limited automation	Primary recovery mode is automatic with manual support
3.3.2.2.1.2 (3-134)	Single DMS network (core)	Double DMS network (core/payload)
3.3.2.3.1.2.8 (3-167 thru 3-169)	Fault Detection and reconfiguration by OMA	Fault management and reconfiguration by OMA
3.3.2.3 (3-154 thru 3-190)	Primary control by OMGA	Primary control by OMA

\* NOTE - List of some of the major differences.

PRECEDING PAGE BLANK NOT FILMED

267

Slide  
IDENTIFICATION MARK

**SLIDE 8**

SUBSEQUENT TO AC, THE REQUIREMENT WILL BE FOR A CONTINUAL EFFORT TO IMPROVE THE ONBOARD HEALTH ASSESSMENT CAPABILITIES. THAT EFFORT SHOULD BE DIRECTED TO ACHIEVE TOTAL RELIABILITY, COMPLETE END-TO-END SSF COVERAGE AND TOTAL AUTONOMY OF HEALTH ASSESSMENT. THE ULTIMATE GOAL SHOULD BE TO PROVIDE AN ONBOARD HEALTH ASSESSMENT AND MAINTENANCE SYSTEM HAVING ALL THESE PROPERTIES THAT WILL FUNCTION WITH MINIMUM DEMAND FOR CREW ATTENTION. THIS GOAL SHOULD BE KEPT IN MIND THROUGHOUT THE LONG OPERATIONAL LIFE OF THE SSF. AS APPLICABLE NEW METHODOLOGIES ARE DEVELOPED AND TECHNOLOGIES ARISE, THEY SHOULD BE INCORPORATED INTO THE ONBOARD SYSTEMS TO ENHANCE THE HEALTH ASSESSMENT AND MAINTENANCE CAPABILITIES. THIS SHOULD BE AN ONGOING ACTIVITY, SINCE THAT CAPABILITIES EVOLUTION PROCESS WILL PROVIDE DEFINITION FOR USE IN OTHER PROGRAMS INVOLVING COMPLEX SYSTEMS WITH LONG OPERATIONAL LIVES.

**SLIDE 8**

**MATURITY/GROWTH**

- REQUIREMENT IS FOR CONTINUAL ENHANCEMENTS AIMED AT:
  - INCREASED RELIABILITY
  - INCREASED COVERAGE
  - LESSENING DEMANDS ON CREW
  - INCREASE OF SSF AUTONOMY
  - END-TO END AUTOMATION OF HEALTH SURVEILLANCE AND MAINTENANCE  
(IDEALIZED GOAL)
  
- METHODOLOGY(IES)???

**SLIDE 9**

REASONABLE SATISFACTION OF THE SSF HEALTH ASSESSMENT REQUIREMENTS AT PMC, AC, AND BEYOND CAN BE ENSURED THROUGH EARLY RECOGNITION OF BASIC NEEDS IN SYSTEM DESIGN. THAT DESIGN MUST BE DIRECTED TOWARD EFFECTIVE USE OF THE CREW. IT MUST PROVIDE AN EFFICIENT AND RELIABLE ONBOARD SYSTEM HEALTH ASSESSMENT/ MAINTENANCE CAPABILITY TO ENSURE CONTINUAL CREW CONFIDENCE IN THEIR EQUIPMENT. EXERCISE OF THAT CAPABILITY MUST BE WITHOUT ADVERSE IMPACT ON NORMAL OPERATIONS OR THE DEMAND FOR THE UNREASONABLE USE OF ONORBIT RESOURCES. DEVELOPMENT OF PROPER DESIGN/ METHODOLOGY REQUIRES COMPLETE AND CLEAR DEFINITION OF THE OVERALL HEALTH ASSESSMENT PROBLEM AND ITS REQUIREMENTS AT PMC, AC AND BEYOND. A PLENTIFUL SUPPLY OF HOOKS AND SCARS WILL BE REQUIRED FOR ITS PROGRESSIVE IMPLEMENTATION. THIS IS A TOUGH DESIGN PROBLEM THAT DEMANDS A WIDESPREAD COOPERATIVE ATTACK FOR PROPER SOLUTION. WE NEED BETTER COOPERATION BETWEEN THE VARIOUS NASA CENTERS AND WE NEED TO INVOLVE ACADEMIA AND INDUSTRY RESEARCH. THE POTENTIAL FOR THE DEVELOPMENT OF TRANSFERRABLE NEW TECHNOLOGY ALONG WITH THE CHALLENGE PRESENTED BY THE PROBLEM SHOULD BE ATTRACTIVE INDUCEMENTS FOR THE PARTICIPATION OF THOSE NON-NASA GROUPS.

**SLIDE 9**

**HOW DO WE GET THERE ?**

- **EARLY RECOGNITION OF THE BASIC NEEDS**
  - **MOST EFFECTIVE USE OF CREW**
  - **MOST EFFECTIVE USE OF ONORBIT TIME/RESOURCES**
  - **MORE COMPLETE AND CLEAR DEFINITION OF THE PROBLEM**
  - **PLENTIFUL SUPPLY OF HOOKS AND SCARS**
  
- **WIDESPREAD ATTACK OF THE PROBLEM**
  - **COOPERATIVE ATTACK- NASA CENTER-TO-CENTER, ACADEMIA AND INDUSTRY R/D EFFORTS**
  - **SIGNIFICANT VIA POTENTIAL FOR TECHNOLOGY TRANSFER TO OTHER PROGRAMS**
  - **TECHNOLOGICAL ADVANCES AND NEW TECHNOLOGY**

**SLIDE 10**

**THE FOLLOWING ARE RECOMMENDED FOR THE ATTACK OF THE SSF HEALTH ASSESSMENT AND MAINTENANCE PROBLEM**

- (1) ADOPT AND ENFORCE THE POLICY OF "DESIGN TO TEST". THIS APPROACH HAS PROVEN MOST EFFECTIVE FOR THE DEVELOPMENT OF TESTING AND HEALTH ASSESSMENT CAPABILITIES FOR LARGE AND COMPLEX SYSTEMS.**
- (2) MAKE CERTAIN THAT THE BASIC DESIGN OF THE SSF SYSTEMS INCORPORATES A PROPER AND PLENTIFUL SUPPLY OF SOFTWARE "HOOKS" AND HARDWARE "SCARS" TO ACCOMMODATE FUTURE GROWTH AND EXPANSION OF HEALTH ASSESSMENT TECHNOLOGY AND CAPABILITIES.**
- (3) STIMULATE INTEREST IN THE PROBLEM THROUGHOUT ALL NASA CENTERS AND NON-NASA RESEARCH ORGANIZATIONS.**
- (4) APPLY APPROPRIATE NEW TECHNOLOGIES TO SOLVE THE PROBLEM AND MAINTAIN FLEXIBILITY IN THEIR SELECTION. ENTERTAIN OUTGROWTHS OF PROVEN DEVELOPMENTS. AND THE PROSPECT OF COMBINING THE BEST FEATURES OF VARIOUS TECHNOLOGIES. AVOID A METHODOLOGY THAT LEADS TO "LOCK IN" TO A GIVEN TECHNOLOGY AND ADOPT ONE THAT IS ADAPTABLE TO GROWTH AND CHANGE.**

**SLIDE 10**

**RECOMMENDATIONS**

- PROMOTE AND ENFORCE DESIGN/DEVELOPMENT REQUIREMENT FOR :
  - DESIGN TO TEST
  - INCORPORATION OF HOOKS/SCARS TO ACCOMMODATE EXPANDED CAPABILITIES/TECHNOLOGICAL GROWTH
  
- EXPAND ARENA OF PROBLEM RECOGNITION
  - ALL NASA CENTERS
  - ACADEMIC RESEARCHERS AND RESEARCH ORGANIZATIONS
  - INDUSTRIAL RESEARCH CENTERS/ORGANIZATIONS
  
- APPLY APPROPRIATE NEW TECHNOLOGIES TO OUR PROBLEM
  - OUTGROWTHS OF PROVEN DEVELOPMENTS
  - TECHNOLOGY COMBINATIONS (ASSEMBLIES OF BEST FEATURES)

**SLIDE 11**

**FOR THE OPERATIONAL SSF WE NEED THE CONTINUAL ONBOARD CAPACITY TO ENSURE CREW AND MISSION SAFETY, OPERATIONAL READINESS AND SUFFICIENT PERFORMANCE RESERVES TO COPE WITH ANY UNFORESEEN EMERGENCY THROUGHOUT THE ONORBIT LIFE OF THE SSF. WE NEED A COMPLETE AND RELIABLE ABILITY TO EFFECTIVELY COPE WITH ANY FAULT OR FAILURE. WE NEED THE ONORBIT ABILITY TO VERIFY THAT ALL REPAIRS, REPLACEMENTS, UPGRADES AND ADDITIONS INTRODUCED TO THE OPERATIONAL SSF ARE PROPER AND CORRECT. WE NEED THE ONORBIT ABILITY TO CONDUCT THE TESTING NECESSARY TO ESTABLISH FULL CONFIDENCE IN THE EQUIPMENT AT ANY TIME. WE NEED THE ONORBIT ABILITY TO BE ASSURED THAT THAT ONBOARD TESTABILITY IS RELIABLE AND EFFICIENT.**



**SLIDE 11**

**WHAT DO WE NEED?**

- ABILITY TO ISOLATE FAULTS AND FAILURES TO AN ORU - 100%.
- ABILITY TO ISOLATE FAULTS & FAILURES TO THE CARD OR SRU (FOR CERTAIN CARDS ie EDP)- 90%.
- ABILITY TO RECOVER FROM ALL FAULTS (TRANSIENTS OR PERMANENT).
- ABILITY TO WORK AROUND FAILURES.
- ABILITY TO ENSURE THAT S/W UPGRADES & CHANGES ARE INSTALLED PROPERLY AND PERFORM AS EXPECTED.
- ABILITY TO CONFIGURE SYSTEM FOR TESTING DURING GROUND OPERATION OR "ON DEMAND".
- ABILITY TO VERIFY SYSTEM/STATION CONFIGURATION/RECONFIGURATION & MODING AT ANY TIME.
- ABILITY TO DO TEST RESULTS PREPROCESSING ONBOARD TO REDUCE TELEMETRY/GROUND SUPPORT BURDEN.
- NEW DESIGNS UTILIZE/TESTABILITY TOOLS DURING DESIGN/DEVELOPMENT PHASE TO ENSURE ONORBIT TEST EFFICIENCY.

**SLIDE 12**

CONSIDERING THE SCOPE OF THE PROBLEM, THERE APPEARS TO BE NO EXISTING TECHNOLOGY THAT, TAKEN ALONE, CAN SATISFY ALL OUR REQUIREMENTS. THE PRIME CANDIDATES, AUTOMATED KNOWLEDGE BASED AND EXPERT DIAGNOSTIC SYSTEMS, APPEAR INADEQUATE AT THEIR CURRENT LEVEL OF DEVELOPMENT. THIS IS ALSO TRUE FOR TH CONVENTIONAL BIT/BITE. ONE PROBLEM WITH THESE IS THAT THE FOCUS OF THEIR DEVELOPMENTS TO THIS TIME HAS HAVE BEEN GENERALLY LIMITED TO LOW LEVELS OF ARCHITECTURE (REPLACEABLE UNITS AND SUBSYSTEMS). A SECOND PROBLEM IS THAT MOST HAVE BEEN DESIGNED TO PROVIDE DIAGNOSTICS FOR AFTER- THE- FACT, IN-SHOP USE. OUR REQUIREMENT IS FOR THE ADDRESS OF FULL AND INTERSYSTEM FAULT/FAILURE MANAGEMENT ONORBIT. THE DEMAND IS FOR NEW TECHNOLOGY THAT, PERHAPS BUILDS ON THESE EXISTING ONES, BUT THAT HAS ADDED SCOPE AND CAPABILITIES. THE INCORPORATION OF ONBOARD SOFTWARE SIMULATIONS AND MODELS INTO KNOWLEDGE BASED EXPERT SYSTEMS APPEARS TO BE ONE ATTRACTIVE POSSIBILITY. DESIGN TO TEST OF SYSTEMS (SYSTEM LEVEL BIT/BITE AND DIAGNOSTICS) IS A SECOND. FINALLY, WHAT ABOUT AN ONBOARD COMPUTER DEDICATED TO SYSTEM/INTER-SYSTEM TESTING ?

**SLIDE 12**

**FOOD FOR THOUGHT**

- **POTENTIAL TECHNOLOGY**
  - ONBOARD USE OF SOFTWARE SIMULATIONS AND MODELS
  
  - EXPERT SYSTEMS
  
  - KNOWLEDGE BASED AUTOMATED SYSTEMS
    - RULE BASED
    - MODEL BASED
    - OTHERS
  
  - SYSTEM LEVEL BIT/BITE/DIAGNOSTIC DESIGN
  
  - NEED FOR DEDICATED ONBOARD TEST COMPUTER?

**SLIDE 13**

LET ME EXPAND A BIT ON THE NOTION OF INCORPORATING MODELS AND SIMULATIONS INTO KNOWLEDGE BASED SYSTEMS. WHY IS THAT POSSIBILITY SO ATTRACTIVE ? FIRST THEY WILL BE READILY AVAILABLE ( DEVELOPED, AND GROWN TO MATURITY IN THE GROUND BASED IT&V PROGRAM). SECONDLY THEIR ONBOARD USE IS DEMANDED TO BYPASS CRITICAL FUNCTIONS DURING INTEGRATED TESTING. FINALLY, A GREAT DEAL OF DESIGN KNOWLEDGE IS NATURALLY EMBEDDED IN THOSE MODELS AND THEY CAN BE EFFECTIVELY EMPLOYED TO GROW KNOWLEDGE THROUGH THEIR USE TO PROVIDE STANDARDS FOR PERFORMANCE COMPARISONS.

SLIDE 13

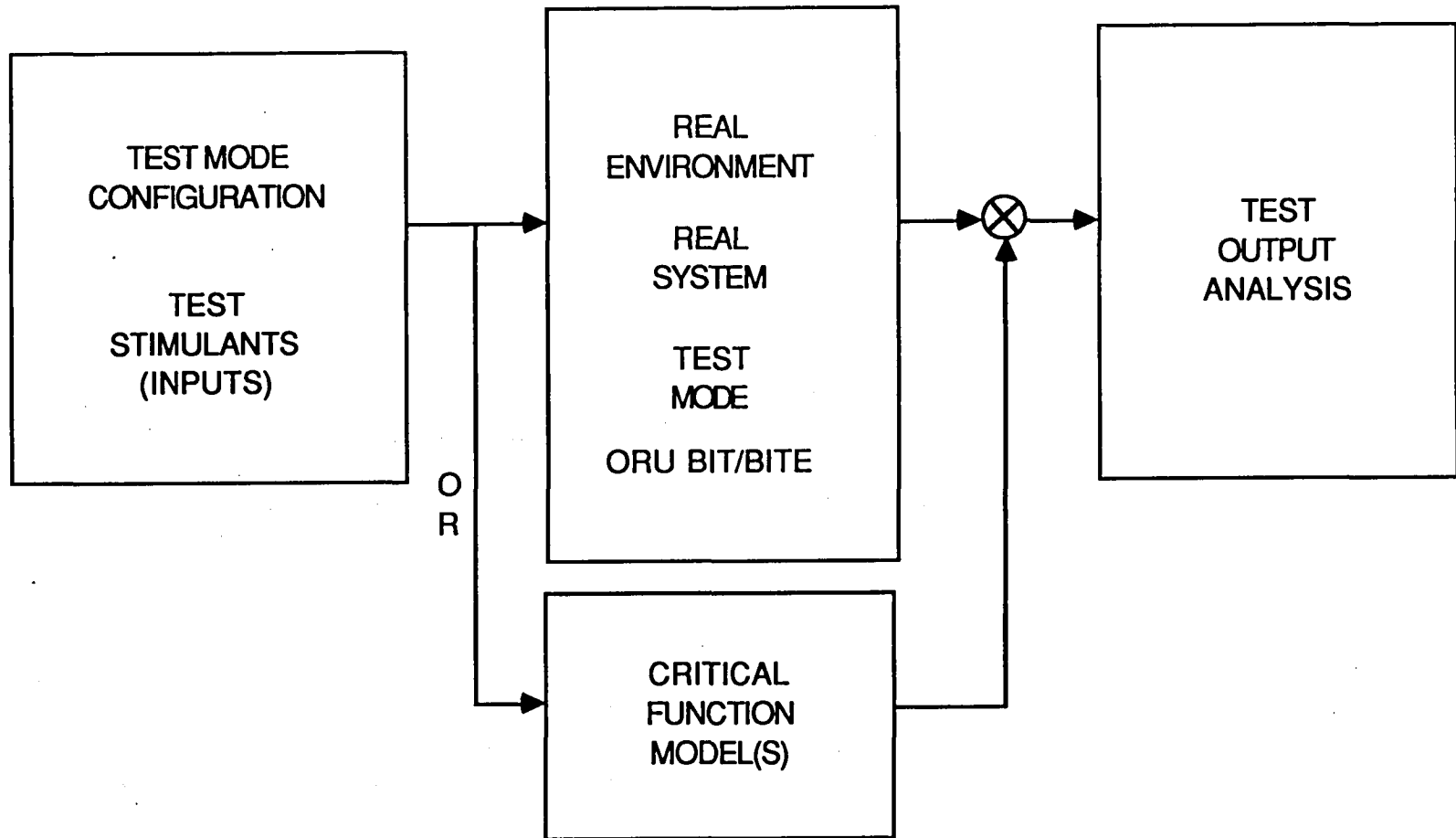

279

**NON INTERFERENCE TESTING**

**SLIDE 14**

CRITERIA FOR THE MEASUREMENT OF PERFORMANCE AND BEHAVIOR FOR FUNCTIONAL SYSTEMS AND COMPLEXES OF SYSTEMS WILL BE DIFFICULT, IF AT ALL POSSIBLE, TO DESCRIBE COMPLETELY AND ACCURATELY IN THE SYMBOLIC FORM REQUIRED BY CONVENTIONAL KNOWLEDGE BASES. THIS IS TO SUGGEST THAT SOFTWARE SIMULATIONS AND MODELS CAN BE EFFECTIVELY USED FOR THAT PURPOSE. THEY CAN BE EMPLOYED IN PARALLEL WITH REAL SYSTEM OPERATIONS TO PROVIDE STANDARDS FOR PERFORMANCE COMPARISONS. THOSE STANDARDS MAY BE OF IDEAL PERFORMANCE FOR THE MONITORING OF SYSTEM PERFORMANCE OR MAY BE SPECIALIZED FOR TESTING CONDUCTED TO ACQUIRE DIAGNOSTICS SHOULD THAT PERFORMANCE PROVE TO BE OUT OF TOLERANCE. SUCH USES WILL YIELD VALUABLE KNOWLEDGE REGARDING SYSTEM PERFORMANCE CHARACTERISTICS AND TRENDS. THEY MAY ALSO BE EMPLOYED FOR "WHAT IF" STUDIES TO EXPAND KNOWLEDGE REGARDING SYSTEM PERFORMANCE AND BEHAVIOR. FOR EXAMPLE, THEY MAY BE MANIPULATED TO SIMULATE SOME FAULT, FAILURE OR OFF NOMINAL CONDITION TO ESTABLISH SYSTEM HEALTH EVALUATION CRITERIA.

**SLIDE 14**

281

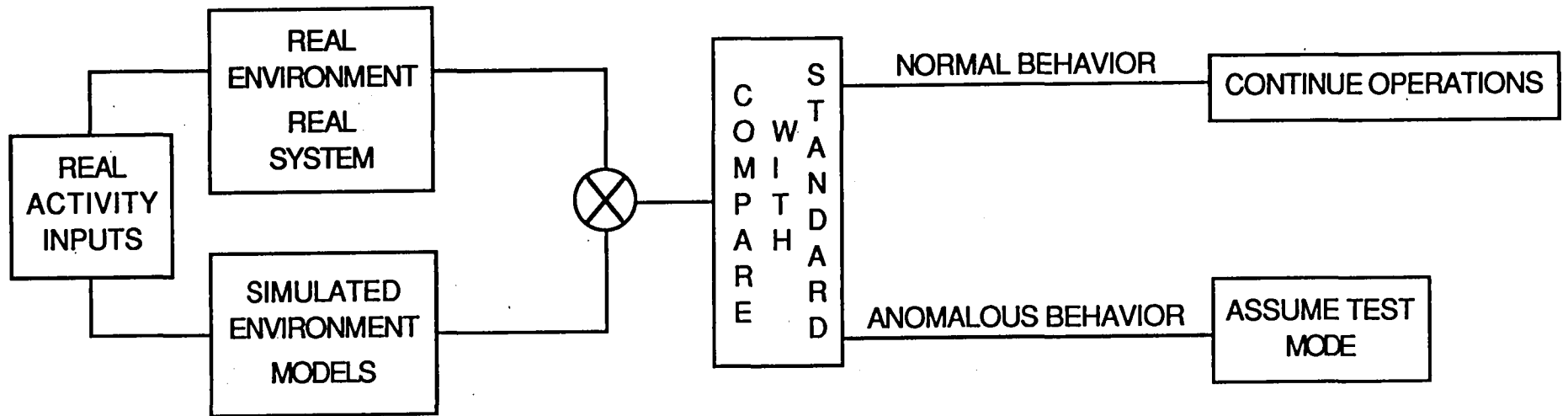

**SIMULATION ASSISTED SURVEILLANCE**

**SLIDE 15**

THE ONBOARD CAPABILITIES MUST PROVIDE FOR APPROPRIATE RESPONSES TO ONBOARD TESTING. THESE MUST INCLUDE THE ABILITY TO EFFECTIVELY ANALYZE TEST RESULTS THEN TO TAKE APPROPRIATE ACTION(S). IF THE RESULTS DON'T INDICATE A PROBLEM, NORMAL OPERATIONS ARE MAINTAINED. IF THERE IS AN INDICATED FAULT OR FAILURE ADDITIONAL TESTING MUST BE DONE, FIRST TO RULE OUT "FALSE ALARMS" THEN TO DERIVE A PROPER SET OF DIAGNOSTICS. SHOULD IT BE A FALSE ALARM, NORMAL OPERATIONS ARE RESUMED WITH INCREASED SURVEILLANCE OF THE SUSPECTED TEST SUBJECT OTHERWISE APPROPRIATE CORRECTIVE ACTION(S) ARE TAKEN (RM SWITCHOVER, WORK-AROUND RECONFIGURATION, REPAIR/REPLACEMENT). IF THE TEST RESULTS INDICATE ONLY PERFORMANCE DEGRADATION, NOT FAULT/FAILURE, THEN ACTIONS TO COUNTER THE PERFORMANCE DEGRADATION ARE IN ORDER. THESE MAY BE ADJUSTMENTS OF SYSTEM CONTROLS OR ACTIVITY SCHEDULES OR THEY MAY BE OF A DIFFERENT NATURE, BUT MUST BE DIRECTED AT RESTORING THE NOMINAL PERFORMANCE CAPABILITY. FOLLOWING ANY CORRECTIVE ACTION, IT MUST BE VERIFIED TO BE COMPLETE AND PROPER BEFORE ITS SUBJECT IS RESTORED TO NORMAL OPERATIONS.



SLIDE 15

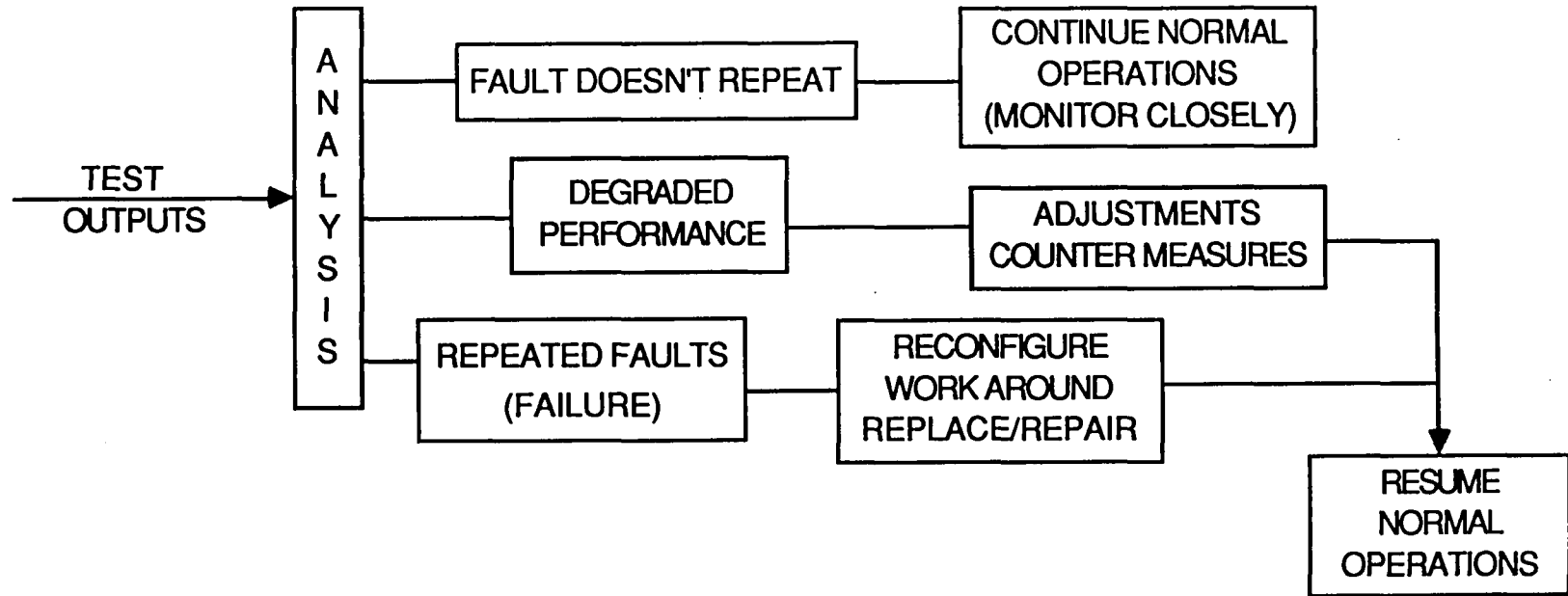

283

**TEST RESPONSE/POST TEST ACTIVITIES**

# An Overview of MCC and its Research

Dr. Stephen F. Lundstrom

Consultant

PARSA

(415) 723-0140

Consulting Associate Professor, Electrical Engineering  
Computer Systems Laboratory  
Stanford University

PRECEDING PAGE BLANK NOT FILMED

285

PAGE 285  
INTENTIONALLY BLANK

513-60  
163605  
N93-27717

# Microelectronics and Computer Technology Corporation (MCC)

The Microelectronics and Computer Technology Corporation is a cooperative enterprise whose mission is to strengthen and sustain America's competitiveness in information technologies. Their objective is excellence in meeting broad industry needs through application-driven research, development and timely deployment of innovative technology.

MCC was chartered in August, 1982. Austin was selected as its headquarters in May, 1983 and research was underway by late that year.

## Research Programs

### Software Technology

To develop technology which will bring about extraordinary increases in software productivity, quality and life-cycle costs

### VLSI/Computer Aided Design

To provide a means to greatly reduce the design time and improve the resulting design quality of complex micro-electronic circuits and systems

### Packaging/Interconnect

To improve shareholder competitiveness in electronic manufacturing

### Electronic Applications of High Temperature Superconductors

To understand the implications and potential impact of newly discovered superconductivity materials to electronics

### Advanced Computing Technology

To develop technologies that will allow MCC shareholders and their customers to design very complex knowledge-based systems for any enterprise that is centered on information

# MCC ORGANIZATION & STAFFING

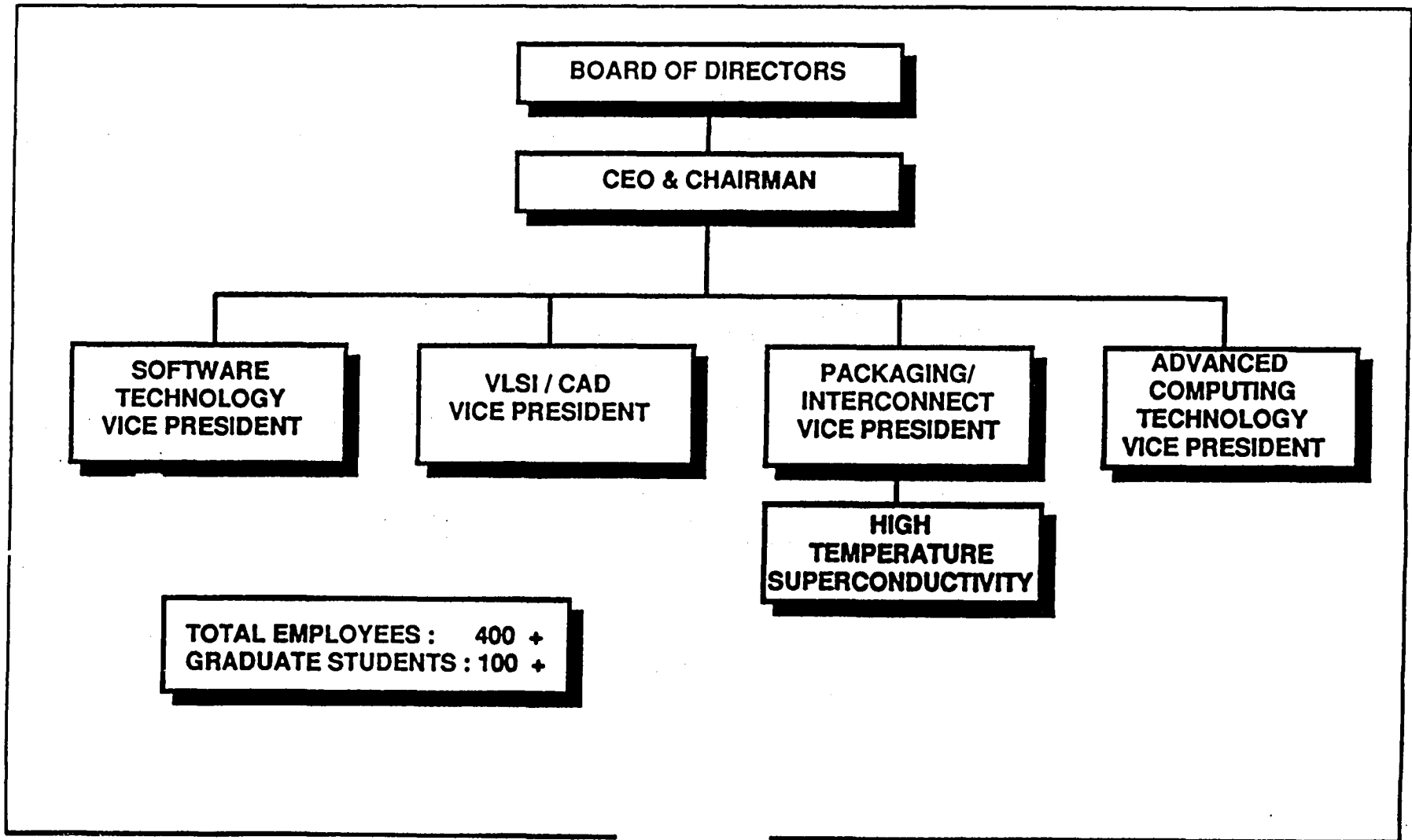

# MCC Governance

## Board of Directors

One director from each of the shareholder companies. The board sets broad policy and meets regularly to consider important new strategic directions.

## Technical Advisory Board

One senior technical advisor or manager from each of the shareholder companies. The TAB reviews the general technical progress of MCC and identifies new and emerging directions which should be considered for new programs. Provides advice to the CEO on technical issues.

## Program Technical Advisory Board

Each of the research programs has an associated Program Technical Advisory Board which consists of members from each of the companies who participate in sponsoring the research in that program. This board monitors progress of the program and recommends technical strategy with respect to the directions of the program.

## Program / Project Technical Panels

Panels associated with each research program conduct detailed reviews of research progress and assist in identifying technology transfer opportunities in the participant organizations.

# MCC GOVERNANCE

MCC

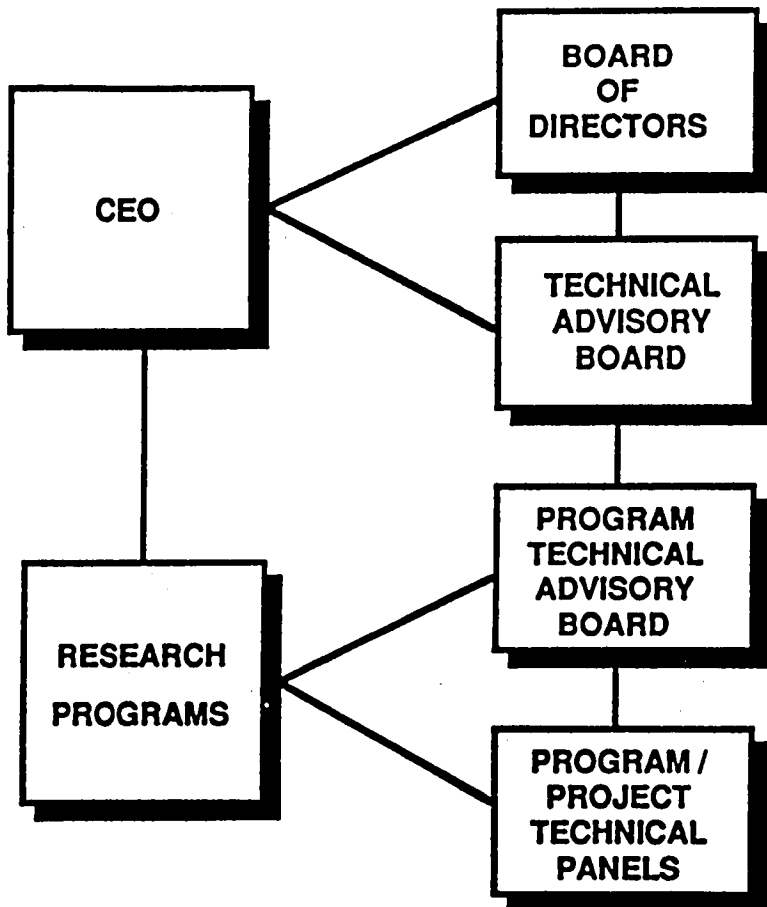

BROAD  
POLICY

ADVICE TO CEO ON  
TECHNICAL ISSUES

PROGRAM MANAGEMENT  
REVIEW

TECHNICAL STRATEGY

TECHNICAL REVIEWS  
AND  
TECHNOLOGY TRANSFER

S  
H  
A  
R  
E  
H  
O  
L  
D  
E  
R  
S

7-D

## SHAREHOLDERS

MCC shareholders each own one share of stock in MCC, participate on the Board of Directors, and in at least one of the research programs. Participation in a research program involves sharing research costs with the others who are also participating, providing at least one researcher as a program liaison or assignee (who work as Members of the Technical Staff or in management positions, depending on their qualifications), and closely following the research progress in order to transfer technology back to the shareholder organization as quickly as possible. Shareholder participants have paid-up licenses for use of the technology developed in the programs in which they participate. They have general knowledge of activities in other programs (through the TAB.)

Shareholders

Advanced Micro Devices  
Bellcore  
Boeing  
Cadence Systems  
Control Data  
Digital Equipment  
Eastman Kodak  
General Electric  
Harris Corporation  
Hewlett-Packard  
Honeywell  
Hughes/GM  
Lockheed  
Martin Marietta  
Motorola  
National Semiconductor  
NCR Corporation  
Rockwell International  
Westinghouse  
3m Corporation



## ASSOCIATES

The MCC Associates Program offers a unique opportunity for U.S. and Canadian firms and organizations to participate in the MCC effort short of full-fledged equity participation. The Associates become part of the MCC community of world-class researchers, high technology corporations and supporting organizations committed to maintaining North American competitiveness in the global technology marketplace. For a modest participation fee, the Associates are kept abreast of progress in the MCC research programs and global technology developments. Associates may participate as non-equity participants in any of the research programs. The Associates Program opens the MCC effort to as many other organizations as possible in a pro-competition, pro-cooperation spirit.

MCC Associates membership offers qualification to join the MCC research programs as a non-equity participant. MCC is being restructured to allow more selective and lower cost ways of participating in their research. The basic differences between Shareholders and Associates are the Shareholders have governance rights over MCC and receive distributions of royalty income from third-party technology licensing. Associates have limited governance rights only for those projects in which they have elected to participate. Specific rights to technology for both Shareholders and Associates are detailed in the Research and Development Agreement for each program or project.

MCC Associates are invited to two or three seminars a year - designed specifically for the Associates - for a detailed look at progress in the MCC Technical Programs. These events provide an excellent opportunity to meet the researchers for a more in-depth assessment of the technology. Special meetings with researchers can be arranged from time to time.

MCC Associates have access to all proprietary technology monitoring and forecasting products of the MCC International Liaison Office. The ILO produces a highly-regarded monthly Newsletter on foreign technology developments, maintains an on-line database on foreign technology, writes occasional detailed technical reports on particular foreign technologies of interest and translates a large volume of Japanese-language technical papers from its unique database of Japanese technical literature. The ILO is in frequent contact with MCC Shareholders and Associates to answer their specific questions. The ILO can save an Associate a substantial part of the overhead of monitoring foreign technologies or advise Associates on how to establish their own monitoring programs. The ILO is also sponsoring a technology forecasting program, focussing on user needs for technology 5 to 10 years out.

**Associates**

Allied-Signal, Inc.  
Apple Computer  
Dell Computer Corporation  
E.I. Dupont Denemours  
E-Systems  
General Dynamics  
LTV Missiles and Electronics Group  
Magnavox Government and Industrial Systems  
Mitre  
National Security Agency  
Northrop  
Olin Corporation  
Power Electronics Application Center  
Software Engineering Institute  
Sun Microsystems  
Symbolics  
Texas Instruments  
Tracor  
TRW  
United Technologies

## PACKAGING / INTERCONNECT PROGRAM

Packaging/Interconnect refers to the process of assembling integrated circuits into systems and providing the systems with power and cooling. Recently, rapid advances in integrated circuit technology have caused many of today's packaging and interconnect techniques and processes to become obsolete. New technologies are needed to assure that the potential of complex circuits is realized.

The aim of MCC's Packaging/Interconnect (P/I) Program is to develop processes for yielding high performance at low cost, thus contributing to the competitiveness of MCC shareholders. The overall mission of the P/I Program is to provide U.S. semiconductor, materials, component and systems companies with superior technology through sharing of talent and material resources. The work includes the processing of ceramics and plastics, deposition of electrical conductors, development of bonding metallurgies, thermal management, laser-processing, and thin-film fabrication. It also includes the development of test techniques and tester technology.

The P/I Program will develop technology which is directed toward a **ten-million gate computer/signal processor** which can be packaged, assembled and tested at a **cost of less than \$1,000**. This would double the performance of today's supercomputers at a small fraction of their cost. The technology will be completed and transferred to the shareholders by the end of 1992.

The Packaging/Interconnect Program is divided into four areas: a core and three satellites. Core research projects are longer range and intended to provide shareholders with a window on future technology, proving concepts and providing valuable know-how. Current satellites are:

- Bonding and Assembly Development
- Multi-Chip System Technology
- Interconnect Technology

## **MCC / Packaging/Interconnect**

---

- **Enable electronic packaging to keep pace with rapid advances in chip integration and speed**
  - **Develop low cost, high performance and reliability, dual use technology**
  - **Multi-chip modules provide improved performance at a lower cost and an increased reliability**
  - **MCC P/I work in substrates, bonding, test and systems**
-

## Performance Potential of Multi-Chip Packaging

The goal of the Multi-Chip System Technology Satellite is to solve several problems related to the application of multi-chip packaging. Issues that are being addressed include heat removal, power handling and regulation capabilities, high performance connections, and testing.

Within this satellite, the Quick Turn Around Time (QTAT) interconnect project is providing design and process for generic or programmable interconnect techniques using a standard "blank." The blank is later customized to specific applications within 24 hours of design completion. MCC P/I is developing both substrate and board level QTAT techniques, so that most packaging levels within a system may be implemented more rapidly and at a lower cost. The project will allow wiring densities up to 500 lines per inch. This compares to current technologies which allow wiring densities of less than 100 lines per inch.

The satellite is conducting technology integration studies, is developing technology in a Chip on Substrate Test (COST) project which will verify that electrical objectives of the interconnect technology are met, and is developing liquid-cooled heat exchangers which can be integrated with MCC TAB (Tape Automated Bonding) and substrate technologies in a multi-chip module. The liquid-cooled heat exchangers will remove 50 watts of heat per square centimeter with low pressure and low flow requirements with either water or organic liquids. Novel air cooling technology which permits the removal of 30 watts of heat per square centimeter has already been developed.

## Performance potential of Multi-Chip Packaging

- improve system performance, reliability and cost
  - chip technologies are too costly
    - don't solve performance and density
    - do not address the major reliability factors
  - reliability limiting parts
    - interconnection and packaging
    - substantial improvement possible
    - high density chip-on-board
    - centimetres to mm.
-

## CONCLUSIONS (P&I)

Packaging and Interconnect continues to be the main gating factor to achieving cost effective systems. Packaging and Interconnect technology is the primary limitation to speed, reliability, testability, and affordability. Therefore, MCC believes that P&I will be a dominant force in the 1990's which will contribute to the competitiveness of the sponsors of the P&I program. The MCC P&I program will continue to emphasize multichip modules with vertically integrated R&D which addresses the issues of design, fabrication, assembly and test. The result is expected to be computers that are fast (3 ns cycle time), large (10 million gate) and low cost (\$5000.)

## Conclusions

---

- PI continues to be main gating factor to cost effective systems
  - PI limits speed, reliability, testability, and affordability
  - It will be dominant force in the 1990's
  - MCC approach emphasizes MCM
    - Vertically Integrated R&D to participants
    - Design, Fabrication, Assembly & Test
    - Computers that are fast (3 ns cycle time), large (10 million gate) and low cost (\$5000)
-



# THE MCC CAD PROGRAM

## GOALS

The complexity of integrated circuits (ICs) continues to increase by as much as 50 percent per year. By the mid-1990s, complex ICs will contain upwards of 10 million devices and the resulting systems will be at least an order of magnitude more complex. This trend continues to affect chip and system makers alike. Electronic system manufacturers and IC suppliers are now designing ICs that have rapidly decreasing line widths and employ increasingly complex processes. In order to remain competitive in the next decade, these companies demand a shorter time-to-market for new products and require lower relative design costs than they have today. Breakthroughs in both CAD application tools and systems are required.

The MCC CAD Program performs state-of-the-art research into CAD tools and systems that will deal effectively with these technology challenges. The program provides computer-aided design tools and an integrating CAD system framework to its participants, which will help them resolve key design time, quality, and resource bottlenecks in the design of complex integrated circuits and electronic systems.

To carry out this objective, the CAD Program identifies targets of opportunity for its research and development (R&D) projects. The CAD Program only undertakes R&D efforts in which CAD technology from other sources available to the participant (CAD vendors, universities, internal participant projects) is projected to be inadequate. MCC monitors new CAD developments in the commercial arena and within universities to target opportunities. The CAD Program also acquires and evaluates the most current commercial tools. MCC CAD constantly evaluates new and ongoing R&D projects from other organizations and monitors its own projects to ensure that at least one of the following criteria is met at the time the company delivers software to its participants: (1) The CAD tool or system to be produced will be functionally superior to software available from other sources to reduce design time and/or cost, or (2) The CAD tool or system will be more cost effective to the MCC CAD participants than other sources of that technology.

# THE MCC CAD PROGRAM

## GOALS

---

- Develop a "best in class" CAD framework that facilitates development and execution of native tools while providing easy integration of external tools.
- Play a leadership role in the creation of industry standards for design data representation, tool management and communication, and other important CAD framework issues.
- Deliver advanced CAD tools in areas that will advance the state of design and are not adequately addressed by commercial efforts.

# THE MCC CAD PROGRAM

## Short Term Plans

MCC organizes its CAD Program resources as a Core and four Satellites: System Design, Digital Design, Test Design and Physical Design. Each area has its defined targets of opportunity that result in short and long term goals. The responsibilities of the Core include development of a "best-in-class" CAD framework, coordination of technology tracking and forecasting activities, and code release preparation for all CAD Program deliverables. In addition, a system engineering function integrates the framework and individual application tools.

Each of the four satellites concentrates on a specific range of tasks in the design process. The System Design satellite addresses high-level problems of designing multi-chip systems, starting from informal requirements or specifications and evolving to component design specifications.

Projects in the Digital Design satellite help create and verify gate-level design, given a system architecture as an input. Current projects in this satellite include: VHDL analysis and simulation tools, hierarchical timing analysis, and mathematical verification of design correctness.

Projects in the Physical Design satellite take a functionally-verified, gate-level description as input and create a mask-level IC design. The satellite continues its work on the C Module Editor (CME) tool, a symbolic IC layout system that employs a unique graphical programming paradigm and a powerful compaction algorithm. The CME is design-rule independent. The Physical Design satellite is also addressing the layout synthesis problem.

The Test satellite focuses on the need to rapidly generate tests for complex systems. Current projects include a comprehensive fault simulation/automatic test pattern generation (FS-ATPG) tool that incorporates key new algorithms to handle high complexity, and the Testability Insertion Guidance Expert (TIGER), a knowledge-based expert system that guides the designer to improve a design's testability at the register-transfer level and above.

# THE MCC CAD PROGRAM

## SHORT TERM PLANS

---

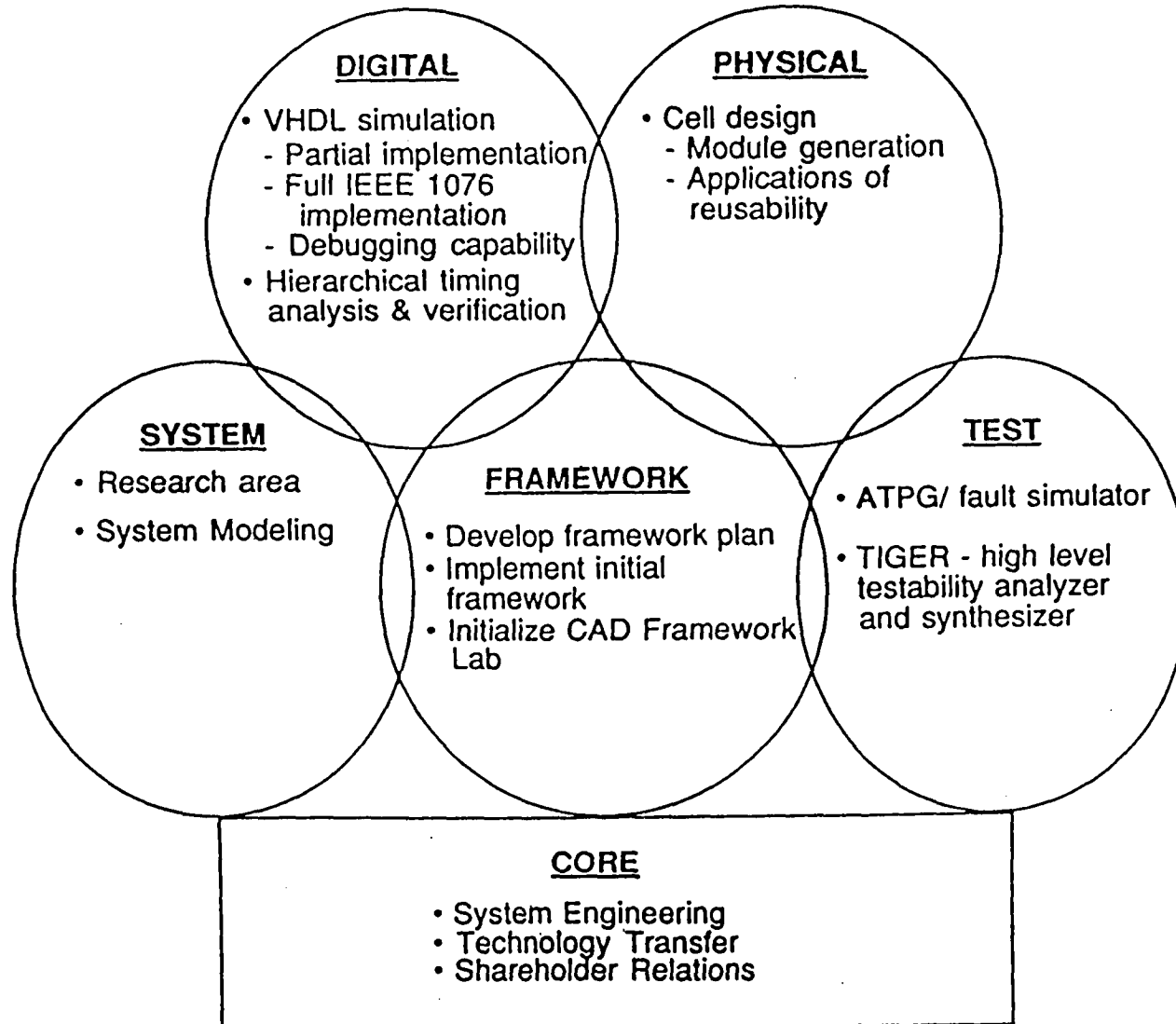

## SOFTWARE TECHNOLOGY PROGRAM

Most large, complex computer systems of the future will be **distributed systems**. In a widely distributed network of hundreds - even thousands - of low-cost, high-performance individual workstations, data can be shared, available, and correct, when and where it is needed. These systems will offer two dramatic benefits:

- **Teamwork and cooperation.** The distributed network will provide tools that greatly assist users in planning, coordinating, and managing resources - including human resources.
- **Reliability.** The effective replication and management of shared data will ensure that a breakdown in one part of the distributed network does not significantly interfere with the smooth functioning of another.

Other work in Software Technology focused on **downstream** activities. Compilers were developed in the 1960s. Structured programming was the focus of the 1970s. Programming environments was the new major issue of the 1980s.

In creating **Leonardo**, STP is focusing its efforts on the *upstream* of the software systems design process. Upstream activities encompass the period from a project's "fuzzy requirements" phase, through its design, to the point at which formal specifications can emerge.

These early, creative phases of design offer great leverage in ensuring a given project's eventual success. Downstream outcomes are, in fact, determined by upstream decision - decisions about customer needs and design assumptions, about resources and components, and about how the system's vision matches its requirements. Indeed, study after study reveals that *over half* of the development effort typically is spent on these and other upstream activities.

Yet currently, the upstream remains unquantified, unarticulated, and poorly addressed by technology. Management and technical tasks are seldom coordinated; communication is haphazard and unfocused. The price, in both human and economic terms, is this: fixing design defects and adding functionality currently account for *over 80 percent* of the cost of maintaining a system once it is in operation.

**Leonardo** computer-aids the upstream, so that everybody involved in a complex system's design - developers, managers, and targeted users alike - can function as a coordinated, focused team. This unique environment promises extraordinary gains in the productivity of the designers and in the quality of the systems they produce.

Software Technology Evolution

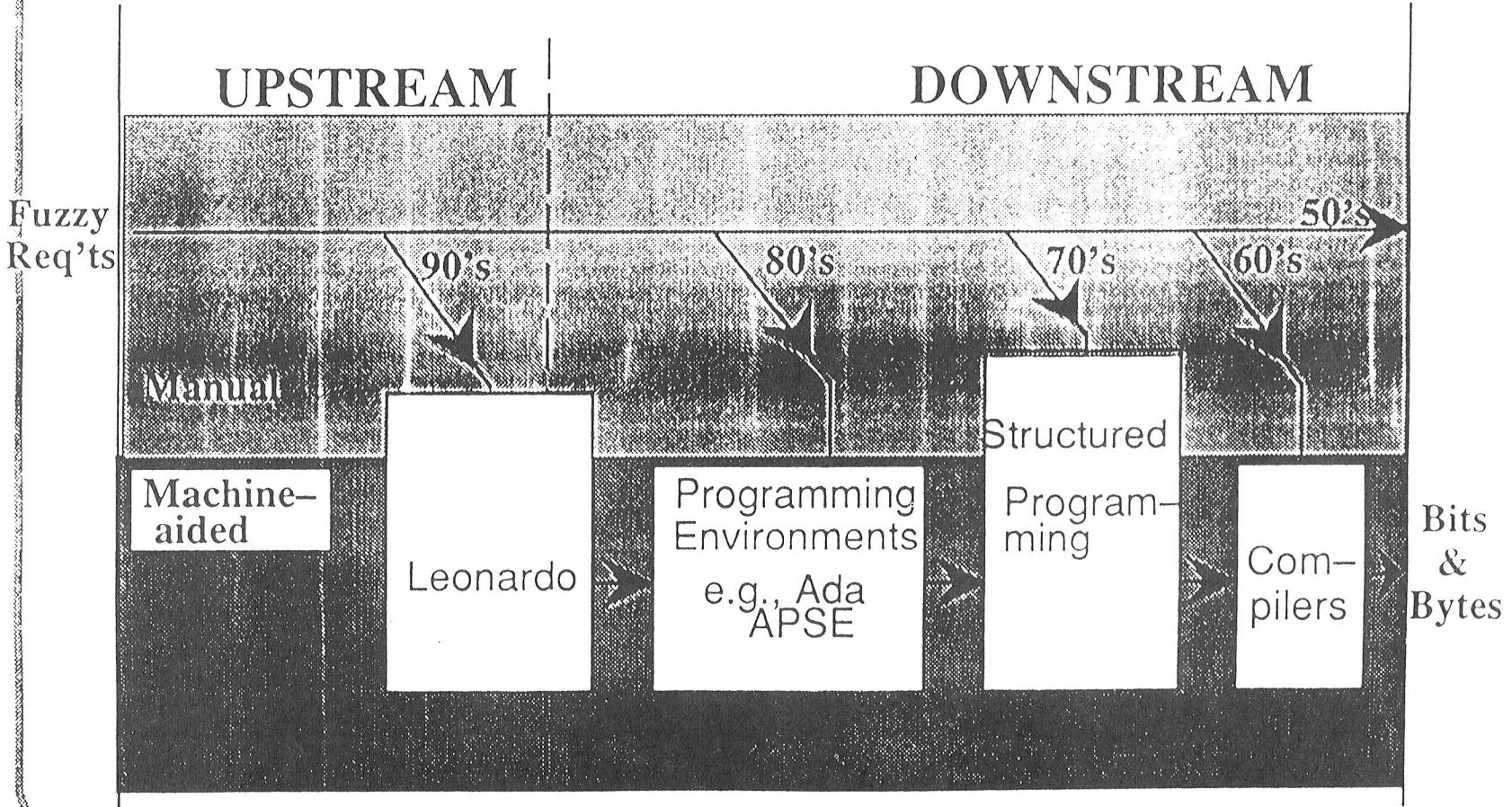

305

ORIGINAL PAGE IS OF POOR QUALITY

# THE LEONARDO VISION

## • COORDINATING THE DESIGN TEAM

The group design of a typical, large complex software system requires the simultaneous efforts of many specialists working cooperatively. Like the system it is designing, this team is often widely distributed in space and time. Like the individual computer processes being created to drive the emerging system, the team must function smoothly.

In most large project teams, the issue of coordination tends to be minimized or ignored. Poor communication - both between processes and between members of the design team - is widely acknowledged to cause rework and inefficiency, and chasing new code-writing technology has not worked as the remedy of choice. The problem is this: until now, there have been no conceptual models of systems design coordination, much less the tools for achieving that coordination. Major work is underway at STP for ensuring that *Leonardo* provides both. Powerful hypermedia tools which represent data in an associative, rather than a linear, way - in graphical networks of nodes and links - have been developed. The data can be text, graphics, or synthesized speech. *Leonardo* includes tools which support the notions of *process teams* and *multiple-party process interactions*. Visual environments are available to edit the coordination scripts which organize the multi-designer interactions in the process that an organization goes through to produce a large, complex software system. Multi-designer interactions are organized by allowing for explicitly written, graphically represented descriptions of the design process. Each member's "electronic desk" serves as an interface to the overall process and to the status of the member's current role in the organization. A graphical tools which allow design argumentation into a hypermedia network that can be constructed, analyzed, and edited by the design team members have been developed.

## SUPPORTING THE SOFTWARE DESIGNER

The software design process continues to be poorly understood - particularly the process of designing large, complex systems in project teams. Little empirical research has examined the cognitive foundation for this process or pinpointed specific components. No theories formally describe or organize the information used by designers. Consequently, information reused across the design process typically remains unidentified and is often redeveloped during a single project. STP conducts **empirical studies** to determine what design tasks must be supported in order for *Leonardo* to have maximum value for its shareholders. A major focus is **Computer-Aided Design Deliberation and Reuse**. One project is focusing on how a designer makes and records design decisions as the project progresses from requirements to code. A graphically oriented technology has been created to capture and represent information about a project's history and about the dependencies between system components. A reuse system provides the designer with two reusable libraries - a library of abstract design schemas and one of abstract algorithms. A design schema is the way in which early design structures are captured. The designer can pull up, edit and refine a design schema to pin down precise elements of the target system's architecture. Once these elements are defined, the *Leonardo* designer will use the abstract algorithm library to customize the abstract designs into code.

**The Leonardo Vision**

- 1 Integrated System Design Environment
  - Upstream Emphasis (Symbolic Comp.)
  - Prototyping & Simulation
- 1 Mission: Extraordinary Productivity & Quality
- 1 Long Range/High Risk Research
- 1 Team Focus
- 1 Visual/Human Orientation to Tools
- 1 Distributed/Embedded Target Systems
- 1 Reuse of Designs

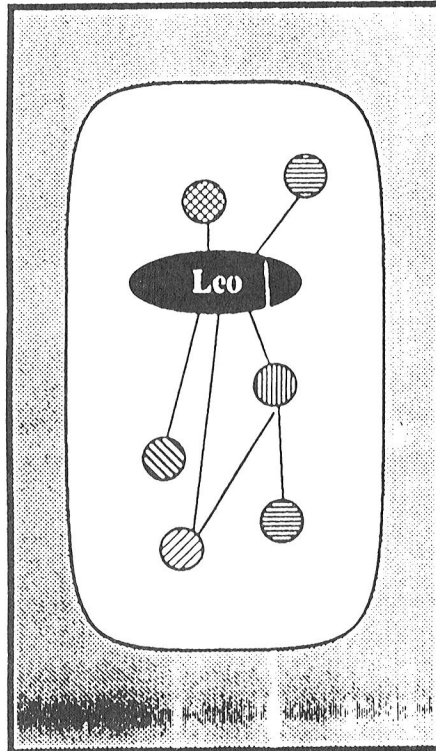

Organize  
 Prototype  
 Integrate  
 Leonardo

85    86-87    88-90    91-92



# ADVANCED COMPUTING TECHNOLOGY (ACT)

## Projects and Organization

### Organization

Shareholders and Associates can choose to participate in each of the programs shown as shaded blocks in the figure. Recently, the Neural Nets program has been moved to the same level as the HI Lab in the organization.

### OODS (Object Oriented and Distributed Systems) LAB

The OODS project provides rich database software capabilities to both object oriented programming environments and data-intensive, symbolic applications, such as CAD/CAM, artificial intelligence, and office information systems. The OODS project has already delivered ORION, a prototype of an object oriented database system on a single workstation. This system is being extended into a distributed database. In addition, the group is working to design and demonstrate a high-performance system architecture to support the concurrent object model by exploiting parallel processing opportunities.

### OPTICS

The optics group is conducting research into the application of optics technology in high performance computing systems. These studies are currently focused in high performance interconnects for highly parallel systems and a high capacity, low latency holographic storage technology (with no moving parts.)

### AI LAB

This group is generating a very large knowledgebase called CYC, that contains a foundation of general (encyclopedic) and common-sense knowledge. The work in Reasoning Architectures is creating expert system shells that provide rich development facilities for the language as well as efficient run-time environments. The Knowledge Based Natural Language group is working to extend computer interaction and understanding capabilities to include unrestricted natural language.

### DEDUCTIVE COMPUTING

This group has designed and implemented a Logic Data Language (LDL). This is a logic-based language intended for data and knowledge intensive applications. The LDL system combines the expressive power and the supporting technologies of logic programming and relational databases. Future extensions will support richer knowledge representation primitives and constraint-based programming.

### HUMAN INTERFACE

The Human Interface Lab is focused on dramatically improving the *usability* of complex systems. The mission of the lab is to develop the scientific and technological foundations for principled and efficient construction of effective interfaces. HITS, a Human Interface Tool Suite, provides tools to support the design of intelligent, multimedia interfaces.

# ACT PROJECTS & ORGANIZATION

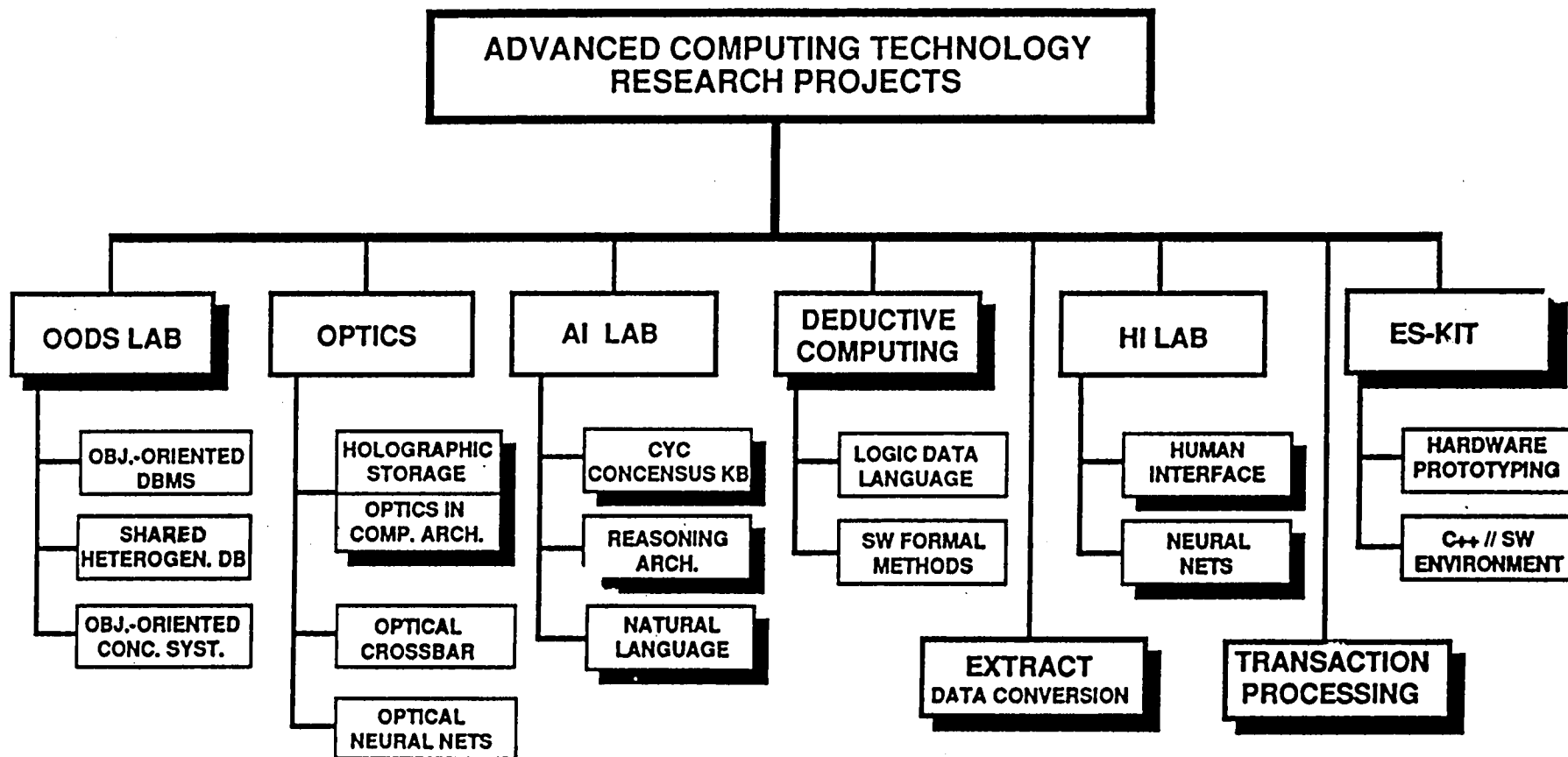

*NOTE : PROJECTS SHOWN IN SHADOW BOXES ARE SEPARATELY FUNDABLE*

**DATA CONVERSION (EXTRACT)  
Project Focus**

The EXTRACT project has developed tools which allow data conversion or migration from one or more databases and file structures into others. The user describes the databases or file structures to be connected and the data to be handled with a formal notation. The system then automatically generates code which connects the EXTRACT system to those databases and file structures. The EXTRACT system includes a temporary database storage and automatic management of the movement of data from one place to another. The work of this project is nearly completed.

# DATA CONVERSION (EXTRACT)

## PROJECT FOCUS

*ALLOW DATA CONVERSION / MIGRATION FROM ONE OR MORE DATABASES / FILE STRUCTURES INTO OTHERS*

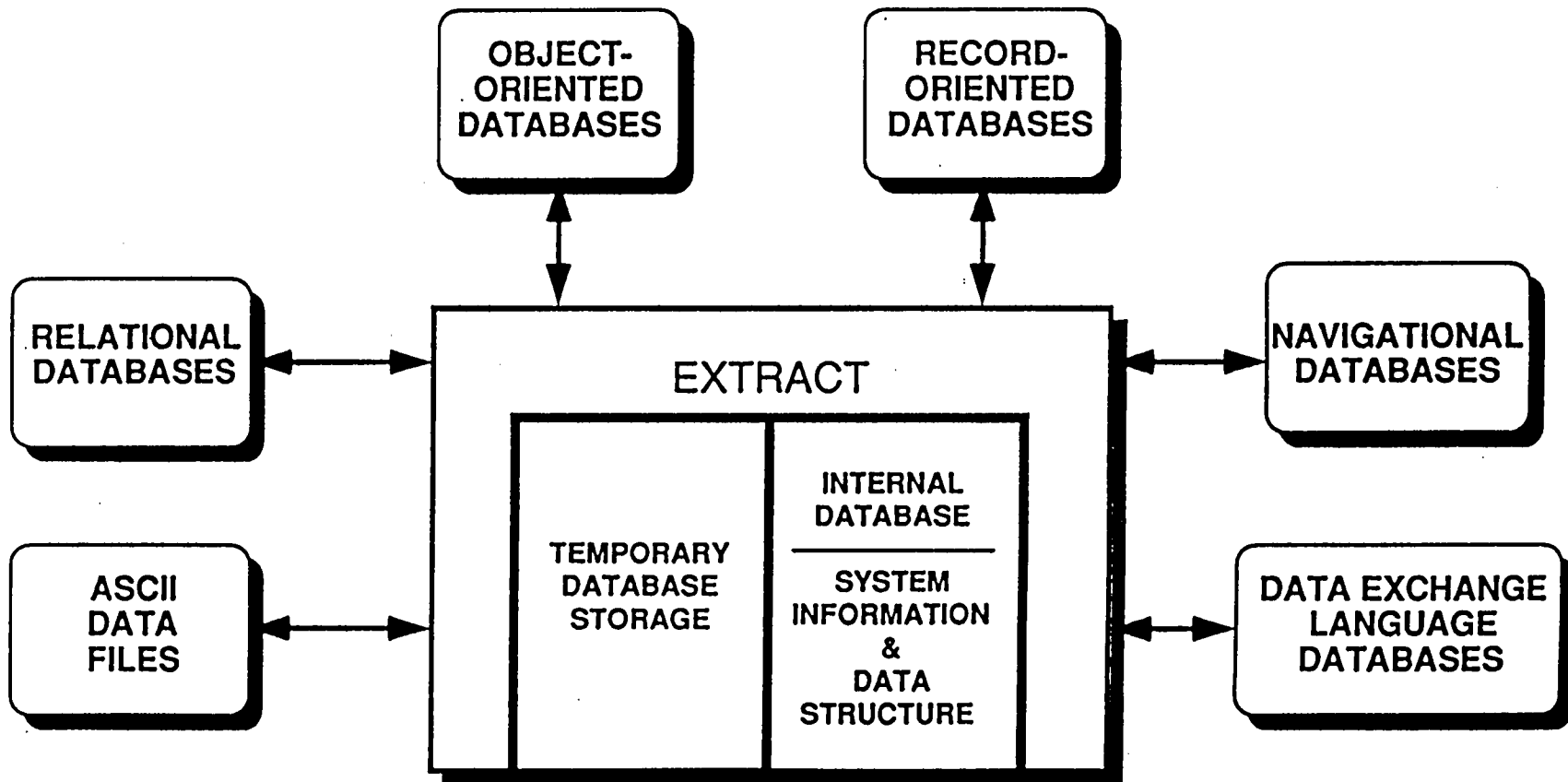

## PARALLEL SYSTEMS PROTOTYPING (ES-KIT)

The Experimental System Builders Kit (ES-KIT) group is developing technologies which allow rapid, low-cost prototyping of experimental high-performance computing systems. The ES-KIT is a set of compatible hardware and software technologies that can be used to very quickly construct unique high-performance systems - parallel systems in particular. The hardware modules include processor, memory, hard disk, message-passing communications, and instrumentation modules. The initial modules are Motorola 88000 based. New modules based on the Intel i860 are under development. The software support includes a parallel C++ compiler, UNIX operating system modules which connect the hardware modules to the UNIX environment in a workstation host, software instrumentation insertion support, and tools to support the presentation of data collected from builtin hardware and software instrumentation. The work of this group has been sponsored by DARPA and is currently being distributed to other researchers around the United States for use in a wide variety of projects.

# PARALLEL SYSTEMS PROTOTYPING ( ES-KIT )

*ANTICIPATE ARCHITECTURAL AND IMPLEMENTATION NEEDS OF EMERGING COMPLEX, PARALLEL SYSTEMS AND DEVELOP MODULAR BUILDING BLOCKS & TOOLS THAT SUPPORT FAST AND AFFORDABLE PROTOTYPING OF THESE SYSTEMS*

E  
S  
  
R  
E  
S  
E  
A  
R  
C  
H

MODULAR REUSABLE  
HARDWARE

MODULAR PORTABLE  
SYSTEM SOFTWARE

DEMONSTRATION/ TEST  
APPLICATIONS

◆ BENEFIT ◆

FAST PROTOTYPING

50 - 75 % LESS TIME  
PARALLEL/ SCALABLE  
ARCHITECTURES  
DISTRIBUTED  
ARCHITECTURES

DRAMATIC REDUCTIONS IN THE TIME AND COST OF COMPLEX SYSTEM PROTOTYPING REQUIRES A BROAD SPECTRUM OF REUSABLE MODULES WHICH ARE RELATIVELY INSENSITIVE TO OVERALL ARCHITECTURES. SW IS OBJECT-ORIENTED & INITIAL HW MODULES ARE MOTOROLA 88000 BASED.

**Environmental Control and Life Support System**  
**Level III**  
**Subsystem Presentation**

PRECEDING PAGE BLANK NOT FILMED

315

~~FOR~~ 314 INTENTIONALLY BLANK

OM 17

# Environmental Control and Life Support System

Charles Ray

Alan Adams

Marshall Space Flight Center

Technology for Space Station Evolution Workshop  
January 16-19, 1990  
Dallas, Texas

PRECEDING PAGE BLANK NOT FILMED

317

316  
INTERNATIONAL

314-544  
163606  
P. 23  
N 93 - 27718



## **ECLSS SUBSYSTEM FUNCTIONS**

**THE ECLSS IS DIVIDED INTO SIX SUBSYSTEMS: TEMPERATURE AND HUMIDITY CONTROL (THC), ATMOSPHERE CONTROL AND AND SUPPLY (ACS), ATMOSPHERE REVITALIZATION (AR), FIRE DETECTION AND SUPPRESSION (FDS), WATER RECOVERY MANAGEMENT (WRM) AND WASTE MANAGEMENT (WM). THIS CHART PROVIDES A LISTING OF THE MAJOR FUNCTIONS OF EACH SUBSYSTEM.**

# Technology For Space Station Evolution - A Workshop

## ECLSS Subsystem Functions

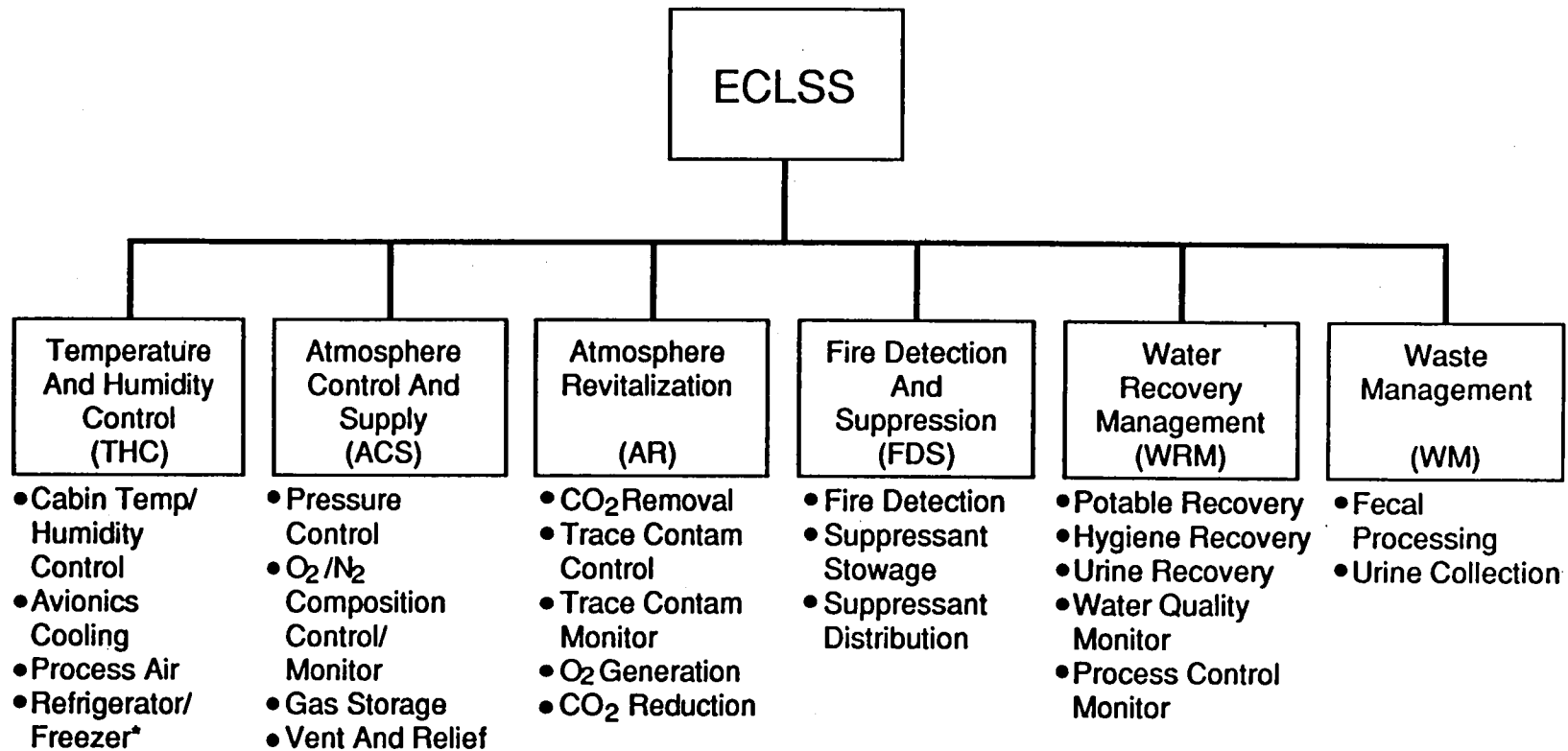

## **ENVIRONMENTAL CONTROL AND LIFE SUPPORT SYSTEM**

**THE ECLSS CONSISTS OF NON-REGENERABLE AND REGENERABLE HARDWARE. THE NON-REGENERABLE HARDWARE IS FOUND MAINLY IN FOUR OF THE MAJOR SUBSYSTEMS: ATMOSPHERE CONTROL AND SUPPLY (ACS), TEMPERATURE AND HUMIDITY CONTROL (THC), FIRE DETECTION AND SUPPRESSION (FDS) AND WASTE MANAGEMENT (WM). THE REGENERABLE HARDWARE, WHICH POSES THE GREATEST TECHNOLOGICAL CHALLENGE, IS FOUND IN THE ATMOSPHERE REVITALIZATION (AR) AND THE WATER RECOVERY AND MANAGEMENT (WRM) SUBSYSTEMS. THE REGENERABLE SYSTEMS PROVIDE A MEANS OF GENERATING OXYGEN, REMOVING/REDUCING CARBON DIOXIDE AND RECLAIMING WATER FOR USE BY THE CREW WHICH MINIMIZES THE SPACE STATION LOGISTICS BURDEN.**

# Technology For Space Station Evolution - A Workshop

## Environmental Control And Life Support System

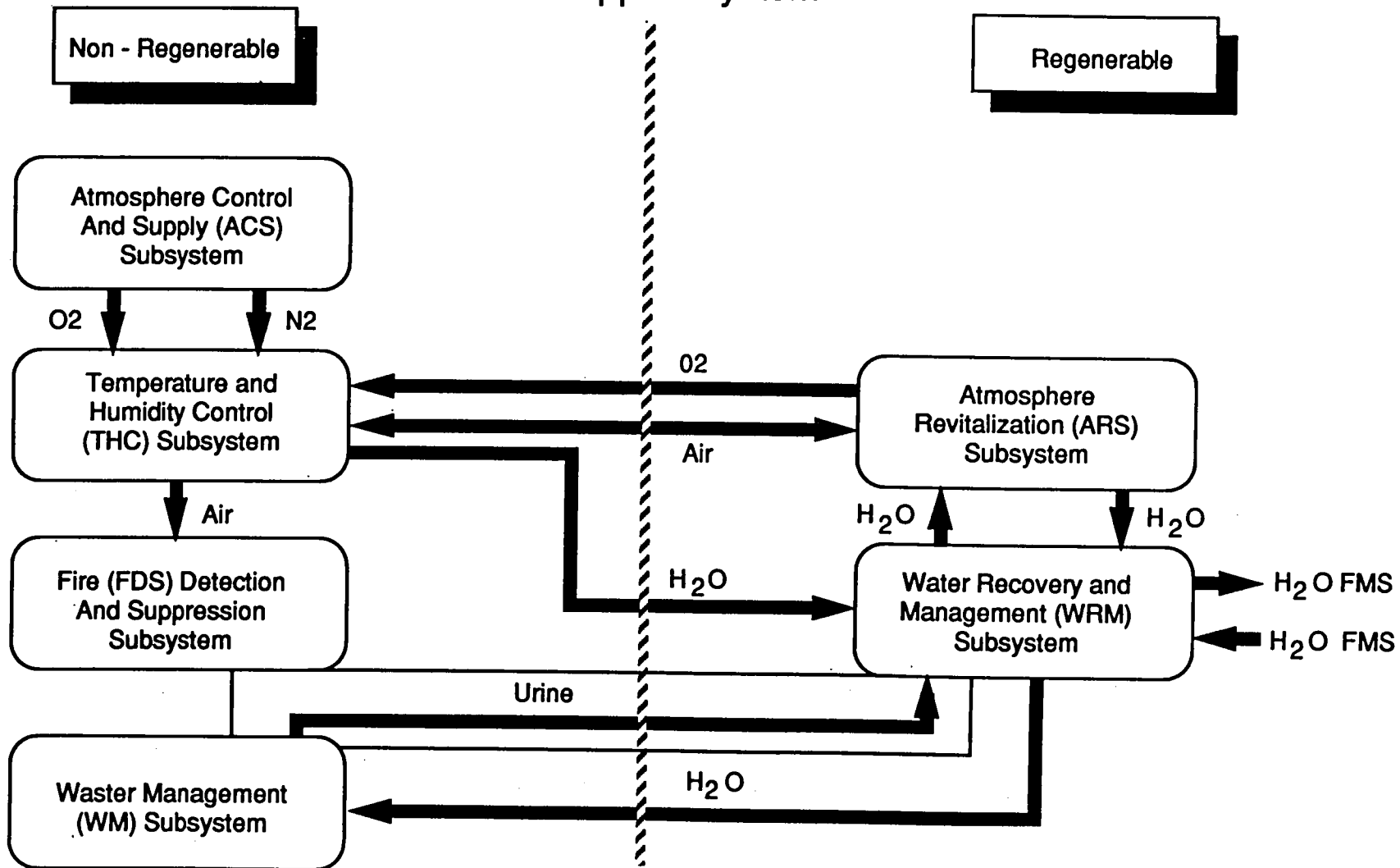

**ECLSS DISTRIBUTED SYSTEM**

**THE ECLSS IS TRULY A DISTRIBUTED SYSTEM. ECLSS HARDWARE/FUNCTION IS FOUND IN EVERY SPACE STATION ELEMENT. ALTHOUGH THE MAJOR COMPONENTS OF THE ECLSS ARE CONCENTRATED IN THE U.S. HABITATION AND LABORATORY MODULES, OTHER ECLSS FUNCTIONS SUCH AS ACS, THC, FDS CAN BE FOUND IN THE NODES, AIRLOCK AND LOGISTICS MODULES.**

# Technology For Space Station Evolution - A Workshop

## ECLSS Distributed System

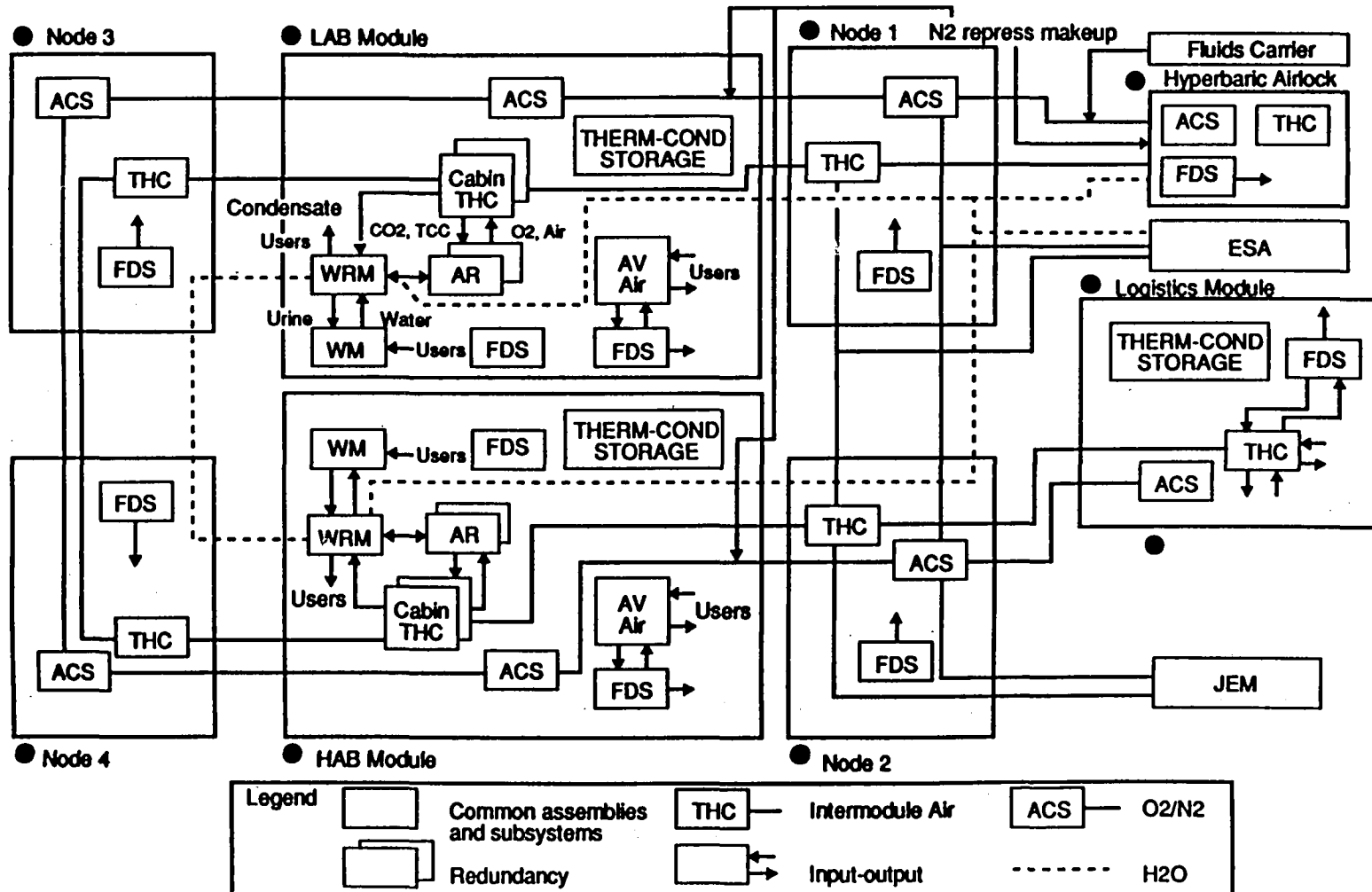

**ECLSS DESIGN FEATURES**

**THIS CHART PROVIDES A SUMMARY OF THE MAJOR DESIGN FEATURES OF EACH ECLSS SUBSYSTEM.**

# Technology For Space Station Evolution – A Workshop

## Environmental Control And Life Support System

### Design Features

#### ● System

- 4 Crewmen At PMC, 8 Crewmen At AC
- Attached Module Services Provided By Distribution System

#### ● Temperature And Humidity Control

- Intermodule Process Air Provides CO<sub>2</sub> Removal O<sub>2</sub> Partial And Total Pressure Control For Station Pressurized Volume
- Avionics Cooling Supplied To All Powered Racks In U.S. Modules
- Redundant Assemblies In Hab And Lab

#### ● Atmospheric Control And Supply

- Oxygen And Nitrogen Distributed To All Pressurized Modules
- Positive And Negative Relief Capability Provided In All U.S. Pressurized Modules

#### ● Atmosphere Revitalization

- Redundant Assemblies In Hab And Lab
- Regenerable O<sub>2</sub> Generators, CO<sub>2</sub> Removal, CO<sub>2</sub> Reduction Units Located In Hab And Lab
- Distribution System To Provide Monitoring Of Trace Contaminants In Any Pressurized Module

#### ● Fire Detection And Suppression

- FDS Functions Provided To All Powered Racks In U.S. Modules
- Portable Extinguisher To Backup Central Suppressant Storage

#### ● Water Recovery Management

- Separated Potable And Hygiene Water Subsystems
- Potable And Hygiene Processors In Hab And Lab Integrated By Distribution Systems
- Urine Processed To Hygiene Water

#### ● Waste Management

- Crew Exposure To Fecal Material Precluded



**ECLSS FUNCTIONAL DISTRIBUTION**

**ECLSS HARDWARE IS LOCATED IN VIRTUALLY EVERY SPACE STATION ELEMENT. HOWEVER, SOME OF THE ECLSS FUNCTIONS ARE PROVIDED TO SOME OF THE SPACE STATION ELEMENTS THROUGH NON-HARDWARE MEANS SUCH AS INTERMODULE VENTILATION AND SAMPLING LINES.**

# Technology For Space Station Evolution – A Workshop

## ECLSS Functional Distribution

ECLSS Function	HAB	LAB	LOG	HAL	Node	JEM	ESA
<b>Temperature/Humidity Control</b>							
Air Temp Control	HW	HW	HW	HW	HW	HW	HW
Humidity Control	HW	HW	HW	HW	HW	HW	HW
Ventilation	HW	HW	HW	HW	HW	HW	HW
Avionics Cooling	HW	HW	HW	HW	HW	HW	HW
Refrigerator/Freezer	HW		HW				
<b>Atmosphere Control/Supply</b>							
O <sub>2</sub> /N <sub>2</sub> Pressure Control	HW	HW	HW	HW	HW	HW	
Vent And Relief	HW	HW	HW	HW	HW	HW	HW
Monitoring	HW	HW	SL	HW	SL	HW	SL
O <sub>2</sub> /N <sub>2</sub> Distribution	HW	HW	HW	HW	HW	HW	HW
<b>Atmosphere Revitalization</b>							
CO <sub>2</sub> Removal	HW	HW	IMV	HW	IMV	HW/ IMV	IMV
CO <sub>2</sub> Reduction	HW	HW					
O <sub>2</sub> Generation	HW	HW					
Contaminant Control	HW	HW	IMV	IMV	IMV	IMV	IMV
Contaminant Monitoring	HW	HW	SL	SL	SL	SL	SL

HW – Hardware

IMV – Intermodule Ventilation

SL – Sampling Line

# Technology For Space Station Evolution – A Workshop

## ECLSS Functional Distribution (Continued)

ECLSS Function	HAB	LAB	LOG	HAL	Node	JEM	ESA
Fire Detection/Suppression	HW	HW	HW	HW	HW	HW	HW
Water Recovery/Management							
Potable H <sub>2</sub> O Processing	HW	HW					
Hygiene H <sub>2</sub> O Processing	HW	HW					
Urine Processing	HW	HW					
Distribution	HW	HW	HW	HW	HW	HW	HW
Waste Management							
Fecal Processing/Storage	HW	HW					
Return Waste Storage			HW				

HW – Hardware

IMV – Intermodule Ventilation

SL – Sampling Line

PRECEDING PAGE BLANK NOT FILMED

329

328

## CARBON DIOXIDE REMOVAL

**THIS CHART PRESENTS THE FUNCTIONAL DESCRIPTION OF THE CARBON DIOXIDE REMOVAL SUBSYSTEM FOR THE SPACE STATION FREEDOM PROGRAM. PROVIDED ALSO IS A GENERAL SCHEMATIC DISPLAYING THE PRIMARY INPUTS AND OUTPUTS OF THE UNIT.**

# Technology For Space Station Evolution - A Workshop

---

## CO<sub>2</sub> Removal

### Functional Description:

- Selectively Remove Carbon Dioxide Generated By The Crew's Metabolic Processes From The Cabin Atmosphere, Maintaining A Maximum pp CO<sub>2</sub> Limit As Shown Below:

<u>Mode Of Operation</u>	<u>ppCO<sub>2</sub></u>
Normal	3.0 mm Hg
90 Day Degraded	7.6 mm Hg
45 Day Emergency	12.0 mm Hg

- Concentrate The Removed CO<sub>2</sub> For Downstream Processing In The Carbon Dioxide Reduction System.

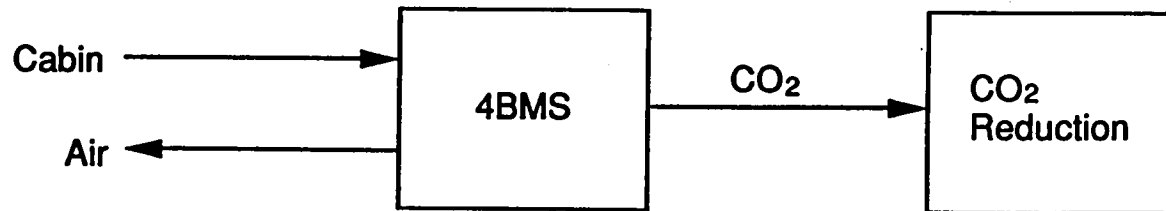

## CARBON DIOXIDE REDUCTION

**THIS CHART PRESENTS THE FUNCTIONAL DESCRIPTION OF THE CARBON DIOXIDE REDUCTION SUBSYSTEM FOR THE SPACE STATION FREEDOM PROGRAM. PROVIDED ALSO IS A GENERAL SCHEMATIC DISPLAYING THE PRIMARY INPUTS AND OUTPUTS OF THE UNIT.**

# Technology For Space Station Evolution - A Workshop

---

## CO<sub>2</sub> Reduction

### Functional Description:

- Reduce CO<sub>2</sub> To Form Solid Carbon By-Product And Potable Water
- CO<sub>2</sub> Is Fed From CO<sub>2</sub> Removal Device
- Processes At A 4-Man Load Under Normal Conditions And 8-Man Load Under Emergency Conditions.

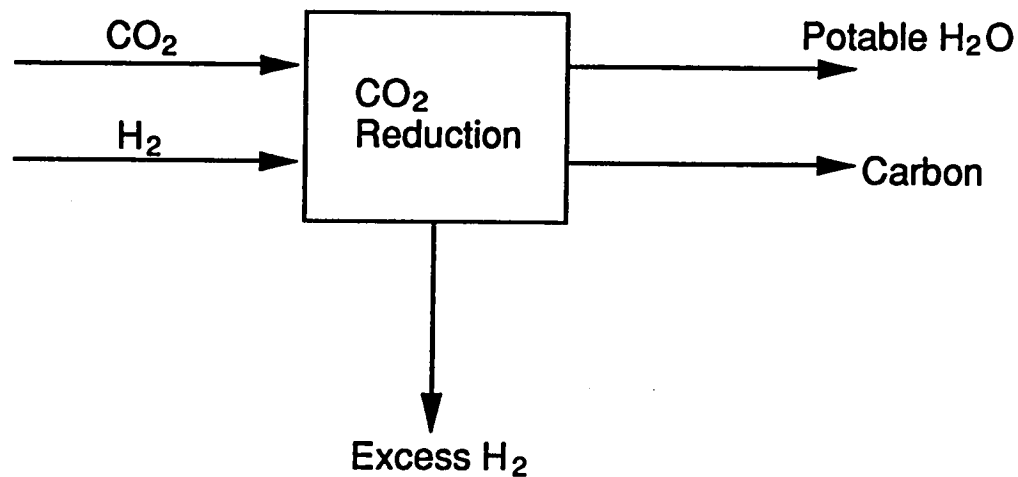





# Technology For Space Station Evolution - A Workshop

---

## Oxygen Generation

### FUNCTIONAL DESCRIPTION

- The OGA Produces Oxygen By Electrolyzing Processed Hygiene Water. Normal Production Is 9.08 lb-O<sub>2</sub>/Day; Emergency Condition 45 Day Production Is 15.75 lb-O<sub>2</sub>/Day.
- The Oxygen Is Delivered To The Cabin Ventilation System Or Stored For EVA.
- The Hydrogen By-Product Is Fed To The Carbon Dioxide Reduction System.

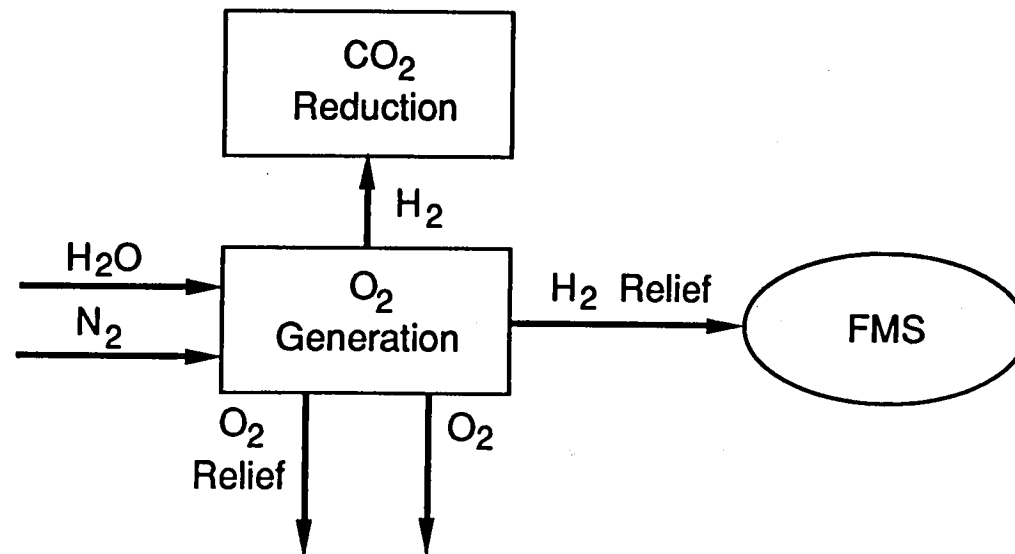

## URINE PROCESSOR

**THIS CHART PRESENTS THE FUNCTIONAL DESCRIPTION OF THE URINE PROCESSOR SUBSYSTEM FOR THE SPACE STATION FREEDOM PROGRAM. PROVIDED ALSO IS A GENERAL SCHEMATIC DISPLAYING THE PRIMARY INPUTS AND OUTPUTS OF THE UNIT.**

# Technology For Space Station Evolution - A Workshop

---

## Urine Processor

### Functional Description:

- Recover Hygiene Water From Human Urine
- Processing Rate Is 50-70 Lbs/Man/Day

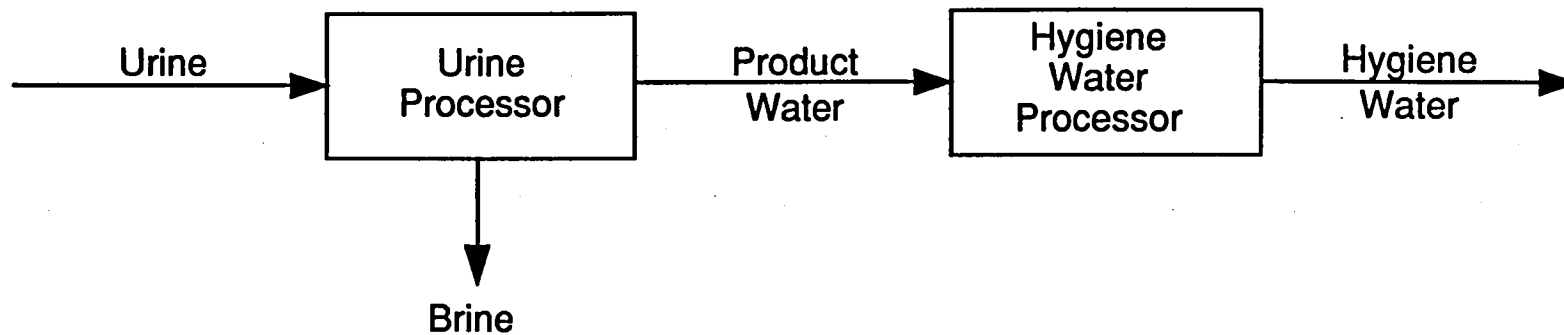

## POTABLE WATER RECOVERY

**THIS CHART PRESENTS THE FUNCTIONAL DESCRIPTION OF THE POTABLE WATER PROCESSOR SUBSYSTEM FOR THE SPACE STATION FREEDOM PROGRAM. PROVIDED ALSO IS A GENERAL SCHEMATIC DISPLAYING THE PRIMARY INPUTS AND OUTPUTS OF THE UNIT.**

# Technology For Space Station Evolution - A Workshop

---

## Potable Water Recovery

### Functional Description:

- Recover Water From Humidity Condensate And CO<sub>2</sub> Reduction Product Water
- Supply Potable Water For Crew (6.26-11.35 LBM/PERSON-DAY)
- Water Quality Must Meet PDRD Specifications
- Supply Water To All Modules At Specific Use Points

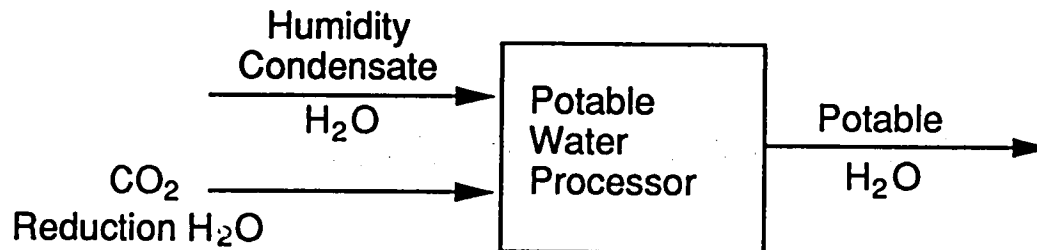

# Environmental Control and Life Support System

## Invited Presentations

341

PRECEDING PAGE BLANK NOT FILMED

INTENTIONALLY BLANK

National Aeronautics and  
Space Administration

George C. Marshall Space Flight Center  
Science and Engineering Directorate

# Technology For Space Station Evolution - A Workshop



## Environmental Control and Life Support System Evolution

Paul Wieland  
Life Support Branch/ED62

N 93-227 19

5/5-54  
163607

PRECEDING PAGE BLANK NOT FILMED

343

DATA

5/5/91

INTENTIONALLY BLANK



## Environmental Control And Life Support System Evolution

### I. Introduction: Space Station *Freedom* Evolution Impact on the ECLSS

The Space Station *Freedom* Environmental Control and Life Support System (ECLSS) will have to accommodate the changes to *Freedom* as it evolves over the design life of 30 years or more. Requirements will change as pressurized modules are added, crew numbers increase, and as the tasks to be performed change. This evolution will result in different demands on the ECLSS and the ECLSS will have to adapt. Technologies other than the baselined ones may be better able to perform the various tasks and technological advances will result in improved life support hardware having better performance, increased reliability, reduced power consumption, weight, and volume, greater autonomy, and fewer resupply requirements. A preliminary study was performed to look at alternative technologies for life support and evaluate them for their integration requirements, focusing on the fluid line interface requirements. (A follow-on study will expand greatly on the scope of this preliminary study.) The integration requirements of the alternative technologies may be different from those of the baselined technologies. If this is the case, then by designing the initial space station to have the necessary fluid lines, etc. required by the selected alternative technologies then the task of replacing the baselined ones will be greatly simplified, thereby reducing the cost in on-orbit time as well as dollars.



## Technology For Space Station Evolution – A Workshop



---

### Space Station *Freedom* Evolution Impact on the ECLSS

- Space Station *Freedom* will evolve over its 30 year or more lifetime, as pressurized modules are added, crew numbers increase, and as the tasks to be performed change.
- Requirements placed on the ECLSS will also change.
- During this time technological advances will lead to improved life support hardware which is better able to meet the new requirements.
- Replacing the initial hardware with the improved technologies will be simplified if the integration requirements of the improved technologies are built into the initial *Freedom* design.
- To better understand the integration requirements a preliminary study was performed to identify the fluid line interface requirements of the advanced technologies most likely to replace the initial technologies.

# Technology For Space Station Evolution – A Workshop



---

This page intentionally blank.

## Technology For Space Station Evolution – A Workshop



---

### Advanced ECLSS Technology: Benefits and Integration Requirements

- Benefits of Advanced ECLSS Technologies:
  - Better performance
  - Increased reliability
  - Reduced power consumption, weight, and volume
  - Greater autonomy
  - Fewer resupply requirements
  
- Integration Requirements of Advanced ECLSS Technologies:
  - System-level integration needs
  - Fluid interface requirements
  - Electrical power requirements
  - Thermal control requirements
  - Control/data requirements
  - Resupply needs



---

## II. Objectives of the Study

The objectives of the preliminary study were to provide answers to some basic questions:

- (1) What requirements will be placed on the ECLSS in the future?
- (2) How will these requirements differ from the initial *Freedom* ECLSS requirements?
- (3) What constraints will affect the ECLSS?
- (4) What technologies will be available to meet the future ECLSS requirements?
- (5) What are the integration requirements of the alternative technologies?
- (6) How do these integration requirements differ from those of the baselined ECLSS subsystems?
- (7) What "scars" would facilitate transparent incorporation of the alternative technologies?



---

## Objectives of the Study

The objectives of the preliminary study were to answer some basic questions:

- (1) What requirements will be placed on the ECLSS in the future?
- (2) How will these requirements differ from the initial *Freedom* ECLSS requirements?
- (3) What constraints will affect the ECLSS?
- (4) What technologies will be available to meet the future ECLSS requirements?
- (5) What are the integration requirements of the alternative technologies?
- (6) How do these integration requirements differ from those of the baselined ECLSS subsystems?
- (7) What "scars" would facilitate transparent incorporation of the alternative technologies?

# Technology For Space Station Evolution – A Workshop



### III. Approach Used

A two-part approach was used to identify the requirements placed on the future ECLSS and to identify and evaluate alternative technologies for their abilities to meet those needs.

#### A. Identification of Future ECLSS Requirements

The NASA documents which define the initial space station design and possible growth scenarios were reviewed for identification of the ECLSS requirements. These documents include: Space Station Program Definition and Requirements Document (PDRD) SSP 30000, Sec. 3; Space Station Mission Requirements Data Base (MRDB); the Space Station Systems Requirements Document, SS-SRD-0001, Sec. 3; MSFC Logistics System Evolution Study; and Growth Requirements for Multidiscipline Research and Development on the Evolutionary Space Station, NASA TM 101497.

From these documents groundrules and assumptions were derived and scenarios which are representative of the most likely evolution paths were identified. It was then possible to identify ECLSS associated constraints.

# Technology For Space Station Evolution – A Workshop



---

## Two-Part Approach

- Identify Future ECLSS Requirements
  - Review of NASA documents defining the space station design and growth scenarios
  - Derive groundrules and assumptions affecting the ECLSS
  - Identify scenarios representative of the most likely evolution paths
  - Identify constraints associated with the ECLSS
- Identify and Evaluate Alternative Technologies
  - Define the ECLSS functions to be considered
  - Identify alternative technologies to perform those functions
  - Evaluate the integration requirements of the alternative technologies
  - Determine the "scars" needed to allow for easy replacement of the baseline technologies

# Technology For Space Station Evolution – A Workshop



## 1. Groundrules and Assumptions

The groundrules and assumptions used as a basis for the study are:

- (1) The ECLSS will provide the capability to depressurize and repressurize all airlocks and hyperbaric airlocks, and will be responsible for makeup of gases lost during airlock operations.
- (2) The ECLSS will be responsible for the supply of Extravehicular Mobility Unit (EMU) potable water, oxygen, and air, and for processing of the EMU CO<sub>2</sub>, urine, and condensate water.
- (3) The ECLSS will be responsible for animal habitat requirements [but the Process Materials Management System (PMMS) will be responsible for experiment (ultrapure) water].
- (4) The ECLSS will be responsible for animal laboratory requirements [but the Fluid Management System (FMS) will be responsible for experiment makeup water].
- (5) The ECLSS will grow by module, i.e., all full sized Lab and Hab modules will contain the same ECLSS equipment as the baseline.
- (6) All pressurized elements (modules, resource nodes, airlocks, pocket labs, etc.) will contain Temperature and Humidity Control (THC) subsystems.
- (7) Intermodule ventilation will use a series/parallel scheme, with the resource nodes serving as plenums for supplying air to the attached pressurized elements.
- (8) EMU-type ECLSS support will be provided to all manned transfer vehicles.



## Technology For Space Station Evolution – A Workshop



---

### Groundrules and Assumptions

The groundrules and assumptions used as a basis for the study are:

- (1) The ECLSS will provide the capability to depressurize and repressurize all airlocks and hyperbaric airlocks, and will be responsible for makeup of gases lost during airlock operations.
- (2) The ECLSS will be responsible for the supply of Extravehicular Mobility Unit (EMU) potable water, oxygen, and air, and for processing of the EMU CO<sub>2</sub>, urine, and condensate water.
- (3) The ECLSS will be responsible for animal habitat requirements.
- (4) The ECLSS will be responsible for animal laboratory requirements.
- (5) The ECLSS will grow by module, i.e., all full sized Lab and Hab modules will contain the same ECLSS equipment as the baseline.
- (6) All pressurized elements (modules, resource nodes, airlocks, pocket labs, etc.) will contain Temperature and Humidity Control (THC) subsystems.
- (7) Intermodule ventilation will use a series/parallel scheme, with the resource nodes serving as plenums for supplying air to the attached pressurized elements.
- (8) EMU-type ECLSS support will be provided to all manned transfer vehicles.

# Technology For Space Station Evolution – A Workshop



---

## 2. Representative Evolution Scenarios and ECLSS Associated Constraints

Two evolution scenarios, the Multi-Discipline Research Scenario and the Transportation Node Scenario, were used as a basis for defining the requirements that will be placed on the ECLSS in the future. Constraints affecting the ECLSS could then also be identified.

### a. Multi-Discipline Research Scenario

The Multi-Discipline Research Scenario provides: "pressurized volume, payload attach points, crew time, electrical power and other essential resources to a diverse user community in support of their scientific research, technology development and commercial endeavors in space." (NASA TM 101497)

For this scenario the number of connected pressurized modules could increase to as many as 6 Lab modules and 3 Hab modules, with the necessary nodes to connect them and up to 3 pocket labs in addition. The crew size could increase to as many as 24 or more, to operate the experiments and operate and maintain *Freedom*.

It is expected that some experiments may require large amounts of EVA time occasionally, for example, during setup or servicing.



---

## Multi-Discipline Research Scenario

- The Multi-Discipline Research Scenario provides: "pressurized volume, payload attach points, crew time, electrical power and other essential resources to a diverse user community in support of their scientific research, technology development and commercial endeavors in space." (NASA TM 101497)
- Features Affecting the ECLSS:
  - Up to 6 Lab modules, 3 Hab modules, nodes, and 3 pocket labs
  - Crew size: 24 or more
  - Large amounts of EVA time occasionally (during experiment setup or servicing)

## Technology For Space Station Evolution – A Workshop



---

### b. Transportation Node Scenario

The Transportation Node Scenario is less well defined at this time. For this scenario *Freedom* serves as a waypoint for missions beyond Low Earth Orbit (LEO). Tasks to be performed include servicing of transfer vehicles, assembly of large spacecraft, and processing of returned payloads.

Large amounts of EVA time on a regular basis are associated with using *Freedom* as a transportation node. Using the present airlock design, a two-person EVA transfer would involve up to 10% air loss by volume per cycle. For servicing of the Lunar Transfer Vehicle (LTV), which would require up to 40 hours per day, about 10 pounds of resupply air per day are required.

One scenario for the transportation node includes an isolated Hab module remote from the main cluster, with two nodes and an airlock, for use by four crew members dedicated to vehicle buildup and servicing tasks.

## Technology For Space Station Evolution – A Workshop



---

### Transportation Node Scenario

- The Transportation Node Scenario is less well defined at this time. For this scenario *Freedom* would serve as a waypoint for missions beyond low Earth orbit. Tasks to be performed include servicing of transfer vehicles, assembly of large spacecraft, and processing of returned vehicles and payloads.
- Features Affecting the ECLSS:
  - Large amounts of EVA time on a regular basis (up to 40 hours per day for servicing of the Lunar Transfer Vehicle)
  - Increased resupply of lost air and water



---

**c. ECLSS Associated Constraints**

There are various constraints associated with different growth scenarios. Critical factors which affect the ECLSS include available power, crew time for maintenance, and launch mass (for resupply needs). Safe haven considerations require that, in an emergency, a single ECLS subsystem group be capable of supporting eight people. Module growth patterns may be limited by the IMV system. Increases in crew size and the number of modules are to maintain a 4:1 crew to US module ratio or an 8:1 crew to US Hab module ratio.



---

## Constraints Affecting the ECLSS

- Critical factors affecting the ECLSS include:
  - Available power
  - Crew time for maintenance
  - Launch mass for resupply
- Safe haven requirements
- Module growth
  - Growth patterns may be limited by the Intermodule Ventilation system
  - A ratio of 4:1 crew members to number of U. S. modules, or 8:1 crew to U. S. Hab modules, is to be maintained

# Technology For Space Station Evolution – A Workshop



---

## B. Identification and Evaluation of Alternative Technologies

Alternative technologies for each ECLSS task were identified and those that could be developed to perform the ECLSS tasks were evaluated for their integration needs. The fluid line interface needs were then compared with those of the baseline ECLSS and the "scars" required to permit replacement subsystems with alternative subsystems were identified.

### 1. ECLSS Functions Considered

The ECLSS consists of several tasks, each consisting of one or more functions: Air Revitalization, Water Recovery and Management, Atmosphere Control and Supply, Temperature and Humidity Control, Fire Detection and Suppression, and Waste Management. The ECLSS functions considered in this study are: CO<sub>2</sub> removal, CO<sub>2</sub> reduction, O<sub>2</sub> generation, trace contaminant control, urine recovery, potable water recovery, hygiene water recovery, and waste management.



# Technology For Space Station Evolution – A Workshop



361

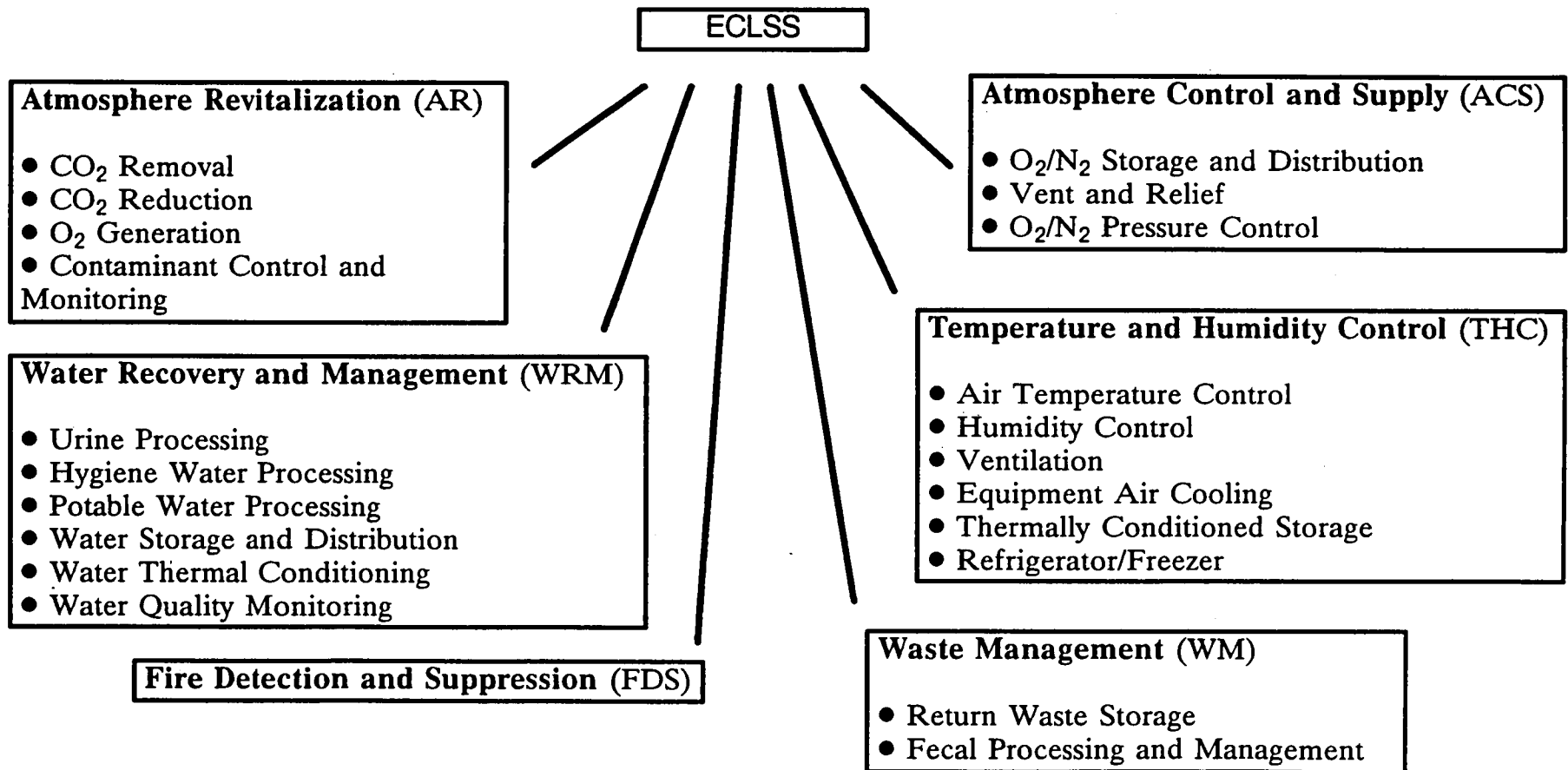

# Technology For Space Station Evolution – A Workshop



---

## 2. Identification of Alternative Technologies

Alternative technologies for the ECLSS tasks were identified by reviewing technical papers and reports (NASA and other) and through contacts with scientists and engineers working on ECLSS technology development.

## 3. Evaluation of the Integration Needs of Each Technology

After identifying the alternative technologies and developing a basic understanding of how each works or would work the next step was identification of the integration requirements, focusing on the fluid interface requirements.

## 4. Determination of the "Scars" Required for Each Technology

The fluid interface requirements of the new technologies were then compared with those of the baseline technologies and the ones not needed by the baseline technologies were identified. These then determine the required "scars."



---

## Identification and Evaluation of Alternative Technologies

- Identification of Alternative Technologies
  - Literature search: review of technical papers and reports
  - Contacts with scientists and engineers working on ECLSS technology development
- Evaluation of the Integration Needs
  - Basic understanding of the alternative technologies
  - Identify the integration needs of each, focusing on the fluid interface requirements
- Determination of the Fluid Interface "Scars" Required
  - Compare the interfaces of the alternative and baseline technologies
  - The interfaces not required by the baseline technologies then determine what "scars" will be required



#### IV. Results

##### A. Database of the Alternative Technologies

A database was created, and computerized, with descriptions, of the alternative technologies and the references where the information was obtained. This database will be expanded as more information becomes available.

##### B. Types of "Scars" Identified

The "scar" requirements for the alternative technologies fall into three general levels: (1) intrarack, (2) interrack (rack interface plate), and (3) module or cluster level. It is assumed that replacement of the ECLSS hardware would occur at the rack level, therefore "scars" at the intrarack level can be ignored. At the interrack or rack interface plate level there may be a need to add extra fluid lines (for example, to provide cooling water not originally needed) or to oversize the tubing or ducting to accommodate a higher flow rate than initially required. On the module or cluster level, additional ECLSS resupply tanks or an additional tank farm (with associated valves, pressure regulators, instrumentation, etc.) may be needed in order to meet the requirements of high levels of EVA and airlock usage.

##### C. Issues and Areas for Further Study

The results of the preliminary study identified several issues and areas to be studied further. More definitive data is needed on the Transportation Node Scenario to adequately determine the requirements and constraints on the ECLSS. Additional Intermodule Ventilation (IMV) analyses are needed in order to evaluate the effects of adding modules in various configurations. The effects of various crew distributions on the  $pCO_2$  and  $pO_2$  levels is also needed. Safe haven requirements may change as *Freedom* evolves and this needs to be evaluated further.

##### D. Scope of the Follow-on Study

The follow-on study will greatly expand the scope of the preliminary study in several ways:

- (1) Computer models of the alternative technologies will be developed and incorporated into existing analysis tools,
- (2) A prioritized list of the potential technologies will be developed and a more thorough assessment of the software control "hooks" and hardware "scars" performed,
- (3) A comparative analysis will be performed against the baseline system, and
- (4) Cost/benefit trade studies will be performed to identify the best candidates to replace the baseline technologies.

## Technology For Space Station Evolution – A Workshop



---

### Results

- Database of Alternative Technologies
- Three Levels of "Scars" Identified
  - Intrarack
  - Interrack
  - Module or cluster
- Issues and Areas for Further Study
  - More definition of the Transportation Node Scenario is needed
  - Additional analyses of Intermodule Ventilation are needed to evaluate the effects of adding modules in various patterns
  - Additional analysis of the effects of crew distribution is needed
  - Possible changes to Safe Haven requirements as *Freedom* evolves need to be evaluated
- Expanded Scope of the Follow-on Study
  - Computer models of the alternative technologies will be developed and incorporated into existing analysis tools,
  - A prioritized list of the potential technologies will be developed and a more thorough assessment of the software control "hooks" and hardware "scars" performed,
  - A comparative analysis will be performed against the baseline system, and
  - Cost/benefit trade studies will be performed to identify the best candidates to replace the baseline technologies.

Technology for Space Station Evolution Workshop  
Dallas, Texas - January 16-19, 1990

Title:

# TECHNOLOGIES FOR ECLSS EVOLUTION

Presenter:

**Bryce L. Diamant**  
McDonnell Douglas Space Systems Company  
Huntsville, Alabama

Performed under contract NAS8-36407 for NASA MSFC

PRECEDING PAGE BLANK NOT FILMED

367

FOR INTENTIONAL USE

366

516-54  
163608  
76  
N93-27720

TECHNOLOGY FOR SPACE STATION EVOLUTION WORKSHOP  
Dallas, Texas - January 16-19, 1990

Presentation Title

TECHNOLOGIES FOR ECLSS EVOLUTION

Presenter

Bryce L. Diamant - Engineer  
McDonnell Douglas Space Systems Company  
Huntsville, Alabama  
(205) 721-7274

Introduction

In this presentation characteristics of existing and advanced physio-chemical technologies are discussed for the Atmosphere Revitalization (AR), Water Recovery and Management (WRM), and Waste Management (WM) subsystems of the Space Station Freedom Environmental Control and Life Support System (ECLSS). All technologies discussed have undergone some degree of experimental testing, and many competed for the space station ECLSS baseline. The primary qualitative advantages and disadvantages of each technology are summarized. Technologies are discussed for the following systems: CO<sub>2</sub> removal, CO<sub>2</sub> reduction, O<sub>2</sub> generation, trace contaminant control, urine processing, hygiene water processing, potable water processing, and waste processing.

# OVERVIEW

## Introduction:

Existing and advanced physio-chemical technologies are discussed for the Atmosphere Revitalization (AR), Water Recovery and Management (WRM), and Waste Management (WM) subsystems of the space station ECLSS.

## Main Body:

Discuss operation, advantages, disadvantages of following:

### I. Atmosphere Revitalization (AR)

CO<sub>2</sub> Removal  
CO<sub>2</sub> Reduction  
O<sub>2</sub> Generation  
Trace Contaminant Control

### II. Water Recovery and Management (WRM)

Urine Processing  
Hygiene Water Processing  
Potable Water Processing

### III. Waste Management (WM)

## Summary:

List of technologies.



## CO<sub>2</sub> Removal

### *Baseline Technology*

#### **Four-Bed Molecular Sieve (4BMS)**

The 4BMS is composed of two adsorbing sorbent beds, one a desiccant bed for water vapor removal, the other a Zeolite 5A molecular sieve for trapping CO<sub>2</sub>. This bed pair operates in parallel with an identical pair of beds in the desorbing mode. Adsorption of CO<sub>2</sub> from the process air is accomplished at low temperature. The adsorbing bed is then heated to desorb the CO<sub>2</sub> to a reduction device. The 4BMS is a mature, flight-proven technology. A similar system was flown on Skylab, where CO<sub>2</sub> was desorbed to space. The 4BMS has no significant impacts on other space station systems, although its power requirement and volume are higher than other available technologies.

### *Candidate Substitute Technologies*

#### **Solid Amine Water Desorbed (SAWD)**

The SAWD operates similarly to the 4BMS, although no desiccant beds are required. The SAWD uses steam-heated solid amine (WA-21) beds to adsorb CO<sub>2</sub>. Desorption is accomplished by steam-heating the CO<sub>2</sub>-laden beds. Solid amines degrade more rapidly than Zeolites, decreasing bed efficiency and increasing bed changeout frequency and resupply. SAWD also penalizes the ECLSS by requiring hygiene water, which is eventually vented in vapor form to the Temperature and Humidity Control System (THC), increasing the load on the cabin condensing heat exchanger. Since condensate is used for potable water, the loss of hygiene water due to the SAWD appears as a gain in the potable supply. SAWD has the advantage that desorption takes place at cabin pressure rather than at the near vacuum conditions required by the 4BMS.

#### **Electrochemical Depolarized CO<sub>2</sub> Concentrator (EDC w/H<sub>2</sub>)**

The EDC reacts H<sub>2</sub> and O<sub>2</sub> inside an electrochemical cell with cabin air containing CO<sub>2</sub>, producing two output streams. The reaction is :

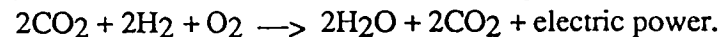

The output from the anode-side cavity of the cell has a high concentration of CO<sub>2</sub> and some H<sub>2</sub>, while the cathode-side cavity output contains air with a low CO<sub>2</sub> concentration that is returned to the cabin. The EDC eliminates inefficient cycling required by technologies that must repeatedly heat and cool adsorbing/desorbing beds. EDC has the disadvantages of consuming oxygen and producing water vapor, increasing the respective loads on the oxygen generation and humidity control systems. EDC is also a safety hazard due to the potential for hydrogen leakage into the cabin atmosphere, which could lead to a fire or explosion. No other CO<sub>2</sub> removal technology employs H<sub>2</sub> in the removal process.

# AR - CO<sub>2</sub> REMOVAL

## *Baseline Technology*

### **Four-Bed Molecular Sieve (4BMS)**

- + Mature flight-proven technology.
- + Low system impacts.
- High power and volume.

## *Candidate Substitute Technologies*

### **Solid Amine Water Desorbed (SAWD)**

- + Only two sorbent beds required, reducing complexity relative to the 4BMS.
- + Ambient pressure desorption. Vacuum pressures not required.
- Impacts to Temperature and Humidity Control system and hygiene water supply.
- Degradation of solid amine beds reduces efficiency and increases resupply.

### **Electrochemical Depolarized Concentrator (EDC w/H<sub>2</sub>)**

- + Eliminates inefficient cycling.
- Potential for hydrogen leakage is safety concern.
- System impacts on O<sub>2</sub> Generation and Temperature and Humidity Control systems.

## CO<sub>2</sub> Removal

### **Air Polarized CO<sub>2</sub> Concentrator (APC or EDC w,wo/H<sub>2</sub>)**

This technology is simply an EDC not requiring H<sub>2</sub> for the CO<sub>2</sub> removal process. The capability to operate without hydrogen reduces the safety concern, although the APC will likely alternate between operating with and without hydrogen to minimize system power requirements. However, switching between operating with and without H<sub>2</sub> accelerates degradation of the cell electrode catalyst. The APC requires an O<sub>2</sub>/CO<sub>2</sub> separator, slightly increasing its weight, power, volume, and complexity relative the EDC.

### **Two-Bed Molecular Sieve (2BMS)**

The 2BMS is similar to the 4BMS, although the 2BMS utilizes a carbon molecular sieve (CMS) instead of Zeolite to adsorb CO<sub>2</sub>. CMS material preferentially adsorbs CO<sub>2</sub> over water vapor, eliminating the need for the two desiccant beds found in the 4BMS. This reduces system power, weight, volume, and complexity relative to the 4BMS without any additional system impacts. CMS material also desorbs at a lower temperature than Zeolite, further decreasing power requirements. The 2BMS is still under development.

### **Membranes**

The use of membrane technology to effectively concentrate CO<sub>2</sub> would likely result in a simple, light, small, low power CO<sub>2</sub> removal system. However, the gas selectivity of current membrane technology is inadequate. Instead of filtering all other gases besides CO<sub>2</sub> from the process air to produce a stream of high CO<sub>2</sub> concentration, the membranes also filter out some CO<sub>2</sub> and return it to the cabin. This inefficient process requires large membranes to remove relatively small quantities of CO<sub>2</sub>.

# AR - CO<sub>2</sub> REMOVAL

## Air Polarized CO<sub>2</sub> Concentrator (APC or EDC w,wo/H<sub>2</sub>)

- + Safety concern reduced.
- W/Wo H<sub>2</sub> operation reduces power consumption, but accelerates electrode catalyst degradation.
- O<sub>2</sub>/CO<sub>2</sub> separator decreases power, weight, volume relative to EDC w/H<sub>2</sub>.
- Advanced version of EDC still under development.

## Two-Bed Molecular Sieve (2BMS)

- + Elimination of desiccant beds reduces system power, weight, volume, complexity.
- + Carbon molecular sieve desorbs at lower temperature than Zeolite, reducing power usage.
- System still under development.

## Membranes

- + Potential for low weight, power, volume, complexity.
- Highly inefficient due to poor gas selectivity.

## CO<sub>2</sub> Removal

### **Fluid Interfaces**

The space station must be designed to easily incorporate advanced technologies that could foreseeably replace the baseline technologies in the future. Designing the station for easy on-orbit technology replacement is referred to as scarring the station. Scarring ensures that all interfaces required by an advanced technology will be available when it comes time to replace the old technology. These interfaces include any fluid interfaces, such as a line to the liquid coolant loop, a gas vent line to trace contaminant control, or a CO<sub>2</sub> output line to the Bosch. Fluid interfaces for advanced technologies not required by the baseline technology are plumbed from the module standoffs to the rack(s) expected to house the future technologies and capped off. These temporarily unused fluid lines are station scars. The included table is a list of the fluids input to and output from CO<sub>2</sub> technologies. These fluid interfaces were obtained by studying available schematics for each technology. Similar tables for the other subsystems (urine processing, trace contaminant control, etc.) are included in this packet, but are not presented.

# CO<sub>2</sub> REMOVAL FLUID INTERFACES

TECHNOLOGY	FLUID INTERFACES	
	LINE IN	LINE OUT
Four-Bed Molecular Sieve	Cabin Air Liquid Coolant	Return Air CO <sub>2</sub> , Liquid Coolant
Two-Bed Molecular Sieve	Cabin Air Liquid Coolant	Return Air CO <sub>2</sub> , Liquid Coolant
EDC	Cabin Air, N <sub>2</sub> Purge Liquid Coolant, H <sub>2</sub>	Return Air, H <sub>2</sub> /CO <sub>2</sub> , Liquid Coolant
SAWD	Cabin Air Hygiene Water	Return Air Steam Pressure Vent, CO <sub>2</sub>
APC	Cabin Air Liquid Coolant H <sub>2</sub> , N <sub>2</sub> Purge	Return Air, H <sub>2</sub> /CO <sub>2</sub> Liquid Coolant
Membranes	Cabin Air	Return Air CO <sub>2</sub>

## CO<sub>2</sub> Reduction

### *Baseline Technology*

#### **Bosch Reactor**

Carbon dioxide is reacted with hydrogen at high temperature (1050°F) in the presence of a nickel catalyst, producing solid waste carbon and water for the potable supply. The reaction is:

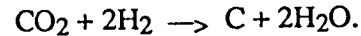

A single pass through the Bosch reactor reduces only about 11% of the input CO<sub>2</sub>, with efficiency decreasing as carbon builds up in the collection cartridges. Complete, 100% conversion is achieved by continuously recirculating the process gases. Bosch carbon cartridges must be resupplied; however, the issue of carbon cartridge replacement vs. replacement of the entire core reactor is still undecided.

### *Candidate Substitute Technologies*

#### **Sabatier Reactor**

Carbon dioxide is reacted with hydrogen at high temperature in the presence of a ruthenium catalyst on a granular substrate, producing methane and water. The reaction is:

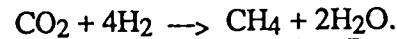

Sabatier has the advantage of being smaller and requiring much less power than Bosch; however, the toxic methane it produces must be vented to space or stored at a high weight and volume penalty. Both of these methods are currently impractical. Sabatier would be a very attractive technology if its product methane could be used as a propellant for space station attitude control resistojets. The Sabatier reactor has a conversion efficiency greater than 98%; however, anything less than 100% results in the loss of oxygen molecules in the form of unreacted CO<sub>2</sub>. Loss of O<sub>2</sub> combined with loss of H<sub>2</sub> in the product CH<sub>4</sub> is a costly disadvantage of Sabatier. The water and oxygen supplies will be slowly depleted, ultimately necessitating increased resupply.

#### **Advanced Carbon Reactor (ACR)**

The ACR consists of a Sabatier reactor, a gas/liquid separator to remove product water from methane, and a carbon formation reactor (CFR) to reduce methane to carbon and hydrogen. The reaction inside the carbon formation reactor is:

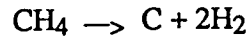

The ACR carbon collection cartridges pack carbon more neatly than the Bosch, reducing resupply. A disadvantage of the ACR is that both the catalytic and pyrolytic versions of the CFR operate above 1600°F, which may present materials problems. The ACR is still under development.

#### **CO<sub>2</sub> Electrolysis**

See the section on O<sub>2</sub> Generation. CO<sub>2</sub> electrolysis is a dual-function technology, where CO<sub>2</sub> is reduced to produce oxygen. CO<sub>2</sub> electrolysis does not require hydrogen as a reactant for the reduction process, although it therefore produces no water for the potable supply. Some hydrogen will appear in the output stream due to electrolysis of water vapor.

# AR - CO<sub>2</sub> REDUCTION

## *Baseline Technology*

### Bosch Reactor

- + 100% CO<sub>2</sub> conversion.
- Single pass CO<sub>2</sub> conversion efficiency only 11%.
- Carbon collection device must be resupplied.

## *Candidate Substitute Technologies*

### Sabatier Reactor

- + Potential for lowest weight, power, volume.
- Incomplete CO<sub>2</sub> conversion necessitates water resupply.
- High weight and volume penalty for waste gas storage.

### Advanced Carbon Reactor (ACR)

- + High density carbon packing reduces resupply.
- High temperature operation may present materials problems.
- Technology still under development.

### CO<sub>2</sub> Electrolysis

- + Dual function technology.
- + Electrolysis of water vapor reduces humidity.
- + H<sub>2</sub> not required as a reactant.
- Water not produced for the potable supply.
- Potential for carbon monoxide leakage.
- High operating temperatures present materials problems.
- Requires Boudouard reactor.
- New technology still under development.



## O<sub>2</sub> Generation

### *Baseline Technology*

#### **Static Feed Water Electrolysis (SFWE)**

The SFWE electrolyzes hygiene water to produce oxygen. The reaction is:

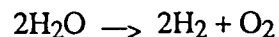

Water resting statically in a feed compartment diffuses as a vapor through the water feed membrane and into an aqueous KOH electrolyte. This passive water feed mechanism has the advantage of no moving parts. Oxygen gas is produced at the anode of the electrolysis cell, while hydrogen is produced at the cathode. Product hydrogen is sent to the CO<sub>2</sub> reduction system. The SFWE is a mature technology that has been tested extensively.

### *Candidate Substitute Technologies*

#### **Liquid Anode Feed Solid Polymer Electrolysis (SPE)**

Similar in concept to the SFWE, the SPE electrolyzes water using a solid polymer electrolyte (sulfonated perfluoro-linear polymer). SPE requires that feed water be in direct contact with the cell anode to provide cooling during the electrolysis process. The need for two liquid/gas separators and a deionizer bed increases SPE system complexity relative to the SFWE. The deionizer is needed to remove contaminants from the hygiene feed water that could otherwise corrode the anode. SPE cell stack technology has been tested extensively, and has been used successfully in submarines.

#### **CO<sub>2</sub> Electrolysis**

CO<sub>2</sub> electrolysis is a dual-function technology, simultaneously performing carbon dioxide reduction and oxygen generation. By combining two functions into one technology, total AR system weight, power, volume, and complexity may be reduced. CO<sub>2</sub> is electrolyzed using a solid oxide electrolyzer, producing O<sub>2</sub> and CO. The electrolysis cell reaction is:

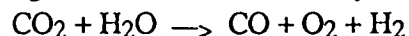

CO is then catalytically decomposed in a Boudouard reactor into solid carbon and CO<sub>2</sub>, and this CO<sub>2</sub> is recycled to the electrolysis unit. Water vapor in the process stream is also electrolyzed, which helps control cabin humidity. CO<sub>2</sub> electrolysis places no burden on the hygiene water supply, virtually eliminating two-phase (liquid/gas) processing, although it penalizes the potable water supply by being the only technology performing CO<sub>2</sub> reduction that does not produce potable water. CO<sub>2</sub> electrolysis operates at very high temperatures (above 1600°F), presenting materials problems, and may have the potential for dangerous carbon monoxide leakage. The CO<sub>2</sub> electrolyzer and particularly its associated Boudouard reactor are new technologies requiring further development.

#### **Water Vapor Electrolysis (WVE)**

WVE electrolyzes water vapor directly from cabin air, producing oxygen and hydrogen. Cabin air containing moisture is fed to the anode-side compartment of the SFWE-style electrolysis cell, producing an O<sub>2</sub>-enriched stream at the anode and hydrogen at the cathode. WVE helps control cabin humidity and, having few interfaces, lends itself as a portable technology to augment the central O<sub>2</sub> generation system for situations when additional oxygen is needed, such as when the crew gathers for a significant period of time.

# AR - O<sub>2</sub> GENERATION

## *Baseline Technology*

### Static Feed Water Electrolysis (SFWE)

- + Extensively tested, mature technology.
- + Passive water feed mechanism has no moving parts.

## *Candidate Substitute Technologies*

### Liquid Anode Feed Solid Polymer Electrolysis (SPE)

- + Extensively tested, mature cell stack technology.
- Two liquid/gas separators and a deionizer increase system complexity.

### CO<sub>2</sub> Electrolysis

- + Dual function technology.
- + No penalty to the hygiene water supply.
- + Eliminates two-phase (liquid/gas) processing.
- + Electrolysis of water vapor reduces cabin humidity.
- Potential for carbon monoxide leakage.
- High operating temperatures present materials problems.
- Requires Boudouard reactor.
- New technology requiring further development.

### Water Vapor Electrolysis (WVE)

- + Helps control cabin humidity.
- Potential as a portable technology to augment centralized system.

## Trace Contaminant Control

### *Baseline Technology*

#### **Carbon Adsorption Beds with Catalytic Oxidizer**

Charcoal (carbon) adsorption beds coupled with platinum catalytic oxidizers remove trace contaminants, such as freons and aromatics, from cabin air. The charcoal beds, similar to those found on previous manned space flight missions, are expendable, incurring a large resupply penalty. This costly disadvantage may eventually be eliminated by developing a safe regenerable system. Pre and post sorbents are required for the oxidizer to prevent catalyst poisoning by halogenated hydrocarbons and acidic gases, such as sulfur oxides. These additional sorbents increase system complexity.

### *Candidate Substitute Technologies*

#### **Reactive Bed Plasma (RBP)**

RBP decomposes contaminants at low temperature (250°F) using a synergistic combination of plasma and catalyst. Process air passes through an annular reactor filled with alumina catalyst, where it is electrically ionized into plasma. The main function of the catalyst is to increase the time contaminant molecules spend in the active plasma region, where plasma-generated high energy electrons and subsequently produced species (mainly active oxygen) oxidize toxic materials. In addition, RBP can perform as a highly efficient electrostatic precipitator to collect and deactivate hazardous particulate material. The RBP system includes low temperature (150°F) regenerable post-treatment of toxic reaction products, particularly nitrous oxides. RBP completely reduces methane, and the system is very difficult to poison. The RBP system currently has a high power requirement of about 1000 W. Another disadvantage is that RBP performance may be degraded by electromagnetic interference, although the magnitude of this problem is presently unclear. RBP is currently under development.

# AR - TRACE CONTAMINANT CONTROL

## *Baseline Technology*

### **Carbon Adsorption Beds with Catalytic Oxidizer**

- + Highly mature technology.
- Expendable charcoal beds incur a large resupply penalty.
- Pre/post sorbents for oxidizer are required to avoid catalyst poisoning.

## *Candidate Substitute Technologies*

### **Reactive Bed Plasma (RBP)**

- + Acts as a highly efficient electrostatic precipitator.
- + Low temperature (250°F) operation.
- + Complete methane reduction.
- + Extremely difficult to poison.
- High power requirement.
- Conversion of CO to CO<sub>2</sub> burdens the CO<sub>2</sub> reduction system.
- Performance may be degraded by electromagnetic interference.
- New system currently under development.

## Urine Processing

### *Baseline Technology*

#### **Thermoelectric Integrated Membrane Evaporation Subsystem (TIMES)**

Before entering the TIMES unit, process urine/flush water is pretreated with oxone and sulfuric acid to fix free ammonia, inhibit microbial growth, control odor, and reduce foaming. The pretreated urine/flush water enters the TIMES through two parallel heat exchangers in contact with the hot side of a thermoelectric heat pump. The heated waste water then flows through hollow fiber membranes that make up the evaporator section of the subsystem, consisting of 600 Nafion tubes assembled into six bundles of 100 tubes each. Long term reliability of the joints connecting the Nafion tubes to the bundle headers is currently a TIMES concern. Water diffuses through the membranes and evaporates from their outer surfaces, which are maintained at low pressure. This steam flows to the main condenser, which is in contact with the cold side of the thermoelectric heat pump. Partially condensed, the steam then flows to an air-cooled heat exchanger, where the condensation process is completed. Latent heat is recovered and reused in the evaporative process. The condensate is tested for water quality and, if acceptable, is delivered as product water to the hygiene processor by a centrifuge-type pump. The pump acts as a gas/liquid separator since it removes non-condensable gases entrained in the condensate stream. Unacceptable condensate is reprocessed. With water recovery efficiency less than 100% (90-95%), the TIMES process involves brine storage, which is a weight, volume, and resupply penalty.

### *Candidate Substitute Technologies*

#### **Vapor Compression Distillation (VCD)**

VCD maintains a vapor/liquid interface using centrifugal force created by a rotating drum. This is more complicated than the static phase separation process employed by the TIMES. Water is evaporated from a thin film of process waste water flowing over the inner surface of a rotating evaporator/condenser drum. The water vapor is compressed, raising its saturation temperature, then directed out of the drum and against its outside surface, where it condenses. The latent heat of condensation is transferred passively from the outside to the inside of the drum through its thin metallic wall, providing the latent heat required to evaporate the next batch of incoming waste water. This passive latent heat transfer makes VCD an energy efficient process. After startup, the only energy used by the process is for water vapor compression and for overcoming mechanical and thermal inefficiencies. Unevaporated waste water is recirculated until the solids concentration builds up to a predetermined level, at which time the concentrated brine is removed for storage. The VCD brine storage penalty is nearly identical to that of the TIMES. A disadvantage of VCD is that its rotating/vibrating parts may create forces that could disrupt the space station microgravity environment. Additionally, mechanical reliability of the peristaltic feed pump is still in question.

# WRM - URINE PROCESSING

## *Baseline Technology*

### Thermoelectric Integrated Membrane Evaporation Subsystem (TIMES)

- + Waste water phase separation is a static process.
- Membrane mechanical reliability questionable over long term.
- Less than 100% water recovery necessitates brine storage.

## *Candidate Substitute Technologies*

### Vapor Compression Distillation (VCD)

- + Produces slightly higher water quality and processes higher flow rates than TIMES.
- + Lowest power consumption due in part to passive latent heat recovery.
- Dynamic waste water phase separation more complex than TIMES static separation.
- Less than 100% water recovery necessitates brine storage.
- Mechanical reliability of peristaltic feed pump questionable.

## Urine Processing

### **Air Evaporation System (AES)**

In the AES, pretreated urine is pumped through a particulate filter to a wick package using a pulse feed technique. The pulse and urine flow rate are controlled by a feed pump that responds to the relative humidity of air leaving the wick package and the amount of liquid processed. Sufficient time is provided between pulses to allow the volume of urine to be distributed before the next pulse. A circulating heated air stream evaporates water from the urine, leaving urine solids in the wicks. When sufficient urine solids accumulate in the wicks, the feed pump is shut off and the loaded wicks are dried down and replaced with a new wick package. Storage of spent wick packages is likely to require less volume than brine storage. During dry-down, humid air leaving the wick package passes through a condensing heat exchanger. A water separator downstream of the condenser removes water from the air stream and pumps it to the product water loop. The complete dry-down procedure results in nearly 100% water recovery. Precise waste water feed control is critical to water recovery efficiency. Feeding too much waste water will saturate the sponge-like wicks, causing waste water to drip off the wicks and continue downstream before entrained contaminants can be absorbed. The complex feed control still requires further development. The AES was tested successfully in manned chamber tests by McDonnell Douglas in the late 1960's, and involves a relatively simple, reliable process. The AES operates at ambient pressure, eliminating potential leakage problems and system impacts associated with vacuum pressures. AES is tolerant of solid precipitates, eliminating the need for an oxidizing pretreatment. Oxone urine pretreatment is required by the TIMES to keep solid precipitates in solution during processing, but oxone is a corrosive, reactive chemical. Nonoxidizing pretreatments, which are safer and easier to handle than oxone, do not hold solid precipitates in solution. This is ideal for the AES, where solids must precipitate out into the wicks. The main disadvantage of AES is that it is an energy-intensive process, requiring much more power than its competitors. Methods for reducing energy consumption are being studied, all of which will likely increase system complexity.

### **Vapor Phase Catalytic Ammonia Removal (VPCAR)**

VPCAR is based on a catalytic chemical process where impurities that vaporize with the process water are oxidized to innocuous gaseous products. The process employs two catalyst beds. In the first bed ammonia is oxidized to a mixture of nitrogen and nitrous oxide, and volatile hydrocarbons are oxidized to carbon dioxide and water vapor. In the second bed nitrous oxide formed in the first bed is catalytically decomposed into oxygen and nitrogen. VPCAR requires neither pretreatment nor posttreatment. As a first-generation system VPCAR produces higher quality water than its more mature competitors. Recovered water has little ammonia, few hydrocarbons, and low conductivity, requiring only adjustment of its pH to meet potable water standards. VPCAR employs the same potentially unreliable hollow fiber evaporator found in the TIMES, and has the additional disadvantage of operating at high temperatures of up to 850°F. VPCAR also requires brine storage, and the process impacts SFWE operation by consuming oxygen.

# WRM - URINE PROCESSING

## Air Evaporation System (AES)

- + Nearly 100% water recovery
- + Reliable, simple process.
- + Tolerant of solid precipitates. A nonoxidizing pretreatment becomes feasible.
- + Air evaporation loop operates at ambient pressure.
- + Storage of spent wick packages may require less volume than brine storage.
- Energy-intensive process.
- Complex control of wastewater feed to wicks requires further development.

## Vapor Phase Catalytic Ammonia Removal (VPCAR)

- + First-generation system produces higher quality water than more mature competitors.
- + Pre/posttreatment not required.
- Consumes oxygen.
- Less than 100% water recovery necessitates brine storage.
- Operation at high temperature and pressure.
- More complex than other urine processors.
- New technology requiring further development.



## Hygiene Water Processing

### *Baseline Technology*

#### **Reverse Osmosis (RO)**

Non-phase change technologies, such as RO and MF, are chosen for hygiene water processing based on their low specific energy relative to phase change technologies and their ability to more readily process the high flow rates associated with hygiene water use. The RO system consists of an ultrafiltration (UF) unit and RO unit in series, each employing membranes for removing contaminants from waste water. Ultrafiltration is a process that filters most suspended solids and macromolecules, while allowing low molecular weight salts and water to permeate the membrane. As the first stage of the RO system, the primary function of UF is to remove large contaminants that would otherwise foul the RO membranes. In the RO unit a semipermeable membrane separates purified product water from input waste water. A pressure is applied to the waste water in excess of its osmotic pressure, reversing the normal osmosis process. Water spontaneously flows across the semipermeable membrane from the concentrated waste water solution to a less concentrated solution, resulting in product water with a reduced impurity concentration. The RO unit rejects all suspended solids, all macromolecules, and most low molecular weight salts, although current membranes are incapable of removing almost all groups of low molecular weight organics. Contaminant removal by membrane filtration is a more flexible method than removal by sorbent beds. Sorbent beds (employed by multifiltration) are designed to remove specific contaminants. An unexpected contaminant introduced into the hygiene water loop is more likely to be removed by the RO membranes than by the multifiltration sorbent beds. In addition, the unexpected contaminant may rapidly foul the sorbent beds. RO has the disadvantage of producing brine that must be processed by the urine processor. RO also requires posttreatment by multifiltration sorbent beds, which must be periodically changed out and resupplied.

### *Candidate Substitute Technologies*

#### **Multifiltration (MF)**

See the section on potable water processing. MF system complexity is lower than RO, and it does not have the system impacts associated with brine handling (demand on urine processor and cycling of RO unit to allow for brine removal). MF has the disadvantage of being more sensitive to waste water characteristics than RO since its unibeds are designed to remove specific contaminants. MF is incapable of removing low molecular weight nonionic organics, particularly alcohols, ketones, and amides.

# WRM - HYGIENE WATER PROCESSING

## *Baseline Technology*

### **Reverse Osmosis (RO)**

- + Filtration more flexible than contaminant removal by sorbents.
- + Low specific energy relative to phase change technologies.
- + Rejects all suspended solids, all macromolecules, and most low molecular weight salts.
- Incapable of removing almost all groups of low molecular weight organics.
- Requires brine processing by urine processor.
- Requires multifiltration posttreatment. Bed changeout is resupply, crew time penalty.

## *Candidate Substitute Technologies*

### **Multifiltration (MF)**

- + Low system complexity.
- + Low specific energy relative to phase change technologies.
- + Highest water recovery percentage.
- + Minimal system impacts.
- Incapable of removing low molecular weight, nonionic organics.
- Performance is sensitive to waste water characteristics.
- Bed changeout is high resupply, crew time penalty.

## Potable Water Processing

### *Baseline Technology*

#### **Multifiltration (MF)**

Potable water is obtained through multifiltration of condensate from the Temperature and Humidity Control (THC) subsystem and from water formed during the CO<sub>2</sub> reduction process. MF consists of a particulate filter upstream of six unibeds in series. Each unibed is composed of sorbent beds and ion exchange resin beds. After about 10-30 days the first unibed in the series will become contaminated. As the first bed to be exposed to input waste water, it becomes contaminated before the remaining unibeds downstream. Once its storage capacity is reached, this unibed is removed and the other five unibeds are moved up to fill the gap. A fresh unibed is placed at the end of the series. Unibed changeout is a resupply and crew time penalty, although the beds do not foul as quickly as the MF hygiene processor unibeds, which handle much dirtier waste water. Microbial growth is impeded by heating and chemically treating (iodine injected by a microbial check valve) the process water. MF has a higher water recovery percentage than RO.

#### **Reverse Osmosis (RO)**

See the section on hygiene water processing. RO/UF modules appear unnecessary for potable processing. Water quality entering the potable processor is relatively high. This water tends to pass through the RO/UF modules relatively unaffected, and the MF posttreatment unit winds up removing the majority of the entrained contaminants.

#### **Electrodeionization**

The electrodeionization process utilizes ion exchange resins and membranes to deionize contaminated feed water. Ion exchange membranes, used as barriers to bulk water flow, divide the system into three adjacent compartments - a diluting compartment bordered on either side by a concentrating compartment. Feed water enters the diluting compartment, which is filled with mixed-bed ion exchange resin. Ions in the feed solution react with the ion exchange resins, transferring through these resins in the direction of an electrical potential gradient applied across the compartments. Due to the semipermeability properties of the ion exchange membranes and the directionality of the potential gradient, ion concentration will decrease in the diluting compartment and increase in the concentrating compartments. The system outputs brine from the concentrating compartments and purified deionized water from the diluting compartment (conductivity as low as 0.1 microsiemen/cm). Pre- and posttreatment of the feed water is required to extract contaminants not removed by the electrodeionization process, including nonionic species, chlorine, and silica. Electrodeionization is capable of deionizing a wide range of feeds, from bulk salt removal to polishing of RO product water. In the electrodeionization system the ion exchange resin is continually electrically regenerated. Regeneration chemicals are not required, eliminating chemical handling, waste neutralization, and corrosion problems. Electrodeionization does not involve sorbent bed changeout required by MF and RO, although its pre/posttreatments will likely entail resupply and regular replacement of expendables by the crew. System disadvantages include high complexity relative to MF, and the production of brine that must be processed by the urine processor.

# WRM - POTABLE WATER PROCESSING

## *Baseline Technology*

### **Multifiltration (MF)**

- + Low system complexity.
- + Minimal system impacts.
- + Highest water recovery percentage.
- Bed changeout is resupply, crew time penalty (not as high as MF hygiene processor).
- Incapable of removing low molecular weight nonionic organics.

## *Candidate Substitute Technologies*

### **Reverse Osmosis (RO)**

- + Filtration more flexible than contaminant removal using sorbents.
- Requires brine processing by urine processor.
- Incapable of removing almost all groups of low molecular weight organics.
- RO/UF modules appear unnecessary for potable processing. MF posttreatment removes majority of contaminants.

### **Electrodeionization**

- High system complexity relative to RO and MF.
- Requires brine processing by urine processor.
- Pre/posttreatment required.

0-5  
688

## Waste Management

### *Baseline Technology*

#### **Storage and Biodegradation**

All solid waste is stored and returned to earth. Human solid waste is compacted and stored in canisters for biodegradation. When full these canisters are returned to earth and resupplied. This is a very simple, safe, low power method for handling waste, but large logistics penalties are involved. The logical improvement to storage is a waste management system capable of processing waste and recovering its useful constituents, an important step in developing a closed ECLSS. Storage and/or venting has been the method for waste management on all past manned space missions.

### *Candidate Substitute Technologies*

#### **Supercritical Water Oxidation (SCWO)**

SCWO is a process in which oxygen and water above its supercritical temperature and pressure (705°F and 3190 psi) are used to oxidize organic waste materials without the presence of a catalyst. When water becomes supercritical its properties as a solvent change. Organic compounds, normally insoluble in water at standard temperature and pressure, become soluble in supercritical water. If sufficient oxygen is available and the reactor temperature and pressure are sufficiently high (750-1200°F and 3675 psi), these organic compounds, along with process atmospheric and trace contaminant gases, are completely oxidized to CO<sub>2</sub>, H<sub>2</sub>, and N<sub>2</sub>. Additionally, inorganic salts become insoluble in supercritical water and precipitate from solution. Efficient processing is achieved with reactor residence times as low as one minute.

SCWO can handle all types of organic spacecraft waste, in addition to processing condensate, wash, and urine/flush waters. SCWO produces potable water from all input waste waters, creating an entirely potable water supply. The process is not applicable to wastes that are composed primarily of inorganics. SCWO is a safety hazard due to its extremely high operating temperatures and pressures, and it is a corrosive process, presenting material and mechanical reliability problems. A posttreatment is required to handle toxic product gases (such as carbon monoxide). SCWO technology is still under development.

# WM - WASTE MANAGEMENT

## *Baseline Technology*

### **Storage and Biodegradation**

- + Very simple and safe technology.
- + Low power consumption.
- High logistics penalties.

## *Candidate Substitute Technologies*

### **Supercritical Water Oxidation (SCWO)**

- + Multifunction technology.
- + Handles a wide variety of organic wastes.
- Posttreatment required to handle toxic gases.
- Safety hazard. Reactor operates at extremely high operating temperature and pressure.
- Corrosive process, presenting material and mechanical reliability problems.
- Consumes O<sub>2</sub>.
- Technology requires further development.

## Waste Management

### **Wet Oxidation (WETOX)**

Wet oxidation refers to the aqueous phase oxidation of organic materials achieved by interacting air with liquid waste in a high temperature, high pressure (550°F, 2200 psi) reactor. Liquid water catalyzes oxidation, allowing reactions to proceed at temperatures lower than those required for oxidation by open flame combustion. Additionally, water moderates oxidation rates by providing a medium for heat transfer and by removal of excess heat by evaporation. Oxidation products are innocuous, primarily consisting of carbon dioxide and water, although oxidation is not as complete as in the SCWO process. WETOX effluent requires posttreatment by catalytic oxidation and may also require a phase change water recovery system for additional posttreatment. The WETOX process consumes oxygen, is a corrosive process and is a safety hazard due to its high pressure and temperature operation. Research on WETOX recently has centered on industrial applications. Further effort is required to develop a system for space environments.

### **Waste Management - Water System (WM-WS or RITE)**

The WM-WS system recovers water from brine and rejection concentrates generated by other water recovery and waste management technologies. Water recovery from brine reduces the need for water resupply, significantly lowering launch costs. WM-WS uses an evaporator to separate process brine into water vapor and solid waste. The water vapor is catalytically oxidized, then condensed and output to posttreatment. Solid waste is pumped to an incinerator, which produces ash that must be stored and returned to earth. The catalytic oxidizer and incineration units each operate at about 1200°F.

WM-WS with a posttreatment could eventually be used to process all types of space station waste water, replacing all the phase change and non-phase change technologies used on the baseline station. The WM-WS process is not affected by bacteria or particulates, and exterminates microorganisms much more effectively than existing water recovery technologies (TIMES, VCD, RO, MF). The original WM-WS system employed a plutonium heat source, and was known as the Radio Isotope Thermal Energy (RITE) system. WM-WS requires further development.

### **Electrochemical Decomposition**

Electrochemical waste decomposition is a non-thermal electrolysis process where solid organic waste and urine can be degraded by oxidation at the surface of catalytic electrodes. CO<sub>2</sub>, N<sub>2</sub>, and O<sub>2</sub> are the oxidation products formed at the cell anode, while H<sub>2</sub> is formed at the cathode. Electrochemical decomposition operates at low temperatures (less than 150°F) and oxidizes waste without the consumption of atmospheric oxygen. The process also consumes relatively little power. The electrochemical decomposition system has the disadvantage of being susceptible to carbon monoxide poisoning. Electrochemical decomposition is in the early stages of development.

# WM - WASTE MANAGEMENT

## Wet Oxidation (WETOX)

- + Handles a wide variety of organic wastes.
- + Oxidation products are innocuous.
- May require extensive posttreatment.
- Safety hazard due to high pressure, high temperature operation.
- Corrosive process.
- Consumes O<sub>2</sub>.
- Further development is required for space applications.

## Waste Management - Water System (WM-WS or RITE)

- + Water recovery from brines results in large long-term cost savings.
- + More efficient than existing water processors at eliminating bacteria and particulates from waste stream.
- + May become capable of processing all types of space station waste water.
- Requires posttreatment.
- Technology requires further development.

## Electrochemical Decomposition

- + High temperatures, pressures not required.
- + Relatively low power consumption.
- + Produces oxygen instead of consuming it.
- Presence of carbon monoxide tends to poison system.
- New technology requiring further development.



# TECHNOLOGY SUMMARY

## Atmosphere Revitalization (AR):

### CO<sub>2</sub> Removal

Four-Bed Molecular Sieve (4BMS)  
Solid Amine Water Desorbed (SAWD)  
Electrochemical Depolarized Concentrator  
(EDC)  
Air Polarized Concentrator (APC or EDC  
w,wo/H<sub>2</sub>)  
Two-Bed Molecular Sieve (2BMS)  
Membranes

### CO<sub>2</sub> Reduction

Bosch Reactor  
Sabatier Reactor  
Advanced Carbon Reactor (ACR)  
CO<sub>2</sub> Electrolysis

### O<sub>2</sub> Generation

Static Feed Water Electrolysis (SFWE)  
Liquid Anode Feed Solid Polymer Electrolysis  
(SPE)  
CO<sub>2</sub> Electrolysis  
Water Vapor Electrolysis (WVE)

### Trace Contaminant Control

Carbon Adsorption Beds with Catalytic Oxidizer  
Reactive Bed Plasma (RBP)

## Water Recovery and Management (WRM):

### Urine Processing

Thermoelectric Integrated Membrane  
Evaporation Subsystem (TIMES)  
Vapor Compression Distillation (VCD)  
Air Evaporation System (AES)  
Vapor Phase Catalytic Ammonia Removal  
(VPCAR)

### Hygiene Water Processing

Reverse Osmosis (RO)  
Multifiltration (MF)

### Potable Water Processing

Multifiltration (MF)  
Reverse Osmosis (RO)  
Electrodeionization

## Waste Management (WM):

Storage and Biodegradation  
Supercritical Water Oxidation (SCWO)  
Wet Oxidation (WETOX)  
Waste Management - Water System (WM-WS  
or RITE)  
Electrochemical Decomposition

**ECLSS TECHNOLOGY  
SCHEMATICS,  
PROCESS DIAGRAMS,  
AND FLUID INTERFACES**

397

PRECEDING PAGE BLANK NOT FILMED

~~FIG 396~~ GENERALLY BLANK

# CO<sub>2</sub> REMOVAL

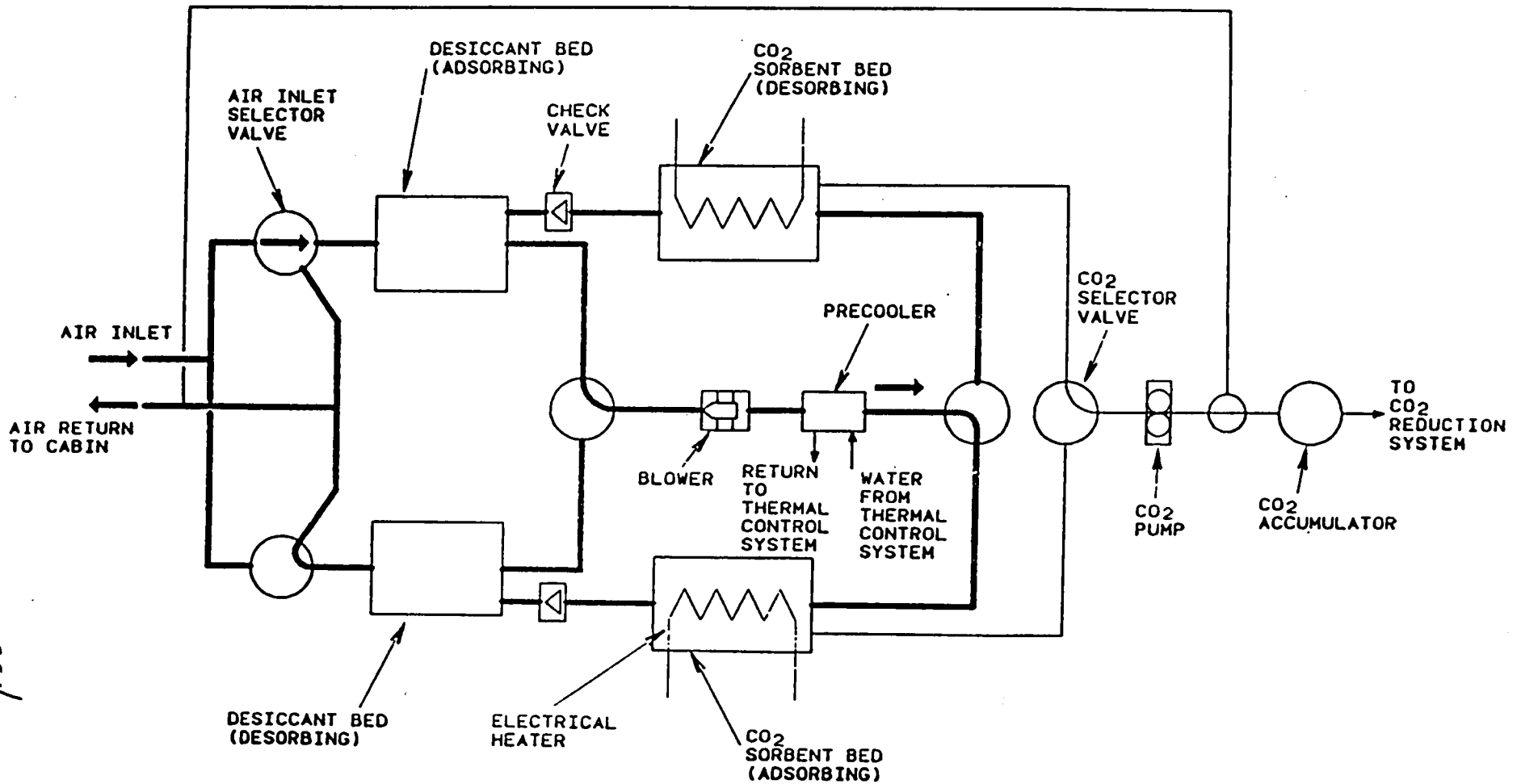

PRECEDING PAGE BLANK NOT FILMED

399

399  
INTENTIONALLY BLANK

Four-Bed Molecular Sieve System Component Integration

PRECEDING PAGE BLANK NOT FILMED

401

4-00

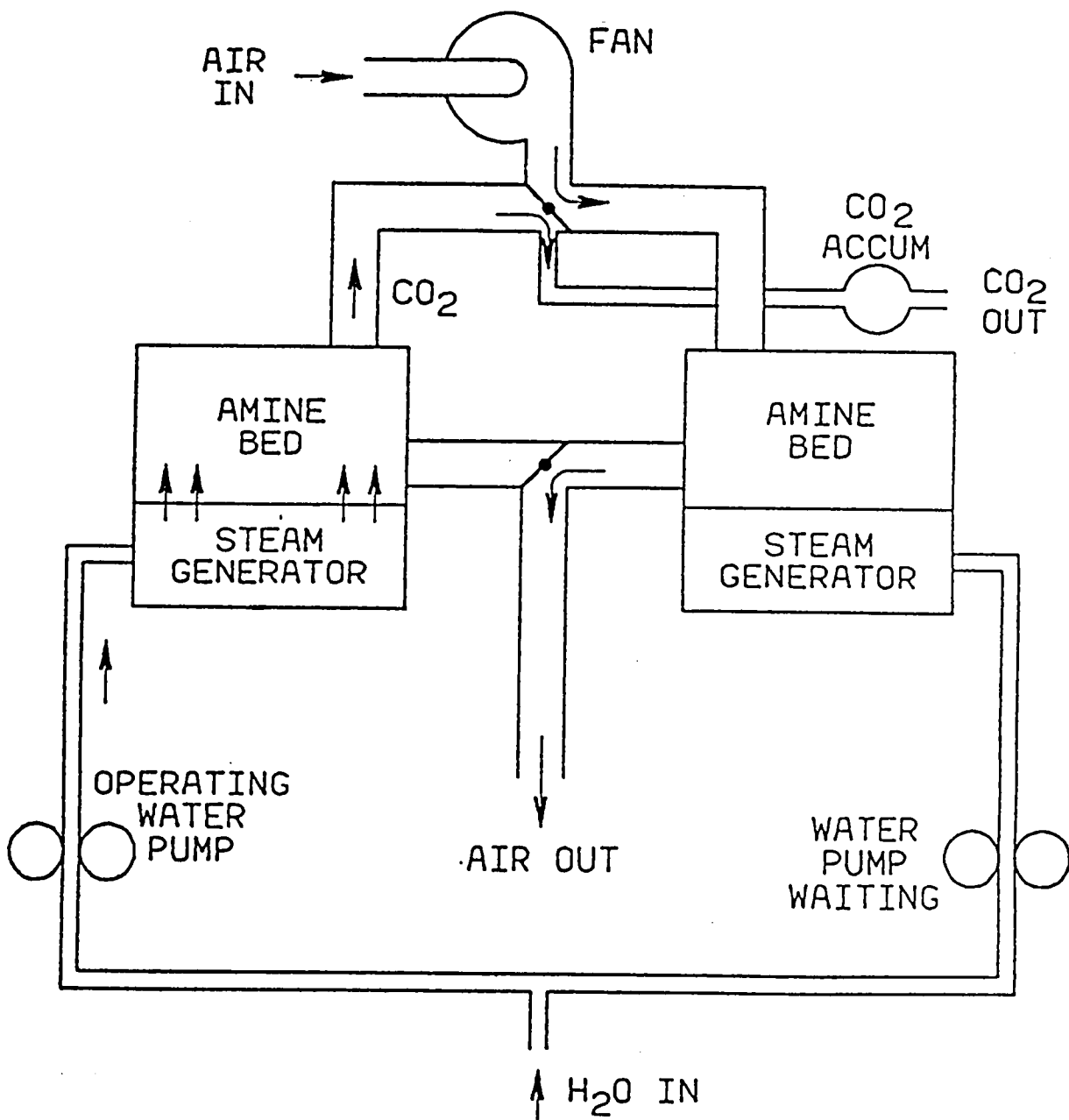

Solid Amine Water Desorbed Process Diagram

402  
INTENTIONALLY BLANK

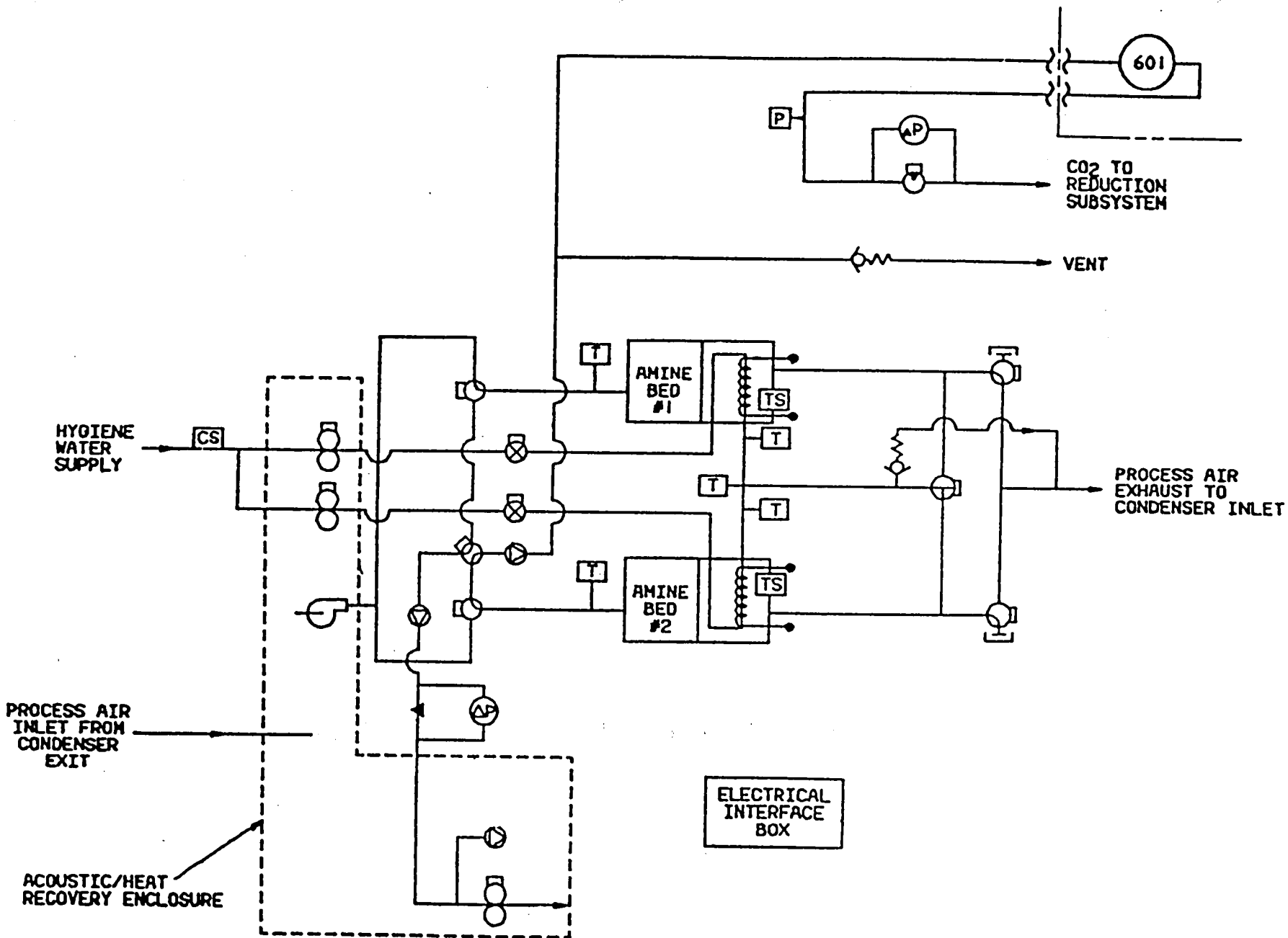

Solid Amine Water Desorbed Mechanical Schematic

PRECEDING PAGE BLANK NOT FILMED 405

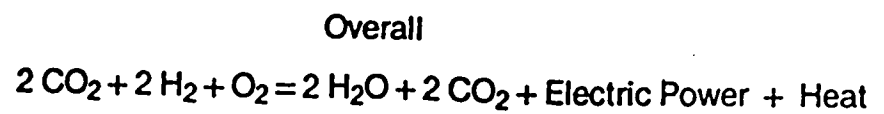
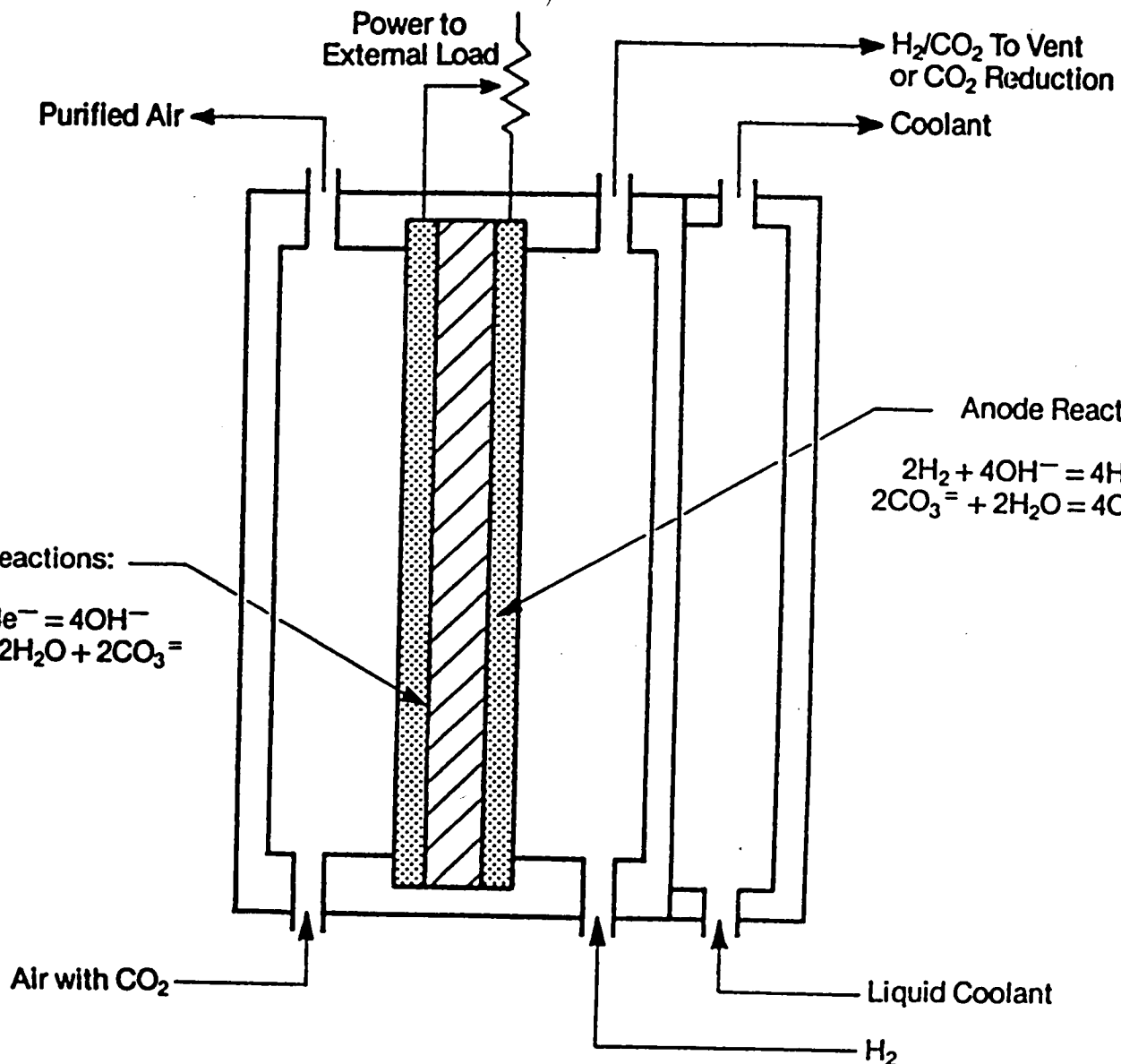

### Electrochemical Depolarized Concentrator Process and Reactions

7218 405 INTENTIONALLY BLANK

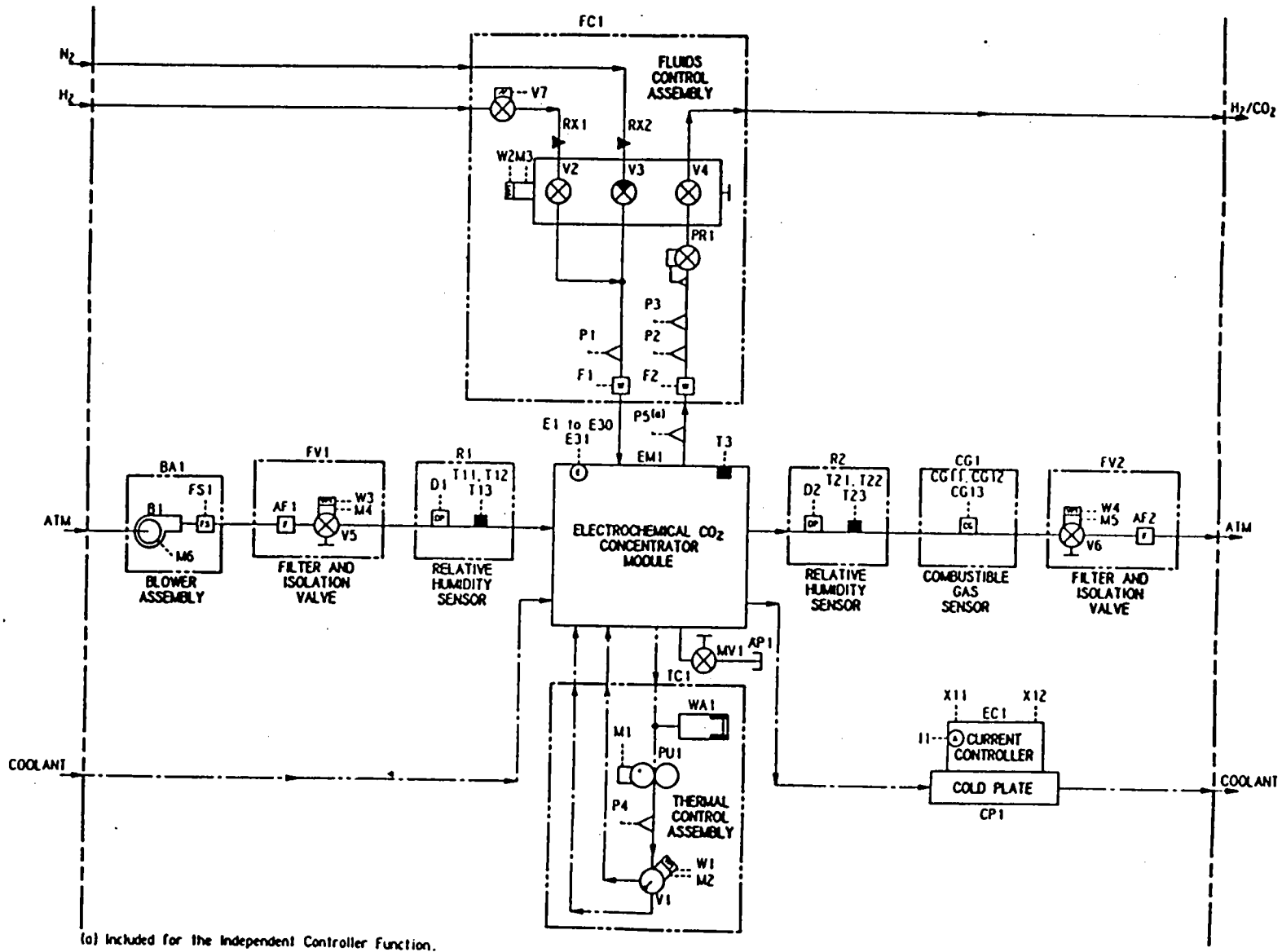

Electrochemical Depolarized Concentrator System Schematic with Sensors

407  
REVISIONALLY DRAWN

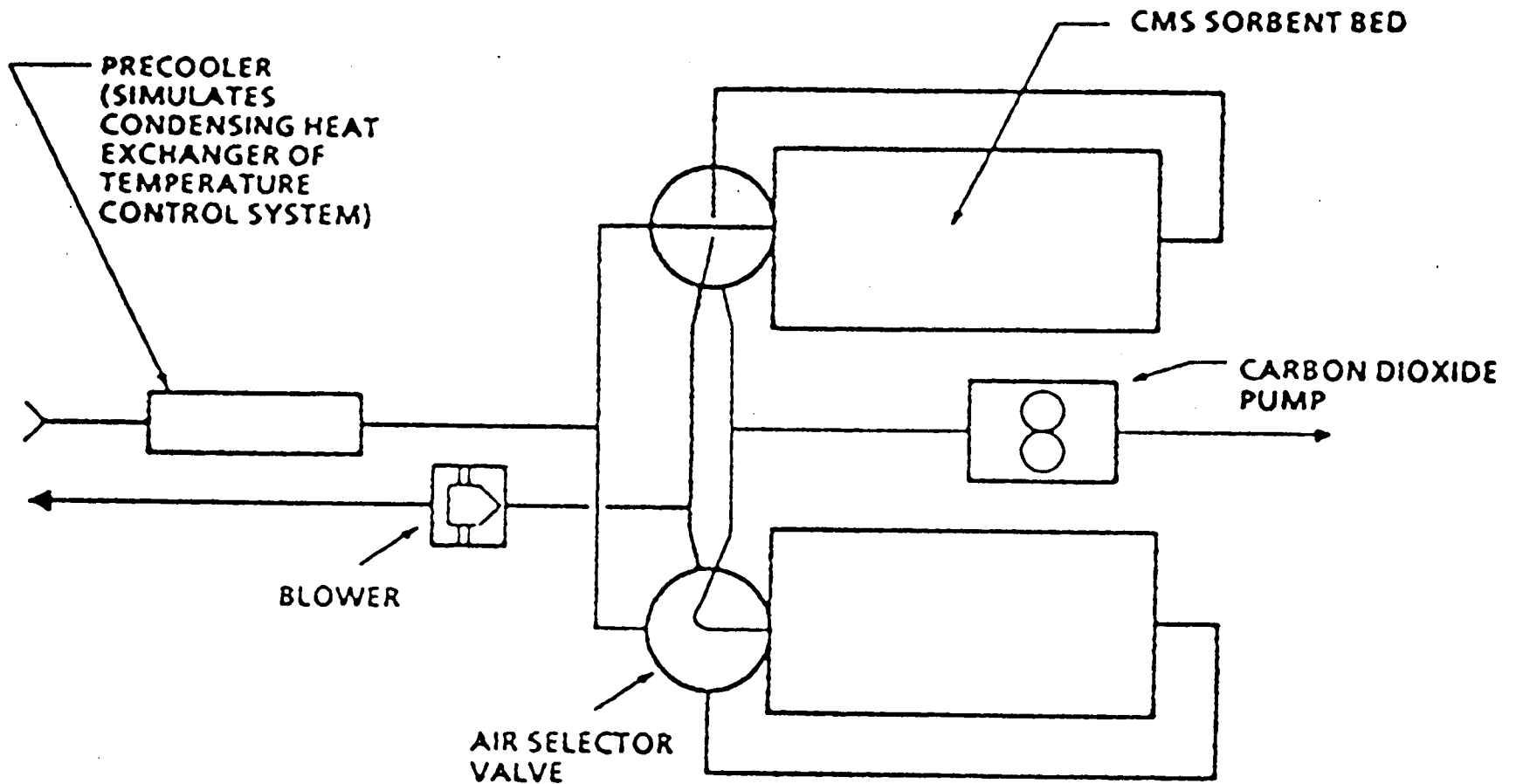

Two-Bed Molecular Sieve Basic Schematic

PRECEDING PAGE BLANK NOT FILMED

409

FORM 488 INTERNATIONALLY BLANK



# CO<sub>2</sub> REDUCTION

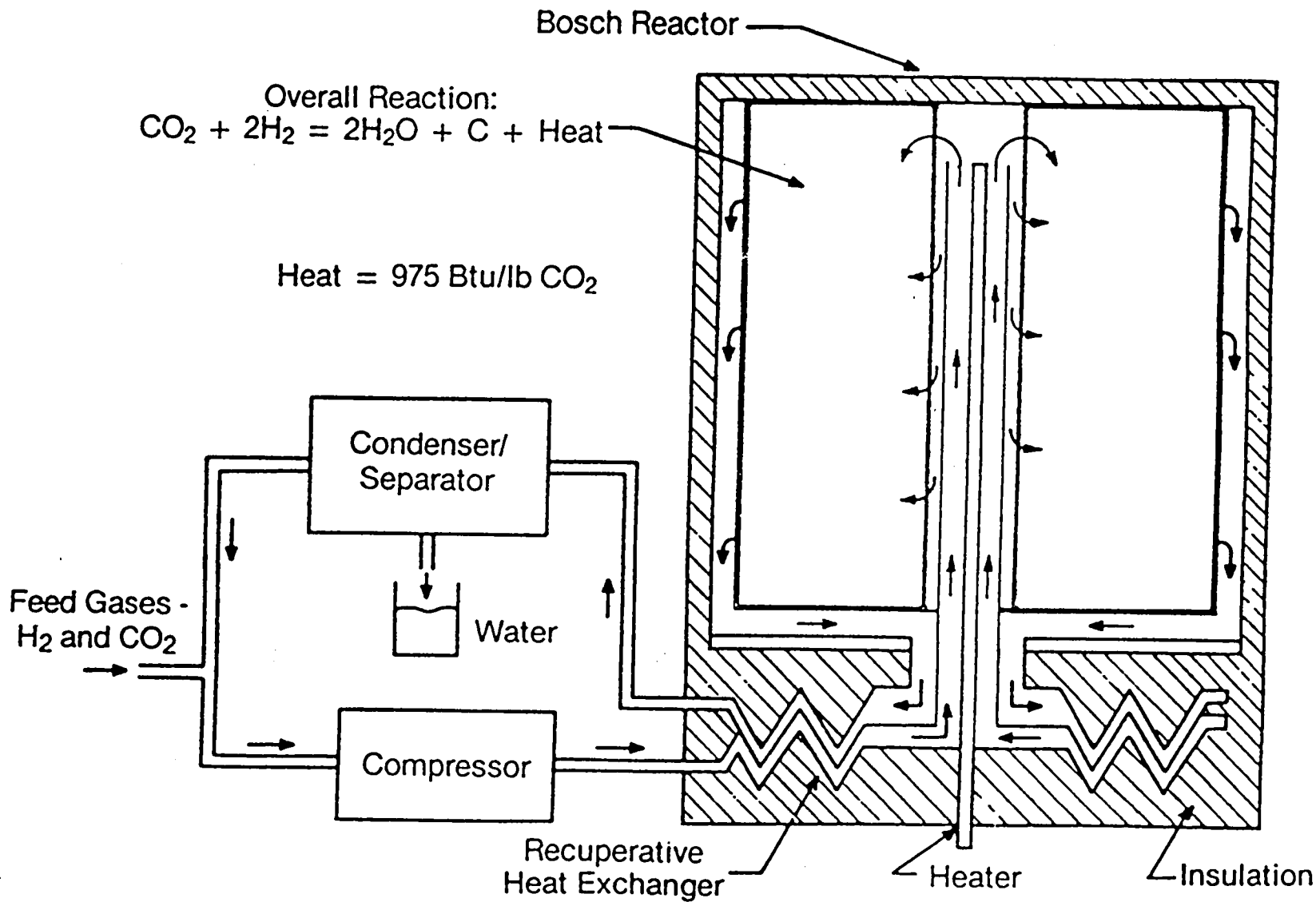

Bosch Process Schematic

PRECEDING PAGE BLANK NOT FILMED

413

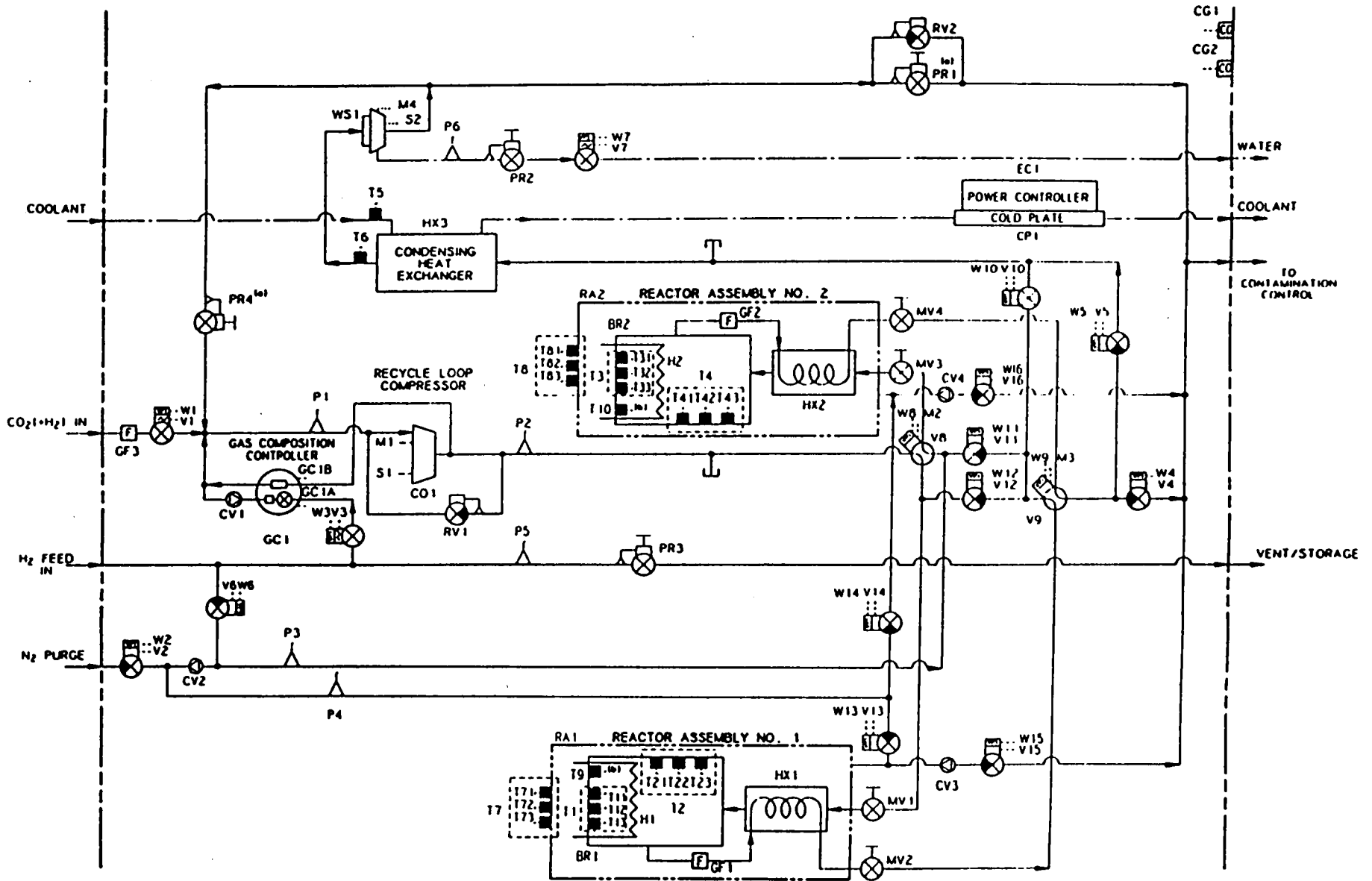

(a) Required for Non-EDC CO<sub>2</sub> Concentrator Interface Only

(b) Sensors Used for SDSU Only.

Bosch Mechanical Schematic with Sensors

INTERNATIONAL RESEARCH

PRECEDING PAGE BLANK NOT FILMED

415

ENGR 416 INTERIORALLY



WATER SEPARATOR

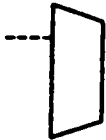

COMPRESSOR



HEATER, ELECTRICAL



HEAT EXCHANGER, REGENERATIVE



SAMPLING OR ACCESS PORT, CAPPED



SENSOR, PRESSURE



SENSOR, TEMPERATURE



SENSOR, COMBUSTIBLE GAS



SENSOR, CARBON MONOXIDE



FILTER



VALVE, MOTOR DRIVEN 4-WAY WITH VALVE POSITION INDICATOR



VALVE, ELECTRICAL SHUTOFF (N/C) WITH VALVE POSITION INDICATOR

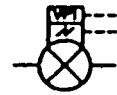

VALVE, ELECTRICAL SHUTOFF (N/C) ENERGIZED OPEN WITH VALVE POSITION INDICATOR



VALVE, ELECTRICAL SHUTOFF (N/O) DE-ENERGIZED WITH VALVE POSITION INDICATOR

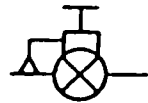

REGULATOR, PRESSURE WITH MANUAL ADJUSTMENT



VALVE, RELIEF



VALVE, CHECK



GAS LINE



LIQUID LINE

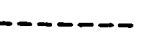

ELECTRICAL LINE

### Bosch Schematic Legend

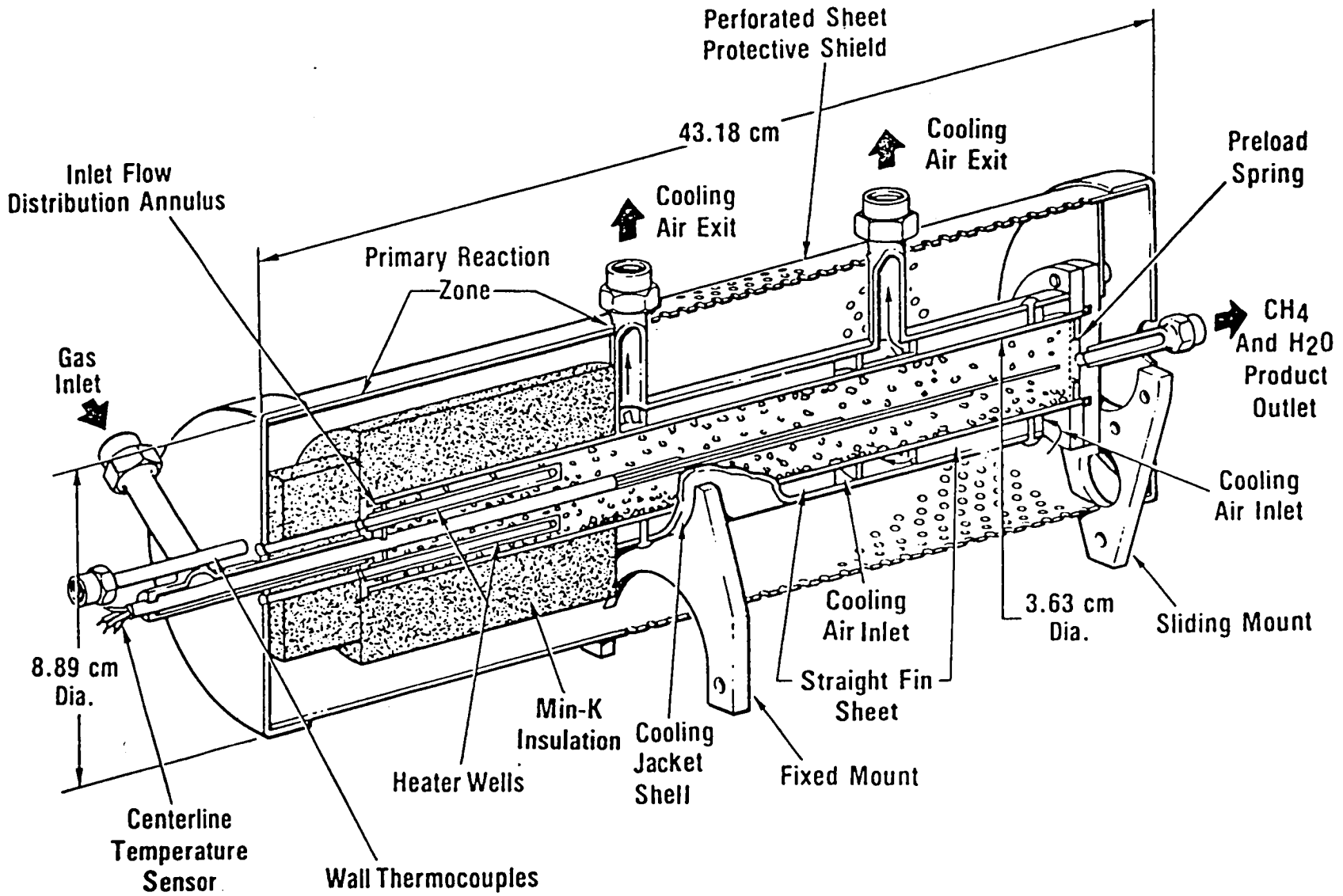

Cross Section of Sabatier Methanation Reactor

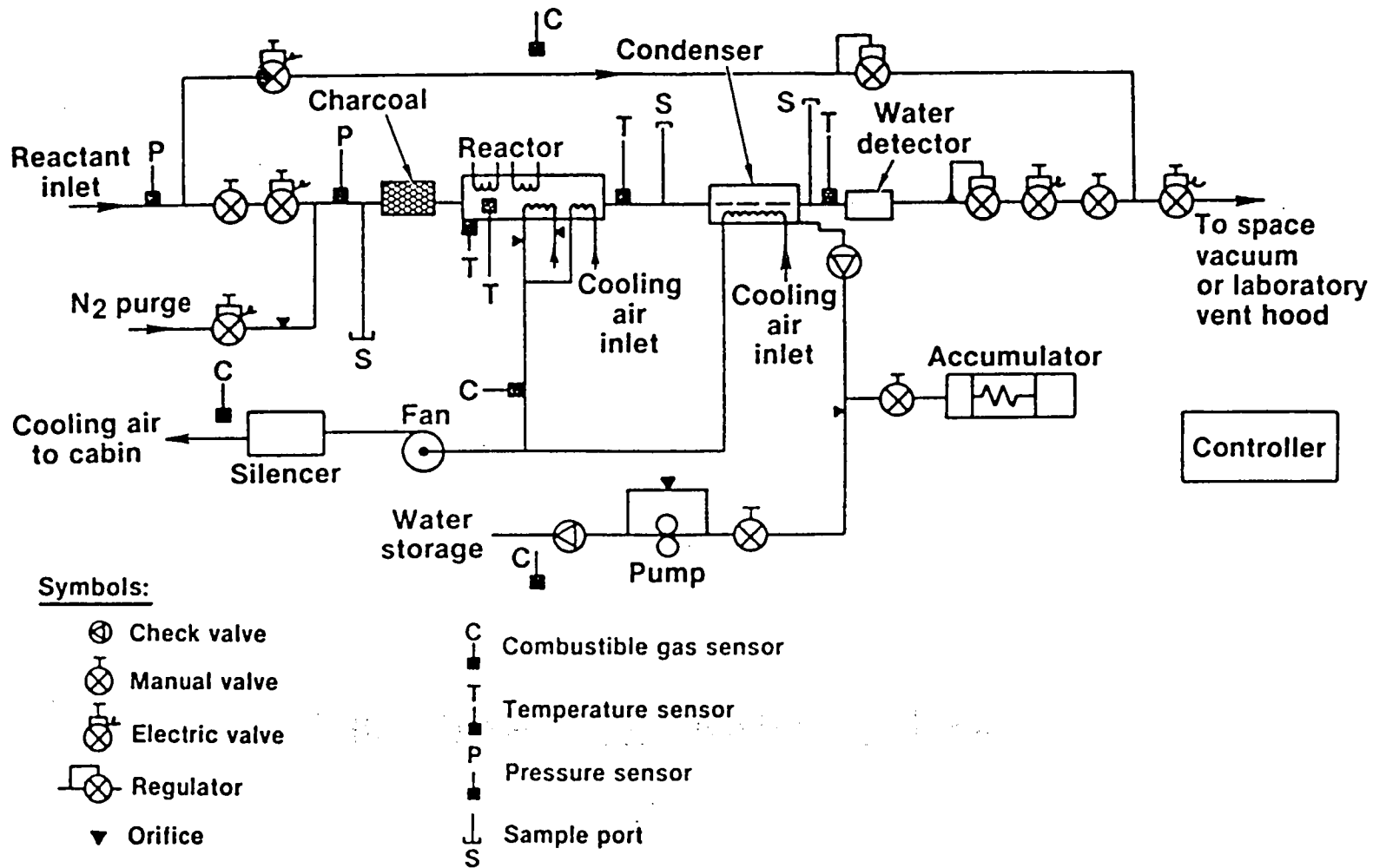

Sabatier System Schematic

PRECEDING PAGE BLANK NOT FILMED  
 419  
 419  
 INTERNALLY FILMED

PRECEDING PAGE BLANK NOT FILMED

421

4-2-80  
INTENTIONALLY BLANK

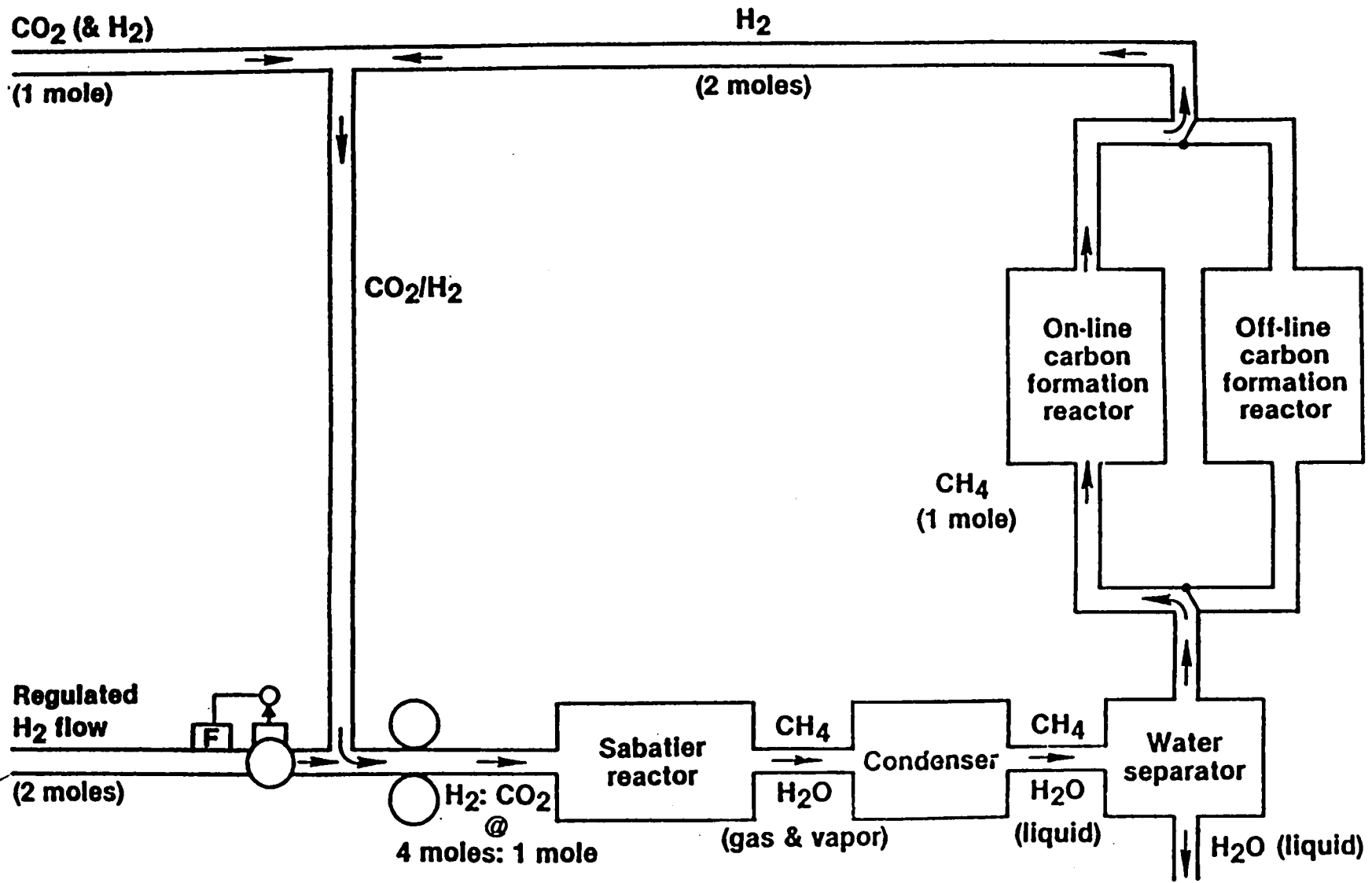

Advanced Carbon Reactor Process Schematic

PRECEDING PAGE BLANK NOT FILMED

423

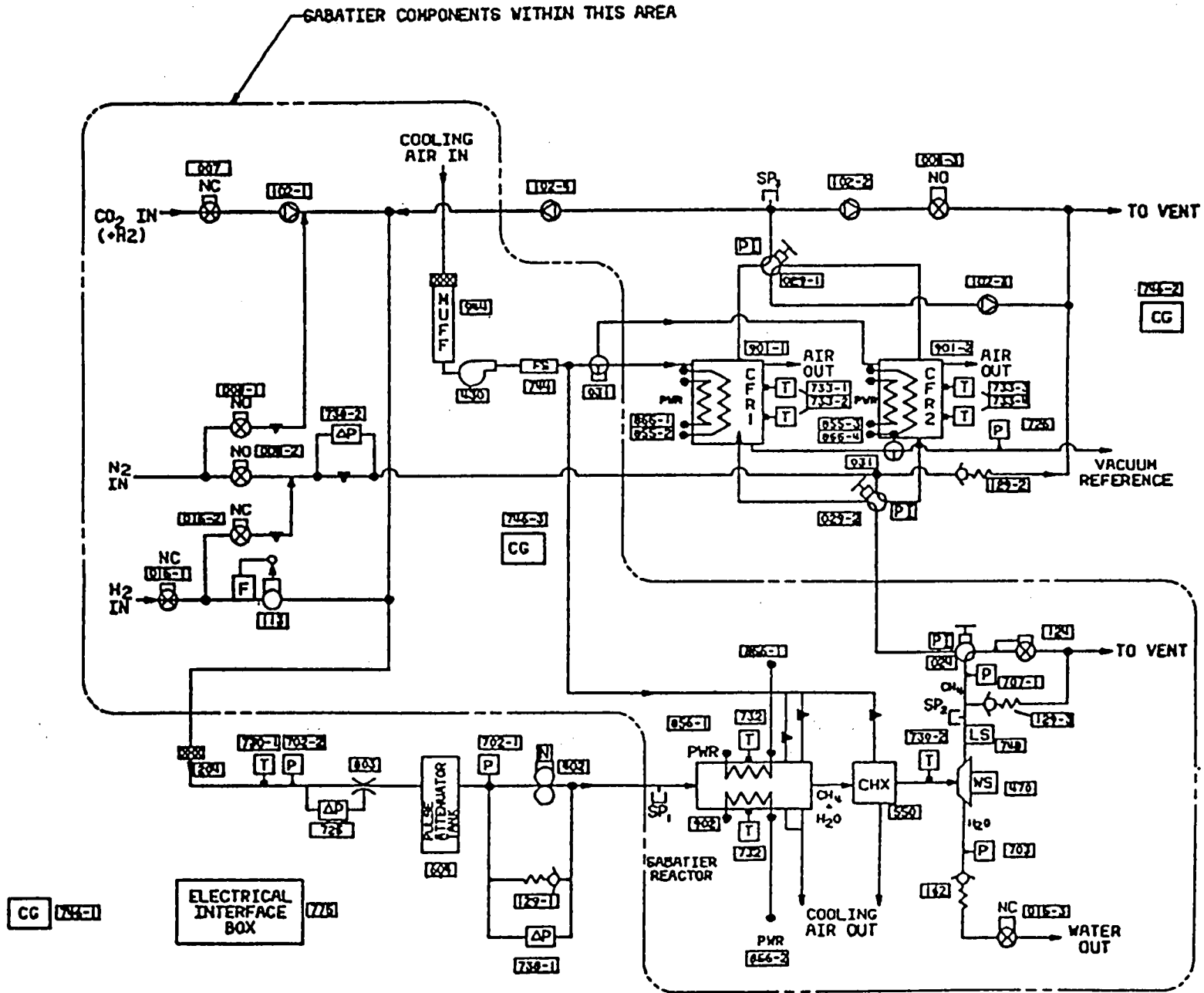

Advanced Carbon Reactor Mechanical Schematic

423  
REPRODUCED FROM  
423

# CO<sub>2</sub> REDUCTION

## FLUID INTERFACES

TECHNOLOGY	FLUID INTERFACES	
	LINE IN	LINE OUT
Bosch Reactor	Liquid Coolant, H <sub>2</sub> N <sub>2</sub> Purge, CO <sub>2</sub>	N <sub>2</sub> Purge Vent Water to Potable Processor H <sub>2</sub> Vent Liquid Coolant
Sabatier Reactor	CO <sub>2</sub> , H <sub>2</sub> Avionics Air	Water to Potable Processor Vent to Storage Avionics Air
Advanced Carbon Reactor	CO <sub>2</sub> , H <sub>2</sub> Avionics Air, N <sub>2</sub>	Water to Potable Processor Avionics Air N <sub>2</sub> Purge Vent, H <sub>2</sub> Vent Vacuum (for vacuum jacket)
CO <sub>2</sub> Electrolysis	CO <sub>2</sub> , N <sub>2</sub> Avionics Air	O <sub>2</sub> , H <sub>2</sub> Vent CO/CO <sub>2</sub> to Carbon Deposition Reactor Avionics Air

PRECEDING PAGE BLANK NOT FILMED

425

424



# O<sub>2</sub> GENERATION

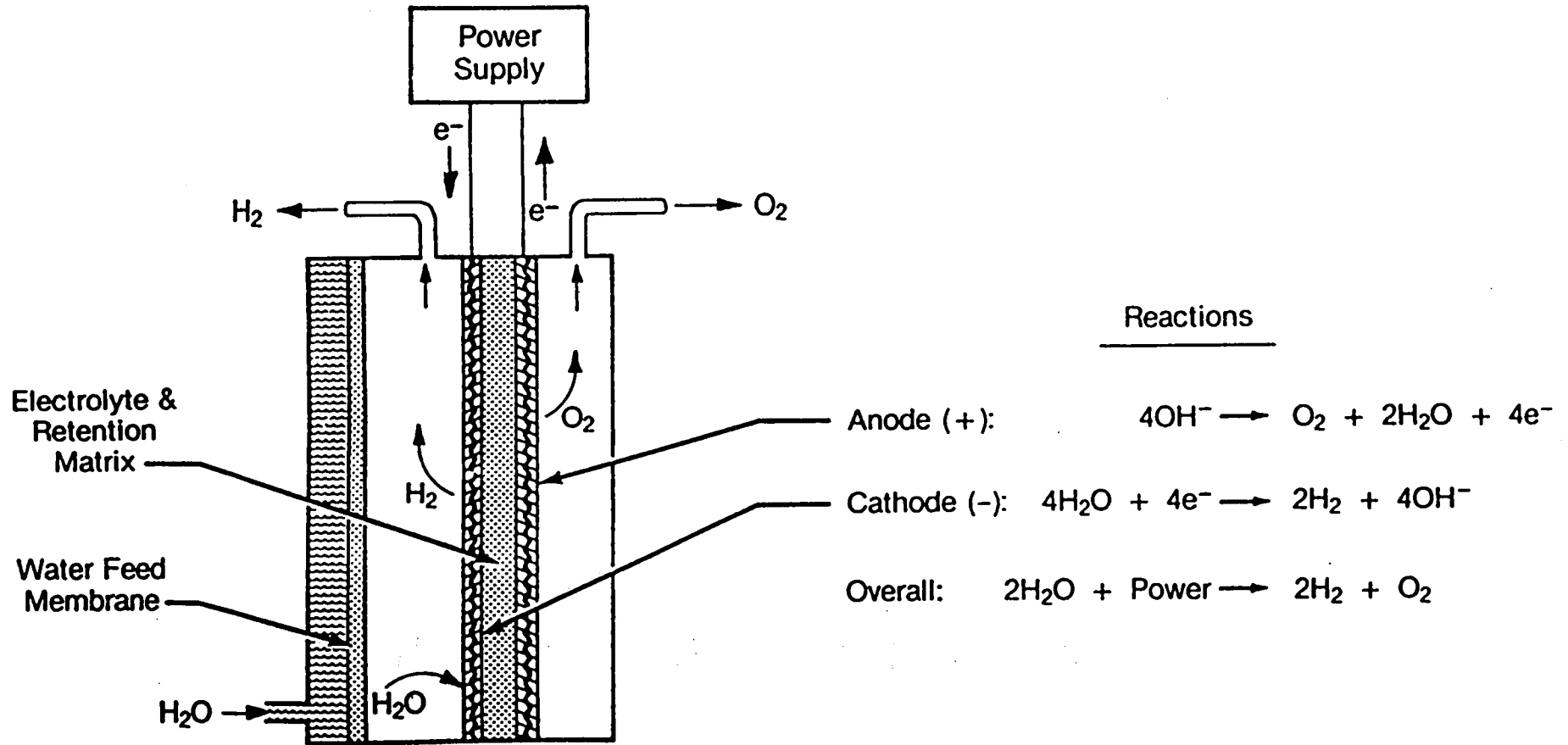

427

PRECEDING PAGE BLANK NOT FILMED

Static Feed Water Electrolysis Cell and Reactions

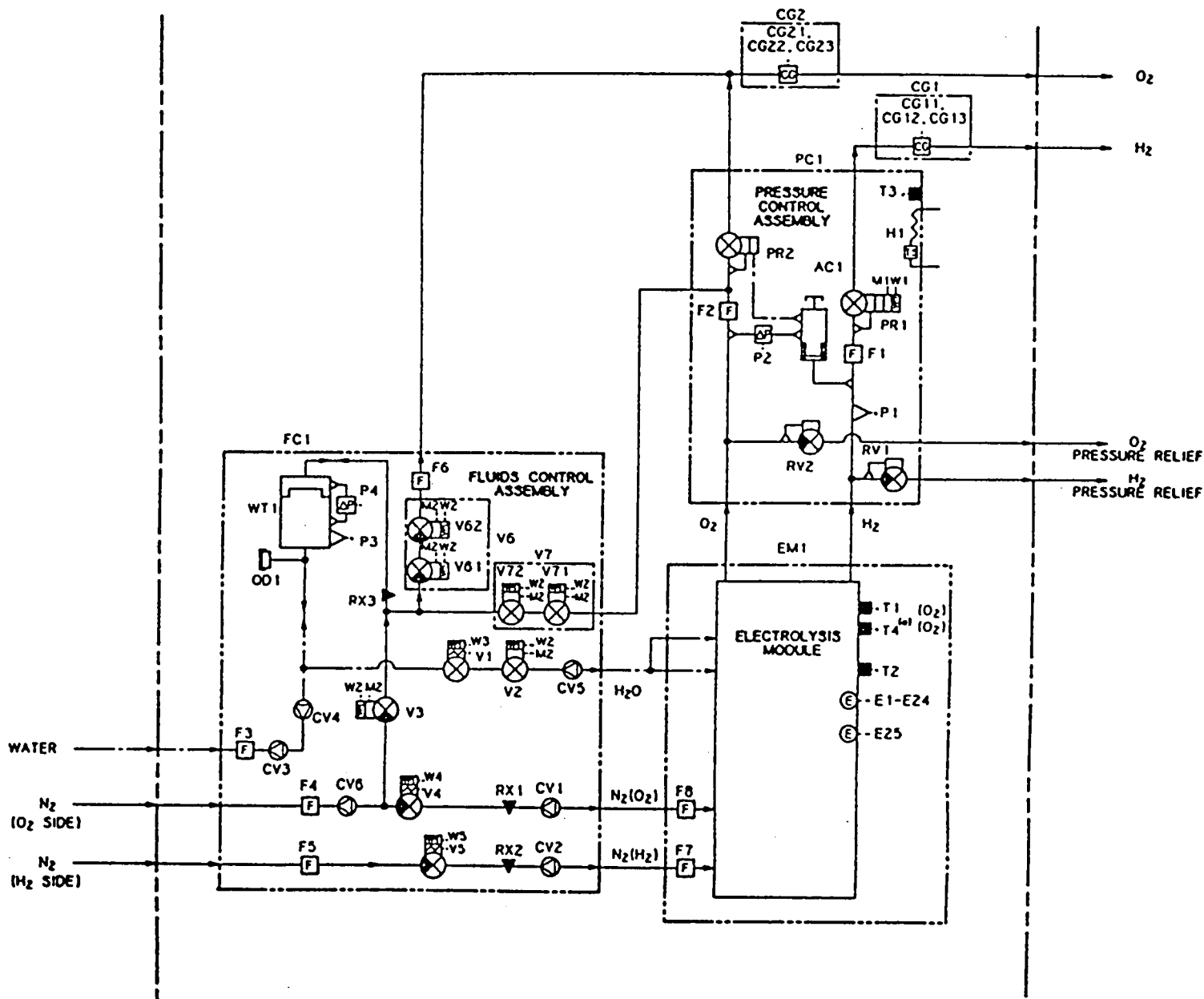

(a) Used by Sensor Dedicated Shutdown Unit (SDSU).

## Static Feed Water Electrolysis Mechanical Schematic

PRECEDING PAGE BLANK NOT FILMED

431

431  
INTERNALLY FILMED

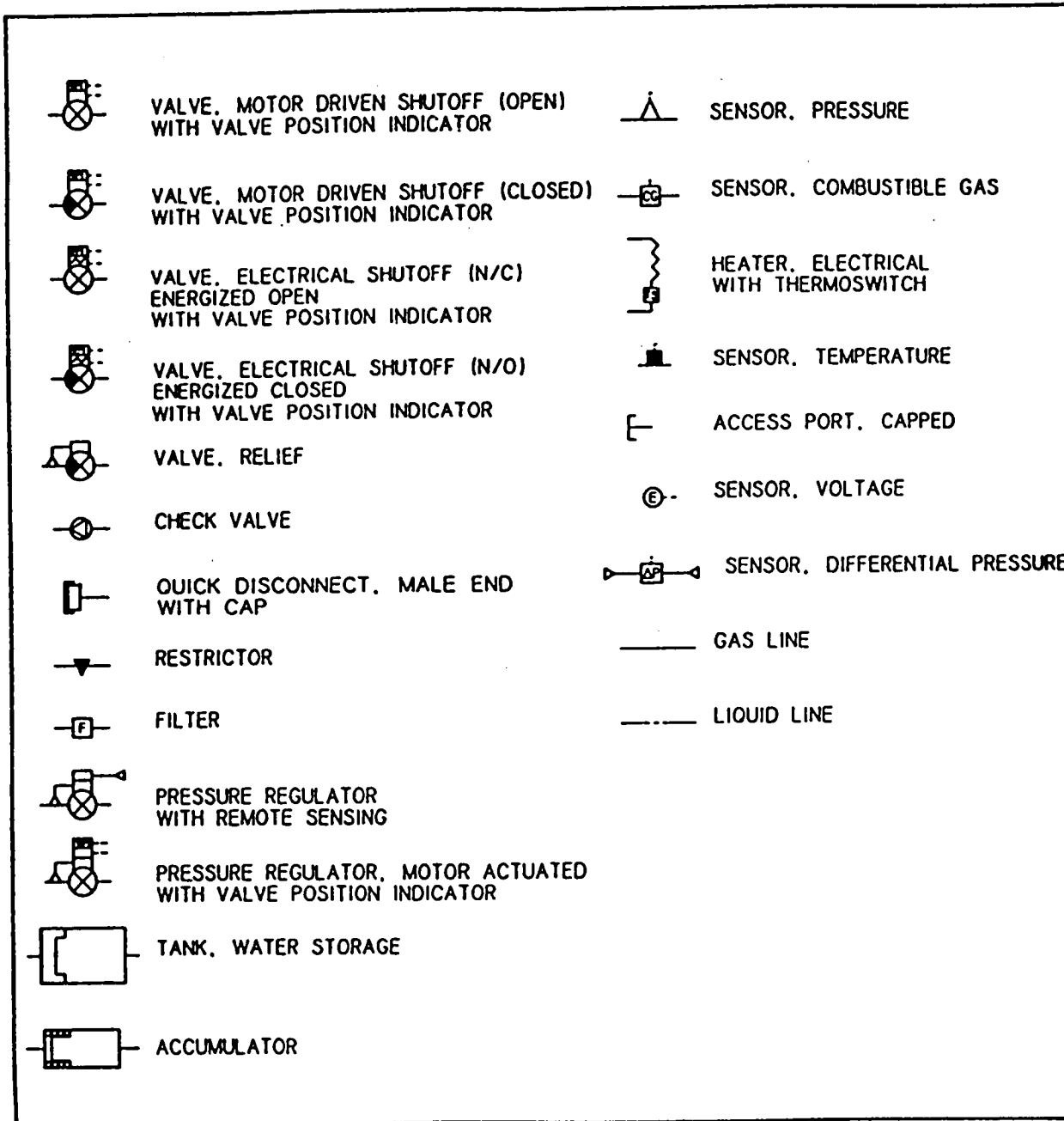

Static Feed Water Electrolysis Schematic Legend

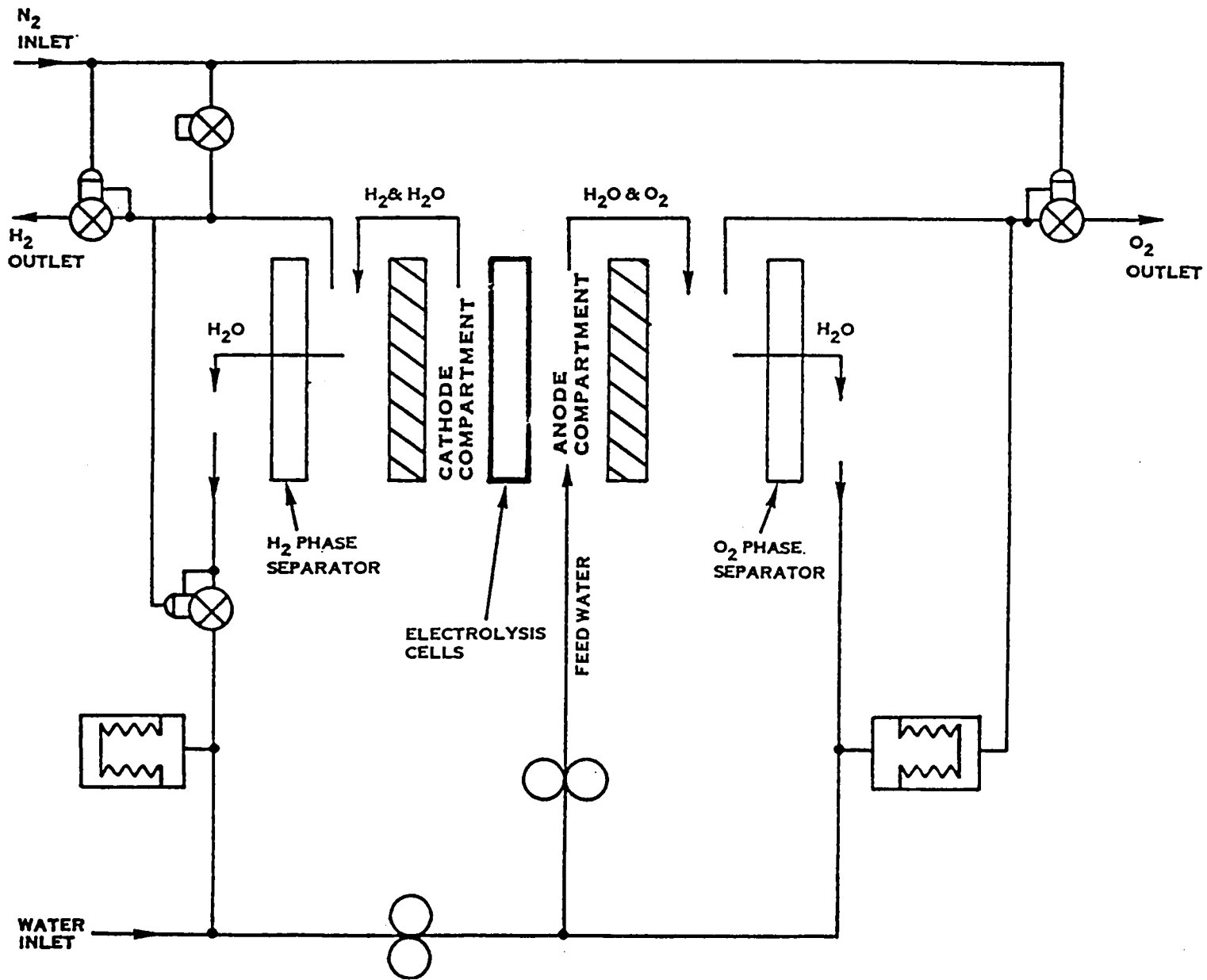

Liquid Anode Feed Solid Polymer Electrolysis Simplified Schematic

PRECEDING PAGE BLANK NOT FILMED

433

433  
 INTERNALLY FILMED

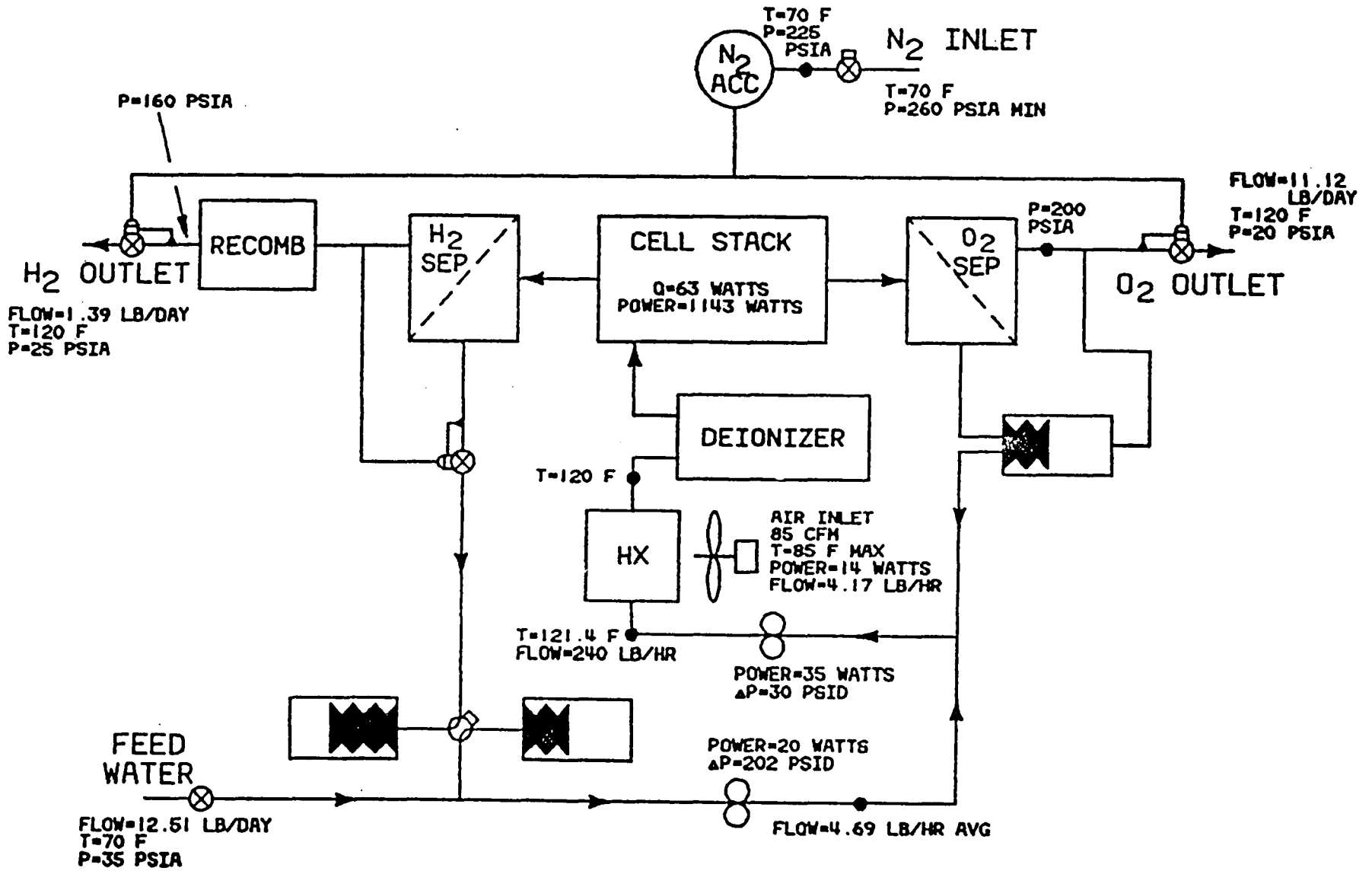

Liquid Anode Feed Solid Polymer Electrolysis Flow Chart

PRECEDING PAGE BLANK NOT FILMED

485

4.94  
 INTERMEDIATE

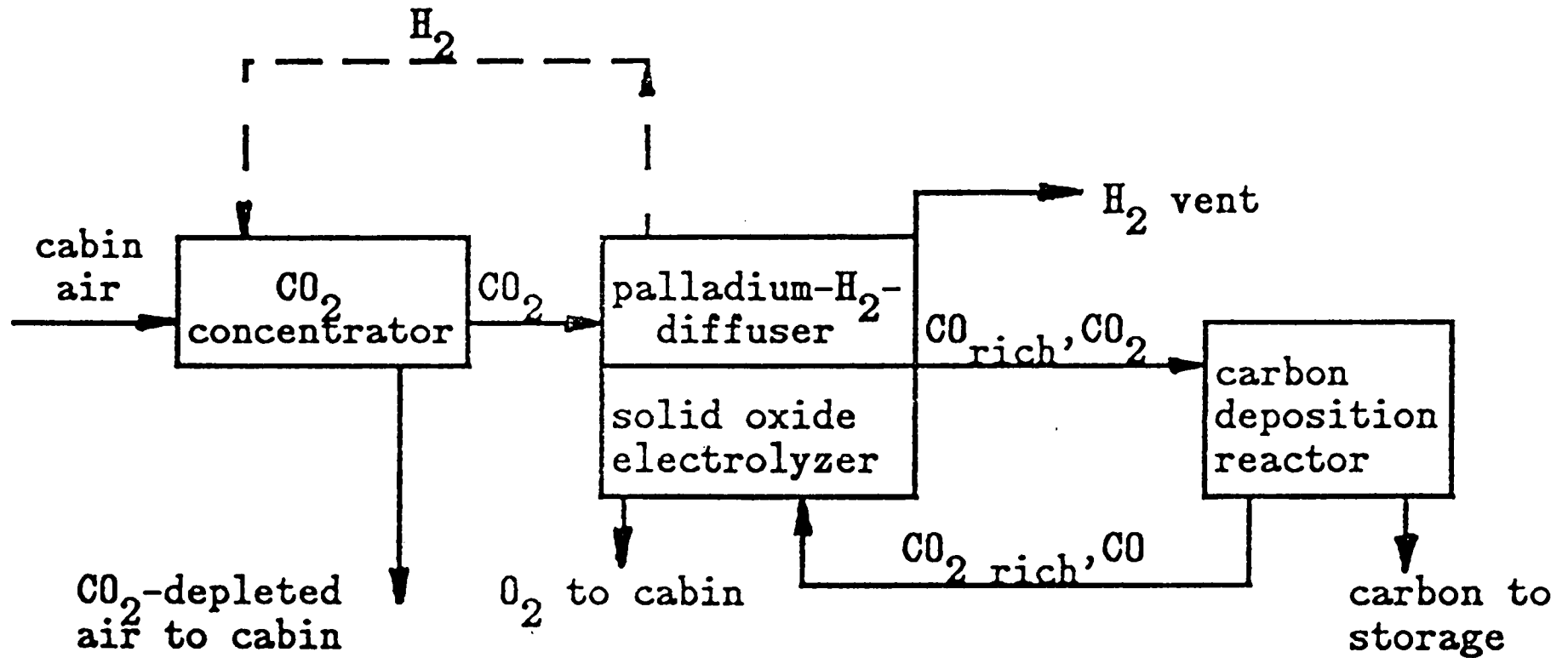

Advanced Concept Oxygen Reclamation Scheme Using CO<sub>2</sub> Electrolysis

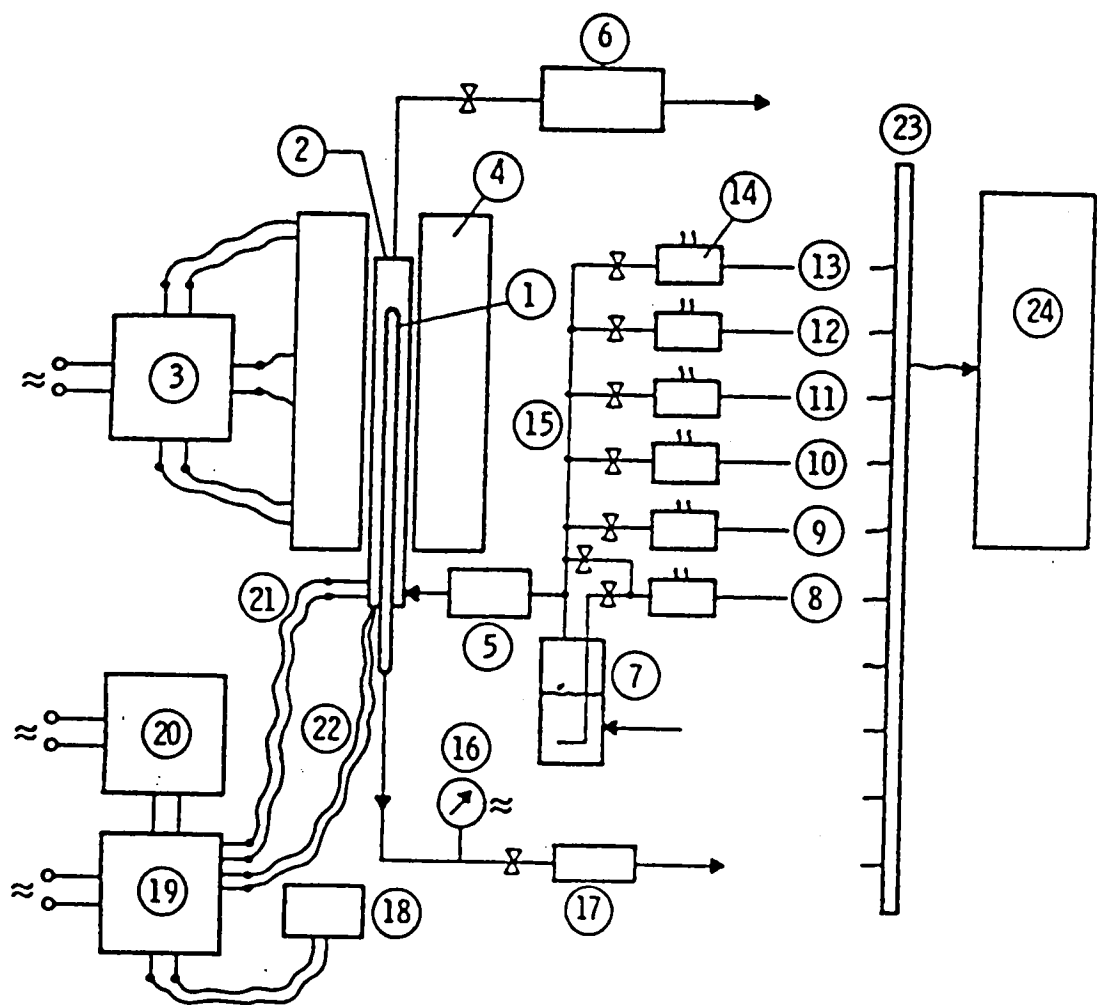

- 1 Cell
- 2 Test Fixture
- 3 A.C. Power Supply
- 4 3-Zone Test Furnace
- 5 Oxygen Sensor Inlet
- 6 Oxygen Sensor Outlet
- 7 Humidifier
- 8-11 Gas Inlets for CO<sub>2</sub>, CO, H<sub>2</sub>, N<sub>2</sub>
- 12, 13 Spare Gas Inlets
- 14 Mass Flow Controllers
- 15 Gas Manifold and Valves
- 16 Oxygen Pressure Control - Monitor
- 17 Mass Flow Meter
- 18 Oscilloscope
- 19 Electronic Switch and Test Circuitry
- 20 D.C. Power Supply
- 21 D.C. Current Line
- 22 D.C. Potential Line
- 23 Data Highway
- 24 Data Acquisition

**Essential Components of a Breadboard CO<sub>2</sub> Electrolysis Unit**

PRECEDING PAGE BLANK NOT FILMED

441

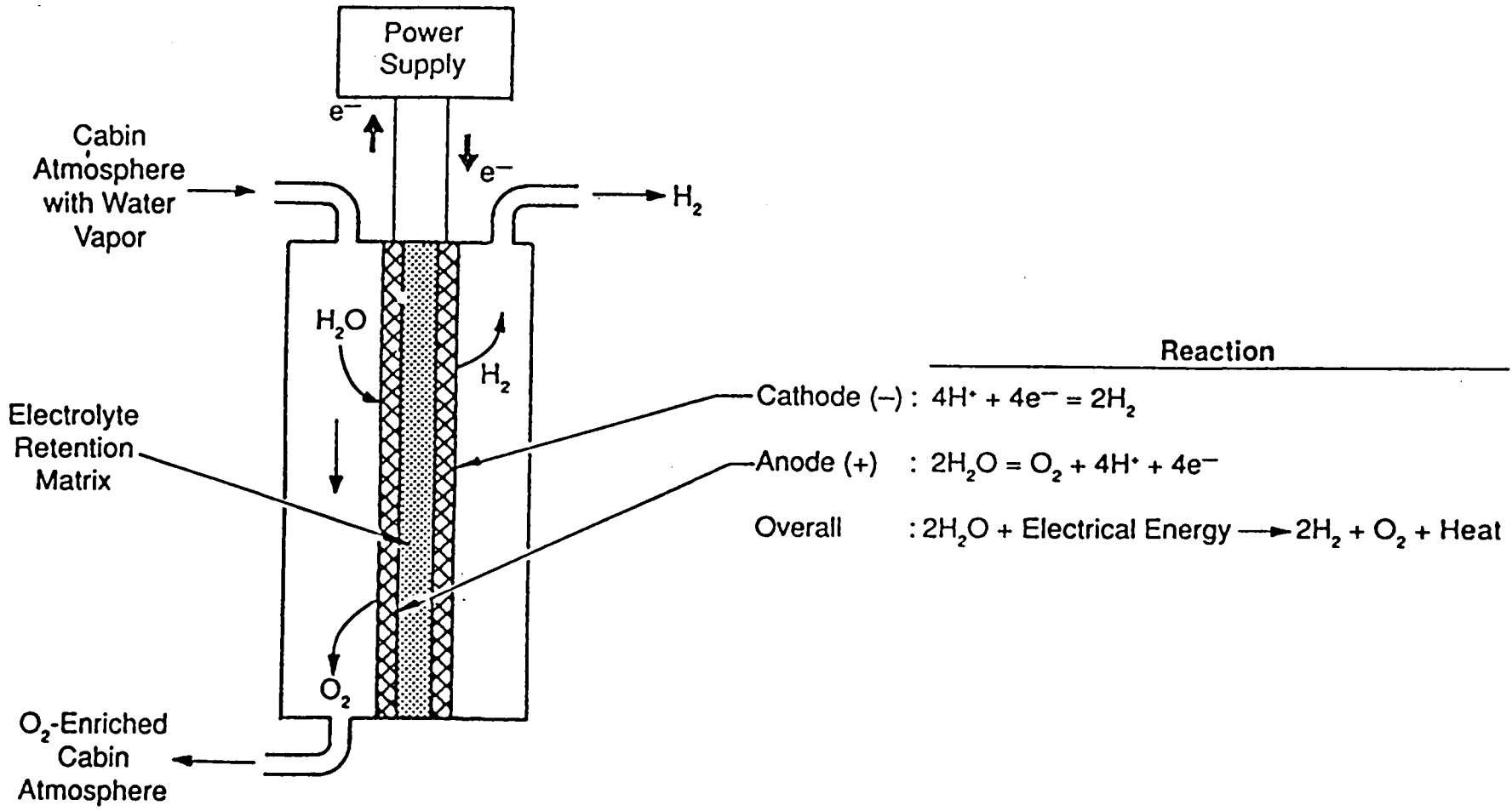

Water Vapor Electrolysis Cell and Reactions



PRECEDING PAGE BLANK NOT FILMED

443

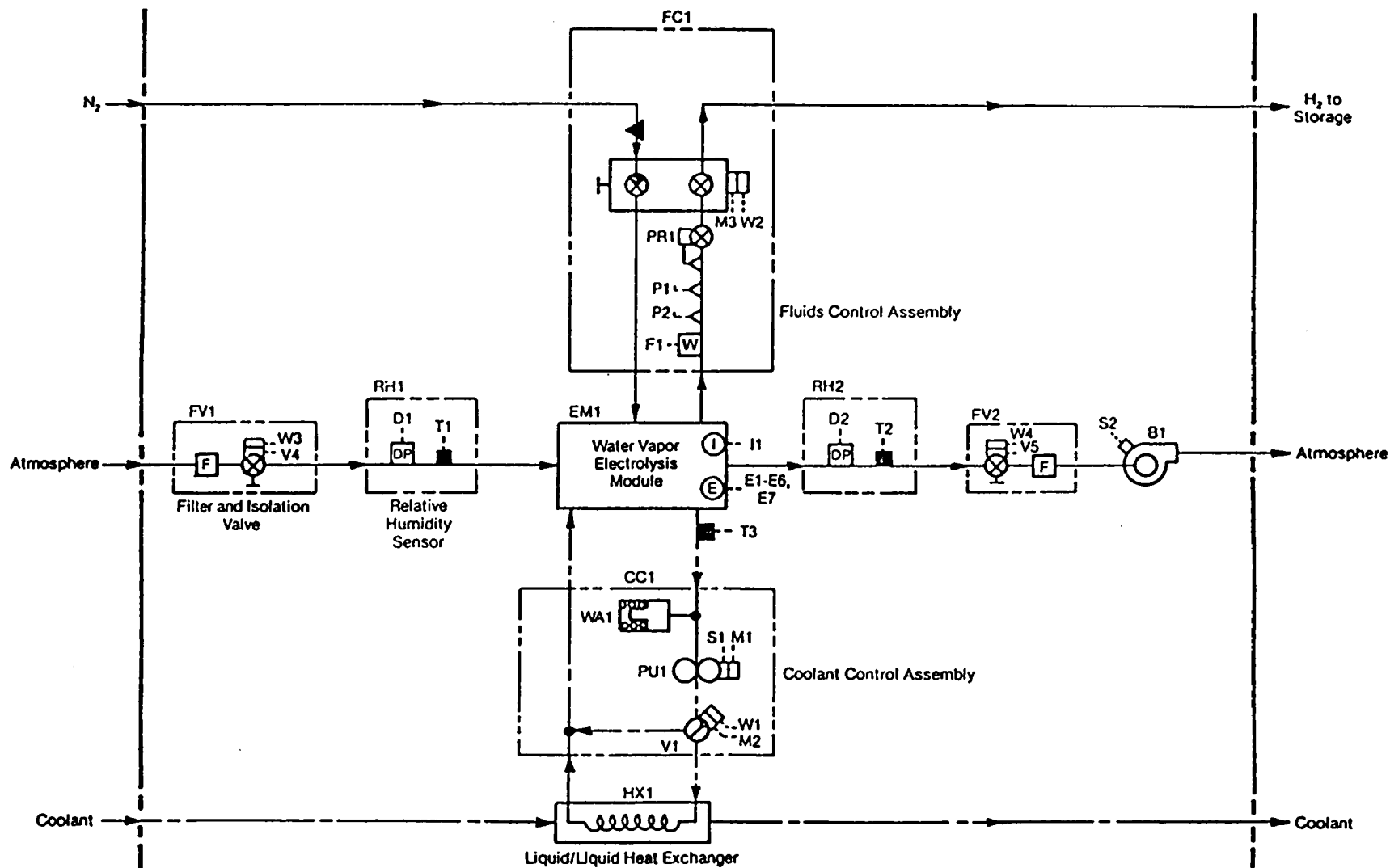

Water Vapor Electrolysis Mechanical Schematic with Sensors

443  
DISCONTINUED FILE

# O<sub>2</sub> GENERATION

## FLUID INTERFACES

TECHNOLOGY	FLUID INTERFACES	
	LINE IN	LINE OUT
Static Feed Water Electrolysis	Hygiene Water N <sub>2</sub> (O <sub>2</sub> Side) N <sub>2</sub> (H <sub>2</sub> Side)	O <sub>2</sub> , H <sub>2</sub>
Liquid Anode Feed Solid Polymer Electrolysis	Hygiene Water N <sub>2</sub> , Avionics Air	O <sub>2</sub> , H <sub>2</sub> Avionics Air
Water Vapor Electrolysis	Cabin Air Liquid Coolant	Return Air, H <sub>2</sub> , Liquid Coolant
CO <sub>2</sub> Electrolysis	See CO <sub>2</sub> Reduction	

PRECEDING PAGE BLANK NOT FILMED

445

444

# TRACE CONTAMINANT CONTROL

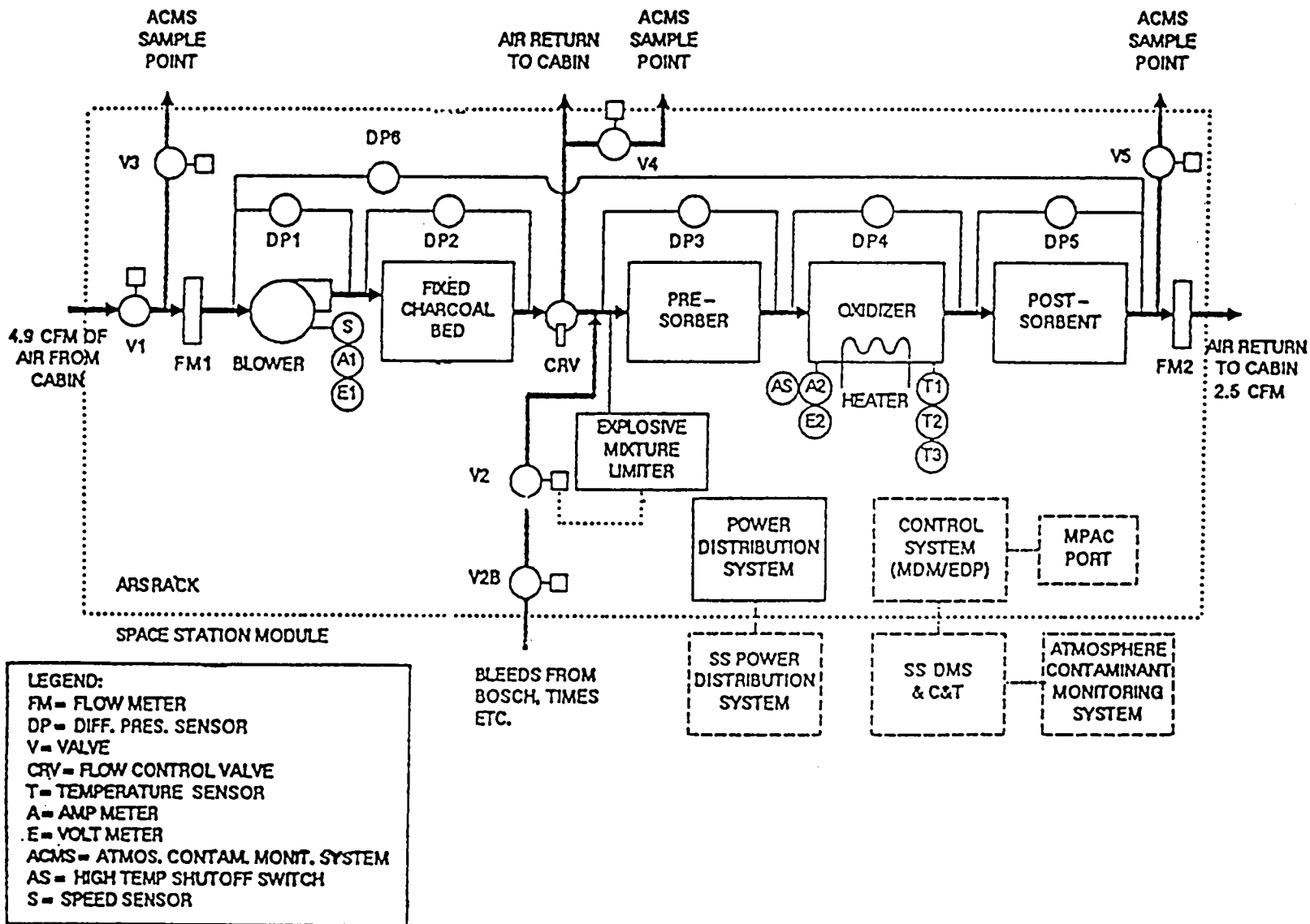

Baselined Trace Contaminant Control System Schematic

PRECEDING PAGE BLANK NOT FILMED

447

447  
 447  
 447

# TRACE CONTAMINANT CONTROL

## FLUID INTERFACES

TECHNOLOGY	FLUID INTERFACES	
	LINE IN	LINE OUT
Expendable Carbon Beds with Catalytic Oxidizer	Cabin Air Avionics Air	Return Air Avionics Air
Reactive Bed Plasma	Cabin Air	Return Air

# URINE PROCESSING

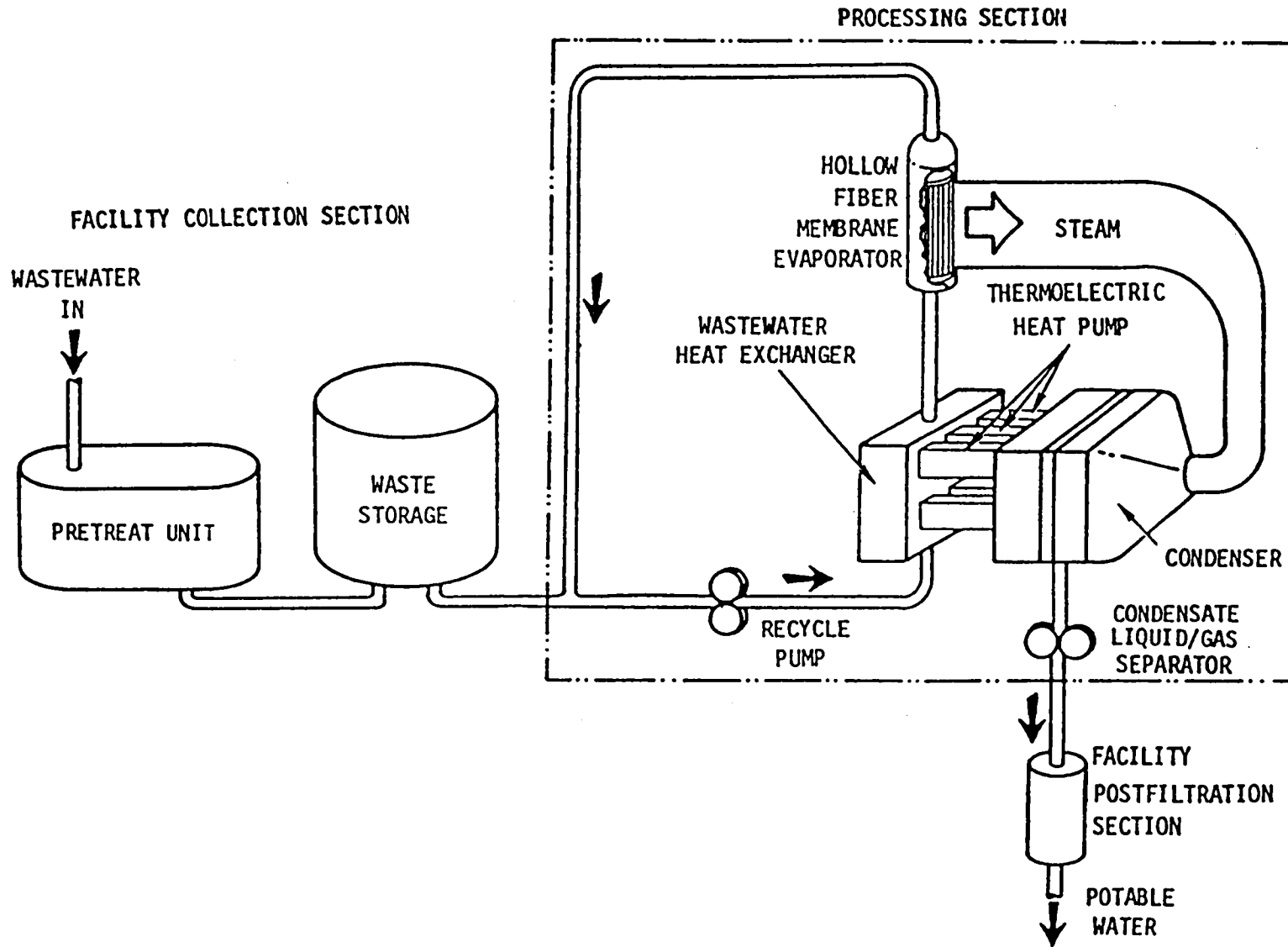

Thermolectric Integrated Membrane Subsystem Process Schematic

PRECEDING PAGE BLANK NOT FILMED

451

450

PRECEDING PAGE BLANK NOT FILMED

453

467  
468

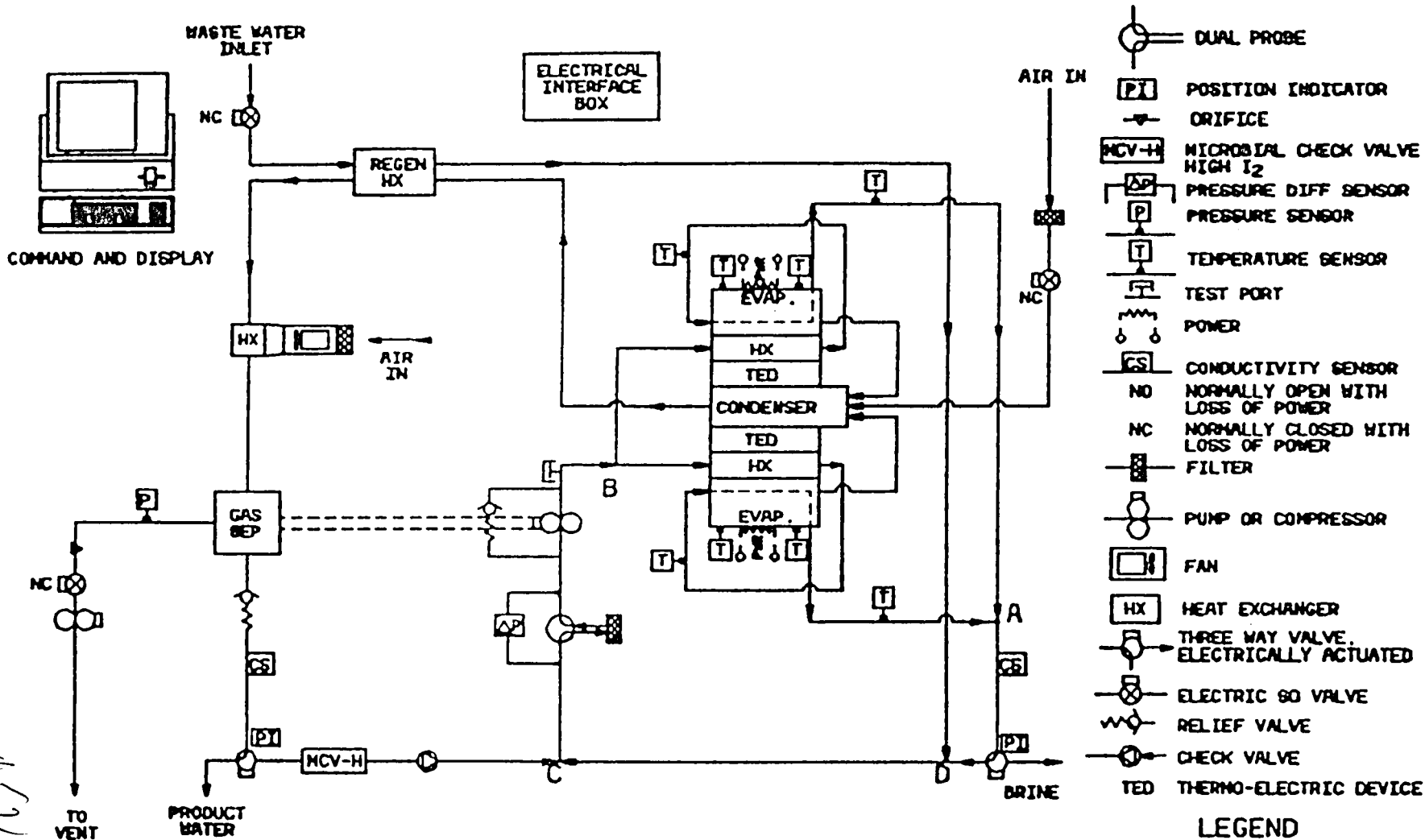

Thermoelectric Integrated Membrane Subsystem Mechanical Schematic

ORIGINAL PAGE IS OF POOR QUALITY

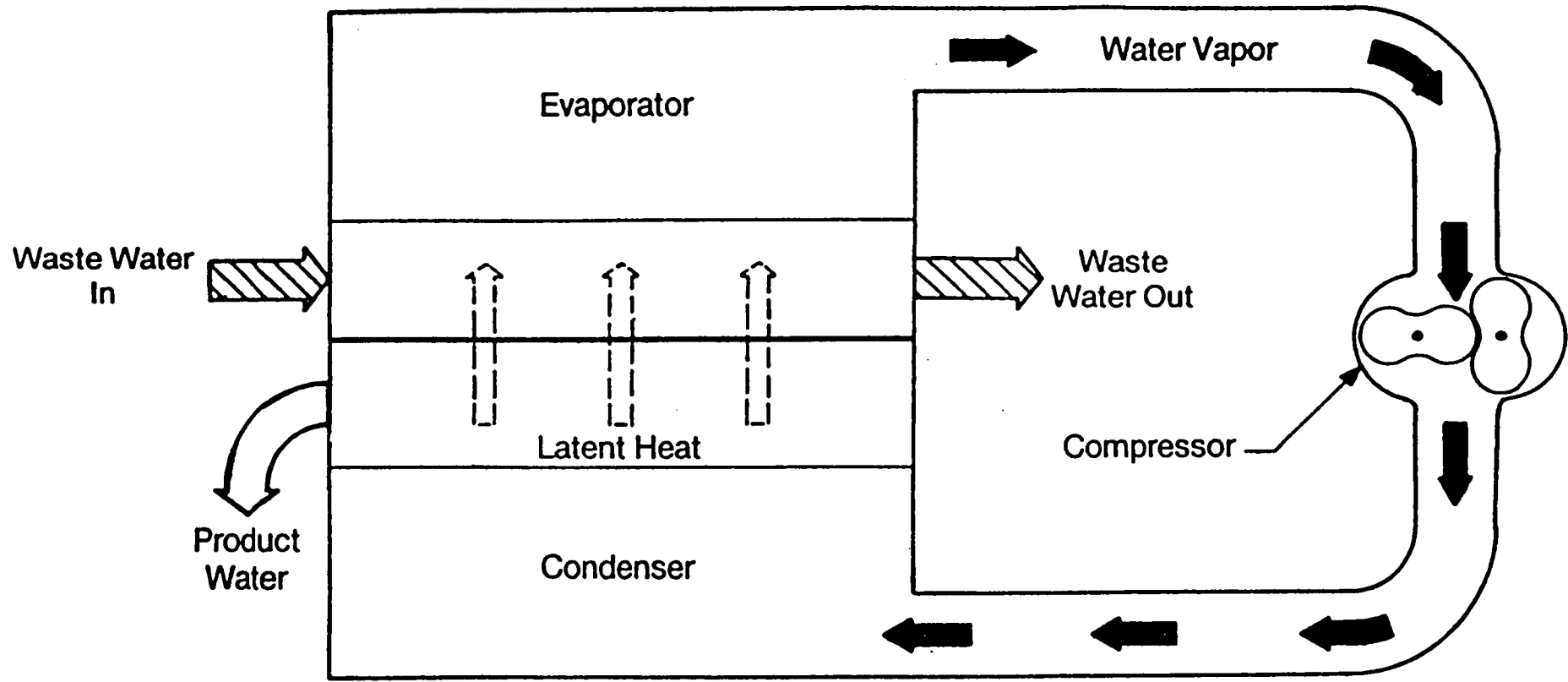

Vapor Compression Distillation Process Schematic

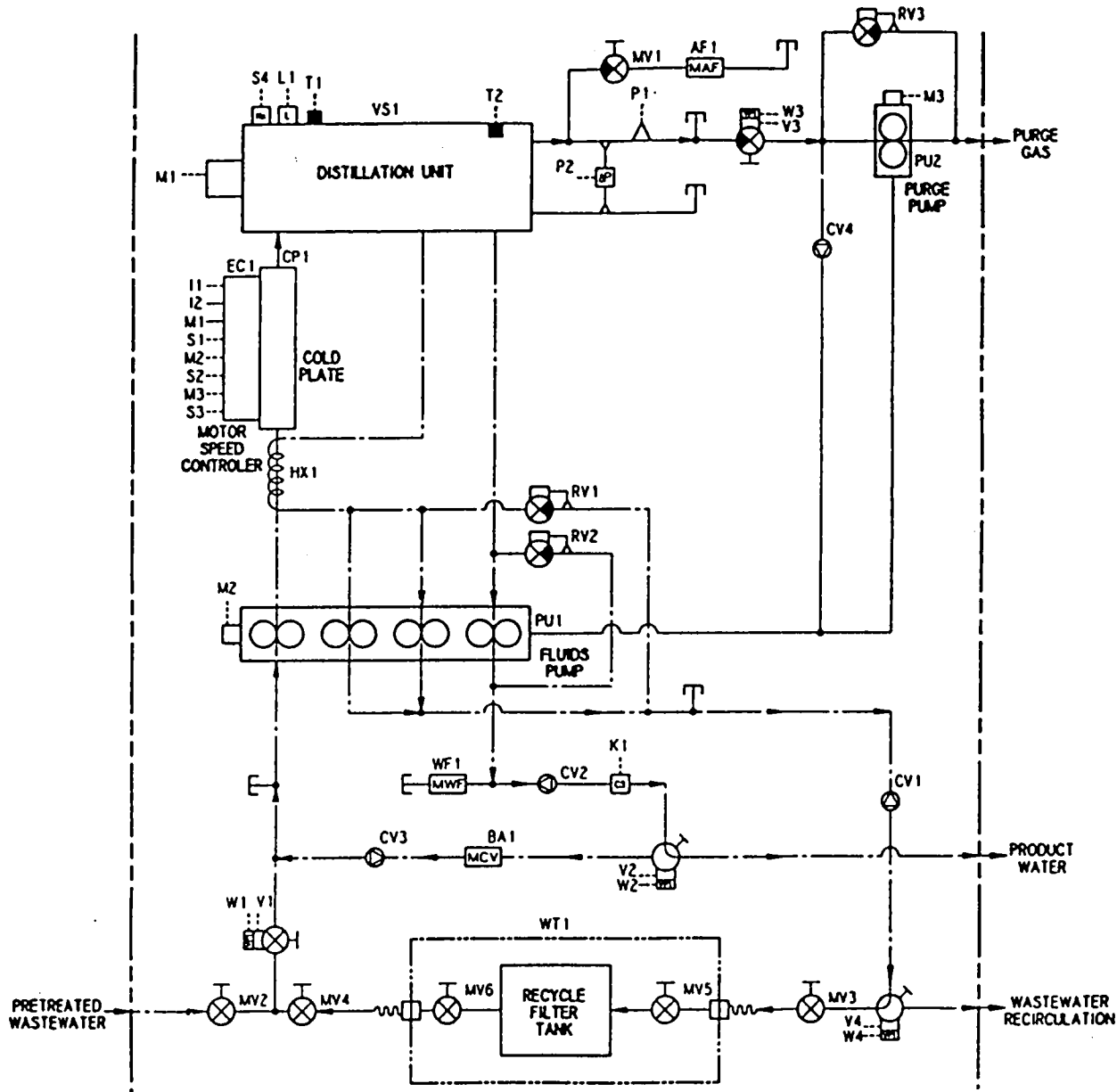















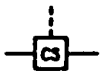
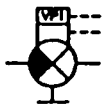
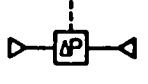
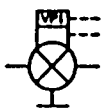

Vapor Compression Distillation Mechanical Schematic

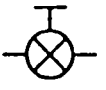
PRECEDING PAGE BLANK NOT FILMED

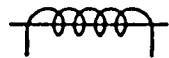
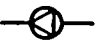

PRECEDING PAGE BLANK NOT FILMED

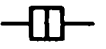
459

	MOTOR ACTUATOR		MICROBIAL AIR FILTER
	SAMPLING OR ACCESS PORT, CAPPED		VALVE, MICROBIAL CHECK
	SENSOR, CONDUCTIVITY		VALVE, MOTOR DRIVEN NORMALLY CLOSED WITH MANUAL OVERRIDE AND VALVE POSITION INDICATOR
	SENSOR, DIFFERENTIAL PRESSURE		VALVE, MOTOR DRIVEN NORMALLY OPEN WITH MANUAL OVERRIDE AND VALVE POSITION INDICATOR
	SENSOR, LIQUID		VALVE, THREE-WAY MOTOR DRIVEN WITH MANUAL OVERRIDE AND VALVE POSITION INDICATOR
	SENSOR, PRESSURE		VALVE, MANUAL SHUTOFF NORMALLY OPEN
	SENSOR, SPEED		VALVE, MANUAL SHUTOFF NORMALLY CLOSED
	SENSOR, TEMPERATURE		HEAT EXCHANGER, REGENERATIVE
	VALVE, CHECK		VALVE, RELIEF
	COUPLING, QUICK DISCONNECT		HOSE, FLEXIBLE

### Vapor Compression Distillation Schematic Legend

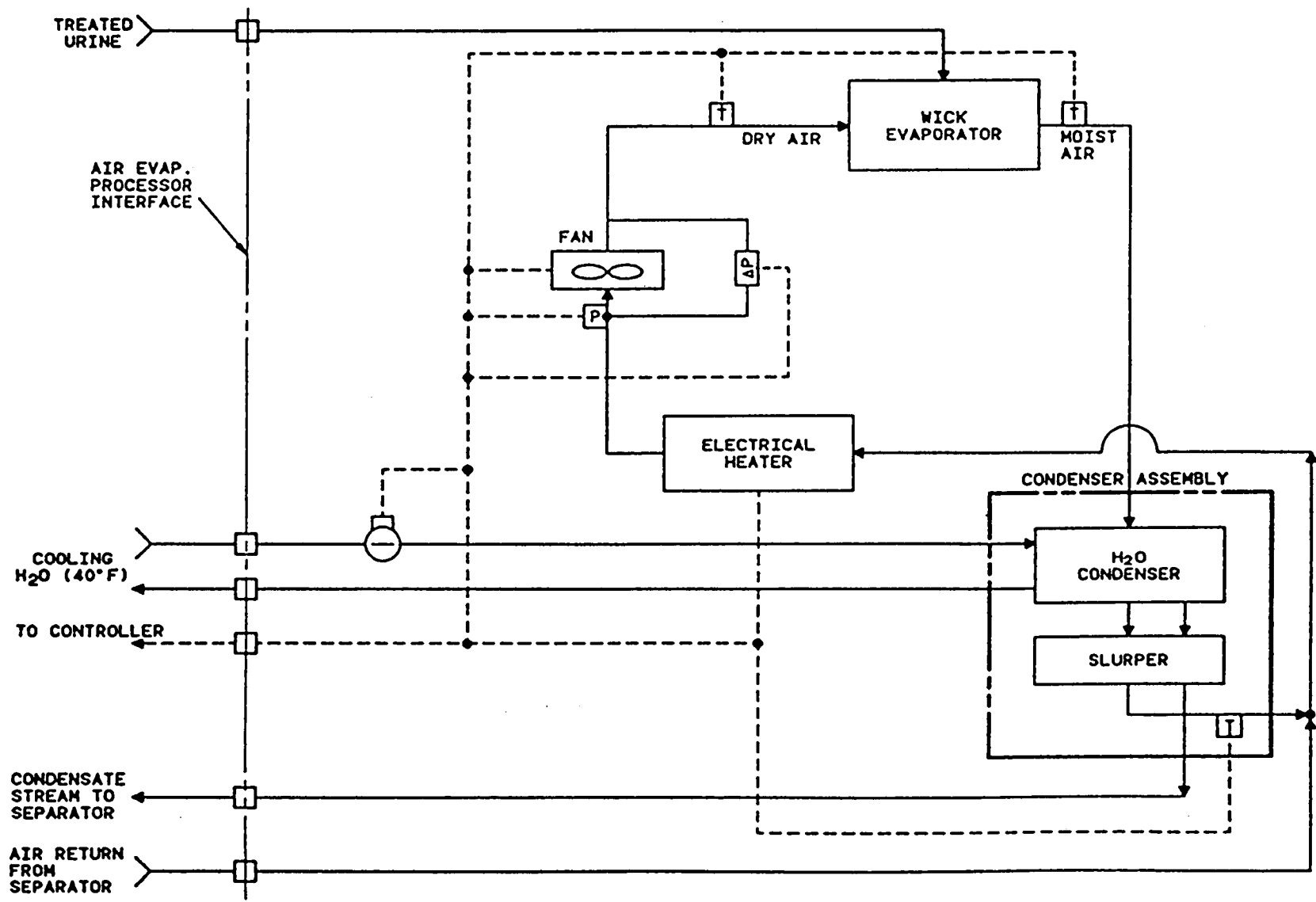

Air Evaporation System Schematic

PRECEDING PAGE BLANK NOT FILMED

461

461

PRECEDING PAGE BLANK NOT FILMED  
463

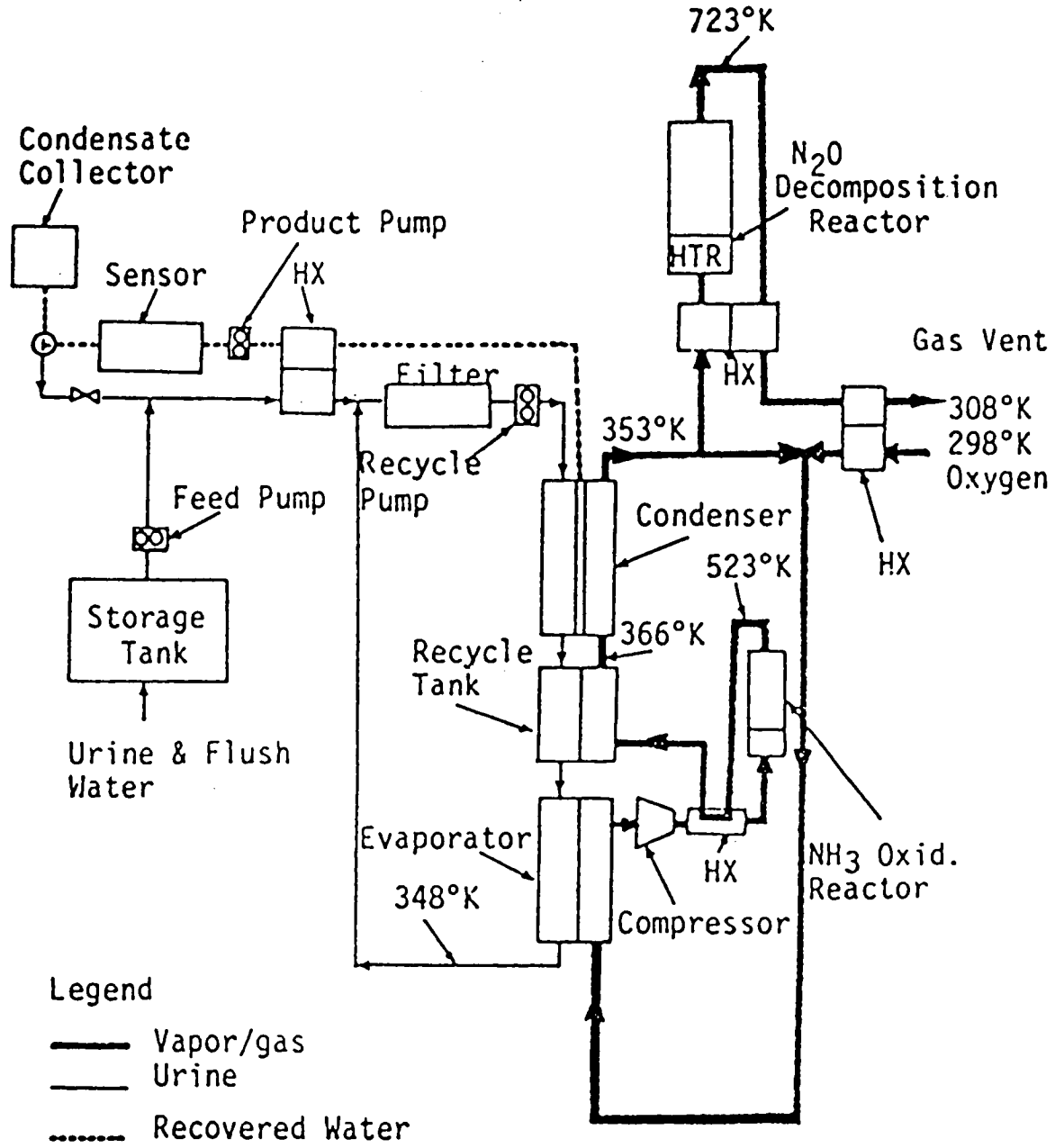

Vapor Phase Catalytic Ammonia Removal Flow Schematic

# URINE PROCESSING

## FLUID INTERFACES

TECHNOLOGY	FLUID INTERFACES	
	LINE IN	LINE OUT
Thermoelectric Integrated Membrane Evaporation Subsystem	Pretreated Urine/Flush Water Avionics Air	Water to Hygiene Processor Brine, Vent Avionics Air
Vapor Compression Distillation	Pretreated Urine/Flush Water	Water to Hygiene Processor Brine, Vent
Vapor Phase Catalytic Ammonia Removal	Untreated Urine/Flush Water O <sub>2</sub> , Cabin Air Liquid Coolant	Water to Potable Processor, Vent Liquid Coolant
Air Evaporation System	Pretreated Urine/Flush Water Liquid Coolant	Water to Hygiene Processor Liquid Coolant Return Air from Separator

# HYGIENE WATER PROCESSING

## Ultrafiltration

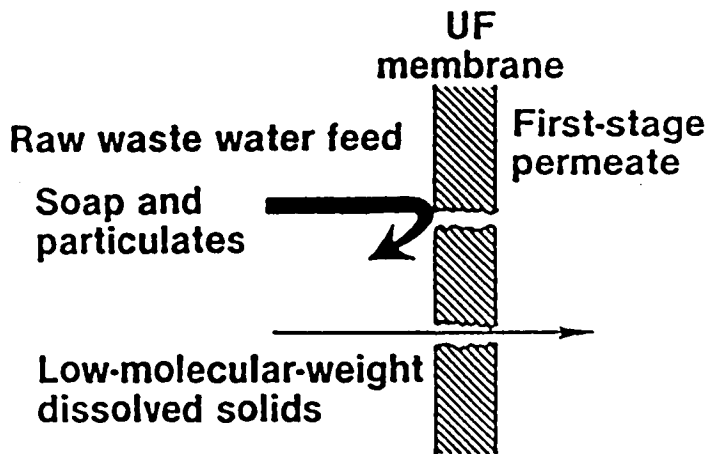

## Reverse Osmosis

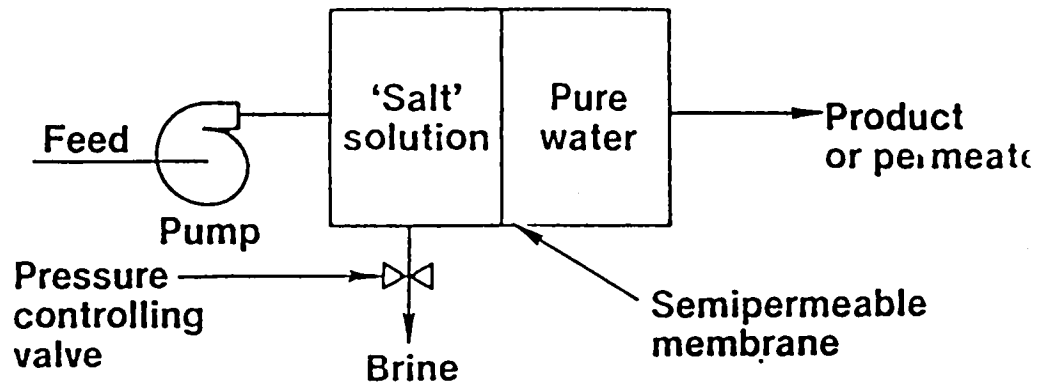

General Operating Characteristics of Ultrafiltration and Reverse Osmosis

PRECEDING PAGE BLANK NOT FILMED

469

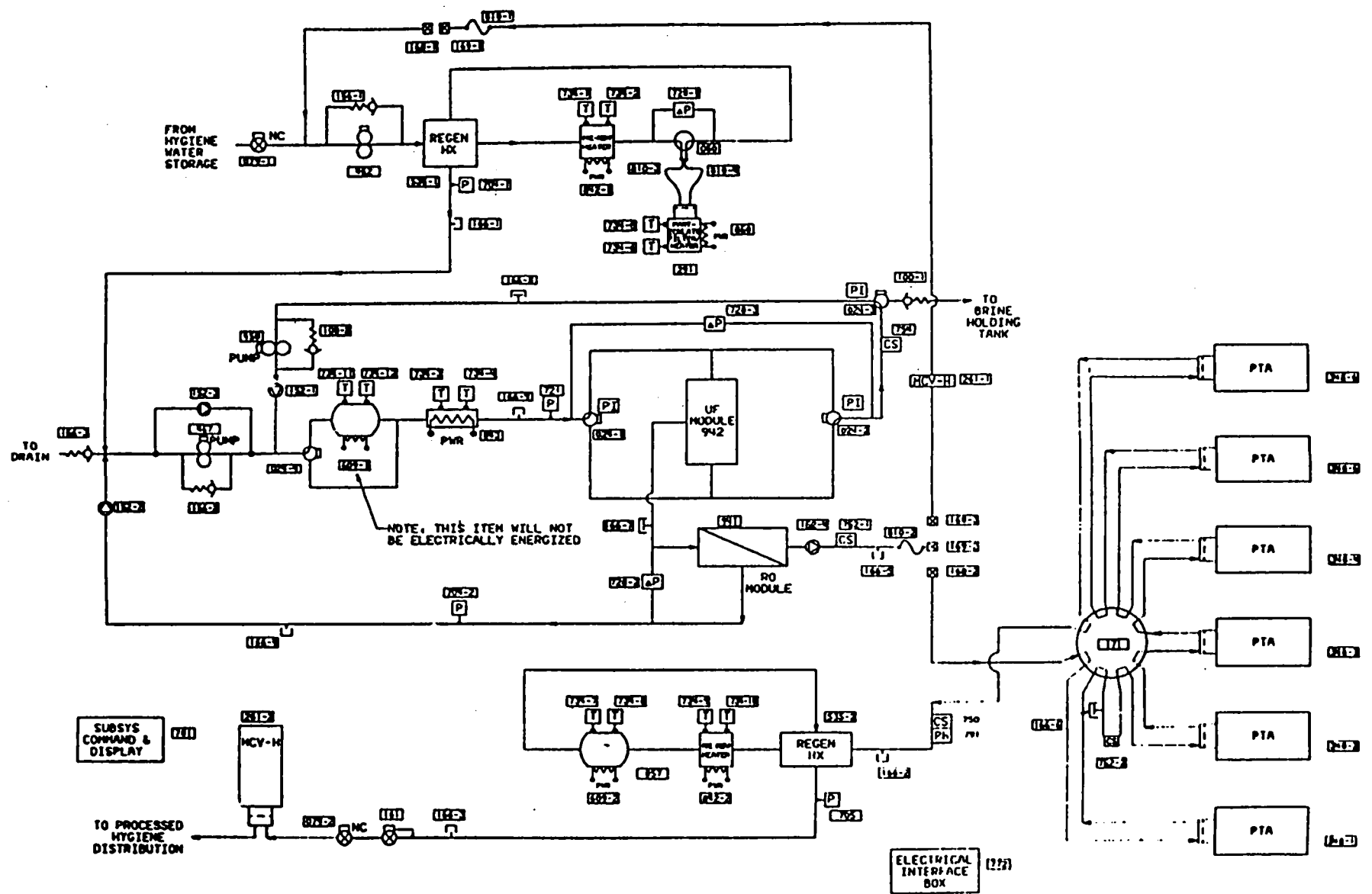

Reverse Osmosis System Schematic for Hygiene Water Recovery

# HYGIENE WATER PROCESSING

## FLUID INTERFACES

TECHNOLOGY	FLUID INTERFACES	
	LINE IN	LINE OUT
Reverse Osmosis	Waste Wash Water/Urine Processor Product Water	Hygiene Water Brine
Multifiltration	See Potable Water Processing	

# POTABLE WATER PROCESSING

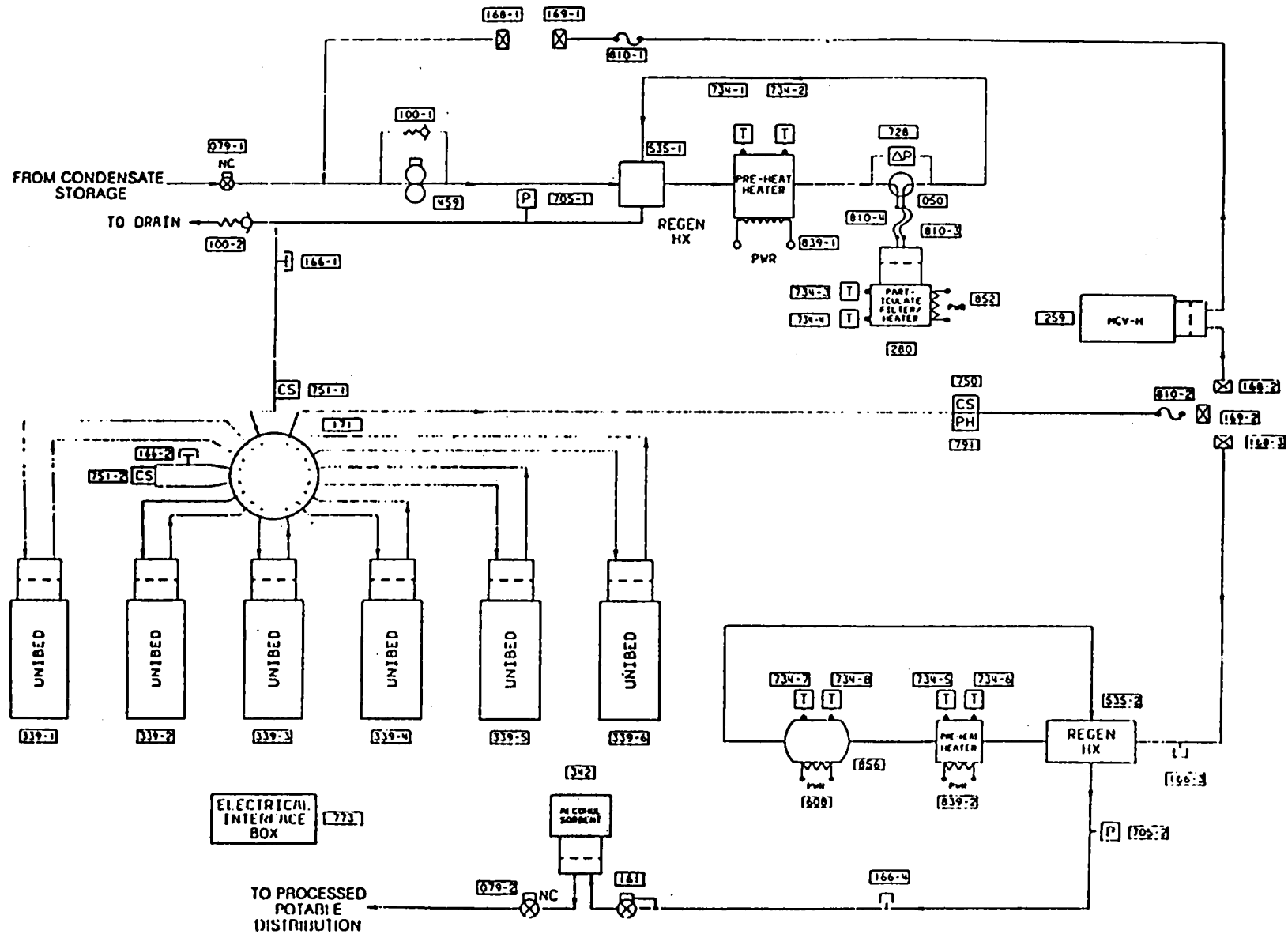

Multifiltration System Schematic for Potable Water Recovery

PRECEDING PAGE BLANK NOT FILMED



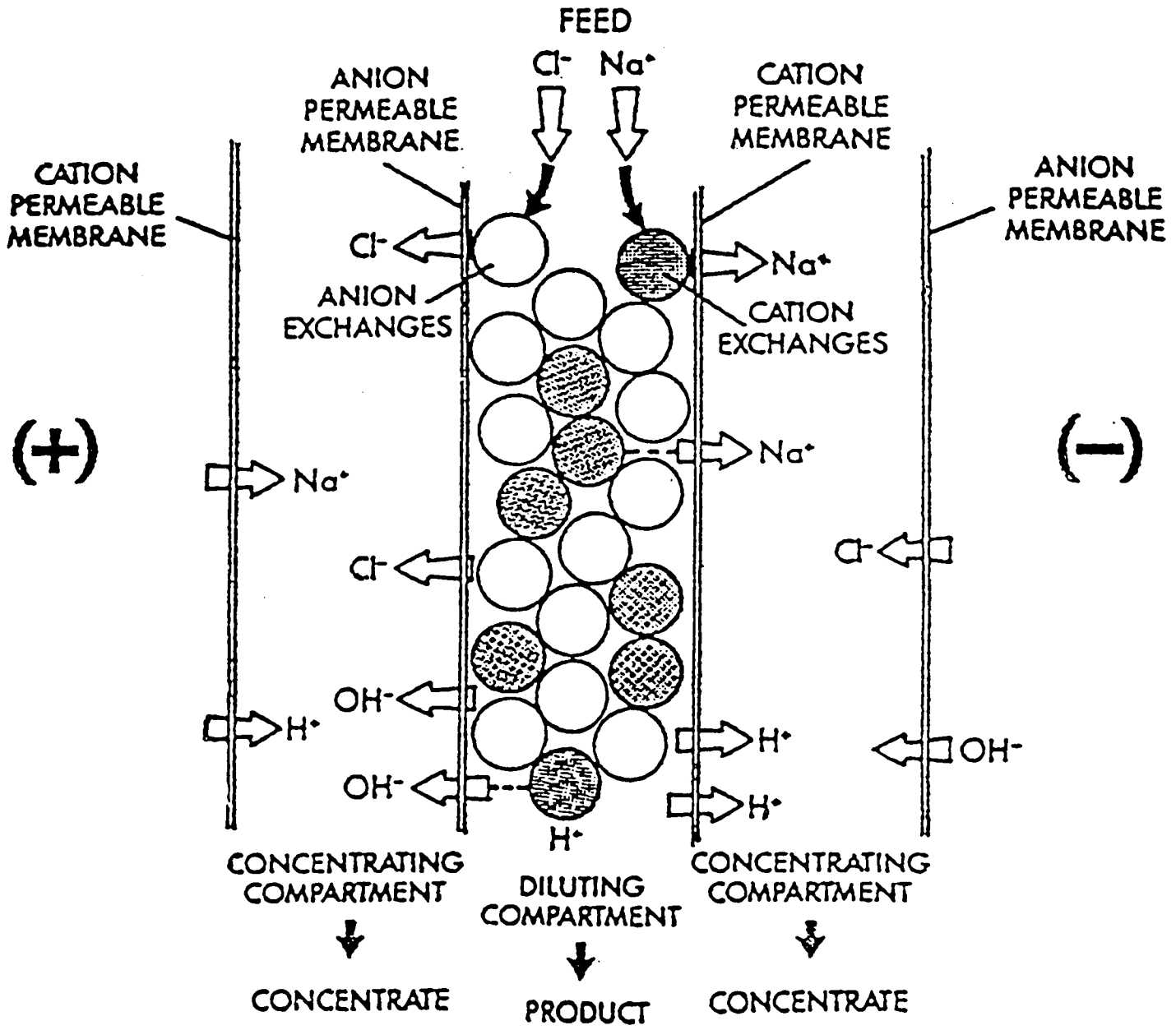

The Electrodeionization Process

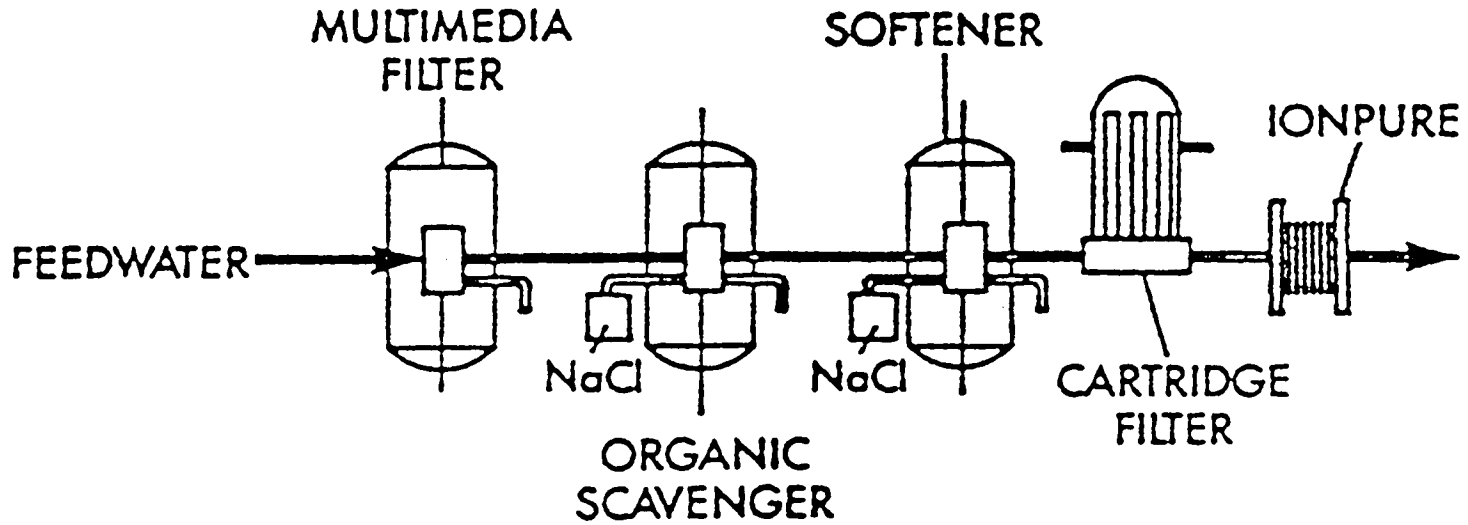

• ASSUMES FEEDWATER SDI<sub>15</sub> < 4.0 AND FREE Cl<sub>2</sub> < 0.2 ppm

**Electrodeionization System ("Ionpure") with Pretreatment**

# POTABLE WATER PROCESSING

## FLUID INTERFACES

TECHNOLOGY	FLUID INTERFACES	
	LINE IN	LINE OUT
Multifiltration	Condensate from THC/CO <sub>2</sub> Reduction	Potable Water
Reverse Osmosis	See Hygiene Water Processing	
Electrodeionization	Condensate Water from THC/CO <sub>2</sub> Reduction	Potable Water Brine

# WASTE MANAGEMENT

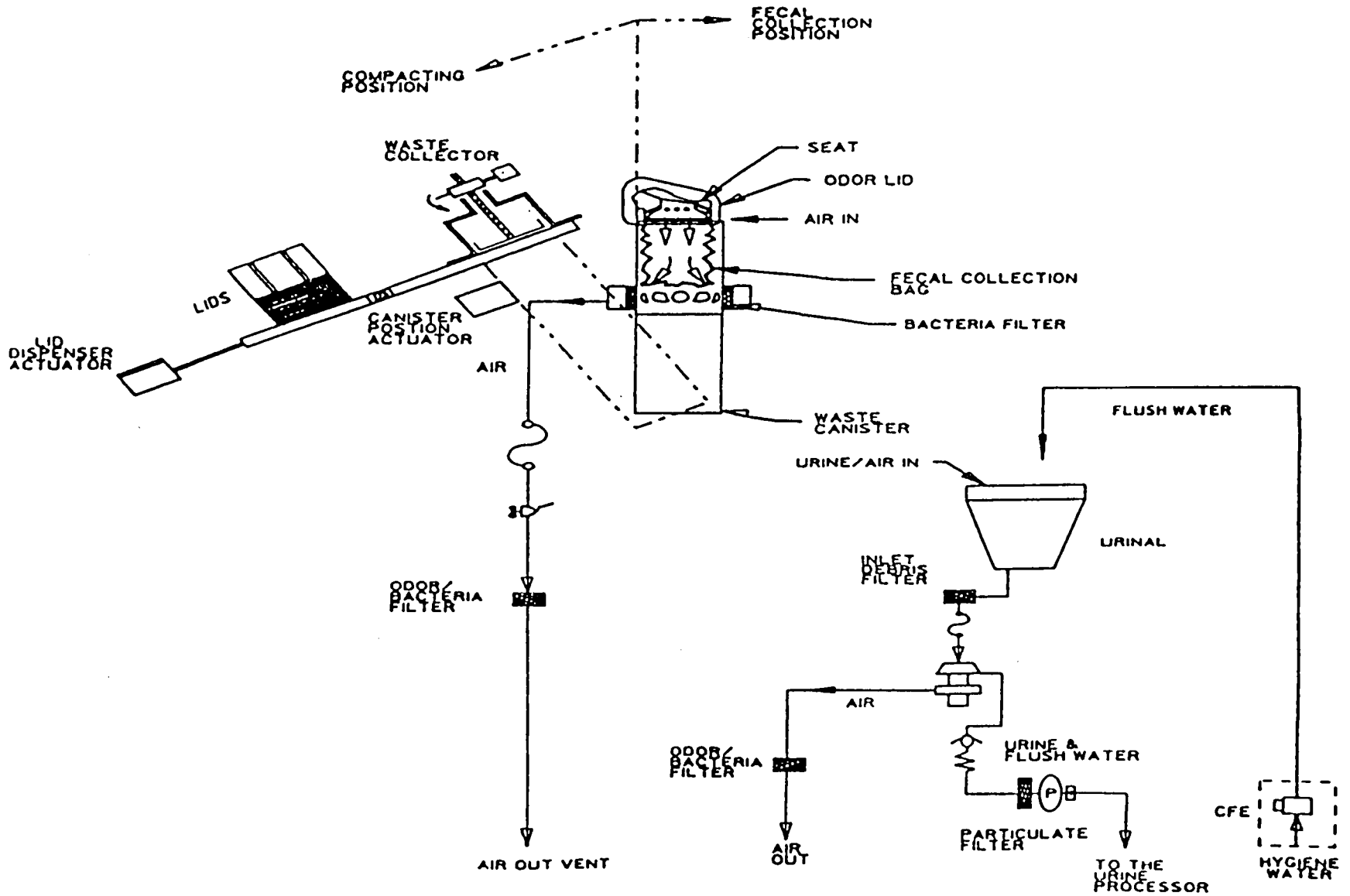

Schematic of the Baseline Urinal/Commode

PRECEDING PAGE BLANK NOT FILMED

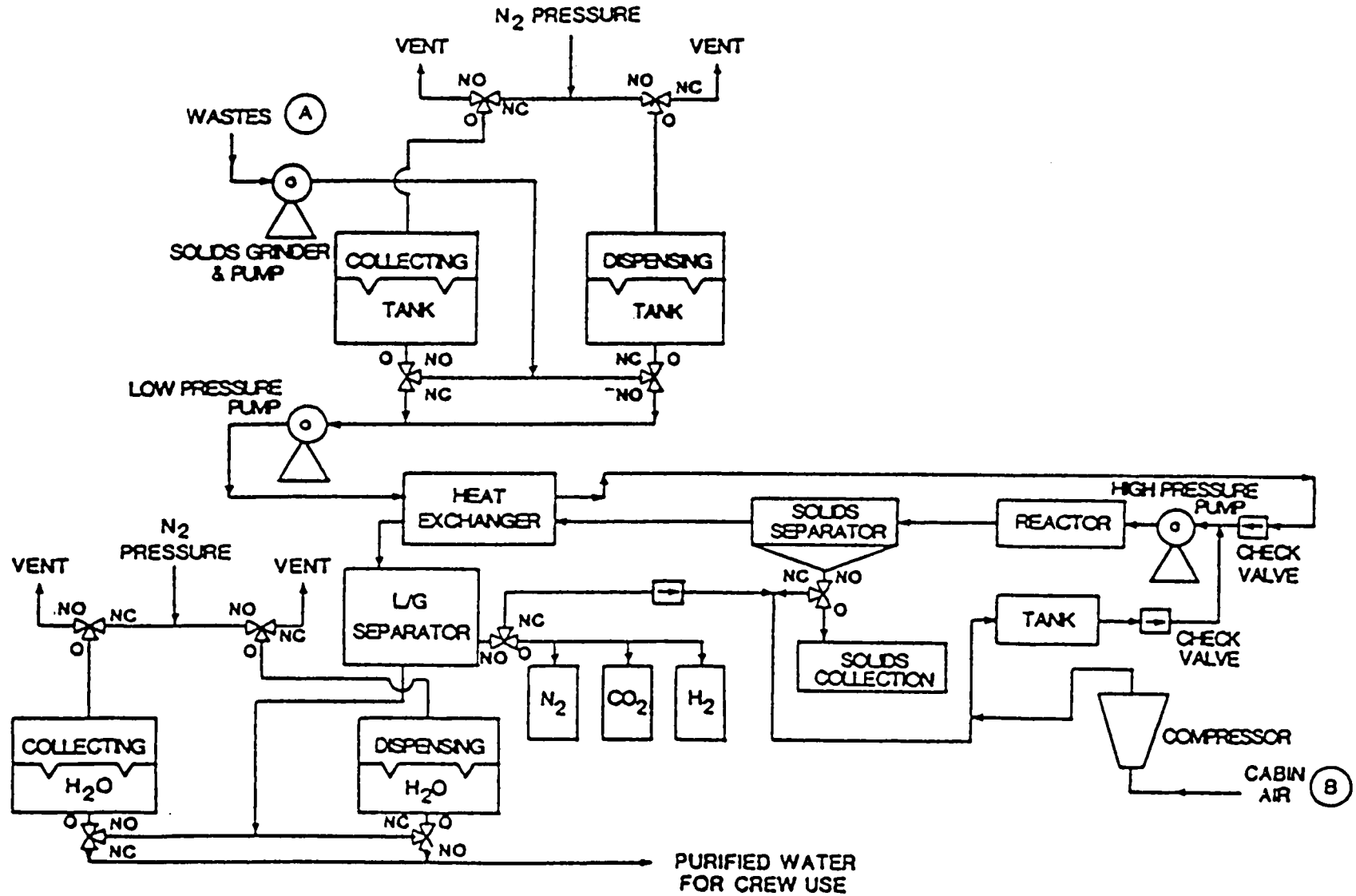

Block Diagram of Supercritical Water Oxidation System

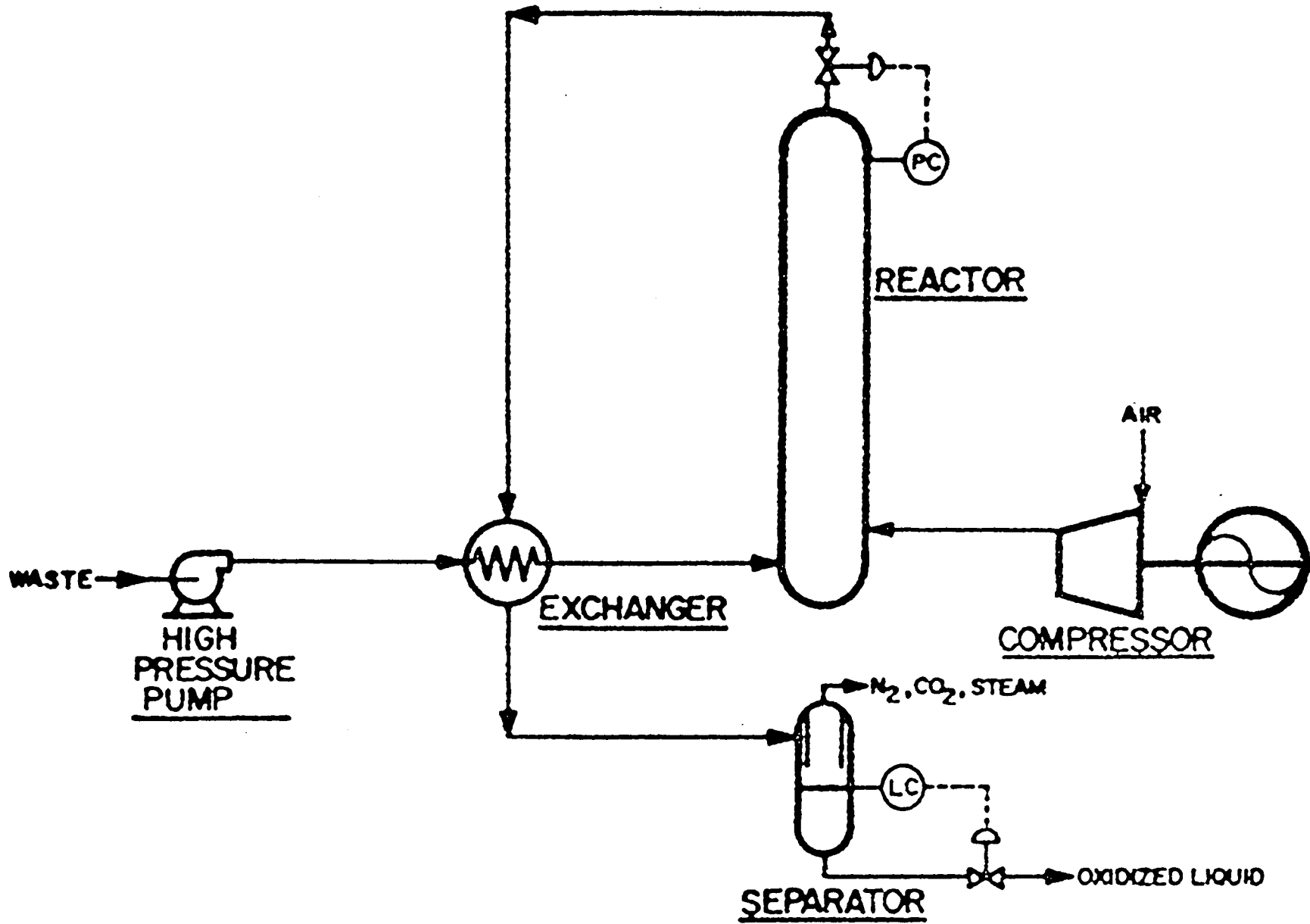

General Wet Oxidation Schematic

PRECEDING PAGE BLANK NOT FILMED 487

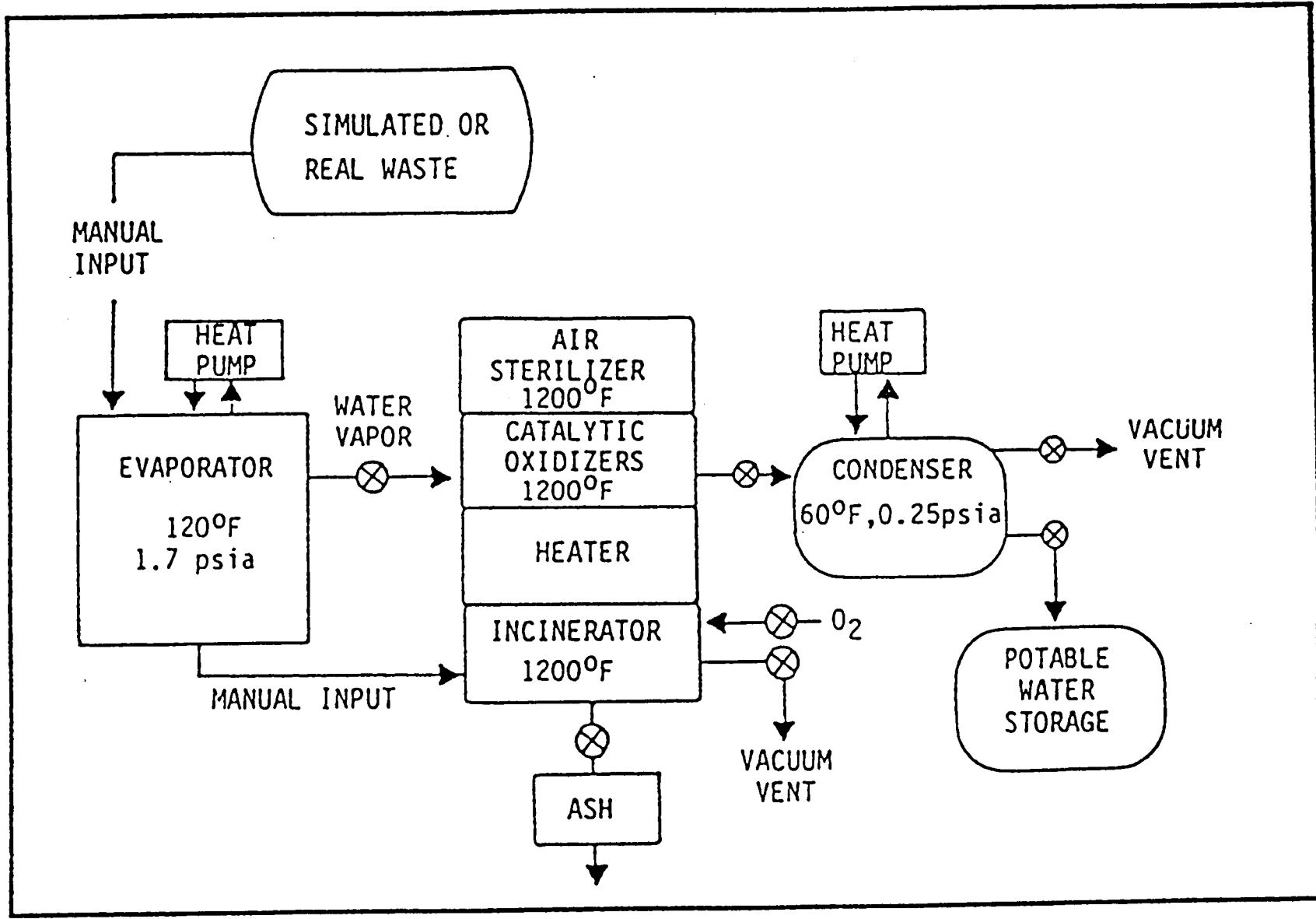

Block Diagram of Waste Management - Water System

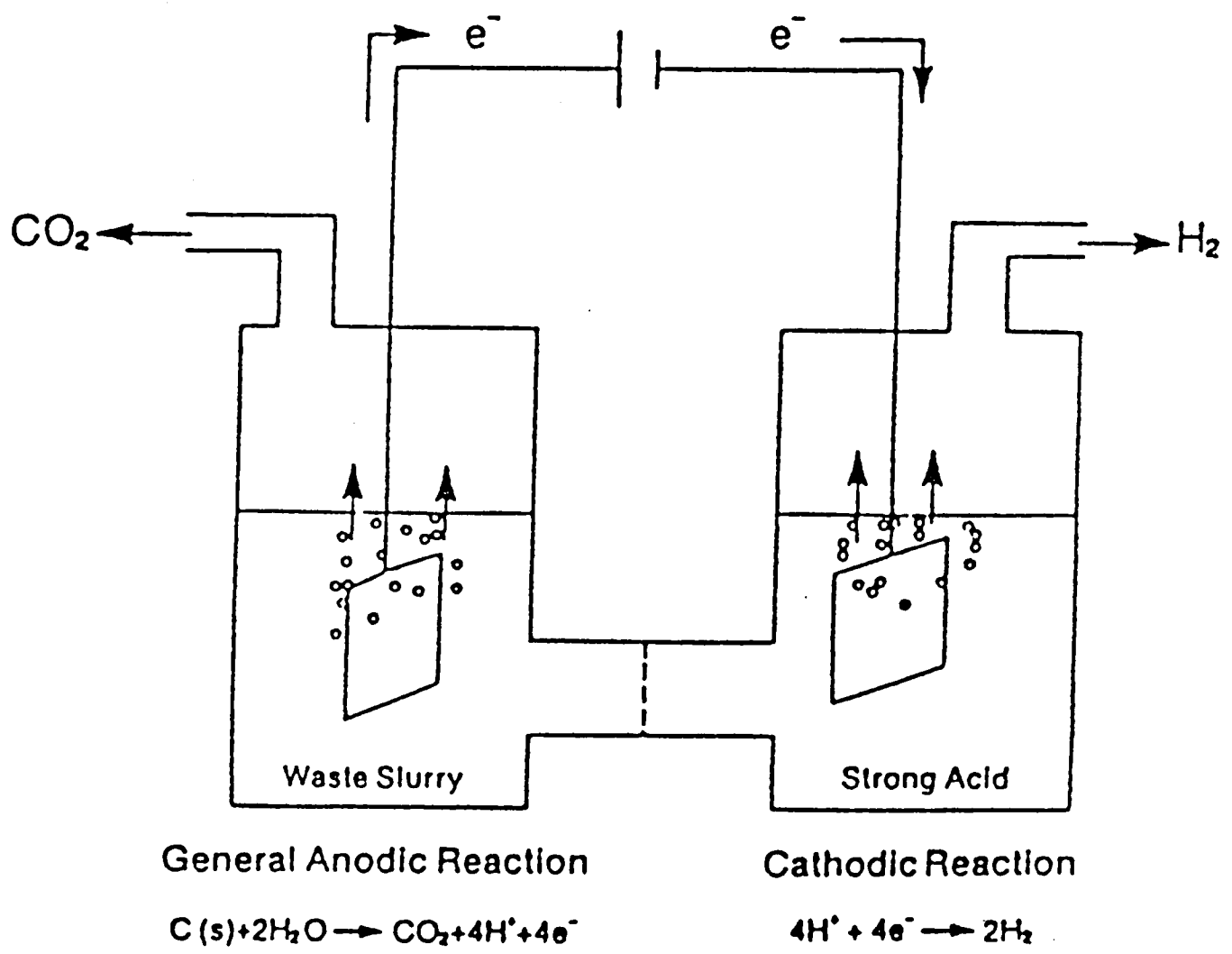

Electrochemical Decomposition Process Schematic



- A Purge Gas Inlet
- B Purge Gas Inlet
- F Glass Frit
- G Sample Gas Outlet
- CW Cold Water Inlet
- W Water Outlet
- RE Saturated Calomel Reference Electrode
- WE Working Electrode
- CE Counter Electrode
- M Magnetic Stirring Bar
- T Solution Exit Trap

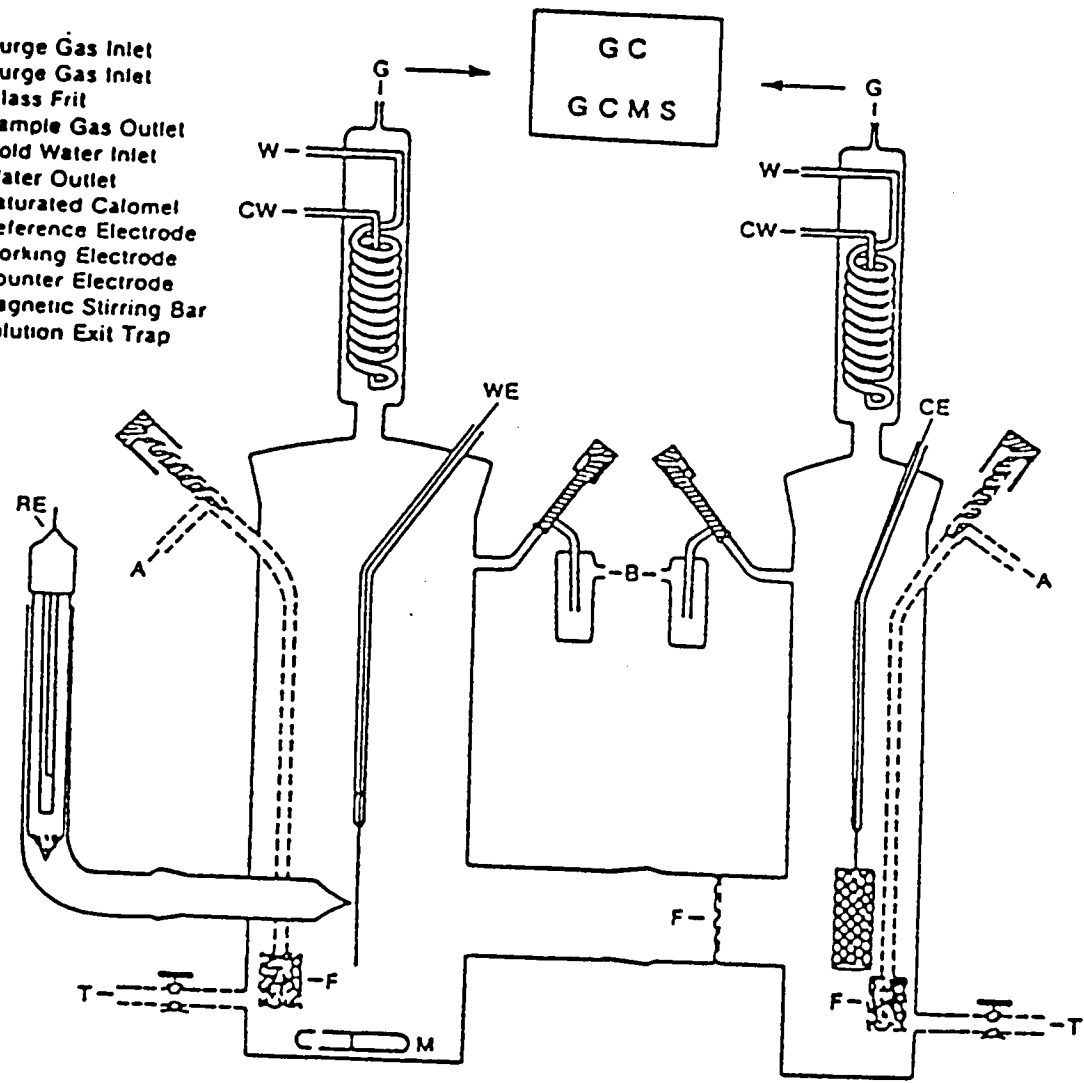

A Diagram of the Electrochemical Decomposition Electrolysis Cell

# WASTE MANAGEMENT

## FLUID INTERFACES

TECHNOLOGY	FLUID INTERFACES	
	LINE IN	LINE OUT
Storage and Biodegradation	Solid Trash/Human Feces	Return to Earth
Wet Oxidation	Waste Water Solid Waste, O <sub>2</sub>	Water and Gases to Posttreatment Solid Waste
Waste Management - Water System	Brine/Rejection Concentrates Air (from urinal)	Return Air Potable Water
Supercritical Water Oxidation	Cabin Air, O <sub>2</sub> , Condensate, Wash Water, Urine/Flush Water, Solid Waste, Liquid Coolant	Return Air, Solid Waste H <sub>2</sub> , N <sub>2</sub> , CO <sub>2</sub> to Storage Potable Water Liquid Coolant Vacuum Vent
Electrochemical Decomposition	New Concept - Interfaces undetermined	

**ALTERNATIVE PROCESSES FOR WATER RECLAMATION AND SOLID  
WASTE PROCESSING IN A PHYSICAL/CHEMICAL-BIOGENERATIVE  
LIFE SUPPORT SYSTEM**

**TOM D. ROGERS  
SPACE RESEARCH CENTER  
REGENERATIVE CONCEPTS LABORATORY  
TEXAS A&M UNIVERSITY**

**WORKSHOP PRESENTATION  
NASA OFFICE OF AERONAUTICS & SPACE TECHNOLOGY  
TECHNOLOGY FOR SPACE STATION EVOLUTION  
DALLAS, TX  
JANUARY 16-19, 1990**

**N 9 8 - 2 7 7 2 1**

517-54  
163669

495

DATA 494 INFORMATION PAGE

PRECEDING PAGE BLANK NOT FILMED

## INTRODUCTION

During the past year, increasing attention has been focused on life support systems and the critical role they have in sustaining spaceflight crews. As these explorers undertake missions traveling greater distances from Earth and for longer periods of time, the more critical the need for regenerative life support capabilities.

The selection and development of the present candidate water reclamation technologies has been driven by the same factors requisite for most, if not all, spacecraft systems (i.e., size, weight, volume, power, etc.).

As more studies are conducted toward selection of the Water Reclamation and Management (WRM) system hardware for Initial Operation Configuration (IOC) of Space Station *Freedom*, the primary criteria (weight, volume, power, etc.) appear to have been adequately met. However, information and data found in a number of reports during the past two years indicate that secondary issues (i.e., waste composition, type and level of chemical contaminants and effects of microorganism (primarily bacterial) are significantly affecting the operation and efficiency of the

candidate systems. These issues are apparently having a greater impact on system development and evaluation than previously anticipated.

The main objective of this presentation is to focus attention on the emerging influences of these secondary factors and to constructively address these issues by discussing approaches which attack them in a more direct manner. It may be that these secondary issues will equal or surpass the primary factors in guiding the direction of evolutionary technology and design of future water reclamation and waste management/processing systems.

Using these secondary issues as a focal point, two technologies (an old one and a new, emerging technology) are briefly discussed. The technologies can be shown to have substantial merit, but more importantly it is hoped this presentation will stimulate new thinking and approaches toward reducing the impact of the secondary issues as a key element of the evolutionary system research and development. In the long run, it may turn out that these issues may be the most critical of all factors.

Tom D. Rogers  
Space Research Center  
Texas A&M University

---

## SPACE STATION WATER RECLAMATION AND MANAGEMENT SYSTEM

The Space Station *Freedom* WRM system will have three systems reclaiming water for crew use. At least two of these systems will include backup units. The U.S. Laboratory will have at least two systems and backup units are included in the plans. This is a total of nine units consisting of four different system configurations. Three or four of these systems will likely have daily duty cycles, thus requiring power, monitoring of system function and water quality, consumables and intervehicular activity (IVA) crew time.

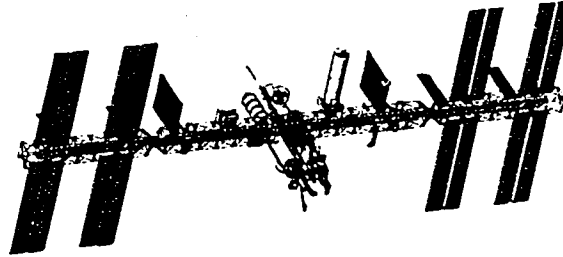

## SPACE STATION WATER RECLAMATION AND MANAGEMENT SYSTEM

WRM SUBSYSTEM	WASTE SOURCE	WATER SPECIFICATION
1. CREW POTABLE WATER (PRIMARY) CREW POTABLE WATER (BACKUP)	<ul style="list-style-type: none"> <li>* Breathing Atmosphere, Humidity Condensate</li> <li>* CO2 Reduction Water</li> </ul>	Potable
2. HYGIENE WATER (PRIMARY) HYGIENE WATER (BACKUP)	<ul style="list-style-type: none"> <li>* Hand/Face Washer, Body Shower</li> <li>* Clothes Washer</li> <li>* Dish Washer</li> </ul>	Hygiene
3. URINE PROCESSOR (PRIMARY)	<ul style="list-style-type: none"> <li>*Urine/Flush Wastewater</li> </ul>	Hygiene
4. U.S. LABORATORY-Animal Experiment Facility (Water Recycle System)	<ul style="list-style-type: none"> <li>* Animal Cage Washer Wastewater</li> </ul>	Hygiene
5. U.S. LABORATORY-Ultrapure Water System (UPWS)	<ul style="list-style-type: none"> <li>* Experiment Waste</li> </ul>	Ultrapure

## GENERALIZED DIAGRAM OF WATER RECLAMATION SYSTEMS

An overview diagram applicable to any of the WRM systems is shown in Figure 2. Various combinations of factors and components influence the design of each of the systems. Waste chemical composition, microorganism load and pretreatment regimen influence effectiveness of the primary process which subsequently influences the post-treatment scheme. Microorganism resistance to pretreatment or break-through of the primary reclamation process impacts the entire system and potentially necessitates primary system changeout (in the case of a Reverse Osmosis primary system) or implementation of cleanup procedures of the hardware (VCD or TIMES).

Looking at this situation from another perspective, assume: (1) two or more of the present waste streams could be combined, (2) chemical composition could be more complex, yet less compromising, and (3) the microorganism load and influence is of no concern on the input side with control of microorganisms being the prevention of back-contamination at enduse points. Such an approach would reduce the number of major systems required for primary water reclamation with more attention being focused on post-treatment assemblies to provide the required water quality. Such a step directly addresses effectiveness and efficiency of the entire WRM.

## GENERALIZED DIAGRAM OF WATER RECLAMATION SYSTEMS

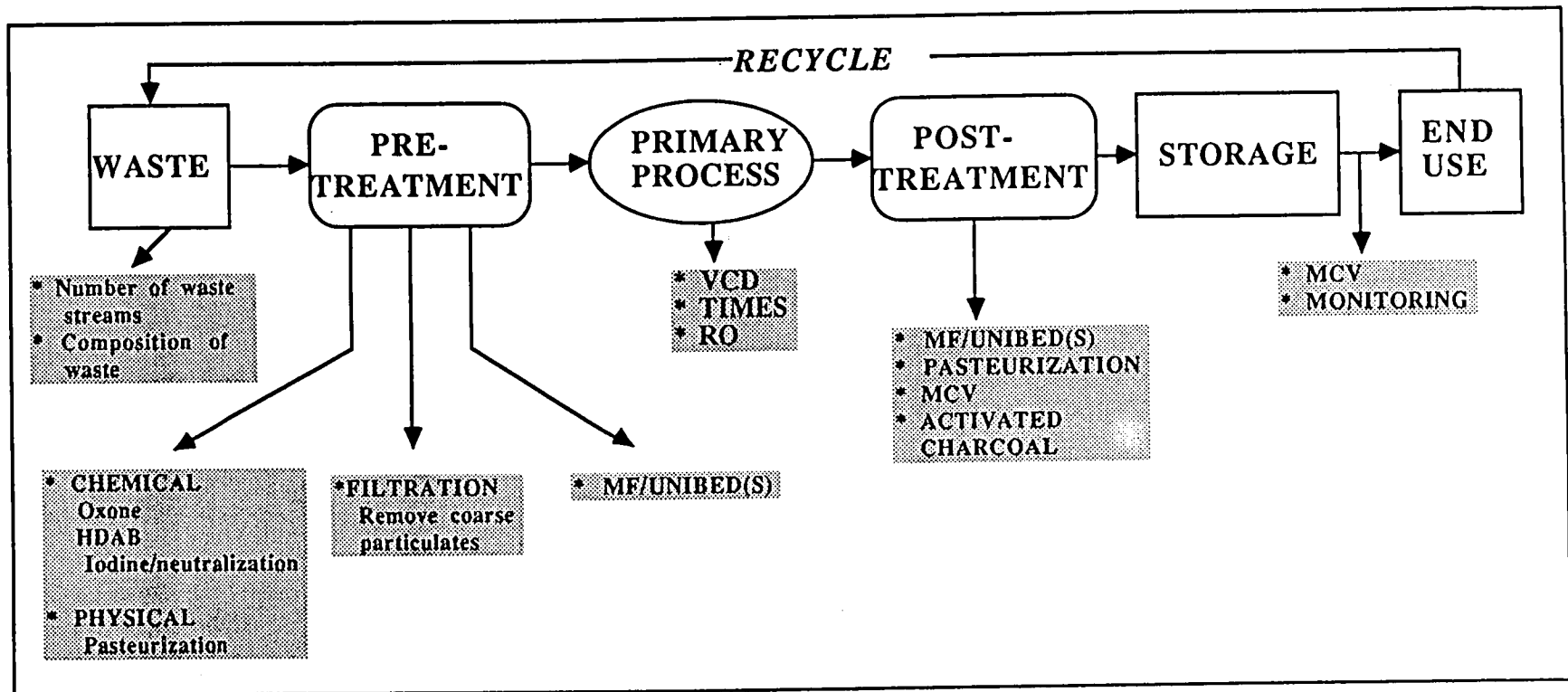



## WATER RECLAMATION USING EVAPORATION, CATALYTIC OXIDATION AND CONDENSATION

Using an evaporation, catalytic oxidation and condensation process (referred to earlier as an "old" technology) chemical wastes containing substances known to compromise the present candidate systems, were prepared and processed as shown in Figure 3. The objective was to assess the capability of this process to reduce the total organic carbon (TOC) content to a reasonable level using single-pass treatment. This objective was achieved and the hardware/components were not compromised by the waste stream chemicals.

No attempt was made to investigate the microorganism influence because this aspect was more than adequately investigated and reported by General Electric in

studies conducted in the early 1970's. Extensive, periodical microbial monitoring of reclaimed water was conducted during a simulation test lasting more than 180 days. Microorganism presence was not detected in any of the sampling tests as a result of process breakthrough, no did microorganisms have any impact on the process from the influent stream side.

It is pointed out that a variety of pretreatment measures have been employed to reduce the presence and effects of microorganisms of influent waste streams relative to the current technologies, yet little or no attention has been accorded the results of the above studies from nearly two decades ago.

## WATER RECLAMATION USING EVAPORATION-CATALYTIC OXIDATION-CONDENSATION

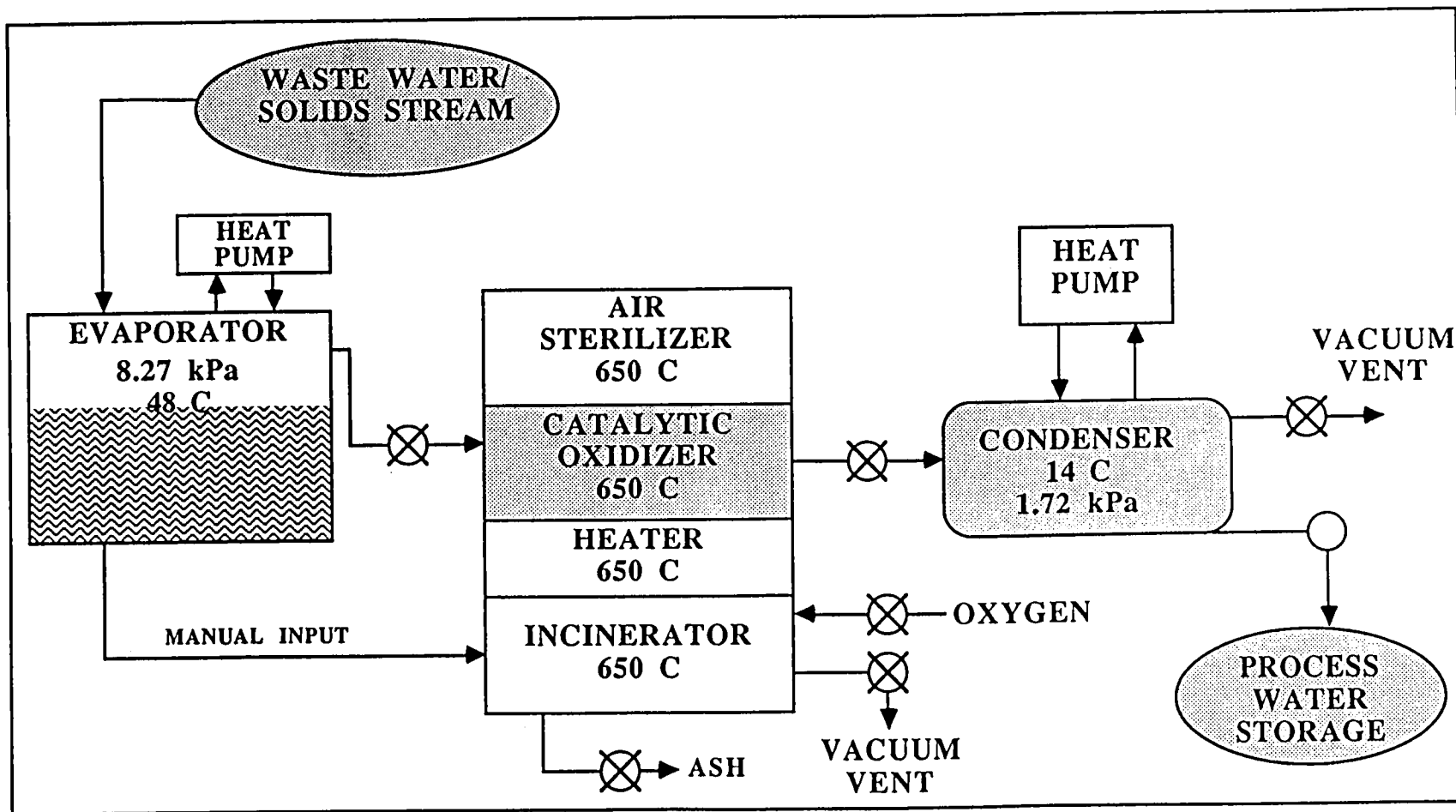

Tom D. Rogers  
Space Research Center  
Texas A&M University

---

**PHASE CHANGE - CATALYTIC OXIDATION -  
CONDENSATION PROCESSING OF CHEMICAL  
WASTE WITH HIGH TOTAL ORGANIC  
CARBON (TOC) CONTENT**

Chemical wastes shown in Figure 4 were prepared and processed in the hardware system outlined in Figure 3. The main point of emphasis in the results is that waste having a high TOC was reduced by single-pass processing to a level within, or approaching the TOC specification for hygiene water (10 ppm).

The sodium lauryl sulfate/sodium hydroxide test

solution was processed because such chemicals represent an appropriate detergent for use in animal cage washing and a suitable chemical (sodium hydroxide) for removal of biofilm. Single-pass reclaimed water within the specifications for hygiene quality water is a feasible starting point for posttreatment processing to produce both potable and ultrapure water.

**PHASE CHANGE - CATALYTIC OXIDATION - CONDENSATION PROCESSING OF CHEMICAL WASTE WITH HIGH TOTAL ORGANIC CARBON (TOC) CONTENT**

CHEMICAL WASTE	PRE- AND POST TREATMENT ANALYSES*					
	SPECIFIC CONDUCTANCE		TOC(mg/l)		AMMONIA NITROGEN(mg/l)	
	PRE-	POST-	PRE-	POST-	PRE-	POST-
Acetic Acid            10 ml/L 2-Propanol            10 ml/L Ammonia Hydroxide   10 ml/L	8890	34	4010	7.5	1050	1.33
Lactic Acid            10 ml/L Methanol              10 ml/L Urea                    2 gm/L	1620	123	5632	12	34.2	0.91
Sodium Lauryl Sulfate 10 gm/L Sodium Hydroxide    20 gm/L	70010	143	640	10	1.98	0.06

\* Analyses performed by Inter-Mountain Laboratories,  
 College Station, TX.

## MINIMIZING EFFECTS OF MICRO-ORGANISMS AND CHEMICAL CONTAMINANTS IN A WATER RECLAMATION SYSTEM

If a single, front-end approach to waste stream treatment is assumed, and effects of chemical composition and microbial load are minimized or negated, the main focus of the reclamation process then centers on the post-treatment assemblies to provide the appropriate type of end-product water.

Another aspect this process addresses is that of solids/particulates. The influent reservoir (also the evaporator) accumulates solids which can be removed without expending consumables (i.e., filters). Furthermore, there is a potential to concentrate the solids by using latent heat of the oxidation process to dry this material to minimize requirements for mass and volume storage and return logistics. A high percentage of solid waste water content or moisture can be recovered and maintained within the recycle loop.

Through application of advances in engineering technology, materials, instrumentation and catalysts at lower temperature regimens, the energy requirements for operating this 18-year old hardware system can be significantly reduced. At least half of the issues listed in the following table are already known to be substantially resolved by using phase-change - catalytic oxidation - condensation to recover water and concentrate solids of a complex waste stream.

## MINIMIZING EFFECTS OF MICROORGANISM AND CHEMICAL CONTAMINANTS IN A WATER RECLAMATION SYSTEM

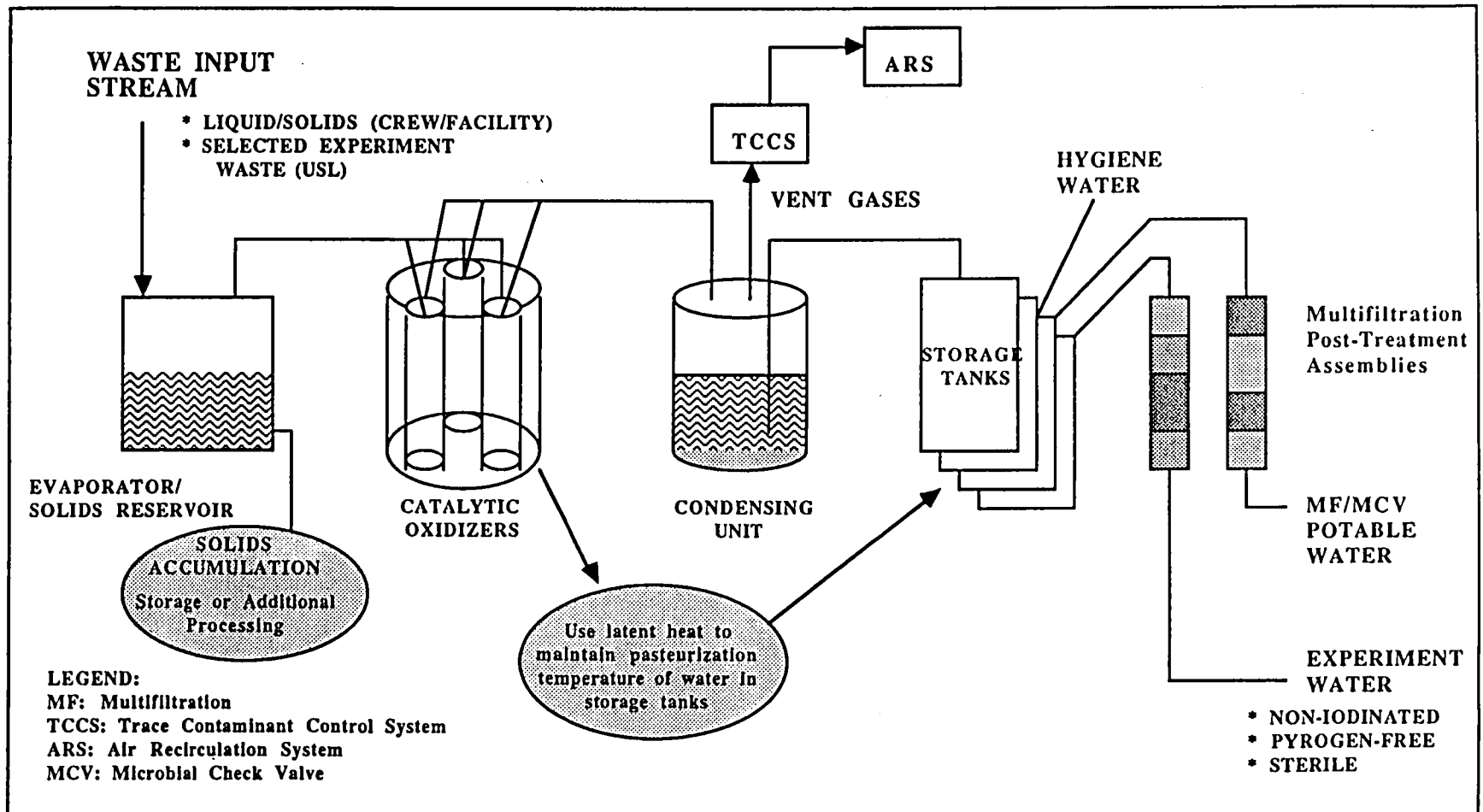

## **ELECTROCHEMICAL UNIT FOR WATER POST TREATMENT**

This process represents a means of treating recovered waste water without the use of chemical expendables and currently is being investigated as a pre and post treatment method. The design is based around the use of a solid polymer electrolyte (SPE) similar to that used in fuel cells. Organic contaminants are removed by oxidation as water is passed over the anode surface.

In feasibility studies, the level of contamination of water containing typical organic contaminants of space craft recovered water was reduced from 50 ppm to 1 ppm and below. Another aspect of this process is that, by utilizing suitable electrolytes, SPE-based electrolysis systems can generate short-lived oxidizing species in the recovered water providing unique post treatment and disinfection capabilities.

## ELECTROCHEMICAL UNIT FOR WATER POST TREATMENT

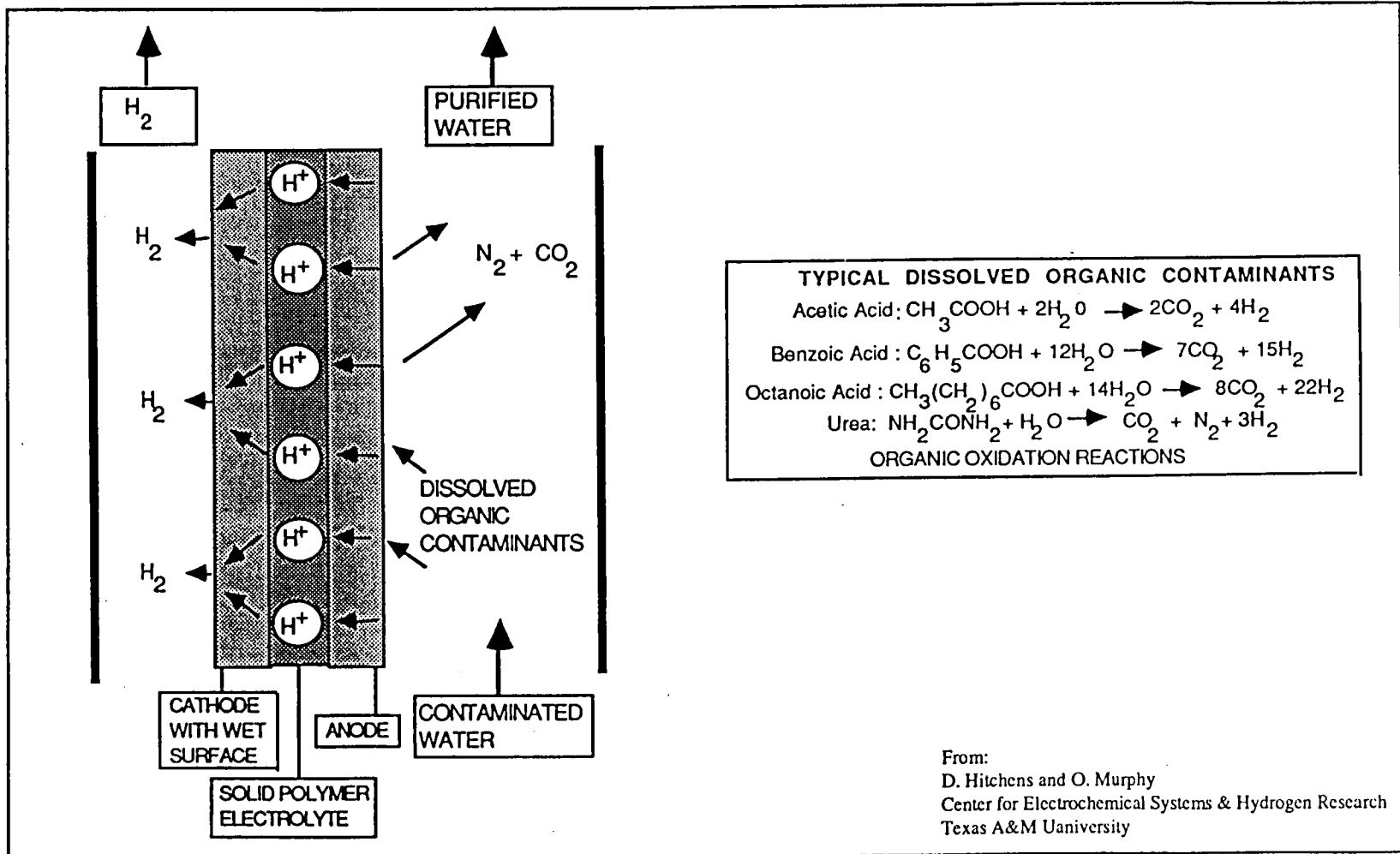

From:  
 D. Hitchens and O. Murphy  
 Center for Electrochemical Systems & Hydrogen Research  
 Texas A&M University



Tom D. Rogers  
Space Research Center  
Texas A&M University

---

## **ELECTROCHEMICAL SOLID WASTE PROCESS- ING AND WATER RECOVERY**

Urine contains high levels of chloride ions. Electrolysis of these wastes produces chlorine at the anode which leads to the buildup of hypochlorite in the waste. Hypochlorite is a powerful disinfectant and particulate solids are dissolved during this treatment. In addition, the treated material is partially purified through the oxidative removal of dissolved organic material. This represents a means of pre-treating urine and solid waste, for recovery of water, without the use of expendables.

## ELECTROCHEMICAL SOLID WASTE PROCESSING AND WATER RECOVERY

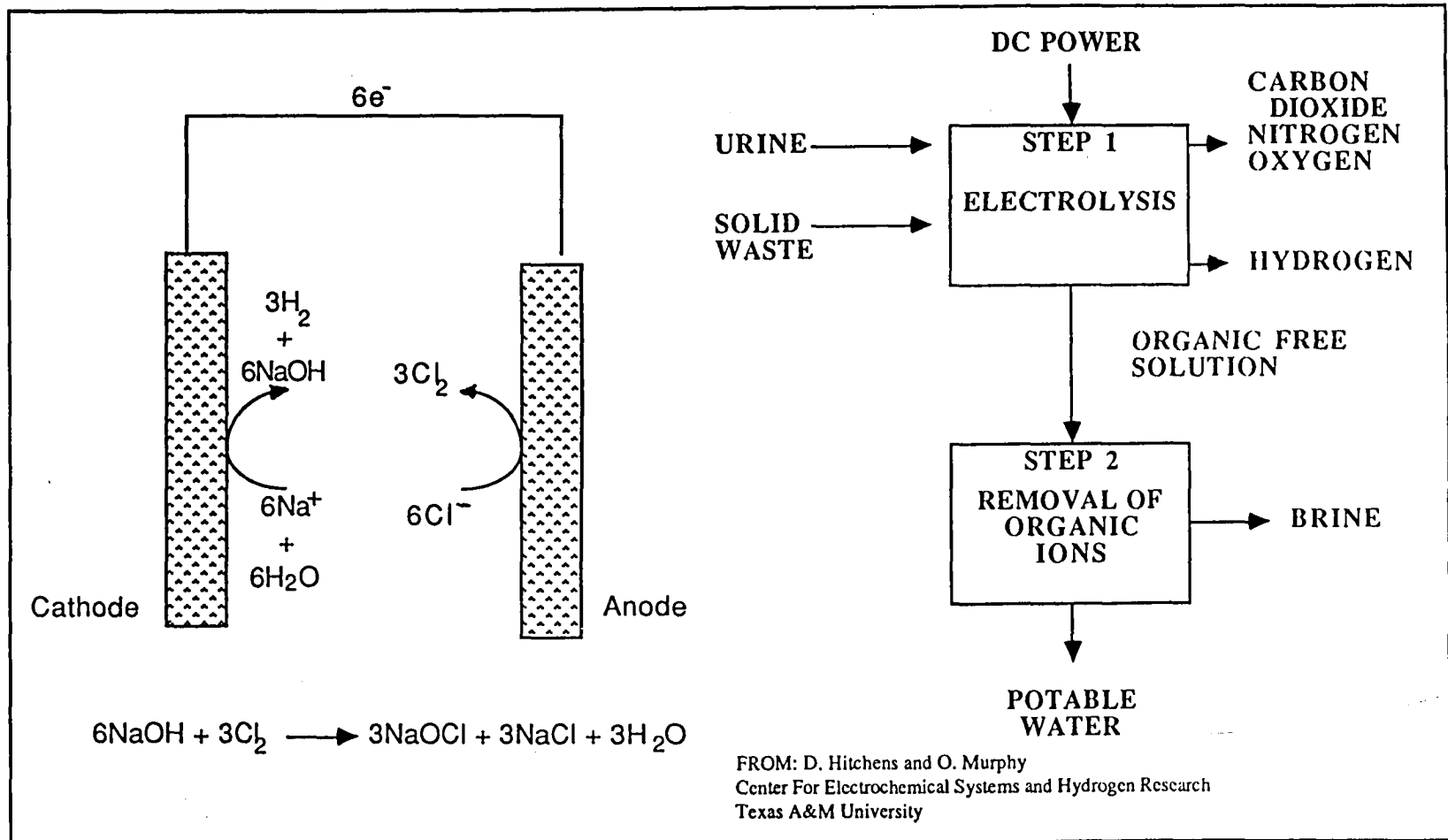

Tom D. Rogers  
Space Research Center  
Texas A&M University

---

## ISSUES INFLUENCING EVOLUTIONARY TECHNOLOGY DEVELOPMENT

No reports have been found assessing the impact the factors previously listed (Fig. 6) would have on IOC Space Station *Freedom* once the selected systems are placed in operation. However, it is understood that since actual system selection and final design are not yet established and extensively tested, the full compliment of factors can not be accurately evaluated.

In the past, studies have been conducted to assess the attributes of a primary reclamation process or a trade study performed where several systems were compared to arrive at cost and efficiency estimates for a 10-year life expectancy, at least half of the above factors were not adequately considered or not considered at all.

## ISSUES INFLUENCING EVOLUTIONARY TECHNOLOGY DEVELOPMENT

### OBJECTIVE:

WRM Technology Development Must Focus On Reducing The Need For:

- \* Waste pretreatment procedures
- \* Number of in-line components or treatment subsystems
- \* Consumables
- \* Process residuals (brines/rejection concentrates)
- \* Monitoring requirements
- \* Storage requirements
- \* Resupply and return logistics
- \* IVA monitoring, maintenance and repair time

## PLANNING FOR EVOLUTIONARY TECHNOLOGY DEVELOPMENT

Figure 7 revisits several excerpts illustrating planned objectives for evolutionary technology direction. The task at hand is to closely assess factors and issues discussed in this report (including issues not mentioned) and use the conclusions to organize and implement the appropriate research, development and testing program.

The primary factors (i.e., size, weight, volume,

power, etc.) which have influenced the present systems may not be as critical in the future. For example, advances in space power generation, storage and delivery will lessen the impact of this factor. Development of a Lunar Outpost moderates the concern for weight and size, and artificial gravity or lunar gravity negates certain issues relative to microgravity.

## PLANNING FOR EVOLUTIONARY TECHNOLOGY DEVELOPMENT

### PLANNING FOR TECHNOLOGY EVOLUTION:

"Water Reclamation: Direct treatment of waste water (urine, wash water, and condensates) by processes not using any expendables to provide potable and hygiene water by reclaiming high content of waste waters by...:"

- \* "Direct removal of the total water content."
- \* "Direct removal of the undesirable chemical impurities (organics/inorganics)."
- \* "Phase-change treatment systems utilizing lunar/Martian gravity or microgravity."
- \* "Handling and treatment of processed water (post treatment) to remove trace contaminants and bacteria without expendables."

From: Small Business Innovation Research, Section 12.03,  
Regenerative Life Support: Air, Water and Waste  
Management. SBIR 89-1, p 81, 1989.

### CURRENT STATUS:

The phase-change(evaporation), catalytic oxidation, condensation process discussed in this presentation already meets most, if not all, of these requirements.

The electrochemical system discussed in this presentation is a prime candidate to meet these requirements.

UV-Ozone treatment is also a prime candidate.

ECLSS  
TOPICS

TECHNOLOGY FOR SPACE STATION EVOLUTION  
JANUARY 16-19, 1990

FIRE AND TOXIC  
GAS DETECTION

# INCREASED FIRE AND TOXIC CONTAMINANT DETECTION RESPONSIVITY BY USE OF DISTRIBUTED, ASPIRATING SENSORS

WALLACE W. YOUNGBLOOD  
WYLE LABORATORIES  
HUNTSVILLE, ALABAMA

518-57  
163610  
25  
N 93-27722

517

DISC 516  
INTERNATIONAL BOARD

PRECEDING PAGE BLANK NOT FILMED

As Space Station Freedom evolves and matures over its lifetime, it is anticipated that there will be a need to enhance its habitable region fire and toxic contaminant responsivity and sensitivity, especially in those regions of low air circulation rates. Such regions may include unpowered equipment racks, storage bins, etc. The use of distributed sensors with centralized detectors is suggested as an efficient means for accomplishing this goal. The use of the concept described herein for Space Station application was suggested by Matt Cole of the NASA Johnson Space Center. The concept has been outlined in Reference 1.

The use of more sensitive detectors and, possibly, detection devices of different types can produce enhanced fire signature information leading to reduced false alarms. The concept described herein is not intended to replace already planned fire detection devices, but is meant to supplement them with increased information.

---

Reference 1: Youngblood, W.W. and Vedha-Nayagam, M.: Advanced Spacecraft Fire Safety: Proposed Projects and Program Plan. NASA CR 185147, October 1989.



**ECLSS  
TOPICS**

**TECHNOLOGY FOR SPACE STATION EVOLUTION  
JANUARY 16-19, 1990**

**FIRE AND TOXIC  
GAS DETECTION**

**OBJECTIVES:**

- **ENHANCE FIRE AND TOXIC CONTAMINANT DETECTION RESPONSIVITY  
IN HABITABLE REGIONS OF SPACE STATION**
- **REDUCE SYSTEM WEIGHT AND COMPLEXITY THROUGH CENTRALIZED  
DETECTOR/MONITOR SYSTEMS**
- **INCREASE FIRE SIGNATURE INFORMATION FROM SELECTED  
LOCATIONS IN A SPACE STATION MODULE**
- **REDUCE FALSE ALARMS**

ECLSS TOPICS	TECHNOLOGY FOR SPACE STATION EVOLUTION JANUARY 16-19, 1990	FIRE AND TOXIC GAS DETECTION
-----------------	---	---------------------------------

The concept of fire detection by means of aspirating flow through long tubes is commonly used in earth-based systems. Fenwal Inc. markets the VESDA (Very Early Smoke Detection Apparatus) fire detection system which draws air through a long tube to a central detector for the early detection of incipient fires in such critical areas as computer rooms (Reference 2). The Brunswick Corporation has developed aspirating flow tube sensors for mining activities such as underground haulageways (Reference 3). Tube lengths in this case measure up to several hundreds of meters. More recently, the Systron/Donner Co. has marketed an aspirating flow smoke detector for use in aircraft cargo bays. This system uses the aircraft ventilation system to induce flow through ionization-type smoke detectors from specific regions of the cargo bay (see accompanying figure).

520

- 
- Reference 2: Johnson, P.F.: Fire Detection In Computer Facilities. Fire Technology, Volume 22, No. 1, February 1986, pp. 14-32.
- Reference 3: Thomas, E.D.: A Pneumatic Sampling Fire Detection System In An Underground Haulageway. IEEE Transactions, Industrial Applications, Volume IA-19, No. 3, Part 1, May-June 1983, pp. 440-444.

### ASPIRATING SMOKE DETECTORS: AIRCRAFT CARGO BAY

521

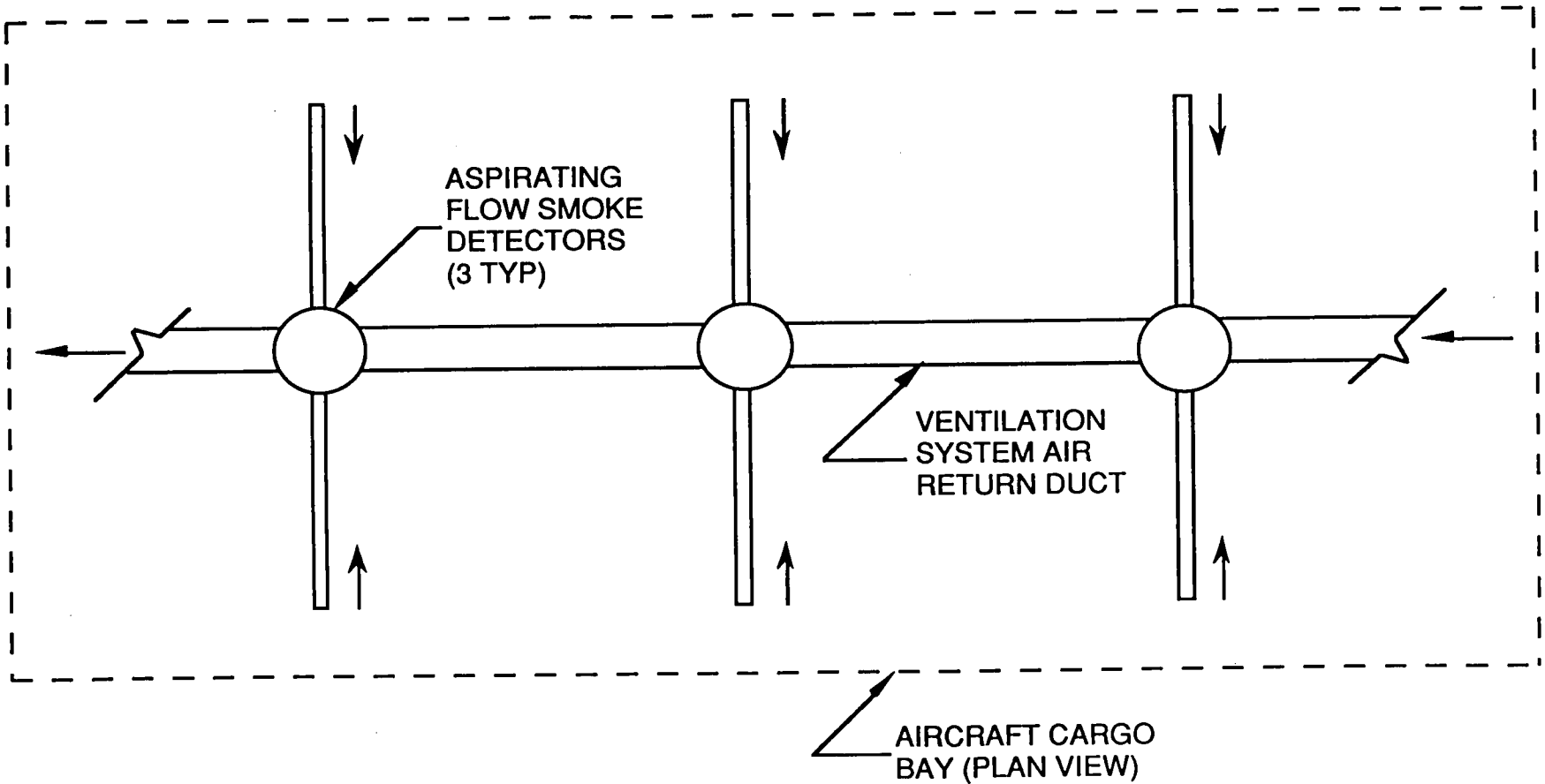

ECLSS TOPICS	TECHNOLOGY FOR SPACE STATION EVOLUTION JANUARY 16-19, 1990	FIRE AND TOXIC GAS DETECTION
-----------------	---	---------------------------------

The schematic of the centralized detector/monitor concept shows a number of distributed sensors (SL(1), SL(2) . . . SL(N)) feeding into a central detector unit via a programmable selection valve. The sensors consist of small diameter tubes through which air from selected locations is induced to flow by means of a fan unit and/or connection to a ventilation system air return duct.

The concept described herein is not intended to replace fire detection devices in powered equipment racks and other potentially hazardous regions. The distributed sensor concept is designed to monitor quiescent regions of spacecraft modules and provide enhanced monitoring of gaseous contamination.

### GENERAL SCHEMATIC OF CENTRALIZED DETECTOR/MONITOR CONCEPT

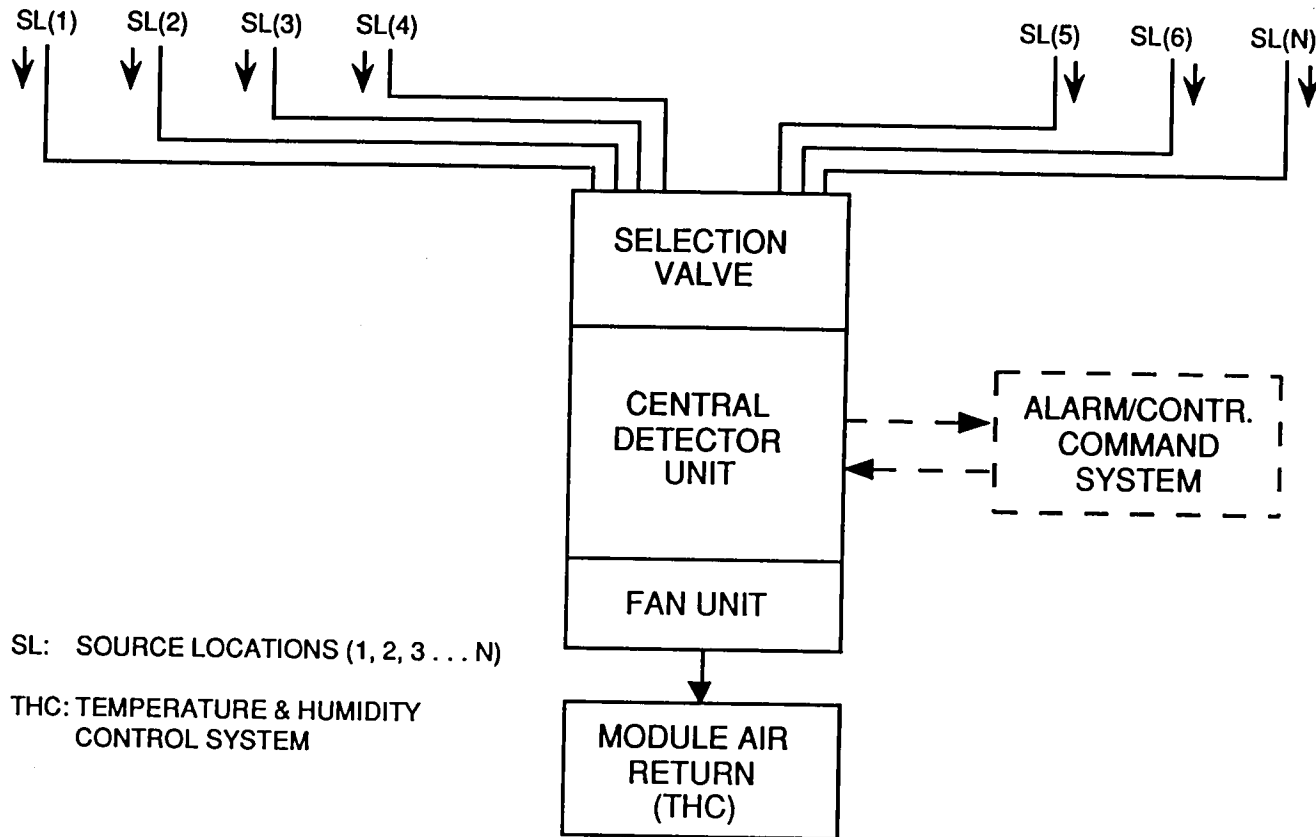

The centralized detector/monitor can include one or more types of fire detectors and/or contamination monitors. Typically, the ionization-type smoke detectors are currently used in pressurized regions of spacecraft and aircraft.

The centralized detector/monitor concept allows the addition of other detector types, i.e., photo-extinction smoke detectors, and specific gas sensors such as those sensitive to CO and CO<sub>2</sub>. In addition, the use of the centralized detector as a source for a mass spectrometer (MS) or gas chromatograph/mass spectrometer (GC/MS) would provide additional fire signature information. Further, the source location of gaseous contamination (especially toxic species) could be more closely determined.

**ECLSS  
TOPICS**

**TECHNOLOGY FOR SPACE STATION EVOLUTION  
JANUARY 16-19, 1990**

**FIRE AND TOXIC  
GAS DETECTION**

**CANDIDATE TYPES OF FIRE/GASEOUS CONTAMINATION  
DETECTION DEVICES FOR CENTRALIZED MONITORING:**

- **SMOKE DETECTORS**
  - IONIZATION
  - PHOTO-EXTINCTION (LIGHT SCATTERING)
  - PARTICLE COUNTERS
- **GAS SENSORS**
  - CO, CO<sub>2</sub>, O<sub>2</sub>, H<sub>2</sub>
  - OTHER
- **GC/MS**

The paper fire signature response, shown opposite (based on UL 217, Test A), is representative of a slowly pyrolyzing process followed by flaming combustion at about 240 seconds in the example. The results shown are from one of several tests on various materials, all of which were intended to illustrate the relative response of different types of fire detectors exposed to different fire scenarios (Reference 4). Also, the test results lend support to the premise that fires may be detected in their early stages by solid state sensor detection of selected smoke gases. In all of the tests related by Reference 4, the standard types of fire detection devices tested (i.e., ionization and light-scattering smoke detectors, UV sensors, and thermal response sensors) lagged in response behind the production and detection of rapid increases in CO and/or CO<sub>2</sub>.

Note that the scale units for the ordinate of the figure shown opposite are as follows: CO<sub>2</sub> (200 ppm/unit), CO (10 ppm/unit), C<sub>x</sub>H<sub>y</sub> (12 ppm/unit), H<sub>2</sub> (10 ppm/unit).

---

Reference 4: Pfister, G.: Detection of Smoke Gases By Solid State Sensors -- A Focus on Research Activities. Fire Safety Journal, Volume 6, No. 3., 1983, pp. 165-174.



PAPER FIRE - UL 217, TEST A (OUTBREAK OF FIRE AT ~240 SEC.)

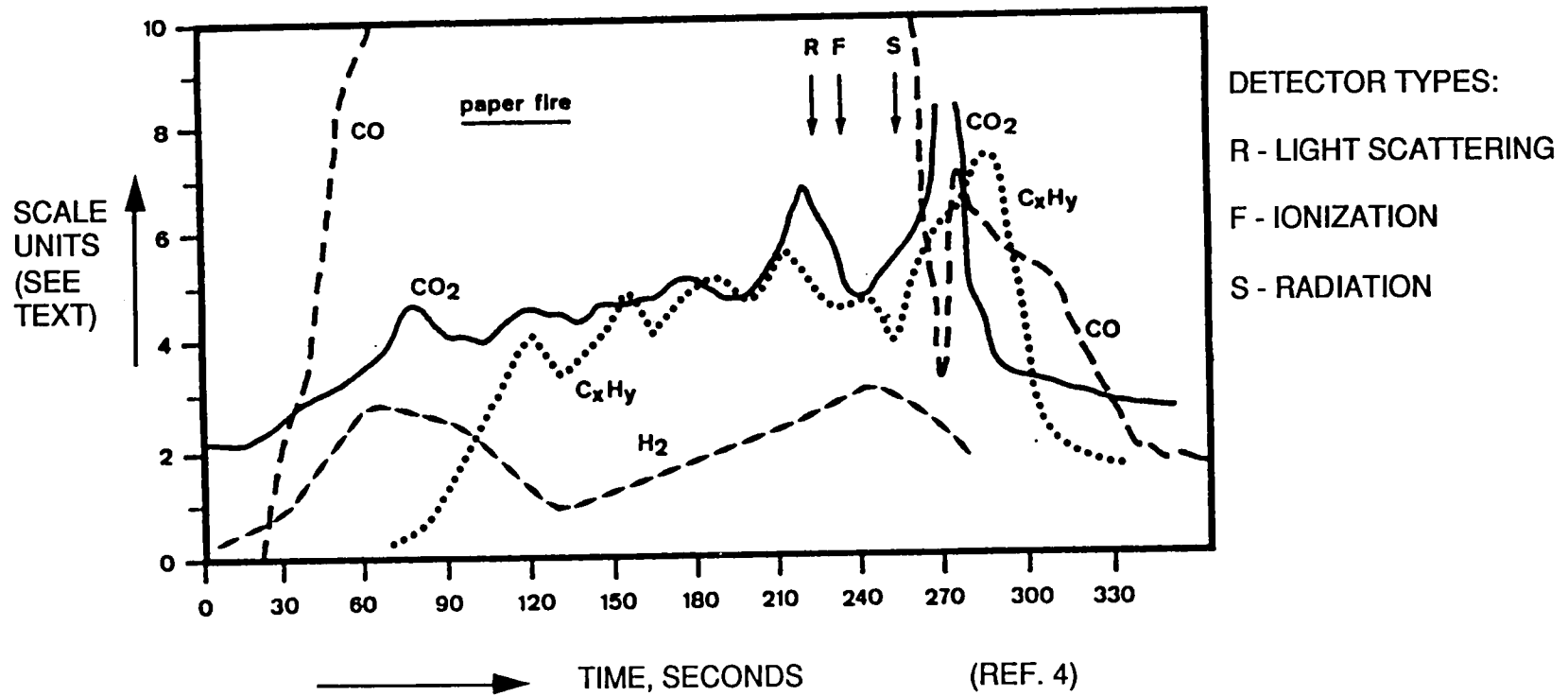

ECLSS TOPICS	TECHNOLOGY FOR SPACE STATION EVOLUTION JANUARY 16-19, 1990	FIRE AND TOXIC GAS DETECTION
-----------------	---	---------------------------------

528

Standard combustion tests are routinely performed on a wide variety of materials to evaluate the lethality of the gases evolved from the process. The figure shown opposite illustrates the production of CO, HCL and HF from a nonflaming combustion test of a specific wire insulation material. The proprietary results were obtained from a standard NIST test wherein the material was inserted into a preheated oven at 25°C below autoignition temperature and maintained in that environment for 30 minutes.

The results shown are not meant to imply that there are universal and unambiguous fire signatures for all fire scenarios in terms of the gaseous species produced. However, the detected increase in any of a number of gases, i.e., CO, CO<sub>2</sub>, H<sub>2</sub>, HCL, HF, HCN, etc., can be an independent indication of an unwanted or threatening event. The indicated event could be a gaseous spill or leak, a severe thermal degradation, a smoldering combustion, etc.

### NONFLAMING COMBUSTION OF A POLYMERIC WIRE INSULATION

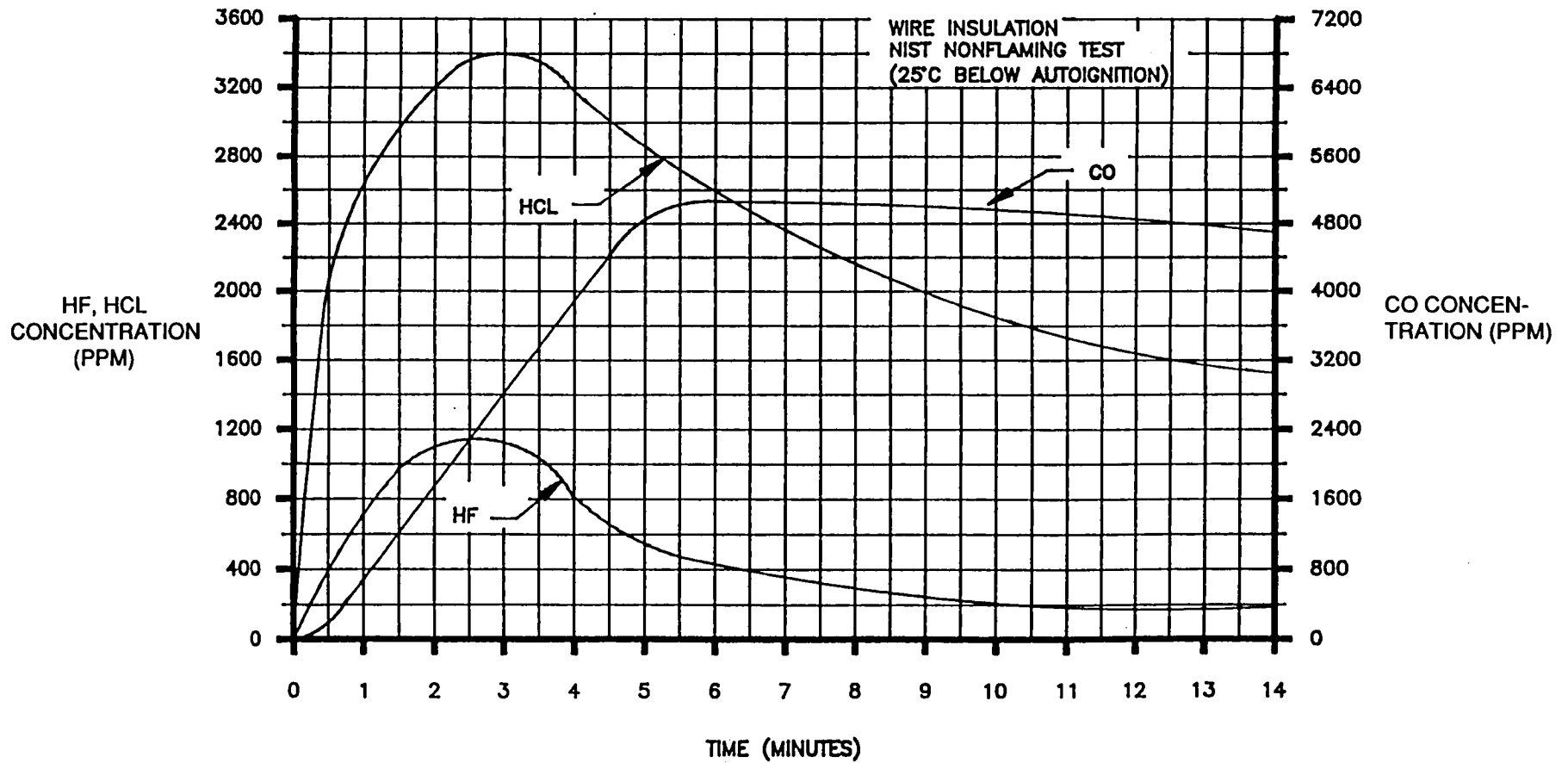

The accompanying figure illustrates the concept wherein multiple sensing tubes are connected to one or more centralized detector/monitor units located in a Space Station module. The sensing tubes may be made of small diameter ( $\leq 0.64 - 0.95$  cm), light-weight materials compatible with all spacecraft safety requirements. Air from the sensing locations is induced to flow to the central unit by means of a fan unit or, alternatively, by connecting the outlet of the unit to the low pressure region of the ECLSS air handling return ducting.

Ideally, no more than one or two central detector/monitor units would be required for each module to supplement the other fire detection and contaminant monitoring devices already planned for Freedom. The time required to sense all of the distributed locations will be determined as a "trade-off" between what is desired and what can be accomplished given the transit times for each sensing tube.

### CENTRALIZED SMOKE DETECTORS/MONITORS: SPACE STATION APPLICATION

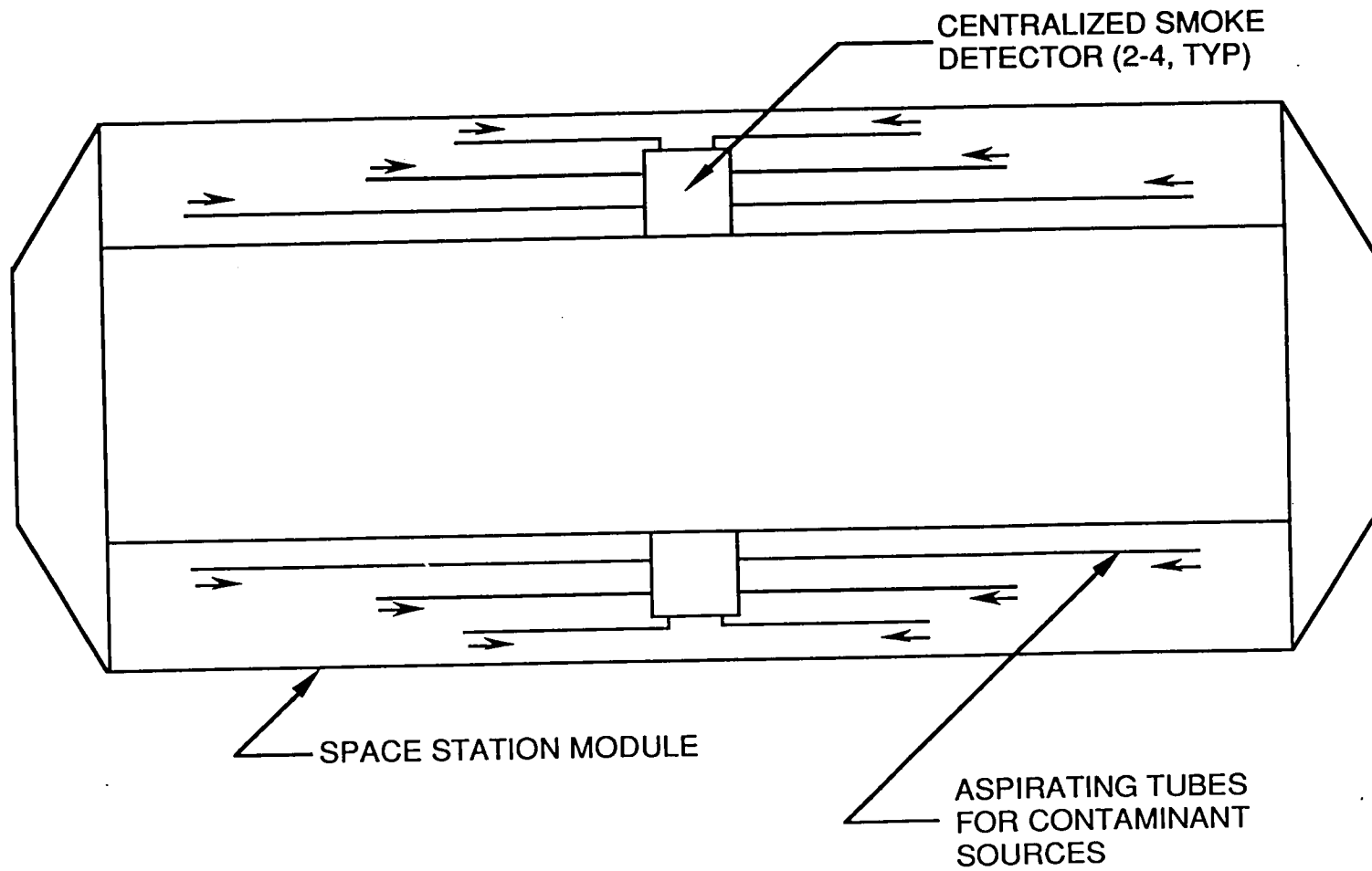

A simplified schematic of a centralized detector/monitor is shown in the figure opposite. Current ground-based systems of this concept typically utilize only the smoke detectors -- usually of the ionization or photo-extinction/light-scattering type. The concept shown in the schematic is somewhat idealized since it assumes the availability of small, solid-state gas detectors sensitive to CO and CO<sub>2</sub>.

The inclusion of a mass spectrometer (MS) or gas chromatograph (GC)/MS makes the centralized detector/monitor especially attractive. Most enclosed, habitable spaces on earth do not have, or cannot afford the luxury of a GC/MS. Its inclusion on Space Station Freedom greatly enhances the use of "expert systems" to interpret and communicate the existence of an incipient fire or some other event producing off-nominal aerosols and/or gaseous contaminants.

### CANDIDATE DETECTORS FOR INCLUSION IN CENTRALIZED MONITOR

ASPIRATING AIR FLOW FROM  
SELECTED SOURCE LOCATIONS

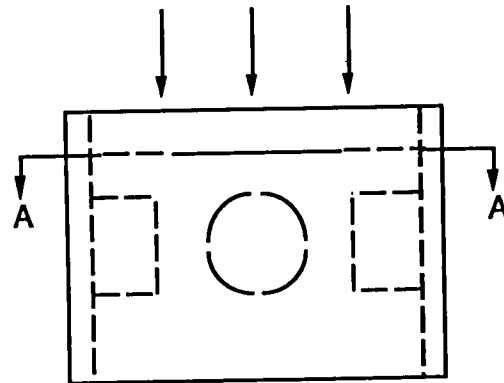

533

**DETECTORS:**

- GASEOUS
  - CO<sub>2</sub>, CO
  - MS, GC/MS
- SMOKE
  - IONIZATION (ION.)
  - PHOTO-EXTINCTION (PE)

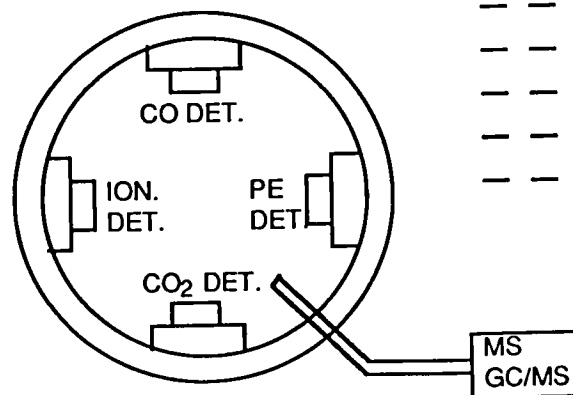

VIEW A-A

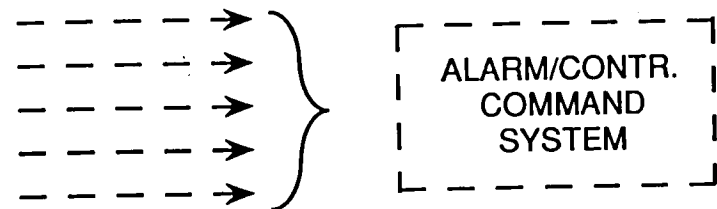

<b>ECLSS TOPICS</b>	<b>TECHNOLOGY FOR SPACE STATION EVOLUTION JANUARY 16-19, 1990</b>	<b>FIRE AND TOXIC GAS DETECTION</b>
-------------------------	---	---

**(This page left intentionally blank.)**



**ECLSS  
TOPICS**

**TECHNOLOGY FOR SPACE STATION EVOLUTION  
JANUARY 16-19, 1990**

**FIRE AND TOXIC  
GAS DETECTION**

**SOME PRACTICAL CONCERNS RELEVANT TO USE OF  
DISTRIBUTED SENSING TUBES:**

- **RESPONSE (TRANSIT) TIMES MUST BE REASONABLY  
SHORT**
- **EXIT SIGNATURES MUST CLOSELY MATCH SENSING  
REGION CONDITIONS**
- **SENSING TUBES MUST NOT INTERFERE WITH OTHER  
SYSTEMS OR OPERATIONS**

ECLSS TOPICS	TECHNOLOGY FOR SPACE STATION EVOLUTION JANUARY 16-19, 1990	FIRE AND TOXIC GAS DETECTION
-----------------	---	---------------------------------

Some effort has already been expended to determine the transit times for smoke laden air through small diameter tubing (e.g., Reference 5). The induced flow may be either turbulent or laminar depending on the tube diameter and mass flow rate through the tube. For very large pressure drops, the flow may correspond to compressible conditions rather than incompressible as normally assumed for air at low velocities and low pressure drops (i.e.,  $< 100$  torr  $\Delta P$ ).

The accompanying figure illustrates some approximate transit times based on relationships derived in Reference 5. For spacecraft applications, it is suggested that transit times of ~ 5-7 seconds may be appropriate.

---

Reference 5. Hertzberg, M. and Litton, C.D.: Multipoint Detection of Products of Combustion With Tube Bundles. BuMines Report RI 8171, USDI, September 1976.

### TYPICAL TRANSIT TIMES FOR AIR THROUGH SMALL DIAMETER TUBING

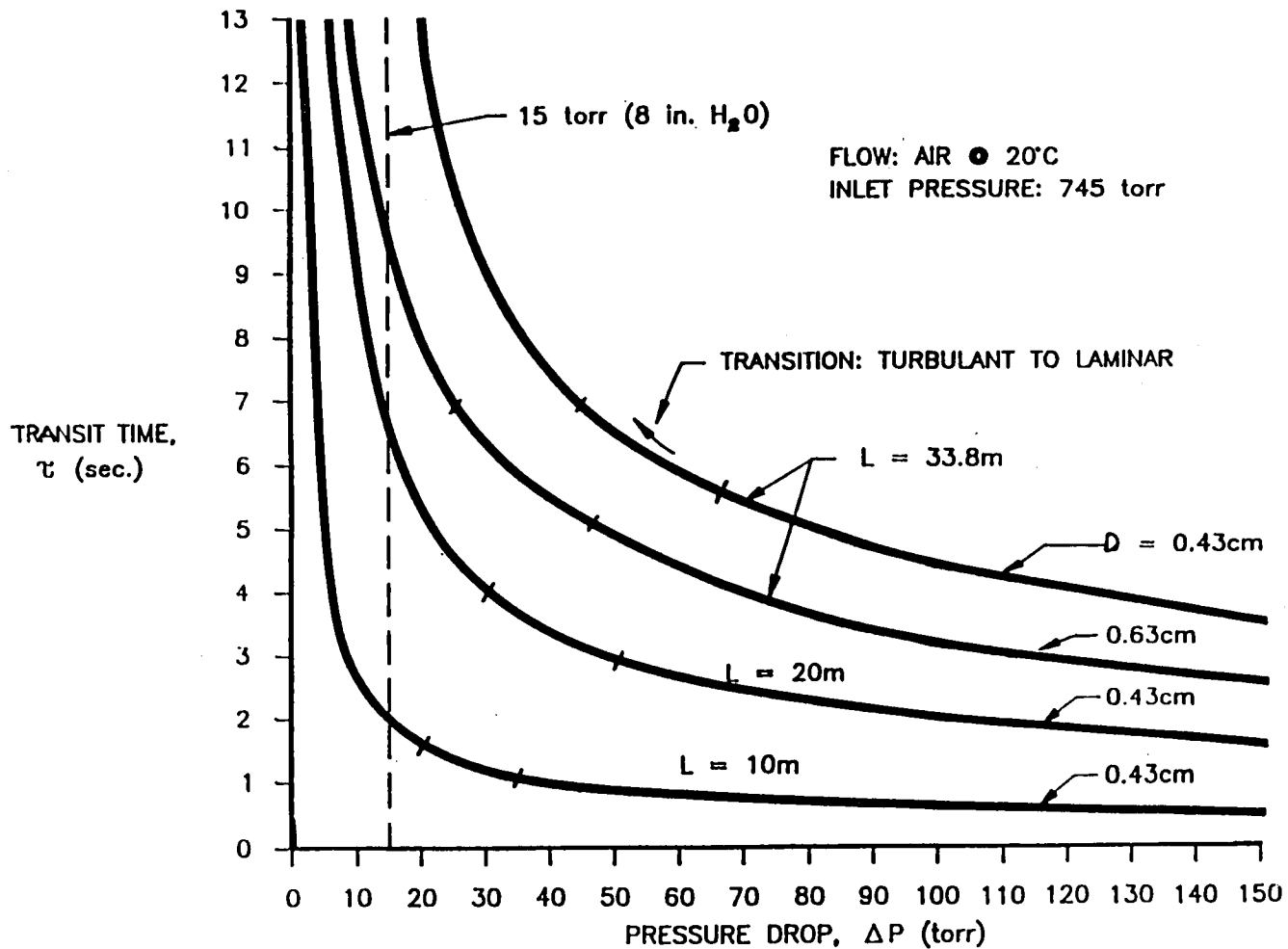

During the transmission of smoke laden air through very long ( $> 100$  m) unheated tubes, some agglomeration and wall condensation will occur with the result that a large percentage of the smallest, submicrometer smoke particles may be "lost." This is especially important to sensing tube systems used in underground mines and haulageways where the tube length may be several hundred meters. This transmission loss is illustrated by the accompanying figure taken from Reference 5 for a tube ID of 0.43 cm.

The short tube lengths anticipated for a spacecraft such as Freedom should pose no significant particle loss problem. However, experimental determination must be undertaken to evaluate both transit times and particle losses for practical spacecraft tube lengths, tube diameters, flow rates, type of smoke, etc.

MEASURED AND PREDICTED SUBMICROMETER  
PARTICULATE TRANSMISSIONS

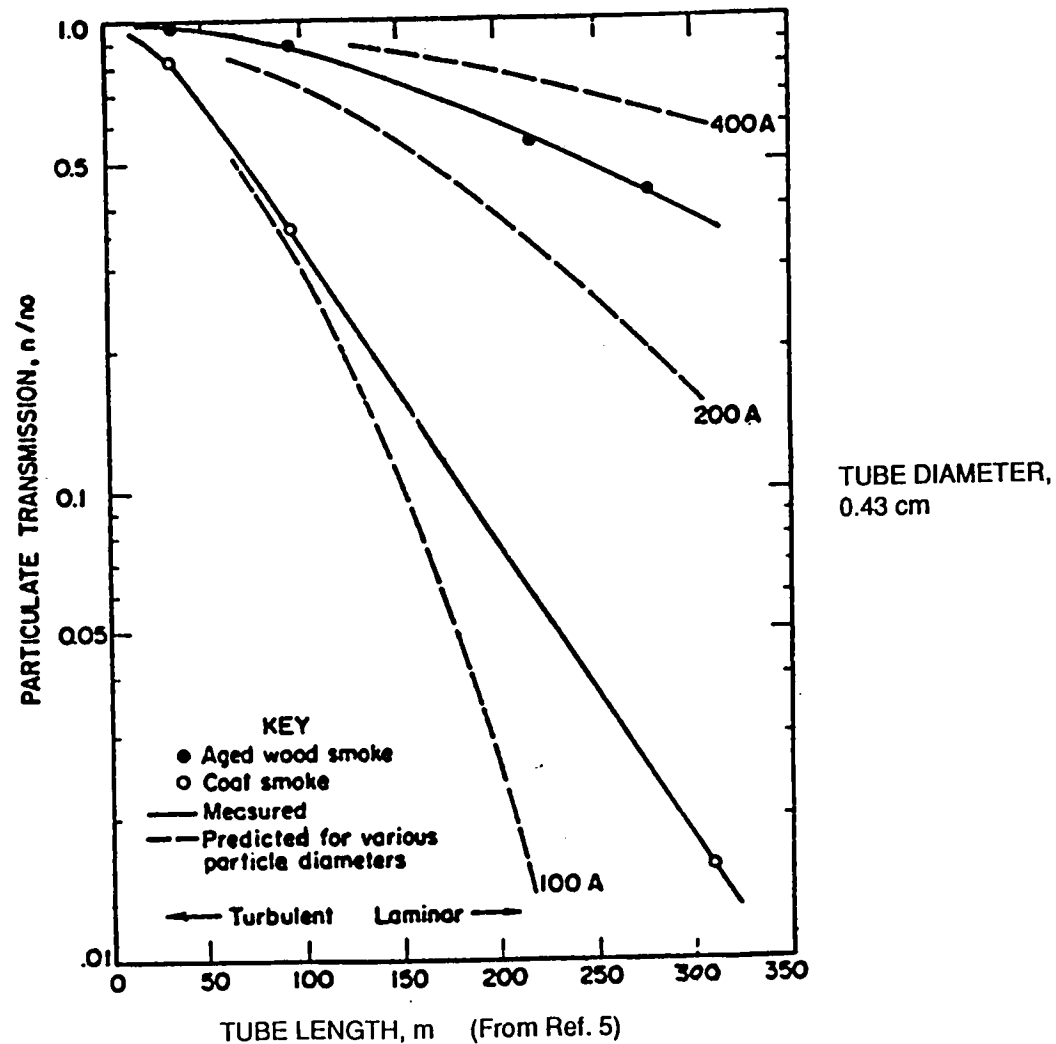

<b>ECLSS TOPICS</b>	<b>TECHNOLOGY FOR SPACE STATION EVOLUTION JANUARY 16-19, 1990</b>	<b>FIRE AND TOXIC GAS DETECTION</b>
-------------------------	---	---

**RECOMMENDATIONS:**

1. **PERFORM DETAILED ESTIMATES OF SENSING TUBE TRANSIT TIMES AND PARTICULATE LOSSES FOR VARIOUS SENSOR SCENARIOS.**
2. **REVIEW CURRENTLY AVAILABLE SMOKE DETECTORS AND GAS DETECTORS (e.g., CO<sub>2</sub> , CO, H<sub>2</sub>) FOR USE WITH THE CENTRALIZED DETECTOR/MONITOR CONCEPT.**
3. **ASSESS VIABILITY OF GC/MS SMOKE-GAS DETECTION IN THE CENTRALIZED DETECTOR/MONITOR CONCEPT.**
4. **CONSTRUCT AND TEST A BREADBOARD SYSTEM FOR EVALUATION OF THIS CONCEPT.**
5. **ESTABLISH SYSTEM OPERATIONAL REQUIREMENTS FOR SPACE STATION FREEDOM USE.**
6. **ENCOURAGE THE DEVELOPMENT OF VERY SMALL, SOLID-STATE GAS DETECTORS FOR SPACECRAFT USE.**

PRECEDING PAGE BLANK NOT FILMED

**The ECLSS Advanced Automation Project  
Evolution and Technology Assessment**

Presented to:  
Technology for Space Station Evolution Workshop  
January 17, 1990

Research by:  
The Environmental Control and Life Support System  
Advanced Automation Project, Transition Definition

Principal Investigator:  
Brandon S. Dewberry  
NASA/MSFC/EB42  
MSFC, AL 35812  
(205) 544-4247  
NASAMAIL: BDEWBERRY

Support:  
James R. Carnes  
Boeing AI Center  
P.O. Box 240002, M/S JA-74  
Huntsville, AL 35824-6402  
(205) 461-2348  
email: ray@huntsai.boeing.com

Johnson Research Center  
Advanced ECLSS Analysis Team  
Brenda D. Lukefahr  
Daniel M. Rochowiak  
Brian L. Benson  
The University of Alabama in Huntsville  
Huntsville, AL 35899  
(205) 895-6257  
John S. Rogers  
James W. McKee

PRECEDING PAGE BLANK NOT FILMED

543

542  
INTERNATIONAL PAVIA

519-574  
163611  
22  
N93-27723

# The ECLSS AAP Evolution & Technology Assessment

## Introduction Description

The Environmental Control and Life Support System (ECLSS) aboard Space Station Freedom will sustain a safe, shirt sleeve environment for its crew and payloads. Development has been divided into six functionally interconnected subsystems: Temperature and Humidity Control (THC), Waste Management (WM), Fire Detection and Suppression (FDS), Atmosphere Control and Supply (ACS), Water Recovery Management (WRM), and Air Revitalization (AR). The last two subsystems, WRM and AR, close air and water environmental loops to an extent never before attempted in space, and will require new technologies which are being extensively tested and analyzed.

## The ECLSS Advanced Automation Project

The objective of the ECLSS Advanced Automation Project (ECLSS AAP) is to recommend and develop advanced software for the initial and evolutionary Space Station Freedom ECLS System that will minimize the crew and ground manpower needed for operations. This will be accomplished by first determining which processes may benefit from advanced automation technologies, second, determining the strategies necessary for development and integration of advanced automation systems into the ECLSS project, third, describing the evolutionary path from the baseline ECLSS automation to the more advanced ECLSS automation processes, and fourth, developing advanced automation systems for the ECLSS domain while demonstrating their utility.

545  
PRECEDING PAGE BLANK NOT FILMED

545  
PRECEDING PAGE BLANK NOT FILMED



## The ECLSS AAP Evolution & Technology Assessment

The first step, determination of ECLSS processes for application of advanced automation technologies, is complete. These processes are outlined in **NASA-MSFC-8-36955-25 ECLSS Advanced Automation Preliminary Requirements - Final Report** and in **The ECLSS Advanced Automation Project Phase I Results presentation to Space Station Transition Definition Code ST**, the sponsor of this work.

The second and third steps are described in the ECLSS AAP Project Plan, Management Plan, and Development and Delivery Plan produced by the Artificial Intelligence Center of Boeing Computer Services. Knowledge acquisition and engineering are currently underway in response to the fourth objective.

# The ECLSS AAP Evolution & Technology Assessment

## Introduction

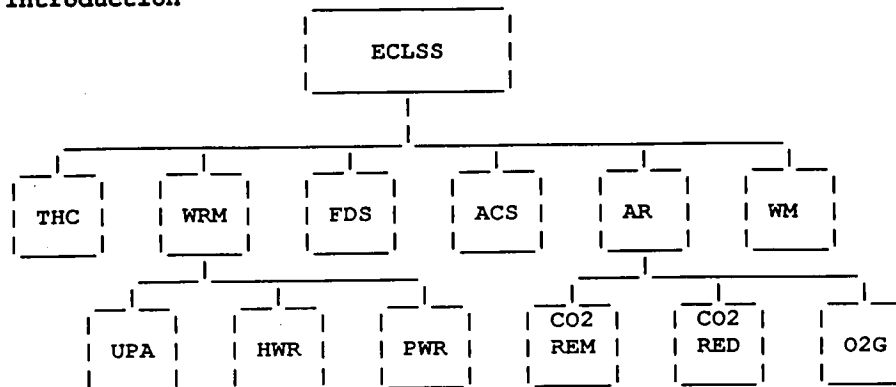

### \* The ECLSS Advanced Automation Project (ECLSS AAP)

\* Objective: Automation of the Evolutionary ECLSS

#### \* Approach:

- 1) determine applicable processes
- 2) determine development and implementation strategies
- 3) describe ECLSS evolution from baseline to advanced
- 4) develop systems and demonstrate their utility.

#### \* Status:

- 1 - completed in phase I - ECLSS Analysis  
Documented:  
MSFC-8-36955-25 ECLSS Advanced Automation  
Preliminary Requirements - Final Report  
The ECLSS Advanced Automation Project Phase I  
Results presentation to Space Station Transition  
Definition Code ST, the sponsor of this work.
- 2&3- completed but in flux  
Documentated:  
The ECLSS AAP Project Plan, Management Plan, and  
Development and Delivery Plan produced by the  
Artificial Intelligence Center of Boeing Computer  
Services.
- 4 - In process  
Knowledge acquisition and engineering development  
currently underway.

**Introduction Description (continued)**

The ECLSS AAP Analysis Overview

Preliminary study indicates the baselined ECLSS is an advanced, flexible, and autonomous system in many areas. Other areas were found in which increased automation should be built in or scarred in its hardware and software systems for evolution. The analysis was performed by both chemical and software experts in order to produce a total ECLSS automation and technology assessment, and applications of advanced software to ECLSS subsystems are emphasized.

Analysis Results

The three research and development areas most apparent in the analysis are autonomous fault detection and isolation of ECLSS processes and subassemblies, advanced chemical and microbial fluid inspection, verifiable closed loop modelling of chemical and microbial recombination in the regenerative processes.

The names applied to these development areas are:

- 1) Automatic Fault Diagnosis of ECLSS Subsystems,
- 2) In-line, Realtime Chemical and Microbial Fluid Analysis,  
and
- 3) Object-oriented, Distributed Chemical and Microbial  
Modelling of Regenerative Environmental Control Systems

These technology topics are discussed individually below, giving a description of the technology including the rationale behind its endeavor, and possible approaches to development.

# The ECLSS AAP Evolution & Technology Assessment

## Introduction (continued)

### \* ECLSS AAP Phase I Analysis Overview

- \* The ECLSS is an advanced, flexible, and autonomous system in many areas.
- \* Deficiencies in  
    FDIR,  
    Fluid Analysis Instrumentation, and  
    Modelling.
- \* Hooks and Scars in the baseline system are suggested to incorporate these technologies in the evolution of the ECLSS.

### \* Analysis Results

- 1) Automatic Fault Diagnosis of ECLSS Subsystems,
- 2) In-line, Realtime Chemical and Microbial Fluid Analysis, and
- 3) Object-oriented, Distributed Chemical and Microbial Modelling of Regenerative Environmental Control Systems

# The ECLSS AAP Evolution & Technology Assessment

## 1) Automatic Fault Diagnosis of ECLSS Subsystems Description

### Description

The ECLSS Software Architecture contains ground based and flight computer software which monitors and diagnoses faults both inside and across subsystems. In the Space Station software environment, these processes can be developed extensively and used on the ground, and migrated to an on-board processor.

The automatic diagnosis software is developed in the ECLSS ground support center. At a sufficient stage (when there is enough computer resource available) the software is migrating on-board, detecting and isolating faults in the process control assemblies of the ECLSS, and recommending recovery action to the crew.

The ECLSS process control environment is extremely applicable, because of its long latency periods, to automatic fault diagnosis and prediction. ECLSS ground support engineers (and computer programs) have a relatively long time to think about faults in the system.

# ECLSS Advanced Automation Project

## ECLSS Domain Functional Schematic

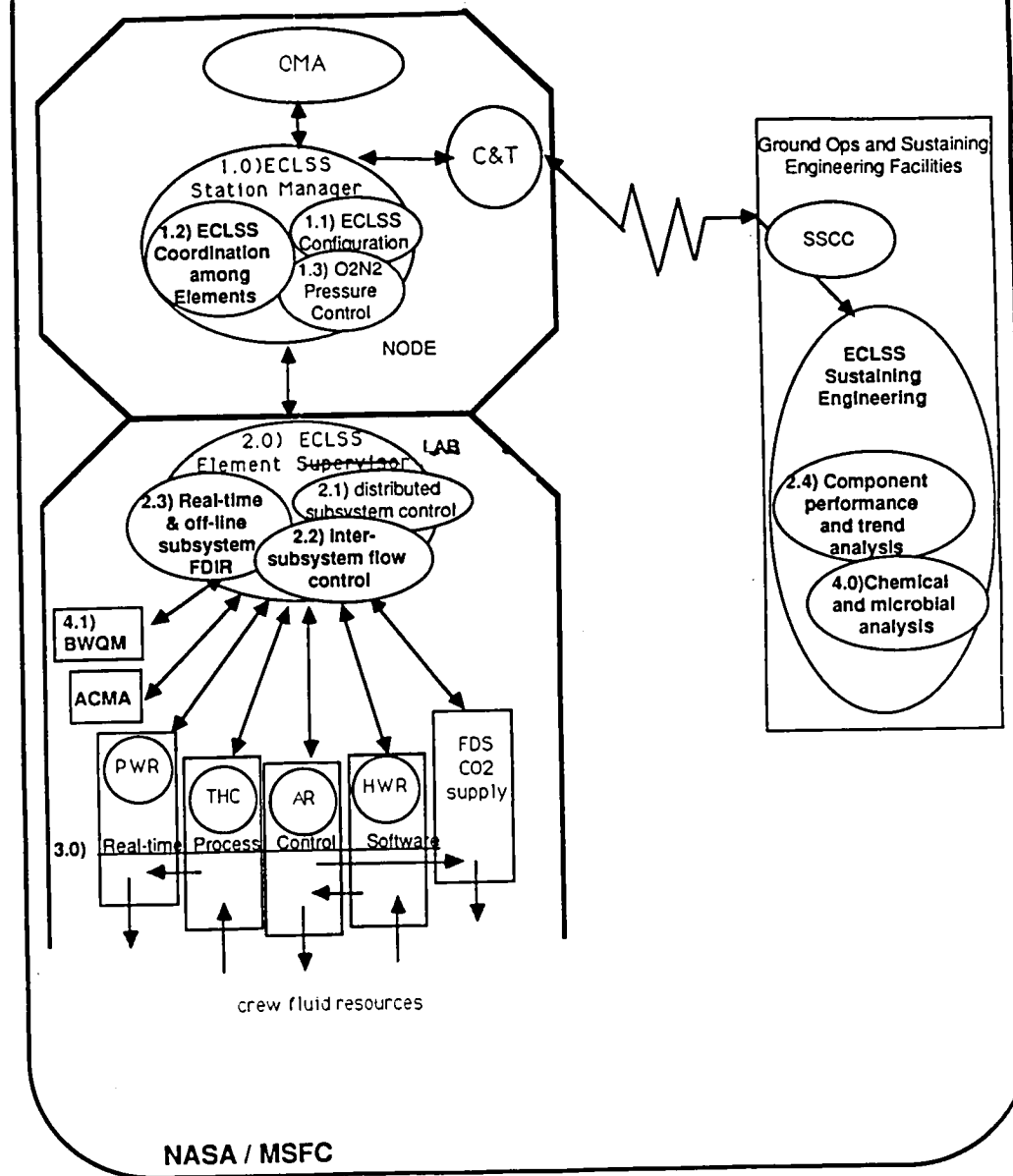

## The ECLSS AAP Evolution & Technology Assessment

### 1) Automatic Fault Diagnosis of ECLSS Subsystems Description (continued)

#### Approach

The ECLSS Advanced Automation Project is currently developing Model Based Reasoning (MBR) software for automatic diagnosis of the ECLSS Potable Water Recovery, Hygiene Water Recovery, and Air Revitalization Subsystems.

Knowledge acquisition for automatic Failure Modes and Effects Analysis (FMEA) will provide failure detection, while MBR will provide the diagnosis and prediction functions.

Design Knowledge of the Space Station ECLS system will be stored using automatic Knowledge Acquisition tools. This knowledge will be useful in augmenting the evolutionary ECLSS and for future environmental control system projects.

The ECLSS Advanced Automation Team is software automation oriented, therefore the applications we chose to automate were software-only or mostly software. But our analysis covered system and process advances, which will need to be addressed for a fully automated ECLSS.

The ECLSS AAP Evolution & Technology Assessment

1) Automatic Fault Diagnosis of ECLSS Subsystems

\* Approach

- \* Model Based Reasoning (MBR) Diagnosis
- \* Automatic Failure Modes and Effects Analysis (FMEA)
- \* Design Knowledge Aquisition for Evolutionary ECLSS and future projects
- \* Software-only oriented advancements, but in analysis system and process advances were found to be necessary in order to completely automate the flight ECLSS.



2) In-line, Real-time Chemical and Microbial Fluid  
Analysis Description

Description

In-line: an automatic part of the fluid recovery loops.

Real-time: constituent data available in seconds.

Provides a running count of a) major Chemical constituents and levels and b) major Microbial constituent levels wherever this smart instrument is hooked into the closed loop fluid system.

This is a difficult but interesting problem that will probably be solved in time to help Space Station ECLSS Evolution, Lunar base, and Mars Mission regenerative environmental control systems.

More complete knowledge of the transitions and interactions which take place in regenerative environmental control systems is necessary to increase the state-of-the-art. Advancements in instrumentation such as this will enhance our analysis and modelling capabilities.

An environmental control system with this degree of regeneration has never been flown before, and the Space Station ECLSS instrumentation must support acquisition of complete fluid constituent data in order to build more robust and autonomous systems in the future.

The ECLSS AAP Evolution & Technology Assessment

2) In-line, Real-time Chemical and Microbial Fluid Analysis

\* Description

- \* In-line: an automatic part of the fluid recovery loops.
- \* Real-time: constituent data available in seconds.
- \* Running count of
  - a) major Chemical constituents and levels
  - b) major Microbial constituent levels
- \* More smarts in the inline water quality monitor needed to use Space Station Freedom as a testbed for space-based regenerative ECLS systems.

# The ECLSS AAP Evolution & Technology Assessment

## 2) In-line, Real-time Chemical and Microbial Fluid Analysis Description (continued)

### Approach

There are three or more implementation possibilities, all involving research in both hardware and software:

- i) **Batch Water Quality Monitor Automation**  
Advanced Mass spectroscopy combined with visual frame microscopic data. Knowledge based systems and/or neural networks may analyze the combined patterns resulting in constituent types and levels.  
On the baseline ECLSS, Batch mass spec data along with visual analysis is used by a water quality expert to determine the contents of the water.  
This seems like the proper place to start in order to use the components and processes currently in the baseline ECLSS.

# ECLSS Advanced Automation Project

## Batch Water Quality Monitor Automation

### Baselined BWQM Technique

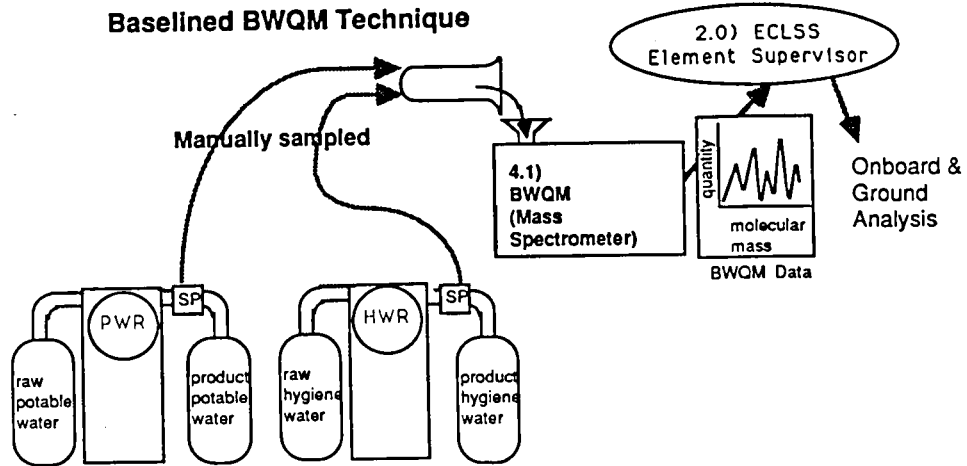

### Automated BWQM Technique

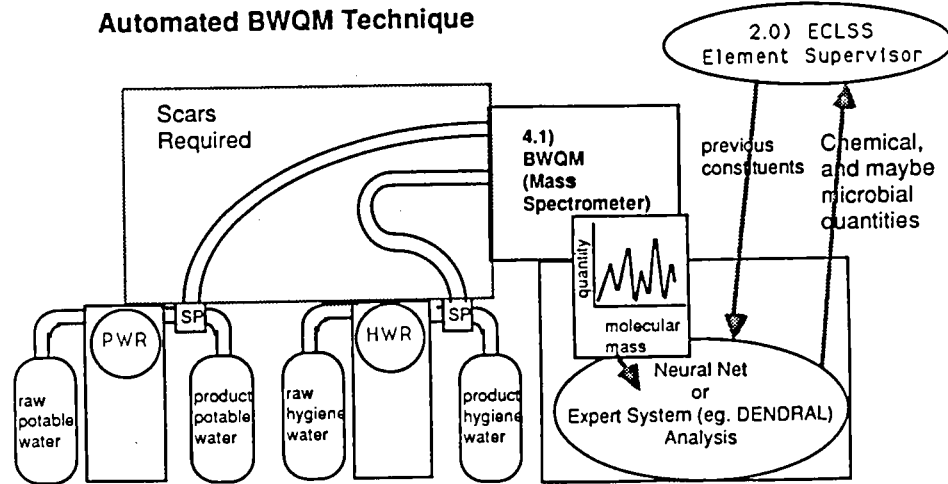

NASA / MSFC

The ECLSS AAP Evolution & Technology Assessment

2) In-line, Real-time Chemical and Microbial Fluid  
Analysis Description (continued)

Approachs (continued)

- ii) Flow cytometry analysis with neural network analysis of resulting data is promising candidate technology. Flow cytometry is the process of determining the size and shape of a microbe by the deflections of a lazer through it. Neural networks may be 'trained' to automatically identify up to two dozen microbe types. There has been promising results from this combination of technologies at MIT in their analysis of sea water.
  
- iii) Enhancements in medical process fluid analysis technologies. Catch-all approach implying that the promising medical technologies emerge daily. This void in automation technology should be filled within the next 10 years and the Freedom Station should be properly prepared to upgrade.

The ECLSS AAP Evolution & Technology Assessment

2) In-line, Real-time Chemical and Microbial Fluid  
Analysis (continued)

\* Approachs

- ii) Flow cytometry analysis with neural network analysis of resulting data.
- iii) Enhancements in medical process fluid analysis technologies.

**3) Object-oriented, Distributed Chemical and Microbial  
Modelling of Regenerative Environmental Control Systems  
Description**

Description

Each process in the ECLSS can be thought of as a semi-independent agent with inputs, processing, and outputs.

Independent enhancement of each subsystem may produce undesired or unknown effects on another subsystem or the stability of the entire ECLSS.

A lab is needed in which models and actual assemblies can be integrated, analyzed, verified, and upgraded with new information due to Space Station ECLSS results.

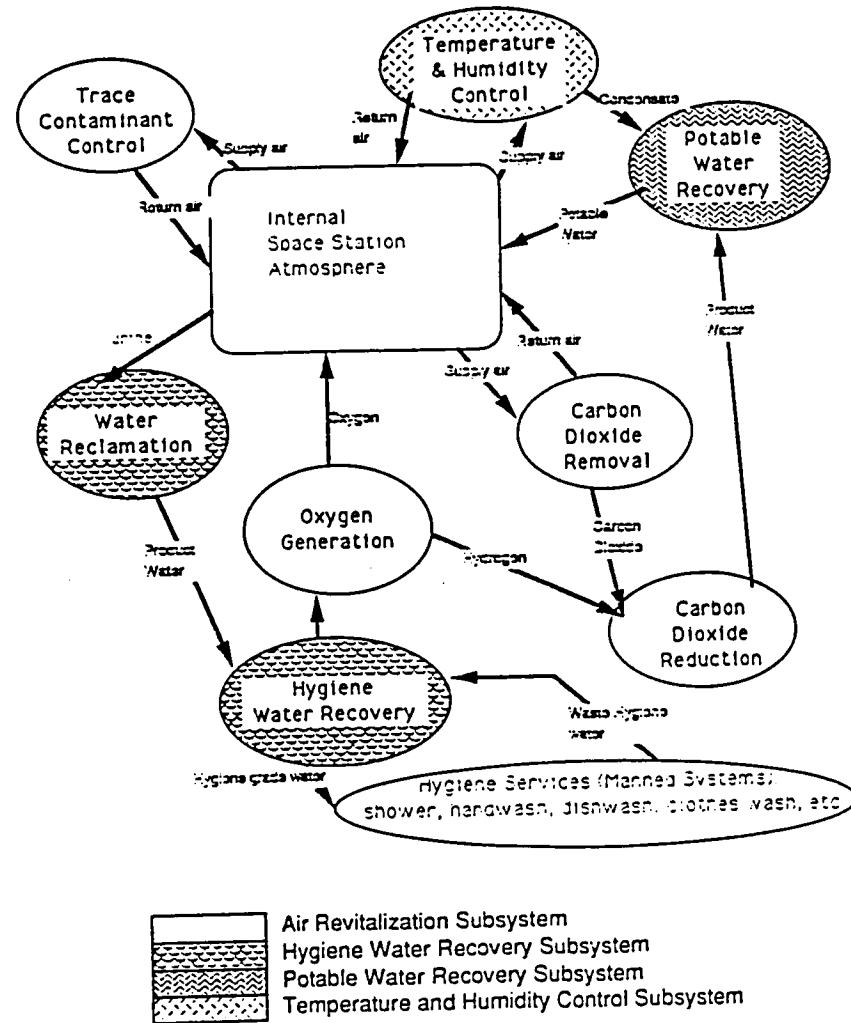

Figure 1 - Regenerative ECLSS Functional Interfaces



## The ECLSS AAP Evolution & Technology Assessment

### 3) Object-oriented, Distributed Chemical and Microbial Modelling of Regenerative Environmental Control Systems Description (continued)

#### Description (continued)

Inputs, transfer functions, and outputs for each subsystem (including chemical, microbial, and process control data) can be independently enhanced.

New technology subassembly and biological models can be exchanged with the old models to analyze effects.

A network acts as the integrating agent.

Evolutionary Space Station ECLSS, Lunar Base, and Mars Mission regenerative environmental control systems development can use such a modelling system with a closed environment testbed to determine the effects, including chemical and microbial closed loop stability, of implementing:

- Evolutionary Space Station ECLSS process control technologies
- Lunar oxygen mining operations
- Plants and biomass systems

Analysis and modelling of closed loop environmental control systems may enhance our knowledge of, or provide a structure for analysis of, inherent instabilities in the Earth environment.

#### Approach

Each node in the testbed network can be either a subassembly model or an actual subassembly under test. Shared environmental data can come from the closed environment testbed or model. Subsystem and their models, developed by independent subsystem developers, can be added to the network.

The modelling system should be verified and enhanced in a ground closed environment testbed, and compared with micro-gravity results from Space Station data. Some unexpected chemical and microbial combinations may take place due to changes in fluid mixing behaviors in micro-gravity.

OBJECT MODEL FOR EACH PROCESS  
(INCLUDING OPEN ATMOSPHERE AND  
CREW)

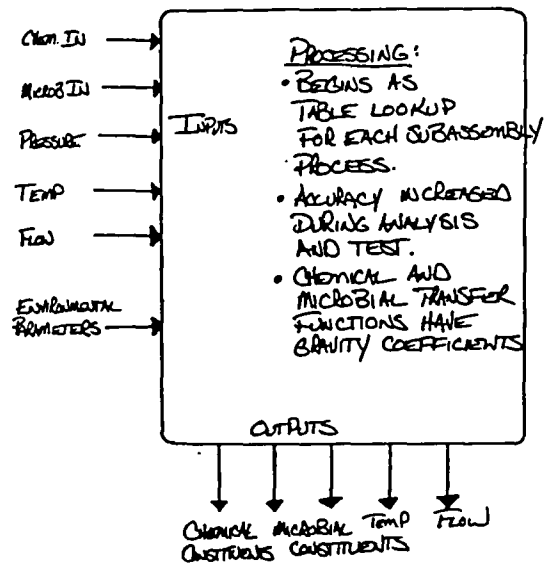

EVOLUTIONARY ECLSS ENGINEERING TESTBED

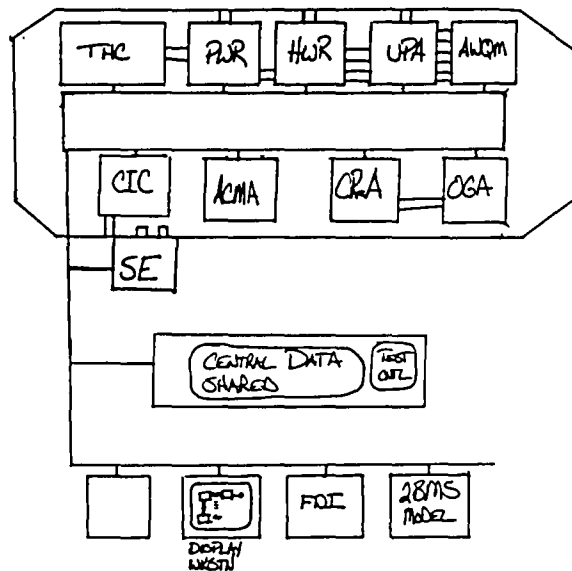

## The ECLSS AAP Evolution & Technology Assessment

### Conclusion Description

In our Environmental Control and Life Support System automation analysis we found three areas which definitely need further research and development: Automatic fault diagnosis of ECLSS subsystems, in-line real-time chemical and microbial water analysis, and object-oriented distributed chemical and microbial modelling of regenerative environmental control systems.

The Space Station ECLS System should act as a testbed for each of these research areas, as it is for automatic fault diagnosis of process control systems in the ECLSS Advanced Automation Project. Modelling of chemical and microbial closed loop interactions should begin immediately in order that our knowledge may be verified on the ground and on board in time for future missions.

We have entered into an exciting time for man-made regenerative environments. With further research in chemical and microbial interactions, the Space Station environmental control system can be used as a spring board to increase man's knowledge of all existing and envisioned closed environments.

## The ECLSS AAP Evolution & Technology Assessment

### Conclusion

- \* Automatic fault diagnosis of ECLSS subsystems
- \* In-line real-time chemical and microbial water analysis, and
- \* Object-oriented distributed chemical and microbial modelling of regenerative environmental control systems.
- \* The Space Station ECLS System should act as a testbed for each of these research areas.
- \* Modelling of chemical and microbial closed loop interactions should begin now.
- \* Joint ventures between research centers and development centers are necessary to increase man's knowledge in regenerative environments.

National Aeronautics and  
Space Administration

# Technology for Space Station Evolution - A Workshop

George C. Marshall Space Flight Center  
Science and Engineering Directorate



## Marshall Space Flight Center ECLSS Technology Activities

Paul Wieland  
Life Support Branch/ED62

N93-27724

520-54  
163612  
p. 31

PRECEDING PAGE BLANK NOT FILMED

567

PAGE 566  
INTERNATIONALLY REPRODUCIBLE



**ONGOING MSFC LIFE SUPPORT ACTIVITIES**

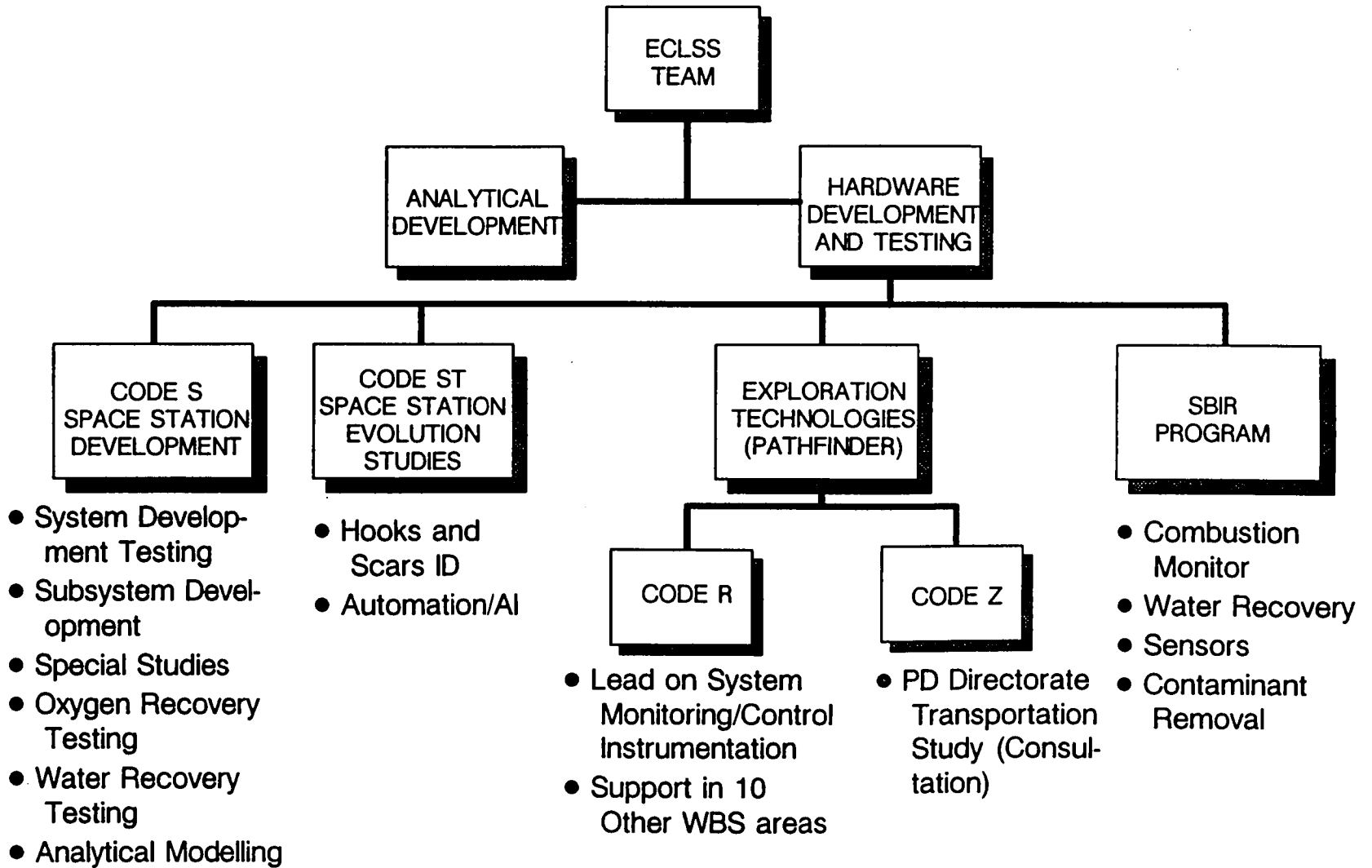

568

National Aeronautics and  
Space Administration

George C. Marshall Space Flight Center  
Science and Engineering Directorate

# Technology for Space Station Evolution – A Workshop



---

## ANALYTICAL DEVELOPMENT

### ECLSS MODELING APPROACH

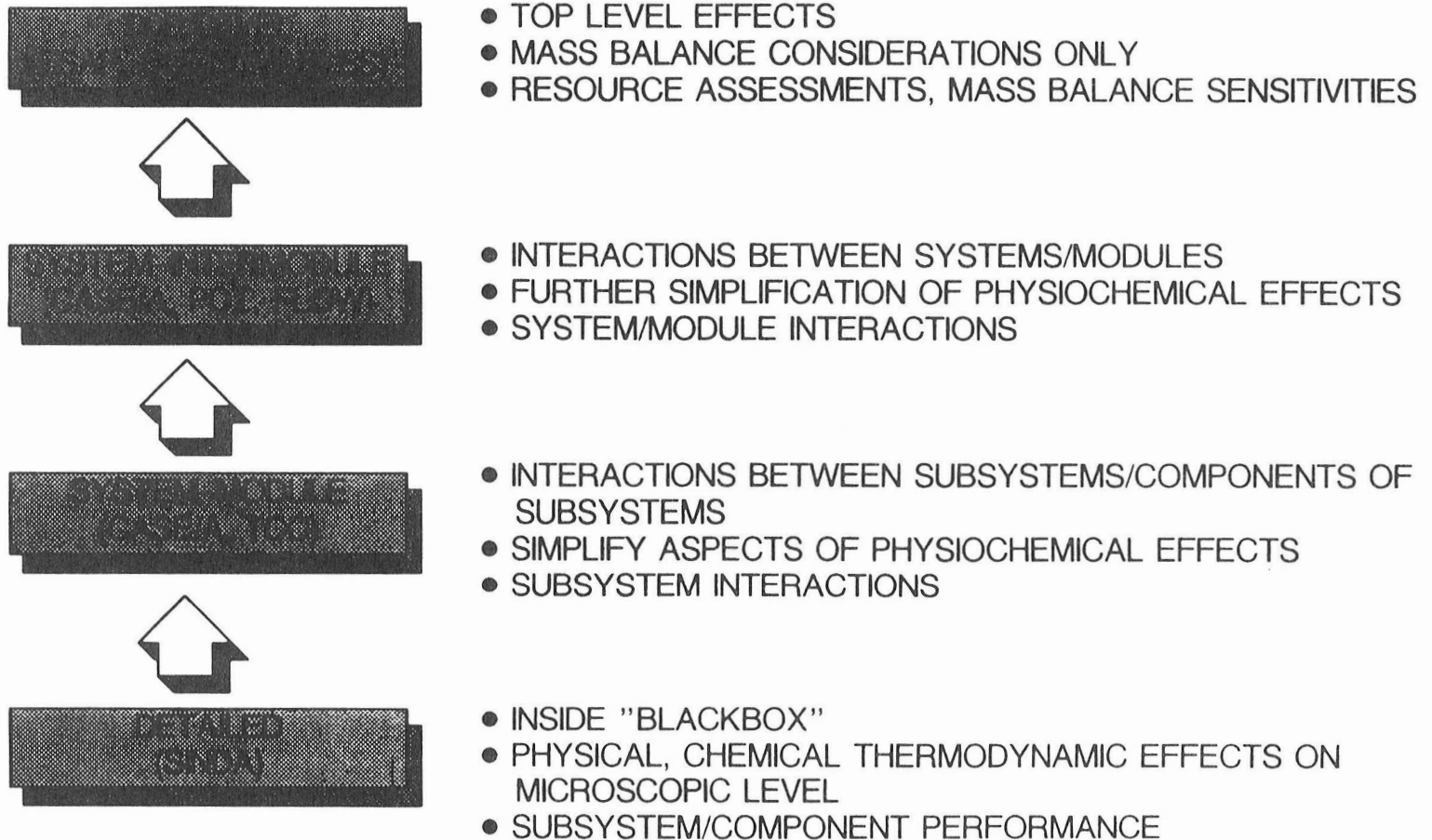





### ECLSS ANALYTICAL AREAS

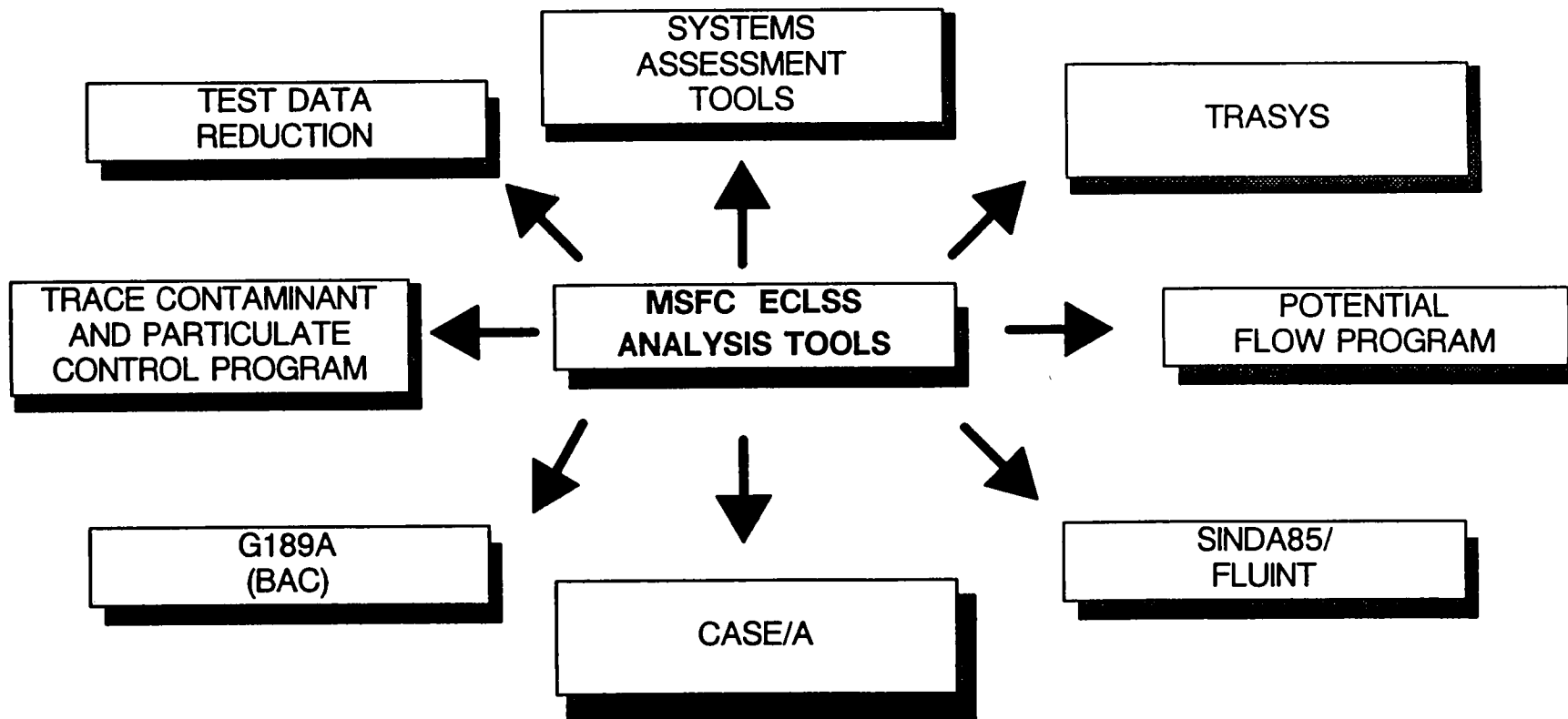



---

## ANALYTICAL MODEL NEEDS

- **Detailed (of components and subsystems, for subsystem design and assessment)**  
e.g., membrane transport evaluation
  - macroscopic/microscopic theory incorporation into detailed "1st principles" models
  - extensive "phenomological level" test data to support model development
  - theory for microbial model development
  - multi-component chemical interaction models
  
- **System-module (for subsystem groups, design and assessment)**  
e.g., detailed transients for water tank sizing
  - simplifications of the above models, which represent detailed processes to good fidelity
  - system interaction data
  - large/fast computers
  - CASE/A program improvements
  
- **System-intermodule (for validation models)**  
e.g., pressurized volume CO<sub>2</sub> level prediction
  - further simplification of the above system-module models
  - large, fast computers
  - CASE/A program improvements
  
- **Top level (for resource assessments)**  
e.g., resupply needs
  - better input data

---

## EXAMPLE OF WATER RECLAMATION MODELING NEEDS

- CURRENT CAPABILITIES:**
- System level representations of water processing operations
    - distillation (TIMES, VCD)
    - reverse osmosis
    - multifiltration (particulate filtration, adsorption, ion exchange)
  - "Curve fit" performance simulations of production rate, sensible loads, etc.
  - Contaminant rejections (and therefore product water quality) from supplier-defined efficiencies
- REQUIRED CAPABILITIES:**
- Detailed models based on the thermodynamic and physiochemical phenomena occurring within the processes
    - Impacts of physiochemical interactions
      - solute/solute
      - solute/solvent
      - solute/process
      - solvent/process
    - Ability to predict transient performance and water quality
- TECHNICAL CHALLENGE:**
- State-of-the-art modeling limited, at best, to wastewater systems containing 2 or 3 known solutes
  - Extension of bi-solute or tri-solute models to multi-solute systems is currently very limited

National Aeronautics and  
Space Administration

George C. Marshall Space Flight Center  
Science and Engineering Directorate

# Technology for Space Station Evolution — A Workshop



## HARDWARE DEVELOPMENT AND TESTING

PRECEDING PAGE BLANK NOT FILMED

575

574  
MICROFILMED COPY



---

## MSFC ECLSS Hardware Development Activities

- I. **Code S – Space Station Freedom**
  - A. Phase I Independent Subsystem Testing (1986–present)
  - B. Phase II Integrated Testing (1987)
  - C. Phase III Integrated Testing (1989–1990)
  - D. Subsystem Comparative Testing (BA) (1989–1990)
  - E. Operational System Tests (1989–1993)
  - F. Microbial Ecology Lab Studies
  
- II. **Code ST – Space Station Freedom Evolution**
  - A. ECLSS Evolution and Evaluation For Hooks And Scars
  - B. Automation/Artificial Intelligence
  
- III. **Code R – Exploration Technologies (Pathfinder)**
  - A. Sensor Development
  - B. Trace Organic Removal Process Development
  - C. Trace Contaminant Monitoring Technology Development
  
- IV. **Code Z – Exploration Studies (Program Development Directorate)**
  
- V. **SBIR – Small Business Innovation Research Program**
  - A. Phase I 1989 awards
    - 1. "Incipient Combustion Monitor for Zero Gravity Environments"
    - 2. "A Reagentless Separator for Removal of Inorganic Carbon From Solution"
    - 3. "Thin Membrane Sensors"
  - B. Phase II 1989 awards
    - 1. "Catalytic Water Purification Development"
  
- VI. **University Involvement**
  - A. University of Alabama in Huntsville
  - B. University of Wisconsin
  - C. Harvard (funding: 80% ARC, 20% MSFC)
  - D. Georgia Institute of Technology



---

## Code S – Space Station *Freedom*

### Phase I Independent Subsystem Testing (1986–present)

**Objectives:** Verification that the subsystems operate properly and familiarization of personnel with subsystem operation, acquisition of performance data, verification of integration requirements in anticipation of later integrated testing, identification of any special problems, determination of off-nominal performance.

#### Subsystems Tested:

**CO<sub>2</sub> Removal** – Four-Bed Molecular Sieve (4BMS)  
Solid Amine Water Desorbed (SAWD)  
Electrochemical Depolarized Cell (EDC) [planned]  
Two-Bed Molecular Sieve (2BMS)

**CO<sub>2</sub> Reduction** – Sabatier  
Bosch

**O<sub>2</sub> Generation** – Static Feed Electrolyzer (SFE)

**Water Reclamation** – Thermoelectric Integrated Membrane Evaporation System (TIMES)  
Vapor Compression Distillation (VCD)

**Trace Contaminant Control** – Trace Contaminant Control Subsystem (TCCS)

**Results:** Operation and performance of the subsystems evaluated, special integration considerations identified, subsystem anomalies identified.

---

## Code S – Space Station *Freedom*

### Phase II Integrated Testing (1987)

**Simplified Integrated Test** – 42 hours of "open door" integrated operation (June 1987)

**Metabolic Control Test** – 148 hours of "closed door" integrated operation (November 1987)

**Objectives:** Verify proper operation of the ECLSS subsystems when integrated and gather performance data for the partial ECLS system used in the test.

**Subsystems Tested:** 4BMS, Sabatier, SFE, TIMES, TCCS

**Results:** Demonstrated the feasibility of operating and maintaining an integrated ECLS system for an extended period, provided baseline data about the stability of an ECLS system, and pointed out what developments and improvements are needed to conduct future integrated ECLS system tests. The knowledge gained is then incorporated into the design of the next generation subsystems.

The results are documented in:

"Space Station ECLSS Simplified Integrated Test Final Report" NASA TM-100363,  
March 1989,

and "Space Station CMIF Extended Duration Metabolic Control Test Final Report"  
NASA TM-100362, March 1989.



---

## Code S – Space Station *Freedom*

### Phase III Integrated Testing (1989–1990)

**Simplified Integrated Test** – 256 hours total of "open door" with 148 hours of integrated operation (August 1989)

**Subsystems:** 4BMS, Bosch, SFE, TCCS

**Objectives:** Investigation of system integration of the Space Station air revitalization subsystems, operation of the Bosch until cartridge "switchover" occurs.

**Results:** Preliminary report expected to be released in November.

**Water Recovery Test** – Testing of the water recovery subsystems planned for February 1990.

**Subsystems:** Multi-filtration, Reverse Osmosis, Water Quality Monitor (TOC), TIMES, VCD

**Objectives:** A major objective is to include people in the loop to provide hygiene water and to drink reclaimed potable water. Water analysis techniques are being developed and verified to ensure quality control and quality assurance during analysis of samples.

Waste water to be reclaimed includes: perspiration, respiration, urine, shower water, and water from a hand washer, a clothes washer, and a dish washer. These waste waters will be generated in the End-use Equipment Facility (EEF) which is a 100K clean room where the test subjects and equipment (exercise, etc.) are located.

An Institutional Review Board (IRB) has been established in accordance with NMI 7100.8A to review protocols and procedures for ECLSS testing using human subjects. This board will address the institutional safety, medical, and legal requirements associated with human research.

**Metabolic Control Test** – Integrated testing planned to begin in mid-1990 for three months.

**Subsystems:** 4BMS, Bosch, SFE, TCCS, TIMES, RO, MF, VCD

**Objectives:** Integration of the Space Station air revitalization and water recovery subsystems.



# Technology for Space Station Evolution - A Workshop

George C. Marshall Space Flight Center  
Science and Engineering Directorate



580

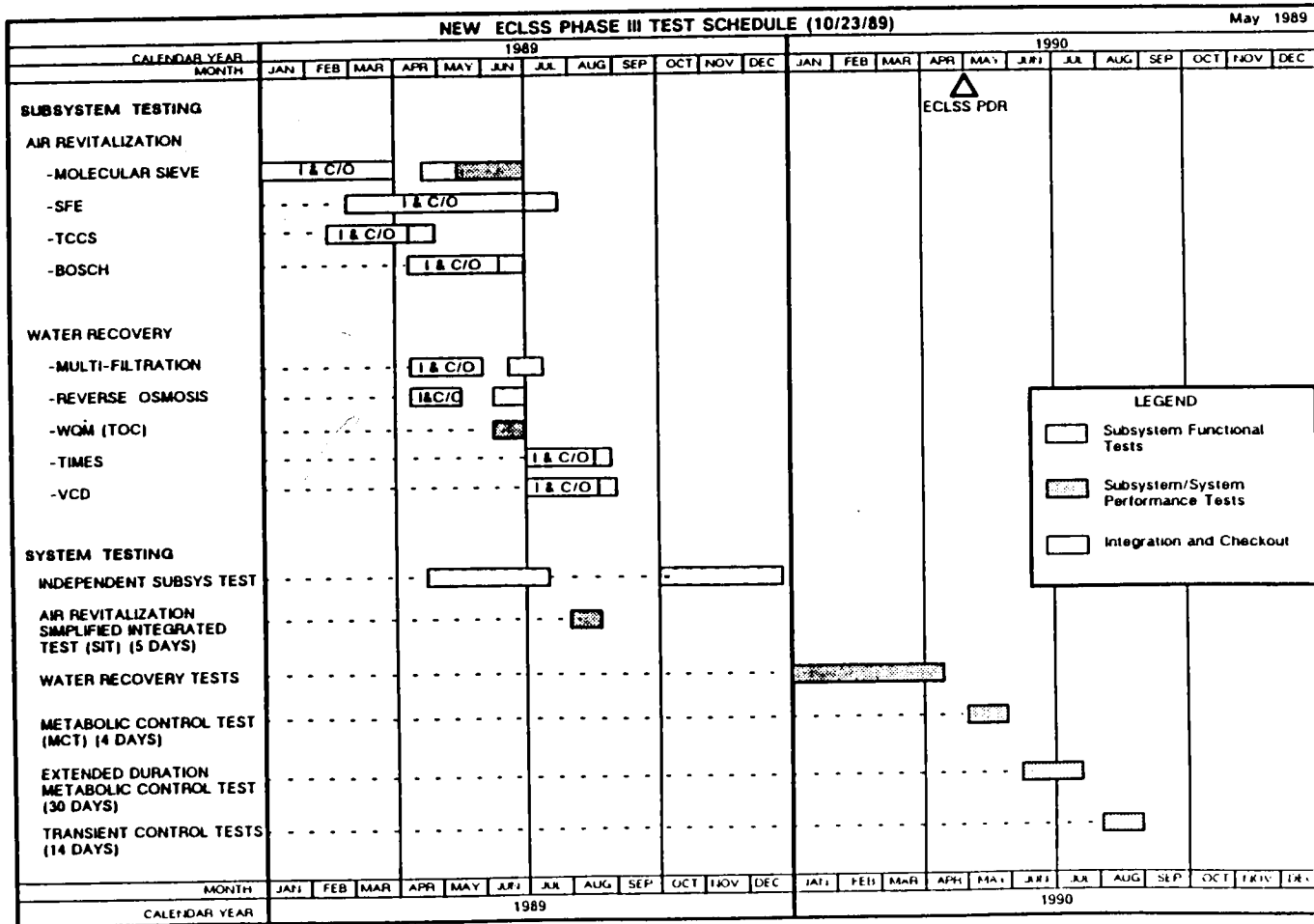



---

## Code S – Space Station *Freedom*

Prime Contractor Subsystem Comparative Testing  
(1989–1990)

### **Independent Subsystem Testing** (Boeing Aerospace) – beginning late 1989

Objective: Evaluation of prototype hardware of comparable maturity and with the same test conditions, for performance, safety, reliability, servicing and maintenance requirements.

Subsystems: CO<sub>2</sub> Removal – Four-Bed Molecular Sieve (4BMS)

CO<sub>2</sub> Reduction – Bosch  
Sabatier

O<sub>2</sub> Generation – Static Feed Electrolyzer (SFE)  
Anode Feed Solid Polymer Electrolyte (AFSPE)

#### Waste Water Reclamation

Urine Recovery – Thermoelectric Integrated Membrane Evaporation System (TIMES)  
Vapor Compression Distillation (VCD)

Hygiene Water – Reverse Osmosis (RO)  
Multi-Filtration (MF)

Potable Water Recovery – Multi-Filtration (MF)  
Reverse Osmosis (RO)

Results: Final selections of the subsystems to be used on the Space Station *Freedom* will be based on the results of these tests.

## Technology for Space Station Evolution – A Workshop



---

### Code S – Space Station *Freedom*

#### Prime Contractor Operational System Tests (1989–1993)

##### **Concept Confirmation Tests (CCT) – 1989–1990**

Testing avionics air flow control to equipment racks and fire suppressant flow control concepts.

##### **Predevelopment Operational System Test (POST) – 1990**

Early evaluation of the baseline concepts, verification of operating interfaces, acquisition of data prior to CDR.

##### **Early Race Track (ERT) – April 1991**

Operational evaluation of the inter-element air circulation system, verification of the ability to control ventilation requirements from centralized locations.

##### **Baselined Operational System Test (BOST) – 1992**

Verification of flight qualifiable hardware including a 30-day unmanned test.

##### **Manned Operational System Test (MOST) – January 1993**

Includes a 90-day manned test. After completion of the test the subsystems will be refurbished and delivered to JSC for further testing.



# Technology for Space Station Evolution - A Workshop



## CORE MODULE INTEGRATION FACILITY

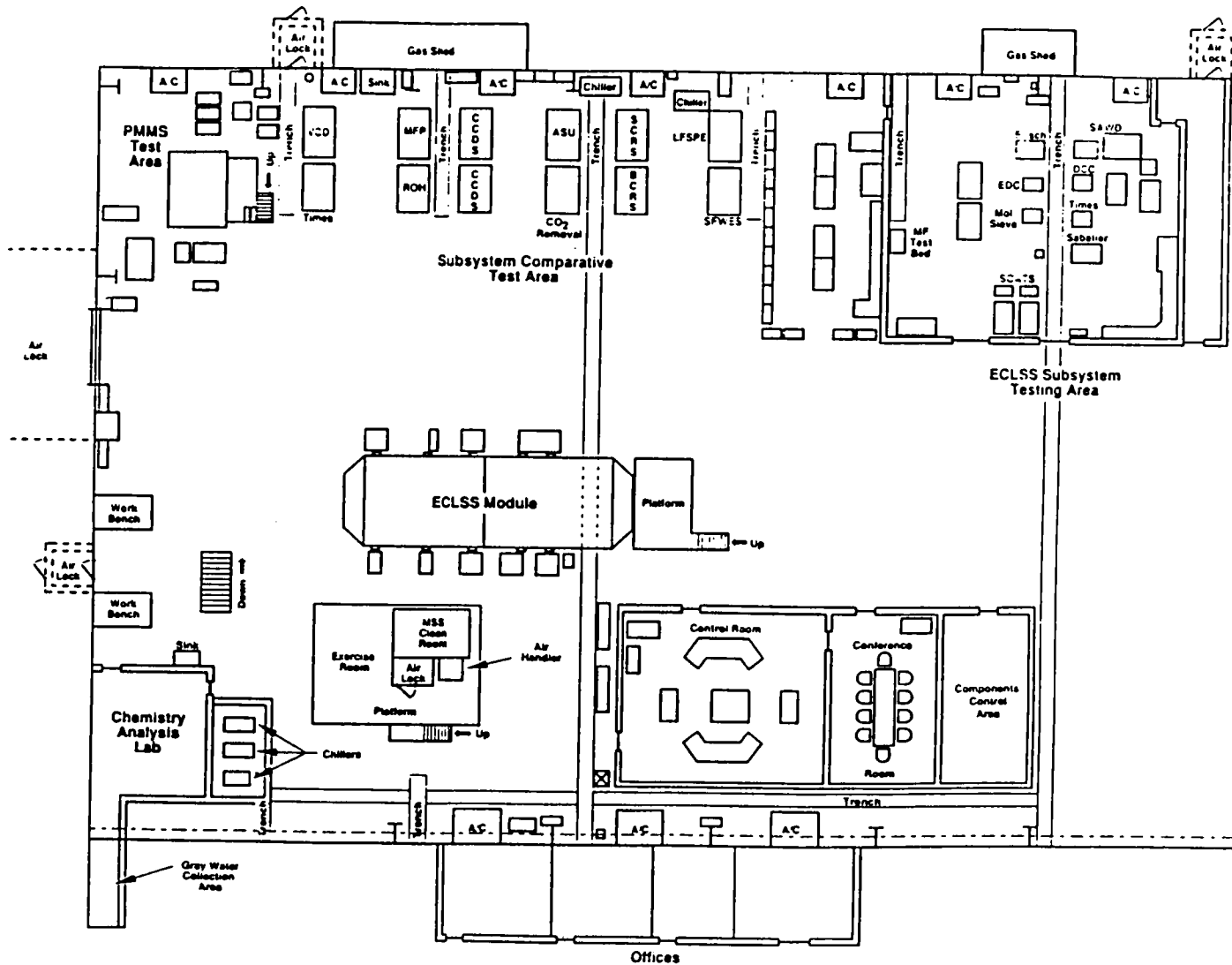

584

# Technology for Space Station Evolution - A Workshop



EARLY RACK TRACK LOCATION IN 4755

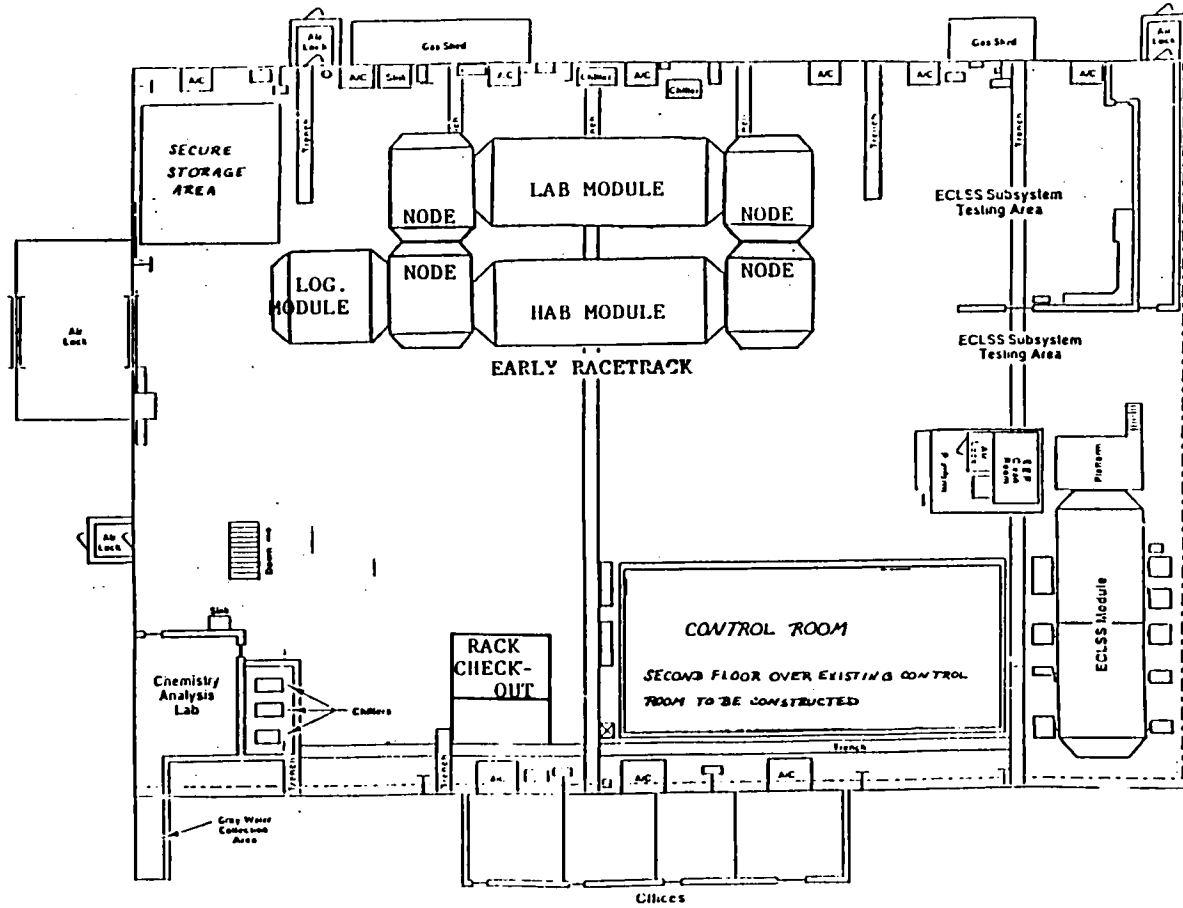

585

# Technology for Space Station Evolution - A Workshop



MOST CONFIGURATION IN 4755

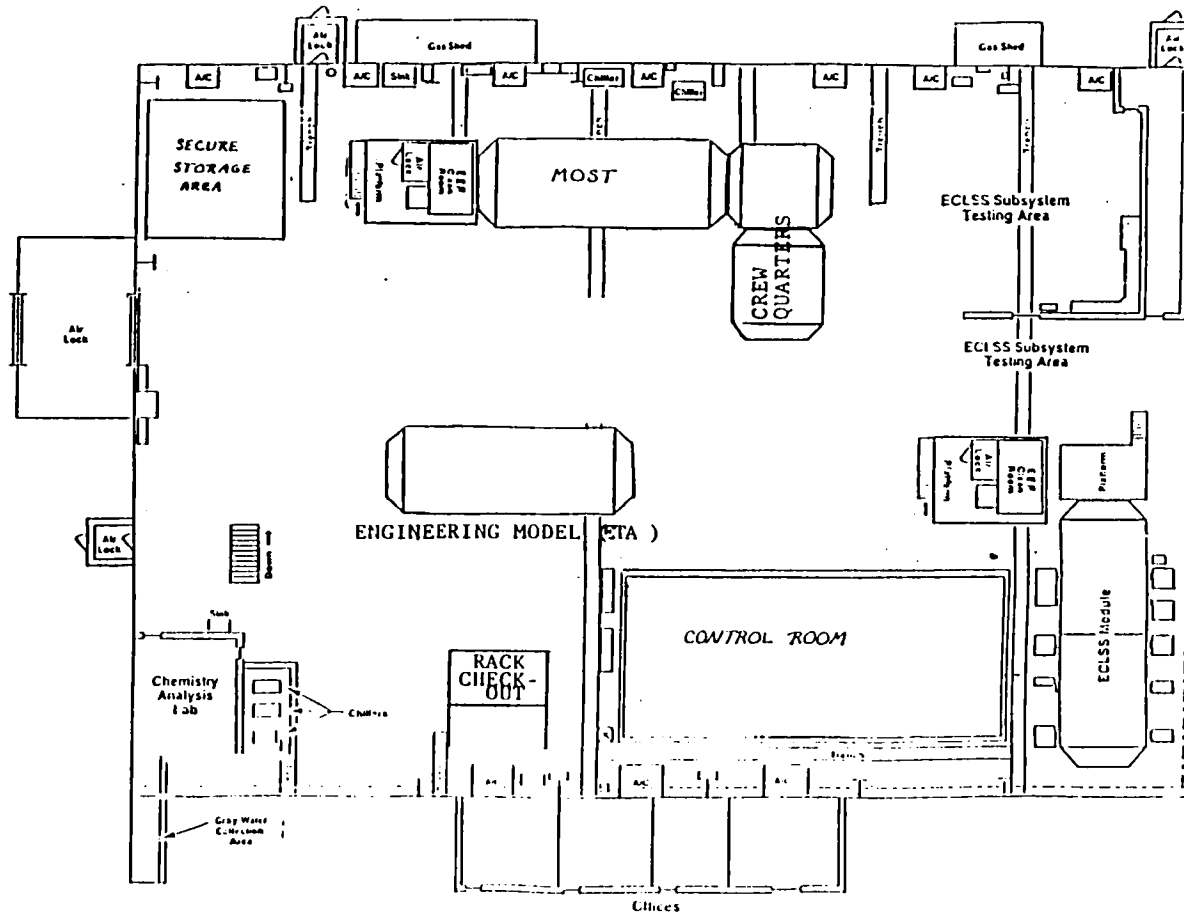

586

# Technology for Space Station Evolution - A Workshop

George C. Marshall Space Flight Center  
Science and Engineering Directorate



## ECLSS DEVELOPMENT TEST PROGRAM

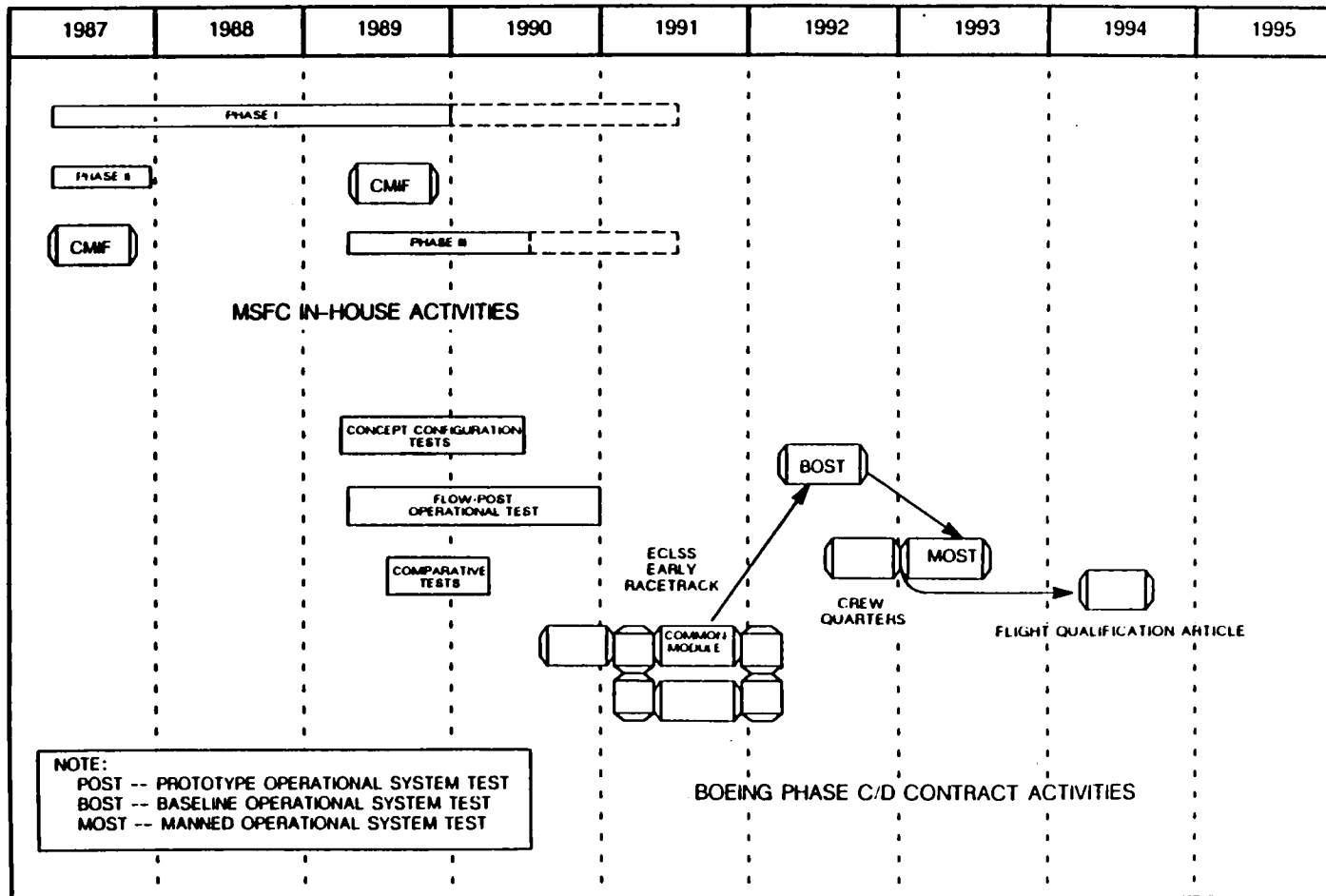



## Technology for Space Station Evolution – A Workshop



---

### Code S – Space Station *Freedom*

#### MSFC Microbial Ecology Lab Studies

- Purpose:
- (1) Provide routine sampling and microbiological identifications for ECLSS test activities.
  - (2) Conduct research leading to predictive models of behavior of microorganisms in the closed loop environment of Space Station *Freedom*.
  - (3) Provide test information on the effects of microbial growth on materials to be used on Space Station *Freedom*.

Technology for Space Station Evolution  
– A Workshop



---

Code ST – Space Station *Freedom* Evolution

**ECLSS Evolution**

**OBJECTIVE:** This task will develop and apply the analytical tools needed to allow the ECLSS to evolve in a manner such that it meets the needs of the users over the long term, and will also identify hooks and scars required to implement the selected growth technologies.

**APPROACH:**

- Conduct a survey to identify ECLSS technologies with growth option potential
- Develop a prioritized list of candidates and perform an IOC hook and scar assessment
- Expand the existing analysis tools
- Perform a comparative analysis against the IOC system
- Perform cost/benefit trade studies based on the analysis

**PRODUCTS:**

- Interface requirements/performance characteristics/figures of merit
- Preliminary hooks and scars requirements
- CASE/A component models and documentation
- Comparative data
- Final report

**STATUS:** A preliminary study has been done and a contract to perform the full study is in the process of being awarded.

---

Code ST – Space Station *Freedom* Evolution

**ECLSS Advanced Automation**

**OBJECTIVE:** To design, test, and evaluate Knowledge Based System (KBS) components for the ECLSS which will assist the crew and increase system autonomy.

- APPROACH:**
- Phase 1
    - Establish the KBS requirements
    - Determine the hooks, scars, and interfaces
    - Study KBS research and techniques in NASA and industry
    - Begin initial prototyping of ECLSS advanced automation software components
  - Phase 2 – Initial proof of concept design and development
  - Phase 3 – Implementation and testing of the KBS on actual subsystem hardware (ECLSS test bed in Building 4755 at MSFC)

- PRODUCTS:**
- Documentation – reports, development plan, design & test specifications
  - Hardware – Software Support Environment (SSE) compatible workstation integrated into the software development environment
  - Software – ECLSS KBS with Ada knowledge based system shell, integrated with the SSE software tools
  - Final system – KB system(s) ready to be integrated with ECLSS hardware and software

National Aeronautics and  
Space Administration

George C. Marshall Space Flight Center  
Science and Engineering Directorate

## Technology for Space Station Evolution – A Workshop



---

### Code R – Exploration Technologies (Pathfinder)

**MSFC is the lead for Systems Monitoring and Control Instrumentation.**

RTOP #591-34-61 System Monitoring, contract with MDSSC  
"real-time sensor" development  
chemical composition monitoring technology

RTOP #591-34- ECLSS Evolution and Advanced Instrumentation, new contract  
continuation of 591-34-61 effort

RTOP #591-34- Trace Contaminant Monitoring

**In support of 10 other WBS categories MSFC has one water recovery technology task.**

RTOP #591-34-21 Water Recovery, contract with MDSSC, subcontracted to Sievers  
Research trace organic removal water reclamation (funded through  
Ames)

# Technology for Space Station Evolution – A Workshop



## CODE R PATHFINDER NASA CENTER ROLES – P/C CLLS OFFICE

	ARC	JPL	JSC	LaRC	MSFC
<b>1.1 PHYSICAL/CHEMICAL LIFE SUPPORT</b>					
1.1.1 THERMAL CONTROL	S		L		S
1.1.2 AIR REVITALIZATION	S	S	L		S
1.1.3 WATER MANAGEMENT	L	S	S		S
1.1.4 SOLID WASTE MANAGEMENT	L	S	S		S
1.1.5 FOOD MANAGEMENT	S		L		S
<b>1.2 PORTABLE LIFE SUPPORT SYSTEMS</b>					
1.2.1 THERMAL CONTROL SYSTEMS	SEE EVA/SUIT PROJECT PLAN FOR DETAILS				
1.2.2 ATMOSPHERE CONTROL					
1.2.3 MONITORING & CONTROL					
1.2.4 SYSTEM INTEGRATION					
<b>1.3 SYSTEMS CONTROL</b>					
1.3.1 SYSTEMS MONITORING & CONTROL INSTR.	S				L
1.3.2 SYSTEMS CONTROL STRATEGY	L				S
<b>1.4 SYSTEM INTEGRATION</b>					
1.4.1 SYSTEM REQUIREMENTS	S	S	L		
1.4.2 P/C BIO SYSTEMS	L	S			
1.4.3 SYSTEMS ANALYSIS & ASSESSMENT	L	S	S	S	S
1.4.4 VALIDATION & VERIFICATION	L		S		S
1.4.5 SYSTEM TESTS	L		S		S
1.4.6 HUMAN-RATED TESTS	S		L		S

L = LEAD CENTER  
S = SUPPORT CENTER



---

## Code R – Exploration Technologies (Pathfinder)

### Sensor Development Needs

- Water Quality Monitor (WQM) – on-line
  - Specific contaminants/mechanical properties
  - Improvement in Trace Organic Contaminant (TOC) sensitivity
- Water Quality Monitor (WQM) – off-line
  - Automation
- Trace gas analyzer
  - Automation
  - Turn-around time
- Specific hazardous gas sensors
  - Hydrogen
  - Methane
  - Other hazardous payload substances



---

## Code R – Exploration Technologies (Pathfinder)

### Other Need Areas

- Different Subsystem Selection Because of:
  - Space Station shortfalls
  - Design differences – e.g., propulsion other than O<sub>2</sub>/H<sub>2</sub>, venting allowed, 90-day resupply, photovoltaic power supply, etc.
  - Different weighting factors and priorities
    - power
    - weight
    - volume
    - other
  - New technology breakthroughs
    - automation improvements
    - improvements/maturing of existing P/C processes
    - advancements in P/C processes
    - CELSS
  
- System Differences
  - Mission scenarios different from the Space Station
  - Local resource usage capability
  - Mission isolation with no resupply

National Aeronautics and  
Space Administration

# Technology for Space Station Evolution – A Workshop

George C. Marshall Space Flight Center  
Science and Engineering Directorate



---

## Code Z – Exploration Technologies

### **PD Directorate Transportation Studies Support**

- Review Technical Content of Contract Studies
- Act as an Advisor to PD Personnel
- Support Reviews
- Provide PD/Contractor Personnel SSF Data and Consultation



Technology for Space Station Evolution  
– A Workshop



---

Phase I Small Business Innovation Research Contract's

1. **TITLE: "Incipient Combustion Monitor for Zero Gravity Environments"**

CONTRACT: TBD (SBIR '89 Phase I)

CONTRACTOR: ADA Technologies, Inc.

PERIOD OF PERFORMANCE: 1/90 – 7/90

GOAL: To investigate the feasibility of using a dynamic expansion condensation nuclei chamber for the detection of submicron particles emitted when combustible materials are heated.

2. **TITLE: "A Reagentless Separator for Removal of Inorganic Carbon from Solution"**

CONTRACT: TBD (SBIR '89 Phase I)

CONTRACTOR: Umpqua Research Co.

PERIOD OF PERFORMANCE: 1/90 – 7/90

GOAL: To investigate removing inorganic carbon by first converting it to CO<sub>2</sub> using a solid-phase acidic material and then separating it using a CO<sub>2</sub> permeable membrane degasser.

3. **TITLE: "Thin Membrane Sensors"**

CONTRACT: TBD (SBIR '89 Phase I)

CONTRACTOR: Resource Technologies Group, Inc.

PERIOD OF PERFORMANCE: 1/90 – 7/90

GOAL: To investigate the feasibility of using a thin membrane sensor with controllable electrical properties to detect a variety of chemical and biological agents.



---

## Phase II Small Business Innovation Research Contract's

**TITLE: "Removal of Contaminants From Experiment Waste Water Using Immobilized Enzymes"**

**CONTRACT: NAS8-37642 (SBIR '87 Phase I)**

**CONTRACTOR: Umpqua Research Co.**

**PERIOD OF PERFORMANCE: Phase I: 1/88 – 7/88, Phase II: 1/90 – 12/91**

**GOAL:** To investigate the use of immobilized enzymes to enhance the removal of low molecular weight organic contaminants from the Process Materials Management System (PMMS) and ECLSS wastewaters

### PHASE I RESULTS:

- Two enzymes were focused on:
  - urease (for removal of urea)
  - alcohol oxidase (for removal of methanol, ethanol, and related contaminants)
- Both enzymes successfully immobilized the contaminants
- Good performance was demonstrated

### PHASE II PROPOSAL:

- Continue development to:
  - optimize enzyme preparation and immobilization methodologies
  - investigate synergistic effects through co-immobilization of complementary enzymes
  - investigate additional enzymes to broaden the range of contaminants removed
  - develop and test alternate reactor designs
  - perform long term parametric and life testing
  - fabricate and deliver prototype reactors to the MSFC for testing
- Contract awarded 12/89



---

## University Involvement

**University of Alabama in Huntsville –**

"Identifying Critical Monitoring Tests for Recycled Water Systems"

**University of Wisconsin –**

Developing a Predictive Model of the Ecological Behavior of Microorganisms

Developing Techniques and/or Equipment Which Facilitate Rapid Monitoring of Microorganisms

**Harvard (funding: 80% ARC, 20% MSFC) –**

"Processes Involved in Microbial Biofilm Formation in Water Reclamation Systems for the Orbiting Space Station"

**Georgia Institute of Technology –**

"CO<sub>2</sub> Reduction Subsystem Combustion Kinetics"



<b>Technology for Space Station Evolution Workshop</b>	Crew and Thermal Systems Division	
	<b>A.F. Behrend</b>	<b>1-16-90</b>

# Technology for Space Station Evolution Workshop

## JSC ECLSS R&T Program Overview

599

Dallas, TX  
January 16-19, 1990

*P-31*  
A.F. Behrend  
NASA - JSC

*521-54*  
N 930737725



<b>Technology for Space Station Evolution Workshop</b>	<b>Crew and Thermal Systems Division</b>	
	<b>A.F. Behrend</b>	<b>1-16-90</b>

**Content**

- **Advancements in Electrochemical CO<sub>2</sub> Removal**
- **Supercritical Water Waste Oxidation**
- **Electrooxidation for Post-treatment of Reclaimed Water**
- **Photocatalytic Post-Treatment of Reclaimed Water**

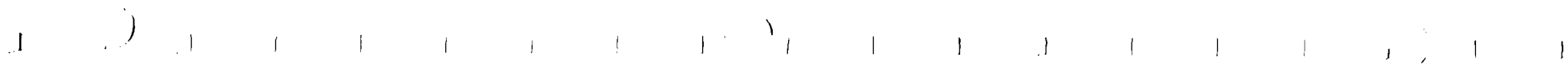
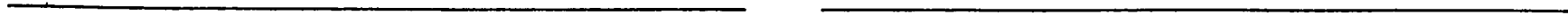



<b>Technology for Space Station Evolution Workshop</b>	<b>Crew and Thermal Systems Division</b>	
	<b>A.F. Behrend</b>	<b>1-16-90</b>

**Advancements in Electrochemical CO2 Removal**

**Objective**

- Investigate and develop fundamental process enhancements in electrochemical CO2 removal

**Benefit**

- Improve performance and reliability
  - CO2 removal efficiency improvement (5-10% improvement achieved)
  - Cell composition improvement
  - Hydrogen feed elimination





<b>Technology for Space Station Evolution Workshop</b>	<b>Crew and Thermal Systems Division</b>	
	<b>A.F. Behrend</b>	<b>1-16-90</b>

### Advancements in Electrochemical CO2 Removal

#### Technical Description

- Air passes through electrochemical cell where CO<sub>2</sub> is absorbed at cathode and evolved at anode
- Electrochemical CO<sub>2</sub> removal with hydrogen utilizes alkaline hydrogen/oxygen fuel cell reaction
  - O<sub>2</sub> from air supplied at cathode where CO<sub>2</sub> is absorbed
  - H<sub>2</sub> supplied at anode where CO<sub>2</sub> is evolved
  - CO<sub>2</sub> reacts with hydroxyl ions (OH<sup>-</sup>) to form carbonate and bicarbonate ions (CO<sub>3</sub><sup>=</sup> and HCO<sup>-</sup>) which migrate to anode where heat energy from the fuel cell reaction releases the CO<sub>2</sub>
  - Half-cell reactions at both electrodes are thermodynamically spontaneous
  - Process generates electricity
- Same process can be carried out without supply of hydrogen
  - Series of reactions not spontaneous
  - Power must be supplied (approximately 105W/per person)



<b>Technology for Space Station Evolution Workshop</b>	Crew and Thermal Systems Division	
	A.F. Behrend	1-16-90

**Advancements in Electrochemical CO2 Removal**

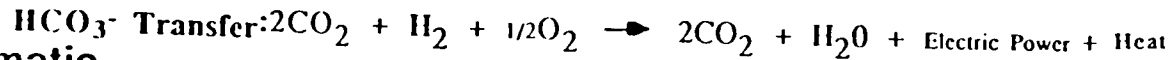
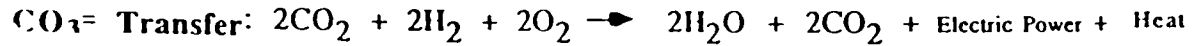

**Schematic**

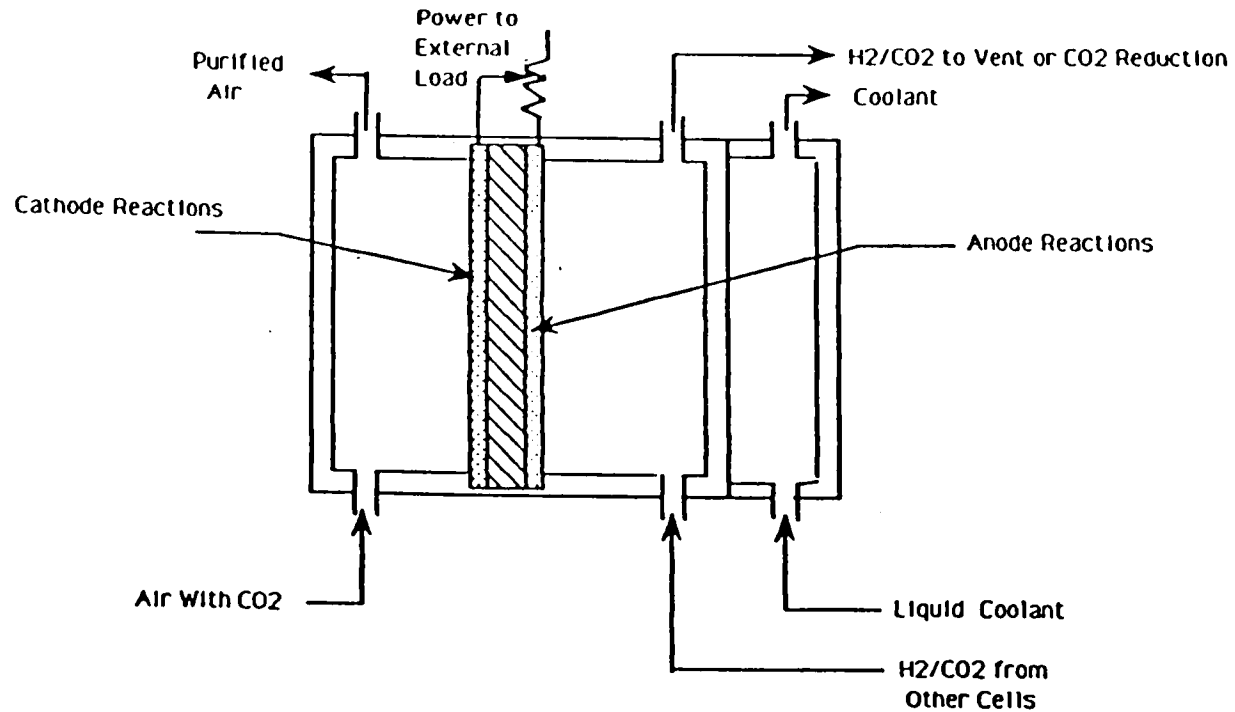

**Electrochemical Carbon Dioxide Removal with Hydrogen**





<b>Technology for Space Station Evolution Workshop</b>	Crew and Thermal Systems Division	
	<b>A.F. Behrend</b>	<b>1-16-90</b>

**Advancements in Electrochemical CO2 Removal**

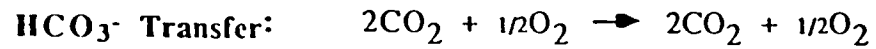
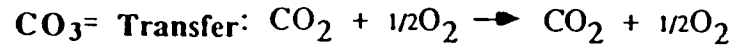

**Schematic**

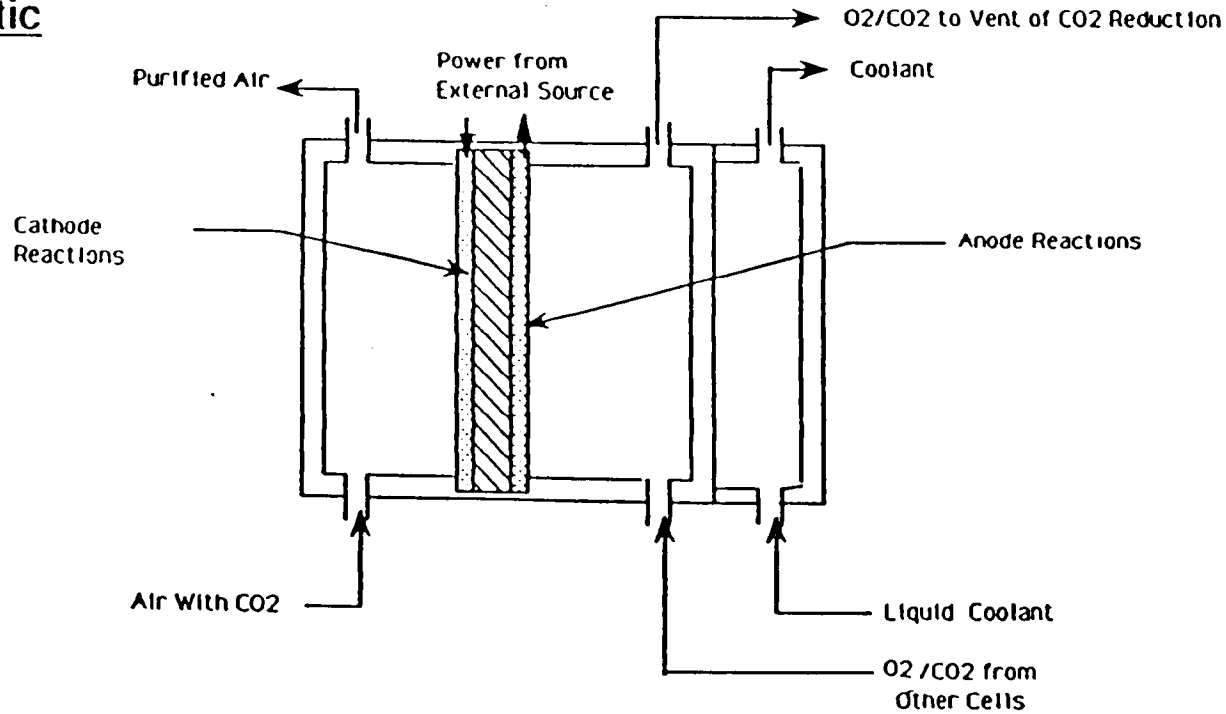

**Electrochemical Carbon Dioxide Removal without Hydrogen**



<b>Technology for Space Station Evolution Workshop</b>	<b>Crew and Thermal Systems Division</b>	
	<b>A.F. Behrend</b>	<b>1-16-90</b>

### Advancements in Electrochemical CO<sub>2</sub> Removal

#### Status

- Program with Life Systems, Inc./Texas A&M; Initiated in December 1987
- 2 year Phase I to investigate and develop fundamental process enhancements
  - Literature review to identify areas of study for improved performance and operational flexibility
  - Bench-scale laboratory testing of cell components to identify best candidates for integrated testing
  - Single cell unit design, fabrication, and testing
- Single cell testing being completed now
- 1 year Phase II for multi-cell unit design, fabrication, and test



<b>Technology for Space Station Evolution Workshop</b>	<b>Crew and Thermal Systems Division</b>	
	<b>A.F. Behrend</b>	<b>1-16-90</b>

**Advancements in Electrochemical CO2 Removal**

**Results**

- **Determined optimum electrocatalyst loading and binding agent content for gas diffusion electrodes**
- **Developed an improved electrode fabrication method using ultrasonic device for the dispersion of gas diffusion electrode components**
- **Proved that the electrolyte matrix thickness can be reduced to half of the baseline matrix thickness for improved performance without sacrificing the differential pressure capability**
- **Identified and developed electrode materials for the anode of the "without hydrogen" electrochemical CO2 removal cell**

606

**FY90 Activity**

- **Documentation of Phase I Results**
  - **Initiation of Phase II Multi-cell Unit Design and Fabrication**
-



<b>Technology for Space Station Evolution Workshop</b>	<b>Crew and Thermal Systems Division</b>	
	<b>A.F. Behrend</b>	<b>1-16-90</b>

**Supercritical Water Waste Oxidation**

**Objective**

- **Expand the fundamental understanding of the SCWO waste treatment process**
- **Determine reaction mechanisms and effect of SCWO process variables (temperature, residence time, feed concentration, pressure) for simple compounds - methane, ammonia, etc.**
- **Determine mechanism of reaction residue (salt) formation - rate, temperature, etc.**

607



**Technology for Space Station  
Evolution Workshop**

Crew and Thermal Systems Division

**A.F. Behrend**

**1-16-90**

**Supercritical Water Waste Oxidation**

**Benefit**

- **System and crew waste approximately 6-8 lb/person-day  
(approximately 0.25 ft<sup>3</sup>/person-day)**
  
- **SCWO process potentially**
  - **Reduces waste storage (35 ft<sup>3</sup> reduced to approximately 0.1 ft<sup>3</sup>)**
  - **Produces excess water**
    - o **Enhanced hygiene**
    - o **Radiation protection supplement**
    - o **EVA support**



<b>Technology for Space Station Evolution Workshop</b>	<b>Crew and Thermal Systems Division</b>	
	<b>A.F. Behrend</b>	<b>1-16-90</b>

### Supercritical Water Waste Oxidation

#### Technology Description

- SCWO process converts organic waste (feces, urine, trash) to carbon dioxide nitrogen, and water
- Process operation above the water critical point ( 3200 psia, 705 °F;  
218 atm, 374 °C)
- Organic material is oxidized leaving reaction residue in the form of salts and oxides
- Process depends upon containment and removal of reaction ash

#### Status

- M.I.T. grant in final phase
    - September 1987 to September 1990
  - Focus upon reaction kinetics and salt formation with analysis and experimental results
-

# HUMAN WASTE TREATMENT AND RECYCLE BY OXIDATION IN SUPERCRITICAL WATER (SCW) (MODAR PROCESS)

## PROCESS STEPS

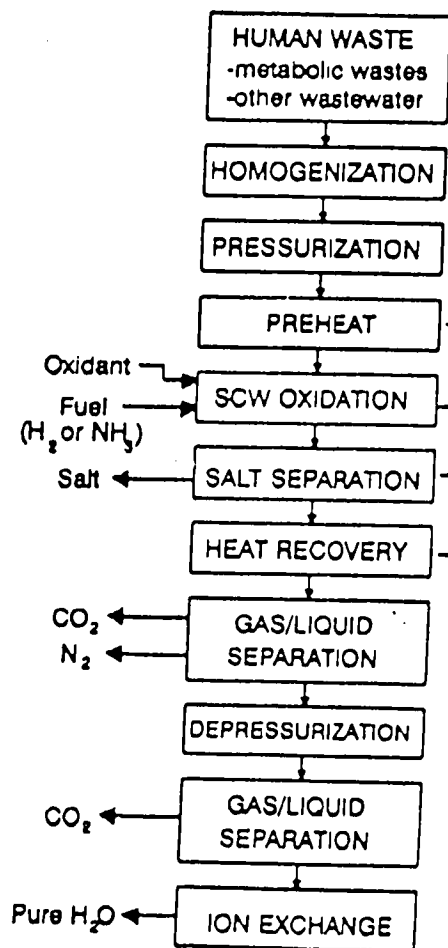

## MIT FUNDAMENTAL RESEARCH

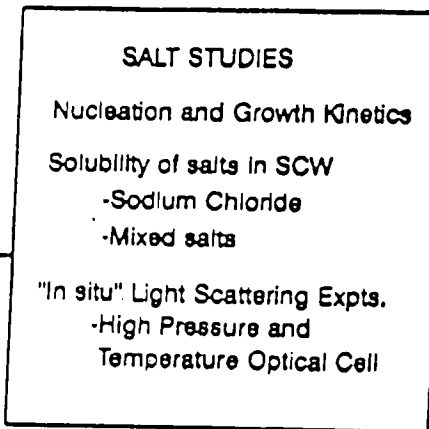
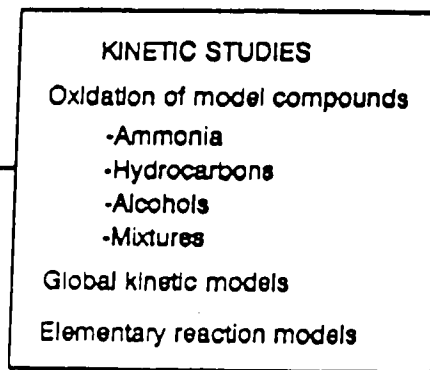



<b>Technology for Space Station Evolution Workshop</b>	Crew and Thermal Systems Division	
	<b>A.F. Behrend</b>	<b>1-16-90</b>

### Supercritical Water Waste Oxidation

#### Results

- **Reaction kinetics**
  - Expanded experimental capability to 700 °C, 300 atm
  - Measurement of kinetics and correlation to analytical models for carbon monoxide, ethanol, methanol, methane, ammonia, ammonia/ethanol, carbon monoxide/ethanol
- **Salt formation**
  - Completed test apparatus assembly and initial checkout with water
  - Initiated preliminary sodium chloride experiments
  - Progressing with numerical modeling of salt mixing and precipitation

#### FY90 Activity

- **Complete salt nucleation and precipitation experiments and modeling**
  - **Expand kinetic database to examine pressure variation, alternate oxidants, dissolved salts, heat transfer rate**
-





<b>Technology for Space Station Evolution Workshop</b>	<b>Crew and Thermal Systems Division</b>	
	<b>A.F. Behrend</b>	<b>1-16-90</b>

**ELECTROOXIDATION FOR POST-TREATMENT OF RECLAIMED WATER**

**OBJECTIVE**

- **DEMONSTRATE FEASIBILITY OF ELECTROOXIDATION TECHNIQUE FOR POST-TREATMENT OF RECLAIMED WASTE WATERS (DISTILLATES, PERMEATES AND HUMIDITY CONDENSATES) FOR POTABLE AND HYGIENE USAGE**

612

**BENEFITS**

- **NEW COMPETING TECHNOLOGY FOR PURIFYING RECLAIMED WASTE WATERS**
  - **NO EXPENDABLES**
  - **REMOVES TOTAL ORGANIC IMPURITIES TO < 500 PPB**
  - **SHOWS POTENTIAL FOR PROVIDING DISINFECTION**
-



<b>Technology for Space Station Evolution Workshop</b>	Crew and Thermal Systems Division	
	A.F. Behrend	1-16-90

## ELECTROOXIDATION FOR POST-TREATMENT OF RECLAIMED WATER

### TECHNICAL DESCRIPTION

- ELECTROCHEMICAL CELL PROVIDES GENERATION OF STRONG OXIDIZING RADICALS (HO·)
- LIQUID ELECTROLYTE (0.7 M SODIUM PERCHLORATE)
- 170 W-HR REQUIRED TO OXIDIZE 50 PPM OF ORGANIC IMPURITY TO < 500 PPB IN 1 LITER OF WATER
- NO MOVING PARTS

### STATUS

- GRANT INITIATED WITH TAMU IN APRIL 1989
  - EVALUATING FEASIBILITY OF CONCEPT AND OBTAINING PARAMETRIC DATA FOR DESIGN AND FABRICATION OF A BREADBOARD SYSTEM
  - COMPLETION OF RESEARCH GRANT IN APRIL 1990
-

**ELECTROLYSIS TEST CELL: INCORPORATING AN ION-CONDUCTING MEMBRANE**

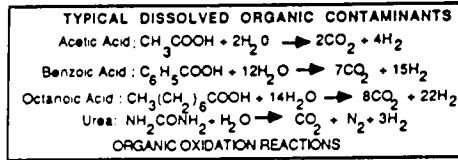
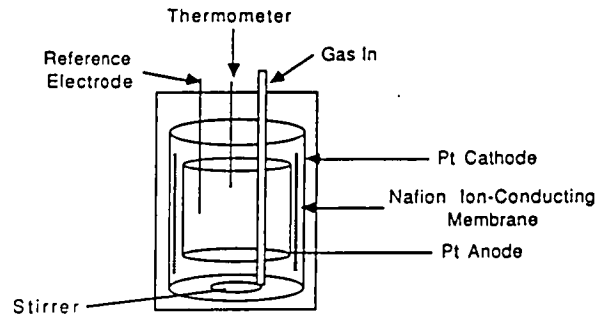

**SCHEMATIC OF ELECTROCHEMICAL WATER POST-TREATMENT UNIT**

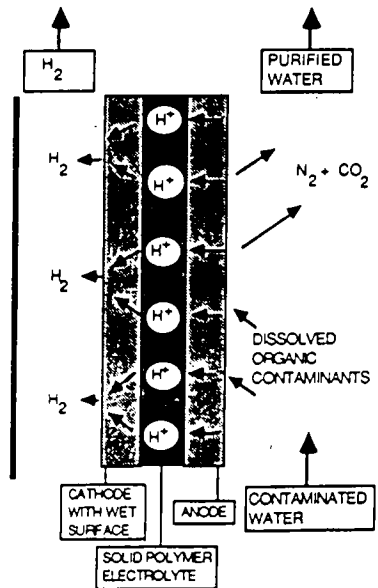



<b>Technology for Space Station Evolution Workshop</b>	<b>Crew and Thermal Systems Division</b>	
	<b>A.F. Behrend</b>	<b>1-16-90</b>

**ELECTROOXIDATION FOR POSTTREATMENT OF RECLAIMED WATER**

**FUTURE PLANS**

- **DEVELOP A BREADBOARD SYSTEM USING A SOLID POLYMER  
ELECTROLYTE FROM FUEL CELL TECHNOLOGY**

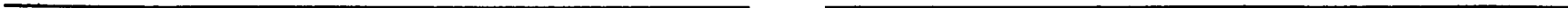



<b>Technology for Space Station Evolution Workshop</b>	<b>Crew and Thermal Systems Division</b>	
	<b>A.F. Behrend</b>	<b>1-16-90</b>

**PHOTOCATALYTIC POST-TREATMENT OF RECLAIMED WATER**

**OBJECTIVE**

- DEVELOP A BREADBOARD PHOTOCATALYTIC SYSTEM FOR POST-TREATMENT OF RECLAIMED WASTE WATERS (DISTILLATES, PERMEATES AND HUMIDITY CONDENSATE) FOR POTABLE AND HYGIENE USAGE

616

**BENEFITS**

- NEW COMPETING TECHNOLOGY FOR PURIFYING RECLAIMED WASTE WATERS
- REMOVES ORGANIC IMPURITIES TO LEVELS < 500 PPB
- PROVIDES DISINFECTION
- NO EXPENDABLES



<b>Technology for Space Station Evolution Workshop</b>	<b>Crew and Thermal Systems Division</b>	
	<b>A.F. Behrend</b>	<b>1-16-90</b>

## PHOTOCATALYTIC POST-TREATMENT OF RECLAIMED WATERS

### TECHNOLOGY DESCRIPTION

- ORGANIC IMPURITIES IN WATER ARE OXIDIZED BY POWERFUL OXIDIZING HYDROXAL RADICALS (OH•) AND HOLES (h +) PRODUCED WITH THE COMBINATION OF FINE METAL OXIDE CATALYST PARTICLES DISPERSED IN WATER WITH UV LIGHT AND DISSOLVED O<sub>2</sub>
- BATCH SYSTEM PROCESSES 12 LITERS OF WATER EVERY 2 HOURS
- SEPARATES CATALYST PARTICLES BY CROSS-FILTRATION THROUGH MICROPOROUS MEMBRANE
- RECOVERS PARTICLES FOR REUSE BY BACKFLUSHING OF MEMBRANE
- OPERATES CLOSE TO AMBIENT TEMPERATURE (35 ° C)



<b>Technology for Space Station Evolution Workshop</b>	<b>Crew and Thermal Systems Division</b>	
	<b>A.F. Behrend</b>	<b>1-16-90</b>

## SCHEMATIC OF PHOTOCATALYTIC BATCH REACTOR POST-TREATMENT SYSTEM

618

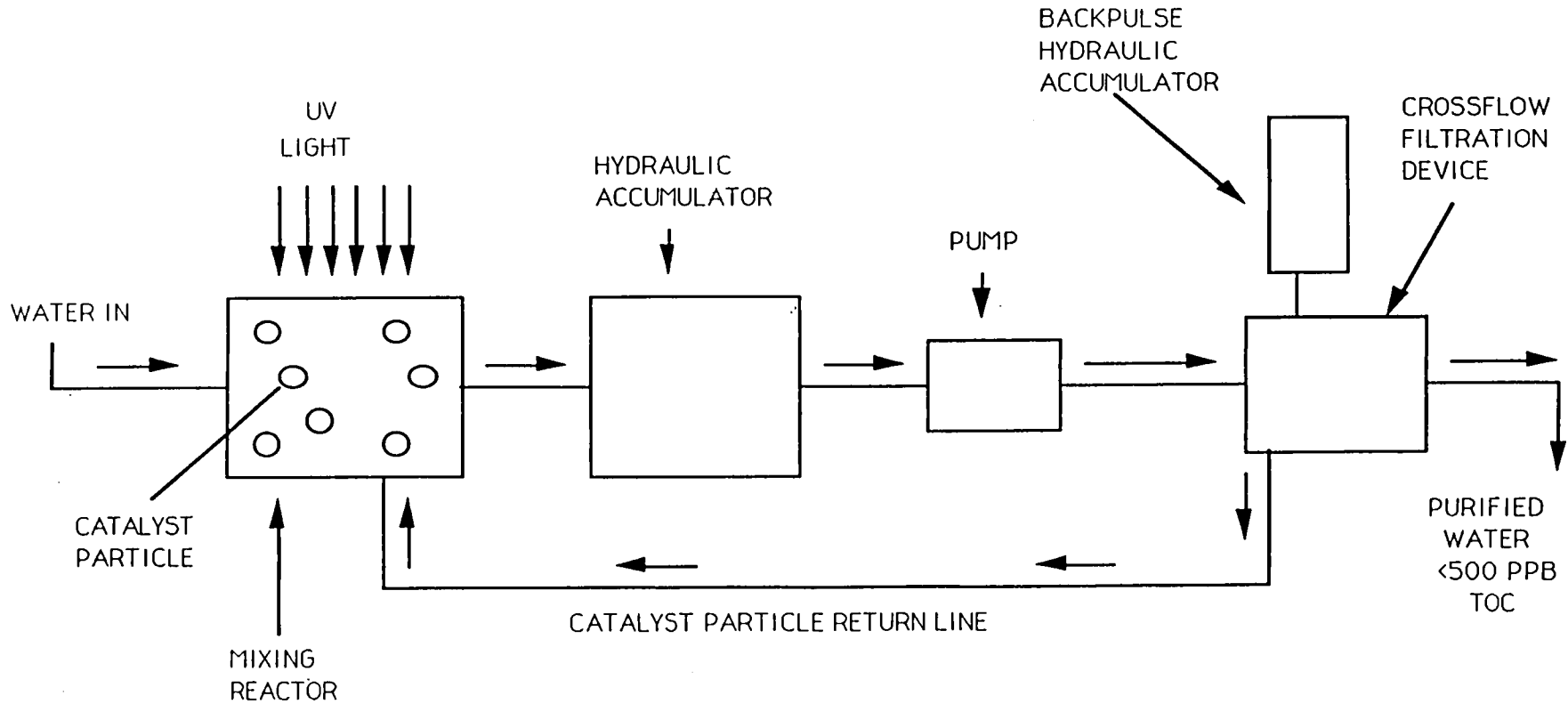

POST-TREATMENT SYSTEM PROCESSES  
12 LITERS PURIFIED WATER PER HOUR



<b>Technology for Space Station Evolution Workshop</b>	Crew and Thermal Systems Division	
	A.F. Behrend	1-16-90

## PHOTOCATALYTIC POST-TREATMENT OF RECLAIMED WATER

### STATUS

- PHASE II SBIR WITH PHOTOCATALYTICS, INC. BOULDER, CO INITIATED IN APRIL 1987
- BREADBOARD SYSTEM IN FABRICATION AND SCHEDULED FOR COMPLETION FEBRUARY

### FY 90 ACTIVITY

- TEST BREADBOARD SYSTEM WITH RECLAIMED WASTE WATERS TO DEMONSTRATE PERFORMANCE FOR
  - REMOVAL OF ORGANIC IMPURITIES TO < 500 PPB
  - DISINFECTION FROM 10 EXP 7 CFU TO 0 MICROORGANISMS
- CONTRACT COMPLETION IS APRIL 1990

### FUTURE PLANS

- CONTINUE TECHNOLOGY DEVELOPMENT