



POTABLE WATER DISTRIBUTION SYSTEM

Design Criteria and Standards



LUCERNE, COLORADO
FINAL - FEBRUARY 8, 2021

(THIS PAGE INTENTIONALLY LEFT BLANK)

DESIGN CRITERIA AND STANDARDS

(INCLUDING STANDARD SPECIFICATIONS AND STANDARD DETAILS)

POTABLE WATER DISTRIBUTION SYSTEM



DESIGN CRITERIA	PART 1
STANDARD SPECIFICATIONS	PART 2
STANDARD DETAILS	PART 3

FINAL

FEBRUARY 08, 2021

LUCERNE, COLORADO

(THIS PAGE INTENTIONALLY LEFT BLANK)

DESIGN CRITERIA AND STANDARDS

POTABLE WATER DISTRIBUTION SYSTEM



PART 1

DESIGN CRITERIA

(THIS PAGE INTENTIONALLY LEFT BLANK)

POTABLE WATER DISTRIBUTION SYSTEM DESIGN CRITERIA

TABLE OF CONTENTS

SECTION 1 - GENERAL REQUIREMENTS	2
1.01. SCOPE.....	2
1.02. DEFINITIONS AND ABBREVIATIONS	2
1.03. MINIMUM STANDARDS	7
1.04. RELATIONSHIP TO OTHER STANDARDS	7
1.05. REVIEW AND ACCEPTANCE	7
SECTION 2 - SUBMITTAL REQUIREMENTS	9
2.01. GENERAL	9
2.02. PRELIMINARY CONSTRUCTION PLAN REQUIREMENTS.....	10
2.03. FINAL CONSTRUCTION PLAN REQUIREMENTS.....	11
2.04. FINAL PLAT AND REPLAT REQUIREMENTS	14
2.05. LANDSCAPE PLANS REQUIREMENTS.....	14
2.06. EASEMENTS	14
2.07. HYDRAULIC REPORT – POTABLE WATER.....	16
2.08. AS-CONSTRUCTED RECORD DRAWING REQUIREMENTS	22
2.09. REIMBURSEMENT FOR MAIN DESIGN AND INSTALLATION COSTS	23
SECTION 3 - POTABLE WATER DISTRIBUTION SYSTEM DESIGN CRITERIA	23
3.01. GENERAL	23
3.02. DEFINITIONS	24
3.03. DESIGN FLOW	24
3.04. PRESSURE REQUIREMENTS.....	27
3.05. HYDRAULIC DESIGN	28
3.06. POTABLE WATER MAIN SIZE	29
3.07. DEPTH OF BURY	29
3.08. CONNECTIONS TO THE EXISTING POTABLE WATER SYSTEM	29
3.09. LOCATION AND LOOPING OF POTABLE WATER MAINS.....	29
3.10. POTABLE WATER SYSTEM PHASED INSTALLATION AND STUBOUTS.....	31
3.11. PIPE MATERIAL	31
3.12. VALVES.....	32
3.13. CURVED PIPE ALIGNMENT	33
3.14. THRUST RESTRAINT.....	34
3.15. POTABLE WATER MAIN AND SERVICE ENCASEMENTS	35
3.16. POTABLE WATER SERVICES AND FIRE SPRINKLER LINES.....	36
3.17. POTABLE WATER MAINS AND SERVICES IN RELATION TO OTHER UTILITIES	37
3.18. FIRE PROTECTION AND HYDRANT SPACING	38
3.19. CROSS CONNECTION AND BACKFLOW PREVENTION.....	39

SECTION 1 - GENERAL REQUIREMENTS

1.01. SCOPE

- A. The purpose of the *Design Criteria* (Criteria) is to present the minimum design and technical criteria for the analysis and design of potable water distribution system for which North Weld County Water District (NWCWD) acceptance is required. The Criteria are Part 1 of the Design Criteria and Standards (DCS) which also include the Standard Specifications (Part 2) and the Standard Details (Part 3).
- B. The Criteria may be amended as new technology is developed or a need for revision is demonstrated and proven through experience and use. The Design Engineer shall be responsible for compliance with these Criteria as well as other applicable design and construction standards and specifications established and in use by CDPHE and Weld and/or Larimer Counties, as appropriate, in the preparation of engineering reports, Construction Drawings, and specifications for NWCWD review and acceptance.

1.02. DEFINITIONS AND ABBREVIATIONS

- A. Wherever the following words, phrases, and abbreviations appear in these Criteria, they shall have the following meanings:

Table 1-1: Definitions and Abbreviations

Acronym or Abbreviation	Definition
ac	acre
ac-ft	acre-feet
ANSI	American National Standards Institute
APPROVED PLAN	The latest revised Construction Drawing(s) accepted by NWCWD
APWA	American Public Works Association
AS-CONSTRUCTED DRAWINGS	Drawings reflecting actual conditions and information for the project after construction is completed
ASME	American Society of Mechanical Engineers
ASTM	American Society for Testing Materials
AWWA	American Water Works Association

Acronym or Abbreviation	Definition
CDOT	Colorado Department of Transportation
CDPHE	Colorado Department of Public Health and Environment
cfs	cubic feet per second, i.e., ft ³ /s
CONSTRUCTION DRAWINGS	Engineered working drawings including plan, profile, and detail sheets of proposed development and utility improvements accepted by NWCWD.
CONTRACTOR	The individual, firm, partnership, corporation, or combination thereof, private, municipal, or public, including joint ventures, which, as an independent contractor, has entered into a contract with the Developer/Owner.
CRITERIA	Design Criteria, Part 1 of the DCS
DCS	NWCWD's Design Criteria and Standards, including the Design Criteria (Part 1), Standard Specifications (Part 2), and Standard Details (Part 3), i.e., this document
DESIGN ENGINEER	The partnership, corporation, or individual who is registered as a Professional Engineer, according to Colorado statutes, who is hired by the Developer/Owner to conduct engineering design services and may be empowered by the Developer/Owner to act as his agent for the project.
DEVELOPER	The owner, corporation, association, partnership, agency, or individual who or which shall participate in development, has entered into a development agreement with NWCWD and has entered into an agreement with the Design Engineer and Contractor to perform the development work.
DEVELOPMENT	Any construction or activity which changes the basic characteristic or use of land on which construction or activity occurs, including but not limited to, any non-natural change to improved or unimproved real estate, substantial improvements to buildings or other structures, installation of utilities, mining, dredging, filling, grading, paving, extraction, or drilling operations.

Acronym or Abbreviation	Definition
DEVELOPMENT CODE	A section of the Municipal/County Code prepared by the Town/County in which the development is occurring which sets forth requirements and standards for land development, land use, and the Subdivision Regulations.
DIP	Ductile iron pipe
DISTRICT	North Weld County Water District
Domestic water use	Refers to all household and corresponding lot irrigation for single family and applicable multifamily residential potable water use. It shall also refer to all potable water use, including potable irrigation, for commercial and industrial uses.
EASEMENT	Shall mean a right granted by the property owner permitting a designated part or interest of the property to be used by others for specific use or purpose.
EPA	Environmental Protection Agency
fps	feet per second
ft ²	square feet
ft/s	feet per second
FIRE FLOW, FF	Shall be inclusive of fire hydrant and fire sprinkler flow, as required by the governing fire protection agency. Residential, commercial, or industrial developments requiring fire sprinkler systems shall have fire sprinkler demands, in addition to hydrant fire flows, placed in the hydraulic water model at appropriate node locations.
GEOTECHNICAL ENGINEER	A partnership, corporation, or individual who is registered as a Professional Engineer, according to Colorado statutes, proficient in the area of soil mechanics, and who is hired by the Developer/Owner to conduct subsurface soils investigations and evaluations, ground water assessments, and other related engineering services.
gpcd	gallons per capita per day

Acronym or Abbreviation	Definition
gpd	gallons per day
gpm	gallons per minute
HP	horsepower
INSPECTOR	Representative of NWCWD designated to conduct construction/field observation.
LAND SURVEYOR	A registered Professional Land Surveyor, according to State of Colorado statutes, who is hired by the Developer/Owner to determine the boundaries and elevations of land and/or structures and other related surveying services.
MAY	A permissive condition. Where the word “may” is used, no requirement for design or application is intended.
MDD	Maximum Day Demand
NEC	National Electric Code
NWCWD	North Weld County Water District
OSHA	Occupational Safety and Health Administration
OWNER	Any person having title or right of ownership in the surface estate of real property or leasehold interest within.
PHD	Peak Hour Demand
PLANS	See CONSTRUCTION DRAWINGS
PLC	Programmable Logic Controller
PROFESSIONAL ENGINEER	An engineer registered with the State of Colorado according to State of Colorado statutes.
PROFESSIONAL LAND SURVEYOR	A land surveyor registered with the State of Colorado according to State of Colorado statutes.
psi	pounds per square inch

Acronym or Abbreviation	Definition
PUD	Planned Unit Development
PVC	Polyvinyl chloride
SHALL	A mandatory condition. Where certain requirements in the design or application are described with the “shall” stipulation, it is mandatory that these requirements be met.
SHOULD	An advisory condition. Where the word “should” is used, it is considered to be advisable usage, but not mandatory. Deviations may be allowed when reasons are given which show that the intent of the standard is met.
SPECIFICATIONS	The Standard Specifications, i.e., Part 2, of the DCS
STANDARDS	The Design Criteria and Standards, i.e., the DCS, inclusive
SUBCONTRACTOR	Any person, firm, or corporation, other than the employees of the Contractor, who enters into a contract with the Contractor, to furnish labor, materials, or labor and materials.
UNCC	Utility Notification Center of Colorado
UTILITY	North Weld County Water District
UTILITIES	Shall mean all utilities, wet and dry, on site prior to the time of any design and development and all utilities proposed with design. Wet utilities shall include, but are not limited to potable water lines, sanitary sewer lines, non-potable irrigation lines, transmission gas lines, storm water lines, underdrains, ditches and other runoff conveyance elements. Dry utilities shall include, but are not limited to electric lines, telephone lines, gas service lines, fiber optic lines, and cable television lines.
VFD	Variable Frequency Drive
WQCD	Water Quality Control Division of CDPHE
WSA	Water Service Agreement

1.03. MINIMUM STANDARDS

- A. NWCWD's review and acceptance will only be to determine if the plans and specifications conform to NWCWD's requirements. NWCWD's review and acceptance will not relieve the Developer, Design Engineer, nor the Contractor from responsibility for any variation from NWCWD requirements or adequate design standards. NWCWD's review and acceptance shall not constitute any assumption of responsibility or liability for the design or construction. It is the intent and purpose of NWCWD's DCS to obtain high quality construction throughout, with the completed work complying with the DCS.

1.04. RELATIONSHIP TO OTHER STANDARDS

- A. Whenever a provision of these Criteria, and any other provision in any law, ordinance, resolution, rule, policy, or regulation of any kind contain any restrictions covering any subject matter within these Criteria, the most restrictive standard shall apply.
- B. The provisions of these Criteria and standards are minimum requirements that do not preclude the use of more restrictive standards by the Design Engineer.
- C. Adherence to these Criteria does not remove the Developer's responsibility to investigate and obtain any other regulatory permits or approvals, from either local, regional, state, or federal agencies, that may be required for a particular project.

1.05. REVIEW AND ACCEPTANCE

- A. All construction plans and specifications submitted to NWCWD for review, comment, and acceptance shall be prepared by, or under the direct supervision of a Professional Engineer. Said Professional Engineer shall be responsible for the design, preparation of the Construction Drawings and reports, determining material specifications, and reviewing the field survey for accuracy.
- B. The construction plan review process for all development as outlined below shall be followed:
 - 1. The preliminary plan set shall be reviewed by NWCWD for general compliance with these Criteria, and NWCWD shall provide comments to the Developer or their agents regarding corrections, additions, and omissions.
 - 2. Upon preliminary acceptance by the governing agency (Town or County), Final Plats and Construction Drawings shall be prepared by the Developer or their agents. Final Plats and Construction Drawings shall be submitted to and reviewed by NWCWD, and NWCWD shall provide comments to the Developer or their agents for corrections, additions, or omissions.
 - 3. After final corrections are made and the plans are accepted, the plans set shall be signed by the District Engineer. The signing of the plans will constitute acceptance.

The acceptance is qualified in that: ***The plans are reviewed and accepted for concept only and the plan acceptance does not imply responsibility by NWCWD for accuracy and correctness. The plans acceptance does not imply that quantities of items indicated on the plans are the final quantities required. The plans acceptance shall not be construed for any reason as acceptance of financial responsibility by NWCWD for additional items not shown that may be required during the planning or engineering phase and the construction phase.***

- C. If the Design Engineer responsible for the plans disagrees with any requested changes to the submitted plans that may be required by NWCWD for acceptance, such disagreement shall be brought to the attention of NWCWD, and if required by NWCWD, in writing.
- D. The Seal of the Design Engineer on plans so corrected and accepted for construction will signify that the Professional Engineer has reviewed, approved, and authorized said corrected plans for construction.
 - 1. Development Documents and Agreements shall be approved by NWCWD Management, the Board of Directors, and/or the District Engineer, subject to the “Policy Regarding Approving Development Documents and Agreements” available at www.nwcwd.org.
 - 2. The NWCWD Board of Directors must approve the required WSA.
 - 3. The NWCWD Board of Directors must approve the required Easement Agreement(s).
- E. No construction shall be undertaken without a NWCWD-accepted and signed set of Construction Drawings and a recorded Final Plat or required potable and non-potable water easements and appropriate WSAs.

SECTION 2 - SUBMITTAL REQUIREMENTS

2.01. GENERAL

- A. Requirements discussed in this section are the minimum for potable water distribution system and are not meant to be all-inclusive. Other requirements may be required for a complete design. The Design Engineer shall consider the maintenance and operational aspects of the potable water distribution and system infrastructure, as well as, constructability in their design.
1. NWCWD shall be contacted at the beginning of the project planning stages to determine if raw water requirements need to be met prior to Construction Drawing acceptance. Contact NWCWD at 970-356-3020 to discuss raw water requirements.
 - a. Refer to NWCWD's current *WATER DEDICATION POLICY* available at www.nwcwd.org.
 2. All Construction Drawings shall be legible and submitted on either:
 - a. 24- by 36-inch sheets; or
 - b. 22- by 34-inch sheets.
 3. A legend describing all line types, symbols, and abbreviations shall be shown either on the cover sheet or each individual sheet.
 4. Each sheet in the Construction Drawings shall be marked "PRELIMINARY, NOT FOR CONSTRUCTION" with the date of submittal. This statement will be removed on the final NWCWD-accepted Construction Drawings.
 5. All sheets pertaining to potable water distribution system (including but not limited to the title sheet, utility plan, conduit plan, plan and profile sheets, notes and details sheets, and landscaping plans) shall contain an acceptance block for the District Engineer's acceptance, which shall appear as follows:

<p>CONSTRUCTION MUST BE IN ACCORDANCE WITH APPLICABLE NWCWD DESIGN CRITERIA AND STANDARDS AND THE CONSTRUCTION DRAWINGS APPROVED BY NWCWD. NWCWD'S ACCEPTANCE OF CONSTRUCTION DRAWINGS SHALL BE VALID FOR A PERIOD OF ONE YEAR FOLLOWING THE DATE OF ITS APPROVAL BELOW. NWCWD'S ACCEPTANCE SHALL NOT RELIEVE OWNER OR ITS ENGINEER FROM LIABILITY FOR ERRORS, OMISSIONS, OR DESIGN DEFICIENCIES AND OWNER AND ITS ENGINEERS SHALL HOLD NWCWD HARMLESS FROM SUCH LIABILITY.</p>	
<p>ACCEPTED BY _____</p> <p>(DISTRICT ENGINEER)</p>	<p>_____</p> <p>(DATE)</p>

6. NWCWD-accepted and signed construction plans are required prior to the commencement of construction.

2.02. PRELIMINARY CONSTRUCTION PLAN REQUIREMENTS

A. Preliminary plans shall be submitted to NWCWD for review and acceptance prior to the preparation of final Construction Drawings. Acceptance of the preliminary submittal shall constitute only a conceptual acceptance and shall not be construed as acceptance of specific design details. The preliminary plans set shall include the following:

1. Cover Sheet
 - a. Project name and location.
 - b. A vicinity map specifying the project's geographical location with north arrow and adequate graphic scale and detail to be clear and uncluttered.
 - c. Sheet index.
 - d. Name of Owner and Developer.
 - e. Name of the Design Engineer responsible for the design and preparation of the Construction Drawings and the Land Surveyor responsible for the project survey information.
 - f. Project benchmarks and two horizontal control points to serve as the basis of the project horizontal control.
 - g. General Project notes.
 - h. Any additional information deemed necessary by the Design Engineer or by NWCWD.

2. Utility Plan

- a. A general overview of the entire project including, but not limited to, streets (complete with names), alleys, lot and block numbers, all proposed and existing utilities on and within 100-feet of the project site, all existing and proposed easements, rights-of-way on and adjacent to the project site, and storm water facilities.
- b. The entire project shall be shown on one sheet, unless the project is too large to show sufficient detail. NWCWD acceptance must be granted to show the project on more than one sheet and a key map to aid in drawing orientation and locating the sheet construction in relation to the overall project will be required on each sheet.
- c. Proposed project phasing for utilities and structures.
- d. Proposed point(s) of connection for potable water mains to the existing system. All existing potable and non-potable water lines shall be labeled with the pipe diameter and type of material.
- e. Any other information deemed necessary by the Design Engineer or by NWCWD.

2.03. FINAL CONSTRUCTION PLAN REQUIREMENTS

- A. Final Construction Plans shall contain the same information as indicated in Section 2.02 of these Criteria with the following additional requirements:
 1. After one year from the original acceptance date, NWCWD may require resubmittal of the plans for review and acceptance due to a revision or update to the DCS.
 2. NWCWD-approved easements or a NWCWD-approved Final Plat must be executed before final acceptance of the Construction Drawings.
 3. One set of reproducible mylar or vellum plans shall be submitted to NWCWD for acceptance signatures when all known issues have been addressed to the satisfaction of NWCWD. Once the mylar/vellum plans receive NWCWD signatures, the Developer or their agents shall make copies of the signed mylars/vellums and provide them to NWCWD.
 4. An electronic version, in a format acceptable to NWCWD, of the final Construction Drawings shall be provided to NWCWD after mylar/vellum plan signatures are complete.

5. Potable water main designs shall be provided on separate plan and profile sheets specific to potable water.
6. The Utility Plan shall contain a signature line for all utilities that are impacted or modified by the project. This shall include existing as well as proposed utilities.
7. The Utility Plan shall contain a signature line for all Ditch Companies, or end user(s) if the ditch is not controlled by a Ditch Company, that have their facilities impacted or modified by the project.
8. "Call Utility Notification Center of Colorado (UNCC) at 1-800-922-1987 or dial 811 for utility locates 48 hours prior to any excavation work" shall be put on all drawing sheets.
9. Construction Plan View
 - a. A key map shall be required on each sheet to aid in drawing orientation and locating the sheet construction in relation to the overall project.
 - b. Provide a north arrow and horizontal graphic scale.
 - c. A design horizontal scale of not less than 1" = 50'.
 - d. Provide existing and proposed roads and alleys complete with names.
 - e. Label proposed lot and block numbers.
 - f. Provide existing wet and dry utilities including potable and non-potable water line pipe material, diameter, and sanitary sewer manhole inverts and pipe diameter.
 - g. Show and label proposed and existing easements, rights-of-way, and property lines.
 - h. Indicate the proposed method of connection to existing potable water distribution system.
 - i. Show all proposed and existing potable water, sanitary sewer, and non-potable irrigation services.
 - j. Provide linear stationing along the potable water mains.
 - k. Provide match lines indicating references to adjacent sheet(s) of design.
10. Construction Profile View
 - a. Provide the design vertical scale of not less than 1" = 10'.

- b. Show all existing and proposed utility crossings. Existing utility crossing locations and elevations shall be obtained from the current project design field survey. Existing utilities shall be potholed as required to perform complete and accurate design prior to construction plan acceptance. Field obtained elevations shall be provided on the Construction Drawings complete with when the field information was gathered, the exact location where it was collected, the firm that performed the potholing and surveying, and the date the survey was conducted.
- c. Provide the diameter, type of pipe material, length of pipe between all fittings for proposed and existing potable water lines.
- d. Provide stationing for all potable and non-potable mainline appurtenances including but not limited to top of pipe elevations on proposed fittings, valves, and points of vertical deflection.
- e. Provide match lines indicating references to adjacent sheet(s) of design.
- f. Any other information deemed necessary by the Design Engineer or NWCWD.

11. Standard Details

- a. Include all project-applicable NWCWD Standard Details as part of the construction plans set. Standard Details are provided as Part 3 of the DCS.
- b. All NWCWD Standard Details shall contain the NWCWD logo in the bottom left corner.
 - (1) If any NWCWD Standard Detail is modified, the NWCWD logo shall be removed from the detail.
- c. Limit the number of Standard Details on each Construction Drawing to no more than eight to maintain clarity.
- d. Where Standard Details are not applicable to the work, provide project-specific construction details. These shall include construction details of critical connections, atypical crossings, special fittings and appurtenances, and any other details deemed necessary by the Design Engineer or by NWCWD.

12. Requirements for Changes to Final Accepted Plans

- a. Should circumstances warrant changes from the Approved Plans, acceptance of the changes shall be obtained from NWCWD.

b. All modified Construction Drawings shall be on sheets of the size(s) described in Paragraph 2.01.A.2.

(1) Depending on the extent of the changes, NWCWD will decide if revised mylars/vellums are required or if paper copies are sufficient.

2.04. FINAL PLAT AND REPLAT REQUIREMENTS

A. Final Plats shall adhere to the requirements set forth by the governing agency, i.e., Town or County.

B. The following requirements shall also apply:

1. Clearly show, label, and dimension newly dedicated and existing potable water easements.

2. All platted lots shall be adjacent to a public potable water distribution system. No potable water services shall cross lot lines.

a. See NWCWD's current *Water Meter Location Policy* at www.nwcwd.org.

C. For all replats where lot lines or street locations change, all existing potable water, services, fire hydrants, fire sprinkler lines, etc. shall be relocated to their appropriate location or abandoned. Potable water distribution system designs in this re-platted area must conform to the current version of the DCS.

2.05. LANDSCAPE PLANS REQUIREMENTS

A. No plant material with mature growth greater than 3-feet in height shall be planted within potable waterline easements.

B. No shrubs shall be planted within 5-feet or trees within 10-feet of potable and non-potable water meters, fire hydrants, or potable water and non-potable irrigation mains and services.

C. Clearly show and label all proposed and existing potable water and non-potable irrigation meter pits/vaults, water mains and services, sanitary sewer mains and services, fire hydrants, and easements on the landscape plans.

D. Show and label all proposed water taps that will be used for landscape irrigation.

E. Add Paragraphs 2.05.A and 2.05.B of these Criteria as notes on the landscape plans.

2.06. EASEMENTS

A. If within a platted subdivision, the potable water main installation shall be within a dedicated right-of-way.

- B. If outside of a platted subdivision, the potable water main installation shall be made within a dedicated easement.
 - 1. The conditions for allowance of an exception shall be determined for each individual case.
 - 2. The minimum easement width acceptable to NWCWD is as follows:
 - a. For a dedicated potable water or non-potable irrigation water main easement containing just one water main, the width shall be a minimum of 30-feet or twice the depth to the bottom of the pipe, whichever is greater. The easement name, which shall be “WATER LINE EASEMENT” and the easement width shall be labeled on the Construction Drawings and Final Plat.
 - b. Combined easement widths are required to be wider than the widths previously stated if other water mains are to be included in the easement or if any line depth requires additional width to be able to safely excavate around the pipe without the use of a trench box. Combined easements shall be named with the type of the water mains included within the easement. The easement name and width shall be labeled on the Construction Drawings and Final Plat. Appropriate naming and width for combined easements shall be determined by NWCWD on a case by case basis.
- C. The water mains within the easement shall be located a minimum of 10-feet from the edge of the easement to the centerline of the water main, or equal to the depth to the bottom of the pipe, whichever is greater.
- D. There shall be no detention ponds, berms greater than 3-feet, permanent structures, fences, trees, shrubs with mature height greater than 3-feet, or other obstructions that will impede the ability of NWCWD to adequately maintain and service the water main(s) located within the easement.
- E. Easements not dedicated with a Final Plat, shall be dedicated by separate document and recorded prior to NWCWD acceptance of the Final Plat and/or Construction Drawings. Easement dedication by separate document shall include:
 - 1. Easement Dedication Form
 - a. A NWCWD Easement Agreement, i.e., the standard form that will be provided by NWCWD and any changes must be approved by NWCWD in advance of execution, shall be completed and executed by the Developer. If a non-standard Easement Agreement is required and a non-standard easement dedication form is needed, NWCWD will provide a revised form

for the non-standard situation. The completed Easement Agreement must be signed by the property Owner and notarized.

(1) A statement of authority may be required if the property owner is an entity pursuant to the provisions of 38-30-172, C.R.S.

b. NWCWD's Board of Directors shall execute final review and approval of all proposed easements at its regularly-scheduled meetings.

c. Standard Easement Dedication Forms may be downloaded from NWCWD's website.

2. Legal Description

a. Subject to NWCWD review and approval, a Legal Description of the dedicated easement boundary shall be prepared by a Professional Land Surveyor.

3. Exhibit Map

a. An Exhibit Map (8½- by 14-inch) depicting the Legal Description with sufficient description information to establish the legal boundary of the easement shall be provided. The Exhibit Map shall show and label all property lines and public rights-of-way. NWCWD may request additional information, not listed here, for the Exhibit Map.

4. Funds for Recording

a. The Developer shall provide cash or a check made out to the **WELD COUNTY CLERK AND RECORDER** for the easement recording fees. NWCWD shall provide the recording fee sum once all easement documents are finalized. ***NWCWD does not provide the funds for recording easement documents.***

5. Once the easement dedication documents are accepted by NWCWD and the recording fees have been provided in the appropriate amount, the Easement Agreement is subject to approval by NWCWD's Board of Directors. Following approval, NWCWD shall have the easement documents recorded with Weld County.

2.07. HYDRAULIC REPORT – POTABLE WATER

A. A hydraulic analysis for the potable water distribution system for a given project shall be submitted by the Design Engineer, as a report, to NWCWD for review and acceptance. The report shall be accepted by NWCWD prior to final Construction Drawing acceptance. The hydraulic analysis report will be reviewed by NWCWD, along with the Construction Drawings, in the same review and acceptance process as outlined in Section 1 of these

Criteria. Projects that move forward to final design without a NWCWD accepted potable water distribution hydraulic analysis report are subject to possible design changes, including but not limited to, pipe re-alignment, upsizing, extensions, and additional stub-outs.

- B. The objective of the hydraulic analysis report is to assist the Design Engineer with designing a project's potable water distribution system to adequately serve peak demands while adhering to the design requirements set forth in these Criteria. For the potable water distribution system, the hydraulic analysis report serves as a tool for demonstrating the necessary number of connection points to the existing system for adequate water line looping, system reliability and required pipe sizing
- C. The written hydraulic report shall include the following information:
 - 1. Title Page
 - a. Report title.
 - b. Project name and location.
 - c. The name, address, and phone number of the Owner, Developer, and Design Engineer that prepared the report.
 - d. Report preparation date.
 - 2. Engineer Certification Sheet
 - a. The report shall be prepared by or under the supervision of a Professional Engineer, licensed to practice in the State of Colorado, possessing adequate experience in the design of potable water distribution systems. The report shall contain a certification sheet with the following statement to be signed and sealed by the Design Engineer:

“I understand NWCWD’s acceptance does not relieve the Design Engineer’s responsibility for errors, omissions, or design deficiencies for which NWCWD is held harmless.”
<hr/> REGISTERED PROFESSIONAL ENGINEER (AFFIX SEAL)

- 3. Table of Contents

4. Project Description and Location
 - a. Clearly state the location of the project. Provide a site vicinity map specifying the project's geographical location and the project area in acres. The project acreage shall be the same as on the project Final Plat.
 - b. Clearly state the land use zoning, estimated number of residential lots or living units, commercial square footages, and the irrigated acreages.
 - c. Indicate if the project will be phased. Elaborate on the anticipated timing for each project phase and the phase's associated building and infrastructure construction.
 - d. For multifamily, commercial, or industrial developments, indicate if potable or non-potable water will be used for landscape irrigation.
 - e. Identify the locations of all potable water connection points to the existing systems.
 - f. Provide the pipe diameter and pipe material for the existing potable and non-potable water lines.
5. References and Appendices
 - a. Provide a page referencing all design criteria, resources, and modeling software used in preparing the hydraulic report.
 - b. Provide appendices as necessary to include modeling result printouts, copies of demand assumption data, and fire flow test results.
6. Potable Water System Report Requirements and Assumptions
 - a. Provide all used equations, demand assumptions, and essential design requirements, parameters, and constraints.
 - b. Indicate the software package(s) and version used for the water system modeling.
 - c. Provide calculations for estimated population, design flows, irrigated acreage, irrigation application rates, peaking factors, and any other necessary design calculations.
 - d. Provide hydrant fire flow and fire sprinkler system flow requirements.
7. Potable Water System Analysis and Modeling
 - a. Modeling Scenarios

- (1) Static
 - (a) The static scenario shall establish the available water pressure for the site with no demands on the system and serves to check that pressure requirements are maintained.
- (2) Maximum Day Demand plus fire flow (MDD plus FF)
 - (a) This scenario shall include maximum day domestic water use demands plus fire flow¹.
- (3) Peak Hour Demand (PHD)
 - (a) This scenario shall include peak hour domestic water use demands.
- (4) Use the more conservative of the two flow scenarios (MDD plus FF versus PHD) for determining the final pipe size.
- (5) Phasing: Water modeling shall be required for the incomplete potable water system as indicated per the planned phasing on the Construction Drawings, in order to demonstrate that the system can meet the criteria for the interim phased condition.
 - (a) The hydraulic report shall verify that a proposed potable water system can provide the required water demands for a given development, at an acceptable pressure, and meet the overall potable water system design requirements set forth in these Criteria. Upsizing water mains within a development as a means to increase water system capacity in lieu of making a connection to another water source, is generally not permitted and will be considered on a case-by-case basis.
 - (b) If the hydraulic water model demonstrates that a larger main is required to serve the phased condition than would be needed for the full build out condition, the Developer is required to install the larger pipe at his expense and is not eligible for pipe oversizing reimbursement from NWCWD when the larger pipe is no longer needed.
- (6) Additional scenarios

¹ *Fire Flow shall be inclusive of fire hydrant and fire sprinkler flow. Residential developments or commercial / industrial uses requiring fire sprinkler systems shall have fire sprinkler demands, in addition to hydrant fire flows, placed in the hydraulic water model at appropriate node locations.*

- (a) NWCWD may require additional scenarios, adjustments to the fire flow placement, reservoir elevations, and existing system connections, revisions to the pipe and node schematic layout, and other model modifications as necessary to verify that the proposed potable water system will meet the design requirements and potable water demands of the development and NWCWD as a whole. At NWCWD's discretion, the existing or future potable water system beyond the limits of the proposed development may require modeling as part of the hydraulic analysis. This analysis will be performed by NWCWD.

b. Modeling Procedure

- (1) Connections to the existing potable water distribution system are typically denoted as reservoirs with the same hydraulic grade elevation. NWCWD shall provide inflow pressure.
- (2) Place estimated domestic water, fire sprinkler, and irrigation tap demands at appropriate node locations within the model as they relate within the project.
- (3) Locate fire flow demands at hydrant locations according to the modeling scenarios in Section 2.07.C.7 of these Criteria. The maximum allowable fire flow provided from any one hydrant shall be 1,500 gpm. If the required fire flow is in excess of 1,500 gpm, the next closest hydrant shall be used until the required fire flow is met.
- (4) Depending on the location of the development, existing potable water system performance and reliability in the area, number of available potable water connections, and surrounding land uses, some of the project's proposed potable water connections may require modeling as a demand point or no connection instead of a water source. NWCWD shall provide additional outflow demands for a development on a case by case basis.

8. Potable Water System Report Results

- a. Provide a schematic layout of the potable water distribution system showing and labeling the reservoir connections, pipe network, and demand nodes as presented and analyzed for each water model scenario.
- b. Provide a Reservoir Report for the static condition. The Reservoir Report shall include the following information:
 - (1) Reservoir Identification Label; and

- (2) Elevation (ft).
 - c. Provide Pipe Reports for all modeled scenarios. Pipe Reports shall include the following information:
 - (1) Modeled Scenario Title;
 - (2) Pipe Identification Label;
 - (3) Pipe Length (ft);
 - (4) Pipe Diameter (in);
 - (5) Pipe Material;
 - (6) Hazen-Williams Coefficient;
 - (7) Pipe Control Status (open or closed);
 - (8) Pipe Velocity (ft/s);
 - (9) Upstream Calculated Pressure (psi); and
 - (10) Headloss (ft).
 - d. Provide Junction/Node Demand Reports for all modeled scenarios. Junction/Node Demand Reports shall include the following information:
 - (1) Modeled Scenario Title;
 - (2) Node Identification Label;
 - (3) Node Elevation (ft);
 - (4) Node Demand (gpm);
 - (5) Calculated Hydraulic Grade (ft); and
 - (6) Pressure (psi).
9. Potable Water System Design Conclusions
- a. Discuss hydraulic analysis results for all modeled scenarios.
 - b. Confirm that the pipe velocity and pressure requirements during the most conservative operating condition, as determined in 2.07.C.7, are met per Section 3 of these Criteria.

- c. Discuss any potable water line oversizing required by NWCWD over and above what is necessary for the development's potable water needs.
- d. For phased developments, discuss phased construction of the potable water distribution system and confirm that potable water pipes are sized appropriately to meet the requirement of these Criteria.

2.08. AS-CONSTRUCTED RECORD DRAWING REQUIREMENTS

- A. The Contractor and Design Engineer shall be responsible for recording As-Constructed information on a set of Record Drawings kept at the construction site. A representative of the Developer shall monitor construction to assure that changes in construction (as approved in writing) and other pertinent details, such as horizontal location of fittings and manholes, valves, top of pipe elevations, manhole inverts, service tap locations, pipe sizes, depths, etc. are kept current on the As-Constructed Record Drawings.
- B. Where the construction is phased with a more than 30-day lapse between phases, As-Constructed Record Drawings shall be submitted to NWCWD after each completed phase. The Construction Drawings for all future phases shall also reflect the "As-Constructed" conditions of the previous phases.
- C. At a minimum, the As-Constructed Record Drawings set shall include the following sheets from the original accepted Construction Drawings:
 - 1. Cover Sheet;
 - 2. Utility Plan;
 - 3. All potable water (and non-potable irrigation, if applicable) plan and profile sheets; and
 - 4. All construction details and NWCWD Standard Drawings that were used in the construction of the potable water distribution system and non-potable irrigation.
- D. The As-Constructed Record Drawings shall show the original design information as well as the As-Constructed information. The original design information shall be shown as "lined through". The As-Constructed information shall be located in the same areas as the design information and shall be either "clouded" and/or made with a heavier line weight as the design information for clear differentiation. The month and year of the construction shall also be noted.
- E. As-Constructed Record Drawings shall be submitted to NWCWD prior to issuance of Substantial Completion. The 2-year warranty period for the installed potable water system will begin **after** the Certificate of Conditional Acceptance has been issued by NWCWD. The request for the Conditional Acceptance may be initiated by NWCWD or requested by the Developer, but in all cases is the sole responsibility of the Developer.

- F. NWCWD will compare the As-Constructed Record Drawing information with the approved Construction Drawings and information NWCWD may be aware of during the construction process. Any corrections, additions, or omissions to the As-Constructed Record Drawings shall be provided to the Design Engineer who prepared the As-Constructed Drawings for changes.
- G. The Certificate of Final Acceptance, which occurs at the end of the warranty period, will NOT be granted until the As-Constructed Drawings for the potable water system are accepted by NWCWD.

2.09. REIMBURSEMENT FOR MAIN DESIGN AND INSTALLATION COSTS

- A. NWCWD may require the Developer to install a potable water main larger than is needed to adequately serve the development. Said oversizing shall be agreed upon with Development and incorporated into the WSA for such Development.
- B. If the Developer is required to design and construct off site potable water mains in order to serve the development, the Developer may be eligible for design and construction cost reimbursements from other developments that connect to that main. If the Developer connects to a potable water main constructed by another party or by NWCWD, the Developer may be required to participate in the design and construction costs of those lines. Refer to NWCWD's:
 - 1. *WATERLINE EXTENSION REIMBURSEMENT POLICY*; and
 - 2. *POLICY REGARDING CONSTRUCTION AND EXTENSION OF IMPROVEMENTS*.

SECTION 3 - POTABLE WATER DISTRIBUTION SYSTEM DESIGN CRITERIA

3.01. GENERAL

- A. The purpose of this Section is to provide information for the design and layout of a potable water distribution system. Potable water distribution system design shall be in accordance with NWCWD's *Water System Master Plan*, latest revision, and these Criteria.
- B. This Section is not intended to be inclusive of all situations, and the Design Engineer may be required to use additional engineering judgment to meet the overall design intent for constructability and long-term operations and maintenance. **The DCS typically applies to potable water mains 16-inches in diameter, and smaller.** The District Engineer reserves the right to make final determinations of the system design based on the best interest of NWCWD's system.

3.02. DEFINITIONS

A. Potable Water Distribution Mains

- 1. A potable water distribution main is a water pipe that primarily serves as a delivery conduit to transport potable water from transmission mains directly to individual water services.
- 2. Potable water distribution mains within NWCWD are 4-inches, 6-inches, 8-inches, 12-inches, and 16-inches in diameter.
 - a. Neither 10- nor 14-inch pipe shall be installed in NWCWD's service area.

B. Potable Water Transmission Mains

- 1. A potable water transmission main is a water pipe that primarily serves as a delivery conduit to transport potable water directly to the distribution mains.
- 2. Potable water transmission mains are 16-inches, and larger, in diameter.
 - a. In some cases, pipes smaller than 16-inches may be classified as transmission mains.

C. Potable Water Services

- 1. Potable water services include all piping, fittings, and appurtenances used to convey potable water from the distribution main to the customer.

3.03. DESIGN FLOW

- A. The potable water distribution system shall be designed to transport the most conservative of maximum day demand plus fire flow or peak hour flow.
 - 1. Ensure hydrant fire flow and fire sprinkler system flow requirements are satisfied and are described in the Potable Water System Report, per Section 2.07.C.6.d.
- B. All water demands used in the design of potable water distribution systems are subject to approval by NWCWD.
- C. Design Flow
 - 1. The water demand criteria presented in the following tables are minimum criteria. These criteria are divided into urban and rural categories based on land use and water tap usage classification, respectively. The urban criteria are applicable to subdivisions and planned unit developments (PUDs) that include single family residential, multifamily residential, and commercial/retail land uses. The residential urban criteria are based on the number of units per acre (density), whereas the commercial urban criteria are based on building square footage. The rural criteria are based on the water tap usage classifications indicated on the NWCWD water tap fee schedule, latest revision.
 - 2. NWCWD reserves the right to modify the Criteria, at any time, for the design of specific projects. Potable water demand criteria for uses not provided in the tables below shall be determined during system design. Where applicable, these design flows shall be determined in accordance with fixture unit methods described in AWWA M22 – *SIZING SERVICE LINES AND METERS*.

Table 3-1: Potable Water Design Flow (Urban Residential)

Usage Classification	Units per Acre	Average Day Demand (gpm/unit)	Maximum Day Demand (gpm/unit)	Peak Hour Demand (gpm/unit)
Single Family – Low Density	1 - 5	0.5	0.7	1.9
Single Family – High Density	6 - 10	0.4	0.6	1.7
Multifamily	11 - 20	0.3	0.4	1.1

Notes: Irrigation is included in the residential water demands for Low and High Density Single Family, but not included for Multifamily.

Table 3-2: Potable Water Design Flow (Urban Commercial, per 1,000 Sq. Ft. of Building Space)

Usage Classification	Average Day Demand (gpm)	Maximum Day Demand (gpm)	Peak Hour Demand (gpm)
Office Building or Small Business	0.14	0.21	0.60
Restaurant	0.35	0.53	1.50
Supermarket, Big Box, Dept. Store	0.14	0.21	0.60
Laundry, Dry Cleaning	0.70	1.10	2.90
Service Station (No Car Wash)	0.02	0.04	0.08
Car Wash	1.32	2.00	5.50
Hotel/Motel	0.24	0.36	1.00
Warehouse (Non-industrial)	0.07	0.11	0.30
Irrigation	N/A	N/A	24 gpm/acre

- Irrigation water is not included in the urban multifamily or commercial water demands. Irrigation demands for urban multifamily and commercial uses shall be determined using a peak hour demand rate of twenty-four gallons per minute per acre (24 gpm/acre) and the estimated irrigated acreage.

Table 3-3: Potable Water Design Flow (Rural)

Usage Classification ²	Maximum Day Demand (gpm/tap)	Peak Hour Demand (gpm/tap) ³
Full Standard	5.00	7.70
Conservation Blue	5.00	7.70
75% Tap	3.75	5.80
50% Tap	2.50	3.90

Table 3-4: Potable Water Design Flow (Industrial)

Usage Classification	Maximum Day Demand (gpm/tap)	Peak Hour Demand (gpm/tap)
Potable water demands have not been provided for industrial uses. Due to the extreme variation in water consumption amongst the different types of industry, industrial water demands shall be determined during system design when the industrial use is known.		

D. Fire Flows

1. Contact the appropriate fire/rescue authority in writing for the latest adopted fire code and to confirm project fire flow requirements.
2. For design purposes, the maximum allowable fire flow provided from any single hydrant is 1,500 gpm. Fire flow may be obtained from more than one (1) fire hydrant providing the additional hydrants are accessible to any possible fire location and meet the spacing requirements and distances from structures as specified in Section 3.18 of these Criteria and by the appropriate fire/rescue authority.

3.04. PRESSURE REQUIREMENTS

- A. Potable water distribution systems must be designed to provide minimum and maximum system pressures as discussed in the following sections. Water system pressure information for NWCWD’s existing system may only be obtained from NWCWD.
 1. The potable water distribution system in all areas shall be designed for a maximum pressure of 145-psi and a minimum pressure of 45-psi for normal conditions.

² Refer to current NWCWD tap fee schedule

³ 1.54 times the Maximum Day Demand

2. 20-psi residual pressure is required at any one hydrant with **maximum day plus fire flow demands**.
3. Pressure zones shall conform to existing NWCWD's pressure zones as provided in the *Water System Master Plan*, latest revision. Specific information on the pressure zones or to confirm which pressure zone a development or site is actually located may only be obtained from NWCWD.
4. Pressure regulating valves (PRV) will be required between pressure zones. The PRV location shall be determined by NWCWD.

3.05. HYDRAULIC DESIGN

A. Friction Coefficient

1. Potable distribution mains shall be designed using a Hazen-Williams friction coefficient "C" equal to:
 - a. 150 for PVC pipe; or
 - b. 130 for all other pipe materials.

B. Velocity

1. All pipes shall be sized for a maximum water velocity of no greater than 10-fps for any max day plus fire flow; fire hydrant laterals are exempt.

C. Head Loss

1. Maximum allowable head loss in pipes **8-inches** in diameter or less, shall not exceed 10-feet of head loss per 1,000 linear feet of pipe (10 ft/1,000 ft).
 - a. This does not apply to fire flow analysis.
2. Maximum allowable head loss in pipes **12-inches** in diameter shall not exceed five 5-feet of head loss per 1,000 linear feet of pipe (5 ft/1,000 ft).
 - a. This does not apply to fire flow analysis.
3. Pipes **16-inches in diameter, and larger**, e.g., transmission mains, shall be evaluated on a case-by-case basis in coordination with NWCWD.
 - a. The allowable unit head loss will be lower than those values stated above for pipes through **12-inches**.

3.06. POTABLE WATER MAIN SIZE

- A. Mains shall be sized appropriately to meet the criteria in Section 3.05. Distribution mains shall have a minimum diameter of 4-inches.
- B. Hydrant leads connecting to the distribution system shall be 6-inch. Other pipe diameters for hydrant leads are prohibited.

3.07. DEPTH OF BURY

- A. Cover depth (minimum and maximum) shall be as specified on Standard Detail No. 3300001, *GENERAL UTILITY NOTES*.
- B. When design or constructability constraints are present, deeper or shallower water main installation may be permitted only with acceptance from NWCWD. Additional design and installation considerations may be required by NWCWD depending on the situation.

3.08. CONNECTIONS TO THE EXISTING POTABLE WATER SYSTEM

- A. Main connections to the existing potable water distribution system may be made by wet tap or by a cut in tee.
- B. The Contractor shall make all wet taps on the existing system using qualified personnel under the direct supervision of NWCWD. Refer to Standard Specification Section 33 05 10, *Tapping Sleeves and Valves*, for requirements. The Contractor is responsible for providing all tapping materials, e.g., tapping sleeves, tapping valves, insulator kits, etc.
- C. All cut-in tees shall be made by the Contractor under the direct supervision of NWCWD.
- D. For direct wet taps on existing waterlines, manufacturer's shop drawings and specifications for the proposed tapping sleeve shall be submitted to NWCWD for review and acceptance prior to installation of the tapping sleeve by the Contractor.

3.09. LOCATION AND LOOPING OF POTABLE WATER MAINS

- A. Potable water mains shall be located in a dedicated street right-of-way, where feasible, or within a dedicated exclusive easement of appropriate width.
- B. The centerline of potable water mains shall not be placed closer than 6-feet to the lip of street gutter.
- C. Potable water mains serving a cul-de-sac shall be extended to within 10-feet of the lip of street gutter at the end of the cul-de-sac and shall have a hydrant assembly placed on the end of the line. Permanent dead-ends in urban subdivision cul-de-sacs, longer than 300-feet, are prohibited.

- D. A potable water main serving one lot shall extend all the way across the frontage for that lot.
- E. Temporary dead-ends shall have a hydrant blowoff at the end of the line.
- F. An adequate number of connections to the existing potable water distribution system shall be provided such that no more than 15 single family units, or the equivalent single family flow for non-residential developments, are out of service at any one time.
 - 1. Water line extensions, including offsite water line connections, shall be extended along dedicated easement along the property frontage, in order to provide a gridded water system for future connections. Water main extensions may be allowed to run within public rights-of-way only on a case-by-case basis with the final determination made by NWCWD. Property or subdivision interiors will be served by connecting to the water line extensions. Potable water mains shall extend to the extremities of the property or the subdivision served. NWCWD shall determine the need for gridded water line extensions on a case-by-case basis.
 - a. Refer to the *POLICY REGARDING CONSTRUCTION AND EXTENSION OF IMPROVEMENTS*.
 - b. *WATERLINE EXTENSION REIMBURSEMENT POLICY* may apply on a case-by-case basis as determined by NWCWD.
 - 2. Extensions shall be in appropriate locations to provide adequate water connections and to maintain looping requirements for adjacent, future developments.
 - 3. Water mains shall be extended offsite when required to tie into the existing distribution system for additional water source connections. Appropriately-sized easements shall be dedicated to NWCWD.
- G. In all instances, NWCWD shall determine the potable water system looping for a development on a case by case basis and may require additional potable water connections over and above those demonstrated by a hydraulic analysis in order to maintain overall water system performance. Ultimately, the required source connections to the existing potable water system shall be solely determined by NWCWD.
 - 1. New developments shall have at least two separate and distinct connections to the existing system to provide redundancy for maximum fire flow in case of pipe failure and better system circulation to maintain acceptable water quality. Source connections shall be made on opposite sides of the development.
 - 2. If an applicant requests new or increased service that will impose a demand in excess of the capacity of the existing infrastructure, NWCWD will require that the

existing infrastructure be enlarged for the new service. The enlarged size may be the ultimate size of the infrastructure as determined by master planning and may be larger than required solely for applicant's needs. The infrastructure design (including size, location, and whether infrastructure must be oversized and shared with other applicants) shall be determined by the NWCWD. All costs for enlargement shall be paid for by the applicant or applicants.

3.10. POTABLE WATER SYSTEM PHASED INSTALLATION AND STUBOUTS

- A. Potable water distribution system phasing, if proposed by the Developer, shall be clearly identified on the master utility plan. Water plan and profile sheets shall clearly show and label the phasing transitions in the potable water line design.
- B. The proposed potable water system phasing shall maintain looping integrity within the system.
- C. The phased potable water system design shall meet the phased water demands for the development and adhere to all potable water system and hydraulic design requirements provided in these Criteria.
- D. Locate line valves and temporary hydrant blowoffs at the end of each phase or stub-out. The stub-out shall be shown on the potable water plan and profile sheets.
- E. Phased water line or stub-out construction shall be extended a minimum ten (10) feet beyond phased street paving to avoid asphalt removal during excavation for future connections.
- F. Phased potable water mains or stub-outs intended for future connections shall be valved such that only one valve needs to be closed when the main is extended and no customers are without water service when the line is extended. The valve must be appropriately restrained so that it will not "blowoff" when the water line is exposed and all thrust blocking is removed for the extension. See Section 3.14 of these Criteria regarding pipe restraint.
- G. The maximum length of a stub-out shall be 50-feet unless otherwise approved by NWCWD.
- H. Potable water main stub-outs not utilized shall be abandoned.

3.11. PIPE MATERIAL

- A. Potable water pipes less than or equal to 24-inches in diameter may be AWWA C151 cement-lined DIP or AWWA C900 PVC pressure pipe.

- B. Potable water pipes larger than 24-inches in diameter shall be AWWA C151 cement-lined DIP. AWWA C900 PVC pressure pipe may be considered by NWCWD on a case-by-case basis.
- C. The Design Engineer shall specify the pipe material and class as required for specific project conditions. The pipe material and class shall be called out on the Construction Drawings.
- D. All buried ductile iron pipe, fittings, and valves shall be polyethylene-encased in accordance with AWWA C105.

3.12. VALVES

- A. All valves shall be located in public right-of-way or within a dedicated easement of appropriate width.
- B. Inline Isolation Valves
 - a. Install inline isolation valves on all branches of tees and crosses, excluding the runs of hydrant tees.
 - b. Inline isolation valves are assigned in the potable water distribution system so that no single accident, break, or repair necessitates shutting down a nominal length of pipe greater than 1,000-feet.
 - c. Inline isolation valves shall be located a minimum 5-feet from the edge of concrete cross pans.
 - d. All inline isolation valves shall have a concrete collar around the valve box if located in asphalt pavement, unless directed otherwise by the municipality.
 - e. Inline isolation valves shall be:
 - (1) Gate Valves
 - (a) For mains through 12-inch.
 - (b) Fire hydrant and fire sprinkler line gate valves shall be placed at the main. These gate valves shall be mechanical joint valves and fasten to a mechanical joint anchor tee (swivel tee) on the main.
 - (2) Butterfly Valves
 - (a) For mains larger than 12-inch.
- C. Air Valves

1. NWCWD will determine the locations of air valves to be installed along the main and shall be properly sized by the Design Engineer in accordance with the manufacturer's recommendations. NWCWD shall have final determination on air valve type, size, and placement of the following:
 - a. Air Release Valves (ARV)
 - (1) ARVs release small volumes of accumulated air from a pipeline during filling operations and while the system operates under pressure exceeding atmospheric pressure.
 - b. Air Release/Vacuum Relief Valves (AVV)
 - (1) AVVs release large volumes of air automatically during pipeline filling and admit large volumes of air automatically when the internal pressure in the pipeline drops below atmospheric pressure.
 - c. Combination Air Valves (CAV)
 - (1) CAVs perform the same functions as an ARV and an AVV.
 - (2) In general, only CAVs will be installed, unless approved otherwise by NWCWD.

D. Pressure Regulating Valves

1. Pressure regulating valves (PRVs) control pressures between potable water distribution system pressure zones.
2. The need for a PRV, its size, and its installation location shall be determined by NWCWD.

3.13. CURVED PIPE ALIGNMENT

- A. Potable water mains may be curved to change alignment or grade or to avoid obstructions, within the limits of curvature of the pipe. If a curved alignment is not feasible or permitted by NWCWD, appropriate fitting(s) shall be used, e.g., elbows.
- B. Allowable Joint Offset
 1. PVC Pipe
 - a. Limit joint offset to no more than 80% of manufacturers recommended joint deflection for a given pressure class and diameter.
 - b. High Deflection (HD) Couplings may only be used to join PVC pipe with specific, prior approval by NWCWD.

- c. Longitudinal Bending
 - (1) PVC pipe, per AWWA C900, may be installed in accordance with the longitudinal bending guidance outlined in AWWA C605, latest edition.
 - 2. Ductile Iron Pipe
 - a. Limit joint offset to no more than 80% of manufacturers recommended joint deflection for a given diameter, pressure class, and joint type.
- 3.14. THRUST RESTRAINT
- A. Thrust Blocks
 - 1. Concrete thrust blocks shall be constructed only at main line connections where the restraint of the existing pipe is in question.
 - 2. The Design Engineer shall determine the required size of thrust blocks to use and NWCWD will have the final determination on size and placement.
 - B. Restrained Joints
 - 1. All horizontal and vertical bends (tees, crosses, elbows, etc.), dead-ends, and inline isolation valves shall be restrained by a mechanical restraint system, e.g., restrained push-on or mechanical joint restraints.
 - 2. The Design Engineer shall determine the length of required pipe restraint, for the pipe material being used, PVC or DIP, in accordance with AWWA M41 *Ductile-Iron Pipe and Fittings* or AWWA M23 *PVC Pipe – Design and Installation*, latest revision.
 - a. Refer to the Standard Details for pipe sizes through 16-inch.
 - b. Restraint calculations shall be submitted to NWCWD for review and acceptance.
 - c. Restrained length(s) shall be provided on the Construction Drawings.
 - d. All situations not listed above that may cause an unbalanced thrust situation, e.g., reducers, shall be analyzed by the Design Engineer.
 - C. In some instances, e.g., fire hydrants, large diameter fire lines, water line lowerings, etc., thrust blocks may be required in addition to restrained joints. NWCWD shall make such determinations on a case-by-case basis.

3.15. POTABLE WATER MAIN AND SERVICE ENCASEMENTS

- A. No general statement can be made to cover all encasement conditions; therefore, only typical encasement situations are addressed in this section. Encasement requirements shall ultimately be determined by NWCWD on a case-by-case basis.
- B. An encasement shall be considered the open-trench installation of a casing pipe.
- C. The use of “line” or “lines” in this section shall refer to both mains and services.
- D. Encasements
 - 1. Where sanitary sewer lines cross beneath potable water lines with less than 18-inches of clearance, sanitary sewer lines cross above potable water lines, or the 10-foot horizontal clearance between potable water lines and sanitary sewer lines cannot be maintained, pipe encasement shall be designed and constructed so as to protect the potable water line.
 - 2. Where non-potable irrigation lines cross above or below potable water lines with less than 18-inches clearance, pipe encasement shall be designed and constructed so as to protect the potable water line.
 - 3. Pipe encasement shall be placed on the sanitary sewer line or non-potable irrigation line except in situations where the sanitary sewer or non-potable irrigation line is existing. Where the sanitary sewer or non-potable irrigation line is already constructed, the pipe encasement shall be placed on the potable water line.
 - 4. The encasement pipe shall extend a minimum 10-feet on either side of the crossing measured from the outside diameter of the crossed pipe. Longer casing pipes may be required depending on the encasement situation.
 - 5. For any atypical encasement situations, the Design Engineer shall size the encasement pipe such that the inside clearance is at least 1-inch greater than the maximum outside diameter of the casing spacer runners. Refer to Specification Section 33 05 08, *Pipe Boring and Jacking*, for encasement pipe material, diameter, and wall thickness (if applicable), casing spacers, end seals, and installation requirements.
- E. Encasements Required by Other Agencies
 - 1. For potable water mains crossing another agency’s right of way or easement, the encasement requirements for that crossing shall be specified by the agency granting permission to cross. Such crossings shall be subject to approval by NWCWD to avoid conflicts in requirements or standards between NWCWD and the agency granting permission to cross.

2. A letter, permit, or approved crossing application from the agency granting permission to cross, must be provided to NWCWD before the crossing will be approved by NWCWD.
3. NWCWD shall not accept any crossings imposed with an annual user or crossing fee from the agency granting permission to cross. All crossing fees, if applicable, shall be paid by the Developer prior to installation of the encasement.

3.16. POTABLE WATER SERVICES AND FIRE SPRINKLER LINES

A. General

1. Potable water service lines shall not be installed in trenches with other conduits/utilities. A service line shall be separated from other conduits a minimum 10-feet horizontally and 18-inches vertically. The only exception will be a fire sprinkler line. In this instance, the horizontal separation may be a minimum of 5-feet, from outside diameter of the pipe. Larger diameter potable water services and fire sprinkler lines may still require 10-feet horizontal separation. This shall be evaluated by NWCWD on a case by case basis.
2. Potable water services and fire sprinkler lines for a given lot must be tapped on the potable water main within the confines of the property lines extended.
3. No potable water service taps shall be made on fire sprinkler lines.
4. Potable water services and fire sprinkler lines not utilized shall be abandoned. The service line shall be cut at the main and the line capped.

B. Water Services

1. Potable water services shall be polyethylene tubing, per Section 33 14 18 of the Standard Specifications.
2. A separate potable water service line and meter must serve each premise.
3. No potable water service lines shall cross property lines.
4. Pressure boosters are prohibited without adequate backflow protection.
5. Potable water services shall be located 5-feet from the side lot line and paired with an adjacent lot, wherever feasible.
 - a. Refer to Standard Detail No. 3314181, *WATER SERVICE LOCATION PLAN*, in the Standard Details.

6. Under no condition is a potable water service to be located under driveways, trees, or other permanent structures.
7. Potable water service taps shall be located as specified in Section 33 14 18 – SERVICE LINES AND APPURTENANCES.
8. Potable water service curb stops shall be located ± 1 -foot from the property line or easement boundary. Potable water service meter pits/vaults shall be located as close as possible beyond the curb stop. Refer to the Standard Specifications and Standard Details for additional service and meter installation requirements.
9. Potable water service meter pits/vaults shall normally be located after the curb stop in a landscaped area. Meter pits/vaults shall not be installed in any street, parking area, driveway, or sidewalk unless otherwise approved by NWCWD. Meter pit/vault shall be rated for HS-20 traffic loadings unless otherwise permitted by NWCWD. Curb stops in paved areas shall be in a street valve box.
10. There shall be no major landscaping (trees, boulders, or shrubs with mature growth greater than 3-feet), buildings, or other permanent structures within 10-feet of the meter pit/vault.

C. Fire Sprinkler Lines

1. Fire sprinkler lines shall be a minimum of 4-inch to the meter vault. Fire sprinkler lines larger than 4-inch shall be restrained C900 PVC pipe or DIP. Fire sprinkler lines require a gate valve at the main.
 - a. ALL fire sprinkler lines are metered.
2. Refer to the Standard Details for meter vault details.

3.17. POTABLE WATER MAINS AND SERVICES IN RELATION TO OTHER UTILITIES

- A. Potable water services and distribution mains shall have a minimum 10-foot horizontal and 18-inches vertical separation from all utilities measured from outside diameter.
- B. Where sanitary sewer lines cross beneath potable water lines with less than 18-inches of clearance, sanitary sewer lines cross above potable water lines, or the 10-foot horizontal clearance between potable water lines and sanitary sewer lines cannot be maintained, pipe encasement shall be designed and constructed so as to protect the potable water main.
- C. Where storm water lines cross above potable water mains, storm water pipe joints shall be grouted a minimum 10-feet on either side of the crossed potable water main, measured from the outside diameter of the pipe.

- D. Potable water main crossings under any open irrigation ditch shall have a minimum of 5-feet of cover and shall be encased.
- E. Right angle utility crossings are permitted above and below the potable water main. Parallel installation of other utilities in exclusive water easements is not permitted.
- F. Bored utility crossings shall have a minimum 24-inches of vertical clearance from the outside diameter of the utility casing to the outside diameter of the potable water line if the bored utility crosses above the potable water line and a minimum of 36-inches of vertical clearance from the outside diameter of the utility casing to the outside diameter of the potable water line if the bored utility crosses below the water line.
- G. If there are horizontal or vertical clearance conflicts between the potable water line and a utility, NWCWD may require that the potable water main be lowered, raised, or realigned in order to maintain the required clearances.
- H. For a potable water line crossing situation not specifically mentioned in this section, the crossing requirements provided in these Criteria shall be applied to that particular situation to the best extent possible.

3.18. FIRE PROTECTION AND HYDRANT SPACING

- A. All fire protection, fire flow, hydrant spacing, and hydrant requirements are subject to approval by the governing fire protection agency.
 - 1. Fire Protection Agencies within NWCWD's service area
 - a. Refer to Section 33 14 22 of the Standard Specifications.
- B. Hydrants shall be located at intersections whenever possible. Hydrants located mid-block shall be aligned with the extension of a property line.
- C. Fire hydrants shall be placed at the end of cul-de-sac.
- D. Fire hydrants shall be installed in accordance with Section 33 14 22 of the Standard Specifications and with the Standard Details, as applicable.
- E. A 3-foot radius in all directions around the hydrant shall be clear of obstructions.
 - 1. Where hydrants are vulnerable to vehicular damage, crash posts shall be provided outside of the 3-foot radius clearance in all directions from the hydrant.
 - 2. Crash posts, i.e., bollards, shall be concrete filled pipes that are 4-inches in diameter and a minimum of 4-feet in height above the finished ground surface with 2-feet of post below the finished ground surface.

F. All hydrants must be within dedicated easements or public rights-of-way.

3.19. CROSS CONNECTION AND BACKFLOW PREVENTION

A. Potable water service lines on any property or inside any building shall have NO physical connection with any pipes, pumps, hydrants, tanks, or non-potable irrigation systems that could draw or discharge any unsafe or contaminated water (including steam condensation or cooling water) into the potable water distribution system.

B. All potable water service connections are required to comply with Cross Connection and Backflow Prevention requirements outlined in:

1. *CROSS CONNECTION CONTROL MANUAL*; and
2. *AN ORDINANCE FOR THE CONTROL OF BACKFLOW AND CROSS-CONNECTIONS*.

C. Refer to Section 33 14 10 of the Standard Specifications for requirements.

END OF DESIGN CRITERIA

(THIS PAGE INTENTIONALLY LEFT BLANK)

DESIGN CRITERIA AND STANDARDS

POTABLE WATER DISTRIBUTION SYSTEM



PART 2

STANDARD SPECIFICATIONS

(THIS PAGE INTENTIONALLY LEFT BLANK)

SECTION 00 01 10

TABLE OF CONTENTS

DIVISION 00 PROCUREMENT AND CONTRACTING REQUIREMENTS

00 01 10 TABLE OF CONTENTS

DIVISION 01 GENERAL REQUIREMENTS

01 11 00 SUMMARY OF WORK

01 33 21 SHOP DRAWINGS, SAMPLES, AND O&M MANUALS

01 45 00 QUALITY CONTROL

01 50 00 CONSTRUCTION FACILITIES AND TEMPORARY CONTROLS

01 60 10 MATERIALS, EQUIPMENT, AND WORKMANSHIP

01 74 11 SITE CLEANUP

01 78 41 PROJECT RECORD DRAWINGS

DIVISION 03 CONCRETE

03 30 10 CAST-IN-PLACE CONCRETE (SMALL VOLUME)

03 40 00 PRECAST CONCRETE

DIVISION 04-30 (NOT USED)

DIVISION 31 EARTHWORK

31 23 25 FLOWABLE CONCRETE BACKFILL

31 23 35 TRENCHING, BACKFILLING, AND COMPACTING

DIVISION 32

EXTERIOR IMPROVEMENTS

32 01 10 PAVEMENT REPAIR AND RESURFACING

DIVISION 33

UTILITIES

33 01 11 DISINFECTION OF DOMESTIC WATER LINES

33 05 06 TESTING PIPING SYSTEM

33 05 08 PIPE BORING AND JACKING

33 05 10 TAPPING SLEEVES AND VALVES

33 05 20 DUCTILE IRON PIPE AND FITTINGS

33 05 22 DIRECTIONAL BORING OF PIPE

33 05 29 PLASTIC PRESSURE PIPE

33 14 10 WATER DISTRIBUTION SYSTEM

33 14 18 SERVICE LINES AND APPURTENANCES

33 14 20 VALVES

33 14 22 HYDRANTS

33 19 00 METERS AND METER SETS

DIVISIONS 34-50

(NOT USED)

END OF SECTION

SECTION 01 11 00

SUMMARY OF WORK

PART 1 - GENERAL

1.01. GENERAL WORK

A. Work Includes

1. [TBD].

B. NWCWD-Furnished Products

1. [TBD].

C. Maintenance of Operation

1. Contractor shall provide all necessary bypasses, temporary connections, and temporary structures to maintain system in operation during the construction period.
2. Connections to existing piping shall only be made at times designated by NWCWD.
3. Discharge of raw wastewater to water-courses is not permitted. Any discharge caused by failure of temporary connections or structures or by Contractor's construction activities shall be Contractor's sole responsibility. Contractor shall be subject to any enforcement or other agency as a result of his activities or failure of temporary connections or structures.

D. Work Sequence

1. Contractor shall determine and submit his own work sequence and schedule. The sequence and schedule shall meet specified substantial and final completion dates, and shall also meet the following constraints:
 - a. [TBD].

E. Use of NWCWD's Equipment

1. Obtain NWCWD's written permission before the use of any equipment furnished under this Contract or other contracts.

F. Documents

1. Drawings

a. Do not scale Drawings.

PART 2 - MATERIALS

(NOT USED)

PART 3 - EXECUTION

(NOT USED)

END OF SECTION

SECTION 01 33 21

SHOP DRAWINGS, SAMPLES, AND O&M MANUALS

PART 1 - GENERAL

1.01. DESCRIPTION

- A. This Section covers the submittal and review of Shop Drawings, Samples, and Operation and Maintenance (O&M) Manuals.

1.02. SUBMITTAL REQUIREMENTS

- A. Submit Shop Drawings, Samples, O&M Manuals, and other submittals as required by individual Sections in accordance with the accepted schedule of Shop Drawing submissions.
 - 1. Engineer will not accept Shop Drawings or other submittals from anyone but Contractor.
 - 2. Contractor shall stamp his approval on Shop Drawings prior to submission to the Engineer as indication of his checking and verification of dimensions and coordination with interrelated items. Marks on Drawings by Contractor shall not be in red. Any marks by Contractor shall be duplicated on all copies submitted. Contractor marks on reproducible transparencies shall be outlined with a rectangular box.
- B. Do not submit operation and maintenance data with Shop Drawings unless so specified or required by the Engineer, to determine if equipment will comply with the Contract Documents.
- C. Identify, in writing, all deviations of submittal from the current revision of these Standard Specifications.
- D. Unless otherwise specified, make all submittals in groups containing all associated items to ensure that information is available for checking each item when it is reviewed. Partial submittals may be rejected as not complying with the current revision of these Standard Specifications.
- E. Submit the information identified by the code symbol in the individual Sections, or, if not so identified, submit the appropriate information outlined below required to define each item proposed to be furnished. The information to be submitted for each code symbol is defined as follows:

DATA REFERENCE SYMBOLS AND DESCRIPTIONS	
SYMBOL	DESCRIPTION
A	Letters of Certification of Compliance on materials, equipment, etc.
B	Samples.
C	Final certified drawings showing outline dimensions, foundation layout or mounting information, and other pertinent dimensions.
D	Field erection instructions, assembly drawings and/or diagrams, detail reference drawings lists, and lists of erection details.
E	Shop detail drawings showing individual subassemblies and fabricated pieces, with material specifications and other applicable data.
F	Installation instructions, Operation and Maintenance Manuals, and preventive maintenance instructions and recommended frequency.
G	Schematic diagrams of power, control, and piping systems.
H	General bulletins and catalog cuts describing complete apparatus, including operating principles and fundamentals.
I	Service data sheets showing design performance, utility requirements, etc., as applicable to the specific duty of the equipment.
J	Head capacity curves for pumps, with impeller size furnished and maximum size available indicated.
K	Curves and/or data for over-all range of operation, from minimum to maximum capacity or load, showing utilities motive medium required, total or incremental differential head, and other pertinent information applicable to the equipment or component assemblies.
L	Materials of construction of all components.
M	Renewal parts list with diagrammatic or cross-section drawings showing part identification. Include material analysis or trade designation for each significant part on parts lists.
N	Stuffing box sizes; packing sizes; and mechanical seal details, arrangement, specifications, etc., if furnished in equipment.

DATA REFERENCE SYMBOLS AND DESCRIPTIONS	
SYMBOL	DESCRIPTION
O	Bearing manufacturer's standard identification and/or interchangeable number for all anti-friction bearings in the equipment proper and its accessory items.
P	Material gradation, design mix, job-mix formula, and/or material analysis.

F. Minimum Numbers Required

1. Shop Drawings

- a. Number Contractor requires plus four (4) copies which will be retained by Engineer, six (6) copies minimum.
- b. Submit four (4) additional copies for inclusion in O&M Manuals where O&M Manuals are required. Where field modifications are made after acceptance, indicate "AS CONSTRUCTED" conditions, mark copies "AS CONSTRUCTED," and submit prior to Substantial Completion.

2. Samples

- a. Two (2) unless required otherwise by individual specification sections.

3. O&M Manuals

- a. The number required by Contractor plus four (4) copies to the Engineer.

1.03. RESUBMITTAL REQUIREMENTS

- A. Make corrections or changes required by the Engineer and re-submit as specified above until acceptable.
- B. Identify in writing all revisions other than those called for by the Engineer on previous submissions.
- C. Any need for one (1) or more re-submissions will not entitle the Contractor to an extension of Contract Time.
- D. Excessive resubmittals, more than two (2) on each submission, will be retained without review unless the Contractor agrees to pay, through the Owner, for the Engineer's review time.

1.04. SHOP DRAWINGS

- A. Include the following pertinent information for each submittal:
1. Field dimensions, clearly identified as such.
 2. Applicable standards, such as ASTM or Federal Specification numbers.
 3. Motors - include the following:
 - a. Horsepower.
 - b. Voltage.
 - c. Temperature rating.
 - d. Service factor.
 - e. Full load current.
 - f. Full load rotative speed.
 - g. Power factor at full load.
 - h. Efficiency at full load.
 - i. Code letter.
 - j. Design letter.
 4. Color charts and similar items.
 5. All pertinent information required by each Section for each submittal shall be highlighted in yellow and or circled with a cloud outline.
- B. Manufacturer's standard drawings, schematics, and diagrams.
1. Clearly mark each copy to identify pertinent products and models and to describe exactly which parts of the Drawings apply to the equipment being furnished.
 2. Delete information not applicable to the Work.
- C. Reproductions or copies of portions of Contract Documents are not acceptable as complete fabrication or erection drawings. However, they may be used as a drawing upon which to indicate information on erection or to identify detail drawings.
- D. Format

1. When practical, electronic format is preferred.
2. Minimum sheet size: 8-1/2" x 11".
3. Maximum sheet size: 24" x 36".
4. Cover Sheet shall delineate:
 - a. Date of submission.
 - b. Project title and number.
 - c. Name of Contractor, supplier, and manufacturers.
 - d. Specification Section number, intended use of item in the Work, and equipment designation.
 - e. Identify details by reference to sheet, detail, schedule, or room numbers shown in the Contract Documents.
 - f. Deviations from Contract Documents.
 - g. Revisions on re-submittals.
 - h. Contractor's stamp, initialed or signed, certifying to review of submittal, verification of products, field measurements and field construction criteria, and coordination of the information within the submittal with requirements of the Work and the Contract Documents.
 - i. Provide a clear space approximately three and one-half inches by two and one-half inches (3-1/2" x 2-1/2") for Engineer's stamp on front page of submittal.
 - j. Submittals shall be numbered sequentially. The submittal numbers shall be clearly noted on the transmittal cover sheet. Original submittals shall begin with the specification number followed by a hyphen and an alphanumeric sequencing number. Resubmittals shall bear the number of the alphanumeric system of the original submittal followed by the subsequent letter of the alphabet to represent that it is a subsequent submittal of the original.
 - (1) For example, if Submittal 330522-01A (the original submittal for ductile iron pipe) requires a resubmittal, the first resubmittal will bear the designation 330522-01B; the second resubmittal will bear the designation 330522-01C, and so on.

1.05. SAMPLES

- A. Samples shall be of sufficient size and quantity to clearly illustrate the functional characteristics of the product with integrally-related parts and attachment devices and the full range of color, texture, and pattern.

1.06. O&M MANUALS

- A. Submit draft O&M Manuals by the time the Work is fifty percent (50%) complete for all equipment so designated in the individual Sections and for which the Shop Drawings were reviewed and marked "NO EXCEPTIONS TAKEN" or "MAKE CORRECTIONS NOTED." In addition, submit instruction books and other pertinent information for equipment not so designated which required special instruction or knowledge for proper operation and maintenance.
- B. Submit final O&M Manual for equipment by the time Work is ninety percent (90%) complete.
- C. Do not start or operate equipment until the respective operation and maintenance data has been reviewed, approved, and copies are made available at the site.

The O&M Manuals shall be in addition to instructions or parts lists packed with or attached to equipment when delivered.

- D. Include (as a minimum) the following information:
 - 1. Equipment function, normal operating characteristics and limiting conditions, complete motor data, test data, and performance curves where applicable.
 - 2. Operating instructions for start-up, routine and normal operations, regulations and control, shutdown, and emergency conditions.
 - 3. Lubrication and routine maintenance instructions.
 - 4. Guide to "troubleshooting."
 - 5. Parts lists, predicted life of parts subject to wear, and recommended list of spare parts to be on hand.
 - 6. Outline, cross-section, and assembly drawings, Engineering data, and wiring diagrams.
 - 7. Copy of accepted or as constructed Shop Drawings.
 - 8. Temperature control diagrams.

9. System balance report including a description of system operation as prepared by the balancing Contractor, which includes a schedule of inspection and maintenance.
10. System schematic flow diagrams.

E. Format

1. Submit in a format suitable for binding in a three-ring binder or a post binder.
2. Minimum sheet size: Eight and one-half inches by eleven inches (8-1/2" x 11").
3. Fold drawings larger than eleven inches by seventeen inches (11" x 17") and insert into individual pockets bound into the manuals.
4. Enclose pages subject to frequent usage by operators in clear plastic.
5. Individually annotate standard drawings that are furnished and describe exactly which parts of the drawing apply to the equipment being furnished.
6. Identify each submission with the following:
 - a. Date of submission.
 - b. Project title and number.
 - c. Names of Contractor, supplier, and manufacturers (include telephone numbers, addresses, and email addresses).
 - d. Names of subcontractors (with telephone numbers, addresses, and email addresses), contracted by Contractor for servicing and maintenance of portions of the project.
 - e. Specification Section number, intended uses of item in the Work, and equipment designation.
 - f. Identify details by reference to sheet detail, schedule, or room numbers shown in the Contract Documents.
 - g. Submitted number consistent with Paragraph 1.04.D.4.j of this Section.

1.07. REVIEW OF SUBMITTALS

- A. A minimum of fourteen (14) days will be required for the Engineer to review each submittal or re-submittal following the receipt of said submittal in the Engineer's office of all information required for review of the submittal. The Engineer will notify the Contractor when the review time must be extended in order to correlate the submittal

with other forthcoming submittals or for any other reason that prevents the Engineer's timely review.

- B. The Engineer will review submittals, affix a stamp and initials or signature, will indicate subsequent action to be taken, and will return the submittals to the Contractor for distribution. The review actions listed on the Engineer's stamp or Cover Sheet are defined as follows:
1. **NO EXCEPTION TAKEN** - Signified material or equipment represented by the submittal conforms with the design concept and complies with the information given in the Contract Documents. Contractor is to proceed with fabrication or procurement of the items and with related work.
 2. **MAKE CORRECTIONS NOTED** - Signified material or equipment represented by the submittal conforms with the design concept and complies with the information given in the Contract Documents and in accordance with the Engineer's notations. Contractor is to proceed with the Work in accordance with the Engineer's notations.
 3. **REVISE AND RESUBMIT** - Signified material or equipment represented by the submittal conforms with the basic design concept; however, it does not comply with the information given in the Contract Documents. Contractor is to submit a revised submittal responsive to the notations marked on the returned submittal and to the information in the Contract Documents.
 4. **REJECTED** - Signifies material or equipment represented by the submittal does not conform with the design concept to comply with the information given in the Contract Documents and is not acceptable for use in the Work. Contractor is to submit material or equipment responsive to the Contract Documents.
 5. **SUBMIT SPECIFIED ITEM** - Signifies material or equipment represented by the submittal is not the item specified in the Contract Documents and is not to be incorporated into the Work. Contractor is to submit only the material or equipment specified in the Contract Documents.
- C. The Engineer will return the number of copies of submittals specified below depending on the action taken.

Action by Engineer	No. Retained by Engineer	No. Returned to Contractor	No. Required for Re-submittal
No Exception Taken	4	2 or more	0
Make Corrections Noted	4	2 or more	0
Revise & Resubmit	4	2 or more	6 or more
Rejected	4	2 or more	6 or more
Submit Specified Item*	4	2 or more	6 or more

*Only one (1) copy of the submittals returned to the Contractor marked with these actions will be stamped annotated.

1.08. DISTRIBUTION

- A. Distribute reproduction or copies of Shop Drawings that carry the Engineer's stamp of acceptance to the Contractor's personnel, the job site file, the project record document file, the subcontractors, the suppliers, the manufacturers, and other affected Contractors.
- B. Distribute samples which carry the Engineer's stamp of acceptance to the project record file and the affected supplier or manufacturer.
- C. The Engineer will distribute reviewed copies of Shop Drawings to NWCWD.

PART 2 - MATERIALS

(NOT USED)

PART 3 - EXECUTION

(NOT USED)

END OF SECTION

(THIS PAGE INTENTIONALLY LEFT BLANK)

SECTION 01 45 00

QUALITY CONTROL

PART 1 – GENERAL

1.01. DESCRIPTION

- A. This Section covers the responsibilities for project staking and for performing the tests required by these Standard Specifications.

1.02. CONSTRUCTION STAKE OUT

A. General

1. Contractor, using qualified, competent personnel, shall provide construction stakes.
2. Engineer will establish base line or grid corners for horizontal control, and temporary benchmarks for vertical control.
3. The grade and alignment shall be maintained by the use of suitable surveying instruments or laser equipment operated continuously during construction.

B. Grade Stakes

1. Waterlines shall be staked on the centerlines of the waterlines, at all fittings and angle points, and any other points necessary for establishing the line. Cuts will be established at all main fittings to ensure proper depth of the line. Fire hydrants will be staked with a five-foot (5'-0") offset.

C. Survey Notes

1. Enter all survey notes and construction stakeout (cut) notes into bound, hardcover field books.
2. All survey data developed by the Contractor in performing the Work shall be available throughout the construction period and shall be provided as part of the Record Drawings.

1.03. TESTS AND INSPECTIONS

- A. Coordinate with NWCWD before backfilling of any waterline of services for inspection and survey.
- B. NWCWD requires every joint, fitting, tap, etc. to be inspected and surveyed by NWCWD personnel.

- C. The Contractor shall employ and pay for the services of a qualified independent testing laboratory to conduct the tests to determine compliance with the Specifications from the following:
 - 1. Soil compaction control as specified in Section 31 23 35 — TRENCHING, BACKFILLING, AND COMPACTING.

- D. Contractor shall conduct the following tests under the observation of, and to the satisfaction of, the Engineer:
 - 1. Pressure and leakage tests as specified in Section 33 05 06 – TESTING PIPING SYSTEM.
 - 2. Bacteriologic tests as specified in Section 33 01 11 – DISINFECTION OF DOMESTIC WATERLINES.

- E. The Contractor shall pay for retest(s) of items which fail to pass initial tests specified above, as well as for all tests the Contractor requires for control of his own construction operations.

PART 2 - MATERIALS

(NOT USED)

PART 3 - EXECUTION

(NOT USED)

END OF SECTION

SECTION 01 50 00

CONSTRUCTION FACILITIES AND TEMPORARY CONTROLS

PART 1 - GENERAL

1.01. TEMPORARY UTILITIES

A. Construction Water

1. Coordinate construction water sources with NWCWD. NWCWD will install meter and cross-connection control, as required.

1.02. TEMPORARY CONTROLS

A. Noise Control

1. Equip construction machinery and vehicles with practical sound and muffling devices and operate in a manner to minimize noise consistent with efficient performance of the Work.

B. Dust Control

1. Take reasonable measures to prevent unnecessary dust.
2. Moisten dirt roads used for transportation and haul with water or apply a chemical dust suppressant to control dust.
3. Cover dusty material in transit when necessary to prevent blowing.

C. Pollution Control

1. Prevent the pollution of drains and water courses by sanitary wastes, sediment, debris, and other substances resulting from construction activities.
2. Retain all spent oils, hydraulic fluids, and other petroleum fluids in containers for disposal off the site.
3. Do not perform equipment maintenance or fueling within fifty feet (50') of any water course.

D. Erosion Control

1. Take such measures as are necessary to prevent erosion of soil on the site and adjacent properties that might result from construction activities.

2. Provide temporary materials such as hay bales, sand bags, plastic sheets, chain link fencing fabric, rip-rap, or culverts to prevent the erosion of banks or excavation where runoff may be increased or concentrated due to construction activities.
3. Comply with the local jurisdiction's erosion control program.

1.03. TRAFFIC REGULATION

- A. Keep traffic areas free of excavated material, construction equipment, pipe, and other materials and equipment, unless otherwise stipulated, and conduct operations in a manner to avoid unnecessary interference with public and roads.
- B. Furnish properly equipped flagmen where necessary to provide for public safety, or where required by jurisdictional authorities.
- C. Warning Signs and Lights
 1. Provide barricades and warning signs for open excavations, parked equipment, and soil stockpiles.
 2. Illuminate by means of warning lights all barricades and obstructions from sunset to sunrise.
 3. Comply with "Manual on Uniform Traffic Control Devices," U.S. Dept. of Transportation, or applicable statutory requirements of State Highway Department, e.g. CDOT.
- D. Provide suitable parking areas for the use of all construction workers and others performing work in furnishing services in connection with the Project so as to avoid interference with construction activities.

1.04. PROJECT IDENTIFICATION AND SIGNS

(NOT USED)

1.05. FIELD OFFICES

(NOT USED)

PART 2 - MATERIALS

(NOT USED)

PART 3 - EXECUTION

(NOT USED)

END OF SECTION

(THIS PAGE INTENTIONALLY LEFT BLANK)

SECTION 01 60 10

MATERIALS, EQUIPMENT, AND WORKMANSHIP

PART 1 - GENERAL

1.01. MATERIALS AND EQUIPMENT

- A. Contractor shall furnish all materials, equipment, labor, and all other facilities and incidentals necessary for the execution, disinfection, testing, and completion of the Work, with the exception of any such items furnished by NWCWD.
 - 1. Reference Section 01 11 00 – SUMMARY OF WORK.
- B. All materials and equipment shall be of good quality and new, except as otherwise provided in these Specifications.
 - 1. When requested by NWCWD, the Contractor shall furnish satisfactory evidence (including manufacturer's certification) as to the kind and quality of materials and equipment, and their compliance with these Specifications.
 - a. NWCWD shall test any manufacturer's material it deems necessary.
 - b. It is the Contractor's responsibility to ensure the manufacturer's materials meet these Specifications.
- C. All materials and equipment shall be installed and used in accordance with the instructions of the applicable manufacturer, fabricator, supplier or distributor, except as otherwise provided in these Specifications.
- D. The specification of materials and equipment shall be understood to be representative of a quality of performance, operation, and construction acceptable to NWCWD.
 - 1. NWCWD may evaluate all written requests for product substitution.
 - a. Refer to Paragraph 1.02 of this Section for procedures.
- E. In approving materials or equipment for installation, NWCWD assumes no responsibility for injury or claims resulting from failure of the materials or equipment to comply with applicable National, State, and local safety codes or requirements, or the safety requirements of a recognized agency; or failure due to faulty design concepts, or defective workmanship.

1.02. PROCEDURE FOR EVALUATION OF MATERIALS

A. GENERAL

1. New products or materials related to the water industry may be evaluated by NWCWD. Sales representatives may petition for consideration and evaluation under the procedures of this Section.

B. REVIEW COMMITTEE

1. Initial application for consideration shall be made by contacting the NWCWD's District Engineer. If determined appropriate, the evaluation of products and materials shall be made by an ad hoc committee called by NWCWD's District Engineer or appointed representative.
2. The committee shall be composed of two or more NWCWD employees. NWCWD's Construction Manager will act as chairman and the remaining committee members shall reflect NWCWD's divisions affected by the proposed products.

C. EVALUATION

1. The review committee will give careful consideration to the products based upon their collective experience and opinions. They will assure themselves that proper criteria exists or they will develop criteria by which the products can be evaluated. They will seek out other knowledgeable persons both inside and outside of NWCWD and attempt to determine by this means whether the product falls clearly into one of the following Categories:
 - a. Acceptable;
 - b. Not acceptable; or
 - c. Borderline
2. Should the product be found in Category a or b, the committee will advise NWCWD's District Engineer or appointed representative who will, in-turn, advise the sales representative in writing of the findings. Should the product fall under the Category c (Borderline), the committee chairman will contact the sales representative for additional data, for product samples, and arrange for testing.

D. TESTING

1. If the product has some promise, but is not clearly acceptable, a testing program may be undertaken with the concurrence of the sales representative. The review committee will arrange actual field testing procedures.
2. The sales representative shall furnish samples to be tested, any special test equipment not already available to the review committee, any necessary appurtenant materials, pipe, gauges, charts, recording equipment, and, when necessary, a location to conduct the tests. In some instances, testing may consist

of trial installations into NWCWD's distribution system. Determination of the nature of the testing shall rest with NWCWD. NWCWD reserves the right to require full reimbursement for test and evaluation expense.

3. Testing shall be undertaken with the object of clearly determining the acceptability of the product. For some products where durability is in question, the test period may necessarily last for several years. NWCWD's goal will be to make an adequate determination within the minimum necessary time. Following completion of tests, the committee will meet with the sales representative to discuss results and any further testing or consideration. The committee will then meet with NWCWD's Engineer or appointed representative to discuss the product and to reach a decision.

E. NOTIFICATION

1. NWCWD's Engineer or appointed representative will notify the sales representative in writing of his/her decision to either accept the product and include it into NWCWD's Standard Specifications or to reject the product as not acceptable.

F. APPEAL

1. If the product is rejected and if the sales representative has good reason to feel that his/her product did not receive an adequate or fair test, he/she may appeal in writing to NWCWD's District Engineer. The sales representative shall fully document his/her allegations and ask for reconsideration based upon new facts, testing, late results, or some such factual basis. If NWCWD's Engineer finds reason for further consideration, he/she will arrange for another meeting including himself/herself, the sales representative, NWCWD's District Engineer or appointed representative and any other NWCWD employee who might contribute, to consider further testing or evaluation. A subsequent final decision will then be rendered in writing under the signature of NWCWD's District Engineer or appointed representative.
2. If NWCWD's District Engineer does not find sufficient cause to further investigate the matter, he/she shall advise the sales representative in writing, and that decision shall be final.

G. LIMITATION ON REAPPLICATION

1. If, after a product is rejected, significant changes are incorporated into its manufacture such as would render it now acceptable, the sales representative may reapply to NWCWD's District Engineer or appointed representative for reconsideration. In the absence of changed conditions, the product will not be

reconsidered for inclusion into the Standard Specifications for a period of three years after having been rejected.

1.03. WORKMANSHIP

- A. Contractor shall provide competent, disciplined, suitably qualified personnel to lay out the Work and perform the construction.
- B. The construction standards, tests, and methods outlined in these Specifications are considered adequate to produce the product desired by NWCWD.
 - 1. NWCWD may evaluate alternative methods of construction upon written request.
 - a. Requests for alternative methods of construction shall include detailed descriptions of the equipment, methods and controls needed for the alternative, and a description of the benefits which might be achieved by this substitution.

PART 2 - MATERIALS

(NOT USED)

PART 3 - EXECUTION

(NOT USED)

END OF SECTION

SECTION 01 74 11

SITE CLEANUP

PART 1 - GENERAL

1.01. GENERAL

- A. Site cleanup shall be executed during the progress of the work, and at the completion of the work.

PART 1 - MATERIALS

(NOT USED)

PART 2 - EXECUTION

2.01. GENERAL

- A. Construction materials shall be neatly stored.
- B. Containers shall be provided for the collection of waste material and debris.
 - 1. Containers shall be stored out of the right-of-way.
- C. Volatile wastes shall be stored in clearly marked, covered metal containers and removed daily.
- D. Construction material, equipment, waste containers, construction buildings, parking etc., shall only be allowed within the limits of the construction easement.
 - 1. Any off-site storage of construction material, equipment, waste containers, construction buildings, parking, etc. shall be allowed only after the Contractor has obtained the written permission from the property owner.
- E. Upon completion of the construction, the job site shall be restored to its original condition.
 - 1. Contractor shall restore any land that will not be paved with asphalt, or concrete, to its original condition.
 - a. All topsoil shall be restored to its original quality.
 - b. Any areas which are stripped of vegetation prior to or during construction shall be reseeded.

2. All exterior paved surfaces shall be broom cleaned, and left in good repair.

2.02. DISPOSAL

- A. In order to maintain an orderly site, waste material and debris shall be removed periodically.
- B. Volatile wastes shall be removed daily.

END OF SECTION

SECTION 01 78 41

PROJECT RECORD DRAWINGS

PART 1 - GENERAL

1.01. RECORDING OF DRAWINGS

- A. Accurate Project Record Drawings shall be compiled by the Contractor and by the Design Engineer, and shall be submitted to NWCWD, for review, prior to Conditional Acceptance of the Work.
- B. Each sheet of the Drawings shall be labeled "DRAWINGS OF RECORD" in neat large printed letters.
- C. Construction information shall be recorded concurrently with construction progress.
- D. Project Record Drawings shall be marked legibly and with an indelible pen.
- E. Project Record Drawings shall record actual construction and contain the following:
 - 1. Field dimensions, elevations, and details.
 - 2. Changes which are made by a modification. Reference the change authorization, e.g., RFI response, work change directive, etc.
 - 3. Details which are not on the original Construction Drawings.
 - 4. Horizontal and vertical locations of underground utilities and appurtenances referenced to a minimum of three permanent surface improvements.
 - 5. Depths of various elements of work in relation to project datum.

1.02. MAINTENANCE OF PROJECT RECORD DRAWINGS DURING CONSTRUCTION

- A. Project Record Drawings shall be stored apart from documents used for construction.
- B. Project Record Drawings shall be maintained in a clean, dry, legible condition and in good order.
 - 1. Project Record Drawings and any documents used for the preparation of said Drawings shall not be used for construction purposes.

1.03. SUBMISSION

- A. Project Record Drawings shall be submitted to NWCWD with a transmittal letter, in duplicate, containing:
 - 1. Date.
 - 2. Project title.
 - 3. Contractor's name, address, telephone number, email address, and website.
 - 4. Developer's name, address, telephone number, email address, and website.
 - 5. Title and number of each Record Document.
- B. Project Record Drawings shall be submitted on 22" x 34", 3 mil (minimum) reproducible, double-matte Mylar.
 - 1. Coordinate system shall be Colorado 501 North - NAD 83 and NAVD 83, Geo Model 9-US.
 - 2. No acceptance of the utility lines will be made until the Project Record Drawings are received and accepted by NWCWD.
- C. Provide submittals in accordance with Section 01 33 21 – SHOP DRAWINGS, SAMPLES, AND O&M MANUALS.

PART 2 - MATERIALS

(NOT USED)

PART 3 - EXECUTION

(NOT USED)

END OF SECTION

SECTION 03 30 10

CAST-IN-PLACE CONCRETE (SMALL VOLUME)

PART 1 - GENERAL

1.01. DESCRIPTION

- A. This Section covers cast-in-place concrete; including forms, reinforcing steel, materials, transporting, placing, finishing, curing, and other appurtenant items of construction.
- B. Inform the Engineer at least forty-eight (48) hours in advance of the times and places at which Contractor intends to place concrete.

1.02. QUALITY ASSURANCE

- A. Perform all work as specified herein and in accordance with the latest revisions of the following codes and standards:
 - 1. Federal, state, and local codes, regulations, and standards.
 - 2. American Society for Testing and Materials, (ASTM).
- B. Reference Standards
 - 1. Except as noted or modified in this Section, all concrete materials, transporting, placing, finishing, and curing shall conform to the requirements of the following standard specifications:
 - a. American Concrete Institute Standards (ACI)
 - (1) 117– Standard Specifications for Tolerances for Concrete Construction and Materials.
 - (2) 301 – Specifications for Structural Concrete.
 - (3) 304 – Guide for Measuring, Mixing, Transporting, and Placing Concrete.
 - (4) 305 – Hot Weather Concreting.
 - (5) 306 – Cold Weather Concreting.
 - (6) 309 – Guide for Consolidation of Concrete.
 - (7) 315 – Details and Detailing of Concrete Reinforcement.

- (8) 318 – Building Code Requirements for Reinforced Concrete.
- (9) 347 – Recommended Practice for Concrete Formwork.

- C. In case of conflict or disagreement between codes, standards, laws, ordinances, rules and regulations, or within any document itself, the more stringent requirements as determined by the Engineer shall govern.
 - 1. Where Work required by the Drawings and Specifications is above the standard required by local regulations or recommended standards, it shall be completed as shown and/ or specified.

1.03. SUBMITTALS

- A. Provide submittal's in accordance with Section 01 33 21 – SHOP DRAWINGS, SAMPLES, AND O&M MANUALS.
- B. Test Results
 - 1. Perform and submit test reports for the following products in accordance with the above general reference standards and specific standards of these Specifications.
- C. Proposed Mix Design
 - 1. Prior to commencing concrete work, submit certified test reports describing proposed concrete mix design, including:
 - a. Fine aggregate - Source, type, gradation, deleterious substances, and bulk-specific gravity on the basis of weight of saturated surface - dry aggregate (ASTM C 128).
 - b. Coarse aggregate - Source, type, gradation, deleterious substances, and bulk-specific gravity on the basis of weight of saturated surface - dry aggregate (ASTM C 217).
 - c. Reactive aggregate test reports (ASTM C 1260).
 - d. Ratio of fine to total aggregates.
 - e. Weight (surface dry) of each aggregate per cubic yard.
 - f. Total water content in gallons per cubic yard and proposed source.
 - g. Slump on which the mix design is based.
 - h. Brand, type, and quantity of cement.

- i. Brand, type, and quantity of admixtures.
- j. Air content.
- k. Two (2) sets of compression test cylinders (two (2) cylinders per set) shall be made for each proposed mix design.
 - (1) Test one (1) set of two (2) cylinders at age seven (7) days and other set at twenty-eight (28) days.

D. Cylinder Compression Test Reports

- 1. Submit two (2) copies of certified test reports to the Engineer.

E. Ready-Mix Delivery Tickets

- 1. Submit delivery tickets for each load at the time of delivery indicating the following:
 - a. Quantity delivered.
 - b. Quantity of each material in batch.
 - c. Amount of water that may be added on site.
 - d. Outdoor temperature in shade.
 - e. Time at which water was added.
 - f. Elapsed time between when water was added and when concrete load was in place.
 - g. Amounts of initial and supplemental water added.
 - h. Name of individual authorizing supplemental water.
 - i. Numerical sequence of delivery by indicating cumulative yardage delivered on each ticket.

F. Shop Drawings

- 1. Show sizes, quantity, and dimensions for fabrication and placing of reinforcing bars, bar supports, and embedments.
- 2. Indicate bar schedules, stirrup and tie spacing, and diagrams of bent bars.
- 3. Show locations and sizes of openings, penetrations, and embedments.

1.04. PRODUCT DELIVERY, STORAGE, AND HANDLING

A. Cement

1. Store in weather-tight enclosures and protect against dampness, contamination, and warehouse set.
2. Do not use cement that has become caked or lumpy.

B. Aggregates

1. Stockpile to prevent excessive segregation or contamination with other sizes of aggregates.
2. Use only one (1) supply source for each aggregate stockpile.
3. The bottom six inches (6") of all aggregate piles in contact with the ground shall not be used.

C. Admixtures

1. Store to prevent contamination, evaporation, or damage.
2. Protect liquid admixtures from freezing or harmful temperature ranges.
3. Agitate emulsions before use.

D. Mixing and Transporting Ready-Mixed Concrete.

1. Maximum elapsed time from time water is added to mix until concrete is in place shall not exceed one and one-half (1-1/2) hours when concrete is transported in revolving-drum truck bodies.

E. Reinforcing Steel.

1. Deliver to site in bundles marked with metal tags indicating bar size and length.
2. Carefully handle and store on supports that will keep the steel from coming in contact with the ground.

1.05. JOB CONDITIONS

A. Environmental Requirements

1. Do not place concrete during rain, sleet, or snow unless adequate protection is provided.

2. Do not allow rainwater to increase mixing water or damage surface finish.

B. Cold Weather Concreting

1. Conform to ACI 306.
2. Temperature of concrete when placed shall not be less than following.

Air Temp. (°F.)	Sections with Least Dimension Under Twelve Inches (12")	Sections with Least Dimension Twelve Inches (12") and Over
30 to 45	60° F	50° F
0 to 30	65° F	55° F
Below 0	70° F	60° F

3. Heated concrete shall not be warmer than eighty degrees Fahrenheit (80°F) when placed.
4. Prior to placing concrete, all ice, snow, and surface and subsurface frost shall be removed.
 - a. The temperature of the surfaces to be in contact with the new concrete shall be raised above thirty-five degrees Fahrenheit (35°F) for a minimum of twenty-four (24) hours immediately prior to placing concrete.
5. Protect concrete from freezing during specified curing period.
 - a. Cold weather protection shall be maintained at a minimum temperature of fifty degrees Fahrenheit (50°F) for a minimum of five (5) days.
6. Heated enclosures shall be strong and windproof to ensure adequate protection of corners, edges, and thin sections.
7. Do not permit heating units to locally heat or dry the concrete.
8. Do not use combustion heaters during the first twenty-four (24) hours unless the concrete is protected from exposure to exhaust gases that contain carbon dioxide.

C. Hot Weather Concreting

1. Conform to ACI 305.

2. Take precautions when ambient air temperature is ninety degrees Fahrenheit (90°F) or above.
3. Temperature of concrete, when placed, shall not exceed eighty-five degrees Fahrenheit (85°F).
4. Cool forms and reinforcing to a maximum of ninety degrees Fahrenheit (90°F) by spraying with water before placing concrete.
5. Do not use cement that has reached a temperature of one hundred seventy degrees Fahrenheit (170°F) or more.
6. Prevent plastic shrinkage and cracking due to rapid evaporation of moisture.
7. Do not place concrete when evaporation rate (actual or anticipated) equals or exceeds specified limits in ACI 305.
8. Set-retarding and water-reducing admixtures may only be used with Engineer's concurrence.

PART 2 - MATERIALS

2.01. CONCRETE

A. Cement

1. ASTM C 150, Type I/II or Type II, sulfate resistant.
2. Tricalcium Aluminate (C_3A) in the Type II cements shall not exceed eight percent (8%).

B. Aggregates

1. Aggregates shall not be potentially alkali-silica reactive as defined in Appendix X1 of ASTM C33, unless otherwise approved by the Engineer.
2. Fine aggregate: ASTM C 33.
3. Coarse aggregate: ASTM C 33.
 - a. Air-cooled blast furnace slag will not be allowed.
 - b. Nominal maximum size of coarse aggregate shall conform to ACI 318.

C. Water

1. Shall be clean, fresh, and free from injurious amounts of oils, acids, alkalis, salts, organic materials, or other substances that may be deleterious to concrete reinforcement.

D. Admixtures

1. Do not use admixtures that cause accelerated setting of cement.
2. Calcium chloride is not permitted.
3. Air-entraining agent: ASTM C 260, nontoxic after thirty (30) days and containing no chlorides.
4. Water-reducing and retarding: ASTM C 494, Type A or Type D.
 - a. May only be used with the Engineer's concurrence.
5. Pozzolan (Fly Ash): Class F fly ash in accordance with ASTM C618, Tables 1 and 2, except as modified herein:
 - a. Loss on Ignition: Maximum 3 percent (3%).
 - b. Water Requirement: Maximum 100 percent of control.
 - c. Available Alkalies: Maximum of one and one-half percent (1-1/2%) Na₂O determined in accordance with ASTM C311 when any portion of aggregates are potentially reactive as defined in Appendix X1 of ASTM C33.
 - d. ASTM C618, Table 3, Effectiveness in Controlling Alkali-Silica Reaction, applies when any portion of aggregates are potentially reactive as defined in Appendix X1 of ASTM C33.
 - e. ASTM C618, Table 2A, Uniformity Requirements, apply when loss on ignition of fly ash furnished exceeds three percent (3%).
6. Superplasticizers: ASTM C 494.
 - a. Use in all structural walls and beams. Use in other elements and slabs at Contractor's option.
7. Waterproofing
 - a. Use waterproofing admixture where specified and shown on the Drawings.
 - b. Submit proposed admixture to the Engineer for review prior to use.

2.02. FORM MATERIALS

1. General

- a. Reference ACI 301.
- b. Where “Smooth and Finish” or “Grout Cleaned Finish” is specified, use prefabricated plywood panel forms, job-built plywood forms, forms lined with plywood or fiberboard, or steel forms.
- c. Where “Rough Form Finish” is specified, unlined wooden forms may be used.
- d. Lumber
 - (1) Straight, uniform width and thickness; free from knots, offsets, holes, dents, and other surface defects.
 - (2) Chamfer Strips: Clean, white pine with the surface against concrete planed.

2. Form Ties

- a. Removable end, permanently-embedded body type, with cones on outer ends.
 - (1) Provide form ties with center waterstop ring at locations where surface water, ground water or hydrostatic conditions may be encountered, as indicated on the drawing, or as directed by the Engineer.
- b. Sufficient strength and rigidity to support and maintain the form in proper position and alignment without the use of auxiliary spreaders.
- c. The permanently-embedded portion shall be recessed a minimum of one inch (1”) from concrete surface.

3. Form Coating

- a. Non-staining chemical release agent that will not damage the concrete surface.
- b. For all exposed surfaces not in contact with earth backfill, use:
 - (1) Symons Corporation, “Magic Kote”;
 - (2) Or approved equal.

2.03. REINFORCEMENT MATERIAL

1. Rebar

- a. Conform to ACI 315 and ACI 318.
- b. Bars shall be Grade 60, unless indicated otherwise on the Drawings, ASTM A 615.
- c. Column spirals shall be cold-drawn wire, ASTM A 82.
- d. Tie wire shall be annealed steel, sixteen (16) gauge minimum, ASTM A 510.
- e. Bar Supports
 - (1) Where concrete surface will be exposed to weather, the portions of the supports or accessories within one-half inch (1/2") of the concrete surface shall be non-corrosive or protected against corrosion (epoxy covered).
 - (2) Plastic bar supports are not acceptable.

2. Welded Wire Fabric

- a. Plain Wire: ASTM A 185.
- b. Deformed Wire: ASTM A 497.

2.04. CONCRETE ACCESSORY MATERIALS

1. Curing Materials

- a. Water.
- b. Sheet material: ASTM C 171.
- c. Liquid membrane: ASTM C 309.

2. Expansion Joint Filler

- a. Bituminous type: ASTM D 994.
- b. Cork type: ASTM D 1752, Type 2 or 3.
- c. Fiber type: ASTM D 1751.

3. Bond Break Material

- a. Felt: ASTM D 2475.
 - b. Polyethylene sheet material.
4. Joint Sealers
- a. Cold-application type: ASTM D 1850.
 - b. Hot-poured elastic type: ASTM D 1190.
 - c. Hydrostatic pressure resistant type sealant.
 - (1) Sikaflex 2C NS/SL;
 - (2) Or equal.
5. Waterstop
- a. Material
 - (1) Polyvinyl chloride (PVC).
 - b. Type
 - (1) Construction joints: Ribbed with center bulb.
 - (2) Expansion joints: Ribbed with center bulb.
 - c. Manufacturer
 - (1) Greenstreak;
 - (2) Or equal.
 - d. Size
 - (1) Six inches (6") wide, minimum.
 - (2) Three-eighths-inch (3/8") thick, minimum.
 - e. Hydrophilic waterstop – where specifically noted on the Drawings.
 - (1) Greenstreak Hydrotite Type CJ-0725-3K, 0.28 inches high by 0.98 inches wide;
 - (2) Or equal.
6. Vapor Barrier Material

- a. Polyethylene sheet, 6 mil minimum thickness.
 - 7. Curing Compound
 - a. Liquid membrane-forming.
 - b. Pigmented and non-pigmented ASTM C 309, VOC compliant.
 - (1) W.R. Meadows, VOCOMP-30.
 - (2) Or equal.
 - 8. Non-Shrink Grout
 - a. Master Builders 713;
 - b. SonogROUT 14K;
 - c. Or equal.
 - 9. Sealer
 - a. Where shown on the Drawings
 - (1) W.R. Meadows, VOCOMP-30;
 - (2) Or equal.
 - 10. Crack Repair Epoxy
 - a. Two-component epoxy injection by Sika Chemical Corporation;
 - b. Or equal.
 - 11. Anchor Epoxy
 - a. Hilti HIT RE 500 SD;
 - b. Or equal.
- 2.05. MIXES
- (NOT USED)
- 2.06. FABRICATION AND MANUFACTURE
- A. Concrete Production

1. Ready-mixed Concrete
 - a. Mixed and delivered, reference ACI 304.
2. Batching and Mixing Equipment
 - a. Conform to ACI 304.
3. Proportioning
 - a. Proportion ingredients to produce a well-graded mix of high density and maximum workability consistent with submitted mix design and subject to the following minimum twenty-eight (28) day compressive strength:
 - (1) 4,000 psi for locations identified in Paragraph 3.01.B of this Section.
 - (2) 3,000 psi for locations identified in Paragraph 3.01.A of this Section.
 - (3) Fine/coarse aggregate ratio:
 - (a) Fine aggregate content: Forty percent to fifty percent (40% - 50%) by total weight of aggregate;
 - (4) Minimum cement content (or combined cement plus fly ash content):
 - (a) Five hundred sixty-four pounds (564 lbs) per cubic yard.
4. Strength
 - a. Design and proportion concrete to meet the following minimum compressive strengths.

Specified Strength, psi	7-Day Test, psi	28-Day Test, psi	W/C Ratio Non-Air Entrained	W/C Ratio Air Entrained
3,000	2,100	3,000	0.58	0.46
4,000	2,800	4,000	0.44	0.40

- b. Water/cement ratios greater than those shown above may be submitted for consideration in accordance with quality provisions of ACI 318.

5. Air Content

- a. Minimum entrained air for concrete required to be watertight, including concrete for all liquid-containing structures:
 - (1) Six percent plus or minus one percent ($6\% \pm 1\%$) for three-quarter-inch ($3/4''$) or one-inch ($1''$) coarse aggregate.
 - (2) Five percent plus or minus one percent ($5\% \pm 1\%$) for one and one-half-inch ($1-1/2''$) coarse aggregate.
 - b. Minimum entrained air for all other concrete:
 - (1) Six percent plus or minus one and one-half percent ($6\% \pm 1.5\%$) for three-quarter-inch ($3/4''$) coarse aggregate.
 - (2) Five percent plus or minus one and one-half percent ($5\% \pm 1-1/2\%$) for one and one-half-inch ($1-1/2''$) coarse aggregate.
 - (3) Refer to ACI 301 for further requirements.
6. Slump Range at Site
- a. Nonsuperplasticized Concrete: Three inches ($3''$) minimum, five inches ($5''$) maximum.
 - b. Superplasticized Concrete: Four and one-half inches ($4-1/2''$) minimum, eight inches ($8''$) maximum.
 - c. Take design mix test cylinders from concrete with slump equal to that used on Project at the point of discharge into the forms.
7. Mixing - Minimum time
- a. Central-mixed concrete, one (1) minute for mixer capacities of one cubic yard (1 CY) or less, plus fifteen (15) seconds for each cubic yard, or fraction thereof, of additional capacity.
 - b. Truck-mixed concrete, one hundred (100) revolutions after introduction of all ingredients.
8. Admixtures
- a. Water-reducing and retarding agents: May only be used with the Engineer's concurrence.
 - b. Fly Ash: Maximum twenty-five percent (25%), minimum fifteen percent (15%) of total weight of fly ash plus cement.

- c. Superplastizicers: Use as specified in Paragraph 2.01.D.6. Control the slump and workability to at least a four and one-half inch (4-1/2") slump at discharge into forms by adjusting the superplasticizer at the batch plant.
- d. Waterproofing: Proportion in accordance with Manufacturer's requirements.

B. Rebar Fabrication

- 1. No plus or minus (\pm) tolerance shall be allowed for rebar fabricated with multiple bends.
 - a. Rebar with multiple bends shall be fabricated such that concrete coverage specified herein or as otherwise indicated in the Specifications or on the Drawings shall be maintained.

PART 3 - EXECUTION

3.01. GENERAL

- A. Thrust Blocks, Manhole Bases, Pipe Encasements, Curbs, Gutters, and Sidewalks
 - 1. Concrete shall have a minimum compressive strength of 3,000 psi at 28 days.
- B. Structures, Cast-in-Place or Precast
 - 1. Concrete shall have a minimum compressive strength of 4,000 psi at 28 days.

3.02. INSPECTION

A. General

- 1. Assure that excavations and formwork are completed.
- 2. Assure that dirt, mud, encrusted concrete, debris, and excess water have been removed from foundation, forms, reinforcement, and embedments.
- 3. Check that reinforcement is properly positioned and secured in place. Verify proper cover on all reinforcement. All reinforcement shall be tied in place. No "stabbed" dowels are allowed.
- 4. Verify that expansion joint material, anchors, waterstops, and other embedded items are secured in proper position.
- 5. Verify that all required tests for pipes under slabs have been completed.

3.03. PREPARATION

A. Concrete Surfaces

1. Before placing fresh concrete against surface of hardened concrete or rock.
 - a. Roughen, clean, and thoroughly wet hardened surface to sound concrete.
 - b. Remove all laitance, foreign substances (including curing compound), wash with clean water, and thoroughly wet hardened surface before placing fresh concrete.
 - c. Blast cleaning shall be required when necessary to assure a clean-bonded joint.
2. Prepare slab subgrades in accordance with ACI 301.

B. Form Surfaces

1. Remove mortar, grout, and other foreign material from form surfaces.
2. Coat form surfaces with form coating material before either the reinforcing steel or concrete is placed.
3. Do not allow form coating to:
 - a. Stand in puddles in the forms.
 - b. Come in contact with the reinforcing steel.
 - c. Come in contact with adjacent hardened concrete against which fresh concrete is to be placed.

C. Reinforcement

1. Remove all mud, oil, loose rust, mill scale, and other foreign materials that may reduce bond of the concrete to the steel reinforcing.
2. Rust or mill scale that is "tight" will be permissible without cleaning or brushing provided weights, dimensions, cross-sectional area, and tensile properties meet requirements of ASTM A 615.

3.04. INSTALLATION, APPLICATION, AND PERFORMANCE

A. Form Erection

1. General

- a. Erect forms substantially and sufficiently tight to prevent leakage of mortar, and braced or tied to maintain the desired position, shape, and alignment before, during, and after concrete placement.
 - b. Use adequate walers, stiffeners, and braces to ensure proper alignment.
 - c. Provide temporary openings at the bottom of column and wall forms and at other locations where necessary to facilitate cleaning and inspection.
 - d. Provide temporary openings in wall or column forms to limit the free fall of concrete to a maximum of four feet (4'-0").
 - (1) 1) If tremies of proper lengths are used for depositing concrete in walls or columns, temporary openings for concrete placement will not be required.
 - e. At other locations, bring forms to a true line and grade, or provide a wooden guide strip at the proper location on the forms so that the top surface can be finished with a screed or template for concrete which is to have a specified elevation, slope, or contour.
 - f. At horizontal construction joints in walls, do not extend the forms on one side more than two feet (2'-0") above the joint.
 - g. Anchor bolts, castings, steel shapes, conduits, sleeves, masonry anchorage, and other materials that are to be embedded in the concrete shall be accurately positioned in the forms and securely anchored.
2. Edges and Corners
- a. Place chamfer strips in forms to bevel exposed edges and projecting corners.
 - b. Tool the top edges of walls and slabs not indicated on the Drawings to beveled.
 - c. Form beveled edges for all vertical and horizontal corners of equipment bases unless indicated otherwise on the Drawings.
 - d. Chamfer strips shall be three-quarter inch (3/4") unless indicated otherwise on the Drawings.
3. Form Removal
- a. Reference ACI 347.

- b. Do not remove or disturb forms until the concrete has attained sufficient strength to safely support all dead and live loads.

4. Tolerances

- a. Maximum variation from plumb

- (1) Lines and surfaces of columns, piers, and walls:

- (a) In any ten feet (10') of length: One-quarter inch (1/4").

- (b) Entire length: One inch (1").

- (2) Exposed corner columns, control-joint grooves, and other conspicuous lines.

- (a) In any twenty feet (20') of length: One-half inch (1/2").

- (b) Entire length: One-half inch (1/2").

- b. Maximum variation from level or specified grade

- (1) Slab soffits, beam soffits, and ceilings:

- (a) In any ten feet (10') of length: One-quarter inch (1/4").

- (b) In any bay or in any twenty feet of length: Three-eighths inch (3/8").

- (c) Entire length: Three-quarter inch (3/4").

- c. Maximum variation of the linear building lines from established position in plan and related position of columns, walls, and partitions

- (1) In any bay: One-half inch (1/2").

- (2) In any twenty feet (20') of length: One-half inch (1/2").

- (3) Entire length: One inch (1").

- d. Refer to ACI 117 for additional requirements.

B. Reinforcement Installation

1. Bar Placement

- a. Conform to ACI 318.

2. Bar Supports
 - a. Conform to ACI 315.
 - b. Do not use pebbles, rocks, pieces of broken stone, common or face brick, metal pipe, or wood blocks to support reinforcement.
 - c. Use one-half (1/2) solid concrete bricks to support rebar on ground.
3. Placement, and Coverage Tolerances
 - a. Reference ACI 318.
4. Splices
 - a. Do not splice bars except at locations shown on the Drawings unless reviewed by the Engineer.
 - b. Minimum lay distance shall be as shown on the Drawings. If not shown, splices shall be as specified in ACI 318.
5. Welded Wire Fabric
 - a. Install in longest practicable length.
 - b. Lap adjoining pieces one (1) full mesh plus two inches (2"), minimum.
 - c. Offset laps in adjacent widths to prevent contiguous laps.
 - d. Extend fabric through contraction joints and construction joints unless otherwise indicated on the Drawings.

C. Concrete Placement

1. General
 - a. Conform to ACI 304.
2. Conveying
 - a. Convey concrete from mixer to final position as rapidly as practicable without segregation or loss of material.
3. Depositing
 - a. Deposit concrete in a continuous operation until section is completed.

- b. Regulate rate of placement so concrete remains plastic and flows into position.
- c. Each layer of concrete shall be plastic when covered with the following layer.
- d. Use tremies to prevent free fall of more than four feet (4'-0").
- e. Do not allow concrete to fall on reinforcement or other objects that would cause segregation.
- f. Do not exceed six feet (6'-0") of vertical height for any portion of wall or column placed monolithically with floor or roof slab.

4. Consolidation

- a. During and immediately after placement, thoroughly compact and work around all reinforcements, embedments, and corners of forms.
- b. Number and type of vibrators shall be subject to concurrence from the Engineer.
- c. Do not use vibrators to transport concrete laterally in forms.
- d. Operate vibrators in order to avoid segregation of materials.

D. Joints

1. Watertight Joints

- a. Provide on water bearing structures.
- b. Provide on structures submerged in groundwater.
- c. Provide at all locations shown on the Drawings.

2. Expansion and Contraction Joints

- a. Provide at all locations shown on the Drawings.
- b. Do not extend reinforcement continuously through expansion joint unless specifically shown on the Drawings.
- c. Form joint with felt extending full depth, where "bond break" or "isolation" joint is indicated.

3. Construction Joints

- a. Provide at all locations shown on the Drawings.
- b. Obtain the Engineer's concurrence for location of construction joints not shown on the Drawings.

E. Finishing

1. Unformed Surfaces

- a. Finish unformed surfaces as specified herein and as shown in the Finish Schedule at the end of this Section.

2. Slabs, floors, stairs, pavements, sidewalks, driveways, curb and gutters, and similar structures.

- a. Provide surface conforming to proper elevation and contour with all aggregates completely embedded in mortar by screeding.
- b. Provide an initial float finish as soon as concrete has stiffened sufficiently for proper working.

(1) Produce a surface of uniform texture and appearance with initial floating, without unnecessary working of surface.

- c. Provide a second floating at time of initial set.

(1) Produce a finish of uniform texture and color with second floating.

3. Brooming

- a. Follow second floating with a broomed treatment of surface to provide a uniform abrasive texture of constant color, in areas where concrete is to remain exposed.

4. Troweling

- a. Perform steel troweling after second floating when surface has hardened sufficiently to prevent excess of fines being drawn to surface.

(1) Produce a dense, smooth, uniform surface, free from blemishes and trowel marks within plus or minus one-quarter-inch ($\pm 1/4"$) of specified grade.

5. Finishing Surfaces for Bonding to be Covered with Concrete Topping

- a. Float finish all surfaces.

- b. Remove by brushing or air blasting at time of initial set, all laitance, surface mortar, and unsound material.
 - c. Surfaces shall be rough, clean, and sound.
 - d. Edging
 - (1) Edge exposed edges of floated or troweled surfaces with a tool having a minimum one-quarter-inch (1/4") corner radius unless these edges are specified to be beveled.
6. Finishing Formed Surfaces
- a. Finish formed surfaces as specified herein and as shown in the Finish Schedule at the end of this Section.
 - b. Rough form finish all surfaces not exposed to view such as surfaces in contact with earth.
 - (1) Remove all fins and other surface projections when dampproofing is specified.
 - (2) Provide a flush surface and use a power grinder, if necessary, to remove fins and projections.
 - (3) Fill all tie holes with non-shrink grout.
 - c. Smooth form finish all exposed surfaces not generally exposed to view including submerged surfaces of tanks.
 - (1) Use form facing to produce a smooth, hard, uniform surface.
 - (2) Keep number of seams to a minimum.
 - (3) Remove all fins and projections.
 - (4) Clean, wet, and fill all tie holes with non-shrink grout.
 - (5) Repair all defects.
 - d. Grout clean finish all concrete surfaces exposed to view.
 - (1) Complete operations for smooth form finish.
 - (2) Wet surface and apply grout mix of one (1) part of Portland Cement and one and one-half (1-1/2) parts of fine sand.

- (3) Use bonding agents as necessary to ensure grout adherence.
- (4) Substitute white Portland Cement for gray as required to match surrounding concrete.
- (5) Rub surface with cork float or stone to fill all air bubbles and holes.
- (6) Remove excess grout by rubbing with a rubber float, burlap bag, or other means.
- (7) Do not begin cleaning until all contiguous surfaces are completed and accessible.

F. Curing

1. Moisture Cure

- a. Keep concrete continuously moist for at least seven (7) days after placement by use of:
 - (1) Ponding, continuous sprinkling, wet burlap or wet absorptive mats.

2. Membrane Curing Compound

- a. Acceptable for use on walls. Use on slabs that are subject to cold weather conditions as specified in Paragraph 1.05.B. Use at other locations only with the Engineer's concurrence on a pour-by-pour basis.
- b. Spray apply two (2) coats at coverage as recommended by Manufacturer to give a total of twice the Manufacturer's required coverage.
- c. Membrane curing compound shall be reapplied each day during curing period after any work activity has occurred on concrete surface.
- d. For concrete surfaces to be painted or top coated, neutralize and remove curing compound after curing period.

3. Film Curing

- a. Use only with the Engineer's concurrence on a pour-by-pour basis.
- b. Begin as quickly as possible after initial set of concrete.
- c. Cover surfaces completely with polyethylene sheeting.
- d. Anchor continuously all edges and anchor surface as necessary to prevent billowing.

- e. Keep concrete continuously wet during curing period.

3.05. BACKFILL AGAINST WALLS

- A. Do not backfill against walls until concrete has obtained twenty-eight (28)-day compressive strength.
- B. Place backfill simultaneously on both sides of wall, where required, to prevent differential pressures.
- C. Do not backfill against structures with top slabs until such slabs reach seven (7) day compressive strength unless approved in writing by the Engineer.

3.06. FIELD QUALITY CONTROL

A. Concrete Tests

- 1. Concrete tests shall be in accordance with the requirements of ACI 301 except as noted or modified in this Section.
 - a. Strength test
 - (1) Mold and cure four (4) cylinders from each sample.
 - (2) Test one (1) cylinder at seven (7) days for information, two (2) cylinders at twenty-eight (28) days for acceptance, and hold one (1) cylinder for future break.
 - (3) If additional cylinders are required for Contractor's information, said cylinders will be in addition to those listed above.
 - b. Minimum samples
 - (1) Collect one (1) sample set for each fifty (50) cubic yards or as designated by the Engineer.
 - c. Slump test
 - (1) Conduct test for each batch.
 - d. Air content
 - (1) Conduct test for each batch.
- 2. Field-cured cylinders

- a. Additional cylinders may be cast and cured in the field to facilitate early removal of forms and shoring or early backfill.
- b. Field-cured cylinders will be prepared and tested by the testing agency at the Contractor's request and at the Contractor's expense. Contractor shall request field cured cylinders at least 24 hours in advance.

3.07. ADJUST AND CLEAN

A. Repair of Defective Concrete

- 1. Repair work shall conform to ACI 301.

3.08. SCHEDULES

A. Finish Schedule

FINISH SCHEDULE	
Surface	Finish
Floor Slabs	Non-slip Mag Float
Formed Surface Exposed to View	Grind Smooth and Grout Holes as needed to prep for paint
Sidewalks/Stoops	Light Broom

END OF SECTION

SECTION 03 40 00

PRECAST CONCRETE

PART 1 - GENERAL

1.01. DESCRIPTION

- A. This Section covers precast vaults and manholes, including ring and covers, steps, grade rings, fittings, and other appurtenances and accessories.

1.02. QUALITY ASSURANCE

A. Reference Standards

- 1. Except as noted or modified in this Section or on the Drawings, all materials, design, fabrication, curing, and testing shall conform to local, county, and state requirements, and the latest revision of the following standard specifications:
 - a. American Concrete Institute (ACI).
 - b. ASTM C478.
 - c. ASTM C857.
 - d. ASTM C858.

- B. In case of conflict or disagreement between codes, standards, laws, ordinances, rules and regulations, or within any document itself, the more stringent requirements as determined by NWCWD shall govern.

- 1. Where Work required by the Drawings and Specifications is above the standard required by local regulations or recommended standards, it shall be completed as shown and/or specified.

C. Design Criteria

- 1. Precast concrete vaults shall be designed by a Structural Engineer registered in the State of Colorado with experience in precast concrete design.
- 2. Deviations from design criteria specified herein will not be allowed.
- 3. Design Loads
 - a. Vaults

(1) Vehicle Loading

(a) The vault lid shall be designed to resist an HS-20 vehicle loading.

(2) The groundwater table fluctuates greatly depending on the season, and structures shall be designed using a groundwater level equal to finish grade elevation. Structures are to be designed to resist the uplift forces and buoyancy from the groundwater by the dead weight of the structure with a factor of safety of 1.1 or by the dead weight of the structure and the soil directly above the footings with a factor of safety of 1.25.

D. Testing

1. Shall be performed in accordance with Section 03 30 10 – CAST-IN-PLACE CONCRETE (SMALL VOLUME).

1.03. SUBMITTALS

A. Reference SECTION 01 33 21 – SHOP DRAWINGS, SAMPLES, AND O&M MANUALS.

B. Shop Drawings

1. Submittal data to include the following:

- a. Plans and/or elevations locating and defining all material furnished by the manufacturer.
- b. Sections and details showing blockouts, cast-in items, and their relation to the structure.
- c. Description of all loose, cast-in, and field hardware.

C. Design Calculations

1. Submit stamped design calculations to the Engineer for review.

D. Design Drawings

1. Submit stamped design drawing(s) to the Engineer for review.

E. Submit PCI Certification of Plant.

1.04. PRODUCT DELIVERY, STORAGE, AND HANDLING

A. Delivery and Handling

1. Precast concrete products shall be lifted and supported during manufacturing, stockpiling, transporting, and erection operations only at the lifting or supporting point, or both, as shown on the Shop Drawings.
2. Keep from contact with adjacent members during and after delivery.
3. Transportation and site handling shall be performed with acceptable equipment and methods and by qualified personnel.

B. Storage

1. Store all units off of the ground on timber skids.
2. Level to avoid twisting or introduction of undesirable stresses.
3. Place units so that identification marks are discernible.

- C. Do not move precast units from manufacturer's yard until design compressive strength of the concrete is achieved.

PART 2 - MATERIALS

2.01. CONCRETE

A. Cast-In-Place

1. Meet the requirements of Section 03 30 10 – CAST-IN-PLACE CONCRETE (SMALL VOLUME).
2. Strength
 - a. Four thousand (4,000) psi at twenty-eight (28) days.

B. Mortar

1. One (1) part Portland Cement, ASTM C150, Type II.
2. Three (3) parts sand, ASTM C144.
3. One-half (1/2) part hydrated lime, ASTM C207, Type S.

C. Grout (Non-shrink)

1. Pre-Mixed
 - a. Master Builders "Masterflow 713";

- b. Sonneborn "Ferrolith G-D.S. Redi-Mixed";
 - c. Or equal.
 - 2. Job-Mixed
 - a. One (1) part Portland Cement, ASTM C150, Type II.
 - b. One (1) part sand, ASTM C144.
 - c. One (1) part shrinkage-correcting aggregate.
 - (1) Master Builders "Embco Aggregate";
 - (2) Sonneborn "Ferrolith G-D.S.";
 - (3) Or equal.
 - D. Reinforcing Steel
 - 1. Minimum of Grade 60 steel.
- 2.02. CIRCULAR MANHOLES
- A. Minimum inside manhole diameter: Five feet (5').
 - B. Provide with a flat-top manhole lid meeting the design requirements of this Section.
 - 1. Flat top lid shall have minimum of a thirty-inch (30") diameter opening to accept the manhole ring and cover.
- 2.03. RECTANGULAR VAULTS
- A. Minimum interior vault dimensions: eight feet (8') long by six feet (6') wide by seven feet (7') high, interior dimensions.
 - 1. 1-1/2- to 4-inch Meters
 - a. 8-feet (length) by 6-Feet (width) by 7-Feet (height).
 - 2. 6-inch and Larger Meters
 - a. 9-Feet (length) by 8-Feet (width) by 7-Feet (height).
 - 3. Larger dimensions may be required to accommodate equipment. These will be considered on a case-by-case basis.

- B. Wall floor, wall, and lid thickness shall be designed to meet the specified loading requirements, but not less than the following:
 - 1. Roof – minimum thickness eight inches (8”).
 - 2. Walls – minimum thickness six inches (6”).
 - 3. Floor – minimum thickness six inches (6”).
- C. Sump
 - 1. Shall have preformed sump in the floor in one corner near the manway.
 - 2. Cover sump with a grate.
 - 3. Acceptable manufacturers
 - a. MA Industries, Model 004-530K-S;
 - b. No substitutions allowed.

2.04. GASKETS

- A. Meet Requirements of F.S. SS-S-00210, Type I, Rope Form.
- B. Diameter
 - 1. One and one-half inch (1½”) for manhole up to sixty inch (60”) diameter.
 - 2. Two-inch (2”) for manholes larger than sixty inch (60”) diameter.
- C. Approved Manufacturers
 - 1. K. T. Snyder Co., “Ram-Nek”;
 - 2. Hamilton-Kent Mfg. Co., “Kent Seal”;
 - 3. NPC Bidco;
 - 4. Or equal.

2.05. RING AND COVER

- A. For traffic area applications:
 - 1. Shall be cast iron designed to support HS-20 loading.
 - 2. Shall have minimum frame clear opening of 27-inches.

3. Shall have an inner "frost proof" lid.
4. Shall have "water" cast on the outside of the lid.
5. Acceptable manufacturers
 - a. Aluminum Ring & Cover shall be Castings, Inc.
 - (1) Model MH-550-31 ALFP (32-inch diameter.)
 - (2) Model MH-700-36 ALFP (Single Lid including lock assembly.)
 - b. No substitutions allowed.

B. For non-traffic area applications:

1. Shall be constructed of fiber reinforced polymer material designed to support HS-20 loading.
2. Shall have a minimum frame clear opening of thirty inches (30").
3. Shall have a gasketed lid.
4. Shall have a cam lock on the lid.
5. Lid shall the word "Water" imprinted in the label area.
6. Acceptable manufacturers
 - a. GMI Composites, Inc.
 - (1) No Frostproof ring.

2.06. STEPS

A. Materials

1. Polypropylene plastic-coated steel.

B. Construction

1. Reinforcing rod: One-half inch (1/2") diameter.
2. Length: Eighteen inches (18"), designed for a minimum 5-7/8-inch (5.875") protrusion from manhole wall.
3. Width: Twelve inches (12").

4. Tread: Notched ridge with retainer lugs on each end.

2.07. PENETRATION SEALS

- A. Install penetration seal assemblies at all pipe penetration locations.

1. Material
 - a. Penetration Seal: EPDM.
2. Accepted Manufacturers
 - a. Thunderline Corp., Link-Seal;
 - b. Or equal.

2.08. INTERIOR COATING

- A. All interior surfaces of manholes and vaults shall be coated with a two part epoxy.
- B. Color: white.
- C. Acceptable Manufacturers
 1. Tamms Duralkote 240;
 2. Or equal.

PART 3 - EXECUTION

3.01. GENERAL

- A. Coat the interior of all manholes and vaults with specified coating system.

3.02. INSTALLATION OF CIRCULAR MANHOLES

- A. Set the two precast deadman beams so that there is not weight from the manhole transferred to the pipeline.
- B. Set each manhole riser section plumb. Use section of various heights to bring ring and cover to grade. Join manhole sections using mortar or pre-formed flexible plastic gaskets. The last barrel section prior to placement of the flat top slab shall be the manufacturer's shortest, but in no case greater than twenty-four inches (24") in height. All joint surfaces shall be clean, dry, and warm during installation. Where mortar joints are used, set each section in a one-inch (1") minimum full bed of mortar. If flexible

gaskets are used, prime entire joint on both barrel sections prior to placement of gasket material.

- C. Install rings and covers on a maximum of one (1) precast adjusting rings or varying heights, not to exceed eight inches (8") in height each. On buried manholes, the total allowable height of adjusting rings and the ring and cover shall be one inch (1") less than the manufacturer's shortest precast barrel section. Set rings in a full bed of mortar and encase in mortar around the entire perimeter. Unless otherwise indicated, set the top of the rings twenty-four inches (24") below finished grade in farmed fields, six inches (6") below finish grade in gravel roadways and such that no part of the ring or cover will project above a point one-quarter inch (1/4") below the finish surface of pavement in paved areas subject to cleaning by snowplows.
- D. Anchor manhole ring and cover to the top of the manhole (or grade rings) with a minimum of 4- 1/2" concrete anchors. If the ring and cover is sitting on grade adjustment rings, the anchors shall be long enough to pass through the grade ring and anchor into the manhole lid.
- E. Fill all lifting holes and other imperfections with mortar. Neatly point inside of joints no matter what joint material is used.

3.03. INSTALLATION OF RECTANGULAR VAULTS

- A. Install vaults at locations indicated on the approved Construction Drawings or located by the Engineer to accommodate field conditions. Record locations of vaults referenced to a minimum of two (2) permanent surface references on "Drawings Record."
- B. Set vault plumb and level.
- C. Join vault sections to lids using mortar or preformed flexible plastic gaskets. All joint surfaces shall be clean, dry, and warm during installation.
- D. Anchor manhole ring and cover to the top of the manhole with a minimum of 4- 1/2" concrete anchors. If the ring and cover is sitting on grade adjustment rings, the anchors shall be long enough to pass through the grade ring and anchor into the vault lid.
- E. Fill all lifting holes and other imperfections with mortar. Neatly point inside of joints no matter what joint material is used.

END OF SECTION

SECTION 31 23 25

FLOWABLE CONCRETE BACKFILL

PART 1 - GENERAL

1.01. DESCRIPTION

- A. This Section covers all work necessary to furnish and install flowable concrete backfill (flowfill) at locations shown on the Drawings, referenced in the Drawings or Specifications, or required by local jurisdiction, e.g., under pavement.

1.02. QUALITY ASSURANCE

- A. All Work shall be performed as specified herein and in accordance with the latest revisions of the following applicable codes and standards:
 - 1. Federal, state, and local codes, regulations, and ordinances.
 - 2. American Society of Testing and Materials (ASTM).
- B. In case of conflict or disagreement between codes, standards, laws, ordinances, rules, and regulations or within any document itself, the more stringent condition shall govern.
 - 1. Where Work required by the Drawings and Specifications is above the standard required by local regulations, the Work shall be completed as shown and/or specified.

1.03. RELATED WORK

- A. Consult all other Sections, determine the extent and character of related Work, and properly coordinate Work specified herein with that specified elsewhere to produce a complete operational installation.

1.04. SUBMITTALS

- A. Submit information as specified in Section 01 33 21 – SHOP DRAWINGS, SAMPLES, AND O&M MANUALS.
- B. Proposed Mix Design
 - 1. Prior to commencing flowfill work, submit proposed mix design with certification that the mix design and components comply with the proportions and physical properties of this section.

PART 2 - MATERIALS

2.01. FLOWFILL MIX

- A. Cement: ASTM C 150, Type II.
- B. Aggregates
 - 1. Fine aggregate: ASTM C 33.
 - 2. Coarse aggregate: ASTM C 33, Size #57.
- C. Water: Shall be clean, fresh, and from a potable source.
- D. Admixtures
 - 1. Air-entraining agent: ASTM C 260.
- E. Fly ash shall not be used.

2.02. PRODUCTION

- A. Flowfill shall be mixed and delivered in a ready-mixed state.
- B. Proportion ingredients to produce a well-graded flowable mix that is consistent with the submitted mix design.
 - 1. Weights shall be based upon aggregates in a saturated, surface dry condition.
 - 2. Air entraining agent shall be used to increase flowability.
- C. Proportions (One (1) Cubic Yard).
 - 1. Cement: One hundred pounds (100 lbs.).
 - 2. Sand: One thousand eight hundred forty-five pounds (1,845 lbs.).
 - 3. Coarse Aggregate: One thousand seven hundred pounds (1,700 lbs.).
 - 4. Water: Three hundred twenty-five pounds (325 lbs.) (39.0 gal.).
 - a. The amount of water shall be such that the flowfill flows into place properly without excessive segregation.
- D. Physical Properties:
 - 1. Minimum twenty-eight (28) day compressive strength: 100 psi.

2. Slump: Six inches (6") to eight inches (8").
3. Air: Six percent (6%) to eight percent (8%).
4. Water/cement ratio (lbs/lb): 3.5.

PART 3 - EXECUTION

3.01. PREPARATION

- A. Install all pipe, fittings, appurtenances, and bedding in accordance with the applicable specification sections or as indicated or shown on the Construction Drawings.

3.02. PLACEMENT

- A. Trench shall be backfilled with flowfill as indicated on the Construction Drawings.
 1. Flowfill shall be vibrated to assure voids will not be present in the flowfill or around or under pipe, fittings, and appurtenances.
- B. Maximum layer thickness for flowfill shall be three feet (3'-0").
 1. Do not place additional layers until the flowfill has lost sufficient moisture to be walked on without indenting more than two (2").

END OF SECTION

SECTION 31 23 35

TRENCHING, BACKFILLING, AND COMPACTING

PART 1 - GENERAL

1.01. DESCRIPTION

- A. This Section addresses excavation and trenching; including subsurface drainage, dewatering, preparation of sub grades, pipe bedding, backfilling, compacting, and finish grading for underground pipelines, service lines and appurtenances.
- B. Reference the Standard Details for various "Bedding Details" pertaining to the type of pipe being installed, e.g., ductile iron, PVC, etc.

1.02. QUALITY ASSURANCE

- A. Soil compaction tests shall be performed in accordance with:
 - 1. ASTM D 2922 - Standard Test Methods for Density of Soil and Soil-Aggregate in Place by Nuclear Methods; or
 - 2. Laboratory Testing.

1.03. JOB CONDITIONS

- A. Drainage and Groundwater
 - 1. Contractor shall obtain all necessary permits prior to starting dewatering operations.
 - a. If groundwater will be discharged into an irrigation ditch, pond, stream or waterway, or will drain to an irrigation ditch, pond, stream or waterway, a Colorado Department of Public Health and Environment (CDPHE) Construction Dewatering Permit will be required.
 - b. Permit applications may take up to 30 days to be reviewed by CDPHE.
 - c. Contractor is required to complete and process the Discharge Monitoring Report (DMR) that is typically a part of the CDPHE Construction Dewatering Permit.
 - d. Upon finishing the work, the Contractor shall be responsible for completing a CDPHE Discharge Termination Notice.

2. Water that is encountered in the trench shall be removed to the extent necessary to:
 - a. Provide a firm sub-grade;
 - b. Permit connections to be made in dry conditions;
3. Groundwater shall be maintained at a minimum level of 12-inches below the bottom of the pipe at all times during installation to prevent the entrance of water into the pipeline.
4. Surface water runoff shall be diverted as necessary to keep excavations and trenches free from water during construction.
5. The excavation or trench shall be kept free from water until the structure, or pipe, to be installed therein, is completed to the extent that no damage from hydrostatic pressure, flotation, or other cause will result.
6. The pipe under construction shall not be used for dewatering.

B. Sequencing

1. Pipeline installation shall be performed within 300 linear feet of the trench excavation process.
 - a. This distance may be amended, with NWCWD's approval, based upon job conditions.
2. Initial trench backfill shall be performed within 300 linear feet of pipeline installation.
 - a. This distance may be amended, with NWCWD's approval, based upon job conditions.
3. Backfill shall be completed, at the end of each day, to the extent that no damage from hydrostatic pressure, floatation, or other cause will result.
4. Where excavation is a hazard to automotive or pedestrian traffic, the amount of open trench and the time duration of that opening is to be minimized.

C. Underground Obstructions

1. The Design Engineer and/or Contractor shall field verify all Record Drawing information obtained from NWCWD.
2. Contractor shall notify each existing Utility Owner and request utilities to be field located by surface reference.

- a. The request for the location of utilities shall be made a minimum of 48 hours prior to trenching or excavation (exclusive of holidays and weekends).
3. The Contractor shall expose and verify (pothole) the size, location, and elevation of underground utilities and other obstructions, sufficiently in advance of construction to permit changes to be made to the Construction Drawings.
 - a. In the event there is a conflict, the Contractor shall notify NWCWD and the affected utility company.
 - b. In the event there is a conflict, the proposed work may be modified, at NWCWD's discretion.
4. Existing improvements, adjacent property (including, but not limited to, private property and public rights-of-way), utilities, trees, and plants that are not to be removed shall be protected from injury or damage resulting from the Contractor's operations.
5. If the Contractor removes any underground obstructions, the following shall apply:
 - a. Drainage culverts may be salvaged and reused in an appropriate location only if certified by the design engineer and if written approval is obtained from NWCWD.
 - (1) All other underground obstructions shall be replaced as directed by the affected utility.
 - (2) All field drains shall be repaired or replaced to their original condition, or better.

1.04. MAINTENANCE AND CORRECTION

1. Contractor shall maintain and repair all trench settlement, resulting from Contractor negligence, which occurs within the two (2) year warranty period, and make necessary repairs to pavement, sidewalks, or other structures which may be damaged as a result of trench settlement.

PART 2 - MATERIALS

2.01. GENERAL

- A. Materials in this Section are classified into the following categories:

1. Stabilization Material;

2. Bedding Zone Materials;
3. Cut-Off Walls;
4. Trench Backfill Material;
5. Crushed Stone or Gravel; and
6. Crushed Rock Base – for Structures.

2.02. STABILIZATION MATERIAL

- A. If the existing soil in the trench bottom is judged to be unstable by NWCWD and/or the Contractor, the unstable material shall be removed and replaced with an acceptable Stabilization Material.
 1. Stabilization Material shall be crusher-run rock, conforming to the latest edition of ASTM C33 for No. 357 Coarse Concrete Aggregate.
- B. Geosynthetics may be used in conjunction with Stabilization Material as described by the design engineer and with the prior written approval of NWCWD.

2.03. BEDDING ZONE MATERIALS

- A. The Bedding Zone shall extend from 4-inches (minimum) below the bottom of the pipe barrel, i.e., the “Pipe Base,” to 6-inches (minimum) above the top of the pipe barrel.
- B. The use of cohesive and/or native soils in the Bedding Zone is prohibited.
- C. Bedding Zone materials shall be one of the following granular materials specified in this Paragraph 2.03.
 1. Flowable concrete backfill may be used if approved by NWCWD.
 - a. Refer to Section 31 23 25 for requirements.
 2. Screened Pipe Bedding Material shall meet the following gradation:

Sieve Size	Percent Passing
1”	100
¾”	90
#4	0-50

3. Squeegee

a. Squeegee shall meet the following gradation:

Sieve Size	Percent Passing
3/8"	100
#4	70
#8	10

4. Sand

a. If noted on the Construction Drawings and approved by the Engineer, the Bedding Zone Material may be sand conforming to the following gradation:

Sieve Size	Percent Passing
3/8"	100
#4	70 – 100
#8	36 – 93
#16	20 – 80
#30	8 – 65
#50	2 – 30
#100	1 - 10

2.04. CUTOFF WALLS

A. If compacted soil is used for cutoff walls, e.g., "trench plugs," it shall meet the following soil classifications:

1. SC - clayey sands, sand-clay mixtures; or
2. CL - inorganic clays of low to medium plasticity, gravelly clays, sandy clays, silty clays, lean clays.

- B. CH - inorganic clays of high plasticity, fat clays may be considered on a case-by-case basis and shall be approved by NWCWD prior to use.
- C. Flowable concrete backfill used for cutoff walls must be approved, in writing, by NWCWD.
 - 1. Refer to Section 31 23 25 for requirements.

2.05. TRENCH BACKFILL MATERIAL

- A. Trench Backfill Material shall be placed from a point six (6) inches above the pipe to twelve (12) inches below the ground surface or to the bottom of the designed thickness of the pavement subgrade, whichever is greater.
- B. Trench Backfill Material shall be either soil excavated from the trench or imported soil.
 - 1. Any soil used for Trench Backfill Material shall be free from frozen matter, stumps, roots, brush, other organic matter, cinders or other corrosive material, debris, and any rocks or stones which are larger than six (6) inches, in any dimension.
 - a. Rocks or stones which are six (6) inches or larger may be used in trench backfill material with prior written approval of NWCWD.
- C. If imported soil is used for Trench Backfill Material, it shall meet CDOT specifications for Class #1 structural backfill.

Sieve Size	Percent Passing
2"	100
#4	30 - 100
#50	10 - 60
#100	5 - 20

2.06. CRUSHED STONE OR GRAVEL

- A. Well-graded crushed stone or gravel meeting the requirement of ASTM D448 (Size No. 3).
 - 1. Refer to the Standard Details for locations.

2.07. CRUSHED ROCK BASE – FOR STRUCTURES

A. Crushed rock base for structures, e.g., vault/manhole bases, shall be Class 4 Aggregate Base Course, per CDOT's Standard Specifications – latest edition.

1. Refer to the Standard Details for locations.

2.08. TRACER WIRE

A. Refer to Section 33 14 10.

2.09. DETECTABLE WARNING TAPE

A. Refer to Section 33 14 10.

PART 3 - EXECUTION

3.01. PREPARATION

A. Topsoil shall be stripped from all areas which are to be disturbed by construction and stockpiled. This shall include all areas that will be disturbed by trenching, areas where spoil piles will be placed along the entire width of the permanent and temporary easements.

1. Topsoil shall be segregated from non-organic trench excavation material and debris.

3.02. TRENCHING

A. Trenches shall be excavated by open cut methods, except where boring or tunneling is shown on drawings, or approved by NWCWD.

B. Care shall be used when operating mechanical equipment in locations where it may cause damage to trees, buildings, culverts, or other existing property, utilities, or structures above or below ground.

C. Mechanical equipment shall be operated in such a manner that the bottom elevation of the trench can be maintained with uniform trench widths and vertical sidewalls of the Bedding Zone.

D. Trench alignment shall be sufficiently accurate to permit pipe to be aligned properly with an eight (8) inch minimum clearance between the pipe and the sidewalls of the trench or trench box.

1. The trench sidewall shall not be undercut in order to obtain clearance.

2. The proper/adequate trench width shall be excavated prior to placement of the pipe in the trench, i.e., not after the pipe is laying in the trench.

E. Preparation of trench bottom.

1. Trench bottom shall be graded uniformly to provide clearance for each section of pipe.
2. Loose material, water, and foreign objects shall be removed from the trench.
3. Contractor shall excavate a bell hole large enough to accommodate the size of pipe being installed. The barrel of the pipe shall be fully supported by bedding material when installed in the trench. Pipe bells shall not be point-loaded due to the lack of sufficiently-large bell holes.
4. The Contractor shall provide a firm sub grade, which is suitable for placement of Bedding Zone Materials.
5. If the trench bottom is judged to be unstable by NWCWD, the unstable material shall be removed and replaced with an acceptable Stabilization Material, specified above.
 - a. The over-excavation depth shall be a minimum of 6-inches.
6. The Contractor shall over-excavate a minimum of 6-inches below the bottom of the pipe wherever the trench bottom is rock or other unsuitable material.
7. Over-excavation shall be backfilled and compacted with Stabilization Material specified above.

3.03. STOCKPILING EXCAVATED MATERIALS

- A. Suitable material for backfilling shall be stockpiled in an orderly manner, and stored a minimum safe distance from the edge of the trench commensurate with OSHA's Trenching and Excavation Safety Guidelines.
- B. Excess excavated materials not suitable or not required for backfilling shall be disposed of away from the immediate work area.
- C. Excavated material shall not be stockpiled against or over existing structures or appurtenances.

3.04. PIPE BEDDING

- A. Placement and compaction.
 1. Reference the "Bedding Details" in the Standard Details.

2. Bedding Zone Material shall be distributed and graded to provide uniform and continuous support beneath the entire pipe barrel at all points between bell ends or pipe joints.
 - a. Pipe shall not be supported by the bells.
 - b. The pipe base, i.e., the Bedding Zone Material under the pipe barrel, shall be prepared to the thickness specified in Paragraph 2.03.A and the grades and elevations shown on the Drawings.
3. To prevent lateral displacement, Bedding Zone Material shall be deposited and compacted uniformly and simultaneously on each side of the pipe.
 - a. Bedding Zone Material shall not be dropped onto unsupported pipe.
4. Bedding Zone Material shall be consolidated under and around the pipe.

3.05. CUTOFF WALLS

- A. Cutoff walls shall be constructed in such a manner as to impede passage of water along the pipeline alignment through bedding material for the full depth of the Bedding Zone Material, as follows:
 1. Cutoff walls shall be approximately four (4) feet long (parallel with the pipeline) and spaced not more than four hundred (400) feet apart, unless shown otherwise on the Drawings.
 2. Both sides and the bottom of cutoff walls shall be keyed one (1) foot into existing trench bottom and side walls, and extend up to original onsite material, or to within one (1) foot of finished grade, the bottom of the topsoil, or the bottom of the designed pavement section.

3.06. BACKFILLING AND COMPACTION

- A. All trench backfill shall be compacted.
 1. Backfill of pipe and appurtenances and around vaults and valve boxes shall be compacted with equipment and in a manner which is capable of producing the required results.
- B. Backfill material shall be deposited in uniform horizontal layers which shall not exceed six (6) inches (compacted depth), in all areas, unless otherwise approved by NWCWD.
- C. Methods and equipment which are appropriate for the backfill of material shall be utilized.

1. Backfill equipment or backfilling methods which may damage the pipe shall not be used.
- D. Compaction shall not be performed by jetting or water settling.
- E. Sheeting (if Contractor elects to use sheeting)
1. Sheeting system shall be designed by a professional engineer (P.E.), registered in the State of Colorado.
 2. Sheeting system design shall include the design, installation, and removal of the sheeting system components..
- F. Topsoil shall be replaced to the depth of stripping over all areas which are to be reseeded.
- G. Excess excavated material and materials not suitable for backfill shall be disposed of properly.

3.07. FIELD QUALITY CONTROL

- A. This section applies to all water lines and appurtenances that are maintained by NWCWD and located within public rights-of-way or within easements on private property.
- B. Field moisture/density control
1. Laboratory testing is required in conjunction with the following field tests:
 - a. Field tests will be conducted to determine compliance of moisture/density requirements in accordance with ASTM D 2922 (Tests for Density of Soil and Soil-Aggregate in Place by Nuclear Methods).
 - b. Moisture/density tests are the responsibility of the Contractor, and shall be performed by a private Geotechnical Consultant.
 - (1) The method of testing of the compacted material and the validity of the results shall be the responsibility of the Geotechnical Consultant.
 - (2) Test results shall be submitted to NWCWD by the Contractor or the Geotechnical Consultant within 24 hours of the test or by the end of the next working day.
 - (a) Copies of the field work sheets are acceptable.
 - c. Summarized test results shall be submitted to NWCWD prior to the Conditional Acceptance of the water system.

- d. Moisture/density tests shall be performed at a depth of two (2) feet above the top of the Bedding Zone and in two (2) foot increments up to the final grade.
 - e. Moisture/density tests shall be performed at a minimum of four hundred (400) linear feet, as measured along the length of the pipe, or as determined by NWCWD.
 - f. Moisture/density tests in the vicinity of vaults and valve boxes shall be performed at a maximum of one (1) foot away from the vault sections or valve box.
 - (1) Tests shall be performed in random directions from the vault or valve box on separate lifts.
 - (2) A minimum of one (1) test shall be performed for every two (2) feet of backfill material.
 - g. Moisture/density tests shall be performed below the finished subgrade, and a minimum of one time for each service line installed, unless otherwise specified by NWCWD.
 - h. All failed test areas shall be re-compacted and retested.
- C. Compaction shall be to the following minimum densities (Reference ASTM D 698 or AASHTO T99, unless otherwise indicated):
- 1. Bedding Zone Material
 - a. 80% of relative density (ASTM D 4253 and D 4254 – or – ASTM D7382); or
 - b. 90% of maximum dry density (ASTM D 698).
 - 2. Cutoff Walls
 - a. 95% of maximum density (ASTM D 698).
 - 3. Trench Backfill Material
 - a. Paved roadways, sidewalks, and other areas which are to be paved: per the local jurisdiction’s requirements, e.g., Weld County, etc.
 - b. Gravel roadways: 95% of maximum dry density (ASTM D 698) – or - per the local jurisdiction’s requirements, e.g., Weld County, etc., whichever is greater.
 - c. Fields and landscaped areas: 85% of maximum dry density (ASTM D 698).

- d. Under footings, foundations, or structures: 100% of maximum dry density (ASTM D 698).
- e. All other locations: 95% of maximum dry density (ASTM D 698).

D. Moisture content

1. All compacted backfill shall be within 2% (+/-) of the optimum moisture content of the soil as determined by ASTM D 698. Variances may be requested by submitting a report and recommendation from a private Geotechnical Consultant accompanied with a letter that specifically identifies the variance. Submittals should be directed to the NWCWD and/or the Engineer.
2. Water shall be added to the material, or the material shall be harrowed, disked, bladed, or otherwise worked to ensure uniform moisture content, as specified.

END OF SECTION

SECTION 32 01 10

PAVEMENT REPAIR AND RESURFACING

PART 1 - GENERAL

1.01. DESCRIPTION

- A. This Section addresses surface obstructions which the Contractor must remove and replace, such as pavement, drives, curbs, gutters, sidewalks, and similar surfaces, as required to perform the Work.
- B. The words Standard Street Specifications, as used herein, refer to the current engineering and construction standards for roads of the agency having jurisdiction, e.g., Weld County Public Works, Larimer County Engineering, CDOT, etc.

PART 2 - MATERIALS

2.01. AGGREGATE, ASPHALT, AND CONCRETE

- A. All materials and workmanship, such as but not limited to aggregate, bituminous material, and concrete, which are used in the repair of surface obstructions, shall conform to the specifications of the agency having jurisdiction. Contact NWCWD for specifications if jurisdiction has not been established.

PART 3 - EXECUTION

3.01. MANHOLE FRAMES AND VALVE BOXES

- A. Prior to placing the base course, manhole frames and water valve boxes shall be raised to final grade. Manholes/vaults shall be adjusted using a minimum of 4-inch and a maximum of 8-inches of adjustment rings.
 - 1. The adjustment rings shall be installed in accordance with the manufacturer's recommendations.
- B. All foreign matter shall be removed from the manholes and valve boxes immediately.
- C. All valve boxes and manhole covers shall be straight and properly aligned.
 - 1. Valve boxes shall be inspected by placing a valve key on the operating nut to assure a proper alignment and that the valve box is plumb.

3.02. ASPHALT AND CONCRETE, INCLUDING BASE AND GRAVEL SURFACING

- A. The Contractor shall remove, dispose of, and restore asphalt, concrete pavement, curbs, drives, sidewalks and gravel surfacing in accordance with the Standard Street Specifications.
 - 1. Contractor shall repair any damage to existing pavement, curbs, drives, or sidewalks which was caused by the work, as shown on the Construction Drawings or as directed by NWCWD.
- B. Concrete drives, curbs, gutters, sidewalks, and similar structures shall be removed, disposed of, and restored in accordance with the agency having jurisdiction. The following minimum thicknesses shall apply if jurisdiction has not been established:
 - 1. Driveways and slabs shall be a minimum six (6) inches thick.
 - 2. Patios shall be a minimum four (4) inches thick.
 - 3. Gutters shall be a minimum six (6) inches thick.
 - 4. Concrete bases for brick pavers and concrete pavement shall be a minimum six (6) inches thick.
 - 5. Sidewalks shall be a minimum six (6) inches thick.
 - 6. Cross pans shall be a minimum eight (8) inches thick.
 - 7. Reference Section 03 30 10 – CAST-IN-PLACE CONCRETE (SMALL VOLUME).

3.03. FIELD QUALITY CONTROL

- A. Reference the Standard Street Specifications of the agency having jurisdiction.

END OF SECTION

SECTION 33 01 11

DISINFECTION OF DOMESTIC WATERLINES

PART 1 - GENERAL

1.01. DESCRIPTION

- A. This Section covers the filling and disinfection of potable water pipelines and associated appurtenances.
- B. NWCWD alone shall operate existing valves to prevent the disinfectant solution from flowing back into the line supplying the water or into adjacent parts of the in-service distribution system.
- C. The Contractor is responsible for the disinfection and testing of water lines.

1.02. PRODUCT DELIVERY, STORAGE, AND HANDLING

- A. Reference the Forwards to AWWA B300 and AWWA C651.

PART 2 - MATERIALS

2.01. HYPOCHLORITES

- A. Reference AWWA B300.

2.02. ADHESIVE

- A. Any adhesive used to adhere hypochlorite tablets to the interior of the pipe shall be a food grade adhesive, which has received NSF/ANSI 61 approval for uses that may involve contact with edible products.

PART 3 - EXECUTION

3.01. GENERAL

- A. The contractor shall flush and satisfactorily disinfect new water lines prior to placing them in service in accordance with AWWA C651.
- B. Filling pipe
 - 1. NWCWD shall operate existing valves to fill the pipe. The Contractor shall open new valves, air valves, blow-offs, and hydrants. NWCWD shall witness testing and operation.

2. Where permanent air valves are not available, the Contractor shall install corporation stops at high points in the water line, in order to evacuate air.

3.02. PRELIMINARY FLUSHING

- A. NWCWD shall flush pipelines at a minimum velocity of 2.5 Feet-Per-Second (FPS) in order to remove foreign material prior to disinfection.

1. Preliminary flushing shall not be performed if the tablet or granular method of disinfection is approved by NWCWD.

3.03. METHODS

A. General

1. NWCWD shall:
 - a. Review the disinfection method proposed by Contractor.
 - b. Sample and test flows from the pipe system extremities until clear, potable water is obtained.
2. The Contractor shall:
 - a. Propose chlorination method.
 - b. Properly dispose of flush water, including dechlorination.

B. Tablet/Granular Method

1. The Tablet Method consists of placing calcium hypochlorite granules and tablets in the water main during construction, and filling the main with potable water when installation is completed.
 - a. The Tablet Method shall not be used if trench water or foreign material has entered the water line, or if the water temperature is below forty-one degrees Fahrenheit (41°F).
 - (1) If trench water or foreign material has entered the water line, or if the water temperature is below forty-one degrees Fahrenheit (41°F), the Continuous-Feed Method of chlorination shall be used.
 - b. Calcium hypochlorite granules shall be placed at the upstream end of the first section of pipe, at the upstream end of each branch main, and at 500-foot intervals.
 - (1) Reference Table 1, AWWA C651.

- c. 5-gram calcium hypochlorite tablets shall be placed in each section of pipe, hydrant, hydrant lateral, and other appurtenances.
 - (1) Reference Table 2, AWWA C651.
- d. Tablets and granules shall be placed in sufficient number and amount to produce a minimum chlorine concentration in the treated water of 50 milligrams per liter (mg/L).
- e. Except in hydrants and joints, tablets shall be attached with an approved adhesive specified above, and shall be on the top of the interior of the pipe in such a manner that there is no adhesive on the tablet except on the broad side of the tablet next to the pipe surface.
- f. NWCWD shall introduce water into the pipes at a velocity of less than 1 FPS.
- g. The chlorinated water shall be retained in the lines for a minimum of 24 hours. At that time, the treated water must contain no less than 25 mg/L of chlorine throughout the entire length of the main. The chlorinated water shall be flushed within five (5) days, unless otherwise approved by NWCWD.

C. Continuous-Feed Method

- 1. The Continuous-Feed Method of disinfecting water mains consists of placing calcium hypochlorite granules in the main during construction, completely filling the main to remove all air pockets, flushing the completed main to remove the particulates, and filling the main with potable water chlorinated so that after a 24 hour holding period in the main, there will be a free chlorine residual of not less than 10 mg/L.
 - a. Calcium hypochlorite granules shall be placed in the pipe sections during construction as specified above for the Tablet/Granular Method.
 - b. Preliminary flushing shall occur.
 - (1) Reference Paragraph 3.02 and AWWA C651.
 - c. Chlorinated water shall be introduced into the water lines at a constant, measured rate so that the chlorine concentration is maintained at a minimum of 25 mg/L of free chlorine.
 - (1) The entire main shall be filled with the chlorine solution.
 - (2) Reference Table 4 of AWWA C651.

- d. The chlorinated water shall be retained in the main for a minimum of 24 hours, at which time the treated water must contain no less than 10 mg/L of free chlorine residual throughout the entire length of the main.

D. Slug Method

1. The Slug Method of disinfecting water lines shall be used only at the direction of NWCWD.
 - a. Reference AWWA C651.

3.04. FINAL FLUSHING

- A. After chlorination, NWCWD shall assist the contractor with flushing the chlorinated water from the water lines until the chlorine concentration is no higher than that prevailing in the system, or is less than 1 mg/L, whichever is higher. The Contractor shall be responsible for all necessary permits and to ensure that no environmental damage occurs.
 1. Reference Appendix B of AWWA C651 for a list of neutralizing chemicals.

3.05. BACTERIOLOGICAL TESTS

- A. An accredited water quality control laboratory, as previously approved by NWCWD, shall collect samples from the pipeline after final flushing, and prior to placing water lines in service, to test for bacteriological quality to show the absence of coliform organisms. Payment for testing shall be the responsibility of the Contractor.
- B. The number and frequency of samples shall be determined by the approved laboratory based upon AWWA C651:
 1. Take one (1) sample for every twelve hundred feet (1,200 ft) of waterline.
 2. Take one (1) sample at every dead end line.
 3. In no case shall the number of samples be less than one (1).

3.06. REPETITION OF PROCEDURE

- A. If the initial disinfection, or subsequent disinfections, fails to produce satisfactory samples, the main shall be reflushed and resampled. If the samples are still not satisfactory, the main shall be rechlorinated by the Continuous-Feed or the Slug Method of chlorination until satisfactory results are obtained.
- B. If the residual is less than 25 mg/L as stated in Paragraph 3.03, the water lines shall be rechlorinated by the Continuous-Feed or Slug Method of chlorination and retested.

END OF SECTION

(THIS PAGE INTENTIONALLY LEFT BLANK)

SECTION 33 05 06

TESTING PIPING SYSTEM

PART 1 - GENERAL

1.01. DESCRIPTION

- A. This Section covers the hydrostatic testing of water distribution lines.
- B. Once the pipeline has been filled and disinfected, and backfilling has been completed and approved, a pressure test shall be conducted.
 - 1. The Contractor shall provide all equipment and personnel to perform the hydrostatic test. Pressure testing equipment shall be approved by NWCWD prior to commencing testing.
 - a. Test equipment shall be able to maintain a continuous internal pipe pressure of 150 pounds-per-square-inch (psi) and accurately measure leakage from the pipe over a 2 hour, minimum, test period.
 - (1) Higher test pressure may be required, as may be required by NWCWD
 - b. The maximum allowable pressure gauge increment shall be 5 psi.
 - c. A water meter shall be used to measure the amount of water used in pressurizing the system.
 - 2. NWCWD will record times, leakage readings, and pressures over the test period.
- C. Testing shall not occur until at least 7 days have elapsed since the last concrete thrust block was poured.
 - 1. A minimum of 72 hours shall have elapsed if high-early-strength cement was used.
- D. Testing shall not occur until after the pipeline has been chlorinated and flushed.
- E. Pipe shall remain filled with water for a minimum of 24 hours prior to the hydrostatic pressure test.
- F. Unless prior permission is given by NWCWD, the hydrostatic pressure test shall be performed against all valves within the new piping system.

1.02. PRESSURE TEST

- A. Test Pressure and Duration

1. For steel pipe, ductile iron pipe, cast iron pipe, and PVC pipe, the minimum test pressure shall be 150 psi.
2. A residual pressure of within 5 psi of the test pressure shall be maintained for a minimum of 2 hours.

B. ALLOWABLE LEAKAGE

1. "Leakage" is the quantity of water that must be added to the pipeline to maintain a pressure of within 5 psi of the specified test pressure, after the air has been expelled and the pipe has been filled with water.
2. The maximum allowable leakage for each test section of ductile iron pipe and PVC pipe shall be determined by the following formula:

$$L = \frac{S \cdot D \cdot \sqrt{P}}{148,000}$$

Where:

L = Maximum allowable leakage, in gallons/hour;

S = Length of pipe tested, in feet;

D = Nominal pipe diameter, in inches; and

P = Average test pressure during the leakage test, in psi.

- a. Reference AWWA C600.

C. Other Requirements

1. Unless prior written permission is given by NWCWD, a test section shall not be any longer than the length of pipe between adjacent line valves.
2. Testing through fire hydrants shall not be allowed, unless approved by NWCWD.

1.03. PASSING

- A. If the tests disclose leakage greater than that allowed, the defective materials and joints shall be located and repaired.
 1. The tests shall be repeated until the leakage is less than the maximum allowed.
- B. With the exception of obvious leaks, passing of the pressure test shall be on the basis of maximum allowable leakage per section tested.

C. All visible leaks shall be repaired regardless of maximum allowable leakage.

PART 2 - MATERIALS

(NOT USED)

PART 3 - EXECUTION

(NOT USED)

END OF SECTION

(THIS PAGE INTENTIONALLY LEFT BLANK)

SECTION 33 05 08

PIPE BORING AND JACKING

PART 1 - GENERAL

1.01. DESCRIPTION

- A. This Section is a minimum guideline and addresses the furnishing and the trenchless installation of casing pipe, either by boring or jacking.
- B. Each casing pipe installation shall be specifically designed by the Design Engineer.
- C. Reference the Standard Details for additional information.

1.02. RELATED WORK SPECIFIED ELSEWHERE

- A. 33 05 22: Directional Boring of Pipe.

1.03. QUALITY ASSURANCE

A. Design Criteria

- 1. Specified thickness for pipe and casings are based upon the superimposed loads and not upon the loads which may be placed on the pipe as a result of jacking operations.
 - a. Increased pipe strength shall be provided as necessary to withstand jacking loads.

B. Construction Criteria

- 1. Owner/Contractor shall obtain the necessary permits from the appropriate agencies prior to commencing construction.
- 2. Owner/Contractor shall obtain the bonds or the indemnity which are required by the permits for protection against any damage and interference with traffic and service which are caused by the construction activities.
- 3. All excavations shall conform to the trenching, backfilling and compacting requirements set forth in Section 31 23 35 – TRENCHING, BACKFILLING, AND COMPACTING.

- C. All work shall be performed as specified herein and in accordance with the latest revisions of the following applicable codes and standards:

1. Federal, state, and local codes, regulations, and ordinances.
 2. American Society of Testing and Materials (ASTM).
 3. American Welding Society (AWS).
 4. American Wood Products Association (AWPA).
 5. American Petroleum Institute (API).
- D. Welding procedures, welders, and welding operations shall be qualified and certified in accordance with the AWS for the type of joint and welding procedure used.
1. Maintain welders' certification(s) on file at site.
 2. Certification or re-certification shall be within six (6) months prior to commencing any welding operations.
- E. Certificates of Insurance
1. Provide all insurance certificates required to NWCWD and appropriate regulatory agencies and/or entities.
- F. In case of conflict or disagreement between codes, standards, laws ordinances, rules and regulations, or within any document itself, the more stringent requirements, as determined by NWCWD, shall govern.
1. Where Work required by the Drawings and Specifications is above the standard required by local regulations or recommended standards, it shall be completed as shown and/or specified.

1.04. SUBMITTALS

- A. Reference SECTION 01 33 21 – SHOP DRAWINGS, SAMPLES, AND O&M MANUALS.
- B. Certification
1. Submit manufacturer's certification that materials meet referenced standards.
- C. Shop Drawings
1. Submit details of the method of operation, support system, and liner to be used.
 2. If tunnel liner plates are to be used, submit manufacturer's drawings and specifications on the proposed materials.

PART 2 - MATERIALS

2.01. CASING PIPE

A. Steel Pipe

1. Nominal inside diameter: As specified on Construction Drawings.
2. Standard: ASTM A 139, Grade B.
3. Yield Point: 35,000 psi.
4. Wall Thickness: Minimum three-eighth inch (3/8") or thicker if required by NWCWD Engineer or by the agency granting crossing permit.
5. Beveled for field welding.
6. Smooth, continuous, and uniform with no exterior voids.

2.02. ACCESSORIES

A. End Seals

1. Shall be high density rubber or polyethylene with stainless steel straps.
2. May be either pull-on or wrap style.
3. Acceptable Manufacturers
 - a. PSI, Model R;
 - b. GTP, Model C or Model W;
 - c. Cascade Waterworks Mfg.;
 - d. No substitutions allowed.

B. Casing Spacers

1. Insulators
 - a. Bands and Risers
 - (1) Stainless steel, Type 304.
 - (2) Minimum twelve-inch (12") wide.
 - (3) Minimum fourteen (14) gauge thickness.

- (4) Riser height as required by casing and carrier pipe.
- b. Two-piece construction.
- c. Liner
 - (1) Elastomeric PVC or Neoprene rubber.
 - (2) Minimum three-thirty-second-inch (3/32") thickness.
- d. Runner
 - (1) Width: Two-inch (2") minimum.
 - (2) Length: Eleven-inch (11") minimum.
 - (3) Material: UHMW polyethylene.
 - (4) Heavy-duty, high abrasion resistance.
 - (5) Low friction coefficient.
- e. Non-corrosive bands and fasteners.
- f. Minimum five-sixteenths-inch (5/16") diameter bolts.
- g. Number of runners
 - (1) Four-inch (4") – sixteen-inch (16"): Two (2) top and two (2) bottom.
 - (a) Note that fourteen-inch (14") pipe is no longer installed in NWCWD.

2. Acceptable Manufacturers

- a. PowerSeal;
- b. Ford;
- c. Pipeline Seal & Insulator;
- d. Cascade Waterworks, Mfg.;
- e. No Substitutions Allowed.

2.03. CONTACT GROUT

A. Grouting Equipment

1. Contractor is responsible for supplying the equipment necessary to complete the work as specified herein.

B. Material

1. Portland cement shall be in accordance with ASTM C150, Type II or Type III.
2. Contact Grout shall be a mixture of Portland cement and water with a maximum water/cement ratio of 1:1 by volume and a 28 day strength of at least 500 psi. Sand may be added only with approval of NWCWD.

C. Grouting Ports

1. The Casing Pipe shall be provided with ports for injection of Contact Grout.
2. Port locations shall be spaced no greater than 10 feet longitudinally.
3. The ports shall be installed during the manufacturing of the pipe. No ports shall be added in the field.
4. The ports shall be supplied with threaded grout port plugs.
5. Ports shall be:
 - a. Specifically designed by the pipe manufacturer;
 - b. In accordance with the pipe manufacturer's specifications and guidelines;
 - c. Plugged following use; and
 - d. Water tight and in full compliance with the pipe design requirements including but not limited to pressure rating, resistance to corrosion, and other forms of degradation and smoothness.

2.04. CATHODIC PROTECTION

- A. Refer to the Standard Detail entitled "STEEL CASING PIPE".
- B. Refer to Section 33 14 10 – WATER DISTRIBUTION SYSTEM.

PART 3 - EXECUTION

3.01. CASING PIPE INSTALLATION

A. General

1. Vertical and horizontal offset staking shall be provided at both ends of bored or jacked crossings.
2. Casing pipe shall be installed at the grade and alignment shown on the Construction Drawings
 - a. Grade and alignment shall not deviate by more than 0.3 feet from that shown on the Construction Drawings.
3. Casing pipe shall be installed as indicated in the Construction Drawings, whether that is by open trench excavation or by jacking methods.
 - a. Open trench installation of the casing pipe shall be in accordance with Section 31 23 35 – TRENCHING, BACKFILLING, AND COMPACTING.
4. The earth which is displaced by the casing pipe shall be disposed of properly.
5. Each section of casing pipe shall be welded with a full penetration butt weld around the entire circumference of the joint to form a watertight continuous conduit capable of resisting all stresses, including jacking stresses.

B. Grouting

1. All spaces between the casing pipe and the earth shall be filled with grout immediately upon installation of the final section of casing pipe.
 - a. Grout connections on the interior of the casing pipe shall be provided at ten (10) feet on-center intervals.
2. Grouting operations shall be performed in a sequence which will preclude any deflections which exceed 5% of the tunnel diameter.
3. After the grout is in place, each hole shall be plugged in order to prevent the backflow of grout.
4. Seal weld all grout plugs.

3.02. CARRIER PIPE INSTALLATION

- A. Carrier pipe shall be installed at the grade shown on the Construction Drawings.
- B. Each section of pipe shall have a minimum of three (3) casing spacers.
- C. Restrain all joints within the casing.
- D. The annular space between the casing and the carrier pipes shall be left vacant.

E. The ends of the casing pipe shall be sealed with casing seals.

3.03. INSTALLATION OF CATHODIC PROTECTION

A. Install anode as shown on the Standard Detail entitled, "STEEL CASING PIPE."

B. Install anode and associated components per the manufacturer's instructions.

END OF SECTION

(THIS PAGE INTENTIONALLY LEFT BLANK)

SECTION 33 05 10

TAPPING SLEEVES AND VALVES

PART 1 - GENERAL

1.01. DESCRIPTION

- A. This Section covers large diameter (3- through 12-inch) connection outlets to pressurized water mains (4- through 30-inch in diameter) by means of sleeve tapping with tapping valves, i.e., not tapping saddles.
 - 1. Wet taps larger than 12-inch on lines larger than 30-inch will be considered on a case-by-case basis by NWCWD.
 - 2. Refer to Section 33 14 18 – SERVICE LINES AND APPURTENANCES – for tapping saddles, i.e., outlets 2-inches and smaller.
- B. Installation and performance of the tapping work is considered a specialty and shall be performed by a Specialty Contractor who can demonstrate sufficient experience and expertise to satisfy the specified Quality Assurance requirements.

1.02. QUALITY ASSURANCE

- A. Perform all work as specified herein and in accordance with the latest revisions of the following codes and standards.
 - 1. Federal, state, and local codes, regulations, and ordinances.
 - 2. American National Standard Institute (ANSI).
 - 3. American Water Works Association (AWWA).
 - 4. American Society for Testing and Materials (ASTM).
- B. In case of conflict or disagreement between codes, standards, laws, ordinances, rules and regulations, or within any document itself, the more stringent condition, as determined by NWCWD, shall govern.
- C. Prior to commencement of the tapping operation the Contractor shall submit sufficient evidence of the tapping Specialty Contractor's experience to satisfy the Engineer and NWCWD that the Specialty Contractor is suitably qualified and experienced to perform this Work.
- D. Minimum requirements for the Specialty Contractor are as follows:

1. Experience of Specialty Contractor
 - a. A minimum of ten (10) consecutive years of experience with performing tapping operations on pressurized water distribution pipelines sized 12-inches and larger, making branch connections between 6-inches and full line size.
2. Experience of Specialty Contractor's staff
 - a. The person in responsible charge in the field for the Specialty Contractor for the tapping operation shall have been regularly engaged in this work for a minimum of one (1) year, and shall have regularly, and successfully, performed similar taps on pressurized pipelines of similar pipe size and pipe material as required for this Contract.
3. References
 - a. Provide contact names and phone numbers from a minimum of three (3) public water systems in the state of Colorado for which similar taps have been successfully performed within the past twelve (12) months by the specialty sub-contractor and staff proposed for use on this Contract.

1.03. SUBMITTALS

A. Certification

1. Submit manufacturer's certification that products meet the referenced standards.
2. Submit manufacturer's certification that products are NSF 61 certified for potable water service.

B. Submit documentation to confirm that the Specialty Contractor satisfies the Quality Assurance requirements specified.

C. Reference SECTION 01 33 21 – SHOP DRAWINGS, SAMPLES, AND O&M MANUALS.

1.04. PRODUCT DELIVERY, STORAGE, AND HANDLING

A. Prevent damage to materials during delivery or storage.

B. Store valves, sleeves, and appurtenances off the ground and away from materials that could contaminate potable water systems.

C. Keep joints and internal parts clean.

1.05. INSTALLATION OF WET TAPS

- A. The Specialty Contractor shall not make any taps without prior permission from NWCWD.
- B. All taps shall be made with a tapping sleeve in accordance with these Specifications and with the manufacturer's recommendations, unless otherwise approved by NWCWD.
- C. Service taps on live mains will be made only under the direct supervision of NWCWD. The Contractor shall coordinate with the NWCWD Representative.
- D. Size on size tapping is prohibited.
- E. Tapping equipment shall be of good quality, used for the purpose intended, and used in accordance with manufacturer's instructions.
 - 1. Reference SECTION 01 60 10 – MATERIALS, EQUIPMENT, AND WORKMANSHIP.

PART 2 - MATERIALS

2.01. TAPPING SLEEVE

- A. Standards for 4- through 30-inch mains and 4- through 12-inch branch outlets, in accordance with AWWA C223 with the following additional requirements or exceptions:
 - 1. Sizes: As shown on approved Construction Drawings.
 - 2. Tapped Main Material
 - a. C900 PVC Pipe;
 - b. Ductile Iron Pipe (DIP); or
 - c. Asbestos Cement (AC) Pipe.
 - 3. Material: Type 304L stainless steel, per ANSI 21.11
 - a. Entire stainless-steel sleeve shall be fully-passivated.
 - 4. Minimum working pressure: One hundred fifty pounds per square inch (150 psi).
 - 5. Outlet connection: Stainless steel mechanical joint (MJ).
 - 6. Testing Outlet

- a. A ¾ inch NPT by welded by welded coupling shall be attached to the outlet nozzle of each tapping sleeve assembly complete with a ¾ inch square head pipe plug.
7. Gasket
- a. Provide a “Waffle: style gasket with a full 360-degree seal.
 - b. Virgin NBR (R78) material, with integral “raised” ring seal to aid in high pressure sealing.
 - c. Gaskets shall be NSF 61-certified for potable water service.
8. Nuts, bolts, and washers
- a. Type 304 stainless steel, per ASTM A193 and ASTM A194.
 - (1) Stainless steel hex nuts shall be furnished with fusion bonded coating to prevent seizing and galling.
9. Flanges shall be fabricated of type 304 stainless steel per ANSI 21.11. In addition, the machined face shall be recessed for tapping valves in accordance with MSS SP-60. The following exception applies for the PowerSeal 3490MJ. This tapping sleeve has a MJ outlet that accepts a MJ x MJ valve.
10. Acceptable Manufacturers and Models
- a. Powerseal, Model 3490 MJ;
 - b. Ford, Model FAST, FTSS, or FTSAS with MJ Adapter Outlet;
 - c. Romac, Model SST III, SS MJ outlet;
 - d. No substitutions allowed.

2.02. TAPPING VALVES

A. GENERAL

- 1. All tapping valves shall be resilient-seated gate valves, manufactured in accordance with AWWA C509, with the following additional requirements or exceptions. Reduced-wall gate valves may be supplied in accordance with AWWA C515.

B. VALVE SIZE AND DESCRIPTION

- 1. Tapping valves specified in this Section are 3- to 12-inch nominal sizes.

2. The standard direction of opening is counterclockwise as viewed from the top (open-left).

C. INLET END OF VALVE

1. Inlet end of valve shall be MJ. All dimensions and drillings of the MJ shall conform to the dimensions of MSS SP-60 in 3- through 12-inch nominal pipe sizes.
2. Inlet end of the valve shall be mechanical joint type if PowerSeal Model 3490MJ sleeve is used.

D. OUTLET END OF VALVE

1. Outlet end of tapping valve mating with the tapping machine must be parallel and concentric with the opposite flange and concentric with the waterway to provide proper alignment for the tapping operation.
2. Outlet end of valve shall have a standard mechanical joint end conforming to AWWA C111.

E. SEAT RING SIZE

1. Body of the valve and seat opening shall be sized large enough to accommodate the following sizes of shell cutters.

APPROVED SHELL CUTTER DIAMETERS		
Tapping Valve Size	Cutter Diameter	Tolerance
4"	3-7/8"	±1/32"
6"	5-13/16"	±1/32"
8"	7-7/8"	±1/32"
10"	9-3/4"	±1/32"
12"	11-7/8"	±1/32"

F. SERVICE

1. All valves shall be suitable for frequent operation as well as service involving long periods of inactivity. Valves shall be capable of operating satisfactorily with flows in either direction, and shall provide zero leakage past the seat. The operating pressure for all sizes shall be 200 psig.

G. TESTING

1. The valve manufacturer shall test all valves according to AWWA C509.

H. COATING

1. All valves shall be epoxy coated inside and out according to AWWA C550.

I. CERTIFICATION

1. The manufacturer shall furnish a sworn statement that the inspection and all of the specified tests have been made, and the results thereof comply with the requirements of the applicable Standards herein specified. A copy of the Certification including compliance with NSF/ANSI 61 shall be sent to NWCWD.

J. ACCEPTABLE MANUFACTURERS

APPROVED RESILIENT SEATED TAPPING VALVES			
Manufacturer	Coating	Open	Joint Ends
Mueller	Epoxy	Left	MJ x MJ
Clow			
Kennedy			
U.S. Pipe			
American AVK			
American Flow Control			

PART 3 - EXECUTION

3.01. GENERAL

- A. Tap PVC Pipe in general accordance with the "PVC Pressure Pipe Tapping Guide" by the Uni-Bell PVC Pipe Association.
 1. In particular, refer to this document for minimum distances from pipe ends, joints, fittings, etc.

3.02. TAPPING

- A. Properly prepare and secure the excavation, exposing the pipe to be tapped. Confirm the pipe material, class, thickness, and type is suitable for the tapping operation and that the correct sleeve is furnished for each tapping operation.
- B. Provide NWCWD with a minimum of forty-eight (48) hours advance notice of the tapping operation.
- C. Coordinate with NWCWD to identify any valves in the vicinity of the work that NWCWD can operate in the event that this should be necessary.
- D. Provide suitable support to the tapping valve, sleeve and accessories to prevent transferring forces to the existing pipeline during the tapping operation and when subsequently backfilling the excavation and carefully compacting the backfill.
- E. Following installation of the tapping sleeve and valve, but prior to beginning the tap, pressure test the sleeve to one hundred fifty pounds per square inch (150 psi) for ten (10) minutes to confirm there is no visible leakage.
- F. Upon completion of the tapping operation inspect the sleeve and valve to ensure there is no leakage. Any visible leakage shall be stopped prior to backfilling.

3.03. INSPECTION

- A. The Contractor shall insure that the tapping sleeve and valve remain exposed until after the inspection/mapping and the approval for backfill is given by NWCWD.
- B. All tap inspections shall be scheduled with NWCWD.
 - 1. A minimum of 48 hours notice is required on all tap and service inspections.

END OF SECTION

(THIS PAGE INTENTIONALLY LEFT BLANK)

SECTION 33 05 20

DUCTILE IRON PIPE AND FITTINGS

PART 1 - GENERAL

1.01. DESCRIPTION

- A. This Section addresses ductile iron pipe, fittings, flanges, special couplings, and other accessories. NWCWD approval is required for the use or installation of ductile iron pipe.
- B. Pipe shall be furnished complete with all fittings, flanges, specials and other accessories.

1.02. QUALITY ASSURANCE

- A. Perform all work in accordance with the latest revisions of the following codes and standards.
 - 1. Federal, state, and local codes, regulations, and ordinances.
 - 2. American National Standard Institute (ANSI).
 - 3. American Water Works Association (AWWA).
 - 4. American Society for Testing and Materials (ASTM).
 - 5. American Society of Mechanical Engineers (ASME).
 - 6. Ductile Iron Pipe Research Association (DIPRA).
- B. In case of conflict or disagreement between codes, standards, laws, ordinances, rules and regulations, or within any document itself, the more stringent condition, as determined by NWCWD, shall govern.

1.03. SUBMITTALS

- A. Certification
 - 1. Submit manufacturer's certification that products meet the referenced standards.
 - 2. Submit manufacturer's certification that products are NSF 61 certified for potable water service.
- B. Shop Drawings
 - 1. Submit complete layout drawings and details of connections for all piping.

C. Reference SECTION 01 33 21 – SHOP DRAWINGS, SAMPLES, AND O&M MANUALS.

1.04. PRODUCT DELIVERY, STORAGE, AND HANDLING

A. Handling

1. Slings, pipe tongs, or skids shall be used for handling pipe.
2. Pipe or fittings shall not be dropped.
3. Care must be taken to prevent damage to the pipe and fittings by impact, bending, compression, or abrasion.
4. Damaged pipe or fittings shall not be installed.

B. Storage

1. Lubricant shall not be stored and used in a manner which will prevent contamination.
2. Rubber gaskets shall be stored in a location which protects them from deterioration or damage.
3. The maximum stacking heights of pipe as listed in AWWA C600 shall not be exceeded.

PART 2 - MATERIALS

2.01. DUCTILE IRON PIPE

A. General

1. Standards

- a. Ductile iron pipe shall conform to ANSI/AWWA C151/A21.51, subject to the following supplemental requirements:

(1) The pipe shall be of the diameter shown, furnished complete with gaskets, all required appurtenances, and fittings, as indicated on the Construction Drawings.

2. Laying Lengths

- a. Pipe laying lengths shall be provided in 20-foot nominal lengths with allowable trim pipe lengths in accordance with ANSI/AWWA C151/A21.51

and special shorter lengths provided as required by the Construction Drawings.

- b. Random lengths shall not be accepted.

B. Design Parameters

1. All ductile iron pipe shall be designed and manufactured in accordance with ANSI/AWWA C150/A21.50 and ANSI/AWWA C151/A21.51, respectively, for the following minimum operating conditions:
 - a. Minimum internal design pressure shall be 150 psi with a 100-psi surge allowance and a safety factor of 2, for a total internal design pressure of 500 psi. No reduction of safety factor for transient pressures shall be allowed.
 - b. The external loads design criteria shall be a minimum of five feet (5'-0") depth of cover at one hundred twenty pounds (120 lbs.) per cubic foot soil weight and live load based on one (1) AASHTO H-20 truck load.
 - c. The thickness design of ductile iron pipe shall be in accordance with ANSI/AWWA C150/A21.50.
 - d. The horizontal deflection of cement-mortar lined ductile iron pipe resulting from external load conditions shall not exceed three percent (3%) of the pipe diameter.

C. Minimum Pipe Class

1. All pipe shall be specified as pressure class and shall have a minimum pressure rating as indicated below:
 - a. 4- through 54-inch: Special Thickness Class 52.
 - b. Standard Pressure Class pipe may be allowed as determined by the Engineer and by NWCWD.

D. Linings

1. General
 - a. Except otherwise provided herein, interior surfaces of all ductile iron pipe shall be lined with cement mortar lining applied in conformity with ANSI/AWWA C104/A21.4.
 - b. Minimum lining thickness shall be the "double" thickness, per ANSI/AWWA C104/A21.4

E. Coatings

1. Underground Locations, e.g., Buried

a. Type:

- (1) The exterior of ductile iron pipe shall be coated with a layer of arc-sprayed zinc per ISO 8179.
- (2) The mass of the zinc applied shall be 200 g/m² of pipe surface area.
- (3) A finishing layer topcoat shall be applied to the zinc.
- (4) The coating system shall conform in every respect to ISO 8179-1 "Ductile iron pipes - External zinc-based coating - Part 1: Metallic zinc with finishing layer. Second edition 2004-06-01."

b. Refer to Paragraph 2.05.D of this Section for polyethylene encasement requirements.

2. Submerged Locations, e.g. Under Water, including Groundwater

a. Type: Tnemec Series 69 Epoxy, or equal.

b. Thickness

- (1) First (1st) Coat: 4-5 mils DFT.
- (2) Second (2nd) Coat: 5-6 mils DFT.

c. Sandblast per Manufacturer's recommendations.

3. Exposed Locations, e.g., Above Ground or In Vaults

a. Pipe primer: Tnemec Series 37H Chem Prime ("77 Red"), or equal.

b. Flange faces: Rust-Oleum "R-9", or equal.

F. Acceptable Manufacturers

1. American Cast Iron Pipe Company;
2. U.S. Pipe;
3. McWane Ductile;
4. No substitutions allowed.

2.02. JOINTS

A. General

1. Ductile iron pipe and fittings shall be furnished with push-on joints, push-on restrained joints, mechanical joints, restrained mechanical joints, and flanged joints as required.
2. Provide joint restraint for all mechanical joints.

B. Push-on Joints

1. Push-on joints shall conform to ANSI/AWWA C111/A21.11.
2. Gasket material shall be styrene-butadiene.
3. Gasket material for air shall be EPDM or Viton as required for operating temperature.
4. Lubricant shall be furnished by pipe manufacturer.
5. Pressure rating for push-on joints shall be a minimum specified pressure rating of the pipe.

C. Flanged Joints

1. Flanged joints shall conform to ANSI/AWWA C115/A21.15, ANSI/AWWA C153/A21.53, ANSI/ASME B16.5, and ANSI/ASME B16.1.
2. Threaded companion flanges for ductile iron pipe shall be ductile iron in accordance with ANSI/AWWA C115/A21.15, not ANSI/ASME B16.1.
3. Bolt circle and bolt holes shall be of ANSI/ASME B16.1 for Class 125 and ANSI/ASME B16.5 for Class 150 flanges.
4. Flanges shall be rated for at least 250 psi working pressure.
5. Bolts, gaskets, and installation shall be in accordance with ANSI/AWWA C115/A21.15 requirements.
6. Gasket material shall be styrene-butadiene.
7. Gasket material for air shall be EPDM or Viton as required for operating temperature.
8. Flanged joints are not acceptable for use in buried service, unless shown otherwise on the Construction Drawing and approved by NWCWD.

D. Restrained Joints

1. General

- a. Restrained joints and restrained joint pipe shall be rated for the specified pressure rating of the pipe.
- b. Gasket material shall be styrene rubber (SBR).

2. Restrained Push-on Joints

- a. Joint design to provide essentially boltless method of joint restraint that prevents disengagement.
- b. Design shall permit deflection of the joint after assembly.
- c. Ductile iron locking components inserted into the bell face to provide positive axial lock between bell interior surface and retainer weldment on spigot end.
 - (1) Design shall allow disassembly without damage to components.
- d. Provide all specialty gaskets and accessories that are required for the system.

2.03. FITTINGS

A. General

- 1. Fittings shall be ductile iron in accordance with ANSI/AWWA C111/A21.11, ANSI/AWWA C110/A21.10, or ANSI/AWWA C153/A21.53.
- 2. Pressure Rating
 - a. Buried service for push-on, restrained push-on, or mechanical joints:
 - (1) 4- through 24-inches: 350 psi.
 - b. Exposed service for flanged joints:
 - (1) 4- through 64-inches: 250 psi.

B. Joint

- 1. Buried locations: Mechanical joint with restraining gland.
- 2. Exposed locations: Flanged joint.

C. Lining

1. Except otherwise provided herein, interior surfaces of all fittings and specials shall be lined with either:
 - a. Cement mortar lining applied in conformity with ANSI/AWWA C104/A21.4; or
 - b. Fusion-bonded epoxy, per AWWA C116.

D. Coatings

1. Underground Locations:
 - a. Zinc with finishing layer topcoat, per Paragraph 2.01.E.1 of this Section; or
 - b. Fusion-bonded epoxy, per AWWA C116.
2. Exposed Locations
 - a. Pipe primer: Tnemec: Series 37H Chem Prime (“77 Red”), or equal.
 - b. Fusion-bonded epoxy, per AWWA C116.
 - c. Flange faces: Rust-Oleum “R-9,” or equal.

E. Acceptable Manufacturers

1. Griffin Pipe Products;
2. Sigma;
3. Star Pipe Products;
4. Tyler Pipe Products;
5. Union Foundry Company;
6. U.S. Pipe;
7. American Cast Iron Pipe Company;
8. No substitutions allowed.

2.04. COUPLINGS

A. General

1. The manufacturer of the coupling shall be experienced in their design and construction shall be regularly engaged in their manufacture and shall have produced couplings of the sizes specified herein which have given successful service for a period of at least 5 years.

B. Mechanical Couplings and Transition Couplings

1. Mechanical couplings shall conform to ANSI/AWWA C219.
2. Type: Mechanical compression sleeve.
3. Materials
 - a. Center Barrel: Ductile Iron in accordance with ASTM A536.
 - b. End Ring: Ductile Iron in accordance with ASTM A536.
 - c. Hardware: Type 304 stainless steel, per ANSI 21.11
 - (1) Stainless steel hex nuts shall be furnished with fusion bonded coating to prevent seizing and galling.
 - (2) The manufacturer shall supply information as to the recommended torque to which the bolts shall be tightened.
4. Coating
 - a. Coating shall conform to ANSI/AWWA C550.
 - (1) Epoxy coated, interior and exterior ferrous surfaces.
5. Gaskets
 - (1) Gaskets shall conform to ASTM D 2000.
 - (a) Gasket material shall be styrene-butadiene.
6. Uses:
 - a. Connect Asbestos Cement (AC) or IPS PVC pipe to C900 PVC or DI pipe.
 - b. Locations where angular deflection greater than the specified joint offset limitations or less than an elbow is required.
7. Accepted Manufacturers and Models
 - a. Non-Restrained

- (1) Romac, XR501 (4- through 12-inch);
- (2) Romac, Macro HP (2- through 12-inch); or
- (3) Power Seal, Power Max 3506/3506LB (2- through 16-inch);
- (4) No substitutions allowed.

b. Restrained

- (1) Romac, Model Alpha;
- (2) Romac, Model 400RG;
- (3) Or Approved Equal.

C. Flanged Coupling Adapters

1. Mechanical couplings shall conform to ANSI/AWWA C219.
2. Material
 - a. Body shall be ductile iron in accordance with ASTM A536.
 - (1) Flange coupling adapters with pipe penetrating anchor or locking pins will not be allowed.
 - b. Hardware: Refer to Paragraph 2.04.B.3 for requirements.
3. Flanges
 - a. Flanges shall be compatible with ASME B16.1, Class 125.
4. Coating
 - a. Coating shall conform to ANSI/AWWA C550.
 - (1) Epoxy-coated, interior and exterior ferrous surfaces.
5. Gaskets
 - a. Gaskets shall conform to ASTM D 2000.
 - (1) Gasket material shall be styrene-butadiene.
6. Accepted Manufacturers
 - a. EBAA Iron Sales, Inc.; or

- b. Romac, Model FCG;
- c. Romac, Model RFCA (Restrained DIP);
- d. Romac, Model RFCA-PVC (Restrained PVC);
- e. No substitutions allowed.

2.05. ACCESSORIES

A. Fastening Hardware

- 1. All nuts and bolts shall be high-strength low-alloy COR-TEN, manufactured in accordance with ANSI-A21.11-85 (AWWA C111).
- 2. Required lengths and torques for T-bolts are listed in the following table:

APPROVED TEE-HEAD BOLT SIZES AND TORQUES				
Pipe Size	Number	Size	Length	Torque (ft/lbs)
3"	4	5/8"	3"	45-60
4"	4	3/4"	3½"	75-90
6"	6	3/4"	4"	75-90
8"	6	3/4"	4"	75-90
10"	8	3/4"	4"	75-90
12"	8	3/4"	4"	75-90

B. Joint Restraint Devices

- 1. Mechanical Joint Restraints
 - a. Joint restraint shall be incorporated in the design of the follower gland, per AWWA C111.
 - b. Multiple wedging action shall be imparted against the pipe when the restraining mechanism is actuated.
 - (1) Resistance shall be increased as pressure increases.
 - c. Flexibility shall be maintained after burial.

- d. Restraining gland and components shall be ductile iron, per ASTM A 536.
 - (1) Dimensions shall permit use with standardized mechanical joint fittings.
 - (2) The gripping surfaces shall be wedges or a 360° grip-ring designed to spread the bearing surfaces on the pipe.
- e. Pressure Rating
 - (1) Minimum 2:1 safety factor.
 - (2) Rated for the full working pressure of the type and pressure rating for the pipe they are installed on.
- f. Provide twist-off nuts to ensure proper actuating of the restraining device.
 - (1) Provide secondary hex-head nuts to permit disassembly without damage to components.
 - (2) Torque range for T-bolts, per AWWA C600.
- g. Provide all specialty gaskets and accessories that are required for the system.
- h. Lubricant shall be furnished by pipe manufacturer.
- i. Pipe penetrating anchor or locking pin restraints will not be allowed.
- j. Acceptable Manufacturers:
 - (1) Approved Mechanical Joint Restraints for AWWA C900 PVC Pipe:

Manufacturer	Model	Pipe Size
Star	PVC Stargrip series 4000	4"-12"
Star	PVCGrip series 3500	4"-12"
Ford	Ford Circle-Lock series 1500C	4"-12"

- (2) Approved Mechanical Joint Restraints for ASTM D2241 PVC (IPS):

Manufacturer	Model	Pipe Size
Star	PVC Stargrip series 4000	4"-12"
Star	PVCGrip series 3500	4"-12"
Ford	Ford Circle-Lock series 1500S	4"-12"

(3) Approved Mechanical Joint Restraints for DI Pipe:

Manufacturer	Model	Pipe Size
EBA	MEGALUG Series 1100	4"-36"
Ford	Series 1400	4"-36"
Star	Series 3000	4"-36"

(4) No substitutions allowed.

C. Gaskets

1. The standard MJ gasket shall be made of vulcanized styrene rubber in accordance with AWWA C111.

D. Polyethylene Encasement

1. Shall be manufactured in accordance with AWWA C105.
2. Raw material used to manufacturer polyethylene film shall be in accordance with ASTM D1248: Type 1, Class A, Grade E-1.
3. Polyethylene encasement shall consist of three layers of co-extruded linear low density polyethylene (LLDPE), fused into a single layer.
4. The inside surface of the polyethylene encasement to be in contact with the pipe, fitting, or valve exterior shall be infused with a blend of anti- microbial biocide to mitigate microbiologically influenced corrosion and a volatile corrosion inhibitor to control galvanic corrosion.
5. Properties
 - a. The polyethylene film shall meet the following properties and requirements:

Property	Minimum Requirements
Tensile Strength	3,600 psi, per ASTM D882
Elongation	800%, per ASTM D882
Dielectric Strength	800 V/mil thickness, per ASTM D149
Impact Resistance	600 g, per ASTM D1709 Method B
Thickness	8 mils (0.008-inches)
Propagation Tear Resistance	2,550 grams force, per ASTM D1922

6. Color:
 - a. Potable Water: Clear or White
 - b. Non-Potable Water: Purple.
7. Products: V-Bio Enhanced Polyethylene Encasement, or approved equal.

E. Tracer Wire

1. Reference Section 33 14 10 – WATER DISTRIBUTION SYSTEM.

PART 3 - EXECUTION

3.01. INSTALLATION

- A. Reference Section 33 14 10 – WATER DISTRIBUTION SYSTEM.

END OF SECTION

(THIS PAGE INTENTIONALLY LEFT BLANK)

SECTION 33 05 22

DIRECTIONAL BORING OF PIPE

PART 1 - GENERAL

1.01. DESCRIPTION

- A. This Section includes materials and installation of fused joint PVC pipe by the directional boring method.

1.02. RELATED WORK SPECIFIED ELSEWHERE

- A. 31 23 35: Trenching, Backfilling, and Compacting.
- B. 33 05 06: Testing Piping System.
- C. 33 05 08: Pipe Boring and Jacking.
- D. 33 05 29: Plastic Pressure Pipe.
- E. 33 14 10: Water Distribution System.

1.03. SUBMITTALS

- A. Submit in accordance with Section 01 33 21.
- B. Qualifications Package:
 - 1. The Contractor shall submit references from at least three similar directional drilling operations as part of the required submittals within the last three years. The reference projects shall have been for directional drilling installation of HDPE water lines, 16-inches in diameter or greater, with one project containing a minimum single pull-in length of at least 1,500 feet.
 - 2. Directional Drilling Operator and Locator
 - a. Submit references and resumes listing projects of similar scopes and sizes.
 - 3. Directional Drilling Equipment Information and Certification
 - a. Submit documentation indicating the applicability of equipment commensurate with the size and scope of the project. Contractor shall perform an analysis and calculate the required pull-back force and submit these calculations and specifications on the directional drilling equipment

to be used to ensure that the equipment will be adequate to complete the project.

C. Work Plan:

1. A description of all equipment to be used, down-hole tools, a list of personnel and their qualifications and experience (including backup personnel in the event that an individual is unavailable), and a list of subcontractors.
2. Submit drawings showing proposed method of construction including location of receiving and sending pits.
3. A schedule of HDD work activity identifying daily work hours and working dates for each installation.
4. Submit proposed pressure testing location for pipe before directional boring.
5. Submit an accurate record of the crossing location in plan view and profile depth. Record all changes on the contract drawings as work progresses.
6. Calculations signed and sealed by a professional engineer licensed in the state of Colorado demonstrating a factor of safety of 20 against buckling of the pipe considering the materials and equipment to be used.
7. A project safety plan (including MSDS of any potentially hazardous substances to be used).
8. An environmental protection and contingency plan which shall include but shall not be limited to drilling fluid containment and cleanup procedures, equipment and plan for compromised utility installations including electrical and power lines, water, wastewater and any other subsurface utility.
9. Work plan should be comprehensive, realistic and based on actual working conditions for this particular project. Plan should document the thoughtful planning required to successfully complete the project.

PART 2 - MATERIALS

2.01. FUSED JOINT PVC PIPE

- A. Refer to Section 33 05 29.

2.02. DRILLING FLUID

- A. Drilling fluid shall be bentonite and water or a combination of bentonite and polymers and water formulated to move cuttings to the surface and lubricate the pipe during pullback.

2.03. DRILL PIPE

- A. Drill pipe shall be steel with sufficient strength to withstand the maximum rated pullback and pushing load of the drilling equipment. Drill pipe joints shall be flush and capable of transmitting maximum rated torque of the drilling equipment.

2.04. DRILLING EQUIPMENT

- A. Drilling equipment shall have a maximum sound power level of 85 dBA (as defined in ANSI S1.4) at 10-feet when operating within 100-feet of a residential unit. Measure sound power level in accordance with ISO 3740 and 3744.

- 1. If the local jurisdiction's requirements are more stringent, comply with the local jurisdiction's requirements.

- B. Mixing, pumping, and holding/separation tanks shall be capable of delivering mixed drilling fluid to the cutting head. Drilling fluids circulating equipment shall be designed to minimize spillage.

2.05. DOWNHOLE TOOLS

- A. Cutting heads, backreamers, and hole openers shall be suitable for the soil and rock conditions anticipated by the Contractor.
- B. Grips, pulling heads, and swivels shall be compatible with the pipe material. Design to transmit without distortion the maximum rated pullback force of the equipment used. Grips, pulling heads, and swivels shall be specifically engineered for directional drilling applications.
- C. Tracking equipment shall be capable of determining the location of the cutting head at depth within ± 3 inches.

2.06. TRACER WIRE

- A. Refer to Section 33 14 10.

PART 3 - EXECUTION

3.01. GENERAL

- A. In general, installation of fused joint PVC pipe by directional boring shall follow the pipe manufacturer's guidelines in addition to the requirements specified herein.

3.02. INSTALLATION

- A. The pipe shall follow the line and grade shown in the Drawings and shall exit the ground within five feet of the design location.
- B. Install the pipe in a manner that does not cause upheaval, settlement, cracking, movement, or distortion of the surface material including, but not limited to retaining walls, roadways, and channel bottom.
- C. Locate the entrance and exit pits to be within the construction limits delineated on the Drawings.

3.03. TRENCHING AND EARTHWORK

- A. Accomplish trenching and earthwork in accordance with Section 31 23 35.

3.04. PIPE JOINING

A. PVC Pipe

- 1. Refer to Section 33 05 19.

- B. Where the staging area permits, join entire length of pipe to be pulled through bore prior to commencement of pullback operation. If not feasible because of the length of the bore and the size of the staging area, each pipe section may be fused or welded to the previous section before the pull back. Support weight of joined pipe suspended on rollers to minimize pulling forces.

3.05. PRE-BORE AND POST-BORE PRESSURE TESTING

- A. Prior to pulling the pipe through the directional bore hole, the pipe shall be tested by conducting a low-pressure air test at 4-5 psi test for two hours.
- B. Perform pressure testing again after final installation of the pipe and before final acceptance by NWCWD in accordance with Section 33 05 06.
- C. At the Contractor's option, pipe need not be pressure tested before pulling the pipe through the bore hole. In such case, if the pipe does not pass the pressure test after installation, then remove the entire pipe from the bore hole, repair the pipe, and perform pressure testing prior to reinstalling the pipe and again after reinstallation.

- D. NWCWD will witness the pressure tests and shall be informed a minimum of 48 hours in advance of pressure tests.

3.06. PILOT BORE

- A. Construct a pilot bore at the centerline alignment and grade as shown in the Drawings. Circulate drilling fluids to maintain an open bore at all times. If the path of the pilot bore is successfully completed, then proceed with the reaming procedure, and pull the pipe from the receiving location (exit pit) to the sending location (entry pit). If the pilot bore could not be successfully completed, then do not proceed with the reaming procedure until NWCWD, the Engineer, and the Contractor have met to discuss alternative options for the pipeline crossing. The pilot bore and reaming procedure shall be controlled by a magnetic survey system including accelerometers, magnetometers, connector wire, and survey probe. The guidance system shall be capable of measuring depth, location, pitch, and roll of the bore and shall be able to indicate depth up to 30 feet.
- B. If the pilot bore is abandoned, fill the pilot bore with abandonment grout. Submit mix design to NWCWD.

3.07. DRILLING FLUID CONTAINMENT AND DISPOSAL

- A. Contain and dispose of the drilling mud in accordance with local, state, and federal regulations and permit conditions. Install erosion and sedimentation control measures including straw bales to prevent drilling mud from inadvertently spilling out of the entrance/exit pit. Monitor drilling fluids at the surface to avoid excessive downhole pressures which may buckle the surface or the pipe during installation.

3.08. BACKREAMING BORE AND PIPE INSTALLATION

- A. Upon completing the pilot bore, pull the drill pipe back through the bore using an oversized backreamer larger than the proposed pipe to be pulled back through the bore hole. Repeat backreaming as necessary to enlarge the bore to provide sufficient clearance for the pipe. Attach pulling head and swivel and pull pipe through with closed end. Pull pipe back in one continuous pull to avoid closure of the bore hole.

3.09. INSTALLATION OF TRACER WIRE

- A. Install along the entire pipeline, regardless of pipe material or size.
- B. Refer to Section 33 14 10 for other requirements.

END OF SECTION

(THIS PAGE INTENTIONALLY LEFT BLANK)

SECTION 33 05 29

PLASTIC PRESSURE PIPE

PART 1 - GENERAL

1.01. DESCRIPTION

- A. This Section addresses plastic pressure pipe from 4- to 30-inch nominal diameters with ductile iron pipe outside diameter and includes the acceptable materials and construction practices which may be used in the installation of plastic pressure pipe.
 - 1. All pipe shall be furnished complete with all fittings, specials, and other accessories.
 - 2. All pipes larger than 30-inch nominal diameter shall be Ductile Iron Pipe. Reference SECTION 33 05 20 – DUCTILE IRON PIPE AND FITTINGS.
- B. This Section covers both potable and non-potable water pipe applications.

1.02. RELATED WORK SPECIFIED ELSEWHERE

- A. 33 05 20: Ductile Iron Pipe and Fittings.
- B. 33 14 10: Water Distribution System.

1.03. QUALITY ASSURANCE

- A. American Water Works Association (AWWA) C900.
- B. NSF 61 rated for potable water service.
- C. Material shall meet ASTM D 1784.
- D. Dimensions shall meet AWWA C900.
- E. Joints gaskets shall meet ASTM F477.
- F. Joints shall meet ASTM D3139 for tightness.
- G. In case of conflict or disagreement between codes, standards, laws, ordinances, rules and regulations, or within any document itself, the more stringent condition, as determined by NWCWD, shall govern.

1.04. SUBMITTALS

- A. Certification

1. Submit manufacturer's certification that products meet the referenced standards.
 2. Submit manufacturer's certification that products are NSF 61 certified for potable water service.
- B. Reference SECTION 01 33 21 – SHOP DRAWINGS, SAMPLES, AND O&M MANUALS.

1.05. PRODUCT DELIVERY, STORAGE, AND HANDLING

A. Handling

1. Pipe shall not be handled in a manner which will cause damage to the pipe.
2. Pipe or fittings shall not be dropped.
3. Care must be taken to prevent damage to the pipe and fittings by impact, bending, compression, or abrasion.
4. Damaged pipe or fittings shall not be installed.

B. Storage

1. Lubricant shall not be stored or handled in a manner which will cause contamination to the lubricant.
2. Rubber gaskets shall be stored in a location which protects them from deterioration.
3. Pipe shall be stored in accordance with the manufacturer's specifications.
4. Pipe shall be stored on a surface which provides even support for the pipe barrel.
5. Pipe shall not be stored in such a way as to be supported by the bell.
6. Pipe which has a longitudinal deflection greater than 1/8 inch per foot shall not be used.
7. Pipe which exhibits any signs of ultraviolet deterioration shall not be used.

PART 2 - MATERIALS

2.01. PLASTIC PRESSURE PIPE 4- THROUGH 30-INCH

A. Shall conform to AWWA C900.

1. Outside diameter basis: Cast Iron Pipe.

2. Pipe Classes

a. Mainline

- (1) Either DR 14 (305 psi) or DR 18 (235 psi), as determined by NWCWD, for pipes 4- through 12-inch.
- (2) Either DR 18 (235 psi) or DR 21 (200 psi), as determined by NWCWD, for pipes 16- through 30-inch.

b. Hydrant Laterals: DR 14 (305 psi).

c. Blowoff Laterals: Shall be DIP, refer to SECTION 33 05 20 – DUCTILE IRON PIPE.

B. Joints

1. Shall be push-on type with an integral bell and elastomeric gasket.
2. Solvent cement (glued) joints are strictly prohibited.

C. Pipe Length and Color

1. Pipes shall be a standard lay length of 20-Feet.
2. Color
 - a. Potable water application: blue.
 - b. Non-potable application: purple.

D. Acceptable Manufacturers

1. North American Pipe Corporation;
2. JM Eagle;
3. Diamond Plastics Corporation;
4. IPEX;
5. Vinyltech Corporation;
6. Certainteed Corporation;
7. No substitutions allowed.

2.02. FUSED JOINT PLASTIC PRESSURE PIPE, 4- THROUGH 16-INCH

- A. Fused joint PVC will be approved for use on a case-by-case basis by NWCWD.
- B. Shall conform to AWWA C900.
 - 1. Outside Diameter Basis: Cast Iron Pipe.
- C. Four-inch (4") through eight-inch (8") and twelve-inch (12") diameter:
 - 1. Pipe Class: DR 14 (305 psi), or as determined otherwise by NWCWD.
- D. Sixteen-inch (16") diameter:
 - 1. Pipe Class: DR 18 (235 psi), or as determined otherwise by NWCWD.
- E. Joints
 - 1. Shall be extruded with plain ends.
 - 2. The ends shall be square to the pipe and free of any bevel or chamfer. There shall be no bell or gasket of any kind incorporated into the pipe. Unless otherwise specified, fusible polyvinylchloride pipe lengths shall be assembled in the field with butt-fused joints. The fusion technician shall follow the pipe supplier's guidelines for this procedure. All fusion joints shall be completed as described in this specification.
- F. Pipe Length and Color
 - 1. Pipes shall be a standard lay length of 40-Feet or 45-Feet.
 - a. Random lengths are not acceptable.
 - 2. Color
 - a. Potable water application: powder blue.
 - b. Non-potable application: purple.
- G. Markings
 - 1. Pipe shall be marked containing the following information: Nominal pipe size, PVC, Dimension Ratio, AWWA standard designation number, extrusion production-record code, trademark and cell classification.
- H. Acceptable Manufacturers

1. Underground Solutions;
2. No substitutions allowed.

2.03. FITTINGS

- A. Reference SECTION 33 05 20 – DUCTILE IRON PIPE AND FITTINGS.

2.04. ACCESSORIES

A. Bolts

1. All nuts and bolts shall be high-strength low-alloy COR-TEN, manufactured in accordance with AWWA C111.
2. Torque ranges for bolts shall comply with AWWA C600.

B. Mechanical Joint Restraint Devices

1. Refer to Section 33 05 20 – DUCTILE IRON PIPE AND FITTINGS.

C. Bell and Spigot Joint Restraints

1. Bell and spigot restraint devices for pipe sizes larger than twelve inch (12”) diameter will be considered on a case-by-case basis.
2. Bell and Spigot Joint Restraints, four inch (4”) through twelve inch (12”) diameter.
 - a. All pipe bell-spigot restraint systems shall be manufactured in accordance with AWWA C111.
 - b. Bell restraint glands shall be manufactured of ductile iron conforming to ASTM A536.
 - c. Split rings shall incorporate a series of machined serrations in the inside diameter. Bell restraint glands shall provide 360° contact and support with the pipe wall so no point loading occurs.
 - d. Pressure rating
 - (1) Rated for the full working pressure of the PVC pipe they are installed on.
 - (2) Minimum safety factor of 2:1.
 - e. Threaded Rods and Nuts

(1) All nuts, bolts and rods shall be high-strength low-alloy COR-TEN, manufactured in accordance with AWWA C111.

f. Acceptable Manufacturers

(1) Star Pipe Products, Series 1100;

(2) EBAA Iron, Series 1500;

(3) Ford Meter Box, Series 1390;

(4) Or approved equal.

D. Tracer Wire

1. Reference SECTION 33 14 10 – WATER DISTRIBUTION SYSTEM.

E. Polyethylene Encasement

1. Shall be manufactured in accordance with AWWA C105.

2. Raw material used to manufacturer polyethylene film shall be in accordance with ASTM D1248.

3. Minimum of eight (8) mil thickness.

4. Color:

a. Potable Water: Clear or White

b. Non-Potable Water: Purple.

PART 3 - EXECUTION

3.01. INSTALLATION - GENERAL

A. Reference SECTION 33 14 10 – WATER DISTRIBUTION SYSTEM.

B. PVC pipe shall not be installed when the air temperature or the soil temperature is 32°F or less, unless otherwise approved by NWCWD.

3.02. DELIVERY – PROTECTION OF PIPE

A. The manufacturer shall provide polyethylene material or other suitable bulkheads on the ends of the pipe and on all special openings to keep the interior of the pipe clean. Bulkheads shall be substantial enough to remain intact during shipping until the pipe is

installed. Tape or adhesive shall not be applied to the spigot end of the pipe from the stab-line to the end of the pipe.

B. HANDLING AND STORAGE

1. Pipe shall be off-loaded, loaded, installed, handled, stored and stacked per the pipe supplier's guidelines. These guidelines include compliance with the minimum recommended bend radius and maximum safe pull force for the specific pipe being used.

3.03. FUSED JOINT PVC PIPE

A. GENERAL

1. Fusible PVC pipe shall be fused by qualified fusion technicians holding current qualification credentials for the pipe size being fused, as documented by the pipe supplier.
2. Pipe supplier's procedures shall be followed at all times during fusion operations.
3. Only appropriately sized and outfitted fusion machines that have been approved by the pipe supplier shall be used for the fusion process. This includes requirements for safety, maintenance, and operation with modifications made for PVC.

B. INSTALLATION

1. Installation guidelines from the pipe supplier shall be followed for all installations. The fusible PVC pipe will be installed in a manner so as not to exceed the recommended bending radius guidelines at any time. Where fusible PVC pipe is installed by pulling in tension, the recommended maximum safe pulling force, established by the pipe supplier, shall not be exceeded.
2. The pipe ends shall be square to the pipe and free from any bevel or chamfer.
3. Shall be assembled in the field with butt-fused joints.
4. Butt-fusion shall be performed by a qualified fusion technician in accordance with the manufacturers recommended procedure.
 - a. Each fusion joint shall be recorded and logged by an approved electronic monitoring device (Data Logger) connected to the fusion machine. Data Logger shall utilize the current version of the pipe supplier's recommended and compatible software.

- b. Only appropriately sized and outfitted fusion machines that have been approved by the pipe supplier shall be used in the fusion process.

END OF SECTION

SECTION 33 14 10

WATER DISTRIBUTION SYSTEM

PART 1 - GENERAL

1.01. DESCRIPTION

- A. This Section addresses the acceptable products, materials, and construction practices which may be used in the installation of water distribution mains.
- B. Items also covered by this Section:
 - 1. Tracer Wire and Accessories.
 - 2. Cathodic Protection Systems and Accessories.
 - 3. Repair Clamps.
 - 4. Reduced-Pressure Backflow Prevention Assemblies.
 - 5. Double-Check Backflow Prevention Assemblies.
 - 6. Detectable Warning Tape.

1.02. QUALITY ASSURANCE

- A. Perform all Work as specified herein and in accordance with the latest revisions of the following codes and standards:
 - 1. Federal, state, and local codes, regulations, and ordinances.
 - 2. American National Standard Institute (ANSI).
 - 3. American Water Works Association (AWWA).
 - 4. American Society for Testing and Materials (ASTM).
- B. In case of conflict or disagreement between codes, standards, laws, ordinances, rules and regulations, or within any document itself, the more stringent condition, as determined by NWCWD, shall govern.
- C. Water system installations shall conform to the regulations of the Colorado Department of Public Health and Environment and the Water Quality Control Commission.
- D. Construction staking

1. Reference Section 01 45 00 – QUALITY CONTROL.
 - E. Horizontal alignment shall not deviate by more than six (6) inches.
 - F. Vertical alignment shall not deviate by more than three (3) inches, as measured from the pipe invert.
 - G. The minimum restrained lengths for Valves and Fittings shall be as specified in the Standard Details. Refer to "Horizontal Bend Restraint" and "Vertical Bend Restraint."
- 1.03. SUBMITTALS
- A. Submit information as specified in each Section.
 - B. Reference SECTION 01 33 21 – SHOP DRAWINGS, SAMPLES, AND O&M MANUALS.
 - C. CERTIFICATION
 1. The manufacturer shall furnish a sworn statement that the inspection and all of the specified tests have been made, and the results thereof comply with the requirements of the applicable Standards herein specified. A copy of the Certification including compliance with NSF/ANSI 61 shall be sent to the District.
- 1.04. PRODUCT DELIVERY, STORAGE, AND HANDLING
- A. Reference the following Sections:
 1. 03 30 10 - CAST-IN-PLACE CONCRETE (SMALL VOLUME).
 2. 03 40 00 – PRECAST CONCRETE.
 3. 31 23 25 – TRENCHING, BACKFILLING, AND COMPACTING.
 4. 32 01 10 – PAVEMENT REPAIR AND RESURFACING.
 5. 33 05 08 – PIPE BORING AND JACKING.
 6. 33 05 10 - TAPPING SLEEVE AND VALVES.
 7. 33 05 20 – DUCTILE IRON PIPE AND FITTINGS.
 8. 33 05 29 - PLASTIC PRESSURE PIPE.
 9. 33 14 18 - SERVICE LINES AND APPRTENANCES.
 10. 33 14 20 – VALVES.
 11. 33 14 22 – HYDRANTS.

1.05. JOB CONDITIONS

- A. Foreign material (debris, tools, clothing, or other material), including trench water, shall not be permitted in the pipe.
- B. In order to prevent water, debris, and animals from entering the pipe, the open ends of the pipe shall have a watertight plug installed when pipe laying is not in progress.
- C. Effective measures shall be used to prevent uplifting or floating of the pipeline prior to completion of the backfilling operations. Dewatering methods and procedures shall be the responsibility of the installation contractor.
- D. Pipe shall not be installed under the following conditions:
 - 1. When the trench contains water.
 - 2. When weather conditions are unsuitable.
 - a. Temperature is less than 10° Fahrenheit. NWCWD approval is required when the temperature is 32° Fahrenheit, or less.
 - 3. When the trench bottom is unstable.
- E. Pipe and appurtenances shall be protected against dropping and damage.
 - 1. Pipe and appurtenances shall not be used if they are damaged.

PART 2 - MATERIALS

2.01. PIPE

- A. Pipe material shall remain the same for each size specified and only interchanged where another material type is specifically indicated on the approved Construction Drawings.
- B. Reference Sections:
 - 1. 33 05 20 – DUCTILE IRON PIPE AND FITTINGS.
 - 2. 33 05 29 - PLASTIC PRESSURE PIPE.

2.02. VALVES

- A. Reference Section 33 14 20 – VALVES.

2.03. HYDRANTS

- A. Reference Section 33 14 22 – HYDRANTS.

2.04. TAPPING SLEEVES AND VALVES

- A. Reference Section 33 05 10 – TAPPING SLEEVES AND VALVES.

2.05. SERVICE LINES AND APPURTENANCES

- A. Reference Section 33 14 18 – SERVICE LINES AND APPURTENANCES.

2.06. PRECAST CONCRETE STRUCTURES

- A. Reference Section 03 40 00 – PRECAST CONCRETE.

2.07. FASTENERS

- 1. Fasteners for use with flanged joints shall conform to AWWA C111 and AWWA C115, latest editions.

2.08. METAL SURFACE PROTECTIVE COATING

- A. Polyethylene Encasement.

- 1. Reference Section 33 05 20 – DUCTILE IRON PIPE AND FITTINGS.
- 2. Reference Section 33 05 29 - PLASTIC PRESSURE PIPE.

- B. Spray on rubberized coating for bolts

- 1. Shall be a rubberized spray-on undercoating.
- 2. Acceptable Manufacturers.
 - a. NAPA: Mac's Rubberized Undercoating; or
 - b. Tite-Seal Rubberized Undercoating.

2.09. TRACER WIRE AND ACCESSORIES

- A. Tracer Wire

- 1. The type of tracer wire installed shall depend upon the method of installation, as follows:
 - a. Direct-Bury Installations:
 - (1) Single-conductor, 12-gauge, insulated stranded copper wire rated for 600-volt service.
 - (2) Suitable for underground service and buried directly with the pipe.

(3) THHN, THWN, or Approved Equal.

b. Trenchless Installations:

(1) Tracer wire shall be a 304 stainless steel alloy, 49 strand, annealed conductor insulated with 45-mil, high molecular weight, high density polyethylene (HMW-HDPE) and rated for direct bury use at 30 volts. Conductor shall be ¼-inch with 7x19 strands and a 6,100-pound break load.

(2) Insulator shall be 0.045-inches.

(3) Products

(a) Performance Wire and Cable, Inc., Stranded SS /45 mil HMW-HDPE; or

(b) Approved Equal.

2. Insulation color shall be:

a. Blue for Potable water pipes; or

b. Purple for Non-Potable water pipes.

3. Tracer wire will be connected at all piping intersections to form one continuous system.

a. Connections shall be watertight.

b. Products

(1) DryConn DBSR Aqua by King Innovations; or

(2) Approved Equal.

B. Test Stations

1. Products

a. 2-inch Cathodic Test Stations by Handley Industries, Inc., or

b. Approved Equal.

2.10. CATHODIC PROTECTION SYSTEMS AND ACCESSORIES

A. Anodes

1. SuperMAG Product No. H-MG-60 HP by Northtown Company; or
2. Approved Equal.

B. Weld Seals

1. Primer
 - a. Royston Roybond 747; or
 - b. Approved Equal.
2. Seal
 - a. Royston Handy Cap; or
 - b. Approved Equal.

C. Adapter Sleeves

1. thermOweld; or
2. Approved Equal.

2.11. STAINLESS STEEL REPAIR CLAMPS

A. GENERAL

1. The manufacturer of repair clamps shall be experienced in their design and construction, shall be regularly engaged in their manufacture and shall have produced repair clamps which have given successful service for a period of at least 5 years.

B. SERVICE

1. The repair clamps shall be installed only on pipes that have structural integrity. The operating pressure for all types of pipe is 150 psig. Repair clamps shall not be installed on Ductile Iron Pipe that has developed a leak due to corrosion.

C. MATERIAL

1. All stainless steel repair clamps and fabrications shall be Type 304 stainless steel per ANSI 21.11. All welds shall be fully passivated by a chemical technique which restores the corrosion resistant characteristics of the stainless steel.

D. GASKET

1. Shall be made of virgin styrene butadiene rubber (SBR) or Nitrile (Buna-N, NBR) compounded for water service. Gasket shall be bonded to stainless steel by suitable means.

E. BOLTS AND HEX NUTS

1. All bolts shall be of Type 304 stainless steel per ASTM A193 and A194. Stainless steel hex nuts shall be furnished with a coating to prevent seizing and galling.

2.12. REDUCED-PRESSURE BACKFLOW PREVENTION ASSEMBLY

A. GENERAL

1. All reduced-pressure backflow assemblies shall be manufactured in accordance with AWWA C511, with the following additional requirements or exceptions.

B. PROTECTION

1. All assemblies shall be protected by a Hot Box fiberglass enclosure and provide electrical hook-up. All enclosures shall be properly sized and installed according to the manufacturer.
 - a. Coordination of the electrical hook-up shall be the responsibility of the contractor.

C. TESTING

1. The manufacturer shall test all reduced-pressure backflow assemblies according to AWWA C511.

D. COATING

1. All reduced-pressure backflow assemblies shall be epoxy coated inside and out according to AWWA C550, for sizes 2½-inches, and larger.

E. ACCEPTABLE MANUFACTURERS

1. Reduced-Pressure Backflow Assemblies:
 - a. Manufacturer: Febco
 - (1) Model: 825YA (Brass); or
 - (2) Model: 880V (Epoxy-Coated);
 - b. No substitutions allowed.

2. Backflow Enclosures:
 - a. Manufacturer: Hot Box
 - (1) Model: HB series.
3. Stainless Steel Repair Clamps:
 - a. Manufacturer:
 - (1) Ford - Model: FS1/FS2;
 - (2) Powerseal - Model 3122AS; or
 - (3) Romac - Model SS1/SS2.

2.13. DOUBLE CHECK BACKFLOW PREVENTION ASSEMBLY

A. GENERAL

1. All double check backflow assemblies shall be manufactured in accordance with AWWA C510, with the following additional requirements or exceptions.

B. PROTECTION

1. All assemblies shall be protected by a Hot Box fiberglass enclosure and provide electrical hook-up. All enclosures shall be properly sized and installed according to the manufacturer.

C. VALVES

1. Sizes 2-1/2-inch, and larger, shall have Non-Rising Stems (NRS).

D. TESTING

1. The manufacturer shall test all reduced-pressure backflow assemblies according to AWWA C510.

E. COATING

1. All backflow assemblies shall be epoxy-lined and coated, according to AWWA C550 for sizes 2-1/2-inches and larger.

F. ACCEPTABLE MANUFACTURERS

1. Double Check Backflow Assemblies:
 - a. Manufacturer:

- (1) Febco
 - (a) Model: 850 (Brass); or
 - (b) Model: 870V (Epoxy-Coated);
- (2) No substitutions allowed.

2.14. DETECTABLE WARNING TAPE

A. Thickness

1. 5 mils with no less than .00035-inch (0.35-mil) aluminum foil thickness.

B. Width

1. 6-inches.

C. Markings

1. Shall bear the printed identification of the utility line below it, such as "Caution Buried Water Line Below."

D. Colors:

1. Blue for potable water; or
2. Purple for non-potable and/or reclaimed water.

E. Products

1. Detectable Underground Marking Tape by Pro-Line Safety Products; or
2. Approved Equal.

PART 3 - EXECUTION

3.01. INSPECTION

- A. Pipe barrel and fittings shall be free of dirt or other foreign objects prior to installation.
- B. Pipe and fittings shall be inspected for cracks, dents, abrasions or other flaws prior to installation.
- C. Pipe and fittings with damaged linings or coatings shall be rejected.

1. Defective pipe shall be marked and remain on the site until removal is approved by NWCWD.

3.02. PREPARATION

- A. Reference Section 31 23 35 – TRENCHING, BACKFILLING, AND COMPACTING.
- B. Connections: The locations and elevations of the existing utilities shall be verified prior to construction.
- C. Joints
 1. Dirt, oil, grit, and other foreign matter shall be removed from the inside of the bell and outside of the spigot.
 2. A thin film of lubricant shall be applied to the inside of the gasket and the spigot end of the pipe, per the manufacturer's recommendations.
 3. The lubricated joint shall be kept clean until joined.
 4. The pipe shall have a depth mark prior to the assembly to ensure that the spigot end is inserted to the proper depth of the bell end joint.
 5. Previously completed joints shall not be disturbed during the jointing operation.
 6. After the initial acceptance of the water main, the Contractor shall be responsible for the repair of any leak, resulting from improper workmanship or materials, which are discovered within the two (2) year warranty period.

3.03. PIPE INSTALLATION

- A. All pipe shall be installed with the bells pointing in the direction that the work is progressing.
- B. The Contractor shall employ effective measures to prevent the separation of joints during bedding and backfilling operations.
 1. Bedding Zone Material shall not be dropped onto unsupported pipe, which has been set to alignment and grade.
 2. Pipe shall be laid and maintained at required lines and grades as specified in the approved Construction Drawings.
- C. Ductile iron pipe and fittings shall be installed with a polyethylene encasement.
- D. Tracer wire shall be installed with all water mains, regardless of size or material.

1. Route wire to surface at all valve boxes, manholes, and required test stations.
 2. Install test stations on pipe runs that are five hundred feet (500') in length that have no valve boxes or manholes.
 3. Terminate tracer wire in accordance with the applicable Standard Details.
- E. The pipe shall be secured in place with the specified Bedding Zone Material consolidated under and around the pipe.
- F. The pipeline shall be installed so that a uniform positive or negative grade is maintained between the designed high and low points.
- G. The minimum depth of cover shall be 5-feet from the finished grade to the top of the pipe, except as otherwise indicated on the Construction Drawings.
- H. The maximum depth of cover shall be 6-feet from the finished grade to the top of the pipe, except as otherwise indicated on the Construction Drawings.
- I. Concrete encasements shall be provided where indicated on the Construction Drawings only. Written NWCWD approval is required for all other cases.
1. Cast-in-Place Concrete
 - a. Reference Section 03 30 10 – CAST-IN-PLACE CONCRETE (SMALL VOLUME).
 2. Encasements and Sewer Line Crossings
 - a. Provide concrete encasement where indicated on the Construction Drawings or required by these Specifications.
 - b. Where watermains cross sewer lines, and the sewer is above the watermain-or-less than eighteen inches (18") clear distance vertically below the watermain, construct the crossing by one (1) of the following methods:
 - (1) Sewer shall be placed in a separate twenty foot (20') long conduit with ten feet (10') of separate conduit on either side of water main centerline.
 - (2) Encase the sewer pipe with reinforced concrete at least six inches (6") thick at all locations within ten feet (10') either side of the watermain. Minimum reinforcement shall be one (1) of the following:
 - (a) No. 5 bars, continuous, placed at each corner of the section tied with No. 3 bars on three-foot (3'-0") centers.

(b) 6 x 6, W4 x W4 with eight-inch (8") minimum lap, tied every twelve inches (12").

3. Provide suitable backfill or other structural protection to preclude settling or failure of higher pipe.

J. Connections to Existing pipelines

1. Make each connection at a time authorized by NWCWD which will least interfere with service.
2. Use suitable fittings for the conditions encountered.
3. Dewater and dispose of water from dewatered lines.
4. Do not contaminate existing potable water lines.
 - a. Do not permit trench water, mud, or other contaminating substances to enter pipelines.
5. Swab the interior of new pipe, fittings, and valves installed in existing pipelines with a solution of five percent (5%) (50,000 ppm) chlorine solution prior to installation.
6. Only NWCWD shall operate existing valves, hydrants, blowoffs, curb stops, and other control units.

3.04. THRUST RESTRAINT

A. Concrete anchorage and blocking

1. Concrete anchorage and blocking is required for fire hydrants and allowed by specific approval only. An approved Construction Drawing does not constitute approval for use in other location.
2. The minimum size of thrust blocks shall be determined by the Design Engineer for the specific operating pressures and site conditions.
3. The concrete thrust block bearing surface shall be excavated into undisturbed soil.
 - a. All loose soil shall be disposed of, and the location where the thrust block is to be poured shall be carefully shaped to provide a uniform bearing surface of the required size.
 - b. The concrete thrust block bottom shall be flat, and sides shall be vertical.

- c. If soil is to be disturbed, making a concrete thrust block unusable, alternate restraining systems must be approved by NWCWD prior to pipeline installation.
 - 4. The concrete thrust block shall be formed to provide access to fittings and hydrants.
 - 5. Concrete shall be separated from fittings and hydrants by installing 8 mil polyethylene encasement as a bond breaker.
 - a. Concrete shall not be poured directly on or over fittings, nuts, bolts, flanges, etc.
 - 6. NWCWD shall be notified 24 hours before concrete is placed.
- B. Mechanical Restraining Devices
 - 1. Reference Section 33 05 20 - DUCTILE IRON PIPE AND FITTINGS.
 - 2. Minimum pipe restrained length shall be per the "Horizontal Bend Restraint" and "Vertical Bend Restraint" drawings in the Standard Details.
 - a. If site conditions (working pressure or soil conditions) vary from the assumption on the appropriate "Restraint Detail", the Design Engineer shall determine the restrained lengths and submit to NWCWD for review.
 - 3. All auxiliary fire hydrant (blowoff) valves shall be restrained to prevent the movement of the valve during hydrant (blowoff) removal or maintenance.

3.05. INSTALLATION OF PIPELINE APPURTENANCES

- A. Valves, hydrants, taps, and other appurtenances to the water distribution lines shall be installed at the locations shown on the Construction Drawings, or as approved by NWCWD to accommodate field conditions.
 - 1. Measurements of the actual location of appurtenances shall be made prior to backfilling for recording in the Project Record Drawings.
 - 2. NWCWD shall inspect/map all pipe, fittings, hydrants, valves, and service lines prior to backfilling.
- B. Dead-end water lines shall have either a fire or flushing hydrant at the end of the waterline to facilitate the discharge of air and water from the waterline.
 - 1. Dead-end water lines that will be extended in the future shall have an inline isolation valve which controls that section of waterline left in the open position.

- a. If the waterline is to be extended in the future, a flushing hydrant may be installed temporarily, until the extension occurs.
- C. Temporary blowoffs which are installed by the Contractor during construction shall be abandoned at the main prior to acceptance of the waterline.
- D. Install fiberglass marker posts at all line valves, air valves, and at intervals not to exceed 1,000 feet as determined by NWCWD.

3.06. PROTECTION OF METAL SURFACES

- A. All buried ductile iron pipe shall be installed with polyethylene encasement.

1. Polyethylene Encasement – Method A.

- a. Cut polyethylene tube to a length approximately two feet (2'-0") longer than that of the pipe section.
- b. Slip the tube around the pipe, centering it to provide a one-foot (1'-0") overlap on each adjacent pipe section, and bunching it accordion-fashion lengthwise until it clears the pipe ends.
- c. A shallow bell-hole must be made at joints to facilitate installation of the polyethylene tube.
- d. After assembling the pipe joint, make the overlap of the polyethylene tube.
- e. Pull the bunched polyethylene from the preceding length of pipe, slip it over the end of the new length of pipe, and secure in place.
- f. Slip the end of the polyethylene from the new pipe section over the end of the first wrap until it overlaps the joint at the end of the preceding length of pipe.
- g. Secure the overlap in place.
- h. Take up the slack width at the top of the pipe to make a snug, but not tight, fit along the barrel of the pipe, securing the fold at quarter points.
- i. Cuts, tears, punctures, and other damage shall be repaired with adhesive tape or a short length of polyethylene sheet wrapped around the pipe to cover the damaged area, and secured in place.

- B. Ductile Iron Fittings

1. All ductile iron fittings shall have a coating applied to the bolts and be polyethylene-encased.

C. Bell and Spigot Joint Restraints

1. All iron bell harness restraint devices shall have a protective coating applied to bolts and be polyethylene-encased.

D. If the supplied material has not been factory coated, or the coating has been damaged by installation, the material shall be protected by one of the following methods:

1. Two coats of coal tar epoxy paint shall be applied to ferrous metal rods, rebar, clamps, bolts, nuts and other accessories which are subject to submergence or contact with earth or fill material, and are not encased in concrete.
 - a. The first coat of coal tar epoxy paint shall be applied to a dry, clean surface.
 - b. The first coat of coal tar epoxy paint shall be allowed to dry before the second coat is applied.
2. Ferrous metal rods, rebar, clamps, bolts, nuts and other accessories which are subject to submergence or contact with earth of fill material, and not encased in concrete shall be protected with coal tar epoxy paint or a rubberized spray-on undercoating, and wrapped by a minimum 8 mil polyethylene film.

3.07. DETECTABLE WARNING TAPE

- A. Install per the manufacturer's instructions at the locations shown in the Standard Details.

END OF SECTION

(THIS PAGE INTENTIONALLY LEFT BLANK)

SECTION 33 14 18

SERVICE LINES AND APPURTENANCES

PART 1 - GENERAL

1.01. DESCRIPTION

- A. This Section addresses the materials and installation of tap saddles, corporation stops, service lines and curb stops for 1-inch residential services in accordance with AWWA C800 with the following additional requirements or exceptions.
- B. Larger service lines, i.e., 1½-inch and up, will be designed on a case-by-case basis by NWCWD.
- C. 1-inch residential services shall be limited to lengths up to 100-feet.
- D. Residential Service runs greater than 100-feet shall be 2-inch.

1.02. QUALITY ASSURANCE

- A. Perform all Work as specified herein and in accordance with the latest revisions of the following codes and standards.
 - 1. Federal, state, and local codes, regulations, and ordinances.
 - 2. American National Standard Institute (ANSI).
 - 3. American Water Works Association (AWWA).
 - 4. American Society for Testing and Materials (ASTM).
- B. In case of conflict or disagreement between codes, standards, laws, ordinances, rules and regulations, or within any document itself, the more stringent condition, as determined by NWCWD, shall govern.

1.03. SUBMITTALS

- A. Certification
 - 1. Submit manufacturer's certification that products meet the referenced standards.
 - 2. Submit manufacturer's certification that products are NSF 61 certified for potable water service.
- B. Reference SECTION 01 33 21 – SHOP DRAWINGS, SAMPLES, AND O&M MANUALS.

1.04. PRODUCT DELIVERY, STORAGE, AND HANDLING

- A. The product shall be handled, stored, and protected in a manner which will prevent damage to materials, coatings, and finishes.
- B. All material shall be kept clean and free from dirt.

PART 2 - MATERIALS

2.01. GENERAL

- A. All service lines, valves, and fittings shall be NSF 61 Certified for potable water service.
- B. All fittings brass, bronze or iron fittings shall be lead free, per NSF 372.
- C. All saddles, valves, and fittings shall conform to AWWA C800.
- D. Polyethylene service tubing shall conform to AWWA C901.

2.02. TAPPING SADDLES

- A. One-inch (1") through two-inch (2"), inclusive, tapping saddles shall meet the following requirements.
 - 1. Shall provide full support around the circumference of the pipe and have bearing area of sufficient width along the axis of the pipe to prevent distortion of the pipe when saddle is tightened.
 - 2. All tap saddles shall have female national pipe taper (FNPT) threads in the size shown on the Drawings.
- B. Tap saddles for PVC pipe (IPS)
 - 1. Saddles shall be bronze type body.
 - 2. Acceptable Manufacturers
 - a. Ford S71;
 - b. A.Y. McDonald 3892 (2- through 8-inch);
 - c. A.Y. McDonald 3802 (12-inch);
 - d. No Substitutions Allowed.
- C. Tap saddles for PVC pipe, per AWWA C900 (4- through 12-inch)

1. Saddles shall be bronze type body.
 2. Acceptable Manufacturers
 - a. Ford S91;
 - (1) -404 (4-inch)
 - (2) -604 (6-inch)
 - (3) -804 (8-inch)
 - (4) -1204 (12-inch)
 - b. A.Y. McDonald 3896;
 - c. No Substitutions Allowed.
- D. Tap saddles for PVC pipe, per AWWA C900 (16- inch and larger)
1. Tap saddle body shall be either:
 - a. Bronze; or have
 - b. Epoxy coated iron body.
 2. Shall have either a single or a double strap (brass or stainless steel).
 3. Acceptable Manufacturers
 - a. Ford 202BS (4- through 30-inch);
 - b. Powerseal 3417SW;
 - c. No Substitutions Allowed.
- E. Tap saddles for DIP and Asbestos Cement (AC) pipe
1. Tap saddle body shall be either:
 - a. nylon; or
 - b. epoxy coated iron body.
 2. Shall have either a single or a double stainless steel strap.
 3. Acceptable Manufacturers

- a. Romac 202N;
- b. Ford FC202;
- c. A.Y. McDonald 4846A (4- through 12-inch);
- d. Powerseal 3417SW (up to 24-inch);
- e. No Substitutions Allowed.

2.03. CORPORATION STOPS

A. One-inch (1") through two-inch (2"), inclusive, corporation stops shall meet the following requirements.

- 1. Shall be a ball style valve having a minimum pressure rating of three hundred pounds per square inch (300 psi).
- 2. Shall be a male national pipe taper (MNPT) threaded inlet and polyethylene (PE) tube outlet.
- 3. Shall have the means to "grip" the polyethylene tubing for mechanical restraint.
- 4. Acceptable Manufacturers
 - a. Ford FB1101-4 series;
 - b. A.Y. McDonald 74704B-33 (1-inch PE);
 - c. No Substitutions Allowed.

2.04. SERVICE TUBING

A. General

- 1. Shall be manufactured with 4710 polyethylene resin, per AWWA C901, latest edition.
- 2. Shall be SIDR 7 and rated for two hundred fifty pounds per square inch (250 psi) working pressure.
- 3. Tubing Color:
 - a. Potable Water – Blue.
 - b. Non-Potable Water – Purple.
- 4. Acceptable Manufacturers

- a. Endot/Endopure;
- b. US Poly/Eagle Pure-core;
- c. Centennial Plastics, Inc., CenCore;
- d. No Substitutions Allowed.

2.05. CURB STOPS FOR POTABLE WATER SERVICE

- A. One-inch (1”) through two-inch (2”), inclusive, curb stops shall meet the following requirements.
 - 1. Shall be a ball style valve having a minimum pressure rating of three hundred pounds per square inch (300 psi).
 - 2. Shall be a polyethylene (PE) tube inlet and outlet.
 - 3. Shall have the means to “grip” the polyethylene tubing for mechanical restraint.
 - 4. Acceptable Manufacturers
 - a. Ford B66 series;
 - (1) -444 (1-inch PEP)
 - (2) -777 (2-inch PEP)
 - b. A.Y. McDonald 76100-33 (1- or 2-inch PEP);
 - c. No Substitutions Allowed.

2.06. CURB STOPS FOR NON-POTABLE WATER SERVICE

- A. One-inch (1”) through two-inch (2”), inclusive, curb stops shall meet the following requirements.
 - 1. Shall be a ball style valve having a minimum pressure rating of three hundred pounds per square inch (300 psi).
 - 2. Shall be a polyethylene (PE) tube inlet and outlet.
 - 3. Shall have the means to “grip” the polyethylene tubing for mechanical restraint.
 - 4. Shall be a stop and waste style valve.
 - 5. Does not need to meet the “lead free” requirement of NSF 372.

6. Acceptable Manufacturers
 - a. A.Y. McDonald 76001-FNPT (1-inch); or
 - b. Ford B66 series w/ stop and waste feature (B66-444SW);
 - c. No Substitutions Allowed.

2.07. CURB STOP BOXES

- A. Shall be a two-piece adjustable screw type valve box made of cast iron meeting ASTM 48, Class 35.
- B. Lid name designation:
 1. Potable water application: "Water".
 2. Non-potable water application: "Irrigation".
- C. Shall be capable of extending from forty-one inches (41") to sixty-four inches (64") in height.
- D. Acceptable Manufacturers
 1. Castings C.I. 95-E;
 2. Tyler 6500 (95E);
 3. AY McDonald 5700;
 4. No Substitutions Allowed.

2.08. ACCESSORIES

- A. Curb Stop Extension Rods
 1. Use on all curb stops.
 2. Acceptable Manufacturers
 - a. A.Y. McDonald 5660 (42-inch length, standard); or
 - b. Ford (ROD-42, 42-inch);
 - c. No Substitutions Allowed.
- B. Polyethylene service tube insert stiffeners

1. Shall be made of 300 series stainless steel.
2. Shall be appropriate size to fit the SIDR 7 (ID-controlled) tubing.
3. Acceptable Manufacturers
 - a. A.Y. McDonald 6136 (1- through 2-inch PEP);
 - b. Ford Series 70 for PEP
 - (1) Insert -72 for 1-inch PEP
 - c. Or Equal.

PART 3 - EXECUTION

3.01. GENERAL

- A. All taps made shall be 1-inch unless specified otherwise.
- B. The Contractor shall make all taps and install the service line to the permanent facilities prior to disinfection and pressure testing of the water main.
- C. The Contractor shall not make any taps without prior permission from NWCWD.
- D. Reference the applicable Standard Details and as modified on the approved Construction Drawings.
- E. All taps shall be made with a tapping saddle in accordance with these specifications and the manufacturer's recommendations, unless otherwise approved by NWCWD.
 1. A static pressure test of 150 psi for ten (10) continuous minutes, with no visible leakage or pressure loss, shall be performed prior to the wet tap on all existing water mains.
- F. Service taps on live mains will be made only under the direct supervision of NWCWD. The Contractor shall coordinate with the NWCWD Representative.
- G. NWCWD reserves the right to make taps in lieu of the Contractor and the right to deny permission for any main to be tapped.
- H. Tapping equipment shall be of good quality, used for the purpose intended and used in accordance with manufacturer's instructions.
 1. Reference Section 01 60 10 – MATERIALS, EQUIPMENT, AND WORKMANSHIP.

3.02. SERVICE LINE TAPS

- A. Taps shall not be made within two (2) feet of any joint or fitting.
- B. Taps shall be separated by at least two (2) feet (measured along the pipe length), even when taps are made on opposite sides of pipe.
- C. Taps which are made on the same side of the pipe and within ten (10) feet of each other (measured along the pipe length), shall be staggered fifteen degrees.
- D. Ductile Iron and PVC Pipe Taps: Corporation Stops shall be installed by means of a tapping saddle.

3.03. CORPORATION STOPS

- A. Install so the valve operator is pointing up.

3.04. SERVICE LINES

- A. All service lines between the main and curb stop shall be installed per the 1-inch SERVICE ASSEMBLY Standard Detail.
- B. All service lines shall be a minimum of four and one half feet (4.5'), and a maximum of five feet (5') below the final grade.
- C. Use insert stiffeners when assembling compression fitting on polyethylene service tubing.
- D. No couplings shall be allowed between the corporation stop and curb stop.
- E. When backfilling the service trench, Bedding Zone Material shall be used at a minimum of four (4) inches under and six (6) inches above any given location of the service line.
 - 1. Reference Section 31 23 25 – TRENCHING, BACKFILLING, AND COMPACTING.
- F. Service trenches shall be subject to compaction specifications.
 - 1. Reference Section 31 23 25 – TRENCHING, BACKFILLING, AND COMPACTING.

3.05. CURB STOP

- A. Install curb stop valve supported by a concrete block.
- B. All curb stops shall be a minimum of four and one half feet (4.5'), and a maximum of five feet (5') below the final grade.

- C. Use insert stiffeners when assembling compression fitting on polyethylene service tubing.
- D. Install curb stop box centered over the valve operator and plumb. Curb stop Box shall be adjusted to one inch (1") above final grade.
- E. All curb stop shall have operator extension rod installed and secured to valve operator with a corrosion resistant cotter pin.
 - 1. Rod must extend operator to a minimum of six inches (6") and a maximum of twenty-four inches (24") from the lid of the curb box.
- F. After installation, the curb stop valve end shall be wrapped with polyethylene encasement and secured with tape to keep dirt out of valve.
- G. Install a 4"X4" post marking the curbstop box. The post shall be buried 3 ft in the ground and have 3 ft exposed above grade. Paint post blue.

3.06. INSPECTION

- A. The Contractor shall ensure that the tap saddle, corporation stop, service line, and curb stop remain exposed until after the inspection/mapping and the approval for backfill is given by NWCWD.
- B. All tap and service inspections shall be scheduled with NWCWD.
 - 1. A minimum of 48 hours notice is required on all tap and service inspections.

END OF SECTION

(THIS PAGE INTENTIONALLY LEFT BLANK)

SECTION 33 14 20

VALVES

PART 1 - GENERAL

1.01. DESCRIPTION

A. This Section addresses:

1. Gate Valves;
2. Butterfly Valves;
3. Valve Boxes;
4. Air Valves;
5. Ball Valves;
6. Check Valves;
7. Pressure Regulating and Flow Control Valves; and
8. Associated Appurtenances.

1.02. QUALITY ASSURANCE

A. Perform all Work as specified herein and in accordance with the latest revisions of the following codes and standards.

1. Federal, state, and local codes, regulations, and ordinances.
2. American National Standard Institute (ANSI).
3. American Water Works Association (AWWA).
4. American Society for Testing and Materials (ASTM).
5. American Society of Mechanical Engineers (ASME).

B. In case of conflict or disagreement between codes, standards, laws, ordinances, rules and regulations, or within any document itself, the more stringent condition, as determined by NWCWD, shall govern.

1.03. SUBMITTALS

A. Certification

1. Submit manufacturer's certification that products meet the referenced standards.
2. Submit manufacturer's certification that products are NSF 61 certified for potable water service.

B. Reference SECTION 01 33 21 – SHOP DRAWINGS, SAMPLES, AND O&M MANUALS.

1.04. PRODUCT DELIVERY, STORAGE, AND HANDLING

- A. Precautions shall be taken to prevent damage to materials during delivery and storage.
- B. Valves shall be stored off of the ground and away from materials that could contaminate potable water systems.
- C. Precautions shall be taken to keep all joints and internal parts clean.

PART 2 - MATERIALS

2.01. GENERAL

- A. All valves shall open counter-clockwise (left).
- B. All valves shall be suitable for frequent operation as well as service involving long periods of inactivity. Valves shall be capable of operating satisfactorily with flows in either direction, and shall provide zero leakage past the seat.
- C. All nuts and bolts shall be stainless steel.
- D. All buried valves shall have a two (2) inch square operating nut.
 1. All operating nuts shall be painted black.
- E. Any valve which will be placed in a vault shall have a valve operator which is specifically approved by NWCWD.

2.02. GATE VALVES (2- THROUGH 2 ½-INCH)

- A. Shall be resilient seated gate valve manufactured and tested in accordance with AWWA C509.
- B. Shall have an operating pressure of 200 psi.
- C. Valve ends shall be threaded.

D. Coatings/Linings

1. Fusion-bonded epoxy on both inside and outside surfaces in accordance AWWA C550.

E. Acceptable Manufacturers

1. Mueller;
2. Clow;
3. Kennedy;
4. U.S. Pipe;
5. American Flow Control;
6. American AVK;
7. No substitutions allowed.

2.03. GATE VALVES (3- THROUGH 12-INCH)

- A. Shall be resilient seated gate valve manufactured and tested in accordance with AWWA C509 or AWWA C515.

- B. Shall have an operating pressure of 200 psi.

- C. Valve ends shall be mechanical joint (MJ).

D. Coatings/Linings

1. Fusion-bonded epoxy on both inside and outside surfaces in accordance AWWA C550.

E. Acceptable Manufacturers

1. Mueller;
2. Clow;
3. Kennedy;
4. U.S. Pipe;
5. American Flow Control;
6. American AVK;

7. No substitutions allowed.

2.04. BUTTERFLY VALVES

A. Shall be used on 16-inch, and larger, nominal pipe sizes.

1. 14-inch pipe is no longer installed in NWCWD.

B. Shall be manufactured and tested in accordance with AWWA C504.

C. Shall have an operating pressure of 250 psi.

D. Valve ends shall be mechanical joint (MJ).

E. Coatings/Linings

1. Fusion-bonded epoxy on both inside and outside surfaces in accordance AWWA C550.

F. Acceptable Manufacturers

1. Mueller;

2. K-Flo;

3. Val-Matic;

4. M&H Valve Company;

5. Pratt;

6. No substitutions allowed.

2.05. TAPPING VALVES

A. Reference Section 33 05 10 – TAPPING SLEEVES AND VALVES.

2.06. VALVE BOXES

A. General

1. The manufacturer of valve box components shall be experienced in their design and construction, shall be regularly engaged in their manufacture and shall have produced valve boxes which have given successful service for a period of at least 5 years.

B. Materials and Construction

1. Materials
 - a. Ductile iron, ASTM A48, Class 35.
2. Type
 - a. Two piece adjustable, screw-type, only.
3. Shaft size: Five and one-quarter inch (5 ¼") I.D.
4. Thickness: Three-sixteenth inch (3/16")
5. Furnish with suitable cover with stamping of:
 - a. For potable water application: "Water".
 - b. For non-potable water application: "Irrigation".
6. Locking lids shall be supplied with all valve boxes.

C. Coating: Dip in bituminous varnish.

D. Acceptable Manufacturers

1. Castings, Inc. (Model C.I. 664-S);
2. Tyler / Union (Model 664-S);
3. EJ (formerly East Jordan Iron Works);
4. No substitution allowed.

2.07. AIR VALVES

A. Air valves shall be designed for clean water service in accordance with AWWA C512 with the following additional requirements, exceptions, and modifications.

B. Air Release Valves

1. Air Release Valves (ARV), also called small orifice valves, are designed to automatically release small pockets of accumulated air from a pipeline while system operates under pressure exceeding atmospheric pressure.

2. Material of Construction

a. Body

- (1) Cast iron or ductile iron; or

- (2) Reinforced Nylon.
 - b. Working parts and seats
 - (1) Brass, stainless steel, or non-corroding material.
 - c. Float and Trim
 - (1) Non-corroding, e.g., stainless steel.
 - 3. Finish Coatings
 - a. Interior and exterior surface shall have an NSF 61 approved epoxy coating.
 - 4. Provide with appropriately-sized NPT threaded connection.
 - a. Reference the Air Valve Schedule for sizes.
 - 5. Shall have a minimum working pressure of two hundred pounds per square inch (200 psi).
 - 6. Orifice size: 3/32-inch.
 - 7. Vacuum Check: All ARVs shall be equipped with a vacuum check or Checking Feature.
 - 8. Acceptable Manufacturers
 - a. APCO, Model 200A ARV only;
 - b. Crispin, PL ARV only series;
 - c. A.R.I., Model S-050;
 - d. No Substitutions Allowed.
- C. Air / Vacuum Valves (AVV)
- (NOT USED)
- D. Combination Air Valves (CAV)
- 1. CAV suitable for potable water service may be supplied in accordance with the following requirements.
 - 2. Acceptable Manufacturers
 - a. A.R.I.

- (1) Model D-040; or
- (2) Model D-040-C.

b. Approved equal.

E. Air Valve Schedule

1. Refer to the Standard Details.

2.08. BALL VALVES

- A. All shut-off (isolation) valves for air valves shall be ball valves except where specified or indicated otherwise.
- B. All ball valves shall be manufactured in accordance with AWWA C800.
- C. Any brass part of the valve in contact with potable water shall be made of “no-lead brass” and contain no more than one fifth of one percent (0.20%) total lead content by weight, per NSF 372.
- D. Shall have a full port stainless steel or chrome plated bronze ball with a Teflon seat.
- E. Minimum WOG pressure rating of four hundred pounds per square inch (400 psi).
- F. Provide with female national pipe thread (FNPT) end connections.
- G. Lever Operator.
- H. Acceptable manufacturers
 1. Watts, lead free model;
 2. Or equal.

2.09. CHECK VALVES

- A. Check valves will be evaluated on a project-specific basis.

2.10. PRESSURE REGULATING AND FLOW CONTROL VALVES

A. GENERAL

1. The Control Valve is an automatic valve designed to control pressures either upstream or downstream of the valve, or to control the flow rate through the valve. It is hydraulically operated, pilot controlled, diaphragm type globe or angle valve.

B. SERVICE

1. Control Valves may be used for pressure sustaining, pressure reducing, flow control or a combination thereof.

C. VALVE DESCRIPTION

1. The pressure regulating valve shall be hydraulically operated, pilot controlled, diaphragm actuated, globe or angle pattern valve.
2. The valve shall be fully stainless steel or bronze-trimmed.
3. An indicator rod shall be furnished as an integral part of the valve to show the valve position.
4. The valve shall be designed to provide an access opening in the valve body for removing the internal parts without removing the main body from the service.

D. MATERIAL

1. Valve body, flanges and covers shall be cast iron conforming to ASTM A126, Class B or ASTM A48, Class 35; ductile iron conforming to ASTM A536, grade 65-45-12; or 300 series stainless steel.
2. Bronze castings or parts for internal trim shall conform to ASTM B62.

E. VALVE ENDS

1. All valves shall be furnished with flanged ends sized and drilled in accordance with ANSI B16.1, Class 125.
2. Flanges shall be machined to a flat surface with a serrated finish in accordance with AWWA C207.

F. PILOT VALVE

1. The pilot valve for controlling operation of the main valve shall be a single seated, diaphragm operated and spring loaded type.
2. The pilot valve shall be attached to the main valve with piping and isolation valves so arranged for easy access in making adjustments and also for its removal from the main valve while the main valve is under pressure.

G. SPEED CONTROL

1. The needle valves shall be all bronze or stainless steel and included with the main valve to control both opening and closing speeds.

H. COATINGS

1. All internal and external ferrous surfaces except machined or bearing surfaces shall be fusion bonded epoxy, to a minimum dry film thickness of 12 mils.
2. Epoxy coating shall conform to AWWA C550, latest edition.

I. TESTING

1. The body of the valve shall be given a hydrostatic test to 150% of the operation pressure specified herein.
2. A seat leakage test shall be made at the operating pressure.

J. ACCEPTABLE MANUFACTURERS

1. Manufacturer: Cla-Val.
2. Model: Hytrol100-01.
3. Coating: Epoxy.
4. Lining: Epoxy.

PART 3 - EXECUTION

3.01. INSTALLATION

- A. Valves and valve boxes shall be examined for cracks, dents, abrasions, and other flaws prior to installation.
1. Defective valves and valve boxes shall be marked and removed from the site.
- B. Valves
1. Refer to the Standard Details.
 2. Flanged valves shall not be buried, unless specifically-approved by NWCWD.
 3. The valve shall be installed in such a manner that the operating nut is perpendicular to the ground surface.
 4. Encase buried valves with polyethylene to finished grade.
 - a. Reference Section 33 05 20 – DUCTILE IRON PIPE AND FITTINGS.
 5. The joined valve shall be supported in place on compacted Bedding Zone Material with a concrete block under the valve body.

- a. Reference Section 31 23 35 – TRENCHING, BACKFILLING, AND COMPACTING.

C. Valve Boxes

1. Valve boxes shall be installed on all buried valves.
2. Valve boxes shall be installed so that no stress is transmitted to the valve.
3. Valve operators which are mounted to one side of the valve shall be located to the North or West of the valve.
4. Valve boxes which are to be set over the valve shall be centered, plumb and directly over the operating nut and valve with the top of the box on grade.
 - a. The soil around the valve box shall be carefully compacted around the barrel, to minimize misalignment and the settling of the backfill.
 - b. Other valve box types shall be adjusted as required on the Construction Drawings.
 - c. Valve boxes installed in farmed fields shall have the top of the valve box lid set 18" – 24" below grade.
5. Wrap valve boxes with polyethylene encasement to finished grade.
 - a. Reference Sections:
 - (1) 33 05 20 – DUCTILE IRON PIPE AND FITTINGS.
 - (2) 33 14 10 – WATER DISTRIBUTION SYSTEM.
6. Tracer wire shall be installed in valve boxes, per the Standard Details. NWCWD retains the right to shift the angle cut to the lower portion of the valve box if final grade elevation is uncertain at the time of installation.

D. Valve Stem Extensions

1. Install extended stems on valves where operating nut is more than five feet (5') below finished grade.
 - a. Stem Extension shall bring operating nut to within four feet (4') of finished grade.

3.02. AIR VALVES

- A. Air valves shall be installed at high points and as shown on the Construction Drawings.

B. Air valves shall be installed in accordance with the Standard Details, and as modified on the approved Construction Drawings.

1. Refer to the "AIR VALVE MH ASSEMBLY" details for on- and off-main installations, as appropriate.

3.03. PRESSURE REGULATING VALVES

A. Pressure regulating valves shall be evaluated on a case-by-case basis.

3.04. OPERATION

A. Valves which have been accepted by NWCWD shall be operated by NWCWD personnel only, unless otherwise authorized by a NWCWD representative.

END OF SECTION

(THIS PAGE INTENTIONALLY LEFT BLANK)

SECTION 33 14 22

HYDRANTS

PART 1 - GENERAL

1.01. DESCRIPTION

- A. This Section addresses dry-barrel fire hydrants and flushing hydrants and includes the acceptable products, materials, and construction practices which may be used in the construction and installation of fire hydrants.

1.02. QUALITY ASSURANCE

- A. Perform all Work as specified herein and in accordance with the latest revisions of the following codes and standards.
 - 1. Federal, state, and local codes, regulations, and ordinances.
 - 2. American National Standard Institute (ANSI).
 - 3. American Water Works Association (AWWA).
 - 4. American Society for Testing and Materials (ASTM).
 - 5. American Society of Mechanical Engineers (ASME).
- B. In case of conflict or disagreement between codes, standards, laws, ordinances, rules and regulations, or within any document itself, the more stringent condition, as determined by NWCWD, shall govern.

1.03. SUBMITTALS

- A. Certification
 - 1. Submit manufacturer's certification that products meet the referenced standards.
 - 2. Submit manufacturer's certification that products are NSF 61 certified for potable water service.
- B. Reference Section 01 33 21 – SHOP DRAWINGS, SAMPLES, AND O&M MANUALS.

1.04. PRODUCT DELIVERY, STORAGE, AND HANDLING

- A. Hydrants shall be handled, stored, and protected in such a manner as to prevent damage to materials, coatings, and finishes.

- B. All fittings and joints shall be kept free from dirt, oil, and grease.

PART 2 - MATERIALS

2.01. FIRE HYDRANTS (DRY BARREL)

A. General

1. All fire hydrants shall be manufactured in accordance with AWWA C502.
2. The auxiliary gate valve on the hydrant lateral shall be a six inch (6") resilient seat gate valve with a valve box, meeting the requirements of Section 33 14 20 - VALVES.
3. Operation Style & Direction
 - a. Reference the specific Fire Protection Authority for the required hydrant color and opening direction:
 - (1) Ault Pierce Fire Protection District.
 - (2) Eaton Fire Protection District.
 - (3) Galeton Fire Protection District.
 - (4) Greeley Fire Department.
 - (5) Nunn Fire Protection District.
 - (6) Platte Valley Fire Protection District
 - (7) Poudre Fire Authority.
 - (8) Western Hills Fire Protection District.
 - (9) Windsor Severance Fire Protection District.
 - b. The design engineer shall be responsible for ensuring the correct opening direction.
 - c. The operating nut shall be pentagonal "weathershield" type nut. The pentagon shall measure 1-1/2 inches from point to flat at the base of the operating nut and 1-7/16 inches at the top; faces shall be tapered uniformly, and the height of the operating nut shall not be less than 1 inch. A stop nut located in the hydrant bonnet on the operating shaft shall prevent over travel of the main valve when being opened.

B. Materials and Construction

1. Type: Dry-barrel with compression shutoff opening against the pressure.
2. Inlet shall be a six-inch (6") mechanical joint (MJ).
3. Dimensions
 - a. Size: Five and one-quarter inch (5-1/4").
 - b. Inlet Shoe: Six inch (6") nominal with mechanical joint.
 - c. Outlet Nozzle Size: Two (2) two and one-half inch (2-1/2"); one (1) four and one-half inch (4-1/2").
 - d. Bury: As dictated by installation location. Refer to the Construction Drawings.
4. Coatings
 - a. All coating shall meet AWWA C550.
 - b. Exterior Color
 - (1) For potable water application: Reference local fire protection district requirements.
 - (2) For non-potable water applications: Valspar, Purple Pantone 522 TGIC, P/N: PT80085, or equal

C. Main Valves and Nozzles

1. The main valve shall be designed so that removal of the assembly from the barrel is accomplished without excavation in accordance with AWWA C502. Hydrants shall be 3-way with one pumper nozzle and two hose nozzles. The pumper nozzle shall be 4-1/2 inches nominal diameter and the hose nozzles shall be 2-1/2 inches nominal diameter. All nozzles shall be furnished with security chains with one end of each securely attached to the upper barrel section of the hydrant.

D. Traffic Features

1. The barrel and operating mechanism shall be designed so that in the event of an accident, damage, or breaking of the hydrant above or near the ground line, the main valve will remain closed and reasonably tight against leakage.
2. Provide with frangible section near the ground line designed to break on impact.

E. Service & Testing

1. All fire hydrants supplied under these specifications shall be designed for a minimum working pressure of 150 psi and each factory assembled unit shall be hydrostatically tested in accordance with AWWA C502.

F. Acceptable Manufacturers

1. Waterous Pacer 250; or
2. Clow Medallion F2545;
3. No substitutions allowed.

2.02. FLUSHING HYDRANTS

A. General

1. All flushing hydrants shall be manufactured and tested in accordance with AWWA C502.
2. The auxiliary gate valve on the hydrant lateral shall be a 2-inch resilient seat gate valve with a valve box, meeting the requirements of Section 33 14 20 - VALVES.
3. Operation Style
 - a. Shall have an operating nut that is open-left.
 - b. Shall be provided with a locking cover over the operating nut.

B. Materials and Construction

1. Type: Dry-barrel with compression shutoff opening against the pressure.
2. Dimensions
 - a. Inlet Size: 2-inch FIP.
 - b. Outlet Nozzle Size: 2-1/2-inch NST.
 - c. Depth of Bury: 5-feet, unless shown otherwise on the Construction Drawings.
3. Operating Pressure: Rated for a minimum of one hundred fifty pounds per square inch (150 psi).
4. Coatings

- a. Coating shall meet AWWA C550.
 - b. Exterior Color: Red.
 5. Provide with section near the ground line designed to break on impact.
 - C. Acceptable Manufacturer
 1. Kupferle Mainguard #77;
 2. No substitutions allowed.
- 2.03. HYDRANT GRAVEL
- A. Use Bedding Zone Materials: Crushed Stone or Gravel.
 1. Refer to Section 31 23 35.

PART 3 - EXECUTION

3.01. FIRE HYDRANTS

- A. All fire hydrants shall be installed in accordance with the "FIRE HYDRANT ASSEMBLY" drawing in the Standard Details and as modified on the approved Construction Drawings.
 1. All hydrant lateral pipe between the 6-inch gate valve and the hydrant shall be either:
 - a. DIP (Special Thickness Class 52) with polyethylene encasement; or
 - b. PVC (AWWA C900 - DR14).
- B. The joining of laterals, valves, and hydrants shall be handled in the same manner as pipe.
 1. The fire hydrant shall be installed vertically plumb with the pumper nozzle facing the direction shown on plans.
 2. The fire hydrant shall be set to the elevation staked, to insure that the bury line is at the final grade.
- C. All fire hydrants shall be supported on a minimum of eighteen (18) inches of compacted hydrant gravel.
 1. The fire hydrant shall be supported with a concrete block.

- D. A sheet of eight (8) mil polyethylene encasement shall be placed between hydrant shoe and concrete thrust block, extending up vertically to finish grade, encapsulating the hydrant barrel.
- E. Fire hydrants shall not be placed in concrete sidewalks or pavement.
- F. There shall not be a post, fence, vehicle, growth, trash, storage, or other material or thing, within a three (3) foot radius of the fire hydrant assembly.
 - 1. The ground surrounding the fire hydrant shall slope away from the hydrant at a minimum grade of 2%, toward the street.
- G. After installation of the fire hydrant is complete, the oil/grease reservoir shall be checked to insure that it is full.
 - 1. If it is necessary to fill the reservoir, it shall be filled with the oil/grease which is specified by the hydrant manufacturer.
- H. If a hydrant is raised, no more than one (1) extension section can be used, unless approved by NWCWD.
 - 1. Each fire hydrant extension installed shall be inspected, by NWCWD, prior to re-installation of the fire hydrant body assembly.

3.02. FLUSHING HYDRANTS

- A. All flushing hydrants shall be installed in accordance with the Standard Detail entitled, "2-INCH BLOWOFF ASSEMBLY", and as modified on the approved Construction Drawings.
- B. All flushing hydrant lateral piping shall be lead free brass piping.
- C. Install at locations indicated on the Construction Drawings.

3.03. FREEZE PROTECTION

- A. Fire hydrants or flushing hydrants installed to standards (where borrow ditch cross section is involved) will be protected from freezing of the lateral piping by either maintaining minimum cover of 4.5-feet from invert of the borrow ditch to top of lead piping or by means of insulating with 4'x8'x2" blueboard insulation on top of lead piping.

3.04. OPERATION

- A. Hydrants which have been accepted by NWCWD shall be operated by NWCWD personnel only, unless otherwise authorized by a NWCWD representative.

END OF SECTION

(THIS PAGE INTENTIONALLY LEFT BLANK)

SECTION 33 19 00

METERS AND METER SETS

PART 1 - GENERAL

1.01. DESCRIPTION

- A. This Section addresses the acceptable products, materials, and construction practices which may be used in the installation of residential, commercial/industrial, and fire service water meters.

1.02. METER SIZING

Displacement-Type Meter Sizing			
Meter Size	Safe Max. Operating Capacity (gpm)	Max. Pressure Loss at Safe Max. Operating Capacity (psi)	Max. Rate for Continuous Operations (gpm)
$\frac{1}{2}$	15	15	7.5
$\frac{1}{2} \times \frac{3}{4}$	15	15	7.5
$\frac{5}{8}$	20	15	10.0
$\frac{5}{8} \times \frac{3}{4}$	20	15	10.0
$\frac{3}{4}$	30	15	15.0
1	50	15	25.0
$1\frac{1}{2}$	100	15	50.0
2	160	15	80.0

Turbine-Type Meter Sizing				
Class/ Type	Meter Size	Safe Max. Operating Capacity (gpm)	Max. Pressure Loss at Safe Max. Operating Capacity (psi)	Max. Rate for Continuous Operations (gpm)
Class I/ Vertical- Shaft Type	$\frac{3}{4}$	30	15	20
	1	50	15	35
	$1\frac{1}{2}$	100	15	65
	2	160	15	100
Class II/ In-Line (High- Velocity) Type	$1\frac{1}{2}$	120	7	90
	2	190	7	160

PART 2 - MATERIALS

2.01. RESIDENTIAL METERS (3/4- THROUGH 1-INCH)

A. GENERAL

1. All magnetic drive displacement type water meters, 3/4-inch through 1-inch, furnished under this standard, shall be manufactured in strict accordance with the latest edition of AWWA C700, C707, and C702 with the following additional requirements.

B. TYPE

1. All residential meters shall be of the magnetic drive displacement type only.

C. MAIN CASES

1. Main cases shall comply with NSF/ANSI 61 requirements.
2. All meters shall have non-corrosive composite alloy outer case.
3. All meters shall have listed on them the size and direction of water flow through the meter.

D. REGISTER

1. Electronic.

E. ACCEPTABLE MANUFACTURERS

1. Sensus iPERL;
2. No Substitutions Allowed.

2.02. COMMERCIAL / INDUSTRIAL METERS: (1½- THROUGH 4-INCH)

A. GENERAL

1. All magnetic drive turbine type water meters, 1-1/2 inch through 4 inch, furnished under this standard, shall be manufactured in strict accordance with the latest edition of AWWA C701, with the following additional requirements.

B. TYPE

1. All commercial/industrial meters shall be of the class II turbine meters only.

C. CONNECTIONS

1. Flanges on 1-1/2" and 2" size meters shall be oval faced and drilled on the horizontal axis with a bolt circle diameter of 4-1/2". Thickness shall be as required for class 125 round flanges.
2. Flanges for 3" and 4" size meters shall be of the class 125 round type, flat faced, and shall conform to ANSI 16.1 for specified diameter, drilling and thickness.

D. MEASURING CHAMBER

1. The measuring chamber shall be of unitized construction. The complete chamber shall consist of the measuring element, calibration device and totalizing register assembly.
2. The measuring element shall be mounted on a horizontal stationary shaft with sleeve bearings and be essentially weightless in water.

E. REGISTER

1. The register assembly shall be permanently hermetically sealed. All registers of similar size and registration shall have contained with them, a standard ratio gear reduction so as to permit complete interchangeability. The register shall be assembled to the measuring chamber in such a tamperproof manner requiring removal only after the measuring chamber is removed from the maincase. The

sweephand reading and odometer wheel detail design shall conform to AWWA C701.

F. ACCEPTABLE MANUFACTURERS

1. Sensus Omni T²;
2. No Substitutions Allowed.

2.03. FIRE HYDRANT METERS

A. GENERAL

1. All fire hydrant meters shall be manufactured in strict accordance with AWWA C701.
2. For Fire Meter Vaults, refer to:
 - a. Section 03 40 00 – PRECAST CONCRETE; and
 - b. The Standard Details.

B. MATERIAL AND CONSTRUCTION

1. Meter housing shall be aluminum with straightening vanes, strainer, fire hose couplings and gate valve after meter or after required backflow device.

C. REGISTERS

1. Registers shall be straight read, permanently sealed, magnetic drive and 100 U.S. Gallon sweep.

D. MEASURING ELEMENT

1. Measuring element shall be easily removed for required maintenance.

E. INSTALLATIONS

1. Fire hydrant meter installation requires a NWCWD approved backflow device. Meters and backflow device shall be completely supported.
 - a. Refer to Section 33 14 10 – WATER DISTRIBUTION SYSTEM – for backflow prevention assemblies.
2. Any fire hydrants and fire hydrant meters that are used and damaged by a contractor will be repaired by NWCWD at the expense of the contractor.

F. ACCEPTABLE MANUFACTURERS

1. Sensus OMNI H²;
2. No Substitutions Allowed.

2.04. RESIDENTIAL METER SET

A. GENERAL

1. All valves and fittings shall be manufactured in accordance with AWWA C800, with the following additional requirements or exceptions.

B. METER YOKES

1. Meter yokes shall be male iron pipe thread to male iron pipe thread, include tandem S bar and shall be of the type listed below or equal, approved by NWCWD
2. Acceptable Manufacturers
 - a. A.Y. McDonald 16D227QFPP (3/4-inch); or
 - b. A.Y. McDonald 16-427QFPP (1-inch);
 - c. No Substitutions Allowed.

C. ANGLE VALVES

1. All angle valves shall be standard port angle valves with a lockwing. All angle valves shall be of the ball style with a maximum pressure rating of 300 psig of the type listed below or equal, approved by NWCWD.
 - a. A.Y. McDonald 764BB (3/4- through 1-inch);
 - b. No Substitutions Allowed.

D. WYE STRAINERS

1. All wye strainers shall have a maximum pressure rating of 400 psig, stainless steel screen, cast bronze main valve body per ASTM B584 and tapped with access cover and pipe plug of the type listed below or equal, approved by NWCWD.
2. Acceptable Manufacturer
 - a. Wilkins YBP;
 - b. No Substitutions Allowed.

E. PRESSURE REDUCING VALVE

1. All valves shall have a maximum pressure rating of 300 psig, cast main valve body, stem, plunger and access covers per ASTM B584, stainless steel fasteners and strainer screen series 300, natural vulcanized fiber acetal cap gaskets and buna nitrile elastomers of the type listed below or equal, approved by NWCWD.
2. Acceptable Manufacturer
 - a. Wilkins
 - (1) 600XLHRL4 75-125 (3/4-inch)
 - (2) 600XLL4 25-75 (3/4-inch)
 - (3) 600XLHLRL4 10-125 (1-inch)
 - b. No Substitutions Allowed.

F. DUAL ANGLE CHECK VALVE

1. All residential meters shall be equipped with a dual angle check valve to prevent backflow and back siphonage. Valves must have meter swivel nut inlet and female iron pipe thread outlet. All dual angle check valves must be of the type listed below or equal, approved by NWCWD.
2. Acceptable Manufacturer
 - a. A.Y. McDonald
 - (1) (NL) 712-3JE43 (3/4-inch);
 - (2) (NL) 712-3JE54 (1-inch).
 - b. No Substitutions Allowed.

G. METER PIT RESIDENTIAL

1. All residential meter pits shall have a minimum tensile strength of 2200 psi.
2. Meter pit dimensions shall be 20 inches in diameter by 48 inches in depth and properly fit meter pit lid assembly.
3. Acceptable Manufacturer
 - a. DFW Model DFW-242148HW; or

- b. Approved Equal.

H. METER PIT LID ASSEMBLY – RESIDENTIAL

- 1. The manufacturer of meter pit lid assemblies shall be experienced in their design and construction, shall be regularly engaged in their manufacture and shall have produced lid assemblies which have given successful service for a period of at least 5 years.
- 2. Acceptable Manufacturer
 - a. Castings CI 70B INPL3 Plastic Lid;
 - b. No Substitutions Allowed.

2.05. 1 ½-INCH METER SET

A. GENERAL

- 1. All valves and fittings shall be manufactured in accordance with AWWA C151, C104, C110, C111, C116, C153, C800, with the following additional requirements or exceptions.

B. PRESSURE REDUCING VALVE

- 1. All valves shall have a maximum pressure rating of 300 psig of the type listed below or equal, approved by NWCWD.
- 2. Acceptable Manufacturer
 - a. Wilkins 600PHRLU;
 - b. No Substitutions Allowed.

C. METER PIT – 1 ½-INCH METER

- 1. All meter pits shall be precast concrete of the type listed below or equal, approved by NWCWD.
- 2. Acceptable Manufacturer
 - a. Old Castle Precast: NWCWD Typical Vault for 1-1/2 to 4-inch Meters;
 - b. No Substitutions Allowed.

2.06. 2- TO 4-INCH METER SET

A. GENERAL

1. All valves and fittings shall be manufactured in accordance with AWWA C151, C104, C110, C111, C116, C153, C800, with the following additional requirements or exceptions.

B. PRESSURE REDUCING VALVE

1. All valves shall have a maximum pressure rating of 300 psig of the type listed below or equal, approved by NWCWD.
2. Acceptable Manufacturer
 - a. Wilkins 2" Meter Set (Light Industrial/Commercial) 500YSBRHRP (125-75) or 600 PHRLU; or
 - b. Watts LFN 55B (Low Range Only with FNPT inlet/outlet); or
 - c. 2" and Larger meter set Cla-Val PRV sized by engineer.

C. METER PIT

1. All meter pits shall be precast concrete, per Section 03 40 00 – PRECAST CONCRETE.
2. Refer to the Standard Details.

PART 3 - EXECUTION

3.01. GENERAL

- A. Install per manufacturer's recommendations and in accordance with these Specifications and the Standard Details.

END OF SECTION

DESIGN CRITERIA AND STANDARDS

POTABLE WATER DISTRIBUTION SYSTEM



PART 3

STANDARD DETAILS

(THIS PAGE INTENTIONALLY LEFT BLANK)

TABLE OF CONTENTS

	DETAIL NO.	TITLE
1	0000001	STANDARD DETAILS (TABLE OF CONTENTS)
2	0340001	VAULT FOR 1.5-INCH TO 4-INCH METERS
3	3300001	GENERAL UTILITY NOTES
4	3300002	TYPICAL UTILITY CROSSING
5	3300003	TYPICAL STREET CROSS-SECTION
6	3300004	TYPICAL ADJUSTABLE SUPPORT
7	3305081	STEEL CASING PIPE
8	3305201	DI PIPE BEDDING DETAILS
9	3305202	POLYETHYLENE ENCASEMENT INSTALLATION
10	3305291	PVC PIPE BEDDING DETAILS
11	3314101	HORIZONTAL BEND RESTRAINT
12	3314102	VERTICAL BEND RESTRAINT
13	3314103	CONNECTION TO AC WATERLINE
14	3314104	TRACER WIRE TEST STATION
15	3314181	WATER SERVICE LOCATION PLAN
16	3314182	1-INCH SERVICE ASSEMBLY
17	3314183	METER PIT CONSTRUCTION ENVELOPE (POTABLE)
18	3314184	METER PIT CONSTRUCTION ENVELOPE (NON-POTABLE)
19	3314201	TYPICAL VALVE OPERATION
20	3314202	GATE VALVE AND BOX
21	3314203	4-INCH TO 12-INCH BLOWOFF ASSEMBLY
22	3314204	AIR VALVE MH ASSEMBLY (ON-MAIN)
23	3314205	AIR VALVE MH ASSEMBLY (OFF-MAIN)
24	3314206	VALVE INSTALL ON EXISTING AC PIPE
25	3314207	BUTTERFLY VALVE AND BOX
26	3314221	FIRE HYDRANT ASSEMBLY
27	3314222	2-INCH BLOWOFF ASSEMBLY



NORTH WELD COUNTY
WATER DISTRICT
 970-356-3020
www.nwcwd.org

STANDARD DETAILS

DETAIL NO:	0000001
NWCWD APPD:	GM
ORIG DATE:	07/17/2020
REV DATE:	02/08/2021

(THIS PAGE INTENTIONALLY LEFT BLANK)

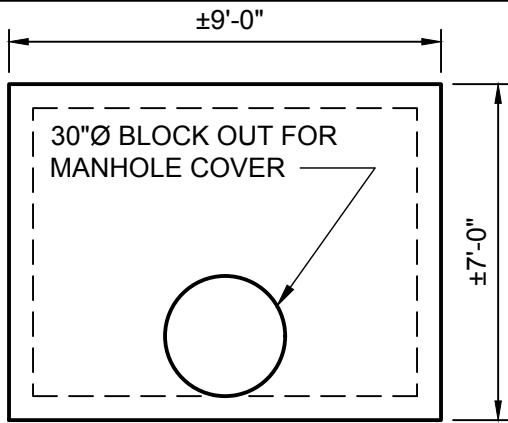

ROOF PLAN

SCALE: 1/4"=1'-0"

NOTES:

1. REFER TO SECTION 03 40 00 FOR PRECAST VAULT REQUIREMENTS. 6-INCH AND LARGER METER VAULTS, SIMILAR.
2. RUN DIP THROUGH VAULT AS SHOWN - WITH NO JOINTS PRIOR TO FIRST MJ FITTING ON EACH SIDE OF VAULT.
3. NWCWD WILL INSTALL HARDWARE INSIDE VAULT ONCE COMPLETE. COORDINATE WITH NWCWD.
4. BOTTOM SECTION OF WALLS SHALL BE INTEGRAL W/ BASE SLAB - NO JOINTS AT WALL-TO-SLAB INTERFACE.
5. CONTINUE 2" PIPING TO FLUSHING HYDRANT PER STD DETAIL NO. 3314222 (ON-MAIN). NIPPLE LENGTH TBD IN FIELD. CONTACT NWCWD TO PADLOCK FLUSHING HYDRANT AFTER INSTALLATION.
6. ALL DI FITTINGS AND VALVES SHALL BE FUSION-BONDED EPOXY COATED.
7. BACKFILL AND COMPACT PIPING, FITTINGS, AND VALVES ON EACH SIDE OF VAULT, PER SECTION 31 23 35.

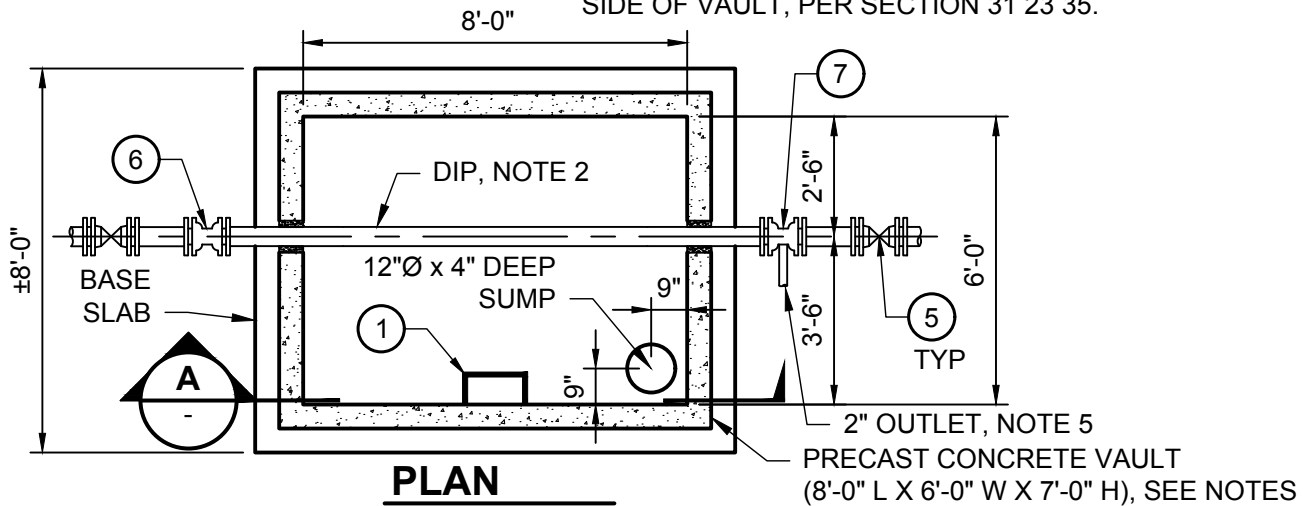

PLAN

SCALE: 1/4"=1'-0"

KEY NOTES:

- ① MANHOLE STEP @ 12" O.C.
- ② KNOCKOUT W/ GROUT (NO LINK-SEALS)
- ③ MANHOLE RING AND COVER, PER SECTION 03 40 00
- ④ VALVE BOX ASSEMBLY, PER SECTION 33 14 20
- ⑤ GATE VALVE, PER SECTION 33 14 20; SIZE SAME AS LINE PIPE
- ⑥ DI MJ SOLID SLEEVE (SHORT), PER SECTION 33 05 20
- ⑦ DI MJ TAPPED TEE W/ 2" FNPT OUTLET, PER SECTION 33 05 20

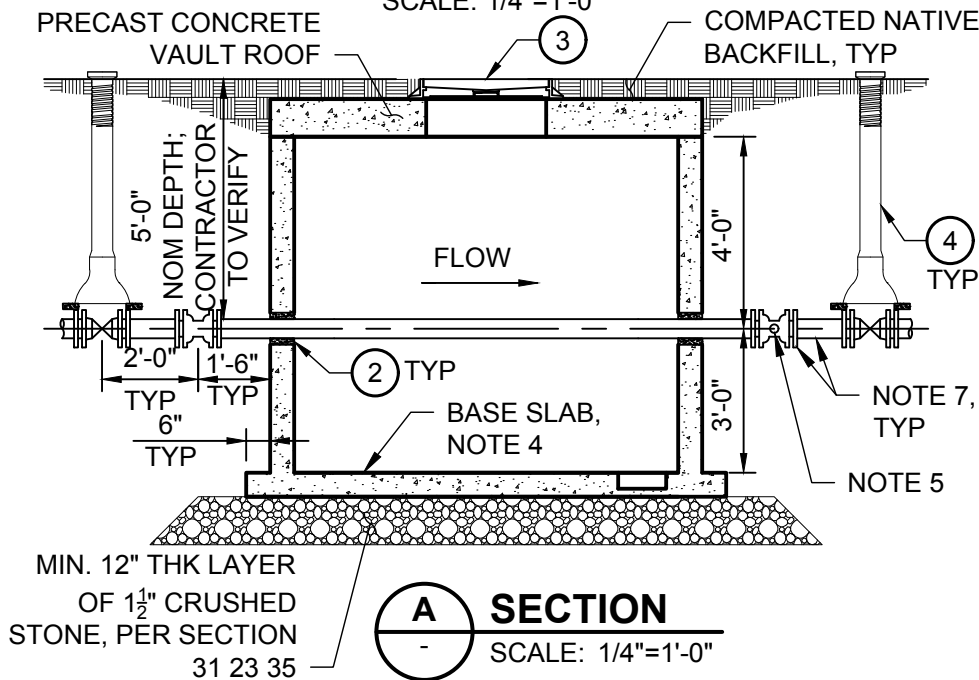

SECTION

SCALE: 1/4"=1'-0"

(THIS PAGE INTENTIONALLY LEFT BLANK)

GENERAL UTILITY NOTES:

1. ALL WATER LINE CONSTRUCTION SHALL CONFORM TO NORTH WELD COUNTY WATER DISTRICT'S (NWCWD) DESIGN CRITERIA AND STANDARDS CURRENT AT DATE PERTAINING TO THIS DEVELOPMENT. PROVIDE SUBMITTALS OF ALL MATERIALS TO NWCWD FOURTEEN (14) DAYS PRIOR TO CONSTRUCTION FOR FULL APPROVAL.
2. PRIOR TO THE COMMENCEMENT OF ANY CONSTRUCTION, THE CONTRACTOR SHALL CONTACT ALL UTILITY COMPANIES AND DEPARTMENTS TO COORDINATE SCHEDULES.
3. ALL CONSTRUCTION ACTIVITIES MUST COMPLY WITH THE COLORADO DEPARTMENT OF PUBLIC HEALTH AND ENVIRONMENT'S (CDPHE) PERMITTING PROCESS FOR "STORM WATER DISCHARGES ASSOCIATED WITH CONSTRUCTION ACTIVITY." FOR INFORMATION, CONTACT: CDPHE, WATER QUALITY CONTROL DIVISION, SQCD-PE-B2, 4300 SOUTH CHERRY CREEK DRIVE SOUTH, DENVER, COLORADO 80222-1530, ATTENTION: PERMITS AND ENFORCEMENT SECTION.
4. IF DEWATERING IS USED TO INSTALL UTILITIES, CULVERTS, ETC., A CDPHE CONSTRUCTION DEWATERING DISCHARGE PERMIT IS REQUIRED FOR DISCHARGING INTO A STORM SEWER, CHANNEL, IRRIGATION DITCH, OR ANY WATERS OF THE UNITED STATES.
5. THE CONTRACTOR SHALL OBTAIN SEPARATE ACCESS OR UTILITY PERMITS FROM CDOT, COUNTY AGENCY OR APPROPRIATE MUNICIPALITY BEFORE UNDERTAKING ANY CONSTRUCTION WORK IN EXISTING HIGHWAY, ROAD, OR STREET RIGHTS-OF-WAY.
6. COORDINATE WITH NWCWD BEFORE BACKFILLING OF ANY WATERLINE FOR SURVEY AND INSPECTION. NWCWD REQUIRES EVERY JOINT, FITTING, TAP, AND APPURTENANCE TO BE SURVEYED.
7. ALL WATERLINES SHALL MAINTAIN A MINIMUM COVER OF FIVE FEET (5'-0") AND A MAXIMUM COVER OF SIX FEET (6'-0"), UNLESS OTHERWISE SPECIFIED.
8. ALL WATERLINES SHALL MAINTAIN GRADE AS SHOWN ON PLANS.
9. TRACER WIRE IS TO BE INSTALLED ON TOP OF ALL PIPING. REFER TO SECTION 33 14 10 FOR REQUIREMENTS.
10. ALL UNDERGROUND DUCTILE IRON FITTINGS AND PIPE SHALL BE TIGHTLY WRAPPED IN POLYETHYLENE ENCASMENT, PER SECTION 33 05 20.
11. ALL VALVES, FITTINGS, AND HYDRANTS ARE TO BE MECHANICALLY RESTRAINED TO THE PIPE USING APPROVED MECHANICAL RESTRAINT DEVICES, PER SECTION 33 05 20.
12. VALVE OPENING DIRECTION, PER DETAIL NO. 3314201, "TYPICAL VALVE OPERATION".
13. ALL WATER TAPS ARE INDIVIDUAL TAPS EXCLUSIVE OF ANY AND ALL OTHER UNITS. REFER TO DETAIL NO. 3314181, "WATER SERVICE LOCATION PLAN".
14. WATER SERVICE LINES SHALL BE 1" IPS POLYETHYLENE TUBING AND HAVE A 1" CURBSTOP INSTALLED. WATER SERVICE LINES SHALL EXTEND THROUGH THE FRONT LOT AND SHALL BE MARKED WITH A 4"X4" WOODEN POST, EXPOSED THREE (3) FEET ABOVE FINISHED GRADE. REFER TO DETAIL NO. 3314182, "1-INCH SERVICE ASSEMBLY".



NORTH WELD COUNTY
WATER DISTRICT
970-356-3020
www.nwcwd.org

GENERAL UTILITY NOTES

DETAIL NO:	3300001
NWCWD APPD:	GM
ORIG DATE:	04/12/2018
REV DATE:	02/08/2021

(THIS PAGE INTENTIONALLY LEFT BLANK)

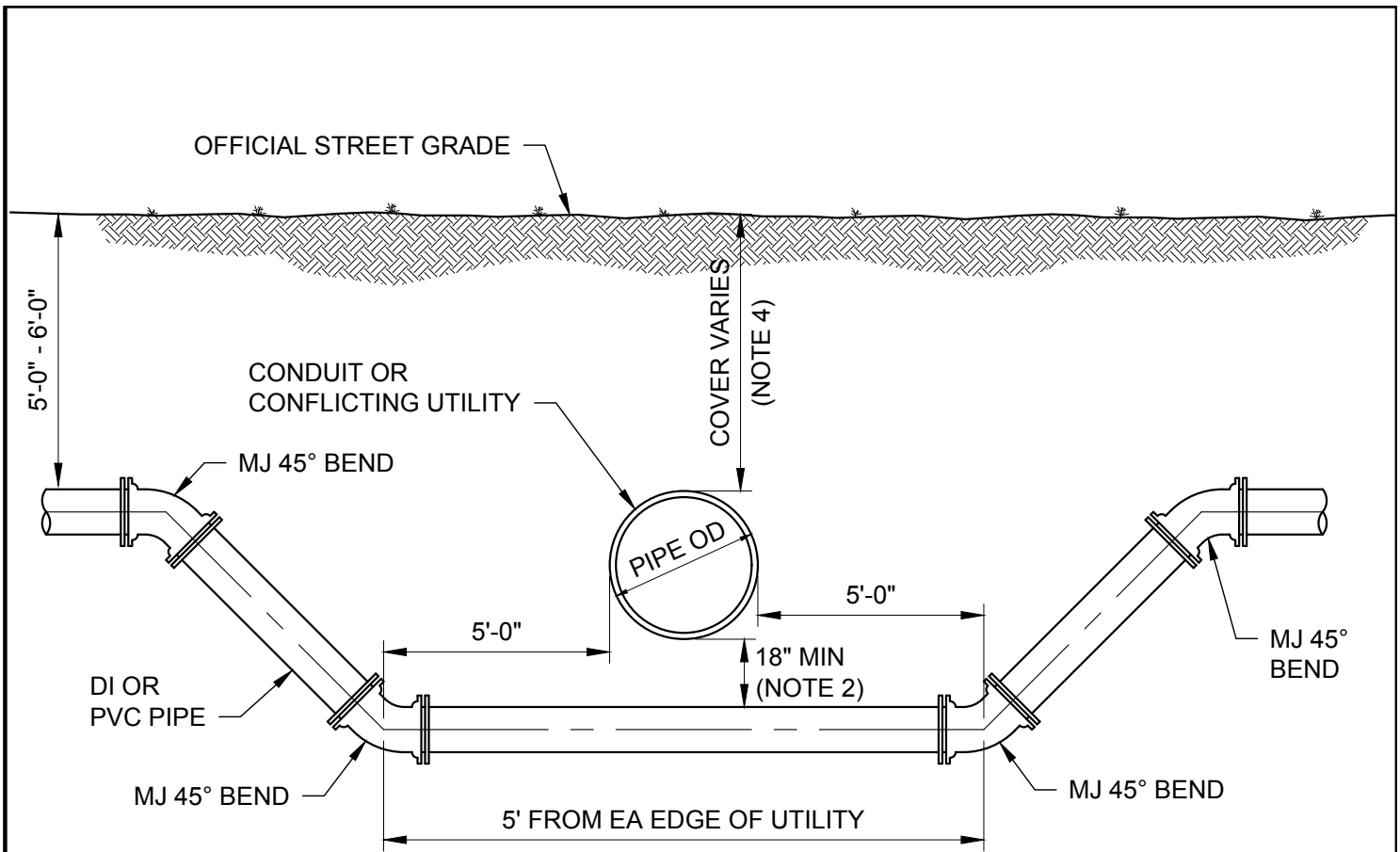

NOTES:

1. REFER TO NWCWD'S STANDARD SPECIFICATIONS FOR ACCEPTABLE PARTS AND MATERIALS.
2. CLEARANCE MAY BE GREATER, DEPENDING ON CROSSED UTILITY OWNER'S SPECIFIC REQUIREMENTS.
3. RESTRAIN ALL JOINTS.
4. POT HOLE CROSSED UTILITIES TO DETERMINE EXACT ELEVATION AT CROSSING LOCATION PRIOR TO INSTALLATION OF WATERLINE.



**NORTH WELD COUNTY
WATER DISTRICT**
970-356-3020
www.nwcwd.org

TYPICAL UTILITY CROSSING

DETAIL NO:	3300002
NWCWD APPD:	GM
ORIG DATE:	04/12/2018
REV DATE:	02/08/2021

(THIS PAGE INTENTIONALLY LEFT BLANK)

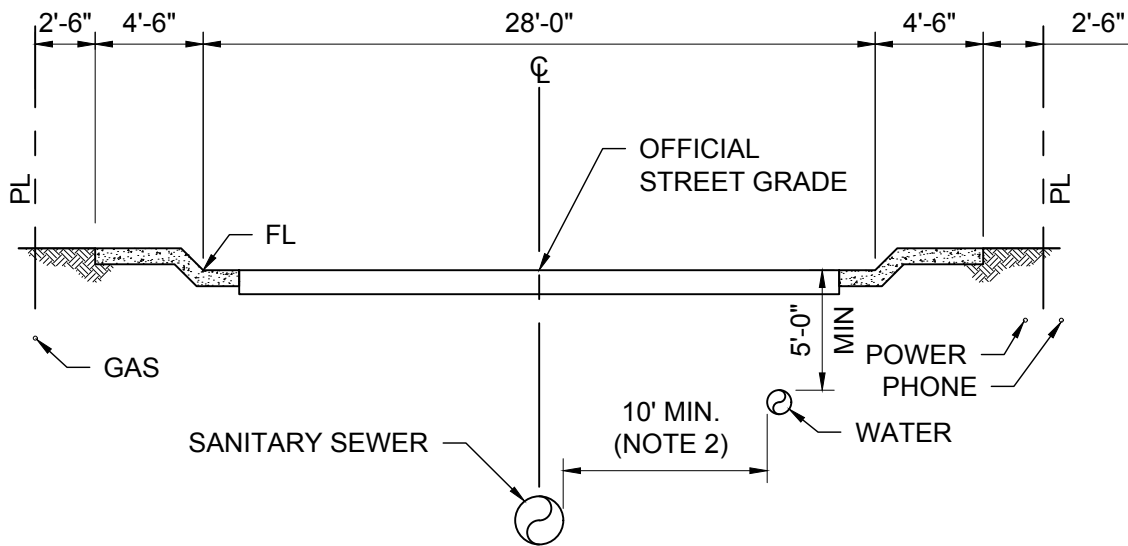

NOTES:

1. REFER TO NWCWD'S STANDARD SPECIFICATIONS FOR ACCEPTABLE PARTS AND MATERIALS.
2. THE MINIMUM 10-FOOT SEPARATION IS MEASURED FROM THE OUTSIDES OF EACH PIPE/UTILITY, I.E., NOT FROM THE CENTERLINES.



NORTH WELD COUNTY
WATER DISTRICT
 970-356-3020
 www.nwcwd.org

TYPICAL STREET CROSS-SECTION

DETAIL NO:	3300003
NWCWD APPD:	GM
ORIG DATE:	04/12/2018
REV DATE:	02/08/2021

(THIS PAGE INTENTIONALLY LEFT BLANK)

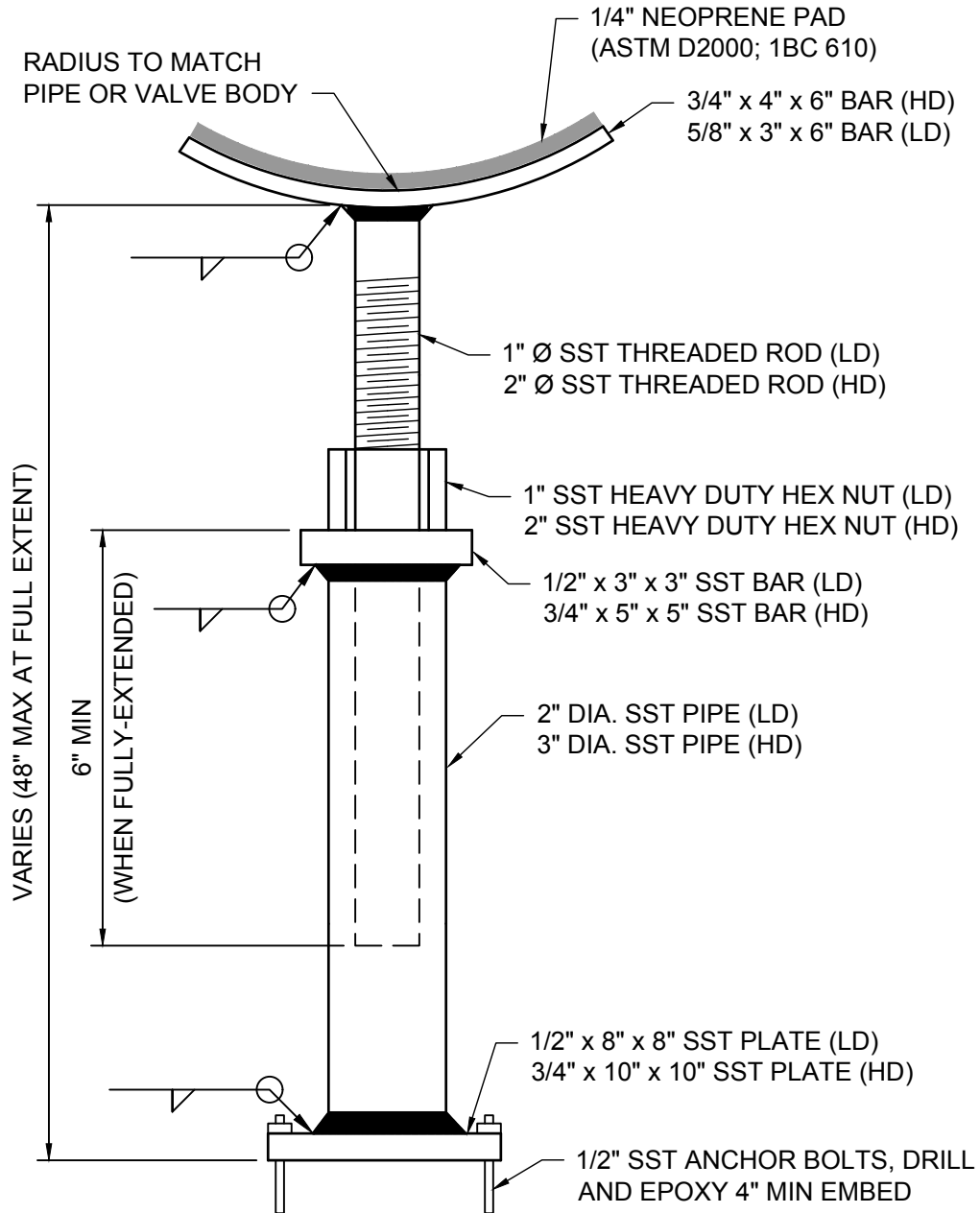

NOTES:

1. HD - HEAVY DUTY; LD - LIGHT DUTY; SST - STAINLESS STEEL.
2. SIMILAR PREFABRICATED SUPPORT BY GRINNELL, BEELINE, OR EQUAL MAY BE SUBSTITUTED.



NORTH WELD COUNTY
WATER DISTRICT
 970-356-3020
 www.nwcwd.org

TYPICAL ADJUSTABLE SUPPORT

DETAIL NO:	3300004
NWCWD APPD:	GM
ORIG DATE:	04/12/2018
REV DATE:	02/08/2021

(THIS PAGE INTENTIONALLY LEFT BLANK)

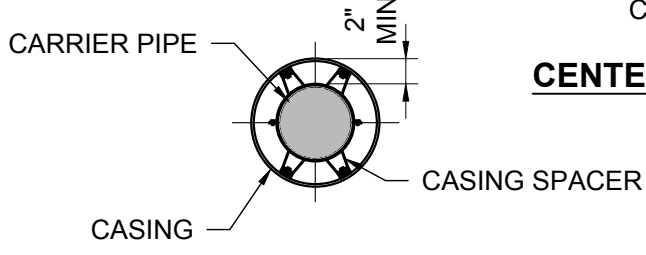
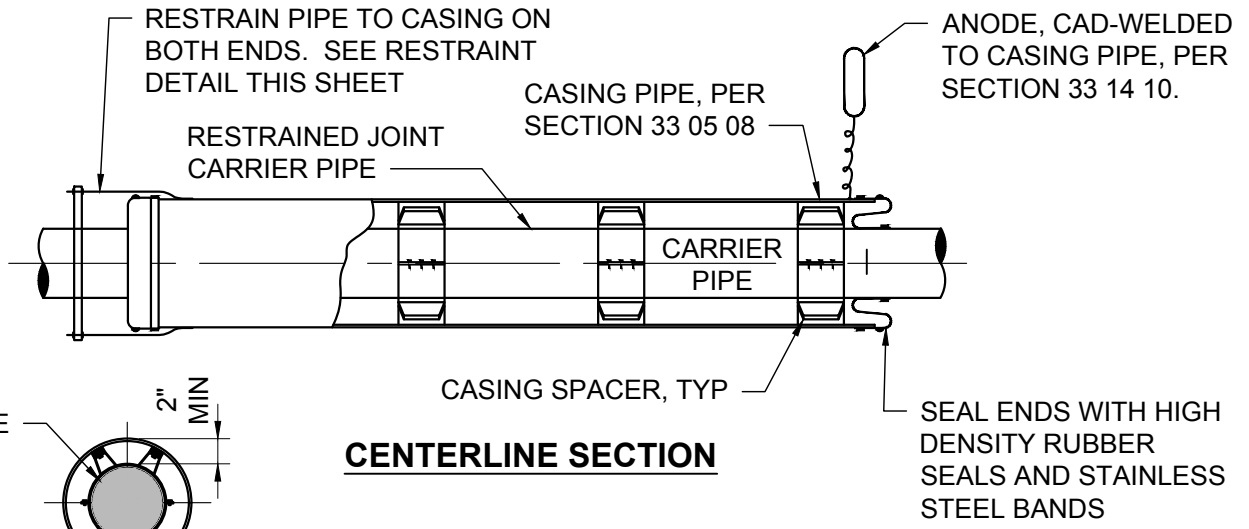

CENTERLINE SECTION

END SECTION

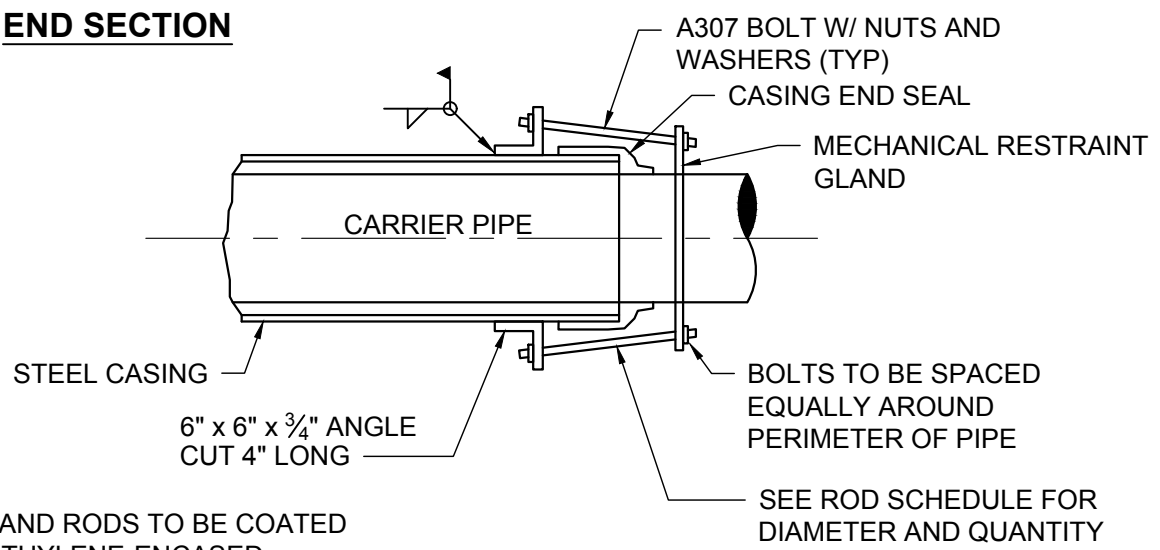

NOTE:
ALL BOLTS AND RODS TO BE COATED AND POLYETHYLENE-ENCASED.

RESTRAINT DETAIL

CARRIER PIPE SIZE (IN)	DIAMETER OF ROD (IN)	QUANTITY OF RODS
4"	1/2"	2
6"	1/2"	2
8"	3/4"	2
12"	3/4"	2
16"	5/8"	6

NOTE:
ROD SIZE ASSUMES 200 PSI TEST PRESSURE AND A307 STEEL.

ROD SCHEDULE



NORTH WELD COUNTY WATER DISTRICT
970-356-3020
www.nwcwd.org

STEEL CASING PIPE

DETAIL NO:	3305081
NWCWD APPD:	GM
ORIG DATE:	04/12/2018
REV DATE:	02/08/2021

(THIS PAGE INTENTIONALLY LEFT BLANK)

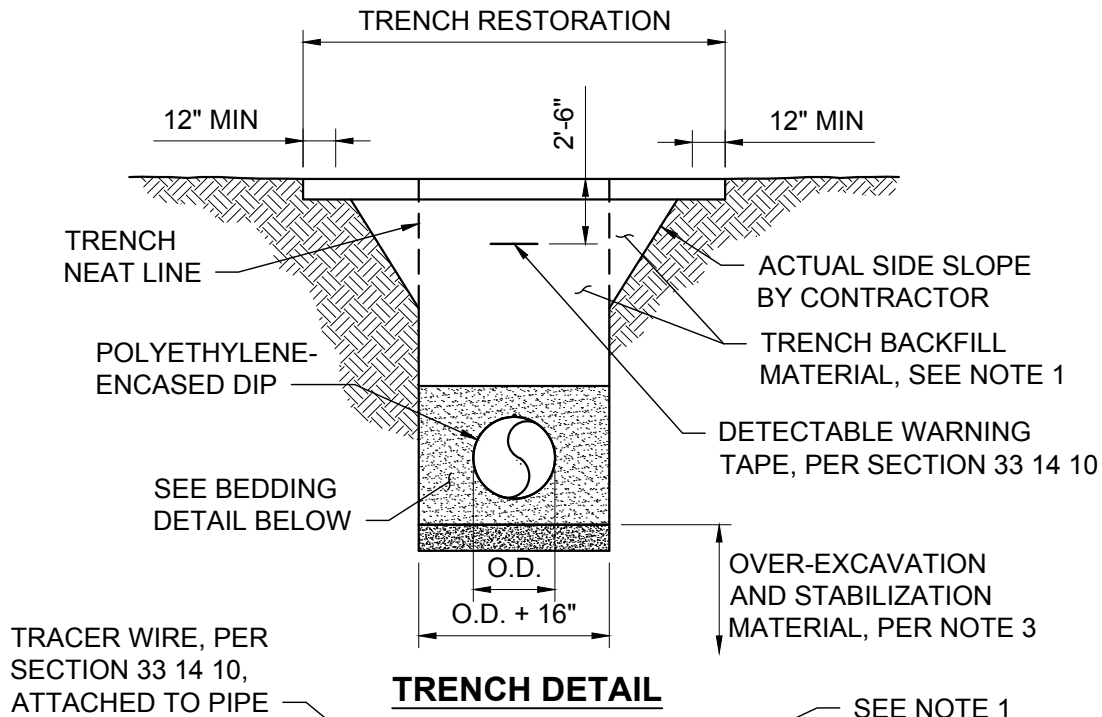

TRENCH DETAIL

BEDDING DETAIL

NOTES:

1. TRENCH BACKFILL MATERIAL SHALL BE IN ACCORDANCE WITH SECTION 31 23 35.
2. "BEDDING ZONE MATERIALS," AS APPROVED BY ENGINEER. REFER TO SECTION 31 23 35.
3. OVER-EXCAVATE UNSUITABLE MATERIAL, & REPLACE WITH "STABILIZATION MATERIAL" AS REQUIRED ON THE DRAWINGS - OR - AS DIRECTED BY THE ENGINEER. REFER TO SECTION 31 23 35.
4. REFER TO NWCWD'S STANDARD SPECIFICATIONS FOR ACCEPTABLE PARTS AND MATERIALS.



**NORTH WELD COUNTY
WATER DISTRICT**
970-356-3020
www.nwcwd.org

DI PIPE BEDDING DETAILS

DETAIL NO:	3305201
NWCWD APPD:	GM
ORIG DATE:	04/12/2018
REV DATE:	02/08/2021

(THIS PAGE INTENTIONALLY LEFT BLANK)

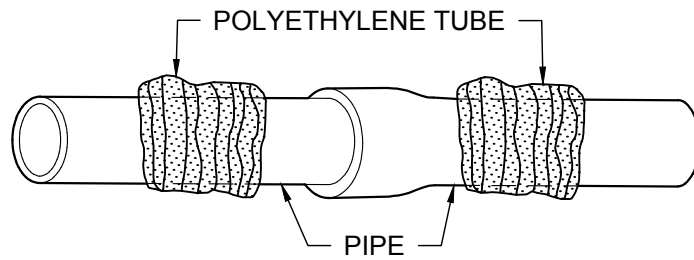

STEP 1

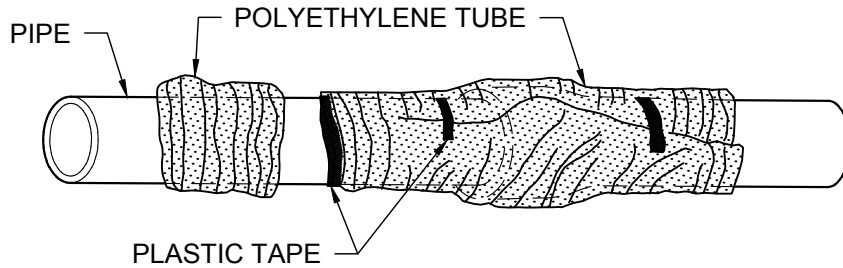

STEP 2

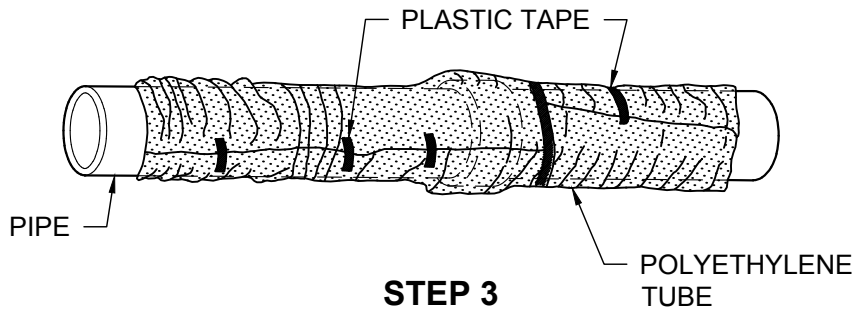

STEP 3

- STEP 1) PLACE TUBE OF POLYETHYLENE MATERIAL ON PIPE PRIOR TO LOWERING IT INTO TRENCH.
- STEP 2) PULL THE TUBE OVER THE LENGTH OF THE PIPE. TAPE TUBE TO PIPE AT JOINT. FOLD MATERIAL AROUND THE ADJACENT SPIGOT END AND WRAP WITH TAPE TO HOLD THE PLASTIC TUBE IN PLACE. EXCESS MATERIAL SHALL BE NEATLY DRAWN UP AROUND THE PIPE BARREL, FOLDED ON TOP OF PIPE AND TAPED IN PLACE.
- STEP 3) OVERLAP FIRST TUBE WITH ADJACENT TUBE AND SECURE WITH PLASTIC ADHESIVE TAPE. THE MATERIAL COVERING THE PIPE SHALL BE LOOSE. EXCESS MATERIAL SHALL BE NEATLY DRAWN UP AROUND THE PIPE BARREL, FOLDED ON TOP OF PIPE AND TAPED IN PLACE.
- STEP 4) CAREFULLY BACKFILL WITH CLEAN MATERIAL THAT WILL NOT DAMAGE ENCASEMENT.
- TAPS) MAKE TAPS BY WRAPPING THREE LAYERS OF COMPATIBLE TAPE AROUND THE PIPE TO COVER THE TAPPING MACHINE AREA. INSTALL CORPORATION STOP THROUGH THE TAPE AND POLYETHYLENE. DIRECT TAPPING WITHOUT A SADDLE IS NOT ALLOWED.



**NORTH WELD COUNTY
WATER DISTRICT**
970-356-3020
www.nwcwd.org

POLYETHYLENE ENCASEMENT INSTALLATION

DETAIL NO:	3305202
NWCWD APPD:	GM
ORIG DATE:	04/12/2018
REV DATE:	02/08/2021

(THIS PAGE INTENTIONALLY LEFT BLANK)

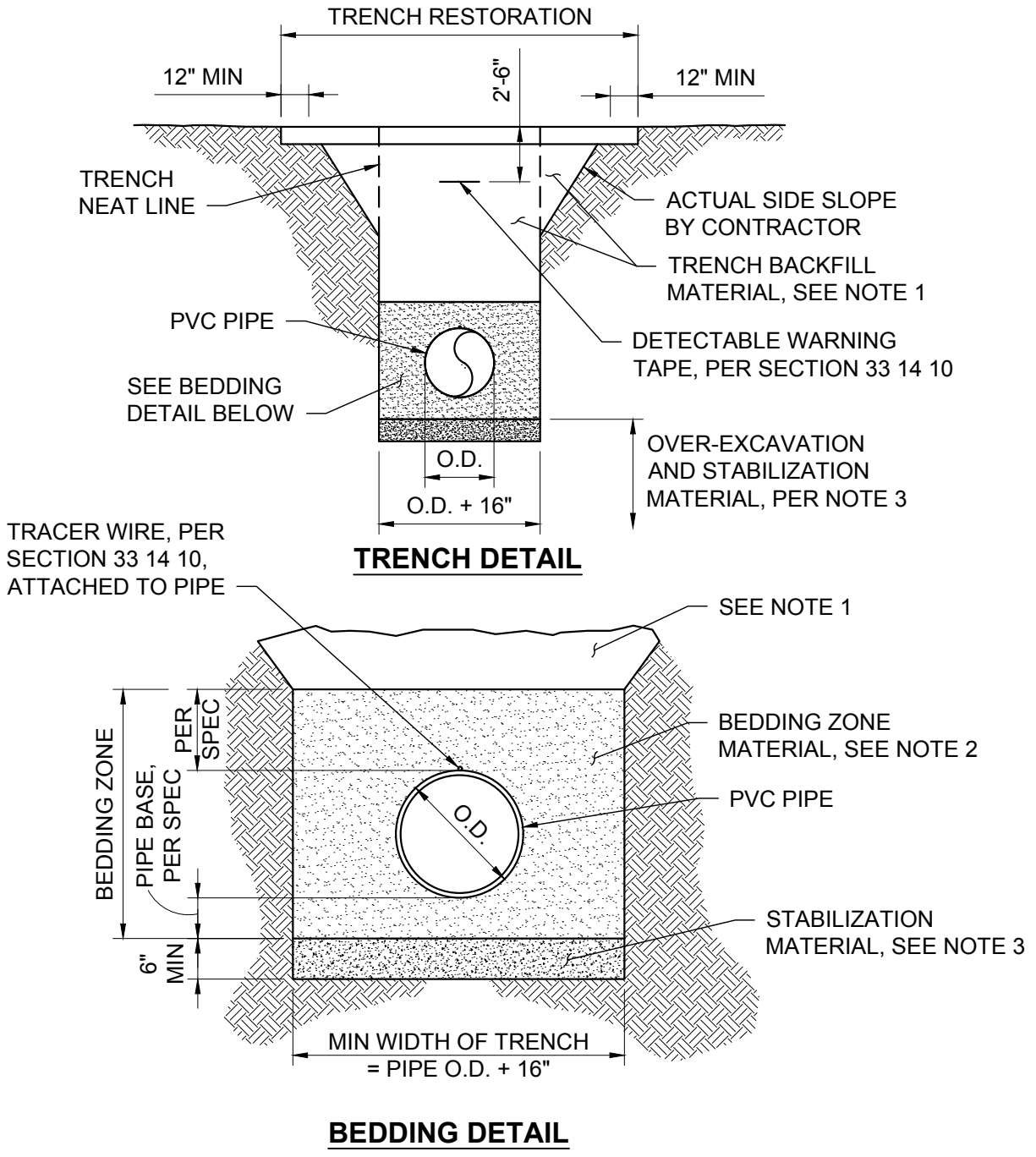

NOTES:

1. TRENCH BACKFILL MATERIAL SHALL BE IN ACCORDANCE WITH SECTION 31 23 35.
2. "BEDDING ZONE MATERIALS," AS APPROVED BY ENGINEER. REFER TO SECTION 31 23 35.
3. OVER-EXCAVATE UNSUITABLE MATERIAL, & REPLACE WITH "STABILIZATION MATERIAL" AS REQUIRED ON THE DRAWINGS - OR - AS DIRECTED BY THE ENGINEER. REFER TO SECTION 31 23 35.
4. REFER TO NWCWD'S STANDARD SPECIFICATIONS FOR ACCEPTABLE PARTS AND MATERIALS.



NORTH WELD COUNTY WATER DISTRICT
 970-356-3020
 www.nwcwd.org

PVC PIPE BEDDING DETAILS

DETAIL NO:	3305291
NWCWD APPD:	GM
ORIG DATE:	04/12/2018
REV DATE:	02/08/2021

(THIS PAGE INTENTIONALLY LEFT BLANK)

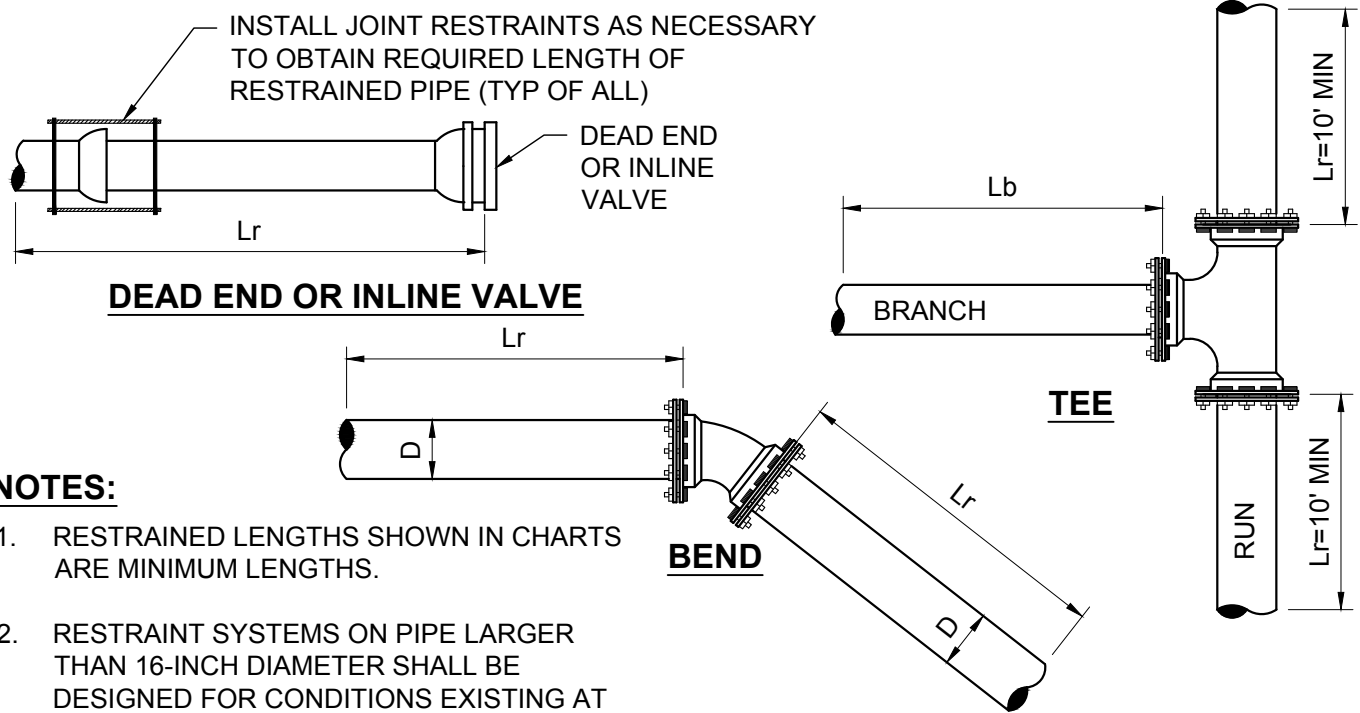

NOTES:

1. RESTRAINED LENGTHS SHOWN IN CHARTS ARE MINIMUM LENGTHS.
2. RESTRAINT SYSTEMS ON PIPE LARGER THAN 16-INCH DIAMETER SHALL BE DESIGNED FOR CONDITIONS EXISTING AT THE INSTALLATION SITE.
3. THE CHARTS ARE BASED ON THE ASSUMPTIONS SHOWN ON STANDARD DETAIL NO. 3314102.
4. THE DESIGN ENGINEER IS RESPONSIBLE FOR VERIFYING THE ACTUAL SITE CONDITIONS WITH RESPECT TO THE ASSUMPTIONS LISTED ON STANDARD DETAIL NO. 3314102.
5. IF LENGTHS CANNOT BE MET FOR DEAD ENDS AND/OR TEES, DESIGN ENGINEER SHALL SPECIFY RESTRAINED LENGTHS OR A COMBINATION OF THRUST BLOCK AND RESTRAINTS.

C900 PVC PIPE: MINIMUM LENGTHS OF RESTRAINED PIPE - IN FEET								
PIPE SIZE (D")		BENDS (Lr)				TEE (Lb)	DEAD END/ INLINE VALVE (Lr)	
RUN	BRANCH	11¼°	22½°	45°	90°			
4	4	5	5	10	20	5	45	
6	4	-	-	-	-	5	-	
6	6	5	5	15	25	20	60	
8	4	-	-	-	-	5	-	
8	6	-	-	-	-	5	-	
8	8	5	10	15	35	40	80	
10	4	-	-	-	-	5	-	
10	6	-	-	-	-	5	-	
10	8	-	-	-	-	30	-	
10	10	5	10	20	40	55	100	
12	4	-	-	-	-	5	-	
12	6	-	-	-	-	5	-	
12	8	-	-	-	-	15	-	
12	10	-	-	-	-	45	-	
12	12	5	10	20	50	70	115	
16	4	-	-	-	-	5	-	
16	6	-	-	-	-	5	-	
16	8	-	-	-	-	5	-	
16	10	-	-	-	-	25	-	
16	12	-	-	-	-	55	-	
16	16	10	15	25	60	105	150	

DI PIPE (POLYETHYLENE-ENCASED): MINIMUM LENGTHS OF RESTRAINED PIPE - IN FEET								
PIPE SIZE (D")		BENDS (Lr)				TEE (Lb)	DEAD END/ INLINE VALVE (Lr)	
RUN	BRANCH	11¼°	22½°	45°	90°			
4	4	5	5	10	20	5	55	
6	4	-	-	-	-	5	-	
6	6	5	10	15	30	25	75	
8	4	-	-	-	-	5	-	
8	6	-	-	-	-	5	-	
8	8	5	10	15	40	45	100	
10	4	-	-	-	-	5	-	
10	6	-	-	-	-	5	-	
10	8	-	-	-	-	35	-	
10	10	5	10	20	45	65	120	
12	4	-	-	-	-	5	-	
12	6	-	-	-	-	5	-	
12	8	-	-	-	-	20	-	
12	10	-	-	-	-	55	-	
12	12	5	10	25	50	85	140	
16	4	-	-	-	-	5	-	
16	6	-	-	-	-	5	-	
16	8	-	-	-	-	5	-	
16	10	-	-	-	-	35	-	
16	12	-	-	-	-	70	-	
16	16	10	15	30	65	125	180	



NORTH WELD COUNTY
WATER DISTRICT
 970-356-3020
 www.nwcwd.org

HORIZONTAL BEND RESTRAINT

DETAIL NO: 3314101
 NWCWD APPD: GM
 ORIG DATE: 04/12/2018
 REV DATE: 02/08/2021

(THIS PAGE INTENTIONALLY LEFT BLANK)

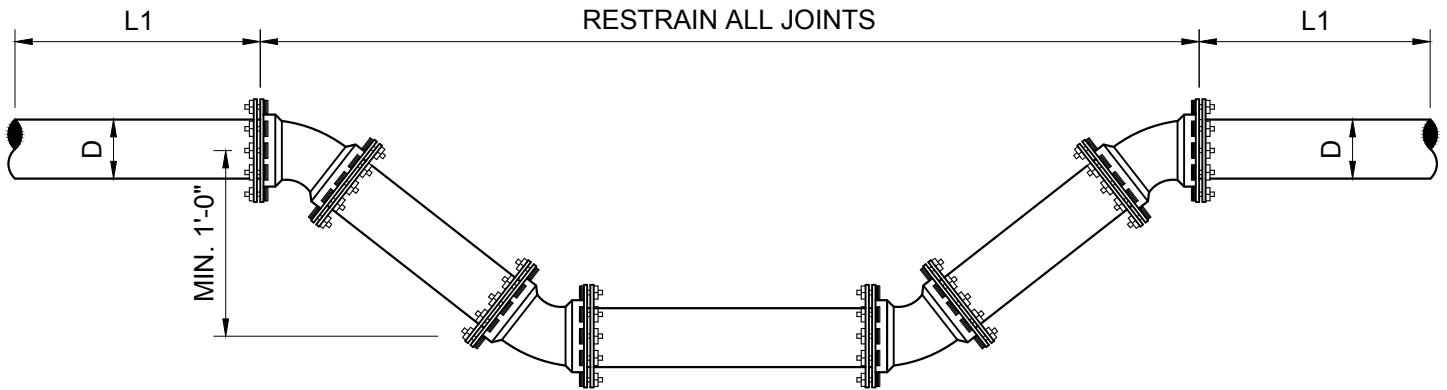

VERTICAL LOWERING

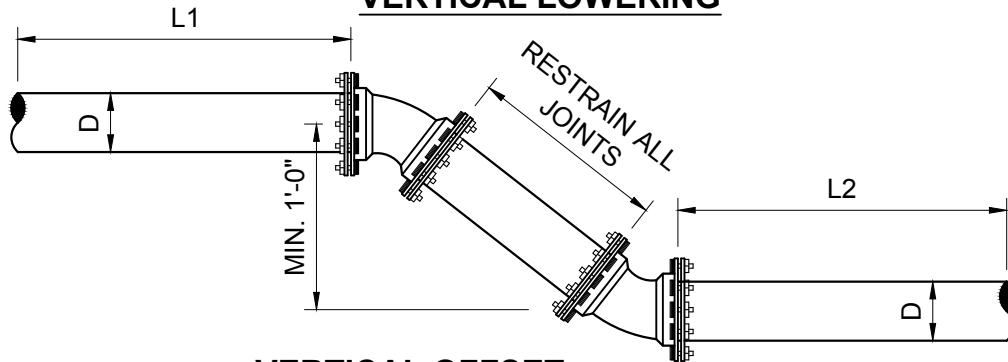

VERTICAL OFFSET

NOTES:

1. RESTRAINED LENGTHS SHOWN IN CHARTS ARE MINIMUM LENGTHS.
2. RESTRAINT SYSTEMS ON PIPE LARGER THAN 16-INCH DIAMETER SHALL BE DESIGNED FOR CONDITIONS EXISTING AT THE INSTALLATION SITE.
3. THE CHARTS ARE BASED ON THE FOLLOWING ASSUMPTIONS:
 - a. 200 PSI TEST PRESSURE
 - b. 1.5 SAFETY FACTOR.
 - c. BURY DEPTH: 5 FT
 - d. SOIL TYPE: ML, AS DEFINED BY AWWA M23 AND M41
 - e. TRENCH TYPE: #3, AS DEFINED BY AWWA M23 AND M41
4. THE DESIGN ENGINEER IS RESPONSIBLE FOR VERIFYING THE ACTUAL SITE CONDITIONS WITH RESPECT TO THE ASSUMPTIONS LISTED ABOVE.
5. IF LENGTHS CANNOT BE MET FOR DEAD ENDS AND/OR TEES, DESIGN ENGINEER SHALL SPECIFY RESTRAINED LENGTHS OR A COMBINATION OF THRUST BLOCK AND RESTRAINTS.

C900 PVC PIPE: MINIMUM LENGTHS OF RESTRAINED PIPE - IN FEET						
PIPE SIZE (D")	VERTICAL BENDS					
	11¼°		22½°		45°	
	L1	L2	L1	L2	L1	L2
4	5	10	10	20	20	35
6	10	15	15	25	25	45
8	10	15	20	30	35	55
10	10	20	20	35	40	65
12	15	20	25	35	50	75
16	15	25	30	45	65	90

DI PIPE (POLYETHYLENE-ENCASED): MINIMUM LENGTHS OF RESTRAINED PIPE - IN FEET						
PIPE SIZE (D")	VERTICAL BENDS					
	11¼°		22½°		45°	
	L1	L2	L1	L2	L1	L2
4	10	10	15	20	25	35
6	10	15	15	25	35	50
8	10	15	20	30	45	60
10	15	20	25	35	50	70
12	15	20	30	40	60	80
16	20	25	40	45	75	95



**NORTH WELD COUNTY
WATER DISTRICT**
970-356-3020
www.nwcwd.org

VERTICAL BEND RESTRAINT

DETAIL NO: 3314102
NWCWD APPD: GM
ORIG DATE: 04/12/2018
REV DATE: 02/08/2021

(THIS PAGE INTENTIONALLY LEFT BLANK)

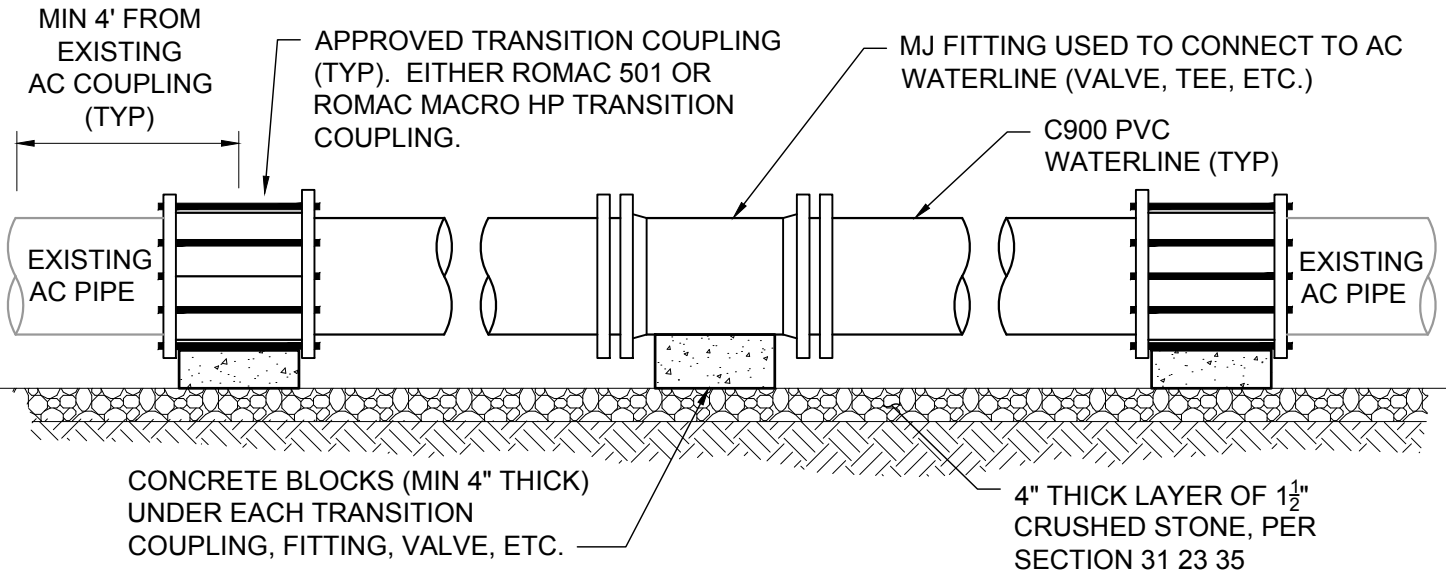

NOTES:

1. ALL FITTINGS, VALVES, AND COUPLINGS SHALL BE POLYETHYLENE-ENCASED. PER SECTION 33 05 20.
2. CONCRETE BLOCKING SHALL BE CENTERED UNDER FITTING AND INSTALLED ON STABILIZATION MATERIAL, AS SHOWN.

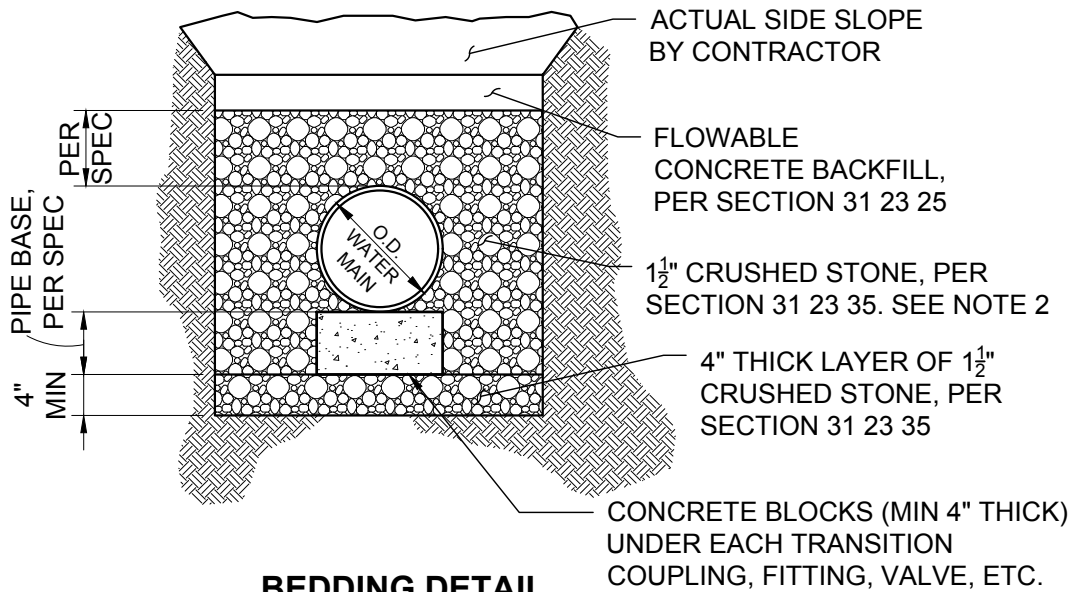

BEDDING DETAIL

NOTES:

1. REFER TO NWCWD'S STANDARD SPECIFICATIONS FOR ACCEPTABLE PARTS AND MATERIALS.
2. PIPE MAY BE BEDDED IN FLOWABLE CONCRETE BACKFILL, PER SECTION 31 23 25 AS AN ALTERNATIVE TO CRUSHED STONE OR GRAVEL. SQUEEGEE SHALL NOT BE USED TO EMBED AC PIPE.
3. INSTALL DETECTABLE WARNING TAPE 2'-6" BELOW FINISHED GRADE, DIRECTLY OVER WATER MAIN. REFER TO SECTION 33 14 10 FOR PRODUCT REQUIREMENTS.



NORTH WELD COUNTY WATER DISTRICT
 970-356-3020
 www.nwcwd.org

CONNECTION TO AC WATERLINE

DETAIL NO:	3314103
NWCWD APPD:	GM
ORIG DATE:	04/18/2018
REV DATE:	02/08/2021

(THIS PAGE INTENTIONALLY LEFT BLANK)

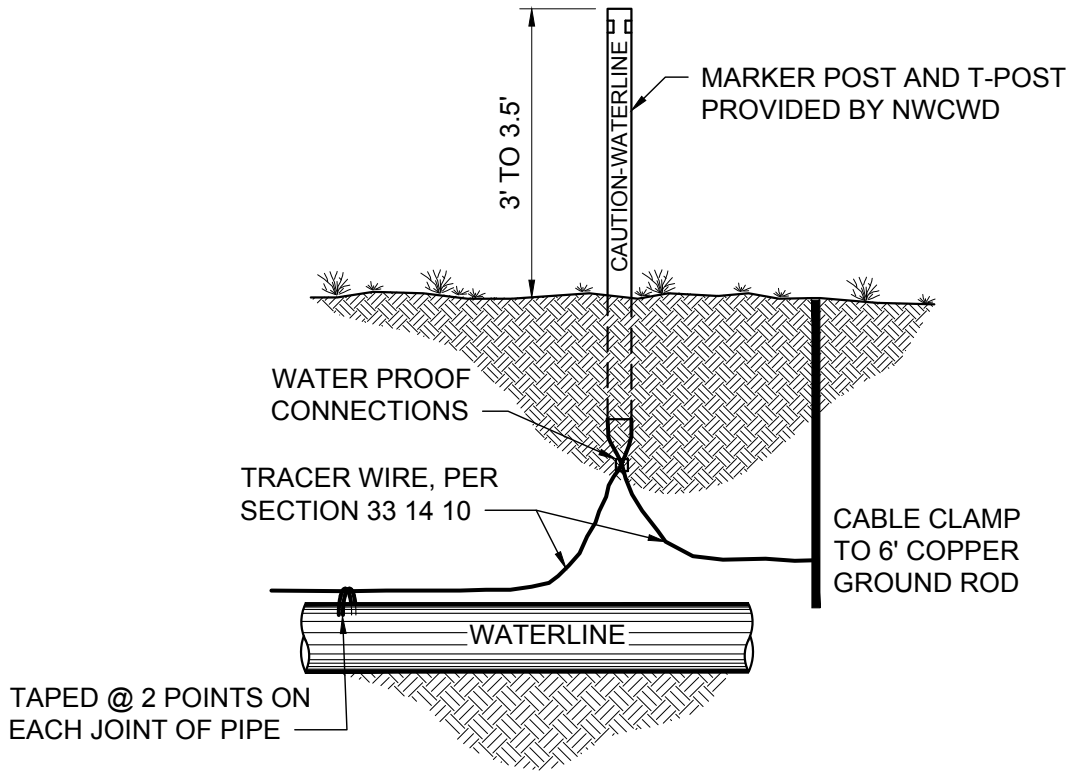

TEST STATION WITH GROUND ROD

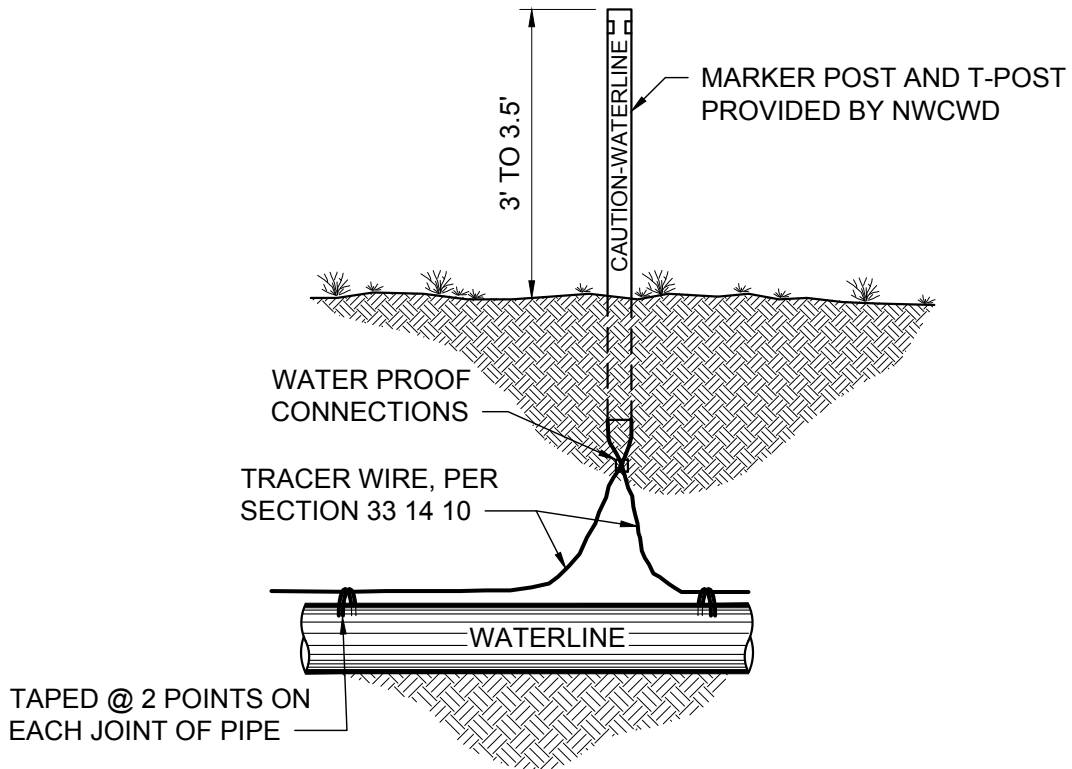

TEST STATION WITHOUT GROUND ROD



**NORTH WELD COUNTY
WATER DISTRICT**
970-356-3020
www.nwcwd.org

TRACER WIRE TEST STATION

DETAIL NO:	3314104
NWCWD APPD:	GM
ORIG DATE:	04/12/2018
REV DATE:	02/08/2021

(THIS PAGE INTENTIONALLY LEFT BLANK)

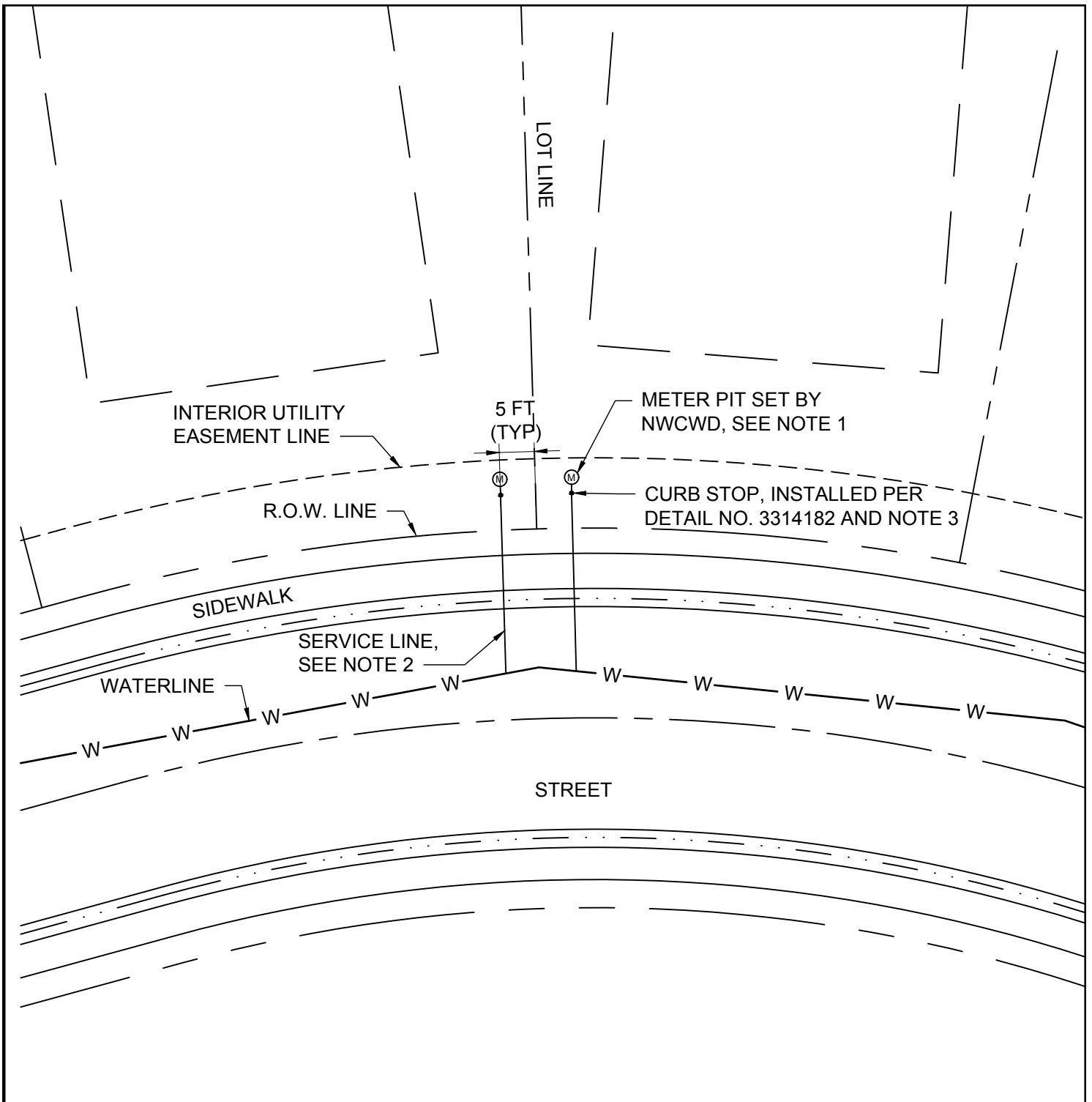

NOTES:

1. REFER TO DETAIL NO. 3314183 FOR "METER PIT CONSTRUCTION ENVELOPE".
2. REFER TO DETAIL NO. 3314182 FOR "1-INCH SERVICE ASSEMBLY".
3. CURB STOP SHALL BE PLACED APPROXIMATELY EIGHT (8) FEET FROM RIGHT-OF-WAY (R.O.W.) LINE.



NORTH WELD COUNTY
WATER DISTRICT
 970-356-3020
 www.nwcwd.org

WATER SERVICE LOCATION PLAN

DETAIL NO:	3314181
NWCWD APPD:	GM
ORIG DATE:	04/02/2019
REV DATE:	02/08/2021

(THIS PAGE INTENTIONALLY LEFT BLANK)

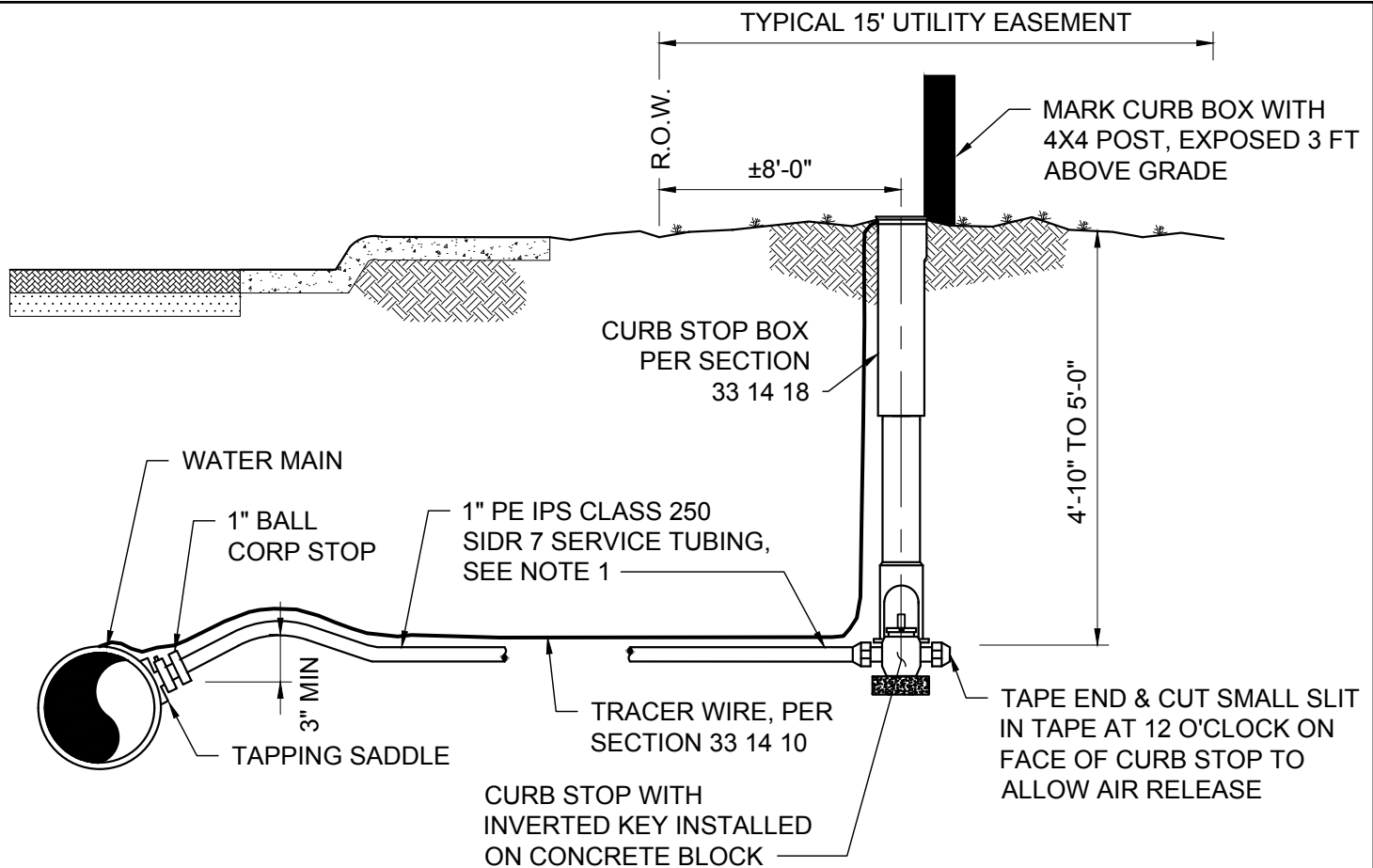

NOTES:

1. USE INSERT STIFFENERS AT ALL COMPRESSION CONNECTIONS.
2. TIGHTEN ALL RESTRAINT BOLTS AT COMPRESSION CONNECTIONS.
3. ALL SERVICES SHALL BE BEDDED IN APPROVED "BEDDING ZONE MATERIALS," FROM MAIN TO CURB STOP, PER SECTION 31 23 35.
4. ALL TAPPING SADDLES, CORP STOPS, CURB STOPS, SERVICE LINE AND FITTINGS SHALL CONFORM TO SECTION 33 14 18 - SERVICE LINES AND APPURTENANCES.
5. NO SUBSTITUTES OF "EQUALS" WITHOUT WRITTEN APPROVAL FROM NWCWD.



NORTH WELD COUNTY
WATER DISTRICT
 970-356-3020
 www.nwcwd.org

1-INCH SERVICE ASSEMBLY

DETAIL NO:	3314182
NWCWD APPD:	GM
ORIG DATE:	04/18/2018
REV DATE:	02/08/2021

(THIS PAGE INTENTIONALLY LEFT BLANK)

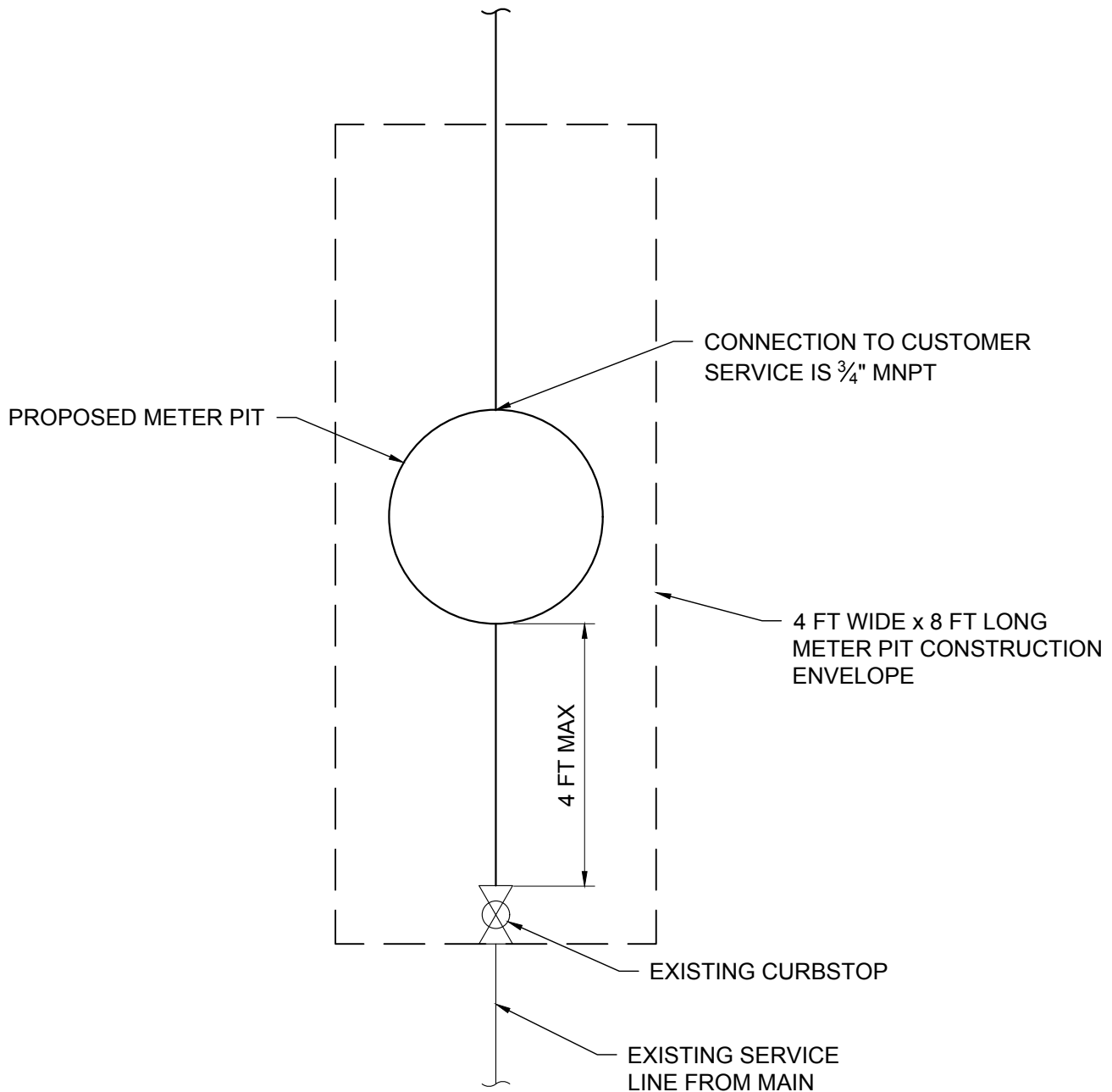

NOTES:

1. AT TIME OF METER PIT INSTALLATION, EXISTING GRADE MUST BE WITHIN 2" OF FINAL LOT GRADE. A STAKE OR STRING LINE SHALL BE USED TO INDICATE FINAL GRADE SO METER PIT CAN BE SET TO PROPER ELEVATION.
2. METER PIT CONSTRUCTION ENVELOPE SHALL NOT BE PLACED WITHIN A HARD SURFACE DRIVEWAY OR SIDEWALK TO FACILITATE EASE OF MAINTENANCE.
3. DO NOT PLACE TREES, SHRUBS, BUSHES OR OTHER EXPENSIVE TO REPLACE LANDSCAPE OVER CONSTRUCTION ENVELOPE.

(THIS PAGE INTENTIONALLY LEFT BLANK)

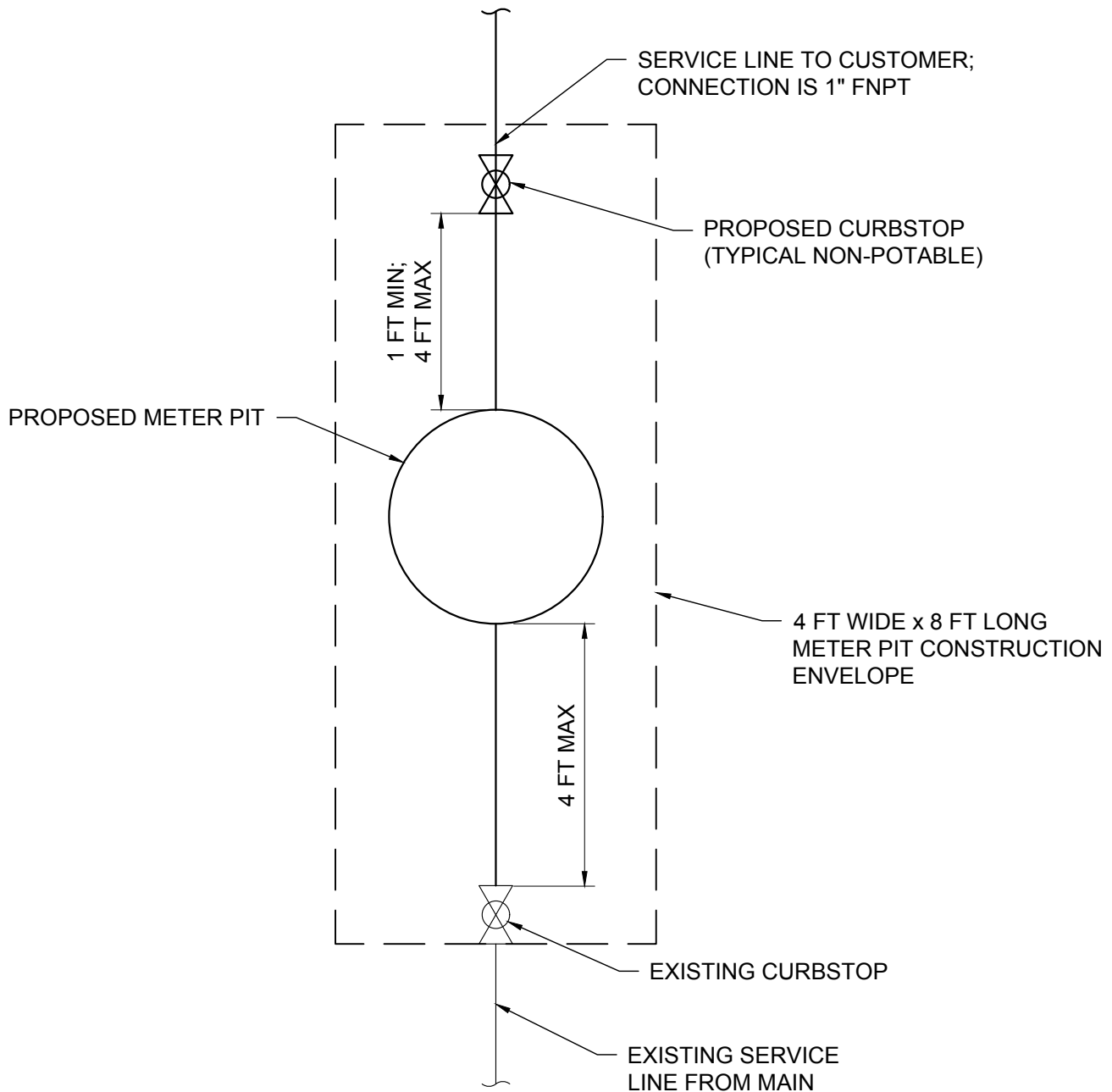

NOTES:

1. AT TIME OF METER PIT INSTALLATION, EXISTING GRADE MUST BE WITHIN 2" OF FINAL LOT GRADE. A STAKE OR STRING LINE SHALL BE USED TO INDICATE FINAL GRADE SO METER PIT CAN BE SET TO PROPER ELEVATION.
2. METER PIT CONSTRUCTION ENVELOPE SHALL NOT BE PLACED WITHIN A HARD SURFACE DRIVEWAY OR SIDEWALK TO FACILITATE EASE OF MAINTENANCE.
3. DO NOT PLACE TREES, SHRUBS, BUSHES OR OTHER EXPENSIVE TO REPLACE LANDSCAPE OVER CONSTRUCTION ENVELOPE.

(THIS PAGE INTENTIONALLY LEFT BLANK)

OPEN - LEFT,
COUNTER-CLOCKWISE

CLOSE - RIGHT,
CLOCKWISE

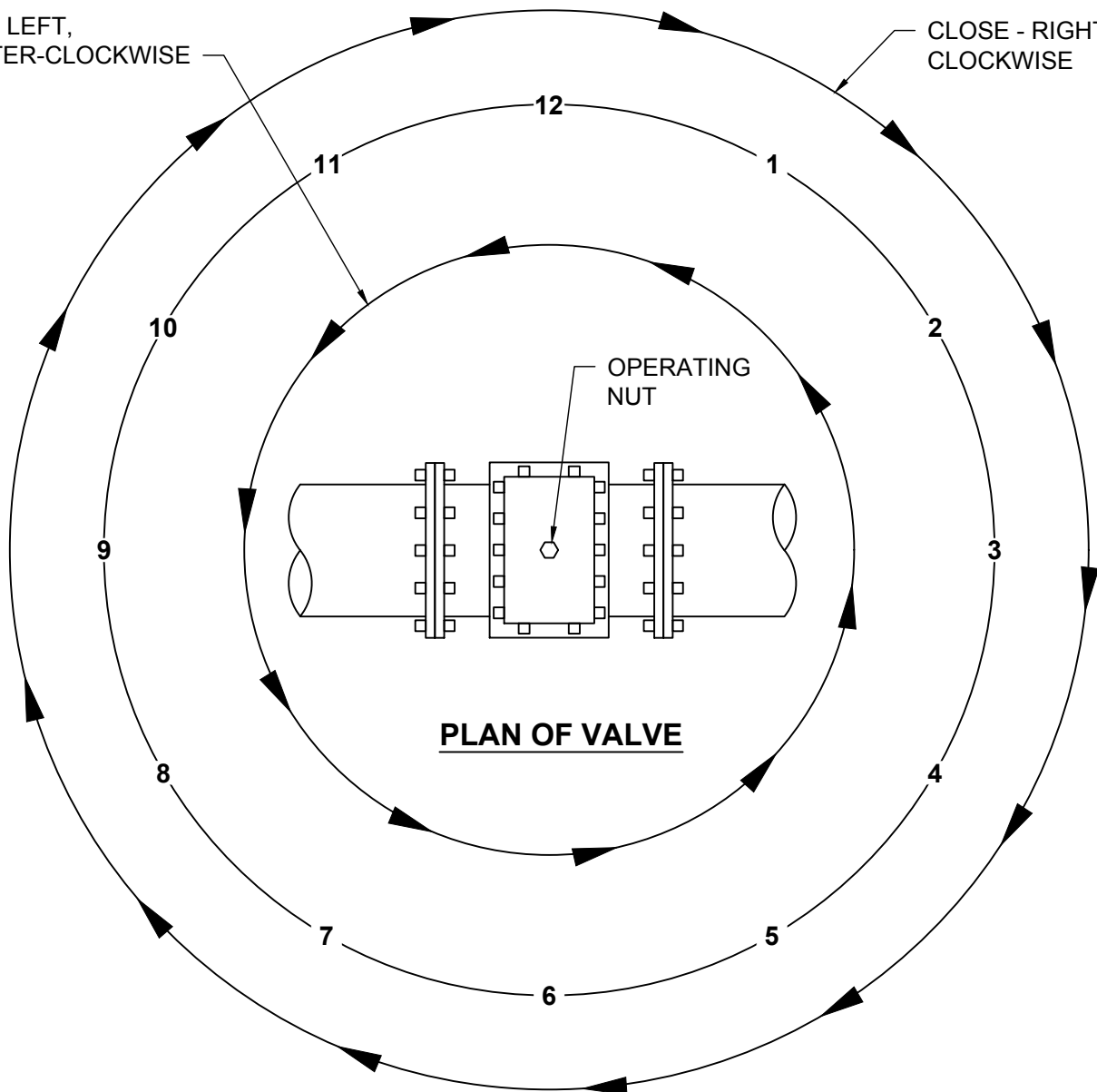

NOTES:

1. REFER TO NWCWD'S STANDARD SPECIFICATIONS FOR ACCEPTABLE PARTS AND MATERIALS.
2. NWCWD VALVES OPEN COUNTER-CLOCKWISE (BLACK NUT) AND CLOSE CLOCKWISE.
3. VALVES WITH RED NUTS TYPICALLY OPEN RIGHT (CLOCKWISE) AND ARE NOT USED WITHIN NWCWD'S SERVICE AREA.
4. REFER TO SECTION 33 14 22 FOR HYDRANT REQUIREMENTS.



NORTH WELD COUNTY
WATER DISTRICT
970-356-3020
www.nwcwd.org

TYPICAL VALVE OPERATION

DETAIL NO:	3314201
NWCWD APPD:	GM
ORIG DATE:	04/12/2018
REV DATE:	02/08/2021

(THIS PAGE INTENTIONALLY LEFT BLANK)

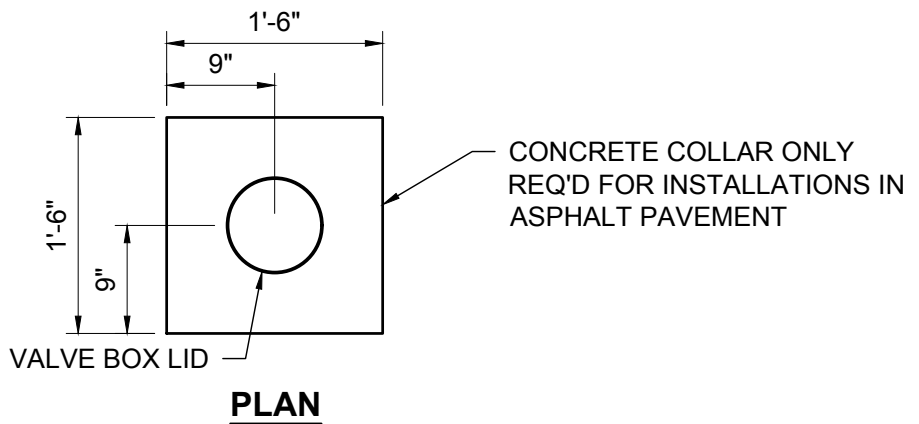
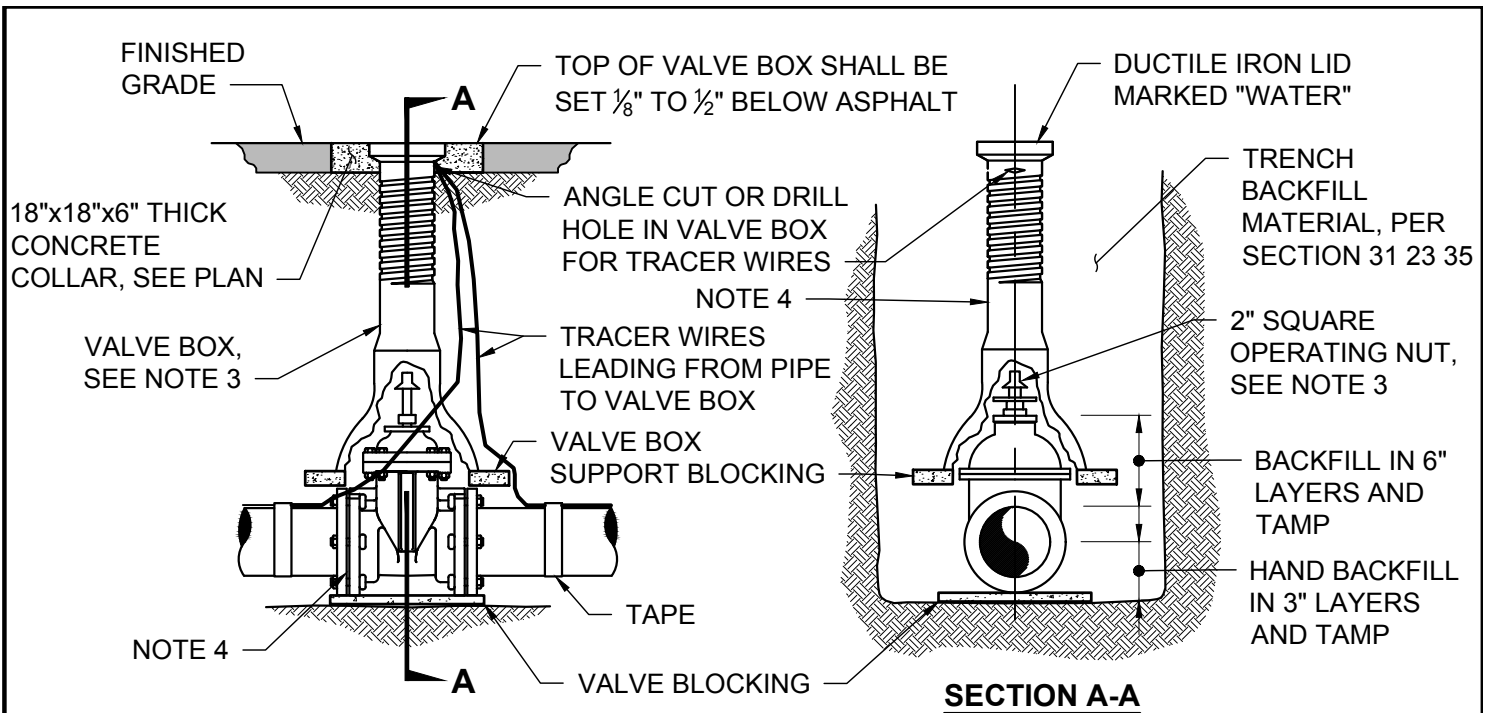

NOTES:

1. VALVE BOX SHALL BE CENTERED AND PLUMB OVER THE OPERATING NUT AND SHALL NOT TRANSMIT SHOCK WAVES OR STRESS TO THE VALVE.
2. VALVE SHALL BE BLOCKED WITH POURED CONCRETE, BRICK, OR OTHER SUITABLE MASONRY MATERIAL.
3. GATE VALVE AND VALVE BOX, PER SECTION 33 14 20. IF DEPTH IS GREATER THAN FIVE (5) FEET, INSTALL STEM EXTENSION TO FOUR (4) FEET BELOW GRADE.
4. WRAP VALVE AND VALVE BOX WITH POLYETHYLENE ENCASEMENT, PER DETAIL NO. 3305202.
5. TRACER WIRE SHALL BE TERMINATED IN VALVE BOX, AS SHOWN. REFER TO SECTION 33 14 10 FOR REQUIREMENTS.

(THIS PAGE INTENTIONALLY LEFT BLANK)

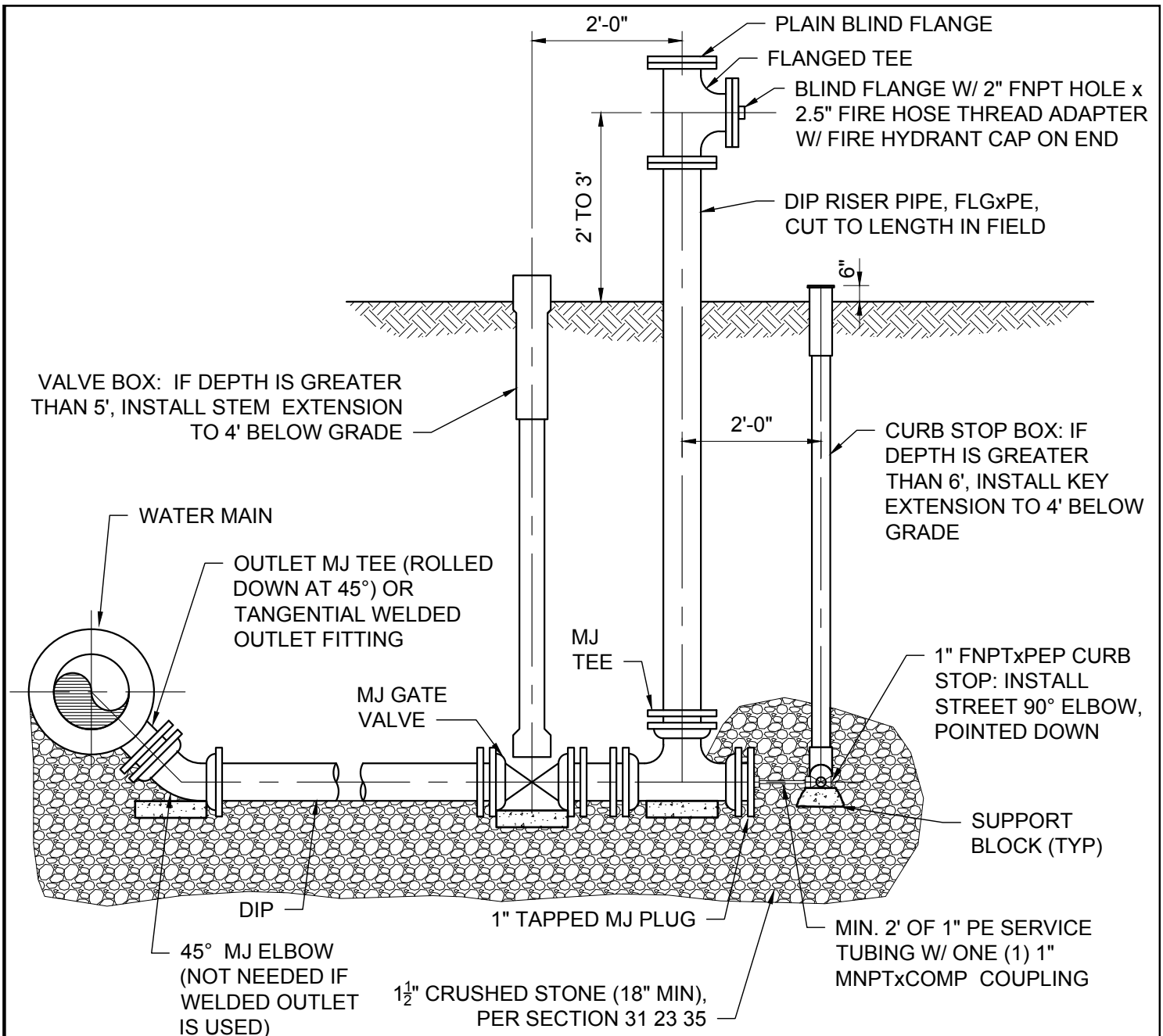

NOTES:

1. ALL FITTINGS TO HAVE MECHANICAL LUG RESTRAINT.
2. ALL BURIED DIP TO BE POLYETHYLENE-ENCASED.
3. BLOWOFF RISER SHALL BE PAINTED "BLUE" FOR POTABLE WATER OR "PURPLE" FOR NON-POTABLE.
4. DIP RISER AND FLANGED TEE SHALL HAVE POLYURETHANE OR FUSION-BONDED EPOXY LINING.
5. COAT ALL (BURIED AND EXPOSED) IRON VALVES, FITTINGS, AND PIPING WITH FUSION-BONDED EPOXY.

MAIN SIZE	BLOWOFF SIZE
6" TO 8"	4"
12" TO 18"	6"
20" TO 30"	8"
36" & LARGER	12"

4-INCH TO 12-INCH BLOWOFF ASSEMBLY

(THIS PAGE INTENTIONALLY LEFT BLANK)

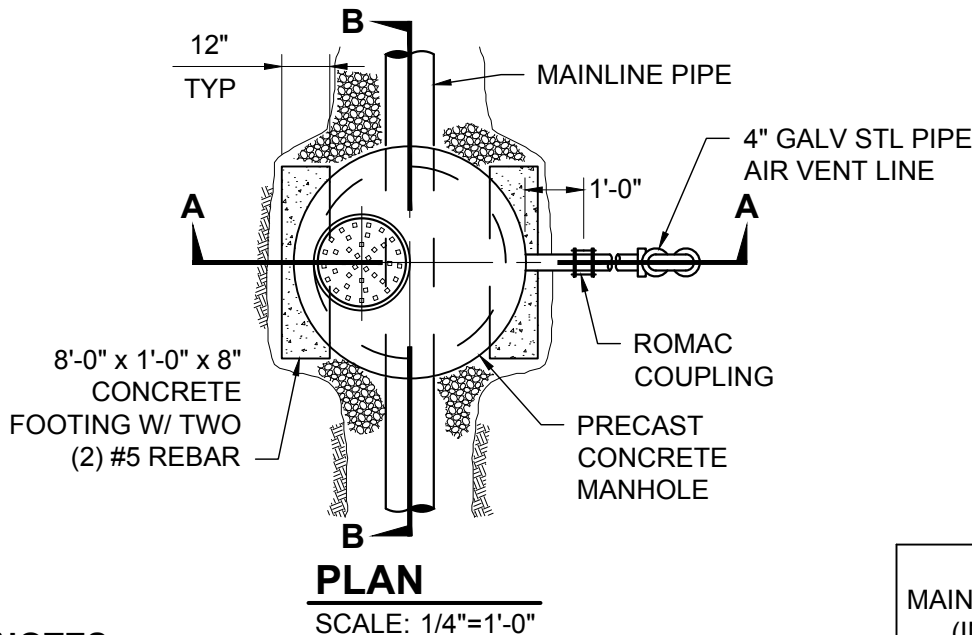
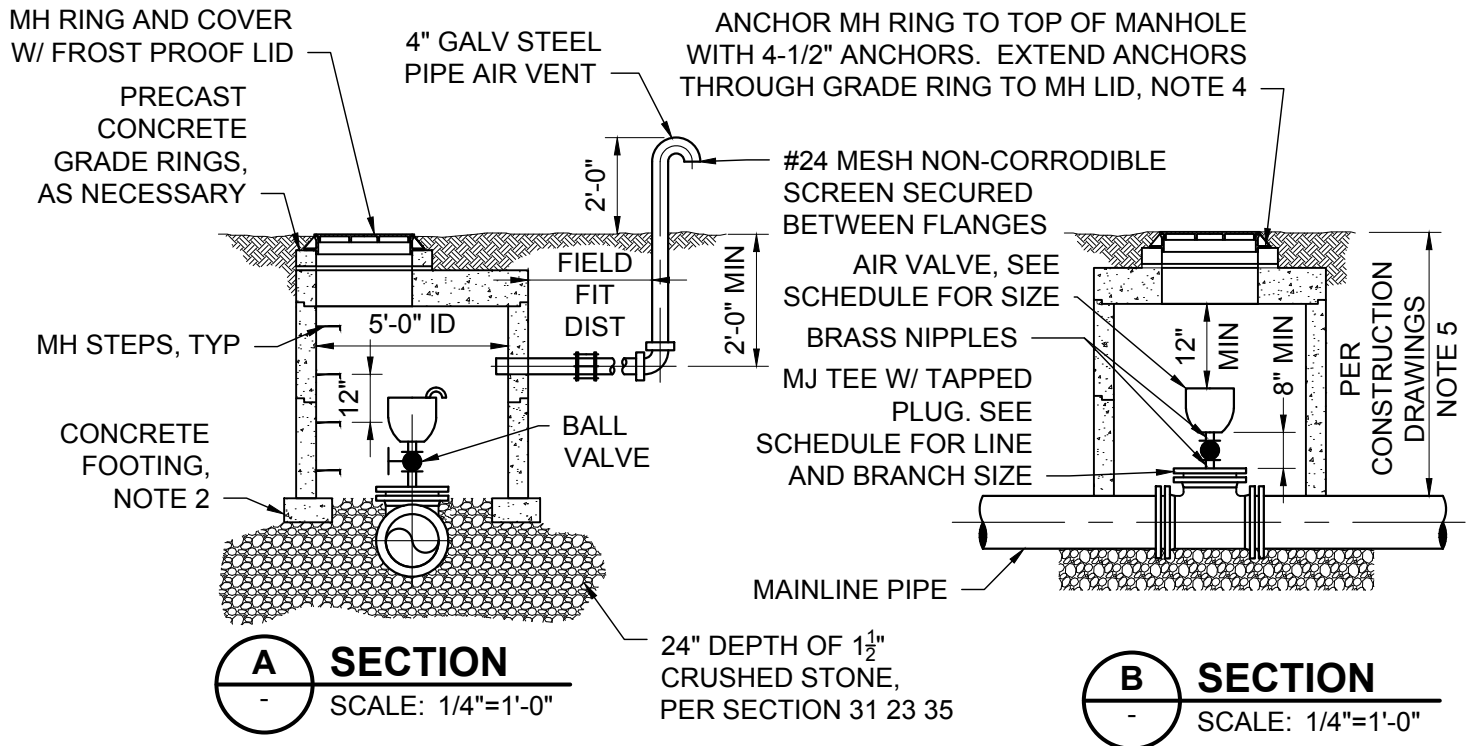

NOTES:

1. SEAL VENT PIPE PENETRATION W/ LINK-SEAL.
2. MANHOLE SHALL NOT REST ON MAINLINE PIPE. TOPS OF CONCRETE FOOTINGS SHALL BE AT LEAST 4" OVER THE TOP OF THE MAINLINE PIPE.
3. ALL PIPING AND BALL VALVES SHALL BE LEAD FREE.
4. RAM-NEK GASKET SHALL BE USED ON LID AND RING & COVER.
5. ALTERNATIVELY, DEPTH MAY BE FIELD-FITTED AS DETERMINED BY NWCWD.

MAIN SIZE (IN)	MJ TEE SIZE (IN)	SIZE (TAP, BALL VALVE, AIR VALVE)
6	6 X 6	2 INCH
8	8 X 8	2 INCH
12	12 X 8	2 INCH
16	16 X 8	2 INCH

AIR VALVE SCHEDULE

NOTE:

AIR VALVES ON MAINS LARGER THAN 16" WILL BE DESIGNED ON A CASE-BY-CASE BASIS



NORTH WELD COUNTY WATER DISTRICT
970-356-3020
www.nwcwd.org

AIR VALVE MH ASSEMBLY (ON-MAIN)

DETAIL NO:	3314204
NWCWD APPD:	GM
ORIG DATE:	04/12/2018
REV DATE:	02/08/2021

(THIS PAGE INTENTIONALLY LEFT BLANK)

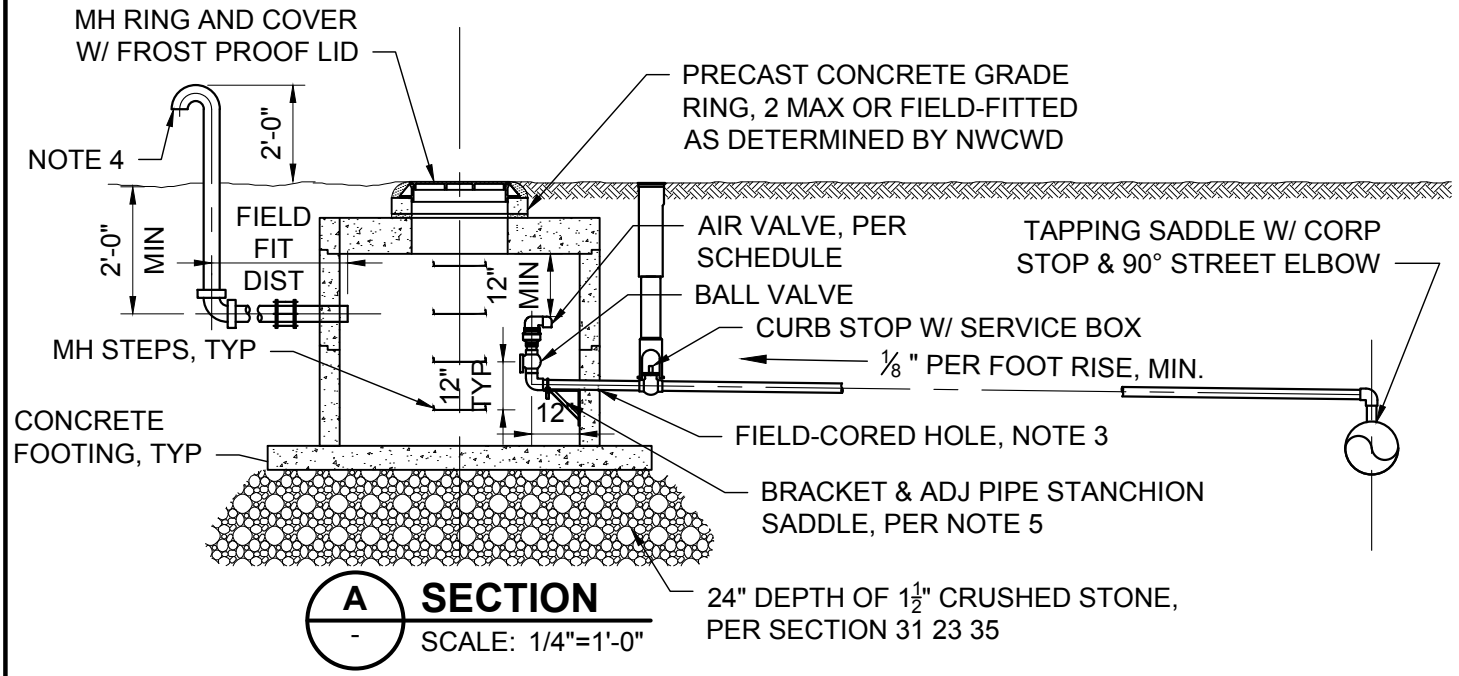
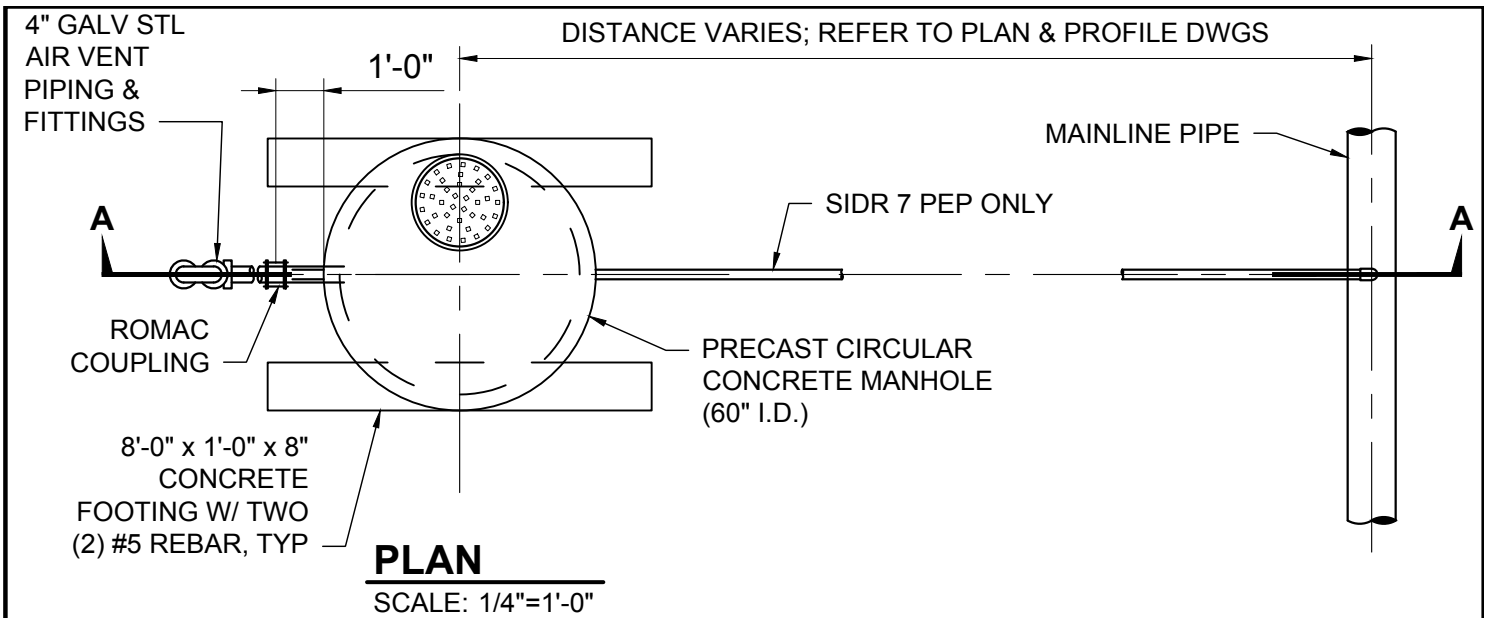

NOTES:

1. SEAL VENT PIPE PENETRATION W/ LINK-SEAL.
2. ALL 2" PIPING AND BALL VALVES SHALL BE LEAD FREE.
3. HOLE LOCATION TBD IN-FIELD. SEAL ANNULUS AROUND PIPE W/ MORTAR; NO LINK-SEAL.
4. #24 MESH NON-CORRODIBLE SCREEN SECURED BETWEEN FLANGES.
5. LIGHT-WELDED STEEL BRACKET (ANVIL FIG. 194) W/ ADJUSTABLE PIPE SADDLE WITH U-BOLT (ANVIL FIG. 191). BOTH W/ GALVANIZED FINISH, ANCHORED TO MH WALL W/ SST HARDWARE.

AIR VALVE SCHEDULE

MAIN SIZE (IN) *	SIZE (TAP, BALL VALVE, AIR VALVE, ETC.)
6	2 INCH
8	2 INCH
12	2 INCH
16	2 INCH

*AIR VALVES ON MAINS LARGER THAN 16" WILL BE DESIGNED ON A CASE-BY-CASE BASIS



NORTH WELD COUNTY WATER DISTRICT
 970-356-3020
 www.nwcwd.org

AIR VALVE MH ASSEMBLY (OFF-MAIN)

DETAIL NO:	3314205
NWCWD APPD:	GM
ORIG DATE:	04/12/2018
REV DATE:	02/08/2021

(THIS PAGE INTENTIONALLY LEFT BLANK)

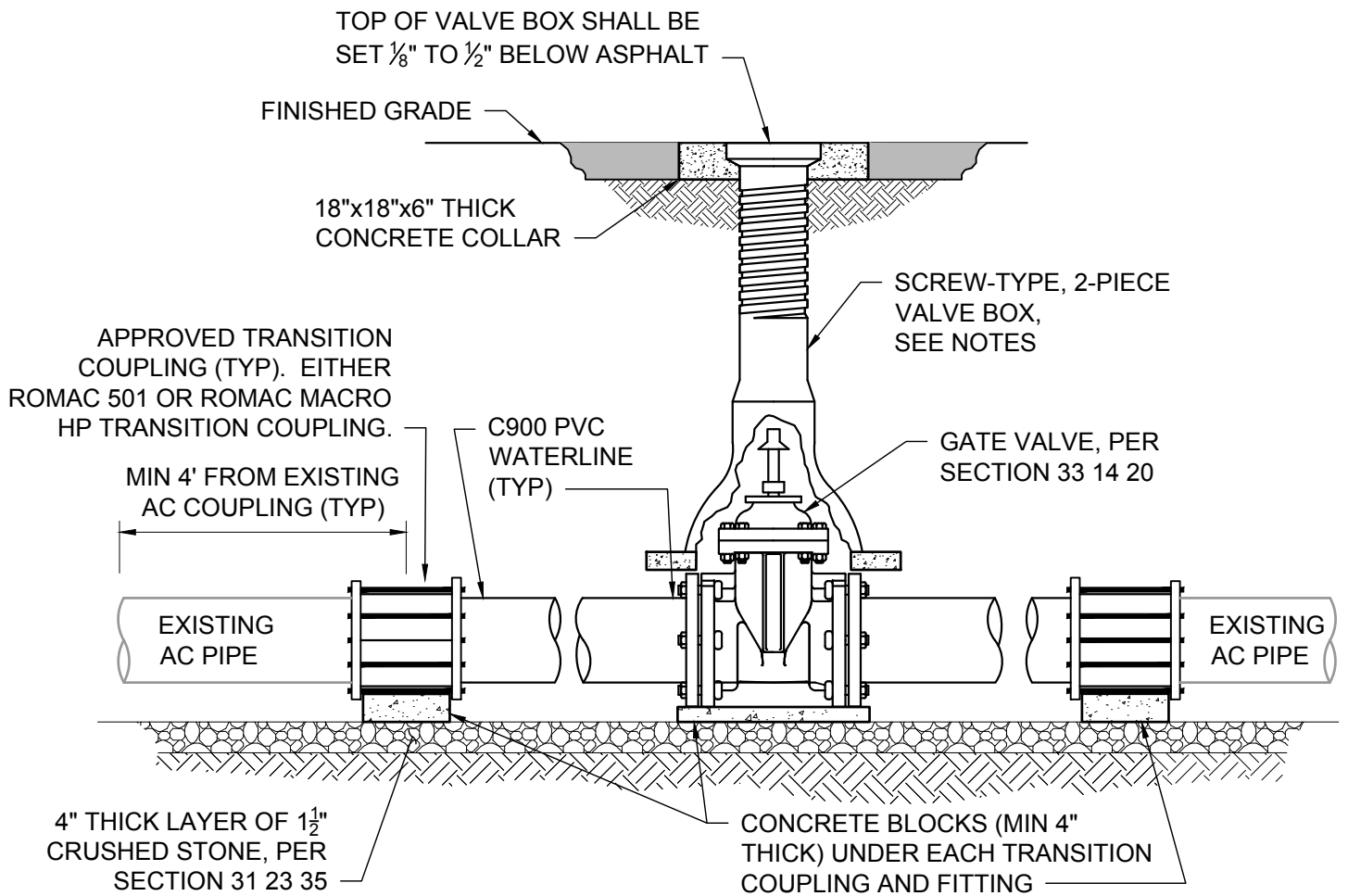

NOTES:

1. VALVE BOX SHALL BE CENTERED AND PLUMB OVER THE WRENCH NUT AND SHALL NOT TRANSMIT SHOCK WAVES OR STRESS TO THE VALVE.
2. VALVE SHALL BE BLOCKED WITH POURED CONCRETE, BRICK, OR OTHER SUITABLE MASONRY MATERIAL.
3. GATE VALVE AND VALVE BOX, PER SECTION 33 14 20.
4. WRAP VALVE AND VALVE BOX WITH POLYETHYLENE ENCASEMENT, PER DETAIL NO. 3305202.
5. IF DEPTH IS GREATER THAN FIVE (5) FEET, INSTALL STEM EXTENSION TO FOUR (4) FEET BELOW GRADE.
6. REFER TO NWCWD'S STANDARD SPECIFICATIONS FOR ACCEPTABLE PARTS AND MATERIALS.
7. REPAIR COUPLINGS TO BE SUPPLIED BY NWCWD. REQUEST 2 WEEKS IN ADVANCE, MIN.
8. WRAP ALL FITTINGS WITH POLYETHYLENE ENCASEMENT.

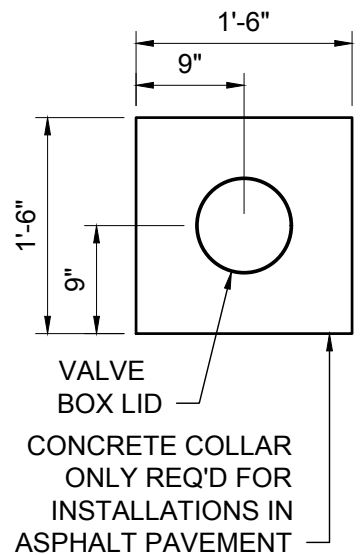

PLAN



**NORTH WELD COUNTY
WATER DISTRICT**
970-356-3020
www.nwcwd.org

**VALVE INSTALL ON
EXISTING AC PIPE**

DETAIL NO:	3314206
NWCWD APPD:	GM
ORIG DATE:	04/12/2018
REV DATE:	02/08/2021

(THIS PAGE INTENTIONALLY LEFT BLANK)

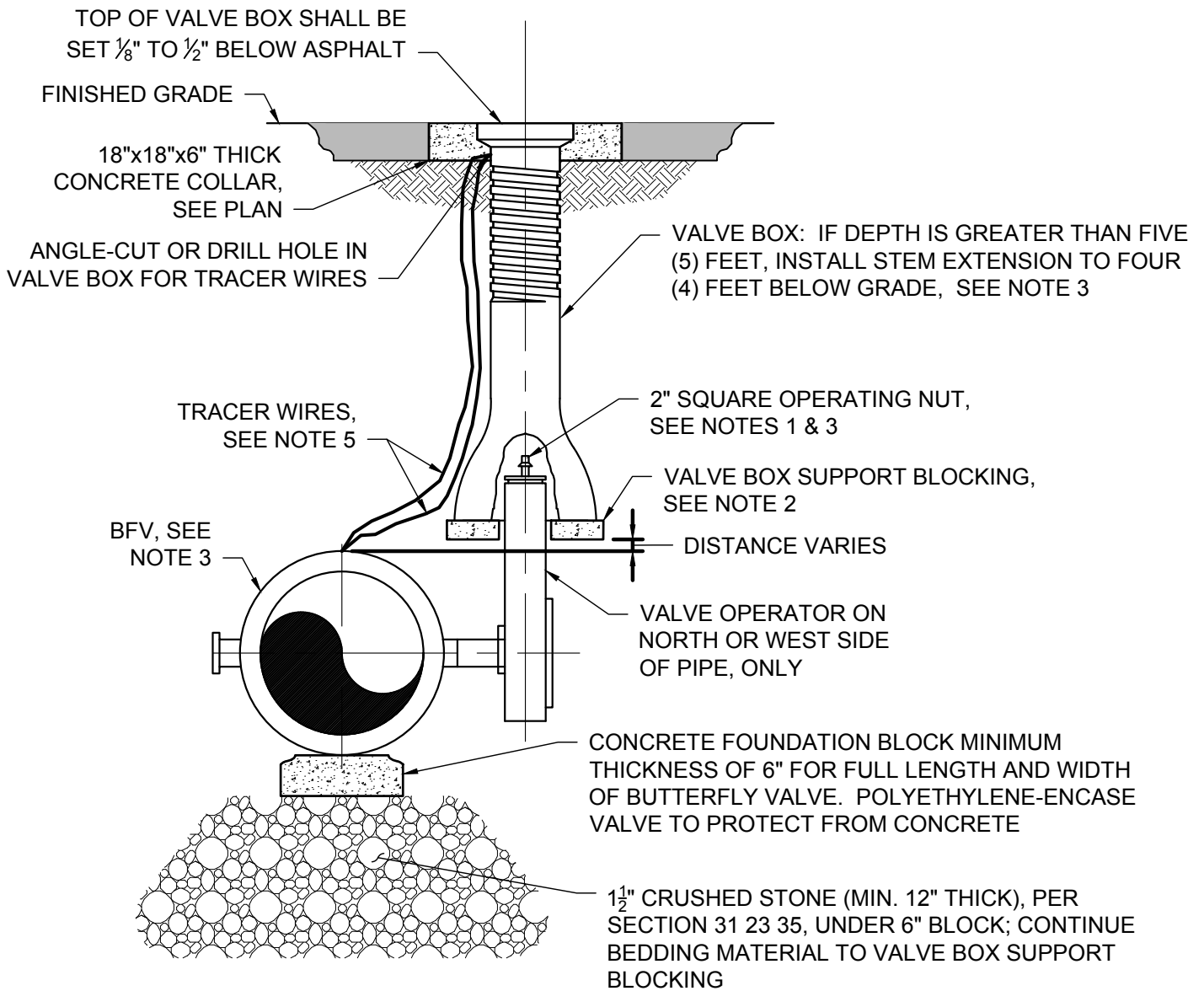

NOTES:

1. VALVE BOX SHALL BE CENTERED AND PLUMB OVER THE OPERATING NUT AND SHALL NOT TRANSMIT SHOCK WAVES OR STRESS TO THE VALVE.
2. VALVE SHALL BE BLOCKED WITH POURED CONCRETE, BRICK, OR OTHER SUITABLE MASONRY MATERIAL.
3. BUTTERFLY VALVE AND VALVE BOX, PER SECTION 33 14 20.
4. WRAP VALVE AND VALVE BOX WITH POLYETHYLENE ENCASMENT, PER DETAIL NO. 3305202.
5. TRACER WIRE SHALL BE TERMINATED IN VALVE BOX, AS SHOWN. REFER TO SECTION 33 14 10 FOR REQUIREMENTS.

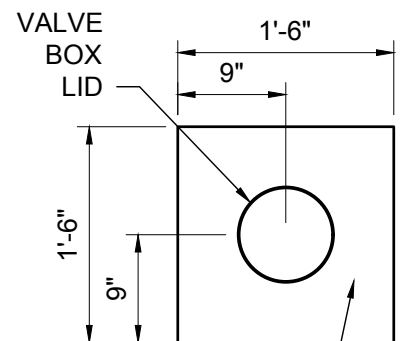

CONCRETE COLLAR ONLY REQ'D FOR INSTALLATIONS IN ASPHALT PAVEMENT

PLAN



**NORTH WELD COUNTY
WATER DISTRICT**
970-356-3020
www.nwcwd.org

BUTTERFLY VALVE AND BOX

DETAIL NO:	3314207
NWCWD APPD:	GM
ORIG DATE:	04/12/2018
REV DATE:	02/08/2021

(THIS PAGE INTENTIONALLY LEFT BLANK)

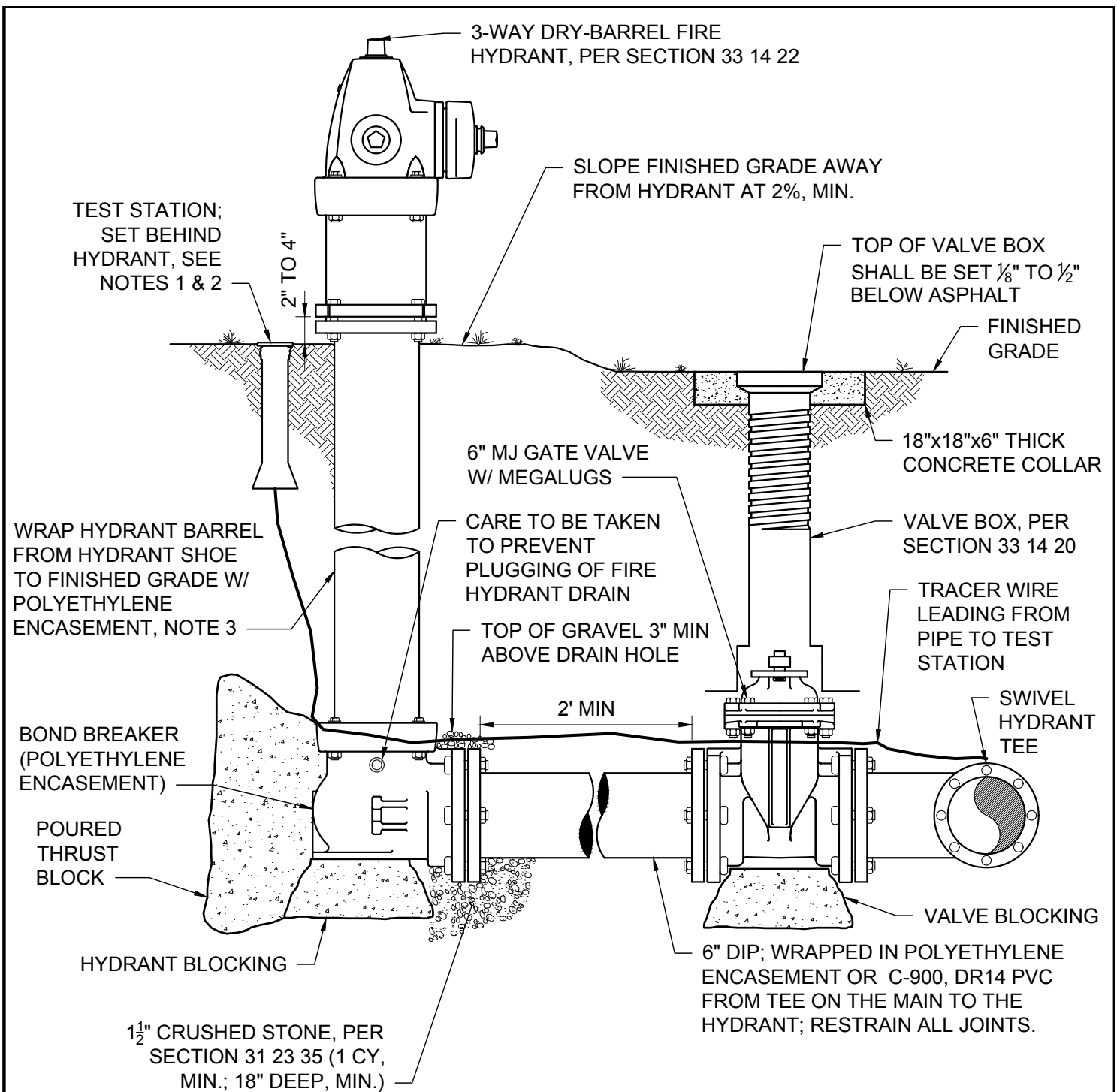

NOTES:

1. TEST STATION AND TRACER WIRE, PER SECTION 33 14 10.
2. TOP OF TEST STATION SHALL BE 1/8" - 1/2" ABOVE FINISHED GRADE.
3. CUT SLITS IN BASE OF POLYETHYLENE ENCASEMENT TO ALLOW FOR DRAINAGE.



**NORTH WELD COUNTY
WATER DISTRICT**
970-356-3020
www.nwcwd.org

FIRE HYDRANT ASSEMBLY

DETAIL NO:	3314221
NWCWD APPD:	GM
ORIG DATE:	04/18/2018
REV DATE:	02/08/2021

(THIS PAGE INTENTIONALLY LEFT BLANK)

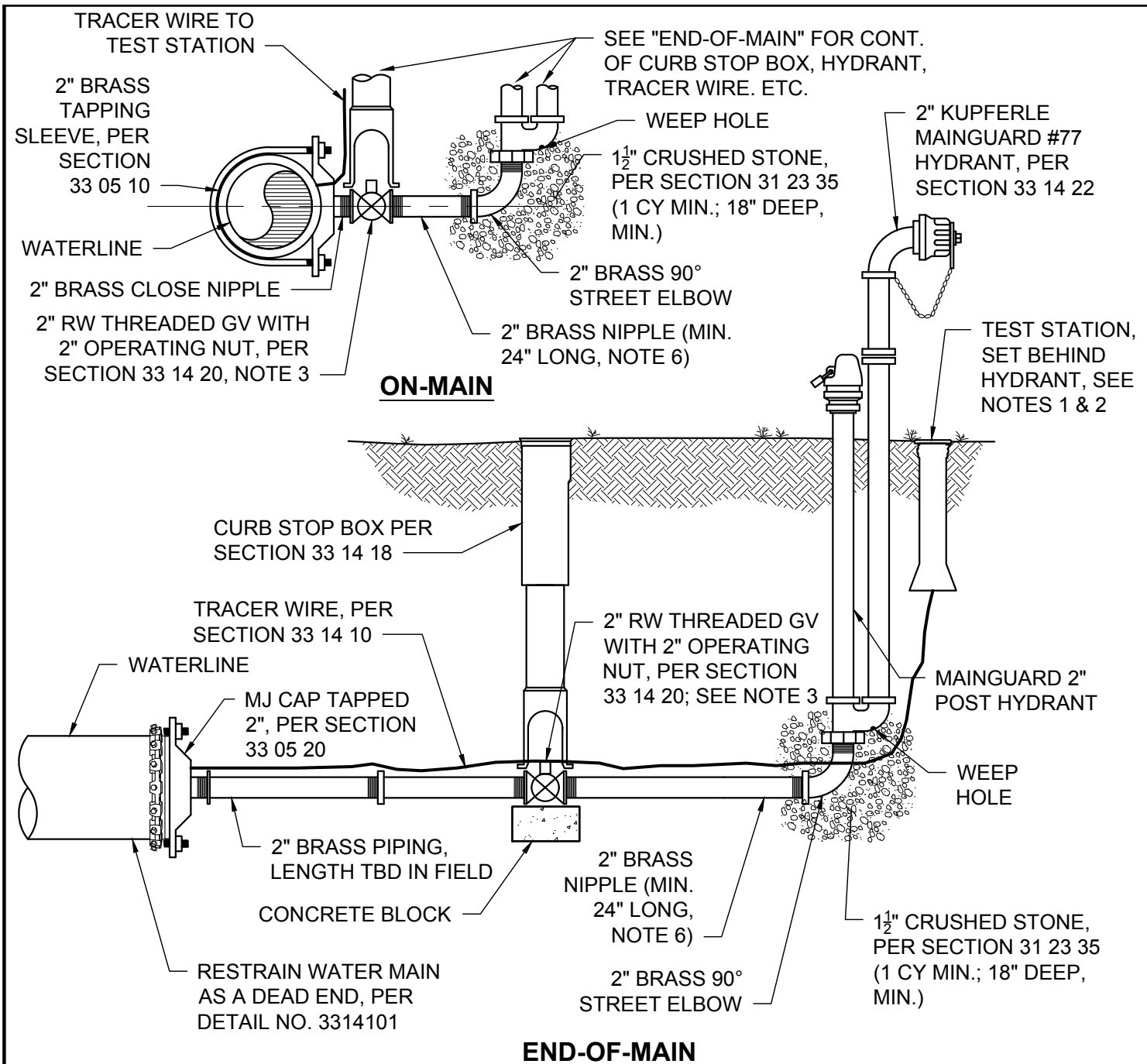

NOTES:

1. TEST STATION AND TRACER WIRE, PER SECTION 33 14 10.
2. TOP OF TEST STATION SHALL BE SET $\frac{1}{8}$ " - $\frac{1}{2}$ " ABOVE FINISHED GRADE.
3. 2" GATE VALVE IS NOT REQ'D IF DISTANCE FROM THE WATERMAIN TO THE FLUSHING HYDRANT IS 20 FT., OR LESS - AND - THERE IS A VALVE AT THE MAIN FOR ISOLATION.
4. WRAP ALL BURIED METAL W/ POLYETHYLENE ENCASEMENT.
5. CUT SLITS IN BASE OF POLYETHYLENE ENCASEMENT TO ALLOW FOR DRAINAGE.
6. FIELD FIT, IF APPLICABLE.



NORTH WELD COUNTY
WATER DISTRICT
 970-356-3020
 www.nwcwd.org

2-INCH BLOWOFF ASSEMBLY

DETAIL NO:	3314222
NWCWD APPD:	GM
ORIG DATE:	04/12/2018
REV DATE:	02/08/2021

(THIS PAGE INTENTIONALLY LEFT BLANK)

(THIS PAGE INTENTIONALLY LEFT BLANK)



North Weld County Water District
32825 WCR 39
Lucerne, Colorado 80646