

HOSES

Hoses carry the air from the source to the air brush. They are available in two types: a vinyl hose for lower pressures, and a braided hose for higher pressures. Coil hoses are vinyl hoses formed in a coil to stay out of the way. Hoses from different manufacturers are usually not interchangeable without adaptors.

- BA-50-0011 Badger 10' Vinyl Air Hose
- BA-50-2011 Badger 10' Braided Air Hose
- BA-50-4011 Badger 10' Coiled Hose
- PAA-906 Paasche 6' Braided Hose
- PAA-908 Paasche 8' Braided Hose
- PAA-910 Paasche 10' Braided Hose
- PAA-930 Paasche 10' Coil Hose



Braided Hose



Vinyl Hose



Coiled Hose

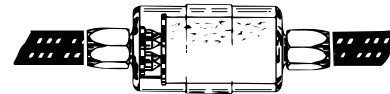

Hose W/Inline Moisture Trap

MOISTURE TRAPS

Moisture traps are small (about 2") cylinders that remove water, the by-product of compressed air. This helps reduce moisture damage and inconvenience. Provided separately and in-line in hoses.

- PAA-825 Paasche Moisture Trap
- PAA-918 Paasche 8' Hose W/In-line Moisture Trap
- BA-50-2012 Badger Filter W/In-line Hose
- BA-50-2015 Badger Filter Only

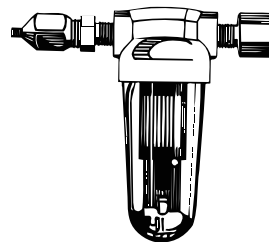

Moisture Trap

COMPRESSORS

BADGER 80-2

Designed for portability and cost effectiveness, this lightweight, quiet compressor can be carried from place to place. It has a 6' cord with a two prong plug. Virtually maintenance free, oil-less and never needs lubrication. Operates one airbrush at about 25 PSI.

- BA-80-2 Badger Compressor

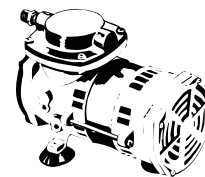

80-2

PAASCHE D500

Economical and suitable for all airbrushes spraying properly thinned fluids. It is capable of delivering up to 30 lbs. pressure, is an oil-less diaphragm unit and comes with 3 wire cord. Delivers .5 C.F.M. at 20 P.S.I.

- PAA-D500 Paasche D500

BADGER 380-2 SILENT II

The high efficiency 1/2 horsepower oil reciprocating piston motor mounted on a larger capacity air tank. It quietly powers one to five airbrushes simultaneously without pulsation. Develops 1.75 CFM at 116 PSI Not for continuous industrial use.

- BA-380-2 Badger Silent II

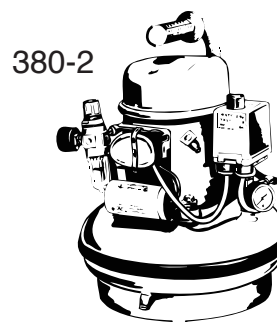

380-2

BADGER 380-11 SILENT I

A silent compressor with in line oil filter that assures no oil enters the air stream. Powered by a 1/4 HP oil reciprocating piston motor with a 1.06 gallon tank that quietly powers up to three air-brushes simultaneously without pulsation. Develops 1.75 CFM at 116 PSI Not for continuous industrial use.

- BA-380-11 Badger Silent I

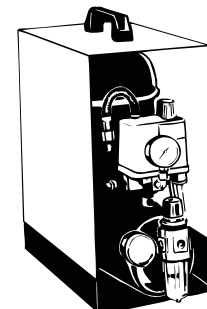

380-11

Drawing

DRAWING PENCILS
CHARCOAL PENCILS
SKETCH PENCILS
MARKING PENCILS
COLORED PENCILS
CRAYONS
GRAPHITE
CHALK
CHARCOAL
DRAWING LEADS
LEAD HOLDERS
ERASERS
SHARPENERS
BLENDERS
SOFT PASTELS
HARD PASTELS
OIL PASTELS
FIXITIF



DRAWING PENCILS

A drawing pencil is a black lead pencil. What makes a drawing pencil special, is that it is made in a wide variety of degrees, or hardnesses. These degrees are also carefully controlled to insure accurate steps between degrees, and uniformity from batch to batch. Most manufacturers also use special combinations of clay and graphite not available in their general use pencils.

9000 CASTELL DRAWING

A quality pencil that is known for purity, durability, and delicacy of tone. It gives good adhesion to paper and reduces smudging to a minimum. Available in 15 degrees from 8B to 6H plus F and HB. In handsome green finish, with tip, 12 per box.

AW-9000-8B	8B	AW-9000-F	F
AW-9000-6B	6B	AW-9000-H	H
AW-9000-5B	5B	AW-9000-2H	2H
AW-9000-4B	4B	AW-9000-3H	3H
AW-9000-3B	3B	AW-9000-4H	4H
AW-9000-2B	2B	AW-9000-5H	5H
AW-9000-B	B	AW-9000-6H	6H
AW-9000-HB	HB		

Sets of 12 in Metal Tins

EF-05022	Art Set	5B-2H
EF-05023	Design Set	5B-5H

GENERAL'S KIMBERLY

The Kimberly features extra dense, non-porous leads that result in extra long, durable points. They are then "carbo-welded" to the wood. Points withstand four times normal pressure and produce lines of high opacity. Finished in lustrous green and gold leaf stamped. Available from 8B through 7H plus HB, F, & XB (Extra Soft). 12 per box.

GP-0525-8B	8B	GP-0525-F	F
GP-0525-7B	7B	GP-0525-H	H
GP-0525-6B	6B	GP-0525-2H	2H
GP-0525-5B	5B	GP-0525-3H	3H
GP-0525-4B	4B	GP-0525-4H	4H
GP-0525-3B	3B	GP-0525-5H	5H
GP-0525-2B	2B	GP-0525-6H	6H
GP-0525-B	B	GP-0525-7H	7H
GP-0525-HB	HB		

DESIGN DRAWING SETS

Three drawing sets that contain the essentials for sketching and drawing. All sets contain a kneaded eraser, Pink Pearl eraser, and an Ebony Sketch Pencil.

The introductory Set also contains: 3 drawing pencils (2B, 4B, & 6B) and 2 charcoal pencils (X-Soft & Med).

EF-02035 Introductory Set

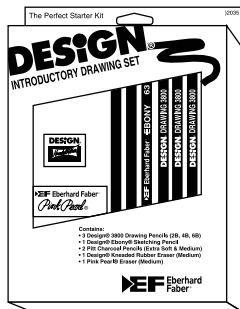

02035 Design Drawing Set - Introductory

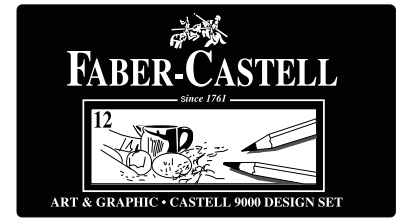
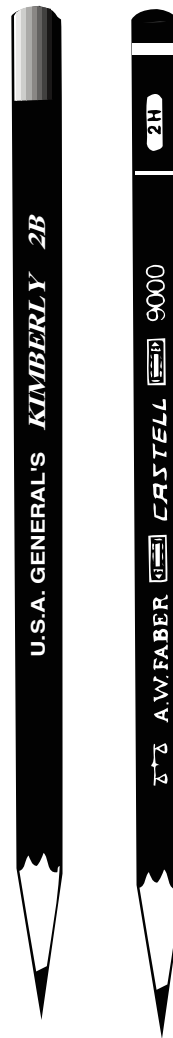

05022 9000 Drawing Set (Art Pencil)

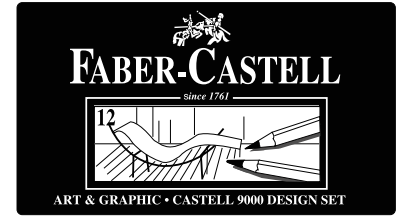

05023 9000 Design Set



KIMBERLY DRAWING SETS

Two sets with an assortment of pencils for the student or professional artist. A blister pack containing one each of 2B, HB, & 2H Kimberly drawing pencils, a layout pencil, and eraser. Also, a boxed set with twelve Kimberly drawing pencils (8B, 6B, 4B, 3B, 2B, B, HB, F, 2H, & H) plus a sharpener and eraser.

GP-0025	Kimberly Boxed Drawing Kit
GP-0525-BP	General Kimberly Carded Drawing Set

2MM LEADS

2mm leads have been a standard tool for artists and draftsmen for many years. Available in uniform degrees in leads about 5" long.

200 STAEDLER MARS LEADS

Mars drawing leads offer the the most accurate and uniformly graded, strongest, and blackest leads available. Made in 7 degrees, 4B, 2B, B, HB, H, 2H, and 4H. 12 per package.

MR-200-XX	Mars 2mm Leads	12 per pkg.
MR-200-E2-XX	Mars 2mm Leads	2 per pkg

FINE LINE LEADS

MARS MICROGRAPH

Fine line leads made to exact standards, assuring high point strength, slow wear, and accurate degrees. An ideal lead for paper & film, producing opaque, ink like lines. Twelve leads per package, twelve packages per box. Availability: .3mm B, HB, H, & 2H .5mm 2B, B, HB, F, H, 2H, & 3H .7mm 2B, B, HB, H, & 2H .9mm B, & HB.

MR-200-03-XX	Mars Micrograph Lead	.3mm
MR-200-05-XX	Mars Micrograph Lead	.5mm
MR-200-07-XX	Mars Micrograph Lead	.7mm
MR-200-09-XX	Mars Micrograph Lead	.9mm

CHARCOAL PENCIL

Charcoal pencils are made from charred wood that is made into cylinders and put into a wood case. They produce matte black lines that can be blended. In this form, they can be sharpened to a fine point.

EURO BLEND CHARCOAL

A pencil with the rich blackness of charcoal, and the smooth feel of graphite. Artists who find charcoal pencils too abrasive, will appreciate the expressive freedom made possible by this beautifully made, remarkable expressive drawing medium. 12 per sleeve.

GP-0059-3B	Euro Charcoal Pencil	3b
GP-0059-B	Euro Charcoal Pencil	B
GP-0059-HB	Euro Charcoal Pencil	HB
GP-0059-W	Euro Charcoal Pencil	White

GENERAL CHARCOAL

Made from highly refined willow charcoal and blended with the finest organic blacks, these pencils yield rich warm black tones unattainable with any other medium. Created to be the ultimate in charcoal medium. 12 per sleeve.

GP-0557-2B	General Charcoal Pencil	2B
GP-0557-4B	General Charcoal Pencil	4B
GP-0557-6B	General Charcoal Pencil	6B
GP-0557-HB	General Charcoal Pencil	HB

CHARCOAL BLISTER PACK

Blister pack containing four pencils (charcoal 2B, 4B, & 6B, plus charcoal White) and a kneaded eraser.

GP-0557-BP	General Charcoal Blister Pack
------------	-------------------------------



GENERAL CHARCOAL WHITE

The ideal compliment for charcoal, this is a special white medium that can be worked over charcoal areas. It is also used on white paper for a brilliant whites, creates amazingly clear photos or photostats, and can be erased clean. For special effects, it can be washed with water and a brush, and fixes without running. 12 per sleeve.

GP-0558	General Charcoal White
---------	------------------------

PAPER WRAPPED CHAR.

This pencil is not wood cased, but with paper wound around the charcoal with a pull string that cuts one small band at a time instead of sharpening. This pencil, by G, has a large diameter lead that is very black. 12 per box.

GP-5631T	Paper Wrapped Charcoal	Hard
GP-5632T	Paper Wrapped Charcoal	Medium
GP-5633T	Paper Wrapped Charcoal	Soft

SKETCH PENCILS

The term sketching pencil is a general term that will fit almost any pencil. By our definition, they are black or brown tones that tend to be dark, blendable, with a limited range of degrees. The leads may be of many compositions, some of which manufacturers do not disclose.

WOODLESS PENCIL

Almost the reinvention of the pencil as we know it, the woodless pencil the ideal drawing tool. To all appearances a conventional pencil, it is also a lacquer coated solid stick of rich, velvety smooth graphite. Although used like a wood cased pencil, it offers a variety of effects unmatched by other drawing media. 12 per box. By General

GP-0097-HB	Woodless Pencil	HB
GP-0097-4B	Woodless Pencil	4B
GP-0097-6B	Woodless Pencil	6B
GP-0097-8B	Woodless Pencil	8B

DESIGN EBONY

The Ebony pencil delivers satiny smooth, jet black lines for roughs, sketches and pencil illustrations. A round wood case pencil with a black finish. By Faber Castell 12 per sleeve.

EF-6325 Ebony Pencil

555 GENERAL LAYOUT

A standard size round pencil with black graphite lead. Very soft, equal to 6B, an excellent tool for art department, sketching, and general layout work. By General Pencil, 12 per sleeve.

GP-0555 General Layout

FLAT LEAD SKETCHING

Flat lead sketching pencils by General Pencil, have a rectangular lead in and oval wood case. The large flat area of lead allows one to cover large areas quickly. Special effects can also be achieved using edges. 12 per sleeve.

GP-0529-2B	Flat Sketching Pencil	2B
GP-0531-4B	Flat Sketching Pencil	4B
GP-0533-6B	Flat Sketching Pencil	6B

CONTE SKETCH PENCILS

These Conte Drawing Pencils are the same as Conte Crayons, except in pencil form. They feature a large diameter lead in a wood case. Conte products are known for their rich brown tones and the Pierre Noir for deep blacks. 12 per box

HU-2269 Pierre Noir Pencil 3B	1710-3B
HU-2270 Pierre Noir Pencil 2B	1710-2B
HU-2271 Pierre Noir Pencil B	1710-B
HU-2272 Pierre Noir Pencil HB	1710-HB
HU-2273 Sanguine	610
HU-2274 Sepia	617
HU-2275 White	630



575 GEN COPYING INDELIBLE

An indelible black pencil for layout, sketching, and type indication. Lavender finish, 12 per sleeve.

GP-0575 General Copying - Indelible

931 GENERAL EXERCISE

An extra large diameter (12/32"), soft thick lead for rough layout or sketching. Banded in Dozens.

GP-0931 General Exercise Pencil

MARKING PENCILS

SKETCH & WASH

Black graphite lead that writes on glass, cellophane, metal, wood, plastics, negatives, etc. Also for water color effects, as the lead is blendable with water. Banded in dozens. By General Pencil. Formerly Scribe All.

GP-0588 Sketch & Wash

CHINA MARKERS

A China Marker, sometimes called a grease pencil, is used to mark on almost any surface, including china, cellophane, metal, glass, etc. A large diameter lead is wrapped in paper, with a pull string for sharpening.

GP-1241	China Marker	Black
GP-1244	China Marker	White
GP-1245	China Marker	Red

SCRIBE ALL- ALL SURFACE

A general purpose marking pencil that is designed to write on almost any surface, including glass, cellophane, plastic film, metal wood, and paper. Available in five colors in a hexagon wood case.

GP-1251	Scribe All	Black
GP-1253	Scribe All	Blue
GP-1254	Scribe All	White
GP-1256	Scribe All	Yellow

KORN'S LITHO PENCILS

Litho crayon in pencil form. This pencil leaves an ink receptive mark on litho stones, plates, and paper. Also used to draw the image on the fabric to form the image in the toosche and glue method of making a silk screen. Paper wrapped with a pull string for sharpening. In Black only, 12 per box.

KN-100-1	Extra Soft	Korn's Litho Pencil
KN-100-2	Soft	Korn's Litho Pencil
KN-100-3	Medium	Korn's Litho Pencil
KN-100-4	Hard	Korn's Litho Pencil
KN-100-5	Extra Hard	Korn's Litho Pencil

WRITING PENCILS

1388 TICODEROGA

The Ticonderoga is one of the best known writing pencils ever made. It has a special lead formula that has been pressure proof bonded for luxurious writing and superior point strength. A hexagon wood case with yellow finish and eraser tip. 12 per pkg.

AC-1388-2	Ticonderoga	Soft
AC-1388-2-1/2	Ticonderoga	Medium

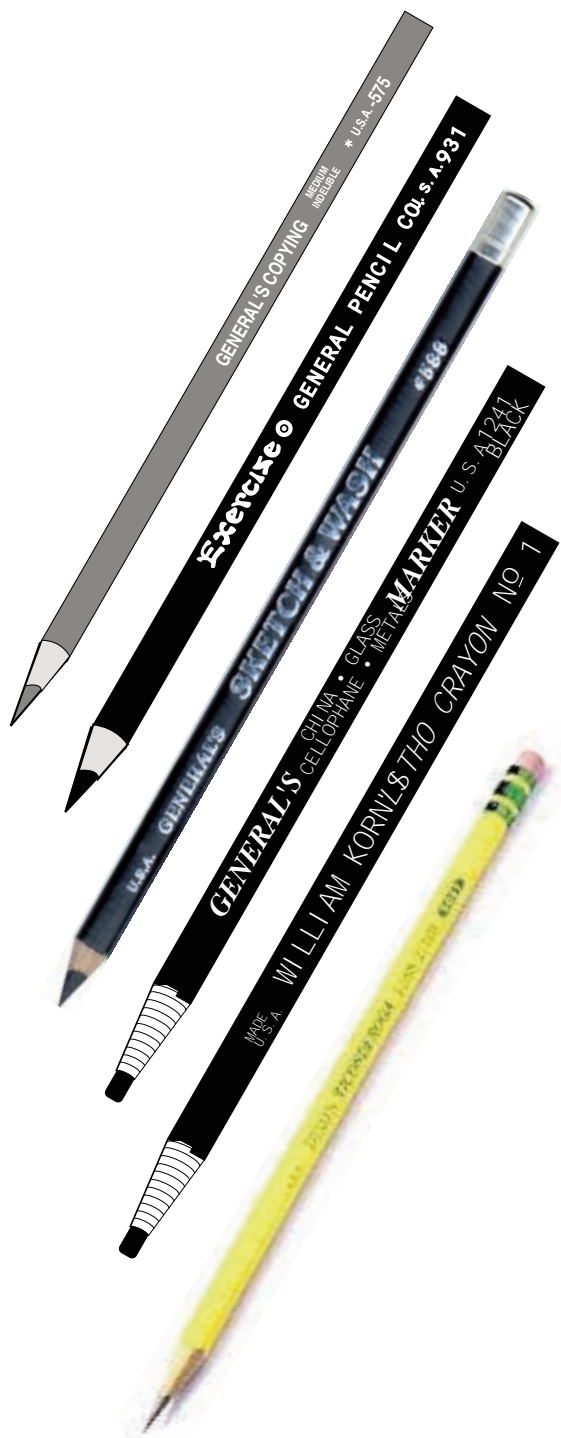

GENERAL DRAWING KITS

#10 DRAWING PENCIL KIT

Contains 2 flat sketch, 3 charcoal, 6B Drawing, 2 layout, and white charcoal pencil, plus 3 graphite sticks. By General Pencil

GP-0010 #10 Drawing Pencil Kit

#20 DRAWING PENCIL KIT

Contains 10 pastel, 5 charcoal, 2 sketch, layout, & drawing pencil, plus kneaded eraser and sharpener. By General Pencil

GP-0020 #20 Drawing Pencil Kit

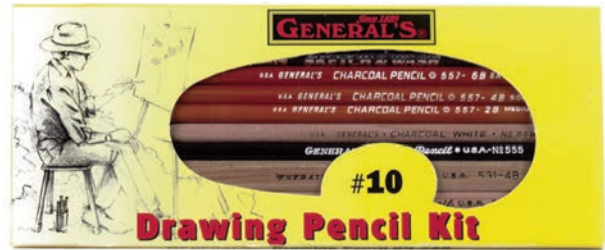

COLORED PENCILS

PRISMACOLOR PENCILS

Prismacolor pencils are known for clear, bright colors of thick lead. Color goes down smoothly from long wearing points. A round pencil with bright, vivid colors that match Prismacolor Markers. By Beroil

12 Color Sets

- | | |
|----------------------|----------------------|
| BC-0952 12 Color Set | BC-0955 48 Color Set |
| BC-0953 24 Color Set | BC-0972 72 Color Set |
| BC-0954 36 Color Set | BC-1096 96 Color Set |

Individual Colors

- | | |
|-------------------------|----------------------------|
| BC-0901 Indigo Blue | BC-0943 Burnt Ochre |
| BC-0902 Ultramarine | BC-0944 Terra Cotta |
| BC-0903 True Blue | BC-0945 Sienna Brown |
| BC-0904 Cerulean Blue | BC-0946 Dark Brown |
| BC-0905 Aquamarine | BC-0947 Dark Umber |
| BC-0906 Copenhagen Blue | BC-0948 Sepia |
| BC-0907 Peacock Green | BC-0949 Metallic Silver |
| BC-0908 Dark Green | BC-0950 Metallic Gold |
| BC-0909 Grass Green | BC-0956 Lilac |
| BC-0910 True Green | BC-0989 Chartreuse |
| BC-0911 Olive Green | BC-0992 Lt. Aqua |
| BC-0912 Apple Green | BC-0993 Hot Pink |
| BC-0913 Spring Green | BC-0994 Process Red |
| BC-0914 Cream | BC-0995 Mulberry |
| BC-0915 Lemon Yellow | BC-0996 Black Grape |
| BC-0916 Canary Yellow | BC-0997 Beige |
| BC-0917 Sunburst Yellow | BC-1001 Salmon Pink |
| BC-0918 Orange | BC-1002 Yellowed Orange |
| BC-0919 Non-Photo Blue | BC-1003 Spanish Orange |
| BC-0920 Light Green | BC-1004 Yellow Chartreuse |
| BC-0921 Pale Vermillion | BC-1005 Limepeel |
| BC-0922 Poppy Red | BC-1006 Parrot Green |
| BC-0923 Scarlet Lake | BC-1007 Imperial Violet |
| BC-0924 Crimson Red | BC-1008 Parma Violet |
| BC-0925 Crimson Red | BC-1009 Dahlia Purple |
| BC-0926 Carmine Lake | BC-1012 Jasmine |
| BC-0927 Lt. Peach | BC-1017 Clay Rose |
| BC-0928 Blush Pink | BC-1018 Pink Rose |
| BC-0929 Pink | BC-1019 Rosy Beige |
| BC-0930 Magenta | BC-1020 Celadon Green |
| BC-0931 Deep Purple | BC-1021 Jade Green |
| BC-0932 Violet | BC-1022 Mediterranean Blue |
| BC-0933 Violet Blue | BC-1023 Cloud Blue |
| BC-0934 Lavender | BC-1024 Blue Slate |
| BC-0935 Black | BC-1025 Periwinkle |
| BC-0936 Slate Gray | BC-1026 Greyed Lavender |
| BC-0937 Tuscan Red | BC-1027 Peacock Blue |
| BC-0938 White | BC-1028 Bronze |
| BC-0939 Peach | BC-1029 Mahogany Red |
| BC-0940 Sand | BC-1030 Raspberry |
| BC-0941 Lt. Umber | BC-1031 Henna |
| BC-0942 Yellow Ochre | BC-1032 Pumpkin Orange |



- | | |
|---------------------------|-------------------------|
| BC-1033 Mineral Orange | BC-1082 Chocolate |
| BC-1034 Goldenrod | BC-1083 Putty Beige |
| BC-1040 Electric Blue | BC-1084 Ginger Root |
| BC-1050 Warm Grey 10% | BC-1085 Peach Beige |
| BC-1051 Warm Grey 20% | BC-1086 Sky Blue Light |
| BC-1052 Warm Grey 30% | BC-1087 Powder Blue |
| BC-1054 Warm Grey 50% | BC-1088 Muted Turquoise |
| BC-1056 Warm Grey 70% | BC-1089 Pale Sage |
| BC-1058 Warm Grey 90% | BC-1090 Kelp Green |
| BC-1059 Cool Grey 10% | BC-1091 Green Ochre |
| BC-1060 Cool Grey 20% | BC-1092 Nectar |
| BC-1061 Cool Grey 30% | BC-1093 Seashell Pink |
| BC-1063 Cool Grey 50% | BC-1094 Sandbar Brown |
| BC-1065 Cool Grey 70% | BC-1095 Black Raspberry |
| BC-1067 Cool Grey 90% | BC-1096 Kelly Green |
| BC-1068 French Grey 10% | BC-1097 Moss Green |
| BC-1069 French Grey 20% | BC-1098 Artichoke |
| BC-1070 French Grey 30% | BC-1099 Espresso |
| BC-1072 French Grey 50% | BC-1100 China Blue |
| BC-1074 French Grey 70% | BC-1101 Denim Blue |
| BC-1076 French Grey 90% | BC-1102 Blue Lake |
| BC-1077 Colorless Blender | BC-1103 Caribbean Sea |
| BC-1078 Black Cherry | |
| BC-1079 Blue Violet Lake | |
| BC-1080 Beige Sienna | |
| BC-1081 Chestnut | |

VERITHIN PENCILS

A thin lead colored pencil with brilliant colors that apply smoothly with little tendency to crumble. Verithin pencils have a rounded hexagon shape and are finished in the same color as the lead. All can be sharpened to a fine, long wearing shape.

BC-0796 12 Color Set
 BC-0731 24 Color Set
 BC-0732 36 Color Set

BC-0734	White	BC-0744	Scarlet
BC-0734-1/2	Light Grey	BC-0745	Carmine Red
BC-0735	Canary Yellow	BC-0745-1/2	Terra Cotta
BC-0735-1/2	Lemon Yellow	BC-0746	Sienna Brown
BC-0736	Yellow Ochre	BC-0746-1/2	Tuscan Red
BC-0736-1/2	Orange Ochre	BC-0747	Black
BC-0737	Orange	BC-0747-1/2	Dark Grey
BC-0737-1/2	Sea Green	BC-0748	Red And Blue
BC-0738	Grass Green	BC-0750	Vermilion
BC-0738-1/2	Light Green	BC-0751	Emerald Green
BC-0739	Green	BC-0752	Purple
BC-0739-1/2	Olive Green	BC-0753	Silver
BC-0740	Ultramarine Blue	BC-0754	Gold
BC-0740-1/2	Sky Blue	BC-0755	Golden Brown
BC-0741	Indigo Blue	BC-0756	Dark Brown
BC-0741-1/2	Azure Blue	BC-0757	Flesh
BC-0742	Violet	BC-0758	True Blue
BC-0742-1/2	Lavender	BC-0759	Magenta
BC-0743	Pink	BC-0760	Blue Violet
BC-0743-1/2	Rose	BC-0761-1/2	Non-Photo Blue



PASTEL PENCILS

CONTE' PASTEL PENCILS

Conte' Pastel Pencils are a soft pastel with a wood case. A pastel is a combination of pigment and an aqueous binder. The result is an easily blendable color that is very permanent. In pencil form, pastels can be used for highlighting or detail work. Conte' pastel pencils have exact equivalents in round pastels and square Conte' Crayons listed later in this section.

HU-2181 12 Color Set
 HU-2182 24 Color Set
 HU-2184 48 Color Set

HU-2101	Bistre	HU-2129	Light Blue
HU-2102	Dark Green	HU-2130	Mineral Green
HU-2103	Red	HU-2131	Red Earth
HU-2104	Yellow	HU-2132	Umber
HU-2105	Violet	HU-2133	Dark Gray
HU-2106	Blue	HU-2134	Emerld Green
HU-2107	Red Brown	HU-2137	Indian Yellow
HU-2108	Light Green	HU-2138	Madder
HU-2109	Black	HU-2139	Garnet Red
HU-2110	Ultra Blue	HU-2140	Red Lead
HU-2111	Pink	HU-2141	Cyclamen
HU-2112	Orange	HU-2142	Sepia
HU-2113	White	HU-2143	Prussian Green
HU-2114	Golden Yellow	HU-2144	St. Michael Green
HU-2116	Olive Green	HU-2146	Dark Ultramarine
HU-2117	Yellow Ochre	HU-2147	Naples Yellow
HU-2118	Natural Sienna	HU-2148	Flesh
HU-2119	Purple	HU-2149	Light Orange
HU-2120	Light Gray	HU-2150	Lime
HU-2121	Blue Green	HU-2151	Gray Green
HU-2122	Prussian Blue	HU-2153	Paynes' Gray
HU-2124	Lemon Yellow	HU-2154	Natural Umber
HU-2126	Lilac	HU-2155	Persian Violet
HU-2128	Scarlet	HU-2156	Sky Blue

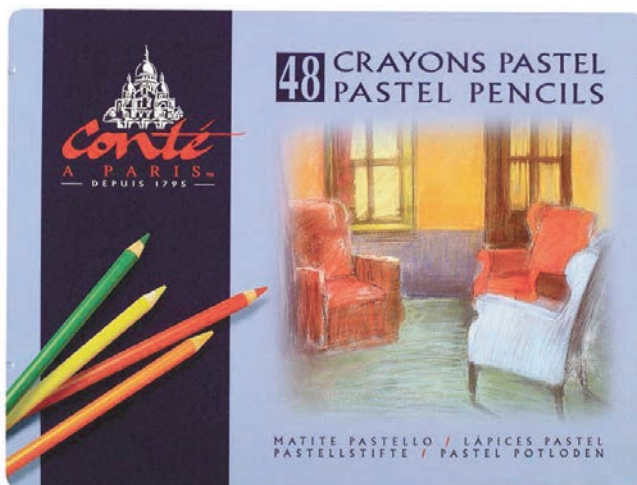

WATER COLOR PENCILS

KARAT AQUARELL COLORED PENCILS

These colored pencils have brilliant, intense colors. All 60 colors allow you to draw with smooth, even color application, on rough or fine-toothed papers. With a brush and water, these colors can become soft washes, deep shadows, or solid areas of color. In tin boxes.

- MR-124A-M06 66 Color Water Color Pencil Set
- MR-124A-M12 12 Color Water Color Pencil Set
- MR-124A-M24 24 Color Water Color Pencil Set
- MR-124A-M36 36 Color Water Color Pencil Set
- MR-124A-M48 48 Color Water Color Pencil Set
- MR-124A-M60 60 Color Water Color Pencil Set

- | | | | |
|-------------|---------------|-------------|----------------|
| MR-124A-000 | White | MR-124A-043 | Flesh |
| MR-124A-001 | Yellow | MR-124A-049 | Fawn |
| MR-124A-002 | Red | MR-124A-050 | Light Green |
| MR-124A-003 | Blue | MR-124A-052 | Sap Green |
| MR-124A-004 | Orange | MR-124A-053 | Lime Green |
| MR-124A-005 | Green | MR-124A-054 | French Green |
| MR-124A-006 | Violet | MR-124A-055 | Green Earth |
| MR-124A-008 | Gray | MR-124A-056 | Light Olive |
| MR-124A-009 | Black | MR-124A-057 | Olive Green |
| MR-124A-010 | Light Yellow | MR-124A-061 | Dark Mauve |
| MR-124A-011 | Sandy Yel. | MR-124A-062 | Lavender |
| MR-124A-012 | Lemon | MR-124A-063 | Delft Blue |
| MR-124A-016 | Gold Ochre | MR-124A-072 | Dark Sand |
| MR-124A-017 | Light Ochre | MR-124A-073 | Burnt Sienna |
| MR-124A-019 | Dark Ochre | MR-124A-076 | Van Dyke Brown |
| MR-124A-020 | Magenta | MR-124A-077 | Warm Sepia |
| MR-124A-021 | Lit Carmine | MR-124A-080 | Light Gray |
| MR-124A-023 | Bordeaux | MR-124A-083 | Dove Gray |
| MR-124A-024 | Scarlet | MR-124A-085 | Warm Gray |
| MR-124A-025 | Lit Vermilion | MR-124A-110 | Bright Yellow |
| MR-124A-029 | Carmine | MR-124A-222 | Salmon |
| MR-124A-030 | Light Blue | MR-124A-260 | Tuscan Red |
| MR-124A-031 | Glacier Blue | MR-124A-302 | Pastel Blue |
| MR-124A-033 | Cobalt Blue | MR-124A-330 | Powder Blue |
| MR-124A-035 | Turquoise | MR-124A-550 | Pale Green |
| MR-124A-036 | Indigo Blue | MR-124A-602 | Pastel Violet |
| MR-124A-037 | Prussian Blu | MR-124A-703 | Rose Wood |
| MR-124A-038 | Sea Green | MR-124A-800 | Cool Gray |
| MR-124A-042 | Light | MR-124A-805 | Warm Gray |
| | | MR-124A-890 | Cool Gray 13 |



GENERAL WATER SOLUABLE PENCILS

The General Pencil Water Color Pencil is like any other colored pencil when dry, and can be used for all drawing and sketching, but the application of water will completely dissolve them. This allows a water color look from a pencil drawing. Available in sets only, in hex. wood case.

- GP-0700-08A 88 Color Set
- GP-0700-12A 12 Color Set
- GP-0700-24A 24 Color Set

588 SKETCH & WASH

Black graphite lead for water color effects, as the lead is blendable with water. Set of Two with sharpener, carded.

- GP-0588-BP Sketch & Wash



MISC COLORED PENCILS

PRANG PENCIL SET

An all time favorite, the Prang set is ideal for the student, professional, or child ready for more than crayons. Full size 7" round wood pencils.

AC-2212 Prang 12 Color Set
AC-2224 Prang 24 Color Set

NON-PHOTO BLUE PENCILS

A non-reproducing pencil made with a special light blue colored lead that most reproduction equipment can not see. This is because Ortho type camera film is blind to blue, the longer the exposure, the less blue can be seen. This makes these pencils ideal for notes, paste up guides, etc. When they are photographed, they won't be seen.

GP-1825 General Pencil Thin Lead
AW-1298 Col-Erase Thin Lead

2mm LEAD HOLDERS

2mm lead holders are designed the 2mm leads shown earlier in this section. There are many different features available. Please check the features that you desire.

5611 KOH-I-NOOR

The Koh-I-Noor Technigraph has been one of the best selling lead holders for many years. It is all metal, lightweight, perfectly balanced, and takes a wide variety of leads. The Adapto-Clutch is non-slip, and non-turn. The barrel is red with a knurled grip and polished nose piece. 24 per box

K-5611 Koh-I-Noor Technigraph Holder

788-C MARS ECONOMY

A high quality holder with the same clutch that is in premium Mars holders, with a plastic body. It also features a pocket clip. 20 per box

MR-788-C Mars Economy Holder

48 KOH-I-NOOR OVERSIZE

A universal holder for oversize leads and eraser plugs up to .22" x 4-3/4" in size. Comes with a push button release and a red hexagonal plastic barrel with knurled grip. 12 per box

K-0048 Koh-I-Noor Oversize Holder

FINE LINE HOLDERS

KOH-I-NOOR MEPHISTO

The professionals ultimate choice for drafting with many features including: non-slip grip, metal push button advance with replaceable eraser, and a 4mm tube.

K-5035BC-5 0.5mm Mephisto Mechanical Pencil
K-5035BC-7 0.7mm Mephisto Mechanical Pencil

925 MARS PENCIL

Features a rubberized grip with knurled grip and pocket clip. Has ISO color coding and lead indicator for .5mm lead diameter. By Staedler Mars.

MR-0925-05WBK Mars 0.5 Pencil

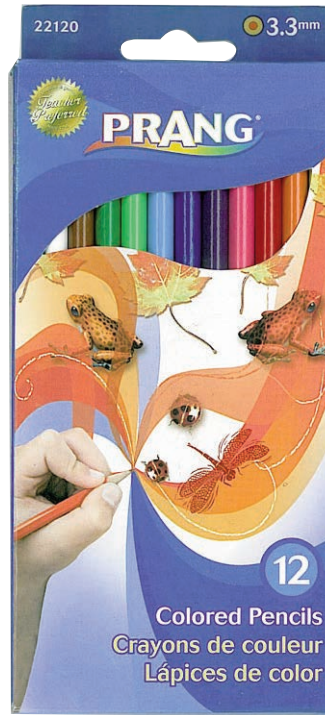

ERASERS

KNEADABLE ERASERS

A soft pliable, block shaped eraser that is excellent for the removal and highlighting of charcoal, pastels, chalks, etc. Can be kneaded into any shape and removes marks cleanly, leaving the surface smooth and bright.

DESIGN (FORMERLY EBERHARD FABER)

SA-70530	#1222 Medium Size	24 Per Box
SA-70531	#1224 Large Size	12 per box
SA-70532	#1225 Ex. Large Size	12 per box

PRANG KNEADABLE ERASER

AC-12222	Medium 1-1/8 x 3/4 x 3/8"	24 per box
AC-12244	Large Size 1-3/4x1-1/4x3/8"	12 per box

GENERAL JUMBO KNEADED ERASER

GP-0140-EBP	General Jumbo	12 per box
-------------	---------------	------------



ARTGUM ERASERS

Artgum erasers dry, clean, and erase with a unique formula of crepe rubber and factice oil. Abrasion created fine powder that cleans deep. For cleaning paper, erasing pencil marks, etc. Will not damage the paper surface. Koh-I-Noor artgum erasers are made with a no crumble formula.



DESIGN ARTGUM

SA-73028	#100 1" x 1" x 7/8"	24 per box
SA-73030	#211 2" x 1" x 7/8"	12 per box

VINYL/PLASTIC ERASERS

These vinyl-plastic erasers do not contain abrasives, and can not harm the drawing surface. They are also self cleaning and will not become brittle or harden with age. For use on paper, tracing cloth, tracing paper, drafting film, and other delicate surfaces. Mainly for removing pencil, but also remove ink from film when combined with liquid eraser.



KOH-I-NOOR

K-0287	Electric Eraser Refill	10 per box
--------	------------------------	------------

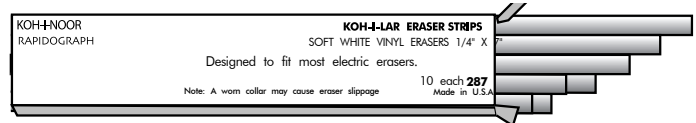

MARS

MR-526-50	Square Edge Eraser	20 per box
-----------	--------------------	------------



VINYL-IMBIBED ERASERS

These are vinyl/plastic erasers, similar to those shown above, except that they are saturated with erasing fluid. This eliminates the need for separate liquid eraser. Ideal for use on drafting film and many non-porous papers and boards.

KOH-I-NOOR

K-0285	Electric Eraser Refill	10 per box
--------	------------------------	------------

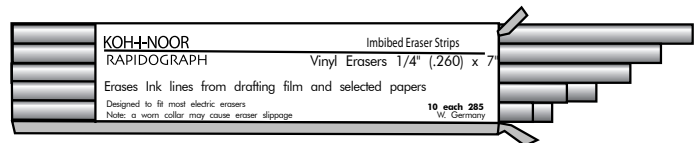

MARS COMBI

Combination of soft viny and impibed vinyl.

MR-526-508	Square Edge Erase	20 per box
------------	-------------------	------------

SOFT ERASERS

Soft, pliable erasers that give exceptional, smudge free erasing every time. Primarily for pencil erasing. By Faber Castell

AC 38910	Pink Carnation	12 per box
EF-101	Pink Pearl Beveled	12 per box



KOH-I-LAR LIQUID ERASER

This is a liquid that is applied to a vinyl/plastic eraser or machine refill, then used to remove ink from drafting film or some non-porous papers and boards. They erase cleanly without marring film surfaces. Film can be reworked immediately. Especially effective for removing aged ink lines, and for the erasure of large areas. By Koh-I-Noor

K-0291F	3/4 oz. Squeeze Bottle	12 per box
---------	------------------------	------------



DRY CLEANING PAD

A pillow shaped pads that contain a grit free powder that absorbs dirt. Eliminates the need for clean up erasing. Recommended for paper, film, or cloth. By Koh-I-Noor

K-25914	Dry Cleaning Pad	12 per box
---------	------------------	------------

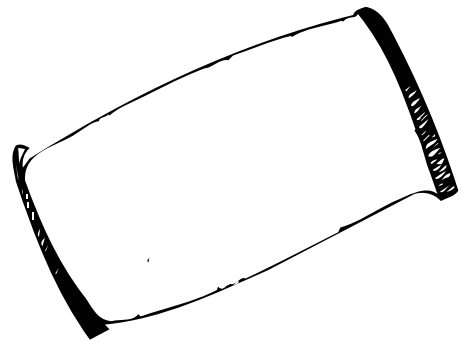

ELECTRIC ERASER

An electric eraser that operates on 115 volt current and is protected by an impact resistant blue lexan case. Holds any of the 7" eraser refills that were listed before. Ideal for artists or draftsmen. By Staedler

MR-527-00	Mars Electric Eraser
-----------	----------------------

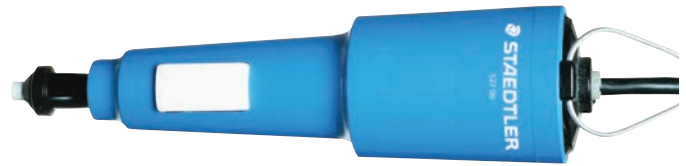

CORDLESS/RECHARGEABLE ELECTRIC ERASER

A trouble free motor that delivers 4500 r.p.m. fully charged. Features two way operation, cordless or A.C. This lightweight unit has a Lexan case and a long lasting rechargeable battery. Complete with charging stand, power pack and a vinyl strip eraser. By Staedler.

MR-527-01	Mars Cordless Electric Eraser
-----------	-------------------------------



PENCIL SHARPENERS

Standard pencil sharpeners designed to sharpen wood case pencils.

1800 BOSTON ELECTRIC

A trimly styled, rectangular shaped electric sharpener. Sharpens pencils with case hardened steel cutters. Overall size is 3-1/2 x 8-1/8 x 4"

HU-1800 Hunt Boston Electric Sharpener



DAHLE PROF SHARPENER

A pencil sharpener that features an adjustable clutch that holds from 1/4" to 1/2" diameter pencils. The automatic cutting system sharpens evenly and prevents over sharpening. Comes with adjustable clamp for mounting on a desk or drawing table, but is not necessary for use.

DH-155 Dahle Professional Sharpener.



GENERAL FLAT

Creates a broad chisel point on flat lead sketching and oval pencils. Also works well on charcoal, graphite, etc. A truly unique instrument for the artist.

GP-6000 General Flat Lead Pencil Sharpener

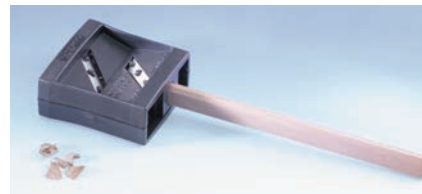

MARS HAND SHARPENER

A small canister style pencil sharpener. The pencil is turned in the hole, and the shavings drop into the bottom of the canister. Ten sharpeners per display carton.

MR-511-63 Mars Pencil Sharpener

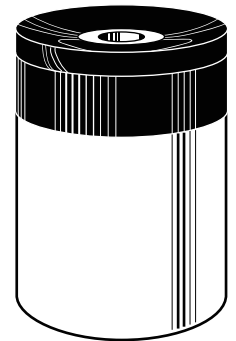

KOH-I-NOOR 3 HOLE

An all metal three hole hand sharpener. One hole for large diameter pencils, one for standard diameter pencils, and the third for fine pointing of the lead. 12 per box.

K-0983 Three Hole Pencil Sharpener

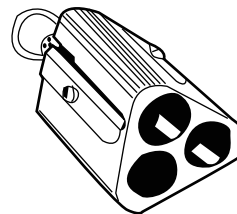

GENERAL 2 HOLE

An all metal two hole hand pencil sharpener. One hole for large diameter pencils, and the other for standard diameter pencils. 12 per box.

GP-2010-BP Two Hole Pencil Sharpener

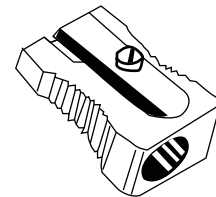

GENERAL 1 HOLE

An all metal one hole hand pencil sharpener. Cuts the wood and sharpens the point in one operation. 12 per box

GP-1050-BP One Hole Pencil Sharpener

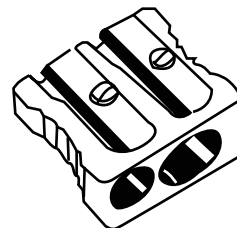

SANDPAPER BLOCKS

A handy pad of medium tooth sandpaper attached to a wooden holder. For pointing pencils, charcoal, pastels, stumps, and tortillions. 12 per box.

K-25916 Sandpaper Pointer Pad

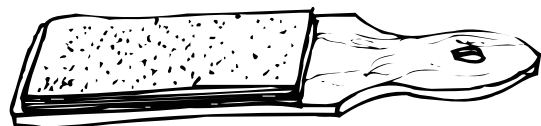

LEAD POINTERS

Lead pointers are designed to sharpen 2mm leads only, they will not accept pencils. Please check specific features for each model. Some are portable, others fix to your table, some have depth guides for different points, and some have point cleaners.

LARGE ROTARY POINTER

A fine lead pointer for all types of lead. Designed to be mounted to a drawing board with the included clamp. It has a handy cleaning and adaptor collars for most lead holders. Uses steel cutting blades.

AL-EP17 Desktop Lead Pointer

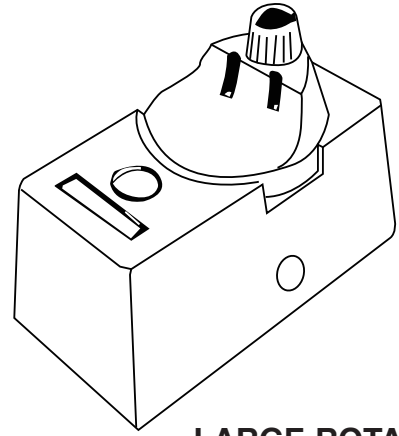

LARGE ROTARY

DAHLE ROTARY

A small hand held pointer with a wear resistant cutter. Has a measuring guide for points and a cleaning pad.

DH-301 Dahle Rotary Pointer

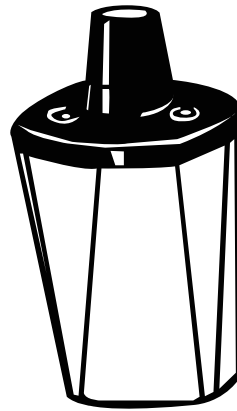

DAHLE ROTARY

STAEDLER MARS ROTARY

Hand held rotary lead pointer for 2mm lead holders. Two holes for different lead sizes. Features an automatic cutting stop and built in cleaner. Two spare cleaning pads included.

MR-502BK Mars Rotary Pointer



MARS ROTARY

233 POINTER

A very small plastic pointer with a steel blade. Completely open with no dust collector. By Koh-I-Noor

K-0233 Koh-I-Noor Pointer



233

DAHLE PERSONAL POINTER

This pointer has steel blades for a very sharp point. Large capacity shavings container, for graphite or colored leads.

DH-53484 Dahle Personal Pointer

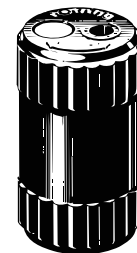

DAHLE PERSONAL

CHARCOAL

Charcoal is one of the oldest mediums known to man. As the name implies, it is charred wood that has been prepared in several ways. By itself, charcoal has no binder, and must be fixed to avoid smudging.

V2 VINE CHARCOAL



Vine charcoal is very soft for black effects. Made from charred vine branches, sticks are 1/8" x 6", and round. By Sanford, 25 sticks per box.

G-V002 Vine Charcoal Extra Soft

V9 JUMBO CHARCOAL



This is an extra thick charcoal, 1/2" in diameter and 6" long. Ideal for large sketching, filling in backgrounds, etc. There are 25 sticks per box in medium degree, by Sanford.

G-V009 Jumbo Charcoal Medium

6A & 17 ROUND CHARCOAL



A regular round shaped charcoal that is 1/4" x 6" long. For all types of sketching, in two package counts, medium degree, by Sanford.

G-V006A Regular Charcoal Medium box 5
G-V017 Regular Charcoal Medium box 50

3 WRAP CHARCOAL

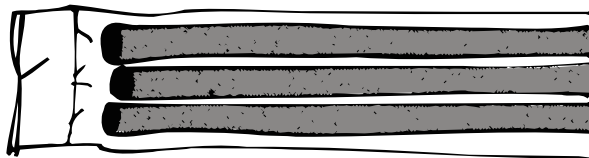

Selected charcoal available in three degrees that are packed 24 sticks per box in eight cellophane envelopes of three sticks each. This helps keep the sticks dry and also helps prevent breakage. Sticks are 3/16" x 6" long, and round in shape. By Sanford.

G-V041 3 Wrap Charcoal Soft
G-V042 3 Wrap Charcoal Medium
G-V043 3 Wrap Charcoal Hard

CHAR-KOLE

A very black, smooth compressed stick that is easily blended. Ideal for fine crisp lines. Sticks are 7/16" x 2-3/4" long, and rectangular in shape. Twelve sticks per box, in a plastic tray. By Weber Costello

LC-0883 Charcoal Sticks

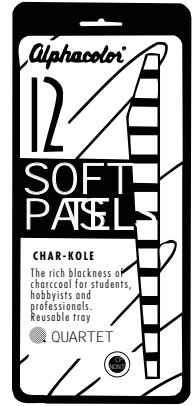

COMPRESSED CHARCOAL



FABER CASTELL PITT Compressed Charcoal

This is a stick made from powdered charcoal pressed with a binder. These sticks are stronger than regular charcoal, but more difficult to remove. Sticks are about 1/4" in diameter by 3" long. Available in four degrees, in boxes of 4

FC-129906 Extra Soft
FC-129903 Soft
FC-129900 Medium
FC-129913 Hard
FC-129916 Extra Hard

GENERAL PENCIL Compressed Charcoal

This is a stick made from powdered charcoal pressed with a binder. These sticks are stronger than regular charcoal, but more difficult to remove. Sticks are about 1/4" Square by 3" long. Available in 3 degrees, in boxes of a dozen.

GP-0957H Hard
GP-0957M Medium
GP-0957S Soft
GP-0958 White
GP-0957A-BP 4 Asst Card
GP-0958-BP 4 White Card



CHARCOAL CHUNK

A large chunk of charcoal that can be broken off, chipped, shaped, etc to create a unique drawing instrument.

GP-0967 Charcoal Chunk



By General

GRAPHITE

GENERAL GRAPHITE

A 1/4" x 3" stick of solid Graphite for lay-outs and sketching. Ideal for combinations with pencil sketches. 12 per box. by General.

GP-0972	2B Graphite Sticks
GP-0974	4B Graphite Sticks
GP-0976	6B Graphite Sticks
GP-0970A-BP	Asst Card



GRAPHITE CHUNK

A large chunk of graphite that can be broken off, chipped, shaped, etc to create a unique drawing instrument.



GP-0987 Charcoal Chunk By General

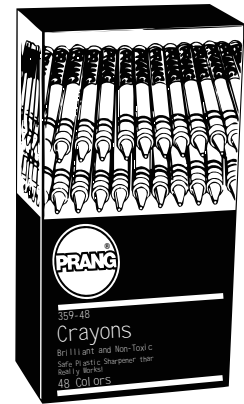

PRANG CRAYONS

Prang crayons are noted for brilliant color and clean, even application of true colors. Ideal for children's art, and some fine art purposes. Round 3/16" x 3-5/8".

AC-38008	8 Color Set
AC-41618	16 Color Set
AC-322-24	24 Color Set
AC-359-48	48 Color Set
AC-640-64	64 Color Set
AC-966	96 Color Set

CRAYONS

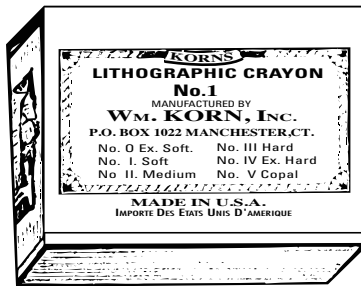

KORNS' LITHO CRAYONS

A crayon that leaves an ink receptive mark on litho stones, plates, and paper. Also used for drawing on fabric to form the image in the touche and glue method of making a screen printing plate. Small sticks are about 3/16" x 1-1/2", twelve per box.

KN-200-00	Extra Soft
KN-200-0	Very Soft
KN-200-1	Soft
KN-200-2	Medium
KN-200-3	Medium Hard
KN-200-4	Hard
KN-200-5	Copal Extra Hard



PRANG LARGE CRAYON

Prang's oversize crayon for children 3 or older or anyone having difficulty gripping a smaller crayon. Ideal for children's art, and some fine art purposes. Round 4" x 7/16".

AC-52808 Prang Large Crayon

WATERCOLOR CRAYONS

KARAT AQUARELL WATER-SOLUBLE CRAYONS

These colored crayons have brilliant, intense colors. All 24 colors allow you to draw with smooth, even color application, on rough or fine-toothed papers. With a brush and water, these colors can become soft washes, deep shadows, or solid areas of color. In tin boxes.

- MR-223-M10 10 Color Water Color Crayon Set
- MR-223-M20 20 Color Water Color Crayon Set



BLENDERS

STUMPS

Soft gray paper that is pointed on both ends for blending pastels and charcoal. Stumps may be kept pointed easily with a sandpaper block. In hanging packages of 2 each

- | | | |
|----------|------------------------|-------|
| LC-8941B | Size #1 1/8" Diameter | Pkg 2 |
| LC-8942B | Size #2 3/16" Diameter | Pkg 2 |
| LC-8943B | Size #3 1/4" Diameter | Pkg 2 |
| LC-8944B | Size #4 5/16" Diameter | Pkg 2 |
| LC-8945B | Size #5 3/8" Diameter | Pkg 2 |
| LC-8946B | Size #6 7/16" Diameter | Pkg 2 |
| LC-8948B | Size #8 5/8" Diameter | Pkg 2 |

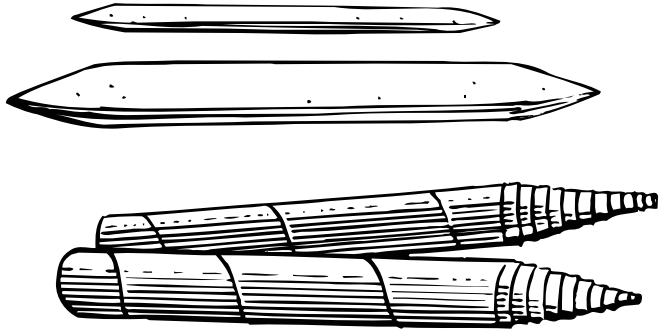

TORTILLIONS

Soft Gray paper that is spiral wound and pointed at one end. Tight winding permits sharpening on a sandpaper block.

- | | | |
|-----------|------------------------|-------|
| LC-0860SB | Size #1 3/16" Diameter | Pkg 6 |
| LC-0860MB | Size #2 1/4" Diameter | Pkg 6 |
| LC-0860LB | Size #3 5/16" Diameter | Pkg 4 |

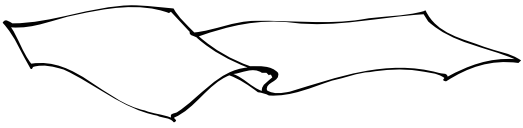

CHAMOIS

Imported, finest quality selected chamois skins for artists use. Chamois are soft and pliable. Ideal for blending pastels or charcoals. Bagged in sealed polyethylene bags. By Grumbacher

- LC-0501 5 x 6-3/4" 1 per bag

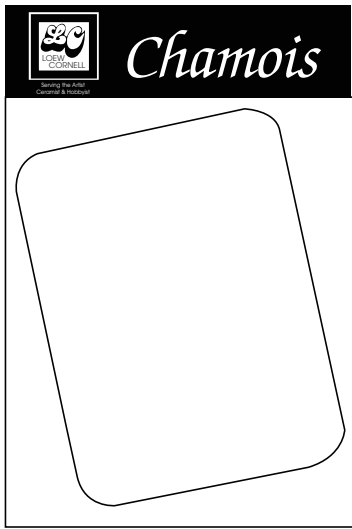

DALER ROWNEY - SOFT PASTELS



Dahler-Rowney are acknowledged masters in the art of making quality soft pastels. The classic soft pastel is characterised by a velvety smoothness obtained from preparations of pure pigment and extender. They are unsurpassed in consistency and handling. Available in open stock and sets.

Card Box Sets

DR-150-900-120	12 Landscape
DR-150-900-121	12 Portrait
DR-150-900-123	12 Assorted
DR-150-900-240	24 Assorted
DR-150-900-243	24 Assorted - Half Size Sticks
DR-150-900-360	36 Assorted
DR-150-900-361	36 Landscape
DR-150-900-362	36 Portrait

Wood Box Sets

DR-150-900-721	72 Landscape
DR-150-900-722	72 Portrait
DR-150-900-723	72 Assorted
DR-150-900-144	144 Assorted

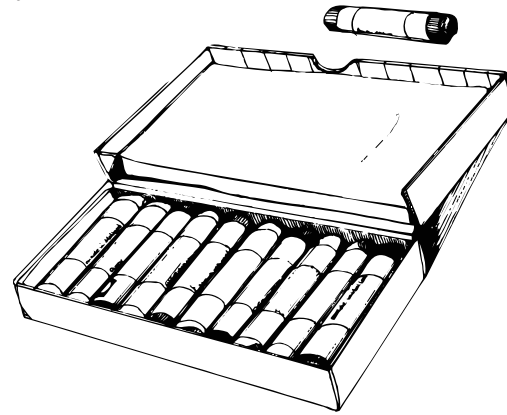

NUMBER	#	COLOR	NUMBER	#	COLOR	NUMBER	#	COLOR
DR-150-000-015	015	SilverWhite (Blue)	DR-150-000-111	111	Coeruleum Blue	DR-150-004-363	363	"
DR-150-000-016	016	White (Cream)	DR-150-002-111	111	"	DR-150-007-363	363	"
DR-150-001-620	620	Cad Yellow Hue	DR-150-004-111	111	"	DR-150-008-363	363	"
DR-150-004-620	620	"	DR-150-006-111	111	"	DR-150-001-375	375	Sap Green
DR-150-006-620	620	"	DR-150-008-111	111	"	DR-150-003-375	375	"
DR-150-001-619	619	Cad Orange Hue	DR-150-000-123	123	French Ultramarine	DR-150-005-375	375	"
DR-150-004-619	619	"	DR-150-001-123	123	"	DR-150-008-375	375	"
DR-150-006-619	619	"	DR-150-003-123	123	"	DR-150-001-379	379	Terre Verte Hue
DR-150-001-512	512	Cad Red Orange	DR-150-004-123	123	"	DR-150-005-379	379	"
DR-150-003-512	512	"	DR-150-006-123	123	"	DR-150-008-379	379	"
DR-150-000-651	651	Lemon Yellow	DR-150-008-123	123	"	DR-150-001-381	381	Viridian
DR-150-002-651	651	"	DR-150-001-127	127	Indigo	DR-150-004-381	381	"
DR-150-004-651	651	"	DR-150-003-127	127	"	DR-150-006-381	381	"
DR-150-006-651	651	"	DR-150-004-127	127	"	DR-150-001-383	383	Yellow Green
DR-150-000-634	634	Naples Yellow	DR-150-006-127	127	"	DR-150-003-383	383	"
DR-150-002-634	634	"	DR-150-001-135	135	Prussian Blue	DR-150-005-383	383	"
DR-150-004-634	634	"	DR-150-003-135	135	"	DR-150-001-201	201	Autumn Brown
DR-150-006-634	634	"	DR-150-005-135	135	"	DR-150-003-201	201	"
DR-150-001-667	667	Raw Sienna	DR-150-008-135	135	"	DR-150-005-201	201	"
DR-150-004-667	667	"	DR-150-001-413	413	Mauve	DR-150-008-201	201	"
DR-150-006-667	667	"	DR-150-002-413	413	"	DR-150-000-221	221	Burnt Sienna
DR-150-000-663	663	Yellow Ochre	DR-150-003-413	413	"	DR-150-002-221	221	"
DR-150-002-663	663	"	DR-150-005-413	413	"	DR-150-004-221	221	"
DR-150-004-663	663	"	DR-150-006-413	413	"	DR-150-006-221	221	"
DR-150-006-663	663	"	DR-150-001-425	425	Pansy Violet	DR-150-008-221	221	"
DR-150-001-503	503	Cad Red Hue	DR-150-003-425	425	"	DR-150-001-223	223	Burnt Umber
DR-150-002-503	503	"	DR-150-005-425	425	"	DR-150-002-223	223	"
DR-150-004-503	503	"	DR-150-007-425	425	"	DR-150-003-223	223	"
DR-150-006-503	503	"	DR-150-008-425	425	"	DR-150-004-223	223	"
DR-150-001-516	516	Cad Tangerine	DR-150-000-433	433	Purple	DR-150-006-223	223	"
DR-150-002-516	516	"	DR-150-002-433	433	"	DR-150-008-223	223	"
DR-150-004-516	516	"	DR-150-004-433	433	"	DR-150-001-053	053	Cool Gray
DR-150-006-516	516	"	DR-150-006-433	433	"	DR-150-002-053	053	"
DR-150-001-514	514	Crimson Lake	DR-150-008-433	433	"	DR-150-004-053	053	"
DR-150-002-514	514	"	DR-150-000-435	435	Purple Gray	DR-150-005-053	053	"
DR-150-004-514	514	"	DR-150-002-435	435	"	DR-150-006-053	053	"
DR-150-006-514	514	"	DR-150-004-435	435	"	DR-150-000-207	207	Madder Brown
DR-150-000-523	523	Indian Red	DR-150-006-435	435	"	DR-150-002-207	207	"
DR-150-002-523	523	"	DR-150-001-443	443	Reddish Purple	DR-150-004-207	207	"
DR-150-004-523	523	"	DR-150-003-443	443	"	DR-150-006-207	207	"
DR-150-006-523	523	"	DR-150-006-443	443	"	DR-150-001-245	245	Purple Brown
DR-150-001-539	539	Poppy Red	DR-150-001-307	307	Blue Green	DR-150-004-245	245	"
DR-150-003-539	539	"	DR-150-005-307	307	"	DR-150-006-245	245	"
DR-150-006-539	539	"	DR-150-008-307	307	"	DR-150-001-247	247	Raw Umber
DR-150-008-539	539	"	DR-150-001-309	309	Brilliant Green	DR-150-003-247	247	"
DR-150-000-551	551	Red Gray	DR-150-003-309	309	"	DR-150-004-247	247	"
DR-150-002-551	551	"	DR-150-005-309	309	"	DR-150-006-247	247	"
DR-150-004-551	551	"	DR-150-006-309	309	"	DR-150-001-251	251	Sepia
DR-150-006-551	551	"	DR-150-001-343	343	Grass Green	DR-150-003-251	251	"
DR-150-000-562	562	Rose Madder	DR-150-004-343	343	"	DR-150-005-251	251	"
DR-150-002-562	562	"	DR-150-006-343	343	"	DR-150-008-251	251	"
DR-150-004-562	562	"	DR-150-001-345	345	Green Gray	DR-150-001-264	264	Vandyke Brown
DR-150-006-562	562	"	DR-150-004-345	345	"	DR-150-002-264	264	"
DR-150-000-588	588	Vermilion Hue	DR-150-006-345	345	"	DR-150-004-264	264	"
DR-150-002-588	588	"	DR-150-001-352	352	Hooker's Green	DR-150-006-264	264	"
DR-150-004-588	588	"	DR-150-003-352	352	"	DR-150-008-264	264	"
DR-150-006-588	588	"	DR-150-005-352	352	"	DR-150-001-073	073	Warm Gray
DR-150-000-104	104	Blue Gray	DR-150-008-352	352	"	DR-150-003-073	073	"
DR-150-002-104	104	"	DR-150-001-357	357	Lizard Green	DR-150-004-073	073	"
DR-150-004-104	104	"	DR-150-003-357	357	"	DR-150-005-073	073	"
DR-150-006-104	104	"	DR-150-005-357	357	"	DR-150-000-031	031	Intense Black
DR-150-000-109	109	Cobalt Blue	DR-150-007-357	357	"	DR-150-000-034	034	Ivory Black
DR-150-002-109	109	"	DR-150-008-357	357	"	DR-150-000-035	035	Lamp Black
DR-150-004-109	109	"	DR-150-000-363	363	Olive Green			
DR-150-006-109	109	"	DR-150-002-363	363	"			

ALL PASTELS PACKED 3PER BOX



HARD PASTELS

Semi soft pastels are similar to soft pastels in that they are made from artists pigments mixed with non-abrasive type binder. The formulation is changed to form a harder stick. This makes them less likely to break, crumble or dust. It also makes them less blendable. They are also very useful for highlighting, and detail work.

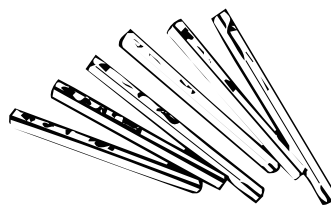

CONTE CRAYONS

Conte crayons are made from pigment in square stick form. Crayons are harder than pastels, and have more adhesive quality. They are also more waxy with less tendency to dust. Ideal for both fine and commercial work. They are available in two packages, a box of twelve, and on a blister card of two. 3/16" x 3" sticks.

CARD OF 2

HU-2350	Sanguine Natural
HU-2351	Sanguine XVIII Century
HU-2352	Sanguine Watteau
HU-2353	Sanguine Medicis
HU-2354	Bistre (Sepia)
HU-2355	White Very Soft
HU-2356	White Soft
HU-2357	White Medium
HU-2358	Grey
HU-2359	Black Very Soft
HU-2360	Black Soft
HU-2361	Black Medium



NUPASTELS

Nupastels provide a full range of 96 colors in a firm stick that resists crumbling and dusting. So firm that they can actually be sharpened to a point. Sticks are square in shape and about 3-5/8" in length.

EF-263-12	12 Color Set	Nupastels
EF-264-24	24 Color Set	Nupastels
EF-273-36	36 Color Set	Nupastels
EF-274-48	48 Color Set	Nupastels
EF-284-60	60 Color Set	Nupastels
EF-294-72	72 Color Set	Nupastels
EF-434-96	96 Color Set	Nupastels



LOEW CORNELL PASTELS

These pastels are chalk like pastels in vibrant colors that make bright pictures on paper or cloth. Ideal for murals. Sticks are square in shape and about 7/16 x 2-3/4" in size. They are very economical and ideal for student use.

LC-0884	12 Color Set	
LC-0885	24 Color Set	
LC-0886	48 Color Set	
LC-0881	12 Color Set	Earth Tones
LC-0882	12 Color set	Hi Fi Grays
LC-0887	24 Color Set	Landscape
LC-0888	24 Color Set	Portrait



OIL PASTELS

Oil pastels are made from pure artist pigments combined with an oil binder. They can be used dry, or reduced with any solvent used for traditional oil paints. Adhesion is very good to almost any surface and they are smudge resistant after drying. Oil Pastels are generally smaller than soft pastels.

LEOW-CORNELL OIL PASTELS

These oil pastels are exceptionally bright and clear, and apply to paper with a smoothness and evenness with no chalking or dusting. Colors are used as either pastels, or oil colors without the mess.

LC-0912	24 Color Set
LC-0924	24 Color Set
LC-0925	36 Color Set
LC-0926	50 Color Set (2 Whites)
LC-0927	60 Color Set (2 Whites)

FIXATIVE

A fixative is a colorless liquid that is applied to drawings and pastel paintings to "set" the medium. This prevents smudging and dusting. Fixatives are available in two forms: aerosol cans and bottles of liquid which is applied through an atomizer.

WORKABLE FIXATIVE

A matte finish coating specially formulated for pastels, charcoal, pencil, etc. Sprayed lightly, workable fixative holds media in place for additional working without smearing or turning pastels "muddy". Also permits paint or ink to be applied over dry media. Can be easily erased. In aerosol form.

GRUMBACHER MYSTON

G-0646	4-3/4 oz.	Grumbacher Myston
G-0546	12-3/4 oz.	Grumbacher Myston

KRYLON WORKABLE FIXATIVE

KR-1306	11 oz.	Krylon Workable Fixatif
---------	--------	-------------------------

CLEAR ACRYLIC SPRAY

A clear acrylic varnish-fixative that protects charcoal and pastel drawings, printed matter, proofs, blueprints, and photographs from dust, dirt, and moisture. These sprays are colorless, transparent, rapid drying, and will not change the hue of colors, or stain papers. This type of spray dries to a high gloss and is NOT WORKABLE! In aerosol can only.

GRUMBACHER TUFFILM GLOSS

G-0543	12-3/4 oz.	Grumbacher Tuffilm Gloss
--------	------------	--------------------------

KRYLON CRYSTAL CLEAR

KR-1303	13 oz.	Krylon Crystal Clear
---------	--------	----------------------

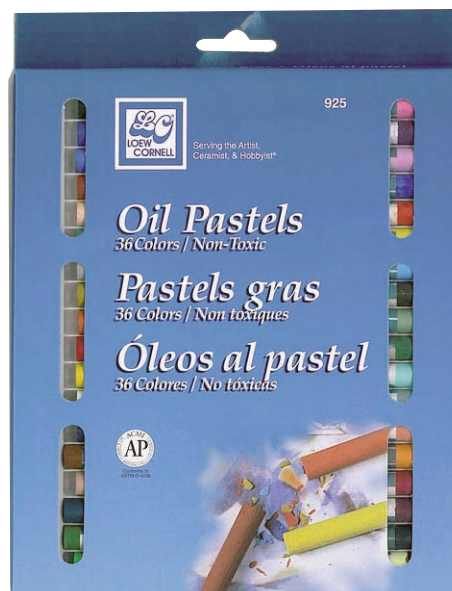

MATTE ACRYLIC SPRAY

A clear acrylic varnish with a matte finish that protects charcoal and pastel drawings, printed matter, proofs, blueprints, and photographs from dust, dirt, or moisture. These sprays are colorless, transparent, rapid drying, and will not change the hue of colors, or stain papers. This type of spray dries to a dull matte and is NOT WORKABLE!

GRUMBACHER TUFFILM MATTE

G-0649	4-3/4 oz.	Grumbacher Tuffilm Matte
G-0549	12-3/4 oz.	Grumbacher Tuffilm Matte

KRYLON CRYSTAL CLEAR

KR-1311	13 oz.	Krylon Matte Finish
---------	--------	---------------------

PCP & JPK



TECHNICAL PENS
FOUNTAIN PENS
CALLIGRAPHY PENS
SKETCH PENS
DIP PENS
PEN HOLDERS
PEN SETS
DRAWING INK
FOUNTAIN PEN INKS
SPECIALTY INKS
PEN CLEANERS
GRAPHIC WHITES
FINE MARKERS
BROAD MARKERS
CALLIGRAPHY MARKERS
HIGHLIGHTERS
O.H.P. MARKERS
NON-REPRO MARKERS
OPAQUING MARKERS
STUDIO MARKERS
MARKER FIXATIVE



TECHNICAL PENS

A technical pen is a writing instrument designed to produce an extremely uniform, dense line. It must meter ink so that the line width remains the same from start to finish, and produces a line dense enough for photographic reproduction. The pen does this using the principal of capillary action. The ink flows down a tube and around a wire that is inside the tube. The wire also breaks the surface tension when the point touches the drawing surface. A technical pen is a sensitive instrument that requires care and must be used with the right ink (see ink products later in this section). It is also recommended that the point and wire not be disassemble during cleaning.

KOH-I-NOOR RAPIDOGRAPH

The Koh-I-Noor Rapidograph features an extra smooth feel on the drawing surface. The patented dry double seal cap system seals the entire nib and tube orifice. This helps eliminate drying out. There is no need to add water, and no mechanical parts to jam. 13 different line widths are available that are marked in standard and metric sizes. Nine of these sizes are in widths that conform to the International Standards Organization (ISO). Based on the square root of 2, these sizes facilitate the "half scale blow back technique, common in microfilm practice.

STEEL POINT

Stainless steel point pens are recommended for use on paper and cloth.

COMPLETE PENS

K-3165-013	6/0	.13mm
K-3165-018	4/0	.18mm
K-3165-025	3/0	.25mm
K-3165-030	2/0	.30mm
K-3165-035	0	.35mm
K-3165-050	1	.50mm
K-3165-060	2	.60mm
K-3165-070	2-1/2	.70mm
K-3165-080	3	.80mm
K-3165-100	3-1/2	1.00mm
K-3165-120	4	1.20mm
K-3165-140	6	1.40mm
K-3165-200	7	2.00mm

POINTS

K-0072D-013
K-0072D-018
K-0072D-025
K-0072D-030
K-0072D-035
K-0072D-050
K-0072D-060
K-0072D-070
K-0072D-080
K-0072D-100
K-0072D-120
K-0072D-140
K-0072D-200

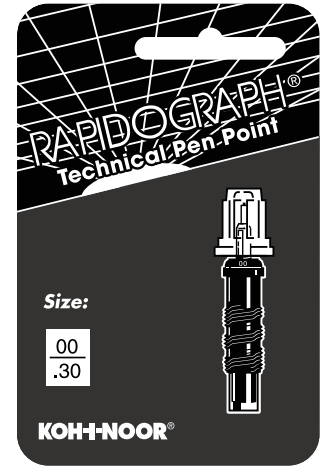

SLIM PACK SETS

Slim Pack Sets are sets in attractive plastic boxes with clear plastic lids and push button release. Each set includes a bottle of ink, and two nib wrenches. Sets are only about an inch thick to fit into drawers.

K-3165-SP-4	2/0, 0, 1, 2	Steel Points
K-3165-SP-7	3/0, 2/0, 0, 1, 2, 3, 4	Steel Points

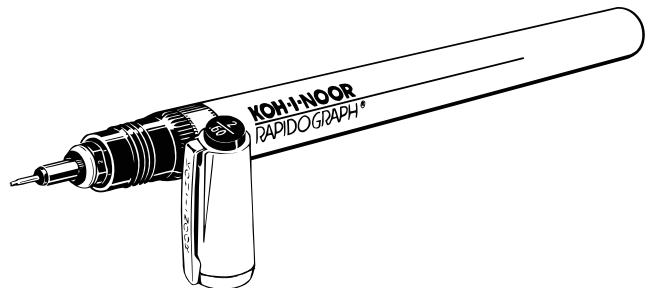
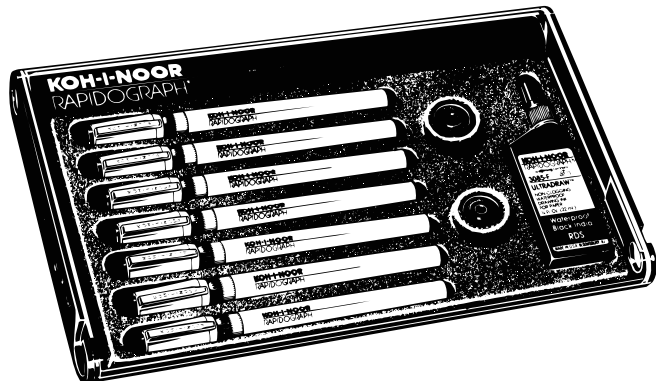
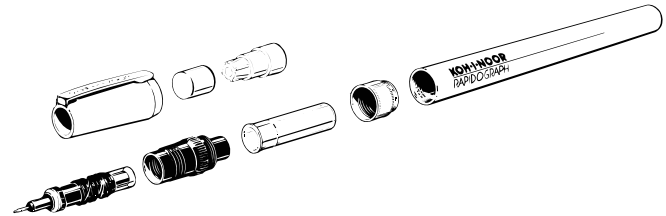

PANACHE

Panache is a new line of calligraphic pens and inks developed by Hunt for the beginner or experienced calligrapher. These cartridge pens allow total control over every stroke. Nibs and ink colors can be changed instantly. You'll see what a joy it is to express yourself with Panache.

CALLIGRAPHY PEN

Includes burgundy pen with medium nib and two cartridges (black & blue).

HU-019901 Calligraphy Pen

BASIC CALLIGRAPHY SET

Provides the essential tools of calligraphy including Teal Pen, 3 nibs (fine, Medium & Broad) and 3 cartridges (Black, Dark Blue & Purple).

HU-019910 Basic Calligraphy Set RH

HU-019916 Basic Calligraphy Set LH

MASTER CALLIGRAPHY SET

An ideal selection of calligraphic tools including: 2 pens (Teal & Burgundy), 5 nibs (Ex Fine, Fine, Medium, Broad, & Scroll) and 4 ink cartridges (Black, Blue, Purple, & Turquoise).

HU-19911 Master Calligraphy Set

WRITING PENS

Panache Writing Pens come with a Medium Writing Nib. The cartridge pen comes with two blue cartridges, the fountain pen comes with a piston convertor.

HU-019903 Cartridge Writing Pen

HU-019904 Fountain Writing Pen

BASIC WRITING SET

Provides the basic tools for writing and calligraphy: Pen, Med Writing Nib, Ex-Fine & Fine Calligraphy Nibs, 2 Ink Cartridges (Blue & Black), and a piston convertor.

HU-019912 Basic Writing Set

NIBS AND ACCESSORIES

HU-019941 Writing Nib

HU-019942 Extra Fine Calligraphy Nib

HU-019943 Fine Calligraphy Nib

HU-019944 Medium Calligraphy Nib

HU-019945 Broad Calligraphy Nib

HU-019946 Scroll Calligraphy Nib

HU-019947 Left Hand Fine Calligraphy Nib

HU-019948 Left Hand Medium Broad Calligraphy Nib

HU-019949 Left Hand Broad Calligraphy Nib

HU-019908 Refillable Cartridge Converter

HU-019936 Black Cartridges Box of 5
HU-019937 Blue Cartridges Box of 5



CALLIGRAPHY MARKERS

Calligraphy markers are unique in that they have a squared flat tip that can draw either thin or thick lines. By controlling the stroke, one can draw lines that progress from thin to thick, or visa versa. This allows the calligraphic technique. These markers are also fun to sketch or doodle with.

ELEGANT WRITER

The Speedball Elegant Writer brings the grace and style of calligraphy to everyday writing with ease. These versatile calligraphic markers are available in seven beautiful colors and six different point sizes to add creativity to your writing.

WATER SOLUABLE ELEGANT WRITERS

Carded

HU-2514	Black	Extra Fine
HU-2841	Black	Fine
HU-2842	Black	Medium
HU-2843	Black	Broad
HU-2515	Black	Extra Broad
HU-2844	Black	Scroll
HU-2849	Blue	Fine
HU-2850	Blue	Medium

ELEGANT WRITER SETS

HU-2881	Color Set Fine	1 Each All Colors
HU-2882	Color Set Medium	1 Each All Colors
HU-2883	Color Set Broad	1 Each All Colors
HU-2884	Color Set Scroll	1 Each All Colors

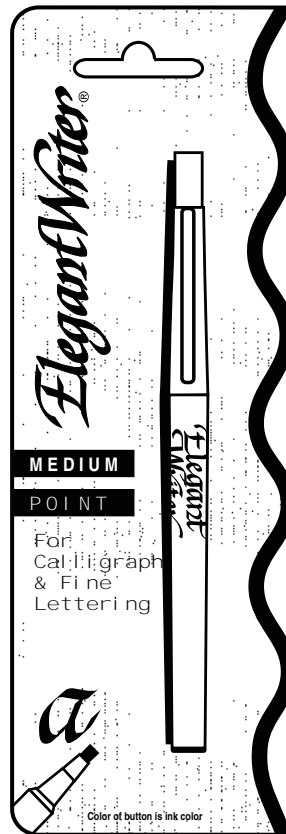

CALLIGRAPHIC DUO

The Calligraphic Duo by Staedler is two markers in one. Each end has a different size nib. One is a 2.0mm the other is a 3.5mm. An odorless ink flows easily while retaining brilliant color. See through caps show nibs easily, click to seal, and interlock so they won't get lost. Available in five individual colors, a set of all five colors, or a set of three colors (red, blue, and black).

MR-3002-2	Calligraph Duo Red
MR-3002-3	Calligraph Duo Blue
MR-3002-6	Calligraph Duo Violet
MR-3002-7	Calligraph Duo Brown
MR-3002-9	Calligraph Duo Black
MR-3002-C3	Calligraph Duo Set of 3
MR-3002-C5	Calligraph Duo Set of 5

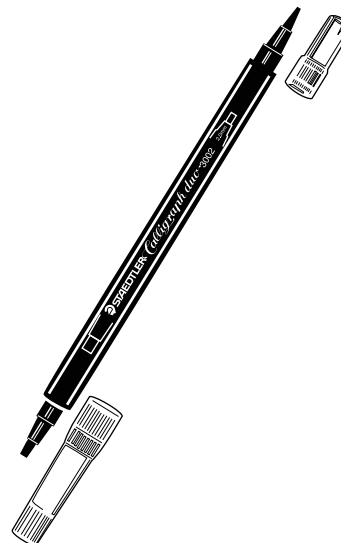

Mars Duo

DIP PENS

These pens do not have an ink reservoir, and are filled by dipping in an ink bottle, or filled with a dropper. This allows the use of much heavier ink than in fountain type pens. They are ideal for all types of art and calligraphic use.

SPEEDBALL PENS

Speedball pens are lettering pens in four styles. There are at least five sizes in each style. Style "A" has a square tab end for square block and poster gothic letters, borders, and decorations. Style "B" has a round tab end for gothic or outline letters, cartoons, borders, and posters. Style "C" has a square cut end for Roman or italic lettering, scrolls, and script. Style "D" has an oval tab end for bold Roman and italic lettering, poster styles, scrolls and script. Points do not include holder.

SPEEDBALL STYLE "A"

HU-3000	A-0	HU-3003	A-3
HU-3001	A-1	HU-3004	A-4
HU-3002	A-2	HU-3005	A-5

Carded			
HU-3101	A0/A1	HU-31003	A2/A3
HU-31005	A4/A5		

SPEEDBALL STYLE "B"

HU-3010	B-0	HU-3014	B-4
HU-3017	B-1/2	HU-3015	B-5
HU-3011	B-1	HU-3018	B-5-1/2
HU-3012	B-2	HU-3016	B-6
HU-3013	B-3		

Carded			
HU-31010	B0/B1/2	HU-31014	B3/B4
HU-31012	B-1/B2	HU-31016	B5/B6

SPEEDBALL STYLE "C"

HU-3020	C-0	HU-3024	C-4
HU-3021	C-1	HU-3025	C-5
HU-3022	C-2	HU-3026	C-6
HU-3023	C-3		

Carded			
HU-31021	C0/C1	HU-31025	C4/C5
HU-31023	C2/C3		

SPEEDBALL STYLE "D"

HU-3036	D-00	HU-3033	D-3
HU-3030	D-0	HU-3034	D-4
HU-3031	D-1	HU-3035	D-5
HU-3032	D-2		

Carded			
HU-31031	D0/D1	HU-31035	D4/D5
HU-31033	D2/D3		

SPEEDBALL STYLE "LC"

Specially created "C" style for left handers.

HU-3050	LC-0	HU-3053	LC-3
HU-3051	LC-1	HU-3054	LC-4
HU-3052	LC-2		

SPEEDBALL STEEL BRUSH

Steel brushes for one stroke type lettering. The four sizes are as easy to change as a pen point. Fits Speedball holder #9451.

HU-31081	1/4" Speedball Steel Brush
HU-31082	3/8" Speedball Steel Brush
HU-31083	1/2" Speedball Steel Brush
HU-31084	3/4" Speedball Steel Brush



STYLE "A" SQUARE for creating block and poster Gothic letters, ornamented borders, designs, and decorations

HOLDER

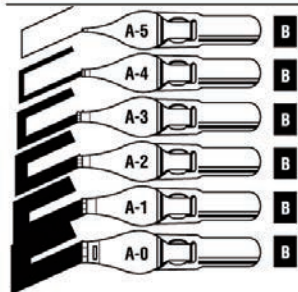

STYLE "B" ROUND is ideal for Gothic or outline letters, cartoons, uniform line drawings, borders, and display posters.

HOLDER

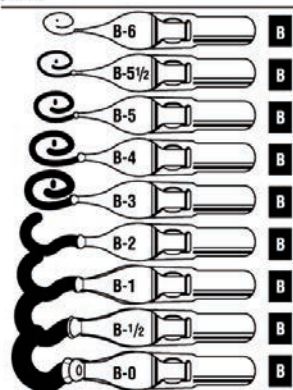

STYLE "C" FLAT is designed for Roman, texts, italic lettering and for accented line drawings, scrolls, or scripts.

HOLDER

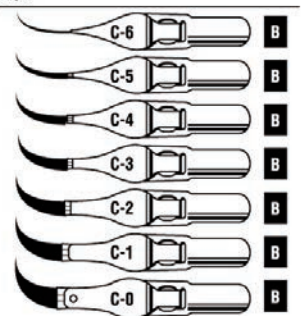

STEEL BRUSH For charts, lettering & illustrations.

HOLDER

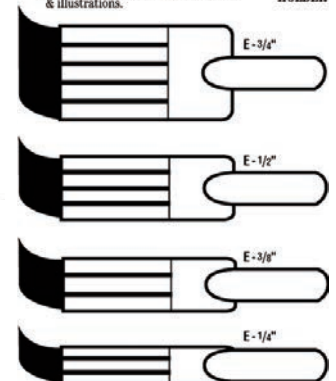

HUNT ARTIST PENS

Hunt Artist Pens come in a variety of styles and hardnesses for all types of drawing, lettering, tracing, and other fine line work. 12 per box

22B EXTRA FINE

A Bronze finished extra fine point for ornamental pen work and ruling. Medium stiff.

HU-9405 #22B Extra Fine

56 SCHOOL

The School point is a fine drawing pen with a bronze finish. Stiff action.

HU-9406 #56 School Point

99 DRAWING

The Drawing point has a special extra fine point for draftsmen and lithographers.

HU-9409 #99 Drawing Point

100 ARTIST

The artist point has a very fine point for delicate lines.

HU-9400 #100 Artist Point

101 IMPERIAL

The Imperial is a very flexible bronze finish pen for ornamental work.

HU-9401 #101 Imperial Point

102 CROW QUILL

The Crow Quill is an old favorite with a super fine, flexible point.

HU9402 #102 Crow Quill

103 MAPPING

The mapping point is for mapping and other fine line work.

HU-9403 #103 Mapping Point

104 FINEST

The finest point is a superfine art pen for fine hair lines and the finest detail.

HU-9404 #104 Finest Point

107 HAWK QUILL

The Hawk Quill has a super fine point that is very durable. For long even lines and cross hatching.

HU-9407 #107 Hawk Quill

108 FLEXIBLE QUILL

The Flexible point is a bronze finished point for cross hatch, flourishing, and lithography.

HU-9408 #108 Flexible Quill

512 BOWL

The Bowl is a fine pointed pen for ruling and lettering.

HU-9412 #512 Bowl

513 EF GLOBE

The Globe is an extra fine bowl pointed pen for industrial arts.

HU-9413 #513EF Globe



CARDED ARTIST PENS

Your favorite artist pens on convenient blister cards. Easy to handle and inventory. Two different points on each card.

- | | |
|----------|-----------------------------|
| HU-94007 | 102/107 Artist Pen Points |
| HU-94013 | 512/513EF Artist Pen Points |
| HU-94022 | 22B/56 Artist Pen Points |
| HU-94101 | 99/101 Artist Pen Points |
| HU-94103 | 103/104 Artist Pen Points |
| HU-94104 | 100/104 Artist Pen Points |
| HU-94108 | 102/108 Artist Pen Points |

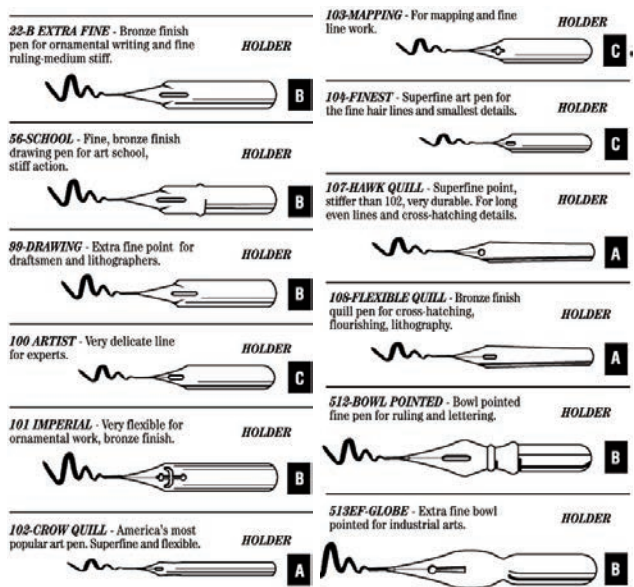

PEN HOLDERS

SPEEDBALL HOLDER

An inexpensive holder for Speedball and other large lettering points. Shaped for hand comfort. Black only.

- | | | |
|----------|------------------|--------|
| HU-9451 | Speedball Holder | Bulk |
| HU-94151 | Speedball Holder | Carded |

CROW QUILL HOLDERS

Two holders for both styles of Hunt Artist Pens. Carded

- | | |
|----------|-----------------------------------------|
| HU-94512 | #102 Holder for pens #102, #107, & #108 |
| HU-94514 | #104 Holder for pens #100, #103, & #104 |

CORK GRIP HOLDER

A pen holder with a cork finger grip, and steel insert. The stem is black and available in wood or plastic. For lettering and larger pen points.

GP-0204-B Cork Grop Holder Plastic

OBLIQUE HOLDER

A holder that is specifically designed to hold a point at the correct angle for Copperplate or Spencerian Script styles of lettering. Holds the #103 & #101 Hunt points.

HU-9455 Speedball Oblique Pen Holder

CROW QUILL CARDS

A card with either twelve Hunt #102 Crow Quill Pens in holders, or twelve #107 Hawk Quill Pens in holders.

HU-9432 Card with #102 Crow Quill Points
 HU-9437 Card with #107 Hawk Quill Points

CALLIGRAPHY SETS

#5 SPEEDBALL SET

A boxed assortment of 6 Speedball pens, and Hunt points #102, 56, & 512, plus a lettering and pen drawing folder. Either in an individual gift box, or carded.

HU-3065 #5 Speedball Set Boxed
 HU-2962 #5 Speedball Set Carded

SPEEDBALL CALL. KIT

A beginner calligraphy set with three Speedball "C" points, a 2 oz. bottle of Super India Ink, pen holder, and easy to follow instructions featuring Roman Italic lettering, as well as a handy guide for all Hunt calligraphic products.

HU-3059 Speedball Calligraphy Kit

SPEEDBALL CARDED SETS

A series of carded sets with nibs and holders for different styles of lettering and drawing.

2956 SPEEDBALL "B" SET

A carded set with six style B Speedball pens for rounded Gothic Alphabets, plus a Speedball #9451 Holder

HU-2956 B Style Speedball Lettering Set

2957 SPEEDBALL "C" SET

A carded set with six style C Speedball pens for square Roman and Italic Alphabets, plus a Speedball #9451 Holder

HU-2957 C Style Speedball Lettering Set

2961 SPEEDBALL CALLIGRAPHY SET

A carded set with four style C Speedball pens for square Roman and Italic Alphabets, two Hunt Artist Pens for ornamental work plus a Speedball #9451 Holder

HU-2961 Speedball Calligraphy Set

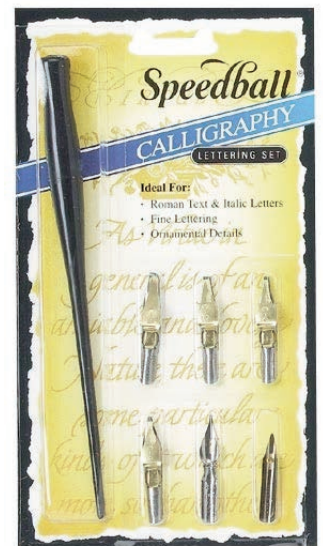
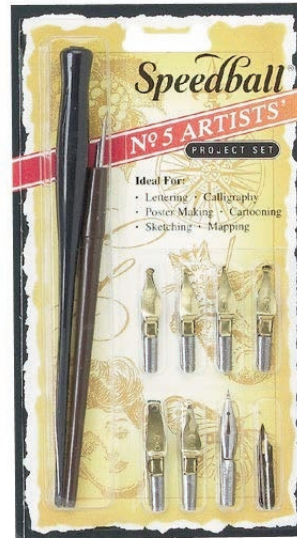

2963 SPEEDBALL POSTER SET

A carded set with three style A and three style B Speedball pens for square and round Gothic lettering, plus a Speedball #9451 Holder

HU-2963 Speedball Poster Set

2966 SPEEDBALL CARTOONING SET

A carded set to bring the cartoonists ideas to life. Six different round, oval and flexible nibs and two types of holders.

HU-2966 Speedball Cartooning Set

2967 SPEEDBALL #20 SET

A carded set with an assortment of Hunt Artist and Mapping Pens for ornamental work, litho, and cross hatching plus a two holders.

HU-2967 Speedball #20 Set

DRAWING INK



DIP PEN

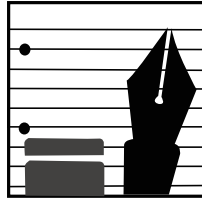

FOUNTAIN PEN

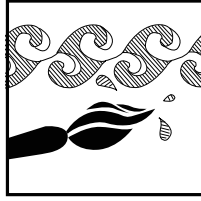

BRUSH

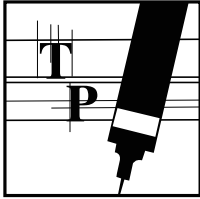

TECHNICAL PEN

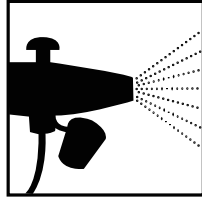

AIR BRUSH

The term drawing ink is a very general term relating to inks that can be used in a variety of applications, and on a variety of surfaces. In this section, we will use symbols to help explain where inks can be used. This should help eliminate the confusion in use of inks in different tools.



3085 ULTRADRAW



A waterproof ink specially formulated to be non-clogging in technical pens. It has a longer open time in the pen, but dries quickly on paper. There is good blackness, easy flow, and is non-smearing. No unpleasant odor.

K-3085F 3/4 oz Bottle Black
K-3085-08 8 oz. Bottle Black

3080 UNIVERSAL



Koh-I-Noor Universal is for use on paper, film, or cloth. It is a fast drying, free flowing india ink with high opacity. An ideal ink for technical pens.

K-3080F Koh-I-Noor Universal Black 3/4 oz.
K-30804 Koh-I-Noor Universal Black 8 oz.
K-30807 Koh-I-Noor Universal Black 32 oz.



HIGGINS BLACK INDIA



An extremely dense india ink for drawing and sketching. Free flowing for use in artist opens and technical pens. Can be thinned with water for washes, otherwise opaque. Waterproof on paper.

HI-4415 Higgins Black India 1 oz..
HI-4417 Higgins Black India 16 oz.
HI-4418 Higgins Black India 32 oz.

NON-WATERPROOF BLACK



An intense carbon formula that is not waterproof and extremely workable for producing a full range of grays. Ideal for washes and Japanese brush work. Removable from paper and film with water, by Higgins

HI-4425 Higgins Non-Waterproof Black 1 oz..



HIGGINS BLACK MAGIC

Black Magic is a waterproof intense black with a semi flat finish. Provides great opacity with adhesion to drafting film, paper or board. The medium viscosity helps prevent clogging. Mixes with Higgins pigmented inks.

HI-4465 Higgins Black Magic 1 oz..
HI-4466 Higgins Black Magic 8 oz.
HI-4467 Higgins Black Magic 16 oz.
HI-4468 Higgins Black Magic 32 oz.

3084 RAPIDRAW INK



Koh-I-Noor Rapiddraw black ink has a special latex binder for high performance on drafting film, paper, and cloth. The latex binder permits high carbon black concentration for optimum blackness and opacity, while maintaining free flowing characteristics. For high quality photo reproduction.

K-3084F Koh-I-Noor Rapiddraw Black 3/4 oz.
3338 SUPER BLACK INDIA



An opaque black ink that contains 100% carbon pigment with no dyes. Unexcelled for lightfastness. Pens must be cleaned thoroughly after use. Dried ink will be difficult to remove.

HU-3338 Speedball Siper Black India 2 oz

3074 RAPIDOMAT INK



A black formulated for automated drafting machines. For plotting on drafting film, paper, or cloth, with the longest possible open pen time to keep ink free flowing. Contains micro fine carbon particles to assure more constant flow while maintaining high density.

K-3074F Koh-I-Noor Rapidomat Black 3/4 oz



COLORED INK

HIGGINS TRANSPARENT



A series of transparent colors in 17 shades. These waterproof inks can be diluted with water, intermixed, or used straight from the bottle. For use on paper, not recommended for drafting film. In 1 oz. plastic bottles with dropper stoppers.

HI-4025	Yellow	HI-4205	Green
HI-4055	Orange	HI-4235	Leaf Green
HI-4065	Red Orange	HI-4255	Neutral Tint
HI-4085	Red	HI-4265	White
HI-4095	Carmine	HI-4275	Brick Red
HI-4105	Red Violet	HI-4285	Russet
HI-4115	Violet	HI-4295	Brown
HI-4145	Blue	HI-4305	Indigo
HI-4175	Turquoise		

HIGGINS PIGMENTED



These rich, vibrant colors dry to a flat, opaque, non-reflective finish that won't fade under light. May be mixed or diluted to achieve shades. Can also be used with Black Magic or Super White. For use on paper, board, or film. In 1 oz. bottles with dropper stoppers.

HI-44625	Lemon	HI-44675	Violet
HI-44635	Yellow	HI-44685	Blue
HI-44645	Red	HI-44695	Green
HI-44655	Carmine	HI-44705	Brown
HI-44665	Magenta		

COLORED INK

9065 KOH-I-NOOR TRANS.



A premium drawing ink for use on paper or cloth. The full range of colors include opaque black india, opaque white, and 16 transparent colors. Transparent colors can be intermixed or diluted to achieve intermediate colors. These are dye inks that will fade with prolonged exposure to direct sunlight or strong artificial light. One ounce bottles have a dropper stopper cap.

INDIVIDUAL COLORS, 1 OZ. BOTTLES

K-9065-01	Scarlet	K-9065-10	Prussian Blue
K-9065-02	Carmine	K-9065-11	Red Violet
K-9065-03	Vermilion	K-9065-12	Blue Violet
K-9065-04	Orange	K-9065-13	Sienna
K-9065-05	Yellow	K-9065-14	Burnt Sienna
K-9065-06	Lt. Green	K-9065-15	Sepia
K-9065-07	Dp. Green	K-9065-16	Grey
K-9065-08	Cobalt Blue	K-9065-17	Black India
K-9065-09	Ultramarine	K-9065-18	Opaque White

BLACK INDIA

K-9065-17	Black India	1 oz.
K-9067-17	Black India	8 oz.

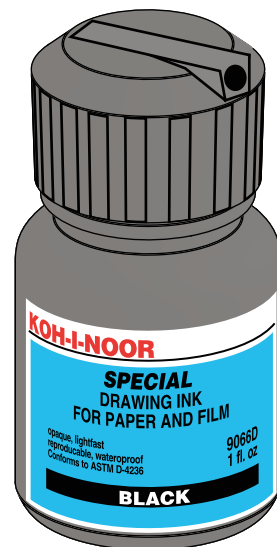

9066 KOH-I-NOOR SPECIAL



Pelikan Special is an opaque ink formulated for technical pens with emphasis on prolonged open time. This helps prevent clogging. For use on drafting film, hard surface papers, and cloth. Colors are fade resistant and permanent, but easily erase from film. Also for plotting. 1 oz.

K-9066-50	Black	K-9066-54	Blue
K-9066-51	Red	K-9066-55	Violet
K-9066-52	Yellow	K-9066-56	Brown
K-9066-53	Green		



HIGGINS PIGMENTED



These rich, vibrant colors dry to a flat, opaque, non-reflective finish that won't fade under light. May be mixed or diluted to achieve shades. Can also be used with Black Magic or Super White. For use on paper, board, or film. In 1 oz. bottles with dropper stoppers.

HI-44625	Lemon	HI-44675	Violet
HI-44635	Yellow	HI-44685	Blue
HI-44645	Red	HI-44695	Green
HI-44655	Carmine	HI-44705	Brown
HI-44665	Magenta		

4015 SUPER WHITE



Higgins Super White is a non-waterproof bright white for opaquing and highlighting with air brush or brush. Covers quickly and wipes off with water. For quill, steel point and technical pens. In 1 oz. bottles

HI-4015 Higgins Super White

FOUNTAIN PEN INKS

These inks are specially formulated for traditional style fountain pens. Most, although not all, tend to be less permanent than drawing inks; however, drawing inks will permanently clog fountain pens and calligraphic fountain pens.

PELIKAN 4001



Pelikan 4001 inks are non-clogging, non-waterproof dye inks that are recommended for use in calligraphic and other fine fountain pens. Ideally suited for calligraphy, sketching, fine line work, and formal signatures. In 1 oz. and 2 oz. bottles

1 oz.		2 oz.	
PEL-01-4001-1	Black	PEL-02-4001-1	Black
PEL-01-4001-2	Blue/Black	PEL-02-4001-2	Blue/Black
PEL-01-4001-3	Royal Blue	PEL-02-4001-3	Royal Blue
PEL-01-4001-4	Brilliant Brown		
PEL-01-4001-5	Brilliant Green		
PEL-01-4001-6	Brilliant Red	PEL-02-4001-5	Brilliant Red
PEL-01-4001-7	Violet		
PEL-01-4001-8	Turquoise		



KOH-I-NOOR FOUNT INDIA



Fount India is a jet black ink used in almost any pen, for all techniques. The ink is smooth flowing with a dense carbon black formula. It is non-clogging, non-waterproof, reproducible, and easily diluted in water. In 1 oz. plastic bottles with dropper.

K-9150 Koh-I-Noor Fount India 1 oz.



FOUNTAIN PEN INDIA



Higgins Fountain Pen India is a free flowing, non-waterproof black ink for lettering, sketching, calligraphy and italic writing. In 2-1/2 oz. plastic bottles.

HI-723 Higgins Fountain Pen India

CALLIGRAPHY INK



Higgins Calligraphy Ink is a permanent carbon, waterproof ink for use in any fountain pen. In 2-1/2 oz. plastic bottles.

HI-44314 Higgins Calligraphy Ink

SEPIA CALLIGRAPHY INK



Higgins Sepia Calligraphy Ink is non-waterproof with a rich antique brown color. Its especially free flowing formula is ideal for use in calligraphy and fountain pens. In 2-1/2 oz. plastic bottles.

HI-733 Higgins Sepia Calligraphy Ink

HIGGINS ETERNAL



Higgins Eternal is a waterproof black ink for all office reproduction work. A free flowing permanent carbon black for all fountain and calligraphy pens. In 2-1/2 oz. plastic bottles.

HI-813 Higgins Eternal

SUMI INK



A form of black ink that has been used for centuries in the Orient. Available in traditional stick form and in liquid. Stick form must be ground for use. Ideal for calligraphy and drawing.

Y-SSB112 Sumi Ink Stick
Y-KF2 Sumi Ink Liquid 2 oz.

INK ACCESSORIES

SUMI INK STONE

A man made suzuri grinding stone to make Sumi ink from Sumi Sticks. 5 x 2-1/2". Make from powdered natural stone combined with a cementing compound, and compressed tightly into a good quality stone.

Y-S165 Suzuri Sumi Ink Stone

PEN CLEANERS

RAPIDO-EZE

Rapido-Eze Pen Cleaner has an improved formula over the original that is faster, and a stronger cleaning agent. Used for direct cleaning as well as in ultrasonic pen cleaners. The 6 oz. jar has a built in parts tray.

K-3068-08 Rapido-Eze 8 oz.
K-3068-16 Rapido-Eze 16 oz.
K-3068-32 Rapido-Eze 32 oz.

SYRINGE CLEANER KIT

The Koh-I-Noor Syringe Pressure Cleaner forces pen cleaner through clogged points. Uses pressure and suction, no aerosol propellants. Provided with connector so that it can be used as an ink flow starter, drawing ink through the point. A 2 oz.. jar of Rapido-Eze is included with the kit.

K-3068-SYKT Syringe Pressure Cleaning Kit.



BALL MARKERS

This section of roller ball markers is made up of fine line, water soluble pens. These are the most popular for everyday writing, providing smooth expressive lines.

MARS 417

This family of roller ball markers provides high quality, smooth, expressive writing in 0.3mm width. The contemporary barrel offers high style with a color coded safety cap. The large visible reservoir provides long life with odorless and safe ink. 12 per box

417 0.3mm

MR-417-9	Black	MR-413-3	Blue
MR-417-2	Red	MR-417-5	Green



FINE WATER SOLUBLE

EXPRESSO

The Espresso family of plastic point writing instruments let you express yourself with smooth, effortless writing. The plastic points remain sharp and don't mush out, even after long use. The "Humistatic" ink formula keeps the points moist and ready to use immediately. Even if the pen has been uncapped for days, a few strokes will make it perform again. The series includes an Extra Fine Point Espresso (0.3mm), and Medium Point Espresso (0.5mm), and a Bold Point Espresso (0.8mm).

REGULAR POINT LIQUID EXPRESSO

SA-21001	Black	SA-21004	Pink
SA-21002	Red	SA-21005	Purple
SA-21003	Blue	SA-21006	Green

FINE POINT LIQUID EXPRESSO

SA-31001	Black	SA-31004	Pink
SA-31002	Red	SA-31005	Purple
SA-31003	Blue	SA-31006	Green

FINE PERMANENT

MARS PIGMENT LINER

Permanent ink that is popular with accountants, students, artists and graphic designers, the Mars basic drawing pen is available in five different sizes. Any size is perfect for renderings, sketches and mechanical drawings. Because the ink dries fast and permanently, artists can wash and color overlay pigment liner ink artwork. There is no feathering or bleeding through paper. 10 per box

MR-308-005-9	Pigment Liner	Black	.005mm
MR-308-01-9	Pigment Liner	Black	0.1mm
MR-308-02-9	Pigment Liner	Black	0.3mm
MR-308-05-9	Pigment Liner	Black	0.5mm
MR-308-07-9	Pigment Liner	Black	0.7mm

Set

MR-308-BK4	Pigment Liner	Set of 4 Black
------------	---------------	----------------



FINE PERMANENT

Permanent markers are solvent soluble, not water soluble. The term "permanent" in markers refers to solubility, not light fastness.

SHARPIE

A water resistant marker for writing on almost any surface. A bullet tip on the regular model or a fine plastic (0.4mm) tip on the Extra Fine Sharpie, mark boldly on metal, glass, plastic, foil, rubber, waxed paper, etc. The high intensity are also used for overhead projection. 12 per box.

SUPER SHARPIE

SA-33001	Black	SA-33003	Blue
SA-33002	Red	SA-33004	Green

REGULAR SHARPIE

SA-30001	Black	SA-30005	Yellow
SA-30002	Red	SA-30006	Orange
SA-30003	Blue	SA-30007	Brown
SA-30004	Green	SA-30008	Purple

EXTRA FINE SHARPIE

SA-35001	Black	SA-35003	Blue
SA-35002	Red	SA-35004	Green

ULTRA FINE SHARPIE

SA-37001	Black	SA-37003	Blue
SA-37002	Red	SA-37004	Green

TWIN TIP SHARPIE

A new Sharpie that features a regular tip in one end and an ultra fine tip in the other.

SA-32001	Black	SA-32003	Blue
SA-32002	Red	SA-32004	Green

MAGNUM 44

The Magnum 44 features a big 1/2" wool nib for broad, bold strokes. The all metal one piece canister keeps the marker going for a long time. The water resistant inks are permanent on most surfaces.

SA-44001	Black	SA-44003	Blue
SA-44002	Red	SA-44004	Green



SANFORD®
Sharpie
PERMANENT MARKER



HIGHLITERS

Special felt tip markers that call attention to printed matter with see through color.

MARS TOP STAR

Mars Top Star markers have a broad wick tip and a large tank for long write out. Colors are clear and transparent. Ideal for books, maps, reports, letters etc. Available in two shapes, the BOSS traditional stub-by marker, and the SWING long slender style. 6 per box, carded.

MR-364-1BK	Yellow	MR-364-23BK	Pink
------------	--------	-------------	------

efficient
for ecology



SPECIALTY MARKERS



PRANG WATERCOLOR MARKERS

Instant watercolors in a marker! These instant watercolors deliver all the brilliance of watercolors without the mess. Colors can be blended to create secondary colors. You can create exciting watercolor effects by blending with brush and water. The conical shape marker tips can apply from thin to broad applications. Caps are designed with safety in mind, and meet safety requirements for small parts. Available in eight colors, in Professional and Fun Pro (water washable).

AC-80680 Fun Pro W/C Marker Set Washable
AC-80128 Prang Professional W/C Markers



BROAD - WATER SOLUBLE

MR. SKETCH

An exciting instrument that draws in bright, clean water colors. Sanford's Mr. Sketch uses a wick applicator with a felt point that produces fine, medium, and broad lines, plus interesting effects by blending colors on paper. Each color has its own pleasing fragrance, no usual marker smell. Colors will not penetrate paper and are safe for children.

SA-21074 4 Color Set
SA-21078 8 Color Set
SA-21072 12 Color Set



PAINT MARKERS

PAINTERS

Speedball "Painters" Paint Markers are filled with real quality acrylic paint. They're opaque, non-toxic and work on wood, metal, plastic, ceramic etc. Ideal for crafts. Carded, 6 per pkg.

FINE

HU-7326 Black
HU-7332 White
HU-7334 Blue
Red
Yellow
Brown
Green
Pink
Violet

MEDIUM

HU-7327
HU-7333
HU-7335
HU-7337
HU-7341
HU-7343
HU-7345
HU-7347
HU-7349

METALLICS

HU-7328 Gold
HU-7330 Silver
HU-7329
HU-7331



OVERHEAD PROJECTION

Special high intensity inks in these markers help to project in vivid color.

MARS LUMOCOLOR AV

Mars Lumocolor markers are a fine line marker system in both water and permanent formulations. Both adhere to acetate paper, film, glass, plastic, ceramic, and other OHP materials, plus dry instantly. While water will remove the water base marker, and mild solvent the permanent, a unique feature is that a lumoplast eraser (MR-526-56) will erase both. Used in a variety of applications in the graphic arts as well as commercial arts industries.



WATER BASE

PERMANENT

SUPERFINE

MR-311-1	Yellow	MR-313-1
MR-311-2	Red	MR-313-2
MR-311-3	Blue	MR-313-3
MR-311-4	Orange	MR-313-4
MR-311-5	Green	MR-313-5
MR-311-6	Violet	MR-313-6
MR-311-7	Brown	MR-313-7
MR-311-9	Black	MR-313-9

FINE

MR-316-1	Yellow	MR-318-1
MR-316-2	Red	MR-318-2
MR-316-3	Blue	MR-318-3
MR-316-4	Orange	MR-318-4
MR-316-5	Green	MR-318-5
MR-316-6	Violet	MR-318-6
MR-316-7	Brown	MR-318-7
MR-316-9	Black	MR-318-9

MEDIUM

MR-315-1	Yellow	MR-317-1
MR-315-2	Red	MR-317-2
MR-315-3	Blue	MR-317-3
MR-315-4	Orange	MR-317-4
MR-315-5	Green	MR-317-5
MR-315-6	Violet	MR-317-6
MR-315-7	Brown	MR-317-7
MR-315-9	Black	MR-317-9

BROAD

MR-312-1	Yellow	MR-314-1
MR-312-2	Red	MR-314-2
MR-312-3	Blue	MR-314-3
MR-312-4	Orange	MR-314-4
MR-312-5	Green	MR-314-5
MR-312-6	Violet	MR-314-6
MR-312-7	Brown	MR-314-7
MR-312-9	Black	MR-314-9

EXTRA BROAD

MR-355-2	Red	MR-357-2
MR-355-3	Blue	MR-357-3
MR-355-5	Green	MR-357-5
MR-355-9	Black	MR-357-9

All of the above series are available in wallet pack sets of 4, 6, and 8 colors. Order by inserting the series number for the "XXX"

MR-XXX-WP4	4 COLOR SET
MR-XXX-WP6	6 COLOR SET
MR-XXX-WP8	8 COLOR SET

BEROL PRISMACOLOR

These Art Markers are twice as handy! Chisel nib on one end and fine point nib on the other. Perfect ink color match from end-to-end. Provides permanent ink coverage without fading or feathering. Available in 116 classic colors plus 4 single nib metallics in Silver and Gold, both chisel and fine point.

PM-001	Process Red	PM-104	Warm Gray 60%
PM-004	Crimson	PM-105	Warm Gray 70%
PM-005	Scarlet Lake	PM-106	Warm Gray 80%
PM-006	Carmine	PM-107	Warm Gray 90%
PM-007	Magenta	PM-108	Cold Gray 10%
PM-008	Pink	PM-109	Cold Gray 20%
PM-010	Blush Pink	PM-110	Cold Gray 30%
PM-011	Deco Peach	PM-111	Cold Gray 40%
PM-012	Light Peach	PM-112	Cold Gray 50%
PM-013	Poppy Red	PM-113	Cold Gray 60%
PM-014	Pale Vermillion	PM-114	Cold Gray 70%
PM-015	Yellowed Orange	PM-115	Cold Gray 80%
PM-016	Orange	PM-116	Cold Gray 90%
PM-017	Sunburst Yellow	PM-117	Metallic Silver, Broad
PM-018	Yellow Ochre	PM-118	Metallic Silver, Fine
PM-019	Canary Yellow	PM-119	Metallic Gold, Broad
PM-021	Tulip Yellow	PM-120	Metallic Gold, Fine
PM-023	Cream	PM-121	Clear Blender
PM-025	Spring Green	PM-122	Salmon Pink
PM-026	Lt Olive Green	PM-123	Spanish Orange
PM-027	Chartreuse	PM-124	Limepeel
PM-028	Olive Green	PM-125	Peacock Blue
PM-031	Dark Green	PM-126	Cerulean Blue
PM-032	Parrot Green	PM-127	Imperial Violet
PM-036	Lime Green	PM-128	Parma Violet
PM-037	Aquamarine	PM-130	Deco Orange
PM-038	Teal Blue	PM-131	Deco Yellow
PM-039	True Blue	PM-132	Jasmine
PM-040	Copenhagen Blue	PM-133	Deco Pink
PM-042	Violet Blue	PM-134	Deco Blue
PM-043	Indigo Blue	PM-135	Deco Green
PM-044	Ultramarine	PM-136	Deco Aqua
PM-045	Navy Blue	PM-137	Clay Rose
PM-046	Light Aqua	PM-138	Pink Rose
PM-047	Non-Photo Blue	PM-139	Rosy Beige
PM-050	Violet	PM-140	Celadon Green
PM-053	Mulberry	PM-141	Jade Green
PM-055	Rhodamine	PM-142	Brittany Blue
PM-060	Violet Mist	PM-143	Mediterranean Blue
PM-061	Dark Umber	PM-144	Cloud Blue
PM-062	Sepia	PM-145	Blue Slate
PM-065	Sienna Brown	PM-146	Periwinkle
PM-069	Goldenrod	PM-147	Grayed Lavender
PM-070	Sand	PM-149	Bronze
PM-071	Buff	PM-150	Mahogany Red
PM-072	Eggshell	PM-151	Raspberry
PM-073	Flagstone Red	PM-152	Henna
PM-078	Brick Beige	PM-153	Pumpkin Orange
PM-079	Brick White	PM-154	Mineral Orange
PM-080	Putty	PM-155	French Gray 10%
PM-082	Terra Cotta	PM-156	French Gray 20%
PM-086	Cherry	PM-157	French Gray 30%
PM-088	Dark Brown	PM-158	French Gray 40%
PM-089	Light Walnut	PM-159	French Gray 50%
PM-090	Walnut	PM-160	French Gray 60%
PM-093	Burnt Ochre	PM-161	French Gray 70%
PM-095	Light Tan	PM-162	French Gray 80%
PM-096	Blond Wood	PM-163	French Gray 90%
PM-097	Warm Black	PM-165	Grass Green
PM-098	Black	PM-166	True Green
PM-099	Warm Gray 10%	PM-167	Apple Green
PM-100	Warm Gray 20%	PM-168	Dark Purple
PM-101	Warm Gray 30%	PM-169	Tuscan Red
PM-102	Warm Gray 40%	PM-170	Peach
PM-103	Warm Gray 50%	PM-171	Lilac

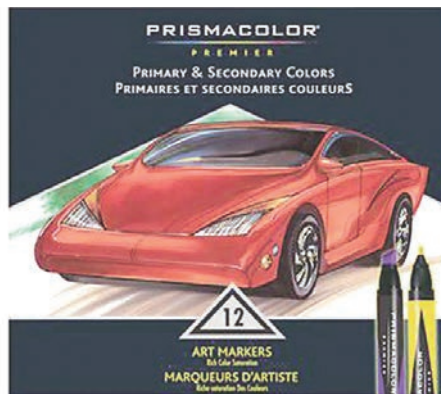

PM-172	Light Umber
PM-173	Light Violet
PM-184	Forest Green
PM-185	Spruce
PM-186	Emerald
PM-187	Leaf Green
PM-188	Melon
PM-189	Orchid
PM-190	Tangerine
PM-191	Jade
PM-192	Avocado
PM-193	Mint Cream
PM-194	Cold Stone
PM-195	Spearmint
PM-196	Wheat
PM-197	Green Tea
PM-198	Muted Turquoise
PM-199	Mocha Light
PM-200	Mocha Dark
PM-201	Cinnamon Toast
PM-202	Sky Blue Light

ORDER:
BC-PM-XXX Color

PRISMACOLOR SETS

BC-BP-012N PRIMARY & SECONDARY SET

PM-4	PM-6	PM-15
PM-19	PM-31	PM-32
PM-44	PM-50	PM-53
PM-57	PM-61	PM-98

BC-BP-012P COOL GRAYS

PM-108	PM-109	PM-110
PM-112	PM-112	PM-113
PM-114	PM-115	PM-116
PM-98	(3)	

BC-BP-012Q WARM GRAYS

PM-99	PM-100	PM-101
PM-102	PM-103	PM-104
PM-105	PM-106	PM-107
PM-98	(3)	

BC-BP-012P FRENCH GRAYS

PM-155	PM-156	PM-157
PM-158	PM-159	PM-160
PM-161	PM-162	PM-163
PM-98	(3)	

BC-BP-024S 24 COLORS

BC-BP-048S 48 COLORS

BC-BP-072S 72 COLORS

DRAFTING

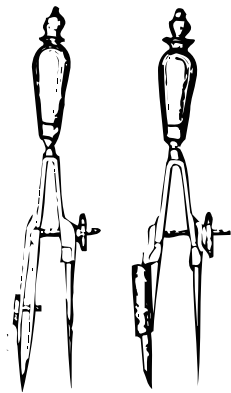
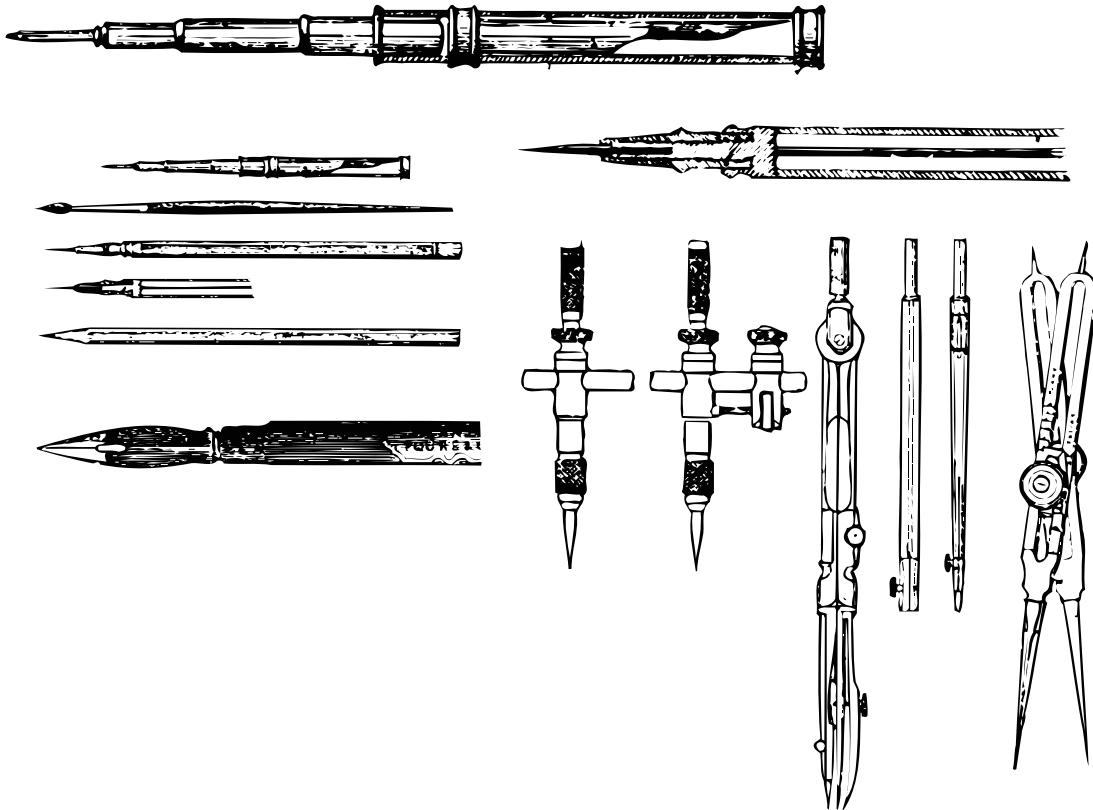

**TRIANGLES
FRENCH CURVES
PROTRACTORS
RULERS
SCALES
T-SQUARES
STRAIGHT EDGES
TEMPLATES
INSTRUMENTS**

TRIANGLES

INKING EDGE TRIANGLE

A premium acrylic triangle with a double bevel inking edge that keeps ink from markers, technical pens, ruling pens, etc. from spreading underneath. Precision made to .10" thickness with a transparent smoke tint for easy visibility. Continuous double bevel inside finger lifts provide easy pick up and placement. The ideal triangle for pen and ink by Koh-I-Noor.

30/60 TRIANGLES

K-7202-04	4" Inking Triangle
K-7202-06	6" Inking Triangle
K-7202-08	8" Inking Triangle
K-7202-10	10" Inking Triangle
K-7202-12	12" Inking Triangle
K-7202-14	14" Inking Triangle

45/90 TRIANGLES

K-7203-04	
K-7203-06	
K-7203-08	
K-7203-10	
K-7203-12	
K-7203-14	

CLEAR ACRYLIC TRIANGLE

Clear acrylic triangles that are precision molded for accuracy, combining clarity with long life. Continuous double bevel inside edges provide fingerlifts for easy pick-up and placement. A professional tool by Koh-I-Noor.

30/60 TRIANGLES

K-7205-04	4" Acrylic Triangle
K-7205-06	6" Acrylic Triangle
K-7205-08	8" Acrylic Triangle
K-7205-10	10" Acrylic Triangle
K-7205-12	12" Acrylic Triangle
K-7205-14	14" Acrylic Triangle
K-7205-18	18" Acrylic Triangle
K-7205-16	16" Acrylic Triangle
K-7205-18	18" Acrylic Triangle

45/90 TRIANGLES

K-7206-04	
K-7206-06	
K-7206-08	
K-7206-10	
K-7206-12	
K-7206-14	

FLUORESCENT TRIANGLE

Professional fluorescent orange, acrylic triangles that are precision molded of .08" acrylic co-polymer. The fluorescent orange color illuminates the ruling edge and offers high visibility either on the board indoors or out. Continuous double bevel inside fingerlifts for easy pick-up and placement. By Koh-I-Noor.

30/60 TRIANGLES

K-7205F-04	4" Fluorescent Triangle
K-7205F-06	6" Fluorescent Triangle
K-7205F-08	8" Fluorescent Triangle
K-7205F-10	10" Fluorescent Triangle
K-7205F-12	12" Fluorescent Triangle
K-7205F-14	14" Fluorescent Triangle

45/90 TRIANGLES

K-7206F-04	
K-7206F-06	
K-7206F-08	
K-7206F-10	
K-7206F-12	

C-THRU ACRYLIC TRIANGLE

Clear transparent triangles of .08" acrylic with square edges. The triangular shaped open centers have beveled finger lifts. Note: 16" and 18" triangles are of .10" acrylic. By C-Thru.

30/60 TRIANGLES

CT-A-390-06	6" Acrylic Triangle
CT-A-390-08	8" Acrylic Triangle
CT-A-390-10	10" Acrylic Triangle
CT-A-390-12	12" Acrylic Triangle
CT-A-390-14	14" Acrylic Triangle
CT-A-390-16	16" Acrylic Triangle
CT-A-390-18	18" Acrylic Triangle

45/90 TRIANGLES

CT-A-450-06	
CT-A-450-08	
CT-A-450-10	
CT-A-450-12	
CT-A-450-14	
CT-A-450-16	
CT-A-450-18	

How To Order

A 60° triangle is measured on the longest cathetus, LC, and a 45° is measured on the length of one of the two equal sides, C.

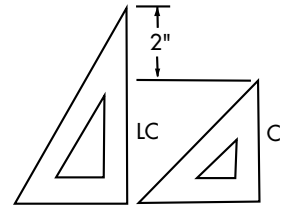

Two triangles are considered a set if LC for a 60° is two inches longer than C for a 45° triangle.

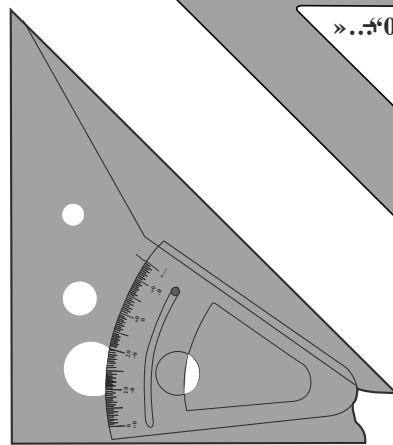
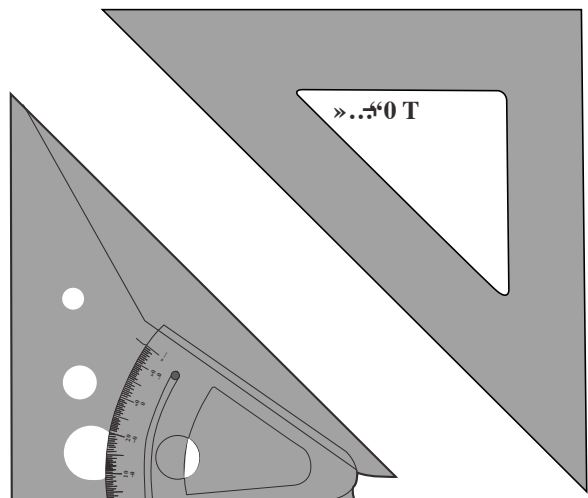
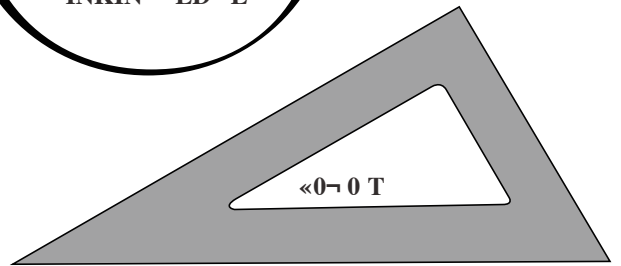
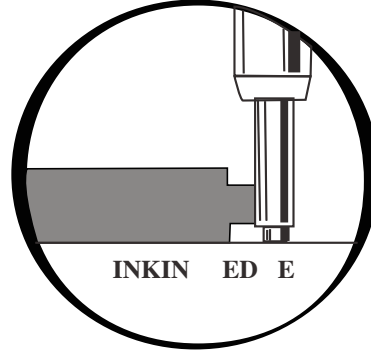

AT10

ADJUSTABLE TRIANGLE

Transparent triangles of clear plastic that permit tracing of any angle from zero to 90 degrees. Inner graduations on the arc give degrees of one angle, while the outer row of figures gives figures of the degrees of the complementary angle. Available in a regular grade from C-Thru, individually boxed.

C-THRU ADJUSTABLE TRIANGLES

CT-AT-08	8" Adjustable Triangle
CT-AT-10	10" Adjustable Triangle

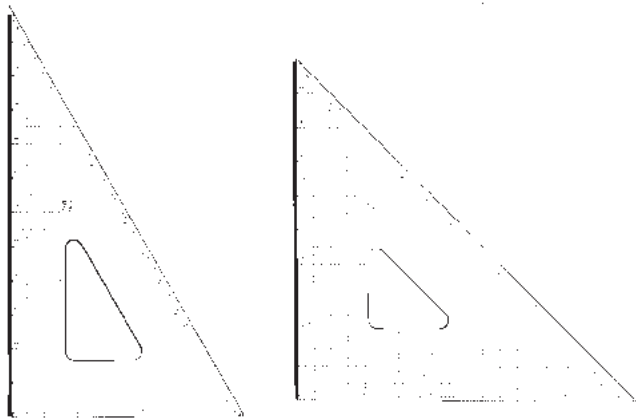

GRIDDED, STAINLESS CUTTING EDGE TRIANGLE

This is a professional .150" thick clear acrylic triangle. It features a stainless steel edge on one side for easy, nick free cutting. Edges are graduated in 16ths of an inch with an 1/8 inch grid on each right angle leg. Grids are visible on both light and dark surfaces. Double bevel and finger lifts for easy pick up.

30/60

N/A
CT-T-4M
CT-T-5M
CT-T-14M

8" Cutting Edge Triangle
10" Cutting Edge Triangle
12" Cutting Edge Triangle
14" Cutting Edge Triangle

45/90

CT-T-6M
CT-T-7M
CT-T-15M
N/A

FRENCH CURVES

French curves made of heavy weight crystal clear plastic. All edges are perfectly smooth. Each comes in its own poly bag.

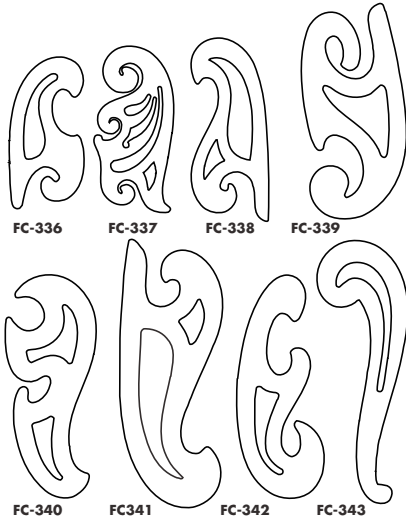

CT-FC-336	French Curve	6"
CT-FC-337	French Curve	6-1/4"
CT-FC-338	French Curve	7-1/4"
CT-FC-339	French Curve	8-1/4"
CT-FC-340	French Curve	8-3/4"
CT-FC-341	French Curve	10-1/2"
CT-FC-342	French Curve	8-1/4"
CT-FC-343	French Curve	10-1/4"

FRENCH CURVE SETS

Sets of the above French Curves that give the artist a range of tools. The set of four contains numbers 334, 337, 343 and 341. The set of eight contains all eight of the curves listed above.

CT-FC-4	French Curve Set	Set of 4
CT-FC-8	French Curve Set	Set of 8

FLEXIBLE CURVES

A flexible curve is a strip of solid lead covered with Vinyl that can be shaped into almost any curve. They can be reshaped many times to fit drawings. They will produce regular or irregular curves and allow full view at all times. Edges are square on one side and beveled on the other for inking.

CT-TC-384	12" Flexible Curve
CT-TC-385	16" Flexible Curve
CT-TC-386	20" Flexible Curve

PROTRACTORS

CIRCULAR PROTRACTORS

These circular protractors are made of heavy plastic with full 360 degree markings around the circle. Center has cut outs for easy handling, and complete outer edge is beveled. In individual poly bags.

CT-260	6" Diameter Circular Protractor
--------	---------------------------------

SEMI-CIRCULAR PROTRACTORS

Acrylic molded semi-circular protractors have beveled outer edges. Calibrated in 1/2 degrees, with ten degrees below base line. The 4" has a solid center, while the 6" and the 8" have cut out centers.

CT-375	4" Semi-Circular Protractor
--------	-----------------------------

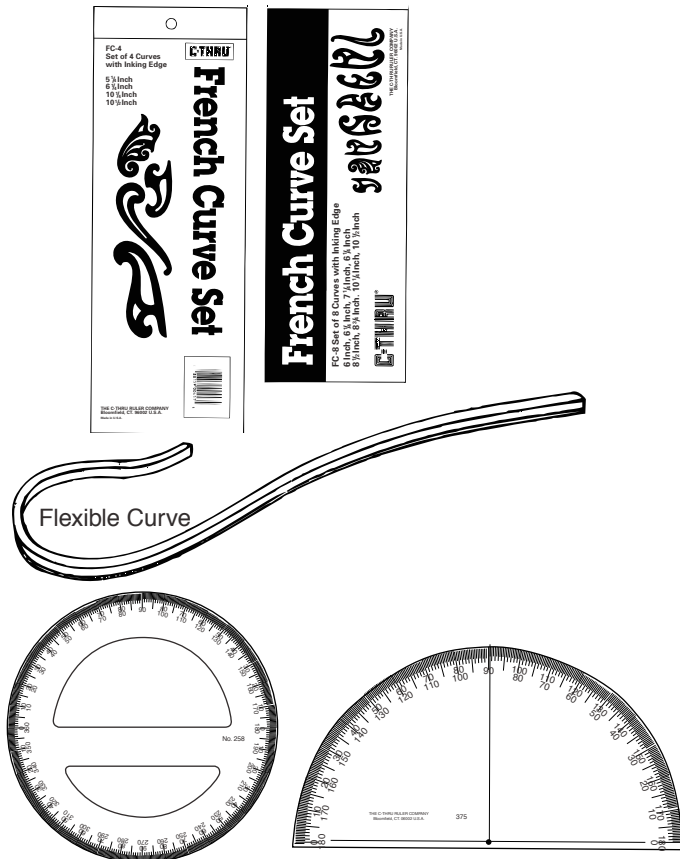

RULERS

C-THRU RULERS

C-Thru rulers are clear plastic with red markings in various scales and grids. These markings are easy to read for close registration over black lines beneath. Markings are laminated so they will not rub off.

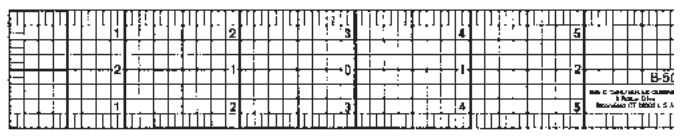

B-50 1 x 6" transparent graph ruler calibrated in sixteenths.
CT-B-50 1 x 6" Ruler

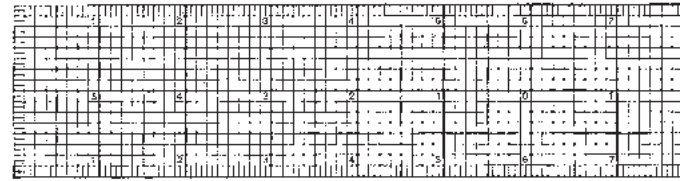

B-70 2 x 12" transparent graph ruler calibrated in sixteenths.
CT-B-70 2 x 12" Ruler

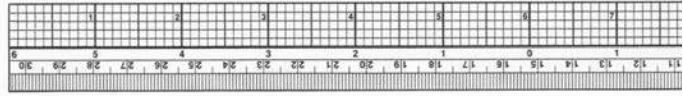

B-65 1 x 12" ruler with standard and metric scales, beveled both sides. Standard marked in tenths.
CT-B-65 1 x 12" Ruler

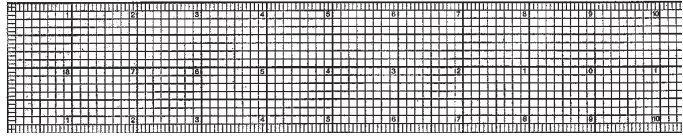

B-85 2 x 18" ruler with standard graph marked in sixteenths.
CT-B-85 2 x 18" Ruler

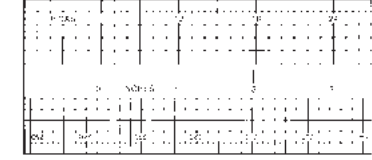

B-90 2 x 18" ruler marked in picas, agates, and inches.
CT-B-90 2 x 18" Pica Ruler

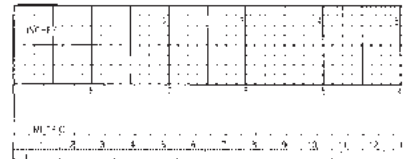

B-95 2 x 18" ruler with one edge divided in sixteenths, and the other in millimeters.
CT-B-95 2 x 18" Metric Ruler

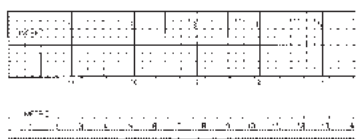

B-97 2 x 24" ruler with one edge divided in sixteenths, and the other in millimeters.

CT-B-97 2 x 24" Metric Ruler

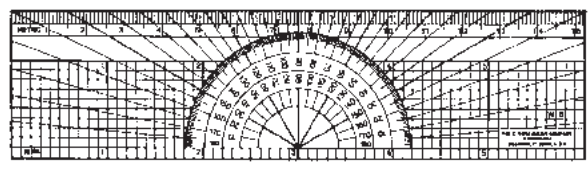

W-8 1-1/2 x 6" engineers protractor ruler with centimeter scale and inch calibrations in tenths.

CT-W-08 1-1/2 x 6" Protractor Ruler

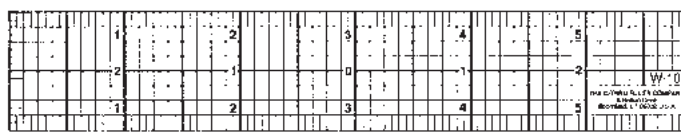

W-10 1 x 6" graph ruler calibrated in sixteenths.

CT-W-10 1 x 6" Graph Ruler

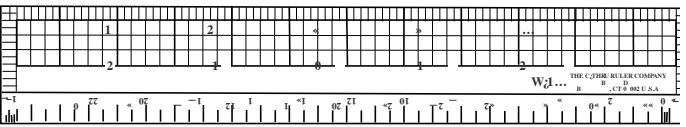

W-15 1 x 6" architectural ruler with scales in inches to sixteenths, plus a 1/4" and 1/8" scale.

CT-W-15 1 x 6" Architectural Ruler

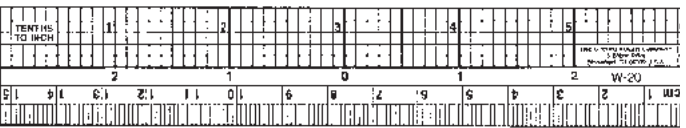

W-20 1 x 6" ruler with one edge in inches divided in tenths, and the other in millimeters.

CT-W-20 1 x 6" Metric Ruler

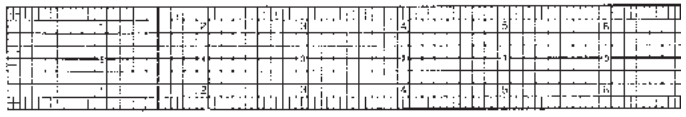

W-25 1 x 12" graph ruler marked in sixteenths of an inch.

CT-W-25 1 x 12" Graph Ruler

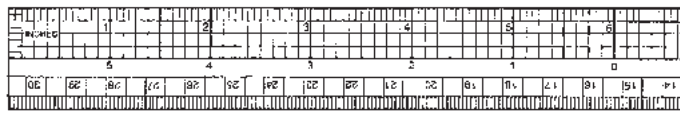

W-30 1 x 12" ruler with inch markings to sixteenths, and metric markings on the other side.

CT-W-30 1 x 12" Metric Ruler

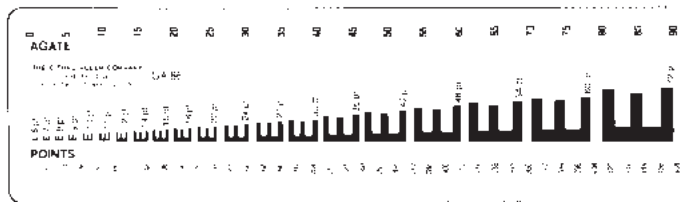

GRAPHIC ARTS RULER

A 2 x 18" opaque laminated ruler with inches, picas, and agate calibrations plus a variety of other data including proof readers symbols, printers rules (hairline to 12 point), ten percentage screens ranging from 10% to solid, halftone screens, plus a simplified copy casting system. Twelve point standard, and ten point elite typewriter copy counters are also offered.

CT-GA-86 2 x 18" Graphic Arts Ruler



GRAPHIC ARTS LEADING GAUGE

3 x 13-3/4" ruler is printed on transparent plastic and laminated for printing permanency. It includes scales in picas, point sizes, printer's rules, sixteenths to the inch and a leading gauge.

CT-GA-96 3 x 13-3/4" Graphic Arts Leading Gauge

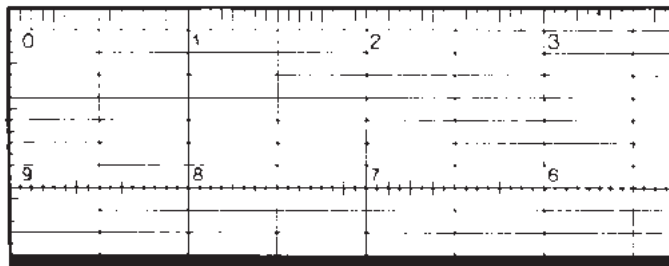

METAL EDGE RULERS

B-1M 1-1/2" x 12-1/2" heavy gauge clear acrylic ruler. .150 thick 0 centering scale. One edge is beveled, the other has a stainless steel edge. Calibrations and grids visible on both dark and light surfaces. Ruler is graduated in 16ths to the inch.

CT-B-1M 1-1/2"x12-1/2" Steel Edge Ruler

B-2M Same as B-1M above except 1-1/2" x 18-1/2".

CT-B-2M 1-1/2"x18-1/2" Steel Edge Ruler



METAL RULERS

GAEBEL RULERS

Gaebel rulers are premium stainless steel rulers that are available in a variety of types for any kind of ruling. Markings are etched into the metal and filled with black ink. This makes a ruler that will provide many years of service.



CORK BACK RULERS

A one sided ruler that has a thin strip of cork laminated to one side. This keeps it from slipping when set down. The ruler is 1-1/8" wide with inches on one side and metric on the other.

- GB-212 12" Gaebel Cork Back Ruler
- GB-215 15" Gaebel Cork Back Ruler
- GB-218 18" Gaebel Cork Back Ruler
- GB-224 24" Gaebel Cork Back Ruler
- GB-236 36" Gaebel Cork Back Ruler

GRAPHIC ARTS RULERS

Rulers for general purpose, printers, and graphic artists.

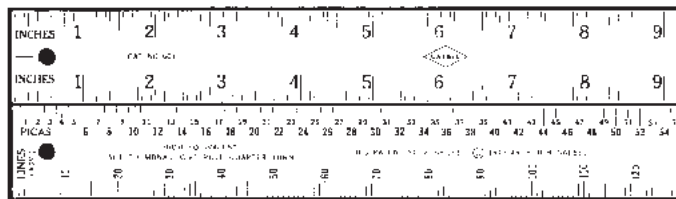

- 601** These two rulers have inches marked to sixteenths on the front, with picas and lines on the back.
- 602**

- GB-601 12" Gaebel Ruler
- GB-602 15" Gaebel Ruler



- 604** Same ruler as above except longer and wider (1-1/2").

- GB-604 24" Gaebel Ruler

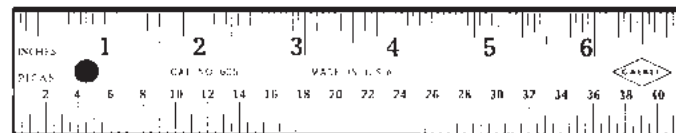

- 605** A 1-1/4" wide ruler that is one sided with inches on one side and picas on the bottom.

- GB-605 36" Gaebel Ruler



608 A narrow, flexible (7/8" wide) ruler graduated in 16ths and 32nds with sub zero end in 32nds and 64ths. One sided.

GB-608 24" Gaebel Ruler

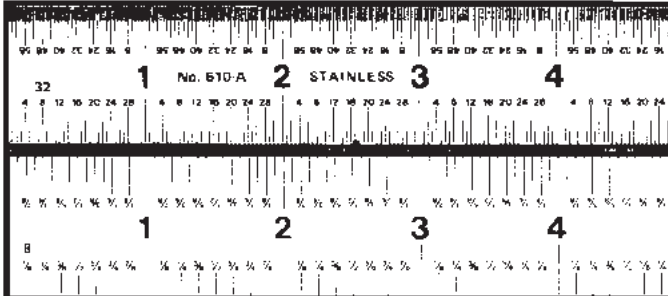

610A A 1" ruler with the front side in 8ths and 16ths and the back in 32nds and 64ths. One sided

GB-610A 24" Gaebel Ruler

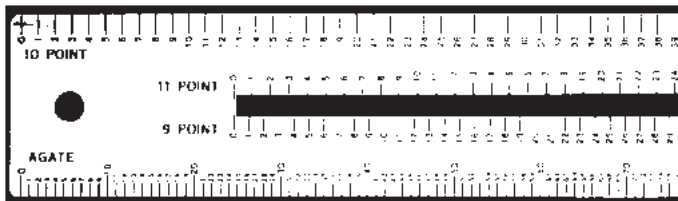
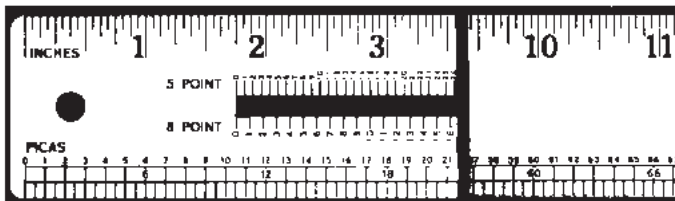

616 THE PUBLISHER A 1-1/2" Publisher ruler with two 5" long slots. Front has inches, picas, 5-point, 5-1/2 point, 7 point and 8 point. Back side has 9 point, 10 point, 11 point, 14 point, 16 point, and agate.

GB-616 18" Gaebel Ruler

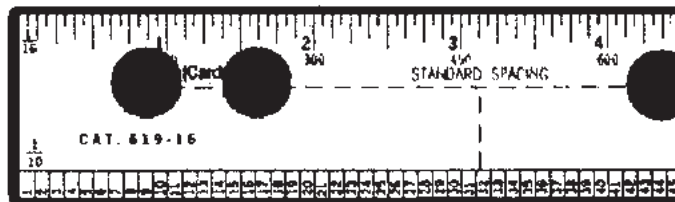

619D A forms ruler that is 1-1/4" wide with 1/16ths, 1/10ths numbered consecutively, 5/32nds, 6ths, and 12ths.

GB-619D 16" Gaebel Forms Ruler

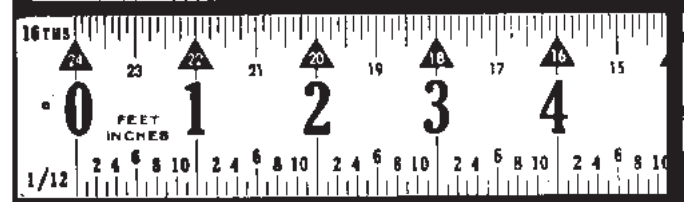
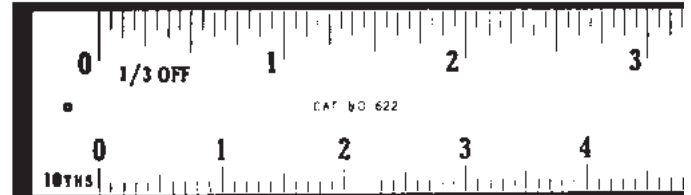

AD ARTIST'S SCALE

622 Two sided, 1-1/2" wide ruler with the front in 10ths and 1/3 off(artist scale), and the back with zero centering and 1/12 scale.

GB-622-24 24" Ad Artist's Gaebel Ruler

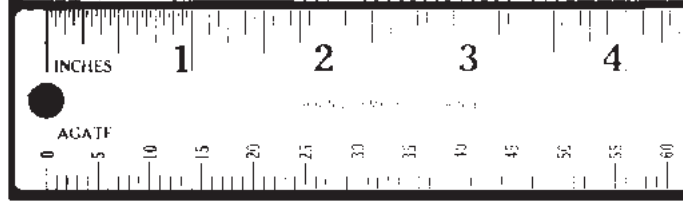
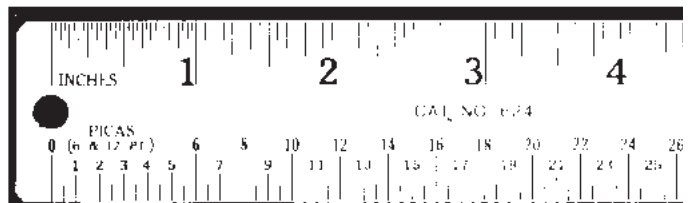

624 A two sided, 1-1/4" wide ruler with the front in inches and picas, and the back in inches and agate.

GB-624-12 12" Gaebel Ruler
GB-624-24 24" Gaebel Ruler

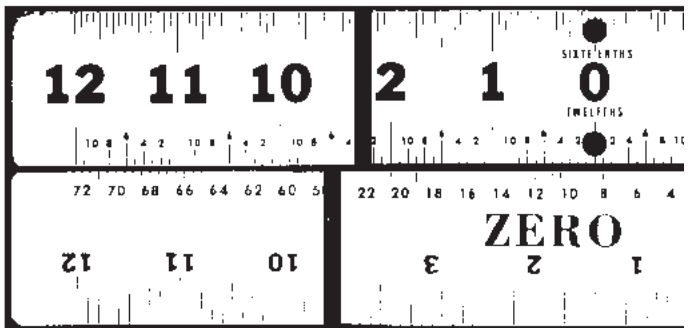

ZERO CENTER SCALE

627 A two sided, 1-1/2" wide ruler that has zero center scales on both sides. All scales read from center hole. Front in 16ths and 12th, back in 10ths and picas.

GB-627-24 24" Zero Center Scale
GB-627-36 36" Zero Center Scale

GAEBEL PRINTERS RULES

Gaebel stainless steel rulers with a special end that catches on the edge of printed stock for easy measuring.

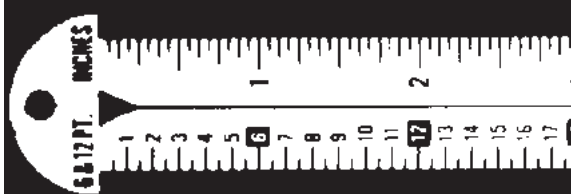

612 A two sided ruler with the front in 6 & 12 point with inches. The back has 6 & 12 point with agate.

GB-612 12" Gaebel Ruler

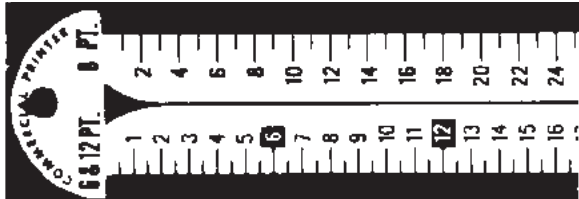

612A A two sided ruler with 6 & 12 point with 8 point on the front, and inches and 8 point on the back.

GB-612A-12 12" Gaebel Ruler

612F Similar to above. A two sided ruler 6 & 12 point on the front, with inches and agates on the back.

GB-612F-12 12" Gaebel Ruler

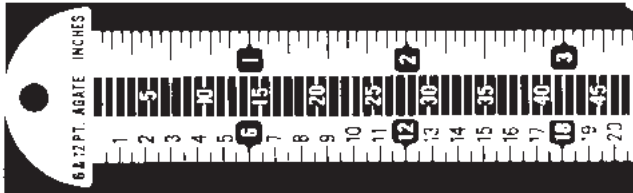

713 A one sided ruler with 6 & 12 point, inches, and agates.

GB-713 12" Gaebel Ruler

T-SQUARES



CLEAR PLASTIC T-SQUARE

A fixed head T-square that is completely made of clear plastic. This allows unhampered view of the subject matter. Special fitting of the arm to the head insures great rigidity and accuracy. By Mars.

CT-FH-24 24" Clear Plastic T-Square

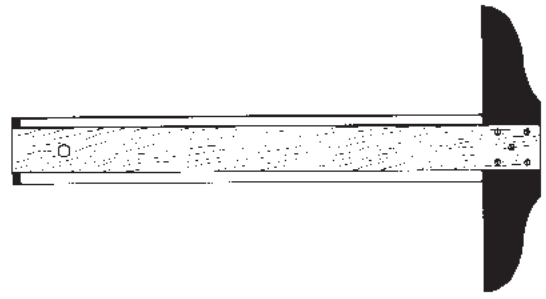

ACRYLIC EDGE T-SQUARE

Acrylic edges are bonded to hardwood blades by Koh-I-Noor. Plastic and hardwood are bonded together in a special process, leaving the edges elevated for inking. Attached to ebony hardwood heads.

- | | |
|--------------|---------------------------|
| MR-970-20-18 | 18" Acrylic Edge T-Square |
| MR-970-20-24 | 24" Acrylic Edge T-Square |
| MR-970-20-30 | 30" Acrylic Edge T-Square |
| MR-970-20-36 | 36" Acrylic Edge T-Square |
| MR-970-20-42 | 42" Acrylic Edge T-Square |

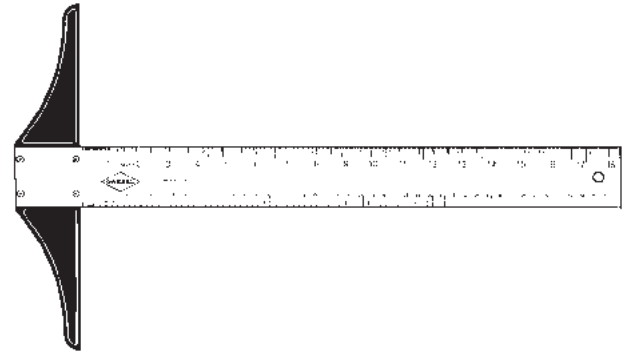

ALUMINUM T-SQUARE

Hard aluminum blades that are accurately graduated on the edges. Markings are sharp and clear, plus blades are anodized and surface treated to minimize scratching and marking. Blades are 2" wide. By Fairgate

- | | |
|---------|-----------------------|
| F63-118 | 18" Aluminum T-Square |
| F60-124 | 24" Aluminum T-Square |
| F60-130 | 30" Aluminum T-Square |
| F60-136 | 36" Aluminum T-Square |
| F60-142 | 42" Aluminum T-Square |
| F60-148 | 48" Aluminum T-Square |

STAINLESS STEEL T-SQUARE

Stainless steel, tempered blades with beveled edges, and a fixed cast aluminum head. The blade is 1-1/2" wide with guaranteed accuracy.

- | | |
|-----------|------------------------------|
| CP-ST5-18 | 18" Stainless Steel T-Square |
| CP-ST5-24 | 24" Stainless Steel T-Square |
| CP-ST5-30 | 30" Stainless Steel T-Square |
| CP-ST5-36 | 36" Stainless Steel T-Square |
| CP-ST5-48 | 48" Stainless Steel T-Square |

JR. 12 T-SQUARE

A clear plastic T-square with a fixed head that is calibrated in 16ths and millimeters. 12" length. Ideal for calligraphers.

CT-JR-12 12" Calibrated T-Square

TRIANGULAR SCALES

Rulers that are in the shape of a triangle when looking from the end. This allows more scales to be put on the same ruler.

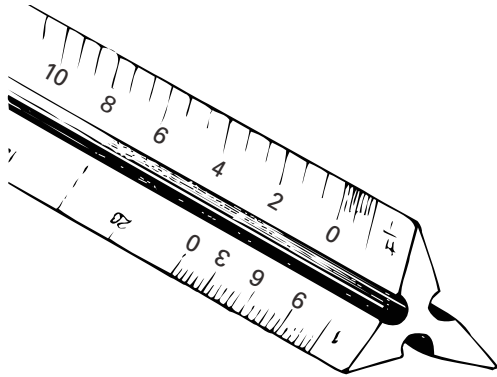

ARCHITECTURAL SCALES

Architectural scales are divided in fractions to a foot. An example would be 1/8" equals one foot. All the following scales are 12" long with scales of 3, 1-1/2, 3/4, 3/8, 3/16, 3/32, 1, 1/2, 1/4, and 1/8, and one bevel in 1/16" to the foot.

C-THRU SCHOLASTIC SCALE

Heavy plastic scale with open, divided graduations. Color coded sides.

CT-TS-654 12" C-Thru Architectural Scale

C-THRU ECONOMY SCALE

An economy scale for students.

CT-TS-656 12" C-Thru Architectural Scale

ENGINEER SCALES

Engineer scales are divided in parts to the inch. An example would be 20 parts to the inch. All have the following scales: 10, 20, 30, 40, 50 and 60 parts to the inch.

C-THRU SCHOLASTIC SCALE

A heavy plastic scale with open, divided graduations. Color coded on three sides.

CT-TS-655 12" C-Thru Engineer Scale

C-THRU ECONOMY SCALE

An economy scale for students.

CT-TS-657 12" C-Thru Engineer Scale

STRAIGHT EDGES

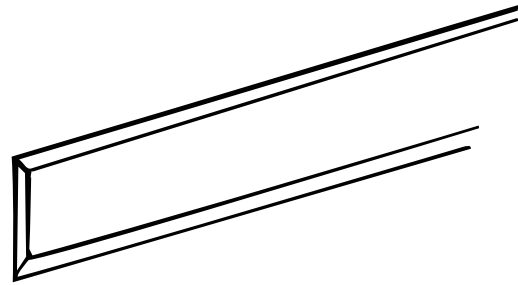

STAINLESS STEEL STRAIGHT EDGE

Stainless steel straight edges that are an extra heavy, .093" thick. Blades are 2" wide and have one beveled and one straight edge.

- | | |
|------|-----------------------------------|
| 1618 | 18" Stainless Steel Straight Edge |
| 1624 | 24" Stainless Steel Straight Edge |
| 1630 | 30" Stainless Steel Straight Edge |
| 1636 | 36" Stainless Steel Straight Edge |
| 1642 | 42" Stainless Steel Straight Edge |
| 1648 | 48" Stainless Steel Straight Edge |
| 1660 | 60" Stainless Steel Straight Edge |
| 1672 | 72" Stainless Steel Straight Edge |

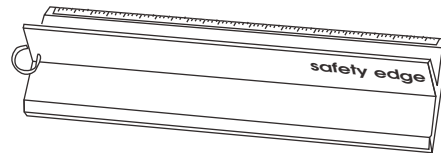

SAFETY EDGE

A uniquely designed tool that provides accurate straight lines, and accident free cutting. The Dahle Safety Edge's protective guard rail protects your fingers from careless injuries. The extra wide, non-skid rubber backing protects your art from accidental cuts or slipping while drawing straight lines. The precision graduated edge makes it perfect for use with a ruling pen. Easy to hold, use and hang for storage, the Safety Edge is a tool you won't want to be without.

- | | |
|----------|-----------------|
| DH-73312 | 12" Safety Edge |
| DH-73318 | 18" Safety Edge |
| DH-73324 | 24" Safety Edge |
| DH-73330 | 30" Safety Edge |
| DH-73336 | 36" Safety Edge |
| DH-73342 | 42" Safety Edge |

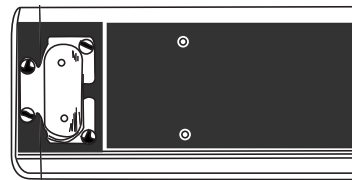

PARALLEL RULE

Paradraft parallel ruling straight edges have an ebony finish with a double thick phenolic blade with clear plastic edges. Parallel rules are faster and more precise than T-squares. Ball bearings make the rule float over the board and eliminate smudging. Slight pressure forces the ball bearings to retract and lock the rule in position. Includes all hardware necessary for mounting.

- | | |
|------------|-------------------|
| AL-1101-30 | 30" Parallel Rule |
| AL-1101-36 | 36" Parallel Rule |
| AL-1101-42 | 42" Parallel Rule |
| AL-1101-48 | 48" Parallel Rule |

DRAWING BOARD

A portable drafting board that weighs only 32 ounces. Ideal for students or professionals, this durable drawing board comes complete with a newly designed locking straight edge for quick and accurate adjustments. Flush mounted clamps hold drawing media firmly, indoors or out. The optional protractor drawing head attaches easily to the straight edge. It sets and locks automatically in increments of 15 degrees. Board is 19-1/2x 14-3/4".

K-25434 Portable Drawing Board
 K-25445 Protractor Drawing Head for 25434

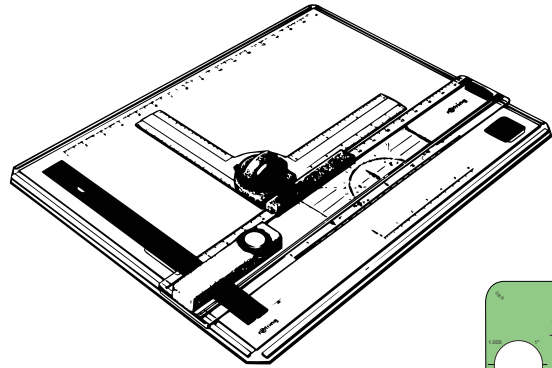

STUDIO DRAWING BOARD

Similar to the above, but a slightly smaller (13x 18.5") and lighter weight version. Comes complete with a lockable, inch graduated straight edge. There are also graduated scales on the sides of the paper clamp. The optional drafting head is graduated in metric and attaches to the straight edge. It can be locked at any angle. For 11 x 17" media.

K-522130 Studio Drawing Board
 K-522230 Drawing Head for 522130

TEMPLATES

Precision templates that help with all types of drawings. Designed for use with technical pens.

RAPIDESIGN CIRCLE TEMPLATE

Diameters from 1/16" to 11/32" in increments of 1/64". From 3/8" to 3/4" in increments of 1/32". From 7/8" to 1" in increments of 1/16". From 1-1/8" to 1-3/8" in increments of an inch. Transparent green color.

CP-R40 Circle template 4 x 7-1/4"

C-THRU CIRCLE TEMPLATE

Decimal and fractional measurements of 41 circles from 1/16" to 1" plus corner radii of 1/16", 1/8", 1/4" and 3/8".

CT-T-800 Circle Template 4 x 8"

RAPIDESIGN COMBO CIRCLE TEMPLATE

A large circle template with 45 circles from 1/16" to 2-1/4".

CP-R140 Combo Circle Template 7-1/4 x 8-1/4"

C-THRU LARGE CIRCLE TEMPLATE

Decimal and fractional measurements of 17 circles from 1" to 2" diameters, with corner radii of 3/16", 5/16", 1/2" and 5/8".

CT-T-801 Large Circle Template 8 x 10"

RAPIDESIGN LARGE CIRCLE TEMPLATE

A large circle template with 11 circles from 1-1/2" to 3-1/2" in varying increments.

CP-R440 Large Circle Template 11x8.5"

C-THRU JUMBO CIRCLE TEMPLATE

A template with very large circles from 1-1/2" to 3-1/2" diameters. Light green transparent color. 8-1/2 x 11".

CT-T-826 Extra Large Circle Template

RAPIDESIGN DECIMAL CIRCLE TEMPLATE

66 circles from .100" to 1.000". Diameter sizes from .100" to .500" in increments of .020". Increments of .010 and .020" are in horizontal rows and increments of .100" are in vertical rows.

CP-R540 Decimal Circle Template 6-1/8 x 8-1/8"

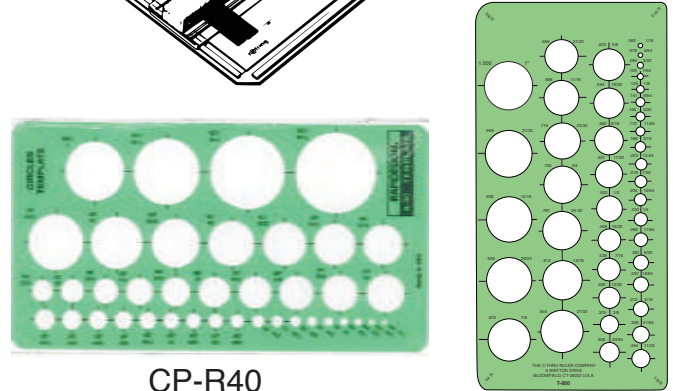

CP-R40

CT-T-800

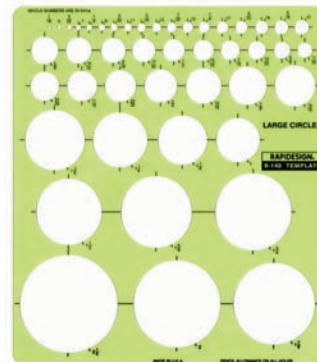

CP-R140

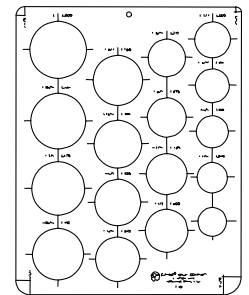

CT-T-801

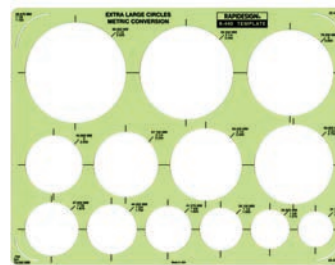

CP-R440

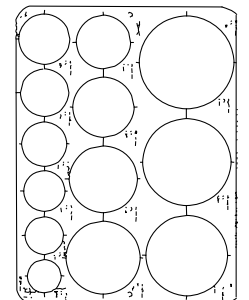

CT-T-826

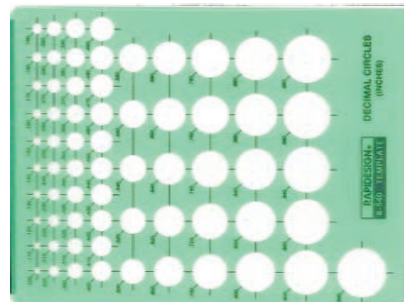

CP R540

C-THRU SMALL ELLIPSE TEMPLATE #1

Features 160 ellipses from 3/32 to 11/16". From 15 to 60 degree projections in 5 degree increments.

CT-T-807 Small Ellipse Template #1 6-3/4 x 8"

RAPIDESIGN ODD ELLIPSE TEMPLATE

Contains 60 ellipses from 1/4 to 1-3/8". Projections of 25, 35, 45 and 60 degrees. Transparent Green

CP-R77 Odd Ellipse Template 5 x 10-7/16"

RAPIDESIGN EVEN ELLIPSE TEMPLATE

Contains 60 ellipses from 1/4 to 1-3/8". Projections of 20, 30, 40, and 50 degrees. Transparent Green

CP-R78 Even Ellipse Template 5 x 10-7/16"

C-THRU ELLIPSE TEMPLATE #2

Features 50 ellipses from 3/4 to 1" in projections from 15 to 60 degrees in 5 degree increments.

CT-T-808 Small Ellipse Template #2 6-3/8 x 8"

C-THRU SMALL ELLIPSE TEMPLATE #3

Features 40 ellipses from 1-1/8 to 1-1/2" with projections from 15 to 60 degrees in 5 degree increments.

CT-T-809 Small Ellipse Template #3 6-3/4 x 12-1/8"

RAPIDESIGN ISOMETRIC ELLIPSE

38 ellipses from 1/8 to 2" in 35 degree 16 feet projection. Has 30 and 60 degree drawing edges relating to the 90 degree base and sides of the template

CP-R123 Isometric Ellipse Template 10 x 6-1/8"

C-THRU LARGE ELLIPSE TEMPLATE #1

Ellipses drawn in halves from 1-3/4 to 3" in 1/4" increments. In projections of 15,30,45, and 60 degrees, plus 35 degrees 16 feet.

CT-T-810 Large Ellipse Template #1 5 x 8"

C-THRU LARGE ELLIPSE TEMPLATE #2

Ellipses drawn in halves from 3-1/4" to 4-1/2" in 1/4" increments. In projections of 15, 30, 45, and 60 degrees, plus 35 degrees 16 feet.

CT-T-811 Large Ellipse Template #2 6 x 10-1/8"

RAPIDESIGN GENERAL USE TEMPLATE

Includes 42 assorted shapes including circles, hexagons, squares, and triangles, plus a 180 degree protractor.

CP-R18 General Use Template 9.5 x 5.5"

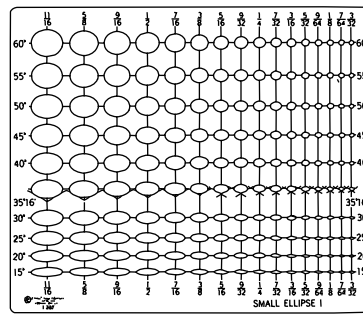

CT-T-807

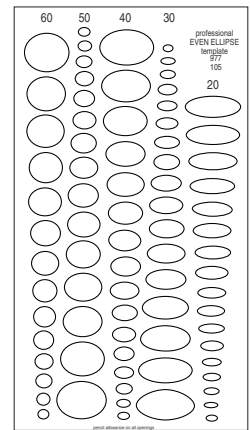

CP-R77

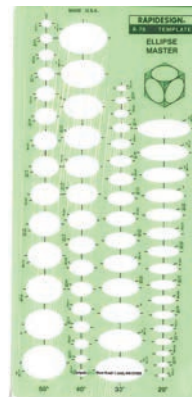

CP-R78

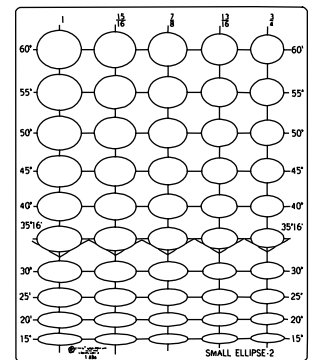

CT-T-808

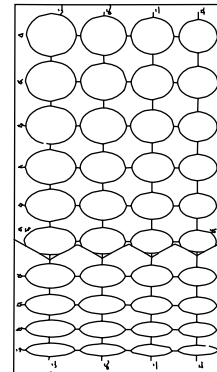

CT-T-809

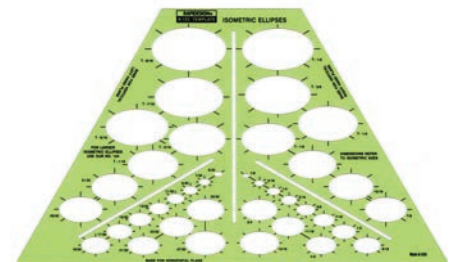

CP-R123

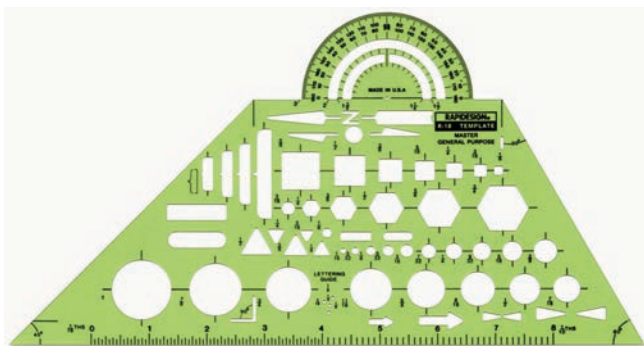

CP-R18

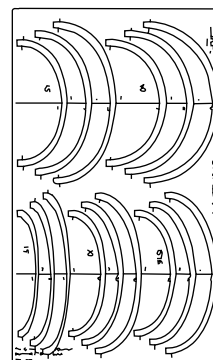

CT-T-811

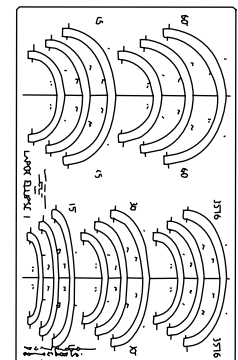

CT-T-810

C-THRU GENERAL PURPOSE TEMPLATE

Offers circles, squares, triangles, rectangles, and hexagons as well as an inch scale.

CT-T-816 General Purpose Template 6 x 10-1/8"

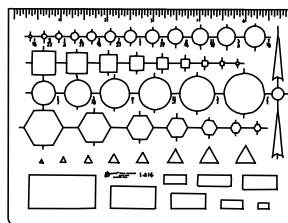

CT-T-816



CP-R30

RAPIDESIGN SQUARE TEMPLATE

37 squares from 1/16 to 1-1/2" in various increments. Full dimensioning in fractional inches with decimal and millimeter equivalents

CP-R30 Square Template 8-5/8 x 5-13/16"

RAPIDESIGN POCKET PAL GENERAL PURPOSE

Contains full dimensioning in fractional inches with decimal and millimeter equivalents. Features circles, squares, triangles, and hexagons.

CP-R50 Pocket Pal General Purpose 5-1/8 x 3-5/8"

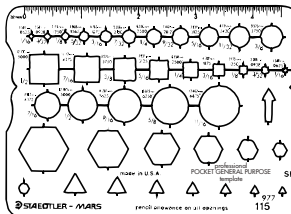

CP-R50

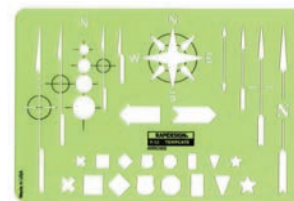

CP-R53

RAPIDESIGN ARROW TEMPLATE

Contains arrows, North indicators, traffic and road sign markers.

CP-R53 Arrow Template 7 x 4-1/8"

RAPIDESIGN ARCHITECTURAL SYMBOLS

Most common symbols used by architects, builders and contractors. Scale 1/4 to 1'.

CP-R33 Architectural Symbols 9-1/4 X 5-1/4"

RAPIDESIGN ARCHITECTURAL SYMBOLS

Same as above except 1/8" scale.

CP-R22A Architectural Symbols 9-1/4 X 5-1/4"

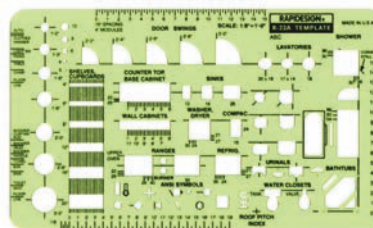

CP-R22 & R22A

C-THRU ARCHITECTURAL TEMPLATE

Incorporates all necessary openings, including fixtures and appliances, ASA symbols, roof pitch, gage, protractor feature with pitch, slope, rise, and run. Scale 1/4" to 1'.

CT-T-806 Architectural Template 6 x 10"

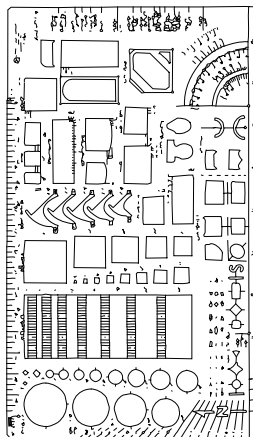

CT-T-806

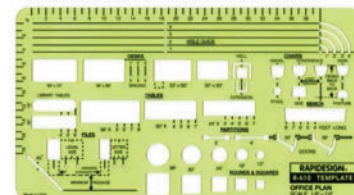

CP-R610

RAPIDESIGN OFFICE LAYOUT TEMPLATE

Symbols for most office furniture and equipment. Scale 1/4" to 1'.

CP-R610 Office Layout Template 8.75 x 5.5"

C-THRU OFFICE LAYOUT TEMPLATE

Has complete openings for furniture, accessories, partitions, door openings and fixtures in both 1/8" and 1/4" to the foot scales.

CT-T-804 Office Layout Template 6 x 10"

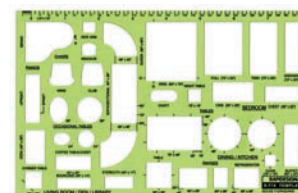

CP-R714

RAPIDESIGN HOUSE FURNISHING TEMPLATE

For planning furniture and appliance arrangements, or for rearrangement of existing layouts. 1/4" to 1' scale.

CP-R714 House Furnishing Template 8 x 5-1/2"

C-THRU HOUSE FURNISHING TEMPLATE

Complete openings for furniture and appliance arrangements in 1/4" to 1" Scale. Expedites planning kitchen, dining room, family, library, living room and bedroom. One side Calibrated in 1/4" scale.

CT-T-830 House Furnishing Template

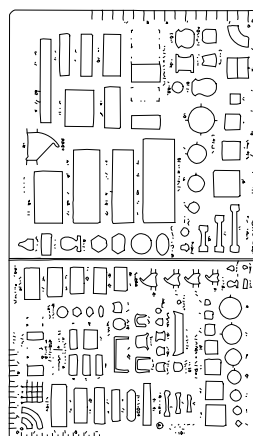

CT-T-804

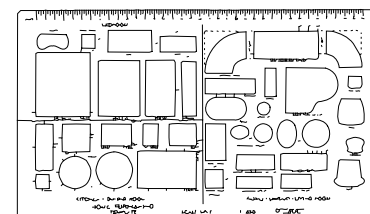

CT-T-830

RAPIDESIGN KITCHEN TEMPLATE

Symbols for kitchen cabinets and appliances. Bowls, sinks, appliances, corner and counter elevations, door swing, and lettering guides. 1/4" & 1/2"

- CP-R719 1/2" Scale Kitchen Template
- CP-R720 1/4" Scale kitchen Template

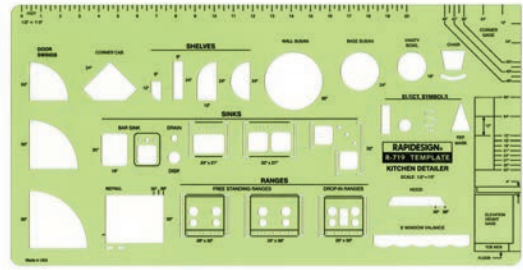

CP-R719/720

C-THRU LANDSCAPE TEMPLATE

Over 35 cut out symbols for landscape layout including trees, shrubs, flagstone for walks and terraces, etc. 1/4" to 1" scale. One side calibrated in 1/4" scale

- CT-T-834 Landscape Template 8.25" x 7.25"

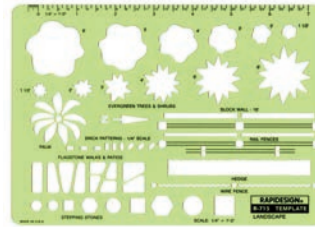

CP-R715

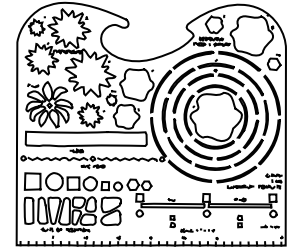

CT-T-834

RAPIDESIGN ELECTRIC DESIGN TEMPLATE

Circuit template combining standard logic, flow chart, electronic and electrical symbols

- CP-R45 Electric Design Template 7.25 x 4.5"

C-THRU ELECTRICAL TEMPLATE

Scaled to .250 grid including semi-conductors, switches, tubes and components, transformers, coils, circuit breakers and others.

- CT-T-805 Electrical Template 5 x 10-1/8"

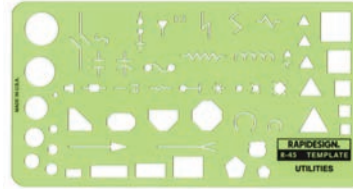

CP-R45

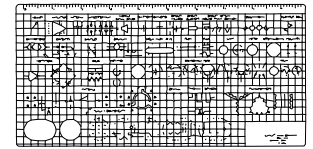

CT-T-805

RAPIDESIGN ELECTRONIC CONTROL TEMPLATE

Symbols to assist in the depiction of circuits in electrically controlled machinery and electric automation of production process. ANSI Y32.2 specifications

- CP-R312 Electric Control Template

RAPIDESIGN ELECTRO MASTER TEMPLATE

Contains electrical and other symbols for utility, power and light fields.

- CP-R375 Electro Master Template 8" 45/90 Triangle

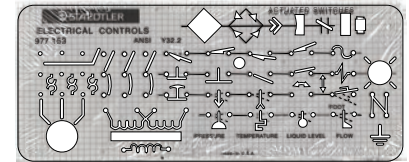

CP-R312

RAPIDESIGN FLOW CHART SYMBOLS

Flow chart symbols in seven sizes of each symbol for operation and flow process charts in accordance with ASME standard.

- CP-R54 Flow Chart 5-5/8 x 3-11/16"

C-THRU COMPUTER FLOW CHART TEMPL.

Complete set of computer flow symbols.

- CT-T-803 Computer Flow Chart

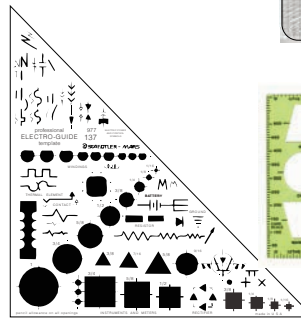

CP-R375



CP-R54

RAPIDESIGN STANDARD LOGIC TEMPLATE

Standard logic symbols for digital processing. MIL-STD 806, and Y322.14

- CP-R542 Half Size Standard Logic 4-1/8 x 3 3/8"
- CP-R543 3/4 Size Standard Logic 6 x 3-3/8"

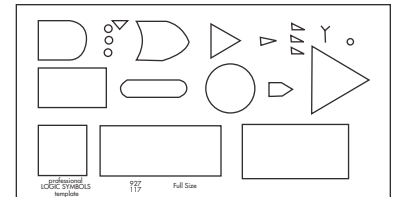

CP-R541

RAPIDESIGN LETTERING AID

Cut-outs for letter sizes 1/8, 5/32, 3/16 and 1/4". Guide lines for equidistant spacing.

- CP-R925 Lettering Aid 4 x 3"

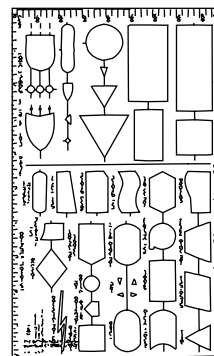

CT-T-803



CP-R925

ERASING SHIELDS

A template made of thin, flexible material with various shaped openings that allow exact erasure of those sections, lines, dots, curves, etc. that need removal. No sharp edges. 3-3/4 x 2-1/4".

MR-529-50 Mars Erasing Shield Stainless Steel

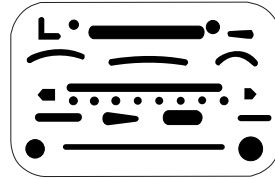

ERASING SHIELD

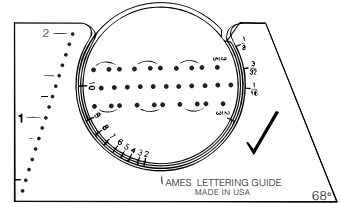

AMES LETTERING GUIDE

AMES LETTERING GUIDE

A template used to make guide lines for lettering. The range of heights can vary from 1/16 to 1-1/2". Also allows height of the letter to vary. Can also be used for cross section lines.

CT-ALG-1 Ames Lettering Guide

INSTRUMENTS

QUICK BOW SETS

These quick setting bow compasses adjust by pulling the legs apart, or pushing them together. Fine adjustment is made by turning the center wheel. The friction head holds the legs true. Available in several models.

KOH-I-NOOR QUICK SET BOW

A 6.5" giant bow with both legs jointed for circles up to 9.5" in diameter. Insert socket 4mm.

K-530135 Double Joint Quick Set Bow



K-530135

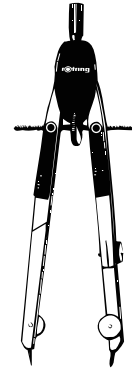

K-530115

KOH-I-NOOR QUICK SET BOW

A 7" giant bow with both legs jointed for easy use with a technical pen. Double release buttons make for quick adjustment. For up to 15.75" circles. Insert socket 4mm.

K-530115 Double Joint Quick Set Bow

MARS SUPERBOW COMPASSES

A single leg joint bow that will draw up to a 14-1/2" diameter circle. Includes pen and pencil part in first number, pencil part only in second. Legs pull apart for rapid adjustment.

MR-552-01 Single Joint Quick Set Bow
MR-552-02 Single Joint Quick Set Bow W/Extension

RING HEAD GIANT BOWS

Ring head bows feature a circular ring shaped spring that holds the legs in tension. Legs are opened and closed with double threaded center screw.

KOH-I-NOOR COMPASS

Draws an 9-1/2" diameter circle.

K-529130 Ring Head Bow

KOH-I-NOOR COMPASS

a 7" rapid adjustment compass that draws a 14" diameter circle.

K-529111 Ring Head Bow

MARS RING HEAD BOWS

Draws up to a 10" diameter circle, both are pencil bows. The first is solid, while the second has one leg jointed and the pencil part removable.

MR-551-WP-00 Single Joint Ring Head Bow
MR-551-40-WP No Joint Ring Head Bow

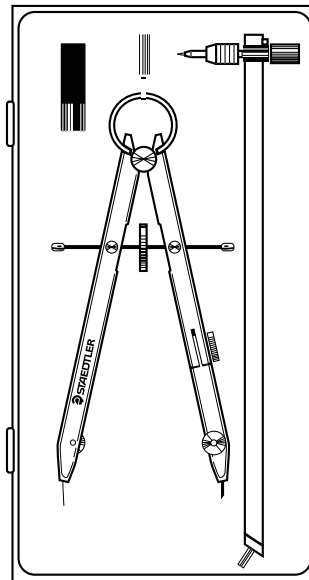

MR-552-01

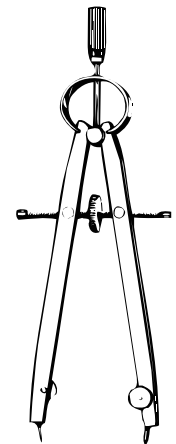

K-529130

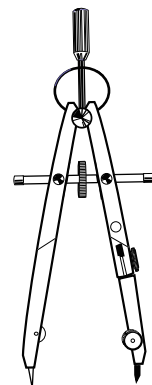

MR-551-WP-00

MARS SUPERBOW SETS

The following sets feature the Mars Superbow, quick bow. Accessories are as listed, and all sets have a handsome plastic case.

555-03 MARS SUPERBOW

Contains a superbow compass with pencil extension beam, technical pen holder, and spare parts.

MR-555-03 Mars Superbow

5561-09 MARS SUPERBOW SET

Contains a superbow with pencil part, pen part, a 6" extension bar, a 6" divider, a 4.5" small bow, plus a ruling pen handle.

MR-5561-09 Mars Superbow Set

553-11 MARS SUPERBOW SET

Contains a superbow with pencil & pen parts, a 6" extension bar, a 6" divider, and spare parts.

MR-553-11 Mars Superbow Set

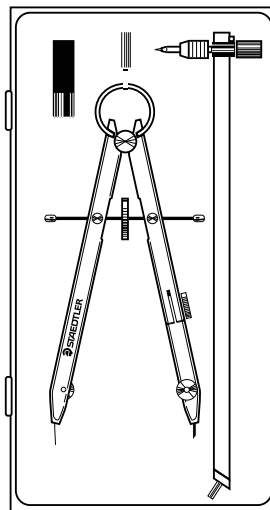

MR-555-03

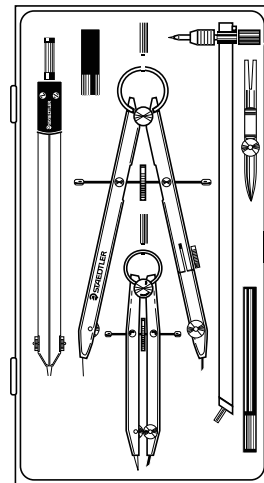

MR-5561-09

MARS MASTERBOW SETS

These sets feature Mars Masterbow ring head compasses. Accessories are as listed, and all sets have a handsome plastic case.

551-09 MARS MASTERBOW SET

Contains a 6" Masterbow with pencil and pen part, 6" extension bar, 6" divider, ruling pen handle, 4" small pencil bow.

MR-551-09 Mars Masterbow Set

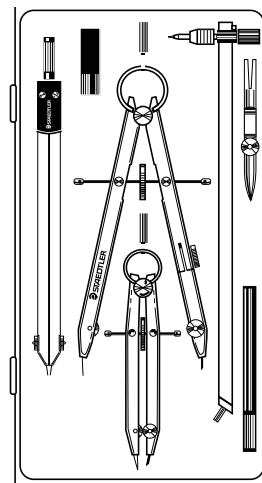

MR-551-09

DIVIDERS

Friction dividers for precise measurement.

MR-5561-55-wp Mars 5-1/2" Divider



MR-5561-55

KOH-I-NOOR BEAM COMPASS

A precision aluminum beam compass by Koh-I-Noor that consists of a 14" aluminum bar with fast acting sliders that can be micro-adjusted with a spring loaded geared wheel. Lock screws assure positive set. Includes divider, pen, and pencil points.

K-531100 Koh-I-Noor 14" Beam Compass

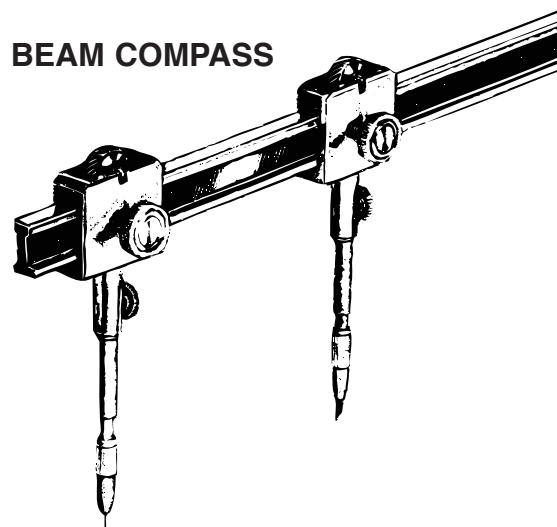

BEAM COMPASS

STUDIO EQUIPMENT



**DRAWING TABLES
DRAWING BOARDS
BOARD COVERING
CHAIRS
TABORETS
FLAT FILES
LAMPS
PROJECTORS
LIGHT TABLES
ALUMINUM EASELS
WOOD EASELS
STEEL EASELS**



ONYX TABLE

This contemporary fold away drafting table is perfect for home, office, or dormitory. The sturdy 1-1/2" diameter tubular steel frame is easy to set up and is available in either black or white powder coated finish that will last for years of service. Four telescoping legs allow the tabletop surface to easily adjust from 29" to 44" in the horizontal position and tilt from 0° to 45°. Fold away gate hinges permit the base to fold flat in seconds to 5" for convenient storage. Base and top ship in separate cartons. Tops are all white.

		Base	Wgt.
AL-ONX36-3	Onyx 24x36"	Black	36 lbs.
AL-ONX36-4	Onyx 24x36"	White	36 lbs.
AL-ONX42-3	Onyx 30x42"	Black	42 lbs.
AL-ONX42-4	Onyx 30x42"	White	42 lbs.



KING SIZE ONYX TABLE

A larger version of the Onyx table above that is perfect for home, office, or dormitory. The sturdy 1-1/2" diameter tubular steel frame is easy to set up and is available in either black or white powder coated finish that will last for years of service. Four telescoping legs allow the tabletop surface to easily adjust from 30" to 44" in the horizontal position and tilt from 0° to 45°. Fold away gate hinges permit the base to fold flat in seconds to 5" for convenient storage. Features a 12" x 39" stabilizing shelf and 44" metal pencil ledge. Base and top ship in separate cartons. Tops are all white.

		Base	Wgt.
AL-OXL48-3	Onyx 36x48"	Black	65lbs.
AL-OXL48-4	Onyx 36x48"	White	65 lbs.
AL-OXL60-3	Onyx 37-1/2x60"	Black	81 lbs.
AL-OXL60-4	Onyx 37-1/2x60"	White	81 lbs.



INTEGRA DRAFTING TABLE

A stylish tubular frame with quality construction makes the Integra a perfect choice for home, office, or studio. Features include a 1-1/2" tubular steel frame with height adjustment from 33" to 45" in the horizontal position. The angle adjusts from 0° to 50° plus a built in floor rest crossbar with rubber tread. Available in black or white powder coat finish with a white warp-free Melamine® table top.

		Base	Wgt.
AL-NTA42-3	Integra 30x42"	Black	43lbs.
AL-NTA42-4	Integra 30x42"	White	43 lbs.
AL-NTA48-3	Integra 36x48"	Black	58 lbs.
AL-NTA48-4	Integra 36x48"	White	58 lbs.



PROFESSIONAL TABLE

Features include a 1" square tubular steel frame with height adjustment from 29" to 45" in the horizontal position. Folds quickly to 4" wide. The angle adjusts from 0° to 45°. Available in black or white powder coat finish with a white warp-free Melamine® table top.

		Base	Wgt.
AL-XI-3-XB	Prof. 31x42"	Black	50 lbs.
AL-XI-4-XB	Prof. 31x42"	White	50 lbs.
AL-XII-3-XB	Prof. 36x48"	Black	64 lbs.
AL-XII-4-XB	Prof. 36x48"	White	64 lbs.

FOLD-A-MATIC TABLE

The most adjustable table we have found. You can literally sit on the floor, sit on a chair, or stand up and this table will adjust to you. Features include a 1" square tubular steel frame with height adjustment from 34" to 47" in the horizontal position. Folds quickly to 4" wide. The angle adjusts from 0° to 90°. Available in black or white powder coat finish with a white warp-free Melamine® table top,

		Base	Wgt.
AL-XV-3-XB	Fold 24x36"	Black	43 lbs.
AL-XV-4-XB	Fold 24x36"	White	43 lbs.
AL-XX-3-XB	Fold 31x42"	Black	58 lbs.
AL-XX-4-XB	Fold 31x42"	White	58 lbs.

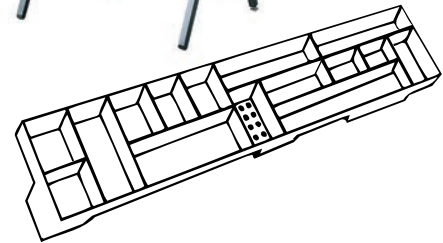

OPTIMA ART TRAY

A European design ABS plastic storage tray for all your tools and accessories. Mounts on any table, comes with mounting brackets for standard tables.

NW-356-07	Optima Art Tray Black
NW-356-08	Optima Art Tray White

PARALLEL RULE BOARD

A professional board with plated steel end channels. This board has been mounted with a parallel straight edge rule of Maple with an acrylic clear edge. Has fold away legs so board can be set at an angle when placed on a table.

AL-PXB24	18 x 24" Parallel Rule Board
AL-PXB31	23 x 31" Parallel Rule Board
AL-PXB36	24 x 36" Parallel Rule Board
AL-PXB42	30 x 42" Parallel Rule Board

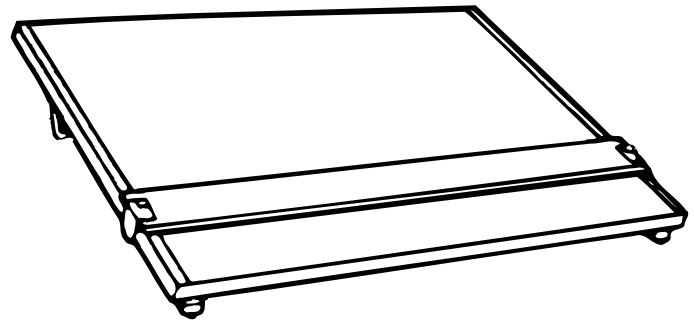

SKETCH BOARD WITH CLIP

A field sketching board of lightweight Masonite that has oversize clips mounted on it. Holds individual sheets or pads. An oversize rubber band holds the bottom securely. There is also a hand hole cut for easy carrying.

JR-400410	Sketch Board with Clip	11 x 17"
JR-400411	Sketch Board with Clip	18 x 18"
JR-400413	Sketch Board with Clip	23 x 26"

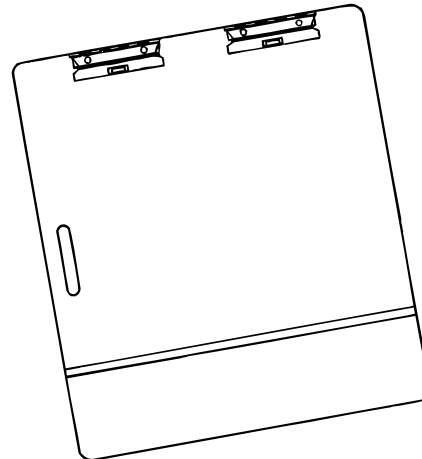

ROTO-TRAY

Roto-Tray is the original rotating plastic receptacle that holds all the items you need in a 10 inch circle. Ideal for brushes, pens, knives, inks, etc. Eliminates clutter in your work area while keeping your tools visible.

CT-TV-B	Roto-Tray Ebony
---------	-----------------

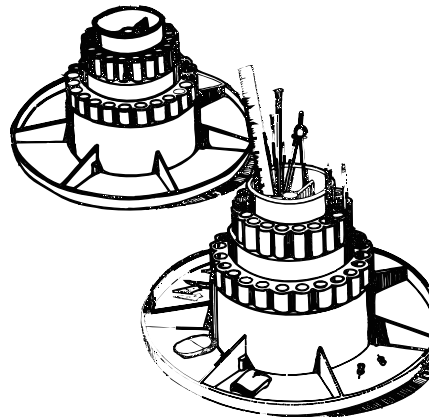

LAMPS

SWING ARM LAMP

An inexpensive swing arm lamp with a 34" reach. Features a 100 watt porcelain socket. Available in (1) Black or (2) White

LS-105-X Swing Arm Lamp

COMBO LAMP

A swing arm lamp with both a circular 22 watt fluorescent lamp and a 100 watt porcelain incandescent lamp socket. Provides a nice blend of warm and cool light. The swing arm has a 45" reach. Available in (1) Black or (2) White.

LSC-160-X Combo Lamp

FLUORESCENT LAMP

A swing arm lamp with two 15 watt fluorescent lamps. The swing arm has a 45" reach. Available in (1) Black or (2) White.

LSF-150-X Fluorescent Lamp

MAGNIFIER LAMP

A swing arm lamp with both a circular 22 watt fluorescent lamp and a 5" diameter either 3 or 5 diopter magnifier lens. Ideal for close inspection work. The swing arm has a 45" reach. Available in (1) Black or (2) White.

LSM-180-X Magnifier Lamp, 3 Diopter
LSM-182-X Magnifier Lamp, 5 Diopter

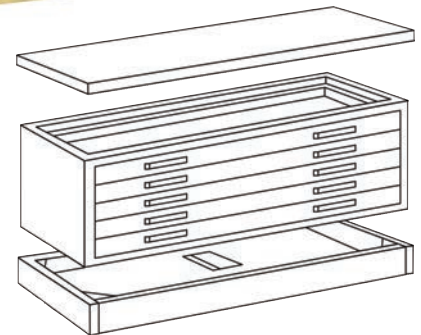
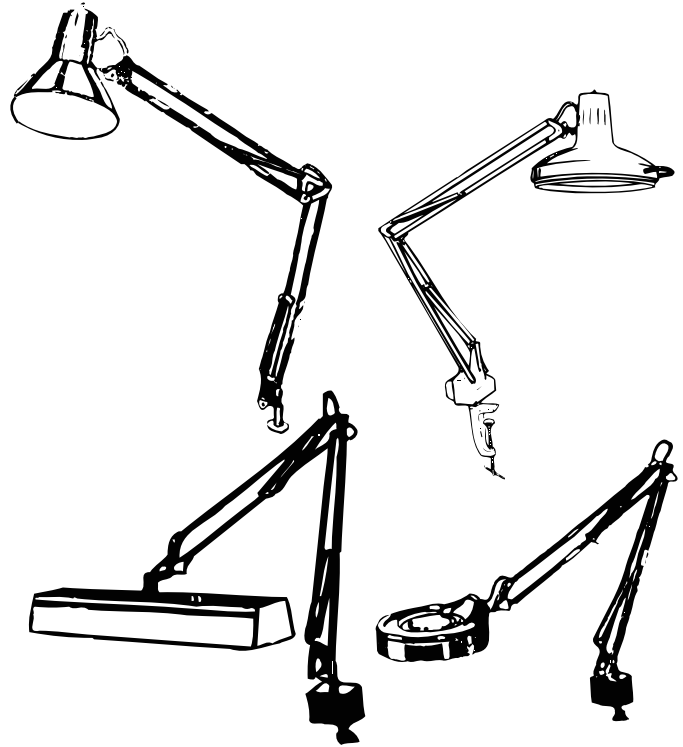

FLAT FILES

FLAT FILES

Flat files provide a reliable place to store valuable graphics. Units are modularly styled for customized use. Units feature solid oak construction with tempered hardboard drawer bottoms.

AL-2436-5D 16-5/8 x 40 x 27-3/4
AL-2436-C Cap
AL-2436-FB Flush Base

AL-3042-5D 16-5/8 x 46 x 33-3/4
AL-3042-C Cap
AL-3042-FB Flush Base

AL-3648-5D 17-5/8 x 52 x 39-3/4
AL-3648-C Cap
AL-3648-FB Flush Base

TABORETS

It's easy to keep these natural oak taborets next to you for maximum convenience with their heavy-duty dual-wheel casters and manageable size. Constructed with the highest quality oak and oak veneers, all drawers are made with superior drawer material and smooth, two-sided tempered hardboard bottoms. Drawers slide smoothly on wood drawer guides and are fitted with solid brass pulls. Taborets are finished with multiple coats of furniture-grade lacquer. Available in two styles. 3-Drawer style has three shallow drawers and an adjustable shelf. 5-Drawer has three shallow drawers (1 3/4"), one deeper (4 1/2"), and one extra deep (7 1/2").

AL-TB300 3 Drawer 27-1/2" h x 17-5/8 w" x 17-3/8" d
AL-TB500 5 Drawer 27-1/2" h x 17-5/8 w" x 17-3/8" d



PROJECTORS

PRISM & SUPER PRISM

Lightweight and compact, the Prism is designed as a direct projector to eliminate hours of tedious scaling. These top loading projectors allow oversize material to slide for full illumination. Project horizontally to 2000% or on the optional, vertical table stand from 300% enlargement to 55% reduction. The Super Prism features a super quality f/4.5 lens for extra sharp imaging.

ART-225-090	Prism Projector
ART-225-190	Super Prism Projector
ART-225-205	Prism Table Stand
ART-225-350	Projector Floor Stand
ART-225-335	Drawing Platform (225-205 Stand Required)
ART-225-197	Prism Super Lens Upgrade for Prism

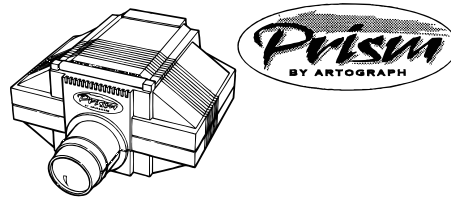

DESIGN MASTER & DES MAST II

This advanced design projector offers up to 1500% horizontal projection or 350% enlargement to 75% reduction when mounted on the drawing platform. Two steel clips hold copy to the 6 x 6" copy board. A micro switch automatically turns lights off when the copy box door is opened. The Design Master II features twice the illumination (500 watts) of the standard model, and a 200mm ground optical glass lens.

ART-225-323	Design Master
ART-225-322	Design Master II
ART-225-350	Projector Floor Stand
ART-225-335	Drawing Platform

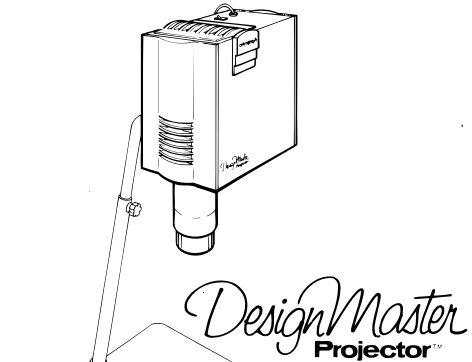

MC-250 PROJECTOR

The ultimate projector for clarity and brightness, ideal for the professional who demands the best in image quality. The superior quality lens of the MC 250™ allows you to enlarge artwork up to 15 times with incredible sharpness and detail. It is unsurpassed for enlarging photos, designs, etc. onto walls, canvas, or any vertical surface. At only 7 pounds this ultra compact model is easy to position and store, and doesn't require much space for projection. A 10 times enlargement needs only 10' of projection range. Fan cooling also allows for projection for long periods. The top-loading 6" x 6" copy area with removable cover easily accommodates oversize artwork or 3D objects allowing for an almost endless list of applications. The MC 250 also features a 300 watt halogen lamp for a whiter and brighter image (approx. life of 75 hours). Simple... Just plug it in, and adjust the focus by turning the threaded lens barrel. Dark room required.

ART-225-152	MC-250 Projector
-------------	------------------

TRACER

A low cost solution for sizing and visualizing. Enlarges up to 10 times with a 5 x 5" copy area. A light weight and portable projector for accurate horizontal projection. Oversized pieces can be projected in sections. Features a 100 watt bulb and single element 200mm lens.

ART-555-360	Tracer Projector
-------------	------------------

DESIGNER

The Designer™ offers dual reduction and enlargement capabilities with one lens. Enlarges up to 30 times and reduces down to 70% the original size. Simply mount your pattern, design or photograph onto the underside of the projector lid. Your image is reduced or enlarged instantly with clarity and in full color for your drawing pleasure. Features 6 x 6" copy area and 250 watt phoro quality illumination. Dark room required

ART-225-354	Designer
-------------	----------

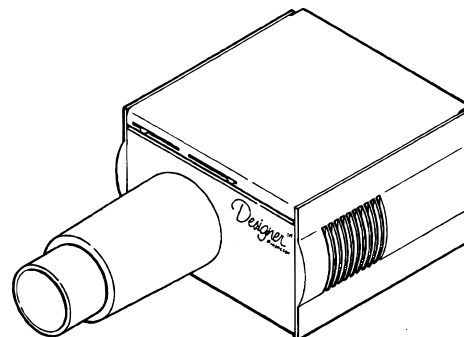
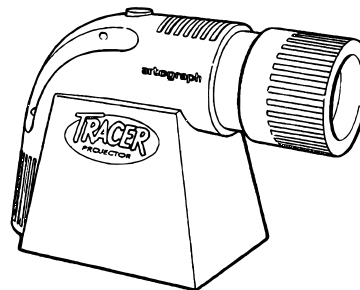

SPRAY SYSTEMS

2025 GRAPHIC ARTS

The Artograph 2025 commercial spray collector is ideal for collecting over spray from aerosol adhesives, fixatives, and paints. Designed for the commercial artist, graphic studio and schools. The system has four separate filters to maximize particle removal. A unique prefilter, inexpensive polyester film on a continuous roll, and activated carbon for a final filter. Eliminates the mess of over sprayed particulates that can soil an office. Reduces noxious odors from aerosols. A two speed air blower pulls spray through filters

- AOG-225-325 Model 2025 Spray System
- AOG-225-329 #25ED Exhaust Adapter
- AOG-200-575 Replacement Hood
- AOG-225-326 #25 Pre-Filter Roll 25" x 50yd.
- AOG-225-327 #25 Filter Pack (4ea. mid filter & Poly carb pads)
- AOG-225-328 #25 Activated Carbon Filter
- AOG-225-330 #25 High Efficiency Activated Carbon Filter

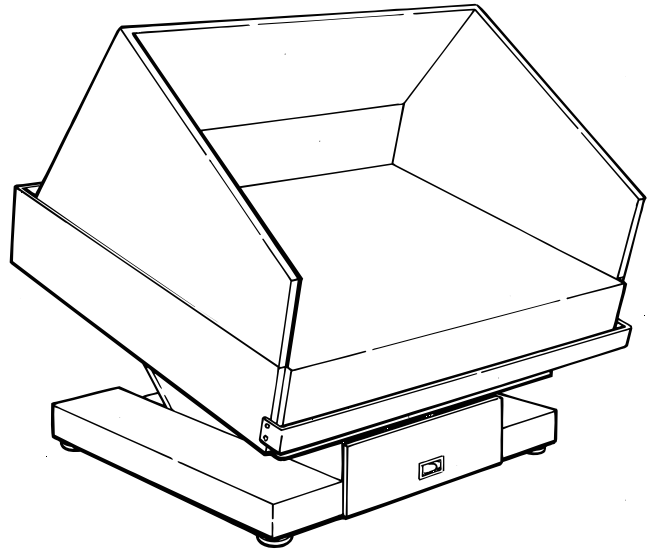

1530 HOBBY BOOTH

Unique spray booth ideal for the model builder or designer. The 15" x 30" (38 x 76 cm) spray booth (accommodates objects up to 28" long and 13" wide) is ideal for reducing the over spray and odors from aerosol or airbrush painting. The 1530 offers a three-stage filter system: a replaceable pre-filter sheet, which captures the bulk of the sprayed materials, thick polyester mid-filter and a polyester/carbon filter. The built in exhaust adapter can be outfitted for venting out-of-doors. The 1530 features a metal hood with a clear window for excellent illumination and a perforated front edge for hanging small parts.

- AOG-225-345 Model 1530 Hobby Spray Booth
- AOG-225-346 Pre-Filter (20 sheet plg.)
- AOG-225-347 Filter Pack (4 ea. mid-filter & poly carb pads)
- AOG-225-348 Pre-filter Roll Tray
- AOG-225-349 Pre-filter roll 30" x 50yd,



MODEL 1530

1520 COMPACT BOOTH

An economical over spray collector for the hobbyist and budget minded user. A 15 x 20" work surface is perfect for trapping spray from adhesives, fixatives, and finishes. Draws 185 cubic feet per minute of air flow to make sure no over spray escapes.

- AOG-225-315 Model 1520H Spray System
- AOG-200-572 #15 Replacement hood
- AOG-225-356 #15 Pre-Filter Roll 20" x 50yd.
- AOG-225-317 #15 Filter Pack (4ea. mid filter & Poly carb pads)
- AOG-225-316 #25 Pre-Filter (20 sheet pac

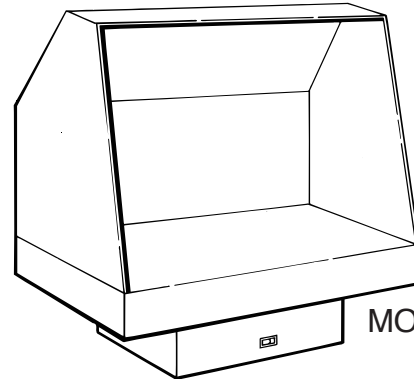

MODEL 1520H

LIGHT BOXES

SEERITE LIGHT BOXES

These portable light boxes have hundreds of uses in the studio or print shot. Ideal for lining up positives and negatives, examining transparencies or slides, cutting film or masks, negative opaquing, overlays, etc. units feature metal body with carrying handle that doubles as a tilt leg. The top is of heavy acrylic that will accept glass for cutting (not included) via sliding angle bars. All are UL approved with eight foot cord and on/off switch. Daylight fluorescent lamps included.

- ST-PC1512-DY 11-1/2x15-3/8" Light Box
- ST-PC1624-DY 16 x 24" Light Box
- ST-PC2436-DY 24 x 36" Light Box

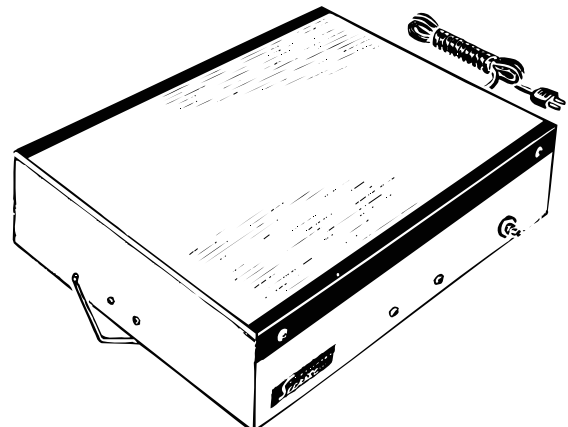

GRAPTEC DIGITAL PLOTTERS/CUTTERS

GRAPTEC
GRAPTEC AMERICA, INC.



CraftROBO

The CraftROBO and CraftROBO Pro are the result of years of research and improvements that allowed Graphtec to produce a professional quality cutting plotter to the desktop.

CE5000MK2

The Graphtec CE5000-60 (24") and CE5000-120 (48") engineering class cutting plotters update the extremely successful CE3000Mk2 series with improved features, as well as a cleaner, "greener" electronic design and manufacturing process to minimize the environmental impact of the equipment throughout its life cycle.

FC8000MK2

The new FC7000MK2 series is available in five model configurations: FC7000MK2-75 30", the FC7000MK2-100 42", the FC7000MK2-130 54", the FC7000MK2-160 64" and the series newest size: FC7000MK2-60 24". Maximum compatible media widths for each model are 30.3", 36", 48", 60", and 72" respectively.



FC2240

The FC2240 Large Format flatbed cutting plotter is available in 47" x 36" and 68.5" x 36" table sizes, with optional tool head configurations and material hold-down systems. Dual Head Design features 1000 grams and 500 grams maximum down force for more efficient marking and cutting workflows.

INKJET PRINTERS



Epson 1400 Inkjet Printer

The Stylus Photo 1400 is Epson's newest Professional grade desktop printer. Best for that small shop or individual who wants professional results.



Epson R1900 Inkjet Printer

The Epson Stylus Photo R1900 is an advanced 13" Wide desktop printer for Professionals. Developed from the popular R1800 but with the focus on better black ink printing, this model is ideal for producing dense film positives on the smaller scale.



Epson Stylus Pro 4880 Inkjet Printer

The Epson Stylus Pro 4880 is an advanced 17" Wide desktop printer. Best for those who want to take the next step into professional film output on a larger scale

Note: The 4880, 4800 and the 4000 are virtually identical when comparing sizes and output quality. The 4000 and 4800 have been discontinued by Epson and replaced by the 4880.



Epson 7880 Inkjet Printer

The Epson Stylus Photo 7880 is an advanced 24" Wide printer. Truly professional output at a large scale.



Epson 9880 Inkjet Printer

The Epson Stylus Photo 9880 is an advanced 44" Wide professional printer best suited for high production shops or shops that specialize in large format printing.

ALUMINUM EASELS

151 ALUMINUM TABLE EASEL

A light weight table easel made from corrugated aluminum tubing. There are rubber tips for rigidity, and a folding canvas tray for canvas up to 20 x 24". Also ideal for displays. In individual poly bags for hanging.

ST-151 Aluminum Table Easel

160 ALUMINUM TABLE EASEL

A heavier aluminum table easel with adjustable "Auto-Lock" canvas holding device. Back leg opens to any angle. For canvas up to 20 x 36" and also displays. Individually boxed.

ST-160 Aluminum Table Easel

100 STANDARD TRIPOD EASEL

A sturdy, rigid deluxe model for the studio, or outdoors. Has 3/4" and 5/8" diameter aluminum legs, with jam-proof locking clutches. Equipped with "Auto-Lock" spring type canvas holder. Extends to 6'9" and folds to 32" while weighing only 3 lbs., 8 oz.

ST-100 Standard Tripod Easel

250 SUPER TRIPOD EASEL

A mid-range easel with tripod legs of 5/8" and 1/2" with jam-proof locking clutches. Extends to 6'8" while folding to 32". Has "Auto-Lock" spring type canvas holder. Weighs 2 lbs. 14 oz.

ST-250 Super Tripod Easel

500 CLASSIC STUDIO EASEL

A sturdy studio easel that can be set up or folded in two minutes. Equipped with adjustable "Auto-Lock" spring type canvas holder, and a sliding utility tray (21" long) with built in palette holder. Built for canvas up to 48" high (larger with extension unit). Has rubber tips on the leg bottoms. Ideal for home or studio.

ST-500 Classic Easel

ST-12 12" Extension

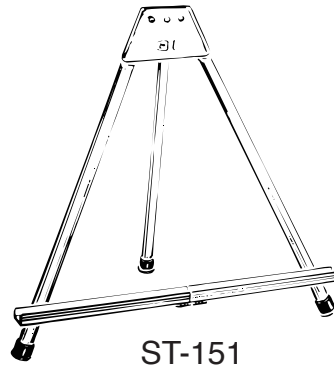

ST-151

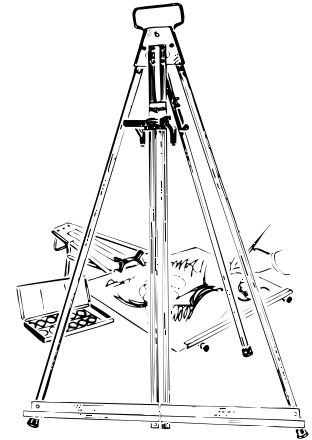

ST-160

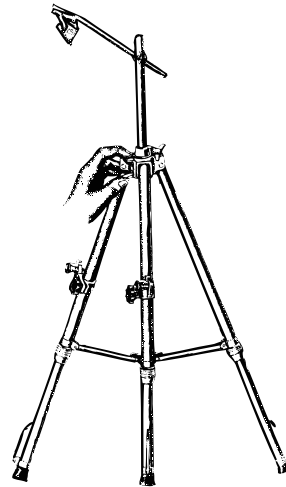

ST-100 & 250

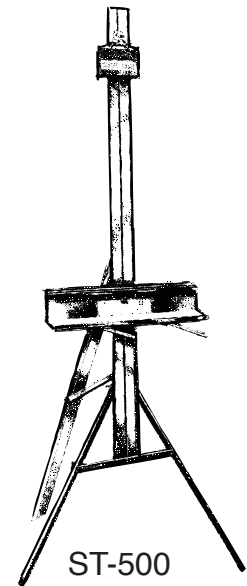

ST-500

WOOD EASELS

#2 WOOD TABLE TRIPOD EASEL

A table top tripod easel that folds for easy storage. Made of select quality dark stained wood, it stands 25" high and will hold canvases up to 22" high. The two piece tray clamps at any height, and the rubber tipped feet prevent slipping. Also excellent for display. By Tara.

FX-6602 Tara #2 Wood Table Top Tripod Easel

TRIPOD FOLDING EASEL

An inexpensive tripod wood easel that is popular with hobbyists and beginners. Sturdily constructed of select wood, walnut stained or plain wood, with plated hardware, metal pins for outdoor use, rubber caps for indoor use, and an adjustable 2" tray. Also ideal for lectures and displays. 66" tall, folds to 35".

FX-6605 Tara #5 Folding Easel

Plain Wood

FX-6610 Tara #10 Folding Easel

Walnut Stained

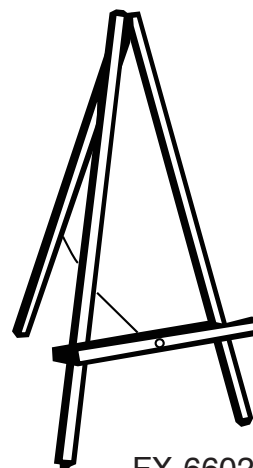

FX-6602



Tripod

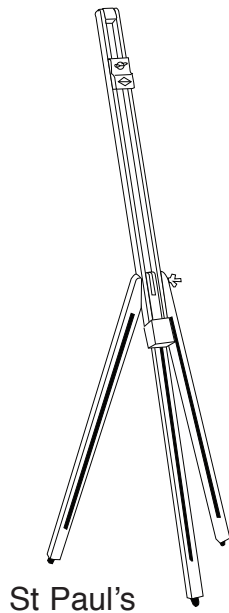

St Paul's

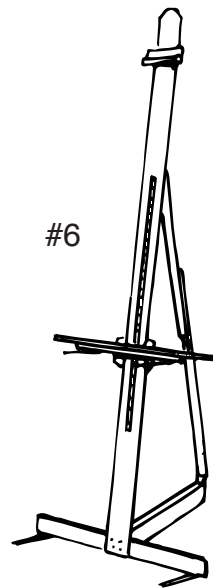

#6

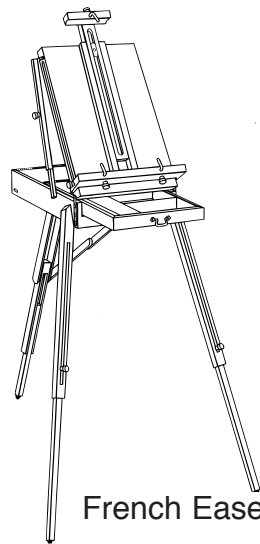

French Easel



A Frame



H Frame

#6 TARA STUDIO EASEL

A softer wood easel with a sanded finish. A Screw clamp knob and groove arrangement makes up and down adjustment very easy. Overall height is 78". Folds for storage

FX-6606 #6 Tara Studio Easel

ST PAUL'S EASEL

Constructed of oiled beech wood, this field easel is compact, portable, and easy to set up. For transport, simply fold and secure the tripod legs with the leather strap and buckle. Hardware allows for easy angle and height adjustment. Legs are tipped with non-skid rubber feet. Holds canvases up to 42" high. Overall measurements: 38" x 38" x 76".

DR-802-000-032 St Paul's Easel/Artist

HERITAGE FRENCH EASEL

This is a world famous, finest quality, combination Sketch Box - Easel-Canvas Carrier in the French style. Made from oiled elm wood, precision hand crafted in the best tradition of cabinet work. The sketch box is easily converted to an easel by unfolding the legs and adjusting to the desired height and position. The canvas carrier section can be raised or lowered to the desired height, or set at any angle from forward to vertical to flat for oil or watercolor painting. Two finished canvases (each up to 33") may be carried in the canvas carrier section with the legs folded up. The drawer is metal lined for colors, brushes and accessories, and locks closed to prevent loss of contents. Includes a wood palette.

AL-HWE208 French Combination Easel

HERITAGE™ A-Frame Easel

Constructed of select oiled beech wood, the A-Frame easel is a three-legged studio easel that's designed to be stable and sturdy. It features an easy-slide canvas holder on top for clamping the canvas and a simple ratchet control that adjusts canvas height and angle. Holds canvases up to 47" high. Folds flat for storage. Overall measurements: 26" x 41" x 91".one side to keep supplies within arm's reach. Drawer is lined with aluminum for easy cleanup and also features adjustable compartments. Top and bottom canvas holders both telescope for maximum flexibility. Also adjusts to various painting angles. Holds canvases up to 33" high. Overall measurements: 15" x 16" x 5".

AL-HWE136 A Frame Easel

HERITAGE™ H-Frame Easel

This heavy-duty studio easel is constructed of oiled beech wood for good looks and durability. The H-frame design provides very rigid support for canvases up to 55" high. The shelf and height adjust using a simple ratchet control. It also features a handy tray below the canvas ledge to store supplies neatly. Folds flat for storage. Overall measurements: 38" x 38" x 76".

AL-HWE150 H Frame Easel

ETCETERA



**KNIVES
BLADES
KNIFE SETS
HOBBY TOOLS
SCISSORS
TRIMMERS
CUTTING BASE
MAT CUTTERS
PRE-CUT MATS**

**NON-GLAS
FRAMES
SCREEN PRINTING
ETCHING
SCULPTURE
SPRAY PAINT
RUB N' BUFF
FABRIC PAINT
WHITE GLUE
HAND CLEANER
ART BOXES
PORTFOLIOS
DRAWING KITS
BOOKS**

CUTTING TOOLS

#6 GRIFHOLD KNIFE

A light weight aluminum handle knife with replacement blade and 5" overall length. Handle is 1/4" in diameter. Uses GR-0006B or X-0204 blades. Ideal for film cutting in schools.

GR-0006 Grifhold #6 Light Knife

#1 STYLE KNIFE

The most popular knife from X-Acto, the #1 knife is an aluminum handle that is 4-7/8" long and comes with a #11 blade. Has unlimited uses from professional graphic artists to hobbyists and accepts a variety of blades including #11, #10, #21, #12, #13, #14, #17 and #18.

X-3201 X-Acto #1 Knife Carded
 X-3001 X-Acto #1 Knife Bulk w/Safety Cap
 GR-0007 Grifhold #7 Knife Card

#2000 X-ACTO KNIFE

A new rubberized comfort grip knife with anti roll wedge and center barrel release. Has unlimited uses from professional graphic artists to hobbyists and accepts #1 knife blades.

X-3722 #2000 Knife Cranberry Carded
 X-3723 #2000 Knife Royal Blue Carded
 X-3724 #2000 Knife Black Carded

GRIPSTER STYLE KNIFE

A new rubberized comfort grip knife with anti roll design. Rear blade release for easy safe replacement. Has unlimited uses from professional graphic artists to hobbyists and accepts a #1 knife blades.

X-3623 X-Acto Gripster Red
 X-3626 X-Acto Gripster Blue
 X-3627 X-Acto Gripster Black

CUT-ALL KNIFE

The Cut-All knife by X-Acto is similar to the #1 knife, except that it has a plastic handle. This handle tapers toward the rear and is attached to an aluminum chuck. Uses the same blade as the #1 knife. All are carded.

X-3290 X-Acto Cut-All Black

#3 X-ACTO KNIFE

A knife with a gold tone barrel and a screw on cap that clips to your pocket. Comes with a #10 blade.

X-3203 X-Acto #3 Knife Carded

#24 STENCIL KNIFE

The Grifhold #24 knife is unique in that it will take both flat and round shank blades. Round shank blades are sometimes preferred by professionals because they are easier to sharpen. Features screw release clutch that holds the same blades as the #1 knife as well as the #24 series of blades by Griffin.

GR-0024 Grifhold #24 Knife Carded

#2 X-ACTO KNIFE

The #2 knife has a slightly larger diameter handle than the #1, and uses larger shank blades. Has screw lock front clutch for blade release. Uses #2, #15, #18, #19, #22, #23, #24, #25, #26, #27 and #2 assortment blades.

X-3202 X-Acto #2 Knife Carded

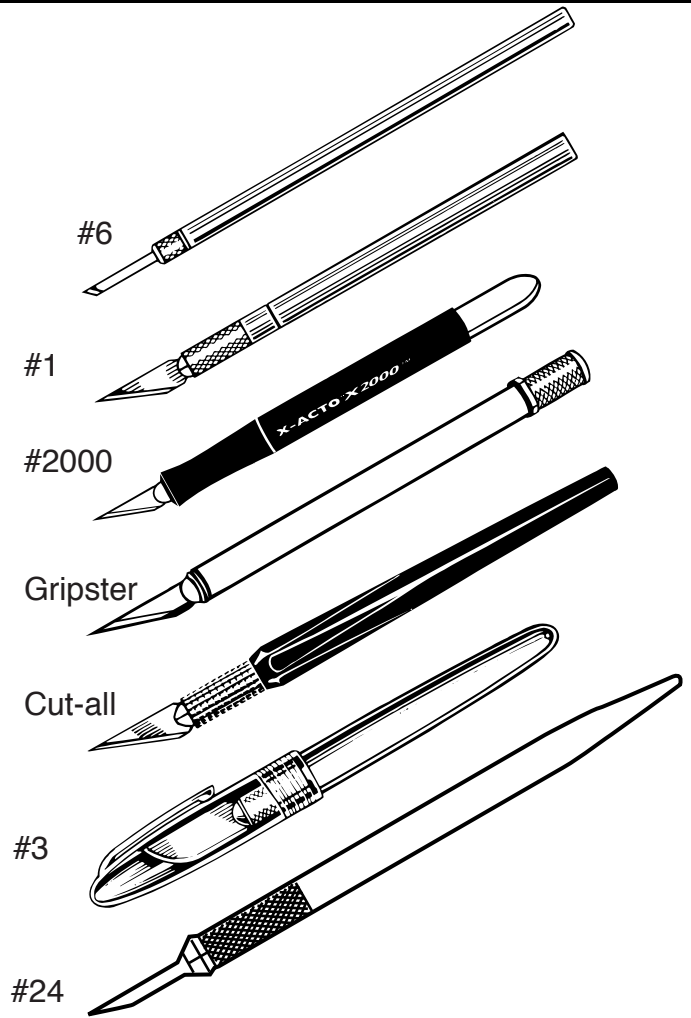

#2

#5

#9

#5 X-ACTO KNIFE

A heavy duty knife with a red plastic handle that is 4-1/4" long. Comes with a #19 blade, and uses the same blades as the #2 knife plus razor saw blades. Ideal for hobby and craft work.

X-3205 X-Acto #5 Knife Carded

#9 RETRACTABLE KNIFE

This all metal knife features a retractable push button release blade with a positive lock when open. Designed for delicate, close work demanding accuracy. Comes with handy pocket clip. Uses #9 blades only.

X-3209 X-Acto #9 Retractable Carded

SWIVEL

#3241 X-ACTO CRAFT SWIVEL

The craft swivel knife has an anodized aluminum handle with cap and a blade that rotates 360 degrees easily. Ideal for paper and friskets. Uses X-Acto #241 blades only.

X-3241 X-Acto Craft Swivel Knife Carded

#113 GRIFHOLD SWIVEL

An all aluminum knife that cuts arcs, curves, etc. in film or paper. Uses Grifhold #113B blade only.

GR-0113 Grifhold Swivel Knife

DUAL CUTTERS

#88 DUAL CUTTER

A double blade knife that makes parallel cuts quickly and easily. Rapid adjustment from very fine to 1/2" is made at the turn of a screw. Ideal for cutting lines on masking film, screen films, stencils, type strips (from strip setting machines), and stencils. Blades are not replaceable.

GR-0088 Grifhold Dual Cutter Carded

#161 DUALFLEX CUTTER

The Dualflex is a double blade knife with flexible spring action for making parallel cuts. The tempered steel blades are encased in an adjustable spring platform. Press more heavily on one blade (as in curves), and the spring effect compensates, holding the opposite blade to the cutting surface, eliminating waver. The light weight aluminum head has a swivel for cutting circles, scrolls, and curves. Ideal for stencil film, type strips, etc. Line width is adjustable from very fine to 5/8". Uses Grifhold #161B blades.

GR-0161 Grifhold Dualflex Cutter Carded

SPECIALTY

#44 PIN VISE

An all aluminum handle that holds #44P pins or drill bits up to 1/16" Ideal for fine scribing, retouching, stenciling, or perforating. Pin retracts into handle when not in use, carded.

GR-0044 Pine Vise Carded

GR-0044-P Pins for above Carded

POUNCE WHEELS

A pounce wheel is made up of a handle that holds a small wheel with little teeth. The teeth on the wheel put a line of holes in paper they are rolled over. Usually the wheel is rolled over a pre-drawn design. The design becomes a pattern that can be held against an object and tapped or pounced with a bag of charcoal. This puts the pattern on the object. Carded.

GR-0009 1/4" Pounce Wheel, 21 Teeth/Inch

GR-0010 1/4" Pounce Wheel, 15 Teeth/Inch

GR-0012 7/16" Pounce Wheel, 15 Teeth/Inch

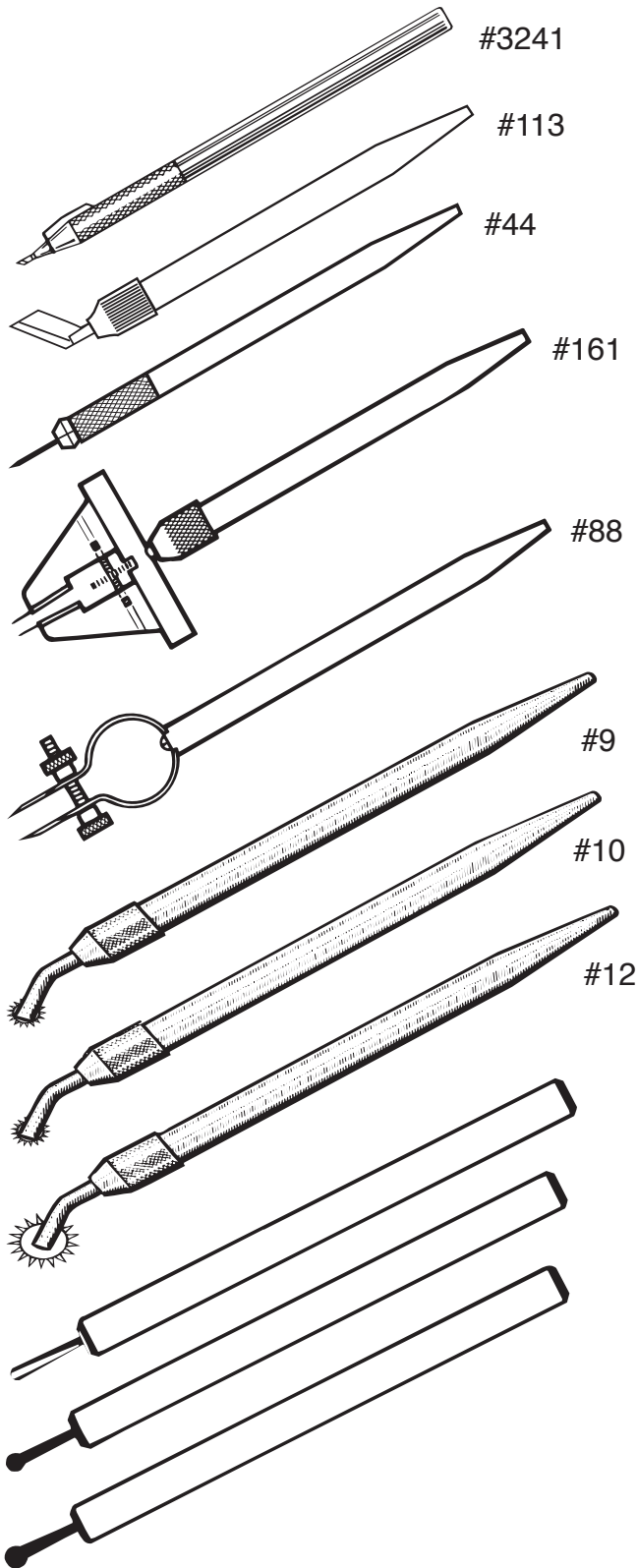

BLADES

These are the replacement blades for the knives listed on the previous pages. They are divided into three sections by the size of the handle chuck that they fit. Packaging is listed in four ways: Tuck box packaging is a unit of blades wrapped in paper. Carded blades are in a plastic tray on a blister card. A safety dispenser is a package of blades in a plastic box with a side compartment for disposal of used blades. Finally, the Bulk Pack is a unit of 100 blades in a paper box.

FOR SMALL HANDLES

These blades fit the popular light weight handles. Knives they fit include the X-Acto #1, #3, Super #1, Cut-All, #1 SGK, and the Grifhold #24. They also fit other brands of comparable knives.

#10 X-ACTO BLADES



A rounded edge blade for general cutting, carving, and correcting stencils.

X-0210	#10 Blades, Carded	Pkg. 5
X-0610	#10 Blades	Pkg. 100

#11 X-ACTO BLADES



An extremely sharp angled point for fine cutting and stencil cutting. Also ideal for masking films.

X-0211	#11 Blades, Carded	Pkg. 5
X-0411	#11 Blades, Safety Disp.	Pkg. 12
X-0611	#11 Blades, Bulk Pack	Pkg. 100

#7E GRIFHOLD BLADES



The same blade as the #11 with an extremely sharp angled point for fine cutting and stencil cutting. Also ideal for masking films. High quality at a lower price.

GR-0007E	#7E Blades, Carded	Pkg. 5
GR-0007E-100	#7E Blades, Bulk Pack	Pkg. 100

#11 X-ACTO BROAD TIP

Same shape and use as the #11 blades above, except in A Broader Point for extra strength.

X-0291	#11 Broad Blades, Carded	Pkg. 5
X-0691	#11 Broad Blades, Bulk	Pkg. 100

#16 X-ACTO BLADES



An angle edge blade with an off set point. Popular for stenciling, scoring, etching, and film cutting.

X-0216	#16 Blades, Carded	Pkg. 5
X-0416	#16 Blades, Safety Disp.	Pkg. 12
X-0616	#16 Blades, Bulk Pack	Pkg. 100



#7F GRIFHOLD BLADES

The same blade as the #16 with an extremely sharp angled point for fine cutting and stencil cutting. Also ideal for masking films. High quality at a lower price.

GR-0007F	#7F Blades, Carded	Pkg. 5
GR-0007F-100	#7F Blades, Bulk Pack	Pkg. 100
GR-0007F-1000	#7F Blades, Bulk Pack	Pkg. 1000

#17 X-ACTO BLADES

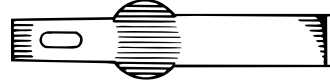

A 1/4" wide chisel blade for narrow cuts.

X-0217	#17 Blades, Carded	Pkg. 5
--------	--------------------	--------

FOR LARGE HANDLES

These following blades fit the common heavier handle knives. Knives they fit include the X-Acto #2, #5, #6, and the #3261 Woodcarving handle, plus other brands of similar knives.

#2 X-ACTO BLADES



An extremely sharp, angled point for fine cutting and stencil cutting. Ideal for masking films.

X-0202	#2 Blade, Carded	Pkg. 5
X-0402	#2 Blade, Carded	Pkg. 12

#18 X-ACTO BLADES



A 1/2" wide chisel blade for deep cross cuts and scraping.

X-0218	#18 Blades, Carded	Pkg. 5
--------	--------------------	--------

#24 X-ACTO BLADES



An angled point used for close corner cuts, templates, mats, deburring, trimming, stripping, gasket cutting etc.

X-0224	#24 Blades, Carded	Pkg. 5
X-0624	#24 Blades, Bulk Pack	Pkg. 100

SPECIALTY BLADES

LIGHT WEIGHT BLADES

A light weight blade that is ideal for stencil cutting. Fits the Grifhold #6 knife. Same blade offered from both companies.



GR-0006-B	#6 Blades, Carded	Pkg. 5
-----------	-------------------	--------

SPECIALTY BLADES

#8 X-ACTO BLADES



A refill for the #8 Utility knife.

X-0208 #8 Blades, Carded Pkg. 5

#9 X-ACTO BLADES

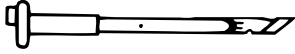

Refill blades for the #9 Retractable knife.

X-0209 #9 Blades, Carded Pkg. 5

CRAFT REFILL BLADES



Refill blade for the X-Acto Craft Swivel knife #3241

X-0245 Craft Swivel Blade Pkg. 2

113-B GRIFHOLD SWIVEL

Replacement blade for the Grifhold #113 Swivel knife.

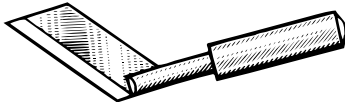

GR-113-B #113 Grifhold Blade

24-E GRIFHOLD STENCIL

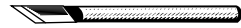

A round shank blade that is angled to a fine point. Ideal for film cutting, stencils, and other fine work. Fits the Grifhold #24 knife. Carded.

GR-0024-E Grifhold Stencil Blades Pkg. 5

24-A & B GRIFHOLD ETCH

Round shank blades sharpened to either the right or left edge. This makes scrib-



ing and etching easier. Fits Grifhold #24 handle. Carded.

GR-0024-A Grifhold Right Hand Etcher Pkg. 5
GR-0024-B Grifhold Left Hand Etcher Pkg. 5

24-F COMPASS CUTTER



A round shank blade with a tapered blade. Shape and diameter are designed to replace lead in a compass for cutting circles in film. Will also fit into lead holders for standard 2mm leads. Carded.

GR-0024-F Grifhold Compass Blades Pkg. 5



161-B DUALFLEX BLADES

Replacement blades for the Grifhold #161 Dualflex cutter.

Hvy. DUTY SNAP OFF BLADE



Fits the large snap off blade knife. For canvas, card, polyester and acetate, posters, mats, etc. Provide a continuous sharp blade.

X-243 Heavy Duty Snap Off Blade Pkg. 5
X-443 Heavy Duty Snap Off Blade Pkg. 10

Lt. DUTY SNAP OFF BLADE



Fits the small snap off blade knife. For canvas, card, polyester and acetate, posters, mats, etc. Provide a continuous sharp blade.

X-244 Light Duty Snap Off Blade Pkg. 5
X-444 Light Duty Snap Off Blade Pkg. 10

UTILITY BLADES

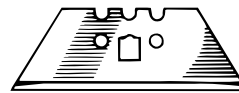

Heavy duty utility blades that fit X-Acto as well as most brands of utility knives. Carded.

X-0292 Utility Blades, Carded Pkg. 5
X-0492 Utility Blades, Safety Pkg. 15
X-0692 Utility Blades, Bulk Pkg. 100

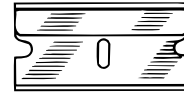

#9 & #12 RAZOR BLADES

Single edge razor blades for a variety of cutting. #12 blades are heavier than #9 and recommended for mat cutters.

X-0270 #9 Razor Blades Pkg. 5
50-5086-9 #9 Razor Blades Bulk Pkg. 100
50-5087-0 #12 Razor Blades Bulk Pkg. 100

UTILITY KNIVES

SNAP-OFF BLADE KNIFE

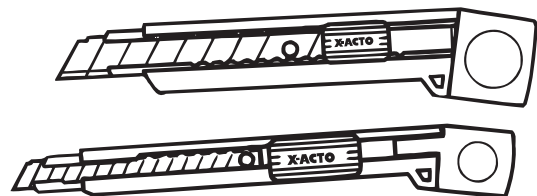

Heavy duty and light duty models for any kind of cutting. Both feature continuous snap-off blades for uninterrupted sharp cutting, and a slide lock mechanism with rigid metal safety sleeve. There is a storage compartment for extra blades, and both come with two extra blades. Carded

X-3243 Heavy Duty Snap-Off Blade Knife
X-3244 Light Duty Snap-Off Blade Knife

HVY DUTY UTILITY KNIVES

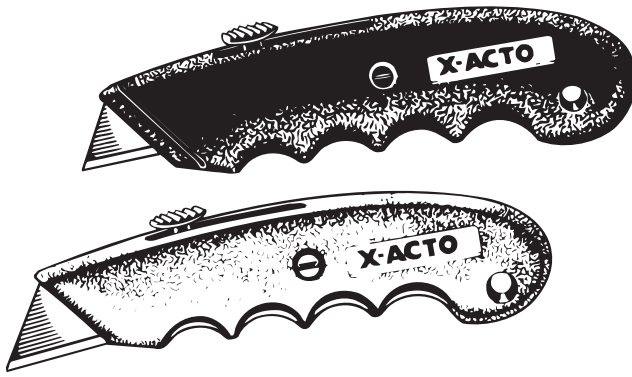

An ideal mat or heavy duty utility knife. All models feature a textured surface with a pistol grip that is shaped to fit the hand and not slip. Available in metal or plastic body models both with retractable blades. Adjustable cutting depths to suit the job, and a large slotted screw for easy blade change. A compartment in the handle holds extra blades. Both models feature a push button for depth selection, and full blade retraction into the handle. Carded. Uses standard utility blades.

X-3272	X-Acto Utility	Plastic Handle
X-3274	X-Acto Utility	Metal Handle

#8R UTILITY KNIFE

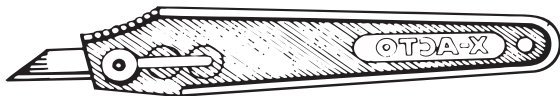

A light weight utility knife that can be used for a variety of uses. The handle is all plastic, while the handle is retractable and reversible. This means two edges can be used on each blade. Uses #208 replacement blades.

X-3208	X-Acto 8R Utility Knife	Carded
X-3008	X-Acto 8R Utility Knife	Bulk

AKUKUT Depth Controlled Cutter

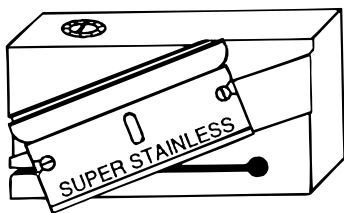

Clamp a standard single edge razor blade into this hand held device and control the depth of cut to 1/1000 of an inch. Slit carrier sheets or cut the top layer of film without disturbing the carrier.

AKUKUT Controlled Depth Cutter

BEAM COMPASS CUTTER

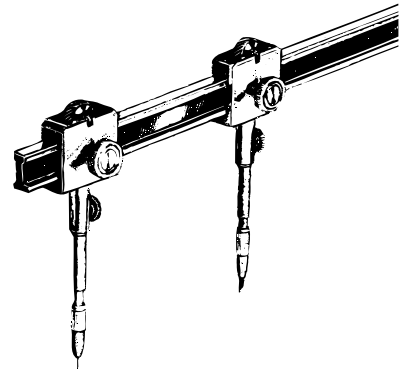

Precision beam compass with 14" aluminum bar with 14" extension for a total span of 28". Micro adjust rollers with lock nuts for precise control. Uses GR-0024F blades.

52-5269-7 Beam Compass Cutter

BOW COMPASS CUTTER

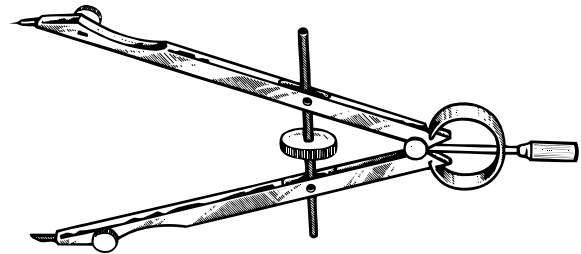

A precision giant bow compass that is also useable as a pencil compass or divider. Rigid construction to prevent creeping. Complete with #24-F blade for film cutting.

GR-2804 Bow Compass Cutter Carded

SHARPENING STONE



A high quality, aluminum oxide sharpening stone that will keep cutting tools in tip-top shape. Measures 3-1/2 x 3/4 x 7/8".

GR-0043 Sharpening Stone Boxed

YARD STICK COMPASS

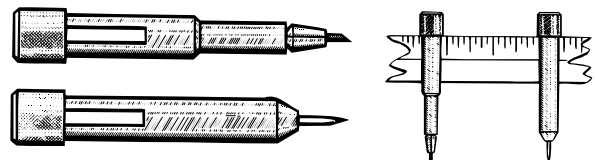

Aluminum pivot point and holder that fit on most wood yardsticks. Turns the yard stick into a compass. Easily adjustable, and holds #19, #20, and #24-F blades for cutting.

GR-0108 Yard Stick Compass Carded

MAHLSTICK

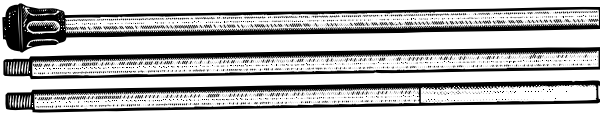

A three part aluminum mahlstick that extends to 30", is strong, and weighs only 3-1/2 oz. Designed for the artist and sign painter with rubber, no mar tip.

GR-0099 Mahlstick

DAHLE SUPER SHEAR



Today's styling in scissors, these scissors feature stainless steel, super sharp blades, contoured acrylic handles, and a light, featherweight touch. Self sharpening Solingen steel blades keep their edges, even through long, hard use. The contoured acrylic handles are more comfortable to hold, fit fingers better, and give better control. Made in America.

DH-50006	6" Super Shear
DH-50008	8" Super Shear
DH-50009	9" Super Shear
DH-50010	10" Super Shear

DAHLE VANTAGE SHEAR



Similar to to Super Shear, this lower priced scissor features stainless steel, rust resistant blades, tough handles, and a light, featherweight touch. The contoured plastic handles are more comfortable to hold, fit fingers better, and give better control.

DH-40005	5" Vantage Shear
DH-40006	6" Vantage Shear
DH-40008	8" Vantage Shear

CUTTING BASE

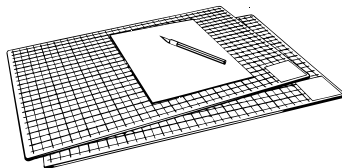

C-THRU CUTTING BASE

This cutting base is a self-sealing mat with an instant heal surface. Surface assures a long lasting, smooth base for both writing and cutting, even after many cuts. Knives cut smoothly and last longer, while pens write easier. Is attractive while also protecting light boxes and tables. There is a grid design on the surface and mats are available in either translucent or blue.

BLUE		TRANSLUCENT
CT-2000B	8-1/2 x 12" Base	CT-2004T
CT-2001B	12 x 18" Cutting Base	CT-2005T
CT-2002B	18 x 24" Cutting Base	CT-2006T
CT-2003B	24 x 36" Cutting Base	CT-2007T

TRIMMERS

DAHLE TRIMMER



Attractive surface to compliment any decor, this cutter features self sharpening stainless steel blades that are ground and tempered to cut up to 15 sheets of paper. Also cuts film, poster board, and textiles. The patented blade design eliminates the need for a blade latch and prevents the blade from popping up or dropping down. A safety shield protects fingers and holds paper in place while maintaining visibility.

DH-012E	12" Dahle Personal Cutter
DH-015E	15" Dahle Personal Cutter
DH-018E	18" Dahle Personal Cutter

DH-212	12" Dahle Professional Cutter
DH-215	15" Dahle Professional Cutter
DH-218	18" Dahle Professional Cutter
DH-124	24" Dahle Professional Cutter

PERSONAL ROLLING TRIMMER



An attractive, lightweight, and portable rolling trimmer for offices, studios, art rooms, etc. The patented self-sharpening rotary blade cuts up to 7 sheets of paper in either direction. The high impact grid surface will not chip, fade, or scratch. Precision cuts from light weight tissue to film.

DH-500	9"	Personal Rolling Cutter
DH-507	12-1/2"	Personal Rolling Cutter
DH-508	18"	Personal Rolling Cutter

HEAVY DUTY ROLLING CUTTER



A precision cutter for light to medium weight material. Features metal base commercial grade construction and a rotary blade shielded for safe cutting. Precision cuts from light weight tissue to film, poster board, laminate, acetate, etc. Lifetime guarantee.

DH-550	13-3/8"	H/D Rolling Cutter
DH-552	18-1/8"	H/D Rolling Cutter
DH-554	26-3/8"	H/D Rolling Cutter
DH-556	37-1/2"	H/D Rolling Cutter
DH-558	50"	H/D Rolling Cutter
DH-696	Stand for #556	
DH-698	Stand for #558	

MAT CUTTERS

We carry a complete line of Logan professional, production mat cutters. Please call or write for additional information.

LOGAN 2000 MAT CUTTER

A push style mat cutter with a retractable blade, start & stop indicator, and fully upgradable to Logan Rail and Board mounted systems. Uses #270 Blade

LOGAN-2000 Logan Hand Mat Cutter



Logan 2000

LOGAN 3000 MAT CUTTER

A pull style mat cutter with a pivoting blade holder, start & stop indicator, and fully upgradable to Logan Rail and Board mounted systems. Uses #270 Blade

LOGAN-3000 Logan Hand Mat Cutter



Logan 3000

LOGAN 4000 MAT CUTTER

A "Original" Logan professional mat cutter. scaled down for use by everyone. A pull type cutter that cuts from the back side of the mat. This eliminates scuffing. A built in marker measures 0 to 5-1/2" borders. This helps eliminate over cuts. The pivotable blade holder keeps the blade up when not in use and has a depth adjustment screw for control. Fully upgradable to Logan Rail and Board mounted systems. Many other features that can help give perfect results! Uses #270 blades.

LOGAN-4000 Logan Hand Mat Cutter



Logan 4000

DEXTER MAT CUTTER

Easy to use, the Dexter mat cutter cuts professional looking mats with either beveled or straight cuts. A push type cutter that cuts from the top surface of the mat. Cut depth can be adjusted to also allow scoring. Chrome plated and shaped to fit the hand.

DX-140 Dexter Mat Cutter Boxed
DX-145 Dexter Blades, Pkg. of 5 Tuck

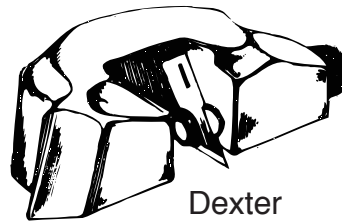

Dexter

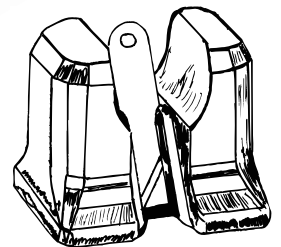

Dexter Mini

DEXTER MINI MAT CUTTER

A smaller version of the famous Dexter mat cutter. Designed to be used by the right or left hand, for multi-directional cutting. It is easy to grip and comfortable to use, with a chrome plated surface. A push type cutter that cuts from the top surface. Uses same blades as the large cutter.

DX-135 Dexter Mini Mat Cutter Boxed
DX-145 Dexter Blades, Pkg. of 5 Tuck

X-Acto 7740

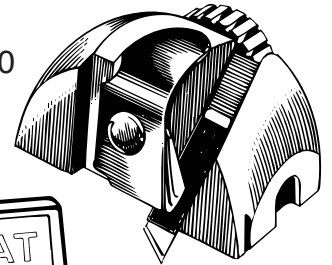

X-ACTO MAT CUTTER

The X-Acto mat cutter features a light weight, high impact molded plastic body with metal blade clamp. Cuts perfect 45 degree bevels or straight 90 degree cut. A push type cutter that cuts from the top surface. Cut depth can be easily controlled to allow scoring. Uses X-Acto #19 blades.

X-7740 X-Acto Mat Cutter Carded

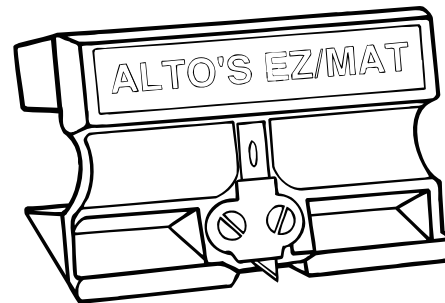

Alto-30

ALTO'S E-Z MAT CUTTER

An easy to use pair of cutters with either 30° or 45° cutting angles. Perfect for cutting free hand or with any straight edge. Uses X-Acto #19 or Dexter blades. Cuts from mats back side.

ALTO-30 30° E-Z Mat Cutter
ALTO-45 45° E-Z Mat Cutter

Alto-45

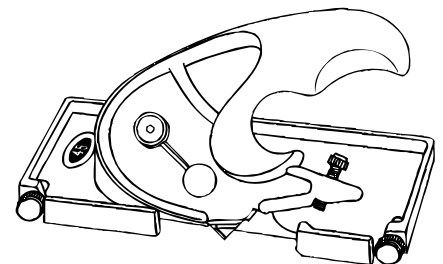

LOGAN COMPACT CUTTERS

32" board mounted mat cutting system with parallel mat guide and creative matting instructions. Available in three versions.

MODEL 300 Includes the 32" board plus screws and bearings to adapt hand held mat cutters #2000, 3000, & 4000.
LOGAN-0300 Compact Mat Cutter Board

MODEL 301 Includes the 32" board plus bevel cutting head and five blades. Uses #270 Blade.
LOGAN-0301 Compact Mat Cutter Board & Cutter

MODEL 301-S Includes the 32" board plus bevel and straight cutting heads and five blades. Uses #270 Blade.
LOGAN-0301S Compact Mat Cutter Board & Cutters

MODEL 401 Includes the 40" board plus bevel and straight cutting heads and five blades. Uses #270 Blade.
LOGAN-0401 Compact Mat Cutter Board & Cutters



Logan 301-S.

LOGAN SIMPLEX PLUS

A board mounted mat cutting system with parallel mat guide in aluminum channels, a 27" squaring arm, and a laminated surface, two guide rail production stops and creative matting instructions.

LOGAN-0750 40" Simplex Plus Mat Cutter Board
LOGAN-0760 60" Simplex Plus Mat Cutter Board

Logan Simplex



LOGAN PROFESSIONAL

Heavy duty framing mat cutters with dual straight and bevel cutting head. A board mounted mat cutting system with parallel mat guide, a 27" squaring arm, and a laminated surface, movable production stop. Uses #269 Blade. Available in two sizes.

LOGAN-0650 40" Professional Mat Cutter Board
LOGAN-0660 60" Professional Mat Cutter Board

Logan Professional

LOGAN TEAM SYSTEM

Kit for upgrading hand held cutters. Included are aluminum guide rail, rubberized base, and screws for 2000, 3000, and 4000 cutters.

LOGAN-0524 24" Adapt-A-Rail
LOGAN-0540 40" Adapt-A-Rail
LOGAN-0560 60" Adapt-A-Rail (not ruled)



Logan Team System

LOGAN 270 BLADE

A rectangular blade with vertical oval notch. Used with many Logan Mat Cutters.

LOGAN-270-100 Plastic Box of 100 Carded
LOGAN 270-050 Plastic Box of 50 Carded
LOGAN 270-010 Pkg. of 10 Carded

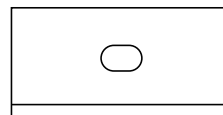

269

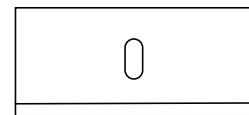

270

LOGAN 269 BLADE

A rectangular blade with horizontal oval notch. Used with Logan Professional Mat Cutters.

LOGAN-269-100 Box of 100

SCREEN PRINTING

SPEEDBALL SCREEN PRINT KIT

A basic screen printing kit for poster (paper) printing that combines the tools and supplies for 4 detailed projects. Contains a frame with fabric, 9" squeegee, 8 oz. acrylic process cyan, process magenta, process yellow, and black inks, plus a 4 oz. screen drawing fluid, a 4 Oz. screen filler, tracing vellum, accessories, and complete instructions. In an attractive shrink wrapped carton.

HU-4521 Speedball Screen Print Kit.



DELUXE SCREEN PRINTING KIT

The Deluxe Screen Printing Kit has both poster and textile supplies. It contains a frame with fabric, 9" squeegee, and four 8 oz. water soluble acrylic inks (process cyan, process magenta, process yellow, and black), textile black and fluorescent pink inks, and base with accessories. Also included are tracing vellum, 4 oz. screen drawing fluid, 4 oz. screen filler, a 55 minute video and complete instructions. In an attractive shrink wrapped box.

HU-4522 Speedball Deluxe Screen Print Kit



FABRIC SCREEN PRINT KIT

Complete fabric screen printing kit combines the tools and supplies with Includes everthing needed to print t-shirts. Comes with screen and fabric, 9" squeegee, 8 oz. water soluble textile ink in black and white, 4 oz. screen filler, 4 oz. drawing fluid, 4 oz. photo emulsion with sensitizer, and instruction booklet. For light colored fabric only. In an attractive shrink wrapped box. In an attractive shrink wrapped box.

HU-4526 Speedball Fabric Screen Print Kit



OPAQUE FABRIC SCREEN KIT

Ideal for use on dark colored shirts. Includes everthing needed to print t-shirts. Comes with screen and fabric, 9" squeegee, 3 jars of 4 oz. opaque textile ink in black and white, 4 oz. screen filler, 4 oz. drawing fluid, 4 oz. photo emulsion with sensitizer, and instruction booklet.

HU-4519 Speedball Opaque Fabric Screen Print Kit

SCREEN INKS

ACRYLIC SCREEN INK

An acrylic base screen ink that offers the permanence of solvent based inks with the ease of water washup. For use on paper, wood, some vinyl's, board, and fabric that will not be laundered. All colors are opaque, brilliant, flexible and non-toxic. Should not be used with water based film or emulsion. AP Non-toxic, conforms to ASTM D-4236

	8 OZ	Quart	Gal
Process Cyan	HU-46210	HU-46410	HU-46610
Process Magenta	HU-46211	HU-46411	HU-46611
Process Yellow	HU-46212	HU-46412	HU-46612
White	HU-4620	HU-4640	HU-4660
Primrose Yellow	HU-4621	HU-4641	HU-4661
Medium Yellow	HU-4623	HU-4643	HU-4663
Orange	HU-4624	HU-4644	HU-4664
Fire Red	HU-4625	HU-4645	HU-4665
Medium Red	HU-4626	HU-4646	HU-4666
Dark Red	HU-4627	HU-4647	HU-4667
Gold	HU-4628	HU-4648	HU-4668
Silver	HU-4629	HU-4669	HU-4689
Violet	HU-4630	HU-4650	HU-4670
Ultra Blue	HU-4631	HU-4651	HU-4671
Dark Blue	HU-4632	HU-4652	HU-4672
Peacock Blue	HU-4633	HU-4653	HU-4673
Emerald Green	HU-4634	HU-4654	HU-4674
Brown	HU-4636	HU-4656	HU-4676
Black	HU-4637	HU-4657	HU-4677





NIGHT GLO SCREEN INK PHOSPHORESCENT

An water base textile screen ink that looks like a standard ink by under normal but glows in the dark. After glo lasts up to eight hours. Can be screen printed or brushed on. Wash fast when properly heat set. Should not be used with water based film or emulsion. AP Non-toxic, conforms to ASTM D-4236. 8 oz. jars only.

Blue HU-47520 Yellow HU-47521
Green HU-47522 White HU-47523



SPEEDBALL FABRIC INK

An water base textile screen ink in 19 brilliant colors including fluorescent and process color for use on cotton, polyester blends, an linen. Also works great on paper and cardboard. Washfast when properly heat set. non-flammable and contains no solvent and no offensive smell. Can be screen printed or painted on with a brush AP non-toxic and conforms top ASTM D-4236.

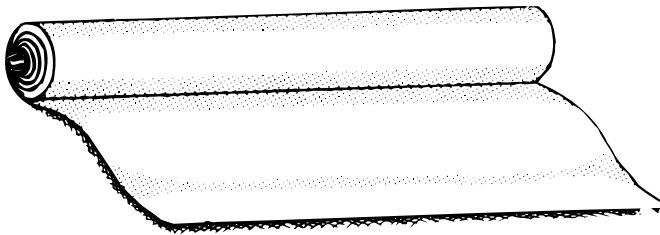

TRANSPARENT COLORS

	<u>8 OZ</u>	<u>Quart</u>	<u>Gal</u>
Process Cyan	HU-45650	HU-45750	
Process Magenta	HU-45651	HU-45751	
Process Yellow	HU-45652	HU-45752	
White	HU-4563	HU-4603	HU-46033
Yellow	HU-4565	HU-4605	HU-46055
Orange	HU-4569	HU-4609	
Red	HU-4561	HU-4601	HU-46011
Burgundy	HU-4684	HU-4686	
Violet	HU-4550	HU-4575	
Blue	HU-4562	HU-4602	HU-46022
Blue Denim	HU-4566	HU-4606	
Peacock Blue	HU-4551	HU-4653	
Green	HU-4564	HU-4604	HU-46044
Brown	HU-4567	HU-4607	
Black	HU-4560	HU-4600	HU-46000

NORTHWEST POLYESTER

Northwest Polyester is a monofilament polyester fabric that is the ultimate for fine detail and perfect registration. It has almost no elasticity, making it unequalled for resolution and dimensional stability. Yellow color helps for finer resolution with direct emulsions. The ultimate fabric for fine line, halftone, and multicolor reproduction.

35-1110-4	110 Polyester, 42" Width
35-1123-4	123 Polyester, 42" Width
35-1137-4	137 Polyester, 42" Width
35-1156-4	156 Polyester, 42" Width
35-1175-4	175 Polyester, 42" Width
35-1195-4	195 Polyester, 42" Width
35-1230-4	230 Polyester, 42" Width
35-1240-4	240 Polyester, 42" Width

POLYESTER MULTIFILAMENT

Multifilament (many threads wound into one, then interwoven) polyester or dacron is of the highest quality. Perfectly finished and uniformly woven, this durable fabric offers non-shift multifilament construction. The rougher finish of multifilament construction makes film and emulsions adhere better. Ideal for textile work or poster work where heavy deposit is required. Prices are per yard, 40" width listed below, larger widths available.

34-7064-8	6XX	Multifilament Polyester, 40" width
34-7084-6	8XX	Multifilament Polyester, 40" width
34-7104-2	10XX	Multifilament Polyester, 40" width
34-7124-0	12XX	Multifilament Polyester, 40" width
34-7144-8	14XX	Multifilament Polyester, 40" width
34-7065-5	6XX	Multifilament Polyester, 50" width
34-7085-3	8XX	Multifilament Polyester, 50" width
34-7105-9	10XX	Multifilament Polyester, 50" width
34-7125-7	12XX	Multifilament Polyester, 50" width

FLUORESCENT

Hot Pink	HU-4687	HU-4693
Lime Green	HU-4690	HU-4695
Orange	HU-4691	HU-4696
Magenta	HU-4692	HU-4697

OPAQUE PEARL COLORS

Raspberry	HU-4801	HU-4821
Blue Topaz	HU-4802	HU-4822
Pearly White	HU-4803	HU-4823
Emerald	HU-4804	HU-4824
Citrine	HU-4805	HU-4825
Amethyst	HU-4806	HU-4826
Silver	HU-4807	HU-4827
Gold	HU-4808	HU-4828
Sherbet	HU-4809	HU-4829
Black Pearl	HU-4810	HU-4830

FRAME MATERIALS

MITE-R-STIX

Top quality, kiln dried Ponderosa Pine that is ideal for screen frames. Sizes are pre-cut exactly with 45 degree angles for easy assembly. Lengths are also pre-grooved for the popular rope method of fabric stretching. Available in two stock sizes: 1-1/8" square for small screens and 1-5/8" square for larger screens. Length shown is inside dimension.

1-1/8" SQUARE

13-1142-2	6" Length
13-1144-8	8" Length
13-1196-8	9" Length
13-1197-6	10" Length
13-1198-4	11" Length
13-1145-5	12" Length
13-1146-3	14" Length
13-1147-1	16" Length
13-1148-9	18" Length
13-1149-7	20" Length
13-1150-5	22" Length
13-1151-3	24" Length
13-1175-2	25" Length
13-1152-1	26" Length
13-1176-0	27" Length
13-1153-9	28" Length
13-1154-7	30" Length
	32" Length
	33" Length
	34" Length
	36" Length
	38" Length
	40" Length
	42" Length
	44" Length
	46" Length
	48" Length

1-5/8" SQUARE

13-1155-4
13-1156-2
13-1157-0
13-1158-8
13-1159-6
13-1160-4
13-1161-2
13-1162-0
13-1199-2
13-1163-8
13-1200-8
13-1164-6
13-1165-3
13-1166-1
13-1201-6
13-1167-9
13-1168-7
13-1169-5
13-1170-3
13-1171-1
13-1172-9
13-1173-7
13-1174-5

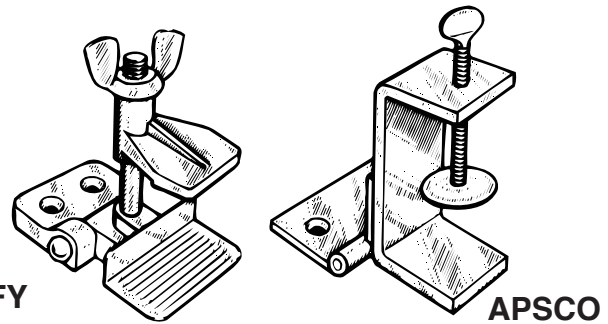
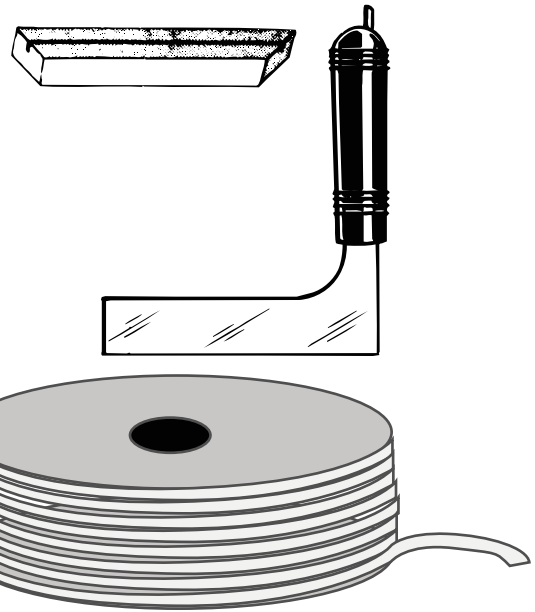

JIFFY

APSCO

TITE STRETCH CORD

Tite-Stretch cord gives a perfect no-slip grip in the groove of Mite-R-Stix listed above. Made from a hard finish, uniform diameter material. The easy way to stretch screens.

15-1132-8 Tite-Stretch Cord 100' Length

TITE STRETCH TOOL

This easy to operate tool presses cord into the groove of Mite-R-Stix, and a tap of the hammer tightens the fabric. Hard steel blade with palm fitting handle, and balluster reamer on the end. Blade is 5" long and 1" high, while handle is 3-1/4".

15-1129-4 Tite-Stretch Tool

HINGE CLAMPS

A hinge clamp is basically a C-clamp with a hinge attached. This allows permanent attachment to the printing table with ease of removal for the screen. Hinge clamps are very stable to eliminate screen wiggle.

APSCO HINGE CLAMP

A simple clamp that will handle wood frames from 3/4" to 1-5/8" thick. Metal is brightly plated and screws are included.

54-1110-3 Apsco Hinge Clamps

JIFFY HINGE CLAMP

A rugged screen clamp featuring cast construction and positive locking action. Accepts frames up to 3" thick.

HU-4513 Jiffy Hinge Clamp

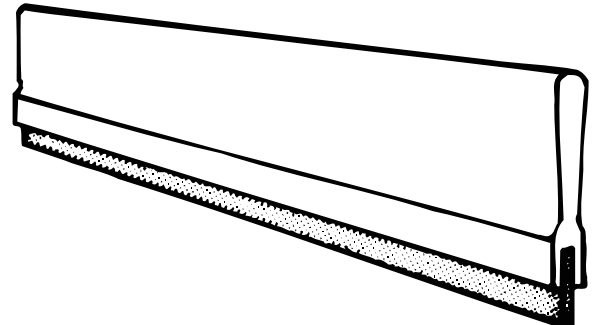

SQUEEGEES

The squeegee is the chief tool for printing. Several types are used in degrees of hardness. All are available in 5" high wood handles that are shaped to fit the hand. The softer the squeegee, the more ink it deposits. Select hardness to fit your type of print. Standard black is the least expensive, an all around squeegee. Everlast tan lasts longer than black before it needs sharpening. Polyplastic lasts the longest before it requires sharpening. Order in inches, and length to 144".

5" HANDLE

14-7215-8	Standard Black-Soft
14-7216-6	Standard Black-Medium
14-7217-4	Standard Black-Hard
14-7225-7	Everlast Tan-Soft
14-7226-5	Everlast Tan-Medium
14-7227-3	Everlast Tan-Hard
14-7236-4	Polyplastic-Medium
14-7237-2	Polyplastic-Hard
14-7441-0	Polyplastic-Extra Hard

HAND CUT FILM

ULANOCUT

Water soluble hand cut film that is available in either Green or Amber color, on a .003" polyester base. Simply cut your design, peel off the film where you want the ink to print, and adhere with plain water. Film will restick to base for correcting mistakes. Ideal for all solvent based inks. Not for water based inks.

UL-UCG-40300	Ulanocut Green	40 x 300"
UL-UCG-44300	Ulanocut Green	44 x 300"
UL-UCG-52300	Ulanocut Green	52 x 300"

STA-SHARP S3S

A lacquer type hand cut film that is on a .003 polyester base. Simply cut your design, peel off film where you want the ink to print, and adhere. Cuts and strips very easily. For use with mild solvent inks (such as poster inks) and all water base inks. Use T-700 adhering liquid.

UL-S3S-40300	Sta-Sharp S3S	40 x 300"
UL-S3S-44300	Sta-Sharp S3S	44 x 300"
UL-S3S-52300	Sta-Sharp S3S	52 x 300"

ULANO ADHERING LIQUID

Adheres film quickly without burning the edges. For all lacquer film types such as Sta-Sharp. Evaporates quickly.

UL-ADH-Q	Adhering Liquid	Quart
UL-ADH-G	Adhering Liquid	Gallon

PRE-SENSITIZED FILM

POLY 2 BLUE FILM

Poly 2 is a blue pre-sensitized film on a .002 polyester backing sheet. Simply expose to a film positive, develop, wash out and adhere. A more sensitive film for fine detail and razor sharp prints. Use developer listed.

UL-POLY2-40300	Poly 2 Film	40 x 300"
----------------	-------------	-----------

HI-FI DEVELOPER

Ulano developer for pre-sensitized films shown at left. Easy to use in pre-measured packets, in sets of A & B chemicals. Available in pints and quarts.

UL-AB-P	Developer	8 sets, pint
UL-AB-Q	Developer	20 sets, quart

ULANO #1 ENZYME

A superconcentrated enzyme digester for removal of gel type presensitized films such as Hi-Fi Green and Poly 2. Will not harm fabric. A neutral, non-toxic, organic material that will not dissolve the toughest films.

UL-001-1	Ulano #1 Enzyme Digester	1 lb.
----------	--------------------------	-------



DIRECT EMULSION

Direct emulsions are coatings to which a sensitizer is added. After sensitizing, coating is applied to a blank screen and allowed to dry. The screen can then be exposed with a film positive and developed with plain water.

HUNT EMULSION KIT

A complete package with 8 oz. of direct emulsion and two 1 oz. bottles of bichromate sensitizer. Half can be sensitized at a time.

HU-4533	Hunt Direct Emulsion Kit
---------	--------------------------

HUNT DIAZO EMULSION KIT

A complete package with 7 oz. of direct emulsion and diazo sensitizer. Diazo sensitized emulsion produces more durable screens than bichromate. Mixed diazo sensitized emulsion can be stored up to 90 days if properly stored (no light and kept cool).

HU-4558	Hunt Diazo Emulsion Kit
---------	-------------------------

WATER RESIST. EMULSION

A special Ulano emulsion developed to resist water based inks. Ideal for textile printing or anywhere extra tough emulsion is needed. Diazo sensitizer is included.

UL-TLX-Q	Ulano TLXt Emulsion	Quart Kit
----------	---------------------	-----------

SPEEDBALL DRAWING FLUID (Liquid Touche)

For "tusche-resist" or "positive" screen printing method. The drawing fluid is applied with a brush, then the entire screen is covered with screen filler. When the screen filler is dry, the drawing fluid can be washed, allowing for the area to be printed.

HU-4531 8 oz. Can Drawing fluid
HU-4571 16 oz. Can Drawing Fluid

SPEEDBALL FILLER

Used to fill in or block out areas not intended to be printed. Also for use in combination with Speedball Drawing Fluid to make tousche style screens.

HU-4530 Speedball Screen Filler 8 oz.
HU-4570 Speedball Screen Filler Quart

AQUASOL BLOCKOUT

A water soluble all purpose blockout for use with films or direct emulsion. Washes out with water and dries fast to a durable, flexible finish. Easy to see Red Color.

SYS-5511-16 Aquasol Blockout Pint
SYS-5511-Q Aquasol Blockout Quart
SYS-5511-G Aquasol Blockout Gallon

EMULSION REMOVER

A clear, non-odorous solution which dissolves all photo emulsions to reclaim after printing. Remove ink from screen, then apply with a brush.

SYS-6000 06 Systems Emulsion Remover, 6 oz.
SYS-6000-32 Systems Emulsion Remover, Quart
SYS-6000-36 Systems Emulsion Remover, Gallon

SCREEN EQUIPMENT

ACUPRINT PRESS SERIES

The Acuprint press series ranges from print sizes of 12 x 18" to 25 x 38". All feature vacuum hold down, timer, smooth squeegee action, easy pressure adjustment, all welded metal construction, and UL approval. We also handle a complete line of equipment for all production needs, please call or write for additional information.

NATIONAL TEXTILE PRINTER

The Rototex is a manual, multicolor textile printer. Screens are easily adjusted and removed, plus they are held from the side for stability. Each color head locks into position for absolute registration. Optional speed table increases production.

RACKS

We handle a complete series of racks from table top "Twin-Shelf" to 52 x 80" industrial "Rack-King" racks. Plus there is the new UPS rack that is ideal for school use in either the art or industrial art department. Please call for complete list and price quote.

E-40-4100-0 Twin Top Table Rack
E-40-4101-8 Twin Rack (Floor Model 100 Shelves)
E-MR-1824 Tensor 18x24" 1 side (Floor Model 40 Shelves)
E-MR-1824D Tensor 18x24" 2 sides (Floor Model 80 Shelves)



Multi-Rack



Tensor 18

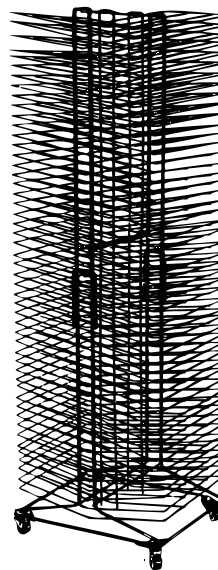

Twin Rack - Floor

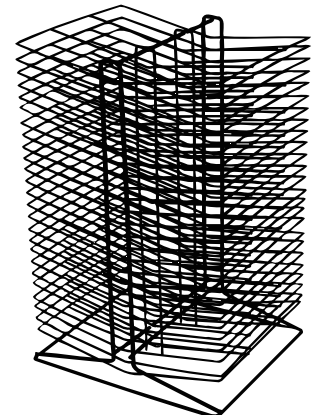

Twin Rack - Table

MULTI RACKS

E-MR-2232-40 22 x 32", 40 Tray
E-MR-2232-50 22 x 32", 50 Tray
E-MR-3248-40 32 x 48", 40 Tray
E-MR-3248 32 x 48", 50 Tray
E-MR-4025 40 x 52", 50 Tray
E-MR-4333 43 x 33", 50 Tray
E-MR-4569 45 x 69", 50 Tray
E-MR-5269 52 x 69", 50 Tray
E-MR-5281 52 x 81", 50 Tray

BLOCK PRINTING

SPEEDBALL BLOCK INK

Speedball block inks are available in oil and water base. The oil base is used where permanency is desired, also for printing on cloth. Clean up oil based inks with T-125, mineral spirits, or turpentine. Where ease of cleaning is desired, water based colors are used.. Colors dry to a rich satin finish and are intermixable. Numbers below are for 1 x 4", 37cc tubes. The same colors are available in 4 oz (75cc), and 8 oz. (147cc) tubes, plus one pound cans on special order, in standard packages.

WATER BASE

HU-3400	Black
HU-3401	Red
HU-3402	Blue
HU-3403	White
HU-3404	Green
HU-3405	Yellow
HU-3406	Brown
HU-3407	Orange
HU-3408	Violet
HU-3409	Turquoise
HU-3410	Magenta
HU-3411	Light Red
HU-3412	Dark Yellow
HU-3413	Gold
HU-3414	Silver

OIL BASE

HU-3450
HU-3451
HU-3452
HU-3453
HU-3454
HU-3455
HU-3456
HU-3458
HU-3459
HU-3460

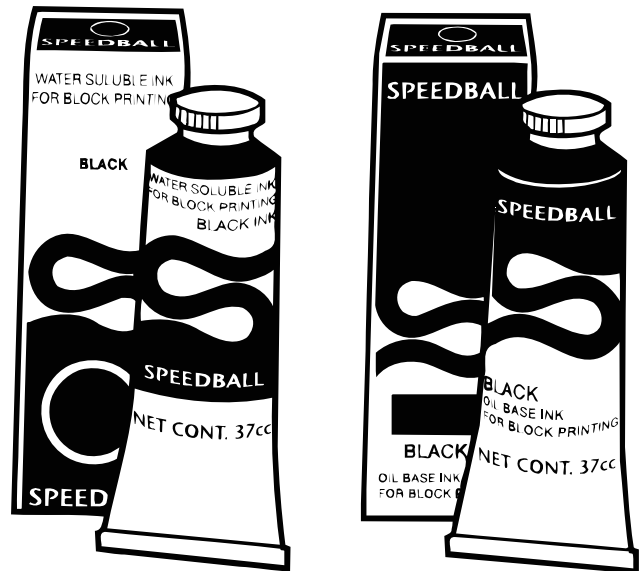

LINOLEUM BLOCKS

Speedball Linoleum Blocks have a smooth linoleum surface mounted on heavy composite wood. The light cream colored surface permits the printmaker to draw on the surface and cut precisely. Cuts to sharp, crisp edges for excellent reproduction. Sizes 5 x 7" and larger, 6 per package, smaller sizes 12 per package.

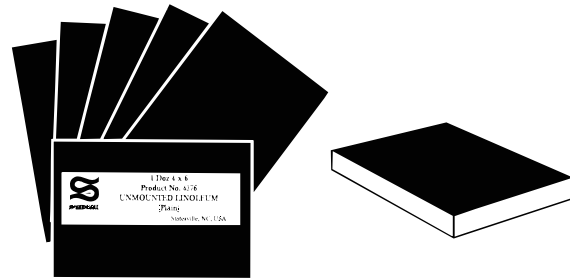

HU-4301	2 x 2"	HU-4309	5 x 7"
HU-4303	2 x 3"	HU-4310	5 x 8"
HU-4304	3 x 3"	HU-4311	6 x 8"
HU-4305	3 x 4"	HU-4312	6 x 9"
HU-4306	3 x 5"	HU-4313	8 x 10"
HU-4307	4 x 5"	HU-4314	9 x 12"
HU-4308	4 x 6"		



SPEEDY BLOCK

A special eraser like material that is easy to carve, faster cutting, and safer than traditional cutting linoleum. Also ideal for using for custom rubber stamps. Available in three sizes.

HU-4341	Speedy Block	3 x 4"	4 per box
HU-4342	Speedy Block	4 x 6"	2 per box
HU-4343	Speedy Block	9 x 12"	2 per box

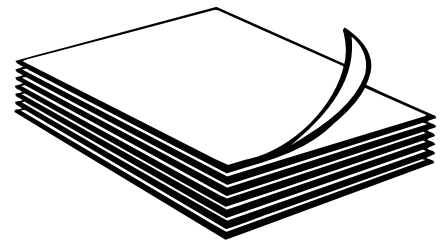

FLEXIBLE PRINTING PLATE

The Speedball Flexible Printing Plate is a soft, flexible vinyl material for print making. It is 1/16" thick with a smooth tan top surface and a pressure sensitive adhesive back. Cutting is extremely easy. After cutting, the plate is mounted on any film surface. Package of 12.

HU-4165	Flexible Printing Plate	9 x 12"
---------	-------------------------	---------

POLYPRINT PLATE

The Speedball Polyprint Printing Plate is an economical sheet of white polystyrene foam with a pressure sensitive backing. It is easily cut, torn, or indented. No cutting tools are required. 12 per box.

HU-4166	Polyprint Printing Plate	9 x 12"
---------	--------------------------	---------

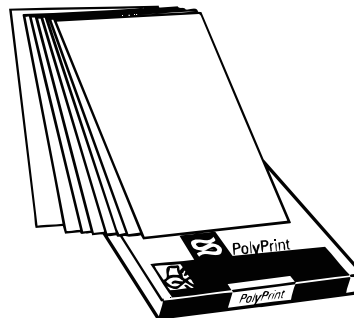

LINOLEUM CUTTERS

High quality cutters of proven durability. Push type, Carded 2 per card.

- HU-41201 #1 Small Liner
- HU-41202 #2 V-Shaped Gouge
- HU-41203 #3 Large Liner
- HU-41204 #4 U-Shaped Gouge
- HU-41205 #5 Large Gouge
- HU-41206 #6 Knife

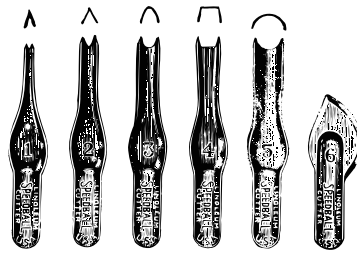

LINOLEUM CUTTERS



LINOZIP CUTTERS

A safe pull type cutter for students and novices. Makes the same cuts as push type, except the pull style helps eliminate cut fingers. 12 per box.

- HU-4111 #21 Liner
- HU-4112 #22 V-Shaped Gouge
- HU-4113 #23 Large Liner
- HU-4114 #25 Large Gouge

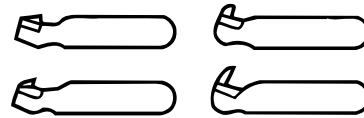

LINOZIP CUTTERS



#1 SET CARDED

LINO CUTTER HANDLE

Handles that are designed to fit the hand, these handles are fitted with adjustable screw chucks to hold cutters securely. For both regular and Linozip cutters, Carded.

- HU-41238 Linoleum Cutter Handle Carded

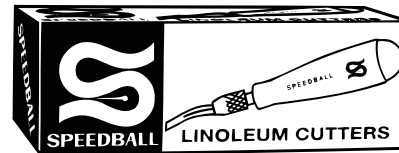

#1 LINO CUTTER SET

#1 LINO CUTTER SET

The Speedball #1 Lino assortment contains a handle and one each of cutters #1, #2, #3, #5 and #6. Individually boxed.

- HU-4131 Speedball #1 Lino Cutter Asst. Boxed
- HU-41231 Speedball #1 Lino Cutter Asst. Carded

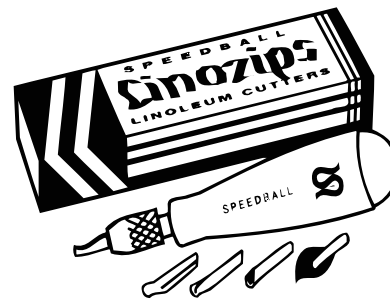

#37 LINOZIP SET

#37 LINOZIP CUTTER SET

The Speedball #37 Linozip assortment contains a handle and one each of Linozip cutters #21, #22, #23, #24 and Lino cutter #6. Individually boxed.

- HU-4137 #37 Speedball Linozip Asst. Boxed

BAREN

The Speedball Baren is a press for hand printing. The base is teflon covered for friction free long wear. Individually boxed.

- HU-4139 Speedball Baren Boxed

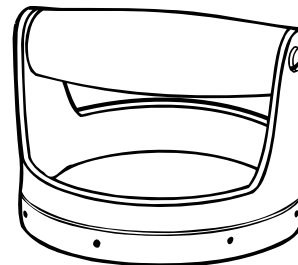

BAREN

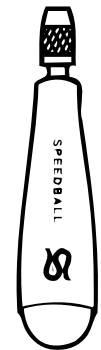

HANDLE

#51 HARD BRAYER

A quality hard rubber brayer with metal brace bar and plastic handle. Individually boxed.

- HU-4124 #51 Brayer 4" Boxed

#49 ECONOMY BRAYER

An economy hard rubber brayer that comes in two versions: the traditional #49 with metal bar and plastic handle, and the #49P with all plastic handle.

- HU-4121 #49 Brayer 4" Boxed
- HU-4128 #49P Brayer (Plastic) 4" Boxed
- HU-41228 #49P Brayer 4" Carded



#49P BRAYER



SOFT BRAYERS

Premium Speedball soft rubber brayers, with smooth, soft rubber mounted on a sturdy metal core to eliminate warping. With deluxe sturdy plastic handle, individually boxed.

HU-4170	#70 Brayer	1-1/2"	Boxed
HU-4171	#71 Brayer	2"	Boxed
HU-4172	#72 Brayer	2-1/2"	Boxed
HU-4173	#73 Brayer	3"	Boxed
HU-4174	#74 Brayer	3-1/2"	Boxed
HU-4126	#64 Brayer	4"	Boxed
HU-4129	#66 Brayer	6"	Boxed

HU-41271	#71 Brayer	2"	Carded
HU-41226	#64 Brayer	4"	Carded

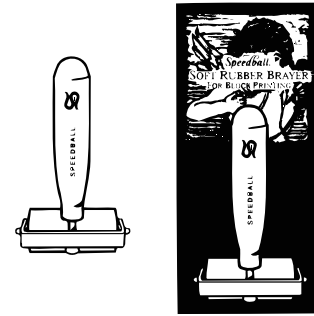

MODEL B PRESS

The Speedball Model B Press is a sturdy, all metal unit for printing work up to 8". Provides good printing pressure.

HU-4136 Model B Block Press

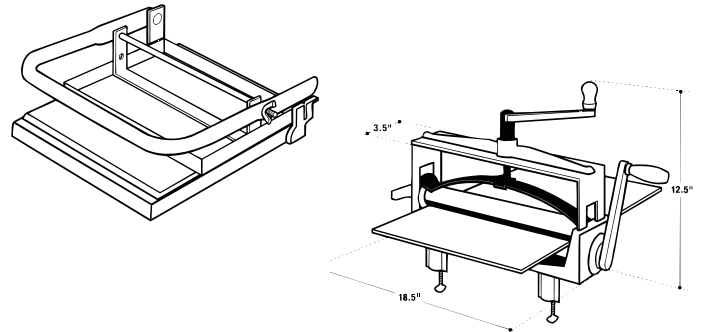

PRINTMASTER PRESS

The Speedball Printmaster Press is a heavy duty press for excellent quality prints from wood cuts, linoleum blocks, even Polyprint. Pressure rollers are spring loaded and adjustable. Mounts with bolts for permanent mounting, or "C" clamps for temporary mounting. Individually boxed.

HU-4119 Speedball Printmaster Press

ETCHING

BURINS

Burins are sharp tools for metal working. They are available in four sizes, in square shapes. Wood handle fits the palm.

LC-60A	Burin 5/64"	LC-60C	Burin 7/64"
LC-60B	Burin 3/32"	LC-60D	Burin 1/8"

BURNISHERS

Burnishers are heavy metal tools with wood handles for smoothing, pushing and polishing metal surfaces.

LC-61	Straight Burnisher	1-1/2" Blade
LC-62	Curved Burnisher	1-1/2" Blade
LC-62A	Curved Burnisher	2-1/2" Blade

HOLLOW SCRAPER

A hollow scraper is a very sharp tool used to scrape off unwanted burrs from etching plates. Cleans up excess solder, smooths surfaces etc.

LC-63 Hollow Scraper 2-1/2" Blade

SCRIBERS

Scribers are for dry point etching (scribing directly on the dry metal plate) on all metal surfaces. Points are very sharp.

LC-64	Twisted Scriber
LC-65	Straight Point-Curved Burnisher
LC-68	Double Point Scriber, Cork Handles

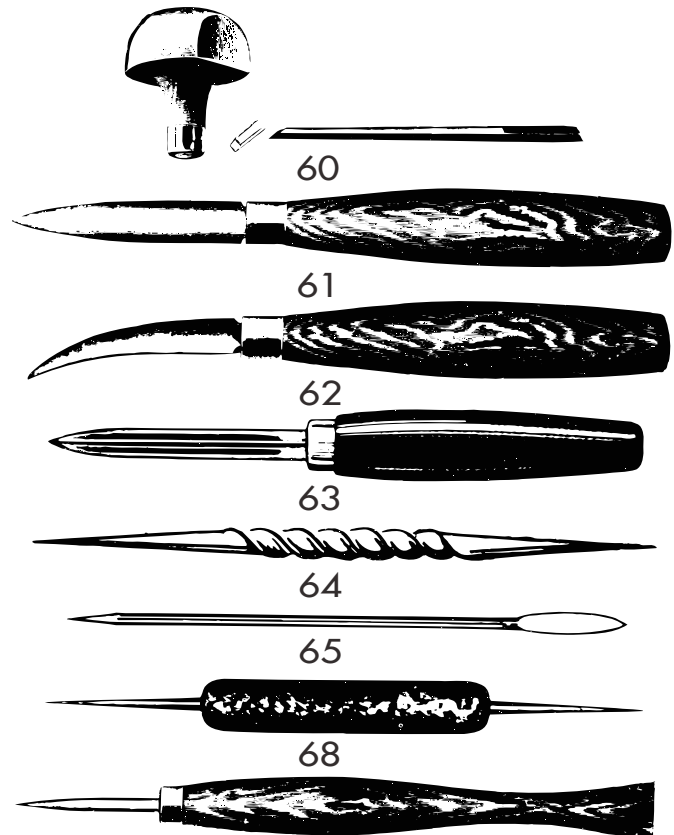

ETCHING NEEDLES

Needles for smoothing, pushing and polishing metal surfaces. 7" long.

LC-E-66	Dry Point Needle	LC-67-5	#5 Etching Needle
LC-67-2	#2 Etching Needle	LC-67-7	#7 Etching Needle

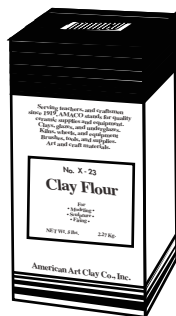
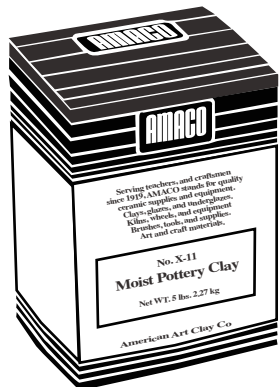

SCULPTURE

AMACO MOIST CLAY

A ready to use, factory prepared moist clay. Objects air dry and can be painted with either acrylic or tempera paint. Air dried objects are chalk hard or can be fired at 1904 to 2174F. A natural gray colored clay.

AM-46313R	X-11 Moist Clay	5 lb.
AM-46315M	X-15 Moist Clay	25 lb.

AMACO CLAY FLOUR

Amaco Clay Flour is a gray, natural clay in dry powder form. Mixed with water, it is smooth and pliable, and suited for all forms of hand modeling. The same clay as listed above, but in dry form.

AM-46311H	X-23 Clay Flour	5 lb.
-----------	-----------------	-------

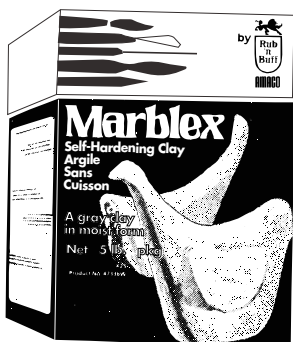

MARBLEX CLAY

A gray clay in moist form that is ready to use and requires no firing. Air dried pieces become hard and durable, but not waterproof. Decorate with tempera or acrylic colors.

AM-47322S	X-242 Marbled	2 lb.
AM-47336W	X-25 Marbled	5 lb.
AM-47340B	X-25A Marbled	25 lb.

MEXICAN CLAY

Objects modeled in Mexican clay are of a rich red color that is similar to Mexican or Indian pottery. Supplied in moist form, ready to use, and may be hand shaped or thrown on a wheel. Air dried objects are hard and durable, but not waterproof. Finished objects can be painted with tempera or acrylic color.

AM-48651B	X-22 Mexican Clay	2 lb.
AM-48652C	X-119 Mexican Clay	5 lb.
AM-48653D	X-117 Mexican Clay	25 lb.

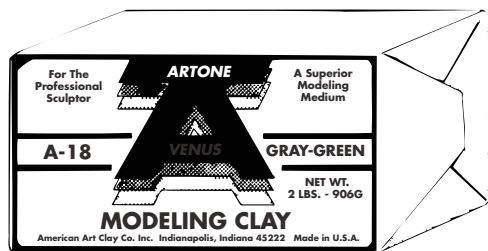

ARTONE VENUS CLAY

Artone Venus clay is a non-hardening professional type modeling clay consisting of the finest and purest ingredients. The texture is smooth and easily modeled with either tools or fingers, yet has sufficient body to retain shape.

AM-51731Y	A-18 Artone Venus Clay	2 lb.
-----------	------------------------	-------

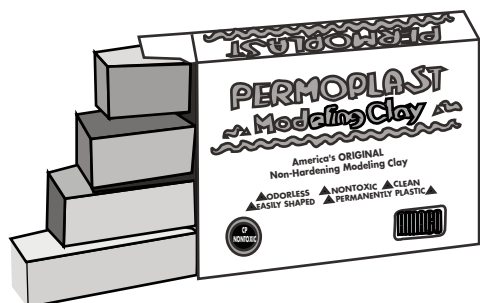

PERMOPLAST CLAY

A first quality, non-hardening, modeling clay with strong, bright non-toxic color. Permoplast comes ready to use, is easily shaped and remains smooth and pliable when used over and over again. Sanitary, harmless and stainless. 1 lb. package.

AM-90051B	Red	AM-90055F	Gray
AM-90052C	Yellow	AM-90056G	Brown
AM-90053D	Blue	AM-90058J	Cream
AM-90054E	Green		

ASSORTED COLORS:

AM-90091E	X-34, Gray, Green, Red and Brown
-----------	----------------------------------

VAN AKEN PLASTALINA

Van Aken Plastalina is a pigmented oil base modeling compound renowned throughout the world for its smooth consistency and brilliant color range. The twenty four color range included eight spectral hues, seven neutral tones, five earth colors, and four pastels. Colors are readily intermixable to achieve tints, tones, and intermediate hues. Can be easily molded by hand or tools, this clay can also be melted at 150° F and poured into molds. Preferred by sculptors, model makers, clay animators and artists of all ages, Van Aken clay is non-toxic, never hardens, and can be used time and time again. 1 lb. package. (5 lb. special order).

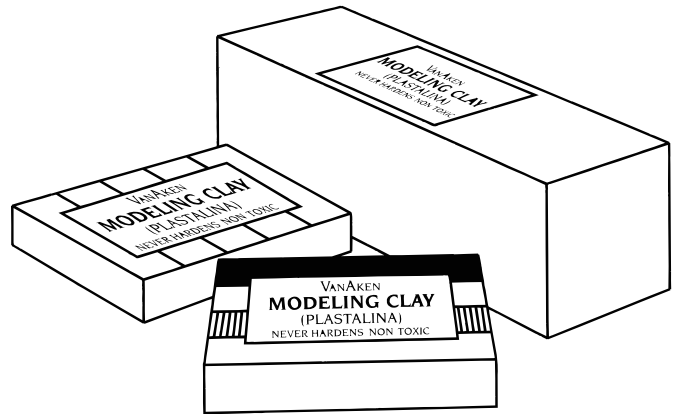

SPECTRAL COLORS

VA-10101	Yellow	VA-10105	Violet
VA-10102	Orange	VA-10106	Ultra Blue
VA-10103	Red	VA-10107	Turquoise
VA-10104	Magenta	VA-10108	Green

NEUTRAL TONES

VA-10109	White	VA-10113	Gray Green
VA-10110	Ivory	VA-10114	Gray, Sculptor
VA-10111	Black	VA-10115	Gray, Silver
VA-10112	Gray		

EARTH TONES

VA-10116	Terra Cotta	VA-10119	Dark Green
VA-10117	Brown	VA-10120	Golden Ochre
VA-10118	Flesh		

PASTEL COLORS

VA-10121	Pastel Yellow	VA-10126	Pastel Blue
VA-10124	Pastel Pink	VA-10128	Pastel Green

ASSORTED COLORS:

VA-18150	Primary Colors - Green, Yellow, Red, Ultra Blue
VA-18151	Sweetheart Asst.- Pas Green, Yellow, Pink, Blue
VA-18153	Neutral Tones - White, Brown, Gray, Black
VA-18157	Hot Colors - Yellow, Orange, Red, Magenta
VA-18158	Cool Colors - Green, Turquoise, Ultra Blue, Violet
VA-18162	Holiday Colors - Red, White, Ultra Blue, Green
VA-18165	Earth Tones - Flesh, Brown, Terra Cotta, Dark Grn



SCULPTAMOLD

Sculptamold combines the best features of clay, plaster and paper mache', eliminating the disadvantages. In dry form, this white, non-toxic compound is quickly prepared by adding water. Sets in 30 minutes, Sculptamold will cling to almost any clean surface and does not shrink. Finished pieces are very lightweight, strong and durable, and may be carved, sanded or sawed.

AM-41821C	SC-3 Sculptamold	3 lb.
AM-41822D	SC-25 Sculptamold	25 lb.

CLAYCRETE PAPER MACHE'

A prepared paper mache' in dry form that is ready to use in 15 or 20 minutes after mixing with water. Claycrete is easy to model, economical and white in color. Lightweight when dry, finished pieces may be painted with almost any paint. Non-toxic.

AM-41810B	CC-1 Claycrete	1 lb.
AM-41811R	CC-5 Claycrete	5 lb.

MIX-A-MOLD

Mix-A-Mold is supplied in powder form and is ready to mold in two minutes after mixing with water. Makes perfect reproductions of three dimensional objects. Can be filled with any casting medium. Non-toxic.

AM-75541B	SC-20 Mix-A-Mold	8 oz.
AM-75542C	SC-20 Mix-A-Mold	2.5 lb.



AMACO CASTING COMPOUND

Casting compound is a replacement for plaster, that is mixed with water and poured into a mold. Sets hard in a few minutes, and pieces are white, fine textured, and durable. By Amaco.

AM-52761T	CP-5 Casting Compound	5 lb.
-----------	-----------------------	-------

FIMO

A versatile modeling material that is also easy to use. After conditioning the clay until it is soft and pliable, it is ready to be shaped by hand, pressed into a mold, or carved with tools. Perfect to craft projects including dolls, figures, miniatures, jewelry, and holiday decorations. Can be made permanent by baking at 265° F for 30 minutes. (Translucent at 212° F) Baked objects may be finished with acrylic paints, markers, and many other media. Two oz. packages.

AM-12000A #0 White	AM-12109E #58 Fir Green
AM-12001B #01 Transparent	AM-12026F #6 Violet
AM-12002C #02 Champagne	AM-12027G #60 Lilac
AM-12145A #05 Mother of Pearl	AM-12111G #62 Lavender
AM-12004E #1 Yellow	AM-12028H #7 Caramel
AM-12369V #11 Gold	AM-12029J #77 Terra Cotta
AM-12005F #15 Golden Yellow	AM-12030K #8 Grey
AM-12006G #17 Ochre	AM-12031L #9 Back
AM-12007H #2 Red	AM-12102W #71 Bronze
AM-12008J #20 Dusty Pink	AM-12362X #81 Silver
AM-12009K #21 Magenta	AM-12103X #91 Anthracite
AM-12010L #23 Bordeaux Red	AM-12070H #F1 Yellow Dayglo
AM-12011M #25 Rosewood	AM-12071J #F2 Red Dayglo
AM-12147C #28 Apricot	AM-12072K #F5 Green Dayglo
AM-12013P #29 Carmine	AM-12073L #F20 Pink Dayglo
AM-12014R #30 Light Blue	AM-12087D #N04 Nightglow
AM-12015S #31 Dove Grey	AM-12239R #S25 Rose Quartz
AM-12016T #32 Lt. Turquoise	AM-12240S #S3 Lapis Lazuli
AM-12017V #34 Navy Blue	AM-12241T #S32 Turquoise
AM-12018W #35 Royal Blue	AM-12242V #S5 China Jade
AM-12110F #36 Midnight Blue	AM-12243W #S7 Jasper
AM-12019X #37 Blue	AM-12244X #S8 Granite
AM-12020Y #38 Turquoise	AM-12078L #T1 Trans. Yellow
AM-12149E #39 Mint	AM-12081W #T2 Trans. Red
AM-12021A #4 Orange	AM-12131G #T21 Trans. Pink
AM-12022B #43 Flesh	AM-12132H #T37 Trans. Blue
AM-12023C #5 Green	AM-12133J #T4 Trans. Orange
AM-12025E #57 Leaf Green	AM-1214K #T5 Trans Green



FIMO SETS

FIMO sets contain 1 oz. packages of FIMO clay a modeling tool, a bottle of FIMO lacquer, and instructions.

AM-12076P Basic Set #1	8 color
AM-12077R Basic Set #2	15 color

FIMO LACQUER

A clear coating for additional protection while intensifying the brilliance of Fimo colors.

AM-12064B 8703 Gloss 10ml	AM-12118P 8705 Matte 10ml
AM-12065C 8704 Gloss 35ml	AM-12066D 8706 Matte 35ml

Waterbase	
AM-12202W 8703-01Gloss 10ml	AM-12201V 8705-01 Matte 10ml
AM-12121T 8704-01Gloss 35ml	AM-12122V 8706-01 Matte 35ml

SCULPEY

Sculpey is a modeling compound that remains pliable until baked. It bakes to a durable hardness at 300° F in less than 20 minutes, depending on size. A unique product that is different than clay.

SC-S/2 Sculpey	2 lb.
SC-S/8 Sculpey	8 lb.

SUPER SCULPEY

Super Sculpey is similar to regular Sculpey, but bakes to a ceramic-like hardness that is shatter-proof and chip resistant. Bakes to hardness at 300° F in a home oven in less than 30 minutes, depending on size.

SC-SS/1 Super Sculpey	1 lb.
-----------------------	-------

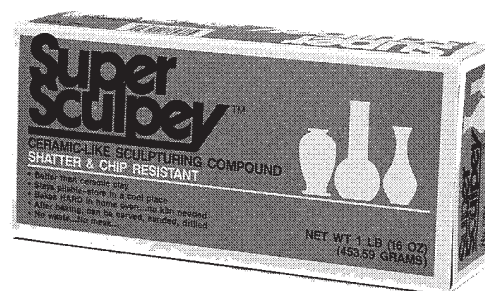
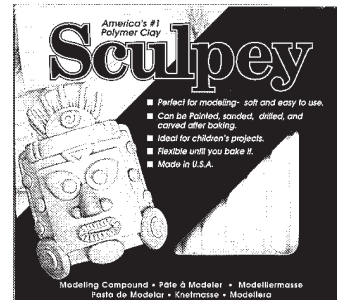

Elephant Ear Sponge

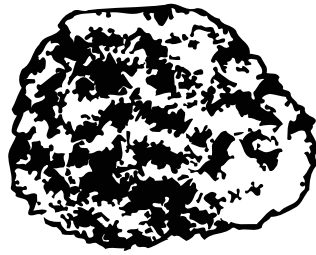
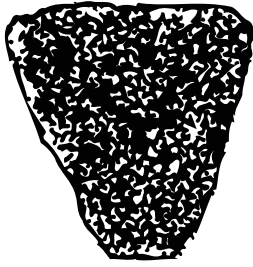

Sea Wool Sponge

Fettling Knife



Round Wire Modeling Tools

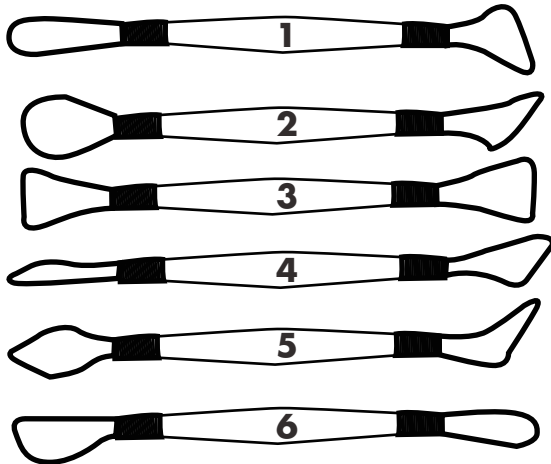

WTC Flat Wire Modeling Tools

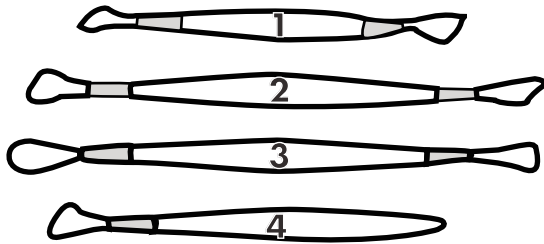

1231 Flat Wire Modeling Tools

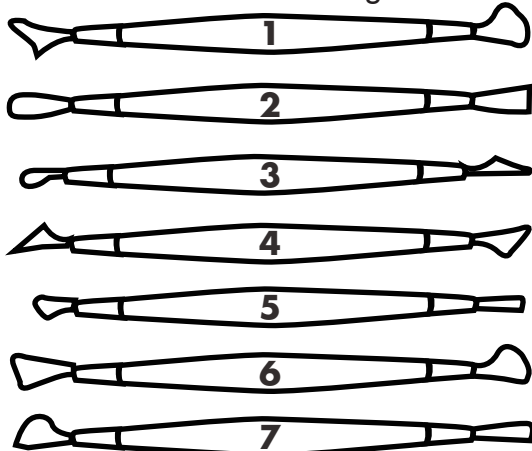

SPONGES

Natural sea sponges used for smoothing clay. Also used by water color artists and print makers for special effects. Sea silk sponges are especially soft with a fine texture for fine control. Sea wool sponges have larger pores and hold more water for soaking. Elephant ear sponges are flat sea silk sponges specially trimmed and shaped to preserve a unique feather edge. Individually packaged with UPC codes.

- LC-496 Sea Silk Sponge, Medium Size
- LC-498 Sea Wool Sponge, Large Size
- LC-499 Elephant Ear Sponge, Small Size
- LC-500 Elephant Ear Sponge, Large Size

FETTLING KNIFE

The Fettling knife is used as a scraper to remove mold marks and shape wet clay. Blades are 4-1/2" long, of spring steel in soft and firm flex.

- LC-96 Fettling Knife Soft Blade
- LC-97 Fettling Knife Firm Blade

ROUND WIRE MODELING

High quality tools of hard maple with solid brass ferrules. The double, round wire ends are of high carbon spring steel. All six models are 8" in length.

- LC-1356-X* Round Wire Modeling Tool

FLAT WIRE MODELING TOOL

Modeling tools of various length with flat ribbon steel blades and solid wood handles.

- LC-WTC-X* Flat Wire Modeling Tool

FLAT WIRE MODELING TOOL

Modeling tools of standard 8" length with flat steel blades and solid wood handles.

- LC-1231-X* Flat Wire Modeling Tool

ALUMINUM FLAT WIRE TOOL

Modeling tools of various length with flat steel ribbon blades and aluminum handles.

- LC-32-XX* Aluminum Flat Wire Tool

* Insert number where "X" is located.

Aluminum Flat Wire Modeling Tools



HARDWOOD POTTERS RIB

Potters ribs are basic shapes for curving, smoothing and trimming wet clay. Made of hardwood.

LC-30-X* Hardwood Potters Rib

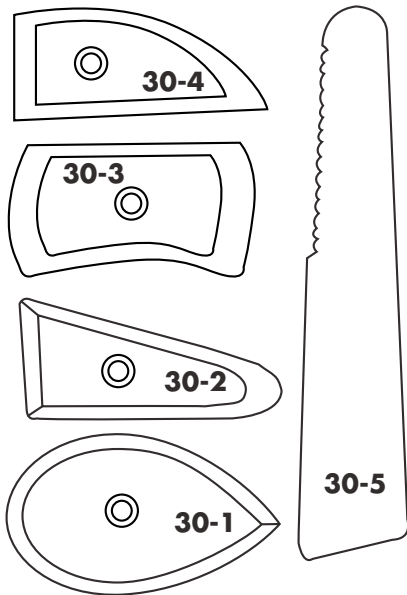

STEEL SCRAPER RIB

Flexible Steel Scraper ribs in basic shapes for smoothing and trimming wet clay. All are 2 x 4" in size.

LC-P-5 Half Round Flexible Steel Rib

LC-P-6 Oval Flexible Steel Rib

LC-P-7 Serrated Half Round Flexible Steel Rib

RUBBER POTTERS RIB

A soft finishing rubber potters rib for smoothing and trimming wet clay.

LC-P-8 Rubber Potters Rib

BOXWOOD MODELING TOOLS

Boxwood modeling tools are 6" long, hand made and finished to a high luster. Add shape number where "X" is located.

LC-1226B-X* Boxwood Modeling Tools

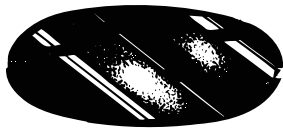

P-6
P-8

P-5
P-7

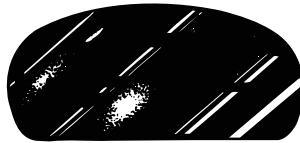

BOXWOOD TOOL SET

Set of six Boxwood modeling tools in either 6" or 8" in a plastic sheath.

LC-1128 6" Boxwood Modeling Tool Set

LC-1129 8" Boxwood Modeling Tool Set

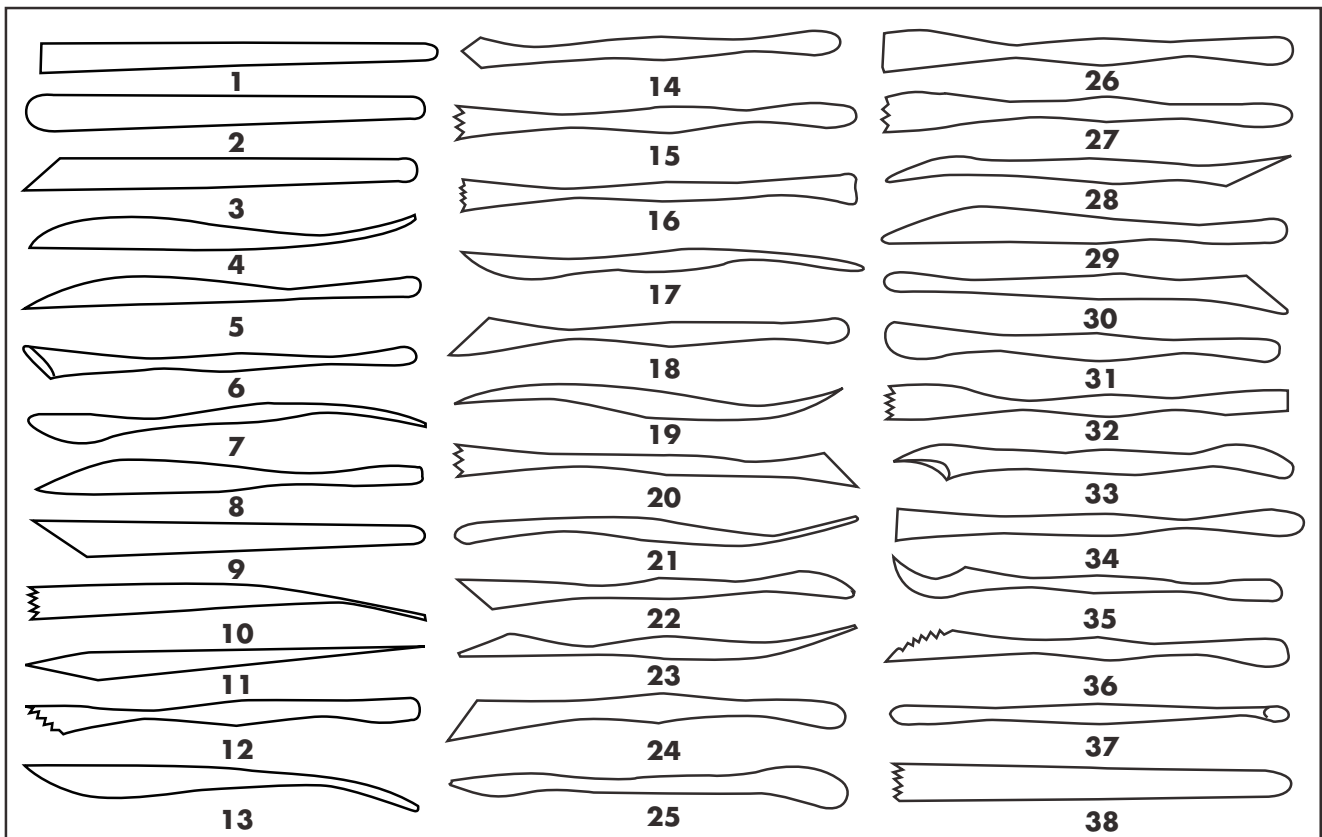

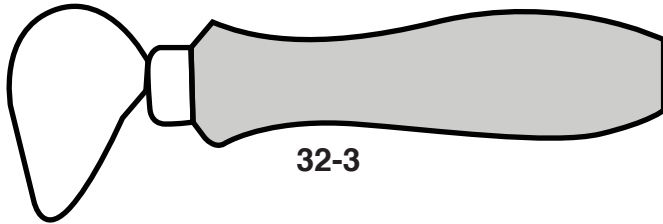

32-3

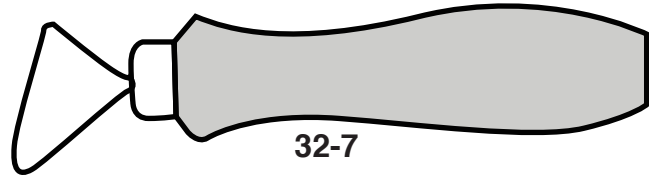

32-7



98

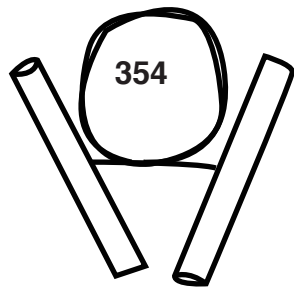

354

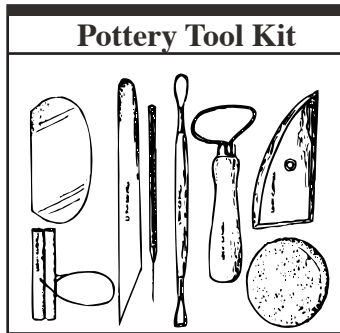

Pottery Tool Kit



112



113



No. 2

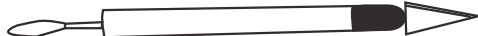

No. 120



No. 1



No. 3



Glaze Saw

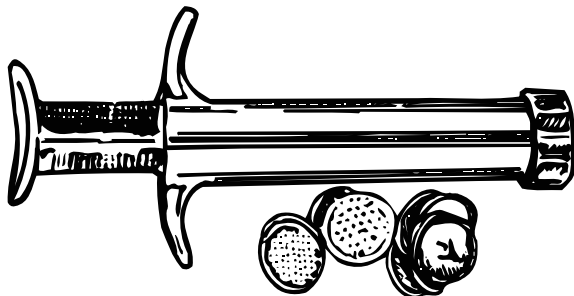

CLAY TRIMMERS

Clay trimmers have a heavy handle with a 1/4" flat metal blade and overall length of 5-1/2".

LC-32-3
LC-32-7

Clay Trimmer, Oval Shape
Clay Trimmer, Triangular Shape

WOOD CALIPER

Caliper made of hardwood that is 10" in length. Ideal for measuring real object to clay replica.

LC-351

Wood Caliper

WIRE TOGGLE CLAY CUTTER

Clay Toggle Cutter of flexible, tough wire that is strung between two wood handles. For fast cutting of large blocks of clay.

LC-354

Toggle Clay Cutter

* Insert number where "X" is located.

NEEDLEPOINT TOOL

Needlepoint tool with 1-3/4" metal needle and 2" wood handle.

LC-98

Needlepoint Tool

POTTERY TOOL KIT

A perfect kit for the beginner or professional. Contains a clay trimmer, wire end tool, rib scraper, needle tool, wood modeling tool, sponge, scraper, and wire clay cutter in a clear vinyl case. Ideal for college book stores.

LC-PTK

Pottery Tool Kit

SCRATCH KNIVES

Two popular shapes for correction, scraping and professional scratch board work. Also used for scratching litho film and other uses. Fits standard pen holders.

HUNT SCRATCH KNIVES

HU-9442
HU-9443

#112 Hunt Pointed
#113 Hunt Bowl

CLEAN UP TOOLS

A variety of metal shapes for scraping and cutting of objects after they are removed from the mold. Mounted in solid wood handles.

LC-001
LC-002
LC-003
LC-004

#1 Clean Up Tool
#2 Clean Up Tool
#3 Clean Up Tool
#120 Clean Up Tool

GLAZE SAW

A circular saw blade mounted in a wood handle for removing of extra glaze.

LC-005

S-21 Glaze Saw

CLAY GUN

A unique tool for clay forming. This all metal clay gun with 19 discs makes it easy to create textured and 3-D pieces in clay, bread dough, modeling compounds, and other pliable materials. Individually packaged.

LC-8325

Clay Gun

RUB 'N BUFF

Lustrous wax base metallic finishes for antiquing, crafts and decorating. Rub on any surface with a finger or dry cloth, then gently buff to a beautiful lustre. Color coded 1/2 oz. tubes, carded with instructions.

AM-76361A	Gold Leaf	AM-76372M	Autumn Gold
AM-76362B	Antique Gold	AM-76373N	Emerald
AM-76363C	Olive Gold	AM-76374P	Sapphire
AM-76365E	Chinese Red	AM-76375R	Jade
AM-76366F	Antique White	AM-76378W	Amethyst
AM-76367G	Pearl Blue	AM-76379X	European Gold
AM-76368H	Spanish Copper	AM-76380A	Pewter
AM-76369J	Ebony	AM-763681B	Turquoise
AM-76370K	Silver Leaf	AM-76376S	Ruby
AM-76371L	Grecian Gold	AM-76364D	Patina

INTERIOR BRUSH 'N LEAF

Decorate or highlight with genuine leafing metallic in one brush-on step. Leafs beautifully on any surface or any material. 1 oz. bottles, carded.

AM-76630K	Gold Leaf	AM-76632M	Silver
AM-76631L	Antique Gold		

EXTERIOR BRUSH 'N LEAF

One brush-on step. Outdoor gold metallics designed to withstand weather and summer sun for 2 full years. 1 oz. bottles, carded.

AM-76640Y	Brass Gold
AM-76641A	Old Gold

GLOW IN THE DARK PAINT

A non-toxic phosphorescent paint that casts a greenish glow in the dark and is easily charged with any light. Thins with water and gives a permanent finish on almost any surface. Ideal for Halloween, night lights, light switches, darkrooms, and more. 1/2 fl. oz bottle, carded.

AM-63166A	Glow In The Dark Paint
-----------	------------------------

SPRAY PAINT

KRYLON SPRAY PAINT

Krylon spray paint is a high quality enamel with rust preventer added. Great for either outdoor or indoor use on almost any clean, dry surface. Paints have good covering power with less tendency to run than other brands. In 13 oz. aerosol cans.

STANDARD COLORS

KR-1401	Brite Silver	KR-1903	Metallic Blue
KR-1501	Gloss White	KR-1910	True Blue
KR-1502	Flat White	KR-2001	Hunter Green
KR-1601	Gloss Black	KR-2011	Jungle Green
KR-1602	Flat Black	KR-2101	Cherry Red
KR-1603	Charcoal Gray	KR-2201	Brite Copper
KR-1605	Dove Gray	KR-2202	Brass
KR-1701	Brite Gold	KR-2301	O.D. Khaki Green
KR-1801	Chrome Yellow	KR-2401	Sunset Orange
KR-1802	Pastel Yellow		
KR-1803	Marigold Yellow		

FLUORESCENT COLORS

KR-3101	Red-Orange	KR-3105	Cerise
KR-3102	Yellow-Orange	KR-3106	Green
KR-3103	Sunset Gold	KR-3107	Blue
KR-3104	Lemon Yellow		

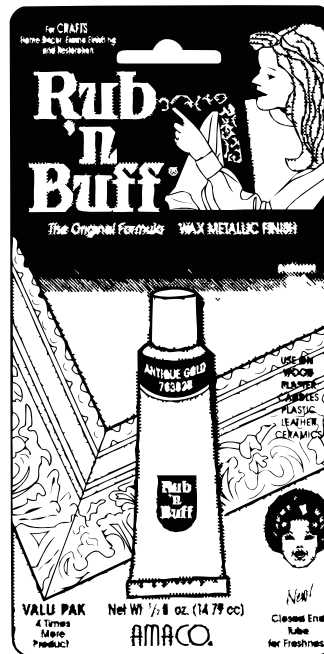

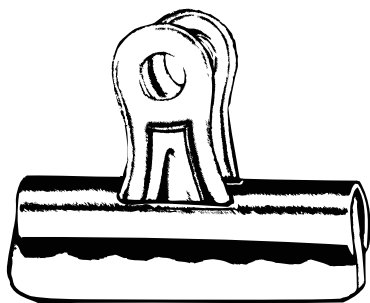

BULLDOG CLIPS

Heavy spring clips for items that are too thick for paper clips, and ideal for holding paper to "Masonite" boards. Handles are very easy to grip.

HU-2000	#0 Bulldog Clip, 1"	Box 36
HU-2001	#1 Bulldog Clip, 1-1/4"	Box 36
HU-2002	#2 Bulldog Clip, 2-1/4"	Box 36
HU-2003	#3 Bulldog Clip, 2-5/8"	Box 12
HU-2004	#4 Bulldog Clip, 3"	Box 12
HU-2005	Suction Cup Bulldog Clip	

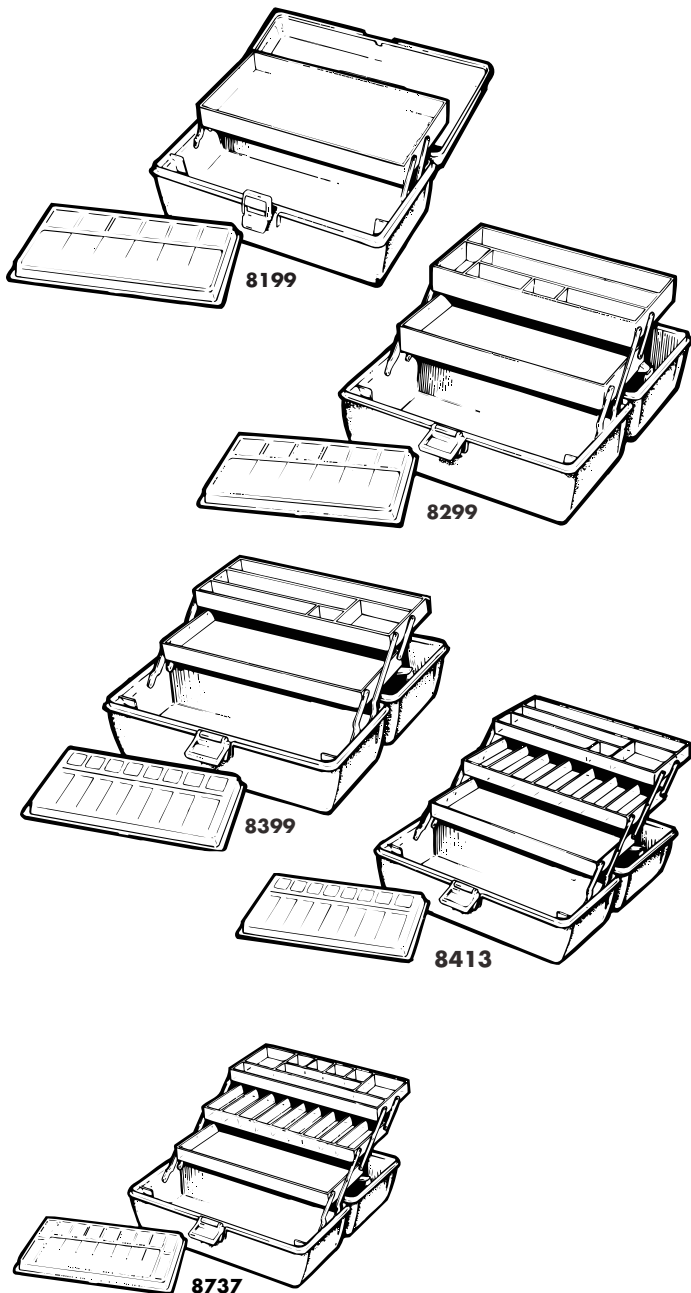

ART BOXES

ART BIN

Sturdy boxes of molded plastic with trays that are ideal for holding tubes of paint. Bottom compartments are deep enough for jars, rags, brushes etc. The ideal way to transport your materials. Excellent for students.

8512 1 TRAY ART BIN

Box with one tray and six compartments. 12-3/8 x 7 x 4-3/8"

VP-8512 Art Bin with 1 Tray Matte Black

8299 2 TRAY ART BIN

Box with two trays and seven compartments. 12-3/8 x 7 x 6"

VP-8299 Art Bin with 2 Trays Raspberry

8399 2 TRAY ART BIN

Larger box with two trays and six compartments. 14-3/8 x 7-5/8 x 7"

VP-8399 Art Bin with 2 Trays Slate Grey

8413 3 TRAY ART BIN

Box with three trays and thirteen compartments. 14-1/8 x 7-5/8 x 7"

VP-8413 Art Bin with 3 Trays Soft Black

8737 3 TRAY ART BIN

Large box with 3 trays and 18 compartments. 16-1/2 x 8-3/4 x 7-1/2"

VP-8737 Art Bin with 3 Trays Slate Grey

PORTFOLIOS

SKETCHMASTER

Sketchmaster is the number one choice of students and professionals. Each Sketchmaster is made of vinyl simulated to look like cowhide, has a heavy zipper, and inside pockets. Finish is scuff resistant. Available in one inch or three inch thick, in Black.

1" THICK

AL-PP1418	18 x 14"
AL-PP1722	22 x 17"
AL-PP2026	26 x 20"
AL-PP2331	31 x 23"
AL-PP2436	36 x 24"
AL-PP3242	42 x 32"

3" THICK

AL-PP1418-3
AL-PP1722-3
AL-PP202-3
AL-PP2331-3
AL-PP2436-3
AL-PP3242-3



PRESENTATION CASE

Presentation cases are portfolios with multi-ring metal binders inserted to hold clear acetate pages. The acetate pages are like an envelope to protect art work inserted in them. Eight acetate pages are furnished with each case, and replacements are available. Cases have a leather-like, scuff resistant exterior, nylon zippers and molded plastic handles. In black only.

AL-PCA0811	11 x 9"
AL-PCA1114	14 x 11"
AL-PCA1417	17 x 14"
AL-PCA1722	22 x 17"
AL-PCA1824	24 x 18"



DISPLAY EASELS

Display Easels are multi-ring binders with acetate page inserts that can be set up to form an easel. Made up of scuff resistant, leather-like vinyl with ten acetate pages included. In black only.

		HOLES ON
AL-EB1401	11 x 9"	11" Side
AL-EB1402	14 x 11"	14" Side
AL-EB1403	17 x 14"	17" Side

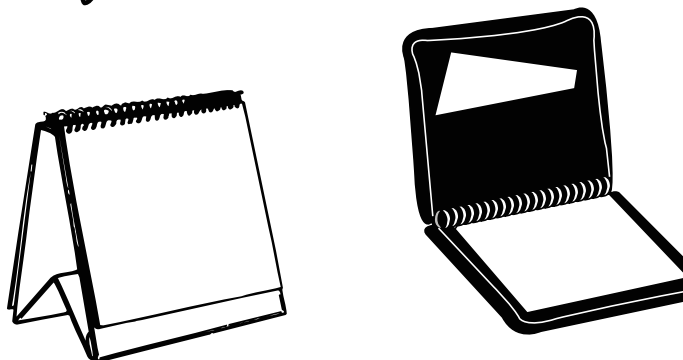

ACETATE REFILL PAGES

Clear acetate refill pages that are punched for multi-rings, with black paper insert.

AL-RF11	11 x 8-1/2"	11" Side
AL-RF14	14 x 11"	14" Side
AL-RF17	17 x 14"	17" Side
AL-RF22	22 x 17"	22" Side
AL-RF24	24 x 18"	24" Side

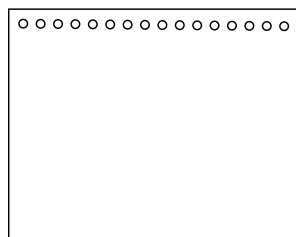

STUDENT PORTFOLIOS

A traditional style artist and student portfolio that has a black pebble finish over hard covers that are scuff and water resistant. Sides are hinged on the long side and tie shut with strong tapes. Corners are reinforced for wear resistance. Excellent for carrying and protecting artwork and other papers. Available with inside flaps that fold over artwork to keep it from sliding out.

NW-055-3	17 X 22"
NW-055-4	20 X 26"
NW-055-5	23 X 31"

BLACK SABLE ENVELOPES

A new type of fibre envelopes made of sturdy black fibre board that is both stain and water resistant. Much more durable than standard red fibre envelopes. All purpose envelopes for transportation or storage of artwork or other important items. Available with handles or without. Both are two inches thick when expanded.

PLAIN		WITH HANDLES
NA-AP419	17 x 22"	NA-413PH
NA-AP420	20 x 26"	NA-420PH
NA-AP423	23 x 31"	NA-423PH

RED FIBRE ENVELOPES

Traditional red fibre envelopes made of sturdy red wallet fibre board. All purpose envelopes for transportation or storage of artwork or other important items. Available with handles or without. Both are two inches thick when expanded.

PLAIN		WITH HANDLES
NA-AP219	17 x 22"	NA-219PH
NA-AP220	20 x 26"	NA-220PH
NA-AP223	23 x 31"	NA-223PH
	24 x 36"	NA-246PH

KRAFT ENVELOPES

Sturdy kraft envelopes used for storing and presenting art work, Ideal for a variety of purposes.

KE-1317	13 x 17"
KE-1520	15 x 20"
KE-1722	17 x 22"
KE-2025	20 x 25"
KE-2227	22 x 27"

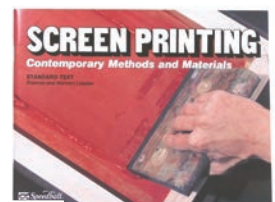
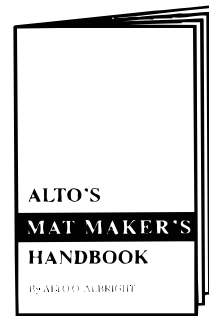
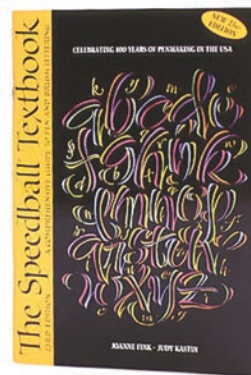
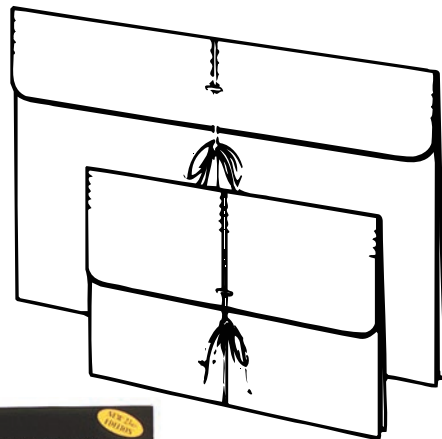
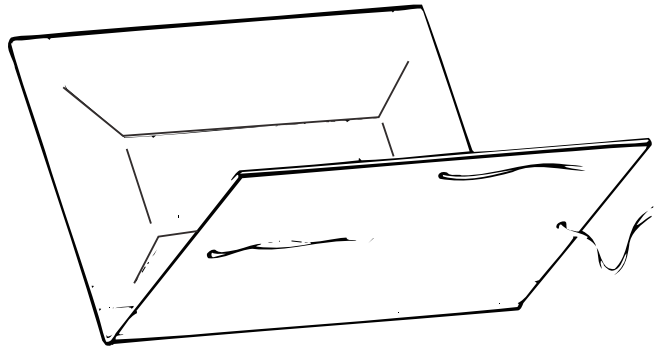

BOOKS

SPEEDBALL TEXTBOOK

A practical 96 page manual on all lettering and poster forms. It offers the widest variety of letter styles of any book on the market. An excellent instruction manual as well as a fine reference book. Edited by Ross F. George

HU-3066 Speedball Textbook

ELEMENTARY ALPHABETS

A 24 page book covering the basic alphabets, drafting alphabet, and manuscript. By Ross F. George

HU-3066 Elementary Alphabets

SCREEN PRINTING

A very good screen printing text that starts on the most basic level and continues through four color process printing. A text that will be valuable for years. By Frances and Norman Lassiter.

HU-4511 Screen Printing

ALTO'S MAT HANDBOOK

A complete guide from the simplest to the most complex mat designs and decorating techniques. Filled with over 200 illustrations demonstrating proven techniques. (Included with #4501 & 4505 systems)

ALTO-03 Alto's Mat Makers Handbook

WALTER FOSTER ART BOOKS

Foster Art Books are among America's Most popular how-to books. A series of practical books with new and better understanding of the amateur and student artist. Books are 10-1/4 x 13-3/4", many of them in full color. Books average from 40 to 48 pages.

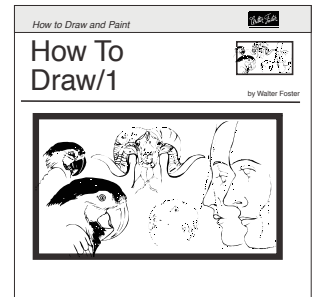

"HOW - TO" SERIES

- | | | | |
|--------|-------------------------------------|--------|--------------------------------------|
| FB-001 | How To Draw/1 | FB-200 | #Adventures in Acrylic & Oil/2 |
| FB-002 | How To Draw/2 | FB-201 | Small Paintings that Sell |
| FB-005 | Watercolors | FB-203 | #Porcelain Painting |
| FB-010 | Dogs | FB-204 | #Gulls & Other Sea Birds |
| FB-011 | Horses | FB-205 | Watercolors Step-By-Step |
| FB-012 | Animals | FB-206 | Clouds & Skyscapes |
| FB-013 | Cats | FB-207 | Special Effects in Watercolors |
| FB-017 | Heads | FB-208 | Secrets To The Magic Of Oil Painting |
| FB-020 | Figures | FB-209 | #Adventure In Primitive Art |
| FB-021 | Anatomy | FB-210 | #Boats In Watercolor |
| FB-025 | Cartoon Animation (Basic Skills) | FB-211 | Calligraphy & Lettering/2 |
| FB-026 | Cartoon Animation | FB-212 | Airbrush Rendering |
| FB-029 | Perspective Drawing | FB-213 | Watercolor Workshop |
| FB-036 | #How To Do Ceramics | FB-214 | Roses & Floral Bouquets |
| FB-056 | Mix ing Colors & Materials To Use | FB-215 | Still Life In Pencil |
| FB-101 | Ocean Sunsets | FB-216 | #Landscape Workshop |
| FB-106 | Faces & Features | FB-217 | Buildings in Pencil |
| FB-134 | Animal Cartoons | FB-218 | Floral Bouquets |
| FB-135 | Horses Heads | FB-219 | #Oils on Watercolor Paper |
| FB-152 | #Oil Pastels | FB-220 | Comic Strips |
| FB-157 | Flowers & Designs to Copy | FB-221 | Creating Cartoon Characters |
| FB-171 | China & Porcelain Painting | FB-222 | Animals In Watercolor |
| FB-180 | Beautiful Landscapes & Seascapes/1 | FB-223 | Introduction To Life Drawing |
| FB-183 | Sea And Landscapes In Oils | FB-224 | #Children In Watercolor |
| FB-184 | #Cats & Kittens | FB-225 | Landscapes In Pencil |
| FB-186 | Adventures in Acrylics & Oils/1 | FB-226 | Painting in 4 Mediums |
| FB-187 | #How To Put Life Into Your Painting | | |
| FB-188 | #Water & Weather /2 | | |
| FB-189 | Little Furry Friends | | |
| FB-190 | Film Cartoons | | |
| FB-191 | Figures In Action | | |
| FB-192 | #Tole Painting | | |
| FB-194 | #Composition Made Easy | | |
| FB-197 | Heads/2 | | |
| FB-198 | Beautiful Landscapes & Seascapes/2 | | |



GRUMBACHER COLOR COMPUTER

Also called the "Dail-A-Color Harmony Wheel" this device was designed for use by artists, illustrators, decorators, students, instructors, or anyone concerned with using color. The color computer answers the problems of color mixing and color harmony by a turn of the wheel. Both sides of the wheel are used. One side is a mixing computer indicating results obtained when colors are mixed with each other or when black or white is added. The Harmony side indicates analogous and complimentary harmonies of color. Packed individually in plastic bags, 12 per carton.

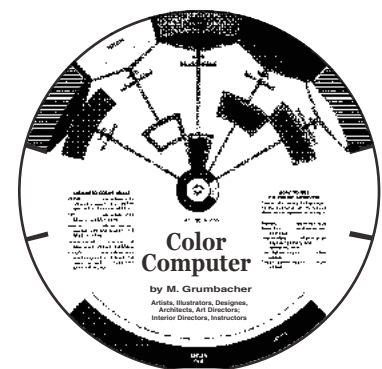

G-B420

Color Computer

Walter Foster

ARTIST'S LIBRARY SERIES

This series offers both beginner and advanced artists opportunities to expand their creativity, conquer technical obstacles, and investigate new media. Each book is written and illustrated by a well known artist who is qualified to help take you to a new level of expertise. Each paperback book is 64 pages AND 6-1/2 X 9-1/2"

- FB-801 Painting In Oils
- FB-802 Watercolor
- FB-803 Pencil Drawing
- FB-804 Acrylics
- FB-805 Color (And How To Use It)
- FB-806 #Drawing With Pen & Ink
- FB-807 Colored Pencils
- FB-808 #Pastels
- FB-809 Airbrushing
- FB-810 #Calligraphy (Techniques & Uses)
- FB-813 Perspective
- FB-814 Cartooning
- FB-815 Calligraphy & Lettering Design
- FB-816 #Watercolor with Mixed Media
- FB-817 Oil Painting Materials
- FB-818 Watercolor & Acrylic Painting Materials
- FB-820 #Felt Pen & Watercolor
- FB-823 Knife Painting
- FB-824 #Marker Rendering
- FB-825 Charcoal Drawing
- FB-826 #Photorealistic Painting
- FB-827 Mix Your Own Watercolors
- FB-828 Mix Your Own Acrylics
- FB-829 Mix Your Own Oils
- FB-830 #Composition
- FB-833 #Modeling w/Polymer Clay
- FB-835 #Floral Painting
- FB-836 #Plein Air Ptg in Oil
- FB-837 Water Color Step by Step
- FB-838 Oil Painting Step by Step
- FB-845 Acrylic Painting Step by Step
- FB-845 Acrylic Painting Step by Step

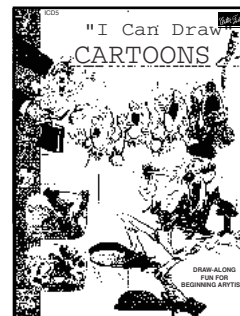
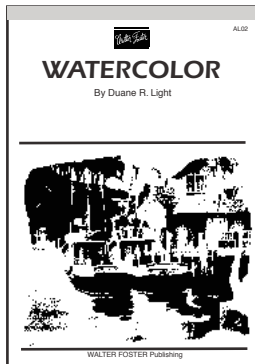

Walter Foster

BEGINNERS ART SERIES

Your never too old or young to begin enjoying art. This is a series where very basic skills are taught. A series that will instill a love of art that can last a lifetime. 8-1/2 x 10-3/4", 64 pages.

- FB-BA-01 #Drawing Fun
- FB-BA-02 #Color Fun
- FB-BA-03 #Clay Fun
- FB-BA-04 #Comic Strip Fun
- FB-BA-05 #Poster Fun
- FB-BA-06 #Art Paper Fun
- FB-BA-07 #Cartoon Fun
- FB-BA-09 #Felt Tip Pen Fun
- FB-BA-10 #Colored Pencil Fun
- FB-BA-11 #Fabric Art Fun
- FB-BA-12 #Art Craft Painting Fun



INDEX

3 Wrap Charcoal 97
77 Spray Adhesive 26

AaAaAaAa

Academy Acrylic Sets 52-53
Academy Acrylics 31
Academy Bristle Brush 74
Academy Oil Sets 54
Academy Oils 41
Academy W/C Sets 56
Academy Water Color 49
Acetate 20
Acrylic Paint 31-42
Acrylic Paint Sets 52-53
Adhesive Transfer Tape 24
Adhesive, Spray 26
Adjustable Triangle 121
Air Brush Accessories 82-83
Air Brushes 80-83
Air Compressors 83
Akucut 149
Alkyd Painting Medium 47
Aluminum Easels 142
Aluminum Flat Wire Tool 164
Ames lettering Guide 132
Aqua Fine Water Color 50
Aquarell Pencils 91
Arches 88 16
Arches W/C Paper 13
Architectural Scales 127
Art Boxes 168
Art Gum Eraser 93
Art Waxer 28
Artist's Oil Color 45
Artist's Water Color 51
Artistico W/C Paper 13
Art-O-Graph Projectors 138
Art-O-Graph Spray Booth 139

BbBbBbBb

Badger Air Brushes 81-83
Bainbridge Board 5-6
Ball Markers 115
Bamboo Brush 70
Beam Compass 133
Best Test 25
BFK Paper 16
Black Magic Ink 110
Blades 147-148
Blenders 99
Block Printing 158-160
Blocks, Linoleum 158
Bob Ross Brushes 77
Bob Ross knives 63
Books 170-172
Bow Compass 132
Boxwood Modeling Tools 165
Boxwood Tool Set 165
Brayers 159-160

Brera Acrylic 41
Bristlette Brush 75
Bristol Board 7-8
Brush Soaps 79
Brush Tub 79
Brush Washers 79
Brushes 66-77
Brushes, Boxed 79
Brushes, Carded Sets 78
Bulldog Clips 168
Bum Wad 8

CcCcCcCc

Calligraphy 105
Calligraphy Markers 106
Calligraphy Pens 105
Calligraphy Sets 109
Canary Tracing 8
Canford Paper 12
Canvas Panels 60
Canvas Pliers 59
Canvas, Roll 58
Canvas, Stretched 60
Canvasette Pads 59
Cardboard Easels 24
Cards 15-16
Casting Compound 162
Cellophane Tape 24
Chamois 99
Charcoal Paper 11-13
Charcoal Pencils 86-87
Charcoal Sticks 97
Classico Oil 43
Clay 161-163
Clay Gun 166
Clay Trimmers 166
Clean Up Tools, Clay 166
Cleaning pad 94
Clearprint Vellum 8
Cobalt Drier 47
Cold Mount 28
Color Computer 171
Color Wheel 171
Color Wheel Palette 62
Colored Ink 111-112
Colored Pencils 89-90
Colormount 28
Compass Cutter 149
Compass, Yard Stick 149
Compasses 132
Compressed Charcoal 97
Compressors 83
Construction Paper 17
Conte Crayons 101
Conte pastel Pencil 90
Conte Sketch Pencil 87
Copal Painting Med. 46
Copperplate 16
Cork Back Rulers 124
Cotton Canvas Rolls 58
Cotton Duck Rolls 58
Cover Paper 7
Crayons 98
Cross Section Paper 7

Crow Quill Pen 108
Crystal Clear 102
C-Thru Rulers 123
Curves 122
Cutter, Digital 140
Cutting Base 150
Cutting Tools 145

DdDdDdDd

D'Arches W/C Paper 13
Dahle Trimmers 150
Daige Waxers 29
Desktop Canvas 22
Desktop Inkjet Media 22
Dexter Mat Cutter 151
Digital Photo Paper 23
Digital Plotters/Cutters 140
Dip Pens 107-108
Direct Emulsions 156
Dispensers, Rubber Cement 25
Display Boards 17
Dividers 133
Drafting Instruments 132-133
Drafting Tape 24
Drawing Bd Portable 128
Drawing Fluid 157
Drawing Ink 110
Drawing Pads 9-10
Drawing Pencils 85
Drawing Tables 135-136
Dry Mount 27-28
Dry Mount Presses 27
Dual Cutters 146
Duo Caligraphic Mkr 106
Easels, Cardboard 24

EeEeEeEe

Ebony Pencil 87
Egbert Brush 74
Electric Erasers 94
Electric Erasers 94
Elegant Writer Pen 106
Engineer Scales 127
Epson Printers 141
Eraser, Rubber Cement 26
Erasers 93
Erasing Shield 132
Etching 160

FfFfFfFf

Fabriano W/C Paper 13
Fan Brush Soft hair 72
Fast Dry Medium 46
Fettling Knife 164
Filbert Bristle Brush 74
Fimo 163
Fine Line Leads 86
Fine Water Sol Mkrs 115
Finest Water Color 49
Finger Paint Pads 16

Fixative 102
Flat Files 137
Flat Lead Pencil 87
Flat Palettes 61
Flat W/C Brush 68
Flat Wire Modeling Tool 164
Flexible Curves 122
Foam Board 5-6
Formula Guide (PMS) 19
Foster Books 171-172
Fount India ink 113
Fountain Pen Inks 113
Frame Materials, Screen 155
Fredrix Inkjet Canvas 21-22
French Curves 122
French Easel 143
Frisket Film 29
Fusion 4000 27

GgGgGgGg

Gabel Rulers 124-126
Gainsborough Brush 73
Gallery Wrap Canvas 60
Gemini W/C Paper 13
Georgian Oils 44
Gesso Brush 77
Gesso, Golden 35
Gesso, Grumbacher 31
Gesso, Liquitex 38
Glaze Saw 166
Glue Sticks 26
Golden Acrylics 32-35
Gouache 50
Graphics #360 Pad 9
Graphite 98
Graphite Transfer Paper 17
Gray & White Mount 5
Greeting Cards 15-16
Grid Paper 7
Grum Ptg Med I 47
Grum Ptg Med II 47
Grum Ptg Med III 46
Grumtine 46
Gum Arabic 50

HhHhHhHh

Haberule 20
Hake Brush 76
Hand Cut Film 156
Hand Pencil Sharpeners 95
Hand Waxers 28
Hard Bound Pads 10-11
Hard Pastels 101
Hardwood Potters Rib 165
Hawk Quill Pen 108
Higgins Ink 110-113
Highlighters 116
Hinge Clamps 156
Hosho Rice paper 16
Hyplar Varnish 48



Illustration Board	5
Index Board	6
India Ink	110-111
India Ink, Fountain Pen	113
Ink Accessories	114
Inkjet Canvas	21-22
Inkjet Greet Cards	16
Inkjet Media	21-23
Inkjet Printers	141

JjJjJjJjJj

Japan Drier	47
Jute Canvas Rolls	58

KkKkKkKk

Kimberly Pencil	85
Kimoto Opaque Markers	19
Kneadable Eraser	93
Knives	145-146
Koh-I-Noor Ink	110-113
Koh-I-Noor Rapidograph	104
Korn Crayons	98
Korn Litho Pencil	88
Krylon Fixatif	102

LlLlLlLlLl

Lamps	137
Layout pencil	87
Lead Holders	92
Lead Pointers	96
Lead Pointers	96
Leads 0.3 - 2mm	86
Lectrostick Waxers	28
Letramax Board	5
Light Boxes	139
Linen Canvas Rolls	58
Liner Brushes	70
Linoleum Cutters	159
Linseed Oil	47
Liquin	46
Liquitex Sets	52
LiquitexAcrylic	36-38
Logan Mat Cutters	151-152

MmMmMm

Machine Eraser Refills	93
Magic Tape	24
Magnifier Lamp	137
Magnifiers	29
Manikins	64
Mapping Pen	108
Marblex	161
Marker Pads	9
Markers, Overhead Projection	118

Markers, Prismacolor	119
Marking Pencils	88
Mars OHP Markers	118
Mars Pigment Liners	115
Mars Plastic Eraser	93
Masa Rice Paper	16
Masking Film	20
Masters Brush Soap	79
Mat Board	6-7
Mat Cutters	151-152
Matte Medium, Oil	47
Max Oil	43
Max Oil Sets	55
Mediums, Acrylic	31-41
Mediums, Oil	40-48
Mesh, Screen	154
Metal Rulers	124-126
MG White	44
Miskit	51
Modeling Clay	161-163
Mounting Board	5-6
Mr. Sketch	117
MSA Varnish	48
Mulberry Rice Paper	16
Needlepoint Tool	166
Newsprint	11
Non-Photo Pencil	92
Nu Pastels	101

NnNnNnNn

Oil Paint Sets	54-55
Oil Paints	41-45
Oil Pastels	102
Oil Sable Brights	71-72
Oil Sable Rnd Brush	71
One Stroke Brush	76
Opaque Markers	19
Opaque W/C Pans	57
Oragami Paper	17
Oval Wash Brush	68
Parallel Rules	127
Parchment #100 Pad	8
Pastel Pencils	90
Patent Office Bristol	7
Pebble Mat	6
Pelikan 4001	113
Pelikan 4001	113
Pen Cleaners	114
Pen Holders	108-109
Pencil Sharpeners	95
Pencil Sharpeners	95
Permalba White	45
Photo Mount	26
Photo Paper, Digital	23
Pick-Up, Rubber Cement	26
Pigment Liners	115
Pin Vise	146
Pink Erasers	94
Plastic Layout Base	20
Plasticene Clay	161
Plotters	140
PMA Adhesive	28
Polyester Film	20
Polyester Multifilament	154
Poppyseed Oil	47
Portfolios	169-170
Portrait Stretched Canvas	60
Post Cards	15
Post-It Notes-Tape	24
Pottery Tool Kit	166
Pounce Wheels	146
Prepared Film	20
Presentation Cases	169
Pre-Tested Odorless Thin	46
Pre-Tested Oil	42
Prima Acrylics	39
Print Paper	16
Printers Rules	126
Prismacolor Marker	119
Prismacolor Pencil	89
Procoat Waxer	28
Project Boards	17
Projectors	138
Proportional Scale	29
Protractors	122
Prte-Tested Oil Sets	54-55
Push Pins	29

PpPpPpPp

Paasche Air Brushes	80-83
Pads, Painting	59
Pads, Palette	61
Paint Markers	117
Painting Knives	63-64
Paints, Acrylic	31-42
Paints, Oil	41-45
Paints, Watercolor	48-51
Pale Drying Oil	47
Palette Cups	62
Palette Knives	63
Palettes	61-62
Pan Watercolor Set	57
Panache	105
Pantone Books	19
Paper Wrapped Charcoal	87

RrRrRrRrRr

Railroad Bd.	6
Rapidograph	104
Raritan Pad	9
Razor Blades	148
Reed Pen	70
Re-Mount	26
Rice Paper	16
Rives BFK Paper	16
Robert Wood Palette	62
Roll Canvas	58
Ross Brushes	77
Ross Painting Knife	63
Roto-Tray	136
Round Wire Modeling	164
Rowney Gouache	50
Rub'N Buff	167
Rubber Cement	25
Rubber Potters Rib	165
Rubylity	20
Rulers	123-126
Rulers, Metal	124-126
Sable W/C Prushes	66-69
Sand paper Pad	95
Scales, Triangular	127
Scissors	150
Scratch Knives	166
Screen Equipment	157
Screen Filler	157
Screen Inks	153-154
Screen Mesh	154
Screen Printing Kits	153
Scribe-All pencil	88
Script Brushes	70
Sculpey	163
Sculptamold	162
Sculpting Supplies	161-163
Seal Dry Mountq	27-28
Seerite Easels	142
Series 7 W/C Brush	66
Sharpeners, Pencil	95
Sharpening Stone	149
Sharpie Markers	116
Sign Bond	9
Signet Brush	73
Sketch & Wash Pencil	88
Sketch Pads	10-11
Sketching Pencils	87
Slants, W/C	61
Snap Off knife	148
Soft Pastels	100
Specialty Cutting Tools	146
Specialty Markers	117
Speedball Block Ink	157
Speedball Pens	107
Speedball Screen Ink	153-154
Sponges	164
Spray Adhesive	26
Spray Ment	26
Spray Mount	26
Spray Paint	167
Spray Systems	139
Squeegees	155
Stand Oil	47
Steel Brush	107
Steel Scraper Rib	165
Stencil Brush	77
Stonehenge paper	16
Straight Edges	127
Strathmore 400 Pads	9
Strathmore Bristol	7
Strathmore W/C Paper	13-14
Stretched Canvas	60
Stretchers Strips	59
Studio Easels	143
Stumps	99
Stylus	20
Superba White	44

SsSsSsSsSs



Swivel Knives	146	Winsor Artist's Oil	45
Synthetic W/C Brushes	67-69	Winsor Artist's W/C	51
Synvar Varnish	48	Wire Toggle Clay Cutter	166
System 3 Acrylics	40	Wood Caliper	166
System 3 Sets	53	Wood Easels	142-143
		Woodless Pencil	87
		Writing Pencils	88

TtTtTtTtTtTt

Taborets	137
Tag Board	6
Take Me Along Pad	10
Tape	24
Tape Dispensers	25
Technical Pens	104
Tempera Paint	51
Templates	128-131
Thumb Tacks	29
Ticonderoga pencil	88
Tortillions	95
Touche Crayons	98
Touche Pencils	88
Touche Replacement	157
Tracing Paper	8
Tracing Rolls	8
Tray Palettes	61
Triangles	121
Triangular Scales	127
Trimmers	150
Tripod Easels	142
T-Squares	126
Turpenoid	46
Turpentine	46

UuUuUuUu

Underpainting White	44
Unryu Rice Paper	16
Utility Knives	148-150
Utility Mount Bd.	5

VvVvVvVvVv

Valvespout Dispenser	25
Varnish, Oil Paints	48
Vellum	8
Venezia Water Color	48
Verithin Pencil	90

WwWwWw

Water Color Brushes	66-69
Water Color Mkr Sets	116
Water Color Palettes	61-62
Water Mix Oils	43
Watercolor Crayons	99
Watercolor Paint Sets	56-57
Watercolor Paper	13-14
Watercolor Pencils	91
Waxers	28
Wet Media Film	20
White Bristle Brush	73-74
White Sable W/C	67

XxXxXxXxXx

X-Acto Blades	147-148
X-Acto Knives	145-146
Grifhold Knives	145-146

ZzzZzzZz

Zero Center Ruler	125
-------------------	-----

NORTHWEST GRAPHIC SUPPLY CO.
carries a complete variety of artist
materials. Check with us to all of
your art supply needs.

Because of limited space we do not list all of the
items that we carry and sell. If you do not see a
product you are looking for that one of the man-
ufacturers we list in the catalog carries or if you
are looking for a product that you don't see in
the catalog please contact us for a quotation or
to find out if we carry the product you are look-
ing for. We will be happy to check into your
request.

NORTHWEST GRAPHIC SUPPLY CO.
carries a complete variety of artist
materials. Check with us to all of
your art supply needs.

Because of limited space we do not list all of the items that we carry and sell. If you do not see a product you are looking for that one of the manufacturers we list in the catalog carries or if you are looking for a product that you don't see in the catalog please contact us for a quotation or to find out if we carry the product you are looking for. We will be happy to check into your request.

