

Endo:Press®

THE BONFILS INTUBATION ENDOSCOPE in Clinical and Emergency Medicine



Tim PIEPHO
Rüdiger NOPPENS

Endo : Press®

**THE BONFILS
INTUBATION ENDOSCOPE**
in Clinical and Emergency Medicine

**Tim PIEPHO
Rüdiger NOPPENS**

Department of Anesthesiology
University Medical Center of the
Johannes Gutenberg University Mainz, Germany

With contributions from:

Andreas THIERBACH
Rita METZ
Pedro BARGON

Important notes:

Medical knowledge is ever changing. As new research and clinical experience broaden our knowledge, changes in treatment and therapy may be required. The authors and editors of the material herein have consulted sources believed to be reliable in their efforts to provide information that is complete and in accord with the standards accepted at the time of publication. However, in view of the possibility of human error by the authors, editors, or publisher, or changes in medical knowledge, neither the authors, editors, publisher, nor any other party who has been involved in the preparation of this booklet, warrants that the information contained herein is in every respect accurate or complete, and they are not responsible for any errors or omissions or for the results obtained from use of such information. The information contained within this booklet is intended for use by doctors and other health care professionals. This material is not intended for use as a basis for treatment decisions, and is not a substitute for professional consultation and/or use of peer-reviewed medical literature.

Some of the product names, patents, and registered designs referred to in this booklet are in fact registered trademarks or proprietary names even though specific reference to this fact is not always made in the text. Therefore, the appearance of a name without designation as proprietary is not to be construed as a representation by the publisher that it is in the public domain.

The use of this booklet as well as any implementation of the information contained within explicitly takes place at the reader's own risk. No liability shall be accepted and no guarantee is given for the work neither from the publisher or the editor nor from the author or any other party who has been involved in the preparation of this work. This particularly applies to the content, the timeliness, the correctness, the completeness as well as to the quality. Printing errors and omissions cannot be completely excluded. The publisher as well as the author or other copyright holders of this work disclaim any liability, particularly for any damages arising out of or associated with the use of the medical procedures mentioned within this booklet.

Any legal claims or claims for damages are excluded.

In case any references are made in this booklet to any 3rd party publication(s) or links to any 3rd party websites are mentioned, it is made clear that neither the publisher nor the author or other copyright holders of this booklet endorse in any way the content of said publication(s) and/or web sites referred to or linked from this booklet and do not assume any form of liability for any factual inaccuracies or breaches of law which may occur therein. Thus, no liability shall be accepted for content within the 3rd party publication(s) or 3rd party websites and no guarantee is given for any other work or any other websites at all.

The BONFILS Intubation Endoscope in Clinical and Emergency Medicine**Tim Piepho and Rüdiger Noppens**Department of Anesthesiology,
University Medical Center of the Johannes Gutenberg University Mainz, Germany**Correspondence address:****Tim Piepho**Klinik für Anästhesiologie
Universitätsmedizin der Johannes Gutenberg-Universität Mainz
Langenbeckstr. 1
Telephone: +49 (0)6131/171
E-mail: piepho@uni-mainz.de

All rights reserved.

1st edition 2011© 2015 **Endo:Press**® GmbH

P.O. Box, 78503 Tuttlingen, Germany

Phone: +49 (0) 74 61/1 45 90

Fax: +49 (0) 74 61/708-529

E-mail: endopress@t-online.de

No part of this publication may be translated, reprinted or reproduced, transmitted in any form or by any means, electronic or mechanical, now known or hereafter invented, including photocopying and recording, or utilized in any information storage or retrieval system without the prior written permission of the copyright holder.

Editions in languages other than English and German are in preparation. For up-to-date information, please contact **Endo:Press**® GmbH at the address shown above.

Design and Composing:**Endo:Press**® GmbH, Germany**Printing and Binding:**

Straub Druck + Medien AG

Max-Planck-Straße 17, 78713 Schramberg, Germany

05.15-0.5

ISBN 978-3-89756-763-4

Table of Contents

Foreword	6
Introduction	7
General	8
Design	8
History and Development	10
Preparations for Intubation	11
Oxygen Administration	12
Patient Positioning and Visualization of the Retropharyngeal Space	14
Retromolar Technique	17
Awake Intubation with the BONFILS Intubation Endoscope	19
Learning Curve	23
Complications and Risk of Injury	23
In-Hospital Use of the BONFILS Intubation Endoscope	24
Unanticipated Difficult Airway	24
Anticipated Difficult Airway	25
Securing the Airway in an In-Hospital Emergency	26
Algorithm for In-Hospital Use of the BONFILS Intubation Endoscope	26
Other Possible Uses	27
Intensive Care Unit	27
Double-Lumen Endotracheal Tube	28
Prehospital Use of the BONFILS Intubation Endoscope	28
Rescue Service in Germany	28
Cervical Spine Injury	29
Prehospital Preparation of the BONFILS Intubation Endoscope	30
Prehospital Use	31
Prehospital Algorithm	33
Comparison with Alternative Procedures	34
Comparison with Video Laryngoscopy	34
Comparison with the Flexible Fiberscope	34
Typical Errors and Problems During Use	35
Fogging of the Lens	35
Difficulty Releasing the Endotracheal Tube from the Adaptor	35
Compatibility with Eyewear	35
Poor Visualization of Anatomy	35
Illustrative Case Reports	36
In-Hospital Unanticipated Difficult Airway	36
Prehospital Intubation with Difficult Patient Access	37
Cleaning, Disinfection, and Sterilization	38
General Part	38
The German Robert Koch Institute (RKI)	38
Manual and Automated Processing	39
Types of Decontamination	39
Assigned Risk Classes of Intubation Endoscopes in the German RKI Recommendations	40
Cleaning and Disinfecting Unit for Flexible Endoscopes	41
Special Part	41
Cleaning and Disinfection of the BONFILS Intubation Endoscope	41
Quality Control	44
References	45

Foreword

Complications in the setting of airway management are the single most important contributing factor to anesthesiologic morbidity and mortality. Up to 30% of anesthesia-related deaths are attributable to problems in securing the airway. Yet the complications are often classified as “preventable” in disability evaluations. Consequently, treatment algorithms, techniques and instrumentation must be available that will preclude failure in patients with a difficult airway. It should be noted, however, that every device is limited in its use to a specific range of indications. Thus it may be difficult to select the optimum instrument for everyday use and acquire a thorough understanding of its applications. As a result, advances in instrumentation and the development of effective algorithms for the difficult airway are dependent upon the constant updating of theoretical knowledge and practical skills.

This booklet describes in detail the theoretical and practical aspects of the BONFILS intubation endoscope, which can be used for both anticipated and unanticipated airway problems. An experienced user can significantly increase the success rate of difficult laryngoscopy with this technology. The instrument can also provide a rapidly available backup for the unanticipated difficult airway. The entire process of endotracheal intubation can be carried out while avoiding collateral injuries to the temporomandibular joint, teeth, and cervical spine.

This booklet provides users with a theoretical foundation as well as guidelines drawn from daily practice. It can also serve as a reference work for the more experienced user.

Mainz, August 2009

Prof. C. Werner, M.D.

Introduction

Modern anesthesiology and emergency medicine employ a variety of techniques and devices for securing the patient's airway. Oral endotracheal intubation is traditionally performed with a laryngoscope and Macintosh blade.³ Because it provides a direct view of the laryngeal inlet, this technique is also known as *direct* laryngoscopy. Various devices are often used to ventilate the patient without endotracheal intubation (e.g., supraglottic and laryngeal devices such as the laryngeal mask and laryngeal tube), especially in elective procedures, but endotracheal intubation continues to be the "gold standard" for airway management. Securing the airway with a cuffed endotracheal tube has several advantages:

- Effectively prevents inadvertent gastric insufflation during ventilation, leading to overdistention and consequent regurgitation of stomach contents.
- Safeguards against tracheal aspiration of fluids or solid foreign bodies.
- Patient can be positioned according to the requirements of the surgical procedure.
- Ability to deliver high inspiratory oxygen concentrations
- Capability for controlled positive-pressure ventilation (e.g., PEEP).
- Capability for endotracheal drug administration via the endotracheal tube.
- Provides access for bronchial toilet, suctioning of secretions, and foreign body removal from the tracheobronchial tract.⁵⁹

Increasingly in recent years, alternatives to classic direct laryngoscopy with the Macintosh blade have been developed that allow visualization of the glottic plane even in patients with a difficult airway.⁴⁴ These techniques are based on a procedure often described as indirect laryngoscopy because they display the glottic plane without a direct line of sight, i.e., in an endoscopic eyepiece or on a video monitor. This category includes the BONFILS intubation endoscope.

Every anesthesia workplace should have access to alternative techniques for solving problems that arise during airway management. Both technical and user-based criteria should be considered in the selection of appropriate instruments or devices. Because it is often impractical to equip every anesthesia workplace with these devices, possible alternative techniques should have the capacity for portable and flexible use. It has proven helpful to use a self-contained battery unit and small portable light source. Immediate availability is essential in dealing with the unanticipated difficult airway. Another practical criterion is that devices should be rugged enough for ordinary clinical use and especially for emergency settings. The range of applications should also be carefully checked prior to acquisition. Training costs and learning curve should be assessed to ensure that all users can be trained within a reasonable time frame. A teaching attachment allowing image display on a video system is a helpful option for training purposes.

General

Design

The BONFILS intubation endoscope is a rigid endoscope. The term “intubation endoscope” is often replaced by “intubation fiberscope,” but the optical fibers are fused together in the latest generation of endoscopes, eliminating interspaces between the individual glass fibers. This arrangement can accommodate a substantially greater number of image fibers (up to 35,000 pixels), leading to better image resolution, however, this fused design results in a more rigid light bundle. Since the typical honeycomb structure of a fiberoptic system is eliminated, it is more accurate to describe the device as an intubation endoscope.

The endoscope consists of a metal body with shaft available in two different diameters: 3.5 mm and 5.0 mm. Light and image bundles are integrated into the endoscope shaft. The design, then, is basically that of an optical stylet. The shaft has an overall length of 35 or 40 cm and is angled 40° its distal segment. Both sizes are available with an eyepiece as well as a DCI (direct-coupled-interface) camera head (see **Table 1** and **Figs. 1** and **2**).



1 Different models of the BONFILS intubation endoscope, available with eyepiece or DCI camera head connector.



2 Basic components of the BONFILS intubation endoscope.

① Eyepiece, ② hinge joint, ③ connector for fiberoptic light cable, ④ adaptor for endotracheal tube fixation and oxygen administration.

Endoscopes with an outer diameter of 2.0 mm and a 22-cm length are available for securing the airway in infants and small children (BRAMBRINK intubation endoscope). Handling is basically similar to that of the BONFILS intubation endoscope,¹³ and other sources may be consulted for a detailed description.

The angle of the eyepiece can be adjusted relative to the axis of the shaft. This improves operator comfort by allowing the viewing angle to be adjusted for patient position. With older instruments, image sharpness can be adjusted by turning the eyepiece. The eyepiece versions can be used by viewing directly through the eyepiece or by coupling the eyepiece to a camera. Intubation endoscopes with a DCI camera head are designed for compatible monitor units, although special adaptors can be used to couple the scope to other systems.

The 5.0-mm BONFILS intubation endoscope is available with an optional working channel (Figs. 3a, b). This channel terminates in a Luer-Lock connector and can be used for oxygenation as well as administering local anesthetic.

All versions of the endoscope can be used with a battery-operated light source or a stationary xenon light source, as desired (Figs. 3c, d). Endotracheal tubes up to 39 cm long with an inner diameter as small as 5.5 mm can be loaded onto the 5-mm BONFILS intubation endoscope. The tube is secured to the endoscope with a standard 15-mm conical adaptor on the stylet. The adaptor can be moved along the instrument shaft to accommodate different tube lengths.



Different models of the BONFILS intubation endoscope with video endoscopic accessories. Video camera (DCI camera head ①, KARL STORZ TELECAM® ②) and the compact KARL STORZ TELE PACK™ documentation unit ③. The battery-powered LED light source adds to portability ④.

Outer diameter	Models	Working channel (1.2 mm diameter)	Compatible endotracheal tube sizes
3.5 mm	Eyepiece	–	4.0–5.5 mm
3.5 mm	DCI camera head	–	4.0–5.5 mm
5.0 mm	Eyepiece	–	≥ 5.5 mm
5.0 mm	Eyepiece	●	≥ 5.5 mm
5.0 mm	DCI camera head	–	≥ 5.5 mm

Tab. 1: Available sizes and models of the BONFILS intubation endoscope.

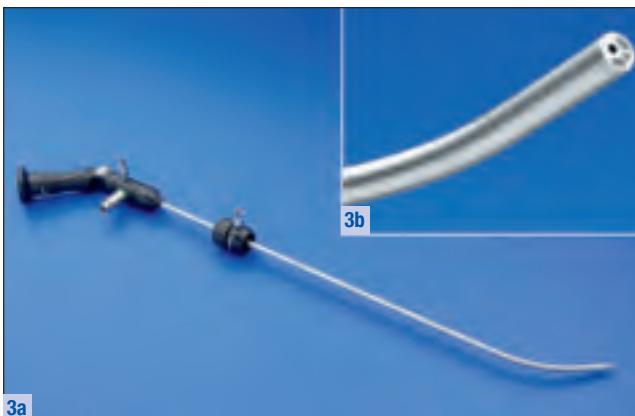

BONFILS intubation endoscope with working channel (10330 B1). The proximal opening of the insufflation channel is at the level of the fiberoptic light connector (a). Tip of the BONFILS intubation endoscope with insufflation channel (b).



Battery-powered LED light source for KARL STORZ endoscopes.

Securing the airway with the BONFILS intubation endoscope offers the following advantages over direct laryngoscopy:

- Oxygen can be administered during laryngoscopy and endotracheal tube placement.
- Laryngoscopy can be performed despite anatomical constraints.
- Intubation can be performed in patients with limited mouth opening (minimum interincisor distance of 2–3 cm).
- Allows accurate visual control of endotracheal tube position.
- Avoids cervical spine movements during intubation.
- Visualization of the glottic plane allows for safe and effective intubation (“*what you see is what you get*”).
- Can be used under topical anesthesia.
- Generally does not require special patient positioning.

History and Development

Some of the basic technical principles incorporated in the BONFILS intubation endoscope were described as early as the 1960s. *Berci and Katz* (1979) later reported on an optical stylet that allowed for intubation under vision.^{15, 38} In their technique, the tongue base was lifted on a laryngoscope, and then the endotracheal tube was introduced using a straight, rigid endoscope as a stylus. The “retromolar” intubation technique was initially performed with a straight laryngoscope blade.⁷

Bonfils described various intubation techniques.^{18, 19} The intubation endoscope described by BONFILS was first used clinically during the 1980s. Angulation of the distal end was a significant change relative to traditional rigid scopes, and the retromolar approach allowed for direct placement of the instrument tip at the laryngeal inlet. Basically, then, this instrument combines the concept of the optical stylet with the technique of retromolar intubation.⁵⁴

Preparations for Intubation

An endotracheal tube appropriate for patient size is loaded onto the BONFILS intubation endoscope prior to intubation. Often there is no need to lubricate the inside of the endotracheal tube. Lubrication is recommended for smaller tube sizes, however, as it will make it easier to slide the tube onto the stylet. The endotracheal tube can also be advanced uniformly and with less resistance during the intubation process. When the tube has been positioned on the scope, the standard adaptor is tightened to hold it in place. The movable adaptor should be positioned such that the tip of the endotracheal tube extends approximately 0.5 cm past the distal end of the BONFILS intubation endoscope (**Fig. 4**). This helps keep secretions from obscuring vision while avoiding possible trauma to the mucosa during insertion. Correct positioning of the tube is easily assessed: After threading the endotracheal tube onto the endoscope, the user looks through the instrument. The tube should be visible at the edges of the field but should not constrict the field of view (**Figs. 5, 6**). When a spiral-wound reinforced tube is used, it should be noted that the tube may collapse somewhat during placement, increasing the risk of minor injuries from the metal tip of the intubation endoscope.²⁵ The user should also make sure that a functioning light source is connected to the scope. Optical sharpness should be checked in older models with an adjustable eyepiece (**Fig. 7**). Additionally, some lidocaine gel can be applied to the tip of the endotracheal tube before it is introduced into the mouth. This should make it easier to advance the tube into the trachea, but this step can often be omitted in an emergency.



5

The endotracheal tube is correctly positioned. The edges of the tube are visible without restricting the field of view.



6

The endotracheal tube projects too far past the endoscope tip.



4

Distal end of the BONFILS intubation endoscope with endotracheal tube in place.

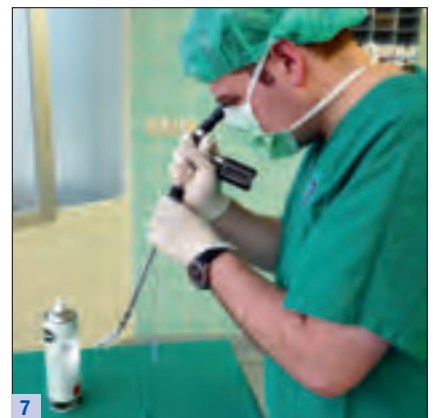

7

Checking the light source and image sharpness.

Oxygen Administration

There are two ways to administer oxygen through the BONFILS endoscope during the intubation process: through the insufflation channel, or between the metal shaft and the lumen of the endotracheal tube.

If the instrument has an insufflation channel, the oxygen line can be connected directly to the insufflation connector. The gas flow can oxygenate the patient while also clearing secretions from the endoscope tip⁶⁴ (**Fig. 8**). This can be very helpful in spontaneously breathing patients, where the intubation process is prolonged by waiting for the topical anesthetic to take effect. In an anesthetized patient, the intubation time is usually so short that there is no need for apneic oxygenation.

It should be added, however, that oxygen administration through the insufflation channel at a high flow rate may lead to barotrauma. Injuries may result from an obstruction in the upper airways or from inadvertent intubation of the esophagus with the BONFILS intubation endoscope.^{23, 36, 37} Consequently, this technique should not be used in patients who have significant upper airway stenosis.⁵⁰

To date only one case report has been published on complications with this method: subcutaneous emphysema of the neck and face developed in a 75-year-old woman undergoing elective surgery. In this case oxygen had been administered through the insufflation channel at a flow rate of 10 L/min.³⁴

We recommend the following precautions to avoid potential complications: Only an experienced user should administer oxygen through the insufflation channel, and the gas flow rate should not exceed 3–6 L/min. If unexpected difficulties arise (e.g., inadequate vision), the BONFILS intubation endoscope should be withdrawn and reintroduced without oxygen flow if necessary.



8

Oxygen is administered through the insufflation channel (KARL STORZ 10330 B1).

Another way to insufflate oxygen during the intubation process is by using the inlet on the tube adaptor (**Fig. 9**). A line connected to the adaptor inlet will deliver oxygen through the space between the metal shaft of the endoscope and the inner wall of the endotracheal tube. This method can also provide effective oxygenation. It is important, however, not to push the endotracheal tube tightly into the adaptor, as this may obstruct gas inflow. Small tube sizes (5.5 mm) may also curtail flow, causing gas leakage to occur above the tube holder. Of course this method has the same potential complications as oxygen administration through the insufflation channel, and therefore the same limitations apply.

Position of the Dominant Hand

The BONFILS intubation endoscope should be held in the dominant hand in such a way that it can easily be simultaneously advanced and rotated. This cannot be done simply by grasping the shaft. We recommend a “pistol grip”²⁶ technique (*Gottschall*) with the thumb and index finger placed around the light connector (**Fig. 10**).

Intubation Approach

Either of two techniques can be used to introduce the BONFILS intubation endoscope into the pharynx. Besides the retromolar technique, the instrument can also be introduced in the midsagittal plane. But before it is inserted in the anesthetized patient, it is first necessary to lift the tongue base and epiglottis to visualize the retropharyngeal space. This can be done by lifting the jaw manually upward with the fingers and thumb or by using a conventional laryngoscope with a Macintosh blade.



10 “Pistol grip” technique.



9

Oxygen is administered between the metal shaft of the endoscope and the inner wall of the endotracheal tube (KARL STORZ 10331 B1 / 10332 B1).

Patient Positioning and Visualization of the Retropharyngeal Space

The head is positioned according to whether the retromolar or midsagittal technique will be used. For a retromolar intubation, the head may generally remain in the neutral position. The “improved Jackson position” is recommended for midsagittal intubation. In this method the patient’s head is slightly elevated on a pad and extended at the atlanto-occipital joint (sniffing position).

The key maneuver for intubating a patient with the BONFILS endoscope is to lift the tongue base and epiglottis away from the posterior pharynx^{14, 16, 31, 45} (**Figs. 11, 12**). If this is not done, the BONFILS intubation endoscope often cannot be advanced under vision. Intubation will often be unsuccessful in this case because key anatomic landmarks cannot be identified and the entrance to the trachea cannot be seen.

Many users have experience with the BONFILS intubation endoscope on an airway trainer. Because the tongue is firmly attached to the floor of the mouth in conventional training models, it cannot sag back and block the upper airway. Also, the tip of the epiglottis is not in contact with the posterior pharyngeal wall in many airway trainers. Because the retropharyngeal space is already visible, the trainee should have no difficulty introducing the BONFILS intubation endoscope under vision (**Fig. 13**). In the anesthetized patient, however, some manipulation is necessary in order to visualize the retropharyngeal space. This is a major factor contributing to the relatively slow learning curve for the BONFILS intubation endoscope (see p. 23).



11

When muscle tone is absent in the unconscious or anesthetized patient, the tongue may obstruct the retropharyngeal space. The epiglottis often sags against the back of the throat.



12

Traction on the lower jaw can lift the tongue and epiglottis from the pharyngeal wall, creating enough room to correctly position the intubation endoscope under vision.

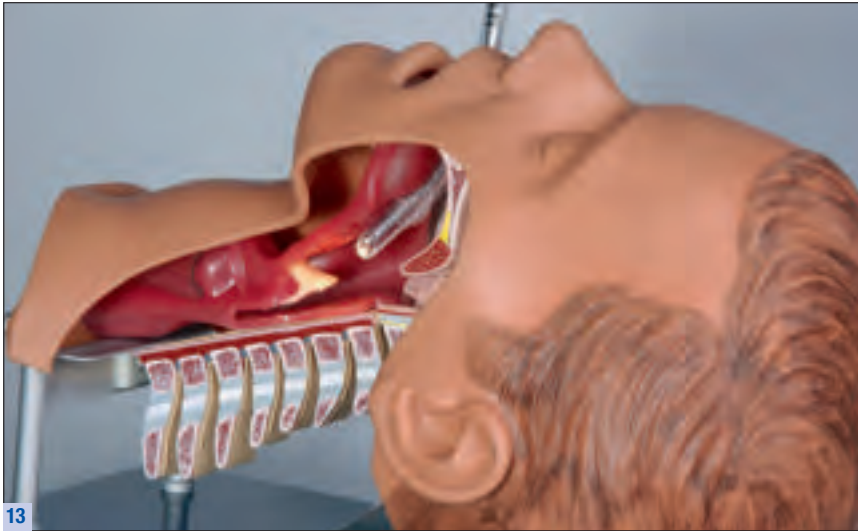

13

In contrast to an actual patient, the tongue and epiglottis in a standard airway trainer are clear of the posterior pharyngeal wall. Thus the mannequin can be intubated under vision without performing a jaw-lift maneuver.

Manual Jaw Lift

The tongue is lifted by placing direct traction on the lower jaw. The user pulls upward on the patient's jaw with the left hand while advancing the BONFILS intubation endoscope with the right hand. The thumb is placed inside the mouth while the index and middle fingers grip the chin (**Fig. 14**). It is important in this maneuver to avoid causing dental or other injuries with the left hand. The best technique is to pull the jaw toward the ceiling; do not pry it upward by bracing the thumb against the upper incisor teeth. Caution must also be exercised in patients with diseases or fractures of the mandible. Of course, the sides may be reversed if desired. A left-handed operator may prefer to guide the instrument with the left hand while opening up the retropharyngeal space with the right hand (**Fig. 15**). Because most users hold the instrument in the right hand, that convention will be used in the descriptions that follow.



14

The jaw is lifted to visualize the retropharyngeal space.



15

While the right hand lifts the jaw, the BONFILS intubation endoscope is introduced with the left hand.



16

The BONFILS intubation endoscope is introduced while the tongue is lifted with a Macintosh laryngoscope.

Another option is to lift the jaw with an Esmarch maneuver, which requires the help of an assistant. If adequate jaw traction is lost, the retropharyngeal space usually cannot be adequately visualized for advancing the BONFILS intubation endoscope to the glottis.

Once the glottic plane has been identified, manual jaw traction or the Esmarch maneuver may be discontinued.

This technique is most difficult in patients with macroglossia or ankylosis of the temporomandibular joint.

Using a Macintosh Laryngoscope

Another technique is to use a laryngoscope to lift the tongue and glottic structures. The laryngoscope blade should position the tongue as far left and forward as possible. Next the BONFILS intubation endoscope is introduced below the blade and positioned just above the tracheal inlet (**Fig. 16**). Once the glottic plane has been located with the intubation endoscope, the laryngoscope can be removed. This technique is particularly recommended for beginners who are using the BONFILS intubation endoscope for the first time.

This technique requires somewhat greater mouth opening than the jaw-lift maneuver, as space is needed for the Macintosh blade in addition to the intubation endoscope. Introducing a second instrument increases the risk of upper airway injury, especially in patients with a difficult airway.⁴¹

In principle, the tongue can also be grasped with a tongue grasping forceps and pulled forward to visualize the retropharyngeal space.

Retromolar Technique

The retromolar technique is especially preferred in patients with limited mouth opening. Generally it is easier to perform in an actual patient than in an airway trainer due to the greater compliance of the buccal soft tissues. Owing to the distal curve of the BONFILS intubation endoscope, the instrument is advanced on the right side, keeping strictly behind the rear molar, and is then tilted toward the user (**Fig. 17**). This technique keeps the tip of the intubation endoscope directed toward the anticipated laryngeal inlet at all times. The endoscope is advanced under vision. In many cases the epiglottis can already be seen when the retropharyngeal space is visualized (**Fig. 18**). The intubation endoscope is then advanced further and positioned beneath the epiglottis (**Fig. 19**). If the epiglottis is in contact with the posterior pharynx, it may be possible to lift it by increasing traction on the jaw. Another technique is to advance the instrument along the right side of the epiglottis and then rotate it back toward the midline while withdrawing it slightly (**Fig. 20**). Usually the endoscope can be positioned beneath the epiglottis in this way.

The endoscope is then advanced until the vocal cords are clearly visible in the eyepiece or on the viewing screen (**Fig. 21**).



17 The intubation endoscope is introduced behind the tongue.



18 Often the epiglottis can be identified immediately after insertion of the BONFILS intubation endoscope.



19 Visualization of the glottic plane.



20 The intubation endoscope can be positioned laterally when the epiglottis is in contact with the posterior pharynx.



21 Once behind the epiglottis, the distal end of the intubation endoscope is positioned just above the glottic plane.



22

The endotracheal tube is advanced into the trachea under endoscopic vision.



23

Markings on the endotracheal tube indicate the depth of tube insertion.

The intubation endoscope is not advanced into the trachea, as this would risk injury to the trachea or vocal cords from the rigid endoscope shaft. When the endoscope has been correctly positioned, the endotracheal tube is slowly advanced along the scope axis under constant vision. This step may be done by an assistant if desired. Meanwhile the endoscope is used to observe the tube sliding into the trachea (**Fig. 22**). This affords direct proof that the endotracheal tube is in the correct position. If there are markings on the tube proximal to the cuff, they can be used to gauge the insertion depth, minimizing the risk of unilateral endobronchial intubation (**Fig. 23**). Following successful intubation, the BONFILS intubation endoscope is removed by stabilizing the endotracheal tube with the hand and withdrawing the endoscope with a forward tipping motion so that the bend of the endoscope will conform to the anatomic pathway (**Fig. 24**). If the position of the endotracheal tube is ever in doubt, the endoscope can be reinserted into the oral cavity to assess placement. Again, the endoscope should always be advanced under vision. The endotracheal tube is followed down to the glottis to evaluate its position (**Figs. 25, 26**).

Golecki describes a modified technique in which the BONFILS intubation endoscope is introduced vertically at the right oral commissure with the tip pointing to the left.²⁵ On reaching the area of the posterior pharyngeal wall, the endoscope is rotated to the right until the epiglottis comes into view. The endoscope is now tilted toward the right side and rotated further about its long axis to advance the tip to the laryngeal inlet under vision. Next the endotracheal tube is advanced into the trachea as described for the other techniques. One drawback of this method is that key anatomic landmarks are less clearly visualized. Another problem is that the endoscope tip tends to become soiled by secretions.



24

The instrument is tipped anteriorly for removal.



25

The instrument is reinserted following successful intubation.



26

Visual confirmation of correct tube placement.

Midsagittal Intubation

The BONFILS intubation endoscope can be introduced in the sagittal plane by advancing it along the tongue, making certain that the endoscope does not rotate toward either side and keeps strictly to the midline. When the endoscope is correctly positioned, the tongue should be visible in the anterior part of the field (**Fig. 27**). The intubation endoscope is then advanced along the posterior pharyngeal wall. The next landmark to appear is the epiglottis. The BONFILS intubation endoscope is advanced beneath the epiglottis, bringing the glottic plane and tracheal inlet into view. If vision is poor or if orientation is lost, the BONFILS intubation endoscope is carefully withdrawn until vision improves or familiar structures can be identified.

This technique may be particularly advantageous for less experienced users, as the position of the endoscope tip is easier to control. It does require adequate mouth opening and adequate mobility of the cervical spine, however. Unlike the retromolar technique, tilting of the endoscope is greatly limited and should be avoided as it may damage the upper incisor teeth or cause bending of the endoscope shaft.



Visualization of the tongue and uvula.

Awake Intubation with the BONFILS Intubation Endoscope

Awake intubation can be performed with the BONFILS intubation endoscope in conscious patients with an anticipated difficult airway.²⁴ The goal is to maintain spontaneous respiration until the endotracheal tube is placed. This technique requires a certain amount of experience in using the BONFILS intubation endoscope and in oral intubation with flexible intubation fiberscopes in conscious patients. Hence it should be performed only by persons who regularly intubate patients with the BONFILS intubation endoscope. A cooperative patient is also essential.

Given the increased risk of trauma (e.g., due to accidental coughing) and the potential for patient discomfort, the authors feel that the indications for awake intubation with the BONFILS endoscope are greatly limited and prefer to use flexible fiberscopes in that setting.

Preparations

Patient preparations are analogous to those for awake flexible fiberoptic intubation. Intravenous sedation is adjusted to ensure maintenance of spontaneous respiration. Initial topical anesthesia of the oropharynx and hypopharynx can be obtained with a local anesthetic. Lidocaine pump spray can be delivered through single-use attachments that may be slightly curved to allow for placement behind the tongue. Often it is helpful to have the patient protrude the tongue for topical anesthesia. It should be noted, however, that each spray generally contains 10 mg of lidocaine, and care should be taken not to exceed the recommended maximum dose. Lidocaine drawn into syringes can be diluted to 1% or 2%, again giving attention to recommended dose limits. The agent can be administered through blunt and curved cannulas, which should be placed behind the tongue. Topical anesthesia can also be induced with a nebulized local anesthetic.

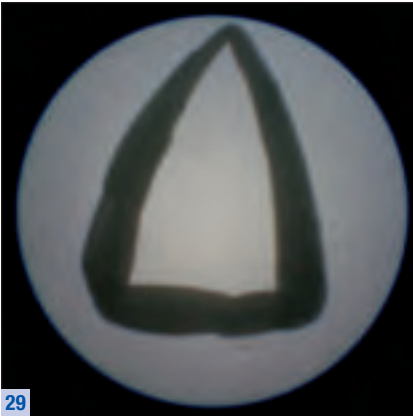

29

The efficacy of local anesthetic administration through the BONFILS intubation endoscope was tested by positioning the instrument over an absorbent medium. A triangle was drawn to represent the glottic plane in its true size as viewed through the eyepiece of a correctly positioned intubation endoscope. Next a blue test solution was administered through the insufflation channel and also between the endoscope shaft and the lumen of the endotracheal tube.



30

Correct distribution of the test solution in the glottic plane. The solution was administered between the endoscope shaft and tube lumen.

Another way to administer local anesthetic is the “gargle technique,” in which the patient gargles the anesthetic as long as possible to suspend the solution and wet the hypopharynx.²⁹

Another option is to inject the local anesthetic directly into the trachea, similar to the technique described for fiberoptic intubation. This requires passing a needle through the cricothyroid ligament. The solution can be coughed up to spread the anesthesia to supraglottic levels.

Technique

Following adequate topical anesthesia and i.v. sedation, the BONFILS intubation endoscope is introduced into the mouth using either the retromolar or midsagittal approach. This can be facilitated by having the patient protrude the tongue, which will expand the retropharyngeal space and make it easier to identify landmarks. With good topical anesthesia, the BONFILS intubation endoscope can be carefully maneuvered to a site just above the glottic plane, and the endotracheal tube can then be advanced into the trachea.

If topical anesthesia is inadequate, additional local anesthetic can be administered through the BONFILS intubation endoscope. Various methods have been described for this mode of administration.

Injection through the Endotracheal Tube Holder

Abramson experienced no problems in administering local anesthetic via the endotracheal tube holder in one case series.⁶ In this method the local anesthetic is injected into the space between the inner wall of the endotracheal tube and the shaft of the BONFILS intubation endoscope (**Fig. 28**). The anesthetic cannot be finely dispersed with this technique, however. The distribution of the agent in the glottic plane cannot be controlled and may even be ineffectual when a large endotracheal tube is used (**Figs. 29, 30**). Adding oxygen administration through the tube holder has not been found to improve anesthetic distribution. With small tubes (5.5 mm I.D.), the residual lumen may be so narrow that the local anesthetic cannot be administered quickly enough or may even leak from the instrument above the tube holder.



28

Local anesthetic is injected into the space between the endoscope shaft and the inner wall of the endotracheal tube.

Once the local anesthetic has been administered, time is allowed for the agent to act before the endoscope is advanced any further. Uncontrolled movements and coughing by the patient during this time may necessitate withdrawal of the endoscope after the local anesthetic has been applied. Then the instrument must be reinserted into the oral cavity and advanced to the glottic plane. Local anesthesia of the proximal trachea may be necessary for positioning the endotracheal tube in the conscious patient. This is obtained by applying another dose of local anesthetic just above the tracheal inlet. Again, time is allowed for the agent to act, and the BONFILS intubation endoscope may have to be withdrawn in the interim. Next the endotracheal tube is carefully advanced into the trachea, followed by induction of general anesthesia.

Injection through the Insufflation Channel

Much as in flexible fiberoptic intubation, local anesthetic can also be injected through the insufflation channel of the BONFILS intubation endoscope.⁴¹ In this method the anesthetic solution is administered in the oxygen stream via the insufflation channel. In flexible fiberoptic intubation this technique is commonly known as the “spray as you go” method. Because the local anesthetic becomes dispersed in the flow of oxygen, it can penetrate more deeply into the airways.⁵⁰ Besides oxygenation, other advantages of this technique are that it provokes less coughing and shortens the intubation process. The following setup has been described for using this technique with the BONFILS intubation endoscope: A 3-way stopcock is connected to the Luer-Lock attachment of the insufflation channel, and local anesthetic is administered through the stopcock parallel to the oxygen stream⁴¹ (**Fig. 31**).



31

Possible setup for administering local anesthetic in the oxygen flow through the insufflation channel.



32

Local anesthetic administered through the insufflation channel is ejected from the tip in a fine stream.



33

Distribution of test solution administered through the insufflation channel of the latest generation of intubation endoscopes.



34

Test solution administered through the insufflation channel of older models is deflected posteriorly, missing the desired target. Varying the oxygen flow rate does not alter this result.

Our own experiments have shown, however, that with newer endoscopes the local anesthetic emerges from the endoscope tip in the form of a thin stream (**Fig. 32**). Due to the rigid design of the endoscope, it is usually difficult to target the stream precisely to the glottis (**Fig. 33**). Older intubation endoscopes have an angled noseguard over the distal opening of the working channel which deflects the local anesthetic and prevents adequate anesthesia of the glottis. Distribution of the anesthetic is limited to posterior portions of the pharynx and the esophageal inlet (**Fig. 34**). Raising the endoscope tip is of only moderate help, as this maneuver is limited by the rigidity of the endoscope shaft.

Administration through an Epidural Catheter

One publication describes passing an epidural catheter through the insufflation channel of the BONFILS intubation endoscope for targeted application of the local anesthetic.⁴¹ This method is technically demanding, however, and cannot be recommended for routine use. One problem is the difficulty of advancing an epidural catheter through the insufflation channel. Another is that the rigid design of the endoscope often prevents directional maneuvers to achieve selective anesthesia of the glottis. Often only the esophageal inlet and posterior pharyngeal wall are wetted with a very fine stream of solution.

Learning Curve

Use of the BONFILS intubation endoscope in emergency situations requires adequate experience on the normal airway.⁴⁸ Following simulations on an airway trainer, the user should proceed to elective anesthesia in cases not expected to have difficult endotracheal intubation or require rapid-sequence induction. As a general rule, from 10 to 25 intubations are necessary to gain adequate experience with the BONFILS intubation endoscope.^{21, 30, 31} Inexperienced users may have particular difficulty learning to view through the eyepiece, which makes anatomical structures appear smaller.

Guidelines issued by the DGAI (German Society of Anesthesiology and Intensive Care Medicine) recommend learning the principles of airway management in four steps. This program can also be applied in modified form to the BONFILS intubation endoscope:

- Learning basic theoretical principles, with special emphasis on upper airway anatomy, and becoming familiar with the endoscope.
- Learning the basic principles of the endoscope on an airway trainer and in simulations.
- Supervised use of the BONFILS intubation endoscope as an alternative device for airway management (**Fig. 35**).
- Perfecting skills. Using the BONFILS intubation endoscope to secure the airway in patients with pathologic conditions. Continued training.



35 The first few intubations with the BONFILS endoscope should be performed under supervision, which is aided by displaying the image on an external video screen.

Contraindications and Limitations

At least 2–3 cm of mouth opening is necessary to ensure that the BONFILS intubation endoscope can be inserted into the mouth and can be advanced to the laryngeal inlet by the retromolar route. Although success has been reported in patients with lesser degrees of mouth opening,³² we have found that successful intubation is questionable in patients with less than 2–3 cm of mouth opening.

Generally the presence of blood or secretions in the upper airways will limit the use of indirect optical intubation devices, as vision is significantly hampered due to soiling of the lens. This also applies to the BONFILS intubation endoscope. Secretions on the tip of the endoscope may obscure vision to a degree that prevents accurate placement under visual control.⁴⁹ It is important to consider this limitation, especially in emergency settings. It may be helpful to suction the pharyngeal space before introducing the endoscope into the oral cavity.⁶

Obstructions of the glottis and trachea would contraindicate use of the BONFILS intubation endoscope, as they would prevent endotracheal tube placement despite visualization of the glottic plane. Obstructions in the oropharynx are also considered contraindications.

Complications and Risk of Injury

Potential injuries that may occur during use of the BONFILS intubation endoscope are trauma to the oropharyngeal soft tissues and glottic plane. Injuries to the teeth and jaw have also been described.³⁰ These complications can be avoided by proceeding gently and carefully. Potential injury to the trachea can be prevented by rigorously avoiding endotracheal insertion of the endoscope.

In-Hospital Use of the BONFILS Intubation Endoscope

Current DGAJ guidelines on *airway management* cite rigid intubation instruments as an alternative to direct laryngoscopy in patients with a difficult airway.³ Problems with in-hospital airway management generally fall into two broad categories: the unanticipated difficult airway and the anticipated difficult airway.

Unanticipated Difficult Airway

Although various clinical studies and scores have improved the predictability of difficult intubation, the anesthesiologist should always be ready for unforeseen difficulties during airway management, even in patients with no apparent abnormalities.

Generally speaking, a difficult airway is present when an anesthesiologist with average training experiences difficulties with mask ventilation or intubation. Intubation is defined as “difficult” if successful endotracheal tube placement by direct laryngoscopy requires more than three attempts or takes longer than 10 minutes. Endotracheal intubation is always unsuccessful in cases where the vocal cords cannot be visualized by direct laryngoscopy.¹²

In principle, it is preferable to deal with an unanticipated difficult airway by using instruments and techniques for which the individual user has adequate training and experience. Conversely, the use of unfamiliar procedures often results in failure and may jeopardize the patient. It is also best to use techniques that are readily available and are capable of solving the problem at hand.

With these principles in mind, the BONFILS intubation endoscope should be used in an unanticipated difficult airway only if the user has adequate experience in its routine use. A key advantage of the intubation endoscope in emergency situations is its portability, which allows for rapid use without lengthy preparations.⁴³ *Bein et al.* conducted a study in 25 patients with failed endotracheal intubation by direct laryngoscopy. Intubation with the BONFILS intubation endoscope was successful on the first attempt in 88% of the patients. There was only one case in which intubation by this method was unsuccessful even with multiple attempts. The patient had copious secretions that prevented visualization of the laryngeal inlet, and the airway had to be secured with a flexible fiberscope.¹⁴ Since multiple failed intubation attempts may provoke heavy secretions, it is good practice to clear the airways by suctioning the oral cavity and pharyngeal space before introducing the BONFILS intubation endoscope.

The authors believe that the BONFILS intubation endoscope has an important application in securing the airway of patients with unanticipated difficult intubation.

Anticipated Difficult Airway

Various anomalies and disorders of the face and jaws may signal an anticipated difficult airway or may preclude conventional intubation. An effort is made to keep the patient conscious and maintain spontaneous respiration until the airway has been successfully secured. Possible techniques include conscious fiberoptic intubation or the placement of a laryngeal mask under sedation. Elective tracheotomy and airway instrumentation after induction of general anesthesia can also be recommended for special situations.³

Awake flexible fiberoptic intubation is considered the current gold standard for the anticipated difficult airway. The necessary equipment is costly, however, and learning the method is a time- and training-intensive process. For these reasons, techniques have increasingly been established in recent years for safely performing endotracheal intubation in patients with an anticipated difficult airway.¹²

For those experienced with using the BONFILS intubation endoscope, the indications for its use can be expanded accordingly (**Fig. 36**). It can provide definitive airway management in anesthetized patients as well as conscious, spontaneously breathing patients. In one study the BONFILS intubation endoscope was compared with the intubation laryngeal mask. Initial intubation with the laryngeal mask could be accomplished in just 28 seconds, compared with an average of 40 seconds with the BONFILS intubation endoscope. But the intubation endoscope provided definitive intubation, whereas laryngeal mask intubation was a two-step process that required a total of 76 seconds before the airway was definitively secured. Moreover, fewer endotracheal intubation attempts were necessary with the intubation endoscope.¹² *Rudolph et al.* also used the BONFILS intubation endoscope successfully in patients with an anticipated difficult airway.⁵⁶ *Gottschall* describes other known pathologic conditions in which the instrument can be used: a critical maxillary incisor status as well as malformations and sequelae involving the maxillofacial region and neck.²⁶ Owing to the rigid shaft of BONFILS intubation endoscope, it is easier to lateralize structures with that instrument than with a flexible fiberscope. This led Halligan to define the BONFILS intubation endoscope as the instrument of choice in patients with periglottic tumors, as it can push the tumor aside to obtain a clear view of the vocal cords.³⁰



In-hospital use of the BONFILS intubation endoscope with attached video camera.

Securing the Airway in an In-Hospital Emergency

With its relatively robust design and rapid accessibility, the BONFILS intubation endoscope can also be used for in-hospital emergency airway management outside the operating suite.^{43, 53} This requires a mobile unit (e.g., bag or carrying case) containing the endoscope along with accessories and other ancillary devices. It is essential that all members of the emergency team have adequate training and experience with the intubation endoscope. This is necessary to ensure that a difficult airway can be secured outside the operating suite using a procedure that is successful, user-friendly, and effective.

Algorithm for In-Hospital Use of the BONFILS Intubation Endoscope

Since the early 1990s, professional societies in the fields of anesthesiology and emergency medicine have made increasing efforts to publish guidelines and algorithms for management of the (difficult) airway.^{1, 2, 35} The DGAI did so in 2004.³ The goal of their guidelines is to ensure the quality of patient care, especially in emergency situations.

The diagram below shows one possible algorithm for in-hospital implementation of the BONFILS intubation endoscope.

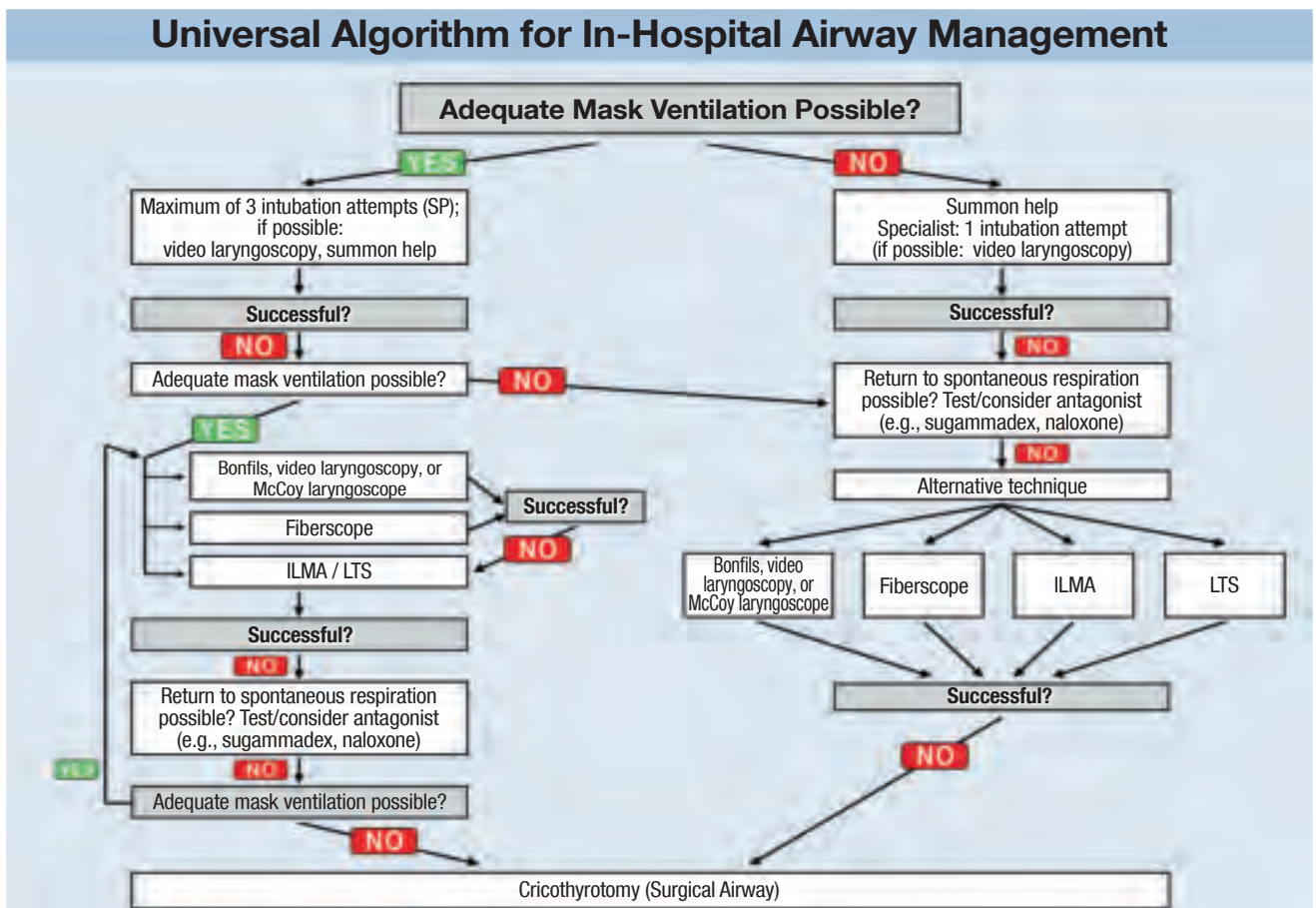

Algorithm for in-hospital airway management. This algorithm is used when unanticipated difficulties are encountered during in-hospital airway management. It begins with mask ventilation, as this is the first backup option for a difficult or failed airway. Choosing among a McCoy laryngoscope, video laryngoscopy, or BONFILS intubation endoscope is a largely matter of familiarity and preference. SP = specialist, ILMA = intubation laryngeal mask, LTS = laryngeal tube suction (laryngeal tube with a second lumen).

Other Possible Uses

Intensive Care Unit

The BONFILS intubation endoscope has another possible application in the setting of percutaneous dilatational tracheostomy. It is customary to use optical endoscopic control when introducing the needle, placing the dilator, and creating the tracheostomy to allow for early recognition and prevention of possible complications. Various methods for visualizing the procedure have been described.^{9, 28} *Buehner* reported on 40 patients who underwent a successful dilatational tracheostomy using the BONFILS intubation endoscope and two modifications. Adequate visualization of landmarks and satisfactory ventilation were achieved in all cases, although this required some modification of the membrane seal.²⁰

The main advantage of the BONFILS intubation endoscope is that the rugged metal shaft prevents damage to the instrument from the percutaneous needle. This can prevent the costly repairs that would result from damage to a fiberscope, for example (see *Comparison with the Flexible Fiberscope below*).

In the authors' experience, there are some limits to the use of the BONFILS intubation endoscope for percutaneous dilatational tracheostomies. Thus, the inherent stiffness of the endoscope precludes its use for transilluminating the neck to identify vulnerable structures. Also, the rigid metal shaft and angled distal end may be problematic for inserting and advancing the instrument into the tracheal tube (**Fig. 37**).



37

Use of the BONFILS intubation endoscope in an intensive care unit.



38 Preparation for use of the double-lumen tube.

Double-Lumen Endotracheal Tube

Double-lumen endotracheal tubes are commonly used for one-lung ventilation. Usually these tubes are placed by the orotracheal route, and the current procedure of choice is direct laryngoscopy. But a double-lumen tube can also be placed with the aid of the BONFILS intubation endoscope. *Bein et al.* describe two cases in which direct laryngoscopy was not possible and the BONFILS intubation endoscope allowed for uncomplicated endotracheal placement of the double-lumen tube.¹¹

With most double-lumen tubes, the connector must first be removed from the tracheal and bronchial limbs of the device (**Fig. 38**). Otherwise the tube would extend too far past the endoscope tip and obscure vision. The tube with the bronchial limb should be lubricated before it is loaded onto the BONFILS intubation endoscope, as the bronchial limb often has an inside diameter less than 5.5 mm. The tube should be checked before use to make sure it can be easily removed from the endoscope. General utilization of a flexible fiberscope is by no means obsolete despite use of the BONFILS intubation endoscope, since a flexible bronchoscope can subsequently be used to confirm correct placement of the double-lumen tube. Bronchoscopy cannot be performed with the BONFILS intubation endoscope due to the rigid design of the endoscope shaft.

Prehospital Use of the BONFILS Intubation Endoscope

Rescue Service in Germany

Emergency rescue services in Germany are regulated by laws which mandate that rescue vehicles and emergency physicians be available on a population-wide basis. Laws also prescribe the necessary response time for rescue personnel to reach the emergency patient. A sophisticated air rescue service is available in addition to ground-based services. All rescue vehicles are coordinated by dispatch centers that maintain contact with the rescue units via a nationwide radio network. The centers work to ensure that the fastest and most suitable rescue vehicle is dispatched to the emergency patient. In cases that involve life-threatening injuries or diseases, a specially trained emergency physician is always sent to the scene of the emergency along with a rescue vehicle. To ensure rapid arrival, the emergency physician is delivered to the scene in a ground-based emergency response vehicle or rescue helicopter, where he or she can provide immediate medical care. These primary care measures include an emergency evaluation (ultrasound, 12-channel ECG, etc.), anesthesia induction, professional airway management with endotracheal intubation, and appropriate pharmacologic therapy. After emergency care has been provided, the patient is transported to a hospital appropriate for the injury or disease.

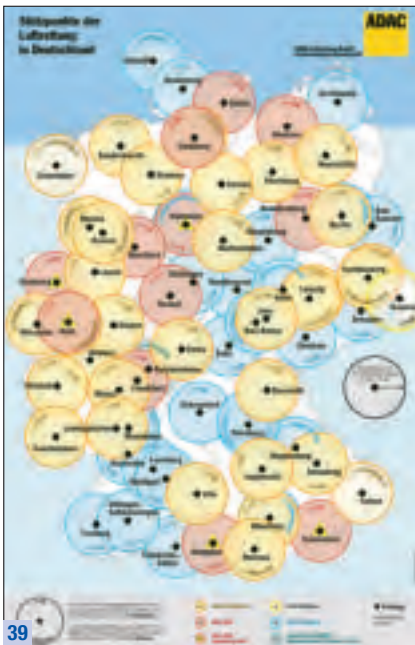

39 Distribution of air rescue stations in Germany.

Special Conditions in the Prehospital Setting

Securing the airway in an emergency setting is often more difficult than in clinical settings and has a higher association with complications and adverse events.^{60, 61} Poor visualization of the larynx is far more common in emergency medicine than in clinical anesthesiology (CL grade 3: 13% vs. 5%, CL grade 4: 7% vs. 1%).⁶⁰ There is a higher incidence of multiple attempts and inadvertent esophageal intubation during prehospital airway management.⁶² Stated reasons include more difficult laryngoscopy and suboptimal patient positioning. Accordingly, it is important that rescuers have access to alternatives to direct laryngoscopy.

Cervical Spine Injury

From 20 to 30% of multiply injured patients have a concomitant injury to the cervical spine.⁶³ It should be assumed, therefore, that unconscious trauma patients have sustained a cervical spine injury.¹⁰ Measures must be taken to avoid additional injuries to the spinal cord and vertebral column. Special emphasis is placed on the cervical spine, which should be immobilized at once with a cervical collar to prevent additional injury.³⁹ At the same time, an immobile cervical spine makes it difficult to perform direct laryngoscopy. It also significantly restricts mouth opening, which is decreased on average from 41 mm to 26 mm with a cervical collar in place.²⁷ This leads to difficult intubation in up to 64% of patients who undergo orotracheal intubation by direct laryngoscopy, with a CL grade 3 or 4 laryngeal view.³³

In one study, movements of the cervical spine were measured fluoroscopically in 20 patients undergoing routine surgery. Use of the BONFILS intubation endoscope was associated with significantly less cervical spine motion than direct laryngoscopy.⁵⁷ In another study patients were fitted with a cervical collar prior to elective surgery, and intubation was carried out randomly either by direct laryngoscopy or with the BONFILS intubation endoscope. With a comparable interincisor distance (26 mm vs. 27 mm), intubation with the Macintosh blade was successful in 39.5% of the patients. By contrast, 81.6% of the patients were successfully intubated with the BONFILS endoscope. Failed intubation attempts with the intubation endoscope resulted from an inability to position the distal tip at the laryngeal inlet. There was only one case where the instrument could not be inserted into the oral cavity because the mouth could not be opened.²²

Prehospital use of the BONFILS intubation endoscope in patients with an immobilized cervical spine has also been described. Endotracheal intubation was successfully accomplished in all patients wearing a cervical collar. In each case a Macintosh laryngoscope was used to lift the tongue and epiglottis to allow for rapid endotracheal intubation. For experienced users, then, the use of the BONFILS intubation endoscope is a safe and effective option in patients with an immobilized cervical spine.²¹

Prehospital Preparation of the BONFILS Intubation Endoscope

The short preparation time of the BONFILS intubation endoscope is also a great advantage in prehospital emergency settings (**Fig. 40**). For example, the battery-operated light source can remain attached to the endoscope, making it independent of an external power supply. Generally it is necessary only to prepare the endotracheal tube, and usually there is no need for lubricants or other aids. Fogging of the distal endoscope tip can be a problem and may compromise the success of the intubation at a critical moment. When a cool endoscope is being used in a chilly environment, introduction of the instrument may cause rapid condensation that fogs the lens. Very experienced users can often dispense with an anti-fogging agent owing to the short intubation time. Otherwise, wetting the endoscope tip with an anti-fogging or NaCl solution can significantly improve vision.

To avoid contamination, the used endoscope can be temporarily placed into disposable suction catheter packaging. Later it can be cleaned and disinfected at the rescue center in accordance with manufacturer's recommendations.



40

Carrying cases for the BONFILS intubation endoscope and flexible fiberscope for emergency medicine.

Prehospital Use

Prehospital use of the BONFILS intubation endoscope is analogous to the in-hospital procedures described above. Again, the key maneuver is visualization of the retropharyngeal space. Byhahn described the use of the Macintosh blade in this setting. Endotracheal intubation could be accomplished more rapidly than by lifting the jaw with the left hand.²¹

As in the hospital, use of the BONFILS intubation endoscope is limited by heavy secretions or bleeding in the pharyngeal space.

In the authors' experience, the intubation endoscope can be used very effectively in the prehospital setting (**Fig. 41**).

In one prospective study, the airways of 30 patients were secured with the BONFILS intubation endoscope in a prehospital setting.⁴⁷ In all cases the intubation endoscope was utilized as the primary instrument for airway management. The tongue base and epiglottis were lifted by traction on the lower jaw. Successful endotracheal intubation was accomplished on the first attempt in 26 (87%) of the patients. Three (10%) of the patients required two intubation attempts.

There was one case in which technical problems prevented visualization of the glottic plane (the endoscope eyepiece was out of focus). A second intubation attempt was withheld in this case due to inadequate vision, but endotracheal intubation was easily accomplished by direct laryngoscopy with a Macintosh blade.



41

Prehospital use of the BONFILS intubation endoscope.

In our experience, the eyepiece cannot spontaneously go out of adjustment even during transport, and it is reasonable to assume that this occurred accidentally during preparation of the endoscope. Thus, users should check the function of the eyepiece each time they go on duty. The latest generation of endoscopes are no longer susceptible to faulty eyepiece adjustment, and so this complication can no longer occur.

The documented intubation process for successful intubation attempts averaged 17 seconds (range from 7 to 30 seconds). No clinically significant difference was found between the two most common field intubation settings (residence and rescue vehicle). Before the airway was secured, four (13%) of the spontaneously breathing patients had been stabilized with a neck collar due to a suspected concomitant cervical spine injury. The cervical collar was left on the patient during airway management with the BONFILS intubation endoscope. Successful intubation required one attempt in three patients and two attempts in one patient (**Fig. 42**). The duration of the successful intubation attempts in this group averaged 14 seconds (range from 11 to 25 seconds) and thus showed no clinically significant difference from the intubation times in patients without an immobilized cervical spine.

It should be noted that successful endotracheal intubation depends directly on the experience of the user. Because regular, quality in-hospital training is difficult to implement for all emergency physicians, the BONFILS intubation endoscope is not yet included in the standard equipment for all emergency vehicles with a physician on board.



42

Use of the BONFILS intubation endoscope in a patient with an immobilized cervical spine.

Prehospital Algorithm

The guidelines of the European Resuscitation Council as stated in the chapter on *Extended Resuscitation Measures for Adults (ALS)* are of special relevance to emergency situations.⁴⁶ These guidelines offer clear recommendations for airway management in patients resuscitated from cardiac arrest.

Owing to the advantages of endotracheal intubation, various techniques have been developed for securing the airway in an emergency. Supraglottic airway devices are particularly important for inexperienced users in emergency medicine. Of course, these users should also have adequate knowledge and training in dealing with available alternatives.

The BONFILS intubation endoscope is easily integrated into existing prehospital airway algorithms. It can be used immediately after the failure of direct laryngoscopy with a Macintosh blade as an alternative of first choice, giving due regard to contraindications and limitations.

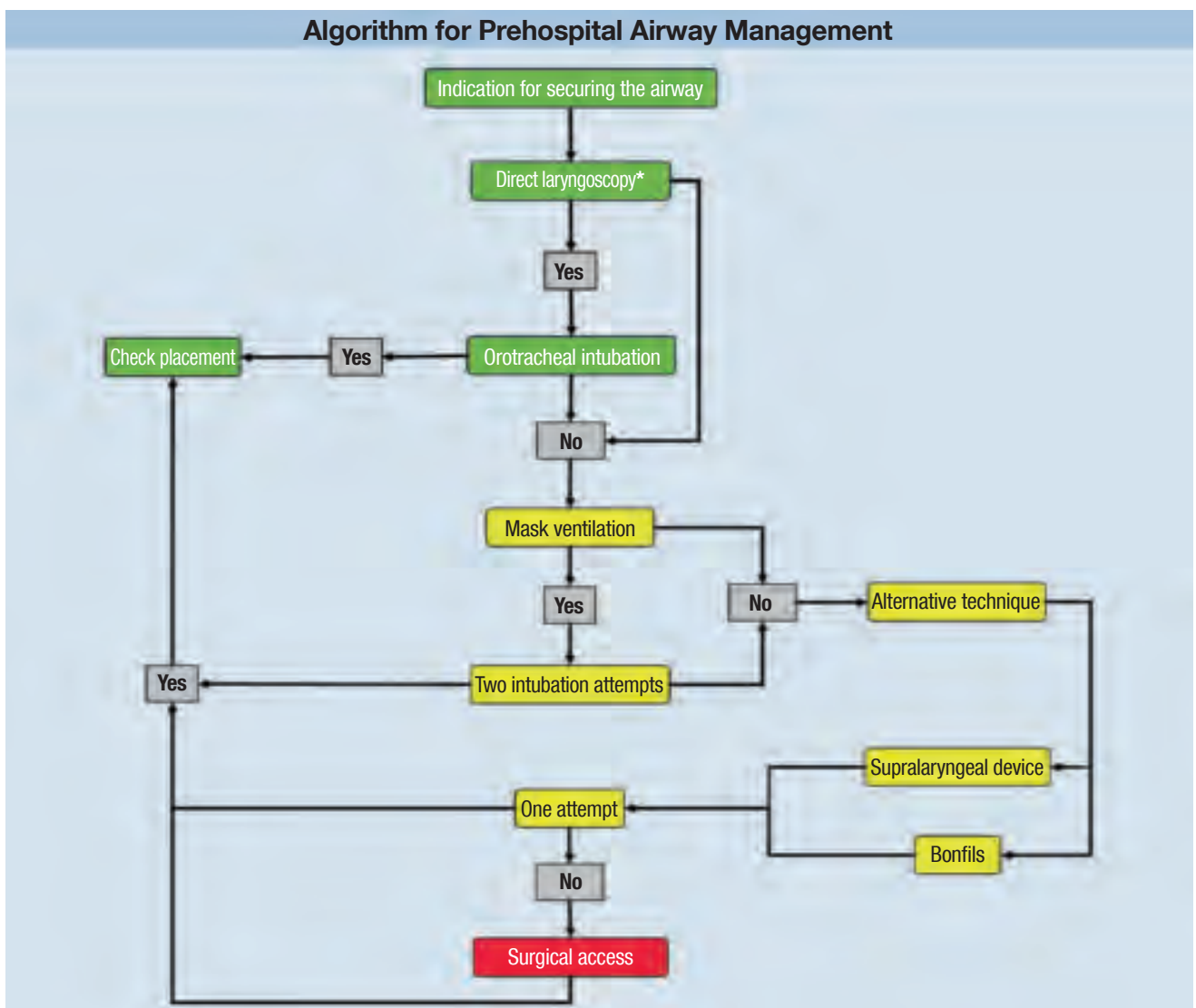

Prehospital algorithm for airway management.
* If immediately available: video laryngoscopy.



43

In-hospital use of the C-MAC® video laryngoscope.

Comparison with Alternative Procedures

Comparison with Video Laryngoscopy

Direct laryngoscopy requires a linear alignment of the oral, pharyngeal, and tracheal axes in order to visualize the glottis. As with the BONFILS intubation endoscope, this is not necessary with the latest generation of video laryngoscopes (e.g., C-MAC®, KARL STORZ; **Fig. 43**). In these devices the image is transmitted to a video screen by a chip mounted at the blade tip. Video laryngoscopes have been found to improve visualization of the glottis compared with direct laryngoscopy.⁵⁸

One possible limitation of video laryngoscopy is the introduction of the endotracheal tube with a rigid stylet through the oral cavity and the tracheal placement of the tube. Because some laryngoscopes do not allow the tube to be advanced into the pharynx under direct vision, there is a potential for upper airway trauma.^{40, 42} Additionally, the tube may be difficult to advance with some video laryngoscopes despite good visualization of the glottic plane. This appears to be less of a problem with the BONFILS intubation endoscope because the tube is directed into place while on the endoscope shaft, and the tube is advanced and introduced into the trachea under direct optical control.

Most video laryngoscopes require a greater degree of mouth opening for instrument insertion than the BONFILS intubation endoscope.

Both techniques may be limited by bleeding or copious secretions in the oral cavity. Two advantages of the BONFILS intubation endoscope are that the optional oxygen flow can help clear the lens, and the patient can be oxygenated during apnea.

Comparison with the Flexible Fiberscope

The BONFILS intubation endoscope is definitely more favorable than the flexible fiberscope in its acquisition and maintenance. Unlike the flexible fiberscope, moreover, it seldom requires costly repairs owing to its rugged design.⁵⁹ Cleaning and processing of the BONFILS intubation endoscope are less time-intensive, and there is no need to test the instrument for seal integrity. While flexible fiberoptic scopes can easily be damaged even during cleaning, this risk is much lower with the BONFILS intubation endoscope.

The design of the intubation endoscope permits flexible handling, which allows for rapid use.⁵⁵ One difference relative to flexible fiberscopes is that secretions cannot be suctioned from the airway through the insufflation channel of the intubation endoscope. It should also be noted that every model is not equipped with an insufflation channel.

The BONFILS intubation endoscope is less complicated to use than a flexible fiberscope, resulting in a shorter learning curve.^{30, 31} Comparative studies have not yet been published on this issue. Unlike flexible intubation fiberscopes, the BONFILS intubation endoscope cannot be used for nasal intubation.

Typical Errors and Problems During Use

Fogging of the Lens

Because the intubation time is usually longer for inexperienced users, fogging of the distal endoscope tip may be a problem. The temperature of the endoscope is also a factor, of course. This problem can be significantly reduced by using suitable anti-fogging agents. Oxygen administration through the insufflation channel can also counteract fogging, and prewarming of the instrument tip may help to prevent condensation on the distal lens surface.

Difficulty Releasing the Endotracheal Tube from the Adaptor

The conical adaptor on the BONFILS intubation endoscope serves to hold the endotracheal tube in place until it reaches the laryngeal inlet. If the tube is pushed too tightly into the adaptor during setup, it may be difficult to release the tube smoothly and easily. If the tube must be forcibly disengaged, the operator may temporarily lose control and vision, causing the tube to plunge into the esophagus.⁶⁴ This is most likely to occur when the user shifts his or her gaze toward the adaptor and away from the advancing tube.

An uncontrolled release also causes a sudden loss of resistance for the endoscope user. The eyepiece on a direct-viewing endoscope may recoil toward the user, causing damage or injury to the eye or eyewear.

Both problems can be prevented by pushing the endotracheal tube carefully and gently into the adaptor during setup. Because little force will be acting on the tube itself, there is no need to fix it tightly in the holder.

Compatibility with Eyewear

Near-sighted eyeglass wearers in particular must decide whether to wear their glasses during the endoscopic procedure. Generally this is not an issue when the image is displayed on a monitor or when protective goggles are worn in a contaminated environment.

Removing eyeglasses brings the eye closer to the eyepiece, causing the image to appear larger. This can also make it easier to concentrate on the eyepiece image since ambient movements are not perceived. On the other hand, near-sighted users may no longer be able to check the patient monitor intermittently (e.g., oxygen saturation, ECG) without their glasses. In any case, often there is no opportunity to remove eyeglasses safely during anesthesia induction. In the latest generation of endoscopes, the eyepiece does not have an adjustable focus that can correct for operator vision defects.

Poor Visualization of Anatomy

As noted earlier, visualization of the retropharyngeal space is the key maneuver during use of the BONFILS intubation endoscope. It is essential to lift the tongue and especially the epiglottis in the anesthetized patient in order to proceed under vision and identify key landmarks as the instrument advances. Besides laryngoscopy, grasping and lifting the jaw with the left hand is perhaps the most commonly used technique for accessing the retropharyngeal space.



44a



44b

The BONFILS intubation endoscope is positioned above the glottis, and the endotracheal tube is advanced into the trachea under vision.

Illustrative Case Reports

In-Hospital Unanticipated Difficult Airway

A 53-year-old man underwent an elective urologic procedure that lasted several hours. Because the surgery was performed laparoscopically in a head-down position, general endotracheal anesthesia was indicated. The preanesthesia evaluation showed no abnormalities. The patient was assigned to ASA class 2 based on various allergies. Evaluation for evidence of potential problems during airway management was negative. The chin-to-larynx distance was normal, and the cervical spine showed good extension. The patient scored a 3 on the Mallampati classification as modified by *Samsoon* and *Young*.

During induction of general anesthesia the patient received adequate mask ventilation and neuromuscular blockade. Following induction, however, no glottic or epiglottic structures were visualized by direct laryngoscopy (Cormack-Lehane score of 4). Mask ventilation was continued without difficulty. A supervising physician was summoned for help and reattempted intubation by direct laryngoscopy, which also failed. A third intubation attempt, this time with the BONFILS intubation endoscope, was performed shortly thereafter. The patient had good mouth opening, and the anesthesiologist introduced the endoscope by the retromolar route while lifting the lower jaw, visualizing the retropharyngeal space. The endoscope was advanced under vision without difficulty, and key anatomic landmarks were clearly identified. The endoscope was positioned above the laryngeal inlet, the endotracheal tube was carefully advanced into the trachea under vision, and the intubation endoscope was withdrawn (Figs. 44a, b). Subsequent capnography and auscultation confirmed correct tube placement. Further anesthesiologic and surgical measures were uneventful. At the end of the operation the patient had good spontaneous respiration and protective reflexes and was extubated postoperatively without incident.

The patient described no complaints during the postanesthesia visit on the following day. In accordance with the Airway Management guidelines of the DGIA, the patient was issued an Anesthesia Problem Card for subsequent surgical procedures (Fig. 45).

This card is made to alert the anaesthetologist to problems that occurred during anaesthesia. The card should always be given to the anaesthetologist before anaesthesia. It should be carried by the holder in case of emergency surgery.

Further: EAA and DGAI have assumed legal liability for the content of this card.

Signature (Surname): _____

Printname (Given name): _____

Date (month/year):

DGAI (Gesellschaft für Reanimations- und Intensivmedizin) 27, D-90419 Nürnberg

45

Sample of an Anesthesia Problem Card issued by the German Society of Anesthesiology and Intensive Care Medicine.

Prehospital Intubation with Difficult Patient Access

An ambulance and an emergency response vehicle with a physician on board were dispatched to aid an “unconscious person.”* Both vehicles arrived simultaneously at the emergency scene, a single-family dwelling. Waiting in front of the house was the female homeowner, who stated that her husband was “not well” and that she would lead the way. The path to the patient led through a staircase heavily littered with old household items. On entering the bedroom, rescue personnel had to climb over old television sets, typewriters, etc. in order to reach the patient. The patient lay unconscious on an old bed littered with various objects. The rescue service pushed several objects aside, creating at least enough room for the emergency physician to stand at the head of the bed.

The approximately 75-year-old man was breathing spontaneously when the emergency physician arrived. He registered a score of 3 on the Glasgow Coma Scale. Both pupils were constricted and showed sluggish response to light. The extremities were cold, initially registering no peripheral saturation. Palpated systolic blood pressure was 100 mmHg. Gross physical examination showed no evidence of injuries. Neurologic findings were consistent with a stroke. With no measurable saturation and given the obstacles of moving the patient to the rescue vehicle, the emergency physician opted for immediate intubation. After preoxygenation and i.v. sedation, and without repositioning the patient, the physician introduced the BONFILS intubation endoscope in the spontaneously breathing patient. While the left hand lifted the jaw, the endoscope was inserted into the right side of the mouth and advanced to the retropharyngeal space by the retromolar route (**Fig. 46a**). No difficulties were encountered in advancing the intubation endoscope and positioning it beneath the epiglottis. The laryngeal inlet was clearly visualized, allowing for controlled endotracheal intubation under continuous vision. The view through the endoscope confirmed correct endotracheal placement of the tube. Subsequent capnometry indicated an end-tidal CO₂ of 43 mmHg, and breath sounds were audible in both lungs. At that point the patient was easily conveyed from the house with the help of additional responders. He was transported to a maximum-care hospital, where he was diagnosed with a severe stroke.



46b Carrying cases for the BONFILS intubation endoscope and a flexible fiberscope for emergency medicine.



46a

Prehospital use of the BONFILS intubation endoscope in a rescue vehicle.

* In Germany, patients with life-threatening injuries or diseases are generally seen by an emergency physician. The situation may require securing the airway at the emergency scene or during transport in a rescue vehicle.

Cleaning, Disinfection, and Sterilization

Rita Metz

**Hygienist, Department of Hospital Hygiene,
Mainz University Hospital, Mainz, Germany**

General Part

Medical products and instruments contaminated by microorganisms may cause infection in humans. Their reuse requires effective decontamination, therefore. Requirements for the decontamination of medical instruments and devices have been specified in numerous laws, regulations, and official guidelines:

- German Medical Devices Act⁴
- German Medical Devices Operator Ordinance⁵
- “Hygienic Requirements for the Decontamination (Cleaning, Disinfection, Sterilization) of Medical Devices”, Recommendation by the Commission for Hospital Hygiene and Infection Prevention at the Robert Koch Institute and Federal Institute for Drugs and Medical Devices.
- DIN EN ISO 15883: Requirements for Cleaning and Disinfection Devices.

Particular care should be taken to follow validated procedures recommended by the manufacturer. For this reason, automated decontamination is usually preferred.⁸ Based on guidelines issued by the Robert Koch Institute in Germany, every medical product should undergo a risk assessment and should be assigned to one of three product classes – noncritical, semicritical, or critical – to determine how the product should be processed for reuse.

The German Robert Koch Institute (RKI)

The Robert Koch Institute (RKI) is the central agency of the German federal government for the surveillance and prevention of diseases. The core tasks of the RKI are the detection, prevention, and control of diseases, particularly infectious diseases.

The RKI has formed a Commission for Hospital Hygiene and Infection Prevention charged with making recommendations for the prevention of nosocomial infections. Included are recommendations for operational, organizational, structural, and functional measures to improve hygiene in hospitals and other medical facilities.

The RKI Commission has issued two recommendations pertaining to endoscopy:

- Hygienic requirements for the decontamination (cleaning, disinfection, sterilization) of flexible endoscopes and endoscopic accessories.⁵¹
- Hygienic requirements for the structural and functional organization and equipment of endoscopy units.⁵²

Manual and Automated Processing

As a rule, manual processing is done by immersing or washing the equipment with cleaning and disinfectant solution and mechanical measures using cleaning/disinfecting brushes/wipes. Generally, this is done only in selected cases because the process cannot be validated and does not follow a standardized protocol. Also, manual processing must rely on chemical disinfection. To minimize the risk of personal infection, safety rules for the decontamination of different product classes should be strictly followed. This includes the wearing of protective clothing, gloves, masks, and eyewear (Fig. 47).

Automated processing involves the use of an approved (DIN EN ISO 15883 compliant) cleaning and disinfecting unit. The processing cycle includes the steps of prerinsing, cleaning, rinsing off the cleaning chemicals, thermal disinfection at $> 90^{\circ}\text{C}$, and drying. The goal is to reduce microbial counts by a factor of 10^{-5} . European standards for cleaning and disinfecting units use the “Ao value” to measure the efficacy of microorganism killing with moist heat. To be effective against heat-resistant viruses such as the HBV, decontamination by automated processing should achieve an Ao value of 3000.

Types of Decontamination

Desinfection

The goal of cleaning and disinfection is to reduce microbial counts on the treated object or surface by a factor of 10^{-5} (99.999%). Disinfection may be accomplished by chemical or physical/thermal processes. Thermal disinfection in an automated cleaning and disinfecting unit is preferred owing to its greater efficacy. The preferred mode of disinfection should already be noted and considered during the acquisition of a medical product.

Chemical disinfection relies on the use of chemical agents and chemical mixtures. Because chemical disinfection is usually performed manually and is not subject to rigorous validation, it is acceptable only in certain situations. A manual disinfection procedure using suitable cleaning/disinfecting agents always carries a higher risk of failure, which may have various causes, e.g., use of the wrong disinfectant, in the wrong concentration, insufficient duration of exposure/contact, or improper use of the agent. Once the disinfectant has been properly used, it must be removed from the medical product. This is done by rinsing the product with water, which carries some risk of recontamination by water-borne microorganisms, depending on the hygienic quality of the water.

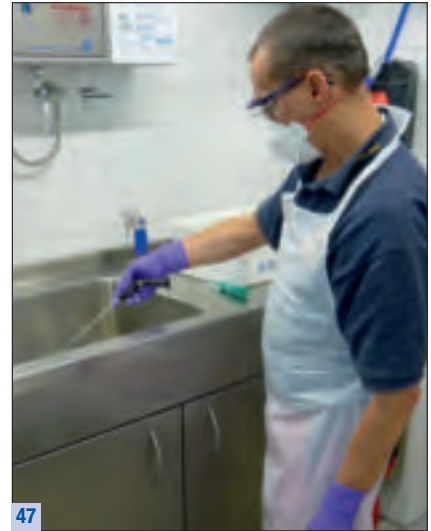

Protective attire is worn for manual cleaning and disinfection.

Sterilization

Sterilization kills all microorganisms including their spores. A successful sterilization process will reduce microbial counts by a factor of 10^{-6} . For sterilization to be effective, the item must first be thoroughly cleaned and disinfected. Owing to their efficacy and reliability, thermal sterilization methods using saturated steam (autoclaving at 121 °C or 134 °C) are preferred. This method can be used only on thermostable medical products, however. Heat-sensitive materials can be sterilized by gas sterilization with ethylene oxide or formaldehyde or by plasma sterilization using H_2O_2 .

Ultrasonic Cleaning

Treatment in an ultrasonic bath produces a cavitation effect that scales off dirt particles from solid surfaces. This effect is considerably attenuated on soft objects, however (rubber, latex, silicone rubber). Moreover, ultrasonic treatment may cause damage to the item being cleaned. Careful attention should be given to the information furnished by the medical product manufacturer. Under no circumstances should ultrasound be used to treat flexible fiberscopes, telescopes, fiberoptic cables, or products assembled with glue. Ultrasonic treatment itself does not disinfect, but this effect can be achieved by adding special cleaning and disinfecting agents specifically approved for ultrasonic use.

Assigned Risk Classes of Intubation Endoscopes in the German RKI Recommendations

Intubation endoscopes and other medical products used in anesthesiology are classified as semicritical items because they come in contact only with mucous membranes or unbroken skin. Generally it is sufficient to clean and disinfect these products for reuse. Some products used for specialized indications or high-risk patients may additionally require sterilization. All treatments should employ validated procedures, preferably by automated processing, in accordance with manufacturers' recommendations. Care should be taken that the washing and disinfecting solution reaches both the outer surface and inner surface (lumen) of the treated item. Generally this is achieved by coupling the item to a special rinsing attachment or ideally by direct coupling to the cleaning / disinfecting unit.

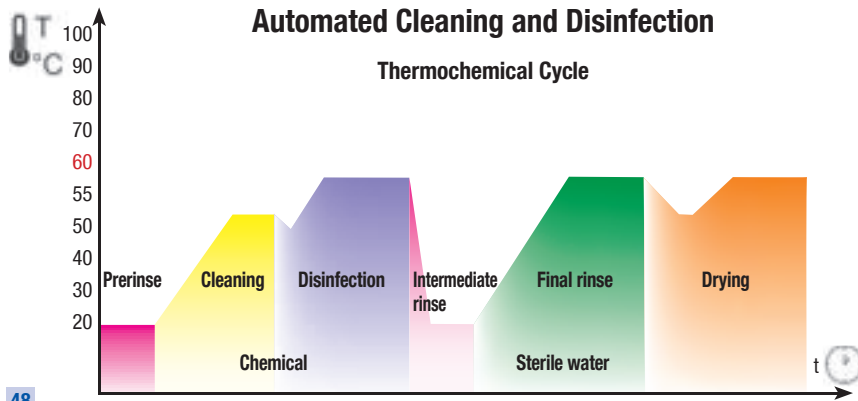

48

Processing steps and temperature cycle used in the automated cleaning and disinfection of flexible endoscopes.

Cleaning and Disinfecting Unit for Flexible Endoscopes

Flexible endoscopes are not thermostable, and temperatures above 60 °C will damage the instrument. Thus, the automated processing of endoscopes relies on thermochemical disinfection. The individual process steps are as follows:

- Prerinse
- Cleaning (at approximately 50 °C)
- Disinfection (at approximately 55 °C) by a chemical disinfectant (usually based on aldehydes or peracetic acid)
- Postrinse
- Drying (**Fig. 48**).

The water for the final rinse must be sterile, i.e., the endoscope cleaning and disinfecting unit must effectively remove microorganisms from the rinse water.

Special Part

Cleaning and Disinfection of the BONFILS Intubation Endoscope

The BONFILS intubation endoscope is a semi-rigid endoscope that demands for thermochemical reprocessing similarly to that used for fiberscopes. It is not equipped with irrigation or instrument channels. The scope can have a channel for oxygen insufflation, depending on the model. The endoscope manufacturer has issued recommendations for both manual and automated processing. Ultrasonic treatment is generally not an option! A list of manufacturer-approved chemical disinfectants is available on the internet (www.karlstorz.de).

Automated Processing

Automated processing of the BONFILS intubation endoscope can be done in an endoscope cleaning and disinfecting unit (ECDU). If the instrument has a channel for oxygen insufflation, the ECDU must be equipped with single-channel rinse attachments.

Process

- Immediately after use, the metal shaft of the instrument is wiped off with a moist, low in lint disposable cloth.
- Next, the instrument is placed in a special tray and transferred for cleaning and disinfection. The adaptor on the light connector and the adaptor for endotracheal tube fixation are removed.
- If there is much grossly visible soiling, the instrument should be manually cleaned prior to automated processing.
- The endoscope is placed into a suitable rinse basket in the ECDU, and the insufflation channel is connected to the single-channel rinse attachment. The adaptors are placed into an accessories basket (Figs. 49, 50).
- The cleaning and disinfection cycle is initiated.
- Once the thermochemical cycle (not exceeding 60°C) is completed, the intubation endoscope is manually removed from the ECDU. (The hands are cleaned with antiseptic before touching the instrument parts.) The processed items are checked to make sure they are in working order. Any residual water is removed from the insufflation channel with medically pure compressed air (**caution:** do not exceed a maximum pressure of 50 kP/0.5 bar!).
- Any smears or residues on the eyepiece or lens can be removed with 70% isopropyl alcohol.
- The processed items are stored in a dry, dust-free environment, preferably in a storage cabinet. Care is taken to protect the endoscope from “jolts” and other mechanical damage, ideally by use of a special storage tray.



49



50

Proper loading of the BONFILS intubation endoscope into the cleaning and disinfecting unit.

Manual Processing

Manual cleaning and disinfection of the BONFILS intubation endoscope consists of the following steps:

1. Precleaning

- Immediately after use, the metal shaft of the endoscope is wiped off with a moist, low in lint disposable cloth (**Fig. 51**).
- Next the instrument is transferred for cleaning and disinfection. The adaptor on the light connector and the adaptor for endotracheal tube fixation are removed and placed into a cleaning solution.
- The endoscope is completely immersed in a cleaning solution. All parts are cleaned with a soft, disinfected sponge or disinfected brush with soft tufts. If the endoscope has an insufflation channel, a pistol-grip nozzle (**Caution:** maximum pressure 50 kP/0.5 bar!) or a disposable syringe is used to flush the channel with cleaning solution.
- All cleaned parts are rinsed with water (drinking-water quality). The insufflation channel, if present, is also flushed clean with water.

2. Disinfection

- Both adaptors and the instrument are immersed in an instrument disinfectant solution, making sure that they are free of air bubbles. A disposable syringe is used to flush the insufflation channel with solution (**Fig. 52**). All parts remain immersed in the disinfectant solution during the exposure period, which depends on the concentration of the solution.
- If no sterilization processing is applied, it is mandated that disinfectants (with a complete virucidal effect!) be used that have been tested for their efficacy on surgical instruments. (In Germany, the National Association for Applied Hygiene keeps a list of validated disinfectants).

3. Final Rinse

- When the exposure period is over, the intubation endoscope and adaptors are removed from the disinfectant solution and rinsed thoroughly with sterile water. The insufflation channel should also be flushed several times with sterile water (**Fig. 53**).

4. Drying

- All parts are carefully dried with a low in lint disposable cloth, and the insufflation channel is dried with medically pure compressed air (**caution:** do not exceed a maximum pressure of 50 kP /0.5 bar!) (**Fig. 54**).
- Any smears or residues on the eyepiece or lens can be removed with 70% isopropyl alcohol.

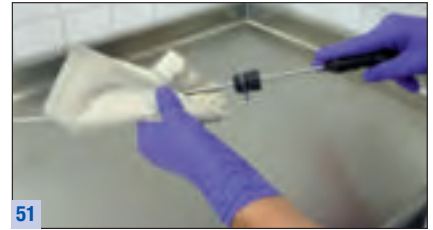

51 The shaft is wiped clean with a disposable low in lint cloth.



52 The insufflation channel is flushed with disinfectant using a disposable syringe.



53 The instrument parts are rinsed with sterile water.

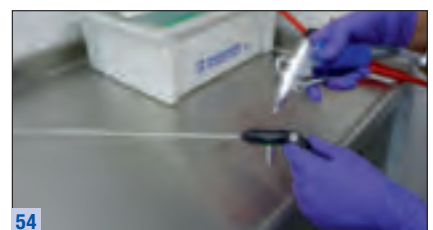

54 All parts are dried with medical-grade compressed air.

Sterilization

The BONFILS intubation endoscope is compatible only with low-temperature sterilization. The manufacturer has approved three processes: plasma sterilization using H₂O₂ (e.g., STERRAD® Sterilization System), gas sterilization with ethylene oxide or formaldehyde, and STERIS® System 1 sterilization.

- Sterilization of the cleaned, disinfected, and functionally sound endoscope is carried out in sterile packaging.
- The sterilized items are stored in a dry, dust-free environment, preferably in a storage cabinet. Care is taken to protect the endoscope from “jolts” and other mechanical damage, ideally by use of a special storage tray.

Quality Control

The RKI recommends the following quality control measures for endoscopic cleaning and disinfection:

1. Automated processing quality control.

The efficacy of automated processing in an endoscope cleaning and disinfecting unit is tested with contaminated test objects designed to simulate the conditions in an endoscope channel. The test objects consist of Teflon tubes (2 m long, 2 mm inside diameter) that have been contaminated with (ovine) blood containing *Enterococcus faecium*.

2. Microbiologic testing of processed endoscopes.

This test should be done at least once a year and should include the endoscope channel and the air-water insufflation channel.

The following steps are recommended:

- Flush the endoscope channels with 20 mL NaCl.
- Take smears from instrument sites that are the most difficult to clean and disinfect (e.g., distal end of the endoscope, Albarran lever recess).
- Sponge test: pull a piece of sponge through the endoscope channel.

3. Additional tests

- Microbiologic testing of the endoscope irrigation system.
- Microbiologic testing of the final rinse water in the cleaning and disinfecting unit.

References

1. (1996) Guidelines for the basic management of the airway and ventilation during resuscitation. A statement by the Airway and Ventilation Management Working Group of the European Resuscitation Council. *Resuscitation* 31:187–200
2. (2003) Practice guidelines for management of the difficult airway: an updated report by the American Society of Anesthesiologists Task Force on Management of the Difficult Airway. *Anesthesiology* 98: 1269–1277
3. (2004) Airway Management. Leitlinie der DGAI. *AnästH Intensivmed* 45:302–306
4. Gesetz über Medizinprodukte (MPG) in der Fassung der Bekanntmachung vom 7. August 2002 (BGBl. I, geändert 14. Juni 2007 (BGBl. I S. 1066))
5. Verordnung über das Errichten, Betreiben und Anwenden von Medizinprodukten (MPBetreibV) in der Fassung der Bekanntmachung vom 21. August 2002 (BGBl. I S. 3396), geändert 2006 (BGBl. I S. 2407)
6. ABRAMSON SI, HOLMES AA, HAGBERG CA (2008): Awake insertion of the Bonfils Retromolar Intubation Fiberscope in five patients with anticipated difficult airways. *Anesth Analg* 106:1215–1217
7. AKDIKMEN SA (1966): A modified technique for direct laryngoscopy and tracheal intubation. *Anesthesiology* 27:321
8. Arbeitskreis „Krankenhaus- & Praxishygiene“ der AWMF (2004) *Hygiene in Klinik und Praxis*. 3. Auflage mhp-Verlag, Wiesbaden
9. BARBA CA, ANGOOD PB, KAUDER DR, LATENSER B, MARTIN K, MCGONIGAL MD, PHILLIPS GR, ROTONDO MF, SCHWAB CW (1995): Bronchoscopic guidance makes percutaneous tracheostomy a safe, cost-effective, and easy-to-teach procedure. *Surgery* 118:879–883
10. BECK A, GEHARD F, KINZL L (2002): Notärztliche Versorgung des Traumapatienten. *Notfall Rettungsmed* 5:57–71
11. BEIN B, CALIEBE D, ROMER T, SCHOLZ J, DORGES V (2005): Using the Bonfils intubation fiberscope with a double-lumen tracheal tube. *Anesthesiology* 102:1290–1291
12. BEIN B, WORTHMANN F, SCHOLZ J, BRINKMANN F, TONNER PH, STEINFATH M, DORGES V (2004): A comparison of the intubating laryngeal mask airway and the Bonfils intubation fibrescope in patients with predicted difficult airways. *Anaesthesia* 59:668–674
13. BEIN B, WORTHMANN F, MEYBOHM P, STEINFATH M, SCHOLZ J, DORGES V (2008): Evaluation of the pediatric Bonfils fiberscope for elective endotracheal intubation. *Paediatr Anaesth* 18:1040–1044
14. BEIN B, YAN M, TONNER PH, SCHOLZ J, STEINFATH M, DORGES V (2004): Tracheal intubation using the Bonfils intubation fibrescope after failed direct laryngoscopy. *Anaesthesia* 59:1207–1209
15. BERCI G, KATZ R (1979): Optical stylet: an aid to intubation and teaching. *Ann Otol Rhinol Laryngol* 88:828–831
16. BOIDIN MP (1985): Airway patency in the unconscious patient. *Br J Anaesth* 57:306–310
17. BONFILS P (1983): Fiberoptische Intubation. *Intensivbehandlung* 8:53–60
18. BONFILS P (1982): Neue Techniken mit einem fiberoptischen Instrument: nasale kontralaterale Intubation. *Anaesthesist* 31:362–365
19. BONFILS P (1983): Schwierige Intubation bei Pierre-Robin-Kindern, eine neue Methode: der retromolare Weg. *Anaesthesist* 32:363–367
20. BUEHNER U, ORAM J, ELLIOT S, MALLICK A, BODENHAM A (2006): Bonfils semirigid endoscope for guidance during percutaneous tracheostomy. *Anaesthesia* 61:665–670
21. BYHAHN C, MEININGER D, WALCHER F, HOFSTETTER C, ZWISSLER B (2007): Prehospital emergency endotracheal intubation using the Bonfils intubation fiberscope. *Eur J Emerg Med* 14:43–46

22. BYHAHN C, NEMETZ S, BREITKREUTZ R, ZWISSLER B, KAUFMANN M, MEININGER D (2008): Brief report: tracheal intubation using the Bonfils intubation fibrescope or direct laryngoscopy for patients with a simulated difficult airway. *Can J Anaesth* 55:232–237
23. CHERALA S, OVASSAPIAN A (1989): A complication of fiberoptic nasal tracheal intubation. *Anesthesiology* 71:319–320
24. CORBANESE U, POSSAMAI C (2009): Awake intubation with the Bonfils fibrescope in patients with difficult airway. *Eur J Anaesthesiol* – in press
25. GOLECKI N, BRAMBRINK, A (2005): Das Airway-Management-Set nach Lipp/Golecki. 1. Auflage Endo-Press®, Tuttlingen
26. GOTTSCHALL R (2006): Laryngoskopie nach Bullard, Bonfils und „Notrohr“. www.anaesthesie-cme.de/135_0.html (gesehen am 31. 1. 2009)
27. GOUTCHER CM, LOCHHEAD V (2005): Reduction in mouth opening with semi-rigid cervical collars. *Br J Anaesth* 95:344–348
28. GRIGO AS, HALL ND, CRERAR-GILBERT AJ, MADDEN BP (2005): Rigid bronchoscopy-guided percutaneous tracheostomy. *Br J Anaesth* 95:417–419
29. GUPTA R, SAINI S, PREET K (2001): The „toothpaste method“ for anesthesia of the difficult airway. *Can J Anaesth* 48:513
30. HALLIGAN M, CHARTERS P (2003): A clinical evaluation of the Bonfils Intubation Fibrescope. *Anaesthesia* 58:1087–1091
31. HALLIGAN M, CHARTERS P (2003): Learning curve for the Bonfils intubation fibrescope. *Br J Anaesth* 90:826P
32. HE N, XUE FS, XU YC, LIAO X, XU XZ (2008): Awake orotracheal intubation under airway topical anesthesia using the Bonfils in patients with a predicted difficult airway. *Can J Anaesth* 55:881–882
33. HEATH KJ (1994): The effect of laryngoscopy of different cervical spine immobilisation techniques. *Anaesthesia* 49:843–845
34. HEMMERLING TM, BRACCO D (2008): Subcutaneous cervical and facial emphysema with the use of the Bonfils fiberscope and high-flow oxygen insufflation. *Anesth Analg* 106:260–262
35. HENDERSON JJ, POPAT MT, LATTO IP, PEARCE AC (2004): Difficult Airway Society guidelines for management of the unanticipated difficult intubation. *Anaesthesia* 59:675–694
36. HERSHEY MD, HANNENBERG AA (1996): Gastric distention and rupture from oxygen insufflation during fiberoptic intubation. *Anesthesiology* 85:1479–1480
37. HO CM, YIN IW, TSOU KF, CHOW LH, TSAI SK (2005): Gastric rupture after awake fibreoptic intubation in a patient with laryngeal carcinoma. *Br J Anaesth* 94:856–858
38. KATZ RL, BERCI G (1979): The optical stylet – a new intubation technique for adults and children with specific reference to teaching. *Anesthesiology* 51:251–254
39. KILL C (2007): Aktuelle Strategien der notärztlichen Erstbehandlung. *Anesthesiol Intensivmed Notfallmed Schmerzther* 42:708–714
40. LEONG WL, LIM Y, SIA AT (2008): Palatopharyngeal wall perforation during Glidescope intubation. *Anaesth Intensive Care* 36:870–874
41. LIAO X, XUE FS, ZHANG YM (2008): Tracheal intubation using the Bonfils intubation fibrescope in patients with a difficult airway. *Can J Anaesth* 55:655–656
42. MALIK AM, FROGEL JK (2007): Anterior tonsillar pillar perforation during GlideScope video laryngoscopy. *Anesth Analg* 104:1610–1611
43. MAYBAUER MO, MAIER S, THIERBACH AR (2005): Eine unerwartet schwierige Intubation: Das starre Intubationsfiberskop nach Bonfils. *Anaesthesist* 54:35–40
44. MIHAI R, BLAIR E, KAY H, COOK TM (2008): A quantitative review and meta-analysis of performance of non-standard laryngoscopes and rigid fibreoptic intubation aids. *Anaesthesia* 63:745–760

45. NANDI PR, CHARLESWORTH CH, TAYLOR SJ, NUNN JF, DORE CJ (1991): Effect of general anaesthesia on the pharynx. *Br J Anaesth* 66:157–162
46. NOLAN JP, DEAKIN CD, SOAR J, BOTTIGER BW, SMITH G (2005): European Resuscitation Council guidelines for resuscitation 2005. Section 4. Adult advanced life support. *Resuscitation* 67 Suppl 1:S39–S86
47. PIEPHO T, NOPPENS RR, BUGGENHAGEN H, THIERBACH AR (2009): Erfolgreicher Einsatz des Intubationsendoskops nach Bonfils in der präklinischen Notfallmedizin. *Notfall Rettungsmed im Druck*
48. PIEPHO T, NOPPENS RR, HEID F, WERNER C, THIERBACH AR (2009): Rigid fibrescope e Bonfils: use in simulated difficult airway by novices. *Scand J Trauma Resusc Emerg Med* 17:33
49. PIEPHO T, THIERBACH A, WERNER C (2005): Nasotracheal intubation: look before you leap. *Br J Anaesth* 94:859–860
50. PIEPHO T, THIERBACH AR, GOBLER SM, MAYBAUER MO, WERNER C (2009): Comparison of two different techniques of fibreoptic intubation. *Eur J Anaesthesiol* 26:328–332
51. Robert Koch-Institut (2002): Anforderung an die Hygiene bei der Aufbereitung flexibler Endoskope und endoskopischen Zusatzinstrumentariums. *Bundesgesundheitsbl – Gesundheitsforsch – Gesundheitsschutz* 45:395–411
52. Robert Koch-Institut (2002): Anforderung der Hygiene an die baulich-funktionelle Gestaltung und apparative Ausstattung von Endoskopieeinheiten. *Bundesgesundheitsbl – Gesundheitsforsch – Gesundheitsschutz* 45:412–414
53. RUDOLPH, C (2004): Starre Intubationsfiberskope. in: Döriges, V. und Paschen, H.-R.: *Management des schwierigen Atemwegs*. Springer-Verlag, Berlin Heidelberg
54. RUDOLPH, C (2007): *Das Intubationsendoskop nach Bonfils: Methode und Indikation*. 1. Auflage Endo-Press, Tuttlingen
55. RUDOLPH C, HENN-BEILHARZ A, GOTTSCHALL R, WALLENBORN J, SCHAFFRANIETZ L (2007): The unanticipated difficult intubation: rigid or flexible endoscope? *Minerva Anesthesiol* 73:567–574
56. RUDOLPH C, SCHLENDER M (1996): Klinische Erfahrungen mit der fiberoptischen Intubation mit dem Intubationsfiberskop nach Bonfils. *Anaesthesiol Reanim* 21:127–130
57. RUDOLPH C, SCHNEIDER JP, WALLENBORN J, SCHAFFRANIETZ L (2005): Movement of the upper cervical spine during laryngoscopy: a comparison of the Bonfils intubation fibrescope and the Macintosh laryngoscope. *Anaesthesia* 60:668–672
58. SHIPPEY B, RAY D, MCKEOWN D (2008): Use of the McGrath videolaryngoscope in the management of difficult and failed tracheal intubation. *Br J Anaesth* 100:116–119
59. THIERBACH A, LIPP M, DICK W (1997): Management der Atemwege im Notfall. *Notfallmedizin* 23:408–411
60. THIERBACH A, PIEPHO T, WOLCKE B, KUSTER S, DICK W (2004): Präklinische Sicherung der Atemwege – Erfolgsraten und Komplikationen. *Anaesthesist* 53:543–550
61. TIMMERMANN A, EICH C, RUSSO SG, NATGE U, BRAUER A, ROSENBLATT WH, BRAUN U (2006): Prehospital airway management: a prospective evaluation of anaesthesia trained emergency physicians. *Resuscitation* 70:179–185
62. TIMMERMANN A, RUSSO SG, EICH C, ROESSLER M, BRAUN U, ROSENBLATT WH, QUINTEL M (2007): The out-of-hospital esophageal and endobronchial intubations performed by emergency physicians. *Anesth Analg* 104:619–623
63. WICK M, EKKERNKAMP A, MUHR G (1997): Epidemiologie des Polytraumas. *Chirurg* 68:1053–1058
64. WONG P (2003): Intubation times for using the Bonfils intubation fibrescope. *Br J Anaesth* 91:757–758

Video Systems for Airway Management

KARL STORZ offers a complete armamentarium of instruments and videoendoscopic devices, that is tailored to a wide range of airway management modalities. The broad scope of KARL STORZ products gives you all

options – for dealing with a standard or unexpectedly difficult intubation. In addition, all of our fiberscopes are powered by an LED battery light source to make sure that even in an emergency you will never be left in the dark.

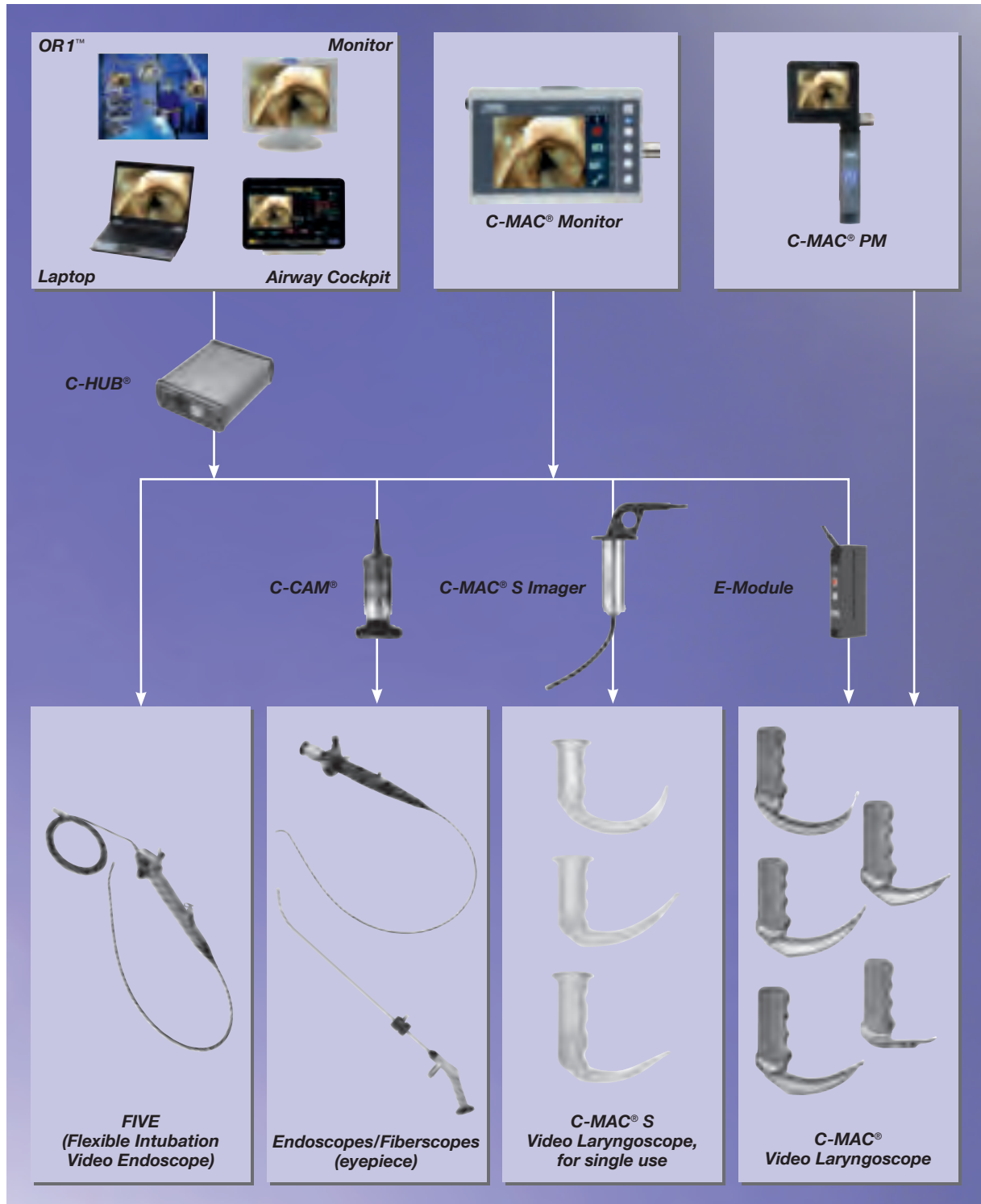

It is recommended to check the suitability of the product for the intended procedure prior to use.

C-MAC® Video Laryngoscope for visual endotracheal intubatio

Monitor/Electronic Module



Special Features:

- Resistant ABS plastic housing
- Splash-proof according to IP54
- 7" TFT wide view angle display with resolution of 800 x 480 pixels
- Ready for use within seconds
- Documentation of still images (JPEG) and videos (MPEG4) on SD memory card
- VESA 75 norm for connecting and attaching racks
- Soft keys enable use within seconds
- Cinch video output for connecting external monitor
- System open for further components
- Operating time with lithium-ion batteries of about 2 hours
- World power supply 100 – 240 VAC, 50/60 Hz
- Operation with line voltage and rechargeable lithium-ion batteries
- Processing of the electronic module: Suitable and validated for the following low-temperature reprocessing methods up to bis max. 60 °C: manual/machine cleaning and disinfection, sterilization with Steris® AMSCO VPRO 1, Sterrad® (50S, 100S, 200S, NX, 100NX) and EtO gas; High-Level Disinfection (HLD) acc. to US standards
- Additional standards: RTCA/DO-160F, EMI Test Report (German air rescue service DRF Luftrettung)



8403 ZX



8402 X

- 8403 ZX **C-MAC® Monitor für CMOS Endoscopes**, screen size 7" with 1280 x 800 pixel resolution, two camera inputs, a USB and a HDMI port, optimized user interface, video and image capturing in real time on SD card, playback of recorded video clips and still images, data transfer from SD card to USB flash drive possible, splash-proof according to IP54, suitable for wipe disinfection, shock-resistant ABS plastic housing, intelligent power management with rechargeable Li-Ion batteries, VESA 75 mounting option, power adaptor for EU, UK, USA and Australia, power supply 110 - 240 VAC, 50/60 Hz
- 8402 ZX **Monitor for CMOS Endoscopes**, screen size 7", documentation can be stored directly on SD card, rechargeable Li-Ion batteries, power adaptor for EU, UK, USA and Australia, power supply 110 – 240 VAC, 50/60 Hz, additional standards: RTCA/DO-160F, EMI Test Report (German air rescue service DRF Luftrettung), **suitable for wipe disinfection**
- 8402 X **Electronic Module**, for C-MAC® Monitor 8402 ZX, for use with C-MAC® video laryngoscopes

Accessories included in delivery with 8402 ZX:



8401 YCA

- 8401 YCA **VESA 75 Quick Clip**, with 4 fixation screws, for mounting C-MAC® to tube up to diameter 25 mm

BERCI-KAPLAN C-MAC® Video Laryngoscope for visual endotracheal intubation

Video Laryngoscope



Special Features:

- European closed laryngoscope blade design
- Angle of view approx. 80°
- Ergonomically designed handle
- CMOS technology with LED illumination
- Proximal slanted blade
- Available with or without suction
- Processing video laryngoscopes: suitable and validated for the following low-temperature reprocessing methods up to bis max. 60 °C: manual/machine cleaning and disinfection, sterilization with Steris® AMSCO V-PRO 1, Sterrad® (50S, 100S, 200S, NX, 100NX) and EtO gas; High-Level Disinfection (HLD) acc. to US standards
- Blade tips of all blade types visible for safe navigation

MACINTOSH

- For direct and indirect laryngoscopy
- Original English MACINTOSH blade shape

D-BLADE

- Special curved blade shape for difficult intubation

MILLER

- For pediatrics and neonatology in the day-to-day clinical routine, teaching and training as well difficult airway management



8401 DXC/GXC



8401 KXC/AXC/BXC

NEW	8401 DXC	MILLER C-MAC® Video Laryngoscope, CMOS technology, size 0, for use with Electronic Modules 8401 X and 8402 X
NEW	8401 GXC	Same , size 1
	8401 KXC	BERCI-KAPLAN C-MAC® Video Laryngoscope #2, CMOS technology, with MACINTOSH laryngoscope blade, size 2, for use with Electronic Modules 8401 X and 8402 X
	8401 AXC	Same , size 3
	8401 BXC	Same , size 4

BOEDEKER-DÖRGES C-MAC® Video Laryngoscope
for visual endotracheal intubation

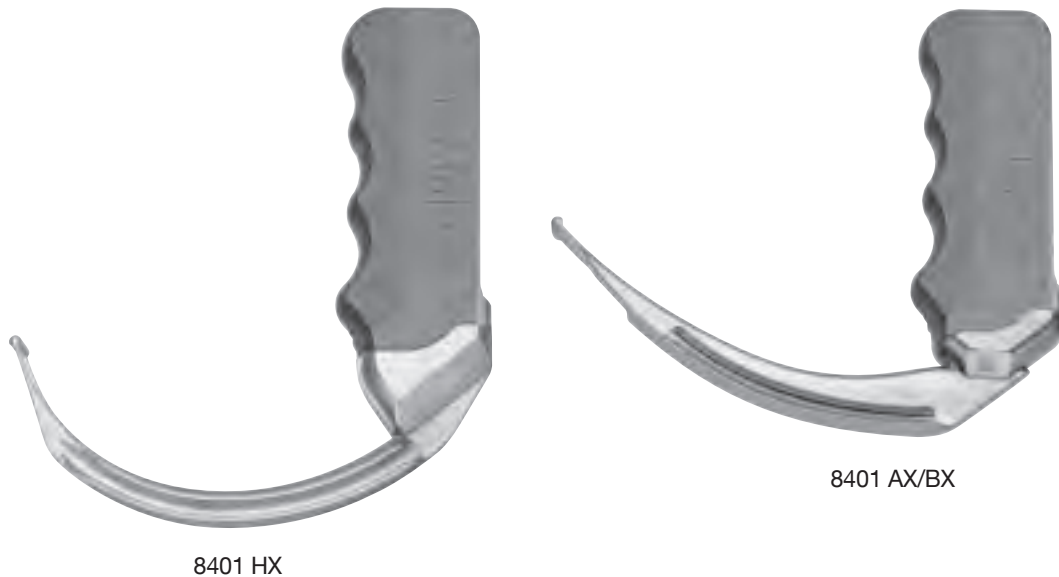

- 8401 AX **BOEDEKER-DÖRGES C-MAC® Video Laryngoscope #3**, CMOS technology, with MACINTOSH laryngoscope blade, size 3, with catheter introduction sizes 14 – 16 Fr., for use with Electronic Modules 8401 X and 8402 X
- 8401 BX **Same**, size 4, with catheter introduction sizes 16 – 18 Fr.
- 8401 HX **C-MAC® Video Laryngoscope D-BLADE**, CMOS technology, with DÖRGES laryngoscope blade, for difficult intubation, with catheter introduction sizes 16 – 18 Fr., for use with Electronic Modules 8401 X and 8402 X

C-MAC® S Video Laryngoscope ^{NEW}

Video Laryngoscope for Single Use



Special Features:

- Blade and handle form one continuous piece: optimum protection against infections
- D-BLADE with short handle
- Original English MACINTOSH blade shape
- Sturdy plastic material
- Compatible with C-MAC® monitor
- Blade tip always under direct view for safe navigation
- Ergonomically designed handle
- Compact design

C-MAC® S Imager:

- Handling oriented towards hygiene
- Reprocessing of the imager: suitable and validated for the following low-temperature reprocessing methods up to bis max. 60 °C: manual/machine cleaning and disinfection, sterilization with EtO gas; High-Level Disinfection (HLD) acc. to US standards
- Compatible with C-MAC® monitor
- Blade can be exchanged within seconds



051113-10



051114-10

- 051113-10* BERIC-KAPLAN **C-MAC® S Video Laryngoscope MAC #3**, with MACINTOSH laryngoscope blade, size 3, for single use, sterile, package of 10, for use with C-MAC® Monitor 8402 ZX and C-MAC® S Imager 8402 XS
- 051114-10* **Same**, size 4



mtp medical technical promotion gmbh,
Take-Off GewerbePark 46, D-78579 Neuhausen ob Eck, Germany

C-MAC® S Video Laryngoscope ^{NEW}



051116-10

051116-10* **C-MAC® S Video Laryngoscope D-BLADE**,
with DÖRGES laryngoscope blade, sterile,
package of 10, for use with C-MAC® Monitor
8402 ZX and C-MAC® S Imager 8402 XS



8402 XS

8402 XS **C-MAC® S Imager**, for C-MAC® Monitor 8402 ZX-1, suitable for
manual and mechanical disinfection up to 60 °C and High-Level
Disinfection (HLD) acc. to US standards, for use with C-MAC®
S-Video Laryngoscopes 051113-10, 051114-10 and 051116-10

C-MAC® PM – The Pocket Monitor ^{NEW}



Special Features:

- Exchange of video laryngoscope within seconds
- Compatible with all C-MAC® video laryngoscopes (D-BLADE, MACINTOSH sizes 2-4, MILLER sizes 0 & 1)
- One hour operating time
- Rechargeable Li-ion battery with capacity control and intelligent power management
- High-resolution 2.4" LED display with 240 x 320 pixels for optimal view
- No additional on/off buttons thanks to the "Open-to-Intubate-Display"(OTI)
- Important for preclinical use: classified for protection class IPX8
- Due to the closed design, the entire pocket monitor unit can be fully immersed in disinfection solution which allows for easy and smooth reprocessing
- Suitable and validated for the following low-temperature reprocessing methods up to max. 60 °C: manual/machine cleaning and disinfection
- Additional standard: RTCA/DO-160F



8401 XDK



8401 XDL

8401 XDK **C-MAC® Pocket Monitor, Set**, unit with LCD monitor and power supply for all C-MAC® laryngoscopes, screen size 2.4", monitor movable via two rotation axis, rechargeable Li-Ion batteries, 1 h operation time, 2 h charging time, power management with capacity indicator: switches off automatically after 10 min, protection class IPX8, additional standard: RTCA/DO-160F, validated for up to a max. of 60 °C, manual/mechanical cleaning and disinfection, for use with C-MAC® video laryngoscopes including:

Protection Cap

8401 XDL **Charging Unit**, for C-MAC® Pocket Monitor 8401 XD, with fix integrated power supply and adaptor for EU, UK and USA, power supply 110 – 240 VAC, 50/60 Hz, suitable for wipe disinfection

FIVE – Flexible Intubation Video Endoscope for C-MAC® ^{NEW}



Special Features:

- Compatible with C-MAC® monitor and C-HUB®
- Compact design
- Ergonomically designed handle
- Lightweight at 385 g
- High image resolution
- Video imaging in 4:3 format
- Possible to exchange components within seconds
- Integrated LED light source
- Suitable and validated for the following low-temperature reprocessing methods up to max. 60 °C: manual/machine cleaning and disinfection, sterilization with Sterrad® (100S, NX, 100NX) and EtO gas; High-Level Disinfection (HLD) acc. to US standards



11301 BN XK

11301 BN XK	Flexible Intubation Video Endoscope 5.5 x 65, CMOS technology, with suction valve, for use with C-MAC® Monitor 8402 ZX and C-HUB® 20 2901 01
	Deflection up/down: 140°/140°
	Direction of view: 0°
	Angle of view: 85°
	Working length: 65 cm
	Total length: 93 cm
	Working channel inner diameter: 2.3 mm
	Distal tip outer diameter: 5.5 mm

Accessories

Flexible Intubation Video Endoscopes

Accessories included in delivery:



29100

Plug, for LUER-Lock connector for cleaning, **black, autoclavable**, package of 10



11301 CD1

Irrigation Adaptor, for machine cleaning, reusable, for Flexible Intubation Video Endoscope 11301 BNX



11301 CE1

Suction Valve, for single use, package of 20, for use with Flexible Intubation Video Endoscope 11301 BNX



10309

Bronchoscope Insertion Tube, size 4, with integrated mouthpiece, for single use, sterile, insertion length 85 mm, made from EVA, package of 10



10310

Bronchoscope Insertion Tube, size 2, with integrated mouthpiece, for single use, sterile, insertion length 65 mm, made from EVA, package of 10



11301 CFX

Tube Holder, for use with Flexible Intubation Video Endoscope 11301 BNX

27677 FV

Case

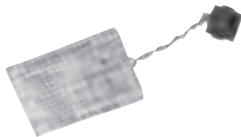

11025 E

Pressure Compensation Cap, for ventilation during gas sterilization



13242 XL

Leakage Tester, with bulb and manometer



27651 B

Cleaning Brush, flexible, round, outer diameter 3 mm, for working channel diameter 1.8 – 2.6 mm, length 100 cm



8401 YZ

Protection Cap, for the C-MAC® video laryngoscope and electronic module, to protect plug contact during reprocessing, cap is reusable

Accessories

Flexible Intubation Video Endoscopes

Optional Accessories:



	11001 KL	Biopsy Forceps , flexible, spoon-shaped, round, double action jaws, diameter 1.8 mm, working length 120 cm
	11002 KS	Grasping Forceps , flexible, alligator jaws, double action jaws, diameter 1.8 mm, working length 120 cm
	11301 CA	Leaflet Valve , for single use, package of 20
	11301 CB1	Suction Valve , reusable, for use with Flexible Intubation Video Endoscope 11301 BNX
	39405 AS	Plastic Container for Flexible Endoscopes , specially suited for gas and hydrogen peroxide (Sterrad®) sterilization and storage, for use with one flexible endoscope, external dimensions (w x d x h): 550 x 260 x 90 mm
	11301 BM	Adaptor , for leakage test, for Belimed washer-disinfectors
	11301 FF2	Adaptor for MIELE Cleaning Machines , with safety valve, for automatic leakage test of flexible KARL STORZ endoscopes
	11301 GG2	Adaptor , for cleaning and disinfecting the irrigation and working channels of flexible endoscopes, for MIELE-ETD washer-disinfectors
	11301 HH	Adaptor for BHT Cleaning Machines , for automatic leakage test of flexible KARL STORZ endoscopes
	11301 KK2	Adaptor , for working channel of flexible endoscopes, for MIELE-ETD 03 washer/disinfectors Please note: Adaptors 11301 FF2 and 11301 GG2 have to be ordered separately!
	6927691	Adaptor for Two-Way Stopcock , LUER-Lock, with O ₂ tube connection
	600007	LUER-Lock Tube Connector , male, tube diameter 6 mm

Accessories

C-MAC® Video Laryngoscope

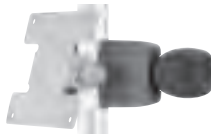

8401 YA

8401 YAA
8401 YAB

8401 YB

- 8401 YA **Stand**, for C-MAC® monitor, height 120 cm, rollable with five feet and antistatic castors, crossbar 25 cm x diameter 25 mm, for positioning the monitor, with tray for laryngoscopes, dimensions (w x d x h): 30 x 20 x 10 cm
- 8401 YAA **Crossbar**, for Stand 8401 YA, 50 cm x diameter 25 mm, or positioning C-MAC® Monitors 8401 ZX and 8402 ZX with VESA 75 Quick Clip 8401 YCA
- 8401 YAB **Same**, 70 cm x diameter 25 mm
- 8401 YB **Clamp**, VESA 75 standard, for fixation of C-MAC® monitor to round profile with diameter 20 – 43 mm and square profile with diameter 16 – 27 mm, for use with Monitors 8401 ZX/8402 ZX

Accessories

C-MAC® Video Laryngoscope

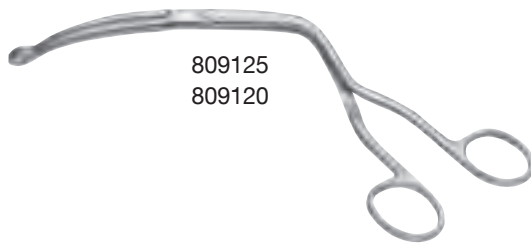

809125
809120



39501 LC2



8401 YZ



8402 YD



8402 YD-1



8402 YD-2



8402 YD-3

- 8402 YD* **Protective Bag**, blue, for C-MAC® system, made of water-resistant and sturdy material, washable, separate compartments for the monitor and two C-MAC® video laryngoscopes with electronic module
- 8402 YD-1* **Same, red**
- 8402 YD-2* **Same, orange**
- 8402 YD-3* **Same, NATO-olive**
- 809125 **MAGILL Forceps**, modified by BOEDEKER, length 25 cm, suitable for endoscopic foreign body removal, for use with video laryngoscopes size 2 – 4
- NEW** 809120 **MAGILL Forceps**, for children, modified by BOEDEKER, length 20 cm, for use with video laryngoscopes size 1 and 2
- 39501 LC2 **Wire Tray for Cleaning, Sterilization and Storage** for two C-MAC® and D-BLADE video laryngoscope blades incl. electronic module, with holder for fixing and sealing electrical connections, external dimensions (w x d x h): 260 x 120 x 170 mm
- 8401 YZ **Protection Cap**, for the C-MAC® video laryngoscope and electronic module, to protect plug contact during reprocessing, cap is reusable

* Crash test carried out by Furtwangen University of Applied Sciences (Germany): C-MAC® system in a protective bag dropped from a height of 5 – 9 meters showed no noteworthy damage.

Please note: The instruments displayed are not included in the sterilization and storage tray.

C-CAM® and C-HUB®

Nothing could be easier!

C-CAM® transforms the C-MAC® video laryngoscope into an all-round system unit for complete airway management. The C-MAC® monitor is at the core of all imaging systems. C-CAM® is a high-grade CMOS camera with VGA resolution which can be connected to all KARL STORZ endoscopes with eyepieces. Illumination is ensured through the Power-LED battery light sources. Consequently, this is the first battery-powered video system to guarantee high-quality documentation. KARL STORZ has once again proven that high quality and mobility are not mutually exclusive.

The C-HUB® is the interface for computer and/or monitor connectivity. The signal from the front end is transmitted directly to a computer or monitor with the aid of the C-HUB®. The enhanced output can be directly linked to any computer via a USB/S-VHS connection. Thanks to the safety offered by galvanic isolation in the C-HUB®, medical products can now be connected to non-medical products (e.g. computer/ monitor).

C-HUB® is the perfect signal converter from C-MAC®/C-CAM® to USB or S-Video.



C-CAM® and C-HUB®**20 2901 32/20 2901 31**

- 20 2901 32** **C-CAM® Camera Head**, 8-pin, one-chip CMOS camera head, resolution 640 x 480, focal length $f = 20$ mm, compatible with C-HUB® **20 2901 01** and C-MAC® 8402 ZX
- 20 2901 31** **C-CAM® Camera Head**, 6-pin, one-chip CMOS camera head, resolution 640 x 480, focal length $f = 20$ mm, compatible with C-MAC® 8401 ZX

**20 2901 01**

- 20 2901 01** **C-HUB® Camera Control Unit**, for use with C-CAM® **20 2901 32**, Electronic Module 8402 X or compatible CMOS video endoscopes, Interfaces: USB 2.0, S-Video output (NTSC), power socket including:
- C-HUB® Power Supply**
 - S-Video (Y/C) Connecting Cable**
 - USB Connecting Cable**

Intubation Fiberscopes

Eyepiece Versions

KARL STORZ provides the instruments you need to meet the special challenges of patients who cannot be intubated with conventional methods. Nasopharyngeal awake intubation is regarded as the gold standard of difficult airway management. We offer solutions for any challenge!

Our versatile intubation fiberscopes can be used in all clinical settings whether in intensive care units or emergency rooms as well as for patients with anticipated difficult airways during induction. The various sheath diameters enable you to select the ideal instrument for your patient and allow a swift reaction thanks to the compact, flexible LED light sources.

Special Features:

- Sheath stiffness adapted to anesthesiological requirements
- Suitable for both fiber optic intubation and bronchoscopy
- Patented sheath surface special treatment requires only minimal lubrication and provides optimal tube insertion
- Developed for use in the OR, ICU, ER
- Even safer tube introduction due to video-assisted control on the monitor
- Tube position of ETT, LMA, DLT can be verified
- Video-assisted monitoring for percutaneous tracheostomy
- Adaptable for foreign body removal or bronchial lavage
- Various outer diameters: 2.8; 3.7; 5.2 mm
- Diameter of working channel ranging from 1.2 to 2.3 mm
- Extremely bright, white light due to the LED light source with rechargeable Li-Ion batteries
- Intubation fiberscope can be directly connected to the C-MAC® monitor with the mobile camera head C-CAM®
- Suitable and validated for the following low-temperature reprocessing methods up to a max. of 60 °C: manual/mechanical cleaning and disinfection, sterilization with Steris® AMSCO VPRO 1, Sterrad® (50S, 100S, 200S, NX, 100NX) and EtO gas; High-Level Disinfection (HLD) acc. to US standards



Intubation Fiberscopes – eyepiece version, with optional LED battery light source

Intubation Fiberscopes

Eyepiece Versions

2.8 x 65 Intubation Fiberscope with optimized imaging

Intubation Fiberscope 11301 AA1 is ideal for use in neonatology due to its small outer diameter of 2.8 mm. This fiberscope is the only one of its size that has a working channel with 1.2 mm.

Intubation Fiberscope 11301 AA1 features a connector for suction valves for single or multiple use.

The special sheath surface combined with increased stiffness improves the gliding properties of the ETT over standard intubation fiberscopes.

The use of a mobile LED light source enables independent work under optimal lighting conditions.

Benefits:

- Effective suction possible via the 1.2 mm working channel
- Suitable for use with endotracheal tubes as of 3.5 mm
- Increased stiffness and smoother passage of the ETT
- Ready for immediate use and easy to clean and reprocess
- Optimized for use with mobile light sources
- Intubation fiberscope can be connected to the C-MAC® monitor via the mobile C-CAM® camera head
- Practical tube fixation via special adaptor



11301 AA1

11301 AA1

Intubation Fiberscope 2.8 x 65,

Deflection up/down:	140°/140°
Direction of view:	0°
Angle of view:	90°
Working length:	65 cm
Working channel inner diameter:	1.2 mm
Distal tip outer diameter:	2.8 mm

Intubation Fiberscopes

Eyepiece Versions

3.7 x 65 Intubation Fiberscope with optimized imaging

The 3.7 x 65 intubation fiberscope is a universal working instrument as it provides gold standard intubation for both adult and pediatric patients. Due to its small diameter, it is an excellent tool for the placement of double lumen tubes. Using a mobile LED light source and C-CAM®, the intubation fiberscope can be directly connected to the C-MAC® monitor for a monitor-assisted intubation solution that is both mobile and flexible – also suitable for electronic documentation.

Benefits:

- Effective suction possible via 1.5 mm working channel
- Suitable for use with endotracheal tubes as of 4 mm
- Increased stiffness and smoother passage of the ETT
- Practical tube fixation via special adaptor
- Ready for immediate use and easy to clean and reprocess
- Optimized for use with mobile light sources
- Intubation fiberscope can be connected to the C-MAC® monitor via the mobile C-CAM® camera head



11302 BD2

11302 BD2

Intubation Fiberscope 3.7 x 65,

Deflection up/down:	140°/140°
Direction of view:	0°
Angle of view:	90°
Working length:	65 cm
Working channel inner diameter:	1.5 mm
Distal tip outer diameter:	3.7 mm

Intubation Fiberscopes

Eyepiece Versions

5.2 x 65 Intubation Fiberscope with optimized imaging

The 5.2 x 65 intubation fiberscope creates an ideal balance between image size, working channel size and fiber optics. Effective suction is possible via the 2.3 mm working channel. The fiberscope is also suitable for removing foreign bodies or for bronchial lavage in the intensive care unit. Using a mobile LED light source and C-CAM®, the intubation fiberscope can be directly connected to the C-MAC® monitor for a monitor-assisted intubation solution that is both mobile and flexible – also for electronic documentation.

Benefits:

- **Effective suction possible via the large 2.3 mm working channel**
- **Suitable for use with endotracheal tubes as of 5.5 mm**
- **Increased stiffness and smoother passage of the endotracheal tube**
- **Practical tube fixation via special adaptor**
- **Ready for immediate use and easy to clean and reprocess**
- **Optimized for use with mobile light sources**
- **Intubation fiberscope can be connected to the C-MAC® monitor via the mobile C-CAM® camera head**









11301 BN1









11301 BN1	Intubation Fiberscope 5.2 x 65,	
	Deflection up/down:	140°/140°
	Direction of view:	0°
	Angle of view:	110°
	Working length:	65 cm
	Working channel inner diameter:	2.3 mm
	Distal tip outer diameter:	5.2 mm

Intubation Fiberscopes

Eyepiece Versions

Intubation Fiberscopes	Order No.	Eye-piece	Deflection up/down	Direction of view	Angle of view	Working length	Total length	Working channel inner diameter	Distal tip outer diameter	Recommended ETT diameter as of*
2.8 x 65	11301 AA1			0°	90°	65 cm	98 cm	1.2 mm	2.8 mm	3.5 mm
3.7 x 65	11302 BD2			0°	90°	65 cm	93 cm	1.5 mm	3.7 mm	4.5 mm
5.2 x 65	11301 BN1			0°	110°	65 cm	93 cm	2.3 mm	5.2 mm	5.5 mm

Accessories included in delivery:

		27677 A	Case
11025 E	13242 XL	11025 E	Pressure Compensation Cap , for ventilation during gas sterilization
		13242 XL	Leakage Tester , with bulb and manometer
11301 CF	27651 A/B	11301 CF	LIPP Tube Holder , for intubation fiberscopes
		27651 A	Cleaning Brush , flexible, long, for working channel diameter 1.2 mm, working length 150 cm
29100	11301 CD	27651 B	Cleaning Brush , flexible, round, outer diameter 3 mm, for working channel diameter 1.8 – 2.6 mm, length 100 cm
		29100	Plug , for LUER-Lock connector for cleaning, black, autoclavable , package of 10
10309/10310	11301 CE	2x 11301 CD	Irrigation Adaptor , for machine cleaning, reusable, for fiberscopes
		11301 CE	Suction Valve , for single use, package of 20
		10309	Bronchoscope Insertion Tube , size 4, with integrated mouthpiece, for single use, sterile, insertion length 85 mm, made from EVA, package of 10
		10310	Same , size 2, insertion length 65 mm

Intubation Fiberscopes

Eyepiece Versions

Case	Accessories (included in delivery)									Add. Accessories	
	Pressure Compensation Cap	Leakage Tester	LIPP Tube Holder	Cleaning Brush	Plug	Irrigation Adaptor	Suction Valve	Bronchoscope Insertion Tube	Biopsy Forceps	Flexible Grasping Forceps	
27677 A	11025 E	13242 XL	11301 CF	27651 A	29100	2x 11301 CD	11301 CE	10309 10310	11003 MA	11003 MB	
27677 A	11025 E	13242 XL	11301 CF	27651 A	29100	2x 11301 CD	11301 CE	10309 10310	11003 MA	11003 MB	
27677 A	11025 E	13242 XL	11301 CF	27651 B	29100	2x 11301 CD	11301 CE	10309	11001 KL	11002 KS	

Optional Accessories:



11003 MA

Biopsy Forceps, flexible, oval, double action jaws, diameter 1 mm, length 110 cm



11003 MB

Grasping Forceps, flexible, double action jaws, diameter 1 mm, length 110 cm, for flexible bronchoscopes



11001 KL

Biopsy Forceps, flexible, spoon-shaped, round, double action jaws, diameter 1.8 mm, working length 120 cm



11002 KS

Grasping Forceps, flexible, alligator jaws, double action jaws, diameter 1.8 mm, working length 120 cm

* Please note that the accuracy of the ETT diameter may vary depending on the manufacturer's quality.

BONFILS Retromolar Intubation Endoscopes

Eyepiece Versions

The expert instrument for multiple applications in airway management combines technical sophistication with utmost reliability

Unexpected difficult airways are always a challenge in airway management. With the BONFILS intubation endoscope and its versatile intubation techniques, this situation can be brought back to a controlled status. The endotracheal tube is guided into the trachea under direct

vision and the possibility of simultaneous application of oxygen provides more safety. Moreover, KARL STORZ offers a solution to meet the most stringent hygiene requirements – the autoclavable SILVER LINE.

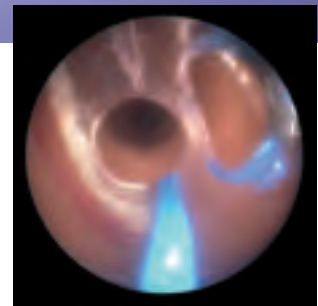
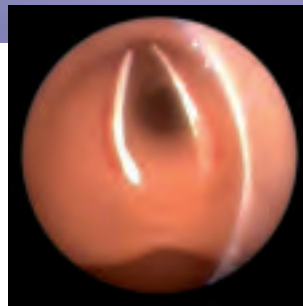
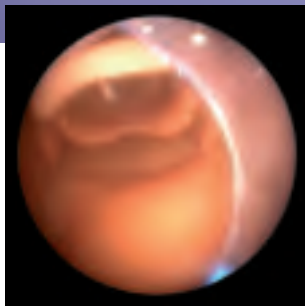

BONFILS Retromolar Intubation Endoscopes Eyepiece Versions

Special Features:



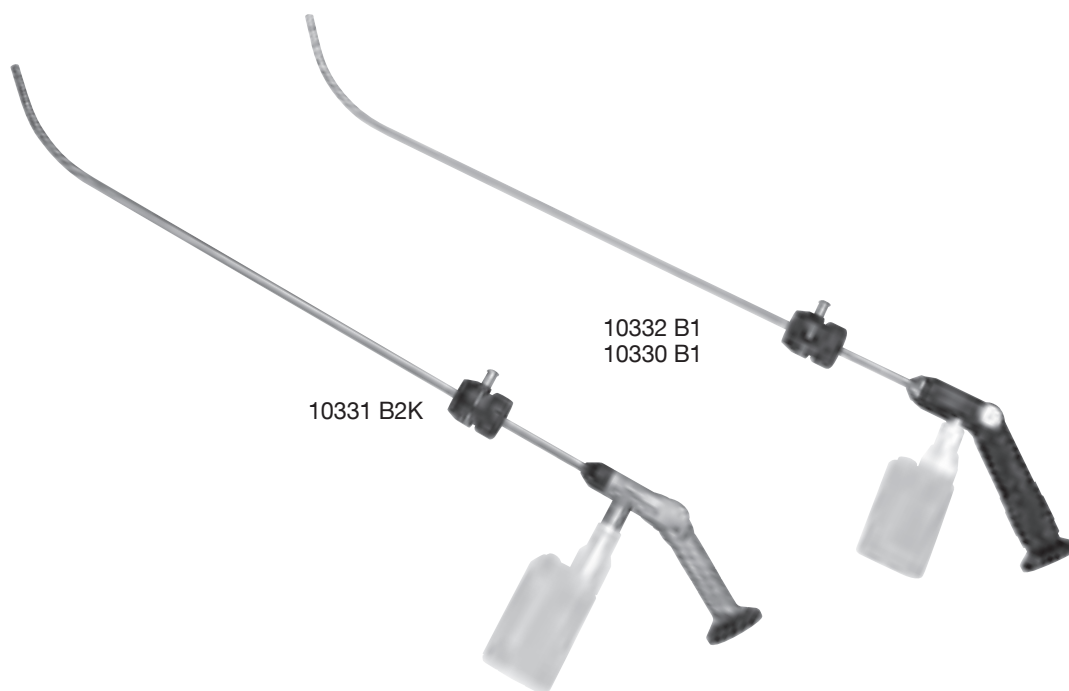



- **SILVER LINE** – autoclavable
- Particularly suitable for the unexpected difficult airway
- Use in the case of minimal mouth opening (> 1 cm) possible
- Introduction of the tube under visualization: **What you see is what you get!**
- Continuous O₂ flow via tube adaptor between tube and instrument
- One-person intubation possible
- Connect and intubate – thanks to the mobile LED “Power of Light” light source
- Quick and easy cleaning
- Suitable and validated for the following low-temperature reprocessing methods up to bis max. 60 °C: manual/machine cleaning and disinfection, sterilization with Steris® AMSCO VPRO 1, Sterrad® (50S, 100S, 200S, NX, 100NX) and EtO gas; High-Level Disinfection (HLD) acc. to US standards
- Recommended for video-assisted intubation with C-CAM® to C-MAC® monitor



	10332 B1	BONFILS Retromolar Intubation Endoscope , outer diameter 3.5 mm, for ETT 4 – 5.5 mm, usable sheath length 35 cm, distal bending 40°, with movable eyepiece, including Tube Holder 10332 BA for tube fixation and O ₂ application
NEW	10331 B2K	BONFILS Retromolar Intubation Endoscope, autoclavable , outer diameter 5 mm, for ETT > 5.5 mm, usable sheath length 40 cm, distal bending 40°, with movable eyepiece, with Tube Holder 10331 BA for tube fixation and O ₂ application
	10330 B1	BONFILS Retromolar Intubation Endoscope , outer diameter 5 mm, for ETT > 5.5 mm, usable sheath length 40 cm, distal bending 40°, working channel diameter 1.2 mm, including Tube Holder 10331 BA for tube fixation and O ₂ application

BONFILS Retromolar Intubation Endoscopes

Eye-piece Versions

Intubation Endoscopes	Order No.		Distal bending
	Eye-piece		
BONFILS 3.5 x 35	10332 B1		
BONFILS 5 x 40	10330 B1		
BONFILS 5 x 40	10331 B2K		

Accessories included in delivery:



27677 BM

Case, internal dimensions (w x d x h): 490 x 290 x 85 mm

27677 C

Plastic Case, without inserts, internal dimensions (w x d x h): 480 x 285 x 80 mm

10332 BA

Tube Holder for ETT, with O₂ application connection, inner diameter 3.5 mm

10331 BA

Tube Holder, inner diameter 5 mm

27651 AE

27651 AE

Cleaning Brush, for Intubation Endoscope 10330 B1

BONFILS Retromolar Intubation Endoscopes
 Eyepiece Versions

Angle of view	Working length	Total length	Working channel diameter	Distal tip outer diameter	Recommended ETT diameter as of*	Accessories (included in delivery)		
						Case	Tube Holder	Cleaning Brush
90°	35 cm	52 cm	–	3.5 mm	4 mm	27677 BM	10332 BA	–
110°	40 cm	52 cm	1.2 mm	5 mm	5.5 mm	27677 C	10331 BA	27651 AE
110°	40 cm	54 cm	–	5 mm	5.5 mm	27677 BM	10331 BA	–

Optional Accessories:

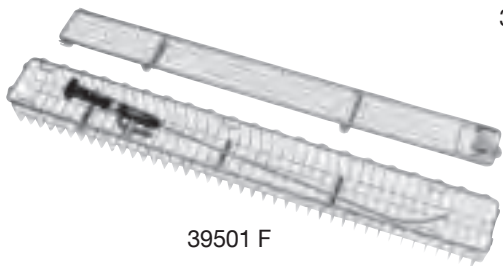

39501 F

Wire Tray for Cleaning, Sterilization and Storage of one rigid **BONFILS** endoscope, including holder for light post adaptors, silicone telescope holders and lid, external dimensions (w x d x h): 570 x 80 x 52 mm

* Please note that the accuracy of the ETT diameter may vary depending on the manufacturer's quality.

LIPP/GOLECKI Airway Management Set

Basic Set

Recommended Set for Difficult and Standard Intubation

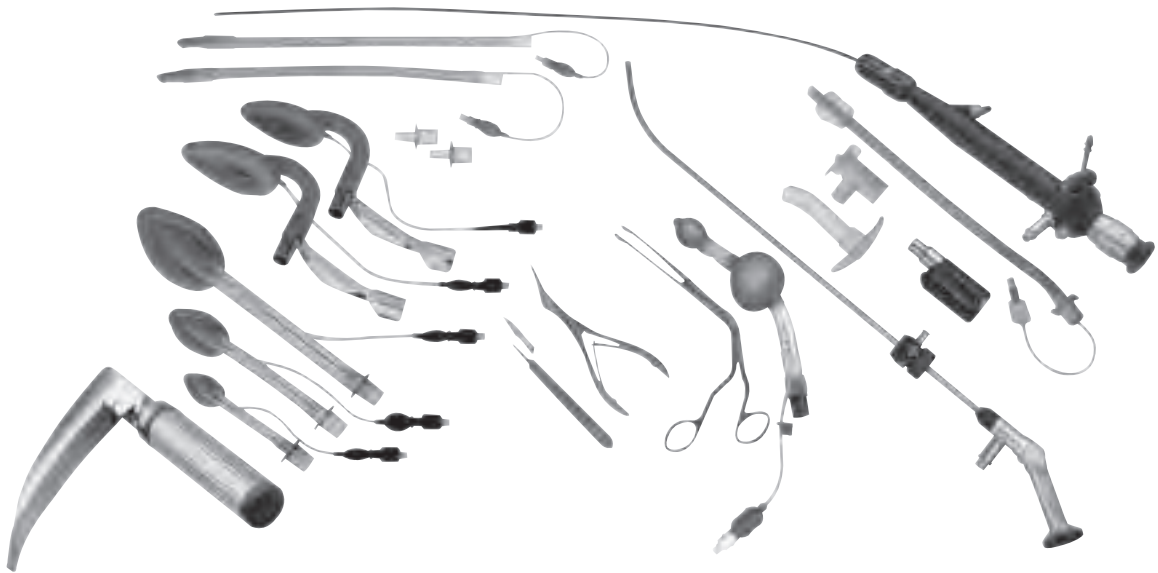

- 11300 B3 **LIPP/GOLECKI Airway Management Set**, for the difficult airway including:
- Intubation Fiberscope**, 3.7 mm x 65 cm
 - BONFILS Retromolar Intubation Endoscope**, 5 x 40, autoclavable
 - Battery Light Source LED for Endoscopes**
 - Mask Adaption "MAINZ Adaptor"**, blue, package of 5
 - Laryngeal Tube**, size 4
 - Laryngeal Tube**, size 3
 - Spiral Tube**, size 6, for single use
 - Bronchoscope Insertion Tube**, size 4
 - Laryngeal Mask**, standard, reusable, size 1
 - Laryngeal Mask**, standard, reusable, size 2
 - Laryngeal Mask**, standard, reusable, size 4
 - Intubation Laryngeal Mask**, reusable, size 3
 - Intubation Laryngeal Mask**, reusable, size 4
 - Laryngeal Mask Tube**, diameter 7 mm
 - Laryngeal Mask Tube**, diameter 7.5 mm
 - LMA Tube Stabilizer**
 - MAGILL Forceps**, length 25 cm
 - Scalpel**, for single use, package of 10
 - COTTLE Nasal Speculum**, blade length 55 mm, length 13 cm
 - DÖRGES Emergency Laryngoscope Blade**, cold light, universal size
 - Handle Sleeve**, ISO 7376
 - Battery Insert**, with 2 Batteries 121306 S and Xenon Lamp 8546 XA
 - Case**

Intubation Set -C22-, ULM Model ^{NEW}

Basic Set



8400 B

Intubation Set -C22-, ULM model

including:

BOEDEKER-DÖRGES C-MAC® Video Laryngoscope, MAC #3**BOEDEKER-DÖRGES C-MAC® Video Laryngoscope, MAC #4****C-MAC® Video Laryngoscope D-BLADE****C-MAC® Pocket Monitor Set****Charging Unit, for C-MAC® pocket monitor****Protective Cap****Handle Sleeve, ISO 7376****DÖRGES Emergency Laryngoscope Blade, cold light****Battery Insert Set LED, with cap****Bag for Intubation Set -C22-, ULM model****MAGILL Forceps, modified by BOEDEKER**

8402 YE

Bag for Ulm Intubation Set -C22-, made of water-resistant and sturdy material, washable, including two compartments with several holding facilities for C-MAC® video laryngoscope blades with C-MAC® pocket monitor and conventional laryngoscopes, for use with C-MAC® Pocket Monitor 8401 XD, C-MAC® video laryngoscopes and conventional laryngoscopes



Emergency Tracheobronchoscopy Set

Basic Set

Recommended Set for Difficult and Standard Intubation

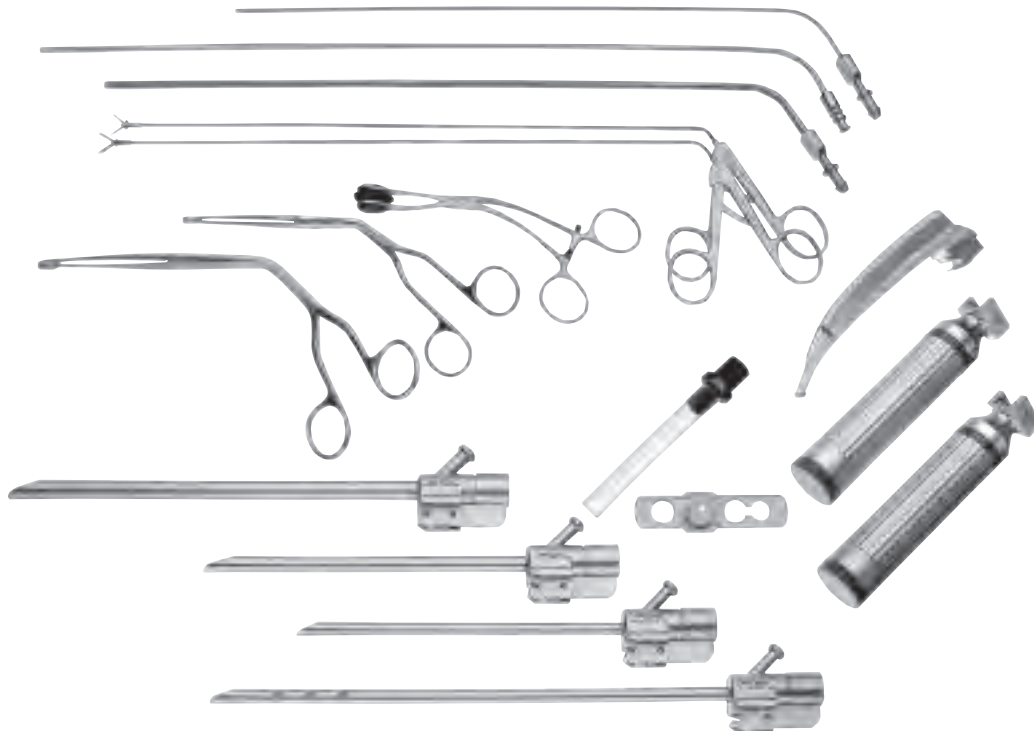

10330 F

Emergency Tracheoscope Set

including:

Emergency Bronchoscope, size 6, length 30 cm

Emergency Tracheoscope, size 9, length 25 cm

Emergency Tracheoscope, size 7, length 20 cm

Emergency Tracheoscope, size 5, length 20 cm

FLUVOG Adaptor

Adaptor for Ventilation

DÖRGES Emergency Laryngoscope Blade, cold light, universal size

2x **Handle Sleeve**, ISO 7376

2x **Battery Insert**, with 2 Batteries 121306 S and Xenon Lamp 8546 XA

Xenon Lamp, package of 6

Forceps, for peanuts and soft foreign bodies

Forceps, alligator, for hard foreign bodies

MAGILL Forceps, length 20 cm

MAGILL Forceps, length 25 cm

YOUNG Tongue Seizing Forceps

Suction Tube, diameter 3 mm, length 35 cm

Suction Tube, diameter 4 mm, length 35 cm

Suction Tube, diameter 5.5 mm, length 35 cm

Case

Battery Light Source LED BRITE LITE

Accessories for Intubation Fiberscopes and Endoscopes



Special Features:

- Battery light source with extremely high light intensity >100 lm / > 150 klx
- Available as battery and rechargeable version
- Absolute white light due to LED technology
- Special light focus allows optimal light adjustment at the endoscope connector
- LED provides up to 50,000 hours lifetime
- Burning time of 120 min
- Waterproof, fully immersible for cleaning and disinfection (11301 D1/D3)



11301 D1/D3/DE/DF



11301 DG

- 11301 D1 **Battery Light Source LED for Endoscopes**, with fine screw thread, brightness > 100 lm / > 150 klx, burning time > 120 min, weight approx. 150 g, waterproof and fully immersible for manual cleaning and disinfection, with 2 Photo Batteries 121306 P
- 11301 D3 **Same**, with coarse thread
- 121306 P **Photo Battery**, lithium, 3 V, CR 123 A
- 11301 DE **Battery Light Source LED for Endoscopes**, rechargeable, with click connection, brightness > 110 lm / >150 klx, color temperature 5500 K, lithium-ion batteries, charging time 60 min, burning time at 100% brightness 40 min, weight approx. 150 g ready for use, **suitable for wipe disinfection**
- 11301 DF **Same**, with fast screw thread
- 11301 DG **Charging Unit**, for 11301 DE/11301 DF, for two LED battery light sources, with fixed integrated power supply and adaptor for EU, UK, USA and Australia, power supply 110 – 240 VAC, 50/60 Hz, **suitable for wipe disinfection**
- 11301 DH **Holder**, for Charging Units 11301 DG, 8546 LE and 8401 XDL

MACINTOSH Laryngoscope Blades

Cold Light, with Replaceable Fiber Optic Light Carrier



Special Features:

- KARL STORZ blades and handles meet the highest cleaning and hygienic standards
- Chromium-plating gives the laryngoscope blades a compact, smooth surface; edges are rounded, thus preventing the formation of microcracks, fission or sharp edges which can harbour germs
- Handles are not knurled (problematic concerning hygiene), instead have an ergonomic shape and smooth surface.
- Handles can be supplied with LED "BRITE LITE" power system with > 50.000 lux and Li-Ion rechargeable batteries.
- The KARL STORZ laryngoscope blades are the only such products currently commercially available that are autoclavable and show no noticeable reduction in light intensity, even after several hundred cleaning cycles**.
- The Xenon lamps in the fiberoptic light carriers generate a neutral white light which is 30 – 40% brighter than standard halogen light.
- Laryngoscopy blades and handles comply with the ISO 7376 standard.
- On request, additional markings can be etched on the laryngoscope/handle free-of-charge (such as, e.g., "1-83-2/Case" or „Christoph 77/Rucksack")



**) MJL BUCX, HM de GAST, J VELDHUIS, LH HASSING, A MEULEMANS, A KAMMEYER:
The effect of mechanical cleaning and thermal disinfection on light intensity provided by fibrelight Macintosh laryngoscopes. Anaesthesia 58: 5, 461-465 (2003).

- 8541 AA MACINTOSH Laryngoscope Blade, size 5
- 8541 A Same, size 4
- 8541 B Same, size 3
- 8541 C Same, size 2
- 8541 D Same, size 1
- 8541 E Same, size 0

MILLER Laryngoscope Blades

Cold Light, Fiber Optic Light Carrier Incorporated

- 8537 A MILLER Laryngoscope Blade, size 4
- 8537 B Same, size 3
- 8537 C Same, size 2
- 8537 D Same, size 1
- 8537 E Same, size 0



Handles with LED Light Source for Cold Light Laryngoscope Blades



Special Features:

- Rechargeable lithium-ion batteries
- Extremely bright LED of more than 50 lm/> 100 klx
- Absolute white light due to LED technology (5500 K)
- Small handle with photo battery
- Special lens system allows optimal light adjustment at the blade connector
- LED provides a lifetime of more than 50,000 hours
- Burning time up to 240 min at 100% brightness
- Charging via inductive technology
- ISO 7376 compatible



8546



8546 LD1



8549 LDX



8548



8548 LDX1

8546 **Handle Sleeve, ISO 7376, autoclavable, length 12 cm, for use with Battery Inserts 8546 A, 8546 LD, 8549 LD and cold light laryngoscopes**

8546 LD1 **Battery Insert, rechargeable, length 12 cm, for Handle Sleeve 8546, with high-power LED, 56 lm/> 100 klx, lithium-ion battery insert, burning time at 100% brightness 240 min, charging via Inductive Charging Unit 8546 LE**

NEW 8549 LDX **Battery Insert Set LED, length 12 cm, for Handle Sleeve 8546 and cold light laryngoscopes, with high-power LED, > 56 lm/ >100 klx, burning time at 100% brightness > 120 min including:**

Battery Insert, high-power LED
2x **Battery, Mignon-Cell, LR 06, 1.5 V**
Cap

8548 **Handle Sleeve, ISO 7376, length 6 cm, autoclavable, for use with Battery Insert Set 8548 LDX**

8548 LDX1 **Battery Insert Set, length 6 cm, for Handle Sleeve 8548, with high-power LED, > 56 lm/> 100 klx, burning time at 100% brightness > 120 min including:**

Battery Insert, high-power LED
Photo Battery, CR 123 A
Cap

Handles with Xenon Light Source for Cold Light Laryngoscope Blades



8546



8546 A

- 8546 **Handle Sleeve**, ISO 7376, **autoclavable**, length 12 cm, for use with Battery Inserts 8546 A, 8546 LD, 8549 LD and cold light laryngoscopes
- 8546 A **Battery Insert**, length 12 cm, with 2 Batteries 121306 S and Xenon Lamp 8546 XA
- 121306 S **Batteries**, Baby-Cell, LR 14, for Battery Inserts 8544 A and 8546 A, package of 2
- 8546 XC **Xenon Lamp**, 2.5 V, for Battery Inserts 8546 A, 8547 A and 8547 B, package of 6

Especially suitable for use with blades sizes 0 and 1



8547



8547 A



8547 B

- 8547 **Handle Sleeve**, ISO 7376, length 12 cm, **autoclavable**, for use with Battery Inserts 8547 A and 8547 B
- 8547 A **Battery Insert**, length 12 cm, including 2 Batteries 121306 KS and Xenon Lamp 8546 XA
- 121306 KS **Batteries**, Mignon-Cell, LR 06, 2 Batteries 121306 K, for Battery Inserts 8545 A, 8547 A and Battery Insert Set High-Power LED 8549 LD
- 8547 B **Rechargeable Battery Insert**, length 12 cm, for Handle Sleeve 8547, with Xenon Lamp 8546 XA, charging via Inductive Charging Unit 8546 LE
- 8546 XC **Xenon Lamp**, 2.5 V, for Battery Inserts 8546 A, 8547 A and 8547 B, package of 6

Inductive Battery Charger

for rechargeable Laryngoscope Handles

Special features:

- No open contacts
- No corrosion and contact problems
- No voltage peaks
- Batteries can be charged with or without handle sleeve, sterile packaging
- For use with LED handles
- Compatible with previous models



8546 LE

- 8546 LE **Inductive Charging Unit**, for two battery inserts (8546 LD, 8544 B, 8545 B, 8547 B), with fully integrated mains adaptor and power adaptor for EU, UK, USA and Australia, power supply 110 – 240 VAC, 50/60 Hz, suitable for wipe disinfection
- 8546 R **Reduction Sleeve**, for Battery Inserts 8545 B and 8547 B, only
- 11301 DH **Holder**, for Charging Units 11301 DG and 8546 LE

