

2021 FULL LINE

#OrtegaGuitars

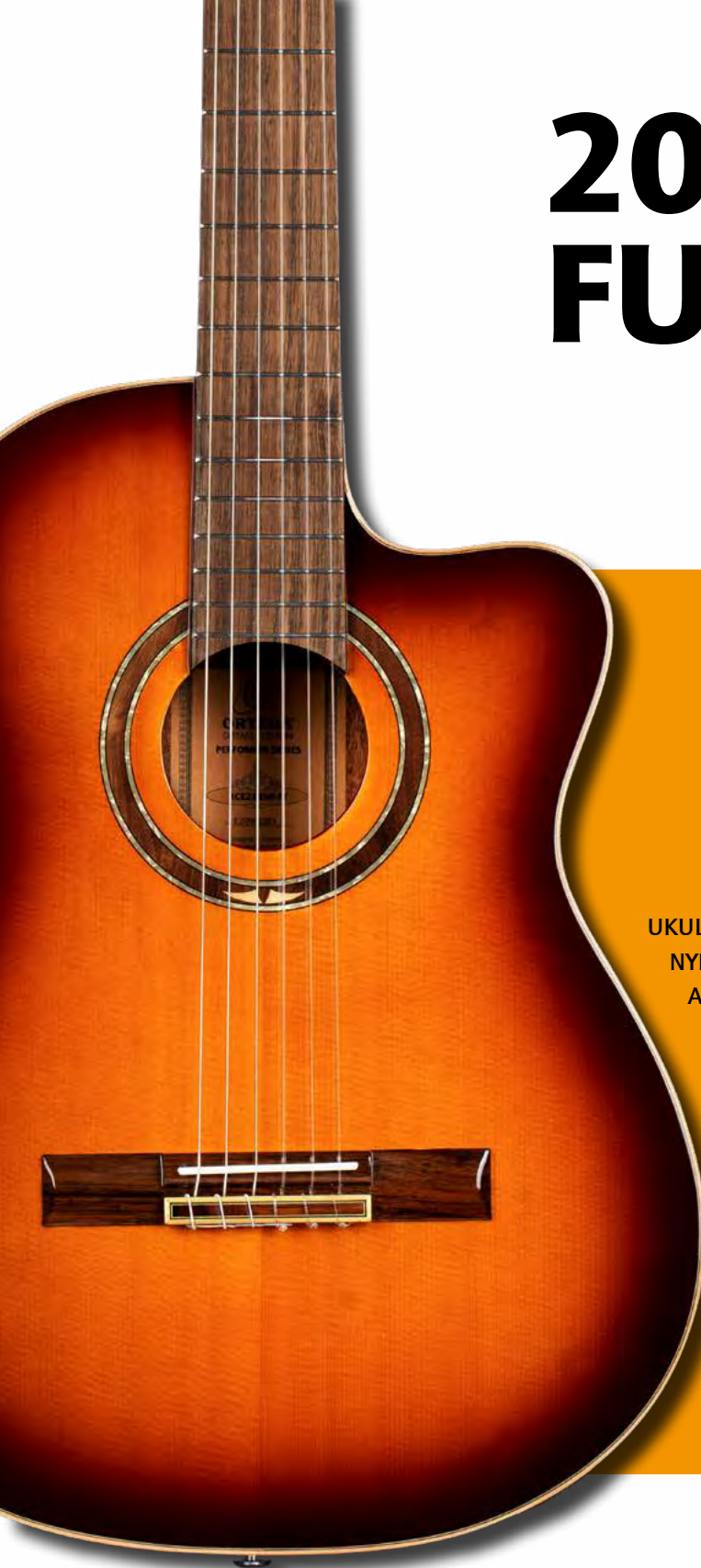

UKULELES
NYLON STRING GUITARS
ACOUSTIC BASSES
MANDOLINS
BANJOS
AMPLIFICATION
STOMP BOXES
PERCUSSION
ACCESSORIES

THE CATALOG

ORTEGA®
GUITARS • EST 1994





ORTEGA[®]
GUITARS • EST. 1994

HANDCRAFTED QUALITY

INNOVATIVE, CREATIVE & DIFFERENT

Established in 1994, Ortega Guitars introduced German design to authentic and traditional methods of guitar making. Committed to innovation and quality, we strive to improve what is expected at every level of all our acoustic instruments. Options like the 12hole bridge, often found only on high-end guitars, are standard on our entry level to professional nylon string guitars. Our wide variety of body and neck sizes accommodates all ages giving everyone an opportunity to learn and play.

2021 FULL LINE CATALOG

INDEX

KEIKI	4	ACOUSTIC BASSES	68
UKULELES	5	Deep Series	69
K1 Ukuleles	5	The Private Room	69
K2 Ukulele Packs	6	MANDOLINS & BANJOS	70
K3 Ukulele Packs	8	Mandolins	70
ACCESSORIES	10	Banjos – Raven Series	72
Picks	10	Banjos – Falcon Series	74
Straps	11	ACOUSTIC AMPLIFICATION SERIES	76
Ukulele Bags	11	STOMP BOX EFFECT SERIES	78
ORTEGA	12	PERCUSSION SERIES	80
UKULELES	13	Kalimbas	80
Bonfire Series	16	Stomp Box Cajon	82
Earth Series	18	Foot Percussion	83
Gaucho Series	20	ACCESSORIES	84
The Private Room	20	Capos	86
Horizon Series	21	Vegan Straps & Accessories	88
Timber Series	22	Straps	89
Prism Series	26	Tuners	93
Lizard Series	26	Digital Wireless System	94
Banjolele Series	27	Cables	96
Custom Built Series	28	Strings	98
UKEBASSES	30	Picks	100
Lizard Series	30	Strap Locks & Tuning Machines	102
NYLON STRING GUITARS	34	Cables & Power	106
Student Series	36	Preamps & Pickups	107
Gaucho Series	38	Useful Helpers	108
Requinto Series	40	Care	110
Family Series	42	Humidifiers	113
Family Series Pro	48	Stands	113
Performer Series	50	Hangers	115
Traditional Series	54	Bags	116
Custom Master Selection Series	58	Cases	119
Signature Series	60		
THE PRIVATE ROOM	64		
Distressed Suites	65		
Eclipse Suite	66		
Spalted Suites	66		
Striped Suites	67		



www.ortegaguitars.com

GLOBAL
HEADQUARTERS
Ortega
Musik-Meintl-Str.1
91468 Gutenstetten
Germany

US HEADQUARTERS
Meinl USA L.C.
Ortega
3427 Ambrose Avenue
Nashville, TN 37207
USA



info@ortegaguitars.com



Keiki®

K1



K1-BL
Soprano

	scale	width at nut
Soprano	284 mm (11.18")	32 mm (1.26")



K1-GR



K1-RD



K1-CO

8 exciting
COLORS



K1-MM



K1-ORG



K1-PNK



K1-PUR

- Laser engraved sea turtle
- Okoume top satin, open pore
- Okoume back & side, satin open pore
- Keiki® headstock design w/ lasered logo
- Okoume neck & headstock veneer, satin finish
- Walnut fretboard & bridge

- Open gear tuning machines chrome w/ black buttons
- Ortega Guitars UWNY-4-SO strings
- Available COLORS:

BL - ocean blue	MM - natural mahogany
GR - forest green	ORG - orange
RD - fire red	PNK - pink
CO - coal	PUR - purple



Keiki® UKULELE PACK

UNIQUE DESIGNS – CREATED BY ITALIAN STREET ARTIST GUGLIELMO GASLOLI

Guglielmo Gasloli – Graphic designer – Visual artist

An Italian artist trained in the environment of street art, his style is characterized by a horror-vacui of subjects elaborated by his personal "flow of conscience". His style is rich in colors, geometries, and attention to detail.

"THE IDEA DOES NOT HAVE TO BE CONVENTIONAL".

www.gasloliartworks.com



K2 Ukulele Pack

K2 UKULELE PACK INCLUDES:

- Keiki® Headstock tuner
- Keiki® Soundhole hook strap/support
- Keiki® medium picks (5 piece)
- Keiki® Drawstring bag



spaceman

el muerto

peace '68

totem

samurai

voodoo puppet

mahogany

maple

K2 Ukulele Pack



K2-68
Soprano
PACK

	scale	width at nut
Soprano	364 mm (14.33")	36 mm (1.42")



K2-SP
PACK

K2-EM
PACK

K2-TM
PACK



K2-SR
PACK

K2-VP
PACK



K2-MAH
PACK

K2-MAP
PACK

- Agathis top, custom designed || Mahogany (MAH) || Maple (MAP) top, satin finish
- ABS body, slightly arched
- Keiki® headstock design w/ custom designed veneer
- Okoume neck, satin finish
- ABS fretboard & bridge
- Open gear tuning machines chrome w/ black buttons

- Ortega Guitars UWNY-4-SO strings
- Headstock tuner, Soundhole hook strap/support, 5 medium picks and drawstring bag included!
- Available PACKS/DESIGNS:

K2-SP - spaceman	K2-EM - el muerto
K2-68 - peace '68	K2-TM - totem
K2-SR - samurai	K2-VP - voodoo puppet
K2-MAH - mahogany	K2-MAP - maple



Keiki® UKULELE PACK BY ORTEGA®

The
EXOTIC WOOD
Collection



NEW

K3-ACA
Soprano



NEW

K3-SPM
Soprano



NEW

K3-WEB
Soprano



	scale	width at nut
Soprano	364 mm (14.33")	36 mm (1.42")

- Acacia (ACA) || Spalted Maple (SPM) || White Ebony (WEB) top, satin finish
- ABS body, slightly arched
- Okoume neck, satin finish
- ABS fretboard & bridge
- Open gear tuning machines chrome w/ black buttons
- Ortega Guitars UWNY-4-SO strings
- Headstock tuner, Soundhole hook strap/support, 5 medium picks and drawstring bag included!



acacia

spalted maple

white ebony



K3
Ukulele Pack

K3 UKULELE PACK INCLUDES:

- Keiki® Headstock tuner
- Keiki® Soundhole hook strap/support
- Keiki® medium picks (5 piece)
- Keiki® Drawstring bag



KEIKI® DESIGNER UKULELE & GUITAR STRAPS

Made from strong but soft nylon and equipped with suede leather ends.
 Sizes: Ukulele 36 mm (1.42") width, up to 1440 mm (56.70") length / Guitar 50 mm (1.97") width, up to 1580 mm (62.20") length. Embossed logo on genuine leather badge.



UKULELES

KNS-SP-U
spaceman

KNS-EM-U
el muerto

KNS-68-U
peace '68

KNS-TM-U
totem

KNS-SR-U
samurai

KNS-VP-U
voodoo puppet



GUITARS

KNS-SP
spaceman

KNS-EM
el muerto

KNS-68
peace '68

KNS-TM
totem

KNS-SR
samurai

KNS-VP
voodoo puppet

Keiki® UKULELE BAGS

KEIKI® DESIGNER UKULELE BAGS

Professional ukulele bags – designed to be different and priced for any budget. Made from sturdy nylon material with a 10 mm soft inside padding. Includes an accessory compartment (fits an ORTEGA OPUSxx portable uke stand) and two adjustable shoulder straps.

KUB-SP-xx spaceman

KUB-EM-xx el muerto

KUB-68-xx peace '68

KUB-TM-xx totem

KUB-SR-xx samurai

KUB-VP-xx voodoo puppet

Sizes: soprano (SO) – concert (CC) – tenor (TE)

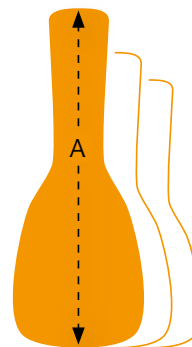

DIMENSIONS	
	A (inside)
soprano length	55.0 cm 21.65"
concert length	62.0 cm 24.41"
tenor length	68.0 cm 26.77"



ORTEGA[®]
GUITARS • EST 1994



UKULELES

OVERVIEW

BONFIRE SERIES (see page 16)



EARTH SERIES (see page 18)



GAUCHO SERIES (see page 20)



THE PRIVATE ROOM (see page 20)



HORIZON SERIES (see page 21)



TIMBER SERIES (see page 22)



PRISM SERIES (see page 26)



LIZARD SERIES (see page 26)



BANJOLELE SERIES (see page 27)



CUSTOM BUILT SERIES (see page 28)





ALL SERIES OPTIONS

scales and sizes

width at nut

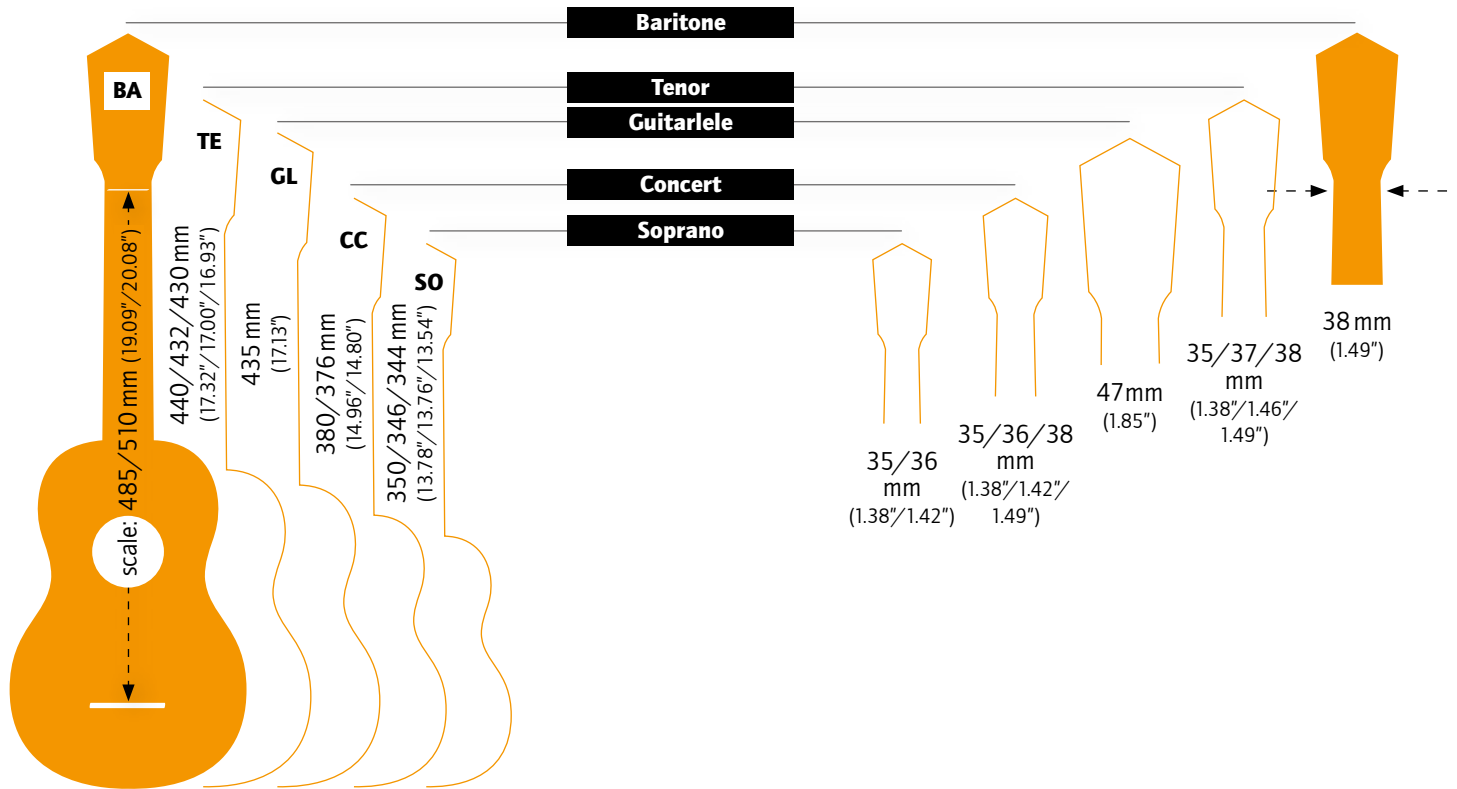

features



double neck ukulele
(see page 29)

tuning

BA = D-G-B-E
 TE/CC/SO = G-C-E-A
 6string TE = G-Cc-E-Aa
 8string TE = Gg-Cc-EE-AA
 BS = E-A-D-E

strings



electronics

**ORTEGA®
MagusUke**

Electronics w/ tuner
(see page 107)



Preamp with built-in tuner

body



bag



non
cutaway



cutaway

Ortega Guitars
 soprano UWNY-4-SO/
 concert UWNY-4-CC/
 tenor UWNY-4-TE/
 baritone UWNY-4-BA/
 tenor UNY-6-TE/
 tenor UNY-8-TE/
 guitarlele GLNY-6
 strings
 (see page 98)

MagusUke electronics
 are powered with
 CR2032 coin cell
 batteries
 (see page 106)



Preinstalled strap button
on all Ortega ukuleles

wood variations: top

wood variations: back & sides



solid mahogany mahogany flamed mahogany sapele



solid mahogany mahogany flamed mahogany sapele



paldao (dao) acacia okoume okoume



paldao (dao) acacia okoume okoume



okoume okoume okoume okoume



okoume okoume okoume okoume



ebony mango walnut zebrawood ebony mango walnut zebrawood



ebony mango walnut zebrawood



agathis agathis ovangkol bamboo agathis agathis ovangkol bamboo

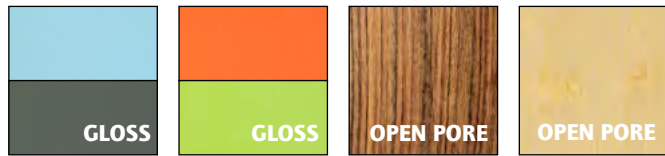

agathis agathis ovangkol bamboo



flamed maple flamed maple ziricote solid cedar



flamed maple flamed maple ziricote



spruce



BONFIRE SERIES

with EQ ELECTRONICS W/ TUNER
ORTEGA
MagusUke



RU5-SO
Soprano



RU5CE-SO with EQ
Soprano



RU5
Concert



RU5CE with EQ
Concert



RUPA5
Concert



RU5-TE
Tenor



RU5CE-TE with EQ
Tenor



RU5-BA
Baritone



RU5CE-BA with EQ
Baritone

- Spruce top, satin finish, laser engraved motif
- Sapele back & side, satin finish
- Mahogany neck, satin finish
- Tortoise style ABS binding
- Walnut fretboard & bridge

- Ortega MagusUke electronics w/ tuner (RU5CE-SO, RU5CE, RU5CE-TE & RU5CE-BA)
- Die-cast tuning machines, chrome w/ black buttons
- Ortega Guitars UWNY-4-SO/-CC/-TE/-BA strings

	scale	width at nut
Soprano	350 mm (13.78")	36 mm (1.42")
Concert	380 mm (14.96")	36 mm (1.42")
Tenor	440 mm (17.32")	37 mm (1.45")
Baritone	485 mm (19.09")	38 mm (1.49")



RGL5
Guitarlele



RGL5C
Guitarlele



RGL5CE
Guitarlele

- Spruce top, satin finish, laser engraved motif
- Mahogany back & side, satin finish
- Mahogany neck, satin finish
- 18 frets
- Ortega MagusUke electronics w/ tuner (RGL5CE)
- Walnut fretboard & bridge
- Ortega GLNY-6 strings

	scale	width at nut
Guitarleles	435 mm (17.13")	47 mm (1.85")



RU5MM-SO
Soprano



RU5MM
Concert



RUP5MM
Concert



RU5MM-CE
Concert

NEW



RU5MM-TE
Tenor



RU5MM-BA
Baritone

- Sapele top, satin finish, laser engraved motif
- Sapele back & side, satin finish
- Mahogany neck, satin finish
- Tortoise style ABS binding
- Walnut fretboard & bridge
- Die-cast tuning machines, chrome w/ black buttons
- Ortega MagusUke electronics w/tuner (RU5MM-CE)
- Ortega Guitars UWNY-4-SO/-CC/-TE/-BA strings

	scale	width at nut
Soprano	350 mm (13.78")	36 mm (1.42")
Concert	380 mm (14.96")	36 mm (1.42")
Tenor	440 mm (17.32")	37 mm (1.46")
Baritone	485 mm (19.09")	38 mm (1.49")



EARTH SERIES

with EQ ELECTRONICS W/ TUNER
ORTEGA
MagusUke



RUDAWN
Concert



RUDAWN-CE



RUFOREST



RUFOREST-CE



RUOCEAN



RUOCEAN-CE



RUFIRE



RUFIRE-CE

	scale	width at nut
Concert	380 mm (14.96")	36 mm (1.42")

- Okoume top, back & side, dawn sunburst (forest green, ocean blue, fire red, hokkaido orange, coal black, ruby raspberry, gold, silver, lagoon turquoise, sun yellow) satin finish
- Mahogany neck
- White ABS binding
- Walnut fretboard & bridge
- Ortega MagusUke electronics w/ tuner (-CE)
- Die-cast tuning machines, chrome
- Ortega Guitars UWNY-4-CC strings



RUPUKI



RUPUKI-CE



RUCOAL



RUCOAL-CE

NEW

NEW

EARTH SERIES



RURUBY



RURUBY-CE 



RUSUN



RUSUN-CE 



RUGOLD



RUSILVER



RULAGOON





GAUCHO SERIES



RUGA-SKY



RUGA-PLT



RUGA-ORG



RUGA-GAP

- Agathis top, back & side (sky blue, platinum gray, orange, green apple) gloss finish
- Ivory ABS binding
- Okoume neck, gloss finish
- Slotted head, Okoume veneer
- Walnut fretboard & bridge

- Maple "bars" fretboard inlays
- Chrome tuning machines w/ white buttons
- Tear drop pickguard
- Ortega Guitars UWNY-4-TE
- Color matched gig bag included

	scale	width at nut
Tenor	432 mm (17.00")	37 mm (1.49")

SKY = sky blue
PLT = platinum gray
ORG = orange
GAP = green apple

THE PRIVATE ROOM

CUSTOM CRAFTED INSTRUMENTS

DISTRESSED SUITES

DSSUITE-UKE



NEW

DISTRESSED SATIN FINISH

Concert scale: 376 mm (14.80")
width at nut: 35 mm (1.38")



- Solid Alaskan spruce top, distressed tobacco satin finish
- Mahogany back & side, distressed tobacco satin finish
- Reversed headstock, 4 in line
- Okoume neck, satin finish
- No body binding, walnut fretboard binding
- Tecwood fretboard & bridge
- Ortega MagusUke electronics w/tuner
- Die-cast tuning machines black, black, chrome, black
- Ortega Guitars UWNY-4-CC strings
- Deluxe gig bag included



ORTEGA
MagusUke



RUHZ-SBK



RUHZ-CE-SBK



RUHZ-MM



RUHZ-CE-MM

- Okoume (SBK) || Mahogany (MM) top, satin open pore finish
- Okoume (SBK) || Mahogany (MM) back & side, satin open pore finish
- Reversed headstock, 4 in line
- Okoume neck & headstock veneer, satin finish (SBK) || Okoume neck & Mahogany headstock veneer, satin finish (MM)
- Black ABS top, bottom & fretboard binding
- Tecwood fretboard & bridge
- Ortega MagusUke electronics w/ tuner (-CE)
- Die-cast tuning machines, black w/ black buttons
- Ortega Guitars UWN4-CC strings

	scale	width at nut
Concert	376 mm (14.80")	35 mm (1.38")

SBK = satin black
MM = natural mahogany



RUMG

RUMG-CE



RUBO

RUBO-CE



RUWN

RUWN-CE



- Mango (MG) || Bamboo (BO) || Walnut (WN) top, satin open pore finish
- Mango (MG) || Bamboo (BO) || Walnut (WN) back & side, satin open pore finish
- Reversed headstock, 4 in line
- Okoume neck, satin finish
- Walnut top, bottom & fretboard binding (MG, BO)
- Maple top, bottom & fretboard binding (WN)
- Tecwood fretboard & bridge
- Ortega MagusUke electronics w/ tuner (-CE)
- Die-cast tuning machines, gold w/ black buttons
- Ortega Guitars UWN4-CC strings
- Deluxe gig bag included

	scale	width at nut
Concert	376 mm (14.80")	35 mm (1.38")

MG = Mango
BO = Bamboo
WN = Walnut



TIMBER SERIES

with EQ ELECTRONICS W/ TUNER
ORTEGA
MagusUke



RFU10S
Soprano



RFU10SE
Soprano



RFU11S
Concert



RFU11SE
Concert



- Sapele top, satin finish
- Sapele back & side, satin finish
- Mahogany neck, satin finish
- Walnut fretboard & bridge
- Ortega MagusUke electronics w/ tuner (E)

- Die-cast tuning machines, chrome w/ black buttons
- Ortega Guitars UWNY-4-SO/-CC strings
- Deluxe gig bag included

	scale	width at nut
Soprano	350 mm (13.78")	36 mm (1.42")
Concert	380 mm (14.96")	36 mm (1.42")



RFU10Z
Soprano



RFU10ZE
Soprano



RFU11Z
Concert



RFU11ZE
Concert



- Zebrawood top, satin finish
- Zebrawood back & side, satin finish
- Mahogany neck, satin finish
- Walnut fretboard & bridge
- Ortega MagusUke electronics w/ tuner (E)

- Die-cast tuning machines, chrome w/ black buttons
- Ortega Guitars UWNY-4-SO/-CC strings
- Deluxe gig bag included

	scale	width at nut
Soprano	350 mm (13.78")	36 mm (1.42")
Concert	380 mm (14.96")	36 mm (1.42")



RUEB-SO
Soprano

RUEB-CC
Concert

RUEB-TE
Tenor



RGL5EB
Guitarlele

RGL5EB-CE 
Guitarlele

- Ebony top, satin open pore finish
- Ebony back & side, satin open pore finish
- Mahogany neck, satin finish
- Ebony headstock veneer
- Tortoise style binding & tortoise style rosette
- 18 frets (RGL)
- Walnut fretboard & bridge
- Ortega MagusUke electronics w/ tuner (RGL5EB-CE)
- Die-cast tuning machines, gold w/ black buttons
- Ortega Guitars UWNY-4-SO/-CC /-TE strings (RUEB) || Ortega GLNY-6 Guitarlele strings (RGL)
- Deluxe gig bag included (RUEB-SO, RUEB-CC & RUEB-TE)

	scale	width at nut
Soprano	350 mm (13.78")	35 mm (1.38")
Concert	380 mm (14.96")	36 mm (1.42")
Tenor	440 mm (17.32")	37 mm (1.45")
Guitarlele	435 mm (17.13")	47 mm (1.85")



TIMBER SERIES

SOLID TOP



RUTI-SO
Soprano



RUTI-CC
Concert



RUTI-TE
Tenor



- Solid cedar top, satin finish
- Walnut back & side, satin finish
- Okoume neck, satin finish
- Walnut/maple body binding
- Walnut fretboard & bridge
- Maple "bar" fretboard inlays
- Walnut fretboard binding

- Classic headstock, Ovangkol veneer
- Bone nut & saddle
- Die-cast tuning machines, gold w/ black buttons
- Ortega Guitars UWNY-4-SO/-CC/-TE strings
- Deluxe gig bag included

	scale	width at nut
Soprano	346 mm (13.62")	35 mm (1.38")
Concert	382 mm (15.04")	36 mm (1.42")
Tenor	432 mm (17.00")	37 mm (1.45")

SOLID TOP & SOLID BACK, OPEN PORE FINISH



RUACA-SO
Soprano



RUACA-CC
Concert



RUACA-TE
Tenor



RUACA-BA
Baritone



- Solid acacia top, satin open pore finish
- Solid acacia back, satin open pore finish
- Acacia side, satin open pore finish
- Okoume neck, satin finish
- Padouk top, back & fretboard binding
- Tecwood fretboard & bridge

- Die-cast tuning machines, gold w/ black buttons
- Ortega Guitars UWNY-4-SO/-CC/-TE/-BA strings
- Deluxe gig bag included

	scale	width at nut
Soprano	344 mm (13.54")	35 mm (1.38")
Concert	376 mm (14.80")	35 mm (1.38")
Tenor	430 mm (16.93")	35 mm (1.38")
Baritone	510 mm (20.08")	38 mm (1.49")

ALL SOLID MAHOGANY



RU10
Soprano



RU11
Concert



- Solid mahogany top, satin finish
- Solid mahogany back & side, satin finish
- Mahogany neck, satin finish
- Ivory ABS binding
- Walnut fretboard & bridge
- Open gear tuning machines, gold w/ white buttons
- Ortega Guitars UWNY-4-SO/-CC strings
- Deluxe gig bag included

	scale	width at nut
Soprano	350 mm (13.78")	36 mm (1.42")
Concert	380 mm (14.96")	36 mm (1.42")

GUITARLELES



RGL18FMH 



RGL18BLF 

 **ELECTRONICS W/ TUNER**
ORTEGA
MagusUke



- Flamed mahogany || flamed mahogany blue fade top, gloss finish
- Flamed mahogany || flamed mahogany blue fade back & side, gloss finish
- Mahogany neck, satin finish || gloss finish
- 18 frets
- Ortega MagusUke electronics w/ tuner
- Walnut fretboard & bridge
- Ortega GLNY-6 strings
- Deluxe gig bag included

	scale	width at nut
Guitarleles	435 mm (17.13")	47 mm (1.85")



PRISM SERIES



RUPR-TRI



RUPR-TQB



RUPR-IVY



- Flamed maple top, transparent color fade, gloss finish
- Flamed maple back & side, transparent color fade, gloss finish
- Maple neck, transparent color fade, gloss finish
- Maple (TRI, TQB) || Walnut (IVY) fretboard, fretboard binding & bridge
- Slotted headstock, flamed maple veneer
- Walnut binding & Abalone style purfling & rosette, transparent color fade, gloss finish
- Bone nut & saddle
- Single tuning machines, gold w/ gold buttons
- Ortega Guitars UWNY-4-TE strings
- Deluxe gig bag included

	scale	width at nut
Tenor	432 mm (17.00")	37 mm (1.49")

TRI = tri color fade
TQB = tequila burst fade
IVY = ivy fade

LIZARD SERIES

 **ELECTRONICS W/ TUNER**
ORTEGA
 MagusUke



LIZARD-SO-GB 
Soprano



LIZARD-CC-GB 
Concert



LIZARD-TE-GB 
Tenor



- Paldao top, satin finish
- Paldao back & side, satin finish
- Mahogany neck, gloss finish
- Walnut binding
- Walnut fretboard & bridge
- Maple Lizard fretboard inlay
- Ortega MagusUke electronics w/ tuner
- Die-cast tuning machines, gold w/ gold buttons
- Ortega Guitars UWNY-4-SO/-CC/-TE strings
- Deluxe gig bag included

	scale	width at nut
Soprano	346 mm (13.76")	35 mm (1.38")
Concert	380 mm (14.96")	36 mm (1.42")
Tenor	432 mm (17.00")	37 mm (1.45")

OUBJ100-SBK



scale: 394 mm (15.51")
width at nut: 35 mm (1.38")



- 4string Banjo
- Hard maple neck, satin black finish
- Maple ply body, open back, satin black finish
- Ovangkol fretboard
- 18 brackets
- Chrome hardware
- Remo ebony head, black
- Open gear tuning machines
- Ortega UWNY-4-CC strings
- Deluxe Banjo bag included

BUILT-IN PICKUP SYSTEM

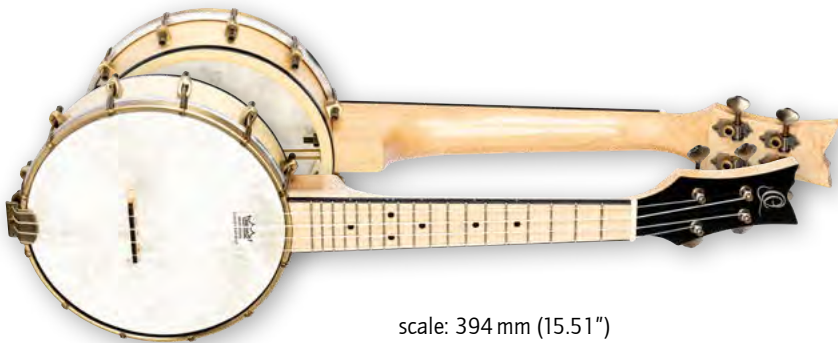

scale: 394 mm (15.51")
width at nut: 35 mm (1.38")

OUBJE90-MA



- 4string Banjo
- Hard maple neck, natural
- Maple body, open back
- Maple fretboard w/ black ABS binding
- 12 brackets, brushed brass
- Remo head, coated
- Open gear brushed brass tuning machines
- Built-in passive transducer pickup system
- Ortega UWNY-4-CC strings
- Deluxe Banjo bag included





CUSTOM BUILT SERIES ALL SOLID MAHOGANY

DOUBLE SOUNDHOLE
BUILT-IN ARMREST
ERGONOMIC CUTAWAY



ECLIPSE-CC4
Concert

ECLIPSE-TE6
Tenor

ECLIPSE-TE8
Tenor

- Solid Mahogany top, gloss finish
- Solid Mahogany back & side, gloss finish
- Solid Okoume neck, gloss finish
- Slotted headstock
- Walnut top, back & fretboard binding
- Walnut rear headstock veneer
- Walnut fretboard & bridge
- Eclipse fretboard inlays, custom made
- Additional side soundhole
- Bone nut & saddle
- Single tuning machines, gold w/ gold buttons || 6string tuning machines w/ tortoise style buttons || 8string tuning machines w/ tortoise style buttons
- Ortega UWN4-CC/UNY-6-TE/UNY-8-TE strings
- Deluxe gig bag included

	scale	width at nut
Concert	380 mm (14.96")	38 mm (1.49")
Tenor 6string	430 mm (16.93")	38 mm (1.49")
Tenor 8string	430 mm (16.93")	38 mm (1.49")

tuning:
CC/TE = G-C-E-A
6string TE = G-Cc-E-Aa
8string TE = Gg-Cc-EE-AA

with EQ ELECTRONICS W/ TUNER
ORTEGA
MagusUke



ARCHED TOP

Concert scale: 382 mm (15.04")
width at nut: 37 mm (1.46")

RUSL-HSB **with EQ**



- Flamed maple, arched top, satin finish
- Flamed maple arched back & side, satin finish
- Okoume neck, satin finish
- Walnut fretboard & Mandolin bridge
- Walnut fretboard binding
- Classic headstock, Ovangkol veneer
- F-holes
- Bone nut & saddle
- Die-cast tuning machines, gold w/ black buttons
- Ortega MagusUke electronics w/ tuner
- Ortega Guitars UWN4-CC strings
- Deluxe gig bag included



DOUBLE NECK UKULELE 4string, Ukebass/4string, Tenor

Ukebass
scale: 510 mm (20.08")
width at nut: 45 mm (1.77")

Tenor Ukulele
scale: 432 mm (17.00")
width at nut: 37 mm (1.45")

tuning:
TE = G-C-E-A
BS = E-A-D-E



HYDRA-BSTE

- Dao top, open pore satin finish
- Dao back & side, open pore satin finish
- Mahogany necks, natural satin finish
- Ukebass 4string & Tenor 4string
- Walnut fretboard & bridge
- Walnut/ABS body binding
- Bone nut & saddle
- Custom built electronics with 3way toggle switch (Ukebass/both/Tenor)
- 4string Ukebass tuning machines black/black & 4string Ukulele single tuning machines black/black
- Ukebass strings & Ortega Guitars Tenor UWNY-4-TE strings
- Deluxe gig bag included



DOUBLE NECK UKULELE 4/8string, Tenor

both necks
scale: 430 mm (16.93")
width at nut: 38 mm (1.49")

tuning:
TE = G-C-E-A
8string TE = Gg-Cc-EE-AA



HYDRA

- Ovangkol top, open pore satin finish
- Ovangkol back & side, open pore satin finish
- Mahogany necks, natural satin finish
- Tenor 8string & Tenor 4string
- Slotted headstocks
- Walnut armrest & fretboard binding
- Walnut fretboard & bridge
- Tortoise style body binding
- Bone nut & saddle
- Custom built electronics with 3way toggle switch (neck 8/both/neck 4)
- 8string tuning machines gold/gold & single tuning machines gold/gold (4string)
- Ortega Guitars Tenor UWNY-4-TE/ UWNY-8-TE strings
- Deluxe gig bag included



DOUBLE NECK UKULELE 4/8string, Tenor

both necks
scale: 430 mm (16.93")
width at nut: 38 mm (1.49")

tuning:
TE = G-C-E-A
8string TE = Gg-Cc-EE-AA



HYDRA-ZS

- Zircote top, open pore satin finish
- Zircote back & side, open pore satin finish
- Mahogany necks, natural satin finish
- Tenor 8string & Tenor 4string
- Slotted headstocks
- Walnut armrest
- Maple fretboards & bridges
- Mahogany body & fretboard binding
- Walnut "tree of life" fretboard inlay
- Bone nut & saddle
- Custom built electronics with 3way toggle switch (neck 8/both/neck 4)
- 8string tuning machines gold/gold & single tuning machines gold/gold (4string)
- Ortega Guitars Tenor UWNY-4-TE/ UWNY-8-TE strings
- Deluxe gig bag included



UKEBASSES



photo: René Anderl | Medienbeweger

OPTIONS

scales and sizes

width at nut

wood variations: top

SOLID			
	mahogany	paldao (dao)	acacia

features

double neck ukulele
(see page 33)

LIZZY-PRO

LIZZY
LIZARD
CAIMAN

45 mm (1.77")

45 mm (1.77")

wood variations: back & sides

mahogany	paldao (dao)	acacia

2way truss rod

body

non cutaway	cutaway

color/ finish

natural NT:
satin finish/gloss finish

bag

electronics

ORTEGA®
MagusUkebass

Electronics w/ tuner
(see page 107)



Ukebass

scale: 510 mm (20.08")
width at nut: 45 mm (1.77")

LIZZY-BS-GB



- Mahogany top, satin finish
- Mahogany back & side, satin finish
- Mahogany neck, satin finish
- Walnut fretboard & bridge
- Black ABS binding/ white purfling
- Lasered Lizard rosette
- Ortega MagusUkeBass electronics w/ tuner
- 15 frets
- 2way truss rod
- Deluxe gig bag included



Ukebass

scale: 510 mm (20.08")
width at nut: 45 mm (1.77")

**LIZZY-BSFL-GB
LINED FRETLESS**



- Mahogany top, satin finish
- Mahogany back & side, satin finish
- Mahogany neck, satin finish
- Walnut fretboard & bridge
- Black ABS binding/ white purfling
- Lasered Lizard rosette
- Ortega MagusUkeBass electronics w/ tuner
- 15 frets
- 2way truss rod
- Deluxe gig bag included



**Longscale
Ukebass**

scale: 625 mm (24.60")
width at nut: 45 mm (1.77")

**LIZZY-PRO
LINED FRETLESS**



- Solid mahogany top, satin finish
- Mahogany back & side, satin finish
- Mahogany neck, satin finish
- Pao Ferro fretboard & bridge
- Black ABS binding/ white purfling
- Lasered Lizard rosette
- Ortega MagusUkeBass electronics w/ tuner
- 2way truss rod
- Deluxe gig bag included



Ukebass

scale: 510 mm (20.08")
width at nut: 45 mm (1.77")

LIZARD-BS-GB



- Dao top, satin finish
- Dao back & side, satin finish
- Mahogany neck, satin finish
- Walnut fretboard & bridge
- Black ABS binding/ white purfling
- Lasered Lizard rosette
- Ortega MagusUkeBass electronics w/ tuner
- 15 frets
- 2way truss rod
- Deluxe gig bag included





LIZARD SERIES



ELECTRONICS W/ TUNER
ORTEGA
MagusUkeBass



Ukebass **ARCHED BACK** scale: 510 mm (20.08")
width at nut: 45 mm (1.77")

CAIMAN-BS-GB



- Acacia top, gloss finish
- Acacia back (arched) & side, gloss finish
- Mahogany neck, gloss finish
- Walnut fretboard & bridge
- Mahogany body & fretboard binding
- Abalone style purfling
- Mahogany dot fretboard inlays
- Ortega MagusUkeBass electronics w/ tuner
- 2way truss rod
- Custom made indirect Ukebass tuning machines, black
- Deluxe gig bag included



Ukebass **ARCHED BACK** scale: 510 mm (20.08")
width at nut: 45 mm (1.77")

CAIMAN-FL-GB LINED FRETLESS



- Acacia top, gloss finish
- Acacia back (arched) & side, gloss finish
- Mahogany neck, gloss finish
- Walnut fretboard & bridge
- Mahogany body & fretboard binding
- Abalone style purfling
- Mahogany dot fretboard inlays
- Ortega MagusUkeBass electronics w/ tuner
- 2way truss rod
- Custom made indirect Ukebass tuning machines, black
- Deluxe gig bag included



ACCESSORIES



OWSH
**WIRELESS SYSTEM
HOLDER**
(see page 95)



DOUBLE NECK UKULELE 4string, Ukebass / 4string, Tenor

Ukebass
scale: 510 mm (20.08")
width at nut: 45 mm (1.77")

Tenor Ukulele
scale: 432 mm (17.00")
width at nut: 37 mm (1.45")

tuning:
TE = G-C-E-A
BS = E-A-D-E



NEW

HYDRA-BSTE

- Dao top, open pore satin finish
- Dao back & side, open pore satin finish
- Mahogany necks, natural satin finish
- Ukebass 4string & Tenor 4string
- Walnut fretboard & bridge
- Walnut/ABS body binding
- Bone nut & saddle
- Custom built electronics with 3way toggle switch (Ukebass/both/Tenor)
- 4string Ukebass tuning machines black/black & 4string Ukulele single tuning machines black/black
- Ukebass strings & Ortega Guitars Tenor UWNY-4-TE strings
- Deluxe gig bag included





artist: Ronja Maltzahn | photo: Danny Lucenara



 **ORTEGA**[®]
GUITARS • EST 1994

NYLON STRING GUITARS

OVERVIEW

STUDENT SERIES (see page 36)



GAUCHO SERIES (see page 38)



REQUINTO SERIES (see page 40)



FAMILY SERIES (see page 42)



FAMILY SERIES PRO (see page 48)



PERFORMER SERIES (see page 50)



TRADITIONAL SERIES (see page 54)



CUSTOM MASTER SERIES (see page 58)



SIGNATURE SERIES (see page 60)



THE PRIVATE ROOM (see page 64)





STUDENT SERIES

OPTIONS

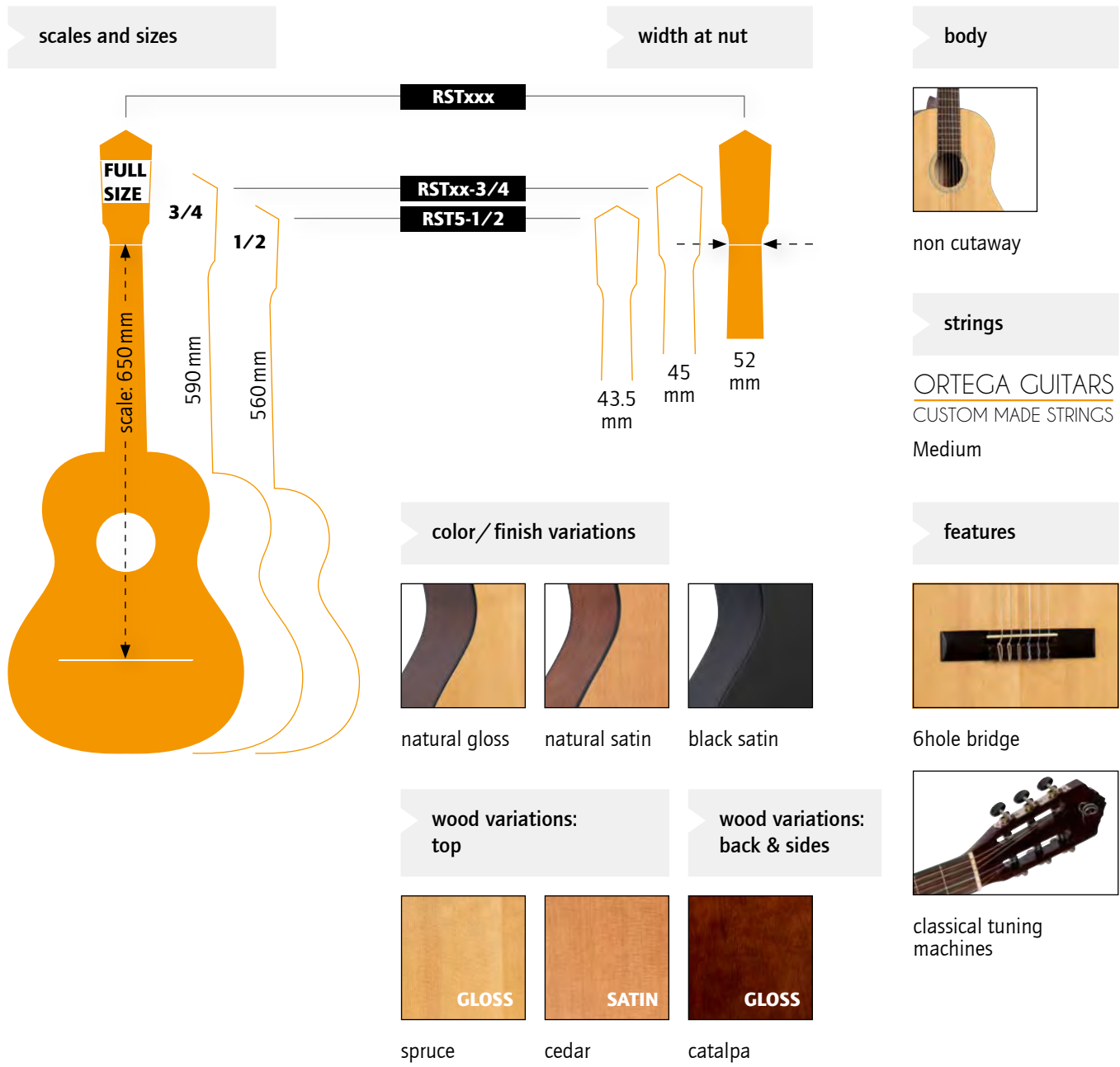



RST5-1/2
1/2 size

RST5-3/4
3/4 size

RST5
full size

- Spruce top, gloss finish
- Catalpa back & side, gloss finish
- ABS binding
- Mahogany neck, gloss finish
- Walnut fretboard & bridge
- Ortega 6hole bridge

	scale	width at nut
1/2 size	560 mm (22.05")	43.5 mm (1.71")
3/4 size	590 mm (23.23")	45 mm (1.77")
full size	650 mm (25.59")	52 mm (2.05")



RST5M
full size

RSTC5M-3/4
3/4 size

RSTC5M
full size

RST5MBK
full size

- Spruce top (RST5M & RST5MBK) || Cedar top, matte satin finish (RSTC5M & RSTC5M-3/4)
- Catalpa back & side
- Pinstripe rosette (RST5M & RST5MBK) || Classical rosette (RSTC5M & RSTC5M-3/4)
- ABS binding
- Mahogany neck
- Walnut fretboard & bridge
- Ortega 6hole bridge

	scale	width at nut
3/4 size	590 mm (23.23")	45 mm (1.77")
full size	650 mm (25.59")	52 mm (2.05")

M = matte satin finish
MBK = matte satin finish black



GAUCHO SERIES

OPTIONS

scales and sizes

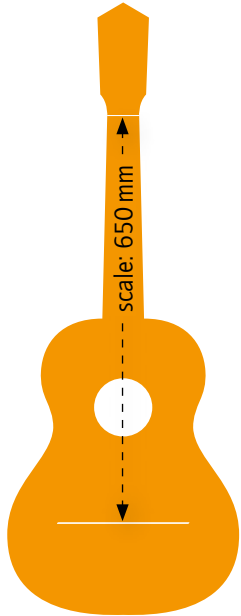

width at nut

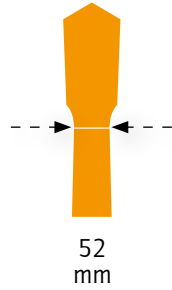

wood variations: top



spruce



spruce

wood variations: back & sides



mahogany

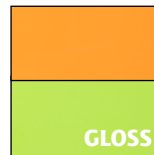

mahogany

features



2way truss rod



color matched bag



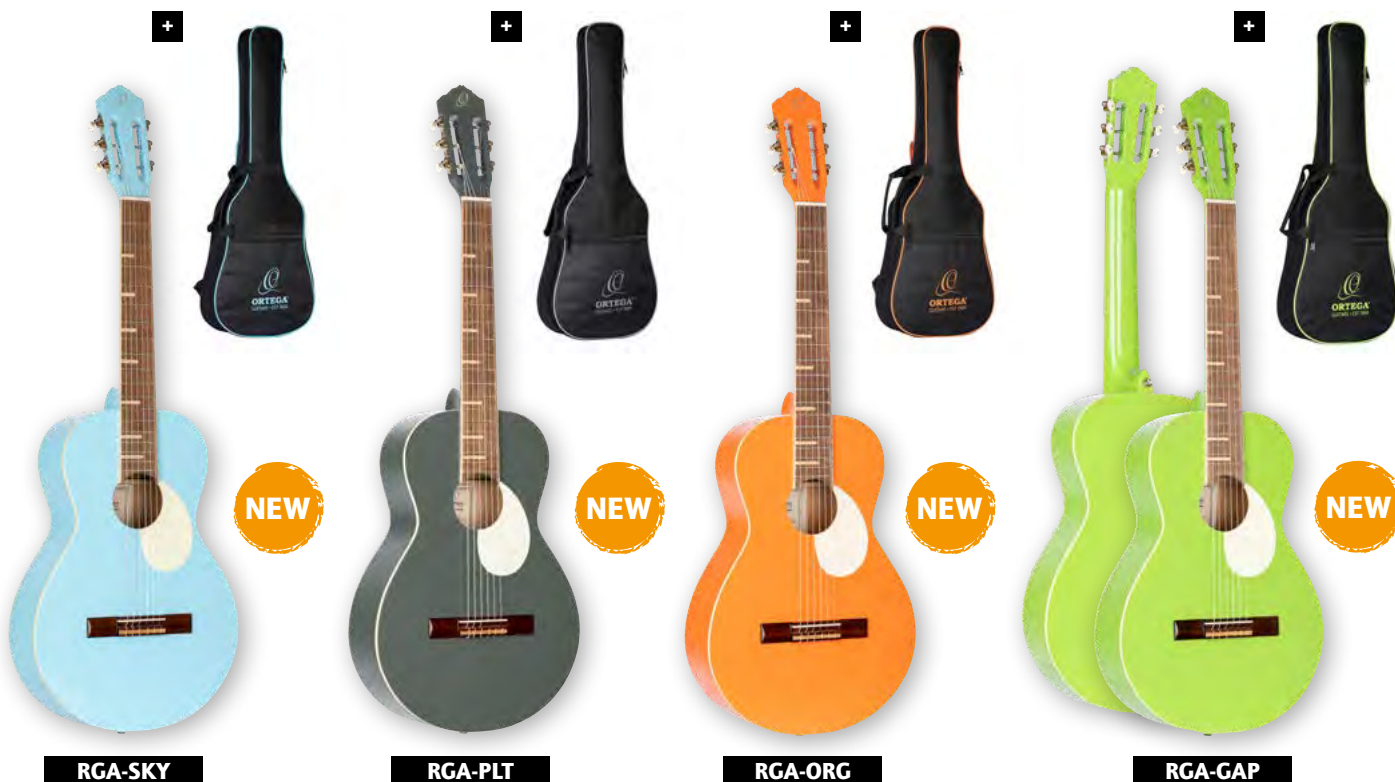

- Agathis top (sky blue, platinum gray, orange, green apple), gloss finish
- Agathis back & side (sky blue, platinum gray, orange, green apple), gloss finish
- Parlor body
- Ivory ABS binging
- Nato neck, gloss finish, 2way truss rod
- Walnut fretboard & bridge
- Maple "bars" fretboard inlays
- Chrome tuning machines w/ white buttons
- Tear drop pickguard
- Color matched gig bag included

PARLOR body size	scale	width at nut
full size	650 mm (25.59")	52 mm (2.05")

SKY = sky blue
ORG = orange
GAP = green apple
PLT = platinum gray

ACCESSORIES



MAGUSGO
ACOUSTIC & NYLON STRING
GUITAR SYSTEMS
 (see page 107)





REQUINTO SERIES

OPTIONS

scales and sizes

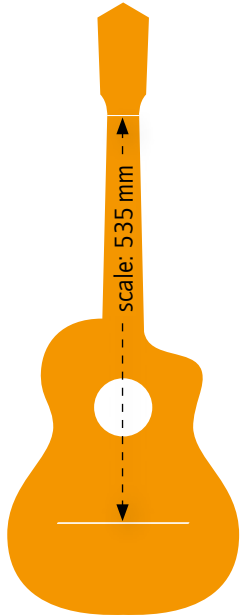

width at nut

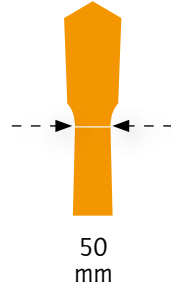

wood variations: back & sides



sapele

wood variations: top (all satin finish)



spruce



cedar



solid Engelmann spruce

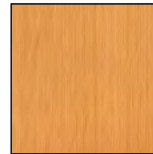

solid cedar

features



2way truss rod



bag

electronics

ORTEGA®
MagusGO

Electronics w/ tuner
(see page 107)



REQUINTO SERIES DEEP BODY



NEW

RQ25



NEW

RQC25

- Spruce top, natural satin finish (RQ25)
- Cedar top, natural satin finish (RQC25)
- Sapele back & side, satin finish
- 110 mm body depth, extra deep
- Okoume neck, satin finish, 2way truss rod
- Walnut headstock veneer
- Walnut fretboard & bridge

full size

scale
535 mm (21.06")

width at nut
50 mm (1.96")

deep body
medium neck

REQUINTO SERIES PRO DEEP BODY

with EQ
ELECTRONICS W/ TUNER
ORTEGA
MagusGO



NEW

RQ38



NEW

RQ39



NEW

RQ39E

- Solid Engelmann Spruce top, natural satin finish (RQ38) || Solid Cedar top, natural satin finish (RQ39)
- Sapele back & side, satin finish
- 110 mm body depth, extra deep
- Okoume neck, satin finish, 2way truss rod
- Walnut headstock veneer
- Walnut fretboard & bridge
- Ortega MagusGo preamp & pickup (RQ39E)
- Deluxe gig bag included



full size

scale
535 mm (21.06")

width at nut
50 mm (1.96")

deep body
medium neck



FAMILY SERIES

OPTIONS

scales and sizes

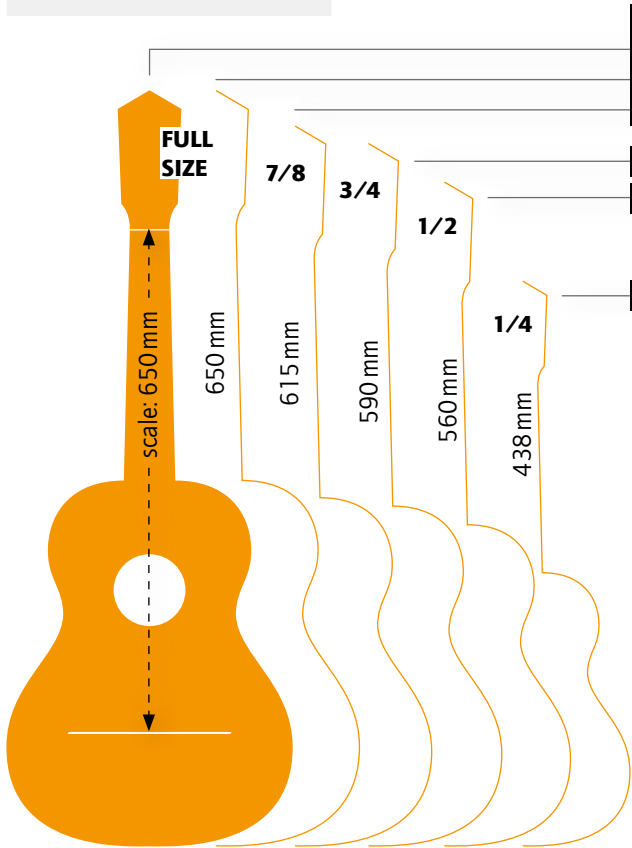

width at nut

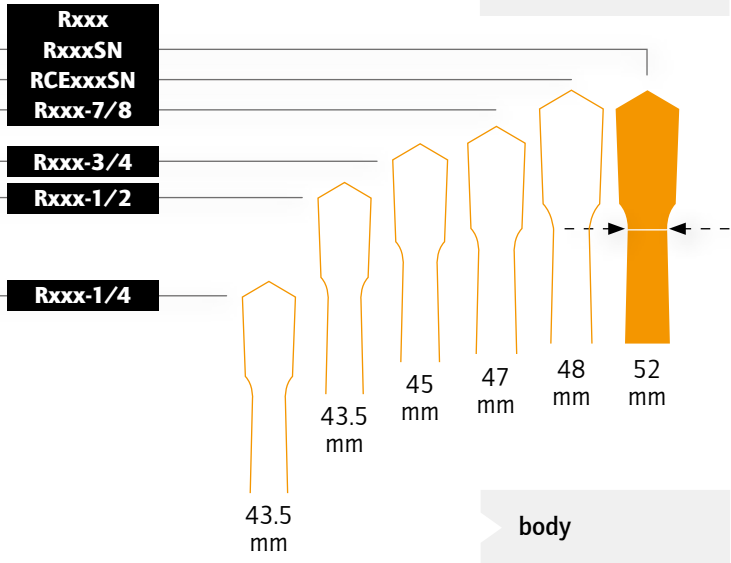

body



non cutaway cutaway

features



12hole bridge



2way truss rod



bag

electronics: RCExxx



Electronics (see page 107)

color/finish variations

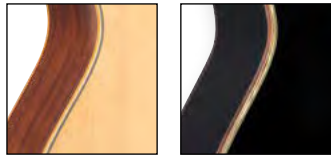

natural NT: satin finish
black BK: gloss finish

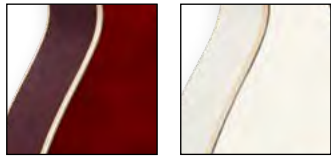

wine red WR: gloss finish
white WH: gloss finish

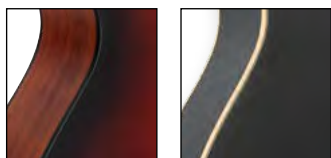

Bourbon fade BFT open pore finish
black SBK: satin finish

wood variations: top



spruce
solid Engelmann spruce
solid Engelmann spruce GLOSS



solid Canadian Western Red cedar SATIN
cedar SATIN
mahogany OPEN PORE

wood variations: back & sides



mahogany OPEN PORE
mahogany SATIN
catalpa SATIN



R121-1/4
1/4 size



R121-1/2
1/2 size



R121-3/4
3/4 size



R121-7/8
7/8 size



R121
full size



R121SN
full size
SLIM NECK



RCE125SN
full size
SLIM NECK
THINLINE BODY



NEW

RCE125MMSN
full size
SLIM NECK
THINLINE BODY



RCE125SN-SBK
full size
SLIM NECK
THINLINE BODY

- Spruce top, satin open pore finish || satin open pore black finish (SBK) || Mahogany top, satin open pore finish (MM)
- Mahogany back & side, satin open pore finish || satin open pore black finish (SBK)
- Mahogany neck, satin finish || satin black finish (SBK)
- Walnut fretboard & bridge || Walnut fretboard w/ white ABS binding, walnut bridge (SBK)
- Ortega MagusPro electronics w/ tuner (RCE)
- Ortega 12hole bridge
- 2way truss rod (1/2, 3/4, 7/8 & full size)
- Deluxe gig bag included

	scale	width at nut
1/4 size	438 mm (17.24")	43.5 mm (1.71")
1/2 size	560 mm (22.05")	43.5 mm (1.71")
3/4 size	590 mm (23.23")	45 mm (1.77")
7/8 size	615 mm (24.21")	47 mm (1.85")
full size SN	650 mm (25.59")	48 mm (1.89")
full size	650 mm (25.59")	52 mm (2.05")

SBK = satin black



FAMILY SERIES CEDAR TOP



R122-1/4
1/4 size



R122-1/2
1/2 size



R122-3/4
3/4 size

+



R122-7/8
7/8 size



R122
full size



R122SN
full size
SLIM NECK

- Cedar top, satin finish
- Mahogany back & side, satin finish
- Mahogany neck, satin finish
- Walnut fretboard & bridge
- Ortega 12hole bridge
- 2way truss rod (1/2, 3/4, 7/8 & full size)
- Deluxe gig bag included

	scale	width at nut
1/4 size	438 mm (17.24")	43.5 mm (1.71")
1/2 size	560 mm (22.05")	43.5 mm (1.71")
3/4 size	590 mm (23.23")	45 mm (1.77")
7/8 size	615 mm (24.21")	47 mm (1.85")
full size SN	650 mm (25.59")	48 mm (1.89")
full size	650 mm (25.59")	52 mm (2.05")



R221BK-3/4
3/4 size

R221BK-7/8
7/8 size

R221SNBK
full size
SLIM NECK

R221BK
full size

- Spruce top, gloss finish black
- Mahogany back & side, gloss finish black
- Mahogany neck, gloss finish black
- Walnut fretboard & bridge
- Mahogany body & fretboard binding
- White abalone style purfling
- Ortega 12hole bridge
- 2way truss rod
- Deluxe gig bag included

	scale	width at nut
3/4 size	590 mm (23.23")	45 mm (1.77")
7/8 size	615 mm (24.21")	47 mm (1.85")
full size SN	650 mm (25.59")	48 mm (1.89")
full size	650 mm (25.59")	52 mm (2.05")

BK = black





FAMILY SERIES SPRUCE TOP



R121-1/4WR
1/4 size



R121-1/2WR
1/2 size



R121-3/4WR
3/4 size



R121-7/8WR
7/8 size

+



R121WR
full size



R121SNWR
full size
SLIM NECK

- Spruce top, gloss finish wine red
- Mahogany back & side, gloss finish wine red
- Mahogany neck, gloss finish wine red
- Walnut fretboard & bridge
- Ortega 12hole bridge
- 2way truss rod (1/2, 3/4, 7/8 & full size)
- Deluxe gig bag included

	scale	width at nut
1/4 size	438 mm (17.24")	43.5 mm (1.71")
1/2 size	560 mm (22.05")	43.5 mm (1.71")
3/4 size	590 mm (23.23")	45 mm (1.77")
7/8 size	615 mm (24.21")	47 mm (1.85")
full size SN	650 mm (25.59")	48 mm (1.89")
full size	650 mm (25.59")	52 mm (2.05")

WR = wine red



R121-1/2WH
1/2 size



R121-3/4WH
3/4 size



R121WH
full size



R121SNWH
full size
SLIM NECK



- Spruce top, gloss finish white
- Mahogany back & side, gloss finish white
- Mahogany neck, gloss finish white
- Walnut fretboard & bridge
- Ortega 12hole bridge
- 2way truss rod
- Deluxe gig bag included

	scale	width at nut
1/2 size	560 mm (22.05")	43.5 mm (1.71")
3/4 size	590 mm (23.23")	45 mm (1.77")
7/8 size	615 mm (24.21")	47 mm (1.85")
full size SN	650 mm (25.59")	48 mm (1.89")
full size	650 mm (25.59")	52 mm (2.05")

WH = white

ACCESSORIES



OPGS-10RBK
PORTABLE GUITAR STAND
(see page 114)



OMS-1BK
MUSIC STAND
(see page 113)



FAMILY SERIES PRO SOLID SPRUCE TOP



NEW

R55



NEW

R55BFT



NEW

R55DLX
ARMREST



NEW

R55DLX-BFT
ARMREST

full size

scale
650 mm (25.59")

width at nut
52 mm (2.04")

BFT = Bourbon fade top

- Solid Engelmann spruce top, natural satin finish (R55) || Bourbon fade satin finish (R55BFT)
- Solid Engelmann spruce top, natural semi gloss finish (R55DLX) || Bourbon fade semi gloss finish (R55DLX-BFT)

- Catalpa back & side, satin finish (R55 & R55BFT) || semi gloss finish (R55DLX & R55DLX-BFT)
- Nato neck, satin finish (R55 & R55BFT) || semi gloss satin finish (R55DLX & R55DLX-BFT)
- 2way truss rod

- Black ABS binding (R55 & R55BFT) || Rosewood style ABS binding
- Walnut headstock veneer
- Walnut fretboard & bridge
- Armrest (R55DLX & R55DLX-BFT)



FAMILY SERIES PRO SOLID CEDAR/SPRUCE TOP

FULL SIZE/SOLID CEDAR



R131

RCE131



**R131SN
SLIM NECK**

**RCE131SN
SLIM NECK**



**R131SN-WR
SLIM NECK**

- Solid Canadian Western Red cedar top, satin finish || gloss finish wine red (transparent)
- Mahogany back & side, satin finish || gloss finish wine red (transparent)
- Mahogany neck, satin finish || gloss finish wine red (transparent)
- Walnut fretboard & bridge
- Ortega MagusPro electronics w/ tuner (RCE131, RCE131SN)
- Ortega 12hole bridge
- 2way truss rod
- Deluxe gig bag included

+



ELECTRONICS W/ TUNER
ORTEGA
MagusPRO/G

full size

scale
650 mm (25.59")

width at nut
52 mm (2.04")
48 mm (1.89") **SN**

SOLID SPRUCE



RCE141BK



RCE145BK



**SLIM NECK
THINLINE BODY DEPTH**

RCE145WH



**SLIM NECK
THINLINE BODY DEPTH**

+



ELECTRONICS W/ TUNER
ORTEGA
MagusPRO/G

- Solid Canadian Engelmann spruce top, gloss finish black || gloss finish white
- Mahogany back & side, gloss finish black || gloss finish white
- Mahogany neck, gloss finish black || gloss finish white
- Walnut fretboard (flat) & bridge
- Ortega MagusPro electronics w/ tuner
- Ortega 12hole bridge
- 2way truss rod
- Deluxe gig bag included

	scale	width at nut
full size SN	650 mm (25.59")	48 mm (1.89")
full size	650 mm (25.59")	52 mm (2.05")

BK = black
WH = white



PERFORMER SERIES

OPTIONS

scales and sizes

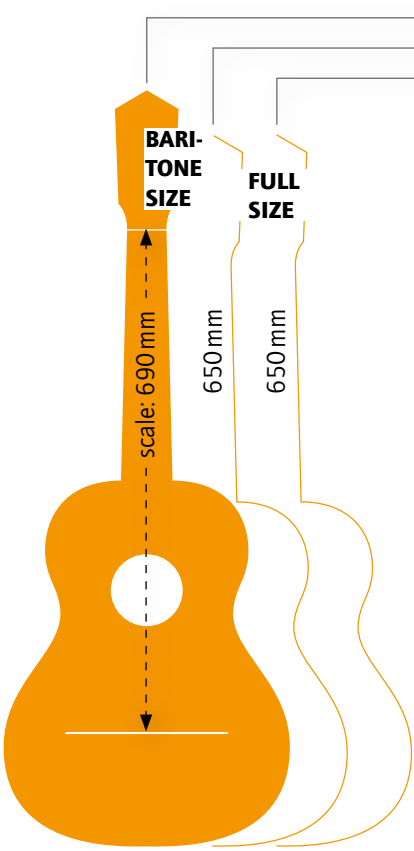

width at nut

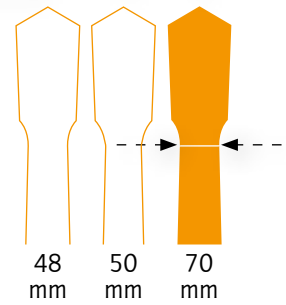

color/finish variations



natural NT:
gloss finish



black BK:
gloss finish



tobacco
sunburst TSB:
gloss finish
(top only)

wood variations: top



solid Alaskan
Sitka spruce



solid North
American cedar

wood variations: back & sides



sapele



walnut



mahogany

body



cutaway



regular depth



thinline

features



Spanish heel

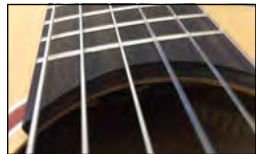

radiused fretboard



14th fret heel to body
connection

strings

ORTEGA GUITARS
CUSTOM MADE STRINGS
8string



12hole/16hole bridge

electronics: RCExxx



Preamp with
built-in tuner
(see page 107)



2way truss rod



bag

PERFORMER SERIES SOLID SPRUCE TOP

SLIM NECK/SPANISH HEEL



+



	scale	width at nut
full size	650 mm (25.59")	48 mm (1.89")

- Solid Alaskan Sitka spruce top, gloss finish
- Sapele back & side, gloss finish
- Mahogany neck, gloss finish
- Indian Laurel fretboard & bridge
- Ortega MagusPro electronics w/ tuner
- Ortega 12hole bridge
- Ortega signature walnut/maple/white pearl rosette
- 2way truss rod
- Deluxe gig bag included

RCE138SN

RADIUS FRETBOARD



NEW



+



RCE138-T4
THINLINE
BODY DEPTH

RCE138-T4STR
THINLINE
BODY DEPTH

RCE138-T4BK
THINLINE
BODY DEPTH

	scale	width at nut
full size	650 mm (25.59")	48 mm (1.89")

STR = stained red
BK = black

- Solid Alaskan Sitka spruce top, gloss finish || gloss finish black
- Sapele back & side, gloss finish || gloss finish black
- Mahogany neck, gloss finish || gloss finish black
- 14th fret heel to body connection
- Indian Laurel radius fretboard & bridge
- Ortega MagusPro electronics w/ tuner
- Ortega 12hole bridge
- Ortega signature walnut/maple/white pearl rosette
- 2way truss rod
- Deluxe gig bag included



PERFORMER SERIES SOLID SPRUCE/CEDAR TOP

SPANISH HEEL



ELECTRONICS W/ TUNER

ORTEGA
MagusPRO/G



NEW

RCE158MN
MEDIUM NECK



RCE158SN
SLIM NECK



RCE158SN-TSB
SLIM NECK



+



full size

scale
650 mm (25.59")

width at nut
SN = 48 mm (1.89")/
MN = 50 mm (1.97")

TSB = tobacco
sunburst, top only
HSB = honey burst,
top only

- Solid Alaskan Sitka spruce top, gloss finish || tobacco sunburst (TSB) gloss finish
- Walnut back & side, gloss finish
- Mahogany neck, gloss finish
- Indian Laurel fretboard & bridge

- Ortega MagusPro electronics w/ tuner
- Ortega 12hole bridge
- Ortega signature walnut/maple/white pearl rosette
- 2way truss rod

- Deluxe gig bag included



RCE159MN
MEDIUM NECK



RCE159SN
SLIM NECK



+



full size

scale
650 mm (25.59")

width at nut
SN = 48 mm (1.89")/
MN = 50 mm (1.97")

- Solid North American cedar top, gloss finish
- Walnut back & side, gloss finish
- Mahogany neck, gloss finish

- Indian Laurel fretboard & bridge
- Ortega MagusPro electronics w/ tuner
- Ortega 12hole bridge
- Ortega signature walnut/maple/white pearl rosette

- 2way truss rod
- Deluxe gig bag included

PERFORMER SERIES SOLID CEDAR/SPRUCE TOP



scale: 690 mm
width at nut: 70 mm **8string Nylon**



RCE159-8 



- 8string NYLON STRING GUITAR
- Solid North American cedar top, gloss finish
- Walnut back & side, gloss finish
- Mahogany neck, gloss finish
- Tecwood fretboard (flat, 70 mm at nut/78 mm on 14th fret/90 mm on saddle)
- Tecwood bridge
- MagusGO-8 electronics
- Ortega 16hole bridge
- Ortega signature walnut/maple/white pearl rosette
- 2way truss rod
- Ortega OCTA-8NS custom made strings
- Deluxe gig bag included



NEW

scale: 650 mm (25.59")
width at nut: 48 mm (1.89")



RCE238SN-FT 



- Solid Alaskan Sitka spruce top, gloss finish, faded
- Mahogany back & side, gloss finish
- Mahogany neck, gloss finish
- Indian Laurel fretboard & bridge
- Ortega OTMLOCK6L-CR locking machines
- Ortega Magus Pro electronics w/ tuner
- Ortega 12hole bridge
- Ortega signature rosette walnut/maple/white pearl
- 2way truss rod
- Deluxe gig bag included

**6 in line locking machines
SLIM NECK**





TRADITIONAL SERIES

OPTIONS

MADE IN SPAIN

scales and sizes

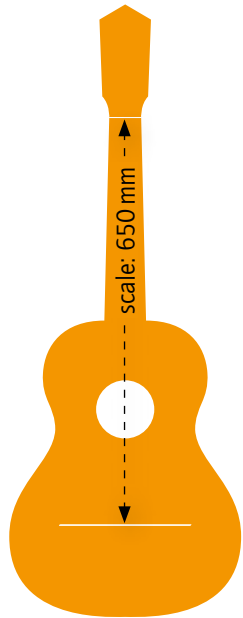

width at nut

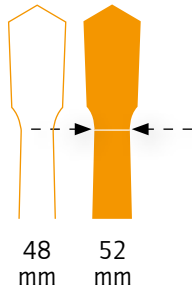

wood variations: back & sides



bubinga



caoba



palo-rojo

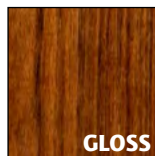

mongoy

wood variations: top



solid North American cedar



solid North American spruce



mahogany



maple

features



Spanish heel



12hole bridge



bag



SPANISH HEEL

scale: 650 mm
width at nut: 52 mm

R180



- Solid North American cedar top, satin finish
- Bubinga back & side, satin finish
- Maple binding
- Mahogany neck, satin finish
- Rosewood fretboard & bridge
- Ortega 12hole bridge
- Handmade in Spain
- Deluxe gig bag included



SPANISH HEEL

scale: 650 mm
width at nut: 52 mm

R190



- Solid North American cedar top, satin finish
- Caoba back & side, satin finish
- Maple binding
- Mahogany neck, satin finish
- Rosewood fretboard & bridge
- Ortega 12hole bridge
- Handmade in Spain
- Deluxe gig bag included



SPANISH HEEL

scale: 650 mm
width at nut: 52 mm

R200



- Solid North American cedar top, gloss finish
- Palo-rojo back & side, gloss finish
- Maple binding
- Mahogany neck, gloss finish
- Rosewood fretboard & bridge
- Ortega 12hole bridge
- Handmade in Spain
- Deluxe gig bag included



SPANISH HEEL

scale: 650 mm
width at nut: 48 mm

SN
(slim neck)

R200SN



- Solid North American cedar top, gloss finish
- Palo-rojo back & side, gloss finish
- Maple binding
- Mahogany neck, gloss finish
- Rosewood fretboard & bridge
- Ortega 12hole bridge
- Handmade in Spain
- Deluxe gig bag included



SPANISH HEEL

scale: 650 mm
width at nut: 52 mm

R220



- Solid North American cedar top, gloss finish
- Mongoy back & side, gloss finish
- Maple binding
- Mahogany neck, gloss finish
- Rosewood fretboard & bridge
- Ortega 12hole bridge
- Handmade in Spain
- Deluxe gig bag included





TRADITIONAL SERIES

MADE IN SPAIN

R210



SPANISH HEEL

scale: 650 mm
width at nut: 52 mm



- Solid North American spruce top, gloss finish
- Mahogany back & side, gloss finish
- Maple binding
- Mahogany neck, gloss finish
- Rosewood fretboard & bridge
- Ortega 12hole bridge
- Handmade in Spain
- Deluxe gig bag included

R270F



FLAMENCO SPANISH HEEL

scale: 650 mm
width at nut: 52 mm



- Solid North American spruce top, gloss finish
- Maple back & side, gloss finish
- Rosewood binding
- Mahogany neck, gloss finish
- Rosewood fretboard & bridge (flat, Flamenco)
- Flamenco scratch plates
- Ortega 12hole bridge
- Handmade in Spain
- Deluxe gig bag included

ACCESSORIES



HUMIGT-BK

HUMIDIFIERS
(see page 113)

CARE PRODUCTS
(see page 110-111)







CUSTOM MASTER SELECTION OPTIONS

MADE IN
SPAIN

scales and sizes

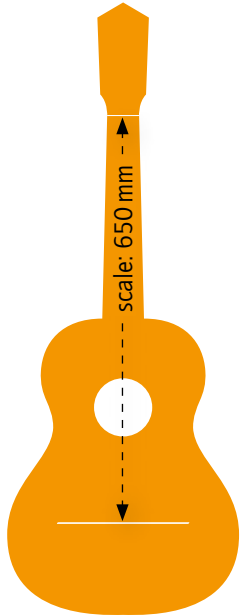

width at nut

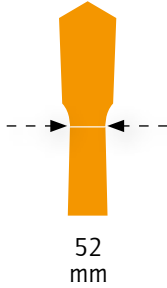

wood variations: top (all gloss finish)



solid European spruce

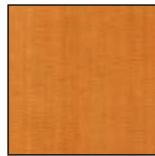

solid Canadian Red Western cedar

wood variations: back & sides



solid mahogany



solid Indian rosewood

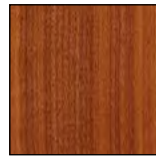

solid European walnut

features



Spanish heel



Deluxe hardcase





**ALL SOLID
SPANISH HEEL**

scale: 650 mm
width at nut: 52 mm

M5CS



- Solid European spruce top, gloss finish
- Solid mahogany back & side, gloss finish
- Rosewood binding
- Mahogany neck, gloss finish
- Rosewood fretboard & bridge
- Handmade in Spain
- Deluxe hardcase included



**ALL SOLID
SPANISH HEEL**

scale: 650 mm
width at nut: 52 mm

M3CS



- Solid Canadian Red Western cedar top, gloss finish
- Solid Indian rosewood back & side, gloss finish
- Rosewood binding
- Mahogany neck, gloss finish
- Rosewood fretboard & bridge
- Handmade in Spain
- Deluxe hardcase included



**ALL SOLID
SPANISH HEEL**

scale: 650 mm
width at nut: 52 mm

M4CS



- Solid Canadian Red Western cedar top, gloss finish
- Solid European walnut back & side, gloss finish
- Rosewood binding
- Mahogany neck, gloss finish
- Rosewood fretboard & bridge
- Handmade in Spain
- Deluxe hardcase included

ACCESSORIES



OWFS-1NT

FOOT STOOL
(see page 114)



OBCF

PROTECTION FOILS
(see page 112)



Signature SERIES

Thomas Zwijsen
Signature model/custom made



photo: Thomas Slupper | ortegaguitars



**SOLID TOP
RADIUS FRETBOARD
SLIM NECK**

NEW

TZSM-3



- Solid Canadian spruce top, gloss finish
- Spalted maple back and side, satin finish
- Mahogany neck, satin finish
- Maple binding w/ walnut support
- Maple fretboard radiused, 12" radiused
- Ortega 6hole bridge, pao ferro
- Ortega/Fishman Clasica Blend System w/ jack & XLR (D.I.) output w/ tuner
- 2way truss rod
- Thomas Zwijsen Signature gig bag included



scale: 650 mm
width at nut: 48 mm



ELECTRONICS W/ TUNER
**ORTEGA
FISHMAN**



**HANDMADE IN SPAIN
ALL SOLID
SPANISH HEEL**

**MADE IN
SPAIN**

TZSM/2



- Solid Canadian spruce top, gloss finish
- Solid spalted maple back and side, satin finish
- Mahogany neck, satin finish
- Maple binding w/ walnut support
- Maple fretboard radiused, 12" radiused
- Ortega 6hole bridge, pao ferro
- Ortega/Fishman Clasica Blend System w/ jack & XLR (D.I.) output w/ tuner
- 2way truss rod
- Thomas Zwijsen Signature soft case included



scale: 650 mm
width at nut: 48 mm



ELECTRONICS W/ TUNER
**ORTEGA
FISHMAN**

Ben Woods
Signature models/custom made



**SUPER THINLINE
FLAMENCO STYLE
SPANISH HEEL
BUILT-IN ARMREST**

scale: 650 mm
width at nut: 48 mm
Reversed Headstock

with EQ
ELECTRONICS W/ TUNER
ORTEGA
FISHMAN

FLAMETAL-TWO **with EQ**

- Solid Western Red cedar top, gloss finish
- Walnut back & side, gloss finish
- SUPER Thinline body depth (72 mm high/75 low)
- Florentine Cutaway design
- Ortega Signature rosette
- Stained mahogany neck, gloss finish
- Walnut body binding/white top purfling
- Reversed headstock, 6 in line
- Pao Ferro fretboard (flat) & bridge
- Ortega 12hole bridge
- Ortega/Fishman Clasica Blend System w/ jack & XLR (D.I.) output w/ tuner
- 2way truss rod
- Mini die-cast tuners, gold w/ black buttons
- FREE Flamenco double scratch plates included
- Ben Woods Signature gig bag included



**HANDMADE IN SPAIN
ALL SOLID
THINLINE FLAMENCO STYLE
SPANISH HEEL**

scale: 650 mm
width at nut: 52 mm

with EQ
ELECTRONICS W/ TUNER
ORTEGA
FISHMAN

**MADE IN
SPAIN**

BWSM/2 **with EQ**

- Solid Western Red cedar top, gloss finish
- Solid European walnut back & side, gloss finish
- Thinline body depth (80 mm)
- Mahogany neck, gloss finish
- Sycamore body binding
- Ebony fretboard (flat) & bridge
- Flamenco double scratch plate
- Ortega 12hole bridge
- Ortega/Fishman Clasica Blend System w/ jack & XLR (D.I.) output w/ tuner
- 2way truss rod
- Ben Woods Signature gig bag included





Javier Reyes – Animals as Leaders
Signature models/custom made



MADE IN SPAIN

**ALL SOLID
8STRING NYLON
SPANISH HEEL**

scale: 690 mm
width at nut: 70 mm



JRSM-COS

- Solid North American spruce top, gloss finish
- Solid American cocobolo back & side, gloss finish
- Mahogany neck, gloss finish
- Rosewood fretboard (flat, 70 mm at nut/ 78 mm on 14th fret/90 mm on saddle)
- Rosewood bridge
- L.R.BAGGS Element electronics
- Ortega signature rosewood/maple/ white pearl rosette
- 2way truss rod
- Ortega OCTA-8NS custom made strings - made in Germany
- Made in Spain
- Road case included



MADE IN SPAIN

**ALL SOLID
8STRING NYLON
SPANISH HEEL**

scale: 690 mm
width at nut: 70 mm



JRSM-RWC

- Solid North American cedar top, gloss finish
- Solid Madagascar rosewood (certified) back & side, gloss finish
- Mahogany neck, gloss finish
- Rosewood fretboard (flat, 70 mm at nut/ 78 mm on 14th fret/90 mm on saddle)
- Rosewood bridge
- L.R.BAGGS Element electronics
- Ortega signature rosewood/maple/ white pearl rosette
- 2way truss rod
- Ortega OCTA-8NS custom made strings - made in Germany
- Made in Spain
- Road case included





Ken Taylor
Signature models/custom made

KT-WALKER-V2 



4STRING

scale: 625 mm (24.60")
width at nut: 44 mm (1.73")
body depth: 88 mm (3.46")

 **ELECTRONICS W/ TUNER**
FISHMAN



- Solid spruce top, satin distressed tobacco burst - open pore finish
- Flamed mahogany back & side, satin distressed tobacco burst - open pore finish
- Thinline body depth (88 mm)
- Mahogany neck, satin distressed tobacco burst
- Pao Ferro fretboard & bridge
- 19 frets
- Custom designed fretboard MOP inlays "Roman Numerals"
- Custom designed & aged Ortega D-Walker tuning machines
- Fishman PRESYS+ electronics w/ Jack & XLR output w/ tuner
- 2way truss rod
- Ortega ODW-4 balanced tension bass strings
- Deluxe gig bag included

KTSM-5 

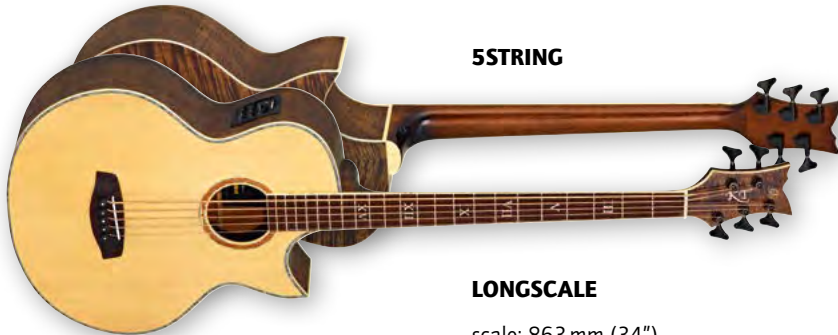

5STRING

LONGSCALE

scale: 863 mm (34")
width at nut: 45 mm (1.77")
body depth: 126 mm (4.96")

 **ELECTRONICS W/ TUNER**
FISHMAN



- Solid North American spruce top, gloss finish
- Flamed mahogany back & side, gloss finish
- Mahogany neck, gloss finish
- Acacia fretboard & bridge
- Custom designed "Roman Numerals" fretboard inlays
- Walnut binding/white purfling
- Black hardware
- Fishman Presys+ electronics w/ tuner
- 2way truss rod
- Deluxe gig bag & straplocks included

KTSM-5FL 



LINED FRETLESS
5STRING

LONGSCALE

scale: 863 mm (34")
width at nut: 45 mm (1.77")
body depth: 126 mm (4.96")

 **ELECTRONICS W/ TUNER**
FISHMAN



- Solid North American spruce top, gloss finish
- Flamed mahogany back & side, gloss finish
- Mahogany neck, gloss finish
- Acacia fretboard & bridge
- Custom designed "Roman Numerals" fretboard inlays
- Walnut binding/white purfling
- Black hardware
- Fishman Presys+ electronics w/ tuner
- 2way truss rod
- Deluxe gig bag & straplocks included



THE PRIVATE ROOM

CUSTOM CRAFTED INSTRUMENTS

|| *The Private Room starts with handpicked tonewoods that are set aside to be custom crafted into exclusive guitars. This selection is limited and truly unique.* ||



DISTRESSED SUITES

DSSUITE-UKE



NEW



**DISTRESSED
SATIN FINISH**

scale: 376 mm (14.80")
width at nut: 35 mm (1.38")



ELECTRONICS W/ TUNER
ORTEGA
MagusUke

- Solid Alaskan spruce top, distressed tobacco satin finish
- Mahogany back & side, distressed tobacco satin finish
- Reversed headstock, 4 in line
- Okoume neck, satin finish
- No body binding, walnut fretboard binding
- Tecwood fretboard & bridge
- Ortega MagusUke electronics w/ tuner
- Die-cast tuning machines black, black, chrome, black
- Ortega Guitars UJWNY-4-CC strings
- Deluxe gig bag included

DSSUITE-E



THINLINE BODY



**DISTRESSED
SATIN FINISH**

scale: 650 mm
width at nut: 48 mm

SN & DTS
(slim neck &
distressed
tobacco
sunburst finish)



ELECTRONICS W/ TUNER
ORTEGA
MagusPRO/G

- Solid Alaskan spruce top, DTS, satin finish
- Mahogany back & side, DTS, satin finish
- NO body binding, walnut fretboard binding
- Mahogany neck, distressed tobacco sunburst, satin
- Heel to body connection on 14th fret
- Indian Laurel fretboard (radius, 400R) with „XII“ inlay on 12th fret
- 2way truss rod
- Spanish heel
- Ortega signature walnut/maple/white pearl rosette
- Ortega 12hole bridge, walnut
- Aged vintage tuning machines, classic 3 bar
- Ortega MagusPro electronics w/ tuner
- Deluxe gig bag & suede leather strap included

DSSUITE-C/E



THINLINE BODY



**DISTRESSED
SATIN FINISH**

scale: 650 mm
width at nut: 48 mm

SN & DTS
(slim neck &
distressed
tobacco
sunburst finish)



ELECTRONICS W/ TUNER
ORTEGA
MagusPRO/G

- Solid Alaskan spruce top, DTS, satin finish
- Mahogany back & side, DTS, satin finish
- NO body binding, walnut fretboard binding
- Mahogany neck, distressed tobacco sunburst, satin
- Heel to body connection on 14th fret
- Indian Laurel fretboard (radius, 400R) with „XII“ inlay on 12th fret
- 2way truss rod
- Spanish heel
- Ortega signature walnut/maple/white pearl rosette
- Ortega 12hole bridge, walnut
- Aged vintage tuning machines, classic 3 bar
- Ortega MagusPro electronics w/ tuner
- Deluxe gig bag & suede leather strap included



ECLIPSE SUITE



SPALTED SUITE

ECLIPSESU.C/E 



BUILT-IN ARMREST

ALL MAHOGANY

scale: 650 mm
width at nut: 48 mm

SN
(slim neck)

 **ELECTRONICS W/ TUNER**
ORTEGA
MagusPRO/G



- Solid mahogany top, eclipse burst gloss finish
- Mahogany back & side, gloss finish
- Walnut top & back binding/ MOP purfling
- Walnut armrest
- Mahogany neck, gloss finish
- Indian Laurel fretboard (flat) & bridge
- 2way truss rod
- Spanish heel
- Eclipse soundhole design
- Eclipse fretboard inlay
- Ortega 12hole bridge
- A class tuning machines matte brass/black w/ black buttons
- Ortega MagusPro electronics w/ tuner
- Deluxe gig bag & suede leather strap included

RSM-REISSUE



NEW

AAA SPALTED MAPLE BACK & SIDE

scale: 650 mm
width at nut: 48 mm

SN & FLAT
(slim & flat neck)



- Spalted maple top, natural semi gloss finish
- Spalted maple back & side, natural semi gloss finish
- Nato neck, natural semi gloss finish
- Sapele & Black ABS top and bottom binding
- Spalted maple headstock veneer
- Walnut fretboard w/ sapele binding
- Walnut bridge, satin
- 2way truss rod
- Chrome tuning machines w/ black posts and buttons
- ABS nut & saddle
- Deluxe gig bag included



STRIPED SUITES

STRIPEDSU.C/E



BUILT-IN ARMREST

AAA STRIPED
EBONY
BACK & SIDE

scale: 650 mm
width at nut: 48 mm

SN
(slim neck)



ELECTRONICS W/ TUNER
ORTEGA
MagusPRO/G



- Solid Alaskan spruce top, gloss finish
- AAA striped ebony back & side, gloss finish
- Acacia binding/ white purfling
- Mahogany neck, gloss finish
- Indian Laurel fretboard (flat) & bridge
- 2way truss rod
- Spanish heel
- Ortega signature walnut/maple/ white pearl rosette
- Ortega 12hole bridge
- A class tuning machines matte brass/black w/ black buttons
- Ortega MagusPro electronics w/ tuner
- Deluxe gig bag & suede leather strap included

STRIPEDSU.ACB

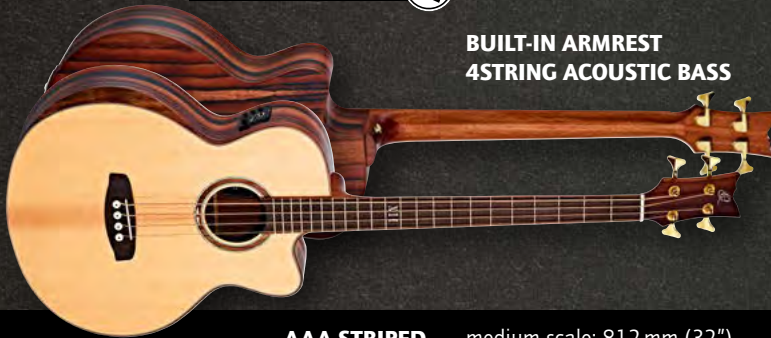

BUILT-IN ARMREST
4STRING ACOUSTIC BASS

AAA STRIPED
EBONY
BACK & SIDE

medium scale: 812 mm (32")
width at nut: 45 mm (1.77")
body depth: 122 mm (4.8")



ELECTRONICS W/ TUNER
ORTEGA
MagusPRO/B



- 4string acoustic bass
- Solid Alaskan spruce top, gloss finish
- AAA striped ebony back & side, gloss finish
- Acacia top & bottom binding/ white purfling
- Mahogany neck, gloss finish
- Medium scale
- Tecwood fretboard w/ walnut binding
- Tecwood bridge
- 2way truss rod
- Ortega signature walnut/maple/ white pearl rosette
- Ortega die-cast tuning machines, gold
- Ortega MagusPro electronics w/ tuner
- Deluxe gig bag & genuine leather strap included

ACCESSORIES



OCCPRO

DELUXE CASE
(see page 121)



OGPW-MIX4

WOODEN PICKS
(see page 100)



ALL ACOUSTIC BASS SERIES



artist: Aram Bedrosian | photo: Danny Lucenara

OPTIONS

scales and sizes

width at nut

wood variations: back & sides

features

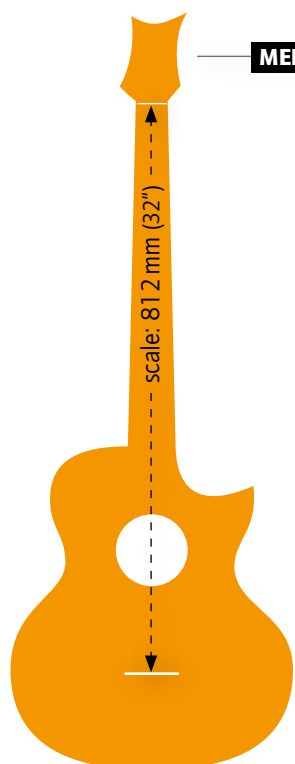

MEDIUM SCALE



45 mm (1.77")

wood variations: top



solid Alaskan spruce



sapele

walnut

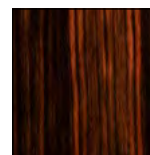

ebony

color/finish variations



satin finish/
open pore



gloss finish



2way truss rod



bag

electronics

ORTEGA®
MagusPRO/B

Electronics w/ tuner
(see page 107)

body



cutaway



SOLID SPRUCE

D538-4



- Solid Alaskan spruce top, satin finish
- Sapele back & side, open pore finish
- Mahogany neck, open pore finish
- Pao Ferro fretboard w/ black ABS binding
- Pao Ferro bridge
- Black ABS binding/bk-wh-bk purfling
- Chrome hardware
- ORTEGA MagusPRO/B electronics w/ tuner
- 2way truss rod

medium scale: 812 mm (32")
width at nut: 45 mm (1.77")
body depth: 122 mm (4.80")

4STRING



ELECTRONICS W/ TUNER
ORTEGA
MagusPRO/B



SOLID SPRUCE

D558-4



- Solid Alaskan spruce top, satin finish
- Walnut back & side, open pore finish
- Mahogany neck, open pore finish
- Pao Ferro fretboard w/ black ABS binding
- Pao Ferro bridge
- Ivory ABS binding/ bk-wh-bk purfling
- Gold hardware
- ORTEGA MagusPRO/B electronics w/ tuner
- 2way truss rod

medium scale: 812 mm (32")
width at nut: 45 mm (1.77")
body depth: 122 mm (4.80")

4STRING



ELECTRONICS W/ TUNER
ORTEGA
MagusPRO/B

THE PRIVATE ROOM
CUSTOM CRAFTED INSTRUMENTS

STRIPED SUITE

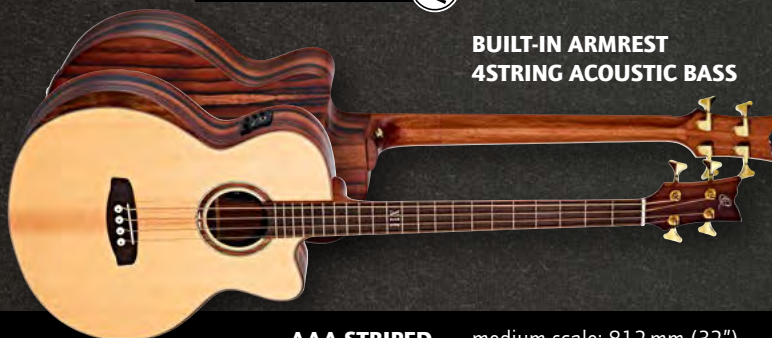

STRIPEDSU.ACB



BUILT-IN ARMREST
4STRING ACOUSTIC BASS

AAA STRIPED
EBONY
BACK & SIDE

medium scale: 812 mm (32")
width at nut: 45 mm (1.77")
body depth: 122 mm (4.8")

- 4string acoustic bass
- Solid Alaskan spruce top, gloss finish
- AAA striped ebony back & side, gloss finish
- Acacia top & bottom binding/ white purfling
- Mahogany neck, gloss finish
- Medium scale
- Tecwood fretboard w/ walnut binding
- Tecwood bridge
- 2way truss rod
- Ortega signature walnut/maple/ white pearl rosette
- Ortega die-cast tuning machines, gold
- Ortega MagusPro electronics w/ tuner
- Deluxe gig bag & genuine leather strap included



ELECTRONICS W/ TUNER
ORTEGA
MagusPRO/B





MANDOLINS & BANJOS



photo: Maria Athens

MANDOLINS



scale: 345 mm (13.58")
width at nut: 28 mm (1.10")

NA
(natural)

RMA5NA

- Mahogany top, open pore satin finish
- Mahogany back (arched) & side, open pore satin finish
- Mahogany neck, satin finish
- Ovangkol fretboard & bridge
- 2way truss rod
- 20 frets



scale: 345 mm (13.58")
width at nut: 28 mm (1.10")

VS
(vintage sunburst)

RMA5VS

- Mahogany top, open pore vintage sunburst satin finish
- Mahogany back (arched) & side, open pore vintage sunburst satin finish
- Mahogany neck, satin finish
- Ovangkol fretboard & bridge
- 2way truss rod
- 20 frets



scale: 345 mm (13.58")
width at nut: 28 mm (1.10") **SBK**
(satin black)

PICKUP BUILT-IN SYSTEM
with EQ PICKUP BUILT-IN

RMAE40SBK with EQ



- Spruce top, satin black finish
- Maple back (arched) & side, satin black finish
- Maple neck, satin black finish
- Rosewood fretboard & bridge
- 2way truss rod
- 20 frets
- Piezo bridge with tone & volume control, passive
- Deluxe gig bag included



scale: 345 mm (13.58")
width at nut: 28 mm (1.10") **SBK**
(satin black)

PICKUP BUILT-IN SYSTEM
with EQ PICKUP BUILT-IN

RMFE40SBK with EQ



- Spruce top, satin black finish
- Maple back (arched) & side, satin black finish
- Maple neck, satin black finish
- Rosewood fretboard & bridge
- 2way truss rod
- 24 frets
- Piezo bridge with tone & volume control, passive
- Deluxe gig bag included



scale: 345 mm (13.58")
width at nut: 28 mm (1.10") **TS**
(tobacco sunburst)

ELECTRONICS W/ TUNER
with EQ **ORTEGA**

RMFE90TS with EQ



- Solid spruce top, gloss tobacco sunburst finish
- Maple back (arched) & side, gloss tobacco sunburst finish
- Maple neck, gloss tobacco sunburst finish
- Rosewood fretboard & ebony bridge
- Ortega SIT electronics w/ tuner
- 2way truss rod
- 24 frets
- One piece die-cast tailpiece, gold
- Deluxe gig bag included



scale: 345 mm (13.58")
width at nut: 28 mm (1.10") **AVO**
(antique violin oil)

ELECTRONICS W/ TUNER
with EQ **ORTEGA**

RMFE100AVO with EQ



- Solid distressed spruce top, antique violin oil finish
- Solid flamed maple back (arched) & side, distressed antique violin oil finish
- Maple neck, gloss tobacco sunburst finish
- Ebony fretboard & ebony bridge
- Ortega SIT electronics w/ tuner
- 2way truss rod
- 24 frets
- One piece die-cast tailpiece, gold
- Grover tuning machines
- Deluxe gig bag included



BANJOS – RAVEN SERIES

OBJ250-SBK



5STRING BANJO



- Mahogany neck & resonator
- Ovangkol fretboard
- Mahogany ply rim
- 24 brackets, chrome hardware
- Remo ebony head, black
- Die-cast machine head
- Deluxe Banjo bag included

OBJE250OP-SBK 



**5STRING BANJO
OPEN BACK**



**PICKUP BUILT-IN SYSTEM
PICKUP BUILT-IN**



- Mahogany neck
- Ovangkol fretboard
- Mahogany ply rim
- 24 brackets, chrome hardware
- Remo ebony head, black
- Die-cast machine head
- Built-in pickup system w/ volume control
- Deluxe Banjo bag included

OBJ350/6-SBK



6STRING GUITAR BANJO



- Mahogany neck & resonator
- Ovangkol fretboard
- Aluminum rim
- Chrome armrest, Ortega engraved
- 30 brackets, chrome hardware
- Remo ebony head, black
- Die-cast machine head
- Deluxe Banjo bag included

OBJE350/6-SBK 



6STRING GUITAR BANJO



**PICKUP BUILT-IN SYSTEM
PICKUP BUILT-IN**



- Mahogany neck & resonator
- Ovangkol fretboard
- Aluminum rim
- Chrome armrest, Ortega engraved
- 30 brackets, chrome hardware
- Remo ebony head, black
- Die-cast machine head
- Built-in pickup system w/ volume control
- Deluxe Banjo bag included

OBJ450-SBK



- Mahogany neck & resonator
- Rosewood fretboard
- Mahogany ply rim
- 24 brackets, chrome hardware
- Remo ebony head, black
- Rolled brass tone ring
- Geared machine head
- Deluxe Banjo bag included

OBJ650-SBK



- Mahogany neck & resonator
- Rosewood fretboard
- 3ply solid maple rim
- Chrome armrest, Ortega engraved
- 24 brackets, chrome hardware
- One piece flange
- Remo ebony head, black
- Zinc alloy tone ring
- Die-cast machine head
- Deluxe Banjo bag included





BANJOS – FALCON SERIES



NEW

OBJE400-TBL 



NEW

OBJE400-TCO 



NEW

OBJE400-TFR 



NEW

OBJE400-TGR 



PICKUP BUILT-IN SYSTEM
PICKUP BUILT-IN



- Quilted maple resonator, TBL || TCO || TFR || TGR, semi-gloss finish
- Maple ply rim, TBL || TCO || TFR || TGR, semi-gloss finish
- Hard maple neck, maple fingerboard
- Brass tone ring, 24 brackets
- Brushed nickel hardware
- Die-cast machine head
- Built-in pickup system w/volume control
- Remo head, fiberskin style
- Deluxe gig bag included

TBL (transparent blue)
TCO (transparent charcoal)
TFR (transparent fire red)
TGR (transparent green)





SATIN FINISH

OBJ550W-SNT



- 5string Banjo
- Walnut neck
- Burl walnut resonator
- Rosewood fretboard
- Walnut ply rim
- Chrome armrest, Ortega engraved
- 24 brackets
- Flat flange
- Chrome hardware
- Remo head, renaissance
- Rolled brass tone ring
- Geared machine head
- Deluxe Banjo bag included



OBJ750-MA



- 5string Banjo
- Hard maple neck
- Flamed maple resonator
- Rosewood fretboard
- 3ply solid maple rim
- Chrome armrest, Ortega engraved
- 24 brackets
- One piece flange
- Chrome hardware
- Remo head, coated
- Brass tone ring
- Geared machine head
- Natural gloss on maple
- Deluxe Banjo bag included



ELABORATELY CARVED HEEL AND HEADSTOCK

OBJ850-MA



- 5string Banjo
- Hard maple neck
- Flamed maple resonator
- Rosewood fretboard
- 3ply solid maple rim
- Golden armrest, Ortega engraved
- 24 brackets
- One piece flange
- Golden hardware
- Remo head, Weatherking clear
- Brass tone ring
- Geared machine head
- Gloss on flamed maple
- Deluxe Banjo bag included



ALL FLAMED MAPLE

OBJ950-FMA



- 5string Banjo
- Flamed maple neck
- Flamed maple resonator
- Ebony fretboard
- 3ply solid maple rim
- Golden armrest, Ortega engraved
- 24 brackets
- One piece flange
- Golden hardware
- Remo head, coated
- Bell brass tone ring
- Geared machine head
- Gloss on all flamed maple
- Deluxe Banjo bag included



AMPLIFICATION SERIES



ORTEGA ACOUSTIC AMPLIFICATION – THE FIRST ACOUSTIC AMP HEAD

With the introduction of the first acoustic amplification head, H ONE, Ortega sets a milestone in flexibility and sound. Featuring true 100 Watt power and two channels in combination with the latest SMT & DSP technology, the H ONE delivers what acoustic players have been searching for. With a satin-finished real ash housing, the H ONE head looks as good as it sounds.

AMPLIFIER

H ONE

- 100 Watt RMS
- 1/4" and 1/4"/XLR combination inputs
- 2x channels
- Built-in DSP reverb & chorus
- Effect send/return
- Headphone out
- PRE/POST EQ D.I. out
- Speaker A/B out
- Carry bag included



H one
H ONE

The ORTEGA acoustic amplification SONE and STWO speaker cabinets are the perfect complement to the H ONE 100 Watt amplifier head. Each cabinet features a satin finished real ash housing, tour-grade spring loaded handles and a speaker pole mount for exceptional convenience and durability. Use separately, or in combination for the ultimate in flexible performance.

SPEAKER CABINET

SONE

- 150 Watt / 4 Ohm
- 40 Hz - 20 kHz frequency range
- 6.5" speaker and additional 3" tweeter
- Carry bag included

STWO

- 150 Watt / 4 Ohm
- 40 Hz - 20 kHz frequency range
- 8" speaker
- Carry bag included

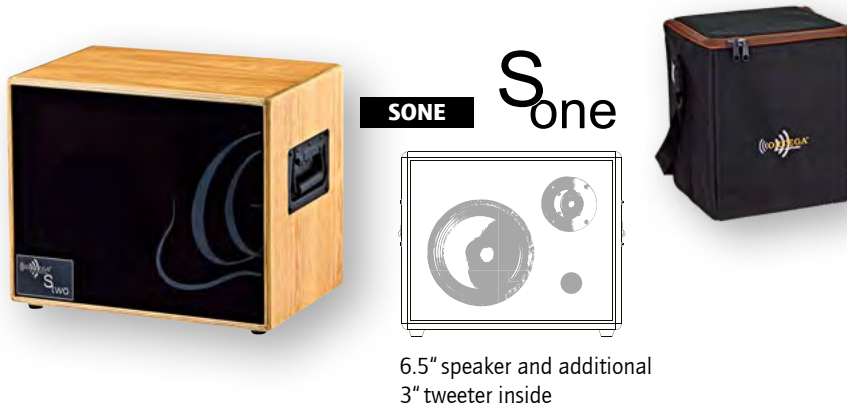

SONE S one

6.5" speaker and additional 3" tweeter inside

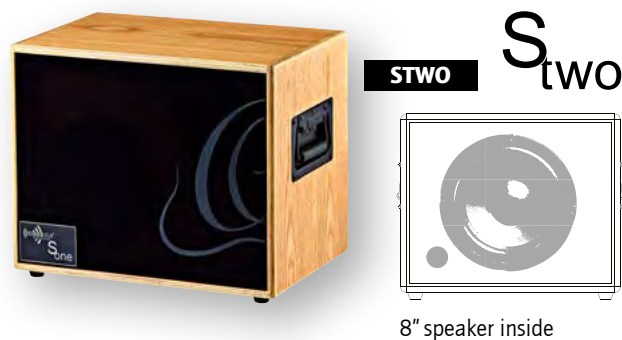

STWO S two

8" speaker inside



Speaker Pole Mount



Closed back



Configure as a half stack using the SONE 6.5" speaker with 3" tweeter to emulate a typical acoustic combo amp

Add the STWO 8" sub cabinet to build a full stack with extra rich, resonant bass response



STOMP BOX EFFECT SERIES

ORTEGA QUANTUMloop - DIGITAL MULTI PERCUSSION STOMP BOX & LOOPER

Choose between **16 DIFFERENT** BUILT-IN DRUM & PERCUSSION SAMPLED SOUNDS...

... PLUS ADD 4 CUSTOM SAMPLES (2 PER BANK) VIA USB.

20 AVAILABLE SAMPLED SOUNDS!

FREE ONLINE DOWNLOAD for sound import software (Mac & Windows)

BANK A		BANK B	
DRY KICK DRUM	SLAP CAJON	BALLAD SNARE	FINGER SNIP
FAT KICK DRUM	DOUMBK SLAP	SOUL SNARE	SHORT SHAKE
SWEET KICK DRUM	COWBELL	THE RIM	TAMBOURINE
80'S ELECTRO	PERSONAL 1	FOOT HIHAT	PERSONAL 1
DEEP CAJON	PERSONAL 2	THE CLAP	PERSONAL 2



For informational video scan QR Code



CHANGE BETWEEN SOUNDS ON THE FLY. WITH 20 SAMPLES AND A LOOPER, YOUR POSSIBILITIES ARE ENDLESS.



QUANTUMexp

For maximum performance add the **QUANTUMexp** to your setup. Once connected with the QUANTUMloop via "trigger input" the sounds of BANK B are under the control of QUANTUMexp.

The QUANTUMexp operates "active" and includes a 9V battery.



QUANTUMloop

BUILT-IN LOOPER for instrument & sound banks

DIGITAL STOMP BOX & LOOPER with 16 built-in drum & percussion samples!

- 16 pre-installed sounds
- 4 empty slots for custom samples
- Built-in looper with unlimited numbers of overdubs
- Loop length: Up to 5 minutes
- Software for uploads & erase (free online download) - Mac & Windows
- Comfortable ergonomic design
- Solid mahogany wood housing
- Non-slip bottom coating & foot rest
- IN & OUT 6.3 mm (1/4") jack - True Bypass



- Removable foot rest (hook & loop)



- Trigger input, instrument in and sweeping looper volume control



- Sweeping volume control, Dynamic (velocity sensitivity) ON/OFF, instrument out (a true discrete pass-through) & USB port for sound import

FREE POWER SUPPLY included!



- FREE 9V certified quality power supply included

ORTEGA DIGITAL STOMP BOXES - PERFECT FOR SINGER/SONGWriters ON THE GO OR IN THE STUDIO

The Ortega **HORSE KICK V2** & **HORSE KICK PRO** digital stomp boxes are great tools for guitarists, singers, songwriters and street performers wanting to add a percussive element to any performance. With digital samples of real percussion sounds the HORSE KICK Stomp Boxes are way ahead of any existing analog/acoustic stomp boxes currently on the market. Just connect your favorite HORSE KICK to any amplifier or sound system and enhance your solo performance.

HORSEKICKPRO

DIGITAL STOMP BOX with multiple built-in digital samples of percussion sounds that can be played on its own, as a percussive instrument, or blended with your stringed instrument signal through the output.

- Digital samples of percussion instruments – just choose between 5 different percussion samples and tap your foot
- Comfortable ergonomic design for foot tapping
- Solid sapele (mahogany) wood housing
- Non-slip bottom coating
- Velocity sensitive for an expressive experience
- Sweeping volume control to adjust percussion sounds (blend the percussion sound with the unaffected instrument signal together through the output to one channel)
- 6.3 mm (1/4") input & output jack
- Powered 9V battery or power supply included



Choose between
5 DIFFERENT PERCUSSION SAMPLES:

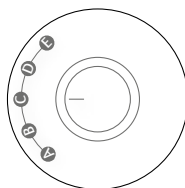

- E: Tambourine
- D: Cabasa
- C: Cowbell
- B: Kick Drum
- A: Cajon Bass

ORTEGA ANALOG STOMP BOX - PERFECT FOR PLAYERS ON THE GO & STREET PERFORMERS

The Ortega **ANNAlog** analog percussion stomp box is the perfect tool for guitarists, singer/songwriters and street performers wanting to add a percussive element to any performance. With it's analog design, no battery or power supply is needed. Plug-In and play. Detailed inner construction minimizes surrounding noise to maximize bass punch. Equipped with an input and output, the True Bypass allows you to blend the percussive sound with your instrument signal to a single channel.

ANNAlog

ANALOG STOMP BOX with built-in sound optimized piezo technology.

- **No battery or power supply needed**
- **Input & output - only one channel needed**
- Comfortable ergonomic design for foot tapping
- Solid cherry wood housing
- Non-slip bottom coating
- Minimized surrounding noise
- Maximized bass punch
- Sweeping volume control to adjust the level of bass punch
- 6.3 mm (1/4") input & output jack

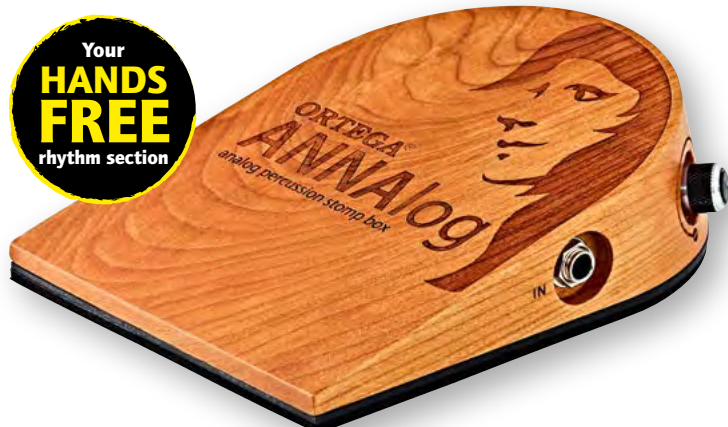



PERCUSSION SERIES

ORTEGA KALIMBAS – LIZARD SERIES

Ortega handmade Kalimbas combine the legacy of their African origin with modern performance aspects. Carefully selected, spectacular looking tone woods, ergonomic shaped handrests, and a crystal clear tonal experience encourage hours of blissful music making.



OKB1

NEW

- Solid Acacia wood, all gloss finish
- Top soundhole with lasered Lizard rosette
- 17 Keys - C Major tuning
- Includes deluxe case, cover bag, tuning hammer, polish cloth



OKB2

NEW

- Solid Bamboo wood, all gloss finish
- Front soundhole
- Lizard top inlay
- 17 Keys - C Major tuning
- Includes deluxe case, cover bag, tuning hammer, polish cloth



OKB3

NEW

- Solid Golden Phoebe, all gloss finish
- Front soundhole
- Lizard top inlay
- 17 Keys - C Major tuning
- Includes deluxe case, cover bag, tuning hammer, polish cloth



ORTEGA[®]
GUITARS • EST. 1994

OKB2



PERCUSSION SERIES

STOMP BOX CAJON BUNDLE

Your **HANDS FREE** rhythm section

BUNDLE ALSO AVAILABLE IN LEFT FOOT CONFIGURATION



OSTBCJ-BU



OSTBCJ-L-BU



Example right foot

TAP IT THE WAY YOU FEEL MOST COMFORTABLE!

Our hands free percussion products are designed specifically for the stringed instrument player. Go busking in the streets, recording in a studio, jam with friends or write a song, adding percussive rhythm elements, all while playing your stringed instrument.

The **ORTEGA STOMP BOX CAJON BUNDLE OSTBCJ-BU & OSTBJ-L-BU** includes:



ORTEGA Cajon (with bundle only)

Size: 30 cm (11.75") W x 46 cm (18") H x 30 cm (11.75") D

Resonating body: Baltic Birch

Front plate OSTBJ-BU: Ammara wood

Front plate OSTBJ-L-BU: Baltic Birch (Golden Brown)

- 2 internal snare wires
- Adjustable front plate for more sound options
- Curved corners for more comfort
- Delivers full, rich tone
- Made in Europe



FREE Cajon backpack bag included!



ORTEGA CAJON PEDAL OCJP-GB or OCJP-L-GB

- Heavy duty metal ground plate and metal pedal
- Soft foam beater (length adjustable)
- Cradle-like mount - fits all common Cajons
- Adjustable spring tension (pedal)



FREE Cajon pedal gig bag & drum key included!



Your
**HANDS
FREE**
rhythm section

CAJON PEDAL



OCJP-GB



OCJP-L-GB



You already own a Cajon? The Ortega Percussion Cajon Pedal attaches firmly with yours. This pedal leaves your hands unrestricted to play along with your stringed instrument while keeping a steady kick drum rhythm beneath.

Create an infinite amount of grooves with your foot while your hands focus on playing guitar!

- Heavy duty metal ground plate and metal pedal
- Soft foam beater (length adjustable)
- Cradle-like mount - fits all common Cajons
- Adjustable spring tension (pedal)

FREE Cajon Pedal gig bag & drum key included!

GUITARIST FOOT TAMBOURINE



OGFT

The Guitarist Foot Tambourine is the perfect match for any stringed instrument player. This light and versatile "hands free" rhythm tool delivers a bright cutting tone, yet not overpowering. Easily mounted on your foot, it will go with any beat.

- Made from rubber wood in Ortega orange
- Bright, light accent for any stringed instrument
- Ergonomic design and hassle-free mounting
- 4 pairs stainless steel jingles

SINGER/SONGWRITER FOOT TAMBOURINE



OSSFT

The Singer/Songwriter Foot Tambourine is the perfect rhythm accessory for acoustic performances, studio applications or a fun jam session. The 5 pairs of stainless steel jingles deliver a precise, light shimmering sound in a small pocket friendly design.

- Made from rubber wood in Ortega orange
- Bright, light accent for any stringed instrument
- Ergonomic design and hassle-free mounting
- 5 pairs stainless steel jingles



ACCESSORIES OVERVIEW

CAPOS

(see page 86)



VEGAN STRAPS & ACCESSORIES

(see page 88)



GUITAR STRAPS

(see page 89)



UKULELE STRAPS

(see page 91)



MANDOLIN & BANJO STRAPS

(see page 92)



TUNERS

(see page 93)



ACCESSORIES

OVERVIEW

DIGITAL WIRELESS SYSTEM

(see page 94)



CABLES

(see page 96)



STRINGS

(see page 98)



PICKS

(see page 100)



STRAP LOCKS

(see page 102)



TUNING MACHINES

(see page 102)



CABLES & POWER

(see page 106)



PREAMPS & PICKUPS

(see page 107)



USEFUL HELPERS

(see page 108)



CARE

(see page 110)



HUMIDIFIERS

(see page 113)



STANDS

(see page 113)



HANGERS

(see page 115)



BAGS

(see page 116)



CASES

(see page 119)





CAPOS



TWCAPO-CR **TWCAPO-SBK** **TWCAPO-MAD** **TWCAPO-WND**

2 IN 1
ONE CAPO FOR
CURVED + FLAT
FRETBOARDS



Bag included



Flat



Curved

TWINGAPOS CURVED/FLAT

Ortega Guitars' brand new TWINcapo is not a one-trick-pony! It covers flat fretboards as well as curved fretboards. Available in satin black/orange, gloss chrome/black, maple design/black & walnut design/black.

- High-grade alloy
- Covers FLAT & CURVED/RADIUS fretboards
- Perfect silicone cushion
- Designed for acoustic guitars, classic guitars (up to 52 mm nut) & electric guitars

TWCAPO-CR

Chrome/black silicone cushion

TWCAPO-SBK

Satin black/orange silicone cushion

TWCAPO-MAD

Maple Design/black silicone cushion

TWCAPO-WND

Walnut Design/black silicone cushion



OCAPO-CR **OCAPO-SBK**



OCAPO-MAD **OCAPO-WND**



Bag included



SMCPAD-OR

CAPOS FLAT

Easily adjustable design made of aluminum alloy and silicone cushion. FLAT fretboard up to 52 mm nut width.

OCAPO-CR

Chrome

OCAPO-SBK

Satin black

OCAPO-MAD

Maple Design

OCAPO-WND

Walnut Design

Made of aluminum alloy the "SPIDER MONKEY" Capos allow micro adjustment for exact tension. Together with a perfect silicone cushion the need to retune the instrument is dramatically reduced.

SMCPAD-OR

Designed for FLAT fretboards, up to 52 mm width at nut



OCAPOCV-CR **OCAPOCV-SBK**



12string proofed



OCAPOCV-MAD **OCAPOCV-WND**



Bag included



SMCPADCV-SBK

CAPOS CURVED

Easily adjustable design made of aluminum alloy and silicone cushion. CURVED (radius) fretboard up to 52 mm nut width.

OCAPOCV-CR

Chrome

OCAPOCV-SBK

Satin black

OCAPOCV-MAD

Maple Design

OCAPOCV-WND

Walnut Design

Made of aluminum alloy the "SPIDER MONKEY" Capos allow micro adjustment for exact tension. Together with a perfect silicone cushion the need to retune the instrument is dramatically reduced.

SMCPADCV-SBK

Designed for CURVED (radius) fretboards, up to 52 mm width at nut

CAPO FLAT UKULELE/BANJO/MANODLIN



OCAPOUKE-CR



OCAPOUKE-SBK



OCAPOUKE-MAD



OCAPOUKE-WND



Bag included

Easily adjustable design made of aluminum alloy and silicone cushion. Optimized for Ukulele and Banjo.

OCAPOUKE-CR

Chrome

OCAPOUKE-SBK

Satin black

OCAPOUKE-MAD

Maple Design

OCAPOUKE-WND

Walnut Design

THE BLACK CHROME EDITION INCLUDES A PREMIUM PRESENTATION GIFT BOX



CAPOS FLAT/CURVED/UKULELE & BANJO

SPECIAL EDITION of the ever popular ORTEGA CAPO Series features a stunning BLACK CHROME surface over aluminum and a premium presentation gift box.

Easily adjustable design made of aluminum alloy with a silicone cushion.

Available versions:

OCAPO-BCR - FLAT

(classic, fretboards up to 52 mm nut width)

OCAPOCV-BCR - CURVED

(radius fretboards up to 52 mm nut width)

OCAPOUKE-BCR - optimized for Ukulele & Banjo



OCAPO-BCR



OCAPOCV-BCR



OCAPOUKE-BCR





VEGAN STRAPS & ACCESSORIES

100% PHTHALATE FREE! 100% HYDROLYSIS FREE! 100% RECYCLABLE!

VEGAN PREMIUM

A new revolutionary vegan laminated synthetic material is the basis for one of the world's first ECO-friendly straps.

The unique and patented material feels so much like leather that it is nearly impossible to tell the difference.



We also offer vegan care products (see page 110).

ECONOMICAL & ENVIRONMENTALLY FRIENDLY

This technology is based on the latest generation of phthalate-free PVC (Polyvinyl Chloride).

100% RECYCLABLE

This material can be totally recycled and reused.

PVC MATERIAL FEATURES

- Vegan
- Resistant to fungi, bacteria & insects
- Weather resistant
- Durable
- Made with low power consumption
- Recyclable



GUITAR/BASS STRAPS – VEGAN SERIES

With embroidered logo. 60 mm (2.36") width, length up to 1460 mm (57.48").



OSVG-BK
black



OSVG-TN
tan

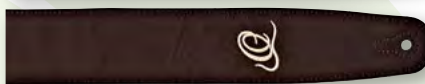

OSVG-BR
brown



OSVG-RD
red

UKULELE STRAPS – VEGAN SERIES

With embroidered logo. 40 mm (1.57") width, length up to 1360 mm (53.55"). Includes CONNECT Headstock Tie, to securely attach the strap to your headstock.



OSVU-BK black
CONNECT Headstock Tie included



OSVU-TN tan
CONNECT Headstock Tie included



OSVU-BR brown
CONNECT Headstock Tie included



OSVU-RD red
CONNECT Headstock Tie included

GUITAR/BASS STRAPS – VEGAN SERIES

Extra wide. 75 mm (3.00") width, length up to 1460 mm (57.48").

NEW



OSVG-75BK
black



OSVG-75TN
tan



OSVG-75BR
brown



OSVG-75RD
red

CONNECT – VEGAN SERIES

VEGAN headstock strap connector. Perfect to attach your strap on the headstock of guitars, ukuleles, mandolins and other stringed instruments. NO additional strap button needed on the heel of instrument.



CONNECT-BK
black



CONNECT-TN
tan



Guitar



Ukulele

COTTON STRAPS - HIGHLAND SERIES

Made from 100% cotton and equipped with strong FAUX LEATHER ends. 49 mm (1.93") width, up to 1580 mm (62.2") length, embossed logo.



- OCS-100**
"faded pink"
- OCS-110**
"stars"



- OCS-120**
"faded grey"
- OCS-130**
"faded brown"
- OCS-140**
"scottish dark"
- OCS-150**
"scottish bright"

COTTON STRAPS - CASUAL SERIES

Made from 100% cotton and equipped with strong FAUX LEATHER ends. 49 mm (1.93") width, up to 1580 mm (62.2") length, embossed logo.



- OCS-200**
"coal cotton"
- OCS-210**
"grey cotton"
- OCS-220**
"brown cotton"
- OCS-230**
"ice cotton"
- OCS-240**
"khaki cotton"
- OCS-250**
"burgundy cotton"
- OCS-260**
"orange cotton"
- OCS-270**
"blue cotton"

COTTON STRAPS - WORLD SERIES

Made from 100% cotton and equipped with strong FAUX LEATHER ends. 49 mm (1.93") width, up to 1580 mm (62.2") length, embossed logo.



- OCS-400**
"indian sky"
- OCS-410**
"indian arts"
- OCS-420**
"desert night"
- OCS-430**
"frisco dance"
- OCS-440**
"african dance"
- OCS-450**
"icelander"
- OCS-460**
"machu pichu"
- OCS-470**
"maya dance"

COTTON STRAPS - SPRING SERIES

Made from 100% cotton and equipped with strong FAUX LEATHER ends. 49 mm (1.93") width, up to 1580 mm (62.2") length, embossed logo.



- OCS-300**
"coal jean"
- OCS-310**
"brown jean"
- OCS-320**
"pink jean"
- OCS-330**
"sun jean"
- OCS-340**
"green jean"
- OCS-350**
"blue jean"
- OCS-360**
"purple jean"

COTTON STRAPS - CREATIVE SERIES

Made from 100% cotton and equipped with strong FAUX LEATHER ends. 49 mm (1.93") width, up to 1580 mm (62.2") length, embossed logo.



- OCS-500**
"striped"
- OCS-510**
"modern arts"
- OCS-520**
"70's psycho"
- OCS-530**
"70's plants"
- OCS-540**
"classic white"
- OCS-550**
"classic blue"
- OCS-560**
"classic yellow"



ALL cotton guitar straps incl. pick holder pocket



GUITAR STRAPS - NYLON & LEATHER

NYLON STRAPS UNICOLOR

50 mm (1.97") width, leather ends with embossed Logo, up to 1800 mm (70.86") length



- ONS50STD-BK**
"black"
- ONS50STD-BR**
"brown"
- ONS50STD-WH**
"white"
- ONS50STD-RD**
"red"
- ONS50STD-BL**
"blue"

NYLON STRAPS - EXTRA WIDE "SKULLS"

65 mm (2.55") width, leather ends with embossed Logo, up to 1460 mm (57.48") length



- OSN-65SKBK**
"black"
- OSN-65SKBU**
"burgundy red"
- OSN-65SKCO**
"charcoal"

SUEDE LEATHER STRAPS

Soft and smooth suede leather, 65 mm (2.56") width, up to 1420 mm (55.9") length



- OSS2-BK**
"black", O-signet embroidered
- OSS2-BR**
"brown", O-signet embroidered
- OSS2-HO**
"honey", O-signet embroidered

NYLON GUITAR STRAPS/SUPPORT - HOOK

Special nylon made acoustic guitar strap with soundhole hook. 37 mm (1.45") width at upper part.

The strap/support is appx. 800 mm (31.5") long and adjustable up to appx. 1000 mm (39").



- OGSHK-BK**
"black"
- OGSHK-BR**
"brown"



GENUINE LEATHER STRAPS

Genuine leather, extra wide 85 mm (3.35"), perfect for guitar and bass, up to 1420 mm (55.9") length



- OSL2-85BK**
"black"
- OSL2-85BR**
"brown"

NYLON STRAPS MOTIF

50 mm (1.97") width, leather ends, up to 1420 mm (55.9") length



- OSN-50OGT**
"ortegaguitars"
- OSN-50EGY**
"egypt"
- OSN-50EVO**
"evolution"
- OSN-50COR**
"corn circuit"
- OSN-50BUB**
"bubbles"



COTTON UKULELE STRAPS - HIGHLAND SERIES

Made from 100% cotton and equipped with strong FAUX LEATHER ends. 37 mm (1.45") width, up to 1390 mm (54.33") length, embossed logo.



OCS-100U
"faded pink"

OCS-110U
"stars"



OCS-120U
"faded grey"

OCS-130U
"faded brown"

OCS-140U
"scottish dark"

OCS-150U
"scottish bright"

COTTON UKULELE STRAPS - CASUAL SERIES

Made from 100 % cotton and equipped with strong FAUX LEATHER ends. 37 mm (1.45") width, up to 1390 mm (54.33") length, embossed logo.



OCS-200U
"coal cotton"

OCS-210U
"grey cotton"



OCS-220U
"brown cotton"

OCS-230U
"ice cotton"

OCS-240U
"khaki cotton"

OCS-250U
"burgundy cotton"

OCS-260U
"orange cotton"

OCS-270U
"blue cotton"

COTTON UKULELE STRAPS - SPRING SERIES

Made from 100% cotton and equipped with strong FAUX LEATHER ends. 37 mm (1.45") width, up to 1390 mm (54.33") length, embossed logo.



OCS-300U
"coal jean"

OCS-310U
"brown jean"

OCS-320U
"pink jean"



OCS-330U
"sun jean"

OCS-340U
"green jean"

OCS-350U
"blue jean"

OCS-360U
"purple jean"

COTTON UKULELE STRAPS - WORLD SERIES

Made from 100 % cotton and equipped with strong FAUX LEATHER ends. 37 mm (1.45") width, up to 1390 mm (54.33") length, embossed logo.



OCS-400U
"indian sky"

OCS-410U
"indian arts"

OCS-420U
"desert night"



OCS-430U
"frisco dance"

OCS-440U
"african dance"

OCS-450U
"icelander"

OCS-460U
"machu pichu"

OCS-470U
"maya dance"



UKULELE STRAPS - COTTON & NYLON

COTTON UKULELE STRAPS - CREATIVE SERIES

Made from 100 % cotton and equipped with strong FAUX LEATHER ends. 37 mm (1.45") width, up to 1390 mm (54.33") length, embossed logo.



OCS-500U
"striped"

OCS-510U
"modern arts"

OCS-520U
"70's psycho"



OCS-530U
"70's plants"

OCS-540U
"classic white"

OCS-550U
"classic blue"

OCS-560U
"classic yellow"

NYLON UKULELE STRAPS/SUPPORT HOOK

Special "slim" nylon uke strap with soundhole hook, 37 mm (1.45") width at upper part, up to 700 mm (27.56") length



OUSHK-BK
"black"

OUSHK-BR
"brown"

OUSHK-WH
"white"

OUSHK-RD
"red"

OUSHK-BL
"blue"



NYLON UKULELE STRAPS

Special "slim" nylon uke straps, leather ends, 37 mm (1.45") width, up to 1350 mm (53.15") length



OUS-GRFL
"green flower"

OUS-MAY
"maya"

OUS-ORFL
"orange flower"

OUS-PALM
"palm island"

OUS-PULF
"purple flower"

OUS-SUN
"sundown"

OUS-VOO
"voodoo"

MANDOLIN & BANJO STRAPS - LEATHER

MANDOLIN STRAPS

Leather, up to 1700 mm (66.92") length



OSM-BK
standard, black

OSM-BR
standard, brown

OSMDLX-BK
deluxe, padded
shoulder, black

OSMDLX-BR
deluxe, padded
shoulder, brown

BANJO STRAPS

60 mm (2.36") width, up to 1300 mm (51.18") length



OBJS-BK
banjo strap standard,
genuine suede
leather,
carabiner (2x)

OBJSDLX-BK
banjo strap deluxe,
genuine suede
leather, padded
carabiner (2x)





OCST-1BK

MULTI-MODE SOUNDHOLE TUNER OCST-1BK

PRE-INSTALLED MODES FOR CHROMATIC - UKULELE - GUITAR - BASS!



Blue backlight - not in tune



Green backlight - in tune

The OCST-1BK multi-mode soundhole tuner was designed specifically with acoustic instruments in mind:

- Discreet and easy to install/remove
- Piezo equipped soundhole clip
- Quick change mode selector
- Easy-to-read 2-color display (blue/green)
- In tune - backlight illuminates fully green!
- Rubberized shockproof housing
- Incl. battery (coin cell, TYPE CR2032)



OCCT-1BK

HEADSTOCK TUNER OCCT-1BK

The OCCT-1BK is a clip-on tuner of the newest generation and comes packed with all the practical features needed:

- Sensitive sensor - tunes in noisy environment
- One-handed swivel clamp
- Large, easy-to-read 2-color display (blue/green)
- In tune - backlight illuminates green!
- Rubberized shockproof body
- Attractive 360 degree rotating design

FEATURES: Ukulele, bass, guitar, violin & chromatic pre-installed modes

COLOR: black

- Incl. battery (coin cell, TYPE CR2032)



Blue backlight - not in tune



Green backlight - in tune



OCAT-2BK

HEADSTOCK TUNER OCAT-2BK

The OCAT-2BK is a tuner and metronome, all in one. Mic and vibration sensor built-in to use anywhere. Fully chromatic and calibratable (410-490 Hz). Flat tuning up to 4 semitones. Built-in VISUAL metronome.

- Incl. battery (coin cell, TYPE CR2032)



SEADEVIL

PEDAL TUNER SEADEVIL

LET THERE BE LIGHT... on your pedal board. The first pedal board tuner with USB connectable LED lights (included!)

PEDAL TUNER

- Tuning range: A0 (27.5 Hz) - C8 (4,186 Hz)
- Accuracy: +/- 1 cent
- Calibration: 436-445 Hz (1 Hz step)
- Flat mode: b, bb, bbb
- Fully chromatic
- Indicator: 39 seg FND & 1LED
- Input: 6.3 mm (1/4") input jack & USB for light
- Output: 6.3 mm (1/4") output jack (true bypass)
- Power: 9V DC adapter (not included - ORTEGA OPS9500 recommended)
- Dimensions: 112 x 60 x 30 mm
- Weight: 250g net.

USB LIGHTS (LED)

- Turn on automatically when connected to pedal tuner via USB port



LED lights



USB port



Pedal tuner





DIGITAL WIRELESS SYSTEM



ODWS-1MAD

DIGITAL WIRELESS SYSTEM | ODWS-1



ODWS-1WND



ODWS-1BK



ODWS-1CAR



ODWS-1



USB double head charger cable included



Plug into a pedal



Plug directly into an amplifier

The Ortega Digital Wireless System features 2.4 Ghz digital technology and broadcasts incredible crystal-clear audio quality. Ready to use in seconds the system offers four operating channels (A, B, C, D), power/charge indicator and a rechargeable, built-in battery (+2500 charging cycles). The latency of < 5 ms and a full range frequency coverage of 20 Hz - 20 kHz secures great, detailed and real time sound. The ODWS supports most active & passive systems as well as acoustic piezo devices*.

The ODWS Digital Wireless System:

- 2.4 GHz ISM worldwide
- Up to 30 meters (100 ft.) of range without any dropout**
- 4 channels
- Up to 4 systems simultaneously
- Rubberized SHOCKPROOF housing (ODWS-1 & ODWS-1BK)
- 24 bit/48 kHz uncompressed digital transmission
- Easy to start in seconds – plug & play
- Auto-standby (sleep mode) after 10 seconds when there is no signal
- One transmitter can serve multiple receivers
- Rechargeable via USB (cable included!)
- Up to 5 hours use on a single charge
- Appx. 225° adjustable jack to fit almost every instrument
- 2.4 GHz technology is permission free/approved for use in America (North and South), Europe, Asia and Australia***
- THD + Noise: > 0.05 % (1KHz @ -10dbFS)
- Dynamic Range: > 103 db A weighted
- Operating temperature: -10° to 50° celcius (14° F - 122° F)

Includes:

- 1x Transmitter
- 1x Receiver
- 1x USB double head charger cable



TRANSMITTER || RECEIVER

ODWS-1 black || orange

ODWS-1BK black || black

ODWS-1CAR carbon || carbon

ODWS-1MAD maple design || maple design

ODWS-1WND walnut design || walnut design

SOFTWARE & HARDWARE UPDATE 2021

* Some high output active systems, especially active acoustic piezos might not match well with 2.4 GHz systems.

** Open field, depends on RF environment, reflections, interference and absorption. Keep distance from WIFI router.

*** Present legislation, please inform yourself about possible changes.



NEW

WIRELESS SYSTEM HOLDER | OWSH

Easy to mount Wireless Transmitter Pouch for Instrument Straps.

- Connector Cable included!
- SIGNIFICANTLY REDUCES DIGITAL INTERFERENCE!

Ideal for comfortably and conveniently holding pocket wireless transmitters on performers strap. The pouch secures easily with hook and loop fasteners on almost any type of strap.

- Made with high quality faux leather
- Fits for ORTEGA ODWS-1 systems and many other compact digital wireless systems
- Flexible nylon strips ensure a secure hold
- Fits any strap
- Easy to install with hook and loop fasteners.



OWSH

EXTENSION CABLE | OWCI



NEW

Extension cable with angle plug. Great for all side output jacks.

- 2,5 ft (75 cm)
- 1/4" (6.3 mm) jack / 1/4" (6.3 mm) female

OWCI





CABLES

INSTRUMENT CABLES - TOUR SERIES W/ PVC JACKET

ORTEGA GUITARS high performance TOUR Series Instrument Cables are designed for the rough daily routine of touring. With an 8 mm diameter, these cable offer perfect signal transmission. The electric plated zinc alloy shell equipped connectors are covered with an inner epoxy resin insulation.

For a perfect and noiseless instrument change the connectors are equipped with MUTEPLUGS muting the signal during plugging in and unplugging.



OTCI-xx

OTCIS-xx



INSTRUMENT CABLE MUTEPLUG STRAIGHT/ANGLE

1/4" (6.3 mm) MUTEPLUG jack, PVC jacket, conductive PE shield, black

OTCI-10 10 ft (3.0 m), 0.8 q

OTCI-15 15 ft (4.5 m), 0.8 q

OTCI-20 20 ft (6.0 m), 0.8 q

OTCI-30 30 ft (9.0 m), 0.8 q

INSTRUMENT CABLE MUTEPLUG STRAIGHT/STRAIGHT

1/4" (6.3 mm) MUTEPLUG jack, PVC jacket, conductive PE shield, black

OTCIS-10 10 ft (3.0 m), 0.8 q

OTCIS-15 15 ft (4.5 m), 0.8 q

OTCIS-20 20 ft (6.0 m), 0.8 q

OTCIS-30 30 ft (9.0 m), 0.8 q

INSTRUMENT CABLES - ECONOMY SERIES W/ BRAIDED NYLON JACKET

ORTEGA GUITARS Economy Series Instrument & Patch Cables offer quality design and sound for all live & studio environments. Reliable & durable, our cables are developed to last and deliver the best balance between performance and players equipment.

- Custom designed with an extra thick O.D. (outside diameter) of 8 mm
- Extra thick braided nylon jacket avoids annoying tangles and minimizes handling noise
- 24 Gauge AWG (American Wire Gauge) with 95% OCC copper braided shielding for flexibility and to minimize interference
- High grade industry standard connectors with heat shrunk sleeves for additional strain relief



OECI-xx



OECIS-xx



INSTRUMENT CABLE STRAIGHT/ANGLE

1/4" (6.3 mm) jack/jack, braided nylon over PVC, black

OECI-5 5 ft (1.5 m), 0.8 q

OECI-10 10 ft (3.0 m), 0.8 q

OECI-15 15 ft (4.5 m), 0.8 q

OECI-20 20 ft (6.0 m), 0.8 q

OECI-30 30 ft (9.0 m), 0.8 q

INSTRUMENT CABLE STRAIGHT/STRAIGHT

1/4" (6.3 mm) jack/jack, braided nylon over PVC, black

OECIS-5 5 ft (1.5 m), 0.8 q

OECIS-10 10 ft (3.0 m), 0.8 q

OECIS-15 15 ft (4.5 m), 0.8 q

OECIS-20 20 ft (6.0 m), 0.8 q

OECIS-30 30 ft (9.0 m), 0.8 q

INSTRUMENT CABLES - RETRO SERIES W/ PVC JACKET

ORTEGA GUITARS high performance RETRO Series Instrument Cables offer quality design in the spirit of the 70's legends.

Custom designed with an O.D. of 6.5 mm and 24 AWG (American Wire Gauge) the extra wide coiled RETRO Series cables deliver freedom on stage and great memories.



ORCCI-30xx



ORCCIS-30xx



INSTRUMENT COIL CABLE STRAIGHT/ANGLE

1/4" (6.3 mm) jack/jack, PVC jacket, conductive PE shield, black (BK) & white (WH)

ORCCI-30BK 30 ft (9.0 m), 0.8 q

ORCCI-30WH 30 ft (9.0 m), 0.8 q

INSTRUMENT COIL CABLE STRAIGHT/STRAIGHT

1/4" (6.3 mm) jack/jack, PVC jacket, conductive PE shield, black (BK) & white (WH)

ORCCIS-30BK 30 ft (9.0 m), 0.8 q

ORCCIS-30WH 30 ft (9.0 m), 0.8 q





OTCPA-04



PU20-OTCPA-04

PATCH CABLE PANCAKE STYLE

1/4" (6.3 mm) „PANCAKE“ jacks w/gold tip, PVC jacket, conductive PE shield, black

OTCPA-04 0.4 ft (13 cm), 0.65 q

PU20-OTCPA-04 PACKING UNIT of 20x OTCPA-04 incl. **attractive Display Bowl**



OECPA3-06

PATCH CABLE ANGLE/ANGLE

1/4" (6,3 mm) jack/jack, braided nylon over PVC, black

OECPA3-06 0.6 ft (18 cm), 0.8 q, pack of 3

LOUDSPEAKER CABLE - TOUR SERIES

ORTEGA LOUDSPEAKER CABLES are manufactured with the highest grade materials in the industry. The copper wire meets AWG rating specifications. The all-metal, nickel plated classic connectors provide durability and exceptional performance.



OTCLS-5JJ



LOUDSPEAKER CABLE OTCLS-5JJ

Ortega Tour Series Speaker Cables – The premium connection for your sound.

- 5 feet | 1.5 m length
- True 12AWG (American Wire Gauge) rated
- Professional Quality and Construction
- Extra thick 10.0 mm Durable & Flexible Rubber Jacket
- 2x reusable Hook and Loop Warp included

MICROPHONE CABLES - ECONOMY SERIES W/ BRAIDED NYLON JACKET

ORTEGA GUITARS Economy Series Instrument, Microphone & Patch Cables offer quality design and sound for all live & studio environments. Reliable & durable, our cables are developed to last and deliver the best balance between performance and players' equipment.

- Custom designed with an extra thick O.D. (diameter) of 8 mm
- Extra thick braided nylon jacket avoids annoying tangles and minimizes handling noise
- 24 Gauge AWG (American Wire Gauge) with 95 % OCC copper braided shielding for flexibility and to minimize interference
- High grade industry standard XLR & JACK connectors with heat shrunk sleeves for additional strain relief



OECM-xxJX



OECM-xxXX



MICROPHONE CABLE 1/4" (6.3 mm) JACK/XLR FEMALE

Braided nylon sleeve over PVC jacket, black

OECM-10JX 10 ft (3.0 m), 0.8 q

OECM-20JX 20 ft (6.0 m), 0.8 q

OECM-30JX 30 ft (9.0 m), 0.8 q

MICROPHONE CABLE XLR MALE/XLR FEMALE

Braided nylon sleeve over PVC jacket, black

OECM-10XX 10 ft (3.0 m), 0.8 q

OECM-20XX 20 ft (6.0 m), 0.8 q

OECM-30XX 30 ft (9.0 m), 0.8 q



STRINGS

4STRING UKULELE



UWNY-4-SO



UWNY-4-CC



UWNY-4-TE



UWNY-4-BA

ORTEGA GUITARS white nylon series ukulele strings are developed in cooperation with the world famous ukulele string maker AQUILA and manufactured in Italy. The combination of materials used are designed to deliver the perfect combination of warm yet punchy tone.

SOPRANO:

UWNY-4-SO .026/.037/.032/.024

CONCERT:

UWNY-4-CC .027/.038/.032/.024

TENOR:

UWNY-4-TE .028/.038/.032/.026

BARITONE:

UWNY-4-BA w/w/.032/.027

6 & 8STRING TENOR UKULELE



UNY-6-TE



UNY-8-TE

ORTEGA Nylon series ukulele strings are created in cooperation with the world-famous ukulele string maker AQUILA and manufactured in Italy. The combination of materials used is designed to deliver the perfect combination of warm yet punchy tone. Precise intonation, tuning stability and comfortable playability are the cornerstones of ORTEGA ukulele strings.

Custom made for 6 & 8string tenor scale.

UNY-6-TE .027/.037/.019/.033/.040/.025

UNY-8-TE .041/.026/.037/.019/.031/.031/.025/.025

6STRING GUITARLELE



GLNY-6

ORTEGA Guitarlele strings are created in cooperation with the world famous ukulele string maker AQUILA and manufactured in Italy. The combination of materials used is designed to deliver the perfect combination of warm yet punchy tone. Precise intonation, tuning stability and comfortable playability are the cornerstones of ORTEGA Guitarlele strings.

Perfect for 420 mm - 440 mm scale.

GLNY-6 .041/.033/.027/.038/.032/.026

8STRING NYLON GUITAR



OCTA-8NS

8string nylon string guitar set - Made in Germany. Custom made of the finest materials, with great precision and HANDCRAFTED by experts. Optimized for 690 mm scale. E/B/E/A/d silver plated copper wound on nylon silk g/b/e - nylon rectified.

OCTA-8NS .029/.032/.041/.031/.037/.046/.060/.083

4STRING ACOUSTIC BASS



ODW-4

Custom made in Germany for short scale acoustic basses (up to 25"). Silver plated copper wound on nylon silk.

ODW-4 .043/.059/.071/.080 fully balanced strings 5.5 kg (12.12 Lbs)

Custom developed for D-Walker bass!

6STRING GUITAR



ATG44NM



ATG44NH



ATMOSPHERE green – a revolutionary step in achieving the ultimate Organic Sound! ORTEGA Guitars atmosphere green strings are created and manufactured in Italy. We replaced the usually oil based treble strings with a newly developed nylon material which is made from 100% plant-based products. Our Atmosphere Green strings deliver a perfect combination of bright, warmth, punchy tone and incredible projection. Precise intonation and long-lasting tuning stability add to their exceptional playability. Our small but important contribution for a cleaner and greener planet.

ATG44NM (MEDIUM)

Diameter	.042 w	.034 w	.028 w	.040	.032	.028
----------	--------	--------	--------	------	------	------

ATG44NH (HARD)

Diameter	.043 w	.035 w	.028 w	.041	.033	.029
----------	--------	--------	--------	------	------	------

6STRING GUITAR



ATB44NM



ATB44NH



ATMOSPHERE balance – a revolutionary step in achieving the ultimate BALANCED TONE! Through our intensive engineering process, we calculate the windings, thickness, and core of the 3 bass strings. This process creates additional flexibility which increases vibration and resonance, ultimately delivering an extraordinary brightness and crystal-clear tonal experience. This creates a fully balanced string which delivers superior feel and tone. All Ortega professional nylon strings are proudly produced with traditional German craftsmanship.

ATB44NM (MEDIUM)

Item-No.	ATB44NM-E6	ATB44NM-A5	ATB44NM-D4	ATB44NM-G3	ATB44NM-B2	ATB44NM-E1
Diameter	.043 w	.035 w	.029 w	.039	.031	.028
Tension (lbs)	13.89	13.89	13.67	11.46	11.68	15.87

ATB44NH (HARD)

Item-No.	ATB44NH-E6	ATB44NH-A5	ATB44NH-D4	ATB44NH-G3	ATB44NH-B2	ATB44NH-E1
Diameter	.044 w	.036 w	.030 w	.039	.031	.028
Tension (lbs)	14.77	14.77	14.99	11.46	11.68	15.87

Single strings available





PICKS

20 ORTEGA PICKS – packing unit



PU20-OGPOR-M

Ortega PU20-OGPOR-M contains 20-piece pack of guitar picks in original Ortega orange featuring a 0.71 mm, medium thickness for great playability. A light “sandy” surface provides a firm comfortable grip.

ORTEGA UKULELE LEATHER PICKS



UKEPICK-ASS

Soft and extra large **REAL LEATHER PICKS** – especially designed for ukulele players but also perfect to use with any Nylon String Guitar.

- Warm soft tones with no loss of volume

UKEPICK-ASS Assorted pack of 3 black/white/red

PERFECT FOR ANY NYLON STRING GUITAR, TOO!

ORTEGA FELT PICKS – SOFT & HARD



OGP-F-S3
OGP-F-H3

Custom designed especially for Ukulele & Nylon String Guitar. Made from high quality compressed synthetic wool, rounded tip, anti-slip “grip hole” – pack of 3

OGP-F-S3 3 mm thickness, **SOFT**
Color: light grey

OGP-F-H3 4 mm thickness, **HARD**
Color: light brown

OGP-V1 – LEATHER & FELT



OGP-V1

Custom designed and perfect for Ukulele, Nylon String Guitar, Bass and many other acoustic instruments.

Variety Pack of 4:

- Leather pick, black
- Leather pick, white
- Felt pick, 3 mm, soft
- Felt pick, 4 mm, hard

ORTEGA PICKS

Guitar picks – Made in Germany. Produced with highest industry standard – pack of 10

OGP-BP-T10

blue pearl, thin

OGP-BP-M10

blue pearl, medium

OGP-BP-H10

blue pearl, heavy

OGP-WP-T10

white pearl, thin

OGP-WP-M10

white pearl, medium

OGP-WP-H10

white pearl, heavy

OGP-TO-T10

tortoise, thin

OGP-TO-M10

tortoise, medium

OGP-TO-H10

tortoise, heavy



OGP-BP **OGP-WP** **OGP-TO**



ORTEGA WOODEN PICKS – CURVED

STANDARD, SHARP TIP, CURVED THUMP GRIP – HANDMADE FROM REAL WOOD

2.5 mm thickness.

Made from high quality real wood, sharp tip.

OGPW-OV2 ovangkol wood, pack of 2

OGPW-PD2 padouk wood, pack of 2

OGPW-SW2 sandalwood, pack of 2

OGPW-CH2 chacate wood, pack of 2

OGPW-MIX4 1x ovangkol, 1x padouk, 1x sandal, 1x chacate – pack of 4



OGPW-OV2
OGPW-PD2

OGPW-SW2
OGPW-CH2

OGPW-MIX4



OGPWXLF-OV2
OGPWXLF-PD2
OGPWXLF-SW2
OGPWXLF-CH2



OGPWXLF-MIX4

ORTEGA WOODEN PICKS – FLAT

TRIANGLE XL, SHARP TIP, FLAT – HANDMADE FROM REAL WOOD

2.0 mm thickness.

Made from high quality real wood, sharp tip.

OGPWXLF-OV2 ovangkol wood, pack of 2

OGPWXLF-PD2 padouk wood, pack of 2

OGPWXLF-SW2 sandalwood, pack of 2

OGPWXLF-CH2 chacate wood, pack of 2

OGPWXLF-MIX4 1x ovangkol, 1x padouk, 1x sandal, 1x chacate – pack of 4

FLEX TECH PICKS – SOFT & HARD



OGP-FTS
OGP-FTH

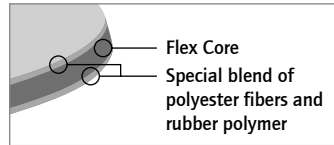

IDEAL FOR UKULELE & NYLON STRING GUITARS

Ortega Guitars FLEX TECH PICKS are handmade in the USA from a flexible composite felt which provides unrivaled tone and performance. Ideal for Ukulele, Nylon String Guitars, Acoustic Bases and many other stringed instruments.

OGP-FTS

SOFT, FLEX TECH with FLEX CORE TECHNOLOGY, 2.5 mm/0.984" goldenrod, pack of 4

OGP-FTH

HARD, FLEX TECH with FLEX CORE TECHNOLOGY, 3.8 mm/1.496" black, pack of 4



OGPST12-050
OGPST12-060
OGPST12-073



OGPST12-088
OGPST12-100
OGPST12-120



S-TECH PICKS

PACK OF 12 PICKS

Made in the USA, Ortega Guitars S-Tech picks combine the highest quality materials with traditional craftsmanship and modern production techniques to produce a professional guitar pick with exceptional durability, a grip friendly granular surface, and dynamic response - pack of 12.

OGPST12-050

pink, 0.50 mm

OGPST12-060

green, 0.60 mm

OGPST12-073

sand, 0.73 mm

OGPST12-088

blue, 0.88 mm

OGPST12-100

red, 1.00 mm

OGPST12-120

black, 1.20 mm

DISPLAY WITH 216 PICKS

Attractive, 100% recyclable hard paper sales display with 216x ORTEGA S-TECH PICKS included.

OGPSD-216

- 1x OGPST36-050 pink, 0.50 mm
- 1x OGPST36-060 green, 0.60 mm
- 1x OGPST36-073 sand, 0.73 mm
- 1x OGPST36-088 blue, 0.88 mm
- 1x OGPST36-100 red, 1.00 mm
- 1x OGPST36-120 black, 1.20 mm



OGPSD-216

REFILL PACKS

Perfect to refill the OGPSD216 sales box or have a safety stock.

Each refill pack contains 36 picks.

OGPST36-050

pink, 0.50 mm

OGPST36-060

green, 0.60 mm

OGPST36-073

sand, 0.73 mm

OGPST36-088

blue, 0.88 mm

OGPST36-100

red, 1.00 mm

OGPST36-120

black, 1.20 mm

STRAP LOCKS & TUNING MACHINES

STRAP LOCK



Professional Strap Locks includes one extra pair of screws/pins
2 Instruments - only one system.
Safely connects your guitar/bass strap with two of your instruments. Includes 1 pair of strap locks with washers, nuts & 2 sets of strap buttons with installation screws.

OSLOPRO-CR

Chrome, bright incl. FREE 2nd pair of screws/pins

OSLOPRO-GB

Gloss black incl. FREE 2nd pair of screws/pins

OSLOPRO-GO

Gold, bright incl. FREE 2nd pair of screws/pins

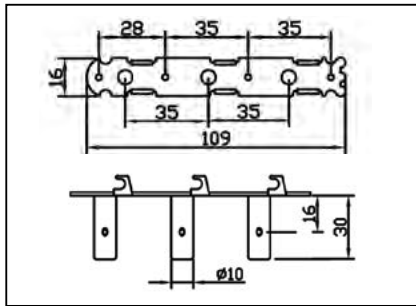

TUNING MACHINES GUITAR



OTM-STUDENT

OTM-STUDENT

RATIO: 14:1

3+3 tuning machine set with chrome plated baseplate, black nylon rollers and black pearl-style buttons.

Original part of the Ortega Student Series.

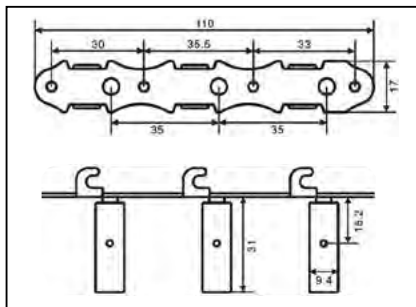

TUNING MACHINES GUITAR



OTM-FAMILYNT

OTM-FAMILYNT

RATIO: 14:1

3+3 tuning machine set with chrome plated baseplate, white nylon rollers and white pearl-style buttons.

Original part of the Family Series - natural.



OTM-FAMILYBK



OTM-FAMILYPRO

OTM-FAMILYBK

RATIO: 14:1

3+3 tuning machine set with golden baseplate, black nylon rollers and black pearl-style buttons.

Original part of the Family Series (black /R221BK).

OTM-FAMILYPRO

RATIO: 14:1

3+3 tuning machine set with golden baseplate, white nylon rollers and white pearl-style buttons.

Original part of the Family Pro Series.

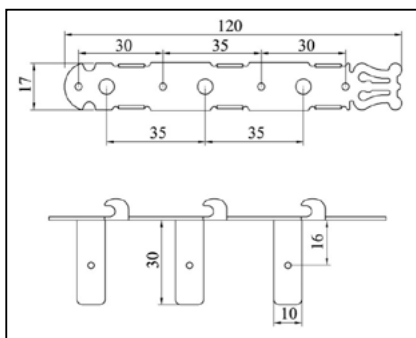

TUNING MACHINES GUITAR



OTMSTD-GOWH

OTMSTD-GOWH

RATIO: 14:1

Golden lyra-design tuning machines with white nylon rollers and white pearl buttons

TUNING MACHINES GUITAR

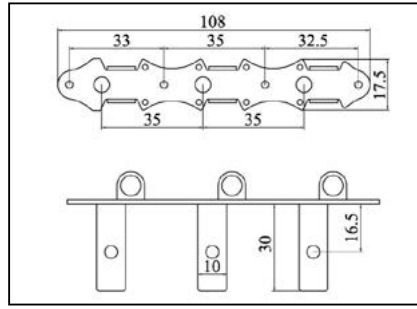
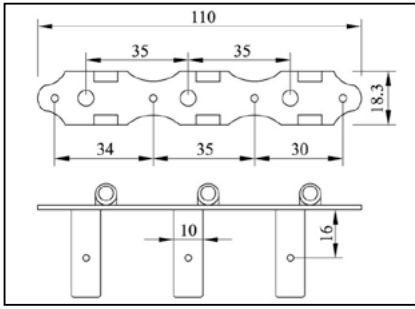

OTMDLX-BKBK



OTMDLX-GOBK

OTMDLX-GOBK
RATIO: 14:1

Golden baseplate tuning machines with black nylon rollers and black ebony-style buttons

OTMDLX-BKBK
RATIO: 14:1

Black baseplate tuning machines with black nylon rollers and black ebony-style buttons

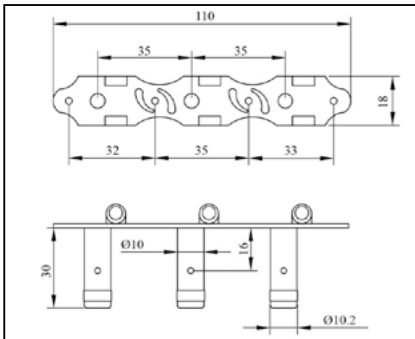

OTMPRIVATE

TUNING MACHINES GUITAR

OTMPRIVATE
RATIO: 18:1

Brushed brass baseplate tuning machines with plated steel worm shafts, black nylon rollers and black ebony-style buttons

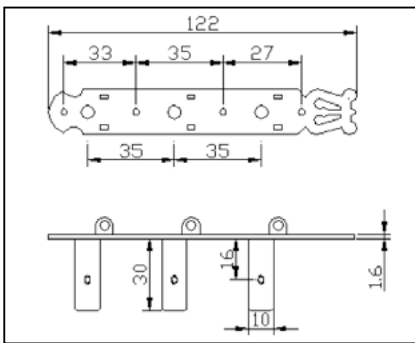

OTMPREMIUM

TUNING MACHINES GUITAR

OTMPREMIUM
RATIO: 18:1

Brushed brass lyra-design baseplate tuning machines with black plated steel worm shafts, black nylon rollers, pearl inlays and black acrylic-style buttons.

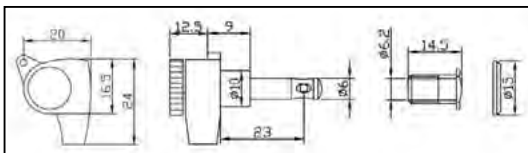

OTMLOCK6L-GB



OTMLOCK6L-GO



OTMLOCK6L-CR



RATIO 18:1

6 in-line locking tuning machine set with (plated) housing and buttons.

OTMLOCK6L-CR chrome

OTMLOCK6L-GB gloss black

OTMLOCK6L-GO gold



OTMLOCK33-GB



OTMLOCK33-GO



OTMLOCK33-CR



RATIO 18:1

3+3 locking tuning machine set with (plated) housing and buttons.

OTMLOCK33-CR chrome

OTMLOCK33-GB gloss black

OTMLOCK33-GO gold

STRAP LOCKS & TUNING MACHINES

TUNING MACHINES GUITAR

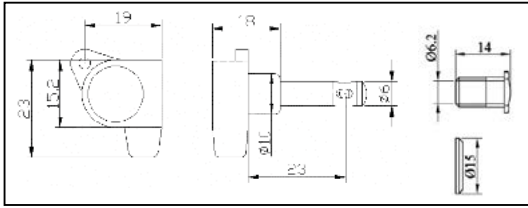

OTMEG33-CR

NEW

RATIO 14:1

3+3 die-cast tuning machine set with (plated) housing and black buttons.

OTMEG33-CR
chrome

OTMEG33-GB
gloss black

OTMEG33-GO
gold



OTMEG33-GB



OTMEG33-GO



OTMEG6L-CR



OTMEG6L-GB



OTMEG6L-GO

NEW

RATIO 14:1

6 in-line die-cast tuning machine set with (plated) housing and black buttons.

OTMEG6L-CR
chrome

OTMEG6L-GB
gloss black

OTMEG6L-GO
gold

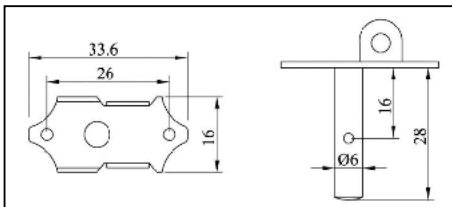

OTMVG-BS

NEW

RATIO 16:1

Open-gear tuning machine set with antique brass satin finish and crème buttons.

OTMVG-BS

TUNING MACHINES UKULELE

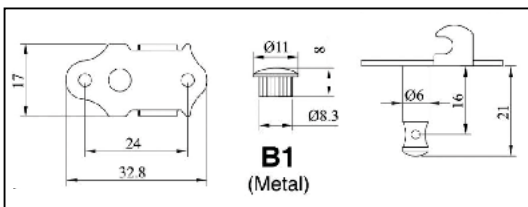

OTMUKOG-CR

NEW

RATIO 14:1

Open-gear ukulele tuning machine set with baseplate and black buttons.

OTMUKOG-CR
nickel

OTMUKOG-GO
gold



OTMUKOG-GO

RATIO 14:1

Die-cast ukulele tuning machine set with base plate and black buttons.

OTMUKDC-CR
chrome

OTMUKDC-GB
gloss black

OTMUKDC-GO
gold

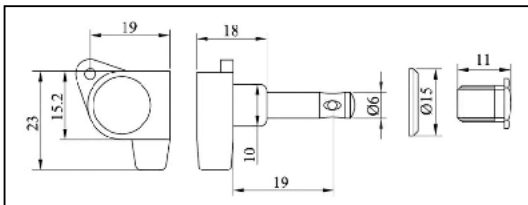

OTMUKDC-CR

NEW

RATIO 14:1

Economic die-cast ukulele tuning machine set with chrome plated housing and black buttons.

OTMUKSTD-CR



OTMUKDC-GB



OTMUKDC-GO



OTMUKSTD-CR

NEW



CABLES & POWER

DC POWER SPLITTER CABLES



ODC4

ODC6

ODC8

The Ortega ODC4/ODC6/ODC8 are perfect to use with 9V & 18V power supplies. Feeds 4, 6 or 8 devices simultaneously.

ODC4 4head version,
1.40 m/4.6 ft cable length

ODC6 6head version,
2.00 m/6.5 ft cable length

ODC8 8head version,
2.70 m/8.9 ft cable length

CABLE LENGTH OF 3 METERS/9.8 FEET!



OPS9500EU

(most European countries)

OPS9500US

(USA & Canada)



OPS9500JP

(Japan)

OPS9500UK

(Great Britain)

POWER SUPPLY

The **OPS9500** power supply series is intended for use with any effect pedals (analog or digital) requiring 9V and good for up to 500 mA.

Special feature:

Cable length of 3 meters /9.8 feet!

- INPUT POWER 100-240 VAC, 50/60 Hz
- OUTPUT POWER 9V DC/500 mA

Ortega power supplies are CE (EUROPE) & UL/class6 (USA) & PSE (Japan) tested and certified.



OER-CR2032/2



Type CR2032

BATTERIES **OER-CR2032/2**

2 pack of 3V coin cell batteries, Type CR2032 (recommended for all Ortega MagusUke and MagusUkePRO preamps and tuners)

ACOUSTIC & NYLON STRING GUITAR SYSTEMS



MagusGO

Active output jack w/ soundhole control preamp system*

- No need to make a side cut, easy to install
- Powered by 9V battery
- Setup with VOLUME and TONE control (designed for inner soundhole attachment)
- Includes piezo pickup (guitar), battery pocket and cable clamp



MagusPRO/G

Professional side mount onboard active preamp system*

- Built-in tuner (mutes output signal when in use)
- 2 color display
- Seamless, separate VOLUME control
- 3 band EQ featuring single BASS, MIDDLE & TREBLE controls
- Phase turn button
- Powered by 9V battery
- Separate battery compartment with output jack
- Includes piezo pickup (guitar), output/battery compartment device and cable clamp

ACOUSTIC BASS SYSTEM



MagusPRO/B

Professional side mount onboard active preamp system*

- Built-in tuner (mutes output signal when in use)
- 2 color display
- Seamless, separate VOLUME control
- 3 band EQ featuring single BASS, MIDDLE & TREBLE controls
- Phase turn button
- Powered by 9V battery
- Separate battery compartment with output jack
- Includes piezo pickup (bass), output/battery compartment device and cable clamp

UKULELE SYSTEMS



MagusUkeGO

Active output jack w/ soundhole control preamp system*

- No need to make a side cut, easy to install
- Powered by 9V battery
- Setup with VOLUME and TONE control (designed for inner soundhole attachment)
- Includes a flexible pickup, battery pocket and cable clamp



MagusUke

Professional side mount onboard active preamp system*

- Built-in tuner (mutes output signal when in use)
- 2 color display
- TONE control & VOLUME control, FREQUENCY control
- Easy to reach battery compartment
- Uses 2x CR2032 coin cells (we recommend Ortega OER-CR2032/2)
- Includes piezo pickup (ukulele), output jack and cable clamp



MagusUkePRO

Professional side mount onboard active preamp system*

- Built-in tuner (mutes output signal when in use)
- 2 color display
- 3 band EQ featuring single BASS, MIDDLE & TREBLE controls
- Separate battery compartment with output jack
- Uses 2x CR2032 coin cells (we recommend Ortega OER-CR2032/2)
- Includes piezo pickup (ukulele), output/battery compartment device and cable clamp

*To get the best results and to avoid irreparable damage to your instrument please consult a specialized guitar technician for proper installation.



USEFUL HELPERS

3 HEAD STRING WINDER & CUTTER



UKULELE



GUITAR



BASS



OSWC-3H

A practical tool to make changing strings effortless. The Ortega Guitars 3 Head Multi-tool is a 3-in-1 tool for ukulele, guitar and bass maintenance: peg winder, bridge pin puller, and string cutter.

The OSWC-3H comes with 3 interchangeable heads for ukulele, guitar and bass. Change the strings on almost any instrument with only one tool. Made of high-quality Japanese steel for highest durability.

STRING CUTTER

Made out of hardened JAPANESE STEEL the OSWC-3H provides superior strength and long-lasting durability and cuts the wire with precision.

PIN PULLER

Quick and easy string changes are guaranteed with the built-in bridge pin puller. The wide contact surface of the bridge-pin puller helps to better protect your bridge from marks.

STRING WINDER

The OSWC-3H comes with 3 interchangeable heads for ukulele, guitar and bass - the perfect fit for all your stringed instruments.

STRING WINDER

String replacement in a few seconds with these classic string winders. The notched head removes bridge pins quickly and safely.

The deluxe version offers additionally a perfectly shaped head for standard and smaller guitar/ukulele machine head knobs and is available in 7 transparent colors.

String Winder Standard:

OSW-STD

Classic string winder, single, orange/black

VE40-OSW-STD

Useful display box - filled with 40xOSW-STD, orange/black

String Winder Deluxe:

OSW-DLX-TBK transparent black

OSW-DLX-TBL transparent blue

OSW-DLX-TYE transparent yellow

OSW-DLX-TCL transparent clear

OSW-DLX-TGR transparent green

OSW-DLX-TOR transparent orange

OSW-DLX-TRD transparent red



VE40-OSW-STD



OSW-STD



OSW-DLX-TBK

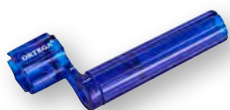

OSW-DLX-TBL



OSW-DLX-TYE



OSW-DLX-TCL



OSW-DLX-TGR



OSW-DLX-TOR



OSW-DLX-TRD

FINGER TRAINER



FEX4



FEX5



Only a few minutes for best results



Lockable pistons for more exercise possibilities



The original Ortega Guitars FEX4 & FEX5 are advanced pocked-sized, light weight training tools for different needs. FEX4 & FEX5 helps you to build-up strength for the entire hand and forearm.

Adjustable tension for each finger

FEX4 3-7 lbs (appx. 1.3-3.2 kg), 4 pistons

FEX5 3-8.5 lbs (appx. 1.3-3.9 kg), 5 lockable pistons for more training possibilities.

Train and maintain strength for your fingers, palm and forearms, supports reaction speed, flexibility and other high difficult action training.

PERFECT PRE-GIG WARM-UP TOOL, PRE-CLIMBING EXERCISE TOOL /SPORTS SUPPORT & MEDICAL REHABILITATION TOOL.*

FEX4 individual adjustable tension for 4 available pistons

FEX5 individual adjustable tension for 5 available pistons

* Ask your doctor IN ADVANCE for medical rehabilitation use.

CABLE TIES PACK OF 10



OCBT-10

Ortega Cable ties keep your cables coiled up and well organized for tidy storage. Works with all instrument, microphone and power cables.

OCBT-10
Cable ties, hook & loop
0.6 x 0.065 ft
(18 cm x 2 cm), orange,
pack of 10

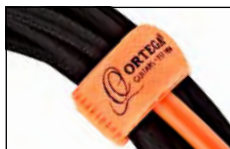

ELIMINATOR



ELIMINATOR100
ELIMINATOR86



FITS ALMOST ALL ACOUSTIC INSTRUMENTS!

Feedback Eliminator/
Soundhole Cover

Simply place the ELIMINATOR into your acoustic's soundhole and start your feedback-free performance. Designed to play at a far greater volume on stage without the risk of unwanted howling or feedback. Safe for the instruments' finish due to its soft rubber.

ELIMINATOR100

100 mm (4") diameter,
fits most steel strings & acoustic
basses

ELIMINATOR86

86 mm (3.38") diameter,
fits most nylon & classical guitars

ORTEGA MUSIC LIGHTS

CLIP ON LED MUSIC LIGHTS

Perfect for travel, music stand lighting, desk and computer or reading.

- Strong and bright LEDs (4/each head)
- Rechargeable via USB!
- Two settings - bright (100%) & dim (50%)
- Adjustable gooseneck(s) for optimal lightning
- Easy to use, strong clamp for mounting
- Easy to install and remove - no tools needed!
- USB charger cable included!

OML-S: SINGLE neck - 8h+ on a single charge

OML-D: DOUBLE neck - 6h+ on a single charge



OML-S

OML-D

**RECHARGEABLE!
NO MORE BATTERIES -
LESS WEIGHT!**



CARE

MADE
IN
GERMANY

LOVE POTION

Give your stringed instrument some love and care! With our Ortega Love Potion guitar, string, and fretboard care, we can offer you the all-round package for your beloved instrument. All three care products are made in Germany and contain jojoba oil, which isn't only a sustainable natural product, it's also perfectly suitable for cleaning and lubricating wooden surfaces.



VEGAN



OLP-PACK

OLP-PACK

Complete cleaning kit for your guitar's body, fretboard, and strings. The Ortega Love Potion Pack consists of **1x OLP-GTR**, **1x OLP-STR**, and **1x OLP-FB** and offers the perfect bundle for your instrument.

NEW

- Ortega Love Potion Guitar Polish gives your guitar a brilliant shine while cleaning it. With Jojoba Oil.
- Ortega Love Potion String Conditioner keeps your strings clean and makes them last longer
- Ortega Love Potion Fretboard cleans and conditions your fretboard



OLP-FB

NEW

Unfinished fretboards are exposed to temperature/humidity changes and therefore need special maintenance. The **OLP-FB** comes in a 20 ml bottle and is perfect for lubricating and cleaning the fretboard of your instrument. The Fretboard Care is a vegan product!

- Ortega Love Potion Fretboard cleans and conditions your fretboard
- VEGAN and with high quality JOJOBA oil
- 20 ml (0.7 fluid oz)
- Made in Germany



OLP-GTR

OLP-GTR

Stains and sweat which occur from playing your instrument can easily be cleaned with this liquid! The **OLP-GTR** comes in a 150 ml spray bottle for an easy application. The Guitar Care is a vegan product!

NEW

- Ortega Love Potion Guitar Polish gives your guitar a brilliant shine while cleaning it. With Jojoba Oil.
- VEGAN and with high quality JOJOBA oil
- 150 ml (5.1 fluid oz)
- Made in Germany



OLP-STR

OLP-STR

Guitar strings often lack care and tend to lose their clear sound due to sweat and dirt, which ultimately leads to corrosion.

You can clean your strings, protect them from corrosion, and preserve their bright tone by using the **OLP-STR**. The **OLP-STR** comes in a 150ml spray bottle for an easy application.

NEW

- Ortega Love Potion String Conditioner keeps your strings clean and makes them last longer
- High quality LANOLIN (anti rust) and JOJOBA oil
- 150 ml (5.1 fluid oz)
- Made in Germany

Corrosion Protection
Formula





OLEM

FRETBOARD OIL OLEM

Lemon oil - cleaning, conditioning & restoring
 The original Ortega Guitars Lemon Oil is perfect to remove dirt, wax and grease from dark wooden surfaces incl. unfinished fretboards.*

60 ml (2.1 fluid oz)

* For best results we recommend you use original Ortega polish cloth OPC-GR/LG, OPC-LY/LB or OPC-XXL

OPC-GR/LG
 PACK OF 2!

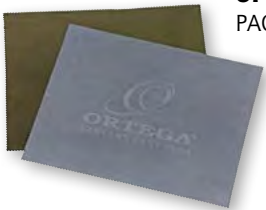

OPC-LY/LB
 PACK OF 2!



OPC-XXL



EXTRA LARGE!

POLISH CLOTH

Professional, extra soft microfiber polishing/cleaning cloth with serrated edge. Features embossed Ortega logo.

OPC-GR/LG - pack of 2! (green/light grey)
 Dimensions: 29 cm x 24 cm (11.5" x 9.5")

OPC-LY/LB - pack of 2!
 (light yellow/light brown)
 Dimensions: 29 cm x 24 cm (11.5" x 9.5")

OPC-XXL - extra large size (light yellow)
 Dimensions: 50 cm x 40 cm (19.70" x 15.75")





CARE

PROTECTION FOILS



**NO GLUE!
ELECTROSTATIC
FEATURES**

OBCF

OERP



Electrostatic reusable foils. The perfect protection against dings & scratches. Clear transparent. To use on gloss finishes only. Removable any time!

OERP

Pickguard for top, transparent

OBCF

Back cover foil, transparent



OPG-FLAM1

**PERMANENT
GLUE!**



OERP-FLAM1

**NO GLUE!
ELECTROSTATIC
FEATURES**

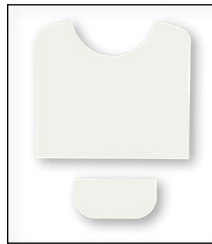

Transparent scratch plates for acoustic guitars protect the top surface against scratches and dings. Clear transparent foil for Flamenco Style playing.

OPG-FLAM1

Permanent glue on FULL TOP foil set.

Usable on gloss & satin finishes. Self-gluing foil for permanent installation. String change protection foil included.

OERP-FLAM1

Reusable electrostatic FULL TOP foil set.

Usable on gloss finishes only. Holds with electrostatic features. String change protection foil included.



OPG-FLAM2

**PERMANENT
GLUE!**



OERP-FLAM2

**NO GLUE!
ELECTROSTATIC
FEATURES**

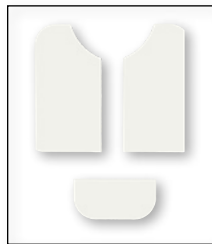

OPG-FLAM2

Permanent glue on DIVIDED foil set.

Usable on gloss & satin finishes. Self-gluing foil for permanent installation. String change protection foil included.

OERP-FLAM2

Reusable electrostatic DIVIDED foil set.

Usable on gloss finishes only. Holds with electrostatic features. String change protection foil included.

WOODEN UKULELE PICKGUARDS



**OWPSC-EB
OWPTB-EB**

**OWPSC-FMA
OWPTB-FMA**

**OWPSC-WN
OWPTB-WN**



Choose your personal style

EBONY – FLAMED MAPLE – WALNUT

Made from REAL wood, the Ortega ukulele pickguards light up your instrument and makes your ukulele stand out with extra flair. Easy to put on with already installed adhesive foil. Shaped for Soprano, Concert, Tenor & Baritone size.

SOPRANO & CONCERT soundhole diameter appx. 55 mm

OWPSC-EB EBONY

OWPSC-FMA FLAMED MAPLE

OWPSC-WN WALNUT

TENOR & BARITONE soundhole diameter appx. 58 mm

OWPTB-EB EBONY

OWPTB-FMA FLAMED MAPLE

OWPTB-WN WALNUT

HUMIDIFIERS



HUMIGT-BK



HUMIGT-SV



HUMIUKE-BK



HUMIUKE-SV



Suspend between the strings – no body touch

Humidifying wooden acoustic instruments is the most underrated topic, but the lack of humidification is the number one cause of repairs. The ORTEGA humidifiers are the easiest and simplest way to maintain your instruments in best humidity condition.

- Ortega humidifiers suspend between the strings and never touch any part of the instruments body
- Easy to refill sponge style system
- Non-drip design – releases moisture (if needed for instrument) evenly and slowly to maintain the proper humidity level
- Includes a syringe for water

Soundhole humidifier for ACOUSTIC GUITAR

HUMIGT-BK BLACK

HUMIGT-SV SILVER

Soundhole humidifier for UKULELE,
1/4 & 1/2 size instruments

HUMIUKE-BK BLACK

HUMIUKE-SV SILVER

HUMIBUSTER



HUMIBUSTER100
HUMIBUSTER80



Includes a syringe for water refill

Feedback killer & Humidifying system. Permanent feedback cover for acoustic instruments with the additional function of a humidifying system. Equipped with a sponge and pores, the system maintains the relative humidity of your instrument and protects the wood from drying out.

HUMIBUSTER100

100 mm (4") diameter, fits most acoustic guitars and acoustic basses

HUMIBUSTER80

85 mm (3.35") diameter, fits most classical guitars

MUSIC STAND OMS-1BK



OMS-1BK



The Ortega portable music stand for the traveling musician or student on the go. Easy to use with 3 seamless tubes for adjusting height, a strong tripod base and a large book tray. FREE bag included.

- Made of lightweight, non-corrosive aluminum
- Height adjustable from 57 cm (22") to 127 cm (50")
- Book tray: 43.5 cm (17.13") x 22 cm (8.66")

ORTEGA TABLET HOLDER – DELUXE VERSION OTBH-DLX



OTBH-DLX



Tablet holder with gooseneck and incl. clamp.

- Heavy duty, universal tablet holder
- Suitable for almost all tablet computers up to 13" displays
- Strong flexible gooseneck
- Freely adjustable/rotatable tablet holder
- Mount to a stand/microphone stand with standard 5/8 thread or with included clamp (up to 35 mm/1.38" diameter)



STANDS

WOODEN GUITAR/UKULE STANDS



GUITAR
OWGS-1

GUITAR
OWGS-2

UKULELE
OWUS-1

UKULELE
OWUS-2

The perfect stand for home, office and shop. Made from birch, the Ortega guitar stand is as beautiful as it is supportive. Soft and safe "anti-slip" padding for best protection. Assembles in minutes.

OWGS-1/OWUS-1
birch, dark brown

OWGS-2/OWUS-2
birch, natural bright

PORTABLE GUITAR/UKULE STANDS



GUITAR
OPGS-1BK*

UKULELE
OPUS-1BK*

GUITAR
OPGS-1ORBK*

UKULELE
OPUS-1ORBK*

Made with extremely lightweight and strong synthetic material. Fits all sizes of guitars, basses, ukuleles, mandolins & more. Divided body rest for electric or acoustic guitars (OPGS) and easy to fold.

4 STEPS AND YOU'RE DONE!

GUITAR: **OPGS-1BK**
full black
OPGS-1ORBK
Ortega orange/black

UKULELE: **OPUS-1BK**
full black
OPUS-1ORBK
Ortega orange/black

1-2-3-4: FITS YOUR INSTRUMENT!

4-3-2-1: FITS YOUR GIG BAG!

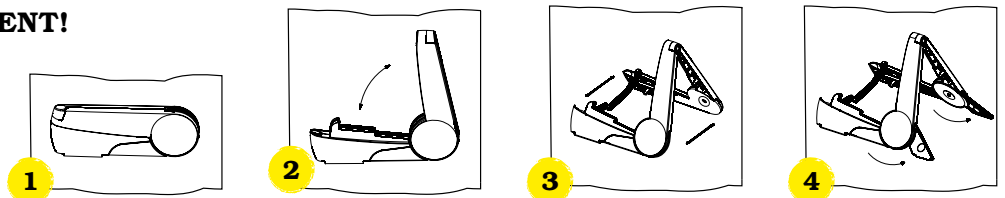

*) not available in the US!

GUITAR STAND OGS-1BK



OGS-1BK

Ortega guitar stand, black/orange.

The perfect rest for acoustic guitars, acoustic basses, electric guitars and electric basses.

- Lightweight and durable steel tubing covered with soft black neoprene rubber tubing to protect your instrument. Folds down for easy transport and storage
- Security strap/neck included
(do not use with nitrocellulose-finished instruments)

FOOT STOOL

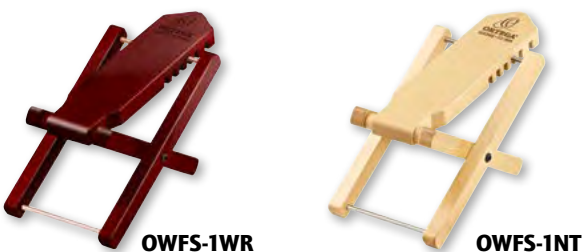

OWFS-1WR

OWFS-1NT

Ortega headstock shaped wooden foot stool

OWFS-1WR
wine red

OWFS-1NT
natural

GUITAR:



UKULELE:



WALL HANGER

Easy to mount with included screws and drywall anchors. Soft padded cradle support.

Wall hanger, straight

Guitar/Bass	Ukulele	
OGH-1WN	OUH-1WN	Walnut wood base, natural
OGH-1CW	OUH-1CW	Cherry wood base, natural
OGH-1	OUH-1	Wood base, black
OGH-1WH	OUH-1WH	Wood base, white
OGH-1WR	OUH-1WR	Wood base, wine red
OGH-1CSB	OUH-1CSB	Wood base, cherry sunburst
OGH-1TSB	OUH-1TSB	Wood base, tobacco sunburst

ADJUSTABLE WALL HANGER



Easy to mount with included screws and drywall anchors. Soft padded cradle support.

OGHAD-1 models have a boom and are angle adjustable. Now available in two additional wood bases.

OGHAD-1 Wood base, black, adjustable angle

OGHAD-1CW Wood base, adjustable angle, 170 mm/6.69", Cherry wood, natural

OGHAD-1WN Wood base, adjustable angle, 170 mm/6.69", Walnut wood, natural

HOLDER **OMUH-BK**

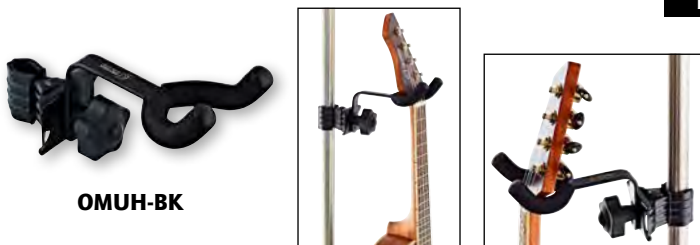

Ukulele holder for microphone, guitar and music stands.

Holder easily clips onto stand. Fits all size ukuleles as well as mandolins or other small folk instruments. Extra strong clamp system and soft padded cradle support.

Color: all black





BAGS SOFT CASES



GUITAR



UKULELE



SOFT CASES

Travel in style with hard-case like protection with significantly less weight!

Ortega premium SOFT CASES are made with a canvas/cotton surface and real suede leather inlays. The 22 mm (0.86") soft sponge padding is supported by a 5 mm (0.20") hardened PE plastic frame. A plush black velvet material interior includes a neck brace with Velcro safety straps. The exterior features heavy duty zippers, comfortable, adjustable shoulder straps, a suede leather covered handle and two front compartments (one for ukulele sizes).

Available in 3 attractive colors:

MOCCA (**MO**) - OCEAN BLUE (**OC**) - BORDEAUX WINE (**BX**)



BANJO

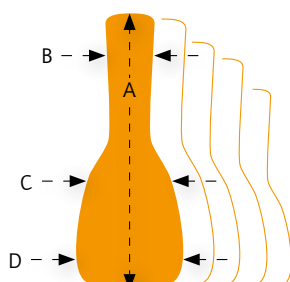

DIMENSIONS

ACOUSTIC DREADNOUGHT	A	B	C	D	Height
OSOCADN-xx dreadnought	107.0 cm 42.13"	14.0 cm 5.51"	33.0 cm 12.99"	42.0 cm 16.54"	13.0 cm 5.12"
CLASSICAL	A	B	C	D	Height
OSOCACL34-xx classic 3/4 size	92.5 cm 36.42"	12.0 cm 4.72"	25.0 cm 9.84"	36.5 cm 14.37"	12.0 cm 4.72"
OSOCACL-xx regular classic size	103.5 cm 40.75"	12.0 cm 4.72"	31.0 cm 12.2"	39.0 cm 15.35"	11.5 cm 4.53"
UKULELE	A	B	C	D	Height
OSOCAUK-SO-xx soprano	55.0 cm 21.65"	9.0 cm 3.54"	13.5 cm 5.31"	19.0 cm 7.48"	9.0 cm 3.54"
OSOCAUK-CC-xx concert	64.0 cm 25.2"	10.0 cm 3.94"	14.5 cm 5.71"	22.0 cm 8.66"	9.5 cm 3.74"
OSOCAUK-TE-xx tenor	67.5 cm 26.57"	10.0 cm 3.94"	16.0 cm 6.3"	23.0 cm 9.06"	10.0 cm 3.94"
BANJO	A	B	C	D	Height
OSOCABJ-xx classic 3/4 size	92.5 cm 36.42"	12.0 cm 4.72"	25.0 cm 9.84"	36.5 cm 14.37"	12.0 cm 4.72"

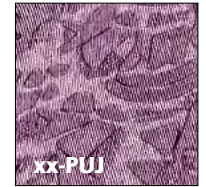
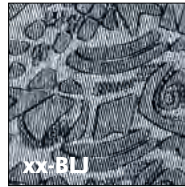

GUITAR



UKULELE



JEAN COLOR BAGS

Travel in style with great protection.

Ortega JEAN BAGS are made with a canvas/cotton surface decorated in fun stonewashed denim colors, covering a 12 mm (0.47") soft padding. A soft, black nylon interior includes a neck brace with Velcro safety straps. The exterior features heavy duty zippers, comfortable, adjustable shoulder straps, and a large front storage pocket.

Available in 4 fantastic colors:

BLUE JEAN (**BLJ**) - GREEN JEAN (**GRJ**) - SUN JEAN (**SUJ**) - PURPLE JEAN (**PUJ**)

front compartment



guitar



ukulele

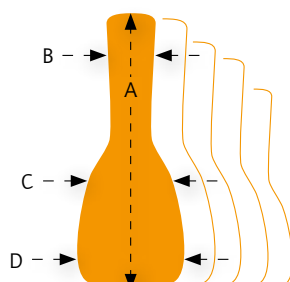

DIMENSIONS

ACOUSTIC DREADNOUGHT	A	B	C	D	Height
OGBAC-DN-xx dreadnought	107.0 cm 42.13"	14.0 cm 5.51"	33.0 cm 12.99"	42.0 cm 16.54"	13.0 cm 5.12"
CLASSICAL	A	B	C	D	Height
OGBCL-xx regular classic size	108.0 cm 42.52"	13.0 cm 5.12"	31.0 cm 12.2"	39.0 cm 15.35"	14.0 cm 5.51"
UKULELE	A	B	C	D	Height
OUB-SO-xx soprano	56.0 cm 22.05"	10.0 cm 3.94"	13.0 cm 5.12"	19.0 cm 7.48"	6.0 cm 2.36"
OUB-CC-xx concert	66.0 cm 25.98"	10.0 cm 3.94"	16.5 cm 6.5"	23.0 cm 9.06"	8.0 cm 3.15"
OUB-TE-xx tenor	69.0 cm 27.17"	10.0 cm 3.94"	17.5 cm 6.89"	24.0 cm 9.45"	8.0 cm 3.15"



BAGS ECONOMY / PRO

GUITAR BAGS ECONOMY OGBSTD-xx



OGBSTD-xx

Quality guitar bags for any budget. Made from sturdy nylon material with a 10 mm soft inside padding and heavy duty zippers. Includes a big accessory compartment (perfect size for music books) and two adjustable shoulder straps.

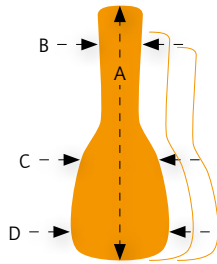

DIMENSIONS

	A	B	C	D
OGBSTD-44	105.0 cm 41.34"	14.0 cm 5.52"	32.0 cm 12.6"	40.0 cm 15.75"
OGBSTD-34	98.0 cm 38.58"	14.0 cm 5.52"	30.0 cm 11.8"	37.0 cm 14.56"
OGBSTD-12	96.0 cm 37.8"	14.0 cm 5.52"	30.0 cm 11.8"	35.0 cm 13.78"

GUITAR BAGS PRO ONB-xx



ONB-xx

Professional classic gig bags made from heavy duty nylon material. Thick padding inside, very wide neck brace with safety straps, heavy duty zippers, wide and comfortable shoulder straps (adjustable), padded handle and two accessory compartments distinguishes this exclusive bag.

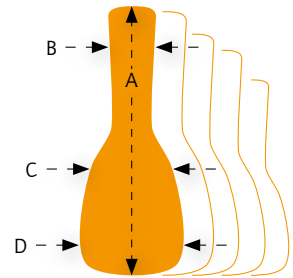

DIMENSIONS

	A	B	C	D
ONB44L full size extra long	105.4 cm 41.5"	14.3 cm 5.63"	31.12 cm 12.25"	40.0 cm 15.75"
ONB44 full size	103.5 cm 40.75"	14.3 cm 5.63"	30.5 cm 12.01"	37.15 cm 14.63"
ONB34 three quarter size	94.62 cm 37.25"	14.3 cm 5.63"	26.7 cm 10.51"	35.88 cm 14.13"
ONB12 half size	88.27 cm 34.75"	14.3 cm 5.63"	23.5 cm 9.25"	32.7 cm 12.87"
ONB14 quarter size	76.84 cm 30.25"	14.3 cm 5.63"	21.6 cm 8.5"	28.25 cm 11.12"

UKULELE BAGS ECONOMY OUBSTD-xx



OUBSTD-xx

Quality guitar bags for any budget. Made from sturdy nylon material with a 10 mm soft inside padding. Includes an accessory compartment (fits an ORTEGA OPUS portable uke stand!) and two adjustable shoulder straps.

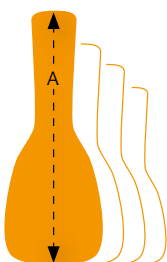

DIMENSIONS

	A (inside)
OUBSTD-SI Sopranino length	54.0 cm 21.26"
OUBSTD-SO soprano length	55.0 cm 21.65"
OUBSTD-CC concert length	62.0 cm 24.41"
OUBSTD-PINE concert length	62.0 cm 24.41"
OUBSTD-TE tenor length	68.0 cm 26.77"
OUBSTD-BA baritone length	78.0 cm 30.71"

UKULELE BAGS PRO OUGB-xx



OUGB-xx

Professional ukulele gig bags made from heavy duty nylon material. Thick padding inside, heavy duty zippers, padded handle and an accessory compartment distinguishes this exclusive bag.



DIMENSIONS

	A (inside)
OUGB-SO soprano length	55.0 cm 21.65"
OUGB-CC concert length	62.0 cm 24.41"
OUGB-TE tenor length	68.0 cm 26.77"
OUGB-BB baritone length	78.0 cm 30.71"



OACCSTD-DN
OCCSTD-34
OCCSTD
OCCSTD-T

OEGCSTD

OCCSTD

CASES ECONOMY

Budget friendly instrument cases in classic black vinyl finish. Flat top, 15 mm padding – covered by "coffee" velvet, accessory compartment, chrome hardware and a strong handle distinguishes these timeless cases.

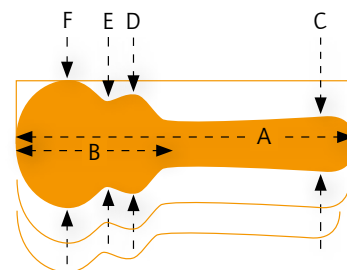

READY TO GO CASE & BACK PACK BUNDLE

OACCSTD-DN-BU
 Acoustic case "Dreadnought" INCL. pre-installed OBPS back pack strap.

OCCSTD-BU
 Regular classic case INCL. pre-installed OBPS back pack strap.

GUITAR CASES							
INNER DIMENSIONS							
ACOUSTIC	A	B	C	D	E	F	Height
OACCSTD-DN dreadnought	107.5 cm 42.32"	58.0 cm 22.83"	15.5 cm 6.1"	29.5 cm 11.61"	28.0 cm 11.02"	41.0 cm 16.14"	13.5 cm 5.31"
OACCSTD-DN-BU case and back pack strap	107.5 cm 42.32"	58.0 cm 22.83"	15.5 cm 6.1"	29.5 cm 11.61"	28.0 cm 11.02"	41.0 cm 16.14"	13.5 cm 5.31"
CLASSICAL	A	B	C	D	E	F	Height
OCCSTD-34 classic 3/4 size	98.0 cm 38.58"	47.0 cm 18.50"	12.5 cm 4.92"	25.0 cm 9.84"	23.0 cm 9.06"	35.0 cm 13.78"	11.0 cm 4.33"
OCCSTD regular classic	103.0 cm 40.55"	56.0 cm 22.05"	14.5 cm 5.71"	27.5 cm 10.83"	26.0 cm 10.24"	38.5 cm 15.16"	12.0 cm 4.72"
OCCSTD-BU case and back pack strap	103.0 cm 40.55"	56.0 cm 22.05"	14.5 cm 5.71"	27.5 cm 10.83"	26.0 cm 10.24"	38.5 cm 15.16"	12.0 cm 4.72"
OCCSTD-T thinline classic	107.0 cm 42.13"	56.0 cm 22.05"	14.5 cm 5.71"	27.5 cm 10.83"	26.0 cm 10.24"	38.5 cm 15.16"	10.5 cm 4.13"
ELECTRIC	A	B	C	D	E	F	Height
OEGCSTD rectangle	105.0 cm 41.34"	50.0 cm 19.68"	–	–	–	33.0 cm 12.99"	9.0 cm 3.54"
OCCSTD single cut	101.0 cm 39.67"	50.0 cm 19.68"	15.0 cm 5.9"	23.0 cm 9.05"	21.0 cm 8.27"	34.0 cm 13.38"	10.0 cm 3.94"





CASES ECONOMY



OABCSTD

OEBSTD

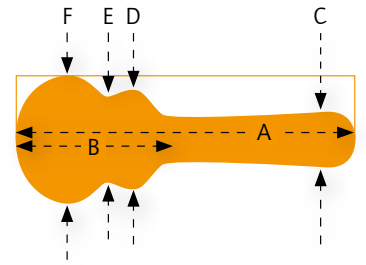

BASS CASE

INNER DIMENSIONS							
ACOUSTIC	A	B	C	D	E	F	Height
OABCSTD acoustic bass	127.0 cm 50.0"	58.5 cm 23.03"	16.0 cm 6.3"	32.0 cm 12.6"	29.5 cm 11.61"	43.0 cm 16.93"	13.5 cm 5.31"
ELECTRIC	A	B	C	D	E	F	Height
OEBSTD electric bass	119.0 cm 46.85"	55.5 cm 21.65"	-	-	-	34.5 cm 13.58"	9.0 cm 3.54"



OBJCSTD

OMCSTD-A

OMCSTD-F

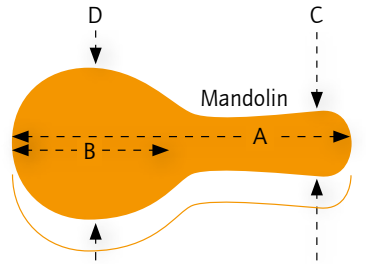
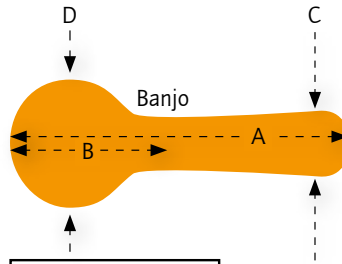

BLUEGRASS CASES

INNER DIMENSIONS					
	A	B	C	D	Height
OBJCSTD Banjo regular 5/6 String	103.0 cm 40.55"	44.0 cm 17.32"	14.0 cm 5.51"	34.5 cm 13.58"	12.5 cm 4.92"
OMCSTD-A Mandolin A-style	71.0 cm 27.95"	39.0 cm 15.35"	15.0 cm 5.91"	27.5 cm 10.83"	10.0 cm 3.94"
OMCSTD-F Mandolin F-style	71.0 cm 27.95"	39.0 cm 15.35"	15.0 cm 5.91"	27.5 cm 10.83"	10.0 cm 3.94"



OUCSTD-SO

OUCSTD-CC

OUCSTD-TE

OUCSTD-BA

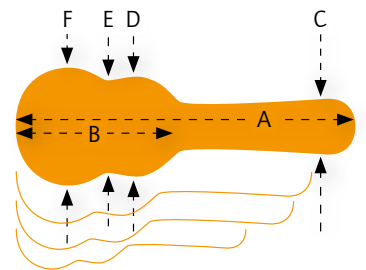

UKULELE CASES

INNER DIMENSIONS							
	A	B	C	D	E	F	Height
OUCSTD-SO soprano	55.0 cm 21.65"	29.0 cm 11.42"	12.0 cm 4.72"	14.5 cm 5.71"	14.0 cm 5.51"	17.0 cm 6.69"	8.5 cm 3.35"
OUCSTD-CC concert	66.5 cm 26.18"	32.5 cm 12.8"	13.0 cm 5.12"	14.5 cm 5.71"	14.0 cm 5.51"	19.5 cm 7.68"	9.0 cm 3.54"
OUCSTD-TE tenor	71.0 cm 27.95"	37.0 cm 14.57"	13.5 cm 5.31"	18.5 cm 7.28"	16.5 cm 6.5"	22.0 cm 8.66"	10.0 cm 3.94"
OUCSTD-BA baritone	81.0 cm 31.89"	40.5 cm 15.94"	16.5 cm 6.5"	21.0 cm 8.27"	18.0 cm 7.09"	25.0 cm 9.84"	10.0 cm 3.94"





OCCPRO

OCCPRO-T

CASES PRO

Extraordinary deluxe instrument cases in modern brown croco style vinyl finish. Arched case top, 15 mm padding - covered by "coffee crushed" velvet, built-in hygrometer, generous accessory compartment, combination lock, bronze vintage style hardware and a comfortable soft double pipe handle distinguishes these exclusive cases.

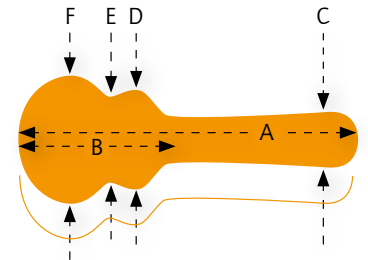

GUITAR CASES

INNER DIMENSIONS

	A	B	C	D	E	F	Height
OCCPRO regular classic	103.0 cm 40.55"	56.0 cm 22.05"	14.5 cm 5.71"	27.5 cm 10.83"	26.0 cm 10.24"	38.5 cm 15.16"	12.0 cm 4.72"
OCCPRO-T thinline classic	107.0 cm 42.13"	56.0 cm 22.05"	14.5 cm 5.71"	27.5 cm 10.83"	26.0 cm 10.24"	38.5 cm 15.16"	10.5 cm 4.13"

CASES BACK PACK STRAPS



ORTEGA BACK PACK STRAP

Designed to carry hard cases like a gig bag.

- Adjustable shoulder straps
- Securely fasten your case with adjustable straps and hard plastic release buckles
- Fits ALL shaped hard cases
- 10 mm soft padding with up to 85 mm wide shoulder pads
- Easy to install and remove - no tools needed!
- Nylon, black

OBPS



ORTEGA BACK PACK STRAP DELUXE

Designed to carry hard cases like a gig bag. The Ortega Back Pack Strap Deluxe features an ergonomic padded back cushion to relax your back while carrying your case.

- Adjustable extra wide shoulder straps
- Ergonomic padded back cushion
- Securely fasten your case with adjustable straps and hard plastic release buckles
- Fits ALL shaped hard cases
- 10 mm soft padding with up to 85 mm wide shoulder pads
- Easy to install and remove - no tools needed
- Nylon, black

OBPS-DLX



POS

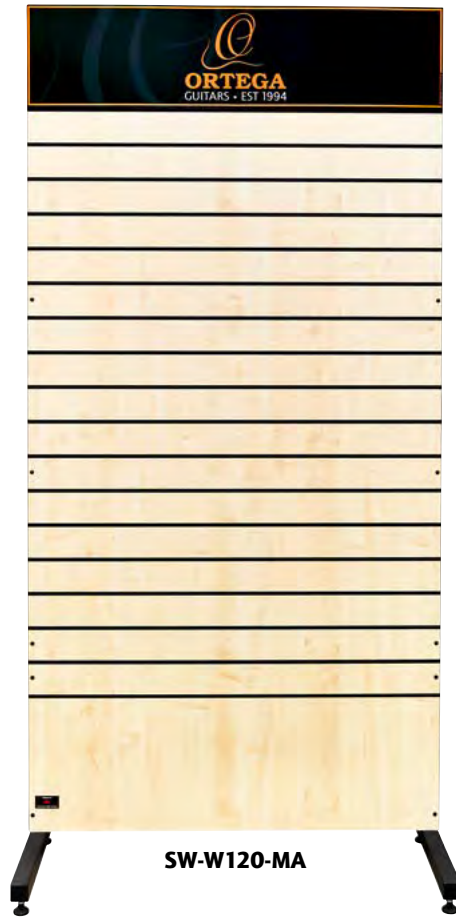

OSWA-U-AD



OSWA-U-ST



OSWA-G-AD



OSWA-G-ST



OSWA-ACC



OSWA-ACC-5MM



DIS-ORUKE-10

SW-W120-MA Ortega point of sale display modular system, 250 cm (98.43") height, 120 cm (47.24") width. Ortega Slatwall modular system all parts: 1x SW-W120-MA | 2x SW-LT, feet | 1x SW-TF, feet extension (option for freestanding) | 1x SW-OP120/30, Ortega Guitars panel | 2x SW-W-SA240, side cover

OSWA-U-AD Slatwall hook for ukulele, long, adjustable

OSWA-U-ST Slatwall hook for ukulele, short, straight

OSWA-G-AD Slatwall hook for guitar, long, adjustable

OSWA-G-ST Slatwall hook for guitar, short, straight

OSWA-ACC Slatwall hook for accessories

OSWA-ACC-5MM Slatwall hook for accessories, long, 5 mm

DIS-ORUKE-10 Ortega ukulele display fits 10 ukuleles from soprano to baritone/Ukubass size, 200 cm (78.70") height, 65 cm (25.60") width

ODECOFLAG Ortega deco flag, 70 cm (27.56") height, 60 cm (23.62") width

OBS24V2 Bar/stage stool, 61 cm (24")

OBS30V2 Bar/stage stool, 76 cm (30")

ORUG Ortega shop/stage rug, 140 x 80 cm (55" x 32"), anti slip rubber bottom



OBS24V2
61 cm (24")

OBS30V2
76 cm (30")



ODECOFLAG70



ORUG 140 x 80 cm (55" x 32")

APPAREL & MERCHANDISE

Ortega Guitars original Apparel & Merchandise available on:

www.ortegaguitars.com/shop





2021 LEFT HANDED

#OrtegaLovesLefties

UKULELES
NYLON STRING GUITARS
ACOUSTIC BASSES
MANDOLINS
BANJOS

THE CATALOG

ORTEGA®
GUITARS • EST 1994

FULL LINE
PLEASE TURN OVER



ORTEGA LOVES LEFTIES!

As a left-handed person, you do not need us to tell you how difficult it is to find a stringed instrument with the exact features, fit, and feel you are looking for.

At Ortega Guitars, we understand this challenge, which is why we offer one of the widest selections of left-handed stringed instruments on the market.

In this catalog, you will find **60 models** of guitars, ukuleles, acoustic basses, mandolins, and banjos specifically designed for the wide variety of left-handed musicians out there.

With our broad selection of sizes, colors, neck widths and configurations, you are sure to find the perfect instrument for your needs, **without** the typical "lefty upcharge"!

#OrtegaLovesLefties



2021 LEFT-HANDED CATALOG

INDEX



KEIKI® UKULELES	4	NYLON STRING GUITARS	12
K1 Ukuleles	4	Student Series	13
K2 Ukulele Packs	4-5	Family Series	14-15
K3 Ukulele Packs	5	Family Series Pro	16
KEIKI® & ORTEGA		Performer Series	17
UKULELES	6	Traditional Series	18
ORTEGA UKULELES	7	Signature Series	19
Bonfire Series	7	ACOUSTIC BASSES	20
Earth Series	8	Deep Series	20
Horizon Series	9	THE PRIVATE ROOM	20
Timber Series	9-10	Striped Suites	20
Lizard Series	10	MANDOLINS & BANJOS	21
Banjolele Series	11	Mandolins	21
UKEBASSES	11	Banjos	21
Lizard Series	11		



www.ortegaguitars.com

GLOBAL HEADQUARTERS
Ortega
Musik-Meinel-Str. 1
91468 Gutenstetten
Germany

US HEADQUARTERS
Meinl USA L.C.
Ortega
3427 Ambrose Avenue
Nashville, TN 37207
USA



info@ortegaguitars.com

Ortega Imprint

Additional changes without notice possible. If necessary - dealer/distributor contact is recommended for detailed information.

Not responsible for typographic errors. No part of this brochure may be reprinted, reproduced or included in any online service or in any other form, in whole or in part, without the prior permission of Ortega. Specifications are subject to change without notice.

Content & Direction:

Bastian Krämer & Ortega Guitars team
Germany/USA - ortegaguitars.com

Concept, Design & Realization:

Werner Stubenvoll & zeitstopp team - zeitstopp.com

Photography and Image Processing:

Christian Habermeier, Sebastian Jäger - studio waldeck
Danny Lucenara - ortegaguitars.com
Manuel Burdeus Mendoza - ortegaguitars.com

Stock footage: istockphoto.com

Cover instruments: RCE238SN-FT & RCE238SN-FT-L

© 2021 - Ortega is a registered brand of
Roland Meinl Musikinstrumente GmbH & Co.KG

ORT-CATALOG21



8 42960 18233 0



ORT-CATALOG21.7.5
Printed in Germany



Keiki® UKULELES

DESIGNED IN GERMANY BY ORTEGA®

NEW



K1-BL-L

NEW



K1-MM-L

Keiki®

- Laser engraved sea turtle
- Okoume top satin, open pore
- Okoume back & side, satin open pore
- Keiki® headstock design w/ laser logo
- Okoume neck & headstock veneer, satin finish
- Walnut fretboard & bridge
- Open gear tuning machines chrome w/ black buttons
- Ortega Guitars UWNY-4-SO strings
- Available COLORS:
BL – ocean blue
MM – natural mahogany

	scale	width at nut
Sopranino	284 mm (11.18")	32 mm (1.26")

Keiki® UKULELE PACK

UNIQUE DESIGN – CREATED BY ITALIAN STREET ARTIST GUGLIELMO GASLOLI

NEW



K2-68-L
PACK

	scale	width at nut
Soprano	364 mm (14.33")	36 mm (1.42")

- Agathis top, custom designed
- ABS body, slightly arched
- Keiki® headstock design w/ custom designed veneer
- Okoume neck, satin finish
- ABS fretboard & bridge
- Open gear tuning machines chrome w/ black buttons
- Ortega Guitars UWNY-4-SO strings
- Headstock tuner, Soundhole hook strap/support, 5 medium picks and drawstring bag included!



"THE IDEA DOES NOT HAVE TO BE CONVENTIONAL".

Guglielmo Gasoli

www.gasloliartworks.com

Keiki®
Ukulele
Pack



Keiki® UKULELE PACK INCLUDES:

- Keiki® Headstock tuner
- Keiki® Soundhole hook strap/support
- Keiki® medium picks (5 piece)
- Keiki® Drawstring bag

NEW



**K2-MAH-L
PACK**

NEW



**K2-MAP-L
PACK**

	scale	width at nut
Soprano	364 mm (14.33")	36 mm (1.42")

- Mahogany (MAH) || Maple (MAP) top, satin finish
- ABS body, slightly arched
- Okoume neck, satin finish
- ABS fretboard & bridge
- Open gear tuning machines chrome w/ black buttons
- Ortega Guitars UWNY-4-SO strings
- Headstock tuner, Soundhole hook strap/support, 5 medium picks and drawstring bag included!
- Available PACKS:
K2-MAH-L - Mahogany
K2-MAP-L - Maple



**K3-SPM-L
PACK**

	scale	width at nut
Soprano	364 mm (14.33")	36 mm (1.42")

- Spalted Maple top, satin finish
- ABS body, slightly arched
- Okoume neck, satin finish
- ABS fretboard & bridge
- Open gear tuning machines chrome w/ black buttons
- Ortega Guitars UWNY-4-SO strings
- Headstock tuner, Soundhole hook strap/support, 5 medium picks and drawstring bag included!

Keiki® Ukulele Pack

Keiki® UKULELE PACK INCLUDES:

- Keiki® Headstock tuner
- Keiki® Soundhole hook strap/support
- Keiki® medium picks (5 piece)
- Keiki® Drawstring bag

ACCESSORIES

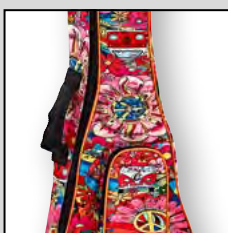

KUB-68-xx

Keiki® DESIGNER UKULELE BAGS
(see page 11 - FULL LINE)



KNS-xx-x

Keiki® DESIGNER UKULELE STRAPS
(see page 11 - FULL LINE)



Keiki® / ORTEGA® OPTIONS

scales and sizes

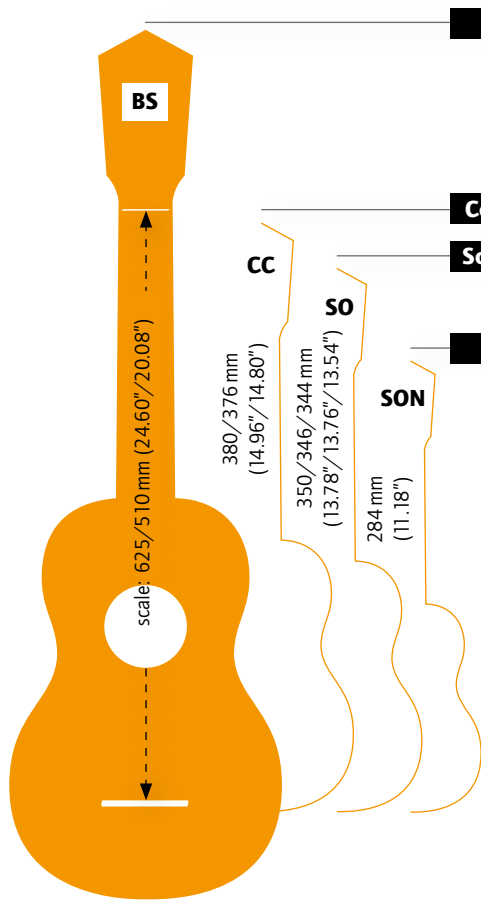

width at nut

Bass

Concert (CC or 11)

Soprano (SO or 10)

Sopranino

45 mm (1.77")

32 mm (1.26")

35 / 36 mm (1.38" / 1.42")

35 / 36 / 38 mm (1.38" / 1.42" / 1.49")

tuning

SON | A-D-F#-B
CC/SO | G-C-E-A
BS | E-A-D-G

strings



Ortega Guitars
Soprano UWNY-4-SO /
Concert UWNY-4-CC /

electronics

ORTEGA®
MagusUke



Preamp with built-in
tuner

ORTEGA®
MagusUkeGO



Plug in electronics
w/soundhole control

wood variations: top

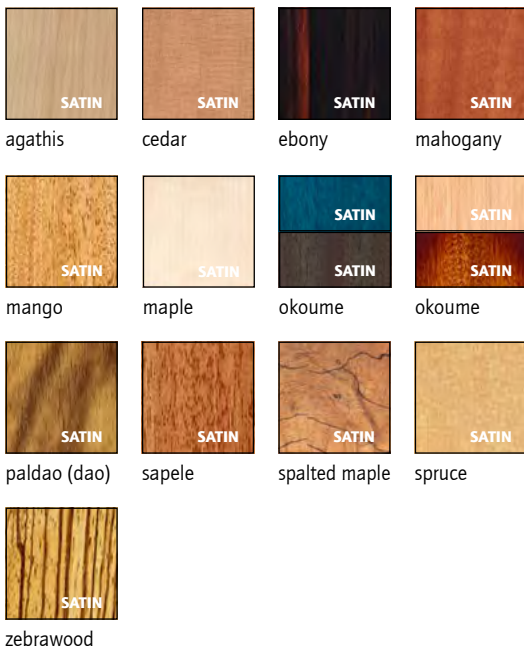

wood variations: back & sides

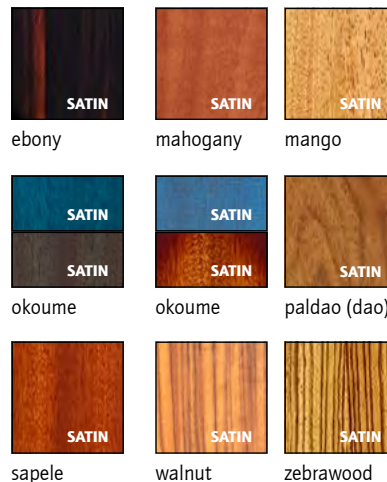

ABS variations: back & sides

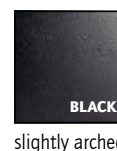

features



bag



Preinstalled strap button
on most Ortega ukuleles



BONFIRE SERIES



RU5L



RU5CE-L 

NEW



RU5MM-L

- Spruce || Mahogany (MM) satin finish, laser engraved motif
- Sapele back & side, satin finish
- Mahogany neck, satin finish
- Tortoise style ABS binding
- Walnut fretboard & bridge

- RU5CE-L: Ortega MagusUkeGO electronics
- Die-cast tuning machines, chrome w/ black buttons
- Ortega Guitars UWNY-4-CC

	scale	width at nut
Concert	380 mm (14.96")	36 mm (1.42")





EARTH SERIES

with **EQ** ELECTRONICS
ORTEGA
MagusUkeGO

NEW

NEW

NEW

NEW

NEW

NEW



RUDAWN-L

RUDAWN-CE-L



RUOCEAN-L

RUOCEAN-CE-L



RUCOAL-L

RUCOAL-CE-L



- Okoume top, back & side, dawn sunburst || ocean blue || coal black, satin finish
- Mahogany neck, satin finish
- White ABS binding
- Walnut fretboard & bridge
- Ortega MagusUkeGO electronics (-CE)
- Die-cast tuning machines, chrome w/black buttons
- Ortega Guitars UWNY-4-CC strings

	scale	width at nut
Concert	380 mm (14.96")	36 mm (1.42")

DAWN = Dawn Sunburst
OCEAN = Ocean Blue
COAL = Coal Black

ENJOY every MOMENT



HORIZON SERIES



NEW

NEW

NEW

+

RUHZ-MM-L

RUMG-L

RUMG-CE-L

- Mahogany (MM) || Mango (MG) top, satin open pore finish
- Mahogany (MM) || Mango (MG) back & side, satin open pore finish
- Reversed headstock, 4 in line
- Okoume neck & Mahogany headstock veneer || Okoume neck & Mango headstock veneer, satin finish
- Walnut top, bottom & fretboard binding
- Tecwood fretboard & bridge
- Die-cast tuning machines, black (MM) || Die-cast tuning machines, gold w/black buttons (MG)
- Ortega MagusUkeGO electronics (-CE)
- Ortega Guitars UWN4-CC strings
- Deluxe gig bag included (RUMGxx)

	scale	width at nut
Concert	376 mm (14.80")	35 mm (1.38")

MM = Natural Mahogany
MG = Mango

TIMBER SERIES



NEW

NEW

+

Concert
scale: 380 mm (14.96")
width at nut: 36 mm (1.42")



RFU11Z-L

RFU11ZE-L

- Zebra wood top, satin finish
- Zebra wood back & side, satin finish
- Mahogany neck, satin finish
- Walnut fretboard & bridge
- Ortega MagusUkeGO electronics (E)
- Die-cast tuning machines, chrome w/ black buttons
- Ortega Guitars UWN4-CC strings
- Deluxe gig bag included





TIMBER SERIES



Concert

scale: 380 mm (14.96")
width at nut: 36 mm (1.42")

RUEB-CC-L

NEW



- Ebony top, satin open pore finish
- Ebony back & side, satin open pore finish
- Mahogany neck, satin finish
- Ebony headstock veneer
- Tortoise style binding & tortoise style rosette
- Walnut fretboard & bridge
- Die-cast tuning machines, gold w/ black buttons
- Ortega Guitars UWNY-4-CC strings
- Deluxe gig bag included

SOLID TOP



Concert

scale: 382 mm (15.04")
width at nut: 36 mm (1.42")

RUTI-CC-L

NEW



- SOLID cedar top, satin finish
- Walnut back & side, satin finish
- Okoume neck, satin finish
- Walnut/maple body binding
- Walnut fretboard & bridge
- Maple "bar" fretboard inlays
- Walnut fretboard binding
- Classic headstock, Ovangkol veneer
- Bone nut & saddle
- Die-cast tuning machines, gold w/ black buttons
- Ortega Guitars UWNY-4-CC strings
- Deluxe gig bag included

LIZARD SERIES



ELECTRONICS

ORTEGA
MagusUkeGO



Concert

scale: 380 mm (14.96")
width at nut: 36 mm (1.42")

LIZARD-CC-GBL



NEW



- Paldao top, satin finish
- Paldao back & side, satin finish
- Mahogany neck, gloss finish
- Walnut binding
- Walnut fretboard & bridge
- Maple Lizard fretboard inlay
- Ortega MagusUkeGO electronics
- Die-cast tuning machines, gold w/ gold buttons
- Ortega Guitars UWNY-4-CC strings
- Deluxe gig bag included

ACCESSORIES



OWUS-1

WOODEN UKE STANDS
(see page 114 - FULL LINE)

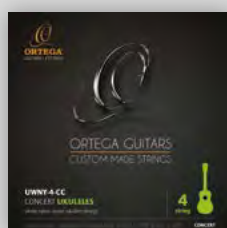

UWN4-CC

UKULELE STRINGS
(see page 98 - FULL LINE)

BANJOLELE SERIES

 BUILT-IN PICKUP SYSTEM
PICKUP BUILT-IN

OUBJE90-MA-L 

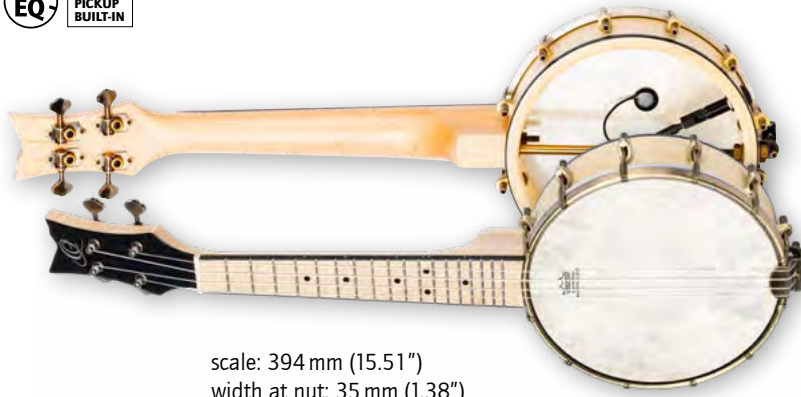

scale: 394 mm (15.51")
width at nut: 35 mm (1.38")

NEW



- 4string Banjolele
- Hard maple neck, natural, satin finish
- Maple body, open back
- Maple fretboard w/ black ABS binding
- 12 brackets, brushed brass
- Remo head, coated
- Open gear brushed brass tuning machines
- Passive transducer pickup system built-in
- Ortega UWNY-4-CC strings
- Deluxe bag included

UKEBASSES



LIZARD SERIES

 ELECTRONICS W/ TUNER
ORTEGA MagusUke

LIZZY-BS-GB-L 



scale: 510 mm (20.08")
width at nut: 45 mm (1.77")

NEW



- Mahogany top, satin finish
- Mahogany back & side, satin finish
- Mahogany neck, satin finish
- Walnut fretboard & bridge
- Black ABS binding/white purfling
- Ortega MagusUkeBass electronics w/ tuner
- 15 frets
- 2way truss rod
- Deluxe gig bag included



NYLON STRING GUITARS

OPTIONS

scales and sizes

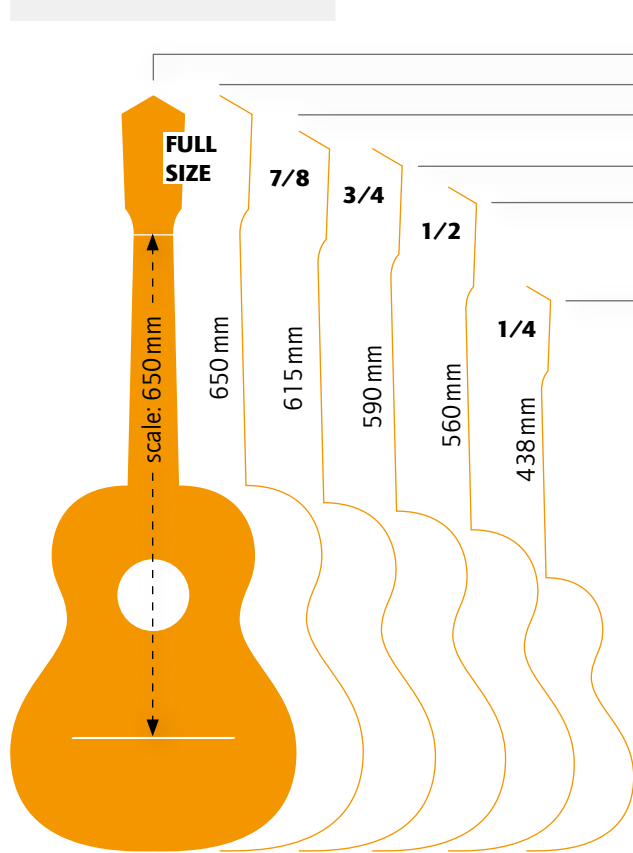

width at nut

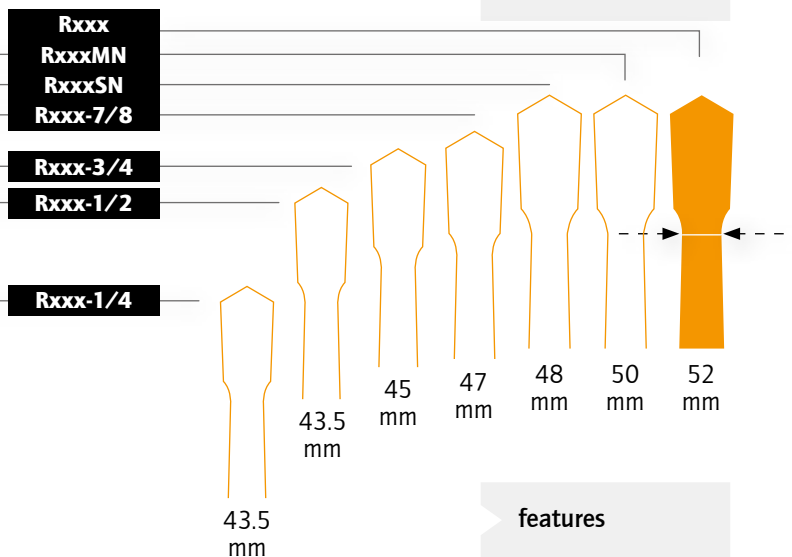

features



12hole bridge

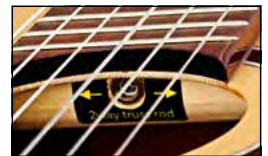

2way truss rod



bag

electronics:

RCExxx



ORTEGA MagusPRO/G

wood variations: top



wood variations: back & sides

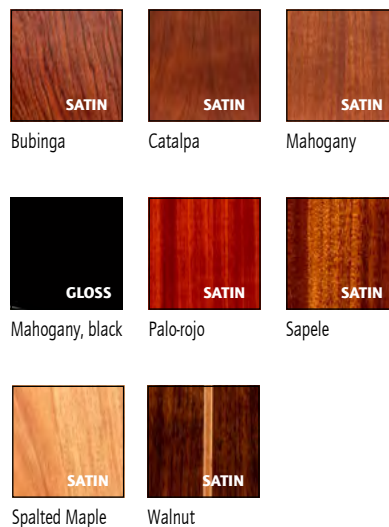



STUDENT SERIES



RSTC5M-L 

NEW

- Cedar top, satin finish
- Catalpa back & side, satin finish
- Classical rosette
- ABS binding
- Mahogany neck, satin finish
- Walnut fretboard & bridge
- Ortega 6hole bridge

	scale	width at nut
full size	650 mm (25.59")	52 mm (2.05")

ACCESSORIES



HUMIGT-BK

HUMIDIFIERS

(see page 113 - FULL LINE)



FAMILY SERIES SPRUCE TOP

with EQ ELECTRONICS W/ TUNER
ORTEGA
MagusPRO/G

NEW



R121-1/4-L
1/4 size



R121L-1/2
1/2 size



R121L-3/4
3/4 size

NEW



R121-7/8-L
7/8 size

NEW



R121SN-L
full size, SLIM NECK



R121L
full size



R121LWR
full size

NEW



R221BK-L
full size



+

	scale	width at nut
1/4 size	438 mm (17.24")	43.5 mm (1.71")
1/2 size	560 mm (22.05")	43.5 mm (1.71")
3/4 size	590 mm (23.23")	45 mm (1.77")
7/8 size	615 mm (24.21")	47 mm (1.85")
full size SN	650 mm (25.59")	48 mm (1.89")
full size	650 mm (25.59")	52 mm (2.05")

WR = wine red
BK = black

R121xx | RCE125SN-L | R221BK-L



- Spruce top, satin finish || gloss finish, wine red (WR) || gloss finish, black (BK)
- Mahogany back & side, satin finish || gloss finish, wine red (WR) || gloss finish, black (BK)
- Mahogany neck, satin finish || gloss finish, wine red (WR) || gloss finish, black (BK)
- Walnut fretboard & bridge
- Mahogany body & fretboard binding (R221BK-L)
- White abalone style purfling (R221BK-L)
- Ortega MagusPro electronics w/ tuner (RCE125SN-L)
- Ortega 12hole bridge
- 2way truss rod (3/4, 7/8 & full size)
- Deluxe gig bag included

NEW



RCE125SN-L
full size
SLIM NECK
THINLINE BODY





R122-1/4-L
1/4 size

R122-1/2-L
1/2 size

R122L-3/4
3/4 size

R122-7/8-L
7/8 size

R122SN-L
full size

R122L
full size, SLIM NECK

- Cedar top, satin finish
- Mahogany back & side, satin finish
- Mahogany neck, satin finish
- Walnut fretboard & bridge
- Ortega 12hole bridge
- 2way truss rod (1/2, 3/4, 7/8 & full size)
- Deluxe gig bag included

	scale	width at nut
1/4 size	438 mm (17.24")	43.5 mm (1.71")
1/2 size	560 mm (22.05")	43.5 mm (1.71")
3/4 size	590 mm (23.23")	45 mm (1.77")
7/8 size	615 mm (24.21")	47 mm (1.85")
full size SN	650 mm (25.59")	48 mm (1.89")
full size	650 mm (25.59")	52 mm (2.05")





FAMILY SERIES PRO SOLID CEDAR TOP

FULL SIZE



ELECTRONICS W/ TUNER

ORTEGA
MagusPRO/G



R131L



RCE131L



NEW



R131SN-L

SLIM NECK

NEW



RCE131SN-L



SLIM NECK

+



- Solid Canadian Western Red Cedar top, satin finish
- Mahogany back & side, satin finish
- Mahogany neck, satin finish
- Walnut fretboard & bridge
- Ortega MagusPro electronics w/ tuner (RCE131L & RCE131SN-L)
- Ortega 12hole bridge
- 2way truss rod
- Deluxe gig bag included

	scale	width at nut
full size SN	650 mm (25.59")	48 mm (1.89")
full size	650 mm (25.59")	52 mm (2.05")

FAMILY SERIES PRO SOLID SPRUCE TOP

FULL SIZE



ELECTRONICS W/ TUNER

ORTEGA
MagusPRO/G



THINLINE
BODY DEPTH
SLIM NECK

RCE145LBK



- Solid Canadian Engelmann spruce top, gloss finish, black
- Mahogany back & side, gloss finish, black
- Mahogany neck, gloss finish black
- Walnut fretboard (flat) & bridge
- Ortega MagusPro electronics w/ tuner
- Ortega 12hole bridge
- 2way truss rod
- Deluxe gig bag included



	scale	width at nut
full size	650 mm (25.59")	48 mm (1.89")

PERFORMER SERIES SOLID SPRUCE TOP/ SOLID CEDAR TOP

SLIM NECK/SPANISH HEEL



ELECTRONICS W/ TUNER
ORTEGA
MagusPRO/G

RCE138SN-L
REGULAR
BODY DEPTH
FLAT
FRETBOARD



NEW

RCE138-T4-L
THINLINE
BODY DEPTH
RADIUS
FRETBOARD



RCE138-T4BK-L
THINLINE
BODY DEPTH
RADIUS
FRETBOARD



+



full size

scale
650 mm (25.59")

width at nut
48 mm (1.89")

- Solid Alaskan Sitka spruce top, gloss finish || gloss finish, black
- Sapele back & side, gloss finish || gloss finish, black
- Mahogany neck, gloss finish || gloss finish, black
- 14th fret heel to body connection (RCE138-T4-L & RCE138-T4BK-L)

- Indian Laurel fretboard & bridge
- Radius fretboard (RCE138-T4-L & RCE138-T4BK-L)
- Ortega MagusPro electronics w/ tuner
- Ortega 12hole bridge

- Ortega signature walnut/maple/white pearl rosette
- 2way truss rod
- Deluxe gig bag included



MEDIUM NECK

	scale	width at nut
full size	650 mm (25.59")	50 mm (1.97")

RCE159MN-L



- Solid North American cedar top, gloss finish
- Walnut back & side, gloss finish
- Mahogany neck, gloss finish
- Indian Laurel fretboard & bridge
- Ortega MagusPro electronics w/ tuner
- Ortega 12hole bridge
- Ortega signature walnut/maple/white pearl rosette
- 2way truss rod
- Deluxe gig bag included



6 IN LINE
LOCKING
MACHINES
SLIM NECK

	scale	width at nut
full size	650 mm (25.59")	48 mm (1.89")

RCE238SN-FT-L

NEW



- Solid Alaskan Sitka spruce top, gloss finish, faded
- Mahogany back & side, gloss finish
- Mahogany neck, gloss finish
- Indian Laurel fretboard & bridge
- Ortega OTMLOCK6L-CR locking machines
- Ortega Magus Pro electronics w/ tuner
- Ortega 12 hole bridge
- Ortega signature rosette walnut/maple/white pearl
- 2way truss rod
- Deluxe gig bag



TRADITIONAL SERIES

MADE IN SPAIN

SPANISH HEEL



scale: 650 mm
width at nut: 52 mm

R180L



- Solid North American cedar top, satin finish
- Bubinga back & side, satin finish
- Maple binding
- Mahogany neck, satin finish
- Rosewood fretboard & bridge
- Ortega 12hole bridge
- Handmade in Spain
- Deluxe gig bag included

SPANISH HEEL



scale: 650 mm
width at nut: 52 mm

R200L



- Solid North American cedar top, gloss finish
- Palo-rojo back & side, gloss finish
- Maple binding
- Mahogany neck, gloss finish
- Rosewood fretboard & bridge
- Ortega 12hole bridge
- Handmade in Spain
- Deluxe gig bag included



ACCESSORIES



OWGS-1

WOODEN GUITAR STANDS
(see page 114 - FULL LINE)



OCCPRO

DELUXE CASE
(see page 121 - FULL LINE)



with EQ ELECTRONICS W/ TUNER
ORTEGA FISHMAN



SOLID TOP
RADIUS
FRETBOARD
SLIM NECK



Thomas Zwijsen
Signature model/custom made



TZSM-3-L with EQ

NEW



- Solid Canadian Spruce top, gloss finish
- Spalted Maple back and side, satin finish
- Mahogany neck, satin finish
- Maple binding w/ walnut support
- Maple fretboard radiused, 12" radiused
- Ortega 6hole bridge, pao ferro
- Ortega/Fishman Clasica Blend System w/ jack & XLR (D.I.) output w/ tuner
- 2way truss rod
- Thomas Zwijsen Signature soft case included

scale: 650 mm
width at nut: 48 mm





DEEP SERIES



D538-4-L



NEW

- Solid Alaskan spruce top, satin finish
- Sapele back & side, open pore finish
- Mahogany neck, open pore finish
- Pao Ferro fretboard w/ black ABS binding
- Pao Ferro bridge
- Black ABS binding/bk-wh-bk purfling
- Chrome hardware
- ORTEGA MagusPRO/B electronics w/ tuner
- 2way truss rod

SOLID SPRUCE



ELECTRONICS W/ TUNER
ORTEGA
MagusPRO/B

medium scale: 812 mm (32")
width at nut: 45 mm (1.77")
body depth: 122 mm (4.80")

THE PRIVATE ROOM

CUSTOM CRAFTED INSTRUMENTS

"The Private Room starts with handpicked tonewoods that are set aside to be custom crafted into exclusive guitars. This selection is limited and truly unique."

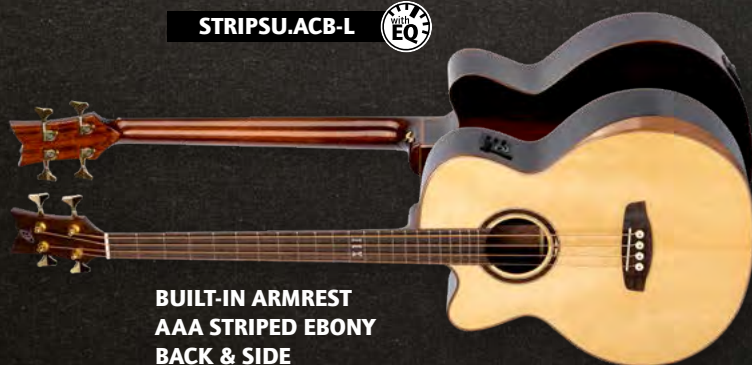

STRIPSU.ACB-L



NEW

BUILT-IN ARMREST
AAA STRIPED EBONY
BACK & SIDE

- Solid Alaskan spruce top, gloss finish
- AAA striped ebony back & side, gloss finish
- Acacia top & bottom binding / white purfling
- Mahogany neck, gloss finish
- Medium scale
- Tecwood fretboard w/ walnut binding
- Tecwood bridge
- 2way truss rod
- Ortega signature walnut/maple/white pearl rosette
- Ortega die-cast tuning machines, gold
- Ortega MagusPro electronics w/ tuner
- Deluxe gig bag & genuine leather strap included



ELECTRONICS W/ TUNER
ORTEGA
MagusPRO/B

• medium scale: 812 mm (32")
width at nut: 45 mm (1.77")
body depth: 122 mm (4.8")



scale: 345 mm (13.58") **NA**
width at nut: 28 mm (1.10") (natural)

RMA5NA-L

NEW

- Mahogany top, open pore satin finish
- Mahogany back (arched) & side, open pore satin finish
- Mahogany neck, satin finish
- Ovangkol fretboard & bridge
- 2way truss rod
- 20 frets

PICKUP BUILT-IN SYSTEM
with EQ PICKUP BUILT-IN



scale: 345 mm (13.58") **SBK**
width at nut: 28 mm (1.10") (satin black)

RMAE4OSBK-L

NEW



- Spruce top, satin finish, black
- Maple back (arched) & side, satin finish, black
- Maple neck, satin finish, black
- Rosewood fretboard & bridge
- 2way truss rod
- 20 frets
- Piezo bridge with tone & volume control, passive
- Deluxe gig bag included

BANJOS

PICKUP BUILT-IN SYSTEM
with EQ PICKUP BUILT-IN



6STRING GUITAR BANJO

OBJE356-SBK-L

NEW



- Mahogany neck & resonator, satin finish, black
- Ovangkol fretboard
- Aluminum rim
- Chrome armrest, Ortega engraved
- 30 brackets, chrome hardware
- Remo ebony head, black
- Die-cast machine head
- Built-in pickup system w/ volume control
- Deluxe gig bag included

PICKUP BUILT-IN SYSTEM
with EQ PICKUP BUILT-IN



5STRING BANJO

OBJE400TCO-L

NEW



- Quilted maple resonator, coal black, semi-gloss finish
- Maple ply rim, coal black, semi-gloss finish
- Hard maple neck, Maple fingerboard
- Brass tone ring, 24 brackets
- Brushed nickel hardware
- Die-cast machine head
- Remo head, fiberskin style
- Deluxe gig bag included



GLOBAL HEADQUARTERS

Ortega
Musik-Meinel-Str. 1
91468 Gutenstetten
Germany

US HEADQUARTERS

Meinl USA L.C.
Ortega
3427 Ambrose Avenue
Nashville, TN 37207
USA

info@ortegaguitars.com
www.ortegaguitars.com