

-
1. During a heavy rainstorm, soil samples *A* and *B* both became saturated with water. However, 10 minutes after the storm ended, the soils appeared as shown below.

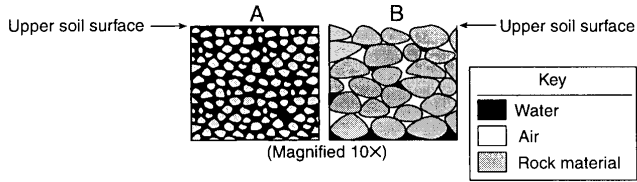

Which statement best explains the observed change in the water content of the soil samples?

- A) **The permeability of *B* is greater than the permeability of *A*.**
- B) The porosity of *B* is greater than the porosity of *A*.
- C) The capillarity of *B* is greater than the capillarity of *A*.
- D) The surface runoff at *B* is greater than the surface runoff at *A*.
-

2. The diagram below shows a laboratory setup. The rubber band holds filter paper across the base of the open tube to hold the soil sample. The tube was placed in the water as shown. The upward movement of water is represented by arrows. The height of the water that moved upward within the soil was measured. Students repeated this procedure using soils with different particle sizes. Results of the experiment are shown in the data table.

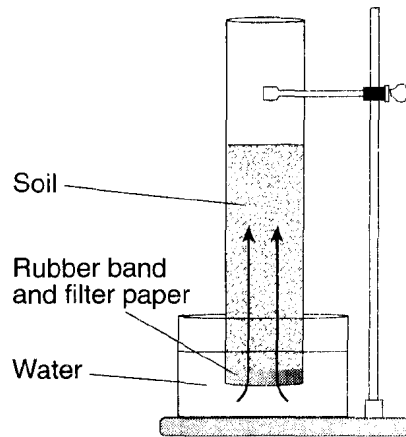

Data Table

Average Soil Particle Diameter (cm)	Height of Water in Column (cm)
0.006	30.0
0.2	8.0
1.0	0.5

Results of this experiment lead to the conclusion that

- A) capillarity is greater in soils with larger particles
B) capillarity is greater in soils with smaller particles
 C) permeability is greater in soils with larger particles
 D) permeability is greater in soils with smaller particles
-
3. Which diagram represents the soil with the greatest permeability?
- KEY
 ■ SOIL PARTICLES
 □ PORE SPACE (AIR)
- A) B) C) D)
4. In which sediments is the capillary action of water greatest?
- A) **silt and sand**
 B) sand and pebbles
 C) pebbles and cobbles
 D) cobbles and boulders
5. Which surface soil type has the slowest permeability rate and is most likely to produce flooding?
- A) pebbles B) sand
 C) silt D) **clay**

6. Base your answer to the following question on the diagram below, which shows four tubes containing 500 milliliters of sediment labeled *A*, *B*, *C*, and *D*. Each tube contains well-sorted, loosely packed particles of uniform shape and size and is open at the top. The classification of the sediment in each tube is labeled.

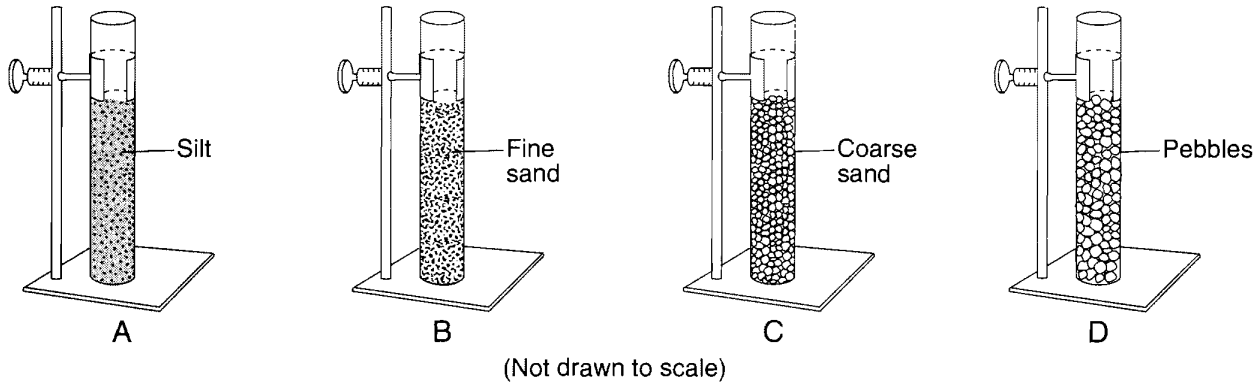

Each tube is filled with water to the top of the sediments and the tube is covered with a fine screen. The tubes are then tipped upside down so the water can drain. In which tube would the sediment retain the most water?

- A) *A* B) *B* C) *C* D) *D*

7. The diagram below represents zones within soil and rock. The zones are determined by the kinds of movement or lack of movement of water occurring within them.

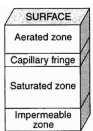

What is the deepest zone into which water can be pulled by gravity?

- A) aerated zone B) capillary fringe
C) **saturated zone** D) impermeable zone

Base your answers to questions 8 through 10 on the diagram below and on your knowledge of Earth science. The diagram represents setups of laboratory equipment, labeled *A*, *B*, *C*, and *D*. This equipment was used to test the infiltration rate and water retention of four different particle sizes. Each column was filled to the same level with uniform-sized dry, spherical particles. Water was poured into each column until the water level rose to the top of the particles. Then, the clamp was opened to allow the water to drain into the beaker beneath each column.

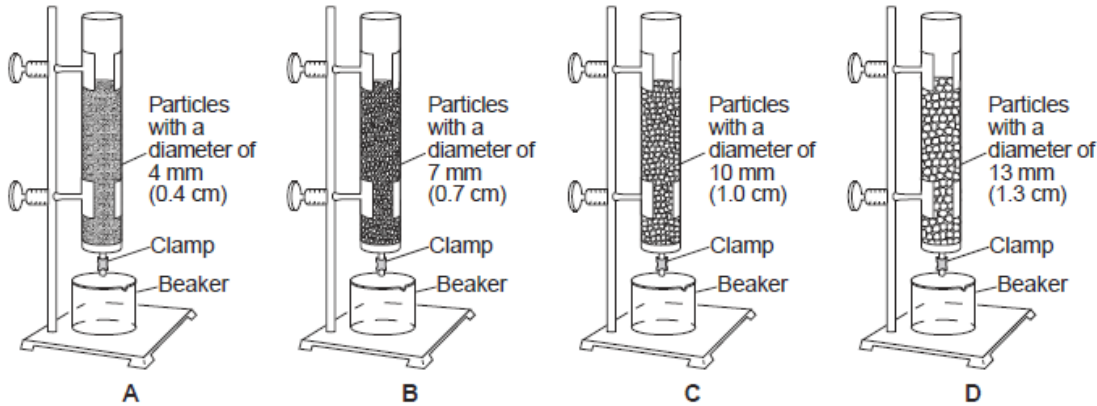

(Not drawn to scale)

8. Which column of particles retained the most water after the clamps were opened and the water was drained into the beakers?

- A) *A* B) *B* C) *C* D) *D*

9. All of the particles in these four columns are classified as

- A) clay B) silt C) sand D) pebbles

10. Which graph best shows the rate of infiltration of water through the particles in these four columns?

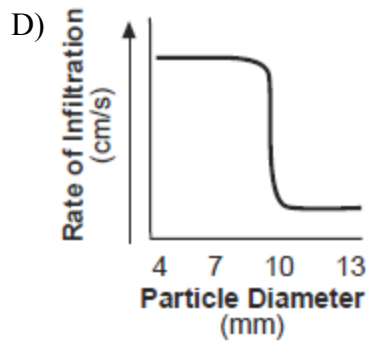
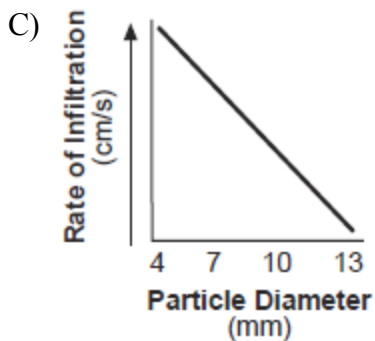
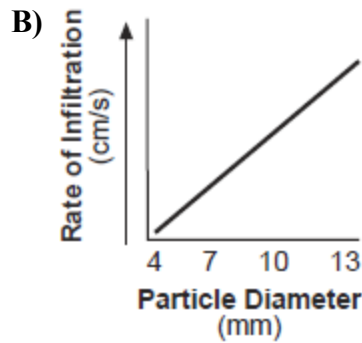
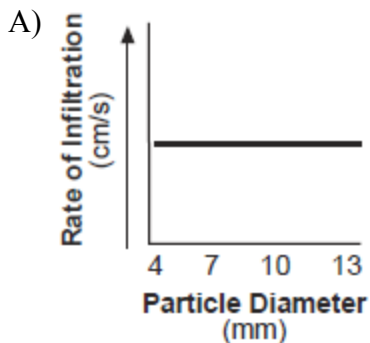

Base your answers to questions 11 and 12 on the diagram below, which represents samples of soil and bedrock at Earth's surface. The arrows represent possible infiltration of rainwater.

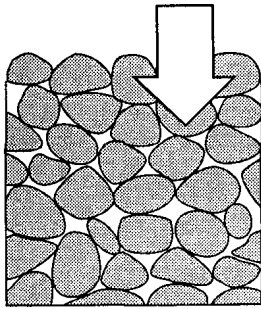

Pebble soil

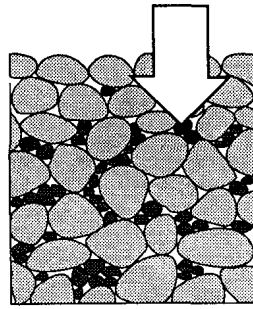

Pebble-and-sand soil

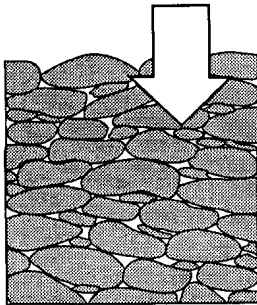

Conglomerate bedrock

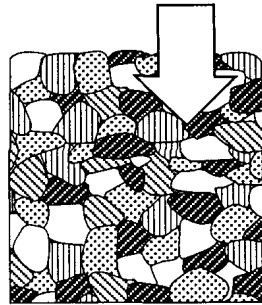

Granite bedrock

11. Zones within soil and rock are classified by the water movement occurring in the zones. Which diagram best represents the most common arrangement of these zones?

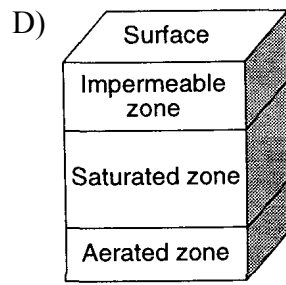
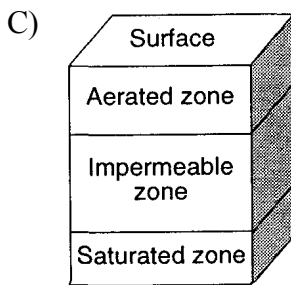
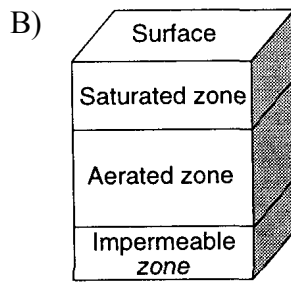
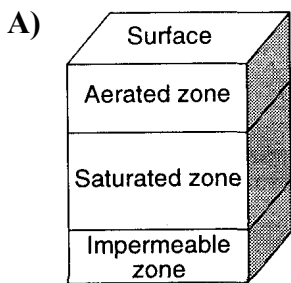

12. The pebble-and-sand soil has greater capillarity than the pebble soil because the pebble and sand soil

- A) is weathering more rapidly
- B) is more loosely packed
- C) **has smaller pore spaces**
- D) has less surface area

13. The diagrams below represent two identical containers filled with nonporous uniform particles. The containers represent models of two different sizes of soil particles.

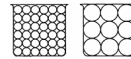

Compared to the model containing larger particles, the model containing smaller particles has

- A) less permeability and greater porosity
 - B) greater porosity and greater capillarity
 - C) **less permeability and greater capillarity**
 - D) greater permeability and greater porosity
14. Soil composed of which particle size usually has the greatest capillarity?

- A) **silt**
- B) fine sand
- C) coarse sand
- D) pebbles

Base your answers to questions 15 and 16 on the diagram below. Columns A, B, C, and D are partially filled with different sediments. Within each column, the sediment is uniform in size. A fine wire mesh screen covers the bottom of each column to prevent the sediment from falling out. The lower part of each column has just been placed in a beaker of water. Sediment sizes are not drawn to scale.

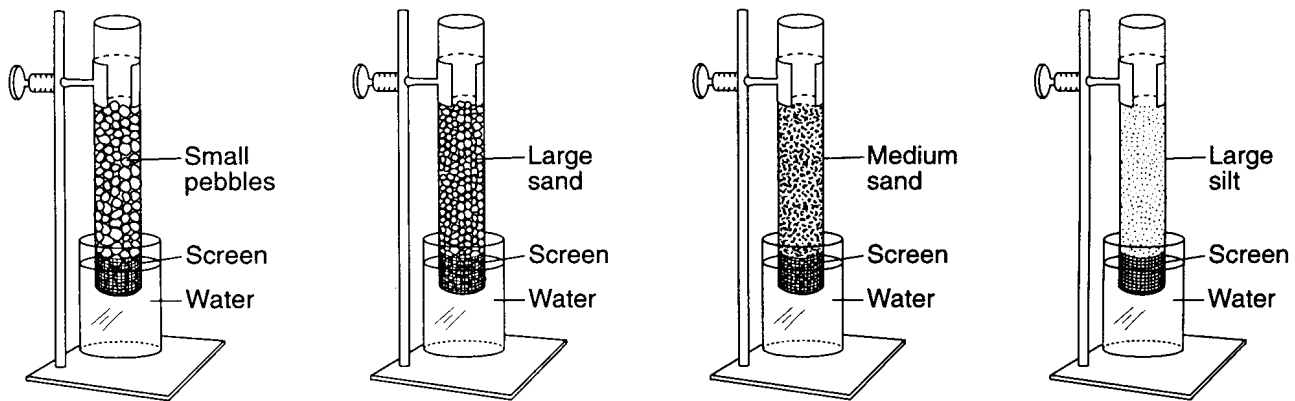

Column A

Column B

Column C

Column D

15. In an experiment, the beakers of water were removed and replaced with empty beakers. The sediments were allowed to dry. Then water was poured into each column to compare the permeability of the sediments. The permeability rate of the medium sand sample was shown to be

- A) less than the silt and pebble samples
- B) less than the silt sample but more than the pebble sample
- C) greater than the silt sample but less than the pebble sample**
- D) greater than the silt and pebble samples

16. In which sediment will capillary action cause the water from the beaker to rise fastest in the column?

- A) small pebbles B) large sand C) medium sand **D) large silt**

Base your answers to questions 17 and 18 on the diagrams below, which represent 500-milliliter containers that are open at the top and the bottom and filled with well-sorted, loosely packed particles of uniform size. A piece of screening placed at the bottom of each container prevents the particles from falling out.

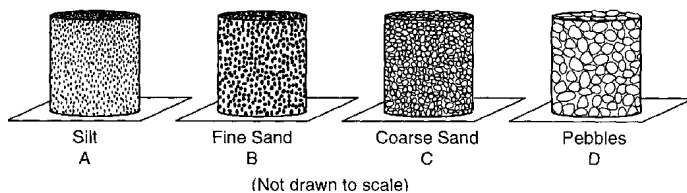

17. The sample in which container would have the greatest capillarity when placed in water?

- A) A** B) B C) C D) D

18. Which graph best represents the rate of permeability of the samples?



19. Base your answer to the following question on the passage below.

Frozen Mammoth

A woolly mammoth was found in 1999 buried in the frozen soil of the Siberian tundra. Carbon-14 dating indicated that it had died about 20,000 years ago. Many fossils represent only the partial remains of organisms. However, a complete mammoth with bones, skin, hair, and internal organs intact represented a unique opportunity for scientists to investigate the lifestyle of this animal and the environment in which it lived.

The low permeability of the tundra soil helped to preserve the mammoth. Explain why the tundra soil has a low permeability.

20. The diagrams below represent two containers, each filled with a sample of nonporous particles of uniform size.

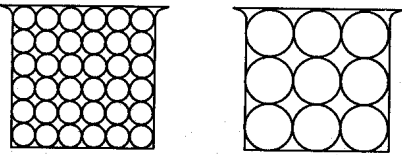

Compared to the sample of larger particles, the sample of smaller particles has

- A) **lower permeability**
 - B) higher permeability
 - C) less porosity
 - D) more porosity
-

21. The diagram below shows three identical plastic tubes filled to the same level with spherical beads of different diameters. Each tube was filled with water to the top of the beads. The clamps were then opened to allow water to drain into the beakers.

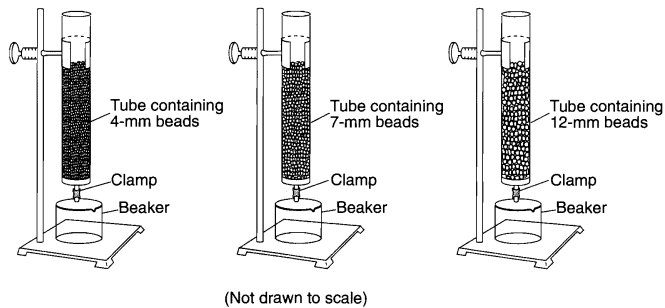

Which graph best represents the relative amount of water retained by the beads in each tube?

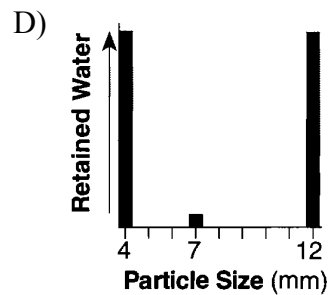
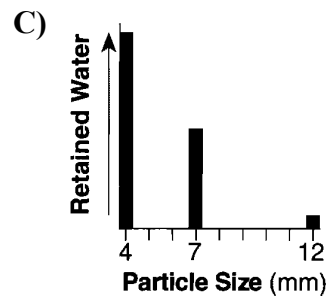
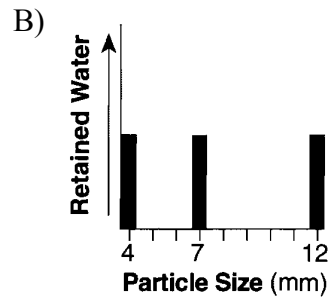
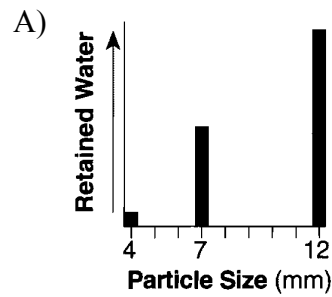

22. Water moves upward through the soil because of

- A) capillary action B) permeability
C) porosity D) infiltration

23. Which graph best represents the relationship between the particle size and the capillarity of a sample of soil?

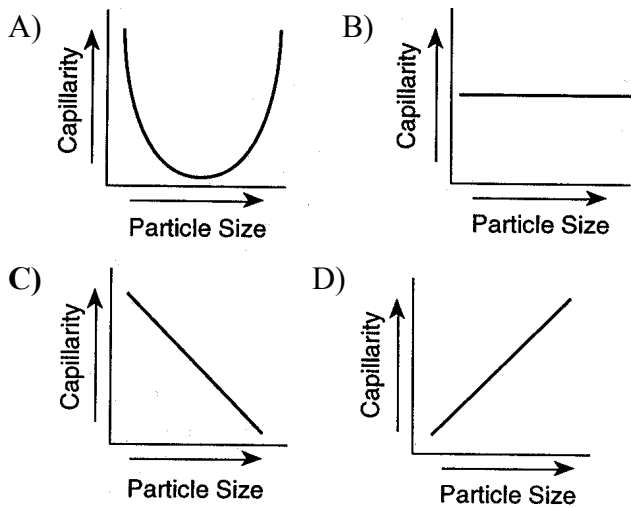

24. Base your answer to the following question on the bedrock cross section below, which represents part of Earth's crust where natural gas, oil, and water have moved upward through a layer of folded sandstone and filled the pore spaces at the top of the sandstone layer.

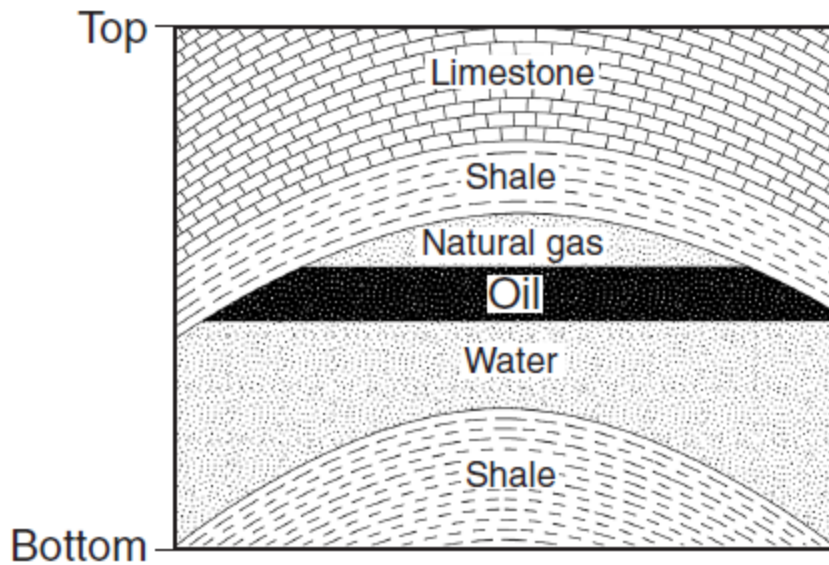

The natural gas, oil, and water are trapped within the top of the sandstone and do not move upward through the shale because, compared to the sandstone, the shale has

- A) lower permeability
- B) less foliation
- C) larger pore spaces
- D) larger particles

25. Which graph best represents the general relationship between soil particle size and the permeability rate of infiltrating rainwater?

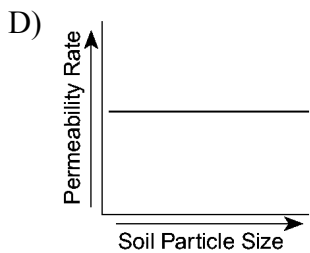
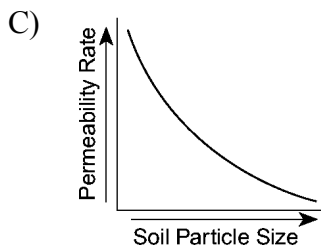
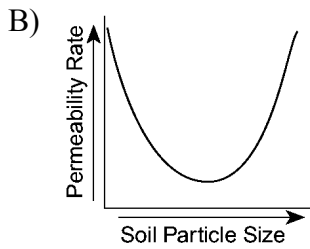
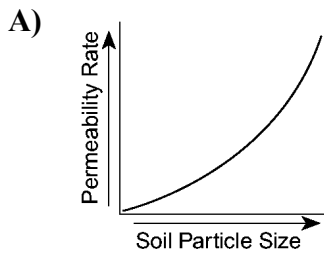

26. The upward movement of water through tiny spaces in soil or rock is called

- A) water retention **B) capillary action**
C) porosity D) permeability

27. Which soil-property measurement usually is greater when particles are fine than when particles are coarse?

- A) infiltration **B) capillarity**
C) porosity D) permeability rate
-

28. Base your answer to the following question on the diagram and field map below. The diagram shows an underground gasoline storage tank at a service station that is leaking gasoline into the soil. Ground-water monitoring wells were drilled to show the pattern of the leakage. The concentration of gasoline, in parts per million, at each well is indicated on the field map.

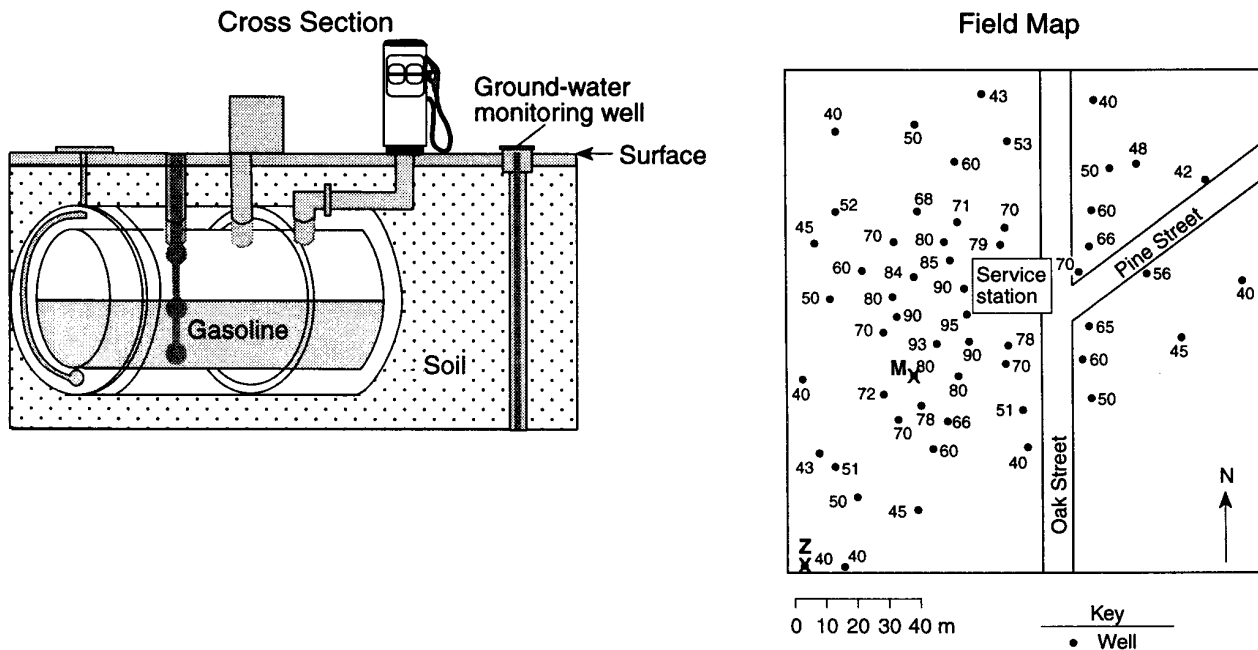

Leaking gasoline is most likely to seep into soil that is

- A) permeable and saturated **B) permeable and unsaturated**
 C) impermeable and saturated D) impermeable and unsaturated

29. The graph below represents soil permeability.

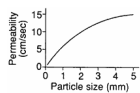

As particle size increases, permeability

- A) decreases **B) increases**
 C) remains the same

30. Which graph shows the general relationship between soil particle size and the capillarity of the soil?

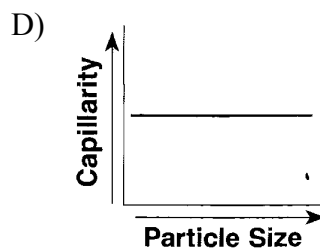
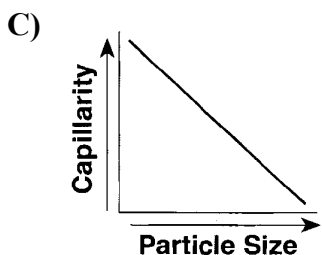
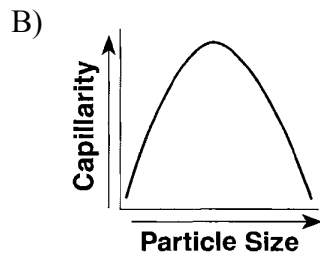
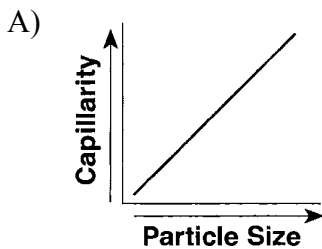

31. Base your answer to the following question on the diagrams below, which show two soil cross sections from adjacent fields in Nebraska. Both soils are the same except that human activities have removed the vegetation from the surface of field *B*. Each field has been receiving rain for several hours.

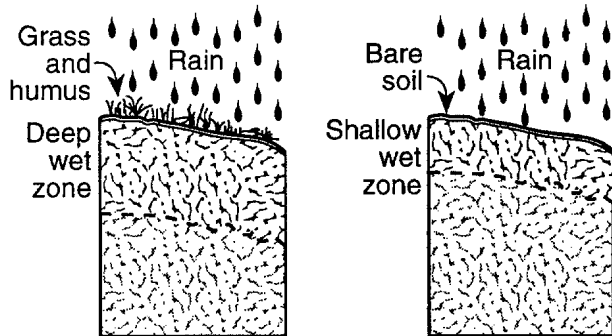

Soil from Field A

Soil from Field B

The soils in field *B* would have a higher rate of permeability if the soils

- A) had lower porosity
 - B) had a steeper surface slope
 - C) were composed of larger rock particles**
 - D) were compacted by machinery traveling over the field
32. Rainfall is most likely to infiltrate into soil that is
- A) permeable and saturated
 - B) permeable and unsaturated**
 - C) impermeable and saturated
 - D) impermeable and unsaturated
33. Sand sediments are usually more permeable than silt sediments because sand grains are
- A) larger**
 - B) smoother
 - C) rounder
 - D) more soluble

34. Base your answer to the following question on the water cycle diagram shown below. Some arrows are numbered 1 through 4 and represent various processes.

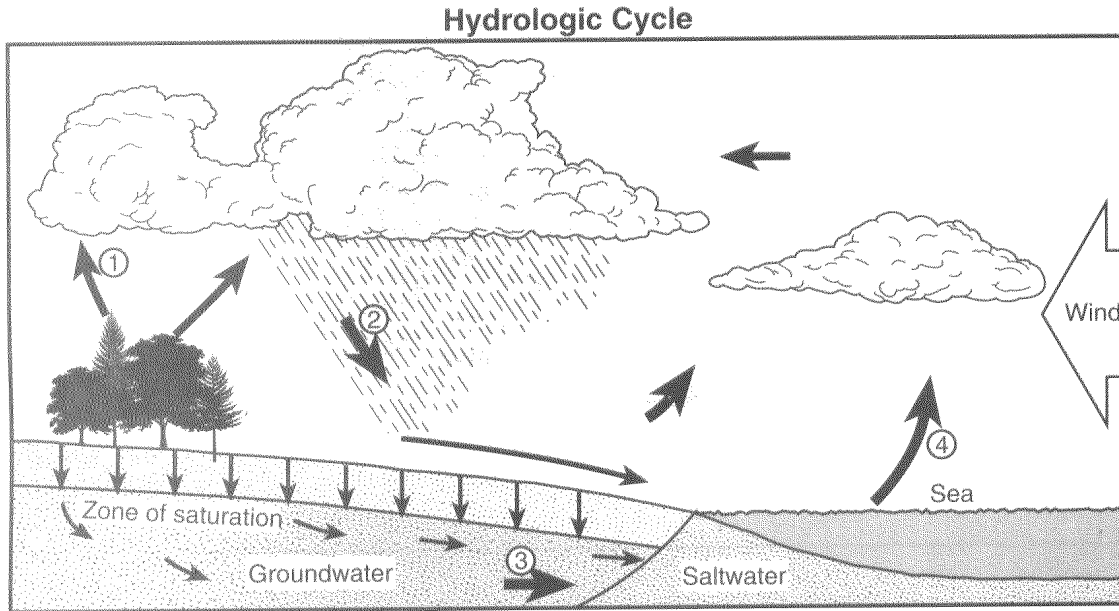

For infiltration to occur, the ground must be

- A) permeable and saturated **B) permeable and not saturated**
C) impermeable and saturated D) impermeable and not saturated

35. Which property of loose earth materials most likely increases as particle size decreases?
- A) **capillarity** B) infiltration
C) permeability D) porosity

36. The diagram below shows an experimental setup to compare water retention and permeability in two columns with equal volumes of spherical plastic beads of different diameters.

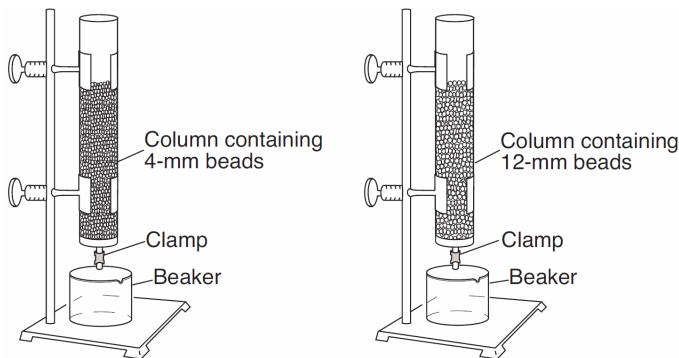

Which statement best describes the water retention and permeability in the two columns of beads?

- A) The column with 4-mm beads has greater water retention and permeability.
- B) The column with 12-mm beads has greater water retention and permeability.
- C) The column with 4-mm beads has greater water retention and the column with 12-mm beads has greater permeability.**
- D) The column with 12-mm beads has greater water retention and the column with 4-mm beads has greater permeability.
37. Immediately after a moderate rainfall, the stream discharge is greater from a stream that drains a clay soil area than from a stream that drains a sand-and-gravel soil area. This discharge differs because the clay soil is
- A) less porous, and allows less runoff
- B) more porous, and allows more runoff
- C) less permeable, and allows more runoff**
- D) more permeable, and allows less runoff
38. Water can pass through a sandstone sample because the sample is
- A) permeable**
- B) organic in origin
- C) composed of pebble-sized particles
- D) well compacted and cemented

39. The diagram below shows the result of leaving an empty, dry clay flowerpot in a full container of water for a period of time. The water level in the container dropped to level *A*. The top of the wet area moved to level *B*.

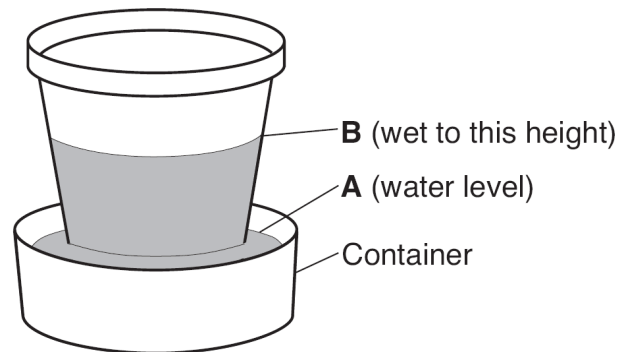

Level *B* is higher than level *A* because water

- A) is less dense than the clay pot
- B) is more dense than the clay pot
- C) traveled upward in the clay pot by capillary action**
- D) traveled downward in the clay pot by capillary action

40. The diagram below represents the setup for an experiment for studying groundwater. Tubes *A*, *B*, *C*, and *D* contain equal volumes of sediments. Within each tube, the sediments are uniform in size, shape, and packing. A test for water retention was conducted by first filling each tube with water and then draining the water into beakers.

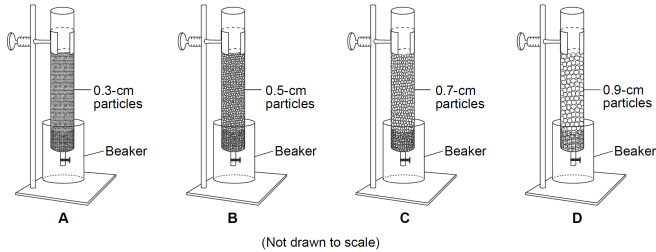

Which graph represents the general relationship between the sediment size and the amount of water retained by the sediments after the tubes had drained?

