

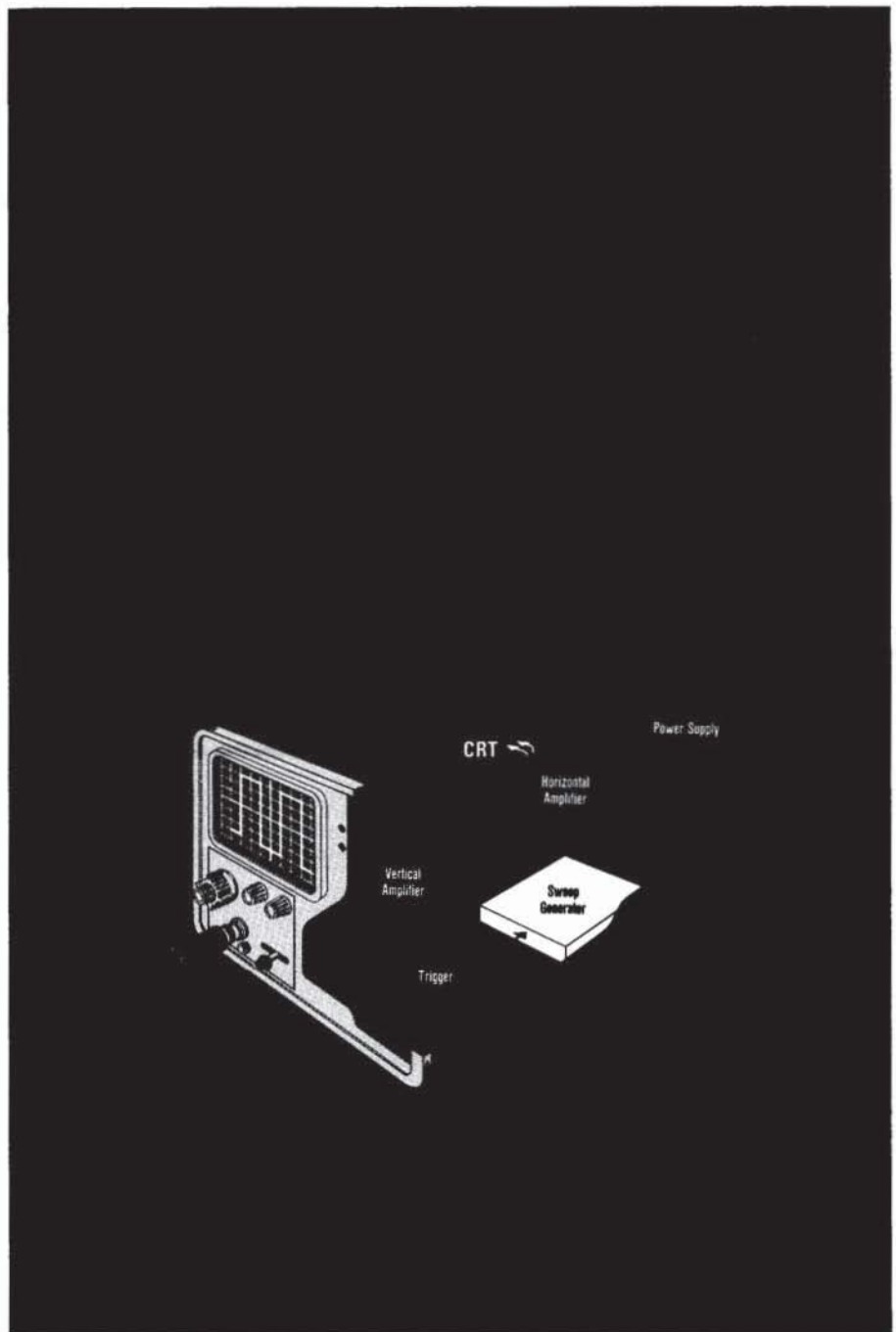

# Circuit Concepts

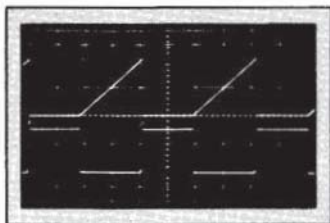

# **SWEEP GENERATOR CIRCUITS**

**BY**

**KENNETH A. KINMAN**



**CIRCUIT CONCEPTS**

FIRST EDITION FIRST PRINTING JUNE 1969  
062-1098-00  
PRICE \$1.00

© 1969, TEKTRONIX, INC.  
BEAVERTON, OREGON 97005  
ALL RIGHTS RESERVED

## CONTENTS

	INTRODUCTION	1
1	SAWTOOTH WAVEFORM CHARACTERISTICS	3
2	THE GATED-CLAMP-TUBE GENERATOR	13
3	THE BOOTSTRAP SWEEP GENERATOR	25
4	THE MILLER INTEGRATOR SWEEP GENERATOR	43
5	SWEEP GENERATOR CONTROL CIRCUITS	73
	INDEX	103

## INTRODUCTION

The cathode-ray oscilloscope (CRO) is a measuring device that displays electrical phenomena. Ordinarily, the phenomenon is displayed as a visual plot of the instantaneous voltage of a wave as a function of time. In most cases, the time-reference (base) is supplied by the instrument itself.

The sweep generator develops a sawtooth voltage, which after being processed in the horizontal amplifier, is applied to the horizontal deflection plates of the CRT, producing the horizontal sweep. When the deflection factor (voltage required to produce a linear unit of beam displacement) and the sawtooth voltage rate-of-rise are known quantities, the horizontal dimensions of any waveform traced on the CRT face plate can be converted to units of time.

If precise time measurements are to be made, it is essential that equal increments of horizontal distance represent equal increments of time. If the displacement of the electron beam is at all times proportional to the voltage applied to the horizontal deflection plates, it follows that the sweep voltage must change at a linear rate.

In this text we shall discuss various techniques of generating this linear sweep function voltage and various control devices used in Tektronix oscilloscopes.

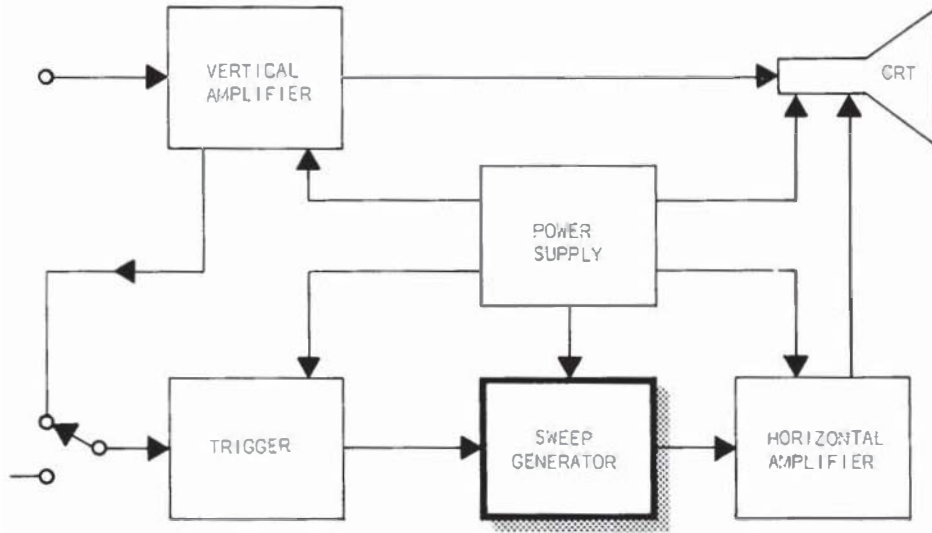

## 1

## SAWTOOTH WAVEFORM CHARACTERISTICS

the  
sawtooth

A sawtooth waveform is described by a voltage or current which starts at a given level, rises at a linear rate to some maximum value (either positive or negative), and then falls abruptly to the original level (Fig. 1-1). The rising portion of the sawtooth is called the *ramp* (A). In the development of a sweep function, the *linearity* of the ramp (or sweep) is of prime concern. The falling portion of the sawtooth is known as the *retrace* or "flyback" portion (B). The period between retrace and ramp-start is called the *holdoff* period (C). The voltage or current level from which the ramp makes its excursions is usually referred to as the *start level*. It will be advantageous to discuss these characteristics before we examine the circuits which generate the sawtooth.

## LINEARITY

When we consider that elapsed time measurements are to be made from the time base of the CRT display, we must give careful consideration to the sawtooth voltage (current) that will be used to establish this time base.

sawtooth  
voltage  
versus spot  
position

Fig. 1-1 illustrates the relationship of the sawtooth voltage to the position of the CRT spot. If we assume that the leading edge (or ramp portion) of the sawtooth voltage waveform is a straight line that produces a truly linear sweep, the spot position would conform to the equation:  $X = KT$ , where  $X$  is the amplitude of the voltage (current) which produces horizontal deflection --  $K$  is a constant -- and  $T$  is the time from start of sweep.

If we apply very accurate time marks and adjust the sweep speed of the oscilloscope properly, the display can be made to resemble that shown in Fig. 1-1. Here the relationship between the horizontal position of the CRT spot and the ramp voltage is clearly revealed. If the ramp is absolutely linear, each pulse will exactly coincide with one of the graticule markings. A perfectly linear ramp is difficult, if not impossible, to generate. For all practical purposes however, the sweep ramps generated by the state-of-the-art sweep generators can be regarded as linear.

sweep  
accuracy

Although the concept of sweep linearity is a simple one, quantitative descriptions of this characteristic differ widely. Before comparing some of these descriptions, it is essential that the difference between sweep linearity and *sweep accuracy* be established.

In this text, the term "sweep accuracy" will mean "the deviation of an observed sweep rate from a standard timing reference rate," and will be expressed in terms of *rate error* as a percentage of *full scale* deflection. (*Full scale* in this context is usually defined as the center 8 divisions of a 10-division graticule.) In Fig. 1-2, line (a) represents the rate-of-rise ( $V_R/T$ ) of the reference voltage. Line (b) represents the rate-of-rise ( $V_O/T$ ) of the observed voltage. Rate error ( $e_r$ ) is equal to  $V_R - V_O$ . The expression for sweep accuracy thus becomes  $\frac{V_R - V_O}{V_R} (100)$ . Fig. 1-2 illustrates the

relationship of the quantities just described to the appearance of an oscilloscope display.



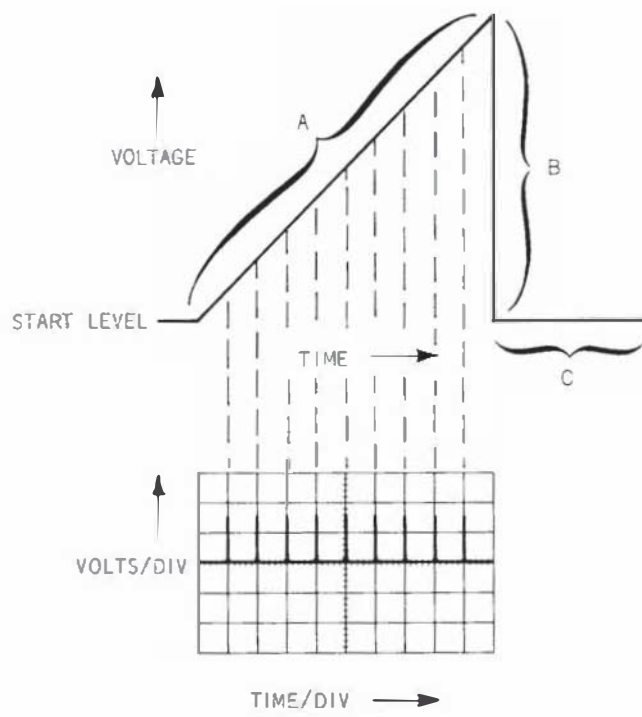

Fig. 1-1. Sawtooth characteristics.



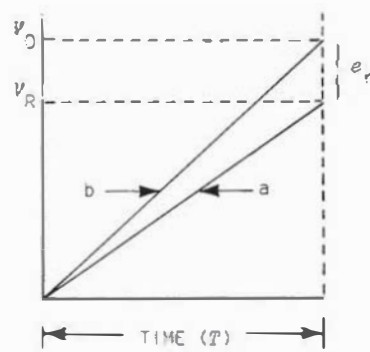
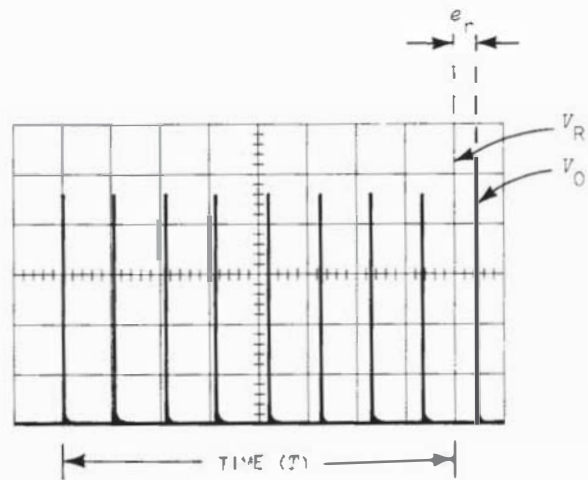

Fig. 1-2. Sweep accuracy =  $\frac{V_R - V_O}{V_R}$ .

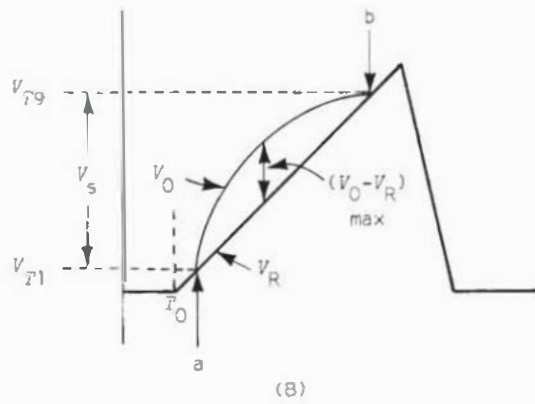
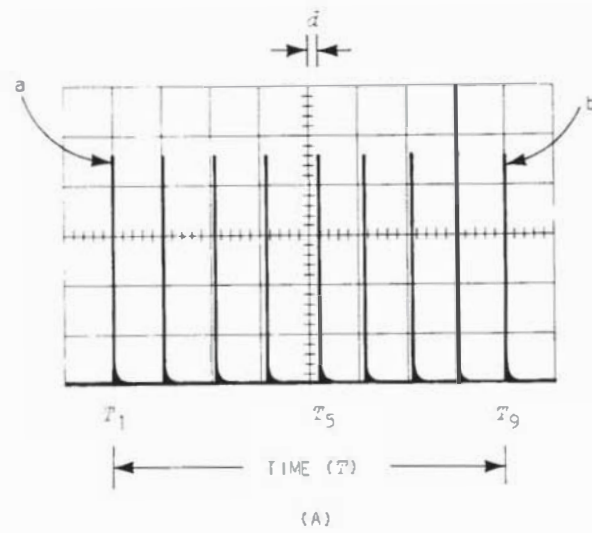

Fig. 1-3. Displacement error  $\frac{d}{T}$  (100).

Let us now compare the concept of sweep accuracy with that of sweep linearity. According to the definition presented in the previous paragraph, the sweep shown in Fig. 1-3B exhibits 0% error, since its beginning and termination lie on the reference sweep. There is obviously something wrong with the sweep however, since the time markers in the oscilloscope display (Fig. 1-3A) do not coincide with every graticule mark. Any measurement of signal duration made at the center of the graticule would obviously include a positive error. The error, of course, is due to the sweep's nonlinearity (shown highly exaggerated).

displacement  
error

One definition of nonlinearity makes use of the quantities labeled in Fig. 1-3B. Linearity is described in terms of *displacement error* and is expressed:

$$e_d = \frac{(V_0 - V_R) \max}{T}$$

Where:  $e_d$  = displacement error  
 $V_0$  = Observed ramp voltage  
 $V_T$  = "Reference" ramp voltage  
 $T = V_{T9} - V_{T1}$

In actual practice, the same results are obtained by measuring the maximum departure from linearity directly from the oscilloscope display, and dividing again by the quantity  $T$ . (Note that neither  $d$  nor  $T$  need be converted to units of time or voltage, but may be expressed in terms of graticule divisions.) It is customary to convert the fraction obtained by this equation to a percentage. Thus displacement error equals  $\frac{d}{T} (100)$ .

deviation  
from  
average

Nonlinearity may also be expressed in terms of *deviation from average* (Fig. 1-4). In this case, it is necessary to measure the total distance (in graticule divisions) between two specified time markers and divide this quantity by the number of intervening marker *intervals*. This calculation yields the average distance between markers ( $t_{av}$ ). Next, measure the distance between the two most widely separated adjacent markers ( $t_d$ ). The expression for nonlinearity, again a percentage, then becomes

$$\frac{t_{av} - t_d}{t_{av}} (100).$$

difference  
measurement

A third method of measuring sweep nonlinearity is illustrated in Fig. 1-5. Sweep time is again adjusted as shown. To obtain the necessary data, first measure the distance between the two most widely separated adjacent markers ( $t_f$ ). Subtract the distance between the two adjacent markers closest together ( $t_c$ ), and divide the difference ( $t_f - t_c$ ) by the length of the trace segment under consideration ( $T$ ). Thus the difference measurement becomes

$$\frac{t_f - t_c}{T} (100).$$

The technique used to determine the accuracy of a displayed sweep should provide the person making incremental time measurements with information that is most meaningful to him.

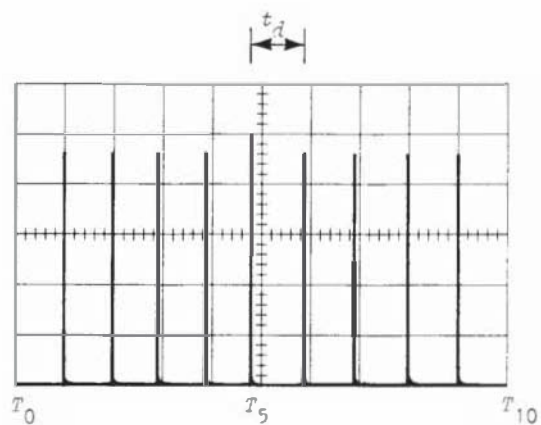

Fig. 1-4. Deviation from average =  $\frac{t_{av} - t_d}{t_{av}}$  (100).

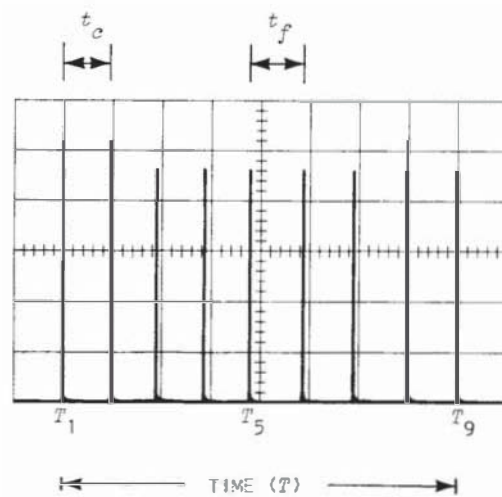

Fig. 1-5. Difference Measurement,  $\frac{t_f - t_c}{T}$  (100).

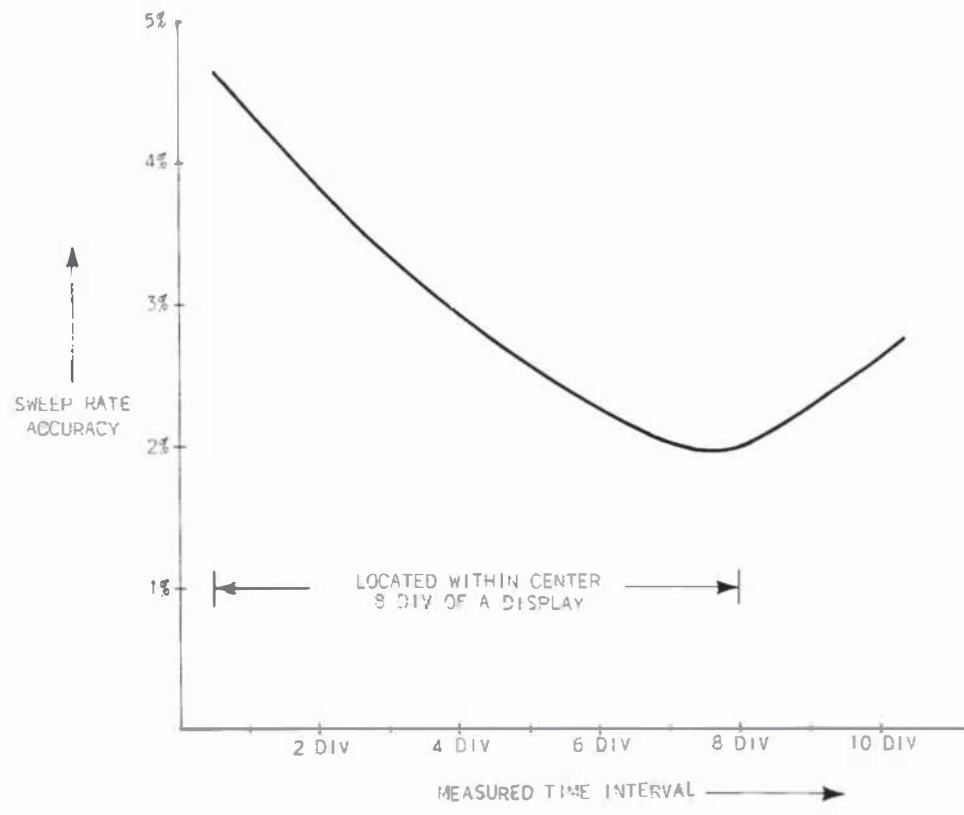

Fig. 1-6. Sweep rate accuracy versus measured time intervals.



combining  
rate  
accuracy and  
linearity  
statements

A recent trend is to state sweep accuracy in terms of defined increments of a display, thus combining sweep rate accuracy and linearity in one statement.

A graph showing how sweep accuracy may change as a function of a specific measured time interval is illustrated in Fig. 1-6. For example, a time base may be accurate to within 3% over a 4-division interval of a centered 8-division display. If a 2-division interval is used when making a measurement, the accuracy may deteriorate to 4%.

Resolution errors are not considered in Fig. 1-6, but must be considered as the interval becomes shorter. It is estimated that statements of sweep accuracy become unreliable when attempting to measure distances of .5 mm or less.

#### RETRACE (RAMP RECOVERY)

Upon termination of the ramp portion of the sawtooth voltage, the sawtooth waveform enters the *retrace* or ramp-recovery period (part B in Fig. 1-1). Ideally, the ramp should recover (and restore the electron beam to its original starting point) in zero time, since no display occurs during that period. (In most oscilloscopes, arrangements are made to cut off the CRT electron beam during retrace time.) A short retrace time also assures maximum sweep duty cycle and therefore a brighter trace. For these and other reasons, retrace time is an important consideration in the generation of a practical sweep function voltage.

#### HOLDOFF

Portion "C" of the sawtooth waveform, Fig. 1-2, is a predetermined period that is commonly referred to as *holdoff*. Holdoff time is purposely designed into the more sophisticated sweep generators to insure the stabilization of all circuitry that is associated with the sweep generator. This circuitry stabilization is necessary for many reasons, some of which will be discussed in the forthcoming chapters.

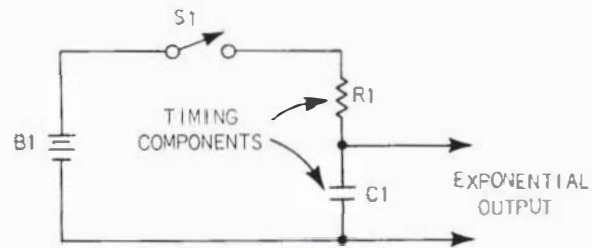

Fig. 2-1. Exponential RC circuit.

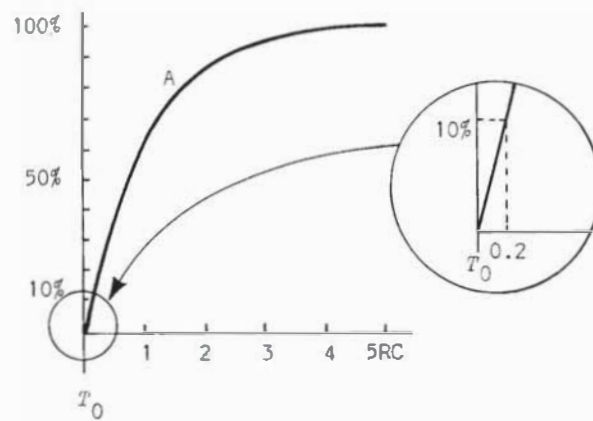

Fig. 2-2. RC exponential curve.

## 2

## THE GATED-CLAMP-TUBE GENERATOR

time  
constant

Basically, all sawtooth voltages are generated by charging a capacitor through a resistance. The *rate-of-charge* is determined by the *time constant* of the circuit, which is defined as the time required to charge a capacitor to 63.2% of the total applied voltage. The time constant is calculated from the equation,  $T = RC$ . For all practical purposes, after 5 RC periods, the capacitor will become fully charged to the total applied voltage.

exponential  
sweep

A basic exponential sweep circuit is illustrated in Fig. 2-1. If switch S1 is closed for a sufficient period, the capacitor will charge to the applied voltage of B1. The rate-of-charge is determined by the product of R and C. Fig. 2-2 shows a typical charge curve, as a plot of percentage-of-charge versus elapsed time.

Due to the exponential characteristic of the capacitor voltage, the total waveform would not provide a linear time base for the CRO. A close examination of curve "A" in Fig. 2-2 will reveal, however, that the first portion of the curve, (corresponding to 10% or less of  $E_{\text{applied}}$ ), is reasonably linear. If switch S1 were opened at approximately .2 RC, the resulting waveform could be useful as a sweep function voltage. This method of ramp derivation will be described in detail in the following discussion of the Gated-Clamp-Tube Generator.

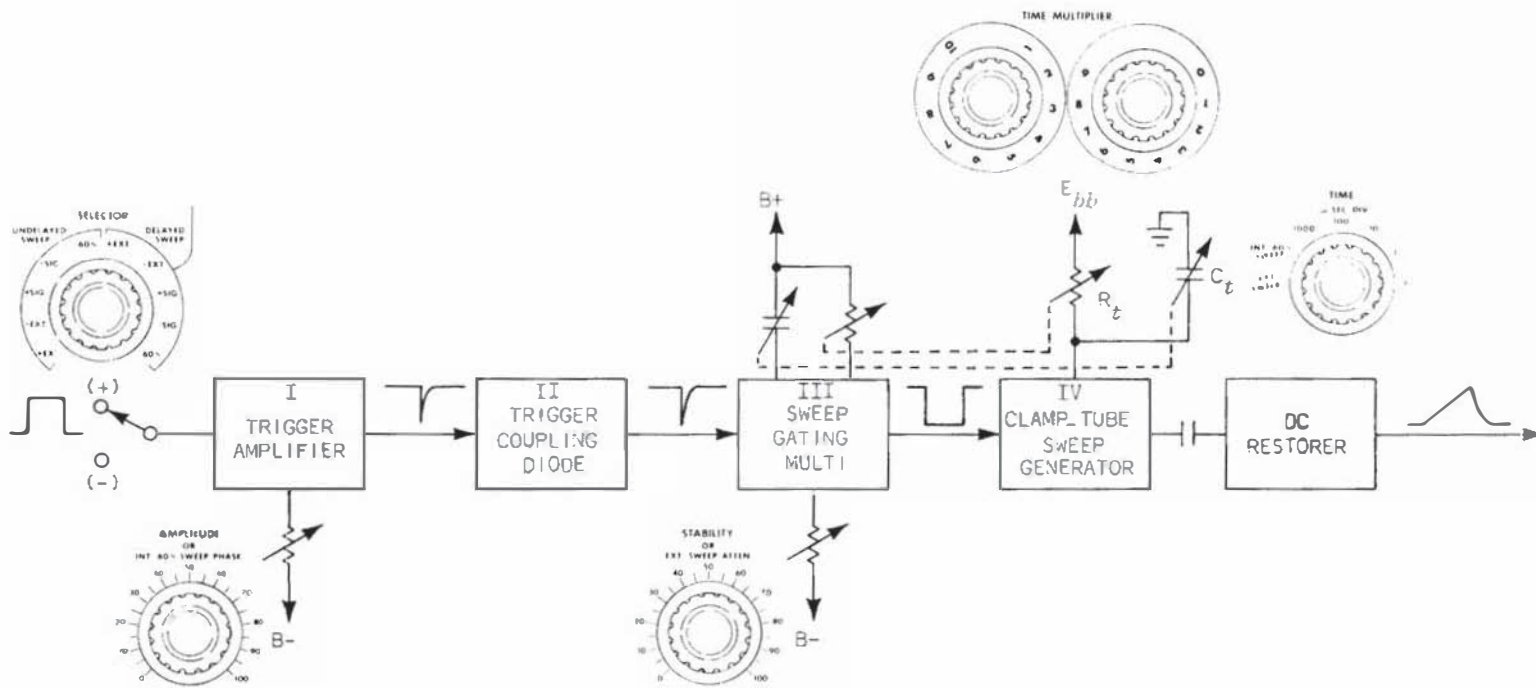

Fig. 2-3.

The block diagram in Fig. 2-3 includes a basic gated-clamp-tube generator and its control circuits. The sweep generator block consists of an active device, in this case a high- $g_m$  vacuum tube, and associated circuitry. The vacuum tube will function as the switch (S1), discussed in Fig. 2-1. Referring to Fig. 2-4A, control-grid divider R1 and R2 establish a fixed bias very close to zero volts. Quiescently, the tube conducts heavily. The plate voltage ( $E_2$ ) is very close to the cathode potential. Upon receiving the negative gate voltage ( $e_{in}$ ) at time  $T_0$ , the plate voltage starts to rise toward the supply voltage  $E_{bb}$ . Due to the circuit configuration, the plate voltage rises at an *exponential* rate, determined by the product of  $R_t$  and  $C_t$ .

charge  
amplitude

The *amplitude* of charge across  $C_t$  is determined by the *duration* of the gating pulse and the *rate-of-charge* of  $C_t$  (See Fig. 2-4B). If the gating-pulse duration is very short with respect to the  $R_t \cdot C_t$  time constant, the charge across  $C_t$  will be small compared to the supply voltage. This ratio of sawtooth voltage to power supply voltage constitutes one of the disadvantages of this technique. To get a practical sawtooth voltage amplitude, the power supply voltage must be very high. The sawtooth voltage  $e_{Ct}$  can be expressed as:

$$e_{Ct} = \frac{E \cdot t}{R_t C_t} \quad \text{where } E = E_{bb} - E_2$$

The percentage of charge can be expressed as:

$$\% \text{ Charge} = \frac{e_{Ct}}{E_{bb}} \quad (100)$$

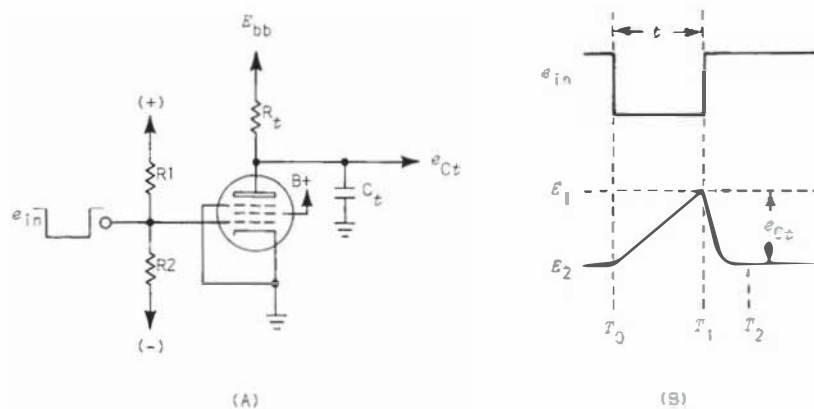

Fig. 2-4.

As was stated previously, if the percentage of charge on  $C_t$  is maintained at 10% of the applied voltage, the ramp will be reasonably linear.

Upon termination of the negative gate pulse (Fig. 2-4A), the tube rapidly returns to its original zero-bias state. The effective  $r_p$  of the tube, under zero-bias conditions, is very small, and provides a relatively low impedance path for the timing capacitor discharge current during retrace time. The time constant of the circuit (Fig. 2-4B) during retrace ( $T_2 - T_1$ ) is the product of the  $r_p$  of the zero biased-vacuum tube and the capacitance ( $C_t$ ) of the timing capacitor. If the control grid is held in its quiescent state, the plate voltage will also return to its quiescent level ( $E_2$ ) and be ready to receive another gate pulse.

It is important to note at this point, that no steps have been taken to insure that the sweep will return to its quiescent condition before another gate pulse arrives. A technique for assuring complete ramp recovery is clearly desirable. In the chapters to follow we shall examine some of the methods by which this "holdoff" period is established.

gate pulse  
width versus  
ramp  
amplitude

It should be apparent that there is an interdependent relationship between the timing components of the gating-multi and the RC timing components of the sweep generator. If the SWEEP TIME/DIV is made variable by permitting changes in the values of  $R_t$  and  $C_t$ , it follows that in order to maintain the required *ratio* of gate-pulse-width to ramp rate-of-rise, the values of the timing components in the gating-multi must be changed proportionately.

sweep  
length

Component values vary within a given tolerance and as a result, the ratio of gate-pulse duration and ramp rate-of-rise varies. The effect of this variation is a noticeable change in *sweep length* on the CRT display, as SWEEP TIME/DIV is changed. To compensate for sweep-length variations, the gate-pulse duration is extended so that the sweep terminates off the face of the CRT. This technique insures adequate sweep length to allow measurements within the entire graticule area at all sweep speeds.

Having completed discussion of the sweep generator block in the block diagram of Fig. 2-3, we will now discuss the relationship of the remaining circuits to the sweep generator.

Previous discussion of the sweep generator indicated that the "clamp-tube" generator is a *driven device*. That is, the sweep generator remains in a given quiescent state indefinitely unless a "gate voltage" is applied. The gate voltage contains all of the information required by the sweep generator to produce sawtooth voltage.

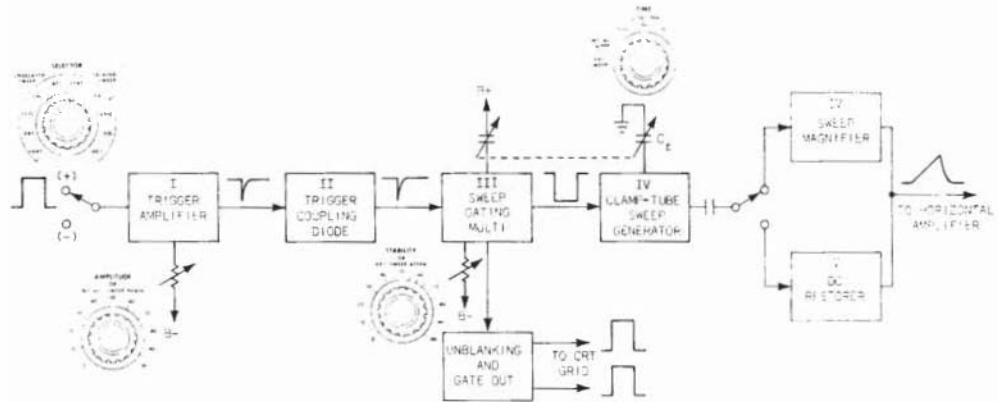

Fig. 2-5.

gated-clamp-tube sweep generator

Block III in Fig. 2-5 represents a Sweep-Gating Multivibrator. Its primary function is to convert trigger signals of various shapes into gate pulses of controlled duration. These gate pulses are then used to: (1) gate the sweep generator, and (2) *unblank* the CRT during sweep time.

Fig. 2-6 is a schematic diagram of a simplified gated-clamp-tube sweep generator and its associated circuitry. We shall refer to this illustration while discussing the operation of the sweep-gating multivibrator.



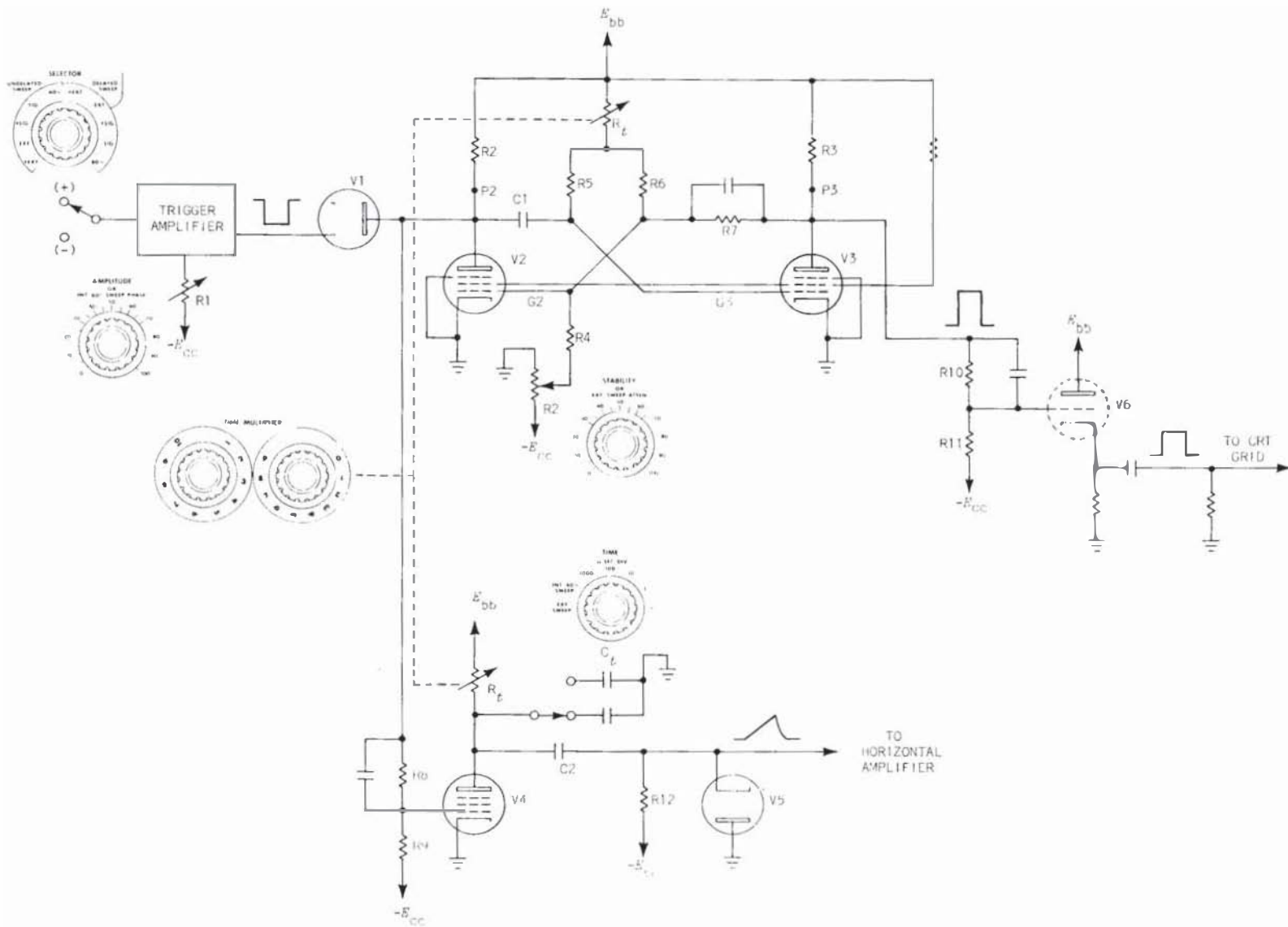

Fig. 2-6. Gated-clamp-tube sweep generator.

The gating-multi operates as a *monostable* device. The mode of operation is dictated by the requirement of the triggered sweep. The multi may also be operated in an *astable* or free-running configuration. The astable mode is useful if a synchronized sweep becomes necessary. Adjustment of the STABILITY control determines the mode of operation of the gating multivibrator.

Prior to the application of a trigger signal, the gating-multi must be in a "ready" state. This state requires that V2 be *off* and V3 *on* (i.e., V3 is in clamp) due to its zero bias. While referring to Fig. 2-6 and the ladder diagram of Fig. 2-7, we will describe the operation of the gating-multi and the effects of its operation upon the associated circuitry.

gating  
operation

After a trigger signal is processed by the trigger circuits, it attains the proper polarity and magnitude required by the sweep-gating multi. The trigger is applied to the coupling diode (V1) at time  $T_0$  (Fig. 2-7), forward biasing V1. The impulse is coupled through C1 to the control grid of V3. V3 begins a rapid transition toward cutoff, which results in a positive step voltage at P3. The positive step is impressed upon the control grid (G2), through the divider R7, R4 and R2, driving G2 into clamp or to a point within its grid base.\* The voltage at P2 falls, carrying G3 with it, insuring cut-off of V3. The multi is now in its quasi-stable state and totally nonreceptive to incoming triggers that may be present.

The duration of this quasi-stable state is determined by the RC time constant of C1, R5,  $R_t$  and the  $r_p$  of V2 during its conducting period. The period of the quasi-stable state is also the period of sweep, since the negative excursion at P2 is impressed upon the control grid of V4. This negative "gate" brings V4 out of clamp and allows  $C_t$  to begin charging toward the supply, starting ramp generation.

---

\*The region of grid bias between that which causes plate current cut-off and that which causes grid current flow.

In Fig. 2-7, during the period  $T_1 - T_0$ , as C1 charges, the voltage at G3 will rise exponentially toward  $E_{bb}$  through  $R_5$ ,  $R_t$  and the dynamic plate resistance ( $r_p$ ) of V2. At time  $T_1$ , the control grid (G3) rises to a voltage that allows V3 to come into conduction. The increased plate current in V3 results in a negative-going voltage at P3. The negative-voltage step is DC coupled to G2 and begins to cut off V2. As a result of the decreasing plate current of V2, the voltage at P2 starts toward  $E_{bb}$ , causing G3 to rise to a point that places V3 in a state of clamp. The tube V3, in clamp, establishes V2 in cutoff and the multi is once again in the "ready" state.

AC  
unblanking

Prior to sweep generation, the INTENSITY control is normally set to establish a near cut-off condition to the CRT electron beam. At time  $T_0$ , when the plate of V3 was rising toward  $E_{bb}$ , the control grid of V6 (the unblanking cathode follower) was carried with it. Through cathode-follower action, V6 couples a positive voltage step, or *unblanking pulse* to the CRT grid via a DC blocking capacitor, and is of the proper amplitude and duration to allow sufficient beam intensity during sweep time. Due to AC coupling the unblanking pulse, it is necessary to readjust the INTENSITY control each time the SWEEP TIME/DIV is changed. The intensity change is caused by changing

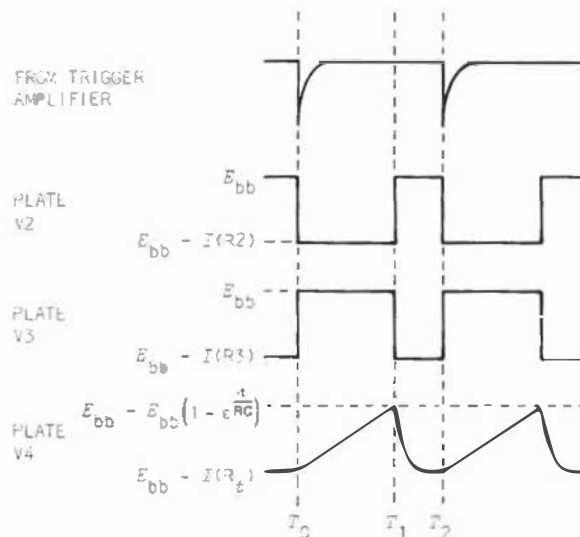

Fig. 2-7.

the duration of the pulse that is driving a circuit having a fixed RC time constant. This results in an average DC level change at the control grid of the CRT. This method of unblanking caused some degree of inconvenience to the operator, and as a result, more sophisticated unblanking methods were to be developed in later instruments.

Having discussed one complete cycle of operation of the gating multi, and its relationship to the associated circuitry in the sweep generator block diagram, several conclusions can be drawn. The gating multi:

- (1) Provides control of the sweep period (sweep length).
- (2) Generates the unblanking signal.
- (3) Converts various-shaped trigger signals to defined pulses of controllable duration, suitable for controlled sweep generation.

DC  
restoration  
(ramp-start  
reference)

The circuit in Fig. 2-6, consisting of V5, C2, and R12, is a DC restorer, or clamping circuit. The circuit provides a fixed starting reference for the ramp voltage.

Under static conditions, diode V5 is conducting and the voltage at its cathode will be about  $-.5$  volts (the forward voltage drop of V5 when conducting). The time constant C2 and R12 is long enough to insure undistorted signal transfer at the slowest sweep speed.

When a positive-going ramp voltage is applied to the coupling capacitor C2, the current through R12 develops a positive voltage which cuts off V5. The ramp continues to run up for the period of the gate pulse. At the end of sweep time, the applied voltage falls rapidly toward the original starting point. The negative-going voltage appears across the nonconducting clamp diode until the turn-on voltage is reached ( $-.5V$ ). When V5 conducts, no appreciable voltage change occurs at its cathode (due to the diode's low forward resistance), even though the applied voltage may continue to fall. The junction of V5 and R12 is now *clamped* to that voltage level established by the forward-biased clamp diode.

The method of DC restoration just described establishes the fixed ramp-start level necessary to assure a relatively stable beam position, independent of sweep speed variations.

dis-  
advantages

The gated-clamp-tube generator has some apparent disadvantages:

- (1) The lack of complete ramp recovery assurance, i. e., holdoff;
- (2) Less than desirable sweep linearity;
- (3) Large power-supply voltage requirements, necessary to provide practical sawtooth voltage amplitudes;
- (4) The DC restorer, having a definite low-frequency cut-off point, limits the minimum sweep speed obtainable;
- (5) Inability to control and adjust sweep length;
- (6) The inconvenience of having to maintain a fixed ratio of sweep-generator timing components to gate-multi timing components.

In the chapter to follow, we will discuss some considerations that brought some modifications and refinements to the gated-clamp-tube generator.

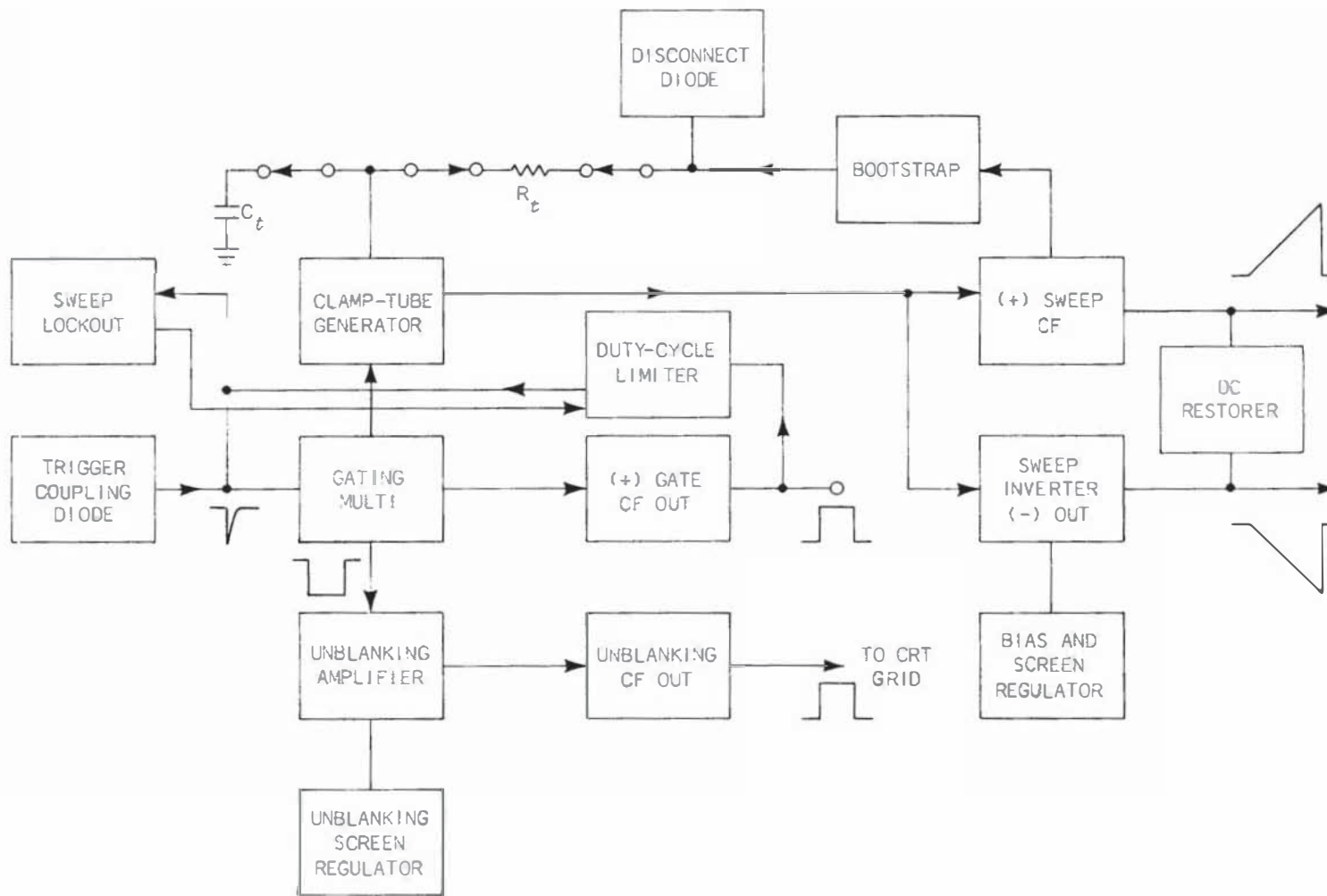

Fig. 3-1. Bootstrap sawtooth generator and associated circuits.

## 3

## THE BOOTSTRAP SWEEP GENERATOR

feedback

One method of improving the quality of sawtooth generation is to incorporate feedback. Feedback will provide a means of supplying a relatively constant current to the charging circuits, in addition to supplying a larger sawtooth-output voltage for a given power supply voltage. In the following paragraphs we will discuss the provision of *positive feedback* as an attempt to overcome some of the disadvantages found in the gated-clamp-tube generator.

constant  
 $I_{Ct}$ 

We are aware that when attempting to charge a capacitor to some voltage, through a resistance, the voltage across the capacitor becomes *series opposing* to the applied voltage. Current in the external circuit is reduced as the capacitor becomes fully charged. This results in a nonlinear voltage rate-of-change. One method of overcoming this exponential characteristic would be to cause the supply voltage to change *exactly* as the capacitor voltage changes, thus maintaining a constant current in the capacitor. One circuit that operates under this principle of *positive feedback* is commonly referred to as the Bootstrap Sweep Generator. (See block diagram in Fig. 3-2).

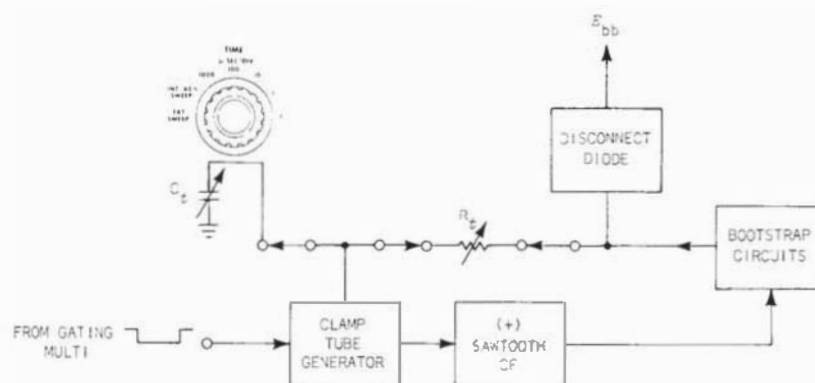

Fig. 3-2. Basic bootstrap generator.

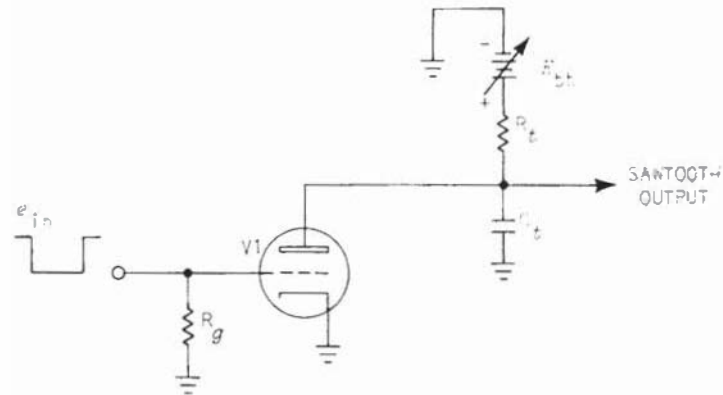

Fig. 3-3. Basic bootstrap generator.

basic  
bootstrap  
generator

Fig. 3-3 is a schematic diagram of the familiar clamp-tube generator, with the addition of a fictitious variable power supply. If a negative gate signal were applied to V1, interrupting plate current flow to  $R_t$ , the timing capacitor ( $C_t$ ) would begin to charge toward  $E_{bb}$ . Referring to the ladder diagram in Fig. 3-5, at time  $T_1$  (+), the capacitor would charge to some voltage ( $X$ ). If we could increase the supply voltage by "X" amount at the same time, we would realize a constant-voltage drop across  $R_t$ , resulting in a constant charging current to capacitor  $C_t$ . As was stated previously; supplying a constant charging current to a capacitor results in a linear voltage rate-of-change.

Fig. 3-4 represents a simple bootstrap sweep generator. Triode V1,  $R_t$  and  $C_t$  make up the clamp-tube generator. Triode V2,  $R_k$  and  $C_b$  make up the feedback circuit that provides the bootstrap effect. The circuit operation is as follows: Prior to gating V1, the sweep generator is established in its quiescent state. V1 is biased at zero volts, supplying a heavy plate current to  $R_t$  and V3. The voltage levels are as indicated in Fig. 3-5. At time  $T_1$ , the grid of V1 is driven sufficiently negative to cut off V1. The timing capacitor ( $C_t$ ) starts to charge through  $R_t$  toward the supply voltage. As the voltage  $E_{C_t}$  rises, the grid of V2 is carried with it. Assuming for the present that V2 has unity gain, its cathode will rise a like amount. At time  $T_2$ , the sum of  $E_{R_k}$  and  $E_{C_b}$  exceeds the power-supply voltage, cutting off V3. The bootstrap capacitor



( $C_b$ ), charged to  $E_{bb} - E_{V3}$ , now becomes the power supply for the charging circuit. The lower plate of  $C_b$  rises with the cathode of  $V_2$ , and if we assume that the voltage across  $C_b$  remains constant, the upper plate of  $C_b$  must increase by the same amount. The charging current path can be traced from the upper plate of  $C_t$ , through  $R_t$  to the positive plate of  $C_b$ , from the lower plate of  $C_b$ , through  $V_2$ , to the  $V_2$  plate supply. To maintain this current during ramp run-up time, the plate supply of  $V_2$  must be considerably higher than  $E_{bb}$ .

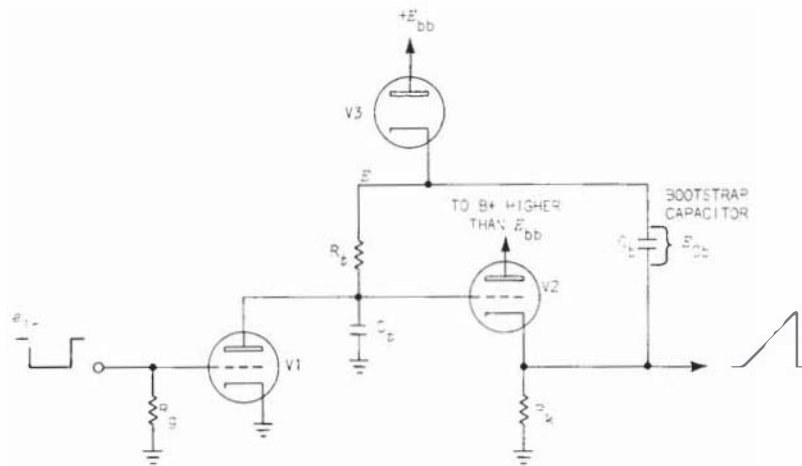

Fig. 3-4. Bootstrap sawtooth generator.

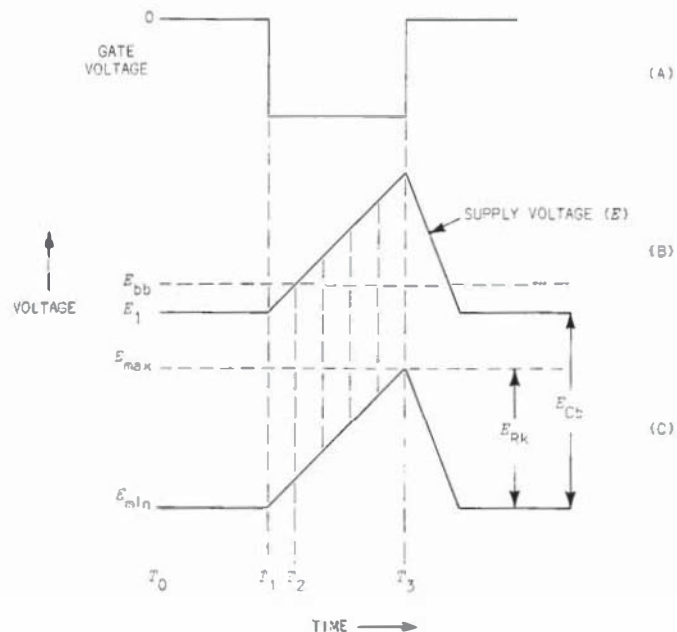

Fig. 3-5. Bootstrap generator voltage waveforms.

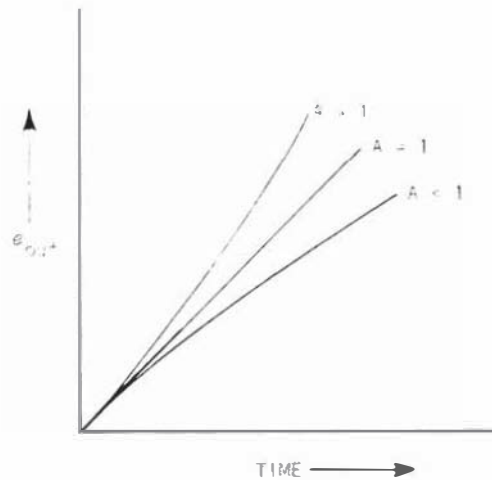

Fig. 3-6. Slope deviation related to amplifier loop gain.

Upon termination of the negative gate pulse, V1 comes back into saturation, allowing  $C_t$  to discharge rapidly through the low  $r_p$  of V1. The abrupt voltage change across  $C_t$  is coupled through V2 and  $C_b$  causing V3 to come into conduction, restoring  $C_b$  to its initial condition. The discharge path for  $C_b$  is through V3,  $R_k$ , back to the lower plate of  $C_b$ .

Due to the positive feedback action just described, the voltage at the cathode of V3 increased by the same amount as  $E_{C_t}$ . We can conclude then, that we have maintained a constant voltage drop across  $R_t$ . By Ohm's Law, a constant voltage across  $R_t$  implies a constant charging current, satisfying the basic requirement for linear ramp generation.

loop gain  
errors

The previous discussion was based on the assumption that several conditions were ideal. For example, the loop gain, (total gain around the feedback loop), was assumed to be unity. Any deviation from unity gain in the bootstrap generator will contribute to ramp nonlinearity. See Fig. 3-6.

$C_b$  to  
 $C_t$  ratio

Notice also that in actual operation, the charging current tends to discharge  $C_b$ . Recalling that during ramp run-up, the voltage across  $C_b$  must remain constant to assure absolute linearity, it is clear that the tendency of the charging current to discharge  $C_b$  would contribute to ramp nonlinearity.

To offset this tendency,  $C_b$  should be much larger than  $C_t$ . As a rule-of-thumb, the ratio of  $C_t$  to  $C_b$  should be about 20. The bootstrap capacitor should not be too large however, lest circuit-restoration time be increased, causing the generator to become sensitive to changes in repetition rate. For a mathematical treatment of linearity, refer to Millman and Taub, *Pulse and Digital Circuits*, pp 230-235.

pentode  
switching  
tube

Fig. 3-3 shows V1 as a triode. This configuration was used simply for ease of illustration. In actual practice, the switching tube, in both the clamp-tube and bootstrap generator, is a high  $G_m$  pentode. The pentode is used mainly because of its constant-current characteristics. For example, for given screen grid and control grid-to-cathode potentials, the plate current of a pentode is relatively independent of plate voltage variations, except when operating at relatively low voltages. A typical example is type 6AG7 power pentode tube. With a grid bias of -2 volts and a screen potential of 150 volts, a change in plate voltage from 300 volts to 200 volts causes a plate current change from about 40 mA to 38 mA. If this current change were not relatively constant, the linearity of the ramp would suffer considerably.

Serious considerations should be given to the bootstrap generator in terms of reliability. Tube aging and line voltage variations (affecting heater temperature) contribute largely to linearity errors in the bootstrap generator. If the loop gain of the bootstrap generator were to change by only 1%, the ramp linearity would change by a factor of 2.

Many of the disadvantages of the clamp-tube-generator have been overcome in bootstrap generator. Through incorporation of positive feedback, it is possible to design a circuit that generates a relatively large-amplitude sawtooth waveform with good linearity, using practical power-supply voltages. The bootstrap generator can be made to generate sawtooth voltages of sufficient amplitude to drive the CRT deflection plates directly, thereby eliminating the need of the horizontal amplifier. Elimination of the horizontal amplifier permits much faster sweep speeds, limited only by the ability of the generator to drive CRT deflection plate

impedance. The bootstrap generator has been utilized in Tektronix instruments to provide sweep speeds (unmagnified) ranging from 20  $\mu$ s to 2 ns/div.

duty cycle  
limiter

The block diagram in Fig. 3-1 represents an entire sweep generator and its control and output circuits. The block labeled "Duty Cycle Limiter" will be discussed in the following paragraphs.

The duty-cycle limiter is included in some bootstrap sweep generator systems to automatically limit the duty cycle of the sweep, thereby compensating for possible over-dissipation of circuit components, should the sweep repetition rate increase significantly.

In Fig. 3-7, the plate of V2 is connected to the control grid of that portion of the multi (A) that drives the clamp tube in the sweep generator. A complimentary output of the gating multi (B), is applied to the control grid of V2, through resistive-voltage divider R6, R7, and R8. The divider R1 and R2 sets the control grid of V1 to some fixed DC voltage. Potentiometer (R7) is adjusted to a voltage slightly more negative than that voltage at the grid of V1, allowing V1 to conduct the current  $I_{R3}$ . Since V2 is cut off, the sensitivity of the multi can be set by adjusting R10. (See circuit description of sweep-gating multi in Chapter 2.) An incoming trigger pulse switches the multi from its stable state to its quasi-stable state. A negative pulse is generated at point (A), cutting off the clamp tube in the sweep generator, allowing the ramp to begin its rise. At the time point (A) goes negative, point (B) steps positive.

For repetitive sweeps, these positive voltage steps are applied to the control grid of V2 through the divider R6, R7, and R8. C1 will charge to the *average* voltage at the junction of R5 and R7. For example, assume that the positive pulses present at the top end of the grid divider have peak amplitudes of 20 V. As C1 charges toward 20 volts, the voltage at the grid of V2 will reach a level more positive than that voltage at the control grid of V1. Current through R3 will then switch from V1 to V2. The voltage at the junction of R4 and R9 will become more negative, reverting the gating multi to its stable state. The multi, in its stable state, clamps the sweep generator, terminating the sweep. The period of the sweep then, is determined by the RC time constant of C1 · R5. The duration of the sweep generator's quiescent period is determined by the *same* RC time constant, but the voltage present for discharge is considerably less than that present at charge time, so the period required for C1's discharge is much greater than that required for its charge. This ratio of charge-to-discharge time of C1 determines the duty cycle of the sweep.

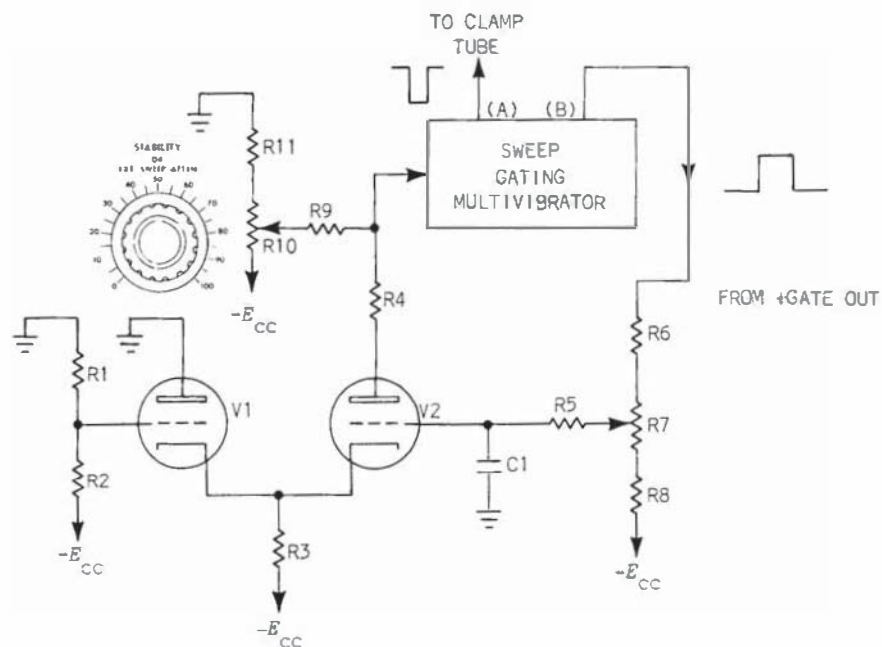

Fig. 3-7. Duty-cycle limiter.

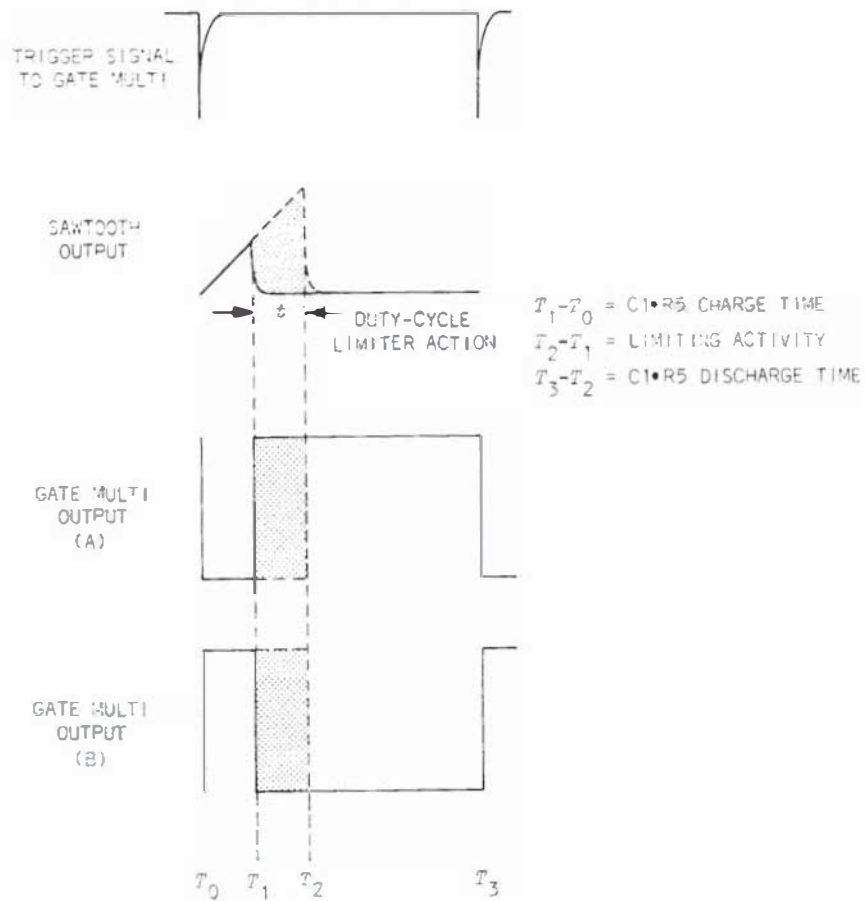

Fig. 3-8. Effects of duty-cycle limiting.

The ladder diagram in Fig. 3-8 illustrates the effect of limiting the sweep duty cycle. Without the limiter, the sweep period would be  $T_2 - T_0$ , the period established by the RC timing components of the gating multi. The addition of the duty-cycle limiter automatically reduces the sweep period to  $T_1 - T_0$ . In short, at relatively low trigger-repetition rates the RC-timing components of the gating multi establish the sweep duty cycle. However, if the trigger repetition rate increases to a point where C1 does not have sufficient time to discharge, the period of the sweep will be reduced. This effect is revealed by a reduction in the trace length on the CRT. If the trigger rep-rate continues to increase, the duty-cycle limiter can disable the sweep generator completely.

high-speed  
sweep  
generation

As wider bandpass vertical systems were developed, faster sweep rates were required. If we require the sweep generator to rise to a given voltage in a given period of time, we must supply the timing capacitor with a given amount of current. The equation  $\Delta I_C = C \frac{\Delta V}{\Delta T}$ , expresses the current demand of the sweep generator for a given ramp rate-of-rise. It is evident that if we wish to increase sweep rate, we must supply a specified change in voltage to the horizontal deflection plates in a shorter period of time. If we assume the sweep generator timing capacitor to be as small as possible, we realize that reducing time ( $\Delta T$ ), keeping  $\Delta V$  and  $C$  constant, the current demand of the sweep generator increases. The power supply must be capable of delivering this current. Power handling capabilities of circuit components must also be increased to insure reliability of the system. Risetime and falltime periods become shorter, requiring additional frequency compensation of the circuits. Special attention must be given to the transmission of various signals within the system to insure proper circuit events that are time related. For example, the CRT must be unblanked prior to sweep generation, if the *entire* sweep is to be displayed. We must be aware of these considerations when we introduce practical techniques of high-speed sweep generation.

signal delay

When a signal is applied to the vertical system of an oscilloscope, it may arrive at the CRT deflection plates before the horizontal sweep is started. The vertical signal must therefore be *delayed* to allow the horizontal deflection system sufficient time to start the sweep. (See Vertical Amplifier Circuit Concepts Book discussing delay lines.) One of the primary considerations in the design of the sweep generator system then, would be to start the sweep display as soon as possible after the application of signal to the vertical system, thereby reducing the amount of delay required by the vertical system.

When a trigger signal is applied to the horizontal deflection system, a finite period of time elapses between the occurrence of the trigger and the start of the sweep display. Under certain conditions, this period may be too long. A practical circuit used to reduce this transition time, using only

passive devices, is shown in Fig. 3-9. The circuit provides gating and unblanking pulses of proper duration, while preserving fast-rise characteristics of the applied trigger signal.

clip  
lines

The following is a discussion of gate generation using the *Clip Line*.

Upon application of a positive trigger pulse, through a lumped-constant delay line, to the clip line, the pulse will travel down the delay line in a predetermined period of time. The pulse is felt by the unblanking amplifier prior to its arrival at the gate amplifier. Initiating the unblanking circuits prior to starting the sweep is necessary if we are to see the entire sweep display. As the pulse travels down the line, the sweep-gating amplifier is activated, which in turn starts the sweep generator. These circuits will continue in an *on* state until the pulse has had sufficient time to travel down the clip line and be reflected. Due to the short-circuit at the end of the clip line, 100% of the pulse is inverted and reflected back to the source. When the reflected pulse arrives at points B and A, in that order, the associated circuits are turned off. The duration of the sweep-gating pulse, or sweep display, is determined by the *length* of the clip line. The clip line technique of gate generation is useful only at very fast sweep speeds, typically 80 ns or faster.

The gate duration is limited by several factors. First, it cannot be longer than the duration of the driving pulse. Secondly, the physical length of the clip line is limited by the available space in the instrument.

gate  
extender

At slower sweep speeds, gate generation is provided by the familiar multivibrator. We must retain ability to start the sweep as quickly as possible. The risetime of the trigger pulse must be preserved while providing longer-gate periods. The gate extender is a device that responds to a fast-rise trigger pulse and assures a suitable *gate duration* for sweep gating and unblanking at slower sweep rates.



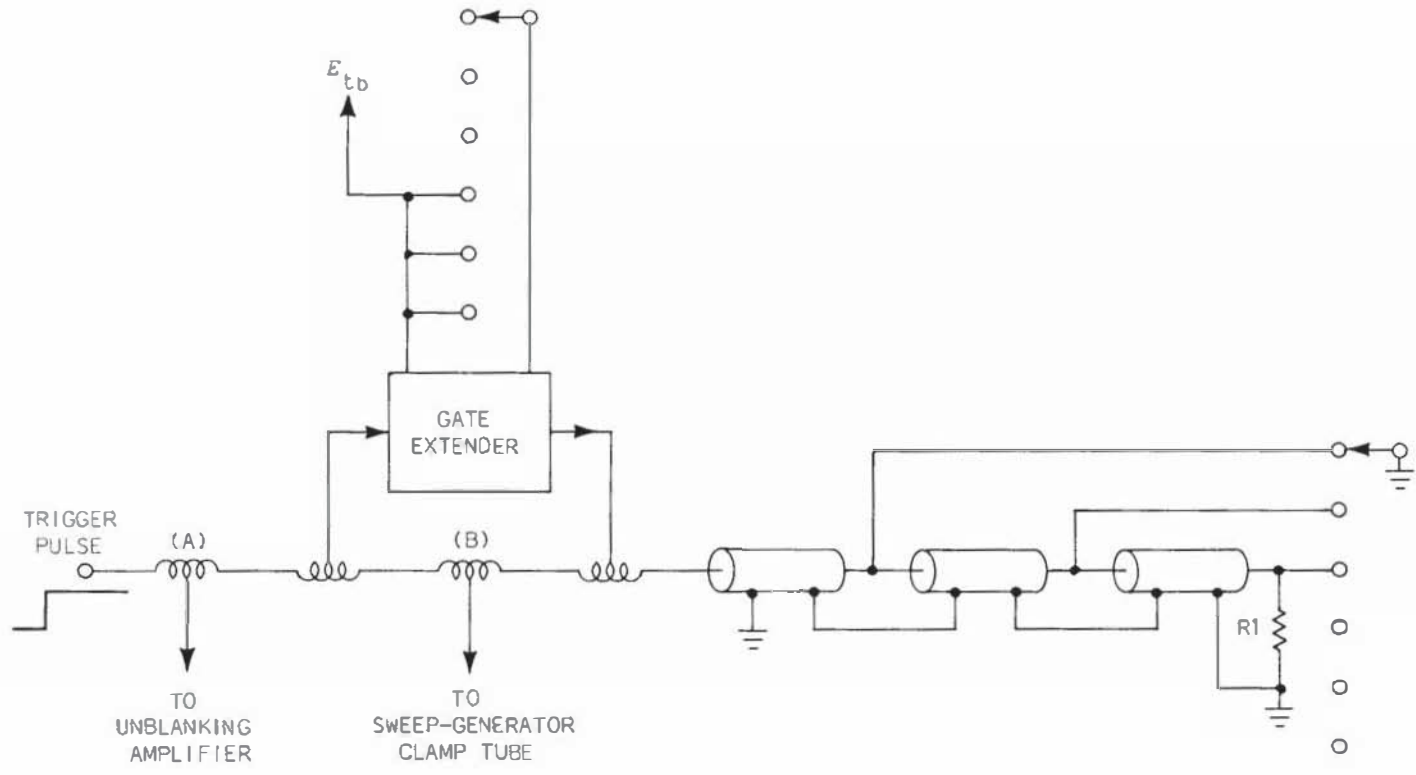

Fig. 3-9. Clip line and gate extender.

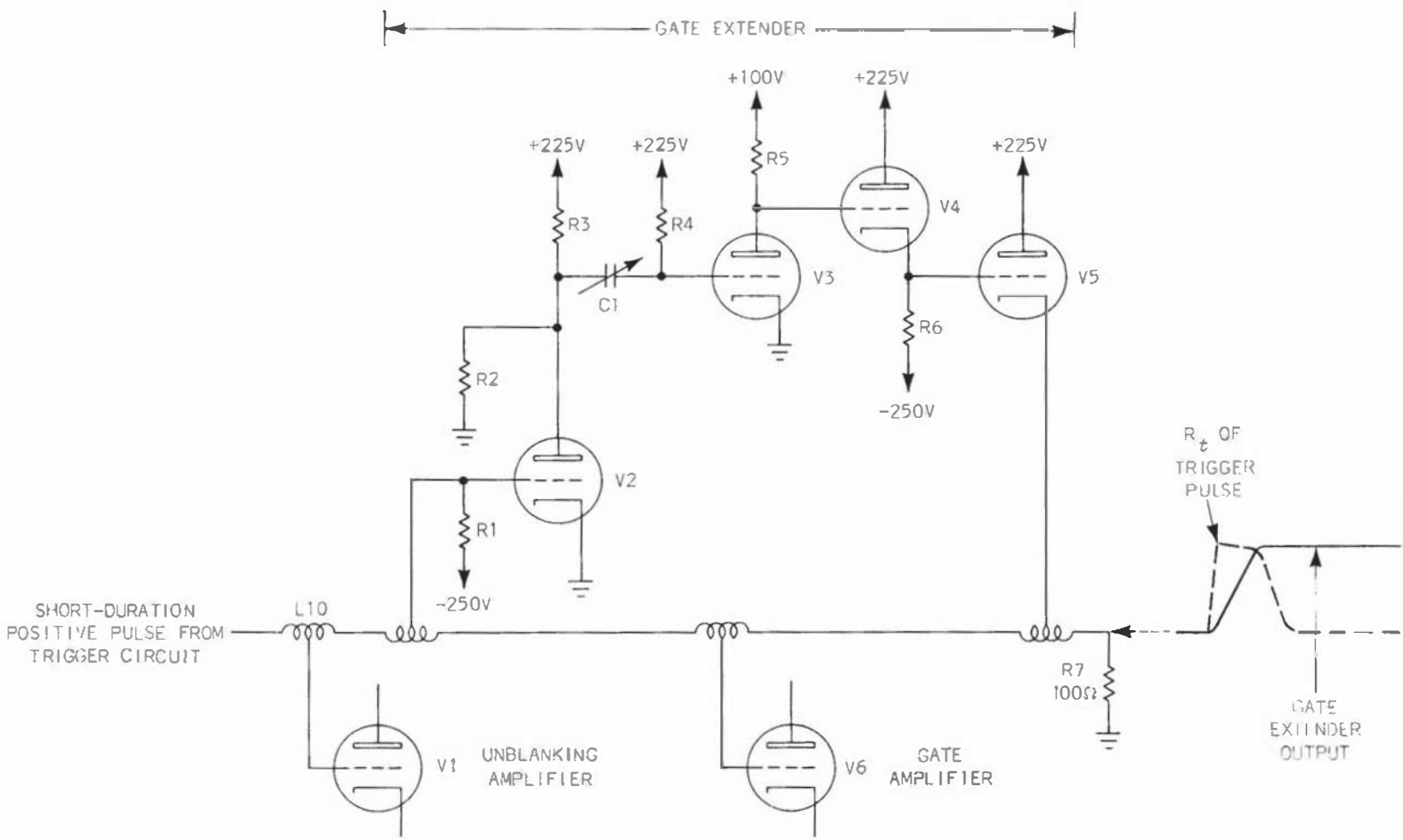

Fig. 3-10. Simplified gate extender.

gate  
extender  
operation

Fig. 3-10 represents a simplified gate-extender circuit. A positive trigger pulse, of very short risetime and pulse duration, is applied to delay line L10. The pulse is first felt by the unblanking amplifier V1, to get the CRT unblanked before sweep start. Later, the gate extender action is initiated. Finally, the sweep-gate amplifier is activated, which in turn drives the clamp tube in the sweep generator to start ramp generation. The trigger pulse is then dissipated in R7 to prevent reflections along the transmission line.

As it travels down the delay line, the positive trigger pulse brings V2 out of cut-off. The voltage at the plate of V2 falls, driving the grid of V3 negative through C1. The voltage at the plate of V3 steps positive toward the supply, carrying the grid of V4 with it. The cathode of V4 follows the grid, thereby increasing the cathode voltage of V5. The regenerative action created by coupling the positive signal at the cathode of V5 to the control grid of V2 insures the quasi-stable state of the gate extender for a period determined by the  $R4 \cdot C1$  time constant.

The output of the gate extender alone cannot start a sweep display fast enough for our requirements. It *is* fast enough however, to maintain the peak voltage level attained by the trigger pulse even after the pulse has been terminated (see composite signal at R7, Fig. 3-10). This peak-voltage-level period (gate-pulse duration) is made adjustable by providing a variable capacitor (C1). The adjustment of C1 then, determines the ramp duration of the sweep generator.

The gate extender operates as a monostable, or one-shot multivibrator, regenerating the input signal to prescribed gate pulses.

DC coupling the sawtooth waveform through some device to the horizontal deflection plates eliminates the need for DC restoration, a practice that also reduces the load capacitance that must be driven by the sweep generator. Without DC restoration, the need for ramp-start-reference assurance again becomes apparent. (See Chapter 1.)

Fig. 3-11 is a block diagram of the bootstrap generator and its associated control circuits. Particular emphasis has been placed on the block labeled Clamp-Tube Plate Regulator, which will be referred to simply as the plate regulator. The plate regulator provides a method of feeding back a specific occurrence from the output of the generator point (A), to the generator input, point (B). The feedback signal establishes a specific DC level (ramp-start reference), to which the sweep generator will recover after termination of the sawtooth leading edge. The term feedback "signal" is deliberately employed to indicate that the plate regulator responds to fast voltage changes.

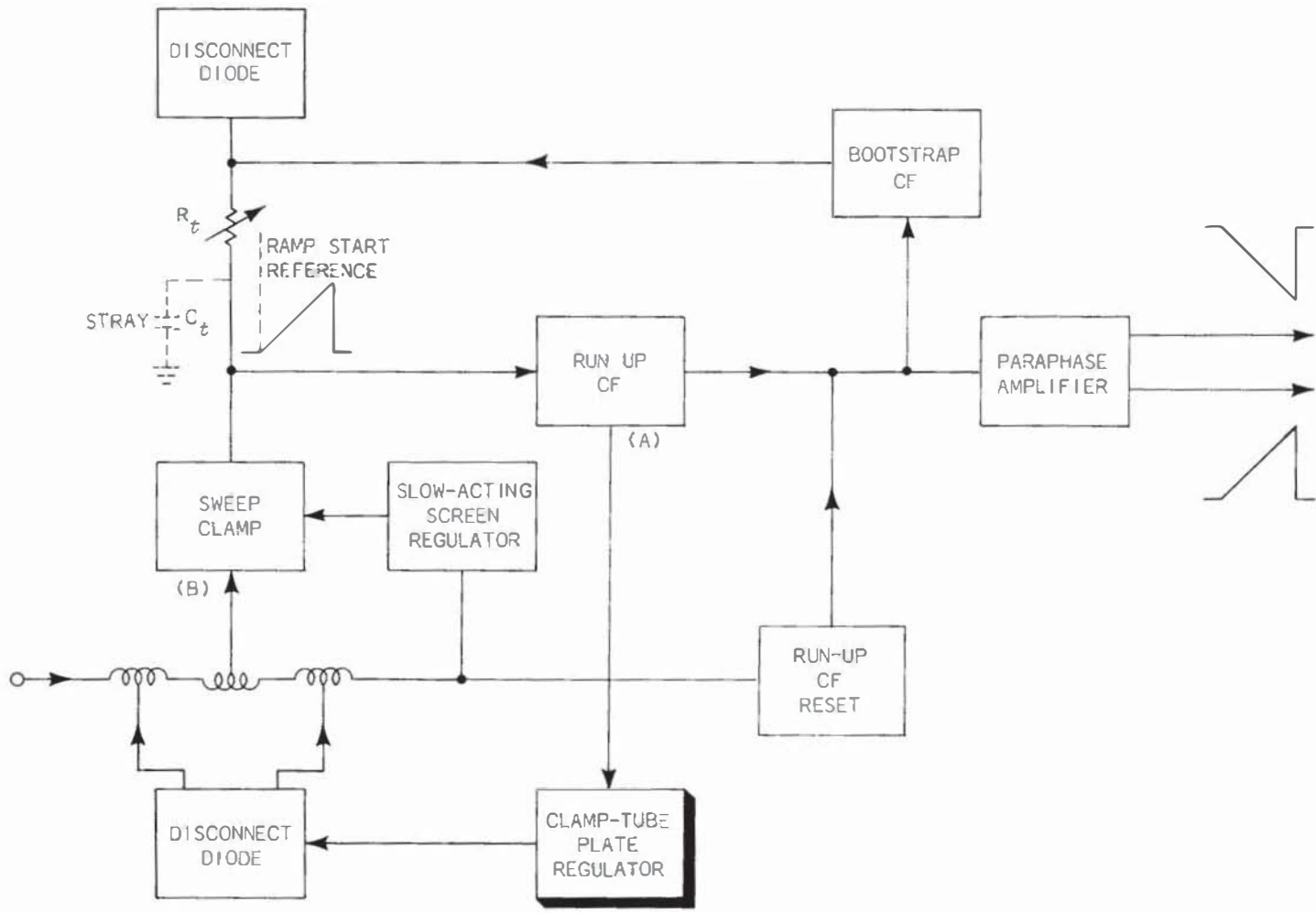

Fig. 3-11. Bootstrap-sweep-generator block diagram.

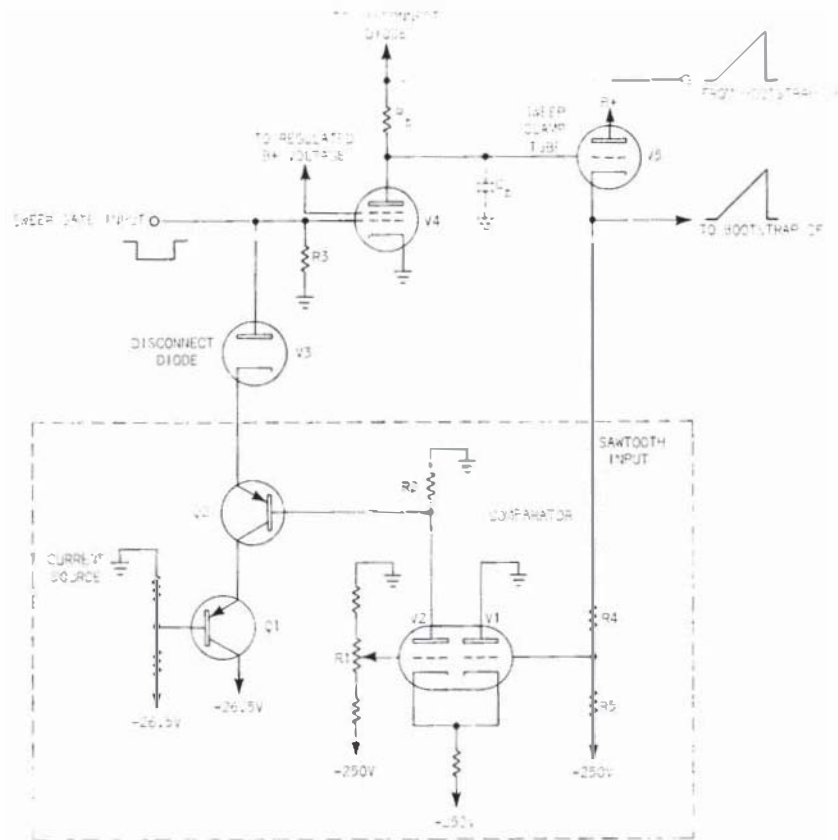

Fig. 3-12. Clamp-tube-plate regulator.

plate  
regulator

The plate regulator consists of a comparator amplifier and a controlled-current source. Fig. 3-12 is a simplified diagram of the plate regulator circuit. V1 and V2 make up the comparator amplifier. Q1 and Q2 provide current to the disconnect diode V3.

For this discussion, we will establish the desired ramp-start-reference voltage (plate voltage of clamp tube V4) at 150 volts.

plate  
regulator  
operation

Assume for now that the plate voltage of V4 is something other than 150 volts. Potentiometer R1, located in the comparator circuit, is the means by which the plate voltage of V4 is adjusted to a desired value. For example, if the plate voltage at V4 is *higher* than 150 volts, R1 must be adjusted to provide a more negative voltage to the control grid of V2. The common cathode bus of the comparator will follow the negative grid voltage change, reducing the plate current in V2 and increasing plate current in V1. The comparator becomes unbalanced for the moment. The reduced plate current through R2 reduces the bias current delivered to Q2, resulting in less current drive to V3 and R3. Reducing the current through R3 reduces the negative-grid voltage developed across R3, increasing plate current in V4. Increasing the V4 plate current *lowers* the plate voltage. The voltage change developed at the plate of V4 is coupled through the cathode follower V5, and applied through the divider R4 and R5, to the control grid of V1. The voltage at the grid of V1 will fall until it approaches the voltage at the grid of V2. When the voltage at the grid of V1 becomes equal to that of V2, the comparator achieves a state of *balance* and all activity within the feedback loop ceases. A *decrease* in V4 plate voltage is compensated by the same mechanism.

Upon receiving a sufficiently large negative gate pulse, the sweep generator begins to generate the ramp voltage. The plate regulator is disconnected by reverse biasing the disconnect diode V3. The ramp portion of the sawtooth will exist for the duration of the negative gate pulse. During the ramp period, (or sweep display period), the action of the plate regulator holds V3 in cut-off.

Upon termination of the ramp, the sweep generator enters into the recovery period. The sawtooth trailing edge is fed back to the grid of V1. The V1 grid is carried negative until it reaches a predetermined voltage level (set by the adjustment of R1) at which time V3 conducts, clamping the control grid of V4 to that bias voltage that will establish the V4 plate voltage at 150 volts, the level from which the ramp started initially.





## 4

## THE MILLER INTEGRATOR SWEEP GENERATOR

Miller  
effect

The sweep generators discussed in this chapter differ from those of the preceding chapters, in that their operation is based on a phenomenon called "Miller Effect."\*

Briefly, Miller effect is an *effective* increase in input capacitance brought about by feedback through plate-to-grid interelectrode capacitance in a plate-loaded vacuum-tube amplifier. The "Miller capacitance" in a given amplifier can be calculated from the equation,  $C_{\text{Miller}} = (A + 1)C_{\text{pg}}$ , where  $A$  represents the stage gain (without feedback), and  $C_{\text{pg}}$  represents the static interelectrode capacitance between plate and grid.

The Miller effect was first noted as a phenomenon of vacuum-tube operation, but the concept can be employed in the analysis of other circuits utilizing multi-terminal active devices.

The following circuit discussion will serve to illustrate how Miller effect influences the input characteristics of an amplifier.

---

\*J. M. Miller: "Dependence of the Input Impedance of a Three-Electrode Vacuum Tube upon the Load in the Plate Circuit." Sci. Papers of the Bureau of Standards, C1919, 15; page 367.

effective  
capacitance

In Fig. 4-1, the plate-loaded vacuum-tube amplifier V1 is in its quiescent state.  $C_{pg}$  is charged to the plate voltage of V1. When a voltage source, with internal impedance  $R_{in}$ , is connected to the input of V1, at the first instant, the entire voltage is impressed across  $R_{in}$  due to the inability of the input capacitance to change its charge in zero time. After some period the capacitors  $C_{gk} + C_{gp}$  begin to charge through  $R_{in}$ . If we assume that V1 has a voltage gain of 10,  $C_{gp} = 5$  pF,  $C_{gk} = 55$  pF, and  $R_{in} = 1$  K, the generator would "see"  $C_{gk} + C_{Miller}$ , or an *effective capacitance*,  $C_{eff}$ , being equal to  $C_{gp}(A + 1) + C_{gk}$  or 110 pF. If the generator voltage is to be developed across the grid-to-cathode circuit, some time must elapse while  $C_{eff}$  charges.

We will assume the fall period of the generator to be much shorter than the RC time constant of the input circuit. The period required for the grid to reach the generator voltage will be determined by  $5(R_{in} \cdot C_{eff})$  or  $5(1 \text{ K} \cdot 110 \text{ pF}) = .55 \text{ } \mu\text{s}$ . If we increase the gain of the stage by a factor of 10, we find that  $C_{eff}$  seen by the generator is  $C_{eff} = (100 + 1)5 \text{ pF} + 55 \text{ pF}$ , or a total of 560 pF. The period required for the grid to reach the generator voltage will now be  $5(1 \text{ K} \cdot 560 \text{ pF}) = 2.8 \text{ } \mu\text{s}$ .

We can conclude from the previous examples, that Miller effect was more pronounced when amplifier gain was increased. By increasing the stage gain ten times, the voltage developed at the grid (during the same period) was less (approximately 63%) than that developed in the first case. Therefore the Miller effect can also be observed as providing negative feedback that tends to oppose any instantaneous change in the input circuit.

A. T. Blumlein obtained a British patent resulting from his development of an integrator circuit, based upon Miller's discovery. The circuit introduced a large degree of negative feedback from the plate to control grid of a pentode vacuum tube through a *deliberately added* external capacitance. See Fig. 4-2.

In the discussion to follow, we will see how Miller effect is utilized in the development of extremely accurate integrating circuits.

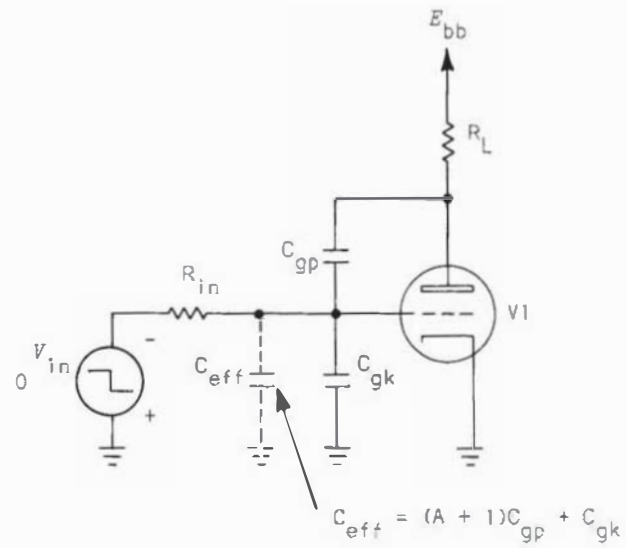

Fig. 4-1. Effective input capacitance due to "Miller effect."

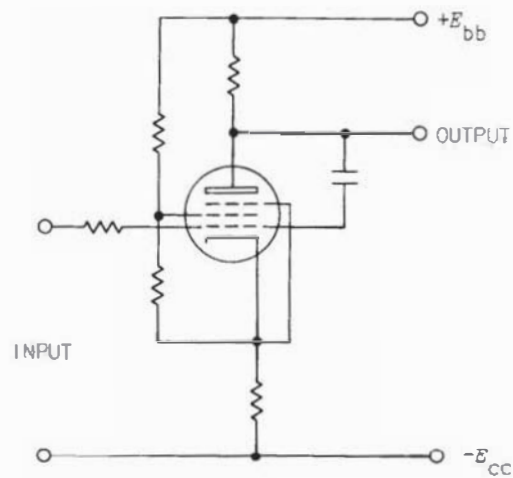

Fig. 4-2. Blumlein's Miller-capacitance integrator.

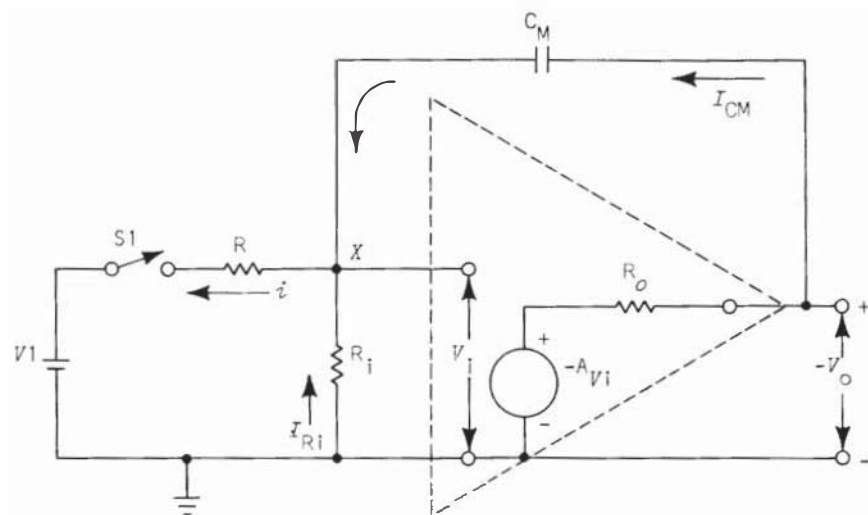

Fig. 4-3.

## THE OPERATIONAL INTEGRATOR

actual  
ground

It is common practice, when designing and building electronic circuits, to establish a common point of reference, to which all other points within those circuits are referred. The reference point is usually connected to a metallic chassis on which the circuitry has been constructed. The chassis then, is referred to as *ground*, and customarily all voltages within the circuitry are referred to that chassis or *actual ground*.

virtual  
ground

In the discussion of the operational integrator, the term *virtual ground* will be used. For our discussion we will define virtual ground as; that point, driven by two signals, being equal in amplitude and frequency, but exactly opposite in phase. This virtual ground may be referred to as a null point.

Recalling the apparent multiplication of input capacitance (Miller effect), we can also conclude that the input impedance *decreases* with stage gain. At first glance, this phenomena would appear to be objectionable. It would appear that the effect of reducing the input impedance would reduce the stage gain, and so it does. This loss of gain may or may not be objectionable, depending on the purpose of the circuit.

Let's examine the circuit in Fig. 4-3.  $R_i$  represents the circuit input impedance.  $R$  represents the internal impedance of the source ( $V_1$ ). The base amplifier (triangle) is described by its Thevenin's equivalent:  $R_o$  = the amplifier output impedance;  $-A_{V_1}$  = open-circuit voltage gain.

operational  
integrator

Assume that S1 is closed at  $T_1$ . (See Fig. 4-4B.) Current through  $R_i$  develops a voltage across  $R_i$ . A voltage change will occur at the output terminals,  $(-A \cdot V_i)$ . [The (-) sign before A indicates polarity inversion.] The voltage  $(-V_o)$  will cause a current through capacitor  $C_M$ . The capacitor current ( $I_{C_M}$ ) will flow through R in a direction that cancels  $I_{R_i}$ . The  $I_{C_M}$  current *opposes* the voltage change initiated by the current  $I_{R_i}$ . This feedback action causes an apparent reduction in the input impedance of the circuit. That is, with sufficient gain, the base amplifier will provide enough current to cancel  $I_{R_i}$ . In that case  $V_i$  will be zero. Point X therefore, appears as a very small impedance to any signal voltage, behaving as a *virtual ground* or a null point.

self-  
balancing  
bridge

The amplifier, using negative feedback, functions as a self-balancing bridge, providing through the feedback element, whatever current is necessary to maintain point X at a null. The amplitude of the output signal is a function of this current and the impedance of the feedback element  $C_M$ .

In Fig. 4-4A the circuit in Fig. 4-3 has been replaced by its Thevenin's equivalent, and,

$$V' = \frac{V_1 \cdot R_i}{R_i + R} \quad \text{and} \quad R' = \frac{R_i \cdot R}{R_i + R}$$

To continue the explanation of the operational integrator, we will assume the following (See Fig. 4-4B.):

$$C_M = 1 \mu\text{F.}$$

$$R' = 1 \text{ M.}$$

$$\dot{V}' = 1 \text{ volt for a period of one second.}$$

When switch S1 closes, the base amplifier will seek to deliver a balancing current through  $C_M$  to produce a null at point X. To provide a *steady, or constant current* of 1  $\mu\text{A}$  through 1  $\mu\text{F}$ , the base amplifier must provide a *continually changing* output voltage of 1 volt per second. The output voltage will continue to change at this rate until the input is changed, or until the base amplifier saturates.

The mathematical expression for the output voltage level reached during the period  $T_2 - T_1$  is:

$$E_{\text{out}} = \frac{-1}{R' C_M} \int_{T_1}^{T_2} e_{\text{in}} dt$$

It is important to remember that the output of the integrator, at the end of some time interval, is proportional to the *net number of volt seconds* applied to the input.

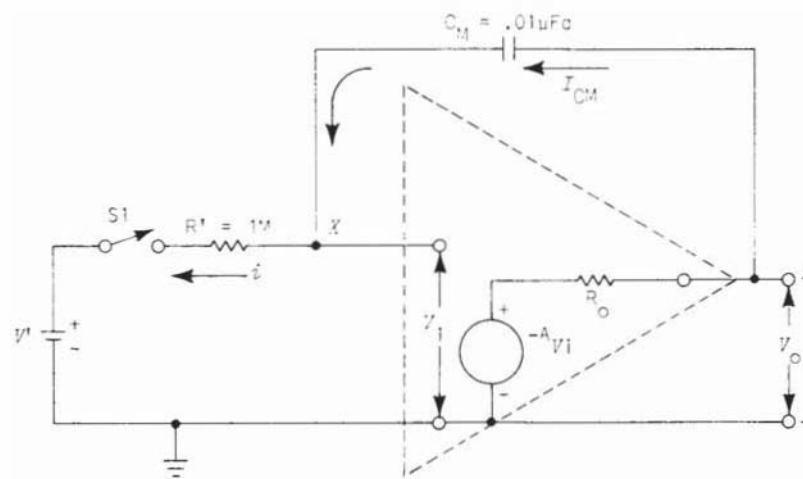

Fig. 4-4A. An operational integrator.

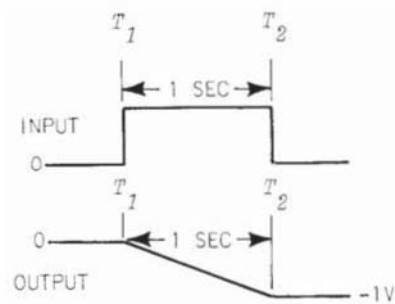

Fig. 4-4B.

If we assume the magnitude of the generator voltage  $V'$  to be equal to the voltage across the capacitor  $C_M$ , the voltage at the input (point  $X$ ) of the amplifier must be zero. Ideally, *all of the current* flow in  $R'$  will flow through capacitor  $C_M$ . The ramp voltage *rate-of-change* appearing at the output will be determined by the values of  $R'$ ,  $C_M$  and the input voltage ( $V'$ ).

$$\text{Sweep speed} = \frac{V'}{R' C_M}$$

Also, in order to obtain an output equal to a true integral of the input, the gain ( $A$ ) of the amplifier should be infinite.

In practice, it is not possible to build an infinite-gain amplifier. We can however, achieve open-loop gains on the order of many thousands. The operational integrator can achieve a very high degree of ramp linearity, because of its ability to deliver reasonably constant current to a capacitor through the provision of a large degree of negative feedback.

The effect of the finite gain on the operational integrator is an *integrating error*, caused by an error voltage ( $V_i$ ) which causes a voltage to be developed in the finite output impedance of the amplifier. This small output voltage ( $E_{RO}$ ) is proportional to the input signal itself, rather than to its integral. However, this undesirable effect is insignificant if the loop gain is sufficiently high. The effect of integration error can be assessed by considering the time constant of integration.  $C$  looks like  $(1 + A)C$  at the input terminal, so the time constant ( $\tau$ ) =  $(1 + A)RC$ . Integration is good only when integration time is *short* compared to this time constant.

When the Miller effect principle has been successfully applied to the development of highly linear sweep generators, the following characteristics are evident:

1. A high degree of negative feedback of the type just described. This feedback keeps the grid potential (in vacuum-tube terminology) within the grid base of the vacuum tube, in addition to keeping grid voltage changes small with



respect to plate voltage changes. The higher the *open-loop-gain* (gain without feedback) of the circuit, the smaller the grid voltage changes during the run-up or run-down period of the sweep generator.

2. A high constant plate current in the base amplifier resulting in extreme ramp linearity.
3. A high degree of amplification with very low output impedance in the complete system.

One consideration which influences linearity is input impedance. For best linearity, it is essential that the input impedance of the base amplifier be very *high*. Therefore, in the following discussion, we will use the vacuum tube as the base amplifier of the Miller integrator. Later, we will examine the input impedance characteristics of the transistor Miller integrator.

Miller  
integrator  
sweep  
generator

The block diagram in Fig. 4-5 represents a basic sweep generator system, incorporating a Miller integrator and its control circuits. The following discussion will deal primarily with the Miller integrator and disconnect-diode blocks, which include the base amplifier, the output cathode follower, and the disconnect-diode circuits.

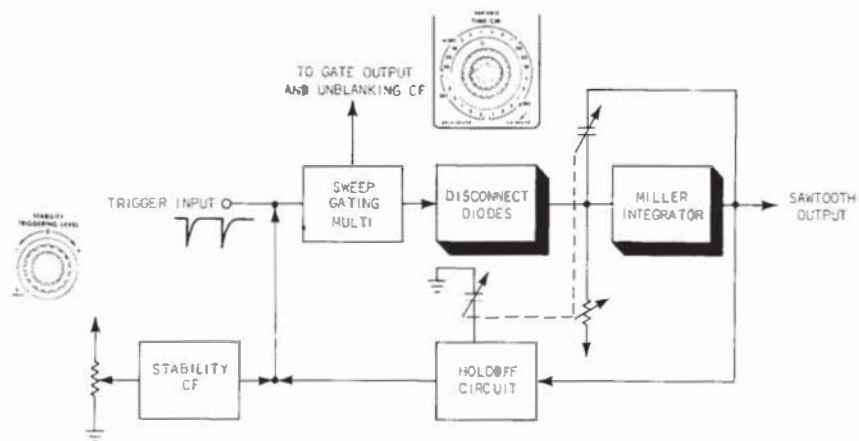

Fig. 4-5. Miller integrator sweep generator block diagram.



A schematic diagram of a practical Miller integrator sweep generator is shown in Fig. 4-6A. The ladder diagram of Fig. 4-6A illustrates events occurring at different points within the circuit during given time periods.

The basic sweep generator consists of base amplifier V1, resistors  $R_L$  and  $R_T$ , and capacitor  $C_T$ . Diodes V2 and V3 function as *disconnect diodes*, or voltage driven switches, and will be discussed later in the text. V4 isolates the plate circuit of V1 from whatever load may be placed upon the generator, in addition to providing a low-impedance charging path for  $I_{Ct}$ .

ramp-start  
reference

Prior to sweep start, the control grid of the base amplifier is clamped to a -4 V source through the conducting diode V2. The voltage at the grid of V1 establishes a plate voltage of approximately 40 volts DC. The voltage at the control grid of V4 is approximately -15 V, set by the divider action of B1 and R2 connected between the -150 V supply and the plate of V1. The cathode of V4 is held at -4.5 V when V3 is conducting. At the time the grid of V4 moves to -15 volts, the cathode follows this change. However, because the cathode of V4 is connected directly to the cathode of V3, when the V3 cathode reaches some voltage (-4.5 V), V3 will come into conduction, clamping the cathode of V4. This level is the *ramp-start reference*. V3 is conducting most of the current through  $R_K$ , therefore the upper plate of the timing capacitor ( $C_T$ ) is disconnected from the plate of the base amplifier. The timing capacitor has virtually no charge at this time.

ramp run-up

The command for ramp start is initiated by changing the condition of the V1 control grid. Since the current ( $I_{Rt}$ ) was flowing from the -150 volt supply, through  $R_t$  and the conducting diode V2 to a -4 V source, none of the ( $I_{Rt}$ ) current flows into the timing capacitor. To begin generation of the ramp,  $I_{Rt}$  must be diverted to the timing capacitor. This current diversion is accomplished by reverse-biasing diode V2, or gating the diode *off*. A gating multivibrator usually provides this gating signal. (The gating multi will be discussed in the control circuit description.)

When the gating source changes from  $-4$  V to  $-8$  V, diode V2 disconnects (recall the description "disconnect diode") the gating source from the control grid of V1. The V1 control grid immediately seeks the  $-150$  volt supply level. The moment the grid of V1 moves negative, the plate voltage moves positive "gain" times as much. As the plate of V1 starts to rise, the control grid of V4 is carried with it. V4, in its conducting state, will carry all of the current through  $R_K$ . This is the charging current for the timing capacitor during ramp run-up time. Diode V3 is cut-off when its plate is driven negative and its cathode is driven positive by the plate voltage of V1. The positive-going voltage at the top end of the timing capacitor forces a charging current through the timing resistor. This current opposes the initial tendency of the V1 control grid to seek the  $-150$  supply level. As was stated previously, if the voltage at the V1 grid were held constant for the period  $R_t \cdot C_t$ , the output voltage change would be 150 volts. Example:  $R_t = 1$  M;  $C_t = .01$   $\mu$ F;  $E_{in} = -150$  volts.

$$\Delta E_{out} = \frac{E_{in}}{R_t C_t} = \frac{150}{.01 \text{ s}} \text{ or } 15 \text{ volts/ms}$$

Notice that for a period of 10 ms, the current  $I_{Rt} = 150$   $\mu$ A. This is the charging current for the timing capacitor.

Recall that the charging current will remain constant only if the base amplifier has an *infinite gain* so that a *virtual ground* is maintained. These ideal conditions cannot be achieved in practice; therefore, we must recognize that the output circuit will have a definite exponential characteristic. The total applied voltage as seen by the timing capacitor will be:  $(A)E_{in}$ .

Referring to Fig. 4-6B(d), the voltage at the grid of V1 is not  $-2$  V, but approximately  $-2.8$  V after period  $T_2 - T_1$ . The plate voltage change of V1 is approximately 150 volts at time  $T_2$ . The gain, therefore, is equal to:  $\frac{E_{out}}{E_{in}}$  or  $\frac{150}{.8} = 175$ . The total applied voltage, as seen by the timing capacitor, would be:  $V = (150)(175) = 26,250$  volts.

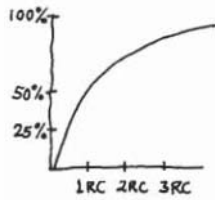

Referring to the universal time constant chart in the margin, it is evident that the sweep will be extremely linear. Less than 1% of the total exponential will be used for the sweep function voltage. The slope error will be approximately:

slope error 
$$e_s = \frac{V_s}{V_{in}(A)} = \frac{150}{26,250} = .57\%$$

Where:  $V_s$  = output voltage.

deviation The percentage of deviation from an ideal ramp will be approximately:  $e_d = 1/8 e_s = .07\%$ .

Other factors that may contribute to slope error and displacement error within the sweep generator are: tolerances of  $R_t$  and  $C_t$ , degree of grid current in V1, and leakage current drawn by V2 when in the nonconducting state.

In Fig. 4-6A, the path for the charging current during ramp-time extends from the -150 volt supply, through the timing resistor  $R_t$ , to the lower plate of  $C_t$ , from the upper plate of  $C_t$  and through the conducting tube V4.

retrace Upon completion of the ramp run-up period, the gating source reverts to its previous state [time  $T_2$ , Fig. 4-6B(a)]. The gating source will raise the plate of V2 sufficiently to cause V2 to conduct. [See point X in Fig. 4-6B(a).] At time  $T_2$ , V2 comes into conduction, diverting current from  $C_t$  to the gating source. This current through the timing resistor, V2, and the gating source raises the voltage at the control grid of V1 toward its initial level. This voltage change occupies a finite period. This period is determined by the time constant  $C_t$ , the forward resistance of V2, the gate generator source impedance, and  $R_k$ . The period  $T_3 - T_2$  then, is the generator *recovery* time, or the *retrace* time of the sweep.

Meanwhile, at the instant the V1 grid moves positive, the plate voltage falls rapidly. During the fall period the timing capacitor is discharging. The control grid of V4 follows the negative plate voltage change at V1. The cathode will follow this grid voltage change, but only to a point [point Y in

Fig. 4-6B(a)]. Notice that at instant  $T_3$ , in Fig. 4-6B(c), the voltage at the cathode of V4 is at the *ramp-start reference* level. When that level is reached, V3 comes into conduction [point Z, Fig. 4-6B(a)]. The voltage level at the plates of V2 and V3 is established, for the period  $T_4 - T_3$ , by the current through the two diodes into the gating source. The voltage change at the V1 grid ceases; therefore, the V1 plate comes to rest at the original quiescent level.

Since the timing capacitor was discharging during the generator run-down period, at time  $T_3$  (Fig. 4-6B)  $C_t$  has completely discharged. The circuit is once again in its quiescent state, and will remain so until another gate signal is applied.

The neon lamp, B1, provides DC coupling of the sawtooth waveform to the control grid of V4 without attenuating the signal. Resistor R1 damps out any oscillations that B1 might tend to generate as a neon-tube relaxation oscillator. Capacitor C1 acts as a "speed-up" cap, bypassing rapidly changing signal components around B1 and R1 to the V4 grid. B2 acts as a protective device for V4. If, for example, the V4 grid-to-cathode potential should exceed the ignition potential of the neon, (this could occur prior to the V1 and V4 filaments reaching proper operating temperature), the neon would ignite, maintaining a safe 50-volt potential between the grid and cathode of V4. The neon will extinguish after the circuit stabilizes. Capacitor C2 provides bootstrapping, i.e., positive feedback to the upper plate of the timing capacitor at fast (10 to 1  $\mu$ s) sweep speeds.

## THE TRANSISTOR MILLER INTEGRATOR

forward-  
biased  
junction

When transistors are used in a Miller integrator, their relatively *low* input resistance becomes evident when we consider that the base-to-emitter junction of a transistor is regarded as a semiconductor diode. (See Fig. 4-7.) As we know, when a forward voltage is applied to the base-to-emitter junction, the junction will exhibit a characteristic similar to that shown in Fig. 4-8.

Line (1) on the graph (Fig. 4-8) is a plot of base-to-emitter voltage versus base current; line (2) is

a plot of base-to-emitter voltage versus emitter current. Any point along these two lines may represent some value of resistance (within the dynamic operating range).

The resistance defined at any point along line (1) is approximately  $\beta + 1$  times that shown at line (2) at any common point of intersection (point A). It follows then, if by some means we can find the resistance at one point on a line, and if we know Beta, we can find a corresponding value of resistance on the other line.

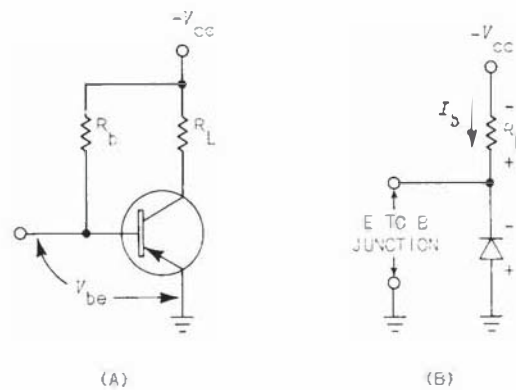

Fig. 4-7.

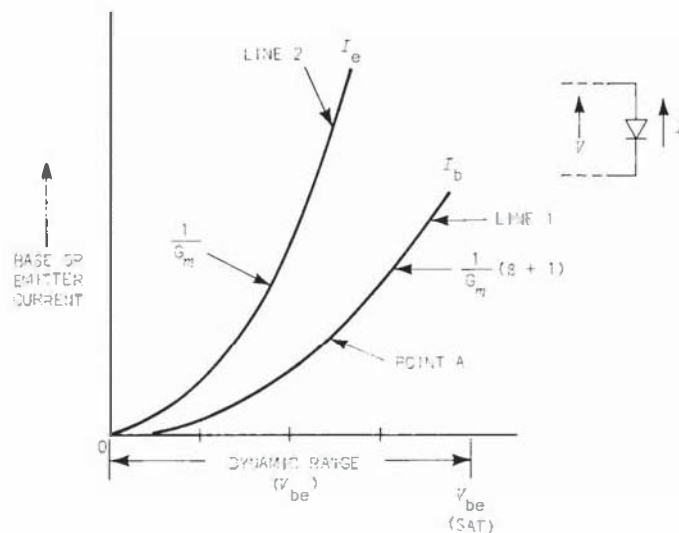

Fig. 4-8. Forward biased junction.

Fortunately, there is a "rule of thumb" equation useful in determining the resistance along either line.  $\frac{0.026 \text{ V}}{I_e}$  defines any resistance along line (2) and  $\frac{0.026 \text{ V}}{I_b}$  defines any resistance along line (1),

where  $I_e$  or  $I_b$  is the DC base or emitter current at the point selected. The value  $0.026/I_e$  is justified by the basic physics of the device and will not be discussed here.

Now let's consider what this has to do with transistor circuits. Note that any portion of line (2) may be

used to find  $\frac{\Delta V_{be}}{\Delta I_e}$ . Assuming that the transistor has a very high Beta, a change in input current ( $\Delta I_e$ ) will very nearly equal a change in collector current ( $\Delta I_c$ ). In vacuum-tube theory, the expression,

$\frac{E_{in}}{I_{out}}$  is called  $\frac{1}{G_m}$ . So let's call the resistance calculated from line (2) by the same name  $\frac{1}{G_m}$ .

All we've said so far, is that the impedance looking into the emitter of a transistor is approximately equal to  $1/G_m$  of the device, and can be calculated by:

$$\frac{1}{G_m} = \frac{26 \text{ mV}}{\text{DC value of emitter current (mA)}}$$

In series with  $\frac{1}{G_m}$  is a small resistance ( $R_{eb}$ ) that is made up of the ohmic resistance of the leads and the semiconductor material.  $R_{eb}$  usually amounts to about 2  $\Omega$  to 5  $\Omega$ . Therefore, the expression,

$R_{eb} + \frac{1}{G_m}$  is an operating characteristic of the

trans-  
resistance

device which we shall call "transresistance." The notation for this expression is  $r_{tr}$ , therefore,

$r_{tr} = R_{eb} + \frac{26 \text{ mV}}{I_e(\text{mA})}$ . To find the input resistance

( $R_{in}$ ) to the device in Fig. 4-7(A) we can use the equation:

$$R_{in} = r_{tr} (\beta + 1)$$



Miller  
transistor  
input  
resistance

If we assume a Beta of 100, and an  $r_{tr}$  of  $8 \Omega$ , the input resistance of the transistor in Fig. 4-7(A) is equal to  $808 \Omega$ . When we compare this to a vacuum tube with a very high input impedance, it is apparent that if the transistor is to be used as the base amplifier for the Miller integrator, methods must be found to overcome the low input resistance characteristic of the transistor. Recall that one of the prerequisites for good integration was the high input impedance amplifier.

The low input resistance of the transistor in Fig. 4-9 provides a current path for base current that will flow in the timing resistor and not in the timing capacitor. Recall that for good integration, the current in the timing resistor must equal that in the timing capacitor during the ramp period. The presence of base current in the timing resistor would contribute to a slope error at the sweep generator output.

One method of increasing the integrator's input resistance would be to use a high Beta transistor as the base amplifier. Recalling the equation:

$$R_{in} = r_{tr} (\beta + 1)$$

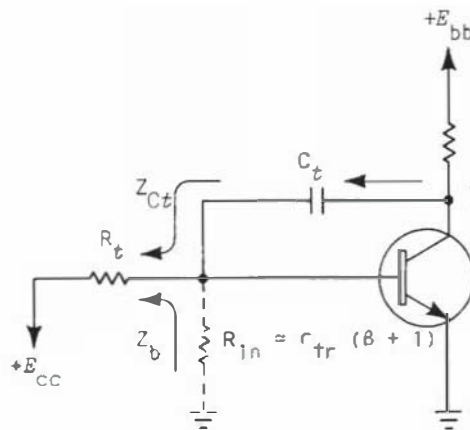

Fig. 4-9.

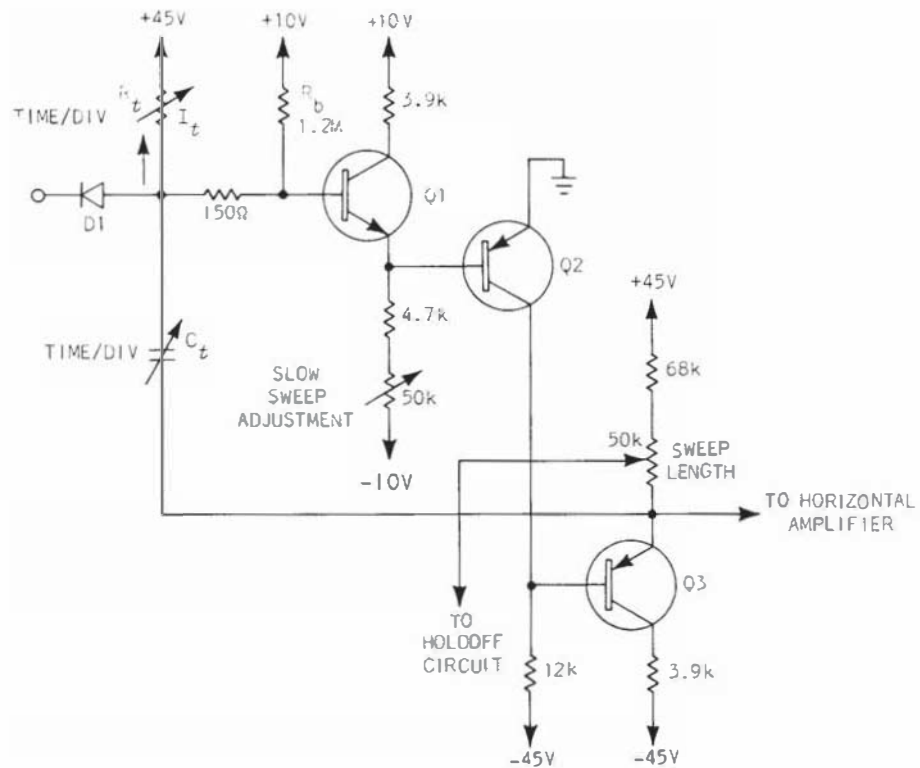

Fig. 4-10. Transistor Miller integrator.

Another method of improvement isolates the "null-seeking" point from the base amplifier input (See Fig. 4-10). This configuration increases the generator input impedance *considerably*, since the input impedance of the generator now becomes the input impedance of Q2, times the Beta of Q1 plus one.

isolating  
timing  
circuit

The bias resistor  $R_b$ , establishes a fixed base current for both transistors that will not flow in the timing circuit. The input resistance of the integrator base-to-emitter thus remains relatively fixed in spite of input signal current variations.

The best method of isolating the timing circuit from the base amplifier input is to use a cathode follower or a source follower. Both of these devices exhibit a very high input impedance.

## HOLD-OFF

In the discussion of "Sawtooth Characteristics" (Chapter 1), the subject of "hold-off" was introduced briefly. We will now discuss the hold-off function and the circuits represented by the hold-off block in Fig. 4-11.

Let us return for a moment to Fig. 4-6B(c). Notice that throughout period  $T_4 - T_3$  the sweep generator is in its quiescent state. This period is referred to as *hold-off*. The term is derived from the function of specific circuits incorporated in most modern sweep generators. The hold-off function serves two purposes:

1. To allow the output voltage of the sawtooth generator to fall to its quiescent level (ramp-start reference), corresponding to the CRT electron beam position at the left side of the CRT.
2. To provide sufficient time for any transients that may develop, during ramp or retrace, to disappear.

The hold-off circuits thus provide the necessary *waiting period* or hold-off time, by rendering the gating source insensitive to any trigger signals that may arrive prior to complete sweep recovery.

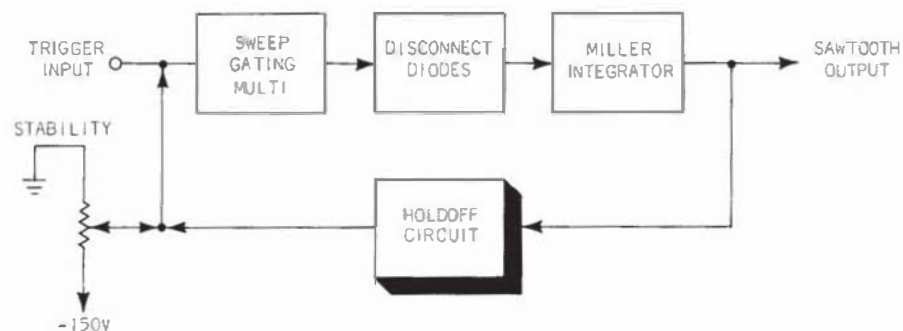
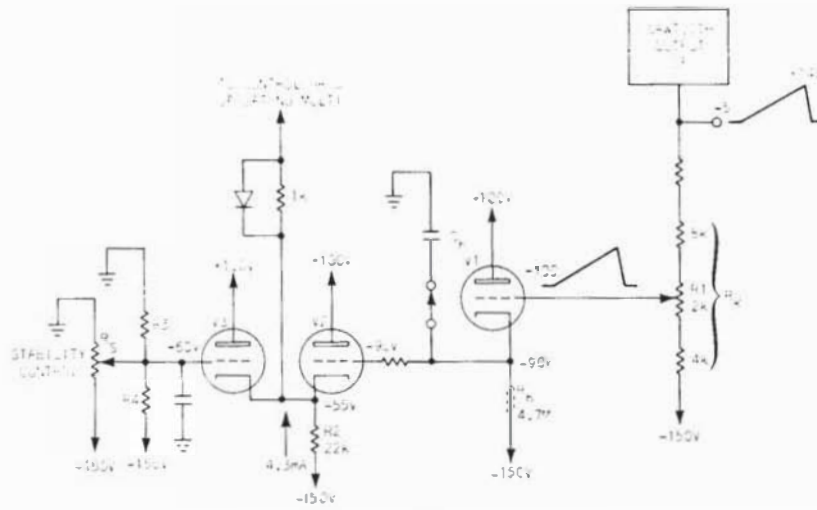
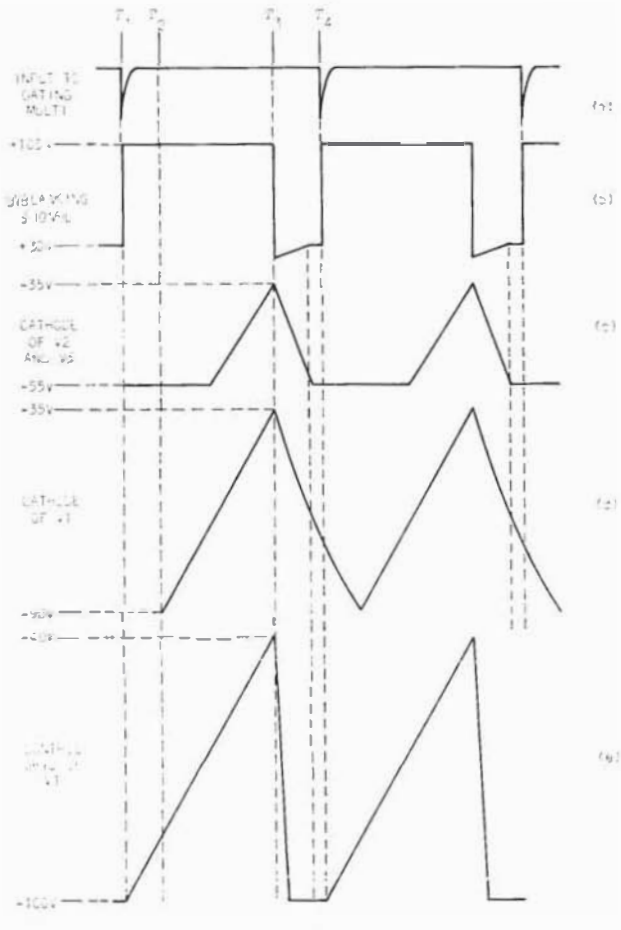

Fig. 4-11. Miller integrator sweep generator.



(A)



(B)

Fig. 4-12. Practical holdoff circuit.

Fig. 4-12A is a schematic diagram of a practical circuit used to provide the hold-off period for the sweep generator. The significant components of the circuits are: hold-off capacitor  $C_h$ , cathode resistor  $R_h$ , and cathode follower V1.  $C_h$  is one of a number of capacitors which are switched into the circuit as the TIME/CM switch is adjusted for different sweep rates. This arrangement insures a maximum sweep duty cycle.

bistable  
Schmitt  
multivibrator

Before we examine the operation of the hold-off circuit itself, we must investigate certain characteristics of the sweep-gating multivibrator. A good example of this type of circuit is commonly known as the bistable Schmitt multivibrator. The term "bistable," indicates that the multi has two stable states. In one state, which we'll call the "ready" state, the multi generates an output only when provided with a specified input trigger signal. In the other state, the multi is insensitive to the input triggers and must be "reset" to its *ready* state before it can provide another output.

sweep length  
adjustment

Referring to Fig. 4-12A, quiescently, a DC voltage of -100 volts is established at the control grid of V1 by the adjustment of the Sweep Length potentiometer R1. (The reason this particular voltage was selected will be explained later in the text.) The cathode of V1 operates at about -90 volts, biasing V1 near cut-off. ( $I_{R_h} = 13 \mu\text{A}.$ ) The direct coupling between the V1 cathode and the control grid of V2 also establishes the latter at about -90 volts. The cathode of V2 rests at approximately -55 volts. Due to the large negative bias on V2, current through R2 flows only through V3.

three-state  
multi

Potentiometer R5, labeled STABILITY, indirectly determines the DC level at the input of the sweep-gating multi. Quiescently, the DC level at the cathodes of V2 and V3 determines which of the following three states the gating multi will be in:

1. Not triggerable -- not responsive to trigger signals.
2. Triggerable -- will provide an output upon receipt of a trigger.

3. Freerunning -- but capable of being synchronized. (Within certain frequency limits. See Fig. 4-13.)

For the purpose of this discussion, assume that the STABILITY control is set to a DC level that will set the gating multi in its triggerable, or "ready" state. (See Fig. 4-14.) When a negative trigger signal, large enough to "punch through" the "trip" level, is applied to the gating multi, the multi will change its state and provide an output that will start ramp generation. The gating multi, having been switched to its other stable state, will not respond to trigger signals during sweep time.

Referring again to Fig. 4-12A, notice that a portion of the positive-going ramp developed across  $R_K$ , is applied to the control grid of V1. As the grid of V1 moves positive, the V1 cathode and the V2 control grid move with it. Hold-off capacitor  $C_h$ , previously charged to -90 volts, discharges through the low impedance of (now) conducting V1. This low impedance discharge path allows the voltage on  $C_h$  to follow the rising ramp very closely. As the control grid of V2 moves positive, the V2 bias is reduced. As the grid of V2 approaches -55 V, the current through R2 switches to V2 and the signal voltage at the V2 grid will be developed across R2. [See Fig. 4-12B(c).] As the grid of V2 takes control of the (V2 - V3) common cathode bus, the bus rises toward the "reset" level of the gating multi.

When the cathode bus reaches the "reset" level, the gating multi switches states, terminating the ramp. Notice in Fig. 4-14 that the multi cannot yet be triggered, since its grid voltage is high above the "trip" level during most of the retrace period.

During recovery, a portion of the trailing-edge voltage is applied to the control grid of V1 (Fig. 4-12A). The cathode of V1 would follow the grid, at the same rate, were it not for the presence of  $C_h$  and  $R_h$ . Remember that during the sawtooth run-up period,  $C_h$  discharged from its quiescent level of -90 volts to about -35 volts. The rate-of-change (voltage) across the hold-off capacitor could keep pace with the voltage change at the V1 grid because of the low impedance path provided by conducting tube V1. During the recovery period however, the

rate-of-change at the V1 grid is about 20 times faster than at run-up time. The grid of V1 therefore, loses control of the cathode. The voltage at the cathode can then fall only at a rate determined by  $C_h R_h$ . The  $C_h R_h$  charge time constant is *much greater* than the discharge time constant ( $C_h$  times the  $Z_k$  of V1). The *time* required for the hold-off capacitor to charge to the initial -90 volts is the *hold-off period*.

When the voltage at the V1 cathode falls (charging  $C_h$ ) to its quiescent level of -90 volts, the control grid of V1 will regain control of the cathode. The

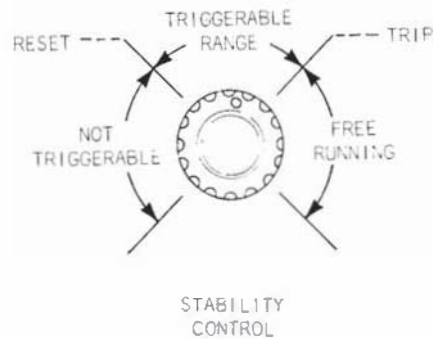

Fig. 4-13. General example of the range of stability control coverage.

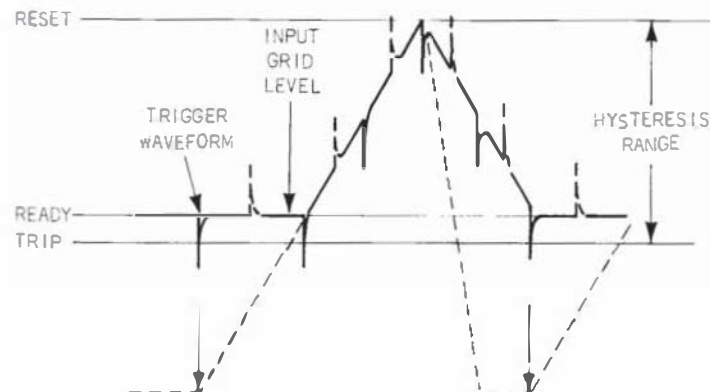

Fig. 4-14. Composite illustration of input conditions occurring at sweep gate multi.

common cathode bus of V2 and V3 will fall at the  $C_h R_h$  rate, but only to the "ready" level of the gating multi. That level, you will recall, was previously set by the STABILITY control. At this level, the gating multi is again ready to receive an incoming trigger signal, which will initiate another ramp.

sweep  
duration

Adjustment of potentiometer R1 (Sweep Length control) determines the duration of the sweep (sweep length). We shall refer to the illustration in Fig. 4-15 during the discussion.

The sweep duration is determined by the duration of the negative gate pulse from the gating multivibrator. Fig. 4-15 shows the relationship between the sawtooth feedback voltage, the gate duration, and the duration of the sweep. Notice the ramp intersecting point (B) in Fig. 4-15(c). The amplitude of the waveform is such that the ramp intersects the "reset" level of the gating multi at point (B), or after the period,  $T_3 - T_1$ . This point of intersection determines the duration of the sweep-gating pulse, which in turn determines sweep length. (Notice however, that sweep rate is unaffected by this adjustment.) In the foregoing example, the CRT sweep display covers 10 graticule divisions.

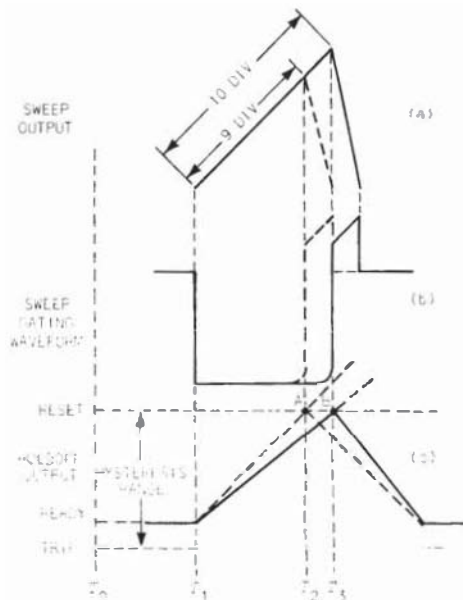

Fig. 4-15. Adjusting sweep length.



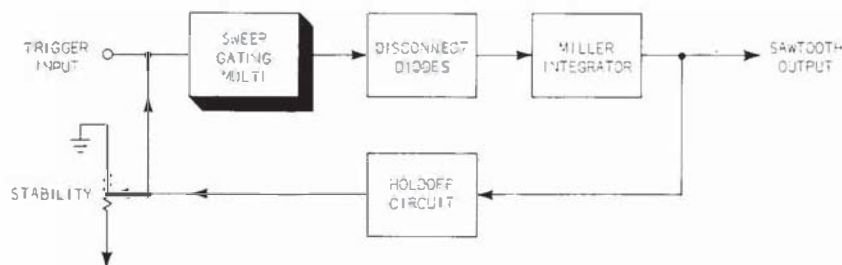

Fig. 4-16. Miller integrator sweep generator.

If the Sweep Length control were adjusted to provide a larger-amplitude feedback signal, the leading edge of the signal would intersect the "reset" level at point (A). Resetting the multi at point (A) terminates the ramp sooner. Therefore, as indicated, the sweep length will be 9 graticule divisions.

Summing up then, the amplitude of the feedback signal, as determined by the Sweep Length control setting, determines the duration of the gate and consequently, the sweep length.

#### SWEEP GATING MULTI

two-level  
output

The block labeled "Sweep-Gating Multivibrator" (Fig. 4-16), represents a circuit commonly used to control the Miller sweep generator. The circuit functions as an electronic switch, responding only to signals possessing certain predetermined characteristics. The output of the gating multi exists at only one of two possible levels. One level allows the sweep generator to run up (or run down) while the other level holds the generator in a quiescent state (no sweep). The sweep-gating device described below is a cathode-coupled bistable multivibrator, commonly called a "Schmitt trigger," after the inventor of the vacuum-tube version. Some advantages of this type of multi are listed below:

1. The input terminal is not affected by the regenerative switching. When the circuit switches states, the voltage at the input terminal is not altered. This feature is desirable if we wish to maneuver the input terminal characteristics.

2. The output load resistance is not necessary to the bistable operation. This resistance may therefore vary over a wide range, depending upon the output requirement.
3. Capacitive loading at the output will not slow the regenerative action (switching time) although such loading will increase the rise and fall time of the output signal.

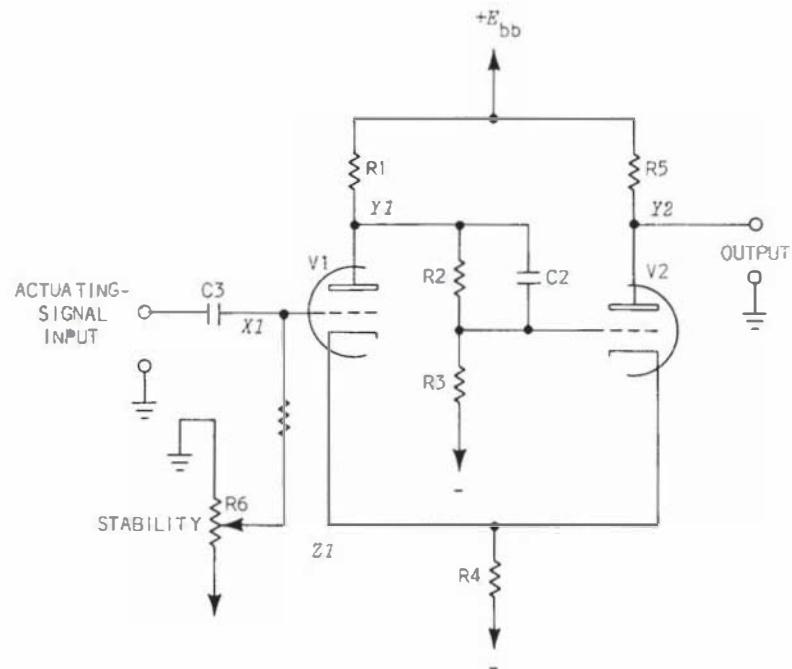

Fig. 4-17. Simplified sweep gating multivibrator "Schmitt trigger".

sweep  
gating

Fig. 4-17 is a simplified diagram of a Schmitt trigger, designed to provide sweep *gating* to the Miller-sweep generator. We will refer to this figure while discussing the basic operation of the sweep-gating multi.

Let us assume V1 is conducting plate current. A voltage developed across R4 appears at Z1. The voltage at X1 therefore is near that voltage at Z1. The multi is in one of its two possible states. V2

is cut off and the output level will be  $+E_{bb}$ . If we wish to switch the multi to its opposite state, we could increase the negative grid voltage at V1. By adjusting the potentiometer (R6) toward the negative supply, we cause the voltage at X1 to move negative. V1 will continue conducting until the V1 grid voltage reaches its cut-off or the "trip" level (described in the hold-off discussion). When V1 cuts off the voltage at Y1 increases toward  $+E_{bb}$  rapidly. The voltage change at the plate of V1 is:  $(\Delta e_{in})(-A)$ , indicating amplification in V1. A portion of this positive signal at Y1 is applied to the grid of V2 through the divider R2 and R3. The V2 cathode follows the positive change at the grid, rapidly increasing the negative bias on V1. This action is regenerative and results in a very rapid transition of the multi. During this transition, the current to R4 was diverted from V1 to V2. The control grid of V2 will continue to rise until V1 cuts off. During this transition the voltage at Y2 changes from  $+E_{bb}$  to  $E_{bb} - I_2R5$ .

To restore the multi to its initial, or "ready" state, we must change the voltage at point X1 in a positive direction until the "reset" level is reached. This could be done by adjusting the STABILITY control. At this time, the regenerative action again occurs, and results in a rapid output voltage change from  $E_{bb} - I_2R5$  to  $E_{bb}$ .

hysteresis

To complete one cycle of multi operation, the grid of V1 must be driven sufficiently negative to start the regenerative action. It must then be driven in the opposite direction to "reset" the multi to its "ready" state. Note (Fig. 4-14) that the voltage difference between the "reset" level and the "trip" level is defined as the "hysteresis" of the multi.\* The hysteresis range is determined by the "loop gain" of the multi, which in turn, is primarily determined by the value of R1.

---

\*For a more detailed discussion of Schmitt trigger "hysteresis," refer to Sect. 10-11, p. 389-394, Millman & Taub, "Pulse, Digital, and Switching Waveforms."

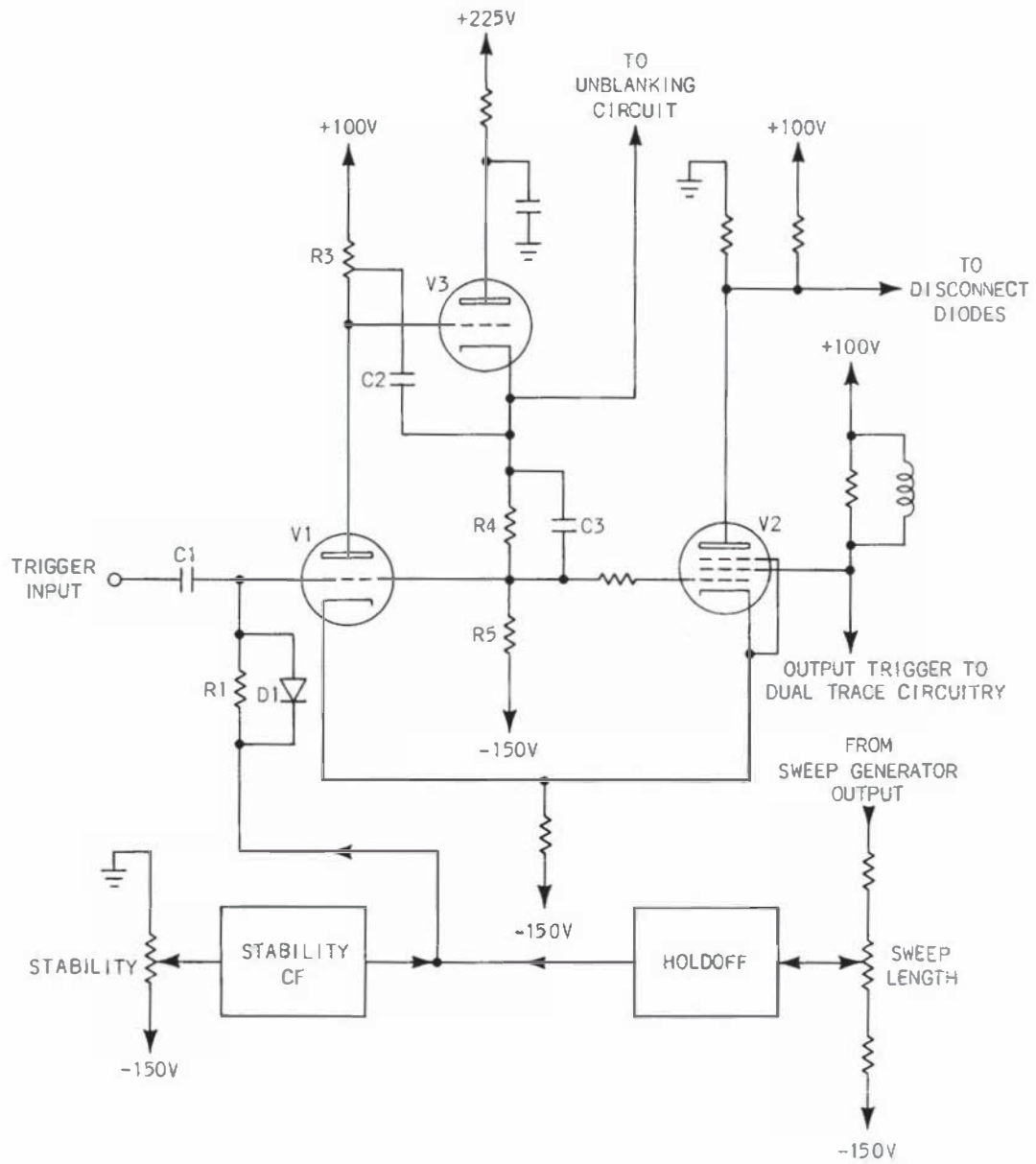

Fig. 4-18.

The vacuum-tube version of the Schmitt trigger requires the hysteresis region to be fairly large, for reasons of reliability. As the tubes age their amplification factor decreases; consequently the loop gain falls off. If the hysteresis region were originally narrow, a small reduction in loop gain would result in unstable sweep triggering, eventually causing the sweep to free-run. On the other hand, loop-gain is limited by transition time requirements. When we recall that an increase in the value of  $R_1$ , (Fig. 4-17) increases the loop gain, it follows that the risetime of  $V_1$  would increase and this would increase the multi-transition time. As we learned earlier, the elapsed time from signal insertion to sweep start *must* be kept to a minimum.

A practical sweep-gating multi is represented by the schematic in Fig. 4-18. Having just described the basic operation, we shall now look at some of the special features that have been provided for improved performance of the device.

cathode-  
follower V3

Notice the cathode-follower  $V_3$ . The output of  $V_1$  is coupled, via the cathode follower, to the grid of  $V_2$ . We include the cathode follower to reduce the effect of shunt capacitance loading on the plate of  $V_1$ . This improves the risetime of  $V_1$  considerably, which improves the multi-transition time.

diode D1

Diode  $D_1$  is added to the input differentiator to shunt positive-going trigger pulses around  $R_1$ . Since the gating multi, in its ready state, will respond to negative trigger pulses, the positive pulses are unnecessary, and in fact impose undesirable effects on sweep length. Referring to Fig. 4-14, notice that the positive pulses (dotted lines) would "punch through" the "reset" level before the ramp itself could reach that level. If this occurred, the sweep length would be *shorter* for a triggered sweep than for a free-running sweep. The sweep length would also vary with trigger repetition rate variations. This possibility is eliminated however, since the *positive* differentiated pulses do not see the resistance of  $R_1$ , but the small resistance of the forward-biased diode  $D_1$ . Therefore, the negative trigger pulses are the predominate signals appearing at the input to the gate multi.

bootstrap  
capacitor C2

Another method of decreasing the gating multi transition period is the addition of a bootstrap capacitor in the plate circuit of V1. This capacitor (C2) connected between the cathode of V3 and a tap of R3, couples the fast-changing voltages, appearing at the V1 plate, to the tap at R3, thereby providing an additional short-term current source that will assure faster transitions at the V1 plate.

frequency  
compensation

Capacitor C3, in conjunction with the input (grid-to-cathode) capacitance of V2, frequency-compensates the divider R4 and R5 to further improve multi-transition time.

The Schmitt trigger proved to be very valuable when incorporated in triggered sweep generator systems. In many current applications of the Schmitt trigger, the transistor "flip flop"\* has replaced the vacuum-tube binary. The basic operation of this device is much the same as that of the vacuum-tube Schmitt trigger. For a detailed discussion of the transistor bistable multi, see the "Oscilloscope Trigger Circuits" book, one of the series of Tektronix Circuit Concepts.

---

\*Common term for the bistable multivibrator.

## 5

## SWEEP GENERATOR CONTROL CIRCUITS

In this chapter we will describe some of the circuits incorporated in modern oscilloscopes that provide a means of sweep generator control. The main topics of discussion will be:

1. Hold-off techniques.
2. Sweep gating.
3. Sweep lock-out.
4. Automatic sweep generation.
5. Sweep switching.

hold-off  
using the  
disconnect  
diode

In Chapter 4 we discussed the hold-off method which utilized a cathode follower to drive the hold-off capacitor. Another method is illustrated in Fig. 5-1. In this circuit the hold-off capacitor is driven by a disconnect diode.

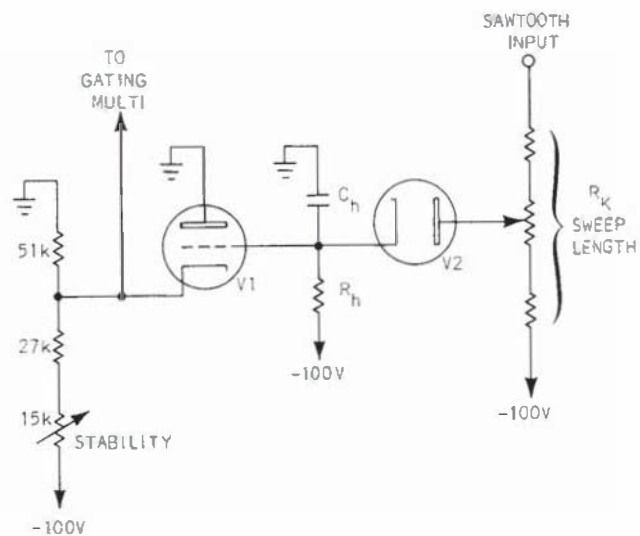

Fig. 5-1. Holdoff (using a disconnect diode).

Quiescently,  $C_h$  will charge toward -100 volts until the cathode of V2 reaches the approximate voltage level at the plate. Cathode follower V1 is cut off due to a large negative bias. The setting of the STABILITY control determines the DC level at the input of the gating multi.

the hold-off  
period

When a sweep is initiated, a portion of the sawtooth is fed back to the plate of V2 through the divider  $R_k$ . As the plate of V2 rises with the ramp,  $C_h$  discharges toward ground. The grid of V1 rises with the V2 cathode until V1 comes into conduction. When this occurs, the positive-going ramp is coupled to the gate multi input, eventually resetting the multi. Resetting the gating multi terminates the ramp which causes the generator to recover. The rapidly falling sawtooth trailing edge, now present at the V2 plate, back-biases V2. The cathode of V1 however, cannot fall at the sawtooth recovery rate, but at a rate determined by the values of  $R_h$  and  $C_h$ . This slower rate allows the generator to completely recover before the gating multi is set "ready." The hold-off capacitor will continue to charge until the disconnect diode conducts. At this point the circuit is in its quiescent state and the gating multi is ready to receive another trigger pulse.



The disconnect diode hold-off technique is used in slower-sweep-speed generators, usually those whose sweep speeds are no faster than 1 div/ $\mu$ s. If this method were used at faster sweeps, the hold-off circuit would present an increasing capacitive load to the sweep generator. In this event, a follower of some type would be necessary to isolate the hold-off circuit from the generator.

#### TUNNEL-DIODE GATING MULTIVIBRATOR

The introduction of the tunnel diode led to the development of an almost ideal means of sweep gating. The tunnel diode is a single active device that performs all the functions of the Schmitt trigger, and is capable of transition periods of subnanosecond durations.

If the tunnel diode is to serve as a bistable switch or multi, the load resistance in the circuit must be greater than the tunnel diode's negative resistance ( $R_L > -R_d$ ). Of course, proper biasing and circuit construction are also necessary.

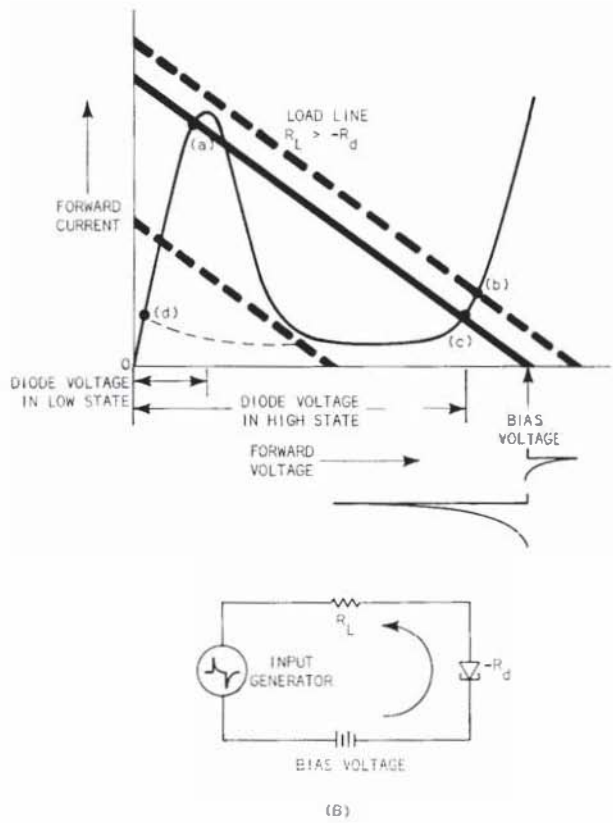
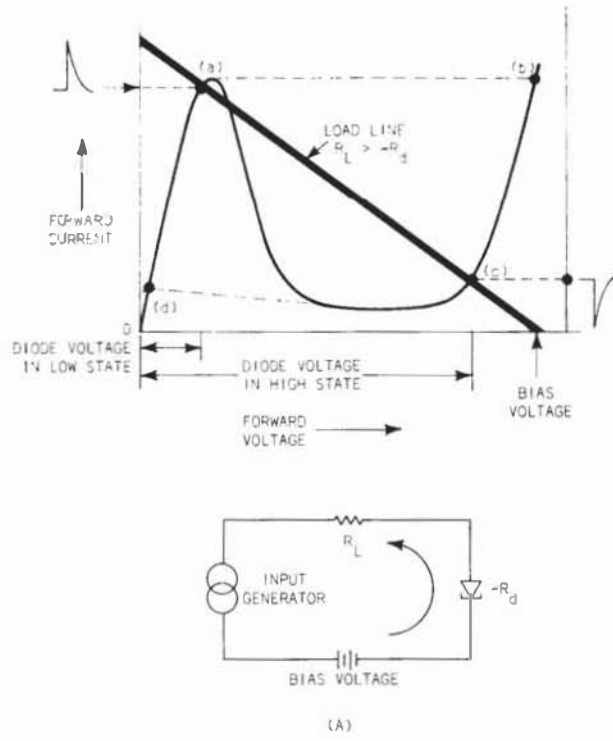

Fig. 5-2. The bistable tunnel-diode switch.

The tunnel diode shown in Fig. 5-2A is biased quiescently at point (a) on its characteristic curve. If the input current is increased above the peak current point of the tunnel diode, the voltage across the TD will switch rapidly to point (b). The transition time from point (a) to (b) may be as fast as .1 to .3 ns. Once the tunnel diode voltage is resting at point (c) (determined by  $R_L$ ) it will remain there until the input current is reduced below the *valley* current level. When this occurs, the TD voltage will switch rapidly from point (c) to point (d) and come to rest at (a) once again. The circuit is bistable, in that it takes a trigger to switch it from its low (forward bias) state to its high state and must also be triggered back to its low state.

In Fig. 5-2B we see a similar action, in that the TD behaves as a bistable switch; but in this case the *applied voltage* is varied to cause the TD to switch. If the same conditions are established, with the TD voltage resting at point (a), an increase in forward bias *voltage* by the generator will move the load line beyond the first positive slope. The TD voltage will switch to point (b), fall to point (c) and remain there. To restore the TD, the forward bias must be reduced below the *valley voltage*. When this is done, the TD will switch back to point (c) and again come to rest at point (a).

If a germanium TD is used, point (a) exists at about 50 mV, and point (b) exists at about 0.35 to 0.5 V.

If the tunnel diode functions as a switch and is biased at point (a), the TD would be extremely sensitive to any external circuit activity; that is, the TD could switch to its high-voltage state accidentally. We may however, reduce the sensitivity of the device by decreasing the forward bias applied to it.

reverse  
biasing  
the TD

In practical circuitry, it often becomes necessary to bias a TD in the *reverse* direction. This will insure that the device will not accidentally change states. To place the TD in this reverse-biased

state, we simply apply a reverse-bias voltage, producing a reverse current. [See point (c) in Fig. 5-3.]

In the discussion to follow, when we talk about the TD drawing reverse current, the operating point will exist somewhere in the reverse current region of the TD's characteristic.

In any countdown circuit (a sweep-gating multi may be considered such a device), the device used to generate the gate must have a transition time significantly shorter than the risetime of the input signal. A fast transition may occur only during one half cycle of the device. As long as *this* transition occurs during trigger interrogation, the device will provide jitter-free triggering. Therefore, the ability of the gating multi to interrogate very fast-risetime or closely spaced pulses, is of prime importance. As we know, the tunnel diode is capable of subnanosecond transition times.

practical  
tunnel-diode  
gate  
generator

A schematic diagram of a practical tunnel diode sweep gating circuit, used to gate a Miller sweep generator, is shown in Fig. 5-4. The circuit consists of a tunnel diode D2, rated at approximately 4.7 mA, a PNP germanium transistor (Q1) used as a gate amplifier, and a disconnect diode (D1), used to disconnect the TD from incoming trigger pulses.



With the circuit in its quiescent state, the sweep-reset multi provides about 3 mA of current for the TD through R1 and R2. The current through the TD sets the diode to its low forward voltage, or "ready" state. With a base-to-emitter voltage of  $-0.05$  V, Q1 is cut off.

triggering  
the TD gate  
generator



To initiate a sweep, the tunnel-diode must be provided with an additional 1.7 mA of forward current. A current trigger is applied through the disconnect diode to the TD. The trigger supplies about 5 to 8 mA of current, which is more than sufficient to switch the TD to its high-voltage state. The TD cathode falls to about  $-500$  mV, back-biasing the disconnect diode. The back-biased diode (D1) will "lock out" any triggers that may arrive during sweep time. The negative pulse generated by the TD is sufficient to drive the gate amplifier (Q1) into

saturation. The collector of Q1 rises rapidly toward the grounded emitter. The positive voltage step at the collector of Q1 is sufficient to back-bias the generator disconnect diode (D3) initiating a ramp.

The saturated gate amplifier draws about .5 mA of base current through R1, R2 and R3, holding the TD in its high state during sweep time.

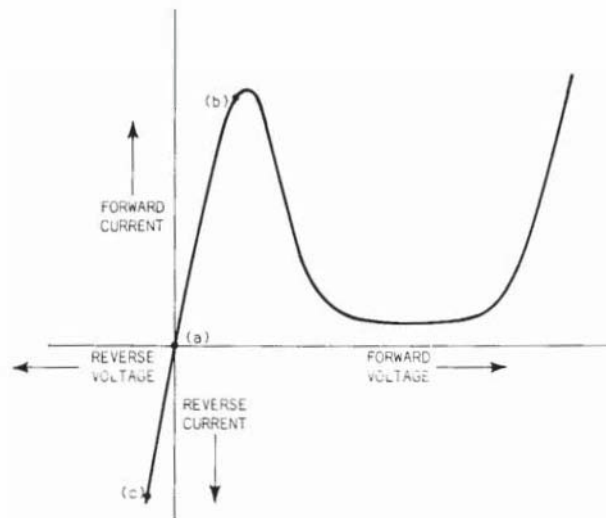

Fig. 5-3. Reverse biasing the tunnel diode.

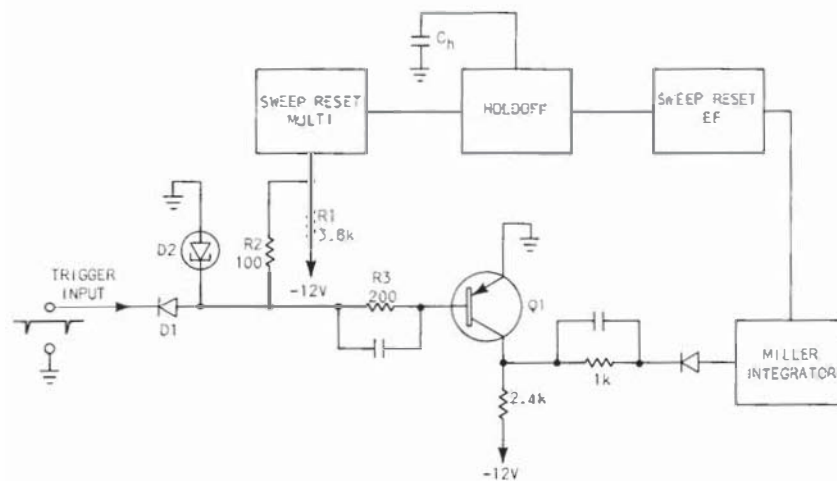

Fig. 5-4. Practical tunnel-diode gate generator.

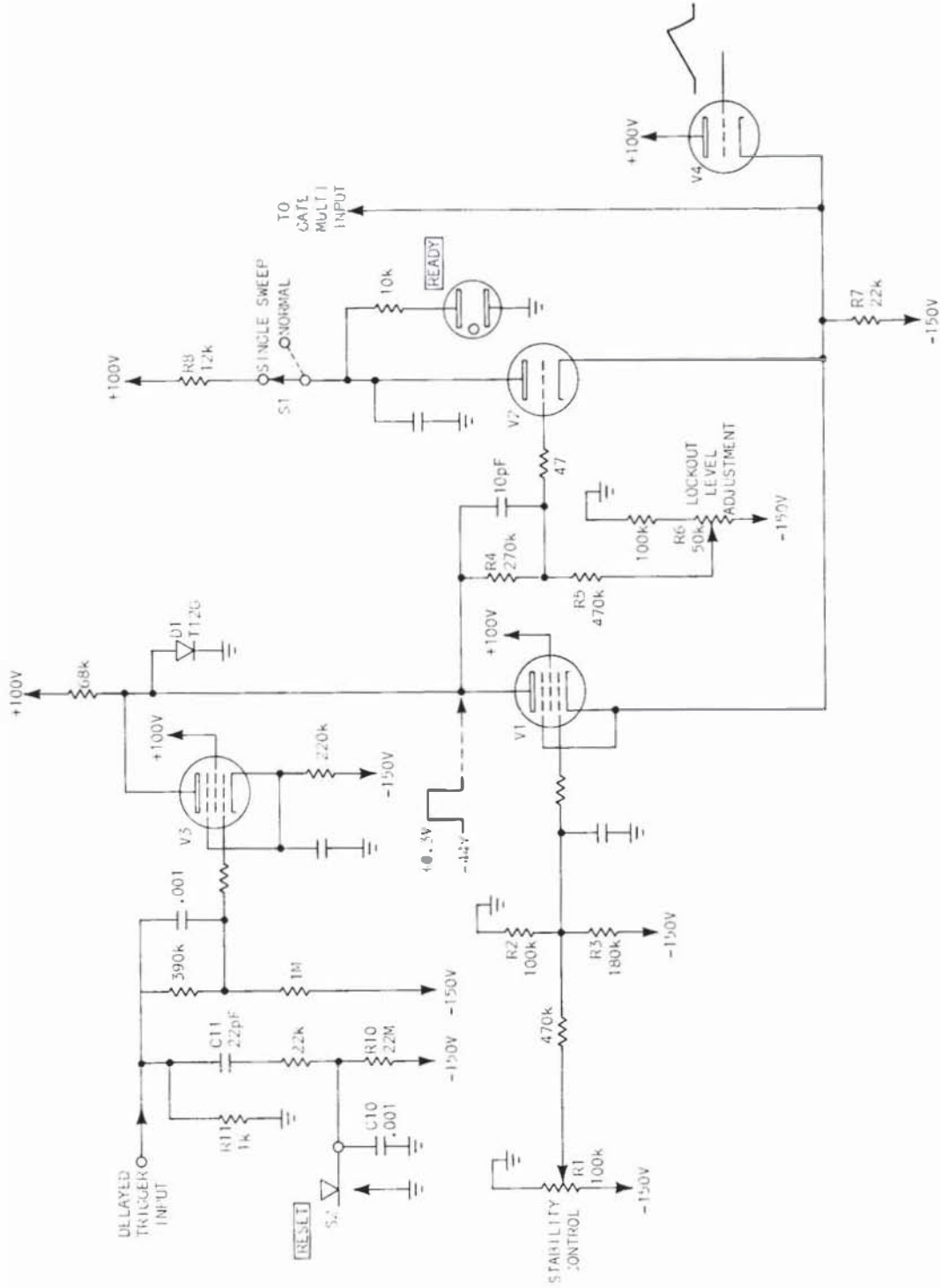

Fig. 5-5. Sweep lockout.

When the sweep generator reaches a predetermined level, the sweep-reset multi switches, pulling the junction of R1 and R2 positive. The positive voltage step at the R1 - R2 junction *reverse biases* D2, switching the TD to a locked-out condition (not triggerable). The switching action of the TD back biases the E-to-B junction of the gate amplifier, cutting off the Q1 collector current. This event forward biases the sweep disconnect diode (D3), terminating the ramp. The sweep generator now enters its recovery period.

restoring  
the TD

After the hold-off period the sweep-reset multi switches back to its quiescent state, again forward biasing the TD. The TD is now in its low (forward voltage) state. Diode D1 is again forward biased and the circuit is "ready" to receive another trigger.

#### SWEEP LOCK-OUT

Another type of control device, incorporated in many sweep generator circuits, is usually referred to as a *lock-out* circuit. The lock-out circuit provides a method of disabling the sweep generator for an indefinite period.

Upon command, the lock-out circuit will set the input of the sweep generator to a "ready" state. In this state, if a trigger is applied, a ramp will be generated. Upon completion of a ramp, the lock-out circuit will hold the sweep generator insensitive to any subsequent trigger signals. The sweep generator cannot be triggered until a second command signal is applied to the lock-out circuit to "ready" the sweep generator.

A schematic diagram of a practical lock-out circuit is shown in Fig. 5-5. The position of S1 activates or deactivates the lock-out circuit. (The reason for the SINGLE SWEEP label will become obvious after the discussion.) With switch S1 in the NORMAL position, V2 cannot conduct. V1 functions as a cathode follower, following the activity of the STABILITY control. Of the total 5 mA of cathode current through R7 only 1.5 mA flows in the V1 plate circuit. The balance is drawn by the screen grid. This configuration allows changes in grid voltage, without appreciable plate voltage changes. The common-cathode voltage of V1, V2, and V4 can be

adjusted by the STABILITY control, thus allowing the gate multi to be set to its triggerable, or "ready" state, during normal operation.

As we recall from the "hold-off" discussion, as the sweep runs up, a portion is fed back to the common cathode bus. The rising ramp cuts off V1 and continues to rise, *resetting* the gating multi. When the sawtooth starts negative, this negative voltage is fed back to the gate input, pulling the gate input voltage down until the stability CF (V1) turns on. This establishes the gate multi "ready" level.

single sweep  
lock-out

When S1 is switched to the SINGLE SWEEP position the +100 V supply is applied to V2. V2 will not conduct, due to the large negative bias present (about -20 V). The READY light (located on the front panel of the instrument) will be lighted, indicating to the operator that the sweep is "ready" to receive a trigger. Now we'll trigger the sweep and describe the activity within the lock-out circuit.

After applying the input trigger, the ramp begins. The positive-going ramp is fed back to the common cathode bus, eventually cutting off the stability CF (V1). When this happens, the plate voltage of V1 rises toward the +100 volt supply, but is clamped at approximately +.3 volts. Clamp diode D1 establishes a reference point to provide stability to the Lock-Out Level adjustment. The positive voltage step at the V1 plate raises the control grid of V2 from about -70 to -40 volts, turning on V2. The cathode bus is now at about -40 volt level. The rising ramp *resets* the gate multi, and the sawtooth voltage starts falling. The negative-going ramp is coupled to the grid of V4, eventually cutting it off. *Normally* the cathode of V4 would follow the negative-going ramp, lowering the cathode bus to the "ready" level. Because V2 is conducting, the negative-going voltage at the V4 grid will not affect the common cathode bus. V2 holds the input level of the gate multi sufficiently high to insure that the multi cannot be triggered. The sweep generator is *locked-out* and will remain so, until some method of restoring the gate multi to its "ready" state is implemented.



resetting  
the sweep  
generator

One method of resetting the sweep generator to its "ready" state is to apply a pulse to the grid of V2 sufficient in amplitude to cut off plate current. The V2 cathode would then fall to the gate input "ready" level (set by the STABILITY control).

The "reset" or "enabling" pulse, may be generated in a circuit consisting of S2, R10 and C10, or by the Delayed Trigger generator, incorporated in some oscilloscopes (See discussion of Delay Pick-off in "Oscilloscope Trigger Circuits" book.)

enabling  
pulse

To understand the generation of the "enabling" pulse, using the RESET switch S2, we should recognize that a charge of -150 volts appears across C10 when S2 is open. When S2 is closed, C10 discharges through the switch, creating a pulse that starts at a -150 V level and rises to 0 volts (almost instantaneously). This positive pulse is differentiated by R11 and C11 and is applied to the control grid of V3. The pulse is amplified (about 10X), inverted, and applied to the control grid of V2 through the divider R4 and R5. The pulse applied to the grid of V2 is approximately -30 V. The V2 cathode will follow the negative-going grid until the common cathode bus reaches the V1 grid voltage. At that time, V1 will conduct, clamping the falling cathode bus to the *preset* "ready" level. The V1 plate will fall to about -40 volts, insuring the cut-off state of V2. When V2 cuts off, its plate voltage increases toward the +100 volt source, providing sufficient ignition potential to the READY neon. The READY neon fires, indicating a "ready" sweep condition at the front panel.

Another method of sweep lock-out will be described while referring to Fig. 5-6. In following this description, keep in mind the requirements of the lock-out circuit previously described.



manual  
reset

When we recall the discussion of hold-off, we realize hold-off can be considered as a form of lock-out. The triggers coming into the sweep gating multi cannot start the sweep until the hold-off circuit sets the gating multi to its "ready" state. Therefore, the hold-off circuit *locks-out* the incoming trigger pulses. The circuit in Fig. 5-6 provides a lock-out capability simply by including a means for disconnecting the hold-off circuit, and substituting a *manual* method of resetting the TD gate generator.

A discussion of this type of lock-out must include: the reset-pulse source (C1, the neon B1, and the pulse amplifier Q1), and the Sweep Reset Multi (Q2 and Q3), used to drive the TD gate generator. Also included is a means of lighting a lamp, located on the front panel of the scope, to indicate to the operator when the sweep generator is "ready" to be triggered. The lamp is labeled RESET, indicating a *sweep ready condition*, and is driven by the lamp driver transistor Q4.

To set the circuit in a quiescent condition, S1 is switched to the SINGLE SWEEP position. This turns on Q2, and cuts off Q3. The *on* state of Q2 is determined by the voltage level at the Q2 base, established by about 4 mA of current through R4 and R5. Note the base-voltage levels\* of Q2 and Q3. Since their emitters are common, Q2 is conducting and Q3 is cut off. The collector current through R6, *reverse biases* TD1, locking out incoming triggers. When Q3 is cut off, a -9 volt level appears at its collector, which sets the junction of R7 and R8 at +.5 volts. A .7 V offset across D11 sets the base of Q4 at -.2 V, holding Q4 in cut-off. The RESET lamp is "off," since Q4 is not conducting and the circuit is in a "locked-out" condition.

Since the sweep generator is locked out, a means must be provided to *reset* the generator to a "ready" condition. The Reset-Pulse Generator provides this means. To initiate a reset pulse, the RESET switch is depressed. C1, charged to +150 volts, is shorted to ground through R1. The voltage at the junction of C1 and B1 falls toward ground at the R1·C1 rate. When the ignition voltage (about 80 V), of B1 is

---

\*Lower voltage levels present during "lock-out" and upper voltage levels present during "ready" conditions.

attained, the neon fires. After ignition, the voltage across B1 *stabilizes* at about 60 V. The negative voltage step created by the neons changing from its ignition state to its stable state (-20 V), changes the charge across C2. The resulting negative current change is applied to the base of Q1, driving it into saturation. The positive voltage change at the collector of Q1 is coupled through C3 to the base of Q2, turning it off. When Q2 cuts off, the current through R9 is switched to Q3, raising the collector voltage of Q3 from -9 V to about -2 V. Sweep-reset multi switching action has two results:

1. The RESET lamp lights, due to the change in collector voltage of Q3, which turns on Q4.
2. The TD is forward biased by the negative collector voltage change at Q2, setting the TD to its low (forward voltage), or "ready" state.

So far, we have described the activity that returns the sweep generator from a "locked-out" to a "ready" condition. Now, we will apply a trigger pulse and describe the subsequent operation of the circuit.

triggering

When a negative trigger pulse is applied through the forward-biased coupling diode (D1) the TD will switch to its high (voltage) state if the trigger contains sufficient energy. This activity back-biases the trigger-coupling diode, and also saturates the gate amplifier. This saturated gate amplifier reverse biases the sweep disconnect diode (D3) allowing the sweep generator to generate a negative-going ramp. The negative-going ramp is coupled through the sweep reset EF to the back-biased diode (D13). As the ramp falls from the +13 volt level to the level at the base of Q2 (about 4.5 V, established when Q3 conducts), D13 will conduct, allowing the base of Q2 to follow. When the ramp drives the Q2 base to about +2.3 V (.6 V more negative than the common emitter level), the multi will switch to the condition: Q2 *on*, Q3 *off*. This sets the base of Q2 to about +.5 V. The conduction of Q2 increases current through R6, causing the TD to switch to its low (reverse voltage) state, drawing about 9 mA of *reverse current* from the TD. The TD, in its reverse-biased state, will not respond to input triggers. Therefore,

the sweep generator will be *locked-out* until the TD can be biased to its low *forward voltage* (high forward current), or "ready" state. As Q3 switches from its *on* to *off* state, the E-to-B junction of Q4 is back-biased. This extinguishes the RESET lamp, indicating at the front panel a "locked-out" sweep.

Meanwhile, as the TD became reverse biased, the gate amplifier was cut off, terminating the sweep. The generator entered its recovery period, rising positive to the ramp-start reference. The positive-going output of the sweep generator, coupled through the sweep reset EF, back-biases D13. The base of Q2 is thus set at about +.5 V and will remain there until a *reset pulse* is applied from the RESET circuit.

Normally (when the hold-off circuit is connected to the Q2 base) the base would follow the positive excursion of the hold-off capacitor until the voltage was sufficient to cut off Q2. This would set the input circuit to its "ready" state.

In the foregoing discussion we have studied two methods of lock-out control. These were selected as typical examples of techniques used to incorporate lock-out into sweep generator systems.

## AUTOMATIC SWEEP TRIGGERING

The ability to generate a sweep automatically is a desirable feature incorporated in many more sophisticated oscilloscopes. This feature provides a reference sweep to the operator for beam positioning prior to application of a vertical signal. Even though the sweep is running, it retains the ability to be triggered. That is, if a trigger is applied, the sweep will function as a triggered sweep (within limits).

One of the earliest automatic-sweep techniques incorporated a free-running multivibrator, used as a sweep-trigger source. (See discussion of Automatic Operation in the "Oscilloscope Trigger Circuits" book.

automatic  
sweep  
generation

A more recent automatic-sweep technique incorporates a circuit which automatically sets the *state* of the sweep generator. Recalling that in earlier instruments, the sweep generator could be set to one

of three states by the STABILITY control (Locked-out, Ready, or Free-running), we will now discuss a circuit that *automatically* sets the sweep generator to either the "free-run," or "ready" state, depending on trigger circuit activity. The term "AUTO-STABILITY" will be used to describe this circuit.

bright-line  
auto

Sometimes the term "Bright-Line-Auto" is used when referring to the Auto-Stability technique. This term originated mainly to emphasize one advantage of the later method of automatic sweep generation. In the early instruments, a free-running multi functioned as a pulse generator. The output of the multi was processed and used as a trigger source for the sweep generator. This technique provided a triggered sweep, even in the absence of externally applied trigger signals. A frequency of approximately 40 to 50 Hz was chosen for the multi, mainly to facilitate measurement of audio frequencies and 50- or 60-Hz line frequencies. Therefore, in the absence of an external trigger, the sweep *repetition rate* was limited to the 40-Hz trigger-multi frequency. This low rep-rate sweep resulted in a gradual decrease in trace brightness as sweep speed was increased. The Auto-Stability technique prevents trace dimming considerably, by setting the sweep generator in a free-running condition in the absence of an external trigger.

The repetition rate of the free-running sweep generator is usually much higher than 40 Hz (typically in excess of 100 kHz). Consequently, the term "Bright-Line-Auto" is sometimes used when referring to an instrument which incorporates the Auto-Stability circuitry.

A schematic diagram of an Auto-Stability circuit is shown in Fig. 5-7A. The integral parts of the circuit are:

auto-  
stability  
circuit

- A. Trigger pulse amplifier and shaper (Q1).
- B. Monostable multi (Q2 and Q3).
- C. Transistor switch (Q4).
- D. Diode gate (D4 and D5).



The main purpose of the circuit is to set the collector level of Q4 to one of two possible conditions, either +12 V or -1 V. When the voltage at the Q4 collector is +12 V, the input to the sweep generator is set to a "ready" condition. When the Q4 collector level is -1 V, the sweep generator free-runs. The output level of Q4 is maintained at +12 V only if triggers are present at the input of Q1, and the period between triggers is not greater than 50 ms.

Quiescently, the output voltage (Q4 collector voltage) is -1 V. At this level, D4 is reverse biased. The sweep-reset multi provides about 3 mA of forward current to the TD, setting the TD to its "ready" state. The level at the junction of D5 and R10 forward biases D5, providing an additional 2 mA of current from R6 to the gating tunnel diode (TD6). The additional 2 mA of current into TD6 causes it to switch to its high (voltage) state, which provides a sweep start. As long as the collector of Q4 remains at -1 V, the TD will oscillate at a rate determined by the switching rate of the sweep reset multi; i.e., the sweep will free-run.

While referring to Fig. 5-7, we will examine the circuit activity initiated by an applied trigger pulse.

When a trigger pulse is applied to the trigger-shaper amplifier (Q1), the pulse is inverted, then differentiated by the collector load L1. The positive output pulse is applied through the forward biased diode (D1), to the base of the normally *off* transistor Q2. The pulse forward biases the E-to-B junction of Q2, bringing it into conduction. The negative-going voltage step at the Q2 collector is coupled through C3 to the base of Q3, cutting it off. The transition (Q2 conducting and Q3 cutting off), is accompanied by a regenerative action in the common-emitter circuit, causing the multi to switch to its quasi-stable state. The negative-going collector voltage of Q2 disconnects diodes D2 and D3, allowing the base of Q4 to fall toward ground. The base of Q4 falls toward ground until the E-to-B junction becomes forward biased, at which time Q4 saturates. When Q4 saturates, its collector rises to the +12 V level, forward-biasing diode D4. When D4 turns on, the quiescent 2 mA of bias current formerly flowing into the TD gate is switched from D5 to D4. This action reverse-biases D5, eliminating



the current path to the TD gate. Consequently, the gate generator receives only 3 mA from the sweep-reset multi. This current reduction terminates the free-running activity, and sets the gate generator to its "ready" state.

The Auto-Stability circuit has a recovery time of approximately 85 ms. If, after one trigger is applied, the multi is allowed to recover, the output will switch back to its -1 V level, setting the sweep generator to its "free-run" state once again.

## SWEEP SWITCHING

A number of Tektronix oscilloscopes incorporate two separate sweep generators. One sweep may be employed as a delay circuit for the other, permitting a variety of useful display modes not available in instruments employing only one sweep generator. This feature may be combined with a system of mechanical and electronic switches, gating circuits and interconnections to provide sweeps that are *alternately* applied to the horizontal deflection system of the oscilloscope. Many advantages, otherwise found only in dual-beam instruments, are gained by this "time sharing" of a single-beam CRT.

When a dual-trace vertical plug-in unit is incorporated in the instrument, the sweep-switching feature provides the user with the equivalent of two complete oscilloscope systems in one package.

Before we examine the actual mechanics of sweep switching, we should become familiar with the principal modes of display made available by the dual-sweep feature itself.

display  
modes

The individual sweeps displayed by a dual-sweep instrument may be labeled "A" and "B." Either "A" or "B" sweep may be displayed separately, or a mode ("A" ALT "B") may be selected to display "A" alternating with "B" sweep.

Another mode, "B" INTENS BY "A," may be selected. In this mode, "B" sweep is displayed, a portion of which is intensified during "A" sweep's ramp duration. The time between the start of "B" sweep and the intensified portion is determined by a comparator circuit within the instrument. Therefore, "A" sweep is *delayed* by "B" sweep.\*

The feature "A" sweep delayed by "B" introduces another mode of display available to the user. The mode, "A" DLY'D, will provide a display of "A" sweep after it has been delayed by the "B" sweep.

In addition, one more mode is made available by the alternate-sweep switching feature, the mode "B" INTENS BY "A" - ALT - "A" DLY'D. In this mode, "B" sweep is displayed while being intensified by "A," after which, "A" sweep is displayed after being delayed by "B"; i.e., "B" INTENS BY "A" is alternated with "A" DLY'D.

sweep-  
switching  
circuitry

Fig. 5-8 is a simplified logic diagram of the sweep-switching circuitry. Diode gates are located between the sweep generator outputs and a common horizontal amplifier input. The symbols used to represent these gates imply an *AND* function, that is, two predetermined signals must appear simultaneously at each input of the gate if a sweep is to be displayed.

The gates are controlled by a sweep-switching multivibrator, the outputs of which (being at opposite levels) hold one gate open and the other closed. For example, in the "A" ALT "B" mode, if the switching multi is in a state that opens "A" gate and "A" sweep runs, it will be displayed, and "B" gate will be closed. When "A" sweep terminates, the multi will switch states, closing "A" gate and opening "B," allowing "B" sweep to be displayed.

"A" ALT "B"

When operating in the "A" ALT "B" mode (Fig. 5-9), a provision is made to insure that while one sweep is being displayed, the other is disabled. A signal, coincidental with that which holds one of the gates closed, is applied to the hold-off multi of the sweep *not being displayed*. This "lock-out" signal insures that the undisplayed sweep will be disabled for the duration of the displayed sweep.

\*See *Delaying Sweep* in "Oscilloscope Trigger Circuits" book.

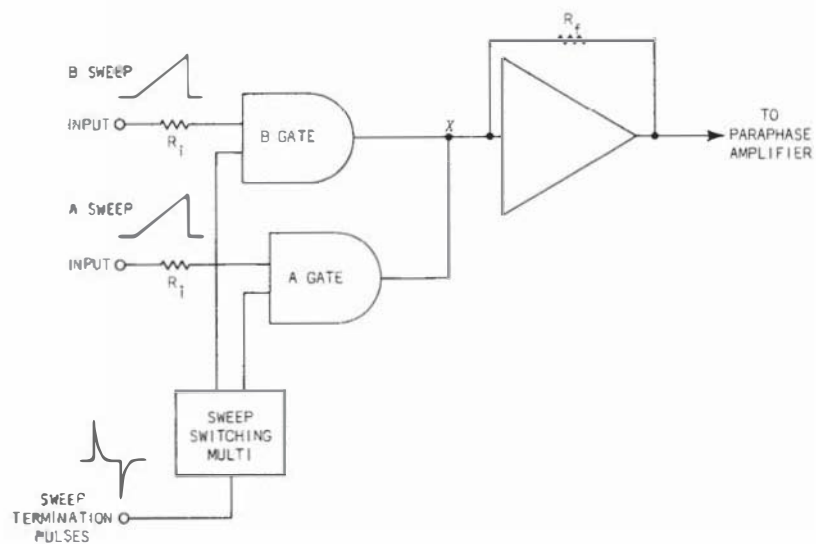

Fig. 5-8. Sweep switching schematic.

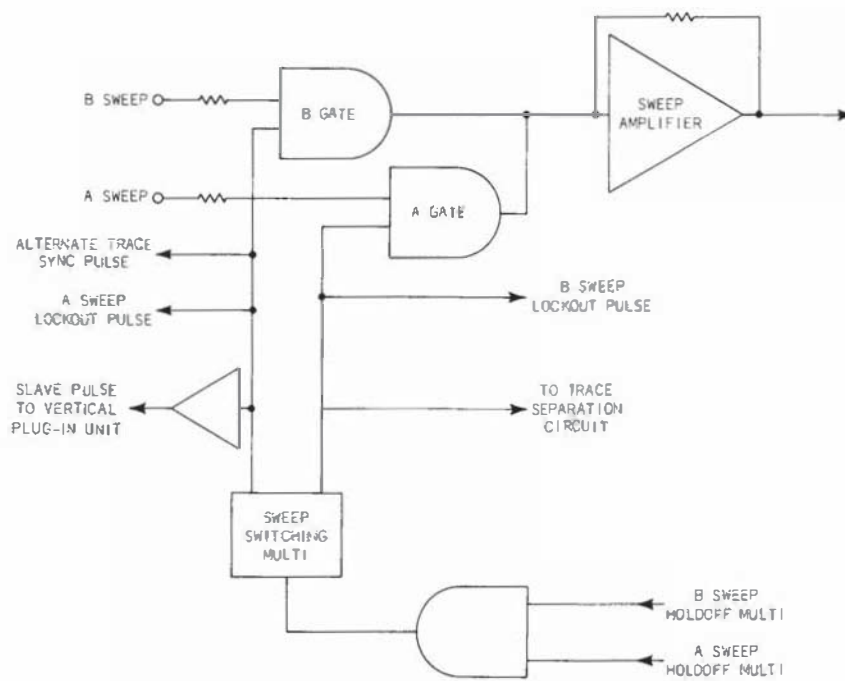

Fig. 5-9.

slave pulse

In addition to providing lock-out pulses, the sweep-switching multi generates a pulse used to "slave" a dual-trace vertical plug-in unit. This slave pulse is applied to a trace-switching multi (within the plug-in), to *insure* that "A" sweep will be *locked* to channel 1 and "B" sweep to channel 2. In addition, "alternate-trace sync pulses" are applied to the trace-switching multi, which allows the vertical channels to be "time-shared" with either "A" or "B" sweep or both (depending on the horizontal-display mode).

trace  
separation

The sweep-switching circuit must perform another function if the alternating sweeps are to be distinguishable on the CRT display. Without this provision, alternating sweeps would share a common base-line. This would be confusing to the viewer. Therefore, a provision is made to vertically separate the traces. An output is provided by the sweep-switching multi to a "trace-separation" circuit. The output of this circuit provides a push-pull DC-offset voltage to the main vertical amplifier whenever "A" sweep is displayed, which offsets the "A" trace from the "B" trace. Signal fidelity is preserved, of course, since we simply change the vertical position of the trace *automatically*. The magnitude and polarity of the "offset voltage" is set by the TRACE SEPARATION control. The sweep-switching multi turns the trace-separation circuit *on* whenever "A" sweep is displayed, whether the plug-in is a multiple or single-channel type.

In the "A" ALT "B" mode of operation then, it is possible to make two individual measurements on the CRT and have many of the advantages of a dual-beam instrument.

sweep rates

It must be remembered, however, that because the channels *time-share* the CRT, if the repetition rates of the two sweeps are widely separated, the channel driven by the faster sweep will not appear often enough to create the desired trace intensity. This occurs because the *slowest sweep* limits the sweep-switching repetition rate. The oscilloscope has a separate BRIGHTNESS control to compensate for this effect (within limits). When the sweep speeds are widely separated, the "A" sweep should be operated at the faster rate, and the INTENSITY control adjusted for a nominal "A" trace brightness. The BRIGHTNESS control should then be adjusted to bring the "B" trace brightness to the level of "A." This procedure is necessary because the BRIGHTNESS control simply attenuates the "B" unblanking pulse; therefore, the "B" trace cannot be brighter than the "A" trace.

single sweep

Another important characteristic of the sweep-switching feature relates to "single sweep" presentations. It must be recalled that both sweeps cannot run at the same time. Consequently, if both sweeps are triggered from a common signal, time coincidence measurements cannot be made using both sweeps simultaneously.

"B" INTENS BY "A"

When the instrument is operated in the "B" INTENS BY "A" mode, if "A" sweep were to continue after "B" sweep terminates, the intensified zone could extend back into the start of the next "B" sweep display. This would appear as a confusing double brightened area on the display. To prevent this, a pulse is taken from the "B" sweep hold-off multi (when the multi transition terminates "B" sweep) and applied to the hold-off multi in the "A" sweep generator circuit. This pulse terminates "A" sweep coincidentally with the completion of "B," a technique sometimes referred to as "anti-wrap around."

In the discussion to follow we will investigate the most significant subcircuits, which when combined, go together to make up the complete sweep-switching circuit. We will confine our discussion mainly to the "A" ALT "B" mode of operation, with occasional references to the other modes as the need arises.

sweep-  
switching  
multi

The first circuits to be considered will be the sweep-switching multi, made up of Q1, Q2 and their associated components. In addition, we will examine switching-pulse amplifier Q3, its associated components, and its relationship to the sweep-switching multi. See Fig. 5-10.

The sweep-switching multi is a bistable device. When operated in the alternate mode, either Q1 or Q2 will conduct until a negative input pulse switches the multi to its opposite state. Diodes D4 and D5 are "catching diodes," used to limit the collector swing of the switching transistors. This is done for two reasons: First, the diodes insure that the C-to-E breakdown voltage of the switching transistors will not be exceeded, and second, the clamping action improves the multi transition time. This is true because the transistor collector voltage must change only 27 volts of a potential 100-volt charge.

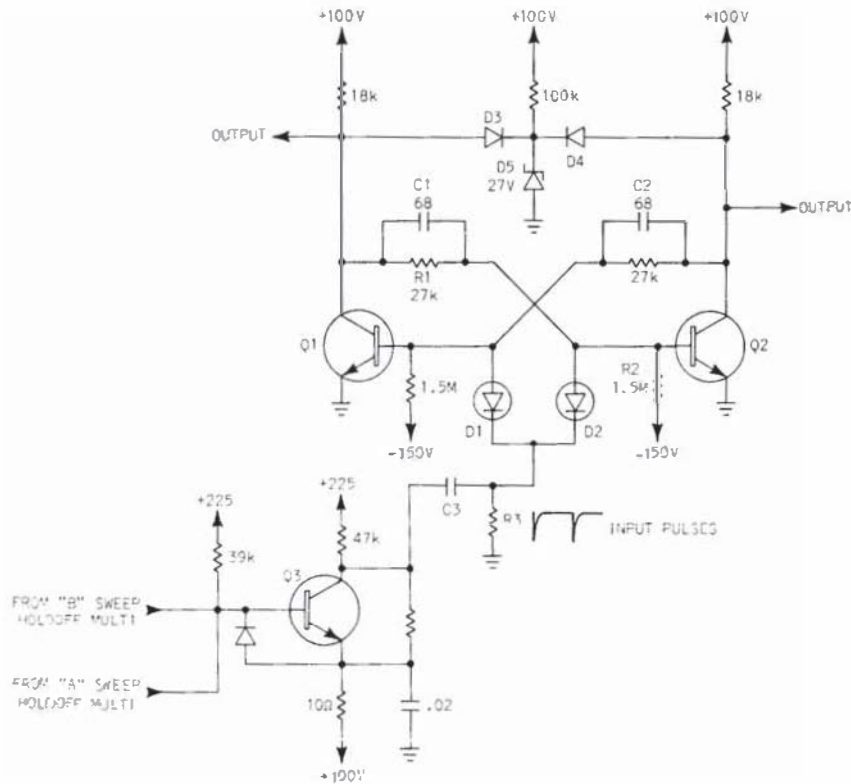

Fig. 5-10. Sweep switching multivibrator.

steering  
diodes

Let us assume that Q2 is conducting (saturated). The voltage at the base of Q2 will be more positive than that at the base of Q1. A negative pulse, applied to the common cathode of D1 and D2, will forward bias D2, and reverse bias the E-to-B junction of Q2, cutting it off. A portion of the positive voltage change at the Q2 collector is coupled to the base of Q1, bringing Q1 into conduction. When Q1 conducts, its collector voltage falls. This negative voltage change is coupled to the base of Q2, insuring the cut-off state of Q2. Thus, the first trigger pulse causes the multi to switch states, resulting in an output voltage change from 0 to 27 volts at the Q2 collector, and a complementary voltage change from 27 to 0 volts at the Q1 collector. If a second trigger were applied, the multi would revert to its initial state. Now that we realize that the multi is "switched" by the applied trigger pulses, it should be apparent that the diodes (D1 and D2) "steer" these pulses to their respective inputs. Diodes used in this manner are sometimes referred to as "steering diodes."

The amplifier (Q3) is designed to respond to a *specific* occurrence at its base-to-emitter junction. Two input leads are connected to this junction. Each of these input leads is connected to the plate circuit of one side of its respective hold-off multi. When both input levels go *high* (voltage), Q3 will saturate. When Q3 saturates, a negative step occurs and is differentiated by R3 and C3. The differentiated pulse drives the steering diodes, one of which will steer the negative pulse to the appropriate base circuit of the sweep-switching multi, causing the multi to switch states.

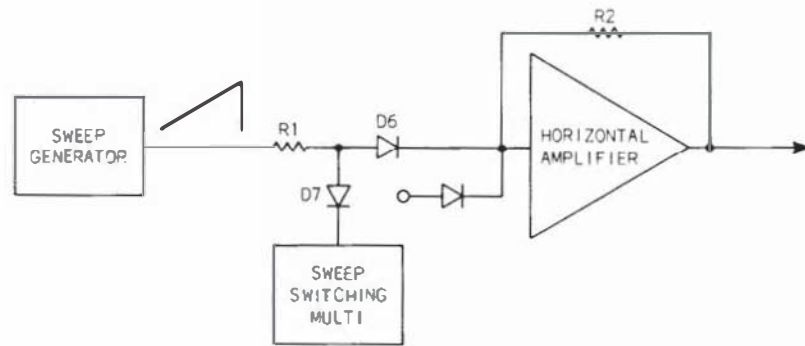

Fig. 5-11. Sweep gate.

sweep gate

The next significant circuit incorporated in the sweep-switching circuit is the sweep gate. Fig. 5-11 shows a schematic diagram of one of the gates. Since the two gates are identical, the following discussion will serve for both.

The output of the sweep-switching multi, as it appears at D7, will exist at one of two levels (27 or 0 volts). When the output level is 27 volts, D7 is reverse biased and D6 conducts. If a sawtooth appears at the gate input, D6 will couple the sawtooth current to the input of the horizontal amplifier. When the sweep-switching multi changes states, D7 becomes forward biased and D6 is reverse biased. Any sawtooth current appearing at the gate will be shunted to ground through D7 and the saturated transistor within the multi. At the same time, D6 (being reverse biased) will prevent any sawtooth current from appearing at the horizontal input.

Referring to Fig. 5-8 once again, we can easily understand the symbol used to represent the diode gates. To obtain an output from the gate, both a sawtooth *and* a positive pulse from the switching multi must simultaneously appear at the inputs to the gate.

trace  
separation  
circuit

Fig. 5-12 shows a schematic of the trace-separation circuit. If we assume that time-base "B" is being displayed, the output level of the switching multi will be 0 volts. This level will forward-bias D1



and D2, setting their anodes equally at about 0.5 volts, clamping the control grids of the amplifier to that level. Under these conditions, the TRACE SEPARATION control *will not* affect the vertical position of the trace. However, when time base "A" is displayed, the voltage at the common cathode bus of D1 and D2 will be 27 volts. This level back-biases the diodes. Under these conditions, if the TRACE SEPARATION control is adjusted, a voltage change will appear at the control grids of the amplifier. A push-pull output voltage change will appear at the plates of the amplifier. This *offset* voltage positions the "A" trace in accordance with the setting of the TRACE SEPARATION control. When time base "B" is again displayed, D1 and D2 become forward biased, clamping the amplifier control grids once again. The trace returns to its previous vertical position.

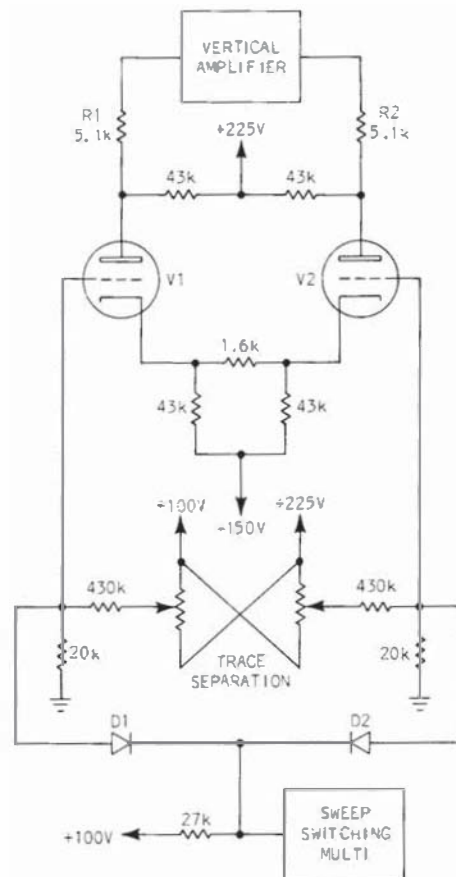

Fig. 5-12. Trace separation amplifier.



In those modes not utilizing sweep switching, the D1 - D2 common cathode bus is grounded directly, disabling the trace separation amplifier.

Fig. 5-13 is a schematic diagram incorporating those circuits which go together to make up the complete sweep-switching control circuit. The previous discussion of the integral parts of this circuit should contribute to a clear concept of sweep switching.



## INDEX

- Actual ground (defined), 47
- Automatic triggering, 87-91
- Auto-stability, 88-91
- Bootstrap capacitor  
(compensation), 52, 72
- Bootstrap sweep generator,  
25-41
- Bright-line auto, 88-91
- Clamp-tube generator, 13-23,  
26
- Clamp-tube plate regulator,  
38
- Clip line, 34
- DC restoration, 22-23
- Deviation from average, 8
- Difference measurement, 8
- Disconnect diode, 51-54, 73
- Displacement error, 7, 55
- Duty-cycle limiter, 30-32
- Exponential sweep, 13-15
- Feedback, 25, 38, 44, 48, 50
- Flyback (defined), 3
- Full scale deflection  
(defined), 4
- Gated-clamp-tube generator,  
13-23
- Gate extender, 34-37
- Grid base (defined), 20
- Hold-off (defined), 3, 11, 61
- Hysteresis (defined), 69
  - Ready level, 65-66
  - Reset level, *see* Ready level
  - Trip level, *see* Ready level
- Integrating error, 50
- Linearity (defined), 3
- Lock-out, 81-87
- Miller effect (defined), 43
- Miller integrator, 43-72
  - Disconnect diodes, 51-54
  - Hold-off, 61-63
  - Input impedance, 51, 56,  
59-60
  - Integrating error, 50
  - Isolation of timing circuit,  
60
  - Speed-up capacitor, 56
  - Sweep-gating multi, 67-72
  - Sweep length, 63, 66, 71
  - Transistor base amplifier,  
56-60
  - Triggering, 63, 67-69
  - Vacuum tube base amplifier,  
51-56
- Nonlinearity, *see* Linearity
- Operational integrator, 48-72
- Plate regulator, 38-41
- Ramp (defined), 3
- Ramp recovery, *see* Retrace
- Ramp start reference, 3, 11,  
22-23, 37-38, 40, 53, 56
- Rate error, 4, 55
- Retrace (defined), 3, 11
- Sawtooth characteristics, 3-11
- Schmitt trigger, 67-72
- Self-balancing bridge, 48
- Signal delay, 33-37
  - Clip line, 34
  - Gate extender, 34-37
  - Delay line, 34-37
- Single sweep, 81-87, 95
- Slope error, *see* Rate error
- Speed-up capacitor, 56
- Start level (defined), 3
- Steering diodes, 97
- Sweep accuracy (defined), 4
- Sweep-gating multi, 18-23
- Sweep length, 17, 22, 63, 66, 71
- Sweep linearity (defined), 3
- Sweep lock-out, *see* Lock-out
- Sweep switching, 91-101
- Time constant (defined), 13
- Trace separation, 94, 98-101
- Transresistance (defined), 58
- Tunnel-diode gating multi,  
75-81
- Unblanking pulse, 21-22
  - AC coupled, 21-22
- Virtual ground (defined), 47

## NOTES

## NOTES

OTHER BOOKS IN THIS SERIES:

*Circuit Concepts*

Power Supply Circuits  
062-0888-01

Oscilloscope Cathode-Ray Tubes  
062-0852-01

Storage Cathode-Ray Tubes and Circuits  
062-0861-01

Television Waveform Processing Circuits  
062-0955-00

Digital Concepts  
062-1030-00

Spectrum Analyzer Circuits  
062-1055-00

Oscilloscope Trigger Circuits  
062-1056-00

*Measurement Concepts*

Information Display Concepts  
062-1005-00

Semiconductor Devices  
062-1009-00

Television System Measurements  
062-1064-00

Spectrum Analyzer Measurements  
062-1070-00

Engine Analysis  
062-1074-00