



Dell EMC PowerEdge R740 and R740xd



Latest 2-socket, 2U rack server designed for complex workloads using highly scalable memory and network options. The following documentation is designed as both an instructional aid and online reference material for the Dell EMC PowerEdge R740 and R740xd rack server. The material introduces new technologies and features specific to the PowerEdge R740 and R740xd.

Notes, cautions, and warnings

-  **NOTE:** A NOTE indicates important information that helps you make better use of your product.
-  **CAUTION:** A CAUTION indicates either potential damage to hardware or loss of data and tells you how to avoid the problem.
-  **WARNING:** A WARNING indicates a potential for property damage, personal injury, or death.

Contents

1 System Overview.....	6
Introduction.....	6
New technologies.....	6
2 System features.....	8
System features comparison.....	8
Specifications.....	9
3 Chassis views and features.....	12
Chassis views.....	12
R740 and R740xd front views.....	12
R740xd.....	13
R740 and R740xd Rear views.....	13
R740xd.....	14
R740 and R740xd internal chassis views.....	14
R740.....	15
R740xd.....	17
Chassis Features.....	18
Left control panel.....	19
Quick Sync 2 moduleStatus LED.....	20
Right Control Panel.....	22
Quick Resource Locator.....	23
Location of Quick Resource Locator (QRL)	24
Physical Security features.....	25
4 Processors.....	26
Processor features.....	26
Supported Processors.....	26
Processor ConfigurationsSingle CPU Configuration.....	31
Chipset.....	31
5 System memory.....	33
General memory module installation guidelines.....	35
NVDIMM-N memory module installation guidelines.....	35
6 Storage.....	36
Storage Controllers.....	36
Supported Drives.....	36
IDSDM with vFlash card.....	37
Optical Drives.....	37
Tape Drives.....	37
Boot Optimized Storage Subsystem (BOSS).....	38

7 Networking and PCIe.....	41
Network card options.....	41
PCIe Expansion cards.....	41
PCIe Expansion card riser.....	41
PCIe expansion card riser configurations.....	44
8 Power, Thermal, and Acoustics.....	46
Power consumption and energy efficiency.....	46
Power supply units.....	47
Thermal and Acoustics.....	47
Thermal design.....	47
Acoustical design.....	47
9 Rack rails.....	49
Sliding rails features summary.....	49
Static rails.....	50
System-to-Rail Installation Method.....	51
Cable management arm (CMA).....	52
Rack Installation.....	53
Installing system into the rack (option A: Drop-In).....	53
Installing the system into the rack (option B: Stab-In).....	55
10 Dell EMC OpenManage systems management.....	60
OpenManage systems management.....	60
iDRAC with Lifecycle controller.....	61
iDRAC features and comparison.....	61
Agent-free management.....	66
Agent-based management.....	66
Dell EMC consoles.....	66
Dell EMC OpenManage systems management tools, utilities and protocols.....	68
Integration with third-party consoles.....	69
OpenManage connections with third-party consoles.....	70
Dell EMC server management operations.....	70
11 Appendix A. Additional specifications.....	72
PSU specifications.....	72
Chassis dimensions.....	73
Environmental specifications.....	74
Video specifications.....	74
USB peripherals.....	74
12 Appendix B. Standards compliance.....	75
13 Appendix C Additional resources.....	76
14 Appendix D. Support and Deployment Services	77

Server Deployment Services.....	77
Remote Consulting Services.....	77
Data Migration Service.....	78
ProSupport Enterprise Suite.....	78
ProSupport Plus.....	78
ProSupport.....	79
ProSupport Flex for Data Center.....	79
Additional professional services.....	79
Dell EMC Education Services.....	79
Dell EMC Global Infrastructure Consulting Services.....	80
Dell EMC managed services.....	80

System Overview

Introduction



Figure 1. PowerEdge R740/R740xd

The PowerEdge R740/R740xd is Dell EMC's latest two socket, 2U rack servers designed to run complex workloads using highly scalable memory, I/O capacity and network options. The R740/R740xd features the Intel Xeon processor scalable family, up to 24 DIMMs, PCI Express (PCIe) 3.0 enabled expansion slots, and a choice of network interface technologies to cover NIC and rNDC.

The PowerEdge R740/R740xd is a general-purpose platform with highly expandable memory (up to 3TB) and impressive I/O capability to match. The R740 is capable of handling demanding workloads and applications, such as data warehouses, E-commerce, databases, and high-performance computing (HPC).

In addition to the R740's capabilities, The R740xd adds extraordinary storage capacity options, making it well-suited for data intensive applications that require greater storage, while not sacrificing I/O performance.

New technologies

Table 1. New technologies in R740 and R740xd

New technology	Detailed description
Intel Xeon processor scalable family	The Intel Xeon processor scalable family has advanced features that deliver exceptional performance and value. See the Processors section.
Intel C620 series chipset	The R740 and R740xd systems incorporates the Intel Platform Controller Hub (PCH) chip.

New technology	Detailed description
2666MT/s DDR4 memory	The Intel Xeon processor scalable family support 2666 MT/s memory. The R740 and R740xd supports two DIMMs per channel at 2666 MT/s with these processors. See the Memory section for details.
Next-generation PERC options	The R740 and R740xd support new PowerEdge RAID Controller (PERC) cards with improved functionality and faster performance. See the Storage section.
iDRAC 9 with Lifecycle Controller	The new embedded system management solution features hardware and firmware inventory and alerting, in-depth memory alerting, faster performance, a dedicated gigabit port and many more features. See the iDRAC section.
Wireless management	The QuickSync 2.0 feature is an extension of Near-field communication(NFC) based low bandwidth Quick sync interface in PowerEdge R730. QuickSync 2.0 will offer feature parity with previous generation server's NFC interface to improve user experience. To extend this QuickSync feature to wide variety of Mobile OS's with higher data throughput, the QuickSync 2.0 version replaces the previous generation server's NFC technology with wireless at-the-box system management.
LCD bezel	The R740 and R740xd LCD control panel will be embedded in the system front bezel for easy access and management. See the LCD bezel section.

System features

Compared to the previous generation of Dell EMC PowerEdge servers, the R740 and R740xd have more drive bay options, more PCIe slots, next-generation RAID controllers and advanced system management.

System features comparison

Table 2. Comparison of PowerEdge R740/R740xd and R730/R730xd

Feature	PowerEdge R740/R740xd	PowerEdge R730/R730xd
CPU	2 x Intel Xeon Processor Scalable Family	Intel Xeon processor E5-2600 v4 product family
Intel Ultra Path Interconnect (UPI)	Intel Ultra Path Interconnect (UPI)	Intel QuickPath Interconnect (QPI)
Memory	24 x DDR4 RDIMM, LRDIMM or 12x NVDIMM up to 3TB	24 x DDR4 RDIMM, LRDIMM up to 1.5TB
Disk drives	<ul style="list-style-type: none"> 3.5" or 2.5" 12Gb/s SAS, 6Gb/s SATA Upto 24 x PCIe SSD 	<ul style="list-style-type: none"> 3.5", 2.5" or 1.8" 12Gb/s SAS, 6Gb/s SATA 4 x PCIe SSD w/common slot
RAID controllers	Adapters: HBA330, H330, H730P, H740P, H840, 12G SAS HBA Mini Mono: HBA330, H330, H730P, H740P SW RAID: S140	Adapters: HBA330, H330, H730, H730P, H830 (ext) Mini Mono: HBA330, H330, H730, H730P, H830 SW RAID: S130
PCIe slots	Max 8 x PCIe 3.0	Max 7 x PCIe 3.0 or 6 x PCIe 3.0
rNDC	Select Network Adapter NDC: 4x 1GB, 4x 10GB, 2x 10GB + 2 x 1GB, or 2 x 25GB	Select Network Adapter NDC: 4 x 1GB, 4x 10GB, or 2 x 10GB + 2 x 1GB
USB ports	Front: two ports (USB 2.0), one managed (micro-usb 2.0) Optional Upsell: one port (USB 3.0) – Not offered on R740xd Rear: two ports (USB 3.0) Internal: one port (USB 3.0)	Front: two ports (USB 2.0), one managed port Rear: two ports (USB 3.0) Internal: one port (USB 3.0)
Rack height	2U	2U
Power supply	2400W AC Platinum 2000W AC Platinum 1600W AC Platinum	1100W AC Platinum 1100W -48V DC Gold 750W AC Platinum 750W AC Titanium

Feature	PowerEdge R740/R740xd	PowerEdge R730/R730xd
	1100W AC and 380V DC Mixed Mode Platinum	750W AC and 240V DC Mixed Mode Platinum
	1100W AC Platinum	495W AC Platinum
	1100W -48V DC Gold	
	750W AC Platinum	
	750W AC Titanium	
	750W AC and 240V DC Mixed Mode Platinum	
	495W AC Platinum	
System management	LC 3.x, OpenManage, QuickSync2.0, Digital License Key, iDRAC Direct(dedicated micro-USB port), Easy Restore, vFlash	LC 3.x, OpenManage, QuickSync1.0, Digital License Key, iDRAC8, iDRAC Direct(dedicated micro-USB port), Easy Restore, vFlash
Internal GPU	<ul style="list-style-type: none"> 3 x 300W (double-wide) or 6 x 150W (single-wide) XD - x24 non NVMe backplane only 	<ul style="list-style-type: none"> 2 x 300W (double-wide) or 4 x 150w (single-wide) Not supported on R730xd
FPGA support	Up to 4 full-height FPGAs	Not supported on R730 or R730xd
Availability	Hot-plug drives	Hot-plug drives
	Hot-plug redundant cooling	Hot-plug redundant cooling
	Hot-plug redundant power supplies	Hot-plug redundant power supplies
	IDSDM support	IDSDM support
	Boot Optimized Storage Subsystem (BOSS)	

Specifications

Table 3. Technical specifications

Feature	Specification
Form factor	2U rack
Processors	Intel Xeon processor scalable family
Processor sockets	Two sockets
Internal interconnect	Two Intel Ultra Path Interconnect (UPI) links, 10.5 GT/s
Cache	Up to 38.5MB per core; core options: 4, 6, 8, 10, 12, 14, 16, 18, 20, 22, 24, 26, 28
Chipset	Intel C620
Memory	Up to 3 TB (24 DIMM slots): 8GB/16GB/32GB/64/128GB DDR4 up to 2666MT/s
PCIe slots	R740: Up to 8 PCIe 3.0 slots plus dedicated PERC slot
RAID controller	<p>Internal controllers:</p> <p>PERC S140</p> <p>PERC HBA330</p> <p>External HBAs (RAID):</p> <p>PERC H840P</p> <p>External HBAs (non-RAID):</p> <p>12G SAS HBA</p>

Feature	Specification
	PERC H730P
	PERC H740P
	PERC H330
Drives	<p>R740 internal hard drive bay and hot-plug backplane: Up to 16 x 2.5" hard drives: SAS, SATA</p> <p>Up to 8 x 2.5" hard drives: SAS, SATA</p> <p>Up to 8 x 3.5" hard drives: SAS, SATA</p> <p>R740xd internal hard drive bay and hot-plug backplane: Up to 12 x 3.5" SAS,SATA(front)</p> <p>Up to 12 x 3.5" SAS,SATA(front) + 4 x 3.5" SAS,SATA(mid) + 2 x 3.5" SAS, SATA(rear)</p> <p>Up to 12 x 3.5" SAS,SATA(front) + 4 x 3.5" SAS,SATA(mid) + 4 x 2.5" SAS, SATA(rear)</p> <p>Up to 12 x 2.5" SAS,SATA + 12 x 2.5" NVMe in universal slots</p> <p>Up to 24 x 2.5" SAS,SATA(front)</p> <p>Up to 24 x 2.5" NVMe drives in bay 1 and bay 2</p> <p>Up to 24 x 2.5" SAS,SATA(front) + 4 x 2.5" SAS, SATA(rear)</p> <p>Up to 24 x 2.5" SAS,SATA(front) + 4 x 2.5" SAS,SATA(mid) + 4 x 2.5" SAS, SATA(rear)</p> <p> NOTE: Universal slots are slots that support SAS, SATA hard drives/SSDs, or NVMe drives in the same slot.</p>
Maximum internal storage	<p>R740: Up to 96 TB using 8 x 3.5" 12 TB SAS hard drives</p> <p>Up to 61 TB using 16 x 2.5" 3840 GB SATA, SAS, SSD hard drives</p> <p>R740xd: Up to 174.7 TB using 12 x 3.5" 12 TB SAS hard drives + 4 x 2.5" 3840 GB SATA, SAS, SSD hard drives + 4 x 2.5" 3840 GB SATA, SAS, SSD hard drives</p> <p>Up to 184.32 TB using 24 x 2.5" 6.4 TB NVMe SSD + 8 x 2.5" 3840 GB, SATA, SAS and SSD hard drives</p>
Embedded NIC	4x 1GB, 4x 10GB, 2x 10GB+2 x 1GB, or 2 x 25GB NDC
Power supply	495W AC, 750W AC, 1100W AC, 1600W AC, 2000W AC, 1100W DC, 750W and 1100W AC/DC mixed mode
Availability	ECC memory, hot-plug hard drives, hot-plug redundant cooling, hot-plug redundant power, IDSDM/vFlash, Single Device Data Correction (SDDC), spare rank, tool-less chassis, support for high availability clustering and virtualization, proactive systems management alerts, iDRAC9 with Lifecycle Controller
Systems management	IPMI 2.0 compliant Dell EMC OpenManage Essentials Dell EMC OpenManage Mobile Dell EMC OpenManage Power Center
	Dell EMC OpenManage Connections: <ul style="list-style-type: none"> HP Operations Manager, IBM Tivoli Netcool and CA Network and Systems Management Dell EMC OpenManage Plug-in for Oracle Database Manager

Feature	Specification
Rack support	<p data-bbox="395 197 762 218">Dell EMC OpenManage Integrations:</p> <ul data-bbox="395 247 877 352" style="list-style-type: none"> <li data-bbox="395 247 877 289">· Dell EMC OpenManage Integration Suite for Microsoft System Center <li data-bbox="395 302 820 352">· Dell EMC OpenManage Integration for VMware vCenter™ <ul data-bbox="395 390 1471 516" style="list-style-type: none"> <li data-bbox="395 390 1471 432">· ReadyRails™ static rails for tool-less mounting in 4-post racks with square or unthreaded round holes or tooling mounting in 4-post threaded and 2-post (Telco) racks <li data-bbox="395 445 1471 516">· ReadyRails II™ sliding rails for tool-less mounting in 4-post racks with square or unthreaded round holes or tooling mounting in 4-post threaded hole racks, with support for optional tool-less cable management arm
Operating systems	<p data-bbox="395 554 660 575">Canonical® Ubuntu® LTS</p> <p data-bbox="395 604 600 625">Citrix® XenServer®</p> <p data-bbox="395 655 826 676">Microsoft Windows Server® with Hyper-V</p> <p data-bbox="395 705 667 726">Red Hat® Enterprise Linux</p> <p data-bbox="395 756 715 777">SUSE® Linux Enterprise Server</p> <p data-bbox="395 806 555 827">VMware® ESXi</p> <p data-bbox="395 865 1260 886">For more information on the specific versions and additions, visit Dell.com/OSsupport.</p>

Chassis views and features

The following sections provide external and internal views of the Dell EMC PowerEdge R740 and R740xd systems and describe the chassis features. For detailed information on features and descriptions for these systems, see the Dell EMC PowerEdge R740 and R740xd Installation and Service Manual on Dell.com/Support/Manuals

Chassis views

The R740 and R740xd are available in several chassis options with varying numbers of drive bays.

 **NOTE: A chassis cannot be reconfigured or upgraded after point of purchase.**

R740 and R740xd front views

The R740 supports up to 16 x 2.5" or up to 8 x 3.5" front-accessible, hot-plug hard drives that are secured by a removable front bezel.

R740 Front view - 8 x 2.5" hard drive configuration

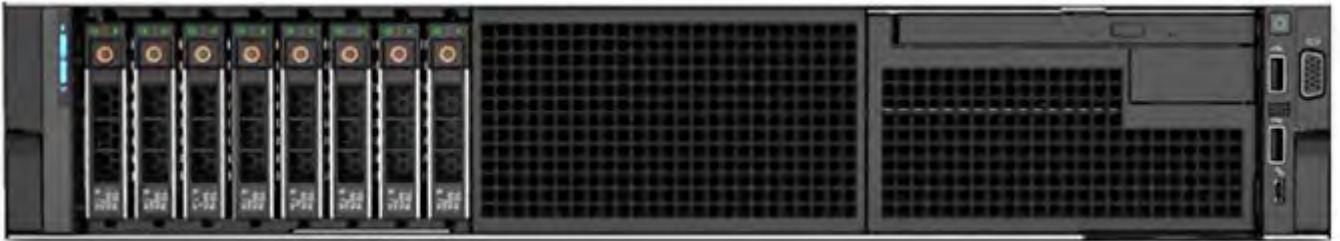

R740 Front view - 16 x 2.5" hard drive configuration



R740 Front view - 8 x 3.5" hard drive configuration

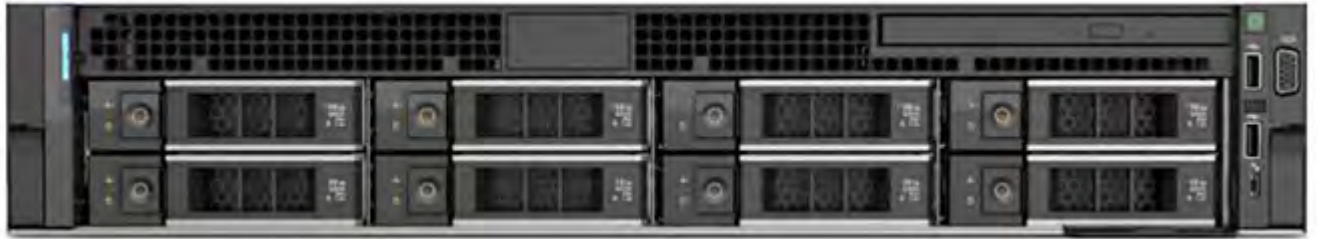

R740xd

The R740xd supports up to 12x 3.5" or up to 24 x 2.5" front-accessible, hot-plug hard drives that are secured by a removable front bezel.

R740xd Front view - 12 x 3.5" hard drive configuration



R740xd Front view - 24 x 2.5" hard drive configuration



R740 and R740xd Rear views

The R740 back panel includes PSUs, Ethernet connectors, PCIe slots and many other features described in this guide

R740 Rear view - with 8x PCIe slots available



R740 Rear view - with 4x PCIe slots available with riser 2 and riser 3 blanks



R740xd

R740xd Rear view - with 2 x 3.5" backplane installed



R740xd Rear view - with 4 x 2.5" backplane installed



R740 and R740xd internal chassis views

The chassis design of the R740 and R740xd is optimized for easy access to components and for airflow for effective and efficient cooling. The R740 and R740xd support up to 24 DIMMs, two processors, hot-plug redundant fans, and many other components and features described in this guide.

R740

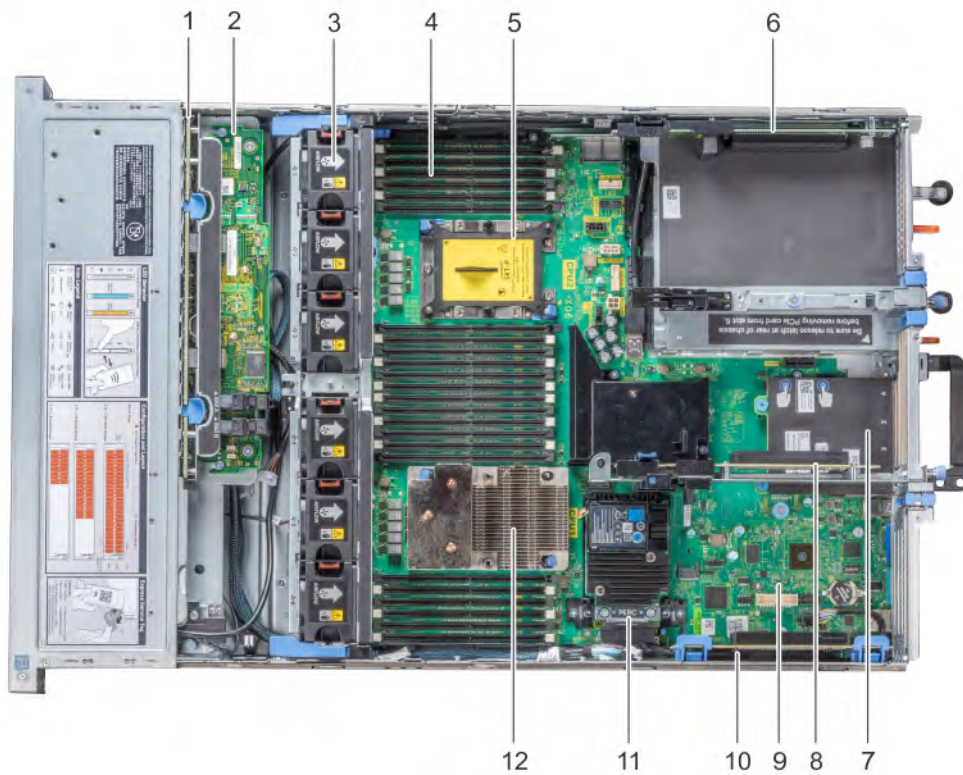

Figure 2. R740 internal chassis view

- | | |
|--|-------------------------------------|
| 1. hard drive backplane | 2. SAS expander card |
| 3. cooling fan in the cooling fan assembly (6) | 4. memory module |
| 5. CPU2 processor heat sink module socket | 6. expansion card riser 3 |
| 7. network daughter card | 8. expansion card riser 2 |
| 9. system board | 10. expansion card riser 1 |
| 11. integrated storage controller card | 12. CPU1 processor heat sink module |

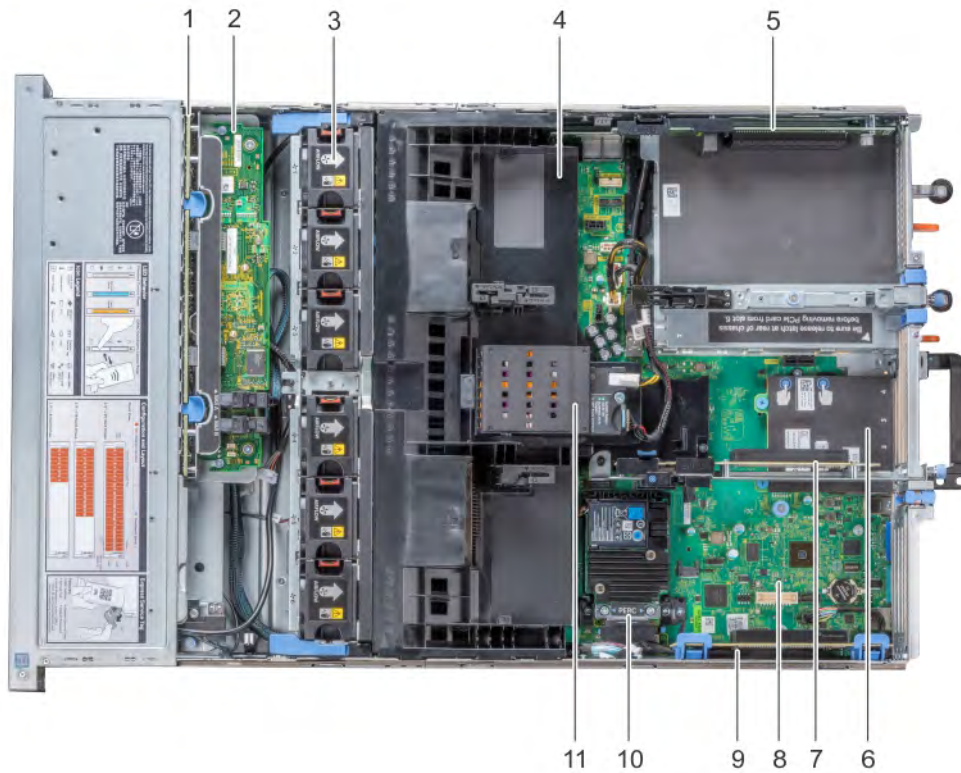

Figure 3. R740 internal chassis view – NVDIMM-N battery

- | | | | |
|-----|---|-----|------------------------------------|
| 1. | hard drive backplane | 2. | SAS expander card |
| 3. | cooling fan (6) in the cooling fan assembly | 4. | air shroud |
| 5. | expansion card riser 3 | 6. | network daughter card |
| 7. | expansion card riser 2 | 8. | system board |
| 9. | expansion card riser 1 | 10. | integrated storage controller card |
| 11. | NVDIMM-N battery | | |

R740xd

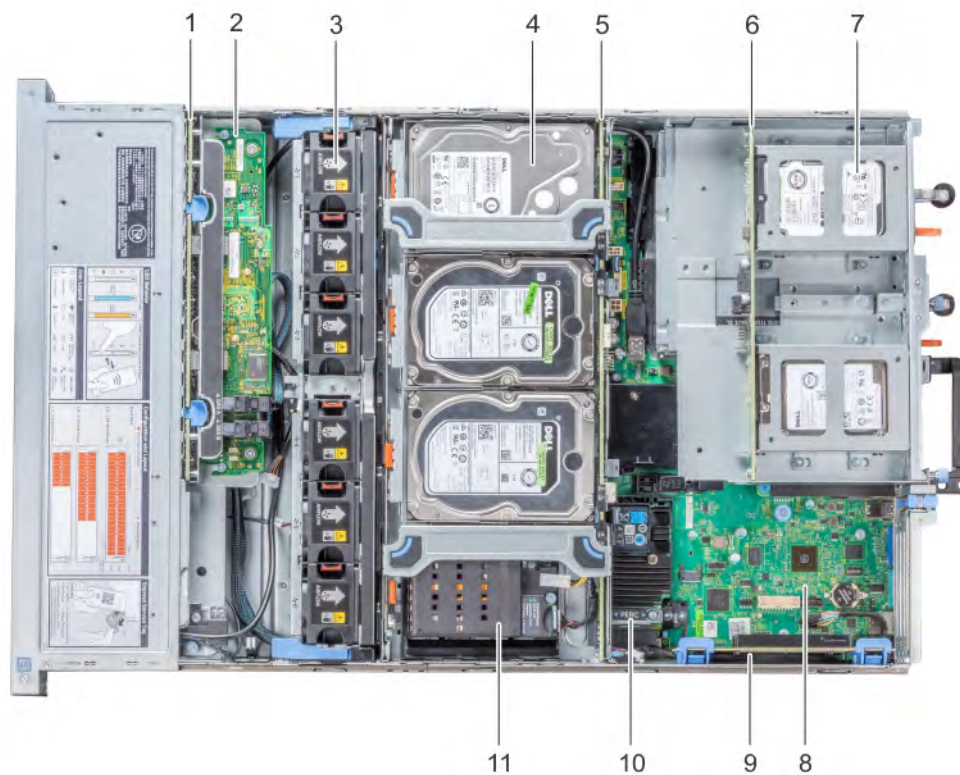

Figure 4. R740xd internal chassis view – hard drive tray and hard drive cage with NVDIMM-N battery

- | | | | |
|-----|---|-----|---------------------------------------|
| 1. | hard drive backplane | 2. | SAS expander card |
| 3. | cooling fan (6) in the cooling fan assembly | 4. | hard drive (4) in the hard drive tray |
| 5. | mid hard drive backplane | 6. | rear hard drive backplane |
| 7. | hard drive (2 or 4) in the hard drive cage | 8. | system board |
| 9. | expansion card riser 1 | 10. | integrated storage controller card |
| 11. | NVDIMM-N battery | | |

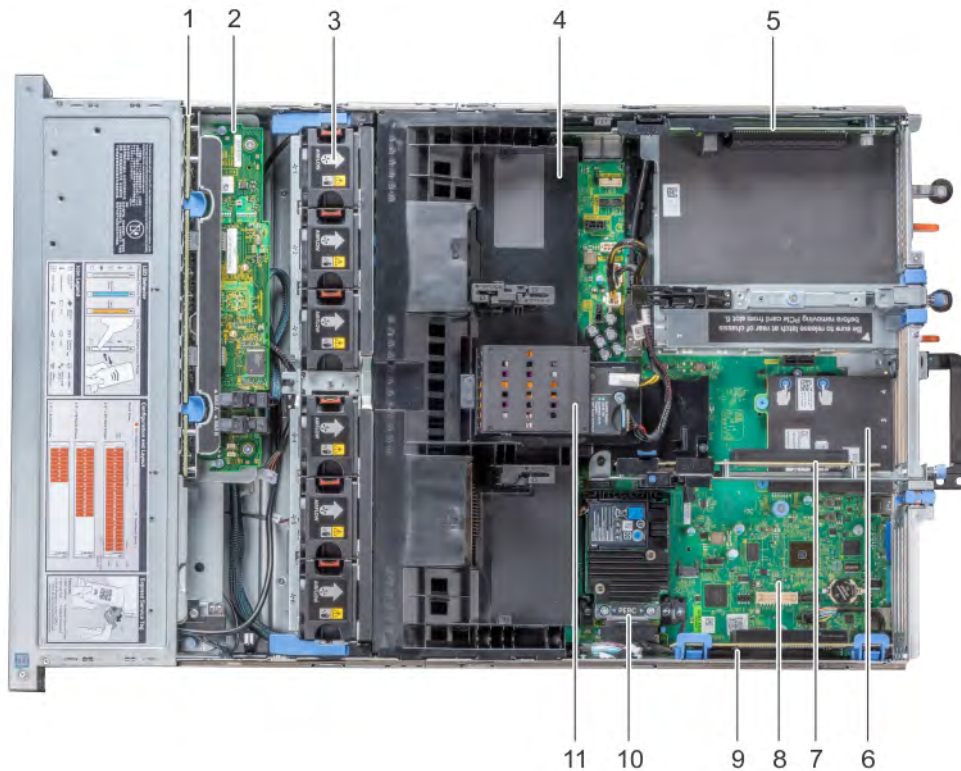

Figure 5. R740Xd internal chassis view with NVDIMM-N battery on the air shroud

- | | |
|--|--|
| 1. hard drive backplane | 2. SAS expander card |
| 3. cooling fan (6) in the cooling fan assembly | 4. air shroud |
| 5. expansion card riser 3 | 6. network daughter card |
| 7. expansion card riser 2 | 8. system board |
| 9. expansion card riser 1 | 10. integrated storage controller card |
| 11. NVDIMM-N battery | |

For additional system views, see the Dell EMC PowerEdge R740 and R740xd installation and service manual on [Dell.com/Support/Manuals](https://www.dell.com/support/manuals)

Chassis Features

Table 4. Chassis Features

Feature	Description
Power button	ACPI- compliant power button with an integrated green power LED
System identification	Buttons (Blue when active) on the front and back of the system to help identify the unit in a data center environment

Feature	Description
Hard drive LEDs	Indicate the status and activity of the hard drives
USB connectors	R740: two front, two back, and one internal with one optional front USB up sell. R740xd: two front, two back, and one internal
Video connectors	R740 & R740xd: one front, one back Both cannot be used at the same time. The front overrides the back.
Bezel	LCD bezel control panel: Provides user access to buttons, display, and I/O interfaces
Control panel	Left control panel: There are 2 SKUs: 1. Status LED Only 2. Quick Sync 2 Right control panel <ul style="list-style-type: none"> · two USB and one micro-USB for iDRAC Direct · one VGA
Luggage tag	Slide-out label panel for system information Content: QRL label, Express Service Tag, QR code for OMM app, iDRAC default password
Serial connector	Connector located in rear of system for serial device connection and console redirection.
iDRAC 9 management port	Dedicated management port for optional iDRAC9 Enterprise located on right control panel.
PCIe expansion slots	Supports up to 8 PCIe Gen3 expansion cards
Power supplies	Location: Up to two, rear-accessible, hot-plug power supplies. Indicator: Bi-color LED in handle to report power supply status to users.
Quick Resource Locator (QRL)	Scan the code on the chassis with smartphone app for additional information and resources including videos, reference materials, service tag information and Dell contact information. Scan the code on the Luggage tag for information specific to the server built for the particular customer and the specific warranty purchased.

Left control panel

The left control panel is intended to provide support for at-the-box-management or system health at a glance. The left control panel will be located on the left ear of the chassis when viewing from the front of the system.

The left control panel will be offered in two SKUs:

1. Quick Sync 2 (wireless)
2. Status LED

 **NOTE: By default, system offers with Status LED control panel and Quick Sync 2 is optional.**



Figure 6. Left control panel light bar

The Left control panel LED behavior is broken in two subsets, **light bar** and **status LEDs**. The light bar also functions as button(s). Upper half of light bar is "Chassis Health" that will also function as "System ID" when pressed. Lower half of the light bar is the "Wireless activation button". Following table highlight the various LED modes for the overall system health:

Table 5. Decoding of LEDs in Light Bar

Status	ID Button(Top)	Wireless Button (Bottom)
Healthy	Solid Blue	OFF
Fault	Blink Amber	OFF
Sys ID	Blink Blue	OFF
Healthy, Wireless ON	Solid Blue	Solid White
Fault, Wireless ON	Blink Amber	Solid White
Sys ID, Wireless ON	Blink Blue	Solid White
Healthy, Wireless Communication	Solid Blue	Blink White
Fault, Wireless Communication	Blink Amber	Blink White
Sys ID, Wireless Communication	Blink blue	Blink White
Healthy, Wireless fault	Solid Blue	Blink Amber
Fault, Wireless fault	Blink Amber	Blink Amber
Sys ID, Wireless fault	Blink Blue	Blink Amber

Quick Sync 2 module

The Quick Sync 2 module allows for wireless at-the-box provisioning of system IP address, boot device, root credential, common BIOS, and location settings. Using BLE, it offers improved performance and usability over 13G NFC technology along with iOS

support. The Quick Sync 2 Wi-Fi module offers support for SupportAssist collection and crash video/screen download/transfer, remote RACADM, VNC remote console connectivity, and access to the iDRAC GUI.

To interact with the Quick Sync 2 module, OpenManage Mobile (OMM) application is required. Only iOS and Android mobile operating systems will be supported at launch. The wireless capability is enabled by an external button referred to as an **Activation Button**, it is deactivated by pressing the button again (or upon disconnect/timeout). It will be located on the front of the mechanical assembly and when pressed will start transmitting and receiving.



Figure 7. Quick Sync 2 Activation Button

Status LED

A common design language is used to maintain commonality and consistent user experience. There are five status LEDs and an overall system health LED (chassis health and system ID) bar to indicate and identify any failed hardware components.

For the users who do not want radio frequency enablement for any reason, an opt-out version of status control panel called "Status LED" control panel, is also offered. Status LED control panel follows same connectivity and LED behavior as described in the QuickSync 2 Module section above, however, there will be no wireless features hardware or software available on this module.



Figure 8. Status LEDs decoded view

Right Control Panel

The right control panel encompasses many of the features no longer supported by the left control panel. The NMI is managed in software and there is no external NMI button for latest Dell EMC PowerEdge systems.



Figure 9. Right Control Panel

Features of the right control panel include:

- Power button with integrated power LED
- Ambient temperature sensor
- Two USB 2.0 ports
- VGA port
- LCD Bezel support
- Micro-USB for iDRAC Direct
- Status LED for iDRAC Direct

Quick Resource Locator

The QRL is a model-specific quick response code located inside the system chassis as shown in graphic of QRL code inside chassis

Use a smartphone to access the Dell QRL app to learn more about the server:

- View step-by-step videos, including overviews of system internals and externals, as well as detailed, concise, task-oriented videos and installation wizards.
- Locate reference materials, including searchable owner's manual content, LCD diagnostics, and an electrical overview.
- Look up your service tag so you can quickly gain access to your specific hardware configuration info and warranty information.
- Contact Dell directly (by link) to get in touch with technical support and sales teams and provide feedback to Dell.

These codes provide an easy way to retrieve the critical support information you need when you need it, making you more efficient and effective in managing your hardware.

Location of Quick Resource Locator (QRL)

The QRL link on System Information Label(SIL), Getting Start Guide(GSG) and installation service manual is a generic QRL link that leads to a web page for for R740 and R740xd. This web page has links to the information of setup and service videos, iDRAC manual, and other generic information related to R740 and R740xd.

However, the QRL on the Luggage tag EST QRL label is unique and specific to the service tag that contains the system Service Tag number and iDRAC password. The label and QRL code within it are printed on demand from the factories. This QRL will have links to a specific web page that shows the exact configuration as it is built and the specific warranty that it is entitled.



Figure 10. Chassis QRL Label



Figure 11. Luggage tag EST QRL label

Physical Security features

A number of physical security features are present on the latest generation of the R740 and R740xd. Additional security features (non-physical) are included in the BIOS and iDRAC sections.

Table 6. Physical Security features

Security feature	Description
Cover latch	The system cover contains a non-keyed locking mechanism integrated into the latch.
Front bezel	An optional bezel may be mounted to the front of the chassis. The bezel includes a keyed lock to prevent its removal and to protect from unauthorized access to externally accessible media, such as hard drives. The system status remains viewable even when the bezel is attached.
Intrusion detection switch	An internal intrusion detection switch allows users to be alerted when the system cover has been removed.
Power button	The power button functionality can be disabled through BIOS.

Processors

The Dell EMC PowerEdge R740 and R740xd feature the Intel Xeon scalable processor family offers versatility across diverse workloads. These processors are designed for next-generation data centers running on, software defined infrastructure supercharged for efficiency, performance, and agile services delivery across cloud-native and traditional applications. The Intel Xeon scalable processor family support workloads for cloud, high-performance computing, networking, and also storage for data centers.

Processor features

The new Intel Xeon scalable processor family is the next generation core architecture with improved Instructions per Cycle (IPC) and other architectural improvements. The Intel Xeon scalable processor family not only adds new features, but also improves upon many features of the predecessor Intel Xeon processor E5-2600 v4 product family, including:

- Virtual address space of 48 bits and a physical address space of 46 bits.
- Intel Hyper-Threading Technology (Intel® HT Technology) when enabled allow each core to support two threads.
- First Level Cache (FLC) 64 KB total. The FLC is comprised of a 32 KB ICU (Instruction Cache) and 32 KB DCU (Data Cache)
- MB Mid-Level Cache (MLC) per core (non-inclusive with the LLC).
- Intel® Advanced Vector Extensions 512 (Intel® AVX-512) with a single AVX512 fused multiply-add (FMA) execution units. processors which support Advanced RAS enable a 2nd FMA execution unit.

Supported Processors

Table 7. Supported Processors for R740 and R740xd

Model	Intel SKU	SKU type	Stepping	Speed(GHz)	Cache(MB)	QPI(GT/s)	Max Memory Speed(MT/s)	Cores	Turbo	TDP
Intel Xeon Processor Scalable Family	8180M	Platinum	XCC	2.5	38.5	10.4	2666	28	Turbo	205W
Intel Xeon Processor Scalable Family	8180	Platinum	XCC	2.5	38.5	10.4	2666	28	Turbo	205W
Intel Xeon Processor Scalable Family	8176M	Platinum	XCC	2.1	38	10.4	2666	28	Turbo	165W
Intel Xeon Processor Scalable Family	8176	Platinum	XCC	2.1	38	10.4	2666	28	Turbo	165W

Model	Intel SKU	SKU type	Stepping	Speed(GHz)	Cache(MB)	QPI(GT/s)	Max Memory Speed(MT/s)	Cores	Turbo	TDP
Intel Xeon Processor Scalable Family	8170M	Platinum	XCC	2.1	36	10.4	2666	26	Turbo	165W
Intel Xeon Processor Scalable Family	8170	Platinum	XCC	2.1	36	10.4	2666	26	Turbo	165W
Intel Xeon Processor Scalable Family	8168	Platinum	XCC	2.7	33	10.4	2666	24	Turbo	205W
Intel Xeon Processor Scalable Family	8164	Platinum	XCC	2.7	33	10.4	2666	26	Turbo	205W
Intel Xeon Processor Scalable Family	8160M	Platinum	XCC	2.1	33	10.4	2666	24	Turbo	150W
Intel Xeon Processor Scalable Family	8160	Platinum	XCC	2.1	33	10.4	2666	24	Turbo	150W
Intel Xeon Processor Scalable Family	8158	Platinum	XCC	3	24.75	10.4	2666	12	Turbo	150W
Intel Xeon Processor Scalable Family	8156	Platinum	XCC	3.6	16.5	10.4	2666	4	Turbo	105W
Intel Xeon Processor Scalable Family	8153	Platinum	XCC	2.0	22	10.4	2666	16	Turbo	125W
Intel Xeon Processor Scalable Family	6154	Gold	XCC	3.0	25	10.4	2666	18	Turbo	200W
Intel Xeon Processor Scalable Family	6152	Gold	XCC	2.1	25	10.4	2666	22	Turbo	140W

Model	Intel SKU	SKU type	Stepping	Speed(GHz)	Cache(MB)	QPI(GT/s)	Max Memory Speed(MT/s)	Cores	Turbo	TDP
Intel Xeon Processor Scalable Family	6150	Gold	XCC	2.7	25	10.4	2666	18	Turbo	165W
Intel Xeon Processor Scalable Family	6148	Gold	XCC	2.4	27	10.4	2666	20	Turbo	150W
Intel Xeon Processor Scalable Family	6146	Gold	XCC	3.2	24.75	10.4	2666	12	Turbo	165W
Intel Xeon Processor Scalable Family	6144	Gold	XCC	3.5	24.75	10.4	2666	8	Turbo	150W
Intel Xeon Processor Scalable Family	6142M	Gold	XCC	2.6	22	10.4	2666	16	Turbo	150W
Intel Xeon Processor Scalable Family	6142	Gold	XCC	2.6	22	10.4	2666	16	Turbo	150W
Intel Xeon Processor Scalable Family	6140M	Gold	XCC	2.3	25	10.4	2666	18	Turbo	140W
Intel Xeon Processor Scalable Family	6140	Gold	XCC	2.3	25	10.4	2666	18	Turbo	140W
Intel Xeon Processor Scalable Family	6138	Gold	XCC	2	27.5	10.4	2666	20	Turbo	125W
Intel Xeon Processor Scalable Family	6136	Gold	XCC	3.0	24.75	10.4	2666	12	Turbo	125W
Intel Xeon Processor Scalable Family	6134M	Gold	XCC	3.2	24.75	10.4	2666	8	Turbo	130W

Model	Intel SKU	SKU type	Stepping	Speed(GHz)	Cache(MB)	QPI(GT/s)	Max Memory Speed(MT/s)	Cores	Turbo	TDP
Intel Xeon Processor Scalable Family	6134	Gold	XCC	3.3	24.75	10.4	2666	8	Turbo	130W
Intel Xeon Processor Scalable Family	6132	Gold	XCC	2.6	19.25	10.4	2666	14	Turbo	140W
Intel Xeon Processor Scalable Family	6130	Gold	XCC	2.1	22	10.4	2666	16	Turbo	125W
Intel Xeon Processor Scalable Family	6128	Gold	XCC	3.4	19.25	10.4	2666	6	Turbo	115W
Intel Xeon Processor Scalable Family	6126	Gold	XCC	2.6	19.25	10.4	2666	12	Turbo	125W
Intel Xeon Processor Scalable Family	5122	Gold	XCC	3.6	16.5	10.4	2400	4	Turbo	105W
Intel Xeon Processor Scalable Family	5120	Gold	HCC	2.2	19.25	10.4	2400	14	Turbo	105W
Intel Xeon Processor Scalable Family	5118	Gold	HCC	2.3	16.5	10.4	2400	12	Turbo	105W
Intel Xeon Processor Scalable Family	5115	Gold	HCC	2.4	13.75	10.4	2400	10	Turbo	85W
Intel Xeon Processor Scalable Family	4116	Silver	HCC	2.1	16	9.6	2400	12	Turbo	85W
Intel Xeon Processor Scalable Family	4114	Silver	LCC	2.2	14	9.6	2400	10	Turbo	85W

Model	Intel SKU	SKU type	Stepping	Speed(GHz)	Cache(MB)	GPI(GT/s)	Max Memory Speed(MT/s)	Cores	Turbo	TDP
Intel Xeon Processor Scalable Family	4112	Silver	LCC	2.6	8.25	9.6	2400	4	Turbo	85W
Intel Xeon Processor Scalable Family	4110	Silver	LCC	2.1	11	9.6	2400	8	Turbo	85W
Intel Xeon Processor Scalable Family	4108	Silver	LCC	1.8	11	9.6	2400	8	Turbo	85W
Intel Xeon Processor Scalable Family	3106	Bronze	LCC	1.7	11	9.6	2133	8	No Turbo	85W
Intel Xeon Processor Scalable Family	3104	Bronze	LCC	1.7	11	9.6	2133	6	No Turbo	85W
Extended Reliability(T) SKUs										
Intel Xeon Processor Scalable Family	8160T	Platinum	XCC	2.1	33	10.4	2666	24	Turbo	150W
Intel Xeon Processor Scalable Family	6138T	Gold	XCC	2	27.5	10.4	2666	20	Turbo	125W
Intel Xeon Processor Scalable Family	6130T	Gold	XCC	2.1	22	10.4	2666	16	Turbo	125W
Intel Xeon Processor Scalable Family	6126T	Gold	XCC	2.6	19.25	10.4	2666	12	Turbo	125W
Intel Xeon Processor Scalable Family	5120T	Gold	HCC	2.2	19.25	10.4	2400	14	Turbo	105W
Intel Xeon Processor Scalable Family	5119T	Gold	HCC	2.2	19.25	10.4	2400	14	Turbo	85W

Model	Intel SKU	SKU type	Stepping	Speed(GHz)	Cache(MB)	QPI(GT/s)	Max Memory Speed(MT/s)	Cores	Turbo	TDP
Intel Xeon Processor Scalable Family	4116T	Silver	HCC	2.2	16.5	9.6	2400	12	Turbo	85W
Intel Xeon Processor Scalable Family	4114T	Silver	LCC	2.2	13.75	9.6	2400	10	Turbo	85W
Intel Xeon Processor Scalable Family	4109T	Silver	LCC	2	24.75	9.6	2400	8	Turbo	70W

 **NOTE: CPU SKUs with SKU numbers ending with M can support up to 1.5TB of memory per socket**

Processor Configurations

The R740 and R740xd supports up to two processors with up to 28 cores per processor.

Single CPU Configuration

The R740 and R740xd will function normally if there is just a single processor placed in the CPU1 socket . However, CPU and memory blanks associated with CPU2 are required to be populated for thermal reasons. The system will not boot if only CPU2 socket is populated. With Single CPU configuration, any Riser1 (1A/1B/1C/1D) card and only Riser 2B will be functional.

Chipset

The DELL EMC PowerEdge R740 and R740xd use the Intel C620 chipset (PCH) that provides extensive I/O support. Functions and capabilities include:

- ACPI Power Management Logic Support, Revision 4.0a
- PCI Express* Base Specification Revision 3.0
- Integrated Serial ATA host controller, supports data transfer rates of up to 6 Gb/s on all ports.
- xHCI USB controller with SuperSpeed USB 3.0 ports
- Direct Media Interface
- Serial Peripheral Interface
- Enhanced Serial Peripheral Interface
- Flexible I/O - Allows some high speed I/O signals to be configured as PCIe root ports, PCIe uplink for use with certain PCH SKUs, SATA (and sSATA), or USB 3.0.
- General Purpose Input Output (GPIO)
- Low Pin Count interface, interrupt controller, and timer functions
- System Management Bus Specification, Version 2.0
- Integrated Clock Controller / Real Time Clock Controller
- Intel High Definition Audio and Intel Smart Sound Technology
- Integrated 10/1 Gb Ethernet
- Integrated 10/100/1000 Mbps Ethernet MAC
- Supports Intel Rapid Storage Technology Enterprise

- Supports Intel Active Management Technology and Server Platform Services
- Supports Intel Virtualization Technology for Directed I/O
- Supports Intel Trusted Execution Technology
- JTAG Boundary Scan support
- Intel QuickAssist Technology
- Intel Trace Hub for debug

For more information, visit [Intel.com](https://www.intel.com)

System memory

The R740/R740xd supports DDR4 registered DIMMs (RDIMMs), load reduced DIMMs (LRDIMMs) and non-volatile dual in-line DIMM-Ns (NVDIMM-Ns). System memory holds the instructions that are executed by the processor.

 **NOTE: MT/s indicates DIMM speed in MegaTransfers per second.**

Memory bus operating frequency can be 2666 MT/s, 2400 MT/s, or 2133 MT/s depending on the following factors:

- DIMM type (RDIMM or LRDIMM)
- Number of DIMMs populated per channel
- System profile selected (for example, Performance Optimized, or Custom [can be run at high speed or lower])
- Maximum supported DIMM frequency of the processors

The R740/R740xd system contains 24 memory sockets split into two sets of 12 sockets, one set per processor. Each 12-socket set is organized into six channels. In each channel, the release tabs of the first socket are marked white, and the second socket black.

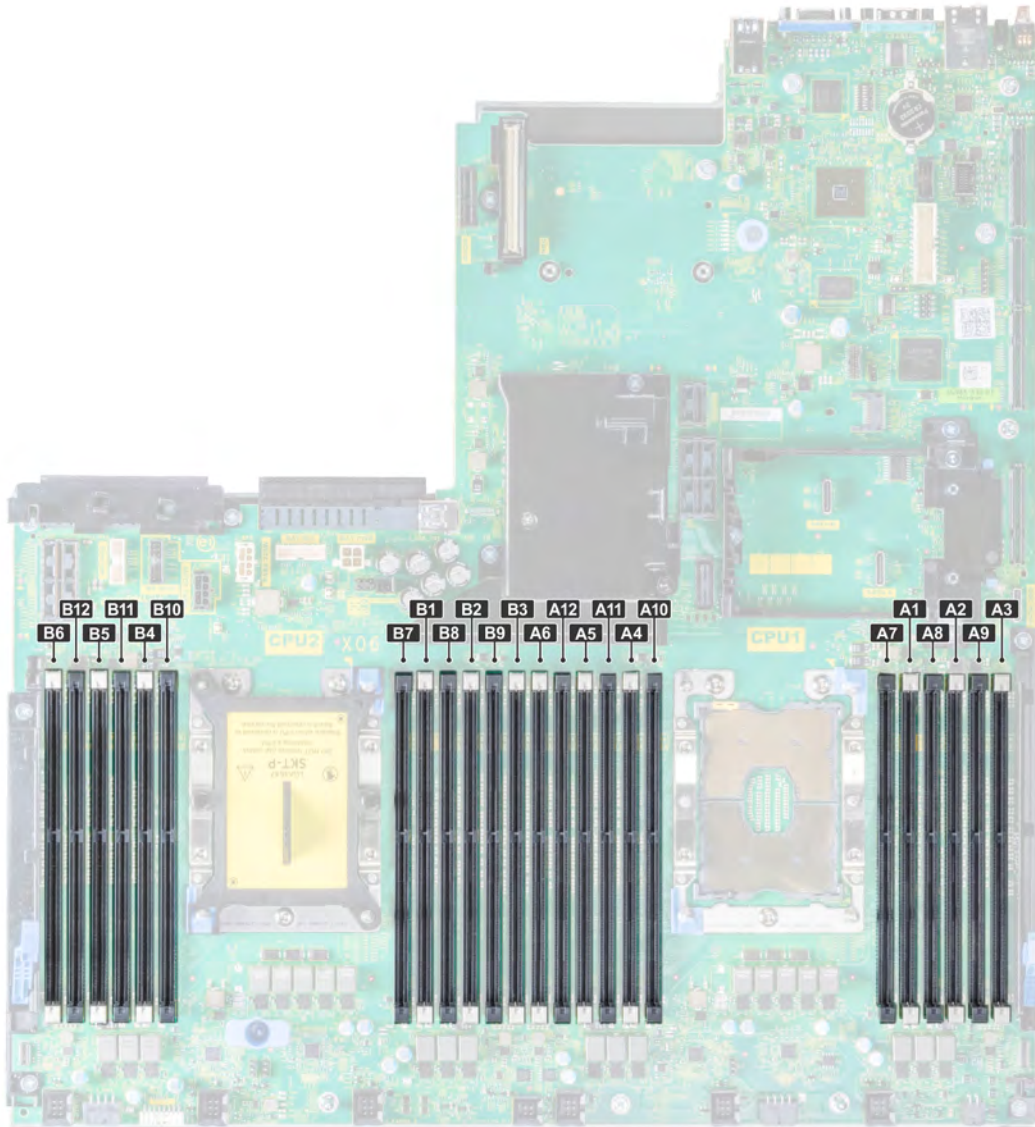



Figure 12. Memory socket locations

Memory channels are organized as follows:

Table 8. Memory channels

Processor	Channel 0	Channel 1	Channel 2	Channel 3	Channel 4	Channel 5
Processor 1	Slots A1 and A7	Slots A2 and A8	Slots A3 and A9	Slots A4 and A10	Slots A5 and A11	Slots A6 and A12
Processor 2	Slots B1 and B7	Slots B2 and B8	Slots B3 and B9	Slots B4 and B10	Slots B5 and B11	Slots B6 and B12

General memory module installation guidelines

 **NOTE: Memory configurations that fail to observe these guidelines can prevent system from booting, stop responding during memory configuration, or operating with reduced memory.**

The R740/R740xd system supports Flexible Memory Configuration, enabling the system to be configured and run in any valid chipset architectural configuration. The following are the recommended guidelines for installing memory modules:

- RDIMMs and LRDIMMs must not be mixed.
- 64 GB LRDIMMs that are DDP (Dual Die Package) LRDIMMs must not be mixed with 128 GB LRDIMMs that are TSV (Through Silicon Via/3DS) LRDIMMs
- x4 and x8 DRAM based memory modules can be mixed.
- Up to two RDIMMs can be populated per channel regardless of rank count.
- Up to two LRDIMMs can be populated per channel regardless of rank count.
- If memory modules with different speeds are installed, they will operate at the speed of the slowest installed memory module(s) or slower depending on the system DIMM configuration.
- Populate memory module sockets only if a processor is installed. For single-processor systems, sockets A1 to A12 are available. For dual-processor systems, sockets A1 to A12 and sockets B1 to B12 are available.
- Populate all the sockets with white release tabs first, followed by the black release tabs.
- When mixing memory modules with different capacities, populate the sockets with memory modules with highest capacity first. For example, if you want to mix 8 GB and 16 GB memory modules, populate 16 GB memory modules in the sockets with white release tabs and 8 GB memory modules in the sockets with black release tabs.
- In a dual-processor configuration, the memory configuration for each processor should be identical. For example, if you populate socket A1 for processor 1, then populate socket B1 for processor 2, and so on.
- Memory modules of different capacities can be mixed provided other memory population rules are followed (for example, 8 GB and 16 GB memory modules can be mixed).
- Mixing of more than two memory module capacities in a system is not supported.
- Populate six memory modules per processor (one DIMM per channel) at a time to maximize performance.

NVDIMM-N memory module installation guidelines

The following are the recommended guidelines for installing NVDIMM-N memory modules:

- Each system supports memory configurations with 1, 2, 4, 6, or 12 NVDIMM-Ns.
- Supported configurations have dual processors and a minimum of 12x RDIMMs.
- LRDIMMs and NVDIMM-Ns must not be mixed.
- Maximum of 12 NVDIMM-Ns can be installed in a system.

For more information on the supported NVDIMM-N configurations, see the *NVDIMM-N User Guide* at [Dell.com/poweredgemanuals](https://www.dell.com/poweredge/manuals)

Storage

The Dell EMC PowerEdge R740 and R740xd provide scalable storage that allows you to adapt to your workload and operational demands. With comprehensive storage options, the R740 and R740xd offer various internal and external storage controllers, drive types and different chassis and backplanes for varied numbers of drives. Features such as Express Flash PCIe SSDs, H740P and H840 RAID controller provide vastly accelerated performance over previous technologies. Dell EMC Express Flash drives use PCIe lanes to connect directly to the processor and chipset and are easily accessible through a hot-plug drive bay.

Storage Controllers

Dell EMC's RAID controller options offer performance improvements, including the Mini PERC solution. Mini PERC provides a base RAID hardware controller without consuming a PCIe slot by using a small form factor and high density connector to the base planar.

The new PERC controller offerings will leverage heavily on previous generation PERC family. The premium performance PERC series controller will drive better IOPs and enhanced the SSD performance.

Table 9. PERC Series Controller Offerings

Performance Level	Controller & Description
Entry	S140 (SATA, NVMe)
Value	HBA330 ,H330, 12Gbps SAS HBA
Value Performance	H730P
Premium Performance	H740P, H840

Supported Drives

Table 10. Supported Drives - SAS and SATA

Form Factor	Type	Speed	Rotational Speed	Capacities
2.5"	SATA, SSD	6 Gb	N/A	120GB Boot, 240GB Boot, 240GB, 400GB, 480GB, 800GB, 960GB, 1600GB, 1920GB, 3200GB, 3840GB
	SATA	6 Gb	7.2K	1TB, 2TB
	SAS	12 Gb	7.2K	1TB, 2TB, 2TB(SED FIPS)
	SAS,SSD	12 Gb	N/A	400GB, 480GB, 800GB, 960GB, 1600GB, 1920GB, 3840GB
	SAS	12 Gb	10K	300GB, 600GB, 1.2TB, 1.8TB, 2.4TB(P-RTS), 1.2TB(SED FIPS),

Form Factor	Type	Speed	Rotational Speed	Capacities
3.5"	SAS	12 Gb	15K	300GB, 600GB, 900GB, 900GB (SED FIPS)
	SATA	6 Gb	7.2K	1TB, 2TB, 4TB, 8TB, 10TB, 12TB
	SAS	12 Gb	7.2K	1TB, 2TB, 4TB, 8TB, 10TB, 4TB (SED FIPS), 8TB (SED FIPS)

Table 11. Supported Drives - NVMe SSD

Supported NVMe SSD

800GB 2.5" Device

1.6TB 2.5" Device

3.2TB 2.5" Device

6.4TB 2.5" Device

KIT,CRD,NVM,1.6,HHHL,PM1725

KIT,CRD,CTL,NVME,PM1725

KIT,CRD,NVM,3.2,HHHL,PM1725

IDSDM with vFlash card

The Internal Dual SD Module (IDSDM) and vFlash card are combined into a single card module in the latest PowerEdge systems. The following are options available for PowerEdge R740 systems:

- vFlash only
- IDSDM only
- vFlash and IDSDM

 **NOTE: The IDSDM only option is available with vFlash hardware and requires an iDRAC Enterprise license to enable the feature.**

The IDSDM with vFlash module is installed in a Dell-proprietary PCIe x1 slot using a USB 3.0 interface as the host. In 14 Gen servers, the IDSDM and vFlash card features microSD in place of an SD card. The supported capacities for the IDSDM microSD cards are 16/32/64 GB while for vFlash the capacity is limited to 16 GB only. The write-protect switch is built on the IDSDM with vFlash module.

Optical Drives

The PowerEdge R740 supports one of the following internal optical drive options:

- DVD-ROM
- DVD+ROM

The R740xd does not support an internal optical drive.

Tape Drives

The R740 and R740xd do not support internal tape drives. However, external tape backup devices will be supported on both R740 and R740xd.

Supported external tape drives:

- External RD1000 USB
- External LTO-5, LTO-6, LTO-7 and 6 Gb SAS tape drives
- 114X rack mount chassis with LTO-5, LTO-6, and LTO-7 6Gb SAS tape drives
- TL1000 with LTO-5, LTO-6, and LTO-7 6 Gb SAS tape drives
- TL2000 with LTO-5, LTO-6, and LTO-7 6 Gb SAS tape drives
- TL4000 with LTO-5, LTO-6, and LTO-7 6 Gb SAS tape drives
- TL4000 with LTO-5, LTO-6, and LTO-7 8Gb FC tape drives
- ML6000 with LTO-5, LTO-6, 6 Gb SAS tape drives
- ML6000 with LTO-5, LTO-6, LTO-7 8Gb FC tape drives

Boot Optimized Storage Subsystem (BOSS)

The BOSS is offered as a means of booting R740/R740xd systems to a full OS mode when,

- target OS is a full OS and not hypervisor that may supported best by IDSMD
- the user does not wish to trade off standard hot plug drive slots for OS install









The Hardware RAID BOSS is a RAID controller with a limited feature set for the purpose of boot up to a full OS drive. The BOSS RAID controller presents M.2 SATA-only Solid State drives (SSD) as either Non-RAID disks or a single RAID1 volume configuration.



Figure 13. Boot Optimized Storage Subsystem (BOSS)

Table 12. BOSS RAID controller features

Function/Feature	Supported
Stripe size supported	64k
Configuration (HII)	Yes
Full initialization	No
Fast initialization	Yes
	 NOTE: Performed on virtual disk creation by default.
Background initialization	No
RAID0	No
RAID1	Yes
Single non-RAID	Yes

Function/Feature	Supported
Dual non-RAID	Yes
Degraded RAID1 and non-RAID	No
Foreign import	Yes
Consistency check	No
Patrol read	No
Load balance	N/A
Rebuild	Yes
	 NOTE: Manually triggered in Human Interface Infrastructure(HII) or via Marvell Command Line Interface (CLI).
Auto-rebuild	Yes
	 NOTE: Auto Rebuild will occur at power up only if there is a surviving native virtual disk and another physical disk is present at power up.
Hot spare	No
Change rebuild priority/rate	No
Virtual disk write back/ read ahead cache	No
	 NOTE: No controller cache.
Battery support	N/A
	 NOTE: No battery.
Non-RAID disk cache policy	Yes
	 NOTE: OS controlled/Device defaults.
SMART Info	Yes
	 NOTE: Can be pulled by Marvell CLI.
Physical disk hot swap	No
Virtual disk expansion	No
Virtual disk slicing	No
Virtual disk migration	Yes
	 NOTE: On new controller, virtual disk must be Imported from HII before presented to OS.
Split mirror	No
	 NOTE: System required to shutdown and migrate one physical disk to another system and continue rebuild.
Non-RAID migration	Yes
BIOS configuration utility (Ctrl-M)	No
Add on driver for data path (OS device driver)	No
	 NOTE: Console Windows driver or Linux library is required for management purposes only.
4K native drive support	No

Function/Feature	Supported
TRIM and UNMAP virtual disk	No
TRIM and UNMAP Non-RAID physical disk	Yes
Self-encrypting drives(SED) support	No
Cryptographic erase (sanitize)	Yes

 **NOTE: If drive supports SANITIZE Crypto Erase. No other encryption support from controller or drive.**

Networking and PCIe

The Dell EMC PowerEdge R740 and R740xd offers offer balanced, scalable I/O capabilities, including integrated PCIe 3.0-capable expansion slots. Dell Select Network Adapters, Dell's network daughter cards, enable you to choose the right network fabric without using up a valuable PCI slot. Pick the speed, technology, vendor, and other options, such as switch independent partitioning, which enable you to share and manage bandwidth on 10GbE connections.

Network card options

The DELL EMC PowerEdge R740 and R740xd system supports four Network Interface Controller (NIC) ports on the back panel, which are available in the following configurations:

- Four 1 Gbps
- Four 10 Gbps
- Two 10 Gbps and two 1 Gbps
- Two 25 Gbps

 **NOTE: You can install up to eight PCIe add-on NIC cards.**

PCIe Expansion cards

The PowerEdge R740 and R740xd system supports up to eight PCI express (PCIe) generation 3 expansion cards, that can be installed on the system board using PCIe expansion card risers.

Below are the risers offerings for both the R740 and R740xd.

PCIe Expansion card riser

Riser 1A - 2 slots, 2x16(top and bottom)

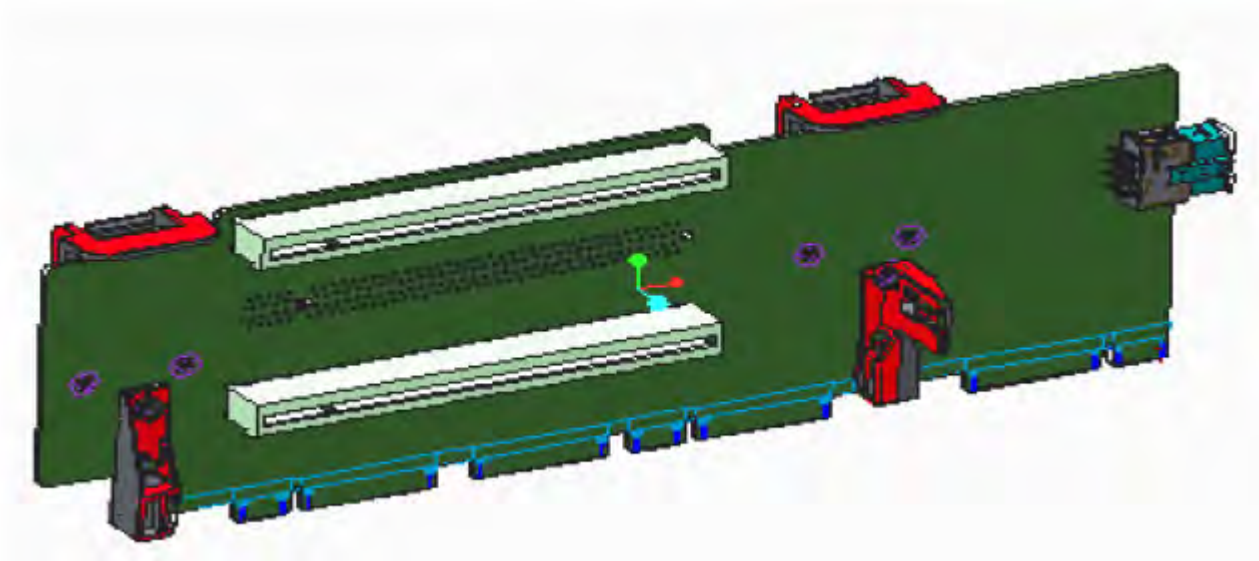

Riser 1B - 3 slots, 3x8 (top, middle and bottom)

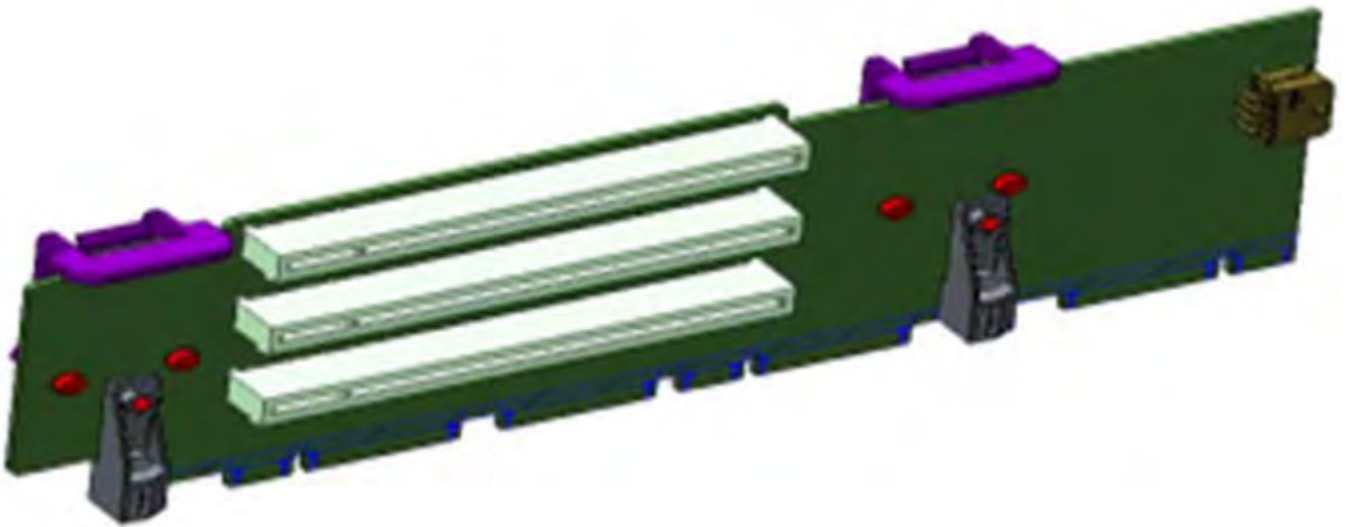

Riser 1D - 3 slots, 3 slots, 1x16 (top) 2 x8 (middle and bottom)

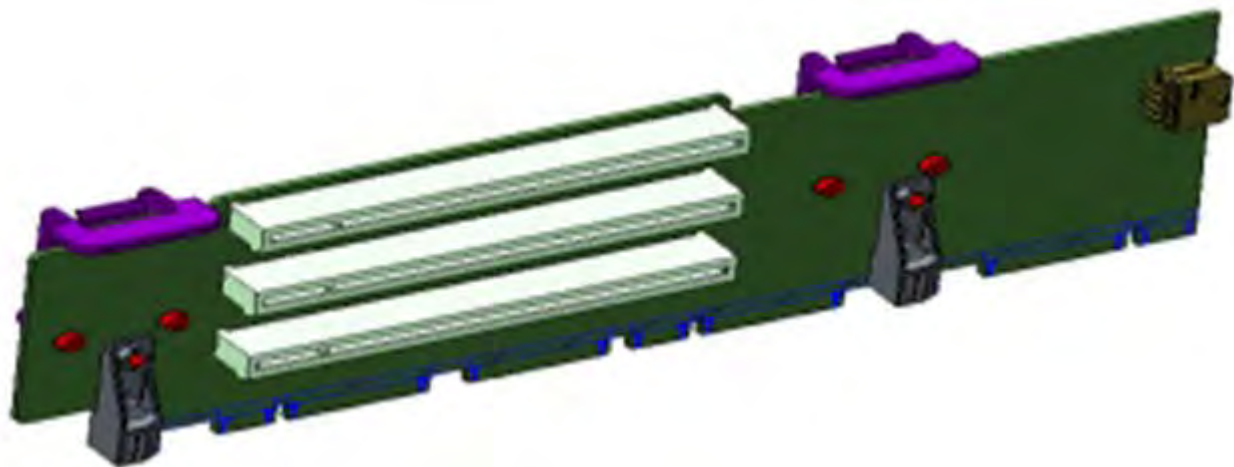

Riser 2A - 2 slots, 3 slots, 3 slots, 1x16 (top) 2 x8 (middle and bottom)



Riser 2B - 1slots, 1x8(Top and bottom)

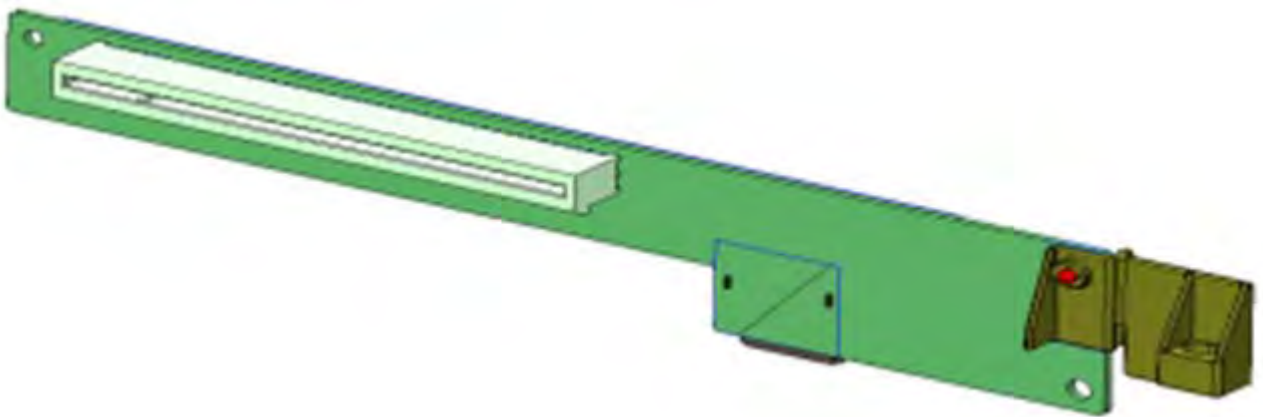

Riser 2C - 1 slots, 1x16(Top and bottom)

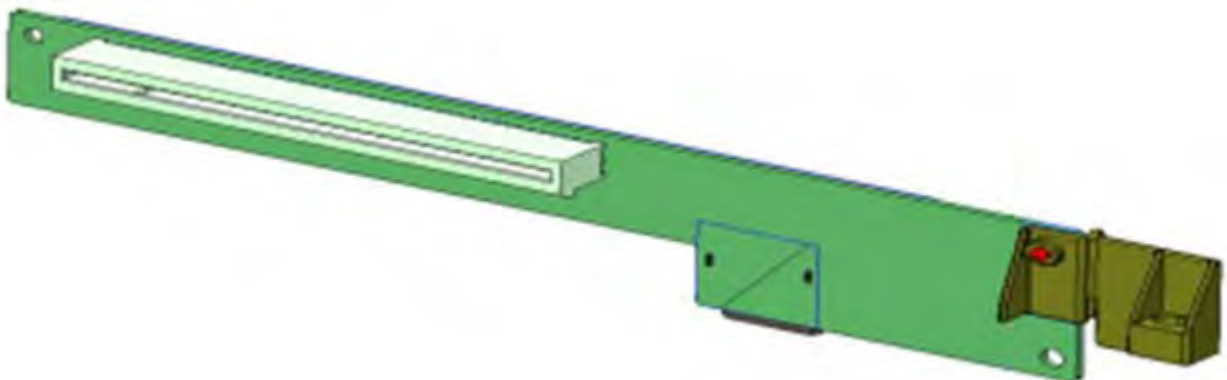

Riser 3A - 2 slots, 1x8(Top), 1 x16 (bottom)

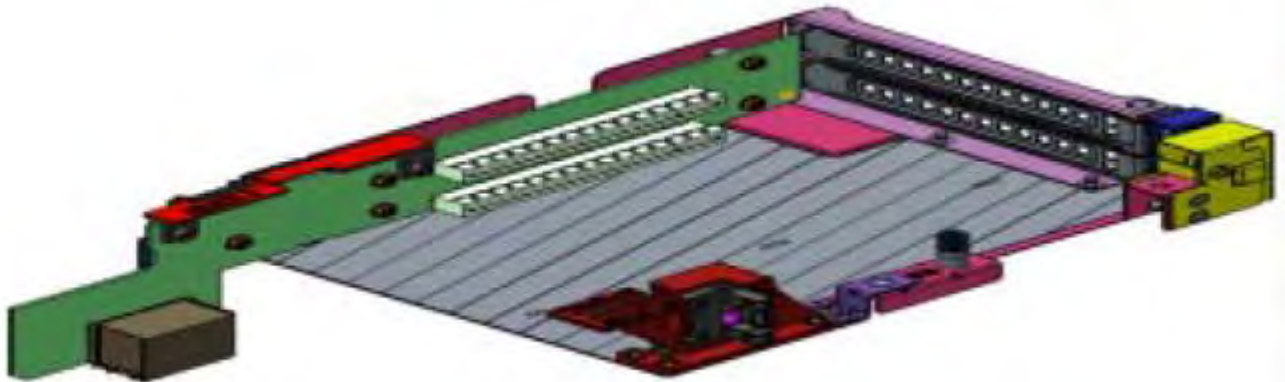

PCIe expansion card riser configurations

Table 13. PCIe Expansion card riser configurations for R740 and R740xd

Expansion card riser	PCIe slots on the riser	Height	Length	Link
Riser 1A	Slot 1	Full Height	Full Length	x16
	Slot 3	Full Height	Half Length	x16
Riser 1B	Slot 1	Full Height	Full Length	x8
	Slot 2	Full Height	Full Length	x8
	Slot 3	Full Height	Half Length	x8
Riser 1D	Slot 1	Full Height	Full Length	x16
	Slot 2	Full Height	Full Length	x8
	Slot 3	Full Height	Half Length	x8
Riser 2A	Slot 4	Full Height	Full Length	x16
	Slot 5	Full Height	Full Length	x8
	Slot 6	Low Profile	Half Length	x8
Riser 2B	Slot 4	Low Profile	Half Length	x8
Riser 2C	Slot 4	Low Profile	Half Length	x16
Riser 3A	Slot 7	Full Height	Full Length	x8
	Slot 8	Full Height	Full Length	x16

Table 14. PCIe riser configuration

Riser configuration	Numbers of CPUs	Supported PERC type	Possible rear storage
No riser	1 or 2	Mini-Mono	Yes
1B+2B	1 or 2	Mini-Mono/Adapter	Yes

Riser configuration	Numbers of CPUs	Supported PERC type	Possible rear storage
1B+2C	2	Mini-Mono/Adapter	Yes
1A+2A	2	Adapter	No
1A+2A+3A	2	Adapter	No
1B+2A+3A	2	Mini-Mono/Adapter	No
1D+2A+3A	2	Adapter	No

Power, Thermal, and Acoustics

The lower overall system-level power draw is a result of the breakthrough system design developed by Dell EMC. The system aims to maximize performance per watt through a combination of energy efficient technologies, optimized thermal designs and intelligent fan control algorithms. The system fan control algorithms use an extensive array of sensors that automatically monitor power and thermal activity to minimize fan speeds based on system cooling requirements, reducing the power required for cooling.

Power consumption and energy efficiency

With the rise in the cost of energy coupled with increasing data center density, Dell EMC provides tools and technologies to help you realize greater performance with lower energy cost and wastage. More efficient data center usage can reduce costs by slowing the need for additional data center space. The following table lists the tools and technologies that Dell EMC offers to help you achieve your data center goals by lowering power consumption and increasing energy efficiency.

Table 15. Power tools and technologies

Feature	Description
Power supply units (PSU) portfolio	PSU portfolio includes intelligent features such as dynamically optimizing efficiency while maintaining availability and redundancy. For more information, see the <i>Power supply units</i> section.
Tools for right-sizing	Enterprise Infrastructure Planning Tool (EIPT) is a tool that helps you plan and tune your computer and infrastructure equipment for maximum efficiency by calculating hardware power consumption, power infrastructure and storage. Learn more at Dell.com/calc .
Power monitoring accuracy	PSU power monitoring improvements include: <ul style="list-style-type: none"> · Power monitoring accuracy of 1%, whereas the industry standard is 5% · More accurate reporting of power · Better performance under a power cap
Power capping	Use Dell EMC systems management tools such as OpenManage Power Center and iDRAC9 with an Enterprise license can be used to set a power limit for your server. This limits the output of a PSU and reduce system power consumption and help in constrained power situations.
Systems management	The integrated Dell Remote Access Controller 9 (iDRAC9) with Lifecycle Controller is embedded within every Dell EMC PowerEdge™ server and provides functionality that helps IT administrators deploy, update, monitor, and maintain servers with no need for any additional software to be installed. iDRAC functions regardless of operating system or hypervisor presence because from a pre-OS or bare-metal state, iDRAC is ready to work because it is embedded within each server from the factory.
Active power management	Dell EMC offers a complete power management solution accessed through the iDRAC9 with Enterprise licensing and OpenManage Power Center to implement policy-based management of power and thermal levels at the individual system, rack, or data center level. Hot spares reduce power consumption of redundant power supplies. Thermal

control of fan speed optimizes the thermal settings for your environment to reduce fan consumption and lower system power consumption.

Power supply units

Energy Smart power supplies have intelligent features, such as the ability to dynamically optimize efficiency while maintaining availability and redundancy. Also featured are enhanced power-consumption reduction technologies, such as high-efficiency power conversion and advanced thermal-management techniques, and embedded power-management features including high-accuracy power monitoring.

The system supports two hot-swappable AC power supplies with 1 + 1 redundancy, auto-sensing and auto-switching capability.

Thermal and Acoustics

The system's thermal management delivers high performance through optimized cooling of components at the lowest fan speeds across a wide range of ambient temperatures from 10°C to 35°C (50°F to 95°F) and to extended ambient temperature ranges. These optimizations result in lower fan power consumption which translate to lower system power and data center power consumption.

Thermal design

The thermal design of the system reflects the following:

- **Optimized thermal design:** The system layout is architected for optimum thermal design. System component placement and layout are designed to provide maximum airflow coverage to critical components with minimal expense of fan power.
- **Comprehensive thermal management:** The thermal control system regulates the system fan speeds based on feedback from system component temperature sensors, as well as for system inventory and subsystem power draw. Temperature monitoring includes components such as processors, DIMMs, chipset, system inlet air temperature and hard disk drives.
- **Open and closed loop fan speed control:** Open loop fan control uses system configuration to determine fan speed based on system inlet air temperature. Closed loop thermal control uses temperature feedback to dynamically adjust fan speeds based on system activity and cooling requirements.
- **User-configurable settings:** With the understanding and realization that every customer has a unique set of circumstances or expectations from the system, in this generation of servers, we have introduced limited user-configurable settings in the iDRAC9 BIOS setup screen. For more information, see the Dell EMC PowerEdge system Installation and Service Manual on Dell.com/Support/Manuals and "[Advanced Thermal Control: Optimizing across Environments and Power Goals](#)" on Dell.com.
- **Cooling redundancy:** The system allows N+1 fan redundancy, allowing continuous operation with one fan failure in the system.

Acoustical design

Dell EMC focuses on sound quality in addition to sound power level and sound pressure level. Sound quality describes how disturbing or pleasing a sound is interpreted, and Dell EMC references a number of psychacoustical metrics and thresholds in delivering to it. Tone prominence is one such metric. Sound power and sound pressure levels increase with greater populations or higher utilization, while sound quality remains good even as the frequency content changes. A reference for comparison to sound pressure levels for familiar noise sources is given in the following table. An extensive description of Dell EMC Enterprise acoustical design and metrics is available in the [Dell Enterprise Acoustics](#) white paper.

Table 16. Acoustical reference points and output comparisons

Value measured at your ears		Equivalent familiar noise experience
LpA, dBA, re 20 µPa	Loudness, sones	
90	80	Loud concert
75	39	Data center, vacuum cleaner, voice must be elevated to be heard
60	10	Conversation levels

45	4	Whispering, open office layout, normal living room
35	2	Quiet office
30	1	Quiet library
20	0	Recording studio

Rack rails

The rail offerings for the PowerEdge R740 consist of two general types: sliding and static

Sliding rails features summary

The sliding rails (two varieties are offered) allow the system to be fully extended out of the rack for service. They are available with or without the optional cable management arm (CMA).



Figure 14. Sliding rails with optional CMA

ReadyRails-Sliding rails for 4-post racks

- Supports Drop-in Installation of the chassis to the rails.
- Support for tool-less installation in 19" EIA-310-E compliant square or unthreaded round hole 4-post racks including all generations of the Dell racks.
- Support for tooled installation in 19" EIA-310-E compliant threaded hole 4-post racks.
- Support full extension of the system out of the rack to allow serviceability of key internal components.
- Support for optional cable management arm (CMA).
- Minimum rail mounting depth without the CMA: 714 mm.
- Minimum rail mounting depth with the CMA: 845 mm.
- Square-hole rack adjustment range: 631-868 mm.
- Round-hole rack adjustment range: 617-861 mm.
- Threaded-hole rack adjustment range: 631-883 mm.

Stab-in/Drop-in sliding rails for 4-post racks (New for 14G systems)

- Supports drop-in or stab-in installation of the chassis to the rails.

- Support for tool-less installation in 19" EIA-310-E compliant square, unthreaded round hole racks including all generations of the Dell racks. Also supports tool-less installation in threaded round hole 4-post racks.
- Required for installing R740 in a Dell EMC Titan or Titan-D rack.
- Support full extension of the system out of the rack to allow serviceability of key internal components.
- Support for optional cable management arm (CMA).
- Minimum rail mounting depth without the CMA: 714 mm.
- Minimum rail mounting depth with the CMA: 845 mm.
- Square-hole rack adjustment range: 603-915 mm.
- Round-hole rack adjustment range: 603-915 mm.
- Threaded-hole rack adjustment range: 603-915 mm.

Static rails

The static rails support a wider variety of racks than the sliding rails. However, they do not support serviceability in the rack and are thus not compatible with the CMA.

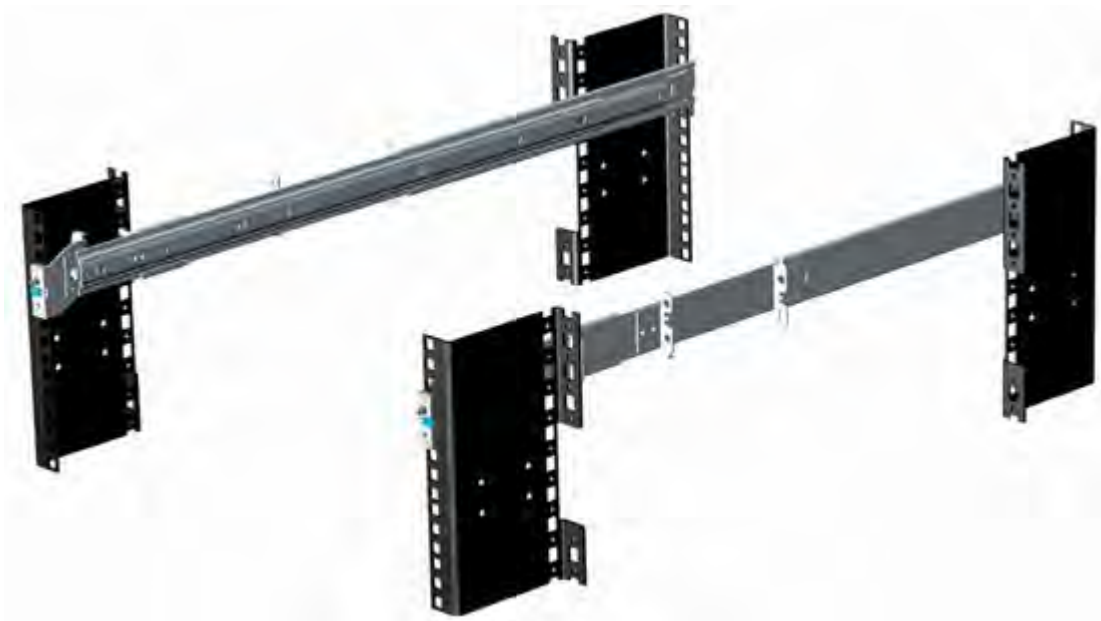

Figure 15. Static rails

Static rails features summary

Static Rails for 4-post & 2-post Racks:

- Supports Stab-in installation of the chassis to the rails.
- Support tool-less installation in 19" EIA-310-E compliant square or unthreaded round hole 4-post racks including all generations of Dell racks.
- Support tool installation in 19" EIA-310-E compliant threaded hole 4-post and 2-post racks.
- Minimum rail mounting depth: 622 mm.
- Square-hole rack adjustment range: 608-879 mm.
- Round-hole rack adjustment range: 594-872 mm.
- Threaded-hole rack adjustment range: 608-890 mm.

NOTE: One key factor in selecting the proper rails is identifying the type of rack in which they are installed.

2-Post racks installation

If installing to 2-Post (Telco) racks, the ReadyRails Static rails (B4) must be used. Both sliding rails support mounting in 4-post racks only.



Figure 16. Static rails in 2-post center mount configuration

Installation in the Dell EMC Titan or Titan-D racks

If installing to Titan or Titan-D racks, the Stab-in/Drop-in Sliding rails (B13) must be used. This rail collapses down sufficiently to fit in racks with mounting flanges spaced about 24 inches apart from front to back. The Stab-in/Drop-in Sliding rail allows bezels of the servers and storage systems to be in alignment when installed in these racks.

System-to-Rail Installation Method

If the customer prefers to use the stab-in installation method for installing their systems to the rails, the Stab-in/Drop-in Sliding rails(B13) or the ReadyRails Static rail (B4) must be selected.

NOTE: ReadyRails Sliding rails (B6) are drop-in only.

Table 17. Static, Sliding, or Stab-in/Drop-in sliding rails

Rail identifier	Rail type	Installation method	Supported rack types					
			Dell EMC Titan or Titan-D Racks	4-Post			2-Post	
				Square	Round	Thread	Flush	Center
B6	Ready Rails Sliding	Drop-in	X	√	√	√ *	X	X
B13	Stab-in/Drop-in Sliding	Stab-in/Drop-in	√	√	√	√	X	X
B4	Ready Rails Static	Stab-in	X	√	√	√ *	√ *	√

* Minor conversion required

NOTE: No screws are required for the Stab-in/Drop-in Sliding (B13) rails when mounting the rails to the racks

NOTE: Screws are not included in either kit as threaded racks are offered with various thread designations. Users must therefore provide their own screws when mounting the rails in threaded racks.

NOTE: Screw head diameter for the sliding rails must be 10 mm or less.

Other key factors governing proper rail selection include the following:

- Spacing between the front and rear mounting flanges of the rack

- Type and location of any equipment mounted in the back of the rack such as power distribution units (PDUs)
- Overall depth of the rack

The static rails offer a greater adjustability range and a smaller overall mounting footprint than the sliding rails. This is because of their reduced complexity and lack of need for CMA support.

Table 18. Rail Adjustability Range and Rail Depth

Rail Identifier	Rail Type	Rail Adjustability Range (mm)*						Rail Depth (mm)+	
		Square		Round		Threaded		Without CMA	With CMA
		Min	Max	Min	Max	Min	Max		
B6	Ready Rails Sliding	676	868	662	861	676	883	714	845
B13	Stab-in/Drop-in Sliding	603	915	603	915	603	915	714	845
B4	Ready Rails Static	608	879	594	872	604	890	622	N/A

* Values represent the distance between the front and rear mounting flanges on the rack

+ Measured from the front surface of the front rack mounting flange

 **NOTE:** For situations where CMA support is not required, the outer CMA mounting brackets can be removed from the sliding rails to reduce the overall length of the rails and eliminate potential interferences with rear-mounted PDUs or the rack rear door.

 **NOTE:** For the ReadyRails Sliding rails(B6) and ReadyRails Static rails (B4), the adjustment range of the rails is a function of the type of rack in which they are being mounted. The Min/Max values listed above represent the allowable distance between the front and rear mounting flanges in the rack. Rail depth without the CMA represents the minimum depth of the rail with the outer CMA brackets removed (if applicable) as measured from the front mounting flanges of the rack.

Cable management arm (CMA)

The optional cable management arm (CMA) organizes and secures the cords and cables exiting the back of the systems. It unfolds to allow the systems to extend out of the rack without having to detach the cables. Some key features of the CMA include:

- Large U-shaped baskets to support dense cable loads.
- Open vent pattern for optimal airflow.
- Ability to be mounted on either side by simply swinging the spring-loaded brackets from one side to the other.
- Utilizes hook-and-loop straps rather than plastic tie wraps to eliminate the risk of cable damage during cycling.
- Includes a low-profile fixed tray to both support and retain the CMA in its fully closed position.
- Both the CMA and the tray mount without the use of tools via simple and intuitive snap-in designs.

The CMA can be mounted to either side of the sliding rails without the use of tools or the need for conversion. However, it is recommended that it be mounted on the side opposite to the power supplies to allow easier access to the power supplies and rear hard drives (if applicable) for service or replacement.



Figure 17. Sliding rails with CMA

Rack Installation

The R740 offers two different varieties of sliding rails: ReadyRail Sliding rails (B6), and combination Stab-in/Drop-in Sliding rails (B13). Only one variety of static rail is offered: ReadyRails Static rails (B4).

A "drop-in" design means that the system is installed vertically into the rails by inserting the standoffs on the sides of the system into the "J-slots" in the inner rail members with the rails in the fully extended position. The recommended method of installation is to first insert the rear standoffs on the system into the rear J-slots on the rails to free up a hand and then rotate the system down into the remaining J-slots while using the free hand to hold the rail against the side of the system.

A "stab-in" design means that the inner (chassis) rail members must first be attached to the sides of the system and then inserted into the outer (cabinet) members installed in the rack. For 2U systems, it is recommended that two people perform this operation.

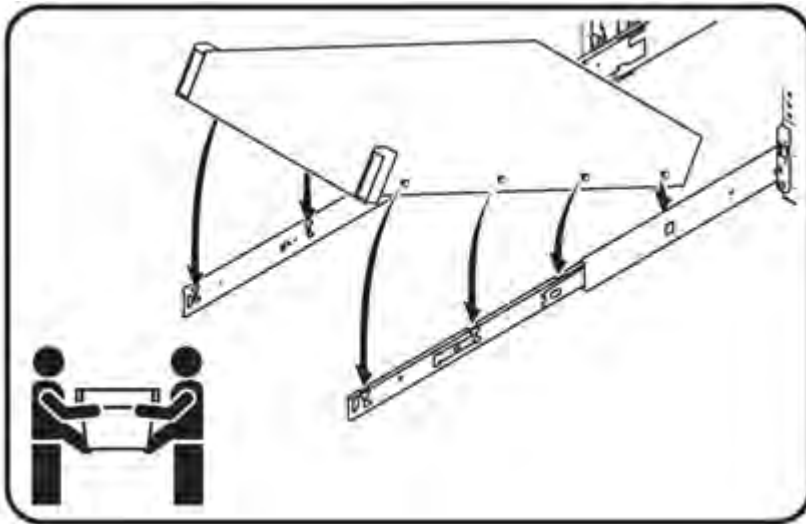

NOTE: The 2U system requires two people for installation due to its heavier weight.

Installing system into the rack (option A: Drop-In)

1. Pull the inner rails out of the rack until they lock into place.



Figure 18. Pull out inner rail

2. Locate the rear rail standoff on each side of the system and lower them into the rear J-slots on the slide assemblies.
3. Rotate the system downward until all the rail standoffs are seated in the J-slots.

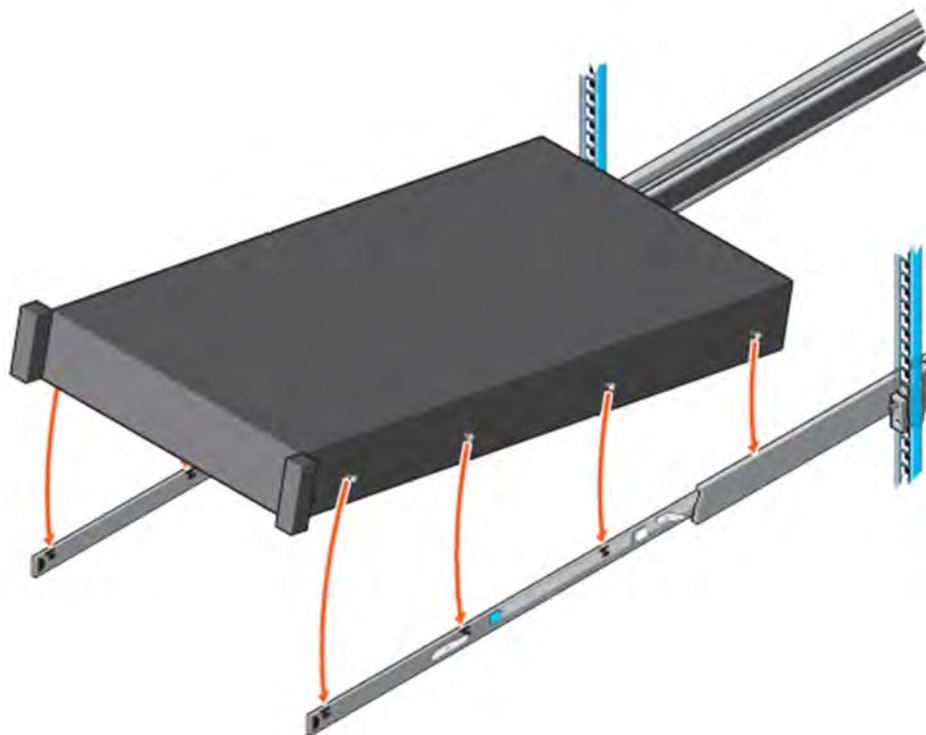

Figure 19. Rail standoffs seated in J-slots

4. Push the system inward until the lock levers click into place.
5. Pull the blue slide release lock tabs forward on both rails and slide the system into the rack until the system is in the rack.



Figure 20. Slide system into the rack

Installing the system into the rack (option B: Stab-In)

1. Pull the intermediate rails out of the rack until they lock into place.
2. Release the inner rail lock by pulling forward on the white tabs and sliding the inner rail out of the intermediate rails.

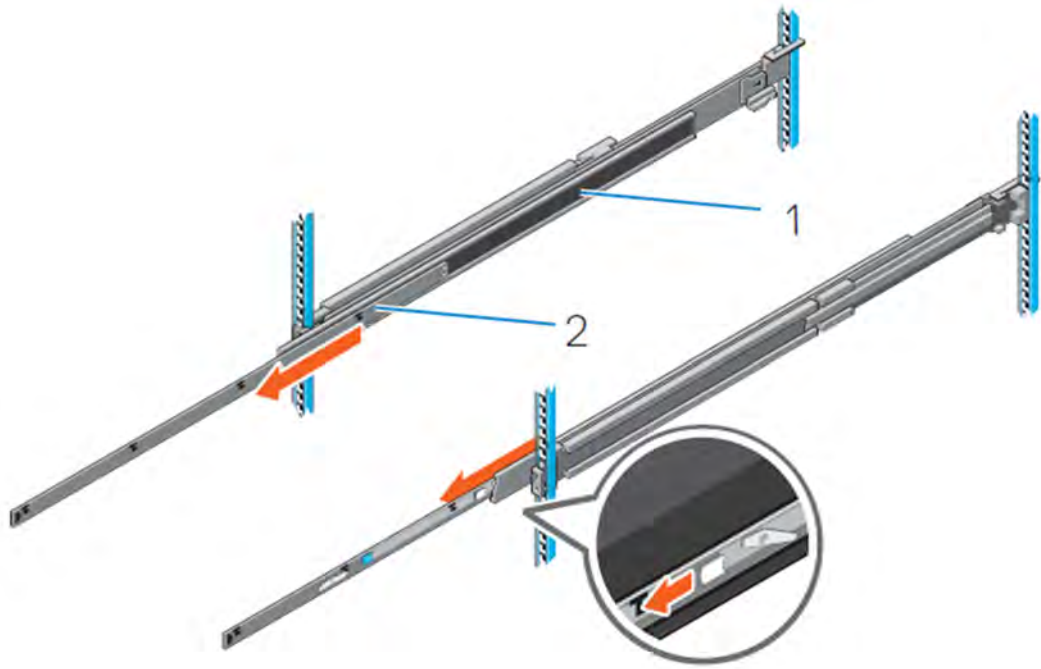

Figure 21. Pull out the intermediate rail

Table 19. Rail component

Number	Component
1	Intermediate rail
2	Inner rail

3. Attach the inner rails to the sides of the system by aligning the J-slots on the rail with the standoffs on the system and sliding forward on the system until they lock into place.

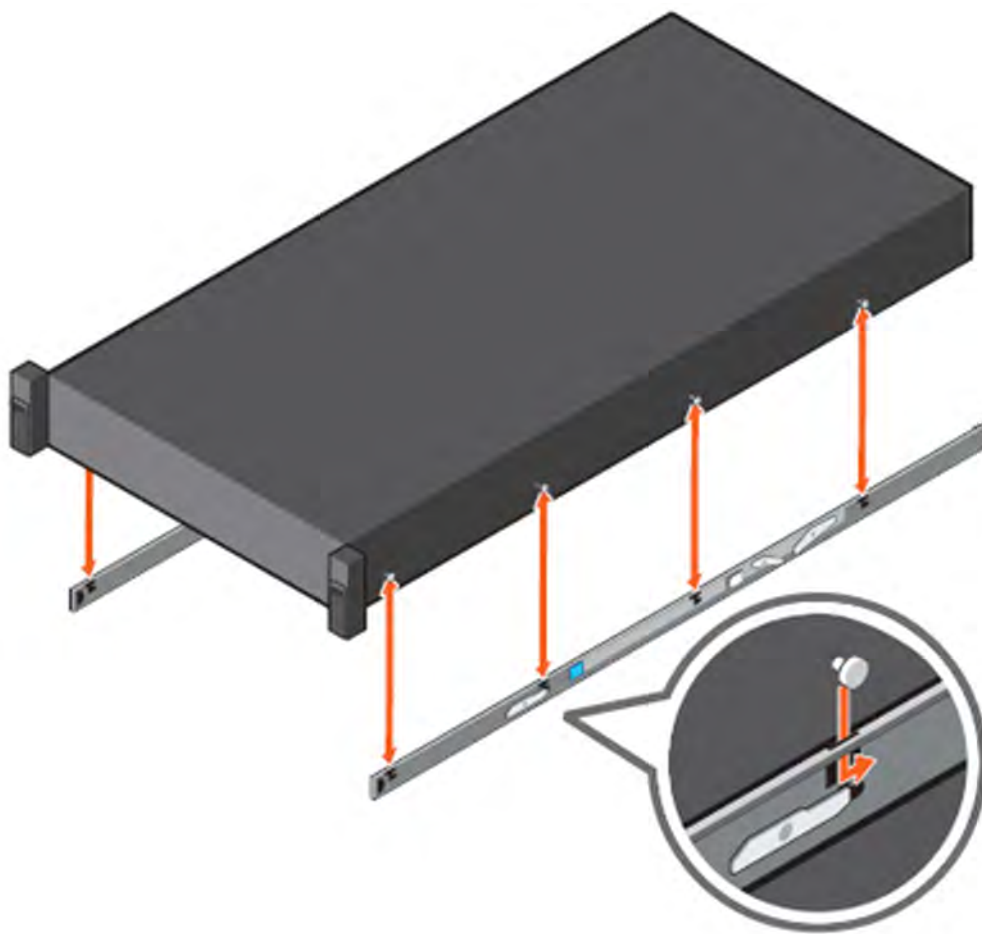

Figure 22. Attach the inner rails to the system

4. With the intermediate rails extended, install the system into the extended rails.

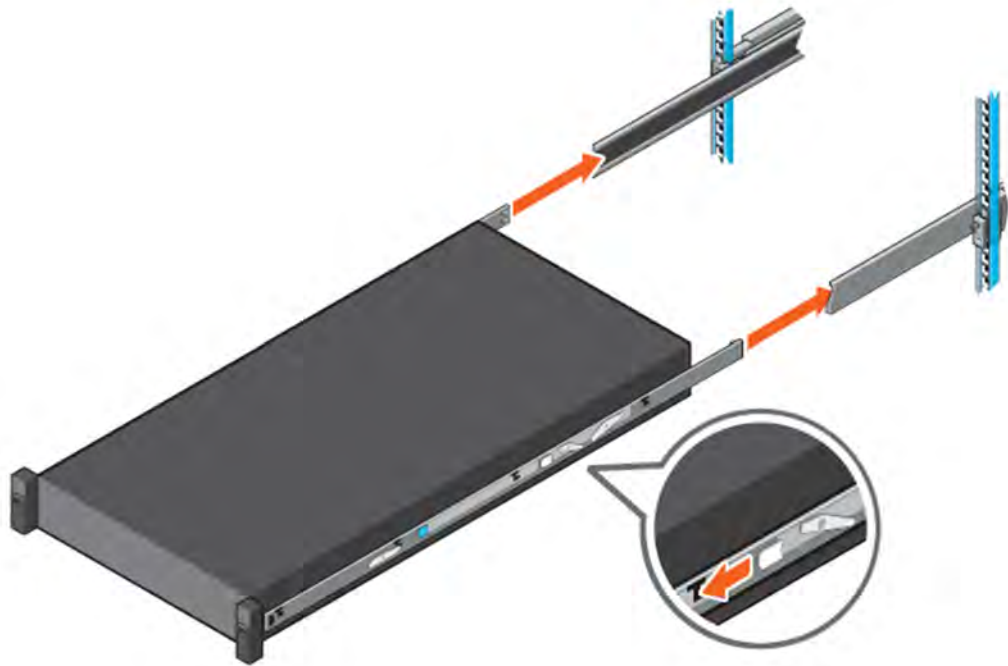

Figure 23. Install system into the extended rails

5. Pull the blue slide release lock tabs forward on both the rails, and slide the system into the rack.



Figure 24. Slide system into the rack

Dell EMC OpenManage systems management

Whether your IT environment consists of a few servers or a few thousand servers, Dell EMC OpenManage systems management solutions provide comprehensive management for evolving IT environments. OpenManage is based on open standards and provides agent-based and agent-free server lifecycle management functionality for Dell EMC PowerEdge servers. OpenManage solutions help you automate and streamline essential hardware management tasks.

Start with a firm foundation for efficient hardware management using OpenManage tools, utilities and management consoles. OpenManage systems management solutions consist of a combination of embedded management features and software products that help you automate and simplify the entire server lifecycle: deploy, update, monitor and maintain. OpenManage solutions are innovatively designed for simplicity and ease of use to help you reduce complexity, save time, achieve efficiency, control costs and empower productivity. OpenManage centers around efficient management of server lifecycle.

The Dell EMC OpenManage Portfolio

Simplifying hardware management through ease of use, intelligent automation and integrated security



Figure 25. Server lifecycle management operations

OpenManage systems management

The Dell EMC OpenManage systems management portfolio includes powerful hardware and software management tools and consoles. OpenManage simplifies the lifecycle of deploying, updating, monitoring and maintaining your Dell EMC PowerEdge servers.

iDRAC with Lifecycle controller

The integrated Dell Remote Access Controller 9 (iDRAC9) with Lifecycle Controller is embedded within every Dell EMC PowerEdge server and provides functionality that helps IT administrators deploy, update, monitor, and maintain servers with no need for any additional software to be installed. iDRAC functions regardless of operating system or hypervisor presence because from a pre-OS or bare-metal state, iDRAC is ready to work because it is embedded within each server from the factory.

iDRAC features and comparison

The R740 supports the following iDRAC licenses – Basic (default), Express (upgrade) and Enterprise (upgrade).

 **NOTE: The features listed in bold in the below table are new for iDRAC9.**

Table 20. iDRAC feature comparison

Features	iDRAC8 Basic	iDRAC9 Basic	iDRAC8 Express	iDRAC9 Express	iDRAC8 Express for Blades	iDRAC9 Express for Blades	iDRAC8 Enterprise	iDRAC9 Enterprise
Interface/Standards								
Redfish	Yes	Yes	Yes	Yes	Yes	Yes	Yes	Yes
IPMI 2.0	Yes	Yes	Yes	Yes	Yes	Yes	Yes	Yes
DCMI 1.5	Yes	Yes	Yes	Yes	Yes	Yes	Yes	Yes
Web-based GUI	Yes	Yes	Yes	Yes	Yes	Yes	Yes	Yes
Racadm command line—local/remote	Yes	Yes	Yes	Yes	Yes	Yes	Yes	Yes
SMASH-CLP—SSH-only	Yes	Yes	Yes	Yes	Yes	Yes	Yes	Yes
Telnet	Yes	Yes	Yes	Yes	Yes	Yes	Yes	Yes
SSH	Yes	Yes	Yes	Yes	Yes	Yes	Yes	Yes
Serial redirection	Yes	Yes	Yes	Yes	Yes	Yes	Yes	Yes
WSMAN	Yes	Yes	Yes	Yes	Yes	Yes	Yes	Yes
Network Time Protocol	No	No	Yes	Yes	Yes	Yes	Yes	Yes
Connectivity								
Shared NIC	Yes	Yes	Yes	Yes	N/A	N/A	Yes	Yes
Dedicated NIC	Yes	Yes	Yes	Yes	Yes	Yes	Yes	Yes
VLAN tagging	Yes	Yes	Yes	Yes	Yes	Yes	Yes	Yes
IPv4	Yes	Yes	Yes	Yes	Yes	Yes	Yes	Yes
IPv6	Yes	Yes	Yes	Yes	Yes	Yes	Yes	Yes
DHCP (new default; no static IP)	Yes	Yes	Yes	Yes	Yes	Yes	Yes	Yes
DHCP with Zero Touch	No	No	No	No	No	No	No	Yes
Dynamic DNS	Yes	Yes	Yes	Yes	Yes	Yes	Yes	Yes
OS pass-through	Yes	Yes	Yes	Yes	Yes	Yes	Yes	Yes

Features	iDRAC8 Basic	iDRAC9 Basic	iDRAC8 Express	iDRAC9 Express	iDRAC8 Express for Blades	iDRAC9 Express for Blades	iDRAC8 Enterprise	iDRAC9 Enterprise
iDRAC Direct-Front panel USB	Yes	Yes	Yes	Yes	Yes	Yes	Yes	Yes
Connection View	No	Yes	No	Yes	No	Yes	No	Yes
NFS v4	No	Yes	No	Yes	No	Yes	No	Yes
NTLM v1 and NTLM v2	No	Yes	No	Yes	No	Yes	No	Yes
Security								
Role-based authority	Yes	Yes	Yes	Yes	Yes	Yes	Yes	Yes
Local users	Yes	Yes	Yes	Yes	Yes	Yes	Yes	Yes
SSL encryption	Yes	Yes	Yes	Yes	Yes	Yes	Yes	Yes
IP blocking	No	No	Yes	Yes	Yes	Yes	Yes	Yes
Directory services—AD, LDAP	No	No	No	No	No	No	Yes	Yes
Two-factor authentication	No	No	No	No	No	No	Yes	Yes
Single sign-on	No	No	No	No	No	No	Yes	Yes
PK authentication	No	No	Yes	Yes	Yes	Yes	Yes	Yes
FIPS 140-2	Yes	Yes	Yes	Yes	Yes	Yes	Yes	Yes
Secure UEFI boot-certificate management	No	Yes	No	Yes	No	Yes	No	Yes
Lock down mode	No		No	No	No	No	No	Yes
Unique iDRAC default password	No	Yes	No	Yes	No	Yes	No	Yes
Customizable Security Policy Banner-login page	No	Yes	No	Yes	No	Yes	No	Yes
Quick Sync 2.0-optional auth for read operations	No	Yes	No	Yes	No	Yes	No	Yes
Quick Sync 2.0-add mobile device number to LCL	No	Yes	No	Yes	No	Yes	No	Yes
Remote Presence								
Power control	Yes	Yes	Yes	Yes	Yes	Yes	Yes	Yes
Boot control	Yes	Yes	Yes	Yes	Yes	Yes	Yes	Yes
Serial-over-LAN	Yes	Yes	Yes	Yes	Yes	Yes	Yes	Yes
Virtual Media	No	No	No	No	Yes	Yes	Yes	Yes
Virtual Folders	No	No	No	No	No	No	Yes	Yes
Remote File Share	No	No	No	No	No	No	Yes	Yes
Virtual Console	No	No	No	No	Yes	Yes	Yes	Yes
HTML5 access to virtual console	No	No	No	No	Yes	Yes	Yes	Yes

Features	iDRAC8 Basic	iDRAC9 Basic	iDRAC8 Express	iDRAC9 Express	iDRAC8 Express for Blades	iDRAC9 Express for Blades	iDRAC8 Enterprise	iDRAC9 Enterprise
VNC connection to OS	No	No	No	No	No	No	Yes	Yes
Quality/bandwidth control	No	No	No	No	No	No	Yes	Yes
Virtual Console collaboration—6 users	No	No	No	No	No	No	Yes	Yes
Virtual Console chat	No	No	No	No	No	No	Yes	Yes
Virtual Flash partitions	No	No	No	No	No	No	Yes	Yes
Group manager	No	No	No	No	No	No	No	Yes
HTTP/HTTPS support along with NFS/CIFS	No	Yes	No	Yes	No	Yes	No	Yes
Power and Thermal								
Real-time power meter	Yes	Yes	Yes	Yes	Yes	Yes	Yes	Yes
Power thresholds & alerts	No	No	Yes	Yes	Yes	Yes	Yes	Yes
Real-time power graphing	No	No	Yes	Yes	Yes	Yes	Yes	Yes
Historical power counters	No	No	Yes	Yes	Yes	Yes	Yes	Yes
Power capping	No	No	No	No	No	No	Yes	Yes
Power Center integration	No	No	No	No	No	No	Yes	Yes
Temperature monitoring	Yes	Yes	Yes	Yes	Yes	Yes	Yes	Yes
Temperature graphing	No	No	Yes	Yes	Yes	Yes	Yes	Yes
Health Monitoring								
Predictive failure monitoring	Yes	Yes	Yes	Yes	Yes	Yes	Yes	Yes
SNMPv1, v2 and v3—traps and gets	Yes	Yes	Yes	Yes	Yes	Yes	Yes	Yes
Email alerting	No	No	Yes	Yes	Yes	Yes	Yes	Yes
Configurable thresholds	Yes	Yes	Yes	Yes	Yes	Yes	Yes	Yes
Fan monitoring	Yes	Yes	Yes	Yes	Yes	Yes	Yes	Yes
Power Supply monitoring	Yes	Yes	Yes	Yes	Yes	Yes	Yes	Yes
Memory monitoring	Yes	Yes	Yes	Yes	Yes	Yes	Yes	Yes
CPU monitoring	Yes	Yes	Yes	Yes	Yes	Yes	Yes	Yes
RAID monitoring	Yes	Yes	Yes	Yes	Yes	Yes	Yes	Yes
NIC monitoring	Yes	Yes	Yes	Yes	Yes	Yes	Yes	Yes
HD monitoring—enclosure	Yes	Yes	Yes	Yes	Yes	Yes	Yes	Yes
Out of Band Performance Monitoring	No	No	No	No	No	No	Yes	Yes
Alerts for excessive SSD wear	No	Yes	No	Yes	No	Yes	No	Yes

Features	iDRAC8 Basic	iDRAC9 Basic	iDRAC8 Express	iDRAC9 Express	iDRAC8 Express for Blades	iDRAC9 Express for Blades	iDRAC8 Enterprise	iDRAC9 Enterprise
Customizable settings for Exhaust Temperature	No	Yes	No	Yes	No	Yes	No	Yes
Update								
Remote agent-free update	Yes	Yes	Yes	Yes	Yes	Yes	Yes	Yes
Embedded update tools	Yes	Yes	Yes	Yes	Yes	Yes	Yes	Yes
Sync with repository—scheduled updates	No	No	No	No	No	No	Yes	Yes
Auto update	No	No	No	No	No	No	Yes	Yes
Improved PSU firmware updates	No	Yes	No	Yes	No	Yes	No	Yes
Deployment and Configuration								
Local configuration via F10	Yes	Yes	Yes	Yes	Yes	Yes	Yes	Yes
Embedded OS deployment tools	Yes	Yes	Yes	Yes	Yes	Yes	Yes	Yes
Embedded configuration tools	Yes	Yes	Yes	Yes	Yes	Yes	Yes	Yes
AutoDiscovery	No	No	Yes	Yes	Yes	Yes	Yes	Yes
Remote OS deployment	No	No	Yes	Yes	Yes	Yes	Yes	Yes
Embedded driver pack	Yes	Yes	Yes	Yes	Yes	Yes	Yes	Yes
Full configuration inventory	Yes	Yes	Yes	Yes	Yes	Yes	Yes	Yes
Inventory export	Yes	Yes	Yes	Yes	Yes	Yes	Yes	Yes
Remote configuration	Yes	Yes	Yes	Yes	Yes	Yes	Yes	Yes
Zerotouch configuration	No	No	No	No	No	No	Yes	Yes
System Retire/Repurpose	Yes	Yes	Yes	Yes	Yes	Yes	Yes	Yes
Server Configuration Profile in GUI	No	Yes	No	Yes	No	Yes	No	Yes
Diagnostics, Service and Logging								
Embedded diagnostic tools	Yes	Yes	Yes	Yes	Yes	Yes	Yes	Yes
Part Replacement	No	No	Yes	Yes	Yes	Yes	Yes	Yes
Server Configuration Backup	No	No	No	No	No	No	Yes	Yes
Server Configuration Restore	Yes	Yes	Yes	Yes	Yes	Yes	Yes	Yes
Easy Restore—system configuration	Yes	Yes	Yes	Yes	Yes	Yes	Yes	Yes
Easy Restore Auto Timeout	No	Yes	No	Yes	No	Yes	No	Yes

Features	iDRAC8 Basic	iDRAC9 Basic	iDRAC8 Express	iDRAC9 Express	iDRAC8 Express for Blades	iDRAC9 Express for Blades	iDRAC8 Enterprise	iDRAC9 Enterprise
LED health status indicator	Yes	Yes	Yes	Yes	Yes	Yes	Yes	Yes
LCD screen—iDRAC9 requires optional bezel	Yes	Yes	Yes	Yes	N/A	N/A	Yes	Yes
Quick Sync—require NFC bezel (13 G only)	Yes	No	Yes	No	N/A	No	Yes	No
Quick Sync 2.0—requires BLE/WiFi hardware	No	Yes	No	Yes	No	N/A	No	Yes
iDRAC Direct—front USB mgmt port	Yes	Yes	Yes	Yes	Yes	Yes	Yes	Yes
iDRAC Service Module (ISM) embedded	No	Yes	No	Yes	No	Yes	No	Yes
ISM to inband alert forwarding to consoles	No	Yes	No	Yes	No	Yes	No	Yes
Crash screen capture	No	No	Yes	Yes	Yes	Yes	Yes	Yes
Crash video capture	No	No	No	No	No	No	Yes	Yes
Boot capture	No	No	No	No	No	No	Yes	Yes
Manual reset for iDRAC—LCD ID button	Yes	Yes	Yes	Yes	Yes	Yes	Yes	Yes
Remote reset for iDRAC—requires iSM	Yes	Yes	Yes	Yes	Yes	Yes	Yes	Yes
Virtual NMI	Yes	Yes	Yes	Yes	Yes	Yes	Yes	Yes
OS watchdog	Yes	Yes	Yes	Yes	Yes	Yes	Yes	Yes
SupportAssist Report—embedded	Yes	Yes	Yes	Yes	Yes	Yes	Yes	Yes
System Event Log	Yes	Yes	Yes	Yes	Yes	Yes	Yes	Yes
Lifecycle Log	Yes	Yes	Yes	Yes	Yes	Yes	Yes	Yes
Enhanced logging in the Lifecycle controller log	Yes	Yes	Yes	Yes	Yes	Yes	Yes	Yes
Work notes	Yes	Yes	Yes	Yes	Yes	Yes	Yes	Yes
Remote Syslog	No	No	No	No	No	No	Yes	Yes
License management	Yes	Yes	Yes	Yes	Yes	Yes	Yes	Yes
Improved customer experience								
iDRAC -Faster processor, more memory	No	Yes	No	Yes	No	Yes	No	Yes
GUI rendered in HTML5	No	Yes	No	Yes	No	Yes	No	Yes
Add BIOS configuration to iDRAC GUI	No	Yes	No	Yes	No	Yes	No	Yes

Features	iDRAC8 Basic	iDRAC9 Basic	iDRAC8 Express	iDRAC9 Express	iDRAC8 Express for Blades	iDRAC9 Express for Blades	iDRAC8 Enterprise	iDRAC9 Enterprise
iDRAC support for SW RAID licensing	No	Yes	No	Yes	No	Yes	No	Yes

Agent-free management

As Dell EMC PowerEdge servers have embedded server lifecycle management, in many cases, there is no need to install an OpenManage systems management software agent into the operating system of a Dell EMC PowerEdge server. This greatly simplifies and streamlines the management footprint.

Agent-based management

Most systems management solutions require pieces of software, called agents, to be installed on each node in order to be managed within the IT environment. Additionally, the same agent is often used as a local interface into the hardware health and may be accessed remotely as a management interface, typically referred to as a one-to-one interface. For customers that continue to use agent-based solutions, Dell EMC provides OpenManage Server Administrator.

Dell EMC consoles

The central console in a systems management solution is often referred to as the one-to-many console. The central console provides a rapid view and insight into the overall health of all systems in the IT environment. The Dell EMC systems management portfolio includes several powerful consoles, depending upon your needs, including the following:

Dell EMC OpenManage Essentials

OpenManage Essentials is the one-to-many management console for monitoring Dell HW infrastructure including server, storage and networking, as well as for lifecycle management of PowerEdge servers. It support Windows, Linux, VMware, and HyperV environments. OME provides a simple and easy interface for system administrators to maximize the uptime and health of Dell systems. It helps to

- Monitor health status and events for PowerEdge servers, EqualLogic or MD series storage, and PowerConnect and Force 10 switches.
- Provide hardware-level control and management for PowerEdge server, blade system, and internal storage arrays.
- Link and Launch element management interfaces, such as, iDRAC, CMC, EQL group manager etc
- Integrate with the following Dell solutions:
 - Dell Repository Manager : Builds customized server update baselines that OpenManage Essentials can use.
 - OpenManage Power Center : Optimize power consumption in the servers.
 - SupportAssist : Enables automatic hardware failure notification to be sent securely to Dell technical support for intelligent analysis and diagnosis to optimize availability and reduce manual intervention. This solution is available as part of Dell ProSupport and ProSupport Plus at no additional cost.
- Provide REST interface API support for 3rd Party Integration.
- Manage Server Configuration - it is a fee-based license available on Dell's 14th generation of PowerEdge servers with iDRAC Enterprise or iDRAC Express licenses. The key features include the following:
 - Configure a server or chassis using a template and deploying an operating system on the PowerEdge bare metal servers.
 - During a server operation, automatically detect and notify any server or chassis drift from a customer-defined baseline configuration.
 - Boot a system from a network-mounted ISO using iDRAC.
 - Replicate of FN-IOM and M-IOA configurations within M1000e chassis.
 - Support VLAN Management for FN-IOM and M-IOA.

- For more information, see delltechcenter.com/OME

OpenManage Mobile

OpenManage Mobile(OMM) is a software application that enables easy, convenient, and secure monitoring and management of PowerEdge servers remotely, or at-the-server. With OpenManage Mobile, IT Administrators can securely perform several data center monitoring and remediation tasks using an Android or iOS mobile device. The OpenManage Mobile app is available as a free software download from the Apple Store and the Google Play Store.

OMM can also monitor and manage PowerEdge servers through a OpenManage Essentials console or by directly accessing the server's iDRAC.

The OpenManage Essentials console can be accessed through OpenManage Mobile over a secure IP network. This allows you to monitor all devices managed by OpenManage Essentials such as Dell EMC servers, storage, networking, firewall, and supported third party devices.

If you are remote, you can access iDRAC over a secure IP network. If you are at-the-server, an iDRAC can be accessed directly by tapping an NFC-enabled android mobile device on a PowerEdge "Quick Sync" bezel to perform several basic bare-metal configuration tasks such as assigning an IP address, and changing server credentials or the boot order.

Key Features of OpenManage Mobile (When connected through OpenManage Essentials console):

- Connect to multiple servers which have OME installed, from a single mobile device.
- Connect to multiple servers individually through the iDRAC interface.
- Receive critical alert notification on your mobile device as they arrive into your OpenManage Essentials management console.
- Acknowledge, forward, and delete alerts from your mobile device.
- Browse through device details, firmware inventory, and event logs of individual systems.
- Perform several server management functions such as power-on, power cycle, reboot, and shutdown from the mobile application.

Key Features of OpenManage Mobile (When connected through iDRAC):

- Connect to any 14th gen, 13th gen, or 12th gen server remotely
- Access 14th gen rack or tower server through Quick Sync 2 module.
- Assign IP address, change credentials, and update common BIOS attributes for Bare Metal Configuration
- Configure one server manually, or multiple servers simultaneously through a template.
- Browse server details, health status, hardware & firmware inventory, networking details, and System Event or LC logs. Share this information easily with other IT Administrators.
- Access SupportAssist reports, Last Crash screen and video (PowerEdge 14th gen servers)
- Access Virtual Console (and reduce the need for crash carts).
- Power On, Shut down, or Reboot your server from anywhere.
- Run any RACADM command

OpenManage Power Center

OpenManage Power Center is a one-to-many application that can read power usage and thermal readings information from Dell EMC servers, Power Distribution Units (PDU), and Uninterruptible Power Supplies (UPS). It can aggregate this information into rack, row, and room-level views. On servers with iDRAC Enterprise license, you can also cap or throttle the power consumption. You may need to set power caps to reduce the power consumption due to external events such as brownouts or failures of data-center cooling devices. You can also use power capping to safely increase the numbers of servers in a rack to match the power that is provisioned for that rack.

For more information, see OpenManage Power Center User's Guide available at Dell.com/openmanagemanuals.

Dell EMC OpenManage systems management tools, utilities and protocols

Dell EMC OpenManage systems management tools and utilities consist of the following:

Dell EMC Repository Manager:

Dell EMC Repository Manager (DRM) is an application that helps you to:

- Identify the updates that are relevant to the systems in your data center.
- Identify and notify when updates are available.
- Package the updates into different deployment format.

To automate the creation of baseline repositories, DRM provides advanced integration capabilities with iDRAC/LC, OpenManage Essentials, Chassis Management Controller, OpenManage Integration for VMware vCenter and OpenManage Integration for Microsoft System Center (OMIMSSC). Also, DRM packages updates into custom catalogs that can be used for deployment.

Dell EMC Repository Manager can create the following deployment tools:

- Custom catalogs
- Lightweight deployment pack
- Bootable Linux ISO
- Custom Server Update Utility (SUU)

For more information, see Dell EMC Repository Manager User's Guide available at Dell.com/support/manuals.

Dell Update Packages

Dell Update Packages (DUP) is a self-contained executable supported by Microsoft Windows or Linux that updates a component on a server and applications like OMSA, iSM, and DSET.

DUPs can be executed in GUI or in CLI mode.

For more information, see Dell EMC Update Packages User's Guide available at www.delltechcenter.com/DSU.

Dell Remote Access Controller Administration (RACADM) CLI

The RACADM command-line utility provides a scriptable interface to perform inventory, configuration, update, and health status check of PowerEdge servers. RACADM operates in multiple modes:

- Local — supports running RACADM commands from the managed server's operating system.
- SSH or Telnet — known as Firmware RACADM; is accessible by logging in to iDRAC using SSH or Telnet
- Remote — supports running RACADM commands from a remote management station such as a laptop or desktop.

RACADM is supported by the iDRAC with Lifecycle Controller and by the Chassis Management Controller of the M1000e, VRTX and FX2 modular systems. Local and Remote RACADM is supported on Windows Server, Windows clients, and on Red Hat, SuSe and Ubuntu Linux.

For more information, see the RACADM Command Line Reference Guide for iDRAC and CMC available at Dell.com/support/manuals.

iDRAC with Lifecycle Controller Embedded Management APIs

iDRAC with Lifecycle Controller provides a range of standards-based applications programming interfaces (APIs) that enable scalable and automated management of PowerEdge servers. Standard systems management APIs have been developed by organizations such as the Institute of Electrical and Electronics Engineers (IEEE) and Distributed Management Task Force (DMTF). These APIs are

widely used by commercial systems management products and by custom programs and scripts developed by IT staff to automate management functions such as discovery, inventory, health status checking, configuration, update, and power management. The APIs supported by iDRAC with Lifecycle Controller include:

- **Redfish** - In 2015, the DMTF Scalable Platforms Management Forum published Redfish, an open industry-standard specification and schema designed to meet the needs of IT administrators for simple, modern, and secure management of scalable platform hardware. Dell is a key contributor to the Redfish standard, acting as co-chair of the SPMF, promoting the benefits of Redfish, and working to deliver those benefits within industry-leading systems management solutions. Redfish is a next generation management standard using a data model representation inside a hypermedia RESTful interface. The data model is defined in terms of a standard, machine-readable schema, with the payload of the messages expressed in JSON and the OData v4 protocol.
- **WSMan** - The Web Services For Management (WSMan) API, first published by the DMTF in 2008, is the most mature and robust API provided by iDRAC with Lifecycle Controller. WSMan uses a Simple Object Access Protocol (SOAP) with data modeled using the Common Information Model. WSMan provides interoperability between management applications and managed resources, and identifies a core set of web service specifications and usage requirements that expose a common set of operations central to all systems management.
- **IPMI** - The Intelligent Platform Management Interface (IPMI) is a message-based, hardware-level interface specification that can operate over both LAN and serial interfaces. IPMI is supported broadly by server vendors, systems management solutions, and open source software.
- **SNMP** - The Simple Network Management Protocol (SNMP) helps in standardizing the management of network devices. SNMP allows commercial management consoles created for monitoring network switches and routers to also monitor X86 servers. SNMP is primarily used to deliver event messages to alert administrators of problems on their systems but can also be used to discover, inventory and configure servers.

To assist automating system management tasks and simplify API integration, Dell provides PowerShell and Python libraries and script examples utilizing the WSMan interface. The iDRAC with LC pages of Dell Techcenter offer a library of technical white papers detailing the use of the embedded management APIs. For more information, see delltechcenter.com/iDRAC and delltechcenter.com/LC.

Integration with third-party consoles

Dell EMC OpenManage provides integration with several leading third-party consoles, including:

OpenManage Integration Suite for Microsoft System Center

The combination of Dell OpenManage Integration Suite and Microsoft System Center simplifies and enhances deployment, configuration, monitoring and updating of Dell servers and storage in physical and virtual environments. Our agent-free and agent-based plug-ins deliver a unique level of integration and efficiency when managing Dell hardware within a System Center environment.

The OpenManage Integration Suite for Microsoft System Center includes: Dell Server and Storage Management Packs for System Center Operations Manager (SCOM); Dell Server Deployment Packs and Update Catalogs for System Center Configuration Manager (SCCM); and tools for optimizing management of Dell PowerEdge servers in virtual environments using System Center Virtual Machine Manager (SCVMM).

OpenManage Integration for VMware vCenter

The OpenManage Integration for VMware vCenter allows you to monitor, provision, and manage PowerEdge server hardware and firmware. You can perform these tasks through a dedicated Dell menu that can be accessed directly through the VMware vCenter console. OMIVV also allows granular control and reporting for the hardware environment using the same role-based access control model as vCenter. The OpenManage Management Pack for vRealize Operations Manager is available with OMIVV v4.0 onwards. This helps in checking hardware health and alerting into vRealize operations, which also includes dashboard and reporting on the server environment.

You can manage and monitor Dell hardware within the virtualized environment

- Alerting and monitoring environment for servers and chassis
- Monitoring and reporting for servers and chassis
- Updating firmware on servers

- Deploying enhanced options

For more information, see delltechcenter.com/omivv

NOTE: The Dell EMC Repository Manager integrates with OpenManage Integration for VMware vCenter. The Dell EMC Repository Manager provides advanced functionality, simplifies the discovery, and deployment of new updates.

BMC Software

Dell EMC and BMC Software work together to simplify IT by ensuring tight integration between Dell EMC server, storage, and network management functionality and the BMC Software process and data center automation products.

OpenManage connections with third-party consoles

Dell EMC OpenManage Connections gives you an easy path to adding support for third-party devices, so you can continue to use your existing management tools while easily adding Dell EMC server systems to your existing IT environment. Integrate new systems at your own pace. Manage new Dell EMC servers and storage with your legacy management tools, while extending the useful life of your existing resources. With OpenManage Connections you can add monitoring and troubleshooting of Dell EMC assets to your IT infrastructure.

- OpenManage Connection for Nagios Core and Nagios XI
- OpenManage Connection for HPE Operations Manager i (OMi)

For more information on these OpenManage Connections, visit Dell.com/openmanage.

Dell EMC server management operations

Dell EMC OpenManage systems management is centered on automating the server management lifecycle — deploy, update, monitor and maintain. To manage an infrastructure properly and efficiently, you must perform all of these functions easily and quickly. iDRAC9 with Lifecycle Controller technology provides you with these intelligent capabilities embedded within the server infrastructure. This allows you to invest more time and energy on business improvements and less on maintenance.

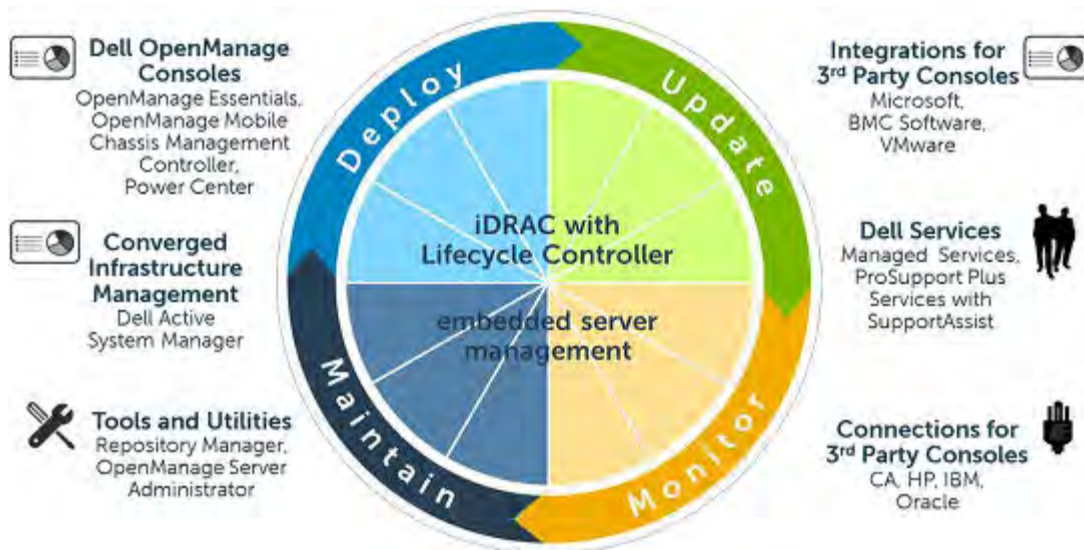

Figure 26. Systems management server lifecycle

Table 21. One-to-one and one-to-many operations

Operation	One-to-one	One-to-many
Deploy	<ul style="list-style-type: none"> · Lifecycle Controller GUI 	<ul style="list-style-type: none"> · OpenManage Integration for VMware vCenter · OpenManage Integration for BMC BladeLogic

	<ul style="list-style-type: none"> • DTK 	<ul style="list-style-type: none"> • OpenManage Integration for Microsoft System Center Configuration Manager
Update	<ul style="list-style-type: none"> • iDRAC9 with Lifecycle Controller • Repository Manager • DUP • SUU • OpenManage Integration for VMware vCenter 	<ul style="list-style-type: none"> • Dell EMC OpenManage Essentials • OpenManage Integration for Microsoft System Center Configuration Manager
Monitor	<ul style="list-style-type: none"> • iDRAC9 with Lifecycle Controller • OMSA 	<ul style="list-style-type: none"> • Dell EMC OpenManage Essentials • Dell EMC OpenManage Power Center • OpenManage Integration for VMware vCenter • OpenManage Integration for Microsoft System Center Operations Manager
Maintain	<ul style="list-style-type: none"> • iDRAC9 with Lifecycle Controller • IPMI 	<ul style="list-style-type: none"> • Lifecycle Controller Remote Services • Remediate and replace parts: • OpenManage Integration for Microsoft System Center Virtual Machine Manager (SCVMM) • Server Pro Management Pack and Lifecycle Controller Integration (DLCI)

For additional detailed information on Dell EMC systems management portfolio, visit Dell.com/OpenManage.

Appendix A. Additional specifications

The following sections contain information about additional system specifications.

PSU specifications

The PowerEdge R740 system supports up to two AC or DC power supply units (PSUs).

Table 22. PSU specifications

PSU	Class	Heat dissipation (maximum)	Frequency	Voltage	High line 200v240 V	Low line 100– 140 V	DC	Current
495 W AC	Platinum	1908 BTU/hr	50/60 Hz	100–240 V AC, autoranging	495 W	495 W		6.5 A–3 A
750 W AC	Platinum	2891 BTU/hr	50/60 Hz	100–240 V AC, autoranging	750 W	750 W		10 A–5 A
750 W AC	Titanium	2843 BTU/hr	50/60 Hz	200–240 V AC, autoranging	750 W			5 A
750 W Mixed Mode HVDC (for China only)	Platinum	2891 BTU/hr	50/60 Hz	100–240 V AC, autoranging	750 W	750 W		10 A–5 A
	N/A	2891 BTU/hr	N/A	240 V DC, autoranging			750W	4.5 A
1100 W AC	Platinum	4100 BTU/hr	50/60 Hz	100–240 V AC, autoranging	1100 W	1050 W		12 A–6.5 A
1100 W DC	N/A	4416 BTU/hr	N/A	–(48–60) V DC, autoranging			1100 W	32 A
1100 W Mixed Mode HVDC (for China and Japan only)	Platinum	4100 BTU/hr	50/60 Hz	100–240 V AC, autoranging	1100 W	1050 W		12 A–6.5 A
	N/A	4100 BTU/hr	N/A	200–380 V DC, autoranging			1100 W	6.4 A–3.2 A
1600 W AC	Platinum	6000 BTU/hr	50/60 Hz	100–240 V AC, autoranging	1600 W	800 W		10 A
2000 W AC	Platinum	7500 BTU/hr	50/60 Hz	100–240 V AC, autoranging	2000 W	1000 W		11.5 A
2400 W AC	Platinum	9000 BTU/hr	50/60 Hz	100–240 V AC, autoranging	2400 W	1400 W		16 A

- NOTE: Heat dissipation is calculated using the PSU wattage rating.
- NOTE: This system is also designed to connect to the IT power systems with a phase to phase voltage not exceeding 240 V.
- NOTE: PSUs rated for 1100 W Mixed Mode HVDC or 1100 W AC and higher require high-line voltage (200–240 V AC) to supply their rated capacity.

Chassis dimensions

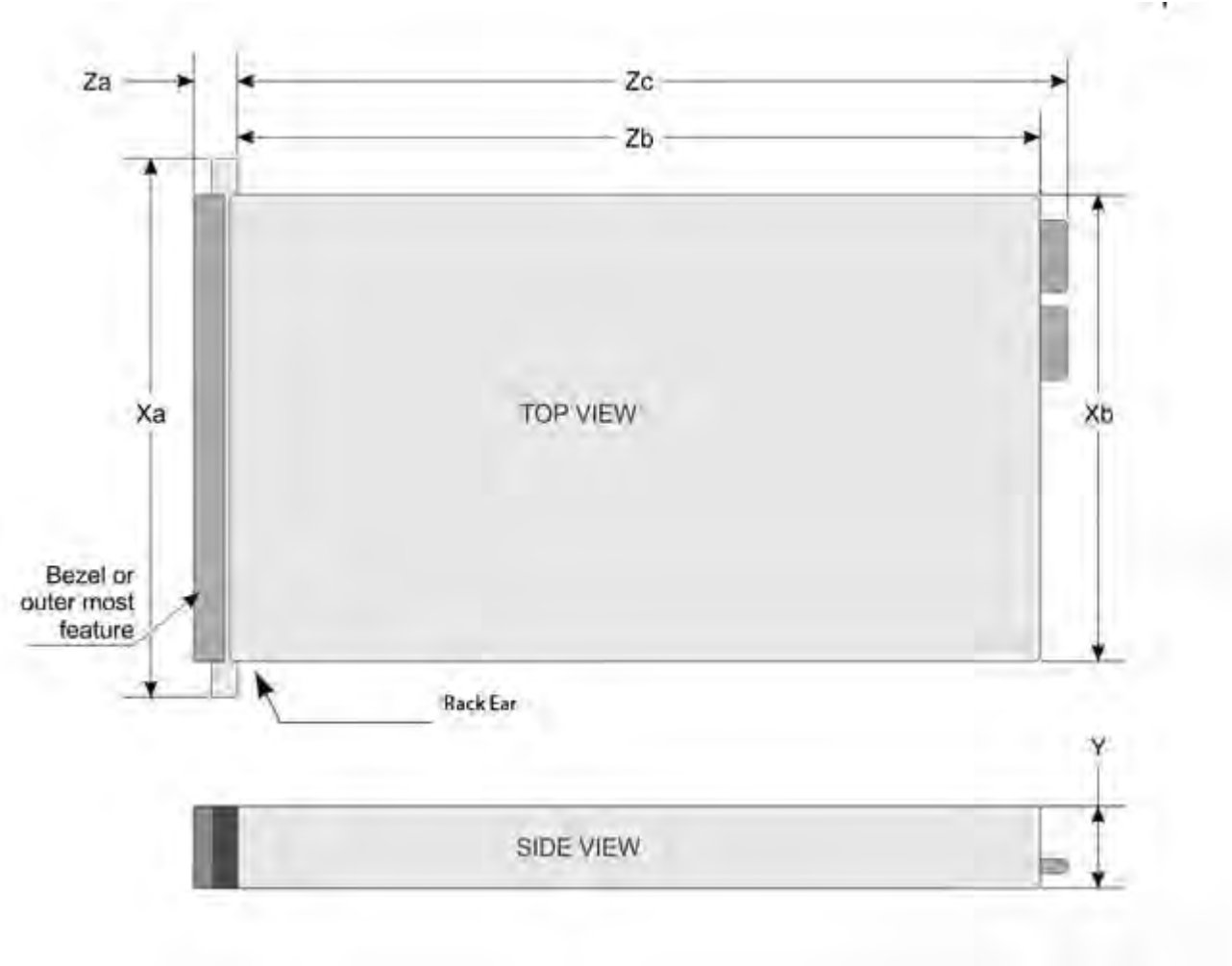

Figure 27. Chassis Dimensions for R740 and R740xd

Table 23. Chassis dimensions (cm)

Chassis dimensions (cm)						
Xa	Xb	Y	Za bezel	Za without bezel	Zb	Zc
482.0 mm	434.0 mm	86.8 mm	35.84mm	22.0 mm	678.8 mm	715.5 mm

Table 24. Chassis weight

Configuration	Maximum Weight
2.5" HDD for R740	26.3Kg
3.5" HDD for R740	28.6Kg
2.5" HDD for R740xd	28.1Kg
3.5" HDD for R740xd	33.1Kg

Environmental specifications

See Dell EMC PowerEdge R740 and R740xd installation service manuals on Dell.com/Support/Manuals for detailed environmental specifications.

Video specifications

The PowerEdge R740 system supports integrated Matrox G200eW3 graphics controller with 16 MB of video frame buffer.

Table 25. Supported video resolution options

Resolution	Refresh rate (Hz)	Color depth (bits)
1024 x 768	60	8, 16, 32
1280 x 800	60	8, 16, 32
1280 x 1024	60	8, 16, 32
1360 x 768	60	8, 16, 32
1440 x 900	60	8, 16, 32
1600 x 900	60	8, 16, 32
1600 x 1200	60	8, 16, 32
1680 x 1050	60	8, 16, 32
1920 x 1080	60	8, 16, 32
1920 x 1200	60	8, 16, 32

 **NOTE: 1920 x 1080 and 1920 x 1200 resolutions are only supported in reduced blanking mode.**

USB peripherals

USB peripherals are supported through the front and back USB ports on the R740 and R740xd. The front USB ports are USB 2.0 compliant, only the back ports are USB 3.0 compliant. The R740 offers an upsell option to add an additional USB 3.0 port to the front of the chassis but this option is not available in R740xd.

Appendix B. Standards compliance

Table 26. Industry standard documents

Standard	URL for information and specifications
ACPI Advance Configuration and Power Interface Specification, v2.0c	acpi.info
Ethernet IEEE 802.3-2005	standards.ieee.org/getieee802/802.3.html
HDG Hardware Design Guide Version 3.0 for Microsoft Windows Server	microsoft.com/whdc/system/platform/pcdesign/designguide/serverdg.mspx
IPMI Intelligent Platform Management Interface, v2.0	intel.com/design/servers/ipmi
DDR4 Memory DDR4 SDRAM Specification	jedec.org/standards-documents/docs/jesd79-4.pdf
PCI Express PCI Express Base Specification Rev. 2.0 and 3.0	pcsig.com/specifications/pciexpress
PMBus Power System Management Protocol Specification, v1.2	pmbus.info/specs.html
SAS Serial Attached SCSI, v1.1	t10.org
SATA Serial ATA Rev. 2.6; SATA II, SATA 1.0a Extensions, Rev. 1.2	sata-io.org
SMBIOS System Management BIOS Reference Specification, v2.7	dmtf.org/standards/smbios
TPM Trusted Platform Module Specification, v1.2 and v2.0	trustedcomputinggroup.org
UEFI Unified Extensible Firmware Interface Specification, v2.1	uefi.org/specifications
USB Universal Serial Bus Specification, Rev. 2.0	usb.org/developers/docs

Appendix C Additional resources

Table 27. Additional resources

Resource	Description of contents	Location
PowerEdge R740/R740xd Installation Service Manuals	<p>This manual, available in PDF format, provides the following information:</p> <ul style="list-style-type: none"> • Chassis features • System Setup program • System messages • System codes and indicators • System BIOS • Remove and replace procedures • Troubleshooting • Diagnostics • Jumpers and connectors 	Dell.com/Support/Manuals
PowerEdge R740/R740xd Getting Started Guide	<p>This guide ships with the system, and is also available in PDF format. This guide provides the following information:</p> <ul style="list-style-type: none"> • Initial setup steps • Key system features • Technical specifications 	Dell.com/Support/Manuals
Rack Installation Instructions	This document ships with the rack kits, and provides instructions for installing a server in a rack.	Dell.com/Support/Manuals
Information Update	This document ships with the system, is also available in PDF format online, and provides information on system updates.	Dell.com/Support/Manuals
System Information Label	The system information label documents the system board layout and system jumper settings. Text is minimized due to space limitations and translation considerations. The label size is standardized across platforms.	Inside the system chassis cover
Quick Resource Locator (QRL)	This code on the chassis can be scanned by a phone application to access additional information and resources for the server, including videos, reference materials, service tag information, and Dell contact information.	Inside the system chassis cover
Energy Smart Solution Advisor (ESSA)	The Dell online ESSA enables easier and more meaningful estimates to help you determine the most efficient configuration possible. Use ESSA to calculate the power consumption of your hardware, power infrastructure, and storage.	Dell.com/calc

Appendix D. Support and Deployment Services

Dell EMC Global Services include a wide, customizable range of service choices to simplify the assessment, design, implementation, management and maintenance of your IT environment and to help you transition from platform to platform. Depending on your current business requirements and the level of service you want, we can provide you with factory, on-site, remote, modular and specialized services that fit your needs and budget. We'll help you with a little or a lot - your choice - and provide you with access to our global resources.

Server Deployment Services

Our Server Deployment Services can maximize the value of your servers quickly using our expert server deployment engineers. With over 10,000 server deployment projects each year, we have experience, best practices, and comprehensive deployment tools to install, configure, and integrate your new solution optimally and correctly. Our deployment experts will assess your environment and understand your goals, then design and integrate your server solution for you.

Table 28. Server deployment capabilities

	Server Installation	Server Integration
Place single server in target workspace	Yes	
Rack, cable, and label servers	Yes	
Install image	Yes	
Connect to network	Yes	Yes
Test and validate connection	Yes	Yes
Install operating system		Yes
Install applications		Yes
Perform advanced configuration services		Yes
Remote configuration services		Yes
Virtualization		Yes
Converged infrastructure		Yes
Test and validate data center integration		Yes

Remote Consulting Services

When you are in the final stages of your PowerEdge server implementation, you can rely on Dell EMC Remote Consulting and our certified technical experts to help you optimize your configuration with best practices for your software, virtualization, server, storage, networking, and systems management.

Data Migration Service

Protect your business and data with our single point of contact to manage your data migration project. Your project manager will work with our experienced team of experts to create a plan using industry-leading tools and proven processes based on global best practices to migrate your existing files and data, so your business gets up and running quickly and smoothly.

ProSupport Enterprise Suite

With Dell EMC ProSupport Services, we can help you keep your operation running smoothly, so you can focus on running your business. We will help you maintain peak performance and availability of your most essential workloads. Dell EMC ProSupport is a suite of support services that enable you to build the solution that is right for your organization. Choose support models based on how you use technology and where you want to allocate resources. From the desktop to the data center, address everyday IT challenges, such as unplanned downtime, mission-critical needs, data and asset protection, support planning, resource allocation, software application management and more. Optimize your IT resources by choosing the right support model.

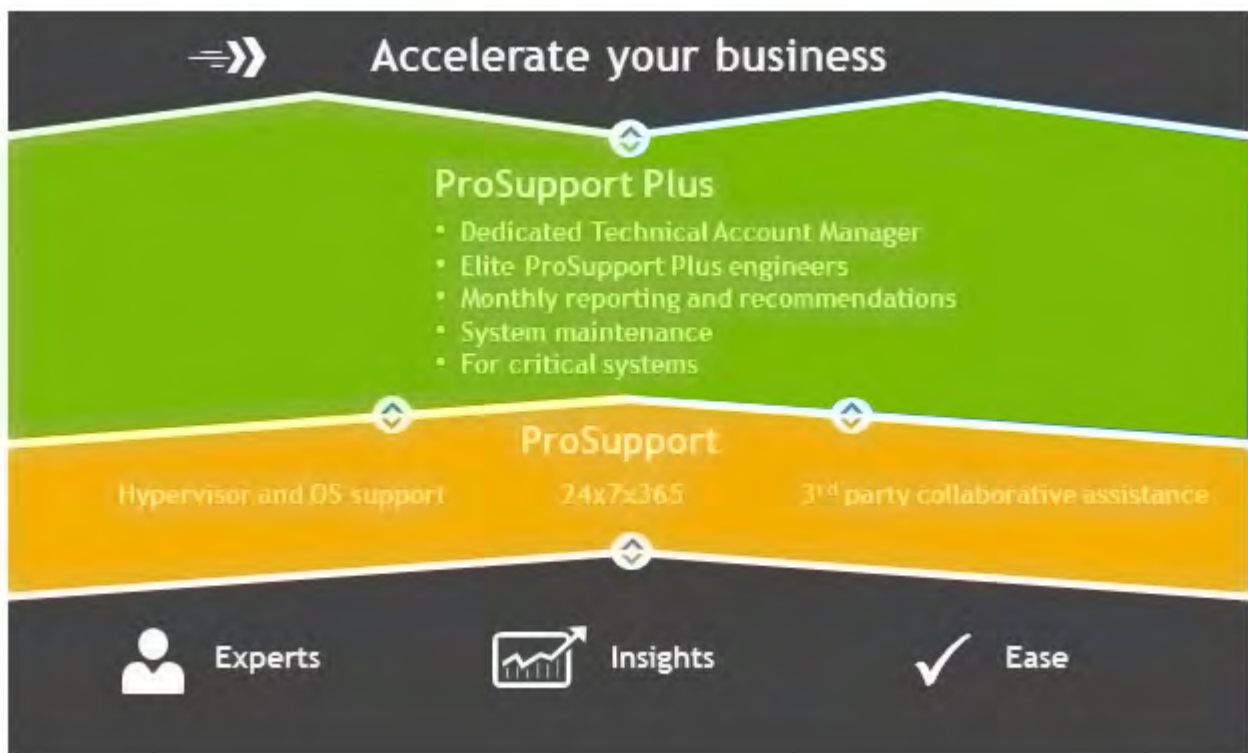

Figure 28. ProSupport Enterprise Suite

ProSupport Plus

When you purchase your PowerEdge server, we recommend ProSupport Plus, our proactive and preventative support for your business-critical systems. Dell EMC ProSupport Plus provides you with all the benefits of ProSupport, plus access to a dedicated Technical Account Manager and our elite ProSupport Plus engineers. ProSupport Plus gives you quick and efficient resolutions, working along with our [SupportAssist](#) technology that enables us to get ahead of issues in your environment before they become problems.

ProSupport

Our ProSupport service offers highly trained experts around the clock and around the globe to address your IT needs. We will help you minimize disruptions and maximize availability of your PowerEdge server workloads with:

- 24x7x365 access to certified hardware experts
- Collaborative support assistance with over 195 third-party vendors
- Hypervisor and operating system support
- Onsite parts and labor response options including next business day or four-hour mission critical

ProSupport Flex for Data Center

Dell EMC ProSupport Flex for Data Center offers flexible site-wide support for hyperscale data centers with more than 1,000 assets. Built on standard Dell EMC ProSupport components, Flex for Data Center leverages our global scale while being tailored to suit your needs. While not for everyone, it offers a flexible solution for those with large and complex environments. When you choose Dell EMC ProSupport Flex for Data Center, you will get:

- Enterprise-wide support that covers your entire data center.
- A dedicated Technical Account Manager with remote, on-site, part-time and full-time options.
- Dedicated elite ProSupport Flex technical and field engineers who are trained on your environment and configurations.
- Flexible on-site support and parts options that fit your operational model
- A tailored support plan for your operations staff.

Enterprise Support Services

Feature Comparison

	ProSupport	ProSupport Plus	ProSupport One for Data Center
Remote technical support	24x7	24x7	24x7
Onsite support	Next Business Day or Mission Critical	Next Business Day ¹ or Mission Critical	Flexible
Automated issue detection and case creation	•	•	•
Self-service case initiation and management	•	•	•
Hypervisor, Operating Environment Software and OS support	•	•	•
Priority access to specialized support experts		•	•
Designated service account management expert		•	•
Periodic assessments and recommendations		•	•
Monthly contract renewal and support history reporting		•	Monthly or Quarterly
Systems Maintenance guidance		Semiannual	Optional
Designated technical and field support teams			•

Next Business Day option available only on applicable legacy Dell products.

Figure 29. ProSupport Enterprise Suite comparison

Additional professional services

Dell EMC Education Services

Dell EMC Education Services offers the PowerEdge server training courses designed to help you achieve more with your hardware investment. The curriculum is designed in conjunction with the server development team, as well as Dell EMC's technical support

team, to ensure that the training delivers the information and practical, hands-on skills you and your team need to confidently manage and maintain your Dell EMC server solution.

Dell EMC Global Infrastructure Consulting Services

Dell EMC Global Infrastructure Consulting Services use skilled solution architects, innovative tools, automated analysis and Dell EMC's intellectual property to give you rapid insight into the root causes of unnecessary complexity. We seek better answers than traditional service models, and our strategy is to help you quickly identify high-impact, short-duration projects that deliver return on investment (ROI) and free up resources. The results are practical, action-oriented plans with specific, predictable, measurable outcomes. From data center optimization to server virtualization to systems management, our consulting services can help you build a more efficient enterprise.

Dell EMC managed services

Dell EMC Managed Services are a modular set of lifecycle services designed to help you automate and centrally configure, deploy, and manage your day-to-day data center operations. These services extend your existing on-premise IT infrastructure with off-premise cloud services designed to better address challenges with mobility, highly distributed organizations, security, compliance, business continuity, and disaster preparedness.