

# A-Class™ Mark II

Operator's Manual ■ ■ ■



right by our customers. ■ ■ ■



datamax·oneil



## Copyright Information

CG Times (based upon Times New Roman) and CG Triumvirate are trademarks of the AGFA Monotype Corporation.

Windows and Windows NT are trademarks of the Microsoft Corporation.

NetWare and Novell are registered trademarks of Novell, Inc.

Ethernet is a registered trademark of Xerox Corporation.

All other brand and product names are trademarks, service marks, registered trademarks, or registered service marks of their respective companies.

## Limitation of Liability

In no event shall Datamax-O'Neil be liable to the purchaser for any indirect, special or consequential damages or lost profits arising out of or relating to Datamax-O'Neil's products, or the performance or a breach thereof, even if Datamax-O'Neil has been advised of the possibility thereof. Datamax-O'Neil's liability, if any, to the purchaser or to the customer of the purchaser hereunder shall in no event exceed the total amounts paid to Datamax-O'Neil hereunder by the purchaser for a defective product.

In no event shall Datamax-O'Neil be liable to the purchaser for any damages resulting from or related to any failure or delay of Datamax-O'Neil in the delivery or installation of the computer hardware, supplies or software or in the performance of any services.

Some states do not permit the exclusion of incidental or consequential damages, and in those states the foregoing limitations may not apply. The warranties here give you specific legal rights, and you may have other legal rights which vary from state to state.

## Firmware (Software) Agreement

The enclosed Firmware (Software) resident in the Printer is owned by Licensor or its suppliers and is licensed for use only on a single printer in the user's Trade or Business. **The User agrees not to, and not to authorize or permit any other person or party to duplicate, or copy the Firmware or the information contained in the non-volatile or programmable memory.** The firmware (Software) is protected by applicable copyright laws and Licensor retains all rights not expressly granted. In no event will Licensor or its suppliers be liable for any damages or loss, including direct, incidental, economic, special, or consequential damages arising out of the use or inability to use the Firmware (Software).

Information in this document is subject to change without notice and does not represent a commitment on the part of Datamax-O'Neil Corporation. No part of this manual may be reproduced or transmitted in any form or by any means, for any purpose other than the purchaser's personal use, without the expressed written permission of Datamax-O'Neil Corporation.

All rights reserved

Copyright © 2012, Datamax-O'Neil

Part Number 88-2349-01

Revision C

## Agency Compliance and Approvals:



UL60950-1 2nd Edition, Information Technology Equipment  
CSA C22.2 No.60950-1-07, 2nd Edition



The manufacturer declares under sole responsibility that this product conforms to the following standards or other normative documents:

EMC: EN 55022 (2006,A1:2007) Class B  
EN 50024 (1998,A1:2001,A2:2003)

Safety: This product complies with the requirements of IEC 60950-1, 2nd Edition,  
2005-12

ROHS: 2002/95/EC  
LVD: 2006/95/EC



Gost-R



GB4943-2001, GB9254-2008 and GB17625.1-2003



DMX-A-4212 model:  
The foregoing equipment has been registered under the Clause 3, Article 58-2 of Radio  
Waves Act

FCC: This device complies with FCC CFR 47 Part 15 Class A.

**Note:** *This equipment has been tested and found to comply with the limits for a Class A digital device, pursuant to Part 15 of the FCC Rules. These limits are designed to provide reasonable protection against harmful interference when the equipment is operated in a commercial environment. This equipment generates, uses, and can radiate radio frequency energy, and if not installed and used in accordance with the instructions in this manual, it may cause harmful interference to radio communications. Operation of this equipment in a residential area is likely to cause harmful interference in which case the user will be required to correct the interference at his own expense.*



## ***Important Safety Instructions***

---



Throughout the literature accompanying this unit, the exclamation point within an equilateral triangle is intended to alert you to the presence of important operating and maintenance instructions.

---

This unit has been carefully designed to provide years of safe, reliable performance. However, as with all electrical equipment, there are some basic precautions that you should follow to avoid personal injury or damage to the printer:

- Before using the print engine, carefully read all the installation and operating instructions.
- Moving parts are present during operation – keep body parts, loose clothing, etc. away from the mechanism.
- Observe all warning instruction labels on the print engine.
- Mount the print engine securely in the applicator system.
- Do not place the print engine on or near a heat source.
- To protect from overheating, make sure no openings on the print engine are blocked.
- Never insert anything into the ventilation slots and openings of the print engine.
- Do not use the print engine near water or spill liquid into it.
- Ensure that the AC power source complies with the ratings listed for the print engine.
- Do not place the AC power cord where it can be stepped on, and if the power cord becomes damaged replace it immediately.
- Consult only qualified, trained personnel to perform service on this device: no user-serviceable parts are inside; do not remove the cover.

## ***Special Text Instructions***

---



*The green check box is intended to alert you to conventions used within this text or to notable operating details and suggestions.*

---

## ***Applicability***

The procedures, functions, and parameters described in this document are written according to an Application Version of printer firmware. To identify the Application Version that corresponds to this text, see Print Configuration in Section 4.3.5. To update the Application Version of your printer, visit our website at [www.datamax-oneil.com](http://www.datamax-oneil.com) to download firmware.



# Contents

<b>Overview</b> .....	<b>1</b>
1.1 About the Printer .....	1
1.1.1 Standard Features.....	2
1.1.2 Optional Features.....	3
<b>Getting Started</b> .....	<b>5</b>
2.1 Unpacking.....	5
2.1.1 Contents.....	6
2.1.2 Additional Requirements .....	6
2.2 Mounting Requirements .....	7
2.3 Connecting to a Host.....	11
2.3.1 Parallel Port Connections.....	12
2.3.2 Serial Port Connections .....	12
2.3.3 RS-422/485 Communications .....	13
2.3.4 USB Port Connections .....	15
2.3.5 SDIO and USB Host Port Connections .....	15
2.4 Connecting an Applicator .....	16
2.5 Connecting Power .....	17
<b>Setting up the Printer</b> .....	<b>19</b>
3.1 Loading Media .....	19
3.2 Adjusting the Media Sensor .....	23
3.3 Loading Ribbon.....	24
3.3.1 Right Hand Models .....	24
3.3.2 Left Hand Models .....	26
3.3.3 Removing Ribbon.....	27
3.4 Quick Calibration .....	28
3.5 Print Quality Controls .....	28
<b>Using the Control Panel</b> .....	<b>29</b>
4.1 Layout.....	29
4.1.1 The Display .....	29
4.1.2 Keypad Functions.....	31

4.2	The System Menu .....	32
4.2.1	Media Settings.....	33
4.2.2	Print Control.....	36
4.2.3	Printer Options .....	38
4.2.4	System Settings .....	46
4.2.5	Communications .....	56
4.2.6	Diagnostics .....	64
4.2.7	MCL Options.....	67
4.3	The Test Menu.....	68
4.3.1	Print Quality Label.....	68
4.3.2	Ribbon Test Label .....	68
4.3.3	Test Label .....	69
4.3.4	Validation Label .....	69
4.3.5	Print Configuration .....	69
4.3.6	Print Last Label.....	70
4.3.7	User-Defined Label.....	70
	<b><i>Operating, Adjusting and Maintaining the Printer.....</i></b>	<b>71</b>
5.1	Displayed Messages .....	71
5.1.1	Prompts and Condition Messages .....	71
5.2	Calibration .....	74
5.2.1	Standard Method .....	74
5.2.2	Advanced Entry .....	76
5.3	Printhead Adjustments.....	83
5.3.1	Leveling Cam Adjustment.....	83
5.3.2	Burn Line Adjustment .....	85
5.4	Printhead Replacement .....	86
5.5	Platen Roller Replacement.....	89
5.6	Maintenance Schedule .....	90
5.6.1	Cleaning the Printhead.....	91
5.6.2	Cleaning the Rollers .....	93
5.6.3	Cleaning the Peel Assembly .....	94
5.6.4	Cleaning the Media Sensor, Media Path, and Peel Bar .....	96
5.6.5	Cleaning Exterior Surfaces .....	97
5.7	Reset Methods.....	97

5.7.1	Soft Reset.....	97
5.7.2	Level One Reset.....	97
5.7.3	Level Two Reset.....	97
5.8	Updating the Firmware .....	98
5.9	Updating the Boot Loader.....	100
5.10	Fonts .....	101
<b>Troubleshooting</b>	.....	<b>103</b>
6.1	Problem Resolution .....	103
6.1.1	General Resolutions.....	103
6.1.2	Warning and Fault Messages.....	106
6.2	Hex Dump Mode .....	113
<b>Specifications</b>	.....	<b>115</b>
7.1	Printer Specifications .....	115
7.2	Approved Media and Ribbon .....	120
<b>Appendix A</b>	.....	<b>123</b>
Module Assignments	.....	123
File Handling Messages.....		124
Cut Behind Setup.....		125
<b>Appendix B</b>	.....	<b>127</b>
Print Resolutions and Widths .....		127
Speed Ranges .....		127
Column & Row Emulation Ranges.....		128
Custom Adjustments: Column, Present, & Row Adjust Ranges.....		128
<b>Appendix C</b>	.....	<b>129</b>
PE Peel Bar Location.....		129
Media Tension Settings.....		129
PE to A-Class GPIO Adapter Cable .....		130
<b>Appendix D</b>	.....	<b>131</b>
Applicator Interface Overview.....		131
<b>Appendix E</b>	.....	<b>139</b>
Multi-Language Menu .....		139

<b>Appendix F</b> .....	<b>143</b>
Saving a Configuration File.....	143
<b>Appendix G</b> .....	<b>145</b>
Ribbon Saver Overview .....	145
<b>Glossary</b> .....	<b>147</b>

# 1 Overview

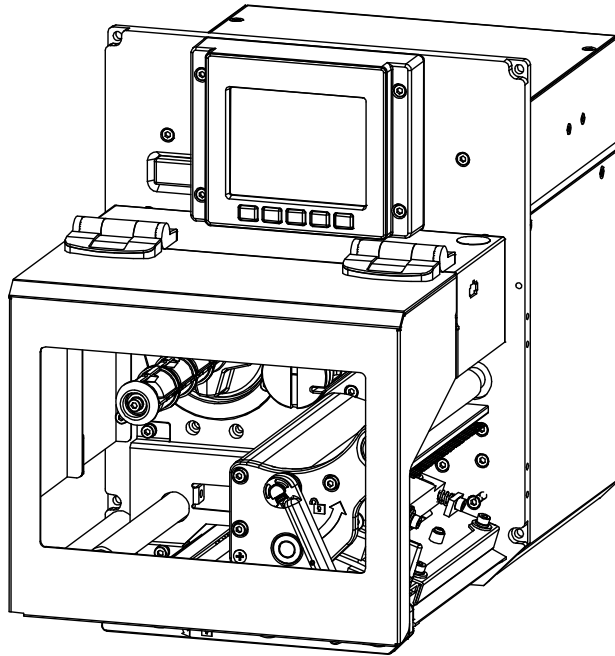

## 1.1 About the Printer

Congratulations on your purchase of an A-Class *Mark II* printer. This print engine (hereafter referred to as “the printer” and, when necessary, by model) is designed for professional integration into an industrial applicator system.

This manual provides all the information necessary for installation, setup and operation of the printer. To begin printing, refer to the instructions provided with your label-creation software; or, to write custom label programs, reference the *Class Series 2 Programmer’s Manual* on the Accessories CD-ROM, also available at <http://www.datamax-oneil.com>

The printer’s model number, located on the Serial Tag affixed to the inside of the front cover, should be used when referencing specific information within this manual.

## 1.1.1 Standard Features

This printer offers the following standard features:

- Right-handed or left-handed configurations
- Electronics card cage
- 8 MB Flash downloadable program memory
- 16 MB DRAM memory
- User accessible memory for graphics, fonts, and label format storage
- Two RS-232 serial interfaces (one of which is also RS-422/RS-485 capable)
- One IEEE 1284 compliant parallel interface
- One Ethernet 10/00 interface
- One USB v1.1 interface
- A programmable GPIO Port
- Backlit graphics display
- EFIGS (English, French, Italian, German, and Spanish) display languages
- Industry standard bar code symbologies
- Time stamp at print capability with time and date battery back-up
- Static brushes
- Printhead resistance verification
- Configurable fault-handling capability with reprint and void selections
- Parse error-tolerant command language interpretation
- Internal test labels for verification, validation, and configuration
- Multiple setup restore capability
- Paper retract control after print
- Ribbon low detection and warning
- Power-up, mode, and resident option hardware diagnostics
- Option hardware auto-detection
- Media peel bar
- Media inch counters
- Line mode (ASCII text input) capability with USB Host
- Firmware upgrades downloadable
- AGFA Scaleable Font Engine featuring dynamic font attributes



## 1.1.2 Optional Features

The following optional features are available:

- **DMXrfNetII**  
A wireless Network Interface Controller with multiple operating system and protocol support, including trap functions.
- **International Language Printing Capability (ILPC)**  
An alternate font set, available for standard or expanded memory:
  - CG-Times (European) Scaleable font (and Enhanced Language Code Pages)
  - Kanji Gothic B Scaleable font
  - Simplified Chinese GB Scaleable font
  - Korean Hangul Scaleable font
- **Cutter**  
A mechanism specifically designed to cut media after printing.
- **MCL**  
A software tool suite for information collection applications, allowing input data from peripheral devices (scanners, weigh scales, keyboards, etc.) without the need of a host computer.
- **Remote Display**  
A factory installed port located on the rear of the printer assembly allowing a 6 foot (1.8 meter) remote display to be attached.
- **RFID**  
A Radio Frequency Identification method that encodes data onto smart labels and tags; available completely installed and ready for use.
- **Thermal Transfer**  
A printing method that uses ribbon to produce exceptional image clarity (as compared to most direct thermal media types).
- **Rear Pinch Roller**  
An additional roller assembly that assists media movement during long backfeed distances.
- **SDIO and USB Host Ports**  
Interface ports that allow the printer to accept external SDIO and USB memory devices for storing graphics, label formats, fonts, and firmware; and that allow USB keyboard connections (and USB scanning device connections for MCL users) for direct data input applications.

## ***Installing Printer Options***

The table below lists competency level recommendations for the installation of the various options. For detailed information regarding an option, contact a dealer or Datamax-O'Neil Technical Support.

<b>Experience Level</b>	
<b>Option</b>	<b>Installer</b>
DMXrfNetII	DMX Certified Technician
SDIO and USB Host Ports	Factory Only
Cutter	DMX Certified Technician
MCL	DMX Certified Technician
Remote Display Port	Factory Only
RFID	Factory Only
Ribbon Saver	Factory Only
Thermal Transfer	DMX Certified Technician
Rear Pinch Roller	Factory Only

# 2 Getting Started

## 2.1 Unpacking

The printer is carefully packaged for transit. Upon arrival, inspect the shipping carton(s) for damage; if evident, immediately report the damage to the freight company.

In order to operate the printer, remove all packaging material:

1. With the Shipping Carton arrows pointing upward, open the Shipping Carton and remove the Accessories Box and the Top Foams.
2. Carefully lift the wrapped Printer from the carton and place it on a solid level surface.

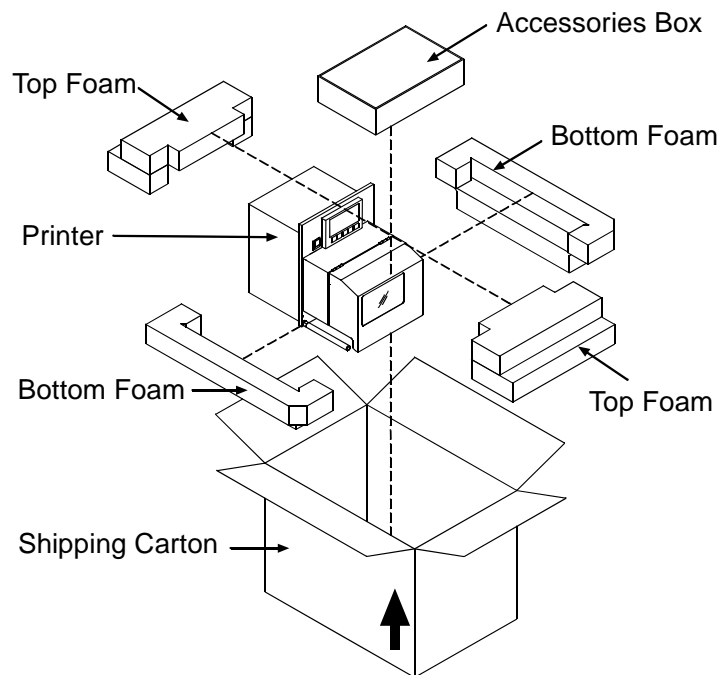

3. Remove the Printer from the plastic bag and then remove all remaining packing materials.



*Save the carton and packing material for future use.*

---

## 2.1.1 Contents

Check the contents of the carton for the following items:

- Printer
- Power cord
- Accessories CD-ROM
- Any additionally purchased items or options.

## 2.1.2 Additional Requirements

Other items can also be needed for operation:

- Media (and ribbon, if necessary); see Section 7.2.
- Interface cables; see Section 2.3 (Host Connections) and Appendix D (Applicator).
- Software; see the Accessories CD-ROM for Windows Drivers and basic labeling software.

## 2.2 Mounting Requirements

Before installing the printer, ensure that the environmental conditions of the site fall within the range specified in Section 7, and always avoid the following environments:

- Do not place the printer in direct sunlight or near a heat source; and,
- Do not place the printer where it will be exposed to liquids, or excessive dust or dirt.

Consider the dimensions of the printer before attaching it to the applicator station. The template below details the opening size and hole locations required for the support structure:

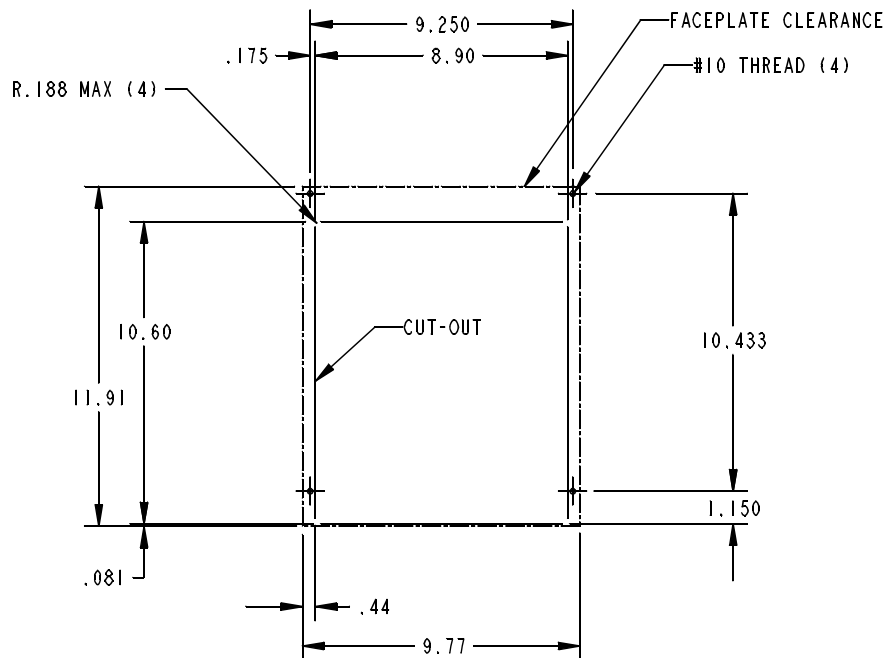

Attach the printer to the support structure using a #10 screw inserted at each Mounting Hole position (see note below).

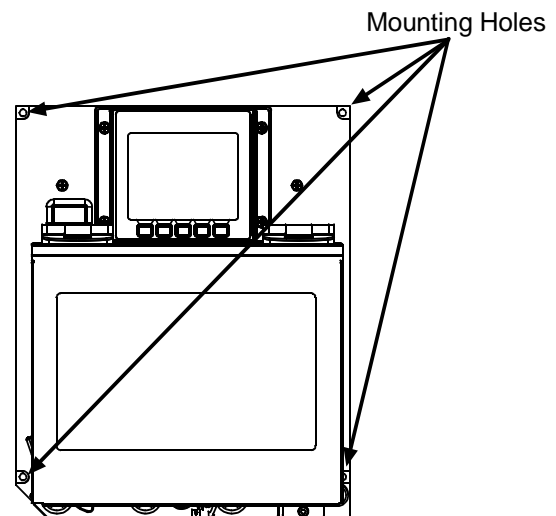

The following drawings detail additional mounting considerations:

A-4xxx models

Front View, Peel Assembly lowered:

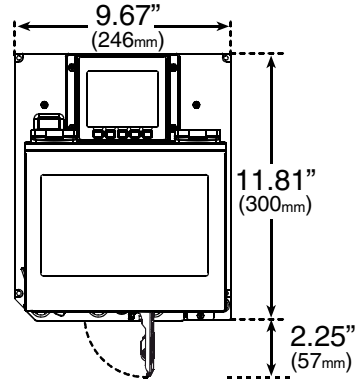

Side View:

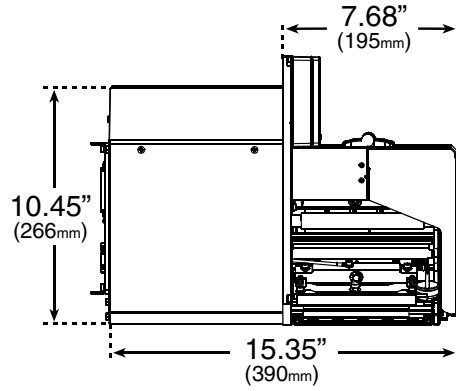

Side View, Cover raised:

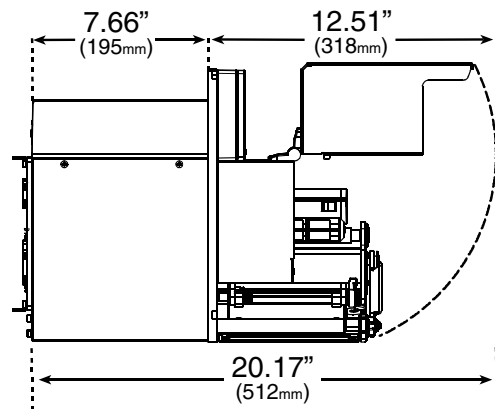

A-6xxx models

Front View, Peel Assembly lowered:

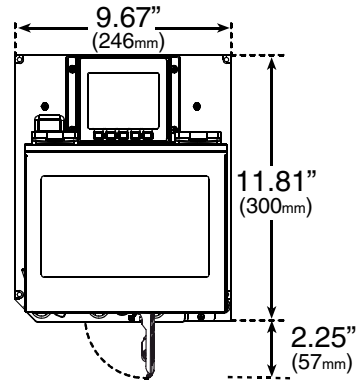

Side View:

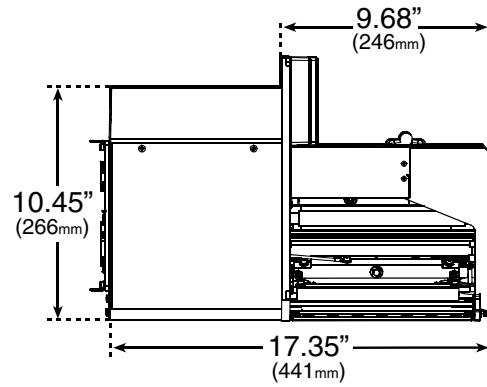

Side View, Cover raised:

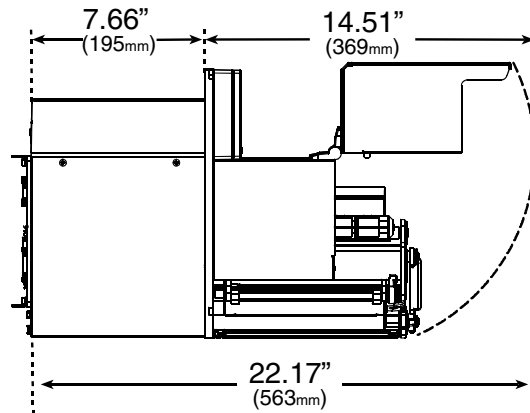

**Peel Point Dimension**

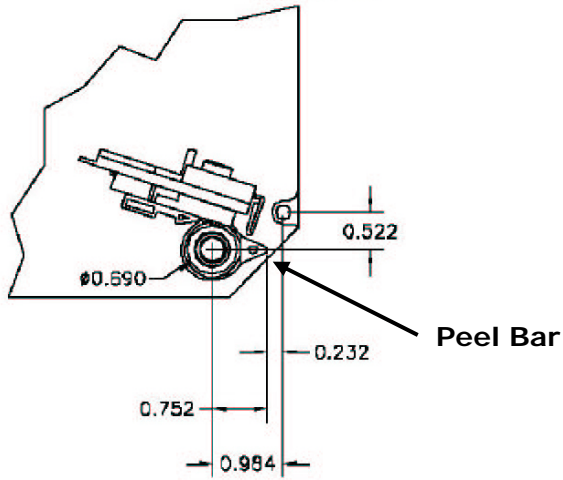

See Appendix C for the PE-Series printer's dimension.



## 2.3 Connecting to a Host



Ensure that the Power Switch is OFF when making printer connections.

The printer can be interfaced to a host via the parallel, serial, Ethernet and USB ports. (Ethernet users, consult the documentation that accompanied the option.) Following power-up (or after a period of inactivity), interface port selection occurs automatically upon detection of valid data. If the incoming data flow stops and the Host Timeout period (see Section 4.2.5) is achieved, partially received formats will be ignored and the port detection process repeated.



- The location of the following connections can vary by printer model and host hardware configuration.
- To change an active port immediately, cycle the power OFF and ON.
- For alternate data processing options, see *INPUT MODE*, Section 4.2.4.

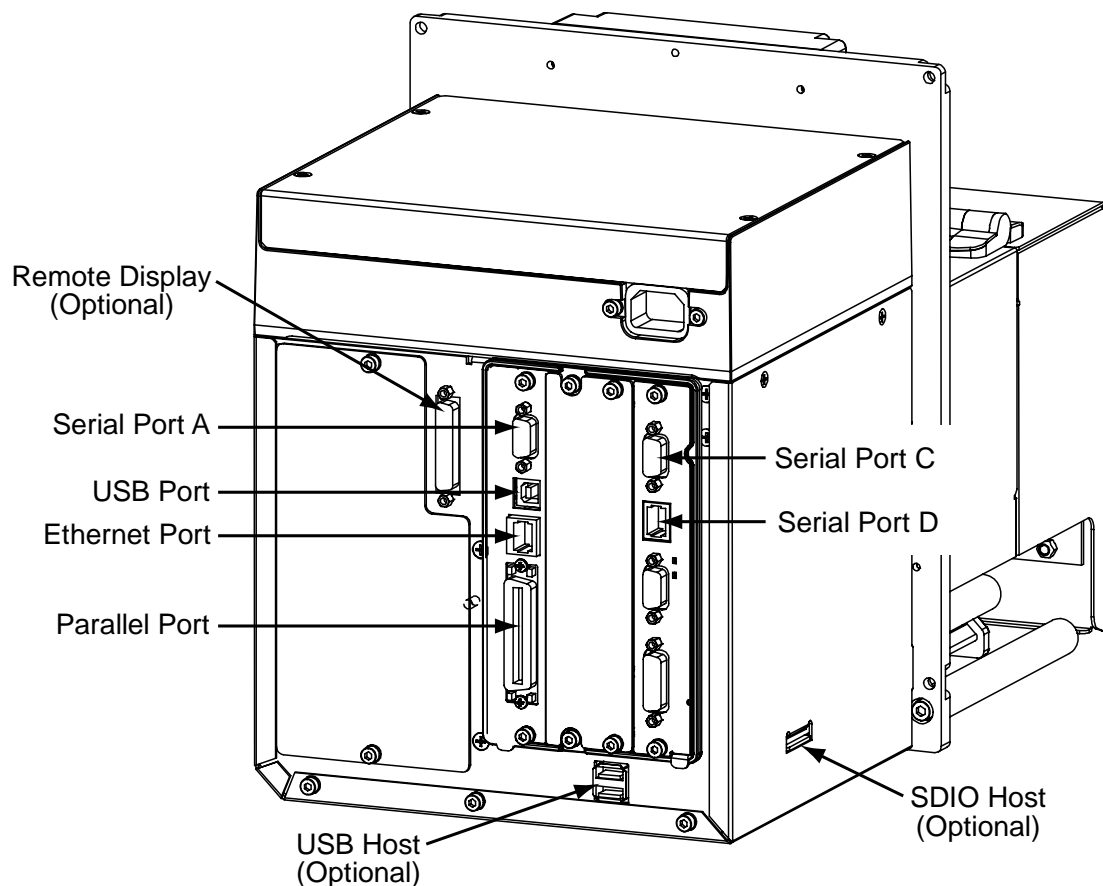

### 2.3.1 Parallel Port Connections

The parallel interface requires a Centronics IEEE 1284 cable with a 36 pin male connector. Bi-directional mode is IEEE 1284 compliant, allowing data to be returned to the host.

### 2.3.2 Serial Port Connections

Serial Port A supports RS-232C and RS-422/RS-485 communications; COM C and COM D support RS-232 (see Appendix D for exceptions). Pin-outs are given below. The port baud rate, word length, parity, stop bits, and protocol must be configured to match the host's settings; see Section 4.2.5.

Pin Number	Port A, and COM C (J4)	Port A, only	COM D (J3)
	RS-232 Function	RS-422 & RS-485 Function	RS-232 Function
1	+5V (@ .5 amps)	---	+5V (@ .5 amps)
2	RX	RX-	RTS
3	TX	TX+	Ground
4	DTR	---	TX
5	Ground	GND	RX
6	---	---	Ground
7	RTS	TX-	CTS
8	CTS	RX+	DTR
9	---	---	---

**For proper data exchange, the serial interface requires specific cable pin-outs.** Serial cable part numbers and wiring diagrams are shown below.

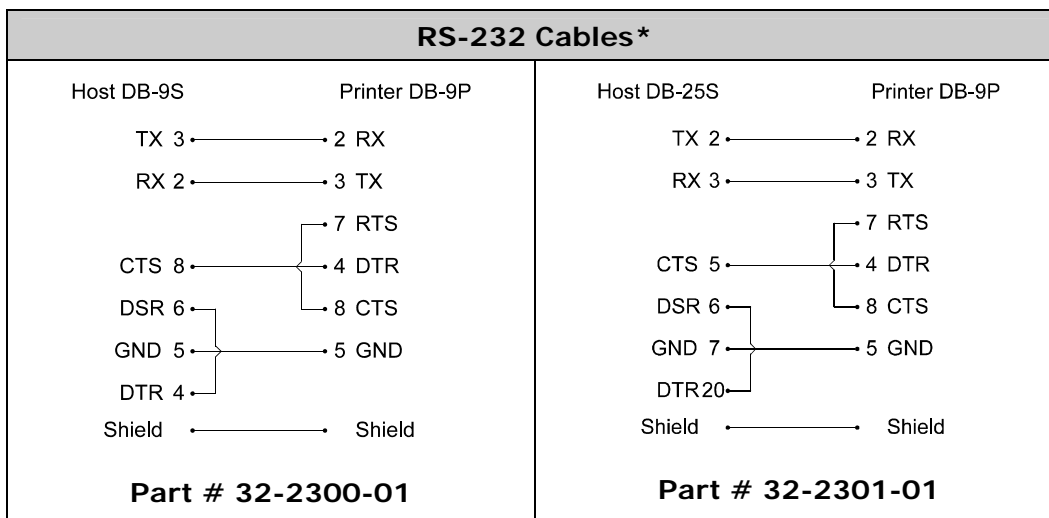

\*Printer serial ports A & C require a DB9 male connector (e.g., Startech C9PSM).

## COM D Port Connections

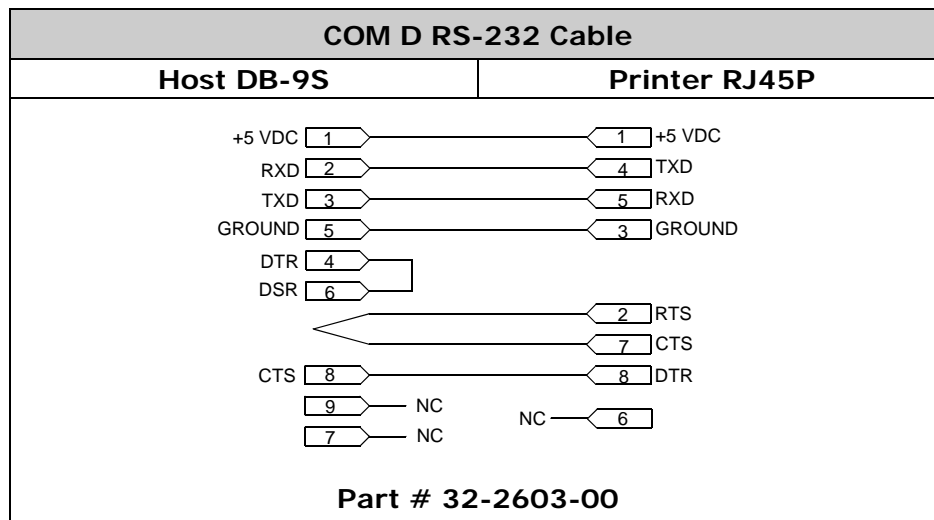

### 2.3.3 RS-422/485 Communications

To use RS-422/485 communications (Port A, only), the main logic card must be reconfigured:



*Always wear a wrist strap and follow standard ESD prevention measures when handling the Main Logic Card.*

1. Turn OFF the power switch, unplug the AC Power Cord from the printer, and remove any interface cable(s) already attached to the Main Logic Card.
2. Remove the two Screws securing the Main Logic Card to the printer. Slide the card out of the printer and place it on a static free work area.

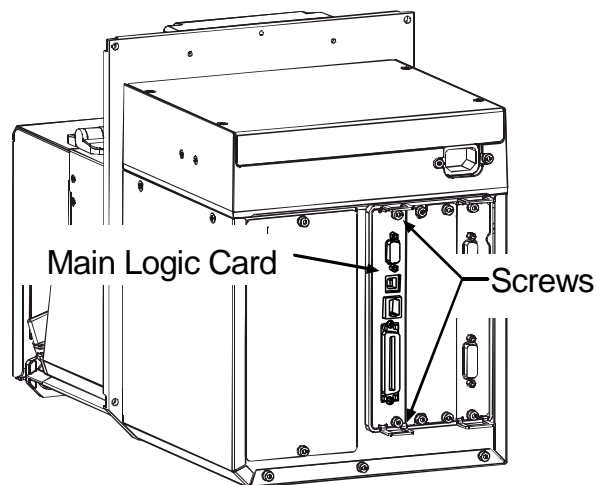

*The Main Logic Card location varies depending upon the model of printer.*

3. Slide the Main Board out of the printer then move the jumpers according application:

- For RS-422/485 operation, place the jumper across pins E4 and E5;
- For +5VDC on Pin 1, place the jumper across pins E1 and E2; or,
- For RS-232 operation (default), place the jumper across pins E5 and E6;
- For no voltage on Pin 1 (default), place the jumper across pins E2 and E3.

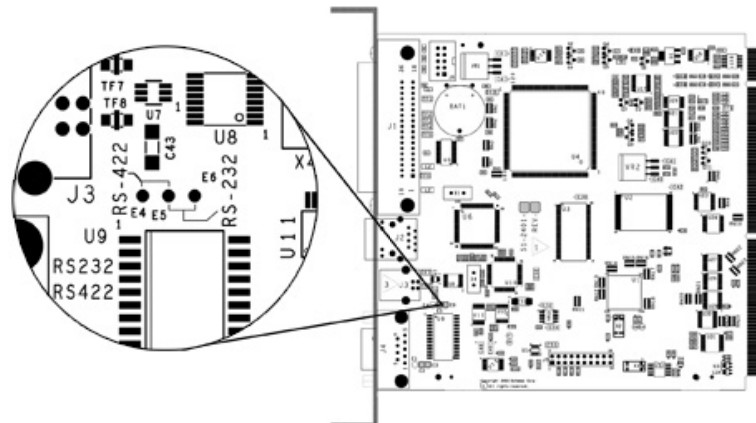

**Communications Jumpers**

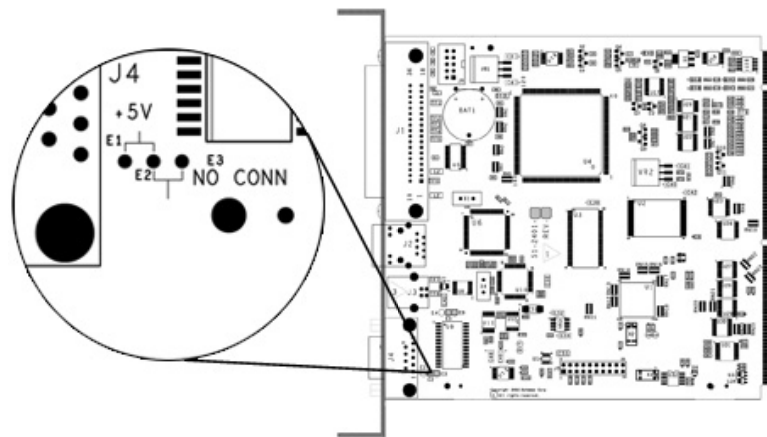

**+5 Volt Jumper**

- Slide the Main Board into the printer and secure it with the two previously removed Screws.
- Connect communication cables to the Main Board and plug in the power cord

*For RS-422/485 communications, ensure that your cable meets the requirements (per the table, right) for proper data transfer.*

Serial Port Pin Number	RS-422 & RS-485 Function
1	---
2	RX-
3	TX+
4	---
5	GND
6	---
7	TX-
8	RX+
9	---

## 2.3.4 USB Port Connections

The Universal Serial Bus port requires a standard USB cable.



*This USB Port is a device-end only connection. Never attach a keyboard, mouse, modem, etc. to this port; damage can result.*

---

## 2.3.5 SDIO and USB Host Port Connections

If equipped with the Secure Digital Input Output (SDIO) and USB Host Ports, the printer can accept external storage devices for fonts, graphics, label formats, and firmware files. The USB Host Port also accepts a USB keyboard for standalone, direct data (Line mode) input applications; see the *Class Series 2 Programmer's Manual* for examples.

**SDIO Connections** - When installing an SDIO Card, turn OFF the printer then slide the card into the slot. Module "F" will be recognized by the printer. When removing a card, turn OFF the printer then press inward on the card to release it.

**USB Host Port Connections** - The USB Host Ports support plug and play device installation and removal. Module "H" and Module "I" will be recognized by the printer.



- *Memory device sizes up to 16 GB are supported.*
  - *If equipped on the memory device, ensure that the Write Protect Switch is OFF.*
  - *Before initial use, format the external memory device; see Section 4.2.3.*
  - *Always allow process completion before removing modules.*
- 

## Using Memory Functions

Download your files to the device using Windows Explorer or DMX Config; see FILE HANDLING DEFINITIONS in Appendix A. The following examples highlight several ways to use memory devices; unless otherwise noted, see MODULES in Section 4.2.3 for details about function selections.



- *Files that reside in Module "X" cannot be copied; see Appendix A for module details.*
  - *For access to all functions, ensure that the Advanced Menu is selected: Press **System Settings** select **Menu Mode** and then **Advanced Menu**.*
- 

- To copy files stored on a module to or from the printer:
  1. Press the **MENU** button then select **Printer Options**.
  2. Select **Modules** and then **Copy File**.
  3. Select the file to copy and then the destination module ID.



*When sharing configuration files between printers, use Restore As Current (see CONFIGURATION FILE, Section 4.2.4) and perform calibration (see Section 5.2).*

---

- To copy firmware stored on a module to the printer:
  1. Press the **TEST** button then select **User Defined Label**.
  2. Select the module ID and the firmware file.
  
- To print files stored on a module:
  1. Press the **TEST** button and then select **User Defined Label**.
  2. Select the module ID then the file to print.

---

 *To print directly from stored files at power-up, see User Label mode in Section 4.2.4.*

---

- To print a previous label format that is stored in memory:
  1. Press the **MENU** button then select **Printer Options**.
  2. Select **Modules** and then **Print File**.

## 2.4 Connecting an Applicator

Setup the GPIO Port using the information in Appendix D and then connect the applicator cable to port(s) on the Applicator Interface Card.



*Failure to properly configure the GPIO Port(s) may result in damage to the printer and / or the applicator.*

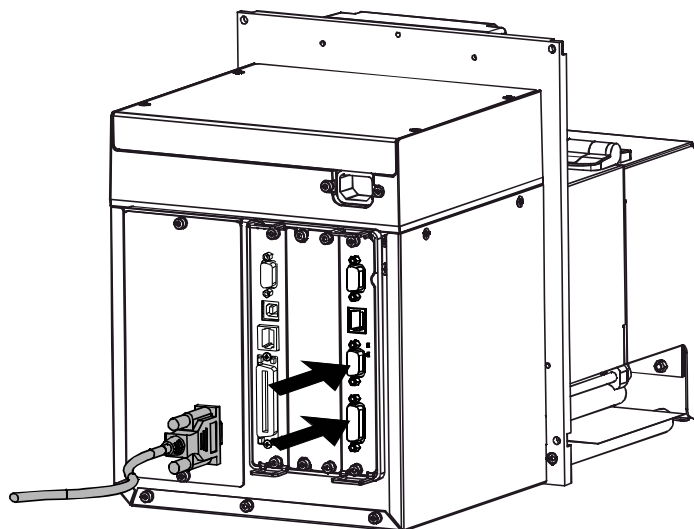

*If upgrading, a PE to A-Class GPIO conversion cable is available; see Appendix C.*

---

## 2.5 Connecting Power

The power cord connects to the AC receptacle on back of the printer. Make the connection and power-up the printer as follows:

1. Ensure that AC power to the host computer and applicator system are OFF.
2. Ensure that the printer's Power Switch is OFF.

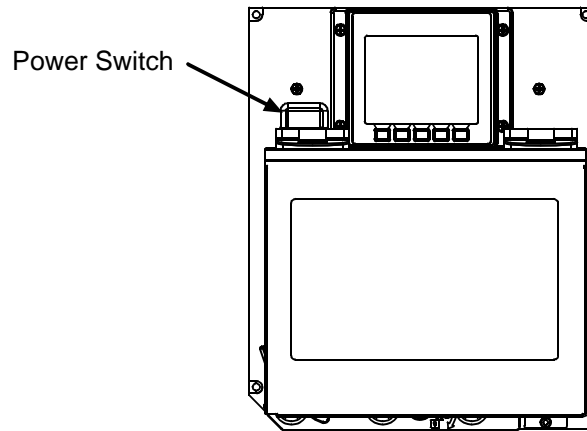

3. Connect the AC Power Cord to the printer and then to a properly grounded outlet.

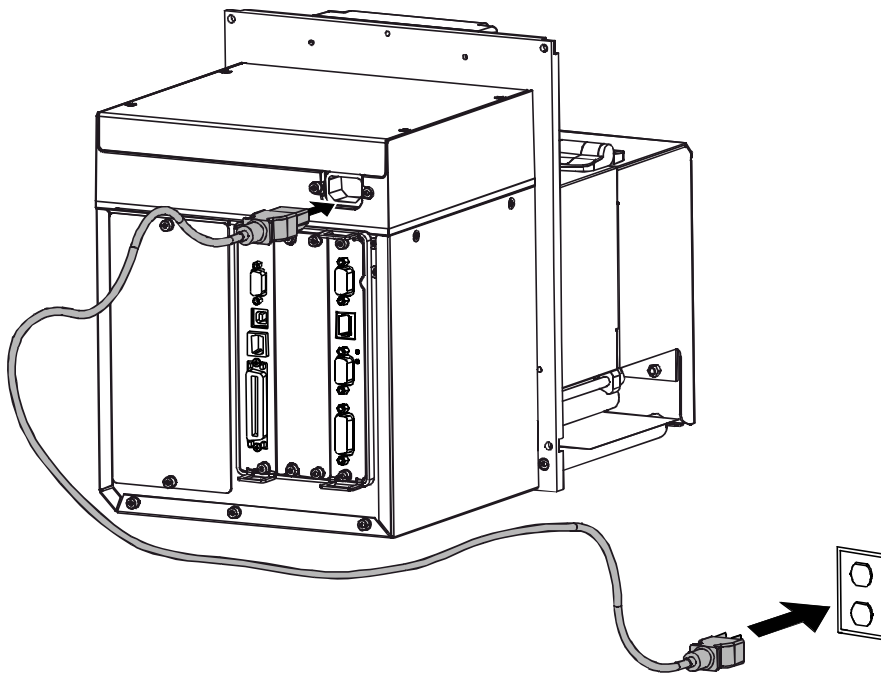

4. Turn ON (in the following order) the host computer, the applicator system, and then the printer.





# 3 *Setting up the Printer*

## 3.1 *Loading Media*

Load media according to its type and desired output:

1. Open the Access Cover and raise the Head Lift Lever.

If your printer is equipped with Rear Pinch Roller option open the Pinch Roller by pulling outward on the Release Knob.

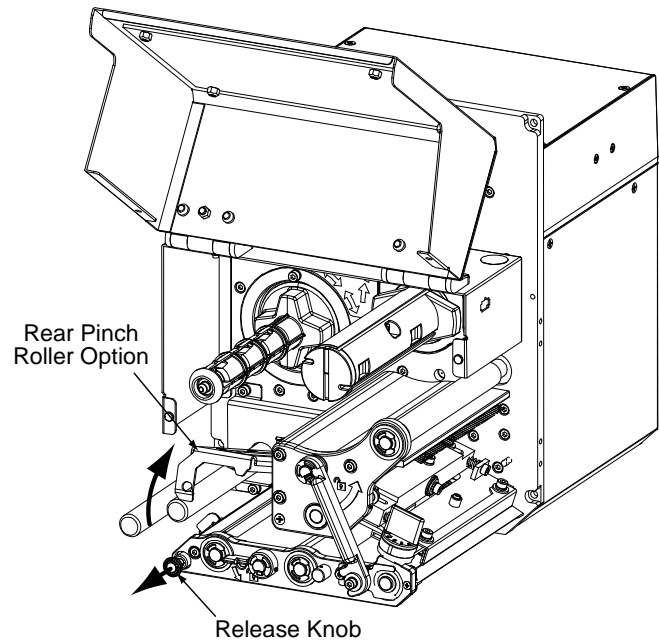

2. Route the Media between the Media Posts, through the Media Sensor, over the Peel Bar, and out of the printer, as shown below.

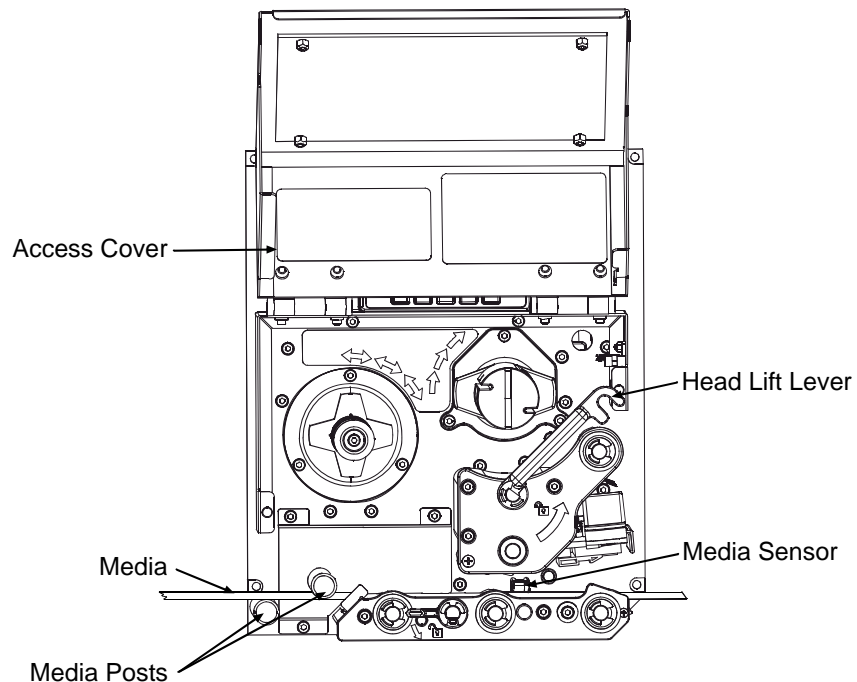

3. To peel die-cut labels after printing, press down on the Peel Assembly Release Lever to lower the Peel Assembly; otherwise, proceed directly to Step 6.

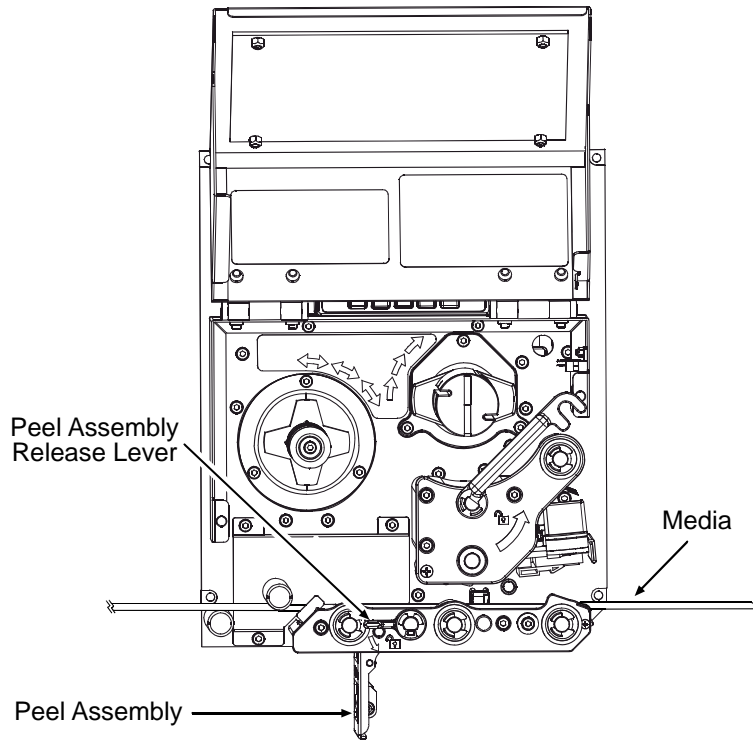

4. Remove the labels from 12 inches (30 cm) of the Media Liner. Route the Media Liner down to the Peel Assembly, over the Latch Roller, and through the Slot as shown below.

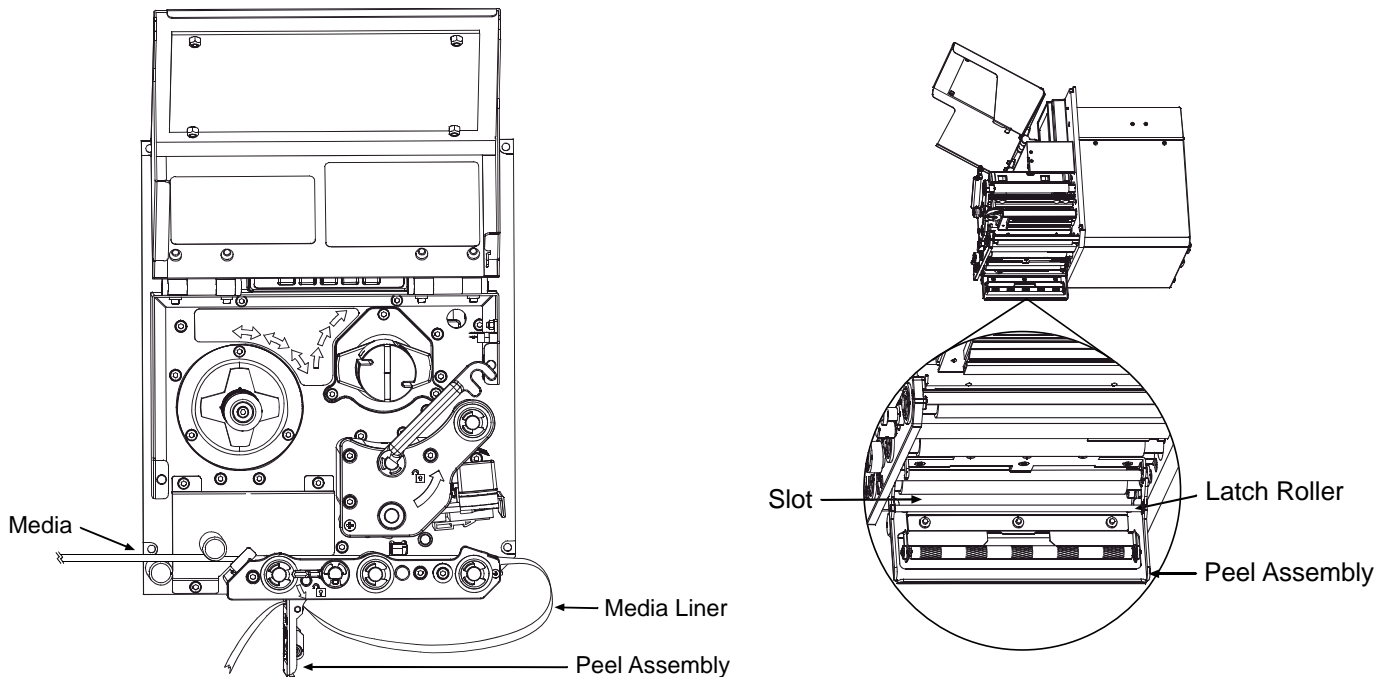

5. Pull the Media Liner through the Slot in the Peel Assembly until all slack is removed. Lifting from the center, raise the Peel Assembly until it locks into place.

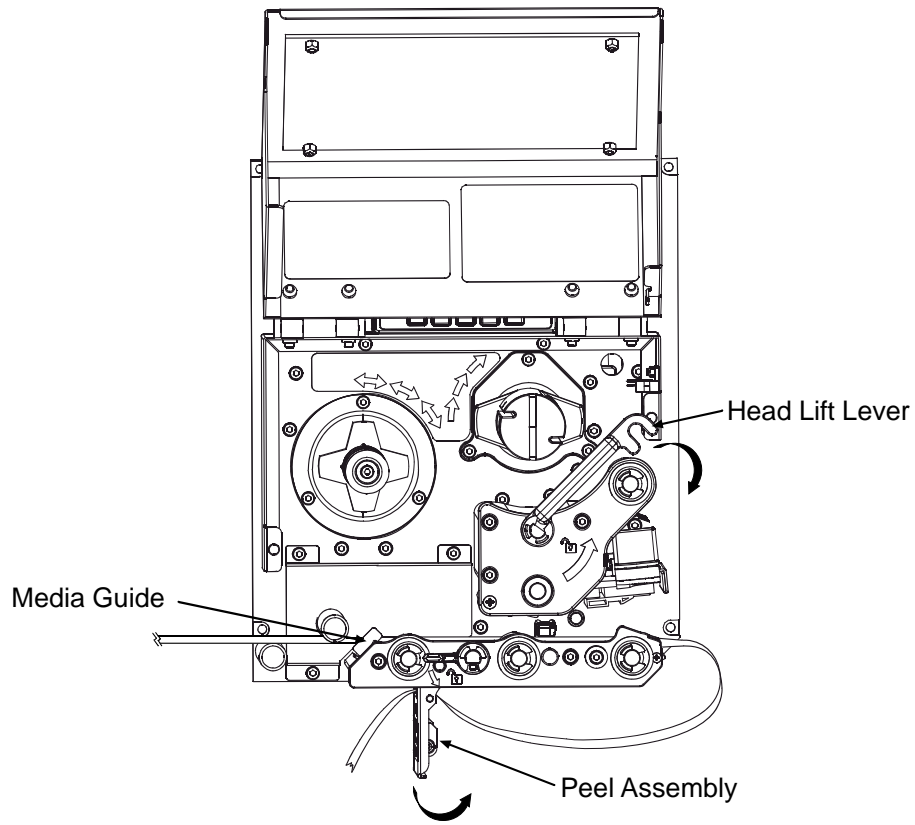

6. Position the Media Guide lightly against the side of the media.

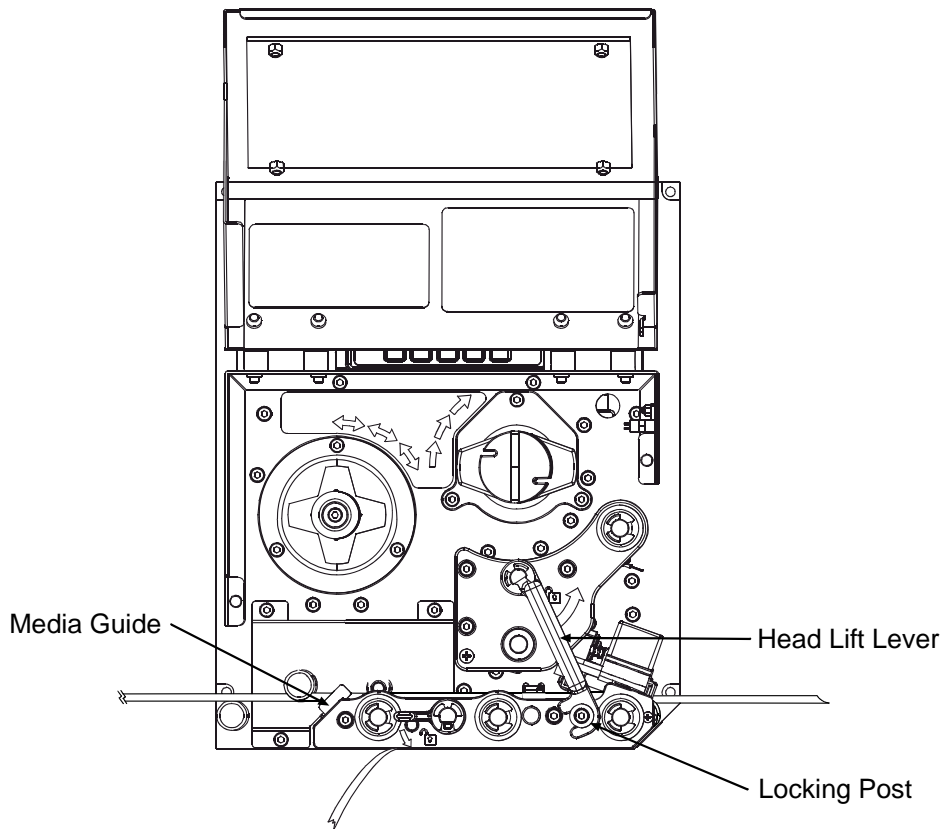

7. Adjust the Media Sensor over the labels (see Section 3.2).

8. If printing on thermal transfer media, load ribbon (see Section 3.3); otherwise go to Step 9.

9. Lower the Head Lift Lever until it is completely and securely engaged onto the Locking Post.

10. If loading media for the first time or if changing to a different media type or size, press and hold the FEED Key until at least two labels have been output (see Section 3.4).

11. Adjust the Leveling Cam (see Section 5.3.1).

## 3.2 Adjusting the Media Sensor

Position the Media Sensor to detect labels as follows:

1. Ensure that media is routed through the Media Sensor; see Section 3.1.

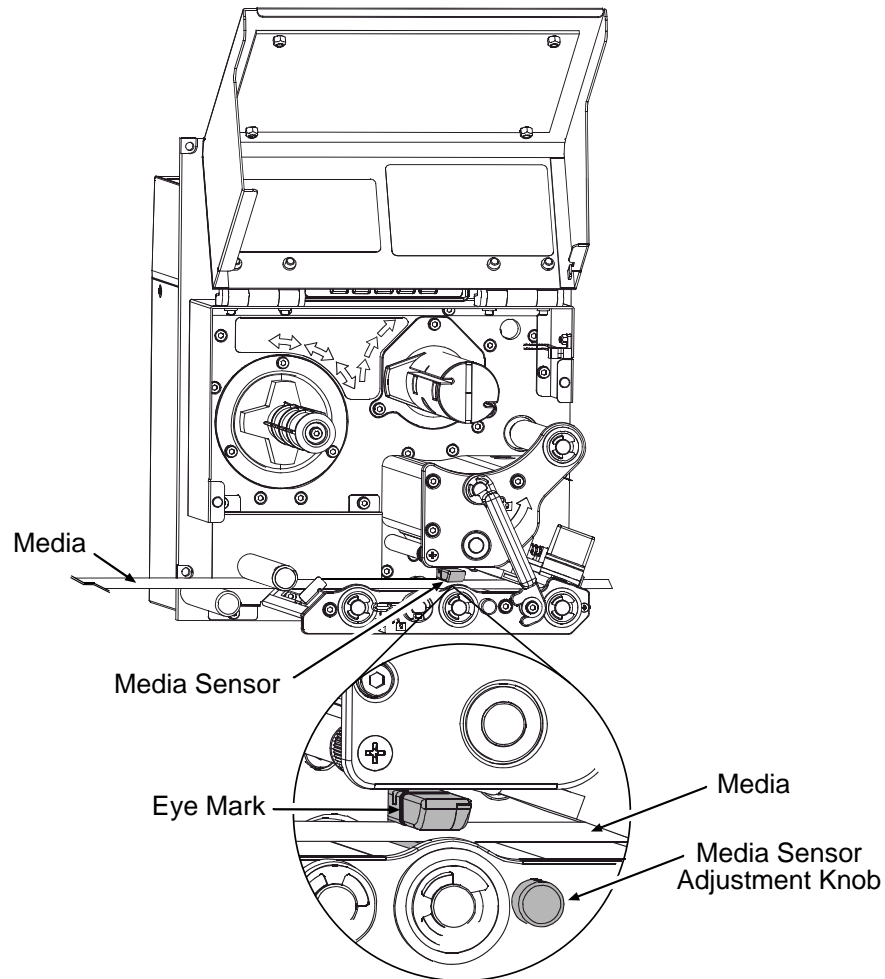

2. Depending on the type of media being used, rotate the Media Sensor Adjustment Knob until the Eye Mark on the Media Sensor is positioned according to the table below.

Media Sensor Adjustment and Type Required		
Media Type	Eye Mark Position	Sensor Type Required
Die-cut	Centered over the label	Gap*
Notched	Centered over the notch	
Reflective	Centered over the black mark	Reflective
Continuous	Near the middle of the media	Continuous

\* Default setting; see Section 4.2.1.

### 3.3 Loading Ribbon

Load ribbon (for thermal transfer media) according to its coated side and the printer model.



*Using a ribbon slightly wider than the media (and liner) is recommended for added protection against abrasive wear.*

#### 3.3.1 Right Hand Models

Load ribbon as follows:

1. Orient the unwind position of the Ribbon according to the coated side (CSI or CSO) and then slide the Ribbon Roll completely onto the Ribbon Supply Hub, as shown below:

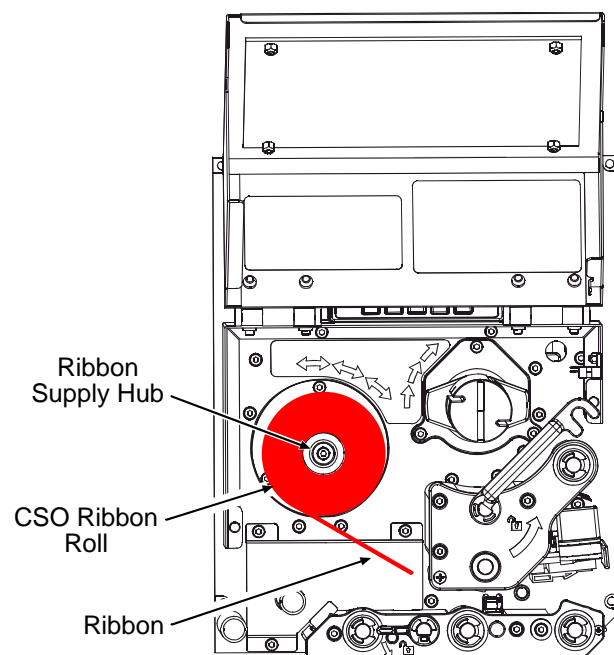

**CSO Ribbon**

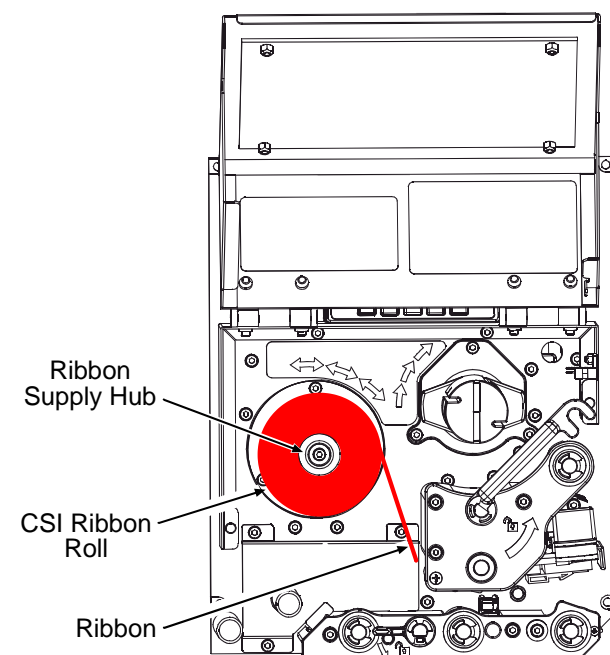

**CSI Ribbon**

2. With the Head Lift Lever raised, route the Ribbon under the Lower Idler, over the Ribbon Shield and Upper Idler, and then clockwise around to the Ribbon Take-Up Hub.
3. Rotate the Ribbon Take-Up Hub clockwise several times to secure the Ribbon.
4. Lower and lock the Head Lift Lever then close the access cover.

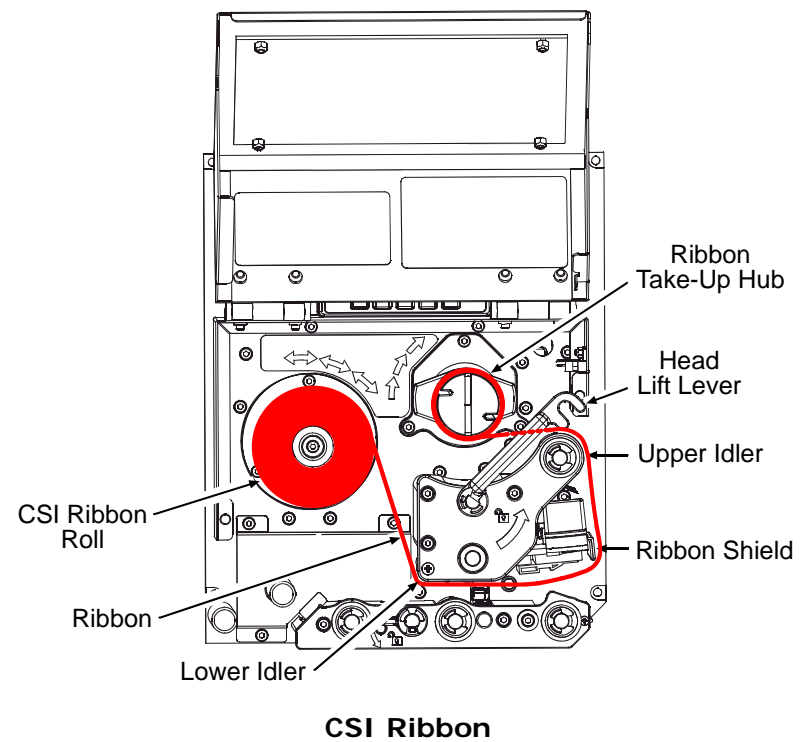
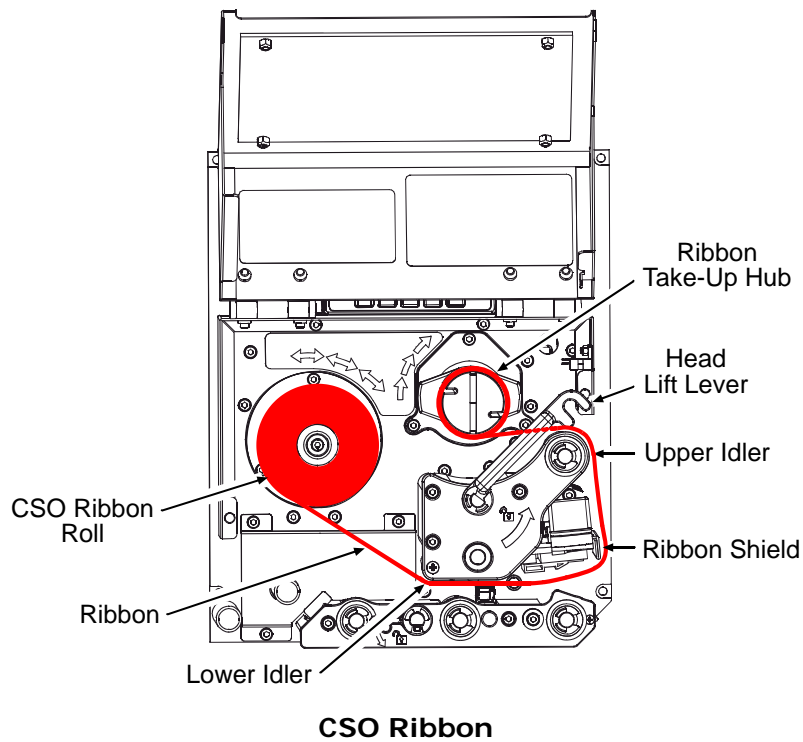

### 3.3.2 Left Hand Models

Load ribbon as follows:

1. Orient the unwind position of the Ribbon according to the coated side (CSI or CSO) and then slide the Ribbon Roll completely onto the Ribbon Supply Hub, as shown below:

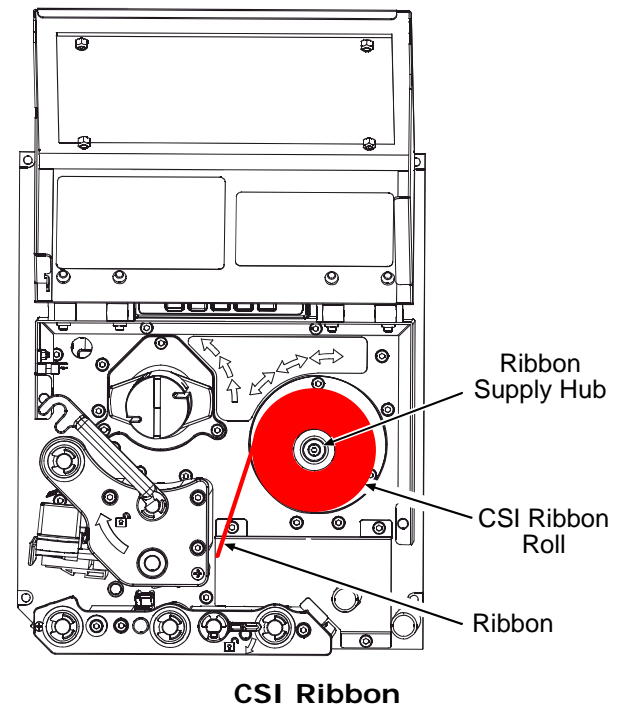
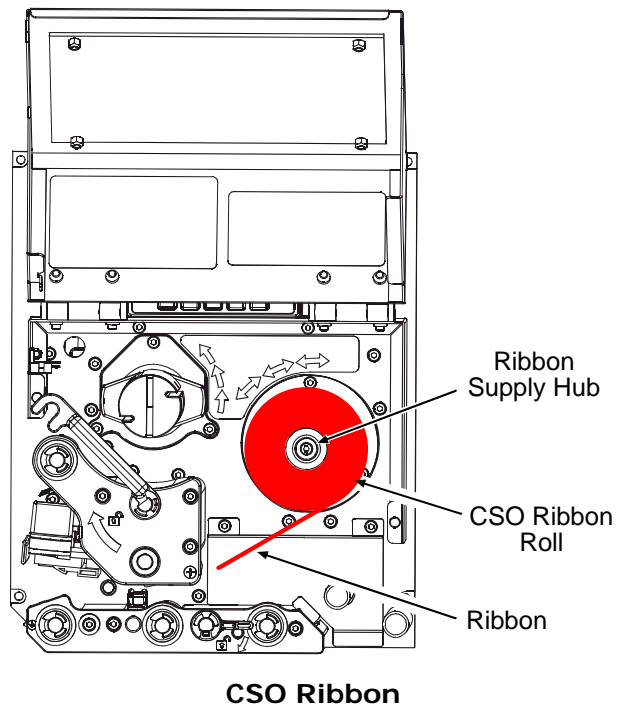

2. With the Head Lift Lever raised, route the Ribbon under the Lower Idler, over the Ribbon Shield and Upper Idler, and then counterclockwise around to the Ribbon Take-Up Hub.
3. Rotate the Ribbon Take-Up Hub counterclockwise several times to secure the Ribbon.
4. Lower and lock the Head Lift Lever then close the access cover.



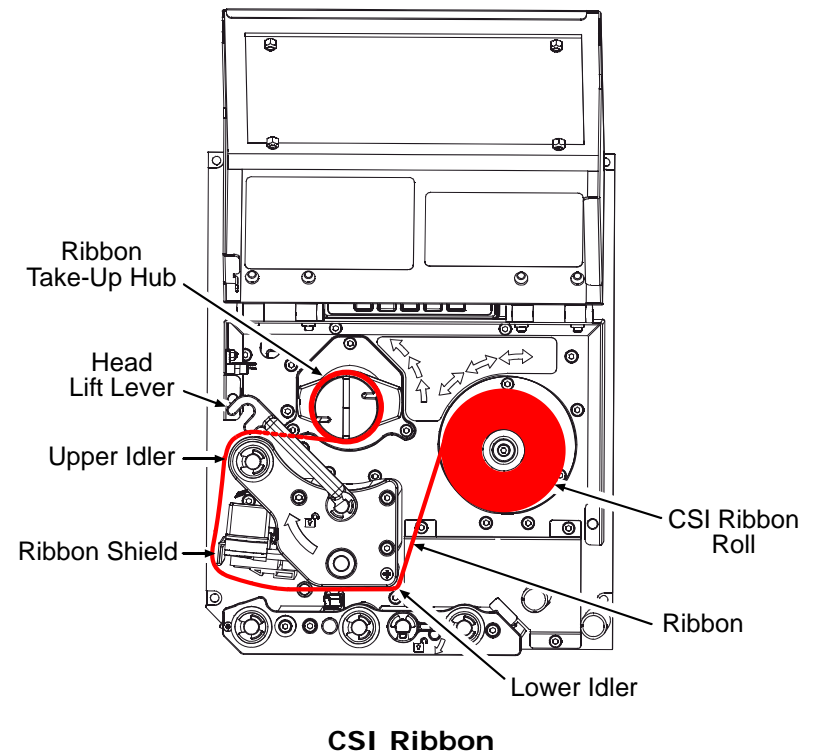
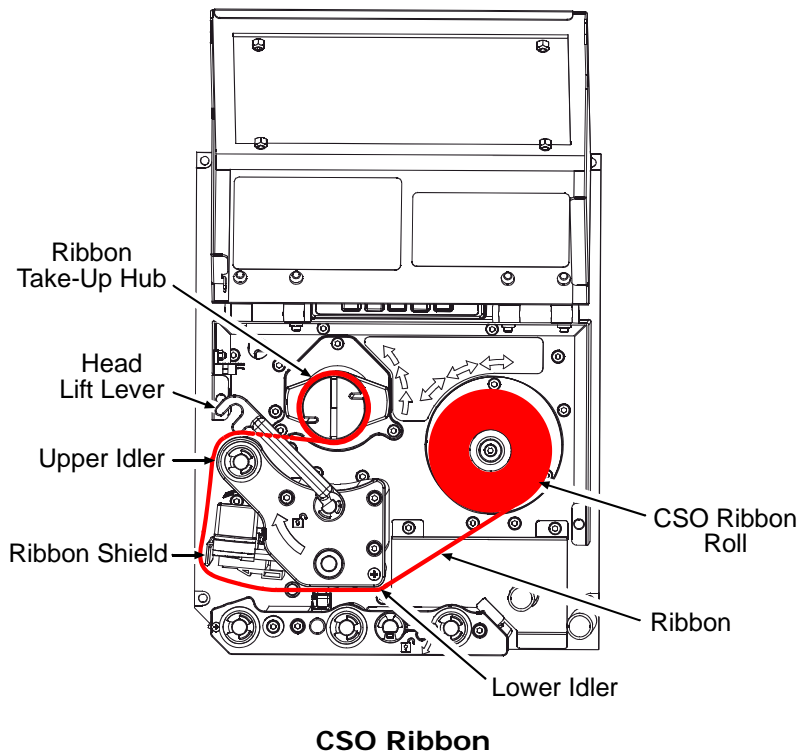

### 3.3.3 Removing Ribbon

After the ribbon supply has been exhausted, grasp the used ribbon and, while squeezing, pull to collapse the Ribbon Take-Up Hub then slip off the ribbon. Next, slip off the empty core from the Ribbon Supply Hub.



*If using a narrow width ribbon, it may be necessary to use one hand to pull and collapse the Ribbon Take-Up Hub, while using your other hand to slide off the ribbon.*

## 3.4 Quick Calibration

Perform Quick Calibration during initial printer setup or after changing the media, but not if using continuous media.

---



*Media with long gaps between labels may require a PAPER OUT DISTANCE change; see Section 4.2.1. Also, if UNCALIBRATED is displayed, see Section 5.2.1.*

---

- With media loaded and the Media Sensor adjusted, press and hold the FEED Key until at least two complete labels advance before releasing the key.

Upon successful completion, CALIBRATION COMPLETED will appear then the printer will feed to the next TOF and READY will be displayed. (A 'Warning Low Backing' message may appear if using notched media or media on a transparent liner; however, the calibration was successful).

### Calibration Hints

With some media, the sensor may have trouble differentiating between the label and liner. If CANNOT CALIBRATE is displayed, try calibrating over a longer distance:

- Press and hold the FEED Key until the printer has output three (or more) labels.

If this method also fails (that is, if UNCALIBRATED is displayed), perform the Standard Calibration; see Section 5.2.1.

## 3.5 Print Quality Controls

Flexible printing controls are provided. Of these, the amount of heat applied and the rate of media movement will have the most effect. Four settings are available via PRINT CONTROL; see Section 4.2.2:

- HEAT – adjust this setting to lighten or darken the print contrast;
- PRINT SPEED – adjust this setting to regulate throughput, where slow speeds allow more time for energy transfer and fast speeds may require more HEAT to achieve the desired contrast;
- CONTRAST – adjust this setting to fine-tune the gray (shaded) areas of the image; and,
- DARKNESS – adjust this setting to fine-tune the solid areas of the image.



*Heat and Speed commands from the host software may override the printer's menu setting; see HOST SETTINGS, Section 4.2.5.*

---

# 4 Using the Control Panel

## 4.1 Layout



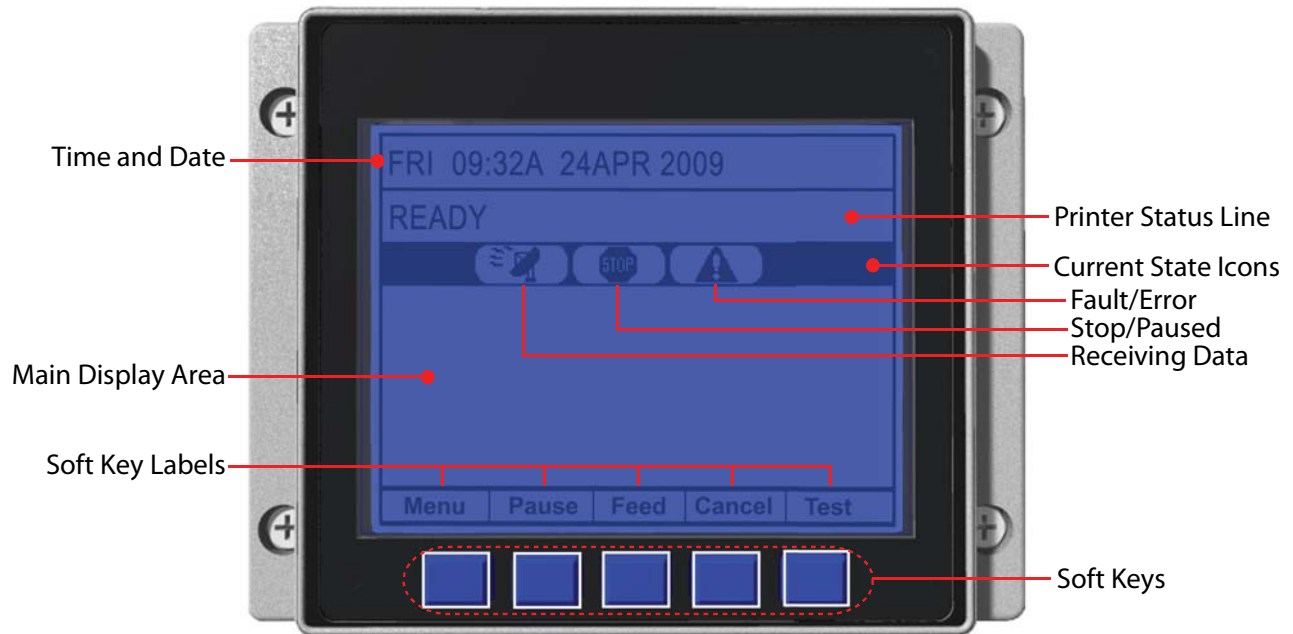











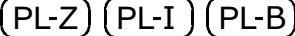

The Control Panel is an event-driven user interface composed of a graphics display and Soft Keys.



### 4.1.1 The Display

The display provides printer information:

- Current time and date;
- Soft Key Labels to denote Soft Key functions;
- Label counts during batch jobs;
- When in Menu mode, the System Menu;
- When in Test mode, the Test Menu;
- Various messages; and,
- Real-time status notifications (see below).

Icon	Description
	Initialization, typically brief (but a damaged or invalid printhead can delay the process).
	Display large fonts; see Section 4.1.2.
	Input Mode – DPL; see Section 4.2.4.
	Input Mode – LINE; see Section 4.2.4.
	Input Mode – Emulation; see Section 4.2.4.
	RFID detected.
	SD memory card detected.
	USB memory (or keyboard) detected.
	Wired network detected.
	Server inaccessible.
	WLAN associated with Access Point.
	WLAN not associated with Access Point.
	WLAN ADHOC Mode.
	Receiving data.
	Paused.
	Faulted, see Section 6.1.2.

## 4.1.2 Keypad Functions

The Soft Keys (see Section 4.1) control printer functions:

- The Soft Keys are mode-dependent, changing functions as needed. Depending upon the printer's state, many functions can be accessed by pressing (or pressing and holding for various durations) the keys and buttons:

Keypad Functions			
Function	Printer State	Pressing Sequence	Related Section
Calibration, Empty Value	Idle	Long PAUSE & FEED	5.2
Calibration, RFID Option	Idle	Long FEED & TEST	4.2.3
Calibration, Quick	Idle	Long FEED	3.4
Display Contrast Adjustment*	Idle	Hold MENU	4.1
Display large fonts	Idle	TEST Key (then ZOOM)	4.1.1
Feed / Clear Fault	Idle	FEED	4.1
Pause	Idle	PAUSE	4.1
Print Label, Configuration	Idle	FEED & CANCEL	4.3.5
Print Label, Network	Idle	PAUSE, FEED, & CANCEL	4.2.5
Print Label, Quality	Idle	PAUSE & FEED	4.3.1
Reset, Soft	Idle	Long CANCEL	5.3.1
System Menu	Idle	MENU	4.2
Test Menu	Idle	TEST Key (then TEST)	4.3
Hex Dump Mode	Power-Up	Hold FEED	6.2
Reset, Level 1	Power-Up	PAUSE & FEED	5.7.2
Reset, Level 2	Power-Up	Hold PAUSE, FEED, & CANCEL	5.7.3

\* When using the remote display option, both the remote display and the display mounted to the printer share the same contrast setting.

## 4.2 The System Menu

The System Menu is composed of seven menu branches:

MEDIA SETTINGS  
PRINT CONTROL  
PRINTER OPTIONS  
SYSTEM SETTINGS  
COMMUNICATIONS  
DIAGNOSTICS  
MCL OPTIONS

To enter the System Menu, press the Menu Soft Key.

(This places the printer in Menu mode, taking it offline, halting the processing of new data.)



- *Prompts may appear before menu access is granted or before changes are enacted; see Section 5.1.1.*
  - *MENU MODE controls the access level; see Section 4.2.4.*
  - *Host software commands may, in some cases, override menu settings; see Section 4.2.5.*
  - *Depending upon the firmware and options, some menu items may not be present or may indicate NOT INSTALLED.*
  - *In the descriptions below “✧” denotes a firmware default setting, while “ ” denotes a setting only modifiable via the menu.*
-

## 4.2.1 Media Settings

The Media Settings menu contains label and ribbon settings, and printhead maintenance selections.

Menu Item	Details
<b>MEDIA TYPE</b>	Selects the printing method, where:
DIRECT THERMAL	Sets printing for heat reactive media.
✧THERMAL TRANSFER	Sets printing for media that requires ribbon to produce an image.
<b>SENSOR TYPE</b>	Selects the Top Of Form (TOF) sensing method used to determine the leading edge of the label, where:
✧GAP	Senses the gaps or notches in the media.
CONTINUOUS	Uses the LABEL LENGTH (see below) to determine the TOF.
REFLECTIVE	Senses the reflective (black) marks on the underside of the media.
<b>LABEL LENGTH</b>	Determines the length of the label when the SENSOR TYPE is set to CONTINUOUS, where:
(0 – 99.99 in.) ✧04.00	Is the desired length of the format.
<b>MAXIMUM LABEL LENGTH</b>	Sets the distance that the printer will feed GAP or REFLECTIVE media before declaring a TOF fault, where:
(0 – 99.99 in.) ✧16.00	Is the length of travel to detect a TOF gap or mark.  <input checked="" type="checkbox"/> <i>This distance should be 2.5 to 3 times the label length.</i>
<b>PAPER EMPTY DISTANCE</b>	Sets the distance the printer will attempt to feed media before declaring an Out Of Stock fault, where:
(0 – 99.99 in.) ✧00.25	Is the length of travel to detect the presence of media.  <input checked="" type="checkbox"/> <i>If using transparent or translucent media, this setting should be longer than the label length.</i>
<b>LABEL WIDTH</b>	Sets the maximum printable width. Objects extending beyond this limit will NOT print, where:
(X.XX – X.XX in.) ✧X.XX	Is the maximum width; see Appendix B for the model dependant default and range.

Media Settings (continued)

Menu Item	Details
<b>RIBBON LOW OPTIONS</b>	Defines the response when THERMAL TRANSFER is selected and the ribbon supply diminishes, where:
RIBBON LOW DIAMETER	Sets the threshold that will trigger a Low Ribbon Warning prompt, where:
(1.0 0 – 2.00 in.) ✦1.38	Is the outer diameter size of the roll.
<b>PAUSE ON RIBBON LOW</b>	Sets the printer to pause when the Ribbon Low Diameter setting is met, where:
ENABLED	Forces you to press the PAUSE Key to proceed with the print job.
✦DISABLED	Allows printing to continue until ribbon empty is declared.
<b>SENSOR CALIBRATION</b>	Selects the method that is used to calibrate the media sensor (see Section 5.2), where:
<b>PERFORM CALIBRATION</b>	Allows automatic calibration, where:
YES	Establishes the best values based on sampled readings.
NO	Exits the menu item without changing the current settings.
<b>ADVANCED ENTRY</b>	Sets the values via manual entry process, where:
PAPER SENSOR LEVEL ✦170 (0 – 255)	Establishes the threshold value for standard paper.
REFL PAPER LEVEL ✦020 (0 – 255)	Establishes the threshold value for reflective paper.
GAP SENSOR LEVEL ✦016 (0 – 255)	Establishes the threshold value for the gap/notch.
MARK SENSOR LEVEL ✦230 (0 – 255)	Establishes the threshold value for the reflective mark.
EMPTY SENSOR LEVEL ✦009 (0 – 255)	Establishes the threshold value for the empty condition.
TRAN SENSOR GAIN ✦31 (0 – 31)	Establishes the sensitivity of the gap/notch sensor.
REFL SENSOR GAIN ✦13 (0 – 31)	Establishes the sensitivity of the reflective sensor.



Media Settings (continued)

Menu Item	Details
<b>PRINthead CLEANING</b>	Controls printhead cleaning alerts and functions, where:
CLEAN HEAD SCHEDULE 0 – 200 in. (* 1000) ✧000	Specifies the inch (or centimeter) count (multiplied by one thousand) at which to clean the printhead. If this count is exceeded three times, a Head Cleaning Fault will occur.  <input checked="" type="checkbox"/> <i>Zero (000) disables this function.</i>
CLEAN HEAD COUNTER	Indicates the number of inches (or centimeters) since a cleaning was last initiated.
RESET COUNTER	Allows the Clean Head Schedule to restart the count, where:
YES	Resets the CLEAN HEAD COUNTER.
NO	Exits the menu item without changing the current setting.
CLEAN HEAD NOW	Allows cleaning to begin, where:
YES	Initiates the cleaning process and resets the Clean Head Counter (see Section 5.6.1).
NO	Exits the menu item without cleaning.

## 4.2.2 Print Control

The Print Control menu contains print quality, throughput and formatting functions:

Menu Item	Details
<b>HEAT</b>	Controls the burn-time of the printhead (selectable as "Heat" in most labeling programs), where:
(0 – 30) ✧10	Is the number based on duration, corresponding to print darkness.
<b>PRINT SPEED</b>	Controls the rate of label movement during printing, where:
✧XX.X in/sec	Is the speed; see Appendix B for the model dependant default and range.  <i>✔ Slower rates may be needed for detailed images, while faster rates may require an increased HEAT setting for sufficient energy transfer.</i>
<b>FEED SPEED</b>	Controls the rate of label movement between printing areas, where:
✧XX.X in/sec	Is the speed; see Appendix B for the model dependant default and range.
<b>REVERSE SPEED</b>	Controls the rate of label movement during backup positioning, where:
✧X.X in/sec	Is the speed; see Appendix B for the default and range.
<b>SLEW SPEED</b>	Controls the rate of label movement between printing areas when using the optional Applicator Interface Card's GPIO function, where:
✧XX.X in/sec	Is the speed; see Appendix B for the default and range.
<b>ROW OFFSET</b>	Shifts the vertical SOP position on the label, where:
(0 – 99.99 in.) ✧00.00	Is the offset distance; see Section 7 for label details.
<b>COLUMN OFFSET</b>	Shifts the horizontal, left-justified SOP position to the right without shifting the Label Width termination point to the right, where:
(0 – 99.99 in.) ✧00.00	Is the offset distance; see Section 7 for label details.

Print Control (continued)

Menu Item	Details
<b>PRESENT DISTANCE</b>	Sets the label stop position, where:
(0 – 4.00 in.) ✧AUTO 0.00	Is the label output distance. The default setting (Auto) configures this distance according to the positioning requirements of the attached device (e.g., tear bar, cutter, etc).  <i>✔ When set to 0.01 in., NONE is assumed; a zero (0) positioning value will be used.</i>
<b>TOF PRECEDENCE</b>	Allows an override of label format data when the form length is exceeded, where:
✧DISABLED	Prints labels formats without TOF truncating.
ENABLED	Ends the label at the next TOF, truncating any print data that extends past this mark.
<b>CUSTOM ADJUSTMENTS</b>	Allows slight, printer-specific adjustments, where:
DARKNESS ✧32 (1 – 64)	Controls the printhead strobe time (see HEAT) to fine-tune the solid areas of an image.
CONTRAST ✧32 (1 – 64)	Fine-tunes the gray areas of an image.
ROW ADJUST ✧0000 (~XXX – XXXX DOTS)	Shifts the vertical SOP position to fine-tune ROW OFFSET; see Appendix B.  <i>✔ If shifting in the negative direction, modify PRESENT ADJUST (below) by the same amount.</i>
COLUMN ADJUST ✧000 (~XXX – XXX DOTS)	Shifts both the horizontal SOP position and the LABEL WIDTH termination point to the right to fine-tune COLUMN OFFSET; see Appendix B.
PRESENT ADJUST ✧000 (~XXX – XXXX DOTS)	Adjusts the label stopping position to fine-tune PRESENT DISTANCE; see Appendix B.

### 4.2.3 Printer Options

The Printer Options menu contains module, file handling, and option functions:

Menu Item	Details
<b>MODULES</b>	Controls memory handling functions, where:
DIRECTORY	Allows viewing and printing of available space and file types (including plug-ins) present on a module. Only detected modules will be listed, and selecting ALL will display all results; see Appendix A.
PRINT FILE	Prints selections from listings of available files, including .dlb, .dpl, .prn and .txt formats; see File Handling Definitions, Appendix A.
PROCESS FILE	Processes a selected file for use by the printer; see File Handling Definitions, Appendix A.
FORMAT MODULE	Formats a selected module; see Appendix A.   <i>FORMAT MODULE will erase all data in the selected module.</i>
DELETE FILE	Deletes a file from a list of available files; see File Handling Messages, Appendix A.  <hr/> <input checked="" type="checkbox"/> <i>Protected modules will not be displayed, and space will not be recovered until packed.</i>
COPY FILE	Selects from a list of available files and prompts for the destination module before copying; see File Handling Messages, Appendix A.
UNPROTECT MODULE	Selects from a list of available modules then prompts regarding the unprotect attempt; see File Handling Messages, Appendix A.

Printer Options (continued)

Menu Item	Details
<b>CUTTER</b>	Controls the Cutter option, where:
MODE	Sets the detection method and response of the printer, where:
DISABLED	Disables the option.
✧AUTO	Detects, enables, and sets the label stop location for the cutter; if not detected, the option will be ignored.
ENABLED	Enables and sets the label stop location for the cutter; if not detected, a fault will be generated.
<b>CUT BEHIND</b>	<p>Allows a number of small labels to queue before a cut is performed, increasing throughput, where:</p> <hr/> <p>✔ <i>This mode can be used without a cutter to allow the presentation of an extra label, with retraction occurring upon the next job or feed operation.</i></p>
(0 – 2) ✧0	<p>Is the queue number.</p> <hr/> <p>✔ <i>After a fault or unknown label position, a leading edge cut will be performed to ensure against extra length on the first label; otherwise, cutting will occur only as specified.</i></p>
<b>RIBBON SAVER</b>	Controls the Ribbon Saver option, where:
DISABLED	Disables the option.
✧AUTO	Detects enables the option. If not detected, the option will be ignored.
ENABLED	Enables the option. If not detected, a fault will be generated.

Printer Options (continued)

Menu Item	Details
<b>RFID</b>	Controls the RFID option, where:  <input checked="" type="checkbox"/> <i>If not detected, this selection will result in a DISABLED message.</i>
RFID MODULE	Sets the mode of RFID operation, where:
DISABLED	Disables the option.
HF	Selects the High Frequency (13.56 MHz) option.
UHF MULTI-PROTOCOL	Selects the Ultra High Frequency (868-956 MHz) option.
RFID POSITION	Sets the RFID encoding position, where:
(1.10 - 4.00 in.) ◇1.10	Is the inlay location (as referenced from the leading edge of the tag moving forward through the printer), where 0.00 uses the print position to encode tag and values greater use the present position (subject to change).
HF SETTINGS	Sets the HF encoding parameters, where:
TAG TYPE	Selects the HF tag type, where:
◇ISO 15693	Is the type to be encoded.
TI	
PHILIPS	
ST LRI512	
ST LRI64	
AFI VALUE	Sets the Application Family Identifier value, where:
(00 - FF) ◇00	Is the hex value.
AFI LOCK	Locks the Application Family Identifier value, where:
ENABLED	Is write-protected.
◇DISABLED	Is not protected.

Printer Options (continued)

Menu Item	Details
DSFID VALUE	Sets the Data Storage Format Identifier value, where:
(00 – FF) ✧00	Is the hex value.
DSFID LOCK	Locks the Data Storage Format Identifier value, where:
ENABLED	Is write-protected.
✧DISABLED	Is not protected.
EAS VALUE	Selects the Electronic Article Surveillance value, where:
(00 – FF) ✧00	Is the hex value.
AUDIO INDICATOR	Controls the buzzer, where:
ENABLED	Allows sound.
✧DISABLED	Inhibits sound.
ERASE ON FAULT	Controls tag erasure if errors are detected, where:
ENABLED	Erases data.
✧DISABLED	Retains faulty data.
UHF SETTINGS	Sets the UHF encoding parameters, where:
TAG TYPE	Selects the tag type, where:
EPC 0	Is the type to be encoded.
EPC 0+ MATRICS	
EPC 0+ IMPINJ	
EPC 1	
UCODE EPC 1.19	
EM 4022/4222	
✧GEN 2	

Printer Options (continued)

Menu Item	Details
TAG DATA SIZE	Sets the tag data size, where:
✧96-BIT	Selects 96 bits (24 hexadecimal characters or 12 ACSII characters).
64-BIT	Selects 64 bits (16 hexadecimal characters or 8 ACSII characters).
POWER ADJUST	Adjusts the applied power, where:
(-04 → 04) ✧000	Is the power level, in 1.0 dBm increments.
KILL CODE	Sets the code to permanently deactivate the tag, where:
✧00 00 00 00	Is the code, in the form B3, B2, B1, B0.
ACCESS CODE	Sets the code to protect tag memory contents, where:
✧00 00 00 00	Is the code, in the form B3, B2, B1, B0.
GEN 2 LOCK ACTION	Sets the lock for Gen 2 tags, where:
✧NONE	Does not lock the tag.
PERMALOCK	Locks data permanently.
PWD-READ/WRITE	Locks data with password-protection for writing data.
BOTH	Allows both Permalock and PWD-Lock to be used.
PAD/TRUNC. EPC DATA	Allows padding or truncating of data with nulls (represented as "00") in order to fit the selected EPC Tag Data Size, where:
✧DISABLED	Does not pad or truncate data.
LEADING	Adds nulls to the front (left) of the data if less than the size, or cuts the data if greater.
TRAILING	Adds nulls to the end (right) of the data if less than the size, or cuts the data if greater.



Printer Options (continued)

Menu Item	Details
LOCK AFTER WRITE	Allows the tag to be locked after programming, where:
ENABLED	Locks the tag.
✧DISABLED	Does not lock the tag.
RETRY ATTEMPTS	Sets the number of retry attempts, where:
(0 - 9) ✧3	Is the retry count before a fault is declared.
PERFORM CALIBRATION	Allows the printer to establish the tag to transducer distance and nominal power setting, where:
YES	Initiates the process; CALIBRATING RFID will be displayed as media is scanned for the tag location and power, followed by TOF positioning and the operational results where, if successful, the database parameters will be updated.
NO	Exits the menu item without calibration.
SET DEFAULTS	Allows the RFID default values to be restored, where:
YES	Restores the default settings.
NO	Exits the menu item without changing the current settings.

Printer Options (continued)

Menu Item	Details
<b>GPIO PORT</b>	Controls the optional Applicator Interface Card's GPIO function, where:
GPIO DEVICE	Sets the option to work with a specific device type, where:
✧DISABLED	Disables the option.
APPLICATOR	Enables parameters for related label applicator functions: <ul style="list-style-type: none"> <li>• Completion upon last SOP, de-asserts Data Ready (DRDY);</li> <li>• FEED allowed at any time; and,</li> <li>• DRDY upon PAUSE.</li> </ul>
APPLICATOR 2	Enables parameters for alternate label applicator functions: <ul style="list-style-type: none"> <li>• Completion upon 1 msec. overlap of Data Ready (DRDY) and End of Print (EOP);</li> <li>• DRDY signal end inhibits FEED; and,</li> <li>• De-asserts DRDY upon PAUSE or FAULT.</li> </ul>
BARCODE VERIFIER	Enables the parameters for bar code verifier functions.
<b>START OF PRINT</b>	Selects the type of input signal required to initiate printing, where:
LOW PULSE	Triggers printing with a low pulse.
HIGH PULSE	Triggers printing with a high pulse.
ACTIVE LOW	Triggers printing with a low signal.
✧ACTIVE HIGH	Triggers printing with a high signal.
EDGE	Triggers printing with a signal edge transition.

Printer Options (continued)

Menu Item	Details
END OF PRINT	Sets the type of output signal generated to indicate EOP, where:
✧LOW PULSE	Outputs a low pulse upon completion.
HIGH PULSE	Outputs a high pulse upon completion.
ACTIVE LOW	Outputs a logic low upon completion.
ACTIVE HIGH	Outputs a logic high upon completion.
RIBBON LOW	Sets the low ribbon signal (as determined by RIBBON LOW OPTIONS; see Section 4.2.1), where:
✧ACTIVE LOW	Outputs a logic low when the roll size reaches the setting.
ACTIVE HIGH	Outputs a logic high when the roll size reaches the setting.
SLEW ENABLE	Selects the type of input signal required to initiate label slew, where:
✧STANDARD	Triggers slew with a low signal.
LOW PULSE	Triggers slew with a low pulse.
HIGH PULSE	Triggers slew with a high pulse.
ACTIVE LOW	Triggers slew with a low signal.
ACTIVE HIGH	Triggers slew with a high signal.
ERR ON PAUSE (APP2)	Sets the output when a service required fault occurs (Applicator Interface Card Type 2 equipped only), where:
✧ENABLED	Enables the output signal.
DISABLED	Disables the output signal.

## 4.2.4 System Settings

The System Settings menu contains operating, control, and formatting functions:

Menu Item	Details
<b>MENU MODE</b>	Sets the menu access level, where:
✧USER MENU	Accesses limited basic menu items.
ADVANCED MENU	Accesses all menu items.
<b>CONFIGURATION FILE</b>	Controls the creation, storage, and recall of printer configuration files (see Appendix E), where:
RESTORE AS CURRENT	Lists the files available and then, after selection, reconfigures the printer according to that file.
SAVE SETTING AS	Saves the effective printer configuration to a named file of up to nineteen characters.
DELETE FILE	Lists the files available and then after selection, removes that file from memory.  <input checked="" type="checkbox"/> <i>An active file cannot be deleted.</i>
FACTORY SETTING FILE	Restores the printer operating parameters to the factory default file ( <code>Aft.cfg</code> ) settings after a Level One reset; see Section 5.7.2.
<b>INTERNAL MODULE</b>	Allocates a number of 1KB memory blocks to the internal memory module; where:
(XXX – XXXX KB) ✧1024	Is the memory allocation; see Appendix A.
<b>DEFAULT MODULE</b>	Designates the storage module when no memory location is specified; where:
G ✧D	Is the module; see Appendix A for availability.
<b>SCALEABLE FONT CACHE</b>	Configures the number of 1KB memory blocks for the scalable font engine; where:
(XXX – XXXX KB) ✧0511	Is the memory allocation; see Appendix A for availability.
<b>SINGLE BYTE SYMBOLS</b>	Sets the code page used for single byte fonts, where:
✧PC-850 MULTILINGUAL	Is the selected code page. (See the <i>Class Series 2 Programmer's Manual</i> for a complete listing.)





System Settings (continued)

Menu Item	Details
<b>DOUBLE BYTE SYMBOLS</b>	Selects the code page (see the <i>Class Series 2 Programmer's Manual</i> ) used for the ILPC option (unless otherwise specified), where:
JIS	Selects Japanese Industry Standard.
SHIFT JIS	Selects Shift Japanese Industry Standard.
EUC	Selects Extended UNIX Code.
✧UNICODE	Selects Unicode (including Korean).
GB	Selects Government Bureau Industry Standard, Chinese (PRC).
BIG 5	Selects Taiwan encoded.
<b>TIME AND DATE</b>	Sets the time and date, where:
SET HOUR 06:30 AM 01 FEB 2005	Enters the time and date information.
<b>MEDIA COUNTERS</b>	Displays and controls various internal counters, where:
ABSOLUTE COUNTER	Are the total inches printed and the set date. (Non-resettable)
PRINthead COUNTER	Is the total number of inches printed. (Non-resettable)
RESETTABLE COUNTER	Are the inches printed and the last reset date.
RESET COUNTER	Returns the RESETTABLE COUNTER to zero.
<b>PRINT CONFIGURATION</b>	Prints current database information; see Section 4.3.5.
<b>CONFIGURATION LEVEL</b>	<p>Displays the hardware and software levels of the printer, where:</p> <hr/> <p><input checked="" type="checkbox"/> This data is also provided on the Configuration Label; see Section 4.3.5.</p> <hr/>

System Settings (continued)

Menu Item	Details
PRINTER KEY	<p>Identifies the unique key number of the printer, in the form:</p> <p style="text-align: center;">VVVV-CWXX-YYYYYY-ZZZ</p> <p>Where:</p> <p>VVVV - Represents the printer model number.</p> <p>CWXX - Represents the hardware and software levels, where:</p> <p style="padding-left: 40px;">c - Is the printer class.</p> <p style="padding-left: 40px;">w - Is the main board hardware level.</p> <p style="padding-left: 40px;">xx - Is the software feature level:</p> <p style="padding-left: 80px;">10 = Standard DPL</p> <p style="padding-left: 80px;">20 = Internal CG Times Font</p> <hr style="width: 20%; margin-left: 40px;"/> <p style="padding-left: 40px;"><input checked="" type="checkbox"/> Increases beyond the feature level require authorization.</p> <hr style="width: 20%; margin-left: 40px;"/> <p>YYYYYY - Is a manufacturing date code.</p> <p>ZZZ - Is a unique time stamp.</p>
APPLICATION VERSION	Displays the firmware program number, version, and date.
BOOT LOADER	Displays the Boot Loader version and date.
UPGRADE PRINTER CODE 0 0 0 0 0 0	Upgrades the printer to the corresponding features level with the correct code entry (where authorization may be required).
UNLOCK FEATURE 0 0 0 0 0 0	Unlocks a feature with the correct code entry.
<b>SET FACTORY DEFAULTS</b>	Returns the factory-programmed values or the Factory Setting File values, where:
YES	<p>Restores the default settings, or if selected the Factory Setting File.</p> <hr style="width: 80%; margin-left: 40px;"/> <p style="padding-left: 40px;"><input checked="" type="checkbox"/> A reset will occur and, if no Factory Setting File is used, all settings returned except CUSTOM ADJUSTMENTS and calibrations.</p> <hr style="width: 80%; margin-left: 40px;"/>
NO	Exits the menu item without changing the current settings.

System Settings (continued)

Menu Item	Details
<b>FORMAT ATTRIBUTES</b>	Defines the way overlapping text, bar codes, and graphics are printed, where:
TRANSPARENT	Prints intersecting areas, for example: 
✧XOR	Obliterates intersecting areas, for example: 
OPAQUE	Overwrites intersecting areas with those last formatted, for example: 
<b>HEAD BIAS</b>	<p>Allows the dot zero orientation to flip, as viewed from the label exit, where:</p> <div style="text-align: center;">  <p><i>Switching this setting will reverse all media movement directions.</i></p> </div>
✧STANDARD	Sets the dot zero origin for left justified printing.
RIGHT HAND	Sets the dot zero origin for right justified printing.
<b>LABEL ROTATION</b>	Allows the label format to be flipped 180 degrees, where:
ENABLED	Prints formats after 180° rotation.
✧DISABLED	Prints formats without rotation.
<b>IMAGING MODE</b>	Also known as "Batch" mode, determines the process used to format labels, where:
✧MULTIPLE LABEL	<p>Formats multiple images, as memory permits, for the fastest throughput.</p> <hr/> <p><input checked="" type="checkbox"/> <i>Time stamps will indicate the moment of imaging rather than printing.</i></p> <hr/>
SINGLE LABEL	Formats an image only after a previous format has been printed (for the most accurate time stamps).

System Settings (continued)

Menu Item	Details
<b>PAUSE MODE</b>	Allows interactive print control, where:
ENABLED	Prints only as the PAUSE Key is pressed.
◇DISABLED	Prints normally, without user intervention.
<b>PEEL MODE</b>	Allows the SOP signal to initiate (via the optional GPIO port) the feeding of labels, where:
ENABLED	Feeds labels only after SOP is received.
◇DISABLED	Feeds labels regardless of SOP.
<b>SECURITY</b>	Allows menu password protection, where:
SELECT SECURITY	Enables or disables the security feature, where: <hr/> <input checked="" type="checkbox"/> <i>The default password must be changed to activate.</i>
◇DISABLED	Accesses all areas.
SECURE MENU	Sets a password requirement for menu access.
MENU AND TEST	Sets a password requirement for menu and test access.
ADVANCED MENU	Sets a password requirement for Advanced Menu access. <hr/> <input checked="" type="checkbox"/> <i>After enabling this selection, return MENU MODE to the USER MENU setting.</i>
<b>MODIFY PASSWORD</b>	Modifies the security password, where:
YES	Allows entry of a four-digit password (after confirmation). <hr/> <input checked="" type="checkbox"/> <i>The default password is 0000.</i>
NO	Exits the menu item without changing the current settings.



System Settings (continued)

Menu Item	Details
<b>UNITS OF MEASURE</b>	Sets the measurement standard of the printer, where:
✧IMPERIAL	Uses inches.
METRIC	Uses millimeters and centimeters.
<b>INPUT MODE</b>	Defines the type of processing that occurs when data is received, where:  <input checked="" type="checkbox"/> See the Class Series 2 Programmer's Manual for detailed information.
✧DPL	Processes data for standard DPL printing.
LINE	Processes data for Line mode (template) printing.
PL-Z, PL-I, or PL-B	Processes data for various emulation printing.
AUTO	Identifies then activates the appropriate emulation parser for the data.  <input checked="" type="checkbox"/> Correct identification can be dependent upon the HOST SETTINGS / HOST TIMEOUT (see Section 4.2.5). Also, extraneous characters may, in some cases, render the data unrecognizable, thus requiring manual selection of the mode.
<b>USER LABEL MODE</b>	Sets the printer to power-up as default, where:
ENABLED	Functions in standalone mode for quick access to user defined formats; see Section 4.3.7.  <input checked="" type="checkbox"/> This mode will remain active until disabled.
✧DISABLED	Functions in normal mode, awaiting commands from a host.
<b>DPL EMULATION</b>	Allows legacy printer emulation, where:  <input checked="" type="checkbox"/> Ignores label commands A, M, n & T; see the Class Series 2 Programmer's Manual for information.
✧STANDARD	Uses no legacy emulation, all commands recognized.
ALLEGRO	Emulates the Allegro®.
PRODIGY PLUS	Emulates the Prodigy Plus®.
PRODIGY	Emulates the Prodigy™.

System Settings (continued)

Menu Item	Details
<b>COLUMN EMULATION</b>	Allows the column dot count to be adjusted, where:
(XXX – XXX DOTS) ◇XXX	Is the printed number of dots per inch (or mm) thereby reducing the width of the produced format; see Appendix B.  <input checked="" type="checkbox"/> No adjustment occurs at the default setting.
<b>ROW EMULATION</b>	Allows the row dot count to be adjusted, where:
(XXX – XXX DOTS) ◇XXX	Is the printed number of dots per inch (or mm) thereby reducing or enlarging the length of the produced format; see Appendix B.  <input checked="" type="checkbox"/> No adjustment occurs at the default setting.
<b>SOP EMULATION</b>	Allows SOP functions with backward compatibility when printing legacy model label formats, where:  <input checked="" type="checkbox"/> Two labels will automatically feed to establish the selected position.
◇DISABLED	Uses the standard print position.
110 (PRODPLUS)	Emulates the Prodigy Plus® print position.
220 (ALLEGRO)	Emulates the Allegro® print position.
250 (PRODIGY)	Emulates the Prodigy™ print position.
<b>BACK AFTER PRINT</b>	Determines media movement when a cutter, present sensor, peel and present, or GPIO is enabled, where:
MODE	Repositions media, where:
ENABLED	Movement occurs according to BACKUP DELAY timing after a cut, cleared sensor, or SOP to allow fastest throughput.
◇DISABLED	Movement occurs only when the next label is ready to print, minimizing edge curling.
<b>BACKUP DELAY (1/50s)</b>	Determines repositioning timing, where:
(0 – 255) ◇000	Is the specified lapse (in fiftieths of a second) between new format processing and label retraction.

System Settings (continued)

Menu Item	Details
<b>FONT EMULATION</b>	Allows font substitution, where:
✧STANDARD FONTS	Prints using standard (internal) fonts.
CGTIMES	Prints using CG Times font.
USER ID S50	Prints using a downloaded font.
<b>LABEL STORE</b>	Determines the data content when retrieving stored label formats, where:
✧STATE & FIELDS	Recalls the printer state (i.e., heat, speeds, etc.) and the formatting commands for a stored label.
FIELDS ONLY	Recalls the formatting commands for a stored label.
<b>MENU LANGUAGE</b>	Selects the language for the System Menu and Configuration Label, where:  <hr/> <input checked="" type="checkbox"/> Only resident languages will be selectable; see Appendix D.
✧ENGLISH	Is standard.
<b>DISPLAY SETTINGS</b>	Determines the appearance of the items in the Main Display Area of the LCD, where:
GRAPHIC DISPLAY MODE	Determines the magnification of the items, where:
✧STANDARD	Is the normal setting.
ENHANCED	Is the enlarged setting.
<b>DISPLAY UNITS</b>	Determines the displayed type of distance information, where:
✧STANDARD	Displays the information according to the UNITS OF MEASURE setting (see above).
IMPERIAL	Displays the information in inches.
METRIC	Displays the information in millimeters and centimeters.

System Settings (continued)

Menu Item	Details
<b>FAULT HANDLING</b>	Determines the label disposition and user action if a fault occurs, where:
LEVEL	Sets the printer response upon declaration of a fault, where:
NO REPRINT	Stops printing and declares a fault. Then, following correction of the problem, the FEED Key must be pressed to clear the fault.
◇STANDARD	Stops printing and declares a fault. Then, following correction of the problem, the FEED Key must be pressed to clear the fault and reprint the label in process.
VOID AND RETRY	<p>Actions depend upon the RETRY COUNT:</p> <ul style="list-style-type: none"> <li>• If the count has not been exceeded, VOID is printed on the failed label and reprinting automatically occurs;</li> <li>• If the count has been exceeded, printing stops and a fault message is displayed. Then, following correction of the problem, the FEED Key must be pressed to clear the fault and reprint the label in process; or,</li> <li>• If the CANCEL Key is pressed, reprinting is optional: press NO to reprint; or, press YES to cancel the reprint (and press YES again to cancel the batch.)</li> </ul> <hr/> <p><input checked="" type="checkbox"/> <i>Linear Scanner or RFID required.</i></p>
DELAYED SCAN FAULT	<p>Increases throughput when bar codes reside near the trailing edge of the label (in the direction of FEED).</p> <hr/> <p><input checked="" type="checkbox"/> <i>Linear Scanner or RFID required.</i></p> <ul style="list-style-type: none"> <li>• <i>If unreadable, the fault will occur after the next label prints;</i></li> <li>• <i>The label immediately following a faulted label is not scanned for errors; and,</i></li> <li>• <i>VOID AND RETRY and REPRINT are automatically disabled; the job can only be cancelled.</i></li> </ul>
VOID RETRY & CONT.	<p>VOID is printed on a faulted label, with reprint attempts occurring automatically, until the RETRY COUNT has been exceeded and then that label will be skipped (discarded) and printing will continue to the next label in queue.</p> <hr/> <p><input checked="" type="checkbox"/> <i>Linear Scanner or RFID required.</i></p>

System Settings (continued)

Menu Item	Details
VOID DISTANCE	Sets the distance to print VOID on a faulted label, where:
(0.10 to 2.00 in.) ◇0.50	<p>Is the distance, measured from the trailing edge, which establishes the text size.</p> <hr/> <p>✔ VOID will not be printed if insufficient text space exists or if the fault occurred after printing completed. Also, the text can be customized; see the Class Series 2 Programmer's Manual.</p>
RETRY COUNT	Sets the number of printing attempts before declaring a fault, where:
(0 – 3) ◇1	<p>Is the count.</p> <hr/> <p>✔ Greater than 1 (one) counts are valid only when Linear Scanner or RFID equipped.</p>
BACKFEED ON CLEAR	Determines positioning after a fault is cleared, where:
ENABLED	Automatically positions the label.
◇DISABLED	<p>No label positioning occurs, as the location is assumed correct.</p> <hr/> <p>✔ If reloading, you must place media at the SOP position.</p>
SCL FONT BOLD FACTOR	Sets a scalable font boldfacing amount, where:
(1 – 36) ◇08	Is the setting, based on an incrementing scale where eight (08) is nominal.

## 4.2.5 Communications

The Communications menu contains interface port and host control functions:

Menu Item	Details
<b>SERIAL PORT A</b>	Controls the RS-232 communications settings for Serial Port A, where:
BAUD RATE	Sets the serial communication rate, where:
1200 BPS	Is the serial speed in Bits Per Second.
2400 BPS	
4800 BPS	
✧9600 BPS	
19200 BPS	
28800 BPS	
38400 BPS	
57600 BPS	
115000 BPS	
PROTOCOL	Sets the data flow control method (handshaking), where:
✧BOTH	Uses XON/XOFF and CTS/DTR.
SOFTWARE	Uses XON/XOFF.
HARDWARE	Uses CTS/DTR.
NONE	Disables flow control.
PARITY	Sets word parity, where:
✧NONE	Uses parity.
ODD	Uses Odd parity.
EVEN	Uses Even parity.
DATA BITS	Sets Word length, where:
(7 - 8) ✧8	Is the number of bits in the word.
STOP BITS	Sets the stop bit count, where:
(1 - 2) ✧1	Is number of stop bits.

Communications (continued)

Menu Item	Details
<b>SERIAL PORT C</b>	<p>Controls the settings for the Applicator Interface COM C (J4) port, where the setting selections are the same as those given for the SERIAL PORT A.</p> <hr/> <p><input checked="" type="checkbox"/> <i>The maximum baud is 38.4K BPS.</i></p>
<b>SERIAL PORT D</b>	<p>Controls the settings for the Applicator Interface COM D (J3) port, where the setting selections are the same as those given for the SERIAL PORT A.</p> <hr/> <p><input checked="" type="checkbox"/> <i>The maximum baud is 38.4K BPS.</i></p>
<b>PARALLEL PORT A</b>	<p>Controls the communications settings for Parallel Port A, where:</p>
PORT DIRECTION	<p>Allows printer data to be returned to the host, where:</p>
UNI-DIRECTIONAL	<p>Returns no data (one-way communication).</p>
✧BI-DIRECTIONAL	<p>Returns data (compliant back-channel operation); see Section 2.3.1 for cable requirements.</p>
<b>NIC ADAPTER</b>	<p>Controls the communications settings for the network interface, where:</p>
QUICK SETUP	<p>Selects settings to configure basic Wired or WiFi operations, where:</p>
WIRED DHCP	<p>Selects Wired operation, where:</p>
NO	<p>Exits the menu item without changing the current settings.</p>
YES	<p>Returns the NIC Adapter to defaults then sets Wired Discovery to "Enable" and Wireless to "Disable."</p>
WLAN UNSECURED	<p>Selects WiFi operation, where:</p>
NO	<p>Exits the menu item without changing the current settings.</p>
YES	<p>Returns the NIC Adapter default values then sets Discovery to "Enable," SSID to "Any," and WLAN network type to "Infrastructure."</p>

Communications (continued)

Menu Item	Details
WLAN ADHOC	Selects the DMXrfNetII default parameters, where:
NO	Exits the menu item without changing the current settings.
YES	Restores WiFi defaults and initiates infrastructure mode with an SSID of "Any." All existing access point associations will be deleted then established with the closest available. (Useful when moving the printer to a geographically distant location.)
SET FACTORY DEFAULTS	Returns the factory-programmed values, where:
NO	Exits the menu item without changing the current settings.
YES	Restores the default settings.
WLAN	Controls the communications settings for the DMXrfNetII Card, where:
MODE	Selects between Wired or WiFi operation, where:
ENABLED	Enables the WiFi interface.
◇DISABLED	Enables the wired interface.
BSS ADDRESS	<p>Specifies the static IP address of the WiFi bridge module.</p> <hr/> <p><input checked="" type="checkbox"/> <i>If DHCP is Enabled, this parameter will be ignored.</i></p>
◇ 000.000.000.000	Is the address in standard octet format.
SIGNAL READINGS	Displays the WLAN signal and noise ratios.
IP ADDRESS	Specifies the static IP Address; where:
◇192.168.010.026	Is the address in standard octet format.



Communications (continued)

Menu Item	Details
SUBNET MASK	Specifies the static Subnet Mask Address, where:
◇255.255.255.000	Is the address in standard octet format.
GATEWAY	Specifies the network Gateway Address, where:
◇192.168.010.026	Is the address in standard octet format.
SNMPTRAP DESTINATION	Specifies the SNMP Trap Address, where:
◇000.000.000.000	Is the address in standard octet format where SNMP traps will be sent when SNMP service is installed on your receiver.
	<input checked="" type="checkbox"/> <i>When zeroed, no traps are sent.</i>
IP DISCOVERY	Controls IP Address discovery, where:
◇ENABLED	Broadcasts over the network at startup to receive addresses from the responsible server. Manual modifications to IP Address, Subnet Mask, or Gateway are not allowed; and, if no server is found, the specified static value will be used.
	 <i>A server assigned IP address takes precedence over any static address stored in the interface.</i>
DISABLED	Uses the stored static IP, Subnet Mask, and / or Gateway Address.
SNMP	Allows management protocols, where:
◇ENABLED	Sends messages to SNMP-compliant devices.
DISABLED	Sends no messages.
ADVANCED	Sets advanced networking functions and parameters, where:
TELNET	Sets Telnet protocol to transfer data, where:
◇ENABLED	Allows Telnet.
DISABLED	Disables Telnet.

Communications (continued)

Menu Item	Details
FTP	Sets File Transfer Protocol to transfer data, where:
✧ENABLED	Allows FTP.
DISABLED	Disables FTP.
MTU	Sets the Maximum Transmission Unit packet size, where:
(512 - 65515) ✧01500	Is the packet size, in bytes.
GRATUITOUS ARP	Sets the Address Resolution Protocol notification rate, where:
(0 - 2048) ✧0000	Is the time, in minutes.
PORT NUMBER	Sets the network communications port, where:
(1 - 65535) ✧09100	Is the Port Number.
TCP KEEPALIVE	Allows monitoring of an open connection to detect any disconnects not properly closed, including reset access points and unplugged printers, where:
ENABLED	Keeps monitoring active.
✧DISABLED	Closes such a disconnection after 2.5 minutes.
DUPLEX CAPABILITY	Sets the communication capability for the Wired network, where:
✧AUTO-NEGOTIATE	Automatically selects the best type.
100BASET HALF	Selects 100 Mbit/s half duplex (in both directions, one way at a time) operation.
100BASET FULL	Selects 100 Mbit/s full duplex (in both directions, simultaneously) operation.
10BASET HALF	Selects 10 Mbit/s half duplex (in both directions, one way at a time) operation.
10BASET FULL	Selects 10 Mbit/s full duplex (in both directions, simultaneously) operation.
ADVERTISE CAPABILITY	Transmits the printer's communication capability for the Wired network, where:
✧AUTOMATIC	Advertises the DUPLEX CAPABILITY set value.
ALL CAPABILITIES	Advertises all possible values for DUPLEX CAPABILITY.

Communications (continued)

Menu Item	Details
NETWORK REPORT	Allows viewing or printing of the network status report, where:
VIEW	Displays the report.
PRINT	Prints the report: <div style="border: 1px solid black; padding: 5px; margin-top: 10px;"> <pre> NETWORK REPORT WED 03:15PM 23JUL2008 CURRENT PRINTER INFO MACO: 00:0D:70:08:88:B9 IP ADDRESS: 192.168.10.26 SUBNET MASK: 255.255.255.0 GATEWAY: 192.168.10.26 DHCP: ENABLED SNMP: ENABLED PORT NUMBER: 9100 NETBIOS NAME: DMX_038BB9  WLAN MODULE MODULE FW VERSION: 4.3.0.24 RADIO FW VERSION: 1.1.1.1118.4.0.145 PORT STATUS: CONNECTED: ESS SSID: 000B2802D55E MACR: 00:0B:28:02:D5:5E BSS ADDRESS: PROVIDED BY DHCP           </pre> </div>
SET FACTORY DEFAULTS	Returns the factory-programmed values, where:
YES	Restores the default settings.  <input checked="" type="checkbox"/> <i>A reset will occur and all settings will be restored except CUSTOM ADJUSTMENTS and calibrations.</i>
NO	Exits without changing the current settings.
<b>HOST SETTINGS</b>	Sets host communication parameters, where:
HOST TIMEOUT	Sets the period that an interface port can be idle before timeout occurs, where:
(1 - 60 SEC) ◇10	Is the time (in seconds) when downloads timeout, and that must elapse before alternate port or alternate parser processing can occur.
CONTROL CODES	Allows changes to the software command interpretation controls, where:
◇STANDARD CODES	Sets these interpretation codes: Hex 01 = SOH command; Hex 02 = STX command; count-by = ^; Hex 1B = ESC; Hex 0x0D = Carriage Return
ALTERNATE CODES	Sets these interpretation codes: Hex 5E = SOH command; Hex 7E = STX command; count-by = @; Hex 1B = ESC; Hex 0x0D = Carriage Return
ALTERNATE CODES 2	Sets these interpretation codes: Hex 5E = SOH command; Hex 7E = STX command; count-by = @; Hex 1B = ESC; Hex 0x7C = Carriage Return
CUSTOM CODES	Sets interpretation codes, where:
STANDARD CODES SOH STX CR CNTBY 01 02 0D 5E	Are the codes according to your definition.  <input checked="" type="checkbox"/> <i>Standard codes serve as default placeholders.</i>

Communications (continued)

Menu Item	Details
FEEDBACK CHARACTERS	Allows the return of printer codes, where:
ENABLED	Sends the host a Hex 1E (RS) after each label and a Hex 1F (US) after each batch successfully prints.
✧DISABLED	Sends no feedback characters.
ESC SEQUENCES	Sets handling for data containing invalid ESC sequences, where:
✧ENABLED	Processes commands normally.
DISABLED	Ignores ESC control codes during processing (as some systems send "banners" to the printer).  <input checked="" type="checkbox"/> <i>Bitmapped font downloads will be disabled.</i>
HEAT COMMAND	Determines how host Heat commands are handled, where:
✧ENABLED	Processes software commands normally.
DISABLED	Controls Heat via the menu setting; see Section 4.2.2.
SPEED COMMANDS	Determines how host Print, Feed, Reverse, and Slew commands are handled, where:
✧ENABLED	Processes software commands normally.
DISABLED	Controls speeds via the menu setting; see Section 4.2.2.
TOF SENSING COMMANDS	Determines how host Gap, Continuous, and Reflective commands are handled, where:
✧ENABLED	Processes software commands normally.
DISABLED	Controls the Sensor Type via the menu setting; see Section 4.2.2.
SYMBOL SET COMMAND	Determines how host Single and Double Symbol Set commands are handled, where:
✧ENABLED	Processes software commands normally.
DISABLED	Controls Symbol Set selection via the menu setting; see Section 4.2.4.

Communications (continued)

Menu Item	Details
CNTRL-CODES (DATA)	Determines how host Control Codes are handled, where:
✧ENABLED	Processes software commands normally.
DISABLED	Controls the setting via the menu; see CONTROL CODES, above.
STX-V SW SETTINGS	Determines how a host option enable command is handled, where:
✧ENABLED	Processes the command normally.
DISABLED	Controls settings via the menu; see Section 4.2.3.
MAX LENGTH COMMAND	Determines how a host Maximum Label Length (<STX>M) command is handled, where:
✧ENABLED	Processes software commands normally.
DISABLED	Controls the setting via the menu; see Section 4.2.1.
OPTION FEEDBACK	<p>Allows feedback characters from an optional device to be returned to the host device, in the format of &lt;A;B;C;D;E;F&gt;[CR], where:</p> <hr/> <p>A - Is the device type: R = RFID; and, S = Linear Scanner            B - Is the status: C = entire label complete; F = faulted (failed) label; and, U = unknown            C - Is the number of expected reads, given in two characters.            D - Is the number of good reads, given in two characters.            E - Is the internal Job and Sub Job Identifier, given in four characters each.            F - Is the data read, delimited with semicolons (;) if multiple reads.</p> <hr/>
✧DISABLED	Reports no data.
SCANNER	Reports Linear Scanner data.
RFID HEX	Reports RFID data in hexadecimal format.
RFID ASCII	Reports RFID data in an ASCII format.

Menu Item	Details
PROCESS SOH (DATA)	Determines the response to an Immediate Command (e.g., Get Status, Module Storage, etc.), where:
✧DISABLED	Processes commands normally.
ENABLED	Interrupts operations upon SOH receipt to process the command.

#### 4.2.6 Diagnostics

The Diagnostics menu contains testing functions:

Menu Item	Details
HEX DUMP MODE	Determines how the printer handles host data, where:
✧DISABLED	Processes data normally.
ENABLED	Prints received ASCII data without interpretation or processing; see Section 6.2.
OPTIONS TESTING	Performs option diagnostics, where:
TEST CUTTER	Tests the Cutter, where:
PERFORM TEST 1 TIME	Selects the number of cuts (1, 10, & 100) to perform then displays the PASS / FAIL results.
TEST RIBBON SAVER	Tests the Ribbon Saver, where:
PERFORM TEST 1 TIME	Selects the number of cycles (1, 10, & 100) to perform then displays the PASS / FAIL results.

Diagnostics (continued)

Menu Item	Details																												
TEST GPIO	Tests the Applicator Interface CCA's GPIO function, where:																												
MONITOR GPIO INPUT  <table border="0" data-bbox="272 422 586 569"> <tr> <td>SOP</td> <td>FEED</td> <td>PAUSE</td> <td>REPRT</td> <td></td> <td></td> </tr> <tr> <td>1</td> <td>1</td> <td>1</td> <td>1</td> <td></td> <td></td> </tr> <tr> <td>i1</td> <td>i2</td> <td>i3</td> <td>i4</td> <td>i5</td> <td>i6</td> </tr> <tr> <td>1</td> <td>1</td> <td>1</td> <td>1</td> <td>1</td> <td>1</td> </tr> </table>	SOP	FEED	PAUSE	REPRT			1	1	1	1			i1	i2	i3	i4	i5	i6	1	1	1	1	1	1	Displays input signal logic values for Start of Print (SOP), Feed, Pause, Reprint (REPRT), and six unassigned input lines. (The values given here are examples only.)  <hr/> <input checked="" type="checkbox"/> <i>Unconnected lines may display a zero or one.</i>				
SOP	FEED	PAUSE	REPRT																										
1	1	1	1																										
i1	i2	i3	i4	i5	i6																								
1	1	1	1	1	1																								
TEST GPIO OUTPUT  <table border="0" data-bbox="272 695 586 842"> <tr> <td>EP</td> <td>RL</td> <td>SR</td> <td>MO</td> <td>RO</td> <td>DR</td> <td>OF</td> </tr> <tr> <td>1</td> <td>1</td> <td>1</td> <td>1</td> <td>1</td> <td>1</td> <td>1</td> </tr> <tr> <td>o1</td> <td>o2</td> <td>o3</td> <td>o4</td> <td>o5</td> <td>o6</td> <td></td> </tr> <tr> <td>1</td> <td>1</td> <td>1</td> <td>1</td> <td>1</td> <td>1</td> <td></td> </tr> </table>	EP	RL	SR	MO	RO	DR	OF	1	1	1	1	1	1	1	o1	o2	o3	o4	o5	o6		1	1	1	1	1	1		Displays output signal logic values for End of Print (EP), Ribbon Low (RL), Service Required (SR), Media Out (MO), Ribbon Out (RO), Data Ready (DR), Option Fault (OF), and six unassigned output lines. (The values given here are examples only.)  <hr/> <input checked="" type="checkbox"/> <i>To change an output signal, cursor over the displayed state to select and then toggle it using the keypad, except Data Ready which cannot be toggled.</i>
EP	RL	SR	MO	RO	DR	OF																							
1	1	1	1	1	1	1																							
o1	o2	o3	o4	o5	o6																								
1	1	1	1	1	1																								
PRINT SIGNAL INFO	Prints a reference label (see Appendix D) containing GPIO signal names, pin and port assignments, programmed settings, and current signal states.																												
TEST RFID	Tests RFID, where:																												
TAG DATA	Reads the data encoded on an RFID tag.																												
DEVICE VERSION	Displays the type and version of the encoding device.																												
TAG ID - HF ONLY	Reads then displays the High Frequency Tag ID number.																												

Diagnostics (continued)

Menu Item	Details																				
<b>PRINT TEST RATE (min)</b>	Allows a label-to-label delay when batch printing Test Labels, where:																				
✧000 (0 - 120)	Is the selected interval, in minutes.																				
<b>SENSOR READINGS</b>	Displays various sensor values (0 - 255), where:																				
<table border="0" style="width: 100%;"> <tr> <td style="text-align: center;">THR</td> <td style="text-align: center;">TRAN</td> <td style="text-align: center;">RIBM</td> <td style="text-align: center;">24V</td> </tr> <tr> <td style="text-align: center;">127</td> <td style="text-align: center;">159</td> <td style="text-align: center;">093</td> <td style="text-align: center;">175</td> </tr> <tr> <td colspan="4"> </td> </tr> <tr> <td style="text-align: center;">PS</td> <td style="text-align: center;">HD</td> <td style="text-align: center;">RANK</td> <td></td> </tr> <tr> <td style="text-align: center;">00</td> <td style="text-align: center;">254</td> <td style="text-align: center;">125</td> <td></td> </tr> </table>	THR	TRAN	RIBM	24V	127	159	093	175					PS	HD	RANK		00	254	125		Are readings for the printhead thermistor sensor (THR), media "gap" (TRAN) or "reflective" (REFL) sensor, ribbon sensor (RIBM), 24VDC power supply sensor (24V), present sensor (PS), printhead assembly sensor (HD), and printhead ranking resistor (RANK). (The values given here are examples only.)
THR	TRAN	RIBM	24V																		
127	159	093	175																		
PS	HD	RANK																			
00	254	125																			
<b>RIBBON SENSOR LIMITS</b>	Displays ribbon sensor values for thermal transfer equipped printers, where:																				
<table border="0" style="width: 100%;"> <tr> <td style="text-align: center;">RIBBON ADC LOW</td> </tr> <tr> <td style="text-align: center;">039</td> </tr> <tr> <td colspan="2"> </td> </tr> <tr> <td style="text-align: center;">RIBBON ADC HIGH</td> </tr> <tr> <td style="text-align: center;">250</td> </tr> </table>	RIBBON ADC LOW	039			RIBBON ADC HIGH	250	Are the sensor readings. (The values given here are examples only.)														
RIBBON ADC LOW																					
039																					
RIBBON ADC HIGH																					
250																					
<b>IPH REPORT</b>	Displays the IntelliSEQ™ data (including the printhead serial number, and installation and maintenance dates) where:																				
VIEW	Displays the data.																				
PRINT	Prints the data: <table border="1" style="margin-left: 20px; width: 300px;"> <tr> <td> <b>IPH REPORT</b>  TUE 12:44PM 23MAY2006  <b>4212-HE25-060224-090</b>  PRINTHEAD SERIAL #: 5x-00289  PRINTHEAD MODEL # 163  PRINTER SERIAL # 60430014  PRINTHEAD INCHES 1334900  INSTALLATION DATE - INITIAL 02/02/2006  INSTALLATION DATE - LAST 08/06/2006  <b>PRINTHEAD CLEANING</b>  CLEAN PROCEDURES: 5  CLEAN COUNTER RESET 5  NUMBER OF INCHES LAST- 0 </td> </tr> </table>	<b>IPH REPORT</b> TUE 12:44PM 23MAY2006 <b>4212-HE25-060224-090</b> PRINTHEAD SERIAL #: 5x-00289 PRINTHEAD MODEL # 163 PRINTER SERIAL # 60430014 PRINTHEAD INCHES 1334900 INSTALLATION DATE - INITIAL 02/02/2006 INSTALLATION DATE - LAST 08/06/2006 <b>PRINTHEAD CLEANING</b> CLEAN PROCEDURES: 5 CLEAN COUNTER RESET 5 NUMBER OF INCHES LAST- 0																			
<b>IPH REPORT</b> TUE 12:44PM 23MAY2006 <b>4212-HE25-060224-090</b> PRINTHEAD SERIAL #: 5x-00289 PRINTHEAD MODEL # 163 PRINTER SERIAL # 60430014 PRINTHEAD INCHES 1334900 INSTALLATION DATE - INITIAL 02/02/2006 INSTALLATION DATE - LAST 08/06/2006 <b>PRINTHEAD CLEANING</b> CLEAN PROCEDURES: 5 CLEAN COUNTER RESET 5 NUMBER OF INCHES LAST- 0																					
SAVE	Saves the data to an external storage device; see Section 2.3.5.																				
<b>FLASH MODULE REPORT</b>	Displays the status and error history of the internal memory modules.																				
VIEW	Displays the data.																				
PRINT	Prints the data.																				



## Diagnostics (continued)

Menu Item	Details
<b>ICON DESCRIPTIONS</b>	Identifies the printer icons (see Section 4.1.1), where:
SYSTEM ICONS	Displays system indicators.
NETWORK ICONS	Displays network indicators.
INPUT TYPE ICONS	Displays input mode indicators.
OPTIONS ICONS	Displays detected option indicators.

### 4.2.7 MCL Options

The MCL Options menu contains alternate operating selections:

Menu Item	Details
<b>MCL OPTIONS</b>	Allows the printer to use the optional MCL (Macro Command Language) tool suite to accept peripheral device input data, where:
MCL AT POWER-UP	Allows MCL operation to begin when the printer is turned ON, where:
✧DISABLED	MCL operation does not occur; the printer uses standard DPL functions.
MCL LINK MODE	Starts MCL in Link mode.
MCL PROGRAM MODE	Starts MCL in Program mode.
START MCL	Starts MCL after exiting the menu.



*Consult your MCL provider for details regarding operation and support.*

---

## 4.3 The Test Menu

The (Quick) Test Menu contains resident format selections that are printed at selected heat and speed settings. Use full width media to capture the entire format; otherwise, adjust the printer and set the Label Width.

To enter the Test Menu, press the TEST Soft Key, then the Enter Soft Key to view the available test label formats

(In Test mode the printer is offline, halting the processing of new data.)



- To print a format, scroll to that item then input a quantity and press ENTER.
  - To stop printing press CANCEL.
  - A printing delay can be set; see Print Test Rate, Section 4.2.6.
- 

### 4.3.1 Print Quality Label

The Print Quality Label serves as an overall quality indicator. Consisting of compliant fence and ladder bar codes, assorted font sizes, and fill patterns, this format can be used to ensure conformance as well as aesthetics.

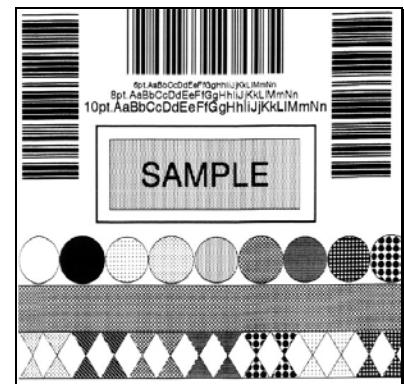

### 4.3.2 Ribbon Test Label

The Ribbon Test Label serves as a transfer function indicator for printers equipped with the thermal transfer option. Consisting of a fence-oriented bar code, this format can be used to ensure component functions and ribbon path alignment.

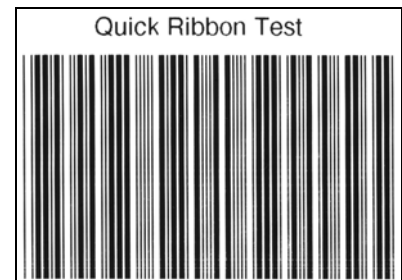

### 4.3.3 Test Label

The Test Label serves as an indicator of printhead functionality. The format consists of patterns that exercise all thermal elements.

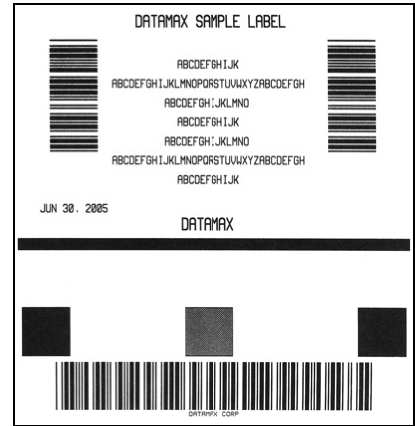

### 4.3.4 Validation Label

The Validation Label serves as an overall quality indicator. Consisting of compliant fence and ladder bar codes, assorted font sizes, and black fill patterns, this format can be used to ensure conformance as well as aesthetics.

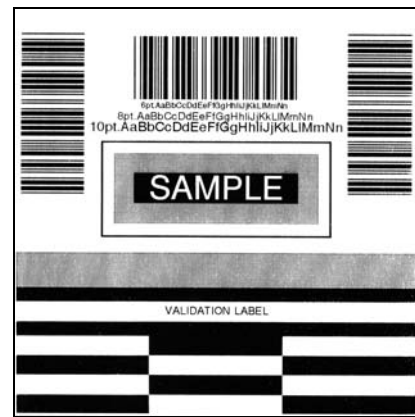

### 4.3.5 Print Configuration

The Configuration Label provides current database information, including the Application Version, which can be output as a label or as a file.



*Bulleted items indicate host changes not yet saved.*

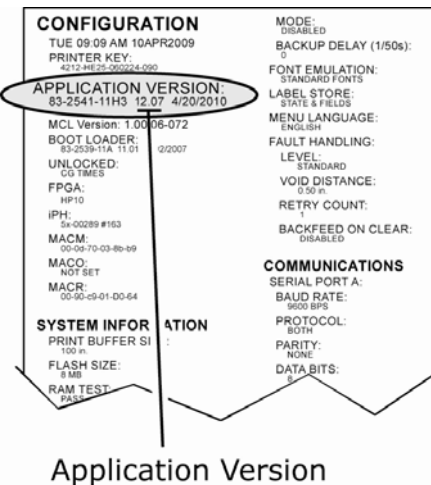

Application Version

### 4.3.6 Print Last Label

Print Last Label reprints the most recent format output by the printer.



*If a job was cancelled prior to completion, or if power was removed since the last print job and this label request, VOID will be printed.*

---

### 4.3.7 User-Defined Label

The User-Defined Label allows a template to be populated by variable data (via the printer's control panel or a USB QWERTY keyboard). The template is a stored label format, where fields delimited by an ampersand (&) become variable.

The printer will prompt you to enter the variable field data. For example, the stored label format could contain the data 19131423443&ENTER NAME&

Afterward, when recalled from memory, the printer's display will indicate the variable field:  
ENTER NAME

- 
- *Variable data can be any part of the DPL format - font ID, positioning, etc.*



- *No error checking will be performed.*
  - *Supports .dlb, .dpl, .prn, and .txt file types.*
-

# 5 *Operating, Adjusting and Maintaining the Printer*

## 5.1 *Displayed Messages*

During operation (when not in Menu or Test mode) the printer displays several types of information:

- Prompts and Condition Messages (see below); and
- Fault and Warning Messages (see Section 6.1.2).

### 5.1.1 *Prompts and Condition Messages*

Prompts appear when an action is required during operation, while Condition Messages indicate an operational state.

Prompts and Condition Messages		
Displayed Message	Description	Action
ACCESS DENIED	The password used to access the secured menu was incorrect.	Enter the correct password.
BUSY...	The printer is performing internal operations.	Allow the operations to complete.
CALIBRATING SENSOR LEVELS	The FEED Key was pressed and held.	Allow the calibration to complete.
CALIBRATION COMPLETE	Calibration has finished.	Normal operation can resume.
CANCEL BATCH ENTER KEY = YES	The CANCEL or TEST Key was pressed during a multiple label job.	Press ENTER to cancel all remaining labels in the job.

<b>Prompts and Condition Messages</b> <i>(continued)</i>		
<b>Displayed Message</b>	<b>Description</b>	<b>Action</b>
CANCEL REPRINT ENTER KEY = YES	The CANCEL or TEST Key was pressed during a fault. (See FAULT HANDLING / VOID AND RETRY, Section 4.2.4.)	Press ENTER to cancel the reprint.
CLEARING FAULTS	The FEED Key was pressed following a fault and now the printer is attempting to clear the condition.	No action is required.
DMXNET INITIALIZING	The network card is initializing, a normal condition following power-up or a reset.	No action is required. Depending upon the settings, it may take a few minutes.
ENTER PASSWORD 0 - - -	This is the menu gateway.	Enter the four-digit password for access.
INVALID ENTRY	An incorrect value has been entered.	Enter a valid setting or selection.
NOT INSTALLED	The selected option or feature cannot be found.	Verify that the option or feature is correctly installed. If so, call for service.
OFFLINE	The MENU or TEST Key was pressed.	Press ESC to return to Ready mode.
PAUSED	The PAUSE Key was pressed (or Pause mode is enabled, see Section 4.2.4) and now the printer is in a paused condition.	Press PAUSE.
PRINTHEAD CLEANING	The TEST Key was pressed and held, or CLEAN HEAD NOW was selected, and now printhead cleaning is in progress.	No action is required.
READY	The printer is waiting to receive label formats, downloads, etc.	Send a label format, download, etc.

Prompts and Condition Messages <i>(continued)</i>		
Displayed Message	Description	Action
REMOVE RIBBON PRESS ANY KEY	The TEST Key was pressed and held, or CLEAN HEAD NOW was selected, but ribbon is installed.	Remove ribbon and press any key to proceed.
SAVE CHANGES?	Database changes were made that require confirmation.	Press YES to accept the changes, or NO to discard them. <hr/> <input checked="" type="checkbox"/> <i>If required, a reset will automatically occur.</i> <hr/>
SUCCESSFUL PRESS ANY KEY	The selected operation was successfully completed.	Press any key to continue.
SYSTEM INITIALIZING	The power switch has been turned ON or a reset has occurred.	No action is required. Wait briefly while the process completes.
SYSTEM RESET IN PROGRESS	A reset has occurred.	No action is required. Wait briefly while the process completes.
UNCALIBRATED	The Media Sensor is not calibrated.	Perform calibration; see Section 5.2.
WAITING FOR DATA	SOP signal has been received, but the printer awaits label data.	Send a format from the host.
WAITING FOR SIGNAL	The printer awaits a SOP signal.	Send the SOP signal from the applicator to the GPIO port.
XXXX OF XXXX PRINTING	A print job is in process, as indicated by the batch total and remaining label count.	No action is required.

## 5.2 Calibration

Calibration ensures correct media detection, and should be performed when Quick Calibration fails (see Section 3.4).

### 5.2.1 Standard Method

Three calibration samples are required:

- Empty – with nothing over the sensor;
- Gap (or Mark) – with media liner, a notch, or a mark over the sensor; and,
- Paper – with the label (and liner, if any) over the sensor.

Calibrate the printer as follows:





Ensure that the correct *SENSOR TYPE* is selected; see Section 4.2.1.

Step	Action	Displayed Message	Comment
A	Turn ON the printer.	CANNOT CALIBRATE -or- UNCALIBRATED	Wait briefly for the printer to initialize.
B	Press the MENU Key. Then, with MEDIA SETTINGS highlighted, press the ENTER Key.	MEDIA SETTINGS	Press the ESC Key to abort this procedure.
C	Using the DOWN Key, scroll to SENSOR CALIBRATION then press the ENTER Key. Press the ENTER Key again to select PERFORM CALIBRATION.	PERFORM CALIBRATION	Press the ESC Key to abort this procedure.
D	With no media in the sensor, press the ESC Key.	REMOVE LABEL STOCK PRESS ESC KEY <yyy>	This sets the empty value, where 'yyy' represents the current sensor reading.

(Continued)



Step	Action	Displayed Message	Comment
E	<p>Proceed according to the media type:</p> <ul style="list-style-type: none"> <li>• Die-Cut –Remove a label or two from the liner then install the media. Position the Media Sensor under the liner area and press the ESC Key.</li> <li>• Notched (or Reflective) – Install media. Position the Media Sensor under a notch (or black mark) and press the ESC Key.</li> <li>• Continuous – Press the ESC Key.</li> </ul>	<p><i>For die-cut media:</i></p> <p>SCAN BACKING</p> <hr/> <p>PRESS ESC KEY &lt;yyy&gt;</p> <hr/> <p><i>- Or, for reflective media:</i></p> <p>SCAN MARK</p> <hr/> <p>PRESS ESC KEY &lt;yyy&gt;</p> <hr/> <p><i>- Or, for continuous media:</i></p> <p>REMOVE LABEL STOCK</p> <hr/> <p>PRESS ESC KEY &lt;yyy&gt;</p>	<p>This sets the gap (or mark) value, where 'yyy' represents the current sensor reading.</p> <hr/> <p></p> <p>(1) See Section 3.2 for sensor adjustment instructions.</p> <p>(2) Do not position a perforation over the sensor when taking the sample.</p> <p>(3) For small notches or reflective marks, ensure that the labels exit straight from the printer.</p> <p>(4) Unless otherwise noted, do not move the Media Sensor after this step.</p>
F	<p>Proceed according to the media type:</p> <ul style="list-style-type: none"> <li>• All media except Continuous – Position label material (and liner, if any) over the sensor then press the ESC Key.</li> <li>• Continuous – Install media. Position the Media Sensor under the stock and press the ESC Key.</li> </ul>	<p>SCAN PAPER</p> <hr/> <p>PRESS ESC KEY &lt;yyy&gt;</p>	<p>This sets the paper value, where 'yyy' represents the current sensor reading.</p> <hr/> <p></p> <p>(1) If using preprinted media, ensure that the area placed over the sensor is free of text, graphics, or borders.</p> <p>(2) See Section 3.2 for sensor adjustment instructions.</p>

(Continued)

Step	Action	Displayed Message	Comment
G	Observe the calibration result.	CALIBRATION COMPLETE	<p>Calibration was successful.</p> <hr/> <p> If 'Warning Low Backing' is displayed, calibration was successful (for possible messages see Section 5.1).</p> <hr/>
H	Press the ESC Key repeatedly to exit menu mode.	<p>CALIBRATION COMPLETE</p> <p><i>Followed by...</i></p> <p>READY</p>	<p>When calibrating gap or reflective media, press and hold the FEED Key until at least one label is output.</p> <p>The printer is now ready for use.</p>

## 5.2.2 Advanced Entry



*Advanced Entry will override all previous calibration settings and should only be used when Standard Calibration attempts fail. Ensure that the correct SENSOR TYPE is selected (see Section 4.2.1) before starting this procedure.*

Advanced Entry is an alternate calibration method for special-case media types, where sensor readings are taken using different sampling algorithms and from a list of these readings the best algorithm is selected for manual entry into the database. Follow the steps below to perform an Advanced Entry Calibration:

Step	Action	Displayed Message	Comment
A	Turn ON the printer.	<p>CANNOT CALIBRATE</p> <p><i>-or-</i></p> <p>UNCALIBRATED</p>	Wait briefly for the printer to initialize.

*(Continued)*

Step	Action	Displayed Message	Comment
B	Press the MENU Key. Then, with MEDIA SETTINGS highlighted, press the ENTER Key.	MEDIA SETTINGS	Press the ESC Key to abort this procedure.
C	Using the DOWN Key, scroll to SENSOR CALIBRATION then press the ENTER Key. Scroll to ADVANCED ENTRY and press the ENTER Key.	ADVANCED ENTRY	Press the ESC Key to abort this procedure.
D	Scroll to SENSOR GAIN then press the ENTER Key.	SENSOR GAIN	Press the ESC Key to abort this procedure.
E	Place the label under the Sensor Eye Mark and latch the Head Lift Lever. Using the DOWN Key, scroll to GAIN TRAN 00 and press the ENTER Key.	<p>GAIN TRAN *00 (0 - 31) &lt;yyy&gt;</p> <p>- Or, for reflective media:</p> <p>GAIN REFL *00 (0 - 31) &lt;yyy&gt;</p>	<ul style="list-style-type: none"> <li>If using preprinted labels, ensure that the sampling area is free of text, graphics, and perforations.</li> <li>After ENTER is pressed, an asterisk (*) appears to denote selection.</li> </ul>
F	Record the sensor reading ('yyy') as a Label Value in a table similar to the one shown below, with 32 rows, four columns, and similar headings.)	<p>GAIN TRAN *00 (0 - 31) &lt;yyy&gt;</p> <p>- Or, for reflective media:</p> <p>GAIN REFL *00 (0 - 31) &lt;yyy&gt;</p>	The sensor reading, where 'yyy' represents the numeric sample, is useful in locating the best sensor position over the media.

Gain Number	Label Value	TOF Value	Difference Value
00	252		
01			
02			
...			
31			

(Continued)

Step	Action	Displayed Message	Comment
G	<p>Press the UP Key, incrementing the Gain Number by one, and then press the ENTER Key. Record the sensor reading as a Label Value in the table.</p> <p>Repeat this step for each of the remaining Gain Numbers.</p>	<p>GAIN TRAN *01 (0 - 31) &lt;yyy&gt;</p> <p>- Or, for reflective media:</p> <p>GAIN REFL *01 (0 - 31) &lt;yyy&gt;</p>	Where 'yyy' represents the current sensor reading.

Gain Number	Label Value	TOF Value	Difference Value
00	252		
01	250		
02	248		
...	...		
31	009		

Step	Action	Displayed Message	Comment
H	<p>Raise the printhead assembly then proceed according to the media type:</p> <ul style="list-style-type: none"> <li>Die-cut Media – Remove a label or two from the liner then position the Eye Mark over that area.</li> <li>Notched Media – Position the Eye Mark over the center of a notch.</li> <li>Reflective Media – Position the Eye Mark over the center of a face-down black mark.</li> </ul>	<p>GAIN TRAN *31 (0 - 31) &lt;yyy&gt;</p> <p>- Or, for reflective media:</p> <p>GAIN REFL *31 (0 - 31) &lt;yyy&gt;</p>	See Section 3.2.

(Continued)

Step	Action	Displayed Message	Comment
I	<p>Lower and latch the Head Lift Lever.</p> <p>Using the UP or the DOWN Key, set the Gain Number to 00 and then press ENTER.</p> <p>Record this reading as a TOF Value for Gain Number 00 in the table.</p>	<p>GAIN TRAN *00 (0 - 31) &lt;yyy&gt;</p> <p>- Or, for reflective media:</p> <p>GAIN REFL *00 (0 - 31) &lt;yyy&gt;</p>	<p>Where 'yyy' represents the current sensor reading.</p> <p>After ENTER is pressed, an asterisk (*) appears to denote selection.</p>

Gain Number	Label Value	TOF Value	Difference Value
00	252	248	
01	250		
02	248		
...	...		
31	09		

Step	Action	Displayed Message	Comment
J	<p>Use the keys to increment the Gain Number by one and then press the ENTER Key. Record the TOF Value. Repeat this step for each Gain Number.</p>	<p>GAIN TRAN *01 (0 - 31) &lt;yyy&gt;</p> <p>- Or, for reflective media:</p> <p>GAIN REFL *01 (0 - 31) &lt;yyy&gt;</p>	<p>Where 'yyy' represents the current sensor reading.</p>

Gain Number	Label Value	TOF Value	Difference Value
00	252	248	
01	250	245	
02	248	234	
...	...	...	
31	09	14	

(Continued)

Step	Action	Displayed Message	Comment
K	<p>In the table, where both the Label Value and TOF Value are at least 20, subtract the amounts and record the result as a Difference Value (see below).</p> <p>Identify the largest Difference Value and then the corresponding Gain Number.</p>	<p style="text-align: center;">GAIN TRAN</p> <p>*31 (0 - 31) &lt;yyy&gt;</p> <p style="text-align: center;"><i>- Or, for reflective media:</i></p> <p style="text-align: center;">GAIN REFL</p> <p>*31 (0 - 31) &lt;yyy&gt;</p>	<ul style="list-style-type: none"> <li>In this example, Gain Number 18 is chosen because, where both values are at least twenty, it has the highest Difference Value.</li> <li>This Gain Number will be used to resample the media.</li> </ul>

Gain Number	Label Value	TOF Value	Difference Value
00	252	248	4
01	250	245	5
02	248	234	14
...	...	...	...
15	188	63	125
16	184	51	133
17	179	38	141
18	174	25	149
19	170	19	N/A
...	...	...	...
31	132	14	N/A

Step	Action	Displayed Message	Comment
L	<p>Scroll to the Gain Number determined in the previous step and then press the ENTER Key.</p>	<p style="text-align: center;">GAIN TRAN</p> <p>*18 (0 - 31) &lt;yyy&gt;</p> <p style="text-align: center;"><i>- Or, for reflective media:</i></p> <p style="text-align: center;">GAIN REFL</p> <p>*18 (0 - 31) &lt;yyy&gt;</p>	<p>After ENTER is pressed, an asterisk (*) appears to denote selection.</p>

(Continued)

Step	Action	Displayed Message	Comment
M	<p>Complete a table (see example below) using three new measurements, as follows:</p> <p>(A) Raise the printhead assembly. Place the label (attached to liner) in the Media Sensor then lower and latch the Head Lift Lever. Record the sensor reading as P.</p> <p>(B) Raise the printhead assembly. Place the liner, notch, or mark in the Media Sensor then lower and latch the Head Lift Lever. Record the sensor reading as G (or M).</p> <p>(C) Raise the printhead assembly. Remove all media from the Media Sensor then lower and latch the Head Lift Lever. Record the sensor reading as E.</p>	<p>GAIN TRAN</p> <p>*18 (0 - 31)</p> <p>&lt;yyy&gt;</p> <p>- or, for reflective media:</p> <p>GAIN REFL</p> <p>*18 (0 - 31)</p> <p>&lt;yyy&gt;</p>	<p>Where 'yyy' represents the current sensor reading.</p> <hr/> <p><input checked="" type="checkbox"/> The re-sampled values may differ from those previously noted. This is normal; do not readjust the Media Sensor.</p>
N	<p>Press the ESC Key and then the DOWN Key. Press the ENTER Key.</p>	<p>SENSOR LEVELS</p>	<p>The sensor readings must now be entered into the printer.</p>

Selected Gain Table			
Gain Number	P (Paper)	G (Gap) or M (Mark)	E (Empty)
18	173	42	9

(Continued)

Step	Action	Displayed Message	Comment
O	<p>Using the DOWN Key set the 'Paper' level to the value determined in the previous step and press the ENTER Key.</p> <p>Repeat this step for the 'Gap' (or 'Mark') and the 'Empty' value.</p>	<p>PAPER SENSOR LEVEL P* 198 G*000 E*000</p> <p style="text-align: center;">↓</p> <p>GAP SENSOR LEVEL P* 198 G*084 E*000</p> <p style="text-align: center;">↓</p> <p>EMPTY SENSOR LEVEL P* 198 G*084 E*014</p> <p><i>-Or, for reflective media:</i></p> <p>PAPER SENSOR LEVEL P* 015 G*000 E*000</p> <p style="text-align: center;">↓</p> <p>GAP SENSOR LEVEL P* 015 G*181 E*000</p> <p style="text-align: center;">↓</p> <p>EMPTY SENSOR LEVEL P* 015 G*181 E*213</p>	<p>The selection will change to indicate the item for entry.</p>
P	<p>Press the ESC Key repeatedly to exit the menu and, when prompted, save the changes.</p>	<p>SAVE CHANGES?</p> <p>NO                      YES</p>	<p>Selecting YES saves the settings, while NO discards them.</p>

(Continued)



Step	Action	Displayed Message	Comment
Q	Press and hold the FEED Key until at least one label has been output.	READY	<p>The printer is ready for use.</p> <hr/> <p> If the calibration attempt fails, try desensitizing the sensor as follows:</p> <p>Go to MEDIA SETTINGS / SENSOR CALIBRATION / ADVANCED ENTRY / SENSOR GAIN and lower the corresponding GAIN SETTING by one. Exit the menu, saving the changes. Test the media at the new setting and if necessary repeat until a usable GAIN SETTING is obtained.</p> <hr/>

## 5.3 Printhead Adjustments

To ensure consistent print quality over the wide range of media types and sizes, the printer is equipped with a Leveling Cam and a Burn Line adjustment.

### 5.3.1 Leveling Cam Adjustment

When using media sizes that are less than full width of the printhead, adjust the Leveling Cam for even pressure distribution, as follows:



*If changing media sizes, readjust the Leveling Cam.*

1. With media loaded and the Head Lift Lever locked down, send a label format (or use a Test format, see Section 4.3). Input a small quantity then begin printing.

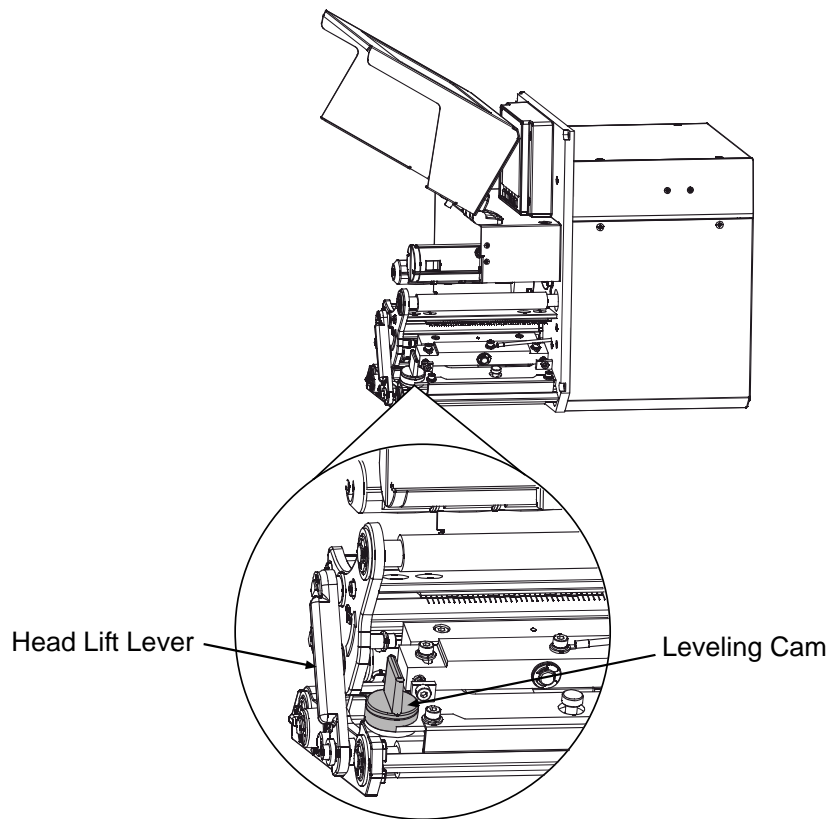

2. While observing the printed output, rotate the Leveling Cam counterclockwise until the image fades across the label, as shown in Example 1 (below).
3. While observing the printed output, rotate the Leveling Cam clockwise until the image is complete, with even contrast, as shown in Example 2 (below).

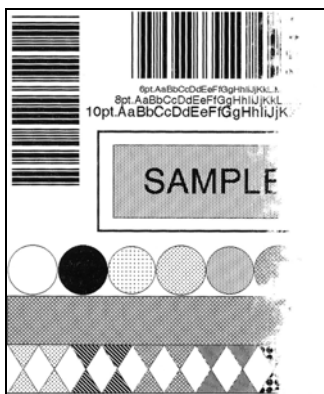

Example 1 - Over adjustment

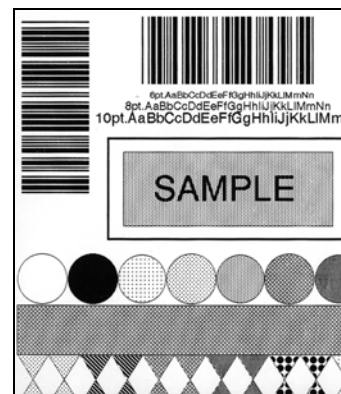

Example 2 - Correct adjustment



*Under-adjustment of the Leveling Cam can cause problems that include ribbon wrinkling, label tracking, and excessive platen and printhead wear.*

### 5.3.2 Burn Line Adjustment

Adjust the Burn Line only after trying suggestions in Sections 5.3.1 and 3.5 to achieve print conformance and aesthetic standards. If print quality remains unacceptable, adjust the Burn Line as follows:



*If you have questions regarding this procedure, contact a qualified technician or Datamax-O'Neil Technical Support before proceeding.*

---

1. Load media (and ribbon, if required), as described in Section 3.1.
2. Loosen the two Locking Screws on the Printhead Assembly approximately ¼ turn counterclockwise.

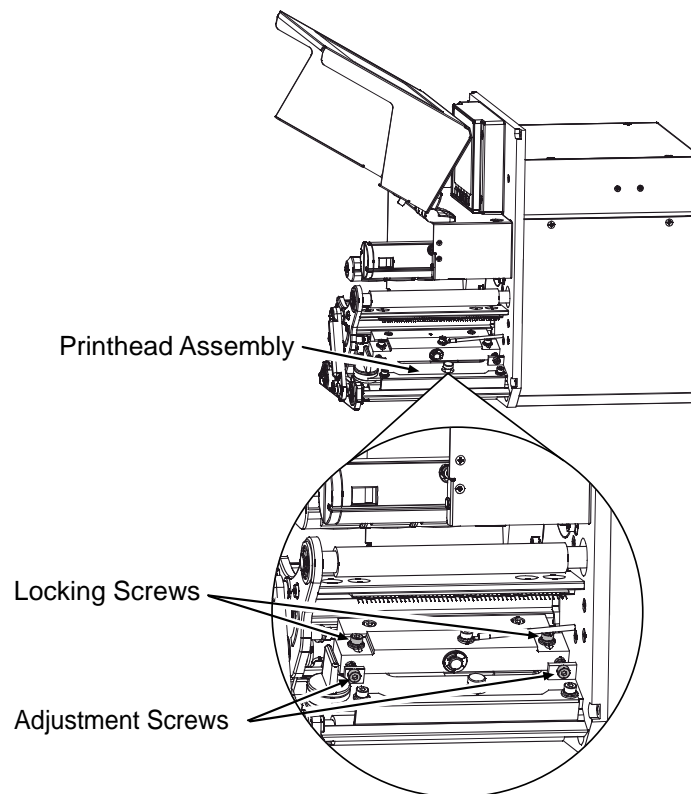

3. Turn the Adjustment Screws counterclockwise to bring the printhead burn line (see illustration, Section 5.6.1) forward (in the FEED direction) of the top of the platen.
4. Print a Validation Label; see Section 4.3.4. (*The label should have a light, uneven appearance.*)

5. Tighten the Locking Screws until 'snug' (that is, tight enough to remove any play in the printhead assembly, yet loose enough to allow the Adjustment Screws to move the printhead).
6. Turn each Adjustment Screw clockwise about a ¼ turn (and 1/8 a turn for finer adjustments). *Typically, thick media requires a slight forward adjustment, while thin media requires a backward adjustment.* Print another Validation Label and examine the print quality. Repeat Step 6 (see note below) until labels are produced that meet conformance as well as aesthetic standards.



*When the Locking Screws are 'snug', turning the Adjustment Screws counterclockwise will NOT move the printhead outward. If the printhead is adjusted too far inward, restart the entire procedure beginning at Step 2.*

---

7. Tighten the Locking Screws. Print a final Validation Label to verify the adjustment.

## 5.4 Printhead Replacement



- Use extreme care when handling the printhead; wear a wrist strap and follow standard ESD prevention procedures.
  - (2) If 24V OUT OF TOLERANCE is displayed (see Section 6.1.2), contact a qualified technician or Datamax-O'Neil Technical Support before proceeding.
- 

Replace the printhead as follows:

1. Turn OFF the printer. Raise the Access Cover.
2. Touch a bare metal part of the printer's frame to discharge any static electricity that may be present on your body. Unplug the printer.
3. With the Printhead Assembly in the down position, loosen the Captive Screw(s). *The following drawings highlight the location of Captive Screws according to printer model:*

*A-4xxx models:*

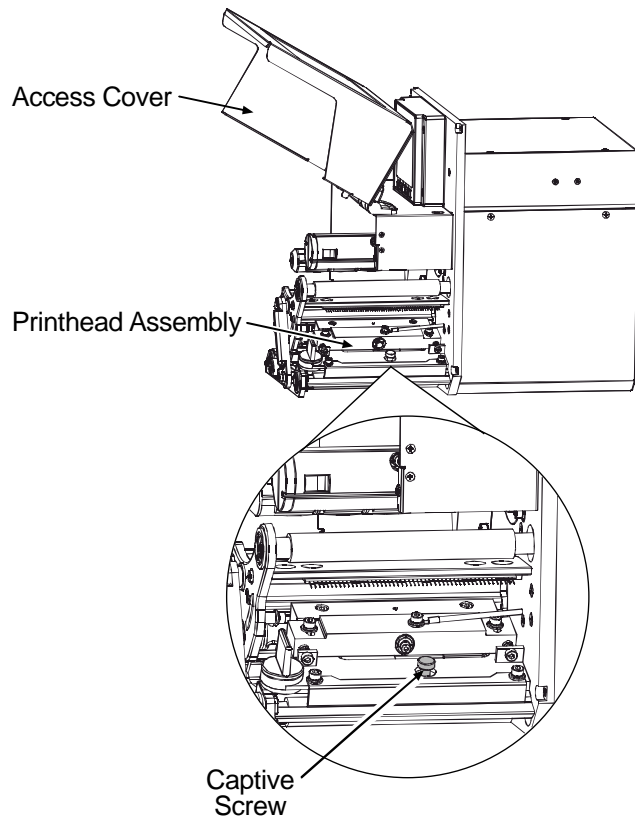

*A-6xxx models:*

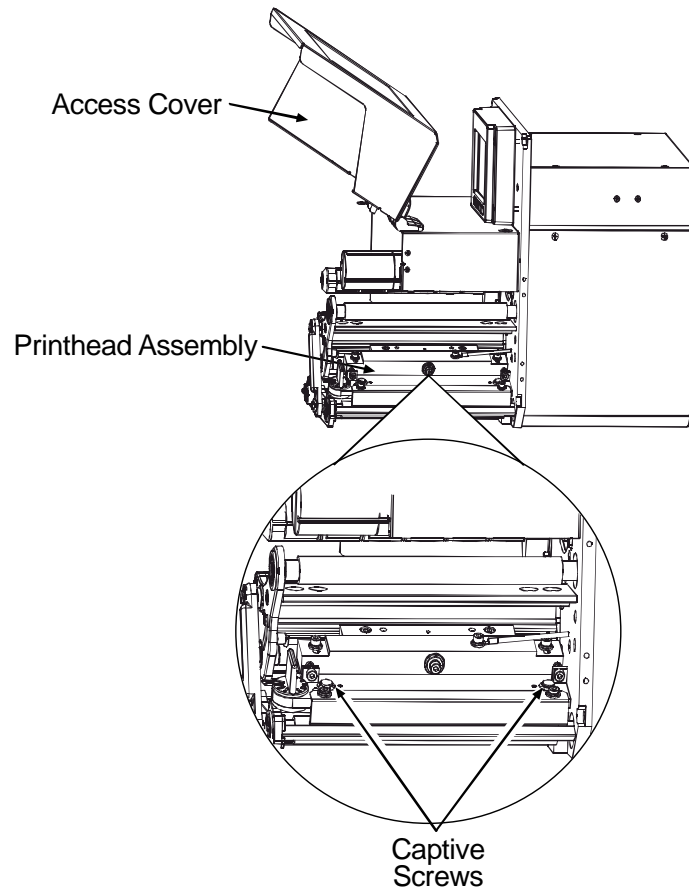

4. Raise the Head Lift Lever then gently slide the Printhead forward. Carefully disconnect both Printhead Cables, and then remove the Printhead.
5. While carefully protecting the *new* Printhead, connect both Printhead Cables.
6. Place the Printhead onto the locating pins (on the underside of the Printhead Assembly). (Use the Alignment Window in the Printhead Assembly to center the edge of the Printhead, as shown below, and then move the Printhead forward or backward to locate the pins.)

---

 *The drawing illustrates the Alignment Window of a right hand model printer, while left hand models are mirrored in orientation.*

---

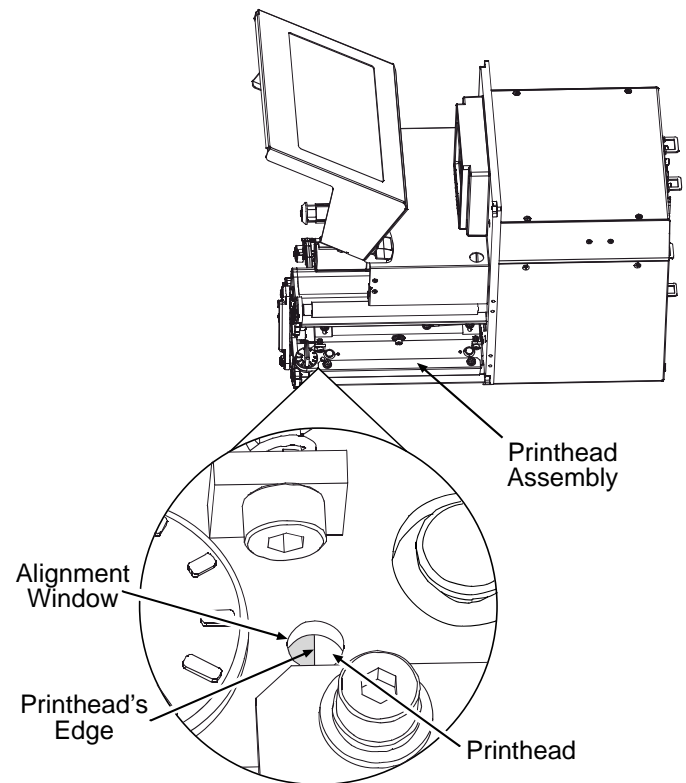

7. Secure the Printhead with the Captive Screw(s), but do not over-tighten.
8. Clean the Printhead using alcohol and allow it to dry; see Section 5.6.1.
9. Reload media, and ribbon (if removed), lower the Head Lift Lever into the locked position. Plug in and turn ON the printer.
10. Print a Validation Label (see Section 4.3.4) then examine the printed label and, if necessary, adjust the DARKNESS setting (see PRINT CONTROL / CUSTOM ADJUSTMENTS, Section 4.2.2) to match the previously produced print contrast.

---

 *A replacement printhead does not typically require alignment; however, if print quality has changed, see Section 5.3.2.*

---

## 5.5 Platen Roller Replacement

Replace the Platen Roller as follows:

1. Turn OFF the printer. Raise the Access Cover.
2. Unlatch and raise the printhead.
3. Remove the Screw, Printhead Latch Post, and Bearing retainer from the printer.

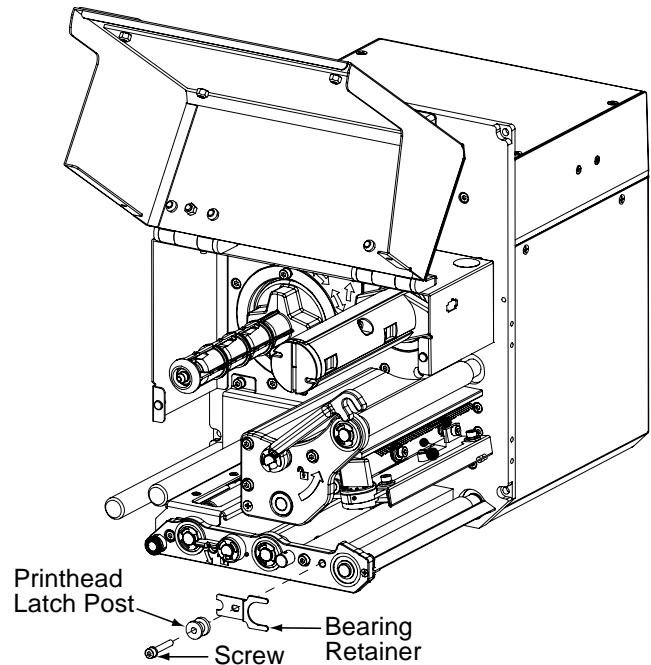

4. Remove the outer bearing and platen roller from the printer

5. Re-install the Platen Roller in the reverse order. Be sure when inserting the Platen roller that the "flat" on the Platen Roller shaft is aligned with the pulley inside the printer.

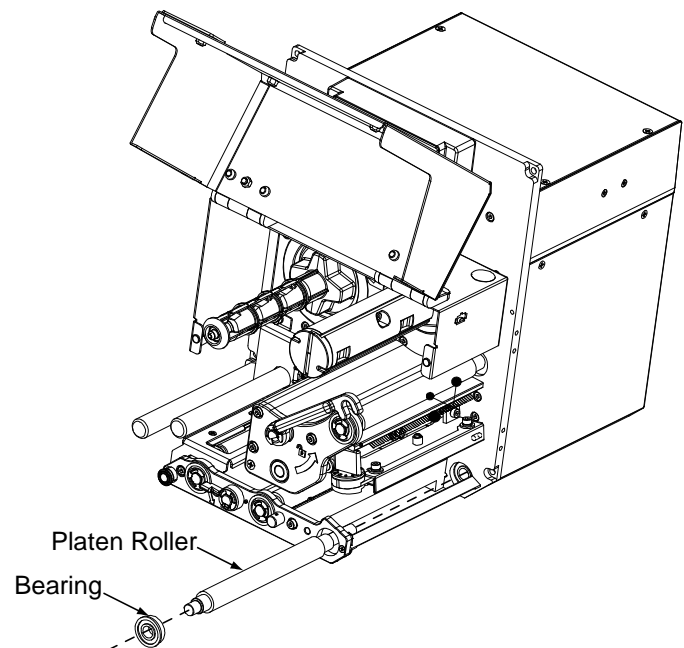

## 5.6 Maintenance Schedule

This section details the recommended maintenance supplies, schedules, and methods.

### Supplies

The following items will help safely and effectively clean the printer:

- Isopropyl alcohol
- Cotton swabs
- A clean, lint-free cloth
- Soft-bristle brush
- Soapy water and a mild detergent
- Compressed air
- Printhead Cleaning Cards or Cleaning Film

### Schedule

The following table details the recommended cleaning schedules for various printer parts.



*For your safety and to avoid damaging the printer, turn OFF and unplug the printer before cleaning. Always take proper precautions when using isopropyl alcohol, a flammable liquid.*

Recommended Maintenance Schedule		
Area / Item(s)	Cleaning Interval *	Method / Supplies
Exterior Surfaces	As needed, based on a weekly visual inspection.	Mild detergent; see Section 5.6.5.
Media Path / Media Sensor / Peel Bar	As needed, based on a weekly visual inspection.	Compressed air or a soft brush and isopropyl alcohol, as needed; see Section 5.6.4.
Peel Assembly	After each roll of labels, after each roll of ribbon, or as needed.	Cotton swab dampened with isopropyl alcohol; see Section 5.6.3.
Printhead	<ul style="list-style-type: none"> <li>• Thermal transfer media – after each roll of ribbon.</li> <li>• Direct thermal media – after each roll of media, or as needed.</li> </ul>	Cotton swab dampened with isopropyl alcohol and, if necessary, Cleaning Cards or Film; see Section 5.6.1.
Rollers	After each roll of labels, after each roll of ribbon, or as needed.	Cotton swab dampened with isopropyl alcohol; see Section 5.6.2.

\* Whichever interval occurs first.



## 5.6.1 Cleaning the Printhead

When bar codes become unreadable or if streaks appear in text and graphics, the printhead may need cleaning. Debris buildup, left unattended, can reduce the printhead service life. (See Section 4.2.1 to program cleaning prompts.) Depending upon the media and parameters used, different cleaning methods are recommended, as detailed below:



Never use a sharp, hard or abrasive object on the printhead.

---

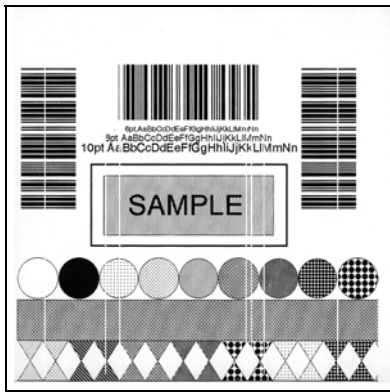

---

 *Streaks can indicate a dirty or faulty printhead.*

---

Proper cleaning is critical. To maintain peak performance of the printer, Datamax-O'Neil offers a complete line of cleaning products including pens, cards, films and swabs. Visit our website at <http://www.datamaxcorp.com/media/products/cleaning> to learn more. **Certified Datamax-O'Neil – The worry free choice for optimal printer performance.**

**Cotton Swab Procedure** (for users of direct thermal media, or thermal transfer media with wax ribbon):

1. Turn OFF and unplug the printer. Open the cover and raise the Head Lift Lever. **Wait a minute for the printhead to cool.** Remove media and ribbon from the printer.
2. Using a Cotton Swab moistened (not soaked) with isopropyl alcohol, clean the Printhead and its Burn Line.

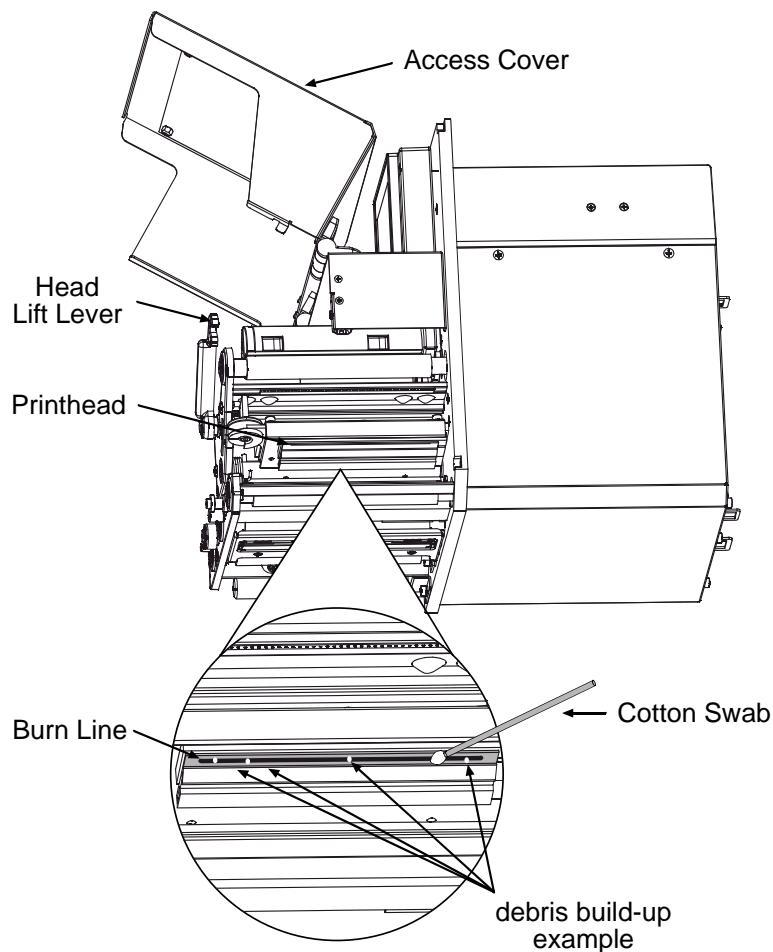

**3. Allow the printhead to dry.**

4. Reinstall media (and ribbon, if needed). Close the cover. Plug in and turn ON the printer. Run a few sample labels and examine them. If symptoms persist, use the Cleaning Card Procedure; otherwise, this completes the process. If the CLEAN HEAD SCHEDULE has been set, enter the menu and select RESET COUNTER; see Section 4.2.1.

***Cleaning Card Procedure*** (for users of direct thermal media, or thermal transfer media with wax/resin ribbon combinations; also for unsuccessful Cotton Swab cleaning attempts):

1. Open the cover and raise the Head Lift Lever. **Wait a minute for the printhead to cool.** Remove media and ribbon.
2. Place a Cleaning Card under the printhead. (Use part number 70-2013-01 for 4-inch model printers and 70-2014-01 for 6-inch model printers.)
3. Lockdown the Head Lift Lever and disengage the Leveling Cam; see Section 5.3.1.

4. Close the cover. Press and hold the TEST Key until the Cleaning Card has been run through the printer. (As an alternate, 'CLEAN HEAD NOW' can be selected, see Section 4.2.1.)
5. Reinstall media (and ribbon, if needed). If necessary, adjust the Leveling Cam. Close the cover. Run a few sample labels and examine them. If symptoms persist, use the Cleaning Film Procedure; otherwise, this completes the process.

**Cleaning Film Procedure** (for users of thermal transfer media and resin ribbon, when printing with a Heat Value of 22 or higher, or when other methods prove unsuccessful):

1. Open the cover and raise the Head Lift Lever. **Wait a minute for the printhead to cool.** Remove media and ribbon.
2. Place a sheet of Cleaning Film under the printhead. (Use part number 70-2087-01 for 4-inch model printers; or, 70-2087-02 for 6-inch model printers.)
3. Lockdown the Head Lift Lever and disengage the Leveling Cam; see Section 5.3.1.
4. Close the cover. Press and hold the TEST Key until the Cleaning Film has been run through the printer. (As an alternate, 'CLEAN HEAD NOW' can be selected, see Section 4.2.1.)
5. Turn OFF and unplug the printer. Open the cover and raise the Head Lift Lever and **wait briefly for the printhead to cool.** Using a cotton swab moistened (not soaked) with isopropyl alcohol, clean the printhead then allow it to dry.
6. Reinstall media (and ribbon, if needed). Plug in and turn ON the printer. Run a few sample labels and examine them; if streaking is still present, see Section 6.1.

## 5.6.2 Cleaning the Rollers



Never use a sharp object to clean the rollers.

---

Clean the rollers as follows:

1. Turn OFF and unplug the printer. Raise the access cover.

2. Raise the Head Lift Lever. Lower the Peel Assembly Release Lever. Remove media and ribbon.

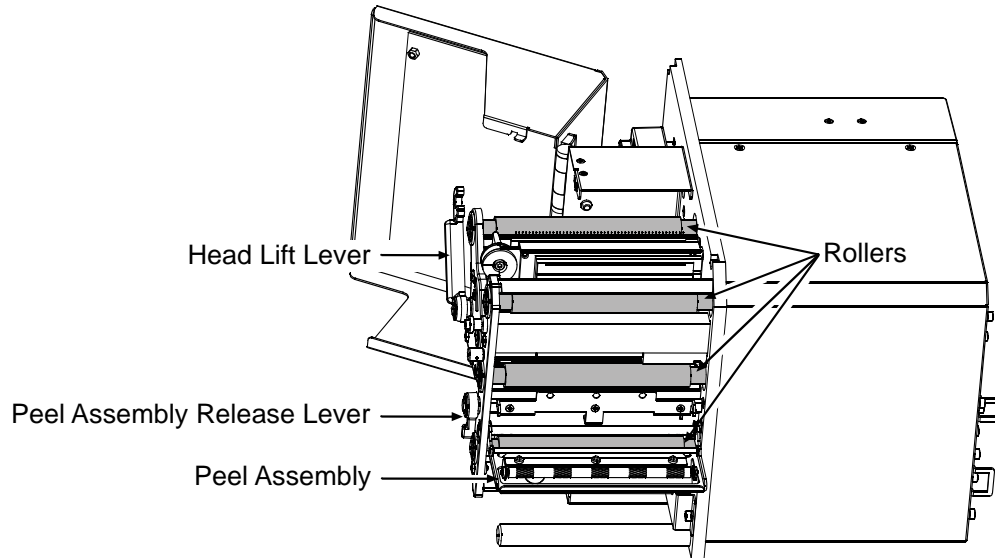

3. Using a cotton swab dampened with isopropyl alcohol, clean the Rollers, rotating each as necessary to clean its entire surface.
4. After allowing the Rollers to dry, replace ribbon and media. Close the Peel Assembly and lower the Head Lift Lever into the locked position.
5. Close the access cover. Plug in and turn ON the printer. This completes the procedure.

### 5.6.3 Cleaning the Peel Assembly

Clean the Peel Assembly as follows:

1. Turn OFF and unplug the printer. Raise the access cover.
2. Raise the Head Lift Lever. Lower the Peel Assembly Release Lever. Remove media and ribbon.

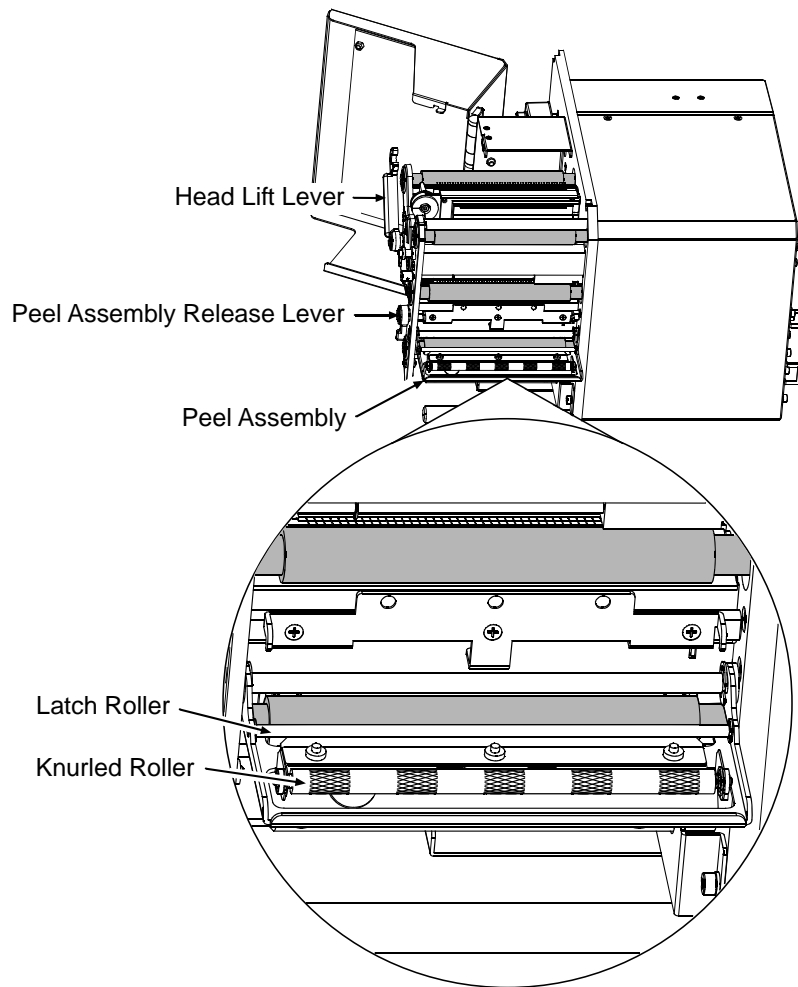

3. Using a cotton swab dampened with isopropyl alcohol, clean the Latch Roller and the Knurled Roller, rotating each as necessary to clean its entire surface.
4. After allowing the rollers to dry, replace ribbon and media. Close the Peel Assembly and lower the Head Lift Lever into the locked position.
5. Close the access cover. Plug in and turn ON the printer. This completes the procedure.

## 5.6.4 Cleaning the Media Sensor, Media Path, and Peel Bar

Clean the Media Sensor, Media Path, and Peel Bar as follows:

1. Turn OFF and unplug the printer. Raise the access cover.
2. Raise the Head Lift Lever. Lower the Peel Assembly Release Lever. Remove media and ribbon.

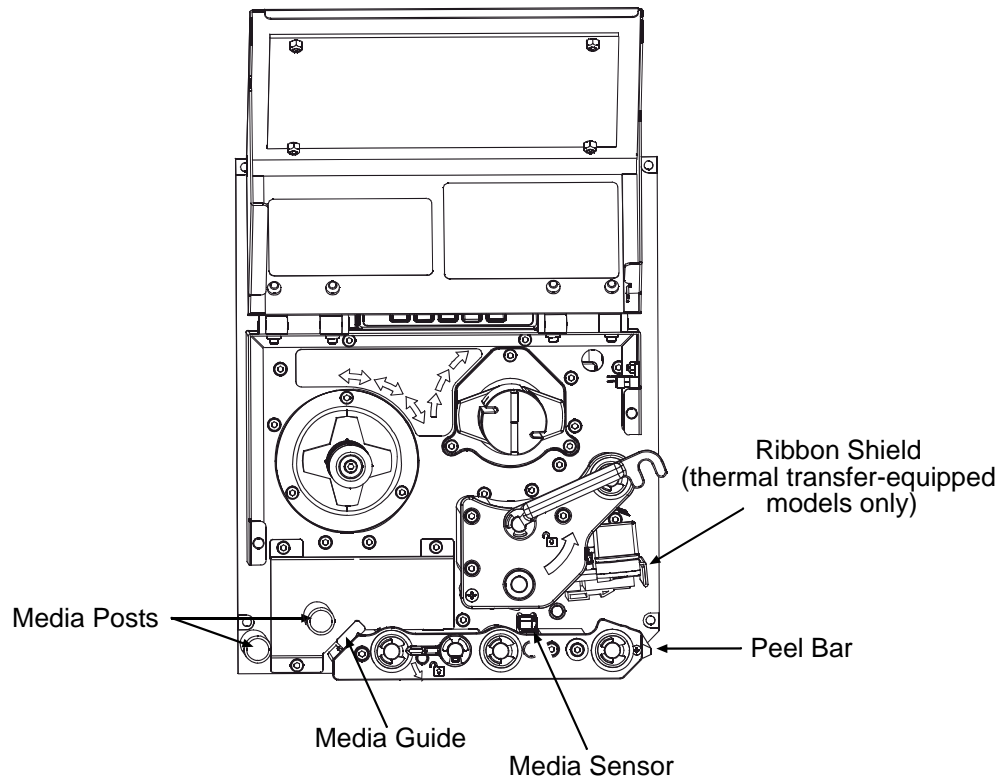

3. Using compressed air or a soft brush, clean the media path (and ribbon path, on units equipped with the thermal transfer option) including the Media Sensor and Peel Bar. Use a cotton swab dampened with isopropyl alcohol as needed on areas of heavy buildup.
4. After allowing the components to dry, replace media, and ribbon (if needed). Close the Peel Assembly and lower the Head Lift Lever into the locked position.
5. Close the access cover. Plug in and turn ON the printer. This completes the procedure.

## 5.6.5 Cleaning Exterior Surfaces

Clean the printer surfaces as follows:

1. Turn OFF and unplug the printer.
2. Using a soft cloth or sponge dampened with cleanser, wipe the exterior surfaces clean.
3. Allow the surfaces to dry.
4. Plug in and turn ON the printer.

## 5.7 Reset Methods

There are three reset levels for the printer.

### 5.7.1 Soft Reset

Soft Reset clears temporary host settings. To perform a Soft Reset, press and hold the CANCEL Key (see Section 4.1) for approximately four seconds.

### 5.7.2 Level One Reset

The Level One Reset returns the factory default settings, or if saved a Factory Setting File. To perform a Level One Reset, select SET FACTORY DEFAULTS (see Section 4.2.4).

### 5.7.3 Level Two Reset

The Level Two Reset returns the firmware default settings and clears all parameters. To perform a Level Two Reset, press and hold the PAUSE, FEED, & CANCEL Keys while turning ON the printer (see Section 4.1).



*Calibration will be required; see Section 5.2.*

---

## 5.8 Updating the Firmware



Depending upon the firmware version, stored data on modules can be lost when performing an update.

The printer's application program (firmware) can be updated as versions become available. Identify then download onto your computer's hard drive the updated version of firmware for your model printer from our web site at <ftp.datamaxcorp.com>

Follow the steps below to install the firmware:



*If updating to version 11.021 or greater, the Boot Loader must be updated before proceeding; see Section 5.9.*

Firmware Update Procedure			
Step	Displayed Message	Action	Comment(s)
A	READY	Using the DOS copy command (where 'filename' is the program to be loaded and 'lpt1' is the selected interface port), enter the following:  <code>copy filename lpt1</code>	As an example, this would be entered as:  <code>copy A4212_1103A.zs lpt1</code>  (Where 'lpt1' is the host computer's port; however, this selection can differ to include a serial or other port, as the printer is equipped.)  As data is received, the Comm Indicator will appear.
B	UPGRADING SOFTWARE	No action required.	The new application program is being stored and verified.
C	A4212 11.03 01/01/2008	No action required.	The printer has automatically reset and is displaying the new firmware version.
D	READY	No action required.	The new application is now running.

You may need to recalibrate the printer and reenter any custom settings. To verify the new firmware version and current configuration, print a Configuration Label; see Section 4.3.2.



*If the download was unsuccessful, the printer will perform a 'warm reset' and the original firmware will remain operational. (If the reset fails to occur, cycle the power switch OFF and ON.) A list of error messages and possible solutions is given below.*



<b>Firmware Update Error Messages</b>	
<b>Displayed Message</b>	<b>Descriptions / Possible Causes / Solutions</b>
DECOMPRESSION ERROR	An error occurred during the decompression and transfer of file data from cache storage into the Flash memory. Confirm the firmware version and try the download again; however, if the problem continues call for service.
ERROR ERASING FLASH	Flash memory could not successfully be erased. Defective Flash memory is a possible cause. Try the download again; however, if the problem continues call for service.
ERROR WRITING FLASH	The program could not successfully be written into Flash memory. Defective Flash memory is a possible cause. Try the download again; however, if the problem continues call for service.
HARDWARE MISMATCH	The firmware downloaded is not compatible with the Main Logic CCA, is for a different model printer, or is not supported by the boot loader version. See CONFIGURATION LEVEL, Section 4.2.4, for details.
INVALID SOFTWARE	<p>A error was detected during download, possible causes and solutions include:</p> <ul style="list-style-type: none"> <li>• An invalid or corrupted file was downloading. Try resaving the file to the host. Download the file to the printer.</li> <li>• A communications error occurred. Recheck the cabling and port settings.</li> </ul>
SOFTWARE MISMATCH	The software level being installed is not authorized for this printer. See PRINTER KEY, Section 4.2.4, for details.

## 5.9 Updating the Boot Loader

Updates for the Boot Loader program can be found at [ftp.datamaxcorp.com](http://ftp.datamaxcorp.com)

Before performing an update, identify the printer's current Boot Loader version by printing a Configuration Label (see Section 4.3.2) and comparing the installed version to those available from the FTP site. Download the desired version onto your computer's hard drive then follow the steps below to install the Boot Loader program.



If power is lost while UPGRADING SOFTWARE is displayed, the printer will become non-functional and will require factory programming or a main logic card.

Boot Loader Update Procedure			
Step	Displayed Message	Action	Comment(s)
A	READY	Using the DOS copy command (where 'filename' is the program to be loaded and 'lpt1' is the selected interface port), enter the following:  <code>copy filename lpt1</code>	As an example, this would be entered as:  <code>copy BOOTXC99_1101.bs lpt1</code>  (Where 'lpt1' can differ to include other ports, as available.)  As data is received, the Comm Indicator will appear.
B	UPGRADING SOFTWARE	No action required.	The new program is being stored and verified.
C	BOOTXC99_1101.bs		The printer has reset.
D	READY		The new application is now running.  <input checked="" type="checkbox"/> If UNCALIBRATED is displayed, see Section 5.2.

*If the boot loader update failed, try this alternate procedure:*



*Press and hold the FEED and CANCEL Keys (see Section 4.1) while turning ON the printer. After SEND SOFTWARE is displayed, release the keys then re-send the file as described above.*

## 5.10 Fonts

### Downloading Kanji, Hangul and Chinese Fonts

KANJI, HANGUL and CHINESE fonts can be downloaded and stored in a printer module. Font files are identified by part number and are protected by lock bits, which unlocked by entering the correct 6-digit code via the Control Panel. The printer can be easily and quickly updated:

- A. Identify then download onto your computer's hard drive the desired file for the printer from our web site at ftp.datamaxcorp.com
- B. Call to get the unlock code and enter it into the printer. Turn OFF the printer.
- C. Turn OFF the printer. Connect your computer to the printer via the parallel or USB port, and then turn ON the printer.
- D. Using the Windows print driver, open the Printer Properties box and select the 'Tools' tab. Then, from the 'Action' drop-down box, select 'Send File to Printer.'
- E. When prompted, browse to the downloaded font file on your computer's hard drive (or floppy disk) and then send that file to the printer.



*If protected, the destination module must first be unprotected.*

---

With a successful download and installation, the printer will reset. Installed fonts can be identified by part number and appear on the configuration label (and system display). The following table lists possible font downloading messages:

Font Download Messages	
Displayed Message	Descriptions / Possible Causes / Solutions
ACCESS DENIED FILE EXISTS	A font file of the same name already exists in memory.
ACCESS DENIED SOFTWARE MISMATCH	The printer has an insufficient configuration level for an encrypted plug-in, an unlocked font bit, or key mismatch. Verify the Configuration Level of the printer by examining the Printer Key then compare it to the software level requirement for the file being installed.
INVALID HEADER	A wrong file format, file header is corrupt or a transmission error has occurred. Confirm the font version and try the download again; however, if the problem continues call for service.
INVALID IMAGE	The download content was corrupted or a transmission error occurred. Check for corruption by printing a configuration label or by looking at the system window; a double question mark before the plug-in part number indicates corruption. Try the download again; however, if the problem continues call for service.
SUCCESSFUL	The file was successfully installed; the printer will perform an automatic reset.

Font Download Messages <i>(continued)</i>	
Displayed Message	Descriptions / Possible Causes / Solutions
SYSTEM FAULT	Insufficient memory space for the file exists in the destination module. Try selecting a different destination module or clear some space on the module and perform the download again.
WRITING FLASH	The file was successfully decrypted, verified, and is now being written into the destination module.
WRITING FLASH FAILED	The file failed checksum verification after being written to the module. Try the download again; however, if the problem continues call for service.

### *Processing TrueType Fonts*

To process TrueType fonts (.TTF) on an external module for use by the printer:

1. Use Windows Explorer to download the font to a module.
2. Install the module in the printer.
3. Press the **MENU** button then select **Printer Options**.
4. Select **Modules** and then **Process File**.
5. Select the module ID and the font file.
6. When prompted enter a 2 character font ID, and then the destination module ID.
7. Ensure that your label formats use the same font ID as assigned in Step 5.

### *Copying TrueType Fonts*

To copy TrueType fonts (.TTF) to an external module for use by the printer:

1. Use Windows Explorer to download the font to the module.
2. Add a 2 digit DPL font ID to the file name (50-99, 9A-9Z, 9a-9z) then change the file extension to .dtf (for example, *aria150.dtf*); see Scalable Font Downloading in the *Class Series 2 Programmer's Manual*.
3. Install the module in the printer.
4. Ensure that your label formats use the same font ID as assigned in Step 2.

### *Removing Fonts*

When deleting a plug-in, all files contained within that directory will also be deleted; see MODULES / DELETE FILE, Section 4.2.3.

# 6 Troubleshooting

## 6.1 Problem Resolution

When a problem is encountered, the information in this section will help resolve it. Locate the description of the problem to find an appropriate solution. For problems that are accompanied by a displayed message, see Section 6.1.2.



*Depending on your labeling program and the printer's menu settings, some commands and selections can be ignored. See HOST SETTINGS (Section 4.2.5) for more information and consult your software vendor for program information. If you have questions or if problems persist, contact a qualified technician or Datamax-O'Neil Technical Support.*

### 6.1.1 General Resolutions

The following table lists problems that may not be accompanied by a displayed message:

Problem	Possible solution
Blank display (but the backlight is ON):	<p>The display contrast may set too low (press and hold the MENU Key; see Section 4.1.1).</p> <hr/> <p> <i>When using the remote display option, both the remote display and the display mounted to the printer share the same contrast setting.</i></p> <hr/>
Erratic feeding:	<p>Calibration may be needed (press and hold the FEED Key; see Section 3.4).</p>
Erratic printing:	<p>Check the following possibilities:</p> <ul style="list-style-type: none"><li>• Hex Dump mode may be enabled (disable it; see Section 6.2); or,</li><li>• If using serial communication, check the host and printer port settings (settings must match; see Section 4.2.5).</li></ul>
Intellifont will not print:	<p>You may be using an incorrect type – Intellifont format is Little/Big Endian specific and the printer uses Big Endian (refer to your font supplier for information).</p>

General Resolutions (continued)

Problem	Possible solution
Light or no print on the side of the label:	<p>Check the following possibilities:</p> <ul style="list-style-type: none"> <li>• The Leveling Cam may be incorrectly adjusted (adjust it; see Section 5.3.1); or,</li> <li>• The Platen may be dirty or worn (clean and inspect; see Section 5.6.2).</li> <li>• The HEAD BIAS setting may be incorrect (check the setting; see Section 4.2.4).</li> </ul>
Missing label information:	<p>Check the following possibilities:</p> <ul style="list-style-type: none"> <li>• Check the format for character or image placement outside the label dimensions (all row / column values must allow for character and bar codes space for printing within the format size);</li> <li>• Available memory may have been exceeded by the format requirements (try reducing the memory allocation to either the INTERNAL MODULE or SCALEABLE FONT; see Section 4.2.4);</li> <li>• If using serial communication, ensure that the interface cable meets requirements (verify necessary pin outs; see Section 2.3.2); or,</li> <li>• The HEAD BIAS setting may be incorrect (check the setting; see Section 4.2.4).</li> </ul>
No power (display backlight is OFF):	<p>Check the following possibilities:</p> <ul style="list-style-type: none"> <li>• Verify that the AC power cord is connected to and that the power switch is ON (for details see Section 2.5);</li> <li>• Verify that the AC outlet is functioning, or move the printer to another location on a different circuit;</li> <li>• Replace a possibly damaged AC cord; or,</li> <li>• The line fuse may be blown (call for service).</li> </ul>

General Resolutions (continued)

Problem	Possible solution
<p>No print using direct thermal media (labels advance normally):</p>	<p>Test the heat reactivity of the labels then proceed accordingly:</p> <ul style="list-style-type: none"> <li>• If the labels react, increase the HEAT setting via the software program or through the menu (see Section 4.2.2); or,</li> <li>• If the labels do not react, install different media.</li> </ul>
<p>No print using thermal transfer media (labels advance normally):</p>	<p>Examine the used ribbon for an image:</p> <ul style="list-style-type: none"> <li>• If an image is on the ribbon, verify that the ribbon was correctly installed. (Confirm the coated side by pressing the label's sticky side against the ribbon, where ink will lift from the coated side.) Clean the printhead (see Section 5.5.1) then correctly install the ribbon (see Section 3.3); or,</li> </ul> <p>If no image is on the used ribbon, try the following:</p> <ul style="list-style-type: none"> <li>• Run a Test label, and if an image printed then ensure that the protocol and port settings for the printer and host match; see Section 4.2.5.</li> <li>• Increase the HEAT setting; see Section 4.2.2.</li> <li>• Verify that the media and ribbon combination is compatible; see Section 7.2.</li> </ul>
<p>Nothing prints when using a software program (Test labels print normally):</p>	<p>Ensure that the printer is at READY then observe the display when sending your label format to the printer and proceed accordingly:</p> <ul style="list-style-type: none"> <li>• If Receiving Data (see Section 4.1) is not indicated, check the protocol, port settings and / or IP Address between the printer and host. If networking, check for the appropriate Current State Icon. Also, ensure that the interface cable meets the requirements of the printer and host, and that it is properly connected; or,</li> <li>• If Receiving Data is indicated, disable COMMUNICATIONS / ESC SEQUENCES; see Section 4.2.5.</li> </ul>

General Resolutions (continued)

Problem	Possible solution
Poor print quality:	Check the following possibilities: <ul style="list-style-type: none"><li>• Check the Leveling Cam for correct adjustment (readjust if necessary; see Section 5.3.1);</li><li>• Review the print quality controls (adjust if necessary; see Section 3.5);</li><li>• If using thermal transfer, check the media and ribbon compatibility (use a recommended combination; see Section 7.2); or,</li><li>• Check for a dirty Printhead (clean it if necessary; see Section 5.6.1).</li></ul>
Skips labels when printing:	Check the following possibilities: <ul style="list-style-type: none"><li>• Calibrate the printer (see Section 3.4);</li><li>• Adjust the Media Sensor (see Section 3.2); or,</li><li>• If the label format is within 1/8 inch of the media's edge, reduce or move the format slightly away.</li></ul>

### 6.1.2 Warning and Fault Messages

The printer displays messages when the possibility of a problem or an actual fault occurs. Depending upon the displayed message, find the possible action or solution in the tables below.



*Warning and Fault Messages do not appear when in Menu or Test mode.*

---

#### Warning Messages

Displayed for about three seconds, Warning Messages assume a low priority and indicate a pending change in printer configuration, or an operating condition that could lead to a fault.



<b>Warning Messages</b>		
<b>Displayed Message</b>	<b>Description</b>	<b>Possible Solution(s)</b>
24V OUT OF TOLERANCE	The printer has detected a drop in the 24-volt power supply.	No action is required. If the problem continues, cycle the power OFF and ON.
DOT FAILURE	Defective printhead elements have been detected.	Replace the printhead if print quality becomes unacceptable.
GAP MODE WARNING LOW BACKING	Only a small difference exists between the measured 'empty' and 'gap' sensor readings.	No action is required. During calibration, labels mounted on a transparent liner or notched media may give this indication. A slight delay in the 'Out of Stock' message may occur.
GOODBYE	Power has been removed and printer shutdown is in progress.	AC line voltage has been lost. The power switch was turned OFF or the line fuse has blown. If unable to restore power using the power switch, try moving the printer to another location and if the condition persists, call for service.
HEAD NEEDS CLEANING	The scheduled printhead cleaning distance has been reached.	Clean the printhead (see Section 5.6.1). To change the cleaning setting, enter Media Settings / Printhead Cleaning Menu.
HOST CHANGES PENDING	The host has changed the configuration of the printer, but those changes cannot take effect until a 'host reset command' is issued.	To save these changes, send a host reset command (in DPL); or, to discard the changes, perform a soft reset (see Section 5.7.1).

Warning Messages Fault Messages <i>(continued)</i>		
Displayed Message	Description	Possible Solution(s)
INVALID ENTRY	The selection you are attempting to make is not valid or is not within the acceptable parameter range.	Enter a different setting or parameter that falls within the acceptable range.
LOW VOLTAGE	The printer has detected a low operating voltage.	Possible low or fluctuating line voltage levels have been sensed. If the condition persists, try moving the printer to another outlet, or call for service.
RIBBON LOW	The ribbon supply is almost empty.	Load ribbon soon.
RTC RAM FAILURE	The printer was unable to save settings in permanent memory.	Possible faulty Main Logic CCA. Retry your save. If the condition persists, call for service.
TEMPERATURE PAUSE	A high printhead temperature has been detected.	Wait for the printhead to cool. Afterward, when the printhead reaches an acceptable temperature, printer operations will automatically resume.

### ***Fault Messages***

These high priority messages alert you to a printer fault condition. (Alternate messages may occur when downloading font, firmware, or Boot Loader files.)



*To return operation after a fault occurs, the fault must be corrected and the FEED Key pressed.*

<b>Fault Messages</b>		
<b>Displayed Message</b>	<b>Description</b>	<b>Possible Solution(s)</b>
ADC FAULT	The printer has detected an analog to digital circuit converter failure.	Cycle printer power OFF and ON. If the fault does not clear, call for service.
CLOSE HEAD / COVER	The printhead is up or the cover is open.	Lock the Head Lift Lever and close the Access Cover.
DMA FAULT	The printer has detected a Direct Memory Access failure.	Cycle printer power OFF and ON. If the fault does not clear, call for service.
GAP MODE CANNOT CALIBRATE	Consistently low sensor readings have been detected for the media.	Press any key to continue. Ensure that media was removed from the media sensor during the appropriate calibration steps; also, ensure that ribbon has been correctly loaded and that the sensor is clean (see Section 5.6.4). Retry the calibration. If the problem persists, try Advanced Entry Calibration (see Section 5.2.2).
GAP MODE FAULTY SENSOR	Consistently high sensor readings have been detected for the media.	Press any key to continue. Ensure that media was removed from the media sensor during the appropriate calibration steps; also, ensure that ribbon has been correctly loaded and that the sensor is clean (see Section 5.6.4). Retry the calibration. If the problem persists, call for service.

<b>Fault Messages</b> <i>(continued)</i>		
<b>Displayed Message</b>	<b>Description</b>	<b>Possible Solution(s)</b>
HEAD CLEANING FAULT	Scheduled cleaning has exceeded three times the selected distance.	Clean the printhead (see Section 5.6.1).
OUT OF STOCK	The printer cannot detect the presence of media.	Examine the printer for media then proceed accordingly: <ul style="list-style-type: none"> <li>• If the printer is out of stock, load media; or,</li> <li>• If stock is loaded, ensure that the Media Sensor is calibrated (see Section 3.4), properly positioned (see Section 3.2) and, if the media has large gaps that the PAPER OUT DISTANCE is adjusted (see Section 4.2.1).</li> </ul>
POSITION FAULT	Possible causes include a firmware update, a power failure or reset during a ribbon, out of stock or TOF fault, and incomplete calibrations.	Press the FEED Key in an attempt to identify and then clear the fault. Perform calibration (see Section 3.4).
PRINT ENGINE FAULT	A problem within the print logic has been detected.	Cycle printer power OFF and ON. If the fault does not clear, call for service.
RAM FAULT	A memory failure has been detected.	Cycle printer power OFF and ON. If the fault does not clear, call for service.

<b>Fault Messages</b> <i>(continued)</i>		
<b>Displayed Message</b>	<b>Description</b>	<b>Possible Solution(s)</b>
REFLECTIVE MODE CANNOT CALIBRATE	Consistently low sensor readings were detected.	Press any key to continue. Ensure that the reflective mark was inserted face down. Also, ensure that the sensor is clean and that the reflective mark is made from carbon-based ink. Retry calibration.
REFLECTIVE MODE FAULTY SENSOR	Consistently high sensor readings were detected.	Press any key to continue. Ensure that media was removed from the media sensor during the appropriate calibration steps; also ensure that no labels are stuck in the media sensor. Retry calibration. If the problem persists, call for service.
RIBBON FAULT	Two causes are possible:  (1) The Thermal Transfer media type has been selected, but no ribbon movement or only sporadic movement has been detected; or,  (2) The ribbon sensor values have changed.	If using direct thermal stock, set the Media Type to Direct Thermal; otherwise, ensure that ribbon is installed.  Press the FEED Key to clear the fault - - if the fault does not clear check the Ribbon Hubs for free movement. Also, ensure that the ribbon core fits snugly onto the supply hub, and that the ribbon is not slipping or stalling as labels print. If no binding, slipping, or stalling is apparent press and hold the FEED Key until at least three labels have been output. If the fault does not clear, call for service.
TEMPERATURE FAULT	The printer has shutdown due to a high printhead temperature.	Turn OFF the printer. Ensure that the printer has been installed within an acceptable environment. DO NOT restart operation until the printhead cools.

Fault Messages <i>(continued)</i>		
Displayed Message	Description	Possible Solution(s)
TOP OF FORM FAULT	<p>The printer could not find a TOF mark within the maximum length setting, or TOF was encountered in an unexpected place.</p> <hr/> <p><input checked="" type="checkbox"/> When the SENSOR TYPE is REFLECTIVE, this indication is given for Out Of Stock.</p> <hr/>	<p>Check the following possibilities:</p> <ul style="list-style-type: none"> <li>• Calibration may be necessary (see Section 3.4);</li> <li>• The Media Sensor may need adjustment (see Section 3.2);</li> <li>• The Media Guide may need adjustment (see Section 3.1);</li> <li>• The Leveling Cam may need adjustment (see Section 5.3.1);</li> <li>• The maximum label length may need to be increased (see Section 4.2.1); or</li> <li>• The Media Sensor may need to be cleaned (see Section 5.6.4).</li> </ul>

## 6.2 Hex Dump Mode

Hex Dump mode is a useful diagnostic tool for debugging label formats and hardware problems, as received host data strings are printed without interpretation by the printer.

- To enter Hex Dump mode, press the MENU Key and select DIAGNOSTICS. Go to HEX DUMP MODE then select ENABLED and press the ENTER Key. Exit the menu, saving your changes.

Afterward, HEX DUMP MODE will be displayed and all received data will be printed in hexadecimal code (along with the ASCII equivalents); see example below:

```
0000 02 4C 0D 44 31 31 0D 31 ^L.D11.1
0008 36 31 31 30 30 30 30 33 61100003
0010 32 30 30 30 31 30 46 4F 200010FO
0018 4E 54 20 36 3A 20 41 4C NT 6: AL
0020 4C 20 56 41 4C 49 44 20 L VALID
0028 20 20 20 20 20 20 20 20
0030 20 20 20 0D 31 36 31 31 1611
0038 30 30 30 30 32 38 30 30 00002800
0040 30 31 30 20 20 20 20 20 010
0048 20 20 20 43 48 41 52 41 CHARA
0050 43 54 45 52 53 3A 0D 31 CTERS:.1
0058 36 31 31 30 30 30 30 32 61100002
0060 34 30 30 30 31 30 23 24 400010#$
0068 25 26 28 29 2A 2B 2E 2D %&()*+,-
```

To decode the data the *Class Series 2 Programmer's Manual* is an essential reference (see the Accessories CD-ROM). Also, some software programs use bit mapping, which can make analysis difficult – contact Datamax-O'Neil Technical Support with any questions.



To return normal operating mode, enter DIAGNOSTICS and disable HEX DUMP MODE. Then, exit the menu, saving your changes.

---





# 7 Specifications

## 7.1 Printer Specifications

This section identifies parameters and features of the printer models.

### *Embedded Bar Codes & Fonts*

See the *Class Series 2 Programmer's Manual* for details.

### *Interfaces*

Types:	Main Logic CCA - (1) Parallel, IEEE 1284 Compliant (1) Serial, DB9 RS-232/422/485 (configurable) (1) USB, Version 1.1 Compliant (1) Ethernet, 10/100Mbps  Applicator Interface CCA - (1) Serial, EIA RS-232 DB9 (configurable) (1) Serial, EIA RS-232 RJ45 (2) General Purpose Input/Output Port: Signal Inputs: Opto-coupled Signal Outputs: 500 mA max. sinking current Voltage Outputs: +5 VDC, fused (resettable) @ 0.75 amps +24 VDC, fused (resettable) @ 1.6 amps
Serial Data Rate:	1200 to 115,000 bits per second (COM A)
Handshaking:	Xon/Xoff; CTS/DTR
Parity:	Even, Odd, or None
Stop Bits:	1 or 2
Data Bits:	7 or 8

## ***Electrical***

Power Supply:	Auto-ranging switching type.
AC Input Voltage Range:	90 – 132 / 180 – 264 VAC @ 47 – 63 Hz, auto-ranging
Grounding:	Unit must be connected to a properly grounded circuit.
Power Consumption:	A-4xxx models: 200 watts, typical operating; 25 watts, standby  A-6xxx models: 220 watts, typical operating; 25 watts, standby
Printhead Protection:	Thermistor sensor shutdown with over-temperature occurrence, and automatic printing resumption after cooling.

## ***Environmental***

Operating Temperature:	32 F – 100 F (0 C – 38 C)
Operating Humidity:	10% – 90% (non-condensing)
Storage Temperature:	-40 F – 150 F (-40 C – 60 C)
Storage Humidity:	5% – 95% (non-condensing)
Dust:	Non-conducting, non-corrosive
Electromagnetic Radiation:	Moderate RF fields can be tolerated.

## ***Mechanical***

Height:	All models:	11.81 inches (30.0 cm)
Width:	All models:	9.67 inches (24.6 cm)
Depth:	A-4xxx models:	15.35 inches (39.0 cm)
	A-6xxx models:	17.35 inches (44.0 cm)
Weight:	A-4xxx models:	34 pounds (15.3 kg)
	A-6xxx models:	37 pounds (16.7 kg)

## Printing

Type:	Direct Thermal or optional Thermal Transfer
Speed Range:	A-4212 & A-6212: 2 – 12 IPS (50 – 304 MMPS) A-4310 & A-6310: 2 – 10 IPS (50 – 254 MMPS) A-4408: 2 – 8 IPS (50 – 203 MMPS) A-4606: 2 – 6 IPS (50 – 152 MMPS)
Resolution:	A-4212 & A-6212: 203 DPI (8.0 DPMM) A-4310 & A-6310: 300 DPI (11.8 DPMM) A-4408: 406 DPI (16.0 DPMM) A-4606: 600 DPI (23.6 DPMM)
Nominal Dot Size:	A-4212 & A-6212: .0043 X .0052 in. (.11 X .13 mm) A-4310 & A-6310: .0027 X .0043 in. (.07 X .11 mm) A-4408: .0013 X .0018 in. (.05 X .07 mm) A-4606: .0008 X .0015 in. (.03 X .06 mm)
Maximum Print Width:	A-4212 & A-4408: 4.10 inches (104.0 mm) A-4310 & A-4606: 4.16 inches (105.7 mm) A-6212: 6.62 inches (168.1mm) A-6310: 6.40 inches (162.6 mm)
Length Range:	.25 – 99.99 inches (6 – 2500 mm)
Flash Memory:	8 MB
DRAM Memory:	16 MB
Justification* (media edge to Dot 1 distance):	All RH models; A-4212 LH; & A-4408 LH: .07 in. (1.8 mm) A-4310 LH; A-4606 LH; & A-6212 LH: 0 A-6310 LH: .054 in. (1.4 mm)

\* Where RH denotes Right Hand and LH denotes Left Hand.

## Media & Ribbon

Media Types:	Wound-out labels only and tag stock; roll-fed, die-cut, notched, reflective, continuous, and fan-fold. Flat printable side, with no more than .0007 in. (.018 mm) protrusions on the opposite side (see below).
Ribbon Types:	'Coated Side In' or 'Coated Side Out'.
Ribbon Width Range*:	A-4xxx models: 1 - 4.65 inches (25 - 118 mm) A-6xxx models: 2 - 6.7 inches (51 - 170 mm) <i>*The ribbon width should slightly exceed the label width (and backing material).</i>
Ribbon Length:	1968 feet (600 meters)
Ribbon Core Size:	1.01 inches .006 inches (25.6 mm .2 mm) inner diameter, and core not to protrude beyond the ribbon edge.
Media Dimensions:	Reference the drawing and table below:

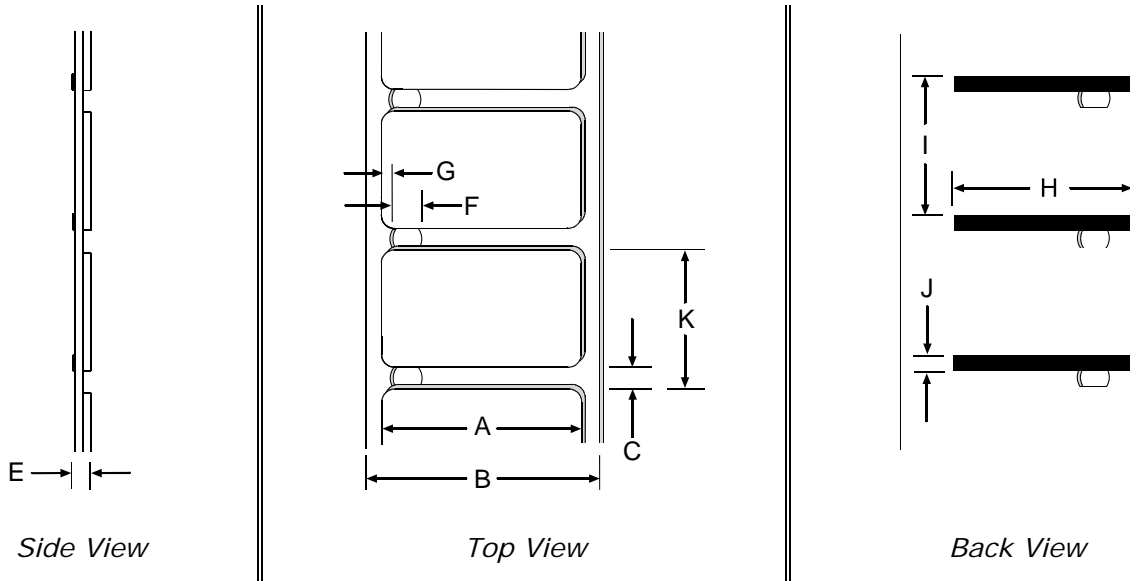

Media Dimensional Requirements <sup>[1]</sup>									
Designator	Description	A-4xxx models				A-6xxx models			
		Minimum		Maximum		Minimum		Maximum	
		inches	mm	inches	mm	inches	mm	inches	mm
A	Label width	1.00	25	4.65	118	2.00	51	6.7	170
B	Liner width	1.00	25	4.65	118	2.00	51	6.7	170
C	Gap (or notch) between labels <sup>[3]</sup>	.08	2	-	-	.08	2	-	-
D	Label length <sup>[3]</sup>	.25	6	-	-	.25	6	-	-
E	Media thickness	.0025	.06	.01	.25	.0025	.06	.01	.25
F	Notch opening width	.08	2	-	-	.08	2	-	-
G	Media edge to sensor aperture	.20	5	2.25	70	.20	5	2.25	70
H	Reflective mark width <sup>[2,3]</sup>	.47	12	4.65	118	.47	12	6.7	170
I	Distance between reflective marks <sup>[2,3]</sup>	.25	6	-	-	.25	6	-	-
J	Reflective mark length <sup>[2,3]</sup>	.08	2	-	-	.08	2	-	-
K	Label repeat distance <sup>[3]</sup>	.33	8	-	-	.33	8	-	-

<sup>[1]</sup> Referenced in the direction of label feed.

<sup>[2]</sup> The reflective (black) mark must be carbon based, placed on the backside of the stock, and the reflectance shall be less than 10% at wavelengths of 640 – 950 nm.

<sup>[3]</sup> The maximum allowable length of the combined label and gap (or mark) measurement cannot exceed 99.99 inches.

## 7.2 Approved Media and Ribbon

Media (and ribbon for thermal transfer) is an important determinant in the throughput, quality, and performance of the printed product. The following overview is an introduction to the different types of material that can be used in the printer. For complete information and advice regarding a specific application, consult a qualified media specialist or a Datamax-O'Neil Media Representative. Also available is an informative white paper, "A Brief Introduction to Media," which can be found on our website at [www.datamax-oneil.com](http://www.datamax-oneil.com)

### Direct Thermal

Consider three important factors when selecting direct thermal stock:

- The abrasiveness of the material that covers the thermal reactive layer of the paper;
- The amount of heat required to start the chemical reaction; and,
- The ability of the media to control that chemical reaction.

### Thermal Transfer

Consider three important factors when selecting thermal transfer media and ribbon combinations:

- Label top coating and ribbon combinations may affect image quality;
- Ribbon back coating can provide printhead protection and, depending upon the formula, help reduce static buildup; and,
- The ribbon width, when slightly wider than the media, can also guard the printhead against media abrasion.

### Media and Ribbon Selection

To achieve optimum print quality and maximum printhead life, we specify the use of Datamax-O'Neil brand media. These supplies are specially formulated for use in our printers; use of non-Datamax-O'Neil supplies may affect the print quality, performance, and life of the printer or its components. For a current list of approved media, please contact a Media Representative at (407) 523-5650.

Suggested applications are listed below:

Media and Ribbon Overview			
Direct Thermal Media	Print Speed*	Print Energy	Image Durability
Datamax-O'Neil DTL-HSM	10 – 12**	Medium	Low
Datamax-O'Neil DTL-HSH	10 – 12**	Medium	Low

<b>Media and Ribbon Overview</b> <i>(continued)</i>				
<b>Thermal Transfer Media</b>	<b>Ribbon Type</b>	<b>Print Speed*</b>	<b>Print Energy</b>	<b>Image Durability</b>
Great Label TTL	GPR Plus	10 – 12**	Medium	Medium
Coated and uncoated paper, tag stock, some films and synthetics	Wax GPRPlus	2 – 10	Low	Low
Coated and glossy paper, tag stock, some films and synthetics	Wax/Resin PGR+	2 – 8	Medium	High
Synthetics and films	Resin SDR	4 – 6	High	High

\* Given in inches per second.

\*\* Highly recommended for optimum quality at speeds above 10 IPS.





# Appendix A

## Module Assignments

Module Assignments		
Designator	Size	Type / Use
D	1024 KB (default size)	DRAM <sup>[1]</sup> . Default, as assigned (see SYSTEM SETTINGS / DEFAULT MODULE, Section 4.2.4). Storage for graphics, fonts, and label formats.
G <sup>[2]</sup>	512 KB	FLASH. Storage for graphics, fonts, and label formats.
	See [3], below.	FLASH (Main Logic CCA). Storage for graphics, fonts, and label formats.
F	Dependant	External SDIO device (if option equipped). Storage for graphics, fonts, and label formats.
H	Dependant	External USB device (if option equipped). Storage for graphics, fonts, and label formats.
I	Dependant	External USB device (if option equipped). Storage for graphics, fonts, and label formats.
X	See [3], below.	FLASH (Main Logic CCA). Storage for graphics, fonts, and label formats.
Y	128 KB	FLASH. Main Logic CCA. Reserved for EFIGS.

<sup>[1]</sup> When power is removed from the printer, stored data will be lost.

<sup>[2]</sup> Availability and size is dependent upon Main Logic CCA type; reference the Configuration Label. Also, Flash memory has a limited number of writes (approximately 100,000) and is intended for permanent (or semi-permanent) storage.

<sup>[3]</sup> Modules G and X are partitioned to equal the sum of the total space available, approximately 6.5MB.

## File Handling Messages

Depending upon the module and operation selected, several messages are possible when using the file handling system:

File Handling Messages		
Displayed Message	Description	Possible Solution(s)
FAILED	The copy or format request has failed.	Insufficient space exists to store the file or the module is protected - try storing to a different location. (If the problem persists, this could indicate a hardware problem.)
FILE EXISTS, OVERWRITE?	An existing file of the same name and type was found.	Select YES to overwrite or NO to exit.
MODULE PROTECTED	Formatting has been denied because the module is protected.	Unprotect the module.
NO FILES AVAILABLE	No associated files can be found to perform the requested action.	<p>Ensure the file is present:</p> <p>Following a Print File request, this is normal when no files are available for printing (also note that some files will print only the file name);</p> <p>Following a Process File request, this is normal when no files are available for processing (also note that some files may not display); or,</p> <p>Following a Copy File request, this is normal when no files are available for copying (also note that internal database files cannot be copied).</p>
NOT SUPPORTED	The file type requested is not supported.	Recheck the type of file requested for printing or processing, and ensure that it matches one of the available types for that function.
PROTECTED, COPY FILE?	The file requested will be copied to a protected module.	Select YES to override protection and copy the file, or NO to exit.
UNFORMATTED	The module is unformatted.	<p>Format the module.</p> <hr/>  <p><i>FORMAT MODULE will erase all data in the selected memory.</i></p>

## Cut Behind Setup

The printer can queue then cut a specified number (0 – 2) of small labels, resulting in a throughput increase. To improve throughput when cutting batches of small labels, follow the procedure below:

- 1) Measure the length (L) of your media, label edge to label edge including gap, if any.
- 2) Determine the distance\*\* (D) from the burn line to cutter blade.

---

*\*\* This distance may vary between printers and require slight modification.*

---

- 3) Calculate the Cut Behind number (N) by dividing the distance (D) by the length (L) of the media.

$$N = D \div L$$

- 4) Calculate the Present Distance (PD) by subtracting the product of the length (L) and Cut Behind number (N) from the distance (D).

$$PD = D - (N \times L)$$

- 5) Enter the calculated Present Distance (PD) as the PRINT CONTROL / PRESENT DISTANCE setting; see Section 4.2.2.
- 6) Enter the calculated Cut Behind number (N) as the PRINTER OPTIONS / CUTTER setting (see Section 4.2.3) and then exit the menu and save your settings.
- 7) Verify the setup. With media installed, repeatedly press FEED to test the cut location:
  - If correct, the printer is ready for use; or,
  - If incorrect, adjust the PRESENT DISTANCE accordingly – increase the setting to move the cut farther out or decrease the setting to move the cut closer.



- If Distance (D) is larger than 4 inches (101 mm), the printer will not retract when idle and blank labels will be lost.
  - FAULT HANDLING / VOID AND RETRY should not be used; see Section 4.2.4.
-



# Appendix B

## Print Resolutions and Widths

Print Resolutions and Widths				
Model	Resolution	Maximum Print Width		Default Setting
		Inches	Millimeters	
A-4212	203 dots/inch (8 dots/mm)	4.10	104	4.10
A-4310	300 dots/inch (11.8 dots/mm)	4.16	105.7	4.16
A-4408	406 dots/inch (16 dots/mm)	4.10	104	4.10
A-4606	600 dots/inch (23.6 dots/mm)	4.16	105.6	4.16
A-6212	203 dots/inch (8 dots/mm)	6.62	168.1	6.62
A-6310	300 dots/inch (11.8 dots/mm)	6.40	162.6	6.40

## Speed Ranges

Speed Ranges and Defaults				
Model & Function	Range		Default Setting	
	IPS	MMPS	IPS	MMPS
A-4212: Print	2-12	51 – 305	8.0	203
Feed	2-12	51 – 305	8.0	203
Reverse	2-5	51 – 127	4.0	102
Slew	2-16	51 – 406	8.0	203
A-4310: Print	2-10	51 – 254	8.0	203
Feed	2-12	51 – 305	8.0	203
Reverse	2-5	51 – 127	4.0	102
Slew	2-16	51 – 406	8.0	203

<b>Speed Ranges and Defaults</b> <i>(continued)</i>				
<b>Model &amp; Function</b>	<b>Range</b>		<b>Default Setting</b>	
	<b>IPS</b>	<b>MMPS</b>	<b>IPS</b>	<b>MMPS</b>
<b>A-4408: Print</b>	2-8	51 – 203	6.0	152
Feed	2-10	51 – 254	6.0	152
Reverse	2-5	51 – 127	4.0	102
Slew	2-16	51 – 406	6.0	152
<b>A-4606: Print</b>	2-6	51 – 152	4.0	102
Feed	2-8	51 – 203	4.0	102
Reverse	2-5	51 – 127	4.0	102
Slew	2-16	51 – 406	4.0	102
<b>A-6212: Print</b>	2-12	51 – 305	8.0	203
Feed	2-14	51 – 356	8.0	203
Reverse	2-5	51 – 127	4.0	102
Slew	2-14	51 – 356	8.0	203
<b>A-6310: Print</b>	2-10	51 – 254	8.0	203
Feed	2-12	51 – 305	8.0	203
Reverse	2-5	51 – 127	4.0	102
Slew	2-14	51 – 356	8.0	203

### **Column & Row Emulation Ranges**

<b>Column and Row Emulation Ranges</b> <i>(in dots)</i>			
<b>Model</b>	<b>Column</b>	<b>Row</b>	<b>Default Setting</b>
<b>A-4212 &amp; A-6212</b>	153 – 203	103 – 303	203
<b>A-4310 &amp; A-6310</b>	250 – 300	200 – 400	300
<b>A-4408</b>	356 – 406	306 – 506	406
<b>A-4606</b>	550 – 600	500 – 700	600

### **Custom Adjustments: Column, Present, & Row Adjust Ranges**

<b>Custom Adjustments: Column, Present, &amp; Row Adjust Ranges</b> <i>(in dots)</i>			
<b>Model</b>	<b>Column Adjust and Present Adjust Ranges</b>	<b>Row Adjust Range</b>	<b>Default Setting</b>
<b>A-4212 &amp; A-6212</b>	-100 – 100	-100 – 2030	000
<b>A-4310 &amp; A-6310</b>	-150 – 150	-150 – 3000	000
<b>A-4408</b>	-200 – 200	-200 – 4060	000
<b>A-4606</b>	-300 – 300	-300 – 6000	000

# Appendix C

## PE Peel Bar Location

Provided as a reference, the drawing below defines the previous peel point of PE models.

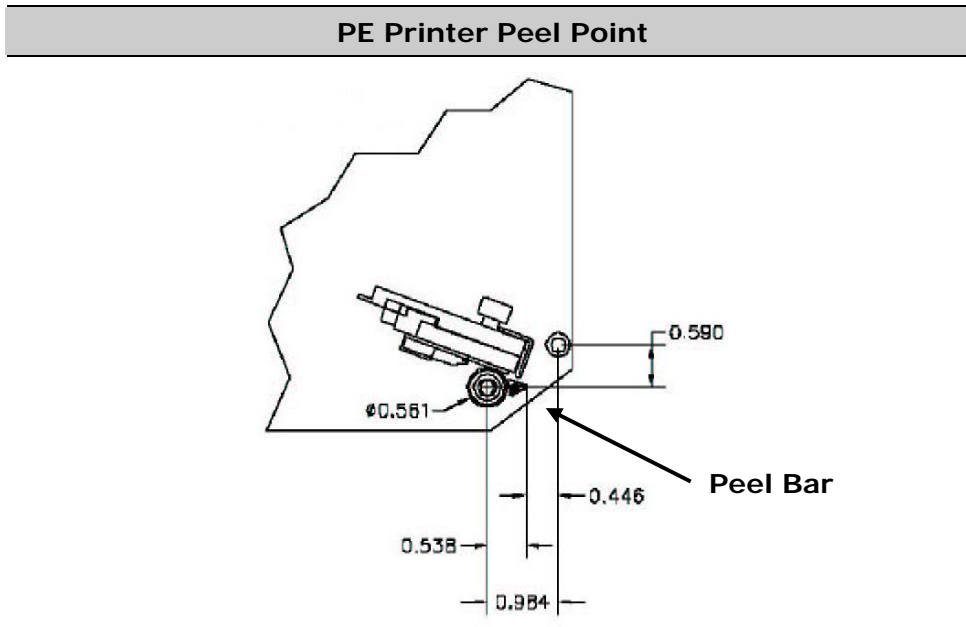

## Media Tension Settings

Provided as a guideline, the parameters below represent recommended applicator media tension settings.



*These numbers do not represent the pull strength of the printer.*

Function	Requirement
Media Rewind Force: Applicator Take-Up	Must be of uniform tension from 1 – 5 pounds (454 – 2268 grams), and must not vary more than 20% during operation
Media Unwind: Steady State	Must be of uniform tension, not to exceed 3 pounds (1361 grams)
Transient (Start/Stop)	Must not exceed 5 pounds (2268 g)

## PE to A-Class GPIO Adapter Cable

A GPIO Adapter Cable (P/N 32-2562-01) for integration of the A-Class into an existing PE installation. The cable converts the connections listed in the table below.

PE to A-Class GPIO Adapter Cable*	
PE DB9 Pin Connections	A-Class DB15 Pin Connections
1	2
2	9
3	10
4	NC
5	3
6	11
7	12
8	13
9	8
Case (shield)	Case (shield)

\*For fabrication, use a DB9 metal-shelled female connector (part numbers, 21-2757-01 & 21-2629-01); and a DB15 metal-shelled male connector (part numbers, 21-2758-01 & 21-2759-01).



# Appendix D

## Applicator Interface Overview

The Applicator Interface CCA contains the printer to an applicator interface circuitry; functions and suggested connections are given below, and in these related sections:

Operational settings; Section 4.2.3.

J3 (COM D) and J4 (COM C) setup; Section 4.2.5.

Testing and diagnostics; Section 4.2.6.



*Always wear a wrist strap and follow ESD prevention measures when handling the Applicator Interface CCA.*

## Applicator Interface CCA Jumper Configuration

The various ports on the card are configured by arranging hardware jumpers (illustrated below):

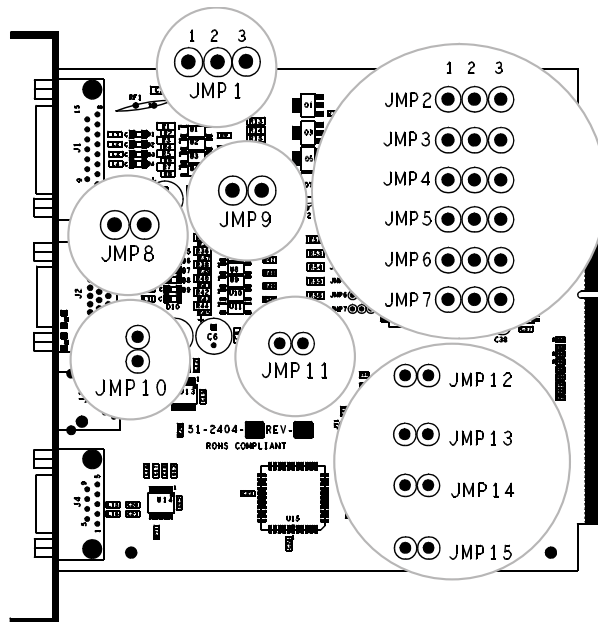

## GPI/O A (J1)

**Four dedicated inputs** are available for control of printer functions. These inputs require no external pull-ups, are designed to interface to open-collector outputs and accept totem pole outputs from +4.5 to + 26 VDC. Optical isolators are available to provide isolation. Two print control circuit examples are given below.

### *For direct inputs –*

Use the printer's +5VDC and Ground to supply the devices interfacing to the GPI/O A inputs (as shown, right).

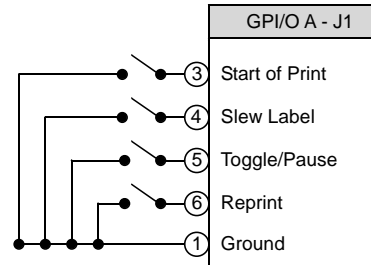

### *For isolated inputs –*

To provide galvanic isolation for the GPI/O A inputs, remove jumper JMP 9 then supply an external +5VDC source voltage to Pin 2, and remove jumper JMP 8 then supply an external Ground to Pin 1 (as shown, right).

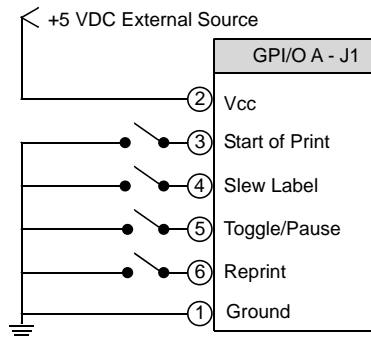

**Seven dedicated outputs** are available for control, warning, and error functions. These open-collector outputs are slew-limited. Optional 10K ohm pull-up resistors, tied to a common point for use at either +5 or +24 VDC, are available via jumper JMP 1.



*If external pull-up resistors are used (that is, without jumper JMP1 installed), then to avoid damage ensure that a common external voltage not exceed +30VDC is used.*

The table below details the GPI/O A pin assignments, settings and functions.



Failure to properly configure the GPIO Port can result in damage to the printer and / or connected devices.

GPIO Port A Overview							
Pin Number	Signal Name	Signal Direction <sup>[1]</sup>	Jumper	Position	Function / Description		
1	Ground	N/A	JMP 8	Installed	Printer chassis is used.		
				Removed	Ground must be supplied.		
2	+5 VDC		JMP 9	Installed	Printer +5VDC is used (.5 amp maximum) <input checked="" type="checkbox"/> Drawing more than .5 amps can result in unreliable printer operation.		
				Removed	+5VDC must be supplied.		
3	SOP <sup>[2]</sup>		Input	N/A	N/A	Programmable <sup>[3]</sup>	
4	Slew Label					Media is advanced until the signal goes HIGH and, if not in continuous mode, the label is positioned at the next available TOF.	
5	Toggle / Pause	The printer pauses when the signal is taken LOW.					
6	Reprint	The last label is reprinted exactly, with no increment or time stamp changes; recommended for use during error conditions. Holding this signal LOW will result in non-stop printing.					
7	+24 VDC	N/A	N/A	N/A	Printer +24 VDC (1.5 amp maximum)		
8	Ground				Printer chassis.		
9	Ribbon Low	Output			JMP 1	When inactive, outputs will be pulled up to a voltage determined by this jumper setting, where: <ul style="list-style-type: none"> <li>▪ Pins 1 – 2 = +5VDC;</li> <li>▪ Pins 2 – 3 = +24VDC; or,</li> <li>▪ None = A common external voltage (not to exceed +30VDC) via external pull-ups (providing a 20K ohm feedback path through any two outputs).</li> </ul>	Programmable <sup>[1]</sup> . Signifies a RIBBON LOW DIAMETER warning condition.
10	Service Required						Evoked by occurrences listed under *Fault Messages.* <sup>[1]</sup> Active LOW.
11	End Of Print						Programmable <sup>[1]</sup> . Signifies the End of Print (EOP) process.
12	Media Out						Evoked during an Out of Stock condition. Active LOW.
13	Ribbon Out		Evoked during an Out of Ribbon condition. Active LOW.				
14	Data Ready		Evoked when a label is waiting to be printed. Then after the printer receives the SOP signal, printing will begin. For synchronization with the print cycle, the End Of Print signal indicates the completion of the print process. Active LOW.				
15	Option Fault		Evoked during an RFID fault condition. Active LOW.				

<sup>[1]</sup> Signal directions are given relative to the printer.

<sup>[2]</sup> If active with no current print job, "WAITING FOR DATA" will be displayed. Specifying a quantity of 9999 while keeping this signal ON will cause non-stop label printing, except in single label Imaging Mode, which will cause the printer to stop between labels.

<sup>[3]</sup> For setting details, see PRINTER OPTIONS / GPIO PORT (Section 4.2.3).

## GPI/O B (J2)

**Six unassigned inputs** are designed to interface to open-collector outputs. These inputs require no external pull-ups and blocking diodes allow the use of totem pole outputs from +4.5 to + 26 VDC. Optical isolators are available to provide isolation. Two print control interface circuit examples are given below.

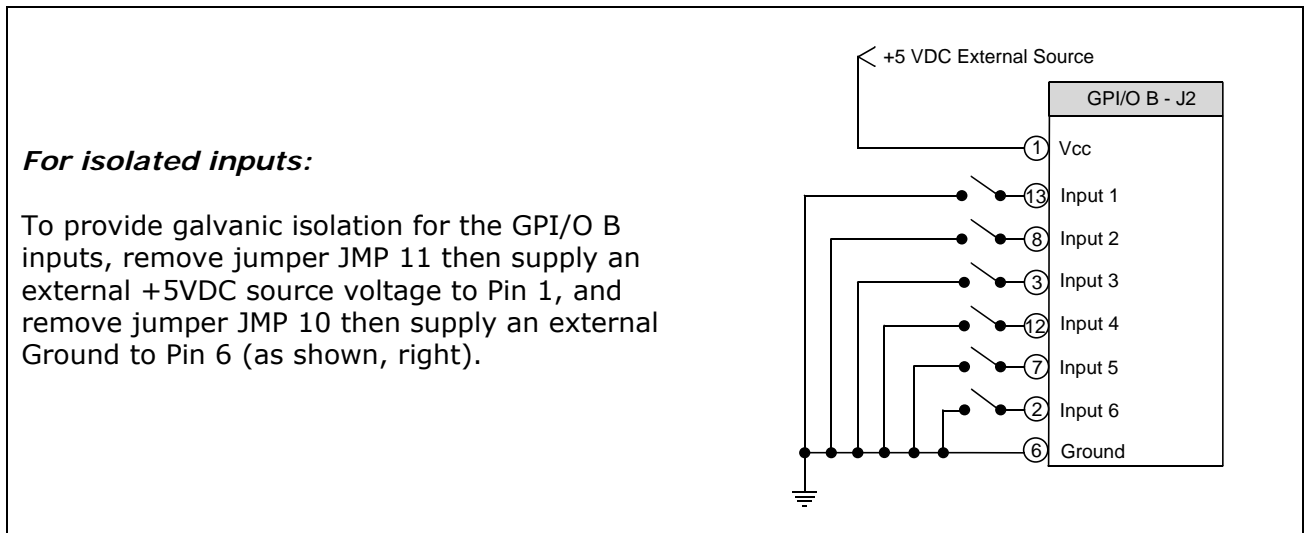
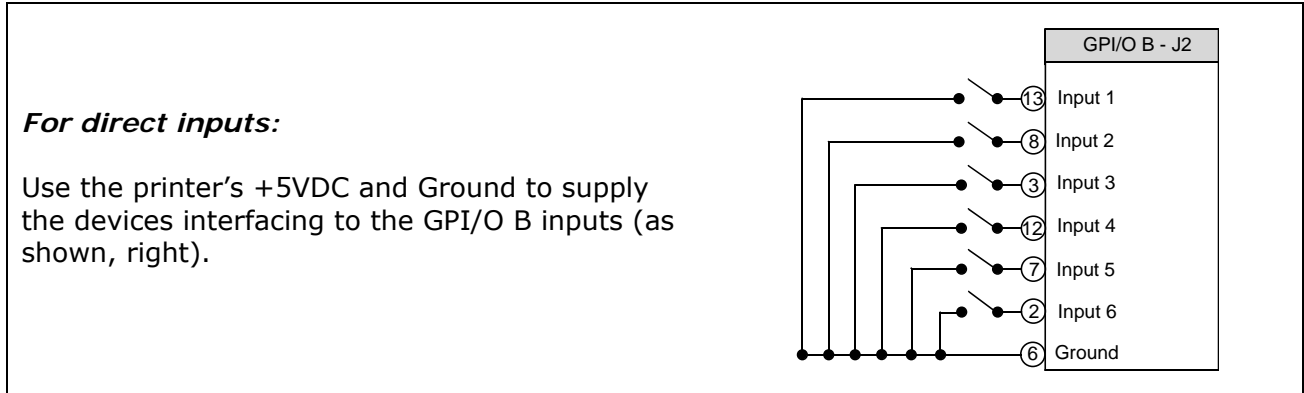

**Six unassigned outputs** are programmable and slew-limited. Optional 10K ohm pull-up resistors, one for each of the output lines, can be used at either +5 or +24 VDC via jumpers JMP 2 - 7.



*If external pull-up resistors are employed (that is, when Jumpers JMP 2 - 7 are not installed), to avoid damage ensure that external voltage does not exceed +30VDC.*

The table below details the GPI/O B pin assignments, settings and functions.



Failure to properly configure the GPIO Port can result in damage to the printer and / or connected devices.

GPIO Port B Overview				
Pin Number	Signal Name / Direction *	Jumper	Position	Function / Description
1	+5 VDC	JMP 11	Installed	Printer +5VDC is used (.5 amp maximum). <input checked="" type="checkbox"/> Drawing more than .5 amps can result in unreliable printer operation.
			Removed	+5VDC must be supplied.
2	Input 6	N/A	N/A	Programmed input function.
3	Input 3	N/A	N/A	Programmed input function.
4	Output 6	JMP 7	Installed: Pins 1 – 2	Programmed output function pulled-up to +5VDC.
			Installed: Pins 2 – 3	Programmed output function pulled-up to +24VDC.
			Removed	An external voltage via external pull-ups will determine this level, not
5	Output 3	JMP 4	Installed: Pins 1 – 2	Programmed output function pulled-up to +5VDC.
			Installed: Pins 2 – 3	Programmed output function pulled-up to +24VDC.
			Removed	An external voltage via external pull-ups will determine this level, not
6	Ground	JMP 10	Installed	Printer chassis is used.
			Removed	Ground must be supplied.
7	Input 5	N/A	N/A	Programmed input function.
8	Input 2	N/A	N/A	Programmed input function.
9	Output 5	JMP 6	Installed: Pins 1 – 2	Programmed output function pulled-up to +5VDC.
			Installed: Pins 2 – 3	Programmed output function pulled-up to +24VDC.
			Removed	An external voltage via external pull-ups will determine this level, not
10	Output 2	JMP 3	Installed: Pins 1 – 2	Programmed output function pulled-up to +5VDC.
			Installed: Pins 2 – 3	Programmed output function pulled-up to +24VDC.
			Removed	An external voltage via external pull-ups will determine this level, not
11	+24 VDC	N/A	N/A	Printer +24 VDC (1.5 amp maximum).
12	Input 4	N/A	N/A	Programmed input function.
13	Input 1	N/A	N/A	Programmed input function.
14	Output 4	JMP 5	Installed: Pins 1 – 2	Programmed output function pulled-up to +5VDC.
			Installed: Pins 2 – 3	Programmed output function pulled-up to +24VDC.
			Removed	An external voltage via external pull-ups will determine this level, not
15	Output 1	JMP 2	Installed: Pins 1 – 2	Programmed output function pulled-up to +5VDC.
			Installed: Pins 2 – 3	Programmed output function pulled-up to +24VDC.
			Removed	An external voltage via external pull-ups will determine this level, not

\* Signal directions are given relative to the printer.

### COM C (J4)

Serial Port C (see Section 2.3.2) functions as an RS-232 interface or as a dedicated device interface, according to the jumper settings indicated below:

COM C Jumper Setting Functions				
Function	Position			
	JMP 12	JMP 13	JMP 14	JMP 15
RS-232 Communications	On	On	On	On
RFID	Off	On	On	On
Remote Display	On	On	Off	On



*Jumper settings will override most printer menu settings.*

### COM D (J3)

Serial Port D is an RS-232 communications interface (see Section 2.3.2).

### Applicator Interface CCA Cable Connections

Depending on the application and port pin connections, you may need the following hardware to complete the interface connections:

- GPI/O A (J1) – DB15 Male connector (e.g., Star Tech C15PCM) and shielded cabling.
- GPI/O B (J2) – High Density DB15 Male VGA connector (e.g., Star Tech C15HPSM) and shielded cabling.
- COM C (J4) – DB9 Male connector (e.g., Star Tech C9PSM) and shielded cabling.
- COM D (J3) – RJ45 Plug (e.g., Belkin R6G088) and cabling (shielding optional).

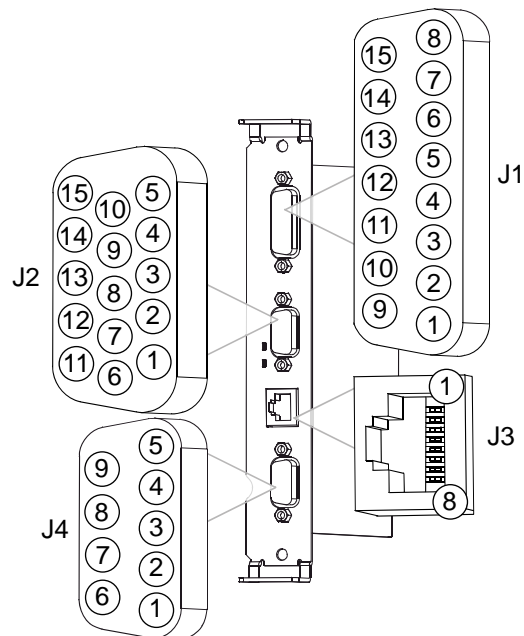

## Indicators and Monitors

Real-time verification of settings and activity of the GPIO ports is available via displayed and printed information:



*Unused, non-connected inputs and outputs will have an indeterminate state and assume a value of 1 or 0.*

**Indicators:** Sampled every millisecond, incoming (IN) and outgoing (OUT) signal activity can be observed on the card, where LED color changes correspond to signal state changes.

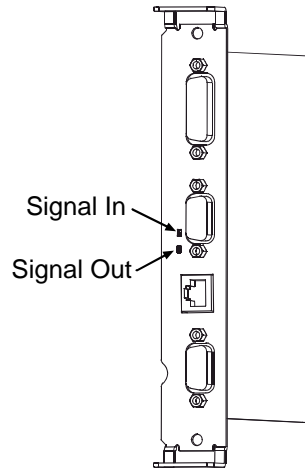

**Input Monitors:** Binary input signal states can be viewed (see Section 4.2.6, TEST GPIO / MONITOR GPIO INPUT) in the following format:

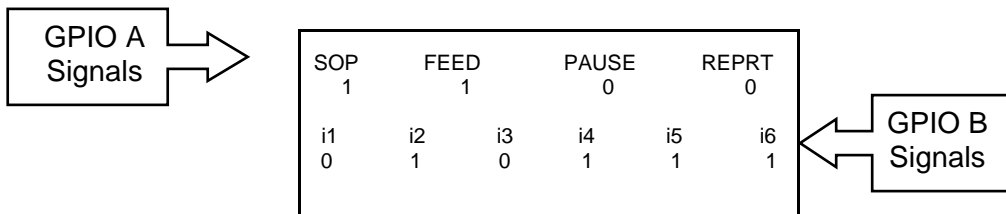

**Output Monitors:** Binary output signal states can be viewed (see Section 4.2.6, TEST GPIO / MONITOR GPIO OUTPUT) in the following format:

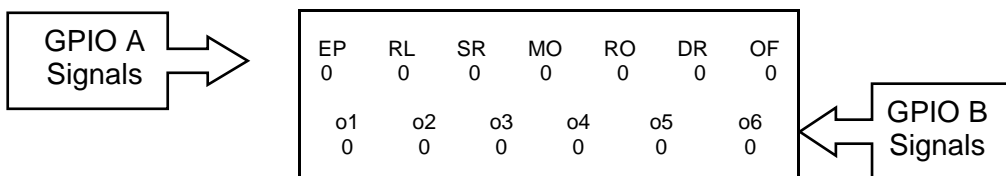

**PRINT SIGNAL INFO:** A hardcopy of the current GPI/O settings and signal states can be output (see Section 4.2.6, TEST GPIO / PRINT SIGNAL INFO) in the following format:

<b>GPIO SIGNAL INFO</b>			
WED 11:04AM 4JUL2005			
CARD ID#3			
<b>OUTPUT SIGNALS</b>		<b>INPUT SIGNALS</b>	
END OF PRINT	o1	START OF PRINT	i1
PIN# 11 GPIO A	PIN# 15 GPIO B	PIN# 3 GPIO A	PIN# 13 GPIO B
LOW PULSE	CURRENT LEVEL 1	ACTIVE HIGH	CURRENT LEVEL 1
CURRENT LEVEL 1		CURRENT LEVEL 1	
RIBBON LOW	o2	FEED	i2
PIN# 9 GPIO A	PIN# 10 GPIO B	PIN# 4 GPIO A	PIN# 8 GPIO B
ACTIVE LOW	CURRENT LEVEL 0	ACTIVE LOW	CURRENT LEVEL 0
CURRENT LEVEL 0		CURRENT LEVEL 1	
SERVICE REQUIRED	o3	TOGGLE PAUSE	i3
PIN# 10 GPIO A	PIN# 5 GPIO B	PIN# 5 GPIO A	PIN# 3 GPIO B
ACTIVE LOW	CURRENT LEVEL 1	ACTIVE LOW	CURRENT LEVEL 1
CURRENT LEVEL 1		CURRENT LEVEL 1	
MEDIA OUT	o4	REPRINT	i4
PIN# 12 GPIO A	PIN# 14 GPIO B	PIN# 6 GPIO A	PIN# 12 GPIO B
ACTIVE LOW	CURRENT LEVEL 1	ACTIVE LOW	CURRENT LEVEL 1
CURRENT LEVEL 1		CURRENT LEVEL 1	
RIBBON OUT	o5		i5
PIN# 13 GPIO A	PIN# 9 GPIO B		PIN# 7 GPIO B
ACTIVE LOW	CURRENT LEVEL 1		CURRENT LEVEL 1
CURRENT LEVEL 1			
DATA READY	o6		i6
PIN# 14 GPIO A	PIN# 4 GPIO B		PIN# 2 GPIO B
ACTIVE LOW	CURRENT LEVEL 1		CURRENT LEVEL 1
CURRENT LEVEL 1			
OPTION FAULT			
PIN# 15 GPIO A			
ACTIVE LOW			
CURRENT LEVEL 1			



# Appendix E

## Multi-Language Menu

Different languages can be downloaded to replace the English menu by constructing a spreadsheet that defines the printer dictionary. To change the language you will add a new language column (or modify the existing column) in the spreadsheet, click on the 'Generate DPL file(s)' radio button, and then send that file(s) to the printer.

Software requirements for modifying the menu language are as follows:

- Microsoft® Excel must be purchased by user;
- Img2dl.exe is a program used during the process to create the DPL file; and,
- Common.xls (also provided at the web site above) is the Menu Dictionary.



*Img2dl.exe provided at <ftp://ftp.datamaxcorp.com/Anonymous/Firmware/EFIGS/>*

*Place Img2dl.exe and Common.xls in the same directory.*

---

Create a Menu Language by following these steps:

A. Invoke Excel and open the Common.xls file. *After the file, the following screen appears:*

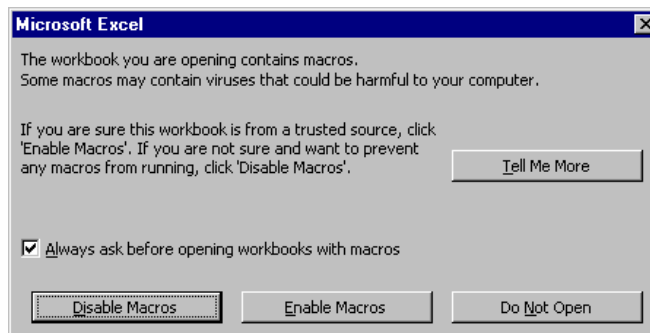

B. Click the "Enable Macro" box. *The following screen appears:*

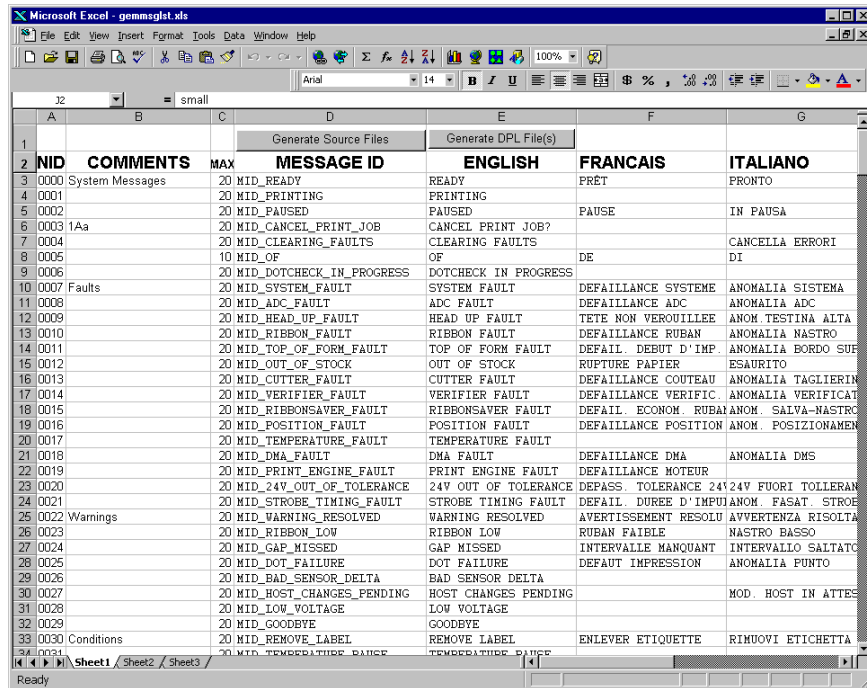

C. Click on Column J and enter your new language, or modify an existing one. Some tips on this process:

- Message Size – When entering new messages, reference the 'MAX' column: this is the maximum number of characters allowed for this field. (Warnings are displayed when the number of characters is exceeded, or when trying to modify the MAX value; however, "cutting and pasting" fields could defeat this warning system.)
- Two Line Messages – Some of the message are displayed as two lines. These are indicated in the comment fields.
- Comments – This field can be modified with no effect.

D. After editing is completed, highlight all of the columns to be created by pressing the letter above the column (more than one language may be selected).

E. Press the Generate DPL File(s) radio button. *A file will be generated for each of the selected columns and Excel will provide confirmation (for example, as shown below, small.ls).*

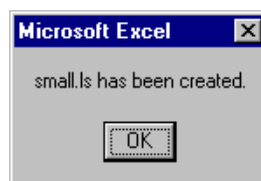

F. Download the generated files to the printer – one method is the DOS copy command:

```
copy small.ls lpt1: /b
```

G. Reset the printer by pressing and holding the CANCEL Key for approximately four seconds.

H. After the resetting, verify operation by printing a Configuration Label. *The new font selection will be printed on the label under SYSTEM INFORMATION / OPTIONAL LANGUAGES. (The new language also appears in the menu: SYSTEM SETTINGS / MENU LANGUAGE.) These are the only methods to determine whether the download was successful.*

*An error has occurred if the menu displays the new language selection, but all the messages remain in English. In this case, re-check your process or contact Datamax-O'Neil Technical Support (be prepared to provide the Common.xls and DPL download files created). Other possible error messages are as follows:*

Menu Language Error Message	Description
Please select the entire column(s) or the desired language(s), by clicking on the column letter(s)	After pressing the Generate DPL File(s) radio button, the languages to convert were not correctly selected.
Message text may not exceed MAX = xx designated characters for this MID	The entered message exceeds the number of characters specified in column C. You may not modify this number.

I. Repeat Steps A – H using the filename misc.xls to translate printer option items. This will output small20.ls.

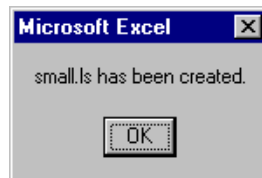

### **Important Advanced File Handling Information**

- The standard printer leaves the factory with EFIGS loaded into Module Y. At this point, Module Y is LOCKED and will only accept additional language downloads.
- After downloading a language update, Module Y is left UNLOCKED until the printer is reset or power is cycled. In this state, Module Y will accept font, image and label format downloads. The module will also honor the Clear Module request. Therefore, following an update it is recommended that a reset be performed to lock the module; otherwise, a software package may 'Clear All Modules' thus destroying the new menu language(s).
- Module Y can be UNLOCKED by sending this DPL string: <STX>KpY0

- To restore the factory generated EFIGS image, download the file \*832296.01A to the printer. This file is located on the Datamax-O'Neil FTP site. The letter at the end of the file name (e.g., A) specifies the revision. The latest revision will be available on the FTP site.
- Downloading the same language twice will automatically delete the first occurrence, but will not free the memory space.
- Deletion of the selected language will reset the printer to English. The total number of languages that the printer can now accept is limited to 10, but this number is dependent upon the size of each language translation. The translation size will vary with the number of messages that are translated for that particular language. Current complete language files are about 7,000 bytes each; but with product growth, the total number of languages is expected to drop to five.

# Appendix F

## Saving a Configuration File

Configuration files can be used to retain special printer settings, eliminating the need for repeated setups. Unique filenames can be assigned then the setups restored, as needed, via the host or printer menu. The following example saves a calibration setting in a configuration file:



*If file sharing among printers, DO NOT include unique parameters (such as calibrations and adjustments) when saving.*

Step	Action	Displayed Message
1	With the printer set for the configuration to be saved, press the MENU Key. (See Section 4.1 for Control Panel details.)	MEDIA SETTINGS
2	Scroll to SYSTEM SETTINGS then press the ENTER Key.	SYSTEM SETTINGS
3	With CONFIGURATION FILE highlighted, press the ENTER Key.	RESTORE AS CURRENT
4	Scroll to SAVE SETTING AS then press the ENTER Key and input a name, using up to nineteen alphanumeric characters, for the configuration file. (This example uses the filename MEDIACAL.)	MEDIACAL
5	Press the ESC Key repeatedly to save the file and return to READY.	MEDIACAL SUCCESSFUL



*To restore a configuration file via the printer, see Section 4.2.4.*



# Appendix G

## Ribbon Saver Overview

With the Ribbon Saver option, the printer can conserve ribbon use in blank label areas. Depending upon the label format, when more than .25 inches (6.4 mm) of ribbon can be saved in no-print areas, the printhead lifts off the platen and a brake stops ribbon motion, while the assist rollers continue to advance media. At about .25 inches before the next line of print, the brake releases as the printhead is lowered to resume printing. Additional parameters and features regarding operation include the following considerations:

- The amount white space passed before the ribbon saver actuates is determined by the media travel speed. For example, at 2 IPS there must be at least .65 inches (16.5 mm) of white space, while at 8 IPS the length increases to 1.2 inches (30.5 mm) before engagement.
- Ribbon savings become more significant as the label white space gets larger.



*Following a Top of Form, Out of Stock, Position, Ribbon or Head Lift Fault, ribbon saving will not occur during the first two inches (51 mm) after restart.*

---

- The ribbon saver will actuate up to twenty times per label.
- The menu can be used for control (see Section 4.2.3).
- Functional tests can be performed (see Section 4.2.6).
- Throughput remains unaffected by operation. At faster speeds, however, a light horizontal mark (produced as the moving label contacts the stationary ribbon) may appear across the label. To minimize this contact mark use a slightly harder wax or wax/resin formulation of ribbon or slow the print speed.





# Glossary

**alphanumeric** Consisting of alphabetic, numeric, punctuation and other symbols.

**backing material** The silicon-coated paper carrier material to which labels with adhesive backing are affixed. Also referred to as "liner".

**bar code** A representation of alphanumeric information in a pattern of machine-readable marks. The basic categories are divided into one-dimensional (UPC, Code 39, Postnet, etc.) and two-dimensional bar codes (Data Matrix, MaxiCode, PDF417, etc.).

**boot loader** The resident program that loads the application from Flash memory, decompresses it into the SRAM, and starts operations.

**burn line** The row of thermal elements in the printhead that create the images on the media.

**calibration** The process through which sensor readings are entered into the printer for correct sensor function (for example, detection of a given media type) and TOF positioning.

**CCA** Circuit Card Assembly.

**CSI (Coated Side In)** Ribbon rolled with the inked coating facing inward.

**CSO (Coated Side Out)** Ribbon rolled with the inked coating facing outward.

**character set** The entire complement of alphanumeric symbols contained in a given font.

**checksum** An alphanumeric error detection method used in many bar code symbologies for informational security.

**continuous media** An uninterrupted roll or box of label or tag stock media that contains no gap, notch, or mark to separate individual labels or tags.

**core diameter** The inside diameter measurement of the cardboard core at the center of a ribbon.

**defaults** The functional setting values returned following a factory reset of the printer.

**diagnostics** Programs used to locate and diagnose hardware problems.

**die-cut media** Media that has been cut into a pattern using a press, where the excess paper is removed leaving individual labels, with gaps between them, attached to a backing material.

**direct thermal** The printing method that uses a heat sensitive media and only the heat of the thermal printhead to create an image on the label.

**direct thermal media** Media coated with chemicals that react and darken with the application of heat.

**DPI (dots per inch)** A measurement of resolution, rated in the number of thermal elements contained in one inch of the printhead.

**DPL (Datamax-O'Neil Programming Language)** Programming commands used specifically for control of and label production in Datamax-O'Neil printers. A complete listing of commands can be found in the *Class Series 2 Programmer's Manual*

**DPMM (dots per millimeter)** A measurement of resolution, rated in the number of thermal elements contained in one millimeter of the printhead.

**EFIGS** English, French, Italian, German, Spanish, and other multi-language support as programmed for the printer's menus and configuration label.

**fan-fold** Media that is folded and stacked.

**feed speed** The rate at which the media moves under the printhead in non-printed areas and between labels.

**Flash memory** Non-volatile memory (does not require printer power to maintain data) that can be erased and reprogrammed, used to hold the printer's operating program.

**font** A set of alphanumeric characters that share a particular typeface.

**gap** A space between die-cut or notched labels used to sense the top-of-form.

**GPIO (General Purpose Input Output)** A specialized interface port for use with external printer control devices including applicators, verifiers, RFID systems, etc.

**IPS (inches per second)** Imperial measurement of speeds.

**label** A paper or synthetic printing material, typically with a pressure sensitive adhesive backing.

**label length** The distance from the top of the label to the bottom of the label as it exits the printer.

**label repeat** The distance from the top of one label to the top of the next label.

**label tracking** Excessive lateral (side to side) movement of the media as it travels under the printhead.

**label width** The left to right measurement of the label as it exits the printer.

**mark** Generalized term for the carbon-based black line on the underside of reflective media used to indicate the top-of-form.

**media** Generalized term for all types of printing stocks, including: roll fed, continuous, die-cut, reflective, and fanfold.

**media hub** Device in the printer used to support roll media.

**media sensor** An electronic device equipped with photo sensors to detect media and the top-of-form on die-cut, notched or reflective media.

**MMPS (millimeters per second)** Metric measurement of speeds.

**notched stock** Media, typically tag stock, with holes or notches in the material that is used to signal the top-of-form. The printer must be set to 'gap' to use this media type.

**preprinted media** Label stock that contains borders, text, or graphics, flood coating, etc.

**perforation** Small cuts extending through the backing and/or label material to facilitate their separation. Also referred to as "perf".

**print speed** The speed at which the media moves under the printhead during the printing process.

**reflective media** Media imprinted with carbon-based black marks on the underside of the material, which is used to signal the top-of-form when the 'reflective' sensor is enabled.

**registration** Repeatable top to bottom alignment of printed labels.

**reverse speed** The backward rate of media motion into the printer during tear-off, peel and present and cutting operations for positioning the label at the start of print position.

**ribbon** An extruded polyester tape with several layers of material, one of which is ink-like, used to produce an image on the label. Also referred to as "foil".

**ribbon wrinkle** An undesirable overlapping of the ribbon during the printing process that leads to voids on the printed label, typically caused by an improper printhead leveling cam adjustment.

**roll media** A form of media that is wound upon a cardboard core.

**slew speed** The speed at which the media moves under the printhead in non-printed areas and between labels using the GPIO function.

**start of print (SOP)** The position on the label where printing begins; also, the signal that initiates GPIO-controlled printing.

**tag stock** A heavy paper or synthetic printing material, typically featuring a notch or black mark for TOF and no adhesive backing.

**thermal transfer** The printing method that creates an image by transferring ink from a ribbon onto the media using the heat from the thermal printhead.

**TOF (top-of-form)** The start of a new label as indicated by a label gap, notch, mark or programming.

**void** An undesirable blank space in a printed image.

