

# LINEAR MOTOR CATALOG



# TABLE OF CONTENTS

<a href="#">A Passion for Technology</a>	3	<a href="#">Phoenix Line</a>	20	<a href="#">Gryphon Line</a>	40
<a href="#">Overview</a>	4	T Features	21	Features	41
<a href="#">Winding Configurations</a>	6	T Performance Specifications	22	M/L Performance Specifications	42
<a href="#">Chiron Line</a>	7	T Mechanical Specifications Without CS	23	M Mechanical Specifications	43
Features	8	T Mechanical Specifications With CS	24	L Mechanical Specifications	44
S-050 Performance Specifications	9	S/M/L/X/U Features	25	M/L Force-Velocity Diagrams	45
S-050 Mechanical Specifications	10	S Performance Specifications	26	L Outgassing Measurements	46
S-080 Performance Specifications	11	S Mechanical Specifications	27	<a href="#">Iris Line</a>	47
S-080 Mechanical Specifications	12	M Performance Specifications	28	Features	48
S-100 Performance Specifications	13	M Mechanical Specifications	29	S/M/L Performance Specifications	49
S-100 Mechanical Specifications	14	L Performance Specifications	30	S-05 Mechanical Specifications	50
S-130 Performance Specifications	15	L Mechanical Specifications	31	S-10 Mechanical Specifications	51
S-130 Mechanical Specifications	16	X Performance Specifications	32	M-12 Mechanical Specifications	52
S-050/080 Force-Velocity Diagrams	17	X Mechanical Specifications	33	L-16 Mechanical Specifications	53
S-100/130 Force-Velocity Diagrams	18	U Performance Specifications	34	<a href="#">Definitions</a>	54
Commutation Sensors	19	U Mechanical Specifications	35	<a href="#">Contact</a>	57
		S/M Force-Velocity Diagrams	36		
		L/X Force-Velocity Diagrams	37		
		U Force-Velocity Diagrams	38		
		Commutation Sensors	39		



## Knowledge

Engineering excellence is the driving force behind linear motor innovation in both design and manufacturing. Prodrive has a highly skilled group of (electro-)mechanical engineers capable of customizing linear motor technology towards your needs.

## Quality

Quality is in the DNA of Prodrive Technologies. With a long history in electronics manufacturing, Prodrive continues in the area of linear motor manufacturing with the same philosophy and processes, setting a new standard within the linear motor market.

## Automation

Design for manufacturing is key to reduce cost and guarantee quality. Winding, assembly, vacuum potting and magnet gluing are highly automated processes which guarantees a constant quality at minimum cost.

## Time to market

Due to the agility of Prodrive Technologies' large development department, customization can be performed in a very short time, providing a short time to market for challenging mechatronic applications.



Prodrive Technologies HQ Campus, The Netherlands



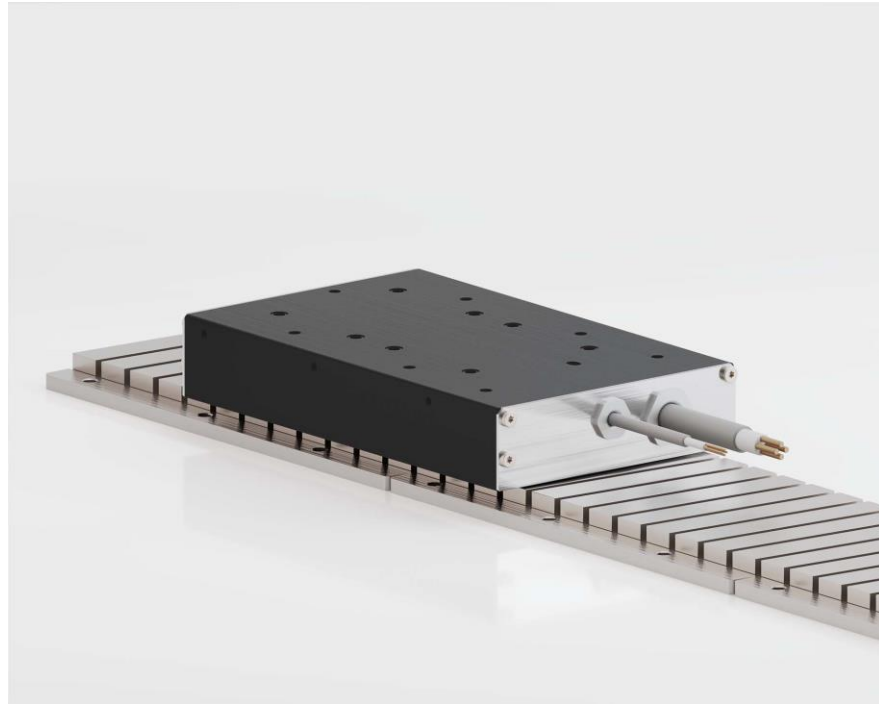

## Chiron

The Chiron line offers iron core linear motors which are optimized for high force and high efficiency. Find the optimal fit for your application due to the many different available form factors.

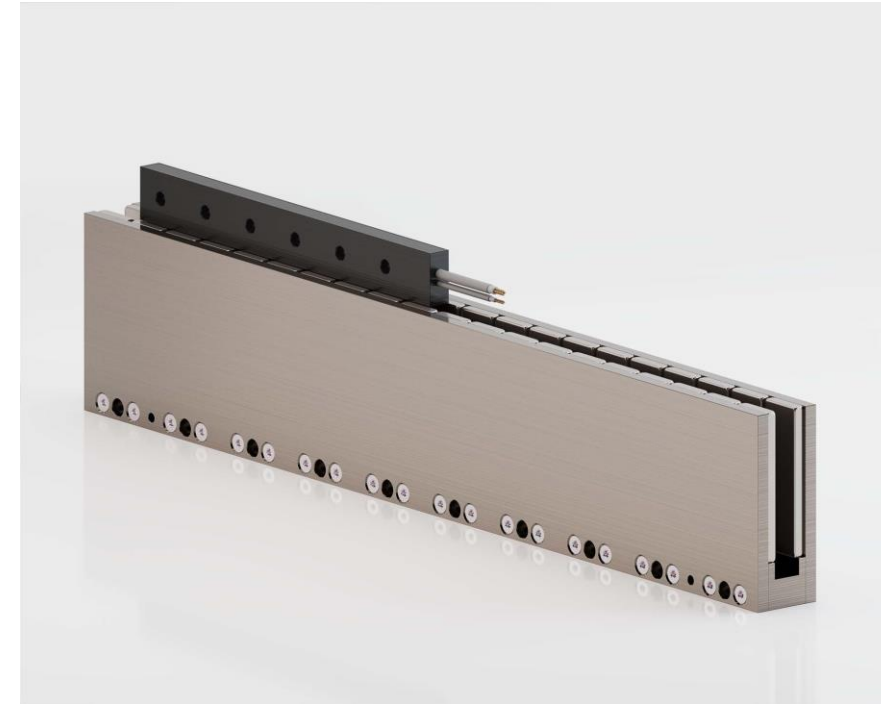

## Phoenix

The Phoenix line offers ironless linear motors, for applications requiring an extremely low force ripple for excellent servo performance without attraction forces. Available in a large range of sizes.



## Gryphon

The Gryphon line offers a cost-effective solution for vacuum-compatible ironless linear motors. These motors also contain features providing magnetic shielding.

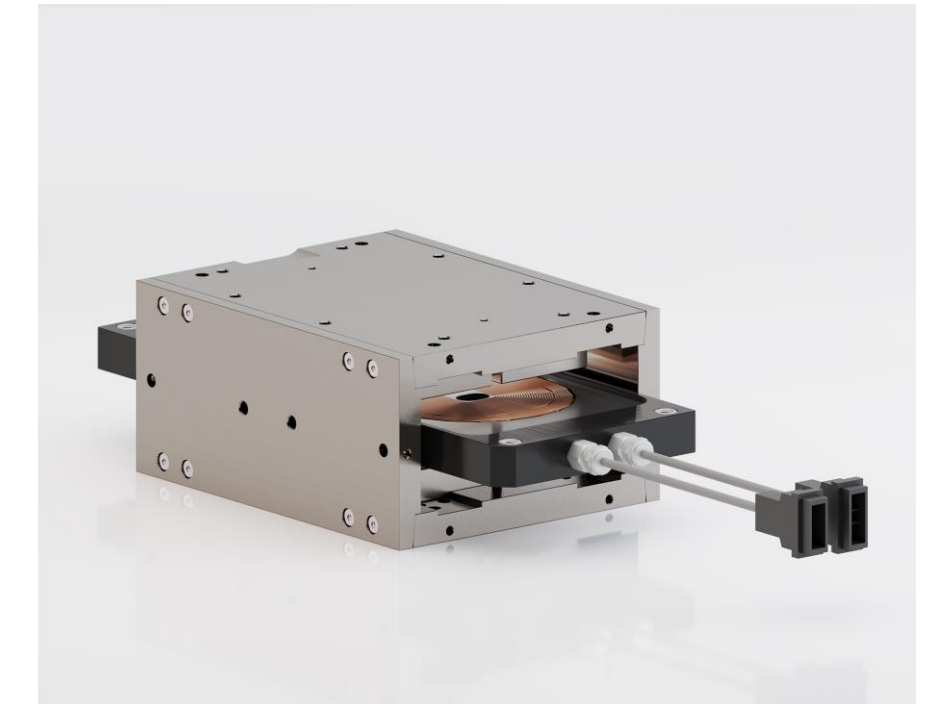

## Iris

For short stroke applications requiring a relatively large displacement in three directions, the Iris line provides a high force density with zero attraction forces in a rectangular form factor.



# OVERVIEW

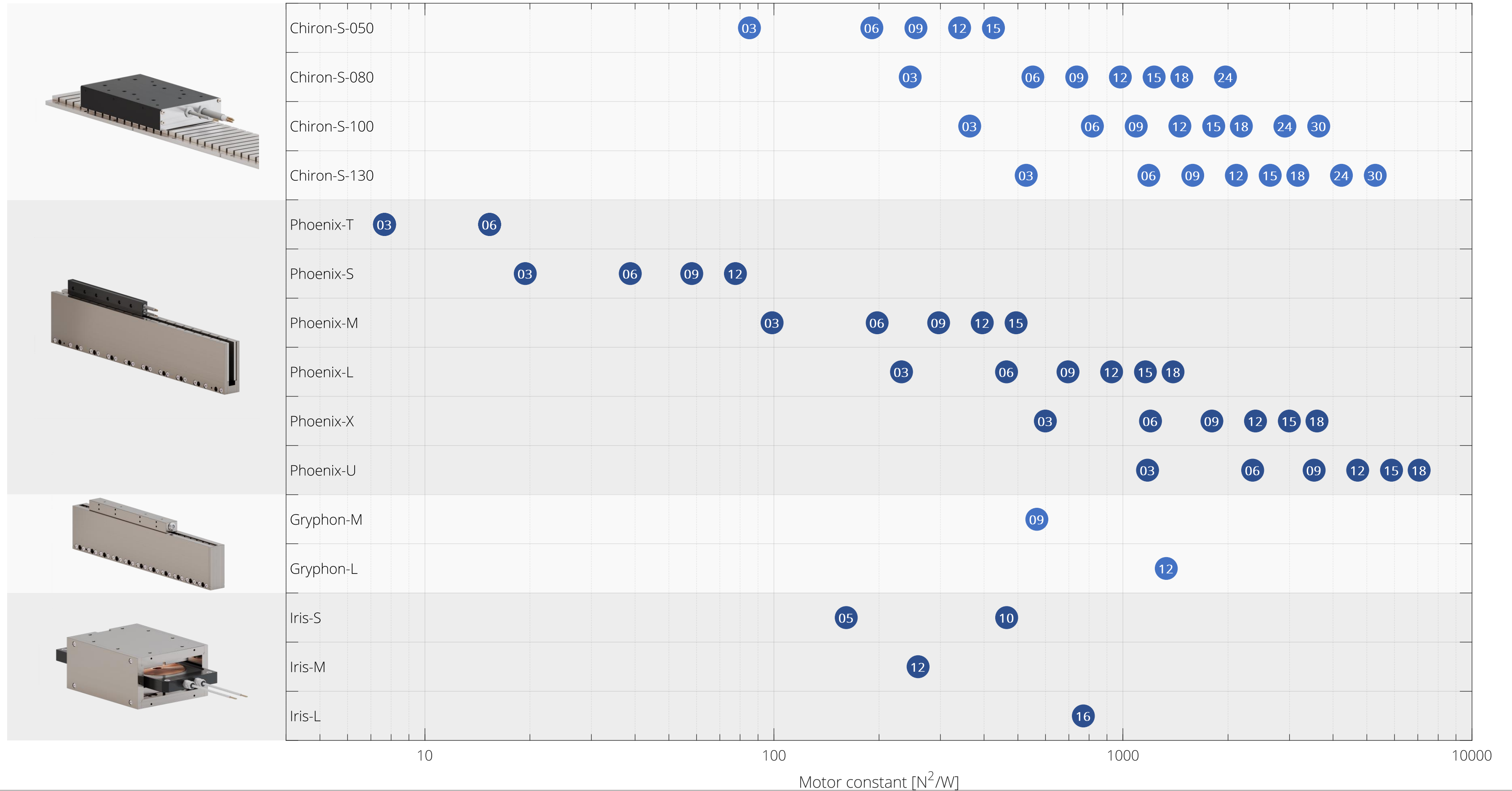



# WINDING CONFIGURATIONS

The phases of all three-phase linear motors are star-connected.

The Chiron, Phoenix and Gryphon line can be selected with different winding configurations to create an optimal fit for your application.

## Winding configuration A

The windings are configured such that independent of the number of coils, the force constant remains equal, and the maximum velocity remains unchanged. The maximum current increases with the number of coils.

## Winding configuration B

The windings are configured like winding configuration A, but this winding configuration can reach higher velocities at the expense of a lower force constant.

## Winding configuration C

The windings are configured such that the current remains constant with increasing number of coils at the expense of reducing the maximum velocity. For the Chiron, Phoenix and Gryphon line, this configuration allows moving magnet applications with partial coil unit overlap.

## Winding configuration D

The windings are configured such that the current remains constant with increasing number of coils at the expense of reducing the maximum velocity. This configuration has a higher maximum velocity compared to winding configuration C. For the Phoenix line, this configuration allows moving magnet applications with partial coil unit overlap.

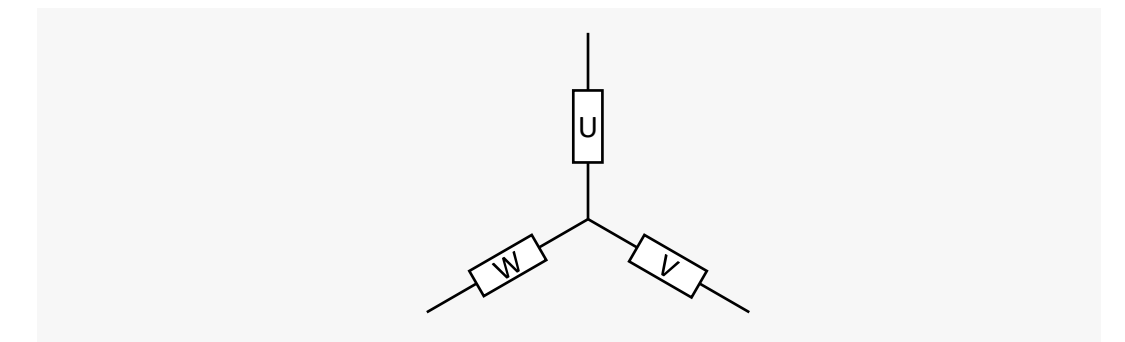

Phase connection chart

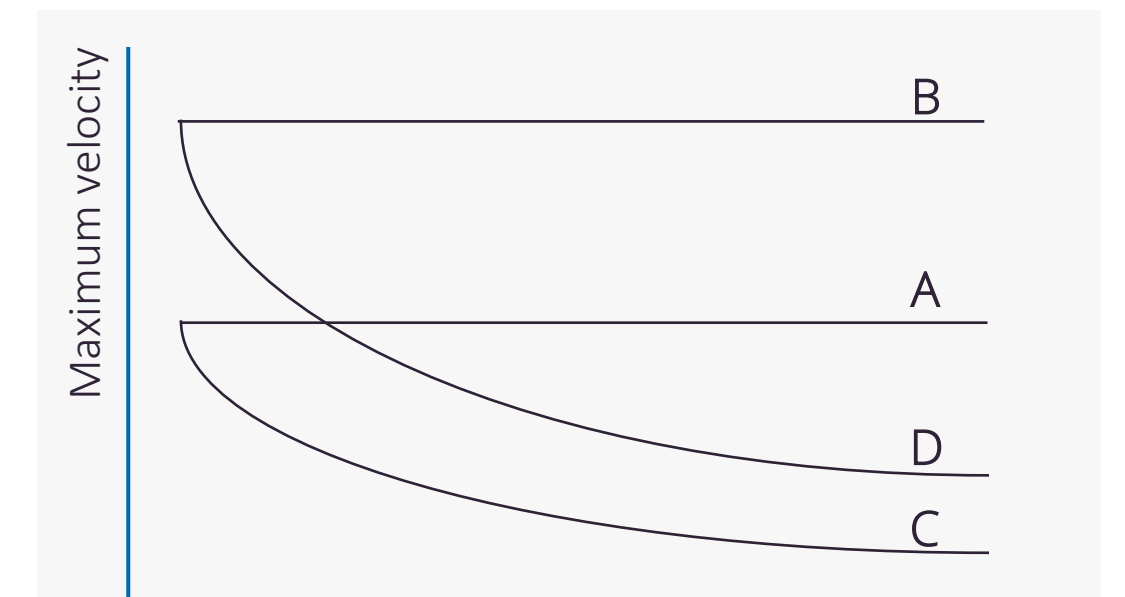

Number of coils

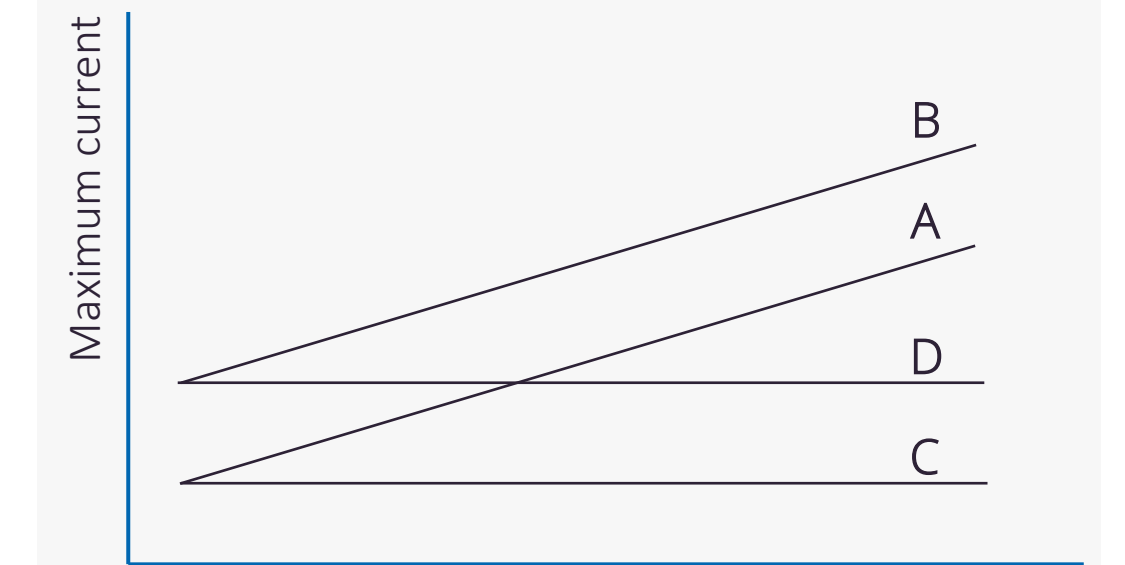

Number of coils

Winding configurations chart



# CHIRON LINE

The Chiron line offers iron core linear motors which are optimized for high force and high efficiency. Find the optimal fit for your application due to the many different available form factors.

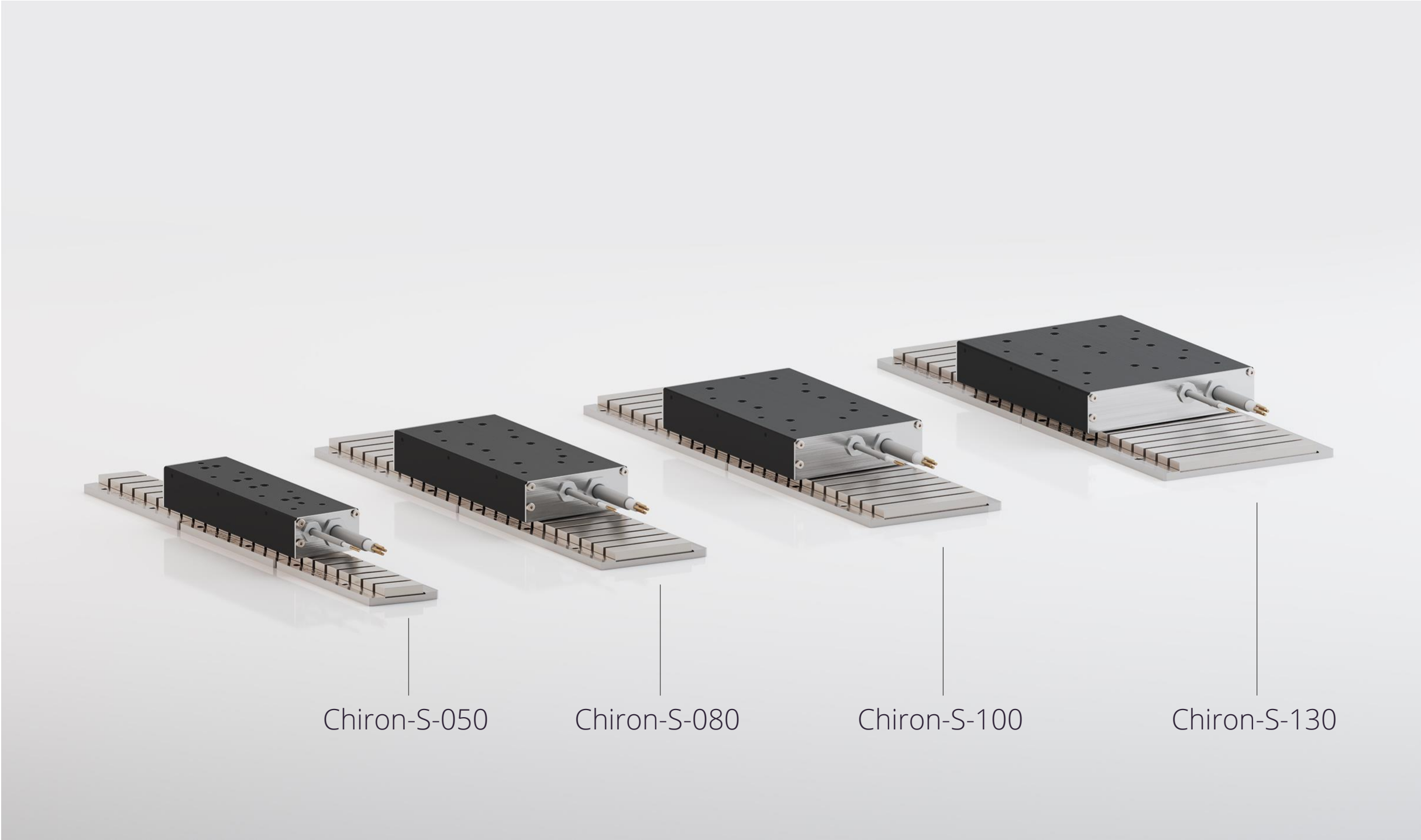

Chiron line linear motors in different sizes



# CHIRON FEATURES

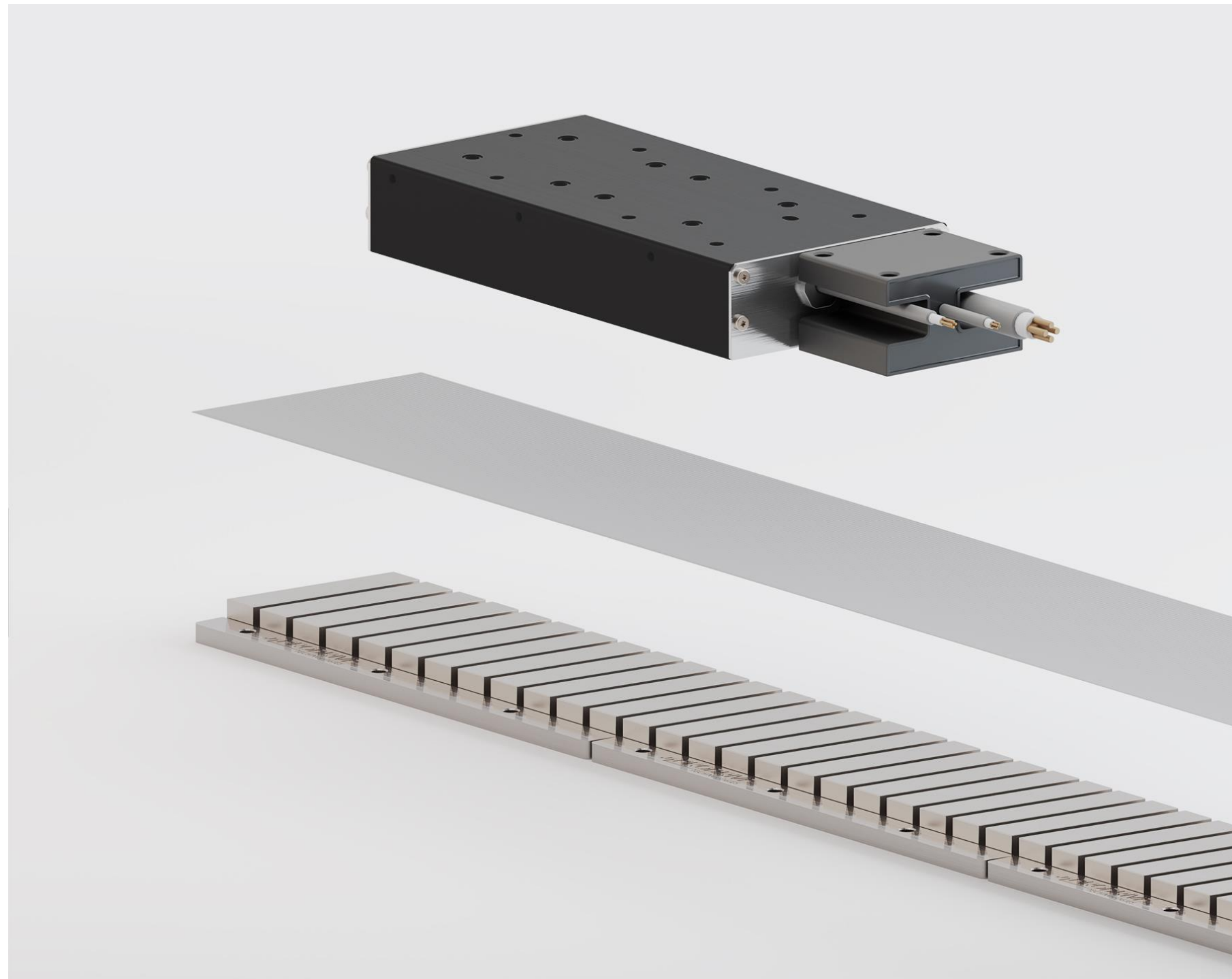

Chiron magnet plates (Chiron-MP-080-12), coil unit (Chiron-CU-S-080-06-A-B), commutation sensor (Chiron-CS-A) and magnet plate cover

## Chiron-CU-S-080-12-A-N

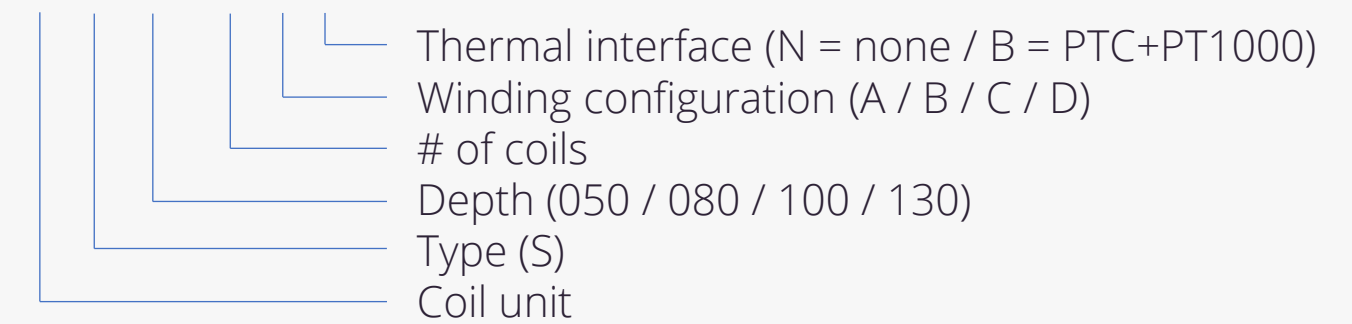

## Chiron-MP-080-16



## Chiron-CS-A



- Modularity in width and depth for optimal mechanical integration
- Multiple winding configurations for optimal current/velocity matching
- Coil units have an optional temperature protection (PTC) and sensor (PT1000)
- Magnet plates can be butted together
- Magnets are skewed to minimize force ripples and detent forces
- IP rating of coil units is IP69K
- Optional stainless-steel cover plate for protection of the magnet plates
- Optional commutation sensor, analog Hall (sin/cos) or digital Hall

# CHIRON-S-050 PERFORMANCE SPECIFICATIONS

Parameter		Symbol	Unit	T <sub>coil</sub> (°C)	CU-S-050-03	CU-S-050-06		CU-S-050-09		CU-S-050-12			CU-S-050-15	
Winding configuration		-	-	-	C	B	C	B	C	A	B	C	B	C
Electromechanical	Peak force ( $\alpha_T = 5^\circ\text{C/s}$ increase)	F <sub>p</sub>	N	20	100	205		300		410			500	
	Continuous force, interface at 20°C	F <sub>c</sub>	N	100	65	135		200		270			330	
	Attraction force (I = 0)	F <sub>att</sub>	N	-	345	600		855		1110			1365	
	Motor constant	S	N <sup>2</sup> /W	20	85	180		255		350			425	
	Force constant (I = I <sub>c</sub> )	K <sub>f,c</sub>	N/A <sub>rms</sub>	-	26	26	55	26	79	54	26	105	26	132
	Force constant (I = I <sub>p</sub> )	K <sub>f,p</sub>	N/A <sub>rms</sub>	-	23	23	49	23	69	48	23	92	23	116
	Maximum velocity (F = 0)	v <sub>m</sub>	m/s	-	31	31	15	31	10	15	31	7.8	31	6.2
	Maximum velocity (F = F <sub>p</sub> )	v <sub>i</sub>	m/s	20	18	18	8.8	18	5.8	8.9	18	4.2	18	3.3
Electrical	Maximum dc bus voltage	V <sub>dc</sub>	V	-	690	690		690		690			690	
	Phase resistance	R <sub>ph,20</sub>	Ohm	20	2.9	1.5	5.8	1.0	8.7	2.9	0.7	12	0.6	15
	Phase inductance	L <sub>ph</sub>	mH	20	14	7.0	28	4.7	42	14	3.5	56	2.8	70
	Peak line emf constant	K <sub>e,ll,p</sub>	Vs/m	-	22	22	47	22	67	46	22	89	22	111
	Maximum rms current	I <sub>p</sub>	A <sub>rms</sub>	20	4.3	8.7	4.3	13	4.3	8.7	17	4.3	22	4.3
	Continuous rms current, interface at 20°C	I <sub>c</sub>	A <sub>rms</sub>	100	2.5	5.0	2.5	7.6	2.5	5.0	10.1	2.5	13	2.5
Thermal	Continuous dissipation, interface at 20°C	P <sub>d,c</sub>	W	100	73	145		218		291			364	
	Thermal resistance, coils to interface	R <sub>th,i</sub>	K/W	-	1.1	0.55		0.37		0.28			0.22	
	Thermal resistance, coils to conv. surface	R <sub>th,c</sub>	K/W	-	0.9	0.43		0.29		0.22			0.17	
	Thermal time constant, interface at 20°C	τ <sub>th</sub>	s	-	67	67		67		67			67	

## Notes

- Specifications are based upon a magnet temperature of 20°C
- Specifications consider complete overlap of the coil unit with a magnet plate
- Specifications consider sinusoidal q-axis commutation
- Velocity specifications are based on the maximum bus voltage
- Specifications are based upon an airgap of 1 mm
- See 'definitions' section at the end of the catalog for more details

## Product marking / approvals

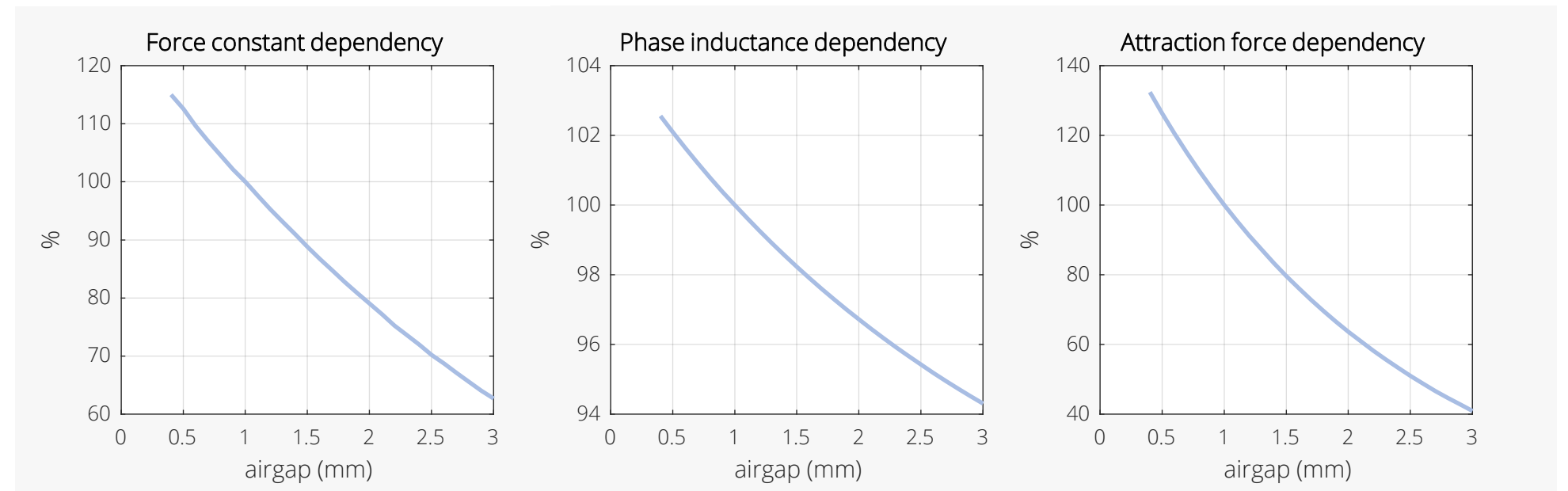

Airgap dependency



# CHIRON-S-050 MECHANICAL SPECIFICATIONS

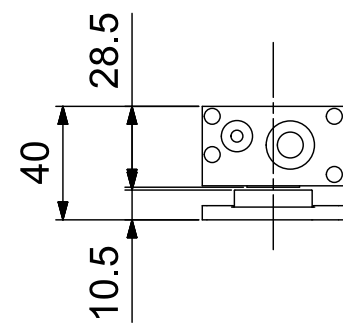
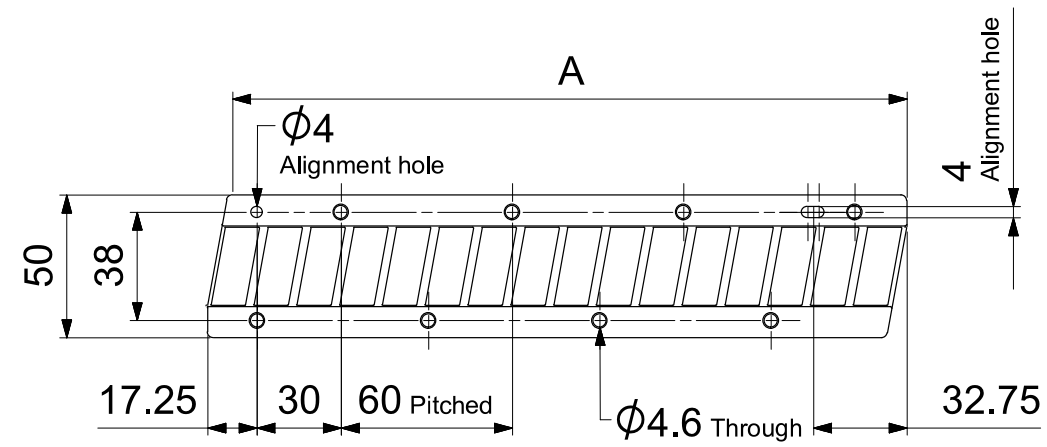

Magnet Plates	Parameter	Symbol	Unit	MP-050-08	MP-050-16	MP-050-28
	Number of poles	$N_p$	-	8	16	28
	Pole pitch (N-N)	$2\tau_p$	mm	30	30	30
	Width	A	mm	120	240	420
Mass	$M_{mp}$	kg	0.4	0.7	1.2	

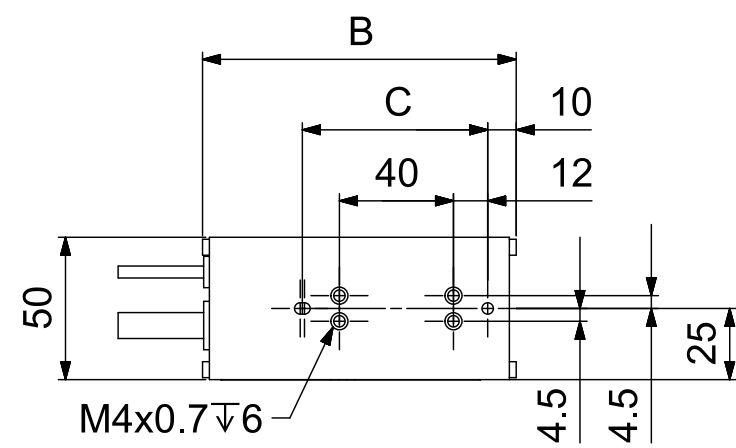

Chiron-CU-S-050-03

Coil Units	Parameter	Symbol	Unit	CU-S-050-03	CU-S-050-06	CU-S-050-09	CU-S-050-12	CU-S-050-15
	Number of coils	$N_{coil}$	-	3	6	9	12	15
	Coil pitch	$\tau_{coil}$	mm	20	20	20	20	20
	Width	B	mm	110	170	230	290	350
	Center pin distance	C	mm	65	125	185	245	305
	Number of 60 mm pitches	D	mm	0	0	0	1	2
	Mass (ex. cable)	$M_{Cu}$	kg	0.5	0.8	1.2	1.5	1.8
	Standard cable length	$L_{cable}$	m	1	1	1	1	1

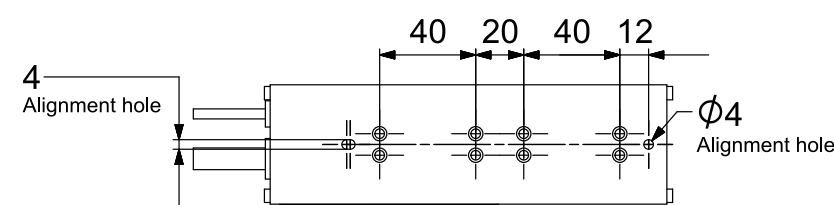

Chiron-CU-S-050-06

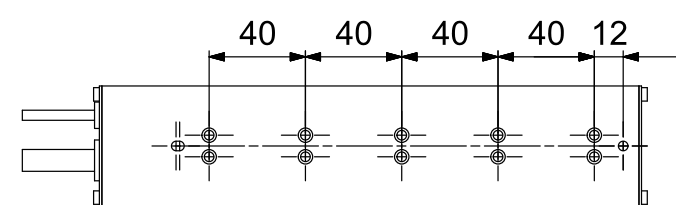

Chiron-CU-S-050-09

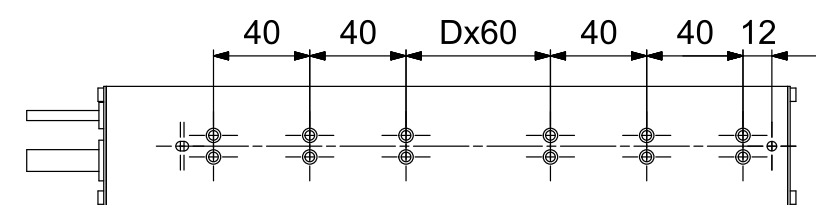

Chiron-CU-S-050-12

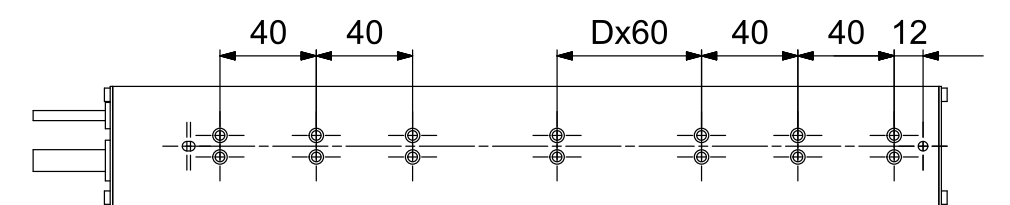

Chiron-CU-S-050-15

# CHIRON-S-080 PERFORMANCE SPECIFICATIONS

Parameter		Symbol	Unit	T <sub>coil</sub> (°C)	CU-S-080-03	CU-S-080-06	CU-S-080-09	CU-S-080-12			CU-S-080-15		CU-S-080-18				CU-S-080-24					
Winding configuration		-	-	-	C	B	C	B	C	A	B	C	B	C	A	B	C	D	A	B	C	D
Electromechanical	Peak force ( $\alpha_T = 5^\circ\text{C/s}$ increase)	F <sub>p</sub>	N	20	250	510	740	1000			1230		1480				1970					
	Continuous force, interface at 20°C	F <sub>c</sub>	N	100	165	335	490	665			820		985				1310					
	Attraction force (I = 0)	F <sub>att</sub>	N	-	830	1440	2050	2660			3270		3880				5100					
	Motor constant	S	N <sup>2</sup> /W	20	250	520	740	1010			1230		1470				1960					
	Force constant (I = I <sub>c</sub> )	K <sub>f,c</sub>	N/A <sub>rms</sub>	-	61	61	128	61	182	124	61	242	61	303	121	61	364	182	121	61	485	242
	Force constant (I = I <sub>p</sub> )	K <sub>f,p</sub>	N/A <sub>rms</sub>	-	56	56	119	56	169	116	56	225	56	282	113	56	338	169	113	56	450	225
	Maximum velocity (F = 0)	v <sub>m</sub>	m/s	-	14	14	6.4	14	4.6	6.7	14	3.4	14	2.7	6.8	14	2.3	4.6	6.8	14	1.7	3.4
	Maximum velocity (F = F <sub>p</sub> )	v <sub>i</sub>	m/s	20	8.2	8.2	3.8	8.2	2.4	3.8	8.2	1.7	8.2	1.2	3.9	8.2	0.9	2.4	3.9	8.2	0.5	1.7
Electrical	Maximum dc bus voltage	V <sub>dc</sub>	V	-	690	690	690	690			690		690				690					
	Phase resistance	R <sub>ph,20</sub>	Ohm	20	5.2	2.6	10	1.7	16	5.2	1.3	21	1.0	26	3.5	0.9	31	7.8	2.6	0.7	42	10
	Phase inductance	L <sub>ph</sub>	mH	20	29	15	58	9.7	87	29	7.3	116	5.8	145	19	4.8	174	44	15	3.6	232	58
	Peak line emf constant	K <sub>e,ll,p</sub>	Vs/m	-	51	51	107	51	152	104	51	202	51	253	101	51	303	152	101	51	404	202
	Maximum rms current	I <sub>p</sub>	A <sub>rms</sub>	20	4.4	8.8	4.4	13	4.4	8.8	18	4.4	22	4.4	13	26	4.4	8.8	18	35	4.4	8.8
	Continuous rms current, interface at 20°C	I <sub>c</sub>	A <sub>rms</sub>	100	2.7	5.4	2.7	8.1	2.7	5.4	10.8	2.7	14	2.7	8.1	16	2.7	5.4	10.8	22	2.7	5.4
Thermal	Continuous dissipation, interface at 20°C	P <sub>d,c</sub>	W	100	150	300	450	600			750		900				1200					
	Thermal resistance, coils to interface	R <sub>th,i</sub>	K/W	-	0.53	0.27	0.18	0.13			0.11		0.09				0.067					
	Thermal resistance, coils to conv. surface	R <sub>th,c</sub>	K/W	-	0.43	0.22	0.14	0.11			0.09		0.07				0.054					
	Thermal time constant, interface at 20°C	τ <sub>th</sub>	s	-	61	61	61	61			61		61				61					

## Notes

- Specifications are based upon a magnet temperature of 20°C
- Specifications consider complete overlap of the coil unit with a magnet plate
- Specifications consider sinusoidal q-axis commutation
- Velocity specifications are based on the maximum bus voltage
- Specifications are based upon an airgap of 1 mm
- See 'definitions' section at the end of the catalog for more details

## Product marking / approvals

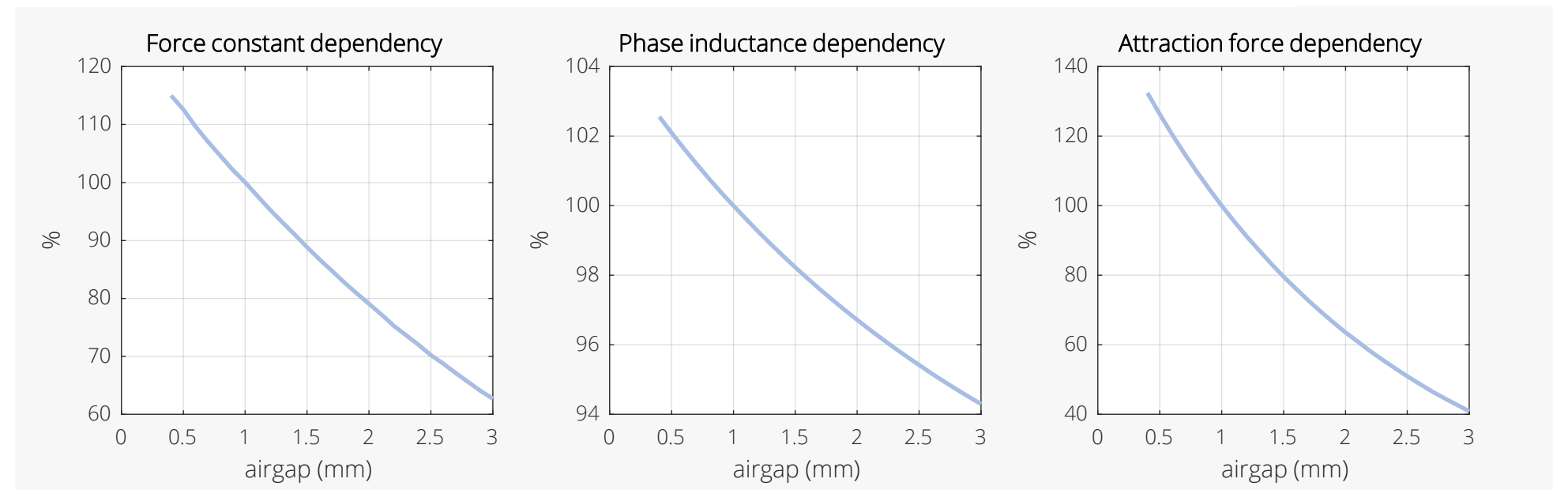

Airgap dependency



# CHIRON-S-080 MECHANICAL SPECIFICATIONS

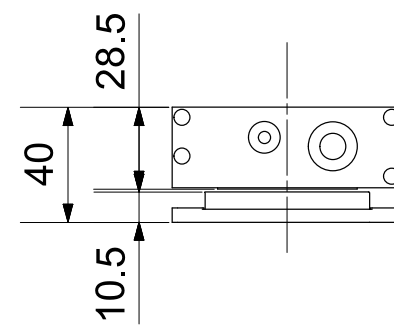
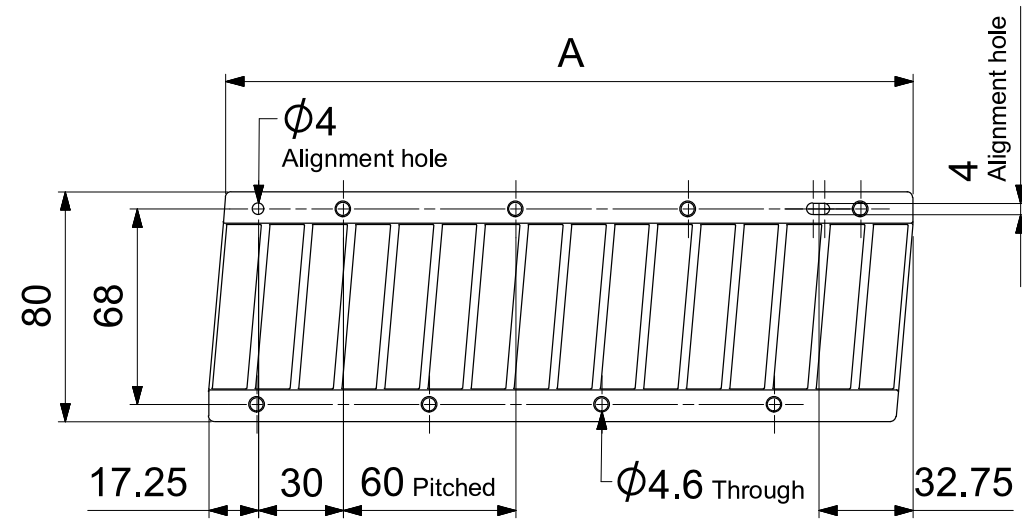

Magnet Plates	Parameter	Symbol	Unit	MP-080-12	MP-080-16	MP-080-28	MP-080-36
	Number of poles	$N_p$	-	12	16	28	36
	Pole pitch (N-N)	$2\tau_p$	mm	30	30	30	30
	Width	A	mm	180	240	420	540
Mass	$M_{mp}$	kg	0.9	1.2	2.1	2.7	

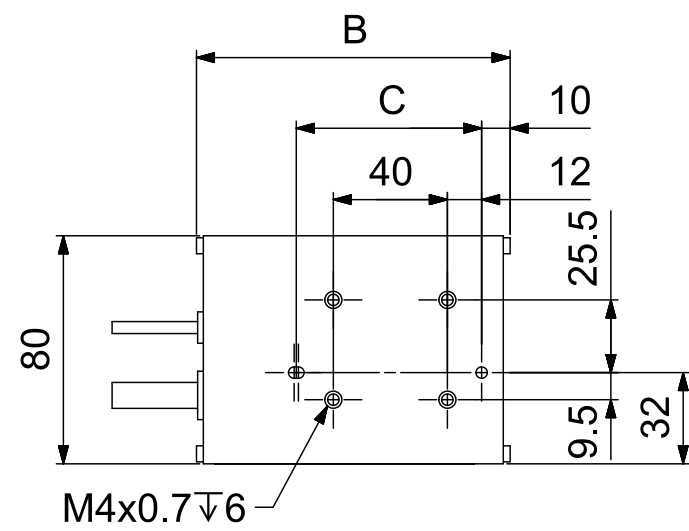

Chiron-CU-S-080-03

Coil Units	Parameter	Symbol	Unit	CU-S-080-03	CU-S-080-06	CU-S-080-09	CU-S-080-12	CU-S-080-15	CU-S-080-18	CU-S-080-24
	Number of coils	$N_{coil}$	-	3	6	9	12	15	18	24
	Coil pitch	$\tau_{coil}$	mm	20	20	20	20	20	20	20
	Width	B	mm	110	170	230	290	350	410	530
	Center pin distance	C	mm	65	125	185	245	305	365	485
	Number of 60 mm pitches	D	mm	0	0	0	1	2	3	5
	Mass (ex. cable)	$M_{cu}$	kg	0.9	1.5	2.2	2.8	3.4	4.1	5.3
	Standard cable length	$L_{cable}$	m	1	1	1	1	1	1	1

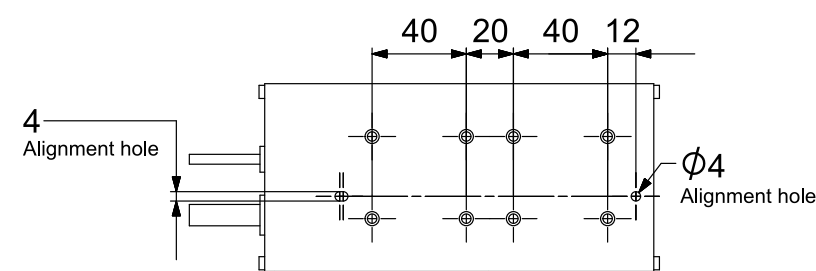

Chiron-CU-S-080-06

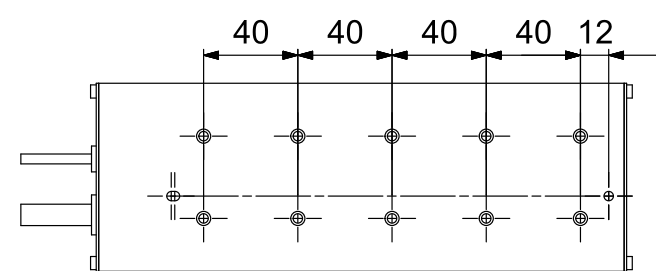

Chiron-CU-S-080-09

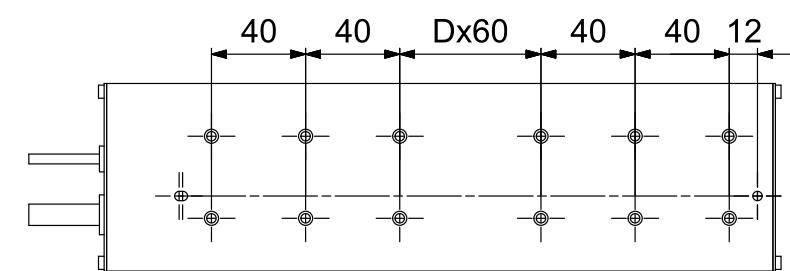

Chiron-CU-S-080-12

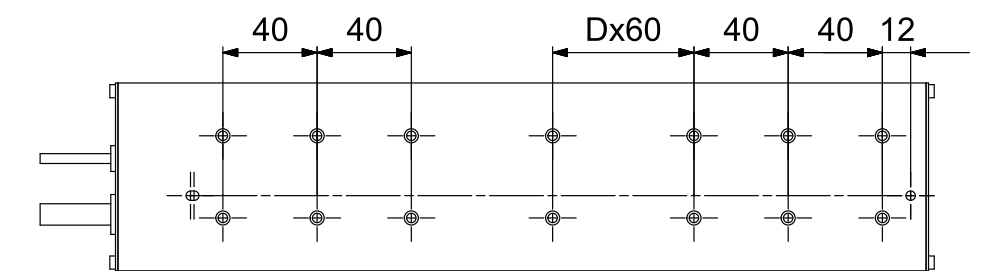

Chiron-CU-S-080-15/18/24

# CHIRON-S-100 PERFORMANCE SPECIFICATIONS

Parameter		Symbol	Unit	T <sub>coil</sub> (°C)	CU-S-100-03	CU-S-100-06	CU-S-100-09	CU-S-100-12	CU-S-100-15	CU-S-100-18	CU-S-100-24	CU-S-100-30														
Winding configuration		-	-	-	C	B	C	B	C	A	B	C	D	A	B	C	D	A	B	C	D	A	B	C	D	
Electromechanical	Peak force ( $\alpha_T = 5^\circ\text{C/s}$ increase)	F <sub>p</sub>	N	20	340	710	1030	1400	1720	2070	2760	3450	3300	3450												
	Continuous force, interface at 20°C	F <sub>c</sub>	N	100	230	470	690	940	1160	1390	1850	2310														
	Attraction force (I = 0)	F <sub>att</sub>	N	-	1160	2020	2890	3750	4620	5480	7210	8940														
	Motor constant	S	N <sup>2</sup> /W	20	360	770	1090	1490	1820	2180	2910	3640														
	Force constant (I = I <sub>d</sub> )	K <sub>f,c</sub>	N/A <sub>rms</sub>	-	84	84	177	84	252	172	84	336	84	420	168	84	503	252	168	84	671	336	168	84	839	420
	Force constant (I = I <sub>p</sub> )	K <sub>f,p</sub>	N/A <sub>rms</sub>	-	78	78	165	78	235	161	78	314	78	392	157	78	470	235	157	78	627	314	157	78	784	392
	Maximum velocity (F = 0)	v <sub>m</sub>	m/s	-	10	10	5	10	3	5	10	2.5	10	2.0	4.9	10	1.6	3.3	4.9	10	1.2	2.5	4.9	10	1.0	2.0
	Maximum velocity (F = F <sub>p</sub> )	v <sub>i</sub>	m/s	20	5.9	5.9	2.7	5.9	1.7	2.7	5.9	1.1	5.9	0.8	2.7	5.9	0.5	1.7	2.7	5.9	0.2	1.1	2.7	5.9	0.0	0.8
Electrical	Maximum dc bus voltage	V <sub>dc</sub>	V	-	690	690	690	690	690	690	690	690	690													
	Phase resistance	R <sub>ph,20</sub>	Ohm	20	6.7	3.4	13	2.2	20	6.7	1.7	27	1.3	34	4.5	1.1	40	10	3.4	0.8	54	13	2.7	0.7	67	17
	Phase inductance	L <sub>ph</sub>	mH	20	39	20	78	13	117	39	9.8	156	7.8	195	26	6.5	234	59	20	4.9	312	78	16	3.9	390	98
	Peak line emf constant	K <sub>e,ll,p</sub>	Vs/m	-	70	70	148	70	209	143	70	279	70	349	140	70	419	209	140	70	558	279	140	70	698	349
	Maximum rms current	I <sub>p</sub>	A <sub>rms</sub>	20	4.4	8.8	4.4	13	4.4	8.8	18	4.4	22	4.4	13	26	4.4	8.8	18	35	4.4	8.8	22	44	4.2	8.8
	Continuous rms current, interface at 20°C	I <sub>c</sub>	A <sub>rms</sub>	100	2.8	5.5	2.8	8.3	2.8	5.5	11	2.8	14	2.8	8.3	17	2.8	5.5	11	22	2.8	5.5	14	28	2.8	5.5
Thermal	Continuous dissipation, interface at 20°C	P <sub>d,c</sub>	W	100	200	400	600	800	1000	1200	1600	2000														
	Thermal resistance, coils to interface	R <sub>th,i</sub>	K/W	-	0.40	0.20	0.13	0.10	0.080	0.067	0.050	0.040														
	Thermal resistance, coils to conv. surface	R <sub>th,c</sub>	K/W	-	0.33	0.17	0.11	0.08	0.067	0.056	0.042	0.033														
	Thermal time constant, interface at 20°C	τ <sub>th</sub>	s	-	59	59	59	59	59	59	59	59														

## Notes

- Specifications are based upon a magnet temperature of 20°C
- Specifications consider complete overlap of the coil unit with a magnet plate
- Specifications consider sinusoidal q-axis commutation
- Velocity specifications are based on the maximum bus voltage
- Specifications are based upon an airgap of 1 mm
- See 'definitions' section at the end of the catalog for more details

## Product marking / approvals

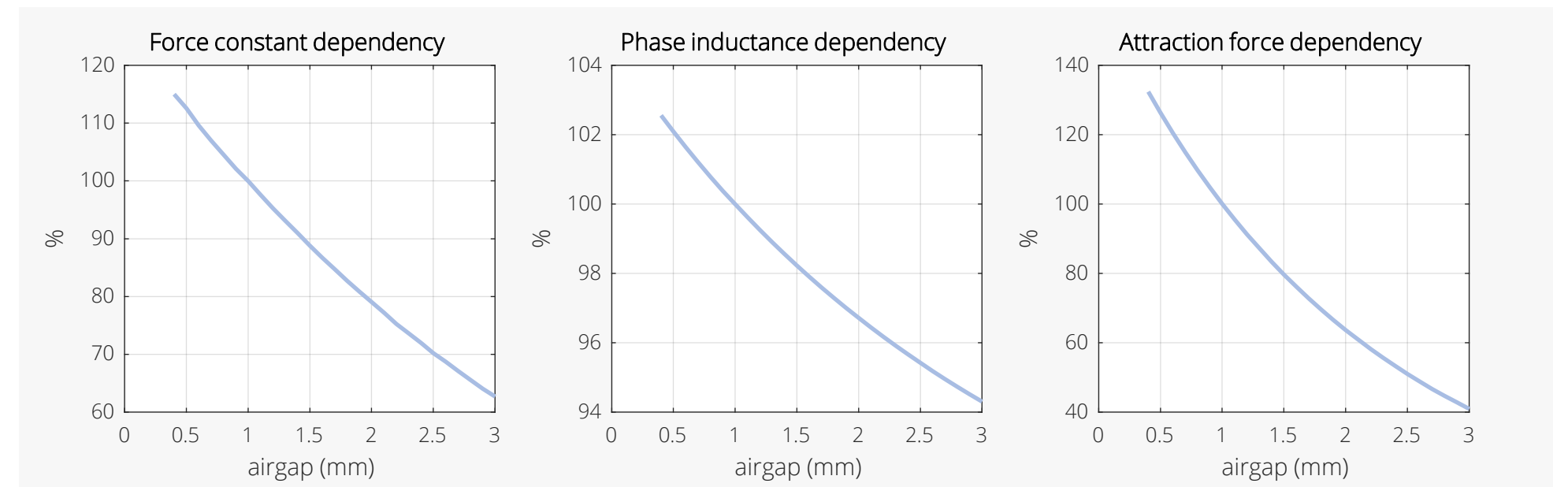

Airgap dependency



# CHIRON-S-100 MECHANICAL SPECIFICATIONS

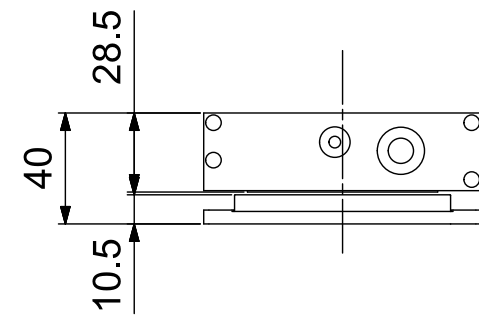
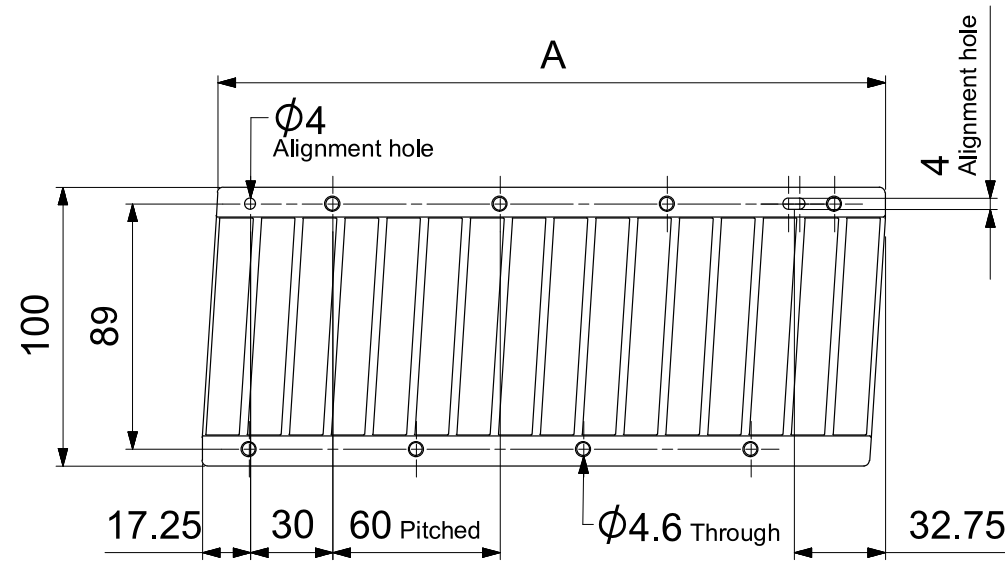

	Parameter	Symbol	Unit	MP-100-12	MP-100-16	MP-100-28	MP-100-36
Magnet Plates	Number of poles	$N_p$	-	12	16	28	36
	Pole pitch (N-N)	$2\tau_p$	mm	30	30	30	30
	Width	A	mm	180	240	420	540
	Mass	$M_{mp}$	kg	1.2	1.5	2.7	3.5

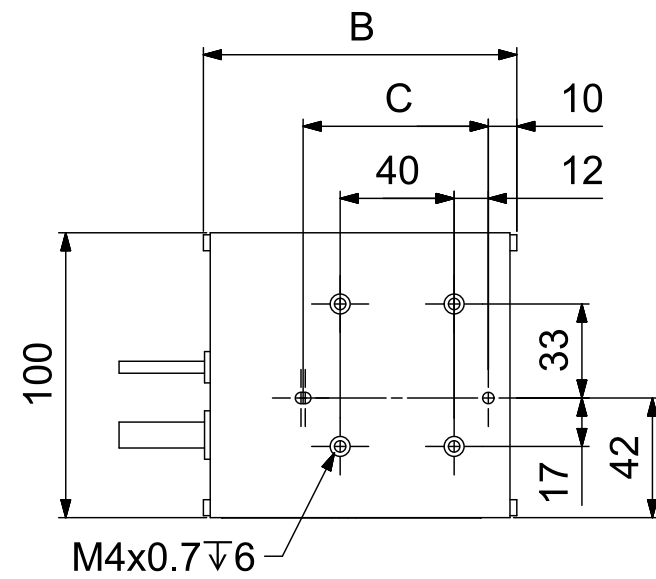

Chiron-CU-S-100-03

	Parameter	Symbol	Unit	CU-S-100-03	CU-S-100-06	CU-S-100-09	CU-S-100-12	CU-S-100-15	CU-S-100-18	CU-S-100-24	CU-S-100-30
Coil Units	Number of coils	$N_{coil}$	-	3	6	9	12	15	18	24	30
	Coil pitch	$\tau_{coil}$	mm	20	20	20	20	20	20	20	20
	Width	B	mm	110	170	230	290	350	410	530	650
	Center pin distance	C	mm	65	125	185	245	305	365	485	605
	Number of 60 mm pitches	D	mm	0	0	0	1	2	3	5	7
	Mass (ex. cable)	$M_{cu}$	kg	1.2	2.0	2.8	3.7	4.5	5.4	7.0	8.7
	Standard cable length	$L_{cable}$	m	1	1	1	1	1	1	1	1

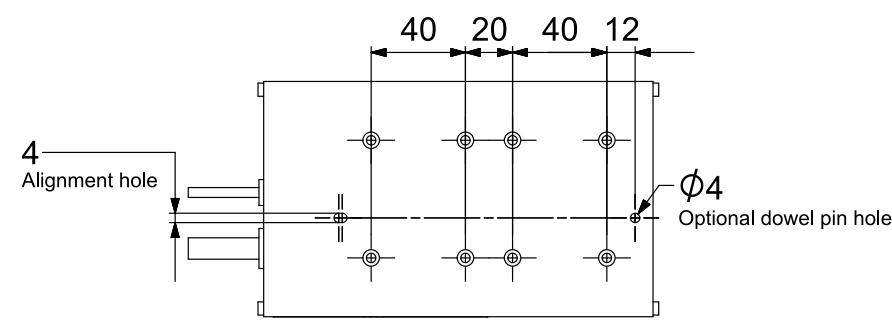

Chiron-CU-S-100-06

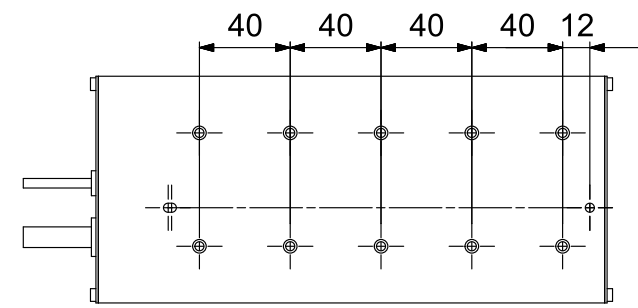

Chiron-CU-S-100-09

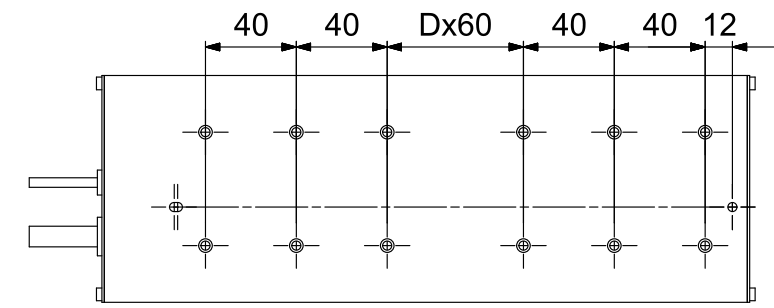

Chiron-CU-S-100-12

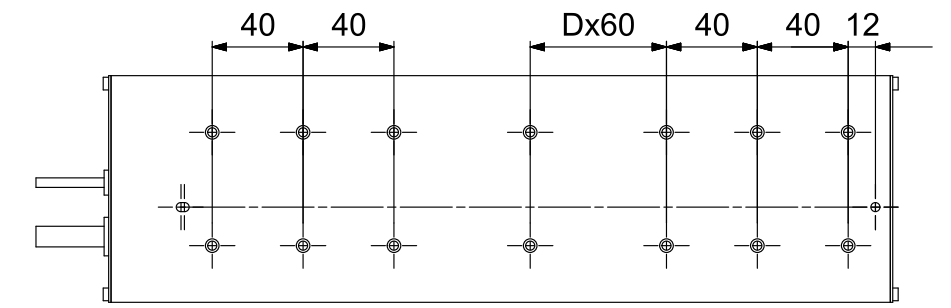

Chiron-CU-S-100-15/18/24/30

# CHIRON-S-130 PERFORMANCE SPECIFICATIONS

Parameter	Symbol	Unit	T <sub>coil</sub> (°C)	CU-S-130-03	CU-S-130-06	CU-S-130-09	CU-S-130-12	CU-S-130-15	CU-S-130-18	CU-S-130-24	CU-S-130-30
				C	B C	B C	A B C	B C	A B C D	A B C D	A B C D
Winding configuration	-	-	-	C	B C	B C	A B C	B C	A B C D	A B C D	A B C D
Peak force (α <sub>T</sub> = 5°C/s increase)	F <sub>p</sub>	N	20	500	1000	1450	2000	2450	2950	3900 3450 3900	4900 3450 4900
Continuous force, interface at 20°C	F <sub>c</sub>	N	100	320	660	970	1310	1610	1930	2580	3220 2800 3220
Attraction force (I = 0)	F <sub>att</sub>	N	-	1640	2860	4090	5310	6540	7760	10210	12660
Motor constant	S	N <sup>2</sup> /W	20	550	1100	1600	2150	2650	3150	4200	5300
Force constant (I = I <sub>c</sub> )	K <sub>f,c</sub>	N/A <sub>rms</sub>	-	118	118 247	118 353	241 118 470	118 588	235 118 705 353	235 118 940 470	235 118 1175 588
Force constant (I = I <sub>p</sub> )	K <sub>f,p</sub>	N/A <sub>rms</sub>	-	111	111 234	111 333	228 111 444	111 555	222 111 665 333	222 111 887 444	222 111 1109 555
Maximum velocity (F = 0)	v <sub>m</sub>	m/s	-	7.1	7.1 3.3	7.1 2.4	3.4 7.1 1.8	7.1 1.4	3.5 7.1 1.2 2.4	3.5 7.1 0.9 1.8	3.5 7.1 0.7 1.4
Maximum velocity (F = F <sub>p</sub> )	v <sub>i</sub>	m/s	20	4.1	4.1 1.8	4.1 1.0	1.8 4.1 0.6	4.1 0.4	1.8 4.1 0.2 1.0	1.8 4.1 0.0 0.6	1.8 4.1 0.0 0.4
Maximum dc bus voltage	V <sub>dc</sub>	V	-	690	690	690	690	690	690	690	690
Phase resistance	R <sub>ph,20</sub>	Ohm	20	9.0	4.5 18	3.0 27	9.0 2.3 36	1.8 45	6.0 1.5 54 14	4.5 1.1 72 18	3.6 0.9 90 23
Phase inductance	L <sub>ph</sub>	mH	20	55	28 110	18.3 165	55 13.8 220	11 275	37 9.2 330 83	28 6.9 440 110	22 5.5 550 138
Peak line emf constant	K <sub>e,ll,p</sub>	Vs/m	-	97	97 207	97 292	200 97 390	97 487	195 97 585 292	195 97 780 390	195 97 975 487
Maximum rms current	I <sub>p</sub>	A <sub>rms</sub>	20	4.4	8.8 4.4	13 4.4	8.8 18 4.4	22 4.4	13 26 4.4 8.8	18 35 3.9 8.8	22 44 3.1 8.8
Continuous rms current, interface at 20°C	I <sub>c</sub>	A <sub>rms</sub>	100	2.7	5.5 2.7	8.2 2.7	5.5 11 2.7	14 2.7	8.2 16 2.7 5.5	11 22 2.7 5.5	14 27 2.4 5.5
Continuous dissipation, interface at 20°C	P <sub>d,c</sub>	W	100	267	533	800	1067	1333	1600	2133	2667
Thermal resistance, coils to interface	R <sub>th,i</sub>	K/W	-	0.30	0.15	0.10	0.08	0.060	0.050	0.038	0.030
Thermal resistance, coils to conv. surface	R <sub>th,c</sub>	K/W	-	0.23	0.12	0.08	0.06	0.047	0.039	0.029	0.023
Thermal time constant, interface at 20°C	τ <sub>th</sub>	s	-	58	58	58	58	58	58	58	58

## Notes

- Specifications are based upon a magnet temperature of 20°C
- Specifications consider complete overlap of the coil unit with a magnet plate
- Specifications consider sinusoidal q-axis commutation
- Velocity specifications are based on the maximum bus voltage
- Specifications are based upon an airgap of 1 mm
- See 'definitions' section at the end of the catalog for more details

## Product marking / approvals

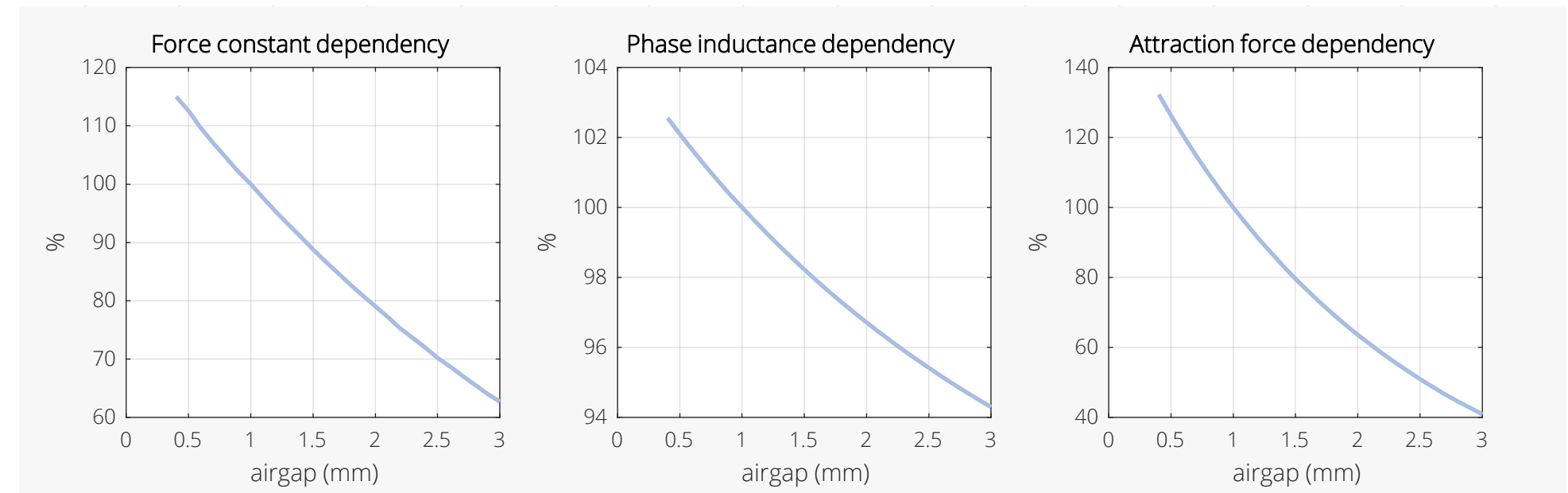

Airgap dependency



# CHIRON-S-130 MECHANICAL SPECIFICATIONS

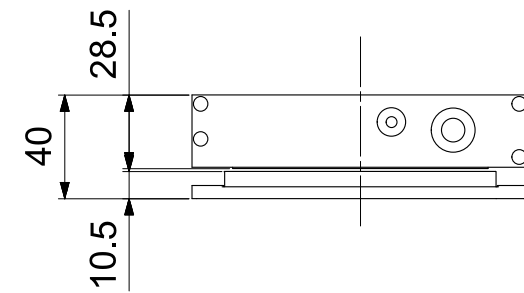
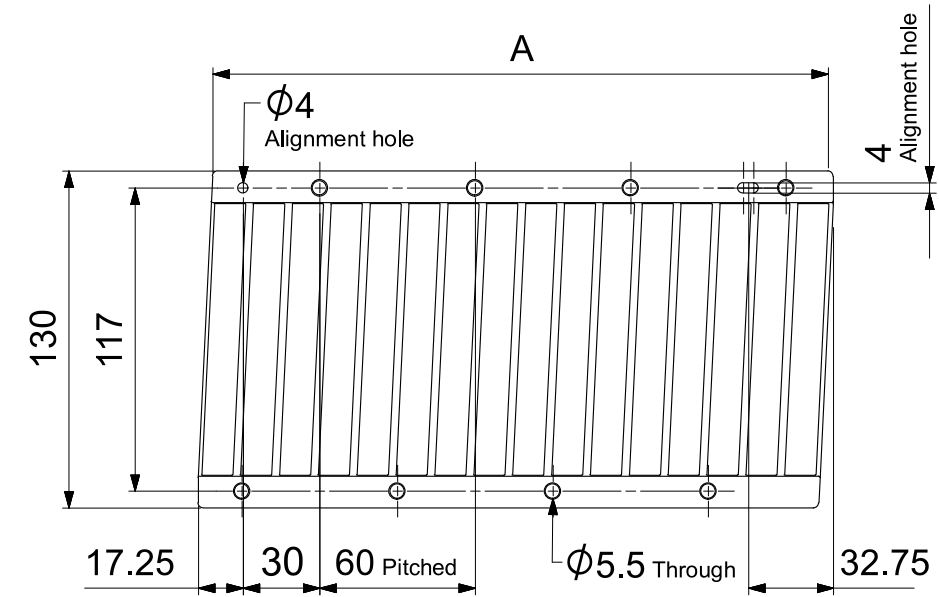

	Parameter	Symbol	Unit	MP-130-12	MP-130-16	MP-130-28	MP-130-36
Magnet Plates	Number of poles	$N_p$	-	12	16	28	36
	Pole pitch (N-N)	$2\tau_p$	mm	30	30	30	30
	Width	A	mm	180	240	420	540
	Mass	$M_{mp}$	kg	1.5	2.0	3.6	4.6

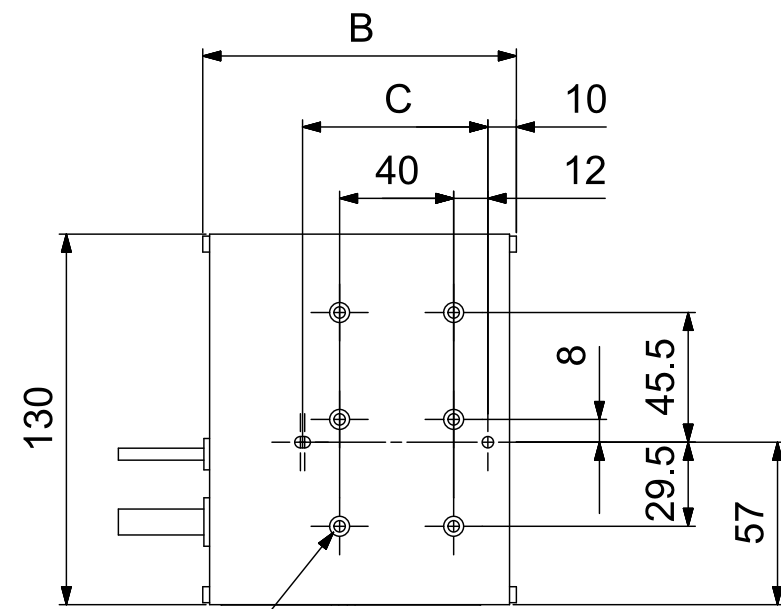

	Parameter	Symbol	Unit	CU-S-130-03	CU-S-130-06	CU-S-130-09	CU-S-130-12	CU-S-130-15	CU-S-130-18	CU-S-130-24	CU-S-130-30
Coil Units	Number of coils	$N_{coil}$	-	3	6	9	12	15	18	24	30
	Coil pitch	$\tau_{coil}$	mm	20	20	20	20	20	20	20	20
	Width	B	mm	110	170	230	290	350	410	530	650
	Center pin distance	C	mm	65	125	185	245	305	365	485	605
	Number of 60 mm pitches	D	mm	0	0	0	1	2	3	5	7
	Mass (ex. cable)	$M_{cu}$	kg	1.5	2.7	3.8	5.0	6.1	7.3	9.6	11.9
	Standard cable length	$L_{cable}$	m	1	1	1	1	1	1	1	1

Chiron-CU-S-130-03

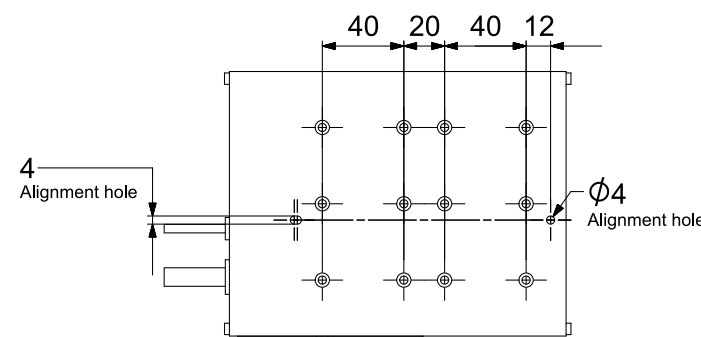

Chiron-CU-S-130-06

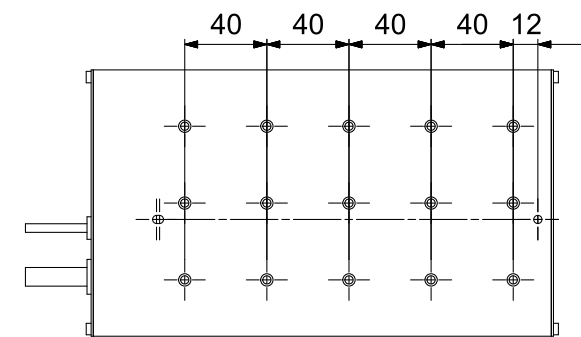

Chiron-CU-S-130-09

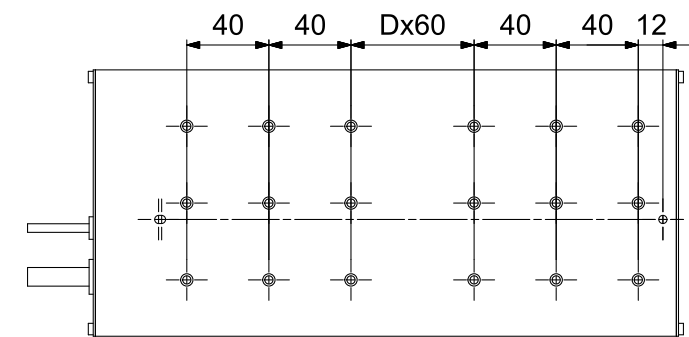

Chiron-CU-S-130-12

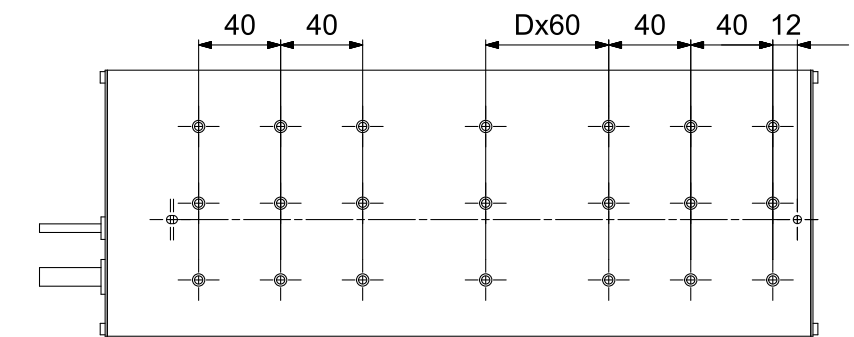

Chiron-CU-S-130-15/18/24/30

# CHIRON-S-050/080 FORCE-VELOCITY DIAGRAMS

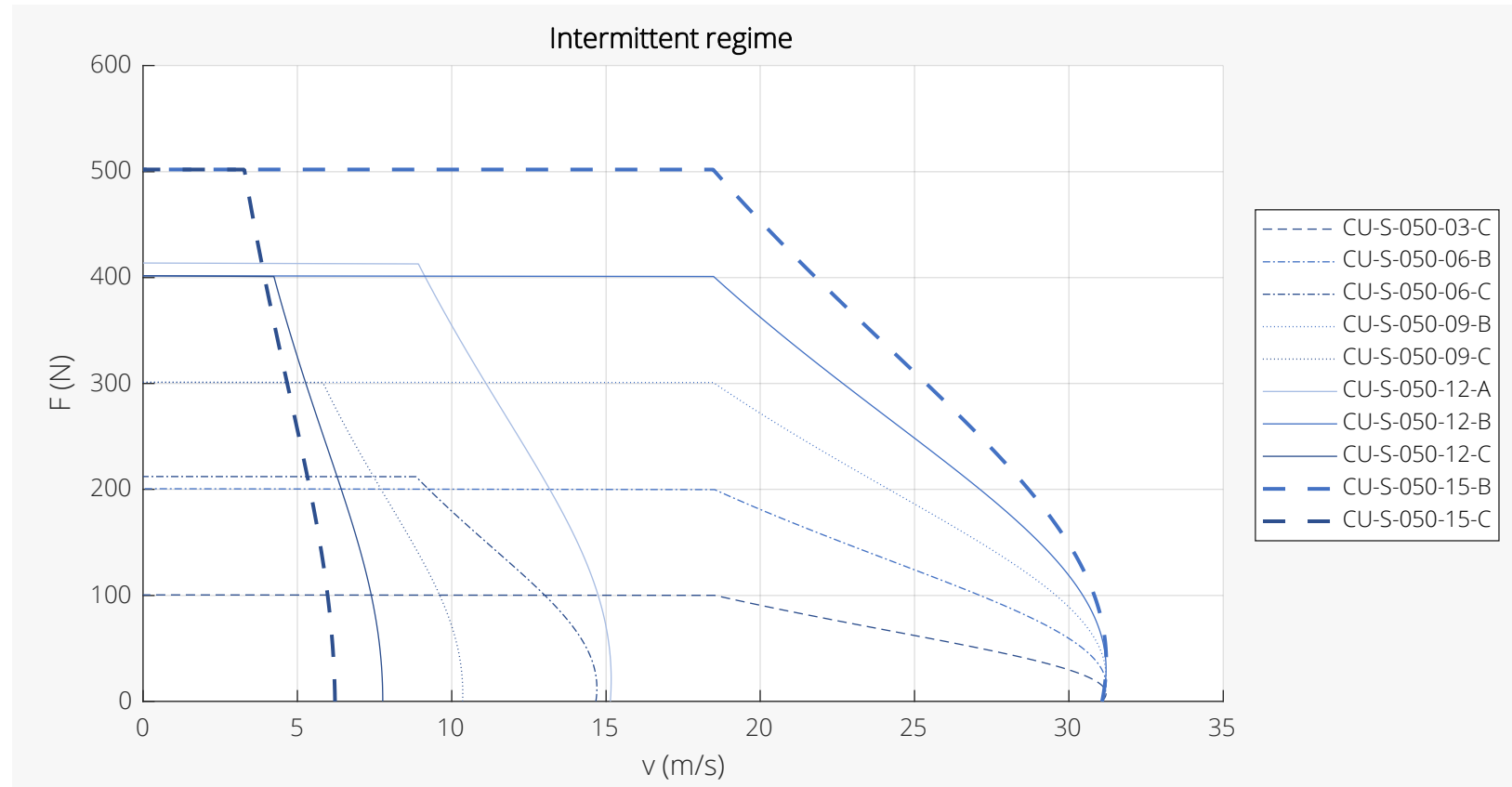

Force-Velocity Diagrams Size S-050 Intermittent Regime

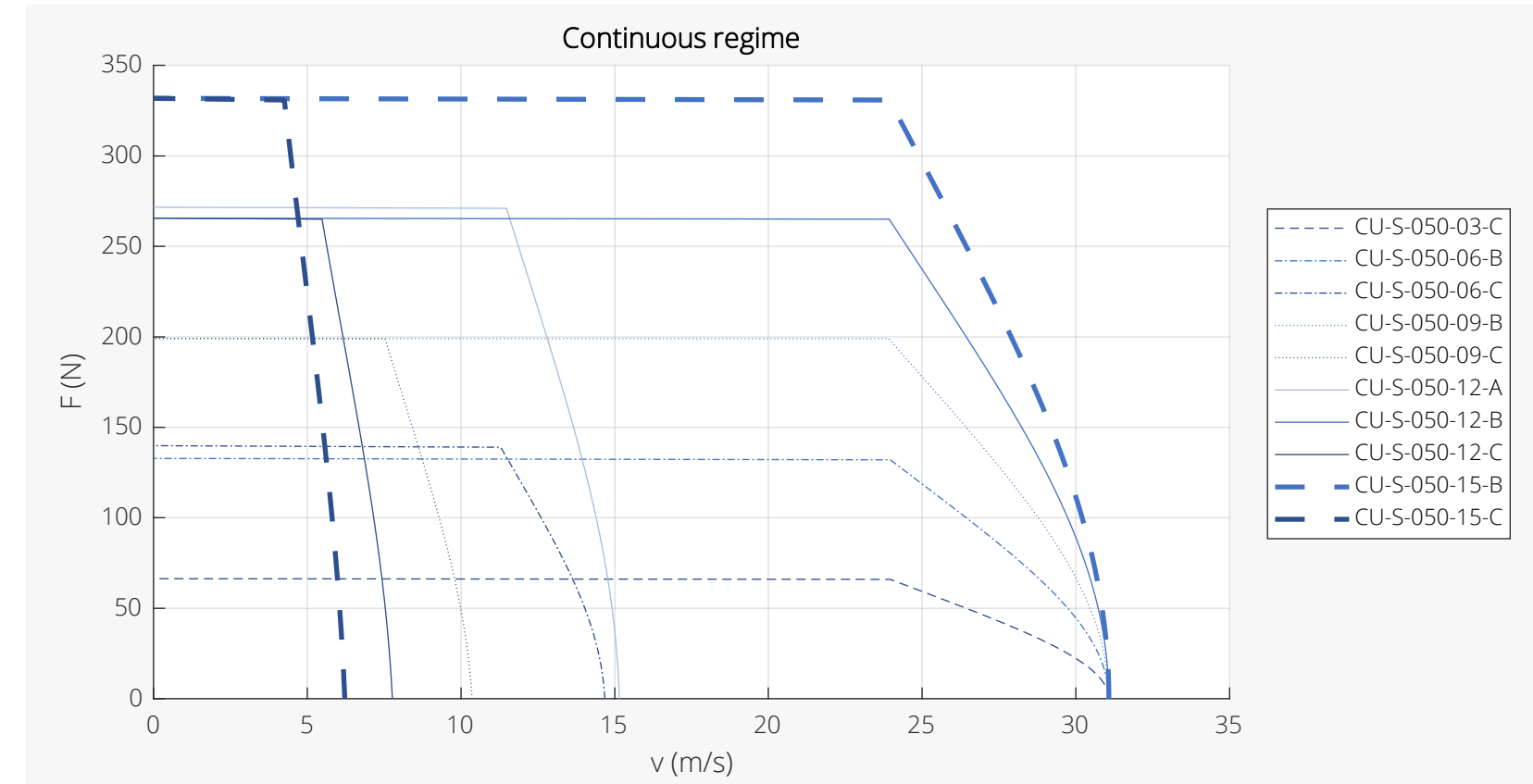

Force-Velocity Diagrams Size S-050 Continuous Regime

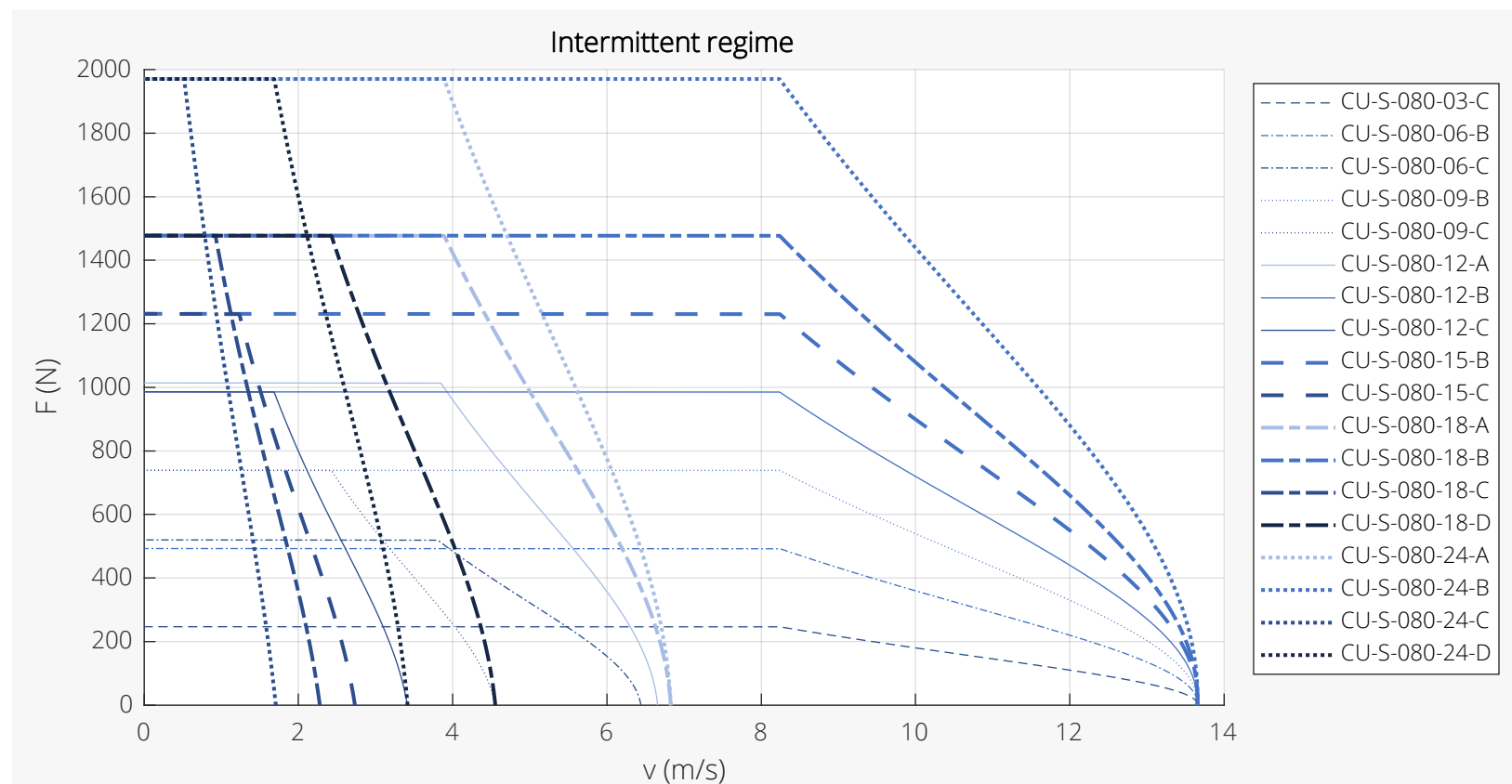

Force-Velocity Diagrams Size S-080 Intermittent Regime

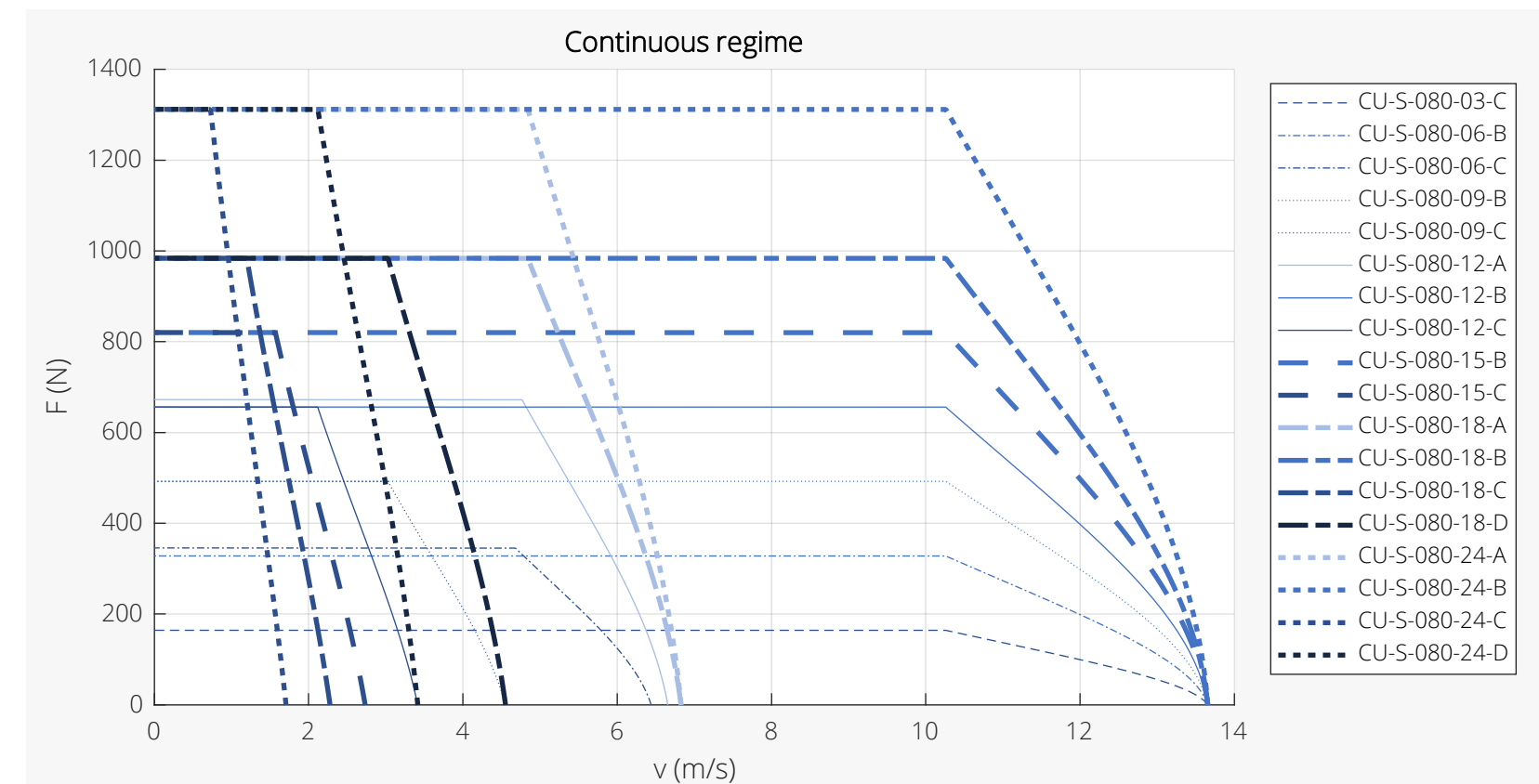

Force-Velocity Diagrams Size S-080 Continuous Regime



# CHIRON-S-100/130 FORCE-VELOCITY DIAGRAMS

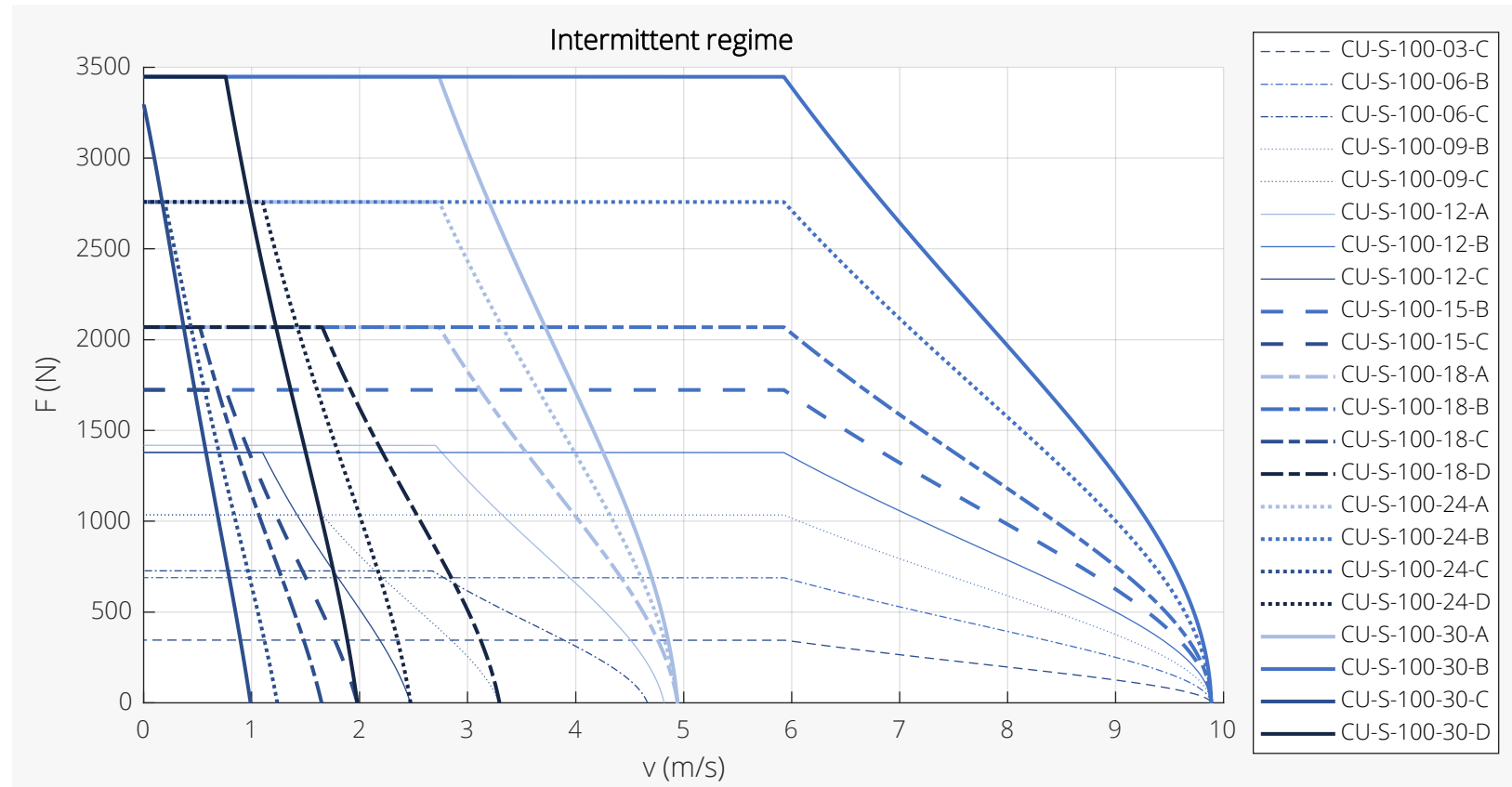

Force-Velocity Diagrams Size S-100 Intermittent Regime

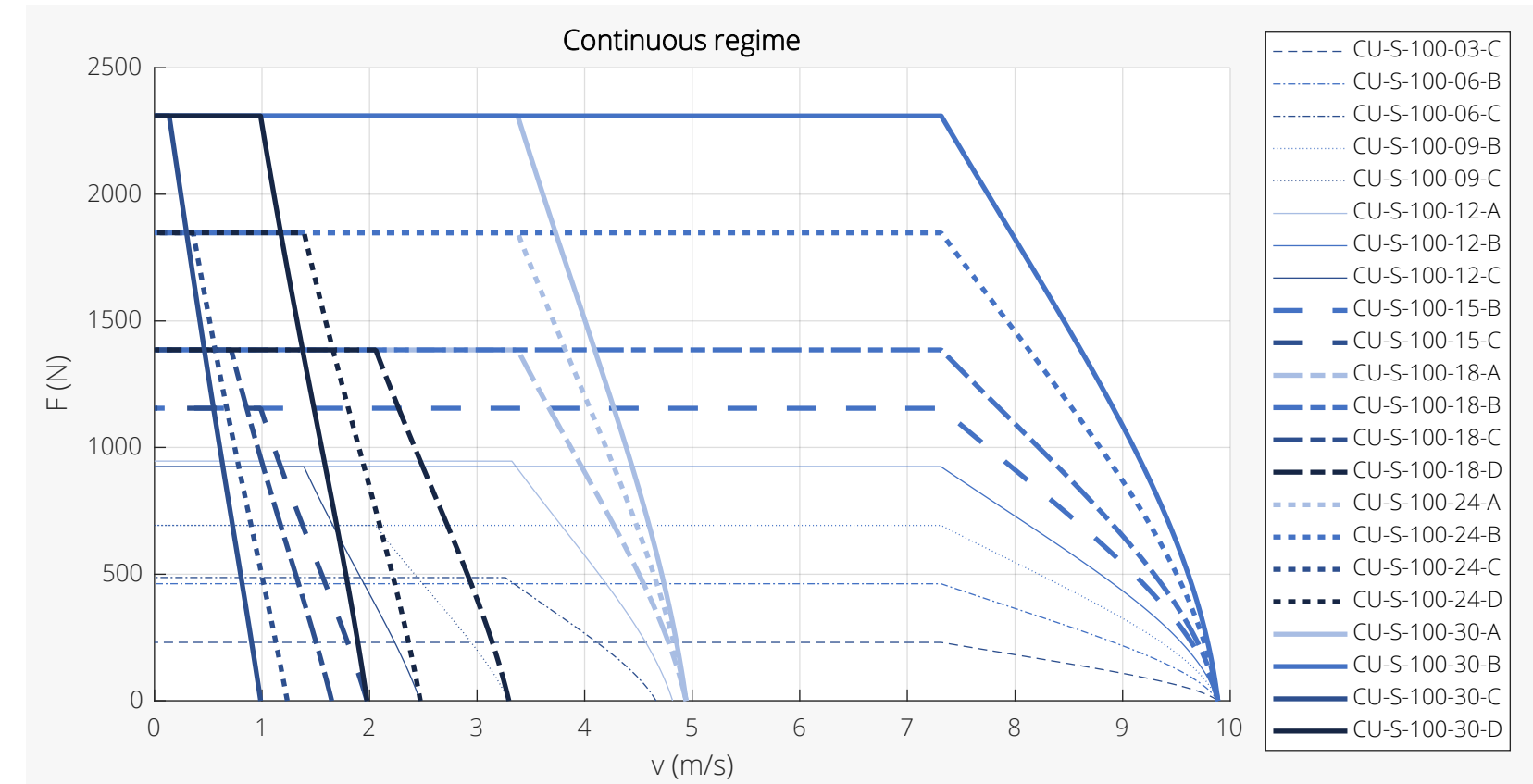

Force-Velocity Diagrams Size S-100 Continuous Regime

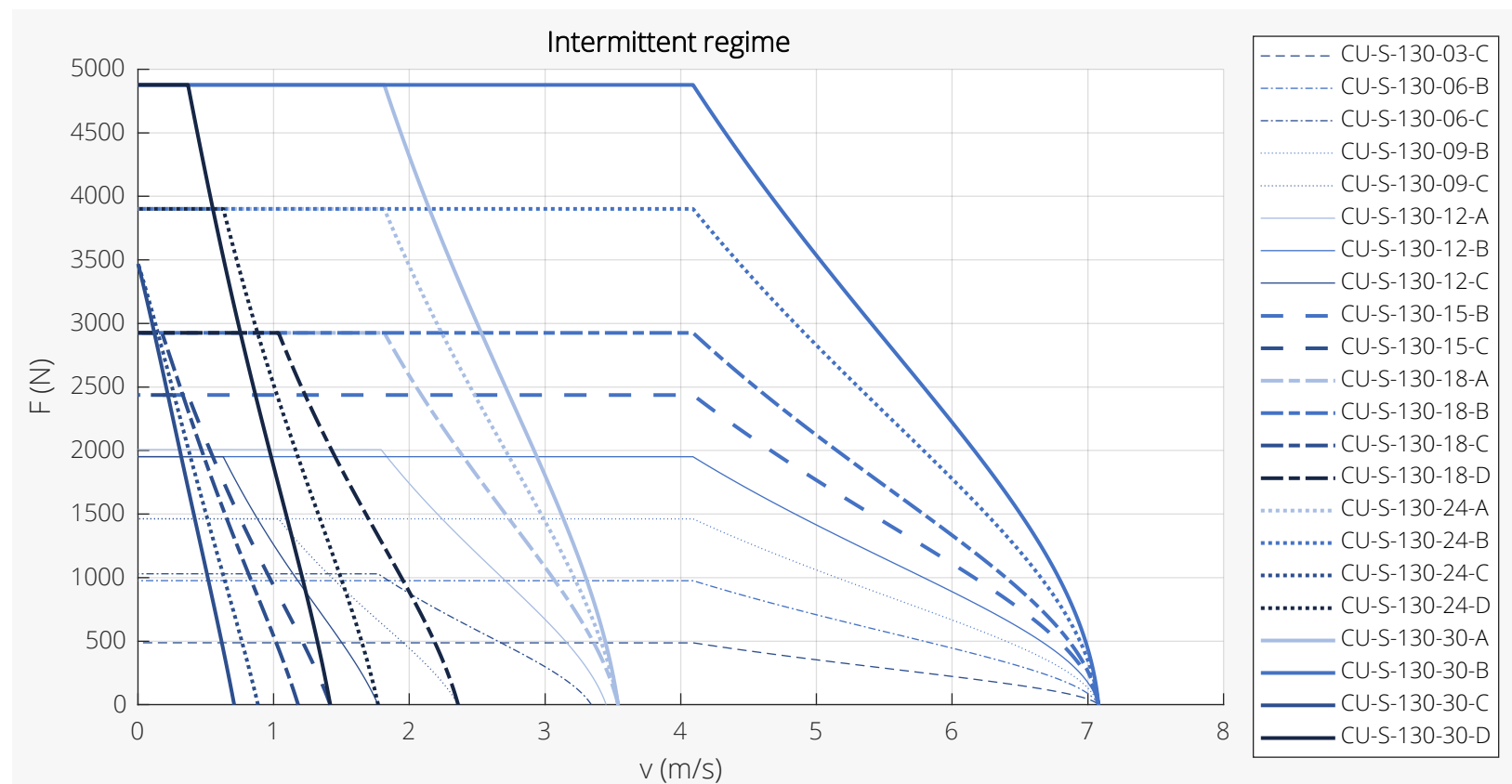

Force-Velocity Diagrams Size S-130 Intermittent Regime

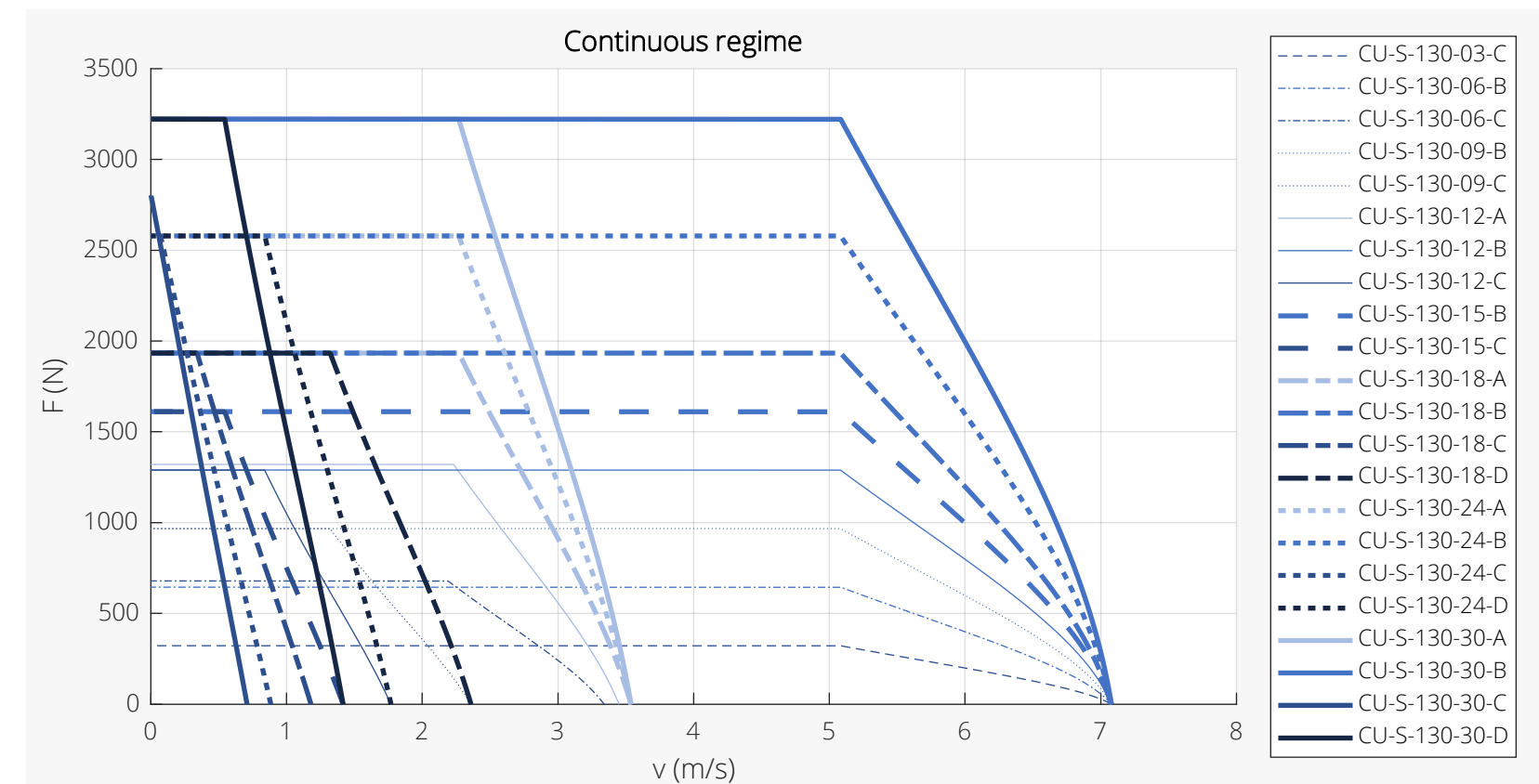

Force-Velocity Diagrams Size S-130 Continuous Regime



Chiron commutations sensor (Chiron-CS-D)

- For correct operation of a linear motor, the commutation angle (the electrical angle between the coil unit and the magnet yoke) should be known. This commutation angle is needed to determine the phase angle of the three phase currents.
- The commutation angle can be derived from the relative displacement, for example using a position sensor. However, the Chiron commutation sensor can directly measure the commutation angle without the need of a position sensor. The Chiron commutation sensor can be added to your motion system which provides a cost-effective alternative to measure the commutation angle.
- The Chiron commutation sensor is available in two types. The digital type (Chiron-CS-D) contains three digital Hall sensors, each shifted by 120 electrical degrees, from which the commutation angle can be derived. The analog type (Chiron-CS-A) contains two analog Hall sensors, each shifted by 90 electrical degrees, providing sin/cos signals for a more accurate measurement of the commutation angle. Both commutation sensor types can be used for the complete range of sizes.
- The digital commutation sensor allows a supply voltage range between 4.5 Vdc and 28 Vdc. The supply voltage of the analog commutation sensor should be 5 Vdc.



# PHOENIX LINE

The Phoenix line offers ironless linear motors, for applications requiring an extremely low force ripple for excellent servo performance without attraction forces. Available in a large range of sizes.

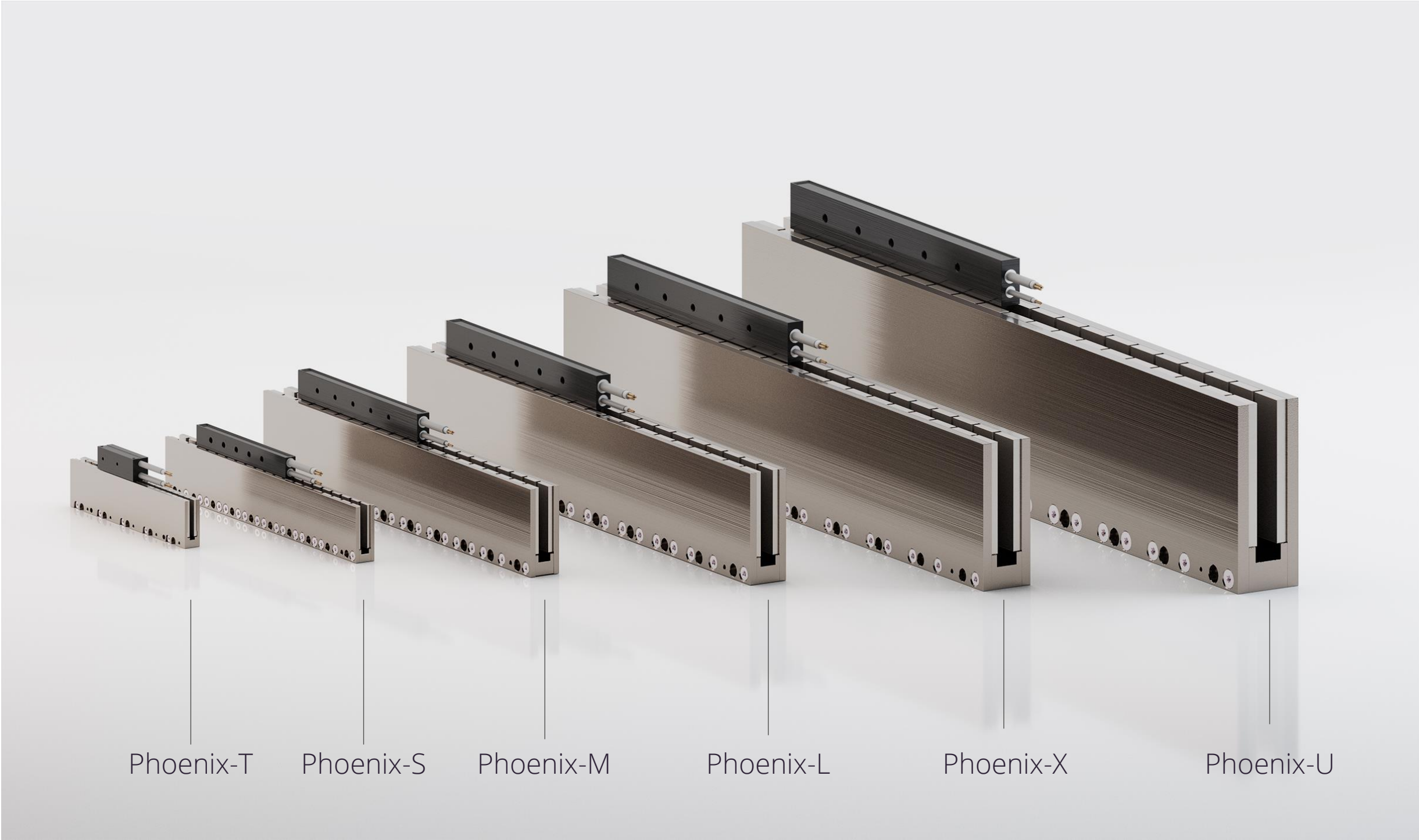

Phoenix line linear motors in different sizes

# PHOENIX-T FEATURES



Phoenix-T magnet yoke (Phoenix-MY-T-20-G00) and coil unit (Phoenix-CU-T-03-C-S-P-CS)

## Phoenix-CU-T-06-A-S-P-CS

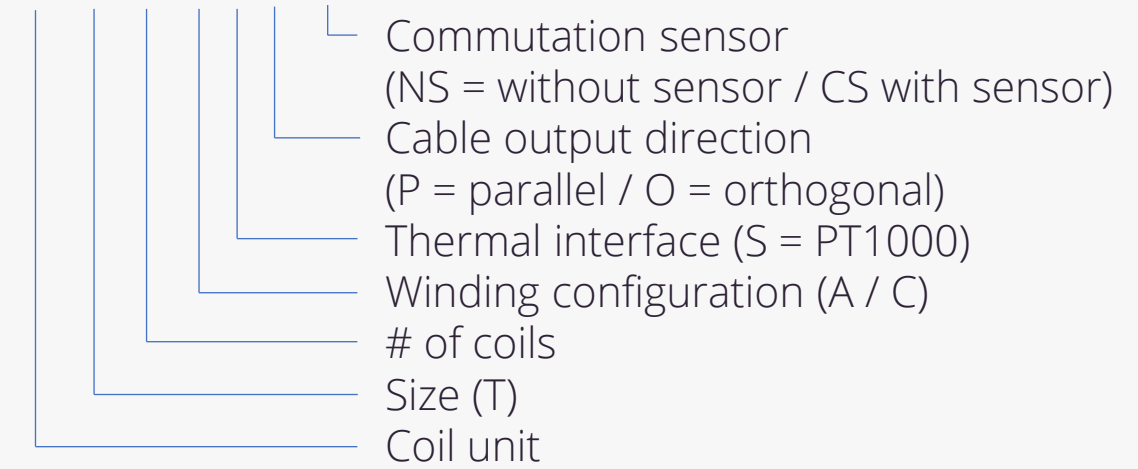

## Phoenix-MY-T-20-G00

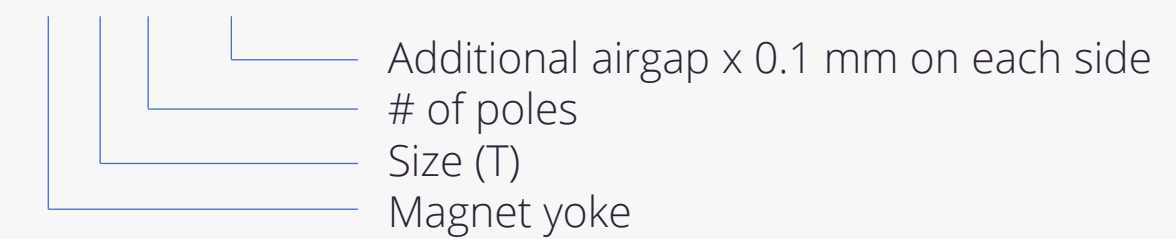

- Different cable output directions for optimal mechanical integration
- Coil units have a temperature sensor (PT1000)
- Motor phases and temperature sensor are integrated in a single cable
- Motor coils are made with PCB technology to improve quality and minimize cost
- Optional commutation sensor (CS), digital Hall, integrated in the coil unit
- Magnet yokes can be butted together
- Magnet yokes can be selected with larger airgaps to allow higher installation tolerances
- Extremely low force ripple due to ironless coil unit
- No attraction force
- Coil units are equipped with flex cables

# PHOENIX-T PERFORMANCE SPECIFICATIONS

	Parameter	Symbol	Unit	T <sub>coil</sub> (°C)	CU-T-03	CU-T-06
	Winding configuration	-	-	-	C	A
Electromechanical	Peak force ( $\alpha_T = 20^\circ\text{C/s}$ increase)	$F_p$	N	20	30	60
	Continuous force, interface at 20°C	$F_c$	N	100	10	20
	Attraction force ( $I = 0$ )	$F_{att}$	N	-	0	0
	Motor constant	$S$	$\text{N}^2/\text{W}$	20	8	15
	Force constant	$K_f$	$\text{N}/\text{A}_{\text{rms}}$	-	10.2	10.2
	Maximum velocity ( $F = 0$ )	$v_m$	m/s	-	7.2	7.2
	Maximum velocity ( $F = F_p$ )	$v_i$	m/s	20	3.4	3.4
Electrical	Maximum dc bus voltage	$V_{dc}$	V	-	60	60
	Phase resistance	$R_{ph,20}$	Ohm	20	4.5	2.3
	Phase inductance	$L_{ph}$	mH	20	0.50	0.25
	Peak line emf constant	$K_{e,ll,p}$	Vs/m	-	8	8
	Maximum rms current	$I_p$	$\text{A}_{\text{rms}}$	20	2.9	5.8
	Continuous rms current, interface at 20°C	$I_c$	$\text{A}_{\text{rms}}$	100	1.0	1.9
Thermal	Continuous dissipation, interface at 20°C	$P_{d,c}$	W	100	16	33
	Thermal resistance, coils to interface	$R_{th,i}$	K/W	-	4.9	2.5
	Thermal resistance, coils to conv. surface	$R_{th,c}$	K/W	-	0.58	0.29
	Thermal time constant, interface at 20°C	$\tau_{th}$	s	-	45	45

## Notes

- Specifications are based upon a magnet temperature of 20°C
- Specifications consider complete overlap of the coil unit with a magnet yoke
- Specifications consider sinusoidal q-axis commutation
- Velocity specifications are based on the maximum bus voltage
- Specifications consider a magnet yoke with nominal airgap (G00)
- See 'definitions' section at the end of the catalog for more details

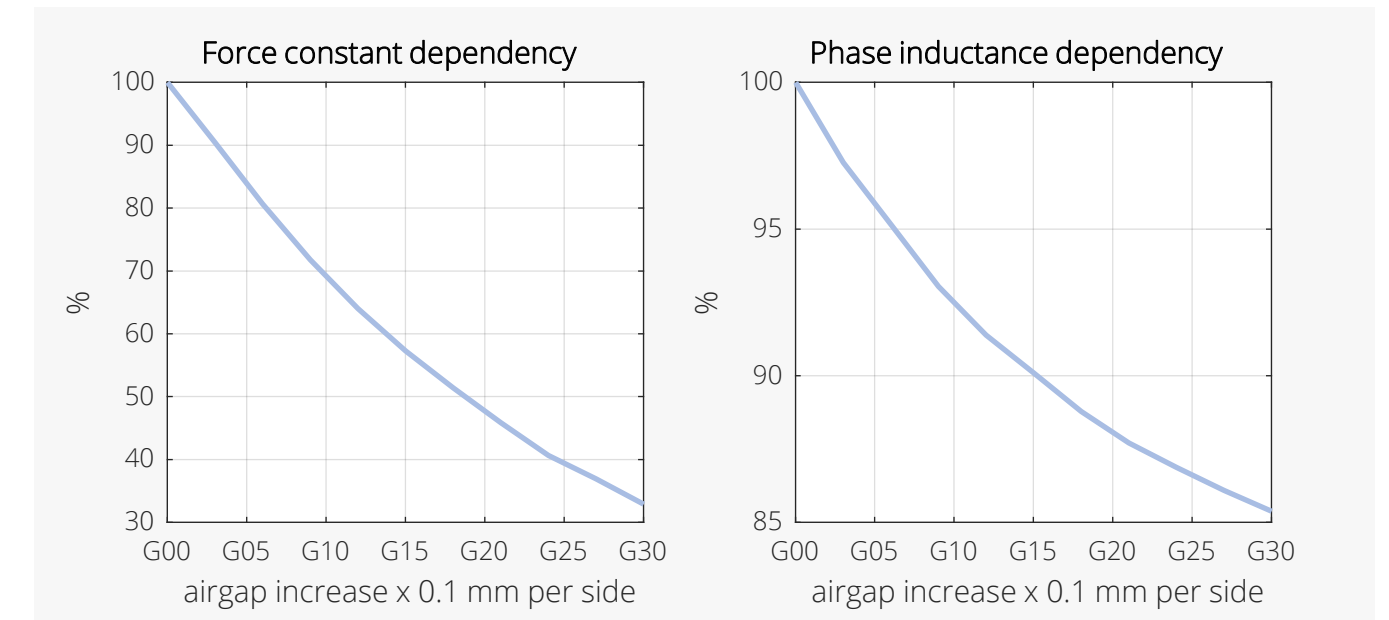

Airgap dependency



# PHOENIX-T MECHANICAL SPECIFICATIONS WITHOUT CS

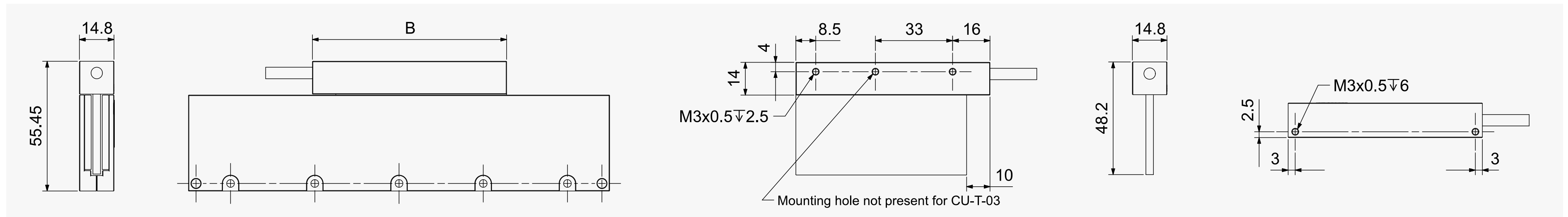

Parallel cable output

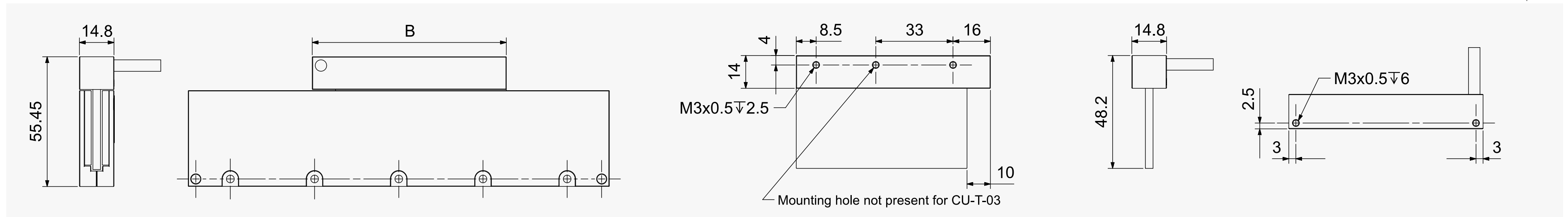

Orthogonal cable output

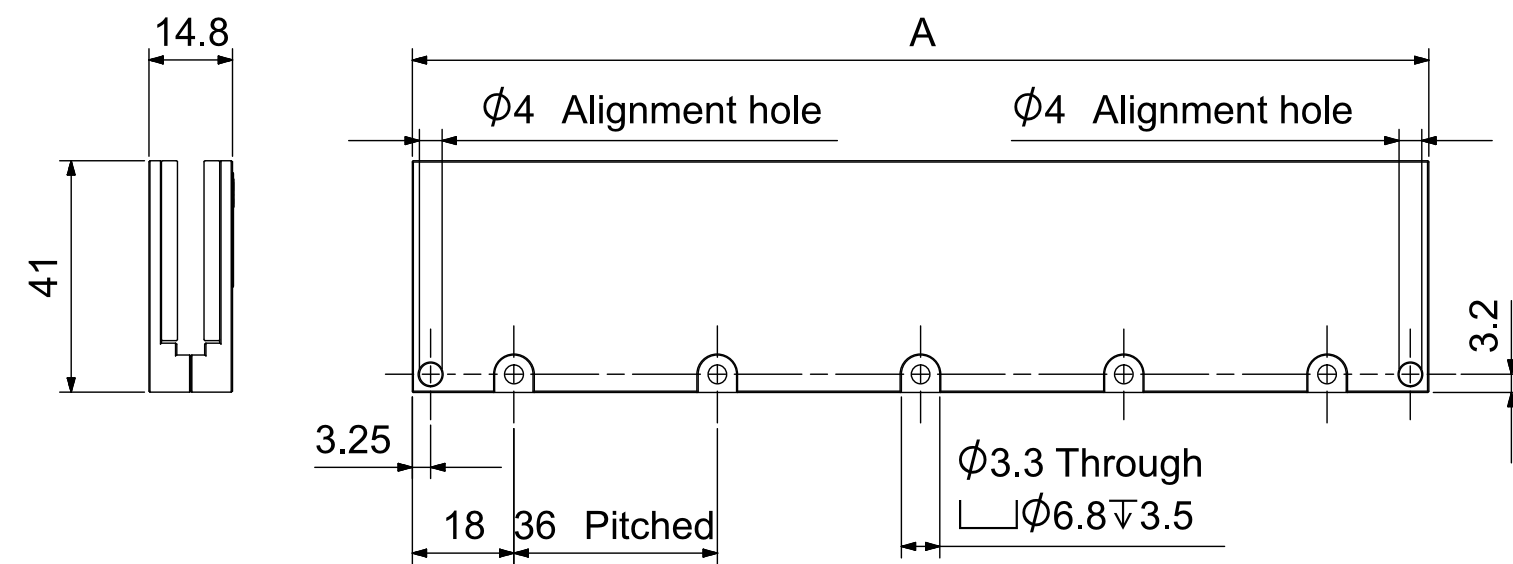

Magnet Yokes	Parameter	Symbol	Unit	MY-T-08	MY-T-12	MY-T-16	MY-T-20
	Number of poles	$N_p$	-	8	12	16	20
	Pole pitch (N-N)	$2\tau_p$	mm	18	18	18	18
	Width	A	mm	72	108	144	180
Mass	$M_{my}$	kg	0.21	0.32	0.43	0.53	

Coil Units	Parameter	Symbol	Unit	CU-T-03	CU-T-06
	Number of coils	$N_{coil}$	-	3	6
	Coil pitch	$\tau_{coil}$	mm	12	12
	Width	B	mm	47	83
	Mass (ex. cable)	$M_{cu}$	kg	0.038	0.071
Standard cable length	$L_{cable}$	m	1	1	

# PHOENIX-T MECHANICAL SPECIFICATIONS WITH CS

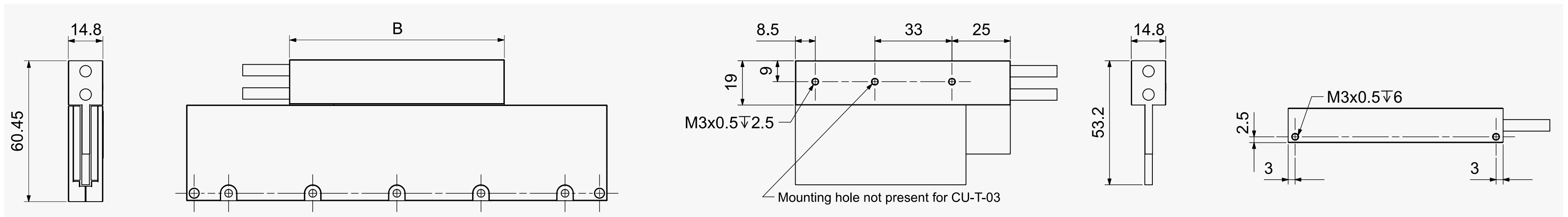

Parallel cable output

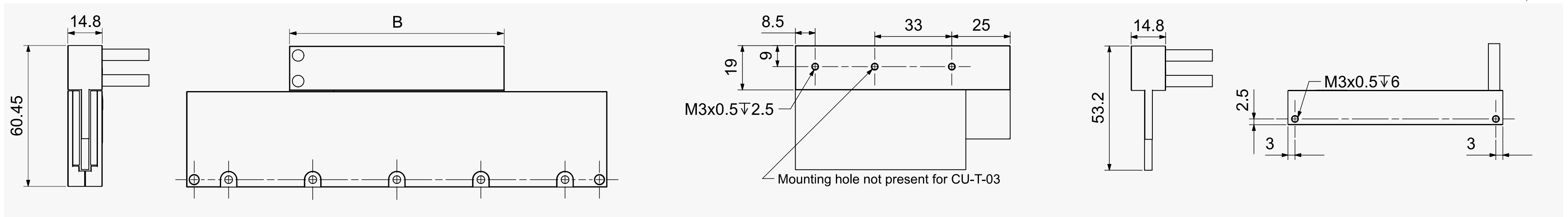

Orthogonal cable output

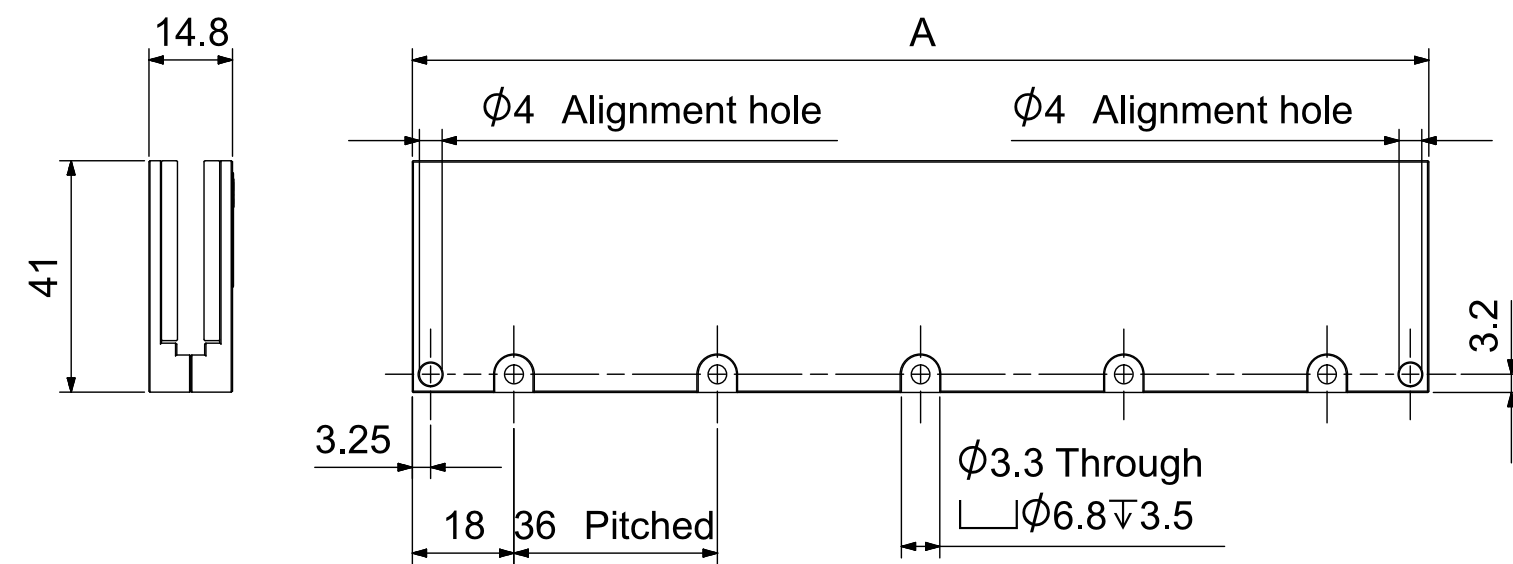

Magnet Yokes	Parameter	Symbol	Unit	MY-T-08	MY-T-12	MY-T-16	MY-T-20
	Number of poles	$N_p$	-	8	12	16	20
	Pole pitch (N-N)	$2\tau_p$	mm	18	18	18	18
	Width	A	mm	72	108	144	180
	Mass	$M_{my}$	kg	0.21	0.32	0.43	0.53

Coil Units	Parameter	Symbol	Unit	CU-T-03	CU-T-06
	Number of coils	$N_{coil}$	-	3	6
	Coil pitch	$\tau_{coil}$	mm	12	12
	Width	B	mm	56	92
	Mass (ex. cable)	$M_{cu}$	kg	0.051	0.089
Standard cable length	$L_{cable}$	m	1	1	

# PHOENIX-S/M/L/X/U FEATURES

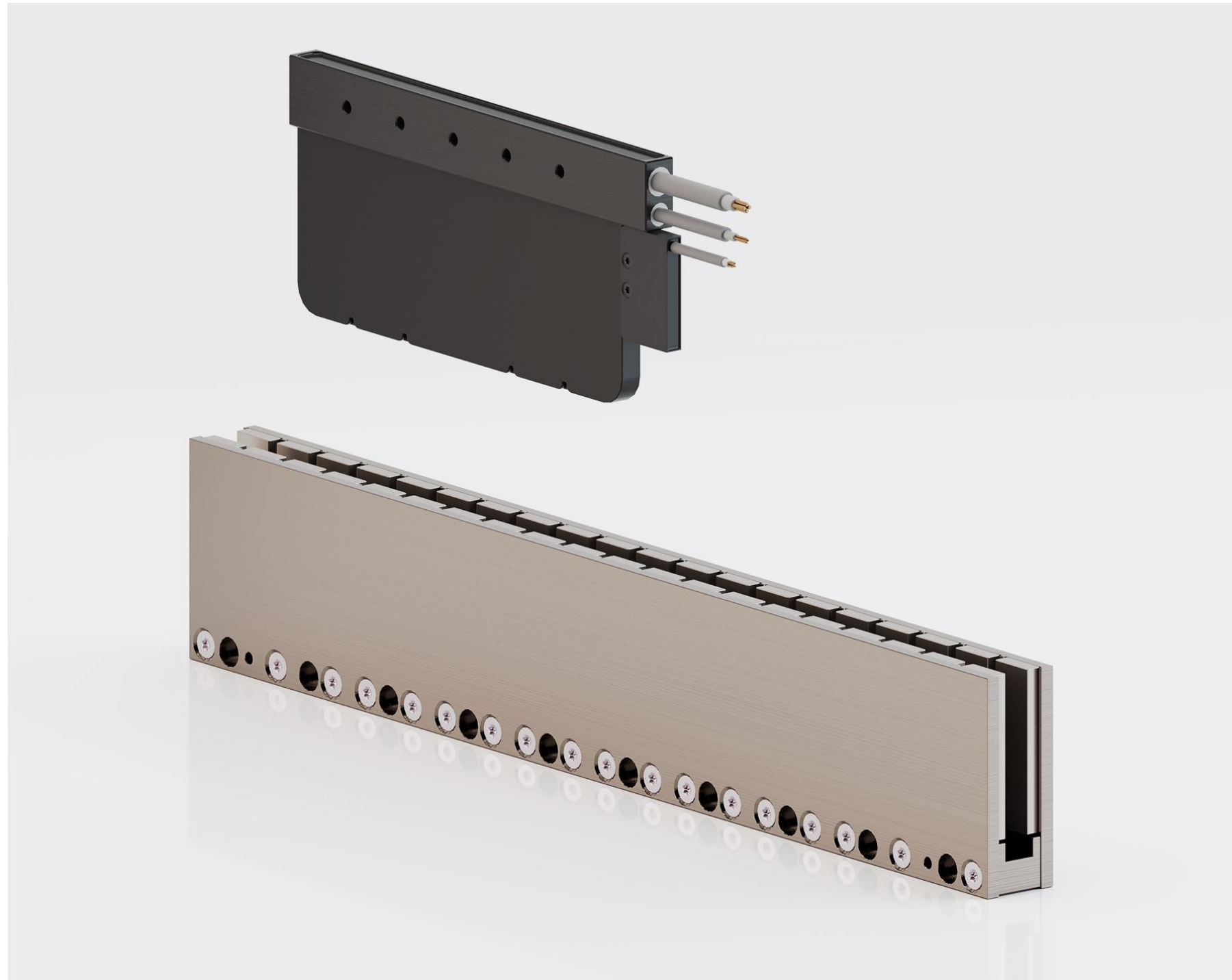

Phoenix-S magnet yoke (Phoenix-MY-S-20-G00), coil unit (Phoenix-CU-S-06-A-B) and commutation sensor (Phoenix-CS-S)

## Phoenix-CU-M-12-A-N

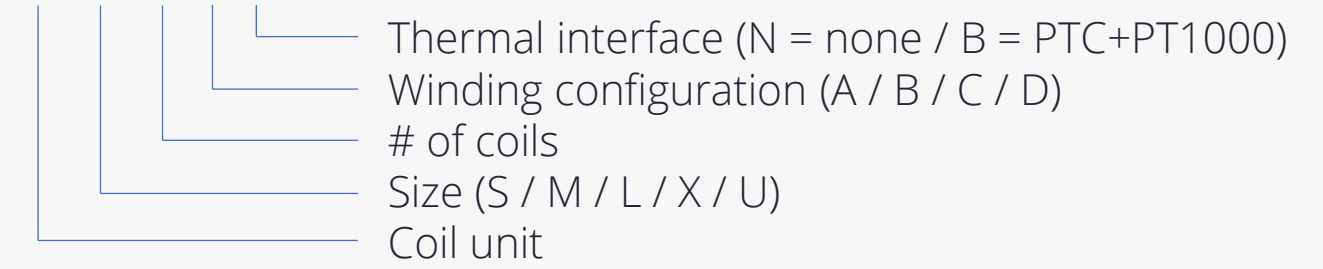

## Phoenix-MY-M-20-G00



## Phoenix-CS-M

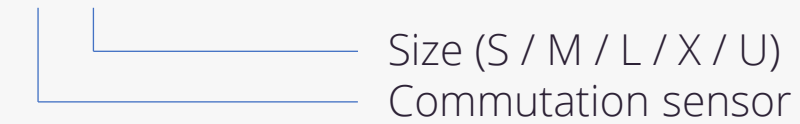

- Multiple sizes for optimal mechanical integration
- Multiple winding configurations for optimal current/velocity matching
- Coil units have an optional temperature protection (PTC) and sensor (PT1000)
- Magnet yokes can be butted together
- Magnet yokes can be selected with larger airgaps to accommodate larger tolerances
- Extremely low force ripple due to ironless coil unit
- No attraction force
- IP rating of coil units is IP69K
- Optional commutation sensor (digital Hall A/B/C) can be connected to the coil unit



# PHOENIX-S PERFORMANCE SPECIFICATIONS

Parameter		Symbol	Unit	T <sub>coil</sub> (°C)	CU-S-03		CU-S-06			CU-S-09				CU-S-12		
Winding configuration		-	-	-	C	D	A	B	C	A	B	C	D	A	C	D
Electromechanical	Peak force ( $\alpha_T = 20^\circ\text{C/s}$ increase)	$F_p$	N	20	80		160			230				310		
	Continuous force, interface at 20°C	$F_c$	N	100	25		50			75				95		
	Attraction force ( $I = 0$ )	$F_{att}$	N	-	0		0			0				0		
	Motor constant	$S$	$\text{N}^2/\text{W}$	20	20		40			60				80		
	Force constant	$K_f$	$\text{N}/\text{A}_{\text{rms}}$	-	17	8.6	17	9	34	17	8.6	51	26	17	68	34
	Maximum velocity ( $F = 0$ )	$v_m$	m/s	-	29	57	29	57	14	29	57	9.5	19	29	7.2	14
	Maximum velocity ( $F = F_p$ )	$v_i$	m/s	20	24	52	24	52	10	24	52	5.4	15	24	3.1	10
Electrical	Maximum dc bus voltage	$V_{dc}$	V	-	400		400			400				400		
	Phase resistance	$R_{ph,20}$	Ohm	20	5.0	1.3	2.5	0.6	10	1.7	0.4	15	3.8	1.3	20	5.0
	Phase inductance	$L_{ph}$	mH	20	1.5	0.4	0.7	0.2	3.0	0.5	0.1	4.4	1.1	0.4	5.9	1.5
	Peak line emf constant	$K_{e,ll,p}$	Vs/m	-	14	7.0	14	7.0	28	14	7.0	42	21	14	56	28
	Maximum rms current	$I_p$	$\text{A}_{\text{rms}}$	20	4.5	9.1	9.1	18.2	4.5	13.6	27	4.5	9.1	18.2	4.5	9.1
	Continuous rms current, interface at 20°C	$I_c$	$\text{A}_{\text{rms}}$	100	1.4	2.8	2.8	5.7	1.4	4.2	8.5	1.4	2.8	5.7	1.4	2.8
Thermal	Continuous dissipation, interface at 20°C	$P_{d,c}$	W	100	40		79			119				159		
	Thermal resistance, coils to interface	$R_{th,i}$	K/W	-	2.0		1.0			0.67				0.50		
	Thermal resistance, coils to conv. surface	$R_{th,c}$	K/W	-	0.19		0.093			0.062				0.047		
	Thermal time constant, interface at 20°C	$\tau_{th}$	s	-	65		65			65				65		

## Notes

- Specifications are based upon a magnet temperature of 20°C
- Specifications consider complete overlap of the coil unit with a magnet yoke
- Specifications consider sinusoidal q-axis commutation
- Velocity specifications are based on the maximum bus voltage
- Specifications consider a magnet yoke with nominal airgap (G00)
- See 'definitions' section at the end of the catalog for more details

## Product marking / approvals

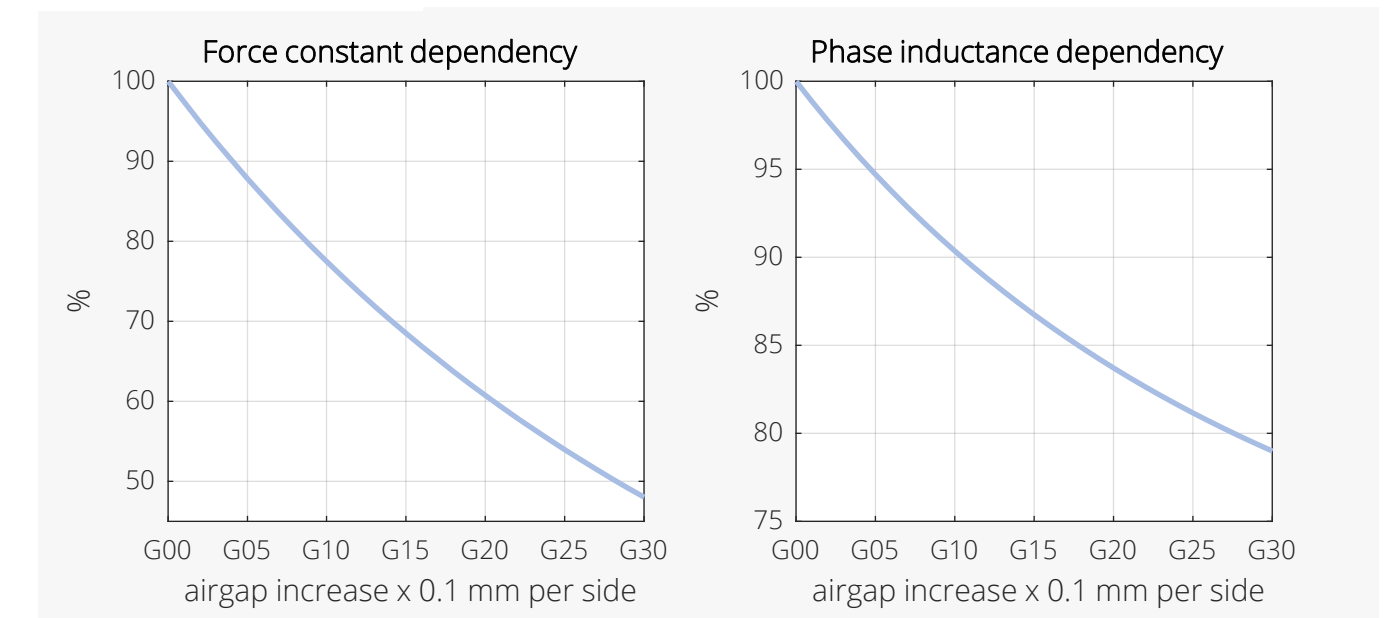

Airgap dependency

# PHOENIX-S MECHANICAL SPECIFICATIONS

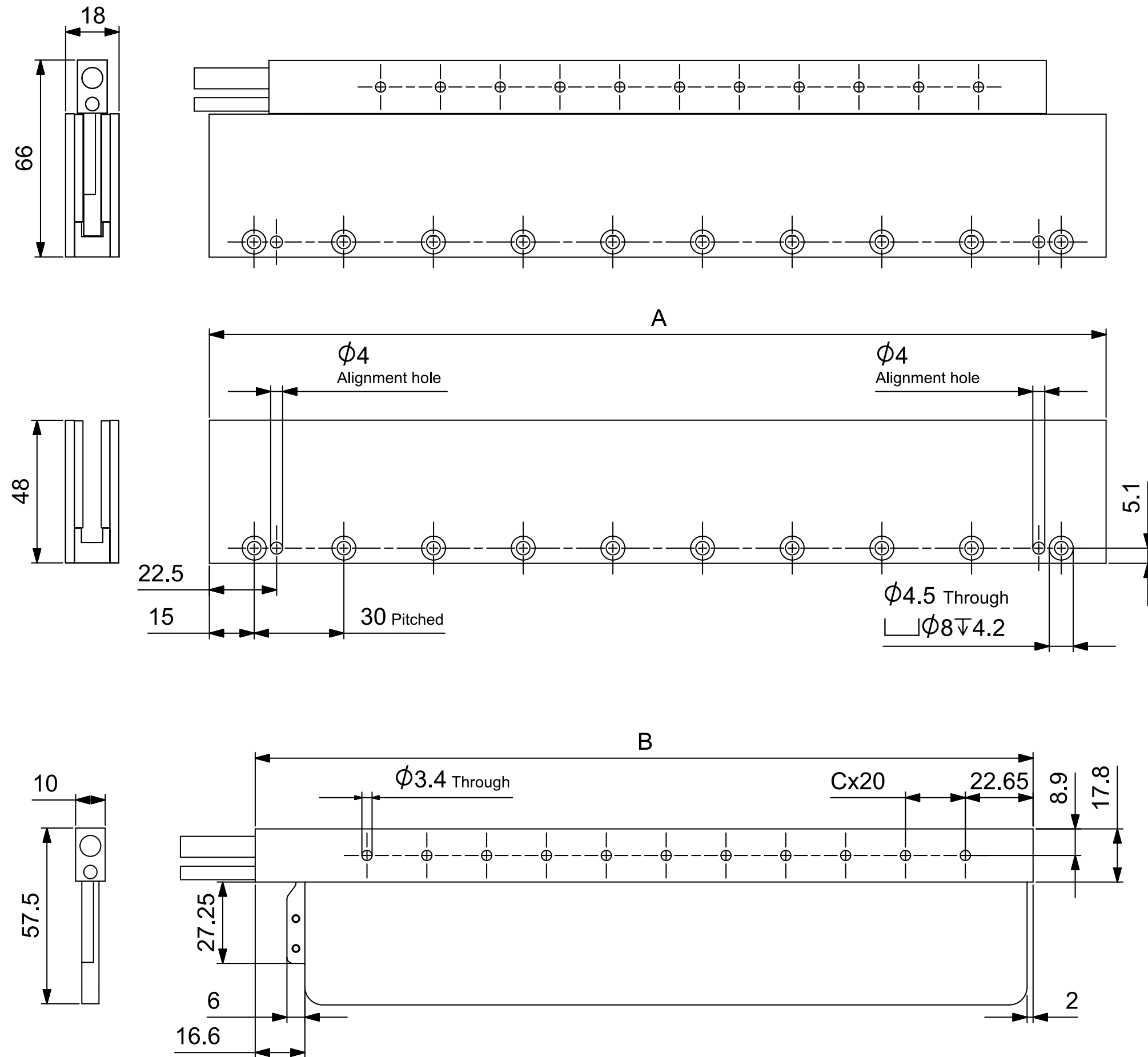

Magnet Yokes	Parameter	Symbol	Unit	MY-S-08	MY-S-10	MY-S-12	MY-S-20	MY-S-28
	Number of poles	$N_p$	-	8	10	12	20	28
	Pole pitch (N-N)	$2\tau_p$	mm	30	30	30	30	30
	Width	A	mm	120	150	180	300	420
	Mass	$M_{my}$	kg	0.4	0.5	0.6	1.0	1.4

Coil Units	Parameter	Symbol	Unit	CU-S-03	CU-S-06	CU-S-09	CU-S-12
	Number of coils	$N_{coil}$	-	3	6	9	12
	Coil pitch	$\tau_{coil}$	mm	20	20	20	20
	Width	B	mm	80	140	200	260
	Number of hole pitches	C	-	1	4	7	10
	Mass (ex. cable)	$M_{cu}$	kg	0.10	0.19	0.27	0.36
Standard cable length	$L_{cable}$	m	1	1	1	1	

# PHOENIX-M PERFORMANCE SPECIFICATIONS

Parameter	Symbol	Unit	T <sub>coil</sub> (°C)	CU-M-03		CU-M-06			CU-M-09				CU-M-12				CU-M-15					
				C	D	A	B	C	A	B	C	D	A	B	C	D	A	B	C	D		
Winding configuration	-	-	-																			
Peak force ( $\alpha_T = 20^\circ\text{C/s}$ increase)	F <sub>p</sub>	N	20	300		650			950		750	950		1250		750	1250		1600		750	1550
Continuous force, interface at 20°C	F <sub>c</sub>	N	100	70		140			210				270				340					
Attraction force (I = 0)	F <sub>att</sub>	N	-	0		0			0				0				0					
Motor constant	S	N <sup>2</sup> /W	20	100		200			300				400				500					
Force constant	K <sub>f</sub>	N/A <sub>rms</sub>	-	63	32	63	32	125	63	32	188	95	63	32	251	126	63	32	314	158		
Maximum velocity (F = 0)	v <sub>m</sub>	m/s	-	7.8	16	7.8	16	3.9	7.8	16	2.6	5.2	7.8	16	2.0	3.9	7.8	16	1.6	3.1		
Maximum velocity (F = F <sub>p</sub> )	v <sub>i</sub>	m/s	20	4.5	12	4.5	12	0.7	4.5	12	0.0	2.0	4.5	12	0.0	0.7	4.5	12	0.0	0.0		
Maximum dc bus voltage	V <sub>dc</sub>	V	-	400		400			400				400				400					
Phase resistance	R <sub>ph,20</sub>	Ohm	20	13	3.3	6.6	1.6	27	4.4	1.1	40	10	3.3	0.8	53	13	2.7	0.7	66	16		
Phase inductance	L <sub>ph</sub>	mH	20	8.3	2.1	4.1	1.0	17	2.8	0.7	25	6.3	2.1	0.5	33	8.4	1.7	0.4	41	10		
Peak line emf constant	K <sub>e,ll,p</sub>	Vs/m	-	51	26	51	26	102	51	26	154	77	51	26	205	103	51	26	256	129		
Maximum rms current	I <sub>p</sub>	A <sub>rms</sub>	20	5.0	10	10	20	5.0	15	30	4.1	10	20	40	3.1	10	25	50	2.5	10		
Continuous rms current, interface at 20°C	I <sub>c</sub>	A <sub>rms</sub>	100	1.1	2.2	2.2	4.4	1.1	3.3	6.6	1.1	2.2	4.4	8.8	1.1	2.2	5.4	11	1.1	2.2		
Continuous dissipation, interface at 20°C	P <sub>d,c</sub>	W	100	62		124			186				247				309					
Thermal resistance, coils to interface	R <sub>th,i</sub>	K/W	-	1.3		0.65			0.43				0.32				0.26					
Thermal resistance, coils to conv. surface	R <sub>th,c</sub>	K/W	-	0.098		0.049			0.033				0.024				0.020					
Thermal time constant, interface at 20°C	τ <sub>th</sub>	s	-	160		160			160				160				160					

## Notes

- Specifications are based upon a magnet temperature of 20°C
- Specifications consider complete overlap of the coil unit with a magnet yoke
- Specifications consider sinusoidal q-axis commutation
- Velocity specifications are based on the maximum bus voltage
- Specifications consider a magnet yoke with nominal airgap (G00)
- See 'definitions' section at the end of the catalog for more details

## Product marking / approvals

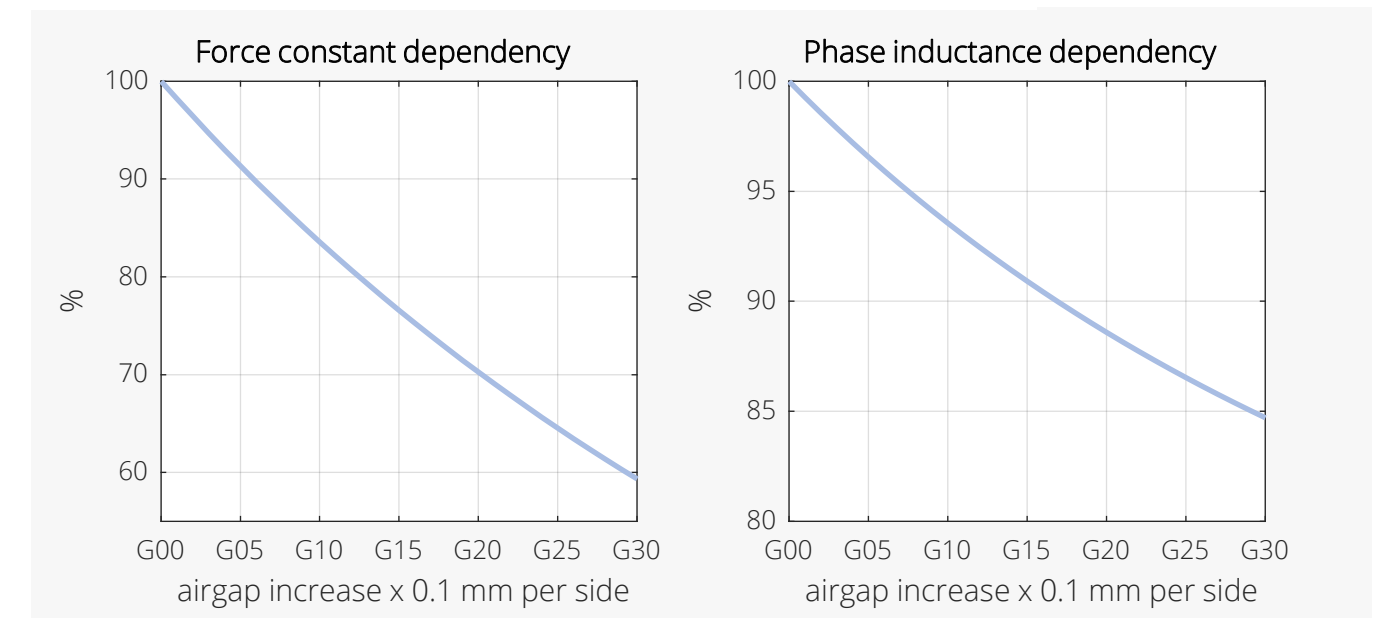

Airgap dependency



# PHOENIX-M MECHANICAL SPECIFICATIONS

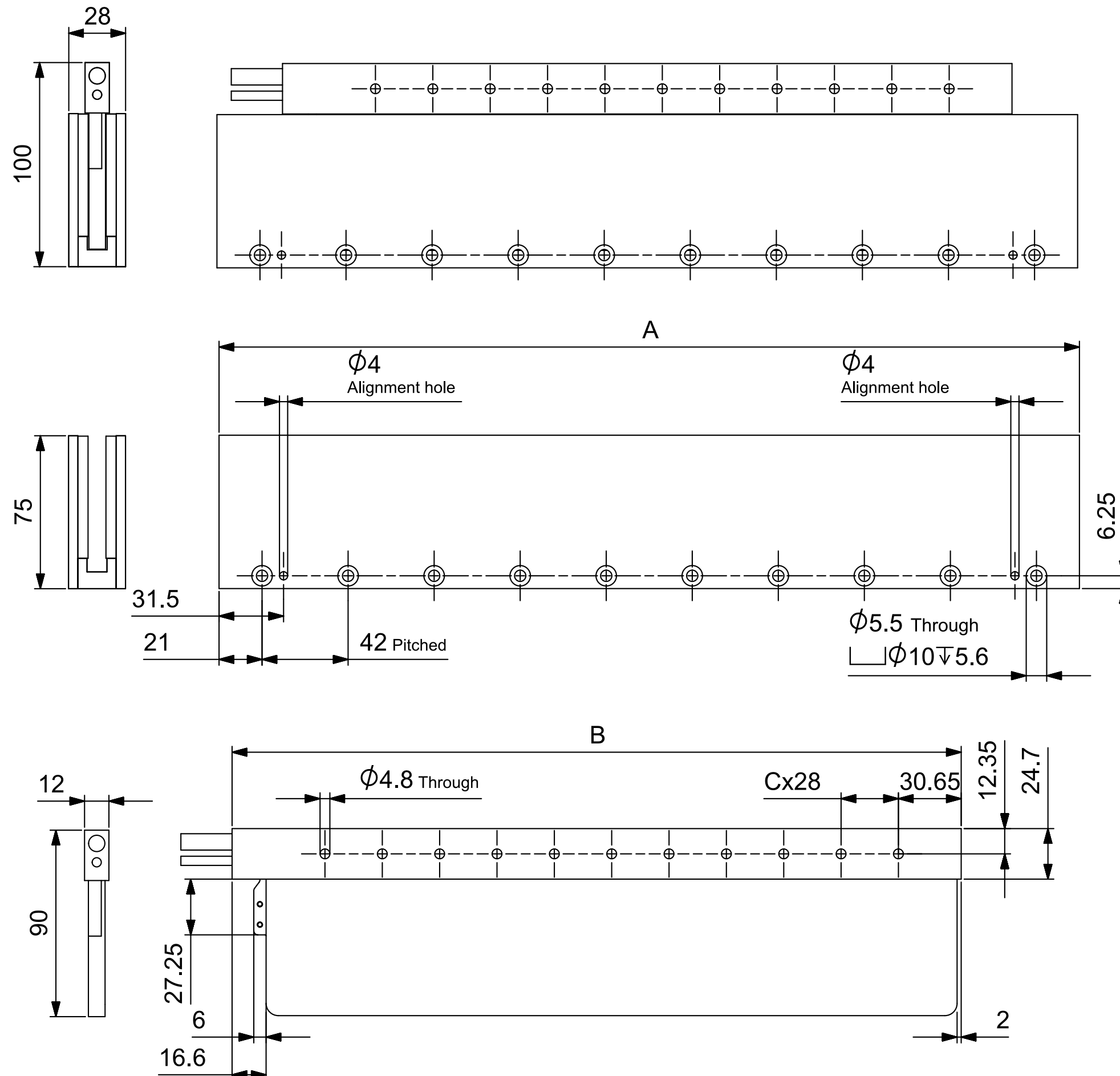

	Parameter	Symbol	Unit	MY-M-08	MY-M-10	MY-M-12	MY-M-20	MY-M-48
Magnet Yokes	Number of poles	$N_p$	-	8	10	12	20	48
	Pole pitch (N-N)	$2\tau_p$	mm	42	42	42	42	42
	Width	A	mm	168	210	252	420	1008
	Mass	$M_{my}$	kg	1.5	1.9	2.3	3.8	9.1

	Parameter	Symbol	Unit	CU-M-03	CU-M-06	CU-M-09	CU-M-12	CU-M-15
Coil Units	Number of coils	$N_{coil}$	-	3	6	9	12	15
	Coil pitch	$\tau_{coil}$	mm	28	28	28	28	28
	Width	B	mm	104	188	272	356	440
	Number of hole pitches	C	-	1	4	7	10	13
	Mass (ex. cable)	$M_{cu}$	kg	0.33	0.64	0.95	1.3	1.6
	Standard cable length	$L_{cable}$	m	1	1	1	1	1

# PHOENIX-L PERFORMANCE SPECIFICATIONS

	Parameter	Symbol	Unit	T <sub>coil</sub> (°C)	CU-L-03		CU-L-06			CU-L-09				CU-L-12				CU-L-15				CU-L-18			
					C	D	A	B	C	A	B	C	D	A	B	C	D	A	B	C	D	A	B	C	D
	Winding configuration	-	-	-																					
Electromechanical	Peak force (α <sub>r</sub> = 20°C/s increase)	F <sub>p</sub>	N	20	700		1350			2050		1850	2050	2700		1850	2700	3400		1850	3400	4050		1850	4050
	Continuous force, interface at 20°C	F <sub>c</sub>	N	100	125		245			370				490				615				735			
	Attraction force (I = 0)	F <sub>att</sub>	N	-	0		0			0				0				0							
	Motor constant	S	N <sup>2</sup> /W	20	230		460			700				930				1160				1400			
	Force constant	K <sub>f</sub>	N/A <sub>rms</sub>	-	107	48	107	48	214	107	48	321	145	107	48	428	193	107	48	535	241	107	48	641	289
	Maximum velocity (F = 0)	v <sub>m</sub>	m/s	-	7.9	18	7.9	18	4.0	7.9	18	2.6	5.8	7.9	18	2.0	4.4	7.9	18	1.6	3.5	7.9	18	1.3	2.9
	Maximum velocity (F = F <sub>p</sub> )	v <sub>i</sub>	m/s	20	4.8	13.9	4.8	14	1.0	4.8	14	0.0	2.8	4.8	14	0.0	1.4	4.8	14	0.0	0.6	4.8	14	0.0	0.0
Electrical	Maximum dc bus voltage	V <sub>dc</sub>	V	-	690		690			690				690				690				690			
	Phase resistance	R <sub>ph,20</sub>	Ohm	20	16	3.3	8.2	1.7	33	5.5	1.1	49	10	4.1	0.8	66	13	3.3	0.7	82	17	2.7	0.6	99	20
	Phase inductance	L <sub>ph</sub>	mH	20	18	3.6	8.9	1.8	35	5.9	1.2	53	11	4.4	0.9	71	14	3.5	0.7	89	18	3.0	0.6	106	22
	Peak line emf constant	K <sub>e,ll,p</sub>	Vs/m	-	87	39	87	39	175	87	39	262	118	87	39	349	157	87	39	436	197	87	39	524	236
	Maximum rms current	I <sub>p</sub>	A <sub>rms</sub>	20	6.3	14	13	28	6.3	19	42	5.7	14	25	56	4.3	14	32	70	3.4	14	38	84	2.9	14
	Continuous rms current, interface at 20°C	I <sub>c</sub>	A <sub>rms</sub>	100	1.1	2.5	2.3	5.1	1.1	3.4	7.6	1.1	2.5	4.6	10	1.1	2.5	5.7	13	1.1	2.5	6.9	15	1.1	2.5
Thermal	Continuous dissipation, interface at 20°C	P <sub>d,c</sub>	W	100	85		170			254				339				424				509			
	Thermal resistance, coils to interface	R <sub>th,i</sub>	K/W	-	0.94		0.47			0.31				0.24				0.19				0.16			
	Thermal resistance, coils to conv. surface	R <sub>th,c</sub>	K/W	-	0.067		0.033			0.022				0.017				0.013				0.011			
	Thermal time constant, interface at 20°C	τ <sub>th</sub>	s	-	180		180			180				180				180				180			

## Notes

- Specifications are based upon a magnet temperature of 20°C
- Specifications consider complete overlap of the coil unit with a magnet yoke
- Specifications consider sinusoidal q-axis commutation
- Velocity specifications are based on the maximum bus voltage
- Specifications consider a magnet yoke with nominal airgap (G00)
- See 'definitions' section at the end of the catalog for more details

## Product marking / approvals

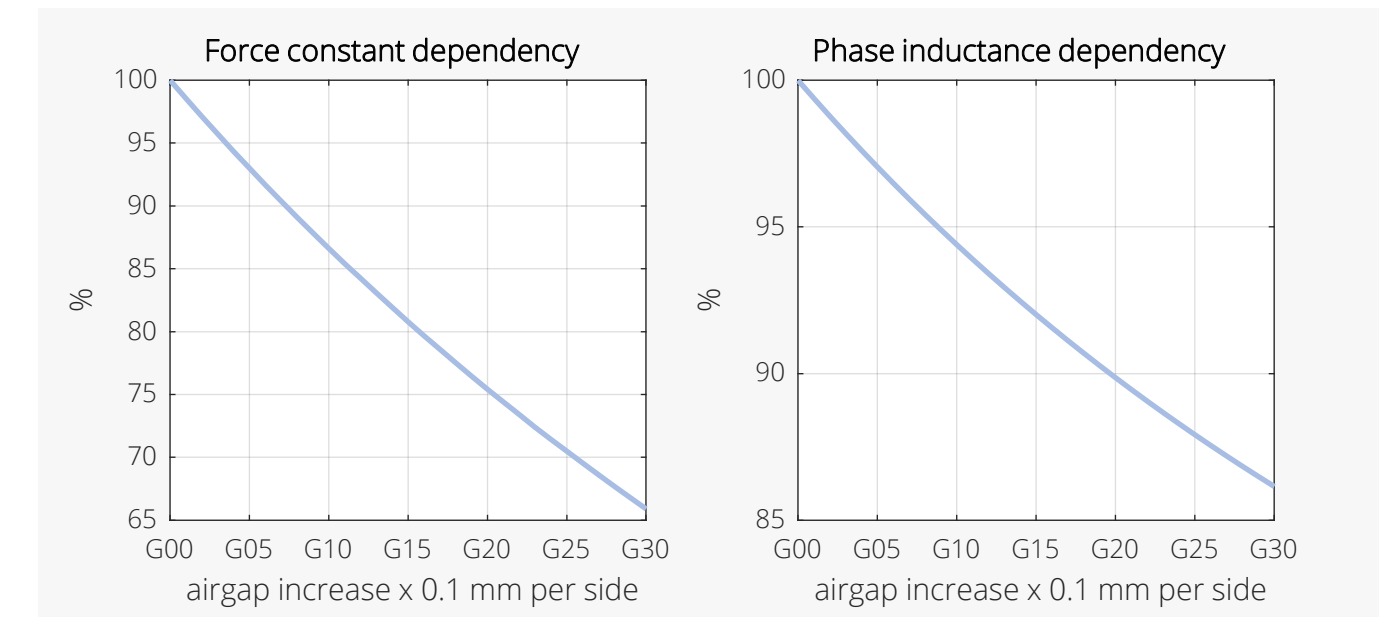

Airgap dependency

# PHOENIX-L MECHANICAL SPECIFICATIONS

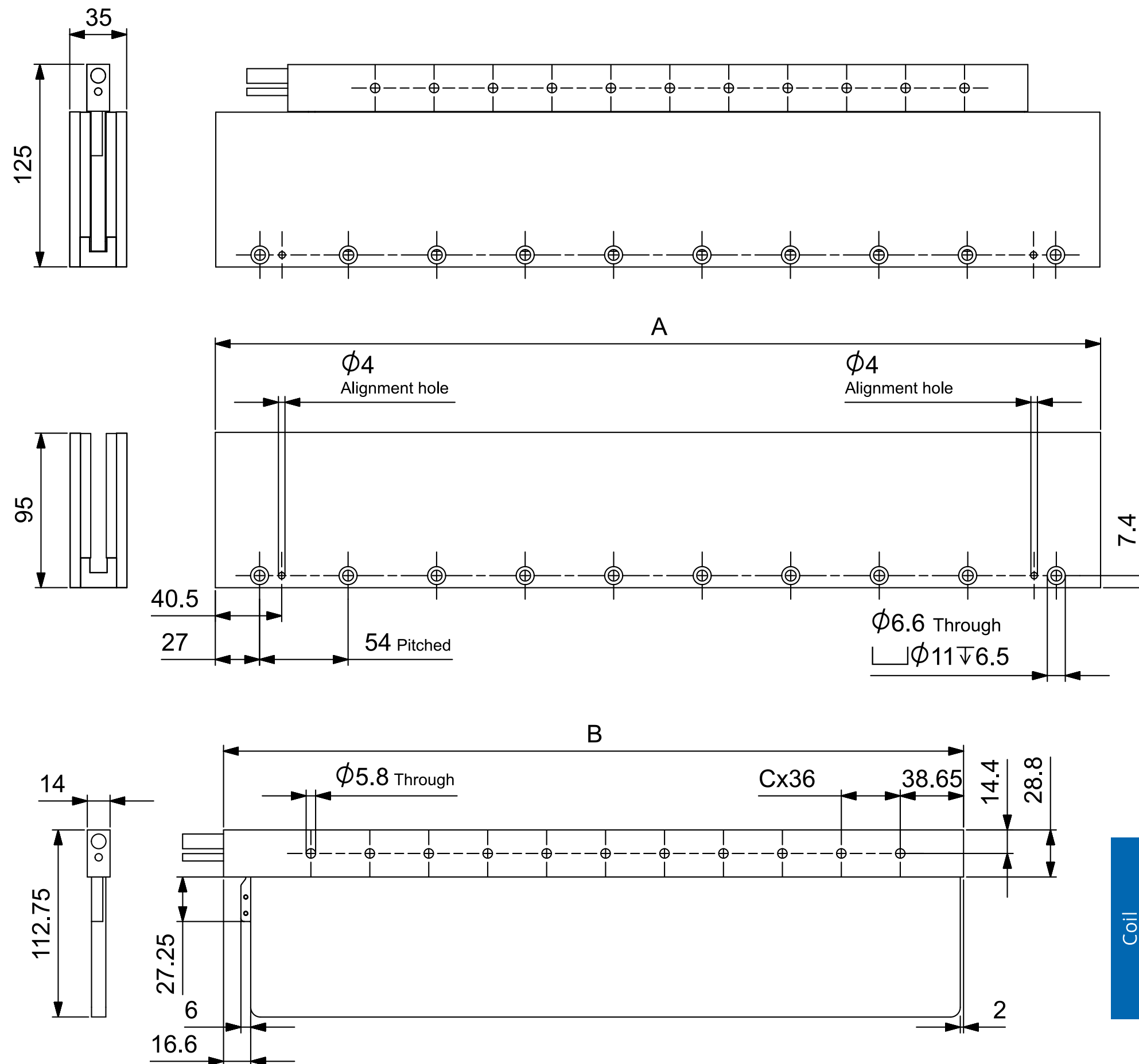

	Parameter	Symbol	Unit	MY-L-08	MY-L-10	MY-L-12	MY-L-20	MY-L-36
Magnet Yokes	Number of poles	$N_p$	-	8	10	12	20	36
	Pole pitch (N-N)	$2\tau_p$	mm	54	54	54	54	54
	Width	A	mm	216	270	324	540	972
	Mass	$M_{my}$	kg	3.2	4.0	4.8	8.0	14.3

	Parameter	Symbol	Unit	CU-L-03	CU-L-06	CU-L-09	CU-L-12	CU-L-15	CU-L-18
Coil Units	Number of coils	$N_{coil}$	-	3	6	9	12	15	18
	Coil pitch	$\tau_{coil}$	mm	36	36	36	36	36	36
	Width	B	mm	128	236	344	452	560	668
	Number of hole pitches	C	-	1	4	7	10	13	16
	Mass (ex. cable)	$M_{cu}$	kg	0.56	1.2	1.8	2.4	3.1	3.7
	Standard cable length	$L_{cable}$	m	1	1	1	1	1	1



# PHOENIX-X PERFORMANCE SPECIFICATIONS

Parameter	Symbol	Unit	T <sub>coil</sub> (°C)	CU-X-03		CU-X-06			CU-X-09				CU-X-12				CU-X-15				CU-X-18										
				C	D	A	B	C	A	B	C	D	A	B	C	D	A	B	C	D	A	C	D								
Winding configuration	-	-	-	C		A			A				A				A				A										
Peak force (α <sub>r</sub> = 20°C/s increase)	F <sub>p</sub>	N	20	1600		3250			4850				3500				4800				6450				3500				6400		
Continuous force, interface at 20°C	F <sub>c</sub>	N	100	215		430			645				860				1075				1295										
Attraction force (I = 0)	F <sub>att</sub>	N	-	0		0			0				0				0				0										
Motor constant	S	N <sup>2</sup> /W	20	590		1190			1780				2370				2960				3570										
Force constant	K <sub>f</sub>	N/A <sub>rms</sub>	-	144	63	144	63	288	144	63	433	189	144	63	577	252	144	63	721	315	144	865	378								
Maximum velocity (F = 0)	v <sub>m</sub>	m/s	-	5.9	13	5.9	13	2.9	5.9	13	2.0	4.5	5.9	13	1.5	3.4	5.9	13	1.2	2.7	5.9	1.0	2.2								
Maximum velocity (F = F <sub>p</sub> )	v <sub>i</sub>	m/s	20	3.0	10	3.0	10	0.2	3.0	10	0.0	1.7	3.0	10	0.0	0.6	3.0	10	0.0	0.0	3.0	0.0	0.0								
Maximum dc bus voltage	V <sub>dc</sub>	V	-	690		690			690				690				690				690										
Phase resistance	R <sub>ph,20</sub>	Ohm	20	11.6	2.3	5.8	1.1	23	3.9	0.8	35	6.8	2.9	0.6	46	9.0	2.3	0.5	58	11	1.9	69	14								
Phase inductance	L <sub>ph</sub>	mH	20	21	4.0	10.5	2.0	42	7.0	1.3	63	12	5.3	1.0	84	16	4.2	0.8	105	20	3.5	126	24								
Peak line emf constant	K <sub>e,ll,p</sub>	Vs/m	-	118	51	118	51	235	118	51	353	154	118	51	471	206	118	51	589	257	118	706	309								
Maximum rms current	I <sub>p</sub>	A <sub>rms</sub>	20	11	25	22	51	11	34	76	8	25	45	102	6.1	25	56	127	4.9	25	67	4.1	21								
Continuous rms current, interface at 20°C	I <sub>c</sub>	A <sub>rms</sub>	100	1.5	3.4	3.0	6.8	1.5	4.5	10	1.5	3.4	6.0	14	1.5	3.4	7.5	17	1.5	3.4	9	1.5	3.4								
Continuous dissipation, interface at 20°C	P <sub>d,c</sub>	W	100	103		205			308				410				513				615										
Thermal resistance, coils to interface	R <sub>th,i</sub>	K/W	-	0.78		0.39			0.26				0.20				0.16				0.13										
Thermal resistance, coils to conv. surface	R <sub>th,c</sub>	K/W	-	0.046		0.023			0.015				0.012				0.0092				0.0077										
Thermal time constant, interface at 20°C	τ <sub>th</sub>	s	-	320		320			320				320				320				320										

## Notes

- Specifications are based upon a magnet temperature of 20°C
- Specifications consider complete overlap of the coil unit with a magnet yoke
- Specifications consider sinusoidal q-axis commutation
- Velocity specifications are based on the maximum bus voltage
- Specifications consider a magnet yoke with nominal airgap (G00)
- See 'definitions' section at the end of the catalog for more details

## Product marking / approvals

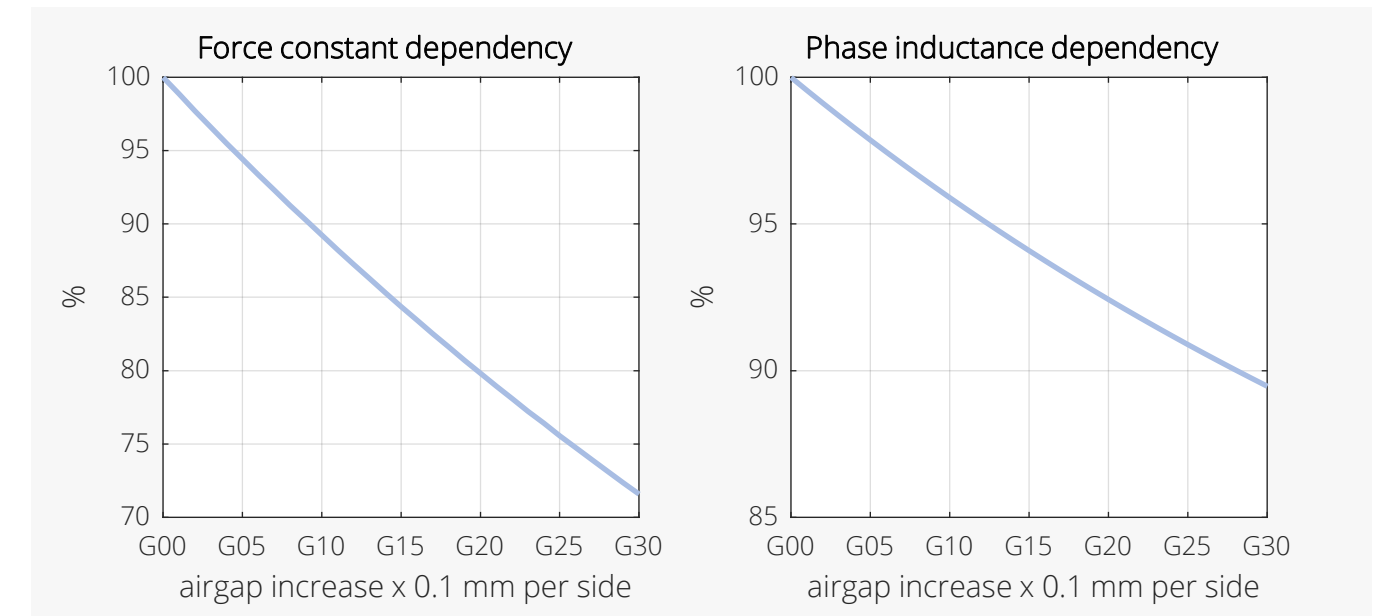

Airgap dependency

# PHOENIX-X MECHANICAL SPECIFICATIONS

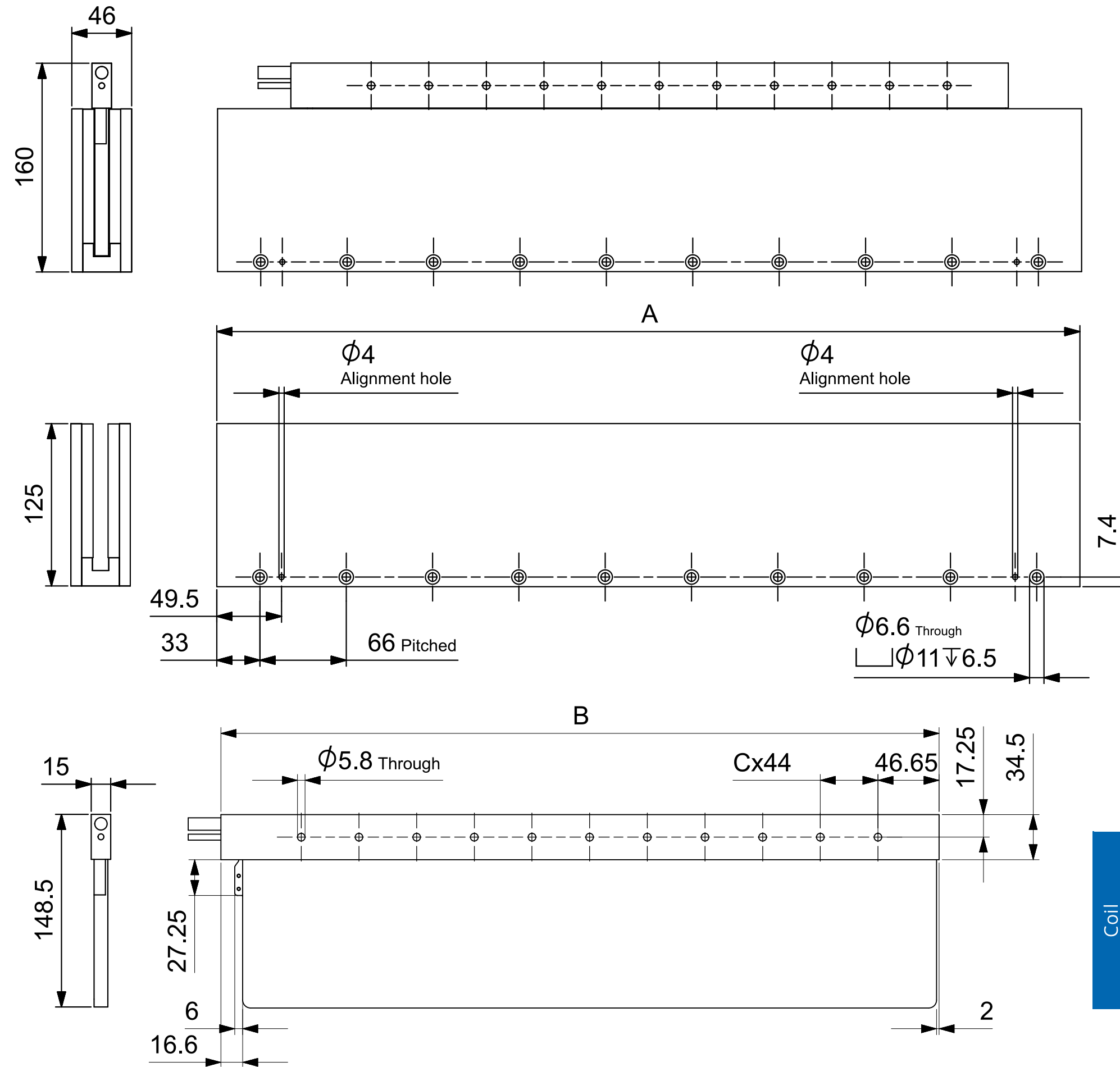

Magnet Yokes	Parameter	Symbol	Unit	MY-X-08	MY-X-10	MY-X-12	MY-X-20
	Number of poles	$N_p$	-	8	10	12	20
	Pole pitch (N-N)	$2\tau_p$	mm	66	66	66	66
	Width	A	mm	264	330	396	660
Mass	$M_{my}$	kg	7.2	9.0	10.8	17.9	

Coil Units	Parameter	Symbol	Unit	CU-X-03	CU-X-06	CU-X-09	CU-X-12	CU-X-15	CU-X-18
	Number of coils	$N_{coil}$	-	3	6	9	12	15	18
	Coil pitch	$\tau_{coil}$	mm	44	44	44	44	44	44
	Width	B	mm	152	284	416	548	680	812
	Number of hole pitches	C	-	1	4	7	10	13	16
	Mass (ex. cable)	$M_{cu}$	kg	1.1	2.2	3.2	4.3	5.4	6.4
Standard cable length	$L_{cable}$	m	1	1	1	1	1	1	

# PHOENIX-U PERFORMANCE SPECIFICATIONS

	Parameter	Symbol	Unit	T <sub>coil</sub> (°C)	CU-U-03		CU-U-06			CU-U-09				CU-U-12			CU-U-15			CU-U-18																													
					C	D	A	B	C	A	B	C	D	A	C	D	A	C	D	A	C	D																											
	Winding configuration	-	-	-	C	D	A	B	C	A	B	C	D	A	C	D	A	C	D	A	C	D																											
Electromechanical	Peak force ( $\alpha_T = 20^\circ\text{C/s}$ increase)	F <sub>p</sub>	N	20	3350		6650			5800				10000			5800			9950			13450			5800			10650			16800			5800			10650			20150			5800			10650		
	Continuous force, interface at 20°C	F <sub>c</sub>	N	100	330		670			1000				1340			1670			2010																													
	Attraction force (I = 0)	F <sub>att</sub>	N	-	0		0			0				0			0			0																													
	Motor constant	S	N <sup>2</sup> /W	20	1150		2350			3500				4950			6400			6850																													
	Force constant	K <sub>f</sub>	N/A <sub>rms</sub>	-	171	91	171	91	342	171	91	513	272	171	684	363	171	856	454	171	1027	544																											
	Maximum velocity (F = 0)	v <sub>m</sub>	m/s	-	4.9	9.3	4.9	9.3	2.5	4.9	9.3	1.6	3.1	4.9	1.2	2.3	4.9	1.0	1.9	4.9	0.8	1.6																											
	Maximum velocity (F = F <sub>p</sub> )	v <sub>i</sub>	m/s	20	1.9	5.6	1.9	5.6	0.0	1.9	5.6	0.0	0.2	1.9	0.0	0.0	1.9	0.0	0.0	1.9	0.0	0.0																											
Electrical	Maximum dc bus voltage	V <sub>dc</sub>	V	-	690		690			690				690			690			690																													
	Phase resistance	R <sub>ph,20</sub>	Ohm	20	8.3	2.4	4.2	1.2	17	2.8	0.8	25	7.2	2.1	33	9.6	1.7	42	12	1.4	50	14																											
	Phase inductance	L <sub>ph</sub>	mH	20	25	6.9	12	3.5	49	8.2	2.3	74	21	6.2	99	28	4.9	124	35	4.1	148	42																											
	Peak line emf constant	K <sub>e,ll,p</sub>	Vs/m	-	140	74	140	74	279	140	74	419	222	140	559	296	140	699	370	140	838	444																											
	Maximum rms current	I <sub>p</sub>	A <sub>rms</sub>	20	20	36	39	73	17	59	109	11	36	78	8.5	29.3	98	6.8	23	118	5.7	20																											
	Continuous rms current, interface at 20°C	I <sub>c</sub>	A <sub>rms</sub>	100	2.0	3.7	3.9	7.3	2.0	5.9	11	2.0	3.7	7.9	2.0	3.7	10	2.0	3.7	12	2.0	3.7																											
Thermal	Continuous dissipation, interface at 20°C	P <sub>d,c</sub>	W	100	126		253			379				537			695			758																													
	Thermal resistance, coils to interface	R <sub>th,i</sub>	K/W	-	0.63		0.32			0.21				0.15			0.12			0.11																													
	Thermal resistance, coils to conv. surface	R <sub>th,c</sub>	K/W	-	0.036		0.018			0.012				0.0086			0.0066			0.0060																													
	Thermal time constant, interface at 20°C	τ <sub>th</sub>	s	-	550		550			550				550			550			550																													

## Notes

- Specifications are based upon a magnet temperature of 20°C
- Specifications consider complete overlap of the coil unit with a magnet yoke
- Specifications consider sinusoidal q-axis commutation
- Velocity specifications are based on the maximum bus voltage
- Specifications consider a magnet yoke with nominal airgap (G00)
- See 'definitions' section at the end of the catalog for more details

## Product marking / approvals

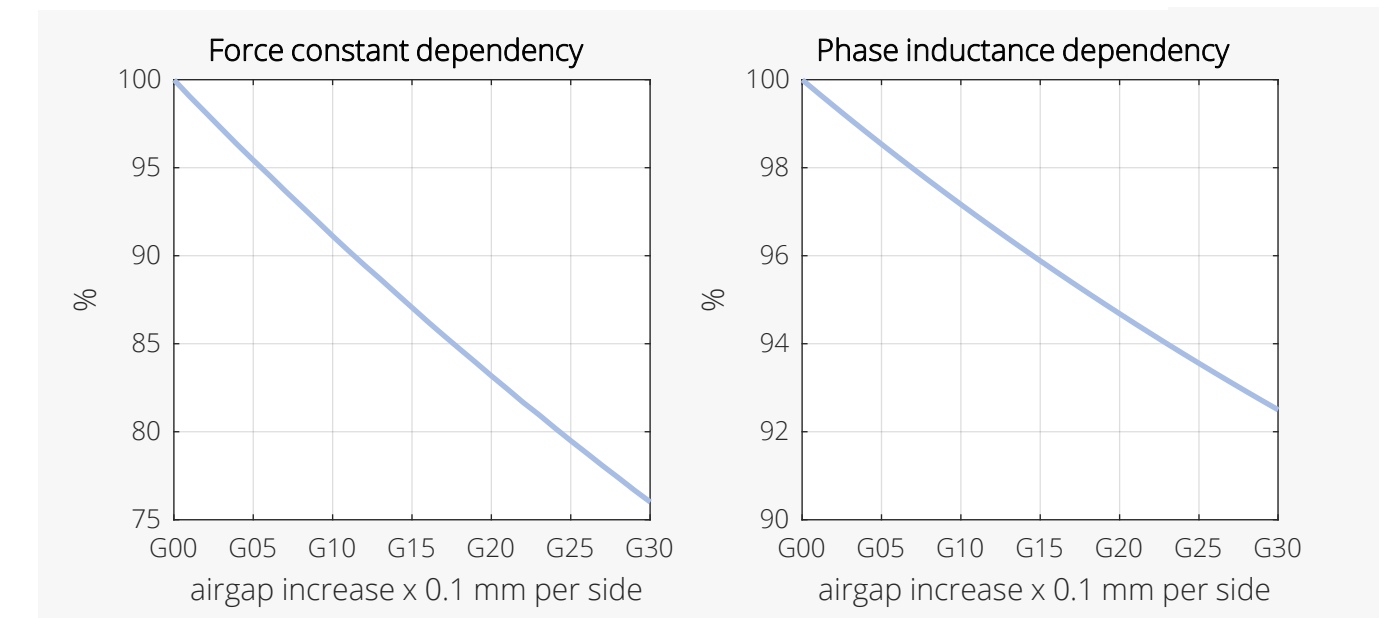

Airgap dependency

# PHOENIX-U MECHANICAL SPECIFICATIONS

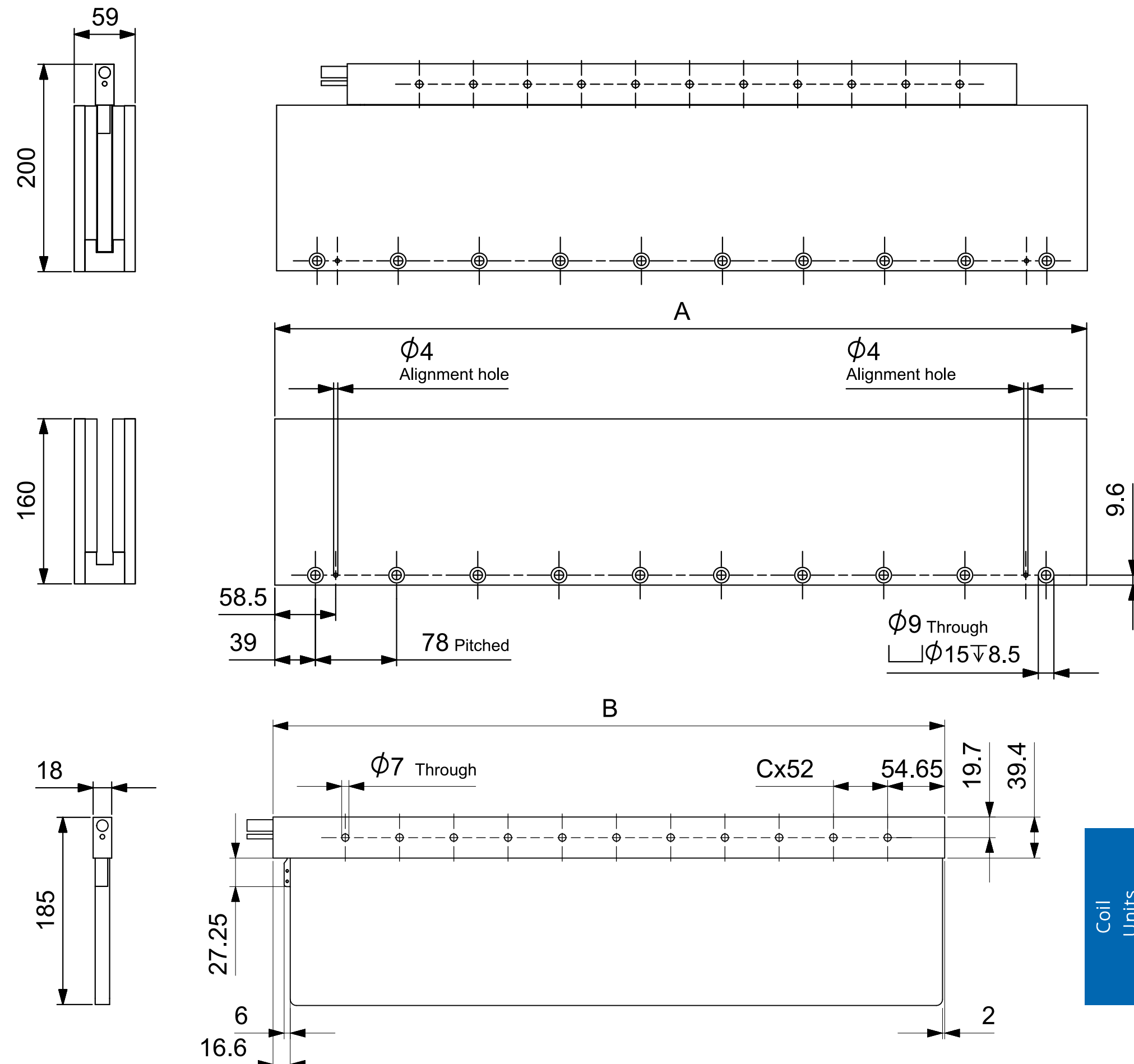

Magnet Yokes	Parameter	Symbol	Unit	MY-U-08	MY-U-10	MY-U-12	MY-U-18
	Number of poles	$N_p$	-	8	10	12	18
	Pole pitch (N-N)	$2\tau_p$	mm	78	78	78	78
	Width	A	mm	312	390	468	702
Mass	$M_{my}$	kg	13.9	17.4	20.8	31.2	

Coil Units	Parameter	Symbol	Unit	CU-U-03	CU-U-06	CU-U-09	CU-U-12	CU-U-15	CU-U-18
	Number of coils	$N_{coil}$	-	3	6	9	12	15	18
	Coil pitch	$\tau_{coil}$	mm	52	52	52	52	52	52
	Width	B	mm	176	332	488	644	800	956
	Number of hole pitches	C	-	1	4	7	10	13	16
	Mass (ex. cable)	$M_{cu}$	kg	2.2	4.4	6.5	8.7	10.9	13.0
Standard cable length	$L_{cable}$	m	1	1	1	1	1	1	



# PHOENIX-T/S FORCE-VELOCITY DIAGRAMS

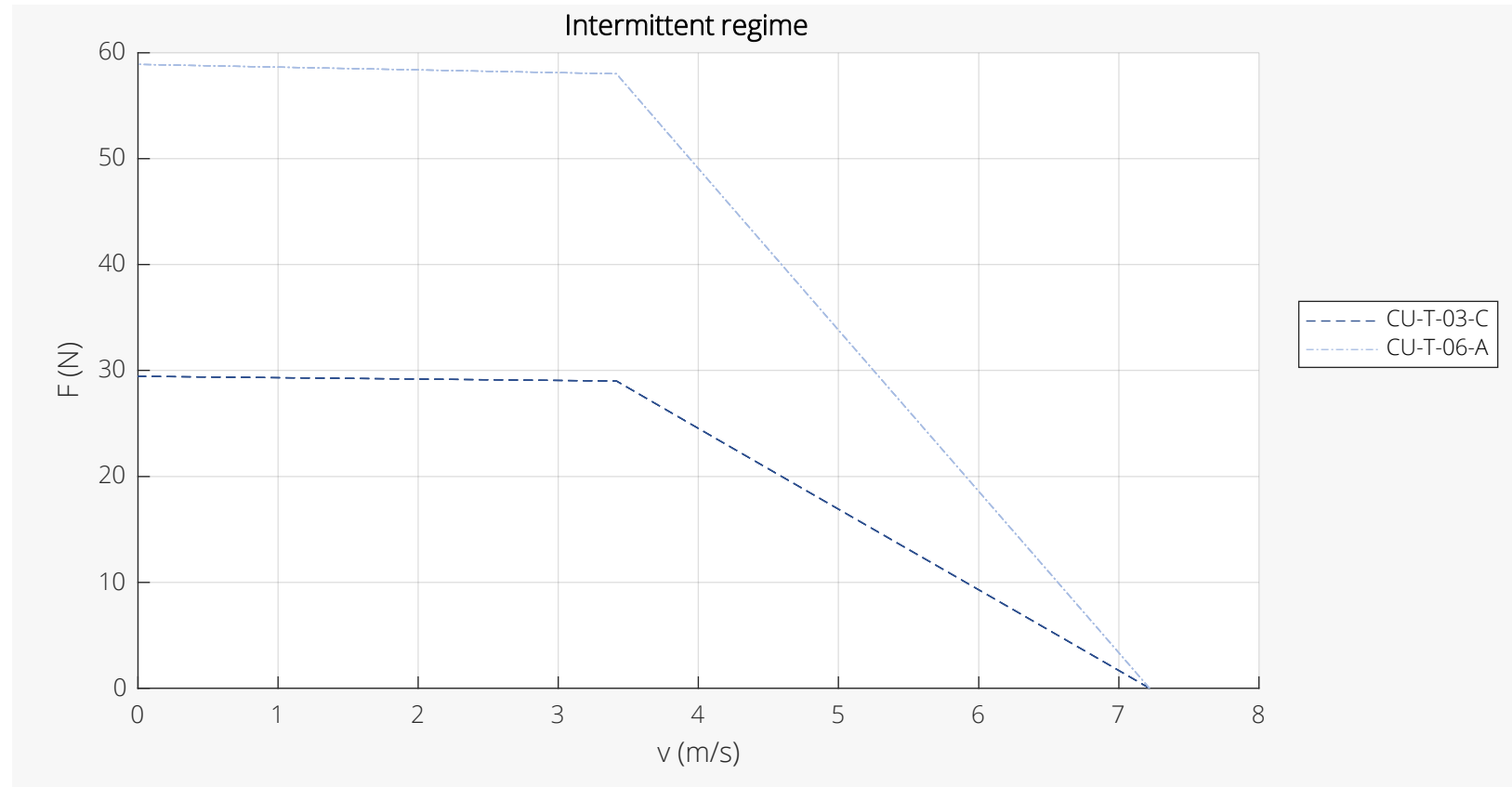

Force-Velocity Diagrams Size T Intermittent Regime

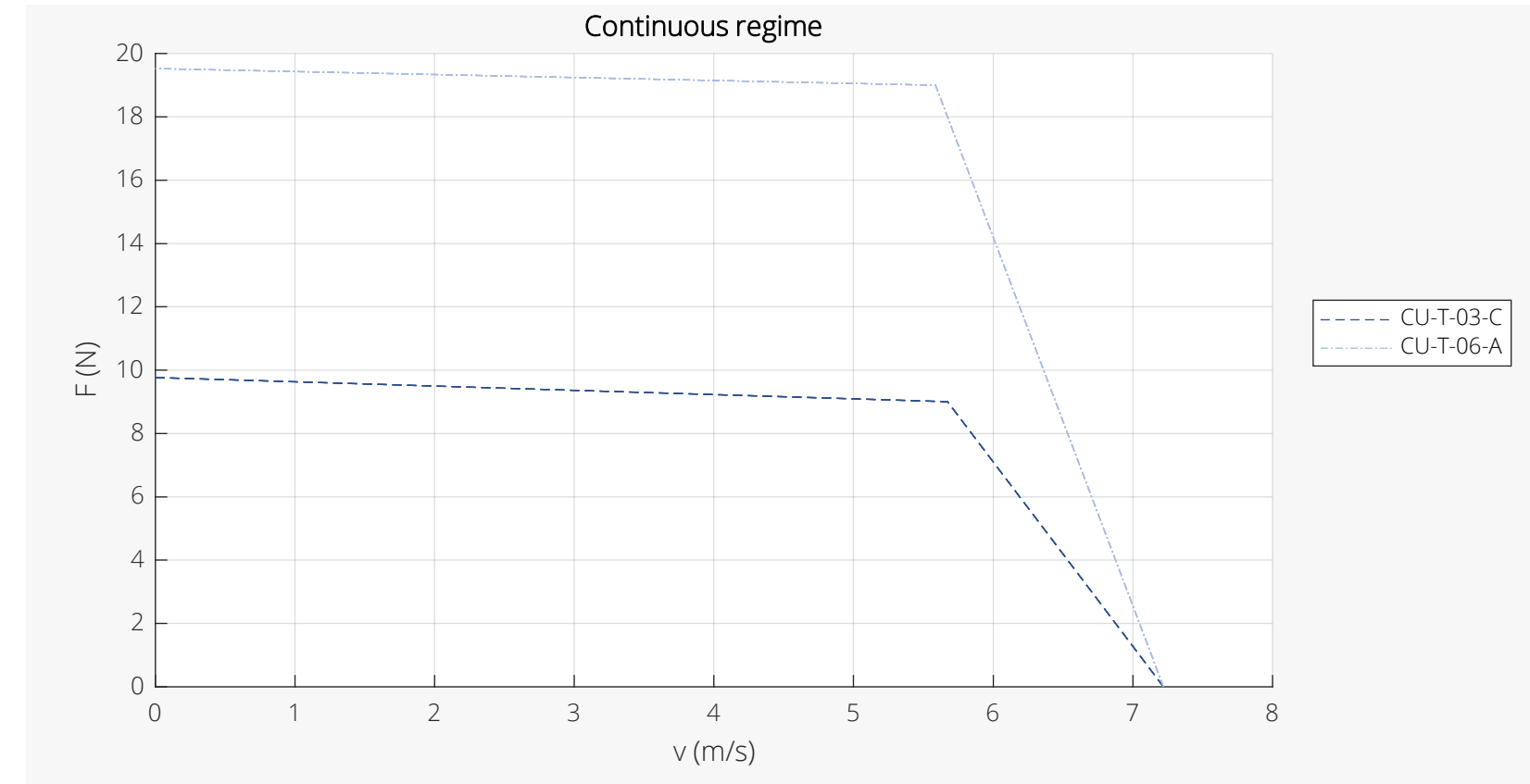

Force-Velocity Diagrams Size T Continuous Regime

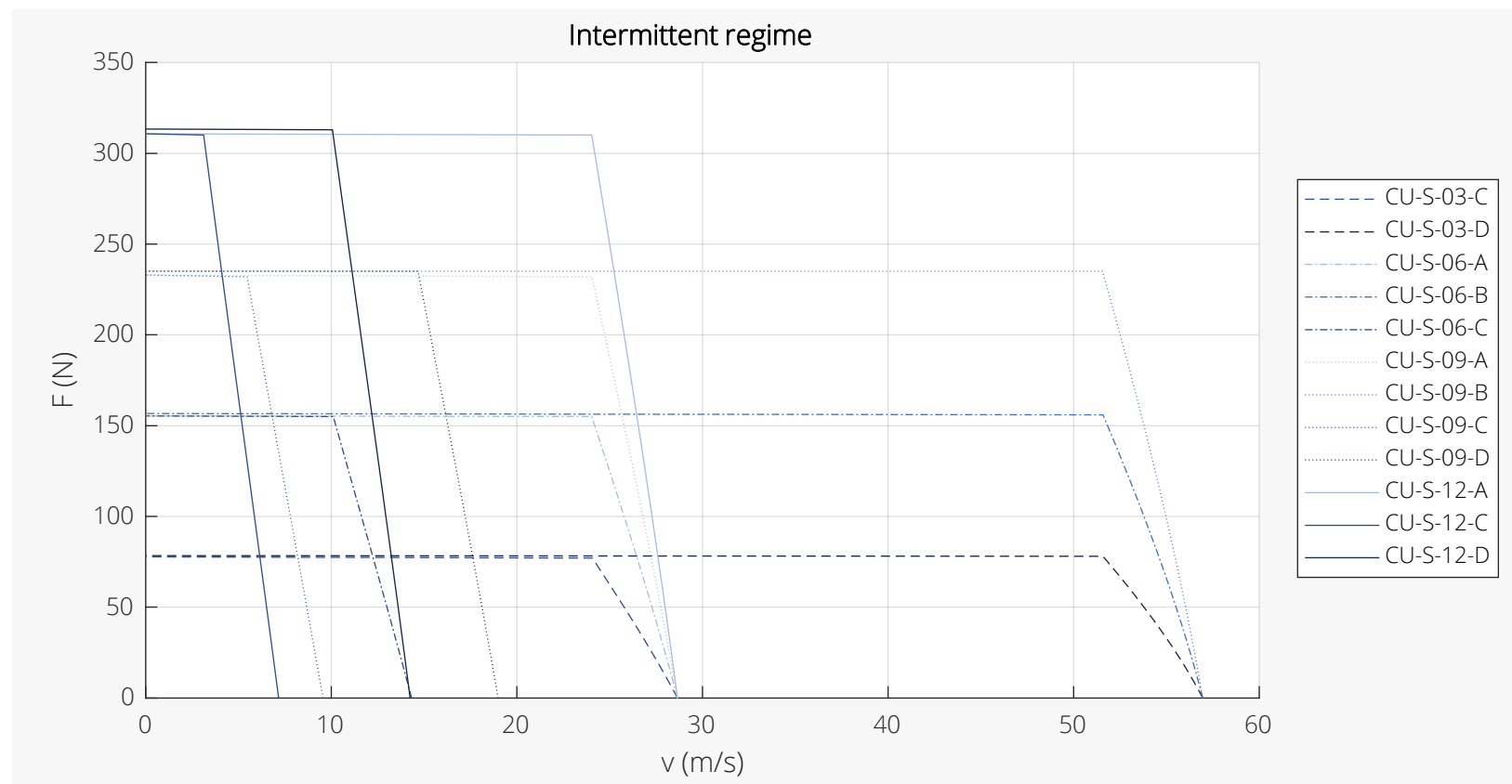

Force-Velocity Diagrams Size S Intermittent Regime

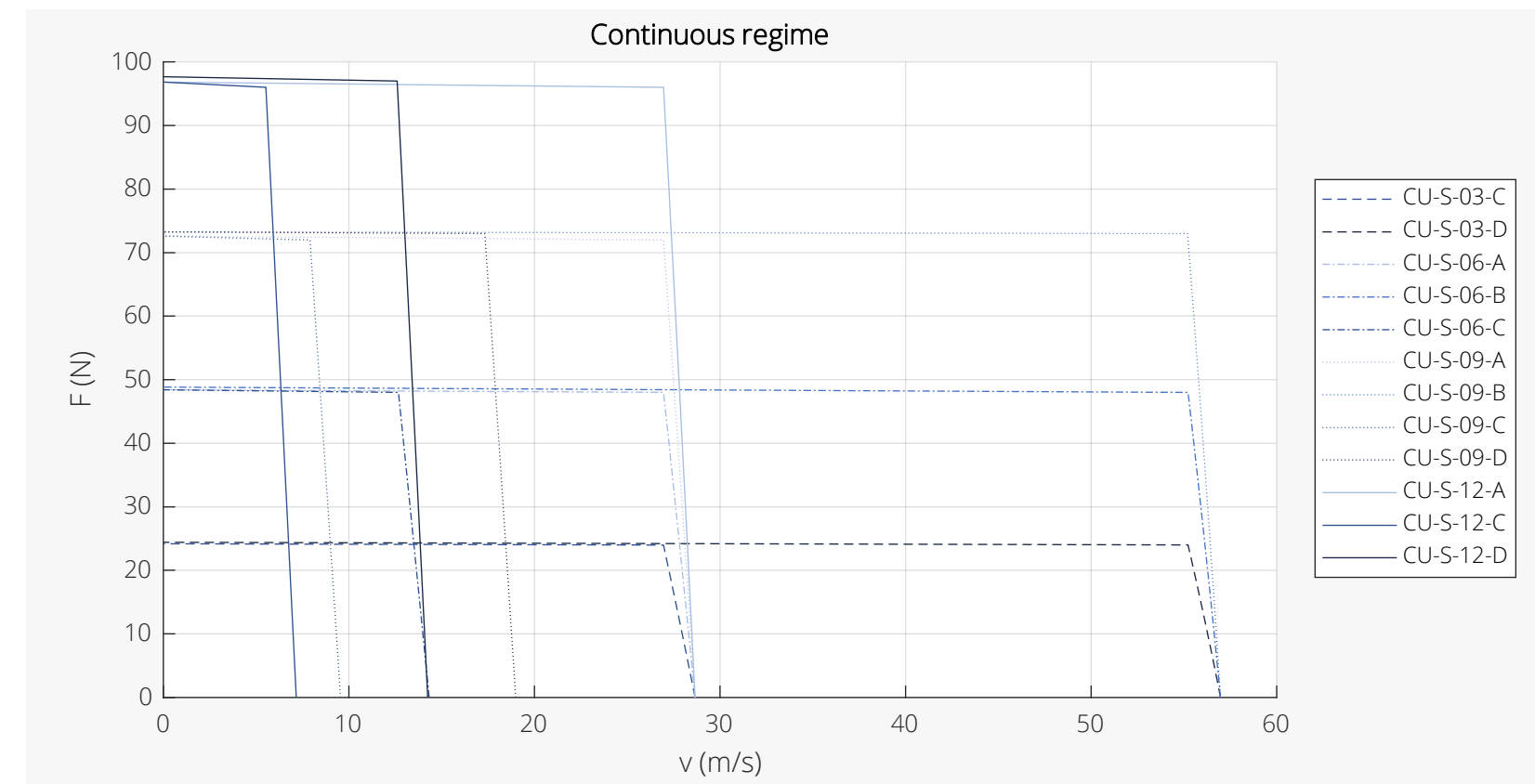

Force-Velocity Diagrams Size S Continuous Regime

# PHOENIX-M/L FORCE-VELOCITY DIAGRAMS

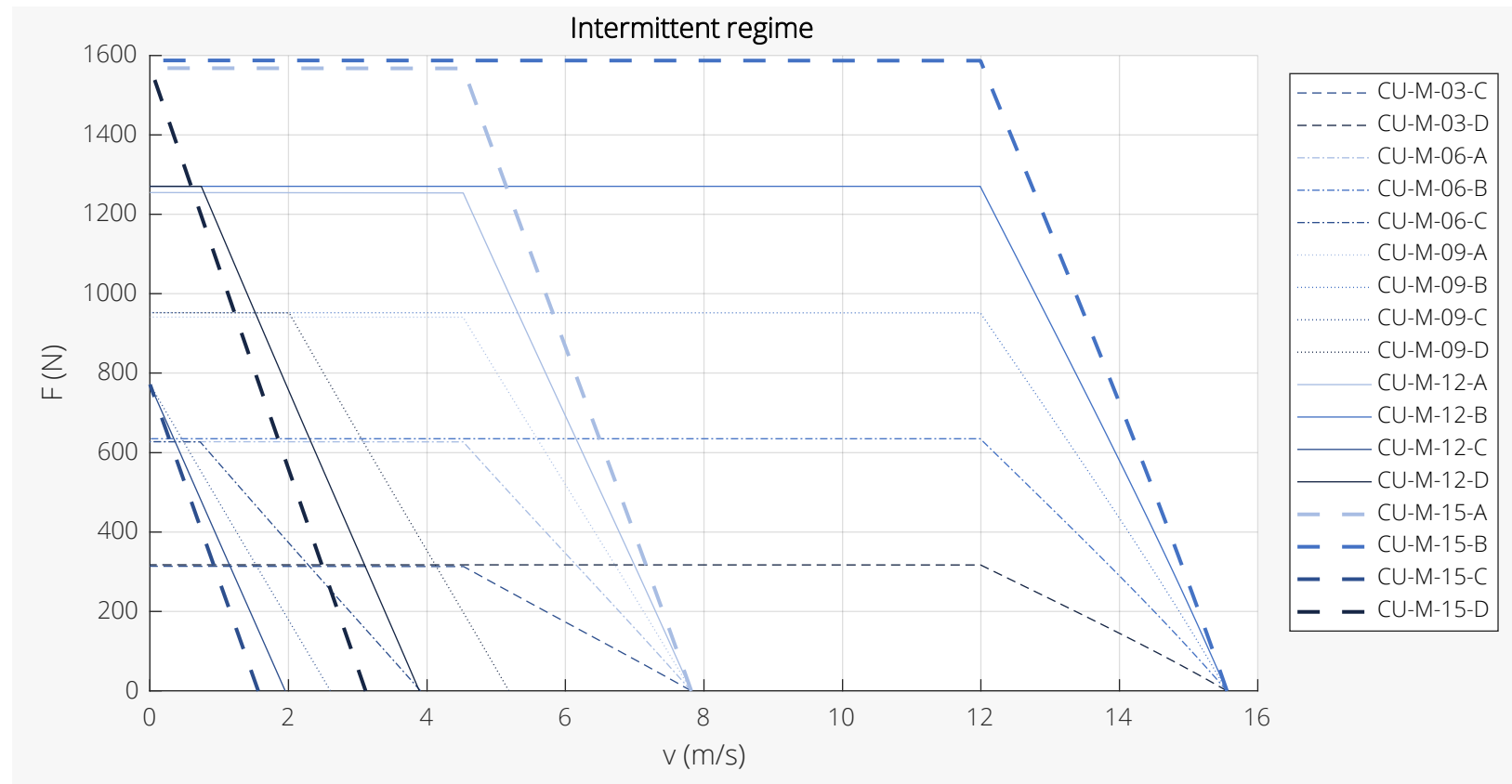

Force-Velocity Diagrams Size M Intermittent Regime

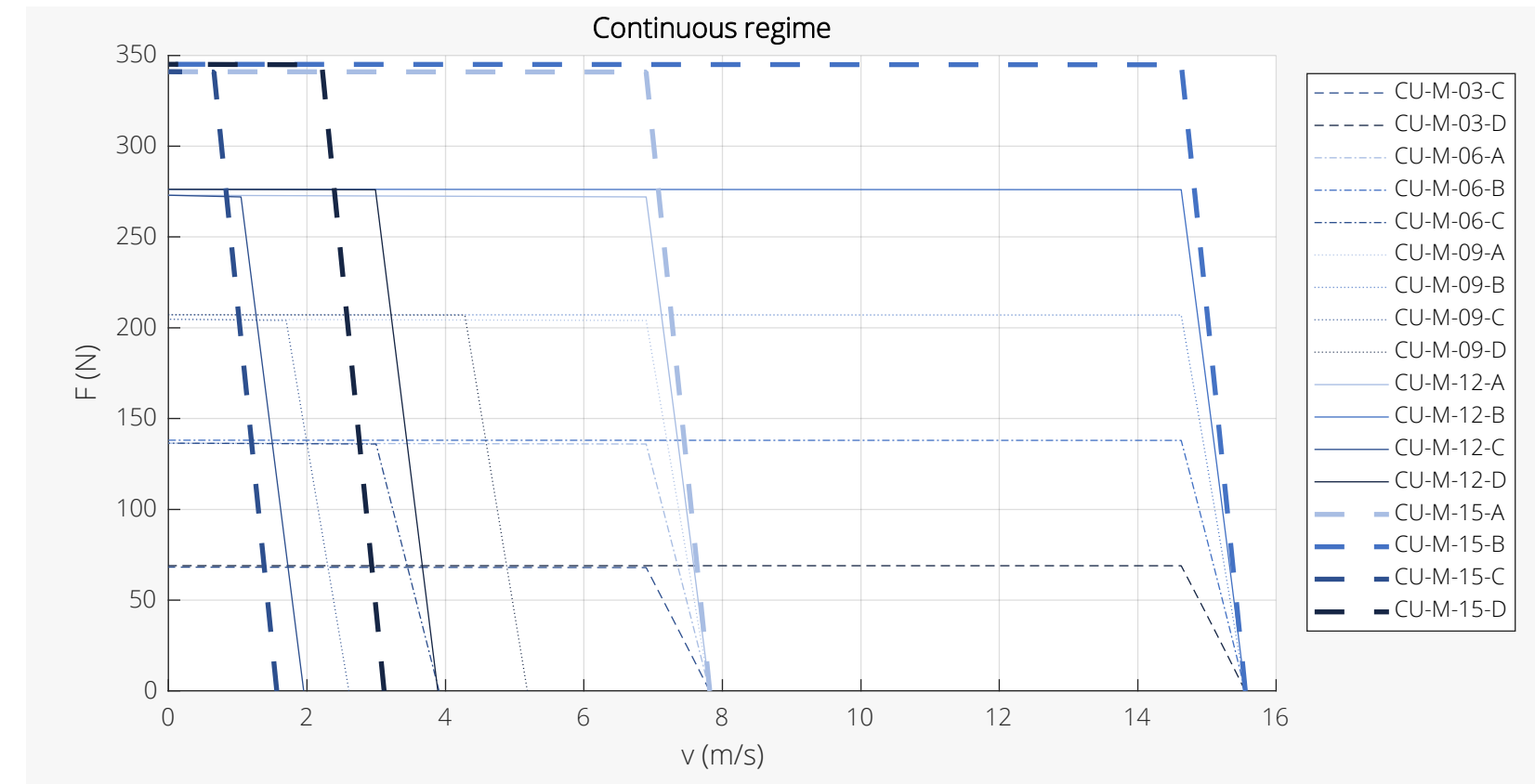

Force-Velocity Diagrams Size M Continuous Regime

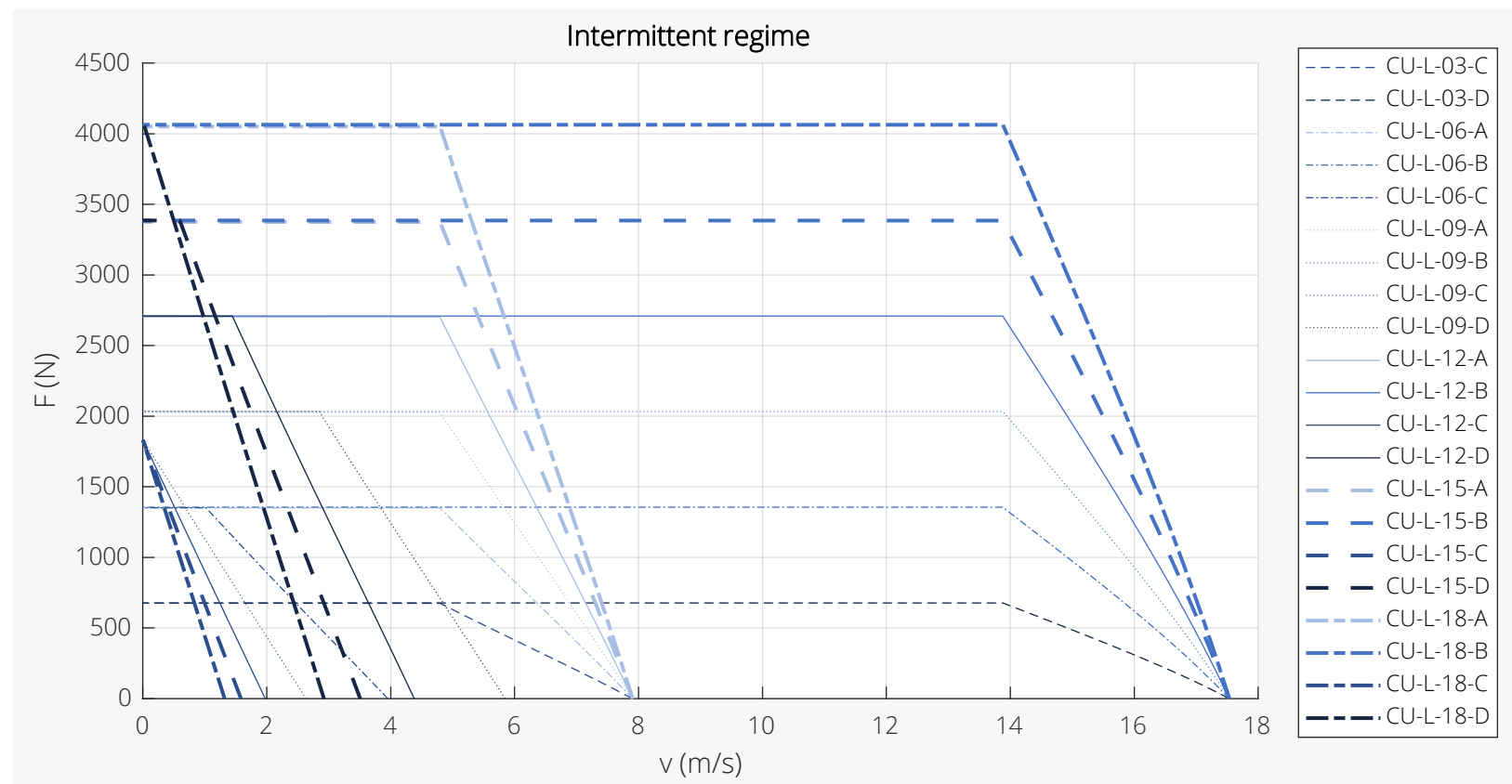

Force-Velocity Diagrams Size L Intermittent Regime

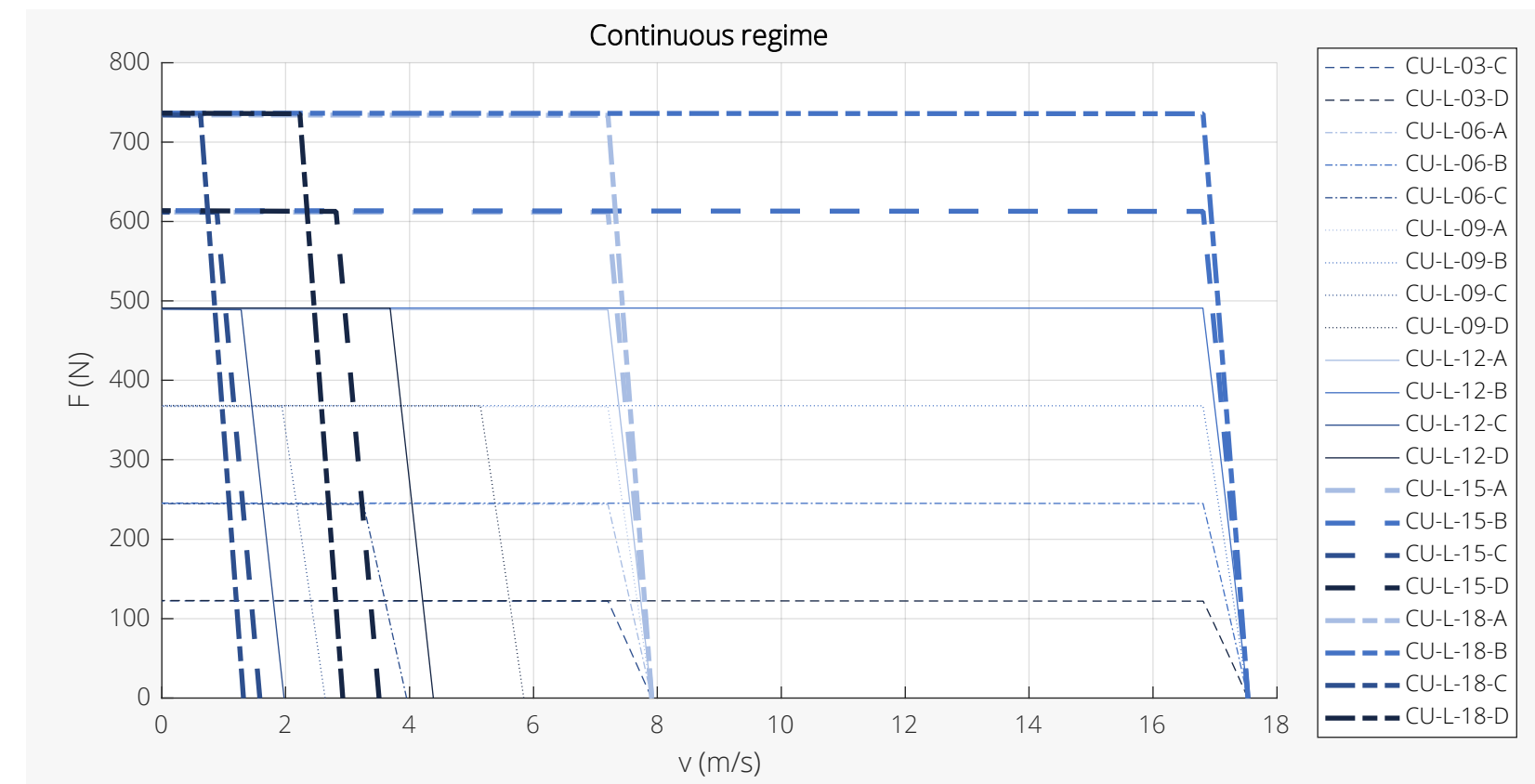

Force-Velocity Diagrams Size L Continuous Regime

# PHOENIX-X/U FORCE-VELOCITY DIAGRAMS

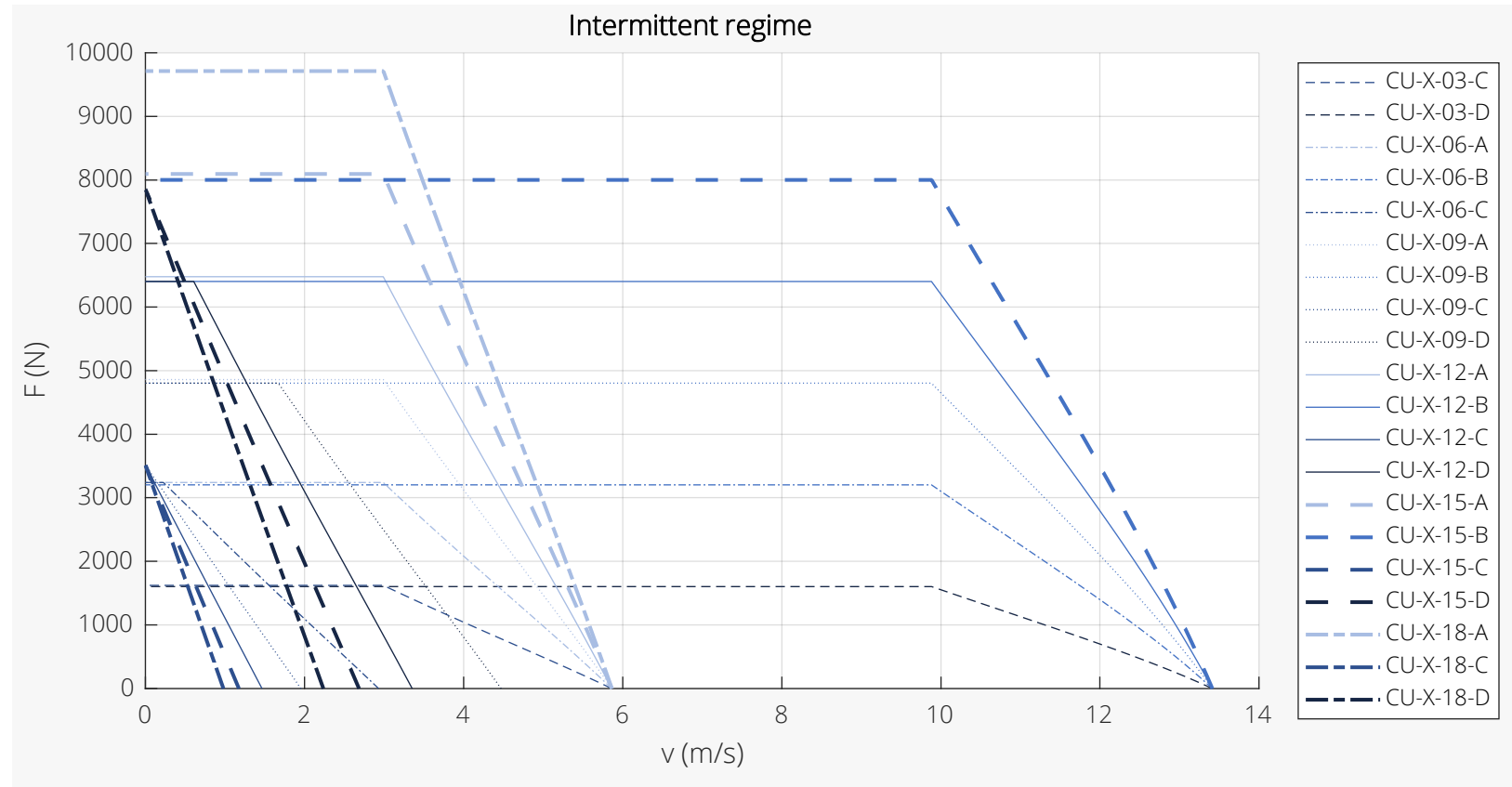

Force-Velocity Diagrams Size X Intermittent Regime

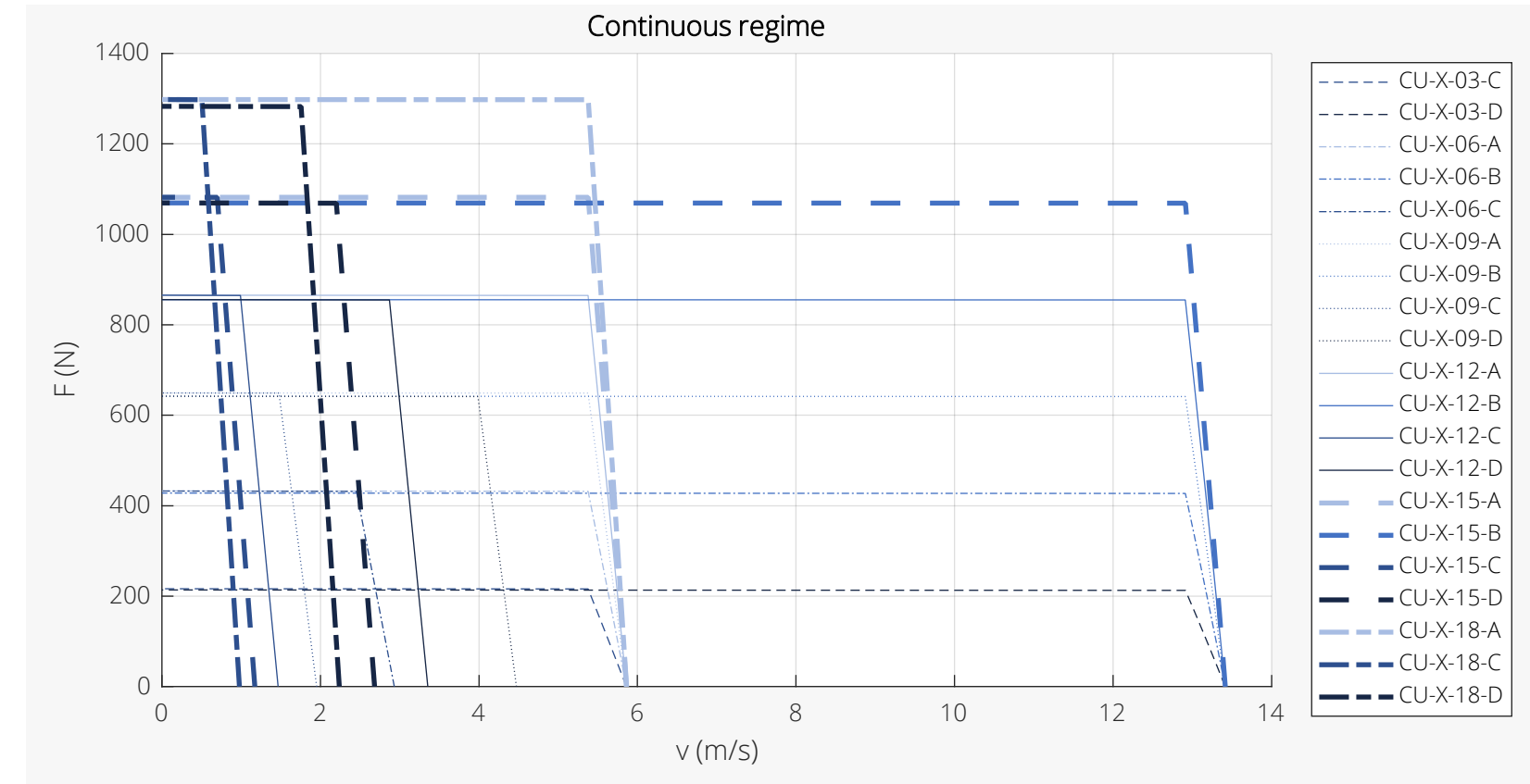

Force-Velocity Diagrams Size X Continuous Regime

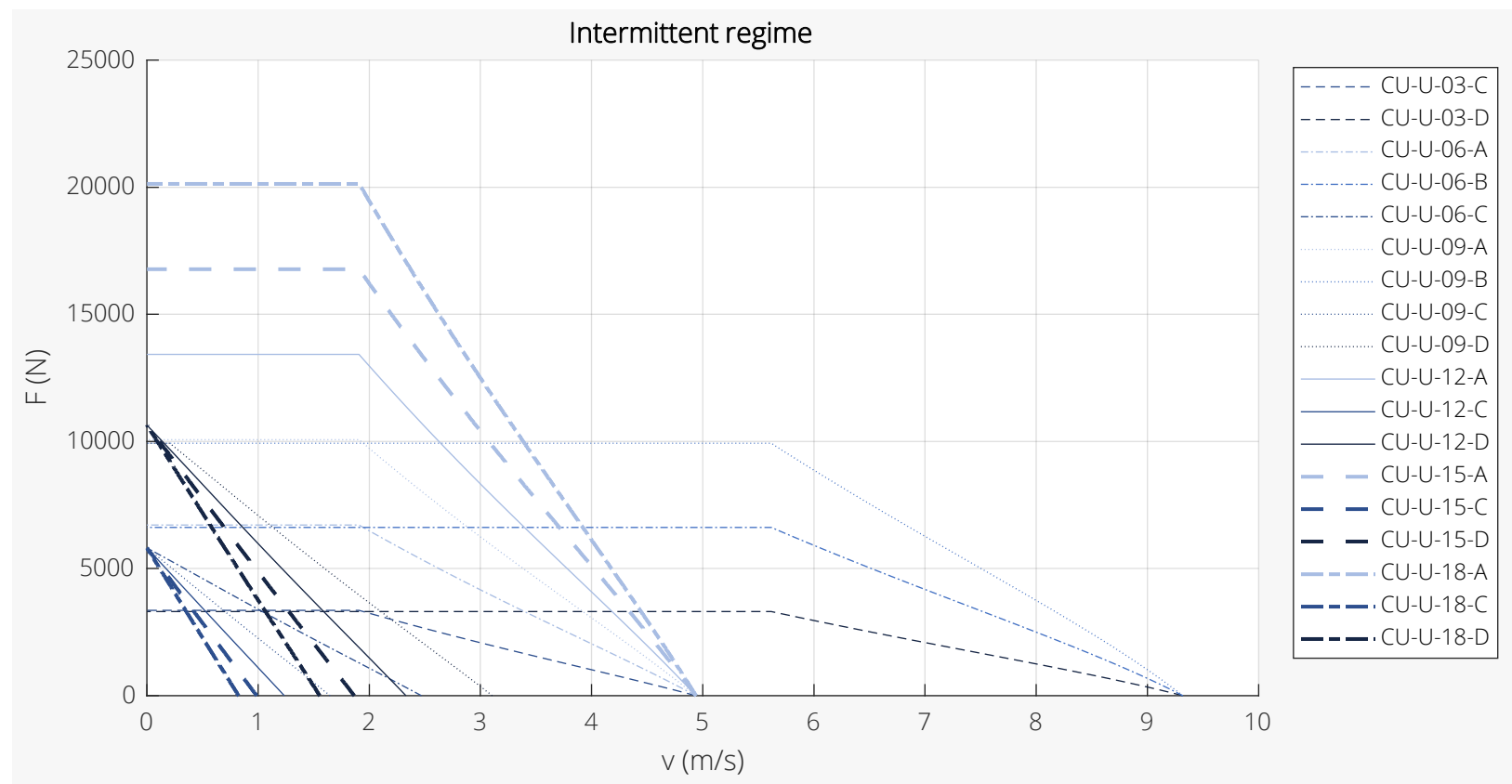

Force-Velocity Diagrams Size U Intermittent Regime

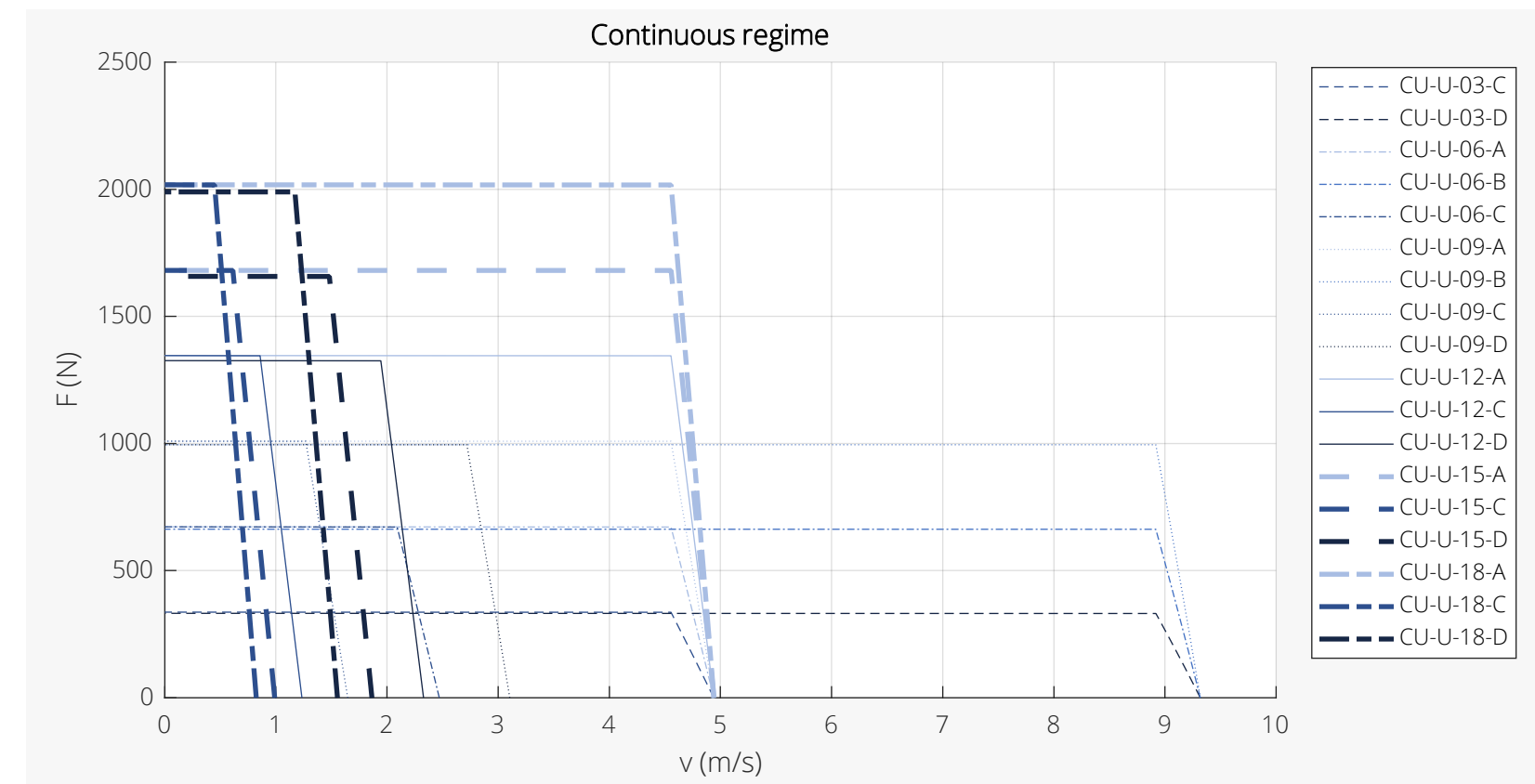

Force-Velocity Diagrams Size U Continuous Regime



- For correct operation of a linear motor, the commutation angle (the electrical angle between the coil unit and the magnet yoke) should be known. This commutation angle is needed to determine the phase angle of the three phase currents.
- The commutation angle can be derived from the relative displacement, for example using a position sensor. However, the Phoenix commutation sensor can directly measure the commutation angle without the need of a position sensor. The Phoenix commutation sensor can be directly attached to the coil unit which provides a cost-effective alternative to measure the commutation angle.
- The Phoenix commutation sensor contains three digital Hall sensors, each shifted by 120 electrical degrees, from which the commutation angle can be derived. Commutation sensors are available for each size of Phoenix (S/M/L/X/U).
- The commutation sensor allows a supply voltage range between 4.5 Vdc and 28 Vdc.

Phoenix-S commutation sensor (Phoenix-CS-S)



# GRYPHON LINE

The Gryphon line offers a cost-effective solution for vacuum-compatible ironless linear motors. These motors also contain features providing magnetic shielding.

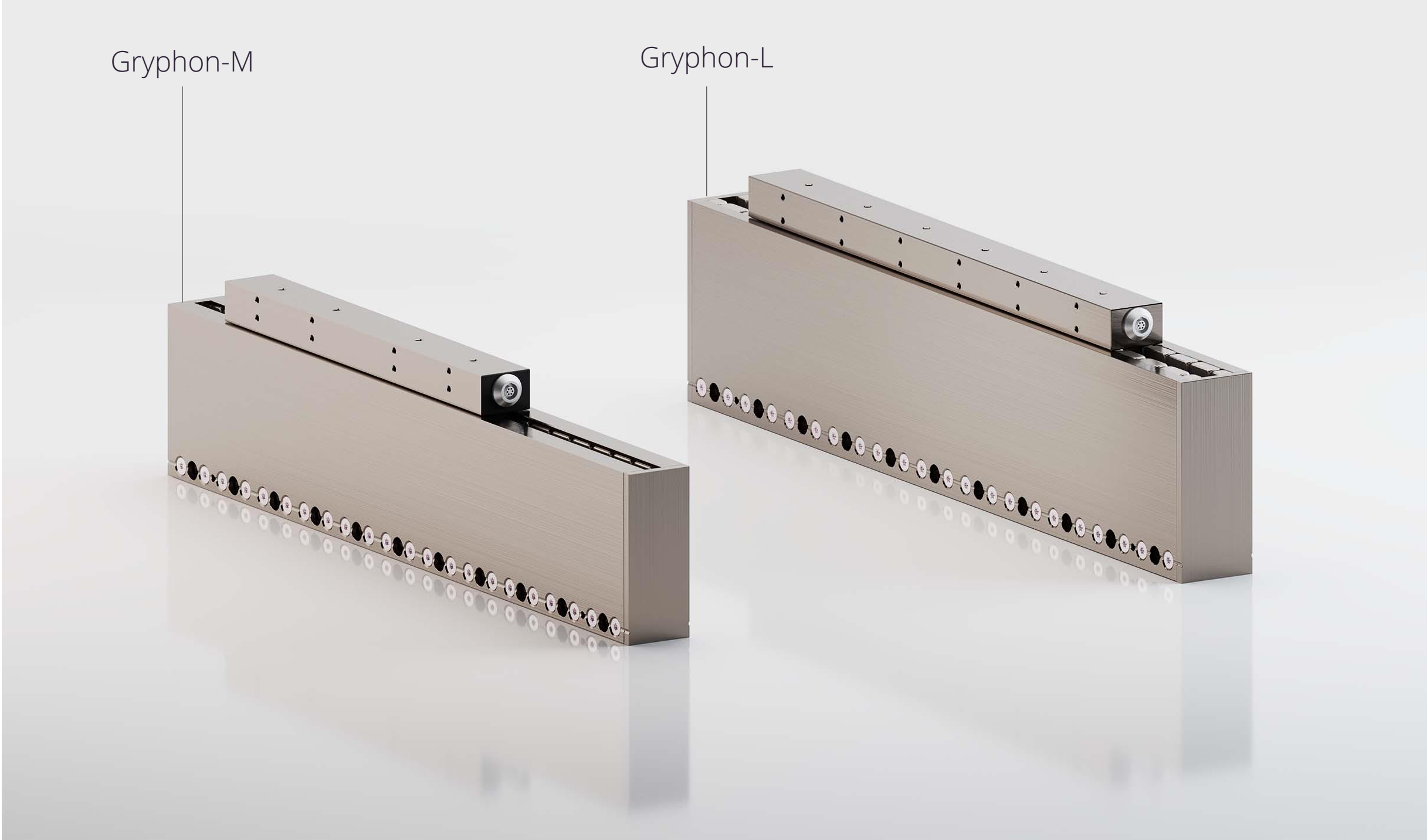

Gryphon line in medium and large configuration

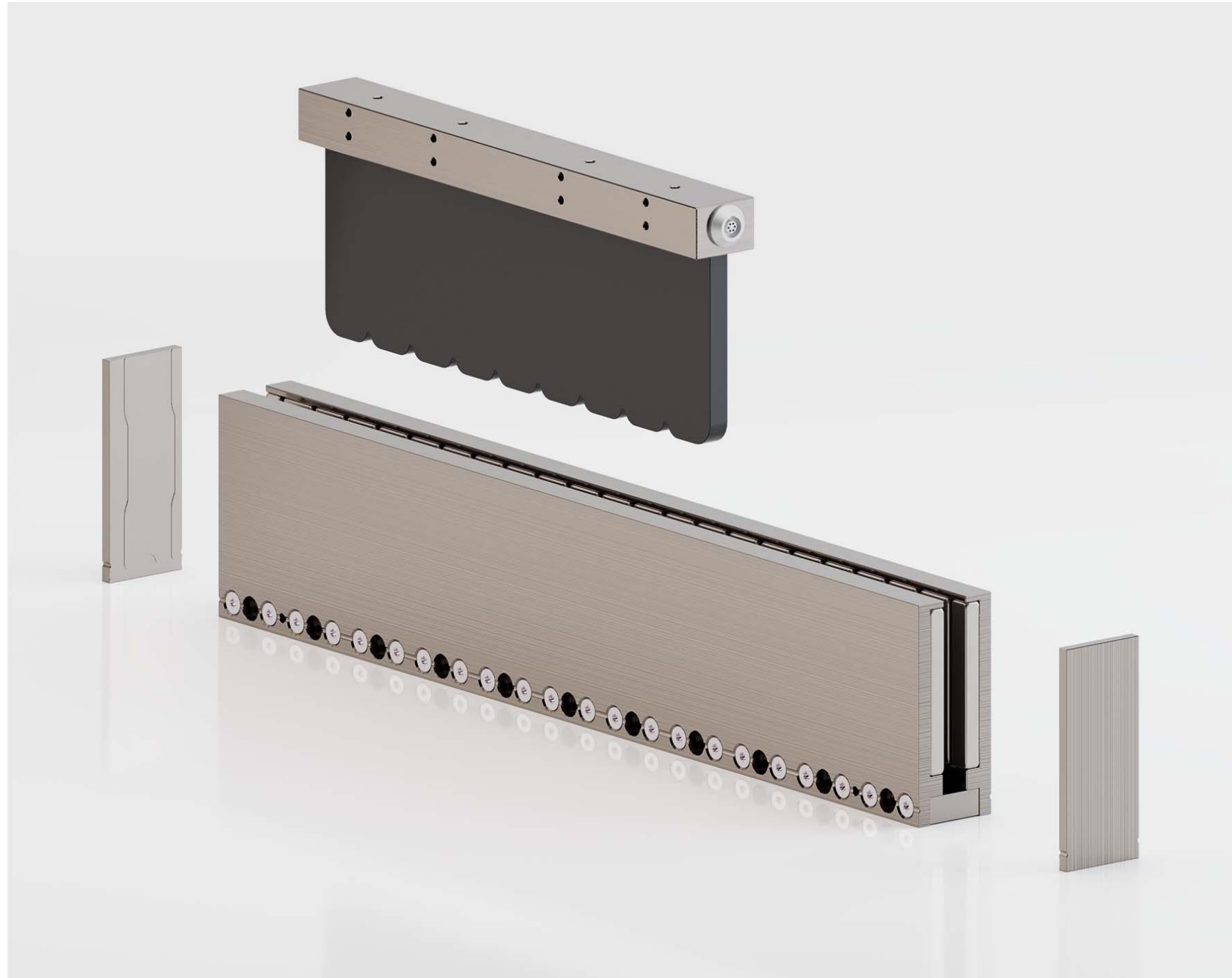

Gryphon magnet yoke (Gryphon-MY-M-22-EB-G00) and coil unit (Gryphon-CU-M-09-C-C)

## Gryphon-CU-M-09-C-C

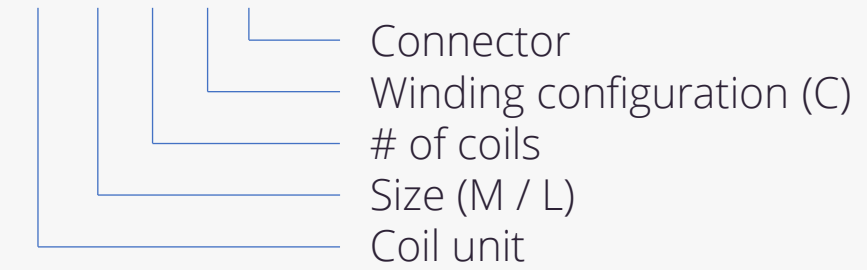

## Gryphon-MY-M-12-FX-G00

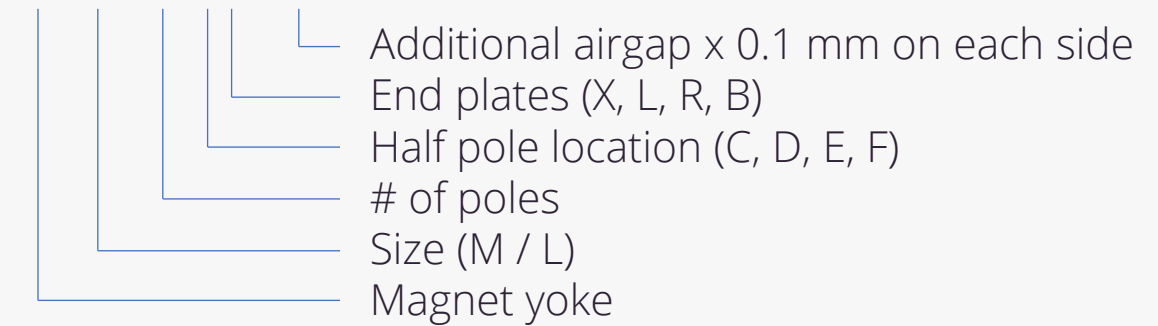

- Magnet yokes and coil units are made of low outgassing materials
- Coil units have a temperature protection (PTC)
- Coil units have a vacuum compatible connector
- Magnet yokes can be butted together
- Magnet yokes can be selected with larger airgaps to allow higher installation tolerances
- Magnet yokes have optional half poles at the end to improve magnetic shielding:
  - C: Half pole on the left side
  - D: Half pole on the right side
  - E: Half pole on both sides
  - F: Full pole on both sides
- Magnet yokes of size M have optional end plates to improve magnetic shielding:
  - X: no end plates
  - L: end plate on the left
  - R: end plate on the right
  - B: end plates on both sides
- IP rating of coil units is IP4X

# GRYPHON-M/L PERFORMANCE SPECIFICATIONS

	Parameter	Symbol	Unit	T <sub>coil</sub> (°C)	CU-M-09	CU-L-12
	Winding configuration	-	-	-	C	C
Electromechanical	Peak force	F <sub>p</sub>	N	20	269	414
	Continuous force, interface at 20°C	F <sub>c</sub>	N	50	161	249
	Attraction force (I = 0)	F <sub>att</sub>	N	-	0	0
	Motor constant	S	N <sup>2</sup> /W	20	566	1330
	Force constant	K <sub>f</sub>	N/A <sub>rms</sub>	-	54	83
	Maximum velocity (F = 0)	v <sub>m</sub>	m/s	-	2.3	1.5
	Maximum velocity (F = F <sub>p</sub> )	v <sub>i</sub>	m/s	20	1.8	1.2
Electrical	Maximum dc bus voltage	V <sub>dc</sub>	V	-	100	100
	Phase resistance	R <sub>ph,20</sub>	Ohm	20	1.7	1.7
	Phase inductance	L <sub>ph</sub>	mH	20	2.3	2.6
	Peak line emf constant	K <sub>e,ll,p</sub>	Vs/m	-	44	68
	Maximum rms current	I <sub>p</sub>	A <sub>rms</sub>	20	5.0	5.0
	Continuous rms current	I <sub>c</sub>	A <sub>rms</sub>	50	3.0	3.0
Thermal	Continuous dissipation	P <sub>d,c</sub>	W	50	51	52
	Thermal resistance, coils to interface	R <sub>th,i</sub>	K/W	-	0.37	0.19
	Thermal time constant, interface at 20°C	τ <sub>th</sub>	s	-	627	541

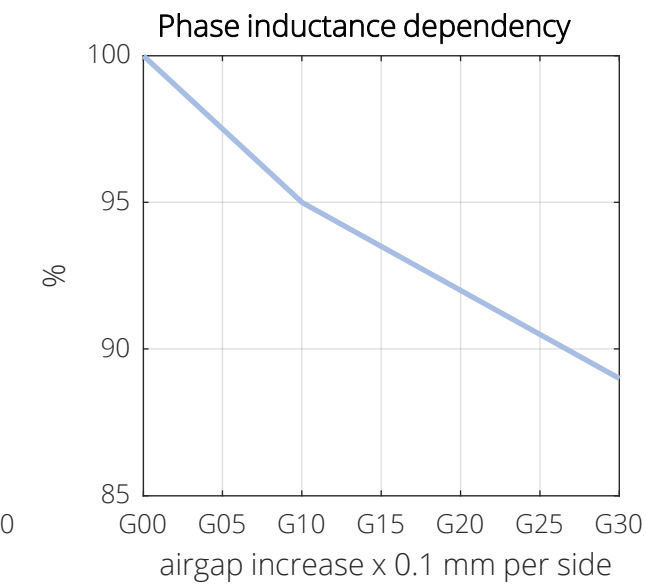
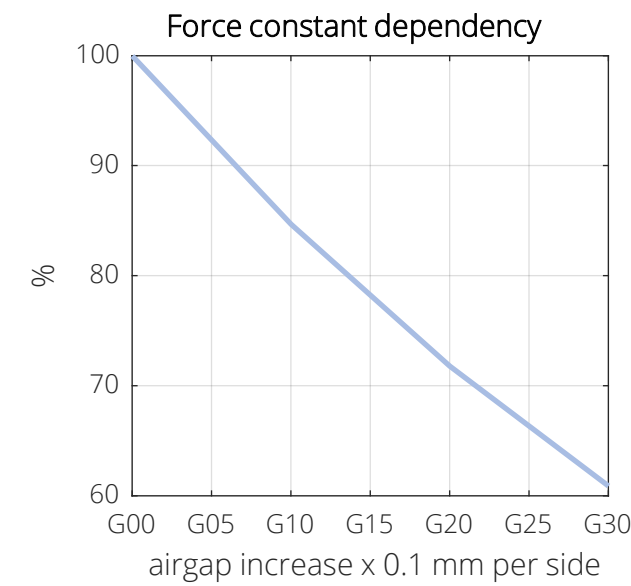

## Notes

- Specifications are based upon a magnet temperature of 20°C
- Specifications consider complete overlap of the coil unit with a magnet yoke
- Specifications consider sinusoidal q-axis commutation
- Velocity specifications are based on the maximum bus voltage
- Specifications consider a magnet yoke with nominal airgap (G00)
- See 'definitions' section at the end of the catalog for more details

## Product marking / approvals

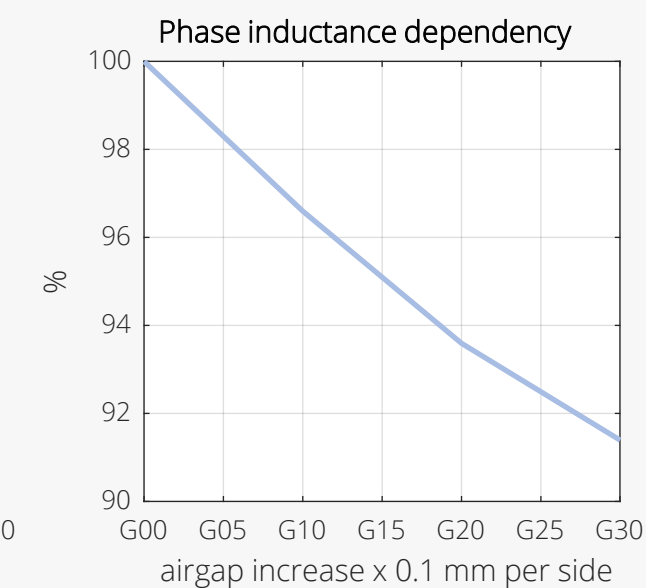
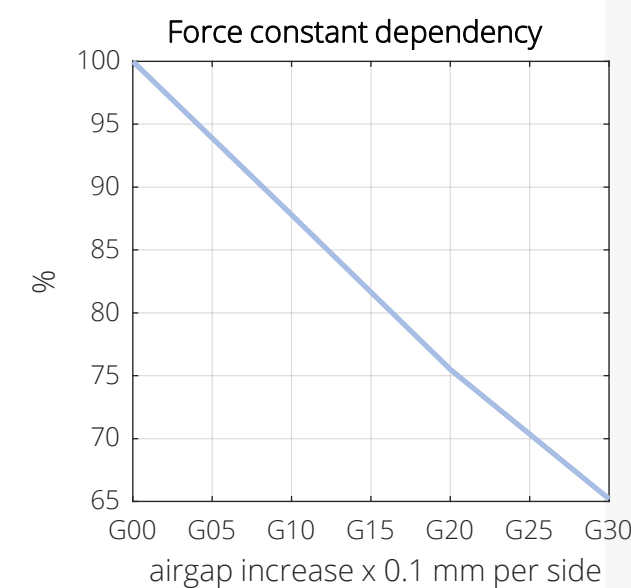

Airgap dependency

# GRYPHON-M MECHANICAL SPECIFICATIONS

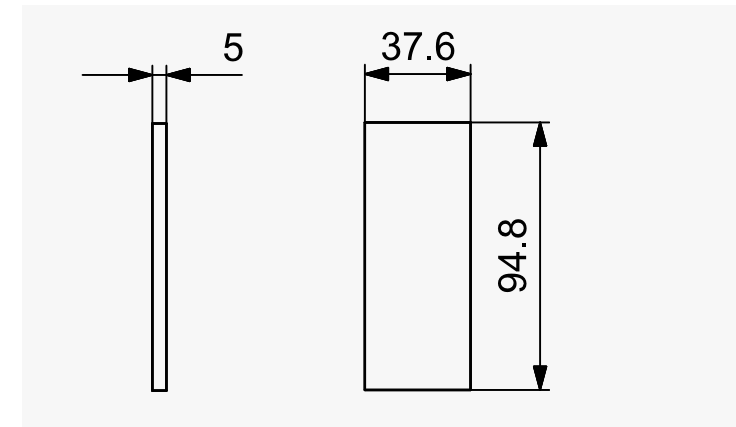
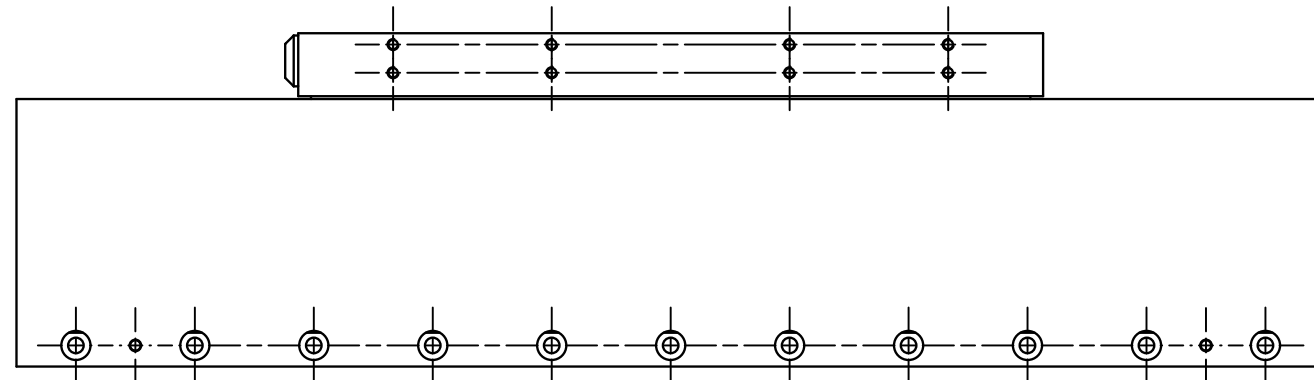
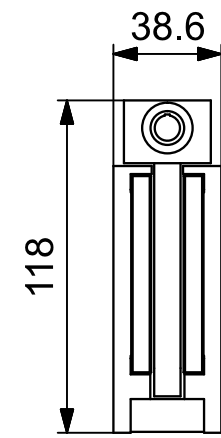

End plate

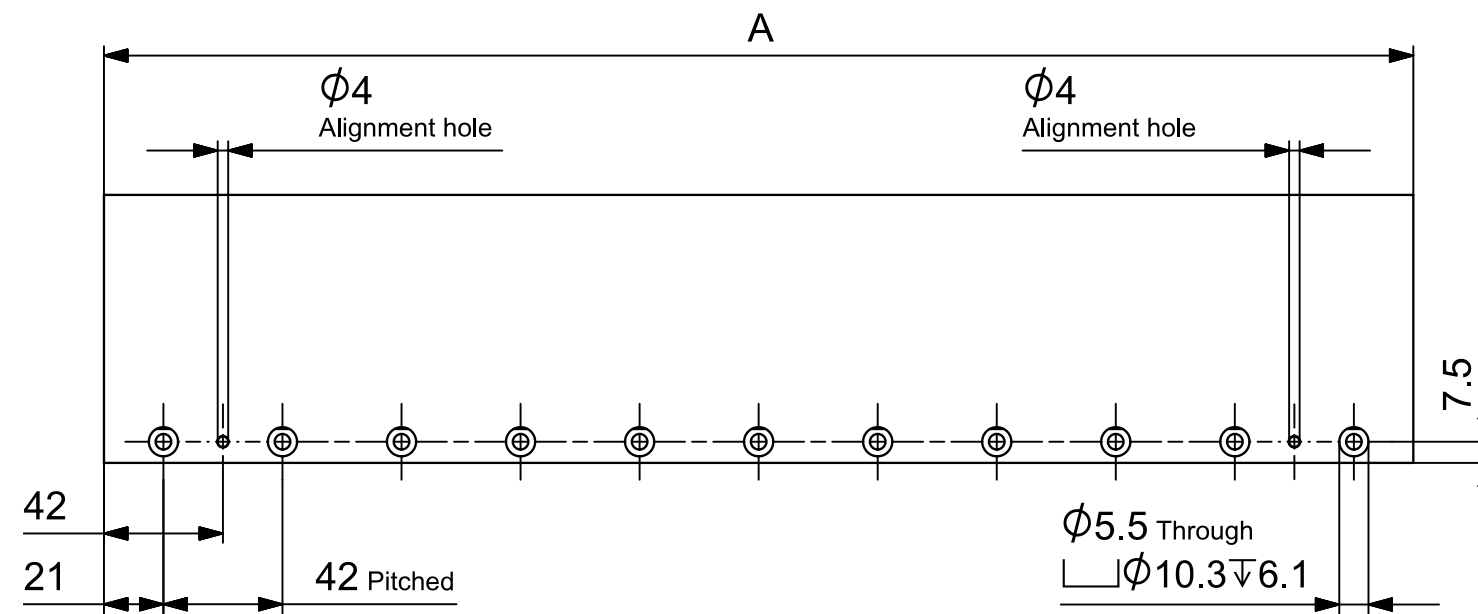
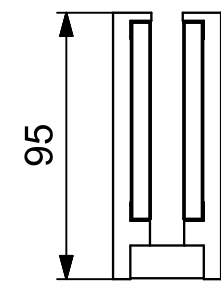

		Parameter	Symbol	Unit	MY-M-12	MY-M-22
Magnet Yokes	Number of poles	$N_p$	-		12	22
	Pole pitch (N-N)	$2\tau_p$	mm		42	42
	Width	A	mm		252	462
	Mass	$M_{my}$	kg		4.6	8.4

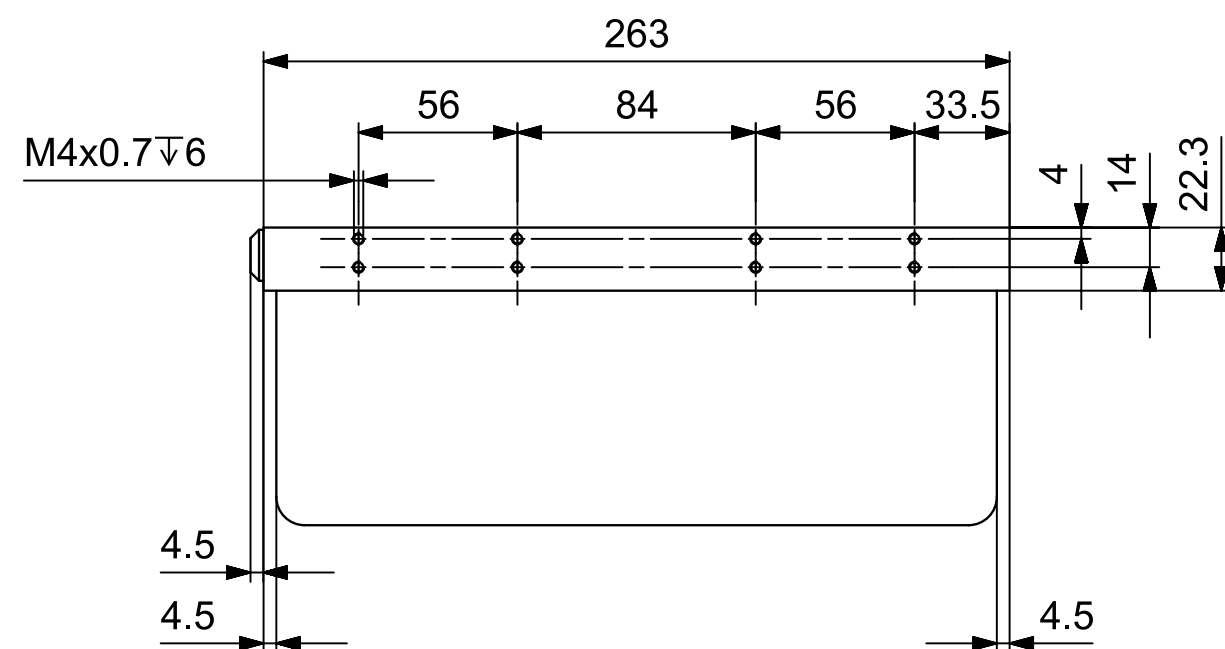
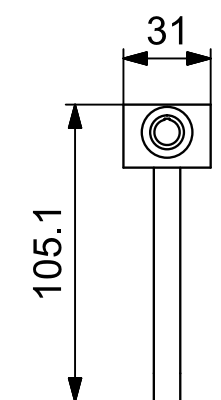

		Parameter	Symbol	Unit	CU-M-09
Coil Units	Number of coils	$N_{coil}$	-		9
	Coil pitch	$\tau_{coil}$	mm		28
	Width	B	mm		263
	Mass	$M_{cu}$	kg		1.4



# GRYPHON-L MECHANICAL SPECIFICATIONS

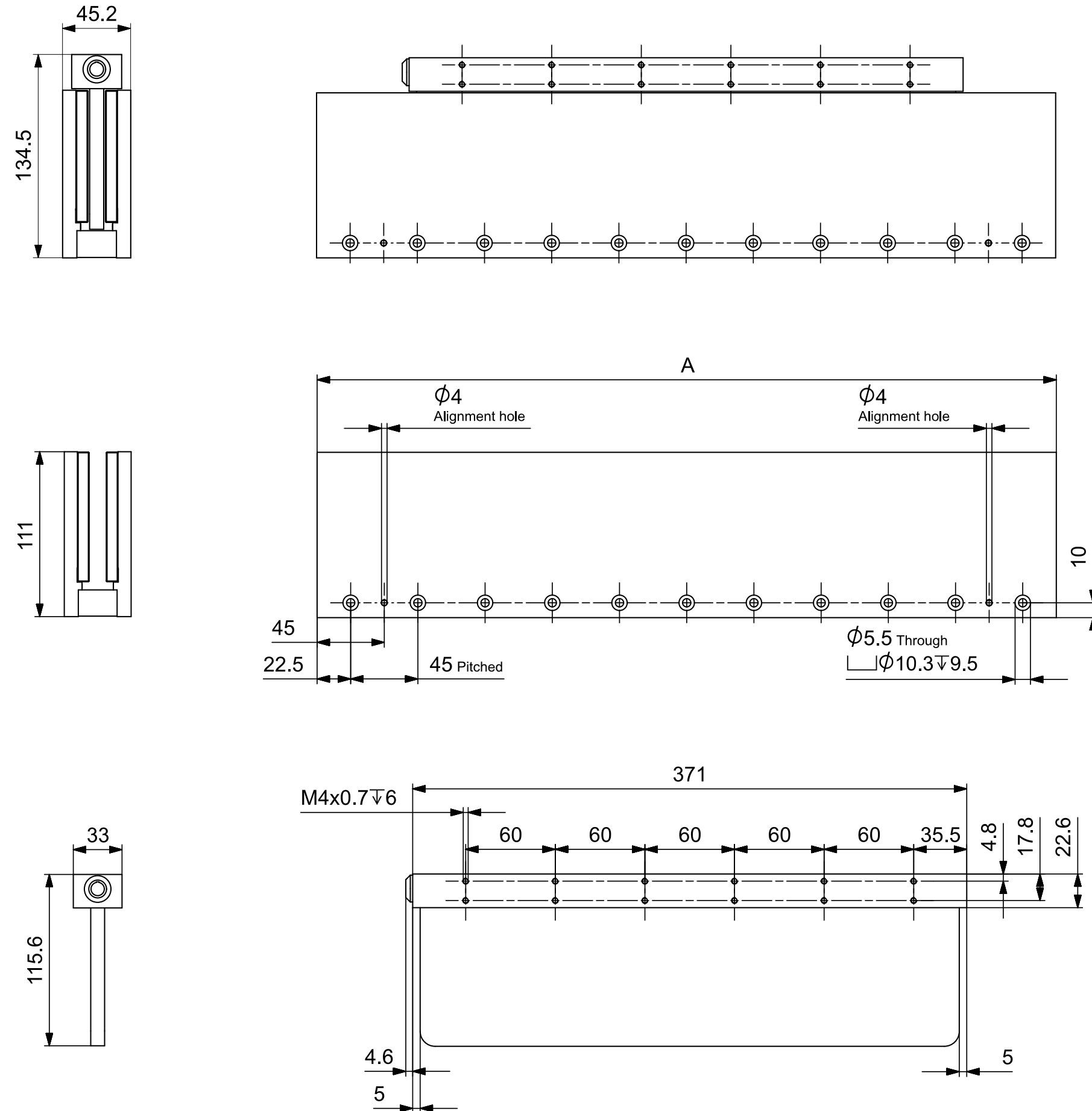

Magnet Yokes	Parameter	Symbol	Unit	MY-L-22	MY-L-24
	Number of poles	$N_p$	-	22	24
	Pole pitch (N-N)	$2\tau_p$	mm	45	45
	Width	A	mm	495	540
Mass	$M_{my}$	kg	13.1	14.2	

Coil Units	Parameter	Symbol	Unit	CU-L-12
	Number of coils	$N_{coil}$	-	12
	Coil pitch	$\tau_{coil}$	mm	30
	Width	B	mm	371
Mass	$M_{cu}$	kg	2.4	

# GRYPHON-M/L FORCE-VELOCITY DIAGRAMS

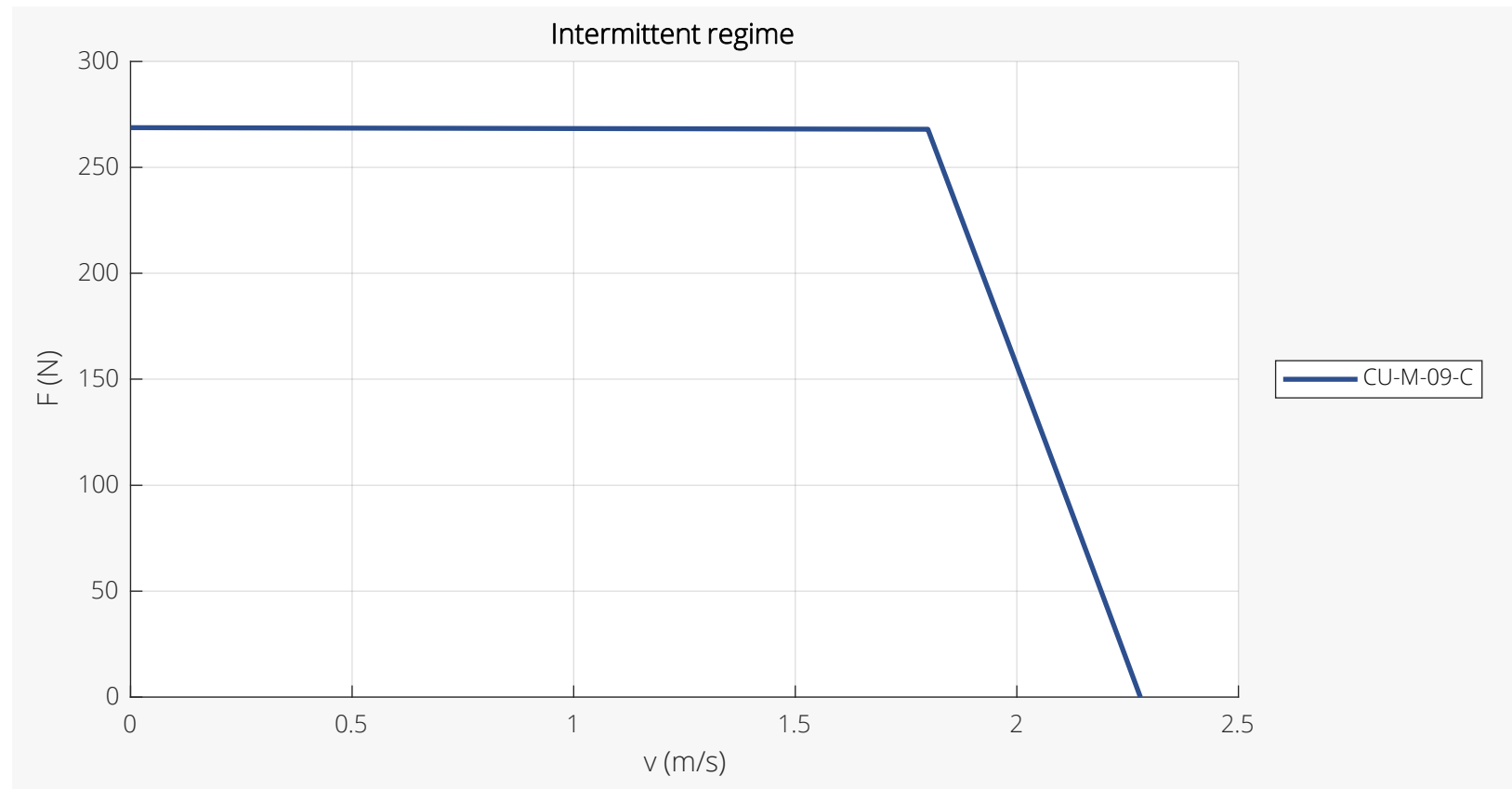

Force-Velocity Diagrams Size M Intermittent Regime

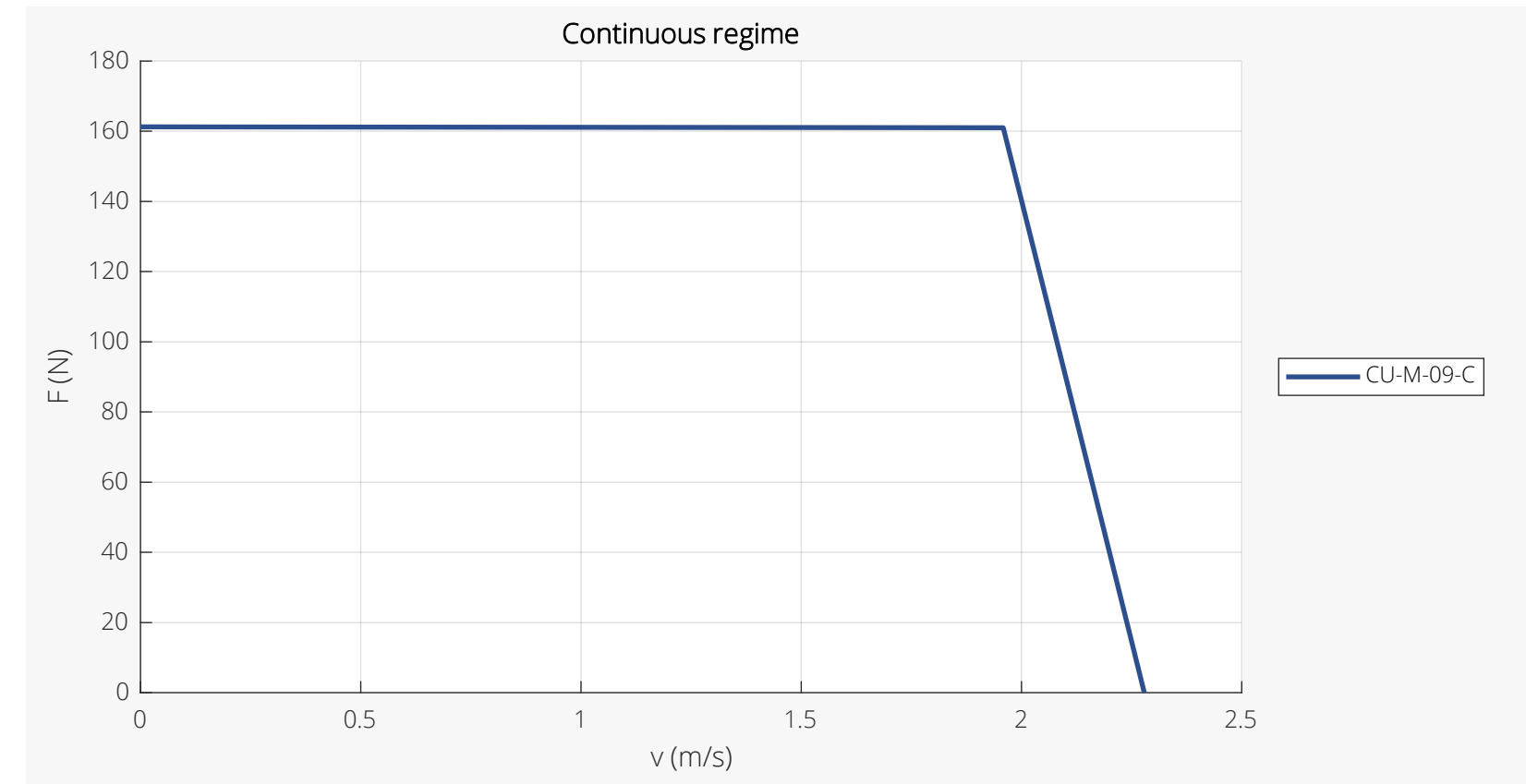

Force-Velocity Diagrams Size M Continuous Regime

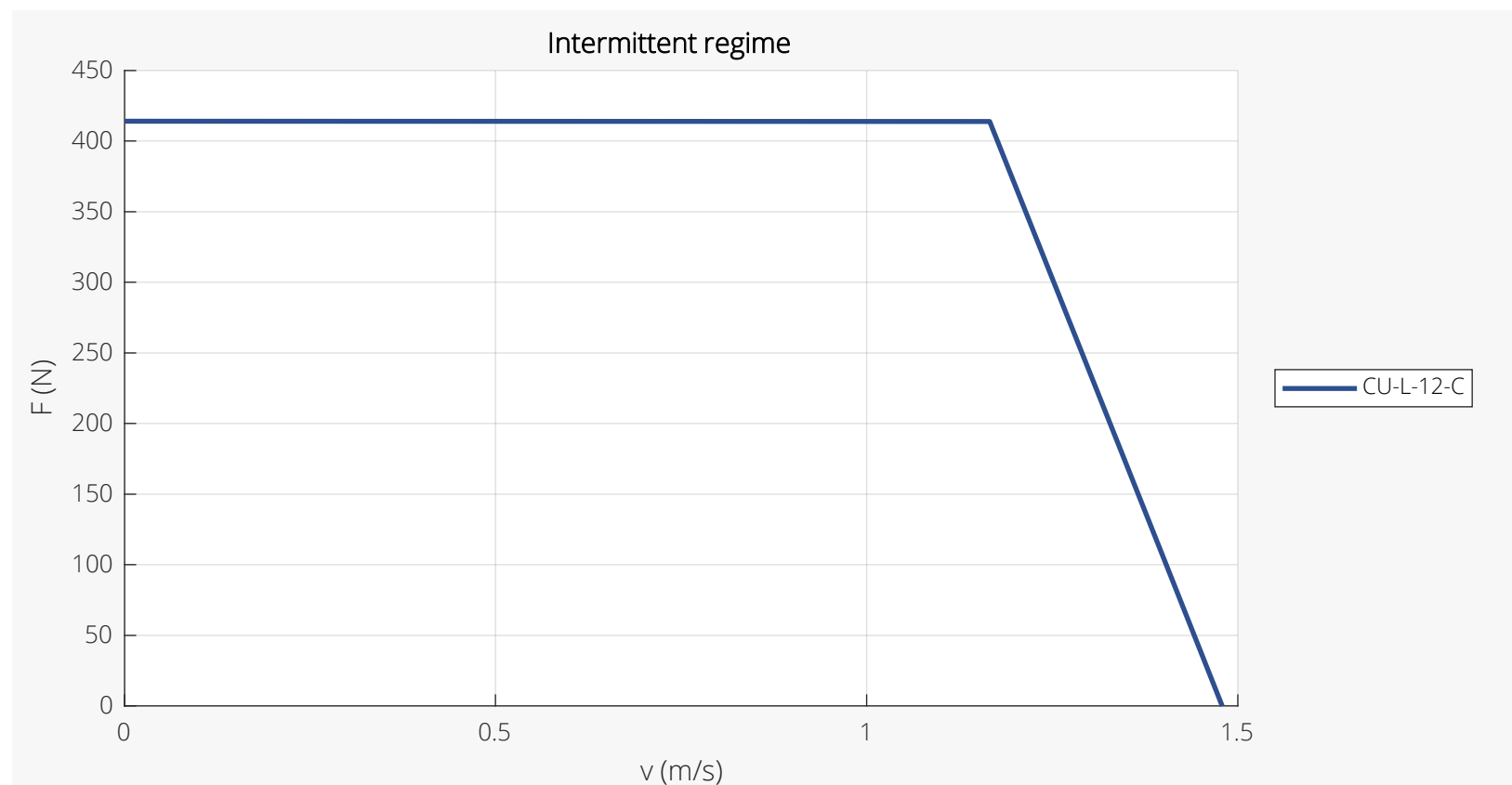

Force-Velocity Diagrams Size L Intermittent Regime

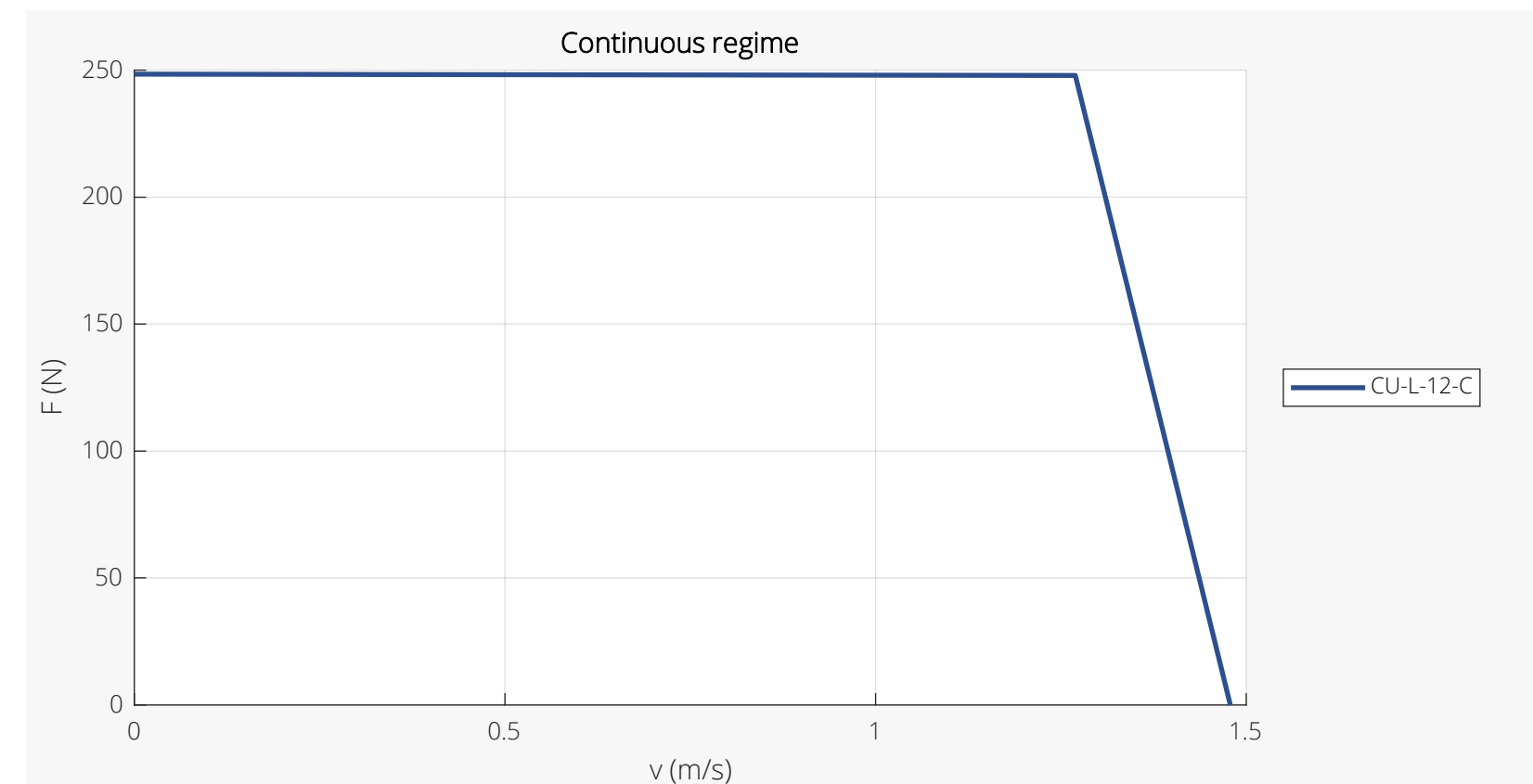

Force-Velocity Diagrams Size L Continuous Regime

# GRYPHON-L OUTGASSING MEASUREMENTS

The outgassing measurement results below are obtained after bakeout of the magnet yoke segments and coil units. Results are obtained at room temperature, 10 hours after TMP start. Vacuum level 1e-7 mbar (1e-5 Pa or 7.5e-8 Torr).

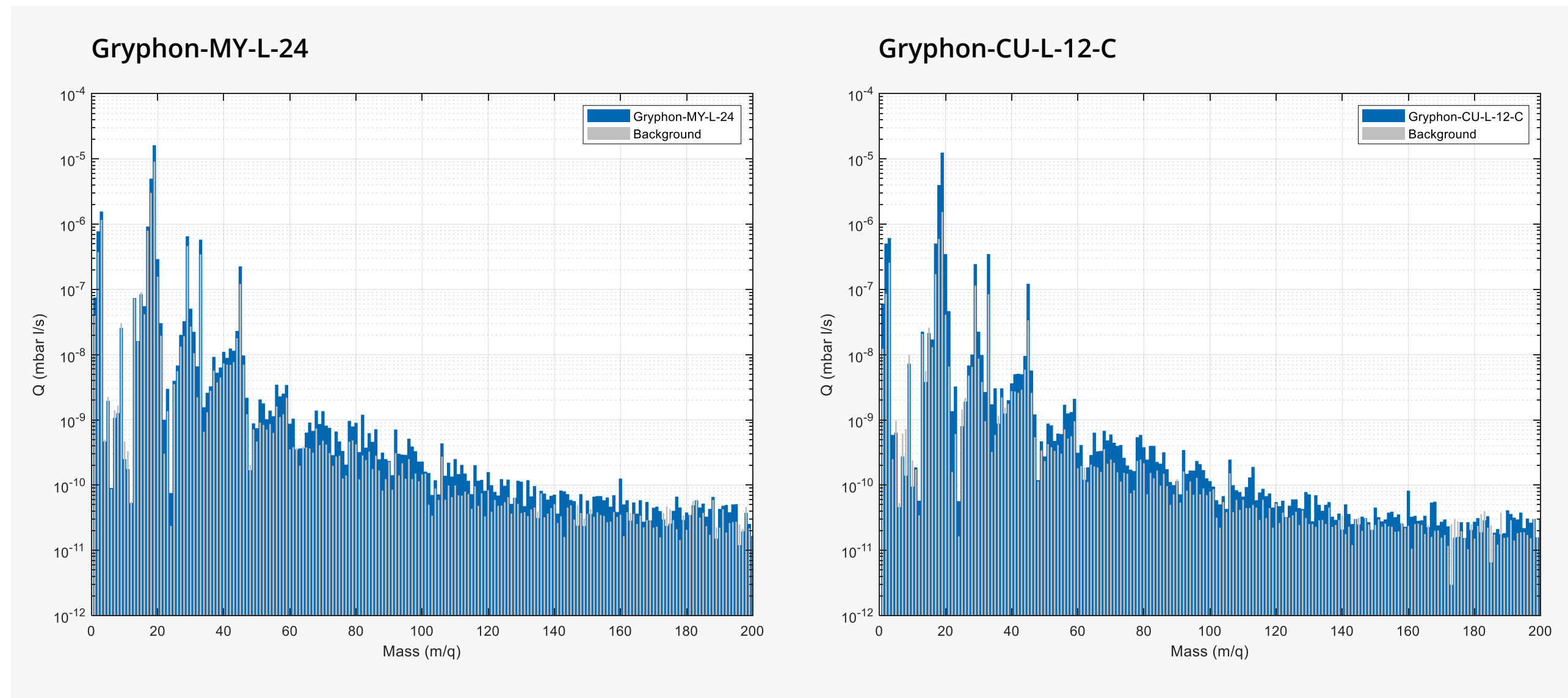

Outgassing measurements

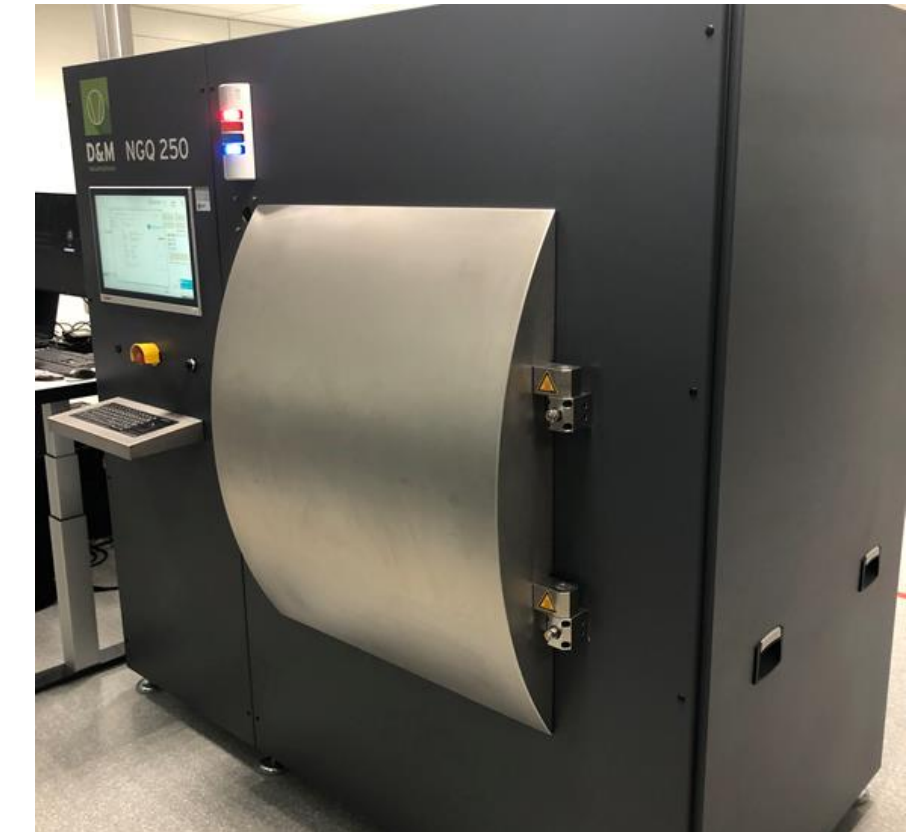

Top picture: In-house RGA equipment  
Bottom Picture: In-house bake out equipment

# IRIS LINE

The Iris line offers short stroke linear motors with a rectangular form factor. The M and L size motors also contain magnetic shielding features.

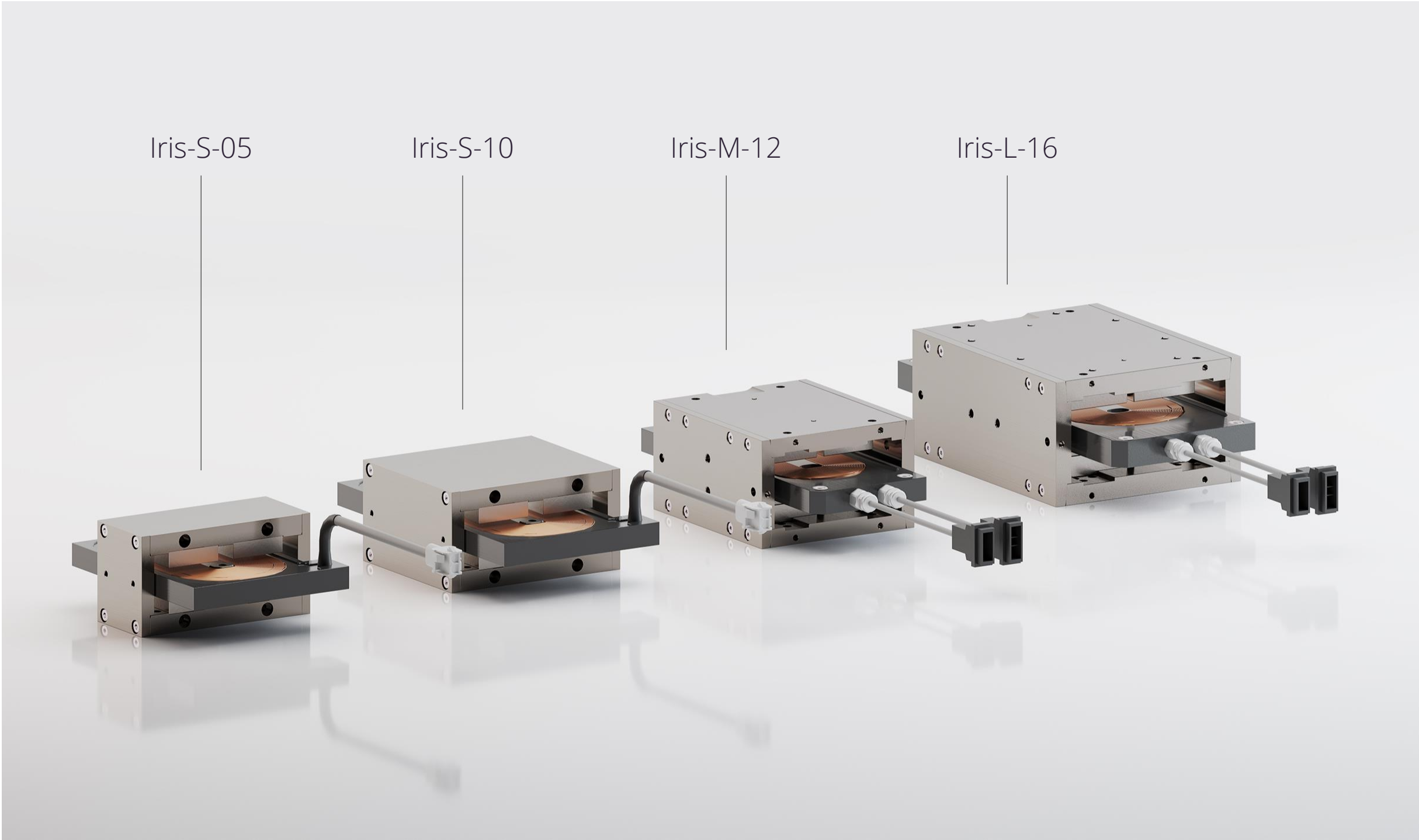

Iris line short stroke motors in different sizes



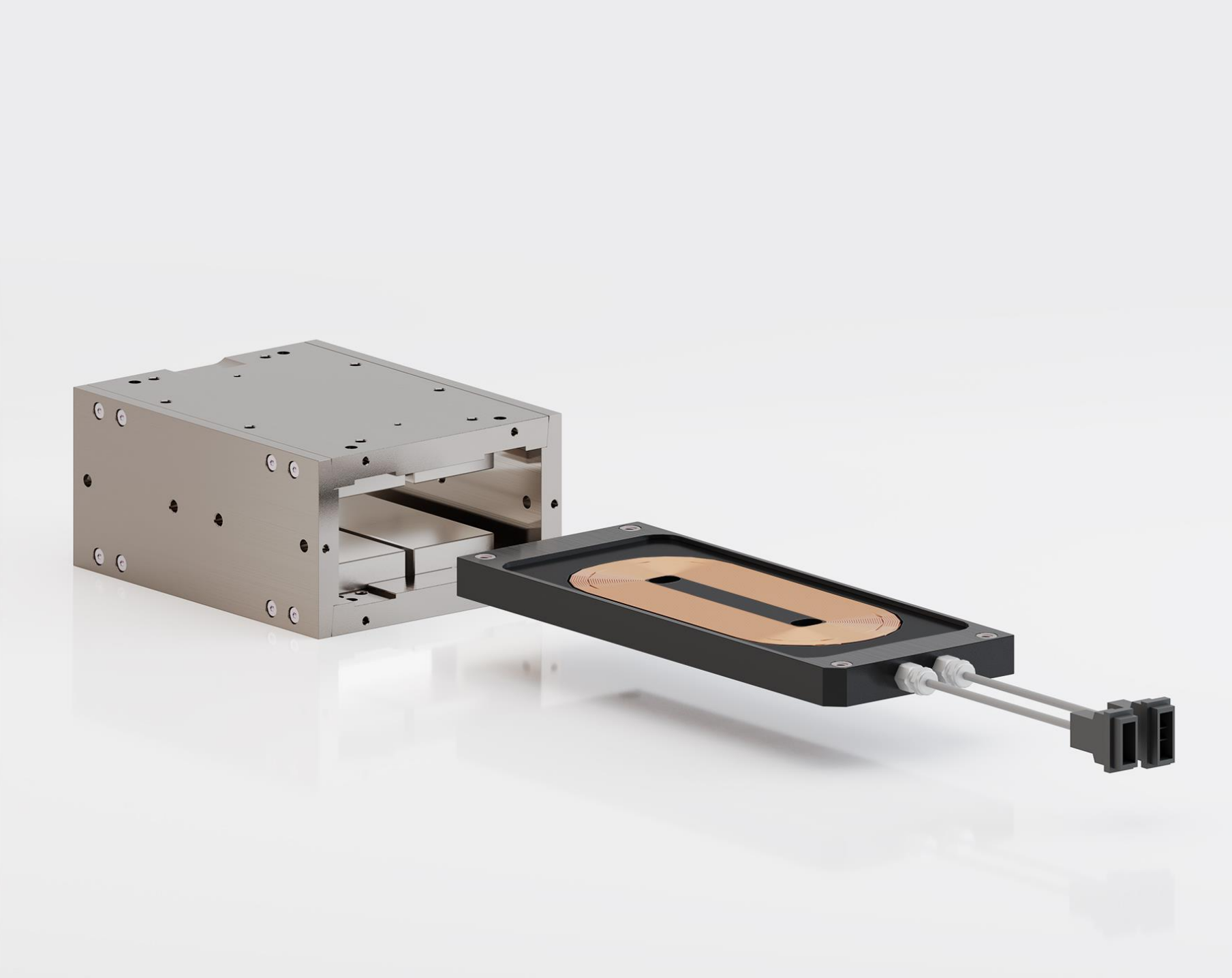

Iris-L-16

### Iris-M-12

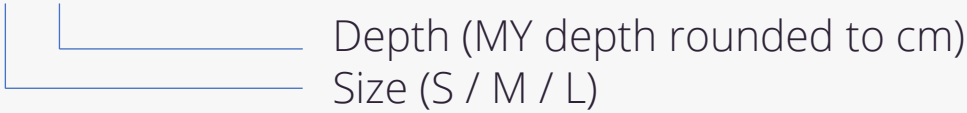

- Different sizes for optimal mechanical integration
- Coil unit housing optimized for heat transfer and force bandwidth
- Coil units are equipped with connectors
- IP rating of coil units is IP10
- The M/L size coil units have a temperature sensor (PT1000)
- The M/L size have magnets which are shorter than the back iron for improved magnetic shielding

# IRIS PERFORMANCE SPECIFICATIONS

	Parameter	Symbol	Unit	T <sub>coil</sub> (°C)	Iris-S-05	Iris-S-10	Iris-M-12	Iris-L-16
Electromech.	Peak force ( $\alpha_T = 5^\circ\text{C/s}$ increase)	F <sub>p</sub>	N	20	400	600	450	1150
	Continuous force	F <sub>c</sub>	N	100	100	180	150	250
	Continuous force (UL rated)	F <sub>c</sub>	N	20	n.a.	n.a.	80	170
	Attraction force (I = 0)	F <sub>att</sub>	N	-	0	0	0	0
	Motor constant	S	N <sup>2</sup> /W	20	161	464	259	770
	Force constant	K <sub>f</sub>	N/A	-	23	47	19	48
Electrical	Maximum dc bus voltage	V <sub>dc</sub>	V	-	60	60	100	100
	Phase resistance	R <sub>ph,20</sub>	Ohm	20	3.4	4.7	1.4	3.0
	Phase inductance	L <sub>ph</sub>	mH	-	16.0	25.9	4.7	15.5
	EMF constant	K <sub>e</sub>	Vs/m	-	23	47	19	48
	Maximum rms current	I <sub>p</sub>	A	20	17.6	12.8	24.3	24.5
	Continuous rms current	I <sub>c</sub>	A	100	4.4	3.9	8.0	5.3
	Continuous rms current (UL rated)	I <sub>c</sub>	A	100	n.a.	n.a.	4.3	3.6
Thermal	Continuous dissipation	P <sub>d,c</sub>	W	100	88	94	120	110
	Continuous dissipation (UL rated)	P <sub>d,c</sub>	W	100	n.a.	n.a.	34	51
	Thermal resistance, coils to interface	R <sub>th,i</sub>	K/W	-	0.91	0.85	0.67	0.73
	Thermal resistance, coils to conv. surface	R <sub>th,c</sub>	K/W	-	0.06	0.04	0.09	0.06
	Thermal time constant	τ <sub>th</sub>	s	-	521	646	358	363

## Notes

- Specifications are based upon a magnet temperature of 20°C
- See 'definitions' section at the end of the catalog for more details

## Product marking / approvals



# IRIS-S-05 MECHANICAL SPECIFICATIONS

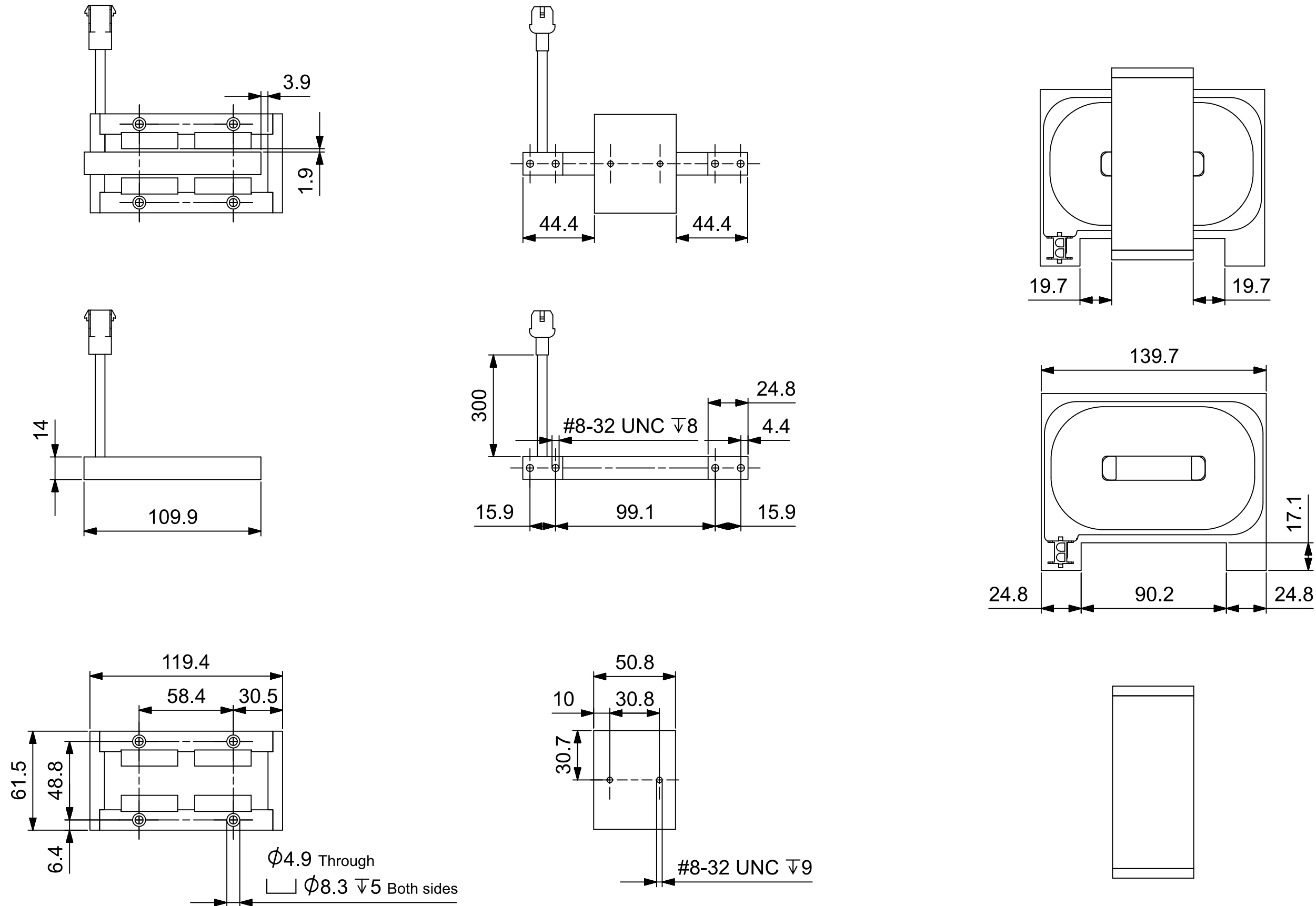

	Parameter	Symbol	Unit	S-05
Mass	Magnet yoke mass	$M_{my}$	kg	1.9
	Coil unit mass (incl. cable)	$M_{cu}$	kg	0.9
	Total mass (incl. cable)	$M_{tot}$	kg	2.8

# IRIS-S-10 MECHANICAL SPECIFICATIONS

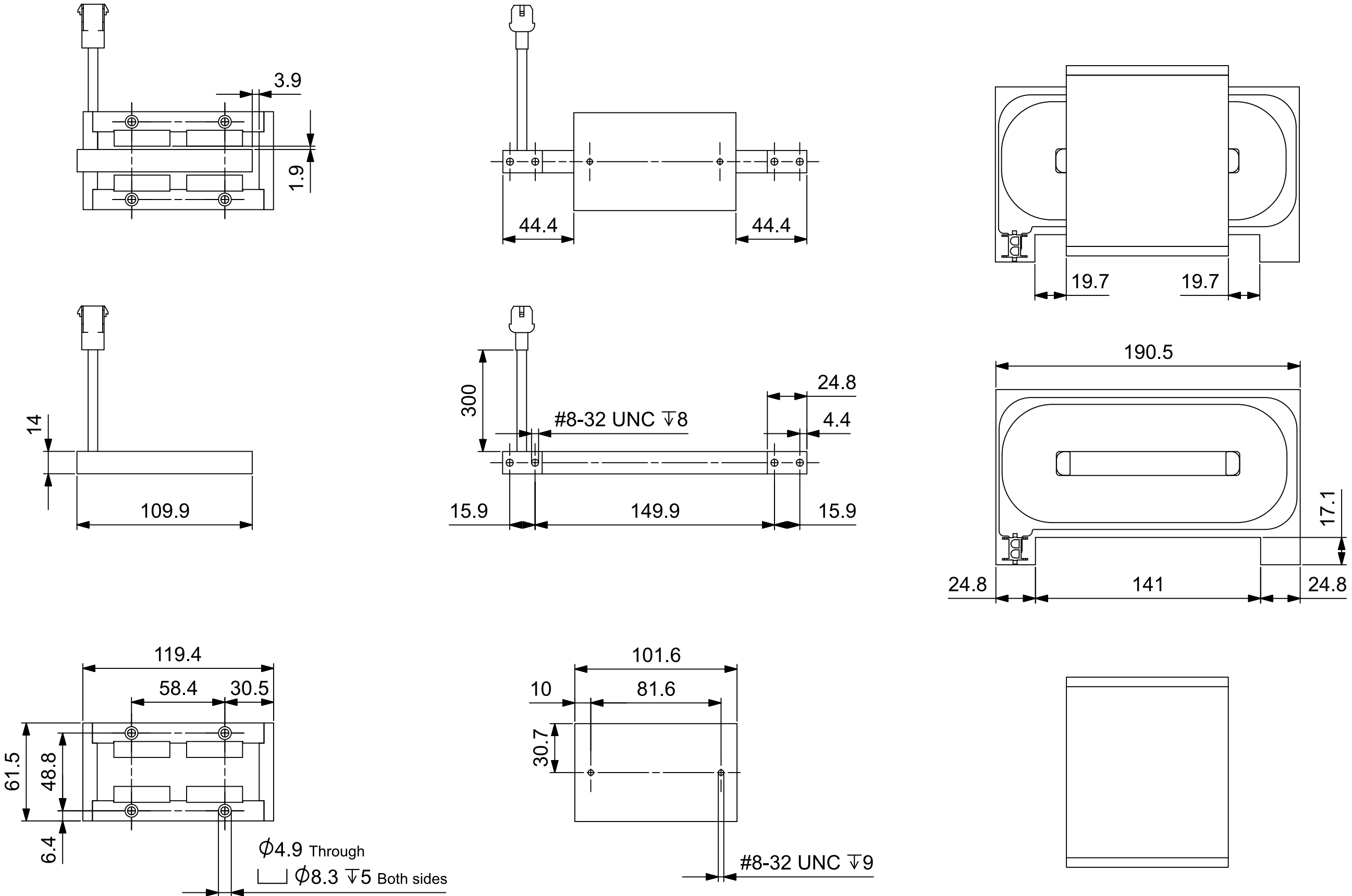

	Parameter	Symbol	Unit	S-10
Mass	Magnet yoke mass	$M_{my}$	kg	3.8
	Coil unit mass (incl. cable)	$M_{cu}$	kg	1.2
	Total mass (incl. cable)	$M_{tot}$	kg	5.0



# IRIS-M-12 MECHANICAL SPECIFICATIONS

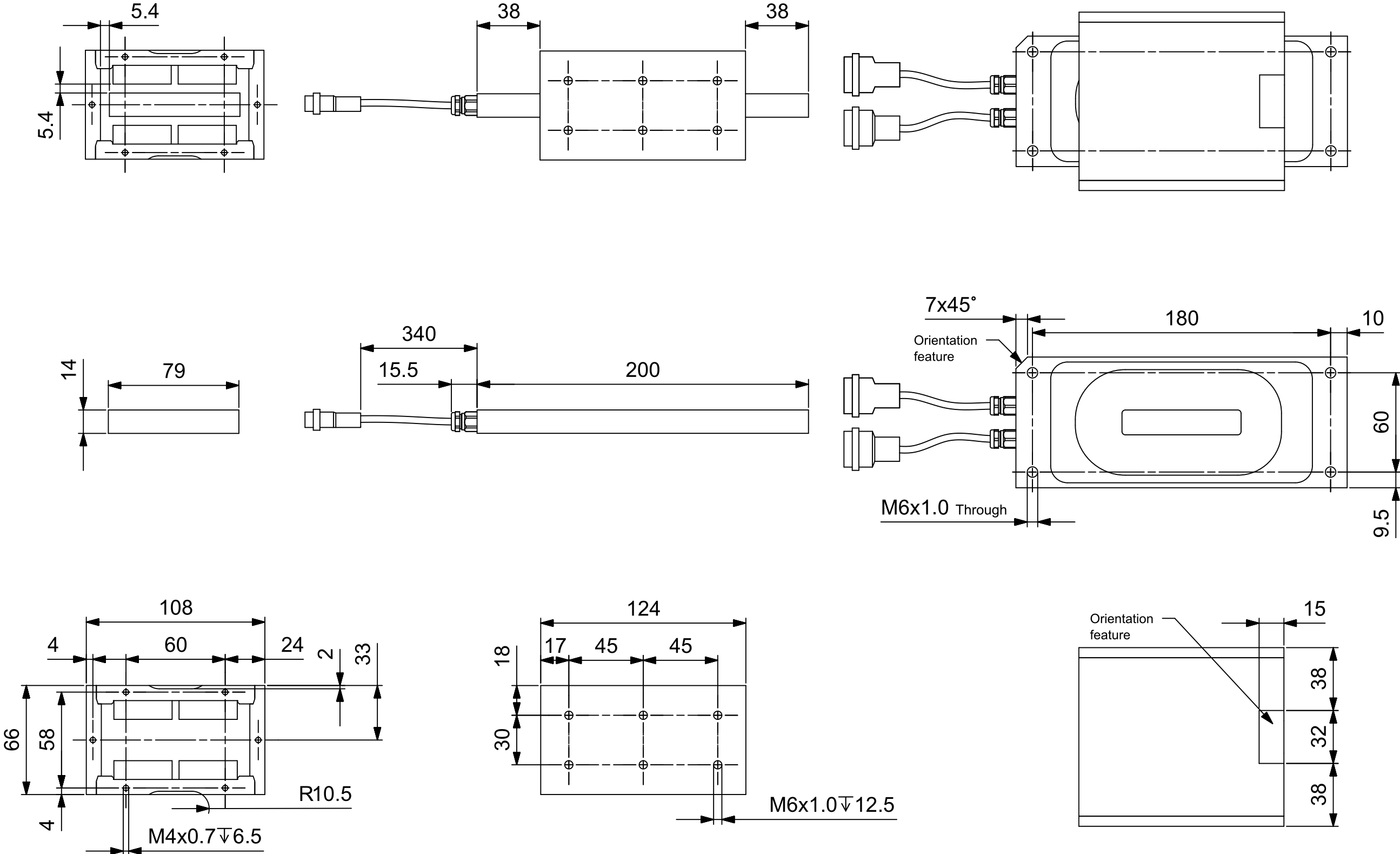

	Parameter	Symbol	Unit	M-12
Mass	Magnet yoke mass	$M_{my}$	kg	3.8
	Coil unit mass (incl. cable)	$M_{cu}$	kg	0.8
	Total mass (incl. cable)	$M_{tot}$	kg	4.6

# IRIS-L-16 MECHANICAL SPECIFICATIONS

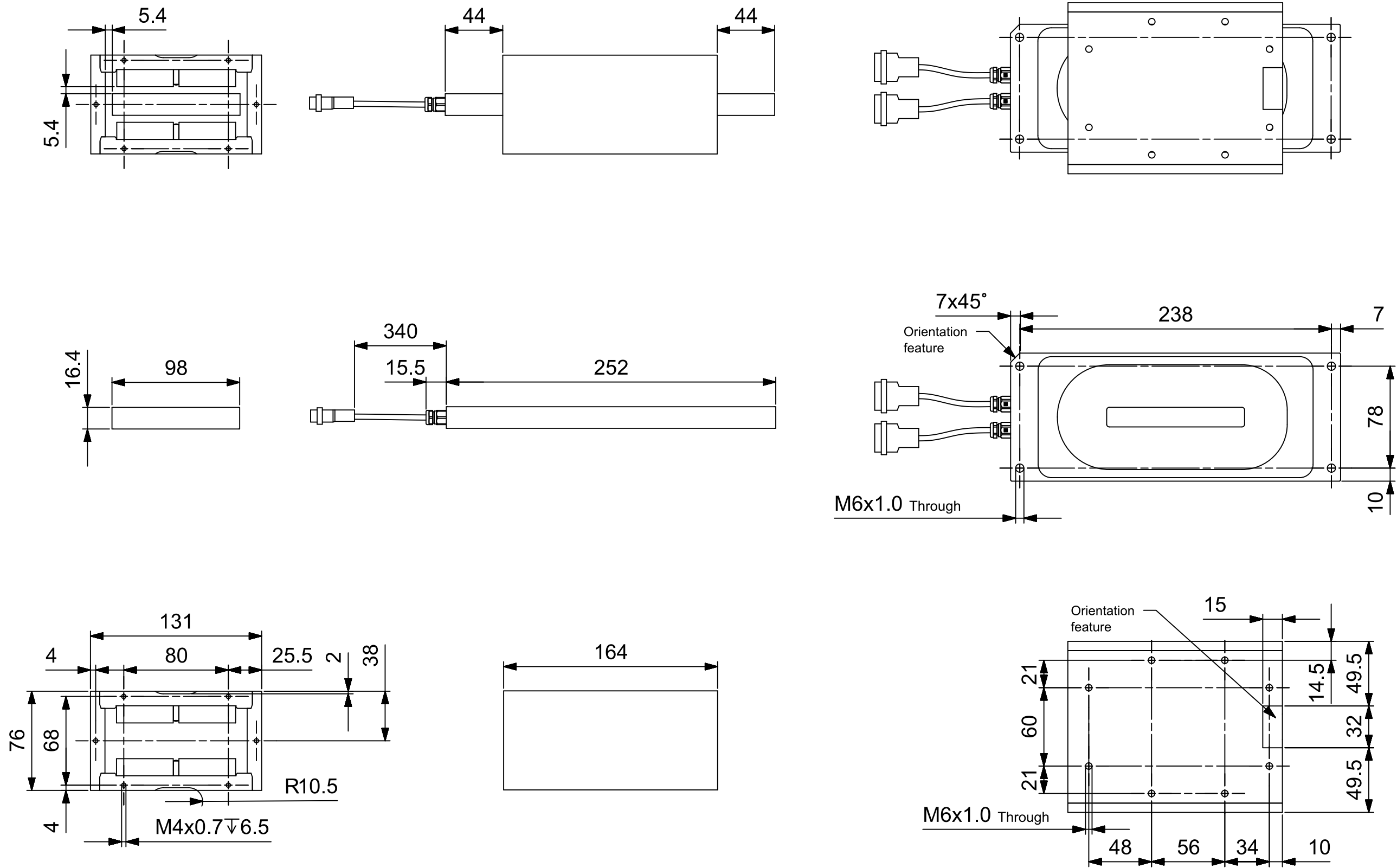

	Parameter	Symbol	Unit	L-16
Mass	Magnet yoke mass	$M_{my}$	kg	7.6
	Coil unit mass (incl. cable)	$M_{cu}$	kg	1.5
	Total mass (incl. cable)	$M_{tot}$	kg	9.1

# DEFINITIONS

Parameter	Symbol / Equation	Unit	Remarks
Coil temperature	$T_{coil}$	$^{\circ}C$	Average temperature over the complete coil volume
Interface temperature	$T_{int}$	$^{\circ}C$	Average temperature over the complete interface surface
Convective surface temperature	$T_{conv}$	$^{\circ}C$	Average temperature over the complete convective surface
Thermal resistance	$R_{th,i}$	K/W	From average coil temperature to average interface temperature
Thermal resistance	$R_{th,c}$	K/W	From average coil temperature to average convective surface temperature
Thermal time constant	$\tau_{th}$	s	The time to reach 63.7% of the steady state temperature considering $T_{int} = 20^{\circ}C$

The actual continuous force is strongly dependent on the cooling conditions available in the application. Depending on the situation (vacuum environment, natural convection, forced convection or other), the thermal resistances of the coil unit ( $R_{th,i}$  and  $R_{th,c}$ ) should be combined with the thermal resistances of the cooling interfaces to determine the overall thermal resistance ( $R_{th}$ ). This overall thermal resistance provides the maximum dissipated power and continuous force.

Please contact us for any support to calculate your specific application.

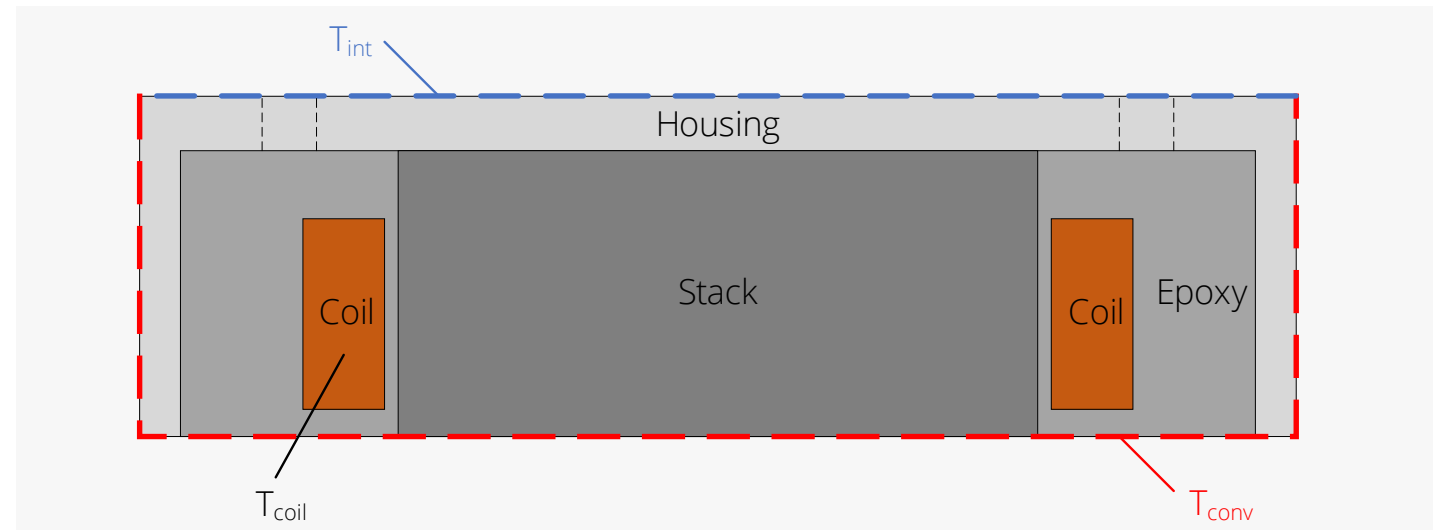

Chiron temperature definitions

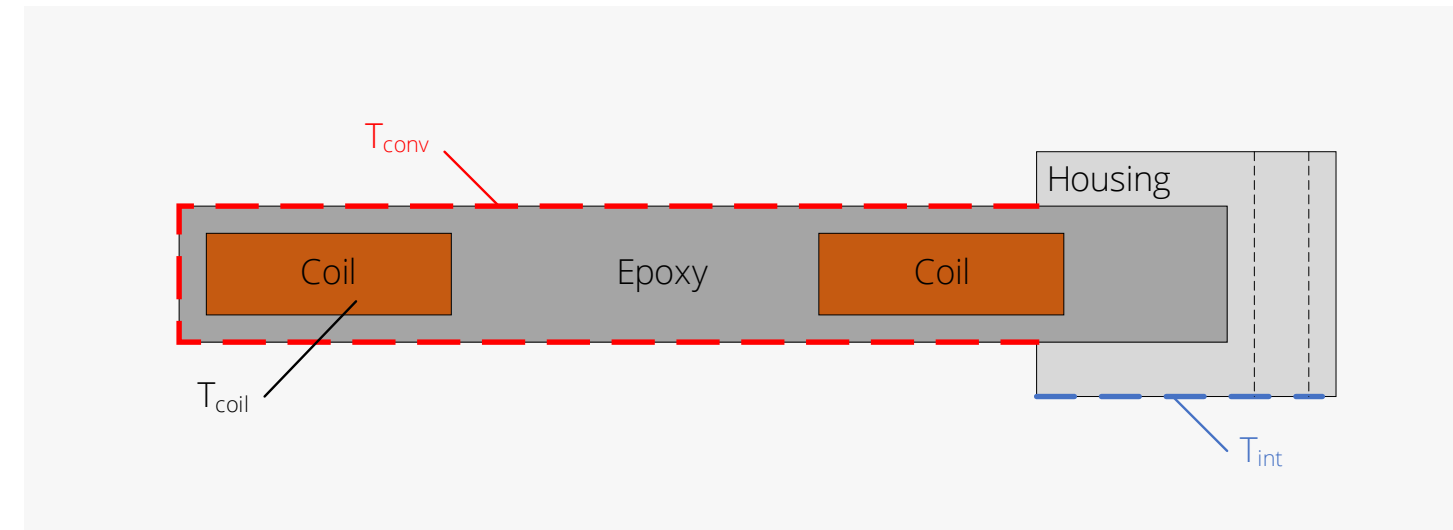

Phoenix / Gryphon temperature definitions

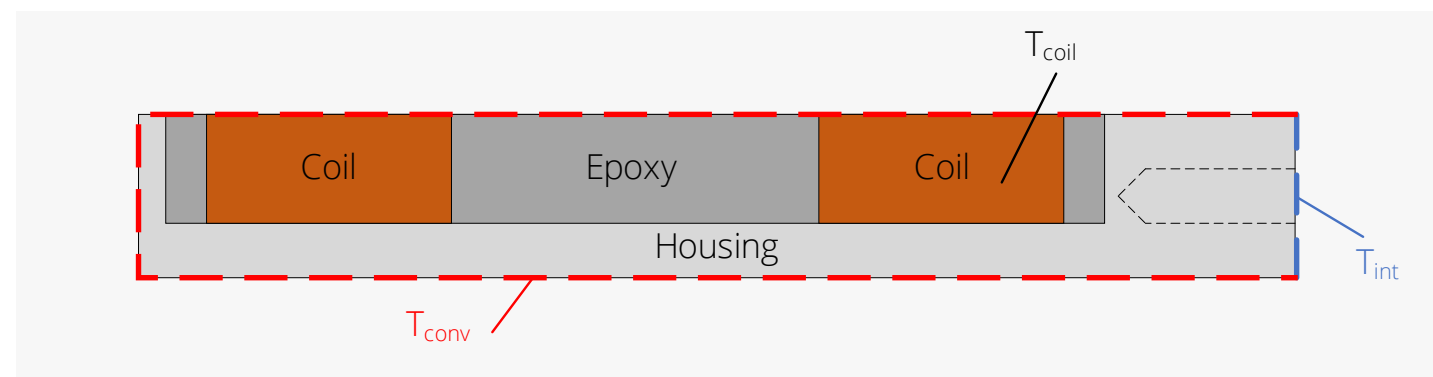

Iris-S temperature definitions

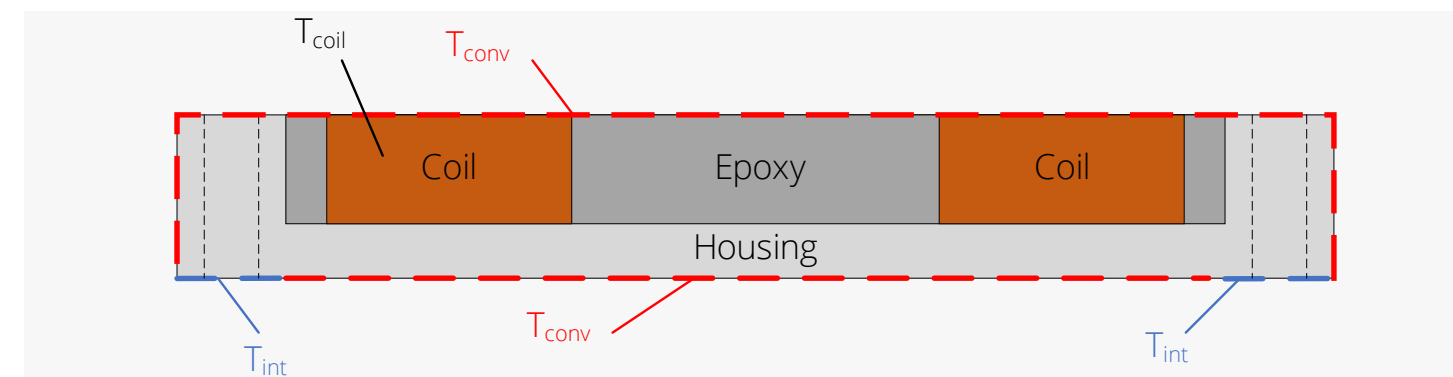

Iris-M/L temperature definitions

# DEFINITIONS CHIRON/PHOENIX/GRYPHON

Description	Equation	Unit	Remarks
Phase resistance at $T_{coil}$	$R_{ph} = R_{ph,20}(1+0.0039(T_{coil}-20))$	Ohm	
Force constant at no load	$K_{f,0} = \sqrt{3/2} K_{e,ll,p}$	N/A <sub>rms</sub>	For Phoenix and Gryphon: $K_{f,0} = K_f$ .
Continuous dissipation	$P_{d,c} = (T_{coil} - T_{int})/R_{th,i}$	W	Only copper losses are considered. This catalog considers $T_{int} = 20^\circ\text{C}$ and only heat dissipation towards the interface.
Peak dissipation	$P_{d,p} = C_{th} \alpha_T$	W	$\alpha_T$ is mentioned at the peak force specification. $C_{th}$ is the heat capacitance of the coils only and not specified separately in the catalog.
Continuous rms current	$I_c = \min\left(\sqrt{\frac{P_{d,c}}{3R_{ph}}}, \frac{V_{dc}}{\sqrt{6}R_{ph}}\right)$	A <sub>rms</sub>	Limited either by continuous dissipation or dc voltage and resistance or connector ratings (if applicable).
Peak rms current	$I_p = \min\left(\sqrt{\frac{P_{d,p}}{3R_{ph,20}}}, \frac{V_{dc}}{\sqrt{6}R_{ph,20}}\right)$	A <sub>rms</sub>	Limited either by peak dissipation or dc voltage and resistance or connector ratings (if applicable).
Continuous force	$F_c = K_{f,c} I_c$	N	For Phoenix and Gryphon: $K_{f,c} = K_f$ .
Peak force	$F_p = K_{f,p} I_p$	N	For Phoenix and Gryphon: $K_{f,p} = K_f$ .
Steepness	$S = \frac{K_{f,0}^2}{3R_{ph,20}}$	N <sup>2</sup> /W	For Phoenix and Gryphon: $K_{f,0} = K_f$ .
Maximum velocity (F = 0)	$v_m = \frac{V_{dc}}{K_{e,ll,p}}$	m/s	Iron losses are not considered.
Maximum velocity (F = F <sub>p</sub> )	$v_i = \left(\tau_p \sqrt{6\tau_p^2 K_{f,p}^2 V_{dc}^2 + 54\pi^2 (L_{ph}^2 I_p^2 V_{dc}^2 - 6L_{ph}^2 R_{ph,20}^2 I_p^4)} - 6\tau_p^2 K_{f,p} R_{ph,20} I_p\right) (2\tau_p^2 K_{f,p}^2 + 18\pi^2 L_{ph}^2 I_p^2)^{-1}$	m/s	For Phoenix and Gryphon: $K_{f,p} = K_f$ . Iron losses are not considered.
Maximum velocity (F = F <sub>c</sub> )	$v_n = \left(\tau_p \sqrt{6\tau_p^2 K_{f,c}^2 V_{dc}^2 + 54\pi^2 (L_{ph}^2 I_c^2 V_{dc}^2 - 6L_{ph}^2 R_{ph,100}^2 I_c^4)} - 6\tau_p^2 K_{f,c} R_{ph,100} I_c\right) (2\tau_p^2 K_{f,c}^2 + 18\pi^2 L_{ph}^2 I_c^2)^{-1}$	m/s	For Phoenix and Gryphon: $K_{f,c} = K_f$ . Iron losses are not considered.

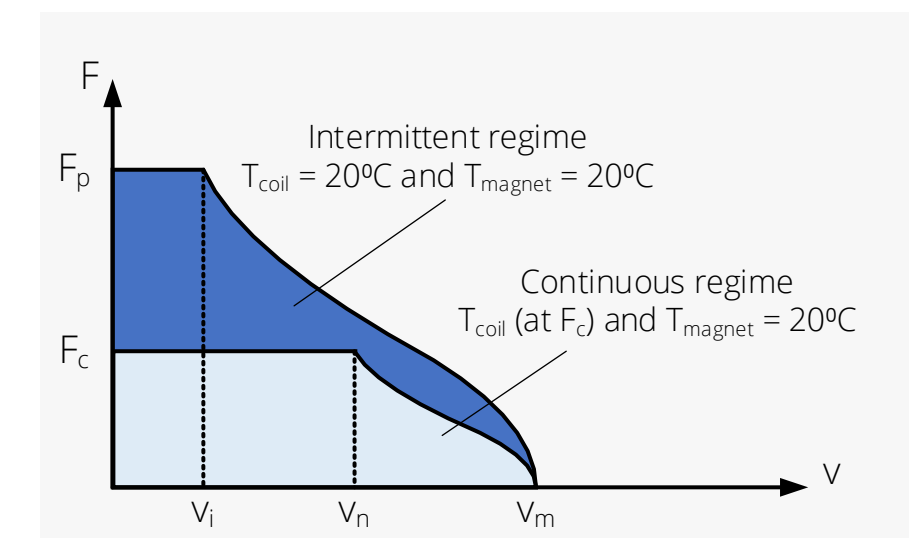

Force-velocity curves



# DEFINITIONS IRIS

Description	Equation	Unit	Remarks
Phase resistance at $T_{coil}$	$R_{ph} = R_{ph,20}(1+0.0039(T_{coil}-20))$	Ohm	
Force constant at no load	$K_f = K_e$	N/A	
Continuous dissipation	$P_{d,c} = (T_{coil} - T_{amb})/R_{th,i}$	W	Only copper losses are considered. This catalogue considers $T_{amb} = 20^\circ\text{C}$ .
Peak dissipation	$P_{d,p} = C_{th} \alpha_T$	W	$\alpha_T$ is mentioned at the peak force specification.
Continuous rms current	$I_c = \min\left(\sqrt{\frac{P_{d,c}}{R_{ph}}}, \frac{V_{dc}}{R_{ph}}\right)$	A	Limited either by continuous dissipation or dc voltage and resistance or cable/connector ratings (if applicable).
Peak rms current	$I_p = \min\left(\sqrt{\frac{P_{d,p}}{R_{ph,20}}}, \frac{V_{dc}}{R_{ph,20}}\right)$	A	Limited either by peak dissipation or dc voltage and resistance or cable/connector ratings (if applicable).
Continuous force	$F_c = K_f I_c$	N	
Peak force	$F_p = K_f I_p$	N	
Motor constant	$S = \frac{K_f^2}{R_{ph,20}}$	N <sup>2</sup> /W	

# CONTACT

**Phone:** +31 (0)40 2676200

**E-mail:** [sales@prodrive-technologies.com](mailto:sales@prodrive-technologies.com)

**Web:** [www.prodrive-technologies.com](http://www.prodrive-technologies.com)

February 2023

The content of this catalog is subject to change without prior notice