

# TANDBERG DATA

Securing your Information



## LTO-5, LTO-4 and LTO-3 HH SAS Tape Drive

*User Guide*

*Part Number 1019257-01 - March 2010*

[www.tandbergdata.com](http://www.tandbergdata.com)

## Copyright

© Copyright 2008, 2010-NaN Tandberg Data Corporation.

All rights reserved. This item and the information contained herein are the property of Tandberg Data Corporation. No part of this document may be reproduced, transmitted, transcribed, stored in a retrieval system, or translated into any language or computer language in any form or by any means, electronic, mechanical, magnetic, optical, chemical, manual, or otherwise, without the express written permission of Tandberg Data Corporation, 2108 55th Street, Boulder, Colorado 80301.

**DISCLAIMER:** Tandberg Data Corporation makes no representation or warranties with respect to the contents of this document and specifically disclaims any implied warranties of merchantability or fitness for any particular purpose. Further, Tandberg Data Corporation reserves the right to revise this publication without obligation of Tandberg Data Corporation to notify any person or organization of such revision or changes.

**TRADEMARK NOTICES:** Tandberg Data Corporation trademarks: Tandberg Data, Exabyte, the Exabyte Logo, EZ17, M2, SmartClean, VXA, and VXAtape are registered trademarks; MammothTape is a trademark; SupportSuite is a service mark. Other trademarks: Linear Tape-Open, LTO, the LTO Logo, Ultrium and the Ultrium Logo are trademarks of HP, IBM, and Quantum in the US and other countries. All other product names are trademarks or registered trademarks of their respective owners.

**Note:** The most current information about this product is available at Tandberg Data's web site (<http://www.tandbergdata.com>).

**Part Number** 1019257



# Contents

<b>About this guide .....</b>	<b>VII</b>
Intended audience .....	VII
Document conventions and symbols .....	VII
Technical support .....	VIII
Product warranties .....	VIII
<b>1 Before you start .....</b>	<b>9</b>
Important information about your new tape drive .....	9
Supported models .....	9
Which operating systems are supported? .....	10
How do I connect the drive to my server? .....	10
Internal drives .....	10
External drives .....	10
Your LTO tape drive .....	11
Power specifications .....	11
Drivers .....	12
Backup software .....	13
Enabling encryption (LTO-5 and LTO-4 only) .....	13
<b>2 Installing an internal LTO tape drive .....</b>	<b>15</b>
Prepare mounting bay .....	15
Attach mounting hardware .....	16
Install drive .....	18
Connect SAS and power cables .....	19
Secure the drive .....	21
Reboot the server .....	23
<b>3 Installing an external LTO tape drive .....</b>	<b>25</b>
Connecting the tape drive to an external SAS port .....	25
Reboot the server .....	27
<b>4 Verify installation .....</b>	<b>29</b>
<b>5 Understanding the LEDs .....</b>	<b>31</b>
Front view of LTO tape drive with LEDs .....	32
Understanding LED sequences .....	32
Encryption LED, LTO-5 models only .....	35

<b>6</b>	<b>Operating your tape drive .....</b>	<b>37</b>
	Loading a cartridge .....	38
	Unloading a cartridge .....	38
	Removing power from the drive .....	39
<b>7</b>	<b>Use the correct media .....</b>	<b>41</b>
	Cartridges .....	41
	Cleaning cartridges .....	41
	Data cartridges .....	42
	WORM data cartridges .....	42
	LTO-5 tape drives and partitioning .....	43
	LTO-5 and LTO-4 tape drives and encryption .....	43
	When should I use encryption? .....	44
	How do I enable encryption? .....	44
	When will I be asked to enter the key? .....	44
	What happens if I don't remember the key? .....	44
	Does encryption affect tape drive performance? .....	45
	Does the tape drive encrypt media in an earlier Ultrium format? .....	45
	Where can I get more information? .....	45
	Write protecting cartridges .....	45
	Cleaning the tape drive .....	46
	Handling cartridges .....	47
	Operating and storage environment .....	47
<b>8</b>	<b>Troubleshooting .....</b>	<b>49</b>
	General Procedure .....	49
	Optimizing performance .....	51
	Problems with cartridges .....	52
	The cartridge is jammed .....	52
	The drive will not accept the cartridge (or ejects it immediately) .....	52
	<b>Index .....</b>	<b>55</b>



# Figures

<b>Figure 1-1</b>	Front view of half-height LTO-5 external tape drive .....	11
<b>Figure 1-2</b>	Front view of half-height LTO-4 and LTO-3 external tape drive .....	11
<b>Figure 2-1</b>	Attaching mounting rails .....	18
<b>Figure 2-2</b>	Attaching locating screws .....	18
<b>Figure 2-3</b>	Installing tape drive .....	19
<b>Figure 2-4</b>	Connecting cables to the LTO-5 tape drive .....	20
<b>Figure 2-5</b>	Connecting cables to the LTO-4 and LTO-3 tape drive .....	20
<b>Figure 2-6</b>	Securing drive, mounting hardware used .....	22
<b>Figure 2-7</b>	Securing drive, no mounting hardware used .....	22
<b>Figure 3-1</b>	Connecting the SAS cable to the server .....	26
<b>Figure 3-2</b>	Connecting the cables to the tape drive .....	27
<b>Figure 5-1</b>	Front view of half-height LTO-5 external tape drive .....	32
<b>Figure 5-2</b>	Front view of half-height LTO-4 and LTO-3 external tape drive .....	32
<b>Figure 6-1</b>	Inserting a cartridge .....	38
<b>Figure 6-2</b>	Ejecting a cartridge .....	39
<b>Figure 7-1</b>	Write protecting a cartridge .....	46



# Tables

<b>Table 1</b>	Document conventions .....	VII
<b>Table 1-1</b>	Power specifications for LTO half-height tape drives .....	12
<b>Table 5-1</b>	LED sequences .....	33
<b>Table 5-2</b>	Encryption LED, LTO-5 tape drives only .....	35
<b>Table 7-1</b>	Data cartridge compatibility .....	42
<b>Table 8-1</b>	Environmental specifications for LTO tape drives .....	50

## About this guide

This guide provides information about:

- Installing the LTO SAS tape drive
- Using the LTO SAS tape drive
- Troubleshooting the LTO SAS tape drive

## Intended audience

This guide is intended for users who install, operate and maintain the LTO tape drive.

## Document conventions and symbols

*Table 1 Document conventions*

Convention	Element
Blue text: <a href="#">Table 1</a> on page VII	Cross-reference links and e-mail addresses
Blue, underlined text: <a href="http://www.tandbergdata.com">http://www.tandbergdata.com</a>	website addresses
<b>Bold text</b>	<ul style="list-style-type: none"><li>• Keys that are pressed</li><li>• Text typed into a GUI element, such as a box</li><li>• GUI elements that are clicked or selected, such as menu and list items, buttons, tabs, and check boxes</li></ul>
<i>Italic text</i>	Text emphasis
Monospace text	<ul style="list-style-type: none"><li>• File and directory names</li><li>• System output</li><li>• Code</li><li>• Commands, their arguments, and argument values</li></ul>
<i>Monospace, italic text</i>	<ul style="list-style-type: none"><li>• Code variables</li><li>• Command variables</li></ul>
<b>Monospace, bold text</b>	Emphasized monospace text



**Warning** Indicates that failure to follow directions could result in bodily harm or death.

---



**Caution** Indicates that failure to follow directions could result in damage to equipment or data.

---



**Important** Provides clarifying information or specific instructions.

---

**Note:** Provides additional information.

## Technical support

For worldwide technical support information, see <http://www.tandbergdata.com>.

Before contacting support, collect the following information:

- Product model names and numbers
- Technical support registration number (if applicable)
- Product serial numbers
- Error messages
- Operating system type and revision level
- Detailed questions

## Product warranties

For information about product warranties, see <http://www.tandbergdata.com>.



# 1

## Before you start

In this chapter:

- “[Important information about your new tape drive](#)” on page 9
- “[Supported models](#)” on page 9
- “[Which operating systems are supported?](#)” on page 10
- “[How do I connect the drive to my server?](#)” on page 10
- “[Your LTO tape drive](#)” on page 11
- “[Power specifications](#)” on page 11
- “[Drivers](#)” on page 12
- “[Backup software](#)” on page 13

### Important information about your new tape drive

This guide describes how to install and operate LTO SAS half-height internal and external tape drives.

The simplest way of connecting a tape drive to your SAS server is to purchase and install one of the supported HBAs. For the most up-to-date information about supported SAS HBAs and cabling configurations, refer to <http://www.tandbergdata.com>.

### Supported models

This guide describes how to install and operate the following LTO tape drive models:

- LTO-5 internal and external tape drives
- LTO-4 internal and external tape drives
- LTO-3 internal and external tape drives

For a detailed product specification, please refer to <http://www.tandbergdata.com>.

## Which operating systems are supported?

LTO tape drives can be connected to servers running under Windows®, Linux and other major operating systems. Refer to <http://www.tandbergdata.com> for the most recent information about the operating system versions that are supported.

## How do I connect the drive to my server?

Installation requires a SAS host controller or host bus adapter (HBA) that supports tape.

### Internal drives

The tape drive is installed into a spare drive bay in your server and is attached to the host server's internal SAS controller or SAS host bus adapter. Refer to <http://www.tandbergdata.com> for supported products.

You need one industry-standard, 5¼-inch, half-height bay in which to install the LTO tape drive. Different models of server require different mounting methods. Refer to your server documentation for detailed information.

### External drives

A SAS cable is required to connect to an external SAS port. If your server does not have an active external SAS port, you must purchase and install an additional HBA. (Some controllers have an external connector, but its default state is inactive because the SAS channels are in use for internal disks.)

See also “[Installing an external tape drive](#)” on page 25.

## Your LTO tape drive

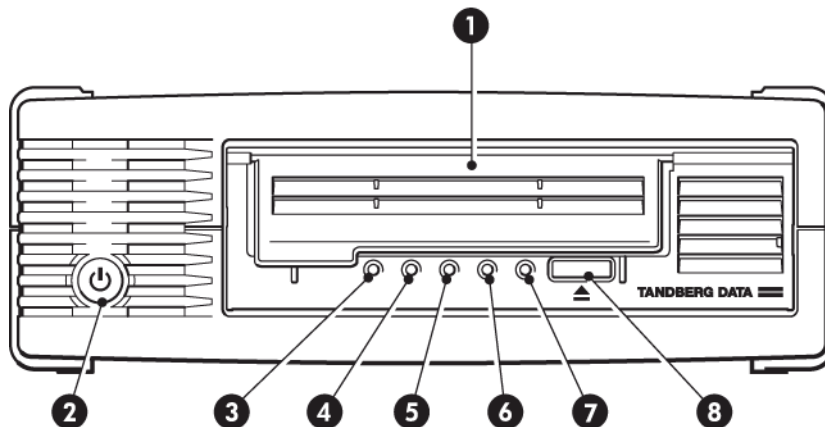

- |   |                 |
|---|-----------------|
| 1. Cassette door                        | 5. Tape LED     |
| 2. On/Off switch (external drives only) | 6. Drive LED    |
| 3. Encryption LED                       | 7. Ready LED    |
| 4. Clean LED                            | 8. Eject button |

**Figure 1-1** Front view of half-height LTO-5 external tape drive

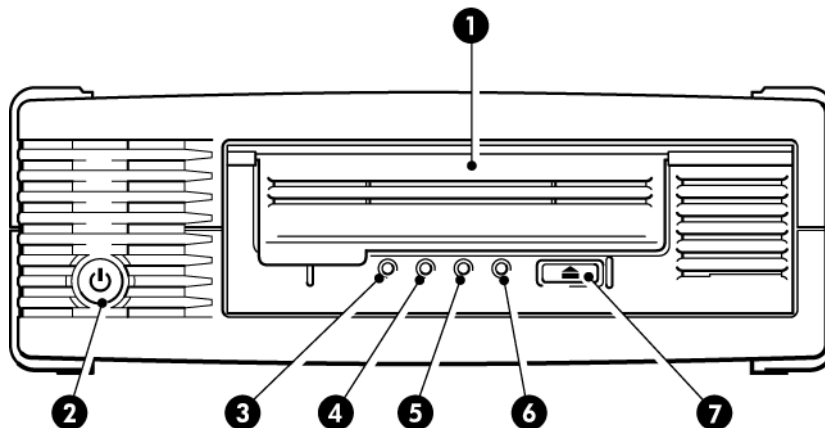

- |   |                 |
|---|-----------------|
| 1. Cassette door                        | 5. Drive LED    |
| 2. On/Off switch (external drives only) | 6. Ready LED    |
| 3. Clean LED                            | 7. Eject button |
| 4. Tape LED                             |                 |

**Figure 1-2** Front view of half-height LTO-4 and LTO-3 external tape drive

## Power specifications

Power for the LTO-5 half-height internal tape drive is supplied through the SAS cable. For all earlier models of tape drive, a separate power cable is required, see <http://www.tandbergdata.com>.

For a detailed product specification, please refer to <http://www.tandbergdata.com>.

**Table 1-1** Power specifications for LTO half-height tape drives

	LTO-5 half-height tape drives	LTO-4 and LTO-3 half-height tape drives
Power consumption	7.5 Watts idle, 24 Watts typical, 40 Watts maximum	13 Watts idle, 20 Watts typical, 33 Watts maximum
Power requirements	+5V @ 4.1A typical +5V @ 4.3A maximum +12V @ 0.75A typical +12V @ 2.3A maximum	+5V @ 2.5A typical +5V @ 2.5A maximum +12V @ 0.7A typical +12V @ 2.1A maximum
Power requirements, external tape drives	100–240 VAC, 50-60 Hz, auto-ranging, 0.8A maximum	100–240 VAC, 50-60 Hz, auto-ranging, 0.7A maximum

## Drivers

The manufacturer's Tape driver is suitable for use in most applications, but refer also to the documentation of your software application to ensure you are using the recommended driver.

On Windows systems, we strongly recommend that you use the installer package supplied by your manufacturer to install the drivers. Updates to the drivers may be provided from time to time on <http://www.tandbergdata.com>. We recommend that these are installed after using the installer package.

On Linux and UNIX operating systems, drivers are included with the operating system and should be loaded automatically. To upgrade drivers we recommend that you patch to the latest version of the operating system.

## Backup software

For optimum performance it is important to use a backup application that is appropriate for your system's configuration. In a direct attach configuration, where the tape drive is attached to a standalone server, you can use backup software that is designed for a single server environment. In network configurations you will need backup software that supports enterprise environments.

Further details about suitable products can be found on <http://www.tandbergdata.com>. It is important to check for software compatibility and install any recommended upgrades.

**Note:** Certain backup applications require you to use their own Tape driver instead of the manufacturer's Tape driver.

### Enabling encryption (LTO-5 and LTO-4 only)

The LTO-5 and LTO-4 tape drive includes hardware capable of performing data encryption while writing and data decryption while reading, both at full speed. This is only possible with Ultrium 3 TB and 1.6 TB media, respectively. See also "[LTO-4 tape drives and encryption](#)" on page 43.

If you wish to make use of the encryption capability, you must enable this feature via the backup software application. Refer to your supplier to find out which applications support this advanced data protection capability.

## Notes

# 2

## Installing an internal LTO tape drive

If you are installing an external LTO tape drive, please refer to “[Installing an external tape drive](#)” on page 25.

**Note:** Always refer to <http://www.tandbergdata.com> to find out which HBAs and cables are appropriate for your combination of server and tape drive.

In this chapter:

- “[Prepare mounting bay](#)” on page 15
- “[Attach mounting hardware](#)” on page 16
- “[Install drive](#)” on page 18
- “[Connect SAS and power cables](#)” on page 19
- “[Secure the drive](#)” on page 21
- “[Reboot the server](#)” on page 23

### Prepare mounting bay

You need one industry-standard, 5¼-inch, half-height bay in which to install the LTO tape drive.



#### **Warning**

To avoid personal injury or damage to the server or tape drive, ensure that the server is disconnected from the mains power supply while you install the drive.

---



**Caution** Static electricity can damage electronic components. Always wear an antistatic wriststrap if one is available. If not, after you have disconnected power from the server and removed the cover, touch a bare metal part of the chassis. Similarly, touch a bare metal part of the drive before installing it.

---

1. Assemble the necessary tools and materials:
  - Phillips screwdriver
  - Flat-bladed screwdriver (if your server uses slotted screws)
  - Torx screwdriver (if your server uses torx screws)
  - Your server manuals (for reference during installation)
2. Perform a normal system shutdown and turn off the server and any connected peripherals.
3. Remove the cover and front panel from the server, as detailed in your server's documentation.

As you work inside the server, you may have to disconnect other signal cables or power cables from other devices to maneuver the new drive into place. If you have to do this, make a note of their position and connections so you can put them back correctly later.

**Note:** The server must provide forced cooling and be capable of drawing 6 cfm (0.17 m<sup>3</sup>/minute or 10.08 m<sup>3</sup>/hour) of air through the tape drive at up to 40° C ambient operation. This reduces to 4 cfm at 35° C ambient operation. Ensure that empty bays have the appropriate blanking plates installed so that airflow is maintained.

4. Remove the filler panel from a spare 5¼-inch bay of your server, as described in your server's documentation. With some servers, you must also remove the half-height device divider.
5. You are now ready to install your tape drive.

## Attach mounting hardware

If your server requires special rails or other hardware to install the tape drive, mount them on the tape drive now.

*If your server does not require special mounting hardware, proceed to “[Install drive](#)” on page 18 now.*

Please check your server documentation to ascertain the correct method of mounting, and to check whether mounting hardware is provided with the server or must be purchased separately.





**Caution**

The LTO half-height drive only allows 3 mm of the engagement of the screw into the drive. If you remove an existing drive, do not assume the screws that you remove are the correct length for your new LTO drive. Always use 3 mm screws and use washers or shims to tighten, if necessary.

---

Different models of server require different mounting methods. Always refer to your server documentation for details. The following diagrams illustrate common mounting methods. If mounting hardware is supplied with your tape drive, it may not be exactly the same as shown in the illustrations.

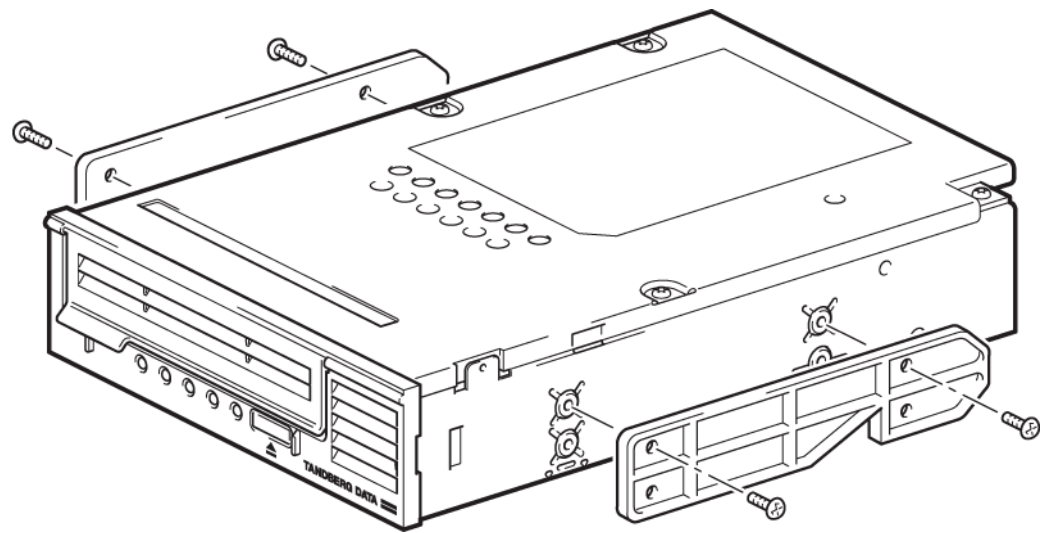

**Figure 2-1** Attaching mounting rails

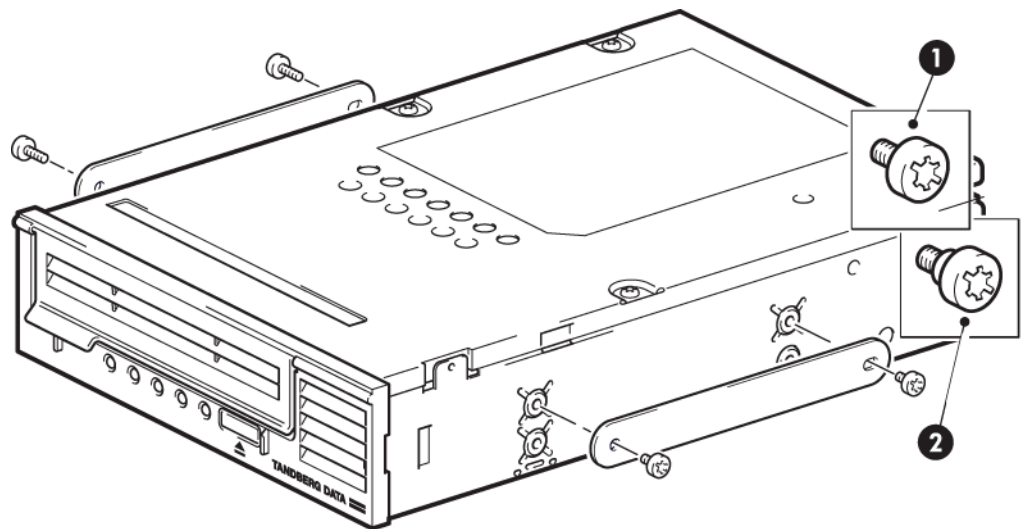

1. M3 mounting screws
2. M3 offset mounting screws

**Figure 2-2** Attaching locating screws

## Install drive

**Note:** If cable access for the tape drive bay is awkward, it may be easier to access power and other connections if the tape drive is installed in the top bay. You may need to move other devices to lower bays to achieve this. Refer also to your server documentation.

Slide the tape drive into the open bay, aligning the tray or rails with the slots in the bay, as shown in [Figure 2-3](#) on page 19.

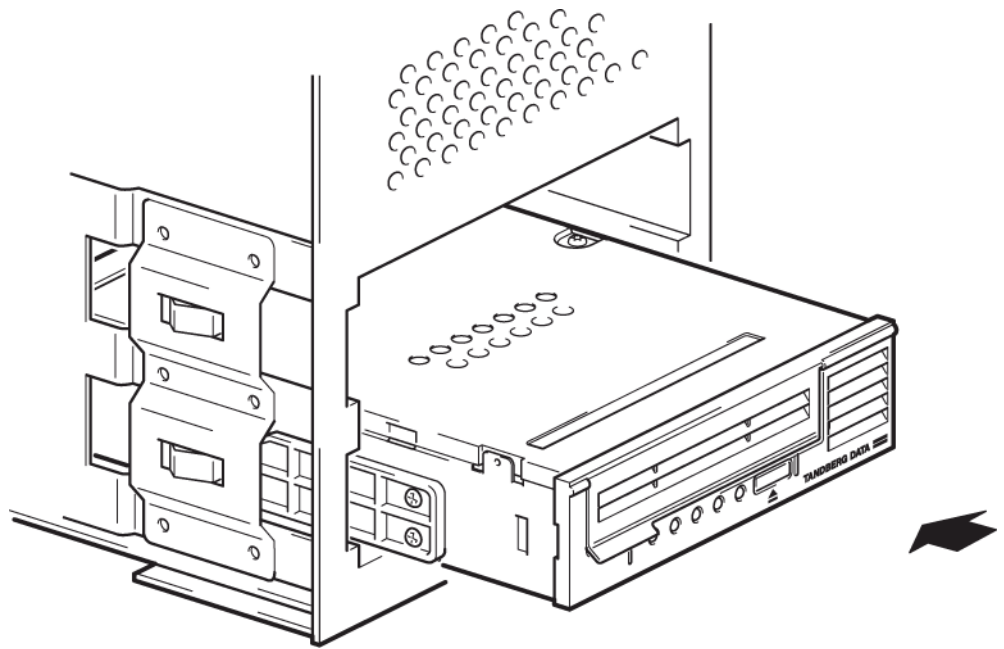

**Figure 2-3** Installing tape drive

**Note:** The illustration shows a server that uses mounting rails. If your server does not use mounting hardware, check that the holes in the chassis are aligned with the holes in the side of the tape drive.

Do not secure the drive at this point because you may have to move the drive to get the cables into place.

## Connect SAS and power cables

---

**!** **Important** A SAS HBA and appropriate SAS cable are required. LTO-5 tape drives require a SAS cable with power connector; LTO-4 and LTO-3 tape drives have a separate power connector on the rear of the tape drive.

---

1. If a SAS HBA is not already installed in the server, follow the instructions supplied with the HBA to install it and any associated drivers before you install the tape drive.
2. Connect the purchased SAS cable to the SAS HBA.

3. Connect the SAS cable to the tape drive, as illustrated below.

**LTO-5 tape drives:** Connect a spare power cable from the server's internal power supply to the power connector on the SAS data cable.

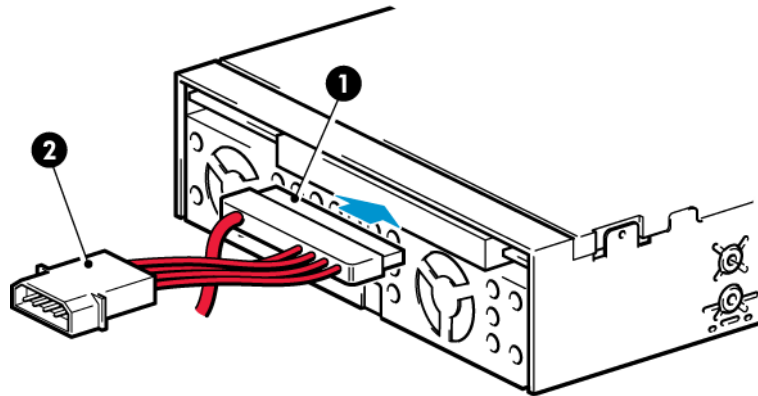

1. SAS connector                      2. Power connector

**Figure 2-4** Connecting cables to the LTO-5 tape drive

**LTO-4 and LTO-3 tape drives:** Connect a spare power cord from the server's internal power supply to the power connector on the tape drive.

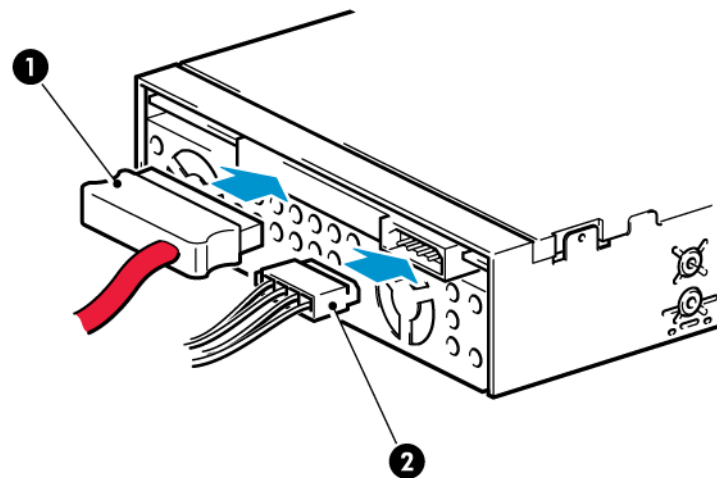

1. SAS connector                      2. Power connector

**Figure 2-5** Connecting cables to the LTO-4 and LTO-3 tape drive



**Caution** Never use a cable where power is supplied through the SAS connector with LTO-4 and LTO-3 tape drives because this may damage the drive. Always use a spare power cable from the server's internal power supply. (This caution does not apply to LTO-5 tape drives.)

## Secure the drive

**Note:** Use 3 mm screws and, if you cannot tighten the screws, use washers to secure them.

1. Secure the drive, as described in your server documentation. The following diagrams are examples only.

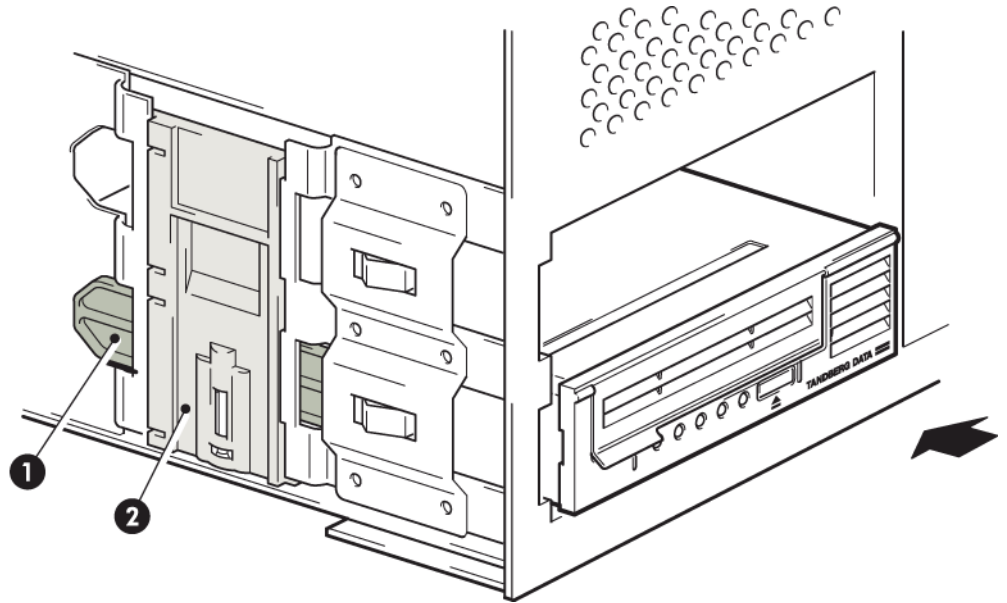

1 Plastic rail

2 Server latch

**Figure 2-6** Securing drive, mounting hardware used

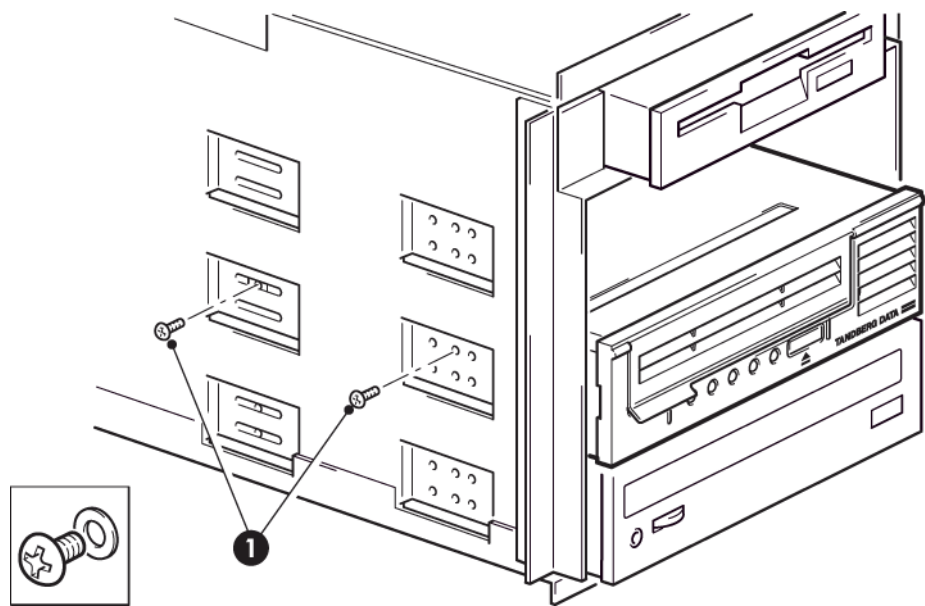

1 M3 screws

**Figure 2-7** Securing drive, no mounting hardware used

2. Ensure blanking plates are in place over empty bays and replace the cover on the server.

## Reboot the server

Reboot the server to power up the tape drive and server.

Watch the boot screen carefully after installation. If there are any error or unexpected messages go back and check the SAS cabling carefully.

If this does not resolve the problem, refer to “[Troubleshooting](#)” on page 49 for further guidelines.

## Notes



# 3

## Installing an external LTO tape drive

This chapter describes how to connect your tape drive to an external port on the host controller or new HBA. If you are installing an internal LTO tape drive, please refer to [“Installing an internal tape drive”](#) on page 15.

In this chapter:

- [“Connecting the tape drive to an external SAS port”](#) on page 25
- [“Reboot the server”](#) on page 27

### Connecting the tape drive to an external SAS port

1. If installing a new HBA, follow the instructions supplied with the HBA to install it and any associated drivers.

2. Connect the purchased SAS cable to the external SAS connector on the SAS HBA.

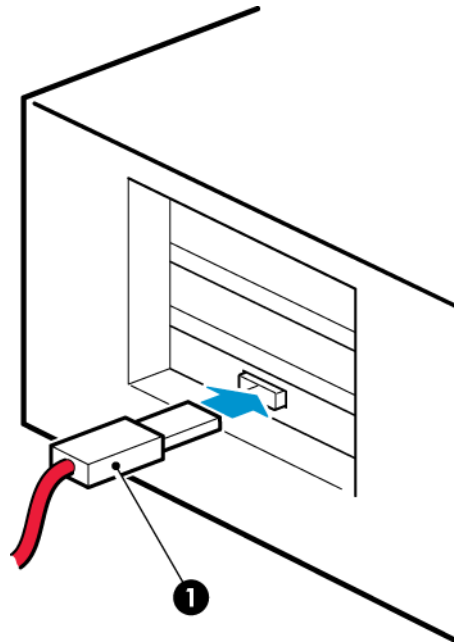

1. SAS connector on server

**Figure 3-1** Connecting the SAS cable to the server

3. Connect the SAS and power cables to the tape drive and plug the other end of the power cable into the power outlet.

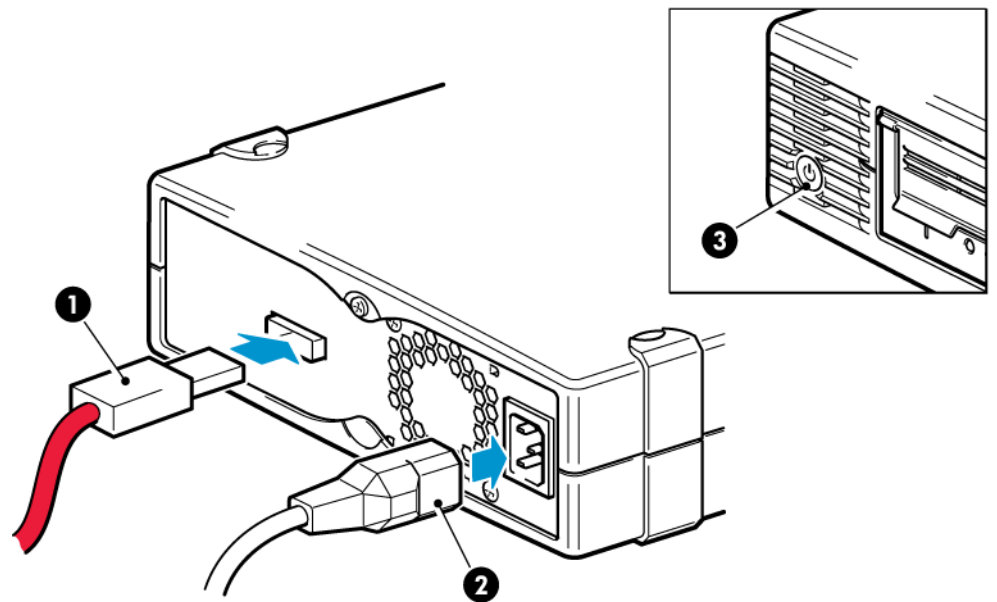

1. SAS connector

3. Power on/off switch

2. Power connector

**Figure 3-2** Connecting the cables to the tape drive



**Caution** Always use the supplied power cable, which is correct for your geographical location.

## Reboot the server

Switch on the tape drive and power up the server. The power on/off switch is on the front panel.

Watch the boot screen carefully after installation. If there are any error or unexpected messages go back and check the cabling carefully.

If this does not resolve the problem, refer to [“Troubleshooting”](#) on page 49 for further guidelines.

## Notes

# 4

## Verify installation

Once you have installed the drive hardware, check that drivers have been installed correctly and you have the correct version of backup software, and verify that the tape drive is functioning properly before you store your valuable data.

1. Switch on the drive and the server.
2. The tape drive will run its hardware self-test, which takes about 5 seconds. If self-test passes, the green Ready LED flashes and then shows steady green. If the test fails, the Drive Error and Tape Error LEDs flash, while the Ready and Clean LEDs are off. This continues until the drive is reset. See “[understanding LEDs](#)” on page 31 for more information about front panel lights.
  - **Installing drivers (Windows)**

We recommend that you download the latest driver from <http://www.tandbergdata.com> before installation. When the Windows Found New Hardware wizard runs, follow the on-screen instructions to install drivers from the download location.
  - **Installing drivers (other operating systems)**

Drivers are included with the operating system and should be loaded automatically. To upgrade drivers we recommend that you patch to the latest version of the operating system.

**Note:** Certain backup applications require you to use their own Tape driver instead of the manufacturer's Tape driver.
3. Verify that the tape drive installation was successful.
4. For all operating systems ensure that you have downloaded any upgrades necessary for your backup application. Check <http://www.tandbergdata.com> for software compatibility and install any recommended upgrades.

5. Carry out a backup and restore test to check that the drive can write data to tape. Use a blank cartridge.

Native backup applications can be used to check basic tape drive operation, but they will not support all the advanced features of your tape drive. We recommend that you upgrade your software application before running this test.

# 5

## Understanding the LEDs

In this chapter:

- [“Front view of LTO tape drive with LEDs”](#) on page 32
- [“Understanding LED sequences”](#) on page 32

### Front view of LTO tape drive with LEDs

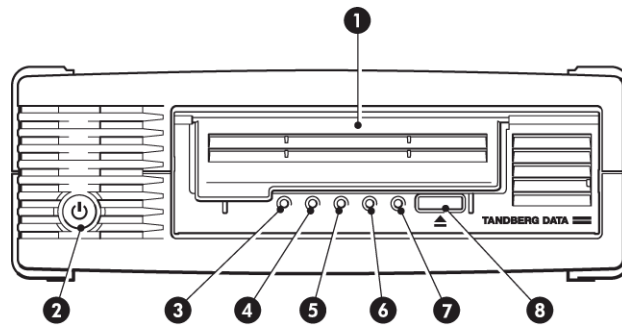

- |   |                 |
|---|-----------------|
| 1. Cassette door                        | 5. Tape LED     |
| 2. On/Off switch (external drives only) | 6. Drive LED    |
| 3. Encryption LED                       | 7. Ready LED    |
| 4. Clean LED                            | 8. Eject button |

**Figure 5-1** Front view of half-height LTO-5 external tape drive

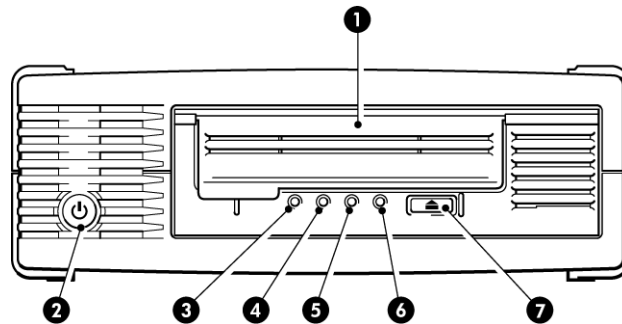

- |   |                 |
|---|-----------------|
| 1. Cassette door                        | 5. Drive LED    |
| 2. On/Off switch (external drives only) | 6. Ready LED    |
| 3. Clean LED                            | 7. Eject button |
| 4. Tape LED                             |                 |







**Figure 5-2** Front view of half-height LTO-4 and LTO-3 external tape drive





### Understanding LED sequences

The meaning of different patterns of LEDs is as follows:

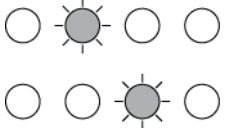

Table 5-1 LED sequences

LED Sequence	Cause	Action required
 <i>All LEDs OFF.</i>	<p>Drive may not have power, may be faulty or may have been power cycled or reset during a firm-ware upgrade.</p>	<p>Make sure the drive is switched on. The power on/off switch on an external drive incorporates a green LED.</p> <p>Check the power cable connection and replace the cable if necessary. On external drives, you can use the power cable from your monitor or another device to check that the connection is working.</p> <p>If the power supply is present and all LEDs remain off, power cycle or reset the drive. If it still fails, call for service.</p>
 <i>Ready and Clean OFF. Drive and Tape FLASH.</i>	<p>The drive has failed to execute power-on self test (POST).</p>	<p>Power cycle or reset the drive. If the error condition reappears, call for service.</p>
 <i>Ready is ON.</i>	<p>The drive is ready for operation.</p>	<p>None. This is normal.</p>
 <i>Ready FLASHES.</i>	<p>The drive is carrying out a normal activity (read, write).</p>	<p>None.</p> <p>If the drive is upgrading firmware, do not reset or power cycle it.</p>
 <i>Ready FLASHES fast.</i>	<p>The drive is downloading firmware.</p>	<p>None.</p> <p>Do not reset or power cycle the drive.</p>
 <i>Ready is OFF, others are ON.</i>	<p>Firmware is being reprogrammed.</p>	<p>None.</p> <p>Do not reset or power cycle the drive.</p>

LED Sequence	Cause	Action required
 <p>Clean <i>FLASHES</i>.</p>	<p>The drive requires cleaning.</p>	<p>Load the LTO cleaning cartridge. See “<a href="#">Cleaning cartridges</a>” on page 41 for supported cartridges and instructions.</p> <p>If the Clean LED is still flashing when you load a new or known good data cartridge after cleaning, call for service.</p>
 <p>Ready <i>FLASHES</i> and Clean is ON.</p>	<p>Cleaning is in progress.</p>	<p>None. The cleaning cartridge will eject on completion.</p> <p>The cleaning cycle can take up to 5 minutes to complete.</p>
 <p>Tape <i>FLASHES</i>.</p>	<p>The drive believes the current tape or the tape just ejected is faulty.</p>	<p>Unload the tape cartridge. Make sure that you are using the correct format cartridge; an LTO data cartridge or LTO Universal Cleaning Cartridge. (See “<a href="#">Use the correct media</a>” on page 41.)</p> <p>Reload the cartridge. If the Tape LED still flashes or starts flashing during the next backup, load a new or known good cartridge.</p> <p>If the Tape LED is now off, discard the 'suspect' tape cartridge. If it is still on, call for service.</p>
 <p>The tape is ejected immediately and Tape <i>FLASHES</i>, or Drive <i>FLASHES</i> on unloading tape.</p>	<p>The tape cartridge memory (CM) may be faulty.</p>	<p>Write-protect the cartridge by sliding the switch on the tape cartridge, see “<a href="#">Write protecting cartridges</a>” on page 45. The tape can be loaded and the data read. Once the data is recovered, the cartridge must be discarded.</p>
 <p>Drive <i>FLASHES</i>.</p>	<p>The drive mechanism has detected an error.</p>	<p>Load a new cartridge. If the error persists, power cycle or reset the drive.</p> <p>If the Drive LED remains on, call for service.</p>

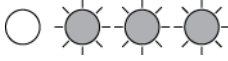
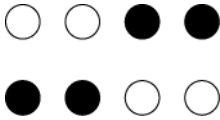
LED Sequence	Cause	Action required
 <i>Drive, Tape and Ready FLASH.</i>	There is a firmware download problem.	Insert a cartridge to clear the LED sequence. If the condition persists, call for service.
 <i>Drive and Ready ON with Tape and Clean OFF. Alternates repeatedly.</i>	The drive has a firmware error.	Power cycle or reset the drive. Upgrade the firmware. If the condition persists, call for service.

### Encryption LED, LTO-5 models only

The encryption LED may be blue or amber, as described in the following table. The state of the other LEDs depends upon the activity, as described below.

**Table 5-2** Encryption LED, LTO-5 tape drives only

Encryption LED (Blue or Amber)	State
On	At power on
Off	The drive is idle and there is no encryption key.
Off with Ready flashing green	The tape drive is reading/writing unencrypted data from another host or unloading a cartridge.
On (solid blue)	The drive is idle but the encryption key is loaded. The drive is ready to read/write encrypted data.
On (solid blue) with Ready flashing green	The drive is reading/writing encrypted data.
Alternate flashing, blue and amber	There is an encryption related error. This is cleared after unload executes or successful encryption/decryption resumes. .

**Note:** The Encryption LED only functions if you are using backup software that supports hardware encryption and this feature is enabled in the backup application. See <http://www.tandbergdata.com> for backup application compatibility.

## Notes

# 6

## Operating your tape drive

In this chapter:

- [“Loading a cartridge”](#) on page 38
- [“Unloading a cartridge”](#) on page 38
- [“Removing power from the drive”](#) on page 39

## Loading a cartridge

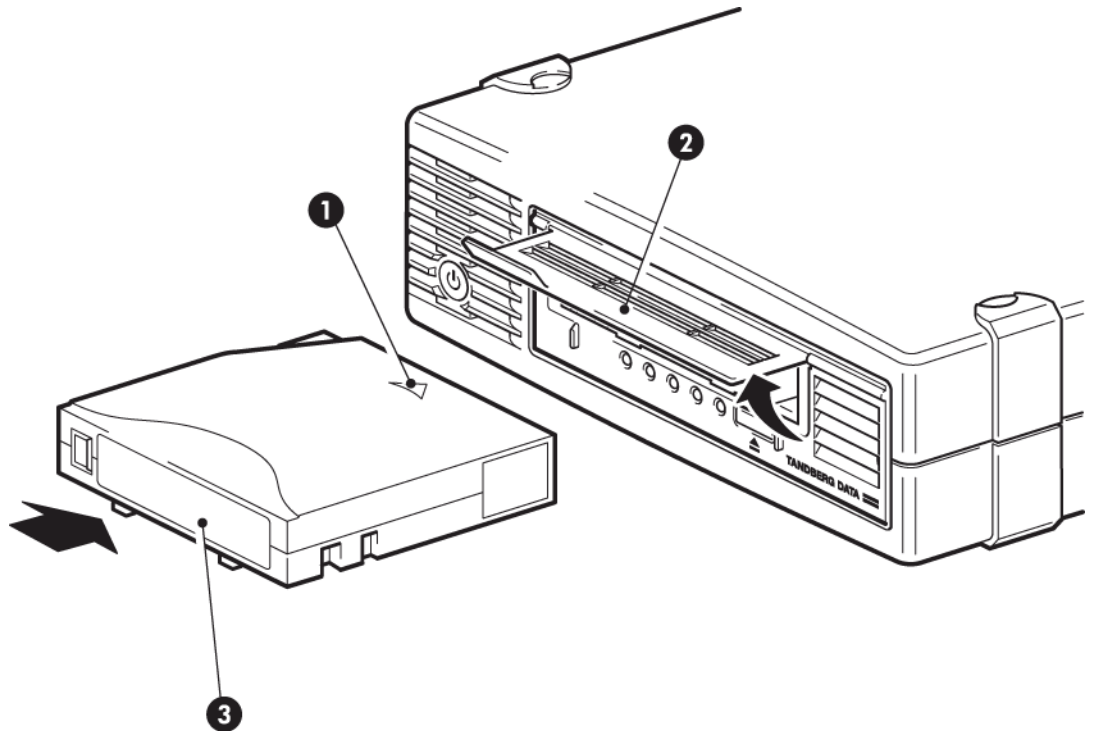

- 1. Arrow indicates leading direction
- 2. Cartridge door
- 3. Label area
- 4. Ready LED

**Figure 6-1** Inserting a cartridge

1. Lift the cartridge door and insert the cartridge into the slot in the front of the drive with the white arrow uppermost and facing the drive door.
2. Apply gentle pressure until the drive takes the cartridge and loads it.
3. The Ready light flashes green while the drive performs its load sequence. When the cartridge is loaded, the Ready light shows steady green.

## Unloading a cartridge



**Caution** Never try to remove a cartridge before it is fully ejected.

1. Press the Eject button on the front panel.

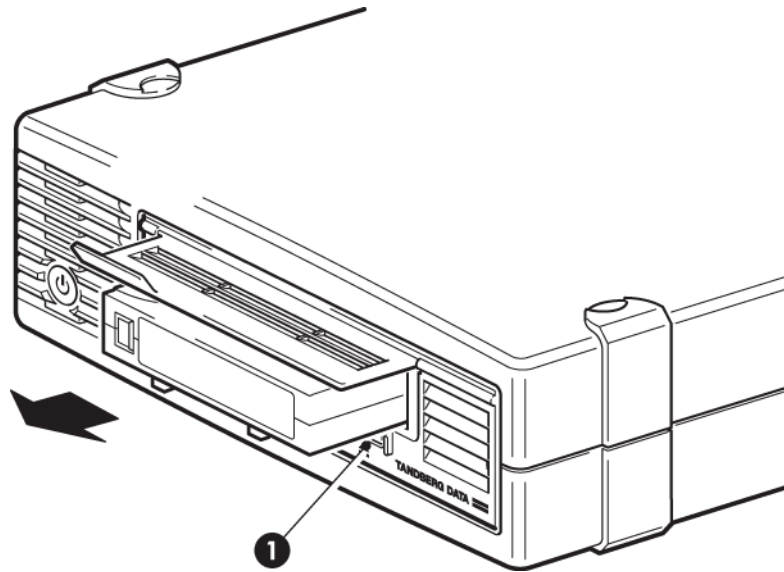

1. Eject button

**Figure 6-2** Ejecting a cartridge

2. The drive will complete its current task, rewind the tape to the beginning, and eject the cartridge. The rewind process may take up to 10 minutes. The Ready light will flash to indicate that the unload is still in progress.

## Removing power from the drive

To ensure reliable operation, do not remove power from the drive during read, write, fast-search, load and unload activities. Do not remove power during a firmware upgrade.

## Notes



# 7

## Use the correct media

For best performance we recommend branded media. See <http://www.tandbergdata.com> for recommended products.

In this chapter:

- “Cartridges” on page 41
- “WORM data cartridges” on page 42
- “LTO-4 tape drives and encryption” on page 43
- “Write protecting cartridges” on page 45
- “Cleaning the tape drive” on page 46
- “Handling cartridges” on page 47
- “Operating and storage environment” on page 47

### Cartridges

#### Cleaning cartridges

The recommended cleaning cartridges is the Ultrium Universal Cleaning Cartridge. This cleaning cartridge is designed to work with any LTO drive. It may be used for up to 50 cleans.

**Note:** Do not use the earlier LTO cleaning cartridge (Blue).

## Data cartridges

LTO tape drives use Ultrium tape cartridges. These are single-reel cartridges that match your drive's format and are optimized for high capacity, throughput and reliability. Compatible media can be recognized by the LTO logo, which is the same as the logo on the front of your drive. Do not use other format cartridges in your tape drive and do not use Ultrium cartridges in other format tape drives.

For optimum performance always use a data cartridge that matches the specification of your tape drive, (see [Table 7-1](#) on page 42). A lower specification will have a lower transfer speed and may not support write activities; a higher specification will not support read or write.

- We recommend Ultrium 3 TB\* RW and 3 TB\* WORM tape cartridges for use with LTO–5 tape drives.
- We recommend Ultrium 1.6 TB\* RW and 1.6 TB\* WORM tape cartridges for use with LTO–4 tape drives.
- We recommend Ultrium 800 GB\* RW and LTO Ultrium GB\* WORM tape cartridges for use with LTO–3 tape drives.

**Table 7-1** Data cartridge compatibility

Tape drive model	Ultrium 200 GB* data cartridge	Ultrium 400 GB* data cartridge	Ultrium 800 GB* data cartridge	Ultrium 1.6 TB* data cartridges	Ultrium 3 TB* data cartridges
LTO-5	not supported	not supported	read only	read/write write once/read many	<b>read/write write once/read many</b>
LTO-4	not supported	read only	read/write write once/read many	<b>read/write write once/read many</b>	not supported
LTO-3	read only	read/write	<b>read/write write once/read many</b>	not supported	not supported
	* Capacity assumes 2:1 compression.				

## WORM data cartridges

LTO tape drives include support for both re-writable and Write-Once, Read-Many, WORM, data cartridges. WORM cartridges provide for an

enhanced level of data security against accidental or malicious alteration of data on the tape cartridge. The WORM data cartridge can be appended to maximize the full capacity of the tape cartridge, but the user will be unable to erase or overwrite data on the cartridge. Any attempt to modify a WORM cartridge to enable writing over existing data will result in the media becoming permanently write protected. It should still be readable in a WORM drive, depending upon the severity of the tampering, but no further appended backups will be possible.

WORM data cartridges are clearly identified by their distinctive, two-tone cartridge color. They can only be used with LTO tape drives that support the WORM feature.

To check whether your backup or archive software application supports WORM cartridges, refer to <http://www.tandbergdata.com>.

## LTO-5 tape drives and partitioning

The LTO—5 tape drive supports two tape partitions, when used with Ultrium 3 TB R/W cartridges. Tape partitioning is not supported with WORM cartridges or with earlier generations of cartridge. It is not supported on earlier-generation tape drives. If you insert a partitioned tape into a tape drive that does not support partitioning, it will be ejected.

To check for the latest information about support for partitioning and any required firmware upgrades, go to <http://www.tandbergdata.com>. Refer to your backup application's documentation for information about creating and using partitions on the tape drive.

## LTO—5 and LTO-4 tape drives and encryption

The LTO-5 and LTO—4 tape drive includes hardware capable of performing data encryption at full speed while writing data, and decrypting when reading.

Encryption is the process of changing data into a form that cannot be read until it is deciphered, protecting the data from unauthorized access and use. LTO—5 and LTO—4 tape drives use the strongest version of the industry-standard AES encrypting algorithm to protect your data.

To make use of this feature you need:

- A backup application that supports hardware encryption
- Ultrium 3 TB (R/W or WORM) or 1.6 TB (R/W or WORM) media; no encryption will be performed when writing earlier generations of tape

## When should I use encryption?

Your company policy will determine when you need to use encryption. For example, it may be mandatory for company confidential and financial data, but not for personal data. Company policy will also define how encryption keys should be generated and managed. Backup applications that support encryption will generate a key for you or allow you to enter a key manually.

**Note:** Encryption with keys that are generated directly from passwords or passphrases may be less secure than encryption using truly random keys. Your application should explain the options and methods that are available. Please refer to your application's user documentation for more information.

## How do I enable encryption?

Hardware encryption is turned off by default and is switched on by settings in your backup application, where you also generate and supply the encryption key. Your backup application must support hardware encryption for this feature to work. The software supplied with the tape drive provides this support. See <http://www.tandbergdata.com> for an up-to-date list of other suitable backup software.

## When will I be asked to enter the key?

Encryption is primarily designed to protect the media once it is offline and to prevent it being accessed from another machine. You will be able to read and append the encrypted media without being prompted for a key as long as it is being accessed by the machine and application that first encrypted it.

There are two main instances when you will need to know the key:

- If you try to import the media to another machine or another instance of the backup application
- If you are recovering your system after a disaster

## What happens if I don't remember the key?

If you are unable to supply the key when requested to do so, neither you nor Technical Support will be able to access the encrypted data.

This guarantees the security of your data, but also means that you must be careful in the management of the encryption key used to generate the tape.



**Warning** You should keep a record or backup of your encryption keys and store them in a secure place separate from the computer running the backup software.

---

### Does encryption affect tape drive performance?

Hardware encryption can be used with or without compression and without speed or capacity penalties.

### Does the tape drive encrypt media in an earlier Ultrium format?

No. Encryption is supported only on Ultrium 3 TB and Ultrium 1.6 TB media (R/W andr WORM).

Encrypted Ultrium 3 TB and 1.6 TB tapes can be read on any compatible LTO tape drive that supports hardware encryption. (LTO-5 tape drives can read and write encrypted Ultrium 3 TB media and Ultrium 1.6 TB media; LTO-4 tape drives can read and write encrypted Ultrium 1.6 TB media.)

Hardware encryption is not supported on any earlier Ultrium media, such as Ultrium 800 GB and Ultrium 400 GB.

### Where can I get more information?

For detailed instructions about enabling encryption please refer to the documentation supplied with your backup application. This will also highlight any default states, for example when copying tapes, that may need changing if using encrypted tapes.

## Write protecting cartridges



**Warning** Always remove the cartridge from the tape drive before you change the write protection.

---

If you want to protect the data on a cartridge from being altered or overwritten, you can write protect the cartridge.

- To write protect a cartridge, push the switch to the right to prevent any data recording on the cartridge. Note the padlock on the tab that indicates that the cartridge is protected.
- To write enable a cartridge, push the switch to the left to allow data recording on the cartridge. [Figure 7-1](#) on page 46 illustrates the location of the write-protect tab.

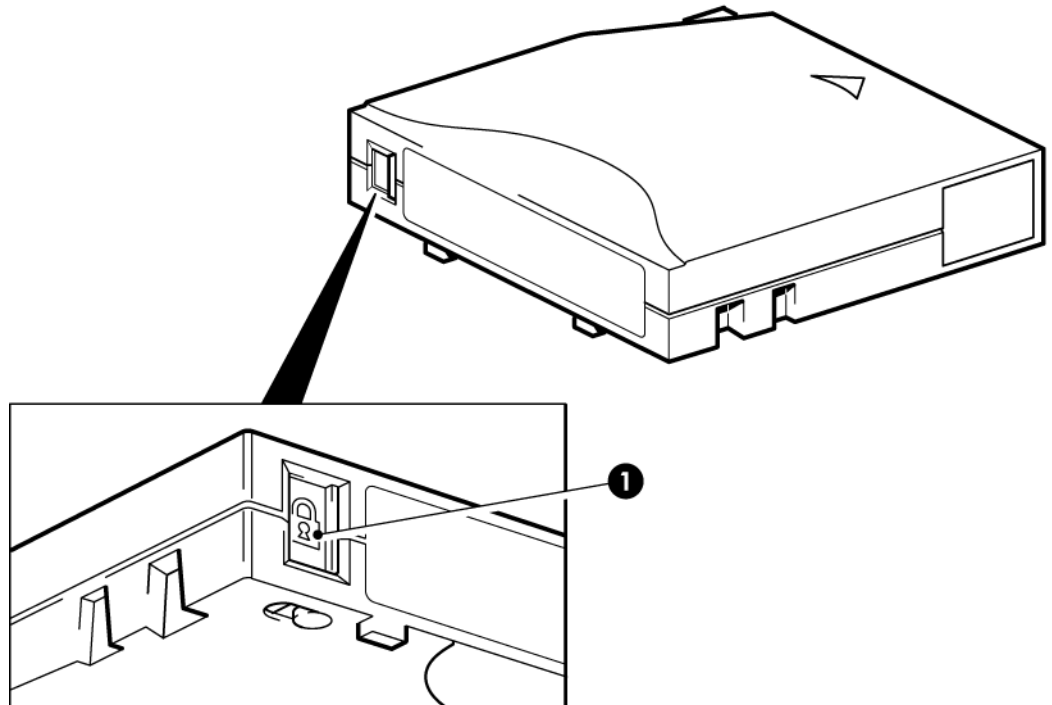

1. Write-protect tab

**Figure 7-1** Write protecting a cartridge

Write-protection will not protect your cartridges against magnets. Write-protection will not prevent a cartridge being erased by bulk-erasure or degaussing. Do **not** bulk erase LTO format cartridges. This will destroy pre-recorded servo information and make the cartridge unusable.

## Cleaning the tape drive

You must use the Ultrium Universal Cleaning Cartridge with LTO tape drives, as other cleaning cartridges will not load and run.

To clean the tape drive:

LTO tape drives do not require regular cleaning. An Ultrium Universal Cleaning Cartridge should only be used when the orange Clean LED is flashing.

1. Insert the Ultrium Universal Cleaning Cartridge.

2. The drive will carry out its cleaning cycle and eject the cartridge on completion (which can take up to 5 minutes). During the cleaning cycle the orange Clean LED will be on solidly and the green Ready LED will flash.

Each Ultrium Universal Cleaning Cartridge cleaning cartridge can be used up to 50 times with LTO tape drives. If the cleaning cartridge is ejected immediately with the Tape LED on, it has expired.

## Handling cartridges

- Do not attempt to clean the tape path or tape guides inside the cartridge.
- Do not leave cartridges in the drive. The tape loses tension in the power-off state, which can lead to problems, particularly if the drive has been moved.
- Do not leave cartridges in excessively dry or humid conditions.
- Do not leave cartridges in direct sunlight or in places where magnetic fields are present (for example, under telephones, next to monitors or near transformers).
- Do not drop cartridges or handle them roughly.
- Stick labels onto the label area only.
- Do not bulk erase (or degauss) LTO format cartridges because this will render them unusable.

## Operating and storage environment

To prevent condensation and for long life, the cartridge should only be operated or stored as follows:

- Operation: 10° C to 45° C (50° F to 113° F)
- Day-to-day storage (in plastic container): 16° C to 32° C (60° F to 90° F)
- Non-condensing relative humidity: 10% to 80% (operating), 20% to 60% (non-operating)
- Wet bulb temperature should not exceed 26° C (79° F)

Tapes intended for long-term storage should be stored in the plastic containers, at temperatures between 5° C and 23° C (41° F and 73° F) and 20% to 60% relative humidity.

## Notes



# 8

## Troubleshooting

In this chapter:

- “[General Procedure](#)” on page 49
- “[Optimizing performance](#)” on page 51
- “[Problems with cartridges](#)” on page 52

### General Procedure

If a problem occurs, the first step is to try to establish whether the problem lies with the cartridge, the drive, the host computer and connections, or the way the system is being operated.

#### **Has the system just been installed?**

There could be an installation problem:

1. Check through the information in the relevant installation chapter of this guide.
2. Has the system booted but the operating system has not seen the tape drive? Check that the drive has power, the READY light should be illuminated. If it is not, check that the power cable is connected correctly to the tape drive. If READY is illuminated, check the cabling between the tape drive and the SAS controller.
3. Are appropriate drivers and application software installed on the host?
4. Check the environmental conditions against the specified limits.

**Table 8-1** Environmental specifications for LTO tape drives

	Temperature range	Non-condensing humidity range
Operating	50° to 95° F (10° to 40° C) at a minimum of 6 CFM airflow	20 to 80% RH (non-condensing)
Storage	-40° to 151° F (-40° to 66° C)	10 to 95% RH (non-condensing)

**Are you using new cartridges or a different brand of cartridge? Have you been using the particular cartridge for a very long time?**

The problem could lie with the cartridge:

1. Check through the media chapter on [“Use the correct media”](#) on page 41.
2. Check that you are using an Ultrium cartridge. Compatible media can be recognized by the LTO logo, which is the same as the logo on the front of your drive.
3. Use the correct media type, for example:
  - Ultrium 3 TB RW and Ultrium 3 TB WORM tape cartridges for use with LTO-5 tape drives.
  - Ultrium 1.6 TB RW and Ultrium 1.6 TB WORM tape cartridges for use with LTO-4 tape drives.
  - Ultrium 800 GB RW and Ultrium 800 GB WORM tape cartridges for use with LTO-3 tape drives.
4. Has the cartridge been write-protected, see [“Write protecting cartridges”](#) on page 45?
5. Clean the tape heads with the cleaning cartridge, see [“Cleaning cartridges”](#) on page 41. Make sure you are using the Ultrium Universal Cleaning Cartridge.
6. Try the operation again.
7. If the problem still occurs, try using a different cartridge.
8. If the problem is still there, the problem probably lies with the drive or the host computer.

**Has the drive been moved recently? Have any cables been disconnected and reconnected? Has the environment changed—unusually hot, cold, damp or dry? Has there been dust or dirt near the drive. Have reasonable precautions against static been taken?**

The problem could lie with the drive:

1. Check the cables and connectors.
2. Clean the tape heads with the cleaning cartridge.

3. If the problem persists, check the environmental conditions against the specified limits, see [Table 8-1](#) on page 50 or refer to <http://www.tandbergdata.com>. Perhaps move the drive to a more suitable site.

**Has a new operating system been installed in the host computer? Has new backup software been installed?**

The problem could lie with the host or the software. Consult the computer's operating manuals, the software manual, or seek help from a service engineer.

## Optimizing performance

Various factors can affect tape drive performance, particularly in a network environment. In nearly all cases when performance is not as expected, it is the data rates of the disk subsystem that cause the bottleneck.

If your tape drive is not performing as well as expected—for example, if backup windows are longer than expected—please consider the following points before contacting Technical Support.

- **Disk subsystem**

A single spindle disk will not be able to deliver good data throughput for an LTO tape drive at any compression ratio. To maximize the capability of these tape drives, utilize aggregated disk sources (RAID) with multiple disk spindles.

- **System architecture**

Be aware of the architecture of your data protection environment; multiple clients backed up over a network may mean you are unable to take advantage of the LTO tape drive because the Ethernet infrastructure connecting such systems may limit performance.

Some enterprise class backup applications can be made to interleave data from multiple sources, such as clients or disks, to keep the tape drive working at optimum performance.

- **Tape media type**

The data cartridge should match the specification of the tape drive. A lower specification will have a lower transfer speed.

- **Data and file types**

The type of data being backed up or restored can affect performance. Typically, small files incur greater overhead in processing and access than large files. Equally, data that is not compressible will always limit the speed at which the drive can write/read data. You will achieve no more than native rates with uncompressible data.

Examples of files that compress well are plain text files, spreadsheets; those that compress poorly are those that are either compressed as part of their format (such as, JPEG photographic files) or stored as compressed (such as, .ZIP files or .gz/.Z files on Unix platforms).

## Problems with cartridges

If you experience any problems using LTO branded cartridges, check:

- The cartridge case is intact and that it contains no splits, cracks or damage.
- The cartridge has been stored at the correct temperature and humidity. This prevents condensation. See the insert included with the tape cartridge for storage conditions.
- The write-protect switch is fully operational. It should move from side to side with a positive click.

### The cartridge is jammed

If the cartridge is jammed or the backup application is unable to eject it, you can force eject the cartridge. If the failure occurs regularly, contact Technical Support.

1. Either press and hold the Eject button on the front of the tape drive for at least 10 seconds.
2. Wait for the cartridge to be ejected. This process may take up to 10 minutes (the maximum rewind time). It is important that you allow sufficient time for the drive to complete this process. If you interrupt it, you may damage the media or the tape drive. The drive is then reset as though you had turned the power off and then on again.

You may lose data if you force eject a cartridge. The tape may also become unreadable because an EOD (End of Data) mark may not be properly written.

3. If the cartridge is still jammed, the tape drive has failed, contact Technical Support.

### The drive will not accept the cartridge (or ejects it immediately)

The cartridge may have been damaged, for example dropped, or the drive may have a fault. If it is a cleaning cartridge, it has probably expired and should be discarded immediately. For data cartridges:

1. Check that the drive has power (the power cable is properly connected and the Ready LED is on).
2. Check that you are using the correct media. Use only Ultrium media, (see [“Use the correct media”](#) on page 41).
3. Make sure that you have loaded the cartridge with the correct orientation (see [“Loading a cartridge”](#) on page 38).

4. Check for damage to your media and discard it if it is damaged.
5. Use a new or known, good piece of media and see if it loads. If it does, the original cartridge is faulty and should be discarded.
6. Check if another LTO drive of the same model will accept the cartridge. If it does, the original drive may be faulty. Before calling customer service, please check that the tape drive is responding.

## Notes

# Index

## A

audience, VII

## B

backup software  
  encryption, 13  
  supported, 13  
backup software problems, 51  
buttons  
  Unload, 39

## C

cabling  
  external drive, 25  
  internal drive, 19  
cartridge  
  loading, 38  
  unloading, 39  
cartridges  
  cleaning, 41  
  compatibility, 42  
  data, 42  
  ejected, 52  
  encryption, 43  
  environment, 47  
  handling, 47  
  inserting, 38  
  jammed, 52  
  problems, 50  
  removing, 39  
  WORM, 42  
  write protecting, 45  
cleaning  
  tape drive, 46  
cleaning cartridges, 41  
compatibility  
  backup software, 13

connecting power cable  
  external drive, 27  
connecting SAS cables  
  external drive, 25  
  internal drive, 19  
conventions  
  document, VII  
  text symbols, VIII

## D

data cartridges, 42  
document  
  conventions, VII  
drive  
  front view, 11  
  installing, 15  
  operating, 38  
drivers  
  installing, 12  
  UNIX, 12  
  Windows, 12

## E

encryption, 43  
  backup software, 13  
encryption LED, 35  
external drive  
  installation, 25

## F

firmware, upgrading  
  drives, 39  
front panel  
  LEDs, 32  
front view, 11

## H

handling cartridges, 47  
help  
  obtaining, VIII  
host  
  problems, 51

## I

inserting cartridges, 38  
install drive, 18

- installation
  - attach mounting hardware, 16
  - connect cables (external), 25
  - connect cables (internal), 19
  - external drive, 25
  - guidelines, 10
  - install drive, 18
  - internal drive, 15
  - prepare mounting bay, 15
  - problems, 49
  - reboot (external), 27
  - reboot (internal), 23
  - secure drive, 21
  - verify, 29
- installing
  - drivers, 12
- internal drive
  - installation, 15
- J**
  - jammed cartridge, 52
- L**
  - LEDs, 32
    - encryption, 35
    - troubleshooting, 32
  - loading
    - cartridge, 38
- M**
  - media, 42
  - mounting bay, 15
  - mounting hardware, 16
- O**
  - operating systems, 10
  - operation
    - drives, 38
  - optimizing performance, 51
- P**
  - performance
    - optimizing, 51
  - power cable
    - external drive, 27
  - power specification, 12
- S**
  - secure drive, 21
  - supported models, 9
- symbols in text, VIII
- T**
  - tape drive
    - cleaning, 46
  - technical support, VIII
  - text symbols, VIII
  - troubleshooting
    - cartridges, 52
    - general procedure, 49
    - LEDs, 32
    - optimizing performance, 51
- U**
  - UNIX
    - drivers, 12
  - Unload button, 39
  - unloading
    - cartridge, 39
  - upgrading firmware
    - drives, 39
- V**
  - verify installation, 29
- W**
  - WORM cartridges, 42
  - write protection, 45