



© Electrolux Italy S.p.A.

Corso Lino Zanussi, 30
I - 33080 Porcia – PN -

Fax: + 39 0434 394096

SOI

Edition: 09-2009 Rev 0.0

599 72 40-73

**TD Electronic
Platform Collection**

**Dryer
Condense / Vented**

INDEX

1	DIAGNOSTICS on dryer EDR 1000 / EDR 2000 / EDR2000 JEWEL / EDR 2000 CLUB DISPLAY	5
1.1	Access to diagnostics	5
1.2	Exiting the diagnostics system.....	5
2	Allarms.....	7
2.1	ALARMS EDR 1000.....	7
2.1.1	Displaying the alarms to the user	7
2.1.2	Alarm display during normal operation.....	7
2.1.3	Reading the alarm codes.....	8
2.1.4	Displaying the alarm code	8
2.1.5	Example of display of alarm code	8
2.1.6	Rapid reading of the alarm codes	9
2.1.7	Cancelling the last alarm memorized	9
2.1.8	Notes concerning certain alarm codes	9
2.2	ALARMS EDR 2000.....	10
2.2.1	Displaying the alarms to the user	10
2.2.2	Alarm display during normal operation.....	10
2.2.3	Reading the alarm codes.....	10
2.2.4	Reading the alarm codes.....	11
2.2.5	Cancelling the last alarm memorized	11
2.2.6	Notes concerning certain alarm codes	11
2.3	ALARMS EDR 2000 JEWEL	12
2.3.1	Displaying the alarms to the user	12
2.3.2	Alarm display during normal operation.....	12
2.3.3	Reading the alarm codes.....	12
2.3.4	Reading the alarm codes.....	13
2.3.5	Cancelling the last alarm memorized	13
2.3.6	Notes concerning certain alarm codes	13
2.4	ALARMS EDR 2000 CLUB DISPLAY.....	14
2.4.1	Displaying the alarms to the user	14
2.4.2	Reading the alarm codes.....	14
2.4.3	Quick reading of the alarm	15
2.4.4	Cancelling the last alarm	15
2.4.5	Notes concerning certain alarm codes	15
2.5	Table of alarms EDR 1000 / EDR 2000 / EDR2000 JEWEL / EDR 2000 CLUB DISPLAY	16
3	DIAGNOSTICS ENV06 / ENV06 AEG / ENV06 CATALOGUE / ENV06 ACTION / ENV06 input	18
3.1	Access to diagnostics	18
3.2	Exiting the diagnostics system.....	18
4	DIAGNOSTICS on ENV06 / ENV06 AEG CLOTHES REFRESHMENT	22
4.1	Access to diagnostics	22
4.2	Exiting the diagnostics system.....	22
5	DIAGNOSTICS on ENV06 HP / ENV06 AEG HP	25
5.1	Access to diagnostics	25
5.2	Exiting the diagnostics system.....	25
6	ALARMS ENV06 dryers.....	28
6.1	Displaying the alarms to the user	28
6.2	Alarm display during normal operation	28
6.3	Reading the alarm codes.....	28
6.4	Displaying the alarm code on models with LCD	28
6.5	Displaying the alarm code in all models without LCD.....	28
6.6	Cancelling the last alarm memorized.....	29
6.7	Notes concerning certain alarm codes	29
7	ENV06 TUMBLE DRYERS ALARMS TABLE SUMMARY	30
8	HEATER	34
9	NTC sensor.....	34
10	MOTOR.....	35
11	CANISTER FILLING PUMP.....	35
12	COMPRESSOR	36
13	PTC Motor protection.....	36
14	FAN COOLING COMPRESSOR	36
15	AIR CIRCULATION FAN	37
16	Checking the efficiency of the heat pump.....	37
17	STEAMER.....	38

18	List of PNC.....	39
18.1	List of PNC - ELC for dryer EDR 1000 NEW.....	39
18.2	List of PNC - ELC for dryer EDR 2000 NEW.....	40
18.3	List of PNC - ELC for dryer EDR 2000 JEWEL.....	41
18.4	List of PNC - ELC for dryer EDR 2000 CLUB DISPLAY.....	43
18.5	List of PNC - ELC for dryer ENV06 / ENV06 AEG / ENV 06 CATALOGUE / ENV06 ACTION / ENV06 INPUT.....	44
18.6	List of PNC - ELC for dryer HEAT PUMP ENV06 / ENV06 AEG.....	57
18.7	List of PNC - ELC for dryer CLOTHES REFRESHMENT ENV06 / ENV06 AEG.....	58

1 DIAGNOSTICS on dryer EDR 1000 / EDR 2000 / EDR2000 JEWEL / EDR 2000 CLUB DISPLAY

1.1 Access to diagnostics

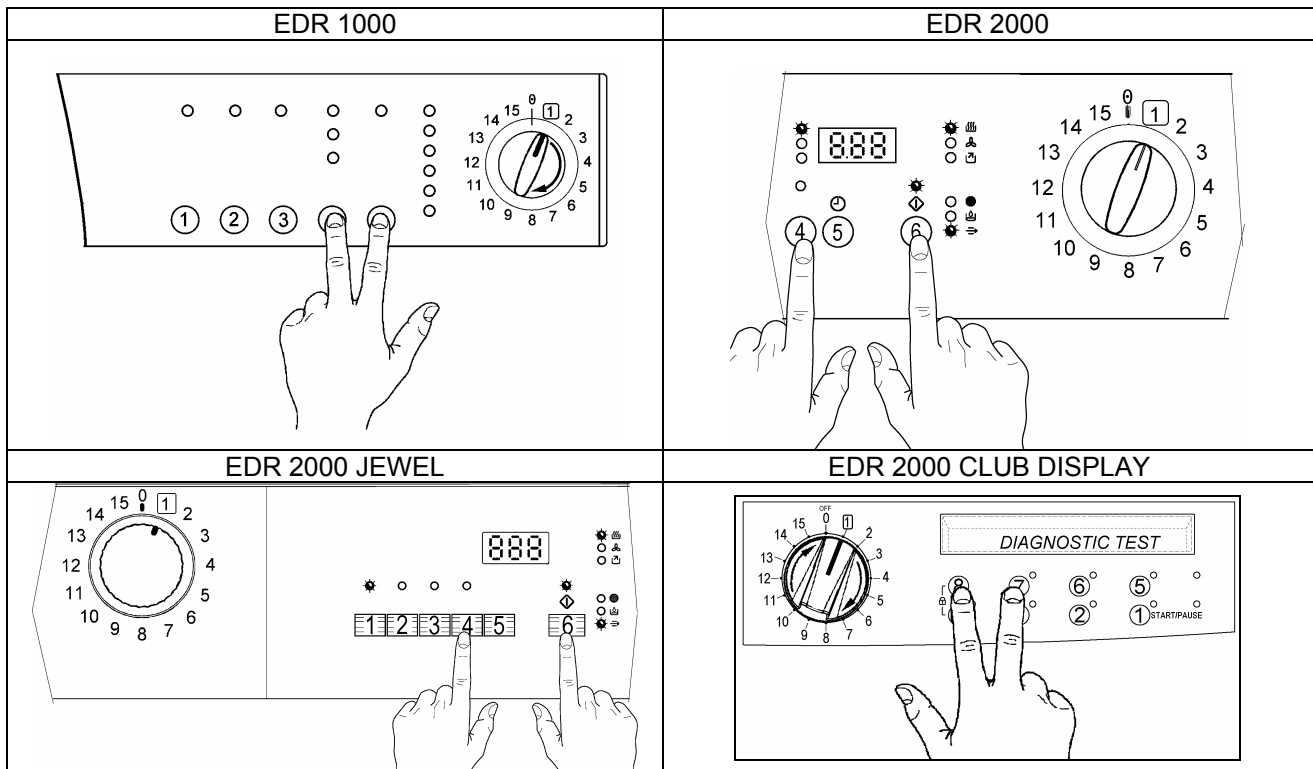

1. The appliance must be switched OFF.
2. Press START/PAUSE and the option buttons simultaneously.
3. Holding these two buttons down, switch the appliance ON by turning the programme selector knob one position clockwise.
4. Continue to hold down the buttons until the LEDs begin to flash and the buzzer sounds (about 5 seconds).

1.2 Exiting the diagnostics system

To exit the diagnostics system, turn the programme selector knob to **zero** to switch the appliance OFF, then switch it ON and OFF again.

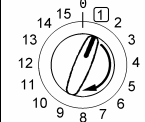
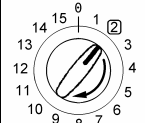
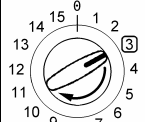
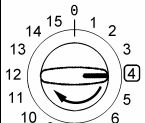
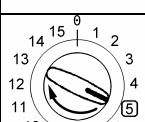
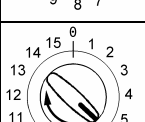
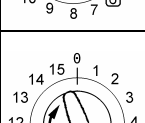
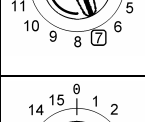
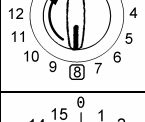
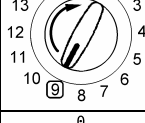
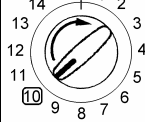
Selector position	Components activated	Operating conditions	Function checked
1 	All the LEDs light in sequence. When a button is pressed, the corresponding LED lights and the buzzer sounds.	Always activated.	Operation of the user interface.
2 	Floating switch. Canister fill pump.	Door closed. Max. time 30 sec. Sump full (0.7 litres approx.)	Operation of the floating switch and canister fill pump.
3 	Motor triac and relay. Canister fill pump always powered.	Door closed. Max. time 10 min. Pump 30 sec.	Controls counter-clockwise drum rotation.
4 	Triac motor in stepping operation.	Door closed. Max. time 10 min.	Control of clockwise drum rotation (low speed for visual inspection of drum shell assembly).
5 	Higher-power (1400W) heating element. Motor triac for ventilation.	Door closed. Max. time 10 min.	Heater unit (half power).
6 	Both branches of the heater unit. Motor triac for ventilation.	Door closed. Max. time 10 min.	Heater unit (full power).
7 	Conductimetric sensor. This check has duration of 4 sec. (1 sec. to create the short circuit). The phase/warning LEDs flash during this period. If the result is correct at the end, the LEDs remain lit; if not, the LEDs flash and alarm E32 is displayed.	Door closed. Short circuit between the two drum shells.	Control of the conductimetric sensor when short-circuited.
8 	Conductimetric sensor. This check has duration of 4 sec. The phase/warning LEDs flash during this period. If the result is correct at the end, the LEDs remain lit; if not, the LEDs flash continuously.	Door closed.	Control of the conductimetric sensor when the circuit is open.
9 	Door opening Triac. After 2 attempts, if the door does not open, an alarm is displayed. Coil of the door interlock.	Door closed After two seconds the triac activates.	Operation of the door opening
10 	Floating switch. Canister fill pump.	Door closed Tempo max. 30 sec.	Operation of the floating switch (sump empty)
11 	Reading/cancellation of the last alarm code Turn the knob till position 11, paying attention not to stop at position 7, because error E32 may occur.	---	---
12-13-14-15	All the LEDs light in sequence. When a button is pressed, the corresponding LED lights and the buzzer sounds.	Always activated	Operation of the user interface.

2 Alarms

2.1 ALARMS EDR 1000

2.1.1 Displaying the alarms to the user

Operation of the alarms is configurable according to the model. Some or all of the alarms may be displayed to the user.

Normally, all alarms except E44, E52, E63, E94, EB2 are displayed to the user.

When an alarm condition occurs, the drying cycle may be interrupted or paused; in some cases, for the sake of safety, a forced cooling cycle is performed. In this case, the electronic board, if possible, disconnects the power relay from the heater unit and powers the motor of the drum cooling fan. The cycle remains active until the user switches off the appliance.

2.1.2 Alarm display during normal operation

The system displays the family of alarms to the user by a repeated flashing sequence of the ANTI-CREASE/END OF CYCLE LED (0.4 seconds on, 0.4 seconds off, with a 2.5 second pause between sequences).

The buzzer emits a series of "bips" in synchronization with the flashing of the LED.

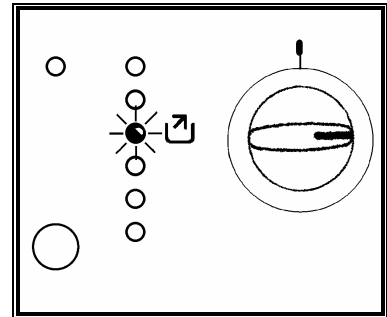

For example, in the case of alarm E53, the cycle would be interrupted and the ANTI-CREASE/END OF CYCLE LED would flash repeatedly in the sequence shown in the table.

The five flashes indicate the **first** of the two numbers in the alarm code E53 (the alarms relative to the same function are grouped into families).

End of cycle LED											
Time (sec)	0.4	0.4	0.4	0.4	0.4	0.4	0.4	0.4	0.4	0.4	2.5
Value	1		2		3		4		5		Pause

Configuration errors (E93) are indicated by all the LEDs flashing.

2.1.3 Reading the alarm codes

To read the last alarm code memorized in the EEPROM of the electronic board, proceed as follows:

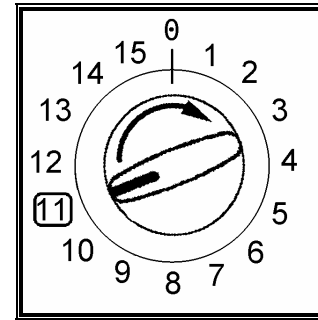

- Access diagnostics mode (see paragraph 9.1)
Turn the programme selector knob **clockwise** to the **eleventh position**

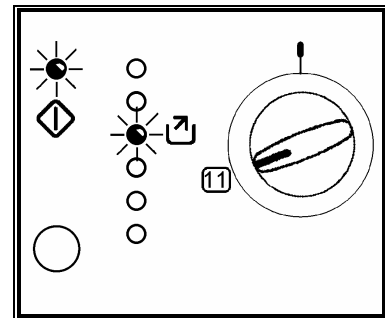

2.1.4 Displaying the alarm code

The alarm code is displayed by a repeated sequence of flashing of the ANTI-CREASE/END OF CYCLE LED (0.4 seconds on, 0.4 seconds off, with a pause of 2.5 seconds between sequences).
The buzzer emits a series of "bips" in synchronization with the flashing of the LED.



	ANTI-CREASE/END OF CYCLE LED: indicates the first number of the alarm code (family)
	START/PAUSE LED: indicates the second number of the alarm code (number within the family category).























N.B.:

- The first letter of the alarm code "E" (error) is not displayed, since it is common to all codes.
- The families of alarm codes are expressed in **hexadecimal**. Therefore;
 - ⇒ **A** is represented by **10** flashes
 - ⇒ **B** is represented by **11** flashes
 - ⇒ **F** is represented by **15** flashes
- **Configuration errors are displayed by the flashing of all the LEDs (user interface not configured).**

2.1.5 Example of display of alarm code

In the event of, for example, alarm E53 (problems with the motor triac), the code will be displayed as follows:

- ⇒ the sequence of **five** flashes of the ANTI-CREASE/END OF CYCLE LED indicates the first of the two numbers in the alarm code E"5"3, which represents the family and is displayed to the user.
- ⇒ the sequence of **three** flashes of the START/PAUSE LED indicates the second number E5"3".

Time (sec)	0.4	0.4	0.4	0.4	0.4	0.4	0.4	0.4	0.4	0.4	2.5
End of cycle LED											
Value	1		2		3		4		5		Pause
Pause LED											
Value	1		2		3	Pause					

2.1.6 Rapid reading of the alarm codes

The last alarm code memorized can be displayed even if the appliance is in normal operating mode (e.g. while the drying programme is being performed):

- ⇒ Press **START/PAUSE** and **any one of the option buttons** simultaneously for at least two seconds. The LEDs switch off, then display the flashing sequence that identifies the alarm code.
- ⇒ The alarm sequence continues to flash as long as the two buttons are held down.
- ⇒ The reading system is as described in paragraph 10.2.1.
- ⇒ The appliance continues the cycle while the alarm codes are being displayed. If the appliance is in programme selection mode, the options previously selected are stored in memory.

2.1.7 Cancelling the last alarm memorized

It is good practise to cancel the alarm code from memory:

- After reading the alarm, to check whether it is repeated during the diagnostics cycle.
 - After effecting repairs to the appliance, to check whether it is repeated during testing.
1. Access diagnostics mode and turn the programme selector knob to the **eleventh** position (alarm reading).
 2. Press **START/PAUSE** and **any one of the option buttons** simultaneously.
 3. Hold down the START/PAUSE and option buttons for about 5 seconds.

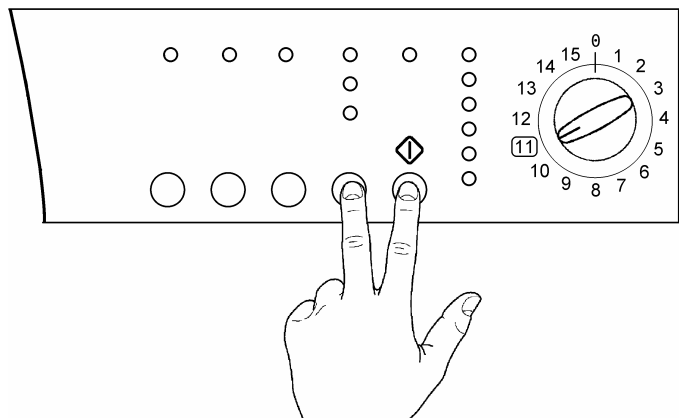

2.1.8 Notes concerning certain alarm codes

- **Configuration alarm E93:** When configuration alarms are displayed (when the appliance is switched on), the appliance is inoperative and all the LEDs light. It is not possible to access diagnostics mode; the only possible operation is that of switching off the appliance (selector knob on position "0").
- **Alarms EB1-EB2-EB3:** In the event of problems with the power supply, the appliance remains in alarm mode until the voltage and frequency are restored to within the normal limits or the appliance is switched off (selector knob on position "0"). Alarm family "B" is displayed and it is not possible to access diagnostics mode nor to use the "rapid alarm display" function. The complete alarm can be read only when the abnormal condition has terminated.

2.2 ALARMS EDR 2000

2.2.1 Displaying the alarms to the user

Operation of the alarms is configurable according to the model. Some or all of the alarms may be displayed to the user.

Normally, all alarms except E61, E97, EB2 are displayed to the user.

When an alarm condition occurs, the drying cycle may be interrupted or paused; in some cases, for the sake of safety, a forced cooling cycle is performed. In this case, the electronic board, if possible, disconnects the power relay from the heater unit and powers the motor of the drum cooling fan. The cycle remains active until the user switches off the appliance.

2.2.2 Alarm display during normal operation

The system displays the family of alarms to the user. If for example we consider E53 alarm (problems with the motor TRIAC) the display will show as follows:

- First digit: letter “E” (error)
- Second-third digit: the no. “5 0”, i.e. the family of alarm (E53)

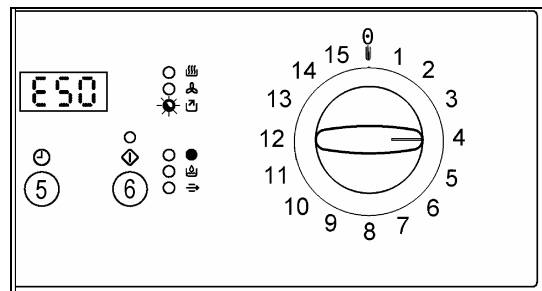

The same number is displayed by a repeated flashing sequence of ANTI-CREASE/END OF CYCLE LED (0,4 seconds on, 0,4 seconds off with a 2,5 second pause between sequences); in the case of alarm E53, The five flashes indicate the **first** of the two numbers in the alarm code E53 (the alarms relative to the same function are grouped into families).

The buzzer emits a series of "bips" in synchronization with the flashing of the LED.

Configuration errors (E93) are indicated by all the LEDs flashing and it is not possible access the diagnostics cycle.

2.2.3 Reading the alarm codes

To read the last alarm code memorized in the EEPROM of the electronic board, proceed as follows:

- ⇒ Access diagnostics mode (see paragraph 9.1)
- ⇒ Turn the programme selector knob **clockwise** to the **eleventh position**. (*Turn the knob till Position 11, paying attention not to stop in Position 7, because error 32 could occur*).

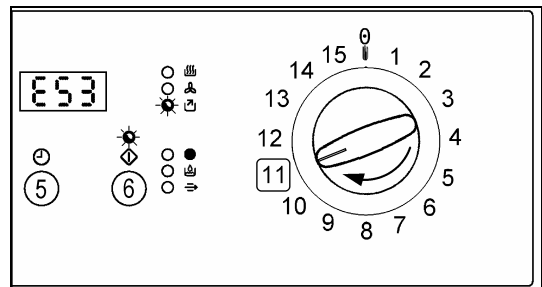

Displaying the alarm code

- First digit: letter “E”
- Second digit: the family of the alarm
- Third digit: the number of the alarm

The alarm code is displayed by a repeated sequence of flashing of the ANTI-CREASE/END OF CYCLE LED (0.4 seconds on, 0.4 seconds off, with a pause of 2.5 seconds between sequences).

The buzzer emits a series of "bips" in synchronization with the flashing of the LED.

	⇒ ANTI-CREASE/END OF CYCLE LED: indicates the first number of the alarm code (family)
	⇒ START/PAUSE LED: indicates the second number of the alarm code (number within the family category).

If no alarm conditions occurred “E00” is displayed.

2.2.4 Reading the alarm codes

The last alarm code memorized can be displayed even if the appliance is in normal operating mode (e.g. while the drying programme is being performed):

Press 6 (start/pause) and 4 simultaneously for at least 5 seconds: the display shows the last alarm. The alarm sequence continues to flash as long as the two buttons are held down.

The appliance continues the cycle while the alarm codes are being displayed. If the appliance is in programme selection mode, the options previously selected are stored in memory.

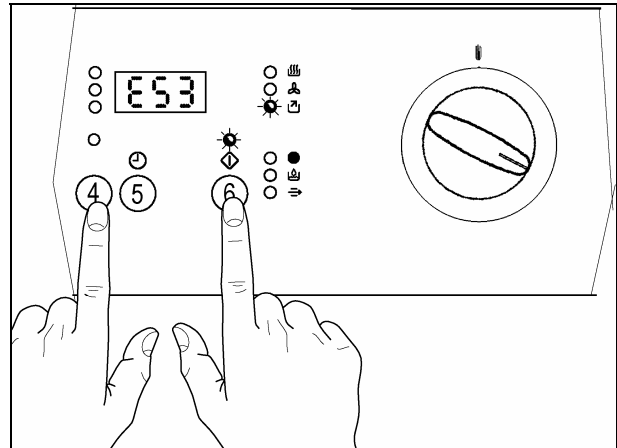

2.2.5 Cancelling the last alarm memorized

It is good practise to cancel the alarm code from memory:

- After reading the alarm, to check whether it is repeated during the diagnostics cycle.
- After effecting repairs to the appliance, to check whether it is repeated during testing.

1. Access diagnostics mode and turn the programme selector knob to the eleventh position (alarm reading)
2. Press buttons 6 (start/pause) and 4 simultaneously.
3. Hold down buttons 6 and 4 (about 5 seconds).
4. Once the alarm has been cancelled, **E00** is displayed.

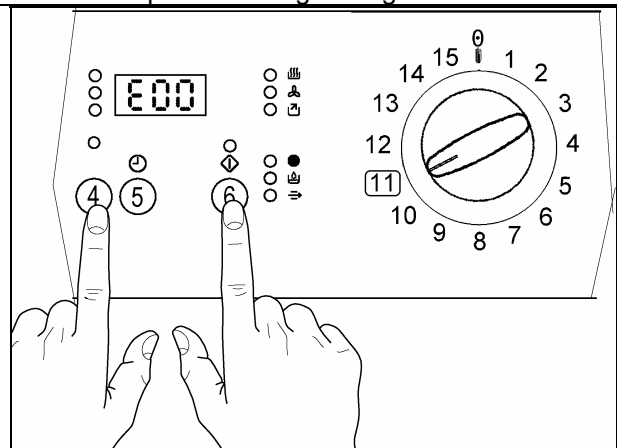

2.2.6 Notes concerning certain alarm codes

- **Configuration alarm E93:** When configuration alarms are displayed (when the appliance is switched on), the appliance is inoperative and all the LEDs light. It is not possible to access diagnostics mode; the only possible operation is that of switching off the appliance (selector knob on position "0").
- **Alarms EB1-EB2-EB3:** In the event of problems with the power supply, the appliance remains in alarm mode until the voltage and frequency are restored to within the normal limits or the appliance is switched off (selector knob on position "0"). Alarm family "B" is displayed and it is not possible to access diagnostics mode nor to use the "rapid alarm display" function. The complete alarm can be read only when the abnormal condition has terminated.

2.3 ALARMS EDR 2000 JEWEL

2.3.1 Displaying the alarms to the user

Operation of the alarms is configurable according to the model. Some or all of the alarms may be displayed to the user.

Normally, all alarms except E94, EB2 are displayed to the user.

When an alarm condition occurs, the drying cycle may be interrupted or paused; in some cases, for the sake of safety, a forced cooling cycle is performed. In this case, the electronic board, if possible, disconnects the power relay from the heater unit and powers the motor of the drum cooling fan. The cycle remains active until the user switches off the appliance.

2.3.2 Alarm display during normal operation

If the DISPLAY is not featured the alarm display is indicated by the flashing of the LEDs.

The system displays the family of alarms to the user.

If for example we consider E53 alarm (problems with the motor TRIAC) the display will show as follows:

- First digit: letter “E” (error)
- Second-third digit: the no. “5 0”, i.e. the family of alarm E53)

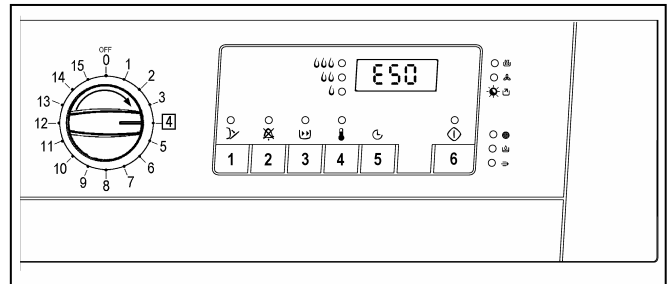

The same number is displayed by a repeated flashing sequence of ANTI-CREASE/END OF CYCLE LED (0,4 seconds on, 0,4 seconds off with a 2,5 second pause between sequences); in the case of alarm E53, The five flashes indicate the **first** of the two numbers in the alarm code E53 (the alarms relative to the same function are grouped into families).

The buzzer emits a series of "bips" in synchronization with the flashing of the LED.

Configuration errors (E93) are indicated by all the LEDs flashing and it is not possible access the diagnostics cycle.

2.3.3 Reading the alarm codes

To read the last alarm code memorized in the EEPROM of the electronic board, proceed as follows:

- ⇒ Access diagnostics mode (see paragraph 9.1)
- ⇒ Turn the programme selector knob **clockwise** to the **eleventh position** (Turn the knob to the position 11, paying attention not to stop at position 7, because error 32 may occur 32).

Displaying the alarm code

- First digit: letter “E”
- Second digit: the family of the alarm
- Third digit: the number of the alarm

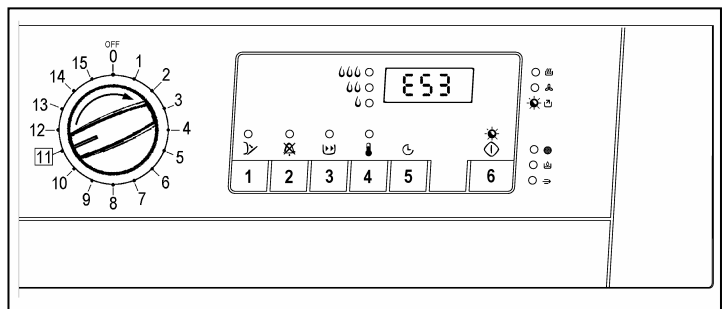

The alarm code is displayed by a repeated sequence of flashing of the ANTI-CREASE/END OF CYCLE LED (0.4 seconds on, 0.4 seconds off, with a pause of 2.5 seconds between sequences).

The buzzer emits a series of "bips" in synchronization with the flashing of the LED.

	⇒ ANTI-CREASE/END OF CYCLE LED: indicates the first number of the alarm code (family)
	⇒ START/PAUSE LED: indicates the second number of the alarm code (number within the family category).

If no alarm conditions occurred “E00” is displayed.

2.3.4 Reading the alarm codes

The last alarm code memorized can be displayed even if the appliance is in normal operating mode (e.g. while the drying programme is being performed):

- ⇒ Press **6** (start/pause) and **4** simultaneously for at least 5 seconds: the display shows the last alarm. If the display is not featured the displaying is indicated by the flashing of the END OF CYCLE / START-PAUSE LEDs.
- ⇒ The alarm sequence continues to flash as long as the two buttons are held down.
- ⇒ The appliance continues the cycle while the alarm codes are being displayed. If the appliance is in programme selection mode, the options previously selected are stored in memory.

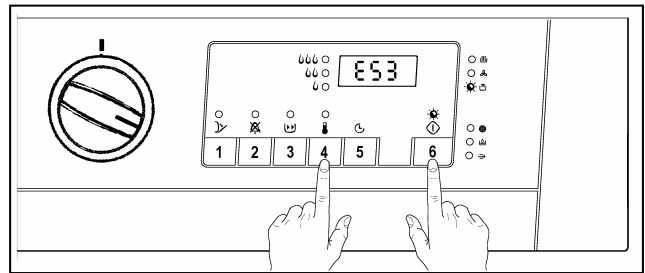

2.3.5 Cancelling the last alarm memorized

It is good practise to cancel the alarm code from memory:

- After reading the alarm, to check whether it is repeated during the diagnostics cycle.
- After effecting repairs to the appliance, to check whether it is repeated during testing.

4. Access diagnostics mode and turn the programme selector knob to the **eleventh** position (alarm reading) *Turn the knob to the position 11, paying attention not to stop at position 7, because error 32 may occur 32.*
5. Press buttons **6** (start/pause) and **4** simultaneously.
6. Hold down buttons **6** and **4** (about 5 seconds).
7. Once the alarm has been cancelled, **E00** is displayed.

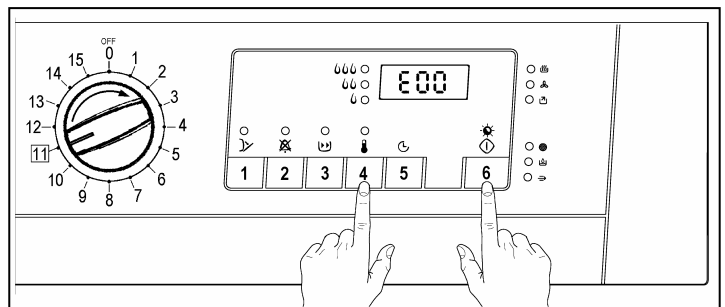

2.3.6 Notes concerning certain alarm codes

- **Configuration alarm E93:** When configuration alarms are displayed (when the appliance is switched on), the appliance is inoperative and all the LEDs light. It is not possible to access diagnostics mode; the only possible operation is that of switching off the appliance (selector knob on position "0").
- **Alarms EB1-EB2-EB3:** In the event of problems with the power supply, the appliance remains in alarm mode until the voltage and frequency are restored to within the normal limits or the appliance is switched off (selector knob on position "0"). Alarm family "B" is displayed and it is not possible to access diagnostics mode nor to use the "rapid alarm display" function. The complete alarm can be read only when the abnormal condition has terminated.

2.4 ALARMS EDR 2000 CLUB DISPLAY

2.4.1 Displaying the alarms to the user

Operation of the alarms is configurable according to the model. Some or all of the alarms may be displayed to the user.

The following alarms are displayed to the user:

Please close the door (when the door is open and the button Start/Pause is pressed).

Please close condenser door (when the door is open and the button Start/Pause is pressed or the door is opened during the drying cycle).

Please clean condenser filter (this information appears at the cycle no. 80).

All other alarms are not displayed to the user (the appliance is blocked).

The service engineer can display the alarm by entering the DIAGNOSTIC SYSTEM (see par. 13.1)

All alarms, except E94, EB2 are normally displayed to the user.

When an alarm condition occurs, the drying cycle may be interrupted or paused; in some cases, for safety reasons, a forced cooling cycle is performed. In this case, the electronic board, if possible, disconnects the power relay from the heater unit and powers the motor of the drum cooling fan. The cycle is active until the user switches off the appliance.

2.4.2 Reading the alarm codes

To read the last alarm code memorized in the EEPROM of the electronic board:

- ⇒ Access the diagnostic mode (see paragraph 13.1)
- ⇒ Turn the programme selector knob **clockwise** to the **eleventh position** (turn the knob to position 11, paying attention not to stop at position 7, because error 32 may occur).

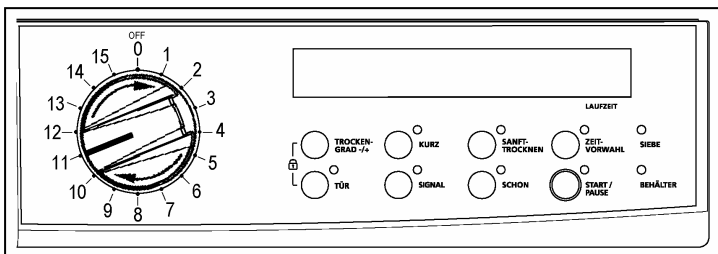

If no alarm conditions occurred **"E00"** is displayed.

2.4.3 Quick reading of the alarm

It is possible to display the last alarm even if the appliance is in normal operation mode (for ex. during the drying programme):

- ⇒ Press buttons 8 and 7 simultaneously for at least 5 seconds: the LCD display shows the last alarm.
- ⇒ The alarm is displayed as long as the two buttons are held down.
- ⇒ The appliance continues the cycle while the alarm codes are being displayed. If the appliance is in programme selection mode, the options previously selected are stored in memory.

2.4.4 Cancelling the last alarm

It is good practise to cancel the alarm code from memory:

- After reading the alarm, to check whether it comes up again during the diagnostic cycle.
- After carrying out the repair, to check whether it comes up again during the test cycle.

8. Access diagnostic mode and turn the programme selector knob to the **eleventh** position (alarm reading) *Turn the knob to position 11, paying attention not to stop at position 7, because error 32 may occur.*
9. Press buttons **8** and **7** simultaneously.
10. Hold them down (about 5 seconds).
11. Once the alarm has been cancelled, **E00** is displayed.

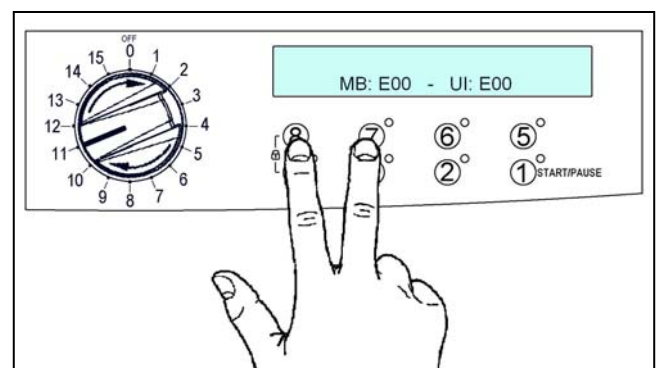

2.4.5 Notes concerning certain alarm codes

- **Configuration alarm E93:** When configuration alarms are displayed (when the appliance is switched on), the appliance stops. It is not possible to access diagnostics; the only operation possible is to switch off the appliance (selector knob on position "0").
- **Alarms EB1-EB2-EB3:** In case of problems with the power supply, the appliance remains in alarm mode until the voltage and frequency are restored to normal values or the appliance is switched off (selector knob on position "0"). Alarm family "B" is displayed and it is not possible to access diagnostic mode nor to use the "rapid alarm display" function. The complete alarm can be read only when the abnormal condition has terminated.

2.5 Table of alarms EDR 1000 / EDR 2000 / EDR2000 JEWEL / EDR 2000 CLUB DISPLAY





Alarm	Description	Possible fault	Action/machine status	Reset command
E00	No alarm	---	---	---
E21	Canister fill pump triac faulty	Wiring faulty. Electronic board faulty.	Cycle interrupted	OFF
E22	Triac "sensing" circuit for the canister fill pump faulty	Electronic board faulty.	Cycle interrupted	OFF
E31	Conductimetric sensor signal frequency too high.	Electronic board faulty.	Alarm activated only during diagnostics	---
E32	Conductimetric sensor signal frequency too low.	Wiring faulty. Brushes worn/faulty. Electronic board faulty.	Cycle interrupted	OFF
E41	Power triac of door opening coil faulty.	Wiring faulty. Electronic board faulty.	Cycle interrupted	OFF
E42	Triac "sensing" circuit for powering the door opening coil faulty	Electronic board faulty.	Cycle interrupted	OFF
E43	Incongruency of the "sensing" signal of the door interlock	Door interlock faulty. Wiring faulty. Electronic board faulty.	Cycle interrupted	OFF
E51	Motor power triac short-circuited.	Motor faulty. Wiring faulty. Electronic board faulty.	Cycle interrupted.	OFF
E52	Intervention of motor overheating safety cut-out.	Motor faulty. Intervention of motor overheating cut-out. Wiring faulty. Electronic board faulty.	Power to the heater unit and reversal of the direction of rotation are interrupted. If the problem does not re-occur, the alarm is memorized and the cycle continues. If the fault persists after several attempts to supply power (about 35 min.), alarm E51 is generated	OFF
E53	Motor triac "sensing" circuit faulty.	Electronic board faulty.	Cycle interrupted.	OFF
E54	Motor inoperational.	Excessive wash load. Voltage too low. Motor/transmission system inoperative.	Cycle paused after several attempts at powering the motor.	Start
E61	Insufficient heating (maximum time exceeded)	Heater unit faulty. Wiring faulty. NTC sensor incorrectly calibrated/out of position. Electronic board faulty.	Cycle paused.	Start
E62	Power relay to heater unit faulty	Heater unit faulty. Wiring faulty. Electronic board faulty.	Forced cooling cycle.	OFF
E63	Intervention of auto-reset thermostat on the heater unit.	Thermostat faulty (replace heater unit). Heater unit faulty. Wiring faulty. Electronic board faulty.	Disconnects the power supply to the heater unit. If the problem does not re-occur, the alarm is memorized and the cycle continues. If, after several attempts to restore power, the fault persists, alarm E62 is generated.	OFF
E71	NTC sensor faulty.	NTC sensor faulty. Wiring faulty. Electronic board faulty.	Forced cooling cycle.	OFF
E91	Error in the communication between electronic board and control/display board	Wiring faulty. Electronic board faulty. Control/display board faulty.	Cycle interrupted	OFF

Alarm	Description	Possible fault	Action/machine status	Reset command
E92	Incongruency in the communication between the electronic board and the display board.	Electronic board not compatible with the display board (part nos. not correct for the affected model)	Cycle interrupted	OFF
E93	Error in the configuration of the appliance.	EEPROM configuration incorrect. Electronic board faulty.	Cycle interrupted with all LEDs flashing	OFF
E94	Error in the configuration of the drying cycle.	EEPROM configuration incorrect. Electronic board faulty.	Cycle interrupted.	OFF
E95	Communication error between microprocessor and EEPROM.	Electronic board faulty.	Cycle interrupted.	OFF
E97	Incongruency between selector and cycles	Configuration error	Cycle interrupted	OFF
EB1	Power frequency to appliance out of limits.	Problems with the power supply (incorrect/interference). Electronic board faulty.	Cycle interrupted. If a stable power supply is restored before the time-out has elapsed, the cycle resumes.	OFF
EB2	Power voltage too low.	Problems with the power supply (incorrect/interference). Electronic board faulty.	Cycle interrupted. If a stable power supply is restored before the time-out has elapsed, the cycle resumes.	OFF
EB3	Power voltage too low.	Problems with the power supply (incorrect/interference). Electronic board faulty.	Cycle interrupted. If a stable power supply is restored before the time-out has elapsed, the cycle resumes.	OFF

3 DIAGNOSTICS ENV06 / ENV06 AEG / ENV06 CATALOGUE / ENV06 ACTION / ENV06 input

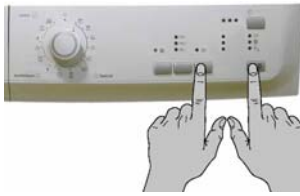
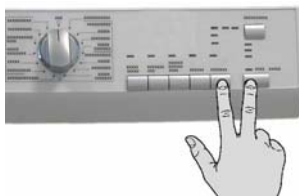
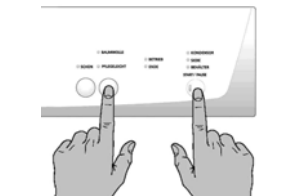
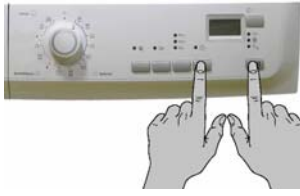
3.1 Access to diagnostics

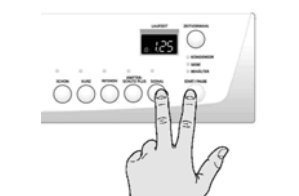
1. Press the defined combination key
(START + the nearest key on the left) and keeping them pressed
2. Switch on the machine rotating the main selector in the 1st position CW..
In the ENV06 INPUT press the ON / OFF push button
3. Within 5 second phases led blinks and buzzer sounds to give acknowledge of the operation.

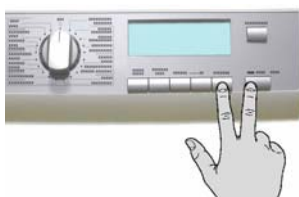
	ENV06	ENV06 AEG	ENV06 Catalogue / action	ENV06 INPUT
TC5				
TC3				
TC2				



3.2 Exiting the diagnostics system

To exit from DIAGNOSTIC mode it's sufficient to switch off the machine.

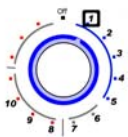

According to the machine configuration, it's possible that the next machine switch on, the electric test cycle will be activated. To stop it, switch off again the machine.

Moving the main knob in clockwise direction, the following tests will be done:

Position 1

User Interface Test	Purpose of test:	To test the functionality of all leds and switches
 	Activated components:	All LEDs and LCD (if present)
	Behaviour	All led in sequence, pushing a button correspondent led is lighted on, the key number is showed on LCD and the buzzer sound. All LCD icons blink together
	Working conditions:	There is any control to run test (always active).

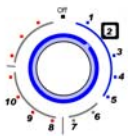

Position 2

Condense Tank Switch and Pump	Purpose of test:	To test the condense tank pump and switch
 	Activated components:	If the pump is full of water and the tank switch recognises the condition, the pump is switched on.
	Behaviour:	Until the condense switch is on full position, phase LEDs blink; When the switch goes on void position the LEDs are switched ON.
	Working conditions:	Door closed (Time out 10 min.)

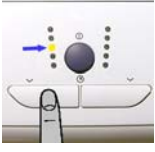

Position 3

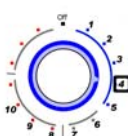
Counter Clockwise drum rotation	Purpose of test:	To test drum motor in counter-clockwise direction.
 	Activated components:	Motor triac and relay of direction (for assembly line request, in this position will be switched on tank pump also).
	Behaviour:	Phase LEDs are switched ON.
	Working conditions:	Door closed (Time out 10 min.)

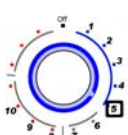

Position 4

Reduced Clockwise drum rotation	Purpose of test:	To test drum motor in clockwise direction.
 	Activated components:	Drum Motor triac. The motor performs a low-speed movement (for assembly line request). Main Fan motor is activated on inverse direction (to test direction relay)
	Behaviour:	Phase LEDs are switched ON.
	Working conditions:	Door closed (Time out 10 min.)



Position 5

Heater ½ power Clockwise drum rotation	Purpose of test:	To test the ½ heating power element.
 	Activated components:	High heating element, Drum Motor on direct direction to give ventilation (full speed).
	Behaviour:	The digits on LCD show NTC1 drying temperature. Phase LEDs are switched ON.
	Working conditions:	Door closed (Time out 10 min.)

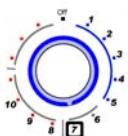

Position 6

Heater full power Clockwise drum rotation	Purpose of test:	To test the ½ & full power-heating element.
 	Activated components:	Both heating elements, Drum Motor on direct direction to give ventilation (full speed).
	Behaviour:	The digits on LCD show NTC1 drying temperature. Phase LEDs are switched ON.
	Working conditions:	Door closed (Time out 10 min.)

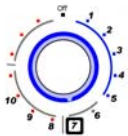

Position 7 (Dryer with CONDUCTIMETRIC sensor)

Conductimetric sensor. Drum short circuit	Purpose of test:	To verify conductimetric sensor in short circuit condition.
 	Activated components:	Conductimetric sensor reading.
	Behaviour:	The step lasts 4 seconds (software configured). During this time all phase LEDs blinks to give information of acquisition phase. At the end of step phase LEDs are switched OFF to give ok, otherwise a sensor alarm is generated (if sensor alarms are enabled, otherwise phase LEDs blinks forever).
	Working conditions:	Door closed. 1 second to create the short circuit

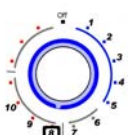

Position 7 (Dryer TEMPEROMETRIC sensor)

Condense Tank Switch	Purpose of test:	To test the tank switch.
 	Activated components:	If the pump is full of water and the tank switch recognises the condition, the pump is switched on.
	Behaviour:	Until the condense switch is on full position, phase LEDs blink. When the switch goes on void position the LEDs are switched OFF.
	Working conditions:	Door closed.

Position 8 (Dryer with CONDUCTIMETRIC sensor)

Conductimetric sensor. Drum open circuit	Purpose of test:	To verify conductimetric sensor in open circuit condition.
 	Activated components:	Conductimetric sensor reading.
	Behaviour:	The step lasts 4 seconds (software configured). During this time all phase LEDs blinks to give information of acquisition phase. At the end of step phase LEDs are switched OFF to give ok, otherwise they blink forever (no sensor alarm are managed in this step).
	Working conditions:	Door closed.

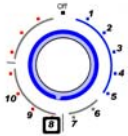
Position 8 (Dryer TEMPEROMETRIC sensor)

Last alarm display and possible reset	Purpose of test:	To see the allarm and reset it
 	Behaviour:	The LCD displays the alarm while the LED will flash on the basis of alarm
	Working conditions:	Turn the knob till position 10, paying attention not to stop to position 7, otherwise error 32 may occur

Position 9 (Dryer with CONDUCTIMETRIC sensor)

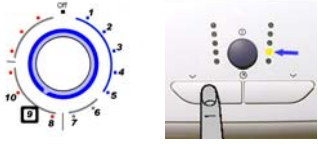
Condense Tank Switch	Purpose of test:	To test the tank switch.
	Activated components:	If the pump is full of water and the tank switch recognises the condition, the pump is switched on.
	Behaviour:	Until the condense switch is on full position, phase LEDs blink. When the switch goes on void position the LEDs are switched OFF.
	Working conditions:	Door closed.

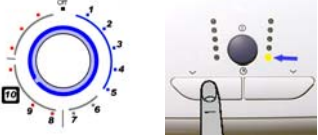

Position 10 (Dryer with CONDUCTIMETRIC sensor)

Last alarm display and possible reset	Purpose of test:	To see the allarm and reset it
	Behaviour:	The LCD displays the alarm while the LED will flash on the basis of alarm
	Working conditions:	Turn the knob till position 10, paying attention not to stop to position 7, otherwise error 32 may occur

4 DIAGNOSTICS on ENV06 / ENV06 AEG CLOTHES REFRESHMENT

4.1 Access to diagnostics

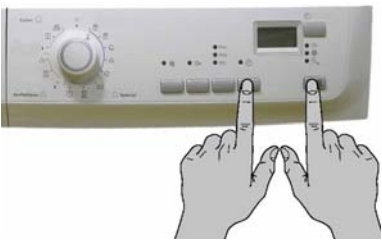
1. Press the defined combination key
(START + the nearest key on the left) and keeping them pressed
2. Switch on the machine rotating the main selector in the 1st position CW..
3. Within 5 second phases led blinks and buzzer sounds to give acknowledge of the operation.

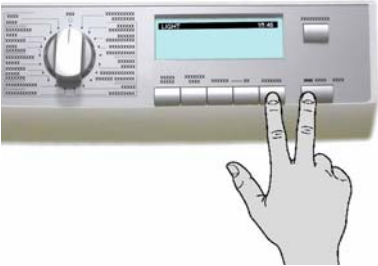
	ENV06	ENV06 AEG	ENV06 Catalogue / action
TC3			
TC2			

4.2 Exiting the diagnostics system

To exit from DIAGNOSTIC mode it's sufficient to switch off the machine.

According to the machine configuration, it's possible that the next machine switch on, the electric test cycle will be activated. To stop it, switch off again the machine.

Moving the main knob in clockwise direction, the following tests will be done:

Position 1

User Interface Test	Purpose of test:	To test the functionality of all leds and switches
	Activated components:	All LEDs and LCD
	Behaviour	All led in sequence, pushing a button correspondent led is lighted on, the key number is showed on LCD and the buzzer sound. All LCD icons blink together.
	Working conditions:	There is any control to run test (always active)

Position 2

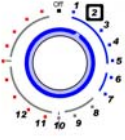
Condense tank switch and pump + steamer tank Switch, heater and NTC	Purpose of test:	To test the condense tank pump and switch. To test the steamer tank switch, heater and NTC
	Activated components:	If the pump is full of water and the tank switch recognises the condition, the pump is switched on. Steamer starts heating up procedure activating heater. Once the temperature reaches heating up setting (135°), it is controlled between working limits (130° - 150°).
	Behaviour	If steamer tank switch is on void position, the related icon blinks on LCD, but this not prevents the steamer to be heated up.

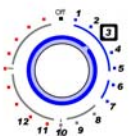
Position 3 Steamer Pump + Steamer Water/Steam Pipes (Visual)	Purpose of test:	To test the steamer pump and steamer in general (pipes, connections, etc.).
	Activated components:	Steamer heater is switched on to maintain steamer temperature between working limits (130° - 150°). The steamer pump is activated with short impulses (as configured) to allow correct steam generation.
	Behaviour	The digits on LCD show NTC2 steamer temperature. Phase LEDs are switched ON.
	Working conditions:	Door closed (Time out 10 min.)

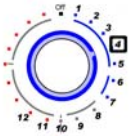
Position 4 Counter clockwise drum rotation	Purpose of test:	To test drum motor in counter-clockwise direction.
	Activated components:	Motor triac and relay of direction (for assembly line request, in this position will be switched on tank pump also).
	Behaviour	Phase LEDs are switched ON
	Working conditions:	Door closed (Time out 10 min.)

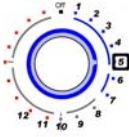
Position 5 Slow Clockwise drum rotation (+ Reduced Fan for ENV06 CRM 2 motors)	Purpose of test:	To test drum motor in clockwise direction
	Activated components:	Drum Motor triac. The motor performs a low-speed movement (for assembly line request). Main Fan motor is activated on inverse direction (to test direction relay)
	Behaviour	Phase LEDs are switched ON
	Working conditions:	Door closed (Time out 10 min.)

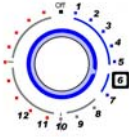
Position 6 Heater ½ power + Clockwise drum rotation + Full Fan	Purpose of test:	To test the ½ heating power element.
	Activated components:	High heating element, Drum Motor and Main Fan on direct direction to give ventilation (full speed).
	Behaviour	The digits on LCD show NTC1 drying temperature. Phase LEDs are switched ON.
	Working conditions:	Door closed (Time out 10 min.)

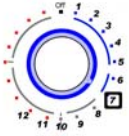
Position 7 Heater full power + Clockwise drum rotation + Full Fan	Purpose of test:	To test the ½ & full power-heating element.
	Activated components:	Both heating elements, Drum Motor and Main Fan on direct direction to give ventilation full speed.
	Behaviour	The digits on LCD show NTC1 drying temperature. Phase LEDs are switched ON.
	Working conditions:	Door closed (Time out 10 min.)

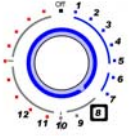
Position 8	
Conductimetric sensor. Drum short circuit	Purpose of test: To verify conductimetric sensor in short circuit condition.
	Activated components: Conductimetric sensor reading.
	Behaviour: The step lasts 4 seconds (software configured). During this time all phase LEDs blink to give information of acquisition phase. At the end of step phase LEDs are switched OFF to give ok, otherwise a sensor alarm is generated (if sensor alarms are enabled, otherwise phase LEDs blink forever).
	Working conditions: Door closed. 1 second to create the short circuit

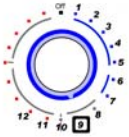
Position 9	
Conductimetric sensor. Drum open circuit	Purpose of test: To verify conductimetric sensor in open circuit condition.
	Activated components: Conductimetric sensor reading.
	Behaviour: The step lasts 4 seconds (software configured). During this time all phase LEDs blink to give information of acquisition phase. At the end of step phase LEDs are switched OFF to give ok, otherwise they blink forever (no sensor alarm are managed in this step).
	Working conditions: Door closed.

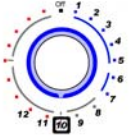
Position 10	
Condense Tank Switch	Purpose of test: To test the tank switch
	Activated components: If the pump is full of water and the tank switch recognises the condition, the pump is switched on.
	Behaviour: Until the condense switch is on full position, phase LEDs blink. When the switch goes on void position the LEDs are switched OFF.
	Working conditions: Door closed.





Position 11	
Condenser Tank Switch	Purpose of test: To test the steamer tank switch. The machine expects to have not water inside steamer tank
	Activated components: Steamer heater and steamer pump are activated to try to remove all water that could be on water circuit
	Behaviour: If steamer tank switch is on void position, the related icon blinks on LCD, but this not prevents the steamer to be heated up. The digits on LCD will show NTC2 steamer temperature. Phase LEDs are switched ON.
	Working conditions: Door closed (Time out 30 sec.)

Position 12	
Last alarm display and possible reset	Purpose of test: To see the alarm and reset it
	Behaviour: The LCD displays the alarm while the LED will flash on the basis of alarm
	Working conditions: Turn the knob till position 10, paying attention not to stop to position 7, otherwise error 32 may occur

5 DIAGNOSTICS on ENV06 HP / ENV06 AEG HP

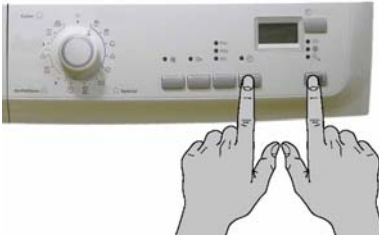
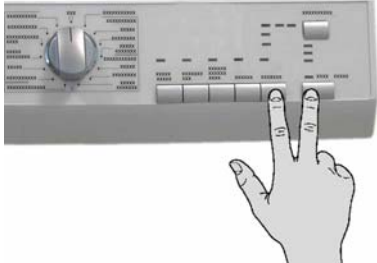
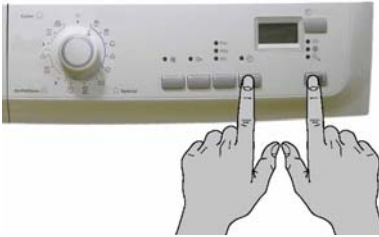
5.1 Access to diagnostics

4. Press the defined combination key
(START + the nearest key on the left) and keeping them pressed
5. Switch on the machine rotating the main selector in the 1st position CW..
6. Within 5 second phases led blinks and buzzer sounds to give acknowledge of the operation.

	ENV06	ENV06 AEG
TC5		
TC3		
TC2		

5.2 Exiting the diagnostics system

To exit from DIAGNOSTIC mode it's sufficient to switch off the machine.

According to the machine configuration, it's possible that the next machine switch on, the electric test cycle will be activated. To stop it, switch off again the machine.

Moving the main knob in clockwise direction, the following tests will be done:

Position 1

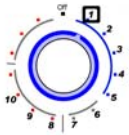
User Interface Test	Purpose of test:	To test the functionality of all leds and switches
	Activated components:	All LEDs and LCD (if present)
	Behaviour	All led in sequence, pushing a button correspondent led is lighted on, the key number is showed on LCD and the buzzer sound. All LCD icons blink together
	Working conditions:	There is any control to run test (always active).

Position 2

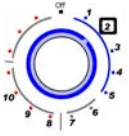
	Condense Tank Switch and Pump	Purpose of test:	To test the condense tank pump and switch
	Activated components:	If the pump is full of water and the tank switch recognises the condition, the pump is switched on.	
	Behaviour:	Until the condense switch is on full position, phase LEDs blink; When the switch goes on void position the LEDs are switched ON.	
	Working conditions:	Door closed (Time out 10 min.)	

Position 3

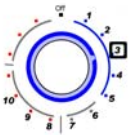
	Counter Clockwise drum rotation	Purpose of test:	To test drum motor in counter-clockwise direction.
	Activated components:	Motor triac and relay of direction (for assembly line request, in this position will be switched on tank pump also).	
	Behaviour:	Phase LEDs are switched ON.	
	Working conditions:	Door closed (Time out 10 min.)	

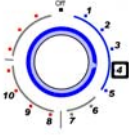

Position 4

	Reduced Clockwise drum rotation	Purpose of test:	To test drum motor in clockwise direction.
	Activated components:	Drum Motor triac. The motor performs a low-speed movement (for assembly line request). Main Fan motor is activated on inverse direction (to test direction relay)	
	Behaviour:	Phase LEDs are switched ON.	
	Working conditions:	Door closed (Time out 10 min.)	

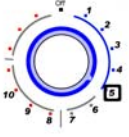
Position 5

	Clockwise drum rotation + Main Fan	Purpose of test:	To test motor in clockwise direction, circulation fan motor TRIAC and the function of the main fan.
	Activated components:	Drum Motor on clockwise direction and the main ventilation motor.	
	Behaviour:	The digits on LCD show NTC1 drying temperature.	
	Working conditions:	Door closed (Time out 10 min.)	

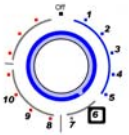
Position 6

	Clockwise drum rotation + Main Fan + compressor	Purpose of test:	To test motor in clockwise direction, circulation fan motor TRIAC, the function of the main fan and the compressor
	Activated components:	Drum Motor on clockwise direction, main ventilation motor, compressor motor and the compressor cooling fan.	
	Behaviour:	The digits on LCD show NTC1 drying temperature.	
	Working conditions:	Door closed (Time out 10 min.)	
			On completion of this test, the compressor re-starts only after a pause of 5 minutes.

Position 7

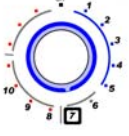
Conductimetric sensor. Drum short circuit 	Purpose of test:	To verify conductimetric sensor in short circuit condition.
	Activated components:	Conductimetric sensor reading.
	Behaviour:	The step lasts 4 seconds (software configured). During this time all phase LEDs blinks to give information of acquisition phase. At the end of step phase LEDs are switched OFF to give ok, otherwise a sensor alarm is generated (if sensor alarms are enabled, otherwise phase LEDs blinks forever).
	Working conditions:	Door closed. 1 second to create the short circuit

Position 8

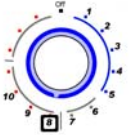
Conductimetric sensor. Drum open circuit 	Purpose of test:	To verify conductimetric sensor in open circuit condition.
	Activated components:	Conductimetric sensor reading.
	Behaviour:	The step lasts 4 seconds (software configured). During this time all phase LEDs blinks to give information of acquisition phase. At the end of step phase LEDs are switched OFF to give ok, otherwise they blink forever (no sensor alarm are managed in this step).
	Working conditions:	Door closed.

Position 9

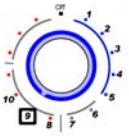
Condense Tank Switch 	Purpose of test:	To test the tank switch
	Activated components:	If the pump is full of water and the tank switch recognises the condition, the pump is switched on.
	Behaviour:	Until the condense switch is on full position, phase LEDs blink. When the switch goes on void position the LEDs are switched OFF.
	Working conditions:	Door closed.

Position 10

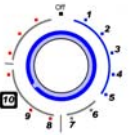
Last alarm display and possible reset 	Purpose of test:	To see the alarm and reset it
	Behaviour:	The LCD displays the alarm while the LED will flash on the basis of alarm
	Working conditions:	Turn the knob till position 10, paying attention not to stop to position 7, otherwise error 32 may occur

6 ALARMS ENV06 dryers

6.1 Displaying the alarms to the user

Operation of the alarms is configurable according to the model. Some or all of the alarms may be displayed to the user.

When an alarm condition occurs, the drying cycle may be interrupted or paused; in some cases, for the sake of safety, a forced cooling cycle is performed. In this case, the electronic board, if possible, disconnects the power relay from the heater unit and powers the motor of the drum cooling fan. The cycle remains active until the user switches off the appliance.

6.2 Alarm display during normal operation

On models with LCD the system displays the family of the current alarm to the user.

If for example we consider E53 alarm (problems with the motor TRIAC) the display will show as follows:

- First digit: letter “E” (error)
- Second-third digit: the no. “5 0”, i.e. the family of alarm E53)

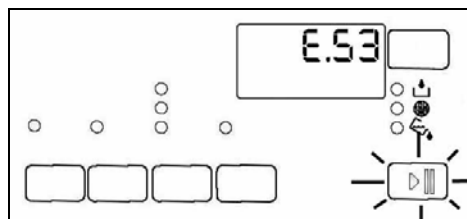

The same number is displayed by a repeated flashing sequence of START LED of RED colour with a cycle (0,4 seconds on, 0,4 seconds off with a 2,5 second pause between the sequences); in case of E53, the series of five flashes indicates the **first** of the two E53 alarm digits (the alarms relative to the same function are grouped in families).

6.3 Reading the alarm codes

To read the last alarm code memorized in the EEPROM of the electronic board:

- ⇒ Access diagnostics mode (see paragraph).
- ⇒ Turn the programme selector knob clockwise to see the last alarm (for more information see the diagnostic section), **paying attention not to stop in other positions, because error 32 could occur**).

6.4 Displaying the alarm code on models with LCD

- First digit: letter “E”
- Second digit: the family of the alarm
- Third digit: the alarm number

6.5 Displaying the alarm code in all models without LCD

The alarm code is displayed by a repeated sequence of flashing of the LED START (0.4 seconds on, 0.4 seconds off, with a pause of 2.5 seconds between sequences).

The buzzer emits a series of "beeps" in synchronization with the flashing of the LED.

START LED with RED light: indicates the first digit of the alarm code (family)

START LED with GREEN light: indicates the second digit of the alarm code (number inside the family).

Displaying other alarm codes

Pressing START button, all alarms in the appliance will be displayed.

The configuration errors E93 are displayed through the flashing of all LEDs and it is not possible to access the diagnostics system.

6.6 Cancelling the last alarm memorized

It is good practise to cancel the alarm code from memory:

- After reading the alarm, to check whether it is repeated during the diagnostics cycle.
 - After effecting repairs to the appliance, to check whether it is repeated during testing.
1. Turn the programme selector knob clockwise to see the last alarm (for more information see the diagnostic section), **paying attention not to stop in other positions, because error 32 could occur**.
 2. Hold down buttons **START + the nearest key on the left** about 5 seconds.
 3. Once the alarm has been cancelled, **E00** is displayed.

6.7 Notes concerning certain alarm codes

- **Configuration alarm E93:** When configuration alarms are displayed (when the appliance is switched on), the appliance is inoperative and all the LEDs light. It is not possible to access diagnostics mode; the only possible operation is that of switching off the appliance (selector knob on position "0").
- **Alarms EH1-EH2-EH3:** In the event of problems with the power supply, the appliance remains in alarm mode until the voltage and frequency are restored to within the normal limits or the appliance is switched off (selector knob on position "0"). Alarm family "**B**" is displayed and it is not possible to access diagnostics mode nor to use the "rapid alarm display" function. The complete alarm can be read only when the abnormal condition has terminated.

7 ENV06 TUMBLE DRYERS ALARMS TABLE SUMMARY

FAMILY		ALARM CODE	Short Name	Full Name	Action	Notes and Possible Causes
Ex20	TANK PUMP	Ex21	PUMP_TRIAC_AL	Condense Pump Alarm	Stops cycle execution. If detected on setup, does not allow cycle start.	<ul style="list-style-type: none"> Tank Pump Disconnected (Wiring or Connector Failure) Tank Pump Failure Tank Pump Triac Failure (Short Circuit, Diode Mode, Open Circuit) (Main Board Failure)
		Ex22	PUMP_TRIAC_S_AL	Condense Pump Sensing Alarm	Stops cycle execution. If detected on setup, does not allow cycle start.	Pump Triac Sensing Circuit Failure (Main Board Failure)
Ex30	CONDUCTIMETRIC SENSOR	Ex31	SENS_F_TOO_HIGH_AL	Conductimetric Sensor Frequency too HIGH	No Action	Active only during HUMIDITY SENSOR SHORT CIRCUIT diagnostic. The oscillation Frequency is out of Range (Main Board Failure)
		Ex32	SENS_F_TOO_LOW_AL	Conductimetric Sensor Frequency too LOW	No Action	Active only during HUMIDITY SENSOR SHORT CIRCUIT diagnostic. <ul style="list-style-type: none"> The Drum is not Shortcuted Wiring Failure The oscillation Frequency is out of Range (Main Board Failure)
Ex40	DOOR	Ex45	DOOR_CLOSED_S_AL	Door Closed Sensing Alarm	Stops cycle execution. If detected on setup, does not allow cycle start.	Door Closed Sensing Circuit Failure (Main Board Failure)
E0x50	DRUM MOTOR	Ex51	MOTOR_TRIAC_AL	Drum Motor Alarm	Stops cycle execution. If detected on setup, does not allow cycle start.	<ul style="list-style-type: none"> Drum Motor Disconnected (Wiring or Connector Failure) Drum Motor Capacitor (disconnected or broken) Drum Motor Failure Drum Motor Triac Failure (Short Circuit, Diode Mode, Open Circuit) (Main Board Failure)
		Ex52	MOTOR_TERM_AL	Drum Motor Thermal cut-off Alarm	Disables motor for a while, waiting for possible thermal restoration. If after 30 minutes (more or less) the situation does not return normal sets 0x51 alarm	<ul style="list-style-type: none"> Drum Motor Failure Drum Motor Triac Failure (Short Circuit, Diode Mode, Open Circuit) (Main Board Failure)
		Ex53	MOTOR_TRIAC_S_AL	Drum Motor Sensing Alarm	Stops cycle execution. If detected on setup, does not allow cycle start.	Drum Motor Triac Sensing Circuit Failure (Main Board Failure)
		Ex54	MOTOR_JAMMED	Motor Jammed Alarm	When the motor is not able to start rotation within 5 seconds from activation command, a retrial procedure starts. The motor is stopped for 10 seconds then is activated again. If it does not start rotation again, this procedure continue (180 times). After these retrials, alarm is set and visualized. The cycle is paused. To clear the alarm and the cycle in enough pressing START.	<ul style="list-style-type: none"> Too much load into the drum Too low power supply voltage Drum/Motor mechanical abnormal frictions Drum Motor Capacitor (disconnected or broken) Drum Motor Failure
		Ex57	FCV_CURRENT_TRIP_AL	FCV Current Trip Failure	Disables motor moving and shutdon FCV board for 2 mintues, then FCV is switched on and drum moving enbaled. If this problem conitues after 5 retrials the cycle is stopped and FCV boards switched off definitively (until next machine reset)	<ul style="list-style-type: none"> FCV Board - Motor Wiring Motor Connector FCV Board

		Ex58	FCV_OVER_CURRENT_AL	FCV over current Failure	Disables motor moving and shutdown FCV board for 20 seconds, then FCV is switched on and drum moving enabled. If this problem continues after 5 retries the cycle is stopped and FCV boards switched off definitively (until next machine reset)	<ul style="list-style-type: none"> ▪ FCV Board - Motor Wiring ▪ Motor Connector ▪ FCV Board
		Ex59	FCV_NOT_FOLLOWING_AL	FCV not following Failure	Disables motor moving and shutdown FCV board for 20 seconds, then FCV is switched on and drum moving enabled. If this problem continues after 5 retries the cycle is stopped and FCV boards switched off definitively (until next machine reset)	<ul style="list-style-type: none"> ▪ FCV Board - Motor Wiring ▪ Motor Connector ▪ FCV Board
		Ex5B	FCV_UNDER_VOLTAGE_AL	FCV under voltage Failure	Disables motor moving and shutdown FCV board for 20 seconds, then FCV is switched on and drum moving enabled. If this problem continues after 5 retries the cycle is stopped and FCV boards switched off definitively (until next machine reset)	<ul style="list-style-type: none"> ▪ Main Board - FCV power supply wiring ▪ FCV Board Failure
		Ex5C	FCV_OVER_VOLTAGE_AL	FCV over voltage Failure	Disables motor moving and shutdown FCV board for 2 minutes, then FCV is switched on and drum moving enabled. If this problem continues after 5 retries the cycle is stopped and FCV boards switched off definitively (until next machine reset)	FCV BOARD Failure
		Ex5D	FCV_UNKNOWN_MSG_AL	FCV unknown message Failure	No action	
		Ex5E	FCV_MB_COM_AL	Wrong FCV - Main Board communication	Disables motor moving and shutdown FCV board for 20 seconds, then FCV is switched on and drum moving enabled. If this problem continues after 47 retries of 20 seconds + last 20 minutes retry, the cycle is stopped and FCV boards switched off definitively (until next machine reset)	<ul style="list-style-type: none"> ▪ Main Board - FCV communication wiring ▪ Main Board - FCV power supply wiring ▪ Motor Thermal Cutoff ▪ Main Board or FCV Board Failure
		Ex5F	FCV_FAULT_AL	FCV Failure	Disables motor moving and shutdown FCV board for 20 seconds, then FCV is switched on and drum moving enabled. If this problem continues after 5 retries the cycle is stopped and FCV boards switched off definitively (until next machine reset)	FCV BOARD Failure
Ex60	HEATING ELEMENTS	Ex62	HEAT_RELAY_FAILURE / COMP_RELAY_FAIL	Heaters Alarm (or Compressor Alarm for Heat Pump)	Stops cycle execution. If is an Heater Alarm (no Heat Pump) starts automatically a safety "Cooling Alarm - 10 minutes". If detected on setup, does not allow cycle start.	<ul style="list-style-type: none"> ▪ Heaters Disconnected (Wiring or Connector Failure, Manual Thermostat Cut-off) ▪ Heaters Failure ▪ Heaters Relay Failure (Main Board Failure)
		Ex63	HEAT_ELEM_AUT_TERM / COMP_AUT_THERM,	Heaters Thermal cut-off Alarm (or Compressor Thermal Alarm for Heat Pump)	Disables heater/compressor for a while, waiting for possible thermal restoration. If after 30 minutes (more or less) the situation does not return normal sets 0x62 alarm	
		Ex64	HEAT_S_AL / COMPRESSOR_S_AL	Heaters Sensing Alarm (or Compressor Sensing Alarm for Heat Pump)	Stops cycle execution. If detected on setup, does not allow cycle start.	Heaters Sensing Circuit Failure (Main Board Failure)
		Ex65	MAIN_FAN_TRIAC_AL	Main Fan Alarm	Stops cycle execution. If detected on setup, does not allow cycle start.	<ul style="list-style-type: none"> ▪ Main Fan Motor Disconnected (Wiring or Connector Failure) ▪ Main Fan Motor Failure ▪ Main Fan Motor Triac Failure (Short Circuit, Diode Mode, Open Circuit) (Satellite Board Failure)
		Ex66	MAIN_FAN_AUT_THERM	Main Fan Thermal cut-off Alarm	Disables main fan and heater/compressor for a while, waiting for possible thermal restoration. If after 30 minutes (more or less) the situation does not return normal sets 0x66 alarm	
		Ex67	MAIN_FAN_TRIAC_S_AL	Main Fan sensing alarm	Stops cycle execution. If detected on setup, does not allow cycle start.	Main Fan Triac Sensing Circuit Failure (Satellite Board Failure)

0x70	NTC	Ex71	DRYING_NTC1_AL	Drying NTC Alarm	Stops cycle execution. If detected on setup, does not allow cycle start.	NTC1 reading out of Range <ul style="list-style-type: none"> Wiring Failure NTC Failure NTC reading circuit Failure (Main Board Failure)
		Ex72	DRYING_NTC2_AL	Steamer NTC Alarm	Stops cycle execution. If detected on setup, does not allow cycle start.	NTC2 reading out of Range <ul style="list-style-type: none"> Wiring Failure NTC Failure Wrong NTC configuration NTC reading circuit Failure (Main Board Failure)
0x80	UI	Ex82	WRONG_RESET_POS_AL	Wrong Reset Position on Selector	Stops cycle execution. If detected on setup, does not allow cycle start.	The Main Board is powered also in RESET Position <ul style="list-style-type: none"> Wiring Failure Selector Failure (Main Board Failure)
		Ex83	WRONG_SEL_READ_AL	Wrong Selector code	No Action	The position code of the selector is not recognized. <ul style="list-style-type: none"> Wrong Selector Configuration (Main Board Failure) Selector Failure (Main Board Failure)
Ex90	CFG	Ex91	UI_MB_COM_AL	User Interface Communication Alarm	Disables cycle execution until the communication is not restored. If detected on setup, does not allow cycle start.	<ul style="list-style-type: none"> Wiring Failure User Interface Board Failure Main Board Failure
		Ex92	UI_MB_PROT_INCONG_AL	User Interface Protocol Incongruence Alarm	Stops cycle execution. If detected on setup, does not allow cycle start.	The User Interface mounted is not compatible with the Main Board connected
		Ex93	CFG_AL	MCF Checksum Alarm	The machine could not work until a right configuration file is programmed	wrong Machine Configuration File
		Ex94	CFG_CYC_AL	CCF Checksum Alarm	The machine could not work until a right configuration file is programmed	wrong Cycle Configuration File
		Ex97	SCFCTF_MISMATCH_AL	Missing Program on CTF Alarm	Detected only on setup. Does not allow cycle start.	wrong selector configuration (MCF) or missing cycle on cycle table (CCF)
		Ex9b	UI_EFL_COMM_AL	User Interface External Flash Communication Alarm	No Action	User Interface Board Failure
		Ex9C	UI_CFG_CHKS_AL	User Interface configuration checksum alarm	No Action	<ul style="list-style-type: none"> Main Board - wrong MCF Main Board - User Interface Communication problems
		Ex9d	UI_RTC_AL_CODE_AL	Real Time Clock alarm	No Action	User Interface Board Failure
ExA0	BUS COMMUNICATION	ExA1	CRM_BOARD_COM_AL	CRM Satellite Board Communication Alarm	Disables cycle execution until the communication is not restored.	<ul style="list-style-type: none"> Wiring Failure Satellite Board Failure Main Board Failure
		ExA2	CRM_BOARD_PROT_INCONG	CRM Satellite Board Protocol Incongruence Alarm	Stops cycle execution. If detected on setup, does not allow cycle start.	Software of Main Board and Satellite Board are not compatible (Main Board or Satellite Failure)
		ExA5	INPUT_BOARD_COMM_AL	Input Board Communication Alarm	No Action	<ul style="list-style-type: none"> Wiring Failure Input Board Failure Main Board Failure

EXB0 (EXH0)	POWER SUPPLY	ExB1	BAD_FREQ_AL	Power Supply Frequency out of Range	If detected in setup, it would not be possible cycle starting. If happens during cycle execution, it suspend working. It is automatically cleared when power supply return within right limits, it would be possible to start. If a cycle was temporary suspended due to this alarm it automatically restarts.	<ul style="list-style-type: none"> Power Supply Problems wrong MCF Main Board failure
		Exh1				
		ExB2	VOLT_TOO_HIGH_AL	Power Supply Amplitude out of Range (too HIGH)		<ul style="list-style-type: none"> Power Supply Problems - Too HIGH VOLTAGE wrong MCF Main Board failure
		Exh2				
		ExB3	VOLT_TOO_LOW_AL	Power Supply Amplitude out of Range (too LOW)		<ul style="list-style-type: none"> Power Supply Problems - TOO LOW VOLTAGE wrong MCF Main Board failure
		Exh3				
EXC0	CLOTHES REFRESHMENT	ExC1	MAIN_V_INCONGR_AL	Power Supply Amplitude out of Range	No Action. It is automatically cleared when power supply return within right limits	<ul style="list-style-type: none"> Wiring Failure Satellite Board Failure
		ExC2	ZC_INCONGR_AL	Power Supply Frequency out of Range		<ul style="list-style-type: none"> Wiring Failure Satellite Board Failure
		ExC3	STEAM_HEATING_TOUT	Steamer Heating-up Timeout Alarm	No Action	Active only on diagnostic cycle. The NTC2 temperature grows too slowly <ul style="list-style-type: none"> NTC2 not well fixed. Steamer Failure
		ExC4	STEAM_HEATER_RL_FAIL	Steamer Heater Alarm	Stops cycle execution. If detected on setup, does not allow cycle start.	<ul style="list-style-type: none"> Steamer Heater Disconnected (Wiring or Connector Failure, Heater Thermal Cut-off) Steamer Heater Failure Steamer Heater Relay Failure (Satellite Board Failure)
		ExC5	STEAM_HEATER_TERM	Steamer Heater Thermal Cut-off Alarm	Stops cycle execution. If detected on setup, does not allow cycle start.	
		ExC6	STEAM_HEATER_S_AL	Steamer Heater Sensing Alarm	Stops cycle execution. If detected on setup, does not allow cycle start.	Steamer Heater Sensing Circuit Failure (Satellite Board Failure)
		ExC7	STEAM_PUMP_TRIAC_AL	Steam Pump Alarm	Stops cycle execution. If detected on setup, does not allow cycle start.	<ul style="list-style-type: none"> Steam Pump Disconnected (Wiring or Connector Failure, Diode broken) Steam Pump Failure Steam Pump Triac Failure (Short Circuit, Diode Mode, Open Circuit) (Satellite Board Failure)
		ExC8	STEAM_PUMP_DIODE_AL	Steam Pump Diode Alarm	Disables steamer activation.	Steam Pump Diode Shortcuted or missing
		ExC9	STEAM_PUMP_TRIAC_S_AL	Steam Pump Sensing Alarm	Stops cycle execution. If detected on setup, does not allow cycle start.	Steam Pump Triac Sensing Circuit Failure (Satellite Board Failure)
		ExCA	NO_STEAM_WATER_AL	Missing Steamer Water Alarm	Disables steamer activation until cycle end. At end cycle signals missing steam water.	<ul style="list-style-type: none"> No water into steam tank (level sensor disconnected or broken) Water pipes clogged or broken Steam pipes clogged or broken

8 HEATER

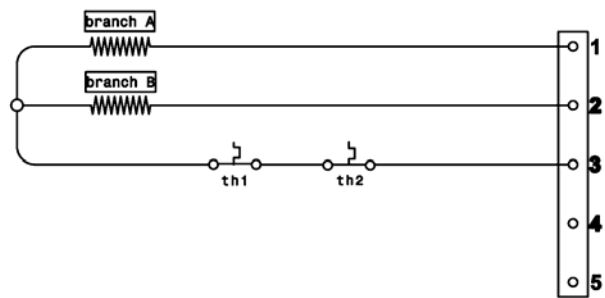
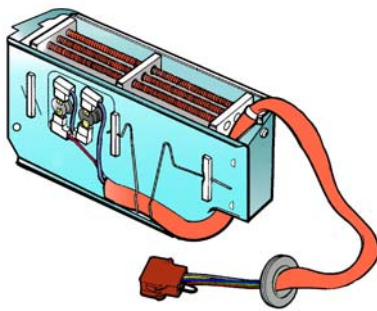

Voltage (V)	Nominal power (W)		20°C Resistance (Ω)	
	Branch A (1-3)	Branch B (2-3)	Branch A (1-3)	Branch B (2-3)
230	1400	800	33,95	79,67
230	1400	800	33,89	59,75
230	1400	900	33,89	53,11
240	1400	800	36,90	86,75
240	1400	800	36,97	65,06
240	1400	900	36,97	57,83
230	1400	700	33,89	67,78
240	1400	700	36,90	73,80

9 NTC sensor

1. Metallic capsule
2. NTC Resistor
3. Terminals

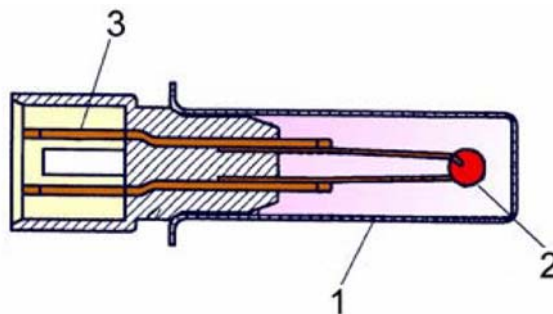

TEMPERATURE (°C)	RESISTANCE (Ω)		
	Rated value	Maximum value	Minimum value
20	6050	6335	5765
60	1250	1278	1222
80	640	620	660

10 MOTOR

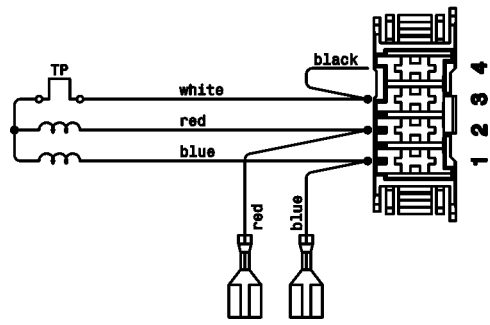
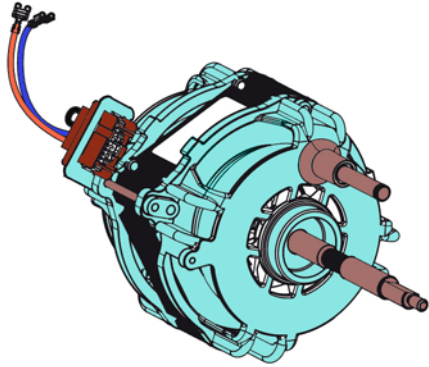

Characteristics

370524117	Voltage Hz Ampere Capacitor Resistance	220/240v 50 Hz 1.1 A 8 μ F PIN 1-3 22 Ω PIN 2-3 20.8 Ω \pm 7%
12512890 12512891	Voltage Hz Ampere Capacitor Resistance	220/240v 50 Hz 0,6A 6 μ F PIN 1-3 26,2 Ω PIN 2-3 26,2 Ω \pm 7%

11 CANISTER FILLING PUMP

The pump is actioned by a synchronous motor.

Volt	220/230
HZ	50/60
Power	17W
Resistance	750 Ω

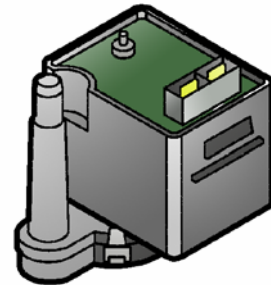

12 COMPRESSOR

Volt 220/230
Power 550W
Oil load 320 cm³ ISO VG 22 ESTER
Liquid coolant R134a
Total weight 14 kg
Resistance of primary winding 3.6 Ohm
Resistance of secondary winding 7.0 Ohm



1. Compressor
2. Run capacitor
3. Motor overload cut-out

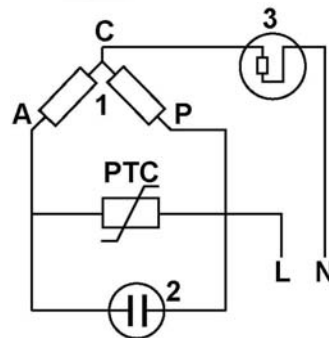

13 PTC Motor protection

1. PTC (positive temperature coefficient) necessary to determine the direction of rotation during the start-up phase
2. protective casing comprising a bimetal element which trips when the motor absorbs too much current due to overloading.

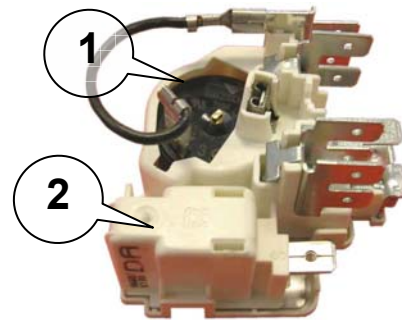

14 FAN COOLING COMPRESSOR

Volt 220/230
HZ 50
Power 23W
2600 / 3000 rpm.



15 AIR CIRCULATION FAN

Volt 220V
 Power 150W
 2450rpm

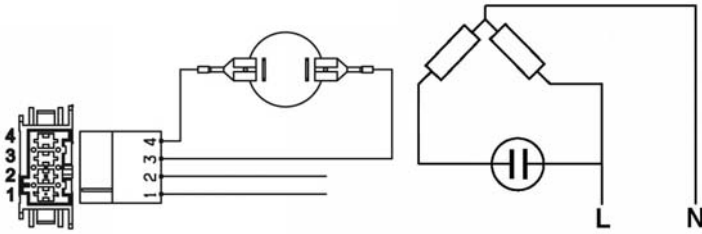

16 Checking the efficiency of the heat pump

To check the efficiency of the heat pump, place the sensors in the positions indicated in the figure and compare the resulting graphs with those shown below.

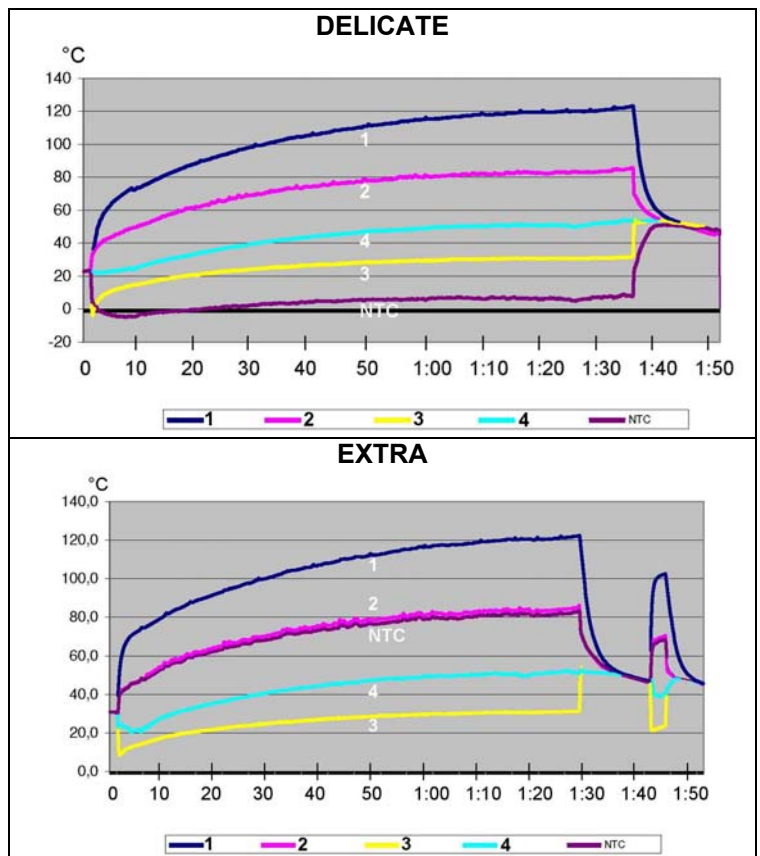
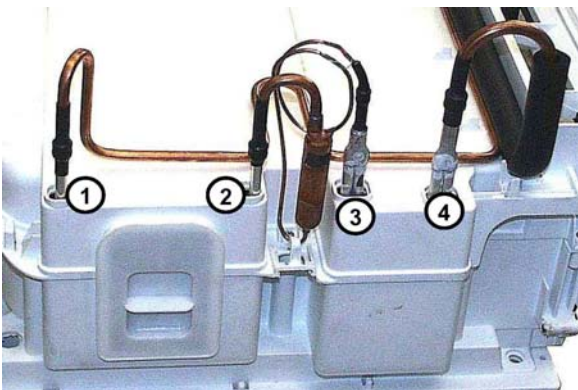

17 STEAMER

Diagrams

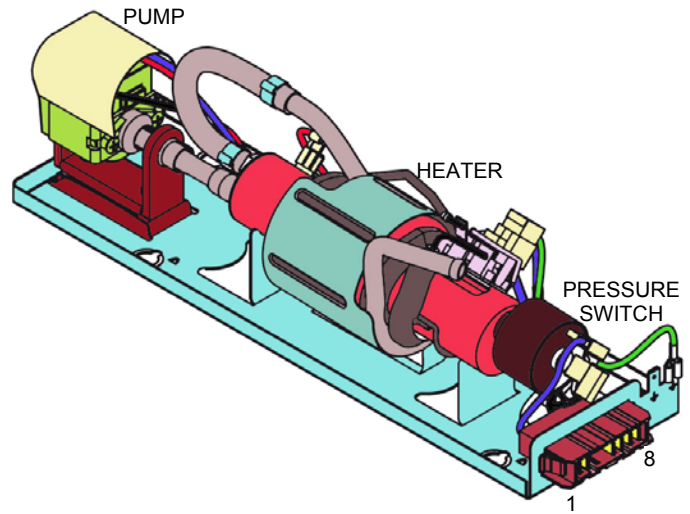
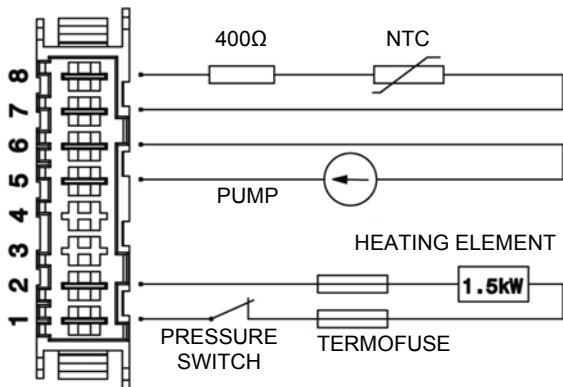

Heater	
Volt	220 / 230 V
Power	1500 W
Hz	50 Hz
Resistance at 25°C	34,93 Ω ± 5%

NTC	
Resistance at 25°C	49,18 KΩ
Resistors in series	400 Ω

Pump	
Volt	220 / 230 V
Power	16 W
Hz	50 Hz
Max Pressure	3,2 Bar

18 List of PNC

18.1 List of PNC - ELC for dryer EDR 1000 NEW

PNC-ELC	Date of first productions	Model	Brand	Service Notes
91609272600	20050902	ADC5330	ArthurMartinElux	599372628
91609272601	20050930	ADC5330	ArthurMartinElux	599373124
91609272602	20051230	ADC5330	ArthurMartinElux	599382977
91609272603	20060110	ADC5330	ArthurMartinElux	599383520
91609272700	20050916	ADC5332	ArthurMartinElux	599372812
91609272701	20060106	ADC5332	ArthurMartinElux	599374549
91609275300	20050930	TCE7127W	Zanussi	599373170
91609372602	20060106	ADC5330	ArthurMartinElux	599374671
91609372701	20060203	ADC5332	ArthurMartinElux	599375679
91609375300	20060106	TCE7127W	Zanussi	599374687
91609375301	20060115	TCE7127W	Zanussi-Electrolux	599380870
91609375302	20060428	TCE7127W	Zanussi-Electrolux	599378713
91609390202	20070920	357_912_00	Zanker	599705659
91609390203	20071221	357_912_00	Zanker	599705661
91609603100	20060203	245610_20453	Privileg	599375711
91609603101	20060210	245610_20453	Privileg	599382608
91609603103	20071025	00245610_20453	Privileg	599708972
91609603104	20090118	00245610_20453	Privileg	599716744
91609603105	20090320	00245610_21215	Privileg	599716747
91609609900	20060707	ADC5340	ArthurMartinElux	599381022
91609612100	20060721	TCE7227W	Zanussi-Electrolux	599381508
91609612200	20060630	887_157_09	Zanker	599380831
91609612201	20071001	887_157_09	Zanker	599717658

18.2 List of PNC - ELC for dryer EDR 2000 NEW

PNC-ELC	Date of first productions	Model	Brand	Service Notes
91609274501	20051021	RA350BE	Rex-Electrolux	599373280
91609274502	20051230	RA350BE	Rex-Electrolux	599374531
91609274700	20051007	ADC5333	ArthurMartinElux	599373241
91609276100	20051007	BKX8680 (PRIVILEG)	Zanker	599373270
91609374501	20060217	RA350BE	Rex-Electrolux	599375960
91609374502	20060210	RA350BE	Rex-Electrolux	599382575
91609374701	20060106	ADC5333	ArthurMartinElux	599374681
91609376100	20060120	BKX8680	Zanker	599375166
91609603800	20060324	887_149_09	Zanker	599377146
91609603801	20071025	887_149_09	Zanker	599710649
91609609800	20060620	ADC5350	ArthurMartinElux	599380828
91609613501	20061201	TK7554	Elektro Helios	599384614

18.3 List of PNC - ELC for dryer EDR 2000 JEWEL

PNC-ELC	Date of first productions	Model	Brand	Service Notes
91609266101	20041008	EDC5330	Electrolux	599366701
91609266102	20050923	EDC5330	Electrolux	599372849
91609266900	20040815	EDC5330	Electrolux	599384279
91609266901	20041015	EDC5330	Electrolux	599366837
91609266902	20050923	EDC5330	Electrolux	599372871
91609267201	20041015	EDC5325	Electrolux	599366848
91609267202	20050923	EDC5325	Electrolux	599372880
91609267203	20051230	EDC5325	Electrolux	599374517
91609267301	20041015	EDC5320	Electrolux	599366857
91609267401	20041015	EDC5330	Electrolux	599366860
91609267402	20050923	EDC5330	Electrolux	599372885
91609268001	20041015	EDC5330	Electrolux	599366898
91609268002	20050923	EDC5330	Electrolux	599372891
91609268100	20040815	EDC5320	Electrolux	599367101
91609268101	20041015	EDC5320	Electrolux	599366901
91609268102	20050923	EDC5320	Electrolux	599372901
91609268501	20041008	EDC5315	Electrolux	599366737
91609268502	20050923	EDC5315	Electrolux	599372909
91609268700	20040709	ZDC5350W	Zanussi-Electrolux	599365333
91609268701	20041008	ZDC5350W	Zanussi-Electrolux	599366749
91609270500	20050204	EDC5322	Electrolux	599368588
91609270501	20050923	EDC5322	Electrolux	599372960
91609270502	20051230	EDC5322	Electrolux	599374521
91609270800	20050204	EDC5330	Electrolux	599368583
91609270801	20050923	EDC5330	Electrolux	599372968
91609270900	20050204	EDC5330	Electrolux	599368593
91609270901	20050923	EDC5330	Electrolux	599372970
91609270902	20051230	EDC5330	Electrolux	599374524
91609271000	20050204	EDC5335	Electrolux	599368596
91609271001	20050930	EDC5335	Electrolux	599373046
91609271100	20050204	EDC5340	Electrolux	599368597
91609271101	20050930	EDC5340	Electrolux	599373048
91609271300	20050204	EDC5335	Electrolux	599368614
91609271301	20050930	EDC5335	Electrolux	599373055
91609271400	20050204	EDC5340	Electrolux	599368615
91609271401	20050930	EDC5340	Electrolux	599373064
91609271402	20051230	EDC5340	Electrolux	599374525
91609274200	20050722	EDC5330	Electrolux	599372117
91609274201	20050930	EDC5330	Electrolux	599373163
91609275600	20050923	EDC5310	Electrolux	599373016
91609366100	20060203	EDC5330	Electrolux	599375391
91609366101	20061215	EDC5330	Electrolux	599385029
91609366900	20060106	EDC5330	Electrolux	599374608
91609367201	20060203	EDC5325	Electrolux	599375553
91609367401	20060203	EDC5330	Electrolux	599375563
91609367402	20061030	EDC5330	Electrolux	599713231
91609368000	20060203	EDC5330	Electrolux	599375566
91609368100	20060203	EDC5320	Electrolux	599375569
91609368500	20060106	EDC5315	Electrolux	599374645
91609368501	20061215	EDC5315	Electrolux	599385042

PNC-ELC	Date of first productions	Model	Brand	Service Notes
91609370501	20060203	EDC5322	Electrolux	599375585
91609370502	20060210	EDC5322	Electrolux	599705639
91609370503	20071221	EDC5322	Electrolux	599705646
91609370800	20060106	EDC5330	Electrolux	599374648
91609370901	20060106	EDC5330	Electrolux	599374649
91609371001	20060106	EDC5335	Electrolux	599374651
91609371101	20060106	EDC5340	Electrolux	599374652
91609371301	20060106	EDC5335	Electrolux	599374654
91609371302	20060210	EDC5335	Electrolux	599382496
91609371401	20060106	EDC5340	Electrolux	599374655
91609371402	20070212	EDC5340	Electrolux	599705950
91609371403	20080215	EDC5340	Electrolux	599705954
91609374200	20060217	EDC5330	Electrolux	599375945
91609374201	20061215	EDC5330	Electrolux	599385060
91609375600	20060113	EDC5310	Electrolux	599375093
91609375601	20061215	EDC5310	Electrolux	599385064
91671680500	20031003	EDC5330	Electrolux	599360784
91671680600	20040716	EDC5330	Electrolux	599365395
91671680700	20040130	EDC5325	Electrolux	599362592
91671680900	20040116	EDC5330	Electrolux	599362328
91671681100	20040213	EDC5330	Electrolux	599362765
91671681200	20040213	EDC5330	Electrolux	599362768
91671681300	20040213	EDC5320	Electrolux	599362774
91671681500	20040220	EDC5315	Electrolux	599362979
91671681600	20040702	ZDC5350W	Zanussi-Electrolux	599365257

18.4 List of PNC - ELC for dryer EDR 2000 CLUB DISPLAY

PNC-ELC	Date of first productions	Model	Brand	Service Notes
91609273800	20050708	058771_10510	Privileg	599371780
91609273801	20050930	058771_10510	Privileg	599373152
91609273803	20060210	058771_10510	Privileg	599377974
91609275000	20051007	RTK2361	Rosenlew	599373182
91609373800	20051201	058771_21210	Privileg	599381801
91609373801	20060106	058771_20637	Privileg	599374673
91609373802	20060210	058771_20637	Privileg	599382517
91609373803	20070713	058771_20964	Privileg	599701040
91609373805	20071002	058771_20964	Privileg	599708359
91609373806	20071231	058771_20964	Privileg	599708360
91609375001	20060217	RTK2361	Rosenlew	599375985
91609600502	20060324	CMKEASYII	Marijnen	599377075
91609603002	20060324	ZTE280	Zanussi	599377141
91609603003	20071025	ZTE280	Zanussi	599710377

18.5 List of PNC - ELC for dryer ENV06 / ENV06 AEG / ENV 06 CATALOGUE / ENV06 ACTION / ENV06 INPUT

PNC-ELC	Date of first productions	Model	Brand	Service Notes
91609336100	20090814	EDE47130W	Electrolux	599720936
91609391400	20060825	RDC66130W	Rex-Electrolux	599382315
91609391401	20070105	RDC66130W	Rex-Electrolux	599385418
91609391700	20060929	EDC66130W	Electrolux	599382841
91609391701	20071231	EDC66130W	Electrolux	599707756
91609391702	20081016	EDC66130W	Electrolux	599717531
91609392500	20061222	615486_20796	Privileg	599385197
91609393301	20070622	RDC77170W	Rex-Electrolux	599389967
91609394400	20080905	EDC67130W	Electrolux	599710937
91609394402	20081007	EDC67130W	Electrolux	599717550
91609394800	20090213	ZTE170	Zanussi	599715651
91609394801	20090626	ZTE170	Zanussi	599719899
91609394900	20090327	TK7526	Elektro Helios	599717147
91609394901	20090918	TK7526	Elektro Helios	599721616
91609395000	20090327	ZTE171	Zanussi	599717152
91609395001	20090918	ZTE171	Zanussi	599721627
91609420101	20070511	ADC37100W	ArthurMartinElux	599388495
91609420103	20080820	ADC37100W	ArthurMartinElux	599717552
91609420104	20081217	ADC37100W	ArthurMartinElux	599718461
91609420105	20090704	ADC37100W	ArthurMartinElux	599721156
91609420700	20080606	TM321W	Tricity Bendix	599708607
91609420701	20080827	TM321W	Tricity Bendix	599717588
91609420702	20081203	TM321W	Tricity Bendix	599718935
91609420704	20090925	TM321W	Tricity Bendix	599721687
91609420800	20080606	ZDC37100W	Zanussi	599708610
91609420801	20080827	ZDC37100W	Zanussi	599717594
91609420802	20080829	ZDC37100W	Zanussi	599713489
91609420803	20081209	ZDC37100W	Zanussi	599718954
91609420805	20090925	ZDC37100W	Zanussi	599721707
91609420900	20080711	ZTK123	Zanussi	599709759
91609420901	20080827	ZTK123	Zanussi	599717564
91609420902	20081007	ZTK123	Zanussi	599717565
91609420903	20090703	ZTK123	Zanussi	599721710
91609420904	20090925	ZTK123	Zanussi	599721721
91609421200	20081128	PSC60M	Curtiss	599712595
91609421300	20081114	SLPC60E	Selecline	599712953
91609421400	20081128	BLS50006	Bluesky	599712602
91609421401	20090925	BLS50006	Bluesky	599721745
91609421500	20090213	SLC6L1M	Listo	599715575
91609421501	20090724	SLC6L1M	Listo	599720665
91609450001	20070511	EDC46130W	Electrolux	599388504
91609450003	20081207	EDC46130W	Electrolux	599715709
91609450004	20090220	EDC46130W	Electrolux	599715714
91609450006	20090925	EDC46130W	Electrolux	599721761
91609450100	20060825	RDC46100W	Rex-Electrolux	599382319
91609450101	20080418	RDC46100W	Rex-Electrolux	599707653
91609450102	20080827	RDC46100W	Rex-Electrolux	599717566
91609450103	20081007	RDC46100W	Rex-Electrolux	599717567

PNC-ELC	Date of first productions	Model	Brand	Service Notes
91609450104	20090109	RDC46100W	Rex-Electrolux	599718464
91609450105	20090704	RDC46100W	Rex-Electrolux	599721839
91609450106	20091002	RDC46100W	Rex-Electrolux	599721841
91609450301	20070511	EDC46130W	Electrolux	599388513
91609450303	20081207	EDC46130W	Electrolux	599715801
91609450304	20090220	EDC46130W	Electrolux	599715787
91609450401	20070511	EDC46130W	Electrolux	599388593
91609450403	20080820	EDC46130W	Electrolux	599717568
91609450404	20081208	EDC46130W	Electrolux	599718983
91609450406	20090925	EDC46130W	Electrolux	599721762
91609450501	20070511	RDC46130W	Rex-Electrolux	599388596
91609450502	20080827	RDC46130W	Rex-Electrolux	599717585
91609450600	20070511	EDC46100W	Electrolux	599388615
91609450602	20080820	EDC46100W	Electrolux	599717584
91609450603	20081208	EDC46100W	Electrolux	599718992
91609450700	20070317	ZDC46130W	Zanussi-Electrolux	599386901
91609450701	20071005	ZDC46130W	Zanussi-Electrolux	599705663
91609450800	20070420	ZDC46130S	Zanussi-Electrolux	599388004
91609450801	20071025	ZDC46130S	Zanussi-Electrolux	599710346
91609450802	20080827	ZDC46130S	Zanussi-Electrolux	599717591
91609450803	20080917	ZDC46130S	Zanussi-Electrolux	599717582
91609450804	20081208	ZDC46130S	Zanussi-Electrolux	599719000
91609450900	20070209	EDC46130W	Electrolux	599385892
91609451100	20070628	ZTE135	Zanussi	599389988
91609451104	20090907	ZTE135	Zanussi	599722073
91609451203	20090703	ZTE130	Zanussi	599722077
91609451204	20090908	ZTE130	Zanussi	599722080
91609451303	20090703	TK7515	Elektro Helios	599722082
91609451304	20090908	TK7515	Elektro Helios	599722087
91609451403	20090703	RTK300	Rosenlew	599722094
91609451404	20090908	RTK300	Rosenlew	599722097
91609451700	20080711	ZDC47100W	Zanussi	599709762
91609451704	20090703	ZDC47100W	Zanussi	599722184
91609451705	20090907	ZDC47100W	Zanussi	599722188
91609451800	20080905	IZTE135	Zanussi	599710939
91609451801	20080827	IZTE135	Zanussi	599717598
91609451802	20081007	IZTE135	Zanussi	599717599
91609452100	20080905	TK606Z	Novamatic	599710940
91609452101	20081007	TK606Z	Novamatic	599717603
91609452102	20090703	TK606Z	Novamatic	599722206
91609452103	20090907	TK606Z	Novamatic	599722208
91609452400	20080905	ZTK123	Zanussi	599710950
91609452401	20081231	ZTK123	Zanussi	599717497
91609452500	20080905	FTE130	Faure	599710962
91609452501	20081205	FTE130	Faure	599713571
91609452502	20090810	FTE130	Faure	599721910
91609452503	20091002	FTE130	Faure	599721915
91609452600	20080801	ADC47130W	ArthurMartinElux	599710401
91609452601	20080820	ADC47130W	ArthurMartinElux	599715131
91609452602	20081208	ADC47130W	ArthurMartinElux	599715079
91609452700	20081128	PSC60E	Curtiss	599712609

PNC-ELC	Date of first productions	Model	Brand	Service Notes
91609452801	20081224	EDC47130W	Electrolux	599714375
91609452901	20081224	ZDC47100S	Zanussi	599714387
91609453100	20090508	EDC47100W	Electrolux	599718875
91609453101	20090715	EDC47100W	Electrolux	599722214
91609453102	20090916	EDC47100W	Electrolux	599722218
91609453200	20090626	EDC47130W	Electrolux	599720034
91609453201	20090703	EDC47130W	Electrolux	599720038
91609453301	20090731	ZDC47100G	Zanussi	599720726
91609453401	20090731	ADC47100W	ArthurMartinElux	599720729
91609453500	20090731	ADC47131W	ArthurMartinElux	599720730
91609453600	20090901	FTE140	Faure	599722270
91609522701	20090903	TN63570	AEG Electrolux	599722256
91609604800	20060908	EDC77550W	Electrolux	599382408
91609604900	20060825	EDC77150W	Electrolux	599382322
91609604901	20061215	EDC77150W	Electrolux	599385099
91609604902	20090322	EDC77150W	Electrolux	599721168
91609604903	20090430	EDC77150W	Electrolux	599721177
91609604904	20090828	EDC77150W	Electrolux	599721183
91609605100	20060908	RDC67550W	Electrolux	599382416
91609605101	20071231	RDC67550W	Electrolux	599707310
91609605102	20080618	RDC67550W	Electrolux	599715162
91609605200	20060929	EDC67150W	Electrolux	599382925
91609605201	20071025	EDC67150W	Electrolux	599710657
91609605202	20081016	EDC67150W	Electrolux	599717607
91609605204	20090713	EDC67150W	Electrolux	599722260
91609605300	20060929	EDC66150W	Electrolux	599382937
91609605301	20070112	EDC66150W	Electrolux	599385428
91609605304	20090327	EDC66150W	Electrolux	599720299
91609605305	20090710	EDC66150W	Electrolux	599720318
91609605401	20060929	EDC67555W	Electrolux	599382938
91609605402	20070910	EDC67555W	Electrolux	599721074
91609605403	20071025	EDC67555W	Electrolux	599710659
91609605404	20081016	EDC67555W	Electrolux	599717608
91609606401	20060929	EDC77570W	Electrolux	599383084
91609606402	20061231	EDC77570W	Electrolux	599708744
91609606403	20071231	EDC77570W	Electrolux	599708787
91609606404	20090115	EDC77570W	Electrolux	599716130
91609606405	20090227	EDC77570W	Electrolux	599716134
91609606406	20090717	EDC77570W	Electrolux	599720518
91609606500	20060929	EDC77570W	Electrolux	599383086
91609606501	20080616	EDC77570W	Electrolux	599716610
91609606502	20081015	EDC77570W	Electrolux	599715528
91609606503	20081230	EDC77570W	Electrolux	599715530
91609606504	20090213	EDC77570W	Electrolux	599715855
91609606505	20090724	EDC77570W	Electrolux	599720689
91609606900	20061013	EDC77150W	Electrolux	599383372
91609606901	20081015	EDC77150W	Electrolux	599716620
91609606902	20081207	EDC77150W	Electrolux	599716629
91609606903	20090320	EDC77150W	Electrolux	599716632
91609607100	20060929	EDC67555W	Electrolux	599383099
91609607101	20071001	EDC67555W	Electrolux	599717601

PNC-ELC	Date of first productions	Model	Brand	Service Notes
91609607102	20080617	EDC67555W	Electrolux	599717604
91609607103	20081016	EDC67555W	Electrolux	599717605
91609607300	20060929	EDC66150W	Electrolux	599383102
91609607301	20061231	EDC66150W	Electrolux	599700171
91609607302	20081007	EDC66150W	Electrolux	599717612
91609607303	20081007	EDC66150W	Electrolux	599717613
91609607305	20090708	EDC66150W	Electrolux	599722266
91609607401	20060929	EDC77550W	Electrolux	599383125
91609607402	20071123	EDC77550W	Electrolux	599704269
91609607403	20090619	EDC77550W	Electrolux	599719808
91609607800	20061002	EDC77570W	Electrolux	599383110
91609607801	20071001	EDC77570W	Electrolux	599717617
91609607802	20080617	EDC77570W	Electrolux	599717616
91609608400	20060825	RDC77570W	Rex-Electrolux	599382391
91609608401	20060908	RDC77570W	Rex-Electrolux	599384503
91609608402	20061222	RDC77570W	Rex-Electrolux	599385221
91609608403	20080616	RDC77570W	Rex-Electrolux	599711873
91609608404	20081010	RDC77570W	Rex-Electrolux	599711882
91609608405	20081016	RDC77570W	Rex-Electrolux	599717625
91609608406	20090120	RDC77570W	Rex-Electrolux	599717624
91609608407	20090626	RDC77570W	Rex-Electrolux	599719910
91609608600	20060929	EDC77150W	Electrolux	599383118
91609608601	20070928	EDC77150W	Electrolux	599707105
91609608602	20080215	EDC77150W	Electrolux	599705903
91609608603	20081016	EDC77150W	Electrolux	599717637
91609608604	20090202	EDC77150W	Electrolux	599718495
91609608605	20090624	EDC77150W	Electrolux	599720526
91609608700	20060929	EDC67150W	Electrolux	599382792
91609608701	20081016	EDC67150W	Electrolux	599714877
91609608702	20081016	EDC67150W	Electrolux	599717645
91609608703	20081208	EDC67150W	Electrolux	599718899
91609608704	20090710	EDC67150W	Electrolux	599720346
91609609400	20061013	T58830	AEG Electrolux	599383443
91609612700	20060929	EDC77570W	Electrolux	599382806
91609612701	20071001	EDC77570W	Electrolux	599717650
91609612702	20080617	EDC77570W	Electrolux	599717649
91609612703	20081016	EDC77570W	Electrolux	599717665
91609613700	20061222	EDC77570W	Electrolux	599385161
91609613701	20071001	EDC77570W	Electrolux	599717672
91609613702	20080617	EDC77570W	Electrolux	599717671
91609613705	20090603	EDC77570W	Electrolux	599722271
91609613800	20061201	EDC67150W	Electrolux	599384914
91609613801	20071001	EDC67150W	Electrolux	599717668
91609613802	20081016	EDC67150W	Electrolux	599717673
91609613803	20081208	EDC67150W	Electrolux	599718903
91609614300	20061201	EDC77550W	Electrolux	599384936
91609614302	20071001	EDC77550W	Electrolux	599717682
91609614303	20071126	EDC77550W	Electrolux	599717680
91609614304	20080617	EDC77550W	Electrolux	599717684
91609614305	20081016	EDC77550W	Electrolux	599717683
91609614306	20090424	EDC77550W	Electrolux	599720694

PNC-ELC	Date of first productions	Model	Brand	Service Notes
91609614307	20090731	EDC77550W	Electrolux	599720699
91609614600	20061201	EDC67555W	Electrolux	599384935
91609614601	20071231	EDC67555W	Electrolux	599713977
91609614602	20081015	EDC67555W	Electrolux	599713979
91609614603	20081212	EDC67555W	Electrolux	599713983
91609614604	20090120	EDC67555W	Electrolux	599717686
91609614605	20090626	EDC67555W	Electrolux	599719926
91609615200	20070112	ADC77570W	ArthurMartinElux	599385436
91609615201	20080615	ADC77570W	ArthurMartinElux	599714933
91609615202	20081015	ADC77570W	ArthurMartinElux	599714938
91609615203	20090123	ADC77570W	ArthurMartinElux	599714943
91609615300	20070126	ADC77550W	ArthurMartinElux	599385535
91609615301	20071001	ADC77550W	ArthurMartinElux	599717691
91609615302	20080617	ADC77550W	ArthurMartinElux	599717692
91609615303	20081016	ADC77550W	ArthurMartinElux	599717693
91609615304	20090123	ADC77550W	ArthurMartinElux	599718480
91609615500	20070126	ADC67555W	ArthurMartinElux	599385684
91609615501	20071130	ADC67555W	ArthurMartinElux	599704411
91609615502	20081015	ADC67555W	ArthurMartinElux	599713432
91609615503	20081205	ADC67555W	ArthurMartinElux	599713438
91609615504	20090120	ADC67555W	ArthurMartinElux	599718904
91609615505	20090710	ADC67555W	ArthurMartinElux	599720354
91609616100	20061222	EDC66150W	Electrolux	599385267
91609616101	20071231	EDC66150W	Electrolux	599714911
91609616102	20081207	EDC66150W	Electrolux	599714913
91609616103	20090116	EDC66150W	Electrolux	599714917
91609616104	20090626	EDC66150W	Electrolux	599719939
91609616200	20061222	EDC77570W	Electrolux	599385272
91609616300	20070112	EDC67550W	Electrolux	599385440
91609616302	20071001	EDC67550W	Electrolux	599717696
91609616303	20071126	EDC67550W	Electrolux	599717699
91609616304	20081015	EDC67550W	Electrolux	599717347
91609616305	20090330	EDC67550W	Electrolux	599717384
91609616306	20090409	EDC67550W	Electrolux	599717388
91609616307	20090601	EDC67550W	Electrolux	599722273
91609616400	20061222	EDC67150W	Electrolux	599385273
91609616401	20071001	EDC67150W	Electrolux	599717701
91609616402	20081016	EDC67150W	Electrolux	599717700
91609616403	20090108	EDC67150W	Electrolux	599718479
91609616404	20090710	EDC67150W	Electrolux	599720383
91609616800	20070317	EDC77570W	Electrolux	599386935
91609616801	20070820	EDC77570W	Electrolux	599717703
91609616802	20081124	EDC77570W	Electrolux	599717395
91609616803	20090119	EDC77570W	Electrolux	599717349
91609616804	20090304	EDC77570W	Electrolux	599717403
91609616900	20070317	ZDC67550W	Zanussi-Electrolux	599386959
91609616901	20071231	ZDC67550W	Zanussi-Electrolux	599707930
91609616902	20081124	ZDC67550W	Zanussi-Electrolux	599716098
91609616903	20090119	ZDC67550W	Zanussi-Electrolux	599716437
91609616904	20090306	ZDC67550W	Zanussi-Electrolux	599716447
91609617300	20070126	EDC66150W	Electrolux	599385542

PNC-ELC	Date of first productions	Model	Brand	Service Notes
91609617301	20071001	EDC66150W	Electrolux	599717667
91609617800	20070830	T58840	AEG Electrolux	599704489
91609617801	20071130	T58840	AEG Electrolux	599704493
91609617802	20081124	T58840	AEG Electrolux	599717663
91609617803	20090226	T58840	AEG Electrolux	599717661
91609618000	20071109	T57849	AEG Electrolux	599703947
91609618001	20071130	T57849	AEG Electrolux	599711356
91609618002	20081124	T57849	AEG Electrolux	599717698
91609618003	20090405	T57849	AEG Electrolux	599719529
91609618004	20090605	T57849	AEG Electrolux	599719545
91609618100	20070824	T56840R	AEG Electrolux	599704620
91609618101	20071130	T56840R	AEG Electrolux	599704622
91609618102	20081124	T56840R	AEG Electrolux	599717716
91609618103	20090401	T56840R	AEG Electrolux	599719632
91609618104	20090612	T56840R	AEG Electrolux	599719637
91609618200	20071026	T56840	AEG Electrolux	599703443
91609618201	20080118	T56840	AEG Electrolux	599705520
91609618202	20090213	T56840	AEG Electrolux	599715721
91609618203	20090414	T56840	AEG Electrolux	599719648
91609618204	20090612	T56840	AEG Electrolux	599719651
91609618300	20071123	T56847	AEG Electrolux	599704399
91609618301	20071126	T56847	AEG Electrolux	599717721
91609618302	20081124	T56847	AEG Electrolux	599717765
91609618303	20090414	T56847	AEG Electrolux	599719660
91609618304	20090612	T56847	AEG Electrolux	599719661
91609618400	20071026	T5684EX	AEG Electrolux	599703342
91609618401	20071231	T5684EX	AEG Electrolux	599712499
91609618402	20081124	T5684EX	AEG Electrolux	599717764
91609618403	20090414	T5684EX	AEG Electrolux	599719666
91609618404	20090612	T5684EX	AEG Electrolux	599719668
91609618500	20070817	T55540	AEG Electrolux	599703845
91609618501	20071109	T55540	AEG Electrolux	599703856
91609619300	20070831	T58840R	AEG Electrolux	599704283
91609619301	20071126	T58840R	AEG Electrolux	599717753
91609619302	20081124	T58840R	AEG Electrolux	599717752
91609619303	20090120	T58840R	AEG Electrolux	599717772
91609619304	20090626	T58840R	AEG Electrolux	599719941
91609619700	20071012	T58840R	AEG Electrolux	599702570
91609619701	20071130	T58840R	AEG Electrolux	599711370
91609619702	20081124	T58840R	AEG Electrolux	599717792
91609619703	20090127	T58840R	AEG Electrolux	599718502
91609619900	20071012	T56840	AEG Electrolux	599702579
91609619901	20071126	T56840	AEG Electrolux	599717796
91609621100	20071026	T55840	AEG Electrolux	599703355
91609621101	20071231	T55840	AEG Electrolux	599708805
91609621101	20071231	T55840	AEG Electrolux	599708805
91609621102	20081231	T55840	AEG Electrolux	599717437
91609621103	20090403	T55840	AEG Electrolux	599717458
91609621104	20090612	T55840	AEG Electrolux	599719696
91609621200	20071012	T55548	AEG Electrolux	599703924
91609621201	20071109	T55548	AEG Electrolux	599703934

PNC-ELC	Date of first productions	Model	Brand	Service Notes
91609621600	20070914	T57840	AEG Electrolux	599701883
91609621601	20071231	T57840	AEG Electrolux	599711968
91609621602	20081110	T57840	AEG Electrolux	599717834
91609621603	20090519	T57840	AEG Electrolux	599719869
91609621604	20090619	T57840	AEG Electrolux	599719877
91609621800	20070914	T56840	AEG Electrolux	599702514
91609621801	20071231	T56840	AEG Electrolux	599708328
91609621802	20081110	T56840	AEG Electrolux	599717835
91609621803	20090120	T56840	AEG Electrolux	599717836
91609621804	20090626	T56840	AEG Electrolux	599719943
91609622500	20070921	ZTE272	Zanussi	599702117
91609622501	20081015	ZTE272	Zanussi	599714833
91609622502	20090116	ZTE272	Zanussi	599714837
91609622800	20071005	T57840	AEG Electrolux	599702400
91609622801	20071126	T57840	AEG Electrolux	599717405
91609623000	20070910	T56640	AEG Electrolux	599703764
91609623001	20071231	T56640	AEG Electrolux	599709312
91609623200	20071003	T55540	AEG Electrolux	599705710
91609623201	20071221	T55540	AEG Electrolux	599705711
91609623300	20070914	T55540	AEG Electrolux	599704570
91609623300	20070914	T55540	AEG Electrolux	599704570
91609623301	20071130	T55540	AEG Electrolux	599704574
91609623301	20071130	T55540	AEG Electrolux	599704574
91609623302	20090227	T55540	AEG Electrolux	599716196
91609623700	20070831	EDC66550W	Electrolux	599704718
91609623701	20071207	EDC66550W	Electrolux	599704723
91609623702	20080617	EDC66550W	Electrolux	599717846
91609623703	20081016	EDC66550W	Electrolux	599717848
91609623704	20090120	EDC66550W	Electrolux	599717849
91609623705	20090710	EDC66550W	Electrolux	599720395
91609624300	20070914	QW451T	Husqvarna Electrolux	599704607
91609624301	20071130	QW451T	Husqvarna Electrolux	599704611
91609624302	20080820	QW451T	Husqvarna Electrolux	599717788
91609624401	20071128	QW503T	Husqvarna Electrolux	599705726
91609624500	20070910	QW483T	Husqvarna Electrolux	599704218
91609624500	20071123	QW483T	Husqvarna Electrolux	599704218
91609624501	20071207	QW483T	Husqvarna Electrolux	599704683
91609624502	20090120	QW483T	Husqvarna Electrolux	599717789
91609624700	20070817	ADC66150W	ArthurMartinElux	599701358
91609624701	20071001	ADC66150W	ArthurMartinElux	599717790
91609624800	20070727	ADC67150W	ArthurMartinElux	599700731
91609624801	20081015	ADC67150W	ArthurMartinElux	599715549
91609624802	20081207	ADC67150W	ArthurMartinElux	599715552
91609624803	20090213	ADC67150W	ArthurMartinElux	599715858
91609624804	20090710	ADC67150W	ArthurMartinElux	599720402

PNC-ELC	Date of first productions	Model	Brand	Service Notes
91609625303	20090428	ZTE290	Zanussi	599719950
91609625304	20090626	ZTE290	Zanussi	599719966
91609625500	20071123	T56840R	AEG Electrolux	599704298
91609625501	20071231	T56840R	AEG Electrolux	599713407
91609625502	20081124	T56840R	AEG Electrolux	599717769
91609625503	20090120	T56840R	AEG Electrolux	599717770
91609625600	20071012	T57840	AEG Electrolux	599705238
91609625601	20071221	T57840	AEG Electrolux	599705240
91609625602	20081124	T57840	AEG Electrolux	599717771
91609625603	20090120	T57840	AEG Electrolux	599717774
91609625604	20090626	T57840	AEG Electrolux	599719988
91609626103	20090717	ZTE272	Zanussi	599720543
91609626700	20070628	EDC67555W	Electrolux	599700072
91609626702	20071001	EDC67555W	Electrolux	599717975
91609627100	20070831	EDC67550W	Electrolux	599705758
91609627101	20071221	EDC67550W	Electrolux	599705756
91609627102	20080617	EDC67550W	Electrolux	599718023
91609627103	20081016	EDC67550W	Electrolux	599718123
91609627104	20090120	EDC67550W	Electrolux	599718124
91609627500	20071026	QW458T	Husqvarna Electrolux	599703212
91609627502	20080820	QW458T	Husqvarna Electrolux	599718037
91609627600	20070910	T55840	AEG Electrolux	599704613
91609627601	20071130	T55840	AEG Electrolux	599704615
91609627601	20071130	T55840	AEG Electrolux	599704615
91609627602	20081110	T55840	AEG Electrolux	599718044
91609627603	20090120	T55840	AEG Electrolux	599718064
91609627604	20090619	T55840	AEG Electrolux	599719704
91609628300	20071116	TKL2E100	Electrolux	599704046
91609628301	20080820	TKL2E100	Electrolux	599718058
91609628500	20071116	TKK2E100	Electrolux	599704057
91609628600	20071019	T55640	AEG Electrolux	599704498
91609628601	20071130	T55640	AEG Electrolux	599704500
91609628700	20080104	T55543	AEG Electrolux	599705291
91609628800	20071116	T55544	AEG Electrolux	599704169
91609629300	20070720	EDC67150W	Electrolux	599701442
91609629302	20081007	EDC67150W	Electrolux	599718114
91609629500	20080208	EDC67150W	Electrolux	599705813
91609629502	20080917	EDC67150W	Electrolux	599718115
91609629600	20071214	T55542	AEG Electrolux	599704906
91609629601	20090227	T55542	AEG Electrolux	599716148
91609629900	20080104	T7032TKF	AEG Electrolux	599705303
91609629901	20081007	T7032TKF	AEG Electrolux	599718118
91609629902	20090925	T7032TKF	AEG Electrolux	599721750
91609630100	20071221	T7022TK	AEG Electrolux	599705759
91609630302	20090120	TKGLES7000	Electrolux	599718116
91609630600	20080222	EDC66150W	Electrolux	599706134
91609630602	20080917	EDC66150W	Electrolux	599718121
91609631200	20080118	T55540	AEG Electrolux	599705549
91609632300	20080215	T5584	AEG Electrolux	599705975

PNC-ELC	Date of first productions	Model	Brand	Service Notes
91609632300	20080215	T5584	AEG Electrolux	599705975
91609632301	20081124	T5584	AEG Electrolux	599718160
91609632302	20090226	T5584	AEG Electrolux	599718156
91609632303	20090717	T5584	AEG Electrolux	599720549
91609632500	20080215	T55545	AEG Electrolux	599705983
91609632900	20080215	T58840R	AEG Electrolux	599705992
91609632901	20081124	T58840R	AEG Electrolux	599718150
91609632902	20090120	T58840R	AEG Electrolux	599718171
91609633700	20080321	JLTDC09	John Lewis	599706744
91609633701	20081125	JLTDC09	John Lewis	599718998
91609633702	20090120	JLTDC09	John Lewis	599718181
91609633800	20080411	QW440T	Husqvarna Electrolux	599707241
91609633801	20081007	QW440T	Husqvarna Electrolux	599718191
91609634200	20080801	T58840B	AEG Electrolux	599710494
91609634300	20080801	QW503TK	Husqvarna Electrolux	599710505
91609634301	20090430	QW503TK	Husqvarna Electrolux	599721192
91609634302	20090918	QW503TK	Husqvarna Electrolux	599721204
91609636600	20080411	00654326_21014	Privileg	599707231
91609636601	20090131	00654326_21292	Privileg	599719511
91609636602	20090506	00654326_70004	Privileg	599719520
91609636800	20080711	T58840B	AEG Electrolux	599709894
91609636801	20081124	T58840B	AEG Electrolux	599718228
91609636802	20090120	T58840B	AEG Electrolux	599718227
91609636900	20080926	T58840B	AEG Electrolux	599711501
91609637100	20080321	FTE285	Faure	599706722
91609637101	20081016	FTE285	Faure	599718206
91609637102	20090120	FTE285	Faure	599719052
91609637103	20090724	FTE285	Faure	599720588
91609637400	20080411	TN85470R	AEG Electrolux	599707298
91609637401	20081124	TN85470R	AEG Electrolux	599718231
91609637500	20080411	TN75470	AEG Electrolux	599707319
91609637501	20081124	TN75470	AEG Electrolux	599718234
91609637502	20090120	TN75470	AEG Electrolux	599718232
91609637503	20090703	TN75470	AEG Electrolux	599720022
91609637600	20080411	TN65570	AEG Electrolux	599707326
91609637601	20081110	TN65570	AEG Electrolux	599718233
91609637602	20090120	TN65570	AEG Electrolux	599718237
91609637603	20090619	TN65570	AEG Electrolux	599719705
91609637700	20080411	TN65470	AEG Electrolux	599707338
91609637701	20080822	TN65470	AEG Electrolux	599718239
91609637800	20080411	TN65477	AEG Electrolux	599707346
91609637900	20080411	TN55460	AEG Electrolux	599707359
91609637900	20080411	TN55460	AEG Electrolux	599707359
91609637901	20080822	TN55460	AEG Electrolux	599718240
91609638000	20080411	TN75479	AEG Electrolux	599707378
91609638100	20080606	TKE7600	FORS	599708646
91609638200	20080606	TK6551	FORS	599708647

PNC-ELC	Date of first productions	Model	Brand	Service Notes
91609638201	20090119	TK6551	FORS	599719584
91609638202	20090506	TK6551	FORS	599719589
91609638300	20080606	TK6241	FORS	599708655
91609638300	20080606	TK6241	FORS	599708655
91609638301	20081007	TK6241	FORS	599718238
91609638400	20080411	T56740	AEG Electrolux	599707382
91609638500	20080606	T58840	AEG Electrolux	599708656
91609638501	20090120	T58840	AEG Electrolux	599718246
91609638700	20081109	T57860	AEG Electrolux	599714021
91609638701	20081212	T57860	AEG Electrolux	599714024
91609639100	20081031	ADC68555W	ArthurMartinElux	599712588
91609639101	20090724	ADC68555W	ArthurMartinElux	599720595
91609639200	20081224	ADC78550W	ArthurMartinElux	599714641
91609639201	20090729	ADC78550W	ArthurMartinElux	599722412
91609639300	20080424	T55849	AEG Electrolux	599707905
91609639300	20080424	T55849	AEG Electrolux	599707905
91609639301	20081110	T55849	AEG Electrolux	599718249
91609639302	20090226	T55849	AEG Electrolux	599718258
91609639303	20090724	T55849	AEG Electrolux	599720621
91609639400	20080606	EDC67550W	Electrolux	599708673
91609639401	20080617	EDC67550W	Electrolux	599718259
91609639402	20081016	EDC67550W	Electrolux	599718267
91609639403	20090120	EDC67550W	Electrolux	599718272
91609639404	20090710	EDC67550W	Electrolux	599720421
91609639600	20080905	T58840B	AEG Electrolux	599711042
91609639900	20080606	T56640R	AEG Electrolux	599708678
91609640000	20080711	T55848	AEG Electrolux	599709902
91609640000	20080711	T55848	AEG Electrolux	599709902
91609640001	20081110	T55848	AEG Electrolux	599718278
91609640002	20090226	T55848	AEG Electrolux	599718281
91609640004	20090710	T55848	AEG Electrolux	599720439
91609640100	20081224	EDC67558W	Electrolux	599714654
91609640101	20090226	EDC67558W	Electrolux	599718314
91609640102	20090724	EDC67558W	Electrolux	599720663
91609640200	20080905	ZTI280	Zanussi	599711051
91609640201	20090120	ZTI280	Zanussi	599718326
91609640202	20090603	ZTI280	Zanussi	599722428
91609640500	20081224	RDC78550W	Rex-Electrolux	599714563
91609640600	20081224	EDC78550W	Electrolux	599714685
91609640700	20081031	EDC68555W	Electrolux	599712625
91609640800	20081224	EDC78550W	Electrolux	599714676
91609640801	20090615	EDC78550W	Electrolux	599719090
91609640900	20080801	T55640	AEG Electrolux	599710598
91609641000	20081023	T58860	AEG Electrolux	599714760
91609641001	20081124	T58860	AEG Electrolux	599718334
91609641100	20081022	T58860	AEG Electrolux	599714761
91609641101	20081110	T58860	AEG Electrolux	599718335
91609641200	20081031	T58860	AEG Electrolux	599712651
91609641201	20081110	T58860	AEG Electrolux	599718336
91609641300	20081022	T58860	AEG Electrolux	599714763
91609641301	20081110	T58860	AEG Electrolux	599718339

PNC-ELC	Date of first productions	Model	Brand	Service Notes
91609641400	20081212	T58860	AEG Electrolux	599714011
91609641401	20081124	T58860	AEG Electrolux	599718341
91609641500	20081107	T57860	AEG Electrolux	599712662
91609641501	20090724	T57860	AEG Electrolux	599720664
91609641600	20081023	T57860	AEG Electrolux	599714765
91609641601	20081110	T57860	AEG Electrolux	599718343
91609642100	20080801	TK660E	Novamatic	599710604
91609642101	20081007	TK660E	Novamatic	599718346
91609642300	20080926	EDC77550W	Electrolux	599711544
91609642301	20090120	EDC77550W	Electrolux	599718355
91609642400	20081023	T57860	AEG Electrolux	599714766
91609642401	20090601	T57860	AEG Electrolux	599722463
91609642500	20081231	QW510T	Husqvarna	599714773
91609642600	20080801	00509465_21083	Privileg	599710612
91609642601	20081218	00509465_21295	Privileg	599718376
91609642602	20090430	00509465_70006	Privileg	599719050
91609642700	20080801	T55820	AEG Electrolux	599710619
91609642701	20081110	T55820	AEG Electrolux	599718385
91609642702	20090226	T55820	AEG Electrolux	599718382
91609642703	20090724	T55820	AEG Electrolux	599720642
91609642800	20080801	T55820	AEG Electrolux	599710620
91609642801	20090210	T55820	AEG Electrolux	599718470
91609642900	20081030	T57869	AEG Electrolux	599714775
91609642901	20081124	T57869	AEG Electrolux	599718389
91609643000	20080801	QW430T	AEG Electrolux	599710622
91609643001	20080820	QW430T	AEG Electrolux	599718379
91609643100	20080801	ZTE285	Zanussi	599710624
91609643101	20090327	ZTE285	Zanussi	599717281
91609643102	20090626	ZTE285	Zanussi	599719973
91609643200	20080926	ADC67550W	ArthurMartinElux	599711550
91609643400	20081031	TN75480	AEG Electrolux	599714776
91609643401	20081124	TN75480	AEG Electrolux	599718388
91609643500	20081028	TN85480	AEG Electrolux	599714777
91609643501	20081124	TN85480	AEG Electrolux	599718386
91609643700	20080801	00130264_21082	Privileg	599710626
91609644000	20080926	EDC67550W	Electrolux	599711559
91609644001	20090120	EDC67550W	Electrolux	599718384
91609644100	20081017	T58860	AEG Electrolux	599718594
91609644101	20081219	T58860	AEG Electrolux	599718516
91609644200	20090109	EDC68555W	Electrolux	599714789
91609644400	20081104	EDC67150W	Electrolux	599718521
91609644401	20081208	EDC67150W	Electrolux	599719049
91609644700	20081031	RDC66550W	Rex-Electrolux	599712270
91609644701	20090120	RDC66550W	Rex-Electrolux	599718383
91609644800	20081027	T56840R	AEG Electrolux	599714358
91609644801	20081224	T56840R	AEG Electrolux	599714359
91609644802	20090120	T56840R	AEG Electrolux	599718381
91609644900	20081212	PE1370D	Zoppas	599714018
91609644901	20081118	PE1370D	Zoppas	599718380
91609644902	20090120	PE1370D	Zoppas	599718378

PNC-ELC	Date of first productions	Model	Brand	Service Notes
91609645000	20090109	QW461T	Husqvarna Electrolux	599714793
91609645001	20090120	QW461T	Husqvarna Electrolux	599718377
91609645100	20090109	QW468T	Husqvarna Electrolux	599714794
91609645101	20090120	QW468T	Husqvarna Electrolux	599718375
91609645102	20090724	QW468T	Husqvarna Electrolux	599720651
91609645300	20090327	T7073TK	AEG Electrolux	599717075
91609645400	20090327	TKGL5E101	Electrolux	599717092
91609645500	20090327	T58860	AEG Electrolux	599717109
91609645600	20090109	EDC78550W	Electrolux	599714796
91609645700	20090109	ZTE275	Zanussi	599714797
91609645701	20090710	ZTE275	Zanussi	599720202
91609645800	20090109	ZTE276	Zanussi	599714820
91609645801	20090724	ZTE276	Zanussi	599720658
91609646701	20090731	EDC67550W	Electrolux	599720775
91609646900	20090417	QW484T	Husqvarna Electrolux	599718079
91609647101	20090403	QW462T	Husqvarna Electrolux	599717490
91609647102	20090619	QW462T	Husqvarna Electrolux	599719721
91609647201	20090417	T56840L	AEG Electrolux	599718103
91609647202	20090619	T56840L	AEG Electrolux	599719723
91609647301	20090403	T56840L	AEG Electrolux	599717493
91609647302	20090619	T56840L	AEG Electrolux	599719737
91609647401	20090403	T56840LR	AEG Electrolux	599717501
91609647402	20090724	T56840LR	AEG Electrolux	599720672
91609647501	20090403	T56840L	AEG Electrolux	599717505
91609647502	20090619	T56840L	AEG Electrolux	599719754
91609647601	20090403	T56840L	AEG Electrolux	599717515
91609647701	20090403	T56840RL	AEG Electrolux	599717523
91609647702	20090619	T56840RL	AEG Electrolux	599719769
91609647800	20090327	T56840L	AEG Electrolux	599717176
91609647900	20090327	T56847L	AEG Electrolux	599717181
91609647901	20090515	T56847L	AEG Electrolux	599719829
91609647902	20090619	T56847L	AEG Electrolux	599719836
91609648000	20090327	T5684EXL	AEG Electrolux	599717185
91609648001	20090519	T5684EXL	AEG Electrolux	599719844
91609648002	20090619	T5684EXL	AEG Electrolux	599719846
91609648102	20090731	TN65570L	AEG Electrolux	599720778
91609648200	20090327	T56845L	AEG Electrolux	599717248
91609648201	20090519	T56845L	AEG Electrolux	599719858
91609648202	20090619	T56845L	AEG Electrolux	599719866
91609648300	20090417	T58860	AEG Electrolux	599718110
91609648901	20090703	T56845L	AEG Electrolux	599720068
91609649100	20090408	T57848	AEG Electrolux	599719243
91609649101	20090518	T57848	AEG Electrolux	599719271
91609649500	20090814	TN85481	AEG Electrolux	599721014
91609649500	20090814	TN85481	AEG Electrolux	599721014

PNC-ELC	Date of first productions	Model	Brand	Service Notes
91609649600	20090814	TN75471	AEG Electrolux	599721081
91609649700	20090717	TN75481	AEG Electrolux	599720511
91609650000	20090605	QW510T	Husqvarna Electrolux	599719467
91609650100	20090703	T57850	AEG Electrolux	599720071
91609650300	20091019	T58870	AEG Electrolux	599722002
91609650400	20090703	ZTE283	Zanussi	599720098
91609650500	20090703	ZTE273	Zanussi	599720089
91609652000	20090703	FTE285	Faure	599720133
91609652100	20090703	FTE280	Faure	599720137
91609652300	20090807	ADC67151W	ArthurMartinElux	599720858
91609652400	20090807	ADC67556W	ArthurMartinElux	599720862
91609652600	20090807	ADC68556W	ArthurMartinElux	599720863
91609652700	20090807	JLTDC03	John Lewis	599720866

18.6 List of PNC - ELC for dryer HEAT PUMP ENV06 / ENV06 AEG

PNC-ELC	Date of first productions	Model	Brand	Service Notes
91609617600	20070727	T59840	AEG Electrolux	599701449
91609618700	20080208	T59840	AEG Electrolux	599705785
91609619000	20071214	T59840	AEG Electrolux	599704854
91609619600	20071012	T59840	AEG Electrolux	599702555
91609620200	20080208	T59840	AEG Electrolux	599705796
91609620300	20071102	T59840	AEG Electrolux	599703735
91609620900	20071019	T59840	AEG Electrolux	599703135
91609621300	20070914	T59840	AEG Electrolux	599702501
91609622600	20071026	T59840	AEG Electrolux	599703368
91609624100	20071123	QW491A	Husqvarna Electrolux	599704207
91609624600	20071116	T59840	AEG Electrolux	599704205
91609626200	20071005	T59840	AEG Electrolux	599705743
91609628000	20071116	TWSL6E100	Electrolux	599704032
91609629700	20080208	8050TW	AEG Electrolux	599705818
91609633100	20080926	RDH97950W	Rex-Electrolux	599711388
91609633300	20080801	EDH97950W	Electrolux	599710629
91609636500	20080424	T59820	AEG Electrolux	599707929
91609637300	20080411	TN95470	AEG Electrolux	599707266
91609642000	20090327	T59820	AEG Electrolux	599717072
91609642200	20080801	T59820	AEG Electrolux	599710613
91609643800	20081107	EDH97950W	Electrolux	599712669
91609644300	20080905	TN95479	AEG Electrolux	599711054
91609645200	20090515	T8030TW	AEG Electrolux	599719211
91609645900	20090327	T59829	AEG Electrolux	599717120
91609646000	20090109	EDH97950W	Electrolux	599714827
91609646100	20090327	T59830	AEG Electrolux	599717142
91609646200	20090327	T59820	AEG Electrolux	599717164
91609646300	20090515	T59820	AEG Electrolux	599719212
91609648400	20090417	TW7757	Novamatic	599718068
91609648500	20090501	TKE7650WP	FORS	599718830
91609648600	20090626	EDH97950W	Electrolux	599719948
91609649000	20090515	T59839	AEG Electrolux	599719236

18.7 List of PNC - ELC for dryer CLOTHES REFRESHMENT ENV06 / ENV06 AEG

PNC-ELC	Date of first productions	Model	Brand	Service Notes
91609604001	20060818	EDI96150W	Electrolux	599382106
91609604002	20061215	EDI96150W	Electrolux	599385039
91609604003	20071231	EDI96150W	Electrolux	599707540
91609606700	20060818	EDI96150W	Electrolux	599382110
91609606701	20060901	EDI96150W	Electrolux	599717621
91609606702	20080107	EDI96150W	Electrolux	599718468
91609607900	20060818	EDI96150W	Electrolux	599382115
91609607901	20071001	EDI96150W	Electrolux	599717630
91609607902	20080107	EDI96150W	Electrolux	599718469
91609608200	20060818	RDI96150W	Rex-Electrolux	599382116
91609608201	20061215	RDI96150W	Rex-Electrolux	599385081
91609608202	20071231	RDI96150W	Rex-Electrolux	599713335
91609608300	20060818	EDI96150W	Electrolux	599382117
91609608301	20061215	EDI96150W	Electrolux	599385078
91609608302	20071231	EDI96150W	Electrolux	599707102
91609608303	20090619	EDI96150W	Electrolux	599719897
91609608500	20060818	EDI96150W	Electrolux	599382119
91609608501	20071001	EDI96150W	Electrolux	599717632
91609608502	20080218	EDI96150W	Electrolux	599718511
91609612500	20061013	EDI96150W	Electrolux	599383382
91609613400	20061201	EDI96150W	Electrolux	599384605
91609613401	20070820	EDI96150W	Electrolux	599717676
91609613402	20080122	EDI96150W	Electrolux	599718487
91609613600	20061201	EDI96150W	Electrolux	599384616
91609613601	20071001	EDI96150W	Electrolux	599717674
91609613602	20090218	EDI96150W	Electrolux	599718292
91609613603	20090417	EDI96150W	Electrolux	599718298
91609615100	20070317	ADI96150W	ArthurMartinElux	599386925
91609615101	20071001	ADI96150W	ArthurMartinElux	599717687
91609615102	20071031	ADI96150W	ArthurMartinElux	599715315
91609616700	20070112	EDI96150W	Electrolux	599385443
91609616701	20071001	EDI96150W	Electrolux	599717702
91609617100	20070302	EDI96150W	Electrolux	599386688
91609617400	20070904	T88800	AEG Electrolux	599703746
91609617400	20070904	T88800	AEG Electrolux	599703746
91609617401	20080114	T88800	AEG Electrolux	599718581
91609619400	20070925	T88800	AEG Electrolux	599705701
91609619401	20071221	T88800	AEG Electrolux	599705708
91609619402	20081007	T88800	AEG Electrolux	599717787
91609619500	20070427	EDI96150W	Electrolux	599388210
91609623900	20071012	T88800	AEG Electrolux	599702775
91609624000	20070921	QW600S	Husqvarna Electrolux	599704553
91609624001	20071130	QW600S	Husqvarna Electrolux	599704557
91609626800	20070907	T88800	AEG Electrolux	599705227
91609626801	20071221	T88800	AEG Electrolux	599705230
91609626901	20071031	T88800	AEG Electrolux	599705734
91609627900	20071116	TKSL5E100	Electrolux	599703960
91609627901	20080822	TKSL5E100	Electrolux	599718212

PNC-ELC	Date of first productions	Model	Brand	Service Notes
91609631300	20080208	ELU EDI96150W	Electrolux	599705852
91609633501	20080211	T88800	AEG Electrolux	599718475
91609634500	20080801	T88840	AEG Electrolux	599710569
91609634501	20081124	T88840	AEG Electrolux	599718193
91609634502	20090226	T88840	AEG Electrolux	599718198
91609634700	20080926	T88840	AEG Electrolux	599711394
91609634702	20090701	T88840	AEG Electrolux	599722371
91609634800	20080926	T88840	AEG Electrolux	599711420
91609634900	20080926	T88840	AEG Electrolux	599711433
91609634901	20081110	T88840	AEG Electrolux	599718199
91609634902	20090120	T88840	AEG Electrolux	599717530
91609635000	20080926	QW601S	Husqvarna Electrolux	599711438
91609635001	20090623	QW601S	Husqvarna Electrolux	599722376
91609635200	20081224	ADI97170S	ArthurMartinElux	599714521
91609635201	20090421	ADI97170S	ArthurMartinElux	599722380
91609635202	20090225	ADI97170S	ArthurMartinElux	599719818
91609635203	20090619	ADI97170S	ArthurMartinElux	599719820
91609635400	20080905	ADI97170W	ArthurMartinElux	599710986
91609635402	20090225	ADI97170W	ArthurMartinElux	599719013
91609635403	20090608	ADI97170W	ArthurMartinElux	599722386
91609635500	20080926	EDI97170W	Electrolux	599711441
91609635502	20090323	EDI97170W	Electrolux	599718600
91609635600	20081224	EDI97170W	Electrolux	599714532
91609635602	20090225	EDI97170W	Electrolux	599719012
91609635700	20080926	RDI97170W	Rex-Electrolux	599711446
91609635702	20090429	RDI97170W	Rex-Electrolux	599720702
91609635800	20080905	EDI97170W	Electrolux	599711001
91609635802	20090225	EDI97170W	Electrolux	599719004
91609635803	20090602	EDI97170W	Electrolux	599722392
91609635900	20080926	EDI97170W	Electrolux	599711489
91609635902	20090225	EDI97170W	Electrolux	599719008
91609636000	20081031	EDI97170W	Electrolux	599712620
91609636100	20080926	EDI97170W	Electrolux	599711491
91609636102	20090225	EDI97170W	Electrolux	599719038
91609636200	20080919	EDI97170W	Electrolux	599711282
91609636300	20080905	EDI97170W	Electrolux	599711030
91609637000	20080801	ADI97150W	ArthurMartinElux	599710588
91609638600	20080926	TN88470	AEG Electrolux	599711514
91609638601	20081124	TN88470	AEG Electrolux	599718247
91609638602	20090120	TN88470	AEG Electrolux	599718250
91609639700	20080905	T88840	AEG Electrolux	599711028
91609639701	20090120	T88840	AEG Electrolux	599718274
91609641700	20080926	EDI97150W	Electrolux	599711533
91609643301	20090108	TKSL5E101	Electrolux	599715488
91609643302	20090120	TKSL5E101	Electrolux	599718387
91609644500	20081031	EDI97170W	Electrolux	599712262
91609646601	20090304	EDI97170W	Electrolux	599717480
91609647000	20090515	EDI97170W	Electrolux	599719226