

Installation of SDWC Structural Screw for Retrofit of Existing Double Wall Houses

**Double Top Plate to Truss, Stud to Double Top Plate
& Stud to Bottom Plate**

**Partners – University of Hawaii Sea Grant
Simpson Strong-Tie**

Background

- ❑ There are many double wall homes without hurricane clips or a continuous load path that can be strengthened, not to the level of a new house under newer codes, but stronger than before.
- ❑ In the past, it has been difficult to retrofit double wall houses. Unlike single wall houses where the intersection of the rafter and wall are readily exposed, the intersection of these components in a double wall house is hidden by siding (the 2nd wall). The SDWC structural screw is driven through the siding to reach the target structural components.
- ❑ The SDWC can be used for new homes (examples on Oahu exist for houses approved by the building department, inspectors and project structural engineer) as well as a retrofit of older homes as shown in this demonstration example.
- ❑ **You may be able to perform the work yourself, but first seek the advice of a licensed structural engineer and architect (especially familiar with your house). This is a relatively straightforward retrofit given the proper guidance. The structural engineer can cover certain aspects of the continuous load path while the architect is especially versed with the envelope of your house (e.g., siding, house wrap, spacing).**

Purpose

- A. To strengthen existing roof (truss) to wall (double top plate) connections for existing homes in the situation where:
 - 1. No hurricane clips since not required (double wall houses generally built on or before 1988 on O‘ahu, on or before 1990 on Maui and Kaua‘i, and on or before 1994 on Hawai‘i).
 - 2. Poor installation with nails missing.
 - 3. Hurricane clips every other rafter under older codes.
 - 4. Proper installation of clips with less capacity (H2.5s or H3s) – building codes in 1990’s to mid – 2000’s, depending on location and wind zone.

- B. To continue the load path downward to the greatest extent possible in the situation where:
 - 1. Houses were built with hurricane clips but not a complete load path (e.g., houses generally built between 1989 & 1995 on O‘ahu, between 1991 and 1995 on Maui, between 1991 and 1993 on Kaua‘i and built before 1994 on Hawai‘i).

Continuous load path with associated connectors.

Structural screw orientations that serve the same function.

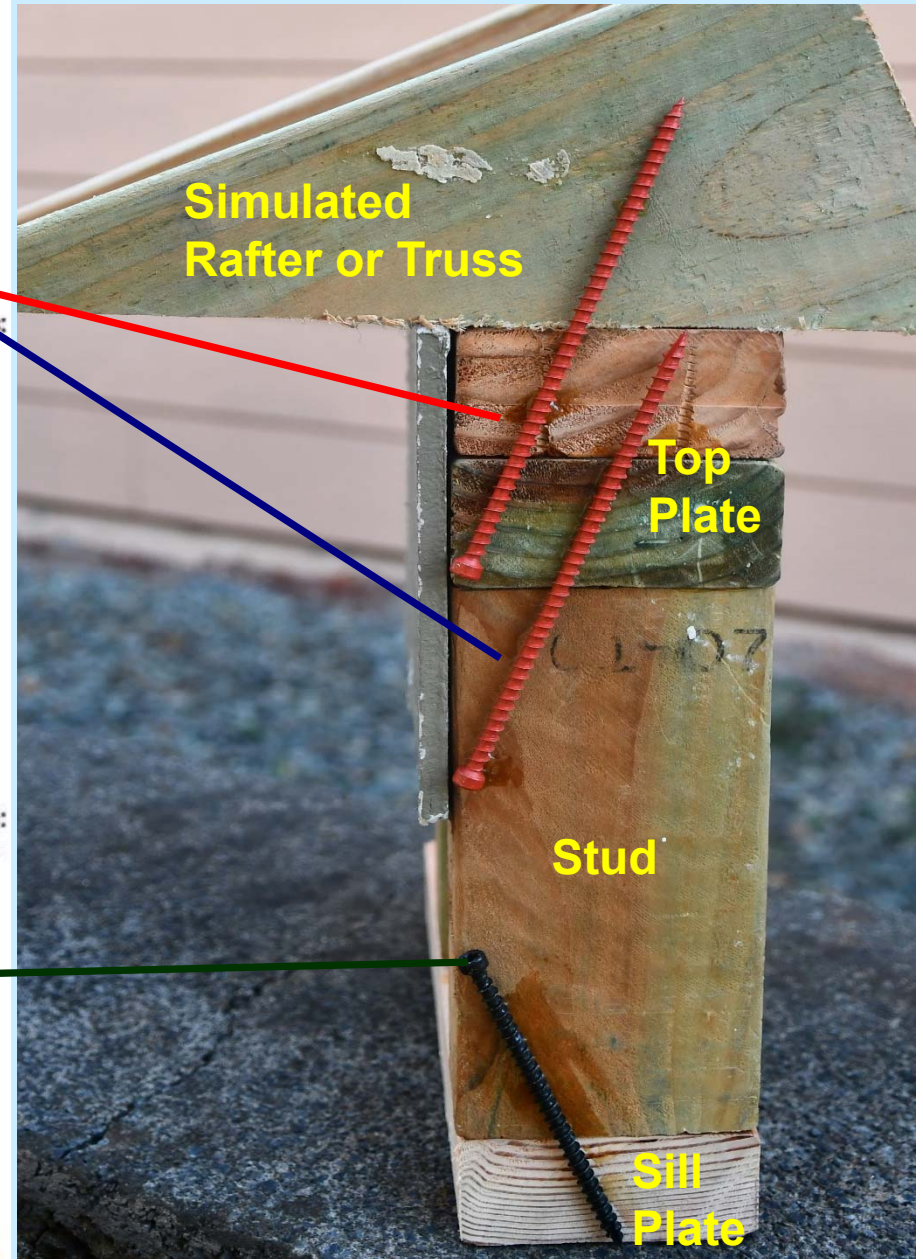
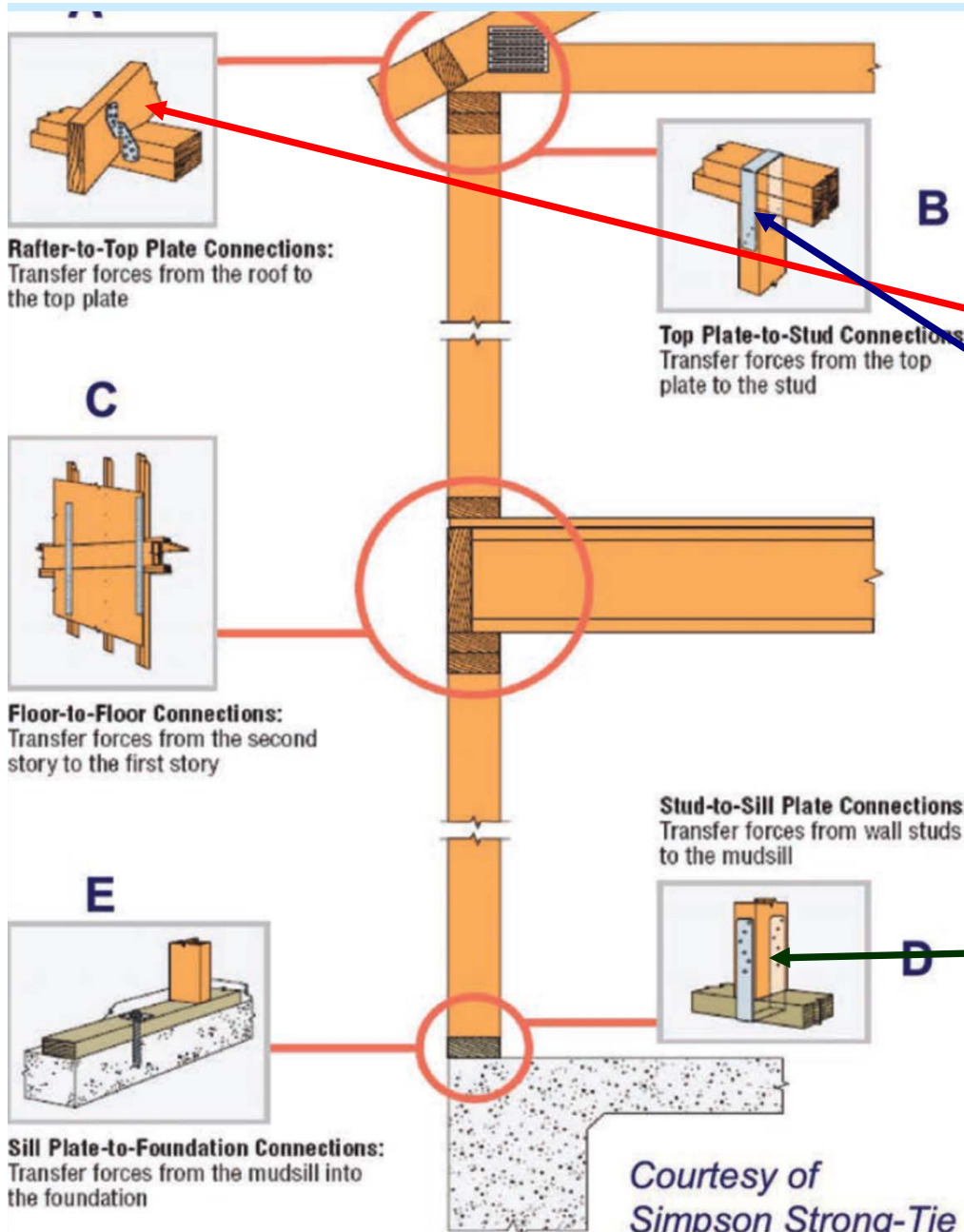

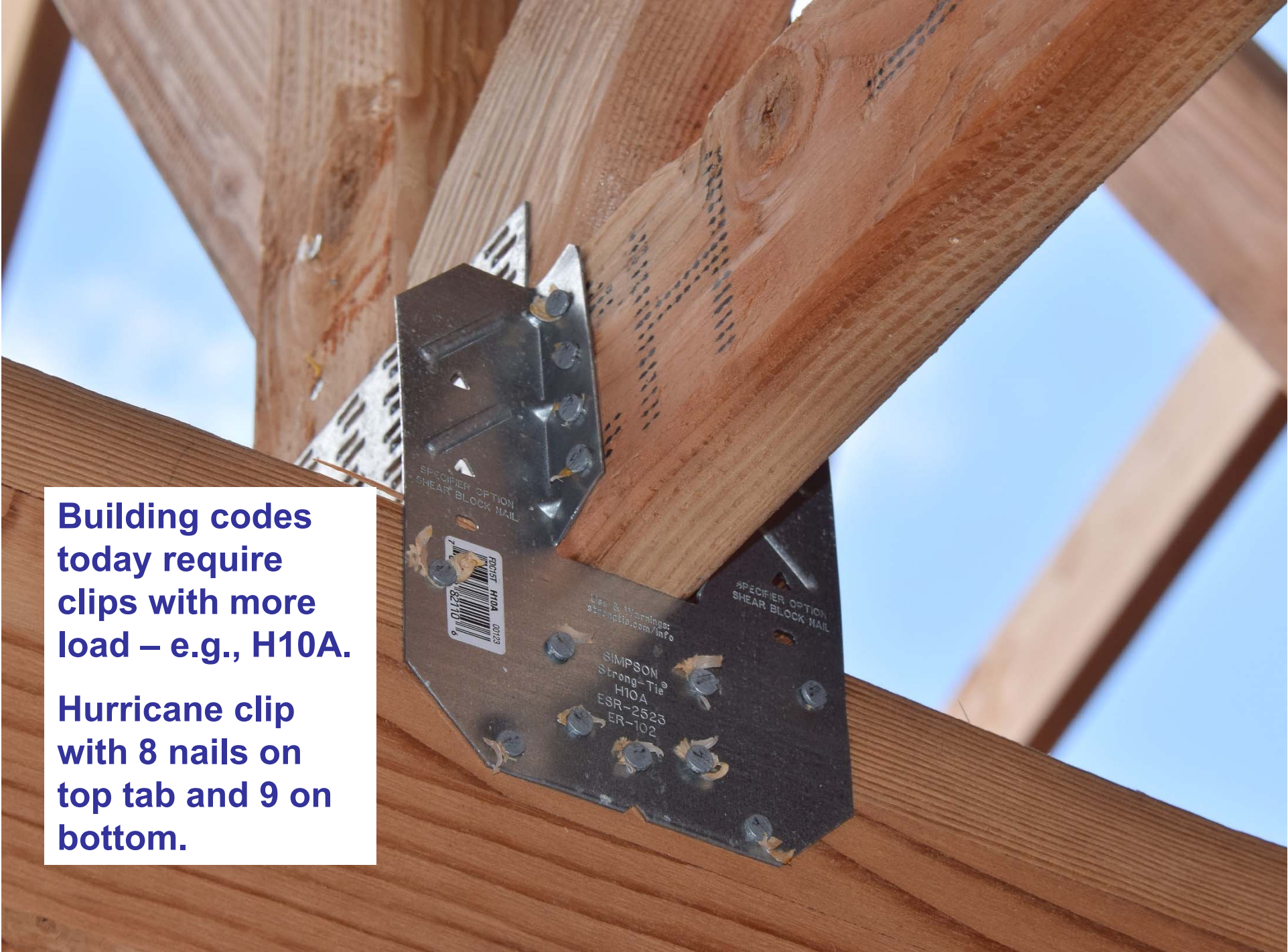

Building codes today require clips with more load – e.g., H10A.

Hurricane clip with 8 nails on top tab and 9 on bottom.

Older building codes could use the H2.5 or H3. In addition, here is not a perfect installation. Hurricane clip with 4 nails on top tab and only 2 on the bottom ties the truss and double top plate.

Even with a hurricane clip, it is possible to fortify this connection with the SDWC, see next slide.



Structural screw purposely misses truss to show can go from top plate to truss. Can fortify the hurricane clip or take place when missing or not perfectly installed.



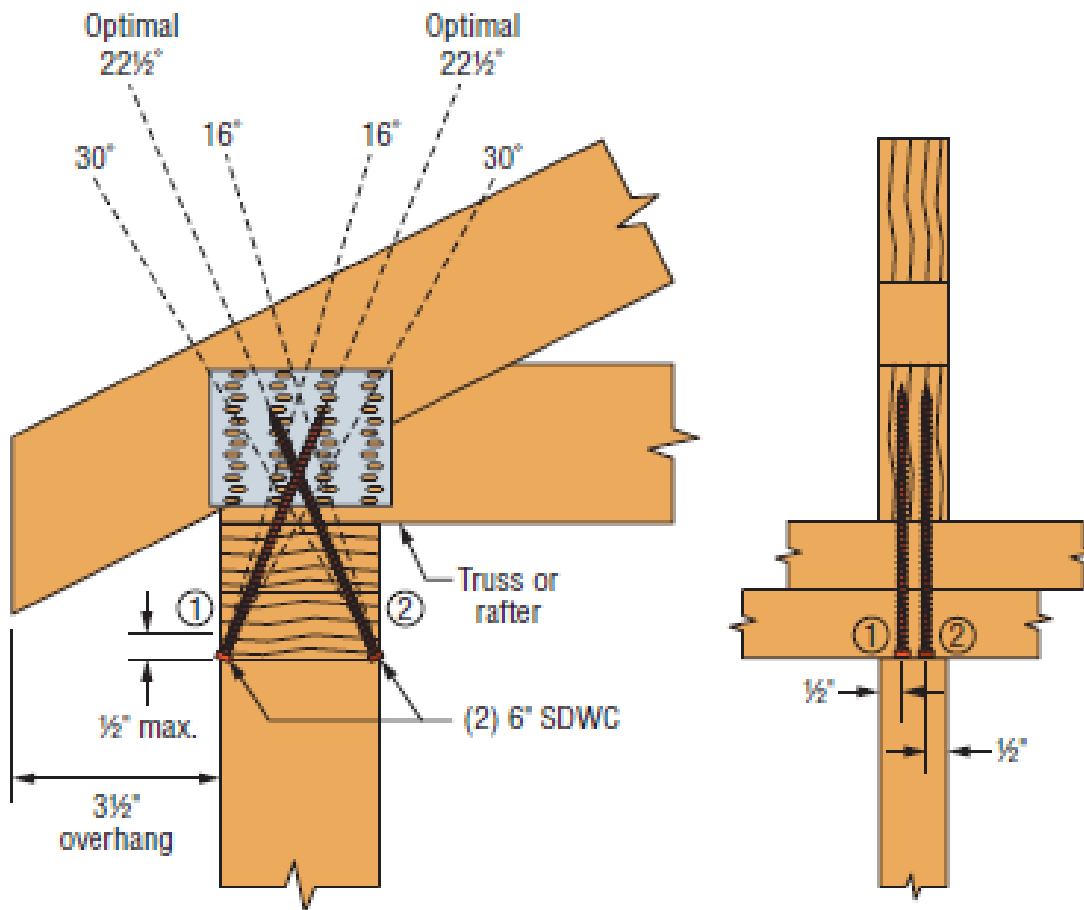

Configuration C:
Install through Top Plate into Truss/Rafter

Both screws installed at a 16°-30° angle, offset ½" from the opposite edges of truss/rafter. Use metal installation guide included in screw kits for optimal 22.5° installation.

About the SDWC

From Simpson 2017-2018 Wood Construction Connectors Catalog Page 321 - Configuration C – with two structural screws, one from inside, one from outside, the uplift load is 905 in DF/SP and 850 in SPF/HF. Optimal angle is 22.5 degrees. On page 319 footnote 4, screws are shown installed on the interior of walls. Installations on the exterior are acceptable if rafter overhangs a minimum of 3.5 inches. This is how it will be used for this retrofit demonstration application.

Many Applications for SDWC Used with Single Screw

5. The F_2 direction is perpendicular to the wall. When the screw is loaded simultaneously in more than one direction, the allowable load must be evaluated using the following equation:

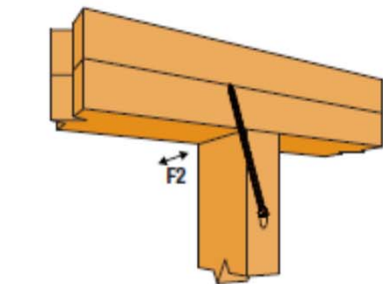

1 Narrow Face of Stud-to-Top Plate Connection
(This application requires SDWC15600)

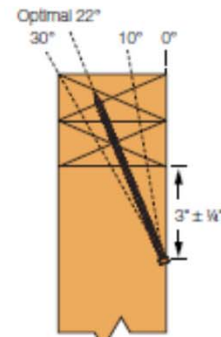

Installation Angle Range

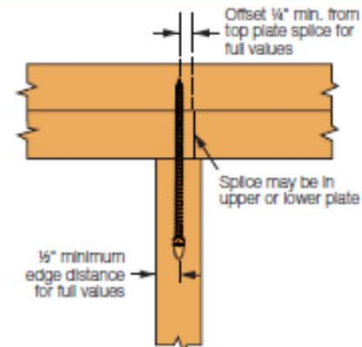

Minimum Edge Distance and Splice Offset Requirements

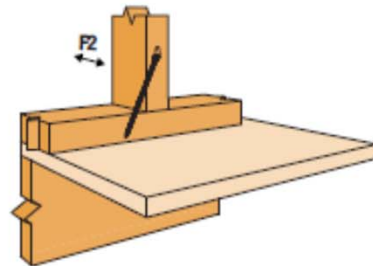

2 Narrow Face of Stud-to-Bottom Plate Connection over Wood Floor
(SDWC15600 shown)

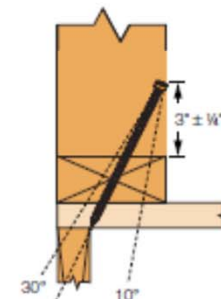

Installation Angle Range

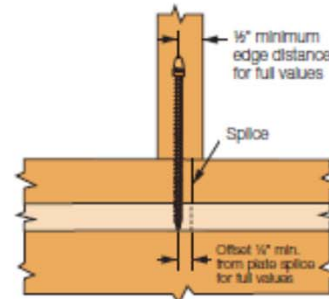

Minimum Edge Distance and Splice Offset Requirements

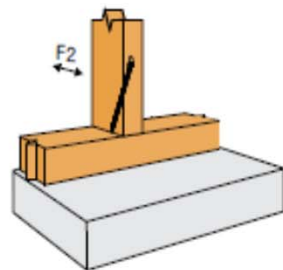

3 Narrow Face of Stud-to-Bottom Plate Connection over Masonry/Concrete Foundation
(This application requires SDWC15450)

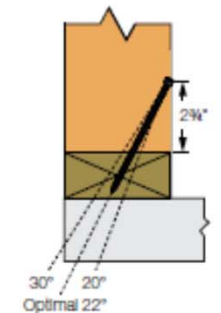

Installation Angle Range

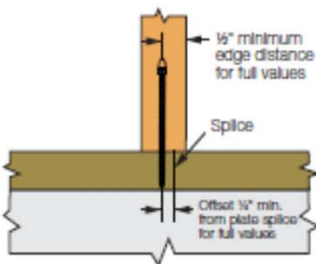

Minimum Edge Distance and Splice Offset Requirements

Many Applications for SDWC Used with Single Screw (cont.)

Typical Roof-to-Wall Connection

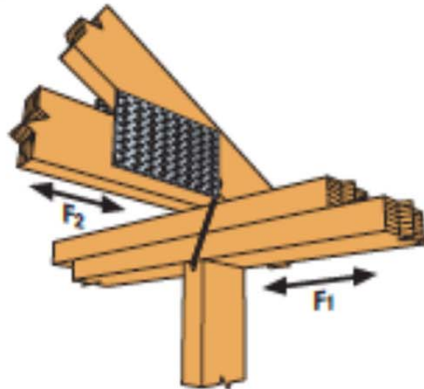

Typical Strong-Drive® SDWC Installation – Truss Aligned with Stud
(Offset truss similar)

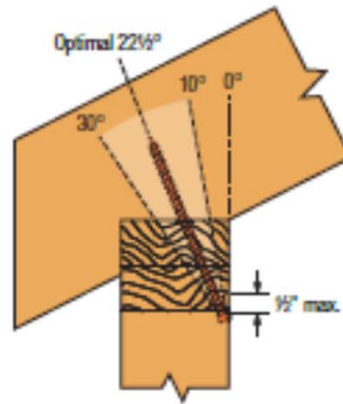

Installation Angle Limit

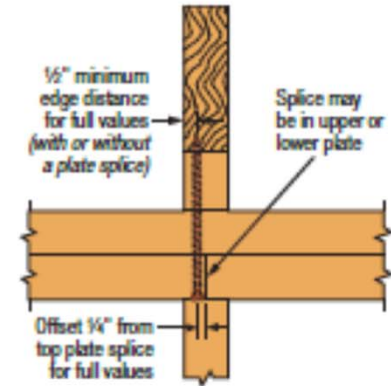

Min. Edge Distance for Top Plate Splice

Optional Roof-to-Wall Connection

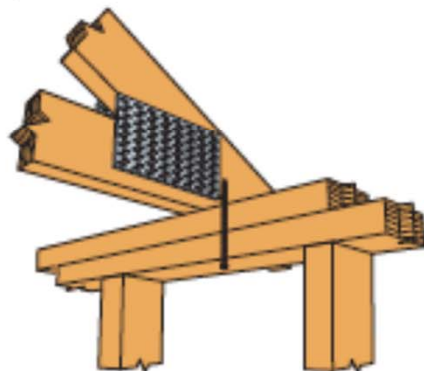

Optional Strong-Drive® SDWC Installation – Truss Offset from Stud

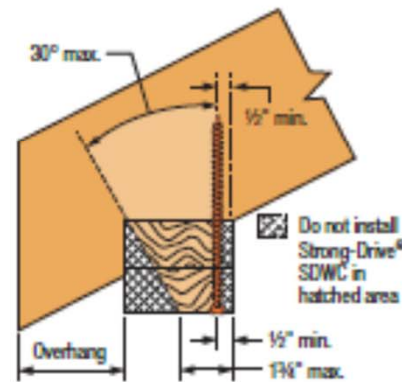

Allowable Installation Range
(Truss offset from stud only)

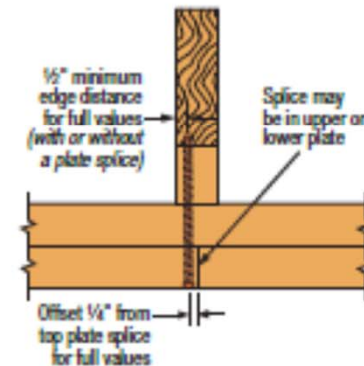

Min. Edge Distance for Top Plate Splice

Many Applications for SDWC Used with Single Screw (cont.) –

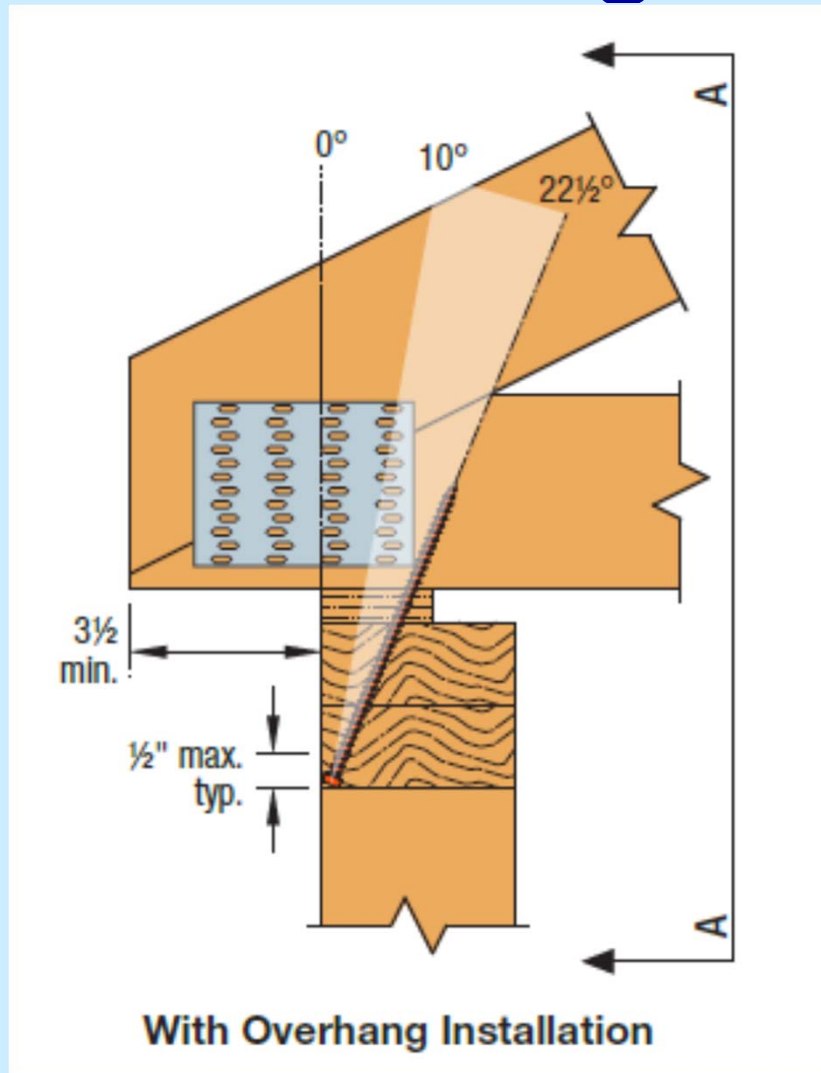

Note: From the Fastening System Catalog (page 351), the installation of a single SDWC is at 22.5 degrees maximum to tie the double top plate to the truss.

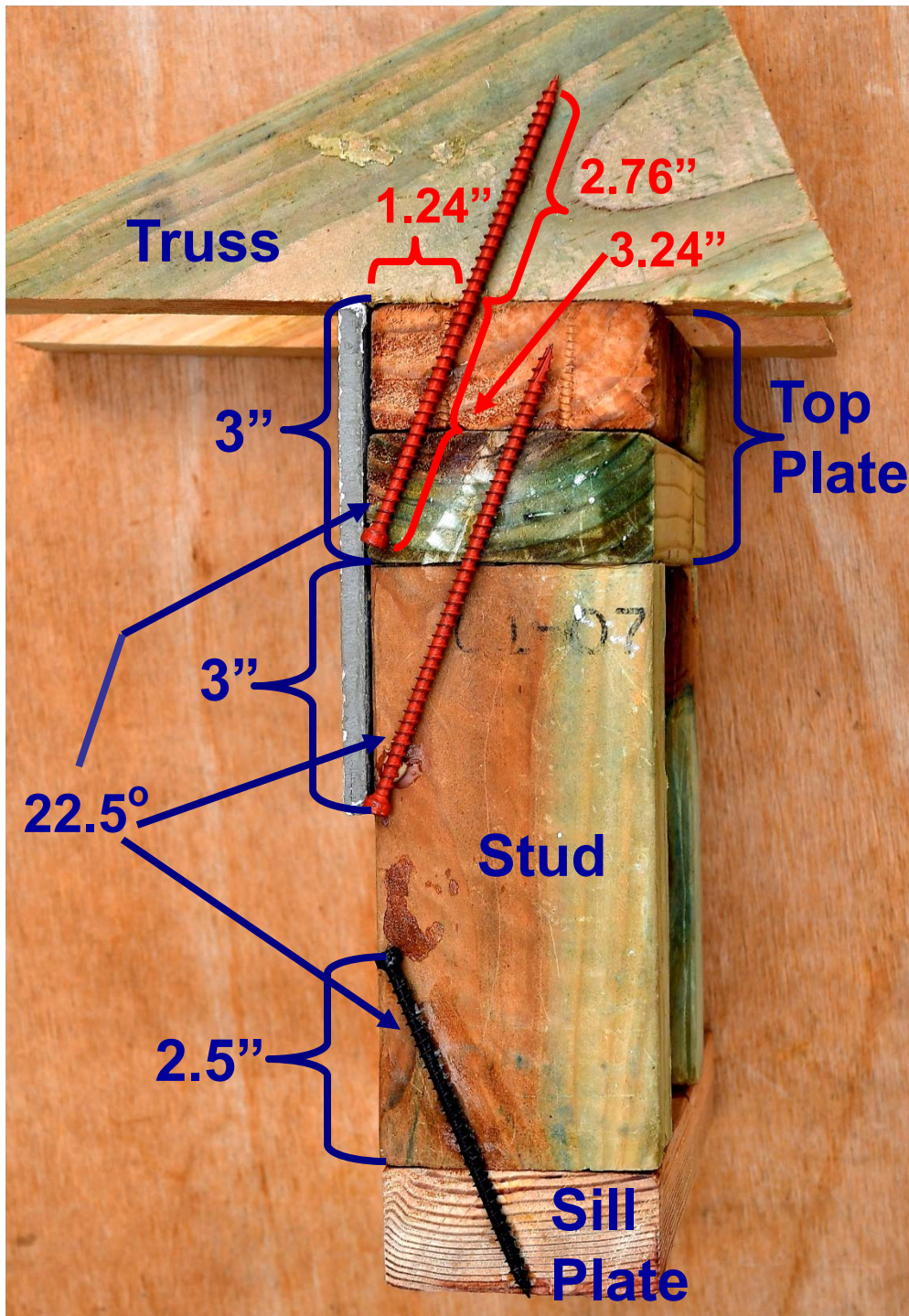

Target Orientations

Double Top Plate to Truss – SDWC enters at lower corner of double top plate at 22.5°.

Stud to Double Top Plate – SDWC enters 3 inches below intersection of double top plate and stud at 22.5°.

Stud to Sill Plate – SDWC enters 2.5 inches above intersection of sill plate and stud at 22.5°.

These are the target orientations from the Catalog once the SDWC clears the siding. Simpson allows leeway. With siding, adjustments are necessary if siding is flush (slide 31), or overlapped (slides 32 & 33). This demonstration house had overlapped Hardie siding.

Part 1 - Double Top Plate to Truss

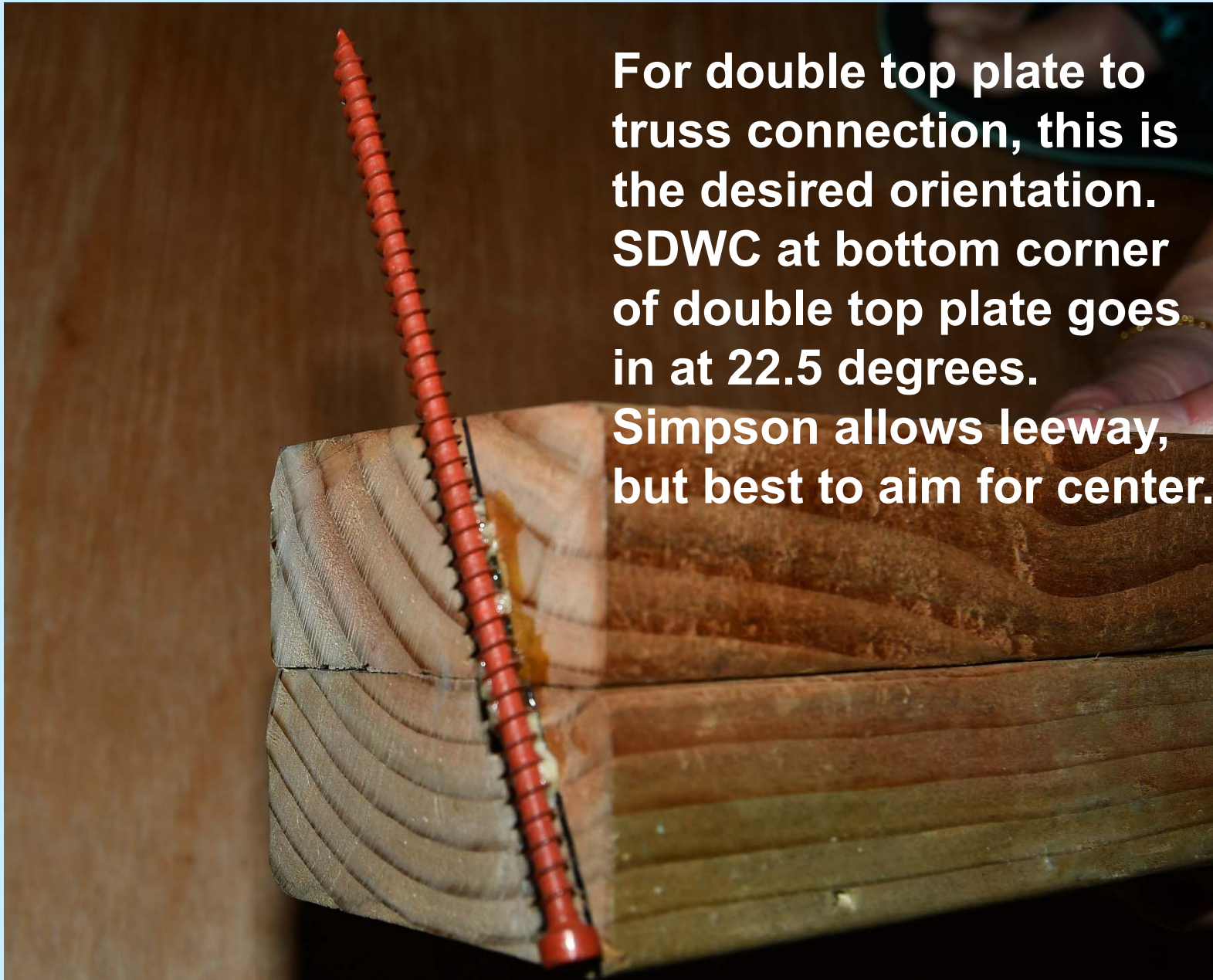

For double top plate to truss connection, this is the desired orientation. SDWC at bottom corner of double top plate goes in at 22.5 degrees. Simpson allows leeway, but best to aim for center.

To obtain proper orientation, take a multi-tool and cut a small rectangular hole below the intersection of the truss and wall (left). This hole can be easily repatched (save cutout). After the retrofit, repair waterproof building wrap with silicone caulk and patch cutout with cement filler for fiber cement siding. Use wood filler for wood siding. Sand and paint.

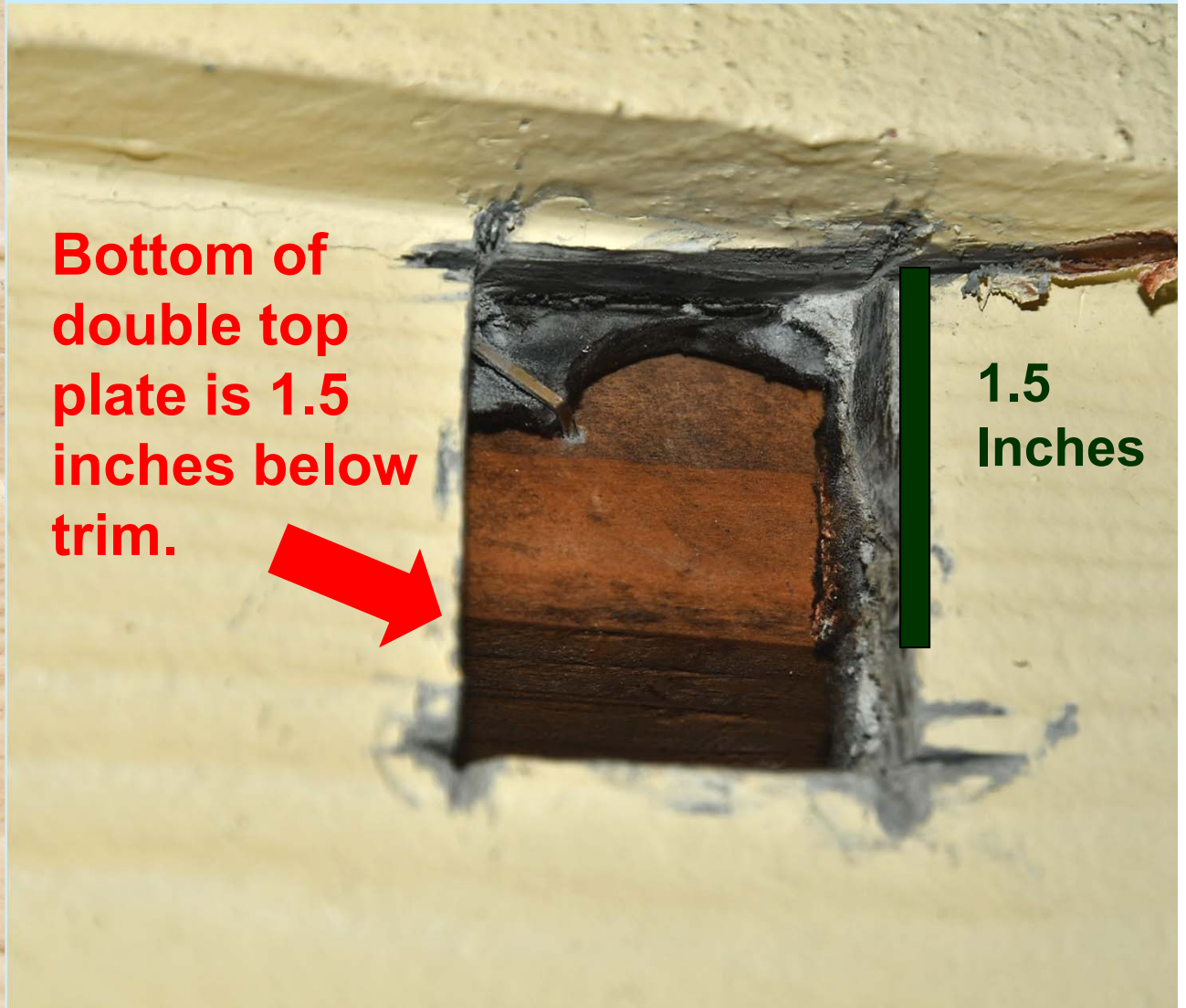
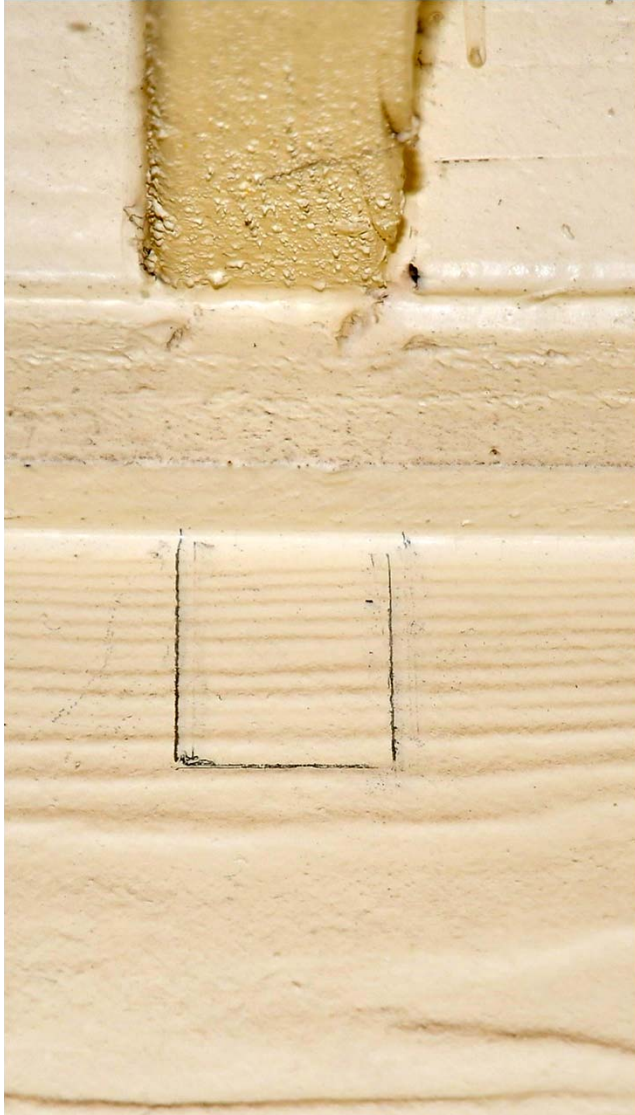

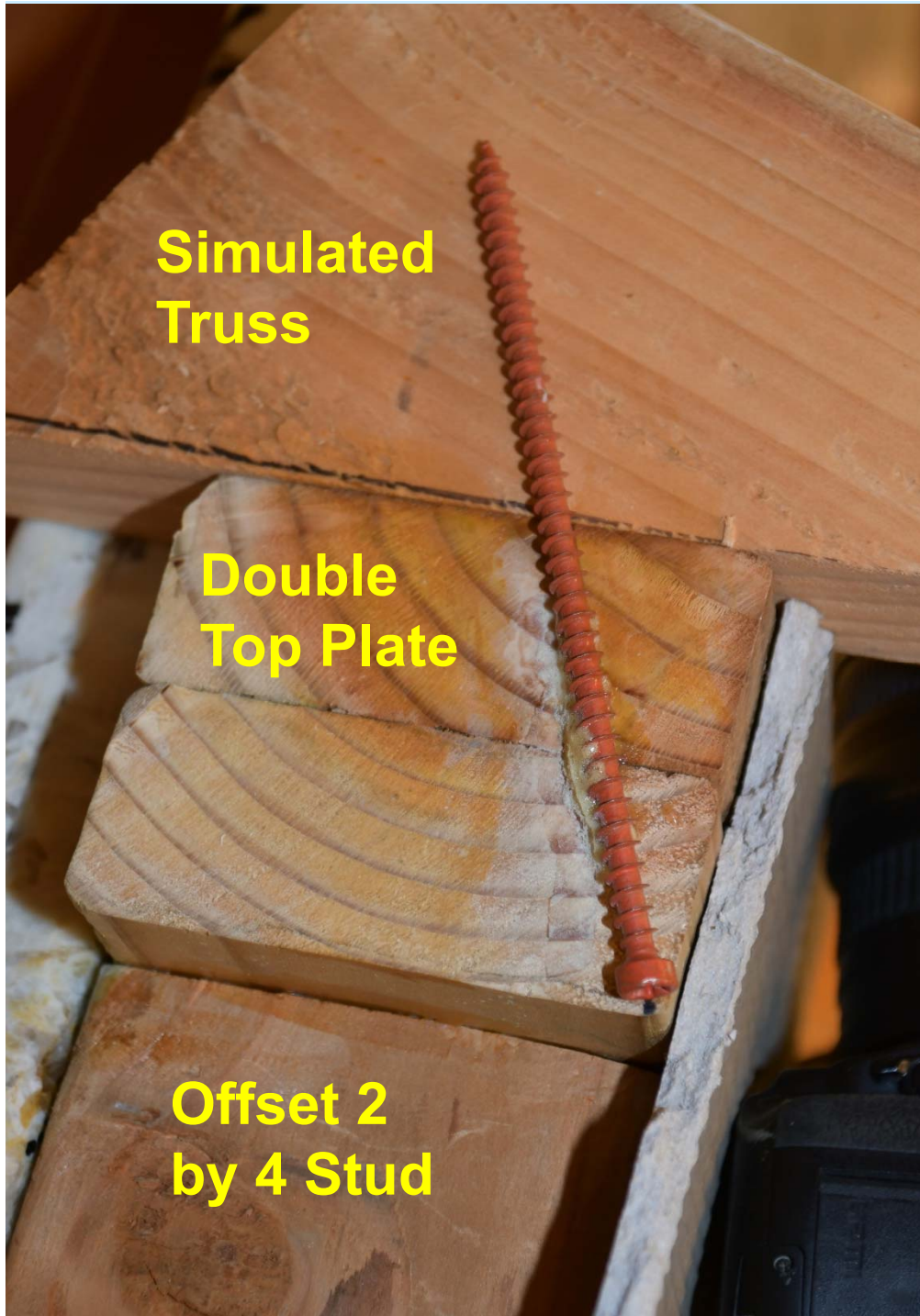

Truss – Double Top Plate

Ideal installation – once bottom of double top plate found, mark and drill 1.1 inches below to account for Hardie siding thickness and overlapped siding (see slide 32). For this house, 1.5 inches below trim plus 1.1 inch = 2.6 inches below trim for this house.

Drill screw completely past siding to target orientation. Head of screw should be past inner plane of siding. Pre-drill to insure 22.5 angle. Pre-drilling may not be needed if drilling into wood, but needed for strong Hardie siding. Since drilling at a shallow angle, it is necessary to drill more than an inch into siding. See slide 19 for the distance to drive screw past the outer surface of siding. Look online, such as at Amazon, for a T30 bit with 3.5 inch length.

Drilling Procedures Used – This may vary with your location and tools.

1.5 inch 3/32 bit to get hole started in difficult to drill Hardie siding and confirm location of top plate or stud in various applications.

4.5 inch 5/32 bit to insure angle is 22.5 degrees by modifying the angle and size of hole.

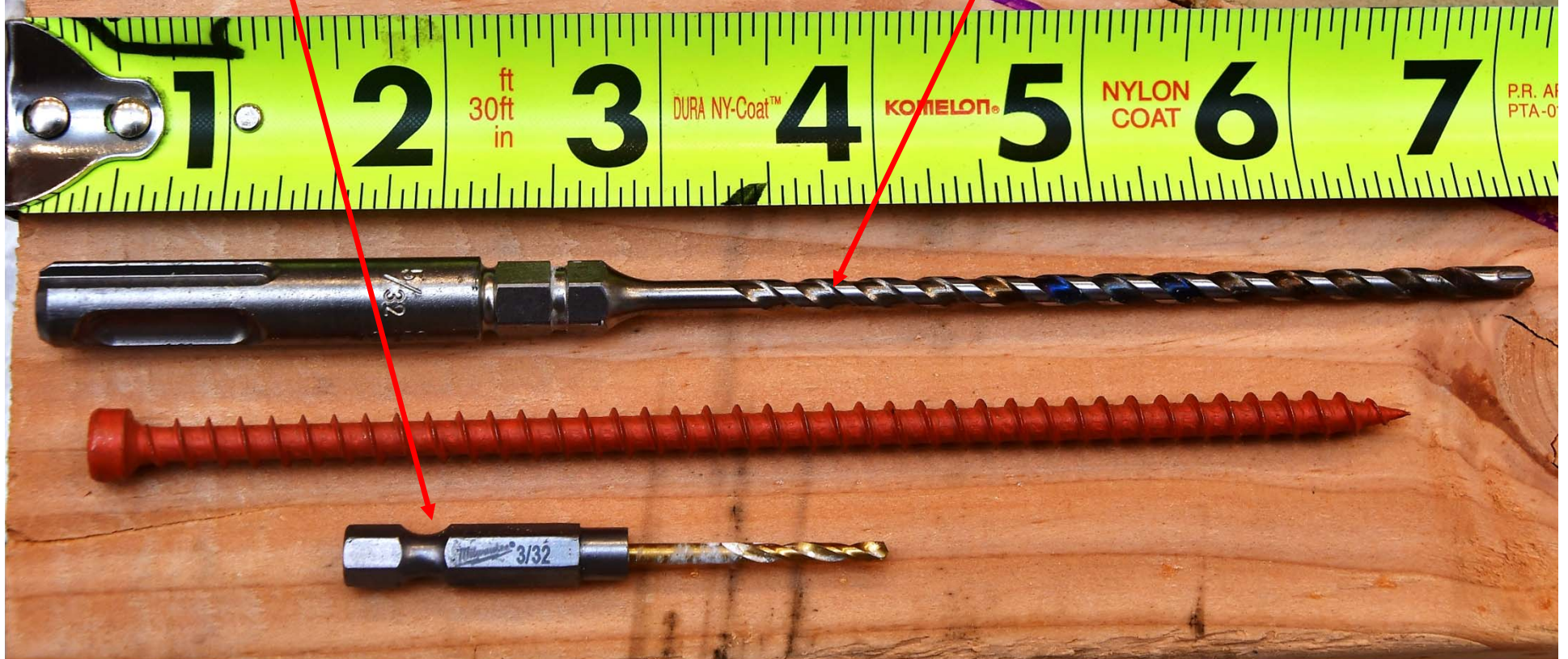

Pre-drill holes twice to prevent wandering. First, with a small short bit, second a longer, wider bit. Pre-drilling may not be necessary in softer materials like wood, but to drill at an angle in hard fiber cement siding it is necessary. Use template to hold the angle. Trimming of template maybe needed to fit under trim.

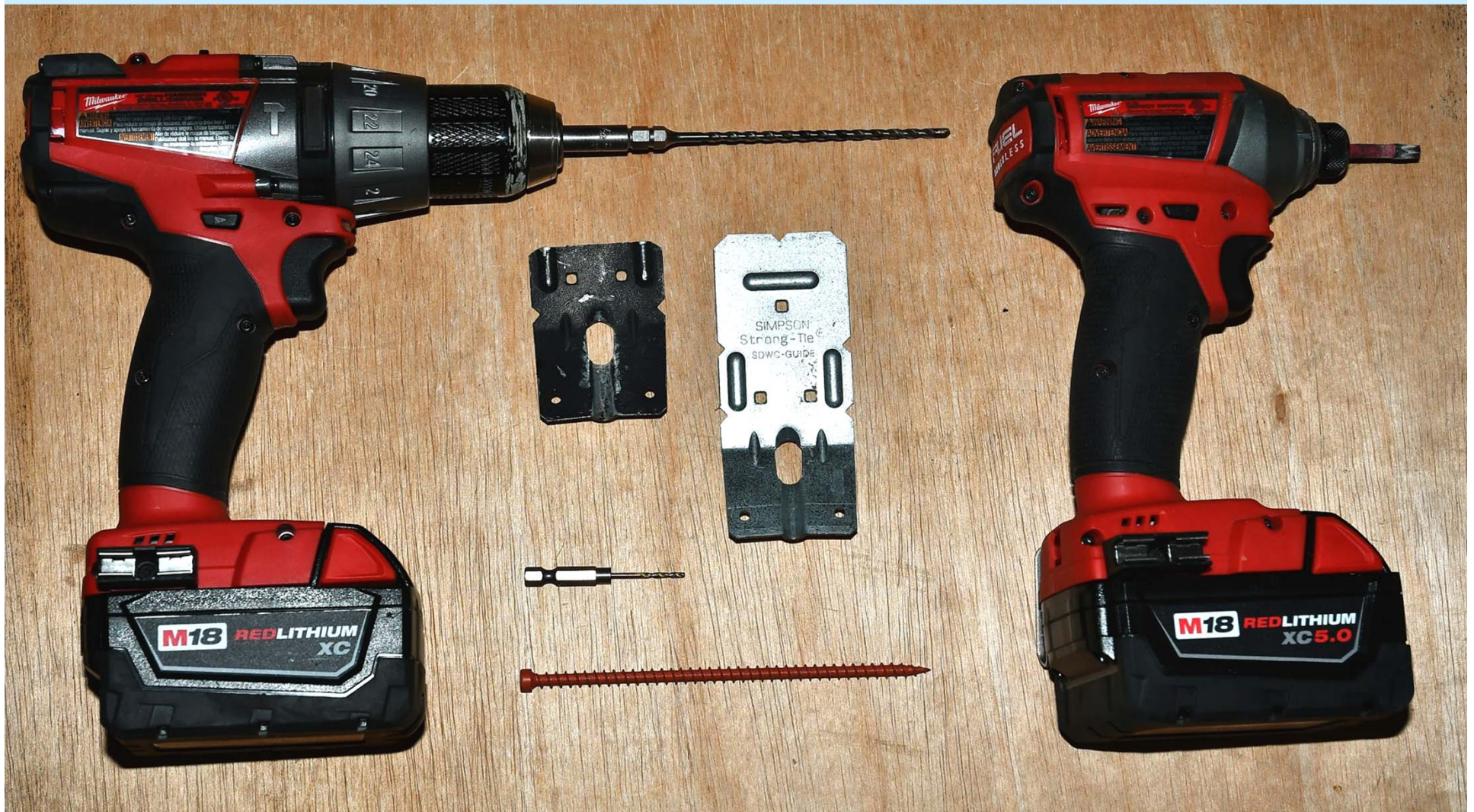

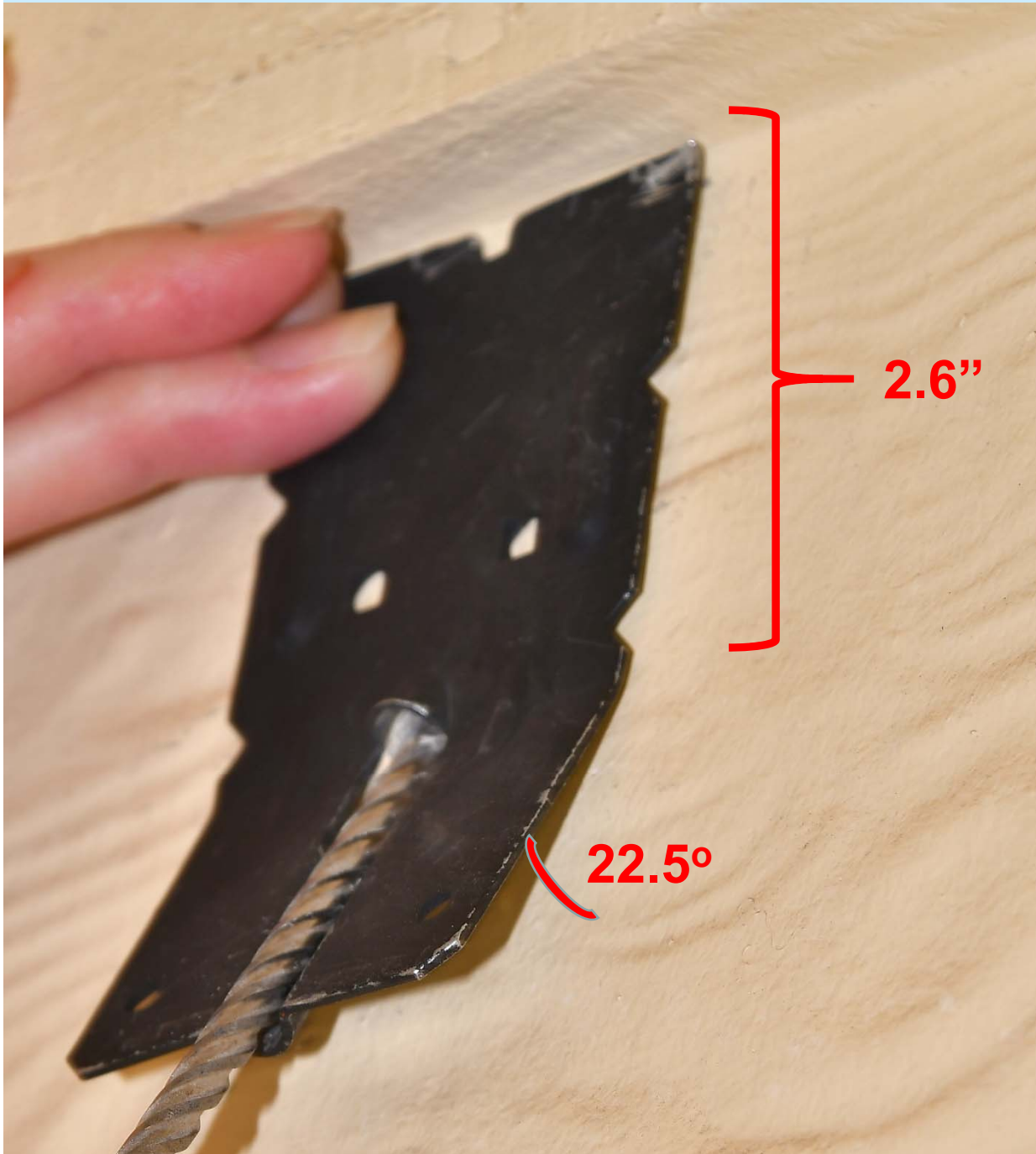

Use the template provided to pre-drill the hole at 22.5 degrees. Continue to use the template when drilling the SDWC structural screw to hold the proper angle.

In this case, a portion of the template was trimmed with a multi-tool metal carbide blade to fit under the trim.

For this house, the hole location was 2.6 inches below the trim (1.5" actual location + 1.1" siding and gap adjustment).

1. Insert 3.5 inch T30 Star bit firmly into Structural Screw
2. Etch with rotary tool 1.2" – based on trigonometry and .46" gap and siding space (see slide 32) **for this top plate to truss connection.**
3. Head of screw should be driven until etch mark encounters wall.
4. Distance **for the stud to double top plate connection** is 1.5"
5. Distance **for the stud to sill plate connection** is 1.3"

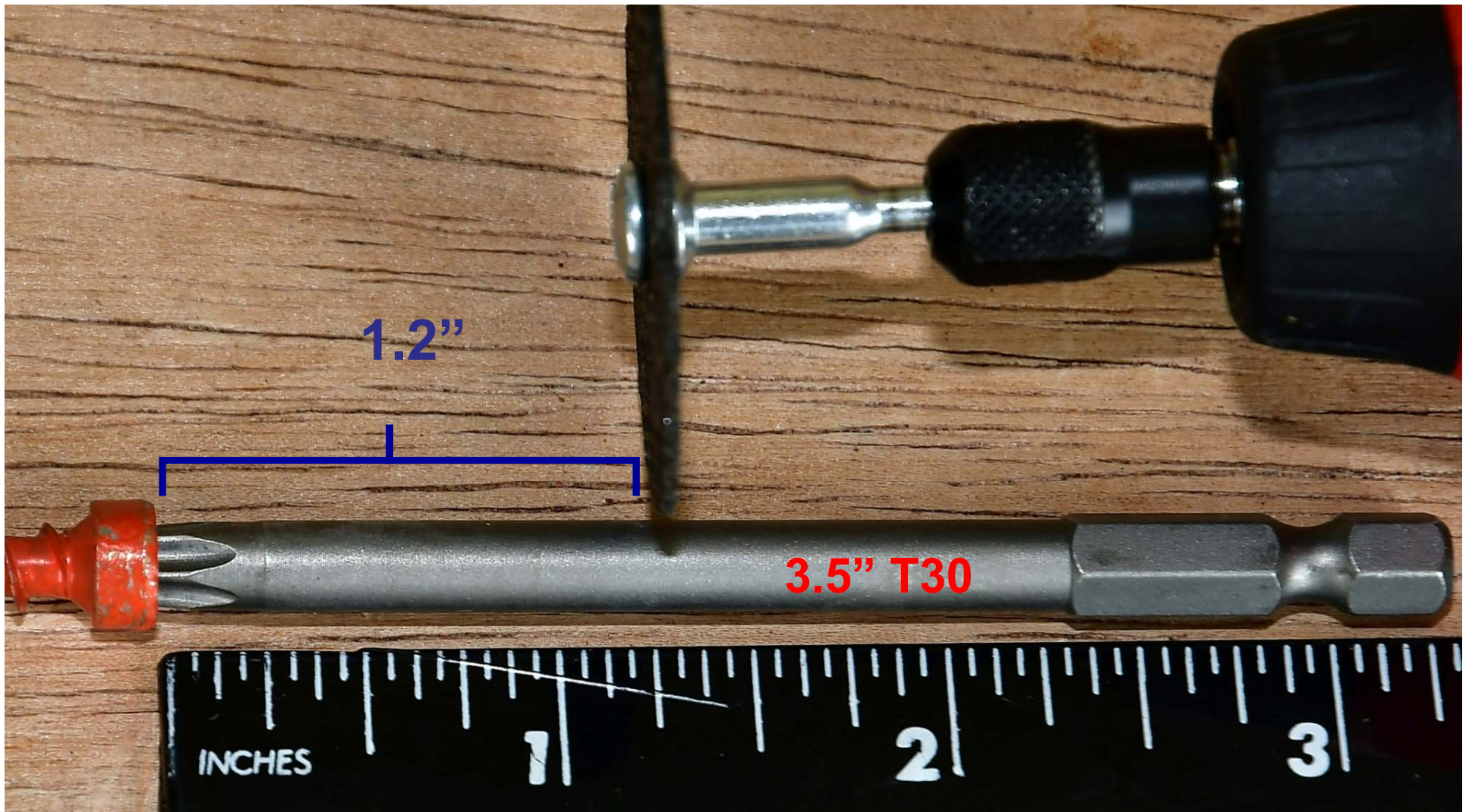

Checking Target Orientation

These structural screws purposely missed the truss but were installed and measured to test the installation methodology. From slide 12, targets are 2.76" outside of top plate and 1.24" from edge of top plate.



Restrict test drilling to areas easily accessible and free from pipes or wires.



Once orientations and installation methodology confirmed, simply drill at easily identifiable locations for the double top plate to truss connections.



Part 2 - Stud to Double Top Plate

1. Effort to continue the load path down for existing double wall houses.
2. By tying truss to double top plate and double top plate to stud, dead load of house is added as uplift resistance.
3. In prior application, the bottom of the double top plate has already been found (See slide 14).

Stud to Double Top Plate Connection



A good stud finder will work through Hardie siding. For double wall houses in Hawaii, the lower nail in the Hardie siding should be in the stud, so it's a direct hint of the location. Also drill with a fine bit to find center of stud. Studs are typically 16 inches apart. Sometimes they are 24. Confirm in the field and with a licensed architect or engineer.

Vertical location of screw entry for double top plate to truss where truss is located.



Vertical location of screw entry for stud to double top plate where stud is located.

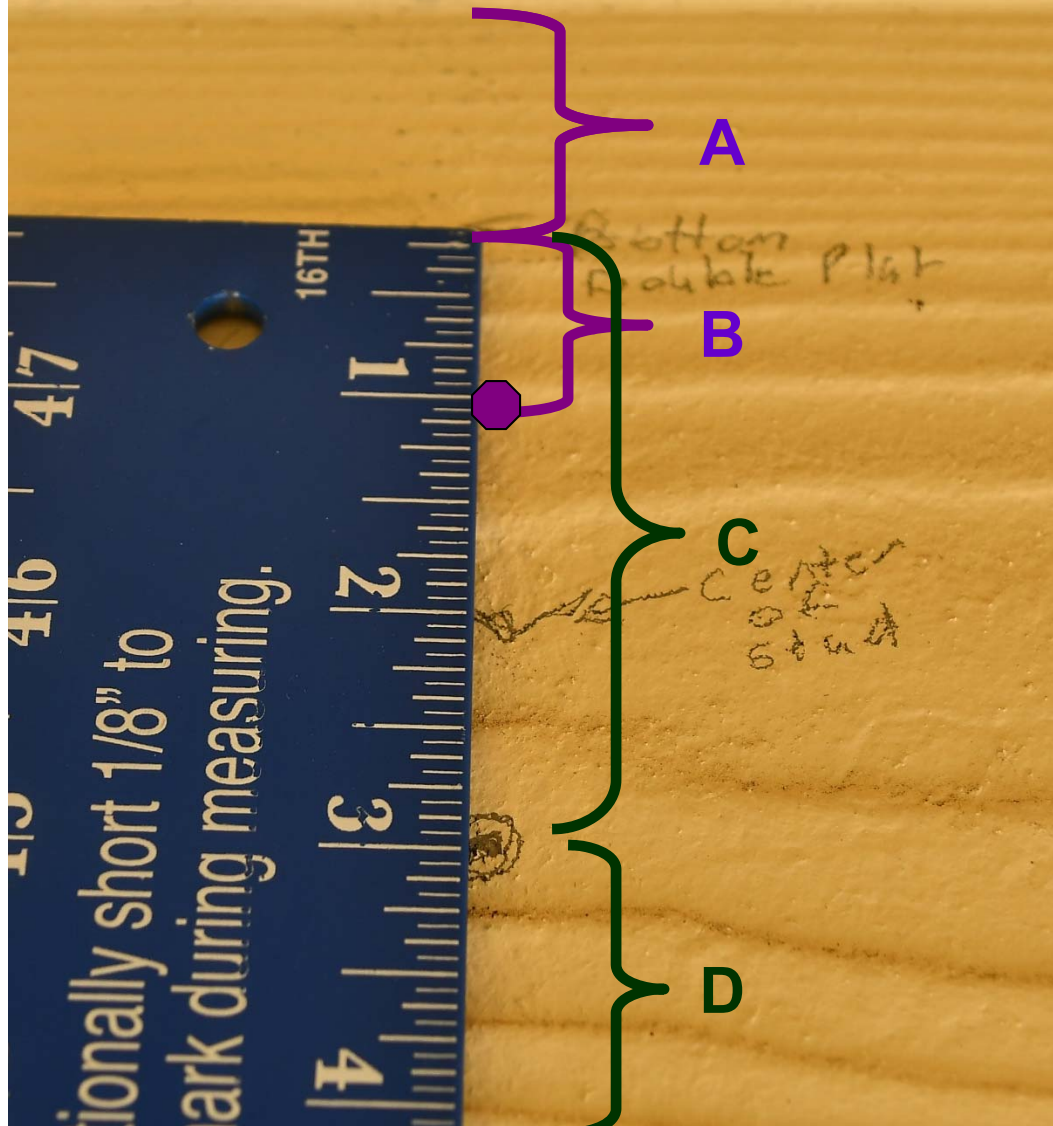

A) The bottom of the double top plate is 1.5 inches below the trim for this house.

B) Siding and gap adjustment is 1.1 inches. See slide 32. Drill point is 2.6 inches below the trim.

C) If there was no siding or overlap of siding, the location of the drill point for the stud-double top plate connection is 3 inches lower than the double top plate to truss connection (see slide 9 – top middle).

D) Siding and gap adjustment is 1.4 inches. See slide 32. Drill point is $1.5 + 3 + 1.4$ or 5.9 inches below the trim.

Exposed siding showing bottom of double top plate. Do this once to reveal correct relationship of truss and double top plate for the house.

Double top plate to truss structural screw.

Stud to double top plate structural screw.

In this house the stud and truss do not align but are offset.

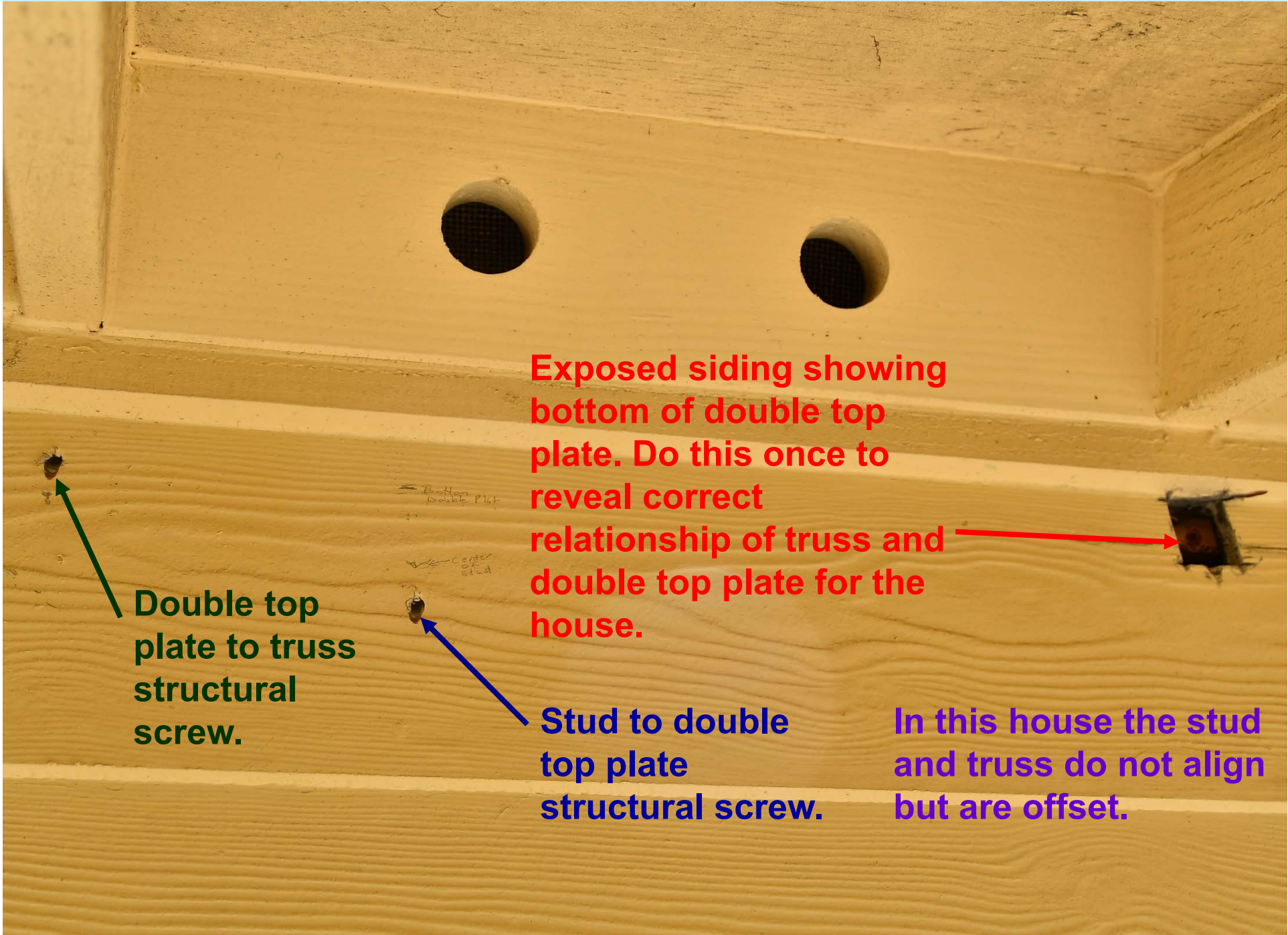

Check the Attic

This SDWC purposely misses truss to show relationship with the double top plate and truss given the installation methodology.



This SDWC purposely overdriven to show relationship of stud and double top plate connection.



Part 3 – Stud to Bottom Plate

1. Effort to continue the load path down for existing double wall houses.
2. This connection requires the black 4.5 inch SDWC, since the lower sill plate consists of one 2" X 4". The prior two connections used the orange 6.0 inch SDWC because of the double top plate.
3. By connecting the stud to the bottom sill plate, the load path is completed provided the bottom plate is anchored to the foundation. Check with builder, licensed architect or engineer.

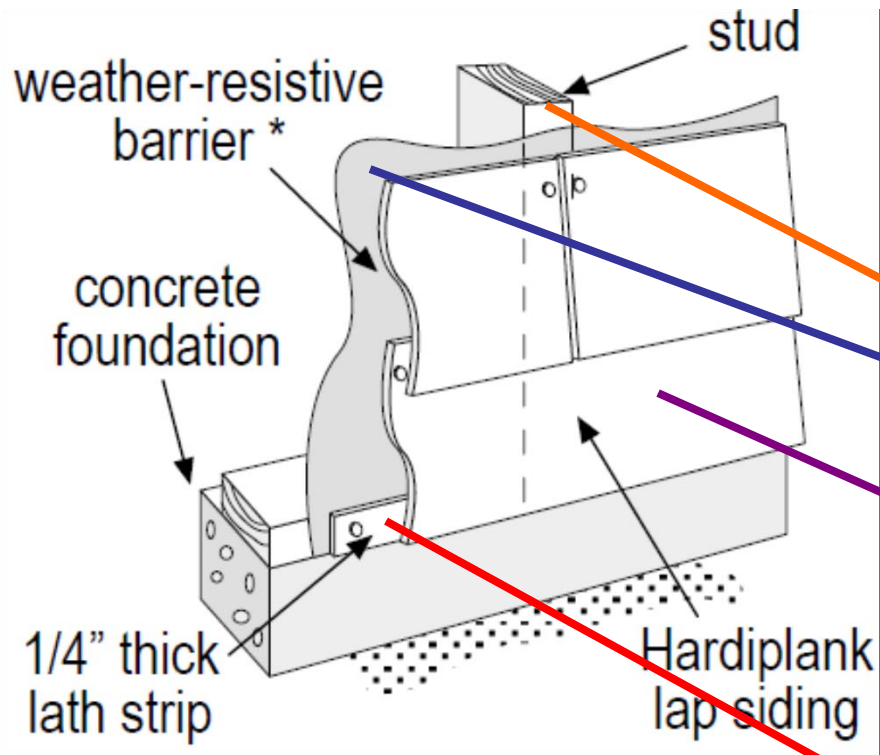

Stud to Bottom Sill Plate

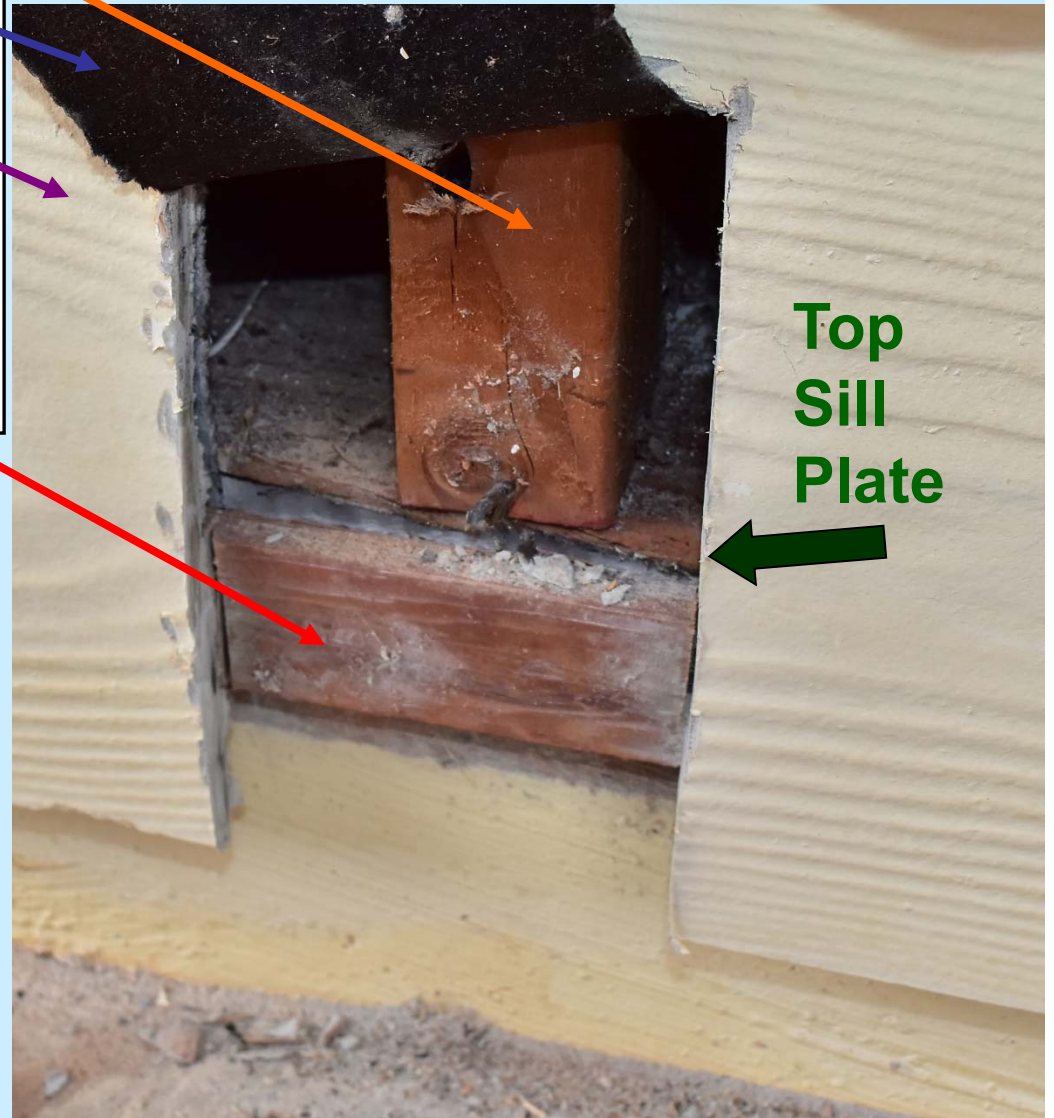

Open once on bottom to determine top of sill plate. Mark with pencil. Weather resistant barrier wrap has been removed.



4.5" SDWC from stud to sill plate.

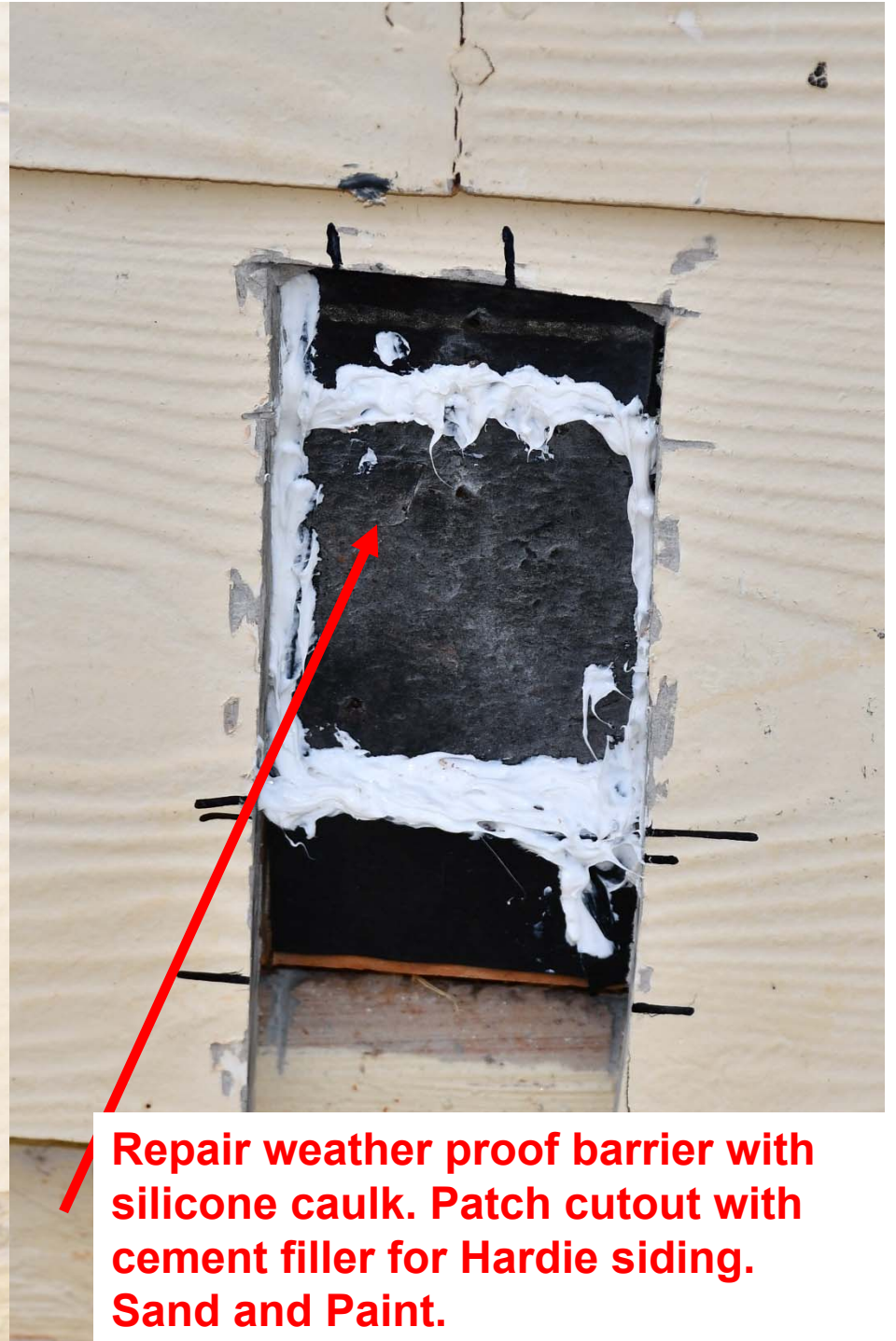

Repair weather proof barrier with silicone caulk. Patch cutout with cement filler for Hardie siding. Sand and Paint.

Summary

- **Significant application in Hawai'i for double wall houses without hurricane clips or a complete continuous load path.**
- **Houses with no hurricane clips – Generally houses built on or before 1988 on O'ahu, on or before 1990 on Maui and Kaua'i and on or before 1994 on Hawai'i**
- **Houses with no continuous load path. Generally houses built on or before 1993 on Kaua'i, on or before 1994 on Hawai'i, and on or before 1995 on Maui and O'ahu**

$$\sin \theta = \frac{\text{Opposite}}{\text{Hypotenuse}}$$

$$\cos \theta = \frac{\text{Adjacent}}{\text{Hypotenuse}}$$

$$\tan \theta = \frac{\text{Opposite}}{\text{Adjacent}}$$

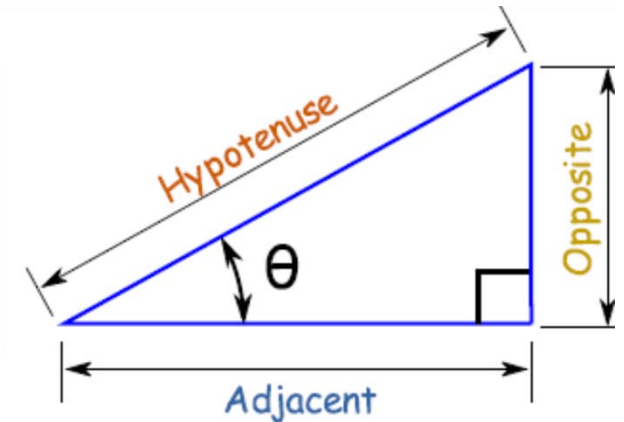

Target orientation of screw, see slide 12.

.31 in.

y

22.5 degrees

Preliminary for Top Plate to Truss

Hardie Siding is 5/16" or .31"

Tangent 22.5° = .31 inches/Y

Y = .31 inches / Tangent 22.5°

Y = .31 inches / .414 = .75

This distance would work for siding that is flush with the wall.

Hardie siding is not flush but overlapped against the lower piece. See next 2 slides for adjustment.

Double Top Plate to Truss

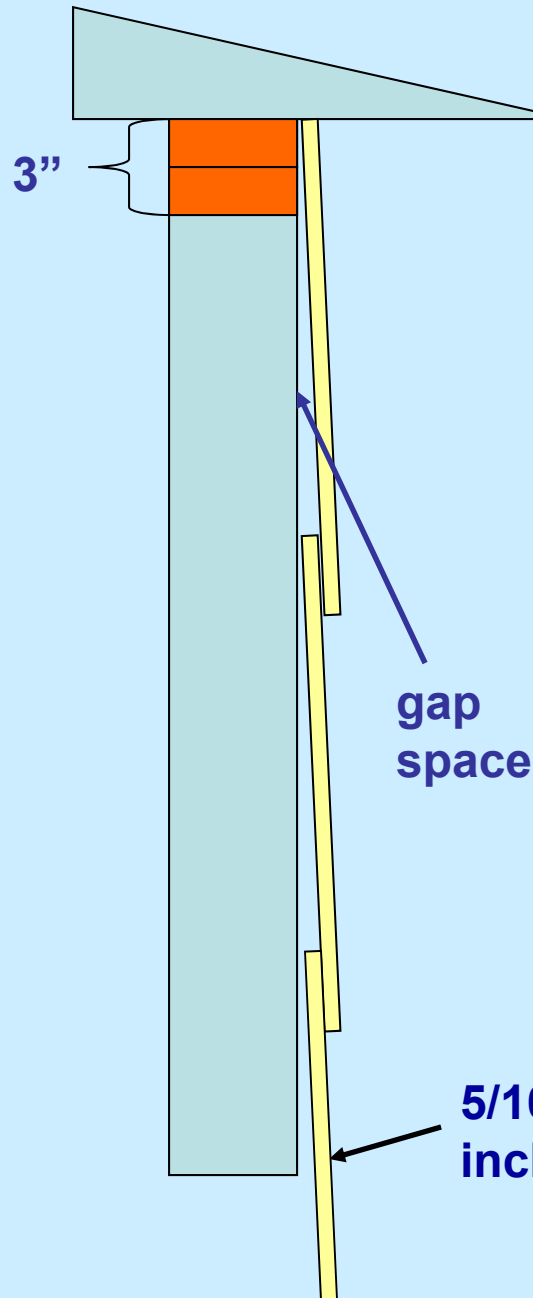

1) $\sin \theta = .31/7.75$ – siding is $5/16$ (.31 inches) and plank is 9.25 inches high with 1.50 overlap

2) Angle is 2.29 degrees

3) At drill location 3.75 inches down – space is

$\tan 2.29 \text{ degrees} = x/3.75$ so $x = .15$ inches

4) Need to drill through .15 inches + .31 inches = .46 inches

5) Need to drill at 22.5 degree angle – $\tan 22.5 = .46/y$ so $y = .46/\tan 22 = \underline{1.1 \text{ Inch below intersection of stud and double top plate as a siding and gap adjustment}}$

Stud to Double Top Plate

At 6.75 (3 + 3 + .75) inches down gap space is $\tan 2.29 \text{ degrees} = x/6.75$ so $x = .27$ inches plus .31 inches = .58 inches

Need to drill at 22.5 angle – $\tan 22.5 = .58/y$ so $y = .58/\tan 22.5 = \underline{1.4 \text{ Inch below target orientation (slide 12) for siding and gap adjustment}}$

Stud to Bottom Plate

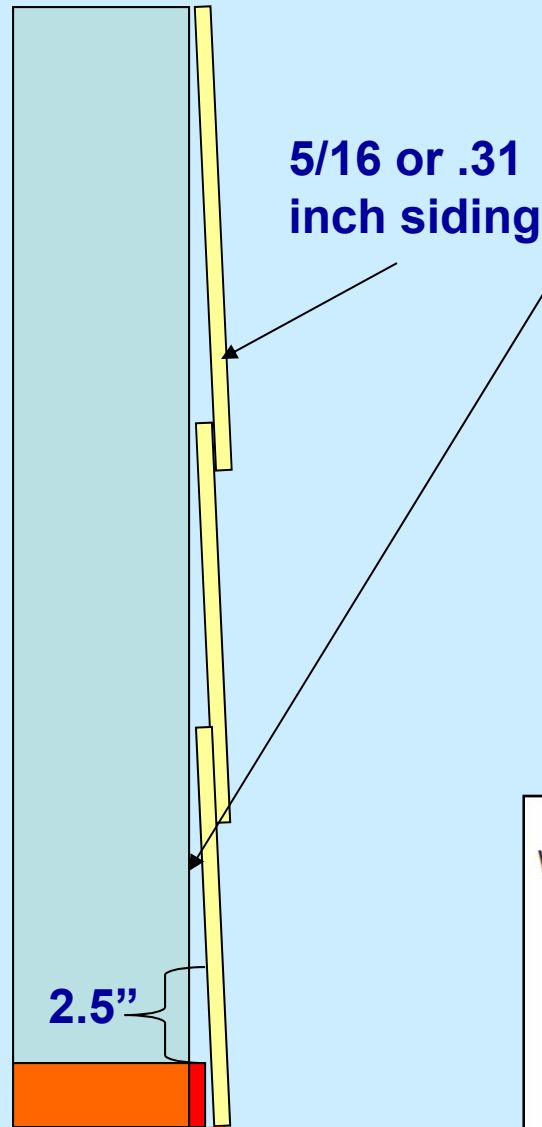

Starter is
.25" by 1.5"

1) $\sin \theta = .25/7.75$ – plank is 9.25 inches high with 1.5 overlap (coinciding with 1.5 inch bottom plate)

2) Angle is 1.85 degrees, $x = .25$, $y = 7.73$

3) At drill location $7.73 - 2.5 = 5.23$ "

$\tan 1.85 \text{ degrees} = x/5.23$ so $x = .17$ inches

4) Need to drill through $.17$ inches + $.31$ inches = $.48$ inches

5) Need to drill at 22.5 degree angle – $\tan 22.5 = .48/y$ so $y = .48/\tan 22.5 = \underline{1.16}$ inches higher

6) Drill $2.5 + 1.16$ inches above top of bottom plate or 3.66 inches above top of sill plate.

