

## Coking and Thermal Process, Delayed Coking

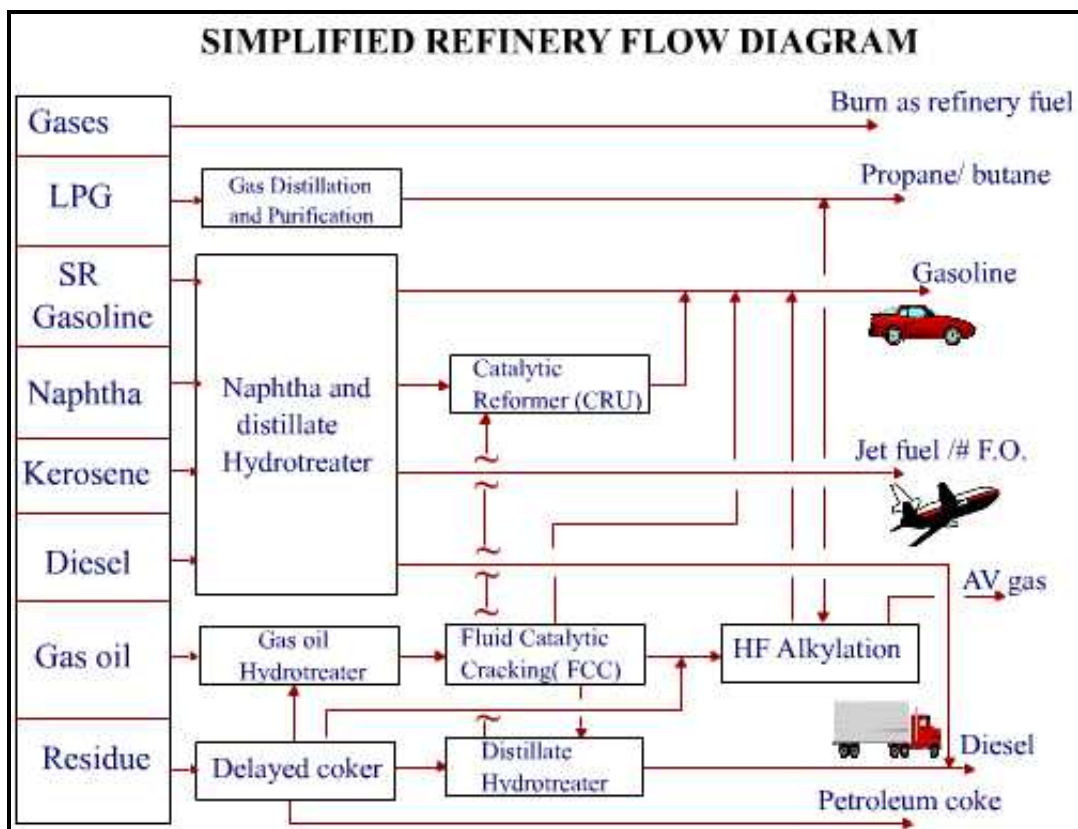

**Fig:4.1 Simplified Refinery Flow Diagram** [1,2]

- ▶ **Treatment processes** : To prepare hydrocarbon streams for additional processing and to prepare finished products.
- ▶ **Treatment:** It include the removal or separation of aromatics and naphthenes as well as impurities and undesirable contaminants.
- ▶ **Treatment involve:**chemical or physical separation such as dissolving, absorption,or precipitation using a variety and combination of processes including desalting,drying,hydrodesulfurizing,solvent refining,sweetening,solvent extraction, and solvent dewaxing.

## THERMAL PROCESSES

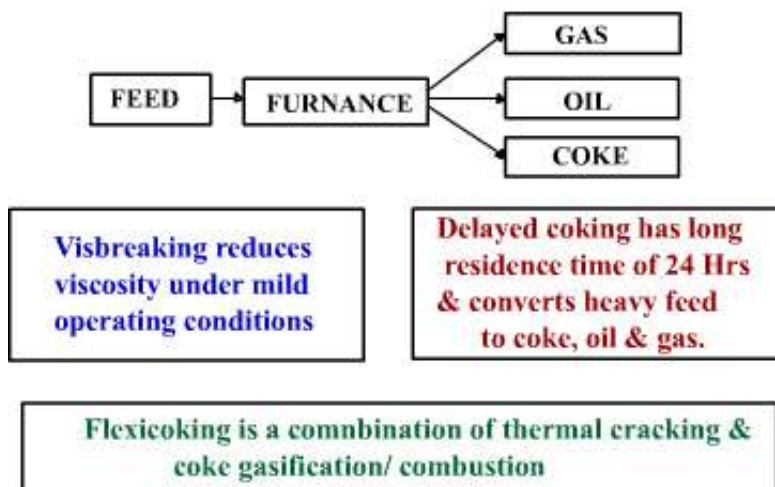

Fig:4.2 Thermal Processes [2,6]

### Delayed Coking

Using time and high temperature one can break large asphalt molecules into gasoline and diesel. Petroleum coke is a solid by product and is blended with coal to use as a solid fuel in power plants. [5,8]

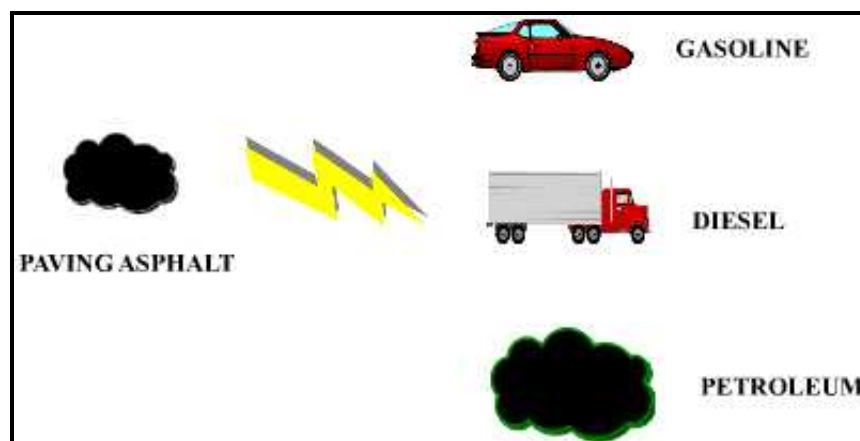
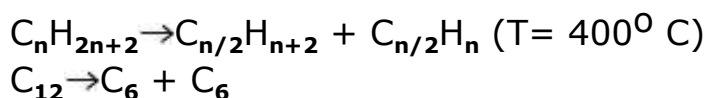

Fig:4.3

### Cracking

Dissociation of high molecular weight hydrocarbon into a smaller fragments through agency of heat alone is termed as thermal cracking or pyrolysis.

Can also be done in presence of catalyst.



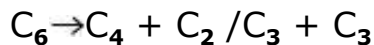

Cracking proceeds via free radical mechanism.



**Unsaturated (olefins) obtained in the process crack again.**<sup>[3,6]</sup>

- $C_4H_8 \rightarrow C_2H_6 + H_2 / C_2H_4 + CH_4 + C$
- $C_4H_8 \rightarrow CH_4 + C_3H_4$  (diolefins / alkynes)
- $C_2H_4 C_3H_4 \rightarrow C + H_2$

**Olefins cracks on dehydrogenation to diolefin or an alkyne.**

[1,2,6]

- Hydrogenation also occur but to less extent.
- $C_3H_4 + H_2 \rightarrow C_3H_6$

**Saturates are converted to unsaturates:**

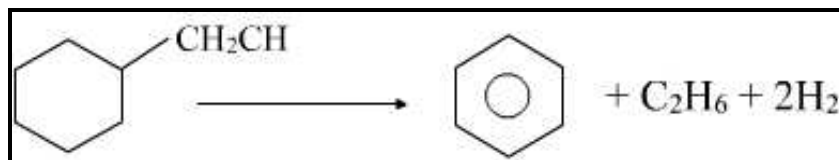

Ring opens in the extreme conditions of cracking

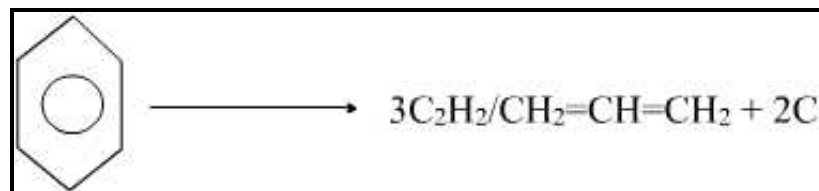
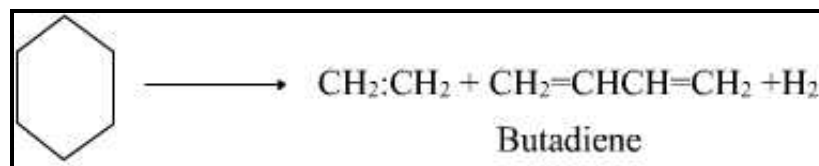

**Chemistry of Catalytic Cracking**<sup>[1-2,6-8]</sup>



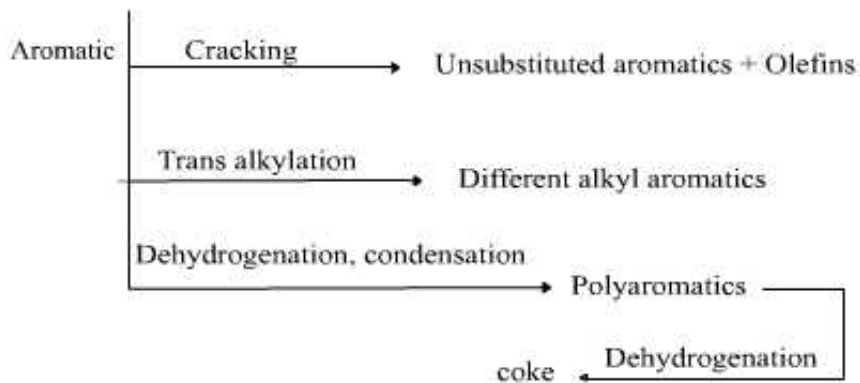
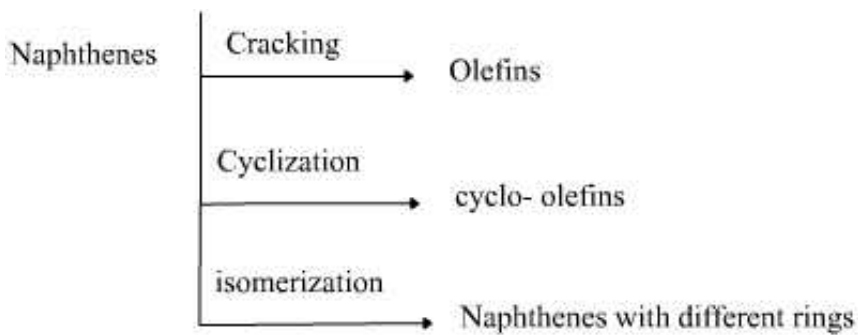
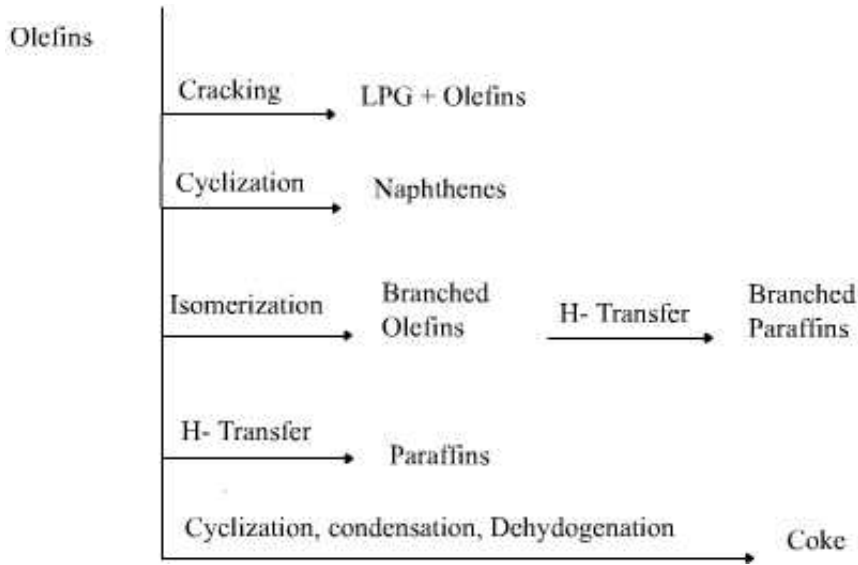

## Thermal cracking operation<sup>[1,2]</sup>

**Tab:4.1**

Cracking temperature (C)	Nature of operation	Products
425-460	Visbreaking	Fuel oil
460-520	Thermal cracking	Gas, gasoline, Tar oils, circulating oils
520-600	Low temperature coking	Gas, asoline , soft coke
800-1000	High temperature	Gas , heavy aromatics
Above 1000	decomposition	H <sub>2</sub> , gas, carbon black

### Thermal cracking<sup>[1,2,6-8]</sup>

#### Properties of cracked materials

Product properties are extensively dependent on the conditions of cracking. The properties that undergo changes during cracking are:

- a) Characterisation factor (decreases due to high aromatic content)
- b) Boiling point , viscosity, pour point decreases.
- c) Unsaturation and Aromatisation increases.
- d) Octane number of gasoline increases.
- e) Sulphur content in the cracked product increases as the rule although the maximum amount in heavier portion only.

### Cracking<sup>[1,2,6-8]</sup>

It is a endothermic process , so external heat is required.

Main parameters affecting cracking:

- Pressure
- Temperature
- and time of cracking.

Pressure has no direct effect on velocity of the reaction. If more gases to be produced then low pressures are desirable.

- ▶ With higher pressures gas to gasoline ratio becomes less.
- ▶ Reaction velocity is directly dependent upon temperature .

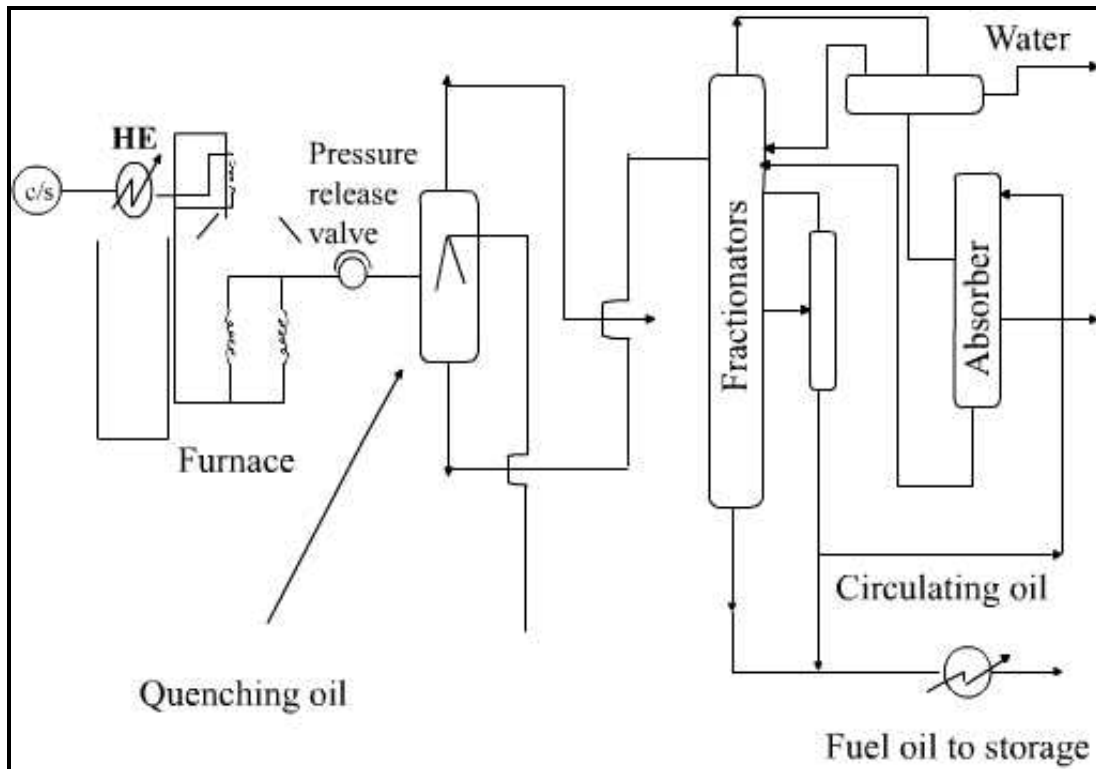

**Fig:4.4**

### **Visbreaking**<sup>[1,2,8]</sup>

- ▶ Reduction in viscosity is Visbreaking.
- ▶ Materials like residuums are not of direct utility or stocks decided with difficulties due to high pour point , from palapable feed stock for this operation.
- ▶ Liquid products may be used as cycle stocks for crackers commercially valuable main products know as fuel oil.
- ▶ Light fraction → gas and gasoline.

#### **Basic parameters:**

Cracking temperature and residence time Soaker type (more gas) or coil type visbreaker(more gasoline due to for short residence time)

#### **High temperature soaker visbreaking**<sup>[1,2,9-12]</sup>

Soaker drum : Large vessel designed to allow for a long residence time for the feedstock.

Cracking in the furnace is minimised by using high liquid velocity and steam injection.

With increase in T and cracking time : light fraction increase => fuel oil yield decrease.

### **High conversion soaker visbreaking**

- ▶ Gives higher conversion and more stable residue compare to conventional soaker visbreaking.
- ▶ Feed stocks : Heavy crude oil, oil shale, long and short residue, visbroken residue.

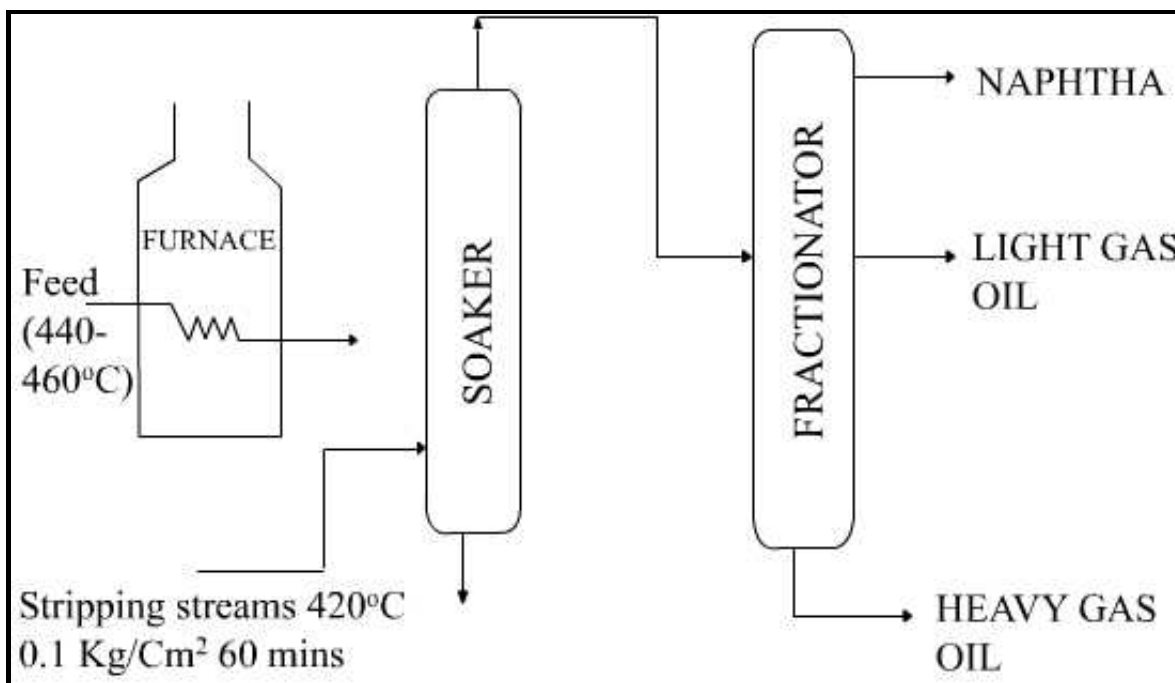

**Fig:4.5**

## Operating conditions and products:<sup>[1,2,9-16]</sup>

- ▣ Increase in cracking time and temperature increases the lighter fraction and decreases the fuel oil yield.
- ▣ Pressure has negligible effect on velocity of reaction. At high pr. gas / gasoline ratio is less.
- ▣ Pressure retards cracking reactions

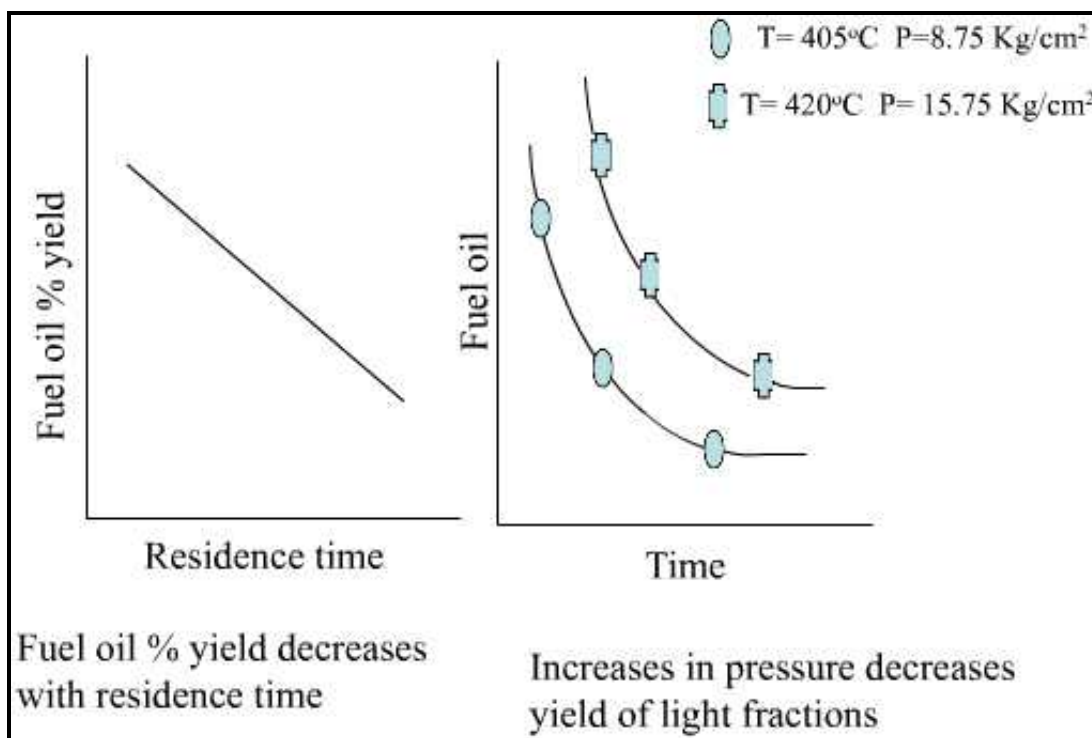

**Fig:4.6**

## Visbreaking Operation<sup>[1,2]</sup>

Feed stock: Asphalt, Short residuum to residuums, and medium oil

### **Steps:**

- 1) Preheating of feed upto 250<sup>0</sup>C
- 2) Heating in furnace up to 470<sup>0</sup> C.
- 3) Pressure 10-15 kg/cm<sub>2</sub> necessary to avoid coke formation. Steam admission in to feed stocks also checks coke formation.
- 4) Fraction (Light and heavy) from quencher goes to distillation column.

## Theory of cracking:

**Thermal cracking proceeds via free radical mechanism.**<sup>[1,2,8-</sup>



17]

Free radicals : atom or group of atom with bare unpaired electron.



Unpaired electrons are very active and try to form stable compound by acquiring unpaired electrons from sources available.

HC (charged) ions are usually referred as carbonium ions.



- Paraffins  $\rightarrow$  rate of reaction increases with increase in carbon number.
- olefins  $\rightarrow$  cracks much faster compared to paraffins.

### Chemistry of catalytic cracking<sup>[1,2,3-14]</sup>

Large molecules smaller Fragments with double bond  
Hydrogen demand net through creation of double bond by means of :

- Hydrogen Transfer
- Cyclization
- Aromatization

### Effect of pressure on cracking:

Pressure retards cracking reactions. But in practice a positive pressure of 10 to 15 Kgs/cm<sup>2</sup> is used to minimize coke formation. Recycling increases refractory nature of stocks and hence recycling should not exceed 2 to 3 times of fresh stock for economic operation.

### Catalytic Cracking<sup>[3-16]</sup>

- Catalytic Cracking is the most widely used refinery process for converting heavy oil into gasoline of high octane value.
- Catalyst Cracking is distinguished from Thermal Cracking in the reaction mechanism Which is called carbonium- ion mechanism.
- Carbonium ion mechanism gives more stable saturated

compounds.

**Protonation of an olefins:**<sup>[1,2,5-13]</sup>

