



**Countries:** CANADA, UNITED STATES **Document ID:** IK1201242  
**Availability:** ISIS, FleetISIS, IsSIR **Revision:** 3  
**Major System:** ENGINES **Created:** 11/20/2014  
**Current Language:** English **Last Modified:** 9/20/2016  
**Other Languages:** [Español](#), **Author:** Dominic Venice  
**Viewed:** 9918

[Less Info](#)

Hide Details

Coding Information

<b>Copy Link</b> 	<b>Copy Relative Link</b> 	<b>Bookmark</b>  <a href="#">View My Bookmarks</a>	<b>Add to Favorites</b> 	<b>Print</b> 	<b>Edit Document</b> 	<b>Provide Feedback</b> 	<b>Helpful</b>  24	<b>Not Helpful</b>  2
----------------------	-------------------------------	--	-----------------------------	------------------	--------------------------	-----------------------------	--------------------------	-----------------------------

**Title:** Big Bore 13L HP Turbocharger Center Section Replacement Procedure

**Applies To:** EPA 10 MaxxForce 13L and N13 Engines

## **CHANGE LOG**

09/20/2016 - Added link for complete turbocharger replacement guidelines.  
 01/26/2015 - Fixed warranty coding for CAC cleaning SRT  
 11/20/2014 - Initial Article Release

## **DESCRIPTION**

This procedure provides instructions for replacing the High-Pressure (HP) turbocharger center section (cartridge) on EPA 10 MaxxForce 13L and N13 Big Bore Engines. If performing turbocharger repairs on a EPA 10 MaxxForce 11L Engine, reference [IK1201073](#).

Reference [IK1200909](#) to help identify if a complete turbocharger replacement is necessary.

Both the factory and new (updated) oil supply tubes are one-time use only items, replace the oil supply tube any time it is removed from either turbocharger.

The following procedure replaces **TSI 13-12-05** and can be located in the Engine Service Manual for both EPA 10 MaxxForce 11/13L & N13 Engines.

## **SYMPTOMS**

### **Customer Observations or Concerns:**

Low Power  
 Noise coming from the turbocharger

## **SPECIAL TOOLS / SOFTWARE**

Tool Description	Tool Number	Comments	Instructions
Navistar Coolant Management Tool	KL5007NAV		
Kit, CAC Cleaning	09-925-01		

[Service Tool Resource Center](#)

## **SERVICE PARTS INFORMATION**

**Order below parts for Engine equipped with new turbocharger oil supply tube:**

Kit Description	Part Number	Qty
Kit, HP Turbo Cartridge	2511792C91	1
Tube, Assembly Turbocharger Oil Supply	3018397C92	1
O-Ring Seal (If Needed, for drain tube)	1820907C2	1

Order below parts for Engine **NOT** equipped with new turbocharger oil supply tube: Reference [IK1201237](#) for further detail on installation.

Table 1. Engine Parts

Kit Description	Part Number	Qty
Tube, Assy Turbo Oil Supply	3018397C92	1
Fitting, Oil Tube	2512772C91	1
Spacer (If required)	62917010831	1
Stud Bolt (If required)	1819245C1	1
Kit, HP Turbo Cartridge	2511792C91	1
O-Ring Seal (If Needed) - Drain Tube	1820907C2	1

Table 2. ProStar® 122 Routing & Clipping Kit

Kit Description	Part Number	Qty
ProStar® 122, Heater Hose Routing Kit	2513145C91	1
Bolt, Carriage	495967R1	1

Table 3. ProStar® 122 Routing & Clipping Kit (2513145C91) Contents

Kit Description	Part Number	Qty
Saddle	3821016C1	4
Nut	31082R1	2
31054R1	Bolt	2
299615C1	Clamp, Cushioned	2

306132C1	Tie Strap	8
3666881C1	Swivel Saddle	1
31046R1	Bolt	1
31081R1	Nut	1
3919779C1	Clamp	1
120377	Nut	1
L2643486	Hose (1900 mm)	1
584067C1	Conduit (1900 mm)	1
3948245C1	Spin Huck Saddle	2
3535872C1	Clamp	2

Table 4. ProStar® 113, CAT®, TranStar®, and PayStar® Routing &amp; Clipping Parts

Kit Description	Part Number	Qty
Swivel Saddle	3666881C1 (Obtain Locally)	1
Tie Straps	306132C1 (Obtain Locally)	2

Table 5. TranStar®, WorkStar®, and PayStar® (SCR Equipped Vehicles with Manual Transmission) Routing &amp; Clipping

Kit Description	Part Number	Qty
Spacer, DEF Coolant Supply	4037501C1	1

Table 6. TranStar® (SCR Equipped Vehicles with Automatic Transmission) Routing &amp; Clipping Parts

Kit Description	Part Number	Qty
Hose, Rubber	3996883C3	1
Hose, Silicone (Do Not Order Unless Vehicle Is Equipped with Silicone Hoses)	3996910C3	1

## **REPAIR OVERVIEW**

 **WARNING:** To prevent property damage, personal injury, and / or death, park vehicle on hard flat surface, turn the engine off, set the parking brake, and install wheel chocks to prevent the vehicle from moving in both directions.

 **WARNING:** To prevent property damage, personal injury, and / or death, do not work under the vehicle supported only by jacks if the vehicle must be raised. Jacks can slip or fall over.

 **WARNING:** To prevent property damage, personal injury, and / or death, always wear safe eye protection when performing vehicle maintenance.

 **WARNING:** To prevent property damage, personal injury, and / or death, keep flames or sparks away from vehicle and do not smoke while servicing the vehicle's batteries. Batteries expel explosive gases.

 **WARNING:** To prevent property damage, personal injury, and / or death, remove the ground cable from the negative terminal of the battery box before disconnecting any electrical components. Always connect the ground cable last.

---

## REMOVAL PROCEDURE

1. Bring truck into shop and park on flat surface.
2. Shift transmission to Park or Neutral, set parking brake, and install wheel chocks.
3. Unlatch and open hood.
4. Using Navistar Coolant Management Tool KL5007NAV, drain coolant from system. Place suitable drain pan under truck to collect any remaining coolant throughout procedure.



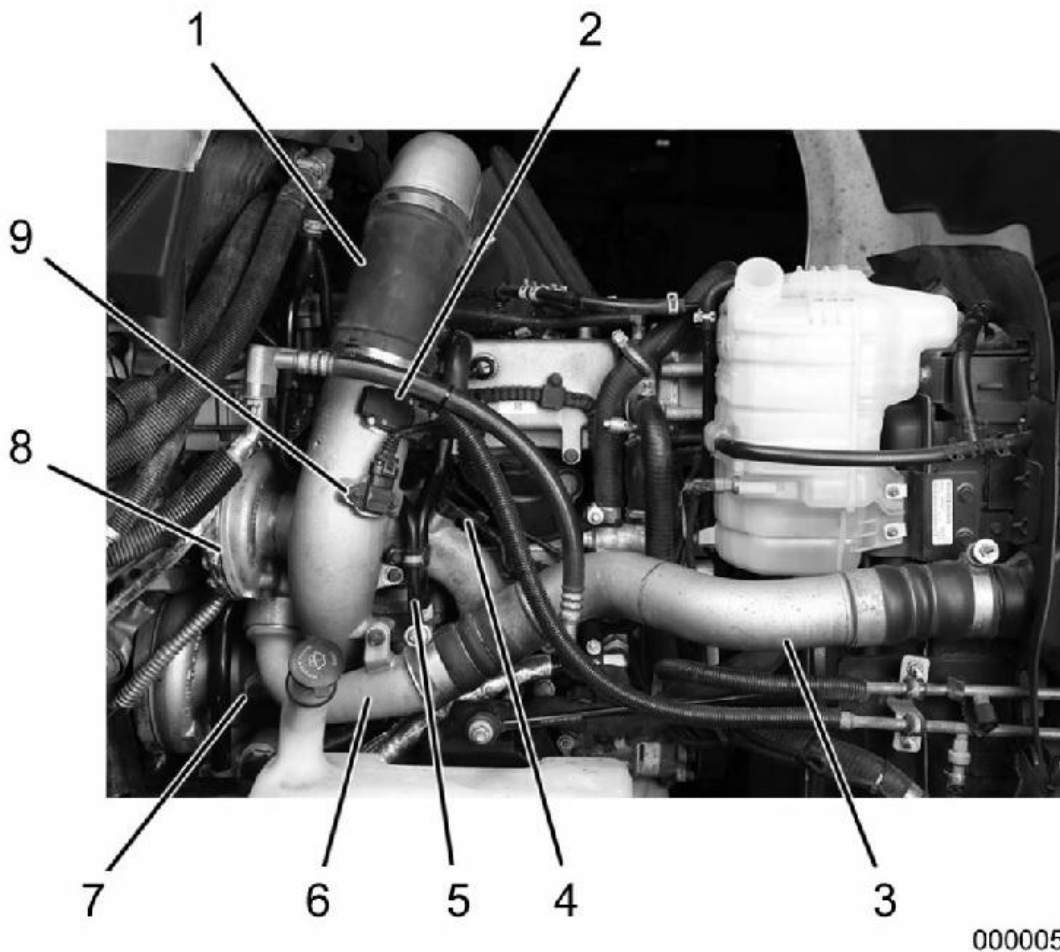

0000052617

**Figure 1: High-Pressure and Low-Pressure Turbochargers and Connections.**

1. Air inlet duct
2. MAF sensor
3. HPCAC pipe
4. TC2CIP sensor
5. Cab heater return and LPCAC coolant supply pipes
6. HP turbocharger outlet duct
7. LP turbocharger air inlet duct
8. HP turbocharger
9. AIT sensor

5. Remove air inlet duct (Figure 1, Item 1).

6. Remove High-Pressure Charge Air Cooler (HPCAC) pipe (Figure 1, Item 3) from HPCAC and HP turbocharger outlet duct (Figure 1, Item 6).

7. Install cap on HPCAC.

8. Disconnect engine harness connectors at Engine Oil Pressure (EOP) sensor, Turbocharger 2 Compressor Inlet Pressure (TC2CIP) sensor (Figure 1, Item 4), Air Inlet Temperature (AIT) sensor (Figure 1, Item 9), and if equipped, Mass Air Flow (MAF) sensor (Figure 1, Item 2).

9. Remove engine harness nut, located on Coolant Control Valve (CCV) mounting bolt, and secure engine harness out of the way.

10. Remove HP turbocharger outlet duct (Figure 1, Item 6). Discard HP turbocharger outlet duct O-ring.

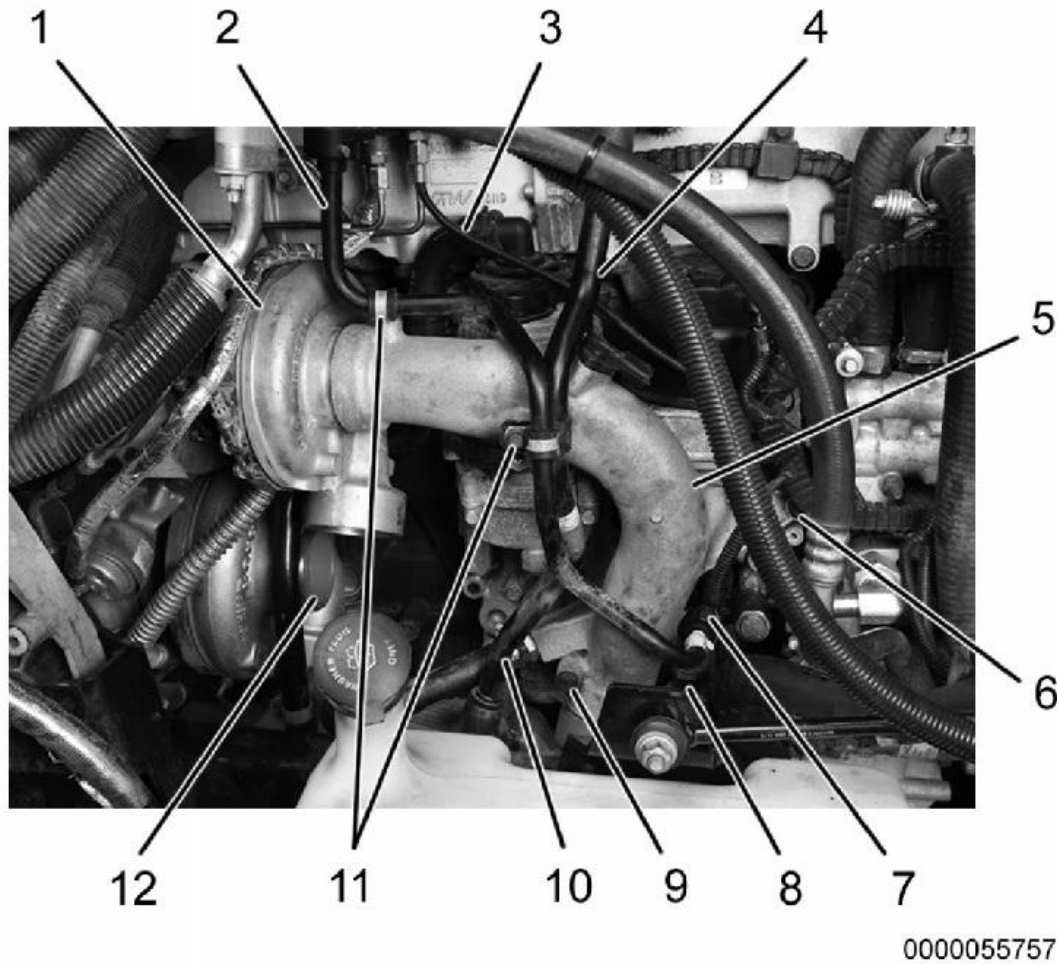

**Figure 2: HP Turbocharger and Connections.**

1. HP turbocharger
2. Cab heater coolant return pipe
3. Air supply line to ACV
4. LPCAC coolant supply pipe
5. HP turbocharger air inlet duct
6. M10 x 200 bolt
7. Cab heater coolant return pipe bolt
8. Coolant return hose
9. M10 x 200 bolt
10. Coolant hose
11. M8 x 20 bolt (2)
12. Cap

11. Remove Low-Pressure (LP) turbocharger air inlet duct (Figure 1, Item 7) and cover LP turbocharger with cap (Figure 2, Item 12). Discard LP turbocharger air inlet duct O-ring.

12. Disconnect air supply line (Figure 2, Item 3) from Air Control Valve (ACV) and secure out of the way.

**NOTE:**

If equipped, disconnect coolant filter line from cab heater coolant return pipe.

13. Remove two bolts (Figure 2, Item 11) securing cab heater coolant return pipe (Figure 2, Item 2) and Low-Pressure Charge Air Cooler (LPCAC) coolant supply pipe (Figure 2, Item 4).
14. Remove bolt (Figure 2, Item 7) and position cab heater coolant return pipe (Figure 2, Item 2) out of the way.
15. Remove two clamps and LPCAC coolant supply pipe (Figure 2, Item 4) from vehicle.
16. Disconnect coolant return hose (Figure 2, Item 8) from HP turbocharger air inlet duct (Figure 2, Item 5).
17. Disconnect coolant hose (Figure 2, Item 10) from HP turbocharger air inlet duct (Figure 2, Item 5).

**NOTE:**

Do not remove HP turbocharger air inlet duct from HP turbocharger (Figure 2, Item 1) at this time.

18. Remove two mounting bolts (Figure 2, Items 6 and 9) from HP turbocharger air inlet duct (Figure 2, Item 5).

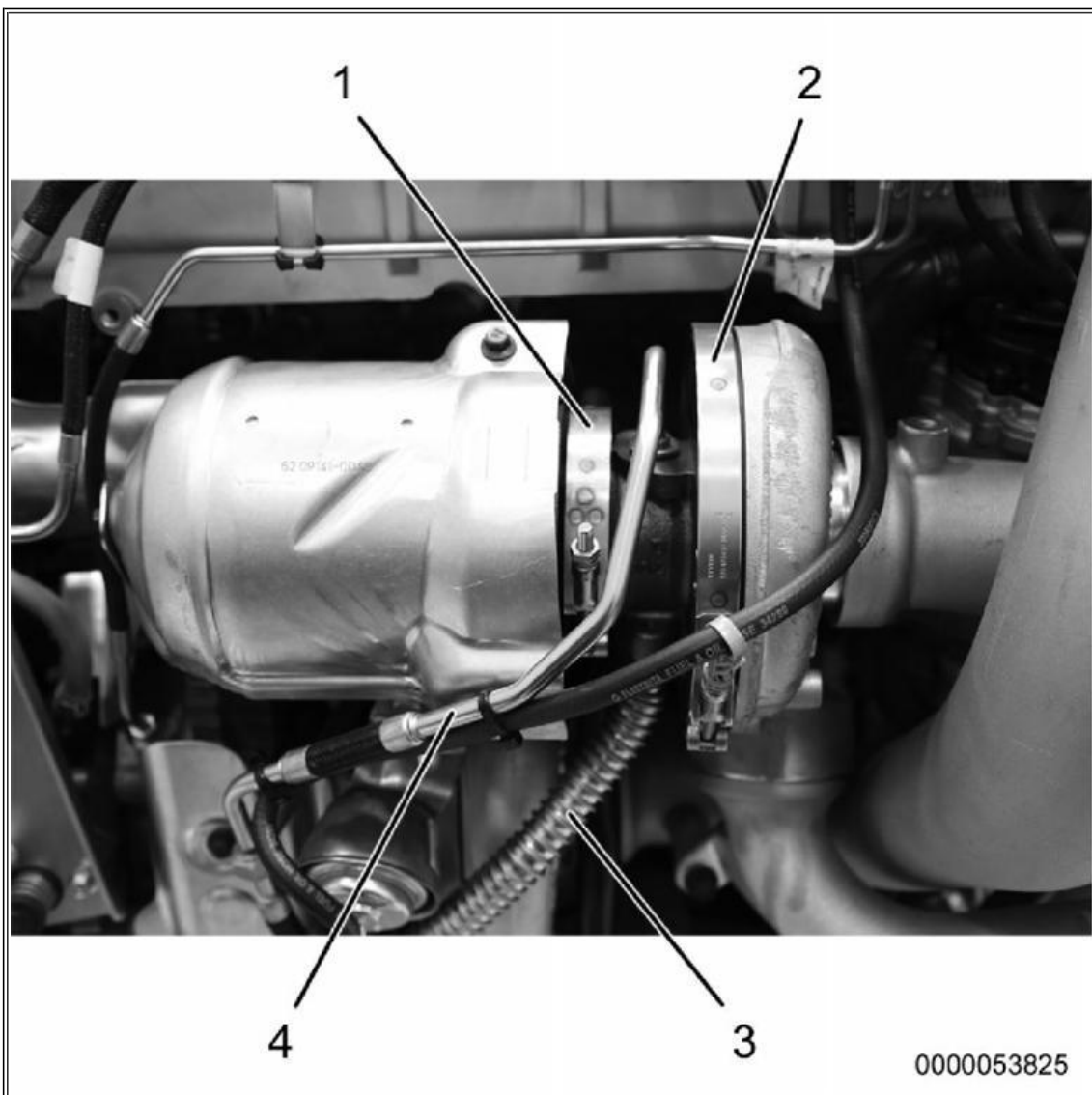

Figure 3: HP Turbocharger.

1. V-band clamp (turbine housing)
2. V-band clamp (compressor housing)
3. HP turbocharger oil return line
4. HP turbocharger oil supply tube

**CAUTION**

The oil supply tube must not be reused or damage to equipment will occur. If oil supply tube will not come out of the HP turbocharger due to seizure, cut the oil supply tube into two pieces and leave the tube in the HP turbocharger for ease of removal, then discard oil supply tube.

19. Remove and discard oil supply tube (Figure 3, Item 4) from vehicle.
20. Disconnect oil return line (Figure 3, Item 3) from HP turbocharger only. Discard gasket.

**NOTE:**

Make sure all coolant hoses and pipes are disconnected from HP turbocharger air inlet duct before removal.

21. Remove HP turbocharger turbine housing V-band clamp (Figure 3, Item 1). Discard V-band clamp.
22. Using a soft-blow mallet, gently tap HP turbocharger until loose.





0000052662

**Figure 4: HP Turbocharger Removal**

23. While pulling on HP turbocharger center cartridge, maneuver it straight out until turbine wheel is free from turbine housing (Figure 4).
24. Separate HP turbocharger and HP turbocharger air inlet duct once free from turbine housing. Discard HP turbocharger air inlet duct tube seal.
25. If HPCAC is internally contaminated with oil, clean using CAC Cleaning Kit, 09-925-01.

---

## INSTALLATION PROCEDURE

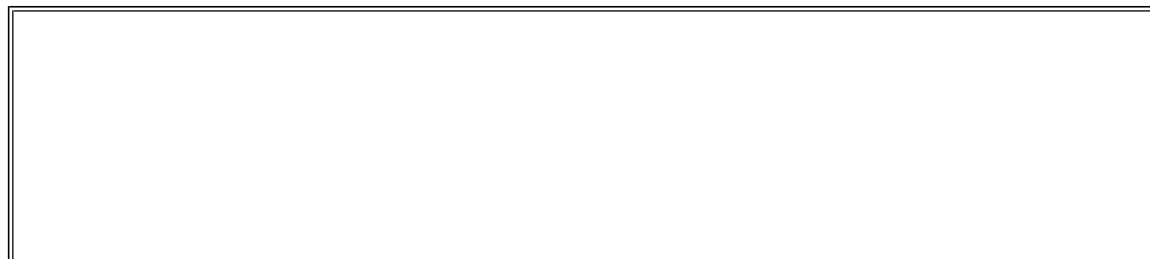

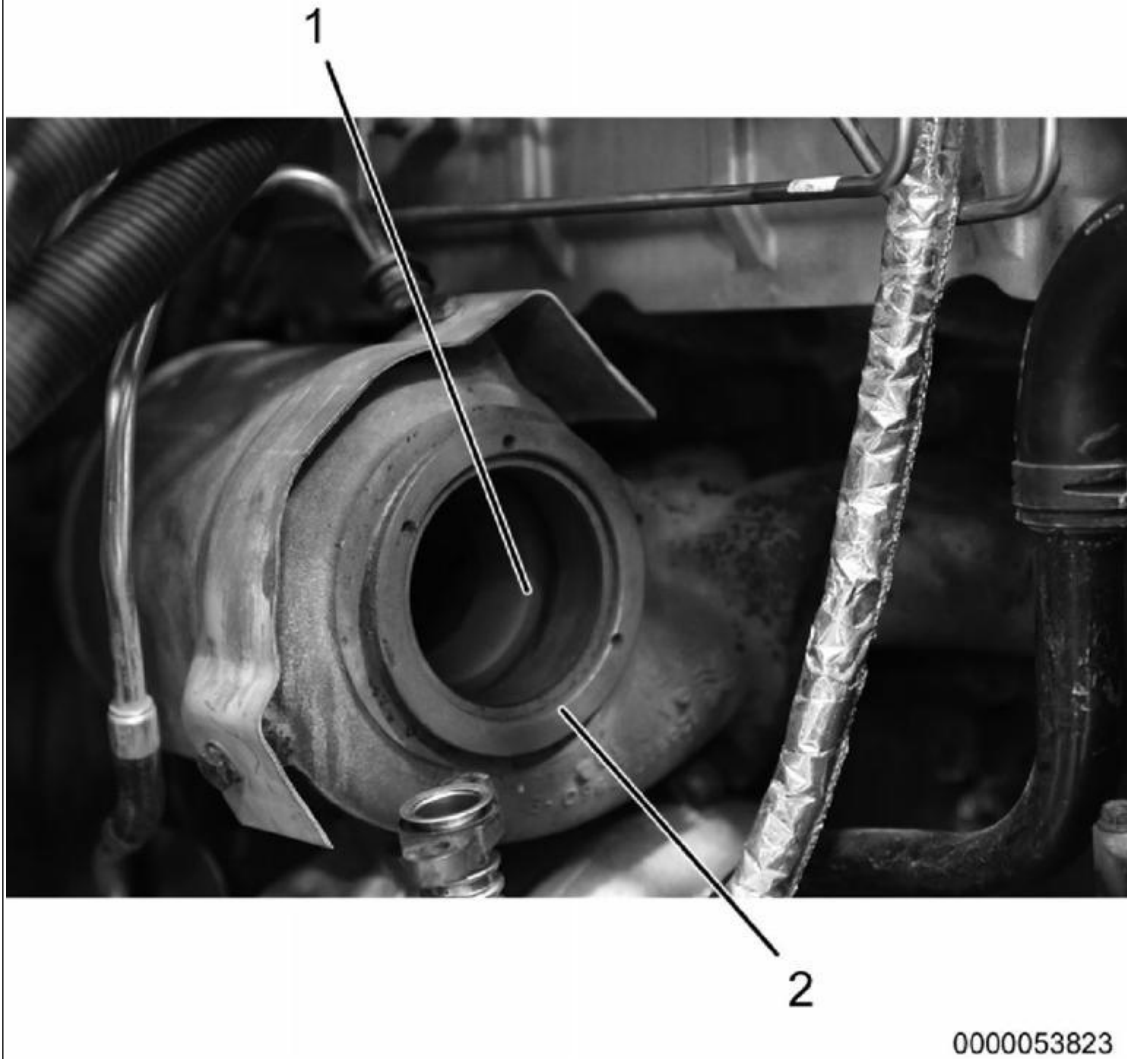
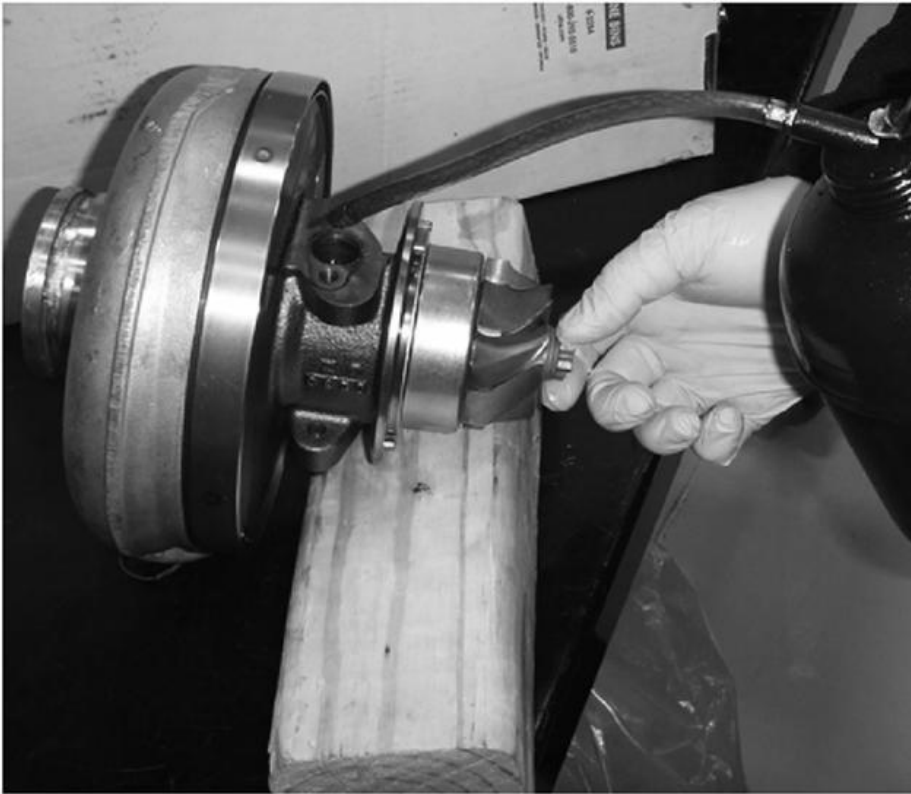

**Figure 5: HP Turbocharger Turbine Housing.**

1. HP turbocharger turbine housing
2. HP turbocharger turbine housing flange (exterior)

1. Using suitable solvent and clean emery cloth, clean inside HP turbocharger turbine housing (Figure 5, Item 1) and exterior flange (Figure 5, Item 2).





000055758

**Figure 6: Turbocharger Prime.**

### **CAUTION**

**You must prime the new HP turbocharger center cartridge with oil prior to installation, or damage to equipment may occur.**

2. While rotating turbocharger turbine wheel, add oil to turbocharger oil supply port until oil comes out of oil drain port (Figure 6).

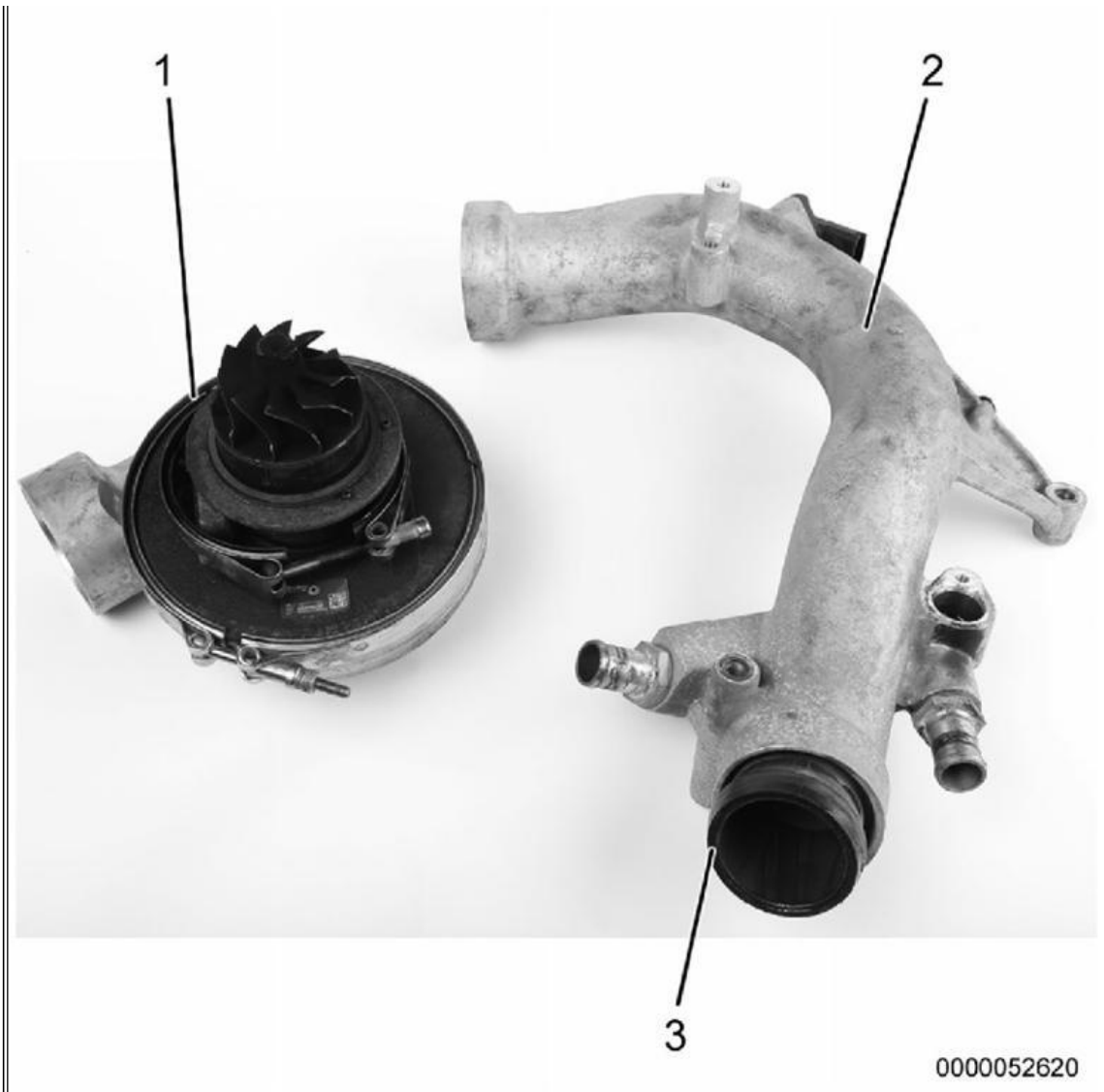

**Figure 7: HP Turbo Center Cartridge and Air Inlet Duct.**

1. HP turbocharger center cartridge
2. HP turbocharger air inlet duct
3. 72.2 x 60 (DMR) tube seal (extension tube)

3. Install new HP turbocharger center cartridge (Figure 7, Item 1) into turbine housing and let it rest freely.

**NOTE:**

Make sure to install lower HP turbocharger air inlet duct mounting bolt before installation is complete. This bolt may not be accessible later in the installation procedure, on some vehicles.

**NOTE:**

Make sure to lubricate rubber fittings and O-rings with P-80® or equivalent lubricant.

4. Install new O-ring onto HP turbocharger housing.

5. Install new 72.2 x 60 (DMR) tube seal (extension tube) (Figure 7, Item 3) to HP turbocharger air inlet duct (Figure 7, Item 2).
6. Position lower HP turbocharger air inlet duct bolt in place and install HP turbocharger air inlet duct with new tube seal into LPCAC.



0000052664

**Figure 8: HP Turbo and HP Turbocharger Air Inlet Duct.**

7. While pulling out on HP turbocharger, mate HP turbocharger air inlet duct to HP turbocharger air inlet (Figure 8), then insert HP turbocharger back into turbine housing.
8. Align and fully seat HP turbocharger on dowels of turbine housing.
9. Install and torque new V-band clamp (Figure 3, Item 1) to 110 lb-in (12.4 N·m).
10. Install and torque HP turbocharger air inlet duct mounting bolts (Figure 2, Items 6 and 9) to 45 lb-ft (62 N·m).

### **CAUTION**

**Make sure new oil supply tube does not bend. Failure to comply will result in damage to HP turbocharger. Damage or distortion will require replacement of oil supply tube.**

**NOTE:**

Some oil drain lines may have an O-ring seal. One will need to be ordered separately.

11. Install new gasket onto oil return line and install into HP turbocharger.

12. Install new oil supply tube on vehicle. See [IK1201237](#) - Title: Turbocharger Oil Supply Tube Retrofit, if the engine is **NOT** equipped with the new oil supply tube.

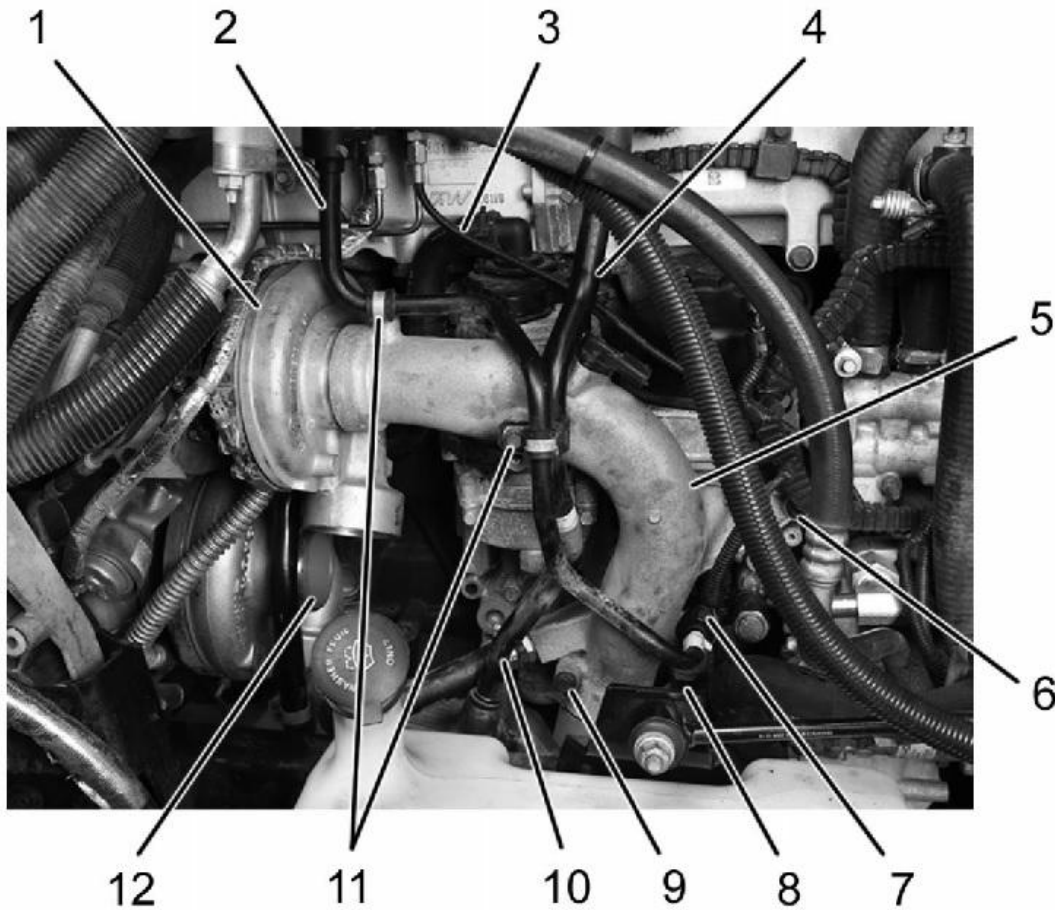

0000055757

**Figure 9: HP Turbocharger and Connections.**

1. HP turbocharger
2. Cab heater coolant return pipe
3. Air supply line to ACV
4. LPCAC coolant supply pipe
5. HP turbocharger air inlet duct
6. M10 x 200 bolt
7. Cab heater coolant return pipe bolt
8. Coolant return hose
9. M10 x 200 bolt
10. Coolant hose
11. M8 x 20 bolt (2)
12. Cap

13. Connect coolant hose (Figure 9, Item 10) to HP turbocharger air inlet duct (Figure 9, Item 5).
14. Connect coolant return hose (Figure 9, Item 8) to HP turbocharger air inlet duct (Figure 9, Item 5).
15. Install LPCAC coolant supply pipe (Figure 9, Item 4) to vehicle with two clamps.
16. Position cab heater coolant return pipe (Figure 9, Item 2) and secure with bolt (Figure 9, Item 7).
17. Install cab heater coolant return pipe (Figure 9, Item 2) and LPCAC coolant supply pipe (Figure 9, Item 4) on HP turbocharger air inlet duct (Figure 9, Item 5) with two bolts (Figure 9, Item 11).

<b>NOTE:</b>
<b>If equipped, connect coolant filter line to cab heater coolant return pipe.</b>

18. Install air supply line (Figure 9, Item 3) to ACV.
19. Install new O-ring into LP turbocharger air inlet duct, remove cap (Figure 9, Item 12) from LP turbocharger, and install LP turbocharger air inlet duct to LP turbocharger. Secure with two bolts.
20. Install new O-ring into HP turbocharger outlet duct and install HP turbocharger outlet duct to HP turbocharger. Secure with two bolts.
21. Connect engine harness connectors at EOP sensor, TC2CIP sensor (Figure 1, Item 4), AIT sensor (Figure 1, Item 9), and if equipped, MAF sensor (Figure 1, Item 2).
22. Secure engine harness to CCV stud with mounting nut.
23. Install HPCAC pipe to HP turbocharger outlet duct and HPCAC. Secure with two clamps.
24. Install upper portion of air inlet duct and secure with clamps.
25. Fill cooling system using Navistar Coolant Management Tool KL5007NAV.
26. Start vehicle to verify proper operation, no leaks, and no fault codes are present.
27. Close and latch hood.
28. Remove wheel chocks.

## **WARRANTY INFORMATION**

### **Warranty Claim Coding:**

Code to Noun 869 if just performing an oil supply tube repair.

<b>Group:</b>	<b>12000</b> - Engine
<b>Noun:</b>	<b>869</b> - Lines, Turbo Oil

Code to Noun 135 if performing an oil supply tube repair **with** a turbo repair.

<b>Group:</b>	<b>12000</b> - Engine
<b>Noun:</b>	<b>135</b> - Turbocharger, High Pressure Turbo

- Link to the Coding Manual: [Click Here](#)

### **Standard Repair Time(s):**

#### **12 - TURBOCHARGER CENTER SECTION, REPLACE**

Step	Description	Chassis	Engine	SRT	Hours
		Prostar	IMAXXFORCE 11/13  2010 Emissions	<a href="#">R12-6135U-21</a>	2.3

		Lonestar	MAXXFORCE 11/13  2010 Emissions	<a href="#">S12-6135U-21</a>	2.3
		8600	MAXXFORCE 11/13  2010 Emissions	<a href="#">Q12-6135U-21</a>	2.3
		7600	MAXXFORCE 11/13  2010 Emissions	<a href="#">N12-6135U-21</a>	2.3
		5000	MAXXFORCE 11/13  2010 Emissions	<a href="#">T12-6135U-21</a>	2.3
		CT660	MAXXFORCE 11/13  2010 Emissions	<a href="#">AR12-6135U-21</a>	2.3
		CAT CT660	MAXXFORCE 11/13  2010 Emissions	<a href="#">TC12-6135U-21</a>	2.3

**Add-On If Required - Turbocharger H.P. Center Section, Replace Add-On**

Step	Description	Chassis	Engine	SRT	Hours
	With Updated Retrofit Oil Supply Line.	Prostar 122	MAXXFORCE 11/13  2010 Emissions	<a href="#">R12-6135U-3</a>	0.3
	With Updated Retrofit Oil Supply Line.	Prostar 113	MAXXFORCE 11/13  2010 Emissions	<a href="#">R12-6135U-4</a>	0.1
	With Updated Retrofit Oil Supply Line.	Lonestar	MAXXFORCE 11/13  2010 Emissions	<a href="#">S12-6135U-4</a>	0.1
	With Updated Retrofit Oil Supply Line.	Workstar	MAXXFORCE 11/13  2010 Emissions	<a href="#">N12-6135U-4</a>	0.1
	With Updated Retrofit Oil Supply Line.	Transtar	MAXXFORCE 11/13  2010 Emissions	<a href="#">Q12-6135U-4</a>	0.1
	With Updated Retrofit Oil Supply Line.	5000	MAXXFORCE 11/13  2010 Emissions	<a href="#">T12-6135U-4</a>	0.1
	With Updated Retrofit Oil Supply Line.	CAT CT660	MAXXFORCE 11/13  2010 Emissions	<a href="#">TC12-6135U-4</a>	0.1
	Engine Cover, Remove and Reinstall W/Premium Interior	Transtar	MAXXFORCE 11/13  2010 Emissions	<a href="#">Q12-6135U-1</a>	0.2

**09 - CAC CLEANING, PERFORM**

Step	Description	Chassis	Engine	SRT	Hours
	With Cleaning Management Tool. CAC R&R Not Included	All Models	All Engines	<a href="#">A09-3925A</a>	1.1

**09 - CHARGE AIR COOLER, REPLACE**

Step	Description	Chassis	Engine	SRT	Hours
		Prostar	MAXXFORCE 11/13  2010 Emissions	<a href="#">R09-3925U-20</a>	1.0
		8600	MAXXFORCE 11/13  2010 Emissions	<a href="#">Q09-3925U-20</a>	1.0
		CT660	MAXXFORCE 11/13  2010 Emissions	<a href="#">AR09-3925U</a>	1.0
	COLD - With Air Conditioning	7600	MAXXFORCE 11/13  2010 Emissions	<a href="#">N09-3925U-20</a>	0.8
	HOT - With Air Conditioning	7600	MAXXFORCE 11/13  2010 Emissions	<a href="#">N09-3925U-22</a>	2.9
	BOTH - With Air Conditioning	7600	MAXXFORCE 11/13  2010 Emissions	<a href="#">N09-3925U-21</a>	3.0

[SRT Manual](#)

**OTHER RESOURCES**

[Master Service Information Site](#)

Title: Turbocharger Oil Supply Tube Retrofit - [IK1201237](#)

Title: Turbo Oil Supply Tube Assembly Return - [PL3000036](#)

Title: 2010 MaxxForce® 11L Turbo Cartridge Replacement - [IK1201073](#)

Title: 2010 EPA MaxxForce® 15L HP Turbo Center Cartridge Replacement - [IK1201134](#)



**Title: Complete High Pressure Turbocharger Replacement Guidelines for MaxxForce® 11/13, 15L, and N13 - [IK1200909](#)**

 Hide Details

Feedback Information

Viewed: 9917  
Helpful: 24  
Not Helpful: 2

No Feedback Found

Copyright © 2016 Navistar, Inc.