

SELECTING A HUMPHREY TWIN ROD CYLINDER

THRUST FORCE

Thrust force (F) is determined by piston area (A) and air pressure (P). $F = A \times P$.

Select an appropriate cylinder bore size based on the thrust force required in your application. Consider the load you have to move and the air pressure you have available to do the work (psig or kg/cm²).

The table below shows calculated thrust forces of Twin Rod cylinders at various line pressures.

Use this formula to select the appropriate cylinder:

$$\text{Load rate} = \frac{\text{Load (weight)}}{\text{Calculated thrust force (from chart below)}}$$

Note: the load rate should be no greater than 70 percent for moderate cycle speeds, and no greater than 50 percent for high cycle speeds.

Example:

- Double acting cylinder, slow speed
- 70 psig operating pressure
- The application is to *push* a 30 pound load.

Calculate:

$$.70 (70\%) = \frac{30 \text{ pounds}}{\text{Calculated value}} \text{ or,}$$

$$42.9 = \text{Calculated value.}$$

Select $\frac{5}{8}$ " (16mm) bore cylinder which can push 44.32 pounds at 71 psig.

Bore Size (I.D.) Inch (nom.) mm (actual)	Rod Size Inch (nom.) mm (actual)	Type		Pressure area Inch ² (cm ²)	Air Pressure psig (kg/cm ²)						
					14 (1)	28 (2)	43 (3)	57 (4)	71 (5)	85 (6)	100 (7)
1/4 (6)	5/32 (4)	Double acting	Push	0.09 (0.56)	-	2.47 (1.12)	3.70 (1.68)	4.94 (2.24)	6.17 (2.80)	7.41 (3.36)	8.64 (3.92)
			Pull	0.05 (0.31)	-	1.37 (0.62)	2.05 (0.93)	2.73 (1.24)	3.42 (1.55)	4.10 (1.86)	4.79 (2.17)
3/8 (10)	1/4 (6)	Double acting	Push	0.24 (1.57)	-	6.92 (3.14)	10.36 (4.70)	13.85 (6.28)	17.29 (7.84)	20.77 (9.42)	24.21 (10.98)
			Pull	0.16 (1.00)	-	4.41 (2.00)	6.61 (3.00)	8.82 (4.00)	11.03 (5.00)	13.23 (6.00)	15.44 (7.00)
		Single acting	Push	0.24 (1.57)	-	-	1.01 (0.46)	4.50 (2.04)	7.94 (3.60)	11.42 (5.18)	14.86 (6.74)
5/8 (16)	5/16 (8)	Double acting	Push	0.62 (4.02)	8.86 (4.02)	17.73 (8.04)	26.59 (12.06)	35.46 (16.08)	44.32 (20.10)	53.19 (24.12)	62.05 (28.14)
			Pull	0.47 (3.01)	6.64 (3.01)	13.27 (6.02)	19.91 (9.03)	26.55 (12.04)	33.19 (15.05)	39.82 (18.06)	46.46 (21.07)
		Single acting	Push	0.62 (4.02)	-	8.49 (3.85)	17.35 (7.87)	26.22 (11.89)	35.08 (15.91)	43.95 (19.93)	52.81 (23.95)
3/4 (20)	3/8 (10)	Double acting	Push	0.97 (6.28)	13.85 (6.28)	27.70 (12.56)	41.54 (18.84)	55.39 (25.12)	69.24 (31.40)	83.08 (37.68)	96.93 (43.96)
			Pull	0.73 (4.71)	10.39 (4.71)	20.77 (9.42)	31.16 (14.13)	41.54 (18.84)	51.93 (23.55)	62.31 (28.26)	72.70 (32.97)
		Single acting	Push	0.97 (6.28)	-	17.05 (7.73)	30.89 (14.01)	44.74 (20.29)	58.54 (26.57)	72.43 (32.85)	86.28 (39.13)
1 (25)	15/32 (12)	Double acting	Push	1.52 (9.81)	21.63 (9.81)	43.26 (19.62)	64.89 (29.43)	86.52 (39.24)	108.16 (49.05)	129.79 (58.86)	151.42 (68.67)
			Pull	1.17 (7.55)	16.65 (7.55)	33.30 (15.10)	49.94 (22.65)	66.59 (30.20)	83.24 (37.75)	99.89 (45.30)	116.53 (52.85)
		Single acting	Push	1.52 (9.81)	-	25.18 (11.42)	46.81 (21.23)	68.44 (31.04)	90.07 (40.85)	111.71 (50.66)	133.34 (60.47)
1 1/4 (32)	5/8 (16)	Double acting	Push	2.49 (16.07)	35.43 (16.07)	70.87 (32.14)	106.30 (48.21)	141.74 (64.28)	177.17 (80.35)	212.61 (96.42)	248.04 (112.49)
			Pull	1.87 (12.05)	26.57 (12.05)	53.14 (24.10)	79.71 (36.15)	106.28 (48.20)	132.85 (60.25)	159.42 (72.30)	185.99 (84.35)

SPRING FORCES

lbs. (kgf)

Bore in. (nom.) (mm) actual	Stroke inches (mm)	Zero stroke	End of stroke
3/8 (10)	1/2	3.46 (1.57)	4.63 (2.10)
	3/4	2.87 (1.30)	
	1	2.27 (1.03)	
	1 1/2	5.82 (2.64)	7.35 (4.24)
	2	4.65 (2.11)	
	2 1/2	3.46 (1.57)	
5/8 (16)	1/2	3.29 (1.47)	4.59 (2.08)
	3/4	2.56 (1.16)	
	1	1.90 (0.86)	
	1 1/2	5.20 (2.36)	9.24 (4.19)
	2	3.86 (1.75)	
	2 1/2	2.51 (1.14)	

Bore in. (nom.) (mm) actual	Stroke inches (mm)	Zero stroke	End of stroke
3/4 (20)	1/2	4.17 (1.89)	5.29 (2.40)
	3/4	3.62 (1.64)	
	1	3.09 (1.38)	
	1 1/2	7.30 (3.31)	10.65 (4.83)
	2	6.17 (2.80)	
	2 1/2	5.05 (2.29)	
1 (25)	1/2	6.99 (3.17)	8.89 (4.03)
	3/4	6.02 (2.73)	
	1	5.07 (2.30)	
	1 1/2	12.37 (5.61)	18.08 (8.20)
	2	10.45 (4.74)	
	2 1/2	8.56 (3.88)	

TWIN ROD CYLINDERS – DOUBLE ACTING

1/4-INCH BORE (NOMINAL) 6mm (ACTUAL)

SYMBOL

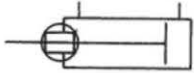

SPECIFICATIONS

Item	Bore size inch (nom.) / mm (actual)
	1/4 (6)
Type	Double acting
Medium	Air
Mounting	Side mount
Pressure range psig (kgf/cm ²)	28-100 (2-7)
Proof pressure psig (kgf/cm ²)	150 (10.5)
Temperature range °F (°C)	32-140 (0-60)
Piston speed range in./s (mm/s)	4-20 (100-500)
Cushion	None
Lubrication	None required
Allowable eccentricity	± 0.45°
Stroke adjustment range in. (mm)	-0.197 to 0 (-5 to 0) per specific stroke
Port size	#10-32

*If lubrication is used, apply a non-detergent 10W oil (ISO VG32), or equivalent.

BORE SIZE AND STROKE in. (mm)

Bore size inch (nom.) / mm (actual)	Standard stroke (in.)	Stroke adjustment range ("pull" side)
1/4 (6)	1/2, 3/4, 1, 1 1/2, 2	-0.197 to 0 (-5 to 0)

SEAL REPAIR KITS

SRK-HTBDA-[6]
Bore
Size

ORDER EXAMPLE

Cylinders

Sensor switches (order separately)

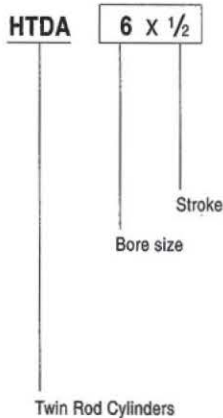

Lead wire length:

- A — 39 In. (nom.) 1000mm (actual)
- B — 108 In. (nom.) 3000mm (actual)
- C — 196 In. (nom.) 5000mm (actual)

Sensor switch model

- ZC130** — Two wire type. Hall effect switch with LED. 10 – 28VDC
- ZC153** — Three wire type. Hall effect switch with LED. 4.5 – 28VDC
- CS5T** — Two wire type. Reed switch without LED. 5 – 28VDC
85 – 115VAC
- CS11T** — Two wire type. Reed switch with LED. 10 – 28VDC

INNER CONSTRUCTION AND MAJOR PARTS

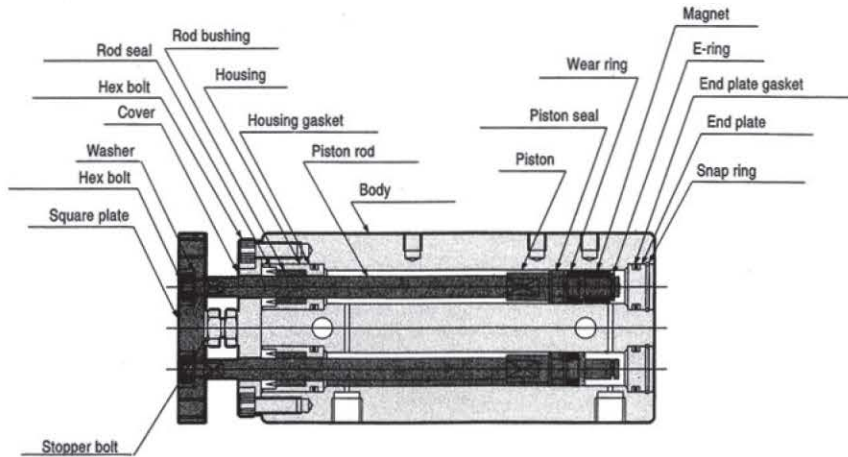

MAJOR PARTS AND MATERIALS OF CONSTRUCTION

Item	Material
Cylinder body	Anodized aluminum
Piston	Anodized aluminum
Cover	Anodized aluminum
Wear ring	Resin
Piston rod	Hard steel, hard chrome plated
Gasket	Buna
Housing	Anodized aluminum
End plate	Resin
Rod bushing	Oil permeated bronze
Seal	Buna
Snap ring	Hard steel, nickel plated
Magnet	Sintered magnet
E-ring	Stainless steel
Washer	Hard steel, black zinc plated
Head plate	Soft steel, black zinc plated
Stopper bolt	Soft steel, zinc plated

WEIGHT

oz. (gf)

Bore size Inch (nom.) / mm (actual)	Added weight		Weight of one sensor switch CS5T□, CS11T□ ZC130□, ZC153□
	Zero stroke weight	Per 1/2-inch stroke	
1/4 (6)	1.94 (55)	0.53 (15)	0.71 (20)

*Indicate desired length of lead wires:
 A - 39 in. (nom.) 1000mm (actual)
 B - 118 in. (nom.) 3000mm (actual)
 C - 196 in. (nom.) 5000mm (actual)

NOTE: Weight shown is for A-type lead length.

Calculation example: The weight of a 1/4-inch bore cylinder with a 1 1/2-inch stroke, together with two CS5TA sensor switches is:

$$1.94 + (0.53 \times 3) + (0.71 \times 2) = 4.95 \text{ (140.33)}$$

└─ 1/2-inch stroke x 3

DIMENSIONS

inch (mm)

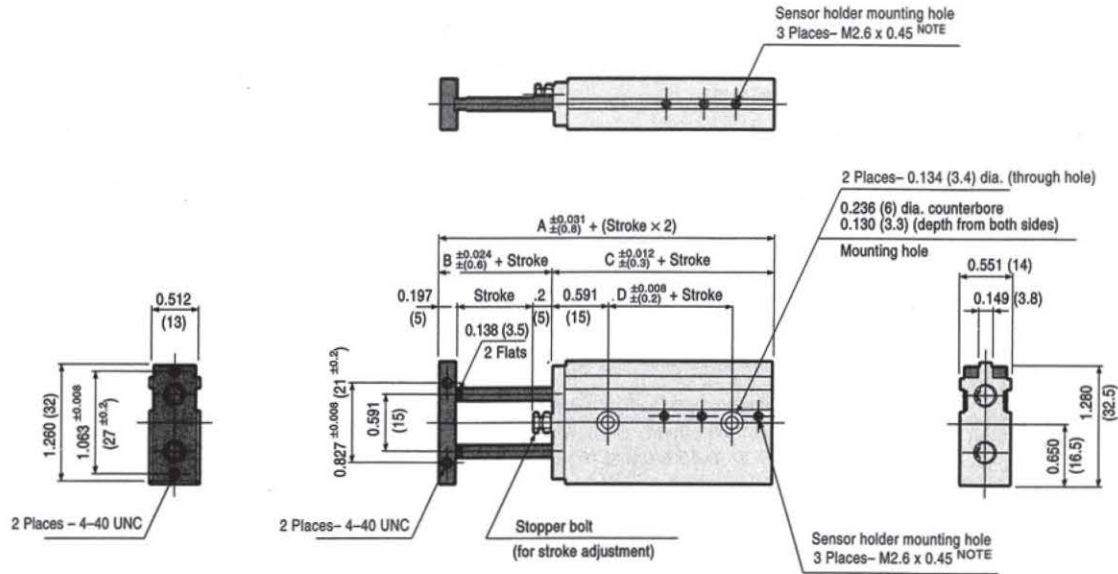

NOTE: 1/2 inch stroke models have two M2.6 x 0.45 holes.

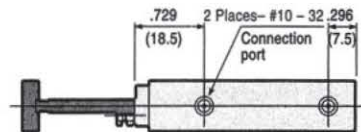

Bore in. (nom.) (mm) (actual)	Letter			
	A	B	C	D
1/4 (6)	1.929 (49)	0.394 (10)	1.535 (39)	0.512 (13)

ROD END DIMENSIONS

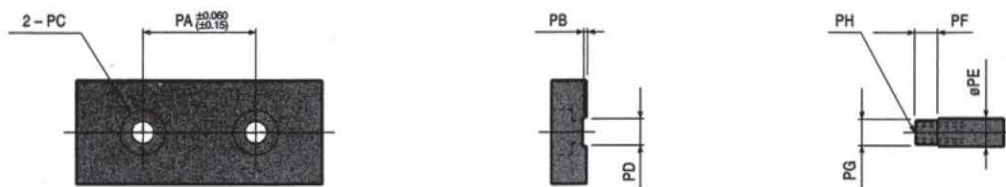

Bore in. (nom.) (mm) (actual)	Letter							
	PA	PB	PC thru hole x c' bore x depth	PD	PE	PF	PG	PH
1/4 (6)	0.591 (15)	0.020 (0.5)	0.118 (3) x 0.236 (6) x 0.126 (3.2)	0.138 ± 0.001 (3.5 ± 0.13)	0.157 (4)	0.118 (3)	0.138 ± 0.000 (3.5 ± 0.15)	M2.6x0.45, 0.197 (5) deep

HANDLING AND CAUTIONS FOR 1/4-INCH BORE (6mm) DOUBLE ACTING CYLINDERS

ALLOWABLE LATERAL LOAD

Lateral load on the rod bearing should be less than that indicated in the accompanying chart.

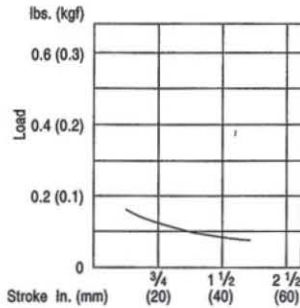

ALLOWABLE ECCENTRICITY

Eccentricity of the rod square plate, without load, is allowable within the following range.

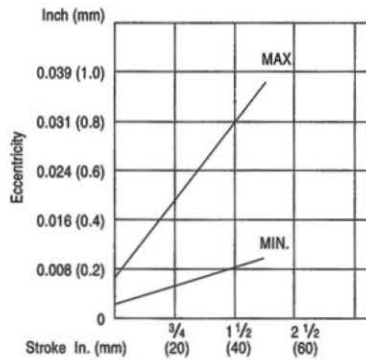

MOUNTING

1. Mount cylinders in any direction; however, mounting surface must be flat. If bending or twisting of the cylinder occurs during mounting, cylinder cycle life may be diminished, the cylinder may leak, or improper operation may occur.
2. Do not damage the mounting surface, as this may affect surface flatness.
3. Washers are used with the hex bolts on the cylinder rod square plate. Make sure bolts are tight before using the cylinder.

STROKE ADJUSTMENT

The stroke of the piston rod can be adjusted within a range of -0.196 to 0 inches (-5 to 0mm). To adjust stroke, turn stopper bolt counterclockwise to obtain new stroke length. After adjustment has been made, re-tighten the locknut. Do not overtighten.

CYLINDER SPEED

Cylinders should not be operated faster than 20 inches per second (500mm/s). When operating cylinders rapidly, prevent direct shock by installing an external stroke limiting device.

SENSOR SWITCH

1. Standard cylinders have magnets for operation of sensor switches.
2. If multiple cylinders with sensor switches are installed in close proximity, it is possible that the switches will operate sporadically. Consult factory.

TWIN ROD CYLINDERS – DOUBLE ACTING

3/8 (10) to 1 1/4 (32) bore

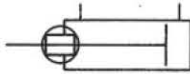

SPECIFICATIONS

Item	Bore size inch (nom.) / mm (actual)				
	3/8 (10)	5/8 (16)	3/4 (20)	1 (25)	1 1/4 (32)
Type	Double acting				
Medium	Air				
Mounting	Side mount				
Pressure range psig (kgf/cm ²)	21-100 (1.5-7)	14-100 (1-7)			
Proof pressure psig (kgf/cm ²)	143 (10.5)				
Temperature range °F (°C)	32-140 (0-60)				
Piston speed range in./s (mm/s)	4-20 (100-500)				
Bumper	None	Buna			
Lubrication	*None required				
Allowable eccentricity	± 0.4°	± 0.3°			
Stroke adjustment range in. (mm)	-0.197 to 0 (-5 to 0) per specific stroke				
Port size	#10-32				1/8

*If lubrication is used, apply a non-detergent 10W oil (ISO VG32), or equivalent.

BORE SIZE AND STROKE

Bore size inch (nom.) / mm (actual)	Standard stroke (in.)	Maximum stroke (in.)	Stroke adjustment range ("pull" side)
3/8 (10)	1/2, 3/4, 1, 1 1/2, 2, 2 1/2, 3	5	-0.197 to 0" (-5 to 0mm)
5/8 (16)	1/2, 3/4, 1, 1 1/2, 2, 2 1/2, 3, 3 1/2, 4	6	
3/4 (20)	1/2, 3/4, 1, 1 1/2, 2, 2 1/2, 3, 3 1/2, 4	7	
1 (25)	1/2, 3/4, 1, 1 1/2, 2, 2 1/2, 3, 3 1/2, 4	7	
1 1/4 (32)	1/2, 3/4, 1, 1 1/2, 2, 2 1/2, 3, 3 1/2, 4	7	

NOTE: 1. Consult factory when using two sensor switches on cylinders with 1/2" stroke.
2. Consult factory for non-standard strokes.

SEAL REPAIR KITS

SRK-HTBDA-10
Bore Size

ORDER EXAMPLE

Cylinders

Sensor Switches (order separately)

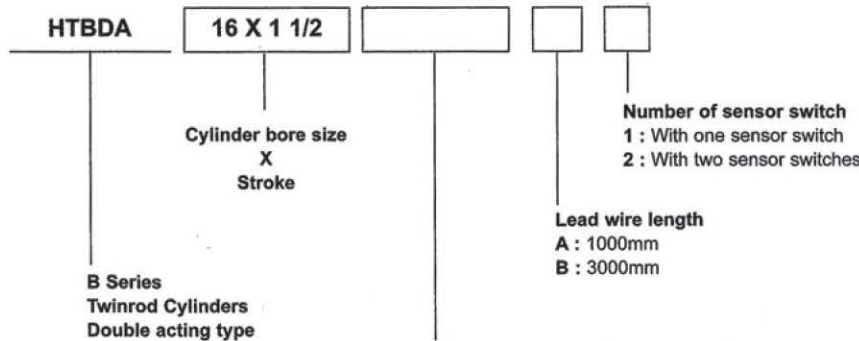

Sensor Switch model

ZE135 - Two lead wires, Hall effect type with indicator	DC10~28V	Horizontal lead wire type
ZE235 - Two lead wires, Hall effect type with indicator	DC10~28V	Vertical lead wire type
ZE155 - Three lead wires, Hall effect type with indicator	DC4.5~28V	Horizontal lead wire type
ZE255 - Three lead wires, Hall effect type with indicator	DC4.5~28V	Vertical lead wire type
ZE101 - Two lead wires, Reed switch type w/o indicator	DC5~28V AC85~115V	Horizontal lead wire type
ZE201 - Two lead wires, Reed switch type w/o indicator	DC5~28V AC85~115V	Vertical lead wire type
ZE102 - Two lead wires, Reed switch type with indicator	DC10~28V AC85~115V	Horizontal lead wire type
ZE202 - Two lead wires, Reed switch type with indicator	DC10~28V AC85~115V	Vertical lead wire type

Note: In the double acting long bushing type, the magnet for the sensor switch is built-in.

TWIN ROD CYLINDERS – DOUBLE ACTING

$\frac{3}{8}$ (10) to $1\frac{1}{4}$ (32) bore

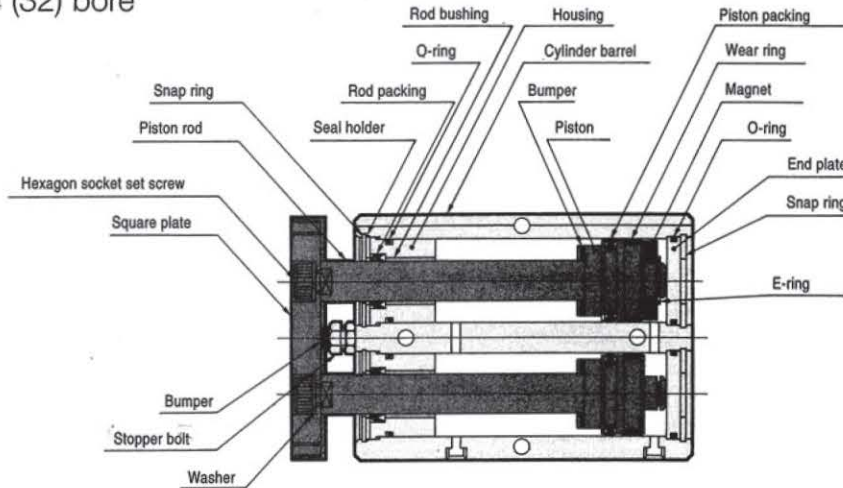

MAJOR PARTS AND MATERIALS OF CONSTRUCTION

Item	Material
Cylinder barrel	Anodized aluminum
Piston	Anodized aluminum
Wear ring	Resin
Piston rod	Hard steel, hard chrome plated
O-ring	Buna
Seal holder	Mild steel, nickel plated
Housing	Anodized aluminum
End plate	Anodized aluminum
Rod bushing	Oil permeated bronze
Seal	Buna
Snap ring	Hard steel, nickel plated
Magnet	Resinous magnet
E-ring	Stainless steel
Washer	Hard steel, black galvanized
Square plate	Mild steel, black galvanized
Bumper*	Buna
Stopper bolt	Mild steel, galvanized

*10mm bore models are not equipped with a bumper.

WEIGHT

oz. (gf)

Bore size Inch (nom.)/mm (actual)	Additional weight			
	Zero stroke weight	Added weight per $\frac{1}{2}$ -inch stroke	Weight of sensor	
			ZE□□□A	ZE□□□B
$\frac{3}{8}$ (10)	3.53 (100)	0.81 (22.96)	0.53 (15)	1.23 (35)
$\frac{5}{8}$ (16)	7.27 (206)	1.21 (34.30)		
$\frac{3}{4}$ (20)	12.06 (342)	1.61 (45.63)		
1 (25)	18.34 (520)	2.29 (64.92)		
$1\frac{1}{4}$ (32)	43.38 (1230)	3.94 (111.70)		

Calculation example: The weight of a $\frac{3}{4}$ -inch bore cylinder with a $1\frac{1}{2}$ -inch stroke, together with two CS3H sensor switches is:

$$11.82 + (1.61 \times 3) + (1.06 \times 2) = 18.77 \text{ oz. (532.12) gf.}$$

└ $\frac{1}{2}$ -inch stroke x 3

DIMENSIONS/DOUBLE-ACTING TYPE

inch (mm)

3/8 (10) bore

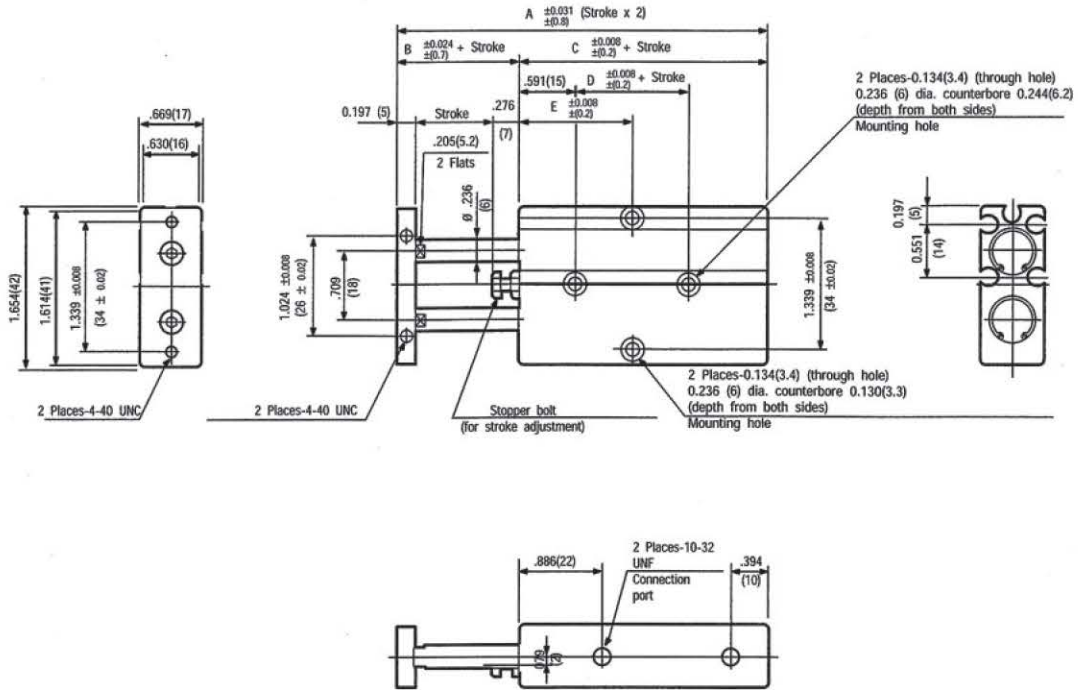

Bore in. (nom.) (mm) (actual)	Letter										
	A	B	C	D	E						3"
					Stroke						
					1/2"	3/4"	1"	1 1/2"	2"	2 1/2"	
3/8 (10)	2.283 (58)	0.472 (12)	1.811 (46)	0.394 (10)	1.181 (30)	1.181 (30)	1.287 (32.70)	1.537 (39.05)	1.787 (45.40)	2.037 (51.75)	2.287 (58.10)

DIMENSIONS/DOUBLE-ACTING TYPE

inch (mm)

5/8 (16) ~1 (25) bore

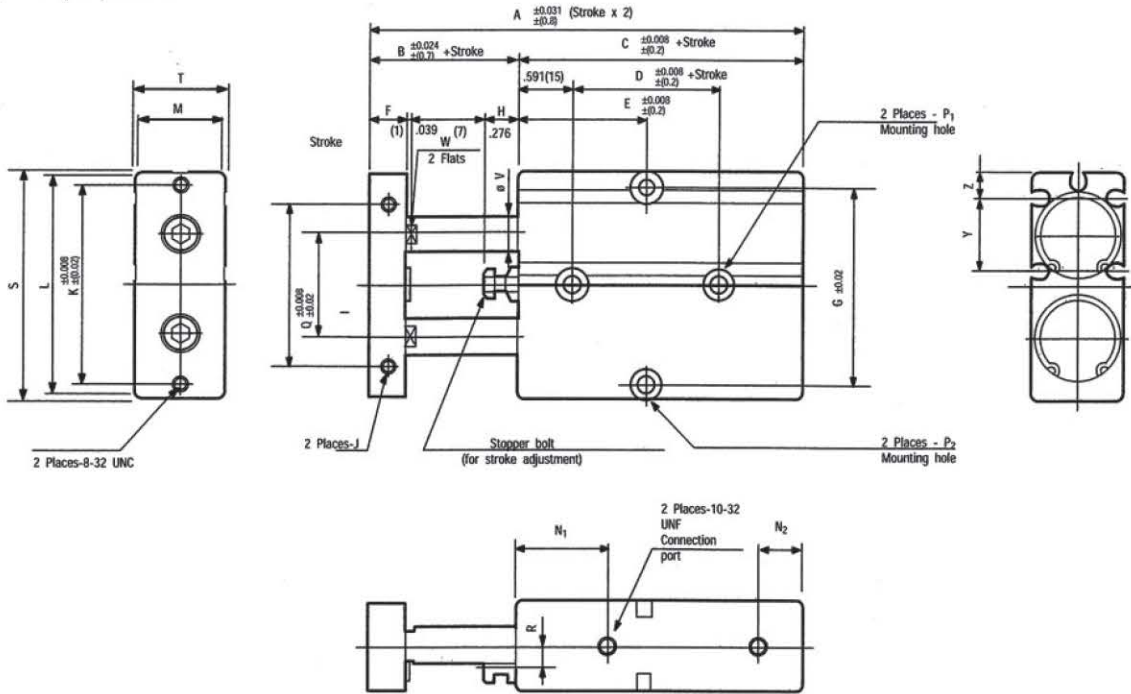

Bore in. (nom.) (mm) (actual)	Letter												
	A	B	C	D	E						3 1/2"	4"	
					Stroke								
5/8 (16)	2.677 (68)	0.591 (15)	2.087 (53)	0.788 (20)	1.234 (31.35)	1.359 (34.53)	1.484 (37.70)	1.734 (44.05)	1.984 (50.40)	2.234 (56.75)	2.484 (63.10)	2.734 (69.45)	2.984 (75.80)
3/4 (20)	3.070 (78)	0.788 (20)	2.283 (58)	0.788 (20)	1.378 (35)	1.378 (35)	1.484 (37.70)	1.734 (44.05)	1.984 (50.40)	2.234 (56.75)	2.484 (63.10)	2.734 (69.45)	2.984 (75.80)
1 (25)	3.189 (81)	0.748 (19)	2.441 (62)	1.181 (30)	1.575 (40)	1.575 (40)	1.681 (42.70)	1.931 (49.05)	2.181 (55.40)	2.431 (61.75)	2.681 (68.10)	2.931 (74.45)	3.181 (80.80)

Bore in. (nom.) (mm) (actual)	Letter									
	F	G	H	I	J	K	L	M	N1	N2
5/8 (16)	0.315 (8)	1.850 (47)	0.236 (6)	0.945 (24)	8-32 UNC x 0.197 deep	1.850 (47)	2.087 (53)	0.787 (20)	0.866 (22)	0.394 (10)
3/4 (20)	0.394 (10)	2.165 (55)	0.354 (9)	1.102 (28)	8-32 UNC x 0.197 deep	2.165 (55)	2.402 (61)	0.945 (24)	0.984 (25)	0.472 (12)
1 (25)	0.394 (10)	2.598 (66)	0.315 (8)	1.339 (34)	10-32 UNF x 0.236 deep	2.598 (66)	2.835 (72)	1.142 (29)	1.181 (30)	0.472 (12)

Bore in. (nom.) (mm) (actual)	Letter									
	P1 NOTE thru hole x c'bore x depth (from both sides)		P2 thru hole x c'bore x depth (from both sides)		Q	R	S	T	V	W
5/8 (16)	0.177 (4.5) x 0.295 (7.5) x 0.283 (7.2)		0.177 (4.5) x 0.315 (8) x 0.173 (4.4)		1.340 (34)	0.157 (4)	2.130 (54)	0.830 (21)	0.315 (8)	0.244 (6.2)
3/4 (20)	0.177 (4.5) x 0.295 (7.5) x 0.283 (7.2)		0.177 (4.5) x 0.315 (8) x 0.173 (4.4)		1.732 (44)	0.236 (6)	2.441 (62)	0.984 (25)	0.394 (10)	0.323 (8.2)
1 (25)	0.177 (4.5) x 0.295 (7.5) x 0.283 (7.2)		0.177 (4.5) x 0.315 (8) x 0.173 (4.4)		2.205 (56)	0.276 (7)	2.874 (73)	1.181 (30)	0.472 (12)	0.402 (10.2)

NOTE: Counterbore is measured from outermost surface of cylinder.

Bore in. (nom.) (mm) (actual)	Y	Z
5/8 (16)	0.728 (18.5)	0.224 (5.7)
3/4 (20)	0.788 (20)	.268 (6.8)
1 (25)	0.889 (22.5)	.327 (8.3)

DIMENSIONS/DOUBLE-ACTING TYPE

inch (mm)

1 1/4 (32) bore

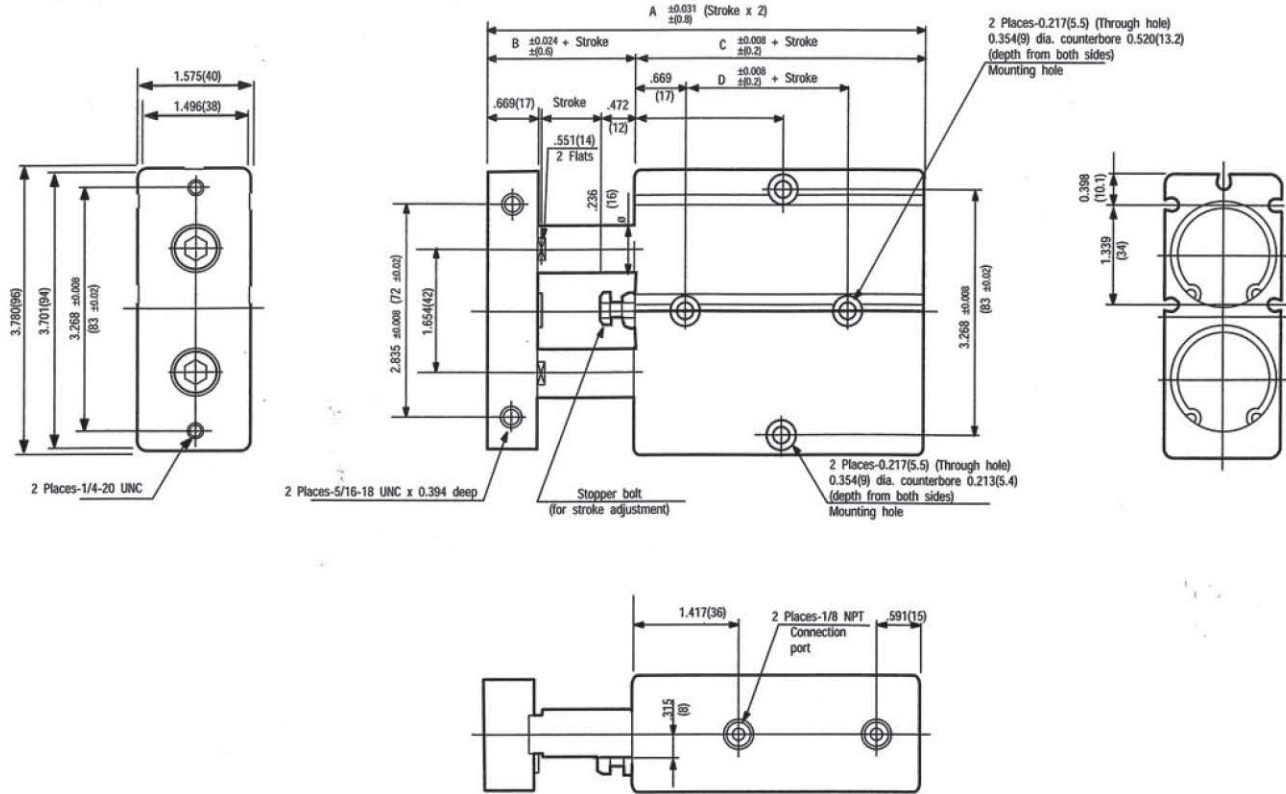

Bore in. (nom.) (mm) (actual)	Letter												
	A	B	C	D	E								
					Stroke								
					1/2"	3/4"	1"	1 1/2"	2"	2 1/2"	3"	3 1/2"	4"
1 1/4 (32)	4.252 (108)	1.181 (30)	3.071 (78)	1.378 (35)	1.825 (46.35)	1.950 (49.53)	2.075 (52.70)	2.325 (59.05)	2.575 (65.40)	2.825 (71.75)	3.075 (78.10)	3.325 (84.45)	3.575 (90.80)

ROD END DIMENSIONS

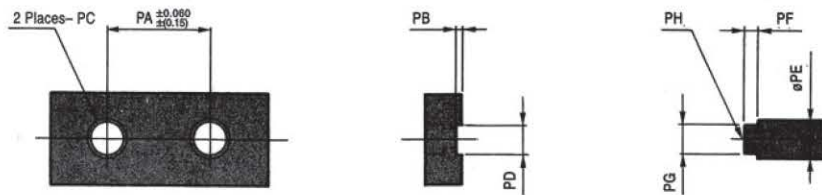

Bore in. (nom.) (mm) (actual)	Letter							
	PA	PB	PC thru hole x c'bore x depth	PD	PE	PF	PG	PH
3/8 (10)	0.709 (18)	0.020 (0.5)	0.130 (3.3) x 0.244 (6.2) x 0.138 (3.5)	0.205 $^{+0.004}_0$ (5.2 $^{+0.1}_0$)	0.236 (6)	0.118 (3)	0.205 $^{+0.002}_{-0.006}$ (5.2 $^{+0.05}_{-0.15}$)	M3x0.5, 0.197 (5) deep
5/8 (16)	0.945 (24)	0.039 (1)	0.169 (4.3) x 0.307 (7.8) x 0.181 (4.6)	0.244 $^{+0.004}_0$ (6.2 $^{+0.1}_0$)	0.315 (8)	0.118 (3)	0.244 $^{+0.002}_{-0.006}$ (6.2 $^{+0.05}_{-0.15}$)	M4x0.7, 0.236 (6) deep
3/4 (20)	1.102 (28)	0.039 (1)	0.256 (6.5) x 0.433 (11) x 0.268 (6.8)	0.323 $^{+0.004}_0$ (8.2 $^{+0.1}_0$)	0.394 (10)	0.118 (3)	0.323 $^{+0.002}_{-0.006}$ (8.2 $^{+0.05}_{-0.15}$)	M6x1, 0.315 (8) deep
1 (25)	1.339 (34)	0.039 (1)	0.256 (6.5) x 0.433 (11) x 0.268 (6.8)	0.402 $^{+0.004}_0$ (10.2 $^{+0.1}_0$)	0.472 (12)	0.118 (3)	0.402 $^{+0.002}_{-0.006}$ (10.2 $^{+0.05}_{-0.15}$)	M6x1, 0.315 (8) deep
1 1/4 (32)	1.654 (42)	0.079 (2)	0.417 (10.6) x 0.670 (17) x 0.472 (12)	0.551 $^{+0.008}_0$ (14 $^{+0.2}_{-0.05}$)	0.630 (16)	0.157 (4)	0.551 $^{+0.008}_0$ (14 $^{+0.2}_{-0.05}$)	M10x1.5, 0.551 (14) deep

TWIN ROD CYLINDERS DOUBLE ACTING, LONG BUSHING TYPE

SYMBOL

- Has more than twice the bushing length of the standard double acting type (Model HTBDA).
- Provides additional rod support for extended cycle life.

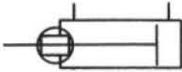

SPECIFICATIONS

Item	Bore size inch (nom.) / mm (actual)				
	3/8 (10)	5/8 (16)	3/4 (20)	1 (25)	1 1/4 (32)
Type	Double acting				
Medium	Air				
Mounting	Side Mount				
Pressure range psig (kgf/cm ²)	28-100 (2-7)	21-100 (1.5-7)			
Proof pressure psig (kgf/cm ²)	143 (10.5)				
Temperature range °F (°C)	32-141 (0-60)				
Piston speed range in./s (mm/s)	4-20 (100-500)				
Bumper	None	Buna			
Lubrication	*None required				
Allowable eccentricity	± 0.4°	± 0.3°			
Stroke adjustment range in. (mm)	-0.197 to 0 (-5 to 0) per specific stroke				
Port size	#10-32			1/8	

*If lubrication is used, apply a non-detergent 10W oil (ISO VG32), or equivalent.

BORE SIZE AND STROKE

Bore size inch (nom.) / mm (actual)	Standard stroke (in.)	Maximum stroke (in.)	Stroke adjustment range ("pull" side)
3/8 (10)	1/2, 3/4, 1, 1 1/2, 2, 2 1/2, 3	5	-0.197 to 0" (-5 to 0mm)
5/8 (16)	1/2, 3/4, 1, 1 1/2, 2, 2 1/2, 3, 3 1/2, 4	6	
3/4 (20)	1/2, 3/4, 1, 1 1/2, 2, 2 1/2, 3, 3 1/2, 4	7	
1 (25)	1/2, 3/4, 1, 1 1/2, 2, 2 1/2, 3, 3 1/2, 4	7	
1 1/4 (32)	1/2, 3/4, 1, 1 1/2, 2, 2 1/2, 3, 3 1/2, 4	7	

NOTE: 1. Consult factory when using two sensor switches on cylinders with 1/2" stroke.
2. Consult factory for non-standard strokes.

SEAL REPAIR KITS

SRK-HTBDA-10
Bore Size

ORDER EXAMPLE

Cylinders

Sensor Switches (order separately)

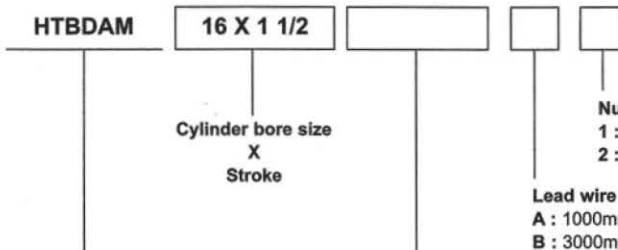

B Series
Twinrod Cylinders
Double acting long
bushing type

Cylinder bore size
X
Stroke

Number of sensor switch
1 : With one sensor switch
2 : With two sensor switches

Lead wire length
A : 1000mm
B : 3000mm

Sensor Switch model

ZE135 - Two lead wires, Hall effect type with indicator (PNP, sourcing)	DC10-28V	Horizontal lead wire type
ZE235 - Two lead wires, Hall effect type with indicator (PNP, sourcing)	DC10-28V	Vertical lead wire type
ZE155 - Three lead wires, Hall effect type with indicator (NPN, sinking)	DC4.5-28V	Horizontal lead wire type
ZE255 - Three lead wires, Hall effect type with indicator (NPN, sinking)	DC4.5-28V	Vertical lead wire type
ZE101 - Two lead wires, Reed switch type w/o indicator	DC5-28V AC85-115V	Horizontal lead wire type
ZE201 - Two lead wires, Reed switch type w/o indicator	DC5-28V AC85-115V	Vertical lead wire type
ZE102 - Two lead wires, Reed switch type with indicator	DC10-28V AC85-115V	Horizontal lead wire type
ZE202 - Two lead wires, Reed switch type with indicator	DC10-28V AC85-115V	Vertical lead wire type

Note: In the double acting long bushing type, the magnet for the sensor switch is built-in.

INNER CONSTRUCTION AND MAJOR PARTS

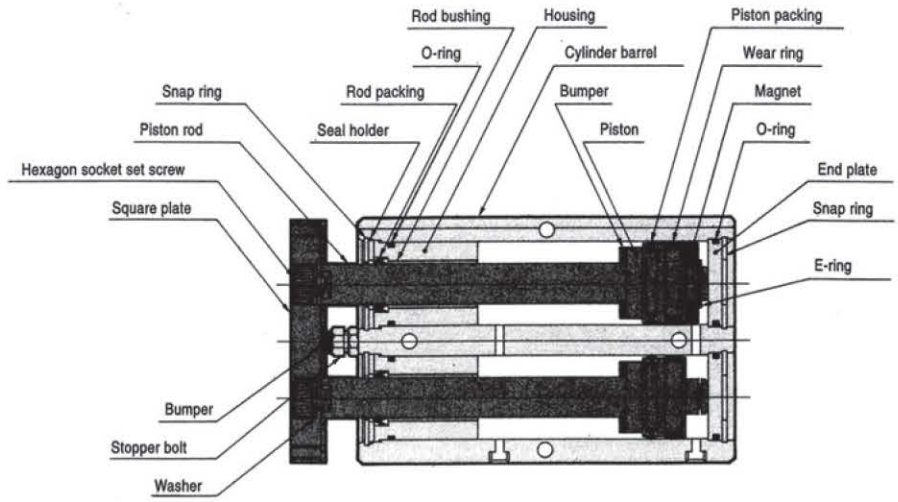

MAJOR PARTS AND MATERIALS OF CONSTRUCTION

Item	Material
Cylinder barrel	Anodized aluminum
Piston	Anodized aluminum
Wear ring	Resin
Piston rod	Hard steel, hard chrome plated
O-ring	Buna
Seal holder	Mild steel, nickel plated
Housing	Anodized aluminum
End plate	Anodized aluminum
Rod bushing	Oil permeated bronze
Seal	Buna
Snap ring	Hard steel, nickel plated
Magnet	Resinous magnet
E-ring	Stainless steel
Washer	Hard steel, black galvanized
Square plate	Mild steel, black galvanized
Bumper*	Buna
Stopper bolt	Mild steel, galvanized

*10mm bore models are not equipped with a bumper.

WEIGHT

oz. (gf)

Bore size Inch (nom.)/mm (actual)	Additional weight			
	Zero stroke weight	Added weight per 1/2-inch stroke	Weight of sensor	
			ZE□□□A	ZE□□□B
3/8 (10)	4.41 (125)	0.81 (22.96)	.053 (15)	1.23 (35)
5/8 (16)	8.61 (244)	1.21 (34.30)		
3/4 (20)	13.86 (393)	1.61 (45.64)		
1 (25)	20.99 (595)	2.29 (64.92)		
1 1/4 (32)	47.76 (1354)	3.94 (111.70)		

Calculation example: The weight of a 3/4-inch bore cylinder with a 1 1/2-inch stroke, together with two CS3H sensor switches is:

$$13.89 + (1.61 \times 3) + (1.06 \times 2) = 20.64 \text{ oz. (585.13) gf.}$$

└─ 1/2-inch stroke x 3

DIMENSIONS/DOUBLE-ACTING LONG BUSHING TYPE

inch (mm)

3/8 (10) bore

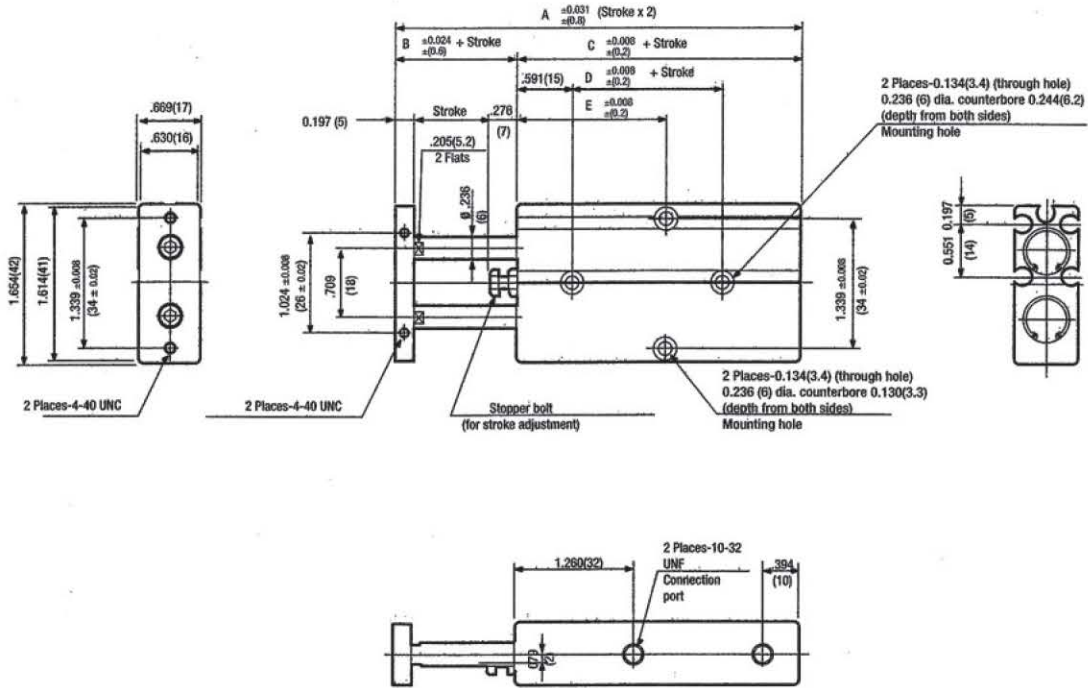

Bore in. (nom.) (mm) (actual)	Letter										
	A	B	C	C	E						
					Stroke						
					1/2"	3/4"	1"	1 1/2"	2"	2 1/2"	3"
3/8 (10)	2.677 (68)	0.472 (12)	2.205 (56)	0.984 (25)	0.984 (25.00)	1.556 (39.53)	1.681 (42.70)	1.931 (49.05)	2.181 (55.40)	2.431 (61.75)	2.681 (68.10)

DIMENSIONS/DOUBLE-ACTING LONG BUSHING TYPE

inch (mm)

5/8 (16) ~ 1 (25) bore

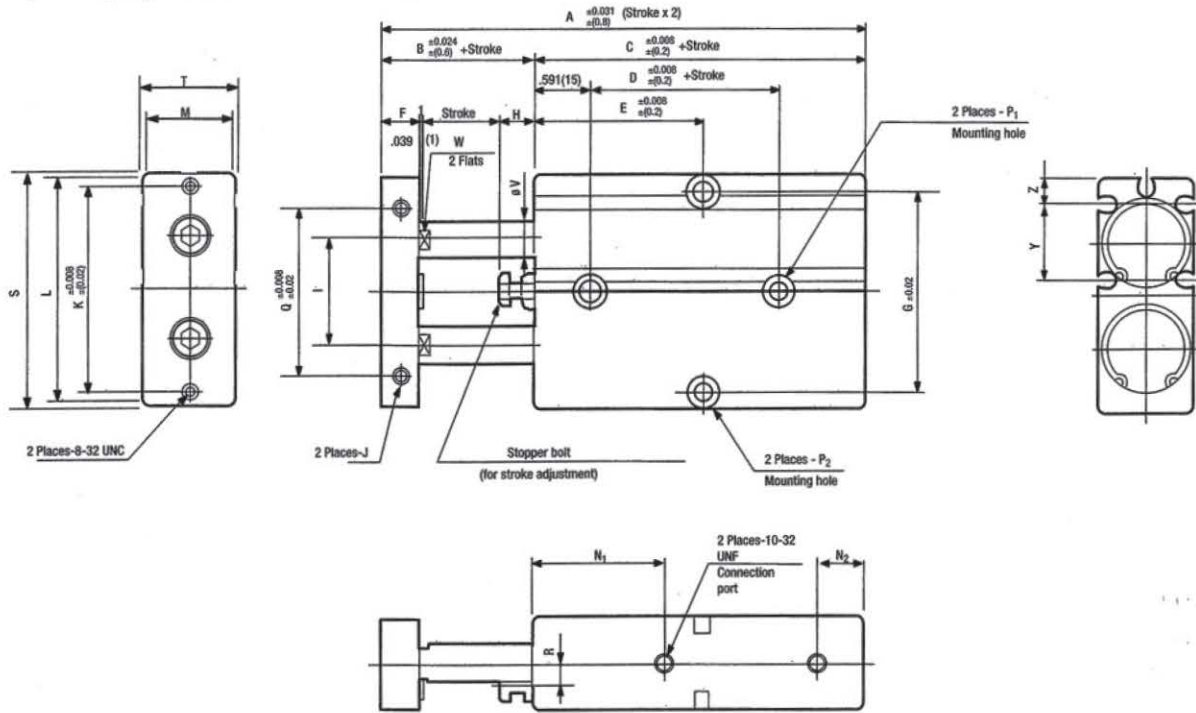

Bore in. (nom.) (mm) (actual)	Letter												
	A	B	C	D	E								
					Stroke								
					1/2"	3/4"	1"	1 1/2"	2"	2 1/2"	3"	3 1/2"	4"
5/8 (16)	3.071 (78)	0.591 (15)	2.480 (63)	1.181 (30)	1.628 (41.35)	1.753 (44.53)	1.878 (47.70)	2.128 (54.05)	2.378 (60.40)	2.628 (66.75)	2.878 (73.10)	3.128 (79.45)	3.378 (85.80)
3/4 (20)	3.465 (88)	0.787 (20)	2.677 (68)	1.181 (30)	1.772 (45.00)	1.772 (45.00)	1.772 (45.00)	1.931 (49.05)	2.181 (55.40)	2.431 (61.75)	2.681 (68.10)	2.931 (74.45)	3.181 (80.80)
1 (25)	3.583 (91)	0.748 (19)	2.835 (72)	1.575 (40)	1.969 (50.00)	1.969 (50.00)	1.969 (50.00)	2.128 (54.05)	2.378 (60.40)	2.628 (66.75)	2.878 (73.10)	3.128 (79.45)	3.378 (85.80)

Bore in. (nom.) (mm) (actual)	Letter									
	F	G	H	I	J	K	L	M	N ₁	N ₂
5/8 (16)	0.315 (8)	1.850 (47)	0.236 (6)	0.945 (24)	8-32 UNC x 0.197 deep	1.850 (47)	2.087 (53)	0.787 (20)	1.260 (32)	0.394 (10)
3/4 (20)	0.394 (10)	2.165 (55)	0.354 (9)	1.102 (28)	8-32 UNC x 0.197 deep	2.165 (55)	2.402 (61)	0.945 (24)	1.378 (35)	0.472 (12)
1 (25)	0.394 (10)	2.598 (66)	0.315 (8)	1.339 (34)	10-32 UNF x 0.236 deep	2.598 (66)	2.835 (72)	1.142 (29)	1.575 (40)	0.472 (12)

Bore in. (nom.) (mm) (actual)	Letter									
	P ₁ NOTE thru hole x c'bore x depth (from both sides)		P ₂ thru hole x c'bore x depth (from both sides)		Q	R	S	T	V	W
5/8 (16)	0.177 (4.5) x 0.295 (7.5) x 0.283 (7.2)		0.177 (4.5) x 0.315 (8) x 0.173 (7.2)		1.340 (34)	0.157 (4)	2.130 (54)	0.830 (21)	0.315 (8)	0.244 (6.2)
3/4 (20)	0.177 (4.5) x 0.295 (7.5) x 0.283 (7.2)		0.177 (4.5) x 0.315 (8) x 0.173 (7.2)		1.732 (44)	0.236 (6)	2.441 (62)	0.984 (25)	0.394 (10)	0.323 (8.2)
1 (25)	0.177 (4.5) x 0.295 (7.5) x 0.283 (7.2)		0.177 (4.5) x 0.315 (8) x 0.173 (7.2)		2.205 (56)	0.276 (7)	2.874 (73)	1.181 (30)	0.472 (12)	0.402 (10.2)

NOTE: Counterbore is measured from outermost surface of cylinder.

Bore in. (nom.) (mm) (actual)	Y	Z
5/8 (16)	0.728 (18.5)	0.224 (5.7)
3/4 (20)	0.788 (20)	0.268 (6.8)
1 (25)	0.889 (22.5)	0.327 (8.3)

DIMENSIONS/DOUBLE-ACTING LONG BUSHING TYPE

inch (mm)

1 1/4 (32) bore

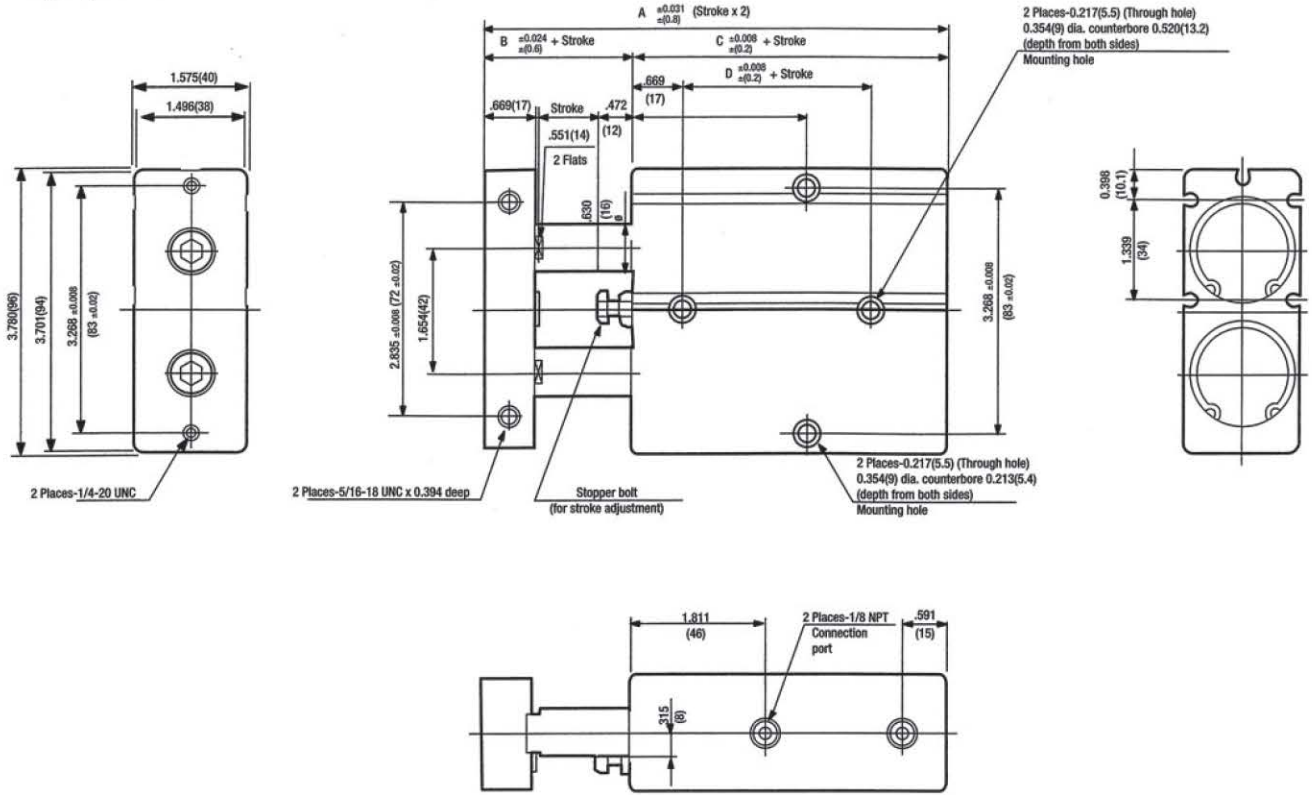

Bore in. (nom.) (mm) (actual)	Letter												
	A	B	C	D	E								
					Stroke								
					1/2"	3/4"	1"	1 1/2"	2"	2 1/2"	3"	3 1/2"	4"
1 1/4 (32)	4.646 (118)	1.18 (30)	3.465 (88)	1.772 (45)	2.219 (56.35)	2.344 (59.53)	2.469 (62.70)	2.719 (69.05)	2.969 (75.40)	3.219 (81.75)	3.469 (88.10)	3.719 (94.45)	3.969 (100.8)

ROD END DIMENSIONS

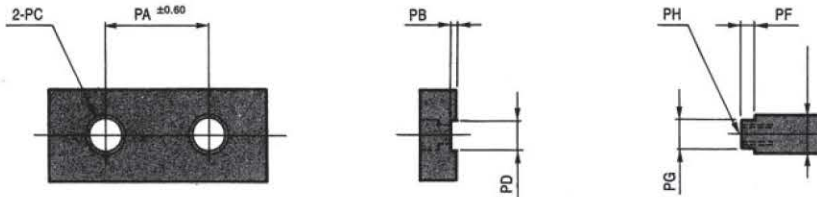

Bore in. (nom.) (mm) (actual)	Letter							
	PA	PB	PC thru hole x c'bore x depth	PD	PE	PF	PG	PH
3/8 (10)	0.709 (18)	0.020 (0.5)	0.130 (3.3) x 0.244 (6.2) x 0.138 (3.5)	0.205 ^{+0.004} / ₀ (5.2 ^{+0.1} / ₀)	0.236 (6)	0.118 (3)	0.205 ^{-0.002} / _{-0.006} (5.2 ^{-0.05} / _{-0.15})	M3x0.5, 0.197 (5) deep
5/8 (16)	0.945 (24)	0.039 (1)	0.169 (4.3) x 0.307 (7.8) x 0.181 (4.6)	0.244 ^{+0.004} / ₀ (6.2 ^{+0.1} / ₀)	0.315 (8)	0.118 (3)	0.244 ^{-0.002} / _{-0.006} (6.2 ^{-0.05} / _{-0.15})	M4x0.7, 0.236 (6) deep
3/4 (20)	1.102 (28)	0.039 (1)	0.256 (6.5) x 0.433 (11) x 0.268 (6.8)	0.323 ^{+0.004} / ₀ (8.2 ^{+0.1} / ₀)	0.394 (10)	0.118 (3)	0.323 ^{-0.002} / _{-0.006} (8.2 ^{-0.05} / _{-0.15})	M6x1, 0.315 (8) deep
1 (25)	1.339 (34)	0.039 (1)	0.256 (6.5) x 0.433 (11) x 0.268 (6.8)	0.402 ^{+0.004} / ₀ (10.2 ^{+0.1} / ₀)	0.472 (12)	0.118 (3)	0.402 ^{-0.002} / _{-0.006} (10.2 ^{-0.05} / _{-0.15})	M6x1, 0.315 (8) deep
1 1/4 (32)	1.654 (42)	0.079 (2)	0.417 (10.6) x 0.670 (17) x 0.472 (12)	0.551 ^{+0.006} / ₀ (14 ^{+0.2} / _{-0.03})	0.630 (16)	0.157 (4)	0.551 ^{-0.008} / _{-0.008} (14 ⁺⁰ / _{-0.2})	M10x1.5, 0.551 (14) deep

TWIN ROD CYLINDERS SINGLE ACTING, PUSH TYPE

SYMBOL



SPECIFICATIONS

Item	Bore size inch (nom.) / mm (actual)			
	3/8 (10)	5/8 (16)	3/4 (20)	1 (25)
Type	Single acting, push type			
Medium	Air			
Mounting	Side Mount			
Pressure range psig (kgf/cm ²)	35-100 (2.5-7)	28-100 (2-7)		
Proof pressure psig (kgf/cm ²)	143 (10.5)			
Temperature range °F (°C)	32-141 (0-60)			
Piston speed range in./s (mm/s)	4-20 (100-500)			
Bumper	None	Buna		
Lubrication	*None required			
Allowable eccentricity	± 0.4°	± 0.3°		
Stroke adjustment range in. (mm)	-0.197 to 0 (-5 to 0) per specific stroke			
Port size	#10-32			

*If lubrication is used, apply a non-detergent 10W oil (ISO VG32), or equivalent.

BORE SIZE AND STROKE

Bore size inch (nom.) / mm (actual)	Standard stroke (in.)	Maximum stroke (in.)	Stroke adjustment range ("pull" side)
3/8 (10)	1/2, 3/4, 1, 1 1/2, 2, 2 1/2	2 1/2	-0.197 to 0" (-5 to 0mm)
5/8 (16)	1/2, 3/4, 1, 1 1/2, 2, 2 1/2	2 1/2	
3/4 (20)	1/2, 3/4, 1, 1 1/2, 2, 2 1/2	2 1/2	
1 (25)	1/2, 3/4, 1, 1 1/2, 2, 2 1/2	2 1/2	

SEAL REPAIR KITS

SRK-HTBDA-10
Bore
Size

ORDER EXAMPLE

Cylinders

Sensor Switches (order separately)

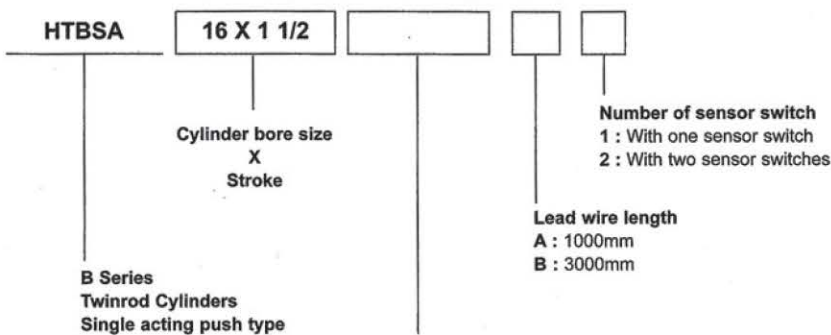

Sensor Switch model

ZE135 - Two lead wires, Hall effect type with indicator (PNP, sourcing)	DC10-28V	Horizontal lead wire type
ZE235 - Two lead wires, Hall effect type with indicator (PNP, sourcing)	DC10-28V	Vertical lead wire type
ZE155 - Three lead wires, Hall effect type with indicator (NPN, sinking)	DC4.5-28V	Horizontal lead wire type
ZE255 - Three lead wires, Hall effect type with indicator (NPN, sinking)	DC4.5-28V	Vertical lead wire type
ZE101 - Two lead wires, Reed switch type w/o indicator	DC5-28V	Horizontal lead wire type
	AC85-115V	
ZE201 - Two lead wires, Reed switch type w/o indicator	DC5-28V	Vertical lead wire type
	AC85-115V	
ZE102 - Two lead wires, Reed switch type with indicator	DC10-28V	Horizontal lead wire type
	AC85-115V	
ZE202 - Two lead wires, Reed switch type with indicator	DC10-28V	Vertical lead wire type
	AC85-115V	

INNER CONSTRUCTION AND MAJOR PARTS

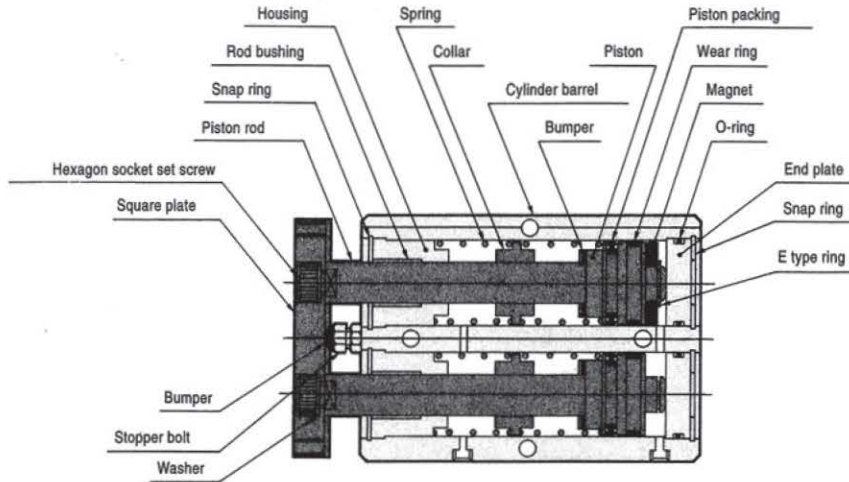

MAJOR PARTS AND MATERIALS OF CONSTRUCTION

Item	Material
Cylinder barrel	Anodized aluminum
Piston	Anodized aluminum
Wear ring	Resin
Piston rod	Hard steel, hard chrome plated
O-ring	Buna
Seal holder	Mild steel, nickel plated
Housing	Anodized aluminum
End plate	Anodized aluminum
Rod bushing	Oil permeated bronze
Seal	Buna
Snap ring	Hard steel, nickel plated
Magnet	Resinous magnet
E-ring	Stainless steel
Washer	Hard steel, black galvanized
Square plate	Mild steel, black galvanized
Bumper*	Buna
Stopper bolt	Mild steel, galvanized

*10mm bore models are not equipped with a bumper.

WEIGHT

oz. (gf)

Bore size in. (nom.) mm (actual)	Stroke (in.)						ZE□□□A	ZE□□□B
	1/2	3/4	1	1 1/2	2	2 1/2		
3/8 (10)	4.34 (123)	4.80 (136)	5.22 (148)	6.84 (194)	7.83 (222)	8.64 (245)	0.53 (15)	1.23 (35)
5/8 (16)	8.64 (245)	9.42 (267)	9.98 (283)	12.35 (350)	13.58 (385)	14.79 (419)		
3/4 (20)	13.72 (389)	14.57 (413)	15.34 (435)	18.87 (535)	20.49 (581)	22.08 (626)		
1 (25)	20.92 (593)	22.01 (624)	23.07 (654)	27.86 (654)	30.37 (861)	32.84 (931)		

DIMENSIONS/SINGLE-ACTING PUSH TYPE

inch (mm)

3/8 (10) bore

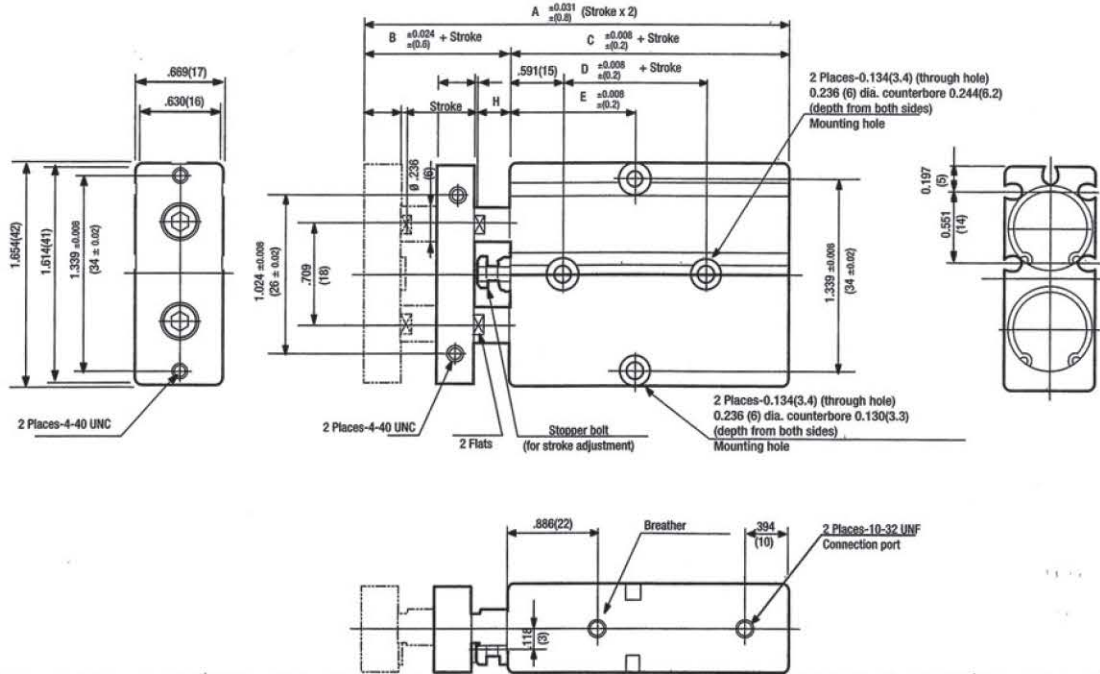

Bore in. (nom.) (mm) (actual)	Letter							
	A		B		C		D	
	Stroke							
	1/2" to 1"	1 1/2" to 2 1/2"	1/2" to 1"	1 1/2" to 2 1/2"	1/2" to 1"	1 1/2" to 2 1/2"	1/2" to 1"	1 1/2" to 2 1/2"
3/8 (10)	2.283 (58)	2.705 (68.7)	0.472 (12)	0.394 (10)	1.811 (46)	2.311 (58.7)	0.394 (10)	0.894 (22.7)

Bore in. (nom.) (mm) (actual)	Letter							
	E						H	
	Stroke							
	1/2"	3/4"	1"	1 1/2"	2"	2 1/2"	1/2" to 1"	1 1/2" to 2 1/2"
3/8 (10)	1.181 (30.00)	1.181 (30.00)	1.287 (32.70)	1.787 (45.40)	2.037 (51.75)	2.287 (58.10)	0.276 (7)	0.197 (5)

ROD END DIMENSIONS

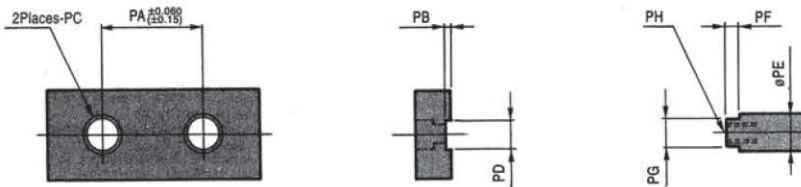

Bore in. (nom.) (mm) (actual)	Letter							
	PA	PB	PC thru hole x c'bore x depth	PD	PE	PF	PG	PH
3/8 (10)	0.709 (18)	0.020 (0.5)	0.130 (3.3) x 0.244 (6.2) x 0.138 (3.5)	0.205 ^{+0.004} / ₀ (5.2 ^{+0.1} / ₀)	0.236 (6)	0.118 (3)	0.205 ^{-0.002} / _{-0.006} (5.2 ^{-0.05} / _{-0.15})	M3x0.5, 0.197 (5) deep
5/8 (16)	0.945 (24)	0.039 (1)	0.169 (4.3) x 0.307 (7.8) x 0.181 (4.6)	0.244 ^{+0.004} / ₀ (6.2 ^{+0.1} / ₀)	0.315 (8)	0.118 (3)	0.244 ^{-0.002} / _{-0.006} (6.2 ^{-0.05} / _{-0.15})	M4x0.7, 0.236 (6) deep
3/4 (20)	1.102 (28)	0.039 (1)	0.256 (6.5) x 0.433 (11) x 0.268 (6.8)	0.323 ^{+0.004} / ₀ (8.2 ^{+0.1} / ₀)	0.394 (10)	0.118 (3)	0.323 ^{-0.002} / _{-0.006} (8.2 ^{-0.05} / _{-0.15})	M6x1, 0.315 (8) deep
1 (25)	1.339 (34)	0.039 (1)	0.256 (6.5) x 0.433 (11) x 0.268 (6.8)	0.402 ^{+0.004} / ₀ (10.2 ^{+0.1} / ₀)	0.472 (12)	0.118 (3)	0.402 ^{-0.002} / _{-0.006} (10.2 ^{-0.05} / _{-0.15})	M6x1, 0.315 (8) deep

DIMENSIONS/SINGLE-ACTING PUSH TYPE

inch (mm)

5/8 (16) ~ 1 (25) bore

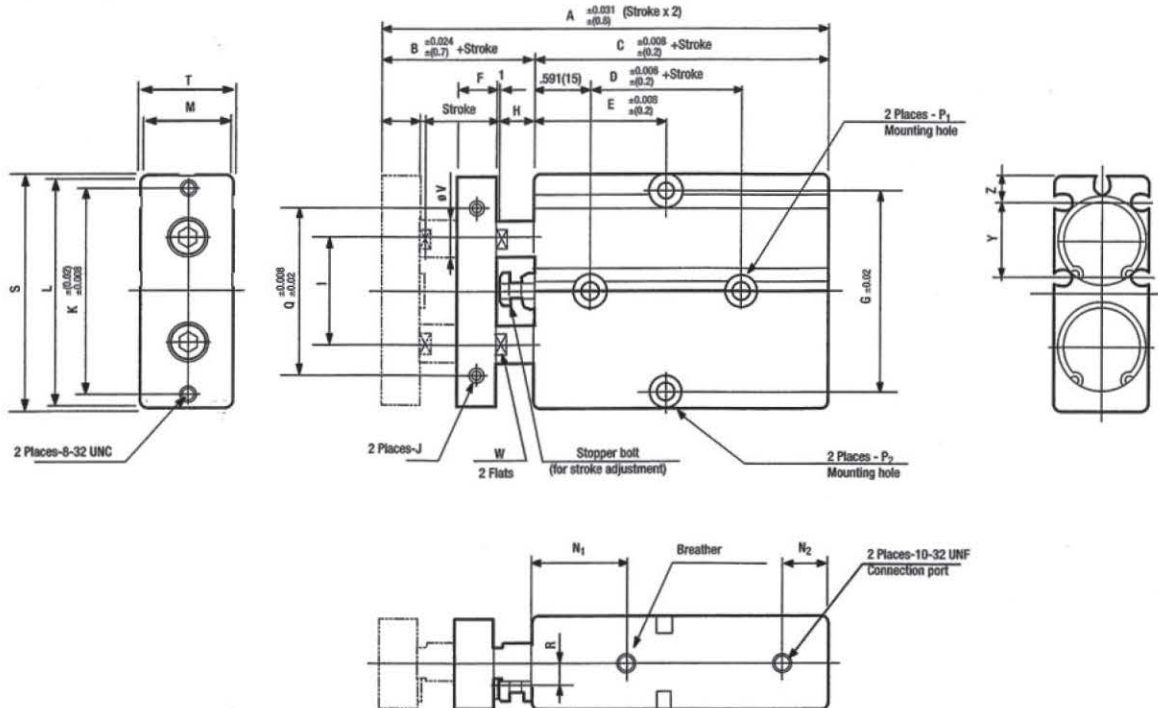

Bore in. (nom.) (mm) (actual)	Letter												
	A		B	C		D		E					
	Stroke			1/2" to 1"	1 1/2" to 2 1/2"	1/2" to 1"	1 1/2" to 2 1/2"	1/2"	3/4"	1"	1 1/2"	2"	2 1/2"
5/8 (16)	2.677 (68)	3.177 (80.7)	0.591 (15)	2.087 (53)	2.587 (65.7)	0.787 (20)	1.287 (32.7)	1.234 (31.35)	1.359 (34.53)	1.484 (37.70)	1.984 (50.40)	2.234 (56.75)	2.484 (63.10)
3/4 (20)	3.071 (78)	3.571 (90.7)	0.787 (20)	2.283 (58)	2.783 (70.7)	0.787 (20)	1.287 (32.7)	1.378 (35.00)	1.378 (35.00)	1.484 (37.70)	1.984 (50.40)	2.234 (56.75)	2.484 (63.10)
1 (25)	3.189 (81)	3.689 (93.7)	0.748 (19)	2.441 (62)	2.941 (74.7)	1.181 (30)	1.681 (42.7)	1.575 (40.00)	1.575 (40.00)	1.681 (42.70)	2.181 (55.40)	2.431 (61.75)	2.681 (68.10)

Bore in. (nom.) (mm) (actual)	Letter									
	F	G	H	I	J	K	L	M	N ₁	N ₂
5/8 (16)	0.315 (8)	1.850 (47)	0.236 (6)	0.945 (24)	8-32 UNC x 0.197 deep	1.850 (47)	2.087 (53)	0.787 (20)	0.866 (22)	0.394 (10)
3/4 (20)	0.394 (10)	2.165 (55)	0.354 (9)	1.102 (28)	8-32 UNC x 0.197 deep	2.165 (55)	2.402 (61)	0.945 (24)	0.984 (25)	0.472 (12)
1 (25)	0.394 (10)	2.598 (66)	0.315 (8)	1.339 (34)	10-32 UNF x 0.236 deep	2.598 (66)	2.853 (72)	1.142 (29)	1.181 (30)	0.472 (12)

Bore in. (nom.) (mm) (actual)	Letter									
	P ₁ NOTE thru hole x c'bore x depth (from both sides)		P ₂ thru hole x c'bore x depth (from both sides)		Q	R	S	T	V	W
5/8 (16)	0.177 (4.5) x 0.295 (7.5) x 0.283 (7.2)		0.177 (4.5) x 0.315 (8) x 0.173 (7.2)		1.340 (34)	0.157 (4)	2.130 (54)	0.830 (21)	0.315 (8)	0.244 (6.2)
3/4 (20)	0.177 (4.5) x 0.295 (7.5) x 0.283 (7.2)		0.177 (4.5) x 0.315 (8) x 0.173 (7.2)		1.732 (44)	0.236 (6)	2.441 (62)	0.984 (25)	0.394 (10)	0.323 (8.2)
1 (25)	0.177 (4.5) x 0.295 (7.5) x 0.283 (7.2)		0.177 (4.5) x 0.315 (8) x 0.173 (7.2)		2.205 (56)	0.276 (7)	2.874 (73)	1.181 (30)	0.472 (12)	0.402 (10.2)

NOTE: Counterbore is measured from outermost surface of cylinder.

Bore in. (nom.) (mm) (actual)	Y	Z
5/8 (16)	0.728 (18.5)	0.224 (5.7)
3/4 (20)	0.788 (20)	0.268 (6.8)
1 (25)	0.889 (22.5)	0.327 (8.3)

TWIN ROD END KEEP CYLINDERS

DOUBLE ACTING

- End Keep Cylinders lock piston rods in the event of pressure loss or failure.
- "HL" models keep the piston rods in the fully retracted position.
- "RL" models keep the piston rods in the fully extended position.
- Piston rods remain locked until pressure is restored or until manual override is applied. This special feature prevents unintended actuation, helps prevent injury to personnel and damage to the cylinder and to adjacent equipment.

NOTE: End Keep function does not operate when cylinders are in mid-position.



SPECIFICATIONS

Item	Bore size inch (nom.) / mm (actual)		
	5/8 (16)	3/4 (20)	1 (25)
Type	Double acting		
Medium	Air		
Mounting	Side mount		
Pressure range psig (kgf/cm ²)	21~100 (1.5~7)		
Temperature range °F (°C)	32~140 (0~60)		
Piston speed range in./s (mm/s)	20 (500)		
Bumper	Buna		
Lubrication	*None required		
Allowable eccentricity	±0.3°		
Stroke adjustment range in. (mm)	-HL fixed stopper bolt -RL 0.197 to 0 (-5 to 0)		
Max. retaining force (at end keep) lb. (kgf)	5/8 (16) 21.6 (9.8)	3/4 (20) 33.0 (15.4)	1 (25) 52.9 (24)
Backlash (at end keep) in. (mm)	0.039 (1) max.		
Port size	#10-32 UNF		

*If lubrication is used, apply Class 1 turbine oil (ISO VG32), or equivalent.

ORDER EXAMPLE

Cylinders

Sensor Switches (order separately)

HTBDAK **16 X 1 1/2** **HL**

B Series End Keep Twin Rod Cylinders

Cylinder bore size X Stroke

End keep position
HL : Head side end keep
RL : Rod side end keep

Number of sensor switch
1 : With one sensor switch
2 : With two sensor switches

Lead wire length
A : 1000mm
B : 3000mm

Sensor Switch model
ZE135 - Two lead wires, Hall effect type with indicator (PNP, sourcing)
ZE235 - Two lead wires, Hall effect type with indicator (PNP, sourcing)
ZE155 - Three lead wires, Hall effect type with indicator (NPN, sinking)
ZE255 - Three lead wires, Hall effect type with indicator (NPN, sinking)
ZE101 - Two lead wires, Reed switch type w/o indicator
ZE201 - Two lead wires, Reed switch type w/o indicator
ZE102 - Two lead wires, Reed switch type with indicator
ZE202 - Two lead wires, Reed switch type with indicator

DC10~28V Horizontal lead wire type
DC10~28V Vertical lead wire type
DC4.5~28V Horizontal lead wire type
DC4.5~28V Vertical lead wire type
DC5~28V AC85~115V Horizontal lead wire type
DC5~28V AC85~115V Vertical lead wire type
DC10~28V AC85~115V Horizontal lead wire type
DC10~28V AC85~115V Vertical lead wire type

Note: In the end keep cylinder, the magnet for the sensor switch is built-in.

BORE SIZE AND STROKE

Bore size inch (nom.) / mm (actual)	Standard stroke (in.)	Pull side stroke adjustment	
		-HL	-RL
5/8 (16)	1/2, 3/4, 1, 1 1/2, 2, 2 1/2, 3	-	-0.197 to 0" (-5 to 0mm)
3/4 (20)	1/2, 3/4, 1, 1 1/2, 2, 2 1/2, 3		
1 (25)	1/2, 3/4, 1, 1 1/2, 2, 2 1/2, 3		

NOTE: Consult factory when using two sensor switches on cylinders with 1/2" stroke.

SEAL REPAIR KITS

SRK-HTBDA-16
Bore Size

TWIN ROD LOCKING CYLINDERS

-HL – Locks in retracted position

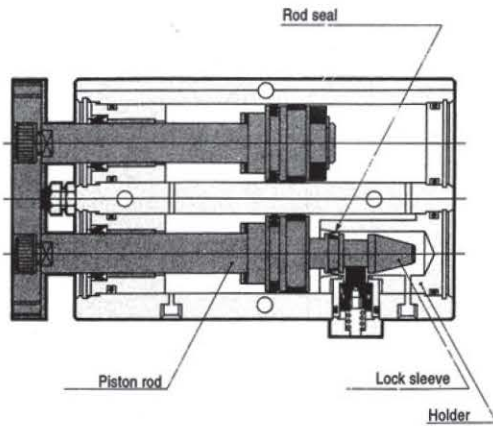

-RL – Locks in extended position

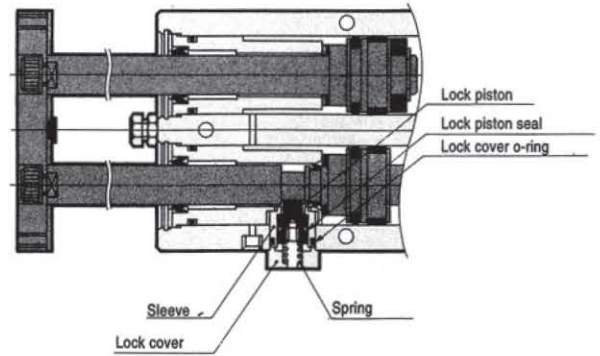

MAJOR PARTS AND MATERIALS OF CONSTRUCTION

Item		Material
Piston rod	-HL	Hard steel (chrome plated)
	-RL	Hard steel (heat treated chrome plate)
Lock sleeve (-HL only)		Hard steel (heat treated)
Holder (-HL only)		Anodized aluminum
Lock piston		Hard steel (heat treated)
Sleeve		Anodized aluminum
Spring		Stainless steel
Lock cover		Anodized aluminum
Lock piston seal		Buna
Rod seal		Buna
Lock cover O-ring		Buna

WEIGHT

oz. (gf)

Bore size Inch (nom.) / mm (actual)		Additional weight			
		Zero stroke weight	Added weight per 1/2-inch stroke	Weight of sensor	
				ZE□□□A	ZE□□□B
5/8 (16)	-HL	8.22 (233)	1.57 (44.51)	0.53 (15)	1.23 (35)
	-RL	9.10 (258)	1.48 (41.96)		
3/4 (20)	-HL	12.87 (365)	2.24 (63.50)		
	-RL	13.54 (384)	2.19 (62.09)		
1 (25)	-HL	22.33 (633)	2.33 (66.05)		
	-RL	23.32 (661)	2.29 (64.92)		

Calculation example: The weight of a 3/4-inch bore "-HL" type cylinder with a 1 1/2-inch stroke, together with two CS3H sensor switches is:

$$11.11 + (2.24 \times 3) + (1.06 \times 2) = 19.95 \text{ oz. (565.57 gf)}$$

└─ 1/2-inch stroke x 3

DIMENSIONS/-HL-LOCKS IN RETRACTED POSITION

inch (mm)

5/8 (16) ~ 1 (25) bore

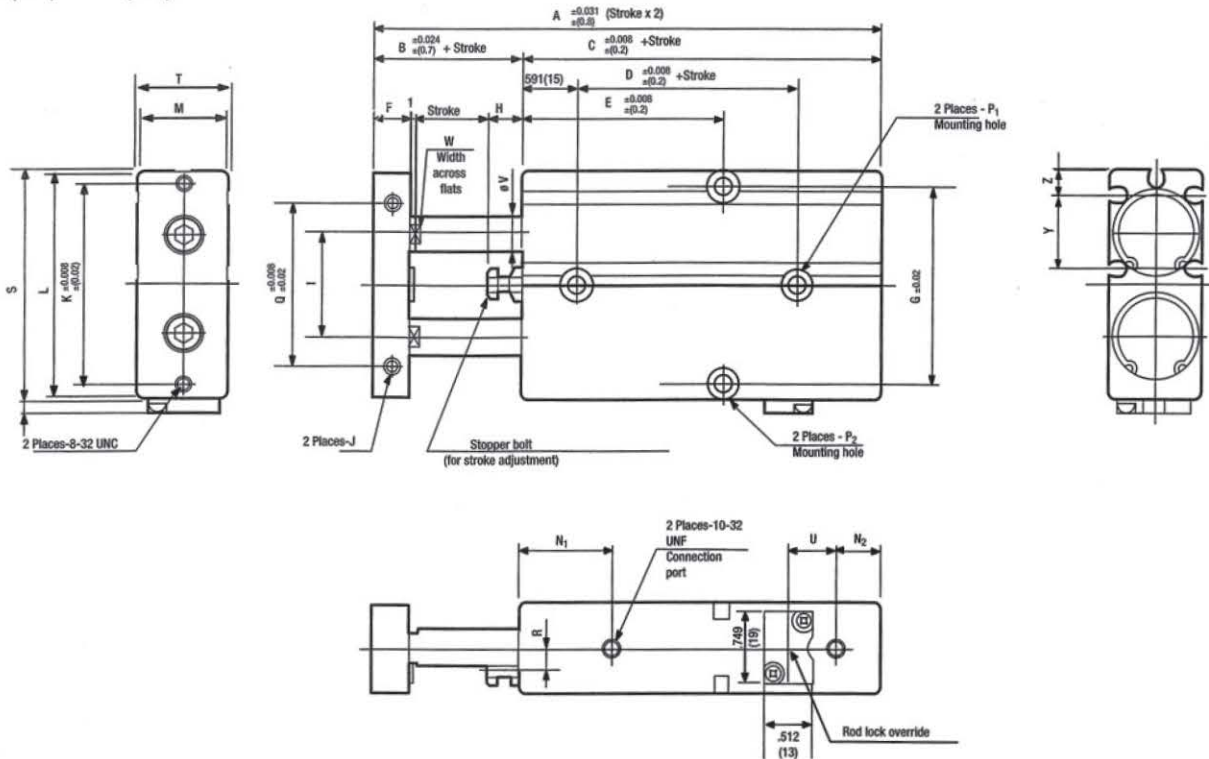

Bore in. (nom.) (mm) (actual)	Letter									
	A	B	C	D	E					
					Stroke					
					1/2"	1"				
5/8 (16)	3.677 (93.4)	0.591 (15)	3.087 (78.4)	1.787 (45.4)	1.734 (44.05)	1.984 (50.4)	2.234 (56.75)	2.484 (63.10)	2.734 (69.45)	2.984 (75.80)
3/4 (20)	4.071 (103.4)	0.787 (20)	3.283 (83.4)	1.787 (45.4)	1.734 (44.05)	1.984 (50.4)	2.234 (56.75)	2.484 (63.10)	2.734 (69.45)	2.984 (75.80)
1 (25)	4.189 (106.4)	0.748 (19)	3.441 (87.4)	2.181 (55.4)	1.931 (49.05)	2.181 (55.4)	2.431 (61.75)	2.681 (68.10)	2.931 (74.45)	3.181 (80.80)

Bore in. (nom.) (mm) (actual)	Letter									
	F	G	H	I	J	K	L	M	N ₁	N ₂
5/8 (16)	0.315 (8)	1.850 (47)	0.236 (6)	0.945 (24)	8-32 UNC x 0.197 deep	1.850 (47)	2.087 (53)	0.787 (20)	0.866 (22)	0.394 (10)
3/4 (20)	0.394 (10)	2.165 (55)	0.354 (9)	1.102 (28)	8-32 UNC x 0.197 deep	2.165 (55)	2.402 (61)	0.945 (24)	0.984 (25)	0.472 (12)
1 (25)	0.394 (10)	2.598 (66)	0.315 (8)	1.339 (34)	10-32 UNF x 0.236 deep	2.598 (66)	2.835 (72)	1.142 (29)	1.181 (30)	0.472 (12)

Bore in. (nom.) (mm) (actual)	Letter									
	P ₁ NOTE thru hole x c'bore x depth (from both sides)		P ₂ thru hole x c'bore x depth (from both sides)		Q	R	S	T	V	W
5/8 (16)	0.177 (4.5) x 0.295 (7.5) x 0.283 (7.2)		0.177 (4.5) x 0.315 (8) x 0.173 (4.4)		1.340 (34)	0.157 (4)	2.130 (54)	0.830 (21)	0.315 (8)	0.244 (6.2)
3/4 (20)	0.177 (4.5) x 0.295 (7.5) x 0.283 (7.2)		0.177 (4.5) x 0.315 (8) x 0.173 (4.4)		1.732 (44)	0.236 (6)	2.441 (62)	0.984 (25)	0.394 (10)	0.323 (8.2)
1 (25)	0.177 (4.5) x 0.295 (7.5) x 0.283 (7.2)		0.177 (4.5) x 0.315 (8) x 0.173 (4.4)		2.205 (56)	0.276 (7)	2.874 (73)	1.181 (30)	0.472 (12)	0.402 (10.2)

NOTE: Counterbore is measured from outermost surface of cylinder.

Bore in. (nom.) (mm) (actual)	Y	Z
5/8 (16)	0.728 (18.5)	0.224 (5.7)
3/4 (20)	0.788 (20)	0.268 (6.8)
1 (25)	0.889 (22.5)	0.327 (8.3)

DIMENSIONS/-HL - LOCKS IN EXTENDED POSITION

inch (mm)

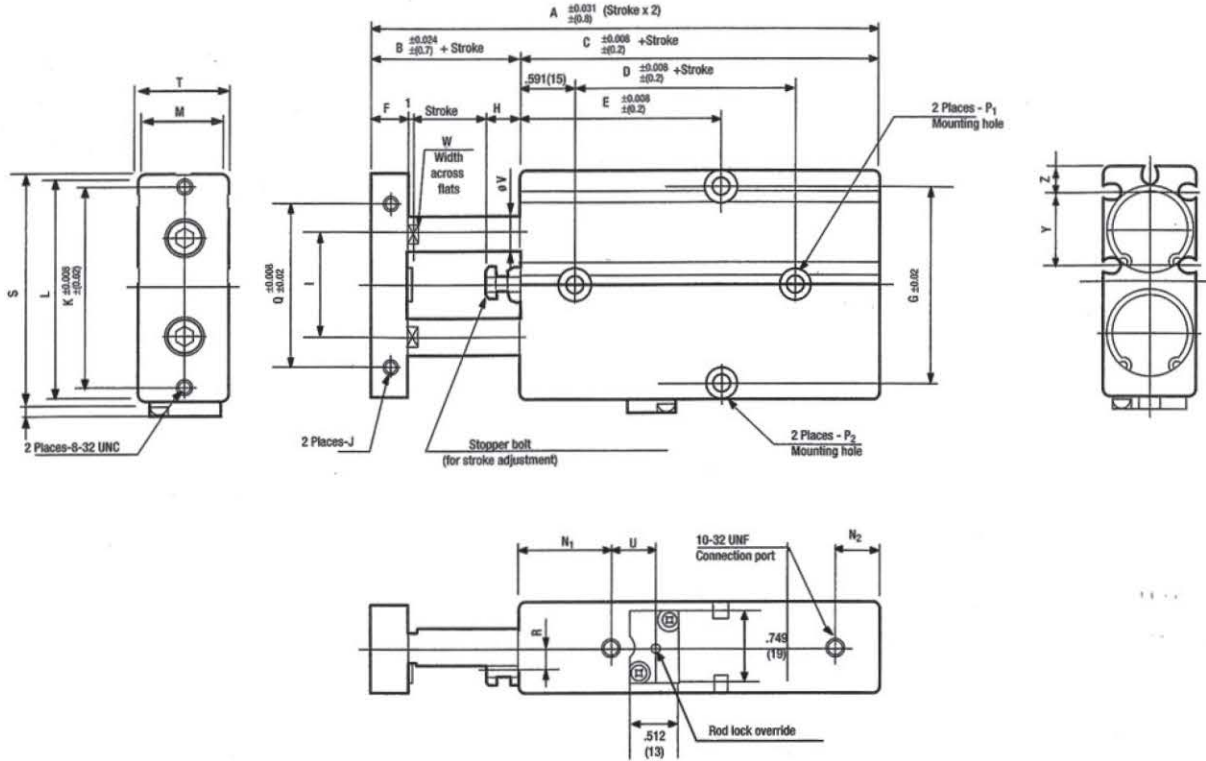

Bore in. (nom.) (mm) (actual)	Letter											
	A	B	C	D	E					N ₁	N ₂	
					Stroke							
					1/2"	1"	1 1/2"	2"	2 1/2"	3"		
5/8 (16)	3.677 (93.4)	0.591 (15)	3.087 (78.4)	3.756 (95.4)	1.984 (50.4)	1.984 (50.4)	2.234 (56.75)	2.484 (63.10)	2.734 (69.45)	2.984 (75.80)		
3/4 (20)	4.071 (103.4)	0.787 (20)	3.283 (83.4)	1.787 (45.4)	2.047 (52.0)	2.047 (52.0)	2.234 (56.75)	2.484 (63.10)	2.734 (69.45)	2.984 (75.80)		
1 (25)	4.189 (106.4)	0.748 (19)	3.441 (87.4)	2.181 (55.4)	2.181 (55.4)	2.181 (55.4)	2.431 (61.75)	2.681 (68.10)	2.931 (74.45)	3.181 (80.80)		

Bore in. (nom.) (mm) (actual)	Letter									
	F	G	H	I	J	K	L	M	N ₁	N ₂
5/8 (16)	0.315 (8)	1.850 (47)	0.236 (6)	0.945 (24)	8-32 UNC x 0.197 deep	1.850 (47)	2.087 (53)	0.787 (20)	0.866 (22)	0.394 (10)
3/4 (20)	0.394 (10)	2.165 (55)	0.354 (9)	1.102 (28)	8-32 UNC x 0.197 deep	2.165 (55)	2.402 (61)	0.945 (24)	0.984 (25)	0.472 (12)
1 (25)	0.394 (10)	2.598 (66)	0.315 (8)	1.339 (34)	10-32 UNF x 0.236 deep	2.598 (66)	2.835 (72)	1.142 (29)	1.181 (30)	0.472 (12)

Bore in. (nom.) (mm) (actual)	Letter									
	P ₁ NOTE thru hole x c'bore x depth (from both sides)		P ₂ thru hole x c'bore x depth (from both sides)		Q	R	S	T	V	W
5/8 (16)	0.177 (4.5) x 0.295 (7.5) x 0.283 (7.2)		0.177 (4.5) x 0.315 (8) x 0.173 (4.4)		1.340 (34)	0.157 (4)	2.130 (54)	0.830 (21)	0.315 (8)	0.244 (6.2)
3/4 (20)	0.177 (4.5) x 0.295 (7.5) x 0.283 (7.2)		0.177 (4.5) x 0.315 (8) x 0.173 (4.4)		1.732 (44)	0.236 (6)	2.441 (62)	0.984 (25)	0.394 (10)	0.323 (8.2)
1 (25)	0.177 (4.5) x 0.295 (7.5) x 0.283 (7.2)		0.177 (4.5) x 0.315 (8) x 0.173 (4.4)		2.205 (56)	0.276 (7)	2.874 (73)	1.181 (30)	0.472 (12)	0.402 (10.2)

NOTE: Counterbore is measured from outermost surface of cylinder.

Bore in. (nom.) (mm) (actual)	Y	Z
5/8 (16)	0.728 (18.5)	0.224 (5.7)
3/4 (20)	0.788 (20)	0.268 (6.8)
1 (25)	0.889 (22.5)	0.327 (8.3)

Solid state type, Reed switch type

Symbol

● Double acting type

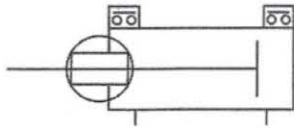

● Single acting push type

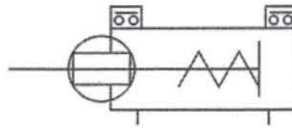

Specifications

● Solid state type

Item	Model	ZE135	ZE155	ZE235	ZE255
Sensor type		DC 2-wire type	DC 3-wire type	DC 2-wire type	DC 3-wire type
Lead wire direction		Horizontal		Vertical	
Power supply voltage		—	DC4.5~28V	—	DC4.5~28V
Load voltage		DC10~28V	DC4.5~28V	DC10~28V	DC4.5~28V
Load current		4~20mA (at 25°C, 10mA at 60°C)	50mA MAX.	4~20mA (at 25°C, 10mA at 60°C)	50mA MAX.
ON current consumption		—	10mA MAX. (DC24V)	—	10mA MAX. (DC24V)
Internal voltage drop ^{note 1}		4.5V MAX.	0.5V MAX. (Less than 10V at 20mA)	4.5V MAX.	0.5V MAX. (Less than 10V at 20mA)
Leakage current		1mA MAX. (DC24V, 25°C)	50 μA MAX. (DC24V)	1mA MAX. (DC24V, 25°C)	50 μA MAX. (DC24V)
Delay time		1ms MAX.			
Insulation resistance		100MΩ MIN. (At DC500V Megger between case and lead wire)			
Dielectric strength		AC500V (50/60Hz) 1min. (between case and lead wire)			
Shock resistance ^{note 2}		294m/s ² (30.0G) (Non repeated shock)			
Vibration resistance ^{note 2}		88.3m/s ² (9.0G) Total amplitude 1.5mm, 10~55Hz			
Environmental protection		IP67 IEC standard (JIS C0920)			
Indicator lamp		ON : Red LED			
Lead wire		PCCV insulated cable (2X0.15SQ) Brown/BlueX ℓ ^{note 3}	PCCV insulated cable (3X0.15SQ) Brown/Blue/BlackX ℓ ^{note 3}	PCCV insulated cable (2X0.15SQ) Brown/BlueX ℓ ^{note 3}	PCCV insulated cable (3X0.15SQ) Brown/Blue/BlackX ℓ ^{note 3}
Temperature range		32~140°F (0~60°C)			
Storage temperature		14~158°F (-10~70°C)			
Weight		15g (For lead wire length A : 1000mm)、35g (For lead wire length B : 3000mm)			

Note1 : Internal voltage drop depends on load current.

2 : Test procedures are our internal standards.

3 : Lead wire length A : 1000mm B : 3000mm

● Reed switch type

Item	Model	ZE101	ZE102	ZE201	ZE202
Sensor type		DC 2-wire type			
Lead wire direction		Horizontal		Vertical	
Load voltage		DC5~28V	AC85~115V (r.m.s)	DC5~28V	AC85~115V (r.m.s)
Load current		40mA MAX.	20mA MAX.	5~40mA	5~20mA
Internal voltage drop ^{note 1}		10mV MAX. (at load current DC40mA)	3.0V MAX.	10mV MAX. (at load current DC40mA)	3.0V MAX.
Leakage current		0mA			
Delay time		1ms MAX.			
Insulation resistance		100MΩ MIN. (At DC500V Megger between case and lead wire)			
Dielectric strength		AC500V (50/60Hz) 1min. (between case and lead wire)			
Shock resistance ^{note 2}		294m/s ² (30.0G) (Non repeated shock)			
Vibration resistance ^{note 2}		88.3m/s ² (9.0G) Total amplitude 1.5mm, 10~55Hz, Resonance frequency 2750±250Hz			
Environmental protection		IP67 IEC standard (JIS C0920)			
Indicator lamp		None	ON : Red LED	None	ON : Red LED
Lead wire		PCCV insulated cable (2X0.15SQ) Brown/BlueX ℓ ^{note 3}			
Temperature range		32~140°F (0~60°C)			
Storage temperature		14~158°F (-10~70°C)			
Sensor switch protection		Required (For more details, refer to page 19)			
Weight		15g (For lead wire length A : 1000mm)、35g (For lead wire length B : 3000mm)			

Note1 : Internal voltage drop depends on load current.

2 : Test procedures are our internal standards.

3 : Lead wire length A : 1000mm B : 3000mm

Order Code

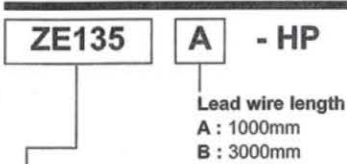

Sensor Switch model

ZE135 - Two lead wires, Hall effect type with indicator	DC10~28V	Horizontal lead wire type	ZE155 - Three lead wires, Hall effect type with indicator	DC4.5~28V	Horizontal lead wire type
ZE235 - Two lead wires, Hall effect type with indicator	DC10~28V	Vertical lead wire type	ZE255 - Three lead wires, Hall effect type with indicator	DC4.5~28V	Vertical lead wire type
ZE101 - Two lead wires, Reed switch type w/o indicator	DC5~28V AC85~115V	Horizontal lead wire type	ZE102 - Two lead wires, Reed switch type with indicator	DC10~28V AC85~115V	Horizontal lead wire type
ZE201 - Two lead wires, Reed switch type w/o indicator	DC5~28V AC85~115V	Vertical lead wire type	ZE202 - Two lead wires, Reed switch type with indicator	DC10~28V AC85~115V	Vertical lead wire type

Circuitry

● Hall effect type

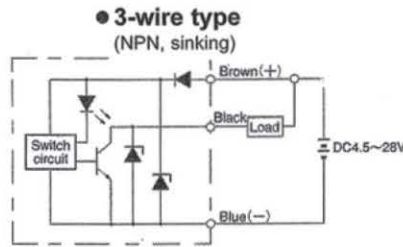
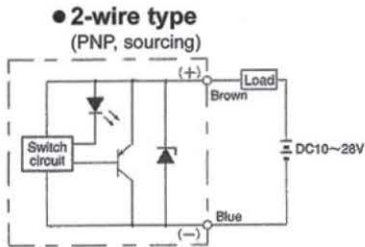

● Reed switch type

● Without indicator

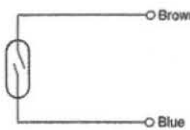

● With indicator

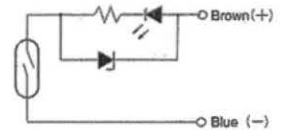

Recommended Protection for Reed Switch Sensors

● Use with inductive loads (magnetic relays, etc.)

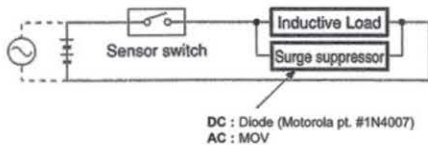

● Use with long lead wires (>32'/10m) between sensor switch and load

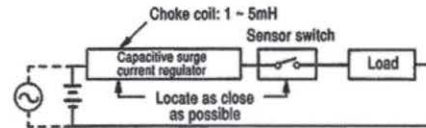

Sensor Switch Operating Range - Response Differential - Maximum Sensing Locations

● Operating range : ℓ

The distance the piston (magnet) travels in one direction while the switch is in the ON position.

● Response differential : C

The distance between the point where the piston (magnet) turns the switch ON in one direction, and the point where the switch turns OFF as the piston (magnet) travels in the opposite direction.

● Mounting surface of the sensor switches

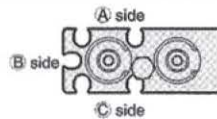

● Solid state type

Item	Mounting surface	Bore size				
		3/8 (10)	5/8 (16)	3/4 (20)	1 (25)	1 1/4 (32)
Operating range : ℓ	A side, C side	0.098~0.236(2.5~6)				
	B side	.098-.157(2.5~4)	0.078-.177(2~4.5)	.098-.217(2.5~5.5)	0.197-.472(5~12)	
Response differential : C	---	Less than .039(1.0)	Less than .047(1.2)	Less than .059(1.5)	Less than .079(2.0)	
Maximum sensing location ^①	---	0.236(6)				

Note : The chart indicates reference value.

● Reed switch type

Item	Mounting surface	Bore size				
		3/8 (10)	5/8 (16)	3/4 (20)	1 (25)	1 1/4 (32)
Operating range : ℓ	---	0.236~0.335(6~8.5)	0.236~0.315(6~8)	0.276~0.374(7~9.5)	0.472~0.650(12~16.5)	
Response differential : C	---	Less than .059(1.5)				
Maximum sensing location ^①	---	0.394(10)				

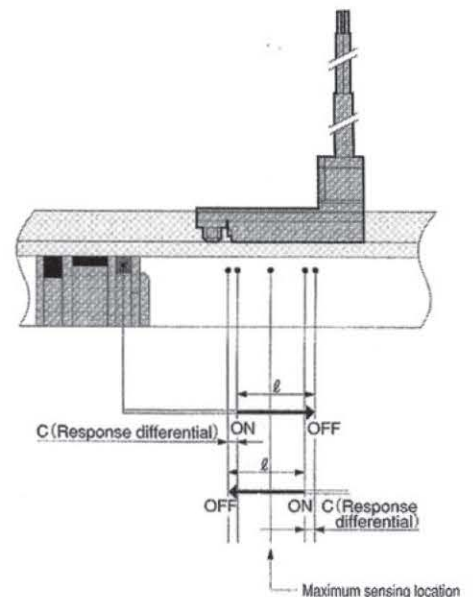

Sensor Switch Mounting Surfaces

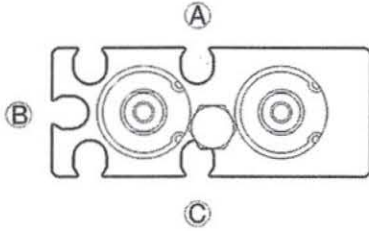

Rod side and head side stroke end can be detected when mounting sensor switches on one or two of the A, B or C sides. Drawing is showing the view from rod side.

Sensor Switch Mounting

- Loose screw. Slide sensor switch along groove on cylinder body.
- Orient switch to desired location and tighten screw. Maximum torque for tightening screw is 0.1N·m~0.2N·m{1kgf·cm~2kgf·cm}.

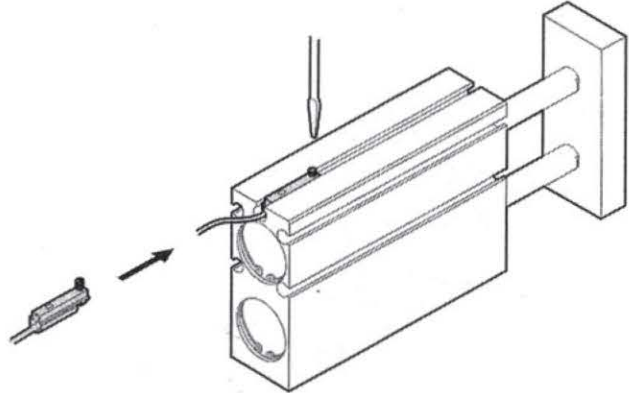

● Double acting type

- Direction of the lead wire is toward the head side

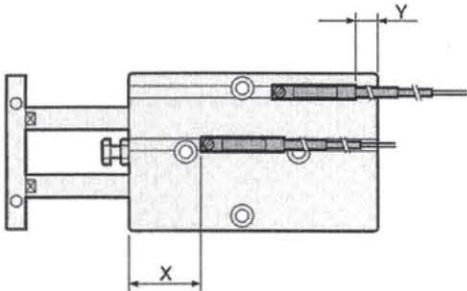

- Direction of the head side switch lead wire only is toward the rod side

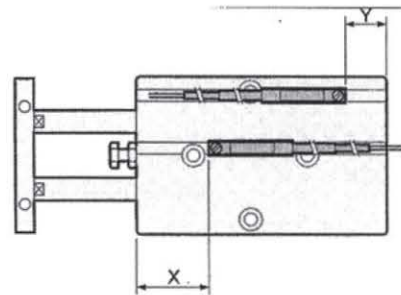

● Single acting push type

- Direction of the lead wire is toward the head side

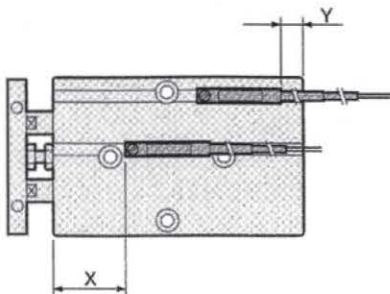

- Direction of the head side switch lead wire only is toward the rod side

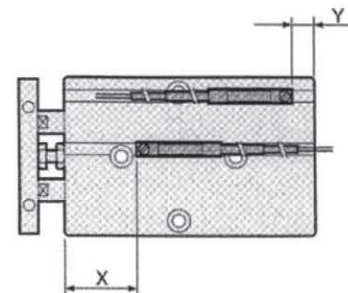

●2-wire type

●Basic connection

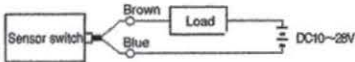

●Connection to relay

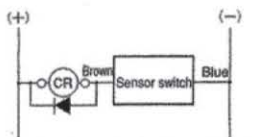

AND connection, OR connection

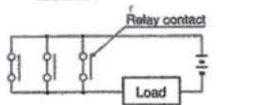
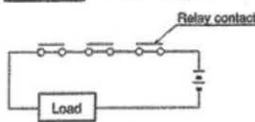
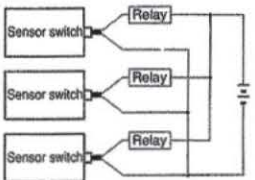

●Connection to solenoid

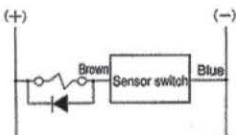

●Connection to sequencer

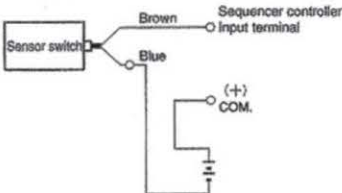

●3-wire type

●Basic connection

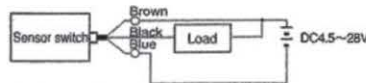

●Connection to relay

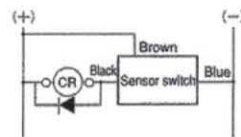

AND connection, OR connection

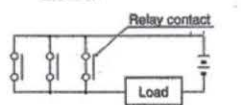
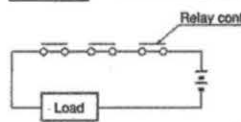
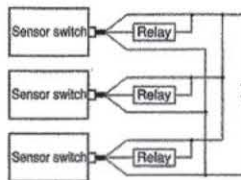

●Connection to solenoid

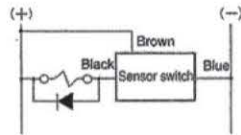

●Connection to sequencer

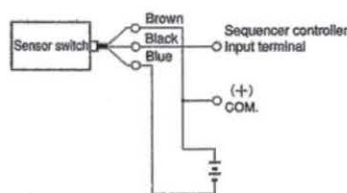

●Connection to TTL

Separate connection

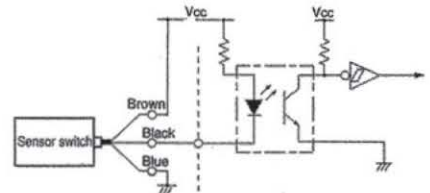

Direct connection

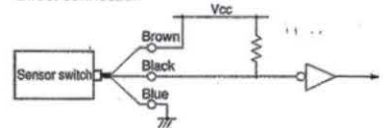

●C-MOS connection

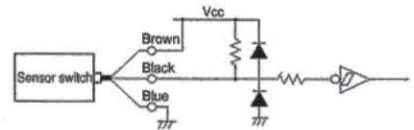

- Note 1. Follow wire color code for proper connection; otherwise switch will malfunction or may be damaged.
 2. Solid state 2-wire type sensor switches should not be connected to TTL or C-MOS.
 3. Use of a surge protection diode is recommended for inductive loads such as relays.

4. For OR Connection, it is possible to directly connect outputs of sensor switches (for example, two brown wires). But the amount of leakage current will increase proportionally by the number of sensor switches. Therefore, be cautious against load return failure.
 5. Avoid using sensor switches in places where other strong magnetic forces are present or near large current such as power lines (switches are actuated by magnetism).
 6. Use care with lead wires. Do not pull or bend lead wires excessively.
 7. Do not use sensor switches in areas where chemically active agents or gas are present.
 8. Consult us before using sensor switches in oily or wet surroundings.

INSTALLATION

ALLOWABLE LATERAL LOAD

The lateral load for the rod square plate should be below the following curves.

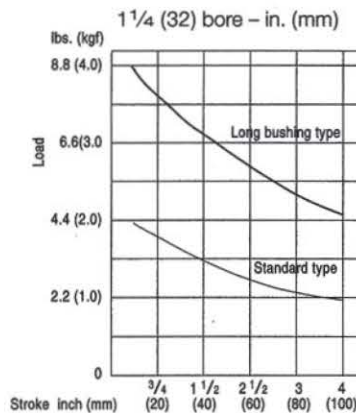
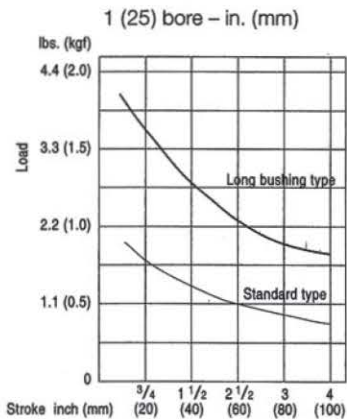
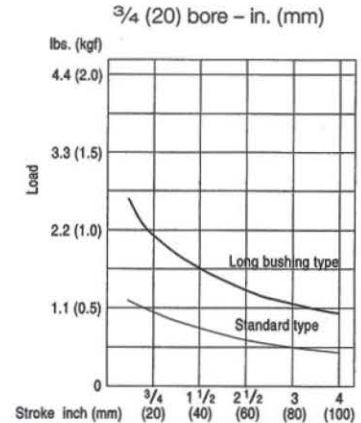
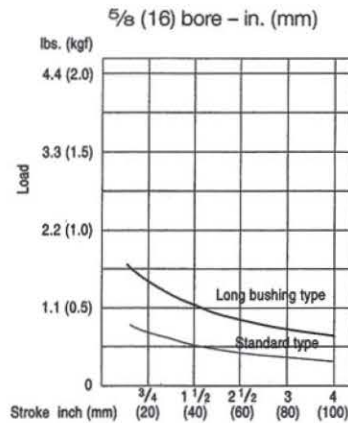
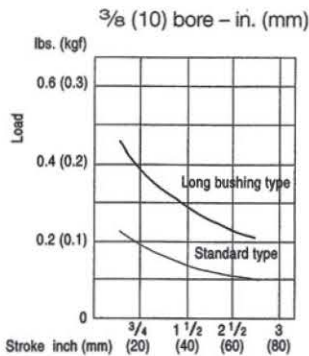

ALLOWABLE ECCENTRICITY

Eccentricity of the rod square plate, without load, is allowable within the following range.

- Standard type
- Long bushing type

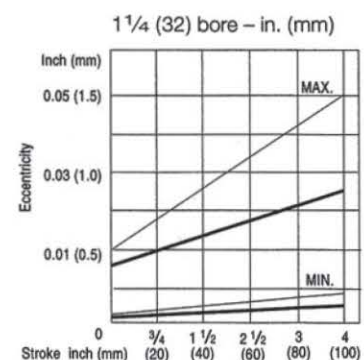
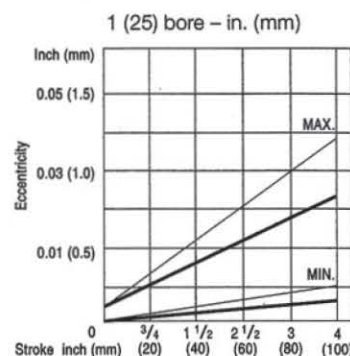
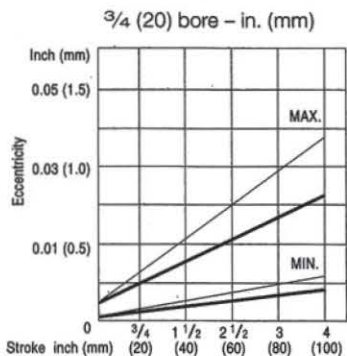
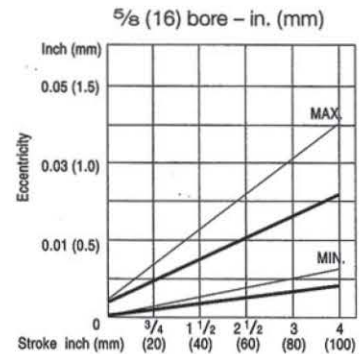
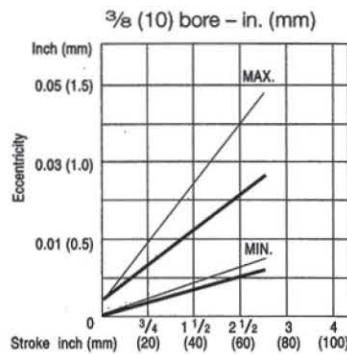

TECHNICAL TIPS & PRECAUTIONS

INSTALLATION AND ADJUSTMENT

INSTALLATION

1. Mount cylinders in any direction; however, the mounting surface must be flat. If there is bending or twisting of the cylinder during mounting, cycle life may be diminished, the cylinder may leak, or it may not operate properly.
2. Ensure that no damage occurs to the mounting surface, as this may adversely affect surface flatness.
3. Cylinder rod square plate hex bolts must be secure before using cylinder.

ADJUSTING CYLINDER STROKE

The stroke of Humphrey Twin Rod Cylinders can be adjusted within a range of -0.197 to 0 inches (-5 to 0mm), except for HTDAK suffix "-HL" models (adjusting the stroke on these cylinders renders the End Keep inoperable).

To adjust stroke, loosen locknut and turn stopper bolt counterclockwise to obtain new stroke length. After adjustment has been made, re-tighten the locknut. Do not over-tighten.

TIPS FOR END KEEP CYLINDERS

1. Use of a 2-position, 4- or 5-port valve is recommended. Do not use 3-position valves in which the center position has delivery ports open to exhaust.
2. For controlling cylinder speed, use a meter-out type flow control. The cylinder's locking mechanism may not release if a meter-in type flow control is used.
3. Supply pressure must be at least 22 psig (1.5 kgf/cm²).

CAUTIONS

1. Do not admit compressed air to the supply port adjacent to the locking mechanism if the opposite supply port has been previously exhausted. This may cause unintended actuation; the piston rod may suddenly extend or retract. This could lead to personal injury, and/or damage the cylinder or adjacent equipment.
2. Before commencing operation of the cylinder after it has been completely exhausted (such as prior to start up, or after an emergency stop), first pressurize the supply port opposite the one nearest the locking mechanism.

MANUAL OPERATION OF LOCKING MECHANISM

1. For manual operation, insert a 4-40 UNC threaded screw into the lock piston opening in the mechanism. Thread the screw into the lock piston about three turns. Pull on the screw to disengage the lock piston. To maintain the manual override, shoulder a 4-40 locknut against the cylinder. This maintains release of the lock piston, and frees-up hands.

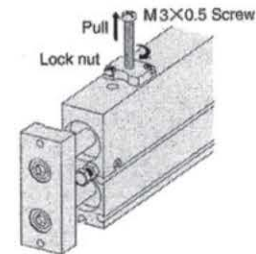

CAUTIONS

1. Do not release locking mechanism when a load is present on the piston rods. This may cause unintended operation which could result in injury to personnel, or damage to equipment. When releasing the locking mechanism, be sure that air is supplied to the port opposite the port adjacent to the locking mechanism, then release mechanism.
2. If difficulty is experienced releasing the locking mechanism manually, the cause may be interference between the lock piston and the piston rods. In this case, supply air to the port opposite the one located adjacent to the locking mechanism, and release the lock as described above.
3. If contaminants (water, oil, dirt or other debris) enter the manual override opening, the locking mechanism may not pull out sufficiently to disengage the piston rod. Provide adequate protection to avoid this condition.

Mounting and Stroke Adjustment

Mounting

1. Cylinders can be mounted in any direction; however, mounting surface must be flat. If bending or twisting of the cylinder occurs during mounting, cylinder performance may be interfered with, the cylinder may leak, or improper operation may occur.
2. Do not damage the mounting surface with scratches or dents, as this may affect surface flatness.
3. Washers are used with the hex bolts on the cylinder rod front plate. Make sure bolts are tight before using the cylinder.

Stroke adjustment

The stroke of the twinrod cylinders can be easily adjusted within a range of -5 to 0mm. To adjust stroke, turn stopper bolt counterclockwise to obtain shorter stroke length. After adjustments have been made, re-tighten the lock nut. Do not over tighten past the standard location. It is impossible to adjust stroke past the standard location.

Cylinder speed

Cylinders should not be operated faster than 500mm per second. (It can be adjusted using speed controller.) When operating cylinders rapidly (more than 500mm/s), prevent direct shock by installing an external stroke limiting device such as an external stopper. If an external stopper can not be installed, please contact us.

Sensor Switches

1. Standard cylinders have built-in magnets for the operation of sensor switches. When sensor switches are mounted on cylinders, they become sensor cylinders.
2. Mount the sensor switch in the mounting grooves on the cylinder body by locating the sensor switch screw toward the cylinder piping ports.

General Cautions

Fluid

1. Use compressed air as fluid. Consult us if using any other fluid.
2. Air should be clean, dry, uncontaminated and contain no oil particles. An air filter (filtration ratio of less than 40 microns) should be installed near the cylinder and valves. Periodically remove, drain, clean or replace filter element. If dust is present in the cylinder, it may result in malfunction.

Lubrication

No lubrication is required. However, if lubrication is used, apply Class 1 turbine oil (ISO VG32) or equivalent. Do not use spindle oil or machine oil.

Atmosphere

1. When operating in ambient conditions such as excessive dust or exposure to water or oil particles, install appropriate protective devices such as a cover.
2. When media or the atmosphere contains the following substances, it should not be used: organic solvents, phosphoric acid ester-type machine oil, sulfurous acid gas, chlorine gas, or acids.