

Appendix A: Figures

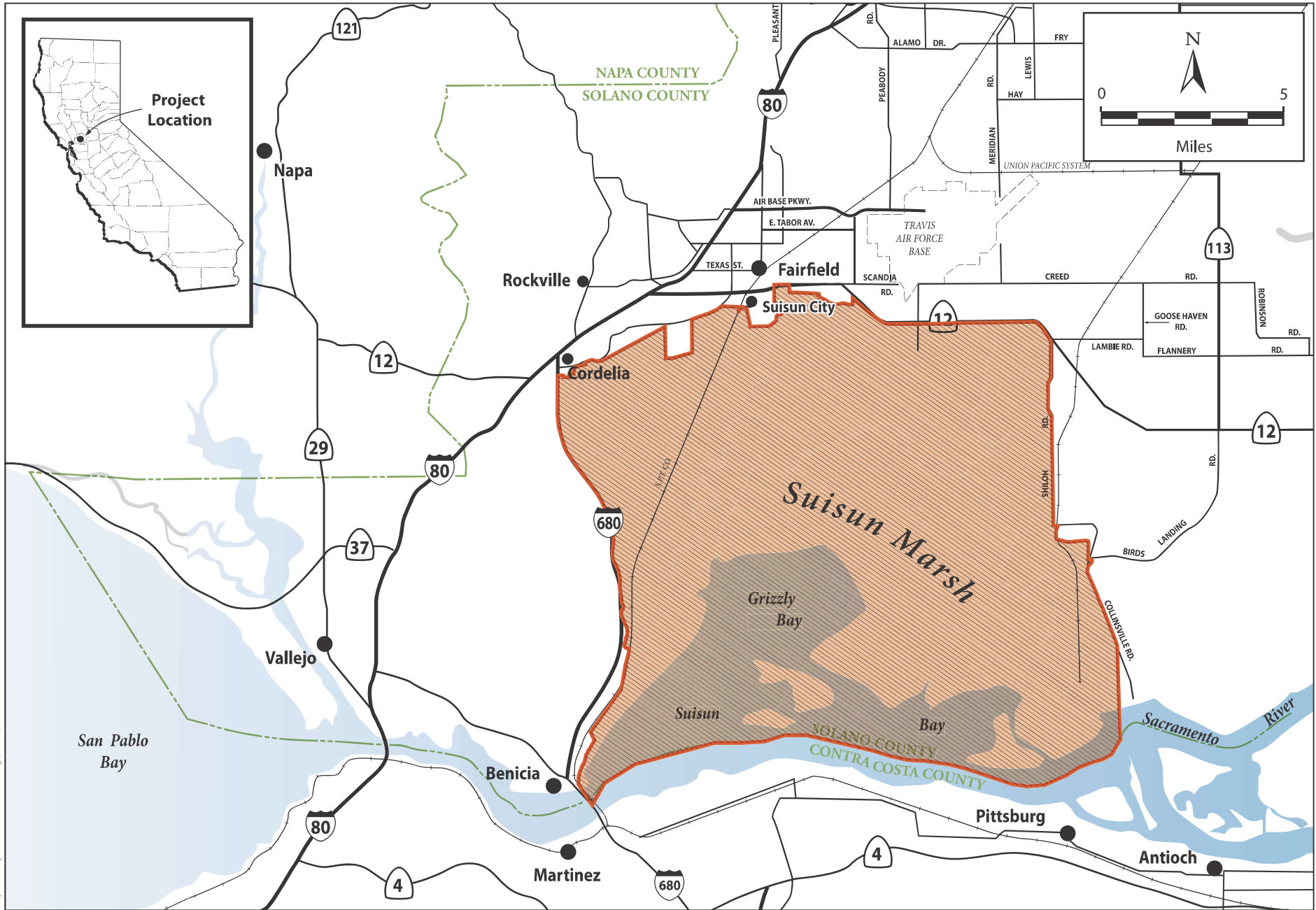

Graphics/Projects/0688806 Permitting (2-2012).JD

Figure 1
Project Location

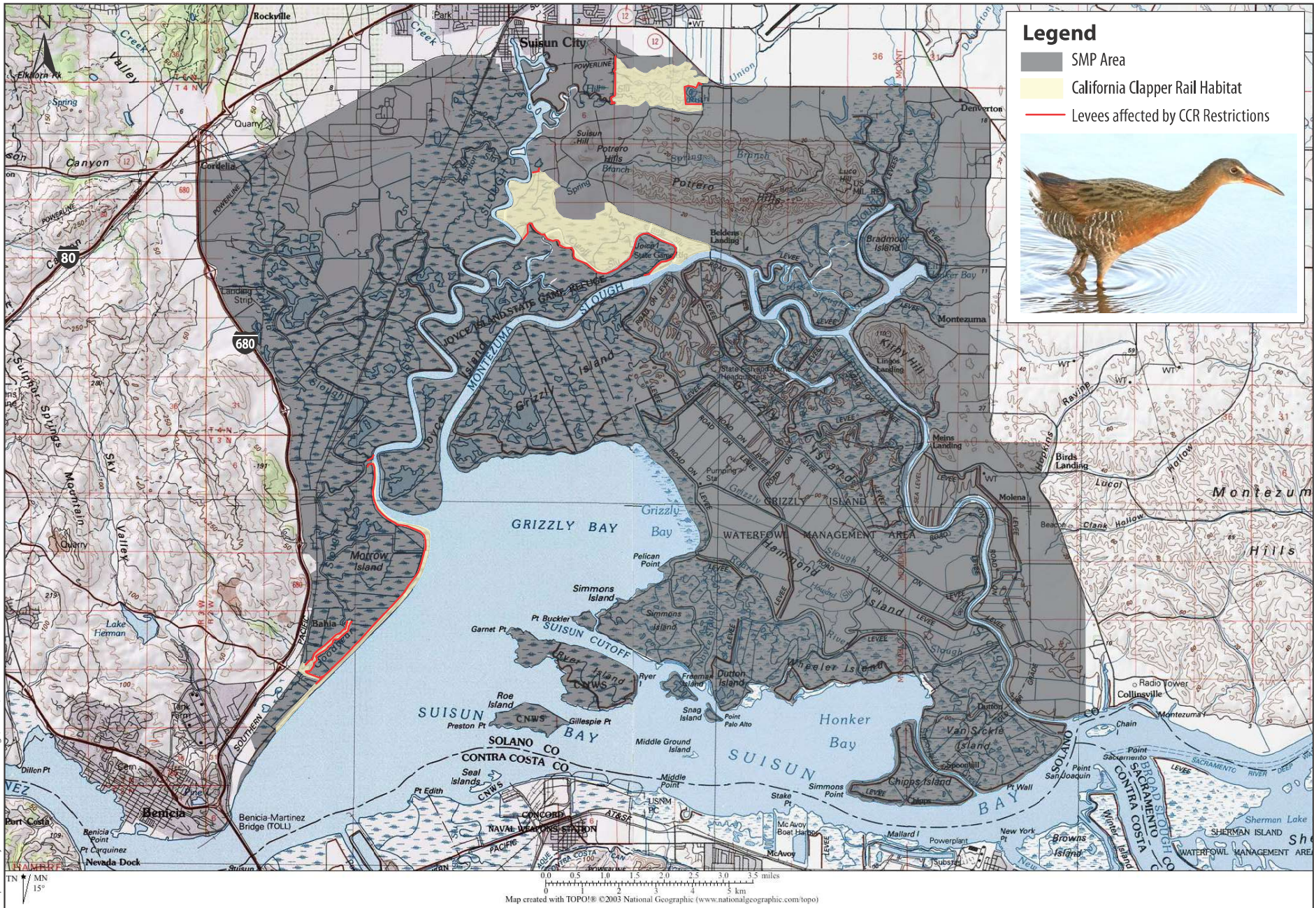

Graphics/Projects/06888.06 Permitting (2-2012) JD

Figure 2
California Clapper Rail Habitat in Suisun Marsh

Appendix B: Cross Sections

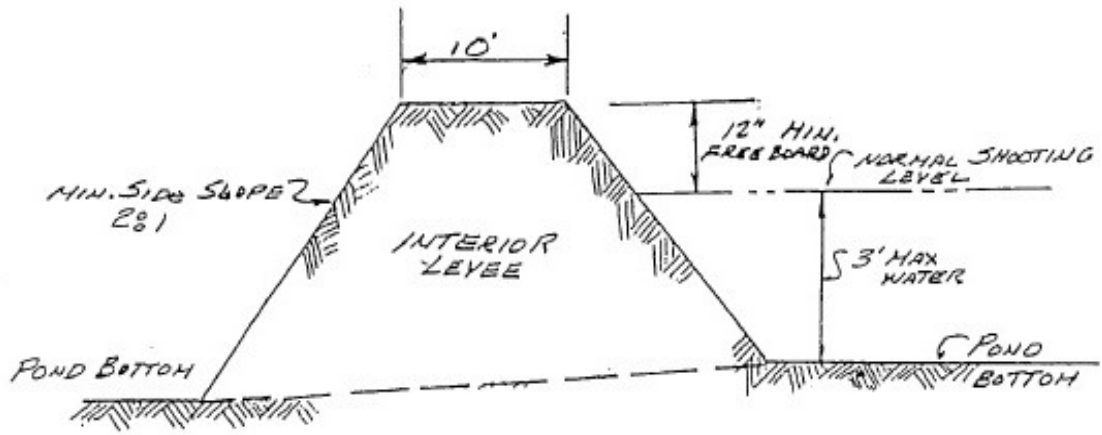

SECTION
INTERIOR LEVEE
NO SCALE

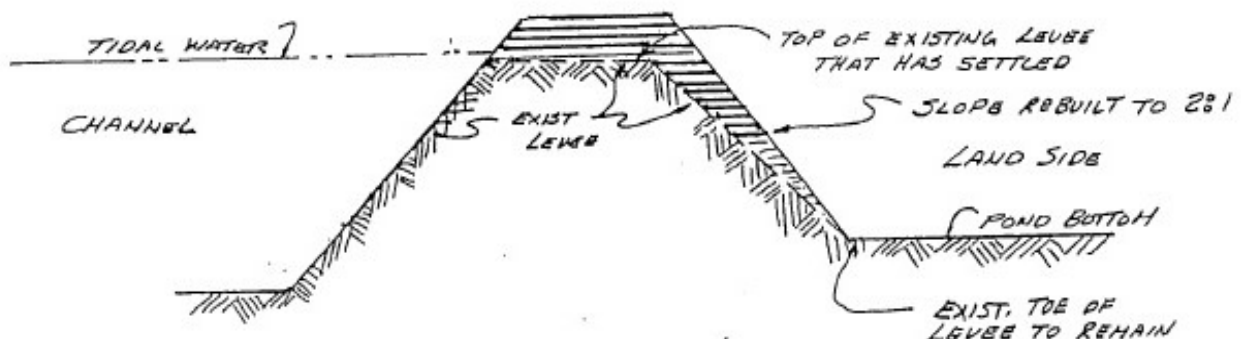

TOPPING OF EXIST. LEVEE
AND REPAIRING SIDE SLOPES
NO SCALE
WITH SETTLEMENT & EROSION

Purpose: To conduct annual wetland maintenance activities to protect and enhance Suisun Marsh managed wetlands.

Property owners:

1. Suisun Resource Conservation District (SRCD) and private landowners
2. California Department of Fish & Wildlife (DFW)
3. California Department of Water Resources (DWR)

Typical Cross Sections

No scale
Datum: MLLW
Location: Suisun Marsh – near Suisun City, Solano County, State of California
At: Individually owned State and private properties

- Application by:
1. SRCD: 2544 Grizzly Island Rd, Suisun, CA. 94585
 2. DFW: 7329 Silverado Trail, Napa, CA. 94558
 3. DWR: 3500 Industrial Blvd., West Sacramento, CA. 95691
 4. U.S. Bureau of Reclamation: 801 I Street, Suite 140, Sacramento, CA. 95814

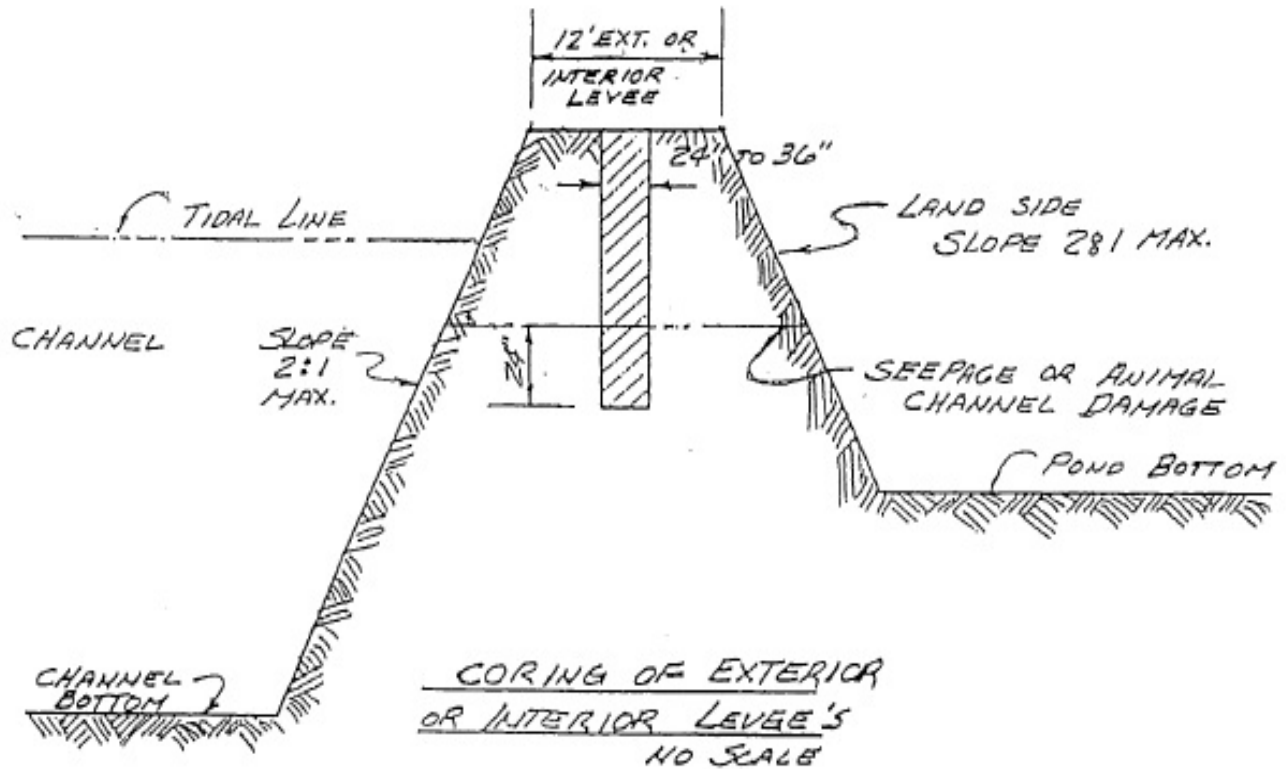
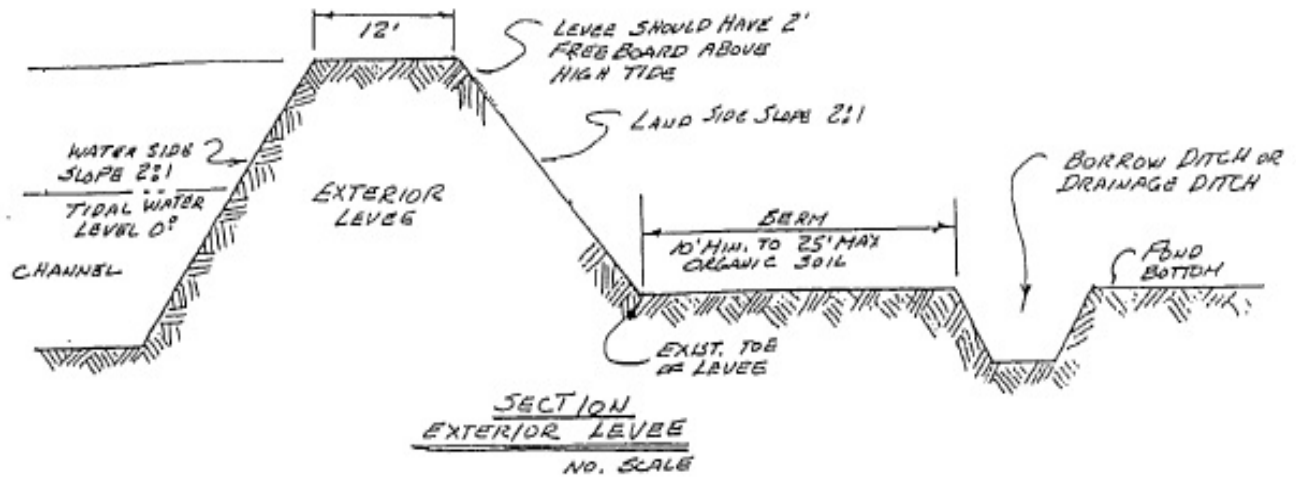

Purpose: To conduct annual wetland maintenance activities to protect and enhance Suisun Marsh managed wetlands.

Property owners:

1. Suisun Resource Conservation District (SRCD) and private landowners
2. California Department of Fish & Wildlife (DFW)
3. California Department of Water Resources (DWR)

Typical Cross Sections

No scale

Datum: MLLW

Location: Suisun Marsh – near Suisun City, Solano County, State of California
At: Individually owned State and private properties

Application by:

1. SRCD: 2544 Grizzly Island Rd, Suisun, CA. 94585
2. DFW: 7329 Silverado Trail, Napa, CA. 94558
3. DWR: 3500 Industrial Blvd., West Sacramento, CA. 95691
4. U.S. Bureau of Reclamation: 801 I Street, Suite 140, Sacramento, CA. 95814

Sheet 2 of 6 Date: 6/5/2017

Cross Section of Primary Ditch

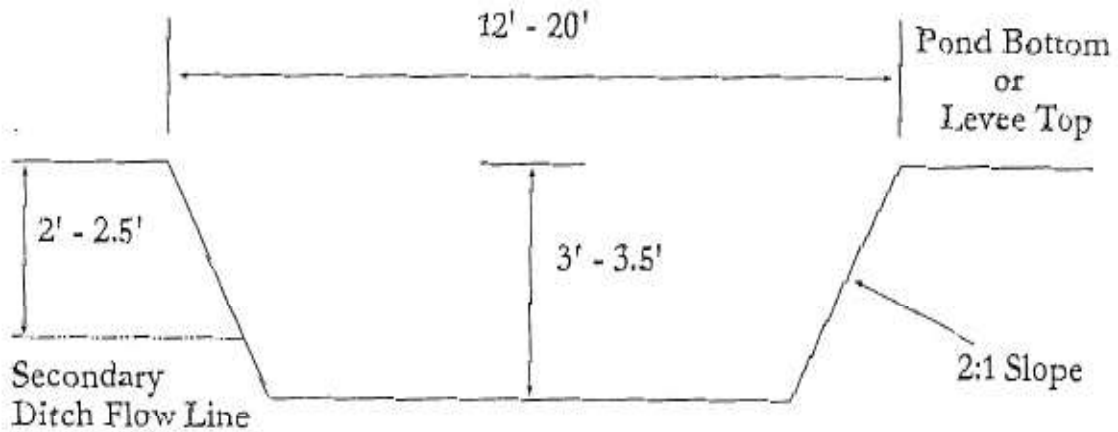

Cross Section of Secondary Ditch

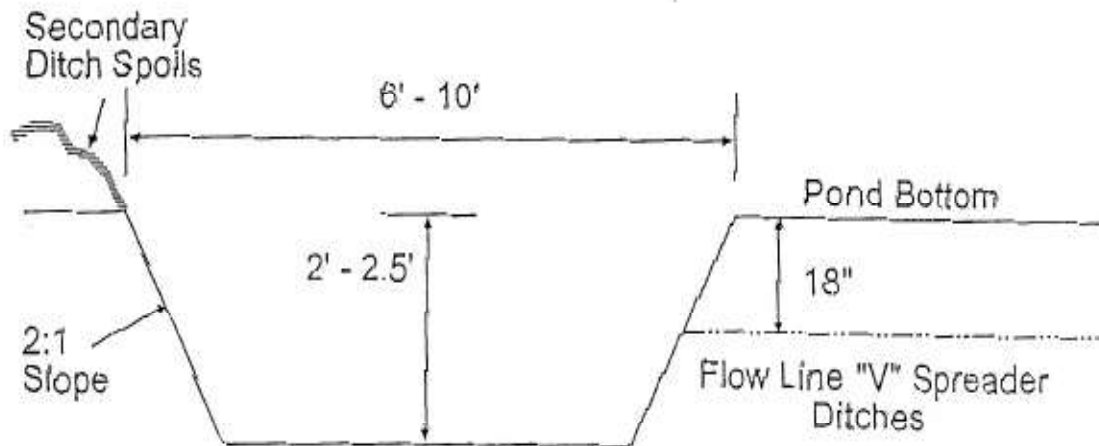

Purpose: To conduct annual wetland maintenance activities to protect and enhance Suisun Marsh managed wetlands.

Property owners:

1. Suisun Resource Conservation District (SRCD) and private landowners
2. California Department of Fish & Wildlife (DFW)
3. California Department of Water Resources (DWR)

Typical Cross Sections

No scale
Datum: MLLW

Location: Suisun Marsh – near Suisun City, Solano County, State of California
At: Individually owned State and private properties

Application by:

1. SRCD: 2544 Grizzly Island Rd, Suisun, CA. 94585
2. DFW: 7329 Silverado Trail, Napa, CA. 94558
3. DWR: 3500 Industrial Blvd., West Sacramento, CA. 95691
4. U.S. Bureau of Reclamation: 801 I Street, Suite 140, Sacramento, CA. 95814

Sheet 3 of 6 Date: 6/5/2017

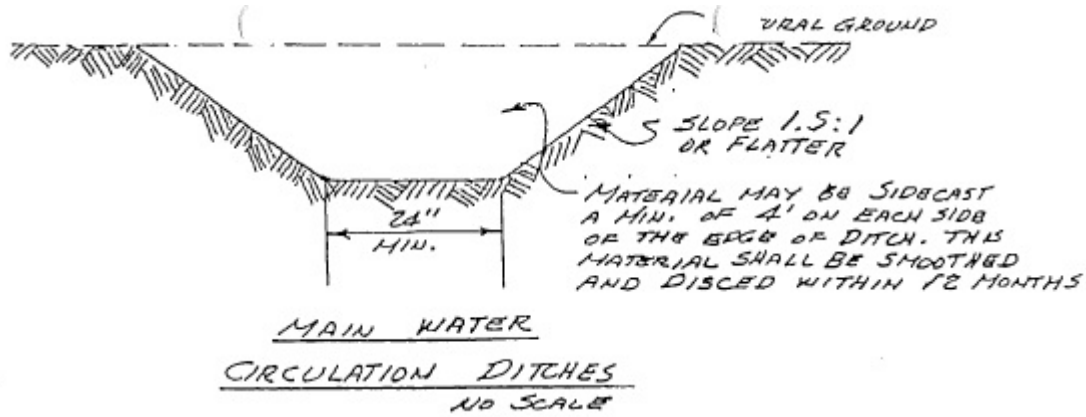

Cross Section "V" Spreader Ditch

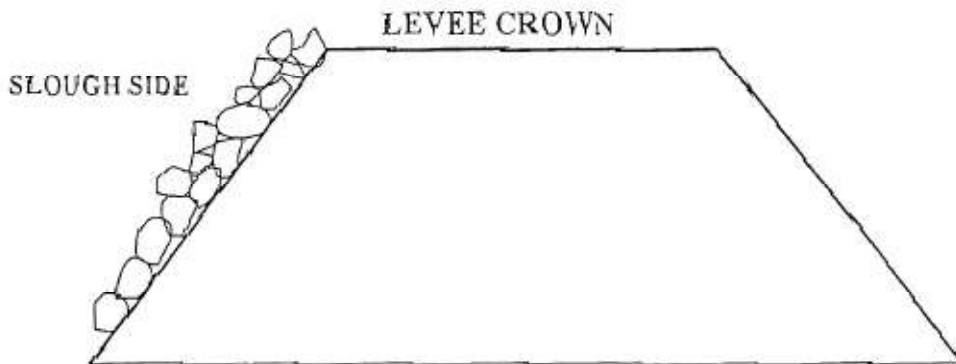
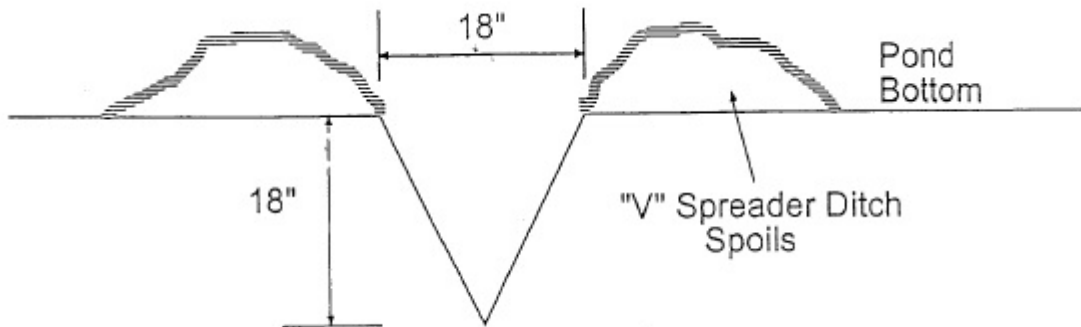

Typical Levee Section For the Replacement of Rip-Rap

Purpose: To conduct annual wetland maintenance activities to protect and enhance Suisun Marsh managed wetlands.

Property owners:

1. Suisun Resource Conservation District (SRCD) and private landowners
2. California Department of Fish & Wildlife (DFW)
3. California Department of Water Resources (DWR)

Typical Cross Sections

No scale
Datum: MLLW
Location: Suisun Marsh – near Suisun City, Solano County, State of California
At: Individually owned State and private properties

Application by:

1. SRCD: 2544 Grizzly Island Rd, Suisun, CA. 94585
2. DFW: 7329 Silverado Trail, Napa, CA. 94558
3. DWR: 3500 Industrial Blvd., West Sacramento, CA. 95691
4. U.S. Bureau of Reclamation: 801 I Street, Suite 140, Sacramento, CA. 95814

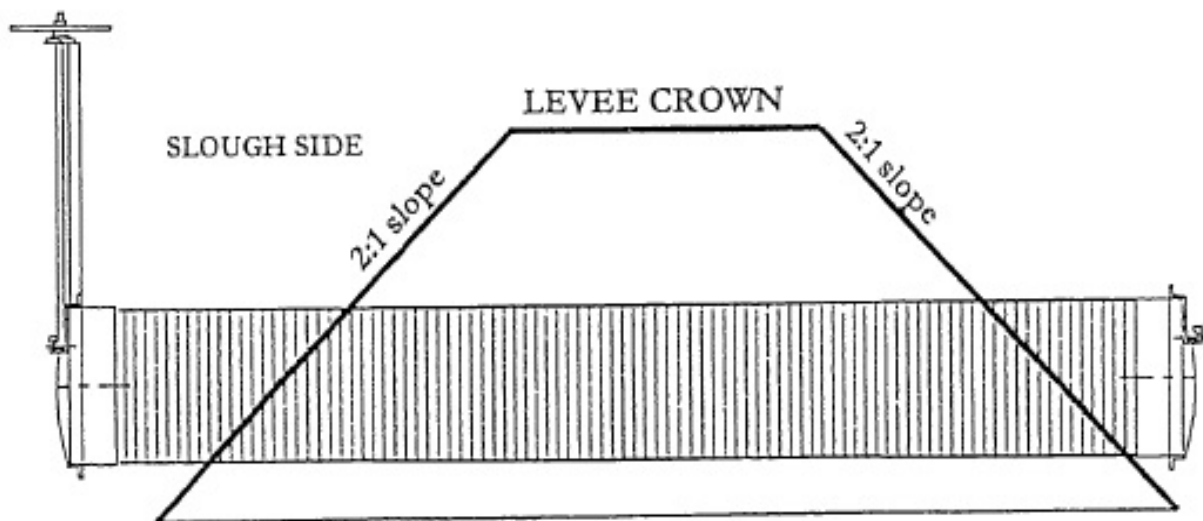

Typical Levee Section For a Flood Gate

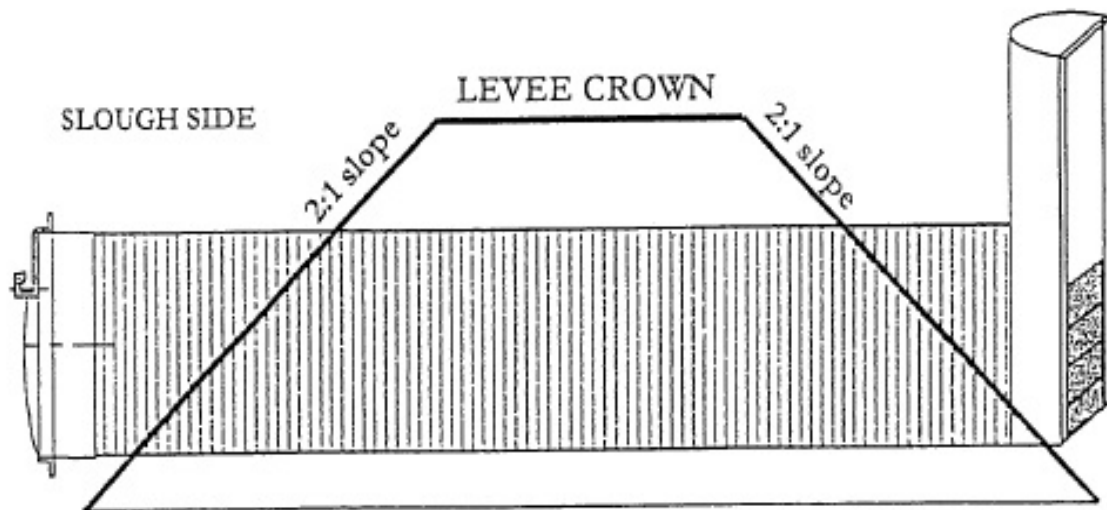

Typical Levee Section For a Drain Gate

Purpose: To conduct annual wetland maintenance activities to protect and enhance Suisun Marsh managed wetlands.

Property owners:

1. Suisun Resource Conservation District (SRCD) and private landowners
2. California Department of Fish & Wildlife (DFW)
3. California Department of Water Resources (DWR)

Typical Cross Sections

No scale

Datum: MLLW

Location: Suisun Marsh – near Suisun City, Solano County, State of California
At: Individually owned State and private properties

Application by:

1. SRCD: 2544 Grizzly Island Rd, Suisun, CA. 94585
2. DFW: 7329 Silverado Trail, Napa, CA. 94558
3. DWR: 3500 Industrial Blvd., West Sacramento, CA. 95691
4. U.S. Bureau of Reclamation: 801 I Street, Suite 140, Sacramento, CA. 95814

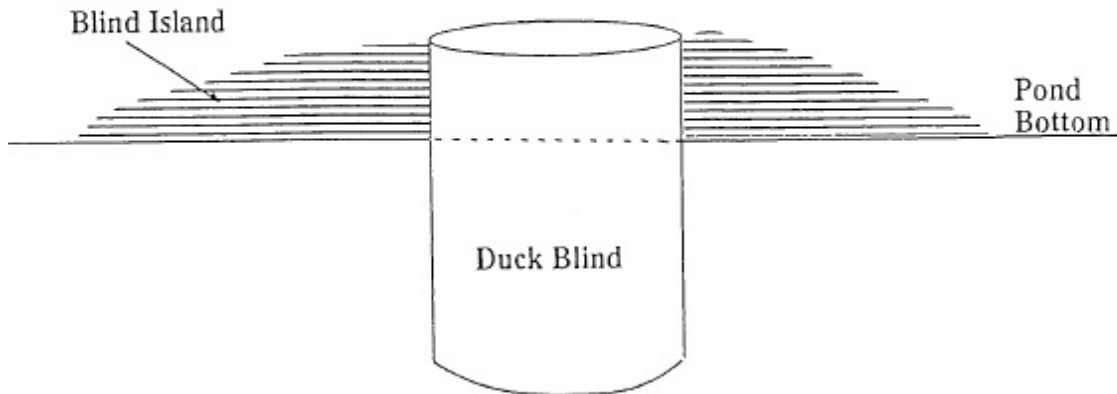
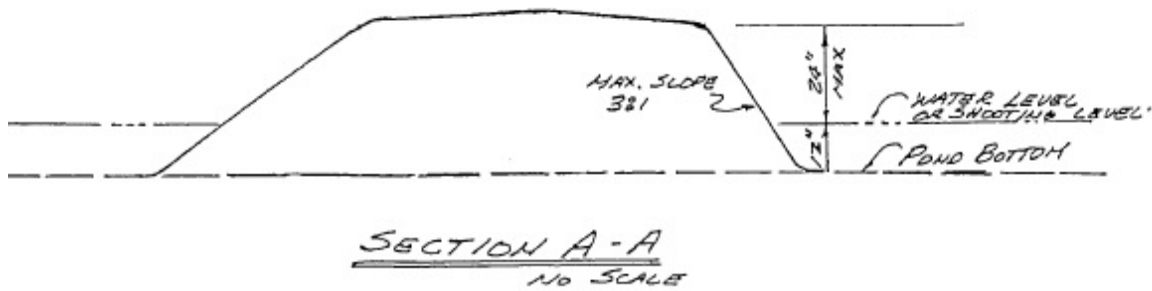
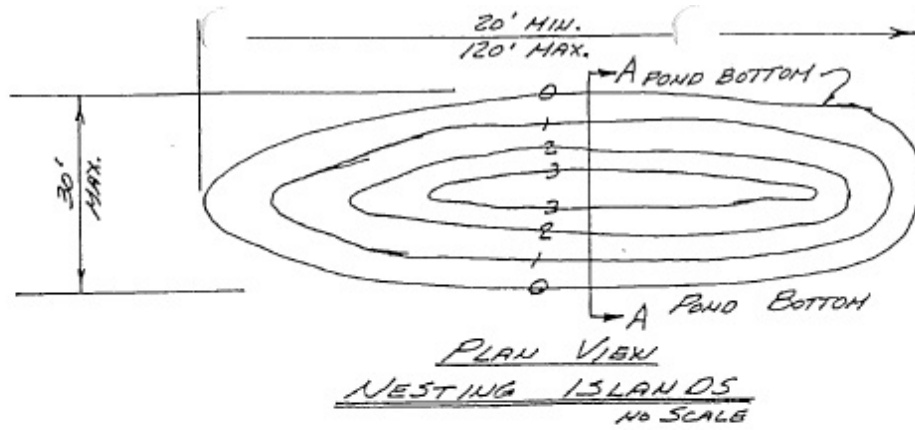

Typical Duck Blind and Blind Island Cross Section

Purpose: To conduct annual wetland maintenance activities to protect and enhance Suisun Marsh managed wetlands.

Property owners:

1. Suisun Resource Conservation District (SRCD) and private landowners
2. California Department of Fish & Wildlife (DFW)
3. California Department of Water Resources (DWR)

Typical Cross Sections

No scale

Datum: MLLW

Location: Suisun Marsh – near Suisun City, Solano County, State of California
At: Individually owned State and private properties

Application by:

1. SRCD: 2544 Grizzly Island Rd, Suisun, CA. 94585
2. DFW: 7329 Silverado Trail, Napa, CA. 94558
3. DWR: 3500 Industrial Blvd., West Sacramento, CA. 95691
4. U.S. Bureau of Reclamation: 801 I Street, Suite 140, Sacramento, CA. 95814

Sheet 6 of 6 Date: 6/5/2017

Appendix C: Inspection Forms

2017 PRE-INSPECTION FORM
SRCD'S USACE WETLANDS MAINTENANCE PERMIT APPLICATION
FOR EXTERIOR PIPE/EXTERIOR RIP-RAP PLACEMENT OR
REPLACEMENT

Club Name and Number: _____

Name of On-site monitor: _____ Date: _____

On-site monitor affiliation (circle one): SRCD / DFW / Landowner / Contractor / Agent

Work activity applied for (Work # and Type of Work): _____

Corps authorization date (mm/dd/yy): _____ Corps File Number: _____

Is a headwall or bulkhead present on the tidal side of levee?: Yes No

If yes, no plant inspection necessary. If no, plant inspection necessary (see bottom of page).

Date of anticipated work commencement (mm/dd/yy): _____

15 day notice to NMFS: Yes No Return receipt received from NMFS: Yes No

Date NMFS notified (mm/dd/yy): _____

Were site conditions identified during pre-inspection that could adversely affect salmonids, green sturgeon, or their habitat? Yes No If yes explain condition below:

Did NMFS request a site visit?: Yes No Date scheduled (mm/dd/yy): _____

Were pre-construction photos of worksite taken? Yes No

If replacing water control structures, were protected plants identified (except for when a headwall is present) and for all installations of new water control structures?

Yes No If yes, check protected plant species below and follow guidelines of RGP 3 (File 2012-00258N) page 5:

soft bird's beak (<i>Cordylanthus mollis ssp. Mollis</i>)	Suisun Marsh aster (<i>Aster lentus</i>)
valley spearscale (<i>Atriplex joaquiniana</i>)	alkali milk-vetch (<i>Astragalus tener</i>)
hispid bird's beak (<i>Cordylanthus mollis ssp. Hispidus</i>)	delta tule pea (<i>Lathyrus jepsonii var. jepsonii</i>)
Mason's lilaepsis (<i>Lilaeopsis masonii</i>)	heartscale (<i>Atriplex cordulata</i>)
Suisun thistle (<i>Cirsium hydrophilum var. hydrophilum</i>)	brittlescale (<i>Atriplex depressa</i>)
salt marsh bird's beak (<i>Cordylanthus maritimus ssp. Maritimus</i>)	

**2017 EXTERIOR PIPE REPLACEMENT
DURING WORK CONSTRUCTION INSPECTION FORM
SRC'D'S USACE WETLANDS MAINTENANCE PERMIT APPLICATION**

Club Name and Number: _____

Name of On-site monitor: _____ Date: _____

Work activity applied for (Work Activity # and Type of Work):

On-site monitor affiliation (circle one): SRC'D / DFW / Landowner / Contractor / Agent

Date of actual work commencement (mm/dd/yy): _____

Were during construction photos of worksite taken? Yes No

Review and check off compliance with all best management practices (BMP) for approved work activity.

Work must be completed within 3 hours prior to 3 hours following low tide (below mean high tide level).

If not checked, explain deviation from BMP for each work activity in notes below:

Pipe replacement for existing exterior drain, flood, or dual-purpose gate

No in-water work.

All work done at low tide.

New pipe pre-assembled before installation.

Pipe placed below depth of emergent vegetation.

Pipe replacement is not done in the rain.

Replacement will not change the existing use or diversion capacity.

Notes: _____

Was the construction equipment used for this project checked daily for fluid leaks? Yes No

If fluid leaks occurred, was the spill contained and removed from affected soils? Yes No

Was there a supply of erosion and pollution control materials onsite? Yes No

During construction project related activities – Discuss specific project performance or efficacy below:

Did NMFS attend a construction inspection? Yes No Name: _____

**2017 INSTALLATION OF NEW EXTERIOR DRAIN STRUCTURE
DURING WORK CONSTRUCTION INSPECTION FORM
SRC'D'S USACE WETLANDS MAINTENANCE PERMIT APPLICATION**

Club Name and Number: _____

Name of On-site monitor: _____ Date: _____

Work activity applied for (Work Activity # and Type of Work):

On-site monitor affiliation (circle one): SRC'D / DFW / Landowner / Contractor / Agent

Date of actual work commencement (mm/dd/yy): _____

Were during construction photos of worksite taken? Yes No

Review and check off compliance with all best management practices (BMP) for approved work activity. Work must be completed within 3 hours prior to 3 hours following low tide (below mean high tide level). If not checked, explain deviation from BMP for each work activity in notes below:

Installation of new exterior drain structure

- New drain placed where discharge channel already exists.
- New drain is installed where exterior levees have no emergent vegetation.
- No in-water work.
- Pipe placed at low tide.
- Pipe is pre-assembled to minimize work time.
- Pipe placed at a depth below emergent vegetation.

Notes: _____

Was the construction equipment used for this project checked daily for fluid leaks? Yes No

If fluid leaks occurred, was the spill contained and removed from affected soils? Yes No

Was there a supply of erosion and pollution control materials onsite? Yes No

During construction project related activities – Discuss specific project performance or efficacy below:

Did NMFS attend a construction inspection? Yes No Name: _____

**2017 REPLACEMENT OF EXISTING RIPRAP ON EXTERIOR LEVEE
DURING WORK CONSTRUCTION INSPECTION FORM
SRC'D'S USACE WETLANDS MAINTENANCE PERMIT APPLICATION**

Club Name and Number: _____

Name of On-site monitor: _____ Date: _____

Work activity applied for (Work Activity # and Type of Work):

On-site monitor affiliation (circle one): SRC'D / DFW / Landowner / Contractor / Agent

Date of actual work commencement (mm/dd/yy): _____

Were during construction photos of worksite taken? Yes No

Review and check off compliance with all best management practices (BMP) for approved work activity. Work must be completed within 3 hours prior to 3 hours following low tide (below mean high tide level). If not checked, explain deviation from BMP for each work activity in notes below:

Replace existing riprap on exterior levee

- Riprap only placed where previously existing riprap was present.
- Riprap is replaced in the minimum amount necessary.
- Riprap not placed on emergent vegetation.
- Riprap is placed during low tide.

Notes: _____

Was the construction equipment used for this project checked daily for fluid leaks? Yes No

If fluid leaks occurred, was the spill contained and removed from affected soils? Yes No

Was there a supply of erosion and pollution control materials onsite? Yes No

During construction project related activities – Discuss specific project performance or efficacy below:

Did NMFS attend a construction inspection? Yes No Name: _____

**2017 PLACEMENT OF RIPRAP ON EXTERIOR LEVEE
DURING WORK CONSTRUCTION INSPECTION FORM
SRC'D'S USACE WETLANDS MAINTENANCE PERMIT APPLICATION**

Club Name and Number: _____

Name of On-site monitor: _____ Date: _____

Work activity applied for (Work Activity # and Type of Work):

On-site monitor affiliation (circle one): SRC'D / DFW / Landowner / Contractor / Agent

Date of actual work commencement (mm/dd/yy): _____

Were during construction photos of worksite taken? Yes No

Review and check off compliance with all best management practices (BMP) for approved work activity. Work must be completed within 3 hours prior to 3 hours following low tide (below mean high tide level). If not checked, explain deviation from BMP for each work activity in notes below:

Replace existing riprap on exterior levee

- Emergent vegetation shall not be uprooted or displaced.
- Riprap not placed on emergent vegetation.
- Riprap is replaced in the minimum amount necessary.
- Riprap is placed during low tide.
- Integrative vegetation shall be applied where it is biologically appropriate

Was the construction equipment used for this project checked daily for fluid leaks? Yes No

If fluid leaks occurred, was the spill contained and removed from affected soils? Yes No

Was there a supply of erosion and pollution control materials onsite? Yes No

During construction project related activities – Discuss specific project performance or efficacy below:

Did NMFS attend a construction inspection? Yes No Name: _____

2017 POST-INSPECTION FORM
SRCD'S USACE WETLANDS MAINTENANCE PERMIT APPLICATION FOR
EXTERIOR PIPE/EXTERIOR RIP-RAP PLACEMENT OR REPLACEMENT

Club Name and Number: _____

Name of On-site monitor: _____ Date: _____

Work activity applied for (Work Activity # and Type of Work):

Were post-construction photos of worksite taken? Yes No

Date of actual work completion (mm/dd/yy): _____

Was pre-inspection completed? Yes No Was during inspection completed? Yes No

Post project related activities – Discuss specific post project performance or efficacy below:

Unanticipated project effects – Discuss any unanticipated project effects or unanticipated levels of project effects on salmonids, green sturgeon, and/or critical habitat; and a description of any and all measures taken to minimize those unanticipated effects and a statement as to whether or not the unanticipated effects had any affect on ESA-listed fish or critical habitat.

Appendix D: Property Owners

105	Sweetwater Gun Club	405	Sunrise Duck Club	532	Windmill Club	907	River Dog's Retreat
106	Ornbaun Kennels	406	Teal Duck Club	536	Marsh Club	908	Montezuma Ranch
108	Ambrose Ranch	407	Ibis Duck Club	537	Westwind Duck Club	909	Montezuma Wetlands
110	SM Hunting Preserve	409	Franciscan Marshview (408)	538	Merganser Farms	912	Honker Bay Farms
112	Suisun Farms	410	Gibson's Horseshoe	539	Westervelt / Tule Red	913	Ninelands
113	Tule Farms Club	411	Wildlands / Greenlodge	601	Can-Can Duck Club	915	Chipps Island (941)
116	Paoli Farms	412	Tule Hilton	604	DWR / Blacklock Ranch	916	A & B Duck Club
117	Mallard Inn Duck Club	413	Sprig A Teal	605	Wohn Hunting Club	917	Island Gun Club
118	Windsong Club (127)	414	Roos Duck Club	607	Ducks A- Go Go	918	Blue Winged Teal
120	WCHB / Tank Pond	415	Arnold Ranch	608	Shurshot Gun Club	926	Webfoot Duck Club
121	DBI / Forrest Pont	416	Tule Belle (417/421)	609	Black Dog Gun Club	927	Spoonbill Club
122	Gray Goose	418	Cygnus Gun Club	610	Westwind Duck Club	928	Hi Gunner Club
123	Walnut Creek Gun Club	419	Miramonte Duck Club	611	The Sleeping Pintail	929	Riverside Gun Club
124	Fat Hen	420	Antioch Golden Eye	613	Kirby Hills	930	Hit & Miss
125	North End Club	422	DFG Family Club W.	618	Hidden Cove	931	Delta Farms
126	Whistler Gun Club	423	The Family Gun Club	619	Schafer Farms (620)	932	Concord Farms
128	Mrs. Murphy's	424	Lower Joice Island	621	Stone Duck	933	Newell's Club
129	Grizzly Bay Preserve	425	California Farms	623	Frost Slough	940	Spinner Island
130	A.D. Seeno / Track	426	Tip End Gun Club	625	Pintail Ranch		
131	Jacksnipe Gun Club	501	The Island Club	627	Honegger Ranch		
132	Hollywood Duck Club	502	Grizzly Duck Club	631	DWR /Meins Landing		
133	Sheldrake Duck Club	503	Montezuma Gun Club	632	Sheriff Pond		
207	Venoco / Lang Tule Ranch	504	Gum Tree Farms	633	Boles Pond		
211	Wings Landing	505	Dead Duck Country Club	634	Grizzly Hilton		
213	Rush Ranch	506	Four Winds Duck Club	635	DWR / Blacklock Restore		
219	Volanti Duck Club	507	Grizz/Fizz Club	701	Good Year Club		
220	Joice Island Mallard Farms	508	Little West Wind Duck	702	Morrow Island Land Co		
302	Pickleweed Ponds	509	Garben Ranch	703	The Friendly Godfather		
303	Westervelt / Potrero Duck	510	The Honkers Club	704	Stone Enterprises		
304	CWA / Denverton (306)	513	Grizzly King Gun Club	705	Mulberry Land Co		
305	Marianno's	514	Tree Slough Farms	706	Mallard Haven Club		
311	Denverton Ranch	515	Long Point Land Co	707	Goodyear Land Dvlpmt		
317	Brass Button	516	Bent Barrel Duck Club	715	Fleetside Farms		
318	Brass Button II	517	Wild Turkey	721	Silver Sprig		
319	Stolte Farms	518	Mendoza Gun Club	802	Rich Island Gun Club		
320	Tule Meadows Club	520	Grizzly Ranch	803	St. Germain Duck Club		
321	Greenhead Duck Club	522	Peidmont Rod & Gun	804	Sprig Farm		
322	DWR / Overlook Club	525	Balboa Farms	805	Grey Island Gun Club (806)		
323	Ducks & R	526	Flatlander	807	Wheeler Island		
329	DWR / Flying D	527	Delta King	902	Wildland / Atlantis		
330	DWR / Wildwing Duck Club	528	Grizzly Fairview Farms	903	Blue Bird Club		
331	Tonnesen Ranch	529	Sprigsville Ranch	904	Wingnuts		
402	Golden Gate Duck Club	530	Bul-Rush Farms	905	Mallard Farms		
404	Cordelia Gun Club	531	Gang Bang Duck Club	906	Wreck Slough		

Appendix E: Exterior Levee Maintenance

RGP 3- Individual Ownership: Annual Exterior Levee Maintenance Volume Limitation

<i>Ownership number</i>	Club Name	USACE file number	Exterior Levee Linear Footage	Repair exterior existing levee (yds ³)
105	Sweetwater Gun Club	2000-253700N	3,373	5,060
106	Ornbaun Kennels	2000-252630N	0	0
110	Bolin Farming Co.	2016-00290N	1,022	1,533
112	Suisun Farms	2000-255870N	1,394	2,091
113	Tule Farms Club	2000-252800N	3,205	4,808
116	Paoli Farms	2013-00261N	1,936	2,904
117	Mallard Inn Duck Club	2000-251920N	10,831	16,247
118/127	Windsong Duck Club	2000-251800N	2,275	3,413
120	Tank Pond	2013-00262N	1,819	2,729
121	Forest Pond	2014-00129N	1,886	2,829
122	Grey Goose Duck Club	2014-00142N	1,618	2,427
123	Walnut Creek Gun Club	2000-251930N	17,466	26,199
124	Fat Hen Farms	2000-251940N	28,702	43,053
125	North End Duck Club	2000-253710N	18,382	27,573
126	Whistler Gun Club	2000-251950N	1,392	2,088
128	Mrs. Murphy's	2000-251810N	9,644	14,466
129	Grizzly Bay Preserve	2012-00396N	7,900	11,850
130	Track Property	2014-00130N	2,345	3,518
131	Jacksnipe Gun Club	2000-253720N	2,793	4,190
132	Hollywood Duck Club	2000-251960N	6,103	9,155
133	Shelldrake Duck Club	2000-251970N	34,531	51,797
207	Veneco/Lang Tule Ranch	2000-271910N	5,084	7,626
211	Wings Landing	2000-252810N	10,666	15,999
213	Solano Land Trust- Rush Ranch	2001-260620N	4,029	6,044
219	Volanti Duck Club	2000-252820N	14,120	21,180
220	Joice Island Mallard Farms	2000-252840N	6,441	9,662
302	Pickleweed Ponds	2002-266840N	1,120	1,680
303	Potrero Duck Club	2000-255880N	6,745	10,118
304	CWA-Denverton	2000-253730N	17,600	26,400
305	Marianno's Ranch	2016-00232N	1,593	2,390
311-313	Denverton Ranch	2000-253740N	1,510	2,265
318	Brass Button Duck Club	2000-255890N	4,570	6,855
319	Stolte Farms Duck Club	2000-251830N	5,035	7,553
320	Tule Meadows Club	2000-251840N	4,219	6,329
321	Greenhead Inc.	2000-252930N	18,046	27,069
322	DWR-Overlook Duck Club	2000-255900N	6,115	9,173
323	Duck&R Gun Club	2014-00128N	8,950	13,425
329	DWR-Flying "D"	2000-251980N	8,000	12,000

RGP 3- Individual Ownership: Annual Exterior Levee Maintenance Volume Limitation

<i>Ownership number</i>	Club Name	USACE file number	Exterior Levee Linear Footage	Repair exterior existing levee (yds ³)
330	DWR-Wildwing Duck Club	2000-251990N	10,505	15,758
331	Tonnesen Ranch	2016-00205N	1,643	2,465
402	Golden Gate Duck Club	2000-250120N	10,677	16,016
404	Cordelia Gun Club	2013-00263N	18,024	27,036
405	Sunrise Island	2000-251850N	15,240	22,860
406	Teal Club	2000-252940N	18,265	27,398
407	Ibis Duck Club	2000-252950N	6,600	9,900
408/409	Franciscan Marshview	2000-252000N	4,917	7,376
410	Gibson Horseshoe	2000-252010N	12,368	18,552
411	Greenlodge Duck Club	2000-253750N	6,862	10,293
412	Tule Hilton	2000-253760N	6,111	9,167
413	Sprigateal Duck Club	2000-253770N	3,980	5,970
414	Drake Sprig Gun Club	2000-252960N	3,930	5,895
415	Arnold Ranch	2000-252160N	16,732	25,098
416/17/21	Tule Belle	2002-268490N	15,451	23,177
418	Cygnus Gun Club	2000-253790N	4,787	7,181
419	Miramonte Gun Club	2000-252180N	9,660	14,490
420	Antioch Goldeneye	2000-252970N	7,245	10,868
423	The Family Club	2000-252980N	9,562	14,343
424	Lower Joice Island	2000-252220N	33,505	50,258
425	Cal Farms Duck Club	2000-252390N	4,868	7,302
426	Tip End Gun Club	2000-252400N	7,979	11,969
501	The Island Club	2000-252990N	6,654	9,981
502	Grizzly Duck Club	2000-253190N	3,109	4,664
503	Montezuma Gun Club	2000-253200N	4,478	6,717
504	Gumtree Farms	2000-252420N	4,693	7,040
505	Dead Duck Country Club	2000-252430N	938	1,407
506	Four Winds Duck Club	2000-253800N	1,447	2,171
507	Grizz/Fizz Club	2000-252440N	0	0
508	Little Westwind Duck Club	2000-255930N	0	0
509	Garben Ranch	1972-269430N	0	0
510	The Honkers Club	2000-253210N	2,709	4,064
513	Grizzly King Gun Club	2000-252450N	14,932	22,398
514	Tree Slough Farms	2002-269440N	9,864	14,796
515	Long Point Gun Club	2000-251860N	4,829	7,244
516	Bent Barrel Duck Club	2000-253810N	448	672
517	Wild Turkey	2000-253820N	0	0
518	Mendoza Gun Club	2004-290730N	1,772	2,658

RGP 3- Individual Ownership: Annual Exterior Levee Maintenance Volume Limitation

<i>Ownership number</i>	Club Name	USACE file number	Exterior Levee Linear Footage	Repair exterior existing levee (yds ³)
520	CWA-Grizzly Ranch	2000-252850N	11,998	17,997
522/23	Peidmont Rod and Gun Club	2016-00295N	4,098	6,147
525	Balboa Farms	2000-253860N	1,092	1,638
526/601	Can Can/ Flatlander	2000-253220N	42,475	63,713
527	Delta King	2000-253870N	3,691	5,537
528	Grizzly Fairview Farms	2002-269450N	0	0
529	Sprigsville Ranch	2000-252460N	0	0
530	Bulrush Farms	2000-252470N	0	0
531	Gangband Duck Club	2000-253890N	0	0
532	Windmill Gun Club	2000-255940N	0	0
536	Marsh Club	2003-278170N	0	0
537	Westwind Duck Club	2000-257210N	1,292	1,938
538	Merganser Farms	2000-253530N	2,986	4,479
539	Westervelt/Tule Red	2014-00131N	340	510
604	Blacklock Ranch	2000-253910N	5,096	7,644
605	Wohn Hunting Club	2014-00211N	13,000	19,500
607	Duck A GoGo	2000-253230N	4,854	7,281
608	Shurshot Gun Club	2000-253240N	3,353	5,030
609	Black Dog Gun Club	2000-253250N	484	726
610	Westwind Duck Club	2000-253260N	3,953	5,930
611	The Sleeping Pintal	2000-253920N	0	0
612	Meridian Gun Club	2000-252480N	0	0
613	Kirby Hill Duck Club	2016-00296N	7,075	10,613
618	Hidden Cove	2000-254110N	5,991	8,987
619/620	Schafer Farms	2000-253270N	0	0
621	Stoned Duck	2000-253280N	0	0
623	Frost Slough Gun Club	2000-253290N	0	0
625	Pintail Ranch	2000-252490N	3,239	4,859
627	Honeggar Ranch	2009-00360N	3,800	5,700
631	DWR-Meins Landing	2000-253300N	14,616	21,924
632	Sheriff Pond	2000-252490N	0	0
633	Boles Pond	2000-253410N	0	0
634	Grizzly Hilton	2000-254120N	6,240	9,360
635	DWR-Blacklock Restore	2005-295110N	6,409	9,614
701	Goodyear Club	2016-00297N	3,000	4,500
702	Morrow Island Land Company	2000-254130N	19,013	28,520
703	The Friendly Godfather	2000-255960N	3,461	5,192
705	Mulberry Land Company	2000-255970N	2,204	3,306

RGP 3- Individual Ownership: Annual Exterior Levee Maintenance Volume Limitation

Ownership number	Club Name	USACE file number	Exterior Levee Linear Footage	Repair exterior existing levee (yds³)
706	Mallard Haven	2000-252510N	3,058	4,587
707	Goodyear Land Development Co.	2000-254140N	8,311	12,467
715	Fleetside Farms	2000-269290N	19,083	28,625
721	Silver Sprig	1972-271920N	2,275	3,413
801	Annie Mason	2015-00230N	0	0
802	Rich Island Gun Club	2000-253420N	17,850	26,775
803	St. Germaine Gun Club	2000-253430N	2,898	4,347
804	Sprig Farm	2000-255980N	0	0
805/806	Grey Island Gun Club	2002-267880N	3,395	5,093
807	Wheeler Island Gun Club	2000-252520N	8,591	12,887
902	Wildlands/Atlantis Duck Club	2000-251890N	2,059	3,089
903	Blue Bird	2000-253440N	1,650	2,475
904	Wingnuts	2000-253450N	2,100	3,150
905	Mallard Farms	2000-251910N	3,165	4,748
906	Wreck Slough Rod & Gun Club	2000-253520N	1,269	1,904
907	River Dog's Retreat	2000-253500N	4,587	6,881
908	The Montezuma Ranch	2000-253460N	3,575	5,363
909	Montezuma Wetlands	2016-00298N	37,202	55,803
910	Dante Farms	2016-00299N	0	0
912	Honker Bay Farms	2002-271900N	2,715	4,073
913	Ninelands	2014-00132N	2,434	3,651
915	Chipps Island Shoot & Social Club	2000-252570N	17,700	26,550
916	A&B Gun Club	2000-254200N	3,300	4,950
917/918	Island Gun Club/Blue-Winged Teal	2002-268480N	217	326
923	Lanzamfame	2004-290740N	630	945
926	Webfoot Gun Club	2001-258540N	3,448	5,172
927	Spoonbill Club	2000-253470N	0	0
928	Hi-Gunner Club	2000-253480N	0	0
929	Riverside Gun Club	2004-290760N	0	0
930	Hit & Miss Gun Club	2000-254150N	2,754	4,131
931	Delta Farms	2000-252580N	4,410	6,615
932	Concord Farms Duck Club	2000-252590N	3,843	5,765
933	Newell Club	2000-253490N	2,650	3,975
934	Vesco	2014-00138N	1,046	1,569
940	Spinner Island	2016-00300N	5,093	7,640

RGP 3- Individual Ownership: Annual Exterior Levee Maintenance Volume Limitation

<i>Ownership number</i>	Club Name	USACE file number	Exterior Levee Linear Footage	Repair exterior existing levee (yds ³)
GIWA				
<i>P1-8</i>	NA	2000-252030N	20,641	30,962
<i>P9-10</i>	NA	2000-252040N	3,860	5,790
<i>P11</i>	NA	2000-252050N	0	0
<i>P12</i>	NA	2000-252060N	0	0
<i>P13-14</i>	NA	2000-252070N	0	0
<i>P15-16</i>	NA	2000-252080N	6,862	10,293
<i>P17</i>	NA	2000-252110N	0	0
<i>P18-21</i>	NA	2000-252120N	0	0
<i>P22-23</i>	NA	2000-252240N	2,460	3,690
<i>Crescent Unit</i>	NA	2000-252250N	725	1,088
<i>Garibaldi</i>	NA	2000-252300N	13,694	20,541
<i>Gold Hills</i>	NA	2000-252290N	2,164	3,246
<i>Goodyear</i>	NA	2000-252090N	8,076	12,114
<i>Hill Slough</i>	NA	2000-252280N	22,375	33,563
<i>Island Slough</i>	NA	2000-252270N	1,200	1,800
<i>Joice Island</i>	NA	2000-252260N	51,370	77,055
<i>West Family</i>	NA	2000-252100N	0	0
CA DWR				
<i>MIDS</i>	NA	2014-00216N	124	186
<i>Roaring River</i>	NA	2013-00264N	15,815	23,723
<i>Goodyear Slough Outfall</i>	NA	2014-00143N	107	161
<i>Hill Slough monitoring</i>	NA	2013-00265N		
<i>Sunrise S-21 Station</i>	NA	2015-00326N		
<i>Morrow S-35 Station</i>	NA	2015-00327N		
<i>Volanti S-42 Station</i>	NA	2015-00328N		
<i>Godfather II S-37 Station</i>	NA	2015-00479N		
<i>National Steel Station</i>	NA	2015-00480N		
<i>Hunter Cut Station</i>	NA	2015-00481N		
Total			1,061,785	1,592,678

Appendix F: Closure Areas

Chinook Closure Areas

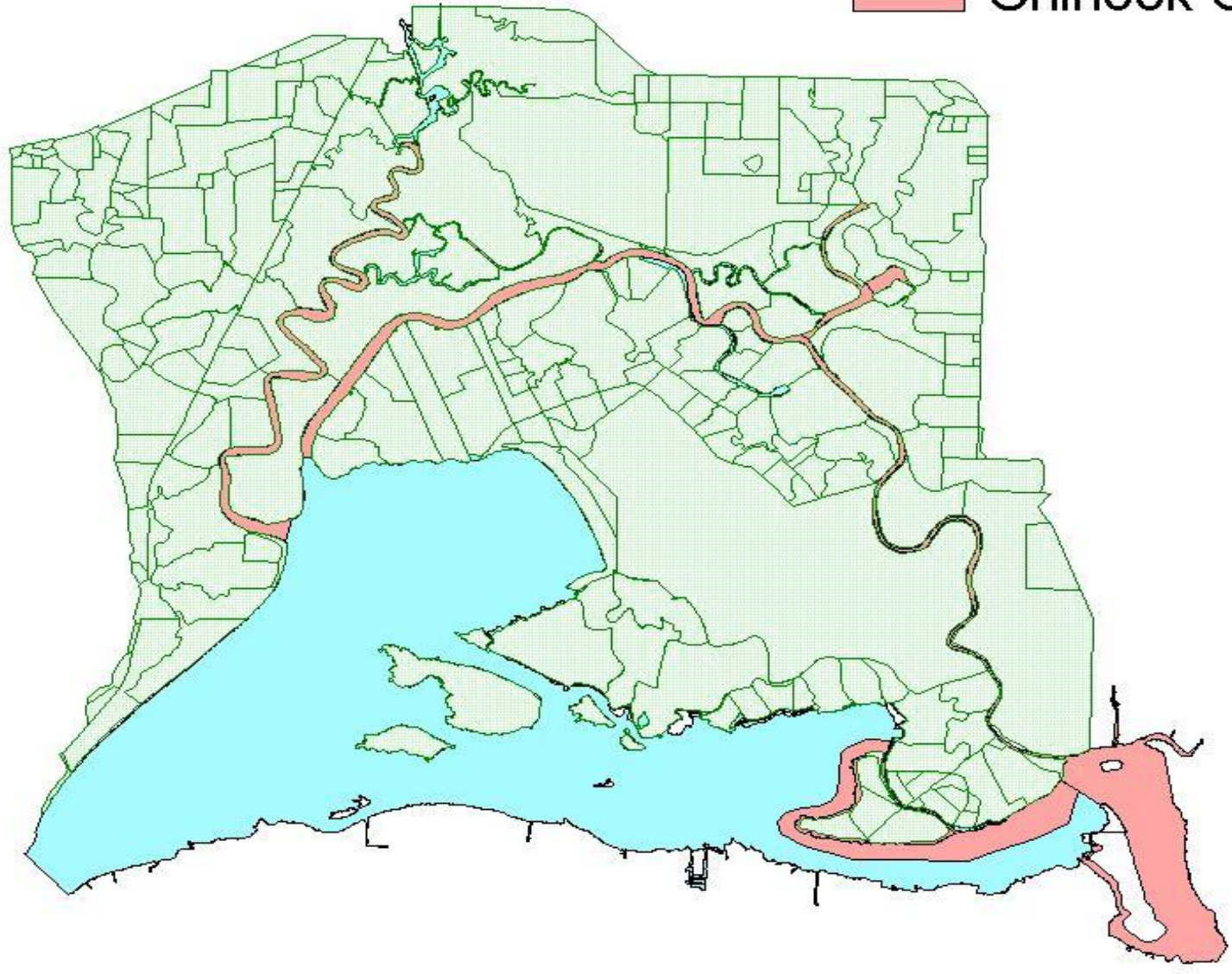

Delta Smelt Closure Areas

