



## Updated PAINTED ALUMINUM WHEEL Refinishing Guidelines

5



**Aero Shutter Humming Sound**

see page 4

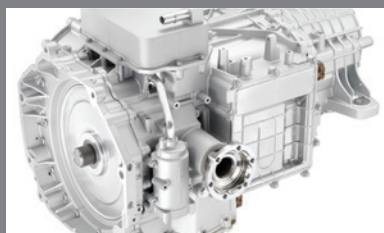

**Multiple Transmission DTCs Set**

see page 5

*Updated Painted Aluminum Wheel Refinishing Guidelines . . . . . 2*

*AFIT Software V14 Now Available . . . . . 3*

*Pop Sound at Rear Roof of Cab . . . . . 7*

*Dual Clutch Transmission MCVN PUN . . . . . 8*

*Active Fuel Management Misfire Codes Setting on HFV6 Gen2 Engines . . . . . 9*

*Water Pump Creating Engine Noise or Belt Squeak Conditions . . 10*

# Updated Painted Aluminum Wheel

## REFINISHING GUIDELINES

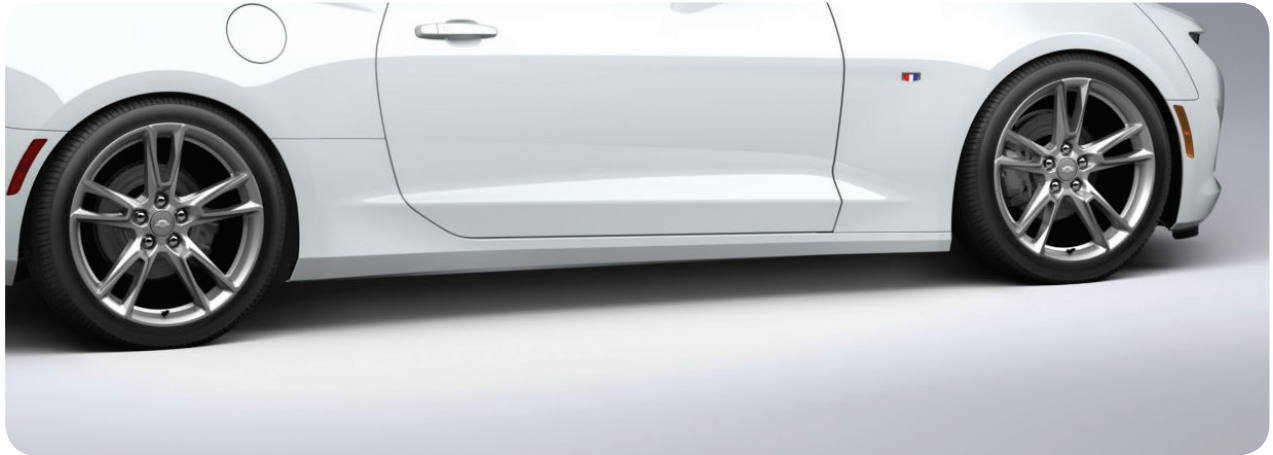

*GM has announced an updated policy for refinishing aluminum wheels under warranty at U.S. dealerships on 2011-2021 passenger cars and trucks. Only cosmetic refinishing of wheels due to quality defects is allowed on fully color painted aluminum wheels.*

Refinishing paint on chromed aluminum wheels and steel wheel refinishing are no longer supported by GM. GM also does not endorse any repairs that involve welding, bending, straightening or re-machining wheels.

### WHEEL REPAIRS

The new RPO Wheel Refinishing Guide, available in the Warranty Administration Resource Center in the GlobalConnect App Center, specifically defines the wheels that are GM approved for refinishing under warranty by model year, brand, vehicle model, and wheel RPO.

If the wheels are determined to be able to be refinished based on warrantable conditions, repairs will be performed by Alloy Wheel Repair Specialists (AWRS). AWRS can provide one-day refinishing services on-site for most GM dealerships in the U.S. The company uses a self-contained trailer unit in order to perform the refinishing procedure. AWRS is the only company permitted by GM to perform wheel refinishing. For a list of the wheels that can be refinished, refer to Bulletin #18-NA-306.

Warranty claims for wheels that cannot be refinished will involve wheel replacement through the GM Pre-Repair Authorization

(PRA) process using the Certified Service Mobile Toolbox (CSMT). Refer to Bulletin #18-NA-306 for more information.

### EVALUATING DAMAGE

It is the dealership's responsibility to inspect the wheel for peeling paint, paint runs, debris in paint, and other conditions that warrant refinishing. The wheel condition must not be deeper than what can be sanded or buffed-off (less than 2 mm deep) or a larger area than 3 x 1 inches. In addition, if there are up to three issue areas on the wheel, and the three areas in total do not



Paint run condition warrantable by refinishing.

exceed an area more than 3 x 1 inches, the wheel may be refinished.

Wheels must be visually inspected for cracks. If cracks are found, the wheel cannot be refinished. Flange cracks caused by road hazard impact damage as well as bent rim flanges should not be refinished under warranty. Other road hazard damage, such as scratches or curb scrapes, also are not warrantable repairs.



Damage from curb scrapes are not warrantable repairs.

For the complete steps required to refinish aluminum wheels for damage under warranty, refer to Bulletin #17-NA-052. It outlines the procedures for wheel refinishing evaluation as well as the repair process.

## REFINISHING WHEELS

To make a service request for wheel refinishing under warranty, contact AWRS at [awrswheelrepair.com/generalmotors](http://awrswheelrepair.com/generalmotors). Required vehicle information will include photos of the issue with labels noting wheel position and areas of concern. AWRS will follow up with the dealership to set up the on-site refinishing repairs.

The dealership is responsible for tire/wheel assembly removal from vehicle, tire deflation, tire beads broken down or tire dismount, and reinstallation of the tire/wheel assembly.

AWRS also can be contacted to perform onsite customer-pay wheel refinishing. For customer-pay repairs, contact AWRS at [awrswheelrepair.com](http://awrswheelrepair.com). Note that some repairs may not be done on-site at the dealership and may take longer than one day.

For additional information on wheel refinishing, refer to the latest version of Bulletin #17-NA-052.

- Thanks to Scott Lewiston

# AFIT Software V14 Now Available

The latest software update (CH-47976-SWV14) for the CH-47976 Active Fuel Injector Tester (AFIT) has recently been released.

The software update includes:

- 2021 model year and early 2022 model year software for all vehicle applications deploying through July 31, 2021
- PC Application Software V4.0 (Windows 10)
- MCU Firmware V3.44 (FP regulator drive timeout enhancements)
- DMU Firmware V1.31 (optimizes support for FP regulator PWM control)
- USB to Serial Driver improved interface compatibility

**TIP:** For Windows 10, the GMDE-approved Bosch USB to Serial Cable CH-47976-3A is required.

## SOFTWARE DOWNLOAD

The CH-47976-SWV14 software update is available through the Service Workbench selection of "Essential Tools – Software Updates" in GM GlobalConnect (U.S. only). Select the link for AFIT (Active Fuel Injector Tester) Software Update – V14.00 February 2021 and follow the instructions.

In Canada, the software is available for download through the Service Application selection of GM Special Tools & Equipment – Software Updates in GM GlobalConnect.

AFIT Update Instructions are available on the GM Tools and Equipment website under the Support Documents link for the software download.

For questions regarding the software release, contact Bosch Automotive Service Solutions Technical Support at 1-800-GM-TOOLS (1-800-468-6657).

► Thanks to John Staman

**CH-47976  
Active Fuel Injector Tester (AFIT)**



**Software Link**  
AFIT (Active Fuel Injector Tester)  
Software Update – V14.00  
February 2021

**Support Document(s)**  
AFIT Update Instructions  
AFIT DMU Instructions Guide Rev B  
AFIT Diesel Diagnostics Reference Guide  
AFIT Quick Reference Guide Rev A  
AFIT User Guide Rev A  
AFIT SIDI Diagnostic Guide

Look for software update V14.00

# AERO SHUTTER

## HUMMING SOUND

2020-2021 Blazers equipped with the 2.0L engine (RPO LSY) may have a humming or vibration sound coming from the front of the vehicle when driving at speeds over 50 mph (80 km/h). The sound may be caused by the aero shutters being closed at highway speeds.

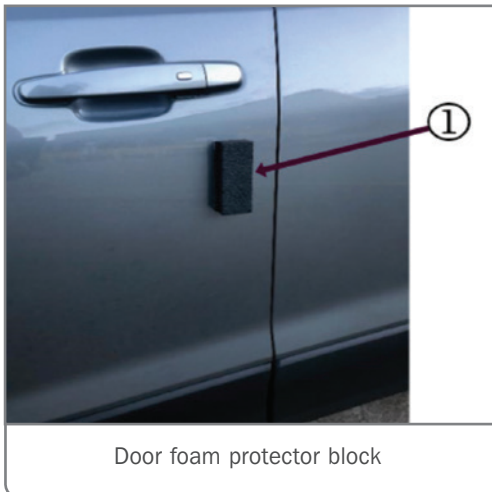

Door foam protector block

When the airflow traveling through the front fascia grille opening hits the closed shutter panels, the air behind the grille opening becomes turbulent. The buildup of air turbulence causes the energy absorber foam to start vibrating and moving up and down, which may result in the foam making

intermittent contact with the lower grille close-out panel and causing it to flutter.

When the panel flutters, it vibrates against the fascia, creating the humming sound. The sound may be heard in the passenger compartment when driving at highway speeds and, in some cases, a vibration may be felt through the shift knob or steering wheel.

If the humming condition is found, install a foam block between the back vertical wall of the grille lower close-out panel and the body center fascia support bracket. The foam block used for the repair can be cut from an existing GM left-side door foam protector block that is on every new vehicle delivery. The foam block is removed from the vehicle during PDI and should be retained for use in this repair procedure. The original foam block is large enough to complete approximately four repairs.



Trim the foam block and insert it between the close-out panel rear vertical wall and center fascia support bracket.

CONTINUED ON PAGE 5

# Multiple Transmission DTCs Set

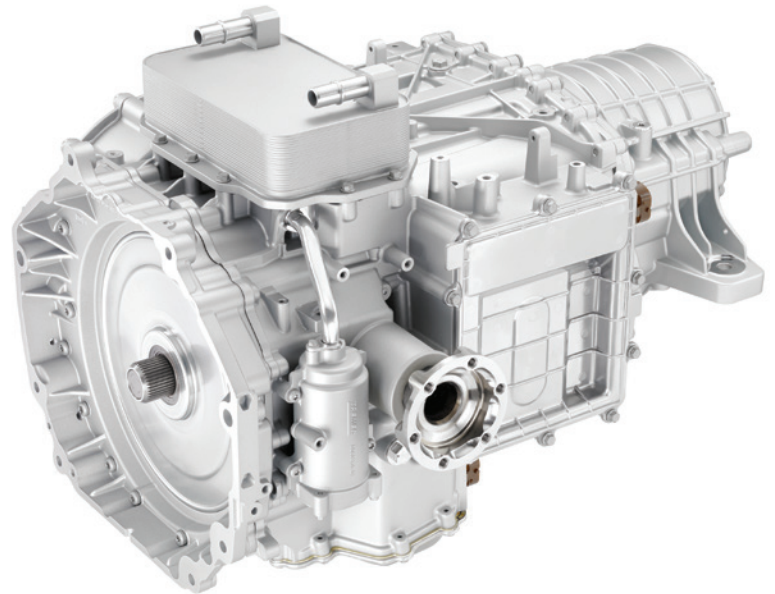

The foam block has a depth of approximately 25 mm (1 inch) and a width of approximately 35 mm (1.4 inches). It should be trimmed to a height of 25 mm (1 inch).

Insert the foam block between the close-out panel rear vertical wall and the center fascia support bracket by reaching through the grille opening on the vehicle. It is not necessary to remove the front fascia in order to install the foam block.

To install the foam block, reach one hand through the grille opening to pull back on the close-out panel rear vertical wall and use the other hand, or a tool such as 90-degree needle nose pliers, to insert the foam block.



The foam block will create a preload to the grille close-out panel.

Once installed, the foam block will create a preload to the grille close-out panel to prevent it from fluttering.

For additional information, refer to Bulletin #21-NA-038.

► Thanks to Pamela Francisco

Some 2020-2021 Corvette models may have multiple DTCs set in the Transmission Control Module (TCM). The DTCs may be caused by an internal transmission solenoid or switch sticking due to debris in the DCT TR-9080 transmission (RPO M1L). Based on the DTCs that are set, GDS2 should be used to perform the appropriate solenoid cleaning procedure.

The cleaning procedure should be performed three times. If required, perform the solenoid cleaning for each additional DTC that may have set as well, completing the solenoid cleaning three times. Once completed, it will be necessary to perform the Service Clean Procedure followed by the Transmission Service Fast Learn.

**TIP:** The cleaning procedure is targeted for mechanical and hydraulic conditions. If circuit diagnostics are required to determine the repair, valve/solenoid cleaning, Service Clean, and the Service Fast Learn will not address the issue.

## CLEANING PROCEDURES BASED ON DTCs SET

Use GDS2 to perform the following cleaning procedures for the DTCs set in the TCM.

CONTINUED ON PAGE 6

If DTCs P194F, P1950, P0747, P0746, P0777, P0776, P2809, P2808, P2724, P2723, P1955, P0797, P0796, P2715, P2714, P2818, P2817, P08C5, P08C4, P27BA, P27B9, P27C2, P27C1, P27CA, P27C9, P27D2, P27D1, P282A, P2829, P1956, P1957, P1958, P1959, and/or P2735 are set:

- Perform the system cleaning procedure based on the DTC that set.
- Next, perform the Service Clean Procedure and then the Service Fast Learn.
- If DTCs return, replace the valve body as necessary.

If DTCs P18A8, P18A9, P2821, P2820, P187D and/or P187E are set:

- Perform the system cleaning procedure based on the DTC that set.
- Next, perform the Service Clean Procedure and then the Service Fast Learn.
- If DTCs return, transmission replacement may be necessary. Contact the GM Technical Assistance Center (TAC) for more information prior to ordering a transmission.

If DTCs P2855, P2853, P2856, P2854, P0869, P0868, P0867, C2A18 and/or C2A19 are set:

- Perform the system cleaning procedure based on the DTC that set.
- Next, perform the Service Clean Procedure and then the Service Fast Learn.
- If DTCs return, replace the valve body as necessary, except if DTC P0867 (Transmission Fluid Pressure Performance) is set. No system pressure is either a serious mechanical issue or extremely low fluid level.

If DTCs: P0844, P0841, P0849, P0846, P0874, P0871, P0879 and/or P0876 are set:

- Perform the system cleaning procedure based on the DTC that set.
- Next, perform the Service Clean Procedure and then Service Fast Learn.
- If no other pressure DTCs are present, proceed to circuit diagnostics.

If DTCs: P1946, P1947, P1948, P1949, P194A, P194B, P194C, P194D, P194E, P073F, P074A, P074B, P074C, P074D, P074E, P074F, P07D8 and/or P073E are set:

- Perform system cleaning IF accompanied with low/high system pressure codes; otherwise, perform the Service Fast Learn.
- Failure of the Service Fast Learn would indicate a mechanical hardware condition.

## SERVICE PROCEDURES

After recording and clearing the DTCs, and with the transmission at operating temperature, use GDS2 to perform the transmission system cleaning procedures.



Select the transmission cleaning services that correspond with the DTCs set. Not all cleaning procedures listed need to be performed.

For more details about each cleaning procedure, refer to SI document #5501008 – K71 Transmission Control Module: Scan Tool Information.

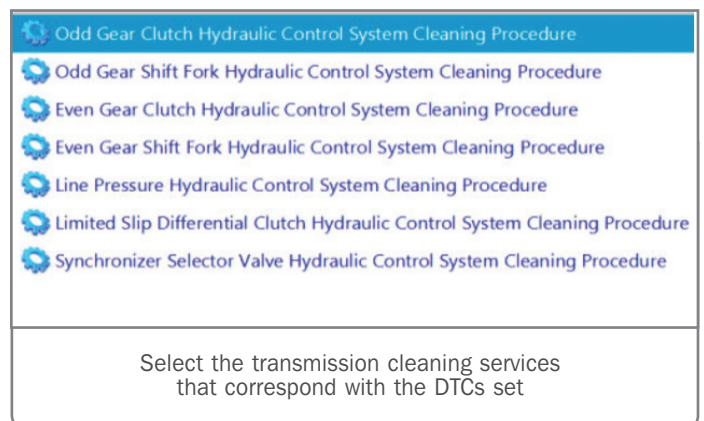

Perform the DTC solenoid cleaning procedure three times for each DTC set. Once the cleaning procedure has been completed three times, select the Configurations/Reset Functions in order to perform the Transmission Service Fast Learn procedure as needed.

Be sure to test drive the vehicle after performing the cleaning procedures to verify that the DTCs do not reset. If the DTCs reset, replace the Control Valve Solenoid (or Main Control Valve, MCV).

For additional information, refer to Bulletin #21-NA- 033.

► Thanks to Dave Rainey

# Pop Sound at Rear Roof of Cab

A pop sound may be heard coming from the rear roof of the cab area on some 2019-2020 Silverado 1500 and Sierra 1500 models and 2020 Silverado 2500HD/3500HD and Sierra 2500HD/3500HD models, built prior to August 3, 2020. The pop sound, which may be heard more often when the cab body is heated or cooled by changing ambient temperatures, may be caused by interference between the Center High Mounted Stop Lamp (CHMSL) and the body of the roof-mounted spoiler.

As these parts expand and contract with changes in ambient conditions, there may be a stick-slip condition that generates the sound. A slight wear mark may be seen in the spoiler paint on some examples.

To create more space between the CHMSL and the spoiler, foam tape should be applied between the CHMSL and the lower corners of the spoiler body following the repair procedure in Bulletin #21-NA-018.

**TIP:** The eight original central roof spoiler nuts are not reusable. The original fasteners should be discarded and replaced.

For the complete repair procedure as well as parts information, refer to Bulletin #21-NA-018.

► Thanks to David MacGillis and Kevin Minor



Interference at the CHMSL and body of the roof-mounted spoiler.



A wear mark may be seen in the spoiler paint.

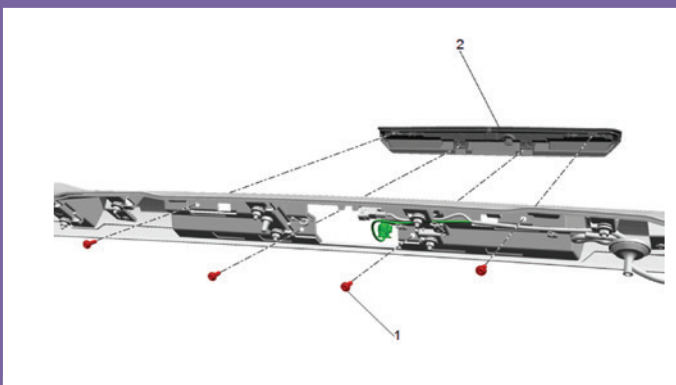

Replace the eight original central roof spoiler nuts.

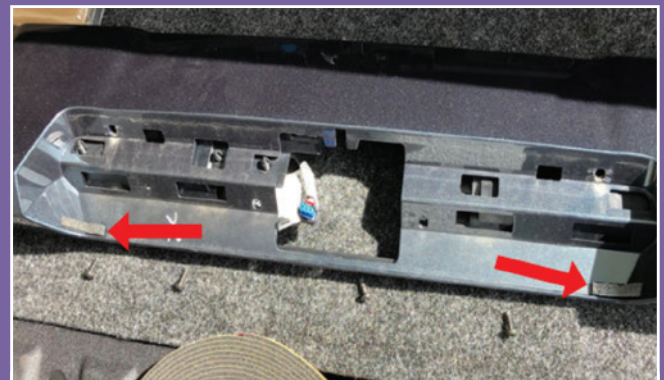

Apply foam tape



# DUAL CLUTCH TRANSMISSION

## MCVM PUN

After making repairs to the Dual Clutch Transmission (RPO M1L) on 2020-2021 Corvette models, including Shift Activation (SAV), Main Control Valve (MCV) or direct clutch replacement, the Transmission Control Module (TCM) needs to be characterized with the new Part Unique Number (PUN) as specifically called out in the repair procedure in the appropriate Service Information. There may be some confusion when comparing the service tool with the Service Information instructions.

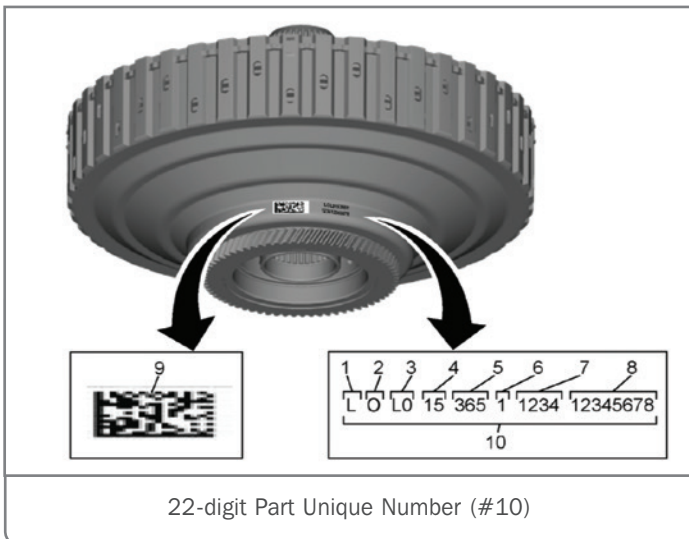

Service Information is very detailed in specifying that the 22-digit PUN is needed. There is a 21-digit and 22-digit PUN on these parts. The 21-digit PUN is for supplier use only and should not be entered when TCM programming.

**TIP:** Take a photo of the 22-digit PUN or document or record the PUN in some way to ensure that it is properly identified before installing the part on the transmission.

To perform the solenoid reprogramming procedure in SPS, select the SPS TCM programming event, "Transmission Control Module" and "MCVM Operations."

After selecting the MCVM operation – Replace Characterized Transmission Components, the next SPS characterization screen states, "Please enter valve body assembly PUN." There is not an

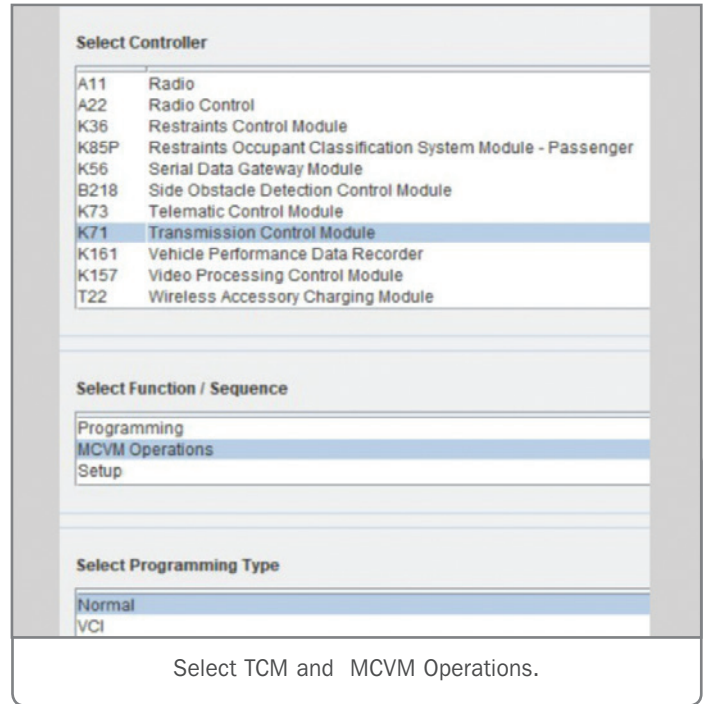

option for the clutch or SAV. Enter the PUN from the component that was replaced and the PUN will be mapped to the correct information. Be sure to complete all steps in the programming procedure in Service Information.

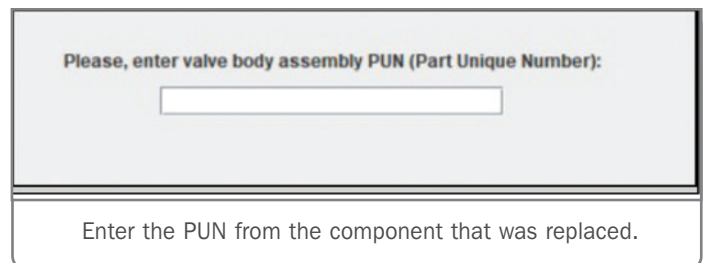

► Thanks to Steve Schipansky



# ACTIVE

# Fuel Management Misfire

## CODES SETTING ON HFV6 GEN2 ENGINES

Misfire DTCs P0300 (Engine Misfire Detected), P0302 (Cylinder 2 Misfire Detected) or P0305 (Cylinder 5 Misfire Detected) may be set on some 2016-2019 ATS; 2016-2020 CT6; 2016-2021 Camaro; 2017-2019 LaCrosse; 2017-2021 XT5, Colorado, Acadia, Canyon; 2018-2020 Regal; 2019-2021 Blazer; 2020-2021 CT5, and XT6 models equipped with the 3.6L engine (RPO LGX, LGZ) or 3.0L engine (RPO LGY, LGW).

Cylinder 2 and 5 are the Active Fuel Management (AFM) cylinders. Oil may be leaking past the AFM oil control valve solenoid, located in the camshaft cover, allowing inadequate oil pressure to the AFM solenoid and, in turn, deactivating the cylinder due to oil bleed off.

Inside the camshaft cover with the solenoid removed, look for the end of the solenoid stuck in the bore. A solenoid stuck in the bore can usually be easily removed using a pick tool or a pair of transmission snap ring pliers. The solenoid will only be held in the bore with the O-ring.



A complete solenoid, top, and a broken solenoid, bottom

If there are not any signs of any ignition or fuel injection concerns, check the AFM solenoid on either cylinder 2 or 5, depending on which DTC is set. Remove and inspect the AFM solenoid and O-rings for any damage and inspect the bore inside the camshaft cover for abnormalities or porosity.

During service, the AFM solenoid may come out of the cover with the end broken off, which does not allow the new solenoid to be installed completely in the camshaft cover. Compare a new solenoid with the current solenoid to ensure the solenoid is still intact. Be sure to check the cover for any broken components where the bottom may have been pulled apart.



A. Clean bore  
B. End of solenoid stuck in the bore

If the solenoid is the not the cause of the misfire, continue with the appropriate Service Information diagnostics.

For additional information, refer to Bulletin #21-NA- 036.

► Thanks to Bryan Salisbury

# Water Pump

## CREATING ENGINE NOISE OR BELT SQUEAK CONDITIONS

A drive belt squeak or engine noise from the front of the engine may be noticed on some 2016-2019 ATS, CTS, Camaro; 2016-2020 CT6; 2017-2019 LaCrosse, Acadia; 2017-2021 XT5, Colorado, Canyon; 2018-2020 Regal; 2019-2021 Blazer; and 2020 XT6 models equipped with the 3.6L engine (RPO LGX) or 3.0L engine (RPO LGW), built prior to October 30, 2020. DTC P0324 (Knock Sensor System Performance) also may be set in the Engine Control Module.

The drive belt squeak or engine noise, which may not be present at the time when the vehicle comes into the dealership, may be caused by the water pump. If the water pump condition is bad enough, the engine will pick up the knock noise.

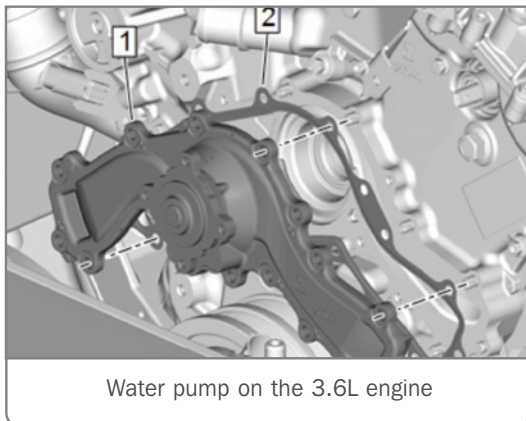

If the condition is found, listen to the water pump with a stethoscope or J-39570 Chassis Ears to determine if any unusual

noises can be heard. Compare the sound to a similar vehicle. In addition, check the knock retard bank-to-bank using GDS2. Next, remove the belt and observe the knock retard again.

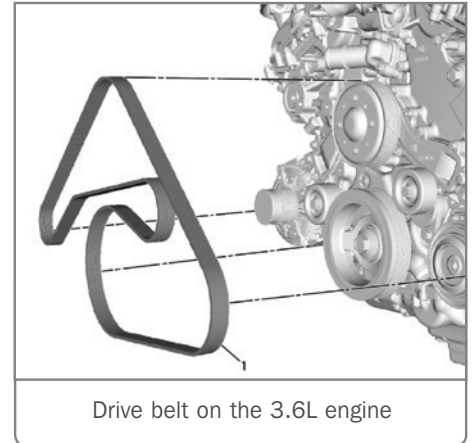

If a noise is heard or there is a difference when removing the belt, replace the water pump. After installing a new water pump, check to ensure the engine noise or belt squeak has been eliminated.

**TIP:** When installing the new water pump, be sure to tighten the water pump and engine front cover bolts in sequence according to the Service Information.

For additional details and parts information, refer to Bulletin #21-NA-030.

► Thanks to Bryan Salisbury

## TECH LINK

GM TechLink is published for all GM retail technicians and service consultants to provide timely information to help increase knowledge about GM products and improve the performance of the service department.

**Publisher:**  
Michael O'Hare  
GM Customer Care and Aftersales

**Editor:**  
Lisa G. Scott  
GM Customer Care and Aftersales

**Technical Editor:**  
Mark Spencer  
mspencer@gpstrategies.com

**Production Manager:**  
Marie Meredith

**Creative Design:**  
5by5 Design LLC  
dkelly@5by5dzign.com

**Write to:**  
TechLink  
PO Box 500, Troy, MI 48007-0500

**GM TechLink on the Web:**  
GM GlobalConnect

General Motors service tips are intended for use by professional technicians, not a "do-it-yourselfer." They are written to inform those technicians of conditions that may occur on some vehicles, or to provide information that could assist in the proper service of a vehicle. Properly trained technicians have the equipment, tools, safety instructions and know-how to do a job properly and safely. If a condition is described, do not assume that the information applies to your vehicle or that your vehicle will have that condition. See a General Motors dealer servicing your brand of General Motors vehicle for information on whether your vehicle may benefit from the information. Inclusion in this publication is not necessarily an endorsement of the individual or the company. All information contained herein is based on the latest information available at the time of publication and is subject to change without notice.  
Copyright © 2021 General Motors. All rights reserved.