

Vacuum Packers Bench Mounted Vacuum Packer - 10 m³/h with inert gas

ITEM # _____

MODEL # _____

NAME # _____

SIS # _____

AIA # _____



600116 (EVP31G)

 Table-top vacuum packer
(inert gas) 10m³/h

Short Form Specification

Item No. _____

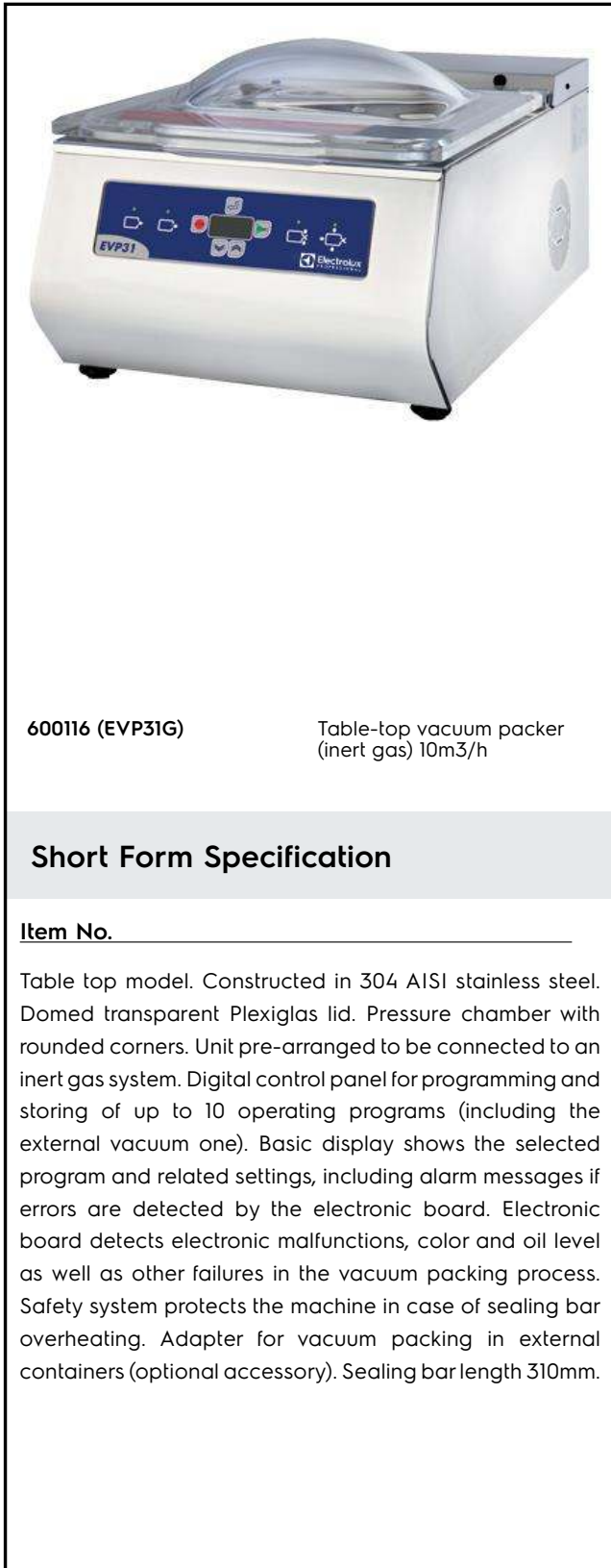
Table top model. Constructed in 304 AISI stainless steel. Domed transparent Plexiglas lid. Pressure chamber with rounded corners. Unit pre-arranged to be connected to an inert gas system. Digital control panel for programming and storing of up to 10 operating programs (including the external vacuum one). Basic display shows the selected program and related settings, including alarm messages if errors are detected by the electronic board. Electronic board detects electronic malfunctions, color and oil level as well as other failures in the vacuum packing process. Safety system protects the machine in case of sealing bar overheating. Adapter for vacuum packing in external containers (optional accessory). Sealing bar length 310mm.

Main Features

- To perfectly meet the requirements of the operator, the digital control panel allows the selection of up to 10 operating programs to guarantee optimized vacuum pressure and heat seal time for any product and each program:-P1 to P4 are composed of 4 adjustable selections (vacuum, extravacuum, gas and sealing)-P5 is the "external outside vacuum" to be used for removing air by two parameters: vacuum and extravacuum-t1, t2, t3 are the advanced functions: infusion cycle for marinating/infusion of foodstuff, compression to soften meat, liquid time to set the sealing stage of bags containing liquid products-Sr1, Sr2 are the special programs, condition to clean the pump and test cycle
- To ensure simplicity of use and maximum reliability electronic board detects electronic malfunctions, color and level of oil as well as failures in the vacuum packaging process.
- Can be equipped with an adapter (available as optional accessory), allowing the vacuum process to take place in external containers or appliances by connecting the external container's pipe to the air sucking valve.
- Safety system protects the machine in case of sealing bar overheat.
- Sealing bar 310 mm.
- Microprocessor automatically controls the exact percentage of negative pressure needed for all the air to be removed.
- Warning light to indicate malfunctioning in the vacuum packing process.
- Unit pre-arranged to be connected to an inert gas system.

Construction

- Liquid or oil residues can be removed from the pump tank using the CP-conditioning program (recommended after long periods of machine inactivity).
- Entirely constructed in 304 AISI stainless steel.
- Unit to have a domed transparent Plexiglass lid.
- Pressure chamber with rounded corners.

Optional Accessories

- Inclined filling table to vacuum pack liquids for 6, 8 and 10 m³/h vacuum packers PNC 650009 □

APPROVAL: _____

Front

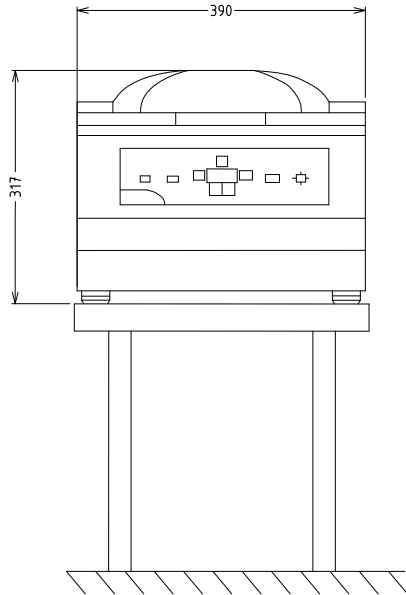

Electric

Supply voltage:

600116 (EVP31G)

230 V/1N ph/50/60 Hz

Total Watts:

0.7 kW

Key Information:

Pump:	10 m ³ /h
External dimensions, Width:	390 mm
External dimensions, Depth:	640 mm
External dimensions, Height:	330 mm
Net weight (kg):	46

Side

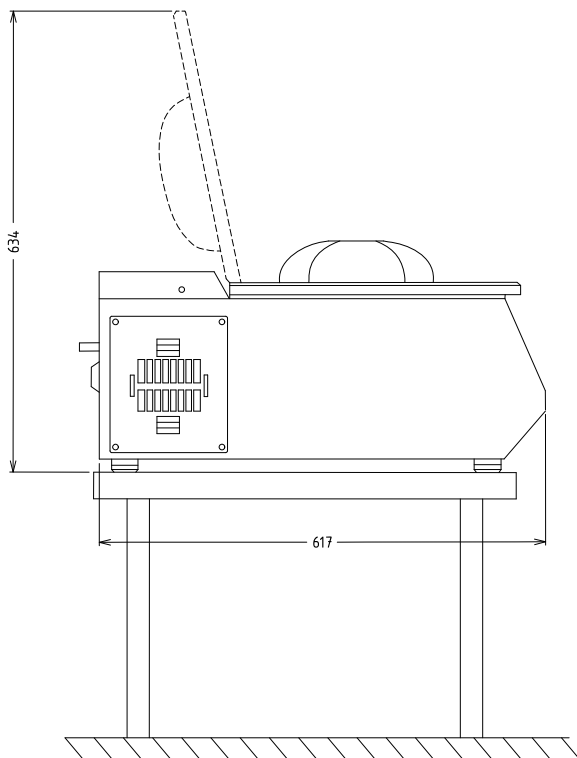

EI = Electrical inlet (power)