

REVISION OF COELOGYNE SECTION VERRUCOSAE (ORCHIDACEAE): A NEW SECTIONAL DELIMITATION BASED ON MORPHOLOGICAL AND MOLECULAR EVIDENCE

S. E. C. SIERRA, B. GRAVENDEEL & E. F. DE VOGEL

Nationaal Herbarium Nederland, Universiteit Leiden branch, P.O. Box 9514,
2300 RA Leiden, The Netherlands

SUMMARY

Section *Verrucosae* Pfitzer & Kraenzl. of the genus *Coelogyne* Lindl. is revised using morphological and molecular data. Eight species are recognized, including two new ones (*C. marthae* and *C. verrucosa*). One name is reduced to synonymy. Four species formerly included by several authors in sect. *Verrucosae* (*C. brachyptera*, *C. papillosa*, *C. parishii* and *C. virescens*) are excluded. A total evidence analysis of morphological characters and ITS and *matK* sequence data supports the monophyly of the section as here recognized. *Coelogyne virescens* (sect. *Brachypterae*) is identified as nearest neighbour to the species of sect. *Verrucosae*. The number of sterile bracts on the rhachis and the shape of the ornamentation on the epichile appear to be phylogenetically informative characters, in contrast with the inflorescence type, ovary indumentum and number of keels on the hypochile.

Key words: *Coelogyne* sect. *Verrucosae*, *matK*, orchids, phylogeny, ribosomal ITS, systematics.

INTRODUCTION

The orchid genus *Coelogyne* Lindl. comprises approximately 200 species, distributed from Southeast Asia to the south-western Pacific Islands. Pfitzer & Kraenzlin (1907), in their revision of subtribe Coelogyneinae, subdivided the genus into 14 different sections, among which is sect. *Verrucosae*. All later authors maintained this section. According to Pfitzer & Kraenzlin sect. *Verrucosae* consists of plants with large pseudobulbs and leaves, with very large flowers having an unusual combination of colours (green with black markings), and a lip with keels and a mass of papillae. In their key to the sections of *Coelogyne* they state in addition that sect. *Verrucosae* is distinguished from sect. *Tomentosae* by a glabrous rhachis, peduncle (probably pedicel is intended), and ovary. As a matter of fact, not all species originally included in sect. *Verrucosae* by Pfitzer & Kraenzlin have green flowers with black markings, and the rhachis, pedicel, and ovary are hairy in some taxa. The size of the flowers and the vegetative parts vary considerably as well.

In this study the following combination of character states was found to be diagnostic for sect. *Verrucosae*: pseudobulbs rounded to strongly flattened, 2-leafed; rhachis at the base with a few sterile bracts, but no such bracts at the base of the peduncle; scattered minute scale-like hairs on rhachis, pedicel, ovary, and the outside of the sepals and petals; flowers opening simultaneously; three keels on the hypochile; ornamenta-

tion on the midlobe of the lip consisting of various kinds of warts or teeth; base of column in front forming a very small to pronounced column foot.

Pfitzer & Kraenzlin (1907) listed a total of 10 species in sect. *Verrucosae*: *C. asperata* Lindl., *C. brachyptera* Rchb.f., *C. densiflora* Ridl., *C. edelfeldtii* F. Muell. & Kraenzl., *C. mayeriana* Rchb.f., *C. pandurata* Lindl., *C. papillosa* Ridl., *C. parishii* Hook., *C. peltastes* Rchb.f., and *C. pustulosa* Ridl. They failed to designate a type species. We have here chosen *C. pandurata* Lindl. as the type species, as this agrees best with the description of the section as given by Pfitzer & Kraenzlin.

Rolfe (1908) added *C. virescens*. Smith (1920, 1927) added *C. imbricans* J.J. Sm. and *C. peltastes* var. *unguiculata* J.J. Sm. Carr (1934) included *C. zurowetzii* Carr. In our view, the two newly described species *C. marthae* S.E.C. Sierra and *C. verrucosa* S.E.C. Sierra should also be placed in sect. *Verrucosae*.

Coelogyne densiflora was reduced to *C. tomentosa* by De Vogel (1992). In this study, *C. edelfeldtii*, *C. lowii*, and *C. pustulosa* are reduced to *C. asperata* and *C. peltastes* var. *unguiculata* is considered to be a synonym of *C. pandurata*. De Vogel (1994) and Clayton (in prep.) place *C. brachyptera*, *C. parishii*, and *C. virescens* in sect. *Brachypterae*, because of the hysterothous inflorescence and imbricate bracts at the base of the peduncle.

The sectional classifications of *Coelogyne* in current use are based on a few diagnostic characters only, and no phylogenetic analyses with all species assigned to sect. *Verrucosae* were performed so far. The main objectives of this study were: 1) to check the monophyly of sect. *Verrucosae* as here recognized; 2) to study interspecific relationships within the section. A taxonomic revision was made, and phylogenetic analyses were performed based on morphological and molecular characters obtained by sequencing the plastid *matK* gene and the nuclear ITS1-5.8S-ITS2 regions.

MATERIALS AND METHODS

Sampling

For the phylogenetic analysis with morphological characters 18 taxa were studied, representing 16 species assigned to *Coelogyne* sect. *Brachypterae*, *Cristatae*, *Rigidiformes*, *Tomentosae* and *Verrucosae* by various authors, and two outgroups. Representatives of two closely related genera in Coelogyninae, *Bracisepalum* and *Dendrochilum*, were chosen as outgroups. These genera are placed in the same clade as species of sect. *Verrucosae* in a molecular phylogeny of *Coelogyne* based on plastid RFLPs, *matK* and ITS sequence data (Gravendeel et al., in prep.). For the molecular analyses plant material was obtained from the living orchid collections of the botanical gardens in Leiden and Zurich and from private orchid collections. Unfortunately, living collections of only 12 taxa were available for the molecular and total evidence analysis. DNA extracted from herbarium collections turned out to be too degraded. Voucher specimens of all accessions surveyed, with their origins, are listed in Table 1 and deposited at L.

Taxonomic study

Collections were examined from the following herbaria: A, AMES, BM, BO, C, HBG, K, KEP, L, NY, P, SAR, SING and W. Depending on the availability of the ma-

Table 1. List of species analysed in the molecular analyses. Arranged by genus according to Dressler (1993). All belong to subtribe Coelogyinae. *B.* = *Bracisepalum*; *C.* = *Coelogyne*; *D.* = *Dendrochilum*; PNG = Papua New Guinea.

Genus and species	Section	Voucher ¹	Origin	ITS1-5.8S-ITS2 ²	matK ²
<i>B. selebicum</i> J.J. Sm.		Leiden cult. 20446	Sulawesi	AF281120	AY003873
<i>D. longifolium</i> Rchb.f.		Leiden cult. 32110	PNG	AF281121	AY003874
<i>C. virescens</i> Rolfe	<i>Brachypterae</i>	Clayton cult. s.n.	Unknown	AF281122	AY003875
<i>C. foerstermannii</i> Rchb.f.	<i>Cristatae</i>	Leiden cult. 970591	Sarawak	AF281123	AY003876
<i>C. sanderiana</i> Rchb.f.	<i>Cristatae</i>	Leiden cult. 30765	Unknown	AF281124	AY003877
<i>C. plicatissima</i> Ames & C. Schweinf.	<i>Rigidiformes</i>	Leiden cult. 980409	Sarawak	AF281125	AY003878
<i>C. dayana</i> Rchb.f.	<i>Tomentosae</i>	Leiden cult. 20247	Unknown	AF281126	AY003879
<i>C. rhabdoulbon</i> Schltr.	<i>Tomentosae</i>	Leiden cult. 26597	Sabah	AF281127	AY003880
<i>C. asperata</i> Lindl.	<i>Verrucosae</i>	Leiden cult. 22279	PNG	AF281128	AY003881
<i>C. mayeriana</i> Rchb.f.	<i>Verrucosae</i>	Leiden cult. 30728	Unknown	AF281129	AY003882
<i>C. pandurata</i> Lindl.	<i>Verrucosae</i>	Leiden cult. 21532	Unknown	AF281130	AY003883
<i>C. verrucosa</i> S.E.C. Sierra	<i>Verrucosae</i>	Leiden cult. 970584	Sarawak	AF281131	AY003884

1) All voucher specimens are deposited in L.

2) GenBank accession number.

terial the dimensions given in the descriptions are based on living, spirit or dry material. Dried flowers were rehydrated before measurements were taken. A data matrix of 27 morphological characters was constructed, of which 5 relate to vegetative and 22 to reproductive structures. The following characters and character states were used.

1. Rhizome scales: 1 = long persistent; 2 = soon disintegrating.
2. Leaves: 1 = herbaceous; 2 = coriaceous.
3. Pseudobulbs: 1 = ovate to ovate-lanceolate; 2 = elliptic to lanceolate; 3 = cylindrical.
4. Pseudobulbs: 1 = slightly to extremely flattened; 2 = terete.
5. Pseudobulbs: 1 = unifoliate; 2 = bifoliate.
6. Flowers per inflorescence: 1 = up to 25; 2 = more than 25.
7. Inflorescence: 1 = heteranthous; 2 = proteranthous; 3 = synanthous; 4 = hysteranthous.
8. Rhachis: 1 = internodes straight to slightly zigzagging; 2 = internodes zigzagging.
9. Sterile bracts on peduncle: 1 = present; 2 = absent.
10. Sterile bracts on rhachis: 1 = 0–2; 2 = more than 2.
11. Floral bracts: 1 = patent; 2 = ascending.
12. Floral bracts: 1 = caducous; 2 = persistent.
13. Ovary: 1 = sparsely hairy; 2 = densely hairy; 3 = glabrous.
14. Petals: 1 = obovate-lanceolate; 2 = lanceolate; 3 = linear-lanceolate.
15. Petals nerves: 1 = 0–3; 2 = 4–9; 3 = more than 9.
16. Hypochile base: 1 = emarginate; 2 = subtruncate; 3 = rounded; 4 = saccate.
17. Median keel compared to lateral keels: 1 = longer; 2 = shorter.
18. Keels on hypochile: 1 = 1; 2 = 2; 3 = 3; 4 = more than 3.
19. Lateral lobes of hypochile: 1 = distinctly developed; 2 = hardly developed or absent.

20. Venation colour on lateral lobes of hypochile: 1 = brown or black; 2 = blackish green; 3 = white; 4 = pink.
21. Venation on lateral lobes of hypochile: 1 = prominent; 2 = not prominent.
22. Claw on epichile: 1 = present; 2 = absent.
23. Lateral lobes of epichile: 1 = with keels or warts; 2 = without keels or warts.
24. Ornamentation on epichile: 1 = swollen, bar-shaped keels; 2 = high, plate-like keels; 3 = low, rounded keels; 4 = keels broken up in flat irregular teeth and warts; 5 = molar or tooth-like warts; 6 = calli; 7 = irregularly rounded warts.
25. Epichile margin: 1 = with regular undulations; 2 = smooth.
26. Column hood margin: 1 = with pronounced teeth; 2 = smooth.
27. Apex of anther: 1 = V-shaped; 2 = obcordate; 3 = triangular; 4 = truncate.

Only characters were used which could be easily divided into discrete, non-overlapping states. A graph of the length of the lip of all taxa analysed did not show discrete gaps. This character was therefore omitted from the analyses. Character states were evaluated from herbarium and spirit collections, where possible from at least 5 collections per species. Distinct species are recognized when at least two morphological characters indicate differences (Van Steenis, 1957). Maps were made with the programme MapInfo Professional version 5.0 (© Media Cybernetics), using the coordinates stated on specimen labels whenever available, otherwise various gazetteers were used.

DNA extractions

Total genomic DNA was extracted from 50 mg of fresh young leaf tissue following the CTAB method of Doyle & Doyle (1987) without further cleaning procedures. Leaf material was taken from one individual per species.

matK and ITS amplifications

The *matK* gene and ITS1-5.8S rDNA-ITS2 regions were chosen because of their proved utility in Coelogyntinae at the subgeneric level (Gravendeel et al., in prep.). A large portion of the *trnK* region (mostly *matK*) was amplified with the following four primers: -19F (5'-CGTTCTGACCATATTGCACTATG-3') and 881R (5'-TMTTCATCAGAATAAGAGT-3'); 731F (5'-TCTGGAGTCTTTCTTGAGCGA-3') and 2R (5'-AACTAGTCGGATGGATGGAGTAG-3'). All primers were designed at the Royal Botanic Gardens, Kew, except for 2R (Johnson & Soltis, 1994). The thermal cycling protocol comprised 28 cycles, each with 1 min. denaturation at 94 °C, 30 sec. annealing at 48 °C, an extension of 1 min. at 72 °C, concluding with an extension of 7 min. at 72 °C. All PCR products were sequenced directly after purification with QIA quick purification columns (QIAGEN, Amsterdam, The Netherlands). ITS1 and ITS2 spacers along with the 5.8S gene were amplified with the primers 17 SE (5'-ACGAATTCATGGTCCGGTGAAGTGTTCG-3') and 26SE (5'-TAGAATTCCCCGGTTCGCTCGCCGTTAC-3') from Sun et al. (1994). The thermal cycling protocol comprised 26 cycles, each with 10 sec. denaturation at 96 °C, 5 sec. annealing at 50 °C and extension of 4 min. at 60 °C. All PCR products were cloned following the protocol of Promega's pGEM-T Easy Vector System and then reamplified from transformed bacterial clones by touching them with a sterile pipet tip and using that sample as template. Amplified, double-stranded DNA fragments were purified using Wizard PCR minicolumns (Promega, Madison, USA) and sequenced on an ABI 377 automated

sequencer, using standard dye-terminator chemistry and following the protocols of PE Applied Biosystems, Inc. Two to four sequencing reactions were performed for each completed sequence, one with each of the two PCR primers, and these generated nearly complete overlapping single-strand sequences for the entire ITS1-5.8-ITS2 region and *matK*-3' *trnK*-fragments .

Phylogenetic analyses

All characters were assessed as independent, unordered and equally weighted, using Fitch parsimony (Fitch, 1971). Only discrete morphological characters were used in the phylogenetic analyses, with multistate coding. When multiple states occurred within one species, they were treated as polymorphisms. Sequences were aligned with MegAlign version 4.03 (DNASTAR, Inc. 1999) and subsequent adjustment by hand. Gaps in the sequence data were coded as missing values. The morphological data matrix and *matK* and ITS alignments are available from the second author upon request (gravendeel@nhn.leidenuniv.nl). All sequences are submitted to Genbank (see Table 1 for accession numbers). Maximum parsimony analyses were performed on the morphological and sequence data with PAUP* version 4.0b64 (Swofford, 1999) using random additions and the MULPARS option. *Bracisepalum selebicum* and *Dendrochilum longifolium* were used as outgroups in all analyses. The relative robustness for clades found in each parsimony analysis was assessed by performing 1000 replicates of bootstrapping (Felsenstein, 1995), using simple stepwise additions, SPR swapping, MULTREES on, and holding only 10 trees per replicate. Congruence of the separate data sets was assessed by visual inspection of the individual bootstrap consensus trees. Bootstrap trees were considered incongruent only if they displayed hard (> 80% supported) incongruencies (Wiens, 1998). Character state evolution of all morphological characters was reconstructed using the assumptions of maximum parsimony with the Trace Character facility in MACCLADE version 3.04 (Maddison & Maddison, 1992).

RESULTS

Morphology

Of the 27 characters scored, 4 were autapomorphies and the remaining 23 were synapomorphies (Table 2). The MP analyses yielded 31 most parsimonious trees (length = 69; CI = 0.65; RI = 0.67). The bootstrap consensus topology and the corresponding branch supports are shown in Fig. 1. Resolution of the morphological bootstrap consensus is low. Only three clades receive strong to moderate support: *Coelogyne* (100%), sect. *Rigidiformes* (100%), and sect. *Verrucosae*, excluding *C. papillosa* and *C. virescens* (76%).

matK and ITS sequences

Length ranges of the *matK* gene and its flanking *trnK* sequences were 1536–1544 and 221–245 bp. Boundaries of the *matK* gene were taken from Johnson & Soltis (1994). The alignment has a total number of 1908 sites, of which 78 were variable and 30 were phylogenetically informative (Table 2). The MP analyses yielded a single most parsimonious tree (length = 87; CI = 0.89; RI = 0.87). The single MPT topology

Table 2. Values and statistics from parsimony analyses of morphology, *matK* and ITS1-5.8S-ITS2 sequences, and combined data.

	Morphology	<i>matK</i>	ITS1-5.8S-ITS2	Total evidence
Total number of characters	27	1908	723	2658
Number of variable characters	27 (100%)	78 (4%)	250 (34%)	354
Number of phylogenetically informative characters	23	30	85	135
Average number of changes per variable site	2.6	1.1	1.4	—
Number of MPTs	31	1	2	1
Tree length (steps)	69	87	344	498
CI	0.65	0.89	0.82	0.80
RI	0.67	0.87	0.55	0.61
Number of clades in bootstrap consensus with >80% support	2	3	2	3

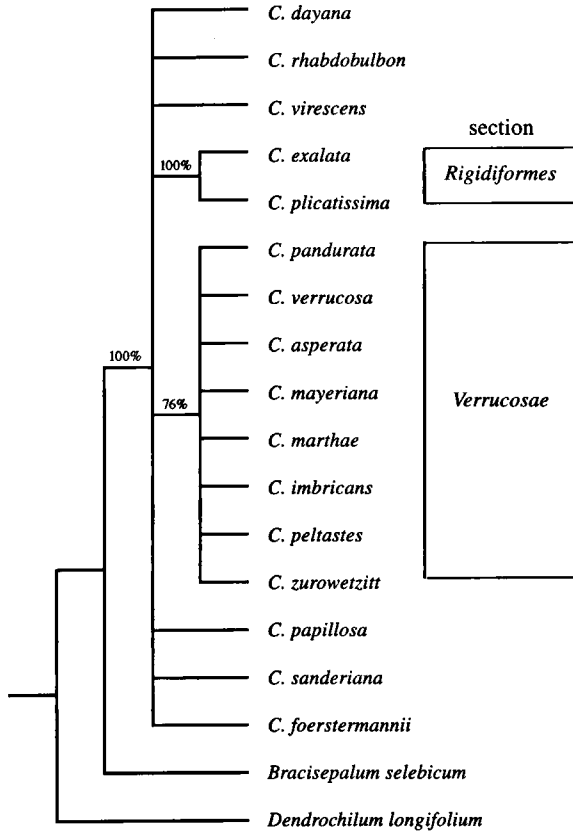

Fig. 1. Bootstrap consensus of 31 trees from parsimony analysis of morphological data (only percentages >50% are given).

and the corresponding branch supports are shown in Fig. 2. Resolution of this single MPT is low, too. Three clades receive high support: *Coelogyne* (100%), sect. *Tomentosae* (93%), and sect. *Verrucosae* excluding *C. virescens* (98%).

Length ranges of the ITS-5.8S-ITS2 sequences were 204–253, 159–163 and 242–271 bp respectively. Boundaries of the 5.8S gene were taken from Hershkovitz & Lewis (1996). The alignment has a total number of 723 sites, of which 250 were variable and 85 were phylogenetically informative (Table 2). The MP analyses yielded two most parsimonious trees (length = 344; CI = 0.82; RI = 0.55). The bootstrap consensus topology and the corresponding branch supports are shown in Fig. 3. Resolution of the ITS consensus is low, too. Three clades receive moderate to strong support: *Coelogyne* (62%), sect. *Verrucosae* excluding *C. virescens* (92%), and *C. asperata*, *C. mayeriana* plus *C. verrucosa* (81%).

Total evidence analysis

Differences in tree topologies between the different analyses are probably due to sampling error (Huelsenbeck et al., 1996). To improve sampling, a combined analysis of all three data sets was performed. Bootstrap analysis of the combined data set provides more resolution and higher internal support for relationships than did any of the individual data sets. The data matrix of the combined molecular and morphological analyses contains 2658 sites, of which 354 were variable and 135 phylogenetically informative (Table 2). The MP analyses yielded a single most parsimonious tree (length = 498; CI = 0.80; RI = 0.61), which is indicated in Fig. 4 with the corresponding branch supports. Resolution of the total evidence analysis is higher than any of the individual data sets. Three strongly supported clades are present: *Coelogyne* (100%), sect. *Verrucosae* excluding *C. virescens* (100%), and sect. *Tomentosae* (87%). A clade consisting

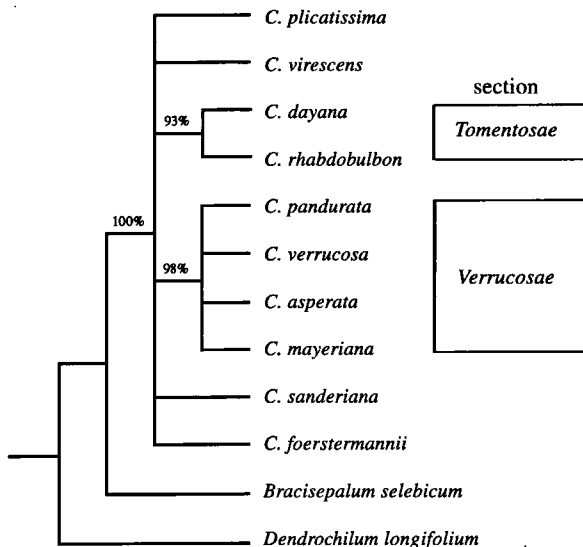

Fig. 2. Single MPT from parsimony analysis of *matK* sequences (only percentages >50% are given).

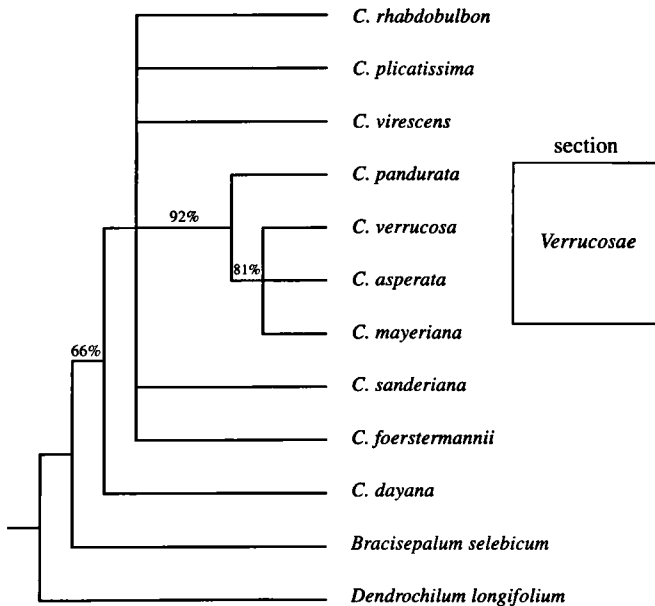

Fig. 3. Bootstrap consensus of 2 trees from parsimony analysis of ITS1-5.8S-ITS2 sequences (only percentages >50% are given).

of *C. asperata*, *C. mayeriana* and *C. verrucosa* receives moderate support (71%). Two weakly supported clades unite *C. sanderiana* with *C. plicatissima* (57%) and sect. *Verrucosae* with sect. *Brachypterae*, sect. *Coelogyne* and sect. *Rigidiformes* (52%).

DISCUSSION

Separate and combined analyses of morphological and molecular data indicate that sect. *Verrucosae* excluding *C. papillosa* and *C. virescens* is monophyletic. The species of sect. *Verrucosae* as here recognized have the following unique synapomorphies: warts, teeth or calli on the epichile and a column hood with smooth margin. All other species analysed have bar-shaped, plate-like or rounded keels and a column hood with a dentate margin. Within sect. *Verrucosae*, a smaller clade, consisting of *C. asperata*, *C. mayeriana* and *C. verrucosa* receives weak support (71%). These species all have an emarginate hypochile base, in *C. pandurata* this can be emarginate to subtruncate.

Neither morphological data nor *matK* or ITS sequences provided sufficient resolution to study interspecific relationships within sect. *Verrucosae*. Variation of *matK* on species level appeared to be too low (only 4%; Table 2). In contrast, the ITS1-5.8S-ITS2 regions seem to lack resolution due to high internal conflict among the sequences collected, as can be deduced from the relatively low RI (0.55; Table 2). This higher level of homoplasy could be caused by a problem of alignment in such a rapidly evolving region. To produce a final phylogeny of the section, data from other DNA regions should be collected.

The results of the total evidence analysis identified *C. virescens* as nearest neighbour to the species of sect. *Verrucosae*. This species shares the herbaceous leaves and the presence of a claw on the hypochile with most of the species of sect. *Verrucosae*. *Coelogyne virescens* has quite a few autapomorphic characters, however, such as a hysteranthous inflorescence, imbricate bracts at the base of the peduncle, a glabrous ovary and linear-lanceolate petals, supporting the view that this species should not be considered as a member of the same section. These characters are also present in *C. brachyptera* and *C. parishii*. A phylogenetic analysis with all three species might show whether they should be placed in a section of their own (sect. *Brachypterae*) as suggested by De Vogel (1994) and Clayton (in prep.).

The results of the morphological analysis support our view that *C. papillosa* should be removed from sect. *Verrucosae* because of its significant morphological differences. *Coelogyne papillosa* has a pronounced zigzagging rhachis, a column hood with dentate margin, a lip with six keels, and nerves on the lateral lobes of the hypochile which are pronounced as low rounded keels. In contrast, the species of sect. *Verrucosae* all have a more or less straight rhachis, a column hood with smooth margin, a lip with three keels, and nerves on the lateral lobes of the hypochile which are not prominent. The characters described for *C. papillosa* occur also in species of sect. *Coelogyne* and sect. *Tomentosae*. Therefore, this species might belong to one of these sections.

Another well supported clade in the total evidence analysis consists of species of sect. *Tomentosae* (87%). They are characterized by the relatively high number of sterile bracts on the base of the rhachis, more than 25 flowers per inflorescence, a subtruncate hypochile base, and white veins on the lateral lobes of the hypochile. This section seems clearly separated from the other *Coelogyne* species sampled (although support for this is weak, only 52%), which all have a relatively low number of sterile bracts on the rhachis, less than 25 flowers per inflorescence, an emarginate or subtruncate hypochile base, and brown, black or green veins on the lateral lobes of the hypochile.

Another weakly supported clade consists of *C. plicatissima* and *C. sanderiana* (57%). These species share one apomorphy: obovate-lanceolate petals. In many other characters, however, such as the shape of the pseudobulbs, type of inflorescence, shape of the hypochile base and lateral lobes, number of the keels on the hypochile, ornamentation of the lateral lobes, plate and margin of the epichile, and shape of the apex of the anther, they show considerable differences. A larger taxon sampling is needed to find out if these species belong to one monophyletic group.

To determine whether traditionally used key characters for sectional delimitation in *Coelogyne* are phylogenetically informative, their character state evolution was reconstructed on the single MPT from the total evidence analysis (Fig. 4). Characters with high phylogenetic potential are the number of sterile bracts on the rhachis and the shape of the ornamentation on the epichile. Less than two sterile bracts on the rhachis seem to be the plesiomorphic condition for the set of taxa analysed, and more than two bracts the derived condition. Swollen, bar-shaped keels on the epichile are the plesiomorphic condition for the set of taxa analysed and molar, tooth like or irregularly rounded warts the apomorphic condition. The inflorescence type, amount of ovary indumentum and number of keels on the hypochile show many parallelisms and appear not to be phylogenetically useful for the set of taxa analysed.

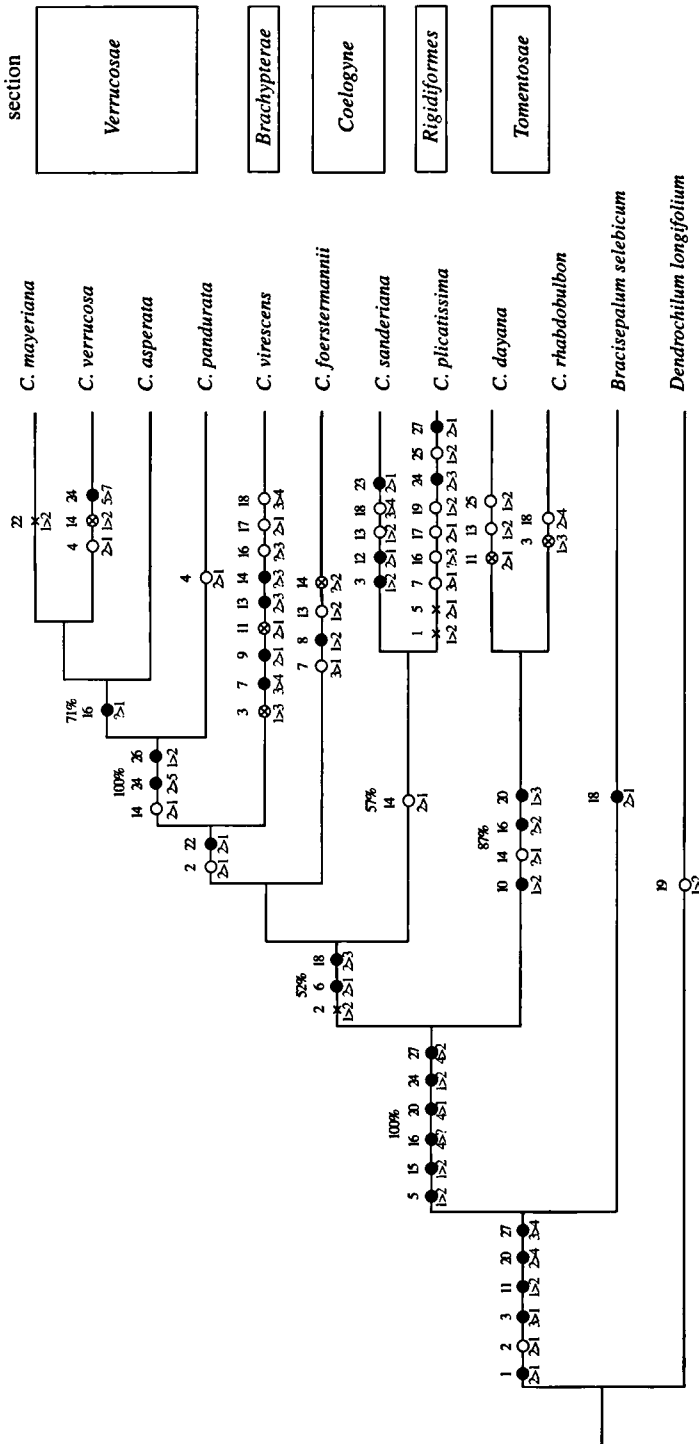

Fig. 4. Single MPT from total evidence analysis with bootstrap support values (only percentages >50% are given). The character state changes of the morphological characters used were traced with MACCLADE version 3.04 (Maddison & Maddison, 1992). ● = unique apomorphy; ⊙ = parallelism; x = reversal; ⊗ = parallel reversal.

CHARACTERS

For easy reference, diagnostic characters and their states for sect. *Verrucosae* are briefly described below. Characters diagnostic for the genus *Coelogyne* are omitted here. These can be found in Butzin (1992) and Dressler (1993).

Pseudobulbs

The outline of the pseudobulbs varies from ovate to ovate-lanceolate to elliptic to lanceolate. The pseudobulbs are round in cross section as in *C. asperata* and *C. mayeriana*, slightly flattened as in *C. pandurata* or strongly flattened as in *C. marthae*, *C. verrucosa*, *C. peltastes*, *C. imbricans* and *C. zurowetzii*. The pseudobulbs of the last four species have an incurved margin.

Inflorescence

The inflorescence is proteranthous or synanthous, and in most cases both conditions are present within one species. Usually the inflorescence is curved from a more or less erect base.

Rhachis

The rhachis is more or less straight to slightly zigzagging, and has scattered minute scale-like hairs. The number of internodes varies from 4 to 24. *Coelogyne asperata* and *C. pandurata* have the largest number.

Floral bracts

Persistent sterile and fertile bracts are present in all species of the section. Both types of bracts have many fine nerves, a midrib which is not prominent, and dense minute scale-like hairs outside. There are one to three sterile imbricate bracts at the base of the rhachis; these are elliptic to oblong or (ovate-)oblong to (ovate-)lanceolate, and more or less appressed to the rhachis. The fertile bracts are elliptic to oblong or (ovate-)oblong to (ovate-)lanceolate with incurved margins, and they clasp the base of the pedicel.

Flowers

The flowers are medium-sized to large, distichous, opening widely, more or less simultaneously, often more or less curved to one side and with scattered minute scale-like hairs on pedicel, ovary and the outside of the sepals and petals. On average most of the species have 3–15 flowers in an inflorescence, with the exception of *C. asperata*, which may have up to 35 flowers.

Hypochile

The hypochile is boat-shaped, when flattened emarginate, subtruncate or rounded at the base. The lateral lobes sometimes project backwards at the back, and are triangular-ligulate or (broadly) rounded in front, with a rounded to semi-orbicular apex. There are three keels on the hypochile in all species of the section. They have an entire margin and are low and rounded at the very base. The median keel is usually low, rounded, single crested and smooth (with the exception of *C. mayeriana*, where it has projections over the entire length). The lateral keels are higher than the median keel, thin to thick plate-like and single- or double-crested.

Epichile

The epichile is spatulate or not depending on the presence or absence of a claw. When present, the claw is more or less rectangular and has straight or irregular margins. The blade is usually irregularly rectangular, quadrangular, ovate or triangular. The margin of the blade is in most species broadly undulate; in *C. zurowetzii* it is finely undulate. The ornamentation varies within the species and consists of molar-like warts (*C. asperata*, *C. pandurata*, *C. peltastes*, *C. zurowetzii*), tooth-like warts (*C. peltastes*, *C. mayeriana*), flattened calli (*C. imbricans*), rounded papillae (*C. verrucosa*, *C. zurowetzii*), or keels that are broken up in flat irregular teeth or warts (*C. marthae*).

SYSTEMATIC TREATMENT

Coelogyne section Verrucosae

Coelogyne Lindl. sect. *Verrucosae* Pfitzer & Kraenzl. in Engl., Pflanzenr. 32 (1907) 73; Schltr., Feddes Rept. Beih. 1 (1911) 101; Butzin, Willdenowia 7 (1974) 252; Seidenf., Dansk Bot. Ark. 29 (1975) 66; Butzin in Schltr. et al., Die Orchideen 1A (1992) 935; De Vogel, Proc. 14th World Orch. Conf. (1994) 204. — Type species: *Coelogyne pandurata* Lindl. (here chosen).

Small to large epiphytes, terrestrials or lithophytes. Roots terete, glabrous. Rhizome creeping or climbing, terete, 3–14 internodes between two pseudobulbs; rhizome scales overlapping or not (*C. mayeriana*), chartaceous, long persistent, densely covered with minute scale-like hairs. *Pseudobulbs* close together to wide apart, in cross section round to strongly flattened, in outline elliptic to lanceolate or ovate to ovate-lanceolate, sometimes with incurved margins, 2-leafed; scales (cataphylls) covering the pseudobulb chartaceous, with dense minute scale-like hairs, long persistent or soon disintegrating in short persistent fibres. *Leaves* herbaceous; petiole semi-terete, channelled, with scattered minute scale-like hairs; blade obovate to obovate-lanceolate or oblong to lanceolate, base gradually narrowing into the petiole, top acute to acuminate, main nerves 3–11, above sunken, below quite prominent, additional nerves not conspicuous. *Inflorescence* proteranthous or synanthous, curved from a more or less erect base, 3–35-flowered. Scape with scattered minute scale-like hairs. Rhachis about straight to slightly zigzagging, with scattered minute scale-like hairs; internodes 4–37. *Bracts* persistent, herbaceous, with many fine nerves and dense minute scale-like hairs on the outside, midrib not prominent; sterile bracts 1–3 at the base of the rhachis, elliptic to oblong or ovate-oblong to ovate-lanceolate, more or less appressed to the rhachis, overlapping; fertile bracts elliptic to oblong or ovate-oblong to ovate-lanceolate, clasping the base of the pedicel, the margins incurved. *Flowers* medium-sized to large, distichous, opening widely, more or less simultaneously, often more or less curved to one side, with scattered minute scale-like hairs on pedicel, ovary and the outside of the sepals and petals; lip in lowermost position due to curving of rhachis or irregular curving or twisting of pedicel and ovary. Pedicel straight to curved, terete; ovary about straight to curved, terete, with 6 broad longitudinal ribs. *Median sepal* ovate-oblong to ovate-lanceolate; top acute; nerves 9–15, median nerve prominent. *Lateral sepals* slightly falcate to falcate, ovate-oblong to ovate-lanceolate; top acute; nerves 7–11. *Petals* (obovate-)lanceolate; top acute; midrib rather prominent to slightly pronounced as a low rounded keel; nerves 3–11. *Lip* 3-lobed, glabrous. *Hypochile* boat-shaped, at

the base emarginate, subtruncate or rounded; lateral lobes projecting backwards or not, in front triangular-ligulate, (broadly) rounded, with rounded to semi-orbicular apex; keels 3 with entire margin, low and rounded at the base, the median keel low, rounded, single crested, smooth, or with projections over the entire length (*C. mayeriana*), the lateral keels higher than the median keel, thin to thick plate-like, single or double crested. *Epichile* without or with a more or less rectangular claw with straight or irregular margins; blade irregularly rectangular, quadrangular, ovate or triangular; top truncate, retuse, acute or rounded, tip mostly acute with a small notch on either side, margins broadly and regularly undulate or finely undulate (*C. zurowetzii*), when flattened about straight or irregular, ornamentation consisting of molar-like warts (*C. asperata*, *C. pandurata*, *C. peltastes*, *C. zurowetzii*), tooth-like warts (*C. peltastes*, *C. mayeriana*), flattened calli (*C. imbricans*), rounded papillae (*C. verrucosa*, *C. zurowetzii*), or keels broken up in flat irregular teeth or warts (*C. marthae*). *Column* (narrowly) spatulate, with scattered minute scale-like hairs; base very slightly thickened to distinctly swollen, in front projecting into a very small to pronounced column foot, on the junction with the stalk with a low cross ridge; stalk slightly and gradually widening from the base; margins slightly winged; hood about rectangular, triangular, rounded, obovate or ovate, top truncate, rounded or broadly rounded, with slightly irregular margin. *Anther* about quadrangular, obovate or obcordate; base triangular or ligulate; top broadly rounded to truncate, emarginate. *Pollinia* four, obovate, each with an oblique central depression which becomes shallower towards the base, all connate at the base by a flattened, broadly triangular caudicle. *Stigma* semi-elliptic; lower margin distinctly raised; rostellum about rectangular. *Fruit* ellipsoid; margins flat; valves with a low keel. *Seeds* shortly fusiform; embryo ellipsoid.

Distribution — Eight species distributed from Sumatra to the Santa Cruz Islands. *Coelogyne asperata* covers the entire distribution area of the section: Java, Sumatra, Peninsular Malaysia, Borneo, Sulawesi, Philippines, Moluccas, New Guinea, Solomon Islands and Santa Cruz Islands. *Coelogyne mayeriana* has been found in Sumatra, Singapore, Peninsular Malaysia and Borneo. *Coelogyne pandurata* occurs in Sumatra, Peninsular Malaysia, Borneo, and possibly the Philippines. The other species are endemic to Borneo, which is the centre of diversity.

Habitat & Ecology — Epiphytes, terrestrials or lithophytes. In peat-swamp and mixed Dipterocarp lowland forest, heath forest, and montane forest, in shaded to quite exposed positions, on granite or ultramafic substrate. Elevation 0–2050 m. Flowering all year round, but only once or twice a year in any given locality.

Conservation status — As far as could be ascertained *Coelogyne mayeriana* has not been collected from the wild for more than 50 years, except for a collection from Sabah. As this conspicuous orchid is not easily overlooked it is probably seriously endangered. *Coelogyne imbricans*, *C. marthae*, *C. peltastes* and *C. zurowetzii* are known from very few collections only, they must be considered rare and vulnerable. *Coelogyne pandurata* is widespread but rather uncommon and *C. verrucosa* is fairly common in North and West Borneo, whereas *C. asperata* is a common and widespread species.

Cultivation — Only *C. asperata* and *C. pandurata* are widely cultivated.

Artificial hybrids — Several hybrids have been produced. Erfkamp & Gruß (1996) mention the following: *C. × brymeriana*, a hybrid between *C. asperata* Lindl. and *C. dayana* Rchb. f., made by W.E. Brymer in 1906. *Coelogyne × burfordiense*, a hybrid

between *C. asperata* Lindl. and *C. pandurata* Lindl., made by Trevor Lawrence in 1907 (Plate 1b). *Coelogyne* × *albanense*, a hybrid between *C. pandurata* Lindl. and *C. sanderiana* Rchb.f., made by C.F. Sander, F.K. Sander & L.L. Sander in 1913. *Memoria Soedjana Kassan*, a hybrid between *C. speciosa* Lindl. and *C. asperata* Lindl., made by A.S. Parnata in 1976. Sander et al. (1927) mention *C. × sanderiana*, a hybrid between *C. pandurata* Lindl. and *C. × albanense*, made by C.F. Sander, F.K. Sander & L.L. Sander in 1913. The Royal Horticultural Society (1993, 1997) mentions *Green dragon*, a hybrid between *C. pandurata* Lindl. and *C. massangeana* Rchb.f., made by the Burnham Nurseries in 1992, and *South Carolina*, a hybrid between *C. × burfordiense* and *C. pandurata* Lindl., made by Carter & Holmes in 1996.

Explanation of terms — Definitions of peduncle and rhachis are given in Vermeulen (1995). A scape is here considered as the part of the peduncle, not covered by the scales of the young shoot.

KEY TO THE SPECIES

- 1a. Pseudobulbs in cross section circular 2
- b. Pseudobulbs in cross section slightly to strongly flattened 3
- 2a. Rhizome scales not overlapping; pseudobulbs (3.5–)8–24 cm apart **4. *C. mayeriana***
- b. Rhizome scales overlapping; pseudobulbs (1.2–)2.5–6.5 cm apart **1. *C. asperata***
- 3a. Claw on midlobe of lip present, longer than or equal to 2.5 mm 4
- b. Claw on midlobe of lip absent, or if present shorter than 2.5 mm 5
- 4a. Pseudobulb 1.5–3 cm diam. when fresh, margins not incurved; ornamentation on the midlobe of the lip consisting of a patch of molar-like warts, the whole patch 8–17 by 7–18 mm **5. *C. pandurata***
- b. Pseudobulb 0.7–1.3 cm diam. when fresh, margins incurved; ornamentation on the midlobe of the lip consisting of a patch of big rounded, projecting warts, the whole patch 4.5–13 by 3–7 mm **7. *C. verrucosa***
- 5a. Claw on midlobe of lip present; 2, 4 or 6 swollen nerves on the claw and base of the epichile 6
- b. Claw on midlobe of lip absent; swollen nerves on the base of the epichile absent 7
- 6a. Margin of midlobe very finely undulate; ornamentation on midlobe consisting of short rows or patches of scattered, single or connected, rounded and molar-like warts **8. *C. zurowetzii***
- b. Margin of midlobe broadly undulate; ornamentation on midlobe consisting of two irregular flattened calli, which together have a more or less ovate shape . . . **2. *C. imbricans***
- 7a. Median keel on the lip continuing on the base of the midlobe; ornamentation on the midlobe consisting of a patch of tooth-like, more or less flattened warts, often arranged in radiating rows, the whole patch 7–12 by 5–10 mm . **6. *C. peltastes***
- b. Median keel on the lip not reaching the base of the midlobe; ornamentation on the midlobe consisting of a patch of 4–6 single-crested, parallel keels which are broken up in flat irregular teeth or warts, the whole patch 5–9 by 5–8 mm **3. *C. marthae***

1. *Coelogyne asperata* Lindl. — Fig. 5, Plate 1a, Map 1

Coelogyne asperata Lindl., J. Hort. Soc. London 4 (1849) 221, t. 7; Fol. Orchid. (1854) 3; Miq., Fl. Ned. Ind. 3 (1859) 666; Rchb.f., Ann. Bot. Syst. 6 (1861) 224; Hook.f., Fl. Brit. India 5 (1890) 835; H.J. Veitch, Man. Orchid. Pl. 6 (1890) 31; Ridl., J. Linn. Soc., Bot. 31 (1896) 287, 326; Pfitzer & Kraenzl. in Engl., Pflanzern. 32 (1907) 76, f. 25C–D, 26A; Ridl., Mat. Fl. Malay. Penins. 1 (1907) 129; J.J. Sm., Nova Guinea 8 (1911) 20, 527; Engl., Bot. Jahrb. Syst. 48 (1912) 96; J.J. Sm., Nova Guinea 12 (1915) 196; Ridl., Trans. Linn. Soc. London II, 9 (1916) 202; J.J. Sm., Teysmannia 31 (1920) 255; Ridl., Fl. Malay. Penins. 4 (1924) 131; Ames in Merr., Enum. Philipp. Flow. Pl. 1 (1924) 280; Burkill & M.R. Hend., Gard. Bull. Straits Settlement. 3 (1925) 438; C.F. Sander, F.K. Sander & L.L. Sander, Sander's Orch. Guide (1927) 212; J.J. Sm., Bull. Jard. Bot. Buitenzorg III, 10 (1928) 104; III, 11 (1931) 105; Ames, J. Arnold Arbor. 13 (1932) 129; J.J. Sm., Bot. Jahrb. Syst. 65 (1933) 464; Feddes Repert. Beih. 32 (1933) 161; Carr, Kew Bull. (1934) 377; Dakkus, Orch. Ned. Ind. 3 (1935) 75, f. 30; Quisumb., Philipp. Orchid Rev. (1951) 9; Davis & Steiner, Philipp. Orchid Rev. (1952) 75; Latif, Bunga Anggerik (1953) 90; Holttum, Orchids of Malaya 3 (1964) 253; Andrée Millar, Orchids of Papua New Guinea (1978) 74; Bechtel in P.J. Cribb & Launert, Orch. Atl. (1980) 100; Chadim, Orchadian 7, 3 (1982) 60, f. 1, 2; B. A. Lewis & P.J. Cribb, Orchids of the Solomon Islands and Bougainville (1991) 88; Seidenf. & J.J. Wood, Orchids of Penins. Malaysia and Singapore (1992) 217, f. 92a–b, pl. 12d. — *Pleione asperata* (Lindl.) Kuntze, Rev. Gen. Pl. 2 (1891) 680. — Type: *Twisden Hodges cult. s.n.* (30/5/1849) (holo K-LINDL, not found), Borneo. Neotype (here chosen): *Lobb s.n.* (Veitch & Son) (holo K-LINDL), Borneo.

Coelogyne lowii Paxton, Paxton's Mag. Bot. 16 (1849) 225; Ames in Merr., Enum. Philipp. Flow. Pl. 1 (1924) 283. — Type: *Low s.n.* (??/1845) (holo K, not found), Borneo.

Coelogyne edelfeldtii F. Muell. & Kraenzl., Oesterr. Bot. Z. 44 (1884) 421; Pfitzer & Kraenzl. in Engl., Pflanzern. 32 (1907) 76. — Type: *Edelfeldt s.n.* (??/1884) (holo HBG, not found), New Guinea.

Coelogyne pustulosa Ridl., J. Bot. 24 (1886) 353; Pfitzer & Kraenzl. in Engl., Pflanzern. 32 (1907) 73, f. 26D; Schltr., Feddes Repert. Beih. 1 (1914) 105; Rendle, J. Bot. (Hooker) 61 (1923) 55. — Type: *Forbes s.n.* (??/1886) (holo BM), New Guinea, South Cape.

Roots 3–5 mm diameter. Rhizome creeping, 1–1.8 cm thick, 7–14 internodes between two pseudobulbs; scales overlapping. *Pseudobulbs* (1.2–)2.5–6.5 cm apart, in cross section terete, with shallow grooves, in outline (ovate-)lanceolate, 7–25 by 3–5.6 by 2–4.5 cm; scales covering the pseudobulb 7–23 by 4–6 cm. *Leaf* petiole 5.5–38 by 0.7–1.5 cm; blade lanceolate, 26–110 by 4.5–20 cm; main nerves 5–9. *Inflorescence* proteranthous or synanthous, 6–35-flowered. Scape 6–22 cm long including the part covered by the scales of the young shoot. Rhachis 12–33 cm long; internodes 7–24, 0.8–4.2 cm long. *Sterile bracts* 1 or 2 (or 3), elliptic to oblong, 2.6–4.7 by 1–2.8 cm; fertile bracts elliptic, 2.5–4 by 1.3–3 cm. Pedicel 10–37 by 2–3 mm; ovary 5–15 by 3–4 mm. *Median sepal* ovate-oblong, 30–45 by 10–17 mm; nerves 9–11, the median one prominent. *Lateral sepals* slightly falcate, ovate-oblong to ovate-lanceolate, 30–42 by 7–15 mm; nerves 7–9. *Petals* obovate-lanceolate, 30–45 by 4.5–8 mm; nerves 3–5, midrib slightly prominent. *Hypochile* 15–25 by 20–32 mm, base emarginate; lateral lobes 15–25 by 5–10 mm, at the base projecting backwards for 2–3 mm, in front triangular-ligulate, projecting for 5–8 mm, with rounded or rarely acuminate apex; keels 3, with entire margin, low and rounded at the base, the median keel low and rounded, gradually lowering to the front, rarely very short, at the top often bifurcate, on the top part of the hypochile continuing into two longitudinal rows of irregular, rounded to acute, raised molar-like structures, the lateral keels higher than the median keel, thick plate-like, continuing into similar raised structures as the median one.

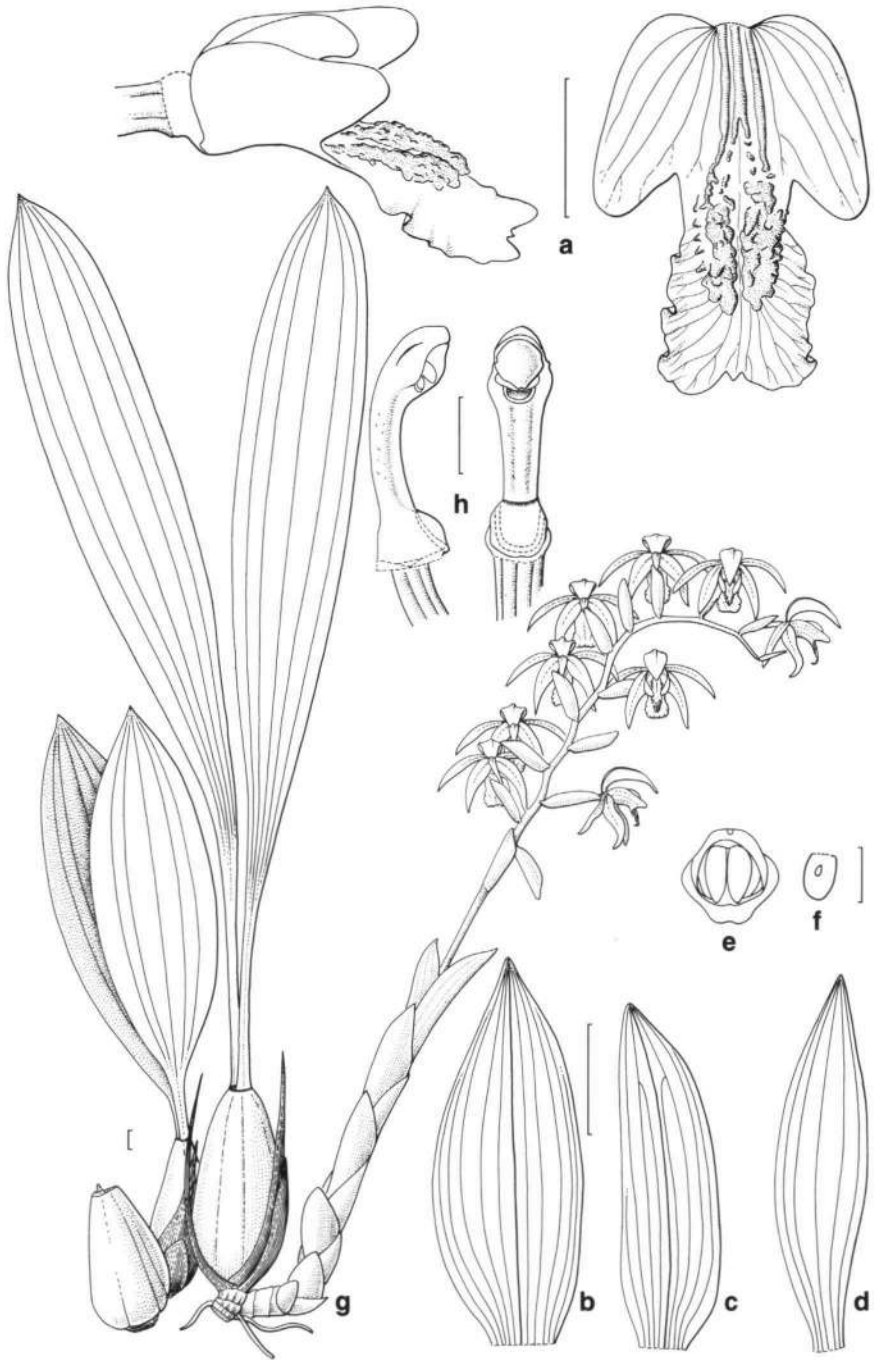

Fig. 5. *Coelogyne asperata* Lindl. a. Lip ornamentation, lateral and front view (*Leiden cult.* 21480); b. median sepal; c. lateral sepal; d. petal; e. anther; f. pollinium; g. habit; h. column: lateral and front view (*Leiden cult.* 22279). — Scale bars: 1 cm (a–d, g); 2 mm (e, f); 5 mm (h).

Epichile about spatulate, 16–26 by 10–17 mm; claw about rectangular, (2–)5–10 by 8–12 mm, margins straight, ornamentation consisting of two raised bands of molar-like structures as on the hypochile, continuing on the blade; blade irregularly rectangular to quadrangular to ovate, 9–15 by 10–17 mm, the top truncate to acute, the tip acute, triangular, mostly with a small notch on either side, the margin broadly and regularly undulate, when flattened about straight, ornamentation consisting of two bands of molar-like structures, the whole patch of these structures on claw and midlobe in outline more or less elliptic, 12–17 by 8–12 mm. *Column* in outline spatulate, 8–17 by 3–4.5 mm; column foot small; stalk 5.5–14 by 2–3 mm; hood about triangular, 4–7 by 3–4.5 mm, top broadly rounded, with slightly irregular margin. *Anther* about quadrangular, 3–4 by 3–4 mm, base triangular, top broadly rounded, tip emarginate. *Pollinia* obovate, 1–1.5 by 1–1.2 mm. *Stigma* semi-elliptic, 2.5–3.5 by 3–4 mm; rostellum about rectangular, 1.3–2 by 2.2–2.7 mm. *Fruit* ellipsoid; body 5–9 by 2.5–5 cm; margins flat, 3–5 mm wide; valves 30–45 mm wide, with a low keel. *Seeds* shortly fusiform, to 2–3 mm long; embryo 0.5–1 mm long.

Distribution — Sumatra, Peninsular Malaysia, Borneo (Sabah, Brunei, Sarawak, Kalimantan), Java, Sulawesi, Philippines, Moluccas, New Guinea (Irian Jaya, Papua New Guinea), Solomon Islands, Santa Cruz Islands.

Habitat & Ecology — Epiphytes on trunks and big branches of trees, lithophytes or terrestrials. Lowland and montane forest, in partial shade to quite exposed, also along rivers, in forest on limestone and in swamp forest. Elevation 10–2042 m. Flowering all the year when considered over its entire range, but in any given area flowering only once or twice a year.

Notes — 1. Pseudobulbs and leaves green. Sepals and petals creamy yellow to almost white, or pale greenish. Lip white or pale greenish, at the extreme base orange; keels white; lateral lobes with 3–5 brown veins; claw and blade with orange-brown

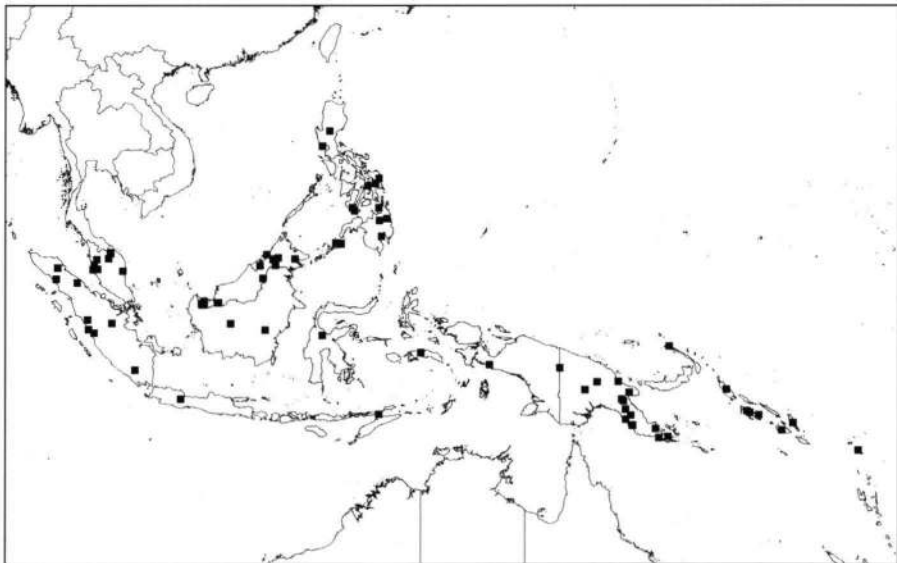

Map 1. Distribution of *Coelogyne asperata* Lindl.

molar-like projections. Column creamy yellow, or sometimes pale greenish, with scattered brown scale-like hairs; cross ridge on column foot orange. Anther creamy yellow or pale greenish; pollinia light yellow. Ovary cream coloured or pale greenish, with brown scale-like hairs. Root tip pale orange. Fragrant. Colour description based on living material, slides, and notes on the labels of the collections.

2. The epithet *asperata* (which is Latin for rough, uneven) refers to the raised patch of projections on the midlobe of the lip.

3. The dimensions are based on living and spirit material.

4. The species can be recognized by the non-flattened pseudobulbs that are close together and the presence of two raised patches of molar-like projections on the claw and the epichile.

5. O'Byrne (1994) reports this species to be pollinated by beetles.

2. *Coelogyne imbricans* J.J. Sm. — Fig. 6, Map 2

Coelogyne imbricans J.J. Sm., Bull. Jard. Bot. Buitenzorg III, 2 (1920) 26; Dakkus, Orch. Ned. Ind. 2 (1931) 70; 3 (1935) 86. — Type: *Bogor cult. s.n. (?/1918)* (H.L.B. 9226298) (holo L; iso L), Borneo.

Roots not seen. Rhizome creeping or climbing (type description), not seen. *Pseudobulbs* 4–5.5 cm apart (type description), in cross section very flattened, thickness not known, imbricate over each other like roof tiles, in outline oblong, with incurved margins, 6–11.5 by 4–8 cm; scales covering the pseudobulb not seen. *Leaf* petiole 1.5–7.5 by 0.4–0.6 cm; blade obovate-oblong or oblong, 11.5–23 by 4–7.6 cm; main nerves 7–11. *Inflorescence* synanthous (type description), 6–10-flowered. Scape 4–7 cm long including the part covered by the scales of the young shoot. Rhachis 11.8–24 cm long; internodes 7–11, 2–4 cm long. *Sterile bract* 1, elliptic to oblong, 2–2.7 by 1–1.2 cm; fertile bracts elliptic, 2–3 by 1.3–1.9 cm. Pedicel 25–42 by 0.8–1.5 mm; ovary 7–9.5 by 1–2 mm. *Median sepal* ovate-lanceolate, 29–35 by 7–11 mm; nerves 9–11, the median one prominent. *Lateral sepals* falcate, ovate-oblong to ovate-lanceolate, 23–32 by 7–12 mm; nerves 7–9. *Petals* obovate-lanceolate, 23–33 by 4–8 mm; nerves 7, midrib slightly prominent. *Hypochile* 11.5–15 by 12–14 mm, when flattened the base subtruncate; lateral lobes 11.5–15 by 3.5–6 mm, at the base not projecting backwards, in front the free part triangular, projecting for 2–3 mm, with rounded apex; keels 3, with entire margin, low and rounded at the base, the median keel low and rounded, gradually lowering to the front, ending near the junction of hypo- and epichile, the lateral keels at the basal half higher than the median keel, plate-like, gradually ascending towards the top of the epichile and there abruptly lowering into the median raised nerves on the claw of the epichile. *Epichile* about spatulate, 10–13 by 7.8–9.5 mm; claw about rectangular, 1.7–2.3 by 4–4.8 mm, margins straight, with 4–6 swollen nerves which continue on the blade; blade irregularly rectangular to quadrangular to ovate, 9–10 by 7.8–9.5 mm, the top truncate, to acute, the tip acute,

Plate 1. — a. *Coelogyne asperata* Lindl. (*Leiden cult.* 27621, Sarawak). Photograph A. Vogel. — b. *C. × burfordiense* (*Leiden cult.* 21413, unknown origin). Photograph B. Kieft. — c. *C. pandurata* Lindl. (*Leiden cult.* 21532, unknown origin). Photograph C.G. Koops. — d. *C. pandurata* Lindl. (*Leiden cult.* 930916, Sarawak). Photograph A. Schuiteman.



a. *Coelogyne asperata*



b. *Coelogyne* × *burfordiense*



c. *Coelogyne pandurata*



d. *Coelogyne pandurata*

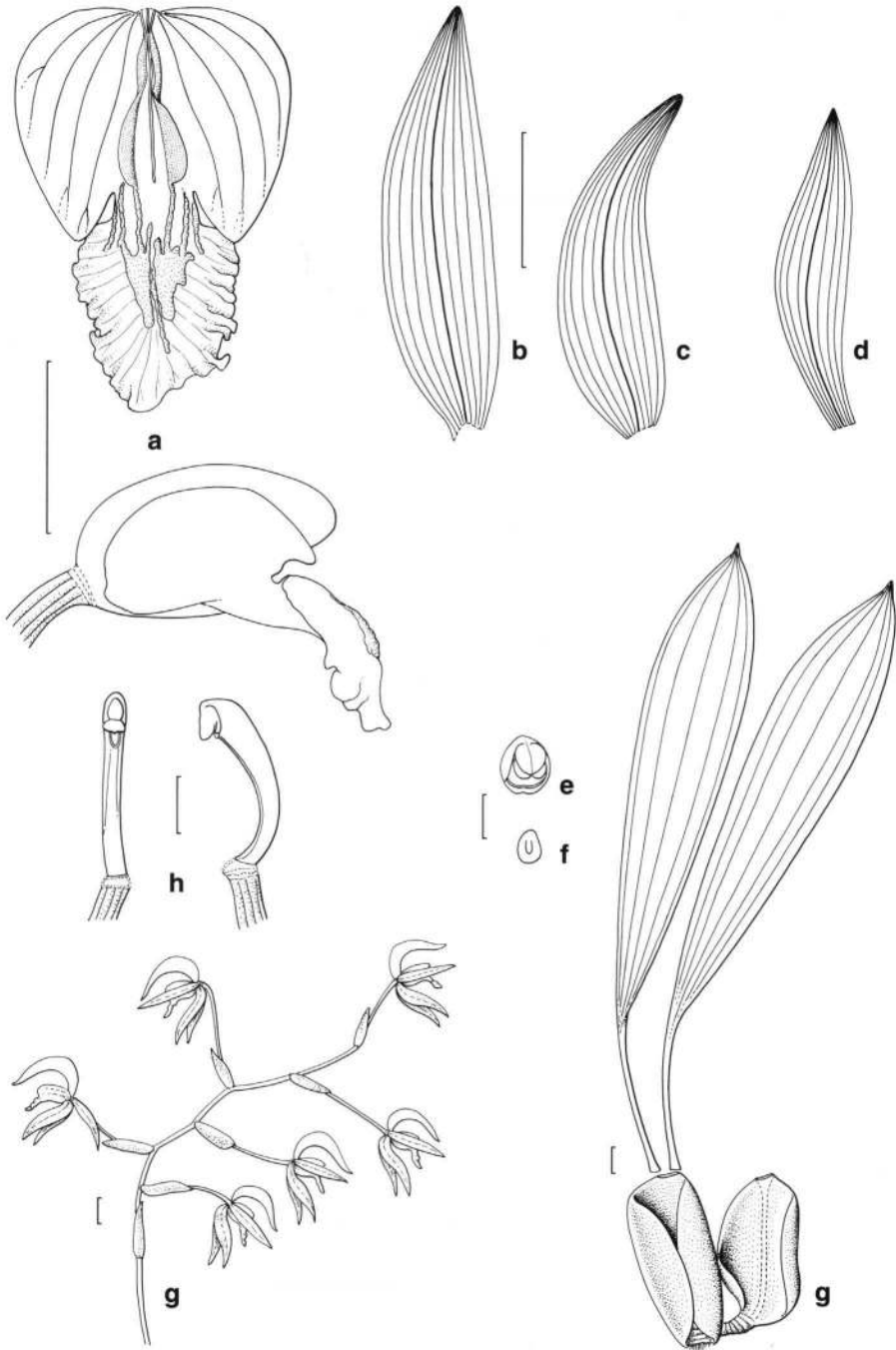
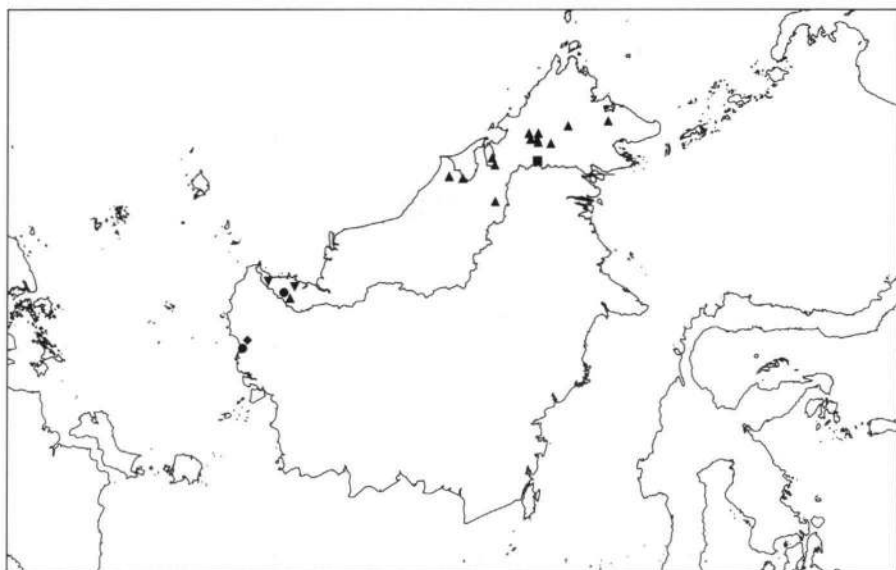

Fig. 6. *Coelogyne imbricans* J.J. Sm. a. Lip ornamentation, front and lateral view; b. median sepal; c. lateral sepal; d. petal; e. anther; f. pollinium; g. habit; h. column: front and lateral view (J.J. Sm. cult., H.L.B. 9226298). — Scale bars: 1 cm (a–d, g); 2 mm (e, f); 5 mm (h).



Map 2. Distribution of *Coelogyne imbricans* J.J. Sm. (●), *C. marthae* S.E.C. Sierra (▼), *C. peltastes* Rchb.f. (◆), *C. verrucosa* S.E.C. Sierra (▲) and *C. zurowetzii* Carr (■).

triangular, mostly with a small notch on either side, the margin broadly and regularly undulate, when flattened about straight, at the base with 4–6 raised nerves, median continuing into two irregular flattened calli which are together more or less ovate, covering a patch 6–6.5 by 4.5–6 mm. *Column* in outline club shaped, distinctly curved, 17–18.4 by 2–2.2 mm; column foot small; stalk 8.4–9 by 1.3–1.8 mm; hood broadly rounded, with slightly irregular margin, 8–10 by 2–2.2 mm, top rounded, with irregular margin. *Anther* obcordate, 2.2–2.8 by 2–2.4 mm, base triangular; top broadly rounded, tip emarginate. *Pollinia* obovate, 1.2–2.5 by 0.7–0.8 mm. *Stigma* semi-elliptic, 2–2.5 by 1.5–2 mm; rostellum about rectangular, 1.2–1.5 by 1–1.2 mm. *Fruit and seeds* not seen.

Distribution — Borneo (Kalimantan, Sarawak).

Habitat & Ecology — Epiphytes. Flowering months unknown.

Notes — 1. Pseudobulbs and leaves green. Sepals and petals pale green. Lip pale greenish, at the extreme base yellow; keels yellow at the base, at the top light green and on the claw light brown; lateral lobes with 6–8 brown veins; claw brown and blade green. Column light greenish; cross ridge on column foot brown, with scattered brown scale-like hairs. Ovary light greenish, with brown scale-like hairs. Scent not recorded. Colour description based on the type publication and on the labels of the specimens seen.

Plate 2. — a. *Coelogyne mayeriana* Rchb.f. (*Leiden cult.* 970767, unknown origin). Photograph C.G. Koops. — b. *C. marthae* S.E.C. Sierra (*Leiden cult.* 27496, Sarawak). Photograph P. Jongejan. — c. *C. verrucosa* S.E.C. Sierra (*Leiden cult.* 970597, Sarawak). Photograph A. Schuiteman. — d. *C. zurowetzii* Carr (*Liem K.W. cult.* 2.84, Kalimantan). Photograph J. Comber.



a. *Coelogyne mayeriana*



b. *Coelogyne marthae*



c. *Coelogyne verrucosa*



d. *Coelogyne zurowetzii*

2. The epithet *imbricans* (which is Latin for overlapping like roof tiles) refers to the overlapping pseudobulbs.

3. The dimensions are based on dry material.

4. The species can be recognized by the very thin imbricate pseudobulbs with flattened incurved margins, two calli on the epichile, and by the brown patch on the top of the lateral lobes.

5. According to Smith (1920) *C. imbricans* is similar to *C. peltastes*, but with more compressed pseudobulbs, smaller and differently coloured flowers, and broader lip with nearly smooth 'keels' (= calli). Although Smith also mentions remarkably small leaves for the size of the pseudobulbs, some leaves of his herbarium specimens are not particularly small.

6. The collection *Maxwell s. n.* (1895) differs in the details of the calli on the epichile, because instead of two single calli, there are a number of rather elliptic, low raised, smooth warts.

3. *Coelogyne marthae* S. E. C. Sierra, *spec. nov.* — Fig. 7, Plate 2b, Map 2

Pseudobulbis parvis planis, labello ungue carenti carinis solitariis cristatis serialibus in lobo mediali dentis vel verrucis irregularibus fractis recognita. — Typus: *Vermeulen 1156* (holo L), Borneo, Sarawak.

Roots 1–3 mm diam. Rhizome climbing, 0.6–0.8 cm thick, 3–6 internodes between two pseudobulbs; scales overlapping. *Pseudobulbs* 0.6–1.3 cm apart, in cross section flattened (in juvenile specimens apparently thicker), in outline ovate-oblong, 1.5–5 by 0.7–2.3 cm, by 0.6–1 cm; scales covering the pseudobulb 6.4–9.7 by 2.8–4 cm. *Leaf* petiole 1–4 by 0.1–0.3 cm; blade lanceolate, 6–28 by 1.2–4.5 cm; main nerves 3–5. *Inflorescence* proteranthous or synanthous, 3–5-flowered. Scape 3.7–8 cm long including the part covered by the scales of the young shoot. Rhachis 7–16.2 cm long; internodes 4–6, 2.3–3.7 cm long. *Sterile bracts* 1 or 2, ovate-lanceolate, 2.3–3.2 by 0.4–1 cm; fertile bracts, ovate-oblong to ovate-lanceolate, 2.4–3 by 0.6–1.2 cm. Pedicel 12–14 by 1.8–2 mm; ovary 5–6 by 2.2–2.5 mm. *Median sepal* ovate-lanceolate, 34–38 by 9–13 mm; nerves 11, the median one prominent. *Lateral sepals* slightly falcate, ovate-lanceolate, 31–35 by 9–10 mm; nerves 7. *Petals* lanceolate, 29–32 by 4–6 mm; nerves 5, midrib slightly prominent. *Hypochile* 14–16 by 17–19 mm, when flattened base emarginate or rounded; lateral lobes 14–16 by 5–7 mm, at the base projecting backwards for 1.8–2.2 mm; in front triangular-ligulate, projecting for 3.8–4.2 mm, with broadly rounded apex; keels 3, with entire margin, low and rounded at the base, the median keel gradually higher, thin plate-like, continuing up to two-thirds of the hypochile or sometimes continuing almost to the top of the epichile, the lateral keels towards the epichile higher than the median keel, widening, thick plate-like, double crested, continuing on the epichile. *Epichile* not spatulate, 13–14 by 15–16 mm; claw absent, blade about irregular quadrangular, the top truncate, the tip acute, triangular, mostly with a small notch on either side, the margin broadly and regularly undulate, when flattened about straight, ornamentation consisting of 4–6 single crested parallel keels, broken up in flat irregular teeth or warts, ending in the top half of the blade, whole patch of ornamentation 5–9 by 5–8 mm. *Column* in outline narrowly spatulate, 14–17 by 3.2–4 mm; column foot rather pronounced; stalk 5–7.3 by 1.8–2.5 mm; hood about rectangular to broadly rounded, 7–10 by 3.2–3.8 mm, top broadly rounded,

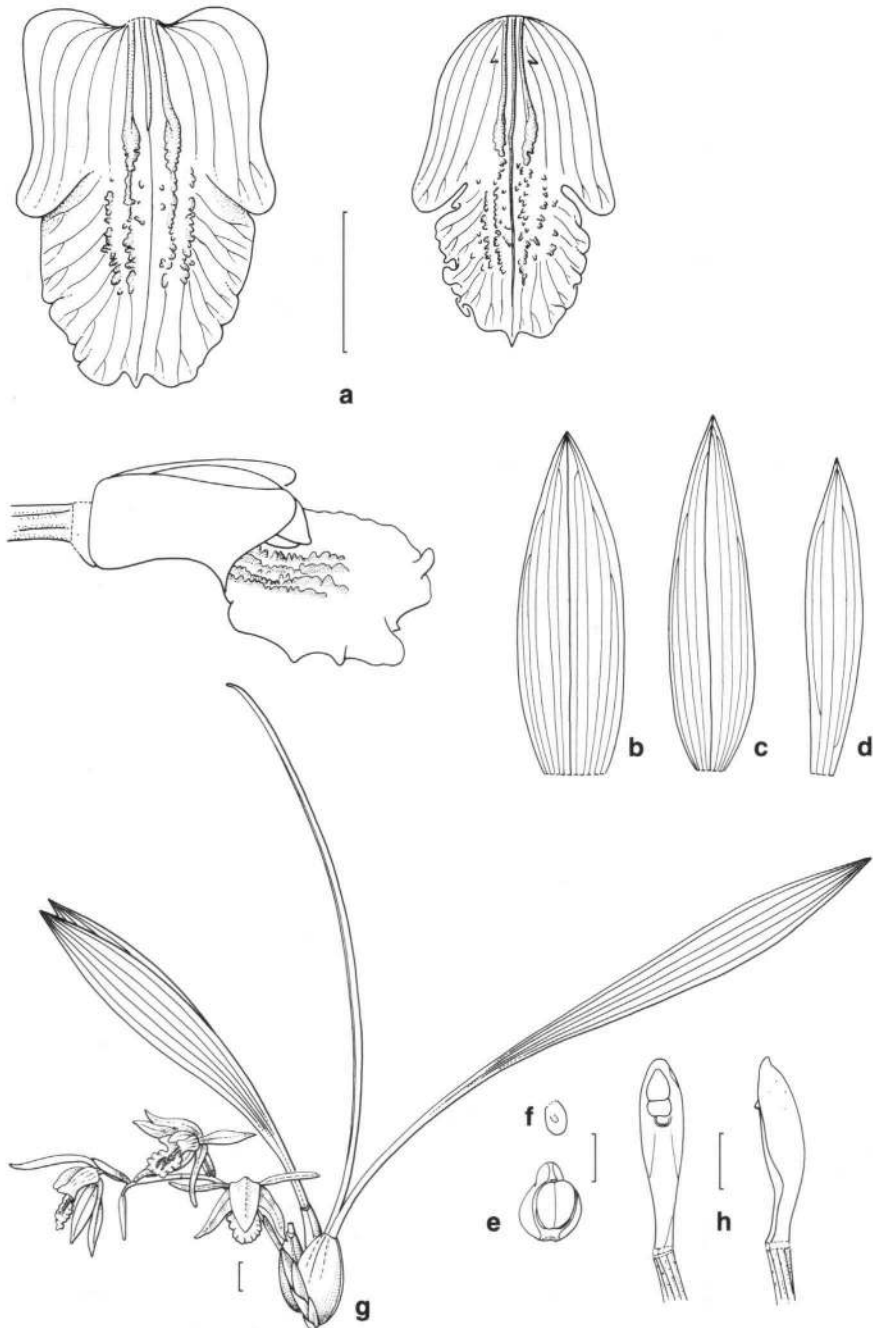

Fig. 7. *Coelogyne marthae* S.E.C. Sierra. a. Lip ornamentation, front view (from left to right: *Leiden cult.* 27496, *De Vogel* 8836) and lateral view (*Leiden cult.* 27496); b. median sepal; c. lateral sepal; d. petal; e. anther; f. pollinium; g. habit; h. column: front and lateral view (*De Vogel* 8836). — Scale bars: 1 cm (a–d, g); 2 mm (e, f); 5 mm (h).

with slightly irregular margin. *Anther* more or less obcordate, 2.8–3.2 by 2.2–2.5 mm, base triangular to ligulate; top broadly rounded, tip emarginate. *Pollinia* obovate, 1.4–1.7 by 1–1.2 mm. *Stigma* semi-elliptic, 2.2–2.8 by 1.9–2.1 mm; rostellum about rectangular, 1.2–1.5 by 1–1.2 mm. *Fruit* and *seeds* not seen.

Distribution — Borneo (Sarawak: Bahagian Kuching).

Habitat & Ecology — Epiphytes. In the lower part of trunks of undergrowth trees. Heath forest, c. 20–30 m high, on level terrain with deep sandy soil overlain by a layer of raw humus, locally with pools of stagnant brown water. Elevation 50–300 m. Flowering: March, December.

Notes — 1. Pseudobulbs and leaves green. Sepals and petals light green. Lip white tinged green, at the very base orange; lateral lobes with 4 or 5 brown veins; hypochile light green, keels at the back light green, in front yellow with brown crests; epichile near the margins light green, middle part with brown rows of papillae. Column, ovary and anther light green. Scent not recorded. Colour description based on slides and notes on the labels of the collections.

2. *Coelogyne marthae* is named after Dr. Martha Tilaar, the benefactor of the newly established Martha Tilaar Chair of Ethnobotanical Knowledge Systems with special reference to Medicinal Plants in Developing Countries at Leiden University, The Netherlands.

3. The dimensions are based on living and spirit material.

4. The species can be recognized by the small flattened pseudobulbs, and a lip with rows of single crested keels breaking up in flat irregular teeth or warts on the midlobe, which lacks a claw.

4. *Coelogyne mayeriana* Rchb.f. — Fig. 8, Plate 2a, Map 3

Coelogyne mayeriana Rchb.f., Gard. Chron. 2, 8 (1877) 134; Ridl., J. Linn. Soc., Bot. 32 (1896) 324; Zörnig, Bot. Jahrb. Syst. 33 (1904) 649, f. 20, 21; Pfitzer & Kraenzl. in Engl., Pflanzenr. 32 (1907) 75; J.J. Sm., Teysmannia 31 (1920) 258; Ridl., Kew Bull. (1925) 91; C.F. Sander, F.K. Sander & L.L. Sander, Sander's Orchid Guide (1927) 125; J.J. Sm., Feddes Repert. Beih. 32 (1933) 165; Bull. Jard. Bot. Buitenzorg III, 16 (1939) 124; Latif, Bunga Anggerik (1953) 95; Holtum, Orchids of Malaya 3 (1964) 254, f. 53; Backer & Bakh.f., Fl. Java 3 (1968) 283; J.B. Comber, Orchids of Java (1990) 116; Seidenf. & J.J. Wood, Orchids of Penins. Malaysia and Singapore (1992) 217, f. 92d. — Type: *Reichenbach Herb. 21506* (?!/1876) (holo W-RCHB; iso W-RCHB), from cultivated specimens of unknown origin.

Roots 1–2 mm diam. Rhizome creeping, 0.4–0.8 cm thick, 5–12 internodes between two pseudobulbs; scales not overlapping. *Pseudobulbs* (3.5–)8–24 cm apart, in cross section terete, in outline ovate, 3.5–9.5 by 3–5 by 1.7–3.4 cm; scales covering the pseudobulb 4–11 by 2.5–5 cm. *Leaf* petiole 1.2–8.5 by 0.5–0.7 cm; blade lanceolate, 12–40 by 2.7–9 cm; main nerves 5–7. *Inflorescence* proteranthous or synanthous, 3–10-flowered. Scape 5–13 cm long including the part covered by the scales of the young shoot. Rhachis 9–30 cm long; internodes 5–12, 1.6–5.5 cm long. *Sterile bracts* 1 or 2, elliptic, 1.7–5 by 1–3.4 cm; fertile bracts elliptic, 1.6–3 by 0.8–1.9 cm. Pedicel 16–40 by 1–2 mm; ovary 5–15 by 1.5–3 mm. *Median sepal* ovate-lanceolate, 28–42 by 9–15 mm; nerves 9–11, the median one prominent. *Lateral sepals* slightly falcate, ovate-lanceolate, 30–40 by 8–15 mm; nerves 7–9. *Petals* obovate-lanceolate, 20–40 by 8–11 mm; nerves 5–7, midrib slightly prominent. *Hypochile* 8–19 by 11–20 mm, when flattened the base emarginate; lateral lobes 8–19 by 7–8 mm, at the base project-

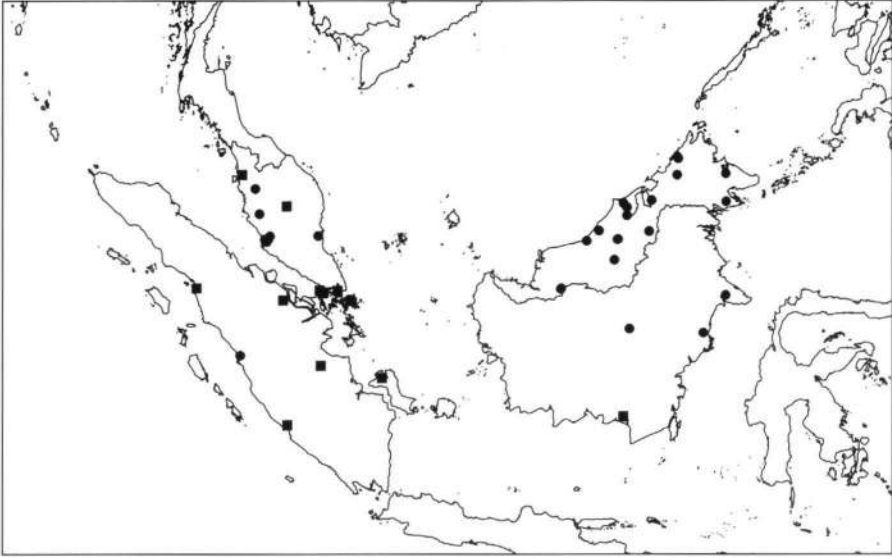

Map 3. Distribution of *Coelogyne mayeriana* Rchb.f. (■) and *C. pandurata* Lindl. (●).

ing backwards for 2–4 mm, in front rounded, projecting for 2.5–3 mm, with round apex; keels 3, over the entire length with small projections, with entire margin, low and rounded at the base, the median keel low and rounded, gradually lowering to the front, continuing to the junction of hypo- and epichile and there ending forming a crest, the lateral keels higher than the median keel, thick plate-like, continuing into the keels on the epichile. *Epichile* about trapeziform, 10–17 by 9–15 mm; claw absent; blade irregularly rectangular to quadrangular, the top truncate, the tip acute, triangular, with a small notch on either side, the margin broadly and regularly undulate, when flattened about straight, with 2 keels as on the hypochile, sometimes with 2 additional rows of cushion-like projections, both continuing in four patches of tooth-like projections which are in outline more or less elliptic, the two middle patches 3.5–6 by 2–4 mm, the lateral patches 2–3.5 by 1–2 mm. *Column* in outline spatulate, 10–16 by 4–6 mm; column foot pronounced; stalk 5–8.5 by 1–1.2 mm; hood about triangular, 6–9 by 4–6 mm, top broadly rounded, with slightly irregular margin. *Anther* obovate, 2.8–3 by 2–3.2 mm, base triangular, top broadly rounded, tip emarginate. *Pollinia* obovate, 1.2–1.5 by 0.8–1 mm. *Stigma* semi-elliptic, 2–2.8 by 2.5–4 mm; rostellum about rectangular, 1.8–2 by 2–2.5 mm. *Fruit* ellipsoid, 5–5.5 by 2.5–3.2 cm; margins flat, 2.8–3.2 mm wide; valves 18–24 mm wide, with a low keel. *Seeds* shortly fusiform, to 2.2–3 mm long; embryo 0.7–1 mm long.

Distribution — Sumatra, Peninsular Malaysia, Singapore, Borneo (one doubtful record from Nusa Kambangan Island, Java).

Habitat & Ecology — Epiphytes, lithophytes or terrestrials. Lowland forest, at the base of *Oncosperma* in sandy places on the coast near mangrove swamps, in partial shade to exposed areas. Elevation 0–100 m. Flowering all the year when considered over its entire range, but in any given area flowering only a few times per year.

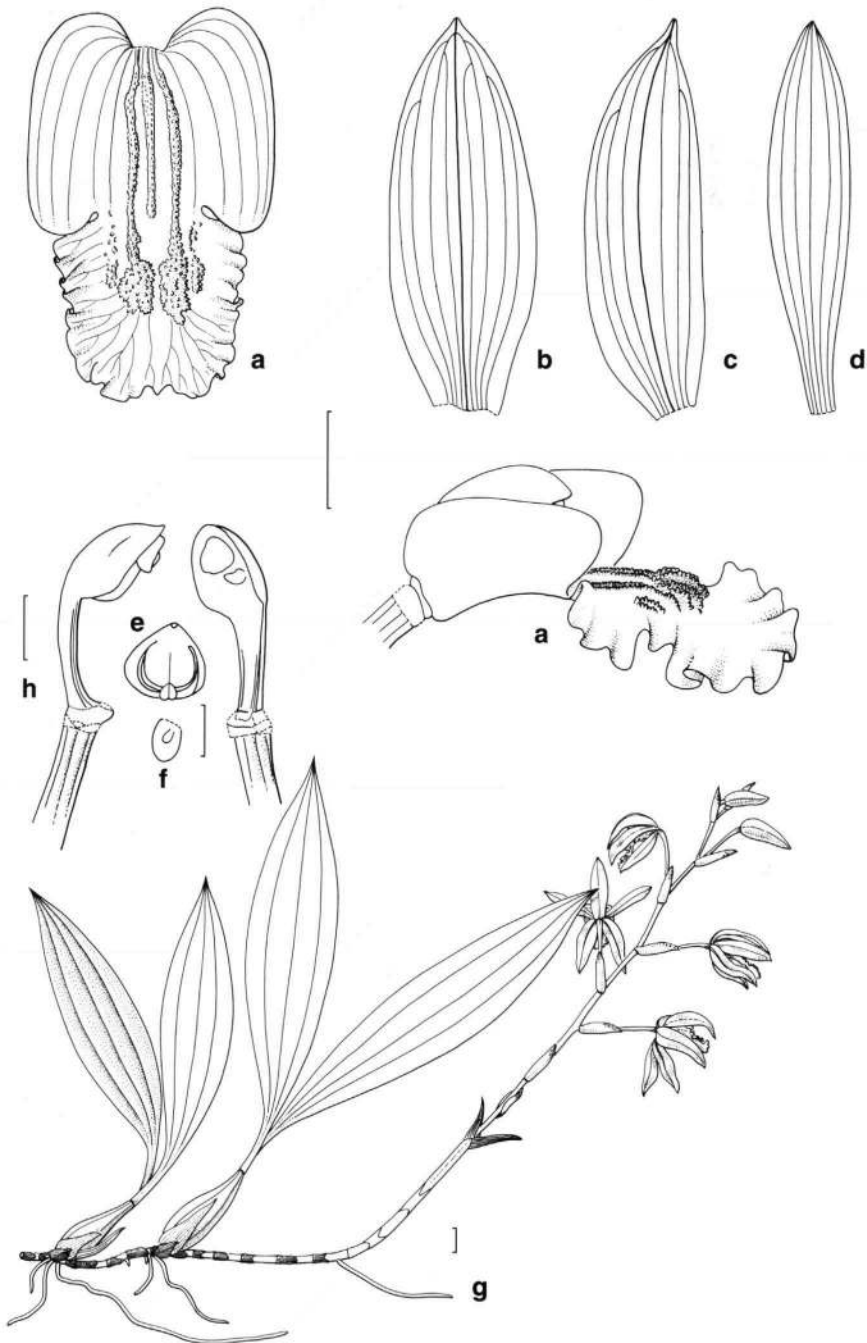

Fig. 8. *Coelogyne mayeriana* Rchb.f. a. Lip ornamentation, front and lateral view; b. median sepal; c. lateral sepal; d. petal; e. anther; f. pollinium; g. habit; h. column: lateral and front view (*Leiden cult.* 27297). — Scale bars: 1 cm (a–d, g); 2 mm (e, f); 5 mm (h).

Notes — 1. Pseudobulbs and leaves green. Sepals and petals light green. Lip light green, at the extreme base orange; central keel whitish, with blackish brown tips, crest green; lateral keels green, with blackish brown tips; lateral lobes inside with 3–5 longitudinal blackish brown veins. Cushion-like projections pale green. Column pale green, lateral lines on each side of the stalk blackish brown; cross ridge on column foot orange. Anther yellow greenish; pollinia light yellow. Root tip pale orange. Fragrant. Colour description based on living material, slides, and notes on the labels of the collections.

2. The epithet *mayeriana* refers to the names of two curators, father and son Mayer of Karlsruhe, Germany, who sent Reichenbach the material from which he described this species.

3. The dimensions are based on living and spirit material.

4. The young parts of the plants are covered with a sticky substance.

5. The species can be recognized by the distant, non-flattened pseudobulbs and the presence of lateral rows of cushion-like projections on the midlobe of the lip.

6. Carr (1928) reported this species to be pollinated by wasps which are attracted by the scent of the flowers. The keels are described as guide structures which ensure that the insect reaches the orange swelling at the centre base of the lip where the nectar is stored.

7. There are no recent collections from the wild of this species. It is probably extinct throughout most of its range.

5. *Coelogyne pandurata* Lindl. — Fig. 9, Plate 1c, 1d, Map 3

Coelogyne pandurata Lindl., Gard. Chron. 1 (1853) 791; Fol. Orchid. (1854) 3; Bot. Mag. 84 (1858) t. 5084; Rchb.f., Ann. Bot. Syst. 6 (1861) 224; H.J. Veitch, Man. Orchid. Pl. 6 (1890) 47; Ridl., J. Linn. Soc., Bot. 31 (1896) 286; 32 (1896) 325; Zörnig, Bot. Jahrb. Syst. 33 (1904) 651, f. 22; Pfitzer & Kraenzl. in Engl., Pflanzenz. 32 (1907) 75, f. 26C; J.J. Sm., Teysmannia 31 (1920) 294; Ames in Merr., Enum. Born. Pl. (1921) 144; Enum. Philipp. Flow. Pl. 1 (1924) 283; C.F. Sander, F.K. Sander & L.L. Sander, Sander's Orch. Guide (1927) 127; M.R. Hend., Gard. Bull. Straits Settlements 4 (1928) 334; J.J. Sm., Feddes Repert. Beih. 32 (1933) 166; Carr, Gard. Bull. Straits Settlements 8 (1935) 76; Quisumb., Philipp. Orchid Rev. (1951) 12, 20; Latif, Bunga Anggerik (1953) 96, pl. 20; Holttum, Orchids of Malaya 3 (1964) 254; Bechtel in P.J. Cribb & Launert, Orch. Atl. (1980) 104; Valmayor, Orchid. Philipp. 1 (1984) 38; Seidenf. & J.J. Wood, Orchids of Penins. Malaysia and Singapore (1992) 217, f. 92C, pl. 13A. — *Pleione pandurata* (Lindl.) Kuntze, Rev. Gen. Pl. 2 (1891) 680. — Type: *Loddiges (Low) s.n.* (1/12/1853) (holo K-LINDL), Borneo.

Coelogyne peltastes Rchb.f. var. *unguiculata* J.J. Sm., Mitt. Inst. Allg. Bot. Hamburg 7 (1927) 33, f. 23, syn. nov. — Type: *Winkler 347* (holo HAMB), Borneo.

Roots 2–3 mm diam. Rhizome creeping or climbing, 0.9–1.3 cm thick, 6–14 internodes between two pseudobulbs; scales overlapping. *Pseudobulbs* 4.5–10 cm apart, in cross section rather flattened, in outline (ovate-)oblong, with slightly flattened sides, 6.5–19 by 4–7 by 1.5–3 cm; the downwards facing side with a distinct swollen ridge; scales covering the pseudobulb 4.5–18 by 4–7 cm. *Leaf* petiole 5–15 by 0.3–0.9 cm; blade lanceolate, 15–66 by 3.5–10.5 cm; main nerves 5–9. *Inflorescence* proteranthous or synanthous, (3–)6–15-flowered. Scape 5.7–21.5 cm long including the part covered by the scales of the young shoot. Rhachis 15–47 cm long; internodes 4–17, 2–5.7 cm long. *Sterile bracts* 1 or 2, oblong, 2.7–5.5 by 1–2.2 cm; fertile bracts oblong, 2.7–4.7

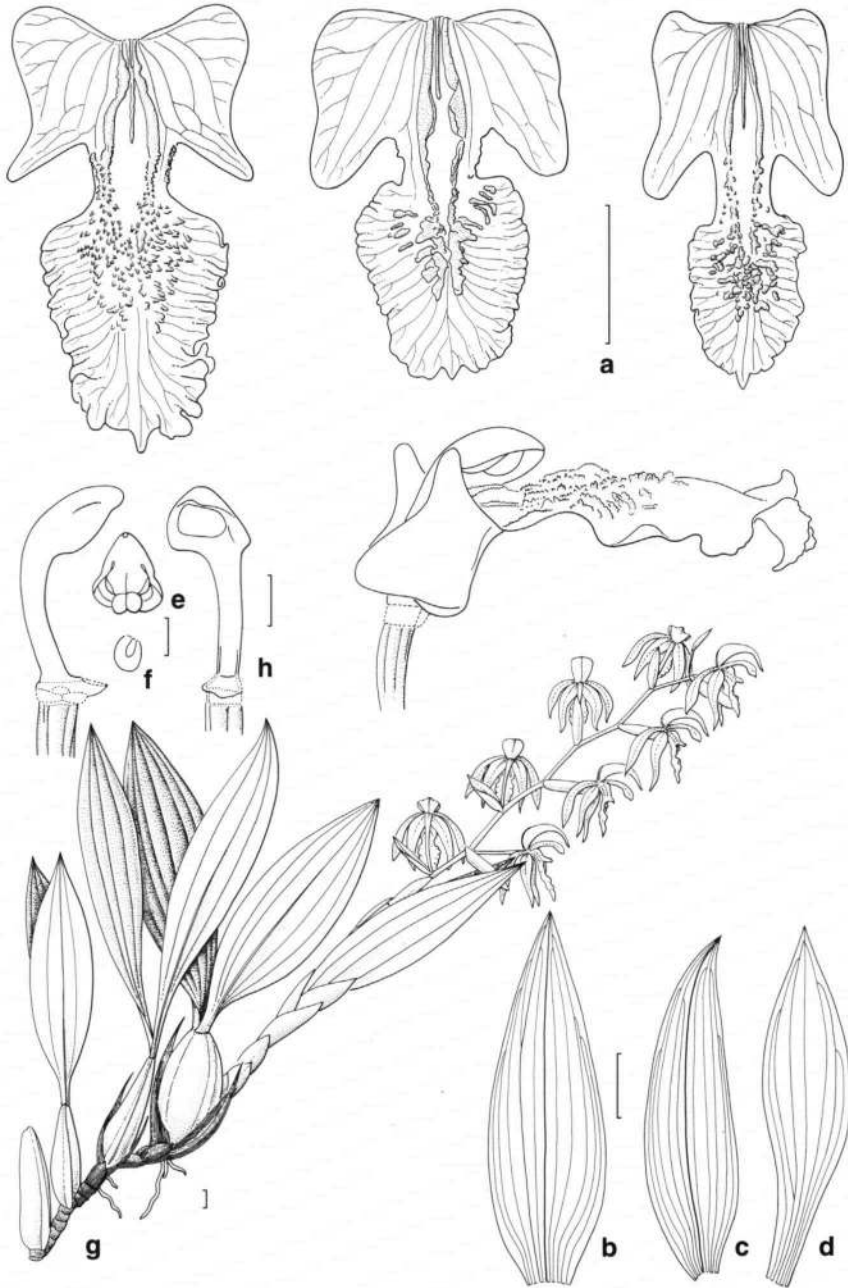

Fig. 9. *Coelogyne pandurata* Lindl. a. Lip ornamentation, front view [from left to right: *Leiden cult.* (De Vogel) 914650, *Leiden cult.* 30607, *Leiden cult.* 930916] and lateral view [*Leiden cult.* (De Vogel) 913562]; b. median sepal; c. lateral sepal; d. petal [*Leiden cult.* (De Vogel) 914650]; e. anther; f. pollinium; g. habit; h. column: lateral and front view [*Leiden cult.* (De Vogel) 913562]. — Scale bars: 1 cm (a–d, g); 2 mm (e, f); 5 mm (h).

by 1–2.4 cm. Pedicel 10–52 by 2–3 mm; ovary 10–20 by 3–5 mm. *Median sepal* ovate-lanceolate, 35–75 by 7–21 mm; nerves 11–15, the median one prominent. *Lateral sepals* falcate, ovate-lanceolate, 32–68 by 8–18 mm; nerves 7–11. *Petals* obovate-lanceolate, 33–70 by 8–16 mm; nerves 7–9(–11), midrib rather prominent. *Hypochile* 12–25 by 15–34 mm, when flattened base emarginate to subtruncate; lateral lobes 12–25 by 6–12 mm, at the base projecting backwards for 1.5–5 mm; in front triangular-ligulate, projecting for 3–10 mm, with rounded apex; keels 3, with entire margin, low and rounded at the base, the median keel low, in the basal half of the hypochile rounded and swollen, gradually lowering to the front, ending below or close to the junction of hypo- and epichile, the lateral keels in the basal half of the hypochile distinctly swollen, with irregularly indentate margin and sides, in the front half of the hypochile distinctly raised, plate-like, in lateral view semi-elliptic, single or double crested, each margin undulate or not undulate, continuing into the much lower keels on the epichile. *Epichile* about spatulate, 17–40 by 9–23 mm; claw about rectangular, 3–8 by 5–10 mm, margins straight, sometimes coarsely dentate, keels 2, low plate-like with a rather irregularly and coarsely broken up single or double top margin, at the top sometimes with molar-like structures on each side which continue into the blade; blade irregularly rectangular to quadrangular to ovate, 15.5–30 by 10–23 mm, the top truncate to acute, the tip acute, triangular, mostly with a small notch on either side, the margin broadly and regularly undulate, when flattened about straight, with molar-like structures as on the claw converging towards the middle of the blade, and there they are lost among a series of higher, transverse, molar-like warts, the whole patch of molar-like structures on midlobe about ovate, 8–17 by 7–18 mm. *Column* in outline spatulate, (12–)15–25 by 3–5 mm; column foot pronounced; stalk 8–15 by 1–3 mm; hood about triangular, 7–10 by 3–5 mm, top broadly rounded, with slightly to very irregular margin. *Anther* obcordate, 2.8–5 by 3–5 mm, base triangular, top broadly rounded to truncate, tip emarginate. *Pollinia* obovate, 1–2 by 0.8–1.5 mm. *Stigma* semi-elliptic, 2.2–3.5 by 3–4 mm; rostellum about rectangular, 1.3–3 by 2.2–3 mm. *Fruit* ellipsoid, 6–8.5 by 4.5–6 cm; margins flat, 3–5 mm wide; valves 40–50 mm wide, with a low keel. *Seeds* shortly fusiform, to 3–4 mm long; embryo 0.7–1.3 mm long.

Distribution — Sumatra [Smith (1933), based on *Bünnemeijer* 32, not seen], Peninsular Malaysia, Borneo (Sabah, Brunei, Sarawak, Kalimantan), and possibly the Philippines [Valmayor (1984), based on specimens from Agusan, Bontoc, Samar and Surigao, not seen].

Habitat & Ecology — Epiphytes on trunks and big branches of trees, lithophytes or terrestrials. Lowland forest and hill forest, in partial shade to quite exposed. Among rocks, on granite or ultramafic substrate. Elevation 10–1000 m. Flowering all the year when considered over its entire range, but in any given area flowering only once or twice a year.

Notes — 1. Pseudobulbs and leaves green. Sepals and petals light greenish. Lip light greenish with black or brown patches, at the extreme base orange; keels pale green with blackish brown tips, at the base white; lateral lobes with 4–8 brown to black veins; midlobe claw and blade with black or brown and light green molar-like projections. Column light greenish; sometimes with blackish brown lateral lines on each side of the stalk; cross ridge on column foot orange. Anther light greenish; pollinia dull yellow. Ovary light greenish, with brown scale-like hairs. Root tip pale orange.

Fragrant. Colour description based on living material, slides, and notes on the labels of the collections.

2. The epithet *pandurata* (which is Latin for violin-shaped) refers to the violin-shaped outline of the lip in natural position.

3. The dimensions are based on living and spirit material.

4. The young parts of the plant are covered with a sticky substance.

5. Considerable variation in size and colour is present among the specimens of *C. pandurata*. Most orchid growers know the large form of this species with the big grass green flowers with pitch black markings on the lip. There are, however, many specimens among the collections which are much smaller or intermediate in size, with brown instead of black markings on the lip (Plate 1d). Pelsner et al. (2000) also describe size plasticity for the species of sect. *Fuliginosae*. *Coelogyne peltastes* var. *unguiculata* J.J. Sm. was based on a small-flowered form of *C. pandurata*.

6. This species can be recognized by the rather flattened pseudobulbs, the relatively small lateral lobes of the lip, and the presence of molar-like structures which converge towards the middle of the blade of the epichile.

6. *Coelogyne peltastes* Rchb.f. — Fig. 10, Map 2

Coelogyne peltastes Rchb.f., Gard. Chron. 2, 14 (1880) 296; Pfitzer & Kraenzl. in Engl., Pflanzenr. 32 (1907) 73, f. 25, 26c; J.J. Sm., Teysmannia 31 (1920) 295; Dakkus, Orch. Ned. Ind. 2 (1931) 70; 3 (1935) 86. — Type: *Veitch s.n.* (?/8/1880) (*Reichenbach Herb.* 21503) (holo W), Borneo.

Roots c. 2.5 mm diam. Rhizome climbing (from type description), not seen. *Pseudobulbs* in cross section very flattened, in outline oblong, with margins which incurve, forming a sort of convex shield over the scandent stem, 8.2 by 5.5 cm. *Leaf* petiole 4.2–4.4 by 0.3–0.5 cm; blade lanceolate, 27.5–28 by 3.9–4 cm; main nerves 5. *Inflorescence* 3–9-flowered. Scape 4.6–10.5 cm long including the part covered by the scales of the young shoot. Rhachis 6–27 cm long; internodes 4–11, 1.9–4.2 cm long. *Sterile bracts* 1 or 2, ovate-oblong to ovate-lanceolate, 3.5–5.2 by 1–1.6 cm; fertile bracts ovate-oblong to ovate-lanceolate, 3–4.2 by 0.8–1.4 cm. Pedicel 15–27 by 1.5–2.2 mm; ovary 7–12 by 1.7–3 mm. *Median sepal* ovate-lanceolate, 34–47 by 7–14 mm; nerves 9–11, the median one prominent. *Lateral sepals* falcate, ovate-lanceolate, 36–40 by 4.5–10 mm; nerves 7. *Petals* obovate-lanceolate, 40–43 by 6–9 mm; nerves 5–7, midrib slightly prominent. *Hypochile* 12–17 by 11–19 mm, when flattened the base emarginate to subtruncate; lateral lobes 12–17 by 4–7 mm, at the base projecting backwards for 1–2 mm; in front either distinctly descending with broadly rounded apex which is not projecting, to slightly descending, the free part about semi-orbicular, projecting for 2–3 mm; keels 3, with entire margin, low and rounded at the base, the median keel beyond the base slightly higher, continuing as a swollen low keel on the base of the epichile, the lateral keels higher than the median keel, thin plate-like, single crested, continuing into the much lower keels on the claw of the epichile, near the epichile with several molar-like projections. *Epichile* not spatulate, 15–20 by 10–16 mm; claw absent, blade irregularly rectangular the top truncate, the tip acute, triangular, mostly with a small notch on either side, margin broadly and regularly and finely undulate, the median keel at the end elevated and thin plate-like, when flattened about straight, ornamentation consisting of a patch 7–12 by 5–10 mm, consisting of tooth-

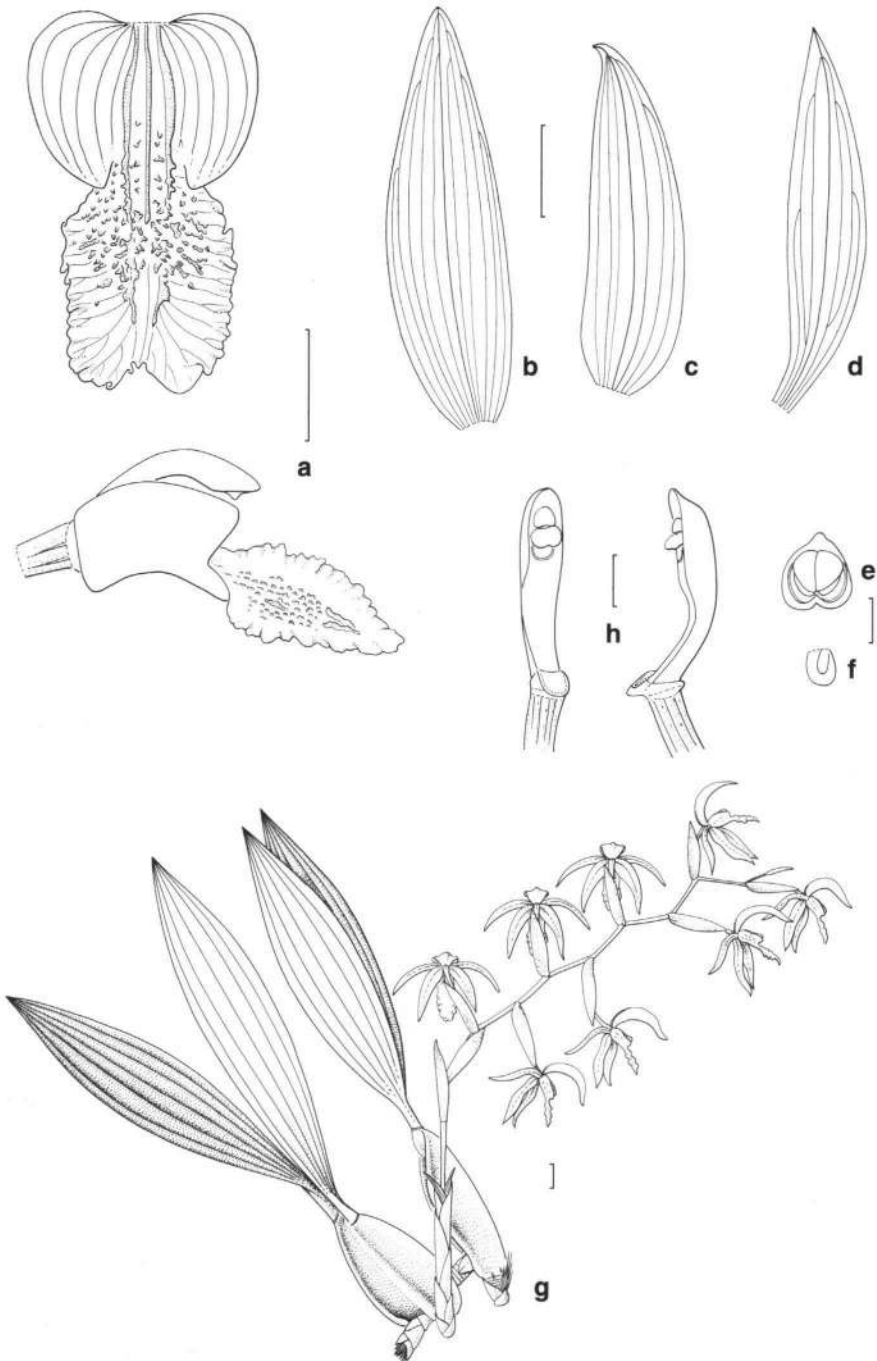

Fig. 10. *Coelogyne peltastes* Rchb. f. a. Lip ornamentation, front and lateral view; b. median sepal; c. lateral sepal; d. petal; e. anther; f. pollinium; g. habit; h. column: front and lateral view (*Bogor cult.* 500). — Scale bars: 1 cm (a–d, g); 2 mm (e, f); 5 mm (h).

like, more or less flattened warts, often arranged in radiating rows, the median ones to the top of the patch higher, more molar-like. *Column* in outline narrowly spatulate, 17–20 by 3.7–5 mm; column foot pronounced; stalk 9–13 by 2.7–3.2 mm; hood about triangular, with slightly irregular margin, 7–9.5 by 3.7–5 mm, top broadly rounded, with irregular margin. *Anther* obcordate, 3.3–3.7 by 2.8–3.2 mm, base triangular; top broadly rounded, tip emarginate. *Pollinia* obovate, 1.6–1.8 by 1.1–1.4 mm. *Stigma* semi-elliptic, 2.5–3 by 4–4.2 mm; rostellum about rectangular, 2.1–2.3 by 2.1–2.4 mm. *Fruit* and *seeds* not seen.

Distribution — Borneo (Kalimantan Barat).

Habitat & Ecology — Epiphytes on tree trunks near the ground in heath forest. Flowering: April, August.

Notes — 1. Pseudobulbs and leaves green. Sepals and petals light yellow to emerald green. Lip white; lateral lobes with 4–8 dark brown veins; midlobe blade with brown and white warts. Column light greenish. Scent not recorded. Colour description based on type description and water colour illustrations from the Reichenbach Herbarium collection (W).

2. The epithet *peltastes* (which is Latin for shield-shaped) refers to the kind of concave shield over the climbing rhizome formed by the pseudobulbs.

3. The dimensions are based on spirit (inflorescence) and dry (vegetative) material.

4. The species can be recognized by the presence of very flattened pseudobulbs with incurved margins, the absence of a claw at the base of the epichile, and the presence of molar-like projections on the midlobe of the lip.

5. The type material present in Reichenbach's Herbarium in Vienna consists of one herbarium sheet with drawings of the plant sent by Veitch in 1880, and a second with dried leaves and pseudobulbs. A watercolour painting made on 1 November 1881 by John Day and preserved in one of his scrapbooks at Kew is based on the same specimen from which Veitch had earlier sent material to Reichenbach.

7. *Coelogyne verrucosa* S. E. C. Sierra, *spec. nov.* — Fig. 11, Plate 2c, Map 2

A Coelogyne pandurata pseudobulbis planissimis, labello in lobo mediali macula magna verrucis satis magnis rotundatis differt. — Typus: *Vermeulen & Lamb 322* (holo L; iso K), Sabah.

Roots 2–4 mm diam. Rhizome climbing, 0.7–1.2 cm thick, 4–10 internodes between two pseudobulbs; scales overlapping. *Pseudobulbs* 1.8–5 cm apart, in cross section very flattened, in outline ovate, with margins which slightly incurve, pressed against the rhizome and the lower part of the subsequent pseudobulb, 5–10 by 3.3–5 by 0.7–1.3 cm; scales covering the pseudobulb 6–9.8 by 3–4 cm. *Leaf* petiole 2–6 by 0.3–0.7 cm; blade lanceolate, 16–38 by 2.5–6 cm; main nerves 7–9. *Inflorescence* proteranthous or synanthous, 6–10-flowered. Scape 3.5–14 cm long including the part covered by the scales of the young shoot. Rhachis 12.5–34 cm long; internodes 8–12, 1.2–5 cm long. *Sterile bracts* 1 or 2, oblong, 2.3–4 by 0.9–1.7 cm; fertile bracts, oblong, 2–3.2 by 0.7–1.8 cm. Pedicel 13–50 by 1–2 mm; ovary 7.5–12 by 1.3–3 mm. *Median sepal* ovate-lanceolate, 18.5–40 by 6–13 mm; nerves 9–11, the median one prominent. *Lateral sepals* falcate, ovate-lanceolate, 20–37.5 by 5.5–9 mm; nerves 7–9. *Petals* lanceolate, 17.5–36 by 3.3–6.2 mm; nerves 5–7 rather prominent. *Hypo-*

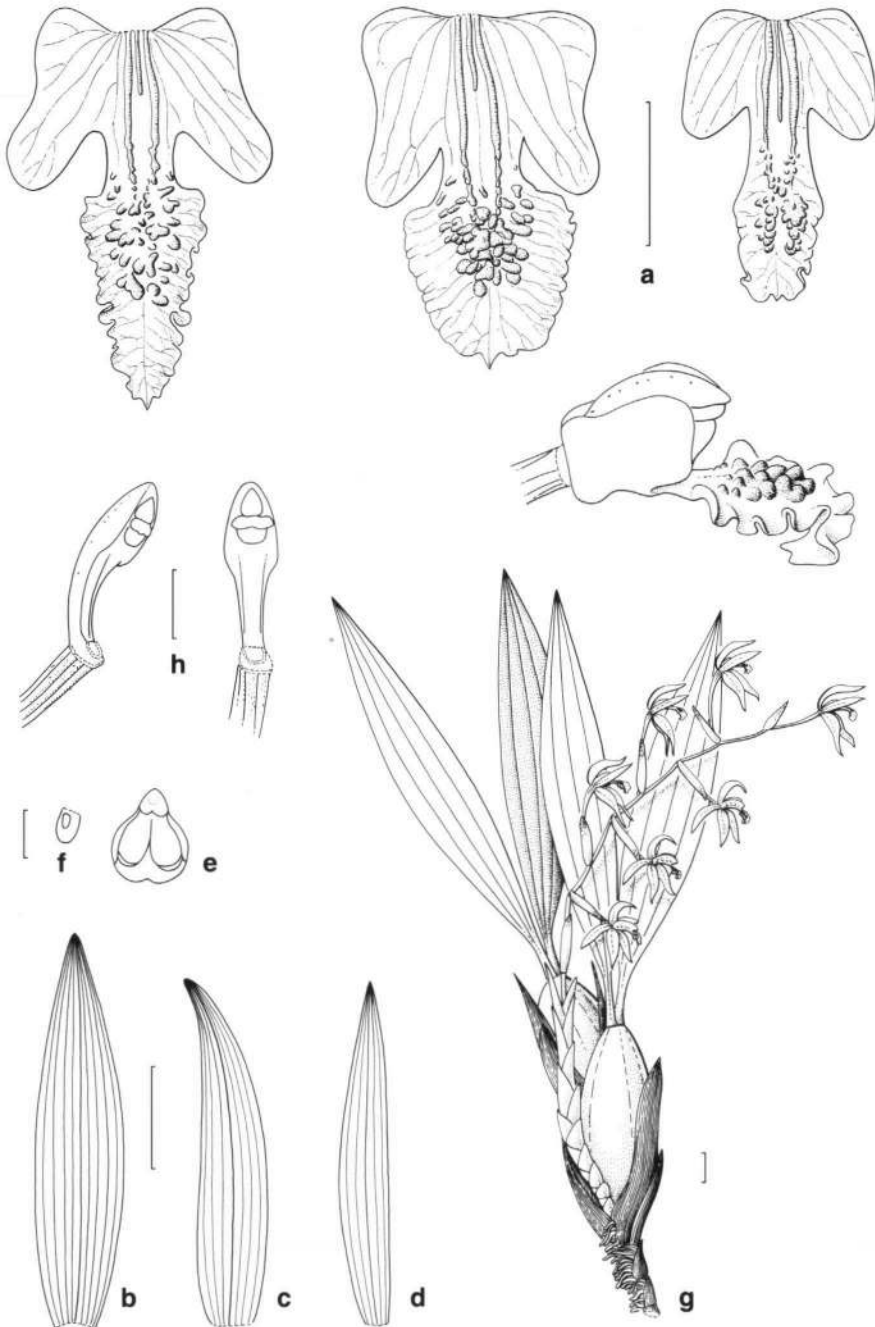

Fig. 11. *Coelogyne verrucosa* S.E.C. Sierra. a. Lip ornamentation, front view (from left to right: *Leiden cult. 970597*, *Leiden cult. 26555*, *O'Byrne CX020*) and lateral view; b. median sepal; c. lateral sepal; d. petal; e. anther; f. pollinium; g. habit; h. column: lateral and front view (*Leiden cult. 970597*). — Scale bars: 1 cm (a–d, g); 2 mm (e, f); 5 mm (h).

chile 9–13.5 by 10–19 mm, when flattened base emarginate to subtruncate; lateral lobes 9–13.5 by 4.5–6 mm, at the base projecting backwards for 0–2.2 mm; in front triangular-ligulate, free part projecting for 2.8–5 mm, with broadly rounded apex; keels 3, with entire margin, low and rounded at the base, the median keel low and rounded, gradually lowering to the front, continuing to the middle or sometimes up to the junction of hypo- and epichile, the lateral keels at the base low, more to the front higher than the median one, rounded, or thin to thick plate-like and then the raised part in lateral view semi-elliptic, widened at the crest, single or double crested, continuing on the epichile. *Epichile* about spatulate, 12–16.5 by 6–12 mm; claw about rectangular, 2.5–4.5 by 3.5–6.5 mm, margins straight, keels 2, low plate-like with a rather irregularly and coarsely broken up single crest, at the top and lateral of the keels with few scattered tooth-like projections which continue on the blade; blade irregularly rectangular to quadrangular to ovate, 8–14 by 6–12 mm, the top acute to rounded, the tip acute, triangular, mostly with a small notch on either side, margin broadly and regularly undulate, when flattened about straight, ornamentation on the very base consisting of few molar-like structures as on the claw, beyond that with a more or less ovate, 4.5–13 by 3–7 mm big patch of rather big, rounded, projecting warts. *Column* in outline spatulate, 11.5–16 by 2.5–5 mm; column foot small; stalk 5–9 by 1.5–3 mm; hood distinctly widened, about ovate, 4.5–9 by 2.5–5 mm, top broadly rounded, with slightly to very irregular margin. *Anther* obcordate, 1.5–3.2 by 2.5–5 mm, base triangular, top broadly rounded, tip emarginate. *Pollinia* obovate, 1.2–1.8 by 0.7–1.2 mm. *Stigma* semi-elliptic, 1.5–2 by 2–3 mm; rostellum about rectangular, 1.3–1.7 by 2–3 mm. *Fruit* ellipsoid, 4 by 2.1 cm; margins flat, 1.5 mm wide; valves 18 mm wide, with a low keel. *Seeds* shortly fusiform to 1.8–2.1 mm long; embryo 0.7–1 mm long.

Distribution — Borneo (Sarawak, Brunei, Sabah).

Habitat & Ecology — Epiphytes on trunks and big branches of trees, or terrestrials. Elevation 10–700 m. Heath, peat and mixed Dipterocarp forest. Flowering all year round when considered over its entire range, but in any given area flowering only once or twice a year.

Notes — 1. Pseudobulbs and leaves green. Bracts, sepals and petals light greenish. Lip light greenish with brown patches, at the extreme base yellow; keels in the basal part of the hypochile white, in the middle pale green, at the top with dark brown tips; lateral lobes with 4–8 brown veins; midlobe claw and blade with light greenish molar-like projections. Column light greenish, sometimes with brown lateral lines on each side of the stalk; cross ridge on column foot yellow. Anther light greenish; pollinia dull yellow. Ovary light greenish, with brown scale-like hairs. Root tips pale orange. Fragrant. Colour description based on living material, slides, and notes on the labels of the collections.

2. The epithet *verrucosa* (which is Latin for warty) refers to the big rounded projecting warts on the midlobe of the lip.

3. The dimensions are based on living and spirit material.

4. Young parts of the plant are covered with a sticky substance.

5. The species can be recognized by the strongly flattened pseudobulbs and a lip with a single big patch of rather large, rounded, projecting warts on the midlobe.

8. *Coelogyne zurowetzii* Carr — Fig. 12, Plate 2d, Map 2

Coelogyne zurowetzii Carr, Orchid Rev. 42 (1934) 44; Backer & Bakh.f., Fl. Java 3 (1968) 283. —

Type: *Zurowetz s.n.*, Borneo, Kalimantan, Sambas (holo SING, not found). Neotype (here chosen): *L'Horticulture Internationale cult. (Linden) s.n.* (2/7/1890) (holo K), Borneo.

Coelogyne peltastes auct. non Rchb.f.: Rolfe, Gard. Chron. 3, 8 (1890) 529.

Roots 1–1.5 mm diam. Rhizome creeping, 0.6–0.7 cm thick, 5–10 internodes between two pseudobulbs; scales overlapping. *Pseudobulbs* 3–5 cm apart, in cross section very flattened, in outline oblong with slightly incurved margins, 4.5–9 by 4–6 by c. 1.5 cm (from type description); scales covering the pseudobulb 8–8.5 by 3–3.5 cm. *Leaf* petiole 4–5 by 3–5 cm; blade obovate-lanceolate, 16–21 by 3.5–6.5 cm; main nerves 5–7. *Inflorescence* synanthous, 4–11-flowered. Scape 2.8–5.7 cm long including the part covered by the scales of the young shoot. Rhachis 10.5–19 cm long; internodes 5–12, 2.5–3 cm long. *Sterile bracts* 1–3, oblong to lanceolate, 2–3.2 by 1–1.7 cm; fertile bracts, oblong to lanceolate, 1.9–2.7 by 0.6–1 cm. Pedicel 12–35 by 1–2 mm; ovary 8–12 by 2–2.5 mm. *Median sepal* ovate-lanceolate, 27–33 by 8–10 mm; nerves 9, the median one prominent. *Lateral sepals* slightly falcate, ovate-lanceolate, 23–37 by 6–8 mm; nerves 7. *Petals* obovate-lanceolate, 26–34 by 3–5 mm; nerves 5, midrib slightly prominent. *Hypochile* 9–13 by 12–14 mm, when flattened base subtruncate or rounded; lateral lobes 10–13 by 3.5–5 mm, at the base not projecting backwards; in front triangular-ligulate, projecting for 2–4.5 mm, with rounded apex; keels 3, with entire margin, low and rounded at the base, the median keel beyond the base higher, the part up to about the middle of the hypochile long semi-elliptic in lateral view, beyond that continuing as a swollen low keel on the very base of the epichile, the lateral keels similar to the median keel, but the long semi-elliptic part higher, the part up to the base of the epichile thick plate-like, single crested, continuing into the much lower keels on the claw of the epichile. *Epichile* about spatulate, 11–17 by 11–12 mm; claw about transverse rectangular, 1.5–2 by 4–5 mm, margins irregular, keels 3, shaped as swollen nerves, low, with a rather irregularly and coarsely broken up single margin; sometimes near the junction with the blade with few, small, scattered tooth-like projections or with 2 additional swollen nerves which continue on the blade; blade irregularly rectangular to ovate, 12–14 by 10–13 mm, the top broadly rounded to truncate, the tip acute, triangular, mostly with a small notch on either side, the margin very finely undulate, when flattened about irregular, ornamentation consisting of a patch of warts and nerves, 7–11 by 6–9 mm, at the base formed mainly by 2–4 raised nerves with few scattered tooth-like projections, higher up the raised nerves break up into short rows or patches of scattered, single or connected, rounded and molar-like warts, the warts towards the margins of the patch single and scattered. *Column* in outline narrowly spatulate, 13–16 by 2–4 mm; column foot very small; stalk 8–10 by 1–2 mm; hood about triangular, 5–7 by 2–4 mm, top broadly rounded, with slightly irregular margin. *Anther* obcordate, 2.2–2.5 by 1.7–2 mm, base triangular; top broadly rounded, tip emarginate. *Pollinia* obovate, 1–1.2 by 0.8–1 mm. *Stigma* semi-elliptic, 2–2.8 by 2–3 mm; rostellum about rectangular, 1.5–1.7 by 2–2.3 mm. *Fruit* and *seeds* not seen.

Distribution — Borneo (Kalimantan, Sabah).

Habitat & Ecology — Epiphytes or terrestrials. Elevation to c. 900 m. Lowland plains, sandy soils. Flowering: April–November.

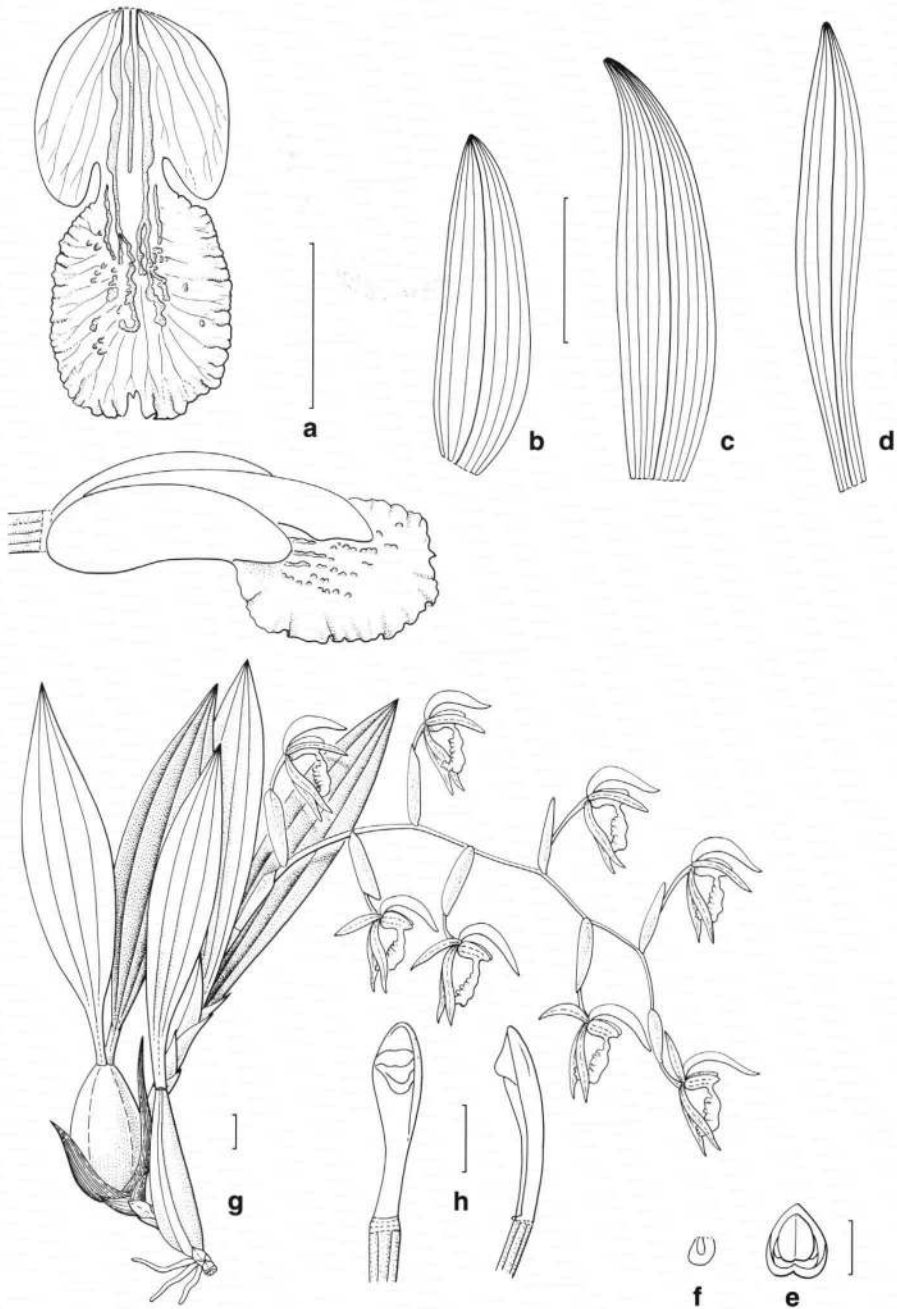

Fig. 12. *Coelogyne zurowetzii* Carr. a. Lip ornamentation, front and lateral view; b. median sepal; c. lateral sepal; d. petal [*Le Douse cult. s.n.* (29/7/92)]; e. anther; f. pollinium [*Kew. cult. s.n.* (2/11/1894)]; g. habit; h. column: front and lateral view [*Le Douse cult. s.n.* (29/7/92)]. — Scale bars: 1 cm (a–d, g); 2 mm (e, f); 5 mm (h).

Notes — 1. Pseudobulbs and leaves green. Sepals and petals light greenish. Lip white, at the extreme base yellow; keels white tipped with green; lateral lobes with 4–8 brown veins; midlobe claw and blade with brown swollen nerves and yellowish white warts. Column green with brown lateral stripes on each margin of the stalk. Anther light greenish; pollinia dull yellow. Ovary light greenish, with brown scale-like hairs. Scent not recorded. Colour description based on slides and notes on the labels of the collections.

2. The epithet *zurowetzii* refers to Mr. J.E. Zurowetz, the collector of the type specimen.

3. The dimensions are based on dry material.

4. The species can be recognized by the strongly flattened pseudobulbs, and the very finely undulate margin of the epichile, which is provided with small, scattered rounded to tooth-like projections.

5. The type was not found in Singapore or in any of the other herbaria from which material was requested on loan.

EXCLUDED SPECIES

9. *Coelogyne papillosa* Ridl. in Stapf, Trans. Linn. Soc. London 4 (1894) 238, f. 14, pl. 26B, C; Ridl., J. Linn. Soc., Bot. 31 (1896) 287; Pfitzer & Kraenzl. in Engl., Pflanzenr. 32 (1907) 78; Rolfe in Gibbs, J. Linn. Soc., Bot. 42 (1914) 154; Carr, Gard. Bull. Straits Settlements. 8 (1935) 211. — Type: *Haviland 1098* (holo SING; iso K), Sabah, Mt Kinabalu.

Note — This species is removed from sect. *Verrucosae* based on the results obtained from the morphological phylogenetic analysis. This species has characters which are not present in the other species of sect. *Verrucosae* as here recognized, such as a pronounced zigzagging rhachis, a column hood with dentate margin, a lip with six keels, and nerves on the lateral lobes of the hypochile, which are pronounced as low rounded keels.

10. *Coelogyne brachyptera* Rchb.f., Gard. Chron. 16 (1881) 6; Hook.f., Fl. Brit. India 5 (1890) 842; Pfitzer & Kraenzl. in Engl., Pflanzenr. 32 (1907) 78; Seidenf., Opera Bot. 114 (1992) 116; Bechtel in P.J. Cribb & Launert, Orch. Atl. (1993) 121. — Type: *Low s.n.* (1881) (holo W), Burma, Tenasserim.

11. *Coelogyne parishii* Hook.f., Bot. Mag. 88 (1862) t. 5323; Fl. Brit. India 5 (1886) 837; Pfitzer & Kraenzl. in Engl., Pflanzenr. 32 (1907) 77; Gagnep., Fl. Gén. Indo-Chine 6 (1933) 312; Bechtel in P.J. Cribb & Launert, Orch. Atl. (1993) 124. — Type: *Parishi s.n.* (1861) (holo K), Burma, Tenasserim, Moulmein.

12. *Coelogyne virescens* Rolfe, Bull. Misc. Inform. (1908) 70. — Type: *Micholitz s.n.* (holo K), Vietnam.

Note — The above mentioned three species have been included in sect. *Verrucosae*, but molecular evidence clearly indicates that at least one of these taxa (*C. virescens*) does not belong to the same clade as the species of sect. *Verrucosae* as here recognized.

Morphologically, *C. brachyptera*, *C. parishii* and *C. virescens* differ from the species of sect. *Verrucosae* by the hysteranthous inflorescence, imbricate bracts at the base of the peduncle, a glabrous ovary, and linear-lanceolate petals. A phylogenetic analysis with all three species might show that they should be placed in a section of their own, as is suggested by De Vogel (1994) and Clayton (in prep.).

ACKNOWLEDGEMENTS

Thanks are due to the directors and curators of the herbaria, mentioned under Material and Methods, for the loan of specimens. Marco Roos, André Schuiteman, Art Vogel, Bertie Joan van Heuven, Jan van Os, Johan Mols, Pieter Pelser, Jan Frits Veldkamp and Hajo Esser for their valuable comments, collaboration and help with the Latin descriptions of the new species. NUFFIC and the Alberta M.W. Mennega Stichting are thanked for their financial support.

REFERENCES

- Butzin, F. 1992. *Coelogyne* Lindl. In: F.G. Brieger, R. Maatsch & K. Senghas (eds.), *Die Orchideen* 1A: 919–940. Verlag Paul Parey, Berlin.
- Carr, C.E. 1928. *Coelogyne mayeriana* Rchb.f. *J. Malayan Branch Roy. Asiat. Soc.* 6: 61.
- Carr, C.E. 1934. *Coelogyne zurowetzii*. *Orchid Rev.* 42: 44.
- Clayton, D.A. In prep. A survey of the genus *Coelogyne*. Royal Botanic Gardens, Kew.
- De Vogel, E.F. 1992. Revisions in *Coelogyninae* (Orchidaceae) IV. *Coelogyne* section *Tomentosae*. *Orchid Monogr.* 6: 4–42.
- De Vogel, E.F. 1994. Character assessment for a subdivision of *Coelogyne* Lindl. In: A. Pridgeon (ed.), *Proceedings of the 14th World Orchid Conference*: 203–205. HMSO Publications, Glasgow.
- Doyle, J. & J. Doyle. 1987. A rapid DNA isolation procedure for small quantities of fresh leaf tissue. *Phytochem. Bull. Bot. Soc. Amer.* 19: 11–15.
- Dressler, R.L. 1993. *Phylogeny and Classification of the Orchid Family*. Cambridge University Press, Melbourne.
- Erfkamp, J. & O. Grub. 1996. Die Hybriden der Gattung *Coelogyne*. *Die Orchidee* 47, 6: 285–286.
- Felsenstein, J. 1995. Confidence limits on phylogenetics: an approach using the bootstrap. *Evolution* 39: 783–791.
- Fitch, W.M. 1971. Toward defining the course of evolution: minimal change for a specific tree topology. *Syst. Zool.* 20: 406–416.
- Gravendeel, B., M.W. Chase, E.F. de Vogel, M.C. Roos, K. Bachmann & T.H.M. Mes. In prep. Molecular phylogeny of *Coelogyne* (Epidendroideae; Orchidaceae) based on plastid RFLPs, matK and ITS sequences: evidence for polyphyly.
- Hershkovitz, M.A. & L.A. Lewis. 1996. Deep level diagnostic value of the rDNA-ITS region. *Molec. Biol. Evol.* 13: 1276–1295.
- Huelsenbeck, J.F., J.J. Bull & C.W. Cunningham. 1996. Combining data in phylogenetic analysis. *Trends Ecol. Evol.* 11: 152–158.
- Johnson, L.A. & D.E. Soltis. 1994. matK DNA sequences and phylogenetic reconstruction in *Saxifragaceae* s. str. *Syst. Bot.* 19: 143–156.
- Maddison, W.P. & D.R. Maddison. 1992. *MacClade*, version 3.04. Sinauer, Sunderland, Massachusetts.
- MapInfo Corporation. 1992–1994. Professional version 5.0, © Media Cybernetics, Troy, New York.
- O'Byrne, P. 1994. *Lowland Orchids of Papua New Guinea*. *Coelogyninae*: 70–79. Singapore Botanic Gardens, Singapore.
- Pelser, P., B. Gravendeel & E.F. de Vogel. 2000. A revision of *Coelogyne* section *Fuliginosae* (Orchidaceae). *Blumea* 45: 253–273.

- Pfitzer, E. & F. Kraenzlin. 1907. *Coelogyne* sect. *Verrucosae*. In: H.G.A. Engler (ed.), *Das Pflanzenreich* 23: 75. Akademie-Verlag, Berlin.
- Rolfe, R.A. 1908. *Coelogyne virescens*. Bull. Misc. Inform.: 70–71.
- Royal Horticultural Society. 1993. New Orchid Hybrids. September–October 1992 registrations. *Orchid Rev.* 101: 24.
- Royal Horticultural Society. 1997. New Orchid Hybrids. August–September–October 1996 registrations. *Orchid Rev.* 105: 52.
- Sander, C.F., F.K. Sander & L.L. Sander. 1927. *Coelogyne* × *sanderiana*. Sanders' Orch. Guide: 128. St. Albans, England.
- Smith, J.J. 1920. *Coelogyne imbricans*. Bull. Jard. Bot. Buitenzorg III, 2: 26.
- Smith, J.J. 1927. *Coelogyne peltastes* var. *unguiculata*. Mitt. Inst. Allg. Bot. Hamburg 7: 33.
- Smith, J.J. 1933. *Coelogyne pandurata*. Feddes Repert. Beih. 32: 166.
- Sun, Y., D.Z. Skinner, G.H. Liang & S.H. Hubert. 1994. Phylogenetic analysis of *Sorghum* and related taxa using internal transcribed spacers of nuclear ribosomal DNA. *Theor. Appl. Genet.* 89: 26–32.
- Swofford, D.L. 1999. PAUP*: phylogenetic analysis using parsimony, version 4.0. Champaign: Illinois Natural History Survey.
- Valmayor, H.L. 1984. *Coelogyne pandurata*. In: B.E. Calleja (ed.), *Orchidiana Philippiniana* 1: 138–139. Samhwa Printing Co., Ltd, South Korea.
- Van Steenis, C.G.G.J. 1957. Specific and infraspecific delimitation. *Flora Malesiana* I, 5: clxviii–ccxxxiv. Noordhoff-Kolff N.V., Jakarta.
- Vermeulen, J.J. 1995. A taxonomic revision of the continental African *Bulbophyllinae*. *Orchid Monogr.* 2: 9.
- Wiens, J.J. 1998. Combining data sets with different phylogenetic histories. *Syst. Biol.* 47: 568–581.

IDENTIFICATION LIST

Dates are used if the number of the collection is unknown. If only the year is known, it is placed between brackets.

- | | |
|------------------------|-------------------------|
| 1. <i>C. asperata</i> | 5. <i>C. pandurata</i> |
| 2. <i>C. imbricans</i> | 6. <i>C. peltastes</i> |
| 3. <i>C. marthae</i> | 7. <i>C. verrucosa</i> |
| 4. <i>C. mayeriana</i> | 8. <i>C. zurowetzii</i> |

- Afriastini 2762: 1; 2777: 1 — Ahwang ?/9/1890: 4 — Alston 13780: 1 — Amdjah 376: 1; 1096: 1 — Anonymous C040: 1; 10/8/1914: 4 — Anthony SA 796: 1 — Argent & Coppins 954: 5.
- B series (Murata, Iwatsuki, Kato et al.) 1770: 1 — Bartlett & La Rue 328: 1 — Beaman 7023: 7 — Bogor cult. 10: 5; 32: 6; 33: 6; 39: 5; 40: 6; 56: 1; 87: 6; 88: 1; 97: 4; 153: 1; 158: 4; 500: 6; (1910): 2; (1918) H.L.B. 9226298: 2; (1920): 5 — Brass 3831: 1; 11834: 1; 13804: 1 — Brooks ?/6/1909: 5; (1909/1910): 5; (1916): 1; 4/2/1928: 4 — BS series (Bolster) 294: 1; (Reillo) 15500: 1; 16257: 1 (Ramos) 17624: 1; (Ramos & Concovar) 84145: 1 — Bünnemeijer 1288: 1 — Burley, Tukirin et al. 1429: 1 — Burrage 17/5/1920: 5.
- Carr 10017: 1; 10160: 1; 16745: 1 — Carrick & Enoch JC441: 7 — Chan 23/11/1986: 7 — Chaplin 780: 1 — Château du Semont cult. ?/7/1894: 4 — Chew Wee-lek CWL695: 1; CWL990: 7 — Clemens et al. 7524: 1 — Collenette 501: 7; (1960): 7 — Courtauld 8/9/1890: 1 — Creagh (1893): 5 — Cruttwell 961: 1 — Curtis (1880): 5; ?/6/1894: 1; (1897): 1.
- Daud 1901: 1 — Day ?/6/1883: 1 — De Vogel 1336: 1; 1431: 1; 8152: 7; 8836: 3; 8879: 7 — De Wilde & De Wilde-Duyfjes 12200: 1; 12523: 1; 13484: 1; 14859: 1 — Dijk 940: 1 — Docters van Leeuwen 83: 1; 11400: 1.
- Elmer 10008: 1 — Elsener 190: 1 — Endert 2402: 1.
- FB series (Hutchinson) 6103: 1; 6109: 1 — Forbes (1885-6): 1 — Franck 700: 4; 701: 4 — Froidemont 1: 1; 3: 1.

- Gamble 29/11/1889: 4 — Garai 57: 1 — Gelder 25: 5 — Gibbs 6232: 1 — Gjellerup 1007: 1 — Glasnevin cult. ?/5/1900: 8 — Groeneveldt 676: 1.
- Haegens, Klazenga, Kiew et al. 620: 7 — Hallier 2146: 1; 3058: 1 — Haviland 89: 1; 842: 2; 853: 1; 21/3/1893: 1; Haviland cult. (Kuching Orchid House) 18/4/1893: 5; 5/6/1908: 5 — HBUM cult. (Stone) BCS/12648: 4 — Hewitt 106: 1; 13/3/1906: 1; 30/10/1908: 1.
- Kajewski 679: 1 — Keith 7696: 1 — KEP series (Ogata) 110163: 1 — Keßler et al. PK2567: 5 — Kew cult. (Herbarium Hookerianum) (c.1867): 5; ?/5/1890: 5; ?/7/1890: 4; ?/11/1894: 8; (Armstrong & Brown) ?/5/1909: 5; ?/7/1914: 4; 30/10/1914: 5; 4/6/1915: 1; 25/6/1924: 1; (Armstrong & Brown) 215-1929: 1 — King's collector 2724: 1; 7176: 5; 7287: 1; (B.P.D.) 8154: 5 — Kleinhoonte 624: 1 — Kloss (1912-1913): 1 — Kokawa & Hotta 329: 7 — Komassi 1239: 1; 1539: 1.
- LAE series (Damas, Anos et al.) 74614: 1 — Lamb AL203/84: 8; AL312/85: 5; AL914/88: 5 — Lawrence ?/5/1891: 1; ?/12/1891: 1 — Le Douse cult. 29/7/92: 8 — Leiden cult. 19932: 1; 20721: 4; (Franken & Roos) 20786: 5; 20895: 5; 21480: 1; 21532: 5; 22279: 1; 22731: 4; 24029: 4; 25692: 1; (Vermeulen) 26555: 7; 27019: 4; (Rijksen) 27091: 4; 27092: 1; 27139: 1; 27279: 4; 27297: 4; (De Vogel) 27425: 1; 27621: 1; 28185: 1; 30607: 5; 30728: 4; 30789: 7; 32113: 1; 32243: 1; 913562: 5; 913662: 5; 914650: 5; 914719: 7; (Jenny) 930916: 5; (Schuiteman, Mulder & Vogel) 932800: 5; 933031: 5; (Roelfsema, Vogel & Van Balgooy) 960136: 1; (Roelfsema, Schuiteman & Vogel) 970407: 5; 970584: 7; 970597: 7; 970767: 4; 981187: 7; 990238: 7 — L'Horticulture Internationale cult. 2/7/1890: 8; 21/7/1890: 8; ?/10/1890: 8 — Lobb (Veitch & Sons) s.n.: 1; 1857: 1 — Loddiges (Low) 1/12/1853: 5 — Lörzing 17005: 1 — Losworthy 20/10/1928: 5 — Lowe (1867): 5 — Lugas 1704: 5.
- Maxwell ?/7/1895: 2 — Mendoza 3172: 5 — Mogeia 3767: 1; 5448: 1 — Motley 588: 4 — Moulton 218: 7.
- Nash 28119: 5 — Native Collector 277: 5; 495: 1 — New York cult. (Nash) 1612: 1; 4334: 1; 5/7/1901: 1 — NGF series (Millar) 18881: 1; (Ridsdale & Lavarack) 30560: 1 — Nongchi 48: 4 — Nootboom & Chai 1680A: 5 — Nur 189: 1.
- Oakes Ames cult. (1896): 5; 1/3/1899: 5 — O'Byrne CX020: 7 — Officers of HMS Penguin (1984-5): 1 — Oxford University 2657: 7.
- Phillips & Lamb AL1417/92: 5 — PNH series (Sulit & Conese) 5393: 1; (Sulit) 21725: 1; (Gutierrez et al.) 117009: 1.
- Ramos et al. ?/4/1931: 1 — Rappard 202: 4 — Rasip 20/12/93: 1 — Reichenbach Herb. 29851: 6; (Veitch) 21503: 6; 21506: 4; 21507: 4; ?/8/1890: 6 — Richards R2657: 7 — Ridley 14400: 1; (1890): 4; 8/1/1890: 4; (1894): 4; ?/5/1896: 5; ?/7/1897: 5; (1898): 4; ?/11/1908: 5; (1909): 4; 26/12/1920: 5 — Royal Society Expedition (Hunt) RSS 3056: 1.
- S series (Syngé) 4: 7; (Harrison) 413: 5; (Ashton) 18156: 5; (Mohidin) 21682: 5; (Soepadmo, Smith & Chai) 27620: 1; (Mamit) 37433: 1; (Lee) 45427: 5; (Puang Ching) 51244: 1; (Yii et al.) 51662: 1; (Rena, Rumi, Rantai et al.) 58375: 1; (Puang Ching) 64751: 1; 65091: 1 — SAN series (Dewol & Kodoh) 88741: 1; (George & Harun) 89553: 5; 89635: 5; (Abang & Sign) 96278: 7; (Krispinus) 118600: 1; 120242: 1 — San Carlos Univ. 762: 1 — Sanders 16/5/1918: 5 — Sands 778: 1; 3753: 7 — Sands, Chan & Lamb 3740: 1 — Sands, Pattison, Wood et al. 1844: 1 — Schlechter 17126: 1; 18969: 1; 19108: 1 — Scortechini 2113: 5; 2183: 5 — SF series (Haniff & Nur) 7750: 4; (Burkill & Haniff) 16511: 5 — Shah & Sidek MS1154: 1 — Smith cult. (Gravenhorst s.n.) H.L.B. 9226268: 2; H.L.B. 9226283: 2; H.L.B. 92262113: 2; H.L.B. 92262197: 2; H.L.B. 920342352: 2; (1910): 2; (1921): 2.
- Tadong 540: 1 — Takeuchi 8884: 1 — Tay & Tan 94-0032: 1 — Tenom Orchid Centre cult. (Chan) 103: 4 — Teijsmann 30: 4 — Trinidad cult. (Broadway) 1/1/1908: 5; 3/3/1920: 5.
- UNESCO 48: 1; 166: 1; 218: 1 — UPNG series (Ombas) 1384: 1.
- Van Gelder 25: 5 — Van Niel 3794: 5 — Van Royen 5070: 1 — Vermeulen 779: 7; 1156: 3 — Vermeulen & Lamb 322: 7; 753: 7 — Versteeg 1345: 1.
- Waterhouse 642: 1; 728: 1 — Weber 55: 1; 250: 1 — Wenzel 532: 1; 602: 1; (1914): 1 — Wickison 125: 1 — Winkler 347: 5 — Wray 2169: 1.
- Yates 2160: 1 — Yenny 183: 1 — Yong & Lamb AL437/85: 5.

INDEX

Accepted species are in roman type, new species in bold and synonyms and excluded species in *italics*. Numbers refer to the species number as used in this revision.

Coelogyne Lindl.

- sect. *Verrucosae* Pfitzer & Kraenzl. [p. 286]
asperata Lindl. 1
brachyptera Rchb.f. 10
edelfeldtii F. Muell. & Kraenzl. 1
imbricans J.J. Sm. 2
lowii Paxton 1
marthae S.E.C. Sierra 3
mayeriana Rchb.f. 4
pandurata Lindl. 5
papillosa Ridl. 9

(Coelogyne)

- parishii* Hook.f. 11
peltastes Rchb.f. 6
 var. *unguiculata* J.J. Sm. 5
peltastes auct. 8
pustulosa Ridl. 1
verrucosa S.E.C. Sierra 7
virescens Rolfe 12
zurowetzii Carr 8
Pleione asperata (Lindl.) Kuntze 1
pandurata (Lindl.) Kuntze 5