

HEWLETT-PACKARD JOURNAL

MARCH 1975



A High-Performance 2-to-18-GHz Sweeper

This precise, compact microwave sweep oscillator is a significant contribution to its field. The latest microelectronic and YIG technology makes it possible.

by Paul R. Hernday and Carl J. Enlow

THE NEED FOR VERY BROADBAND swept microwave sources is well established. Production testing of multi-octave devices requires a broadband sweeper that is simple to operate. Automated test systems need a source that is programmable and can be phase locked. Broadband receiver testing often requires a compact unit for on-site swept tests. The broad area of microwave design calls for a general-purpose sweeper that offers precision performance and is simple to interface with related equipment and convenient to operate.

The truly broadband source, a single oscillator capable of sweeping a frequency range such as 2 to 18 GHz in one uninterrupted sweep, is not presently available, but there are alternatives. The most direct method is to sequence several narrower-band sweepers by means of an external controller so the resulting sweep covers the desired range. Another approach, using one sweeper and several plug-in RF heads installed in a "head-holder", reduces circuit redundancy and simplifies operation by giving frequency control to a single sweeper, but the equipment is still physically large.

A more compact scheme is to put the required oscillators in a single sweeper and sequence them internally. More compact yet is a single oscillator followed by a harmonic multiplier to produce the higher frequencies.

A New Sweeper

This last scheme is used in the new Model 86290A 2-to-18-GHz RF Plug-In for the 8620A Sweep Oscillator mainframe, making the combination the most compact broadband sweeper currently available (see Fig. 1). Designed to meet the requirements of all major sweeper applications, the 8620A/86290A provides more than +5 dBm of power, leveled to within ± 0.9 dB, in fast, continuous sweeps over the 2-to-18-GHz frequency range or any portion of this range (Fig. 2).

Besides the 2-to-18-GHz band, the 86290A provides three narrower bands: 2-6.2, 6-12.4, and 12-18 GHz. All bands are selectable by means of a front-panel dial drum switch on the 8620A mainframe. In CW mode in any of the narrower bands, the output frequency is accurate within ± 20 MHz and resolution is 100 kHz, specifications approaching those of the traditionally more precise signal generator. Sweeping over the widest band the frequency is accurate within ± 80 MHz. Undesired harmonics are at least 25 dB and typically 30 dB below the desired output signal.

The new sweeper weighs just 15 kg (33 lb), so it can



Cover: *In the background is the new Model 86290A 2-to-18-GHz RF Plug-in installed in an 8620A Sweep Oscillator mainframe. In the foreground are the three components whose development made the broadband RF plug-in possible: a YIG-tuned oscillator (top), a power amplifier (left), and a YIG-tuned multiplier (right).*

In this Issue:

- A High-Performance 2-to-18-GHz Sweeper, by Paul R. Hernday and Carl J. Enlow* **page 2**
- Broadband Swept Network Measurements, by John J. Dupre and Cyril J. Yansouni* **page 15**
- The Dual Function Generator: A Source of a Wide Variety of Test Signals, by Ronald J. Riedel and Dan D. Danielson* **page 18**



Fig. 1. Model 86290A is a new RF plug-in for Model 8620A Sweep Oscillator. Four frequency bands are selectable by front-panel controls: 2-6.2, 6-12.4, 12-18, and 2-18 GHz. The combination is the most compact broadband sweeper currently available.

easily be carried to field sites. Its versatility makes it useful in a wide array of applications, some of which are described in the article beginning on page 15.

RF Design

Fig. 3 is the RF block diagram of the 86290A. The basic elements are a single wide-band YIG-tuned oscillator (YTO), a power amplifier, and a 2-to-18-GHz YIG-tuned multiplier (YTM). Consisting of a step-recovery-diode and a YIG-tuned filter, the multiplier converts the amplified YTO signal to useful RF power levels at twice and three times the YTO frequency.

The YTO's tuning range is 2-6.2 GHz. The YTM passes this signal directly to provide the first of the three narrower bands mentioned earlier. The other two bands, 6-12.4 and 12-18 GHz, are derived by tuning the YTM to twice and three times the YTO frequency as the YTO is tuned over 3-6.2 and 4-6 GHz respectively. Here the YTM is specially biased to provide maximum harmonic level. These three single bands will be referred to as bands 1, 2, and 3, corresponding to their respective harmonic numbers and 8620A dial drum positions. Band 4, 2-18 GHz, is obtained by automatically sweeping, in sequence, the required portions of these three bands.

Power leveling in the 86290A is achieved by sensing output power with a broadband directional detec-

tor, comparing this signal to a level control voltage, and applying the error signal to a PIN modulator. The modulator precedes the amplifier so the modulator's insertion loss is cancelled by the excess small-signal gain of the amplifier (see box, page 11). The modulator also contains a directional coupler to sample the YTO signal and route it to the rear panel for counting or phase-lock applications.

In general, the conversion efficiency of a harmonic multiplier drops as the harmonic number n increases. Therefore, for a given drive power, the highest output power is achieved by keeping n as small as possible. In a sweeper, small n means fewer band switch points and correspondingly simpler drive circuitry and cleaner display. However, small n implies greater oscillator range, since the YTO must tune, in this case, from 2 GHz to an upper limit set by $18/n$ GHz. The choice of $n = 3$ as the maximum for the 86290A was determined by the state of the art in YIG oscillator technology.

While the multiplier approach is compact and does not require the development of multi-octave oscillators, it does pose several tough design constraints. The YTM and YTO must have excellent tuning characteristics to permit good tracking of the desired harmonic by the narrow passband of the YIG filter. Multiplier conversion loss must be 11 dB or better and the power amplifier must supply at least 100 mW at 2-6.2 GHz to guarantee the +5 dBm power output specification. In addition, the YIG control circuitry must be very stable with temperature and time and must compensate for the tuning errors inherent in magnetically tuned devices.

Tracking YIG Components

Tracking the YTO harmonic with the single-pole YIG-tuned filter proved to be a challenging design task. The YTM 1-dB bandwidth, as low as 20 MHz at some frequencies, dictates how closely the two must track to avoid unacceptable variations in output power.

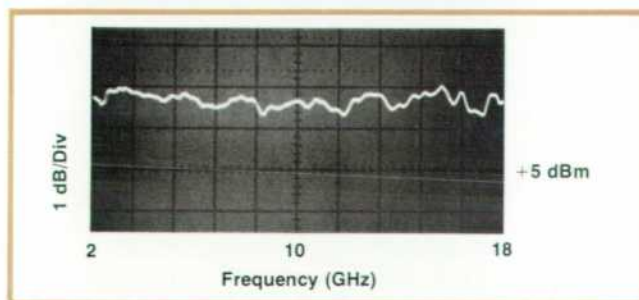

Fig. 2. The 2-18 GHz plug-in provides more than +5 dBm of power output, internally leveled to within ± 0.9 dB. External leveling is also possible.

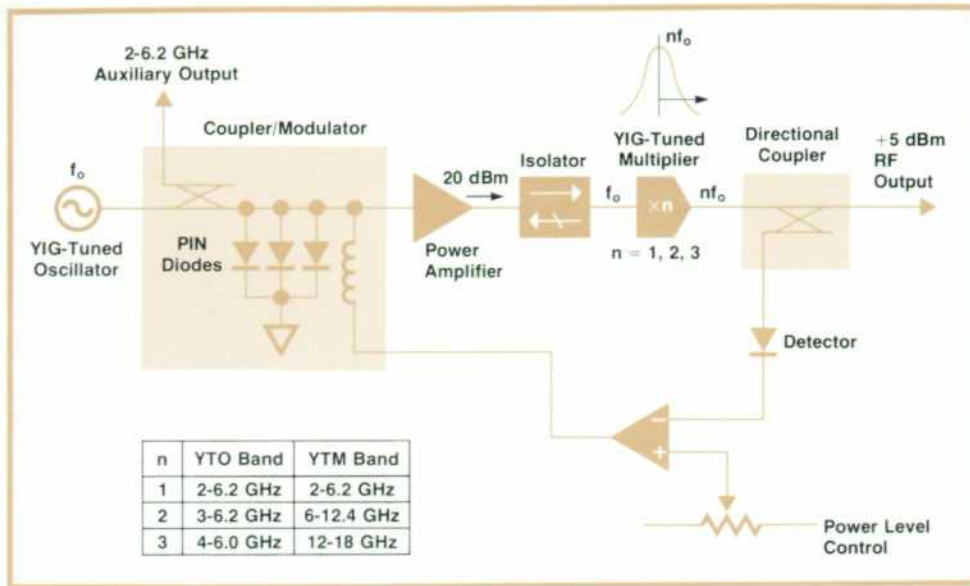

Fig. 3. RF block diagram of the 2-18 GHz plug-in. The YIG-tuned oscillator and YIG-tuned harmonic multiplier track each other in frequency.

The sources of tracking error include magnetic saturation, hysteresis, and delay, and thermal drift and aging in both the YIG devices and the control circuits. Some of the magnetic effects can be compensated in the control circuits. Others must be controlled by optimizing the design of the YIG magnets themselves.

Each YIG-device/driver block has its own set of frequency errors. One way to guarantee tracking would be to modify the errors of one block to make it track the other. Another way is to correct the errors of both blocks independently, so when they are put together only very minor adjustments are necessary. This is the approach taken for the 86290A. The benefits are many. It simplifies production and service, provides excellent frequency accuracy, and results in a typical frequency nonlinearity* less than ± 8 MHz in bands 1, 2, and 3 and ± 30 MHz in the 2-18 GHz band.

Magnet Design

Hysteresis and saturation are familiar effects whose magnitudes depend upon the magnet core material. Saturation is also influenced strongly by the magnet geometry, particularly the shape of the pole. For the 86290A, the magnet gap and pole face diameter were chosen based on YIG sphere size, and the optimum pole taper for these dimensions was derived.¹

Hysteresis is also affected by geometry in that the overall magnetic hysteresis is a function of the length of core that is made from high-hysteresis material and of the flux density in this portion of the core. Magnet core materials must be chosen to minimize both hysteresis and saturation. Of the soft magnetic materials generally used in these applications, the 50% and 80% nickel alloys are the most convenient.

*Nonlinearity is the difference between the actual output frequency and that indicated by the SWEEP OUTPUT voltage in the MANUAL mode.

The configuration of these materials in the magnet is complicated by their thermal expansion characteristics. Unless applied correctly, these materials can contribute significantly, through gap change, to the overall temperature dependence of the YIG device. In the 86290A magnets, these materials are used where required by hysteresis and saturation considerations and their lengths are chosen to satisfy a zero-gap-drift constraint. Applying this technique to the design of the YTO and YTM magnet structures resulted in the following magnetic properties, measured in bands 1, 2 and 3.

	YTO	YTM
Maximum Hysteresis Error (MHz)	± 1	± 2
Maximum Saturation Error (MHz)	± 3	± 18

The effect of hysteresis errors is further reduced by the fact that the two magnet structures are similar and have similar sweep histories. Thus there is considerable cancellation. The remaining nonlinearity caused by saturation can be compensated by the YIG control circuits, to be described later.

The third magnetic effect, sweep delay, is caused by the bucking effect of eddy currents induced in core and package materials by a change in applied magnetic field. The lagging field at the YIG causes a lag in the actual tuned frequency. A large portion of this delay comes from the magnetic core itself and cannot be eliminated without laminating the core, which decreases rigidity and makes hermetic sealing difficult. However, eddy currents in the circuit support structure can be reduced by avoiding closed loops and by using thin, high-resistance metals. The remaining influence is compensated very well by the control circuits, as explained later.

Magnet gap change is not the only source of ther-

mal drift in the YIG components. The YIG spheres themselves and the oscillator transistor in the YTO can contribute drifts more than an order of magnitude greater than even an uncompensated magnet. Careful alignment of the YIG sphere's anisotropic field and the use of heater/regulators greatly reduce these effects in the new sweeper (see boxes, pages 6 and 8). Aging, mentioned earlier as a source of tracking error, results mainly from gradual change of the gap itself. At 6 GHz, a 0.0025-mm variation in a 2.5-mm gap causes a frequency shift of 6 MHz. This sort of variation can be expected over a few weeks time unless great care is taken in the attachment of the magnets. YIG magnets for the 86290A are held in place by strong metal clamps so there is negligible gap change with time.

YIG Driver Design

Ideally, spherical YIG resonators tune linearly with applied magnetic field according to the relation $f = \gamma H$, where H is the applied field in gauss and γ is approximately 2.8 MHz/gauss (see box, page 13). Magnetic field is proportional to current through the magnets, so a linear frequency sweep requires a linear current ramp.

The YIG driver circuits have three main sections:

the circuits that change the tuning current ranges as the YIG components are swept across the bands, the driving current sources, and finally, the compensation for the effects of magnetic saturation and delay.

A representative driver schematic is shown in Fig. 4. A frequency control signal of zero to ten volts is applied for each of bands 1, 2, and 3. Depending on the band, zero volts represents 2, 6, or 12 GHz, and ten volts represents 6.2, 12.4, or 18 GHz. U1 and the resistive networks around it constitute an inverting amplifier with three possible combinations of gain and dc offset. Each resistive network corresponds to one of the three bands and is switched into effect by the band control inputs. For an increasing input voltage, V' falls and the feedback loop comprised of U2, Q1, Q2, Q3, and R_{ref} assures that $V_{ref} = V'$. The current through R_{ref} increases proportionally. Q1's base current is negligible and U2's input impedance is high; therefore, the entire current is delivered to the magnet.

Each YIG device has a driver of this type. Every range-switching network has two adjustments, and must be aligned for proper YTO frequency excursion and optimum YTM harmonic tracking.

If the YIG components were ideal, this would be

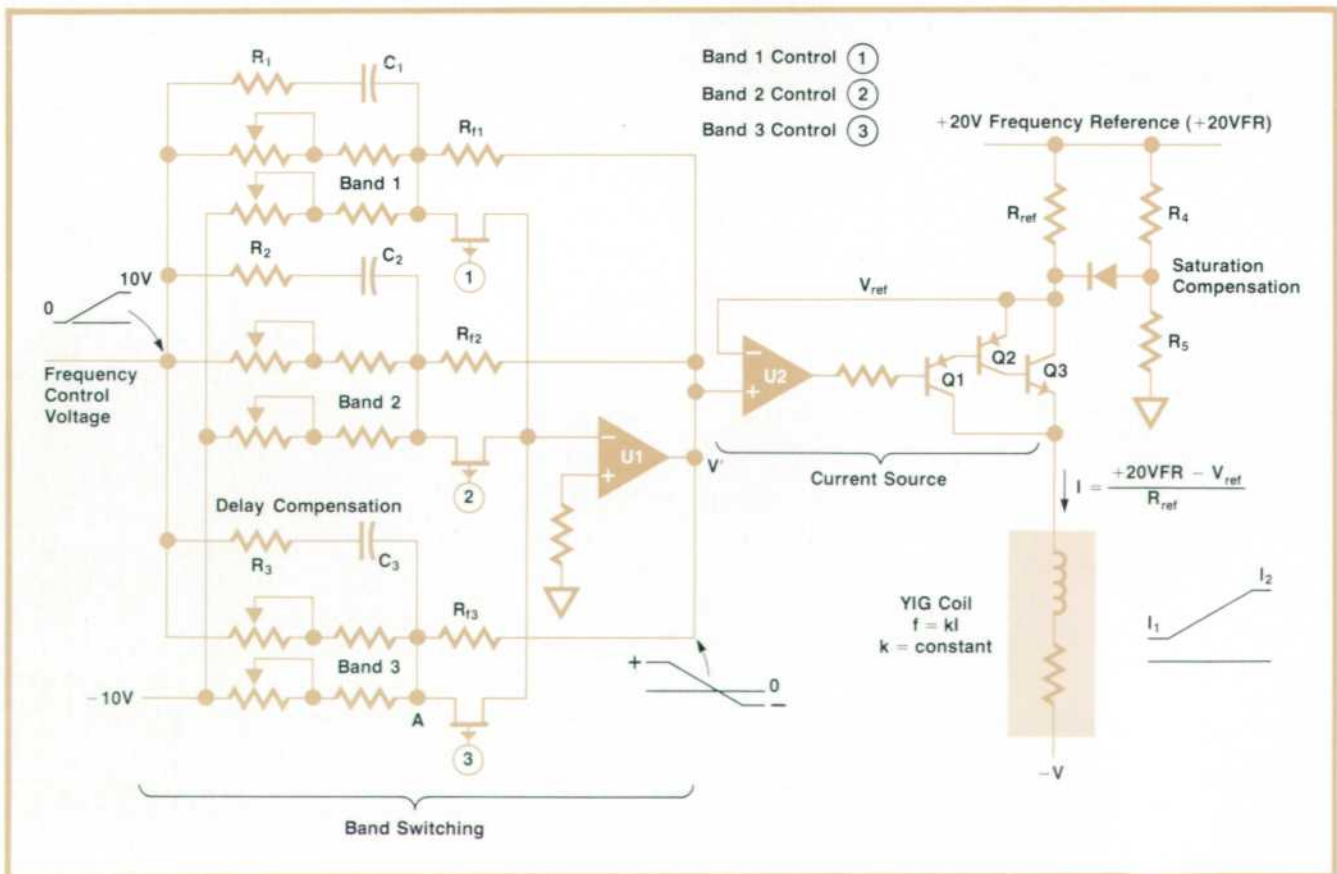

Fig. 4. YIG driver circuits provide the linear current ramps that tune the YIG resonators. The drivers also compensate for magnetic saturation and delay in the YIG magnets.

A 2-18-GHz YIG-Tuned Multiplier

The YIG-tuned multiplier (YTM) is the key to the 86290A's broad frequency range. While multipliers have an established place in microwave design, the important contributions of this device are its extremely wide input and output frequency ranges and its efficient generation of harmonic power. Given a high-level, 2-6.2-GHz drive signal, the YTM provides second and third harmonic power to 18 GHz with conversion loss under 11 dB. It can also pass the fundamental signal with approximately 6 dB loss, completing the frequency range without the need to bypass the YTM. These features, combined with tuning linearity better than ± 18 MHz in any of the harmonic ranges, make the YTM a very powerful microwave component.

The YTM is shown schematically in Fig. 1. An HP step-recovery-diode (SRD) is employed as the nonlinear, harmonic-generating element. It is followed by a single-sphere YIG-tuned filter, which tracks the desired harmonic and rejects the others. To minimize conversion loss, the SRD's self-biased condition is modified with an external bias signal. This signal is shaped from the 86290A's frequency control voltage and is set in the factory for optimum YTM performance. The SRD is forward biased for 2.0-6.2 GHz output.

Coupling to and from the YIG resonator is accomplished via conducting loops that pass over opposite sides of the sphere to ground. These loops are situated at right angles to the applied magnetic tuning field, H , and are at right angles to one another to avoid direct coupling from input to output. The output power is proportional to RF current (see box, page 13), so the SRD must be driven from a low-impedance source. The input matching circuit provides this low impedance, transforming the 50Ω generator impedance to less than 10Ω over a broad frequency range. It also prevents the flow of harmonic energy back into the driving source.

The input circuit, the SRD, and the YIG filter's input coupling loop are on a sapphire substrate, and the output loop is located on a second substrate. Beneath each loop is a hole slightly larger than the YIG sphere. The substrates are placed back to back with the sphere between the loops.

Temperature compensation of the YIG filter is accomplished

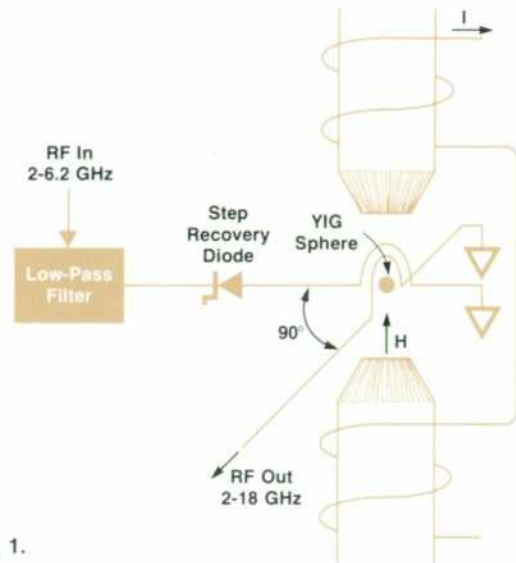

Fig. 1.

using two established techniques. First, the sphere is mounted near a known crystalline axis to reduce temperature dependence. Then, when the circuit is in operation, the entire substrate assembly is heated to a constant 75°C . A tiny bead-style thermistor monitors the temperature near the sphere. An external circuit, mounted on an attached printed circuit board, supplies a control signal to a resistive heater alongside the substrates.

Robert Joly
Alejandro Chu

References

1. J. Moll and S. Hamilton, "Physical Modeling of the SRD for Pulse & Harmonic Generator Circuits", Proceedings of the IEEE, Vol. 57, No. 7, July 1969.
2. "Harmonic Generator Using SRD & SRD Modules", HP Application Note 920.
3. Matthaei, Young, and Jones, "Handbook of Microwave Filter Design", McGraw-Hill Book Company, 1964.

enough. In reality, saturation and delay make additional circuitry necessary. Linearity is improved by shunting R_{ref} with selected resistors as the YIG frequency is increased. The circuit that does this is indicated in Fig. 4. As V_{ref} drops with increasing magnet current, it crosses the level set by the divider, R_4 and R_5 , and the diode conducts. The ratio of R_4 and R_5 determines the switch point, and their magnitudes govern the amount of correction applied. Several such networks are used as needed to reduce non-linearity of a given YIG device to a few megahertz across any band.

Delay compensation can be implemented at the reference resistor or in the range switching circuitry. The delay mechanism itself can be represented quite well by a simple RC low-pass circuit (Fig. 5). The circuit's response to a linear ramp is given by

$$e_{\text{out}}(t) = at - aRC(1 - e^{-t/RC}),$$

where $e_{\text{in}}(t) = at$. Thus a signal of the form $1 - e^{-t/RC}$ is

required to compensate the magnet for delay. This is present in the current flowing through the low-pass circuit, given by

$$i(t) = aC[1 - e^{-t/RC}].$$

Magnetic delay τ_m is approximately 150 microseconds for unlaminated structures of good design. RC is analogous to τ_m , so compensation can be realized with components of convenient size.

The use of this circuit in an actual driver is illustrated in Fig. 4. Point A is a virtual ground when connected to U1 by the FET switch. Current into this node causes an increase in frequency. Elements R_i and C_i ($i = 1, 2, 3$) are selected to duplicate the magnet time constant and to provide, in conjunction with the feedback resistor R_{fi} , a signal level consistent with the actual delay effect. A second RC leg may be paralleled with the first to tailor the compensation more closely for a particular device.

The selection and loading of the proper R and C val-

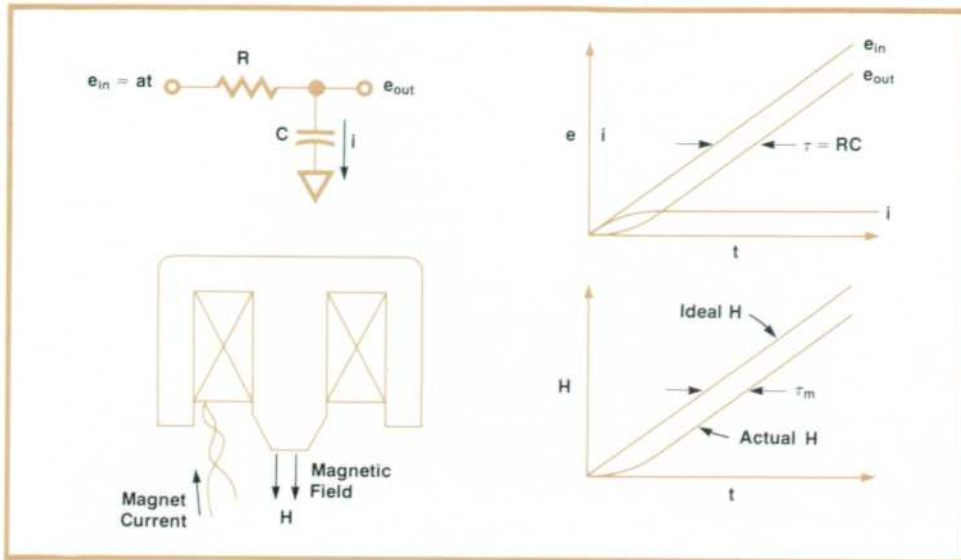

Fig. 5. Magnetic delay is represented well by an RC network. Thus a simple network can provide a compensating signal.

ues for each range could be a tedious affair. In the 86290A, a fixed capacitor, an operational amplifier, and variable resistors provide a compensating waveform that is continuously variable in both time constant and magnitude, eliminating the need for selected components.

Minimizing Drift

Drift of the frequency control voltage causes a frequency error, but since this signal is common to both drivers, no tracking error occurs. However, great care must be taken to minimize sources of drift within the drivers. All operational amplifier offsets are nulled and ± 2 ppm/ $^{\circ}$ C metal film resistors are used in gain and offset functions. The driver reference resistors are matched to ± 1 ppm/ $^{\circ}$ C and are derated greatly to reduce self-heating. In the band-switching circuits, the FETs are operated directly into the high-impedance operational amplifier to eliminate the effects of FET on-resistance drift.

Another source of drift is found in the 8620A mainframe's +20V frequency reference (+20VFR), which is the reference voltage for both current sources. It is related to drive current by the equation,

$$I = \frac{+20VFR - V_{ref}}{R_{ref}}$$

Variations in +20VFR may be as high as ± 0.4 mV/ $^{\circ}$ C. To avoid the corresponding frequency and tracking drifts, the supply is compared to a stable reference in the 86290A and a correction signal is applied to the drivers. This technique also makes the instrument immune to variations in +20VFR among mainframes.

Frequency Control

Two types of signals control the 86290A output frequency: logic signals that select the range of the current source in the YIG driver, and the 0-10V frequency control voltage that drives the current source

across the selected range. The control scheme for generating these inputs is illustrated in Fig. 6.

For the narrow ranges (2-6.2 GHz, 6-12.4 GHz, and 12-18 GHz), the 0-10V tuning voltage from the 8620A mainframe is essentially a direct input to the YIG drivers. In all three of these ranges, Q1 is switched on, routing the tuning voltage through U4, a voltage follower, to the drivers. Similarly, the range logic is determined by direct mainframe inputs: the band 1, 2, and 3 lines are routed through dual-input OR gates to an IC that shifts the TTL level to 0-10V for driving the FET switches in the YIG drivers.

When the 2-to-18-GHz range is selected, the 0-10V tuning voltage from the mainframe is no longer suitable as a direct input to the YIG drivers. To cover this range, the drivers must sweep across the narrow ranges sequentially. This requires that for each 0-10V excursion by the mainframe tuning voltage, the YIG driver frequency control voltage must make three 0-10V excursions. Waveforms 4 and 5 in Fig. 6 show this relationship.

Selection of band 4, 2-18 GHz, causes Q1 to turn off, Q2 to turn on, and K1 to close. The mainframe tuning voltage is then directed through K1 to the inputs of two comparators, U1 and U2, which are referenced at +2.625 volts and +6.500 volts, respectively. The combined outputs of these comparators, waveforms 1, 2, and 3 in Fig. 6, indicate the desired YIG driver range as a function of mainframe tuning voltage: 0-2.625V corresponds to 2-6.2 GHz, 2.625-6.500V corresponds to 6-12.4 GHz, and 6.500-10.000V corresponds to 12-18 GHz. In addition to controlling the YIG driver range, these signals switch offset and gain around U3 to convert the tuning voltage into the required frequency control voltage, waveform 5 in Fig. 6.

From this discussion, it might be concluded that

A 2.0-6.2-GHz YIG-Tuned Oscillator

The fundamental signal source in the 86290A is a 2.0-6.2-GHz, YIG-tuned transistor oscillator (see Fig. 1). It features a 20-mW output level, ± 3 -MHz tuning accuracy, hysteresis under 2 MHz, and frequency drift of less than 150 kHz/ $^{\circ}$ C.



Fig. 1.

The YTO circuit is built in microstrip on a sapphire substrate. All transistors are HP 35820. The circuit is shown schematically in Fig. 2. The oscillator stage consists of Q1, feedback inductance L1, and the YIG sphere with its coupling loop. Q1 presents a negative resistance to the resonator over the desired frequency range. Oscillation amplitude grows until the average negative resistance seen looking into the emitter of Q1 equals the resistance of the YIG resonator.¹ The resonator detunes very slightly to present a reactance equal and opposite to that seen at the emitter of Q1. Q2 and Q3, along with their matching structures, form a broadband buffer amplifier.² The five bias resistors are located externally and allow the selec-

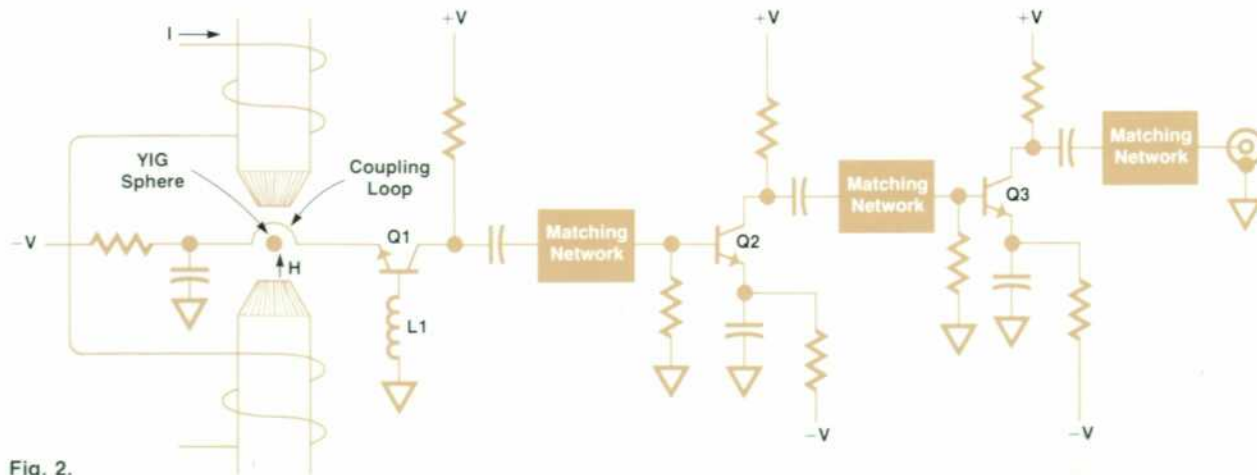

Fig. 2.

tion of a unique operating point for each transistor; hence each stage can be optimized for maximum output power or adjusted for desired harmonic level.

The choice of YIG sphere parameters is crucial to oscillator performance. RF coupling increases with sphere size, given a constant coupling loop diameter. As sphere and loop diameters become comparable, however, the uniformity of the RF coupling field degrades. This enhances spurious YIG resonances which show up as sharp frequency discontinuities as the oscillator is swept. Sphere and loop diameters in the YTO are 0.063 mm and 0.127 mm respectively.

The density of magnetic dipoles within the sphere is determined by its saturation magnetization. This parameter is bounded on the high side by the intrusion of spurious YIG resonances in the lower portion of the band, and on the low side by a decrease in RF coupling. For the 2-6.2 GHz range, a 600-gauss sphere is the best compromise.

The greater portion of the YTO's uncompensated frequency drift is caused by the temperature dependence of the sphere's anisotropic field. Such drift can be reduced greatly by orienting the YIG for zero anisotropy. With proper initial orientation, as many as eight temperature compensated (TC) points may be found in a single 360 $^{\circ}$ rotation of the sphere about an axis perpendicular to the applied dc magnetic field. In this oscillator, the YIG sphere is mounted on a beryllium oxide rod in such an orientation. It is then rotated until a TC point is found. Finally, a 75 $^{\circ}$ C heater is attached to the rod to further reduce the effect of ambient temperature changes. The whole assembly is supported in a quartz tube to minimize heat losses (see Fig. 1).

The design of the tuning magnet is discussed in the main text. Magnets are held in place with pairs of metal clamps, and are hermetically sealed with a stable, moisture-resistant epoxy. The oscillator is housed in a mu-metal shield can. Heat is transferred from the oscillator circuit via a copper bar that supports the circuit and passes through the wall of the center body and shielding can to make thermal contact with the 86290A's aluminum heat sink casting.

Roger Stancliff
Paul Hernday

References

1. P. M. Ollivier, "Microwave YIG-Tuned Transistor Oscillator-Amplifier Design: Application to C-Band", IEEE Journal of Solid-State Circuits, Volume SC-7, pp. 54-60, February 1972.
2. J. Dupre, "1.8 to 4.2 GHz YIG-Tuned Transistor Oscillator with a Wideband Buffer Amplifier", IEEE GMTT Symposium Digest, 1969, pp. 432-438.

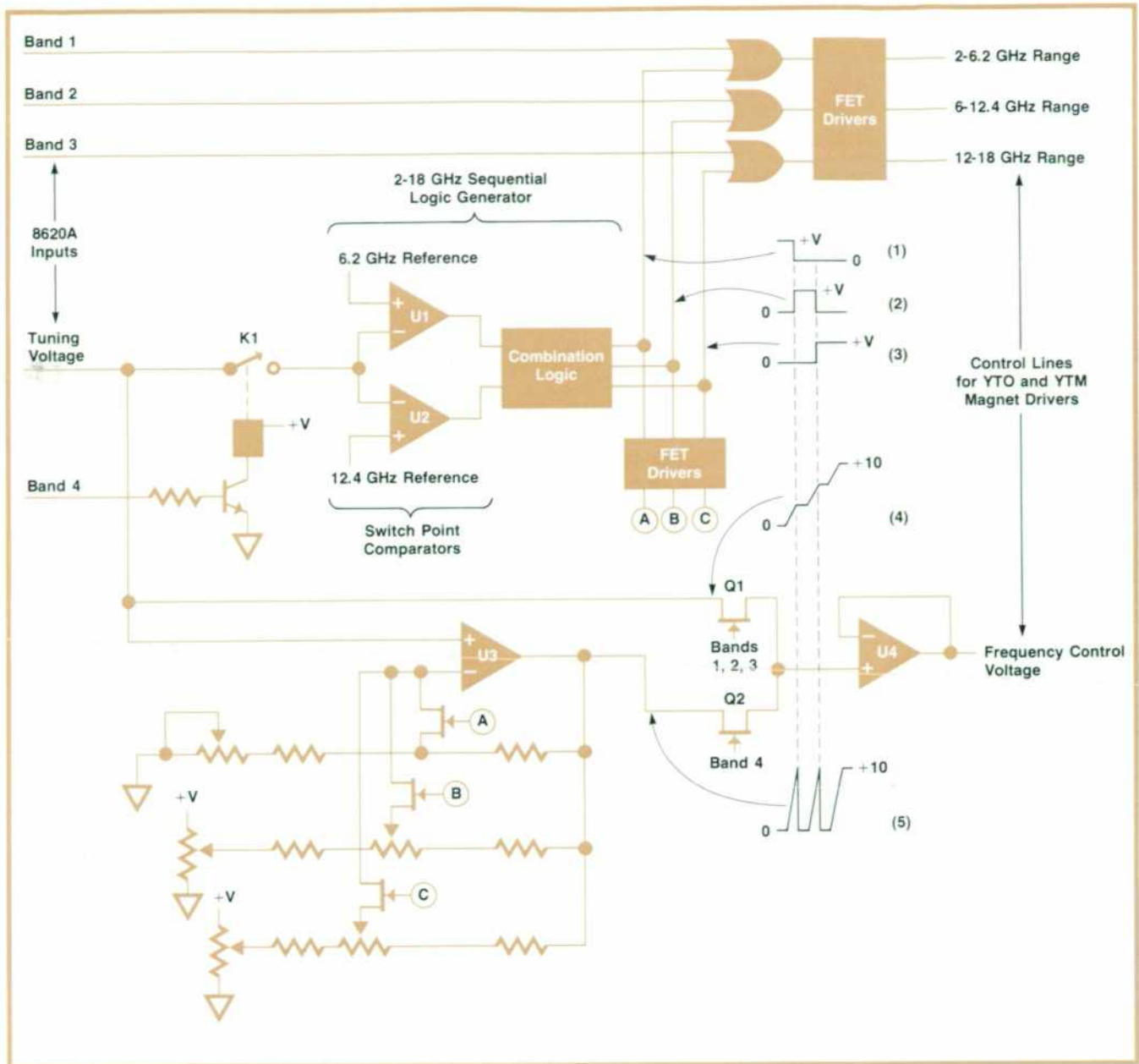

Fig. 6. Frequency control circuits take the tuning voltage and band-select signals from the 8620A mainframe and provide 0-10V ramps that drive the YIG-driver current sources across the proper ranges. In band 4, 2-18 GHz, the sweep stops momentarily at band-switch points to avoid frequency and power gaps.

there is considerable overlap—200 MHz and 400 MHz—at the range switch points. This would be the case if on each excursion of the frequency control voltage the limits were exactly 0 and +10 volts. Actually, the limits are adjusted at U3 so the overlap is less than 20 MHz at each switch point.

Mainframe/Plug-In Interface (Band 4)

The 86290A plug-in carries on a two-way communication with the 8620A mainframe. To avoid frequency and power gaps as it sweeps across three separate ranges sequentially, the 86290A must have a means

of stopping the sweep generator in the mainframe during range switching intervals. (This is what causes the two flat levels in waveform 4 of Fig. 6.) Also, to achieve fast sweep tracking between YTO and YTM in sequential operation, the maximum rate of frequency change must be no greater than in single-range operation. Since the 2-to-18-GHz range is about three times wider than the other ranges, the plug-in needs a way to reduce the maximum sweep rate by a factor of three when operating sequentially. The mechanism for accomplishing both of these things is shown in Fig. 7.

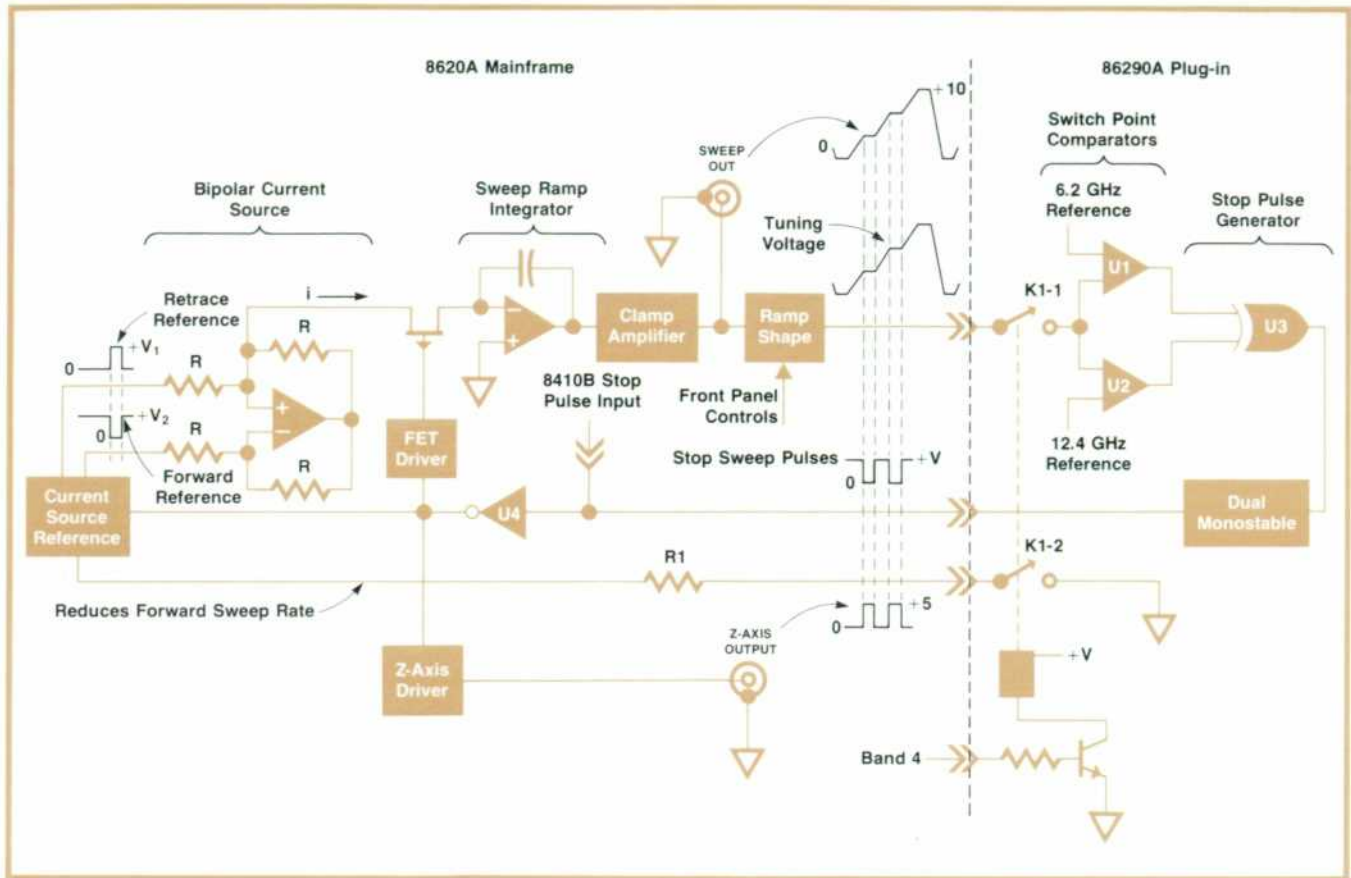

Fig. 7. 8620A/86290A interface circuits generate stop-sweep signals and limit the maximum sweep rate in band 4.

To follow the sequence of events, assume that band 4, 2-18 GHz, has just been selected. The band 4 logic line causes K1 to close and the tuning voltage is directed through K1-1 to the switch point comparators, U1 and U2 (these are the same comparators shown in Fig. 6 as a part of the logic generator). The outputs of U1 and U2 are monitored by an EXCLUSIVE OR gate, U3, which triggers a monostable circuit whenever U1 or U2 changes output states. The output of this monostable is a six-millisecond pulse, which is returned to the mainframe. This pulse is inverted in the mainframe and used to gate open the path between the current source and the ramp integrator. This pulse also goes to the Z-axis output, where it is available for blanking an oscilloscope display during the stop-sweep interval, thus avoiding bright spots and spikes that might otherwise appear on the display at the two range switch points. Continuing around the circuit path, the output of the sweep ramp integrator is clamped at its two extremes and amplified to produce a zero-to-ten-volt sweep output voltage. This ramp voltage is then offset and attenuated as a function of front-panel control settings to generate the desired tuning voltage and complete the stop-sweep loop.

The maximum sweep rate in band 4 is fixed by switching a single resistor in the 86290A, R1, to ground. R1 loads the current source reference circuitry to reduce the forward sweep rate reference voltage, V_2 , by a factor of three.

The mainframe stop-sweep inverter, U4, has one other important input path. It comes from the programming connector on the rear panel. This input is used in test systems with the 8410B network analyzer (see article, page 15). It allows the 8410B to stop the sweep oscillator in the same manner that the 86290A does. In a system where both the 86290A and the 8410B are used, this input is a wired-OR line, which allows either instrument to stop the sweep. This is a particularly important feature. It allows the 8410B to make continuous phase and amplitude measurements from 2 to 18 GHz when used with the 86290A.

Leveling Loop

As Fig. 8 shows, 86290A power leveling is accomplished by controlling the operating point of the PIN modulator as a function of V_{sense} and V_{set} . V_{sense} is a voltage derived by detecting and amplifying a small portion, -16 dB, of the 2-18 GHz output signal. V_{set}

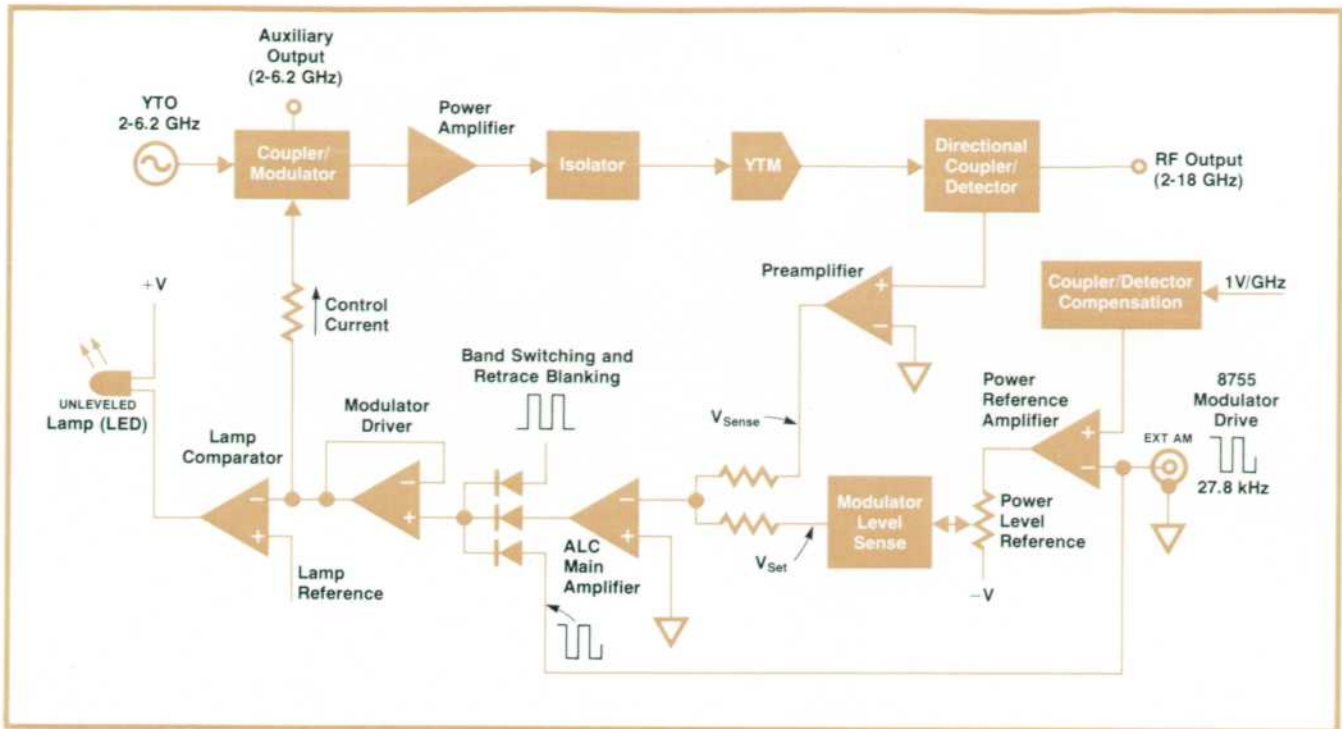

Fig. 8. 86290A power is internally leveled by controlling the operating point of the PIN modulator. The ALC loop is designed to have a high enough slew rate to respond to the square-wave modulation from the 8755A Network Analyzer.

is a shaped reference voltage; its magnitude is determined by the front-panel power level control.

In the loop, V_{sense} and V_{set} are summed, and their sum is compared to zero volts at the main amplifier.

A 2.0-6.2-GHz Power Amplifier

The power amplifier used in the 86290A had to meet one major requirement: it had to provide 20 dBm (100 mW) of power output to the YIG-tuned multiplier, given an input power of approximately 10 dBm. The term "power amplifier" might be surprising, because much higher powers have been achieved at these frequencies. However, to obtain the power and the bandwidth at the same time is a real design challenge.

The amplifier design is based on the HP 35820 transistor. The amplifier has two stages of preamplification that account for 4.5 dB gain, and three stages of power amplification that account for an additional 5.5 dB. The preamplifier has been described in detail elsewhere.¹

Power amplifier design could have followed any of three avenues. A large number of preamplifier stages could have been paralleled, using power dividers and combiners, or two-stage power amplifiers with 18 dBm power output could have been built and paralleled to get the desired output. A third method was to parallel two transistors within a stage and obtain the 20 dBm output with three stages. Although it required more circuit optimization, this option had the advantages of lower manufacturing cost, smaller size, and lower power dissipation, and was therefore used in the amplifier. The HP 35820 transistor pair was modeled as a single device to obtain its small-signal S-parameters. The large-signal parameters were obtained experimentally using external tuners at high RF power levels. The input, interstage and output matching networks were then designed and the designs verified using a computer.

All amplifier stages are built on sapphire substrates. Fig. 1 shows the amplifier with its lid removed.

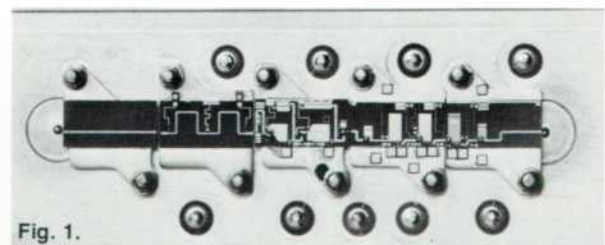

Fig. 1.

The amplifier has a rather large small-signal gain between 2 and 3 GHz. Since the amplifier follows the PIN modulator, amplifier gain compression detracts from system on/off ratio, an important parameter when the 86290A is being modulated by the 8755A Network Analyzer (see text, page 13). To shape the gain and saturating characteristics, a frequency selective attenuator consisting of three PIN diodes imbedded in a microstrip filter is used at the input of the amplifier. Its attenuation is set with an external bias voltage and ranges from 2 to 8 dB at 2 GHz. Loss drops to 1 dB above 4 GHz, where compression is slight.

Ganesh Basawapatna

References

1. P. Chen, "Design & Applications of 2-6.5 GHz Transistor Amplifiers", IEEE Journal of Solid-State Circuits, August 1974, Vol. SC-9, No. 4.

Product Design of the 86290A

Along with the RF performance goals that defined the 86290A in the early development stage were some equally demanding mechanical objectives. The plug-in had to fit into what seemed like an impossibly small space for a 2-18-GHz source ($13 \times 15 \times 28$ cm). It had to be quick and easy to assemble and every section had to be readily accessible for easy servicing. It had to dissipate approximately 50 watts; yet, it would have to run with no more than a $15\text{-}20^\circ\text{C}$ temperature rise throughout to ensure good reliability.

The 86290A is a fully modular design consisting of four main assemblies (Fig. 1): an RF section that houses the microcircuits, a control section, and front and rear panel assemblies. Communication between the control and RF sections takes place via flexible shielded cables for YTO FM coil drive and ALC detector signals, and a single ribbon cable from which each micro-circuit takes its supply voltages and control signals.

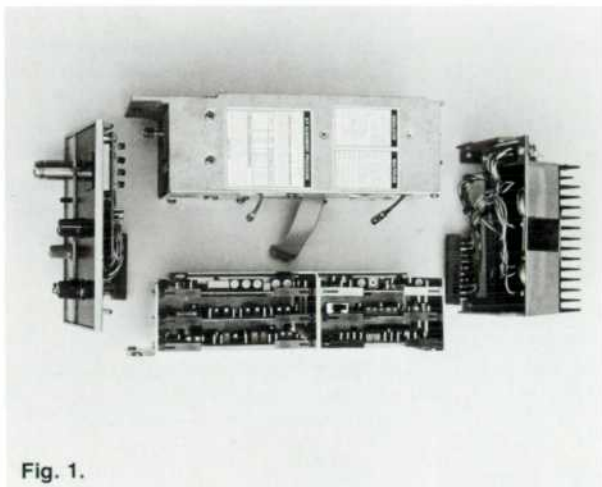

Printed-circuit boards are dedicated to separate electrical functions for optimum servicing and minimum repair cost. They are interconnected by a single, multilayer printed-circuit motherboard. Edge connectors at the ends of this board form the sole interface with the front and rear panel assemblies.

This design greatly streamlines production of the instrument. The RF section is preassembled, connected to a special test set, and fully RF tested before being installed in the instrument. Front and rear panel assemblies are processed similarly. Printed-circuit boards are dc pretested by computer and then functionally pretested in a simulated instrument before being plugged into the final instrument. These techniques allow troubleshooting at the lowest, simplest levels, and result in little if any troubleshooting at final turn-on.

The same modular features result in excellent serviceability. The front and rear panels come off with the removal of four screws. They can be tilted outward and tested with the instrument operating normally, and will then readily unplug for con-

venient replacement of a failed component. As a further service aid, a printed-circuit extender board is mounted on the underside of the control section. With the 8620A top cover removed, this extender can be used to elevate any of the six boards for convenient testing.

The RF section (Fig. 2) is easily removed and opened. The extra-length interconnect cables allow servicing of the RF components. A special RF test cable clipped to the side of the RF section casting aids in servicing.

Product design of the RF section and rear panel focused on cooling the microcircuits and YIG-driver components. Since microcircuit reliability was the most important objective, a special heat sink casting design was undertaken. The result was a structure that makes maximum use of the air flow from the fan in the 8620A. The air passes through this casting first, then over the circuit boards and through the rear panel, where a finned

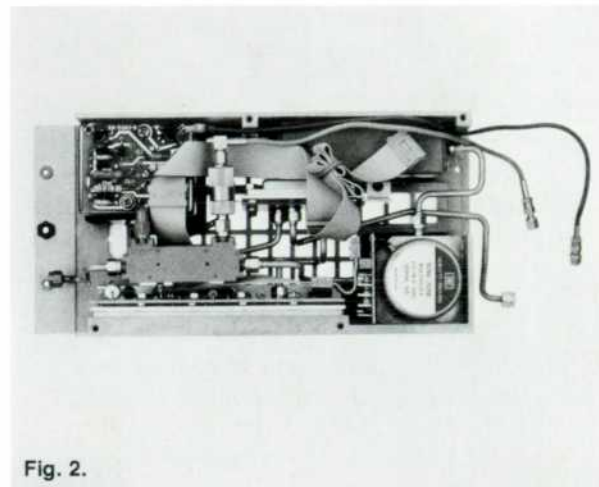

casting provides heat sinking for the YIG-driver reference resistors and driver transistors.

The main text describes the care taken to provide excellent frequency accuracy and ensure tracking between the YTM filter and the desired YTO harmonic. Absolute delay compensation is built into the YTO-driver pair. As a result, the YTO and its driver are treated as an assembly. If a YTO fails, a new YTO and dedicated driver board are installed. Adjustments can be done with basic test equipment.

Mounted atop the RF section are three labels. One explains a simple service technique for aligning YTO and YTM for optimum frequency accuracy and tracking. The others call out resistor values selected at the factory for YTO and YTM linearity compensation—a reference, should a part be misplaced during servicing.

*William Misson
Billy Knorpp*

Any deviation from zero is amplified and sent to a modulator driver stage which shifts the modulator operating point, changing V_{sense} so that its sum with V_{set} is returned to zero.

In a swept, broadband leveling application such as this, unflat power sensing elements can degrade the maximum leveled power if their frequency responses are not properly compensated. For the 86290A,

this compensation is provided by shaping the internally generated 1-volt/GHz sweep reference voltage and using that waveform as one input to the power reference amplifier shown in Fig. 8. Shaping is adjusted once in each instrument to compensate for variations in directional detector sensitivity. The corresponding frequency-related variations in V_{set} force the loop to make the desired correction.

How YIG Tuning Works

The resonators in the 86290A's wide-band oscillator and tunable multiplier are tiny 0.5-0.6-mm spheres fabricated from single crystals of the ferrite Yttrium-Iron-Garnet (YIG).

Placed in an RF coupling structure in a dc magnetic field, highly polished YIG spheres exhibit a high-Q resonance at a frequency proportional to the dc field. When electromagnets are used to produce this field, the resonant frequency is proportional to magnet current. While YIG of other shapes is useful in microwave design, spheres are used here because of their linear tuning characteristic.

To understand the phenomenon of ferrimagnetic resonance, consider diagrams (a) through (d). In the ferrite with no dc magnetic field applied, there is a high density of randomly oriented magnetic dipoles, each consisting of the minute current loop formed by a spinning electron. When a dc magnetic field, H_0 , of sufficient magnitude is applied, the dipoles align parallel to the applied field, producing a strong net magnetization, M_0 , in the direction of H_0 . If an RF magnetic field is applied at right angles to H_0 , the net magnetization vector will

precess, at the frequency of the RF field, about an axis coincident with H_0 . The precessing magnetization vector may be represented as the sum of M_0 and two sinusoidally varying RF magnetization components m_x and m_y . The angle of precession ϕ , and therefore the magnitudes of m_x and m_y , will be small except at the natural precession frequency. This frequency, known as the ferrimagnetic resonant frequency, is a linear function of the dc field H_0 .

Diagram (d) shows the basic elements of a YIG bandpass filter.¹ The filter consists of a YIG sphere at the center of two loops, whose axes are perpendicular to each other and to the dc field H_0 . One loop carries the RF input current, and the other loop is connected to the load. When H_0 is zero, the mutually perpendicular orientation of the loops results in large input-to-output isolation. With H_0 applied, there is a net magnetization vector in the direction of H_0 . The magnetic field h_x produced by the RF driving current in the input loop causes the net magnetization vector to precess about the z-axis. The resulting RF magnetization component, m_y , induces a voltage in the output loop. At frequencies away from the ferrimagnetic resonant frequency, m_y and the voltage it induces are small, so input-to-output isolation is high. When the input current is at the ferrimagnetic resonant frequency, ϕ and m_y are maximum. There is a large transfer of power from input to output, and insertion loss is low. Thus the filter center frequency is the ferrimagnetic resonant frequency and can be tuned by varying H_0 with magnet current.

In oscillator designs, a single loop couples the YIG sphere to an active circuit having a negative resistance over the desired frequency range. The resonator can be modeled as a parallel RLC circuit. When the resonator resistance is greater than the negative resistance of the active circuit, and the imaginary parts of the two impedances are equal and opposite, oscillation will occur. Oscillation amplitude will grow until the average values of the resonant and negative resistances are equal.

Frequency stability in both filter and oscillator designs is affected by the temperature dependence of the YIG sphere's inherent anisotropic field. The contribution of anisotropy to resonant frequency is dependent, in turn, on the orientation of the sphere's crystalline axes with respect to H_0 , the dc magnetic field. The sphere can be rotated such that this contribution is zero.

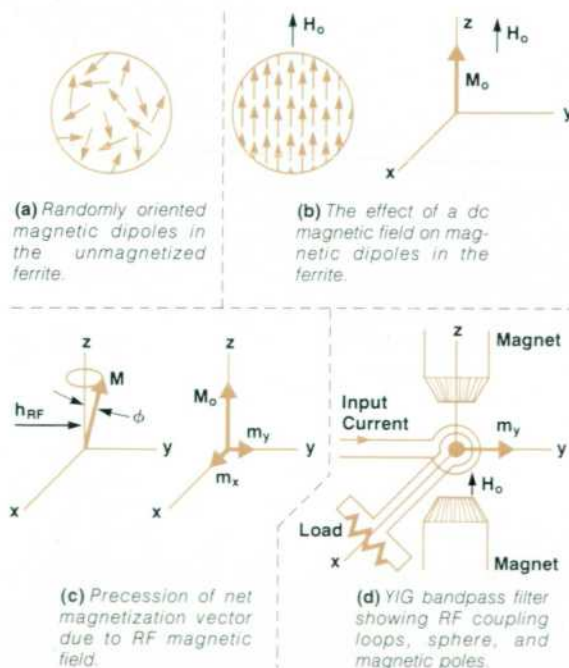

Reference

¹For a detailed treatment see, for instance, P.S. Carter, Jr., "Magnetically Tunable Microwave Filters Using Single-Crystal Yttrium-Iron-Garnet Resonators", IRE Transactions on Microwave Theory and Techniques, Vol. MTT-9, No. 3, May 1961.

As with any high-performance ALC loop in a swept source, the 86290A loop had to have sufficient bandwidth that power variations as a function of sweep rate would be negligible. Also, a primary design goal was to achieve loop slew rates great enough that the instrument could be modulated directly when used with the 8755A Network Analyzer (see article, page 15). This would eliminate the need for the external modulator normally required in this application, and as a consequence, deliver the full +5 dBm to the device under test.

Satisfying this requirement meant that the loop would have to respond to the 27.8-kHz square wave

modulating signal produced by the 8755A. This signal would drive the loop into and out of saturation for a minimum on/off ratio of 20 dB. Also, the loop would have to come out of saturation fast enough to maintain no worse than 45/55 symmetry. To add a further complication, equally good performance was expected over the 10-dB range of the power level control.

In general, as modulator attenuation approaches saturation in an ALC loop, the corresponding loss of sensitivity in control current constitutes a loss in loop gain, and hence a loss of bandwidth and slew rate. However, the slewing capability of the modulator itself is not reduced. Consequently, a technique

for achieving a uniformly fast slew rate, even while approaching saturation, involves alternately switching between closed and open-loop control of the modulator drive current. Ideally, for a pulse input, the loop would remain closed until it began to lose gain as the modulator neared saturation. At this point the loop would be switched open, and the modulator would be driven into saturation by bypassing the main amplifier and driving the modulator directly. In recovering from maximum attenuation, the reverse sequence would occur. The 86290A ALC loop uses this technique to satisfy the 8755A modulation requirement. Level sensing circuitry establishes the attenuation level at which the closed-to-open-loop transition occurs.

Acknowledgments

The authors gratefully acknowledge the contributions of the many talented people who cooperated very effectively to make the 86290A a reality. The detailed YTM concept was provided by Rit Keiter, and Robert Joly did the early design and optimization. Earl Heldt did much of the early magnet and circuit package designs for the YIG tuned devices. Alejandro Chu made several important improvements in YTM performance, did the original ALC design, and gave valuable help in many other areas, including FET switching and delay compensation in the YIG drivers. Ganesh Basawapatna designed the 2-6.2 GHz power amplifier and contributed greatly to several other RF designs. Roger Stancliff made valuable improvements in the ALC design and did final design of the YTO. Gary Holmlund did the exacting YTO and YTM driver designs and helped to coordinate the many changes that took place during the prototype phase. Bill Misson did the excellent product design and Bill

Knorpp designed the RF section heat sink casting. Dick Bingham designed the FM driver board. Jack Kuhlman provided the coupler/modulator design. Phil Chen did the early YTO design. Industrial design support came from Dave Eng and Roy Church. We also wish to thank Callum Logan, Jeff Gomer and Jim Yarnell for fabricated part process development.

The lab team had important assistance in micro-electronic technology from Weldon Jackson, Yeng Wong, Jim Smith and Pete Planting. Phil Froess and Harry Portwood of the transistor fabrication group helped ensure a good supply of high-performance devices.

Production Engineering support for the 86290A is provided by John Turner at the instrument level and Alejandro Chu and Val Peterson for the components. Additional help has been given by Jeff Ho and Alan Kafton, and by Bud Edgar for the 8620A modification.

The 86290A operation and service manual was written by Doug Andrus and Don Jackson. Jim Arnold set up the fine instrument support program.

We are indebted to Cyril Yansouni and Jack Dupre for their leadership and encouragement over the several years of developmental work. 🙏

References

1. Y. Ishikawa and S. Chikazumi, "Design of High Power Electromagnets", Japanese Journal of Applied Physics, Volume 1, No. 3, September 1962.

SPECIFICATIONS					POWER VARIATION:				RF BLANKING (selected by mainframe switch) On/Off ratio (dB)				
HP Model 86290A RF Plug-in					INTERNALLY LEVELED (dB)	-7	-7	+8	+9	>30	>30	>30	>30
Specifications with unit installed in an 8620A mainframe					EXTERNALLY LEVELED (excluding coupler and detector variation)					SWEEP TIME: (max sweep speed) typically (ms)			
	BAND 1	BAND 2	BAND 3	BAND 4	Crystal Detector (dB)					10	10	10	60
					Power Meter (dB)					CW REMOTE PROGRAMMING			
					WITH TEMPERATURE typically (dB/°C)					SETTLING TIME:			
					SPURIOUS SIGNALS: (below fundamental at specified maximum power) HARMONICALLY RELATED					Typical time to settle into CW frequency accuracy specification (FM switch in FAMP.L) (ms)			
					SIGNALS (dB)	>25	>25	>25	>25	5	5	5	10
					NONHARMONICS (dB)	>50	>50	>50	>50	General			
					RESIDUAL AM in 100 kHz band width (below fundamental at specified maximum power) (dB)	-55	-55	-55	-55	SWITCH POINTS: Broadband switch points are at 6.2 and 12.4 GHz. Frequency overlap is typically 0 to 20 MHz at switch points.			
					SOURCE VSWR: Internally leveled, 50:1 nominal impedance	-1.9	-1.9	-1.9	-1.9	AUXILIARY OUTPUT: Rear panel 2 to 6.2 GHz fundamental oscillator output, typically -10 dBm.			
					EXTERNAL FM MODULATION: MAXIMUM DEVIATIONS FOR MODULATION FREQUENCIES DC to 100 Hz (MHz)					SLOPE CONTROL: Front panel control allowing compensation for frequency dependent losses of a test setup.			
					100 Hz to 2 MHz (MHz)	+75	+75	+75	+75	SWEEP REFERENCE OUTPUT: 1 volt/GHz rear panel BNC output, CW frequency accuracy typically ±35 MHz.			
					SENSITIVITY: (typically) FM Mode (MHz/volt)	-20	-20	-20	-20	MAINFRAME MODIFICATION: Order modification kit for sequential sweep capability on all 8620B mainframes, and on existing 8620A mainframes with serial prefix 1332A and below. (Kit included for 8620A mainframe with 86290A option 060.)			
					Phase-Lock Mode (MHz/volt)	-6	-6	-6	-6	WEIGHT: Net, 9.6 lb (4.4 kg); Shipping, 13 lbs (5.9 kg)			
					EXTERNAL AM MODULATION: (at specified maximum power) Specific requirements guaranteeing HP 8755 operation with ±6V, 27.8 kHz square wave mod drive connected to external AM input. ON/OFF RATIO (dB)	-30	-30	-30	-30	PRICES IN U.S.A.:			
					ATTENUATION FOR +5 VOLT INPUT (dB)	45/55	45/55	45/55	45/55	8620A SWEEP OSCILLATOR MAINFRAME: \$1750			
					INTERNAL 1 KHZ SQUARE WAVE ON/OFF RATIO (dB)	-25	-25	-25	-25	86290A 2-TO-18-GHZ PLUG-IN (Internal leveling standard): \$13,250			
										OPTION 004: rear panel RF output: \$80			
										OPTION 005: APC-7 RF output connector: \$40			
										OPTION 060: Modification kit included for existing 8620A mainframes: \$300			
										SEQUENTIAL SWEEP MODIFICATION KITS (ordered separately):			
										08620-60099: for existing 8620A mainframes with serial prefix 1332A and below: \$300			
										08620-60100: for all 8620B mainframes (8620B dial scales included): \$300			
										MANUFACTURING DIVISION: SANTA ROSA DIVISION			
										3273 Arroyo Drive			
										Santa Rosa, California 95401			

Broadband Swept Network Measurements

Vector and scalar measurements can be made from 2 to 18 GHz in one sweep by pairing the new 2-18-GHz sweep oscillator with other microwave instruments.

by John J. Dupre and Cyril J. Yansouni

BROADBAND COVERAGE, precision frequency characteristics, and compactness make the new 8620A/86290A Sweep Oscillator (see article, page 2) suitable for a wide variety of network measurement applications. Its internally leveled output power and low harmonic and spurious levels over the 2-to-18-GHz frequency range are important in the measurement of broadband microwave components. Its frequency accuracy and stability are important for testing narrow-band, high-Q devices.

Vector Network Measurements

Complete characterization of a network requires measurement of the magnitude and phase of its driving point and transfer characteristics. Phase information is vital for component design and often necessary for system, component, and antenna testing. At microwave frequencies, scattering parameters¹ are widely used because they relate incident to reflected and transmitted waves at the network terminals.

Measurement of network scattering parameters in one continuous 2-to-18-GHz sweep is now possible with a new Network Analyzer, the HP 8410B, and the 8620A/86290A Sweep Oscillator. The HP 8410B, like its predecessor, the 8410A,² measures complex ratios by translating the microwave signal to an IF by a sampling process. A phase-lock loop locks a harmonic of the VTO that drives the sampler to the microwave signal. The contribution of the 8410B is new circuitry that interfaces with the 8620A Sweep Oscillator and allows phase-locking over broad frequency sweeps instead of only over octave ranges.

Three interface lines are necessary for reliable broadband phase-locking (Fig. 1). A frequency reference line from the oscillator provides an analog voltage corresponding to the output frequency with an accuracy of ± 35 MHz. A blanking line provides a pulse during retrace and at band-switch points. Finally, a stop-sweep line from the analyzer can command the 86290A to stop sweeping momentarily. At the beginning of each sweep and at band-switch points, the analyzer VTO is tuned approximately to the locking

frequency by the frequency reference voltage. The VTO searches around that frequency until phase-lock is achieved. The sweep oscillator then begins its sweep with the analyzer maintaining phase-lock. When the VTO reaches the end of its range, the analyzer commands the sweeper to stop sweeping and the search and lock procedure is repeated before the sweep is resumed.

An example of this capability is shown in Fig. 2. The input reflection coefficient of a ferrite junction circulator from 2 to 18 GHz is displayed in polar format. Although designed primarily for the 5-to-10-GHz range, its out-of-band performance including the phase of the reflection coefficient is often important. This display allows convenient adjustment of in-band and out-of-band parameters.

Transmission gain and phase may also be measured with the system of Fig. 1. Since the system is frequency selective and therefore unaffected by sweeper harmonic output, dynamic range is 60 dB.

Scalar Network Measurements

For a broad range of applications, amplitude-only or scalar measurements are sufficient to characterize

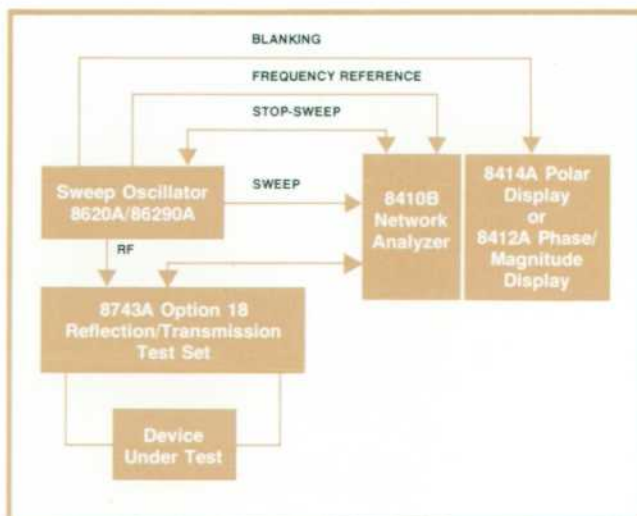

Fig. 1. A 2-to-18-GHz scattering parameter measurement system.

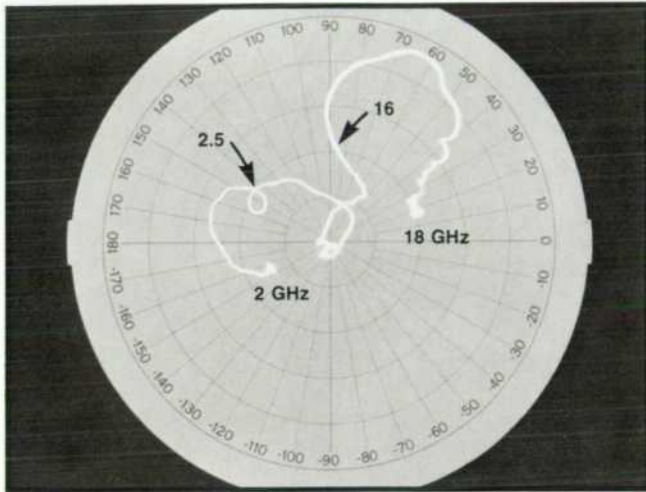

Fig. 2. Reflection coefficient of a ferrite junction circulator from 2 to 18 GHz. Full scale is unity reflection.

the component under test. This is the case for insertion loss or gain and return loss or reflection coefficient (magnitude) measurements.³ The 8755A Swept Amplitude Analyzer⁴ allows for simultaneous display of return loss and transmission parameters. When it is used with the 8620A/86290A Sweep Oscillator and the 11692D Dual Directional Coupler, this simultaneous measurement can be made continuously over the entire 2-to-18-GHz range. For precision transmission measurement (low insertion loss), the new 11667A Power Splitter can be used. In both cases, the required modulation of the signal can be

achieved by direct modulation of the sweep oscillator by the 8755A Analyzer instead of an external modulator. This external modulation capability of the sweeper (see article, page 2) makes its full power available at the test device and leads to greater measurement dynamic range.

A typical setup for simultaneous reflection and transmission measurements is shown in Fig. 3. The dual directional coupler covers the 2-to-18-GHz frequency range with a directivity better than 30 dB at 2 GHz and 26 dB at 18 GHz. The 8755A displays simultaneously the return loss (A/R) and the transmission characteristic (B/R) of the device under test (Fig. 4). Absolute power measurement is also possible by displaying any one of the three channels (R, A, B).

For accurate transmission measurement, typically low-loss measurements (cable loss, attenuation, etc.), one would use the power splitter in an alternative setup, also shown in Fig. 3. The power splitter exhibits better than 0.25 dB tracking between the two arms over the full dc-to-18-GHz frequency range. Coupled with the ratio capability of the 8755A, it provides a means of accurately measuring insertion loss without having to measure and correct for system errors. The equivalent output SWR of this splitter when used either for ratio measurement or as a source leveling device is typically better than 1.25 over the same frequency range. Thus the power splitter minimizes measurement uncertainty caused by source mismatch.

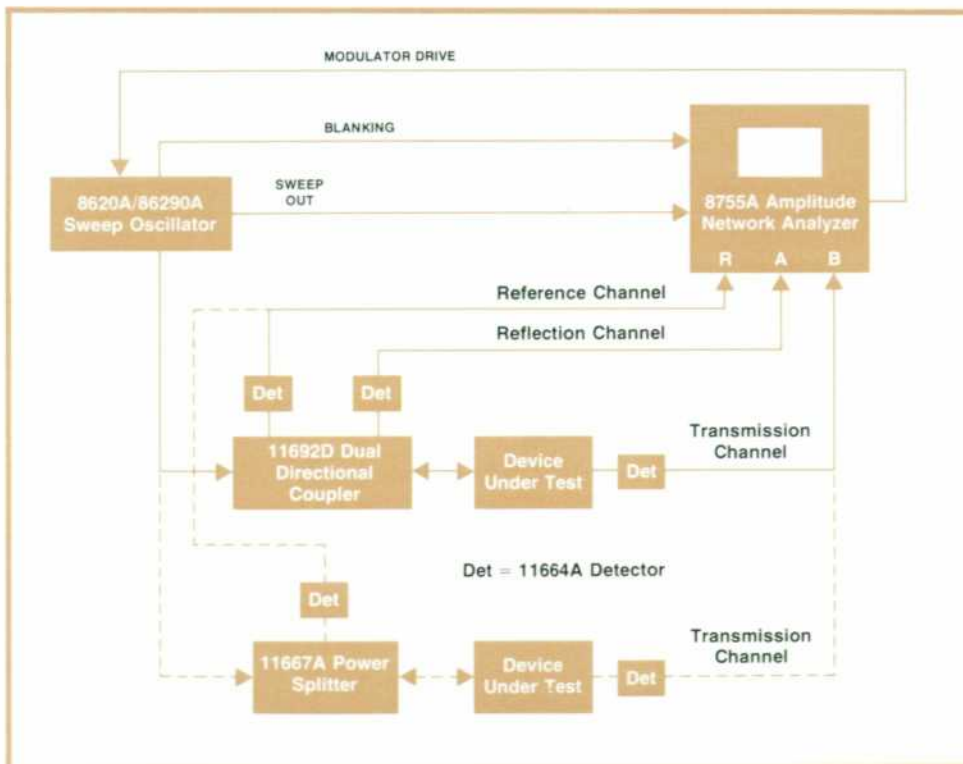

Fig. 3. System for simultaneously measuring transmission and reflection parameters.

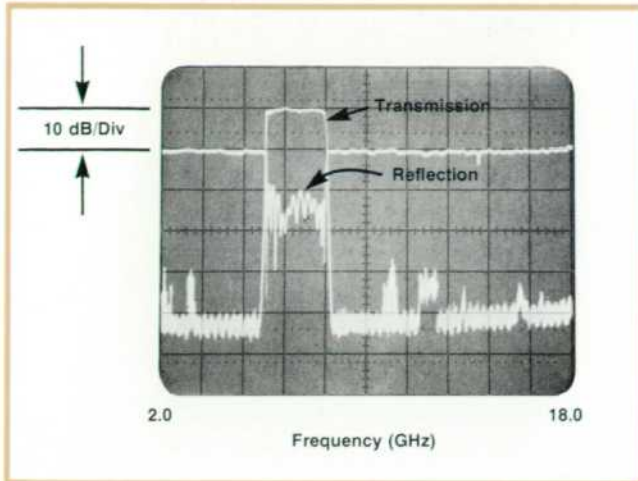

Fig. 4. Frequency response of a bandpass filter measured by the system of Fig. 3.

Acknowledgments

We would like to acknowledge the contributions of Doug Rytting, Bruce Donecker, Lewis Newton, and Richard Barg for the 8410B Network Analyzer. The 11667A Power Splitter was designed by Julius Botka and Brent Palmer. Jim Davis, Russ Johnson, and Jim Kaylor have contributed in the area of network analyzer applications.

References

1. R.W. Anderson, "S-Parameter Techniques for Faster, More Accurate Network Design," Hewlett-Packard Journal, February 1967.
2. R.W. Anderson and O.T. Dennison, "An Advanced New Network Analyzer for Sweep-Measuring Amplitude and Phase from 0.1 to 12.4 GHz," Hewlett-Packard Journal, February 1967.
3. "High-Frequency Swept Measurements," Hewlett-Packard Application Note 183.
4. H. Vifian, F. David, and W. Frederick, "A 'Voltmeter' for the Microwave Engineer," Hewlett-Packard Journal, November 1972.

John J. Dupre



Jack Dupre is section manager for sweep oscillators at HP's Santa Rosa (California) Division. He's been designing YIG-tuned oscillators and other components for sweepers and spectrum analyzers since he came to HP in 1964, just after receiving his BS degree in electronic engineering from California Polytechnic University (San Luis Obispo). Along the way he's earned his MSEE degree at Stanford University (1967) and been awarded a patent for a YIG-tuned Gunn-

effect oscillator design. He's a member of IEEE. Jack was born in Louisville, Kentucky. He and his wife and three children live in Santa Rosa and enjoy traveling and photography.

Paul R. Hernday



Paul Hernday, project manager for the 86290A RF Plug-in, received his BSEE degree from the University of Wisconsin (Madison) in 1968 and joined HP in 1969. Besides the 86290A, he's worked on analyzers and Gunn oscillators and, before joining HP, on Van de Graff accelerators. He's a member of IEEE. A native of southern California, Paul is married, has two small children, and lives in Santa Rosa, where he serves on the board of directors of the Family Service Agency of Sonoma County. A major interest, shared by his wife, is the evolution of life styles that emphasize human values and a respect for the natural environment. Paul also enjoys hiking and camping with his family, woodworking, gardening, reading, and keeping up with developments in many areas of science.

Carl J. Enlow



Carl Enlow has been with HP since 1967, designing various parts of the 8620 Sweep Oscillator family. He's now project manager for the 8620A/86290A interface and is responsible for introducing the 86290A to production. Born in Kilgore, Texas, Carl spent three years as a guided missile technician in the U.S. Navy before entering the University of Illinois (Champaign-Urbana) to work for his BSEE degree, which he received in 1967. Now living in Santa Rosa, California, Carl is married and has a son and a daughter. He's an active tennis player and golfer, likes to play the stock market, and enjoys seeing new places with the family and participating in Indian Guide activities with his son.

Cyril J. Yansouni



Cyril Yansouni is engineering manager for sweep oscillators and network analyzers at HP's Santa Rosa Division. With HP since 1967, he's been a sweeper designer, YTO and amplifier project leader, and sweeper section manager. Born in Alexandria, Egypt, Cyril graduated from the Catholic University of Louvain, Belgium in 1965 with a degree in electrical and mechanical engineering, and in 1967 received his MSEE degree from Stanford University. Cyril is married and has

two children. He enjoys traveling with his family, and usually encounters no language barriers; he's fluent in English, French, Italian, and Arabic. A tennis player and music lover, Cyril serves on the board of directors of the Santa Rosa Symphony Orchestra and on the electronic advisory committee of Santa Rosa Junior College.

The Dual Function Generator: A Source of a Wide Variety of Test Signals

FM signals, AM signals, dc levels, tone bursts, pulses and ramps, in addition to sine, square, and triangular waves, are produced by this new dual-source function generator.

by Ronald J. Riedel and Dan D. Danielson

MANY LAB-BENCH APPLICATIONS in the audio, ultrasonic, video, and RF fields require the engineer to have more than one signal source available. Such would be the case when sweep-frequency testing amplifiers and filters, testing modulation and detections systems, evaluating discriminators, and simulating transducer outputs.

With this in mind, we set out to design a truly general-purpose signal source that in many cases could replace combinations of sine-wave oscillators, signal generators, sweep oscillators, and pulse generators now used. Such an instrument, besides the obvious cost savings, would enhance user convenience by making the various test signals pushbutton selectable so the user wouldn't have to sort out and reconnect wires and cables. Neither would he have to worry about signal level incompatibility or logic threshold mismatch.

The result of this design effort is the Model 3312A Function Generator (Fig. 1). This instrument has two independent waveform generators that can be used separately, or in combination with one modulating, gating, sweeping, or otherwise controlling the other. The main generator operates over a range of 0.1 Hz to 13 MHz and the other generator, called the modulation generator, covers a range of 0.01 Hz to 10 kHz,



Fig. 1. Model 3312A Function Generator combines two signal sources to produce a wide variety of test signals. Total frequency coverage is from 0.01 Hz to 13 MHz.

giving a total coverage of 9 decades for the two generators.

Like other HP function generators, the new Model 3312A produces sine, square, and triangular waveforms of high quality (Fig. 2a). It also generates pulses and ramps with continuous control of the

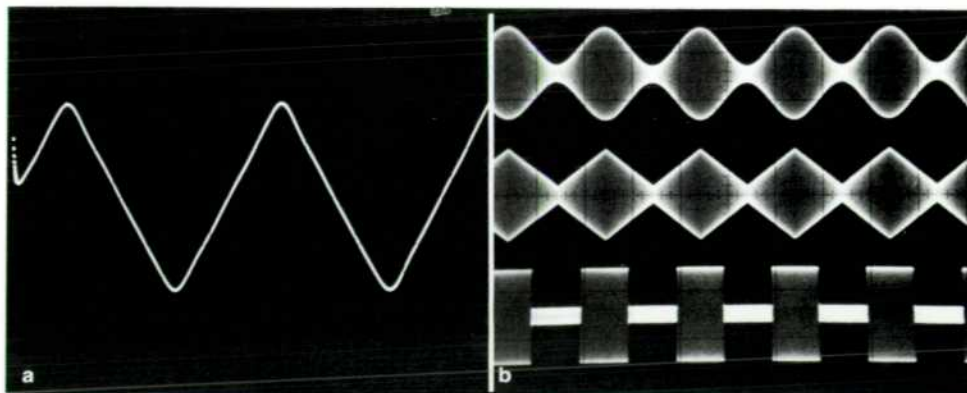

Fig. 2. Oscillogram (a), made by a sampling scope of the triangle waveform, demonstrates preservation of good waveform shape at high frequencies, in this case 10 MHz (sweep time is 20 ns/div and vertical deflection factor is 1 V/div). Multiple exposure oscillogram (b) shows the main generator output at 100 kHz modulated by various internally-generated waveforms at 1 kHz.

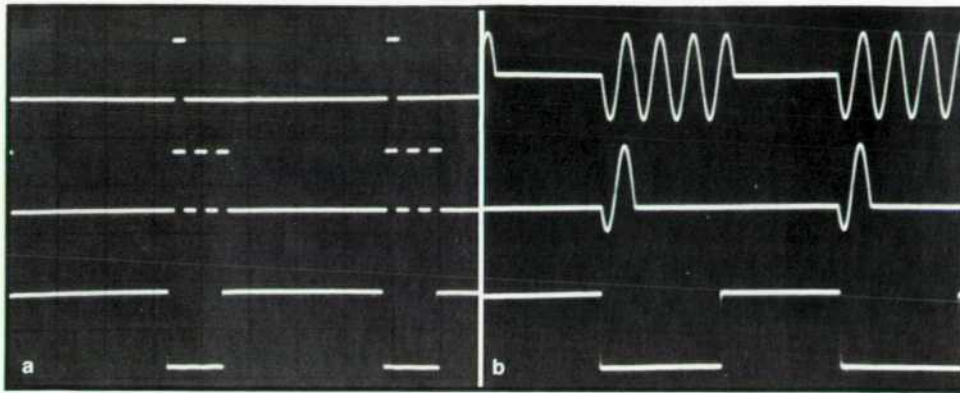

Fig. 3. Multiple exposure oscillogram (a) shows pulse trains generated in the single-cycle and multiple-cycle modes; the bottom trace shows the internally-generated gating waveform. Oscillogram (b) shows how the waveform is always completed in the multiple-cycle mode (top) and single-cycle mode (center); the gating waveform is at bottom. The start/stop phase is selectable over a range of -80° to $+90^\circ$.

ratio between up and down slope of the ramps or the on and off times of the pulses (see box, page 20). Also generated are one-volt rectangular waves with a rise time of less than 10 ns, available from the main generator's SYNC output. These are useful not only as triggers for oscilloscopes and counters, but also as a source of fast rise pulses for testing logic circuits and for low-level testing of the transient response of wideband amplifiers.

A 60-dB step attenuator and a 20-dB vernier give the main generator an amplitude range of 1 mV to 10 V into a 50Ω load (20V into an open circuit). A dc offset voltage can be added to the output. The output of the modulation generator is fixed at 1 volt into a high impedance.

Multiple Combinations

The two generators can be used separately for tests of multiple input devices such as modulators. On the other hand, the main generator can be amplitude or frequency modulated by the second generator (or an external source), giving the user a built-in choice of sine, square, or triangular waveform modulation (Fig. 2b). Square-wave modulation in the FM mode, for example, produces an FSK (frequency-shift-keying) waveform. Triangular modulation provides a convenient waveform for testing detector linearity.

The modulation generator (or an external source) can also gate or trigger the main generator to give sin-

gle-cycle or multiple-cycle modes of operation. These modes greatly expand the variety of waveforms that the new Function Generator can produce. Narrow, low-duty-cycle pulse trains can be obtained by setting the main generator to a relatively high frequency and using the trigger mode with a low-frequency gating signal, as shown in Fig. 3a. Pulse bursts, useful for testing counting circuits, are obtained by using the multiple-cycle mode.

When operating in the single cycle or multiple-cycle modes, the starting phase can be adjusted over a range of $+90^\circ$ to -80° . The generator always completes the last cycle and stops on the same phase on which it started (Fig. 3b).

These modes can be used at the same time as the AM and FM modes, making it possible to generate a wide variety of waveforms such as tone bursts or the "chirp" waveform shown in Fig. 4a.

The modulation generator can also sweep the main generator up to two decades in frequency at sweep rates as slow as 1 sweep per 100 seconds, useful for plotting frequency response on X-Y recorders, or at rates up to 100 sweeps per second for oscilloscope display (Fig. 4b). The gating mode can be used in combination with this mode to provide retrace blanking.

What's Inside

A simplified block diagram of the new function

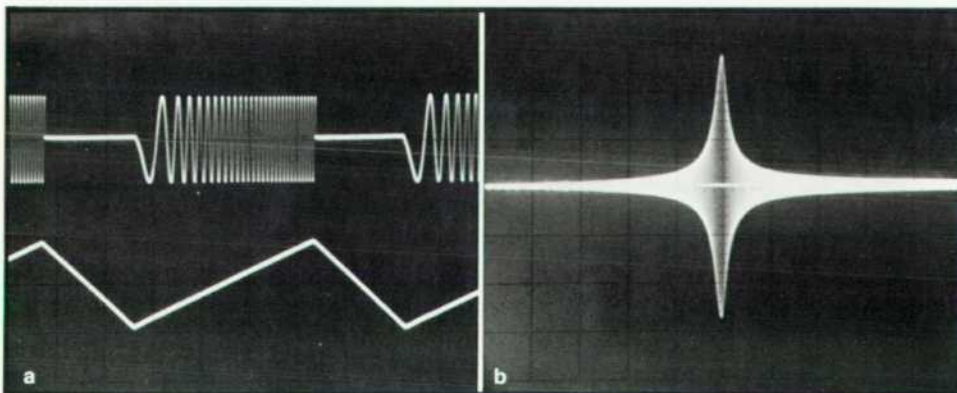

Fig. 4. "Chirp" or swept-burst waveform, upper trace in (a), is made by sweeping the main generator with the ramp from the modulation generator, shown in the lower trace, and gating it off during retrace. Sweep is from 7 to 70 kHz. Oscillogram (b) shows the output of a series R-L-C circuit driven from 3 kHz to 1 MHz by the main generator (vertical scale is 100 mV/div). The oscilloscope horizontal axis was driven by the ramp output of the modulation generator.

Variable Symmetry with Constant Frequency

The versatility of a function generator can be increased by equipping it to generate pulses and ramps in addition to its other waveforms. Pulses and ramps are produced by varying the duty cycle of the square and triangular waveforms. However, it would also be desirable to maintain a constant repetition rate as the duty cycle varies so that frequency may be read directly from the front-panel controls. This can be done using only a single control with the circuit in the diagram below.

In the diagram, the period T_1 of the positive slope of the triangle is proportional to $1/I_1$ while T_2 , the period of the negative slope, is proportional to $1/I_2$. I_1 and I_2 are in turn linear functions of e_1 and e_2 thus:

$$k/T_1 = e_1 \text{ and } k/T_2 = e_2 \quad (1)$$

where k is a constant determined by the frequency range controls.

To maintain constant frequency f_0 ,

$$T_1 + T_2 = 1/f_0 \quad (2)$$

Therefore from (1) and (2), we have:

$$\frac{1}{e_1} + \frac{1}{e_2} = \frac{1}{kf_0} \quad (3)$$

To maintain a constant frequency while the symmetry is varied, e_1 and e_2 must be varied in such a way as to keep the left side of equation (3) constant. Since the relationship between e_1 and e_2 is not linear, this requirement could represent some difficulty in realization.

The rather simple circuit shown in the diagram solves this problem nicely. It is easily seen that:

$$e_1 = e_0 \left[\frac{R_2}{R_1 + R(1-\alpha)} \right] \quad (4)$$

$$e_2 = e_0 \left(\frac{R_2}{R_1 + R\alpha} \right) \quad (5)$$

Where α is the fractional rotation of the symmetry control, and ranges from 0 to 1.

Substituting (4) and (5) into (3), we have:

$$\frac{R_1 + R(1-\alpha)}{e_0 R_2} + \frac{R_1 + R\alpha}{e_0 R_2} = \frac{1}{kf_0}$$

Combining terms yields:

$$\frac{R_1 + R}{e_0 R_2} = \frac{1}{kf_0}$$

Thus, the frequency f_0 is completely independent of α , the symmetry control setting.

e_1 and e_2 may vary over the range:

$$e_0 \left(\frac{R_2}{R_1 + R} \right) \leq e_1 \text{ (or } e_2) \leq e_0 \frac{R_2}{R_1}$$

In the Model 3312A, this range was selected to provide a duty cycle range of 20% to 80%.

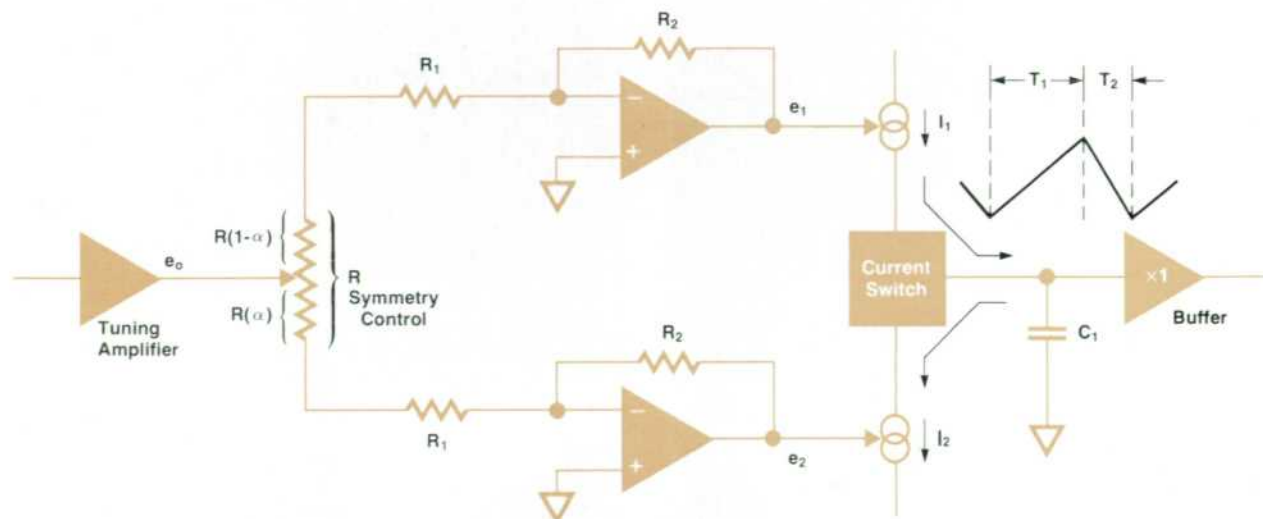

generator is shown in Fig. 5. The heart of the instrument is the main triangle generator, shown in more detail in Fig. 6.

As shown in Fig. 6, a triangular waveform is generated by alternately charging and discharging capaci-

tor C_1 through constant-current sources I_1 and I_2 , a technique similar to that used in other HP function generators.^{1,2,3} The direction of current flow is determined by the diode current switch under control of the comparator. The comparator, in turn, is set or

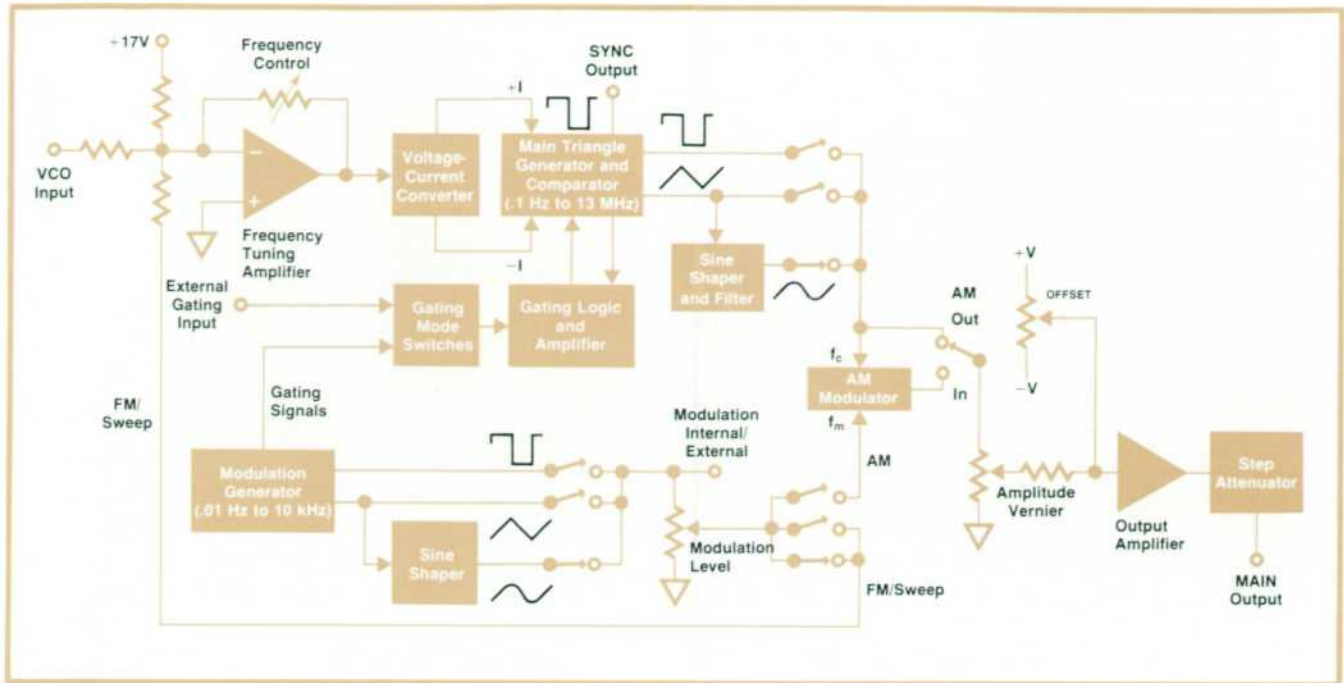

Fig. 5. Simplified diagram of the Model 3312A Function Generator. The frequency of the main generator is controlled by a front-panel knob, by the modulation generator, by an external voltage, or by any combination of the three.

reset as the triangular waveform reaches a positive or negative limit. Positive feedback around the comparator provides hysteresis that sets the limits and thus the peak-to-peak amplitude of the triangle.

Frequency ranges are selected by switching capacitor C1 and changing resistors in the current sources. Frequency control within each range is accomplished by varying the control voltage applied to the current sources. As shown in the block diagram of Fig. 5, this may be done with the front-panel frequency dial, by applying a voltage from the modula-

tion generator, or with an external voltage (applied through a rear-panel connector). An external voltage can control the frequency over a 1000:1 range, thus enabling the generator to serve as a highly linear voltage-controlled oscillator in a phase-lock loop or in voltage-to-frequency converter applications.

High-Quality Waveforms

The triangular waveform is shaped into a sine wave with less than 0.5% distortion (below 50 kHz) by a 12-diode nonlinear shaping network.³ The per-

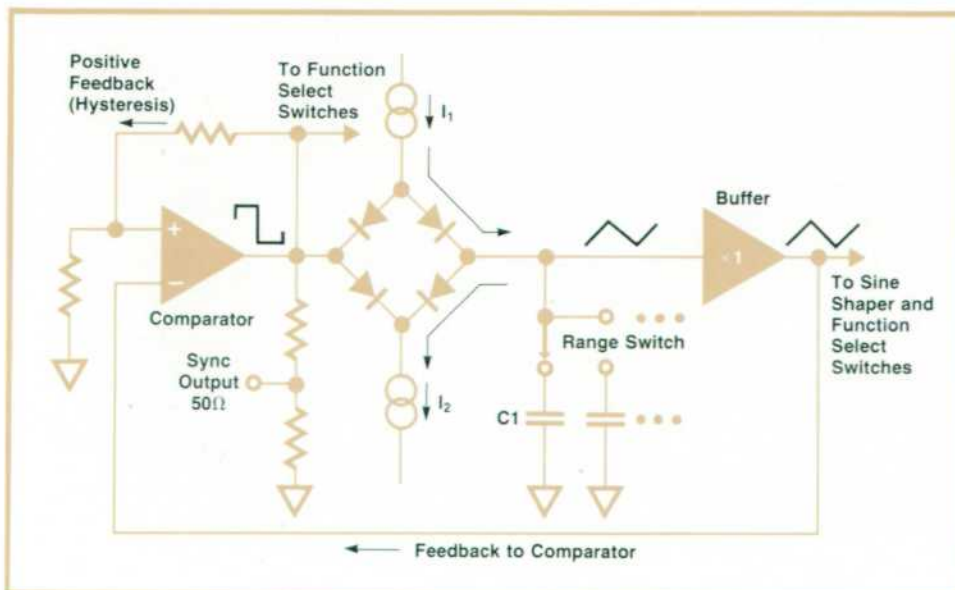

Fig. 6. Main generator produces triangle waves and square waves as part of its normal operation. The square wave is divided down to 1 volt peak for the sync output. Asymmetrical control of currents I1 and I2 provides a means of varying the up-down ratio of the triangle (see box on opposite page).

formance of most diode sine shapers tends to degrade seriously at frequencies of several megahertz and higher, particularly with respect to third harmonic distortion. In the Model 3312A, the sine shaper is followed by a low-pass LC filter that has a sharp cut-off at 14 MHz. This filter attenuates third harmonics substantially at generator frequencies above 5 MHz, enabling the instrument to produce sine waves with all harmonics more than 30 dB below the fundamental up to its maximum frequency.

The output amplifier has separate parallel paths for the high and low frequencies. This gives it wide bandwidth and a high slew rate to maintain good square and triangle wave shape without compromising dc stability and low offset. An integrated-circuit operational amplifier is used for the low frequencies while the ac-coupled high-frequency path is optimized for wide bandwidth. The two paths are summed in the final gain stage and then buffered through cascaded emitter-followers to the output.

Slow Ramps

The design of the modulation generator differs from that of the main generator because it has to generate very slow ramps for the sweep function while it does not have to operate to frequencies as high as the main generator. Therefore, it was designed around an integrator that effectively gives the large capacitance needed for the very slow ramps.⁴

A block diagram is shown in Fig. 7. The triangular wave is generated by integrating the square wave. The triangle level is compared to the square wave level and when the two are equal, the comparator switches the square wave generator to its other state.

The sine wave is derived by shaping the triangular wave as in the main generator.

Currents for charging and discharging the integrator are supplied through the diode-resistor networks at the integrator input. The range of current provided by the FREQUENCY control gives a 100:1 frequency span on any range. The symmetry control, however, affects only the run-down time so frequency is also affected by this control.

In the sweep mode, these networks supply unequal currents, giving a 90:10 ratio of up to down times. At the same time, the reference input to the comparator is changed so that the ramp operates between -9 and 0 volts, rather than the symmetrical ± 5 -volt range of the triangle. This places the top end of a frequency sweep at the frequency indicated on the main generator's frequency dial. The bottom end is then determined by the setting of the modulation level control. In the FM mode, on the other hand, the modulating waveforms are centered on the zero axis and thus give frequency modulation (up to $\pm 5\%$) centered on the frequency set on the main tuning dial.

When operating in the sweep mode, the symmetry control affects the "retrace" time. This can be extended up to 10 \times its normal time.

To facilitate setting up a frequency sweep, a "0 Hz" position is provided on the modulation frequency range switch. In this position, the modulation generator ramps down to its lowest level and then stops. Then, when the frequency range switch is moved to one of the other positions, the main generator starts at the lower limit and sweeps up.

The "0 Hz" position is obtained by the circuit driv-

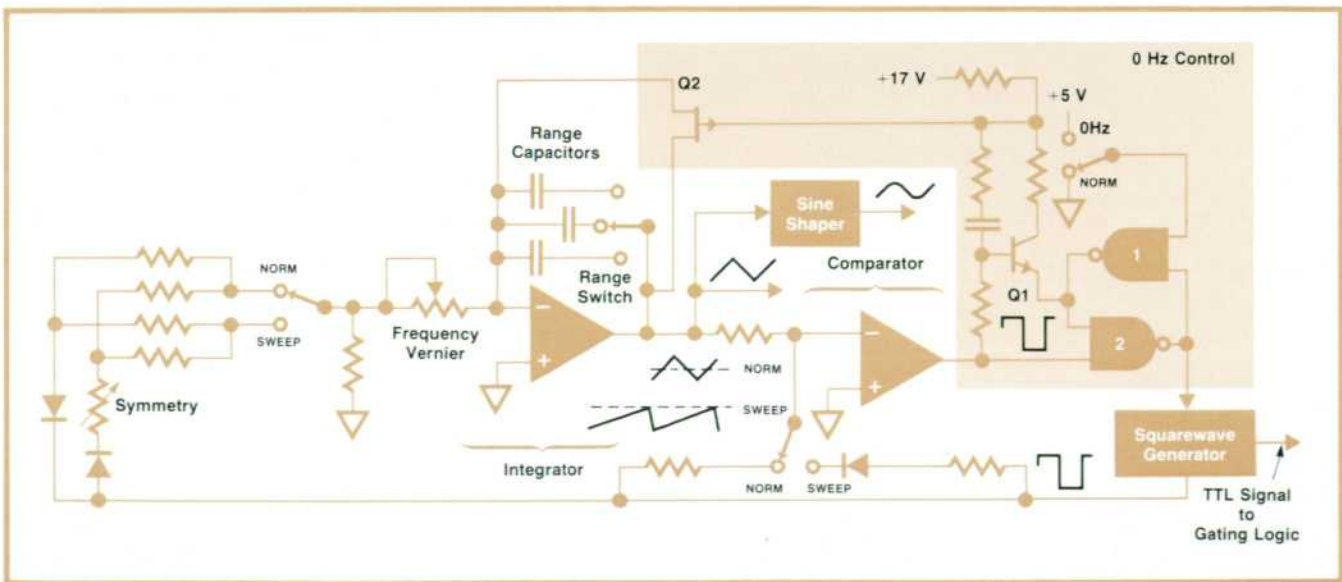

Fig. 7. Modulation generator uses an integrator for very low frequency operation. Reset level and symmetry are altered for ramp waveforms.

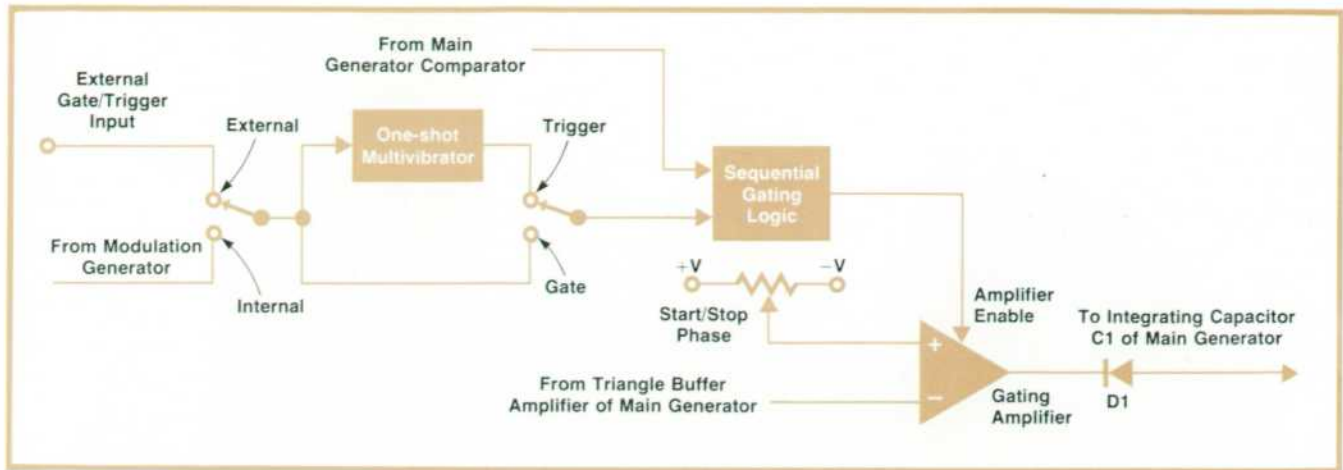

Fig. 8. Gating control circuit prevents the main generator from operating when a gate signal is not present. (The switches are on the rear panel.)

ing the FET switch Q2 on the integrator shown in Fig. 7. When the range switch is set to "0 Hz", one input to gate 1 goes high. Assuming the other input is high, the output of gate 1 goes low, Q1 is turned on which in turn turns on Q2, clamping the integrator at its lowest level. Gates 1 and 2 form a flip-flop that prevents Q2 from being turned on until the modulation generator completes its current cycle.

Versatile Modulation

The waveforms generated by the modulation generator are available at a front-panel connector. In AM or FM operation, the signal at this port is the sine, triangle, or square wave selected by the modulation function buttons. In the sweep mode, the output is the sweep ramp which is then available for driving the horizontal axis of a scope or X-Y recorder during a frequency sweep.

For AM modulation, the main and modulation signals are routed to an integrated circuit balanced modulator. The modulator output is amplified and then routed to the main output amplifier. Because any of

the waveforms may be applied to the modulator, it is possible to have sine, square, or triangle modulation of sine, square, or triangle carriers.

If none of the modulation function buttons (sine, square, or triangle) is depressed, an external waveform may be applied to the front-panel connector for amplitude or frequency modulating the main generator, as selected by the modulation mode buttons (AM or FM).

Gate and Trigger Functions

The versatility of the Model 3312A is greatly enhanced by the gate and trigger functions. These allow the main generator to be gated on and off under control of either the modulation generator or an external source.

A block diagram of the trigger/gate circuit is shown in Fig. 8. The gating amplifier shown closes a negative feedback loop around the main triangle generator, preventing oscillation. Whenever the gating amplifier is disabled by the gating signal, the main generator is released to generate the output

SPECIFICATIONS HP Model 3312A Function Generator

Main Generator

OUTPUT WAVEFORMS
Sine, square, triangle, ramp, pulse, sweep, trigger, gate, AM, and FM.

FREQUENCY CHARACTERISTICS
RANGE: 0.1 Hz to 13 MHz in 8 decade ranges.
DIAL ACCURACY: $\pm 5\%$ of full scale.
SQUARE WAVE RISE OR FALL TIME (10% to 90%): ≤ 18 nsec at full rated output.
ABERRATIONS: $\leq 10\%$.
TRIANGLE LINEARITY ERROR: $\leq 1\%$ at 100 Hz.
VARIABLE SYMMETRY: 80:20 to 1:1 MHz. Pushing the CAL button results in a time asymmetric waveform.

SPECTRAL PURITY
SINE WAVE DISTORTION: $\leq 0.5\%$ THD from 10 Hz to 50 kHz; ≥ 30 dB below fundamental from 50 kHz to 13 MHz.

OUTPUT CHARACTERISTICS
IMPEDANCE: 500 Ω $\pm 10\%$.
LEVEL: 20 V p-p into open circuit, 10 V p-p into 50 Ω .
LEVEL FLATNESS (SINE WAVE): $\pm 3\%$ from 10 Hz to 100 kHz at full rated output (1 kHz reference); $\pm 10\%$ from 100 kHz to 10 MHz at full rated output.
ATTENUATOR: 1:1, 10:1, 100:1, and 1000:1 Vernier gates $> 10:1$ continuous control.
STEP ATTENUATOR ACCURACY: Better than 5%.
SYNC OUTPUT: ~ 1 V p-p square wave into open circuit. Impedance: 50 Ω .

$\leq 10\%$. Rise or fall time (10% to 90%): < 10 nsec. Duty cycle varies with symmetry control.
DC OFFSET: ~ 10 volts, continuously adjustable, attenuated by step attenuator but independent of vernier setting. Pushing the CAL button removes the DC offset. Independent ac voltage \pm ac offset limited to 50V.
EXTERNAL FREQUENCY CONTROL
RANGE: 1000:1 on any range.
INPUT REQUIREMENT: With dial set at 10:0 to ~ 2 V $\pm 20\%$ linearly decreases frequency $> 1000:1$. An ac voltage modulates the frequency about a dial setting within the limits (1:1-10:1) \times range setting.
LINEARITY: Ratio of output frequency to input voltage (30:1V) is linear within 0.5% over a 100:1 frequency range.
INPUT IMPEDANCE: $2.8 \times \pm 5\%$.
MODULATING CHARACTERISTICS
TYPES: AM, FM, Sweep, Trigger, Gate or Burst, Internal or External.
AMPLITUDE MODULATION
DEPTH: 0 to 100%.
MODULATION FREQUENCY: DC to > 1 MHz, external.
EXTERNAL SENSITIVITY: ~ 10 V p-p for 100% modulation.
CARRIER 3 dB BANDWIDTH: ~ 100 Hz to ~ 5 MHz.
CARRIER ENVELOPE DISTORTION: $\sim 2\%$ at 70% sine wave modulation with $f_c = 1$ MHz, $f_m = 1$ kHz.
FREQUENCY MODULATION
MODULATION FREQUENCY: DC to ~ 50 kHz, external.
DISTORTION: ~ 35 dB at $f_c = 10$ MHz, $f_m = 1$ kHz, 10% modulation.
DEVIATION (INTERNAL MODULATION): 0 to $\pm 5\%$.
INTERNAL MODULATION SOURCE
FREQUENCY RANGE: 0.01 Hz to 10 kHz.

OUTPUT LEVEL: ~ 1.0 V p-p into 10 k Ω .
SPECTRAL PURITY: Sine Wave Distortion: $\sim 2\%$ THD from 10 Hz to 10 kHz.
SYMMETRY: Variable.
SWEEP CHARACTERISTICS
SWEEP WIDTH: 100:1 on any range.
SWEEP RATE: 0.01 Hz to 100 Hz, 90:10 ramp; 0 Hz provides manual setting of "Sweep Start" with Modulation Generator operation suppressed.
SWEEP MODE: Repetitive linear sweep between start and stop frequency settings. Repetition rate can be increased with symmetry control.
RAMP LINEARITY ERROR: $\leq 1\%$ at 100 Hz.
GATE CHARACTERISTICS
FREQUENCY RANGE: 0.1 Hz to 1 MHz (single or multiple cycles).
START/STOP PHASE RANGE: $\sim 90^\circ$ to $\sim 80^\circ$.
GATING SIGNAL FREQUENCY RANGE:
Internal: 0.01 Hz to 10 kHz.
External: DC to 1 MHz (TTL compatible input level).

General

OPERATING TEMPERATURE: 0°C to $\sim 55^\circ$ C, specifications apply from 0°C to 40°C.
POWER: 100/120/200/240 V $\pm 5\%$, $\sim 10\%$, switchable, 48 Hz to 440 Hz, ~ 25 VA.
DIMENSIONS: 213 \times 100 \times 377 mm (8.375 \times 4 \times 14.825 in).
WEIGHT: 3.9 kg (7.75 lbs).
PRICE IN U.S.A.: 2312A, \$900.
MANUFACTURING DIVISION: LOVELAND INSTRUMENT DIVISION
P.O. Box 301
815 Fourteenth Street, S.W.
Loveland, Colorado 80537

waveform. When the gating amplifier is again enabled at the end of the gating signal, diode D1 is initially back-biased, so waveform generation continues until the waveform reaches a level set by the START/STOP PHASE control, at which time diode D1 becomes forward biased, closing the negative feedback loop and stopping the main generator.

When in the trigger mode, the one-shot multivibrator, fired by the positive transition of the gating signal, generates a short pulse that disables the gating amplifier only long enough to allow waveform generation to get under way. The modulation generator then produces one full cycle and stops.

Acknowledgments

Product design and mechanical layout were done by Bob Moomaw. Industrial design was by Jon Pennington. Thanks go to group leader Noel Pace for his guidance throughout the project, and to section manager Bob Dudley and initial product manager Jerry

Estes for help in defining the instrument. Also, special thanks are due Doc Hadley, who moved on to IC production before the project's completion, but whose early design efforts, particularly in the symmetry control circuits, exerted a positive influence on the project. 

References

1. H. Heflin, "Compact Function Generator with Enhanced Capability/Cost Ratio," Hewlett-Packard Journal, July 1973.
2. R.C. Hanson, "Compact Function Generator Covers 0.0005 Hz to 5 MHz," Hewlett-Packard Journal, June 1969.
3. R.L. Dudley, "A Voltage-Programmable Low-Frequency Function Generator with Plug-in Versatility," Hewlett-Packard Journal, November 1965.
4. R.H. Brunner, "A New Generator of Frequencies Down to 0.01 CPS," Hewlett-Packard Journal, June 1951.



Dan D. Danielson
From the city of Grand Junction on Colorado's western slope, Dan Danielson crossed the continental divide to earn a BSEE degree at the University of Colorado (1972). From there, he went straight to work for Hewlett-Packard in function generator development. Dan's spare time activities include the standard Colorado outdoors (skiing, fishing, hiking).



Ronald J. Riedel
A Missouri native, Ron Riedel earned BSEE and MSEE degrees at the University of Missouri in Columbia. He then joined Hewlett-Packard (1972), going to work on function generators. Like other residents of Loveland, Colorado, he skis, fishes, and goes hiking but he's also learning classic guitar and spends time as a counselor in church youth work.

Hewlett-Packard Company, 1501 Page Mill Road, Palo Alto, California 94304

Bulk Rate
U.S. Postage
Paid
Hewlett-Packard
Company

HEWLETT-PACKARD JOURNAL
MARCH 1975 Volume 26 • Number 7
Technical Information from the Laboratories of
Hewlett-Packard Company
Hewlett-Packard S.A., CH-1217 Meyrin 2
Geneva, Switzerland
Yokogawa-Hewlett-Packard Ltd., Shibuya-Ku
Tokyo 151 Japan
Editorial Director • Howard L. Roberts
Managing Editor • Richard P. Dolan
Art Director, Photographer • Arvid A. Danielson
Illustrator • Sue M. Perez
Administrative Services, Typography • Anne S. LoPresti
European Production Manager • Michel Foglia

CHANGE OF ADDRESS • To change your address or delete your name from our mailing list please send us your old address label (it peels off). Send changes to Hewlett-Packard Journal, 1501 Page Mill Road, Palo Alto, California 94304 U.S.A. Allow 60 days.