

# Atmospheric Waves

Weston Anderson

April 18, 2017

## Contents

<b>1</b>	<b>Introduction</b>	<b>1</b>
<b>2</b>	<b>Properties of waves</b>	<b>1</b>
<b>3</b>	<b>Types of waves</b>	<b>3</b>
3.1	Kelvin waves . . . . .	3
3.2	Rossby waves . . . . .	4
3.2.1	Wave propagation . . . . .	5
3.2.2	Stationary waves . . . . .	8
3.2.3	A simplified one-layer stationary wave model . . . . .	11
3.2.4	Propagation of stationary waves . . . . .	16
3.2.5	Stationary wave response to thermal forcing . . . . .	16
3.3	Origin of stationary waves (and associated storm tracks) . . . . .	18

## 1 Introduction

In this set of notes we'll cover a brief overview of atmospheric waves, specifically the generation and propagation of **Rossby waves** and why the mean climate has stationary waves.

## 2 Properties of waves

When describing waves in the ocean or the atmosphere we make a number of simplifications, often representing waves as an idealized sine wave (or Fourier Series of sine waves). By doing so we are making use of the approximation that for waves of sufficiently small amplitude the period is independent of amplitude.

For any given wave, we therefore describe it in terms of its **wave number**, **frequency** and **phase speed**, which describes the number of complete oscillations a wave makes around a circle. When we use the concept with reference to a latitude circle, we define its zonal wavenumber as  $k = 2\pi s/L$  where  $s$  is the planetary wave number (i.e. the number of waves around a latitude) and  $L$  is the circumference around that latitude. The frequency of the oscillation

is often expressed using the symbol  $\omega$ . The phase speed describes the rate and direction in which the wave propagates and is defined as  $c = \omega/k$

Waves in the atmosphere and ocean exist in groups of sine waves rather than as a single oscillation, so we can also describe properties of groups of waves. We primarily describe groups of waves as **dispersive** or **non-dispersive**. If a wave is non-dispersive, its phase speed is independent of its wave number. In other words, all of the sinusoidal components of the signal will propagate at the same rate (and in the same direction), and the signal shape will be unchanged as it moves through a medium. If a wave is **dispersive** then the phase speed does depend on wave number, so that as the waves propagate they will change shape and spread out. We also describe **group velocity**, which is the way in which the amplitude of waves travel (i.e. the visible disturbance). The group velocity, by definition, is also a description of how the energy of the waves travel. Figure 1 (defined as  $c_g = \partial\omega/\partial k$ ) describes how two sinusoidal components of a wave can be dispersive or non dispersive and how a dispersive wave propagates with different phase speeds and group speeds.

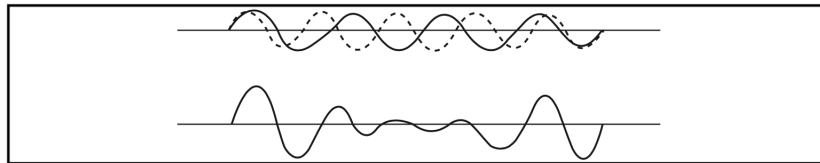

**FIGURE 5.3** Wave groups formed from two sinusoidal components of slightly different wavelengths. For nondispersive waves, the pattern in the lower part of the diagram propagates without change of shape. For dispersive waves, the shape of the pattern changes in time.

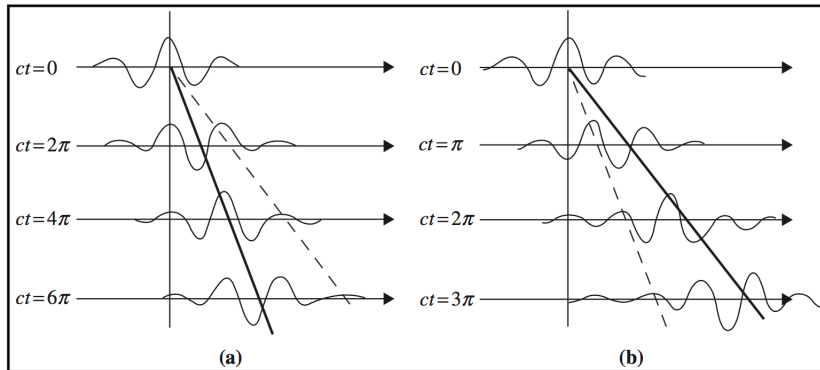

**FIGURE 5.4** Schematic showing propagation of wave groups: (a) group velocity less than phase speed and (b) group velocity greater than phase speed. *Heavy lines* show group velocity, and *light lines* show phase speed.

Figure 1: Figure credit: Holton and Hakim (2012)

So as a quick review, below is a list of terms and formulas used to describe

waves:

$$k = \frac{2\pi s}{L} = \text{wave number}$$
$$\omega = \text{frequency}$$
$$c = \frac{\omega}{k} = \text{phase speed}$$
$$c_g = \frac{\partial\omega}{\partial k} = \text{group velocity}$$

Because waves are described as a series of sine waves, we can also describe them using a Fourier Series in which each component is modeled as:

$$f(x) = \text{Re}[C_s \cos(kx) + iC_s \sin(kx) = e^{ikx}]$$

where  $C_s$  is a complex coefficient and  $k$  is the wavenumber

### 3 Types of waves

In this section we'll describe a few of the common types of waves (Rossby, Kelvin and gravity), as well as their propagation and dispersion. Each of these waves have their own restoring force.

#### 3.1 Kelvin waves

A Kelvin wave is a type of low-frequency gravity wave that balances the Coriolis force against a topographic boundary, such as a coastline, or against a waveguide, such as the equator. Because the Coriolis force balances with the pressure gradient force of water built up against a shoreline, Kelvin waves propagate with the coast to the right in the Northern Hemisphere, or to the left in the Southern Hemisphere. When the wave runs into the coast, the zonal pressure gradient forces meridional velocity, driving the Kelvin wave (see Figure 2)

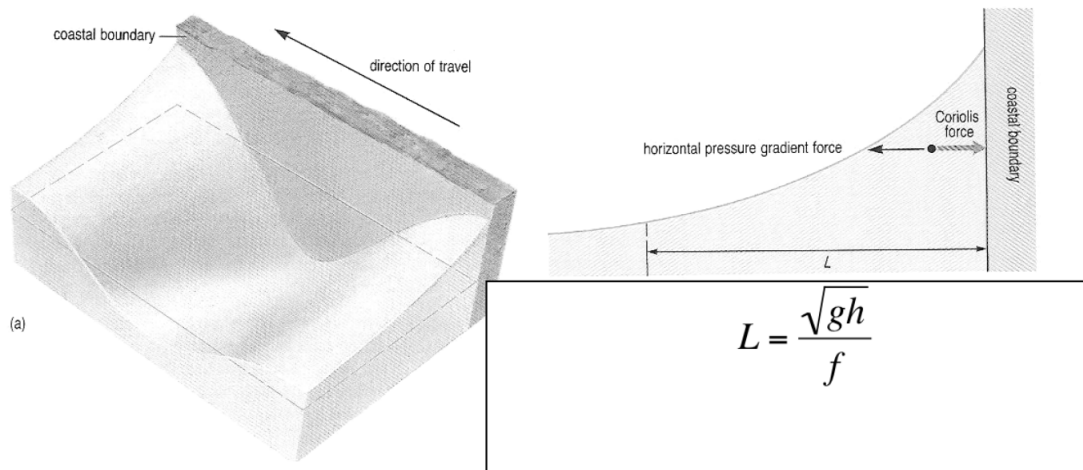

Figure 2:

Figure source: [www.geo.cornell.edu/ocean/p\\_ocean/ppt\\_notes/21\\_KelvinRossbyWaves.pdf](http://www.geo.cornell.edu/ocean/p_ocean/ppt_notes/21_KelvinRossbyWaves.pdf)

The distance off shore ( $L$ ) at which the Kelvin wave amplitude becomes negligible is the Rossby radius of deformation. It depends on whether the Kelvin wave is at the surface or in the thermocline. On the ocean surface, the Rossby radius of deformation is about 200 km in the mid-latitudes but is only about 25 km for mid-latitude thermocline Kelvin waves.

Kelvin waves can also propagate along the equator, using the fact that the Coriolis force changes sign as the restoring force. So equatorial Kelvin waves balance the Coriolis force from the NH (acting to the right) against its counterpart in the SH (acting to the left) as the wave travels east. The Coriolis forces would be divergent if the wave were to travel west, which is why equatorial Kelvin waves only travel east. Figure 3 demonstrates how off-equatorial Rossby waves propagate westward (discussed in the next section) while equatorially trapped Kelvin waves propagate eastward until they reach the eastern boundary, at which point they become coastal Kelvin waves.

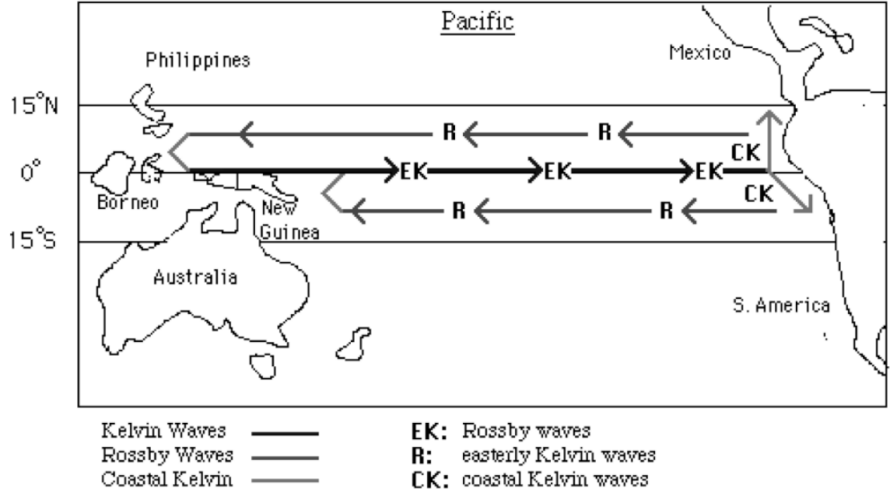

Figure 3:

Figure source: [www.geo.cornell.edu/ocean/p\\_ocean/ppt\\_notes/21\\_KelvinRossbyWaves.pdf](http://www.geo.cornell.edu/ocean/p_ocean/ppt_notes/21_KelvinRossbyWaves.pdf)

### 3.2 Rossby waves

Rossby waves are not bound to wave guides and instead conserve potential vorticity (PV). Rossby waves exist because of the gradient in planetary vorticity with latitude. Remember that we can describe absolute vorticity as:

$$PV = \frac{\zeta_a}{H} = \frac{\zeta' + f}{H}$$

where  $\zeta_a$  is the absolute vorticity,  $\zeta'$  is the relative vorticity and  $f$  is the planetary vorticity. Remember also that the planetary vorticity changes with latitude as

$$f = f_0 + \beta y$$

where  $\beta = \frac{\partial f}{\partial y} = 2\Omega \cos \frac{\phi}{a}$

#### 3.2.1 Wave propagation

With this in mind, we can consider Rossby wave propagation by thinking about the PV a chain of parcels that don't change height (H). If we further assume that the parcel is meridionally displaced at time  $t_1$ , and that its relative vorticity was 0 initially ( $\zeta_{t_0} = 0$ ), then given the conservation of PV we can write:

$$(f)_{t_0} = (\zeta' + f)_{t_1}$$

$$\zeta'_{t_1} = f_{t_0} - f_{t_1} = -\beta\delta y$$

Because  $\beta$  is positive, the new relative vorticity will be positive for a southward displacement and negative for a northward displacement. The perturbation vorticity field induces a meridional velocity south west of the vorticity maximum and northward west of the vorticity minimum (see Figure 4). Alternatively, we can consider the fact that positive vorticity is counter-clockwise in the northern hemisphere. This picture indicates a progressive westward propagation of the vorticity anomalies. These propagating vorticity anomalies are Rossby waves.

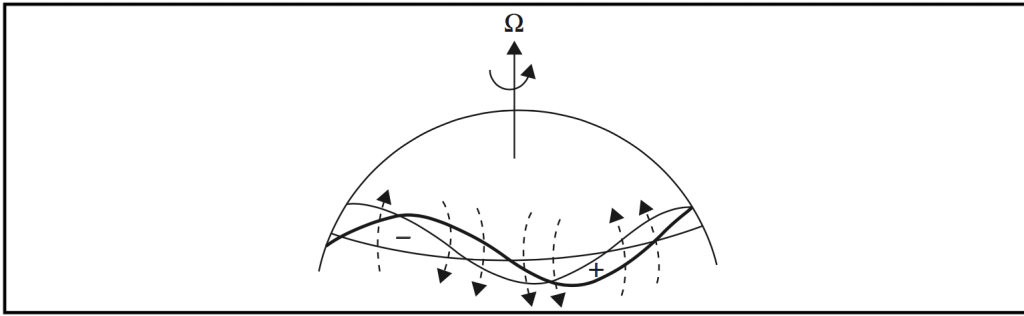

**FIGURE 5.14** Perturbation vorticity field and induced velocity field (*dashed arrows*) for a meridionally displaced chain of fluid parcels. The *heavy wavy line* shows original perturbation position; the *light line* shows westward displacement of the pattern due to advection by the induced velocity.

Figure 4: Figure credit: Holton and Hakim (2012)

The process we have just described is the manner in which the meridional gradient of potential vorticity acts as the restoring force for Rossby waves (i.e. the meridional gradient resists meridional displacements). The speed of westward propagation is the Rossby wave phase speed,  $c$ , and can be described as:

$$c = \frac{\omega}{k} = \bar{U} - \frac{\beta}{l^2 + k^2}$$

The phase speed is therefore west relative to the mean flow,  $\bar{U}$ , and is inversely proportional to the square of the wave number. We can now consider a few properties of the phase speed:

- 1 Since  $c = \frac{\omega}{k} < 0$  the phase speed of Rossby waves is negative and they propagate westward relative to the mean flow. Note, however, that if the

mean flow is greater than the phase speed the waves may appear to move eastward relative to the ground even if they are moving westward relative to the mean flow.

- 2 since  $\omega$  is a nonlinear function of  $k$ , Rossby waves are dispersive
- 3 We can consider the group velocity ( $\frac{\partial \omega}{\partial k}$ ).  $\frac{\partial \omega}{\partial k} > 0$  for  $k/l > 1$  and  $\frac{\partial \omega}{\partial k} < 0$  for  $k/l < 1$ . So the group velocity (energy propagation) for Rossby waves is eastward for zonally short waves and westward for zonally long waves
- 4 The magnitude of the group velocity (see the slope in the below figure) is typically greater for the westward-propagating long waves compared to the eastward-propagating short waves.

The final point relates to the dispersion relation, which (ignoring the background flow) is typically written as

$$\omega = \frac{\beta k}{l^2 + k^2}$$

The Rossby waves appear on the bottom left of the figure. The figure can be interpreted as follows. All Rossby waves travel west, and therefore appear in the bottom left of the diagram, but the slope of the curve is negative for small wave numbers (i.e. long Rossby waves have westward group velocity) while the slope is positive for larger wave numbers (i.e. short Rossby waves have eastward group velocity).

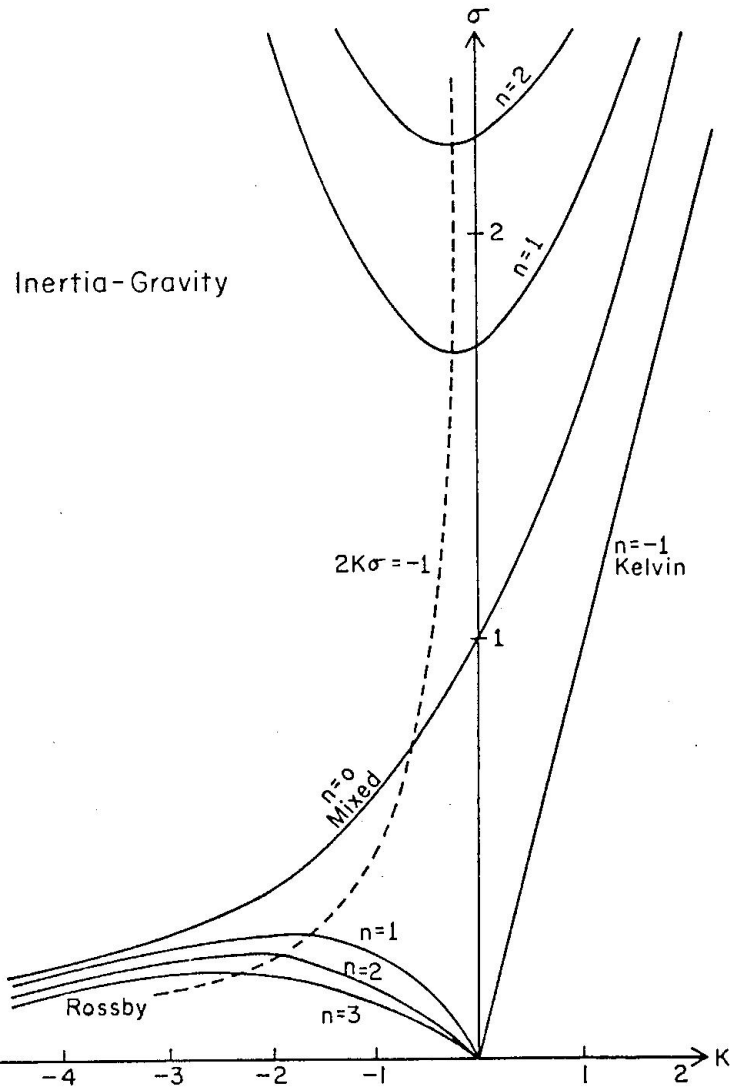

**Figure 3.8.** Dispersion diagram for equatorially trapped modes. The unit of frequency is  $(\beta c)^{1/2}$  and the unit of zonal wave number  $k$  is the inverse of the radius of deformation  $(c/\beta)^{1/2}$ . [From Cane and Sarachik (1976).]

Figure 5: Figure credit: Holton and Hakim (2012)

Let's now consider a few specific numbers. For a mid-latitude synoptic scale disturbance, where  $l \approx k$ , and the zonal wavelength is order 6000 km the phase speed of the Rossby waves is -8 m/s. Because the westerly wind speed often



exceeds this (indeed it often exceeds 25 m/s), the Rossby waves may appear to move east, although they move east less quickly than the mean flow. As the wave number decreases the wavelength increases and so does the phase speed. When the frequency of the wave is zero, the Rossby waves become stationary (i.e. they are static relative to the earth surface).

### 3.2.2 Stationary waves

Stationary eddies are driven by zonal anomalies of elevation (i.e. mountains) and temperature (land-sea contrasts). Both of these forcings are most pronounced in the Northern Hemisphere, which contains the majority of the earth's land masses. This explains why stationary eddies are important in the Northern Hemisphere but less so in the Southern Hemisphere, as shown in Figure ???. But why the seasonal dependence? Well, orographic forcing is one means of producing stationary eddies (and indeed this does depend on the seasonally varying background flow) but stationary eddies are also produced by land-sea temperature contrasts. And because oceans have a much larger heat capacity than does the land, the land experiences much larger seasonal swings in temperature, which means that continents tend to be warmer than the oceans in the summer and cooler than the oceans in the winter. Cold flow off of the continents in the wintertime move over the warm Gulf Stream to induce large baroclinicity.

In Figure 6 we are plotting mean sea level pressure (SLP) for the winter and summer months. The longitudinal variations in this plot, most notably the low pressure centers over the Pacific and Atlantic oceans in the winter, indicate stationary eddies. Sea level pressure is a useful indicator of atmospheric flow because at the surface air tends to spiral cyclonically (anti-clockwise in the NH) inwards towards low pressure centers, and anti-cyclonically (clockwise in the NH) away from high pressure centers.

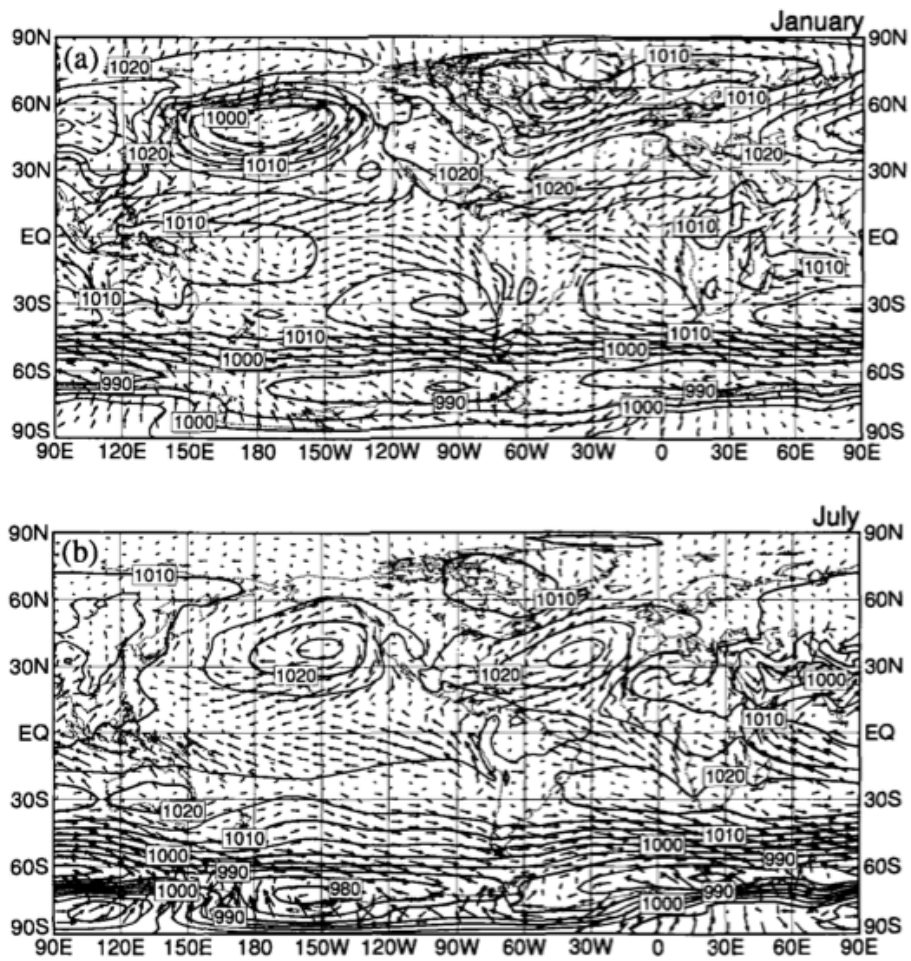

**Fig. 6.18** Maps of mean sea-level pressure for (a) January and (b) July. Wind vectors for the 1000-mb level are superimposed. Data are 1980–87 analyses from a forecast model. Contour interval is 5 mb and largest vector represents a wind speed of 12 m s<sup>-1</sup>.

Figure 6: Credit: (?)

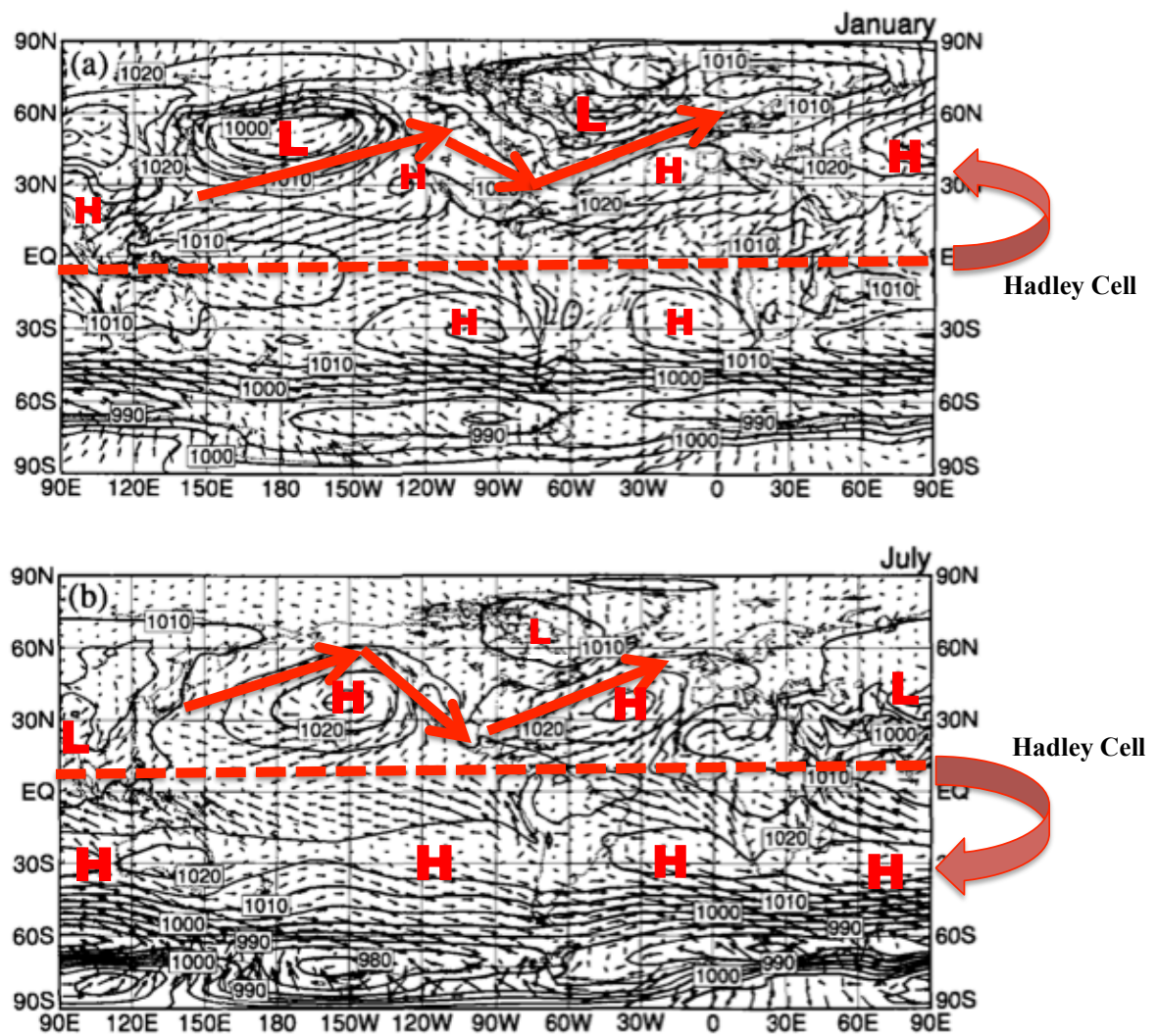

**Fig. 6.18** Maps of mean sea-level pressure for (a) January and (b) July. Wind vectors for the 1000-mb level are superimposed. Data are 1980–87 analyses from a forecast model. Contour interval is 5 mb and largest vector represents a wind speed of 12 m s<sup>-1</sup>.

When we discuss stationary eddies, we're more precisely referencing forced Rossby waves (often in the mid-latitudes) that have a phase velocity that's static with respect to the earth's surface (i.e.  $\omega = 0$  so  $c = 0$ ). Another way of thinking of this is that the waves propagate westward at the same speed as the eastward mean flow. Note, however, that these waves can still have a group velocity. Consider a Rossby wave in a uniform background flow,  $U$ . The dispersion relation for this wave is:

$$\omega = Uk - \frac{\beta k}{k^2 + l^2}$$

so if  $\omega = 0$  for stationary waves we can rewrite this as:

$$U = \frac{\beta}{k^2 + l^2}$$

### 3.2.3 A simplified one-layer stationary wave model

We can illustrate many of the principles of forced and stationary waves by considering the vorticity equation of a one-layer quasi-geostrophic model:

$$\frac{Dq}{Dt} = 0, \quad q = \zeta + \beta y - \frac{f_0}{H}(\eta' - h_b)$$

where  $q$  is the potential vorticity,  $H$  is the thickness of the layer,  $h_b$  is variations in the bottom topography,  $\eta$  is variation in the surface height,  $\zeta$  is the relative vorticity and  $\beta = \frac{\partial f}{\partial y}$ . Now if we linearize the equation we get:

$$\left( \frac{\partial}{\partial t} + \bar{U} \frac{\partial}{\partial x} \right) q' + v' \bar{q}_y = D'$$

where:

$$q' = \zeta' - \frac{f_0}{H_0}(\eta' - h'_b)$$

$$\bar{q}_y = \beta - \frac{f_0}{H_0} \bar{\eta}_y = \beta + \frac{f_0^2}{gH} U$$

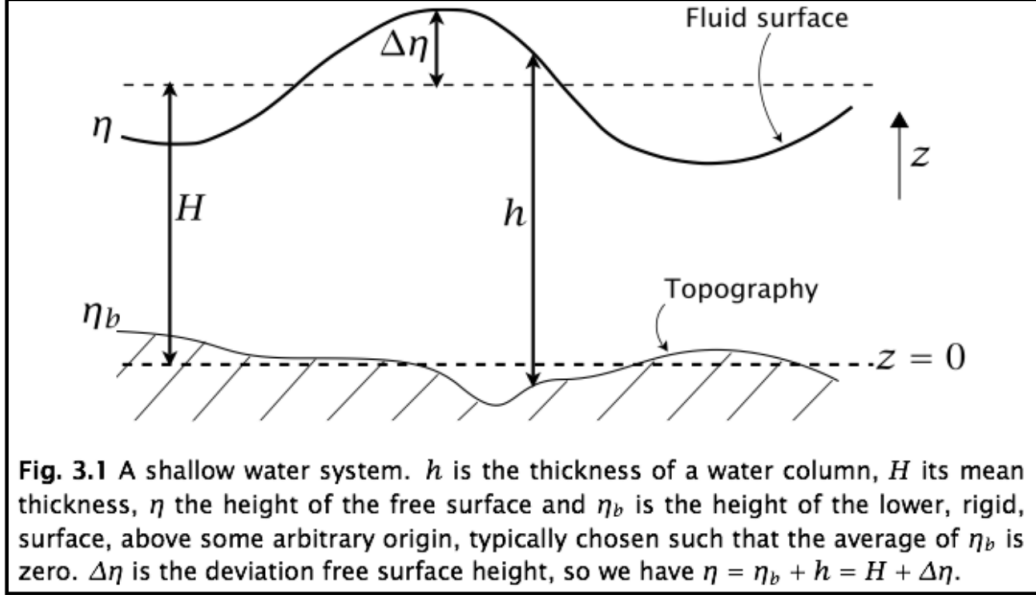

Figure 8: Vallis uses  $\eta_b$  while we use  $h_b$  and Vallis uses  $\Delta\eta$  while we use  $\eta'$ .  
Credit: (?)

Where the last equality followed from geostrophy. Here we assume that the perturbation is in geostrophic balance so that

$$\bar{U} = \text{constant}, \quad \bar{V} = 0, \quad f_0 \bar{U} = -g \bar{\eta}_y$$

$$-f_0 v' = -g \eta'_x \quad \text{and} \quad f_0 u = -g \eta'_y$$

Then we can define  $\psi' = \frac{g}{f_0} \eta'$  so that  $\zeta' = \nabla_h^2 \psi'$ .

$$\left( \frac{\partial}{\partial t} + \bar{U} \frac{\partial}{\partial x} \right) \left( \nabla_h^2 - \frac{1}{L_d^2} \right) \psi' + \psi'_x \bar{q}_y = -\bar{U} \frac{f_0}{H} \frac{\partial}{\partial x} h'_B - r \nabla_h^2 \psi'$$

where  $L_d = \frac{\sqrt{gH}}{f_0}$  is the Rossby radius of deformation. The first term on the right hand side is the forcing term, and the second is the damping term. Note that because we assume  $\bar{V}$  to be zero, the forcing term is only a function of zonal variations in bottom topography.

We can then find the free and forced solutions. For the free solution we can derive a dispersion relation for a damped Rossby wave as:

$$kc = \omega = k\bar{U} - \frac{(\beta + \frac{\bar{U}}{L_d^2})k}{K + L_d^{-2}} - ir \frac{K}{K + L_d^{-2}}$$

where  $K = k^2 + l^2$ . From this dispersion relation, we can find that any stationary wave ( $\omega = 0$ ) must satisfy:

$$\bar{U} = \frac{\beta}{k^2 + l^2} \equiv \bar{U}_R$$

Where  $\bar{U}_R$  is the background flow at which the free solution is resonant. To see where this occurs with regard to the imposed forcing, we find the plane-wave solution to our linearized PV equation from above and get:

$$\tilde{\psi}(k, l) = \left[ \frac{\bar{U} \frac{f_0}{H}}{K(\bar{U} - \frac{ir}{k}) - \beta} \right] \tilde{h}_b(k, l)$$

and we can substitute in for  $\beta$  to get:

$$\tilde{\psi}(k, l) = \left[ \frac{\bar{U} \frac{f_0}{H}}{K(\bar{U} - \bar{U}_R - \frac{ir}{k})} \right] \tilde{h}_b(k, l)$$

In the case of vanishing damping this solution has a singularity at  $\bar{U} = \bar{U}_R$  (i.e. where  $K = \frac{\beta}{\bar{U}}$ ). This can be interpreted as the resonant wave number pair. Here we can see that the resonant wavenumber depends on the background flow  $\bar{U}$ , on how close the wavenumber pair is to the resonant value of  $\frac{\beta}{\bar{U}}$ , and on the projection of the forcing  $\tilde{h}$  onto the wavenumber pair.

We can now use these equations to look at the response of stationary wave to orographic forcing, depicted in Figure 9. The top-left panel shows the stationary wave response to a mountain. The mountain excites a range of wavenumbers including the resonant wavenumber, which dominates the solution. The trough downstream of the mountain has a scale that corresponds to the resonant wavenumber. In the right hand panels we see a case in which sinusoidal topography forces only a single wavelength response, which is not the resonant wavenumber. We can also compare a slightly more detailed model to observations in Figure 3.2.3 to see the good agreement with the real world (but it's important to note that this solution is 'tuned' to match observations!). And although we still need to consider the stationary wave response to heating, this calculation at least shows that a stationary wave response to orography can resemble what we see in the real world

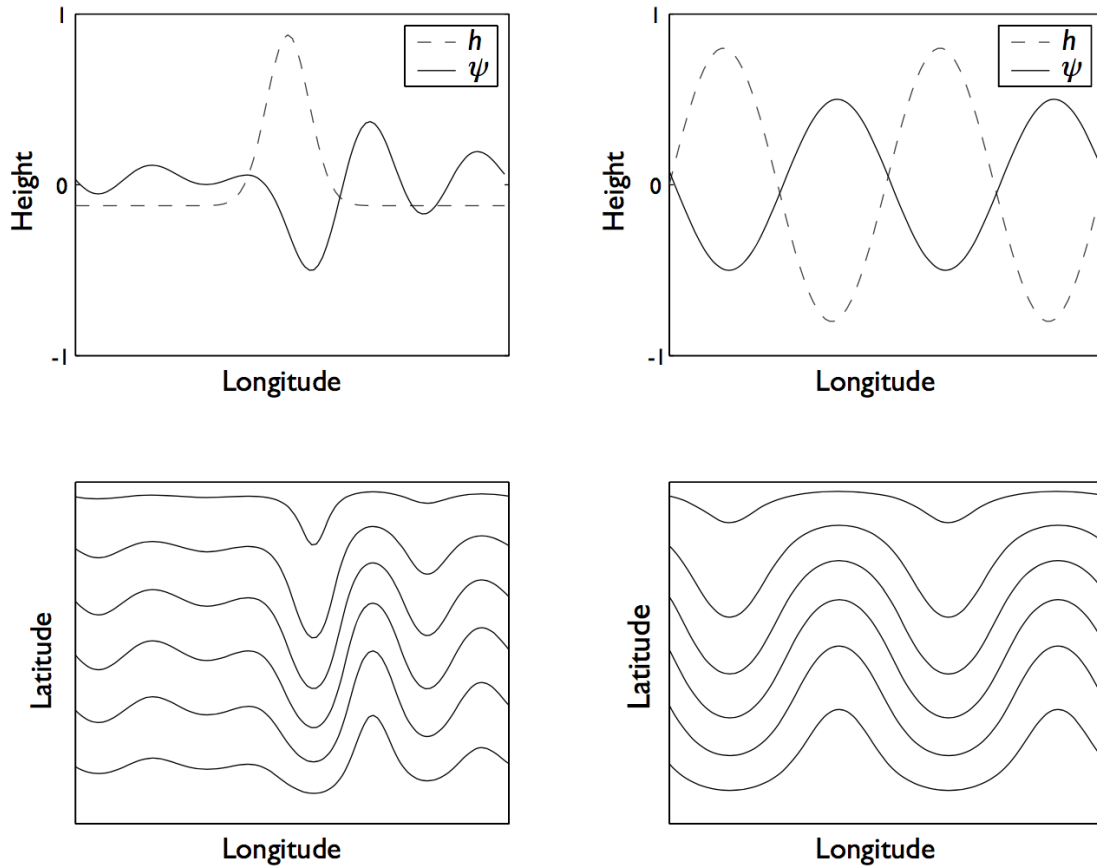

**Fig. 13.1** The response to topographic forcing, i.e., the solution to the steady version of (13.10), for topography consisting of an isolated Gaussian ridge (left panels) and a pure sinusoid (right panels). The wavenumber of the stationary wave is about 4 and  $r/(\bar{u}k) = 1$ . The upper panels show the amplitude of the topography (dashed curve) and the perturbation streamfunction response (solid curve). The lower panels are contour plots of the streamfunction, including the mean flow. With the ridge, the response is dominated by the resonant wave and there is a streamfunction minimum, a 'trough', just downstream of the ridge. In the case on the right, the flow cannot resonate with the topography, which consists only of wavenumber 2, and the response is exactly out of phase with the topography.

Figure 9: Credit: (?)

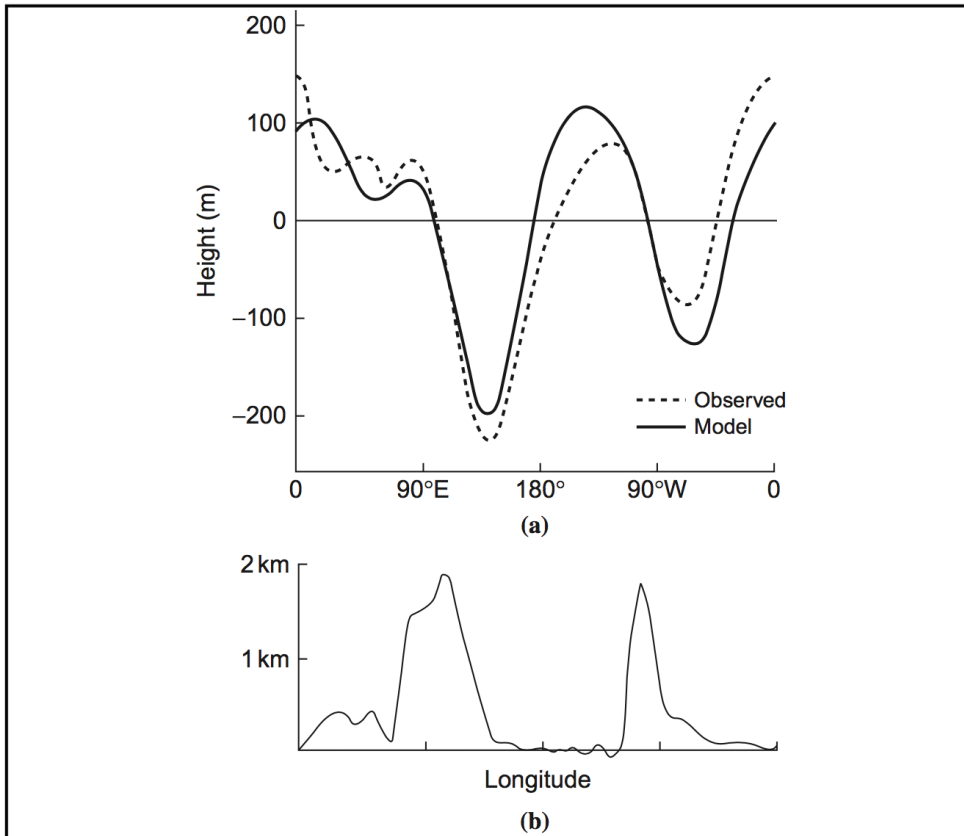

**FIGURE 5.15** (a) Longitudinal variation of the disturbance in geopotential height ( $\equiv f_0\Psi/g$ ) in the Charney–Eliassen model for the parameters given in the text (*solid line*) compared with the observed 500-hPa height perturbations at  $45^\circ\text{N}$  in January (*dashed line*). (b) Smoothed profile of topography at  $45^\circ\text{N}$  used in the computation. (*After Held, 1983.*)

Figure source: <https://ocw.mit.edu/courses/earth-atmospheric-and-planetary-sciences/12-333-atmospheric-and-ocean-circulations-spring-2004/lecture-notes/ch6.pdf>

Although we defined the resonant wavenumber using the background flow, we could also define the stationary wavenumber pair as  $K = K_s = \sqrt{\beta/\bar{U}}$ . And so we can finally make a note that for wavenumbers much larger than the stationary wavenumber ( $K^2 \gg K_s^2$ ) the topographic vorticity source is balanced by zonal advection of relative vorticity, while for wavenumbers that are smaller than the resonant wavenumber ( $K^2 < K_s^2$ ) the topographic source is balanced by



the advection of planetary vorticity ( $\beta v$ ). And as we have mentioned before,  $K^2 = K_s^2$  is the resonant frequency.

### 3.2.4 Propagation of stationary waves

Although the phase velocity of stationary waves is zero, the group velocity is non-zero, which means that the wave energy still propagates. The propagation depends on the horizontal wavenumbers (which are themselves a function of topography and background flow).

The dispersion relation for Rossby waves in a uniform current  $\bar{U}$  is

$$\omega = k\bar{U} - \frac{(\beta k)}{k^2 + l^2 + (m^2 + \frac{1}{4H_0^2})\frac{f_0^2}{N^2}}$$

so that the zonal group velocity is

$$c_{g,x} \equiv \frac{\partial \omega}{\partial k} = \bar{U} + \frac{\beta[k^2 - l^2 - (m^2 + \frac{1}{4H_0^2})\frac{f_0^2}{N^2}]}{K^4}$$

where  $K = k^2 + l^2 + (m^2 + \frac{1}{4H_0^2})\frac{f_0^2}{N^2}$  and the meridional and vertical group velocities are

$$c_{g,y} = \frac{\partial \omega}{\partial l} = \frac{2\beta kl}{K^4}; \quad c_{g,z} = \frac{\partial \omega}{\partial m} = \frac{2\beta km}{K^4} \frac{f_0^2}{N^2}$$

So we can see that the direction of propagation depends on:

- 1  $\bar{U}$
- 2 the sign of  $l$  and  $m$
- 3 whether  $k^2 > l^2 + (m^2 + \frac{1}{4H_0^2})\frac{f_0^2}{N^2}$

### 3.2.5 Stationary wave response to thermal forcing

We'll first consider the response to thermal forcing by considering the steady linear thermodynamic equation:

$$f_0\bar{U}\frac{\partial v'}{\partial z} - f_0v'\frac{\partial \bar{U}}{\partial z} + N^2w' = Q$$

where  $Q$  is the heating term. We can also consider the vorticity equation:

$$\bar{U}\frac{\partial \zeta'}{\partial x} + \beta v' = \frac{f_0}{\rho_R}\frac{\partial \rho_R w''}{\partial z}$$

From these equations we can envision three potential balances, depending on which process dominates

- 1 zonal advection dominates, and  $v' \sim \frac{QH_Q}{f_0\bar{U}}$

2 meridional advection dominates and  $v' \sim \frac{QH_U}{f_0U}$

3 vertical advection dominates and  $w' \sim \frac{Q}{N^2}$ . Then for large horizontal scales the vorticity balance is  $\beta v' \sim f_0 \frac{\partial w'}{\partial z}$ . For smaller horizontal scales advection of relative vorticity may dominate the advection of planetary vorticity

In the above equations  $H_Q$  is the vertical scale of the heat source and  $H_U$  is the vertical scale of the zonal flow. We can apply these principles to a numerical simulation below in Figure 10, which is a response to a ‘deep’ heating source at 15N. The velocity field is vertical near the source (i.e. boundary heating is balanced by adiabatic cooling), but in the far field it is dominated by a wavetrain with a simple vertical structure of the form described by the 1-D topographically forced barotropic Rossby wavetrain. This means that the remote solution to boundary heating is equivalent to the a topographically forced solution that induces the same vertical velocity (i.e. induces the same anomalous vorticity).

The local response to heating will depend on whether the solution is in the tropics or extratropics. In the tropics small horizontal gradients in temperature mean that anomalous heat sources are balanced by vertical motions ( $\beta v = f \frac{\partial w}{\partial z}$ ), which leads to vortex stretching and on large spatial scales to advection of planetary vorticity. In the extratropics the same heat anomaly will be balanced by horizontal advection of temperature (i.e. advection of cool air from the north  $v' < 0$ ), which may actually lead to sinking motion over the heat source.

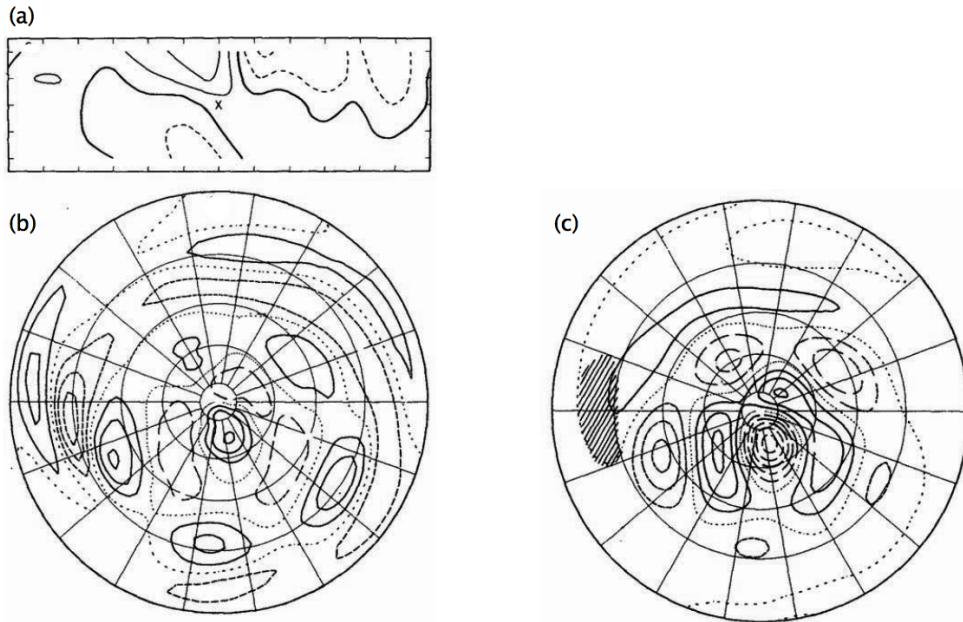

**Fig. 13.8** Numerical solution of a baroclinic primitive equation model with a deep heat source at  $15^{\circ}\text{N}$  and a zonal flow similar to that of northern hemisphere winter. (a) Height field in a longitude height at  $18^{\circ}\text{N}$  (vertical tick marks at 100, 300, 500, 700 and 900 mb); (b) 300 mb vorticity field; (c) 300 mb height field. The cross in (a) and the hatched region in (c) indicate the location of the heating.<sup>15</sup>

Figure 10: Credit: (?)

### 3.3 Origin of stationary waves (and associated storm tracks)

The stationary waves may therefore be a combination of any number of factors, including

- **Orography** excites downstream troughs. Additionally, air that deflects around orography creates a pool of cold air to the northeast of the mountain (advection of cold air that was deflected to the north returning southward) and warm, precipitating air on the leeward side of the mountain (as winds that were deflected to the south return northwards and rise along sloping isentropes to induce precipitation). So the local effects of mountains reinforce the SW-NE tilt of precipitation / storm tracks.
- **Land-ocean contrasts** create differences in drag and moisture availability as well as temperature contrasts.
- **SST fronts** such as the Gulf Stream and North Atlantic Drift create closely spaced and diffuse isentropes, respectively.

We can now revisit Figure 6, which provides an observational estimate of the storm tracks in DJF. We can see that they have a decidedly SW-NE tilt, and that the baroclinicity is greatest over the western boundary currents of the oceans, downstream of the Rockies and Himalayas.

## References

James R Holton and Gregory J Hakim. *An introduction to dynamic meteorology*, volume 88. Academic press, 2012.