

www.hi-fiworld.co.uk

JUNE 2002

UK £2.75  
Malaysia Rm18

WORLD



DIY SUPPLEMENT No. 66  
INSIDE THIS ISSUE!

& computer audio

ALL TOGETHER

We test Linn's superb new  
CMS one box DVD system



plus

- Meridian 507 CD player
- Unison Research C5P/P30K pre & power amps
- Exposure 2010 CD player
- Pink Triangle Integral amp
- Mission m51 'speakers
- Tannoy Eyris 1 'speakers
- Castle Stirling 'speakers
- Opera SP2 'speakers
- ATC Active 10 'speakers
- Computer Audio World
- MP3 after Napster
- Steinberg's Get In On CD 3.0
- Inspire 5300 5.1 multimedia 'speakers

JUNE 2002



**COMPETITION**  
Win A superb Exposure  
CD/amp combination in  
this month's competition

+ 100s of classified ads full of secondhand bargains!!!

World Radio History



The Klimax Twin is designed to match the Klimax Solo and sets new standards for single component stereo power amplification.

The Klimax Twin delivers unsurpassed signal pitch accuracy, thermal efficiency and reliability producing 125W into 8ohms and 230W into 4ohms of clean, silent power, all beautifully housed in a cool running unit that is only 2 inches thick and weighs less than 22 pounds.

The stunning compact casing protects, screens and stabilises the sensitive internal electronics and forms a heat exchanger with further diffusion being provided by a separate cooling

## **LOOKS CAN BE DECEIVING. KLIMAX TWIN.**

channel with back-up fan assist. Inside the Klimax Twin you'll find two isolated circuit boards, one the unique Linn Silent Power Switch Mode Power Supply and the second containing the board for the twin channel audio circuitry.

To experience the outstanding performance of the Klimax Twin in a stereo music system or multi-channel audio-visual system visit your nearest Linn specialist, which can be found at [www.linn.co.uk](http://www.linn.co.uk) or call the Linn Helpline on 0500 888 909.



**A**uthenticity has traditionally been important in the worlds of both hi-fi and music. These days, however, the inexorable rise of digital technology (specifically digital signal processing) is challenging the old order. Aspiring Pete Townshends now practice their scales and chords using Fender guitars fed into 'digitally enhanced' amplifiers, with a host of different settings designed to emulate 'classic' amplification and effects pedals.

Surely there must be some kind of sonic sacrifices when changing from a fully valved Marshall to a Trace Eliot or Mesa Boogie at the flick of a switch? Well, according to my sources, not really. Whilst each of the classic emulated amps has its own sonic attributes that aren't completely recreated by these digital devices, they come pretty damn close. This makes me wonder whether we can soon expect a box of tricks that can reproduce the slam of a Krell muscle amp or the sweetness of a 4W directly heated triode valve amp - at the flick of a switch. You might think it sounds daft, but if you can store 24MB of information on a memory card the size of a postage stamp then why not?

In some respects we're already getting there. There are a number of Class D so-called 'digital amplifiers' on the market and the professional recording industry has been using quality digital effects units for many a year. Indeed, we've already got a raft of AV digital effects processors which recreate the acoustics of everything from Abbey Road Studio Two to your back garden. It's surely only a matter of time before some bright spark in the hi-fi industry makes a digital valve emulator!

The fact is that - as everything is done in the digital domain - the cost of loading audio systems with a multitude of effects and features is relatively low (after the initial development work has been done, of course). Take, for example, Pioneer's DVD-747A - despite being a relatively modest £950 machine (not much in the great, high spending scheme of 'real hi-fi'),

it plays DVD-As, SACDs, CDs, CD-Rs, MP3 CDs and probably croquet as well! In a couple of years' time the same money will buy you all this and digital recording too - and a FireWire port to interface with your PC.

The point is that - thanks to the joys of digital - anything is possible, and manufacturers are now falling over themselves to make it happen. All well and good, but isn't it losing sight of what listening to recorded music is all about? Staying in the digital domain until the last possible moment (i.e. the loudspeakers) can let you do just about anything - but do you really need to? Hi-fi, pro audio and AV is becoming wilfully complex - but to what end? Will eighteen different digitally recreated acoustics from your preamp do anything except make playing good old stereo vinyl far more fussy and complicated?

Of course we should embrace technology with open arms, but we shouldn't let it push us around. That's why a number of audiophiles are going back to basics. In one room they have their all-singing, all-dancing digital system for AV use, whilst in the other sit valves and vinyl. One does one job brilliantly, and the other another! Call it 'technological segregation' if you like, but for me at least, it means there's one system in the house I know how to switch on and off! ■ ▲



Simon Pope

## how we test the products

- Hi-Fi World has its own advanced test laboratory and acoustically treated listening room.
- Hi-Fi World has a dedicated in-house team of experienced listeners. We review thoroughly by extensive auditioning, rather than by quick-fire group listening tests.
- Hi-Fi World's engineering team designs a wide range of products in-house. No other hi-fi magazine is so expert and dedicated.

- £ ——— NICE PRICE - Represents excellent value for money.
- 🌐🌐🌐 EXCELLENT - Superb sound, among the best available.
- 🌐🌐🌐 ——— VERY GOOD - Well worth a listen.
- 🌐🌐 ——— ADEQUATE - Room for improvement.
- 🌐 ——— POOR - Seriously flawed. Forget it!
- 🌐 ——— Half globes are added for those products that we feel are between categories

## HI-FI WORLD

SUITE G4, ARGO HOUSE  
KILBURN PARK ROAD  
LONDON, NW6 5LF

www.hi-fiworld.co.uk

### Contact Numbers

Mon-Fri 9am-5pm

### Editor

Simon Pope  
tel/fax: +44 (020) 8786 8141  
e-mail: editorial@hi-fiworld.co.uk

### Computer Audio World Editor

David Price  
email: editorial@computeraudio.co.uk

### Design & Layout Editor

Faiza Chunara  
tel: +44 (020) 7625 3129  
fax: +44 (020) 7328 1844  
e-mail: adproduction@hi-fiworld.co.uk

### Production/Photography Editor

David Noble  
tel: +44 (020) 7625 3134  
fax: +44 (020) 7328 1844  
e-mail: classifieds@hi-fiworld.co.uk

### Advertising

Amanda Sweeney  
tel/fax: +44 (020) 8864 4760  
e-mail: advertising@hi-fiworld.co.uk

### Accounts

tel: +44 (020) 7625 8032  
fax: +44 (020) 7328 1844

### Credit Control

Louise Palfrey  
tel: +44 (0) 1923 270833  
fax: +44 (0) 1923 260588  
e-mail: subscriptions@hi-fiworld.co.uk

### WORLD AUDIO DESIGN

Technical Manager - Nick Lucas

www.worldaudiodesign.co.uk

tel/fax: +44 (0) 1908 218 836  
e-mail: nick@worldaudiodesign.co.uk

### Publisher

Noel Keywood  
e-mail: publisher@hi-fiworld.co.uk

### Private & Trade Classified Ads

tel: +44 (020) 7625 3134  
fax: +44 (020) 7328 1844  
e-mail: classifieds@hi-fiworld.co.uk

### Subscriptions & Back Issues

9.30am - 12.00 noon  
tel: +44 (0) 1923 270833  
fax: +44 (0) 1923 260 588  
e-mail: subscriptions@hi-fiworld.co.uk

### Distributed by

Comag Magazine Marketing,  
Tavisstock Road, West Drayton,  
Middlesex UB7 7QE  
Tel: +44 (0) 1895 444 055

### Printed by

Southern Print, Dorset  
Tel: +44 (0) 1202 622 226

### Our Agents in Malaysia

Millennium Hi-Fi & AV  
Simon Chang  
Showroom & office, 500-1-3 First Floor  
Wisma Indah (Shen Court), Jalan Tun Razak  
50400 Kuala Lumpur, Malaysia  
Tel: 603 9283 8171 Fax: 603 9281 3762  
e-mail: info@millennium-audio.com

All unsolicited submissions and goods are at the owner's risk. We accept no responsibility for such submissions, nor do we undertake to return them.

No material may be reproduced from this magazine without the publisher's written permission.  
© Audio Publishing Ltd

# contents

## reviews

### systems

LINN CLASSIK MOVIE SYSTEM 8



This is the impressive AV answer to the superb Linn Classik audio system. Here is a one box, five channel amp and DVD player that also promises to deliver the goods with music.

### digital players

EXPOSURE 2010 CD PLAYER 19



The latest product from the new Exposure is this midrange CD player which Dominic Todd finds to be a bit of an eye opener!

MERIDIAN 507 CD PLAYER 26



David Price gets first crack at the latest entry level CD spinner from the digital experts.

### amplifiers

PINK TRIANGLE INTEGRAL 12



Pink Triangle mark their return to the world of high end audio with this beautifully crafted integrated. Mani Sandher thinks Pink.

HEADPHONE AMPLIFIERS 39



Simon Pope gets his head round two audiophile headphone amps from Creek and Sugden.

UNISON RESEARCH P30K/C5P 41



This latest stylish combination from the Italian valve specialists attempts to marry transparency with power. Simon Pope discovers whether it succeeds or not.

### loudspeakers

CASTLE STIRLING 3 15

The latest incarnation of the classic Stirling floorstander comes under the stethoscope (or is that oscilloscope?) of audio doctor Noel Keywood. How will it fare?

TANNOY EYRIS 1 24

The Eyris I is the entry level model in the new 'wideband' series from Tannoy. Featuring an extended frequency tweeter it's intended to be ideal for the latest high resolution formats.

OPERA SP2 34

These slim and sophisticated floorstanders feature a beautiful solid hardwood cabinet with an unusual 'boat tail' curved back for extra rigidity. Simon Pope spends a night with the Operas...

MISSION m51 50

Check out these brand new, ultra stylish £300 standmounts from Mission in our exclusive review.

MJ ACOUSTICS PRO 50 58

MJ Acoustics are the new kids on the bass block. How will their Pro 50 subwoofer compare with the competition?

ATC ACTIVE 10 56

Ever felt the urge to 'go active'? Find out what we think of ATC's latest powered loudspeaker.

### tuners

TVOLJ AUDIO MODEL ONE RADIO 58

Described as an audiophile quality portable radio, the Model One was designed by the late, great Henry Kloss. Find out what we think of it.

accessories

ACCESS ALL AREAS 59

David Price and Simon Pope check out some of the latest gadgets and tweaks in the audiophile universe, including a 'plug in' sound enhancer, some magic film and a cardboard 'speaker'!

features

HIGH RESOLUTION, LOW PROFILE 22



Noel Keywood hunts for the latest high res software and has to look harder than anticipated ...

NEW ADVENTURES IN HI-FI 52



David Price cuts through the technobabble and scrutinises the latest 'high resolution' surround sound formats.

regulars

WORLD NEWS 6

NEXT ISSUE 7

SUBSCRIPTIONS 38



Hi-Fi World is second to none for news and reviews. Subscribe today!

READERS LETTERS 44  
Hi-Fi World's team reply to your letters and e-mails.

HI-FI WORLD KITS 64

HI-FI WORLD LIBRARY 68  
A comprehensive selection of titles covering audio, valve amplifiers, loudspeakers, solid state electronics and more.

COLUMNS 71,73,75  
The World team get to grips with issues facing both the industry and hi-fi alike.

SPECIALIST HI-FI DEALERS 77  
Got a problem? - see a specialist.

DIAL-A-DEALER 78  
Who sells what, and where to find them.

MEET YOUR MAKER 80  
Who makes what, and how to get in touch.

WORLD FAVOURITES 87  
Components which we know to be truly worthy of audition.

WORLD CLASSICS 92  
Our list of products that have stood the test of time.

SUPPLEMENT NO.66 95

DIY NEWS 97

SIMPLY SINGLE 98



Introducing World Audio Design's new integrated amplifier kit, using 2A3's in parallel single-ended configuration.

DIY LETTERS 105

MARKETPLACE 107

READERS CLASSIFIED 123  
The definitive place to find classic audio components.

ADVERTISERS INDEX 130

computer audio world

PEER POWER 81  
David Price looks at the state of the post-Napster file sharing world.

GET IT ON? 85  
David Price tries out Steinberg's brand new 'Get It On CD 3.0' CD authoring software.

INSPIRED THINKING? 86



David Price tries out Creative Labs' next big thing, the Inspire 5300 5.1 multimedia surround speaker system.

# world news

## ▶▶ AUDIO RESEARCH'S 'BUDGET' BULBS

In response to requests for Audio Research's renowned valve amps to be made available to a wider public, the company have launched two new products in the lower price bracket.

The new SPI6 preamplifier is completely single-ended. It has five sets of inputs and is available as a line only (SPI6L) or phono equipped version. There are two sets of main outputs and a tape out. The preamp also has a 12-volt trigger to switch on power amplifiers, plus full remote control of all functions.

Inside the SPI6 there is the Audio Research construction quality found in their higher priced products. It uses six 12AX7 valves (three in each circuit). Other highlights are regulated power supplies consisting of eight high and low voltage regulators and a seventy-step, digitally controlled, analogue-switch volume control with precision tracking, represented by a horizontal row of twenty LEDs on the front panel.



The VS55 power amplifier, a sonic and economic match for the SPI6, features a new open chassis design. Power is produced by two matched pairs of 6550EH beam-tetrodes and there are taps at the rear for both 4 and 8ohms. Prices are £2199 for the SPI6L (line-only input model), £2599 for the SPI6 (inc. phono input) and £2699 for the VS55.

Absolute Sounds  
58 Durham Road  
London SW20 0TW  
Tel: 020 8971 3909  
[www.absolute-sounds.com](http://www.absolute-sounds.com)

## ▶▶ ONCE MORE, IN UNISON!

This attractive new Unison Research product could be a valve amp bargain. The Unico hybrid



integrated amplifier, priced at £750, features a triode valve input stage, plus a solid-state Mosfet output stage producing a rated 80W per channel of continuous power into 8ohms. The power output Mosfets are fitted to a massive 1kilo heatsink for thermal stability and the amp is fully protected against overload by an automatic electronic circuit. There are five line inputs, an MM/MC switchable phono option and, like the rest of the Unison range, the remote control is a radiowave unit. The volume can therefore be adjusted from another room, should you so wish!

UKD  
23 Richings Way  
Iver, Bucks  
SL0 9DA  
Tel: 01753 652669  
[www.ukd.co.uk](http://www.ukd.co.uk)

## ▶▶ ON ME HEAD, SON!

News reaches us of a new, affordable line up of hi-fi headphones from Sennheiser. The first two products in the series to be launched are both top models. The company claim the HD 497 at £49.99 and HD477 at £39.95 will perform equally well with both hi-fi and portable applications. They feature neodymium iron magnets for efficiency, ultra-light diaphragms, and weigh just 130gms.

There is a two year guarantee on the products. Two more models in the range, priced under £30, are to be launched soon.



Sennheiser UK Ltd.  
3 Century Point  
Halifax Road  
High Wycombe  
Bucks HP12 3SL  
Tel: 01494 551551  
[www.sennheiser.co.uk](http://www.sennheiser.co.uk)

## ▶ ALL SINGING, ALL DANCING, ALL KNOWING!

A new monolithic, top of the range DVD player returns to the Denon line up. It has the same high quality build of the company's traditional flagship players like the monster DVD-5000, designed when battleship DVD players were a rarity. Now Denon bring you an even more battleship-like DVD-AI reference class DVD player. It weighs in at over 18kilos.

This beauty features DVD-Audio and THX-Ultra playback, as well as reading DVD-Video, CD/CD-R/CD-RW, MP3 CD-R/RWs and JPEG photo discs. Although not bargain basement in price, with a list of features as long as a gibbon's arm, the DVD-AI offers a lot for its £2,500 asking price.

New technology includes Denon's Digital Link digital output for 24/192 audio to a matching Denon amp making it apparently the first player available with a digital output for 24/192 stereo and 24/96 multichannel. Also new is its use of twin 14bit 108MHz video DACs with Noise Shaped Video.

For the audio side of things Denon's

AL24 Processing Plus uses no less than eight Burr-Brown 24bit 192 kHz PCM 1704 audio DACs and will also decode HDCD discs. There's also a "full and flexible" bass management system for DVD-Audio playback.

On paper, the construction is awesome, featuring multi layer casework, an alloy fascia and side panels, a sintered aluminium transport, internal use of copper and "organic" anti-vibration coatings!

Inside, the player has a three box, six block internal layout for isolating analogue, digital and video circuits and has multiple independent power supplies. It's available from the end of April - watch this space for a future review. . .

Hayden Laboratories  
Hayden House  
Chiltern Hill  
Chalfont St. Peter  
Bucks SL9 9UG  
Tel: 01753 888447  
[www.denon.co.uk](http://www.denon.co.uk)



## ▶ SIGN OF QUALITY



Those cable maestros, the Chord Company have a new top of the range interconnect on the retailers' shelves. The Signature RCA is described as a continuation of the process of development that led to the company's previous range topper, the Anthem.

Single runs of heavily silver-plated oxygen-free copper carry the Signal and Return. These are surrounded by Teflon insulation, which is wrapped as opposed to extruded. The Teflon can then be applied to the conductor at a lower temperature, which the company claim is a contributing factor to the tonal characteristic of the cable. There's an unusual screening system which uses a silver plated flat wire braid covered with an overlapped aluminium composite foil and surrounded by a conventional silver wire braid. The screen is not connected to the RCA plugs but is left 'fully floating'. Earthing connections are supplied with each cable and should be experimented with as the optimal configuration is said to vary from system to system. The Signature is available now with a retail price of £499.95.

The Chord Company  
30a Sarum Business Park  
Portway  
Salisbury  
Wilts SP4 6EA  
Tel: 01722 331674  
[www.chord.co.uk](http://www.chord.co.uk)

## next issue

here's a little taster of what we hope to bring you in July's issue

### SUGDEN MASTERCLASS MONOBLOCKS

These top of the range amps from Sugden pump out 100W of pure Class A power. See what we make of them next month

### KEF REFERENCE 201 LOUDSPEAKERS

Next month sees the arrival at HFW of KEF's new entry level 'speaker in the flagship reference range. How will this much anticipated newcomer fare?

### BUDGET INTEGRATED AMP GROUP TEST

Despite the market onslaught of AV there are still plenty of options for the two channel audiophile on a budget. We test out the class leading integrations in the next issue.

# COME TOGETHER



David Price discovers Linn's brand new Classik Movie System is a brilliant marriage of high quality sound and vision.

It is to Linn's credit that it dared to make the original Classik. Looked at dispassionately, you may wonder what the big deal was - after all, it was just another 'one box' audio centre. But set in the context of a conservative audiophile separates market, and a tediously unimaginative 'lifestyle systems' scene, you can see why it caused such a stir. Here was a product with the performance of the former and the convenience of the latter, the result being greater than the sum of its parts. The Classik showed that you could have your audiophile cake and eat it, so to speak.

Still, I reckon the Classik Movie System is an even more important product. If the original bridged the gap between separates and lifestyle, so this brings the wider audio and 'home entertainment' gulfs together. Although the latter term doubtless induces shivers and vomiting in many

hi-fi purists, the fact remains that there's a natural symmetry between sound and vision.

Retailing for £1,995 the CMS is a lot more expensive than the original Classik, but it does a lot more too. Its 80x320x325mm dimensions and 5kg weight are pretty similar, but inside you'll find a fully featured DVD player (which plays CDs too, obviously) and a 5.1 channel preamp with a host of facilities (which can also work in standard 2-channel stereo). There's also full Dolby Digital, Dolby Pro-Logic and DTS decoding, a high quality stereo radio tuner with 80 definable presets and a 5 channel power amp offering 40W (into 8ohms) per speaker output.

All you need to do is add speakers, but you can also beef things up with the addition of external power amps (using the CMS as a preamp) or turn it into the centre of

a fully fledged multi-room system. For example, this would let you play films in 5.1 channels in the main room, and feed a two-channel downmix of the soundtrack to other rooms around the house! Linn cater for all these possibilities, offering variously a new matching 5.1 Classik speaker system and the 5125 five channel power amp.

The unit itself is beautifully finished - and looks gorgeous even in its 1980s black! The control system is pretty intuitive, the left side ostensibly handling the disc transport, source and volume selection, while the other side takes care of DVD menu, set-up and track selection matters. The display is now an elegant bright blue fluorescent alphanumeric affair, and provides a useful addition to the on-screen display which handles all of the set-up menus. Via the remote you can get into the Speaker Setup page (which lets you specify small or large



◀ speakers, subwoofer operation, front, centre and rear position (a kind of 'surround sound balance control) and a test tone. There's also an Audio Setup option which, among other things, lets you output 96kHz PCM through the digital output and add dynamic compression for low level listening.

It's a veritable hornet's nest round the back. There's the usual preamp outs for front and rear left and right channels, plus centre and sub, plus matching speaker outputs from the power amp section, plus two SCARTs, S-video in and out, digital coaxial output (a welcome addition to the Classik!), RCA phono tape in and outs, AM and FM aerial connectors, a single auxiliary input and the usual Linn multi-room connectors. A front panel mounted headphone socket is a welcome feature.

I auditioned the Classik Movie System in the context of a two channel hi-fi system. Its video capabilities are excellent, but what's the point if the sound is below par? To wit, I tried a range of audio CDs in its DVD drive and did some wave surfing with its AM/FM tuner. I used its internal preamp (in stereo mode) and front channel power amp outputs, driving my Mission 782

loudspeakers.

The CMS's CD sound is better than practically any separate DVD player I've heard (in 16/44 mode). Running its front channel preamp outs through my reference Cyrus 7/PSX-R amplifier gave an extremely natural, musical performance that - if anything - is slightly more full bodied than I remember the original Classik being. You won't get mind-blowing levels of detail or hallucinogenic imaging, but you'll still be amazed by its incredibly bouncy, enjoyable and bubbly sound. Better still, it's also very refined too.

Running through the CMS's own pre and power amps, things were no less impressive. Being a multi-channel amp in a small box, you wouldn't expect thunderous levels of power, but you do get a very taut, grippy and fast sound that retains the refinement of the source. There's a good deal of depth and space to the recorded acoustic, with strongly articulated stereo images and a fine sense of proportion. Dynamics are great - given benign speaker loads this little box goes surprisingly loud with little sign of stress.

Like its audio-only little brother, the new Classik sounds far better than any budget hi-fi amplifier - you'd have to get into £500 plus territory

to really improve on it. In absolute terms, it's a little dry and lacking in tonal colour, and the addition of a separate power amp wouldn't hurt with less sensitive speakers, but - considering what it does for the money - it's almost churlish to criticise. As you'd expect, FM and AM sound was excellent - streets ahead of the rubbish you get from your average one-boxers.

Without doubt, this is a genuinely important and special product - it will probably do more to bring audiophiles into the DVD fold than any other to date. I do have one question, however: Of course, the Classik Movie System plays DTS discs (with superb results), and it will also play the few 24bit/96kHz 'super audio' discs made to fit into the DVD video specification. It is not, however, DVD-Audio or SACD compatible - yet. Rumours are rife that the CD12 will gain this functionality, so what of the Classik? Surely it wouldn't take a great deal of re-engineering to provide this feature?

Linn Classik Movie System £1,995

Linn Products Ltd.  
Eaglesham, Glasgow, G76 0EP  
Tel: 0141 307 7777  
www.linn.co.uk

## MEASURED PERFORMANCE

The Classik produces a useful 40W per channel in stereo, rising to 64W into 4ohms, so it handles modern low impedance loudspeakers quite well and will develop good volume.

The Auxilliary input had a peculiarly curtailed bass response that reached down to 145Hz (-1dB) before rolling off. Other wise, distortion was satisfactorily low and input sensitivity usefully high.

The CD/DVD player had a subsonic roll off below 25Hz, but otherwise had a smooth frequency response that extended up to 20kHz (CD), our analysis shows. With a 24/96 DVD output that reached 48kHz, unlike so many players to date, the Classik produces extended bandwidth information and is a proper high definition player with potentially better-than-CD sound quality. Distortion levels were low, and all other figures normal, so this

section of the Classik worked well.

The VHF/FM tuner looked like a bit of an afterthought, with a treble peak and curtailed bass, meaning it will have a light and bright sound.

The Classik falls quite a long way short of the performance of individual hi-fi separates, except for the main DVD player which was neat enough in all areas - but don't expect sledgehammer bass. It should sound fast and clean, all the same. **NK**

Power 40W

Frequency response 146Hz-54kHz

Distortion (-30dB) 0.01%

Sensitivity 270mV

CD/DVD

Frequency response

25Hz-20kHz/48kHz

Distortion (-30dB) 0.1%

### CD/DVD PLAYER

#### Frequency response

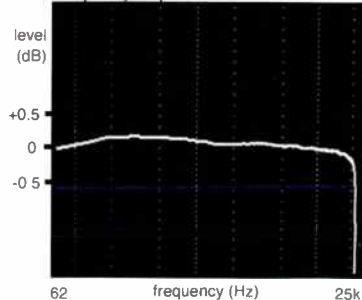

### VHF/FM TUNER

#### Frequency response

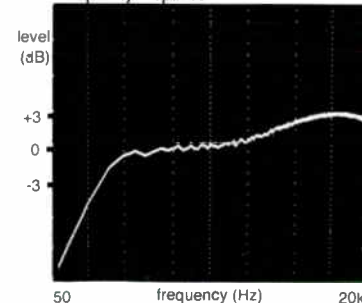

World Verdict  
★★★★★

Another great crossover product from Linn, the CMS offers tremendously satisfying sound and vision.

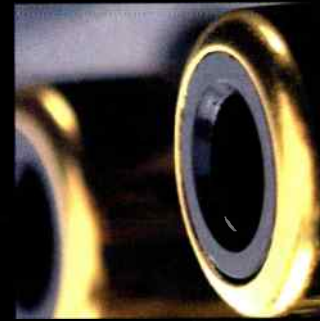
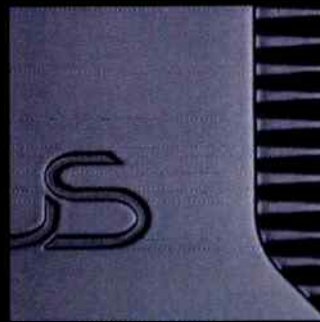
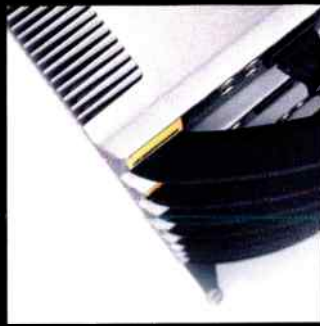

Advanced Audio and Video Systems

Spitfire Close, Ermine Business Park, Huntingdon, Cambridgeshire, PE29 6XY Tel: +44 (0)1480 435577 Fax: +44 (0)1480 437715 [www.cyrusaudio.com](http://www.cyrusaudio.com)

HI-FI WORLD'S

# GREAT COMPETITION GIVEAWAY

WIN A SUPERB EXPOSURE ELECTRONICS 2010 CD PLAYER AND MATCHING 2010 INTEGRATED AMPLIFIER COMBINATION IN THIS MONTH'S COMPETITION

**T**his month we've a real treat for our readers. The new line up of products from Exposure Electronics have taken the market by storm, offering superb sound and build quality. We've managed to procure a 2010 CD player (reviewed in this very issue) and a matching 2010 integrated amplifier for this month's competition prize.



Founded in 1977, Exposure Electronics will be a familiar name to many readers from their commitment to hi-fi over a period of twenty five years. For a company that have been in the industry this long it comes as little surprise that their new products meet the highest standards available at the price.

The first Exposure designs were amplifiers developed from the company's background in professional studio recording. Thereafter their philosophy had been to produce products that "combine class leading performance with exceptional value".

After a period competing with the best around with fast and powerful sounding amplifiers, Exposure trailed off production until Malaysian backing in March 2000 helped them relaunch into the audiophile limelight. The company started to design and produce a new range of products from scratch, including amplifiers, CD players and tuners.

First in this new wave came the impressive 2010 integrated amplifier, with its sleek no-nonsense look and high quality components, including use of the much admired Alps volume pot. The amp has six line inputs and the model we have to give away comes complete with a moving

magnet phono stage. There's a pre out for future upgrading and a lateral MOSFET output stage ensuring a warm yet powerful sound.

The 2010 has a fast and exciting response, very much in keeping with the traditional Exposure sound, but with a nice, warm touch that is also very cohesive. Bass response is very tuneful, fast and deep and treble and midrange highly detailed. We summed up the amp thus: "Audiophilia at a sensible price. A big, generous sound that's cohesive and controlled. A rocking sound that's not for the faint hearted."

Exposure waited until 1997 before releasing their first CD player and the brand new 2010 builds on that first model. Using the same styling as the 2010 integrated amplifier, it features coaxial and digital outputs, an extinguishable display and remote control. Inside there's a brand spanking new 24bit/96kHz DAC mounted on a separate board and fed by a high quality toroidal power transformer. Good quality ancillary components are used throughout. As

far as sound is concerned Dominic Todd thinks it's a winner, having an immediate and deeply staged sound, saying "The 2010 has a very exciting and

forward sound that is totally involving."

And you, too, could be a winner! Entering couldn't be easier. Simply answer the questions below on a postcard and send it to the address below by May 31st. The first correct entry out of the bag will receive this cracking prize. ■ ▲

### Hi-Fi & Computer Audio World Competition rules and conditions of entry

1. Only one entry per house hold.
2. Multiple entries will be automatically disqualified.
3. Purchase of the magazine is not a pre-condition of entry.
4. No correspondence will be entered into.
5. The Editor's decision is final.
6. No employees of Audio Publishing Limited, or of any companies associated with the production or distribution of the prizes may enter.

## CONGRATULATIONS!

...to Mr. Ian Smith of Frimley, Surrey, the winner of our April competition. An Audio Note Zero system is on its way to you!

### Competition Questions

[1] In which year was Exposure originally founded?

- [a] 1997
- [b] 1977
- [c] 2000
- [d] 1877

[2] The company's new backers are of which nationality?

- [a] Malaysian
- [b] Japanese
- [c] Chinese
- [d] Icelandic

[3] The 2010 integrated amplifier uses which type of volume potentiometer?

- [a] Andes
- [b] Alps
- [c] Rockies
- [d] Mendips

[4] In which year did Exposure make their first CD player

- [a] 1988
- [b] 2002
- [c] 1998
- [d] 1997

June Competition  
Hi-Fi World Magazine  
Unit G4 Argo House  
The Park Business  
Centre  
Kilburn Park Rd.  
London NW6 5LF

# PINK



After a short sabbatical Pink Triangle have returned with a new look, superbly built integrated amplifier. High-end addict Mani Sandher gives the Hi-Fi World verdict. . .

Originally founded in 1980, Pink Triangle quickly became established as a manufacturer of quirky high-end turntables (with pink platters no less!) and of the battery-powered 'Pip' preamp. Whilst the sound quality of these products was never in doubt, at times the build quality left a little to be desired and to a certain extent this reputation stuck with them.

Now, the re-launched and re-structured company have hit back. Pink Triangle's latest and more conventional offering is the £3995 'Integral' amplifier. It will be followed soon by the matching 'Da Capo II' CD player.

The aesthetics and build-quality of the Integral are of a standard that earlier Pink Triangle products didn't match. It is housed in a gorgeous all-aluminium extruded case, with a symmetrical array of source selector buttons either side of a centrally positioned volume control. When switched on, blue LEDs adorn the fascia, giving the Integral a decidedly fresh and interesting look. It's a

shame then that the remote handset looks and feels so cheap. If Audio Analogue can deliver a stylish metal one with a amp costing £850. . .

At the rear of the Integral are a pair of balanced inputs, three pairs of phono inputs, two tape loops and one A/V loop. High-quality WBT speaker connectors complete the package.

Rated at 100W per channel into 8ohms, the Integral is claimed to provide 200W into 4ohms and 300W+ into 2ohms. Remaining true to Pink Triangle's innovative and forward-looking design philosophy, the Integral sports a host of features: independent transformers, banked low-ESR reservoir capacitors, ultra-fast soft-recovery rectification on each channel, full protection circuitry incorporating soft-clipping, and most interestingly, a parallel cascoded Darlington output stage. The latter allows the use of a faster, higher gain, more linear transistor, which should improve output stage non-linearity as well as reducing non-linear loading on the driver stage.

Eager to hear how all this innovation translates into sound quality, I connected the Integral to my reference system: Marantz SA-1 (via Integral's balanced input), Wilson Benesch Chimeras, Analysis Plus Silver Oval interconnects and speaker cables and Kimber power cords. The Integral was placed on a Townshend Seismic Sink to reduce the affect of any external vibrations and was left playing music for a couple of days before any serious evaluation.

First impressions were very positive. The Integral has a gorgeously full-bodied mid-range and is especially mouth-watering playing vocals – being almost tube-like in this respect. On track 10 of Chesky's 'An Introduction to SACD', the Integral produced the full texture and tonal shading of Rebecca Pidgeon's voice without a hint of sibilance. Kim Catrall sounded even sexier than usual reciting 'Little Dog's Day' on Hubby Levinson's 'Live at Red Rose Music Volume One' SACD. But not only vocals benefit from the Integral's full-bodied nature; instruments also

# PERK

sound natural and smooth. The Integral revealed in the complex textures of Mike Oldfield's 'Tubular Bells II' CD. I've heard this music sounding muddled and confused through lesser equipment, but through the Integral, it was produced in an easy, non-fatiguing way that allowed me to focus on the music with no other distractions. Indeed, the Integral's mid-range performance is good enough to be compared to that of a single-ended Class-A amplifier, which is quite an achievement.

Tonally, the Integral is well balanced across the sonic spectrum, though perhaps slightly recessed in the treble. Certainly, it has no problem going low, its massive power reserves obviously helping to drive my difficult Chimeras. The Integral took in its stride the low frequency rumblings that kick off 'A Thousand Years' on Sting's 'Brand New Day' CD. Sting's bass on 'Perfect Love... Gone Wrong', was produced in a full and deep way. My only slight criticism here is that it could have been tighter, adding more to the rhythm of the music. Not surprisingly though, Sting's voice sounded superb.

I could go on at length about the Integral's virtues. But how does it compare with my reference Pass Labs XI/X600s amplifier? Firstly, bear in mind that my reference amp's retail for some five times the cost of the Integral! In comparison, the Integral's main weaknesses lie in the areas of focus, depth and dynamics. The opening piano on Track 7 of the Chesky SACD should be placed to the far distant left of centre, with each note being clearly struck and slowly decaying thereafter. Through the Integral, the piano was more vaguely placed and each note less well defined, though the harmonic structure remained intact. Carla Lother's voice on this track was less focused at the front centre of the stage.

On 'Tubular Bells II', the numerous instruments should be spread out across the soundstage, each well focused from left to right and back to front. Again, through the Integral they were more vaguely placed and less clearly defined, especially front to back. Finally, Antonio Forcione and Sabina Sciubba's 'Meet Me In London' CD sounded flat and two-dimensional.

Track 6, 'Could You Believe?' starts with a complex and dynamic riff on Antonio's guitar. The Integral couldn't quite produce enough dynamic contrast between the leading edge of each plucked guitar string and the silent black background.

But I really like the Integral. It is a smooth and accomplished performer with a mid-range to die for and a tonally well balanced sound. If you will, it gives you an 'oil painting' of the music rather than a 'high-resolution photograph'. In terms of absolute sonic accuracy, your £4K may be better spent elsewhere. However, if you're after an amplifier that will lure you to sit down and listen to music for hours, I advise you to put the Integral high on your list. It excels sonically in many key areas, is aesthetically compact and pleasing, and is as well made as anything on this planet. ■ ▲

Pink Triangle Integral £3995

Pink Triangle Partnership Ltd.  
Unit 226, Bizspace  
Lomond Grove  
London SE5 7HN  
Tel: 020 7703 5498

## MEASURED PERFORMANCE

The Integral produces a useful 98W per channel into 8ohms and nearly double into 4ohms at 170W. It's enough to develop good volume levels in most rooms, with most loudspeakers. Since loudspeakers nowadays commonly use 4ohm bass units it is the 170W figure that would be delivered in practice and the Integral can handle such current hungry loads easily enough.

Distortion levels were low, although not down at zero. However, this is not necessarily a bad thing; zero-distortion amplifiers were first designed in the late seventies, but they didn't sound any good. The Integral produces some odd-order

harmonics our analysis shows, but levels were low, reaching no higher than 0.04%. The amp should sound clean enough in practice.

Frequency response was wide enough for SACD and DVD-A, running out to a high 150kHz. Down at the other end, subsonic response rolled down below 12Hz, enough to cover what is on CD.

With low noise and wide channel separation the Integral measured well in all areas. **NK**

Power 98watts

CD/tuner/aux.

Frequency response 12Hz-150kHz

Separation	80dB
Noise	-92dB
Distortion	0.01%
Sensitivity	540mV
d.c. offset	37/17mV

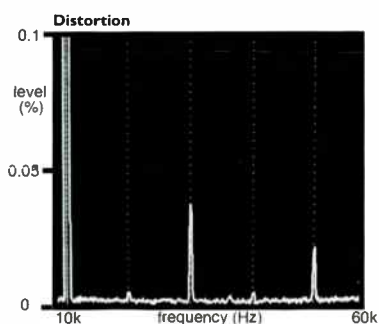

## World Verdict



Superbly musical with plenty of power and bass. Not the most intricate sounding of amps at the price but definitely one for music lovers.

# MICHELL GYRODEC SE

A SYMBOL OF PRECISION



WHAT HI-FI?  
June 1999

Michell Engineering Ltd, 2 Theobald St, Borehamwood, Herts, WD6 4SE  
Tel: 0208 953 0771 Web:www.michell-engineering

## THE AFFORDABLE PHONO AMPLIFIER

FROM TRICHORD RESEARCH

ONLY £299.00 inc VAT (COMPLETE WITH TOROIDAL PSU)

# DINO

Moving Coil  
Moving Magnet  
Switchable Gain  
Switchable Loading  
Super Regulators  
Discrete Output Stage  
Add a 'Dino+' PSU for true  
high end performance



WHAT HI-FI?  
June 2001



**FOR** Sweet and revealing sound;  
fine soundstaging; upgradability  
**Against** Nothing we can think of.  
**Verdict** A great moving magnet/  
moving coil phono stage that offers  
a slice of high-end performance at  
a very competitive price.

### World Verdict



A real 'hi-fi' sound and  
all that many will need.  
Highly recommended.

October 2001

tel: +44(0)1684 573524  
fax: +44(0)1684 577380

[www.trichordresearch.com](http://www.trichordresearch.com)

# STIRLING WORK

Noel Keywood casts his eyes and ears over the latest version of the Stirling floorstander from the Yorkshire stalwarts, Castle Acoustics.



Loudspeakers are both an art and a science. Castle consistently do a great job in balancing the two to produce loudspeakers that not only measure well but sound superb in a smooth, natural and unassuming manner. The artistry comes from balancing numerous subtle variables that affect a loudspeaker's sound, but cannot be measured. And one of the most important in Castle's case is their use of carbon fibre drive units. The floor standing Stirling has two of them to cover bass and midrange, with a tweeter sandwiched in-between. It's a compact floor stander that stands 870mm high, but is narrow at 200mm and not so deep either at just 230mm.

Our review samples came in a dark teak veneer, making for a conservative, middle-England appearance designed to blend quietly into the home. Castle are known for the quality of their veneering and consequently offer no fewer than nine different finishes: Santos Rosewood, Teak, Walnut, Cheery Wood, Mahogany, Maple, Oak, Antique Oak and Black Oak.

It makes sense to get a small floor stander. You don't need a stand and they take up no more floor space. But the popularity of this slot in the market has attracted a sea of competitors and inevitably a price war has broken out, bringing prices spiralling down. Superficially, this looks great, but quality has been the victim. If you put a couple of cheap drivers in a flimsy box the result can be quite unpleasant. The product might look the part, but it isn't really in keeping with what's expected. Imagine buying a sports car with a weedy engine; one contradicts the

other. The Stirling is a quality product with a price to match. It isn't cheap, but I feel it isn't expensive for what you get.

The Stirling has a downward firing port that vents between cabinet and base plinth. After unpacking, the plinth must be screwed to the cabinet, the two held apart by spacers to create a resistive vent. It took me a few minutes with a screwdriver to do this, then attach spikes.

The speaker is bi-wirable and has links so single wire can also be used. I used single and double cables from



**A large reflex port in the base of the cabinet exhausts onto a base plate. A small air gap between them provides resistive damping. Inside, Castle use high quality polypropylene capacitors in the crossover.**

van den Hul, in short 2m runs. Castle describe the Stirlings as downward firing reflex and their quoted performance figures were verified by our tests. Each speaker weighs 14.9kgs or 33lbs - solid but liftable. They fitted into my 16ft x 12ft lounge easily enough and this sort of environment suits them.

## SMOOTH OPERATORS

In use the Stirlings were much as I expected, taking into account their engineering and Castle's desire and consistent ability to deliver loudspeakers that expertly balance all the various design trade-offs. Where floorstanding Missions will come at you with their upfront sound and vivid enthusiasm, the Stirlings tread a more refined path, seemingly taking a step back with a sound that's less ostentatious and immediately engaging, but arguably easier to live with in the long term. That's not to say the Stirling is soft or dull. It is right up with the best in having a tweeter that extends smoothly up to 20kHz and at all times and with all types of music I was constantly aware of the 'speakers smooth but extended bandwidth. Clean, fast edged transients from plucked guitar strings stabbed out from the speaker at the start of Toni Braxton's Spanish Guitar, short, subdued intakes of breath bringing an impression of detailing and atmosphere to the performance. Toni Braxton was

placed just forward of the 'speakers and well established depth perspectives let the sound stage appear to stretch far back. Like most modern Castle loudspeakers the Stirlings set up a deep sound stage and seem less forward and a little less forced than most rivals in this area.

The tweeter is smooth but not reticent, giving Spanish Guitar the sort of hard edged definition it truly has as a good, modern recording. I got much the same result from Jackie Leven's Extremely Violent Man from Fairly Tales from Hard Men. Leven's laconic but gritty delivery was very well resolved by the Stirlings; his lyrics and intonations were vividly portrayed, bringing both the threat and suspense of this song into the room with the sort of realism that a good hi-fi loudspeaker should achieve.

At the same time clearly recorded male vocals can also reveal colorations in the lower mid-band and this the Stirlings have. There's some boxiness in the sound and it tinged Leven's voice with a little woodenness, plus a bit of box echo. This was likely a return from the rear cabinet wall. It was an effect that also showed up with live Radio 2 studio chat, as another example. The 'thoracic thrum' (shall we call it!) of the male voice caught by microphone got a little bit of extra oomph from the Stirling. It wasn't great, but it did

tug at the independence of the images, attempting to pull them back into the cabinet - always a problem with boxiness.

Spatial imaging was excellent. The d'Apollito arrangement of drivers gave a nicely balanced sound all round. Whilst there was extra focus and detail listening directly in front, on the axis of the tweeter, the Stirlings sounded much the same when walking around the room. This does make a loudspeaker easier to live with; it sounds good all the time, rather than just in one physical hot spot. Being forced to sit in one position to enjoy music can be tediously restrictive.

As Castle have engineered it, the Stirlings have a good, full sound. Vocalists have body and instruments in the lower octaves, such as plucked bass and bass guitar, have plenty of strength and presence in the scheme of things. The Stirlings go low, getting right down to the lowest strings on a string bass. Bass quality was generally good, with some bloom and a little bouncy boxiness - but that's how it usually is with compact floorstanders. They don't have the extreme depth or tight control of the larger Howards, which set standards in this area, even though Castle have tried to transfer these strengths. All the same, the Stirlings never sound short of bass power, largely through their voluminous upper bass. The walking bass line in Angeliqe Kidjo's Houngbati, from Aye, had a vibrant power, but in fact the lower fundamentals were kept in tight rein, rather than being allowed to billow and swamp things. Bigger loudspeakers have these bass lines shaking the building; the Stirlings don't let their limitations overcome them, which is where Castle show how deft they are at striking a cleverly engineered balance.

## CLASSICAL PERFORMERS

Franck's intriguing Choral No2 sees the Organ at the Basilica of Saint-Sernin gliding downward with sombre majesty towards 'thunder' from its 16ft Contrabass pipes and although the Stirling doesn't reproduce them fully, it gives a good impression of their 32Hz output. Although the 32ft Principal Bass is in the recording, there are few speakers or rooms able to sustain its presence. Less extreme



pieces, like Chopin's well worked Opus 48, No 1, showed the Stirlings reproduce piano convincingly, giving it body and a beautifully wrought sense of presence in the room. I was aware that the carbon fibre drive units, which do most of the work in a performance like this, deliver a deliciously natural tone that alludes other cone materials. I am a great lover of good carbon-fibre drive units; they do avoid the colour and character imposed by other materials.

With orchestra the Stirlings again showed how well Castle try to produce a fully capable all-rounder, rather than a Rock machine. Violins sounded smooth and detailed, although the tweeters could add a little sheen at times, depending upon the balance struck in the recording. Woodwind sounded woody, brass had a good rasp and plenty of tonal colour. Trumpets sounded as if they were of brass, not steel.

I started out listening to the Stirlings with my Cyrus 7 amplifier, which represents a good, modern solid-state design. The Cyrus is smooth and very capable, generally a delight to use. However, since the Stirlings are an efficient 8ohm load I wheeled in my beloved 300B valve amp, with valve KLPP1 pre-amp. This was like adding a Morton Thiokol booster to the little Stirlings; they got their act together fast and really showed what was possible. With

amplification like this, aided by the usual sprinkling of Jensens and Black Gates, the speakers showed they could sound dramatic. They have a lot of innate ability and, if you happen to use valve amps or want to graduate to them, then these 'speakers make fine partners. They're affordable, domestically practicable and a nice, easy amplifier load.

In a nutshell, the Stirlings are an expertly wrought loudspeaker that deliver a full bodied but accurately balanced sound. They are easy to live with over a period, having an amenable sense of clarity that make them pleasant companions in the home. Castle have balanced them well to suit both Classical and Rock. I could easily live with them and would always be happy with their balance, which suits my tastes and expectations. If you're in the market for compact floor standers, I'd suggest you listen to them first and then last. They set a good standard for others to beat - and whether others beat them will be open to question. ■ ▲

Castle Stirling 3 £729.90  
(standard finish)

Castle Acoustics Ltd.  
Park Mill  
Shortbank Road, Skipton  
North Yorkshire BD23 2TT  
Tel: 01756 795333  
[www.castleacoustics.co.uk](http://www.castleacoustics.co.uk)



*A fabric dome tweeter sits between two carbon-fibre bass/midrange units in d'Appolito arrangement. This improves vertical dispersion.*

## MEASURED PERFORMANCE

The Stirling's forward response stretches from 40Hz (-6dB) up to 20kHz in a usefully even manner, without dips or peaks. Our third-octave analysis shows the tweeter gives a few dB less output than the main drivers, just enough to give a smooth or warm balance. The drive units integrate well, absence of a crossover suckout ensuring the 'speaker will deliver plenty of detail. This is a nicely balanced performance that ensures the Stirling is both accurate but palatable to listen to.

The reflex port is tuned to 50Hz, providing well spread symmetrical damping for the bass driver, our analysis shows. Port output extends down to 25Hz, rolling down smoothly below this.

With an unusually high overall impedance of 9ohms, the Stirling was surprisingly sensitive, producing no less than 89dB SPL from one nominal watt (2.8V) of input. To get this sort of output designers usually resort to using a 4ohm bass unit, which draws far more current. The Stirling is a light load, and a reasonably non-reactive one too. Its efficient conversion of energy and high impedance make it more suitable for (8ohm) valve amps than most rivals too.

The Stirling is a nicely balanced design which is very amplifier friendly, much more so than usual. This is neat loudspeaker engineering.

NK

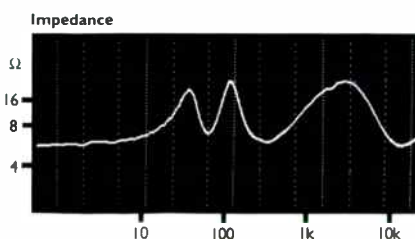
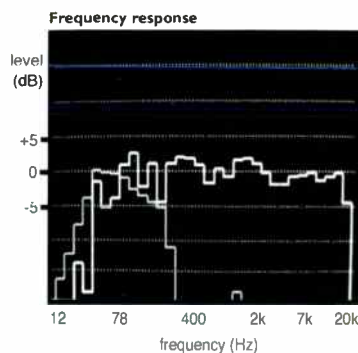

## World Verdict



An accurate and well balanced sound with good body and oodles of detail. Some slight coloration, but otherwise spot on the money. Good for solid-state and valves.

# Walrus Systems

11 New Quebec St, London W1

allaerts  
amazon  
apollo furniture  
argento  
audible illusions  
audio note  
audio physic  
avantgarde  
benz micro  
breuer dynamic  
brinkmann  
carfrae  
cartridge man  
clearaudio  
conrad johnson  
coph nia  
croft  
decca london  
dnm  
duevel  
dynavector  
ear yoshino  
es lab  
final lab  
gamut  
hadcock  
incognito  
kuzma  
lyra



## What's new, Pussycat?

Where do we start?!

Conrad Johnson - superb amps from the US. The fabulous MV60 power amp is on demo now, with the PV-10 preamp.

Duevel - omnidirectional speakers from Germany which are rapidly gaining loyal followers. We now have all 3 models on demo.

Kuzma - well respected turntable/tonerarm.

Origin Live - their brilliant new tonearm, plus Rega arm wiring and counterweight mods.

ES Lab - British built full digital amp.

Gamut - solid state powerhouse from Denmark.

Trichord - the well known and liked Dino and Delphini phono amps.

Plus loads more, too much to mention here. Come and see us now before our floor collapses!



michell engineering  
morch  
musical fidelity  
nordost  
nottingham analogue  
origin live  
ortofon  
papworth  
phy cables  
pink triangle  
pluto  
pro-ject  
rega turntables  
ringmat  
schroder  
shun mook  
sme  
spendor  
stax  
sugden  
sumiko  
tci cables  
tivoli audio  
tom evans  
townshend audio  
transfiguration  
trichord  
vaessen  
van den hul  
verdier



For info on these, and much more, including our numerous second-hand items, please visit our popular website: [www.walrus.co.uk](http://www.walrus.co.uk)

\* interest free credit available on most items, subject to status \*

tel: 020 7724 7224

fax: 020 7724 4347

email: [mail@walrus.co.uk](mailto:mail@walrus.co.uk)

web: [www.walrus.co.uk](http://www.walrus.co.uk)

## If you want a massive leap in performance



## THE SILVER 250

"this is probably the best tonearm in the world right now...words can't express how good this is....one of the designs of the decade."

HI-FI WORLD 2002

Very occasionally a new product appears that is so advanced as to render all previous benchmarks obsolete. People believe the Silver 250 is just such a product and we invite you to experience an unprecedented leap in your system performance - regardless of your current tonearm. Arrange for an audition now - The Silver 250 is £599 and our top arm - the Silver Taper is £970. Both products carry a full no risk money back guarantee and are available via your nearest Origin Live dealer or by direct mail order.

### FULL INFORMATION ON WEB SITE OR CONTACT

Origin Live, Unit 5, 362b Spring Road, Sholing, Southampton, SO19 2PB U.K.

Tel:- 023 80578877 / 80363249 Fax:- 023 80578877 e mail:

[originlive@originlive.com](mailto:originlive@originlive.com)

web site: [www.originlive.com](http://www.originlive.com)

# FULL FRONTAL

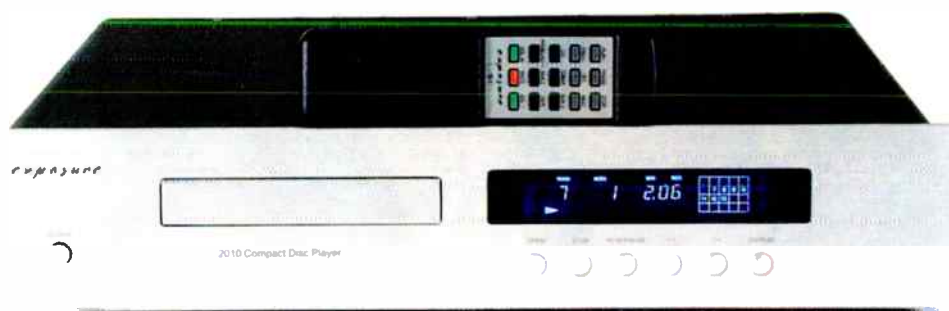

Revamped Exposure electronics are looking to worry the competition. Will their new 2010 CD player have them quaking in their boots? Dominic Todd investigates. . .

So much for SACD. Over the past few months there appears to have been an explosion of new mid-priced CD players. This is the very area where SACD was supposed to be making inroads, but if the recent non-SACD crop is anything to go by then the new technology has some way to go yet.

Last month Rotel's RCD 1070 showed great talent and put in a performance that one could have expected from a machine twice its price only a few years ago. This time it's the turn of amplifier experts, Exposure, to show off their latest entrant, the 2010.

At just short of £600 it stands just above its immediate opposition from Arcam, Roksan and the aforementioned Rotel. One area the extra money certainly hasn't gone into features. The 2010 is just about as bare bones as you're going to get, although it is handy enough. There's BNC-coaxial and, unlike the Rotel, optical digital outputs, an extinguishable display and basic

remote control. Of more importance to most potential buyers are the gubbins inside and it is here the Exposure shines. An up-to-the-minute 24bit/96kHz DAC is mounted on a separate board and fed via a decent quality toroidal power transformer. Construction is neat, layout thoughtful and good quality ancillary components are used throughout.

Leaving the technical specification aside, of even more importance here is the sound quality. With a Rotel RCD-1070 to hand for comparison, I began by listening to Ian Shaw's 'Ruby'. Two aspects of the Exposure's performance were immediately apparent. The first was a vivid portrayal of percussion decay. There was detail and ambience here far beyond what you'd expect from a £600 machine. What there wasn't, however, was the vast staging of the Rotel. The bass response wasn't quite so lush and the whole performance sounded somewhat lean by comparison. Yet the bass that was presented was, as with the rest of the performance, beautifully controlled

and of very high quality. Timing was greatly improved and there was a sense of real interaction between the musicians. The electric guitar possessed a fine, sharp edged, definition that lent it an air of authority missing from other players.

It wasn't just the instruments that benefited from the 2010's insight into the music. Shaw's vocals had great texture and presence, and the tightly focused presentation ensured they appeared dead centre within the sound stage, with little blur. Overall then, a beguiling listen, despite perhaps a lack of weight at the bottom end of things.

O.T. Quarter's 'Hold That Sucker Down' provided a complete change of tempo that suited the Exposure well. During the build up of the track there's a rippling bassline in which the 2010 appeared to find an additional pulsating aspect. Furthermore, the complex synthesised rhythms were played to a tee, with the vivacious and fleet of foot Exposure injecting plenty of anticipation and excitement into the piece. Again, separation and

# Ortofon



# Pro-Ject



The new  
**Pro-Ject  
RPM9**

Exclusively at  
**Centres of  
EXCELLENCE**

#### Town

Aldridge (West Mids)  
Ashby De La Zouch  
Bedford  
Birmingham  
Brentwood  
Bristol  
Bristol  
Cambridge  
Cardiff  
Chester  
Colchester  
Coventry  
Darlington  
Doncaster  
East Grinstead  
Edinburgh  
Edinburgh  
Exeter  
Glasgow  
Harrow  
Helston, Cornwall  
Hitchin, Herts  
Ipswich  
Ireland (Dingannon)  
Kidderminster  
Leamington

#### Dealer

Sound Cinergy  
Zouch Audio  
Richards A/V  
Music Matters  
Audio T  
Radford HiFi  
Audio Excellence  
The Audiofile  
Sevenoaks S&V  
Audio Excellence  
Grayston S&V  
Frank Harvey  
Hi-Fi Experience  
The Hi-Fi Studios  
Audio Designs\*\*  
Hi-Fi Corner  
Russ Andrews\*  
Sevenoaks S&V\*\*  
Glasgow Audio  
Harrow Audio\*\*  
Sounds Perfection  
David Orton A/V  
Sevenoaks S&V  
Kronos Hi-Fi  
Midland Audio Ex\*  
Stratford Hi-Fi

#### Town

Leeds  
Leicester  
Lincoln  
London (Euston)  
London (Holburn)  
Manchester  
Manchester  
New Malden, Surrey  
Newbury  
Newcastle  
Norwich  
Nottingham  
Oxford  
Peterborough  
Rainham (Kent)  
Reading  
Reading  
Salisbury  
Sheffield  
Southampton  
Swansea  
Swiss Cottage  
Tuxford (Notts)  
Warrington  
Worthing  
Yeovil

#### Dealer

Sevenoaks S&V  
Leicester Hi-Fi  
Sevenoaks S&V  
Kamla  
Sevenoaks S&V  
Practical HiFi  
Sevenoaks S&V\*\*  
Unilet  
B&B Hi-Fi\*\*  
L'Intone Audio  
Sevenoaks S&V  
Notts Hi-Fi Centre  
Oxford Audio  
Sevenoaks S&V  
Progressive Audio  
B&B Hi-Fi\*\*  
Audio T\*  
Salisbury Hi-Fi\*\*  
Moorgate Acoustics  
Phase Three\*\*  
Sevenoaks S&V  
Sevenoaks S&V  
Chantry Audio\*  
Doug Brady\*  
Phase Three  
Mike Manning\*

\* Ortofon only    \*\* Pro-Ject only

For a full dealer list and more information contact:

Henley Designs Ltd, Unit 10 Moorbrook, Southmead Industrial Park, Didcot, Oxon. OX11 7HR  
Tel: 01235 511166, Fax: 01235 511266, E-mail henley.designs@virgin.net, WWW.henleydesigns.co.uk

control were first rate, although I did occasionally feel there were times when perhaps the 2010 became slightly over exuberant. At higher volumes in particular, the balance could become just a little too edgy and forward. Despite this though, I felt the player got away with the occasional rough edge as it kept the performance engaging, thanks to first rate timing. By comparison the Rotel couldn't help but sound heavy handed even though it definitely possessed more impact through its stronger upper bass response.

Female vocalists, The Corrs, proved a tougher challenge. It came as quite a relief to find that the 2010 didn't emphasise sibilance as much as I thought it might. Furthermore, as with Shaw, there was texture and colour in the vocals that many a more expensive machine can simply gloss over. The violin was given a rare prominence too, and stood out as a solo instrument rather than merely being a part of the background mix.

More of a surprise was a certain softness towards some bass notes. It was here in particular that the Rotel scored over the Exposure in providing firmer and more expansive foundations to the music. It also had a touch more refinement to the vocals, although it didn't quite catch some of the subtler nuances of the 2010.

Pachelbel's Canon provided the Exposure with a Classical diet. Of key importance with this music is timbre and timing. Generally, there were few problems with either. The stringed instruments possessed a sweet timbre although subtle changes of bow stroke were sometimes hard to identify. In this respect though the 2010 still had the measure of the 1070, even though it didn't quite manage to extricate the same level of depth from the double bass. The upside of such a lightweight bass response though was that the timing was fast, breezy and as fluid as one could hope for.

In the final score the Exposure scores as a definite success. It has the sort of rhythm, balance and vibrant timing that you'd normally have to pay Naim money for. In addition, the 2010 manages, just, not to sound too harsh, cold or uninvolved. Exactly the opposite in fact is true. With most types of music, I found the Exposure thoroughly involving and offering great insight into the music. Yet this isn't to say that it will suit everyone or all systems. If your system is already on the bright side then this particular CD player could just tip the balance toward aggression. Furthermore, the 2010 doesn't have the best bass response around. Those who have just listened to the Rotel, or even Arcam CD72, could find the

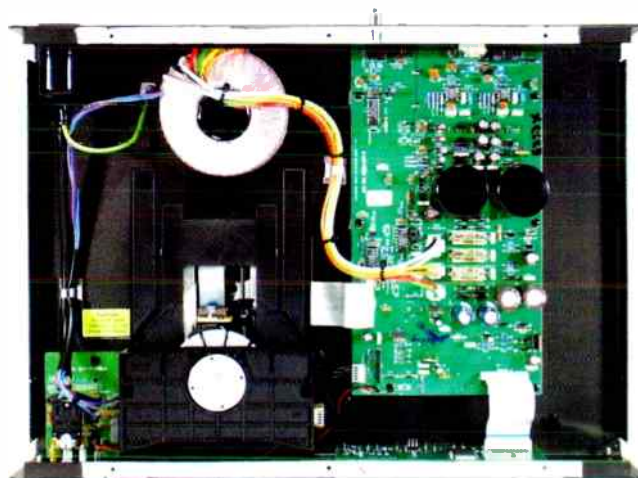

Exposure too lean. For these reasons I'd recommend the 2010 highly, but wouldn't criticise anyone for choosing the Rotel over it. With choices like these, those in the mid-range CD market really have never had it so good. ■ ▲

Exposure CD 2010 £599

Exposure Electronics  
The Works  
59 North Street  
Portslade  
E. Sussex BN41 1DH  
Tel: 01273 423877

**MEASURED PERFORMANCE**

The Exposure was one of a small bunch of players unable to reproduce our short test pulse. As a result we had to measure it with a gliding tone test signal and third-octave analysis. The amplitude resolution of this test method is equally high, however, even if the frequency resolution is not. This measurement shows the player gives a flat response from 20Hz to 20kHz within fractions of a dB, displaying just the slightest top end roll down, so it should sound tonally well balanced in use.

At higher signal levels the converters were linear, producing little distortion or noise our -30dB analysis shows. As level decreased performance deteriorated a little compared to the best players but was respectable all the same. As a result the EIAJ dynamic range figure

was a good 110dB. With output exactly at 2V and wide channel separation across the audio band the Exposure player measured well. **NK**

Frequency response	20Hz - 20kHz		
		left	right
Distortion			
-6dB		0.005	0.005
-30dB		0.016	0.017
-60dB		0.4	0.42
-90		29	30
Separation		left	right
1kHz		120	121
20kHz		90	90
Noise			-105dB
with emphasis			-105dB
Dynamic range			110dB
Output			2V

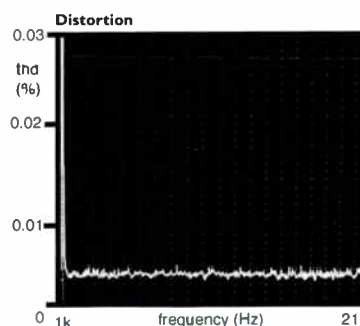
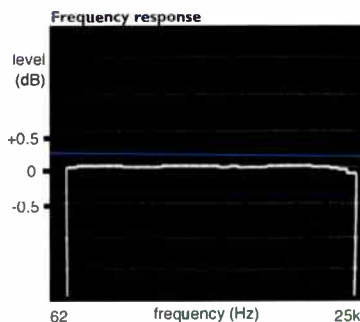

**World Verdict**

Another great midpriced CD player with good pound for sound value. The Exposure has a very exciting and forward sound that is totally involving.

# HIGH RESC IS LOW PR

Noel Keywood tours the big stores looking for SACD and DVD-Audio.



**Virgin place SACD beside MiniDisc - in the basement!**

Is CD on its way out? Are the big stores now stocking SACD or DVD-A? I toured the Central London music megastores of HMV and Virgin in Oxford Street, and Tower Piccadilly to see how they were treating these new formats, to give you some idea of what to expect 'on the ground' in the near future. After all, there's not much point in getting a shiny new, high resolution audio player if no one is stocking the discs. And the big stores can help make or break a format by choosing to stock it – or otherwise. But as Genaro Castaldo of HMV put it, this is a "chicken or egg" situation over which comes first - discs in the stores or demand from the public.

The big music stores historically don't like 'multiple inventory', stocking of the same song on LP, cassette, CD and Minidisc. Happy about the current dominance of CD as a format, they are in no hurry to take on two more audio formats, I found. Counterbalancing this is the success of DVD Video. All the music stores have areas or departments for DVD Video.

That HMV are reticent about the

new formats was obvious from my visit to their Oxford Street store, where there was no special racking for the discs. High resolution discs are put in the racks under the artist's name, I was told by an assistant. The press office were not particularly aware of specific issues surrounding the new formats and it seemed to me that HMV were at present a bit unconcerned about SACD and DVD-A.

At the other end of Oxford Street Virgin have recently tidied up their megastore and the new layout gives some idea about their priorities. A big area has been devoted to the LP but MiniDisc has been moved down to a small rack in the basement. I couldn't help feeling this was the departure lounge for MD. But Virgin seems no more enthusiastic about the new formats because SACD, in its own rack, ominously sits alongside MiniDisc. There was a light sprinkling of titles, classical and Rock, but much of the Rock was re-release. I saw little modern material from major artists, where recording quality might do

SACD justice. To make the rack look fuller TDK blank CD-Rs sat ten deep or more behind solitary SACDs. "We don't have much in that section", an assistant told me, in a slight understatement. And price? Mostly around £23.99, but there was some variation; SACD is expensive.

Upstairs in the DVD Video racks Virgin have a music section with a good selection of videos with audio soundtracks. However, there were no DVD-Audio discs.

Tower Records were altogether more aware of the new formats and better stocked than Virgin or HMV. Whilst their Piccadilly Circus store doesn't have a large rack, it is situated in the busy entrance area and Colin Young, the floor manager, told me they get a useful volume of sales.

# LUTION O FILE



## SACD TECHNOLOGY

Super Audio Compact Disc is an audio-only format using a fixed standard, high rate DSD bitstream that offers 24-bit resolution and 96kHz analogue bandwidth (192kHz sampling rate). Programme is generally available in both surround-sound, with a stereo mixdown for conventional systems.

Two types of disc are available. Dual layer types will play on CD players as well as SACD players, but they are more expensive to manufacture, since the two layers must be physically bonded in a separate manufacturing process. Single layer discs are cheaper to make, although not necessarily cheaper to buy, but will play only on SACD players. Both types are available in the shops, at present only identified by stickers.

*Tower have a clearly identified SACD and DVD-Audio rack. Colin Young was happy with sales. Other stores will be getting these racks.*

Tower mix SACD with DVD-Audio, knowing that buyers will be quality conscious and aware of the issues involved, at least to some extent. Colin told me they would be rolling this specialist rack out to other stores around the UK in the near future and he was quite enthusiastic about the formats. Prices were around the £23-£24, which appears to be the norm.

Downstairs in the DVD Video music section Tower were stocking some DVD Audio discs of the Doors, re-mixed to 24/96 surround-sound. These were in with the video discs, but being marked 'DVD Audio' should need a proper DVD Audio player to reproduce them. With a low price of £16 I wonder whether they were truly DVD-As, rather than DVD Video discs with 24/96, 5.1 surround-sound. Such fine distinctions are not made on the packaging of course and this is where DVD has become hopelessly confusing.

Tower has more confidence in SACD, because it is easier to understand. Prices for SACD are high, again up to £23 or so.

At present SACD and DVD-A sales are so low the British Phonographic Institute (BPI) don't

record them, they told me. Because the discs are at present categorized as CDs or DVDs, they may never do so, so whether sales will rise may forever remain a mystery. Whilst prices remain so high demand is likely to remain limited, I feel, especially in the absence of chart topping artists.

In spite of all the confusion surrounding DVD, it may well be that DVD Video discs carrying high quality 24/96 audio could seep into the market. Priced around £16.99 they are compatible with all normal DVD (video) players and can give better sound quality than CD. Questioning Meridian Audio about DVD (it uses Meridian lossless packing) they told me that in their view 24/96 was all we need for perfect CD sound quality. That makes 24/192 technological overkill. Sony and Philips, developers of SACD, wouldn't agree with them of course.

Confused? So is everybody. As discs trickle into the stores it will be interesting to see how HMV, Virgin and Tower cope. At present though, high prices and limited selections will give them an easy time and buyers a headache. On the retail front SACD and DVD-A has made little progress. ■ ▲

## DVD TECHNOLOGY

Conceived as a video medium, DVD has nevertheless always been able to carry audio as a movie soundtrack. Bear this in mind, because it does tend to confuse matters. DVD movie soundtrack is usually CD quality, meaning 16-bit at 44.1kHz sampling rate. However, this soundtrack can come in superior 24-bit, 96kHz resolution stereo or compressed multi-channel (Dolby 5.1). These are basically DVD Video discs, but their audio is better quality than CD and they may not even have video on them, acting purely as audio CDs. Unfortunately, not many early video players fully reproduce 24/96, they truncate it to 20kHz. This is an early unpublicized problem with DVD.

DVD-A (DVD Audio) is a pure audio format, with no video on the disc. It offers even higher sound quality: 24-bit at 192kHz sampling rate, two channel (stereo), or 24/96 six channel. Although 24/192 will give better sound quality than 24/96, stereo recordings in this format are rare. Even studios aren't commonly equipped to record to such high resolution, necessary 192kHz A/D converters only recently coming to market. As a result, 24/96 six channel is more common and may carry 5.1 format surround sound or other info, such as height information (periphery).

DVD gets even more confusing when discs carry both DVD-Audio and DVD-Video. This makes them compatible with old DVD video players, as well as newer DVD-A players, but playing time will suffer, unless the disc has two layers or uses both sides.

# THE EYE OF

The new Eyris series from Tannoy features their 'wideband' technology in the shape of a new titanium dome tweeter. Dominic Todd auditions the baby of the range, the Eyris 1.



There's been much talk of wide band of late. Due to the increased frequency response of formats such as DVD-A, amp and 'speaker manufacturers have been quick to cash in by offering products suitable for the 'new' expanded frequency products. Of course there's nothing really new here as analogue sources already offer a technically near unlimited frequency response. None the less, it hasn't done Tannoy any harm with their high end Dimension range. Now the technology has filtered down to the middle orders, and the specifications are truly impressive. The ultra thin titanium dome tweeter will stretch to a phenomenal 44kHz! It may be well outside the human hearing spectrum, but the effects of reduced top end compression can often be worth the effort.

In other respects the Eyris 1 is a fairly straightforward affair. The cabinet is solidly built with 18mm MDF and beautifully finished in a choice of real wood veneers. With such a high tech tweeter it comes as something of a surprise to find an ordinary looking 145mm fibre woofer in these days of woven Kevlar and alloy units. Yet many a 'speaker has sounded more than fine with just such a bass unit so there's no cause for undue concern.

One final unusual feature is the five binding posts. Yes, you read that right, five! There's four for conventional bi-wiring and a fifth to act as a ground. Attach this to your amp as you would a turntable earth.

In the best Tannoy tradition I found the Eyris a sensitive 'speaker to drive even though Tannoy themselves claim an average 88dB.

Listening to The Art Of Noise's 'On Being Blue' I found the claim of a wide band frequency response to be more than mere marketing hype. The operatic vocals fairly soared from the 'speakers, which could make even the most open of rivals seem compressed in comparison. The guitar's texture and depth was also most impressive, leading to great insight into the music. Not for nothing is Tannoy renowned for their studio monitors, it would appear.

With such a far reaching tweeter it came as a relief to find that integration with the woofer hadn't been overlooked. The paper cone melded seamlessly with the tweeter to form a cohesive balance. Further down the range though, the balance

wasn't quite as impressive. Compared with the lucidity of the treble and mid band, I found the lower bass response just a tad soft and lazy. Bunging the front mounted ports with the supplied foam inserts helped to a degree but there still wasn't quite the firm control of rivals such as B&W's CDMINT or Neat's Critique. However this slight flaw didn't detract from the palpable sense of depth and fine imaging.

The Rip Chord's 'Just A Man' provided a starker, more grungy backdrop. If anything, the balance sounded just a little too polite, with the thrashed guitar in particular losing out on its coarser qualities. That having been said the timing couldn't be faulted and the Tannoys afforded excellent insight into the vocal characteristics of the lead singer. Overall though, I still felt that the whole performance seemed just a little tame. It appears that Tannoy were so concerned by the extra "hash" that the expanded frequency response might have introduced, that they've gone out of their way to engineer in more refinement than is



# THE TIGER

strictly necessary.

Eagle-Eye Cherry's 'She Didn't Believe' can cause component problems. Vocals are often closely microphoned and the recording has a few rough edges. Yet, the Eyris 1s made a fine effort. Vocals were intimate and truthfully reproduced. The guitars showed good resolution too, although they did seem to miss the last degree of analysis, in that others would etch the notes slightly more precisely. Bass response proved fine, although it didn't quite have the weight and control needed to really drive the natural rhythm of the song. Otherwise, the 'speakers had little problem separating the various instruments and avoided the harsh compression that can set in with more exuberant rivals.

Tannoys have often excelled with high level Dance music, so I thought I'd try Mouse TV's Hot N Juicy's 'Horny' and crank up the volume. The Eyris 1s remained true to their heritage by offering a near faultless

performance. The smooth refinement proved a blessing at ear piercing levels, and they remained clean and linear at volumes that would have the neighbours raising merry hell. At these higher levels the Tannoys showed a much greater sense of attack, and there was real presence from the vocals which helped create the impression of a 'wall of sound', rather than simply boxy compression. Detail remained excellent and the only aspect the committed club fan might miss would be a lack of truly deep bass. The up side of this though, was the decent timing and pace. As before, the baby Tannoys showed a real fluency between the frequencies.

It's hard to see how any Tannoy fan would be disappointed with these 'speakers. They have all the traditional Tannoy qualities of decent efficiency, broad sound staging and sustained high volume handling. Added to that, comes a real sense of openness in the treble, and excellent refinement thanks, in part, to the balanced

frequency response. Yet they're not quite perfect. At lower levels the bass response can seem just a little lazy, and that high level of refinement also brings about disadvantages. Whilst allowing poorer recordings to sound listenable, other rivals will show greater insight into higher quality material.

For all that though, the Eyris 1s are certainly worthy of an audition, and would particularly suit a great number of the many powerful transistor amps around that err on the side of brash. Recommended for Tannoy afficianados and those new to the brand alike. ■ ▲

Tannoy Eyris 1 £599.90

Tannoy Ltd.  
Rosehall Ind. Estate  
Coatbridge  
North Lanarkshire  
ML5 4TF  
Tel: 01236 420199  
www.tannoy.co.uk

## MEASURED PERFORMANCE

The Eyris is a little unusual in conception, having a paper coned bass/mid driver and a wideband tweeter capable of reaching above 20kHz. Since our measuring microphone reaches no higher than 20kHz we could not check this. The bass/mid driver doesn't have a particularly smooth response by current standards, our analysis shows, and tweeter level is set around -2dB lower perhaps to soften the sound a little. I'd expect a lively sound from this 'speaker and good vocal projection, due to the presence of a peak at 1.6kHz. There's no crossover dip so detailing should be strong and the tweeter looks reasonably smooth.

Low frequency output rolls down steadily below 80Hz. This suggests well damped and perhaps dry bass, aligned to suit near wall

positioning. With a port tuned to 50Hz the bass end of things looks as if it was designed to be punchy and tight rather than deep.

The impedance curve sits unusually high and measurement showed an overall impedance of exactly 8ohms. With little reactance too, the Eyris is a relatively light and unreactive amplifier load. The penalty for high impedance is low sensitivity and at 85dB SPL for one nominal watt of input the 'speaker was nothing special here, but not to be bad either. Lower impedance rivals manage 86dB or so these days, but they are not so easy to drive.

The Eyris looks like it is meant to be a lively 'speaker that is amplifier friendly. It

should have an interesting and distinctive sound. **NK**

Frequency response

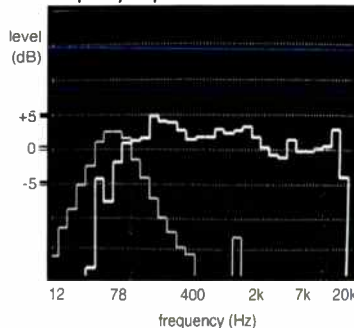

Impedance

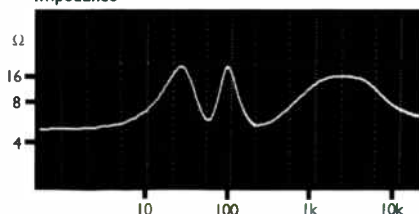

## World Verdict



Fine, open 'speakers in the traditional Tannoy mould. The fine detail and treble response is slightly marred by a slightly lazy bass, though.

# ECONOMY,



Most companies wouldn't call a twelve hundred pound CD player 'entry level', but then most aren't Meridian. David Price tries out the new 507.

Meridian calls itself the 'inventor of audiophile CD'. Now, I know many analogue addicts who'd argue that there's no such thing, but even if you accept the premise, that's still an ambitious claim. The company's first silver disc spinner was little more than a lightly re-heated Philips CD100, and moreover, one of a number of similar reworkings from various companies. Still, there's no doubting Meridian's commitment to the format. Since that first 1984 machine they've produced twenty different models, none of which have sounded bad at all. Indeed - interestingly - they've all had quite a distinctive, warm and sweet, family sound!

I have to admit a soft spot for the 506.24 which I reviewed back in the summer of 2000. At £1,195 the new 507 is a direct replacement for this very capable machine and has much to live up to. Most of its predecessor's charm came from its very smooth, subtle and engaging nature - one that was far more finessed than its immediate rivals, if not quite so striking.

This formula is pure Meridian, carried through from the original MCD. Headbangers won't like it, but

classical music aficionados with refined palettes do. To this end, you'd hardly expect the 507 to represent a dramatic break with tradition - and it doesn't.

New to the party are the 24bit, 192kHz DACs - running of course in 16/44 mode because this is a CD-only spinner - with a direct-coupled audiophile-standard output amplifier. The CD-ROM derived transport reads CD-Rs and CD-RWs in addition to standard pressed audio CDs, and has been carefully conceived to keep jitter to very low levels, achieved by double buffering techniques originally found in the 508. The digital output is precision re-clocked and 6-layer PCBs, 4 separate power supplies, the latest surface-mount technology and 'selected' components are all used for the best possible sound.

The 507 is built as befits any Meridian - it's heavy (6.4kg) for its diminutive dimensions (88mmx321x332mm) and beautifully finished to boot. Thanks to superb ergonomics it's a joy to use and all the commands (Open/Close, Play, Stop, Pause, Previous, Next and Off) are duplicated on the rather swanky 'Meridian System Remote' which is

supplied. Combined with its built-in RS232 port, this can control an entire Meridian system - the fine 551 integrated amplifier (which I reviewed over 7 years ago and is still going strong) would be an ideal partner.

Round the back there's the usual coaxial and optical digital outputs, plus RCA stereo line outs and aforementioned connection port. My only lament is the lack of that wonderful chunky CD drawer of Meridians of yore - now it's the flimsy, plasticky computer CD drive type.

Now to the sound through my reference World Audio pre-power and Yamaha NS1000Ms. It's a Meridian CD player so we're talking - yes you've guessed it - warm and sweet and beguiling and smooth and musical. No surprises there, then. Indeed, I'd go so far to say that - with the onset of DVD-A etc. - this may be the last CD you'd need to buy. It does so much so well, and what it doesn't do frankly isn't easily do-able by Red Book CD without chucking vast sums at the problem. If you really want more then you might as well go for a 'high resolution digital' solution - or a turntable of at least the calibre of a Rega P2!

# CLASS

I kicked off with my favourite torture track, Mercury Rev's 'Goddess on a Highway', which can sound shrill with even quite pricey kit. The Meridian was unrelentingly civilised and sophisticated - but not, repeat not, bland. Soundstaging was excellent - it tends to hang instruments fairly well back, but still there's a great sense of perspective and wide, boldly carried left-to-right imaging. Image articulation wasn't quite as rock-solid as Naim's CD5 or Cyrus's CD7/PSX-R, but is wider and more 'capacious' nevertheless.

Tonally the 507 is as graceful as you'll get from 16/44. Bass is sumptuous and slightly over-warm (it's like what musos would call 'valve bass'), although not quite as extended as Cyrus CD7/PSX-R. Hall and Oates' 'I Can't Go for That' showed that its midband isn't as brightly lit as Naim's CD5 or even Arcam's new FMJ CD23. It's hardly recessed, but neither does it come out to shout hello. It's rather vinyl-like in this respect, and none the worse for it - vocals sound smooth and you can enjoy their timbre,

whereas lesser players either screech them out at you or simply muffle them. Treble was deliciously sweet and satisfying, but you may get the feeling that just the tiniest bit has been lopped off the high end.

Kraftwerk's 'Expo 2000' proved an interesting challenge for the Meridian. Frankly I doubt most 507 users will be into electronic dance music (exquisite as this particular example of the breed is), but this player still made a great show of it. Despite its 'polite' tonality, the Meridian is actually very grippy (obviously more so than the 506.24) and duly held on very tight as the track's bassline energetically modulated up and down. True, Naim's CD5 and Cyrus's CD7/PSX-R are just that bit tighter, but they are lighter too, and lack the impactful 'grunt' of the Meridian.

Lee Morgan's 'The Rajah' on BlueNote proved the 507's mettle at recreating 'real' recorded acoustics. With plenty of air and space, and lots of low level ambient cues, you get a real sense of 'being there'. Dynamics are very good - but not quite up to

the superlative standards of the Arcam FMJ CD23, Naim CD5 or Cyrus CD7/PSX-R. I always got the sense that the 507 was just 'rounding the edges' off transients, even if it proved excellent at the 'microdynamic' nuances and accents of the playing.

Overall it's thumbs skyward for this new Meridian. It's not the most riveting listen, but for yours truly at least, it's none the worse for it. Just as the fastest car isn't necessarily the most satisfying to live with on a day-to-day basis, the 507 more than makes up any ground it loses to excellent rivals with sheer grace and musicality. An excellent new product - and I'd imagine it would make quite a pairing with the oft-overlooked 551 integrated amplifier. ■ ▲

Meridian 507 £1,195

Meridian Audio Ltd.  
Stonehill, Huntingdon  
Cambs  
PE29 6EX  
Tel: 01480 445678  
[www.meridian-audio.com](http://www.meridian-audio.com)

## MEASURED PERFORMANCE

Although this is called a '24 Bit' player it plays 16-bit CDs to 16-bit resolution and it will not play 24-bit DVDs, for example. In this case the machine's internal processing is of 24-bit resolution and as a result it should be more linear than usual. Tests showed this was the case, from maximum output right down to -90dB. Differences were slight, but they were there; the 507 produces a tad less distortion than just about any other CD player I have measured. In terms of sound quality it is probably not the distortion that matters, per se, but the general quality of the internal circuitry and this is an advanced player.

With a normal flat frequency response that extends to 21.25kHz (-1dB), and low noise, this player measures very well all round and is

likely to deliver superb sound quality from CD. **NK**

Frequency response 4Hz-21.25kHz

	left	right
Distortion		
-6dB	0.004	0.004
-30dB	0.016	0.016
-60dB	0.36	0.37
-90 29	30	31

	left	right
Separation		
1kHz	117	116
20kHz	92	91

Noise -107dB  
with emphasis -107dB

Dynamic range 112dB

Output 2.3V

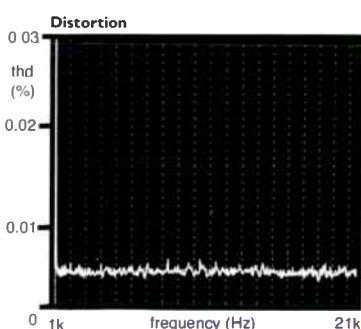
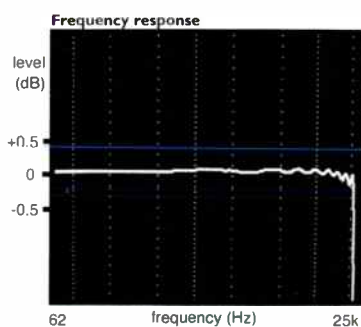

## World Verdict



Another quintessentially Meridian silver disc spinner, the 507 is a wondrously endearing and engaging listen.



## PRO-JECT Debut II Turntable £114.95

"The original Debut turntable romped away with a Product of the Year Award in 1999, and the MKII version continues the extremely good work. It's a simple affair, that's easy to set up, but don't let the price fool you - it sounds a whole lot more expensive than that. This is a fine turntable, and it clearly reveals the benefits of listening to vinyl, with a rich and detailed soundstage, and a good dynamic response.

It's available in six funky colours, so you should find one to suit your decor, and at just a smidge over £100, you can have no excuse not to keep that old vinyl collection in employment for a good few years yet."

★★★★★ What Hi-Fi? Awards 2000

Selected outlets are Project Turntable Centres. Colour Options are available at additional cost



### Turntables & Tuners

Arcam DiVA T51 Tuner .....	£279.95
Denon TU260L MKII Tuner.....	£109.95
Linn LP12/Basik/Akito Turntable .....	£1749.95
Marantz ST4000 Tuner.....	£129.95
Michell Gyro SE/RB300 Turntable.....	£1017.95
Project Debut Phono Turntable .....	£144.95
Sony ST-D777ES FM/DAB Tuner.....	£429.95
Videologic DRX-601E DAB Tuner .....	£279.95

### MUSICAL FIDELITY

**A3 CD Player** £799.95  
**A3 Amplifier** £849.95

**A3 CD Player** "OK, so not everyone will be drawn to the styling, but when it comes to turning on the sonic fireworks, few players come even close at this price... A class act and a worthy winner."

**A3 Amplifier** "The A3 does a wonderful trick of conveying a great romantic sweep of music while at the same time delivering as much internal detail as anyone could possibly want. This is an amplifier capable of performing well beyond its price. We guarantee you won't be disappointed." ★★★★★ What Hi-Fi? Awards 2000



### CD Players

Arcam DiVA CD62T.....	£349.95
Arcam DiVA CD92T.....	£849.95
Arcam FMJ CD23T.....	£1149.95
Denon DCD485.....	£139.95
Linn Genki.....	£994.95
Linn Ikemi.....	£1949.95
Marantz CD4000.....	£99.95
Marantz CD6000Ki Signature.....	£449.95
Musical Fidelity NuVista 3D.....	£2999.95
Roksan Caspian MKII.....	£994.95
Roksan Kandy.....	£544.95
Rotel RCD1070.....	£499.95
Sony CDPXE570.....	£119.95



## DM601S3 Speakers £249.95

"Ultimately it's the 601 S3s' lack of any weakness that makes them so special. Their talent is so widespread that most of the competition is left reeling. Detail, resolution, dynamics, insight... everything is present and correct, and these speakers rate highly in every area.



What more can we say? These new B&Ws are a terrific buy. The price rise over their predecessors pits them against tougher rivals, but on this showing B&W has little to worry about. Unlike the competition."

★★★★★ What Hi-Fi? January 2002

### Recorder Selection

Marantz DR6000 CD-RW.....	£349.95
Pioneer PDR609 CD-RW.....	£199.95
Sony MDS-JE770 MiniDisc.....	£229.95
Yamaha KX393 Cassette Deck.....	£119.95
Yamaha KX580SE Cassette Deck.....	£199.95

Please Note: Some products may not be available at all outlets. Advertisement valid until at least 8th May 2002. E&OE



more entertaining

World Radio History



### Amplifier Selection

<b>Arcam</b> DIVA A65 Plus Amplifier .....	<b>£349.95</b>
<b>Arcam</b> DiVA A75 Plus Amplifier .....	<b>£449.95</b>
<b>Arcam</b> FMJ A32 Amplifier .....	<b>£1099.95</b>
<b>Cyrus</b> ACA7.5 Pre Amplifier .....	<b>£699.95</b>
<b>Cyrus</b> Smart Power Amplifier .....	<b>£549.95</b>
<b>Denon</b> PMA355 Amplifier .....	<b>£229.95</b>
<b>Linn</b> Kolofort Pre Amplifier .....	<b>£494.95</b>
<b>Linn</b> LK85 Power Amplifier .....	<b>£494.95</b>
<b>Marantz</b> PM4200 Amplifier .....	<b>£159.95</b>
<b>Musical Fidelity</b> A300 Amplifier .....	<b>£1399.95</b>
<b>Musical Fidelity</b> NuVista Amplifier .....	<b>£2974.95</b>
<b>Roksan</b> Caspian MKII Amplifier .....	<b>£894.95</b>
<b>Roksan</b> Kandy Amplifier .....	<b>£544.95</b>
<b>Rotel</b> RA931/II Amplifier .....	<b>£189.95</b>



## ARCAM

**DiVA CD72T CD Player** £429.95

**DiVA A85 Integrated Amplifier** £749.95

**DiVA CD72** "The CD72 will have you jumping out of your seat from the very first notes. Both powerful and punchy, it delivers every ounce of air and detail present from detailed midrange to smooth, singing treble. Sometimes a product comes along that sets new standards..." ★★★★★ **What Hi-Fi? Awards 2001**

**DiVA A85** "You'll have realised by now that we rather like this amp. It took us completely by surprise, and further strengthens Arcam's already impressive product range... The A85 is superb, and we can't wait to put it up against its peer in a group test." ★★★★★ **What Hi-Fi? March 2001**



## MONITOR AUDIO Silver 8i Speakers £699.95

"No other speaker in this test can match the Monitor Audios when it comes to delivering seismic basslines with sofa rattling power and weight. That this part of the spectrum also enjoys plenty of speed and control confirms the Silver 8is' position as bass kings... A great speaker needs more than simply great bass, however, and the Silver 8is do far more than merely thump. With the likes of Curtis Mayfield's 'Move On Up', they produce a sound of such verve that it becomes hard to sit still... They produce music with plenty of excitement - but don't forget the subtleties too. Add excellent build and an easy load and these Monitor Audios make a formidable case for themselves." ★★★★★ **What Hi-Fi? April 2001**

## VideoLogic

**DRX-601ES Digital Tuner** £329.95

"New name, new format, new winner: the VideoLogic story is as simple as that. The £299 DRX-601E digital tuner came out of nowhere to establish the firm as a major player in the digital tuner market. With this upgrade, VideoLogic goes one step further: it's still a DRX-601E at heart, but quite apart from the sleek silver styling and sexy blue LEDs it now has a better, white-on-blue display, and what the company calls 'Psycho-acoustic Compensation' - a form of signal processing designed to make the tuner sound less digital.

And it works: the DRX-601ES has a presentation that's rich, clean and extremely informative. Bass is big and powerful, while the midband and treble are well controlled. The style alone would justify the slight price rise; the sound quality makes it a Product of the Year." ★★★★★ **What Hi-Fi? Awards 2001**





CYRUS

**CD7 CD Player** £799.95  
**7 Integrated Amplifier** £699.95

**Cyrus 7 CD** "This player is just as convincing with thundering orchestral strings and brass, making a great job of Bernstein's recording of Mahler's Symphony No 5 and it has the definition to unravel the instrumental strands in the Kronos Quartet's disc of Phillip Glass string quartets... It's that that makes it special - and this is a very special player indeed."

★★★★★ What Hi-Fi? November 1999

**Cyrus 7 Amplifier** "This is a fabulous amplifier. It's fast, punchy and has bags of power on tap but crucially delivers huge sackfuls of subtlety when the music requires. Some of the other amplifiers in this group may be better with particular genres of music but as an all-rounder it takes some beating." ★★★★★ What Hi-Fi? November 1999

MISSION

## 78 Series

**782** bases its performance on a 165mm Nomex bass unit fitted to a reflex enclosure ensuring excellent low frequency extension from a graceful and compact cabinet. The **783** houses a larger 200mm bass unit with massive motor system, capable of floor shaking, yet tightly controlled low frequency extension. Both use Keraform midrange drivers for outstanding clarity and midrange detail coupled to superb dynamic range together with Mission's silk dome tweeter.

The **780** and **781** are the pinnacle of Mission's research into creating a three dimensional soundstage, extensive bandwidth and dynamic range from the smallest possible cabinet dimensions. The **780** is massive in its sonic capabilities. Its 130mm Keraform bass unit is carefully matched to a novel reflex enclosure for full bodied bass extension, the qualities of Keraform produce a dynamic and ultra detailed midrange. In the **781** a 165mm Keraform driver takes advantage of a larger cabinet to extend bass performance and increase efficiency whilst maintaining that superb midband transparency and finely detailed treble.

**780** "Versatile and with a sound that works well with a wide variety of hi-fi kit, these speakers were worthy of this title last year, and this year have achieved the tough task of making it the double."

★★★★★ What Hi-Fi? Awards 2001



### Speaker Selection

<b>Acoustic Energy</b> AE1 Series II.....	£699.95
<b>B&amp;W</b> CDM 1NT.....	£749.95
<b>B&amp;W</b> CDM 7NT.....	£1249.95
<b>B&amp;W</b> DM303.....	£179.95
<b>B&amp;W</b> DM603 S3.....	£599.95
<b>Cyrus</b> CLS70 (Black).....	£799.95
<b>KEF</b> Cresta 2.....	£119.95
<b>Linn</b> Katan (Maple).....	£634.95
<b>Linn</b> Ninka (Maple).....	£894.95
<b>Mission</b> 780.....	£299.95
<b>Mission</b> M71.....	£119.95
<b>Monitor Audio</b> Gold Reference 10.....	£799.95
<b>Monitor Audio</b> Gold Reference 20.....	£1499.95
<b>Ruark</b> Epilogue II.....	£344.95
<b>Wharfedale</b> Diamond 8.1.....	£99.95



## Q3 Speakers £399.95

Like its award-winning predecessor, the floorstanding Q3 offers exceptional value for money. With the new Ferrofluid-cooled metal dome neodymium tweeter derived from the Reference Series unit, the coincident source 160 mm (6.5") Uni-Q driver creates a spacious and intricate sound image throughout the room, and bass extension from the large front-firing port is accurately controlled to preserve the clarity of the midrange. KEF's unique bracing system increases cabinet rigidity to minimize distortion, and the sophisticated crossovers are connected directly to the bi-wire terminals for optimum signal integrity.



more entertaining

World Radio History



### System Selection

- Cyrus** Quattro Ex Power Amplifier & Speakers ..... **£849.95**
- Denon** 201 Ex Speakers ..... **£649.95**
- Denon** DM50 Ex Speakers ..... **£279.95**
- Marantz** Eclipse 19 Inc Speakers ..... **£599.95**
- Marantz** Eclipse 21 Inc Speakers ..... **£699.95**
- Marantz** Eclipse 22 Inc Speakers ..... **£799.95**
- Marantz** Eclipse 25 Inc Speakers ..... **£899.95**
- Tag McLaren** Aphrodite Ex Speakers ..... **£2994.95**
- Teac** Reference 100 Inc Speakers ..... **£299.95**
- Teac** Reference 500 Ex Speakers ..... **£699.95**
- Yamaha** Pianocraft E150 Inc Speakers ..... **£249.95**



**LINN**

### Classik Music System **£999.95**

The Classik Music System is an alternative to the sound and looks of mass market compact systems. Designed to be useful throughout the home, the Classik is simple and stylish with all the advanced features needed to satisfy the most demanding hi-fi enthusiast or discriminating music lover.

"Since the Scottish company added a tuner to the amp/CD player, mouths have gaped even wider in appreciation. The addition of colour options panders to the public's taste for kit to match their interior design, but it doesn't just look lovely in the lounge: the Classik sounds simply marvellous. Boasting fine impact and drive, it retains its grip even as it thumps out rock and dance tracks. Ask it to play quiet acoustic music and its smooth, liquid presentation impresses still further. The Classik offers the performance you'd expect from high quality separates in one lovely package - this is a very superior product." ★★★★★ What Hi-Fi? Awards 2001



### **TEAC** Reference 300 System **£549.95**

"Teac's Reference 300 system is an absolute belter. The company's Reference series has won lots of awards and many admirers in the past, and the 300 range at £200 less than the bigger 500 series, is no disappointment. Your £600 buys you everything but speakers: an amplifier, tuner, CD player and cassette deck... As beautifully built as we've come to expect from Teac, this system delivers the goods with style." ★★★★★ What Hi-Fi? Awards 2001

### DENON

### D-M30 CD Receiver **£229.95** SC-M50 Speakers **£69.95**

"Denon's gorgeous D-M30 has a fine pedigree - and a record of success. Its forebear the D-M3 kept impressing us with its balance of good looks and great sound, winning two What Hi-Fi? Awards on the trot. Now the latest generation takes home a Product of the Year going two years in a row. On its own merits, too, as this is much more than a rehash of the D-M3. Upgraded audio circuitry improved power supply and the Mission-designed speakers all improve the package. The sound is superb, well-balanced and weighty... It's a big system in a very cute box." ★★★★★ What Hi-Fi? Awards 2001

#### Optional Recorders:

CDR-M30 CD-RW Recorder • DMD-M30 MiniDisc Recorder • DRR-M30 Cassette Deck

**Please Note:** Some products may not be available at all outlets. Advertisement valid until at least 8th May 2002, E&OE.





## J A Michell Gyro SE Turntable **£1017.95**

Founded in Borehamwood by mechanical engineer John Michell. For over thirty years, Michell Engineering have been at the forefront of quality audio, with world-wide appreciated products like the GyroDec and Orbe Turntables.

In the early eighties, the revolutionary GyroDec Turntable, with its elegant and effective suspension system, was introduced. The Gyro SE is a smaller and cheaper package that retains the classy sound of the GyroDec and can be upgraded to the full GyroDec specification by adding a plinth and dustcover. **Price includes Rega RB300 Tone Arm**

"The beautifully engineered Gyro SE not only looks the part but has a wonderfully clean and fluid sound." **★★★★★ What Hi-Fi? July 1999**



LINN

**Genki CD Player £994.95**

**Majik Line Amplifier £694.95**

**Genki** "Tempting though it is to think of Genki as a Glaswegian word, it's actually Japanese, and the nearest definitions we could find involve vitality, vigour and spirit. And used as adjectives, these words go a long way towards describing the sound of the Genki, which always manages to communicate the music first and foremost, and let the rest of the hi-fi thing look after itself.

It's a very well-thought-out player, too, from its clear and simple control layout to the provision of four sets of analogue outputs, two at fixed level, and two with level control. Completing the package is a 24-bit Burr-Brown DAC and Pacific Microsonics HDCD filter. Few owners will worry about all that stuff, however, as they'll be too busy enjoying the way Genki plays music, its purity of tone and sense of drama on Mozart's Don Giovanni being a fine example of its talent. By any standards this is a superb player, and not just one for the army of Linn enthusiasts." **★★★★★ What Hi-Fi? March 2000**

**Majik** The Linn Majik is a sophisticated control amplifier complete with on-board stereo power amplifiers. A core entry-level product for powerful and flexible control of hi-fi, video or multi-room installations. "Sneaky" add-on modules expand its functions. It can accommodate many source components. The Majik is available in two versions: The 'Phono' version has five line-level inputs and one Moving Magnet phono input and the 'Line-level' version has six line-level inputs.



### A limited edition of 500

Musical Fidelity has enough nuvistor tubes to build 500 Nu-Vista 3Ds and also to hold a spare set for every unit. (The limited edition Nu-Vista preamp, power amp and integrated are proving to be remarkably reliable, with a tube failure rate of about 0.1%). Music lovers don't need SACD technology, they just need a better CD player. Now a lucky few will be able to own the Nu-Vista 3D compact disc player. Out of the total production of 500, 265 are allocated for sale in England, and of these, 97 have already been reserved.

**Please Note:** Some products may not be available at all outlets. Advertisement valid until at least 8th May 2002, E&OE.

### MUSICAL FIDELITY

**Nu-Vista 3D CD Player £2999.95**

"It's hard to put your finger on exactly why and how the 3D CD Player turns in such a performance and to a certain extent it's a pointless exercise: it just does. OK, so at three grand it's a serious financial commitment, but if you're after a CD player to last 'til you take your final breath it could well fit the bill. Get a move on, though, numbers are limited to just five hundred and they'll sell, believe me. Simply get a listen to one and go back to your reference player - all will be revealed." **Hi-Fi World October 2001**



**more** entertaining World Radio History





## scotland and north

- Aberdeen** 491 Union Street **01224 587070**
- Edinburgh** 5 The Grassmarket **0131 229 7267**
- Glasgow** 88 Great Western Road **0141 332 9655** Open Sunday
- Hull** 1 Savile Row, Savile Street **01482 587171**
- Leeds** 112 Vicar Lane **0113 245 2775** Open Sunday
- Liverpool** 16 Lord Street **0151 707 8417**
- Manchester** 69 High Street, City Centre **0161 831 7969**
- Newcastle** 19 Newgate Street **0191 221 2320**
- Preston** 40-41 Lune Street **01772 825777** Open Sunday
- Sheffield** 635 Queens Road, Heeley **0114 255 5861** Open Sunday

## midlands and east

- Bedford** 29-31 St Peters Street **01234 272779**
- Cambridge** 17 Burleigh Street **01223 304770**
- Ipswich** 12-14 Dogs Head Street **01473 286977**
- Leicester** 10 Loseby Lane **0116 253 6567**
- Lincoln** 20-22 Corporation Street **01522 527397**
- Norwich** 29/29a St Giles Street **01603 767605**
- Nottingham** 597-599 Mansfield Road **0115 911 2121**
- Oxford** 41 St Clements Street **01865 241773**
- Peterborough** 36-38 Park Road **01733 897697** Open Sunday

## midlands and west

- Birmingham** 12 Queensway Arches, Livery Street **0121 233 2977**
- Bristol** 92b White Ladies Road, Clifton **0117 974 3727**
- Cardiff** 104-106 Albany Road **029 2047 2899**
- Cheltenham** 14 Pitville Street **01242 241171**
- Exeter** 28 Cowick Street **01392 218895**
- Plymouth** 107 Cornwall Street **01752 226011**
- Swansea** 24 Mansel Street **01792 465777** Open Sunday

## london and south east

- Brighton** 57 Western Road, Hove **01273 733338**
- Bromley** 39a East Street **020 8290 1988**
- Chelsea** 403 Kings Road **020 7352 9466**
- Crawley** 32 The Boulevard **01293 510777**
- Croydon** 369-373 London Road **020 8665 1203** Open Sunday
- Epsom** 12 Upper High Street **01372 720720** Open Sunday
- Guildford** 73b North Street **01483 536666**
- Holborn** 144-148 Grays Inn Road **020 7837 7540** Open Sunday
- Kingston** 43 Fife Road **020 8547 0717** Open Sunday
- Maidstone** 96 Week Street **01622 686366** Open Sunday
- Reading** 3-4 Kings Walk Shopping Centre **0118 959 7768**
- Sevenoaks** 109-113 London Road **01732 459555**
- Southampton** 33 London Road **023 8033 7770**
- Southgate** 79-81 Chase Side **020 8886 2777**
- Swiss Cottage** 21 Northways Parade, Finchley Rd **020 7722 9777** Open Sunday
- Tunbridge Wells** 28-30 St Johns Road **01892 531543**
- Watford** 478 St Albans Road **01923 213533** Open Sunday
- Witham (Essex)** 1 The Grove Centre **01376 501733**

Please call to verify hours of business.

Contact our outlets via **E-Mail** [outlet@sevenoakssoundandvision.com](mailto:outlet@sevenoakssoundandvision.com)

## who are sevenoaks?

Founded in 1972, Sevenoaks Sound & Vision are one of the largest, and most successful hi-fi and home cinema retailers in the country.

Each Sevenoaks Sound & Vision outlet stocks a wide range of quality products, covering all categories of specialist home entertainment, from DVD Players to Widescreen Plasma Televisions and Projection Systems, all at highly competitive prices.

Friendly staff are available in all stores to advise, demonstrate and guide you through the home entertainment jungle.



## sevenoaks online

The Sevenoaks Sound & Vision website has news and information on the Sevenoaks group and its 44 outlets nationwide. The website is designed to provide you with answers to the questions you may have when buying new equipment.

The site has comprehensive guides to a range of products and technologies from vinyl and compact disc to all the latest formats, including DVD Audio, SACD and widescreen plasma monitors and front projection systems.

There are regularly updated stock clearance lists with hundreds of products on offer and detailed pages to help you locate your nearest outlet.

For impartial advice and information, just click on [sevenoakssoundandvision.com](http://sevenoakssoundandvision.com)

## stock clearance

With over forty outlets nationwide, the Sevenoaks Sound & Vision group stock and display a wide range of products. As technology delivers improvements in performance, so individual models and product ranges are changed or superseded. The preceding models are made available at a reduced price, for clearance. Visit our Website for an up-to-date list of the clearance stock, listed by outlet, within the Sevenoaks Sound and Vision group.

## 0% finance option†

Spread the cost of buying. 0% finance option is available on the vast majority of products we stock. †Written details on request. Licensed credit brokers. Minimum balance £200. Subject to status.

## pricing policy

Whilst we do not claim always to be the cheapest, we try to ensure our prices are highly competitive. Take into account the expert advice, unrivalled product selection, demonstration facilities and excellent pre, during and after sales service and the lower price might not look such good value.

In the event you can find the same products and excellent service at a lower price, please bring it to our store managers' attention. We will always endeavour to offer you the best deal.

# SECOND TIME

The SP2s from Opera are the latest version of their SuperPavarotti floor-stander. Will Simon Pope find them in good voice?

Not so long ago in this very fine journal, I encountered a pair of slim floostanders from the Opera stable whose compact dimensions somewhat belied their name, the SuperPavarotti. Allegedly the great (in more ways than one) man even received a pair as a small gesture. What they did have in common with their namesake, though, was a full throated sound, rich tone and an unmistakably Italian style, as demonstrated in their fine hardwood cabinets. Unlike the man himself, the SuperPavarottis have now had a bit of a re-shape and a change to the vocal chords.

The gorgeous hardwood cabinet remains (a company trademark for twelve years) but we now have an elegantly rounded back in curved boat tail, or "marine" fashion, formed from a single piece of wood which is locked to the front baffle in the hallmark of time-honoured craftsmanship - tongue and groove fashion. Although time consuming, this method has found favour with Opera due to its extra rigidity and structural integrity. In addition to the fine cabinet work, the SP2 has an all round excellent finish, with Opera's high quality 24kt gold plated solid brass (albeit single wire) connectors.

The 'speakers are attached to a base plinth (again with quality adjustable brass cones fitted) with exact spacing for the downward firing port to operate correctly. This port signifies the overall design of the SP2 - the same as in the original version- which is known as a 'double asymmetric cavity loading' configuration. For the technically challenged, this basically means their are two separate, yet interconnected chambers within the cabinet which are of differing volume. The second

(larger) of these has the downward firing port. Drivers used are high quality; two SEAS 11cm mid/bass units. These two units operate together at frequencies below 100Hz, but above this frequency the lower unit is rolled off. The upper one takes over midrange duties up to 2.5 kHz, after which a ScanSpeak 26mm tweeter takes over - a unit rightly held in high regard throughout the business, incidentally.

The crossover itself deliberately employs a minimum of components but what it does use are close tolerance for suitable matching.

Listening was carried out using a Meridian 506.24 CD player matched with Quad II-Forty valve power amps and a solid-state Meridian 557 200W power amp. Preamp duties were down to Creek's invaluable passive preamplifier, whilst Kimber and Chord Company cabling was put into action.

Take a stroll through any major (or minor) Italian city and you'll find a certain amount of Englishness in the appearance of certain individuals. It's a well known fact that continentals seem to carry off wearing traditional English attire far better than those who it was originally designed to enrobe. It seems that loudspeaker design is going this way, too. As the



likes of Tannoy and KEF aim for a wider ranging dynamic and more immediate sound, so the likes of Opera are harkening back to the days of the Leak sandwich and classic Wharfedale designs. Yes, there's perhaps more air and space here than we associate with these classic English models but the overall appeal is similar.

Knowing the general overall trademark sound of Opera I wasn't surprised to find the SP2s had a warm and smooth appeal, totally free from sterility. What this means is that you get a certain amount of coloration, but it's in the valve amp mould - pleasant as opposed to intrusive. What did surprise me though was the quality of the treble. The ScanSpeak is a change for the better when compared to the unit in the original model. What this open

# ROUND

sounding treble does is inject a bit of life into the sound, putting more space and ambience into recordings. Playing an SACD hybrid disc of a fascinating collection of Sicilian medieval songs on the Fone label brought impressive results. A good sense of perspective and depth was created, with the resonant acoustics of the recording venue superbly recreated. The raw vibrancy of the period percussion (drums in particular) and instruments was well relayed, with an impressive amount of detail in the upper frequencies and midrange. John Coltrane's 'A Love Supreme' also demonstrated that the SP2s were comfortably at home with natural and well balanced acoustic material, giving an easy, warm performance.

Knowing that it wouldn't be a marriage made in heaven I put the SP2s through the trials of Underworld's "Push...Upstairs". The pumping electronic bass lines proved to be a little out of sorts here. Whilst ambient and acoustic bass is good,

the dry, low rumblings of Underworld failed to materialise to their full effect - no real surprise when the slim cabinet dimensions are considered. What these slim cabinets do bring, though, is sharp imaging which is both impressive yet natural, with good depth of sound stage, too, as Paul Weller's brilliantly mixed 'Stanley Road' CD proved.

Those seeking impact above all else may not always appreciate the SP2s but they image almost perfectly and have an endearing musical quality that many manufacturers have sacrificed for sonic fireworks. The new choice of tweeter makes a big difference. Like the rest of the Opera range, and indeed Italian hi-fi in general, the SP2s aren't the type of 'speaker that will make you jump out of your seat and get you air guitaring, Spinal Tap style. Where they impress most is with the ease in which they produce music, with not a hint of edginess of scratch. Although ultimately they sacrifice a little excitement and bounce for

refinement this is no bad thing and they are consequently a good match for smooth, sweet sounding gear such as valve amps, or Meridian CD players!

As with the likes of say, an electrostatic design the attraction is in the subtle detail and imaging, as well as the sound as an organic whole, as opposed to hard-nosed dynamics. That is not to say they lack bass or drive, because they don't, especially when used in a smallish or mid-sized room, but those who require ultimate clout and depth may find the SP2s do not fit the bill. On the other hand, if you favour traditional smoothness and warmth these are well worth a listen as they are extremely easy to live with. ■ ▲

Opera SP2 £1100

UKD  
23 Richings Way  
Iver  
Bucks SL9  
Tel: 01753 652669

## MEASURED PERFORMANCE

The Operas had surprisingly good vertical dispersion, meaning their drive units were well matched in terms of phase response. The result in practice is a consistent sound from a seated position to walking around the room, where the ear is much higher. It's a useful but uncommon property.

Our third-octave analysis of frequency response shows the 'speakers measured flat from 40Hz to 20kHz, fluctuations at the low end of our analysis being due to room effects. Otherwise the SP2s stay within a few dB of flatness right across the audio band, from 40Hz to 20kHz - an impressive result. However, perfect flatness points to the use of highly damped cone materials that in practice can sound a little lifeless, so there's a trade-off here. The SP2 will sound detailed though, and its port goes low, so it

should also have quite good bass too. On this topic, the impedance curve suggests the floor positioned port has a broad bass spectrum and applies effective damping to the bass cones around resonance. This gives the 'speakers a flat-ish impedance curve that rises steadily from 4ohms up to 10ohms, giving an overall figure of 6ohms under measurement. There's virtually no reactance in the load, except around bass resonance, so the SP2 is an easy load. Sensitivity was mediocre, measuring 85dB SPL from one nominal watt of input. The Castles in this issue managed 89dB by way of comparison, with higher impedance, so were more efficient.

The Opera SP2s are well engineered. They will be easy enough as an amplifier load, although 60W or more is needed. They are likely to

sound detailed and accurate, with good bass, but also a bit less lively than the best current designs. **NK**

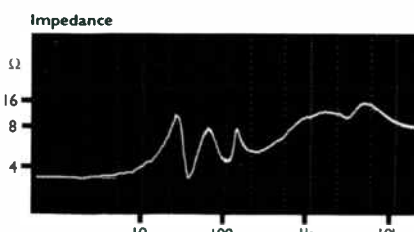
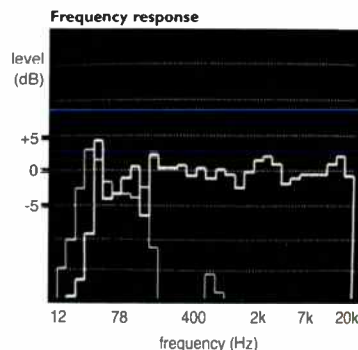

## World Verdict



An open, easy going sound make these a well balanced and user friendly loudspeaker. Not the fastest or lowest bass around but the midrange and treble is excellent. Headbangers, stay clear.

**FREE CATALOGUE**

RUSS ANDREWS ACCESSORIES LTD  
**RA**  
 150th ANNIVERSARY

**Why settle for anything else when you can OWN something this good!**

The Classic PowerKord™  
 "Impressively detailed and crisp, improving imaging and reducing high-frequency hash. Rhythmic portrayal was excellent, and so too was clarity."  
*Hi-Fi Choice - Sept 01*

**HI-FI CHOICE RECOMMENDED**

Sole UK Distributor for KIMBER KABLE

**Mail Order Direct on UK Freephone 0800 373467**  
 quoting ref: AH62 and request a catalogue

Russ Andrews Accessories Ltd., Windermere Rd, Staveley, Kendal, Cumbria LA8 9PL.  
 E-mail: AH62@russandrews.com www.russandrews.com

**Completely unspoilt by progress!**

Supplied with attractive stainless steel cover (not shown).

**icon Audio MC34-A**

Beautiful valve amplifier. Old fashioned build quality. All hand wired. No printed circuit board. 2x 30 watts RMS. Audiophile components used. Beautiful sweet, transparent, musical sound. Find out why eight valves sound better than a bag full of micro chips!

**Incredible value at only £599.95\***

Try it for 30 days, refund if not delighted. Order now by phone or ask now for our free illustrated leaflet. Visit our website at: [www.iconaudio.co.uk](http://www.iconaudio.co.uk)  
 Find out what you're missing

**New, optional HT delay timer to protect the valves!**

Demonstrations by appointment. Export orders welcome  
 Phone 07787 158791. email [sales@iconaudio.co.uk](mailto:sales@iconaudio.co.uk)

**icon Audio** 351 Aylestone Road Leicester LE2 8TA  
 We accept Visa and MasterCard. CE certified

See us at the **Vintage Radio Fair NEC Sun 5th May**

**VISA** MasterCard

\*including UK delivery and 12 months guarantee including valves.

**VINYL**

For vinyl lovers, the basis for good sound has to be the support of the LP on the platter. Ringmat is the pre-eminent record mat for virtually all turntables, either the famous XLR at £50 or, even better, the new Anniversary at £70.

Further improvements can then be achieved by using;

- LP Blue Statmat and Statcap to remove static, at £45;
- Ringcap, at £15, to remove vibrations emanating from the centre of the record;
- Ringmat Spacers to remove resonance from your turntable and platter and to fine tune stylus rake angle/VTA.

All of these can be purchased separately or in one fell swoop as the Ringmat Support System, the best value for money upgrade possible for any turntable at £205. Without it, the stylus of your cartridge will never track properly.

**CD, SACD, DVD, CD-ROM**

For digital sources, the CDi Blue Statmat at £37.50 will totally transform playback, removing all that edginess and those other unwelcome features associated with using the silver disc. You will find a staggering increase in performance from the most modest to the most expensive players. Close to the very finest in analogue reproduction without quite surpassing it. Can also improve picture quality when used with DVD and similar equipment.

**PUTTING SOUND INTO FOCUS**

**UPGRADE NOW**

from this... to this

**RINGMAT**

**YOUR WHOLE SYSTEM**

All your components and speakers, even your TV, should be protected from static and other unwanted electronic fields by using a Statfoot underneath each one of them, from £12.50. Ringmat Feet and/or Ringmat Domes, our "soft feet" approach from £18.95, should also be used if you want the best sound (and picture) from your system. The icing on the cake is Ringmat Audiophile Cables. We researched these because no other cable provided the level of performance required to realize the potential of other Ringmat and Statmat products. Available shortly.

**UPGRADING**

If you have earlier Ringmat or Statmat products, these can be exchanged for the latest versions at a special upgrade price

**MONEY-BACK GUARANTEE**

All products purchased from us have a no-quibble money-back guarantee as well as help and advice in getting the best out of our products in your system.

**RINGMAT DEVELOPMENTS**  
 PO Box 200 Brentwood  
 Essex CM15 9FB GB

call 01277 200 210  
 visit [www.ringmat.com](http://www.ringmat.com)  
 or e-mail us at [enqhw@ringmat.com](mailto:enqhw@ringmat.com)

# RETRO GRADE



The phrase 'traditional values in a modern setting' best describes AMC's remarkable CVT3030 valve amplifier, says David Price.

It's surprising that AMC should go the way of the dodo. Their £750 CVT3030 integrated valve amplifier was a cracking product, one that deserved to succeed more than most. The truth is that its concept was probably just a little too ahead of its time.

If NAD had ever made a tube amp, then this would have been it. Designed by Peter Bath (who worked for Dolby, AR and indeed NAD), and manufactured by IEEE in Taipei (makers of Cambridge Audio, Luxman, Proton and indeed NAD products), it shared considerable DNA with the ubiquitous 3020. While the technical design was different, the concept was remarkably similar - an innovative, beautifully built, plainly styled, no-nonsense integrated amplifier with focus very much on sonics. This time though, valves were used to deliver the sonic goods.

In 1992 tubes were about as trendy as 1970s fashion. Despite the efforts of - among others - this magazine, the joys of the thermionic valve weren't as universally recognised back then as now. Many were mystified then when the CVT3030 appeared on the scene. It looked like a transistor amplifier, worked like a transistor amplifier (in terms of its reliability, low noise and user-friendliness) but certainly didn't sound like

one!

Its construction was a sublime mix of the old and the new. The boxy, dark grey 430x115x285mm case housed a sturdy metal chassis, explaining its considerable 12kg weight. Beautifully laid out inside, it featured separate pre and power amp sections. The latter was split into discrete left and right sides, each running two fixed bias EL34s complete with their own thermostatically controlled silent running cooling fans, plus seven high voltage MOSFETs. Each output transformer was a large, generously specified affair with both 4 and 8ohm taps, while extensive attention was given to power supplies.

Despite its sparse aesthetics, the AMC was as generously specified as many early nineties midi systems. A phono stage was provided (and very good it was too), along with inputs for Phono, Tape, DAT, CD, Tuner, Video and Aux. A switchable Tape Monitor, Source Direct switch, headphone socket and even Bass and Treble controls were provided. Round the back, there was no less than three high quality gold plated speaker binding posts per channel.

The result was a convincing musical performer which sounded quite unlike any of its price rivals. Its warm, big hearted nature made the

most of music from any source. Bass is strong (if a little loose) with a very fluid and supple feel, midband lacks the clarity of its transistor rivals, but is very smooth and even handed without the slightest hint of an edge. Treble is sweet and silky, but still spacious and detailed. The result is an amplifier which drives most modern loudspeakers as effortlessly as any solid-stater, yet invests the music with a delightfully natural, organic sound.

Of course, the AMC's sonics weren't perfect. Although nowhere near as coloured as the Quad IIs or Leak TL12s of yore, it certainly isn't as neutral as its (then) contemporary rivals like Cyrus's 3/PSX-R or Exposure's XX. Dyed-in-the-grain tube aficionados won't like it either, because it lacks the languid, rose tinted presentation of the likes of Leak's Stereo 20. In truth, it should be judged as an attempt to bring some of the musicality of valves together with the user-friendliness of solid-state - and on those terms at least, it succeeds admirably. Although something rare these days, there are more CVT3030s around than you'd think. Look hard and you can pick one up for as little as £250, although you should expect to add another £100 to that for a mint, boxed example. Even at this price though, you've got yourself a timeless bargain. ■ ▲

# UK SUBSCRIPTION £27

VISIT OUR WEBSITE: [www.hi-fiworld.co.uk](http://www.hi-fiworld.co.uk)



**Get your issue of hi-fi world straight to your door!**

**Get to our amazing classified ads first and grab a bargain!!**

- > **Run by dedicated hi-fi engineers and enthusiasts.**
- > **Hi-Fi World has become famous for its informative reviews and radical kit designs.**

**Credit Card Hotline**  
**+44 01923 270 833**  
 Monday - Friday 9.30am - 12.00 noon: Fax +44 01923 260 588

## MISSED AN ISSUE?

Back issues also available at a cost of £3.50 only (includes P&P), payment by cheque only - **overseas** please contact subscriptions department for details.  
 Send cheque to: Hi-Fi World, Freepost LON3478, London, NW6 6YR.

**YES!** I want to subscribe to Hi-Fi World for:-

£27.00 for 12 months

Your Details

Title \_\_\_\_\_ Initial \_\_\_\_\_ Surname \_\_\_\_\_

Address \_\_\_\_\_  
 \_\_\_\_\_

Post Code \_\_\_\_\_

Daytime Tel: \_\_\_\_\_

Start Issue \_\_\_\_\_

Delivery Address (if different) \_\_\_\_\_  
 \_\_\_\_\_  
 \_\_\_\_\_  
 \_\_\_\_\_

I would like to pay by cheque made payable to Audio Publishing Ltd.

Please debit my VISA  MASTER  SWITCH  AMEX

Switch card issue No   Expiry Date: \_\_\_\_\_/\_\_\_\_\_/\_\_\_\_\_

Cardholder Signature: \_\_\_\_\_



**Please choose service:-**

- Airmail**  
Middle East & South-East Asia **£60**
- Airmail**  
Europe **£50**
- Airmail**  
USA, Canada, Australia, Japan, Korea & China **£70**
- Surface Mail** **£40**

**Send this form to:**  
 Hi-Fi World, Freepost LON3478,  
 London, NW6 6YR

# A HEAD OF THE GAME

A decent headphone amp is just the thing when the rest of the family are settling down for Eastenders and all you want is audiophile entertainment. Simon Pope tests two top spec models. . .



**SUGDEN HEADMASTER £599**

them! You'll also be reaching for the majority of your record collection as the sound is so easy going that listening to your favourite tunes is never a

chore or a bore. Main traits are smoothness, fullness and richness of sound married with a good sense of detail. It's a presentation you can enjoy even for prolonged listening. Add to this the fact that it also doubles as a damn fine line preamp which will pair up even with the company's top spec Masterclass power amps and you have a bit of an audiophile bargain. An unusual and highly recommended bit of kit.

Audio Synergy  
Tel: 01924 404088

## CREEK OBH-11SE £230



The OBH-11SE is the more expensive of the two identical looking headphone amps in the OBH range and consequently has the higher specification and better quality components. It's a simple design and far more of an accessory

and less of a full scale product than the Sugden Headmaster. Don't let this sway your opinion, however, as this is a very finely crafted bit of gear; what's important here is what goes on in the inside. The OBH-11SE is a 'Class A' amplifier with zero feedback which, unlike the 'ordinary' version can drive two pairs of headphones at the same time. Compatible with any source at line level, the 11SE has just a single input and output and is powered by Creek's very fine separate OBH-1 or OBH-2 DC power supplies. When both headphone sockets are used, the output from each socket is identical; if only one pair of headphones is being used then the impedance on each socket differs to give a better match with the choice of 'phones.

Sound wise, the 11SE is very good. With an excellent SACD hybrid disc of Sicilian Medieval songs on the Fone label there was good ambience and space and a high level of detail. Beyerdynamic and Sennheisers headphones provided fuller and rounder results than the Jecklins (from both headphone sockets), giving an enjoyable and involving listen. Intricacies such as bowing in chamber music were highlighted well and vocals had a natural and realistic presence bereft of any synthesis. More expensive headphone amps bring a touch more smoothness and subtlety but this is definitely one to consider carefully at the price and another little gem from the house of Creek! ■▲

Creek Audio  
Tel: 020 8361 4133  
[www.creekaudio.co.uk](http://www.creekaudio.co.uk)

From the stalwarts of traditional high-end British hi-fi - a company that never pampers to whims or fads - comes one of the quirkiest little bits of kit on the market, with a witty name to boot! The Class A Headmaster is a headphone amp that also doubles as a basic but high quality preamp with three line inputs. Its style follows that of the new Sugden Bijou/Master Reference 'midi' size items, but with a different finish. The look is pure high-end, with a fantastic finish and high quality matching machined knobs. The fascia is simply furnished with a selector knob, volume control and a single socket for headphones, but a handy remote control for volume is also supplied, for those wish to stretch their headphone wire across the room!

As both a headphone amp and indeed a simple powered preamp, the Headmaster has all the properties Sugden are famous for. Namely fluid and lyrical musicality and depth of sound. You'll get no hi-tech detail or over intricate sterility but a somewhat dry (in the best possible way) and organic sound that will have you reaching for the Jecklin Floats and not caring how daft you look in

Audiophiles have been waiting a long time for the promises of a new super CD format to come true. Now things are starting to happen...

**SACD** =

*The real dawn?*

After some false dawns we believe SACD is emerging as the new audiophile music format because:

- a new high speed **INTERFACE** (IEEE1394) has been agreed for separate transports and DACs
- several major **RECORD LABELS** are committing to SACD with many new releases promised
- difficulties continue with a reliable **COPY PROTECTION** code for DVD-A.

SACD/CD transports will now appear, eg the **dCS VERDI**, able to play both formats at high quality. Some of the early one-box SACD players were compromised on CD.

We believe record companies are keen to back SACD because it is secure and cannot be copied.

**DELIUS** and **ELGAR** DACs from dCS are ready now to decode SACD/DSD input. It is even possible to convert CD to DSD or to **UPSAMPLE** the signal with the **PURCELL** for near-SACD results.

It will be some years before there is a full library of SACD recordings, but **UPSAMPLING** CDs will still bring a new lease of life to those discs.

Dual layer SACD/CD discs offer an alternative transition.

Read more about this new format on [www.superaudio-CD.com](http://www.superaudio-CD.com)

Customers say we make some of the **BEST SOUNDS** they have ever heard, so you know we can do the same in your home. Our advice will take account of your best components and guide you where change is needed, in stages you can afford.

You **AVOID EXPENSIVE MISTAKES**, enjoy music along the way and save money in the long run.

**JUST LISTEN AND YOU'LL KNOW**

The  
Right  
Note  
*Music with a Difference*



01225 874728

**CD:** ACCUPHASE, ADVANTAGE, AUDIO SYNTHESIS, BAT, dCS (ELGAR, DELIUS PURCELL, GRIEG, VERDI) MERACUS, PASS, SAT, SUGDEN, WADIA. **VINYL:** BASIS, CLEARAUDIO, CROWN JEWEL, DNM, GRAHAM, THE GROOVE, LEHMANN, MICHELL, SUMIKO BLUE POINT SPECIAL, TRANSFIGURATION. **AMPLIFIERS:** ACCUPHASE, ADVANTAGE, BALANCED AUDIO TECHNOLOGY, CAT, DNM, GAMUT, HOVLAND, NAGRA, PASS, SONNETEER, SUGDEN. **LOUDSPEAKERS:** AUDIO PHYSIC, BKS, ETHOS, NEAT, TOTEM, VERITY AUDIO. **TUNERS:** ACCUPHASE, MAGNUM DYNALAB. **CABLES:** ARGENTO, CHORD Co., DNM, HOVLAND, NORDOST, SILTECH, YAMAMURA CHURCHILL ETC. **SUPPORTS:** STANDS UNIQUE, VERTEX AQ, VIBRAPLANE

 **SOUNDS**   
**PERFECTION**



**SPECIALIST IN ANALOGUE AND DIGITAL  
WE STOCK**

J.M.LABS \* LEXICON \* PARASOUND PRIMARE \* PROJECT \* TRIANGLE  
REL SUBWOOFERS \* VIENNA ACOUSTICS AVID \* PROJECT \* SME \*  
ROKSAN \* STRAIGHT WIRE \* MICHELL ACOUSTIC DESIGN \*  
AUDIONOTE \* MONITOR AUDIO \* BOSTON \* SUGDEN  
AUDIO ANALOGUE \* GRAFF \* PHILOSOPHY CABLES

**PLUS MANY OTHER TOP BRANDS  
NORDOST VALHALLA CABLES**

SUGDEN MASTERCLASS POWER AMP BOXED MINT	£1795
LINN LP12 / EKOS / TROIKA / LINGO / CYRCUS MINT NO BOX	£1495
PARASOUND DAC 2000 (JOHN CURL SPECIAL) ONLY	£995
VIENNA ACOUSTIC MOZART SPKS ROSENUIT BOXED	£1095
AUDIONOTE P1 SE POWER AMP BOXED	£695
PRIMARE A30.5 AMPLIFIER BOXED NEW	£1495
AUDIONOTE OTO SE LINE, WITH BORDER PATROL PSU	£1195
TRIANGLE ZEPHYRS XS BOXED SLIGHT MARK	£425
VIENNA ACOUSTICS HADYNS BOXED MINT	£475
PRIMARE A 20 AMP BOXED MINT	£395
PARASOUND CD-P 1000 CD PLAYER	£249
ARCAYDIS BABY 2 NEW BOXED £400 NOW ONLY	£295
AUDIONOTE AN/J SPX BLACK EX CON. NOT BOXED HENCE	£775
ELEMENTAL AUDIO REF SPEAKER STANDS BARGIN AT	£795
MERIDIAN M60C ACTIVE CENTRE SPEAKER BOXED	£795
PRIMARE D30.2 CD PLAYER MK 1 BOXED	£875
QUAD II SE MONO BLOCKS RARE CHROME MINT UNITS	£775
MERIDIAN 555 POWER AMPLIFIER	£495
AUDIONOTE AZ 3 SPEAKERS ROSENUIT, MARKED HENCE	£475
NAKAMICHI CD 1 CASSETTE DECK MINT ONLY	£425
TRIANGLE COMETE XS BOXED DEMO ALMOST NEW	£335
MANA 2 TIER STAND PLUS T/TABLE SUPPORT ONLY	£249
NAD 804 SPEAKERS BOXED EX COND	£225
ARISTON RD 80 TURNTABLE EX COND BOXED	£195
ARCAM ALPHA CD PLAYER BOXED EX COND	£175
LEXICON MC 1 PROCESSOR NEW BOXED	£3995
ATC SIA 2 150 INTEGRATED AMP MINT BOXED	£1595
BOSTON ACOUSTIC 10X SATS SET OF 4 MINT BOXED	£795
AUDIONOTE CD 3 PLAYER BOXED	£775
AUDIONOTE ZERO PRE & MONOBLOCKS MINT BOX	£795
ALCHEMIST 2 24BIT CD PLAYER BOXED	£595

**FOR FRIENDLY SERVICE CALL NIGEL**

01326 221372

**MOBILE:- 07798 554357**

**Email :- [nigel@soundsperfection.co.uk](mailto:nigel@soundsperfection.co.uk)**

[kathryn@soundsperfection.co.uk](mailto:kathryn@soundsperfection.co.uk)

**Web :- [www.soundsperfection.co.uk](http://www.soundsperfection.co.uk)**



# ALL TOGETHER NOW

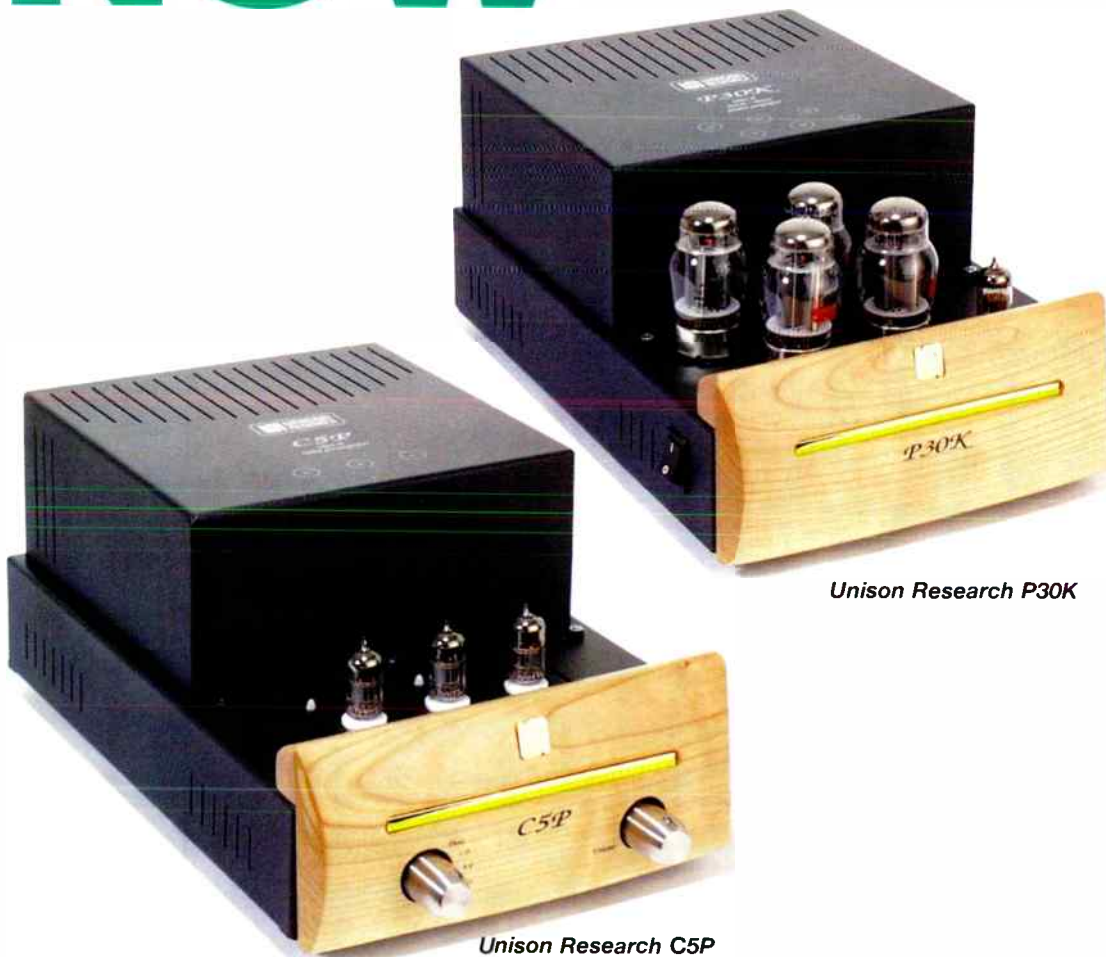

*Unison Research P30K*

*Unison Research C5P*

Unison Research have a knack of producing eye catching valve amplifiers with a nod to modern style and old technology. Their latest pre and power amps come under our microscope. Simon Pope reports.

There are two schools of thought when it comes to amplification. Most prefer the drive, clout and trouble free practicality of solid-state. On the other side of the fence sit a small but ardent group that swear by the thermionic valve. The traditional valve sound is one of warmth and richness coupled with midrange transparency and musical insight.

Those who sit on the fence either plump for a Mosfet design or a valve/solid state hybrid, hoping for the best of both worlds, sometimes getting the worst.

The complications that come with valve amps such as tube wear and excessive heat are simply too much for some, who wish for a more hassle free option. But it needn't be so bad.

Valve amps can be made that are user friendly, aesthetically attractive and able to bridge the gap between solid-state and esoteric tube designs. One company that takes this design approach is the Italian stable of Unison Research, famous for their lavish use of wood. These new tube amps from the company represent the top end of the scale as tube amps go, because

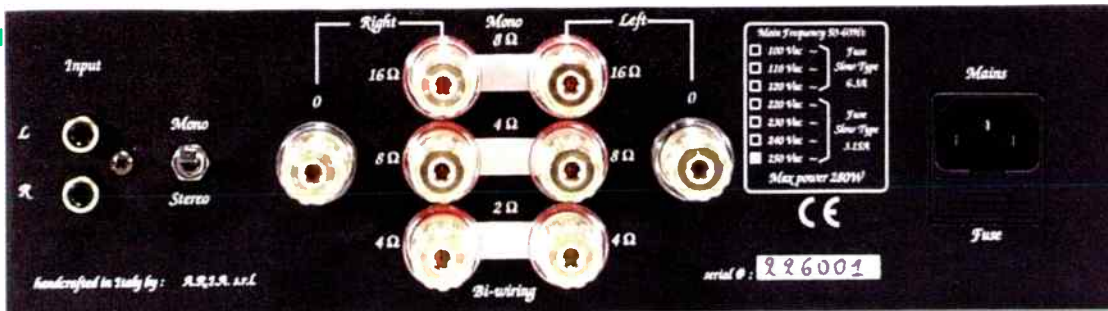

**The P30K has taps for 2-16ohms for accomodating a variety of speakers**

they are single-ended and pure Class A as a result. You can't get more pure than that. Yet their design and technology comes with a relatively humble price tag - one that's at least a half that of other similar valve designs.

The preamplifier half of the combination is the new CSP all-valve design, featuring four line inputs plus an all valve MM/MC switchable phono stage. The circuit board has been designed to keep intrusions to the signal path down to a minimum and special attention has been paid to layout, to minimise capacitance.

The phono stage employs three twin-triode valves in a pure Class A design and the phono board is mounted in the top section of the chassis, on rubber suspension to reduce microphony. The amplifier is finished with typical Italian flare and a fine eye for cosmetic detail. The usual hardwood Unison front panel is there, this time with a striking row of linked green LEDs. Attractive machined stainless steel input and volume knobs and the company's trademark radiowave remote volume control is included for those who wish to raise or lower the volume whilst rummaging in the garage.

The matching P30K power amplifier was designed to deliver the

highest possible output whilst retaining the openness and transparency of a pure Class A parallel single-ended (PSE) design. The P30K power amp uses KT88 valves in the output stage (accompanied by two twin-triode ECC883s) to deliver a quoted 30W of power. When used as a monoblock this can be doubled to 60W with the quick flip of a switch found on the rear panel. It's an extra touch of versatility.

Also at the rear are a selection of high quality 'speaker connections with taps on each channel ranging from 2-16ohms for detailed matching of all types of loudspeakers, including those with difficult impedance characteristics.

In keeping with a single ended design, the power supply and output transformers are key elements. Both of these are designed and, as always with the company, made in-house after "pain staking" research and development. It's an ideal amp for Bulgarian weight lifters, being built like the proverbial brick outhouse and weighing in at a not insubstantial 25kilos.

To assess sound quality I linked the amps to a pair of highly sensitive Living Voice Avatars. For a more difficult load I also used Jamo's Concert 8s (now D80!). Source

material was courtesy of Meridian (206.24 CD player) and a Michell Gyro SE with RB300 with an Ortofon Kontrapunkt A moving coil cartridge.

Parallel single-ended amps bring out the best and worst in people. Some revel in their transparency and detail whilst others find the sound a little too fey and lacking in breadth. However, the first thing that struck me, sound wise, was the beefiness of bass and rhythmic grip - generally not characteristics of the breed. Here was a PSE design that also had bass extension - a veritable middle finger to all the cynics! Whilst not quite as tight as, say, a Krell monoblock the CSP/P30K combination still had plenty of life in the lower regions and never succumbed to flabbiness or sloth.

One thing to note, though, is that these amps do like a good recording. Ploughing through my collection of a few sonic nasties such as Dodgy's 'Greatest Hits' and Skunk Anansie's 'Weak' resulted in an overall 'squashing' of the sound as the amps highlighted the compressed nature of the recordings.

More refined fare, though, brought marvellously detailed yet powerful results. Paul Weller's ubiquitous but classic 'Stanley Road' CD saw the amps delivering a full

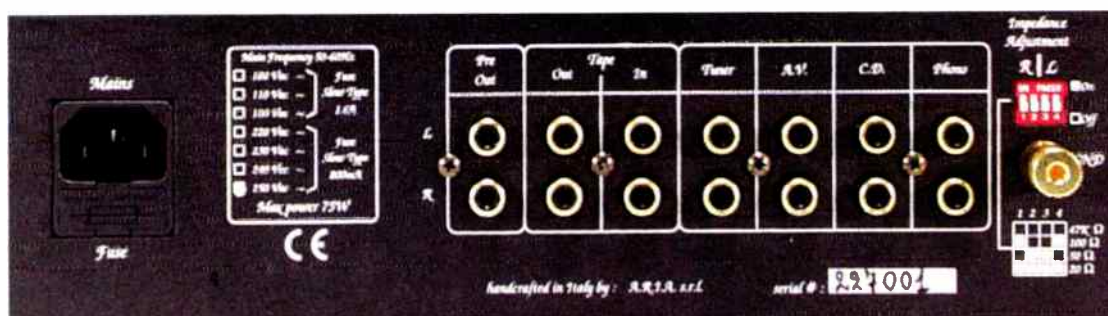

**C5P has a range of line inputs and an optional phono stage**

and involving sound with good emphasis on vocals and midrange guitar detail. There was also good drive and control to the sound, with the bass guitar and well utilised drum kit having a fine 'groove'.

The detail available was even more pronounced with Eric Bibb's 'Good Stuff' HDCD on Opus3 records. The simple yet natural nature of the recording saw the amps responding accordingly, with a pure sound - acoustic guitars and harmonica especially - having a genuinely 'see-through' quality.

Large scale classical works in the shape of Bruckner's ninth symphony on CD had breadth and depth with detailed and spacious woodwind and a good sense of scale. The only gripe here was a slight edge to the upper register of the violins when pushed but this is small fry when all is considered.

Another classical disc of Fauré and Ravel piano Trios (SACD hybrid on Hyperion) sounded effortless and typically 'acoustic' in a way that only

the valve can deliver. Those with a large vinyl LP collection will be glad to know that the C5P has as sweet a phono stage as you could wish for. Switchable on the back panel, it gave a natural and highly detailed response with all types of music, even making the best of bad recordings (making it not quite as fussy as the line inputs, strangely). A good phono stage is a blessing, but a good valve phono stage is simply mana from heaven, and the C5P has one!

OK, so this combination may not have the ultimate see through appeal of the very best PSEs in the business but these can cost the price of a new Mercedes. No other company I can think of offers quite the combination of valve amp sound and build quality as this. The Quad combination comes close, but is a push-pull design and the overall sound is somewhat softer around the edges with less bass extension and speed, for example. The Unison Research pair may at times sound a

little too pushed in the midrange with studio based recordings, with vocals a bit hard but this was more prominent with the harder sounding Jamos than with the Avatars.

The C5P and P30K are a fine buy and, all being relative, represent outstanding value for money, similar designs costing at least twice as much. Those looking to make the leap from transistor to valve and have three grand to blow should check these out first. . .

C5P preamplifier £1195  
(with phono £1350)

P30K power amplifier £1750

UKD  
23 Richings Way  
Iver  
Bucks  
SL0 9DA  
Tel: 01753 652669

MEASURED PERFORMANCE

The P30K is a Single-Ended design using two 6550 beam-tetrodes working in parallel on each channel. The 6550 is a rugged American power valve, upon which GEC based their later KT-88. The two are very similar. Unison Research coax no less than 28W out of this pairing, much more than SE's usually provide. At these power levels the transformers, which must carry a large magnetizing direct current, have to be huge to resist magnetic saturation. The transformers used in this amplifier worked well, tests showed, but the amp was barely liftable. Full power was delivered at 10kHz and 40Hz, the latter being particularly impressive.

Single-ended amps can be as smooth as silk, but they are also a bit limp sounding in real life, because most manage a meagre 3W-9W. This amp should be an interesting and entertaining improvement on the herd.

Distortion levels look high, measuring around 0.4% at 1W right across the audio band. However, it was all innocuous sounding second harmonic. SEs, by their very nature,

are pure Class A and do not have crossover distortion, so they measure and sound different. Unison have successfully capitalized upon this set of properties our tests show.

Bandwidth was wide, frequency response running from a low 4Hz to a high 60kHz, within 1dB limits. Where so many valve amplifiers roll down above 20kHz Unison get theirs up to 60kHz. Input sensitivity was high too, just 170mV giving full output (CD)

The disc stage was sensitive enough to take a high output moving coil cartridge, needing just 0.65mV for full output. This is enough for an Ortofon MC for example. Overload started gradually at 4mV. Since moving magnet cartridges actually rarely produce more than 5mV on peaks, for the most part this stage will seem fine for MM or MCs. It is however a bit hissy, with 0.91uV of input noise (IEC A wtd), something that would become apparent when low output cartridges are used.

This amplifier was very well engineered. It is difficult to get an SE to deliver a clean and neatly balanced set of measurements, as provided by

the P30K. **NK**

Power	29watts
CD/tuner/aux.	
Frequency response	4Hz-60kHz
Separation	86dB
Noise	-98dB
Distortion	0.4%
Sensitivity	mV
d.c. offset	1mV
Disc	
Frequency response	30Hz-40kHz
Separation	72dB
Noise	0.91uV
Distortion	0.4%
Sensitivity	0.65mV
Overload	5mV

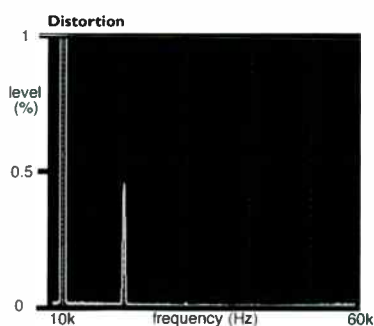

World Verdict

Fine sounding and classy looking valve combination with both refinement and power. Unusually deep bass for a parallel single ended.

# letters & e-mails

Visit our website at [www.hi-fiworld.co.uk](http://www.hi-fiworld.co.uk) or send your e-mails to [letters@hi-fiworld.co.uk](mailto:letters@hi-fiworld.co.uk)

Every letter we print wins a superb prize including Precious Metals interconnects and a **FREE** subscription to **Hi-Fi World** for the best letter of the month!!

## LETTER OF THE MONTH

### WALL OR NOTHING?

Dear Hi Fi World Thanks for a refreshingly bull\*\*\*t free magazine. You're

always reassuringly direct and honest and that's rare and extremely welcome in an otherwise cloudy hi-fi magazine market.

I've got a pretty cheap, but perfectly acceptable separates system running at the moment, which I'm looking to upgrade wholesale. I'm particularly keen on the Cyrus7/CD7 combo. The problem? At the moment the system is up the other end of a lengthy room, yards away from the only listening position and with speakers firing in the wrong direction. If I'm to spend a couple of grand on a new system and speakers I want to be able to sit in the thick of things. Why is that a problem? At the business end of my room (i.e. where the sofa is and, more importantly, the only place the sofa will fit), there is absolutely no floor-space left for floorstanders or stands - unless I sell the TV and fill in my nice open fire.

So to my question: is there a wall-

mounted solution to my problem? Are there any speakers (or sub-sat systems) out there capable of being wall-mounted that would do the Cyrus combo any justice at all? Budget for speakers: anything from £300 to £800. Again, thanks for a great mag.

Best regards

Tom Blakeson

You're not one to mince your words, are you Tom? Thanks anyway! As far as your query is concerned it brings up a number of interesting points. Firstly, most 'speakers that are put up on walls will sound OK as long as you're not a dedicated audiophile and merely want to have music filling your room. If you want to experience imaging, sound staging and all the rest of it and be really "in the thick of things", wall mounting may not be the answer. It's a matter of priorities. If you have to wall mount, pick up something like Wharfedale's Diamond 8.1s, which are as neutral sounding as you're going to get in a budget 'speaker, and front ported. Both of these factors will cut down on bass boom, which is the main problem of

wall mounting, especially with corner placement. Otherwise an infinite baffle (closed cabinet design) such as NHT's SuperOne could be equally well suited.

The best position on a wall is at 'stand height' where you'll benefit much more from imaging and staging than if mounted high up or, worse, in the corners.

As wall mounting isn't really the ideal option, don't shell out too much as the performance will be slightly compromised. Stick maybe to a £200 maximum - think of it thus: you wouldn't mix Coke with a malt whisky, would you?

There is one last option, that of the sub-woofer/satellite system. The best for you is perhaps Mission's fs2 system using NXT flat panels. Available in a stereo pair with matching (small) sub that can be chucked behind the sofa, these tiny panels give a good all-round sound and are designed for wall mounting. Being NXT there is no extreme directionality and the sound is better distributed through the listening room. **SP** ■

# ARCAM

Visit [www.arcam.co.uk](http://www.arcam.co.uk)

for Arcam news, product information, technical support and advice on how to get the best from your system

Arcam, Pembroke Avenue, Waterbeach, Cambridge, CB5 9PB, England  
Tel: +44 (0) 1223 203203 Fax: +44 (0) 1223 863384  
[support@arcam.co.uk](mailto:support@arcam.co.uk) [www.arcam.co.uk](http://www.arcam.co.uk)



**if you have to wall mount the Mission fs2 system could be the best option**

**FINAL VINYL?**

A while ago, I bought my first new set-up for many years. Being a novice, I went for a well-regarded same-brand system - the TEAC Reference 500 - comprising multi-play CD mini-disc unit, integrated amp/tuner and cassette deck. My primary reasons for selecting it were threefold - it sounded good in the demo room, the build quality seemed superior to similar offerings from Denon and Pioneer and it had a phono stage. The speakers are B&W DM602. The most important element - the turntable is a Dual CS505-4, thanks to the name, easy speed change and reasonable sound. However, having got used to a half-decent system, I now want to upgrade, starting with the turntable.

The TEAC still seems as good as new but I will want to change in due course, possibly to a Cyrus - I am not confident enough to mix brands - and space is an issue. The next turntable I want is to be my last (we all say that, don't we?) and I am prepared to spend up to a grand so that the turntable is ready for my next level system. Therefore, I don't want the TEAC to restrict turntable selection. I want to switch speeds without dismantling the unit, something with a footprint that does not exceed 45cm in width, for the turntable to look the part and something that will not be embarrassed by connection to a higher level system than the TEAC. I don't know whether to go for MM or MC and the implications for my amp? What are the pros and cons?

Also, should I buy new or second-hand? Can I use MM or MC with a

turntable or are they designed with one or the other in mind? If I go for a unit without a tonearm, am I okay with a standard mid-range such as the RB250/RB300? What are the issues surrounding power supply, separate motors and such like? What about classic units such as the Technics SL10? I have considered the Michell GyroDec SE, Project RPM4, Origin Live turntable kit, Thorens 166, Rega Planet, Pink Triangle Tarantella So, there you go - I am confused! Any advice would be appreciated for a less knowledgeable enthusiast.

**Many thanks,  
Dominic.**

Your shortlist is good, but I'd narrow it down to either the Michell or the Project RPM-9. Ultimately the Gyro is considerably more capable (and more upgradeable) than the RPM-9, but the latter is a great value package if you consider the deals available with Ortofon cartridges. Only you can choose between the two - I'd opt for the basic Michell with RB250 tonearm and a starter cartridge like the excellent (and oft overlooked AT110E). As you're a bit of a novice I'd rule out the OL deck, the Thorens is a fossil, and the PT is outclassed and badly built. However, you could always go for the £619 Rega P25, which would be a great improvement on the Dual (but not really up to Gyro standards). The main problem is that it isn't easily upgradeable, and you might find it wouldn't do well as a 'last' deck.

Turntables in this league will all work with MC cartridges, but some are better than others. Generally the Rega RB250 is the arm to have, especially with the Origin Live counterweight mod - it's a lot better than the Project arm, even in carbon-fibre RPM-9 guise. More important is your TEAC's phono stage - the amp itself is surprisingly good for its type, but the phono section is invariably a bit of an afterthought. My advice would be to buy a Creek OBH-8SE phono stage as soon as possible to use with the TEAC. This will stand you in good stead for future upgrades, too.

The new vs. second-hand dilemma is older than time itself, but generally it's far better to go for new (or nearly new) if it's turntables we're talking. They've come a long way in the past fifteen years, as many who migrated to CD in the eighties are surprised to find out! Much progress has been made in the area of power supplies (early nineties) and off-board motors (late nineties), and now it seems DC motors are in. A classic Technics SL10 (do you mean SP10?) is a beautiful thing to behold, but quite a way behind any Michell, high-end Project or Rega. Theoretically, independently sprung designs like the Gyro are superior to non-sprung decks like the Rega or Project, and the difference becomes more and more apparent the higher you go upmarket.

If possible, go for MC cartridges - the upside is that they tend to have a much more lively, musical and sophisticated sound, but you'll need a decent phono stage, which is easier said than done. A great compromise at your price level is Dynavector's £199 DV10X4, which is a high output MC offering (something of) the best of both worlds. **DP**

**DEM DIFFICULTIES**

Dear Mr Pope,  
Following on from Mr. Keating's letter on LP12 upgrades, I have been banging on about the difficulty of deciding on and auditioning turntable upgrades to anyone who will listen for some time. No one listens by the way, but I'm not bitter. I have had so much vague, conflicting advice I don't know where I am. In particular the question of power upgrades is a very expensive one. I have an LP12 Valhalla/Ittok/Audio Technica



A3 RANGE.  
MACHINED, MIL-SPEC ALUMINIUM  
FRONT PANEL.

TWENTY-FOUR CARAT GOLD  
PLATED FITTINGS.

REMOTE CONTROLLED.

PHONO STAGE.

POWERFUL, ROBUST, BUILT.

## MUSICAL FIDELITY

OC9 and I have worried over a Naim Armageddon or Origin Live DC motor. I am glad you suggest the latter. It was my view too, not least because it's less than half the price, but how could you ever compare them? I wondered about an Origin Live modded RB250 but was advised by a dealer that it did not give a good result on the LPI 2! What's a guy to think? My cartridge is a weakness and I thought of a Kontrapunkt B (I'm allowed to dream). Another dealer said Ortofon didn't sound musical on the Ittok and a Dynavector would sound better. I think I'll go back to my Dansette record player. You knew where you were with that!

**Best Wishes**

**Dr David Wise**

*P.S. In the unlikely event you print this, I'll try and get you a can of John Smith's*

Many thanks for your concern, Dr. Wise. I remember our meeting well - on the staircase between floors 2 and 3 if I'm not mistaken. Anyway, being a magazine editor is a tough job, but someone's got to do it, as they say! For your little turntable problems I'll pass you over to 'in house' turntable tweak expert, Mr. Price. My personal favourite tittle, incidentally, is a chilled glass of Tio Pepe before bed! **SP** ■

Why thank you, Mr. Pope! I take your point - it's nigh on impossible to hear every permutation of turntable 'tackle' these days, but I suspect I've heard more than many. I'd go for OL DC motor too, on account of its superior sound (to the Naim) and far lower price. I'd also go for the OL modded RB250 - I had a standard RB300 on my LPI 2 and it comfortably beat my Ittok in every respect except bass. In particular, the Rega's midrange detail and imaging was a revelation. With this in mind, the latest tweaked RB250 should be a tremendous improvement and will also match your AT better.

Ultimately though, I'd go for an Ortofon Kontrapunkt B or Lyra Lydian Beta as soon as possible - the OC9 has always been an overrated cartridge and isn't really up to the standards set by your deck. Dynavectors are superb, but the DV17/2 (which falls into this bracket) is less price-competitive than the company's cheaper fare. Another approach would be to get Linn's own

Ekos tonearm (which is still a superb arm and possibly even more musical than the OL RB250, if a little less tonally pure) with a starter cartridge like an Audio Technica AT110E, but that's probably taking the 'source-first' philosophy to extremes. So, can I claim a glass of Jacob's Creek Chardonnay? **DP** ■

**SPIN CITY**

*I have been pondering the next upgrade to my system, and have now narrowed it down to two items: a turntable and phonostage, or a new set of speakers. I have around £350-400 to spend. My system currently comprises an Alchemist Kraken MkII integrated, a Marantz CD48 and Eltax Symphony 6.2 speakers. The interconnects are QED and the speaker cable is Naim NACOS. Until recently, I was certain that I needed a new source for my system. However, my friend recently purchased Proac Super Tablettes for his system and the sound difference was incredible! I have an idea of the speakers I would like which come within my budget with ATC SCM7s (which I can get for £375 with a trade-in) being the best I've heard at the price. As for turntable and phono stage, a Systemdek II X and a Musical Fidelity X-LP would be the combination I would be most likely to buy.*

*I would appreciate it greatly if you could recommend any other speakers or turntables within my range. I listen to a wide range of music, so they must be good all-rounders. Detail, resolution and musicality are the main aspects I am looking for. Any help would be greatly appreciated!!*

**Thank you  
Nicolas Adie**

The most obvious option, it seems to me, to gain the best possible sound is to trade in those Eltax for another pair of transducers. If you're happy with the sound of the ATCs, then go for these; they're dry and a bit bass thin but very detailed. You'll certainly get a cleaner and more detailed presentation from these, as opposed to the Symphony 6.2s which will sound unfocused and wooly in comparison. Other options could be Mission's 780s at £300 which will have more warmth and space than the ATCs, or pushing the boat out to £500, there's Epos's excellent M12s, which have space, air and a good solid bass response.

After you've replaced the 'speakers you can then save up for your turntable. Perhaps your best bet would be to opt for Project's RPM4 - a stylish little spinner for £300 with a more than decent sound quality that makes it a true audiophile bargain. It's supplied with the reliable but not brilliant Ortofon 510 Mk2, which can either be changed for another option at a similar price or upgraded with trade-in at a later date. You could match this with Creek's OBH-8 (MM) or OBH-9 (MC) phono stages (£110 and £130 respectively), depending on final cartridge choice. If you want a cheaper phono stage option with the view to upgrade at a later date you could always consider the Project phono box which can take both MM and MC cartridges for a bargain £40. **SP** ■



*The RPM4 is a bit of a bargain!*

**REFERENCE NEEDED FOR SYSTEM CALMING!**

Firstly thanks for an excellent magazine. My system comprises an Arcam Delta 290 integrated and power amp, Delta 280 tuner and 100 cassette deck. CD replay is via a Linn Genki which has been a recent upgrade and has had me going through my CD collection listening with amazement.

Record playing is accomplished with a Thorens 160 with a Rega 300 arm and Goldring 1042 cartridge. I built my own plinth for the Thorens and have it sat on metal spikes which can be adjusted to get the deck exactly level. Sound quality does beat the Genki!

I am also very much into recording and have a Tascam DAT player (Da-Pi) hooked up to Tape 2. This replaced a Tandberg reel to reel which my wife never got on with. Being a guitar player I also have a Tascam porta studio hooked up to the aux. and am impressed at the quality that can be achieved from cassette running at double speed and going through a DBX noise processor.

Speakers for my main room are Ruark Talismans and on the two B

outputs of the amps I have Mission 70 speakers in the kitchen and conservatory.

I'll now get to the point of my letter. Even though I am very happy with the sound I feel the Talismans are a little too polite and am looking to upgrade them. What I have in mind is the Kef 1.2s which are a similar size and from your review will sound good in a small room (12 by 12). Do you think the rest of my system is good enough to warrant them? I don't want to change the amps as I need all the inputs and outputs. The only thing I'll probably upgrade is the Genki when DVD audio or SACD are finally settled. Your opinion will be greatly appreciated.

**Rich Willerton.**

Well, congratulations on a slightly bananas (in the nicest possible sense) system - a true Hi-Fi World set up! Not too sure about the double speed tape but each to their own. I used to own a couple of Revox reel-to-reels which, as much as I persuaded her that they were a style statement, my wife never got

on with either, so they no longer grace the front room (or any other room, for that matter).

To get to the point: yes. The KEFs are a very good buy and give a taste of high-end smoothness and detail in the old school mould. The latest Reference models now employ a "hyper tweeter" ready for DVD-A and SACD information. The 'old' models have just one Uni-Q driver. They offer a sweet and full sound that never grates and will give many hours of enjoyment. They do indeed work well in smaller rooms (as my 14ft x12ft room confirmed) and won't overwhelm in the bass department, but still have enough to impress.

As for the Genki - it's a fine little player for the money and you'll probably hang onto it a lot longer than you ever imagined as the real growth of the new formats is still a bit of a twinkle in the record company bosses eyes! **SP**

**HIGH RES RECORDING**

After six years I am assembling a new computer with the intention of using it

**definitive audio**

Living Voice • Lowther • Vitavox • Electrofluidics • Art Audio • Border Patrol Canary • DNM • Sugden • Wavac • Lyra • Monarchy • Western Electric • EMT Wadia • Michell • Stax • Tom Evans • Nott'm Analogue • SME • Van den Hul

**Part exchanged and ex-dem clearance.**

	Sale	New
<b>Digital</b>		
Sugden Masterclass CD - new - boxed.	£1800	£2500
Wadia 860x - ex dem - boxed.	£5200	£7950

<b>Analogue</b>		
Nottingham Analogue Spacedeck - *NEW*	£650	£750
Helius Cyalene	£350	£1350

<b>Loudspeakers</b>		
Linn Keilidh LS300 (passive) - Walnut	£400	£750
Goya "Perro enterrado en la arena"	barking	
Audio Note ANSP speaker cable - various lengths.	EPOA	

<b>Amplifiers</b>		
Border Patrol 300B SE - with new Western Electric valves - light oak - the best SE available - New - excess stock.	£4000	£4500
Art Audio VPS - valve line pre-amp.	£450	£1400
Art Audio Diavolo - with 320B valves - chrome + gold - line integrated - juicy. Go on, be a devil.	£2900	£4500
Art Audio Concerto - 40w line integrated - black + chrome. giveaways	£1250	£2650
Art Audio Concerto - 40w power amp.	£1150	£2250
Cary '2A3' - 7 watt PSE power amp. 1992	£850	-
Cary 5500 - line pre-amp. 1992	£490	-
Unison Mystery One pre-amp - it's a mystery	£750	£1750
Audio Innovations S. 500 integrated (+ phono) - 25w Class A	£550	-
Audio Innovations S. 700 line integrated - 25w class A	£650	-
Western Electric 300B Valves! New matched pairs in stock.	£600	

Tel 0115 973 3222 Fax 0115 973 3666  
internet: www.definitiveaudio.co.uk email: shout@definitiveaudio.co.uk

campaign audio design

Hi-Fi Cables Manufacturer and Supplier

**"Love Hertz"**



Getting a better, more involving sound often means spending a lot of hard earned money. It's such a waste, because every system can benefit from our cables and accessories, at a fraction of the cost of some new "black box". Here are some of the ways we can help.

We have Linear Crystal Oxygen Free Copper interconnects (£12.48) up to High Purity Silver balanced cables (£99.00) and high definition

loudspeaker cables in Silver Plated Copper or Pure Silver. Our mains cables add weight, power and scale, and with non-inductive RF filtering (£10.00) and over-voltage protection (£3.00) enhance performance still further. Gold plated AV cables, both RF (£19.95) and OFC Scart with PTFE insulation (£30.19), help bring picture quality in line with NICAM sound resolution.

We also have a cure for your noisy fridge or central heating motor (£3.50), enabling you to throw away your big mains noise suppressor, which has been giving you that "sat upon sound" for years. There's lots we can do to bring you closer to the emotion and energy of the performance. So confident are we, that we offer a 21 day money back guarantee.

Ring or write for details:-

**CAMPAIGN AUDIO DESIGN**  
Ty-Mawr Road (HW)  
Cardiff CF3 3BS  
Tel:- 02920 779401

Website: <http://business.virgin.net/cad.cables/>



Trade and International Enquiries Welcome.





for a wide range of audio options. However, I initially want to start archiving vinyl onto CD-ROM with the best possible sound. My card of choice until recently was the Guillemot Isis, with my main reservation being the lack of 96kHz, 20+ bit recording capability. However, just released with 24/96 capability are both Creative's new Extigy card and the TerraTec EWS96M. Presumably after over two years, Guillemot also has a 24/96 successor waiting in the wings? So who offers the best ADC for under £250? I will have to decide in the next month or two, and no doubt live with the result for sometime.

By the way, I'm glad the cactus damping was a spoof, as some of the larger *Echinocactus grusonii* and relatives in the photo must be over 20 years old. If you really want to use cacti for damping, place many large cacti around the room and in corners. They come in columnar and spherical models for this purpose, the more spines the better. Unfortunately you need to return them to proper growing conditions fairly promptly, or your dampers will up and die! Is DP's Cactus Damping truly 'organic'? I suppose it would be, if doused with organic fertiliser (i.e. bull s\*\*\*)!  
**Richard**

Cactus Damping is the way forward, a credo, a design for life, a call to arms for audiophiles everywhere. As you yourself say, they make great diffusers. Got a standing wave problem or an unwanted resonant mode - then get a cactus!

Now to the less rarefied climes of computer audio. Right now the answer for you is the aforementioned TerraTec. The Creative is a great package, but not as good for serious transcription use. The problem is that if you buy anything now you're shutting yourself off to a number of forthcoming 24/96 cards and converters which are currently in the pipeline - wait till Christmas and you'll get a far better choice. Watch this space! **DP**

## ▶▶ IMAGE CONSCIOUS

I am a Brit living in Belgium and am currently planning to replace my hi-fi system. I do not have the possibility to audition widely as the opportunities here in Belgium appear to be very much more limited than in the UK, so

some astute pre-selection is called for. My tastes in music are almost exclusively in the classical and jazz fields. I do not need an all singing, all dancing feature-laden set up, but rather a minimalist system that brings out the best in my CDs.

After much thought and comparison (so far limited to price and reviews), I am persuaded that I should really give Audio Analogue a listen. My preference would be for the following components: Audio Analogue Paganini CD/Bellini pre-amp/Donizetti power amp. Because of the severe limits on speaker placement I need speakers that can handle corner placement. I have read good reports of the Audio Note AZ Threes which are designed with corner placement in mind. However, they are not the most discrete of speakers (large and less than pretty!). My other consideration is a pair of Mission 782s. Provided they were placed a little out from the corner with the bass speaker directed inward (to avoid boom from the side wall) do you think these speakers would be able to handle corner placement? Just as importantly, which of these speakers in your view would more happily respond to the Audio Analogue set up? I look forward to hearing from you.  
**Reg Green**

I can almost answer this in real time, Reg. I've just nipped downstairs and fixed up my 782s with Audio Analogue amplification. This was just to refresh my mind as I once used the 782s with a Puccini SE as a mid price reference and found it to be a great match, with fine imaging and great insight into recordings. And so it remains. The other problem with the corners can be sorted by a little moving and tweaking. I find that the 782s will work in corners OK, even in my boomy room with wooden floorboards with at least 3" of empty space under them. They even work very well (unlike many other brands) firing straight down the room (ie. without any 'toe-in') and you'll lose no imaging properties due to the company's inherent mastery in this field.

If you're worried about bass boom, placed with the side firing bass units facing inward, you get a tighter bass sound, and that pristine imaging is highlighted further. The Audio Notes are by no means bad

(aesthetic point, taken) but work better when matched to Audio Note valve equipment. They bring out the natural vibrancy in the design which would be somewhat lost with the solid-state Audio Analogue amps. Hopefully you'll find this a combination that will sound equally as good the morning after a session on the Trappist beers! **SP**

## ▶▶ POWER PLAY

I'm thinking of upgrading the Basik power supply on my LP12 to either the Naim Armageddon or the Lingo. What sort of benefits might I expect? Will I think "wow" when I listen or will it be more subtle? Which one should I go for? This will be fed to a Naim 72/Hi-cap/180 to Shahinian superElf speakers. Might my money be better spent saving up for a new arm such as the ARO? I also have a Naim CD3.  
**Bruce Rhodes**

**Durban**  
**South Africa**

This is a great question, Bruce - on a philosophical level if nothing else! Assuming you've got an Akito on the Linn, you'll get a big improvement going to the superb ARO. Likewise, an Armageddon or Lingo PSU will transform your sound, but in a very different way. First the arm - the ARO will give you a far more musically cohesive performance. You won't find massive gains at the frequency extremes (especially with a unipivot), but you'll find the LP12 suddenly 'gels' and 'coheres' and finds its true purpose in life, which is as we all know, to make sweet music.

The PSU mod (I'd go for the Lingo, or if you're DIY minded the OL DC motor) will bring real firmness and confidence to the sound. You'll find tighter, stronger bass, better stereo imaging and depth perspectives, less mush, more midband clarity and crisper treble. In a sense, the arm can't do its proper job without the PSU, and vice versa, so specifying a preference is like comparing your eyes with your ears - both ultimately come in rather handy. Follow Ivor Tiefenbrun's much vaunted 'source first' credo and get the basics sorted ('scuse the pun) by starting with the power supply change. **DP**

# SPACE

The m51 heralds the start of Mission's new, sci-fi styled m5 series. Simon Pope auditions the baby of the range.



In the autumn of last year a press release was issued on behalf of Mission inviting audio scribes to the launch of their latest product in a posh (not to mention very expensive) London hotel. You can guess what the new product was - a stylish and very, very expensive new loudspeaker.

Some hacks were surprised, not to say shocked, that a company who are undoubtedly one of the most consistently impressive budget/midrange manufacturers should release the £20,000 Pilastro. It's as fine a high-end loudspeaker as you'll get, with a striking appearance that's both modern yet beyond fad. The Pilastro has been a great success, silencing the sceptics. There are plenty of rich people there are out there it seems!

It was inevitable that the influence of the Pilastro would filter down to Mission's new designs. The new replacement range for the classic 75 series, the m5 series, bears more than a striking resemblance to the Pilastro in terms of styling. Like the 78 series, the range will comprise three models - two sizes of floorstanders and a standmount (featured here), plus the ubiquitous centre 'speaker and subwoofer.

In the entry level m51 we have, for a £300 standmount, a pretty hefty customer with a deep cabinet and a nice ergonomic look, the rounded corners and edges offering more than

just a passing resemblance to the Pilastro. Mission's fourth generation Transverse Folded Cabinet Technology (TFCT) is employed in the m51, giving a solid cabinet with a 38mm thick front baffle and a 25mm MDF cabinet with real wood veneer.

The m51 makes use of a newly designed drive unit. Its bass/mid unit is a 150mm 'Paramid' driver, chosen for its midrange clarity and bass quality. Whilst the 78 series uses a Keraform 'porcelain' drive unit, the m51 employs a cone formed from a sandwich of Aramid fibres fitted with a highly pliant nitrile rubber surround, for superb bass response.

The 25mm microfibre dome tweeter found in the m7 range is unique to Mission and is mounted inside its distinctive silver moulded front plate. As is usual with all Mission 'full range' products, the drivers are configured in house style Inverted Drive Unit geometry where the treble unit sits below the bass/mid in direct opposition to the norm.

This has worked well in the past, providing good integration and balance. The silver moulded front panel continues the rounded theme, profiled edges used to ensure minimum interference from

diffraction effects. At the rear there is a sizeable anti-turbulence port and two pairs of connectors for single or bi-wiring. Inside the box, audiophile grade high power silicon steel inductors and polypropylene capacitors are used in the crossover.

The main sonic criteria for the M51 was for it to produce a sound that excels in both midrange and bass, delivering the kind of bass you'd normally expect from a floorstander. To see if it met these criteria I used a Cyrus 7 integrated and our own KIT6550 40W valve amp with NAD's top range Silverline CD player.

As far as immediate impressions were concerned the 51s gave a good, full sound with the trademark excellent Mission imaging in full operation. With Goldie's Saturn Returns CD, I gave the Missions a chance to see what they could do with some seriously low and powerful bass. To be truthful, at first there wasn't an awesome amount of depth, but what was there was fast and tight and after all, quality is always preferable to width (or rather, depth)! Moving the 'speakers slightly closer to the rear wall, within a foot, brought a more rounded response to the bass but the dexterity was still there, a very fine trait in a budget/midrange 'speaker.

Playing through a selection of my usual review discs highlighted the fact

# MISSION

that the Missions were a bit fussy when it comes to recordings. In this respect they are a true audiophile 'speaker. The well-produced Goldie disc had plenty of presence and breadth but the more 'compressed' music became, such as with modern 'indie' type rock recordings, the more the 51s tended to shout and spit out the notes, which was more pronounced than the difference found in the similarly priced stablemate, the 780.

The 'speakers midrange, which was nice and open with good recordings, became a trifle too hard with such fare. However, get a good acoustic or even electronic recording such as the Fone SACD sampler or Orbital's 'In Sides' and the m51s will really sing, loosening up in all the right ways.

Treble was smooth and well detailed and there was a very immediate sense of timing to the sound, which although fast, isn't too forward. With the Orbital disc nice

nuances in the upper frequencies were highlighted and the overall wide frequency range of the music was well displayed - no mean feat from a £300 standmount.

The classical Fone disc showed that no matter what the style or genre, if the source is good then the 51s will perform to the best of their ability. Although perhaps a little too dry with this type of ambient recording, the Mission's nevertheless showed that when it comes to presence they have it in abundance. Instrumental timbre wasn't bad here and vocals were pleasantly natural, whilst earlier in a Soundgarden rock CD, they sounded synthetic and pushed.

Overall, the new m51s are a fine addition to the current crop of midrange/entry level standmounts, in which there are many strong contenders. There's a problem with the in-house competition of the 780s, which are a fine 'speaker in their own right. They offer slightly less

coloration and a little more detail. However, they don't have the speed and depth of bass of the 51s - the choice is yours here.

One other thing to note is that the 51s only perform to the best of their ability with good equipment, recordings and even stands, so they are fussy. Any hard sounding source or disc will be accentuated. That said, if you're listening area is small to medium and you want a 'speaker that delivers a room filling and balanced sound, they are well worth an audition. Mission know what they are doing when it comes to 'speaker design and it shows. ■ ▲

Mission m51 £300

Symphonix Ltd.  
Stonehill  
Huntingdon  
Cambs PE29 6EY  
Tel: 01480 451777  
www.mission.co.uk

## MEASURED PERFORMANCE

Mission like their 'speakers to sound clean and fast (like ATC in this issue). They tend to response-tailor so that the top end is a little prominent, making for a detailed but bright sound.

The new m51 sits very much in this mould. Not only does it have absolutely no sign of a crossover suckout, but it also has slightly rising treble. The tweeter's output is very smooth, suggesting it will be colouration free and quite amenable to listen to. Cymbals are likely to come across strongly though and violins may well seem prominent in contrast to the norm. However, the m51 is fundamentally an accurate loudspeaker, staying within about 1dB of perfect response flatness - quite an achievement.

There's some sign of an internal rear wall box reflection around

500Hz that may be heard as a "whoomph" or a little boxy colouration. Otherwise, response runs flat down to 63Hz before rolling off. Below this the port, tuned to 48Hz, works to carry output down to about 25Hz. It has a broad flat output, suggesting it applies good acoustic damping. The impedance curve suggests likewise.

At 85dB, sensitivity wasn't high considering the impedance of the 'speaker is low at 5.3ohms. As usual it uses a 4ohm bass unit to keep voltage sensitivity up, but this means it demands quite a lot of current from an amplifier. It should, ideally, be used with a beefy amplifier.

The m51 will sound clean and fast. It will certainly have the characteristic Mission sound and should be fine for

Rock in particular. As always with Mission, it is very well engineered.

NK

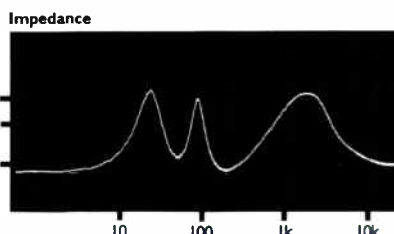
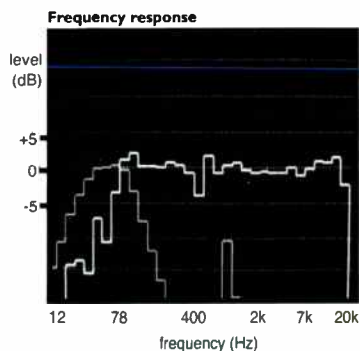

## World Verdict



The m51s are very well engineered and have a taut and tuneful bass rarely found at this price point. Can sound hard when ill matched and fed bad recordings, though.

# NEW ADVENT



Bewitched, bothered and bewildered? David Price cuts through the techbabble and tells the story of multi-channel audio, and details the latest 'high resolution' surround sound formats.

▶ **T**he words 'home cinema' still send shivers down the spines of many self-respecting audiophiles. After all, big black boxes packed to the gunwales with digital signal processing trickery, serious graphic equalisers and just about every flavour-of-the-month gimmick are hardly the stuff of dyed-in-the-grain audiophile systems, are they? True enough, but don't use this as a reason to dismiss multi-channel audio out of hand.

Stereo, lest we forget, is just one particular take on the problem of recreating a recorded acoustic in the home. Ever since a squeak came out of the very first loudspeaker, audio engineers have been scratching their heads over this, and have come up with a variety of solutions. Of course, the film industry has driven most of the development of multi-channel - as far back as the 1940s, Walt Disney used 'Fantasound' surround sound technology to heighten the

experience of his animations - but don't let that put you off. Creating a believable acoustic is just as important in the home!

## BACK TO BASICS - THE EARLY DAYS OF ANALOGUE MULTI-CHANNEL

### MONO

Hard as it is to imagine today, mono is what most audiophiles used until the sixties, and it was capable of incredible musicality when 'done properly'. Monophonic sound is single-channel, unidirectional reproduction using one amplifier and speaker combination. It has an abiding virtue - wherever you are in the listening room, you hear everything identically (room acoustics notwithstanding, obviously). Everything appears from a single 'point' in space and - fascinatingly - even if you use two mono channels, the sound still seems to come from a point

equidistant between the two speakers, creating a 'phantom' channel.

### STEREO

This was experimented with in various forms for many years before it made it into the home in 1958. Bell Laboratories' system used three channels, whereas the film industry used between four and as many as seven channels in early cinema installations. Two channel stereo in the home came about simply because it was all that LP records could realistically cope with. Then two channel stereo FM broadcasting arrived, further popularising the format and entrenching the idea that 'two channel' was 'stereo'. Now an entire generation of audiophiles has accepted it as the norm, although in truth it's just as arbitrary a way of recreating music as mono or multi-channel.

Generally it offers a much more

# URES IN HI-FI



open sound than mono with a real sense of a 'sound stage'. Still, the experience very much depends on the mix. For example, when a symphony orchestra is recorded then even a simple pair of crossed cardioid microphones will capture the space and proportion of the sound. However, studio recordings often follow a convention where, along with various instruments panned left and right, strong monophonic elements are included to give more substance. By mixing, say, vocals to both left and right channels, the singer seems to be in the centre 'phantom' channel. Done well, it can be extremely convincing, but still has its limitations. Earlier stereo mixes were pretty bad - as many Beatles aficionados will attest - giving an extremely unnatural sound due to insufficient 'phantom' centre channel content.

techniques which folded the rear channels into the front channels by recording them with different relative phase, although there was also a 'Discrete' system that used four separate channels.

Quad - as it was known - effectively carried four channels of information within a two channel recording, and could be read by a normal phono stylus and passed through to a receiver or amplifier with a quadraphonic decoder. Although it was never called 'surround sound', and shared nothing in common with the cinema systems, quadraphonic could be justifiably regarded as the forerunner of modern Dolby Surround technologies. Sadly though, the world wasn't ready for it - thanks to turntable pick up cartridge (and record pressing) technology, Discrete quadraphonic wasn't practical, and the less adventurous matrixed systems proved a flop due to the high investment required. To cap it all, the systems proved largely incompatible with one another!

use matrixing techniques developed for quadraphonic home stereo, where a centre and surround channel were 'extracted' from the two channel mix using clever signal processing.

Dolby Surround fast became the standard for cinemas all around the world and the advent of stereo video machines in 1978, and then Laser Disc in 1980 (extremely popular in Japan, much less so in Europe) added impetus to the surround project. The arrival of the 'music video' also ushered things along - for the first time people were using their TVs for the enjoyment of music. In 1987, domestic Dolby Pro Logic decoders arrived, making it possible to decode front left, front right, centre and rear channels (often via two speakers) from a standard two-channel stereo source. The main sounds came from the left and right channels, the vocal or dialogue emanating from the centre phantom channel, and the ambience or effects information coming from behind the listener.

Thanks to its limited bandwidth (the surround channel only went from 100-7,000Hz), Dolby Pro Logic wasn't much cop with music but was surprisingly effective with film soundtracks, able to convey the sensation of sounds moving from front to rear and left to right. This said, it has been used for music-only applications - record companies including Delos, RCA Victor, BMG Classics and Concord Jazz have all produced Dolby Surround-encoded audio releases, with little success.



## DOLBY SURROUND/ PRO LOGIC

Modern surround sound got its first breath of life in mid seventies cinemas with films such as Star Wars, Tommy, and Close Encounters of the Third

Kind. A new format designed expressly for 35mm film prints, Dolby Surround used two tracks squeezed into the same space on the print occupied by the traditional mono soundtrack, made possible by the use of Dolby A noise reduction. Of course, two channels weren't enough for cinema use (due to the wide gap between the left and right of the screen), but it was impossible to cram more than this on to the print, due to excessive noise. The answer was to

## QUADRAPHONIC

As technology progressed and prices fell, various early nineteen seventies manufacturers began to think there was a market for multi-channel. Thus was born the ill-fated quadraphonic system, which required two extra speakers in the rear corners of the listening room to reproduce specially encoded program sources. Several variants were produced, most of which were based on 'matrixing'

## FUTURE PERFECT - THE INEXORABLE RISE OF DIGITAL SURROUND: DOLBY DIGITAL

Dolby's much vaunted digital format arrived in cinemas in 1992. While the 35mm film prints used in cinemas retained analogue Dolby Stereo soundtracks for backwards compatibility, an additional new digital optical track was placed between the sprocket holes. This permitted the famous 5.1 configuration that has become the industry standard. Front

left and right, rear left and right, centre and LFE (low frequency effects) channels are provided, all offering the same quality. However, because the LFE channel only takes around one

tenth of the bandwidth, it's known as 'point one'. Dolby digital offers a range of special features, such as downmixing from multi-channel discs for stereo listening or Dolby Surround decoding. It can provide dynamic compression to increase the level of quiet passages (making late night viewing/listening a reality) and even route low bass only to speakers capable of reproducing it.

This is all made possible by clever data reduction techniques, using perceptual coding to shave the digital datastream down to one twelfth of its original size. While the format's theoretical maximum bitrate is 640kbps, DVD discs allow only 448kbps in two channel and 384kbps in 5.1 modes. Dolby Labs argues that this, "provides sound quality that critical listening tests have consistently confirmed as on a par with original master tapes". Joseph Hull, Dolby Laboratories' Marketing Communications Manager, calls Dolby Digital, "the final link between the multichannel producer and home listener".



### DTS 5.1 SURROUND SOUND

While Dolby Digital fast became de rigeur on the home and cinema surround scene, a renegade format arrived with the appearance of Stephen Spielberg's Jurassic Park in 1993. The famous Hollywood producer took the view that Dolby Digital simply didn't sound good enough for his purposes, and turned to Digital Theater Systems for the answer. There are two key differences: First, running bitrates of 1.5mbps, DTS runs at a compression ratio of just 1:3, which is dramatically lower than Dolby Digital. As any MP3 user will know, this has obvious sound quality benefits. The second advantage is the sound of the actual codec itself - even running at identical bitrates, most believe that DTS sounds superior.

DTS is an interesting point at which movie-driven surround sound crosses back into audio with real benefits. And much of the industry agrees - Pioneer's John Bamford says, "there's something very nice about this codec, everybody goes for it every time". So while DTS is a 5.1 surround system just like Dolby Digital, thanks to its better sonics, it

has found itself being used for pure audio purposes too.

Indeed a range of DTS High Definition discs

Conveniently, there are three types of

DTS discs around right now.

First are the aforementioned DVD video discs with DTS 5.1 sound, second are discs on the DTS Entertainment label (mostly DVD-A with DTS mixes) and third are discs from DTS's High

Definition Surround series such as this. These play in most DVD machines and all CD players connected to an off-board DTS decoder via the digital output. Combined - don't blame you! This disc falls into the latter category - mastering was done by Steve Gut with a Phem AG-1 analogue-to-digital converter, with mastering courtesy of a Real KPS-32 CD player and Matrikeln 2.4.6 DTS decoder/preamp.

Clapton addicts will know it's a 'terminal' album of course, and while the CD release may not have been enough to coax them to part with cash, this may well. If you have a decent DTS decoder (whether at your DVD player or AV preamp or processor) you'll be extremely impressed with the sonic. Frankly, the original recording isn't particularly special (the original vinyl first pressing isn't anything to write home about), but this DTS disc seems to get to the bottom of it in a way no other disc has ever done before.

It's very sweet and smooth, adding a lot of extra timbre and textural detail which the CD simply lacks. The surround rev is brilliant - nothing too way out, it simply adds subtle strands of ambient information to make you feel like you're in a concert hall. Two channel stereo sounds great too by comparison. It's actually very sweet and beguiling - almost as impressive as some more classical DVD-A pressings, in fact. By comparison, the original vinyl adds a touch more emotion and a little warmth and space, but I could happily listen to either through any system.

Title: 461 Ocean Boulevard  
 Artist: Eric Clapton  
 Formats: DTS (Dolby 5.1)  
 Catalogue: HDG-4419



Everyone and his dog has a DVD video of 'Hotel California', but it's taken a surprisingly long time for an Eagles DVD-A to appear. Unsurprisingly it's the band's most famous, but one of the typical cash 'n' will be questioned when you look at the strategic worth of the release. This 1977 Grammy award winning (and it's deserved) song California is brilliantly recreated with a choice of 24/192-2-channel (or channel) from the original analogue two-track master) and a 5.1 channel surround (DTS or Dolby MLP), by original producer/engineer Bill Szymczyk and surround expert Elton Scheiner. This was accom-

panied from the original 24-track analogue tapes via a Sony 2348 48-track digital recorder with dB Technologies 24-bit 192kHz 600 series A/D converters. The disc was mastered 448kbps Dolby Digital mix and DTS alternative. Whichever standard DVD video machines will play it (although not to DVD-A resolution).

The DVD-A 5.1 mix sounds amazing, gently decaying electric sounds in the limbo channel, added to BURN! (the channel depth file, like all the guitars right to the left of the room). True, there are a couple of 'oddy' all-around-the-room pan pots (which is probably how they'd have mixed that at the time) but no, truth be told, but the overall 5.1 mix is

superb. Fidelity of both the multi-channel and stereo mixes is excellent - my Michael Onda playing a Japanese vinyl pressing of the album was given a close run by a Pioneer DV-FATA DVD-A player. The vinyl pressing was slightly more musical, with better accents and phrasing on the guitar work, but the silver disc displayed superior depth and breadth. The only question mark is slightly audible clipping on 'Life in the Fast Lane'.

Title: Hotel California  
 Artist: The Eagles  
 Formats: DVD-A 2 channel, 5.1  
 Catalogue #: 80500-0

almost all DVD (and DVD-A) machines have built in DTS decoding, these should play DTS HD discs without an additional processor.

Right now, you can get DVD video discs encoded with both DTS and Dolby Digital soundtracks. Curiously, the format used doesn't depend on the title as much as the region it's destined for. Many Region 2 PAL (i.e. European spec) discs come with Dolby Digital soundtracks, whereas a surprising amount of new Region 1 NTSC releases (i.e. from the US) come with DTS sound. This is why multi-region compatibility is such an important issue for movie buffs and audiophiles alike - the former love the early movie release dates, the latter lust after the superior DTS coding used!

### DVD-AUDIO

Although this new format has been much celebrated by the world's hi-fi press for 'pushing the envelope' to 24bit, 192kHz digital linear PCM audio, it's important to remember that it introduces a new audio surround format, namely six channel sound in uncompressed 24/96 PCM (using Meridian Lossless Packing - which is a compaction, rather than a reduction, algorithm) too. This is arguably the highest theoretical sound quality that domestic multi-channel can achieve.

This offers interesting creative possibilities - not only will discs offer a straight analogue-to-digital conversion of the original stereo two-track analogue masters (obviously digital recordings can only be upsampled, rather than converted), but a 5.1 mix too. This has to be made in the studio from the original multi-track tapes - essentially 'creating' a new interpretation of the musical work, in a way never previously heard.

It also gives space for the artists to get closer to how they wanted the original mix to sound. Queen's Bryan May, for example, is said to have taken the opportunity of the new release of 'A Night at the Opera' to 'correct mistakes in the original recording'. The repercussions of this are many - we may well be in for a raft of multi-channel remixes and a whole new software sales boom as the world goes 'surround sound' on the back of the DVD movie boom.

The SACD format is growing fast - in some markets at least - and multichannel is an obvious allure. This hybrid release on the audio b label contains stereo CD, stereo DSD and surround DSD mixes - and can be played on any silver disc player as a result (in CD quality). The CD and DSD layers are physically separate, and within the DSD layer there are three individual partitions containing the two channel and multichannel mixes, along with an additional text and graphics area.

Acoustic Triangle is formed by the respective talents of Malcolm Greese (double bass), John Horler (grand piano) and Tim Garland (soprano and tenor saxophones and bass clarinet). Interactions is an album of "melodic modern jazz with European classical influences", and very interesting it is too - I'd call it Debussy meets Dexter Gordon. Musically adventurous but loving all the same, the content quality is undeniable and the sound is utterly exquisite. In both 2-channel and 5.1 mixes, you get a cathedral-like acoustic in which you sit aghast and agog.

In truth, if your surround system is properly set up, it's quite a lot more impressive than the stereo mix - but either is quite stunning. That grand piano is beautifully deep and sonorous, while the double bass seems to go down to the centre of the earth itself. Saxes sound quite unlike anything you'll get from CD - smooth but raw and breathy. Best of all though is the sound of St. George's in Bristol - the recording venue - which is amazingly spacious, and all the more atmospheric in multichannel mode. Superb.

Title:	Interactions
Artist:	Acoustic Triangle
Formats:	SACD Multichannel, SACD 2-channel, CD
Catalogue #	SABCD 5012

### SACD MULTICHANNEL

Another new surround sound format arrived with the advent of Super Audio Compact Disc. While unabashedly a music format (unlike DVD, of course), its co-creators Sony and Philips were enthusiastic enough about multichannel to make it a key part of the specification. It runs up to six channels at the full DSD bitrate, and accordingly the full sound quality is possible, and many discs also carry a standard Red Book layer readable by existing Compact Disc spinners. Like DVD-A, it offers a whole vista of possibilities for multichannel remixes and reissues, and unlike DVD-A is readable in a standard CD player (in two channel CD quality, of course).

Whether this is better than DVD-A 5.1 surround (using 24/96 packed



PCM) is a contentious issue to say the least. Suffice to say that the two respective formats do have different technical specifications. While DVD-A multichannel runs out of bandwidth at 48kHz, SACD multi is claimed to stretch up to 100kHz thanks to its brickwall-filterless Direct Stream Digital (DSD) coding system. While this isn't the place to get into the relative merits of DSD vs. PCM, suffice to say that SACD multi is theoretically capable of superb sound. Right now, the real limiting factor is the quality of the recordings, SACD transfers and mixes, and of the SACD decoders and DACs themselves.

### MULTI CHOICE - THE VERDICT

On a purely practical level, surround-sound is not for everyone, as more physical space is required for all the loudspeakers and in the modern world we need as much space as possible.

It's also still early days. Properly done, multichannel SACD and DVD-A can really enhance the musical enjoyment of your favourite albums - there really is more to surround sound now than cheesy movie effects. The problem is the paucity of titles available (and the sometimes dubious mixing techniques). In this respect there's a real feeling of déjà-vu echoing the early days of Compact Disc. Indeed, Vivante's Shaun Ormond says the worst thing about the software is the sheer conservatism of the titles being drip-fed to audiophiles (although a few specialist classical labels such as Hyperion and Fone are releasing imaginative SACD titles). "It's all safe seventies rock music, like CD all over again". Quite so, but time is on our side. ■ ▲

**Thanks to Vivante Music Ltd (01293 822186) for supplying the review discs. Check out their website at [www.vivante.co.uk](http://www.vivante.co.uk) for the latest high resolution digital software.**

# ACTIVE

ATC have made a name for themselves on the professional circuit. How will their active 'speakers sound in the home. Simon Pope reveals all with the Active 10s.



Walk into many studios throughout the country, or indeed the world, be it recording or mastering and you're bound to come across a product from ATC. Over the years the company have made a fairly formidable name for themselves in the professional monitor market, delivering a well engineered and solidly constructed product that delivers the goods in a professional situation.

Any cynical engineer will tell you there's very little difference between professional audio gear and the stuff that you'd buy in your local specialist retailers. Good professional monitors excel in imaging, transparency and reliability. ATC have become well established in the pro field with their range of monitors and now hope to take a share of the domestic market, like PMC and Bryston for example, with their compatible range of both active and passive loudspeakers and amplifiers.

All the company's products are designed and constructed at its factory in Stroud, Gloucestershire, mixing the traditional arts of hand-

crafted products with modern computer-controlled production.

The Active 10s reviewed here were introduced towards the end of last year and feature the attractive curved design of the award winning SCM 70ASL system. The Active 10 is constructed from heavyweight, laminated, machined MDF composite with aluminium extrusions added to provide rigidity, as well as improve imaging properties and aesthetic appeal. The standard finish is two tone grey gloss, although other colours are available.

On board we have ATC's own proprietary twin channel amplifier with 'grounded source' output stages and multiple power supplies, which together deliver 200W to the bass/mid driver and 50W to the tweeter. They operate in "Class A" mode up to two thirds of maximum output.

The bass/mid drive unit is the latest version of founder Bill Woodman's 125mm design. Weighing over 3.5kilos, it features the company's "no compromise" hand-wound voice coil employing flat

oxygen free copper wire to apparently help maximise the copper in the magnetic gap. What this drive unit excels in, though, is cone excursion, quoted as being in excess of 20mm, to deliver a healthy bass response. High frequency information is conveyed by way of a soft dome tweeter from VIFA, a nice change from the traditional metal dome of active 'speakers of the past.

For the review I used the Active 10s in conjunction with ATC's entry level preamplifier, the £750 CA2. This was linked to the Active 10s via the XLR connection. Also put into play was my trusty Creek passive preamp with phono to XLR adaptors. Source material was delivered by a Meridian 206.24 CD player.

Placed atop of a pair of sand filled stands the ATC's immediately displayed a fantastically quick and immediate response. Rock recordings in the form of Soundgarden's 'Superunknown' and The Smashing Pumpkin's 'Machina' showed the Active 10s in their best light. Plenty of fine detail was present, with ride cymbals and tom toms in the drum



# ADVOCATES



kit easily discernable. Also apparent was smooth treble, a sign that ATC are turning their hand to audio in the home as opposed to the studio. The soft dome tweeter adds more sweetness to the sound than the more widely used metal domes of most active monitors.

Bass was incredibly fast and taut, with good extension. Bass guitars and kick drums were visceral and muscular, giving real presence and clout to the music - ideal for this kind of Rock, which is completely lost on valves and electrostatics, for

example.

Moving on to jazz with John Coltrane's 'A Love Supreme', the Active 10s showed a surprisingly good midrange, giving Coltrane's tenor sax plenty of room to breathe. Dispersion was impressive, the 10s creating a rare 'out of the box' sound. Again, detail was to the fore but to a certain extent the innate laid back character of the music was sacrificed for such traits, although the reproduction of the recording was fine.

With classical I found the ATCs reacted better to chamber music than full scale orchestral. A disc of Fauré and Ravel piano trios on the Hyperion label had good scale and realistic dynamics with superb detail in the bow work. This powerful dynamic capability benefits large scale classical, as does the good dispersion, but the forward sound of the 10s made the brass section in a Bruckner symphony sound a tad hard and synthetic and the violin section unrealistic in timbre.

These are mightily impressive with rock and dance music, where the full effect of their muscular power is best displayed, so if this type of music floats your boat, it might be

a good bet to go active with the 10s and buy yourself a passive or cheap preamp to match.

Competition at this price is strong and whilst the ATCs may seem expensive it's worth remembering that power amplification is included! On the flip side, if you like to settle down with a single malt at the end of the night and chill out to some warm jazz or classical you may find their inherently 'active' and full-on nature a bit tiring after a while. All the same, their muscular, forward nature is more refined than that of active monitors using metal dome tweeters.

It's hard to pigeon hole the SCMI0s. Many will find them exciting performers that excel in speed and dexterity. On the other hand they just may be a little too much for others. ■ ▲

ATC Active 10 £1299

ATC Loudspeaker Technology Ltd.  
Gypsy Lane  
Aston Down  
Stroud  
Gloucestershire  
GL6 8HR  
Tel: 012885 760561  
[www.atc-gb.net](http://www.atc-gb.net)

## MEASURED PERFORMANCE

The SCMI0-2 is unusual in a few ways. Being an active loudspeaker it has an on-board amplifier, and the bass unit works into a sealed (Infinite Baffle) enclosure. Because an IB doesn't go as low as a ported reflex, volume for volume, most loudspeakers are the latter nowadays. Once upon a time, before computers were able to calculate the alignments needed to make a reflex work decently, most loudspeakers were sealed like this one - and they gave tighter, more tuneful bass than is usual with a reflex.

The SCMI0-2 has a very tightly controlled frequency response that

stays within about 2dB total variation right across the audio band, our analysis shows. It is academically flat in fact and 'speakers like this often sound bright in real life, unless used in a well damped room. The complete absence of a crossover suckout and very good driver integration/dispersion also means plenty of treble energy will be produced, providing high levels of detail and insight, but also a fairly remorseless delivery.

Bass should be tight, tuneful and deep, since it runs flat down to 40Hz, before rolling off more slowly than a reflex.

All in all, this is a very well engineered loudspeaker, but it must be auditioned, since it will be 'upfront' sounding. It should also sound unusually clean and fast. **NK**

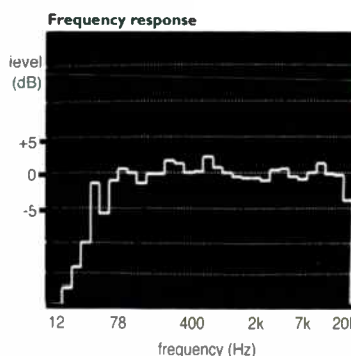

## World Verdict



Well engineered with a powerful muscular sound. Good dispersion and imaging but could be tiring during prolonged listening.

# BIG SOUND, SMALL SPACE

Like the idea of something small sounding big? Simon Pope encounters a poles apart pair with just one thing in common.



## ▶▶ TIVOLI AUDIO MODEL ONE £99

**Q**uestion: when does a tranny radio get praise from world-wide audiophile writers?

Answer: when it's the American Tivoli Audio Model One! Distributed over here by Ruark, this smart little number is the brainchild of the late and highly respected US Audio Hall of Fame Member Henry Kloss, and it's a real treat.

There are three main factors that make this product a good one. Firstly, the Tivoli has an attractive aesthetic appeal, nicely 'retro' in appearance (and available in three colours) without looking like a bit of cheapo reproduction furniture. The most striking feature is the large concentric tuning dial which is accompanied on the front by a couple of simple knobs for band selection and power. Secondly, it measures just 8"x4"x5" (w,h,d) and is designed to be placed on a work surface or desk, and last but not least, thirdly it's perhaps the best performing mono radio I've encountered.

Using a discrete technology developed for mobile phones, the Tivoli manages to pull in an impressive number of stations using

its internal aerial, and pulls them in with as clear a signal as I've encountered with portable radio. It has a 5:1 gear ratio analogue dial which results in smaller and more precise movement of the mechanism for better tuning. The sound is detailed and warm with a truly surprising amount of bass and three-dimensionality to the sound. It's by far the best sound I've heard from anything this size. It has a very natural way with voices, which are rounded and warm, and good BBC broadcasts sound realistically impressive. If you're a radio fan than wants the best from the airwaves in the kitchen you can do no better than this - it's a real eye opener.

Ruark Acoustics Ltd.  
Tel: 01702 601 410  
[www.tivoliaudio.com](http://www.tivoliaudio.com)

## MJ ACOUSTICS PRO 50 £299

**D**ue to the nature of the market and the swift shift to AV, there are now more subwoofers around that you could shake a dirty stick at but from my experience there are only a few brands whose products really cut the mustard in this field. Specialists such as M&K, Velodyne and, of course, REL produce products that stand out from the crowd. Now there's another contender for the King of Bass crown. New boys MJ Acoustics have recently launched a range of subs that promise to give the big boys a run for their money.

At £299 the Pro50 is a serious bit of kit for the money. A 50W DC-coupled MOSFET amp is the muscle behind the 8" long throw woofer found in the sensibly proportioned

chassis and a manageable weight of 8kilos - there's no hope (or fear) of doubling it up as a dining table. Connection, a la REL, is via a Neutrik Speakon and a set of unbalanced phono sockets. The crossover is between 40-240Hz in variable increments and there is a phase control adjustable between 0 and 180 degrees, as well a gain control for each type of input. Black finish is standard but there are attractive real wood veneer options available.

Sound wise it's a fine performer with both movies, and especially music. It has real depth and perspective and when used with an ambient acoustic recording, adds space and clarity to the midrange, really demonstrating its quality. For out and out clout, the sub's dimensions belie its powerful and taut sound. Underworld's pumping bass line in 'Push, Upstairs' had the Pro 50 delivering some really fast and powerful low frequencies, hitherto the sole traits of the likes of REL. Rarely do you get this quality of bass from such humble dimensions, and if this is anything to go by the larger models will be crackers. With a hoard of subwoofers out there hardly worth the effort I think the Pro 50 could well be responsible for a handout of P45s! ■ ▲



MJ Acoustics  
Tel: 08707 44 50 80  
[www.mjacoustics.com](http://www.mjacoustics.com)

# ACCESS ALL AREAS

Simon Pope and David Price listen to the latest selection of goodies from the weird and wonderful world of the audio accessory.

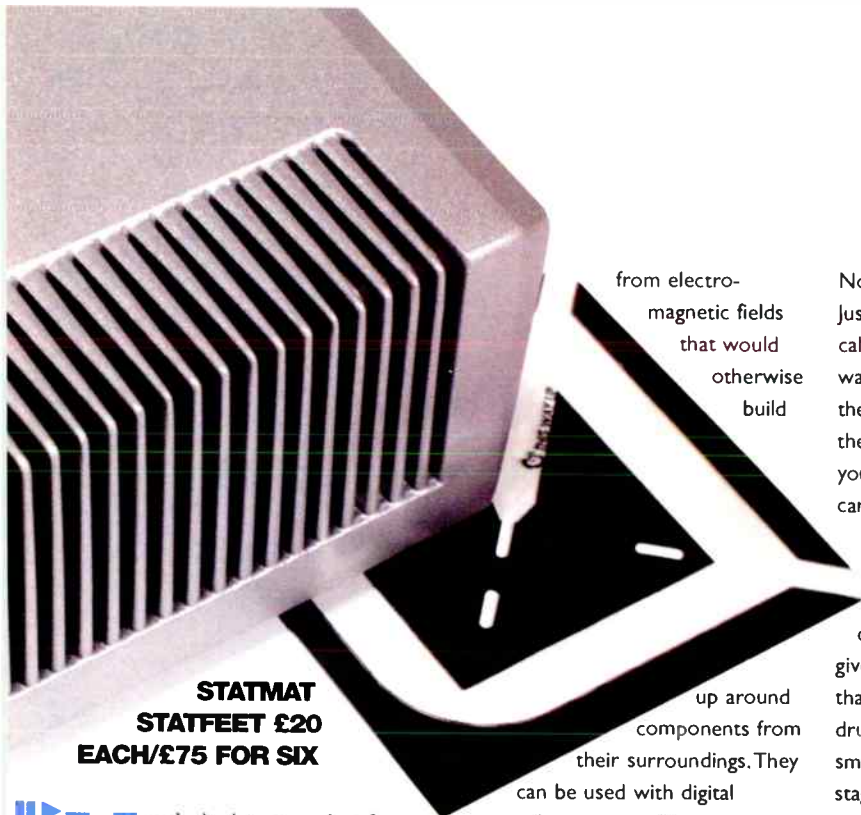

**STATMAT  
STATFEET £20  
EACH/£75 FOR SIX**

Here's the latest product from the people that brought us the Statmat static eliminator and Ringmat support system. Like the Statmat, Statfeet are made from conductive polypropylene film, with specially formulated conductive ink applied to each side. As a consequence, the company claim, they form a powerful, passive, electrical device in which the size and geometric patterns cut out of them are an important factor.

Statfeet are designed to be placed under one foot of any component to reduce electro-magnetic fields and consequently tighten up the sound. Their unique design, using Ringmat Developments' proprietary Statmat technology, claims to break up the interference

from electro-magnetic fields that would otherwise build

up around components from their surroundings. They can be used with digital

source players, turntables, amps, televisions - you name it. Statfeet are recommended to be used under only one foot of any component, cone or other form of single point isolation support, where these are used in place of a component's own feet or where a component has no feet of its own. Placement is best at the rear of the component and the company have apparently found they work best on rear right, with the two cut out circles facing toward the centre of the component (except TVs where it should be placed at the front, with the two holes again facing the centre).

Now, perhaps this all sounds like hocus pocus. And you'd be right in thinking as much, except for one thing: the fact that they actually work!

Not a lot mind you - but they work. Just to make sure, a third party was called in to confirm that insanity wasn't to blame and he, too, found the same differences. Don't think these differences are the same as you'd find swapping 'speakers or cartridges, because they are not.

Subtlety is even perhaps too bold a word for the effect, but there is a discernable difference. The overall sound is given a little spring clean as such, so that details such as cymbals, snare drums and vocals are just that one smidgen cleaner and sharper. Also, the staging is extended a fraction to make a larger and better focussed picture. The manufacturer claims that using one Statfoot on top of another will create even further improvements but here, I fear, no significant results were found.

At £20 each or £75 for six the Statfeet are no real bargain but they definitely work, albeit in a subtle way. They are an unusual and in certain regards, a fun bit of kit as you really don't expect an 89mm square of film to change the sound of your hi-fi. Use them on a source player, where they deliver the best results and you could be pleasantly surprised, but don't expect miracles!

Ringmat Developments  
Tel: 01277 200210  
[www.ringmat.com](http://www.ringmat.com)







**AR TDS202 Sound Enhancer**

**AR TDS202 SOUND ENHANCER £69.99**

**H**ere's a little black box that promises to do great things for your system's sound almost by magic - never heard that before! The AR Sound Enhancer is claimed to transform lo-fi into hi-fi no less - and said to greatly enhance playback of CDs and DVDs. It's supposed to create a wider and more detailed sound field, "achieving greater aural balance and detailed imaging" according to Recoton Corporation. "The technology developed by TDS allows music enthusiasts to enjoy a much richer listening experience than previously thought possible" they say.

The technology is based on compensation for the human hearing system's inability to pick up certain audio frequencies. Its makers point out that our ears aren't as sensitive to lower and higher range sounds as they should be, thus removing the richness and sparkle of recorded music. AR's Sound Enhancer, "finds and unlocks these 'hidden' sounds, making them prominent so that you can enjoy music and movie soundtracks on a new level of perception". It works with any type of equipment, from mini systems to PlayStations to high-end home cinema surround-sound set-ups. It's the first AR product to incorporate this patented True Dimensional Sound technology, originally introduced to the audio market back in 1997. It has already been used in movie soundtracks such as Air Force One, U-571, The Mummy and Jerry Maguire.

This raises some interesting questions. We all know that the ear is less sensitive to low and high

frequencies, especially at lower (domestic) volume levels. That's why every cheapo amp since the 1960s has featured a loudness control (or suchlike) to give it showroom credibility - one press of the button gets you an earful of impressive sounding boom-tizz. However, how can we miss something we can't hear anyway, and if we can't hear it, is it 'real' in the first place?

Anyway, the Sound Enhancer is a neat little gizmo. It's passive, so it doesn't introduce noise or interference during playback, and is easily hooked up to any receiver or preamplifier via RCA phono inputs and outputs. It's non-adjustable, so there's no capacity for tweaking - you just switch it in or out of circuit. Hooked up between a Cyrus CD7 CD player and Cyrus 7/PSX-R/Mission 782 and speaker system, it certainly made a difference!

The first thing you notice is that the music seems louder, which considering it's a passive device makes it a clever trick, alright. Just as it says on the box, you get a wider soundstage with greater perceived depth. Rather than simply acting as a 21st century 'loudness' button, there's quite a change in the midband as well as at the frequency extremes. Without a doubt, everything sounds a little crisper, a touch more defined and explicit. The sound is (apparently) a little more dynamic and punchy, and you do get the feeling you're listening to a different system.

Did we like it, then? No, not really. To be fair, the TDS202 will really pull up the socks of a slow, lazy, dull system. Indeed, it lost a deal of subtlety and poise - although it's nowhere near as malign as those



'stereo wide' buttons on eighties boom boxes, it still has a tendency to saturate music to the point where you end up listening to the Sound Enhancer rather than the music. For computer audio, portables, and even car use this could be good, but steer clear of it for serious hi-fi.

Ara Accessories Ltd.  
Tel: 0161 702 5010  
[www.araccessories.com](http://www.araccessories.com)

**SOUNDPAX £30**

**B**illed as the first full range, hi-fi quality, ultra lightweight cardboard loudspeakers, my first reaction to these curious arti-



facts was "so what?" Why would anyone want to buy a set of cheapo speakers the height of a traffic cone and weighing the same as a bag of sugar?

Some might because they are 'miracles of modern technology', being state-of-the-art NXT designs from NXT themselves, rather than licensees. They generally turn out better NXT speakers than licensees thanks to the Huntingdon company's feel for its own intellectual property.

The product itself was conceived by innovative European packaging manufacturer DS Smith, which gives some clue of its intended application. Don't expect to chuck your Quad 988s in the skip after you've bought a pair; they're more 'cardboard' than 'hi-fi'! However, as far as corrugated paper pulp goes, they're also pretty amazing - simply by virtue of the fact

these pages - suffice to say that they use 'exciters' which vibrate the Acoustic Fluted Composite panels at an ideal position to introduce complex sets of bending waves in the panel structure. The advantages - aside from compactness and low weight - include low directionality and room interactions.

As with all NXT panel speakers, the Soundpax showcase these advantages very convincingly. In this respect they're far better than practically any conventional design at any price! No, they're not quite in the Martin Logan class, but they certainly fill rooms with music very well.

They're surprisingly musical too - the lack of any boxes to resonate makes for an engagingly direct listening experience. Of course, they lack the clarity, detail, frequency extremes or dynamics of hi-fi

loudspeakers - but what do you expect for £30? If it's a cheap and cheerful way of getting music into the shed/ garage/ patio (etc.) you are after, I can't think of a more fun way. I've heard a lot worse in the 'multimedia speaker' department than these. My only reservation is the awful cartoon pictures of moving coil loudspeakers they carry - which is either post-modern irony or just rubbish marketing.

NXT Ltd.  
Tel: 0870 777 5555  
[www.soundpax.com](http://www.soundpax.com)



**SENNHEISER HD497 HEADPHONES £49.95**

that no one's made an all-cardboard speaker before!

The benefits of cornflake-packet construction are lightness and portability (a fact not missed by Kellogg's, either!) - so if you're moving around all the time (students/kids!) then 'speakers like this may actually be useful. They can be pulled out of their packaging and set up in a matter of seconds. With an impedance of 8ohms and a power handling of 6W they're ideal for portable applications. Vital statistics are 720x450x540mm and 0.9kg each.

Their NXT SurfaceSound technology has been well explained in

In a sense, the 497s continue the same formula as Sennheiser designs of some twenty years on. Right now, DJ phones are all the rage, but here's an unashamed stab at the budget audiophile market, complete with an up-to-the minute silver finish and an affordable price.

Developed to bring Sennheiser to a younger market, the 'new 400 Series' cans are nearly as well made as the old ones - which is really saying something. Basically, you can drop them, sit on them, tread on them, yank them by their cord and generally

trash them and they'll still look and sound as good as new. Top quality materials are used throughout, from the strong single-sided OFC copper cable (3m long, with 3.5mm plug and quarter inch adapter) and durable plastic headband to the hypoallergenic, leather look earpads. Powerful neodymium-iron magnets and advanced ultra-light diaphragms are used for efficiency. By comparison, the likes of Vivanco pail.

They're also very light - 130g - and comfortable to wear over long periods (as very few headphones are) with a claimed contact pressure of 2.5N.

Other vital statistics include a quoted frequency response of 24-22,000Hz, a nominal impedance of 32ohms, 112dB maximum sound pressure level and a distortion figure of under 0.2%. As per usual Sennheiser practice (DJ range notwithstanding), they're of dynamic, open backed design. Replacement parts are easily available at audio retailers nation-wide, and the phones themselves are guaranteed for two years.

Sound is excellent - at the price. I've been less enamoured by Sennheiser budget phones of late but these rather buck the trend. You get a large, crisp, fast and open sound, with plenty of detail and grip. There's noticeably less roughness and 'fuzz' than previous Sennheiser cans at this price, with the result that they're less obviously biased to the boom-tizz of rock or dance. In fact, you can actually play soul or jazz music through them and enjoy the timbre and texture of the music, as well as the start-stop of the rhythms.

Bass is tight and taut in a characteristically Sennheiser way - although it's noticeably less extended than models further up the company range. Still, it's decently bouncy which - combined with fine midband dynamics - makes for a highly involving listen. Treble isn't a particular strong point - it does the job but lacks the sweetness and extension of only slightly more expensive designs. Still, these cans are beautifully made, musically engaging and offer a good degree of subtlety too. Top value. ■ ▲

Sennheiser UK Ltd.  
Tel: 01494 551551  
[www.sennheiser.co.uk](http://www.sennheiser.co.uk)

# PROBABLY THE BEST

NEW DEMONSTRATION ROOM NOW OPEN AT 12A SPRING GARDENS, NEWPORT PAGNELL,

## KIT6550 VALVE INTEGRATED AMPLIFIER KIT & KAT6550 VALVE POWER AMPLIFIER KIT

£595

NEW KITS

£580



**KIT6550**  
upgrade kit now  
available £130



**KaT6550**  
upgrade kit now  
available £120

These are our new 6550 series amplifiers. A pure class A design providing 40 watts into a 8 ohm load. (available in a 4 ohm version if required) A truly high end design by Andy Grove, using Svetlana 6550Cs in push-pull (any 6550 or KT88 tube can be used with this amp). It features valve rectification (5U4) a choke pi filter power supply and is hard wired. Weighs 19kg with dimensions 390mm(w) x 330mm(d) x 190mm(h)

with valves or 220mm(h) with cage. Simon Pope says - "If you favour attack and rhythmic grip, together with a smoothness of sound that's incredibly easy to live with, the KiT6550 could well be the kit amp for you. The 6550 is one for those who like a valve sound married to the attack and clout of a good quality solid state design".

## Kel84 VALVE INTEGRATED AMPLIFIER KIT

This is our brand new, low cost, beginner level amplifier kit. It features a pair of EL84 valves per channel in push-pull configuration. They give 15 watts into an 8 ohm load - plenty for medium sensitivity loudspeakers. The output transformers are Ultra Linear, keeping distortion down to a minimum. Up front the ECF80 input/phase splitter valve has an extremely smooth sound.

The Kel84 has very low hum, to solid-state standards. For simplicity the kit is built on a printed circuit board. A strong steel chassis is fronted by a 3mm anodised front panel and attractive chromed custom made knobs. There are five line level inputs, plus one monitor input, with a tape output included, all controlled from the front panel. The phono input sockets and 4mm banana socket speaker terminals are gold plated.

At rear is a mains switch, an IEC power input and an earth post. This kit is aimed at beginners. The instructions include pictures as well as diagrams, making them very easy to follow. At a UK price of £278.00 all inclusive you cannot ignore Kel84. Simon Pope says, "The quality that can be gleaned from this amp is a fine introduction to the joys of the valve sound. The Kel84 will highlight all the intricacies and depth of detail in your favourite recordings whilst retaining a warmth and fullness that is almost exclusive to pure valve amps and is rare at this price point."

Kel84 weighs 10kg. External dimensions with valves are 300mm(w) x 270mm(d) x 150mm(h).

£278



## 2A3 PSE INTEGRATED AMPLIFIER KIT

The 2A3 PSE integrated amplifier offers a seriously hi-end sound, but without the cost usually associated with single-ended amplifiers. The stereo chassis houses, on the output, 2 x 2A3 in parallel single ended configuration and a single 65N7 as the driver tube per channel. The valve rectified power supply consists of a 5U4, with a combination of a hefty 10H chokes and 2 x 100uF 500V capacitor in a pi filter configuration, giving superb smoothing. This feedbackless design provides 8.5watts into an 8 ohm load, so a good sensitivity speaker is required above 91dB. It can accept 6 line-level inputs fully controllable from the front panel. We provide the excellent Alps Blue potentiometer as standard. The amplifier is hard wired so plenty of scope for tweaking in the future. Simon Pope says, "The 2A3 PSE is extremely impressive piece of kit, good imaging, wide sound stage, nicely extended on the high frequency and tremendous bass thump - I want one".

weight - 20kg, external dimensions with valves fitted - 390mm(w) x 360mm(d) x 220mm(h)

£550





# DIY KITS IN THE WORLD

MILTON KEYNES, BUCKS MK16 0EE - CALL FOR DETAILS ON 01908 218836

## ALL NEW SERIES II MODULAR PRE-AMP KIT

The PRE-II is a valve pre-amplifier with six inputs, tape monitor and two sets of output sockets. It utilises a high quality line driver transformer and x5 gain. The PHONO-II is a dedicated valve phono stage that incorporates a step-up transformer for MC users. Finally, PSU-II is a power supply unit that feeds both the PRE-II and PHONO-II.

Power Supply Unit (PSU-II)	£195.00
Pre-amplifier (PRE-II)	£195.00
Phono Stage (PHONO-II)	£110.00
Moving coil step-up transformer	£77.00
Passive pre-amplifier (PAS-II)	£215.00

**NEW!**



## KAT34 VALVE POWER AMPLIFIER KIT & KIT34 VALVE INTEGRATED AMPLIFIER KIT

**£480**



**KAT34  
upgrade kit now  
available £120**

**NEW KITS**

**£495**



**KIT34  
upgrade kit now  
available £130**

KAT34 is a 32 watt stereo valve integrated amplifier, featuring a pair of EL34s, in push-pull mode, per channel, plus an ECF80 pentode/triode as input/phase splitter. The power supply is valve rectified (2 x 5U4), using a heavy duty choke to achieve exceptional smoothing. The output transformers are 14% Ultra Linear tapped to keep distortion down to its lowest level and the kit is totally hard wired utilising three tag boards. It has five line level inputs, plus a tape-in and tape out, all controllable from the front.

Simon Pope says, "This integrated bring together the best sonic virtues of our KIT88, kel34 and top of the range 300B PSE in an affordable package. The highlights of the sound are a deep and taut bass response, together with an open and highly detailed mid and high frequency response that only the best valve designs can achieve... a true valve classic" Weight 22kg, External dimensions with valves fitted - 390mm(w) x 360mm(d) x 210mm(h)

## 300B PSE MONOBLOC KIT

Our Parallel Single Ended amplifiers offer ultimate sound quality Each monobloc has two of the beautifully linear 300B directly heated triode in its output stage, producing 20 watts into an 8 ohm load. At the front we have a 6AU6 pentode and an ECC82 as the driver valve. This design utilises a 5U4 rectifier valve in the power supply, in combination with a 10H choke, giving an extremely quiet supply. Both mains and output transformers we E/I pattern.

For purists, feedback is switchable and the kit is totally hard-wired. For those that require valves we provide the superb Tesla 300Bs, Russian 5U4s and European 6AU6s & ECC82. Simon Pope says, "Not to put too fine a point on it, the sound these monoblocs create is among the finest that can be encountered in hi-fi." Our 300B PSE kit bears an affordable price of £875.00 (UK price) excluding valves. Each monobloc weighs 23kgs., external dimensions with valves:

25cm(w) x 38cm(h) x 22cm(d) per monobloc.

**300B PSU  
upgrade kit now  
available £150**

**£875  
A pair**



## KEL80 MONOBLOC AMPLIFIER KIT

Following the success of our budget KEL34 40watt kit amplifier, we have come up with a 'big brother' design. The output stage uses two pairs of TESLA EL34 pentodes in parallel-push-pull mode, allowing KEL80 to turn out 80 watts into an 8ohm load. Heading up the Input stage we have the wonderfully linear Russian 6AU6 working into an American 5687 phase-splitter. KEL80's output transformers are 4ohm and 8ohm tapped. With an input sensitivity at around 380mV for full output, it will happily partner both passive and active pre-amplifiers. It is easy to assemble. Simon Pope says, "The proof of the pudding is in the eating and the KEL80 is a feast for the ears, with solid bass attack, lightning fast reactions, that emphasises musicality as well as power. At £649.00 a pair, a definite valve winner. Each monobloc weighs 12kgs., external dimensions with valves: 14cm(w) x 8cm(h) x 43.5cm(d).

**£649  
A pair**



## HD83 VALVE HEADPHONE AMPLIFIER KIT

The HD83 headphone amplifier is a beautifully simple design using Mullard ECL83 valves, a triode and power pentode housed in the same envelope. It works directly from any source, be it CD, tape, tuner etc., or from an amplifier's tape out or pre-amp out sockets. The circuit uses high specification E/I output transformers that will drive any headphone load from 16 ohms to over 300 ohms depending on how the secondaries are wired up. The HD83 is a single-ended design with the power pentode wired up in triode configuration for added sonic purity, and it is as quiet as a mouse. For sound quality Jon Marks says, "The bass is punchy and controlled without becoming artificial, while treble has the crispness of the best

solid-state, with the tonal purity, delicacy and speed associated with valves." External dimensions 18cm(w) x 30cm(l) x 8cm (h) weight 4kg.

**£195**



World Audio design

# PROBABLY THE BEST DIY KITS IN THE WORLD

NEW DEMONSTRATION ROOM NOW OPEN AT 12A SPRING GARDENS, NEWPORT PAGNELL, MILTON KEYNES, BUCKS MK16 0EE- CALL FOR DETAILS ON 01908 218836

## KLS10 HIGH TECHNOLOGY COMPACT MONITOR

Our mini-marvel uses an Audax carbon fibre bass/midrange unit, married to the world's most advanced tweeter, the piezo-electric gold dome HD3P from Audax. KLS10 offers high performance from a small package. The main 'speakers are designed to work alone, or with a dedicated subwoofer to extend their bass. Alone, they are suited to near-wall mounting and can be tuned by port adjustment to suit personal taste and location. They are easy to drive and need just 30-60watts. KLS10 is unique. Technically advanced, yet compact and relatively inexpensive, there is little to match it. Sensitivity 89dB 1W/1m, 15mm MDF, internal volume 9Ltrs, external dimensions 19cm(w) x 31cm(h) x 23cm(d).

Drive Unit & Crossover kit **£433.00**  
Drive Unit only **£394.00**



**£433**

## KLS10 GOLD SUBWOOFER

Designed to complement KLS10 Gold stand mounters by providing deep and open bass. The subwoofer is inexpensive, easy to build, comprising a simple crossover network with a high quality 8 inch Aerogel dual voice coil unit. A must for all KLS10 Gold customers. Sens. 89dB, volume 25 litres, external dimensions 28cm(w) x 43cm(h) x 34cm(d).

Drive Unit & Crossover kit **£164.00**  
Drive Unit only **£78.00**



**£164**

## KLS3 GOLD MK II ADVANCED TECHNOLOGY 3 WAY LOUDSPEAKER

KLS3 Gold uses the latest version of Audax's innovative oval gold dome piezo electric tweeter, giving it the sweetest and most extended treble. Married to a 4in. carbon fibre cone midrange driver for neutral and clear reproduction, and a powerful 8in. bass driver for superb depth, this is our top-of-the-line reference 'speaker. Sensitivity 90dB at 1W/1m, 25mm MDF, internal volume 60ltrs, external dimensions 26cm(w) x 100cm(h) x 35cm(d).

Drive Unit & Crossover kit **£633.00**  
Drive Unit Pack **£495.00**



**£633**

Upgrade your KLS3s to Gold status. Includes latest oval gold dome piezo tweeter and all components.

**for**

**£363**

## Mains transformers & Chokes

**KIT6550/KAT6550 mains transformers**  
2 inch stack, 130mm(h) x 120mm(w) x 135mm(l) drop through fitting with zinc cap. Secondaries: 425V-0V, 425V, 350mA, 0V-5V, 6A, 3.15V-0V-3.15V, 9A, suitable for 120V & 240Vac operation

**KEL84 mains transformer**  
1.5 inch stack, 90mm(h) x 80mm(w) x 95mm(d) drop through fitting with zinc cap. Secondaries: 0V-240V 300mA, 3.15V-0V-3.15V, 3.5A, suitable for 120/240V operation

**KIT88/KAT88 mains toroidal transformer**  
120mm dia. x 60mm(h). Secondaries: 195V-0V-95V, 450mA/0V-27V, 100mA/3.15V-0V-3.15V, 9A, suitable for 120/240V operation

**KIT34/KAT34/KIT6550/KAT6550 choke**  
1.25 inch stack, 65mm(h) x 105mm(w) with fitting holes x 60mm(d). clamp fitting, 2.5 H. 350mA

**300B PSE mains E/I transformer**  
130mm(h) x 95mm(w) x 115mm(d). drop through fitting with zinc cap. Secondaries: 380V-0V-380V, 180mA/150-0V-150V, 25mA/0V-5V, 1.2A/0V-5V, 1.2A/0V-5V, 3A/3.15V-0V-3.15V, 0.4A suitable for 120/240V operation

**KEL80 mains toroidal transformer (encapsulated)**  
130mm dia. x 65mm(h). Secondaries: 195V-0V, 195V, 390mA/0V-27V, 100mA/3.15V-0V-3.15V, 7.5A, suitable for 120/240V operation

**HD83 mains toroidal transformer**  
80mm dia. x 35mm(h). Secondaries: 0V-165V, 75mA/3.15V-0V-3.15V, 1A, suitable for 120/240V operation

**PSU-II mains toroidal transformer**  
80mm dia. x 35mm(h). Secondaries: 0V-270V, 60mA/0V-10V, 2A, suitable for 120/240V operation

**TRANS1 mains toroidal transformer**  
95mm dia. x 50mm(h). Secondaries: 0V-370V, 150mA/0V-6.3V, 3.5A 300B E/I choke 65mm(h) x 70mm(d) x 80mm(w) open frame fitting, 10H, 180mA.

**KEL84 E/I choke**  
0.5 inch stack, 40mm(h) x 35mm(d) x 70mm(w) clamp fitting, 1H, 250mA

**PSU-II E/I**  
40mm(h) x 35mm(d) x 70mm (w) clamp fitting, 15H, 20mA

**KIT34/KAT34 mains transformer**  
2.5 inch stack, 120mm(h) x 115mm(w) x 95mm(d), drop through fitting with zinc cap. Secondaries: 365V-0V-365V, 300mA/0V-5V, 6A/3.15V-0V-3.15V, 7.5A, suitable for 120/240V operation.

## Output transformers

**KIT6550/KAT6550 E/I 16% TAPPED UL push-pull output transformer**  
2 inch stack, 80mm(w) x 95mm(l) x 100mm(h), drop through fitting with zinc cap. Primary-secondary 4.5K, 16% UL tapped. Secondary 4 or 8 ohm, pls specify on order. max output 45 watts, max current 180mA, valves, KT88, 6550 etc

**KEL84 E/I Ultra Linear push-pull output transformer**  
1.25 inch stack, 76mm(h) x 65mm(w) x 76mm(d) Primary - secondary, 8K with 12.5% UL tap - 8ohms, max ofp-1.5watts, max current 150mA valves EL84 etc

**KIT88/KAT88 E/I push-pull output transformer**  
80mm(w) x 95mm(l) x 100mm(h). Primary-secondary 10K - 8ohms, max ofp-40watts, max current-160mA valves-KT88, 6550, EL34

**KIT34/KAT34 E/I 14% tapped Ultra Linear push-pull output transformer**  
2 inch stack, 80mm(w) x 95mm(l) x 100mm(h), drop through fitting with zinc cap. Primary-secondary 6.4K, 14% UL taps, Secondary 8ohm, max output 34watts, max current 150mA, valves EL34, 6L6, 6CA7

**KEL80 E/I parallel-push-pull output transformer**  
95mm(w) x 115mm(l) x 135mm(h). Primary-secondary 4.6K - 8 & 4ohms, max ofp-80watts, max current-250mA valves-EL34, 5881, 6L6

**HD83 E/I single ended output transformer**  
40mm(w) x 50mm(l) x 55mm(h). Primary-secondary 4K - 4 x 64ohms windings, max ofp-1watts, max current-25mA valves-ECL83 etc

**Pre-II E/I driver transformer**  
80mm(w) x 60mm(l) x 65mm(h). 6:1 step down transformer, max current-10mA valves-6922 etc pre-amp stage

**300B PSE E/I parallel single ended output transformer**  
130mm(h) x 95mm(w) x 115mm(d). drop through fitting with zinc cap. Primary 1K5 Secondary 8R, output .

## Printed circuit boards

Kel84 Printed Circuit Board 280mm(w) x 135mm(l) x 1.6mm(d).

**KIT88/KAT88 Printed Circuit Board** 140mm(w) x 310mm(l) x 2.4mm(d).

Kel34 Printed Circuit Board 140mm(w) x 310mm(l) x 2.4mm(d).

**Kel80 Printed Circuit Board (a pair)** 120mm(w) x 215mm(l) x 2.4mm(d).

HD83 Printed Circuit Board 140mm(w) x 160mm(l) x 1.6mm(d).

**PSU-II Printed Circuit Board** 105mm(w) x 130mm(l) x 1.6mm(d).

**PRE-II Printed Circuit Board** 105mm(w) x 130mm(l) x 1.6mm(d).

**PHONO-II Printed Circuit Board** 105mm(w) x 130mm(l) x 1.6mm(d).



## Hi-Fi World in Malaysia at Millennium Hi-Fi & Av. Kuala Lumpur, Malaysia

Hi-Fi World is now distributed through good bookshops and newstands in Malaysia. For back issues, general enquiries and advertising, contact Simon Chang at Millennium Hi-Fi & Av.

Also available are products by World Audio Design, Michell, Trichord, Lowther and ReThm loudspeakers.

**Millennium Hi-Fi & Av**  
500-1-3 First Floor, Wisma Indah (Shen Court),  
Jalan Tun Razak 50400 K.L.

tel: 603 9283 8171 fax: 603 9281 3762

137 Jalan Pendekar 2, Taman Skudai Baru, 81300 Skudai, Johor DT  
tel: 607 554 5171 fax: 607 554 7645

e-mail: [info@millennium-audio.com](mailto:info@millennium-audio.com)





order on our web site @

www.worldaudiodesign.co.uk

World Audio Design

amplifier kits description

2A3 PSE valve integrated amplifier kit (with valves)
2A3 PSE valve integrated amplifier kit (without valves)
KaT6550 valve power amplifier kit (with valves)
KaT6550 valve power amplifier kit (without valves)
KaT 6550 upgrade kit
KIT6550 valve integrated amplifier kit (with valves)
KIT6550 valve integrated amplifier kit (without valves)
KIT 6550 upgrade kit
KAT34 valve power amplifier kit (with valves)
KAT34 valve power amplifier kit (without valves)
KaT34 upgrade kit
KIT34 valve integrated amplifier kit (with valves)
KIT34 valve integrated amplifier kit (without valves)
KIT 34 upgrade kit
Kel84 valve integrated amplifier kit (with valves)
Kel84 valve integrated amplifier kit (without valves)
Kel84 upgrade kit
PSU II power supply unit module
PRE II pre-amplifier module
PHONO - II phono stage module (with valves)
PAS II passive pre-amplifier module with 10K or 50K attenuator (pls specify)
Moving Coil step up transformers
KIT88 upgrade kit
KaT88 Valve integrated amplifier kit (with valves)
KaT88 Valve integrated amplifier kit (without valves)
KaT88 upgrade kit
HD83 Valve Headphone amplifier kit (with valves)
Kel80 Valve Monobloc amplifier kit (with valves) - a pair
Kel80 Valve Monobloc amplifier kit (without valves) - a pair
300B PSE Valve Monobloc amplifier kit (with valves) - a pair
300B PSE Valve Monobloc amplifier kit (without valves) - a pair
300B PSE Upgrade Kit - a pair

order No.

2A3 PSE (with valves)
2A3 PSE (without valves)
KaT6550 (with valves)
KaT6550 (without valves)
KaT 6550 upgrade
KIT6550 (with valves)
KIT6550 (without valves)
KIT 6550 upgrade
KAT34(with valves)
KAT34(without valves)
KaT34 upgrade
KIT34 (with valves)
KIT34 (without valves)
KIT34 upgrade
Kel84 (with valves)
Kel84 (without valves)
Kel84 upgrade
PSU - II
PRE - II
PHONO II
PAS II
MC - step up (pair)
KIT88 upgrade
KaT88(with valves)
KaT88(without valves)
KaT88 upgrade
HD83 (with valves)
Kel80 (with valves)
Kel80 (without valves)
300B PSE (with valves)
300B PSE (no valves)
300B PSE upgrade kit

qty

Vertical column of checkboxes for quantity selection

uk

(inc vat & carriage)
£550.00
£450.00
£580.00
£450.00
£120.00
£595.00
£465.00
£130.00
£480.00
£415.00
£120.00
£495.00
£430.00
£130.00
£278.00
£248.00
£100.00
£195.00
£195.00
£110.00
£215.00
£77.00
£150.00
£468.00
£341.00
£140.00
£195.00
£649.00
£572.00
£1177.00
£875.00
£150.00

overseas

(exc. vat & carriage)
£471.00
£385.00
£495.00
£380.00
£105.00
£510.00
£395.00
£110.00
£410.00
£354.00
£105.00
£420.00
£365.00
£110.00
£237.00
£212.00
£85.00
£167.00
£167.00
£95.00
£185.00
£66.00
£130.00
£399.00
£291.00
£120.00
£167.00
£553.00
£487.00
£1002.00
£745.00
£130.00

loudspeaker kits

KLS3 Goid mkII Drive Units
KLS3 Gold mk II Drive Units + Crossover Kit etc
KLS10 Drive Units
KLS10 Drive Units + Crossover Kit etc
KLS10-Subwoofer Drive Units
KLS10 Drive Units + Crossover Kit etc

order No.

KLS3G-D
KLS3G-C
KLS10D
KLS10C
KLS10-subD
KLS10-subC

qty

Vertical column of checkboxes for quantity selection

uk

(inc vat & carriage)
£495.00
£633.00
£394.00
£433.00
£78.00
£164.00

overseas

(exc. vat & carriage)
£422.00
£539.00
£336.00
£369.00
£67.00
£140.00

parts description

KIT/KaT6550 mains transformer
KIT34 mains transformer
Kel84 E/I mains transformer
Kel80 mains toroidal transformer(encapsulated)
HD83 mains toroidal transformer
PSU-II mains toroidal transformer
300B PSE E/I mains transformer
KIT34 E/I choke
Kel84 E/I choke
KIT6550 choke
300B PSE choke
PSU-II E/I choke
KIT34 E/I UL push pull output transformer
Kel84 E/I push-pull output transformer
Kit88/Kat88 E/I push-pull output transformer
Kel80 E/I parallel-push-pull output transformer
HD83 E/I single ended output transformer
Pre-II E/I driver transformer
300B PSE E/I output transformer
Kel84 Printed Circuit board
KIT88/KaT88 Printed Circuit Board
Kel34 Printed Circuit Board
Kel80 Printed Circuit Board
HD83 Printed Circuit Board
PSU-II Printed Circuit Board
PRE-II Printed Circuit Board
PHONO-II Printed Circuit Board
Tag board 2 x 16 connections (hard wiring)
Alps blue audio grade 50K dual log potentiometer
Alps blue audio grade 100K dual log potentiometer
Stepped attenuator with resistor pack 10K of 50K (pls specify)
LCR 22.5uF 440Vdc polypropylene capacitors
Ansar 22.5uF 630Vdc polypropylene capacitors
Jensen 0.47uF 630Vdc paper in oil capacitor
Jensen 0.22uF 630Vdc paper in oil capacitor
Jensen 0.22uF, 400V paper in oil capacitor
Black Gate 220uF 50Vdc electrolytic
Black Gate 4700uF 16Vdc electrolytic
Black Gate 100uF 100Vdc electrolytic
Black Gate 470uF 16Vdc electrolytic
Black Gate 1000uF, 16V electrolytic
Black Gate 100uF, 50V electrolytic
650V safety gloves (a pair)
2A3 PSE/6550/34 cage

order No.

6550 mains T
KIT34 - mains T
Kel84 - mains T
Kel80 - mains T
HD83 - mains T
PSU-II - mains T
300B - mains T (each)
KIT34 - choke
Kel84 - choke
KIT6550 choke
300B - choke
PSU-choke
34 - O/P T (pair)
Kel84 - O/P T (pair)
88 - O/P T (pair)
Kel80 - O/P T (pair)
HD83 - O/P T (pair)
PRE-II - driver T (pair)
300B - O/P T (each)
Kel84 - PCB
88 - PCB
Kel34 - PCB
Kel80 - PCB(pair)
HD83 - PCB
PSU-II - PCB
PRE-II - PCB
PHONO-II - PCB
TAG
ALPS - 50K
ALPS - 100K
Attenuator + resistor pack
LCR - 22.5U
ANSAR - 22.5U
JEN - 0.47U
JEN - 0.22U
JEN - 0.22U, 400V
BG - 220U
BG - 4700U
BG - 100U
BG - 470U
BG - 1000U16V
BG - 100U50V
SAFETY GLOVES
2A3 PSE/34/6550 cage

qty

Vertical column of checkboxes for quantity selection

uk

(inc vat & carriage)
£110.00
£100.00
£55.00
£83.00
£39.00
£39.00
£130.00
£45.00
£20.00
£45.00
£50.00
£20.00
£130.00
£88.00
£143.00
£187.00
£94.00
£77.00
£140.00
£24.00
£41.00
£12.00
£52.00
£20.00
£20.00
£20.00
£20.00
£3.50
£14.00
£14.00
£75.00
£10.00
£18.00
£20.00
£16.00
£12.00
£12.00
£12.00
£16.00
£10.00
£8.00
£8.00
£6.00
£14.00
£65.00

overseas

(exc. vat & carriage)
£95.00
£85.00
£47.00
£71.00
£34.00
£34.00
£111.00
£39.00
£17.00
£38.00
£43.00
£17.00
£110.00
£75.00
£122.00
£160.00
£80.00
£66.50
£119.00
£20.90
£35.15
£11.40
£44.65
£17.00
£17.00
£17.00
£17.00
£3.00
£12.00
£12.00
£65.00
£8.50
£15.20
£17.00
£14.00
£10.20
£10.20
£13.60
£8.50
£7.00
£6.80
£5.20
£12.00
£55.00

World Audio Design Amplifiers fully built from Malaysia

Table with 2 columns: Title, Description, Price (exc. VAT + Carriage)

Order from our Far East Distributor: Millenium Hi-Fi & AV

137 Jalan Pendekar 2, Taman Skudai Baru, 81300 Skudai, Johor DT, Malaysia
Tel: 07 554 5171 - Fax: 07 554 7645 - email:mha8@pd.jaring.my

order information

NAME:
ADDRESS:
POST CODE:
COUNTRY:
TEL. (DAY):

Tel/Fax: 01908 218 836

I enclose cheque/postal order for £ made payable to World Audio Publishing Ltd. I wish to pay by Mastercard / Visa /Switch/ Solo. Please debit my account no:

Expiry Date: Signature: Issue No. (Switch/Solo only) Valid Date:

Prices were correct at time of print, 01/01/02 they are subject to change
If you wish for a built item, please phone for a quote / Valves included except where otherwise stated.If you would like a data sheet on any of the kits, please write a 'D' in the qty box
WARNING - World Audio Publishing Ltd accept no responsibility for kits, parts or modifications made or supplied by third parties.Order on our website www.worldaudiodesign.co.uk
Please send your completed order form to: WORLD AUDIO PUBLISHING LTD 12a Spring Gardens, Newport Pagnell, Milton Keynes, Bucks MK16 0EE
Tel/Fax 01908 218836 e mail orders@worldaudiodesign.co.uk



## WE HAVE OVER 30

### AUDIO ELECTRONIC THEORY BOOKS



**Electronics made Simple**  
by **Ian Sinclair**  
This books covers the basic theory and principles of electronics. A good read for the beginner.  
Code No. 1420  
£12.99 + £2.00 P&P (UK)



**Build your own High-End Audio Equipment**  
by **Elektor**  
Build your own High-End Audio equipment contains construction projects for solid state preamplifiers and power amplifiers, active cross-over filters, an active subwoofer, a mono/stereo compressor and a headphone amplifier.  
Code No. 1390  
£14.95 + £2.25 P&P (UK)



**Practical Electronic Fault-Finding and Troubleshooting**  
by **Robin Pain**  
This book explains the basic techniques needed to be a troubleshooter, using only basic equipment: a digital multimeter and an oscilloscope. Simple circuit examples are used to illustrate principles and concepts fundamental to the process of fault finding.  
240pp 235mm x 156mm Paperback  
Code No. 1430  
£20.99 + £2.25 P&P (UK)



**Build your own Electronic Test Instruments**  
by **Elektor**  
This book contains designs for 17 measuring instruments, seven generators and analysers, ten miscellaneous instruments and a number of test ancillaries and auxiliaries. The designs range from a simple multicore cable designs contain a special printed circuit, drawing of which are given in an appendix.  
Code No. 1400  
£15.95 + £3.25 P&P (UK)



**The LP is back**  
by **Audio Amateurs**  
Your complete guide to LP care and maintenance designed to offer you everything useful for those who love and enjoy this older music medium. This covers the theory and care of LPs and the electronics and mechanics of its players.  
154pp Paperback  
Code No. 1620  
£8.00 + £1.50 P&P (UK)

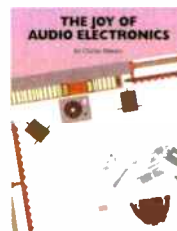

**The Joy of Audio Electronics**  
by **Charles Hansen**  
This is a fail-safe guide to the pleasures of hands-on electronic construction. This book covers test and measurement projects, how to build simple kits, safety issues, the workplace, theory and resources. A must for the beginner who plans to build more advanced electronic projects in the future.  
124pp Paperback  
Code No. 1650  
£10.50 + £2.25 P&P (UK)

### VALVE BOOKS

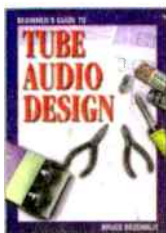

**The Beginner's Guide to Tube Design**  
by **Bruce Rozenblitz**  
This book takes a comprehensive look at tube audio design. It explains how vacuum tubes work and how to design with them. Rozenblitz covers stabilisation and testing, a description of 13 famous and classic amps and preamps and how to work effectively as a designer. A hands-on guide to construction techniques, tools and choosing components and tubes is provided. 1997. 132pp., 8 1/2" x 11" Paper back  
Code No. 1340  
£15.50 + £2.25 P&P (UK)



**Vacuum Tube Amplifiers**  
by **Valley & Walkman**  
This book is a well known reference valve text book and is assembled from pieces by ten knowledgeable authors. An absolute bible when it comes to valve electronics.  
734pp 140mm x 210mm  
Paperback  
Code 1770  
£29.95 + £ 4.00 P&P (UK)

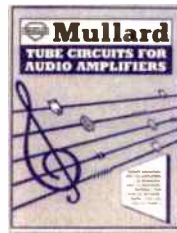

**Mullard Tube Circuits for Audio Amplifiers**  
Includes full designs for eleven power and control amps, including 5-20, using valves. Begins with a four chapter tutorial on getting the best sound from valve amplifiers.  
142pp 8" x 10" Paperback  
Code 1030  
£13.95 + £1.50 P&P (UK)

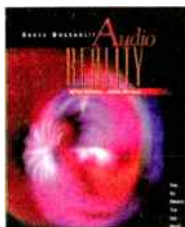

**Audio Reality**  
by **Bruce Rozenblitz**  
A fine read that investigates conductors, skin effect, impedance, interconnects, speaker cables, balanced lines, transmission lines, power cords, isolation transformers, damping systems, tubes, acoustics and much more. Also, includes 6 excellent detailed valve design projects, 80watt OTL, 25watt OTL, grounded grid pre-amp, 150watt amp., 6550 SE amp. and a grounded grid cascode phono preamp.  
Paperback 128pp  
Code No 1640  
Price 21.50 + 2.25 P&P (UK)



**An Approach to Audio Electronic Valves in Audio Frequency Amplifiers**  
by **E. Rodenhuis**  
Originally published in 1954 by Philips, this book encourages amp. builders to experiment with design elements. Discussing the use of valve data, the function of different amplifier stages and includes detailed descriptions of eight designs. A wealth of practical data, measurements and interesting features will be found. A very good read.  
Paperback 147pp  
Code No. 1520  
Price £12.95 + £2.00 P&P (UK)

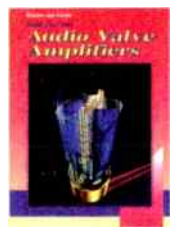

**Build your own Audio Valve Amplifiers**  
by **Rainer Zur Linde**  
This book covers construction projects for preamplifiers, power amplifiers and tv amplifiers for musical instruments aimed at the practical audio/hi-fi enthusiast, it offers much information on the operation of electron tubes, while the first chapter gives a short history of the thermionic valve.  
paperback, 251 pp., 235mm x 13mm  
Code No. 1320 £14.95 + 2.25 P&P (UK)



**Radio Designer's Handbook 4th Edition**  
by **Fritz Langford-Smith**  
This is a classic reference handbook for all who are interested in the design and application of audio amplifiers and radio receivers, and deals with basic principles and the practical design of all types of classic audio amplifiers, radio receivers and record-producing equipment up to the invention of the transistor, covering valves, valve testing, general theory and components: audio and radio frequencies: power supplies, design of complete AM and FM receivers, and reference information.  
1498pp 216mm x 138mm Hard back  
Code No. 1600  
£39.99 + £6.00 P&P (UK)

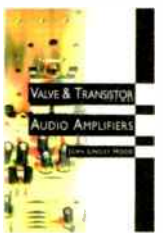

**Valve & Transistor Audio Amplifiers**  
by **J.L. Hood**  
This is J.L. Hood's greatest work yet, describing the milestones that have marked the development of audio amplifiers, from the earliest valve amps to the latest solid state design. It is the complete world guide to audio amp design. Other contents: active & passive components, amplifiers, pre-amplifiers and power supplies.  
250pp., 156mm x 232mm Paperback  
Code No. 1530  
£20.99 + £3.50 P&P (UK)

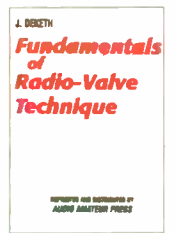

**Fundamentals of Radio-Valve Technique**  
by **J. Dekeith**  
This is part of the Philips technical series written in 1947 it was one of the most authoritative and comprehensive treatment of the nature and function of the vacuum tube.  
534pp 6" x 9" Paper back  
Code No. 1630  
£21.50 + £2.50 P&P (UK)

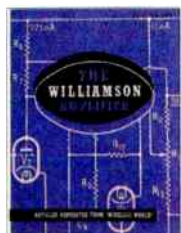

**The Williamson Amplifier**  
by **D.T.N. Williamson**  
Offers practical advice on how to build and set up the amplifier for best results.  
40pp 8 1/2" x 11" Paper back  
Code No. 1040  
£9.95 + £1.50 P&P (UK)



**Valve Amplifiers (second edition)**  
by **Morgan Jones, Audio Engineer**  
This book allows those with a limited knowledge of the field to understand both the theory and the practice of valve audio amplifier design, such that they can analyse and modify circuits, and rebuild an amplifier. Constructional techniques are also provided so readers can build from scratch designs that actually work.  
488pp 6" x 9 1/4" Paper back  
Code No. 1330  
£25.99 + 3.50 P&P (UK)



**The Best of Audion editorial projects**  
by **Luciano Marci**  
This book contains six excellent audio project: a high sensitivity speaker, a superb tube pre-amp a 2A3 amplifier design, a project using the Russian 6C33CB and two projects using 300B as output valves. Overall the book is a fabulous read.  
62pp. paper back  
book code 1750  
£12.00 + £2.00 UK ptp

ORDER 4 BOOKS & OVER & PAY ONLY £7.00 FOR P&P (UK ONLY)

## TITLES ON OFFER!!!



**Manuale HI-FI a valvole Schemario 2'**  
An Italian publication with all circuit diagrams in standard conformation, therefore, all circuits are easy to follow. This book is dedicated to self makers and to HI-FI tube engineers. With a wealth of circuit diagrams from some of the best valve amplifiers, pre-amplifiers and phono equipment producers in the world. Including, Audio Research, Altec, Conrad Johnson, Art Audio, Luxman, Carver, Dynaco, Electrovoice, Leak, McIntosh, Marantz, Quad, Radford, Quick Silver, numerous OTL designs, Verdier, VTL and Western Electric. Well worth the money.  
208pp, 210mm x 300mm Paperback  
Code No. 1720  
£44.00 + £4.00 P&P (UK)



**Getting the most out of Vacuum Tubes**  
by Robert B. Tonner  
From the cover, "Types and causes of tube failures, what to expect from tubes, testing methods and all about tube maintenance programs." This book is intended to offer explanations of why tubes fail and what to do about it. Discussions of catastrophic and degenerative failures; selecting tubes and tube types and testing and predicting tube performance.  
160pp 140mm x 216mm  
Paperback,  
Code No. 1710  
£13.95 + £2.00 P&P (UK)

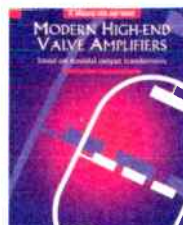

**Modern High-End Valve Amplifiers Based on Toroidal Output Transformers**  
by Menno van der Veen  
Explains the why and whereof of toroidal output transformers at various technical levels. Discussed extensively within this book are designs for amplifiers from 10 to 100 watts. Finally, the author gives some attention to a number of special valve amplifiers, and to the theory and practice of negative feedback.  
250pp 170mm x 240mm  
Hard back  
Code No. 1670  
£24.95 + £2.50 P+P (UK)



**First in High Fidelity The Products and History of H. J. Leak & Co. Ltd.**  
by Steven Spicer  
This book is the unique and comprehensive story about one of the world's best high-fidelity audio companies. Contained are 300 pictures, 30 circuit diagrams for classic designs of the day. There are also numerous anecdotes and contributions from ex-employees. A wonderful historical read.  
270pp 195mm x 264mm Paperback  
Code no. 1740  
£19.95 + £3.25 p+p UK



**Basic Theory and Application of Electron Tubes**  
A US Army & Navy Publication  
This book is an excellent introduction into valves. It does just about everything its title suggests. Written in 1957 it was used by the US military as a text book in their electronics department. Superbly written it contains all you need to know.  
215pp  
200mm x 260mm Paperback  
book code 1760  
£17.95 + £3.25 P&P (UK)



**Sylvania Technical Manual**  
by Sylvania Electric Products Inc.  
This 13th edition contains data on more than 3300 electron tubes and semiconductor devices. Reprinted here without the TV picture tube section, this manual contains detailed information on Sylvania's devices including charts and diagrams. A master index is found in the front of the book for reference.  
516pp 140mm x 216mm Paper back  
Code No. 1700  
£16.95 + £3.50 UK p+p

### LOUDSPEAKER BOOKS



**Testing Loudspeakers+**  
by Joe D'Appolito  
Joe D'Appolito, loudspeaker designer and consultant, has written the definitive text on testing loudspeakers. Dr. D'Appolito brings his expertise to the subject and provides you with a hands-on discussion of testing drivers and systems. He brings you the theory and physics behind loudspeaker testing in this volume.  
Paperback  
Code No. 1580  
£24.95 + £2.50 P&P (UK)

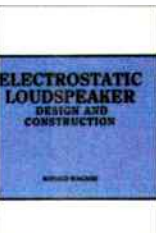

**Electrostatic Loudspeaker Design and Construction**  
by Ronald Wagner  
Step by step guide to the design and construction of a full range electrostatic loudspeaker, including basic operating principles. Strongly recommended for those wanting to either build, repair and/or restore, or who are just interested in electrostatics.  
243pp 7" x 9 5/8" Paperback  
Code No. 1080  
£16.95 + £3.25 P&P (UK)



**The Loudspeaker Design Cookbook, 6th edition (new)**  
by Vance Dickason  
This best seller offers up-to-date design information for the home constructor. It uses modern Thiele-Small theory and parameters.  
288pp 8 1/2" x 11 1/2" Paperback  
Code No. 1090  
£29.50 + £4.00 P&P (UK)



**Bullock On Boxes**  
by Robert M. Bullock III  
Using Thiele-Small parameters clearly, it offers lots of helpful tables and graphs to get to grips with the sizing of the box and port of a reflex loudspeaker.  
72pp 8 1/2" x 11" Paperback  
Code No. 1100  
£12.95 + £2.00 P&P (UK)

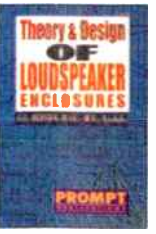

**Theory and Design of Loudspeaker Enclosures**  
by J. E. Benson  
Covers infinite baffle, reflex, passive radiator etc. in great detail with a highly mathematical approach, making it unsuitable for beginners but highly authoritative for experienced designers.  
244pp 8" x 9" Paperback  
Code: 1140  
£23.95 + £2.50 P&P (UK)



**Horn Loudspeaker Design**  
by Mr. J. Dinsdale  
A collection of papers by Mr. J. Dinsdale, that discuss the design and theory of the wonderful breed of loudspeaker. The book contains detailed drawings of numerous designs, including some Lowther classics. Also included with the book is a 3.5inch floppy disc with straight forward software to assist in the design process. A serious reference for those with an interest in horn speakers.  
112pp paper back & 3.5 floppy disc  
210mm x 300mm  
Code: 1730  
£29.50 + £2.50 P&P (UK)



**Audio Amateur Loudspeaker Projects**  
A collection of the 25 best speaker articles published in the Audio Amateur throughout the 1970s, this popular book is proof that great designs are never out of date. This volume is a rich source of theory, practice and design.  
135pp 8 1/2" x 11" Paperback  
Code No. 1550  
£16.95 + £2.50 P&P (UK)

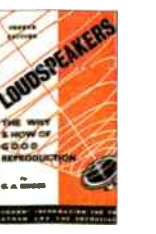

**Loudspeakers: The Why and How of Good Reproduction**  
by G.A. Briggs  
An easy to understand book on building loudspeakers, using empirical techniques that pre-date computer analysis. Strongly recommended for beginners.  
88pp 5 1/2" x 8 1/2" Paperback  
Code: 1070  
£10.95 + £1.50 P&P (UK)

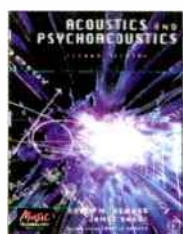

**Acoustics & Psychoacoustics 2nd Edition**  
by David M. Howard & James Angus  
An introduction to acoustics, covering human perception of sound, notes and harmony, musical dynamics, timbre of musical instruments, acoustic model for musical instruments, hearing music different environments, deceiving the ear and processing sound electronically.  
224pp 244 x 189mm  
paperback  
Code: 1370  
£29.99 + £3.50 P&P (UK)

### ORDER FORM

Please send (Code No.) \_\_\_\_\_ (enter codes clearly)  
Pay: World Audio Publishing Ltd. £ \_\_\_\_\_ or debit my Mastercard/Visa/Switch/Solo (Card No) \_\_\_\_\_  
Expiry date: \_\_\_\_\_ (Switch/Solo only) Valid Date: \_\_\_\_\_ Issue No. \_\_\_\_\_ Name: \_\_\_\_\_ Signed: \_\_\_\_\_  
Delivery Address: \_\_\_\_\_  
Tel: (Day) \_\_\_\_\_ Please return to: W.A.P. Ltd, 12A Spring Gardens, Newport Pagnell, Milton Keynes, MK16  
OEE, ENGLAND TEL/FAX: 01908 218836 **ORDER ON LINE** Website: [www.worldaudiodesign.co.uk](http://www.worldaudiodesign.co.uk) E-Mail: [nick@worldaudiodesign.co.uk](mailto:nick@worldaudiodesign.co.uk)  
Please contact us for overseas P&P charges. Allow 28 days for delivery. All orders subject to availability. If further space is required please attach separate sheet.  
 TICK BOX IF YOU HAVE ORDERED BEFORE

ORDER 4 BOOKS & OVER & PAY ONLY £7.00 FOR P&P (UK ONLY)



HI-FI

HOME CINEMA

MULTIROOM INSTALL

BUY / SELL

**Quarterly Sale items**

	Our Price	Original Retail Price
Kenwood LI000C pre/ LI000M Power Amp	£795.00	£2,500.00
Pioneer A300 Int	£90.00	£180.00
Exposure VII pre + XII psu	£595.00	£1,200.00
Cyrus Dac Master & Cyrus Disc Master	£695.00	£1,798.00
Harmon Kardon AVPI	£175.00	£ -
Cary 572 se Monoblocks	£1,295.00	£2,350.00

**New this month**

**POWER AMPLIFIERS**

Bryston 4 BST	£On Dem	£2,050.00
Musical Fidelity A 300 int	£995.00	£1,600.00
Musical Fidelity A370 mk II	£1,295.00	£ -
Krell FPB 600	£7,995.00	£12,900.00
Krell FPB 250M Monoblocks	£6,450	£10,000

**PRE AMPLIFIERS**

AVI S2000 MP remote pre	£495.00	£1,000.00
-------------------------	---------	-----------

**LOUDSPEAKERS**

ATC SCM 20A	£1,995.00	£3,300.00
Audio Physic Avant III X-dem	£6,499.00	£7,499.00
Dynaudio Contour 1.3 + stds	£695.00	£1,400.00
Sonus Faber Concerto + stds	£750.00	£1,300.00
Genelec 205 Active Monitors	£On Dem	£750.00
Audio Physic Caldera	£5,995.00	£10,000.00

**CD PLAYERS & DACS**

Wadia WT 3200 Transport AT&T	£1,295.00	£3,000.00
Wadia X 64.4 AT&T/ Bal	£1,395.00	£5,000.00

**TURNTABLES, ANALOGUE, VARIOUS**

Marantz ST17 Tuner	£295.00	£600.00
Adjuster Racks (Aluminium/ Perspex)	£On Dem	firm £300.00
Musical Fidelity x Cans	£85.00	£149.00
DPA Mains Conditioner	£75.00	£140.00

**PLASMA MONITORS**

Panasonic TH-42 PWD4 "new"	£4,995.00	
----------------------------	-----------	--

**Power amplifiers**

Krell KSA 250	£2,995.00	£6,995.00
Krell Kav 250a	£2,695.00	£3,698.00
Krell 300i Integrated	£1,795.00	£2,550.00
Audio Research M300 Monoblocks	£4,995.00	£12,000.00
Naim Nap 30	£295.00	£650.00
Krell MDA 300	£4,995.00	£12,000.00
Oracle S3000 Integrated amplifier "new"	£On Dem	£9,500.00
Bryston 7 BST Monoblocks "new"	£On Dem	£4,000.00
Cary SLA 70 mk II Silver	£1,295.00	£2,250.00
Linn LK 100	£345.00	£650.00
Boulder 500 AE	£2,850.00	£5,500.00
Acuphase E203 Integrated Amp	£795.00	£ -
Melos 402 Monoblocks	£4,495.00	£9,000.00
Krell FPB 300	£5,995.00	£9,990.00
Linn Klassik	£895.00	£1,030.00
Boulder 1060 Power "new"	£On Dem	£16,500.00
Cary Audio 300 SE Sig.VVE300B	£3,495.00	£5,304.00
Primare 30.1 mk II Integrated	£1,350.00	£1,500.00
Plinius SA100 "new"	£On Dem	£3,400.00
Krell 250 A/3 3 Chanel amp	£2,995.00	£4,698.00
Graff GM200	£4,750.00	£8,000.00
Cary SLA 70 mk II	£995.00	£2,250.00
Audio Research Ref 600 mk II	POA	£40,000.00
YBA Passion Monoblocks "new"	£On Dem	£8,995.00
YBA Passion Stereo "new"	£On Dem	£5,995.00
Krell FPB 300c	£8,500.00	£9,998.00
Sunfire 300 Power Amp	£995.00	£2,400.00
Plinius 250 mk IV "new"	£On Dem	£6,000.00
Audio Note Kasi	£12,495.00	£30,000.00
Cary 805 C Monoblocks "new"	£On Dem	£8,250.00
Krell FPB 600 c	£9,995.00	£14,994.00

**AV components**

**AV COMPONENTS**

Krell HTS (AV Processor)	£4,495.00	£6,498.00
Audio Refinement Pre 5 "new"	£On Dem	£895.00
Audio Refinement Multi 5 (Power) "new"	£On Dem	£2,250.00
Lexicon MC1 "new"	£3,500.00	£5,500.00
Lexicon MC12 "new"	£On Dem	£8,100.00

**TELEVISIONS & DVD PLAYERS BY LOEWE**

Loewe Xemix DVD "new"	£On Dem	£495.00
Loewe Aconda	£POA	
Loewe Planus + Std	£POA	
Loewe Xelos + Std	£POA	
Loewe L2A Active Speakers	£POA	

**PLASMA/LCD/PROJECTORS**

From NEC/ Panasonic/Pioneer/Sharp	frm £4000.00	POA
Electrograph Delphi/Seleco/Sony/Sanyo	-	POA

**Pre amplifiers**

Audio Research SP9 mk II	£995.00	-
Mark Levinson 380 S	£4,250.00	£6,900.00
Audio Research LS3B (Black/ remote)	£1,395.00	£2,700.00
Krell KRC 2	£1,995.00	£3,400.00
CAT SLI Sig Pre Amp	£2,495.00	£5,995.00
Hovland HP100 Line Pre	£POA	£4,950.00
Audio Synthesis Passion 8M bal/ remote	£1,095.00	£1,895.00
BAT VK50SE	£5,295.00	£6,500.00
Krell KSL 2 Pre	£1,750.00	£3,000.00
Cary SLP98L Remote Pre	£1,495.00	£2,794.00
BAT VK5i + remote	£2,350.00	£3,995.00

Cary SLP 74 pre	£695.00	£1,500.00
Boulder 1012 (pre amp/ 24.96 dac/ Phono)	£On Dem	£13,000.00
Trilogy 901 Pre	£495.00	£995.00
Krell KSL + Phono	£1,295.00	£ -
YBA I Alpha Pre mm/mc + psu "new"	£On Dem	£4,900.00
YBA Passion Pre + mc "new"	£On Dem	£5,595.00
Boulder 2010 Pre	£POA	£30,000.00
Plinius 16L "new"	£On Dem	£3,200.00
C.A.T. ultimate reference Pre Amp Inc/ Phono "new"	£On Dem	£5,750.00
Audible Illusions P3A Pre MM/MC mk II "new"	£On Dem	£3,140.00
Mark Levinson No 28	£1,295.00	£4,000.00
Naim 42.5	£150.00	£450.00

**Quality speakers**

Proac Response 3 (Black)	£1,695.00	£3,250.00
Kef Ref 3 Pallisander	£1,495.00	£2,900.00
Audio Physic Virgo II	£1,895.00	£3,200.00
Proac Response 1 sc	£795.00	£1,295.00
Audio Physic Virgo III "new"	£On Dem	£4,000.00
Apogee Stage	£795.00	£ -
Wilson System 5.1	£7,995.00	£18,000.00
Acoustic Research LST	£495.00	£ -
Thiel 7.2	£7,995.00	£14,000.00
ATC SCM 20 SL (Black)	£1,495.00	£2,051.00
Soundlab A3 Plus	£3,995.00	£12,000.00
JM Lab Utopia (Ex Dem)	£12,495.00	£18,799.00
Vienna Acoustics Mozart	£1,095.00	£1,500.00
Audio Plan Contrast 3	£1,395.00	£3,200.00
Avalon Ascents	£6,995.00	£12,000.00
JM Lab Micro Utopia + Std	£2,750.00	£4,248.00
JM Lab Mini Utopia + Std	£2,995.00	£5,248.00
JM Lab Mezzo Utopia	£5,499.00	£7,799.00
Audio Physic Tempo III "new"	£On Dem	£2,000.00
Naim SBL's	£1,295.00	£2,225.00
ClaraVox Magnifica	£6,995.00	£14,500.00
Ensemble Speakers PAI	£995.00	£2,000.00
Audio Physic Caldera "new"	£On Dem	£10,000.00
Audio Physic Libra	X-demo	£4,799.00
Audio Physic Rhea Sub	£1,850.00	£3,099.00
Audio Physic Spark "new"	£On Dem	£1,749.00
Rogers LS55 "new"	£330.00	£430.00

**CD players & DACS**

Micromega Duo CD 3	£895.00	£1,795.00
Wadia 860 x	£4,295.00	£7,500.00
DPA Enlightenment DAC	£395.00	£825.00
Theda Pro Geny	£595.00	£1,295.00
YBA CD1 Delta "new"	£On Dem	£4,000.00
Audio Aero "new"	£On Dem	£3,500.00
Meridian 508 (24/96)	£1,195.00	£2,250.00
Oracle CD1000 Transport "new"	£On Dem	£3,950.00
Tag Maclaren CD220R	£995.00	£1,500.00
Audio Lab 8000 DAX	£995.00	£1,600.00
Mark Levinson 30.5/ 31	£9,995.00	£24,000.00
Mark Levinson 31/35	£ -	£5,995.00
Oracle CD2000 Transport "new"	£On Dem	£17,000.00
Sony CDRP/ DAS R1	£2,995.00	£6,000.00
Krell KPS 25s 24/96	£14,995.00	£22,500.00
Audiomeca Kreatura Transport/ Elexir DAC	£1,295.00	£2,800.00
Acuphase DP70	£1,895.00	£ -
Acuphase 90/91	£6,999.00	£16,000.00
YBA CD Speciale	£395.00	£675.00
Audio Refinement CD Complete	£650.00	£875.00
Boulder 2020 dac	£POA	£24,000.00
Krell KPS 25sc	£18,995.00	£23,498.00
Theda Data II Transport AT + link	£1,995.00	£4,000.00
YBA CD Integre "new"	£On Dem	£1,195.00

**Turtables & analogue**

Krell Kav Processor	£6,500.00	£14,000.00
Transparent Music Link Ultra XL	£995.00	£2,100.00
Cardas Golden Ref 8ft Pair	£995.00	£2,200.00
SME 30/2 A "new"	£9,850.00	£12,289.00
Pierre Lurine J1/ SL5	£1,695.00	£4,000.00
Michel Iso Phono + Hera	£325.00	£495.00
Goldmund Reference/ T3F	£8,995.00	£30,000.00
Ortofon Kontrapunkt a/b "new"	£On Dem	£500.00

Michell Gyro SE/ RB300 "new"	£On Dem	£1,100.00
Elemental 4 Tier (Fixed)	£1,295.00	£2,000.00
Roksan Shiraz	£450.00	£1,000.00
Michell Orbel/QC	£1,495.00	£2,200.00
Audio Synthesis Phono Eq mm/mc	£795.00	£ -
Voyd Valdi/ Orion	£695.00	£ -
Gryphon Phono Pre-Amp (dual mono) Head Amp	£795.00	£1,600.00
Parasound TQ1600 (remote tuner)	£295.00	£400.00
SME Series V Arm	£995.00	£1,650.00
Wilson Benesch Act 2	£895.00	£1,400.00
Rotel Michi Phono	£695.00	£1,200.00
Rockport System II c/w Air stand, vac hold & arm	£18,000.00	£33,000.00
Michell Surroundings Phenomena Phono Stage	£495.00	£ -
Pink Triangle PTToo SA/RB300S/W	£795.00	£ -
Plinius 14 Phono "new"	£On Dem	£2,750.00
Transparent Audio Music Wave Ultra XL Bi-Wire	£2,100.00	£4,000.00
Cary PH301 MM/MC	£895.00	£1,695.00
Nackamichi DR 3	£225.00	£400.00
Tom Evans - The Groove "new"	£On Dem	£1,795.00
Clear Audio Reference Mc phono stage X-demo	£1,695.00	£2,065.00
Rega Planer 3 + Hi Fi News Out Board		
Power Supply	£320.00	£423.00
Clear Audio Symphono phono stage		
X-demo MM/MC	£640.00	£740.00
Lavardin Reference Phono "new"	£On Dem	£2,500.00

\* Reduced this month

**Choice hi-fi you choose**

Choice hi-fi make it easy for you to fulfill your sonic dreams. Quality hi-fi is not just about expensive brandnames. It's about aspiring to the very best sound, about choosing your ideal system from the widest selection in the country, in a unique no-pressure environment.

**your choice**

- Acoustic Energy
- Advantage
- ATC
- Audible Illusions
- Audio Physic
- B.A.T
- Boulder
- Bryston
- Cary
- C.A.T.
- Chord
- Clear Audio
- Denon
- DNM
- Egglaston Works
- Electrograph Delphi
- Genelec
- Gryphon
- Graham
- Imerge
- J M Lab
- Krell
- Lexicon
- Linn
- Loewe
- Lutron
- Lyra
- Mark Levinson
- Michell Eng.
- Musical Fidelity
- Naim
- NEC
- Nordost
- Oracle
- Ortofon
- Plinius
- P.M.C.
- Primare
- Project
- Quadraspire
- REL
- Rockport
- Roksan
- Rotel
- Ruark
- Seleco
- SME
- Straight Wire
- Sugden
- Tara Labs
- Teac
- Totem
- Transfiguration
- Trichord
- Trilogy
- Van den Hul
- VPI
- Wilson Audio
- Wilson Research
- YBA

tel: 020 8392 1959 & 020 8392 1963  
 fax: 020 8392 1994 info@choice-hifi.com

Open from 10am to 6pm Mon-Sat and other times by appointment. Buy, sell, exchange quality hi-fi equipment.

We accept all World Radio History cards. Finance available subject to status

"Everyone knows that blue-laser technology exists," he said. "We've decided that it's best to announce our technology agreement early on, in order to avoid confusion and speculation." I had to smile at this comment, because since Jan Oosterveld of Philips made it there's been a torrent of speculation about Blu-ray. As for confusion, there's so much of that right now it couldn't get any worse. Or could it? With frightening predictions that Blu-ray could hit the market in 2003, just one year's time, one report I've seen has already accused the consumer electronics industry of cannibalism: "they're doing what they like to do – eat their young!" This is good, torrid journalism, but with Blu-ray the writer has a point. Just as people around the world have decided DVD is for them the CE business suddenly announces its successor, suggesting it is all over for DVD just as it was gaining life. I know the CE business can get it a little wrong at times, but this wrong? I suspected Blu-ray was not about to appear in one year's time and soon found, after a few strategic telephone calls, that all sorts of complications and accusations lie behind this story.

Blu-ray is a new recordable video disc, the size of a CD and able to store a massive 27GB of information. That's way above CD's 0.6GB and DVD's 4.7GB. On paper it looks like Blu-ray is a potential successor to DVD - but I'm assured it is not, so let's take a look at this. Whilst the only person enthusiastic about digital TV in Britain is a monkey and his mate, there's little talk of trying to get people to watch anything more complex, especially digital HDTV. In America the picture is very different. There, the plan is to roll out digital TV progressively and switch off all analogue transmissions by 2006. This represents a bonanza for the world's TV makers, so understandably they're busy developing everything from TVs through to new video recorders to cope.

Recordable DVD as it stands can't readily cope with anything more demanding than conventional TV. It uses a single-layer, single-sided disc of 4.7GB capacity that can just manage 2hrs TV at a quality level that I have found to be

pretty mediocre. Playback-only DVD discs can be stretched to 9GB of storage using a double layer disc, or even 18GB with a double-sided double layer disc, so they may well be satisfactory for high quality pre-recorded movies, but this precludes them from home recording use.

The race is on for a recording system both more capable and less confusing than DVD. We now have three recordable DVD formats: DVD-RAM, DVD-RW and DVD+RW. They should all produce a playable (i.e. compatible) DVD disc, but they do not.

## On paper it looks like Blu-ray is a potential successor to DVD.

The Japanese DVD forum, led by Toshiba, fouled up on this, which has muddied the waters no end. It has also encouraged speculation that Blu-ray is an attempt to launch a more advanced and compatible video recording system that eliminates the confusion surrounding recordable DVD. Nine manufacturers have formed an independent group outside the DVD forum to promote Blu-ray: Hitachi, LG Electronics, Matsushita (Panasonic, Technics), Pioneer, Philips, Samsung, Sharp, Sony and Thomson Multimedia. Meanwhile, the DVD forum continues to plan its own, new higher capacity formats. It was pointed out to me that it is not in the interests of companies developing Blu-ray to provide any sustenance to recordable DVD, hence the rumours of Blu-ray becoming available in just one year. The idea is to discourage people from buying recordable DVD of course. My source said it will be more like 4 years before Blu-ray recorders appear, although I wonder whether that might be a little pessimistic.

I somehow can't help feeling we'll see the technology before this, but there are some problems. The main one is cost. Blu-ray would require significant investment by disc pressing plants, because the system uses a blue-violet 405nm wavelength laser instead of DVD's 650nm red laser. Its shorter wavelength means the grooves and pits can be shrunk

down, greatly increasing disc capacity. Disc pressing equipment would have to be updated and there's resistance to this from film companies. Also, the disc is protected by a caddy, which historically increases media cost. Both DVD-RAM and Minidisc have suffered because of this.

All in all, Blu-ray recorders and discs will be more expensive than DVDs, that's for sure, and traditionally the total ownership cost of a medium has been a key issue determining its acceptance.

What about audio? So far the audio soundtrack standard is a little odd, providing up to six channels of conventional surround-sound, sampled at 48kHz with up to 24-bit resolution. I am a bit surprised they didn't go for 24/96 here, to rival DVD. Using the full data capacity of the disc, audio of virtually any resolution could be recorded of course and a Blu-ray recorder may well be able to play back all audio formats, from CD through to DVD-A. I don't think Blu-ray is about to hit the streets tomorrow in any form you or I would find practical or affordable, but there's going to be plenty of speculation and confusion about it after February's announcement. ●



Noel Keywood

# INTEGRITY



New! Sugden's Masterclass



ATC Integrated amp



New! Levinson No 383



New! Gryphon's Callisto



- ATC
- Art Audio
- Art Loudspeakers
- EAR
- The GRYPHON
- JPSLabs
- Mark Levinson
- MICHELL
- ProAc
- Revel
- SME
- Simon Yorke
- SUGDEN
- ZINGALI

The man who seeks the cheapest price will get what he bargains for. Contacting The Audio Salon avoids the costly mistakes and disappointments. People have been doing it since 1979. Sound investments are the current crop of integrated amplifiers, and we can compare and contrast separate pre- and power amps from the world's most successful brands.

Why compromise? From £890 to £2,990 you can enjoy Sugden's latest integrated amplifiers, Class A solid state all the way to full power. ATC's 150watt per channel amplifier has been acclaimed in many reviews and needs no introduction here; at £2,375 value is high. New to the UK is The Gryphon from Denmark. The Callisto integrated amplifier combines software operating with sonic purity and detail from £3,600 to £4,800 (200 watts per channel, doubling with lower loads). Or maybe you will seek the ultimate in integrity, Mark Levinson's first and the only, dual monaural, five power supply, software-upgradeable and utterly magnificent project No 383. Seriously underpriced, hewn from solid, at £5,995.

We have the best amplifiers for you ... and CD players ... and speakers. And what's more, we specialise in the art and science of unleashing the high performance from these components: mains cords and audio cables, without which you are running any music system on three pistons. Experience counts.

## TRY AN £800 INTERCONNECT IN YOUR SYSTEM AND KEEP IT FOR ONLY £125

*Audio Salon is exclusive outlet for AudioSource, our own badged interconnect from an internationally renowned audio designer. Stratos is now in its eighth year and series 3. Much copied, but very much ahead of the pack as you can readily hear for yourself with our innovative and original challenge.*

*Enjoy the up-market sonorities (purity and detail, rather than a mere sonic character from a commercial cable) from a true XLR (Chassis with separate Line and Return) as used by the pros! In our regular single-ended (RCA) interconnect, you get separate Left and Right thus configured, with RF rejecting braid drained at source to the cold (return) line. These are made from unprecedented 8 noughts purity copper, electromagnetically annealed, 140 strands. Our own phono plugs are simply the best made: machined from solid phosphor bronze and direct gold-plated for optimum long-term signal transfer. Full information on request. Now supplied fully run-in for 14 day home trial, £99 for 0.5 metre, £125 for 1.0 metre, for RCA or fully-balanced; digital cords cost only £69 and £49 (0.5 metre), please state termination.*

## PRE-OWNED & EX-DEMO EQUIPMENT

	NEW	OURS		NEW	OURS		NEW	OURS
<b>ISOLATION STAND</b>			<b>AMPLIFIERS</b>			<b>AMPLIFIERS</b>		
Townshend's original Seismic Sink			ART Audio Diavolo-SE/WE	4750	POA	QUAD 66 pre-and 606 power amp		
Six-tier, size 2 shelves	1500	850	ATC SLA-150 integrated amplifier	2375	POA	With remote control		
<b>ANALOGUE</b>			Audio Note P4 monoblocks			SimAudio Moon 1-5 Integrated amp, remote		
Rock Reference Turntable	classic	1500	6 months use, Black Gates, 2 matched pairs	5895	2995	70 wpc, boxed, mint, as new	2995	1450
with latest spec. Excalibur arm The Source	classic	450	new Western Electric 300B			<b>SURROUND AND 5.1</b>		
(black ash) with 3-D PSU			Border Patrol 300B power amp,	2500	1250	New, and not grey imports!		
Fine high-end on a budget			with volume control			Sony SCD-XB770		
<b>DIGITAL</b>			Balanced Audio Technologies VK-200	3250	1750	At this price, you can afford a dedicated		
David Manley The RefDAC			Ex-dem, gem, 2 x 100 watts into 8 ohm	Classic	550	CD and dedicated SACD	399	359
The reference valve DAC	5995	1995	Copland CSA8 integrated amp (Ex-Dem)			Linn Klassik DVD/CI/CD-R player		
Mark Levinson 31.5 CD Transport			New, boxed, full warranty	999	475	Black/ silver/Pastel blue/white/green		
The world's finest CD turntable	9995	POA	Linn LK-100 power amps (3 available)	650	295	5 x 75wpc, AM/FM tuner		
Mark Levinson No 39 CD Processor			Mark Levinson 380 pre-amp	4495	POA	Dolby Digital, ProLogic and DTS 5.1	1995	POA
Integrated DAC and Analogue volume	5249	POA	Mark Levinson 380S pre-amp	6995	POA	<b>LOUDSPEAKERS</b>		
Mark Levinson No 37 CD Transport	4495	2250	Mark Levinson 333 power amp			Castle Howards (Cherry) mint, boxed		
Musical Fidelity 3-D - rare, limited ed,			350 wpc, now at £10,000	8500	3995	As new, virtually new	1400	750
Unused, bought by speculator!!	2990	2750	Musical Fidelity M-3 - the NuVista	2974	2550	Living Voice Auditorium (Cherry)	1495	850
Wadia 20 CD Transport	3995	2250	Integrated Amp, boxed, unused			Jamo Concert 8 (Cherry)		
			Mint but used sample	2974	2550	Cherry, boxed, as new (2 years old)	1400	700
			(see also matching CD Player)	2974	2250	Magneplanar SMGa with Midas Pedestals		
			Musical Fidelity X-A50 monoblock pair	495	325	Original boxes. (Oak/white grille)	995	650
			With daisy-chaining for bi-amping, mint, boxed			Zingali Overture .4S (Walnut)		
						Brand new but transit dented corner	4650	2950

Tel: 0141 357 5700 • Fax: 0141 339 9762 • E-Mail: [Info@audiosalon.co.uk](mailto:Info@audiosalon.co.uk)

5 Crown Terrace, Hyndland, Glasgow G12 9HA Scotland





**“T**he C.D player's there for when I'm doing the ironing”. Not my words, but those of a customer of mine. Over the years I've seen him gradually upgrade his system. It began with the most basic NAD turntable in the form of the legendary “bouncy” 5120, a Cambridge P25 amplifier and Mission's classic 760 loudspeakers. All in all then an iconic classic starter system of the early 1990s if ever there was one.

A decade later the system now comprises of a near range topping Nottingham Analogue turntable, Croft and Musical Fidelity amplification and Celestion's mighty A3 floorstanders. He also has a Pioneer Precision CD player but, as he says, it's the vinyl that really gets the attention and bucks lavished upon it.

Chatting about his latest upgrade, he told me that he was starting to buy far more albums on vinyl. He was finding that the ideal way to relax to music wasn't via a CD - little surprise there really - but also he had, until quite recently, been very much a singles man when he began to discover the true allure of a decent vinyl album.

I won't even begin to rake over the embers of the CD versus vinyl sound quality debate but I must just say that, sound quality aside, there is something innately right about a record's structure and composition. It's split into two sides of course, and the length of each side seems to have been designed to perfection; time enough to captivate, but not so long as to bore the listener. The break in the middle is also ideal as it allows for a quick tea break, bladder release or a little silent contemplation.

Furthermore one can cue through various sections of a record far faster and with greater confidence than with any digital format, or for that matter, that other double-sided special, the compact cassette. For proof of this just look at how many DJs are reluctant to give up their decks in favour of digital.

This aside, the ultimate musical experience for most people is still a live concert, and it's not hard to see how the record apes many of the concert experiences. There are usually two

halves to each concert or gig, for a start, plus there's always some sort of small distraction for the mind to filter out. It might be coughing, sneezing or chattering at the concert, and the odd pop, click and a touch of surface noise from the LP.

When it comes to relaxing to music, as an activity in itself rather than simply a background distraction, an LP takes some beating. Imagine my horror then as I read about HitClip (World editorial column March 2002). This is the total antithesis of the LP. The music is squeezed into mono and chopped

**” To see proof of this just look at how many DJs are still reluctant to give up their decks in favour of digital.**

down to the laughable length of 60 seconds. Well, it would be laughable were it not true. What possible sense of well being can be derived from 60 seconds of compressed music is truly beyond me. It's bad enough to have to endure it within a short lift journey, let alone being asked to pay for the irritating experience.

I suppose this shouldn't come as a surprise as Britain has always had a “singles” culture. Singles rather than albums are the prime format for promotion on radio and TV. Top Of The Pops and Top 40 shows across the land focus upon singles and not albums. As someone whose singles collection numbers approximately three, I've never really seen the point of them. Three to five minutes really isn't time to relax to music, and I have little desire to hear the “radio”, “remix” and “X-rated” versions of exactly the same song in quick succession. I can see the point of twelve inch singles for DJs but, other than that, why not stick with the album? If I wanted to read a book I wouldn't simply buy a random chapter!

Of course there can be a delay between single and album releases, and the more cynical side of me can't help but feel it's a ploy by record companies to milk out every last penny from the music buying public. As has already been discussed in these pages, the

advent of HitClip merely provides yet another spin off for the record producers.

Perhaps such comical measures shouldn't come as too much of a surprise with such a sense of desperation amongst parts of the music industry. EMI, who recently laid off 1800 employees, blamed their recent hard times upon increased piracy primarily, but not wholly, due to the Internet. HitClip is a means of clawing back revenue lost to the piracy Internet sites.

Whilst I have absolutely no qualms about EMI and others in the record industry attempting to do something about their predicament, I can't help but think that they may have become preoccupied to the point of distraction with copyright issues. Perhaps it's time they began to focus more upon the quality of their artists, and particularly the quality of their recordings. This way more of us may actually choose to take the time to listen to music, rather than it being something that's merely “on” as we do the ironing. ●



**Dominic Todd**



just compare OUR prices for the BEST deals.



A selection of our ever changing offers for sale (all fully guaranteed)      Equivalent Sale      A selection of our ever changing offers for sale      Equivalent Sale  
New Price      Price      (all fully guaranteed)      New Price      Price

AMPLIFIERS		TURNTABLES			
Audio Research SP-11 Mk. II Valve Pre-Amp. (Fully-Variable Phono-Stage) (Two-Box) MINT	6000.00	1895.00	Voyd (The Voyd) c/w Helios Orion Silver	2800.00	995.00
Naim NAP-250 Power-Amp.(New Style) MINT	1855.00	P.O.A.	Wired Tonearm / Koetsu Black M.C. (Standard PSU) VGC / Manuals (May Slip)	2450.00	995.00
Naim Flat-Cap PSU. MINT / Boxed	450.00	279.95	Michell Gyrodek c/w Roksan Artamez Tonearm / A.T. OC-9 Moving-Coil MINT	600.00	299.95
Pioneer A-300R Precision (Phono-Stage / Remote) MINT	400.00	229.95	Linn Axis / Basik Plus / Ortofon FF-10E VGC	200.00 +	79.95
Tube Technology Seer-L Pre. /Unisys Power.(2 x 30 Watts Valve Amplifier) MINT / As New / Boxed/ Manuals	2035.00	1195.00	Dual CS-505 I C/W Ortofon M.M. Cartridge G/C	N / A	79.95
A.V.I. S-2000P Pre-Amp. / S2000M Mono-Blocs.(2 x 150 Watts / Remote Control) MINT / Manuals	2350.00	995.00	Technics SL-L20(Linear-Tracking Turntable / Cartridge)VGC / Manuals	N / A	15.00
Revox B-250 (2 x 150 Watts Int.Amp.With Full Remote-Control) MINT / Boxed / Manuals	1200.00	450.00	Shure M-75ED Type II Mag. Cartridge(Elliptical) MINT / Boxed	N / A	10.00
Micromega Tempo I Int.(2 x 50 Watts) MINT / Manuals	700.00	319.95	Monacor SPR (M.M. Phono-Stage) NEW / Excellent Value	N / A	29.95
Onkyo A-8170 Int.(2 x 100Watts / M.M./ M.C. Phono-Stage) VGC / Boxed / Manuals	N / A	129.95	<p>(Lots of Vinyl in Stock and always WANTED) (Record-Cleaning Service Available) Your Records Cleaned to Perfection on Moth Machine For £1.00 Each Including New Inner-Sleeve. (Maximum 10 at a time please) ...Turntables / Tonearms / Cartridges (M.M./ M.C.) "Urgently" Required... ...Also any "interesting" Vinyl Accessories. Clamps, Protractors, Stylus Scales, Cleaning Devices etc:</p>		
Meridian 101B Pre-amp.(Black) (M.M. Phono-Boards) MINT	N / A	119.95			
Exposure XII Pre. / XII Power Supply MINT / Boxed	1300.00	495.00			
Rotel RB-956 AX(6-Channel Power-Amp.) MINT / Boxed / Manuals	350.00	169.95			
Arcam Alpha II Int.Amp.VGC	200.00	99.95			
Q.E.D.A-230 Int. / Phono-Stage(Matching Tuner Available) VGC / Manuals	180.00	79.95			

**PRODUCT OF THE MONTH**  
**Naim NAC-82 Pre-Amp.(Phono)Moving-Coil Boards**  
**MINT Condition With Manuals and Snaic.**  
**Equivalent New Price £2,520.00**  
**Affordable-Audio Price @ £1395.00**

RECORDING EQUIPMENT		LOUDSPEAKERS			
JVC XD-250Z D.A.T. Recorder Fair C.	800.00 +	229.95	Ruark Equinox (Plano-Black) MINT	2000.00	995.00
Rotel RD-865(2-Motor / HX-Pro) MINT / Boxed	230.00	99.95	Sonus Faber Minima Amator MINT / Boxed / Manuals	1566.00	899.95
Technics RS-B405( DBX Etc) VGC / Manuals	200.00	69.95	Loth X ion 3 / Stands mint	1300.00	695.00
Teac X-3 Reel to Reel (4-Track)(3-Head) (Including Quantity Of Tapes) MINT	N / A	129.95	Chario Syntar 100T Floorstanders GC	550.00	269.95

DIGITAL		MISCELLANEOUS			
Linn Mimik (Remote / Digital-Out) VGC	875.00	399.95	Yamaha DVD-S700 Remote DVD Player (Region Two) (DVD's In Stock And Always Wanted) MINT / Boxed / Manual	600.00	229.95
Audio Alchemy Digital-Drive-Engine 1.0 / Power-Station II DAC. MINT / As New / Boxed	600.00	289.95	Target 18" Column Stands VGC	60.00	34.95
Mendian 208 C.D. / Pre-Amp. MINT / Boxed	1500.00	479.95	Target Speaker Wall Stands VGC	N / A	25.00 Pair
Cambridge Discmagic / Dacmagic II(Two-Box Remote C.D.) MINT / Boxed / Manuals	450.00	199.95	Soundstyle X122BS L.S. Stands.(Silver-Finish)(Sand-Filled) MINT / Boxed	100.00	69.95
Creek DAC-60(20-Bit. D.A.C.) VGC	600.00	169.95	Monacor SPS-35 Spike Kit (Gold or Anodised Black Finish) Loudspeaker Spikes NEW	9.95 (Per 4)	
Rotel RCD 965 BX Remote (Digital-Out Etc) VGC / Boxed / Manuals	350.00	149.95	Monacor SPS-45 Spike Kit (Small) Loudspeaker Spikes NEW	7.95 (Per 4)	
Marantz CD-52 SE Remote VGC	450.00	109.95	Monacor SPS-65 Spike Kit (Large) Loudspeaker Spikes NEW	9.95 (Per 4)	
Mission DAD-5 / DAC-5 (Two-Box Player) MINT	600.00	179.95	Q.E.D. Compact Disc Switching Unit VGC / Boxed	N / A	15.00
Philips CD-730 Remote MINT / Manuals	150.00	89.95	Q.E.D. Headphone Control Box (With Volume Control) VGC / Boxed / Manuals	N / A	15.00

SYSTEMS		TUNERS			
<b>affordable-audio will happily "build" Systems to your individual requirements, and if you purchase three or more components, i.e. (C.D. Player, Amplifier, &amp; Loudspeakers), we will give you a *15% Discount on the total price! Please enquire for further details.</b> <b>*(Does Not Apply To Commission-Based Sales)</b>					
Audiolab 8000T FM. / A.M. Tuner MINT / Manuals	750.00	399.95	(Blue And Black) affordable-audio Bi-Wire LS. Cable (In Brown or White) NEW	1.5M. or 14.95 5.0M.	
A&R (Arcam) T-21 FM. Tuner With Pre-Sets VGC	N / A	69.95	79-Strand L.S. Cable (Black-Round-Section or White-Flat-Section) NEW	Only 3.50 Metre	
Rotel RT-820L 3-Band Tuner VGC	N / A	49.95	Allsop Carbonoptic Record Brush VGC	Only 1.25 Metre	
Monacor DC-100 Carbon-Fibre Brush NEW 6.95(Essential) Various Plugs(RCA / DIN / Cannon Etc.) Various NEW / SH				N/A	5.00
P.O.A.					

**PLEASE VISIT OUR WEB-SITE (UPDATED DAILY)**  
**E-MAIL: Sales@affordable-audio.CO.UK**  
**WWW.affordable-audio.CO.UK**

**\*\*\* GOOD HIFI SEPARATES WANTED \*\*\***  
Phone anytime with your wants, stock changing daily. All equipment is sold with warranties.  
**Don't forget we can offer mail order. All major credit cards accepted.**  
We welcome part-exchange on any of the above.  
Affordable Audio is always keen to buy, (or part-exchange) Good quality Hi-Fi separates in good condition. Especially top British manufacturers products!



**We can also sell your equipment for you on a commission basis.**  
**(Lowest rates/best return)**  
**(Please phone Paul for details!)**

**P**icture - if you can - the hi-fi world pre-Compact Disc, pre-Margaret Thatcher and pre-boom and bust. Remember the look and feel of the kit we used to play our seventies sounds on? With a few notable exceptions like the staunchly (small c) conservative A&R A60 amplifier, British separates varied from the plain bonkers to the merely 'characterful'.

Needless to say, Allen Boothroyd's pioneering industrial design work made a huge impact - from the madcap Lecson pre-power combo to his 'less is more' Meridian 100 series components. Naim's early 42/110 was another classic, its shoebox sized cases tipped with a tasteful silver pinstripe and those trademark large control knobs. Nytech, in the guise of the CTA 252XD, gave us the 'calculator tuner amplifier'. The spitting image of a 1973 Casio desktop calculator, it conferred a 'tech look' on what was still a relatively low technology business. And just for good measure, a nice tasteful sleeve of walnut was provided to keep the Missus happy!

The world of turntables was no saner, as the likes of early Regas, JBEs, Strathearns and Transcriptors proved. The nineteen seventies was, lest we forget, the 'decade of the podule', where ridiculously impractical platters were used because they, ermm, 'looked good'. A legion of British decks could be found sporting utterly unsupportive supports that variously wrecked the sound or ruined your stylus if you mis-cued it.

This was nothing compared to the Japanese, though. Generally, British designs sported some tenuous relationship between form and function but audio from the land of the rising sun had no such distinction. Essentially, Japanese designers and stylists saw the art of selling hi-fi as the practice of offering the highest number of facilities they were physically able to cram onto a 430mm long bright silver fascia.

The result was an orgy of knobs, buttons and switches, growing ever bigger year by year, to the point

where it was actually impossible to use the equipment in question unless you'd committed every last line of the instruction manual to memory. Want to play your turntable through your 1978 Pioneer SA-9800 amplifier? First ensure the elaborate network of tape monitoring and dubbing options are disabled, find the source selector, specify your cartridge gain and loading, switch to PHONO, re-set the range of your power meters, pull your filters out, flatten your tone and kill the muting - and go. As easy as B&O - not!

**“A new survey by MORI goes as far as stating that the British are actually gadget-mad.”**

After this excess, the eighties was a breath of fresh air. Suddenly amps started appearing without 95% of the purchase price devoted to useless fripperies you just knew you'd never use. Instead, sir could enjoy the 'tasteful, minimalist sparsity' of the amplifier's design. You got a black box - if it was British it invariably felt like it was hewn from pig iron - with a volume control, source selector and err, that's it! If it was truly politically incorrect, your amp might sport a front-mounted on-off switch and even - heaven forbid - a balance control. Anything more than this and it would justly be regarded as a 'seventies throwback' and go the way of the Space Hopper and Raleigh Chopper.

In a sense, this was a good thing - if the seventies had been the decade of the graphic equaliser then the eighties was the age of 'source direct'. The trouble was that its minimalist aesthetic has shackled 'dyed-in-the-grain' audiophile purists ever since.

A new survey by MORI goes as far as stating that the British are actually gadget-mad. The poll, commissioned by Iomega in Great Britain, France and Germany shows that we use more technology than any of our

cousins across the Channel. No less than 91% of us have a CD player (compared to 78% and 74% in France and Germany respectively).

We're also far ahead on games consoles (33%, 28%, 20%), DVD players (23%, 18%, 9%) and MP3 players (8%, 5%, 1% respectively).

It's amazing, isn't it, that only recently have we seen mass market hi-fi coming back to offering sensible real-world facilities? For most of the nineties, eighties orthodoxy was so omnipresent that only a handful of British amps (Audiolab 8000a and a few Arcams) actually had tone controls. Now though - in 2002 - the time seems right to get back to some kind of sense. Any manufacturer who can combine the usefulness of seventies-style facilities with purist 'sound-first' principles gets my vote. ●



**David Price**

## SUNFIRE CORPORATION



**New for 2002 Sunfire True Sub Woofer MKIV 11 inch cube.** Signature True Sub Woofer 13 inch cube and Junior Sub Woofer 9 inch cube -all with two drivers, to as low as 16hz, 116 SPL and 360 cu ins of air movement, 1200 or 2700 watt patented amp technology. Classic Tube Pre-amp, Solid state power amps 2 channel (300 x 2 or 600 x 2) and 5 channel (220 x 5 or 430 x 5 - yes total of 2150 watts into 8 ohms or 4300 watts into 4 ohms) patented amp technology (no heat sinks) and Theatre Grand II processor pre-amp.



### AUDUSA EUPEN CSA 2.5 MAINS CABLE - HI FI CHOICE SEPT 2001 BEST BUY AWARD



AUDUSA-Eupen CSA 2.5

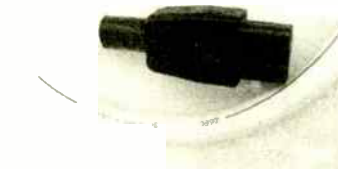

AUDUSA EUPEN GNLN 5.0 mains cable

CSA and GNLM Cable with FERRITE TECHNOLOGY - A polymer material mixed with a considerable quantity of homogeneously fine high quality ferrite powder. This compound is called EMC/COM and it can be extruded around copper conductors. The ferrite itself is a non-conducting material, but it has a very interesting magnetic behaviour. As a ferromagnetic material, it will go through hysteresis loops whenever it is under influence of an alternating magnetic field. Consecutively magnetizing and demagnetizing the material will cause considerable losses of high frequency energy. This energy is absorbed in the ferrite grains and converted into heat. This effect is more or less proportional to the field frequency. By coating conductors with a thin layer of ferrite compound, high frequencies will be strongly attenuated, because their energy will be absorbed by the ferrite powder. This applies to high frequency disturbances that are propagating on the conductor and which we don't want to disturb the environment, as well as to surrounding interferences, which we want to prevent from disturbing the signals on our cable. The CSA cable which in addition to the above described ferrite technology is further protected with a foil shield and a drain wire and specifically manufactured for High End audio use.

£48 for 1.0m  
£58 for 1.5m  
£68 for 2.0m  
off the reel £30  
for 1st meter, £20  
per m thereafter.

Fitted with IEC (Martin Kaiser) and MK Tough Plug. Figure of eight, 16 amp IEC, Bulgin etc also available as well as USA, European Schuko, and other mains plugs. Cable can be supplied fitted to our all steel 4, 6 and 8 way distribution blocks. We can rewire the distribution blocks with Eupen cable as an extra cost option. Refer to our web site for details.

### L A T INTERNATIONAL NJ USA - all cables now with SILVERFUSE conductors

#### LAT AC-2 HI-FI CHOICE - SEPT 2001 - RECOMENDED MAINS CABLE



AC-2  
Power cable  
compare with  
products costing  
ten times as  
much, then  
decide

**LAT AC-2 Power cable.** We have developed a cabling (weaving) pattern along with an unusual shielding/filtering system that gets rid of the garbage that contaminates your components. The difference you hear with our cord is astounding. Our power cord takes advantage of silver in its design through use of our proprietary Silverfuse conductors. The conductors are 10 gauge and insulated with Teflon; the best insulation available. Fitted as standard with an IEC and MK Toughplug. Other connectors are available incl Schuko, 16 amp IEC, Figure of eight etc. 2ft £56, 3ft £68, 4ft £78, 6ft £99. other lengths available and off the reel at £39 per meter. SE version available with GP Tough plug and IEC, outer black braid all for an extra £12 irrespective of length **4,6 and 8 way all steel mains distribution blocks** fitted with UK, Schuko or USA type sockets. CE tested and approved mains distribution units manufactured out of heavy gauge steel, finished in black and fitted with high quality Wadsworth 13amp sockets. It has no filters, circuit breakers, surge protection, transformers, resistors, capacitors, LED's, on/off switches, chokes, regulators, just fitted with 3ft of LAT AC-2 mains cable. From £161 for 4 way, £194 for 6 way, £226 for 8 way.

**NEW SILVERFUSE**  
**GOLD**  
**MK**  
Tough  
plug with  
gold  
plated  
pins (£14)  
**Otto Heil**  
IEC with  
gold  
plated  
contacts  
(£10).

**SILVERFUSE** is a near alloy of silver and copper. IT IS NOT SILVER PLATED OR SILVER CLAD. Plating (or clad, which is the same thing as plating) causes a dioding effect when signal is passed through resulting in brightness and distortion. The Silverfuse process starts with seven nines OFHC copper wire with a diameter that is slightly larger than the required size. It is then pulled through a trough of molten silver. The wire with a silver deposit, is then forced through a compacting die where it is subject to tremendous pressure. The silver and the high purity copper are fused together into a near alloy. The compacting fusion also reduces the wire diameter to the desired size. No dioding subsequently occurs with this process. The result provides for the benefits of silver; which are excellent definition and clarity, with the high purity copper benefits of warmth and mellowness.

**LAT AC-2 mains cable available with 16 amp IEC (MF, KRELL etc), Figure of eight, Bulgin, USA mains and European Schuko plugs. Check our web site for available variants.**



LAT INTERNATIONAL - Analogue, Digital and Video interconnects and Speaker cable. Refer to [www.audusa.com](http://www.audusa.com) for further details or ask for reviews etc

### SIEA 3D-LABS CDP, DAC, TRANSPORT AND DVD's 24/192

with SRC sampling rate and bit converter translates 16,18 and 20 bit inputs to 24 bits format. All 32, 44.1 and 48kHz frequency is re-sampled to 192kHz. This is known as upsampling. The SRC is comparable with that used by DCS in the Purcell unit. Prices start from £1110 for a CDP with SRC.

**DVD with SRC and CV2** - Video system for unmatched picture quality - best with projection systems . DVD with SRC and CV2 start from £1470. DVD with CV2 £1210.



**LONDON**



INSTANT 0% FINANCE AVAILABLE SERVING LONDON FROM BATTERSEA

**ORANGES & LEMONS**

Juicy fruit from London's newest, freshest hi-fi/home cinema retailer. Telephone demonstrations or just pop in. All the usual, i.e. friendly and efficient service, free home installation + credit cards.

THE INNOVATIVE AUDIOVISUAL HI-FI RETAILER. ARCAM, CABI ETALK, CHORD CO, DENON, EPOS, MARANTZ, NAD, NAIM, REGA, ROKSAN, ROTEL, ROYD, RUARK, SOUNDSTYLE, STANDS UNIQUE, YAMAHA

NOW IN OUR SEVENTH SPARKLING YEAR.

020-7924 2040

61/63 WEBBS ROAD, SW11  
Visit [www.orangesandlemonshifi.com](http://www.orangesandlemonshifi.com)

We aim to provide a well chosen selection of quality hi-fi and accessories including FMJ, ARCAM, B&W, NAUTILUS, DYNAVECTOR, LINN, LOEWE, MERIDIAN, M&K, NAIM, PIONEER, PROCEED, NEAT, REGA, ROTEL, SHAHINIAN, YAMAHA + more  
[www.infidelity.co.uk](http://www.infidelity.co.uk)

Open:  
Tues-Fri  
10.30am-7pm  
Saturday  
10am-6pm

**Infidelity**  
INDECENTLY GOOD HI-FI

9 High Street, Hampton Wick,  
Kingston upon Thames, Surrey KT1 4DA  
Tel: 020 8943 3530

**SOUTH**

**WORTHING AUDIO**

20 Treville Gate, W.Sussex BN11 1UA  
(01903) 212133

The friendly shop with the best sound system in the South.  
Talk Electronics - Friendly Advice - 3 Year Guarantee  
Easy Parking - Open Mon-Sat. 10am-6pm.  
Late Night Wed 7.30pm.  
Agencies include: Dynaudio, Ruark, Gradient, Roksan, Reatek, Orella, Sonneteer, Korra, Cymbal, Talk Electronics, and many more.....

**SOUTH WEST**

**SOUTH WEST ANALOGUE**

SME - MICHELL - NOTTINGHAM ANALOGUE - LORICRAFT GARRARD - PROJECT - ORTOFON - TUBE TECHNOLOGY 64bit Valve CD Player, Remote Control Hybrid Integrated Valve Amplifier CROFT VOODOO Isolation platforms/Loudspeakers, Equipment Stands and T/Turntable lift off Perspex Covers. Record cleaning service - Secondhand equipment  
01643 851 351  
[graham@southwestanalogue.fsnet.co.uk](mailto:graham@southwestanalogue.fsnet.co.uk)

**NORTH**

**Basically Sound**

**NORWICH • NORFOLK**

Audio Analogue, Bryston, Cabletalk, Chamo, Chord Co, Denon, Epos, Final, Isoblu, Naim Audio, PMC, Prolog, Rega, Stax, Talk Electronics, Teac, UKD Opera, Audio Note and many others

The Old School  
School Road, Bracon Ash  
Nr Norwich, Norfolk NR14 8HG  
Tel (01508) 570829

**EAST**

**STOWSOUNDS**  
*audio consultants*

These And More Available From:

Creek Epos Exposure	JM Labs Living Voice Neat Acoustics
---------------------------	---

For A Demonstration & Expert Advice Call  
**Stowmarket (01449) 675060**  
Stone Farm, Borough Lane, Gt. Finborough, Stowmarket

**VINYL**

**THE DIRECT DISC**  
VINYL VINYL VINYL

Thousands of records always in stock.  
+ a full range of sought after compact discs.  
Extensive search service for wanted albums.  
Comprehensive 96 page full catalogue available at £1.50  
Telephone / Fax 01992 447764  
Or visit our web site on  
[www.directdisc.demon.co.uk](http://www.directdisc.demon.co.uk)

**CHERISHED RECORD CO**

UK SUPPLIERS OF VPI TURNTABLES, RECORD CLEANING MACHINES AND ACCs. HUGE SELECTION OF NEW & USED LPS & CDS  
[www.cherished-record-company.co.uk](http://www.cherished-record-company.co.uk)  
**01579 363 603**

**VALVES & TUBES**



**Chelmer Valve Company**  
*for audio valves*

Buy CVC PREMIUM HI-FI valves direct from us. All valves processed for improved performance. We also have stock of MAJOR BRAND types inc. MULLARD, GEC, BRIMAR, RCA, GE, PHILIPS, etc.

The Stables, Raddon Park, Great Raddon, Chelmsford, Essex, CM2 7SY  
Tel: 01245 241301 Fax: 01245 241309  
Email: [sales@chelmervalve.com](mailto:sales@chelmervalve.com)



**£600**

Mr. Andrew Everard in Gramophone Magazine  
"Delivers a sound that's both smooth and refined ... allied to a good degree of clarity and finesse"  
Hi-Fi Choice "It's a classic valve sound"... warm and cuddly... vocals are generally lifelike and involving"  
FREE colour literature. **£600 with free delivery**  
Phone 01634 373410 anytime. **1 month home trial**  
[www.affordablevalvecompany.com](http://www.affordablevalvecompany.com) **40 watts**

**SERVICES & CONSULTANTS**

**Front End Problem?**

contact

**The Cartridge Man**

It doesn't have to cost an arm and a leg to get the best - listen to my Koetsu - and Decca - eater.

Also agents for Croft, Hadcock, E.A.R. Michell & Moth.

plus cartridge re-tipping service  
**020 8688 6565**

Website: [www.thecartridgeman.com](http://www.thecartridgeman.com)

**atv**

- Service & Repairs
- Valve & transistor amplifiers
- Vintage valve Radios
- Hi-Fi VCR's
- Valves Tested

ATV SERVICES  
LEATHERHEAD  
01372 456921

**TO ADVERTISE**

**PLEASE CALL**

**AMANDA**

**SWEENEY ON**

**020 8864 4760**

**MAIL ORDER**



**Russ Andrews Accessories**  
Mail Order Direct



**Q. How do I get the best sound from my system?**  
A. Order our free booklet!  
It's essential reading for anyone who wants to hear the best music their system can deliver, and it's full of free tips and advice on how to upgrade your system.  
Call and request your free copy quoting ref. AH62 or visit our website where you can download it now.

UK FREEPHONE  
**0800 373467**

Russ Andrews Accessories Ltd.,  
FREEPOST NWW881A, Kendal LA8 9ZA  
Tel: +44 (0)1539 825500 Fax: +44 (0)1539 825540  
E-mail: [AH62@russandrews.com](mailto:AH62@russandrews.com)  
[www.russandrews.com](http://www.russandrews.com)

**SPECIALIST HI-FI DEALERS**

# DIAL-A-DEALER

This is a comprehensive directory of Hi-Fi Dealers throughout the UK and Ireland.

## BEDFORDSHIRE

**RICHARD'S AUDIO VISUAL** 4 Greyfriars Bedford. Tel: 01234 365165. Stockists of: Arcam, Audioquest, Beyer, B&W, Bose, Cable Talk, Cyrus Denon, Marantz, Mission, Moth, Ortofon, Pioneer, Pro-Ject, Quad, REL, Rotel, Ruark, Sennheiser, Sound Style, Stands Unique, Teac, van den Hul & more! Expert friendly service: Listening room, Pioneer Reference Point, Visa / Access.

## BRISTOL & BATH

**THE RIGHT NOTE** Tel: (01225) 874728. Just think: most audiophiles listen for most of the time to systems that are 'not quite right'. Are you happy with yours? Forget the reviews and trying to put together a system like a patchwork quilt with the 'best' bits around. It's our job to do the assessing, you judge our results. We'll help you to plan a system for the future, even if you spread the purchases. Leave the 'up-grades' behind, save money and enjoy music all the time. Just listen, and you'll know. CD: Acuras, Audio Synthesis, Classe, DCS, Enlightened Audio Design, Meracus, Orelle, Wadia, XTC. Vinyl: Basis, Crown, Jewel, Graham, Michel, Sumiko, Transfiguration, Amps: Acuras, Audio Sculpture & more. Speakers: Audio Artistry, Audio Physics & more. Tuners: Fanfare, Magnum Dynalab & many more. Cables: Chord, DNM, Silver Sounds & more. (Credit Cards Accepted).

**V'AUDIO** HiFi Consultants: 36 Druid Hill, Stoke Bishop, Bristol, BS9 1EJ. Tel: 0117 968 6005. ATC, AVI, Alon, Audio Analogue, Audiomeca, Cadence Valve, Chord Amps, Electrocompaniet, Harman Kardon, Heybrook, Jamo, LFD, Lyra, Opera, Ortofon, Pink Triangle, Ruark, Mark Levinson, Michel, REL, SME, Shearman, Sonic Link, Sugden, Townshend, Triangle, Unison Research Valve Amps. Home Cinema demonstrated including, AV Amps, DVD Players, Video Projectors and Screens. Demos by appointment only. Home trial facilities. Free installations. We are not a shop.

## BUCKINGHAMSHIRE

**NORTHWOOD AUDIO** 98 Cambridge St, Aylesbury. Tel: 01296 428790. Established since 1992. Independent specialist retailer. Extensive Hi-Fi, A/V and Multiroom experience catering to your needs. From Vinyl to SACD, Valve to Solid State, from LCD to Plasma. Audiomeca, Audio Note, Cable Talk, Castle, Chord, The Chord Company, Cura, Denon, Elac, Epos, Exposure, Heart, JM Labs, KEF, Linn, Marantz, Michel, Micromega, Monitor Audio, NAD, Nakamichi, PMC, ProAc, Quadraspire, Rega, REL, Revox, Roksan, Rose, Rotel, Ruark, Sony, Sennheiser, Sonus, Talk Electronics, Tannoy, Teac, Tube Technology, Videologic, Vienna Acoustic. Export orders welcome. 2 demo rooms. Credit facilities available. Website: [www.northwoodaudio.co.uk](http://www.northwoodaudio.co.uk) Email: [info@northwoodaudio.co.uk](mailto:info@northwoodaudio.co.uk)

**TECHNOSOUND** 8 Granville Square, Willen, Milton Keynes, MK15 9JL. Tel: (01908) 604949. Fax: (01908) 202166. Audiophile Hi-Fi and Home Cinema specialists. All major brands stocked from Arcam to Yamaha. Meridian Digital Home Theatre dealer. Video projection, Plasma screens. Custom installation, 2 dem rooms and expert advice. Email: [hifi@technosound.co.uk](mailto:hifi@technosound.co.uk) [www.technosound.co.uk](http://www.technosound.co.uk)

## CAMBRIDGESHIRE

**THE AUDIO FILE** 41 Victoria Road, Cambridge. Tel: 01223 368305. For the best in British Hi-Fi and Home Cinema entertainment. Visit or call to arrange a dem with products from: Arcam, Linn, Naim, Rega, Cyrus, Absolute Sounds, Kef, Sony, Yamaha, Rel, Ruark, Denon.

## CHESHIRE

**ACOUSTICA** 17 Hoole Rd, Chester CH2 3NH. [www.acoustica.co.uk](http://www.acoustica.co.uk) Tel 01244 344227. All that's best in HiFi & Home Cinema from quality manufacturers including Naim, Rega, Arcam, Musical Fidelity, Rotel, Selego Projectors, Kef, Ruark, Densen, Primare, Teac, JM Lab, Nakamichi, Quadraspire, Celestion & Crimson. We offer friendly, helpful advice, interest free credit & trade-in facilities, and deliver & install systems throughout Cheshire, Merseyside & North Wales. Opening hours are Tuesday to Saturday 10.00 until 5.30, evenings by arrangement.

**ACTON GATE AUDIO** 4 Ruabon Road, Wrexham, North Wales. Tel: 01978 364500. Audio Visual Specialists. Arcam, Audio Analogue, Bose, B&W, Celestion, Castle, Denon, Harman Kardon, Jamo, Marantz, Michel, Mission, Onkyo, Pro-Ject, Musical Fidelity, NAD, Micromega, Myrad, QUAD, Radford, Rotel, Ruark, Tannoy, TDL, Teac, Thorens, UKD, Unison Research, Yamaha, DSP Club Member,

Demo Room, installation service. Easy Parking and Motorway access. All major credit cards accepted. 9.30 - 5.30 daily. Closed Sunday & Monday.

**DOUG BRADY HI-FI** Kingsway Studios, Kingsway North, Warrington, WA1 3NU Tel 01925 828009 Fax 01925 825773. Visa, Mastercard, Lombard Tricity. 2 dem rooms, home trial; Agencies include: Arcam, Tag McLaren, AVI, B&W, Castle, Caspian, Chord Electronics, Exposure, Harbeth, Heybrook, Krell, LFD, Michell, Meridian, Musical Fidelity, Monitor Audio, Naim, Nautilus 800 series, Pink Triangle, ProAc, Roksan, SME, Wilson Benesch, XTC and many more.

## CORNWALL

**SOUNDS PERFECTION** Cornwall's most exclusive Audio retailer. Agencies include: Audio Analogue, Audio Design, Audio Note, AudioQuest, Audio Spectrum, AR, Avid, Border Patrol, Boston, Dynavector, Electrocompaniet, Graaf, Henley, JM Labs, Lexicon, Michell, Monitor Audio, Musical Fidelity, Ortofon, Parasound, Primare, Project, NAD, Nakamichi, Nordost, Philosophy, REL, Roksan, Ruark, Rotel, Totem, Tom Evans, Tsunami, S.M.E., Sugden, Stands Unique, Unison Research, Teac, Vienna Acoustics, Triangle, Trichords, WBT, Sonic Link. Home Demonstrations by Appointment. Tel/Fax: 01326 221372 Mobile 07798 554357 email [nigel@soundsperfection.co.uk](mailto:nigel@soundsperfection.co.uk) website [www.soundsperfection.co.uk](http://www.soundsperfection.co.uk)

## DORSET

**MOVEMENT AUDIO** 588 Ashley Road, Poole, Parkstone, Dorset BH14 0AQ. Tel: (01202) 730865/380018. Arcam, B&W, Castle, Chord Electronics, Cyrus, Denon, Marantz, Michell, Mission, Pioneer, Tannoy Dimension, Yamaha. 2 Dem rooms. Listen to the available choice and decide at your leisure - no pressure, no obligation. Our staff enjoy music, with our choice of products, you can too! Service Department. Free installation. Home trial facilities. Access, Visa, Amex, Diners Card. Credit facilities available. Open Tuesday-Saturday 10-5.30. [www.movement-audio.co.uk](http://www.movement-audio.co.uk)

**MOVEMENT AUDIO** 926 Wimborne Road, Winton, Bournemouth, Dorset. BH9 4DH. Tel: (01202) 529988/520066. Arcam, B&W, Denon, KEF, Marantz, Mission, Musical Fidelity, Opera, Pioneer, Quad, Roksan, Ruark, Yamaha. Full dem facilities available, also home dem. Friendly expert advice. Service Department. Free installation. Home trial facilities. Access, Visa, Amex. Open Tuesday-Saturday 9.30-5.30

**DAWSONS OF WESTBOURNE** Home Cinema Specialists. Main agents for Bang & Olufsen, Harman Kardon, JBL, REL, Mordaunt Short, Sony, Technics and TDL. Demonstration facilities include our unique Dolby pro-logic system comparator for the ultimate way to choose the perfect system. Also on demonstration large screen televisions from Thomson, Sony and Ferguson with video projectors from Sharp and Selego. Dawson's, 23 Seamoor Road, Westbourne, Bournemouth 01202 764965

**WEYMOUTH HI-FI** 33-35 Maiden Street, Weymouth, Dorset DT4 8BA. Tel (01305) 785729/766345. Arcam, B&W, Denon, KEF, Marantz, Mission, Musical Fidelity, Panasonic, Pioneer, Quad, Sony, Tannoy, Yamaha. Dem room. Friendly professional advice. Only quality hi-fi dealer in Weymouth area. Service Department. Free installation. Home trial facilities. Access, Visa, Amex, Switch, Delta Mastercard. Interest free credit. Instant credit. Open Mon-Sat 9.30-5.30

## ESSEX

**GRAYSTON SOUND & VISION** 33 Sir Isaac's Walk, Colchester. (01206) 577682. Alchemist, Arcam, B&W, Boston Acoustics, Castle, Denon, Harman Kardon, KEF, Linn, Loewe Opta, Meridian, Michell, Musical Fidelity, Philips, Pioneer, Project, Rotel, Sennheiser. Superb demo rooms, free regional delivery and installation. Regular musical and surround evenings, home demonstrations. Excellent credit facilities.

## GLOUCESTERSHIRE

**THE RIGHT NOTE** - Bath. For specialist advice and home demonstrations. See BRISTOL & BATH.

## HEREFORDSHIRE

**ENGLISH AUDIO** 37 Whitecross Road, Hereford, HR4 0DE. (01432) 355081. Arcam, A.T.C., B&W, Castle, Cura, Cyrus Centre, Elac, Denon, JM Lab, KEF, Loewe, Marantz, Mission, Musical Fidelity, NAD, Naim, Pink Triangle, Pioneer, Project, QED Systemline, REL, Rotel, Ruark, John Shearne, Stax, System Audio, Teac, Vienna Acoustics, Wadia, and

Yamaha. Single speaker dem room, home trial facilities, free installation, service dept, Access/Visa, Credit arranged. Open Mon-Sat. 9.30-5.30pm. BADA members.

## HERTFORDSHIRE

**AUDIO FILE (THE)** 27 Hockerill Street, Bishops Cleeve, Herts. Tel. (01279) 506576.

**DARBY'S OF ST. ALBANS** 6 Market Place, St Albans, Herts. Tel: (01727) 851596. Fax: (01727 812217) Email: [sales@darbystvhifi.co.uk](mailto:sales@darbystvhifi.co.uk) Hertfordshire's premier Hi-Fi/Audio Visual specialists established 1946. Full Home Cinema demonstration suite. Whether your needs are large or small, we stock it all: Arcam, Cyrus, JVC, Yamaha, Quad, Denon, Sony, Bang & Olufsen, Pioneer, REL, KEF, Mission, Ruark, Celestion and many more. Free planning service. Free Delivery and basic installation. Full workshop facilities. Open 9-6 Mon-Sat.

## LANCASHIRE

**ADVENTURES IN HI-FI** 5, Bishopgate, off Hallgate, Wigan, WNI 1NL. Tel: 01942 234202. For the best hi-fi and home cinema products from quality manufacturers including Naim, Rega, Cyrus, NAD, KEF, Denon, Dynavector, Rotel, Shalinian, JM Lab, PMC, Project, Quadraspire, Selego and Sanyo projectors. We offer friendly advice, excellent demonstration facilities, 0% finance, free delivery and installation throughout the North West. Opening hours 10.00 - 5.30pm Tuesday to Saturday evenings by appointment.

## LEICESTERSHIRE

**LEICESTER HI-FI** 6 Silver Walk, St Martins Square, Leicester LE1 5EW. Tel: (0116) 2539753. Email: [info@leicestershifi.co.uk](mailto:info@leicestershifi.co.uk) [www.leicestershifi.co.uk](http://www.leicestershifi.co.uk) Arcam, B&W, Chord Electronics, Copland, Cyrus, Denon, Greig Loudspeakers, KEF, Marantz, Michell, Miller & Kreisel, Musical Fidelity, NAD, Nakamichi, Nautilus, Mission, Project, Rotel, Sanyo Projection, Talk Electronics, Teac, Technics, Yamaha, and many more. 4 Listening areas over 3 floors. We can demonstrate, deliver and install. Including A.V. and Multiroom. Credit Facilities. All cards taken, open 6 days 9.30-5.30.

## LONDON

**BABBER ELECTRONICS SERVICE CENTRE** 158 Uxbridge Road, West Ealing, London, W13 8SB Tel: 020 8579 6315 Akai, Aiwa, A&R, Celestion, Dual, Goodmans, Harman Kardon, JBL, JVC, Kenwood, Marantz, Panasonic, Sennheiser, Sony, ES range, Tannoy, Technics, Vharfedale, Yamaha and many more. Auth. Service Dept. Credit Facilities, Open 10.30 - 5.30 Mon-Sat.

**INFIDELITY** 9 High Street, Hampton Wick, Kingston-upon-Thames. Tel: (020) 8943 3530. for full details see entry under SURREY

**HIFI EXPERIENCE** 227 Tottenham Court Road, London W1, 020 7580 3535. Arcam, Cyrus, Denon Gold, Quad, Kef, Meridian, Yamaha, Marantz, McCormack, Mirage, Nakamichi, Musical Fidelity, PAF & many more. Open 10.00-7.00 Mon-Fri, 9-6 on Sat. Service dept, Credit facilities, delivery and free installation.

**THE LISTENING ROOMS** 161 Old Brompton Road, London SW5 0LJ. (020) 7244 7750/59. Fax (020) 7370 0192. Linn, Quad, Meridian, Nakamichi, Arcam, Audiolab, Acoustic Energy, SME, Audio Research, Krell, Wadia, Theta, Apogee, Martin Logan, Pioneer, Tannoy, Systemdek, Stax, Pink Triangle, Michell, Monitor Audio, Yamaha, Marantz, KEF, Bose, Celestion, Epos, Mission, Denon, Neat Petite. Mon-Sat 10-6pm.

**THOMAS HEINITZ LTD** 35 Moscow Road, Bayswater, London, W2 4AH. Tel: 020 7229 2077. Fax: 020 7277 9348. Email: [info@thomasheinitz.com](mailto:info@thomasheinitz.com).

Web site: [www.thomasheinitz.com](http://www.thomasheinitz.com). Established in 1952, Thomas Heinitz has a long history of providing the best music and AV systems available. We continue to offer the highest standard of service in the most relaxed atmosphere. Whatever your needs, from multiroom and home cinema to a high quality stereo system, we offer consultation, design specification, architect liaison and installation in order to ensure your system is tailored to your exact requirements. For quotes contact our manager Johnny Drum.

## GREATER MANCHESTER

**ADVENTURES IN HI-FI** 5, Bishopgate, off Hallgate, Wigan, WNI 1NL. Tel: 01942 234202. See our main entry under LANCSHIRE



# MEET-YOUR-MAKER

A reference guide to Britain's manufacturers and distributors

**AFFORDABLE VALVE COMPANY** £600 Valve amplifier. Powerful 40 watts. Powerful bass. See colour photograph in "Specialist Hi-Fi Dealers" section. Mr Andrew Everard in Gramophone Magazine "delivers a sound that's both smooth and refined....allied to a good degree of clarity and finesse" Free colour literature. Telephone 01634 373 410 anytime. Website: [www.affordablevalvecompany.com](http://www.affordablevalvecompany.com)

**AUDIOPHILE FURNITURE LTD** The Square, Forest Row, East Sussex RH18 5ES Tel: 01342 826262. Fax: 01342 824845. Manufacturers of the patented BASE Vibration Control Platforms and the Modular Audio Support System. These Products are endorsed by Hi-Fi World. Also newly introduced are the Resonance Controlled Hi-Fi Cabinets which are multi level modular design and available in various sizes and wood finishes. Please telephone for more details and a product portfolio.

**AUDIO SYNTHESIS** Manufacturers of the outstanding DAX digital to analogue converter, comes DAX-2, a new Hi-End reference converter able to dig deeper into the digital source than ever before! A new addition to the superb PASSION series of all Vishay controllers has just been introduced in the form of PASSION 8, a fully remote controlled uniquely transparent passive preamplifier, the perfect match for DESIRE. By word of mouth our DESIRE power amplifier is rapidly convincing listeners, whether passive or active! New for 1997 is TRANSCEND a state of art CD transport with AES, coaxial, AT&T glass and Toslink outputs. Audio Synthesis, PO BOX 50, Nottingham, NG9 1DZ. Tel: (+44) (0)115 922 4138. Fax: (+44) (0)115 922 9701.

**BORDER PATROL** 63 Berriedale Avenue Hove BN3 4JD Tel/Fax 01273 276716. Manufacturers of Power Supply Units for valve amplifiers, Single-Ended Power Amplifiers and high quality Transformers. The Border Patrol PSU: valve-rectified choke input filter power supply units which dramatically improves the sound of valve amplifiers: models available to suit Audionote, Audio Innovations, Audion, Art Audio, Cary, Unison Research, World Audio Designs. The Border Patrol 300B SE single-ended valve amplifier featuring interstage driver transformers and valve rectified choke input filter power supplies. Border Patrol transformers: high quality output (PP and SE), interstage and pre-amp output transformers and high value inductors.

**CREEK AUDIO LTD** 2 Bellevue Road, Friern Barnet, London N11 3ER Tel: 020 8361 4133. Fax: 020 8361 4136. E-mail: [info@creekaudio.co.uk](mailto:info@creekaudio.co.uk) Internet: [www.creekaudio.co.uk](http://www.creekaudio.co.uk) - Creek Audio build stylish Hi-Fi products in the UK, combining state of the art electronic design, with full bodied, accurate and musically rewarding sound. Our standard size products come in two award-winning ranges, the entry level 43 series and higher priced 53 series. These include: CD43 Mk2 - CD player with 24 bit resolution DAC, T43 AM/FM Tuner, Integrated Amps - 5350, 5350SE and 4330 Mk2 (described by Stereophile Magazine as the best amp under \$1000). Our A43 Mk2 and A53 Power Amps range from 50 to 250 Watts and both P43 and P53 Pre-Amps offer passive and active operation with remote control. In addition we have an award winning OBH range of small products: OBH-8/8SE MM and OBH-9 MC Phono Pre-Amplifiers, OBH-11 and 11 SE Headphone Amplifiers, OBH-10 and 12 Remote Control Passive Pre-Amps and OBH-14 - 24 bit DAC. See our home page for further details or call us for leaflets.

**DBS AUDIO.** PO BOX 91, Bury St Edmunds, Suffolk, IP32 7JU. Phone: 01284 723933 Fax: 01284 723933. Suppliers of Electro-Acoustic measuring equipment and CAD software to the audio industry. NEW: Clio win and Clio win Lite, the latest Windows versions of the Globally-established Clio Electro-Acoustic measuring system, used for loudspeaker design, Quality Control and electronics testing by many major audio companies. Clio win is the full (lab) system and Clio win Lite a lower-cost version for smaller companies and serious hobbyists. Both use the same purpose-built Clio HR200 ISA card, with its in-built mic, pre-amp and phantom powering. The matching Mic 01 (or Mic Lite) plugs straight in to make a complete system. Both versions offer the same high accuracy and ease of use: Clio win Lite simply has fewer functions. Common features include MLS testing (to eliminate sound reflections), sine and third-octave analysis, impedance, Thiele Small Parameters, LC meter, software and manual on CD ROM -- plus much more. Measurements may be exported to our Netcalk soft-

ware for accurate and easy crossover design. Also available: Boxcalc and Boxdraw bass optimisation packages and Outline speaker measuring turntable. Write or E mail and we will send fuller information and prices. Also, visit Audiomatica's new Website at: [www.audiomatica.com](http://www.audiomatica.com)

**EMINENT AUDIO** Distributor of Croft Valve Amplification. Tel 01902 656517. Fax: 0121 681 8772 Mobile 0956 921740 U.K. Stockists are: Classique Sounds (Leicester) GT Audio (London NW) Nottingham Analogue, Purist Audio, The Cartridge Man (Len Gregory - Croydon), call for overseas distributors.

**EPOS ACOUSTICS** 2 Bellevue Road, Friern Barnet, London N11 3ER. Tel: 020 8631 8864. Fax: 020 83614136. Email: [info@epos-acoustics.com](mailto:info@epos-acoustics.com) Website: [www.epos-acoustics.com](http://www.epos-acoustics.com) Innovative design and superior sound distinguish EPOS speakers from other brands in a similar price category. Adhering to the EPOS tradition of musicality and communication, the new M12 follows closely the style of the successful ES12, and was awarded five gold stars in the March 2001 edition of *What Hi-Fi?* For more information about the M12 or the new M15 please see our home page or call us for leaflets.

**FALCON ACOUSTICS LTD** Tabor House, Norwich Road, Mulbarton, Norwich, Norfolk, NR14 8JT. Tel: (01508) 578272. U.K. distributors of FOCAL drive units and SOLEN (Chateauroux) polypropylene capacitors and the largest inductor manufacturer in the U.K. Comprehensive range of DIY Speaker Parts and Kits, Sub-Bass and Electronic Filters. "Everything but the wood" Enquiries should be accompanied by a 44p stamped addressed envelope.

**IAN EDWARDS** The Old Chapel, 282 Skipton Road, Harrogate, Yorks. Tel: 01423 500442. Somebody Somewhere must make better storage units for CDs, Music, LPs, HiFi, Books, etc. than Ian Edwards. BUT until he appears, why not send for the brochure showing a selection of HAND MADE units. To do this please send 3 x 2nd class stamps.

**JEM DISTRIBUTION (FI RAX)** Springfield Mills, Spa Street, Ossett, Wakefield. WF5 0HW. Tel: 01924 277626. Fax: 01924 270759. Fi-Rax offers a new dimension in audio visual racking. High quality aluminium construction. Finishes available to your choice. Fully adjustable 6mm glass shelving, sound insulation on shelf/feet. Custom created to suit your system. Free delivery throughout the UK. For further information or a free brochure contact JEM Distribution.

**LANGREX SUPPLIES LTD** 1 Mayo Road, Croydon, Surrey. CR0 2QP. Tel: 020 8684 1166. Fax: 020 8684 3056. One of the largest distributors of electronic valves, tubes and semi-conductors in the UK and USA manufacturers. stock. We specialise in obsolete types including original UK and USA made audio valves. Telephone or fax for an immediate quotation.

**NORTON TECHNOLOGIES LTD** Manufacturers of the acclaimed AirPower LP12 Power Supply. 14 Rothesay Avenue, Chelmsford CM2 9BU. (01245) 283125

**NOTTINGHAM ANALOGUE STUDIO** Tel: 01773 762947. Design and manufacture of quality analogue audio. We're in the business because we realise how important music is. Our turntable arms and cartridges sell the world over. Our Main UK Dealers: Radlett Audio: Tel: 01727 85577. The Audio Consultants: Tel: 020 7380 0866. Walrus Systems: Tel: 020 7724 7224.

**PLATFORM 7** High density marble ISOLATION PLATFORMS for all makes of equipment RACKS/STANDS. An elegant way to UPGRADE. Improves clarity: better BASS control. 3 Abbots Drive, North Wembley, Middlesex HA0 3SB. Tel: 020 8904 2646. Also NEALGAR DISTRIBUTION Tel/fax 01296 24756.

**PMC/BRYSTON** Emmy award winning manufacturers of the highest quality loudspeakers and amplification. Industry standard in Mastering, Film Scoring, Broadcast and Post Productions. (5.1 & Stereo) PMC Products: Compacts, Floorstanders, and Large passive & active monitors. Prices range from £500 to £32,000. Finished in a large selection of exquisite real wood veneers, all PMC loudspeakers are available in horizontal mirrored pairs, centre channels and complementary subs for 5.1 surround systems. Bryston's balanced range of products include R/C Preamps, Integrated Amp modules for all the PMC range, Mono, Stereo 150W to 800w per ch, 3 Ch, 4 ch and 5 channel THX amplifiers, Surround processors,

all with distortion figures and build quality to die for. Every product is available in silver or black backed by a 20 year warranty. PMC Ltd 43-45 Crawley Green Road, Luton, LU2 0AA. Tel: 08704 441044 Fax: 08704 441045 Email: [sales@promonitor.co.uk](mailto:sales@promonitor.co.uk) Web: [www.pmc-speakers.com](http://www.pmc-speakers.com)

**REL ACOUSTICS** North Road, Bridgend Ind Est, Bridgend, Mid Glamorgan, CF31 3TP. UK. Tel: 01656 768 777, international +44 656 768 777. Fax: 01656 766 093, international. +44 656 766 093. Email: [contact@rel.net](mailto:contact@rel.net) Web: <http://rel.net> The UK's only specialist sub-bass speaker manufacturer. "The only one that works". Get your dealer to give you a home demo and find out what the fuss is all about.

**RDE TANDBERG HI-FI SERVICES** Holly Tree House, The Green, Full Sutton, YORK YO4 1HW. Tel: 01759 372795. The service, overhaul and reconditioning of all Tandberg hi-fi products regardless of age.

**SONIC LINK** The Derwent Business Centre, Clarke Street, Derby, DE1 2BU. Tel: 01332 361390. Fax: 01332 200698. "Makes the World's Finest Hi-Fi Cable from the Highest Quality Materials" SonicLink Black Rhodium interconnect uses Rhodium plated wire. Vermilion uses pure Titanium wire. S-Gold mains cable improves the picture quality in TVs, computer monitors and home cinema as well as sound in hi-fi systems. Best selling products include Red, Silver Pink and Violet interconnects, AST75x2 AST200x2 and S130x2 Biwire loudspeakers cables and Green digital 75 ohm interconnect.

**SOUND BYTES** 72 Novar Drive, Hyndland, Glasgow, G12 9TZ. Tel: 0141 339 7595. Fax: 0141 339 7592. e-mail [bytes@colloquium.co.uk](mailto:bytes@colloquium.co.uk). We specialise only in mass loading material. After hours exhaustively testing SOUND BYTES with various types of speakers, we know it works and so do you - we have never had a single complaint. Call us for advice on how much to add to your equipment for the best performance and the location of your nearest dealer.

**SOUND IMAGE UK LTD.** 52 Milton Road, London SW14 8JR. Tel: 020 -8255-6868. Importers and distributors of the finest audio equipment, featuring the stunning Boulder 2,000 series and the complete range from Norwegian manufacturer Electrocompaniet.

**J E SUGDEN & CO LTD** Valley Works, Station Lane, Heckmondwike, West Yorkshire, WF16 0NF. Tel: 01924 404088. Email [jesugden@compuserve.com](mailto:jesugden@compuserve.com). Superb amplifiers and compact disc players from the original class A Company. Our unique wide-bandwidth Masterclass series sets new standards in sound reproduction and can be upgraded to 180 Watt balanced monoblocks. Prices start from £549.00 for the incredible Audition-T and £649 for the legendary A21a. Contact us now for Brochures, reviews and purchase details. British owned - British built.

**TALK ELECTRONICS** Unit 12, Farnborough Business Centre, Eelmoor Road, Farnborough, Hampshire, GU14 7XA. Tel: 01252 378383. Please ring for details.

**TAG McLAREN AUDIO** - The Summit, 11 Latham Road, Huntingdon, Cambs, PE18 6ZU. Tel: +44 (0) 1480 415600 Fax +44 (0) 1480 52159. Combining science and technology with distinct style, TAG McLaren Audio's complete range of audio and audio-visula products are designed to bring maximum pleasure to the discerning listener. To find out more visit our website at [www.tagmclarenaudio.com](http://www.tagmclarenaudio.com), email us on HelpDesk@tagmclarenaudio.com or contact our helpdesk on freephone 0800 783 8007.

**tech\*link** distributes some of the best performing hi-fi and a/v accessories currently available in the UK. These include: Puresonic, best known for its range of high performance interconnects and connectors, and cable adapters for a wide variety of hi-fi and a/v applications in its range; tech\*link's own brand of high quality interconnects and connectors - digital compatible, 24k gold plated metal connectors; and hi-fi furniture - a selection of high quality speaker floor stands, surround sound stands and hi-fi racks. For more information, contact: tech\*link International, Unit 8, Bat and Ball Enterprise Centre, Bat and Ball Road, Sevenoaks, Kent, TN11 5LJ. Tel: +44 (0) 1732 779400 Fax: +44 (0) 1732 449344

To advertise in Meet Your Maker please  
call Amanda Sweeney on  
020 8864 4760

MEET-YOUR-MAKER



# computer

advertising@computeraudio.co.uk

editorial@computeraudio.co.uk

news@computeraudio.co.uk

# audio world

www.computeraudio.co.uk

# PEER POWER

David Price looks at the state of the post-Napster file sharing world.

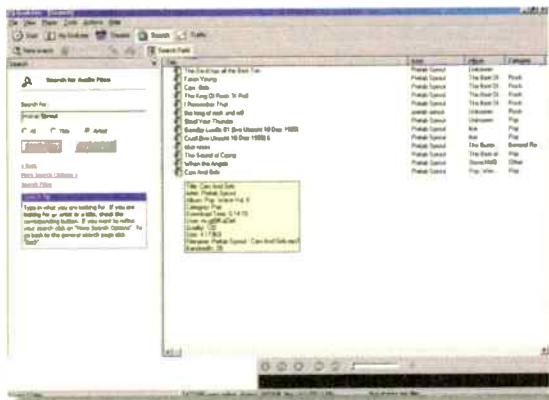
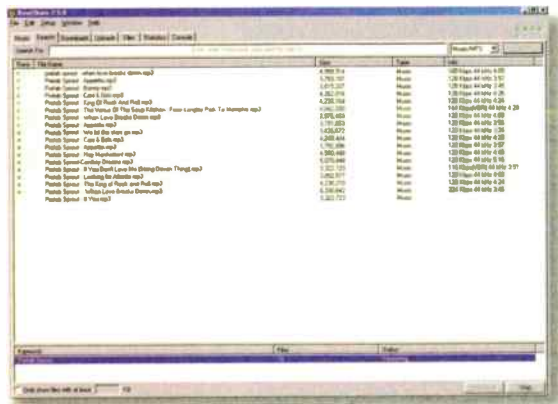

Remember the BPI's (British Phonographic Industry) 'Home Taping is Killing Music' campaign back in the early eighties? Well, compared to today's online, music file-sharing world, the problems caused by cheap cassette decks twenty years ago amount to a big fat zero. It is estimated that world-wide CD sales were down around 10% last year thanks to computer audio - Napster and CD burners.

To wit, the RIAA (Recording Industry Association of America) is now on the warpath. Having litigated against a number of 'P2P' (peer-to-peer) file sharing websites and enjoyed a major 'headline' victory against Napster (for the moment at least), it is now widening its purview

to trade sanctions. The association says that the former Soviet Republic of the Ukraine is one of the leading manufacturers of pirated CDs, and has duly endorsed economic sanctions imposed by the USTR (Office of the United State Trade Representative).

Many music industry figures are more worried about domestic CD copying (now a ludicrously easy pursuit) than illicit MP3 swapping from Napster clones. Also, CD piracy, from Russia or China, is easier to police than 'dodgy' download sites. This is because the design of the new, post-Napster generation of P2P file swapping internet sites has made the RIAA's job more difficult. To stop Napster, pulling the plug on the

central servers would cause them to disintegrate, but today's systems are more robust.

The pressure started with the RIAA's support of Metallica, the blockage of hundreds of thousands of Napster users, and then the piecemeal destruction of Napster. In a sense this was myopic, because rather than 'curing' the problem it just moved it. Millions of angry 'file swapping' music lovers simply went elsewhere to systems like Morpheus and Kazaa, for example, which automatically choose a few powerful computers with fast connections to act as temporary index and switching stations, making fast searches and downloads a reality. Another alternative is Gnutella, which works

◀ by connecting every personal computer running the software in a vast, centreless web, with each computer relaying search requests and results to the next. Unlike Napster, Aimster, Scour et al, its network architecture is totally decentralised, working independently of the software used to perform the swapping. To understand it, you need to think of it more as a 'structure' than an object which performs an (illegal) function.

The clever bit is that Gnutella uses a number of independent 'clients', which are pieces of third party software that use the structure to do the file swapping, which in turn

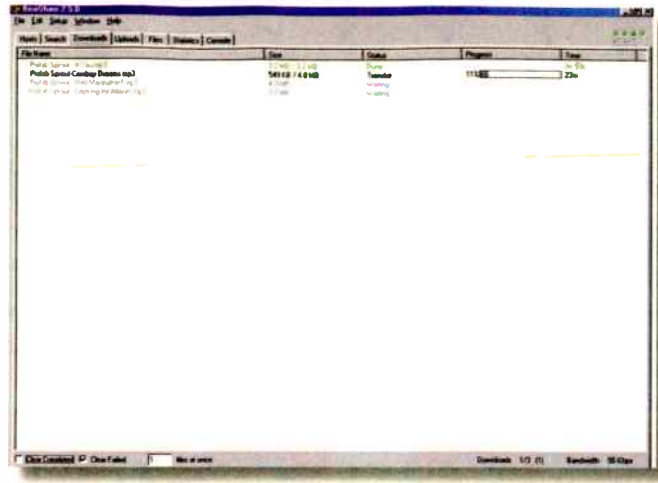

makes litigation an even more problematic process! This has confounded the RIAA to the point where it's now hoping that computer manufacturers will incorporate copy protection into their hardware in a bid to stop the flow of copyrighted material off individual user's hard drives. The idea is that it will dry up the flow of swappable files like a dammed river.

This in itself is problematic. All previous hardware and software-based copy protection systems have failed, including the SDMI (Secure Digital Music Initiative), Microsoft's copy protection on their WMA music format and even the much-vaunted SCMS (Serial Copyright Management System) which simply isn't enabled when copying CDs on computers. It's a tough one, and perhaps the major factor limiting file sharing will be the 'ease-of-use' of the actual software itself.

When Napster was shut down last year, many smaller file sharing

networks, from OpenNap to eDonkey2000, began to boom and Gnutella, reputed to be the best P2P system, showed astonishing growth. Before Napster died, it had around 10,000 users, but soon Gnutella swelled to over 50,000 in August 2001. Then a cloud appeared on Gnutella's horizon in the shape of FastTrack, which grew so rapidly that it now claims nearly 1.5 million users.

To wit, Gnutella has now dwindled to around 20,000 and now the race is on to get users back. Both BearShare and LimeWire, the two top Gnutella 'client' developers, have been adding new features and trying new network configurations. So we decided to put BearShare (a Gnutella client) against Grokster (a FastTrack client), with the intention of discovering which offers the best fix for the music hungry file swapper.

## BEARSHARE 2.5.0

[www.bearshare.com](http://www.bearshare.com)

A popular file-sharing program that

uses the Gnutella network, BearShare works by connecting to the thousands of different servers integrated into the system, 'blindly' hoping for a hit. This obviously takes time, and so isn't really practical on a dial-up connection unless you really aren't in a hurry. All Gnutella clients share this characteristic - and it's this way purely so the RIAA can't close it down.

The program isn't the most user-friendly of things - but once you get the hang of it, it's easy enough. You get a choice of options - HOSTS displays the computers it's accessing, SEARCH lets you search for music files, DOWNLOADS lists the files you are currently downloading - or trying to download and UPLOADS does the same for files on your computer you're sharing with others. FILES lists the files you've downloaded, and gives a great scrolling display of the songs on the network it's searching through currently (which it does continuously). STATISTICS gives a dizzying array of stats on things such as bandwidth, transfer speeds and all sorts of server details. CONSOLE gives a progress report about error encountered.

Generally, BearShare is hard to criticise. This latest 2.5.0 version lets you choose between music, video, and any other types of media to be downloaded. Previous versions simply went looking for anything. It would be nice if it had an audio player or video player built in, but then again your Windows OS is bound to have one these days. It works pretty robustly - downloads are decently fast and you can resume broken ones if need be. One quibble is that it's rumoured

**QUICK TEST:**

A search was performed for a willfully obscure eighties indie band, namely PREFAB SPROUT. The name was entered into the search engine of both programs. BearShare via Gnutella found 18 files, of which only 3 successful downloads were made around 10pm on Sunday 24th March. Grokster via FastTrack found 13 files, of which 7 were successfully downloaded. BearShare had a wider variety of media (i.e. one video was found), whereas Grokster found two interesting bootlegs, completely unavailable on commercial CD release. These downloaded without a hitch, and the quality was good for 128kbps. BearShare offered a wider variety of bitrates - most were between 320kbps and 192kbps - whereas Grokster's files were all between 192kbps and 128kbps.

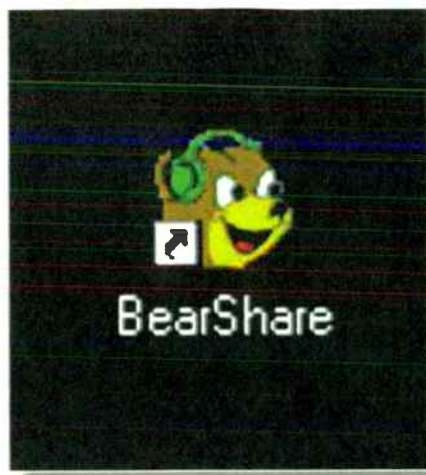

that BearShare contains spyware (software that monitors what you do when you are on the net). If you have a problem with this, it's best to investigate further.

**GROKSTER 1.5.1**

[www.grokster.com](http://www.grokster.com)

Based on the FastTrack system, Grokster claims to solve the three fundamental problems of file-sharing services: slow search speeds, limited search capabilities and failed downloads. It uses distributed, self-organising network where neither search requests nor actual downloads pass through any central server. It's multi-layered, so that more powerful computers get to be search hubs (or 'SuperNodes') which are automatically switched on and off as need be. It boasts an 'Intelligent Download system' to improve download speed and reliability - it searches for the fastest source of any particular file and duly selects it.

Interestingly it divides files into several chunks, each chunk being downloaded from a separate source. For example, users on fast cable modems can download simultaneously from 5 users, achieving a total download speed 5 times higher than a single modem. If a download

fails from one source, the next source is tried until a new network search is performed to find more sources. Grokster also boasts Automatic Meta Data Assignment (AMDA) which automatically extracts all the file information. For MP3 files this comprises Title, Album, Artist, Length, and bitrate; for Video files it comprises Resolution, Colour Depth and Codec; for Word documents it comprises Author, Title and Version. This meta data is then automatically arranged in a personalised media library.

Using Grokster is also pretty easy. MY GROKSTER gives you Windows Explorer-style file menu with all the music you've downloaded. SEARCH lets you search for any files you wish to download, TRAFFIC shows what files are either being downloaded or trying to be downloaded. NEW SEARCH lets you search again (i.e. refresh the search) assuming you've drawn a blank. As with BearShare, there's a small amount of advertising popping up in various areas, but nothing that's big enough to obstruct what you're doing.

Again, Grokster is hard to criticise. Frankly both of these programs are much of a muchness.

They're good, solid bits of code that get the job done, but don't have the beautiful look, slick navigation and high standards of presentation that, say, Microsoft's Windows Media Player 7 or Steinberg's GetItOn CD boast. Ultimately, Grokster is marginally more powerful (i.e. 'tweakable') and commensurately fiddly - but there's really not much in it.

**THE VERDICT**

The overall message is that - whatever the politics of their respective systems - BearShare and Grokster are effective ways to get free music. Neither has the slick ergonomics of Napster, but frankly they're not that far off. So if you want free music, it's still readily available. Don't think that the end of Napster means the end of free downloads. Much to the chagrin of the RIAA it's still very much alive and kicking. But home taping never did kill music, and it seems unlikely file sharing will do so either, according to the music industry's own figures. Back in 1980 Britons bought 92.6m albums; twenty years later they bought a massive 216.5m albums. Perhaps copying or file sharing brings music to a wider audience and increases sales. ■ ▲

# improve your listening pleasure

visit our web site for reviews, up-to-date stock lists and much much more

## NEW & EX DEMO EQUIPMENT

**Wilson Benesch** NEW £  
We are delighted to announce that we have just been appointed dealers for this superb brand. ACT1 and ARC both on demo. Visit our web site for full specification and links reviews on the whole range.

**CHORD**  
DAC64 (£1900) & CPM 3300 (£5595) on Demo, full range available.  
Visit our web site for details, prices, specifications & reviews

**PS Audio**  
PS600 with multi wave on demo - Amazing review. See what can be achieved with mains regeneration - £2700  
Visit our web site for details, prices, specifications & reviews

**Audio Note**  
Full range available. Many items on demonstration.  
Visit our web site for details, prices, specifications & reviews

**STAX Headphones**  
Full range available  
Visit our web site for details, prices, specifications & reviews

**Perpetual Technologies**  
If you read the HiFi News review on the amazing PA-1A Digital to Digital processor and the P-3A Up sampling DAC 24/96, you will realize how good they actually are at £1099 & £799 respectively. They will transform your CD playback in a way you could never imagine. Visit our web site for details, prices, specifications & reviews.  
P-3a Signature model now also available at £1099. We also have the Monolithic power supply unit at £349

**CEC**  
Full range of these amazing Belt drive CD player transport and DACs available including the incredible TL51Z Belt Drive CD player with 24/356 upsampling for only £1625 - on demo. Visit our web site for details, prices, specifications & reviews

**Conrad Johnson**  
Full range available. Visit our web site for details, prices, specifications & reviews

**Magnum Dynalab Tuners** NEW £  
Visit our web site for details, prices, specifications & reviews  
**EAR**

EAR V20 Integrated. Great reviews & a visual masterpiece - on demo 2799  
EAR 861 power amp, Great reviews on demo 3799  
EAR 864 pre. Balanced inputs/outputs - on demo 1529  
EAR 834P deluxe. MM/MC phono stage - on demo 889  
MC3 MC step up transformer. Probably the best available - on demo  
Full range available. Visit our web site for details, prices, specifications & reviews

**Veritas**  
P400 Digital power amp 240W - on demo 2995

**Unison Research**  
NEW Model - DM dual mono power amplifier 150W per channel, can be bridged to form a 500W monoblock. - on demo 850  
S2K pure class A using the legendary KT-88 power valve.  
Single ended heaven - on demo 1300

S2 single ended ultralinear Class A ex demo 975  
SR1 valve & solid state ex demo 1250  
S6 single ended pure Class A ex demo 1600  
S8 single ended Class A 24W - on demo 2950

Simply Phono - Stunning all valve. New - on Demo 510  
PSU for Simply Phono NEW 400  
Smart 845 mono blocks - on demo 3450

**Kuzma**  
Stabi S with -Stagi S tone arm - on demo 1245

**HEART**  
CD6000 valve CD player. If you can find a better CD player under £1,000 we would like to know! - new model - on demo 640

**Plinius**  
8100 100W - on demo 1450  
1450Jarah phono stage on demo 599  
8200 integrated 175W with phono stage 2250

**Pathos**  
Classic One - on demo 995  
Twin Towers RR - Hybrid valve & solid state. The best of both worlds. HiFi News loved it - so will you - on demo 3250

**Pink Triangle** NEW £  
We have the all new integral amplifier on demonstration. At £3999 we think it's a bargain. Have a listen & judge for yourself

**Audio Analogue**  
Bellini power amplifier. Superb - on demo 540  
Donnizetti 100W monoblocks - on demo - pair 920  
Maestro CD player - 24 bit 96 KHz upsampling - on demo 1500

Puccini SE integrated amp - on demo 635 540  
Paganini 24 Bit CD player latest model - on demo 795 695  
Maestro 150W Integrated amp - on demo 2500

**Audio Physic Speakers**  
Virgo 111. New model - on demo 3999  
Avanti 111 £7599, Virgo 111 £3000, Spork 111 £1695  
Visit our web site for details, prices, specifications & reviews

**Croft**  
Chorisma X pre amp on demo 2050  
Vitole pre amp. New - on demo 379  
Dakshini S. New model 50W - on demo 3300

Epoch Elite pre amp, reference quality, valve regulated PSU - on demo 1000  
Apporition Elite 15W per channel OTL power amp - on demo 1600  
Opera speakers, Triangle Loudspeakers, Monitor Audio, Benz Micro, Lyra, Sumiko, Dynavector

Visit our web site for details, prices, specifications & reviews

**Final Electrostatics**  
0.3 ex demo 1495 995  
0.4 New - on demo 2500 2195

**Loth-X**  
Othello precision turntable - on demo 1145  
Ion BS-1 speakers, 94 db. Great HiFi News review 400  
The all new Amoze. 98 db efficient - on demo 750  
The all new Aura Floorstander. 98 db efficient - on demo 1600

**Lavardin**  
Full range available. Visit our web site for details, prices, specifications & reviews



Origin Live Silver 250 tonearm  
"This is probably the best tonearm in the world right now" - David Price HiFi World Magazine, March 2002.  
**£599**



**PERPETUAL TECHNOLOGIES**  
P-1A & P-3A  
Stereophile Grade A listed  
P-1A On Demo P-3A  
**£1099 £799**



**Audio Physic Virgo III**  
Taking Virgo speakers to a new level  
**£3999**



**CHORD DAC 64**  
On demo - probably the most significant new product available for CD playback  
**£1900**



**EAR 834P SIGNATURE**  
MM/MC - Boxed  
**£390**



**PS AUDIO**  
PS600 with multiwave on demo - see what can be achieved with mains regeneration  
**£2700**

## CARED FOR USED EQUIPMENT

Turntables/Cartridges/Phono Stages	NEW	£
EAR 834P Signature MM/MC all valve phono stage	390	
Michell Gyrodac SE with acrylic cover + RB300 - BOXED	1175	795
Michell Orbe SE Boxed with Origin Live RB250	2495	1695
Michell ISO HR with Hera.	1200	495
Ortofon Jubilee boxed unused	1250	795
Ortikon Rokmann, boxed new	1200	649

Amplifiers - Pre, Power, Integrated	NEW	£
Audion Black Shadow 845 Monos. 2 months old boxed with bal of Audion warranty	5000	3800
Audion Premier 2.0. 2 box with MM/MC phono stage. 2 months old	2000	1100
Lavardin IT. Boxed as new. Very rare	550	2600
EAR 834L, all valve line stage, as new	550	350
Musical Fidelity XP100 pre. Boxed as new	799	499
Chord SPM 600. 3 months old	2195	1495
Pathos Classic One, hybrid 50W ex demo	995	795
Perreaux SM6P pre amplifier with 350P 350W amplifier	5500	2495
Chord CPM 3300 integrated amplifier with optional Intregre legs. Ex demo	6135	3900
Veritas P400 digital amplifier. Boxed as new. Ex demo	3000	2400
Musical Fidelity XA-200R Boxed unused	799	599

Amplifiers - Pre, Power, Integrated	NEW	£
Audio Note OTO SE Boxed	1199	899
Bow Wazoo XL - Boxed, one owner	2600	1295
Arcom Alpha 10 with DAVE and 10 3P - Boxed	2500	999
Pass Labs Aleph 3 amplifier, Stereophile recommended	2500	1295
Plinius CD Lad Pre-amp, great reviews, 2 months old	2250	1495
Roksan Caspian Integrated, boxed.	795	495
EAR V20 Integrated. Only 1 month old boxed as new	2800	1999
Unison Feather One remote control pre amp with external PSU. Ex demo	1095	595
Plinius 8100 integrated 100W. Ex demo	1495	995
Lavardin IS. Amazing reviews. 5 mths old. Bxd	1495	1095

Speakers	NEW	£
Gershman Acoustics Avantgarda RK-20. Boxed	4900	2990
Monitor Audio GR20 (new model) Bxd as new	1595	1095
ATC SCM 50-A SL. Latest spec. V. Rare.		
Yew burr - premium finish. Bxd as new.	7999	3900
Wilson Benesch Actor. Latest spec. Bxd as new	4000	2800
Wilson Audio Witt speakers-series II. Finished in Piono Black-unmarked. They come with original shipping crates and 2x Paws(£390 per pair)		
These could be described as new	11000	4999
Monitor Audio Silver Bi Floor standing speakers		
Boxed as new with full warranty	800	565
Loth-X Ion BS-1, no grilles, 94db efficient 400	250	

Speakers	NEW	£
Monitor Audio FB1 10 fast bass subwoofer	499	369
Quad ESL 63 speakers. These are as close to a New pair you will find. Fully rebuilt by Quad recently, boxed as new one owner.	3600	1595
Castle Stirling S3, boxed as new in premium Yew finish	890	590
JM Labs Micro Utopia with matching stands, 2 months old.	4349	2595

CD Players, Transports, DACs	NEW	£
DCS Purcell. New Jan 2001. Bal of 5 yr warranty	4000	2795
Electrocompaniet EMC-1. Latest spec. NEW	2390	1995
CEC TL-51z CD player. Bxd. Ex demo 24/356 DAC	1825	1199
Sugden AU51 Transport and DAC.		
Very rare. bxd as new	2600	1295
Audio Analogue Maestro - Top of the range, boxed as new	1500	1090
Marantz CD-17 Ki Signature MkII, Boxed as new	1295	795
Mark Levinson No36s 24 Bit DAC. Boxed as new	6000	2495
Classo DAC 1 - boxed one owner	3995	1495
Roksan Caspian CD player Boxed as new	895	595

Tuners / Accessories	NEW	£
Synergistic Research Designer Ref speaker cable		
3m terminated pair, 'The Ultimate'	4000	1895
Kerwood L-100T Tuner	600	190

- Croft
- Kuzma
- Conrad Johnson
- Benz Micro
- Cardas
- Loth-X
- Unison Research
- Opera
- Audio Analogue
- Final
- Pathos
- Graaf
- LAT
- Monrio
- Diapason
- Esopower
- Ecosse
- Veritas
- Plinius
- Triangle
- Michell
- Audio Physic
- Lavardin
- EAR
- CHORD
- PS Audio
- QEC
- Perpetual Technologies
- Monitor Audio
- STAX
- Magnum Dynalab Tuners
- Wilson Benesch

Open: Mon - Sat 9.30 - 5.30 pm  
E Mail: info@connoisseuraudio.co.uk

**01592 630652**

**Connoisseur Audio**

[www.connoisseuraudio.co.uk](http://www.connoisseuraudio.co.uk)

# GET IT ON?

David Price tries out Steinberg's brand new 'get it on CD 3.0' CD authoring software.

Just a couple of years ago, if you wanted to burn CDs on your PC, you could count the number of software options available to you on the fingers of one hand. There was the evergreen EzCD (then from Adaptec, not Roxio as now), Nero and err, that's it. Now though, barely a day goes by without another product joining the fray. Why should we be anything more than faintly disinterested in Steinberg's latest 'get it on CD'? Well, I have to register my bias. Over the past few months, the company has released a stream of brilliant computer audio products - from My MP3 Pro to Clean. For this reason alone, Steinberg's latest CD burning package deserves more than a cursory glance.

As CD burning is more than just about audio, this package comes fully tooled up for burning a range of media to silver disc. To wit, you get MovieXone software from AIST which lets you view, edit and enhance your home videos, along with a Photo CD browser and a CD-Extra burner which creates mixed audio and data discs (letting you burn music CDs with enhanced videos for playing on your DVD). But Steinberg hasn't skimped on the audio, for this is just about the most comprehensive product I've come across for committing your choice tunes to Compact Disc.

For example, get it on CD combines several modules from its other software. When I first clicked on the icon on my desktop and the program loaded up, I was surprised to see WaveLab's effects tools pop up on the screen before me. These are permanently available should you decide any of the tracks you wish to burn are in need of additional volume, equalisation, stereo spread etc. and you can even add dither

(what Sony call 'Super Bit Mapping') for better sound! Then there's WaveLab's audio editor - which lets you cut, paste, delete, crossfade or fade in or out your tracks.

Despite its complexity, GIOCD isn't hard to use. Once again, I'd cite Roxio's Easy CD Creator as a shining example of how to make the process easy (and Nero as the polar opposite), but Steinberg's product falls adroitly in the middle. If you follow the Wizard - which loads upon launching, it's almost as easy as EzCD. You get a choice of creating an audio CD, creating a data/mixed CD, backing up your data to CD, copying a CD (doing a direct bit-for-bit copy), grabbing audio from CD, designing CD labels or converting your files to MP3 or WMA.

Essentially, the 'grabbing audio from your CD' choice is the mainstay of the program, as it works around the idea of importing music (be it in MP3, WAV, WMA format from your hard drive or tracks from an audio CD) into the editing window, where it can be processed using the aforementioned digital effects or edited and then burned. In the process, the program will log into the net, go to the CDDDB database and find all the relevant text information (i.e. artist, title etc.) for you, should you wish - and turn it into CD Text which it will write onto your disc (assuming your burner is thus equipped). It even translates MP3 ID tag data to CD Text too!

For a program of such incredible depth and diversity, get it on CD is impressively straightforward. Navigation is simple - a number of tool bars pop up giving direct access to Photo CD editing, CD transport, audio editing etc., so there's no need to click through an exhaustive set of menus and sub-menus to get where

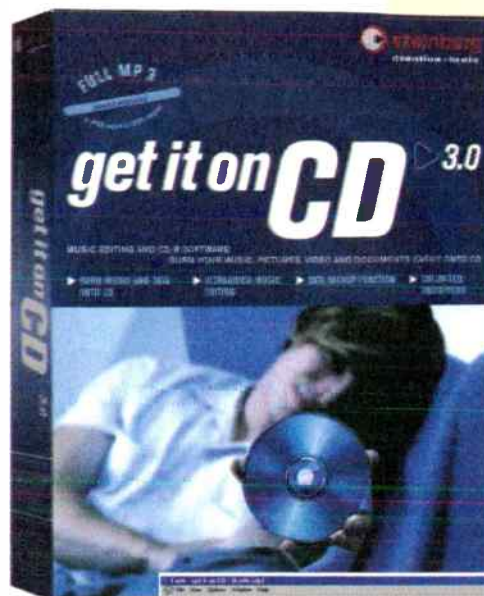

you want to go. Familiar Windows Explorer-style file menus are used for dragging and dropping the files you want to burn to the 'burn window', and then it's simply a case of clicking on CD/WRITE CD, entering the disc label and sitting back to watch the action.

Steinberg's get it on CD is easily the most versatile CD authoring package I've seen. EzCD is a touch more user friendly but not as versatile, while Nero is more powerful (if you want complete control of every disc sector on your CD-R) yet much harder to use. The joy of this product is how impressively it bridges the gap between the two extremes, and adds a host of useful extra facilities too. ■ ▲

Steinberg get it on CD 3.0 £29.99

Steinberg Media Technologies  
AG Neuer Hoeltigbaum 22-32  
22143 Hamburg  
Germany  
Tel: +49-40-21035-0  
[info@steinberg.de](mailto:info@steinberg.de)

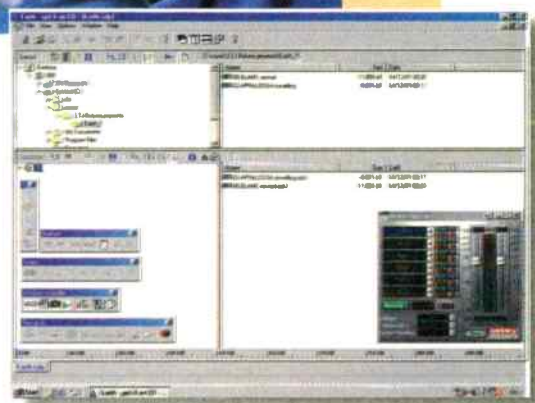

# INSPIRED THINKING?

**David Price tries out Creative Labs' next big thing, the Inspire 5300 5.1 multimedia surround speaker system.**

Now that two channel computer audio is firmly established, the race is on to capture the surround-sound market. As most new PCs have DVD drives built in - capable of reading 5.1 channel movie discs - there's been a dramatic rise in the number of multi-channel soundcards sold. According to Chart Track, 50% are now 5.1 thus equipped. To wit, there's a growing need of multi-channel speaker systems - right now 23% sold in the UK are of this type, and the number's growing fast.

Enter Creative Labs' Inspire 5.1, the company's entry level multi satellite and sub set-up which sells for £99.99. For £279.99 the company will sell you the same system with built in DTS decoding, or a cheaper alternative is the 'surround' kit which comprises the Inspire 5300 and Creative's own Audigy soundcard (complete with 5.1 DTS) for £149.99.

The package comprises five 6W RMS satellite speakers, the front three having 2m cables and the rear two coming with 5m. Five desktop stands are supplied, along with an additional monitor stand for the front centre speaker. The 18W RMS subwoofer comes complete with a wired master volume control, and an AC power adapter. The satellites have contoured face plates with colour-customisable grilles should you tire of their boring black finish. Together, the system has a claimed frequency response of 47Hz-20kHz and a claimed signal-to-noise ratio of 75dB. For something of such modest cost,

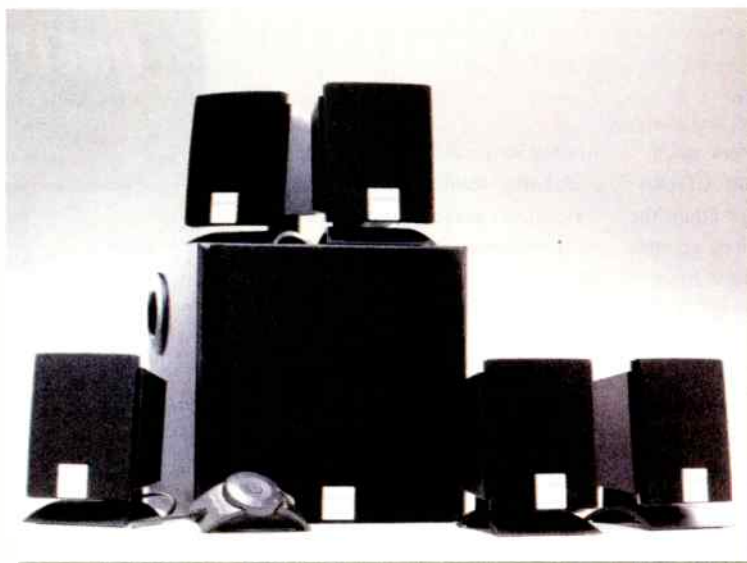

build quality is better than you'd expect. Heavily reminiscent of last year's Creative Labs' Cambridge SoundWorks Digital (a cracking two-channel system for just £60, complete with built-in DAC!), the 436g satellites are quite solid considering their dinky 92x96x112mm dimensions. The 3.6kg sub is made of black MDF and measures up at 240x220x222mm. With all the wires provided, connecting up is straightforward enough, and there's precious little hum or hiss from the internal amp even at high volumes.

Connected up to Creative Labs' own Audigy soundcard, fed by a Pioneer DVD-ROM drive, the Inspire system didn't sound half bad. Indeed, considering that its rivals are little more than toys (at the end of the market), it was a star. You get a surprisingly clean and distortion-free midband. Thanks to those small drivers it's fast and tight, with practically no overhang. Moving up the frequency range, treble is crisp and clear, although frankly I doubt the claimed 20kHz frequency response - it's hardly the most spacious and airy of high ends and simply sounds like it rolls off a lot lower. Bass isn't bad either. Through judicious twiddling of the sub level controls and some careful positioning, you can get the

sub and sats to crossover surprisingly smoothly. The bass unit isn't particularly boomy, and the whole shebang integrates quite well.

Thanks to those tiny cabinets, these things beam out of the box brilliantly - image projection is great and, in small rooms at least, they can really surround you with sound. Whether it's Pulp Fiction's Dolby Digital 5.1 soundtrack or indeed Pulp's decidedly two channel 'Disco 2000', they're uncannily tight, lithe and punchy. Indeed, for near field playback, this is a superb system for the money, and so much better than its price rivals that it's almost unfair to make comparisons.

The problem comes if you like high levels. At this stage you remember that the Inspire 5300 really is just a cheapie, and not something higher up the food chain. Even at relatively modest levels, it breaks up and starts to lose its brilliant sense of timing and impressive dynamics as the sub gets increasingly more asthmatic. Remember its £100 price tag though and you can't fail to be impressed - if you're PC is now 5.1 channel equipped, this is brilliant value. ■ ▲

**Creative Labs Inspire 5.1 5300 £99.95**  
[www.europe.creative.com](http://www.europe.creative.com)

**World Verdict**  
 £

Superb value if you want surround sound on a budget, and they also do two-channel pretty well too. Another quintessential Creative Labs budget blockbuster!

welcome to

# world favourites

Here's a list of products that are a good buy. We've tried to cater for a range of tastes, identifying strong products in every area. We're agnostic so you'll find a wide range of products, from valve pre-amps through to MiniDisc players. Products marked \* are recently out of production but make a good second-hand buy.

Prices shown are those at the time of the review



Roksan Caspian CD player  
Solid as a ROK

## COMPACT DISC

**ARCAM FMJ CD23** £1100  
This British-built player is extremely versatile. Controlled and detailed with a musical insight that few match. (Jul 2000)

**CAMBRIDGE CD4SE\*** £200  
A touch soft in the treble but outstanding in every other respect. (Feb 98)

**KENWOOD DP-3080/11\*** £180  
Has great clarity and presence for the price. Not as naturally expressive as the CD4SE though. (Feb 98)

**LINN KARIK III\*** £1775  
Under rated and overlooked, the final Karik was a gem. Superb transport gives a brilliantly tight, grippy dynamic sound, albeit tonally rather dry.

**MARANTZ CD-17 KI-S** £1100  
The Marantz excels in all areas. Without doubt this is one of the most involving CD players on the planet. Build quality is also exemplary. (Sep 97)

**MARANTZ CD-63 MKII KI-S\*** £400  
Similar to the CD-63SE but more powerful bass and an all-round smoother sound. The famous KI tweaks pay off again. Whether or not it is still pre-eminent against the vastly improved competition is a matter of opinion.

**MERIDIAN 506 20-BIT\*** £1100  
Very detailed and revealing player. More cerebral than visceral sounding, however. (May 95)

**MUSICAL FIDELITY X-RAY** £800  
Commonsense sturdy CD player of exceptional ability. Clear and detailed with high quality internal processing system. The X-Ray is inclined to show up poor recordings, but it's only doing its job! (Feb 99)

**NAD S500** £1000  
This dynamic top of the range Silverline spinner delights with any type of music. Exciting, sophisticated sounding and highly recommended. (Jun 2000)

**ROKSAN CASPIAN** £895  
The Caspian has a smooth, slightly bright sound with some of the clearest treble in the business. Very engaging, dynamic character. (Aug 97)

**ROTEL RCD 951** £300  
HDCD capability at a midrange price. Plain Jane looks but solid construction. There is some higher than average measured distortion which may take the edge off this otherwise tempting product. (Aug 99)

## COMPACT DISC TRANSPORTS

**SONIC FRONTIERS TRANSPORT** £6999  
Cutting-edge design and technology combine to make this one very desirable product. The only problem is the fantasy hi-fi price. (Sep 98)

**TEAC P-30** £2500  
Cheap it isn't, but then it sounds like a million digital dollars. Nothing short of superb. (Jun 97)

**TEAC VRDS-T1** £600  
Excellent mid-price silver disc spinner with a powerful, expansive and warm sound. Easily beats most sub-£1000 designs. A good choice for the budget conscious who want the best. (Feb 95)

## DACS

**CAMBRIDGE AUDIO DACMAGIC 3\*** £99  
Superb value for money with extensive facilities and solid, detailed sonics. Upgrades any sub-£300 player.

**DCS ELGAR** £8500  
Future-proof convertor which will handle 24/96 and 24/192. Extremely open and natural performer. (Nov 97)

**DPA LITTLE BIT 3\*** £299  
A taste of the high end on a budget. Rich, clean, punchy sound transforms budget CD players.

**MIDIMAN FLYING COW** £299  
Excellent as a DAC and doubles as an ADC for archiving to CDR. (Jun 98) Great value, as is junior version Flying Calf at £109. (Feb 99)

**MUSICAL FIDELITY X-DAC\*** £300  
A bargain for normal CDs and even better with HDCDs. (Nov 97)

**SONIC FRONTIERS PROCESSOR 3** £6999  
Quality never comes cheap! This DAC oozes class and when matched with the Transport 3 is certainly up with the best. (Sep 98)

## TURNTABLES

**LINN SONDEK LP12 BASIK** £1100  
Off the pace these days in many respects but still an extremely sweet and engaging listen with a quintessentially analogue sound.

**MICHELL GYRODEC SE** £775  
Exquisitely built, infinitely upgradeable deck that gives true high end sound at mid-fi prices.

**MICHELL ORBE** £2000  
Fantastically capable all rounder with commanding, powerful, detailed sound that gets the best from almost any arm and cartridge. Supreme build, brilliant value. (Apr 95)

**ORIGIN LIVE STANDARD (KIT)** £145  
Good in standard form with AC motor; frighteningly good with a DC motor and battery PSU.

**PINK TRIANGLE TARANTELLA** £680  
Not only does the Tarantella have more style than a catwalk full of models, it also combines PT's usual clarity with real authority. (Oct 97)

**PRO-JECT DEBUT** £110  
Straight out of the box and onto the shelf! Nothing short of a bargain. Vinyl's never had it so good, so cheaply!

**REGA PLANAR 2** £214  
Brilliant starter deck with extremely polished manner. Better built £274 Planar 3 is a great all-in-one package that eats mid-price CD players for breakfast.

**ROKSAN XERXES X** £1295  
DSU or XPS 3.5 power supply £150/170 extra. Excellent pitch stability from a new Swiss motor and outboard power supply. Very tight bass, fine dynamics and revealing clarity. (Jan 97)

**SYSTEMDEK IIX900\*/RB250** £330  
A fine all-rounder and easy to upgrade too. More depth and breadth than Rega Planar 3. (Sep 94)

**VESTAX BDT-2000** £225  
A stylish looking deck with infinitely variable speed 16-90 rpm, DC belt drive and built-in MM phono stage. Good value, with plenty of chassis room for alternative arms, if required. (Sep 99)

## TONERMS

**HADCOCK 242 SE** £649  
Latest of a long line of unipivot arms. Added mass makes the 242 suitable for both low compliance MCs and straw-in-the-wind high compliance types. Revised geometry and chromium plating completes a first-class job. (Jun 2000)

**NAIM ARO\*** £975  
Truly endearing and charismatic performer - wonderfully engaging mid-band makes up for softened frequency extremes

**REGA RB300** £180  
Some may prefer the simpler RB250 at £130. Detailed, tight, rhythmic sound but tonally rather grey and cold-sounding. Still excellent value, though.



# AUDIOVECTOR

Call us to arrange a demo or visit our **UPDATED** website at: [www.audiovector.co.uk](http://www.audiovector.co.uk)

- \* New S6 Signature (shown right) which replaces old X Series.
- \* New "Avantgarde" versions of all M Series speakers
- \* New "Improved" M Series
- \* New AV3C Improved centre channel, including Signature version
- \* New MSub Active subwoofer

Visit our website or clip the coupon for details and prices of all of the above new products to be sent to you.



Post to: Audiovector UK, Unit 7, Wren Industrial Estate, Coldred Road, Maidstone, ME15 9YT Tel: 01622 201983  
Web: [www.audiovector.co.uk](http://www.audiovector.co.uk)  
Please send me info on Audiovector

Name: .....

Address: .....

Post code: ..... HFW0206

## [www.supradirect.co.uk](http://www.supradirect.co.uk)

The **ONE-STOP SECURE WEBSITE** for SUPRA cables to improve your Hi-Fi and/or Home Cinema system.

\*\* ONLINE CREDIT CARD PURCHASES via 128bit SSL \*\*

### Hi-Fi Nuts

Upgrade your existing cheap cables and enjoy better sound quality with **AWARD-WINNING Supra speaker and interlink cables!**

### Home Cinema Users

Choose from Supra's range of composite, s-video, or RGB/Component video cables to improve your picture quality. Or use Supra co-ax digital or fibre optic cables from DVD to AV processor/amp/receiver

### DIY'ers

Fit Supra Boxcon 4mm terminals to your kit amplifier or loudspeakers.

Quick and simple instructions for obtaining better cables:

- 1 - VISIT: [www.supradirect.co.uk](http://www.supradirect.co.uk)
- 2 - VIEW the range on/offline (download the PDF catalogue)
- 3 - SELECT from the wide range
- 4 - SAVE money when you make your purchase
- 5 - ENJOY

### Products now available:

**EFF-ISL "25th Anniversary"** the updated version of the Hi-Fi Choice "Best Buy" EFF-ISL cable

### Classic 4T

What Video - "Best Buy" cable

### Quattro 4x4T Bi-Wire

Hi-Fi World - "Highly recommended"

**Ply 3.4 & Ply 3.4/S shielded** Hi-Fi Choice - "Recommended"

### AV6 RGB scart to scart

What Hi-Fi - 5 STAR winner

### OTHER NEW PRODUCTS:

**Trico Co-ax digital cable**

**ZAC Fibre Optic cable**

**AV2 s-video cable**

**AV3 RGB/component video cable**

**Lo-Rad shielded mains cable**



We belong to the Which? Webtrader Code of Practice

## Bocchino Audio Connectors

Australia's finest range of high-end phono connectors

Upgrade your phono cable connectors from the **low-conductivity, gold-plated brass types** to the **Bocchino Brenda phono plugs**.

Each plug is fabricated from one-piece of **HIGH CONDUCTIVITY, OXYGEN FREE COPPER**, luxuriously silver-plated and finished with hard-gold-plating.



- Brenda™ B7 (single bay, short) - £99/pair**
- Brenda™ B7 (dual bay) - £109/pair (top left picture)**
- Brenda™ B9 (dual bay) - £149/pair (top right picture)**

Common features: Each plug machined from a solid billet of 99.94%+ pure High Conductivity Oxygen Free Copper, then plated with 15+ micron silver and 1.0+ micron hard gold. Signal tips plated with 3.0+ micron hard gold.

Now available from specialist accessory dealers. Or **BUY DIRECT** via our **SECURE** website at: [www.bocchino-audio.co.uk](http://www.bocchino-audio.co.uk)

### Trade/OEM enquiries welcome

- please contact sole UK distributor -

Bocchino Audio UK, PO Box 364, Maidstone, ME15 9FE

Email: [sales@bocchino-audio.co.uk](mailto:sales@bocchino-audio.co.uk)

Tel: 01622 201983 Fax: 01622 761560

## SONIC DESIGN® DAMPING FEET

[www.sonicdesign.co.uk](http://www.sonicdesign.co.uk)

### Virtues of using Sonic Design Damping Feet

These feet will give a substantial decrease in loudspeaker cabinet movements. This is apparent when you put one finger softly against the top of the front baffle, as it vibrates much less after damping. The transmission of vibrations from the cabinet into the floor will also be reduced. The music will be cleaner, with a less coloured sound quality.

### For Loudspeakers:

Audiophile Damping Feet provide the best possible isolation and damping but it is important that the feet are optimised to the weight of your loudspeakers. Both the stiffness and size of the feet are selected to achieve this. Speakers within the range 5 to 200 kg can be optimised. Let us know the mass of your loudspeakers and we can advise you the correct set to purchase.

The Standard Loudspeaker Damping Feet have a large overload margin, and are lower priced than the Audiophile version. The resonance frequency is a few Hertz higher. The colour is nut brown, except for the stiffest feet which are grey. The standard feet are produced in four different weight classes and do not need to be fine tuned to specific loudspeaker models.

### For CD/DVD Players:

The CD Damping Feet are made from the same material as the Standard Damping Feet. If the sound of your CD/DVD player is sensitive to vibrations, the CD Feet will be the way to go. The sensitivity to shock and the accompanying mistracking will be reduced with the use of the CD feet. They can also be used with any other audio product that you would like to isolate from vibrations. The set contains four small and one large foot. The large foot is used if the centre of gravity is off-centre or for those CD/DVD players that have five feet.

BEFORE >>:  
(top) 125 Hz sine signal to the speaker, (lower) floor movement, using spikes

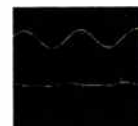

<< AFTER:  
(top) 125 Hz Sine signal to the speaker, (lower) floor movement, using soft feet (note floor signal magnified x2)

### Damping Feet for CD players (pack of 5) - £9.99

Available in three sizes: 2-5kg, 5-10kg, 10-25kg

### Damping Feet for Loudspeakers (pack of 8) - £19.99

Available in four sizes: upto 12kg, 12-28kg, 28-50kg, 50-100kg

### Audiophile Damping Feet for Loudspeakers - £44.99

Available for most high-end loudspeakers from 5kg upto 200kg

Available from all good specialist hi-fi/accessory dealers (trade enquiries welcome - email [sales@sonicdesign.co.uk](mailto:sales@sonicdesign.co.uk) or fax 01622 761560)

Or, in case of difficulty, on the internet at: [www.sonicdesign.co.uk](http://www.sonicdesign.co.uk)



Prices shown are those at the time of the review



Musical Fidelity X-Cans2  
Warm, sumptuous, sweet sound

**SME 3009SII** £309  
Once state of the art, but no longer. Weak at frequency extremes and detail, but its legendary serviceability makes it a cult in Japan. Can be picked up for peanuts second-hand. (Jan 93)

**SME 309** £689  
A down-market version of the IV and V with aluminium armtube and detachable headshell. Tight, neutral sound with good tonality, but lacks the IV's pace and precision. Like the older SME 3009 series, this arm is also available in 10" and 12" versions. (Jan 93)

**CARTRIDGES**

**AUDIO TECHNICA AT-110E** £30  
Great starter cartridge that's refined, detailed and musical beyond its price. Best value MM under £50

**GOLDRING 1012GX** £74  
An accomplished MM with a solid bass, slightly forward midband and clean transients. Very reasonable price for such an able performer. (Jul 93)

**DNM MICA** £185  
Better Goldring's 1042 and costs only £135 on trade-in. An assured and transparent MM. (Feb 98)

**DYNAVECTOR DV20X-H** £299  
The best modern budget MC combines deliciously sweet sound with fantastic get-up-and-go. High output version works a treat with valve phono stages too.

**MUSIC MAKER** £575  
When mated with a good quality arm, this hand finished high-output pick-up gives an ear-boggling account of itself. Very high compliance ensures maximum information retrieval. An absolute (grain orientated) gem. (Feb 99)

**ORTOFON MC 7500** £2000  
Conclusive proof that there's hope for the world. It's a long time ago now but this high-priced favourite still earns its niche - CD lovers would die if they heard it. (May 94)

**ORTOFON MC 15 SUPER II** £140  
Not quite as good as the dearer Supremes but the Super II is a splendid introduction to the joys of moving-coil cartridges.

**GOLDRING 1042** £130  
One of the best Moving Magnet cartridges going, with beautiful treble and muscular bass. New low price makes it a bargain.

**ORTOFON ROHMANN** £1000  
In a way it's MC 2000 meets MC 7500 with great tonal strengths and a dynamo sound. (Apr 96)

**INTEGRATED AMPLIFIERS**

**AUDIO ANALOGUE PUCCINI SE** £595  
This superbly-built Italian integrated has a lucidity and control which leaves others nowhere. Sound stage a wow. (Dec 97)

**AUDIOLAB 8000a \*** £495  
Well rounded integrated with smooth and detailed sound plus a huge feature count. Great build makes later versions a top used buy.

**DENON PMA-250SE** £160  
It might not have bags of grunt but the Denon can sound exceedingly natural and open. (Feb 97)

**McINTOSH MA6800\*** £3735  
The MA6800 not so much plays music as takes control of it, with effortless bass drive. (Sep 95)

**MISSION CYRUS 2 \*** £299  
Classic eighties minimalism combines arresting styling with clean, open, lively sound. Further upgradable with PSX power supply.

**MUSICAL FIDELITY X-CANS2** £160  
Warm, sumptuous, sweet sound h/phone amp. gives startling results with a decent set of headphones.

**NAIM NAIT 3 \*** £575  
Superb rhythms and dynamics make for great music making, but tonally monochromatic. Super optional phono stage makes it ideal for vinyl junkies.

**ROKSAN CASPIAN** £695  
Smooth, warm integrated with remote control that works happily into most 'speakers. (Dec 97)

**SONNETEER ALABASTER** £995  
Builds on the strengths of the Champion with ample control, colour and drive. (Oct 97)

**PHONO STAGES**

**CREEK OBH-8 SE** £180  
Punchy, rhythmic character with oodles of detail makes this a great budget audiophile product.

**LFD MISTRAL PHONO STAGE \*** £300  
The Mistral has a warmth and involvement that make many pricier stages sound overpriced.

**MICHELL DELPHINI MONOBLOCS** £1995  
Analogue tour-de-force gives supremely clean, detailed and finely resolved sound with breathtaking dynamics. Great value, even at this price.

**MUSICAL FIDELITY X-LP** £125  
One of the famous MF X series. Full marks throughout for clarity and detail. Switchable between MM and MC. Indestructible build! (May 99)

**PRO-JECT PHONO BOX** £39  
Not the last word in many respects but a thoroughly honest piece of work. Inexpensive introduction to all that vinyl has to offer. MM and MC provision plus choice of two impedances.

**ROKSAN ARTAXERXES X** £950  
With the Atessa PSU the Artaxerxes X MM/MC stage still shines. Great stage depth, neutrality and tonal colour. (Oct 97)

**Billy Vee**  
SOUND • SYSTEMS

248 Lee High Rd, London SE13 5PL (Mon - Sat 10am to 6.30pm Closed Thurs & Sun)

**NOT ONLY A CLASSIK BUT MUCH MORE**

Call 020 8318 5755 or 8852 1321 now!

Save over £300 on this Linn/Celestion System

This is just one of the fabulous systems available during our Autumn promotion. The offer may be limited in quantity but you can be sure that any product or system we stock is available for audition and backed by experienced staff who work to fulfill the Billy Vee pledge - to give the ultimate in musical satisfaction

- Free delivery (U.K. Mainland) & local installation included
- Five year parts and two year labour warranty on this system
- Deferred & Interest Free Credit available 0% APR - Call for details.
- Arcam, B&W, Linn, Naim, Rega, TAG & more available for audition

Complete with speaker leads - just plug & play only :-



Individually, Linn Klassik - any colour £995. Celestion Compact A £599

**SONNETEER SEDLEY** £399  
Combines transparency and fine dynamics with excellent rhythmic ability. (May 98)

## PRE-AMPLIFIERS

**AMC 1100** £150  
Suffers from un-defeatable tone controls but an extremely good value piece of kit. Partners the similarly budget level AMC 2200 power amplifier, also at £150. Comfortable beginners' choice. (Mar 99)

**AUDIO ANALOGUE BELLINI** £475  
Showcases AA's characteristic mix of clarity and musicality and blasts the competition. (Apr 98)

**CHORD CPA1800** £1800  
Clarity, insight and control are second to none - an addictive mixture. (Mar 98)

**CROFT VITALE** £350  
A modestly priced valve pre-amp with exceptionally transparent performance. MM phono stage plus three line stages are standard. Volume controls are separate for each channel, thus giving balance adjustment. A remarkable item in all respects. (Feb 2000)

**XTC PRE-1 \*** £1000  
Almost valve-like in its smoothness, the line-level Pre-1 is warm and seductively clear. (Nov 96)

## POWER AMPLIFIERS

**ARCAM 9 \*** £400  
With 70W on tap, the 9P will drive most loudspeakers with a spacious and detailed sound. Good bass welly too. (Dec 96)

**CHORD SPM400** £1400  
There's a sense of effortless power to the Chord that gives music real scale and presence. (Mar 98)

**MARANTZ MODEL 9 \*** £8000  
Authentic reproduction monoblocs still more than cut the sonic mustard. Highly expensive and highly sought after. (Mar 97)

**MICHELL ALECTO** £1989  
Crisp, clean and beautifully controlled with gorgeous styling. Partnered with the £1650 Orca this is a superb winning combo. (Oct 98)

**MUSICAL FIDELITY X-A200** £1000/pair  
200W of high-end monobloc power in a grooved tube. (Aug 98)

**NAIM NAPI80** £1060  
Partnered with a NAC82, this has classic Naim control, and a superbly rhythmic presentation.

## TUNERS

**CAMBRIDGE T500** £180  
An extremely engaging tuner with a performance at odds with its low price. Not exactly a Troughline, but you may not notice... (Feb 99)

**CREEK T43** £399  
Excellent detail, separation and dynamics. A great little tuner and unbeatable at this price. (May 98)

**MARANTZ ST17** £600  
A positive dreadnought of a tuner. Sweet and refined but with a heavy punch when needed. A tuner of this quality demands a decent aerial. (Jul 99)

**MISSION CYRUS FM7\*** £300  
Clear and lucid sound puts it up with the best. Superb build too. (Apr 94)

**NAIM NAT03** £595  
The NAT03's warm, atmospheric sound is further proof of Naim's proficiency with tuners. (Sep 93)

**SONY ST-SA3ES\*** £250  
Beguiling RDS tuner for the sonically discerning. Good ergonomics and sensitive too. (Apr 97)

## CASSETTE DECKS

**AIWA AD-S750\*** £200  
Sonically a very decent machine at the price. Comes fitted with Dolby B, C and the dead handy Dolby S. (Apr 96)

**AIWA AD-S950\*** £300  
A stable transport, superb head and Dolby S make the AD-S950 an excellent all-rounder. (Feb 95)

**KENWOOD KX-3080\*** £160  
A simple deck, but excellent-quality head and transport give top quality sound. (Oct 96)

**PIONEER CT-S740S** £430  
A great piece of engineering from Pioneer, with first-rate sound. (Jun 96)

**YAMAHA KX-580SE\*** £250  
The 'SE' tag is more than a marketing gimmick. Sound is solid and clear with Dolby S. (Sep 97)

## LOUDSPEAKERS

**CASTLE EDEN** £469  
Impressively vice-free 'speakers that offer great transparency and involvement. One of a select band that simply makes music regardless. (Mar 97)

**EPOS ES12 \*** £495  
Strong, punchy bass is allied to finely detailed, articulate midrange and sparkling treble. (Oct 96)



**Kef Cresta I loudspeakers**  
A very musical sound

**KEF CRESTA I** £100  
Delightfully sophisticated presentation for the price. Won't blow the roof off, but will deliver a very musical sound. (April 2000)

**KLIPSCH HERESY II** £1100  
An outstanding high sensitivity loudspeaker with midrange and treble horns coupled with infinite baffle 12" bass driver. Effortless, fast and accurate. (May 99)

**MISSION 752 \*** £495  
Cracking mid-price mini towers combined HDA drive units and metal dome tweeters with surprisingly warm results. Benign load characteristics makes them great for valves.

**MISSION 771** £170  
Characteristically fast, punchy Mission sound from the Aerogel mid/bass and silk-dome tweeter. (Jul 98)

**Billy Vee**  
SOUND SYSTEMS

248 Lee High Rd, London SE13 5PL (Mon - Sat 10am to 6.30pm Closed Thurs & Sun)  
You can't touch it but you sure can feel it  
You can't see it but you really can hear it  
Call 020 8318 5755 & join us for true -

# HI-FI PERFORMANCE



What is true hi-fi performance?

Here's a simple truth. You *can* believe what you read but you will never really know how good something is until you listen. A demonstration is worth a thousand words and our hi-fi systems all have one thing in common, we guarantee you will get more from your music! When you hear what we mean, you will never look back. Honest!



**Rega**  
The New Brio Amplifier

**QUAD ESL 63 \*** £3450  
A reference against which all other loudspeakers are judged, the '63s have superb imaging and genuine transparency.

**TANNOY AMS8 \*** £2700  
Bold sounding pro active monitor with solid bass, clear midrange and delicious treble. (Aug 96)

**TANNOY MERCURY m2 \*** £140  
A true audiophile bargain which embarrasses many more expensive boxes. Never mind the price, let your ears decide. (May 97)

**MINIDISC PLAYERS**

**KENWOOD DM-9090** £500  
One of the best MD players yet. ATRAC 4.5 gives clean and very musical recordings from this Kenwood. (Jan 98)

**SONY MDS-JB930Q** £250  
Great mid-price machine that adds better build and facilities to the '530's already excellent sonics.

**SONY MDS-JA50ES \*** £1300  
This Sony can put the wind up Nakamichi cassette decks when used with better blank MDs. (Apr 98)

**SONY MDS-JE55ES**  
**MiniDisc recorder** £520  
The best sounding MD deck made so far, thanks to awesome build and heroic ATRAC-DSP Type R coding.



**Alesis Masterdisk**  
A glimpse of the future

**SONY MDS-JE510** £300  
An impressive sound and unmatched convenience make this MiniDisc player an excellent buy.

**DIGITAL RECORDERS**

**ALESIS MASTERDISK** £1400  
A groundbreaking hard disc recorder with a built-in CD drive. An amazing bit of kit, and a glimpse of the future. (July 2000)

**KENWOOD DMF-9020** £500  
An excellent tool for home recording, combines convenience, superb sound and a fair price. (Aug 99)

**MARANTZ DR-17** £1100  
Probably the best sounding CD recoder on the market. Built like a brick out house with a true audiophile sound. HDCD compatible. (July 2000)

**PHILIPS CDR-765** £360  
One of the first twin deck recorders/players that boasts high speed dub facility. Playback could be warmer, but still a bargain. (Oct 99)

**PIONEER PDR-555RW** £480  
Excellent mid-priced CD recorder that both plays and records with equal panache. (Oct 99)

**SONY TCD-8 DATMAN \*** £599  
Super clean and detailed sound makes this an amazing portable. Not as robust as it should be though.

**DVD PLAYERS**

**DENON DVD-5000** £1600  
Monster build, as you'd expect at this price. Facilities and gadgets galore and drop-dead high end looks. A very smooth and sophisticated sound, although not as good as similarly-priced CD players. (Mar 99)

**PIONEER DV-717** £700  
Well built and a solid performer, with a 'true' 24/96 digital output. Facilities in abundance and a controlled, exciting way with CD replay. Shame it lacks a Dolby Digital decoder! (Sep 99)

**SONY DVP-S725** £490  
One of the best buys in the DVD market. Available in a dodgy white case, but the facilities and performance more than make up for this. Excellent with both music and visuals, and a whole host of up to the minute facilities to keep you occupied. (Mar 2000)

**HEADPHONES**

**JECKLIN FLOAT MODEL TWO** £99  
Wonderful panel-like and open sound from these esoteric-looking headclamps. Do not wear in public unless you like being made a fool of!

**SENNHEISSER HD-490** £50  
Good value cans with an exciting and bassy sound. Everything one should look for in headphones at a sensible price.



**Nordost Blue Heaven**  
A simple and effective upgrade

**INTERCONNECTS**

**CHORD COMPANY CHAMELEON 2** £90/m  
One of our favourite favourites, the Chameleons are musical performers with a smooth yet open sound.

**DNM RESON** £40/m  
Neutral and transparent, and a steal at forty quid!

**NORDOST BLUE HEAVEN** £150/m  
Some of the fastest and most transparent cable around. A simple and effective upgrade.

**VAN DEN HUL ULTIMATE THE FIRST** £260/0.6m  
Carbon interconnects that help you forget the electronics and concentrate on the music. Miraculous transparency.

**LOUDSPEAKER CABLE**

**CHORD COMPANY RUMOUR** £9.95/m  
The Rumour is our reference at the price. Tight and tuneful bass mixed with air and space results in a cracking cable for the money.

**DNM RESON** £6.95/m  
This cable has a transparency of sound that's rarely heard at the price. Excellent value for money.

**NORDOST BLUE HEAVEN** £375/3m pair  
This isn't cheap, but it sounds absolutely fab. An open and spacious sound that simply carries music.

**Billy Vee**  
SOUND SYSTEMS

**NEW YEAR DISPLAY CLEARANCE BARGAINS**

SOME AS NEW WITH 1 YR WARRANTY. 24HR DEL ONLY £5. CHECK AVAILABILITY BEFORE ORDERING

CALL SALES: (020) 8318 5755 or 8852 1321 - 248 Lee High Road, London, SE13 5PL

0% APR is available on purchases of more than £660. Please call for details. Confirm stock before visit. E&OC

<b>Arcam AVR100</b> AV Receiver (2Yr G/tee) . . . (799.00)	<b>£499.00</b>	<b>Linn CD12</b> CD Player E/D (2Yr G/tee) . . . (12000.00)	<b>£7995.00</b>
<b>Blueroom Minipod</b> Speakers Var colours . . (289.00)	<b>£199.00</b>	<b>Marantz DV4100</b> DVD Player (1Yr G/tee) . . . (399.00)	<b>£199.00</b>
<b>Elac CL82</b> Speakers . . . . . (399.00)	<b>£199.00</b>	<b>Marantz DV7000</b> DVD Player (1Yr G/tee) . . . (599.00)	<b>£329.00</b>
<b>Linn Karik/2</b> CD PlayerS/H (1Yr G/tee) (new 1850.00)	<b>£895.00</b>	<b>Naim NAP 250</b> Power Amp S/H (1Yr G/tee) (1805.00)	<b>£1000.00</b>
<b>Linn 5105</b> Power Amplifiers (2 Yr G/tee) . . . (1200.00)	<b>£699.00</b>	<b>Naim NAP 250</b> Power Amp (2Yr G/tee) . . . (1805.00)	<b>£1445.00</b>
<b>Linn Kan</b> Speakers (2Yr G/tee) . . . . . (325.00)	<b>£239.00</b>	<b>Naim Intro</b> Spkrs - Beech (1Yr /Gtee) . . . . . (790.00)	<b>£579.00</b>
<b>Linn Keosa</b> Speakers (2Yr G/tee) . . . . . (495.00)	<b>£299.00</b>	<b>ProAc Tablette</b> Speakers (2Yr G/tee) . . . . . (649.00)	<b>£459.00</b>
<b>Linn Ninka</b> Cherry Spkrs (2Yr G/tee) . . . . . (985.00)	<b>£725.00</b>	<b>Pioneer LCV10</b> Laptop Port/DVD (1Yr G/tee) (999.00)	<b>£499.00</b>
<b>Linn 5150</b> Subwoofer-Cherry (2Yr G/tee) . . . (2999.00)	<b>£1995.00</b>	<b>Rotel RCD 971</b> CD Player (2Yr G/tee) . . . . . (450.00)	<b>£269.00</b>
<b>Linn Kairn</b> Line Preamp (1Yr G/tee) . . . . . (1400.00)	<b>£799.00</b>	<b>Rotel RV 985</b> DVD Player (2Yr G/tee) . . . . . (625.00)	<b>£399.00</b>
<b>Linn LP12/Lingo/Akito</b> S/H (1Yr G/tee) . . . (2250.00)	<b>£1250.00</b>	<b>Vision 42"</b> Plasma Screen (1Yr G/tee) . . . . . (5150.00)	<b>£2990.00</b>
<b>Linn Keilidh</b> Blk S/H (1Yr G/tee) . . . . . (775.00)	<b>£395.00</b>	<b>Yamaha KX393</b> Cassette Deck (2Yr G/tee) . . . (129.00)	<b>£99.00</b>
<b>Linn Keltik</b> Speakers Wal (2Yr G/tee) . . . . . (6000.00)	<b>£3950.00</b>	<b>Yamaha KX493</b> Cassette Deck (2Yr G/tee) . . . (179.00)	<b>£129.00</b>

welcome to

# world classics

## CASSETTE

### NAKAMICHI DR-2

A great machine with Nakamichi's legendary heads. The lowest cost 'true' Nakamichi at the time, retailing for £600.

### NAKAMICHI CR-7

The last of the great ones, and definitely the best Nakamichi ever (yes, better than a Dragon)

### YAMAHA TC-800G

Early classic in serious cassette. Its ski-slope looks got it a cult following once it had ceased to be simply ugly.

## CD PLAYERS

### MERIDIAN 207

Beautifully-built two-box with pre-amp stage. Very musical although not as refined as modern Bitstream gear. No digital output.

### PIONEER PD-91

Built-to-last player with easy upgrade routes for modifiers. Not knockout as it stands but get one cheap and have a go!

### CAMBRIDGE CD1

The first two box player with weighted Drop-out/error counter. Radical and effective at the time - a classic.

## AMPLIFIERS

### LEAK POINT ONE, TL12 & TL10

Ancestors of hi-fi, consequently expensive nowadays. As with all vintage valve stuff, overhauling is de rigeur before use, using original parts if possible.

### LEAK PRE-AMPS

Line of 'good for their time' pre-amps. Use of EF86 pentode valve for high gain rules out ultra performance. Not the highest-fi.

### LEAK STEREO 20

Excellent workaday classic valve amp. In good order the 20 will not disgrace itself. Various upgrades are available from specialist repairers.

### LEAK TL12+

Plentiful monobloc equivalent of Stereo 20. Reasonably inexpensive and a tweakers' dream. Genuine valve hi-fi on a budget.

### NAD 3020

You can't argue with success! NAD's budget transistor integrated gave thousands their first taste of hi-fi and remains great value.

### QUAD 33/303 PRE/POWER

Great style and construction, also bullet proof. Warm and wooly sound, but easy going. A good introduction to early transistor audio classics.



Garrard 401  
A legendary turntable.

### QUAD 22/II PRE/POWER

One of the all-time classic valve amplifiers. Unusual circuit but it works beautifully. 22 pre-amp not up to today's standards.

### SUGDEN A21

Seventies transistor integrated has an eminently likeable smoothness and musicality. Limited inputs via DIN sockets.

### TECHNICS SE-A5 Mk2

Nice transformer and electronics, shame about the casework. With tweaking, this 150watter can sound sweet.

## LOUDSPEAKERS

### KLIPSCHORN

Not exactly plentiful or cheap but a splendid beast. For efficiency they have seldom been equalled. Space hungry!

## AUDIO ILLUSION

23 Langley Broom  
Langley, Berkshire SL3 8NB  
(2 mins. Junc. 5 off the M4)  
TEL: (01753) 542761 FAX: (01753) 772532  
www.audioillusion.co.uk  
mailto:audioillusion@btinternet.com

Two completely different ways to achieve the ultimate goal -

# PERFECT SOUND

Whether it be Home Cinema or Audio - there should be no compromise -



Each System winners of an



### PIËGA OF SWITZERLAND

"these speakers blow that 'posh design equals poor sound', concept to pieces"  
- Adam Rayner  
HCC

### AERIAL ACOUSTICS

"this is a Home Theatre experience of the highest order"  
- Stuart Robinson  
HCC



0% FINANCE (subject to status) with up to 3 years to pay.

For further information and your local dealer please contact AUDIO ILLUSION

**LEAK SANDWICH**

Rather warm sounding big infinite baffle but cheap with it. With a reasonably powerful amp can sound quite satisfying.

**LOWTHER PM6A**

High quality full-range driver; still manufactured. High sensitivity, as fitted to many classic horn designs.

**MAGNEPLANAR SMGa**

Touch dry in the bass but a technological loudspeaker with genuinely musical abilities.

**MISSION 770**

Father of the 77 range which continues to this day. Well mannered with a warm sound and a kind load to amplifiers.

**QUAD ESL57**

Unrivalled. Properly serviced there is nothing like them. Their natural presentation may make them caviar to the general.

**YAMAHA NS1000M**

Hi-tech favourites of the Japanese and Americans. Viewed more warily in the UK but can give excellent results.

**TANNOY GRF & AUTOGRAPH**

Folded horn monsters which certainly sound good if you have the space. For Tannoy vintage see HFV November 1998.

**WHARFEDALE SUPER 8 RS DD**

Ideal experimenters' driver. High sensitivity ~14,000 Gauss magnet and extended frequency range. Inexpensive too!

**TANNOY YORK, LANCASTER**

Many similar models of infinite baffle or reflex design. Not the last word in tautness but the drivers work well in modern cabinets.

**VINYL**

**ACOS LUSTRE**

Very honest piece of kit, well made and easily adjusted. Vinyl beginners could do very much worse.

**ALPHASON HRI005**

First class arm, up to present-day standards. Buy carefully, though, as there's no service available now.

**ARISTON RD11**

A one-time king of turntables very similar to the Linn LP12. Now deposited but worth a look at the right price.

**LINN AXIS**

Uncomplicated, lower-price version of the famous Sondek. Less expensive than some of its stablemates.

**GARRARD 301 & 401**

Legendary turntables, once fairly plentiful. Excellent back-up available; many different custom plinths available. High quality.

**GOLDRING Lenco 88 & 99**

Great deck for the kitchen table enthusiast. Garrard fans won't look at 'em but cheap and capable. Servicing available.

**HADCOCK 228**

Recently out-classed by Hadcock's updated 228 Special Edition but a proper hi-fi arm for all that. Makers still service.

**MICHELL FOCUS ONE**

20 years and still going strong. Early runner in the 'modern' turntable cycle with a first class arm. Factory servicing available.

**SHURE M75**

Recent line-contact improvements have left the M75 behind but the wide range of needles make it a handy tool.

**SME 3009 IIS**

Everlasting classic tone-arm. Spares permanently available from SME. No longer the last word but peanuts second-hand.

**THORENS TD124**

Best classic deck ever? Judging by the prices they fetch it's possible - 78rpm too!

**THORENS TD150**

Mid-price deck with a keen following. No real difficulty with servicing - novices may find the suspension system unnerving.

**TRIO L-07D**

Knockout heavyweight from 1980 with stainless bearing and 11lb platter! Not a give-away and beware! - spares scarce.

**TUNERS**

**LEAK TROUGHLINE (ORIGINAL)**

Interesting ornament but no longer hi-fi. Limited coverage of 88MHz to 100MHz only.

**LEAK TROUGHLINE II & III MONO**

Arguably the best-sounding tuners ever. Adaptation for stereo easy via phono multiplex socket.

**LEAK TROUGHLINE III STEREO**

Excellent tuner with indifferent stereo decoding circuit. Best when adapted to use modern outboard decoder.

**MARANTZ ST-8**

Possibly the ultimate Tardis console, including an oscilloscope for checking the strength of signal. Expensive even now.



**Leak Troughline II Mono**  
Arguably the best sounding tuner ever

**Genius,  
Pure Genius**

Distributed by:  
Henley Designs  
01235 511166  
www.henleydesigns.co.uk

**MANTRA AUDIO**  
Specialist Suppliers of Audio Accessories  
[www.mantra-audio.co.uk](http://www.mantra-audio.co.uk)

CARTRIDGE SELECTION	STYLUS	REPLACEMENT STYLI
Goldring 1006 £76 £52 GEX £52 1012 GX £95 £67 GEX £67 1022 GX £124 £86 GEX £86 1042 £143 £100 GEX £100 Eroica LX/H £133 £95 GEX Elite £232 £163 GEX		Swiss Quality Diamond Styli ADC XLM Mk III £16.00 Akai AN 5, AN 60 £12.00 AN2, AN 70 £14.00 Dual DN 145 E, DN 165 E £16.00 Goldring G800 Super E £16.00 JVC DT 55, DT 60 £12.00 National EPS 24 CS, P 30 D, P 33 D £12.00 Ortofon FF 15 E II, VMS 20 E II, OM 20 £16.00 Pioneer TN 210, PN 220, PN 240 £19.00 Shure N 75 C, SC 35 C, £12.00 N 75 ED T2, N 75 EJ T2 £16.00 N 95 ED, N 95 EJ, N 75 3 (78) £16.00 VN 35 E £18.00 N 95 HE, N 97 HE, VN 35 HE £25.00 Sony ND 142 G, ND 155 G, CN234 £12.00 ND 143 G, ND 150 G, ND 200 G £14.00
<b>GEX - Exchange price for a Goldring Any make/model of cartridge accepted</b>		*** Over 500 Styli Types Stocked ***
Audio Technica AT 95 E £23 £15 AT 110 E £28 £16 AT OC 9 ML £330 £280 EX		<b>HEADPHONE SELECTION</b>
Denon DL 110 £79 £62 EX DL 160 £95 £74 EX		GRADO Prestige Series SR-60 £77 SR-80 £95 SR-125 £143 SR-225 £190 SR-325 £285 Reference Series RS-1 £626 RS-2 (new) £446
Grado Prestige Black £47 £26 Prestige Gold £142 £98		<b>All items guaranteed authentic new originals see our website for full selection of accessories order direct from our secure online catalogue</b>
Ortofon 510 Mk II £34 £22 MC 15 Super II £130 £110 EX MC 25 FL £227 £193 EX MC 10 Supreme £304 £258 EX MC 20 Supreme £382 £323 EX MC 30 Supreme £452 £385 EX Kontrapunkt B £643 £548 EX Rohmann £837 £742 EX		MAIL ORDER (7-10 DAYS) PRICES (INC P&P); INSURANCE FOR UK DELIVERY - £5 FOR EUROPE DELIVERY & £12 FOR US/WORLDWIDE DELIVERY TO COVER INSURANCE ON ORDERS OVER £50 VALUE
Shure M 97 XE £98 £58 V 15 V XMR £304 £204		MANTRA AUDIO (HFV), 22 GARTH AVENUE, NORTH DUFFIELD, SELBY, NORTH YORKS YO8 5RP
Sumiko Blue Point Special £265 £237 EX		Tel/Fax (01757) 288652 e-mail: enquiry@mantra-audio.co.uk
<b>EX - Exchange price against any Audio Technica, Denon, Goldring or Ortofon moving coil type cartridges</b>		VISA



**hi-fi**  
world

**HI-FI WORLD**  
ARGO HOUSE,  
THE PARK BUSINESS CENTRE,  
KILBURN PARK ROAD,  
LONDON, NW6 5LF

**Web Sites**  
www.hi-fiworld.co.uk  
www.worldaudiodesign.co.uk

**NEWS & LETTERS e-mail**  
diynews@hi-fiworld.co.uk  
diyletters@hi-fiworld.co.uk

**Subscriptions & Back Issues**  
9.30am - 2.30pm  
+44 (0)1923 270833

**Private & Trade Classified Ads**  
020 7625 3134  
Fax: 020 7328 1844

**Contact Numbers**  
9am - 5pm Mon - Fri

**Editor**  
Nick Lucas  
+44 (0) 1908 218836  
nick@worldaudiodesign.co.uk

**Technical Editor**  
Noel Keywood  
publisher@hi-fiworld.co.uk

**Design & Production**  
Faiza Chunara  
020 7625 3129  
Fax: 020 7328 1844

**Photography**  
David Noble  
020 7625 3134

**Sales and Marketing Manager**  
Amanda Sweeney  
020 8864 4760  
Fax: 020 7328 1844

**Credit Control**  
Louise Palfrey  
+44 (0)1923 270033  
Fax: +44 (0)1923 270833

**Publisher**  
Noel Keywood

**WORLD AUDIO DESIGN**  
Technical Manager  
Nick Lucas  
Tel/Fax: +44 (0)1908 218836  
nick@worldaudiodesign.co.uk

**Distributed by**  
Comag Magazine Marketing,  
Tavistock Road, West Drayton,  
Middlesex UB7 7QE  
Tel: +44 (0)1895 444 055

**Printed by**  
Southernprint, Dorset.  
Tel: +44 (0)1202 622 226

All unsolicited submissions are made at the owner's risk. We accept no responsibility for such submissions, nor do we undertake to return them.

No material may be reproduced from this magazine without the publisher's written permission.  
© Audio Publishing Ltd

All rights to the designs are reserved by World Audio Publishing Ltd. They are published for single use by private individuals. They are not to be used for commercial gain without prior permission from World Audio Publishing Ltd.

World Audio Publishing Ltd accept no responsibility for accident or injury arising from the construction or use of any of the designs published. All of the projects in this supplement have gone through rigorous listening and test procedures. The performance and specification of these projects can only be guaranteed on kits bought directly from World Audio Publishing Ltd.

# diy supplement/contents

*Noble*

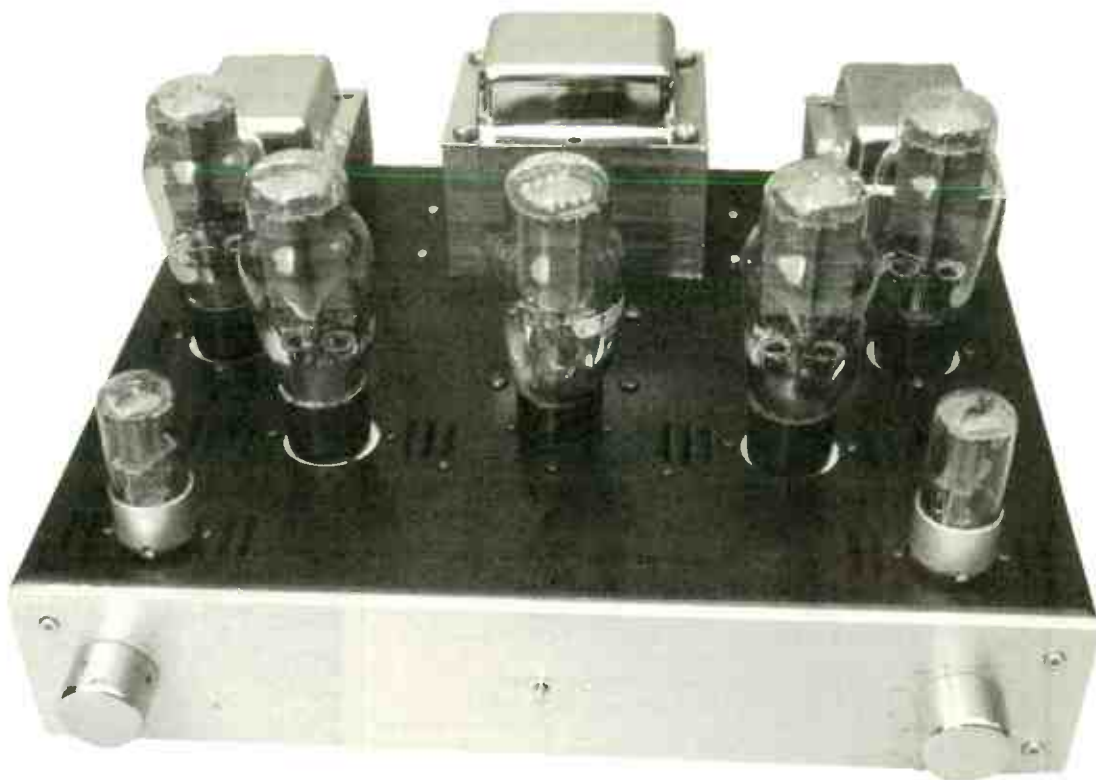

## DIY NEWS

97

## SINGLE ENDED

98

*Introducing our new 2A3 Parallel Single Ended integrated amplifier*

## DIY LETTERS

105





e-mail us with news at - [diynews@hi-fiworld.co.uk](mailto:diynews@hi-fiworld.co.uk)

# KIT & COMPONENT NEWS

## ► Horns to look at

Here's a site that might give DIYers a few ideas. Have a look at [www.northstarleading.com](http://www.northstarleading.com), a showcase of hugely expensive loudspeaker and huge amplifiers. The amplifier shown here is the JA800 from Jadis a four channel amp that can be bridge to provide 2 channels at 800watts. Definitely, not a good amplifier to run these beautiful Jadis Eurythme horn loaded speakers at 103dB. The designs are perhaps inspirational for budding designers.

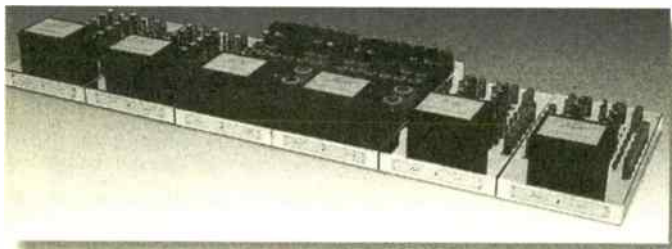

## ► A Passion for Projects

Here's an excellent site that is worth visiting. It's a non-



commercial, English language site by a Dutch DIY hi-fi enthusiast/budding web designer/ amateur photographer that documents all the projects he has built. There's a fair few, and included are circuit diagrams, plus detailed pictures with accompanying text.



For the technically minded there are a lot of circuit diagrams. The site owner invites others to submit their projects and he will even create the necessary web pages for you free of charge. It's a good site for all DIYers, but more for valve heads. There is an excellent links page, which leads on to many other equally unusual sites. Go to <http://vt52.com>

## ► Njoe Tjoeb

Following the article in DIY Supplement No. 64, inside April 2002 issue, detailing the Dutch Njoe Tjoeb 4000 valve output CD player, we have been inundated with requests for contact details. "New Tube" contact information is as follows -

[www.hi-finotes.com](http://www.hi-finotes.com)

e-mail [herman.van.dendungen@tip.nl](mailto:herman.van.dendungen@tip.nl)

De Hifiwinkel  
Pijksstraatweg 251  
6573 CW Beek  
Nijmegen  
tel 00 31 (0) 24 684 20 91  
fax 00 31 (0) 24 684 26 02

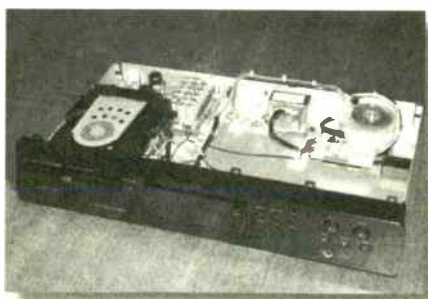

*The Jjoe Tjoeb 4000 with top removed*



*Valves in a modern Philips circuit board*



*Philips transport finds itself in unusual company*

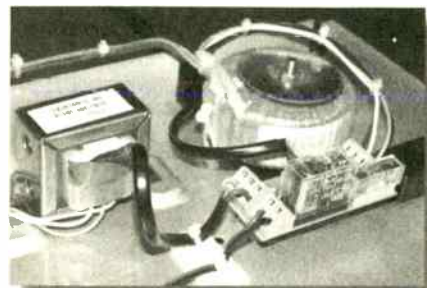

*Mains transformer and power relay*

# SIMPLY

Single Ended amplifiers offer a hi-end sound, but often at a high price. Here is our budget 8.5W zero-feedback valve integrated amplifier.

## II ► INTRODUCTION

**Y**ou may think that World Audio Design have produced just about every type of valve amplifier kit under the sun, but you couldn't be further from the truth. Our latest project was inspired by the growing interest among our contributors and readers in low powered valve amplifiers driving high efficiency speakers. The Japanese have been reveling in this combination for many years. Pick up a copy of MJ, a Japanese hi-fi enthusiast magazine, and you will see numerous triode single-ended amplifiers in all shape and sizes.

Similarly, DIYers from the States are very into their single-ended amps. Here in England push-pull amplifiers have predominated, thanks to the legacy of Leak, Quad and Rogers to name a few, but tastes are changing. As awareness of the benefits of valve amplifiers has slowly risen over the past ten years or so, people have been slowly but surely exposed to esoteric singled-ended types. The limiting aspect of this genre is their low efficiency and lack of power: 4watts is not going to drive your ESL57s. In order to appreciate these low watters you need high efficiency speakers but not necessarily 110dB horn loaded speakers that look like a couple of caravans parked in the living room. Modern drive units in reasonably sized cabinets can easily achieve good sensitivity: look at Living Voice's Avatars reviewed in last month's Hi-Fi World.

As the sensitivity and efficiency of speakers rises, more and more people are turning to single-ended amplifiers for their unique properties. You will probably be aware that they come with a large price tag; a typical fully built commercial unit can cost well over

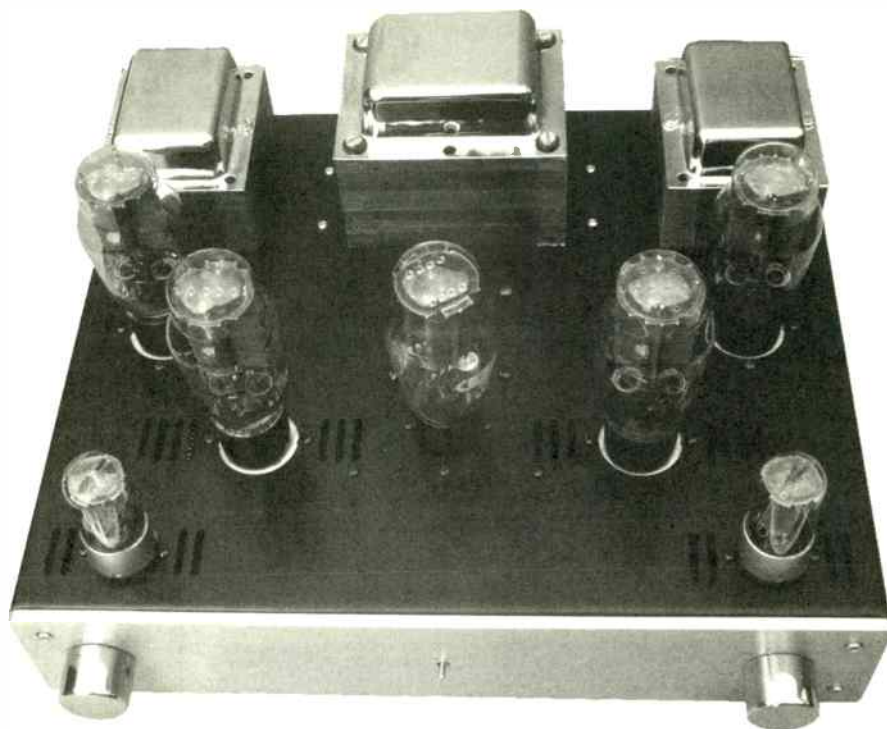

£1500 - and that is at the lower end of the scale. This is where kits come to the fore, costing a quarter of the price.

### 2A3 PSE IS BORN

For this design we wanted a truly hi-end amplifier but it had to be affordable, use world renown valves and be a stereo integrated. The output power had to be reasonable - not too low, not too high. We strived for around 8 watts. To be totally esoteric you have to use a directly heated triode, an amplifying device in its simplest form. One would immediately think of a single 300B as an output tube and this would provide in the region of 8-9 watts. But 300Bs are too expensive at around £70.00 each for a JJ, the same type we use in our 300B PSE monobloc.

What about a 2A3? A single 2A3 would give you about 3.5 watts - a tad on the low side, but how about two of them? We calculated that 2 x 2A3 in parallel single ended mode would give around 7 - 8 watts, and they are not too expensive: £22.00 for a Sovtek. Now what to drive two 2A3s? The

answer is a 6SN7, which looks funky and sounds great.

The 2A3 valve is a golden oldie the Japanese have been using for decades and they are quite a fad in America at the moment. These valves are also used for push-pull amplifiers. They appear in Moth Audio's Si2A3 monobloc, Welbourne Labs Moondag 2A3 and Cary Audio Designs 2A3-SE monobloc. There are numerous makes. New old stock (NOS) are quite expensive; RCAs go for \$300.00, whereas Sylvania's and Raytheon's come in at \$80 (prices are taken from [www.thetubestore.com](http://www.thetubestore.com)). In current production you have Golden Dragon (Chinese), Sovtek and KR 2A3. The latter is made by KR Enterprises, a small manufacturer in the Czech Republic, risen from the old Tesla Company (before it became JJ). They began producing them in 1998 and are very specialised. Although costing \$240.00 each they are very popular.

We went for the Sovtek as it has a very good reputation. For the 6SN7 my immediate choice from current production was Sovtek, but we ended up switching to Chinese manufacture.

# SINGLE

## 2A3 PSE INTEGRATED AMPLIFIER CIRCUIT DIAGRAM SIGNAL CIRCUIT (ONE CHANNEL)

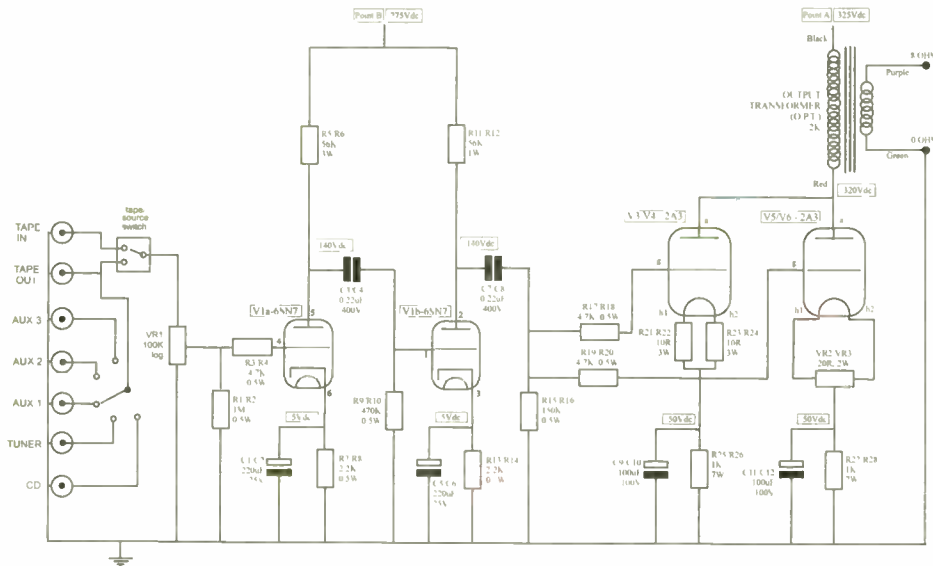

VALVE PIN LAYOUT

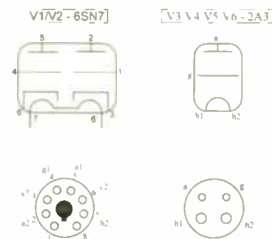

Views are from underneath valve or valve holder  
h1, h2 = heater; hct = heater center tap; +, - = cathode; a, anode; g = grid; no = no connection

### Circuit description by Andy Grove

The 2A3 PSE is a straight forward design, simple and elegant. The 6SN7, an octal based, indirectly heated double triode, forms a two stage voltage amplifier. Each 6SN7 stage has a gain of approximately 13.5 generating the 50 volts peak-to-peak required to drive the output stage properly.

The output stage consists of two 2A3s in parallel; each has a separate cathode resistor to balance the anode current. The relatively high anode voltage, 285V (Va - Vc) and a load impedance of 2kohm for the primary of the output transformer provides an output of 8.5watts, a slightly higher output than one

would expect from a 2A3 parallel single ended amplifier.

The power supply is valve rectified using a single 5U4, with a hefty 10H choke and two 100μF 500V capacitor in pi filter formation, giving a very clean HT supply. The 275Vdc needed for the anode resistors is achieved by a dropper resistor, R14, further smoothed by another 100μF, 500V capacitor, C15. The 2A3 filaments each require a 2.5V, 2A supply. We chose a dc supply to keep hum to a minimum. A 4Vdc supply is rectified through a 15A bridge (always best to over spec. in these cases) BR2 - BR5. A small voltage is dropped across a 0.47R 5W resistor in series, R31 - R34, to limit the peak current in the rectifier circuit and to limit the surge

current in the 2A3 filaments at switch on. A hum-bucker potentiometer, VR2 and VR3 is used on one 2A3 per channel to balance out any remaining hum. The 6SN7 filaments required something a little more sophisticated, a regulated 6.3Vdc supply. Utilising a familiar circuit, used in our PSU II module, 9Vac is feed to a bridge rectifier and C16, then the raw dc onto the 'Volts in' of a 78S05 (5V, 2A regulator chip) mounted on a heat sink and bolted onto the chassis for maximum heat dissipation. The common terminal is lifted by 1.3V through 2 diodes stacked to earth. The 'Volts out' is further smoothed by C17 and the resulting 6.3Vdc is incredibly clean, reducing the possible hum content further.

# Kit & Component Suppliers

## CLASSIC TURNTABLES

### Technical & General

P.O. Box 53, Crowborough,  
East Sussex TN6 2BY.  
Tel: 01892 65 45 34.

The original specialist source of spares, replacements and expertise for the classic turntables. Years of actual experience and comprehensive range of parts (originals and re-manufactures), manuals, ancillaries. No dubious 'improvements' - no harmful 'modifications'. Our specialities: Connoisseur; Garrard; Goldring; Lenco; S.M.E.; Thorens; Watts; Ortofon; Shure; Cartridges and styli for 78s, Mono LPs, Stereo LPs.

## COMPONENT SUPPLIERS

**AudioCom (UK),**  
Unit 14 Pier Road  
Pembroke Dock  
Pembrokeshire, SA72 6TR  
Tel: 01646 685601  
Fax: 01646 685602

Website: [www.audiocom-uk.com](http://www.audiocom-uk.com)  
E-Mail: [enquiries@audiocom-uk.com](mailto:enquiries@audiocom-uk.com)

Massive range of audio components and accessories available including Black Gate electrolytics, Elna SILMIC (Silk Fibre) electrolytics, Audyn-Cap film and foil capacitors, OFC air core and copper foil inductors, high power resistors, loudspeaker crossovers, high-end cable, Vishay & Holco resistors, 99.9999% pure Silver wire, DACT CT1 & CT2 attenuators, audio connectors, spikes & damping materials, plus over 50 loudspeaker kits. Active products include the SUPERCLOCK master clock plus super-low noise PSU, & Q-power super-low noise discrete regulators. A new, 365 page 2001 handbook is available for £3.50 (UK) and £5.00 (overseas).

### White Noise

11, Station Road, Bearsden  
Glasgow G61 4AW  
Tel: 0141 942 2460  
Fax: 0141 587 7377

Email: [david.white38@ntlworld.com](mailto:david.white38@ntlworld.com)

Supplier of the widest range of standard and audiophile kits for solid state pre-amplifiers, power amplifiers, headphone amplifiers, power supplies, MM/MC phono stages, active crossovers, balanced i/o modules, and stepped attenuators; more kits in the pipeline. All kits use the highest quality, glass fibre, solder masked, silkscreened, PCBs. We also supply a wide range of active (esp. Japanese transistors and Exicon mos-fets) and passive components, gold plated connectors, and silver plated wires.

Write, phone or email for a free catalogue. Mail order only.

### Audio-Links

7 Faimont Crescent,  
Scunthorpe,  
North Lincolnshire DN16 1EL  
Tel: 01724 870432  
Fax: 01724 875340

Email: [audiolinks@ukonline.co.uk](mailto:audiolinks@ukonline.co.uk)  
Extensive stock of specialist audiophile components for valve and solid state enthusiasts. Supplier of the largest range of high-end audio volume controls in Europe. 30 page catalogue - Free via e-mail or £3.00 posted.

## LOUDSPEAKER KIT SUPPLIERS

**Audio Note (UK Ltd)**  
Unit C, Peacock Ind. Est.  
125-127 Davigdor Road  
Hove, East Sussex BN13 1SG  
Tel: 01273 220511  
Fax: 01273 731298

Suppliers of a large amount of components for the Audiophile Kit builder. Valve amplification data and vintage circuits also available. See the double page spread in the back section of the main issue for extra & more detailed information.

**Falcon DIY Speakers**  
Falcon Acoustics Ltd.,  
Tabor House,  
Norwich Road, Mulbarton,  
Norfolk NR14 8JT.  
Tel: 01508 578272

UK distributors of FOCAL drive units & kits, and ETON loudspeakers, plus SOLEN (SCR-Chateauroux) polypropylene capacitors. We are the largest specialist Audio inductor manufacturer in the UK. We also stock Audio Amateur Publications and Audio Computer Software and a comprehensive range of D.I.Y speaker kits, parts, accessories and books. Please send large SAE (44p) for free price list. "Everything but the wood".

**IPL Acoustics, Chelsea Villa, Tors Park, Ilfracombe, North Devon, EX34 8AY**  
Tel/Fax: 01271 867 439

Website: [www.iplacoustics.co.uk](http://www.iplacoustics.co.uk)

IPL Acoustics supply a range of 7 transmission line, 3 conventional, speaker kits, and kits for centre speakers and active subwoofers. We also supply a full range of drive units from Audax, SEAS, Morel and Legend Acoustics (Ribbon Tweeters) as well as custom built metal coned drivers. Also included is a range of capacitors, inductors and quality cabi-

net accessories as well as Silver Plated PTFE insulated cables.

## SPECIALIST UPGRADE SERVICES

**AudioCom (UK),**  
Unit 14 Pier Road  
Pembroke Dock  
Pembrokeshire, SA72 6TR  
Tel: 01646 685601  
Fax: 01646 685602

Website: [www.audiocom-uk.com](http://www.audiocom-uk.com)

E-Mail: [enquiries@audiocom-uk.com](mailto:enquiries@audiocom-uk.com)

Release the full potential of your digital source with CD/DVD upgrades from audiocom. Available is the highly acclaimed SUPERCLOCK master clock oscillator. (Dave Berriman fits the S-Clock to the Teac VRDS-10SE and comments..."there was not one area of music reproduction which didn't improve".)

SUPERCLOCK super low noise power supply, & Q-power ultra-low noise discrete regulators. Why not contact us to see how this service can be adapted to suit your requirements?

## VALVE AND OUPUT TRANSFORMER SUPPLIERS

**Wilson Valves, 28 Banks Avenue, Golcar, Huddersfield, West Yorks HD7 4LZ.**  
Tel: 01484 654650/844554  
Fax: 01484 655699

E-mail: [wilsonv@zoo.co.uk](mailto:wilsonv@zoo.co.uk)

We stock over 2,500 different types of valves, N.O.S. and New. Please send a S.A.E. for full list. No charge for matching. Most major credit cards accepted.

**Watford Valves**  
3 Ryall Close, Bricket Wood,  
St. Albans, Herts AL2 3TS  
Tel: 01923 893270  
Fax: 01923 679207

Specialist in new old stock and current production valves. Sole UK distributor of the Harma Diamond range selected for their superior performance. Huge range held, stockists of Mullard, GE, Philips, National, Brimar, Sylvania, Telefunken, RCA, MOV and many more. All valves are new boxed and guaranteed. For free price list and specialist advice call or fax Derek Rocco, Watford Valves.

**Chelmer Valve Company Ltd**  
The Stables, Baddow Park  
Great Baddow, Chelmsford, Essex CM2 7SY  
Tel: 01245 241301  
Fax: 01245 241309.

Email: [sales@chelmervalue.com](mailto:sales@chelmervalue.com)  
Web Site: [www.chelmervalue.com](http://www.chelmervalue.com)  
Supplier of premium range of audio

valves, other valves and components also available. (Please see our main advertisement in this supplement).

**Langrex Supplies Ltd**  
1 Mayo Road, Croydon,  
Surrey CRO 2QP  
Tel: 020 86841166  
Fax: 020 86843056

One of the largest distributors of electronic valves, tubes and semi-conductors in the UK by original UK and USA manufacturers. Obsolete types are a speciality. Telephone or fax for an immediate quotation.

**Billington Export Ltd.**  
1E Gillmans Trading Estate,  
Billingshurst,  
West Sussex  
RH14 9EZ

Visitors by appointment only please  
Fax: 01403 783519

E-Mail: [sales@bel-tubes.co.uk](mailto:sales@bel-tubes.co.uk)  
Website: [www.bel-tubes.co.uk](http://www.bel-tubes.co.uk)

Specialists in guaranteed new/old stock, current production valves & tubes. Also CRT for audio, hi fi (as well as industrial uses). A vast archive of vintage and obsolete types including limited quantities of Mullard, GEC, Sylvania, Philips, Brimar, Telefunken, RCA and others. Large stocks of Chinese, Russian, EI and Tesla etc. A 50-page valve catalogue is available on request. Major stockists of the excellent Billington Gold brand. Contact us for quotations - attractive price on larger orders.

**Audio Specialist,**  
W. Marriott  
73 Stonyford Road,  
Sutton-in-Ashfield,  
Notts,  
NG17 2DL  
Tel: 01623 461128

Email: [wasmariott@talk21.com](mailto:wasmariott@talk21.com)  
Transformers. One of the world's widest range manufactured. Mains choke's, output transformers etc. From the standard I/E M6 to the awesome Hi-B nickle double C-Core's wound with the superb 6N cardas copper cable. All types of transformers manufactured. One off a speciality. A superb range of accessories and components supplied. Steel copper, brass etc cases available for that special project. All types of repairs, modification undertaken. Rebuilds, kits built to both thermionic solid state. Classic vintage equipment always sought, working or not. Catalogue £3.50 redeemed on first order over £30.00

TO ADVERTISE IN THE KIT & COMPONENT SUPPLIERS PAGE PLEASE CALL

020 8864 4760

Email: [diyadvertising@hi-fiworld.co.uk](mailto:diyadvertising@hi-fiworld.co.uk)

◀ R&D TIME

The development of this amplifier holds an interesting tale. Andy Grove's initial design used a 6AC7, a metal enveloped pentode, in the voltage amplifier stage. The idea of a metal valve made me a little uneasy, let alone the fact that it was a pentode, straying slightly from the triode aspect of the amp but, always up for something new, I let it go ahead. When the 6AC7 samples arrived, they were painted black with a few splurges of iron oxide as decoration; rust was never a problem with glass valves! Anyway, knowing that these guys had been around the world a few times and that there were other fresher tubes that were sitting in Russia, I kept going. On first switch on everything seemed okay, but looking at the scope I could see noise was going to be an issue as the trace danced around like a shore line on a windy day.

Okay, so they were a little noisy, but they were old. The amp sounded great apart from the odd whistle. With the Bristol 2002 show looming and my whistling friend potentially headlining, I ask for more 6AC7s to be sent over, even though, they had accompanied the originals in the same box on their world tour. Out of seven that came the next day, I found one that wasn't too bad. It joined the better of the original two. I was beginning to think that these guys hadn't been around the world at all and had fallen overboard 2 miles out of port. Anyway they performed well at the show and people showed a lot of interest, but being a slightly superstitious fellow who likes things to run reasonably smoothly from the outset I gave Andy a call and asked if we could use a 6SN7 instead of a 6AC7.

I came the circuit changes and the sample Russian 6SN7s. I carried out the mod, and Andy came in for a quick check. All seemed fine: the heaters of the 6SN7s were being fed by 6.3Vdc, a bridge rectifier and a 4700uF 10V cap for smoothing. Looking at the hum levels, a vital criteria for this breed of amplifier, it look like hum was about 2mV - a touch too high.

Andy had to rush off and I was left to mess about. I decided to connect up the 6.3Vdc regulated supply that sits on our PSU II module. This took the hum down to 0.5mV. When Andy returned he was armed with Chinese 6SN7s that achieved a hum level of 0.7mV with the unregulated supply. The long

and short of it is, I incorporated the same regulated 6.3Vdc supply for the heaters of the 6SN7 to make the 2A3 PSE ultra quiet, ideal for high efficiency speakers.

**KIT DESCRIPTION**

The kit has a 2mm mild steel chassis with a black powder coat finish, providing an extremely strong platform on which to mount all 15kg of iron; I speak here of the mains, two output transformers and the 10H choke, all of the E/I type. The externally mounted transformers are topped with chrome plated caps.

The chassis is fronted by an attractive 6mm thick anodized alloy plate that bolts in place. The front plate holds two custom made chrome plated knobs for operating the volume control and the input selector switch. The amplifier can receive six line level inputs and has a tape out. The phono sockets are high quality gold plated insulated sockets, the

speaker terminals are a new heavy duty 60A, gold plated socket from Cliff Electronics that can receive 4mm bananas and spades.

All seven valves are exposed. The rear mounted IEC mains socket also carries the on-off switch, which is easily reached from the front because it is situated at the left corner of the amp. A rear panel location avoids an internal mains loom which in a valve amp in particular, with its high input impedance, is a bad idea. Hum pick up can occur, especially if the mains loom gets anywhere near the input valves, which is inevitable with front located on-off switches.

The mains transformer has been wound to accept 110V/120Vac or 220V/230Vac depending upon how you wire the primary, so it's suitable for all territories.

All components supplied are of a good quality, using carbon film for low 0.5watt resistors, metal oxide for the 3watt resistors and wirewound ceramic for 5watt and 7 watt. ▶▶

2A3 PSE INTEGRATED AMPLIFIER  
CIRCUIT DIAGRAM  
POWER SUPPLY CIRCUIT (BOTH CHANNELS)

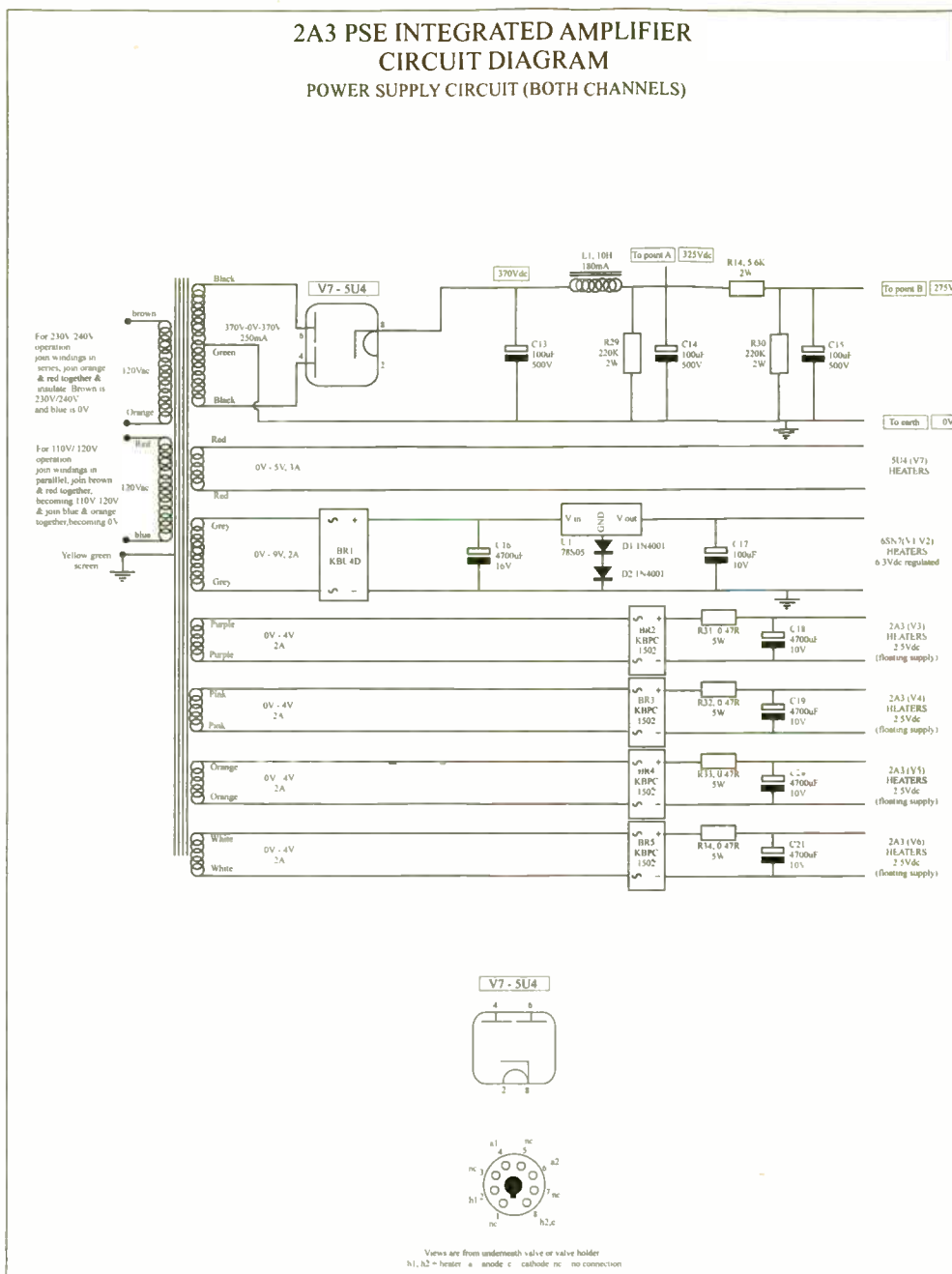

◀◀ All electrolytics are manufactured by Forever, the high voltage electrolytics are JJs, and the 0.22uF 400V capacitors are BC components type 368. As a bonus we are providing the Alps blue 100K volume pot for that touch of class.

Being a specialised design the unit is hardwired. Components are located on 18 way tag boards, that are fitted on 25mm stand-offs. There are 2.5 boards, one per channel and half a board for the regulated 6.3Vdc supply. All valve bases are chassis mount types. There is plenty of space inside should you want to fit bulkier upgrade components at a later date.

The kit is accompanied by a detailed instruction booklet to aid construction. The booklet runs through the build sequence, describing each step.

### 2A3 MEASURED PERFORMANCE

Output	8.5watts into an 8 ohm load
Sensitivity	200mV
Noise	0.5mV
frequency response	10Hz - 45kHz +/- 3dB

### SOUND QUALITY

Not all valve amps - including World Audio design kits - sound the same. The 2A3 PSE is a prime example of this. Being an 8.5V per channel parallel single-ended design you may think it's a typical example of the breed - highly detailed and transparent, but somewhat lacking in weight and depth. Detail and transparent - you bet, but lacking in weight and depth - no way! The 2A3 has an amazing amount of bass weight for its (on paper)

humble power output. Matched with 'speakers of reasonably high sensitivity it has an amazing sound. Well recorded discs such as Paul Weller's 'Stanley Road' and Siouxsie and the Banshees' 'The Rapture' had a remarkable amount of rhythmic dexterity and bass slam and the detail present was exceptional, with particularly good imaging.

Classical music in the form of Dvorak's Slavonic Dances had a good sense of scale

and depth, with instruments well spaced and airy in true PSE fashion. Instrumental timbre was very natural and there was also a good balance of tonality.

The 2A3 delivers a full sounding, rich and rhythmic response that also happens to be highly transparent and detailed. In this respect it's one heck of an amp, and one of the finest PSE designs you'll come across. Essential gear for PSE-loving DIYers. ■ ▲

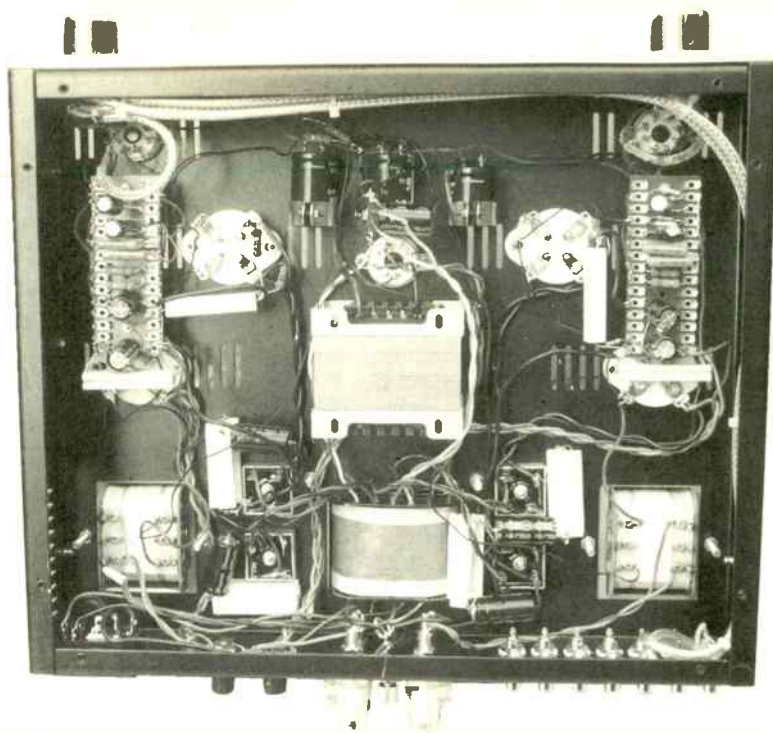

*An internal view of 2A3 PSE integrated amplifier showing drop-through mains transformer (bottom centre), a huge 10A frame core choke (centre) and drop-through output transformers. Above are the tag boards.*



*Rear view of the 2A3 PSE integrated amplifier showing heavy duty 'speaker terminals (centre), six inputs and tape out, plus mains switch (right).*

2A3 PSE INTEGRATED AMPLIFIER PARTS LIST		CAPACITORS: SIGNAL CIRCUIT		VALVES	
R1	1M, 0.5W	R33	0.47R, 5W		2A3 Sovtek 4
R2	1M, 0.5W	R34	0.47R, 5W		Chinese 6SN7 2
R3	4.7K, 0.5W	C1	220uF, 25V		5U4 Russian 1
R4	4.7K, 0.5W	C2	220uF, 25V		<b>HARDWARE</b>
R5	56K, 3W	C3	0.22uF, 400V		chassis, base plate and front panel 1
R6	56K, 3W	C4	0.22uF, 400V		chrome knob 2
R7	2.2K, 0.5W	C5	220uF, 25V		chassis mount octal valve base 3
R8	2.2K, 0.5W	C6	220uF, 25V		chassis mount UX4 valve base 4
R9	470K, 0.5W	C7	0.22uF, 400V		red insulated, gold plated phono sockets 7
R10	470K, 0.5W	C8	0.22uF, 400V		black insulated, gold plated phono sockets 7
R11	56K, 3W	C9	100uF, 100V		tape/source switch 1
R12	56K, 3W	C10	100uF, 100V		selector switch 1
R13	2.2K, 0.5W	C11	100uF, 100V		gold plated speaker terminal post (pair) 2
R14	2.2K, 0.5W	C12	100uF, 100V		earth post 1
R15	150K, 0.5W	<b>CAPACITORS &amp; SEMICONDUCTORS:</b>			IEC mains input/switch 1
R16	150K, 0.5W	<b>POWER SUPPLY CIRCUIT</b>			IEC mains lead 1
R17	4.7K, 0.5W	C13	100uF, 500V		18 hole tag board 2.5
R18	4.7K, 0.5W	C14	100uF, 500V		capacitor clip 3
R21	10R, 3W	C15	100uF, 500V		knob for humbuckers 2
R22	10R, 3W	C16	4700uF, 16V		self adhesive feet 4
R23	10R, 3W	C17	100uF, 10V		tie wraps 10
R24	10R, 3W	C18	4700uF, 10V		M4 x 8mm hexagonal bolt 4
R25	1K, 0.5W	C19	4700uF, 10V		M4 nut 8
R26	1K, 0.5W	C20	4700uF, 10V		M4 x 8mm pozidrive screw 4
R27	1K, 0.5W	C21	4700uF, 10V		M3 x 20mm pozidrive screw 4
R28	1K, 0.5W	BR1	KBU4D		M3 x 12mm pozidrive screw 25
VR1	ALPS BLUE 100K	BR2-5	KBPC1502	4	M3 x 6mm pozidrive screw 9
VR2	20R, 2W POT.	DI-2	1N4001	2	M3 x 6mm grub screw 2
VR3	20R, 2W POT.	UI	78S05 2amp 5V reg.	1	M3 nut 30
<b>RESISTORS: POWER SUPPLY CIRCUIT</b>		heat sink for UI			M3 stand offs 6
R29	220K, 2W	<b>TRANSFORMERS</b>			wire various
R30	220K, 2W	OUTPUT	E/I 78 lam with chrome top cap	2	instructions 1
R31	0.47R, 5W	MAINS	E/I 120 lam with chrome top cap	1	safety gloves 1
R32	0.47R, 5W	CHOKE	10H, 250mA	1	

## 2A3 PSE INTEGRATED AMPLIFIER KIT

2A3 PSE integrated amplifier is available from  
World Audio Publishing Ltd

UK (inc. vat & p&p)

Overseas  
(exc. vat & carriage)

2A3 PSE integrated	£450.00	£385.00
2A3 PSE valve set	£100.00	£86.00
2A3 cage	£65.00	£59.00

Call or fax Nick Lucas on: +44 (0) 1908 218836 (9am-5pm, Monday-Friday)  
e-mail: [nick@worldaudiodesign.co.uk](mailto:nick@worldaudiodesign.co.uk)  
For overseas freight charges, please call, fax or e-mail.  
order online - [www.worldaudiodesign.co.uk](http://www.worldaudiodesign.co.uk)

# LANGREX SUPPLIES LTD

DISTRIBUTORS OF ELECTRONIC VALVES, TUBES AND SEMI-CONDUCTORS AND I.C.S.

1 MAYO ROAD • CROYDON • SURREY CRO 2QP

24 HOURS EXPRESS MAIL ORDER SERVICE ON STOCK ITEMS

E-MAIL LANGREX@AOL.COM

PHONE

020 8684 1166

FAX

020 8684 3056

A selection of our stocks of **New Original Valves/Tubes.**  
Many other brands available

STANDARD TYPES			SPECIAL QUALITY TYPES						
ECC83	E.I	5.00	A2900/CV6091	GEC	17.50	12BY7A	GE	7.00	
ECC85	RFT	5.00	E82CC	SIEMENS	7.50	5687WB	ECG	6.00	
ECC88	BRIMAR	6.00	E83CC	TESLA	7.50	5814A	GE	5.00	
ECC88	MULLARD	10.00	E88CC/CV2492	BRIMAR	15.00	6072A	GE	10.00	
ECH81	MULLARD	3.00	E88CC GOLD PIN	TESLA	8.50	6146B	GE	15.00	
ECL82	MULLARD	5.00	ECC81/CV4024	MULLARD	6.00	6201	GE	6.00	
ECL86	PHILIPS	10.00	ECC81/M8162	MULLARD	7.50	6336A	RCA	35.00	
EL36	MULLARD	5.00	ECC81/6201	MULLARD	10.00	6922	ECG	6.00	
EL37	MULLARD	30.00	ECC82/CV4003	MULLARD	10.00	7027A	GE	25.00	
EZ81	MULLARD	10.00	ECC82/M8136	MULLARD	12.50	7308	SYL	5.00	
EZ80	MULLARD	5.00	ECC83/CV4004	MULLARD	40.00				
GZ33/37	MULLARD	20.00							
GZ32	MULLARD	25.00							
5Z4G	BRIMAR	6.00	AMERICAN TYPES			E88CC	TESLA	4.00	
6V6GT	BRIMAR	7.50	5R4GY	RCA	7.50	ECC81	RFT	3.00	
12BH7	BRIMAR	12.00	5U4GB	SYLVANIA	10.00	ECC82	RFT	6.00	
12E1	STC	10.00	5Y3WGT	SYLVANIA	5.00	ECC83	RFT	8.00	
13E1	STC	85.00	6BX7GT	GE	7.50	EF86	USSR	5.00	
807	HYTRON	7.50	6B4G	SYLVANIA	22.00	EL84	USSR	3.00	
811A	RCA	25.00	6FQ7	SYLVANIA	7.50	EL34G	SOVTEK	5.00	
6080	MULLARD	10.00	6L6GC	GE/SYL	20.00	EL34	E.I	6.00	
			6L6WGB	SYL	15.00	6SL7GT	USA	7.50	
			12AX7WA	SYLVANIA	6.00	6SN7GT	USA	7.50	

THESE ARE A SELECTION FROM OUR STOCK OF OVER 6000 TYPES. PLEASE CALL OR FAX FOR AN IMMEDIATE QUOTATION ON ANY TYPES NOT LISTED. WE ARE ONE OF THE LARGEST DISTRIBUTORS OF VALVES IN THE UK. SAME DAY DESPATCH VISA/ACCESS ACCEPTABLE. OBSOLETE TYPES A SPECIALITY.

CREDIT CARD MIN ORDER £10.00.

OPEN TO CALLERS MON. - FRI. 9AM - 4PM. CLOSED SATURDAY

U.K. P & P 1-3 VALVES £2.00, 4-6 VALVES £3.00 ADD 17.5% VAT TO TOTAL INC P+P O'SEAS P & P PLEASE ENQUIRE

VISA



## Watford Valves

**7 DAYS A WEEK 9AM - 9PM** The Audiophiles Choice  
All output valves multi-tested and digitally matched  
Full no quibble guarantee. Expert advice on all valve amps

		£
ECC81	Philips	7.00
ECC82	R.T.	10.00
ECC83	Philips	10.00
ECC83S	JJ Tesla	7.00
ECC84	R.F.T.	7.00
ECC85	R.F.T.	8.00
E88CC/6922	Philips	8.00
ECF80	G.E.	8.00
ECL86	A.E.G	10.00
EF80	Mazda	6.00
EF86	Mullard	20.00
EL34	Svetlana	10.64
EL34	Siemens	45.00
EL84	JJ Tesla	7.00
GZ32	Dario	25.00
GZ34	Sovtek	8.00
KT66	Harma	25.00
KT88	JJ Tesla	25.00
KT88	Svetlana	34.00
300B	JJ Tesla	68.00
5881WXT	Sovtek	7.00
6550C	Svetlana	22.00
6500EH	Sovtek	22.00
6SL7GT	Brimar	6.00
12AX7LPS	Sovtek	8.00
12AX7	Svetlana	7.23

World Audio design

### WORLD AUDIO DESIGN UPGRADE

Many readers have enjoyed the huge improvements made to these fine W.A.D. kits simply by fitting specially selected valves. They are guaranteed to provide tighter bass with improved detail and lower noise with increased dynamics. So take advantage of this special offer and make a great audio upgrade whilst stocks last.

#### KIT 6550 & KAT 6550 Upgrade



KIT6550



KAT6550

4 x 6550C Svetlana matched  
2 x ECF80 GE  
2 x 5U4G Russian  
£99 the set + vat & carriage

#### KEL 80 Monobloc Upgrade



8 x EL34 Svetlana matched  
2 x 6AU6WC Philips  
2 x 5687WB Philips  
£90 the set + vat & carriage

#### KIT 34 & KAT 34 Upgrade



KIT34



KAT34

4 x EL34 Svetlana matched  
2 x ECF80 GE  
2 x 5U4G Russian  
£55 the set + vat & carriage

#### 300B PSE MONOBLOC Upgrade



4 x JJ Tesla 300B matched  
2 x Philips 6AU6WC  
2 x Philips ECC82  
2 x Harma 5U4G  
£284 the set plus vat & carriage

WATFORD VALVES 3 Ryall Close,  
Bricket Wood, St Albans, Herts AL2 3TS

Fast mail order/next day delivery/World Wide shipping  
1000's more valves stocked. Prices exclude VAT and carriage.

VISA



01923 893270

Fax: 01923 679207

www.watfordvalves.com

EuroCard  
MasterCard



e-mail us with news at - diynews@hi-fiworld.co.uk

# D.I.Y. LETTERS

## Got a problem? Hi-Fi World's experts answer your DIY and kit queries

### II ► QUAD BEHAVING BADLY

Hello!  
Suddenly one of my Quad IIs started to hum (constant) and the sound also became distorted and the output valve (6P3S) closest to the mains transformer goes really red.

The new 0.1uF capacitors from Lithuania arrived so I changed all 0.1uFs, switched on (sounded a bit clearer, actually), checked the grid voltages, 0.1V and 1.2V respectively. Cathode voltage 26V.

After a while with the new capacitors, the same thing occurred: the grid voltage on one of the output tubes was 46V, the cathode voltage was also around 46V, but the voltage at L1 has sunk to about 320-330V. The humming appears at the end, when these voltages are reached. The process takes about 15-20 mins. The sound improves a short moment when I put the voltmeter probe on the grid of the red-hot output tube and the grids of the EF86.

Help needed!  
thanks Tom



Quad II

I would be very suspicious of the 6P3s in this instance as the grids should sit at 0V, although it is possible that the EF86 (V2) is faulty as well,

as the three grids are all interconnected.

What you could do is remove the 0.1uFs for a start and then measure the voltages. If the grids return to 0V then you have leaky capacitors. If the grids are still positive remove the EF86 (V2). If the grids return to 0V the EF86 is the likely culprit. If the grids are still positive I would definitely suspect the 6P3s.

It is also possible, however, that if you have changed any resistors you may have a dry joint on one of them or the associated wiring. In this case measure from the 6P3 grids to ground, where you should get approximately 680k. If not, there is either a poor joint or a

resistor has gone open circuit or something like that.

I don't know where you live, but if you care to e-mail me 'off-board' with a tel. no. we could perhaps sort it out over the phone and then you can put comments on the bulletin board to help others.

from Dr John ■

### II ► SPEAKER WISE

Just like to share what I consider to be some excellent software for building and testing speakers for the princely sum of, well a couple minutes connection to the web. Check out Speaker Workshop from Audua(www.audua.com).

At the moment it's available as shareware to the web community to assist in it's development. I've been using it for sometime now. Initially it took some setting up with the calibration etc, but once there it's been great. I'd

Audax project found that while excellent for home cinema it just didn't do it for music for me, which was fair enough as it was designed for movies. So far, the modifications are working out



Parts Xpress website

not too bad. For the money in parts, nothing yet in the shops has compared...

The Aerogels and tweeters used are available from Maplin for very reasonable prices, and I've found Falcon acoustics very helpful for the crossover bits. Also, while I remember, parts express(www.partsexpress.com) have a subwoofer range that appears to be extremely good value for money. The only downside is the shipping cost to

the UK. In their Dayton 'dvc' range. (xmax on the 12inch is 15mm) do you know if there is anything available here with similar spec or any distributors that might be able to import the range?)

Well, that's my two cents for now. If you're able to check out any of the above let me know what you think, there's a lot of good stuff available out there via the web for us diy'ers, happy surfing and thanks for many years of decent hi-fi reading!

Adrian Stuart

Thanks for the information. NL ■

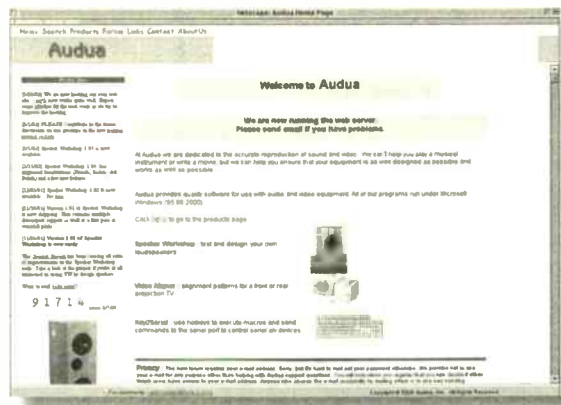

Audua website

recommend building the 'wallin' jig(http://www.gti.net/wallin/audio/audio.html) to use with it and also the electret mic preamp. How about doing a write up on it and comparing to other commercial testing software?

Also wondered if you might consider some more speaker DIY projects? How about a home cinema setup? (uproar from the purists no doubt...). Audax have a project on their website with a design by Joe D'Appolito using their Aerogels. I've recently started a new speaker project based on this Audax project, but one to produce better results with music as well. My initial testing of the

# WHITE NOISE

## AUDIO KITS, MODULES, COMPONENTS

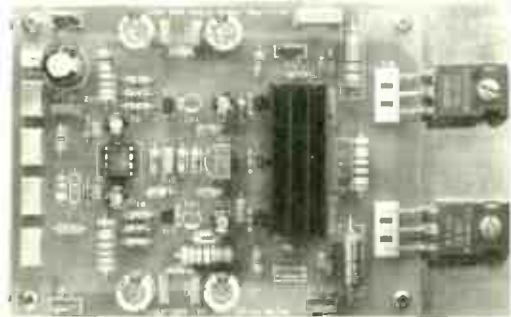

PRODUCTS INCLUDE:- Power Amplifiers 30-250W, Preamplifiers, Phono stages, Active Crossovers, Power Supplies, Buffer Amplifiers, Balanced line drivers / receivers, Stepped attenuators, Gold plated connectors, Cables, Capacitors, Resistors, Semiconductors, Transformers, Subwoofers, Loudspeaker drive units

WHITE NOISE  
11 STATION ROAD  
BEARSDEN  
GLASGOW  
G61-4AW

<http://homepage.ntlworld.com/david.white38>  
Email:- david.white38@ntlworld.com  
Tel:- 0141-942-2460 (until 9pm)  
Fax:- 0141-587-7377

## English Analogue

Supplier of quality second-hand classical records  
Reasonable prices for truly collectable original vinyl from  
the 1950s to the 1970s. Labels include:

**DECCA** - SXL, SDD, SET, RCS, SPA, PFS  
**HMV** - ALP, ASD, SAN, SLS  
**COLUMBIA** - 33CX, SAX  
**RCA** - SB - 2000/6000, VICS, SER  
**DEUTSCHE GRAMMOPHON, PHILIPS**  
etc, also available

To increase your satisfaction, all the records sold are  
cleaned and audibly checked before being sold, free of  
charge, as well as a guarantee. The records are also  
supplied with a new innersleeve, as well as the old, to  
ensure a high standard. In addition, if you have any  
classical LPs you wish to sell or want a free  
catalogue, please contact:

3 Naseby Rise, Newbury, Berks, RG14 2SF, England  
Tel: 44 (0) 1635 40242./ 44 (0) 7786 060994  
Fax: 44 (0) 1635 524239

[www.multiplex.co.uk/Records](http://www.multiplex.co.uk/Records)

## audioXpress... It Just Sounds Better

### Your Favorite Audio - One New Magazine!

- PROJECTS
- REVIEWS
- THE NEWEST TECHNOLOGIES
- AUDIO CLASSROOM
- and Much More!

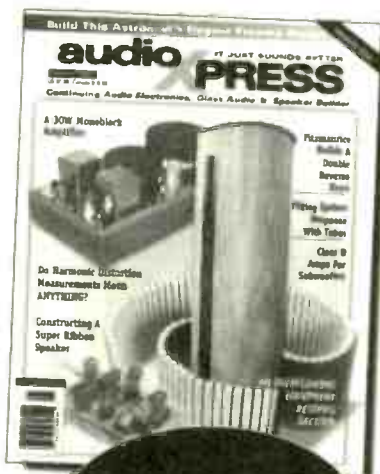

**Only \$59.95 US  
for 12 Issues!**

Subscribe To This  
Great Monthly  
Publication Today!

audioXpress • PO Box 876 • Peterborough, NH  
03458-0876 USA • Phone: 603-924-9464  
Fax: 603-924-9467 • E-mail: [custserv@audioXpress.com](mailto:custserv@audioXpress.com)

ORDER  
ONLINE AT: [www.audioXpress.com](http://www.audioXpress.com)

## AWARD WINNING SUPPORT RANGE

You've read about it for years.  
You've seen it on TV.

Now experience The Mana Effect™  
at your local retailer...

BRISTOL AUDIO EXCELLENCE 0117 926 4975  
CARDIFF AUDIO EXCELLENCE 029 2022 8565  
CHELTENHAM AUDIO T 01242 583960  
CHESTER AUDIO EXCELLENCE 01244 345576  
EDINBURGH LOUD AND CLEAR 0131 226 6500  
EXETER AUDIO EXCELLENCE 01392 491194  
GLASGOW LOUD AND CLEAR 0141 221 0221  
GLOUCESTER AUDIO EXCELLENCE 01452 300046  
HARROW HARROW AUDIO 020 8930 9933  
HIGH WYCOMBE AUDIO T 01494 558585  
HULL ZEN AUDIO 01482 587397  
LEEDS IMAGE AUDIO 0113 278 9374  
LONDON THE CORNFLAKE SHOP 020 7631 0472  
SWANSEA AUDIO EXCELLENCE 01792 474608  
WIGAN ADVENTURES IN HI-FI 01942 234202

# Mana Audio LTD

Unit E, Amlwch Industrial Estate, Anglesey LL68 9BX  
Tel: 01248 751 043 or 01407 830 530 Fax: 01407 830 535  
E-mail: [post@mana.co.uk](mailto:post@mana.co.uk) [www.mana.co.uk](http://www.mana.co.uk)  
Visit the Mana forum: [www.manaforum.atinfopop.com](http://www.manaforum.atinfopop.com)

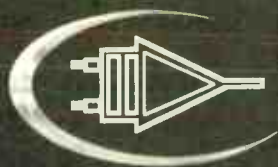

TRUE COLOURS INDUSTRIES

Music Without Compromise, Cables Without Equal



HI-FI INTERCONNECTS  
 CUSTOM VIDEO LEADS  
 MAINS POWER LEADS  
 SPEAKER CABLES

2002 CATALOGUE NOW AVAILABLE

WWW.TRUE-COLOURS.COM  
 TEL. 077 1019 6949

# Audio Classics are back!

Item	Condition	
Leak TL12 "point one"	4.0	Pair Original.
Leak TL12+ CHROME	£600 5.0	Rebuilt, perfect pair
Leak TL12+ Bronze	£450 3.1	Rebuilt, perfect pair
Decca Kelly DK30	£300 4.9	Pair ribbon tweeters
Leak Troughline III	£100 4.9	Mono FM tuner, perfect
Garrard 301	£450 4.5	Perfect Garrard TT
Garrard 401	£250 4.9	Perfect Garrard TT
Tannoy III Z Monitor Gold	£400 3.9	No badges, nice pair
Lowther TP1	£1200 3.9	No grills, original PM3A
B&W P2H	£1200 4.8	Fully working IONICS
RCA Cinema Monoblocks	£500 3.1	Fully working pair
Gaumont Kalee "Duosonic"	£600 2.9	HUGE monoblocks, pair
<b>Turntables &amp; Tone Arms</b>		
B&O Beogram 4000	£400 4.3	Jacobsen classic, new cart
Technics SP-10/II	£250 1.9	EX-Studio turntable
Nottingham Analogue Hyper Space™ And Space Arm	£2300*	Vinyl perfection
<b>Pre-amplifiers</b>		
EAR MC-3	£600*	High-End MC step up
EAR 834P (MC/A)	£500*	MM/MC phono stage.
EAR CLEAR	£350*	MM phono & control (great for Leaks)
Full EAR range available*		Budget BARGAIN!
Croft Vitale	£360*	
Full Croft range available*		
<b>Amplifiers, Radio Tuners &amp; Receivers</b>		
B&O Beomaster 8000	£500 4.7	Remote Receiver
Lescon API / CPI	£650 3.9	Design classics
Micromega Microdac	DUE 4.7	Quality DAC
EAR V20	£2800*	Simply AMAZING!
<b>Loudspeakers</b>		
KLIPSCHORN	£2000 3.0	Painted white?
KEF LS3/5a L.E.	£1000 5.0	Raymond Cook, pair # 20
JBL L100	£350 3.0	Damage to grill on one
Audio Classics Model "C"	£1500*	
Snell "J"	DUE	

Key \* = New item 1 = Poor 2 = Presentable 3 = Average 4 = Good 5 = Mint, like new.  
 Part Exchange Welcomed! FREE delivery on all new items, everything else, please enquire.  
 Callers welcome by special appointment. New dealers for EAR, Croft, Nottingham Analogue.

Tel: 01942 257525 [www.audioclassics.co.uk](http://www.audioclassics.co.uk)

# WANTED

# HI-FI & HOME CINEMA EQUIPMENT & ACCESSORIES

BUY · SELL · TRADE

OPEN 7 DAYS 10am - 8pm

Please bring official ID with address & signature when selling or exchanging

MUSIC & VIDEO EXCHANGE

56 Notting Hill Gate, London W11

☎ 020 7792 3474

[www.nottinghillexchanges.com](http://www.nottinghillexchanges.com)



# EX-DEM & DISPLAY STOCK All Fully Guaranteed

New, Boxed, Ex-Dem & Trade Excess Stock  
**One Only of Each Item**

APOGEE Centaur Speakers	£2300	£1600
APOGEE Mini Grand GS Speakers	£7595	£5495
ARCAM FMJ T21 AM/FM Tuner	£399	£294
ARCAM Alpha 10 DAB Tuner	£799	£696
ARIEL ACOUSTICS Model 8's (stands)	£5679	£4276
AUDIO ANALOGUE Donizetti Stereo (N/O/S)	£595	£497
AUDIO ANALOGUE Donizetti Mono's (X/D)	£920	£727
AUDIOGRAM MB1 Integrated Amplifier	£599	£419
AUDIOGRAM MB2 Integrated Amplifier	£499	£349
AUDION 300B Integrated	£1125	£976
AUDIO RESEARCH BL1	£699	£556
AUDIO RESEARCH LS16 (Black)	£3699	£2796
AUDIO RESEARCH DAC1-20	£3739	£899
AUDIO RESEARCH LS8 Pre-amp	£5290	£3690
AUDIO RESEARCH PH3 Pre-amp	£2199	£1649
AUDIO RESEARCH REF 600 Ref Amps	£43,995	£29,995
AUDIO RESEARCH VT50 Power Amp	£3499	£2899
AUDIO RESEARCH VT200 Power Amp	£9998	£8248
B&W CDM Surround	£750	£500
COPLAND CSA303 Pre-amp	£1349	£1079
COPLAND CTA301 Pre-amp	£1299	£1049
COPLAND CTA504 Amp	£1999	£1599
DCS Elgar D/A	£9500	£8496
DCS Delius D/A	£5499	£4796
DCS Purcell Upsampler	£3999	£3496
DIAPASON Karis (Walnut)	£995	£747
DIAPASON Adamantes 3 (Walnut)	£1975	£1497
DENON AVR-2801 AV Receiver	£549	£POA
DUNTECH PLC500 Speakers	£5250	£3250
EPOS ES22	£1350	£896
FINAL 0.3 (Alum)	£1495	£997
FINAL 0.4 (Black/Cherry) Ex-Dem	£2795	£1957
GOLDMUND Mimesis 6 Amp	£2900	£2029
GOLDMUND Mimesis 6b Pre-amp	£3124	£1796
GOLDMUND Mimesis 4 Tuner	£6100	£3900
GRAAF Venticinque (X/D)	£1795	£997
GRAAF Venticinque Latest	£2100	£1747
GRAAF VT5.35.5 5 Ch Pwr (X/D)	£2500	£1577
GRAAF 5050	£1995	£1197
GRAAF 5050 (Factory Refurbished)		£747
GRAAF GM20	£2950	£1997
GRAAF 13.5 BII Pre	£3950	£3396
GRAAF GM20 OTL Power	£2950	£2346
KEF Reference 1/2	£1300	£900
KRELL KAV300CD	£4289	£3399
KRELL FPB 300C	£9998	£8496
LINN Karik Trans	£1800	£1196

LINN Numeric D-A	£1500	£996
LINN Tune Box for active boards	£550	£444
MARTIN LOGAN Quest	£5349	£3849
MARTIN LOGAN Scenario	£1895	£1596
MARTIN LOGAN Aerious I	£2298	£1896
MARTIN LOGAN CLS (2)	£6998	£4496
McINTOSH MCD751 CD Trans	£2549	£1896
McINTOSH MDA700 Bal DAC	£2549	£1896
McINTOSH 700/751	£5100	£3996
MCINTOSH C.15 Pre	£1549	£1246
MCINTOSH C.42 Pre	£4200	£3496
MCINTOSH MC352 Power	£5095	£4196
MCINTOSH MC7108 8 Channel	£2549	£1996
MCINTOSH CR12 AV Pre	£3349	£2596
McINTOSH LS320	£1790	£1446
MERIDIAN 518 Digital Processor	£2150	£1796
MERIDIAN M1500 (Active sub)	£895	£746
MERIDIAN 563	£700	£446
MERIDIAN 518 Digital Processor	£985	£746
M&K VX100 Sub	£795	£634
MICHELL ISO HR Phono Stage	£895	£696
MONRIO ASTI CD Player	£695	£497
MONRIO ASTI CD Player (24/96)	£800	£577
MONRIO 18B.2 (DAC)	£400	£247
MONRIO 55w Integrated Amp (Line)	£450	£397
MONRIO 55w Integrated Amp (Line + Phono)	£500	£427
MONRIO Bitmatch Transport	£400	£297
MONRIO 18B.2 DAC	£400	£247
NAIM NAIT 5 Integrated	£799	£680
NAIM NAC 92R Pre	£689	£554
NAIM NAC 112 Pre	£625	£530
NAIM NAC 82 Pre	£2435	£2070
NAIM NAP 150 Power	£750	£640
NAIM Prefix phono stage	£405	£324
NAIM CDX CD Player	£2400	£2040
NAIM Intro Speakers (Cherry)	£790	£675
NAIM Credo Speakers (Ebony)	£1350	£1150
OPERA Aida (Integrated Amp - X/D)	£595	£327
OPERA Callas Gold (Mahog -X/D)	£1095	£797
OPERA Operetta	£795	£597
OPERA Pavarotti (Black) Ex/Dem		£497
OPERA Super Pavarotti	£1095	£847
OPERA Lux Loudspeaker Stands		£ POA
PATHOS Classic One (Ex-dem)	£995	£797
PIONEER M6 Exclusive ***** 400 wpc Class A Monoblocks (New old stock)	£8000	£2996
PIONEER VSA-E08 (AV Amp)	£1599	£1246
PIONEER SD-T5000 (4.3) 50" TV	£3999	£1496

## NOTHING TO PAY FOR SIX MONTHS

then choose either  
**Interest Free Settlement**  
or **competitive repayment terms\***

\*FINANCE ARRANGED IN-STORE & SUBJECT TO STATUS

PRIMARE A30.5	£1699	£1246
PRIMARE P30 Processor	£1999	£1596
PRIMARE V.20 (Multi)	£1000	£846
PS AUDIO Digilink 1	£995	£595
PS AUDIO Digilink 2	£995	£595
PS AUDIO Reference Link	£4549	£3189
PS AUDIO D/A Converter	£2590	£1790
PS AUDIO 4.5 Pre-amp	£998	£548
PS AUDIO 6.1 Pre-amp	£799	£479
PS AUDIO 6.2 Pre-amp	£899	£539
REGA Brio Mk2	£298	£234
REGA Naos	£998	£794
ROTEL RT940AX Tuner	£235	£194
SONUS FABER Musica (Intgrtd)	£2295	£1729
SONUS FABER Electa speakers	£1789	£1349
SONUS FABER Speaker stands - wood	£595	£445
SONUS FABER Musica	£2295	£1896
SONUS FABER Guarneri	£5295	£4296
SONUS FABER Electra Amator II	£2698	£2196
TDS Audio Transformer	£349	£266
THETA ProPrime Converter	£1449	£1099
THETA Dreadnaught S	£6899	£5176
THETA Casanova Pre	£4478	£3596
THETA Casanova Pre Chassis	£3998	£2996
THETA Casanova (Multi)	£5652	£4496
TRIANGLE Titus XS	£325	£247
TRIANGLE Comete XS (Slight damage)	£400	£177
TRIANGLE Zephyr XS	£590	£427
TRIANGLE Antal XS [HFC Best Buy]	£875	£627
TRIANGLE Antal XS (Ex-Dem)	£875	£577
TRIANGLE Lyr XS	£1650	£1197
UNISON RESEARCH Unico 1 (Manual)	£795	£697
UNISON RESEARCH Unico 1 (Remote)	£895	£747
UNISON RESEARCH Power 35	£1500	£1097
UNISON RESEARCH Performance One		£POA
UNISON RESEARCH Simply 4P	£1595	£1296
UNISON RESEARCH Simply 4	£1595	£1197
UNISON RESEARCH S8	£2950	£2346
UNISON RESEARCH S8	£2950	£2147
UNISON RESEARCH Feather 1	£795	£597
UNISON RESEARCH Feather 1 Remote Control version	£845	£647
UNISON RESEARCH Power Supply (For Feather 1/Simply Phono)	£350	£297
WILSON Cub speakers (Black Laminate)	£5495	£4125
WILSON Cub speakers (Gloss)	£6890	£4995
WILSON Maxx	£38998	£24996
WILSON W/itt 1	£8887	£4996
Z SYSTEMS Digital Pre-amp	£5449	£3999

**There's More!**  
For the latest stock  
please check our  
**WEB SITE**  
hifitradingstation.com  
**UP-DATED DAILY**

The Hi Fi Company's  
**Trading  
Station**

35 Cowgate  
Peterborough PE1 1LZ

World Radio History

**PHONE**  
**(01733) 555514**

**FAX:**  
**(01733) 358141**

**email:**  
audiotrader@talk21.com

**SHOP HOURS**  
**TUES - SAT: 10am - 5.30pm**  
**CLOSED ALL DAY MONDAY**

### CD players DACs & Transports

	Was	Now
Advantage S1 Re-sampling CD Player 3 months old S/H	4250	2500
Densen Beat 400 CD Player S/H	1280	799
Einstein "The last Record Player" Valve CD Player x-demo	3200	1999
Linn CD12 S/H	12000	6999
Mark Levinson No 37 Transport S/H	4500	2799
Mark Levinson No 31.5 Transport S/H	9999	4999
Mark Levinson No 39 S/H	5249	3795
Mark Levinson No39 x-demo	5249	4499
Roksan DA2 DAC S/H	599	299
Roksan DS5 PSU S/H	579	325
Sony SACD1 S/H	4000	2795
Sony DVP-9000ES SACD/DVD Player S/H	1200	650
Wadia 3200 Transport AT&T S/H	4200	1599
Wadia X64-4 DAC S/H	4999	1599

### Turntables Tonearms & Cartridges

Audio Note AN-S2 Transformer S/H	450	279
Avid Volvere Turntable 6 months old S/H	2000	1499
Basis 1400/RB250 (New & Boxed)	1300	899
Basis 2000 Turntable x-Demo	1999	1399
Basis 2001 Turntable x-Demo	2999	2399
Basis 2004 Turntable x-Demo	4500	2999
Conrad Johnson EV-1 Phono Stage x-Demo	1499	1299
Koetsu Red Signature S/H 700hrs	1899	699
Kuzma Stogi/Stabi S Turntable (New & Boxed)	1299	1099
Lyra Clavis DC Evolve 99 150 hrs S/H	995	799
Lyra Clavis DC MC Cartridge 800hrs S/H	1295	399
Roksan Artexerxes X Phono Stage S/H	425	279
Roksan Xerxes Blk XPS 1/RB300/K9	1098	399
Roksan Xerxes Blk XPSII/Tabrizi/Corus	1290	599
Roksan Xerxes Blk SME Cut S/H	N/A	299
SME Series V Tonearm S/H	1700	950

### Preamplifiers

Audio Analogue Bellini Preamplifier x-demo	575	399
CAT SL1 Valve Preamplifier S/H	6500	2299
Conrad Johnson Premier 17LS x-Demo	4500	3750
Conrad Johnson PV 14L x-Demo	1999	1499
Conrad Johnson PV10A Preamplifier S/H	1099	599
DNM Primus preamplifier x-demo	2100	1799
Einstein "The Tube" Preamplifier x-Demo	6000	3999
Krell KAV-S Processor/Preamplifier DTS/AC3/Pro Logic S/H	14989	4999
Musical Fidelity Nu-Vista Preamplifier S/H	1299	995
Naim NAC 52 (4 months old) S/H	3655	2700
Naim Supercap (4 months old) S/H	2250	1799
Naim 72 K S/H	790	395
Naim Hi-Cap S/H	760	495
Pass Aleph P Preamplifier S/H	3595	1995
Roksan L2 preamplifier S/H	1295	499

### Amplifiers

Accuphase E307v Integrated Amplifier New	3295	2799
Audio Analogue Donesetti Power Amplifier x-demo	599	425
Audio Research VT50 Valve Power Amplifier S/H	4400	2199
ATC SIA-2 150 Integrated S/H	2495	1799
Border Patrol 300b Western Electric x-demo	4500	2400
Bow Technologies Wazoo XL Amplifier (New&Boxed)	2495	1950
Densen Beat 300 power Amplifier x-demo	795	599
DNM PA3 Power amplifier x-Demo	1900	1499
Electrocompaniet AW60 x-Demo	999	699
Electrocompaniet ECI-1 Amplifier S/H	3250	1599
Gamut D200 Power Amplifier S/H	3250	2299
Graaf GM20 OTL Stereo Valve Amplifier S/H	3295	1995
Mark Levinson No 434 Mono Block Power Amplifiers 3 months old S/H	9000	7999
Mark Levinson No334 Power amplifier x-demo	5495	4499
Musical Fidelity Nu-Vista 300 S/H	3299	2799
Naim NAP135s Amplifiers (4 months old) S/H	3810	2799
Naim NAP 180 Amplifier S/H	1155	679
Plinius 8150 Integrated R/C S/H	1799	899
Roksan Rok S1.5 Power Amplifier S/H	1499	945

### Loudspeakers

Audio Physic Virgo 2 Birds eye maple x-Demo	3250	2499
Boston Acoustic Lynfield Monitors inc Stands S/H	2000	995
Boston Acoustics VR 10 Centre Channel (New&Boxed)	250	175
Martin Logan Prodigy Ash S/H	9999	6995
Opera Operetta Mahogany x-demo	795	575
ProAc Response 1SC Ebony Rosewood S/H	1395	799
ProAc Response 2 Mahogany S/H	1795	899
ProAc Response 1.5 Ebony x-Demo	2140	1499
ProAC studio 100 Cherry x-demo	799	599
Sonus Faber Concerto S/H	850	599
Revel Salon Black/Aluminium (3 months old) S/H	15000	11999
Robertson Audio DX7 Cherry x-Demo	995	599
Totem Tabu Mahogany x-Demo	2300	1599

### Cables & Accessories

Audio Note AN-V 1m Silver interconnect S/H	420	199
BCD Model 1000 3 Tier Support S/H	1295	699
Cardas Quadlink 5C 1mRCA S/H	240	150
Finite Element Pagode E55/04 4 Tier Maple Stand X-Demo	799	549
Finite Element Pagode E55/014 4 Tier Maple Stand x-Demo	849	599
Goertz MI-2 2x6mCopper Ribbon Speaker S/H	650	399
Mandrake Silver Balanced 1m S/H	1295	399
Naim Audio2x5m Speaker cables white S/H	N/A	45
Opera Lux 3 Tier Table Clear/Stainless x-Demo	950	499
QED Genesis Silver Spiral 2X 3 M S/H	395	199
Roksan HA01 1M Interconnect S/H	99	49
Roksan HA01D 0.5m Digital Interconnect S/H	49	25
Sound Style 4 Tier in Green S/H	325	159
Stax Signature System Electrostatic Headphones S/H	1195	795
Tara Labs "Floating GroundStation" New	775	499
Tara Labs "The One" 1m Balanced New	2175	1499
Tara Labs RSC Prime Balanced 1m S/H	250	149
Transparent Music Link Ultra Balanced 1m S/H	1499	995
Transparent Music Wave Bi-Wire 2x 10ft S/H	455	249
Transparent Music Link Balanced 1m S/H	329	199
Transparent The Wave 2X7m S/H	599	299

### Tuners & Tape Decks

Magnum Dynalab FT-R Remote Switcher for FT101A/Etude (New&Boxed)	450	299
Magnum Dynalab Etude Analogue FM Tuner S/H	1299	599
Teac T-BX10 Tuner S/H	399	179

Midland Audio X-change are looking for Audio Research, Krell, Mark Levinson, Naim Audio, Theta, Wadia, cash paid call John Roberts on 01562 822236 now!



- Suppliers and installers of High Quality Audio Systems:
- 47 Laboratory : Graff
  - Accuphase : Gryphon
  - Audio Note : Lavardin
  - Audio Research : Mark Levinson
  - Avid : Martin Logan
  - Basis : Michell
  - Cabasse : Nagra
  - Cardas : Primare
  - Clearaudio : ProAc
  - Conrad Johnston : Rega
  - Copland : Resolution Audio
  - Dcs : Sonus Faber
  - DNM / Reson : Spectral
  - Einstein : SPM
  - Electrocompaniet : Sugden
  - Final : UKD
  - Finite Element :

[www.midlandaudiox-change.co.uk](http://www.midlandaudiox-change.co.uk)

call John Roberts Tel: 01562 822236

or fax on: 01562 750246

181 Franche Rd • Kidderminster • Worcs • DY11 5AD

e-mail [sales@midlandaudiox-change.co.uk](mailto:sales@midlandaudiox-change.co.uk)

Mobile 07721 605966

# WILLIAMS HART ELECTRONICS

HART ELECTRONIC KITS TRADED FOR OVER 30 YEARS



**NEW LAYOUT**

80Watt Mosfet Stereo Power Amp Kit  
110Watt Mosfet Monoblock Power Amp Kits  
ONE OF THE BEST AMPLIFIERS YOU WILL HEAR! Regardless of price  
ON DEMO @ Bala, Southend, Peterborough and Burnley



Single Ended Class A Valve Sound  
15Watt Power Amp modules  
FOR THOSE WHO WANT THAT V.M.I.  
MIDBAND BUT BASS AND TREBLE TO MATCH



ACTIVE RCControl SUBWOOFER MODUL 11 L177 30



Range of speaker Kits  
Passive and Active

Advertise your Hi-Fi on my website (FREE)  
Also Award Winning Phono Stage Kit, Active Crossover Modules, Speaker Drive Units,  
M Cap Capacitors, Caddock Resistors, Remote Control Volume and much more

WEB SITE [www.williamshart.com](http://www.williamshart.com)

e-mail: [williamshart@classicfm.net](mailto:williamshart@classicfm.net)

Tyn-Y-Coed, Llanidau, Bala, Gwynedd, LL23 7SG Tel/Fax for catalogue 01678 520757

PERSONAL VISITORS SHOULD PHONE FIRST TO AVOID DISAPPOINTMENT

Run by former Technical Director of Wilmslow Audio



# MUSICAL IMAGES

PRODUCT		LIST	NOW
ARCAM DIVA AVR100 Silver AV Receiver	EX/DEMO	£800	£600
ATC 20SL Speakers	S/H	£2,400	£1,200
ATC A7 TOWER Cherry Speakers	EX/DEMO	£1,200	£700
AVI S2000MC/20 CD Player	EX/DEMO	£1,400	£700
DENON DVD3300 Black DVD Player	EX/DEMO	£650	£475
KEF REFERENCE 1-2 Cherry Speakers	EX/DEMO	£1,350	£1,000
KEF REFERENCE 3-2 Albina Burr Speakers	EX/DEMO	£2,750	£2,000
KEF REFERENCE 4-2 Cherry Speakers	EX/DEMO	£3,650	£2,800
KEF TDM23C Black Centre Speaker	EX/DEMO	£400	£275
KEF TDM23F Black Speakers	EX/DEMO	£800	£525
KEF TDM45B THX Subwoofer	EX/DEMO	£800	£575
LINN 5110 Black Speaker	EX/DEMO	£195	£120
LINN AV5150 Power Amp	EX/DEMO	£1,200	£650
LINN KARIN Pre Amp	EX/DEMO	£1,400	£900
LINN LP12 Black Turntable	EX/DEMO	£1,075	£700
LINN SEKRIK Black Wall Speakers	EX/DEMO	£395	£200
MARANTZ DR6000 CD Recorder/Player	EX/DEMO	£400	£300
MERIDIAN 500 CD Player	S/H	£1,350	£750
MERIDIAN DSP5000 Cherry Speakers	EX/DEMO	£3,885	£3,100
MERIDIAN DSP5000C Black Centre Speaker	EX/DEMO	£1,995	£1,600
MERIDIAN DSP5500 Speakers	EX/DEMO	£6,995	£5,600
MUSICAL FIDELITY A300 Amp	EX/DEMO	£1,400	£1,000
MUSICAL FIDELITY XA100R Amp	EX/DEMO	£1,000	£750
MUSICAL FIDELITY XDAC HDCD DAC	EX/DEMO	£300	£150
MUSICAL FIDELITY XP100 Pre Amp	EX/DEMO	£800	£640
NAIM INTRO Black Speakers	EX/DEMO	£790	£550
NAIM NAC92R Pre Amp	S/H	£720	£400
NAIM NAPSC Power Supply	EX/DEMO	£190	£130
NAIM NASBL Speakers	EX/DEMO	£2,360	£1,600
NAIM PREFIXMC Phono Stage	EX/DEMO	£405	£250
NAIM SNAXO 2-4 Crossover	EX/DEMO	£800	£500
PROAC RESPONSE 1SC Speakers	EX/DEMO	£1,200	£850
PROAC RESPONSE 2.5 Yew Speakers	EX/DEMO	£3,000	£2,100
PROAC RESPONSE 3.8 Cherry Speakers	EX/DEMO	£3,990	£2,800
SONY CDPXB930E QS CD Player	EX/DEMO	£300	£225
SONY DVPFX1 Portable DVD Player	EX/DEMO	£1,300	£1,050
SONY STRDB1070 AV Receiver	EX/DEMO	£600	£475
SONY STS3000ES Gold ES Tuner	EX/DEMO	£250	£150
SONY STSA3ES Black Tuner	EX/DEMO	£300	£225
SONY STSA3ES Gold Tuner	EX/DEMO	£300	£225
THORENS TD166 MK2 Turntable + RB250 & AT450E	S/H	£500	£350

**PLEASE VISIT OUR SHOWROOMS  
OR CALL OUR HOTLINE  
NUMBER FOR DETAILS.  
MANY ARE ONE-OFF ITEMS!!**

**HOTLINE 020 7497 1346**  
Convent Garden  
18 Monmouth Street  
Convent Garden  
London WC2H 9HJ  
Tel: 020 7497 1346  
**E-Mail: [sales@musical-images.co.uk](mailto:sales@musical-images.co.uk)**  
NOT VALID WITH ANY OTHER OFFERS OR PROMOTIONS E&OE

74" 'V-Max' can hold 660 CDs etc



*Elegant Storage  
Solutions for  
Hi-Fi, Books,  
LPs, CDs,  
DVDs  
Any veneer  
supplied*



Charlotte Drawer unit for 480 CDs & 75 Cassettes 32" x 21" x 21"

## IAN EDWARDS MAKERS OF FINE HANDMADE FURNITURE

Tel: 01423 500442 Fax: 01423 705200  
[www.iansbespokefurniture.co.uk](http://www.iansbespokefurniture.co.uk)

'Wizard' Rotary Unit. 1525 CDs, etc



*The Old Chapel  
282 Skipton Road  
Harrogate, N. Yorks  
HG1 3HB*

*Est.  
1970*

*New Brochure  
now available*



JT Hi-Fi CD/Cassette Unit

# HICAM

**CHERISHED PRE-OWNED HI-FI EQUIPMENT SOLD, PURCHASED, P/X. CASH WAITING FOR THE FOLLOWING BRANDS  
NAIM, MERIDIAN, AUDIOLAB, KRELL, WADIA, SONUS FABER, MARTIN LOGAN, MARK LEVINSON, COPLAND, QUAD**

	WASNOW			
MERIDIAN 508 CD PLAYER	795	MICHELL GYRODECK /RB 300 ARM AS NEW	1190	1095
ALPHASON AKROS 2 SPEAKER STANDS BOXED	60 30	STAX OMEGA REF SR 007/SPM 717 TUBE ENERGISER	2795	
ATACAMA SE 24 SPEAKER STANDS NEW	75 65	PRECIOUS METALS GAMMA 1 MTR INTERCONNECT NEW	60	50
AUDIONOTE OTO INT AMP LINE LEVEL AS NEW	999 850	PRECIOUS METALS SILVER SIGNAL 202B		
LYRA HELIKON SL MC CARTRIDGE NEW	1249	BALANCED NEW	500	425
EAR HEADPHONE AMP HP4 AS NEW	1695 1500	PRECIOUS METALS SILVER SIGNAL 204		
AV1 S2000 MM MONOBLOCKS 2 WEEKS OLD	1399 1225	INTERCONNECT 1 METRE	490	425
AVI S2000MT11 AM/FM		NAIM INTRO LOUDSPEAKERS BLACK BOXED	695	425
REFERENCE TUNER 2 WEEKS OLD	899 800	AUDIONOTE AN CD 2 1X INT CD PLAYER AS NEW	999	895
AVI S2000MC REFERENCE 24/96		LINN CLASSIK DVD/TUNER/AMP BLACK AS NEW	1995	1895
CD PLAYER 2 WEEKS OLD	999 895	PSB ALPHA 6 ACTIVE SUBWOOFER AS NEW	500	325
AUDUSA EUPEN POWER CABLES FULL RANGE	POA	ELAC CL 3301 JET INC STANDS NEW		2499
EARV 20 INTERGRATED CLASS A 6 WEEKS OLD	2198 2498	RUARK CL10 CHERRY FINISH / NEW SLIGHT MARK	900	625
NAIM 01 TUNER	995	AUDIONOTE ANTT THREE SUPER TURN TABLE	2450	2250
AUDIONOTE OTO PHONO INT AMP 1 MONTH OLD	1300 1100	RUARK PROLOGUE CHERRY (NEW) SLIGHT MARK	995	625
AUDIONOTE DAC 2 1X 24/96 AS NEW	1149 975	NAIM 62/90 OLD STYLE PRE/POWER		295
EAR 861 POWER AMP CLASS A 1 MONTH OLD	3599 2995	STAX SRS 4040 SYSTEM SIGNATURE 2 NEW		1195
EAR BL6 INTERGRATED/PRE/MAIN AMP NEW	2298	SONETEER CAMPION INT AMP AS NEW	599	425
EAR 834P CHROME DELUXE MM/MC PHONO AS NEW	778 695	AUDIONOTE ANS1 CARTRIDGE TRANSFORMER	400	195
EAR 834P MM/MC PHONO STAGE	549 475	TRICHORD DINO PSU NEW		225
EAR MC3 MC TRANSFORMER 1 MONTH OLD	658 595	SONICLINK AST200 BIWIRE SPK CABLE NEW	10	8
EAR 834 INT AMP NEW	2198	SONICLINK THE BASE 1 METRE PAIR INTERCONNECT NEW	25	18
HEYBROOK QUARTET ROSEWOOD FINISH	595 225	SONICLINK 8 WAY DISTRIBUTION BLOCK 2 MTR CABLE NEW	299	250
AUDIONOTE AZ TWO LOUDSPEAKERS 93 DB MINT	599 500	SONICLINK SIMPLICITY 1 MTR PAIR INTERCONNECT NEW	35	27
LAT SS800 SPEAKER CABLE 5MTR NEW	206 175	AUDIOLAB 8000 MONOBLOCKS		995
LAT 8 WAY DISTRIBUTION BLOCK 3 FT NEW	226 195	SONICLINK VIOLET INTERCONNECT (OFF THE REEL) 15 PER MTR		
LAT AC2 6 WAY DISTRIBUTION BLOCK 3 FT NEW	195 160	STAX SRS 2020 MK2 EARSPEAKERS MINT	449	375
LAT AC2 POWER CABLE 3 FT NEW	68 63	AUDIONOTE M5 LINE LEVEL PRE AMP MINT	4650	4100
LAT IC100 MK2 1 METRE BOXED NEW	105 90	VDH INTERGRATION 8 MTR NEW	240	150
SONICLINK 8 DISTRIBUTION BLOCK NEW	299 250	SUMIKO PEARL MM CARTRIDGE NEW		79
AUDIONOTE ZERO TRANSPORT/DAC NEW	1048 925	SUMIKO BLUE POINT SPECIAL MC NEW	279	249
NAIM 72 PRE AMP	395	AUDIONOTE ANVX 1 METRE PAIR NEVER USED	574	495
MERIDIAN D500 CONVERTED TO M60 ACTIVE	2000 995	TRICHORD PSU FOR DINO PHONO STAGE NEW		225
NAIM HICAP PSU	450	VDH THE SECOND 8 MTR NEW	230	150
EXPOSURE XV11 AMP BOXED MM PHONO STAGE	1000 550	TRICHORD RESEARCH 500 POWERBLOCK	299	275
LYRA LYDIAN BETA MC CARTRIDGE NOT USED	599 525	QED FULL RANGE	POA	
MUSIC FIDELITY X AI INTERGRATED AMP	490 295	VDH INTERGRATION 1 METRE PAIR BOXED	300	250
MERIDIAN ACTIVE CENTRE SPEAKER	1995 895	SOUND ORGANISATION FULL RANGE	POA	
MICHELL LARGE PSU NEW	399 399	VDH THE FIRST 1 MTR NEW	240	150
MICHELL ALECTO MONOBLOCKS AS NEW	1589 1800	MYRYAD MD 600 CD PLAYER NEW		1299
MICHELL GYRO SE/RB300 ARM	1017 925	AUDIONOTE ANCD 3 1X CD PLAYER NEW		1499
MICHELL ORBE SEALED BOX	2095 1895	AUDIOLAB 8000 Q PRE AMP BOXED	1400	650
MICHELL ORCA PRE AMP	1251 1095	VDH FIRST ULTIMATE 0.6 METRE NEW	220	190
MYRYAD MT 100 FM TUNER NEW	599 95	VDH THE SOURCE HB 0.8 METRE NEW	65	57.5

**AGENTS FOR, EAR, TRICHORD, AUDIONOTE, MICHELL MYRYAD, AVI, STAX, LAT, VDH, ELAC, RUARK, SME, BLACK RHODIUM, LYRA, SUMIKO, QED**

**OPEN MON-SUN 10AM-6PM  
FOR FURTHER DETAILS: TEL 01726 74474 / FAX 01726 70387  
MOBILE: 07973 233 380  
E-MAIL HICAM1@FREENETNAME.CO.UK  
OR VISIT OUR WEBPAGE HICAM.CO.UK**



**2nd YEAR**

# AUDIOMANIA

**2nd YEAR**

**SUNDAY 30 JUNE 2002  
CASTLE SPORTS COMPLEX  
SPALDING, LINCOLNSHIRE  
10.30a.m. - 4.00p.m.**

**ADMISSION £2  
EARLY ENTRY 9.30 a.m. £5  
STALLS £20**

**HUGE HALL.  
LEVEL ENTRY.  
REFRESHMENTS.  
AMPLE PARKING.**

**THE FRIENDLY SHOW  
FOR ANYONE INTERESTED IN CLASSIC AUDIO**

**AMPLIFIERS, TURNTABLES, CD PLAYERS,  
TAPE DECKS, VALVES, REEL-REEL, RECORDS,  
CD'S, COMPONENTS, LITERATURE,  
EVERYTHING & ANYTHING CONNECTED  
WITH AUDIO.**

### DIRECTION

**APPROACH SPALDING VIA A16. THEN TAKE A151 INTO  
SPALDING AT SPRINGFIELDS ROUNDABOUT.  
CROSS OVER BRIDGE. PAST CHURCH. PASS WESTONS GARDEN  
MACHINERY. KEEP ON TO TRAFFIC LIGHTS THEN CROSS  
OVER BRIDGE AND TURN HARD LEFT INTO ALBION STREET.  
CASTLE SPORTS COMPLEX IS ON YOUR RIGHT**

**DETAILS / STALL BOOKING 01777 680030 AFTER 1.00p.m.**

**IAN HARRISON HI-FI** TEL: 01283 702875  
HI-FI AT DISCOUNT PRICES. FREE NATIONWIDE DELIVERY

**9am-9pm  
INCLUDING SUNDAYS**

**SALE NOW ON!**

**TRADE IN YOUR OLD MOVING COIL CARTRIDGE & SAVE UP TO 60% OFF THE RRP.**

CARTRIDGES & STYLUS	HI-FI FURNITURE	HEADPHONES	DVD
DENON	APOLLO	SENNHEISER	SONY
SHURE	SOUND STYLE	SONY	DENON
AUDIO TECHNICA	SOUND	AKG	<b>PHONO STAGES</b>
GOLDRING	ORGANISATION	GRADO	MICHELL
SUMIKO	ALPHASON	AUDIO-TECHNICA	CREEK
TRANS-FIGURATION		<b>DAT</b>	NAD
LONDON (DECCA)	<b>CABLES</b>	TASCAM	AUDIO NOTE
GRADO	SONIC LINK	SONY	EAR
ROKSAN	AUDIOQUEST	PANASONIC	ROKSAN
VAN DEN HUL	VAN DEN HUL	<b>CASSETTE DECKS</b>	TOM EVANS
ORTOFON	QED	PIONEER	<b>LOUDSPEAKERS</b>
AUDIO NOTE	ORTOFON	TEAC	HARBETH
RESON	NORDOST	SONY	CABASSE
CLEAR AUDIO	ARGENTO	DENON	SHUN MOOK
KOETSU	AUDIO	<b>MINI DISCS</b>	EPOS
<b>TONEARMS</b>	<b>TURNTABLES</b>	SONY	<b>AMPLIFIERS</b>
ROKSAN	ROKSAN	DENON	DENON
SOUTHER	MICHELL	<b>TUNERS</b>	AUDIO NOTE
GRAHAM	CLEAR AUDIO	SONY	C.A.T.
MOTH	AUDIO NOTE	DENON	GAMUT
CLEAR AUDIO			ALOIA
HADCOCK			EAR
<b>ACCESSORIES</b>			
Hifi News Cartridge Alignment Gauge	£5	Milty Zerostat 3	£30
Hifi News Test Record & Alignment Gauge	£15	Audio Technica Stylus Cleaning Fluid	£5
Shure SFG2 Tracking Force Gauge	£25	Clearaudio Carbon Fibre Record	
		Cleaning Brush	£14

**PLEASE PHONE TO CONFIRM PRICE & AVAILABILITY PRIOR TO ORDERING.  
ALL GOODS ARE BRAND NEW & BOXED WITH FULL U.K. GUARANTEES.  
NO EX. DUTY OR EX DISPLAY GOODS. NO GREY IMPORTS. GOODS ARE NOT  
SUPPLIED ON APPROVAL. SORRY, NO GENERAL CATALOGUES. PLEASE PHONE  
OR WRITE FOR SPECIFIC REVIEWS, BROCHURES OR PRICES.**

**MAIL ORDER ONLY FROM: IAN HARRISON, 7 MILL HILL, REPTON,  
DERBY, DE65 6GQ. TEL: 01283 702875. 9am - 9pm INCLUDING SUNDAYS.**



We are best known for our single-ended 300B power amplifiers and power supply upgrades for valve amplifiers, but did you know that we supply complete systems, new and used equipment, and components? We also provide support and servicing for Audio Innovations valve products. For full information visit [www.borderpatrol.net](http://www.borderpatrol.net) or ring 01273 276716.

# passion, grace & fire

## [www.borderpatrol.net](http://www.borderpatrol.net)

Selected products from:

BorderPatrol • Living Voice • SME • Audio Note • Cartridge Man • Goldring  
Western Electric • Electrofluidics

BorderPatrol Brighton UK  
Tel/Fax +44 (0)1273 276716  
e-mail: [bp@borderpatrol.net](mailto:bp@borderpatrol.net)  
[www.borderpatrol.net](http://www.borderpatrol.net)



**BorderPatrol**



## MUSONIC STYLI

**SPECIALIST MANUFACTURER &  
SUPPLIER FOR MORE THAN 40 YEARS**

**REPLACEMENTS & ORIGINALS**

**MANY OBSOLETE/78 VERSIONS**

**PICK-UP CARTRIDGES**

**RECORD/TAPE/CD ACCESSORIES**

**WHY NOT TRY US AND HEAR THE  
DIFFERENCE !!**

*See us at the N.V.C.F. Show  
at NEC Birmingham  
on Sunday 5th May 2002*

**NAGAOKA CARTRIDGES NOW IN STOCK**

**For further information tel/fax/e-mail to:-**

**MUSONIC (UK) LIMITED**  
Unit 13 Wenta Business Centre Colne Way  
Watford Hertfordshire WD24 7ND

Tel: 01923 213344 Fax: 01923 213355  
E-mail: [sales@musonic.co.uk](mailto:sales@musonic.co.uk)

**VISIT OUR NEW WEBSITE**  
[www.musonic.co.uk](http://www.musonic.co.uk)



Trade and Export enquiries welcome



## PROGRESSIVE AUDIO



2 Maryland Court, Rainham, Kent, ME8 8QY  
Telephone / Fax No. 01634 389004

WEBSITE: [www.progressiveaudio.co.uk](http://www.progressiveaudio.co.uk) E-MAIL: [dave@progressiveaudio.co.uk](mailto:dave@progressiveaudio.co.uk)

We have the following ex demonstration and part exchange items for sale :

- ALCHEMIST Forsetti Remote integrated amplifier. Mint. Boxed. £825. S/H.
- ROKSAN Caspian power amp. Mint. Boxed. £425 S/H.
- LINN LP12, Valhalla, Nirvana and Cirkus bearing. Black. £425. S/H.
- APOGEE Centaur Minor hybrid speakers. Mint. Boxed. £850. S/H.
- KEF Q55.2 speakers. Mint. Boxed. £350. S/H.
- AUDIONOTE TT1/RB300 (with AN-V cable) IQ2 cartridge. £550. S/H.
- MICHELL Syncro/RB250 turntable. £175. S/H.
- ALON V loudspeakers. Natural Oak. Very good condition. £2550. S/H.
- LINN LP12. Afrosimia. Lingo power supply. Ittock 11 tonearm. £925. S/H.
- SPENDOR SP2/3 loudspeakers. Walnut. Good condition. £525. S/H.
- DNM Series 3 Start pre amp. £550. S/H.
- TSUNAMI TS300 active subwoofer. Rosewood. Mint. £150. S/H.
- SUMIKO Celebration Pearwood Signature m/c cartridge. 10 hours dem use only. £800
- IMPULSE H2 horn loudspeakers. Mahogany. Slightly tatty cloth. £950. S/H.
- SILTECH SL 2.60 speaker cabel. 2.75m single wire set. £550. S/H.
- ILLUMINATI D-60 Digital interconnect cable. 0.5m. £120. S/H.
- ANTHEM (by Sonic Frontiers) amp 2 (silver) Mint £1200 S/H.
- DNM series 3 pre amp with twin power supply £750 S/H
- PROAC Response 1 SC loudspeakers. Black. With Target R stands. Mint. Boxed. £1050. S/H.
- THETA D5 pro progeny DAC. Mint £850 S/H
- LFD L51 Line stage. £525. S/H
- REGA Jupiter /lo CD Transport and DAC with digital interconnect. £795. S/H.
- VERITAS H3 Horns. Piano black. As new. £4600. X/D.
- VERITAS 20'S. Piano Black. With stands. As new. £1250. X/D.
- BLACK Rhodium interconnect. 1.5m. Boxed as new. £795. S/H.
- ALON Petite loudspeakers. Walnut. As new. Boxed. £850. X/D.
- ALON 1 loudspeakers. Walnut. Excellent condition. Boxed. £795. X/D.
- MICHELL Iso HR Line pre amp. With Hera P/S. £650. X/D.
- MICHELL Iso HR phono stage. With Hera P/S. Excellent condition. £495. S/H.
- ACOUSTIC SOLUTIONS "Eight" loudspeakers. Oak. As new. With stands. £1200. X/D.
- LINN Kaber loudspeakers with stone stands. £825. S/H.
- JEFF ROWLAND Model 2 power amp with BPS 2 battery power supply plus SYNERGY 11 pre amp. £6000. S/H.
- AUDIONOTE AN-KSp speakers ( Oak ) with matching Audionote stands. £725. S/H.
- QUAD 989 loudspeakers. Ex Dem. little use. £4000.
- MERIDIAN 500 transport/563 DAC £1500. S/H

**NOW ON PERMANENT DEMONSTRATION THE SUGDEN  
MASTERCLASS INTEGRATED AMP AND CD PLAYER,  
RED ROSE ROSETTA AND ROSEBUDS, MOON  
ELECTRONICS, VELODYNE SUBWOOFERS, WADIA CD  
PLAYERS, AUDIO ANALOGUE MAESTRO CD PLAYER  
AND AMP MUSICAL FIDELITY 3D CD PLAYER, LIVING  
VOICE AND AUDIO PHYSICS LOUDSPEAKERS, AVID  
TURNTABLES AND CHAPTER AUDIO POWER AMP**

# Oxford Audio Consultants Ltd.

OUR SUPERB SERVICE IS THE SAME REGARDLESS OF PRICE



## Now Demonstrating



Ex-Demonstration & Previously Owned Equipment

### SALE LIST - April 2002

SONUS FABER MINIMA AMATORS	£750	SH
SONUS FABER CONCERTOS PIANO BLACK	£595	SH
SONUS FABER PICCOLO CENTRE SPKR	£195	SH
MARANTZ CD 75X DEM	£2795	XD
GRAAF GN20 POWER AMP	P.O.A.	
WILSON SYSTEM 5.1	£795	SH
WILSON SYSTEM 6.1 FERRARI GRUY	P.O.A.	SH
AUDIO ANALOGUE PUCCINI SE NON REMOTE EX DEM	£475	XD
PATHOS ACOUSTICS TWIN TOWERS AMPLIFIER	£2295	SH
MERIDIAN 207	£ 295	SH
MUSICAL FIDELITY A3 CD PLAYER EX DEM	£ 600	XD
MUSICAL FIDELITY A3 AMPLIFIER EX DEM	£ 650	XD
MUSICAL FIDELITY X FLORA TUNER EX DEM	£ 449	XD
MUSICAL FIDELITY A200R AMPLIFIER EX DEM	£ 525	XD
REL STADIUM 3	£1095	SH
KRELL KSL PREAMPLIFIER	£ 795	SH
KRELL KST100 POWER AMPLIFIER	£1395	SH
KRELL KAS 2		
KRELL KPS25c CD PLAYER	P.O.A.	SH
KRELL AVS - FULLY LOADED	£3495	SH
KRELL 500/4 OR 3	P.O.A.	
KRELL FPB200C POWER AMPLIFIER - EX DEM	£7995	XD
KRELL FPB300C POWER AMP - OUR DEM MODEL	£9955	XD
KRELL KPS30	£2350	SH
KRELL 250P PREAMPLIFIER	£1795	XD
KRELL KAV300CD CD PLAYER	£1995	SH
KRELL 300I AMPLIFIER	£1795	SH
NAIM CDS MK 2 EX DEM	£4750	XD
NAIM SUPERCAP EX DEM	£1850	XD
NAIM 250 POWER AMPLIFIER	£ 995	SH
NAIM AUDIO 140	£ 350	SH
NAIM SBL SPKRS ACTIVE UPGRADED BASS DRIVERS/NANO	£ 795	SH
NAIM 00.3 POWER AMP	£ 295	SH
TRANSPARENT REF XL INTERCONNECT/POWER CABLES	P.O.A.	
TRANSPARENT MUSIC LINK BAL IM	£195	SH
TRANSPARENT PDL IM DIGITAL	£150	SH
AUDIO RESEARCH VTM120 POWER AMPS	P.O.A.	
AUDIO ANALOGUE BEL LINI PRE AMP SILVER	£325	SH
AUDIO RESEARCH CA50 INTEGRATED AMP EX DEM	£2495	XD
AUDIO RESEARCH LS9 PREAMPLIFIER	£ 995	SH
AUDIO RESEARCH D130 POWER AMPLIFIER EX DEM	£1295	XD
AUDIO RESEARCH D100 2	£2995	XD
LOWE PLANUS 32" WITH CABINET ARCTIC EX DEM	£1295	XD
LOWE XELOS 28" ARCTIC	£695	XD

SH - Second Hand XD - EX Demonstration

0% interest free credit

Licensed Credit Broker

REFER TO OUR WEBSITE FOR THE LATEST UPDATED SALE LIST.

Agencies include: Acoustic Energy, Alphason, Atacama, Audio Analogue, Audio Research, Beyer, BOSE, Castle Chord Company, Copland, Creston, Denon, Diapason Dwn Electronics, Einstein Fujitsu, GM Audio, Goldring, Graaf, Integra Systems, IKOS, Jadis, Jamo, Kef, Koetsu, Krell, Lexicon, Loewe TV/Video, Linn Classik, Lyra, Marantz, Martin Logan, Michiel, MRS Multiroom Systems, Musical Fidelity, NAD, Naim, NEC Gas Plasma Screens, Nakamichi, Nordost, Onkyo, Opera, Ortofon, Parasound, Pioneer, ProAc, Project Turntables, QED Multiroom, Quad, Quadraspe, REL Subwoofers, Rotel, Sennheiser, Sharp, LCD TVs, SME, Sonus Faber, Sonus Systems, SoundByte, Standesign, Stands Unique, Star, Stewart, Screens, Tag McLaren, Tannoy, Teac, Theta, Transparent, Unison Research, Van den Hul, Vibe Acoustics, VibeAudio, VideoLogic, Vienna Acoustics, Wilson, Yamaha.

TAX FREE EXPORT SERVICE  
MAIL-ORDER AVAILABLE ON MANY ITEMS

Cantay House, Park End Street  
Oxford OX1 1JD

Telephone: Oxford (01865) 790879  
Facsimile: Oxford (01865) 791665

E-MAIL: Oxford.Audio@btinternet.com

WEBSITE: www.oxfordaudio.co.uk



V.A.T. No.  
729580013



QUALITY USED  
EQUIPMENT,  
BOUGHT, SOLD,  
PART EXCHANGE

TEL/FAX  
0121 747 4246



URGENTLY REQUIRED  
LINN, NAIM,  
MERIDIAN, QUAD,  
CASH WAITING

	RRP	NOW £
ACUPHASE DP70V DIGITAL VOLUME	5500	1995
ACOUSTIC ENERGY AEGIS CENTRE	150	70
ADVANTAGE A300 POWER AMP	2800	1495
ADVANTAGE M300 MONO'S NEW SEALED BOX	4600	2995
ART AUDIO QUINTET VALVE POWER	1800	695
AUDIO INNOVATIONS 2ND AUDIO'S SERIES 11	4000	1395
AUDIO NOTE AN-S3 TRANSFORMER	1000	295
AUDIO RESEARCH D115 MK11	N/A	1295
AUDIO RESEARCH SP9 MK 11	N/A	095
AVI S2000 PRE	900	350
BALANCED AUDIO TECHNOLOGIES VK20 PHONO REMOTE	4000	1995
BALANCED AUDIO TECHNOLOGIES VK50SE REMOTE	7350	3995
BASIS 1400 REGA RB300	1300	695
BOW TECHNOLOGIES WAZOO XL INTEGRATED AMP	2500	1395
BOW TECHNOLOGIES WAZOO INTEGRATED AMP	2000	995
BURMESTER 006 CD	3685	2195
BURMESTER 935 PRE	3280	1995
BURMESTER 956 POWER	5425	3695
CAL DX-2 CD EX DEM	650	195
CAL ICON MK 11 CD EX DEM	1100	295
CARY SLP-50 VALVE PRE	1400	450
CHARIO SYNTAR 100 TOWER BLACK	450	195
COPLAND CTA 505 POWER AMP	1900	895
COUNTERPOINT BUOU-MYSTIC-ORPHEUM 5 SPEAKER SYSTEM	1500	295
DENSEN BEAT B100	800	350
GOLDEN TUBE AUDIO SEP-1 VALVE PRE BALANCED PHONO	1500	795
GRAFF GM 20	3300	1995
HOVLAND HP-100 + M/C PHONO	5750	4495
HOVLAND SAPHIRE POWER AMP	7000	4995
JM LABS MINI UTOPIA + STANDS	5250	3295
KRELL DSP CD MK11	5000	1795
LINN TRAMPOLIN BASE	150	75
LINN KAN MAPLE 1 WEEK OLD	325	250
LINN KOLEKTOR SILVER 3 WEEKS OLD	530	395
LINN PEKIN TUNER SILVER 3 WEEKS OLD	575	395
LINN LK85 SILVER 3 WEEKS OLD	525	395
LUXMAN K-351 CASSETTE DECK	N/A	250
LYRA CLAVIS DC LOW HOURS	1300	495
MAGNUM DYNALAB MD10 VIRTUAL DECODER EX DEM	700	295
MARANTZ SACD 12 NEW UNUSED	3500	2695
MARK LEVINSON NO 26 PRE	N/A	1995
MARK LEVINSON NO29 POWERAMP	N/A	1695
MARTIN LOGAN QUESTS OAK	5500	1795
MARTIN LOGAN ASCENT	4500	3295
McINTOSH C28 PRE	N/A	495
McINTOSH MR73 TUNER	N/A	495
MONITOR AUDIO STUDIO 5 BLACK ASH	700	350
MONITOR AUDIO STUDIO 20SE ROSEWOOD	2000	795
MONSTER ZR REFERENCE SPEAKER CABLE 2X10 FT	350	150
MUSE MODEL 8/296 DVD/CD TRANS + 24/96 KHZ DAC	7000	2995
NAIM NBL CHERRY	7165	4500
NAIM 140	840	495
NAIM FLATCAP	400	295
NAIM CD3.5	1100	650
NAIM IXO	N/A	295
NAIM 102 PHONO NAPSC	1450	895
NAIM CREDO EBONY	1350	795
NAIM CDI MK2	2000	895
NAIM 72	800	395
NAIM NAIT 5 NEW UNUSED	800	595
NAIM HEADLINE	225	150
NAIM 92 PHONO	520	250
NAIM 90/3 X2	550	250
NAKAMICHI 700 TRI TRACER REMOTE & SERVICE MANUAL	N/A	295
NHT 1.3A SPEAKERS PIANO BLACK EX DEM	500	195
NHT 1.1 SPEAKERS PIANO BLACK EX DEM	400	150
PIONEER DVD 717 MULTIREGION	550	150
PROAC RESPONSE 2.5 BLACK	2700	1595
PROAC RESPONSE 1SC CHERRY TARGET R4 STANDS	1600	895
PROCEED AMP 3 (3 channel) THX	3000	1295
QUAD 77 POWER AMP	700	395
QUAD 77 PRE + SYSTEM REMOTE	850	450
QUAD 77 CD BUS	700	395
QUAD 77 TUNER	700	395
QUAD 99 MONOBLOCKS	1300	895
QUAD 606	N/A	395
QUAD 306	N/A	195
REGA CURSA/MAIA PRE POWER	1000	495
REL STENTOR MK1 OAK	1800	695
REVEL ULTIMA GEM PIANO BLACK + stands	8000	3500
ROGERS E40A INTEGRATED VALVE AMP	2500	795
SAT COFIX 24/96 KHZ WITH UPSAMPLER NEW SEALED BOX	1500	995
SIM AUDIO CELESTE 4000 INTEGRATED	1000	250
SONY TA-N9000E5 5 CHANNEL POWER AMP	1000	395
SONY SACD 1	4000	2695
SONY 777ES DAB TUNER NEW SEALED BOX	700	495
SONY DVP-S7700 DVD MULTI REGION	1100	495
STD TURNTABLE SME 3009 SHURE V15	N/A	150
TAG DAC 20	1250	495
TANNOY MERCURY M3	250	150
TANNOY LANCASTER 15" MONITOR GOLD	N/A	995
TEAC VRDS-T1 TRANSPORT	600	350
TEAC D-T1 DAC	400	150
THETA CARMEN CD/DVD TRANSPORT BLACK	3400	2595
VAN DEN HUL THE SECOND DIGITAL XLR	150	50
VAN DEN HUL REVELATION HB 2X 1.5 PAIR	800	295
WADIA 6 CD DIGI VOL	5000	1795
XLO 4.1 SIG DIGITAL CABLE 1 MTR	395	150
YAMAHA SW 160 SUB	275	150

OPEN MON-SUN 10.00 TO 8.00  
Website: www.centralaudio.co.uk  
E-mail: tony@centralaudio.co.uk

**BRAND NEW TONEARMS**  
**Eminent Technology Air Bearing Tonearm**  
**Normal Price £2500 Our Price (standard) £1495**

HEATHERDALE PRE-OWNED GUARANTEED EQUIPMENT EXPORT FACILITIES AVAILABLE

**SPEAKERS**

Lynn Kaber Speakers (boxed, mint) £575  
 Yamaha Ns1000 (Not M) Ebony Speakers £825  
 Thiel Scs 2 Speakers (Walnut, Factory Sealed Boxes) £1595  
 Normal Price £2395 Our Price £1395  
 Quad ESL63 Speakers with Stands £1395

**PRE AMPS**

Toft Pre amp (FULLY BALANCED) £595  
 Adcom GTP 450 Tuner/Pre Amp £350  
 Oakley High-end Valve Pre Amp (similar to Conrad Johnson) £650  
 Naim NAC 42.5 Pre-Amp £1150

**AMPLIFIERS**

Quad 77 Integrated Amp (Remote) £495  
 Arcam Delta 290 Power Amp £350  
 Arcam Delta 290p Power Amp £250  
 Bnw Wazoo Integrated Amp (Retail £2500) £1995

ALL USED CARTRIDGES ARE CHECKED UNDER A MICROSCOPE BEFORE BEING OFFERED FOR SALE.

Audiolab 8000a Integrated Amp  
 Jeff Rowland Model 5 Power Amp  
 Adcom GFA 5300 Power Amp  
 AVI 2000MI Integrated Amp (ex demo)  
 Audio Note Hero Power Amp  
 Rogers E40a Integrated Amplifier with phono-stage (NEW)

**CD PLAYERS & TRANSPORT**

Philips Cdr 880 Cd Recorder  
 Marantz Cd 72 MK2 Se Cd Player (Mint)  
 Micromega T Drive CD Transport  
 Marantz CD 94 Transport, CDA 94 DAC

**DAC'S**

Meridian 563 Dac (Mint, Boxed)  
 Sonic Frontiers SF01 Digital Processor  
 Theta Chroma HDCD DAC (ex demo)

**MISCELLANEOUS**

Selection Of Moving Coil Cartridges At Discount Prices  
 Nakamichi Cr40 Tape Deck  
 Harmonix Record Clamp  
 Revox Reel To Reel Tape Recorder  
 Sonic Frontiers Ultra Jitterbug

£275 Luxman K331 W Cassette Deck £150  
 £1995 Audio Note ANS7 MC Transformer with Phono-Phono Stage £8495  
 £350  
 £750  
**TURNTABLES, CARTRIDGES & TONEARMS**  
 Eminent Technology Air Bearing Tonearm (Retail £2500) £1495  
 Garrard 301 In-Slate Audio Plinth With Slate  
 Audio Power Supply & Sme Arm £995  
 Micro Seltki DOX 1000 Turntable £1250  
 Helus Silver wired tonearm £995

**SPRING SALE EQUIPMENT**

Mission 782 Speakers (Stand Mount Model) £150  
 Exposure 21 Pre Amp (New, With Remote) £795  
 Exposure 11/12 Pre And Power Amp £650  
 Teac An60 Noise Reduction Unit £25  
 Thorens Td125 Turntable £145  
 Beyer 811 Headphones £65  
 Mit Terminator 4 Interconnect 1m (Retail £59.95) £39  
 Selection Of Equipment Stands All Reduced Prices

**NOW DEMONSTRATING THE MARK LEVINSON 383 INTEGRATED AMP**

We now offer 0% finance (subject to status)

PLEASE PHONE TO ARRANGE AN AUDITION

MAIN DEALERS FOR MARK LEVINSON, THIEL, AND ABSOLUTE SOUNDS

VISA - SWITCH - MASTER CARD - AMEX - DINERS CLUB WELCOME.  
 WE TAKE PART EXCHANGE ON NEW & USED STOCK AND BUY IN FOR CASH

**Soundcraft HiFi.com** At 40 High Street, Ashford, Kent. TN24 8TE

**SPECIAL CLEARANCE SALE June 2002**

**Hi-Fi Separates (! = Ex - demonstration)**

B&W DM-303 9maple) £160!	Linn LP-12 Basik/Val £699
B&W 802 Nautilus (red cherry) £4995	Linn 5105 Power Amp £799!
B&W CDM-1s (light cherry) £499!	Logic DM-104 Turntable £295
B&W 602s (black) £249!	Marantz DV-7000 DVD £349!
Castle Richmond ant/oak £199!	M/F X-A1 Amp £349!
Castle Severn 2's (Birch) £499	Michell Prisma Turntable £1000
Castle Harlechs ant/oak £850!	Naim CDS/CDPS £2999
H/K AVR-4000 AV/Rcr £450!	Naim NAC-62/ NAP 90/3 £499
KEF Q-35 (apple) I £299	Naim NAP 90/3 £399!
KEF Concerto 1 £299!	Pioneer DV-444 DVD player £399!
Linn Index II's + Stands £199	Pioneer DV-535 DVD zone free £199!
Linn CD-12 I £7995!	Pioneer NS-DV1 DVD System £399!
Linn Mimik CD £499	Rega Jura's (cherry) £399!
	Rega Radio £150!
	Yamaha AX-620 AV Amp £349!

Our exciting range includes: Arcam, DiVA & FMJ, Chord Electronics, Linn, Lexicon, MC-12, Naim, Rega, Musical Fidelity, Denon, Yamaha, Rotel, B&W Nautilus, PMC, Ruark, Kef, Loewe TV, Hitachi & Pioneer Plasma, Sim 2 DPL!  
**Hotline: 01233 624441 Fax: 01233 640333.**

**AV Separates (! = demonstration)**

Arcam AVR 100 Receiver £599	Pioneer VSX-859 THX Rcr £599!
Denon DVD 5000 DVD player £499!	Rotel DSP-966AX Processor £699!
Naim AV-1 Processor £650	Rotel RSX-972 AV Amp/Rcr £799!
Nakamichi 10-S DVD player £449!	Sony DVP S-715 DVD player £179!
Pioneer DV-444 DVD player £249!	Sony DVPS 335 £149
Pioneer DV-535 DVD zone free £179!	Sony DVP S-7700 DVD player £599!
Pioneer NS-DV1 DVD System £999!	Yamaha AX-1 Amplifier £799!
Pioneer XV-DV55 + S-59 spkrs £649!	Yamaha DVD-S510 zone free £199!
Pioneer PDP-502 Plasma £6500!	Yamaha DSP E 800 processor £249!

Check our web site: [soundcraftthifi.com](http://soundcraftthifi.com)

**Sound Investment**

If you have invested expertise and money in building up a sound system to your own unique specifications, then why compromise with indifferent housing units?

- \*High quality aluminium construction.
- \*Finishes available to your choice.
- \*Fully adjustable 6mm glass shelving.
- \*Sound isolation on shelving/feet.
- \*Custom created to suit your system.
- \*Free delivery throughout the UK.

Fi-Rax offers a new dimension in audio visual racking - from a range of standard designs to the flexibility to custom create a unit to suit your particular sound system and lifestyle.

Fi-Rax - a sound investment for those who want the best from their equipment.

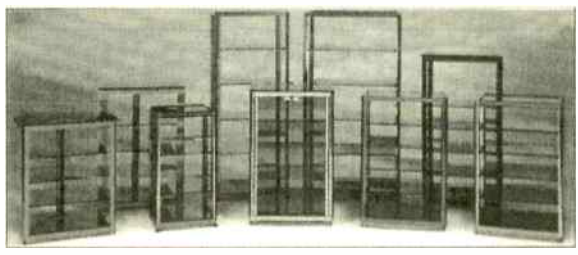

**Audio Visual Furniture**

For further information or a free brochure contact: JEM Distribution, Springfield Mills, Spa Street, Ossett Wakefield WF5 0HW.  
**Tel: 01924 277626 Fax: 01924 270759**

**Are you making the right connections?**

Send for Britain's biggest catalogue of specialist cable and connections.

All available by mail order.  
 Phone **020-8942 9124** or clip the coupon for your Free copy  
**www.custom-cable.co.uk**



**PO Box 4007, London SW17 8XG**

Please send me your FREE Custom Cable Catalogue

Name \_\_\_\_\_

Address \_\_\_\_\_

Postcode \_\_\_\_\_

NO FURTHER INFORMATION REQUIRED

Send to: Custom Cable Service  
 PO Box 4007  
 London SW17 8XG

HFV 06/02



# X electrical

**We buy, sell & part exchange quality Hi-fi**

AMPLIFIERS / RECEIVERS	CD PLAYERS	TRANSPORTS & DACS	Mitchell Syncretdek	SPEAKERS
Marantz PM 310	Marantz CD 73 Golden oldie	Marantz CD 63 SE	£195	Final Acoustics 0.3hybrid
Arcam Alpha 8 Power amp	Marantz CD 17 K1 signature	Meridian 203B DAC	£125	Magneplanar SMGa
Yamaha AX470 Integrated	Sony CDPM235 200 disc	Teac DT1 DAC	£145	B&O RL140
Denon PMA 1500R	Arcam Alpha 7	Technics SLP777	£150	Castle Chesters
Yamaha MX70 Power amp	Musical Fidelity A3	Arcam Diva 72	£290	Bose 305
Arcam Xeta 1	Musical Fidelity XA50 (pair)	Marantz CD67	£110	Rogers Export Monitors
J.E Sugden CS1/PS1	Linn Majik integrated	Pink Triangle Ordinal DAC	£325	Meridian DSP33(M33)Actives
Cyrus 3 + PSX	Audiolab 8000 A Integrated	Mission PCM	£75	Bose acoustimass7 (w/Siats)
Musical Fidelity A3	Arcam Alpha 5			Quadral Minstrals
Musical Fidelity XA50 (pair)	Sony STADE475			REF C95
Linn Majik integrated	Mission Cyrus One			Mission M74
Audiolab 8000 A Integrated	Quad 405-2			B&W 602 s3
Arcam Alpha 5	Pioneer a676			
Sony STADE475	QED A270 power amp			
Mission Cyrus One	NAD 3020			
Quad 405-2	Alchemist Nexus			
Pioneer a676	NAD 3130			
QED A270 power amp	Quad 44 Pre (grey)			
NAD 3020	NAD P270 power			
Alchemist Nexus	NAD C370 Integrated			
NAD 3130	Uher UPA 200			
Quad 44 Pre (grey)	Tandberg Huldra valve receiver			
NAD P270 power				
NAD C370 Integrated				
Uher UPA 200				
Tandberg Huldra valve receiver				

**Please call us if you have any equipment to sell or are looking for anything in particular. New stock daily**  
**All equipment is fully tested and guaranteed**

**Also: Music CDs, Games, Musical Equipment, Computers, TV, VCR & Photographic**

Web page [www.xelectrical.com](http://www.xelectrical.com) email [x@xelectrical.com](mailto:x@xelectrical.com)  
**125 King Street Hammersmith 020 - 8563 7383**  
**4 Station Bldgs Fife Road Kingston 020 - 8546 1233**  
**Games & CDs upstairs at Kingston 020 - 8546 4442**  
**43 Church Street Croydon 020 - 8680 0007**

**A  
p  
e  
x  
  
A  
c  
o  
u  
s  
t  
i  
c  
s**

## SPRING SALE USED AND EX DEM EQUIPMENT

Arcam Alpha 8 SE CD	£ 250.00
Audio Analogue Bellini Pre Amp Silver	£ 275.00
B & W CDM CNT Centre Black	£ 300.00
B & W CDM SNT Rears Cherry	£ 600.00
Base Isclation Plateforms From	£ 99.00
Copland CDA 266 CD	£1095.00
Cyrus Disc/DAC Master	£ 725.00
Ecosse Ref. MS2.3 S/Cable 3m pairs From	£ 120.00
Ecosse Ref. I/Connects MA2 (Maestro) From	£ 110.00
Ecosse Ref. I/Connects The Legend	£ 390.00
Meridian 200 Transport	£ 475.00
Manley Stingray Valve Amp	£1375.00
Musical Fidelity A3 CD Silver Trim	£ 495.00
Musical Fidelity A3 Int.Amp Silver Trim	£ 595.00
Musical Fidelity A3.24 DAC	£ 695.00
Naim 72/140 Pre/Power	£ 795.00
Quadraspire Q4 Maple/Silver	£ 245.00
Quadraspire Q AV Cherry/Black	£ 335.00
Rega Mira Int.Amp	£ 395.00
Rega Planet CD	£ 395.00
Rega P3/Elys Cartridge	£ 285.00
Theta DS Pro Prime DAC & Digital I/C	£ 575.00
Sugden A21A Int. Amp Latest Spec.	£ 750.00
Teac VRDS10SE CD	£ 475.00
Totem Arros Maple	£ 840.00
Trichord Dino Phono Stage	£ 265.00
Townshend Isolda Deep Cryogenic I/C's	£ 220.00
VdH The First I/C	£ 130.00
VdH The First Ultimate I/C	£ 215.00
Veritas 7's Satin Oak	£ 650.00

### MORE BARGAINS ONLINE

PHONE STEVE ON 01527 450500 /  
**MOBILE : 07773198336**  
**E-MAIL [Apexnm@aol.com](mailto:Apexnm@aol.com)**  
**[www.apexacoustics.co.uk](http://www.apexacoustics.co.uk)**

## Components



We stock a huge range of electrolytic and film capacitors, resistors, inductors, etc.

## Speaker Kits

Choose from 50 loudspeaker kits, from bookshelf to floor-standing, and choose your own finish.

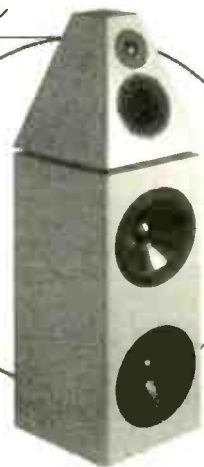

## Cable and Wire



State-of-the-art cable and wire from Neotech using 7N zero crystal copper and silver conductors.

## Connectors & Accessories

Superb range of binding posts, spikes, sockets plugs and adaptors.



T: 01646 685601  
 F: 01646 685602  
 W: [www.audiocom-uk.com](http://www.audiocom-uk.com)  
 E: [sales@audiocom-uk.com](mailto:sales@audiocom-uk.com)

  
**audiocom**

Online Store: [www.audiocom-uk.com](http://www.audiocom-uk.com)



# AUDIOVECTOR

Call us to arrange a demo or visit our **UPDATED** website at: [www.audiovector.co.uk](http://www.audiovector.co.uk)

- \* New S6 Signature (shown right) which replaces old X Series.
- \* New "Avantgarde" versions of all M Series speakers
- \* New "Improved" M Series
- \* New AV3C Improved centre channel, including Signature version
- \* New MSub Active subwoofer



Visit our website or clip the coupon for details and prices of all of the above new products to be sent to you.

Post to: Audiovector UK, Unit 7, Wren Industrial Estate, Coldred Road, Maidstone, ME15 9YT Tel: 01622 201983  
Web: [www.audiovector.co.uk](http://www.audiovector.co.uk)  
Please send me info on Audiovector

Name: .....

Address: .....

.....

.....

Post code: ..... HFW0206

## www.supradirect.co.uk

The **ONE-STOP SECURE WEBSITE** for SUPRA cables to improve your Hi-Fi and/or Home Cinema system.

\*\* ONLINE CREDIT CARD PURCHASES via 128bit SSL \*\*

### Hi-Fi Nuts

Upgrade your existing cheap cables and enjoy better sound quality with **AWARD-WINNING Supra speaker and interlink cables!**

### Home Cinema Users

Choose from Supra's range of composite, s-video, or RGB/Component video cables to improve your picture quality. Or use Supra co-ax digital or fibre optic cables from DVD to AV processor/amp/receiver

### DIY'ers

Fit Supra Boxcon 4mm terminals to your kit amplifier or loudspeakers.

**Quick and simple instructions for obtaining better cables:**

- 1 - VISIT: [www.supradirect.co.uk](http://www.supradirect.co.uk)
- 2 - VIEW the range on/offline (download the PDF catalogue)
- 3 - SELECT from the wide range
- 4 - SAVE money when you make your purchase
- 5 - ENJOY

### Products now available:

**EFF-ISL "25th Anniversary"** the updated version of the Hi-Fi Choice "Best Buy" EFF-ISL cable

### Classic 4T

What Video - "Best Buy" cable

### Quattro 4x4T Bi-Wire

Hi-Fi World - "Highly recommended"

**Ply 3.4 & Ply 3.4/S shielded** Hi-Fi Choice - "Recommended"

### AV6 RGB scart to scart

What Hi-Fi - 5 STAR winner

### OTHER NEW PRODUCTS:

Trico Co-ax digital cable

ZAC Fibre Optic cable

AV2 s-video cable

AV3 RGB/component video cable

Lo-Rad shielded mains cable



We belong to the Which? Webtrader Code of Practice

## Bocchino Audio Connectors

Australia's finest range of high-end phono connectors

Upgrade your phono cable connectors from the **low-conductivity, gold-plated brass types**

to the **Bocchino Brenda phono plugs.**

Each plug is fabricated from one-piece of **HIGH CONDUCTIVITY, OXYGEN FREE COPPER**, luxuriously silver-plated and finished with hard-gold-plating.



- Brenda™ B7 (single bay, short) - £99/pair**
- Brenda™ B7 (dual bay) - £109/pair (top left picture)**
- Brenda™ B9 (dual bay) - £149/pair (top right picture)**

Common features: Each plug machined from a solid billet of 99.94%+ pure High Conductivity Oxygen Free Copper, then plated with 15+ micron silver and 1.0+ micron hard gold. Signal tips plated with 3.0+ micron hard gold.

Now available from specialist accessory dealers. Or **BUY DIRECT** via our **SECURE** website at: [www.bocchino-audio.co.uk](http://www.bocchino-audio.co.uk)

### Trade/OEM enquiries welcome

- please contact sole UK distributor -

Bocchino Audio UK, PO Box 364, Maidstone, ME15 9FE

Email: [sales@bocchino-audio.co.uk](mailto:sales@bocchino-audio.co.uk)

Tel: 01622 201983 Fax: 01622 761560

## SONIC DESIGN® DAMPING FEET

[www.sonicdesign.co.uk](http://www.sonicdesign.co.uk)

### Virtues of using Sonic Design Damping Feet

These feet will give a substantial decrease in loudspeaker cabinet movements. This is apparent when you put one finger softly against the top of the front baffle, as it vibrates much less after damping. The transmission of vibrations from the cabinet into the floor will also be reduced. The music will be cleaner, with a less coloured sound quality.

### For Loudspeakers:

Audiophile Damping Feet provide the best possible isolation and damping but it is important that the feet are optimised to the weight of your loudspeakers. Both the stiffness and size of the feet are selected to achieve this. Speakers within the range 5 to 200 kg can be optimised. Let us know the mass of your loudspeakers and we can advise you the correct set to purchase.

The Standard Loudspeaker Damping Feet have a large overload margin, and are lower priced than the Audiophile version. The resonance frequency is a few Hertz higher. The colour is nut brown, except for the stiffest feet which are grey. The standard feet are produced in four different weight classes and do not need to be fine tuned to specific loudspeaker models.

### For CD/DVD Players:

The CD Damping Feet are made from the same material as the Standard Damping Feet. If the sound of your CD/DVD player is sensitive to vibrations, the CD Feet will be the way to go. The sensitivity to shock and the accompanying mistracking will be reduced with the use of the CD feet. They can also be used with any other audio product that you would like to isolate from vibrations. The set contains four small and one large foot. The large foot is used if the centre of gravity is off-centre or for those CD/DVD players that have five feet.

BEFORE >>:  
(top) 125 Hz sine signal to the speaker, (lower) floor movement, using spikes



<< AFTER:  
(top) 125Hz Sine signal to the speaker, (lower) floor movement, using soft feet (note floor signal magnified x2)

### Damping Feet for CD players (pack of 5) - £9.99

Available in three sizes: 2-5kg, 5-10kg, 10-25kg

### Damping Feet for Loudspeakers (pack of 8) - £19.99

Available in four sizes: upto 12kg, 12-28kg, 28-50kg, 50-100kg

### Audiophile Damping Feet for Loudspeakers - £44.99

Available for most high-end loudspeakers from 5kg upto 200kg

Available from all good specialist hi-fi/accessory dealers (trade enquiries welcome - email [sales@sonicdesign.co.uk](mailto:sales@sonicdesign.co.uk) or fax 01622 761560)

Or, in case of difficulty, on the internet at: [www.sonicdesign.co.uk](http://www.sonicdesign.co.uk)

5 MINS FROM M25

# MATRIX HI-FI

VALVE AMP  
REPAIRS

VALVE CD PLAYERS FROM £330.00 ON DEMO - PLEASE PHONE FOR DETAILS..

AUDIO NOTE ANJ/SPE INCLUDING STANDS BLACK	799.00
AUDIO NOTE AN-B SPEAKERS - LIGHT OAK	350.00
ARCAM ALPHA 8 AMP	200.00
BASIS DABU GOLD DECK WITH AIRTANGENT UPGRADED	6,999.00
2B TUNE ARM, SPARE TUBE, 2nd ARM - GRAHAM 1.5LT	675.00
WITH KETSU URUSHI CARTRIDGE ON ARM BOARD.	399.00
WARD P100 KT88 - VGC	399.00
CELESTION A1 SPEAKERS BLACK	599.00
CONRAD JONSON PV6 PRE-AMP	900.00
DPA ENLIGHTENMENT CD & DAC	550.00
HI-FI WORLD KAT-88 VASLTU UPGRADED	650.00
HEART/MARANTZ VALVE O/PUT CD PLAYER - IMPROVED	499.00
JOLIDA TUBE AMP MODEL JD202 INTERGRATED EL34	999.00
KRELL KSA 50 (TWO OFF VGC) - EACH	399.00
LEAK STEREO 20 VGC	350.00
LEAK TL12+ PAIR VGC	699.00
LEAK TL25 PLUS PR.RARE	895.00
LINN CLASSIC VARIOUS COLOURS	350.00
LINN KEOSA FLOOR STANDERS - BLACK/MAPLE/CHERRY	700.00
LUXMAN MQ3600 POWER AMP KT88	2,250.00
MARK LEVINSON No. 35 DAC HDCD - SERIOUS DAC	1,550.00
MUSE MODEL 18 ACTIVE SUB WOOFER - SERIOUS SUB	200.00
NAKAMICHI LX2 CASSETTE DECK	4,299.00
PHILIPS 420P1000 42" PLASMA SCREEN - SPECIAL	195.00
PIONEER ER-420 VALVE RECEIVER	

PM AUDIO LABS PM 211 MONO BLOCS GE 211 VALVES	1,299.00
PRECIOUS METALS COPPERTECH DELTA	59.00
PRECIOUS METALS SILVER S5200 SIGNAL	187.00
PRECIOUS METALS SILVERCOPPERTECH 102 SIGNAL	110.00
PRECIOUS METALS SILVERTECH 52 SIGNAL	81.00
PROJECT 2 RECORD DECK WITH ORTOFON CART. CHERRY	399.00
QED PASSIVE CD PRE AMP ALPS POT.	65.00
QUAD II PAIR. MINT	650.00
QUAD II PAIR. BIT TATTY.	500.00
QUAD FM 1 TUNER	50.00
QUAD FM 3 TUNER	95.00
RADFORD MA50 MONOBLOCS - MINT	1,499.00
ROGERS LS88 FLOOR STANDERS - NEW BOXED FEW LEFT.	199.00
ROGERS HG88 MK2 CHASSIS - WORKS FINE	175.00
ROGERS RAVENSBROOK	75.00
ROGERS JUNIOR STEREO CHASSIS + PRE AMP - RARE	350.00
ROTHWELL INDUS PASSIVE PRE AMP STEPPED CONT.	399.00
ROTHWELL RUBICON POWER VALVE AMP	799.00
SANSUI MODEL 250 VALVE RECIEVER	225.00
SNELL ACOUSTICS TYPE J/II SPEAKERS - OAK	750.00
SONY MDS-JE320 MINI DISK PLAYER-NO REMOTE	120.00
SOUND ORGANISATION RACK - SILVER 4 SHELVES 40% OFF	120.00
SOUND STYLE XS RACK - ICE BLUE GLASS - 5 SHELVES	299.00
SUGDEN CD 98 PLAYER	299.00
TRIPLETONE STEREO INTERGRATED	95.00
VAL 20WATT INTERGRATED VALVE STEREO EL34	399.00
VERDIK QUALITY 10 VALVE MONOBLOCS	299.00
GTA SE-40 AMERICAN SINGLE ENDED VALVE AMP	750.00
YAMAHA CT710 TUNER	100.00



## ● HI-FI/THEATRE DEM ROOM NOW AVAILABLE ● VINTAGE HI-FI FOR SALE & WANTED

MICHELL - ALCHEMIST, CELESTION, QED, AUDIOQUEST, MARANTZ - ETC...  
NEW AND VINTAGE VALVES - INTERCONNECTS & SPEAKER - OFC & SILVER  
WEALTH OF KNOWLEDGE SPANNING OVER 30 YEARS, FOR ENQUIRIES OR  
A CONTROVERSIAL CHAT, ASK FOR DAVE OR LEE.

PHONE : (01322) 292391

FAX : (01322) 229908

E-MAIL: INFO@MATRIXHI-FI.CO.UK

WEB: WWW.MATRIXHI-FI.CO.UK

SHOWROOM

65 DARENTH ROAD

DARTFORD

KENT DA1 1LU

FREE EASY PARKING



01376 521132

07802 483698

CHELMSFORD, ESSEX

E-MAIL: soundstage@netlineuk.net

BY APPOINTMENT ONLY

### PRE-OWNED EQUIPMENT

ARCAM DELTA 280 TUNER BOXED AND IMMACULATE	£199
AUDIO INNOVATIONS SERIES 1000 MKII MONO'S WITH L1 VALVE PRE AMP	£1195
AUDIOLAB 8000A-GRAY-PHONO-SOME SCRATCHES	£149
AUDIOLAB 8000DAC	£399
AUDION SILVER KNIGHTS 300B MONO'S NEW GOLDEN DRAGON VALVES	£995
DENON AVP A1 GOLD BOXED AND IMMACULATE (€3000 NEW)	£995
DENON DVD-5000 GOLD WITH MULTI REGION CHIP FITTED SUPERB MACHINE	£895
DENON AVC-A1 DOLBY DIGITAL AV AMP-GOLD (€2000 NEW)	£799
EPOS ES14 WALNUT SUPERB CONDITION	£349
LINN KEILIDH BLACK ASH	£299
LINN ISOBARIKS DMS WALNUT 10VELY CONDITION BUYER COLLECTS	£595
MERIDIAN 500/566-20 BIT TRANSPORT/DAC BOXED AND IMMACULATE	£1195
MERIDIAN 606 DAC-BOXED AND IMMACULATE	£595
MICROMEGA DVD PREMIUM-MULTI REGION	£595
MICROMEGA STAGE 6 IMMACULATE AND BOXED	£495
MICROMEGA DRIVE 3/DAC BOXED AND IMMACULATE	£995
MONITOR AUDIO MA1800 REFERENCE GOLD LOUDSPEAKERS-BOXED	£595
MUSE MODEL 3 PRE-AMP REMOTE BLACK BOXED AND IMMACULATE	£995
MUSICAL FIDELITY T1 FM ONLY TUNER BOXED AND IMMACULATE	£199
NAIM SAC R2 GREEN CASE 1 YEAR OLD SUPERB CONDITION	£1895
NAIM NAP140 NEW STYLE BOXED SUPERB CONDITION	£449
NAIM SAC32/SNAPS/NAP250 OLD STYLE SUPERB CONDITION	£995
NAIM HI-CAP-NEW STYLE-GREEN CASE-BOXED AND IMMACULATE	£479
NAIM SAC 92 PRE AMP BOXED AND IMMACULATE	£279
NAIM NAIT3/PRE OUT MODIFICATION BOXED AND IMMACULATE (1999 MODEL)	£399
NAIM IXO 2-WAY ACTIVE X-OVER WITH VARIABLE FREQUENCY	£349
NAIM NAP140 OLD STYLE-SUPERB CONDITION	£399
NAIM NAP90/3 BOXED AND IMMACULATE	£329
NAKAMICHI OMS5E/II CD PLAYER-WAS £1500 NEW-LOVELY CONDITION	£399
NAKAMICHI CASSETTE DECK 2	£179
PIONEER DV-717 MULTI REGION DVD PLAYER-GOLD	£399
PRO-AC TABLETT 50 MAHOGANY-IMMACULATE	£395
PRO-AC TABLETT SERIES 3 CD PLAYER (€3500 NEW)	£1695
QUAD ESL63-1.ATE MODEL APPROX 1992/93 BLACK WITH STANDS SUPERB	£1295
REVOX B760 TUNER-SUPERB CONDITION	£349
ROKSAN DP1/DA1/DS4 BOXED SUPERB CONDITION	£849
R1 ARK CURSADERS II WALNUT VGC BOXED	£695
TAG MACLAREN DAC 20-24 BIT BOXED SUPERB CONDITION	£595
RUARK CL30 CHERRY WOOD (NEW £2500) WITH SILTECH AND X10 INTERNAL HARD WIRE UPGRADES AND WBT BINDING POSTS-SAVE OVER £500	£1895

PROFESSIONAL RECORD CLEANING SERVICE - KEITH MONKS MACHINE -  
PLEASE RING FOR FURTHER DETAILS AND PRICES.

THREE MONTH WARRANTY ON ALL ITEMS

www.sound-stage.co.uk

# STOWSOUNDS

Stone Farm Borough Lane, Great Finborough, Stowmarket, Suffolk, IP14 3AS

Special prices on the following new and used products:

<b>Engine</b>	
Creek Cd 53	999
Michell Gyrodek bronze with SME V arm	1100
Nakamichi BX 2	125
Musical Fidelity X Ray	625
Trichord Revelation CD	450
YBA CD 3	1400
Alchemist Nexus	295
<b>GEARBOX</b>	
Creek 5350SE	700
Linn LK 100	300
Exposure 25 integrated	700
Musical Fidelity XA 100R	300
Nad 310	70
Sonneteer Campion integrated	425
YBA 3 Pre Power	1600
<b>EXHAUST</b>	
Neat Petite	675
Castle Seven 2	350
JM Lab Tantal 515	325
Linn Keosa Maple	349
JM Lab Cobalt 810	525
JM Lab Electra 905	795
Living Voice Auditorium	1350
Rogers LS4a	120
<b>FURRY DICE</b>	
Quad FM 4 Bronze/Yellow	140
Tripod Rack with LP storage	75
Sound Organisation Z545	100
Soundstyle X105	160
Linn Classic	800
Rotel RT 950BX	75
Beyerdynamic DT911	140
Beyerdynamic DT531	80
Grado SR60	65
Atacama SE24	50
SonicLink - all stock 40% off	poa
Van den Hul - all stock 40% off	poa
Soundstyle X midi width racks 320mm	90

Various interconnects, supports, cables at reduced prices.

Phone for details  
Sale of CDs. Phone for latest list.

TEL: 01449 675060









listening  
rooms

## PHONE FOR LATEST LIST

### NEW, EX-DEM AND CLEARANCE ITEMS

	RRP	SALE	
Acoustic Energy AE1 MKII	£995.00	£695.00	D
Arcam Alpha 10	£799.00	£549.00	D
Arcam Alpha 8R Amp.	£350.00	£259.00	N+D
Arcam Alpha 7R Amp.	£280.00	£229.00	N+D
Copeland CDA277	£1,649.00	£795.00	S/H
Copeland CDA289	£1,985.00	£1,295.00	D
Cyrus SL Amp	£400.00	£250.00	D
Cyrus AV Master Processor	—	£200.00	D
Cyrus CLS50 speakers (mint)	£499.00	£379.00	D
Krell KAV 500i Int. Amp.	£5,498.00	£3,495.00	D
Linn Kaber	£1,995.00	£695.00	D
Linn Keosa	£499.00	£369.00	D
Meridian 500 Transport (mint)	£1,350.00	£849.00	D
Meridian M33 Active speakers	£1495.00	£995.00	N+D
Mission 701 speakers	£160.00	£119.00	N
Musical Fidelity XP100 BARGAIN!!!!	£799.00	£549.00	N
Musical Fidelity XA200R	£699.00	£559.00	D
Neate Mystique	£735.00	£499.00	D
ProAc 3.8	£3,990.00	£2,990.00	D
Rotel RX965RDS A/V receiver	£950.00	£695.00	D

D = EX DEMONSTRATION, N = NEW, S/H = SECOND HAND

### Hi-Fi Multiroom and home cinema

ACOUSTIC ENERGY ARCAM ASH DESIGN AUDIO  
RESEARCH CELESTION COPELAND CYRUS  
DENON KEF KRELL LINN TAG MCLAREN MARTIN  
LOGAN MERIDIAN MICHELL MISSION MONITOR  
AUDIO MUSICAL FIDELITY NEAT ACOUSTICS  
PIONEER PROAC QED QUADRASPIRE REL SONUS  
FABER SME STANDS UNIQUE STAX THETA  
WILSON AUDIO ETC...

#### THE LISTENING ROOMS LTD

161 OLD BROMPTON ROAD LONDON SW5 0LJ

TEL: 020- 7244 7750/59 FAX: 020 - 7370 0192

www.listeningrooms.com E-mail: tlr@dial.pipex.com

Mon-Sat 10-6pm

diverse vinyl

10 charles st newport south wales np20 1ju  
01633 259661/256261 sales@diversevinyl.com

### Forthcoming Releases

Alicia Keys	Songs in A Minor	£14.90
Billie Holiday	Songs For Distingue Lovers	£26.90
Led Zeppelin	Coda / In Through The Out Door	£26.90
Miles Davis	Volume 3 (10" Mono)	£26.90
Pete Townsend	Another Scoop (classic record)	£49.90
The Doves	The Last Broadcast	£TBC
Tom Waits	Alice/Blood Money (Epitaph)	£TBC
Various Artists	Mali Music (feat Damon Albarn)	£TBC
Wilco	Yankee Hotel Foxtrot	£12.90

### New Stock And Recent Releases

The first release on DIVERSE RECORDS  
**ALISON KRAUSS & UNION STATION -  
NEW FAVORITE**

the multi grammy winning artists - £16.90 plus postage

### ALBUM OF THE MONTH

Badly Drawn Boy - About A Boy soundtrack £10.90

A Certain Ratio	Early (Soul Jazz Retrospective)	£14.90
Alfie	A Word In Your Ear	£10.90
Angie Stone	Mahogany Soul	£12.90
Cat Stevens	Teaser & Firecat	£16.90
Chimera	Chimera (Tenth Planet)	£15.90
Cinematic Orchestra	TBC	£13.90
Cornershop	Hand Cream For A Generation	£9.90
Electric Soft Parade	Holes In The Wall double 45rpm	£14.90
Giant Sand	A Cover Magazine (Thrill Jockey)	£12.90
Gomez	In Our Gun	£18.90
Harry Nilsson	Nilsson Schmilsson (Simply Vinyl)	£18.90
Hives	Your New Favourite Band	£10.90
Iron Maiden	Rock In Rio (3LP picture disc)	£24.90
Jewel	This Way (US import)	£17.90
Jon Spencer Blues	Plastic Fang	£13.90
Joseph Arthur	Junkyard Hearts 1	£5.90
Lift To Experience	Texas Jerusalem Crossroads Ltd	£15.90
McClusky	McClusky Does Dallas	£10.90
Neil Young	Are You Passionate? 2LP	£18.90
Patti Smith	Horses (Simply Vinyl 180g)	£18.90
Sergio Mendes &	Brasil 66 Equinox(Speakers Cnr)	£19.90
Small Faces	Immediate Hits & Mod Rarities	£15.90
The Streets	Original Pirate Material	£14.90
U2	Rattle & Hum (German reissue)	£16.90
Yardbirds	Greatest Hits	£15.90

### DISCO ANTI STAT LP CLEANER

Probably the most economical LP cleaning device on  
the market

Only £41.95

Call for details

Call for a catalogue of over 3500

brand new LPs, or visit



www.diversevinyl.com

# RETRO Reproduction



*PS*

When Tim de Paravicini does a job, he does it properly, whether it is a custom studio installation of an affordable phono pre-amplifier like the EAR 834P. With years of experience in design and manufacturing, nobody can come close to the unique point of view and life experience he puts into all of his designs.

When first launched, the 834P was the only valve phono stage you could buy with facilities for both good quality moving coil (MC) and moving magnet (MM) cartridges. In addition, the unit could be purchased with a volume control, allowing direct connection to a power amplifier. Now in its 1740th year of production it's still set the standard with fantastic soundstaging that all transistor phono stages can just dream of, coupled to low background noise and enviable reliability.

### There are now four models in the EAR lineup:

The classic 834P uses the same circuit architecture as its more expensive brothers, and shares the same high quality sound through MM type cartridges, it is enclosed in a tough, rigid metal case and is fully "CE" type approved. price £380.00

The signature builds on the Classic 834P specification by adding a superb moving coil (MC) input stage, as well as the no-extra-price option of a high quality volume control. price £530.00

Top of the range, the Deluxe 834P comes in stunning chrome and gold cabinet, and has extra attention and quality control. With different moving coil input options, this unit will fit the most demanding of audiophile systems. For the true vinyl enthusiast. price £800.00

MC3 - The ultimate stage for MC matching with 3 fixed transformer taps to cover all types of moving coil cartridges, and separate left/right grounding. MC3 in used in the new £10,000 312 pre. price £630.00

**"HARMONIC TECHNOLOGY SINGLE CRYSTAL CABLE"**  
 ... I HAVE A BATTLE TO DO ...  
 ... AND AT A RIDICULOUS LOW PRICE" PHONE FOR MORE DETAILS

**New Showroom & Dem rooms now open**  
 28a Haddington Place Edinburgh EH7 4AF Phone/Fax 0131 558 9989  
 Open 11.00am - 5.30pm - closed Monday & Sunday



*PS*

**STOP PRESS - NOW DEMONSTRATING**  
**THE NEW EAR KT90 70W PER CHANNEL BALANCED**  
**BRIDGEABLE POWER AMPLIFIER PHONE FOR DETAILS**

**Ear 869 single ended triode integrated amplifier**

Improved version of the classic 859 with revised output transformers modified input stage with the addition of a extra signal valve which has allowed an increase to 15watt of single ended power, also the 869 can be used as a power amp. Don't be fooled by its modest power output this amp drives real world speakers. price £2100.99

### Ear 8L6 Integrated/Pre-main amplifier

Using 8 EL34 power valves to produce 50watt per channel in push-pull class A with in-house designed output transformers. The 8L6 has been designed to meet a wide variety of needs from the most demanding of audio files to the professional seeking high quality monitoring equipment in the studio field. Valve life is long and replacement cost are modest. There is also a balanced power amp version with monoblocking capabilities, to produce 100watt per channel. Price £2199.00

**\*LIMITED PERIOD\***

**Part Exchange your existing equipment against any Ear product and it will be valued at private prices not usual dealer rates.**

**"NOW DEMONSTRATING"**

**A17C CLASS A ACTIVE 16 SPEAKERS WITH SA7 REMOTE PRE AMP AT A VERY ATTRACTIVE PRICE**

### Used Equipment For Sale

Tannoy Super Gold Monitors fantastic detail  
 Naim MAT160  
 Naim NAT101 Tuner with Snaps  
 Naim 32 pre amp  
 Crimsan 610 pre amp  
 Rotel RC6 965BX CD player  
 AVI Reference S2000 MC CD player new £1300  
 Micromega junior CD player  
 Marantz CD63 top loading CD player full working order  
 Triangle Titus XS bookshelf speakers valve friendly  
 Opera IIIA floorstanding speakers new £1100  
 Spondor prelude loudspeakers  
 Rotel RT330 AX Tuner  
 Yamaha GT400 Tuner  
 Sony CDP101 original CD player  
 Revox professional 877 open reel digital counter XLR connections  
 B&W 603 S2 speakers  
 Quad 77 complete system  
 Audiolabs 800MM monoblocs  
 Audio Research SP9 superb phono stage mint boxed  
 Concordant Excelsior preamp outboard psu  
 Harmon Kardon 23DE receiver  
 Meridian 603 digital control unit  
 Linn Isobarik outboard crossover  
 Naim NAT90 power amp  
 Rogers 481 LS35A subwoofer stands  
 Macintosh C27 preamplifier  
 Audiolab 8000S pre  
 Audio Innovations 2nd audio mono blocks superb sounding  
 Horning one spks lowther drive units, Birch ply cabinet wonderful

with low power valve amps  
 Troughline Tuner 3 various  
 Tube Technology prophet 2 box pre with rare MC stage new £2700  
 Quad 44 pre old style  
 Mission 753 rosewood speakers boxed  
 Audio Innovations series 800 valve power amp  
 Sugden A48  
 Leak Troughline stereo Tuner GT upgrade  
 MAD 4020A tuner  
 Copeland CS48 integrated amp as new  
 Theta chroma DAC  
 Theta progeny DAC  
 Primare T20 FM Tuner  
 Fons C030 with Mission tonearm 78rpm facility  
 Quad 77 int amp grey/blue finish  
 Sony 337 E30 10kg monster a very fine player new £800  
 JBL-T1 2x boxed un-opened new £1600  
 Naim SBL speakers black finish  
 Lumley 120 mono block 120 watt per channel  
 Primare A20 MMII integrated amp new £700  
 System Deck 11K turntable UPGRADE YDUR REGA from  
 MAD 312 integrated amp boxed mint  
 Epos M15 floorstanding speakers cherry new model  
 Rogers LS33 with AB33  
 Solstice Advanced Acoustic Design open baffle design speakers  
 outboard crossover with stands new £1000's?  
 SME V tonearm boxed  
 Rogers LS3 speakers  
 Musical Fidelity F25 remote pre  
 Pink Triangle Ordinal 22bit DAC with filter  
 Tube Technology Genesis 100watts monoblocs re-valved  
 Kel Reference 1.2 rosenut finish new mint

£1250  
 £120  
 £895  
 £195  
 £350  
 £350  
 £95  
 £235  
 £75  
 £595  
 £495  
 £695  
 £295  
 £250  
 £275  
 £225  
 £1200  
 £695  
 £1600  
 £395  
 £195  
 £95  
 £295  
 £695  
 £995  
 £125  
 £795  
 £250  
 £1350  
 £995

Orms III I integrated amp  
 Sugden T48 stereo tuner  
 Pioneer PDS703 CD player  
 Pioneer precision CD player  
 Sonus Faber Signum boxed new  
 Audion golden knights 300b mono blocs new valves  
 Revox G36 open reel mint  
 Conrad Johnson PV10 pre amplifier as new  
 Audio Research SP14 valve pre amp  
 Audio Research CDII cd player  
 EAR 834P  
 EAR 834 L valve line stage  
 Revox A77 Open Reel  
 Counterpoint SA 5000 Pre - the ultimate Valve Pre Amp (very rare)  
 rosewood end stops new £1500  
 Audiolab 8000A int amp various from  
 Celestion Dilton 1D bookshelf spk's  
 KEF K2 bookshelf spk's  
 Leak Sandwich 250 spk's  
 Nytech power amp  
 Meridian 206 CD player  
 Audio Innovations L2 valve line stage

**Due In**  
 Mark Levinson 26 229  
 Audio Research remote integrated amp  
 Quad II monoblocs consecutive serial numbers  
 various centre speakers  
 Gale 401 chrome ended speakers with matching stands

Selected products from: AI Audio physic speakers, Ear Yoshino, Nottingham Analogue Creek Triangle Sugden, Dynavector

# ERGO ago-go

Mail order service for quality Swiss headphones  
 Free next day delivery hotline 01924 406016

ERGO MODEL ONE	£109.00	=====
ERGO MODEL TWO	£149.00	=====
ERGO MODEL AMT	£599.00	=====

ERGOPHONES are designed for fatigue free listening and can be used for many pleasure filled hours without discomfort. Acting as a true earspeaker, they have a wide bandwidth capability coupled with low distortion figures of less than 0.30%.

All music types are replayed beautifully, offering a remarkable near-field listening experience. We guarantee superb sound quality at sensible price points.

More info available at [www.precide.ch](http://www.precide.ch) and [info@audiosynergy.co.uk](mailto:info@audiosynergy.co.uk)  
 Distributed in the UK by Audio Synergy Limited

SUGDEN HEIL AMT PRECIDE MDM ACE ERGO JECKLIN FLOAT

# Private Ads

Dealers must not advertise in the Private Classified section. Monthly consecutive insertions will be considered Trade advertising. The Publisher reserves the right to judge submissions.

NAIM NAC 102 pre-amp £700.  
 Naim Nap 180 power-amp £700.  
 Hi-Cap (new style) £350, Hi-Cap  
 (old style) £300. Tel: Matthew  
 01452 610 466 (Gloucester)  
 (Jun/I)

AUDIO NOTE P4 monoblock  
 amps excellent condition £1600  
 ono. Audio Innovations 800 Mk3  
 excellent condition £400 ono all  
 with original boxes and instruc-  
 tions. Tel: 01642 482393 (Jun/I)

COPLAND CSA28 integrated  
 amplifier excellent condition  
 £500 ono. Rega P2 turntable mint  
 £150 ono Tel: Richard 0774 8457  
 422 (West Sussex) (Jun/I)

**NORDOST BLUE Heaven 3m  
 pair bi-wire (£500) £265.  
 Nordost Blue Heaven inter-  
 connect (£150) 2 x pairs  
 £175. Nordost Red Dawn bal-  
 anced interconnect (£330)  
 £180. Transparent balanced  
 Music Link Plus (£469). 2 x  
 pairs £500 Tel: 07984 580389  
 (Jun/I)**

WANTED: LEAK TL Point One  
 monoblock, Pye Mozart, quality  
 speakers, Tannoys Red, Silver,  
 Black, Gold, good quality tran-  
 scription deck, SME arm, Thorens  
 TD224, multichanger, anything  
 unusual or interesting. Tel: 01726  
 812966 (St Austell) (Jul/I)

WANTED SME 3009 improved,  
 or 3012 arm in good condition.  
 Tel: 07712 767142 Mobile: 01775  
 761880 (Jul/I)

WANTED SANSUI S-M77 speak-  
 ers part of 1980's M77 Hi-Fi sys-  
 tem. Might consider taking part of  
 M77 system. Must be S-M77. Tel:  
 Mr Ian 01463 791449 (Jul/I)

NAIM HI-FI SYSTEM SALE, CD2  
 CD player, NAC 82 pre-amp, Hi-  
 Cap power supply, NAP 250  
 power amp, SBL loudspeakers  
 (cherry), QLN Projekt equipment  
 rack (cherry). Complete system  
 purchased from and installed by  
 Grahams Hi-Fi in December  
 1997. Mint condition, very low  
 usage, with all boxes and manuals.  
 Sell complete for £6500. Tel:  
 Mark 01708 224319 (Essex)  
 (Jun/I)

HALF PRICE Lowther drivers,  
 DX45 mini-marvels complete  
 with phase equalisers. Virtually  
 unused (10 hours) - experimental  
 use only. £330 the pair. Tel: 07000  
 78 28 31 or email: info@  
 hornutopialoudspeakers.co.uk  
 (Jul/I)

A.V.I. S2000 MC CD player 1995  
 boxed first class machine £250.  
 Tel: 01502 518938 (Jun/I)

SONY CDP-X303es high end CD  
 player £195. Philips CD100 1st  
 gen CD player - Rare! £195.  
 Optonica 7200 high end direct  
 drive turntable £95. Yamaha TC-  
 800GL high end ski-slope cassette  
 deck £145. Kenwood Car DAT  
 player - ultra rare! £145. Sony PS-  
 X55 high end auto direct drive  
 turntable £95. All mint, boxed.  
 Can arrange carriage. Tel: 07870  
 657 173 (Jun/I)

MERIDIAN 518 £550. 562V £550.  
 MSR £50. (£1000 the lot). KEF  
 Concerto's £100. Ferrograph LSI  
 loudspeakers £150. Originlive  
 modified Pink Triangle PTT00  
 £450. Tel: 01926 747060 Mobile:  
 07740 635786 (Jun/I)

TANDBERG 621X R2R, 3 speed  
 stereo tape recorder for sale.  
 Mint condition. Recently over-  
 hauled. Carrying case. Collect  
 SW Surrey. £300. Tel: 01428 684  
 111 (Jun/I)

VALVE FM tuner Leak Troughline  
 Mono, serviced, realigned, G P  
 Multiplex for addition outboard  
 decoder £95. Pye Mozart ditto  
 £65. Quad FM2 stereo internal  
 'OneThing' decoder £175. Better  
 than DAB. Tel: 01202 481 386  
 (Jun/I)

NAIM NAC 82 pre-amp &  
 NAPSC (both April 98) boxed,  
 manual etc. £1450. Tel: 07713  
 000450 inc. voicemail (Jun/I)

LINN SONDEK LP12, Ittok,  
 Cirkus, Trampolin, Audio  
 Technica ATOC5 M/C, £850 ono.  
 Tone deaf wife forces sale!! Tel:  
 0114 286 3889 or Email:  
 hc.photo@virgin.net (Jun/I)

QUAD 2 amps, with pre-amp.  
 Boxed as new, never used,  
 absolutely original, £950 ono. Tel:  
 01179 311 633 or 07870 633 925  
 (Jun/I)

UNUSED - EXPORT Audio  
 Innovations Series 300 with  
 Border Patrol Supply, Living Voice  
 Auditorium, not yet run in.  
 Hitachi cable and XLO intercon-  
 nect plus amp stand, £1700 ono.  
 Tel: 020 7204 8434 or 07736 781  
 544 (West Sussex) (Jun/I)

LINN KABERS, latest specifica-  
 tion, (active but X-overs available)  
 3x Linn LK100 power amps.  
 Kaber active cards. All in excel-  
 lent condition, can demo, £1625  
 ono. Tel: 01745 540 210 after  
 6.30pm (Jun/I)

BEAÛHORN VIRTUOSO £1700  
 ono. Croft Vitale pre £200 ono.  
 Ear phonostage chrome fascia  
 MM/MC £350 ono. Audionote Kit  
 One 300B amplifier £300. All  
 good condition. Tel: 0141 357  
 0000 or Email:  
 simon.smith24@ntlworld.com  
 (Glasgow) (Jun/I)

MUSICAL FIDELITY 3D Nu Vista  
 CD player £2400. Musical Fidelity  
 M3 Nu Vista amplifier £2400.  
 Thiel CS3.6 loudspeakers (£5495)  
 £2800. Tel: 01508 499586 (Jun/I)

LINN MIMIK CD player £350.  
 LK100 power amplifier £290.  
 Both boxed with manuals. Please  
 phone Mike 07711 363661 or  
 0115 910 9617 (Nottingham)  
 (Jun/I)

LEXICON CPI digital audio envi-  
 ronment processor £200. Revox  
 B760 digital synthesizer FM tuner  
 with programmer for rotating  
 aerial £200. Hi-Fi stand in black  
 £20. Tel: 01353 778560 (Ely,  
 Cambs area) (Jun/I)

GOLDRING Lenco GL75/P and  
 cover £40. Leak Sandwich pair  
 18w £25. Armstrong 524 stereo  
 tuner 521 stereo amplifier Akai  
 GXC 46 D stereo cassette deck  
 and cover. All boxed instructions,  
 offers. Tel: 01252 783174 (Jun)

THIEL 2.3 cherrywood latest  
 model, long guarantee, hardly  
 used RRP £3.7k, no competition  
 at £2.7k. Possible P/X for occas-  
 sional listening (toddler permit-  
 ting!) Offers, eloquent balanced,  
 open presentation. Tel: 01245  
 251235 (Jun/I)

WORLD FAVOURITE Teac P30  
 CD transport (£2500) £1500.  
 Classic Conrad Johnson D/A-2b  
 DAC (£1500) £900. Delightful  
 CJ12L valve pre-amp (£2000)  
 £1200. Tel: Tony Chessington 020  
 8397 4978 (Jun/I)

**COPLAND CSA 14 hybrid  
 valve/transistor integrated amp  
 inc. owners manual and spare  
 valves. Silver, mint condition  
 (£1700) £450. Arcam Alpha 9  
 integrated amp. Boxed as new  
 (£500) £200. Rogers ABI  
 subs, black ash inc. owners  
 manual, excellent condition  
 (£550) £200. Tel: 01992 719  
 320 (Jun/I)**

VOYD POINT Five with silver  
 wired Orion two arm goldbug  
 cartridge £1250. Thoren 125  
 Technica 1100 arm with plinth  
 £250. AR Legend £200.  
 Nakamichi 582 serviced £200.  
 Tel: 01522 820179 (Lincs) (Jun/I)

MUSICAL FIDELITY E600 CD  
 player £150. Tubalog valve DAC  
 £150. Musical Fidelity X10D line  
 valve amp £50. PSU £50. Acoustic  
 Energy floor standing speakers  
 AE120 black finish £125. Croft  
 Super Micro pre amp £125. Croft  
 Series V power amp £150.  
 Townsend Seismic Sinks (2) £100  
 and £50. van den Hul 'The Wind'  
 speaker cable. Five feet tri wired  
 lengths £75. van den Hul 'The  
 Second' interconnect 2 x 1 mtr  
 £75 each and 2x 1/2 mtr £40  
 each. Franciscan Crosstalk unit  
 £25. Target two tier table £25.  
 Wall shelf £25. Tel: Malcolm  
 01483 275389 (Jun/I)

AUDIOLAB 8000P 100 watt x 2  
 power amp £285 ono. Marantz  
 CD63 remote control cost  
 £300+, £75 ono. Tel: 01492  
 516875 after 5pm (Jun/I)  
 A.V.I. S2000 MC CD player 1995  
 boxed first class machine £250.  
 Tel: 01502 518938 (Jun/I)

TEAC P30 stunning! £1850.  
 Audio Synthesis Dax (UA) £650.  
 Sublime! Avant Garde active subs  
 150w.p.ch, feel the force! £750  
 the pair. Mana supports, various,  
 ask. Tel: Geoff 01922 477682  
 (Jul/I)

**Classified Ads**

# HEATHCOTE AUDIO

TEL: 01992 653999 MOBILE: 07860 511111 E-MAIL ADDRESS: HeathcoteAudio@aol.com

## VALVE AMPS

JADIS JA80 CLASS A MONOBLOCS (WERE £10,000) RE-VALVED SUPERB  
NESTAROVICH LABS 150 WATT MONOBLOCS (VERY RARE)RE-VALVED ETC  
MANLEY M-50 50 WATT MONOBLOCS  
UNISON RESEARCH SIMPLY-4  
LUMLEY REFERENCE 120 MONOBLOCS TRIODE SWITCHABLE  
AUDIONOTE MI PRE AMP (WITH PHONO STAGE)  
AUDIONOTE ZERO REMOTE PRE AMP EX DEM  
AUDIO RESEARCH LS7 PRE-AMP  
CONRAD JOHNSON PV-10 (WITH PHONO STAGE)  
CONRAD JOHNSON PV10-AL PRE AMP  
MONRIO ASTY VALVE PRE (VERY PRETTY) NEW  
CARY AE- ONE P LINE PRE AMP (EXPOSED VALVES)  
AUDIO INNOVATIONS 300 INTEGRATED MM/MC PHONO (CREAM EXPORT CASE)

MINT £3750  
MINT £2495  
MINT/BOXED £TBA  
MINT/BOXED £895  
MINT/BOXED £1750  
MINT/BOXED £395  
MINT/BOXED £395  
MINT £795  
MINT/BOXED £695  
MINT/BOXED £595  
NEW/BOXED £395  
MINT £495  
EXCLT £375

## SOLID STATE

MUSICAL FIDELITY P-270 POWER AMP RARE AND SOUGHT AFTER  
MUSICAL FIDELITY XA-200 MONOBLOCS  
MUSICAL FIDELITY XA-50 MONOBLOCS  
AUDIO ANALOGUE BELLINI/DONEZETTI PRE/POWER  
EXPOSURE XXI RC REMOTE PRE. (£1100 NEW.)  
ELECTROCOMPANET EC-1 REMOTE INTEGRATED (WITH PRE-OUT) EX. DIS/DEM  
SUGDEN AU-51 HIGH BIAS POWER AMP  
SUGDEN AU-41C PRE AMP  
CRIMSON AUDIO 630C MONOBLOCS & MATCHING 610 PRE/ MC PHONO  
CAIRN 4808 REMOTE INTEGRATED + PRE OUT (TWO MONTHS OLD)  
CAIRN K2 100 WATT MONOCBLOCS (TO MATCH ABOVE)  
CAIRN EZO ARIA REMOTE INTEGRATED (VERY PRETTY) AS NEW- FEW HOURS USE  
AUDIOLAB 8000-C PRE AMP  
AUDIOLAB 8000-C PRE AMP  
REGA CURA PRE-AMP  
ECA VISTA PRE AMP(SUPERBI)  
TAG MACLAREN 60-I INTEGRATED FEW HOURS USE ONLY  
ALCHEMIST FREYA PRE AMP & 2 GENESIS MONOBLOCS EXTREMELY RARE/BEAUTIFUL  
TECHNICS SUC-2000 REMOTE PRE & SEA-2000 POWER AMP  
MUSICAL FIDELITY 2 X P-180 POWER AMPS & CHOKE REG PSU  
MUSICAL FIDELITY MVT-3 2 BOX PRE AMP  
MUSICAL FIDELITY THE PRE-AMP & 2 TYPHOON BRIDGEABLE POWER AMPS( BALANCED)  
MUSICAL FIDELITY 3B PREP-140 POWER AMPS  
MUSICAL FIDELITY P140 STEREO/MONOBLOCS X 2  
MUSICAL FIDELITY 3A PRE AMP (CHOICE £150-£175)  
LINX STRATOS PRE AMP & 2X 120 WATT MONOBLOCS MM/MC ETC (VERY RARE/GOOD)  
DPA ENLIGHTENMENT REMOTE PRE AMP (LIGHT DEM USE ONLY SUPERB)  
MAGNUM REFERENCE MP 125 PRE & 2 X MF-125 MONOBLOCS(140WATTS)

EXCLT/BOXED £795  
EXCLT/BOXED £695  
EXCLT/BOXED £375  
MINT/BOXED TBA  
MINT/BOXED £750  
AS NEW/BOXED £750  
EX. DIS /BOXED £985  
MINT/BOXED £325  
VGC £750  
AS NEW/BOXED TBA  
AS NEW BOXED TBA  
MINT/BOXED £350  
MINT/BOXED £275  
MINT/BOXED £225  
MINT BOXED TBA  
AS NEW/BOXED £550  
MINT BOXED £425  
MINT £1250  
MINT BOXED £895  
MINT/BOXED £950  
MINT/BOXED £475  
MINT £525  
EXCLT £350  
MINT/BOXED £350  
MINT/BOXED £550  
VGC £695

## CD

TEAC VRDS 25 (BALANCED AND PHONO OUTPUTS)  
REGA JUPITER TRANSPORT IO DAC  
TECHNICS SL-P2000 REFERENCE PLAYER  
MERIDIAN 563 DAC (BALANCED & PHONO OUTPUTS )  
ROTEL RDP/980 DIGITAL PROCESSER (LOADS OF INPUTS)  
ARCAM 8 CD PLAYER  
ARCAM DELTA 70 2 CD PLAYER /VOLUME OUT/ETC  
MYRIAD T-10 CD PLAYER  
AMC CD8A( BALANCED&PHONO OUTPUTS)  
ROKSAN DP 1.5 TOP LOADING TRANSPORT  
ARCAM DELTA 170 TRANSPORT  
ARCAM BLACK BOX 3 DAC  
AUDIOLAB 8000 DAC  
AUDIONOTE DAC-1 EX. DIS.  
DPA ENLIGHTENMENT DAC  
OPA LITTLE BIT-2 DAC  
TEAC D-TI DAC  
MERIDIAN 203 DAC  
ORELLE DA-188 DAC  
WOODSIDE DAC

MINT/BOXED £950  
MINT/BOXED £650  
MINT £575  
MINT/BOXED £495  
MINT/BOXED £295  
VGC £250  
MINT/BOXED £195  
MINT £275  
NEW/BOXED £145  
MINT/BOXED £495  
V.G.C. £225  
V.G.C. £125  
MINT/BOXED £395  
AS NEW/BOXED £495  
MINT/BOXED £475  
£275  
BRAND NEW BOXED £250  
MINT £175  
MINT/BOXED £300  
MINT/BOXED £195

## VINYL

NOTTINGHAM ANALOGUE MENTOR REFERENCE & ARM (APPROX 100 KILO'S WEIGHT!)

ROKSAN XERXES/REGA RB300/LINN K-9 MINT £650  
PINK TRIANGLE PT TOO & PSU (WALNUT/BLACK LID) MINT/BOXED £395  
PROJECT 6 TURNTABLE & ARM G.C. £295  
LOGIC TEMPO ELECTRONIC & DATUM ARM VGC £225  
MUSICAL FIDELITY XLP-2/X-PSU 3 BOX PHONO STAGE MINT/BOXED £375  
DPA DSP 2005-D MM/MC PHONO STAGE (VERY RARE) MINT/BOXED £295  
PS AUDIO IIB MM PHONO STAGE GWO £175  
NAD PP-1 PHONO STAGE MINT/BOXED £30

## LOUDSPEAKERS

SNELL TYPE A MK III (LEGENDRY TOP CLASS 2 BOX REFERENCE SPEAKER)  
KLIPSCHORN'S FAMOUS CORNER HORN 104 DB SENSITIVE RING FOR DETAILS TBA  
KLIPSCH HERESY 'S' (ONE YEAR OLD) MINT/BOXED £675  
B.K.S. 107 MK.2 RIBBON HYBRID FLOORSTANDERS (HIGHLY REVIEWED) MINT/BOXED £1250  
ROKSAN QJANS 3X (ROSEWOOD) MINT/BOXED £795  
AUDIONOTE ANE-SP SILVER WIRED BLACK ASH MINT £1095  
AUDIONOTE ANE-SP(A AMERICAN OAK FINISH) EX.DISPLAY (NEW £3000+) MINT/BOXED £1750  
AUDIONOTE ANJD (WALNUT) MINT/BOXED £595  
SNELL TYPE E MK3 VERY RARE MINT/BOXED £995  
TANNOY ARDEN'S 15" MINT £895  
TANNOY LANCASTERS 15" HPD MINT £595  
CELESTION 7000 4FT. HIGH RIBBON TWEETER VERY RARE MINT/BOXED £675  
SD OBS FLOORSTANDERS( OPEN Baffle) SMALLER BROTHER TO SD1 BOXED £675  
MISSION 753 FREEDOM'S BLACK ASH MINT £475  
PROAC-3 STUDIO MONITORS (ATC DRIVERS) WALNUT MINT £795  
PROAC-2 MONITORS (ONE OWNER) MINT £350  
PROAC SUPER TABLETTES VGC £225  
CASTLE EDENS MINT/BOXED £395  
INFINITY REFERENCE STANDARD KAPPA 5 EMIT RIBBON TWEETER SANTOS ROSEWOOD MINT/BOXED £475  
ROYD EDEN'S VGC £250  
MORDANT SHORT MS20x PEARL (LIGHT FINISH) MINT £95

## TUNERS /TAPE

SONY 730ES DIRECT COMPARATOR TUNER MINT £175  
HITACHI FT-5500 TUNER MINT/BOXED £95  
TEAC V1010 3 HEAD CASSETTE DECK MINT £149  
MERIDIAN 209 REMOTE MINT £50

## RACKS/STANDS

SOUNDSTYLE XS 105 NEW STYLE (CURVED GLASS) 5 SHELF BLACK OR SILVER EX DIS £195  
SOUNDSTYLE XS 310 A/V TABLE EX DIS £195  
SOUNDSTYLE A/V TABLE SILVER EX DIS/NEW £175  
SOUNDSTYLE X105 BLACK/BLACK MARBLE GLASS/GOLD TOPS & CONES £150  
SOUNDSTYLE TOP TABLES BLACK/MARBLE 3 OFF EACH £50  
SOUND ORG Z540 NEW BLACK FINISH MIDI SIZE EX DIS £100  
KUDOS S50? 18 INCH SPEAKER STANDS SAND FILLED GC £50  
SOUNDSTYLE SELECT 4 PILLAR 22 INCH SPEAKER STANDS BLACK NEW/BOXED £175  
ATTACAMA R724/ATTABITE (FEW WEEKS OLD WAS £250) MINT £175  
AUDIONOTE HEAVY STANDS FOR ANJ/E ETC VGC £175  
TARGET 16 INCH VERY HEAVY 4 PILLAR VGC £175

## LOUDSPEAKER CABLE

CARDAS HEXLINK 2 METRE PAIR (FACTORY TERMINATED) £325  
AUDIOQUEST CRYTAL HYPERLITZ 6 METRE PAIR (BI-WIREABLE TERMINATED) £200  
AUDIONOTE AN-L 2 METRES (2 PAIRS) £75 (pair)  
SONICLINK SILVER AERO BI-WIRE 3 METRE PAIR (TERMINATED) £80  
LINN LK-400 BI-WIRE 2.5 METRE PAIR (TERMINATED) £75  
DPA IS19 4.5 METRE PAIR (TERMINATED) £175

## VINTAGE

SUGDEN P51/C51/T51 PRE/POWER/TUNER EXCLT. £350  
MERIDIAN MCA COMPONENT SYSTEM (CHOICE OF TWO) EXCL £275/£250  
REVOX A-7B AMP EXCLT/BOXED £150  
TECHNICS SL-110 TURNTABLE (NO STROBE) VGC £140  
ORTOFON T-10 MOVING COIL STEELPUP £70  
IMF TLS 80'S ONE OWNER EXCLT CONDITION £395  
KEF 104 REFERENCE EXCLT/BOXED £225  
B&W P2 IONOPHANE TWEETER RING RING

**MOST EQUIPMENT STOCKED IS ONE OWNER MINT/BOXED, SIMILAR QUALITY VINTAGE AND MODERN EQUIPMENT REQUIRED FOR IMMEDIATE CASH PURCHASE.THIS IS A SELECTION OF STOCK FOR A FULL CURRENT LIST PLEASE PHONE/E-MAIL GEORGE. MAIL ORDER A SPECIALITY**

# www.soundsexpensive.com

Hi-Fi & Audio Consultants, Sales and Service

Buy What Hi Fi's Award winners at the cheapest prices!

ACCESSORIES SOUNDSTYLE X058 rack W/X042 symphony grey £85. Trichord pulsewires 1 metre £60 pr. Digi-pulsewire 1 metre BNC £29. Moth Layline black 1 metre £45. Kimber PBj 0.6 metre £20. Philips PCD 865 player £60. Tel: 07811 440039 (Jun/I)

FOR SALE: Magnum Dynalab FM tuner, FT101A, black, superb sound, manual and boxed £395. Tel: 01903 247779 (Sussex) (Jun/I)

YAMAHA CL10 separates system, amp, tuner, cass-deck, CD player, manuals, TDL2 speakers, Atacama stands, hi-fi cabinet, Russ Andrews power cords, QED cables, all mint condition £725 ono (£1725). Tel: Dave 01903 732 357 (Little Hampton, West Sussex) (Jun/I)

BAT VK3i mint with remote £1250 ono. Copland CTA401 mint £750. Z-Systems VP sampler £1000 ono. Tel: 020 8856 1047 (Jun)

TDL STUDIO '4' transmission line speakers. Very good condition, walnut veneer finish £425 ono. Tel: 07814 027030 (Jun/I)

AUDIOLAB 8000S used only as a standby for a valve based system, rarely used. Excellent boxed condition £325. Tel: 01446 792727 (Jul/I)

VAN DEN Hul The Third loudspeaker cable 4 x mono 2m strands absolute reference new £4000 accept £1900. Tel: 01904 705787 (Jun)

SONY CDPX 559ES clock 3 dig-output £295. Trichord pulsar HDCD DAC £695. P/supply £195. NAD C160 £250. NAD C270 power £295. Tascam 134 pro-cass deck £295. Wilmslow Kevlar 1 speakers £245. Tel: 07811 440039 (Jun/I)

B & W 801 Matrix Two loudspeakers. Black. Xovers, professionally re-configured and built into external cases. Professionally re-wired with Kelvin silver cable. £1500 for quick sale. Can demonstrate. Tel: 01429 274867 or Email: stephen.petch@ntlworld.com (Jun/I)

PHILIPS CD100, one of the first ever CD players, professionally cleaned, all original parts including de-interleave delay correction. Offers around £500. Tel: 07814 754206 (Brighton, Sussex) (Jun/I)

SCANSPEAK 8544 with 2905/9300 tweeter double chamber bass reflex floor standers. Lined oak finish twin bass drivers £345. Marantz CD320 3 head cass deck £70. Philips FR732 prologic receiver £80. Tel: 07811 440039 (Jun/I)

AVI/ATC - AVI S2000MM 150 watt monoblock amplifiers and ATC SCM10 speakers walnut with ATC stands together £1100. Separate £600 each. Upgrading to SCM50 Tel: 01428 661393 (Jun/I)

MERIDIAN 500 transport with latest trichord clock upgrade. Trichord Pulsar DAC with makers HDCD and Oscon transistor upgrade. Includes external power supply. Must be heard! £1500 the lot! Tel: 01243 773814 (Jun/I)

SONUS FABER Concertinas custom made stands excellent condition £275. Linn Sondek basic arm Ortofon MC15 all very good condition £300. Audio Technologies phono stage £75. Tel: 01253 724668 (Jun/I)

NAKAMICHI 680ZX auto azimuth adjustment two speed, three heads, instructions, £165 cash only sale, buyer collects. Luxman T34 tuner £45. Tel: 02380 737823 (Southampton area, all are cash only) (Jun/I)

**CHORD DAC 64. Used only twice as new boxed. Retail £2000 offers over £1200 please to Steven 07774 703030 or 020 8203 9099 (Jun/I)**

QUANTUM 202D power amp, needs slight attention and cosmetics £70. Quantum 207 DA cosmetics only £110. Crimson 510 pre amp needs attention £55. NAD C370 nearly new mint £350. Tel: 01704 563619 (Jun/I)

**NAIM IBL speakers walnut, NAP 140 old style, Ittok LVII arm with boxes, excellent sound and condition. First £500 ono secures. Reasonable separate offers considered. Sale due to upgrading. Tel: 01404 891380 (East Devon) (Jun/I)**

COMPLETE CYRUS system, excellent condition, fantastic sound, buyer collects, boxes included. Cyrus DAD3 CD, FM7 tuner, III amp. Mission 752F black floorstanding speakers. Package price £1100. Tel: 020 8852 2370 after 6pm (Jun/I)

QUAD PACKAGE, FM4 tuner, 34 pre amplifier, 606 amplifier £768. Bose 901 IV speakers £250. Pioneer PD91 compact disc player £290. Excellent condition, everything purchased from new. Tel: 01554 751972 (Jun I)

AUDIO ALCHEMY DTI Pro 32 and DDE 3.0 with Power Station Three's £450 and £400 respectively. DTI 2.0 with Power Station Four £200. Audio-Pro Bi-45 subwoofer £75. Tel: 01642 559078 (Stockton) (Jun I)

**CONRAD JOHNSON PFR remote control FET pre-amp £1200 (£2600). EFi FET phono stage £1000 (£2000) or £2000 the pair. PV-8 valve pre-amp £700 (£2000) Tel: 020 7774 6641 or 01245 283175 (Essex) (July/I)**

PIONEER PL100 record deck 1974. Boxed with manual excellent condition, £35. Trio KR2120 receiver, vgc, boxed, manual £30. Philips 1970's GA212 record deck vgc, boxed, manual. Tel: 07831 111062 (Hertfordshire) (Jun I)

MERIDIAN 200 transport reclocked £375. Vimak DAC Ken Kessler rave review £750. 4.8 metre OPC/silver biwire speaker cable £175. Tel: 029 2023 5881 day / 029 2077 7156 evening or Mobile: 07770 227998 (Jul/I)

TOTEM MODEL 1 Signature speakers £850. Transparent Musicwave plus bi-wire speaker cable 7.5m £650. Bryston pwr amp 4NRB (ST) £1350. Bryston BP 25 pre amp (inc. phono boards) £800. Serious saving, all boxed as new. Tel: 01636 830944 or 07979 536753 (Jun/I)

MERIDIAN 200 and 203 CD and DAC Meridian 201 - 205 pre amp and monoblocks, 204 tuner £1500. Meridian 518 digital processor £450. All in excellent condition. will split. Tel: 0117 944 6014 eves (Bristol) (Jun/I)

TUBE TECHNOLOGY Prophet pre-amp, two Unis valve power amps. Fulcrum CD player, Vibex stand £3995. Proac Response 2.5 speakers £1150. Tube Technology integrated valve amp £895. Tel: 01491 628075 (Jun/I)

QUAD ELS63 brown, Aframosa, caps serviced four years ago (Quad) stands mint. Audio Synthesis Dax 2 boxed mint £995. Tel: 01277 211685 Mobile: 07966 267404 or Email: coomb@btinternet.com (Jun/I)

MARK LEVINSON 28 (pre) 29 (pwr) PLS (power)s manuals, leads, (£7500) Wow! £2495 Tel: 01277 211685 Mobile: 07966 267404 or Email: coomb@btinternet.com (Jun/I)

KRELL KAV250, 2 years old, manuals, boxed, mint £1595. KAV 3001 amplifier, boxed, mint, £1495. Roksan Attesa DP2 wonderful top loading transport £595. Tel: 01277 211685 Mobile: 07966 267404 or Email: coomb@btinternet.com (Jun I)

**MERIDIAN 200, 606 DAC, 201 pre, 205 monoblocs, Castle Chester rosewood re-wired with V.D.H. The Wind, REL Q-Bass, The First Ultimate Digital, The Second and The Storm Interconnect. Moving forces sale, hence £2395 ovno (£5500). Cannot split. Meridian 263 £220 (£650) Tel: 07753 569686 (East London) (Jun/I)**

NAIM 102 pre-amp complete with MC boards £700. Hicap new style £400. Tel: 01708 760571 (Jun/I)

MUSICAL FIDELITY X-200 monoblocs as new boxed £600 ono. Contact iain@iakers.fsnet.co.uk or 01224 589471 after 6pm (Jun/I)

SONUS FABER stonewood stands. Bargain at £275. Tel: 020 8672 6181 (Jun/I)

LEAK 2075 speakers £350. Radford STA15 22 preamp £600. Quad 57, late pair £500. Roksan CD DPI DAC1 power supply £650. Woodside STA50 26 pre-amp MC MM £1500. Garrard 301 grease bearing SME 12" just back from SME in new plinth, British racing green, must be seen £550. Hadcock G228E still in the box, offers. Tel: 01446 418 207 (Jun/I)

THETA PRO-PRIME DAC mint boxed (£1500 new) £400. Meridian 200 transport mint boxed £250. Will part-ex Exposure power amplifier. Tel: 01509 215230 ask for Mike (Jun/I)

REL STORM Three subwoofer. 15 months old but virtually unused. Brand new condition £450. Tel: 020 8994 2030 after 6pm (Jun/I)

ELECTROCOMPANET EC3 MC pre amp, black front, gold handles, excellent condition, balanced input and output, £1250 ovno. Tel: 01884 253518 (evenings) (Jul/I)

## Upgrade your turntable

"It's value is nothing short of tremendous"  
LISTENER MAGAZINE



"The single most important upgrade you can ever make to any record deck concerns the motor drive ...nothing can compare you for the shock of going DC, in a word Gobsmacking" COMMON GROUND MAGAZINE

"if you are thinking of upgrading your system, .....the Origin Live dc-motor kit should be high on your list for consideration"  
TNT AUDIO internet magazine April 2000.

Whatever your current turntable, the results in upgrading to the Origin Live dc motor and power supply are simply astounding. Designed as a drop in replacement for almost all turntables, the Origin Live upgrade kit provides vast improvements to all versions of Linn turntables, as well as Ariston, Rega, Systemdeck, Roksan, Rock, Oracle, Thorens, Well Tempered etc. With only a 12 Volt power supply and a full set of illustrated instructions our upgrade is both easy and safe to install. The upgrade is also offered with a full money back guarantee if you are not satisfied. The kit consists of a high grade dc motor, soldered regulator board and power supply at only £262. This provides an extremely cost effective route to truly high end audio and is significantly superior in performance to other power supply upgrades costing 4 times the price. A larger purpose made transformer is also available as an optional extra at £175.

## New breakthrough design - Laminar flow interconnect

A high end sound with a sensible look and price tag  
HI-FI WORLD July 2001

The Ultra's are a deeply satisfying musical product and a supreme bargain  
STEREO TIMES Aug 2001

"The reference interconnects are a must listen...highly recommended and another winner ..  
STEREO TIMES Feb 2002

The new Laminar flow range of interconnects embody an all new ground-breaking design. The "Ultra" version is guaranteed to outperform all other interconnects up to 4 times it's price and the "Reference" is a cable that reviewers use to judge other cables due to it's incredible transparency and musicality.

Don't purchase a more expensive interconnect until you have heard new laminar flow cable. With a full 3 week, cast iron money back guarantee if not satisfied, arrange an audition with your local Origin Live dealer or place an order with us directly.



Advanced interconnect:  
£45 per stereo pair

Laminar flow Ultra Interconnect:  
£85 per stereo pair

Laminar flow Reference Interconnect:  
£159 per stereo pair

## Origin live turntables In self assembly form

"this Vinyl front end had my jaw heading towards the floor with the solidity and transparency of the music it was making"...the standard came up with crystal clear images set in a broad sound stage"...with all these goodies in place the Standard would give turntables at the £1200 - £1400 mark a hard time"

HI FI WORLD SUPPLEMENT

"Overall a deeply impressive deck...Brilliant value for money ...component quality is superb and the build process is a doddle"  
HI FI WORLD March 2002  
"the best sounding deck here...sounds fantastic"  
(5 stars symbols) WHAT HI-FI MAGAZINE group comparison test of 8 leading turntables



Now you can own a professionally built, high performance turntable at a fraction of the normal cost. Origin Live turntable kits are supplied in 3 different specifications:

1. The complete standard kit offered with a non-suspended pre-drilled & finished plinth at £349.
2. The complete ultra kit offering a truly high end suspended sub-chassis turntable with beautifully finished solid cherry-wood plinth at £538
3. A standard kit of parts for a plinth of your own design at £282.

All kits are supplied with well illustrated instructions and are easier to assemble than many of today's pre-built turntables.

Optional parts are also offered to allow flexibility and upgrading.

## Turbocharging your Rega arm

"Nothing less than total dynamite" HI-FI WORLD



If you are the proud owner of any Rega tonearm, you are now in the enviable position to catapult it's performance into the league of super arms with modifications offered by Origin Live - the structural modification at £75 will enable your Rega to perform at a level exceeding that of arms costing over £1200. High performance rewiring with high grade litz cable is also offered at an additional £70 and external rewiring is £70- this further increases the performance.

"I have to say the Rega modifications turn this humble arm into a real Giant killer. Gone is the rather grey, sterile sound of the cooking Rega. Instead, tonal colour is fresh, dynamics have great speed and impact, and the sound stage is huge."

HI FI WORLD SUPPLEMENT NOV 97  
(structural modification to an RB250)

WHAT HI-FI MAGAZINE gave this modification a 5 star rating.

For arm modifications we normally return your arm in 2 - 3 days

FOR FULL INFORMATION SEE WEB SITE OR CONTACT  
Origin live, Unit 5, 362b Spring Road, Sholing, Southampton SO19 2PB  
Tel: 023 80578877 / 80363249 Fax: 023 80398905 E MAIL: [originlive@originlive.com](mailto:originlive@originlive.com)  
WEB SITE: <http://www.originlive.com>

**KLIPSCH HERESY** speakers £550. Dynaco ST70 new valves vgc £500. Totem Arro Mk2 speakers mint £600. Various cables and interconnects all 1/2 price. Tel: 01923 224404 or Mobile: 07930 524246 (Jun/I)

**LINN LP12**, Valhalla, Ittok, Grado £525, Naim 32.5, 110, hicap old style £550. Linn Kans, Naim cable, wall brkts £125. Rotel RCD 865 £20. Appollo speaker stands 600mm tall £50. Tripod table 4-shelf £50. All items good condition Tel: 01702 711817 (Jun)

**SUGDEN AU41** Signature remote line pre, AU41 power £550. Power recent Sugden service. Marantz CD94 transport and DAC £450. Separate ATW Modified DAC £350. Tannoy M3 floorstanders £160. Tel: 01733 810516 (Jun/I)

**MICHELL ISO** phono stage with Hera P.S.U. £325. XLO Reference interconnect £175. Tel: Andrew 01623 752036 work or 0115 964 1033 home (Jun/I)

**TANNOY D700** speakers, as new £1350. KEL34 valve amplifier, upgrade kit fitted, built by electronics engineer £290. Leak Stereo 20, refurbished £250. Leak Troughline 3, mono, refurbished £60. Tannoy Devon speakers £85. Tel: 01276 503653 (Jun/I)

**AE1 MK1** speakers with stands new drivers £500. Hi-Fi World KLSI 3-way speaker kit supplements 3/4 all parts. to complete. Cost £700 sell £500. Tel: 01444 239927 day or 01444 239927 evening. Email: leagraham@pavilion.co.uk (July/I)

**LINN EKOS** arm excellent condition £595. Linn Lineo mint condition £425 Tel: 0121 422 4371 after 6pm (Jun/I)

**MUSICAL FIDELITY A3CR** pre-amplifier. New January 2002. Superb. One of two in dual system now dropped, £650. Tel: 01752 773369 (Jun/I)

**LINN KEILIDHS** cherrywood finish £350 ono. Audiolab 8000 DAC best offer. Each in good condition, boxes, receipts etc. Wanted Linn Numerik and Klout or LK140 recent SMP5 Axis turntable Tel: 01228 514966 (Carlisle) (Jun/I)

**WANTED – DEAD or alive –** B&W DM70 electrostatic loudspeakers parts considered – check your attic! Tel: John 02380 732024 (Jun/I)

**TOWNSEND ROCK** turntable – Merlin power supply – Origin Live arm £600. Rega RB250 £60. Dynaco ST70 new valves ex.con £500. Totem Arro 2 speakers mint £600. Various interconnects all 1/2 price Tel: 01923 224404 (Jun/I)

**WANTED: PRECISION** devices 24 inch and 21 inch bass drive units. Please tel: Brian 01952 606403 anytime (Telford) (Jun/I)

**AUDIO ANALOGUE** pre-power £750 ono. Sonus Faber Concertinos in rare piano black immaculate £400. Atacama SE24 stands £45. Wanted: Bryston P20/P25 pre-amp or Conrad Johnson PV14L. Call Martin 0208 800 6124 (North London) (Jun/I)

**DECCA LONDON** pair, Rogers A75 Ser II, Thorens TD 124 with SME 3012, Revox G36, Hi-Fi News from 1980 cash offers please Tel: Vimal 020 8689 9187 daytime (Jun/I)

**ARCAM CD72** CD player £290. Arcam A75 and P75 integrated and power amps £425 for both. All 10 months old mint boxed Tel: 01788 844771 or Mobile: 07973 869193 (Jun/I)

**EXPOSURE** CD player with remote control mint boxed £490. Klipsch Heresy II's ex. con. £490. Sony TC 229 SD with remote, brushed silver, display meters absolute classic like new condition £85. Tel: 01923 224404 (Jun/I)

**AUDION SILVER** Knight valve mono blocks, new valve excellent condition vivid clarity 300B Golden Dragon tubes, Audion Premier 1.0 pre-amplifier with phono stage, mint, gold finish, boxed, £1450. Tel: Ian 07779 945881 (Jun/I)

**PINK TRIANGLE PT1** turntable RB300 arm lid and acrylic platter £300. Call Ed on 01252 518220 (Jun/I)

**MUSICAL FIDELITY E1** amplifier boxed £80. Marantz CD 72 SE '2' remote £200. Alpha 9C pre amp remote boxed. Alpha 8P power amps x 2 vgc. Sell for £600 or split. Tel: 01752 555955 (work) (Jun/I)

**NAIM CD2** player all boxed £850. Teac CD player converter D700 drive unit P700 £900. Tel: 01594 810567 (Jun/I)

**SONNETEER SEDLEY** phono stage. Fully adjustable, very quiet, audiophile quality at a budget price. £300 ovno. Tel: Malcolm Lee (office) 01274 582266 (home) 0161 284 8651 (Jun/I)

**LINN NEXUS** speakers £120. Rotel compact disc player RCD 9658X £100. Cyrus amp £100. Custom design stand five shelves £50. All very good condition Tel: 01325 465126 (Jun/I)

**DAT RECORDER.** Sony DTC-750. Barely used, boxed, excellent condition. Comes with 26 free tapes to record on £250 the lot. Tel: 01283 704227 (Burton area) (Jun/I)

**GRADO 325** headphones mint £120. Audionote Spa 2.6 metre biwired speakers cables terminated with banana plugs £300. Tel: 01952 406759 Mobile: 07973 941910 (Jun/I)

**MARANTZ PM17 KI** Signature amplifier £650. Linn Axis + Linn Basik tonearm £250. Nakamichi DR3 cassette deck £200. Mission DAD 5 DAC 5 CD player £200. All mint, boxed. Tel: 01484 307096 (Jun/I)

**ROGERS COMPACT** monitor speakers excellent condition £110. Cyrus One amp brand new. Boxed. £120. NAD 3140 amp excellent condition £85. 4 Troughline III, tuners need service £90 all. Tel: 01372 467264 (Surrey) (Jun/I)

**NAIM CDS2/XDS £3995.** Naim Nac 52/Supercap £3995. Dynavector HX1.2 £3300. Naim NAT01/PSU £1200. Shahinian Obelisks light oak £2395. All in mint condition. Call Raphael 01256 819198 or 07767 235323 (Jun/I)

**SPENDOR SPI** originals black boxed little used £325. Lynx Theta tuner boxed £150. Minim ambisonic decoder + leads for Quad (4 pin din) £50. Tel: 01983 297903 (Jun/I)

**LINN LK280** stereo power amp. 80w/ch into 8 ohms, 140 w/ch into 4 ohms. With owners manual, excellent condition £280. Cassette decks Sony TC-K61 Yamaha K-320 £50 each. Speakers Mordaunt-Short MS-10 £60. Tel: 01743 891143 (Jun/I)

**LINN ISOBARIKS** late model serial number 7699 7700 excellent condition will demonstrate £595. Tel: 01484 841482 (Jun/I)

**QUAD 405** power amplifier, 44 control unit, FM3 tuner. All in mint condition, in original boxes with manuals. Rare opportunity never used. £625. Tel: 01934 418124 (Jun/I)

**RUSS ANDREWS** purifier block £400. 8TC speaker cable 4.5m pr £300. Torlyte speaker platforms 275mm x 200mm x 32mm £120. Linn Ekos arm £800. Linn Klout power amp £980. Linn Kairn pre-amp £600. Mana Ref table £220. Tel: 020 8926 6916 Mobile: 07764 851339 (Jun)

**ART AUDIO** Quintet monoblocs 15 watts triode coupled Class A beautiful sound excellent condition (£2000) £800 Can demonstrate. Tel: Paul 01603 410828 (Jun/I)

**ARCAM ALPHA 6** CD £190. Denon DCD 825 £95. Royd Minstrel floorstanding speakers, black, rewired, £95. All in excellent condition, boxed, with manuals. Tel: Mark 01543 414936 or 07958 917576 (Staffordshire) (Jun/I)

**ARCAM DELTA 250** transport, Black Box 5 DAC, Audioquest Video Z digital interconnect, excellent sound. DAC upgraded to Black Box 50 specification £375 cost £1250. Tel: 01642 604544 evenings (Teeside) (Jun/I)

**GAMMA ACOUSTICS** Aeon MkIII 211 silver s.ended power-amp monoblocs as new. Magical sound stunning looks and build, totally transparent, mint condition, can use from linesource direct. Cost £5500 accept £1500 ovno. Tel: 07980 676071 (Jun/I)

**TANNOY M20s** £75. Target HJ20/2 stands £50. Dual CS704 £100. Nakamichi cassette deck 2 £140. Wanted: Klipsch speakers Heresy II Chorus II KG5.5 or KG4.5 in black ash. Tel: 01306 887554 (Jun)

**MUSICAL FIDELITY A1** amp £100. Tannoy M20 gold speakers £125. Target 5 shelf rack £60. Akai GX95 tapedeck £60. Technics SLP33 CD £50. All items vgc. Tel: 01483 480212 or Email: rclutterbuck@yahoo.com (Jun/I)

**ARCAM DELTA 290** amplifier unused since full Arcam service £190. Arcam Alpha 6 CD player £170. Arcam Alpha 5 tuner £90. Hugh Bolton (London) 0207 633 4695 or Email: hugh@hmbolton.freeserve.com (Jun/I)

## SUNFIRE CORPORATION



**New for 2002 Sunfire True Sub Woofer MKIV 11 inch cube.** Signature True Sub Woofer 13 inch cube and Junior Sub Woofer 9 inch cube -all with two drivers, to as low as 16hz, 116 SPL and 360 cu ins of air movement, 1200 or 2700 watt patented amp technology. Classic Tube Pre-amp, Solid state power amps 2 channel (300 x 2 or 600 x 2) and 5 channel (220 x 5 or 430 x 5 - yes total of 2150 watts into 8 ohms or 4300 watts into 4 ohms) patented amp technology (no heat sinks) and Theatre Grand II processor pre-amp.



### AUDUSA EUPEN CSA 2.5 MAINS CABLE - HI FI CHOICE SEPT 2001 BEST BUY AWARD



AUDUSA-Eupen CSA 2.5

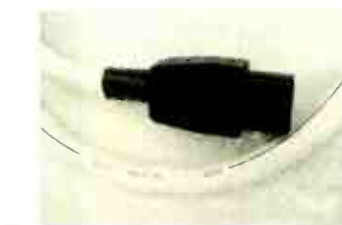

AUDUSA EUPEN GNLM 5.0 mains cable

CSA and GNLM Cable with FERRITE TECHNOLOGY - A polymer material mixed with a considerable quantity of homogeneously fine high quality ferrite powder. This compound is called EMC/COM and it can be extruded around copper conductors. The ferrite itself is a non-conducting material, but it has a very interesting magnetic behaviour. As a ferromagnetic material, it will go through hysteresis loops whenever it is under influence of an alternating magnetic field. Consecutively magnetizing and demagnetizing the material will cause considerable losses of high frequency energy. This energy is absorbed in the ferrite grains and converted into heat. This effect is more or less proportional to the field frequency. By coating conductors with a thin layer of ferrite compound, high frequencies will be strongly attenuated, because their energy will be absorbed by the ferrite powder. This applies to high frequency disturbances that are propagating on the conductor and which we don't want to disturb the environment, as well as to surrounding interferences, which we want to prevent from disturbing the signals on our cable. The CSA cable which in addition to the above described ferrite technology is further protected with a foil shield and a drain wire and specifically manufactured for High End audio use.

£48 for 1.0m  
£58 for 1.5m  
£68 for 2.0m  
off the reel £30  
for 1st meter, £20  
per m thereafter.

Fitted with IEC (Martin Kaiser) and MK Tough Plug. Figure of eight, 16 amp IEC, Bulgin etc also available as well as USA, European Schuko, and other mains plugs. Cable can be supplied fitted to our all steel 4, 6 and 8 way distribution blocks. We can rewire the distribution blocks with Eupen cable as an extra cost option. Refer to our web site for details.

### L A T INTERNATIONAL NJ USA - all cables now with SILVERFUSE conductors

#### LAT AC-2 HI-FI CHOICE - SEPT 2001 - RECOMENDED MAINS CABLE



AC-2  
Power cable  
compare with  
products costing  
ten times as  
much, then  
decide

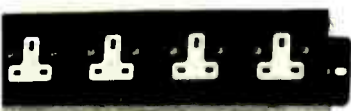

**LAT AC-2 Power cable.** We have developed a cabling (weaving) pattern along with an unusual shielding/filtering system that gets rid of the garbage that contaminates your components. The difference you hear with our cord is astounding. Our power cord takes advantage of silver in its design through use of our proprietary Silverfuse conductors. The conductors are 10 gauge and insulated with Teflon; the best insulation available. Fitted as standard with an IEC and MK Toughplug. Other connectors are available incl Schuko, 16 amp IEC, Figure of eight etc. 2ft £56, 3ft £68, 4ft £78, 6ft £99. other lengths available and off the reel at £39 per meter. SE version available with GP Tough plug and IEC, outer black braid all for an extra £12 irrespective of length 4,6 and 8 way all steel mains distribution blocks fitted with UK, Schuko or USA type sockets. CE tested and approved mains distribution units manufactured out of heavy gauge steel, finished in black and fitted with high quality Wadsworth 13amp sockets. It has no filters, circuit breakers, surge protection, transformers, resistors, capacitors, LED's, on/off switches, chokes, regulators, just fitted with 3ft of LAT AC-2 mains cable. From £161 for 4 way, £194 for 6 way, £226 for 8 way.

**NEW SILVERFUSE GOLD MK Tough plug with gold plated pins (£14)**  
Otto Heil IEC with gold plated contacts (£10).

**SILVERFUSE** is a near alloy of silver and copper. IT IS NOT SILVER PLATED OR SILVER CLAD. Plating (or clad, which is the same thing as plating) causes a dioding effect when signal is passed through resulting in brightness and distortion. The Silverfuse process starts with seven nines OFHC copper wire with a diameter that is slightly larger than the required size. It is then pulled through a trough of molten silver. The wire with a silver deposit, is then forced through a compacting die where it is subject to tremendous pressure. The silver and the high purity copper are fused together into a near alloy. The compacting fusion also reduces the wire diameter to the desired size. No dioding subsequently occurs with this process. The result provides for the benefits of silver; which are excellent definition and clarity, with the high purity copper benefits of warmth and mellowness.

**LAT AC-2 mains cable available with 16 amp IEC (MF, KRELL etc), Figure of eight, Bulgin, USA mains and European Schuko plugs. Check our web site for available variants.**

LAT INTERNATIONAL - Analogue, Digital and Video interconnects and Speaker cable. Refer to [www.audusa.com](http://www.audusa.com) for further details or ask for reviews etc

### SIEA 3D-LABS CDP, DAC, TRANSPORT AND DVD's 24/192

with SRC sampling rate and bit converter translates 16,18 and 20 bit inputs to 24 bits format. All 32, 44.1 and 48kHz frequency is re-sampled to 192kHz. This is known as upsampling. The SRC is comparable with that used by DCS in the Purcell unit. Prices start from £1110 for a CDP with SRC.

**DVD with SRC and CV2 - Video system for unmatched picture quality - best with projection systems . DVD with SRC and CV2 start from £1470. DVD with CV2 £1210.**



MICHELL REFERENCE hydraulic transcription turntable with SME 3009 II and Pickering D625 cartridge excellent condition, one owner from new, original box and instructions £395. Tel: 07960 615375 (York) (Jun/1)

B & W MATRIX 805 £450. Black, immaculate, boxed with Target stands, ProAc 2S, yew £1000 ono. Proac Studio 1 Mk2 black £250. Tel: 01277 210541 (Jun/1)

PHILIPS CD850 MkII £100. NAD 3020i £60. Technics Cassette RS-B605 £60. Technics tuner ST-ZIL £30. JPW Sonatas £30. Tel: 0191 251 6297 or Mobile 07957 189 064 (Jun/1)

TRICHORD DINO unused £250. Denon DCD 715 CD player £60. Tel: 01635 299244 (Berks) (Jun/1)

TUBE TECHNOLOGY Fusion CD player, mint condition, 24bit 96 kHz, £775 ovno. Beard P35 MkII amp, exposed valves, mint condition, excellent sound, £525 ovno. Single ended 211 monoblocks, mint, £1250. Tel: 01634 723 223 (Jun/1)

WANTED: FERROGRAPH Reel to reel tape recorder. First class condition. Preferably Series Six but would consider Series Four. Advise price, condition and location. Tel: 01308 485 463 after 6pm (Dorset) (Jun/1)

DPA RENAISSANCE CD player £325 (£950) new. Box, remote and Deltran sync-lock cable. Tel: Adam 01268 711536 daytime or Email: adamtaz@hotmail.com (Jun/1)

NAIM AUDIO NAC102, MC, NAPSC, £775. NAPI80 £650, Hi-Cap £350. Tel: 01621 742 185 eves (Jun/1)

WANTED: QUAD 34 pre-amp and FM4 tuner. Both grey with phono sockets. Must be unmarked and working perfectly. For sale: Tandberg TR220 receiver vgc £100. Tel: 01793 702976 (Wiltshire) (Jun/1)

CYRUS AV5 highly rated digital surround pre amp processor warranted as new £750. Cyrus power amps +2 warranted as new boxed with instructions £250 each. Tel: 07747 664742 (Jun/1)

LINN KAN Speakers plus stands. Teak finish. Excellent condition, £175 ono. Tel: 01579 342 372 (Cornwall) (Jun/1)

TANNOY LANCASTERS 12" Golds, v. good cond. offers over £500. SME 12" arm, boxed, £250. Pair Pamphonic J. Victors, v. big, late 50s, £150. Rotel RC850 pre, 2x RB850 power. Tel: 01239 858 946 (Jun/1)



VINTAGE WIRELESS COMPANY LONDON  
Website: [www.vintagewirelesslondon.co.uk](http://www.vintagewirelesslondon.co.uk)  
Buy-Sell-Exchange. Vintage wireless and classical audio. Repairs, spares, restoration, modification to all valve equipment. Quad II, Leaks etc, shipped worldwide, best prices, call us at: 17 Bell Street, London, NW1 5BY. Tel: 020 7258 3448  
Fax 020 7258 3449 Email: [vwirelesslondon@aol.com](mailto:vwirelesslondon@aol.com) (Oct02/1)

WOODSIDE ELECTRONICS service and repair. Woodside, Radford and Quad valve products. Replacement transformers are available to original specifications (Quad transformers are approved by Quad). Tel: 01758 741026, Email: [m.davis@virgin.net](mailto:m.davis@virgin.net)  
Website: <http://freespace.virgin.net/m.davis> (Jun/1)

AMAZING INTERCONNECTS! Hand built pure silver cables with world class connectors. Fantastic performance, money back guarantee. £105 per metre pair, £5 p&p. Other lengths available. Details: 0115 982 5772 after 7pm, Email: [Bob@skydivers.co.uk](mailto:Bob@skydivers.co.uk) (Jul/1)

CONCRETE CABINET loudspeakers 'a sonic revelation!'. For low density concrete enclosure loudspeakers please visit [www.faradaysound.co.uk](http://www.faradaysound.co.uk)  
Excellent reviews, unsurpassable sound quality since 1989. Stand or floorstanding from £495. Faraday Sound 01603 762967 (Jul/1)

HORN SPEAKERS direct from designer maker. Unique construction gives amazing sound at affordable price. Ideal for low powered valve amps. Tel: 01284 750686 (Jun/1)

KRELL CD 10 Signature Transport, mint, (£10,000) £4000. Krell KRC- 2 pre-amp, as new £1900. Michell ISO / Hera £330 ono. Tel: Jules on 01792 280061, Email: [sales@sounddrjuleshifi.co.uk](mailto:sales@sounddrjuleshifi.co.uk)  
Web: [www.sounddrjuleshifi.com](http://www.sounddrjuleshifi.com) (Jun/1)

SONY CDP RI Reference. Transport Das RI Dac mint. (£6000) £2600. UKD Opera Callas Gold speakers as new £680, Tel: Jules on 01792 280061, Email: [sales@sounddrjuleshifi.co.uk](mailto:sales@sounddrjuleshifi.co.uk)  
Web: [www.sounddrjuleshifi.com](http://www.sounddrjuleshifi.com) (Jun/1)

MARK LEVINSON ML383 (brand new) (£6000) £5000. Linn Sondek, £300. Transparent Music Link Super 25ft, interconnect RCA £600. Transparent Music Wave Plus Bi Wire Speaker cable 8ft £300. Tel: Jules on 01792 280061, Email: [info@sounddrjuleshifi.co.uk](mailto:info@sounddrjuleshifi.co.uk)  
Web: [www.sounddrjuleshifi.com](http://www.sounddrjuleshifi.com) (Jun/1)

LEIDER SPOOR pure silver speaker cable, 2.01 mtr (£1200) £600. Audio Technica OC9 cartridge brand new £270. Tel: Jules on 01792 280061, E-mail: [info@sounddrjuleshifi.co.uk](mailto:info@sounddrjuleshifi.co.uk)  
Web: [www.sounddrjuleshifi.com](http://www.sounddrjuleshifi.com) (Jun/1)

TEAC 300 reference Midi separates, Mini Disc, etc, mint, (£800) £400. Audio Research SP7 Pre, D60 Power, Inc heavy duty transformer, pair price £800 ono. Tel: Jules on 01792 280061, E-mail: [info@sounddrjuleshifi.co.uk](mailto:info@sounddrjuleshifi.co.uk)  
Web: [www.sounddrjuleshifi.com](http://www.sounddrjuleshifi.com) (Jun/1)

AUDIO RESEARCH SPI4, pre-amp, black, boxed, manual, mint, £1350 ono. Bruce Moore Dual Mono pre-amp, immaculate (£8000) £2900. Tel: Jules on 01792 280061, E-mail: [info@sounddrjuleshifi.co.uk](mailto:info@sounddrjuleshifi.co.uk)  
Web: [www.sounddrjuleshifi.com](http://www.sounddrjuleshifi.com) (Jun/1)

ROGERS LS 5/8 pair £300. Nagra IVS £1200. T-Audio £1800. E-Mono £400. Studer D780 £600. A710 £400. B67 VU £800. A80 VU £950. AB10 VU £1100. A807 VU £1400. A80 line £800. A807 line £750. B62 VU £1200. EMT 948 £550. 950 £975. Technics SPI0 MkII £280. SLP1200 £400. Soundcraft SAC 200 12-2 desk £2500. Sony 3000 pro twin CD £1200. Tel: 01246 275479 Fax: 01246 550421 Email: [j.i.tipping@amnserv.net](mailto:j.i.tipping@amnserv.net) (Jun/1)

REVOX PR99 MkIII HS £950. PR99 MkII HS £750. Studer A810 VU 45P £1100. A80 RC VU £850. B67 MkII VU £750. A710 £350. A807 MkII VU £1100. Technics SLP 1200B CD £350. SPI0 MkII £275. Rogers LS 5/8 £400 pair. LS 5/9 £200 pair. Nagra IVS £1200. Tel: 01246 275479 Fax: 01246 550421 (Jun/1)

DOMAIN NAMES FOR SALE. A rare opportunity to acquire the following set of names, all unused and available for immediate transfer:  
[valve-sound.com](http://valve-sound.com)  
[valve-sound.info](http://valve-sound.info)  
[valve-sound.co.uk](http://valve-sound.co.uk)  
[valvesound.com](http://valvesound.com)  
[valvesound.info](http://valvesound.info)  
[valvesound.co.uk](http://valvesound.co.uk)  
£5000 the lot. Contact Mr Wells, phone or fax: 0190 837 4755. Email: [audioldie.aol.com](mailto:audioldie.aol.com) (Jun/1)

HORSHAM HI-FI Offer: Audio Research VT100 MkII £3995. Wadia 21 CD player £1995. Jeff Rowland Model I £1195. Gamut C2R preamp £850. VAC 20.1 preamp £495. Revox B26 tuner £495. Linn Keosa speakers £395. Tel: 01403 272 931 or 07890 390 310 (Jun/1)

THE WORLDS best interconnect? Probably! Hand crafted! 'Fine' silver foil conductors! Lifetime guarantee! Full money back within 30 days if not amazed! £200 per 1 mtr pair. Tel: Worthing Audio 01903 212133 (Jun/1)

VINYL & CD FAIRS. Oxford Town Hall May 4th. Reading Rivermead May 6th. 100s of stalls selling rare rock, pop, jazz, dance. Also held in Bristol, Southampton and Portsmouth. Entry £2. 10am-4pm. Mention Hi-Fi World and get in free. [www.tvmusicuk.com](http://www.tvmusicuk.com) (Jun/1)

# Trade Ads

Dealers must not advertise in the Private Classified section. Monthly consecutive insertions will be considered Trade advertising. The Publisher reserves the right to judge submissions.

**Classified Ads**



classified ads order form

Dealers must not advertise in the Private Classified section. Monthly consecutive insertions will be considered Trade advertising. The Publisher reserves the right to judge submissions

**SPECIAL OFFER**  
Book a private or trade classified advert, and get one month's \*FREE internet advert  
**\*FREE internet adverts are published three weeks AFTER the magazine has been published**

**In a rush to get your advert published? Why not use our Instant Internet Advert to get on our website immediately. Only £15 per week (7 days)**

**RATES - ALL ADVERTS MUST BE PRE-PAID**

Maximum length per advert is 30 words, each additional word is 50p extra. Telephone numbers and E-mail addresses are treated as one word. Model numbers are treated as one word i.e. Quad 303 = two words. Please tick the box for the advert required

- Instant Internet Only Advert Private or Trade published immediately £15 per week
- Private magazine advert plus \*FREE internet advert £10 per month
- Private magazine advert display black box plus \*FREE internet advert £15 per month
- Trade magazine advert plus \*FREE internet advert £10 per month
- Trade magazine advert display black box plus \*FREE internet advert £15 per month
- Please tick here if you **DO NOT WANT** your FREE internet advert

Please write or type your advertisement copy in block capitals with one word per box. Please continue on a separate sheet if necessary. WE WILL ACCEPT PHOTOCOPIES OF THIS FORM

1	2
3	4
5	6
7	8
9	10
11	12
13	14
15	16
17	18
19	20
21	22
23	24
25	26
27	28
29	30

Name \_\_\_\_\_  
 Address \_\_\_\_\_  
 Post Code \_\_\_\_\_  
 Daytime Tel: \_\_\_\_\_

Please debit my VISA/MASTER/SWITCH Card No. (Switch card issue No \_\_\_\_\_)  
 Expiry Date: \_\_\_\_\_ Cardholder Signature: \_\_\_\_\_

I enclose a cheque/postal order for £ \_\_\_\_\_ Made payable to: Audio Publishing Ltd.  
 Send in your private classified ads with our NEW Freepost service. No need for a stamp!  
 Send this form together with your payment in an envelope marked:

**Hi-Fi World, FREEPOST LON3478, LONDON NW6 6YR**

**PRIVATE & TRADE CLASSIFIED ADVERTS COPY DEADLINES**  
 JULY 2002 ISSUE - FRIDAY 10TH MAY 2002  
 AUGUST 2002 ISSUE - THURSDAY 6TH JUNE 2002

**ADVERTISERS INDEX**

Affordable Audio	74
Apex Acoustics	116
Arcam	44
Audio Classics	107
Audio Illusion	92
Audio Mania	112
Audio Salon	72
Audio Synergy	122
Audio Vector	117
Audio Xpress	106
Audiocom	116
Audusa	128
Billy V	89,90,91
Bocchino Audio UK	117
Campaign Audio Design	48
Central Audio	114
Choice Hi-Fi	94
Classique Sounds	119
Connoisseur Audio	84
Custom Cable	115
<input type="checkbox"/> Definitive Audio (Brighton)	113
<input type="checkbox"/> Definitive Audio (Notts)	48
<input type="checkbox"/> Diverse Vinyl	121
<input type="checkbox"/> Emporium (The)	120
<input type="checkbox"/> English Analogue	106
<input type="checkbox"/> Heathcote Audio	124
Heatherdale	115
Henley Designs	20,93
Hi-Fi Trading Co	108,109
Hicam	112
Ian Edwards	111
Ian Harrison	112
JEM Distribution	115
Listening Rooms	121
Mana Acoustics	106
Mantra Audio	93
Matrix	118
Michell Engineering	14
Midland Audio Exchange	110
Mission	BC
Music & Video Exchange	107
Musical Fidelity	46
Musical Images	111
Musonic	113
Origin Live	18,126
Oxford Audio	114
Progressive Audio	113
Retro Reproductions	122
Ringmat	36
Russ Andrews	36
Sevenoaks	28,29,30,31,32,33
Sevenoaks	60,61
Sonic Design	117
Sound Of Music (Crewe)	119
Sound Stage	118
Soundcraft	115
Sounds Expensive	124
Sounds Perfection	40
Stowsounds	118
Supradirect	117
The Right Note	40
Trichord Research	14
True Colours	107
V'Audio	119
Walrus	18
White Noise	106
Williams Hart Electronics	111
X Electrical	116

**DIY SUPPLEMENT No.66**

Audio Lab (Leeds)	96
Chelmer Valves	96
Falcon Acoustics	96
Kit & Components	100
Langrex	104
Technical & General	96
Watford Valves	104

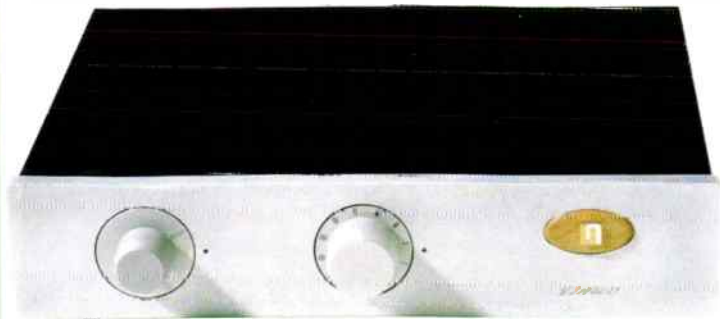

## UNISON RESEARCH UNICO

The new Unico integrated amplifier from Unison Research has an impeccable pedigree. Triode valves give the purity of sound that makes listening a pleasure. With styling of understated elegance and 80 watts of power, Unico offers an unbeatable package. Complete with radiowave remote control.

Unico £750

## OPERA SP2

Beautiful to behold and a delight listen to, Opera loudspeakers are the genuine article. Italian craftsmanship, advanced acoustic technology and the very finest materials make SP2 the perfect choice for the discerning music lover.



\* Opera SP2 (mahogany), £1,350/pair.  
Other finishes available

## TRIANGLE Loudspeakers that love music

Five stars for sound and five stars for value. Triangle are regular winners of top accolades from the world's most prestigious reviewers. As What Hi Fi recently put it "They turn in a sparkling performance that makes others seem bland in comparison"



## Zerius 202

Zerius 202, £695/pair

## KEMP ELECTRONIKS Clean Mains - the professional way

KE's range of products is designed to clean up all types of mains pollution problems. From the full system conditioner KE Power Source (8-way/3.8kW) to the Noise Suppressor plug and a range of fully shielded Mains cables, there is a KE product that will solve every problem, and make your audio or AV system perform better.



\* KE Power Source, £795. KE-SNS Plug, £75

*Contact us for more information or visit our website*



23 Richings Way, Iver, Bucks, SL0 9DA, England  
Tel: 01753 652 669 Tel: 07000 853 443 Fax: 01753 654 531

[www.ukd.co.uk](http://www.ukd.co.uk)

World Radio History

# MISSION

WHAT HI-FI?  
SOUND AND VISION

Awards

2001  
BEST BUY

AV Speaker Packages  
Best Buy up to £500

WHAT HI-FI?  
SOUND AND VISION

Awards

2000  
BEST BUY

m71 loudspeakers  
Best Buy up to £150



# m70

series

Mission, Symphonix Ltd, Huntingdon PE29 6EY

Tel: +44 (0) 1480 423700

Fax: +44 (0) 1480 423701

www.mission.co.uk