

RA Roe

Repeater Str.

THE POST OFFICE ELECTRICAL ENGINEERS' JOURNAL



Vol. 51 Part 3

OCTOBER 1958

CONTENTS

	Page
THE NEW SIGNALLING SYSTEM FOR DIVISIONS AND COUNTS IN THE HOUSE OF COMMONS—W. S. Proctor, M.I.E.E., F.R.S.E., D. M. Rogers, A.M.I.E.E., and W. J. W. Paynter	163
THE 4000-TYPE SELECTOR R. F. Purves, A.M.I.E.E., and A. Walker	168
A MICROWAVE MODEL EQUIPMENT FOR USE IN THE STUDY OF THE DIRECTIVITY CHARACTERISTICS OF SHORT-WAVE AERIALS, Part 2—Some Investigations Carried Out with the Model Equipment—D. W. Morris, B.Sc.(Eng.), A.M.I.E.E., E. W. Thurlow, A.M.I.E.E., and W. N. Genna, Associate I.E.E.	173
A CALIBRATED SIGNAL GENERATOR AND MEASURING APPARATUS FOR INTERNATIONAL SIGNALLING SYSTEMS—C. J. Maurer, B.Sc.(Eng.), and R. A. Notman, Graduate I.E.E.	180
A BORING BIT FOR TESTING WOOD POLES R. O. Boocock, B.Sc., A.M.I.E.E., and E. N. Clark	186
A SINGLE-OPERATOR LETTER-SORTING MACHINE, Part 2—The Production Machine and Future Development—H. J. Langton, A.M.I.E.E.	188
AUTOMATIC SWITCHING FOR THE TELEX SERVICE A. E. T. Forster, A.M.I.E.E.	193
AN IMPROVED FORM OF MECHANICAL CONSTRUCTION FOR TRANSMISSION EQUIPMENT—51-TYPE CONSTRUCTION—E. T. C. Harris, B.Sc.(Eng.), A.M.I.E.E., and C. J. Spratt, Associate I.E.E.	197
RADIO INTERFERENCE, Part 5—Industrial, Scientific and Medical Apparatus and Radiating Receivers—C. W. Sowton, B.Sc.(Eng.), A.M.I.E.E., and G. A. C. R. Britton, A.M.I.E.E.	202
THE PRINCIPLES OF NEGATIVE-IMPEDANCE CONVERTORS AND THE DEVELOPMENT OF A NEGATIVE-IMPEDANCE 2-WIRE REPEATER—D. Turner, B.Sc.(Eng.), and T. B. M. Neill, B.Sc., A.M.I.E.E.	206
THE ECONOMIC USAGE OF BROADBAND TRANSMISSION SYSTEMS—R. J. Halsey, C.M.G., B.Sc.(Eng.), F.C.G.I., D.I.C., M.I.E.E.	212
TELEPRINTING OVER LONG-DISTANCE RADIO LINKS, Part 2—Automatic Error-Correcting Methods Used Over Long-Distance Radio Links—A. C. Croisdale, M.B.E., B.Sc.(Eng.), A.M.I.E.E.	219
DEVELOPMENT	226
NOTES AND COMMENTS	228
INSTITUTION OF POST OFFICE ELECTRICAL ENGINEERS	236
REGIONAL NOTES	238
ASSOCIATE SECTION NOTES	249
STAFF CHANGES	252
BOOK REVIEWS	185, 187, 201, 225, 235, 237, 248, 251

THE POST OFFICE ELECTRICAL ENGINEERS' JOURNAL

Vol. 51 Part 3

OCTOBER 1958

The New Signalling System for Divisions and Counts in the House of Commons

W. S. PROCTER, M.I.E.E., F.R.S.E., D. M. ROGERS, A.M.I.E.E., and W. J. W. PAYNTER†

U.D.C. 654.923:725.11

Foreword by the Assistant Postmaster General

The House of Commons is proud of the long usage which has given authority and prestige to its forms and practices. Erskine May, to which we look for guidance, is not a book of rules but a series of chapters on how and why things are done as they are. Practice is the product of precedent.

The bells which summon Members to their duties in the Chamber and Division Lobby are a part of this Parliamentary life. When the new Chamber was built after the bombing many methods of summoning Members were possible that were not available to our forbears. All were rejected in favour of the old system which had a place in our history. Even to improve it is a daring enterprise. What follows is a description of how the system has been improved to meet the wishes of the House. The change has been made without offence to familiar practices. Tradition and convenience have been shaped into a happy alliance. It is an accomplishment of which Post Office engineers can be proud and which Parliamentarians may admire.

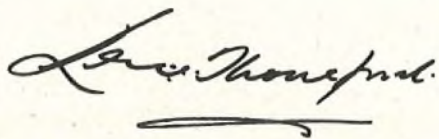

INTRODUCTION

It is perhaps not generally appreciated that the provision and servicing of the bell system used in the House of Commons to summon Members of Parliament to Divisions and Counts is the responsibility of the Post Office.

The decision to call a Division or a Count is taken by the Speaker of the House. His call is relayed orally by staff of the Serjeant-at-Arms, "badge messengers," present inside the Chamber, to their colleagues outside. This call "Division" is shouted through the corridors of the House by the police. At the same time as the Speaker calls the Division, the Clerk to the House, sitting before him, starts a timing device while the doorkeeper, warned by the Serjeant-at-Arms, operates the bells.

For a Count, the Clerk informs the Speaker after two minutes have elapsed. A quorum comprising not less than 40 Members must then be present to enable the business of the House to continue. For a Division, the procedure is similar except that Members have six minutes during which they must reach the Division Lobbies. After this time the Division Lobbies are locked. For a Division, it is possible for Members residing outside, but reasonably close to, the House to attend and external bells are provided in the residences of these Members as well as in the offices of Ministers in nearby government buildings.

This method of communicating calls by the Speaker to the officials of the House, including the person appointed to operate the apparatus used to initiate signals to operate the internal and external bells, is part of established parliamentary procedure and much may depend upon its efficient working.

The maintenance of the apparatus used to originate signals, the internal and external bells and common equipment, e.g. batteries and guard facilities, is the function of resident Post Office engineering staff.

THE OLD SYSTEM

The code of ringing with the old system was, for a Count, ringing for a period of 25 seconds; for a Division, four periods of ringing of 25 seconds each, with intervals of 10 seconds. The most serious disadvantage of this system lay in the fact that some 35 seconds had to elapse

† The authors are, respectively, Chief Regional Engineer, Senior Executive Engineer and Assistant Engineer, London Telecommunications Region.

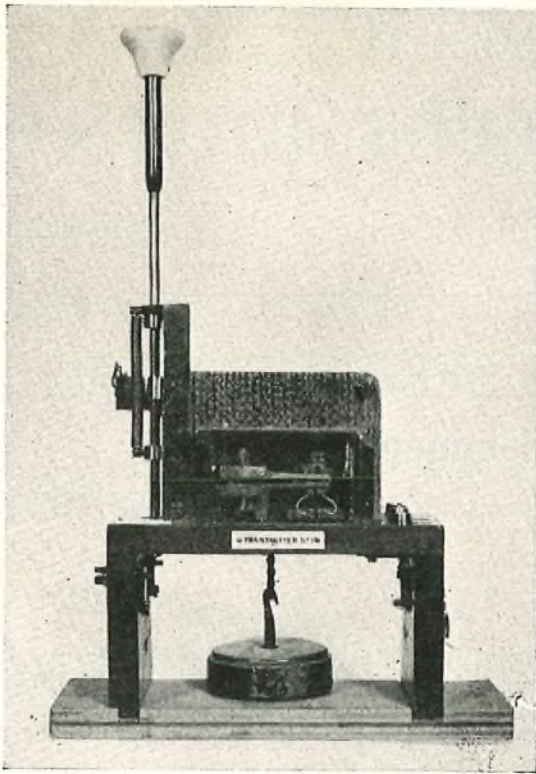

FIG. 1—ORIGINAL TYPE OF TRANSMITTER

before members could recognize whether a Division or Count had been called.

The date of introduction of the transmitter used to signal this code of ringing is obscure. Little specific information has been discovered despite searching enquiries. As far as it is possible to say, the system must have been installed about the turn of the century. Before this time advice to Members of a Division or a Count was given orally.

The original transmitters were of the type shown in Fig. 1 and contained parts similar to those used in the construction of telegraph equipment, in particular the Wheatstone high-speed automatic transmitter. Depression of the plunger caused a rocker-arm assembly to oscillate under the driving action of the weights that can be seen suspended below. Two platinum rods operating as a contact breaker oscillated at right-angles to two fixed bars, enabling positive and negative potential derived from dry cells to be applied alternately to the bell circuit. Once the plunger had been operated, the transmitter remained functioning for a nominal 25 seconds, although this was adjustable over quite wide limits by the addition or removal of weights. The ringing of the bells could not be cancelled once the plunger had been operated. If weights were altered, in addition to varying the overall time of ringing from 25 seconds, the frequency of ringing would also change. For a Division the operator was required to be in attendance to operate the plunger four separate times, the intervals between the periods of ringing being judged by himself to be 10 seconds. Auxiliary contacts of the transmitter fed 17 c/s ringing current to the external bells wired in locations situated near the House, and it is known that this facility was provided about 1910.

Fig. 2 shows one of the polarized bells used in the old

system and required to be retained under the new. They are of rather large physical dimensions, being 10 in. wide by 12 in. high with 4½-in. diameter gongs. The majority of bells installed in the House are built into the furniture, usually being behind a grille. Constancy of ringing throughout the nominal 25 seconds was not a feature of the old system because the frequency of ringing was a function of the frequency of oscillation of the weight-driven rocker assembly.

Experiments made during the development of the new system established the fact that 3 c/s was the best frequency of ringing. Attempts to ring at a higher frequency into a circuit comprising 128 bells in series, bearing in mind the relatively large mass of the armature and the highly inductive load, led to intermittent failures. Ringing at a lower frequency did not appeal to the officials of the House. The reason for wiring all the internal bells in series was to ensure that should a disconnection occur in the wiring or bell coils the fact that no bell would ring would give a positive indication of a fault. Some time after the original installation a guard facility was introduced which gave advance warning of such a disconnection, a low current being fed continuously via a relay in series with the bells.

The original transmitters were designed to supply current from the dry cells to considerably fewer internal bells than exist at the present time and in the intervening years it has been the practice to maintain a ringing current of 1 amp by adding dry cells. The location of the transmitters for the old system was in the arm rests of the doorkeeper's chair. Two working transmitters were provided, one in the recesses of each arm, access being obtained by lifting a flap.

When the House of Commons was bombed during the Second World War a number of the bells and transmitters were damaged. Replicas of these were made and the whole system re-installed as before.

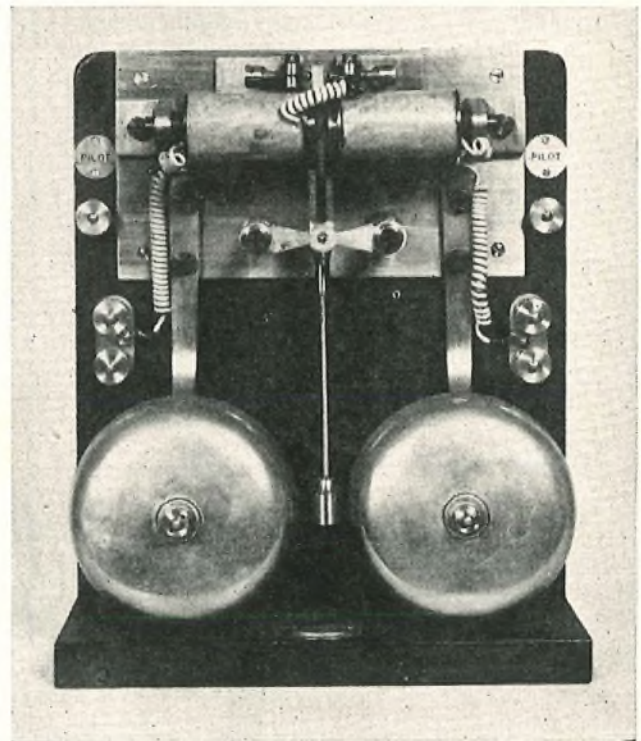

FIG. 2—ORIGINAL TYPE OF INTERNAL BELL

REPLACEMENT OF THE OLD SYSTEM

Confusion by Members in readily differentiating between Division and Count signals has become more pronounced in recent years but absence of a desire to make any change to the old system prevented steps being taken to provide any major improvement. In March 1958, however, at the request of the Assistant Postmaster General, engineering officers of the London Telecommunications Region demonstrated to an assembly including the Assistant Postmaster General, the Serjeant-at-Arms and Party Chief Whips the advantages of differential ringing for the two types of calls. For the purpose of this demonstration a tape recording was used to illustrate a continuous 2.5 c/s ring for a Division and a continuous 0.5 c/s ring for a Count. At this meeting, it was agreed that some form of differential ringing was necessary but the lower-frequency ring did not find favour and it was finally agreed that an interrupted ring of 4 seconds on and 2 seconds off should be used for the Count call.

The design and production of a machine generating these signals was requested as a matter of urgency. Within a week a prototype machine with lever-switch control was demonstrated to the same assembly, including on this occasion the Speaker of the House, and accepted in principle. In the following weeks additional facilities were requested and plans were made to incorporate them in the final design. It was an express wish of the Serjeant-at-Arms that, although accepting the improvements, the existing installation should be changed as little as possible. It was necessary therefore to design the complete installation legislating for no change to the type of bells used, their wiring, the two dry-cell installations and the guard facility. It was further requested that only the keys for initiating signalling conditions should be accommodated in the doorkeeper's chair. The standard Post Office lever-type key was not acceptable to the officials of the House and it was necessary to design and construct an entirely new type of lever switch to the approval of the Serjeant-at-Arms.

As with the old system, two working sets and one maintenance-spare set were required. The transmitters were produced in the London Telecommunications Regional Headquarters' workshop and after installation were subjected to accelerated life tests equivalent to approximately five years of normal use. On 15 May 1958 the Speaker made an announcement* from the Chair that a change in the system would be made. This announcement was followed by demonstrations of the equipment to Members and the Press, and the new system came into operation on 19 May 1958.

Amongst the newspaper correspondents reporting on the Speaker's announcement and the subsequent demonstration, the political correspondent of "The Times" observed the following in the issue of 16 May 1958: "Yet it was true that M.P.s had already asked if the rings could be made more distinct because of the chance of confusion, and experiments were already being conducted by the authorities of the House. It was felt that modern science could probably produce something better than the present transmitters, operated by a white-knobbed plunger hidden in the arm of the seat in the Members' Lobby, which although newly made when the new Chamber was opened was a replica of apparatus made about 100 years ago."

It is doubtful whether the original system is quite so old as stated, but however dated the old system might

* Hansard, Vol. 588, No. 110, Cols. 623/624.

appear to present-day Post Office engineers, its passing must not occur without tribute being paid to the craftsmanship which went into the manufacture of the components and the sterling service the units gave through many momentous years in the history of the House.

THE NEW SYSTEM

The new code of ringing the bells for a Division uses a frequency of 3 c/s for 55 seconds on, 10 seconds off, 55 seconds on, and for a Count the same frequency for 4 seconds on, 2 seconds off over a period of one minute. Within approximately 6 seconds Members can now differentiate between a Division and a Count.

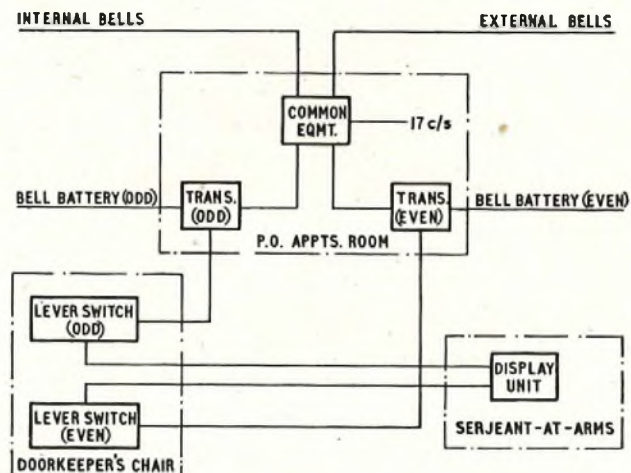

FIG. 3—BLOCK SCHEMATIC DIAGRAM OF THE NEW INSTALLATION

The general arrangement of the installation is shown in the block schematic of Fig. 3. The two transmitters, designated "odd" and "even," are mounted with the common equipment remote from the Chamber in the Post Office apparatus room. The transmitters are actuated by the lever-type switches installed in the same position as the old transmitters. A visual check of the selected cycle is given by a display unit fitted at the Serjeant-at-Arms position in the Chamber, where no bells are installed nor are any audible. Power supplies include two dry-cell installations to operate the internal bells, a 40-volt d.c. supply to run the motors of the transmitters, and a 17 c/s supply to ring the external bells.

Whereas in the old system the transmitter and operating lever were combined, the unit being of a mechanical rather than electro-mechanical nature, they are quite separate items in the new system.

Lever-Switch Assembly

Fig. 4 shows a plan view of a lever-switch assembly and Fig. 5 a view of the underside.

The facilities provided by each lever-switch include the following:

(a) Sending of start conditions for a Count or

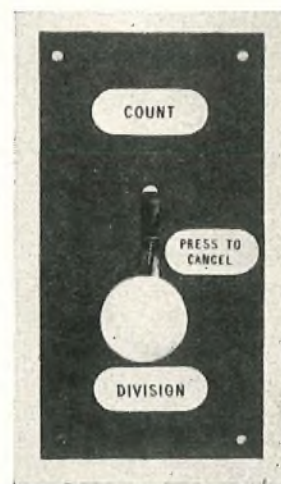

FIG. 4—PLAN VIEW OF LEVER-SWITCH ASSEMBLY

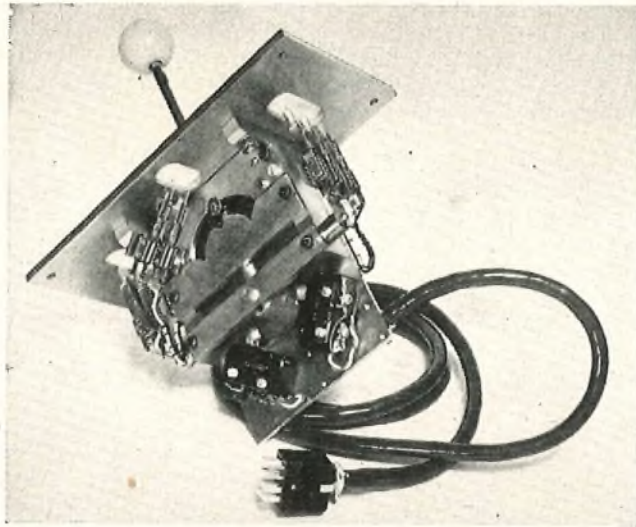

FIG. 5—UNDERSIDE VIEW OF LEVER-SWITCH ASSEMBLY

Division to its appropriate transmitter.

(b) Each assembly can be jacked out and replaced by a maintenance-spare switch if desired, all three assemblies being completely interchangeable.

(c) The operating lever locks in its central position so that it is capable of lateral movement only when depressed. The risk of accidental operation is thus almost eliminated.

(d) Depression of the operating lever whilst in the central position causes cancellation of any previous selection.

(e) Each assembly contains three displays, one to light when the Division cycle is in progress, the second when the Count cycle is in progress and the third after the Division cycle has been operating for 30 seconds. Each display is illuminated by more than one lamp to reduce the inconvenience should failure of one occur.

Much of the mechanism of the lever-switch assembly can be seen from Fig. 5. The locking of the lever is accomplished by a ball-bearing assembly which is held into a semi-circular recess in the quadrant under the action of a coiled spring exerting an upward pressure. After operation by hand to one extreme position or the other the hand may be removed and the lever immediately restores itself automatically to its normal locked central position due to the ball-bearing assembly acting against the specially curved surface of the quadrant.

As the lever-switch is depressed in its central position a projection on the central shaft causes a micro-switch to operate. This micro-switch is not shown in Fig. 5, being fitted on the side hidden from view. It was found in practice that there was a tendency by operators to cause rocking of the lever when attempting to cancel, which if pronounced would cause operation of the micro-switches associated with initiating conditions for signalling a Division or Count. A cross-bar was therefore fitted below the ball-bearing assembly with a V-shaped notch cut into it at its central point. This arrangement provides stability once the switch is depressed. Additionally the micro-switches for initiating Count and Division ringing cycles do not operate until the lever switch assumes an extreme position. Operation of these micro-switches is caused by projections on the surface of the cam fixed to the pivot of the switch. To cater for wear on cams and

bearings all mounting holes of the three micro-switches are slotted.

The reasons for using micro-switches included the positive action derived from a toggle operation of a switch and the ease with which the enclosed assembly could be changed should failure occur. The compact assembly of the micro-switch, with contacts completely enclosed, made them particularly suitable for a unit required to be sunk into a recess of an arm rest.

The whole assembly is of particularly rigid construction, the top plate being $\frac{3}{16}$ in. thick brass covered by green plastic material of the same shade as the leatherwork of the chair. This plate is secured to a ledge in the recess by four knurled screws fitted one in each corner. Electrical connexions are made using a 12-point plug and a socket which is permanently cabled to the Post Office apparatus room and the Serjeant-at-Arms position.

The Transmitters and Common Equipment

The odd and even transmitters, together with the common equipment, are mounted on a standard 19 in. panel on a rack in the Post Office apparatus room. The third, maintenance spare, transmitter and lever-switch are mounted separately on the rack in a position suitably wired to facilitate functional tests using the third, maintenance spare, lever-switch. This position may also be used to accommodate either of the two working machines for testing or faulting.

Fig. 6 shows one of the transmitters with covers removed. In addition to giving a source of ringing reversals, the transmitters and common equipment provide for:

(a) Output of the odd machine to be disconnected whilst the even machine is running. One machine thus takes precedence over the other, preventing both odd and even machines being operated within two minutes

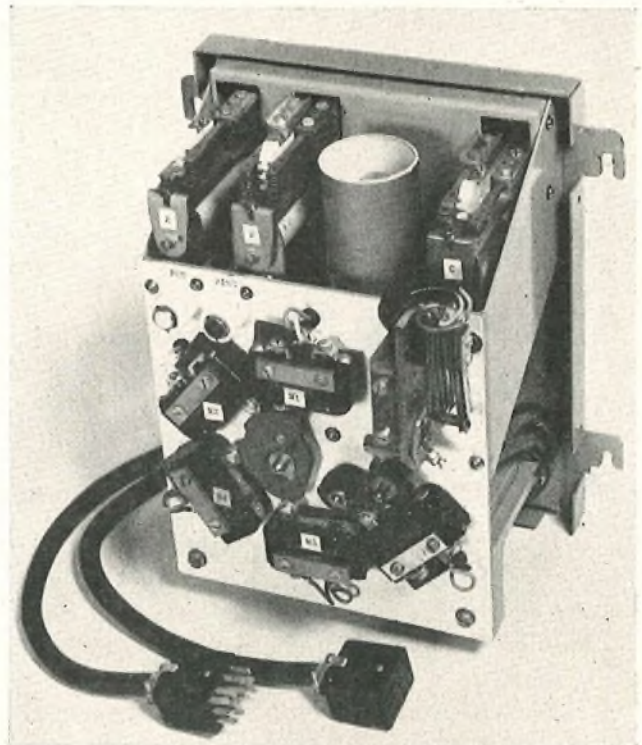

FIG. 6—THE NEW TRANSMITTER

of each other, with undesirable repercussions on ringing and battery supplies.

(b) A magnetic clutch to enable immediate cancellation of an existing cycle when signalled by the lever-switch, and rapid restoration to normal of the mechanism at the end of a Count cycle of 1 minute duration or Division cycle of 2 minutes duration.

(c) A signal to illuminate a display marked "Press to Cancel" on the lever-switch after the Division cycle has been in progress for 30 seconds. The purpose of this signal is to give the doorkeeper a measure of time indicating the point at which to cancel a Division cycle. Apart from Division and Count a third call, of 30 seconds continuous ringing, is used to indicate any one of three conditions—Speaker in the Chair, Speaker at Prayers, Who goes home?

(d) Adequate speed control, r.f. suppression, and spark quenching for contacts.

(e) A guard facility giving an alarm should there be a break in continuity of the bell circuit.

The shunt-wound motor of the transmitter operates at 1,800 r.p.m. and by suitable reduction gears three cam-shaft speeds of 60 r.p.m., 10 r.p.m., and 0.1 r.p.m. are obtained. The cam used to supply reversals of battery polarity for ringing the bells at 3 c/s is fitted to the 60 r.p.m. shaft and is on the right of Fig. 6. This cam is the only one not operating micro-switches because of the relatively higher frequency of operation. A relay spring-set assembly operated by an armature with roller bearing acting on the surface of the cam is used.

Four micro-switches, M1, M2, M3 and M4, function on the cam shaft operating at 0.1 r.p.m. The shaft, however, moves through only $\frac{1}{6}$ th of a complete revolution and is therefore termed the 2-minute cam shaft. M1 operates after 2 minutes, being the time of the Division cycle, M2 operates after 1 minute, being the time of the Count cycle, M3 operates 30 seconds after the commencement of the Division cycle and M4 operates 55 seconds after the start of the cycle, operating for 10 seconds to indicate the break of ringing in the Division cycle. The remaining micro-switch operates on the cam shaft rotating at 10 r.p.m., the cam being cut to provide the source of 4 seconds on, 2 seconds off, Count ringing. The motor is partially hidden behind the front plate although the cylindrical casing with perspex top cover housing the speed governor can be seen in Fig. 6.

A local indication when the motor is running or the ringing power supply is connected to the bell circuit is given by the two supervisory lamps mounted on the plate.

The common equipment comprises such units as fuse mounting, alarm relay, guard relay and connexion strips.

A problem was presented by the request for a facility to restore any selected cycle to normal immediately, bearing in mind that the motor was being used to drive a series of cams operating micro-switches at specific stages throughout a cycle. It was decided to use a magnetic clutch to provide the facility. It was necessary to consider only the 2-minute cam since it was not particularly important for the cams operating the ringing contacts or ringing interruptions to be phased. The 2-minute cam, however, operates micro-switches M1 to M4 concerned with the progress of either Division or Count cycles.

The elements comprising the magnetic clutch are shown in Fig. 7. The clutch windings are situated within an annular groove contained in the clutch body.

The clutch body is held against the back-stop, as shown, a projection being fitted to the rim; a tensioned spring is provided at the remote end of the shaft to give the restoring torque.

The shaft can be considered as comprising two parts, the driven portion being the 2-minute cam shaft operating micro-switches M1 to M4, to which the clutch body is rigidly fixed, and the driving portion consisting of a sleeve fitting over the driven shaft at the point where this shaft is of reduced diameter. The clutch plate is normally keyed to this sleeve so that it is in close proximity with the clutch body. To this same sleeve is brazed a worm wheel deriving its motion from the motor via reduction gears in the gear box.

The clutch coil, armature and field coils are wired in parallel, all therefore being energized at the same time by a contact of a relay operated from a micro-switch of the lever switch assembly. When the clutch coils are energized the driving and driven shafts move together until either micro-switch M1 or M2 is operated. Either micro-switch releases the holding circuit of the relay but M2 is arranged to be ineffective when a Division cycle is in progress.

The circuits of clutch and motor are then de-energized and the clutch body restores to normal against the back-stop position under the action of the spring. To cancel a cycle at any time before its end, the micro-switch

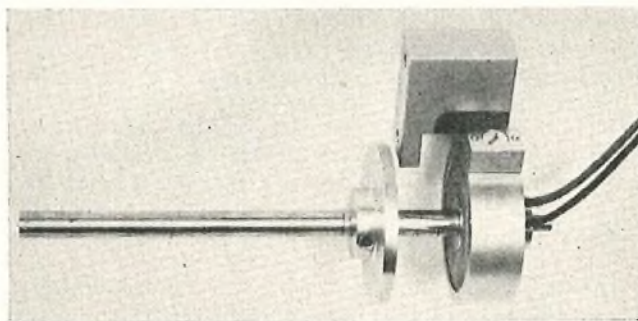

FIG. 7—ELEMENTS OF THE MAGNETIC-CLUTCH ASSEMBLY

operated on depression of the lever-switch similarly disconnects the holding circuit of the relay and the same conditions obtain.

CONCLUSION

The equipment has operated efficiently since its inception, the display unit fitted at the Serjeant-at-Arms position enabling a rapid check of correct selection to be made.

The design of the equipment has provided the London Telecommunications Region with an interesting exercise of producing, within a short period, an item as reliable as possible and containing a number of novel features.

ACKNOWLEDGEMENTS

The authors wish to acknowledge the assistance received from the Serjeant-at-Arms at the House of Commons, Major-General I.T.P. Hughes, C.B., C.B.E., D.S.O., M.C., and his staff and the co-operation of colleagues of the Engineering Branch and of the staff of the Telephone Manager, Centre Telephone Area, London Telecommunications Region.

The 4000-Type Selector

R. F. PURVES, A.M.I.E.E., and A. WALKER†

U.D.C. 621.395.6:621.395.342.22

A new 2-motion selector has recently been standardized by the British Post Office. Known as the 4000-Type Selector, it is based on the design of the SE 50 selector developed by the General Electric Company, Ltd. It is completely interchangeable with the 2000-type selector as regards facilities, mounting and rack arrangement. There are, however, small circuit differences, mainly due to the use of a release magnet.

INTRODUCTION

THE Strowger system of automatic telephony has been the Post Office standard since 1921, and it has remained pre-eminent because of the inherent simplicity of step-by-step operation on a decimal basis, with selectors responding directly to the dialled pulses. While the Strowger system remains fundamentally as originally designed, the basic mechanism of the system, the 2-motion selector, has received a great deal of attention from designers. Many readers will already be familiar with the Post Office 2000¹ and pre-2000 types of this switch.

During the last 10 years a new selector, known as the SE 50, has been under development by the General Electric Co., Ltd., and with minor alterations it has now been accepted as the Post Office 4000-type selector. It is completely interchangeable with its 2000-type counterpart as regards facilities, mounting and rack arrangement, although minor circuit differences exist, mainly due to the use of a release magnet, as described later. Concurrently with the adoption of the 4000-type selector for new exchanges other than U.A.X.'s, the Post Office has taken the opportunity to effect circuit changes which will facilitate the introduction of subscriber trunk dialling in due course.

The decision to adopt the switch was taken following the satisfactory results obtained from extensive testing in the Telephone Branch Circuit Laboratory, and from field trials of about three years' duration.

The minor alterations referred to above, and described in later paragraphs, resulted mainly from the laboratory tests, which included the taking of high-speed film records. These films proved particularly useful in assessing the extent of the adjustment range and manufacturing tolerances permissible on various parts and the technique was used to show the points at which mechanical vibration and "bounce" were liable to occur, and hence to determine the adequacy of methods adopted for their reduction.

On the normal functional tests, tests under adverse adjustment, life tests and field trials, the performance of the 4000-type selector has been such as to suggest that switches of this type should give reliable service coupled with economic maintenance over long periods.

MECHANICAL DESIGN

In appearance, size and function, the 4000-type selector (Fig. 1) resembles the 2000-type quite closely; it

† The authors are, respectively, Executive Engineer and Assistant Engineer, Telephone Exchange Standards and Maintenance Branch, E.-in-C.'s Office.

¹ YOUNG, J. S. The Post Office 2000-Type Selector. Its Development and Mechanical Details. *P.O.E.E.J.*, Vol. 28, p. 249, Jan. 1936.

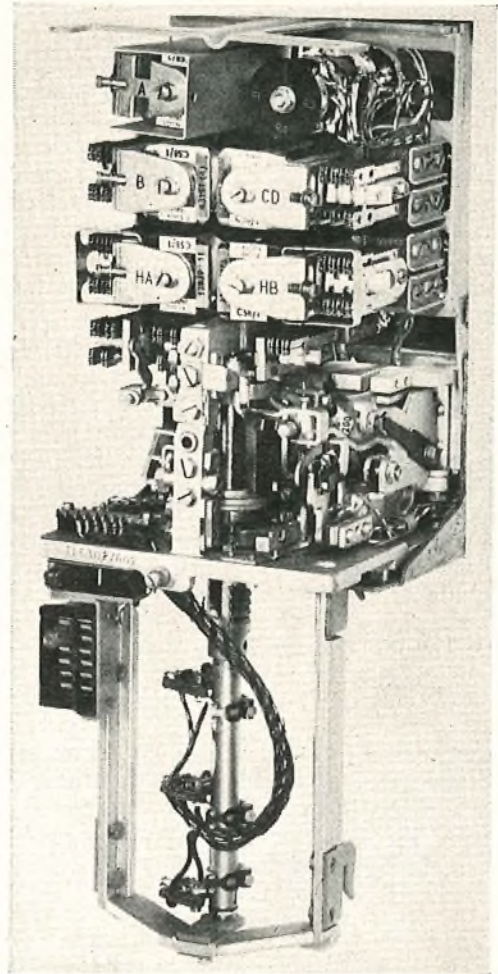
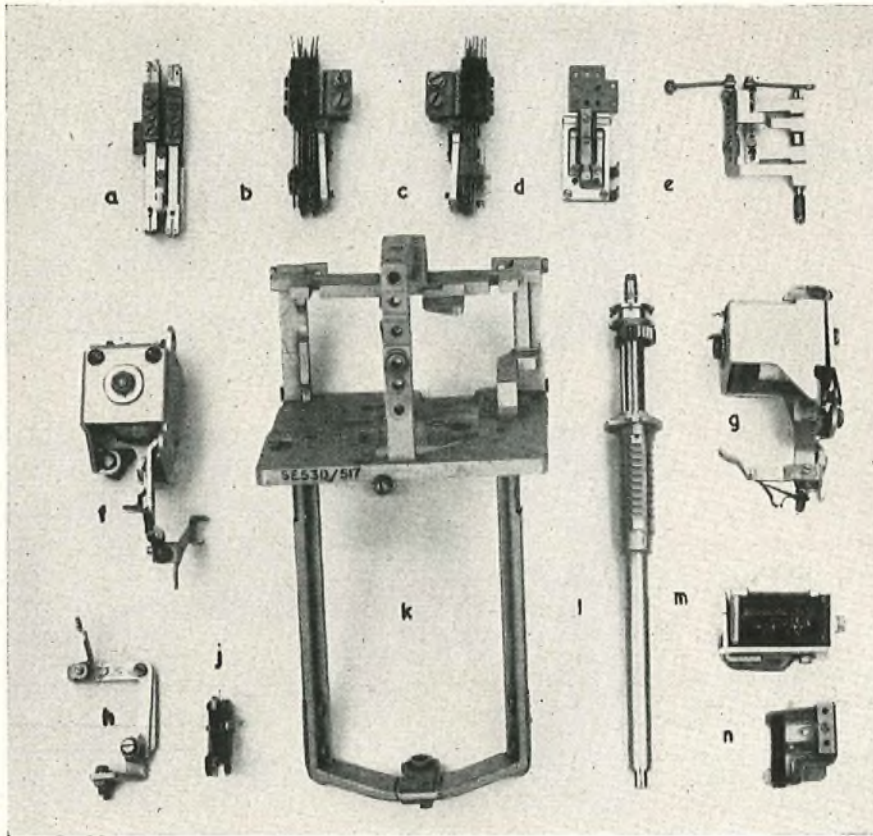

FIG. 1—THE 4000-TYPE GROUP SELECTOR

occupies the same volume and shape, but it is slightly lighter in weight. Vertical and rotary operation of the switch are precisely the same as those of the 2000-type, but release occurs through the operation of a release magnet, which causes the wipers to return over the same path under control of the rotary and vertical return springs. This represents a reversion to the pre-2000-type release principle and a departure from the forward rectangular release given by the 2000-type selector.

All parts of the mechanism are made to a standard of accuracy which ensures a good fit with a minimum of adjustment, and the adjustments themselves are independent of each other. The materials used for all important parts have been carefully specified in order to avoid any wide divergencies in performance.

The complete mechanism comprises a number of sub-assemblies (about 15 in all) covering all the main components, plus a number of small parts which can be replaced separately. The sub-assemblies are accurately aligned in jigs in the factory and are sent out fully adjusted as complete units which can be put into service



a = N spring-set
 b = NR spring-set
 c = S spring-set
 d = NPA and NPB spring-set platform
 e = NPA and NPB actuating mechanism
 f = vertical magnet
 g = rotary magnet
 h = N spring-set operating lever
 j = vertical interrupter
 k = frame
 l = shaft and carriage assembly
 m = release magnet
 n = rotary interrupter

FIG. 2—TYPICAL SUB-ASSEMBLIES

with minimum difficulty and delay. Typical sub-assemblies are shown in Fig. 2.

Replacement sub-assemblies will not be broken down into individual parts but certain screws, nuts, springs, clamping plates, etc., although forming parts of the various sub-assemblies, will be available separately so as to avoid any expensive replacements due to inadvertent loss of, or damage to, small parts.

High standards of accuracy in manufacture are required with workshop production of parts to close tolerances and, in consequence, the assembly work is considerably simplified. The actual works tolerances used by one manufacturer for the shaft-and-ratchet assembly (which forms one of the sub-assemblies) is an example which may be of interest; the dimensional limits are:

- (i) Shaft diameter, 0.2465 — 0.2470 in.
- (ii) Top-frame hole diameter, 0.2477 ± 0.0005 in.
- (iii) Rotary-ratchet hole diameter, 0.2480 ± 0.0005 in.
- (iv) Lower-shaft gland bearing, 0.2480 ± 0.0006 in.
- (v) Rotary-ratchet outer diameter, $0.4120 + 0.0000$ and -0.001 in.
- (vi) Vertical-ratchet internal diameter, $0.4130 + 0.0002$ and -0.0003 in.
- (vii) Vertical-ratchet spline guides, $0.1864 + 0.0006$ and -0.0000 in.
- (viii) Rotary-ratchet splines, $0.1857 + 0.0000$ and -0.0007 in.

The tolerances on hole sizes and centre-to-centre dimensions are also tightly controlled in order to minimize mal-alignment and adjustment during assembly.

Maintenance adjustments are made by screw and locknut, screw-in-slot, or eccentric screw, and the type of bending adjustment common on 2000-type mechanisms has been practically eliminated. The amount of readjustment required after "bedding-down" in service is negligible due to the accurate construction of the sub-assemblies, and because large areas of contact, rather than point or line contact, exist at the working surfaces.

Frame and Columns

The frame casting is designed to give maximum strength consistent with lightness and to avoid severe stresses under working conditions. It is so proportioned that, when fixing various parts, no distortion of the frame occurs. Datum faces are provided for alignment with the cradle and for positioning many of the sub-assemblies. The number of threaded holes has been reduced to a minimum in order to avoid the scrapping of frames due to threads being stripped or screws broken.

The use of solid cast frame-extension columns gives improved shaft and ratchet rigidity. The

rotary ratchet is located near to the top of the shaft and, by virtue of its position, appreciable bending or whip in the shaft during rotary stepping is avoided.

The frame is produced from a selected aluminium-silicon alloy by the cold-chamber process of pressure die-casting; the frame columns and the sub-armatures for mounting mechanically-operated spring-sets are cast from the same material.

Ratchets

The rotary ratchet has no vertical movement, and its long central bearing embraces the main shaft, resulting in a robust structure with free rotary movement and a minimum of play. Due to the absence of vertical movement, it has been possible to reduce the area of the ratchet teeth by about 80 per cent as compared with the 2000-type selector. The ratchet is made from high-grade aluminium-bronze and is produced by the hobbing process, which provides distinct advantages, both in accuracy and ease of production, over the single-cutter or the shaping processes.

The vertical ratchet moves up and down an accurately cut spline in the cylindrical portion of the rotary ratchet, and is located by internally-broached guides in the vertical cam, mounted on top of the vertical ratchet (see Fig. 3). Some of the important dimensions of this part of the mechanism were quoted in an earlier paragraph, but it should be emphasized that the main interest lies in

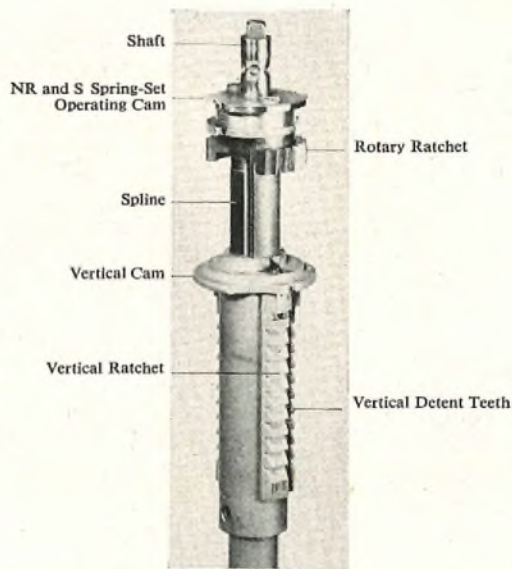

FIG. 3—RATCHET ASSEMBLY

the overall amount of play occurring at the wiper tips. Tolerances on individual parts forming sub-assemblies are not required on Post Office drawings, but as a check on the accuracy of manufacture, overall limits must be met. In the case of the vertical and rotary ratchet assembly, the maximum play at the wiper tips is specified, and this is a function of spline play, shaft bearing play and diametral differences between the rotary and vertical ratchets. Possible wiper overshoot is therefore limited to an amount which eliminates such troubles as overstepping free outlets or switching to busy outlets.

Shaft-and-Ratchet Assembly

The design of the complete shaft-and-ratchet assembly has been the subject of much careful trial and investigation into the type of material, processing, working tolerances and other requirements of a mechanical system of this nature. Adjustable spline guides were initially provided, but have now been replaced by guides which are broached in the vertical cam, as previously stated. This simplification has been introduced because no measurable wear occurred between spline and guides in service and the adjustment therefore proved to be unnecessary as the play can be accurately controlled during manufacture.

Magnet Assemblies

The vertical- and rotary-magnet assemblies have the box-shaped yoke (Fig. 4 and 5) already in use with the Type-2 and Type-3 uniselectors. The electromagnets are sufficiently powerful to operate the selector at appropriate speeds with an adequate reserve of power. The armatures are of rigid construction with a minimum of weight. The forms of the pawls and the positions and shapes of the pawl stops are such that the momentum of the moving ratchet systems is absorbed easily and quickly with the minimum of shock. The travel of the armatures is controlled by backstops screwed in the coil box and the interrupter spring-sets are mounted on brackets attached to the coil box.

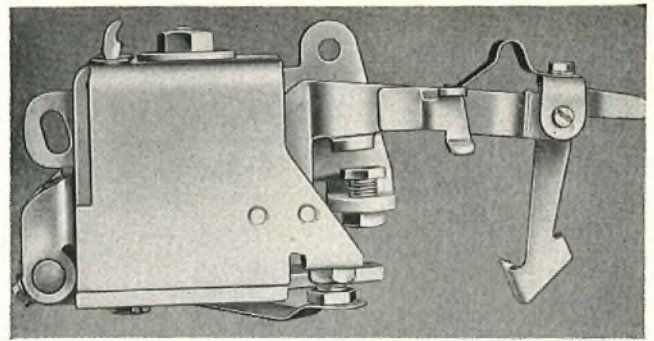

FIG. 4—VERTICAL-MAGNET ASSEMBLY

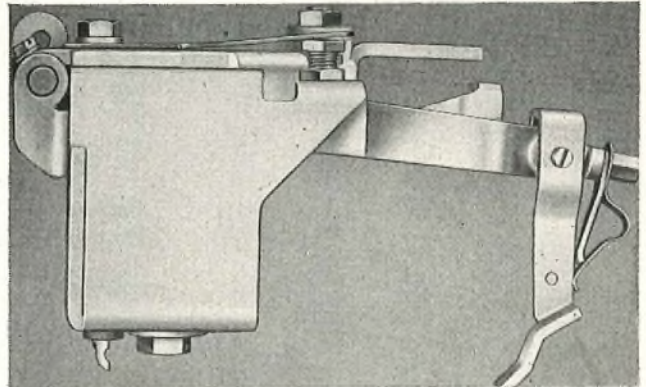
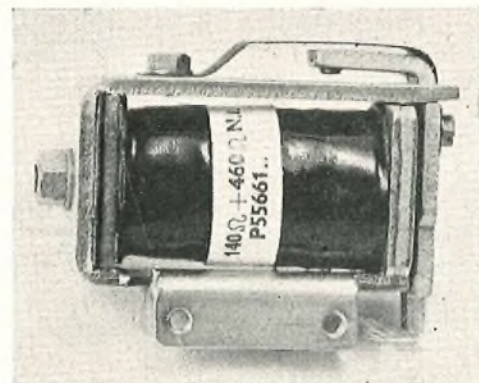

FIG. 5—ROTARY-MAGNET ASSEMBLY

The release magnet is located at the rear of the frame base and the armature engages with the release bar to provide rotary and then vertical release. Fig. 6 shows the armature in the operated position.

Detents

The vertical and rotary detents are pivoted on a spindle which is adjustable to permit correct engagement with the respective ratchet teeth, and also to engage with a release bar operated from the release magnet. The release bar has a hand-release feature at the front of the switch, so that pressure from the front end causes release in the same manner as electrical operation of the release magnet. Initial movement of the bar releases the rotary detent and further movement releases the vertical



Armature is shown in the operated position
FIG. 6—RELEASE MAGNET

detent. A stationary detent engages with the vertical detent teeth in order to restrain the carriage from vertical release until rotary release is complete. The switch design provides for the inclusion of a small interceptor magnet operating on the release bar to give rotary release only, so that "hunting" over more than one level can be used on "over-20" P.B.X. groups. This feature is not required on Post Office circuits at present and the interceptor magnet is therefore omitted.

Interrupters

The vertical and rotary interrupters are identical in design and use a form of toggle action which is reliable and unlikely to suffer from wear of the bearing or need readjustment in service. The design has been improved over early models as regards vibration and "contact bounce" (this trouble having been identified on high-speed films). The assembly of springs allows for "make," "break" or "change-over" actions.

Wipers

Post Office standard wipers are used throughout, i.e. Wipers No. 22 for line and private wipers and Wipers No. 23 for the vertical-marking wiper.

The line and private wipers originally designed for use on the SE 50 selector were of a "cross-over" type, with independent vertical and rotary adjustments. To obtain this adjustment feature the wiper-carriage tube was splined externally. Laboratory tests on various versions of this type of wiper showed that tip-gap adjustment was not maintained in service and the wiper was unreliable in that a number fractured during test as a result of "crashing" on rotary rebound. Wipers No. 22 were then tested on the SE 50 selector and as they gave a superior performance were adopted as the Post Office standard. The use of a spring clamp for wiper fixing resulted in a simpler design of wiper carriage as the splines were no longer required.

The wiper cords are terminated on a standard 10-way 2000-type terminal block.

Test Jack

The test jack, which is secured by a single screw, is similar in design to that used on the 2000-type selector, but to obtain easy access to the uppermost wiper, part of the test jack is mounted vertically.

Mechanically-Operated Spring-Sets (Fig. 7)

The springs, which are of 600-type relay pattern, are 12 mils thick, and "make," "break" and "change-over" units are provided. The spring-set assemblies are operated by auxiliary armatures in much the same manner as the latest design of mechanically-operated springs on the 2000-type selector.² The auxiliary armatures pivot about generous-sized phosphor-bronze bearings.

The relative positions of the mechanically-operated spring-sets differ from those on the 2000-type selector in that the NR spring-sets are adjacent to the shaft and the N spring-sets occupy the outer position.

Vertical Off-Normal Springs (N). As in the case of the 2000-type selector, the "N" springs of the new selector are in the operated position when the selector is in the normal position.

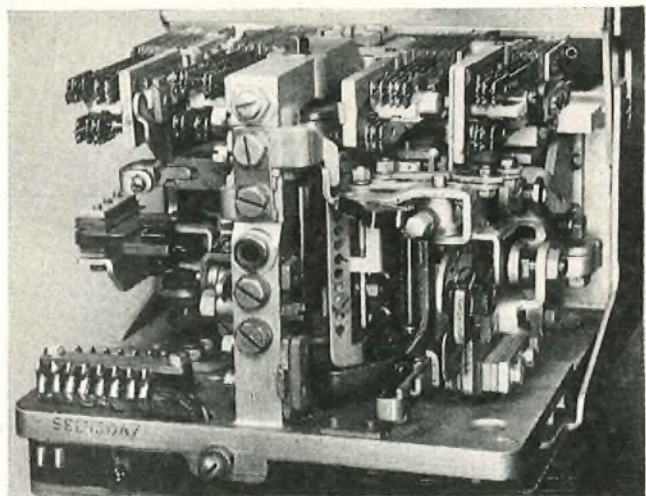

FIG. 7.—MECHANISM, SHOWING MECHANICALLY-OPERATED SPRING-SETS AND LINKAGES

The linkage system used to operate the auxiliary armature consists of a cranked lever, having one end fitted with a cam-follower and the other end forked to operate a toggle-type lever. In the normal position the tension of the "N" springs, via the linkage, holds the cam-follower in contact with the vertical cam, which forms part of the vertical-ratchet assembly. On the first vertical step the vertical cam is lifted clear of its cam-follower and the tension of the "N" springs is relieved. On restoration the cam-follower is picked up by the vertical cam as the selector reaches the normal position, and the "N" springs are re-operated.

Normal-Post Springs (NP). The NPA and NPB normal-post spring assemblies are both operated via auxiliary armatures fitted to a common mounting plate. Level cams are fitted to the NP "gates," which hinge about a common bearing spindle. These gates are each connected to their associated auxiliary armature by a coupling link, and adjustment of the spring-set travel is obtained by the use of an eccentric screw which forms the pivot for one end of the coupling link. Movement of the NP springs is effected by the vertical cam, which imparts a sideways thrust to the NP linkage.

Unlike the 2000-type selector, the NP springs may be re-operated as the selector restores to normal.

Rotary Off-Normal (NR) and 11th Step (S) Springs. The NR and S auxiliary armatures are operated direct from a 2-lobed concentric cam rigidly attached to the rotary ratchet.

MAINTENANCE

Most parts of the mechanism are easily accessible for maintenance purposes and many adjustments can be made from the front of the switch. For example, on the central frame-member are located the shaft-locking plunger, rotary-return stop, rotary-pawl front-stop, rotary-pawl guide, vertical-pawl front-stop, vertical-pawl guide and stationary detent.

The vertical and rotary magnets are self-contained units and, although adjustments can be made from the front of the selector, each magnet unit can, if necessary, be removed from the frame, adjusted and replaced in the frame without interfering with any other adjustments.

² SEYMOUR, E. H. Improvements to the 2000-Type Selector. P.O.E.E.J., Vol. 47, p. 25, Apr. 1954.

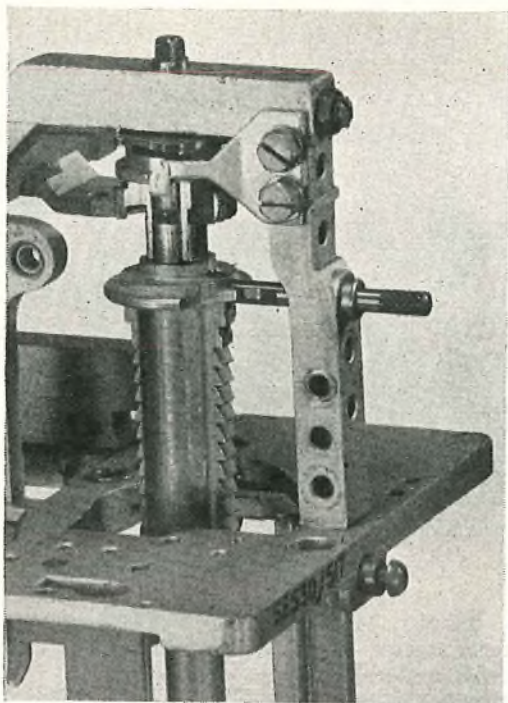

FIG. 8—SHAFT ASSEMBLY LOCKED IN POSITION BY DATUM PIN

One of the main features of the 4000-type selector from the adjustment point of view is that a fixed datum point is provided about which adjustments to various parts of the mechanism can be made independently without disturbing the adjustment of associated parts. This datum point is located in the normal rotary position on the 8th level and the shaft assembly can be locked in this position by the insertion of a datum pin through a bushed hole in the central frame member. This datum pin engages in a slot in the vertical cam (see Fig. 8). With the datum pin in position, assembly and alignment of all units associated with the shaft assembly are readily accomplished. Further, during adjustment, the mechanism can be easily returned to the datum point and any re-adjustments necessary can be related correctly to a uniform and consistent point.

Tools

A number of new tools have been introduced to cater for the new adjustment technique. Amongst these are the datum pin, a setting gauge for adjustment of carriage height, non-magnetic double-ended gauges for checking armature travel and a special gauge to align the shaft assembly should this unit be removed for any reason. This latter gauge is required in order to maintain the accurate relationship between the shaft and the various datum faces, which involves a special jiggling operation during assembly.

CIRCUIT ARRANGEMENTS

The circuits follow closely the 2000-type equivalents, except in respect of the provision of the release magnet, which entails a contact change on the B relay. A slight alteration has been made, however, to facilitate the clearing of "called-subscriber-held" faults. In the past these were traced back to the line circuit and a disconnection was made at the M.D.F. to release the selector train, or the B relay in the final selector was released manually. The 4000-type selectors are being provided with a test-jack point from the battery-connected side of the B relay so that the relay can be released by short-circuiting this test point with an adjacent earth-connected point; the called-subscriber-held condition is then cleared from the final selector and indicated as a "P.G." on the first selector.

The new selector circuits for director exchanges, however, will incorporate optional periodic metering in the first-code selectors in order to achieve considerable savings as against later modification, and discrimination for "Code 100" assistance calls has been included in those directors with manual-board access.

As rack design is not affected by the new switch, the term "4000-Type" will be used only in the titles of new selector-circuit diagrams, and not in those applicable to relay-sets and strip-mounted equipment, which will continue to be styled "2000-Type." Thus, the term "4000-Type" on a diagram merely implies that the new selector is fitted, the rack still being "2000-Type."

The associated routiner circuits are at present being examined; some are being slightly altered to suit both types of equipment, while in other cases new circuits will be introduced for the 4000-type circuits.

CONCLUSION

The SE 50 switch was designed and developed as a production item by the General Electric Co., Ltd., the final work of standardization as the Post Office 4000-type selector being carried out subsequently by co-operative effort through the British Telephone Technical Development Committee. All manufacturers will shortly commence to supply the switch for new telephone exchanges but, for the present, the 2000-type selector will remain the standard for U.A.X.s and for extensions to existing exchanges.

It will require many years of field service with large numbers of the new switch in operation for conclusive evidence to be obtained on its performance in comparison with earlier types of 2-motion switch. Experience to date in the laboratory and field, however, suggests that the long-term results may be awaited with confidence.

ACKNOWLEDGEMENTS

The authors wish to thank the General Electric Co., Ltd., and their colleagues in the Telephone Branch Circuit Laboratory for their assistance and co-operation in the preparation of this article.

A Microwave Model Equipment for Use in the Study of the Directivity Characteristics of Short-Wave Aerials

Part 2—Some Investigations Carried Out with the Model Equipment

D. W. MORRIS, B.Sc.(Eng.), A.M.I.E.E., E. W. THURLOW, A.M.I.E.E.,
and W. N. GENNA, Associate I.E.E.†

U.D.C. 621.396.67.001.57:621.3.012.12

Part 1 of this article described a technique that has been developed for studying the performance of short-wave aerials by the use of small models operating at microwave frequencies. Part 2, the concluding part, gives the results of various problems that have been investigated using the model equipment. These include studies of the directivity characteristics of a rhombic aerial and a horizontal array of dipoles and the effect on aerial performance of nearby metallic structures. The article concludes with some information about the use made of the equipment in solving some typical development and siting problems.

INTRODUCTION

THE microwave model equipment has been used to investigate various problems relating to the directivity characteristics of aerials. With its aid it has been possible to acquire detailed information which in many cases could not be obtained by any other means or only by an undue expenditure of time and effort. Thus it has been possible to measure the three-dimensional directivity characteristics of some of the more commonly used short-wave directional aerials and so deduce the overall performances which could be expected from them in the field. Two types of aerial whose directivity characteristics are of particular interest are the rhombic aerial and the horizontal array of dipoles (H.A.D.), since in their most common forms they have similar forward gains and are not dissimilar in their overall space requirements when allowance is made for their relative operational band-widths. A comprehensive study of the directivity characteristics of these two aerials included measurements with the model aerial equipment and observations of traffic signals received on full-scale aerials.

The above-mentioned study illustrates the use of the model-aerial equipment to determine the performance of any given type of aerial under ideal conditions, i.e. when isolated from any form of structure that might influence its performance. This performance is in general similar to that which can be obtained by normal computing methods (although as shown in Part 1 the accuracy in detail of these methods is limited by the necessity to assume a form of current distribution which is amenable to mathematical treatment). In practice, however, aerials are inevitably associated with some form of supporting structure and are usually erected in the vicinity of other aerials, masts, buildings, etc., and a knowledge of the effects of these on the "ideal" performance of any given aerial is very desirable if optimum aerial performance is to be realized with economy of ground space and equipment. In many cases these effects are not readily calculable, whereas the construction of scale models of the various types of obstacles encountered in practice presents no difficulties.

† The authors are, respectively, Senior Executive Engineer and Executive Engineer, Radio Systems Development Division, Post Office Research Station, and Executive Engineer, Overseas Radio Planning and Provision Branch, E.-in-C.'s Office.

Accordingly, the model-aerial equipment has been used to give quantitative information on the effects of the presence of such obstacles at various distances from, and orientations relative to, a test aerial.

A useful aspect of the model-aerial technique is the ease with which conditions peculiar to a specific problem can be simulated. This is a very desirable facility when, for example, consideration is being given to the optimum siting of aerials in planning new radio stations or extensions to existing stations. Similarly, when the design details of an aerial and its associated supporting structure are being considered, it is invaluable to be able to determine quickly the effect of varying the relevant parameters by comparatively simple modifications of the scale model (sometimes merely changes in the relative positions of component items) rather than by theoretical studies, which tend to be laborious and time-consuming and may well yield only approximate results. These features of the model-aerial equipment make it a useful tool for use in the development of aerial systems. Several examples of problems of a specific nature which have been investigated with the aid of the equipment are given in this article.

DIRECTIVITY CHARACTERISTICS OF RHOMBIC AND H.A.D. AERIALS

Model Measurements

Horizontal Polarization. Measurements were made on a model rhombic aerial and a model horizontal array of dipoles (H.A.D.) of the form shown in Fig. 8. The

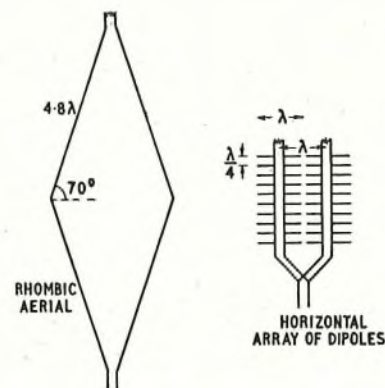

Height of each aerial above ground = 1.1λ
FIG. 8—DETAILS OF TEST AERIALS

models were scaled relative to typical full-scale aerials by a factor of 1 : 200 and were energized at a frequency of 3,000 Mc/s, corresponding to the design frequency (15 Mc/s) of the full-scale aerials. Azimuthal directivity characteristics of the aerials were recorded for every 2° or 4° of elevation from almost horizontal to almost vertical and the measurements were then repeated at

RHOMBIC AERIAL

HORIZONTAL ARRAY OF DIPOLES

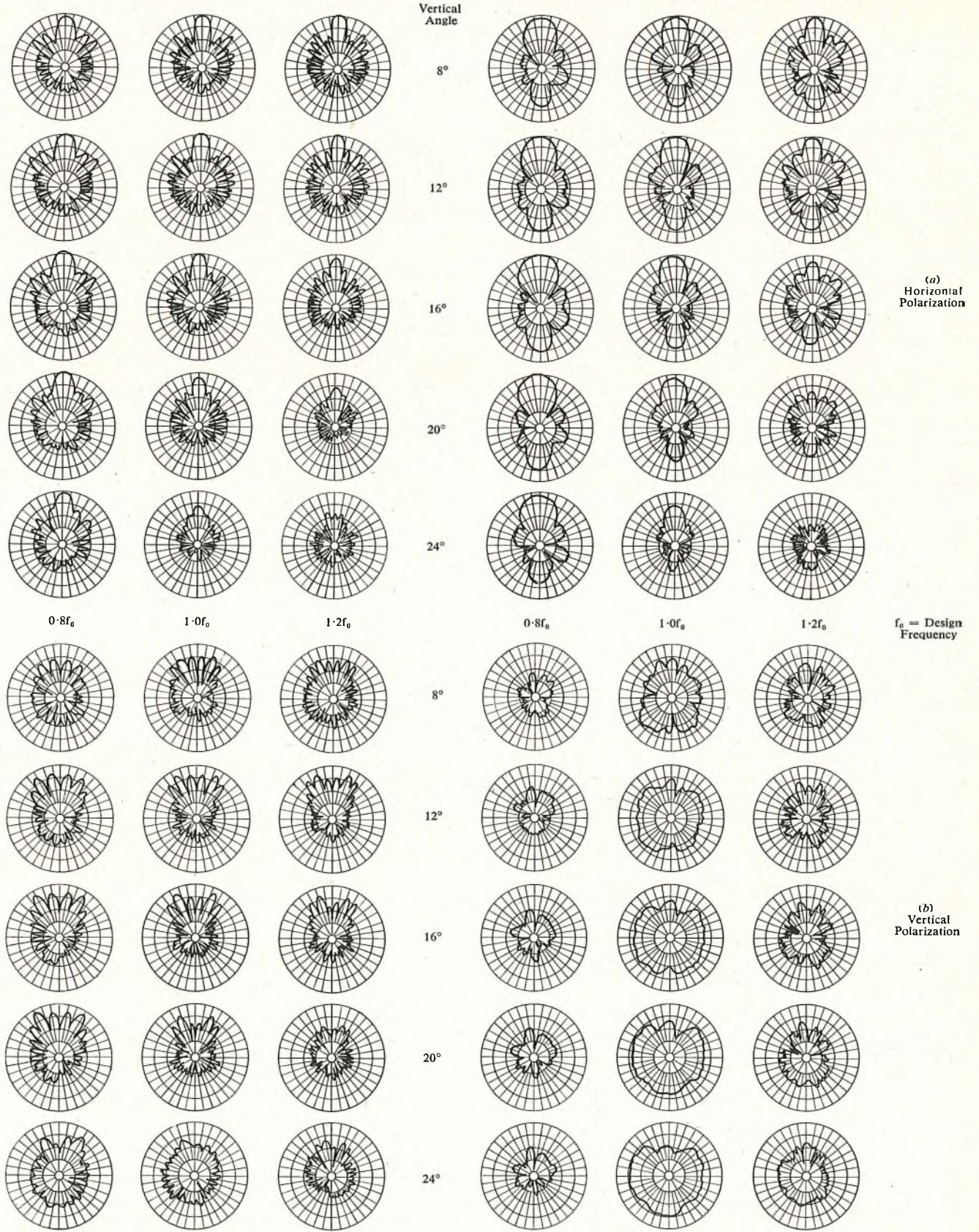

Graticule circles are spaced 10 db apart

FIG. 9—AZIMUTHAL DIRECTIVITY CHARACTERISTICS OF RHOMBIC AERIAL AND HORIZONTAL ARRAY OF DIPOLES

frequencies 20 per cent above and below the design frequency. Fig. 9 (a) shows directivity characteristics for vertical angles in the range 8°-24°, which includes the more usual angles of reception on short-wave circuits.

For each aerial the vertical angle was set for maximum response and the amplitude of the major lobe appearing on the face of the cathode-ray tube was then adjusted to coincide with the 0 db circle of the graticule. Hence, all the recorded directivity characteristics pertaining to one frequency can be compared on an amplitude basis; they cannot be directly related to those applicable to other frequencies, however, due to the frequency-sensitive nature of the signal source arrangements.

Vertical Polarization. The model-aerial equipment has been so designed that, when desired, the horn observation aerial can be rotated through 90°, in which condition it accepts only the vertically-polarized radiation from the aerial under test instead of the horizontally-polarized radiation considered hitherto; the cross-polarization ratio of the horn is about 35 db. Using this technique, the azimuthal directivity characteristics of the rhombic and H.A.D. aerials with respect to vertically-polarized signals were recorded. At each test frequency the vertical angle was set for maximum response with the observation aerial arranged for horizontal polarization and the amplitude of the major lobe was adjusted to coincide with the 0 db circle; the observation aerial was then rotated through 90° and the directivity characteristics for vertical polarization were recorded without further amplitude adjustment. Thus, the results of the vertical polarization measurements shown in Fig. 9 (b) for vertical angles in the range 8°-24° are expressed on the same scale as for the corresponding horizontal polarization measurements.

In estimating the performance of a full-scale receiving aerial from directivity characteristics obtained in this way by horizontal and vertical polarization measurements on models, it should be noted that the two sets of characteristics have the same relative significance when the aerial under consideration is used to receive radio waves in which the horizontally and vertically polarized components are equal. When one type of polarization is dominant only the appropriate set of characteristics need be considered. In general, radio waves reflected from the ionosphere are elliptically polarized; the precise form of the ellipse defining the polarization is determined by the relative amplitude and phases of the horizontal and vertical polarization components and depends on propagation conditions and frequency.

Measurements on Full-Scale Aerials by Observations of Traffic Signals

Measurements on full-scale aerials involving transmissions from aircraft, described in the first part of this article, provide very precise information regarding the directivity characteristic appropriate to one vertical angle of arrival (or at best a few selected angles) and to a signal of known polarization under single-path conditions. In practice, however, short-wave signals arrive at various vertical angles, by various paths, and with varying polarization conditions. It is important, therefore, to know the performances of full-scale rhombic aerials and H.A.D. aerials when measured with signals typical of those encountered operationally and thus be able to compare the results of the model measurements with those obtained in this manner. Accordingly, tests using normal traffic transmissions were carried out at

Cooling Radio Station on a rhombic and an H.A.D. aerial of the form shown in Fig. 8; the design frequency in each case was 15 Mc/s and both aerials were oriented for reception from Laurenceville, the American transmitting station of the transatlantic radio-telephony system. Two series of tests were carried out.

For the first, the two aerials were automatically connected in turn for five-minute periods to a single-sideband receiver tuned to the Laurenceville (on course) signal and a recording milliammeter was used to record the a.g.c. voltage, as a measure of the carrier level. The receiver was then tuned to any signal in the frequency band 12 to 18 Mc/s which could be identified (and thus the direction of its source known*) and the carrier levels were recorded using the aerials in turn, as before. This procedure was repeated for other signals of suitable frequency that could be identified. Mean values of the signal levels for the five-minute periods were then estimated from visual examination of the chart records and the relative levels of each signal as received on the two aerials were determined.

In the "on-course" directions the two aerials appeared to be equal in performance in that the signal levels measured were equal; it was observed, however, that interference from unwanted stations was more pronounced on the H.A.D. than on the rhombic aerial. The relative performances of the two aerials for any given "off-course" direction can be expressed as

$$P = \frac{\text{Protection Ratio of H.A.D.}}{\text{Protection Ratio of Rhombic}} \\ = \frac{(\text{Level of on-course signal on H.A.D.})/(\text{Level of off-course signal on H.A.D.})}{(\text{Level of on-course signal on Rhombic})/(\text{Level of off-course signal on Rhombic})} \text{ db,}$$

and, since the levels of the on-course signals are equal for the two aerials,

$$P = \frac{\text{Level of off-course signal on Rhombic}}{\text{Level of off-course signal on H.A.D.}} \text{ db.}$$

The values of P thus determined for several directions are shown in Fig. 10 by dotted lines. The length of each radial line from the circular datum line indicates the measure of the ratio of the protection ratios of the two aerials at the relevant azimuthal angle; outward-drawn lines indicate that the rhombic aerial has a better protection ratio and inward-drawn lines that the H.A.D. is better.

The chart records in the above tests indicated that for any given received signal the ratio of the levels from the two aerials, i.e. the protection ratio, varied with time, and accordingly a second series of tests was carried out in which the variation of the signal level from each aerial was analysed by the use of a level-distribution analyser. Each aerial in turn was connected for half-hourly periods to the single-sideband receiver, which was tuned initially to the on-course signal. An a.g.c. time-constant of 85 sec was used, so that the receiver gain was held substantially constant over a long period, and a recording milliammeter was arranged to record the a.g.c. voltage as a measure of the slow general changes of signal level. The more rapid changes of signal level were recorded by connecting the level-distribution analyser to the receiver carrier-alarm diode; this diode, which is at an earlier

* It should be noted that propagation conditions may sometimes be such that the actual azimuthal direction of arrival of a short-wave signal does not coincide with the true bearing of the transmitting source.

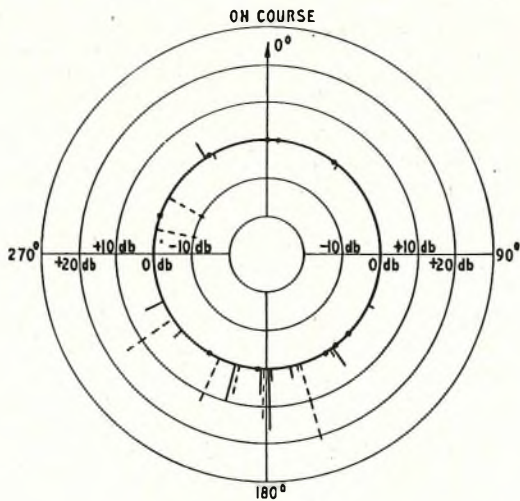

----- Direct Recording Tests Positive values = Rhombic better than H.A.D.
 ----- Level Distribution Tests Negative values = H.A.D. better than Rhombic
 • = Aerials equal in performance

FIG. 10—RELATIVE PROTECTION RATIOS OF H.A.D. AND RHOMBIC AERIAL FROM RESULTS OF TRAFFIC OBSERVATIONS

stage in the receiver than the a.g.c. diode, is associated with a short-time-constant circuit and so reproduces changes of signal level which are too rapid to be affected by the a.g.c. action of the receiver. The analyser was adjusted to cover a range of receiver input levels from +30 to +50 db relative to $1 \mu\text{V}$ in series with 75 ohms, in six steps spaced by 4 db intervals.

For each half-hour period the percentage of time that the recorded signal level exceeded each of the six analyser levels was determined from the analyser clock readings, and the results for each pair of adjacent half-hours (one with rhombic, one with H.A.D.) were plotted on "probability" graph paper. From each pair of curves the levels from each aerial which were exceeded for 99 per cent, 50 per cent and 1 per cent of the time were read off and the corresponding differences between the levels from the two aerials determined, taking into account the differences in the two a.g.c. settings of the receiver as indicated on the recorder chart. For the great majority of the transmissions observed the scatter of the 99 per cent, 50 per cent and 1 per cent figures did not exceed 2 db, and it is reasonable in each of these cases to take the 50 per cent figure as being representative of the relative responses of the two aerials to the particular transmission observed. The values of P for the different transmissions observed are shown in Fig. 10 by full lines.

Comparison of Results of Model and Full-scale Traffic Tests

Consideration of the directivity characteristics of the two aerials, as measured on microwave models, indicates that in general the rhombic aerial has a narrower major lobe in the forward direction and a better protection ratio in the backward direction. The H.A.D. has a better protection ratio at certain azimuthal angles about 30–40° off-course, but in general around the sides the relative performances of the two aerials depend very much on the particular azimuthal angle.

The measurements on full-scale aerials using normal traffic signals were necessarily limited by such factors as traffic schedules, the geographical positions of transmitters, and difficulties of identifying the source of

incoming signals, but the relative performances that were measured (summarized in Fig. 10) can be seen to be in good agreement qualitatively with those deduced from the results of the model tests.

THE EFFECT OF THE PROXIMITY OF METALLIC STRUCTURES

In the past little has been known about the extent to which the performance of a short-wave aerial-system can be influenced by the composition of its supporting structure and by the proximity of metal objects such as other aerials, metal masts and steel-frame buildings. Some guidance derived from early experience of long-wave aerials suggested that resonant lengths of metal in the supporting structure and close spacing between aerials should be avoided, but the lack of precise information was a serious handicap to the promotion of economy in the construction and siting of short-wave aerials. When post-war planning of new radio stations indicated that upwards of 30 aerials, each occupying nearly one acre of ground, might well be required at a single station, the problem of simplifying aerial construction and of determining the minimum permissible separation between aerials on a radio station site assumed great importance.

The investigation of such problems was well within the scope of the model-aerial equipment, and it was decided to carry out tests on a model of a typical rhombic aerial having dimensions, at a frequency of 20 Mc/s, as follows: side length 6λ , semi-side angle 70° , height 1.1λ .

Preliminary investigations established that a metallic structure produced a measurable change in the strength of the signal incident on the observation aerial only if it intercepted the path between the test aerial and the observation aerial or caused a substantial irregularity in the ground plane in front of the test aerial. With a few exceptions, therefore, measurements were restricted to determining the effect of various test conditions on the field intensity of the rhombic aerial only in the direction of maximum response. No evidence of distortion of the directivity characteristic was observed under any conditions likely to occur in practice.

Effect on a Rhombic Aerial of the Composition of its Supporting Structure

The scale model of the rhombic aerial was first supported by poles and stays made entirely of insulating material; the signal strength at the observation aerial measured under these conditions constituted the reference level for subsequent measurements. Metal poles and stays were then substituted step by step and measurements made with the combinations of pole and stay arrangements detailed below:

(i) Poles made of insulating material with continuous wire stays.

(ii) As (i) but with single wire stays broken up into $\frac{\lambda}{4}$ or $\frac{\lambda}{2}$ lengths, and either earthed to or insulated from the ground plane.

(iii) End poles fitted with two stays 90° apart, for all the variations of lengths and conditions referred to under (ii).

(iv) Metal poles, either earthed to, or insulated from, the ground plane, with insulated stays.

(v) Metal poles with the stay combinations detailed under (i) and (ii).

In no case could any change in the signal strength at the observation aerial be detected. It can be assumed therefore that the use of metal for the corresponding

components supporting a full-scale aerial has no significant effect on the performance of the aerial.

Effect of a Metal Lattice Mast in the Vicinity of a Rhombic Aerial

These tests were carried out using a 1:150 scale model of a 187 ft lattice mast fitted with a 28 ft horizontal top gantry. With this scale the effect of the full-scale mast at 20 Mc/s would be simulated by model tests at 3,000 Mc/s. For these tests two opposite faces of the model mast were rigged with K-bracing and two with cross-bracing; detachable horizontal bracing was also provided for all four faces. Details of the bracing arrangements are shown in Fig. 11. The reduction in signal level at the observation aerial was measured with the mast positioned at various distances in front of the rhombic test aerial, for each of the following test conditions:

- (i) With the K-braced faces of the mast parallel to the minor axis of the rhombic.
- (ii) As (i) but with horizontal bracing added.
- (iii) With the cross-braced faces of the mast parallel to the minor axis of the rhombic.
- (iv) As (iii) but with horizontal bracing added.

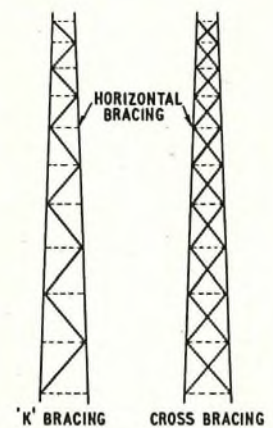

FIG. 11—BRACING ON MODEL LATTICE MAST

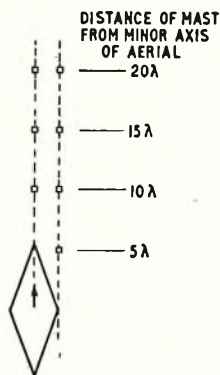

FIG. 12—POSITION OF MAST RELATIVE TO RHOMBIC AERIAL

Measurements were made with the mast directly ahead of the aerial, i.e. in line with its major axis, and also with the mast directly ahead of one of the side-poles, as shown in Fig. 12. The results are shown in Table 1.

TABLE 1
Effect of Metal Lattice Mast in Front of Rhombic Aerial

Position of Mast relative to Aerial		Reduction in Signal Level due to Mast			
Direction	Distance from Minor Axis of Aerial	With K-Braced Faces Parallel to Minor Axis of Aerial		With Cross-braced Faces Parallel to Minor Axis of Aerial	
		Without Horizontal Bracing	With Horizontal Bracing	Without Horizontal Bracing	With Horizontal Bracing
Directly ahead of front pole	Wavelengths				
	10	0.5	1.25	2.5	2.5
	15	0.5	0.75	1.75	1.25
	20	0.25	0.5	1	0.75
Directly ahead of side pole	5	0.5	2	2	1.75
	10	0.25	1.25	1	0.75
	15	0	1.5	0.5	0.5
	20	0	0.25	0.75	0.5

The results in Table 1 indicate that K-bracing alone is less troublesome than cross-bracing, as might be expected. However, the table also shows that pro-

gressive increases in the number of braces do not necessarily make the mast more troublesome. These results indicate that, when the bracing is such that the mast is partially "transparent," the distribution of currents in the mast and therefore the effect of the mast on a near-by aerial is determined by the particular configuration of the bracing. On the other hand, when bracing is so complex that the mast can be regarded as "solid," no increase of bracing will modify the effects caused by the mast. Measurements on a model mast made of continuous metal sheet produced results which differed little from those for cross-bracing with horizontal bracing, indicating that the latter combination may be considered as being effectively "solid."

The Effect of a Rhombic Aerial in the Vicinity of the Rhombic Test Aerial

Measurements were made in which a rhombic aerial of side length 6λ , erected at a height of 1.1λ and correctly terminated at both ends, was in the vicinity of the test aerial. The effect of this aerial was assessed for the configurations shown in Fig. 13 and the measurements were repeated with a smaller aerial of sidelength 3λ . The results are given in Table 2.

TABLE 2
Effect of Another Rhombic Aerial in Vicinity of Rhombic Aerial

Relative Position of Aerials (See Fig. 13)	Distance Between Centres of Aerials	Reduction in Signal Level	
		Due to 6λ Rhombic	Due to 3λ Rhombic
a	Wavelengths	db	db
	13	2.5	0.5
	15	1.75	0
	20	0.75	0
b	10	1.5	0.25
	12	1.5	—
	15	1	0
	18	0.5	0
c	8	0.5	0
	10	0	0
d	10	1	0.75
	15	0.75	0.5
	20	0	0
e	—	—	0.75
	8	1.5	—
	9	0.75	—
	10	0.5	—
	11	0.25	—

The Effect of a Koomans Array in the Vicinity of the Rhombic Test Aerial

For these tests a model of a horizontally-polarized Koomans array, comprising two 4-element bays with a detachable reflector curtain, was constructed. The array was scaled to be resonant at the test frequency, and was supported within a framework made of insulating material which by itself produced no effect upon the signal level at the observation aerial. Measurements were made with the normally-energized curtain terminated at the feed points, both with and without the reflector curtain fitted to the array, using the configurations shown in Fig. 14. The results given in Table 3 are for the energized curtain facing towards the test rhombic aerial; reversing the array, so that the reflector curtain

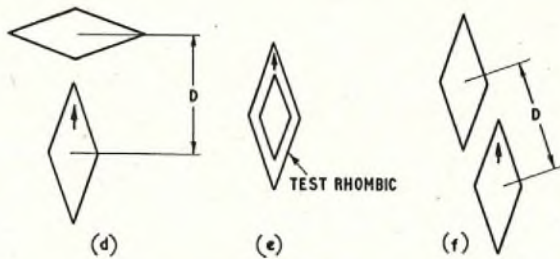
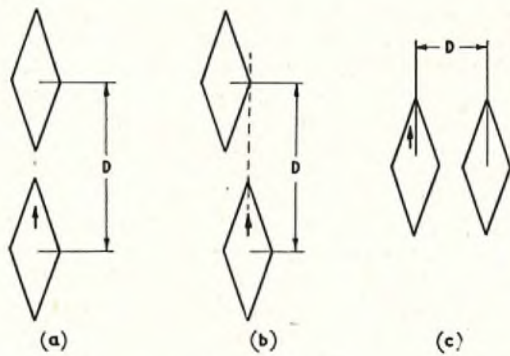

↑ denotes the test rhombic aerial
D denotes distance between centres of aerials
FIG. 13—RELATIVE POSITIONS OF RHOMBIC AERIALS

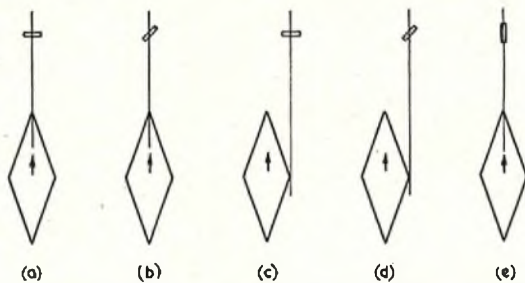

FIG. 14—POSITION OF KOOMANS ARRAY RELATIVE TO RHOMBIC AERIAL

was towards the rhombic, caused the figures given to be reduced by not more than 0.5 db.

TABLE 3
Effect of Koomans Array in Vicinity of Rhombic Aerial

Relative Positions of Aerials (See Fig. 14)	Distance Between Centres of Aerials	Reduction in Signal Level	
		Due to Array with Single Curtain	Due to Array with Double Curtain
a	Wavelengths	db	db
	9	1.25	2.75
	12	1.25	3
	15	1	2.5
b	9	—	0.5
	12	—	0.25
c	6	0.75	2.5
	9	0.5	2
	12	0.5	1.5
	15	0.25	1
	20	0	0.5
d	6	—	0.75
	9	—	0.25
e	9 to 20	0	0

The Effect of a Steel-frame Building in the Vicinity of the Rhombic Test Aerial

A steel-frame building was simulated by means of a five-sided box made of metal sheet. This is not an exact representation but since, in the general case, a building intercepts only the ground reflected ray from a rhombic aerial, it was considered adequate for the present investigations. Three sizes of box were used to simulate the effects produced at a frequency of 20 Mc/s of buildings having the dimensions quoted in Table 4. The values of reduction of signal level shown in Table 4 were measured with the building directly ahead of the aerial and with its broadside face parallel to the minor axis of the aerial. Distances were measured between the centre of the rhombic aerial and the nearer face of the building.

TABLE 4
Effect of Steel-frame Building in Vicinity of Rhombic Aerial

Distance from Centre of Aerial to Near Face of Building	Reduction in Signal Level due to Building of Dimensions given below		
	75 ft long 50 ft wide 25 ft high	150 ft long 50 ft wide 25 ft high	300 ft long 50 ft wide 25 ft high
Wavelengths	db	db	db
9	0.5	0.75	1
12	0.25	0.5	0.75
15	0	0.25	0.5

When a building was placed very close to, and to one side of, the rhombic aerial there was some slight evidence of distortion of the directivity characteristic. This effect was not investigated further since it was observed only with a spacing much closer than any likely to be encountered in practice.

SOME TYPICAL DEVELOPMENT AND SITING PROBLEMS New Rugby Transmitting Station

When the new transmitting station at Rugby was being planned it was proposed that a line of rhombic aerials be erected about 3,000 ft east of the existing GBR aerial-system. Such an arrangement, however, was open to the objection that the masts and cage aerials of the GBR aerial-system were liable to intercept transmissions from the rhombic aerials directed to the west, particularly at lower frequencies at which the spacing between the rhombic aerials and the GBR aerial-system was about 20 wavelengths. Scale-model tests were carried out therefore to determine the extent to which the performances of the rhombic aerials in their proposed positions would be influenced by the presence of the existing GBR aerial-system. Since the radiation from a rhombic aerial is largely concentrated in a beam, which could be intercepted by only a small part of the extensive GBR aerial-system, the investigation was simplified to the study of the effects of a single mast and a single cage aerial on the performance of a rhombic aerial. A further simplification was the use of a metal tube (of the appropriate dimensions) to simulate the mast; at the frequencies of interest the effect of the tube would be so close to that of a precisely-scaled model that the expense of constructing the latter was not justified. On the other hand, the stay wires were modelled fairly accurately because of their wide lateral spread. The tests were carried out with a rhombic aerial at a fixed height above the ground plane and operated at a fixed frequency, and interception over

a range of angles was simulated by raising and lowering the model mast and cage aerial.

The tests showed that the presence of the mast directly in front of the rhombic aerial, and at distances of between 20 and 100 wavelengths from it, had no significant effect on the performance of the aerial. The presence of the cage aerial affected the performance of the rhombic aerial only when the cage actually intercepted the beam of the rhombic aerial; grazing incidence produced no measurable change. When the cage aerial directly intercepted the beam and was at 90° to it the loss of signal strength was 1.5 db and 1.0 db at distances of 20 and 80 wavelengths respectively. When the cage aerial was at 45° to the beam the loss was 0.5 db at a distance of 20 wavelengths.

Bearley Receiving Station

The Bearley Receiving Station was installed on the site of a wartime aerodrome on the edge of which stood several aircraft hangars. The aerial-system for the station, which comprised a ring of 30 rhombic aeri-als, was designed for reception of signals on any bearing from 0° to 360° E of N, and so it was unavoidable that in some cases a hangar would lie in the direction of a signal being received. It was therefore essential, before the aeri-als were erected, to know the expected loss of performance of an aerial with a hangar directly ahead of it, i.e. the aerial "firing" over the hangar.

The hangar, which was 250 ft long, 120 ft wide and 50 ft high, was composed of metal sheets supported on a metal framework, and was readily simulated for model tests by a sheet of tin-plate cut and bent to the appropriate shape and size. The model "hangar" was then placed in front of a model rhombic aerial erected on the test turntable and the resulting reduction in the response of the aerial was observed. Measurements were made with the hangar broadside to the aerial and also end-on, with the hangar symmetrically disposed about the "line of fire" of the aerial in each case. Table 5 shows some typical results relating to a full-scale operational frequency of 13 Mc/s. The distances quoted are measured from the centre of the aerial to the leading edge of the hangar.

TABLE 5
Effect of "Firing" Over a Steel Hangar

Distance from Centre of Aerial to Leading Edge of Hangar	Reduction in Signal Level due to Hangar	
	Hangar Broadside-on	Hangar End-on
Wavelengths	db	db
9	4.5	2.75
11	3.5	2.5
13	2.5	2.25
15	2.0	1.75
17	1.0	1.25
19	0.75	0.75

Direct-Pick-up Aerials on the London-Isle of Wight Television Link

In the first London-Isle of Wight television link the normal program transmission from Alexandra Palace was received on a Yagi array supported on the 325 ft mast at the Golden Pot repeater station. After the link had been opened for service it was found that interference from the Eiffel Tower transmission was experienced during periods of abnormal propagation conditions,

despite the existence in the theoretical directivity characteristic of the Yagi array of a deep null in the azimuthal direction of the Eiffel Tower, and it was evident that the directional properties of the array had been influenced by the juxtaposition of the array and the mast. Scaled models were used first to confirm that this was so, and then to determine a position of the model array relative to the model mast in which the distortion of the relevant part of the directivity characteristic was minimized. The full-size array was moved to the corresponding position on the mast at the Golden Pot repeater station and the rearrangement proved effective in considerably reducing the level of the interference.

Unit Aerial for a Steerable Aerial-System

As part of a development project aimed at producing a steerable aerial-system it was necessary to develop a unit aerial with directivity and impedance characteristics substantially uniform for all azimuths and for a wide range of angles of elevation and of operational frequencies. Theory indicated that the form of aerial that would provide the nearest approach to these characteristics would be a cone-like structure, but it was important to know the effect of varying various parameters in the interests of simplicity and economy of construction. Accordingly, a number of models, scaled to about 1 in 200 for operation at microwave frequencies, were made and tested on the test turntable in order to determine the relative merits of their directivity characteristics. Those forms of aerial which were shown to be satisfactory in this respect were then modelled at a scale of 1 : 3 for field measurements to enable their impedance characteristics to be studied.

USE OF THE MODEL EQUIPMENT FOR DEMONSTRATIONS

Apart from its value as a measuring instrument the equipment has proved extremely useful for demonstration purposes. It has been used by the authors to demonstrate how directional aerials are built up from their constituent elements, i.e. from dipole elements in the case of resonant aerials such as Koomans arrays, and from long-wire elements in the case of travelling-wave aerials such as rhombics. The effects of obstacles can be demonstrated quickly and convincingly, including such aspects as the dependence of the degree of absorption on polarization. In this way the equipment may be employed as an educational aid.

ACKNOWLEDGEMENTS

The authors wish to record their indebtedness to Mr. W. G. Shaddick for his part in the work and in particular for the calculation of the theoretical characteristics.

Acknowledgements are due also to staff of the Royal Aeronautical Establishment, Farnborough, who provided the aircraft and ground/air two-way radiotelephony equipment for the measurements on the full-scale aerials, and to members of the External Telecommunications Executive who provided the aerials at Cooling Radio Station and excellent ground facilities. The success of the aircraft tests owed much to the skill, patience and cheerful co-operation of the personnel of these two organizations.

The authors also wish to thank Mr. W. S. Rodger and their other colleagues who assisted in the various facets of the work.

A Calibrated Signal Generator and Measuring Apparatus for International Signalling Systems

C. J. MAURER, B.Sc.(Eng.), and R. A. NOTMAN, Graduate I.E.E.†

U.D.C. 621.373.42:621.395.63:621.394.441

With the introduction of international telephone voice-frequency signalling systems the C.C.I.T.T. has recommended the provision of accurately calibrated signal generators and signal measuring apparatus. This article describes equipment, provided at the London International Maintenance Centre, for generating and measuring all 1 v.f. and 2 v.f. line signals, and for checking received 2 v.f. digit signals, as specified for international voice-frequency signalling systems.

INTRODUCTION

THE measuring equipment described in this article has been developed to meet the need for a convenient and accurate means of ascertaining the amount of distortion introduced by the transmission of voice-frequency pulses over international circuits, when one of the recommended international telephone voice-frequency signalling systems is used.^{1,2} While less accurate methods may be used to verify that the signalling equipment is functioning correctly, it is of great value from the points of view of speedy localization of faults and co-operation between maintenance personnel in different countries to be able to ascertain quickly and precisely the lengths of the pulses sent, or received, at any international centre. The International Telephone and Telegraph Consultative Committee (C.C.I.T.T.), realizing the importance of this facility, has recommended that each International Maintenance Centre shall have available:

- (a) a calibrated signal generator, and
- (b) a signal measuring apparatus,

capable of generating and measuring signals to an accuracy which is set by the higher of the two following values: 1 ms or ± 1 per cent of the nominal value of sent, or received, line signals.

Two signalling systems have been specified by the C.C.I.T.T., one of which employs two frequencies (2 v.f.) used singly or in combination, and the other a single-frequency system (1 v.f.). The v.f. signals to be used with these systems have been defined with respect to frequency, level, and duration, together with the permissible limits of distortion which may be introduced at the sending end, by the line and at the receiving end of an international circuit.³

When a fault occurs, it is obviously useful for the maintenance officer to be able to check accurately the durations of the received and transmitted signals, and to localize faults caused by pulse distortion to the particular division of the international circuit, including the measurement of the distortion introduced within these divisions, e.g. by a v.f. signal receiver.

The signal measuring apparatus could be designed to accept voice-frequency signals, or d.c. signals, and to display the duration of either. If the duration of a signal sent from an international centre is measured as the time during which a d.c. condition is extended from the terminal relay-set to the v.f. transmitting device, the time indicated will not necessarily represent the duration of

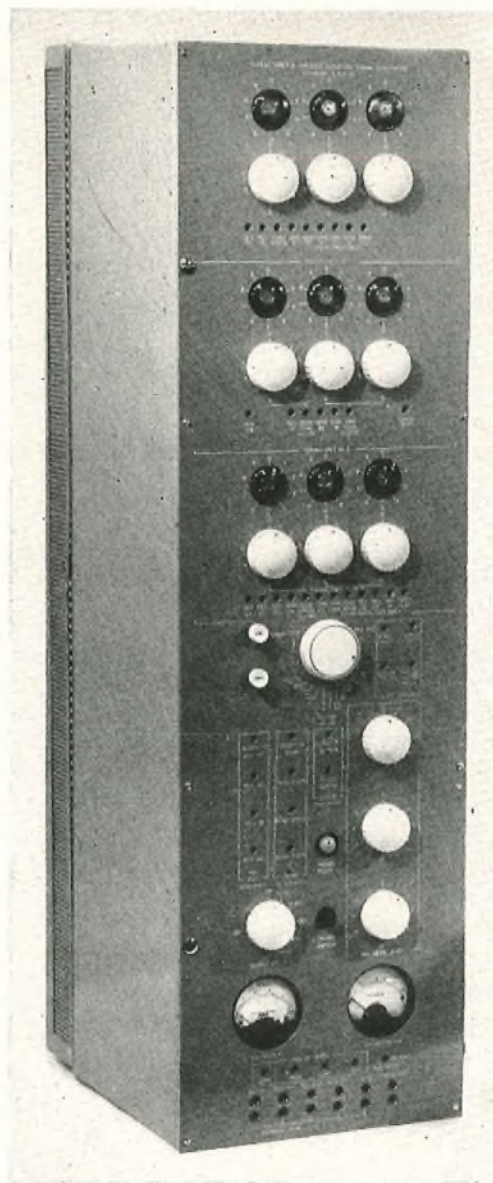

FIG. 1—SIGNAL GENERATOR AND MEASURING APPARATUS FOR INTERNATIONAL SIGNALLING SYSTEMS

the v.f. pulse sent to line, since the d.c. to a.c. conversion may introduce distortion. Furthermore, at the receiving station a measurement of the duration of the d.c. output of the v.f. signal receiver will include the distortion introduced by the a.c. to d.c. conversion. It is therefore preferable that the maintenance officers at the sending and receiving international centres should measure the duration of the v.f. signals sent to, or received from, the line, and hence the signal measuring apparatus should be designed to accept v.f. signals. Before the duration of the v.f. signals can be determined, some form of

† The authors are, respectively, Executive Engineer and Assistant Engineer, Telephone Exchange Systems Development Branch, E.-in-C.'s Office.

detection is necessary and, preferably, the detector should be distortionless. The test equipment described in this article incorporates v.f. detectors that can be adjusted to operate without introducing any significant distortion, and includes arrangements to check their adjustment. The complete signal generator and measuring apparatus is shown in Fig. 1. The physical layout was designed so that the front panel, containing the display timing units, with their associated time selector switches, the master selector switch and all other controls, fits a standard panel on one of the test positions at the London International Maintenance Centre.

MEASUREMENT OF 2 V.F. LINE SIGNALS

The line signals of the international 2 v.f. signalling system are pulses of tones of 2,040 c/s (X tone) and 2,400 c/s (Y tone). The tones may be transmitted singly, as either long or short pulses (simple signals), or together (compound signals). In addition, complex signals consisting of a compound prefix followed by a simple suffix (X or Y tone) are employed. The complex signals have no intentional interval between the compound prefix and the simple suffix, but should an interval occur due, for example, to the change-over time of relay contacts, the C.C.I.T.T. has specified that the interval must not exceed 5 ms.

The signal measuring apparatus has therefore been designed to measure the duration of the following signals:

- (i) A compound-signal element (2,040 + 2,400 c/s).
- (ii) A simple-signal element (2,040 or 2,400 c/s).
- (iii) A silent interval following the receipt of a compound-signal element.

A group of three decade counters operating from a 1 kc/s standard supply, and therefore capable of measuring elapsed time directly in milliseconds, is provided to measure and display the duration of received signals. A v.f. receiver detects the line signals and generates the necessary start/stop conditions, which are applied to the appropriate counters via a sequence-control unit, as shown in Fig. 2.

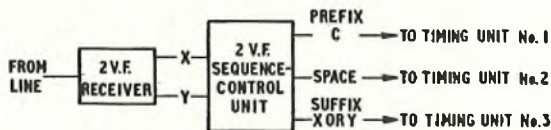

FIG. 2—MEASUREMENT OF 2 V.F. LINE SIGNALS

The 2 v.f. Receiver and Sequence Control

The v.f. signals appearing on the line are amplified and detected by a conventional 2 v.f. receiver. Positive-going signals, taken from the relay operating stages, are connected to the sequence-control unit, which provides output signals to indicate the presence, or absence, of:

- (i) A compound prefix.
- (ii) A space following a compound prefix.
- (iii) A single-frequency suffix.

The suffix signal may be either X or Y tone and a lamp indication is given to indicate the signal frequency.

A schematic diagram showing the logic of the 2 v.f. detector and sequence control appears in Fig. 3. In the idle condition the sequence-control unit maintains a stop signal to each of the timing units. The presence of a simple signal of X tone opens gate B or, if of tone Y,

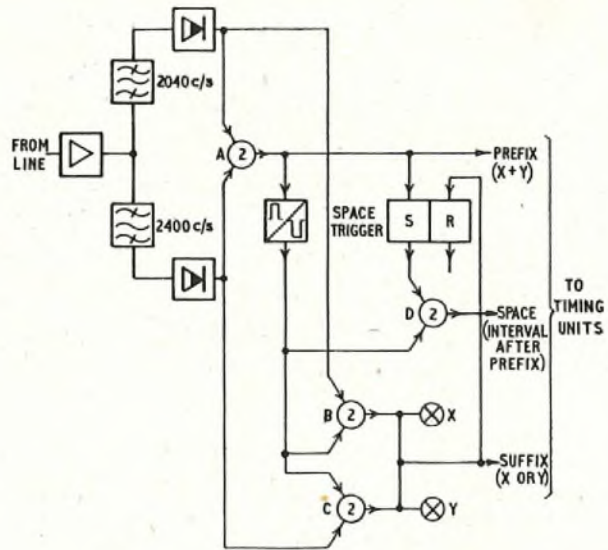

In the idle condition the inverter gives a positive output signal. With an input signal (from gate A) the output is inverted

FIG. 3—THE 2 V.F. DETECTOR AND SEQUENCE CONTROL

opens gate C, to change the condition on the suffix output lead to the start condition. When X and Y frequencies are present simultaneously gate A is opened and a start signal is connected to the prefix output lead; at the same time the space trigger is set to prepare for the timing of a silent period following the compound prefix.

The operation of the sequence control on the receipt of a complex signal is as follows: gate A opens to the compound signal, extending a start signal to the prefix timer and setting the space trigger. Gate D is prevented from opening at this stage by the inversion of the output from gate A. When the compound tone ceases, gate A closes and gate D opens to extend a start signal to the space timer. The arrival of the suffix signal opens either gate B or gate C to re-set the space trigger, which in turn closes gate D to terminate the start signal to the space timer. The suffix-timing-unit start signal is terminated when the suffix signal ceases.

Normally suffix signals do not persist sufficiently long for the indicator lamps to identify the frequency of the received signal and therefore memory triggers are used to retain the lamp indication.

Timing Units

The outputs from the sequence-control unit are connected via a multi-bank selector switch to three separate timing units. A schematic diagram of one of the timing units is shown in Fig. 4. Each timing unit has an input gating stage and three decade counters, which are interconnected by pulse-transfer circuits. The decade counters are cold-cathode selector tubes bearing the trade name of Dekatron,⁴ and timing is accomplished by counting cycles of a standard 1 kc/s supply. The operation of

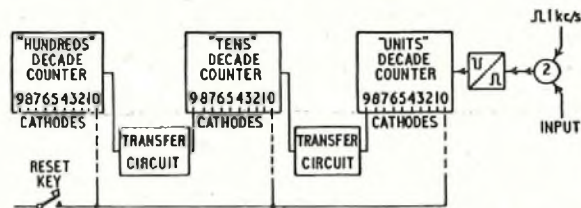

FIG. 4—SCHEMATIC DIAGRAM OF A TIMING UNIT

decade counting has been described elsewhere.⁵ It should be noted that in the present application, when the glow steps off the ninth working cathode the negative-going pulse so produced is inverted and used to strike a cold-cathode coupling tube which generates a negative pulse to step the next decade. The use of the departure of the glow from the ninth cathode, instead of its arrival at the tenth, or home cathode, as a signal for operating the next decade results in a saving of transfer time.

Automatic re-setting of the timers may be accomplished either by making the home cathode more negative than the remainder, or by raising the potential of cathodes 1-9 relative to the home cathode; the latter method is used in this timing equipment and is combined with a manual re-setting device.

CHECK OF 2 V.F. DIGITS

The numerical signals and certain inter-register signals of the international 2 v.f. system are sent in the form of 4-element combinations of X or Y frequencies, arranged in binary code. Apart from the working limits for frequency and level, which are closely controlled at the transmitting terminal of an international circuit, the most important requirement of the elements making up the binary digits is that they should persist long enough to be correctly recognized. The C.C.I.T.T. has specified that the sending duration of the signal elements X or Y, and the interval of silence between the signal elements, shall be within the limits of 28-42 ms, while the recognition time of the incoming switching equipment (after detection by the v.f. receiver) shall be within the limits of 5-15 ms. The number of digits transmitted over an international line may be 16, although nine is more probable; therefore, equipment required to check and display each tone and space element of each digit would be costly and bulky. A technique has been adopted for the digit check to test whether or not each tone and space element in a digit persists for a predetermined period. If a short element is detected the checking process is stopped, and information is displayed to indicate:

- (i) The digit containing the faulty element (1st, 2nd, 3rd, etc.).
- (ii) The particular element concerned (1st, 2nd, 3rd or 4th tone, or space).
- (iii) The duration of the faulty element (in milliseconds).

As a further economy in equipment the three timing units, suitably switched, have been utilized to perform the digit check. Timing unit No. 1 has been arranged to count the digits. Two decades of timing unit No. 2 have been arranged to measure the duration of the tone elements and to reset if the duration of the received signal exceeds a predetermined duration. The actual duration can be set between the limits of 1-99 ms by selector switches associated with each timing unit. The third decade of timing unit No. 2 has been arranged to count the four tone elements comprising a digit and to reset when the duration of the fourth element exceeds the predetermined duration. In a similar manner timing unit No. 3 has been arranged to measure and count the silent intervals between the tone elements of the digits.

During the setting up of an international call the digits are closely preceded by a terminal or transit seizure signal, both of which are complex signals, and it is necessary to ensure that the X or Y suffix portion of the seizure signal is not treated as the first element of a digit. Arrangements are therefore made to maintain the digit-checking equipment inoperative until the seizure signal has been recognized and accepted.

Summarizing, the sequence of operations of the digit-check unit is:

- (a) To absorb the seizure signal.
- (b) To check that each tone or space element received persists for a minimum predetermined period.
- (c) To display the duration of an element that is less than the predetermined minimum period.
- (d) To indicate the digit containing the faulty element, and the particular element concerned.
- (e) To prevent further elements being accepted by the equipment when a fault has been determined.

Consideration was given to the provision of an additional facility to enable the pre-selection of any element of any digit, and to display the actual duration of this element. Such a measurement, however, would not assist the maintenance officer, for his main concern is to ensure that the signals persist long enough to be recog-

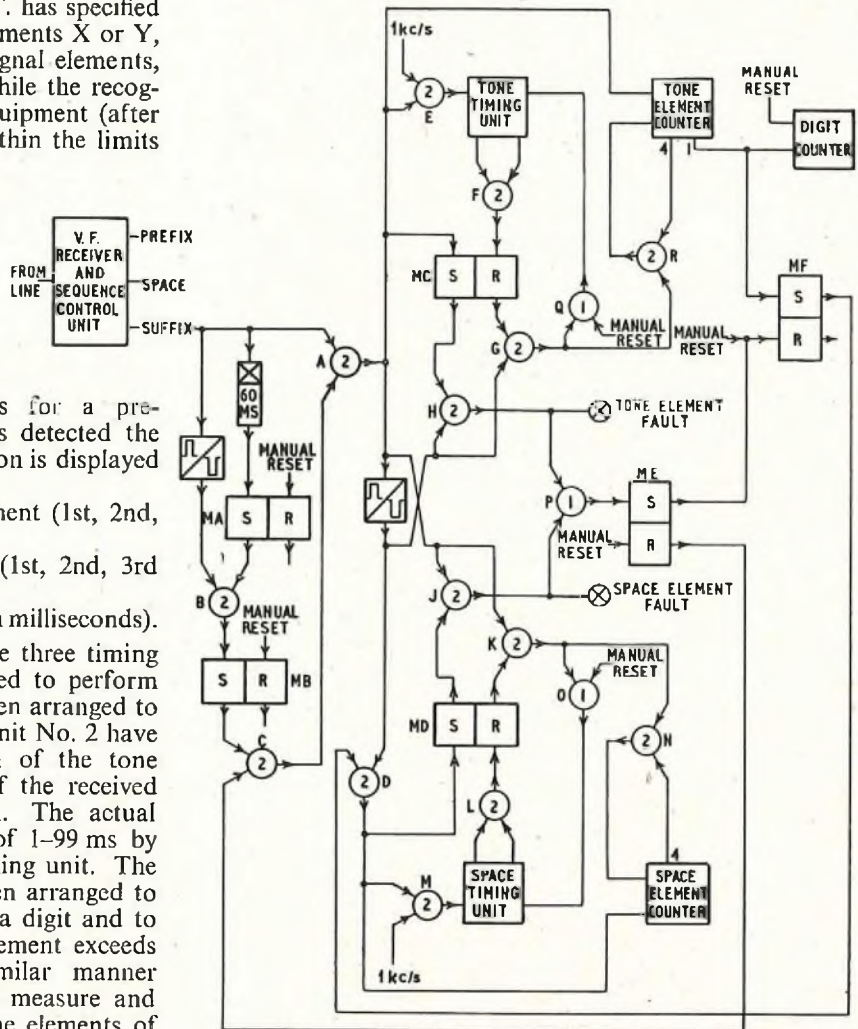

FIG. 5—LOGIC CIRCUIT FOR THE DIGIT CHECK

nized by the incoming or outgoing registers. The duration of the first tone, or space element, can be measured by setting the minimum acceptance time to, say, 99 ms.

Circuit Logic of the Digit Check

A diagram illustrating the logic of the digit-check unit is shown in Fig. 5. In the idle condition the decade counters are set on the home positions and all triggers are in the reset condition. Receipt of the suffix portion of the seizure signal for a minimum period of 60 ms sets trigger MA. At the end of the suffix signal gate B opens to set trigger MB. As trigger ME is in the reset condition, gate C opens and prepares the circuit for gate A to open on receipt of the first tone element of the first digit.

When the first tone element of the first digit is received, gate A opens and extends a signal to gate E and to the tone-element counting circuits, as well as setting trigger MC. The tone-element counting dekatron display is, therefore, moved to the first position to indicate receipt of the first tone element, and with the dekatron display at this position, a signal is extended to the digit counter to register receipt of the first digit. At the same time trigger MF is set to prepare gate D for receipt of the first space element.

For the duration of the first tone element, gates A and E remain open and the timing unit counts, at 1 ms intervals, the positive-going pulses of the 1 kc/s supply. When the two decade counters of the tone-timing unit indicate the duration selected on the minimum-duration selector switches, gate F opens and resets trigger MC to prepare for automatic resetting of the timing unit at the end of the tone element. A negative signal will then exist at the output of gate A, which is inverted to a positive signal to operate gate D. Timing of the space signal now starts with trigger MD and gates M and L performing the same functions for the space element as trigger MC and gates E and F of the tone-checking circuit. The positive signal from the inverter extended to gate D is also extended to gates G and H. If the duration of the received tone element was equal to, or exceeded, the pre-selected minimum duration, gate G opens and resets the timing unit. As each tone and space element is received the tone and space element counters move on one position. When four tone and four space elements have been received gates R and N open, respectively, and prepare circuits to reset the element counters to zero when gates G and K open at the end of the fourth-tone and fourth-space element, respectively. The digit counter steps each time the tone-element counter has recorded the first tone element of each digit received.

If the duration of the tone element is less than the pre-selected minimum duration, trigger MC will be in the set condition at the end of the tone period. Gate G is thus prevented from opening and resetting the tone-timing unit, and gate H is opened to set trigger ME and reset trigger MF, via gate P. Timing of the space signal is stopped by closing gate D from trigger MF, and the timing of all subsequent tone elements is prevented by closing gate C from trigger ME. The digit check is therefore stopped and the display indicates that a tone-element fault has occurred, the particular element being displayed on the element-counting dekatron and the digit containing the faulty element being displayed on the digit-counting dekatrons. The duration of the faulty tone element is displayed on the tone-timing dekatrons.

A similar sequence occurs if a space element is received having a duration less than the pre-selected minimum.

MEASUREMENT OF 1 V.F. LINE SIGNALS

The line signals of the international 1 v.f. signalling system are formed by using long or short pulses of tone. These are used singly and, in addition, signals consisting of two long, or two short, pulses of tone separated by a short silent period are employed. The frequency of the tone used is 2,280 c/s. To check the 1 v.f. line signals the apparatus has been designed to measure the duration of the following signals:

- (i) First tone-signal element.
- (ii) Silent interval after receipt of the first tone element.
- (iii) Second tone-signal element.

1 V.F. Detector and Sequence Control

A schematic diagram showing the logic of the 1 v.f. detector and sequence-control units is shown in Fig. 6.

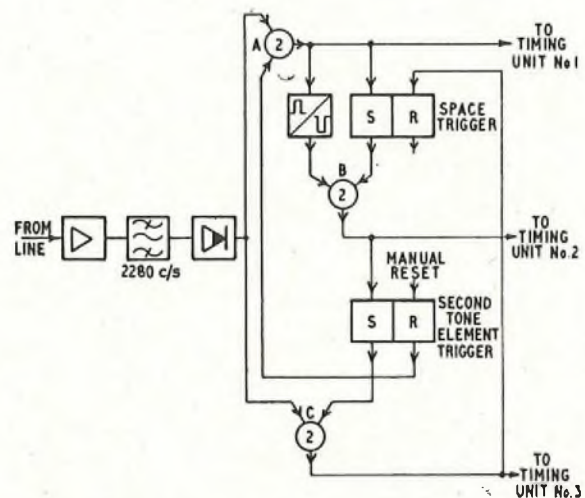

FIG. 6—THE 1 V.F. DETECTOR AND SEQUENCE CONTROL

The purpose of the sequence control is to apportion the elements of a line signal to the appropriate timing units in the correct sequence.

The v.f. signals appearing on the line are amplified and detected by a conventional 1 v.f. receiver, and a gating signal taken from the normal relay-operating valve of the receiver is extended to the sequence-control unit. Receipt of the first tone-signal element opens gate A, which extends a start signal, via the master selector switch, to the first timing unit and sets the space trigger. Timing of the first tone-signal element now commences. At the end of this tone-signal element the start signal is disconnected from the first timing unit, which now displays the duration of the first X signal, and, at the same time, gate B is opened to connect a start signal to the second timing unit. The signal extended to the second timing unit starts the timing of the space-signal element and sets the second tone-signal element trigger. When the second tone-signal element is received gate A is closed but gate C opens to extend a start signal to the third timing unit. Timing of the second tone-signal element now commences. The output of gate C resets the space trigger, thereby closing gate B, which terminates the space timing on timing unit No. 2. Timing unit No. 2 therefore displays the duration of the space signal. At the end of the second tone-signal element gate C closes to stop timing unit No. 3, which displays the duration of the second tone-signal element.

The timing units used to measure the duration of the first tone, space and second tone-signal elements are the same units as previously used to measure the duration of the 2 v.f. prefix, space and suffix signals.

VARIABLE-DURATION SIGNAL GENERATOR

Most of the line signals of the 2 v.f. and 1 v.f. signalling systems may be considered as consisting of three elements, tone-space-tone, and the particular signals are defined by the duration of the three elements. For example, 150 ms of compound tone, followed by 1 ms silent interval, followed by 100 ms of Y tone would indicate a transit seizure signal; by changing the duration of the third element to 350 ms, the complete signal would indicate a forward transfer. To make the signal generator suitable for all signals, equipment has been provided to control the duration of three elements and, by suitable switching, the frequency of each tone element can be selected. In addition, an attenuator has been included in the output circuit to permit the level of the signals transmitted to be adjusted to meet the testing requirements. A schematic diagram of the signal-generator unit is shown in Fig. 7. The three decade timing units

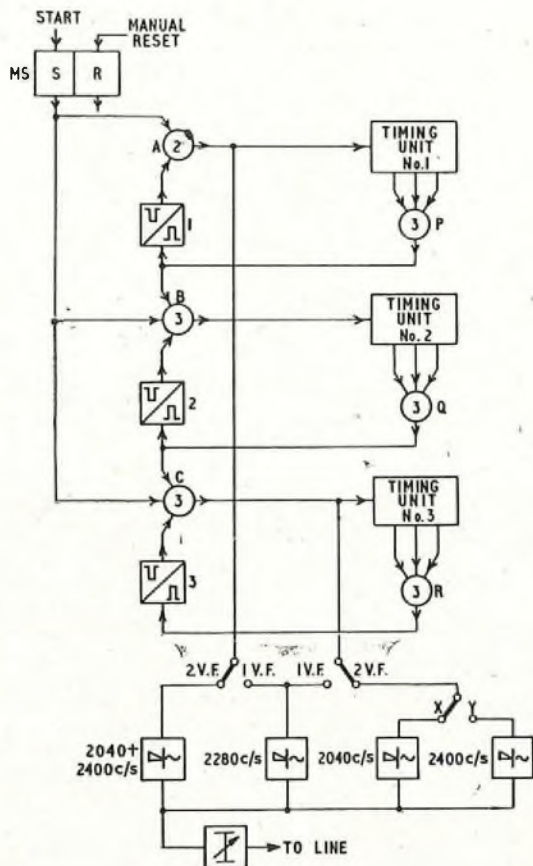

FIG. 7—SCHEMATIC DIAGRAM OF SIGNAL-GENERATOR UNIT

previously used to measure the duration of the line signals and to perform digit checking functions have been re-used to control the duration of the three signal elements. The start signals to timing units No. 1 and 3 are also connected to the compound-frequency or simple-frequency static modulators as required, by means of contacts of the master selector switch.

To send a signal the master selector switch is set to the 2 v.f. or 1 v.f. tone combination and the time-selector switches associated with each timing unit are set to the durations required. Depression of the start key sets trigger MS, which in turn opens gate A. A start signal is therefore applied to the selected static modulator and transmission of the first tone element commences. The same start condition is applied to timing unit No. 1. When the selected duration of the first element set on timing unit No. 1 has been reached, coincidence of the three inputs to gate P occurs and a signal is connected to gate B. This signal is inverted to close gate A, which stops timing unit No. 1 and terminates the transmission of the first tone element. With gate B open, timing unit No. 2 starts to time the second element, which is a silent interval. Coincidence of signals to gate Q closes gate B, which terminates the second element and opens gate C to start the timing of the third element. At the same time the start signal from gate C is applied to the selected static modulator to transmit tone to line. The third element is terminated by coincidence of the inputs to gate R, which closes gate C. After transmission of the required signal the timing units indicate the durations of the three elements transmitted.

When a simple 2 v.f., or single 1 v.f., signal is required, the selector switches of timing units No. 1 and 2 are set to zero and the duration of the simple signal is set up by the time-selector switches associated with timing unit No. 3. The operation is then as follows: gate P holds gate A closed via inverter No. 1 and gate Q holds gate B closed via inverter No. 2. Operation of trigger MS from the start key opens gate C and the simple signal is timed. The transmission of a 2 v.f. signal without a silent interval is accomplished by setting the time selector switches of timing unit No. 2 to zero.

The outputs of the 2 v.f. X and Y, and 1 v.f., static modulators are adjusted to provide an input of 0 db relative to 1 mW to the attenuator, and the output of the compound static modulator is adjusted to be +3 db. With this arrangement the setting of the attenuator indicates the level below zero at which the 2 v.f. suffix and 1 v.f. signals are transmitted, the compound prefix being transmitted 3 db higher than the suffix signal in the international 2 v.f. system.

EQUIPMENT CHECKING FACILITIES

Timing Unit Check

The accuracy of the three timing units is a function of the accuracy of the 1 kc/s supply, and for this equipment the Post Office 1 kc/s primary standard of frequency, accurate to one part in 10^8 , has been used. To check that the timing units are responding correctly to the 1 kc/s pulses, the individual input gates for the three timing units (see Fig. 4) may be connected together via the master selector switch to a common gating signal. The three timing units operate continuously until the gating signal is disconnected, and if operating satisfactorily they will display the same readings. It is possible to use the timing-unit check circuit to time such items as relays operating or releasing.

V.F. Receiver Distortion Check

The distortion introduced by a v.f. receiver suitable for use with an international circuit is quite small over the working range of level and frequency, ± 2 ms being about average. Nevertheless, in view of the high standard

of accuracy specified by the C.C.I.T.T., it becomes a limiting factor on the overall performance of the timing equipment. It is desirable that the performance of the v.f. receiver with regard to sensitivity, band-width and operate time, etc., should not differ from the receivers used on the international circuit. With this proviso in mind, the v.f. receivers associated with the timing equipment have been modified to reduce the inherent distortion to a low level, and external controls have been fitted to cancel out the remaining distortion. To set these controls the sending and timing functions of the equipment can be combined via contacts of the master selector switch. Timing unit No. 1 is used to control the duration of the test signal, and timing unit No. 3 is used to measure the received signal. A schematic diagram

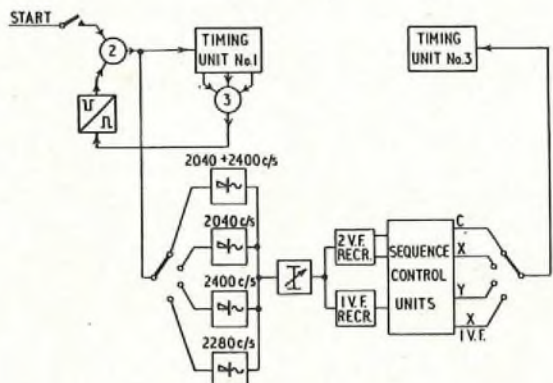

FIG. 8—SCHEMATIC DIAGRAM OF CIRCUIT USED TO CHECK DISTORTION OF V.F. RECEIVERS

of the distortion-checking circuit is shown in Fig. 8. If the receivers are distortionless, the display of timing units No. 1 and 3 should be the same. By changing the setting of the time selector switches of timing unit No. 1,

the equipment can be checked over a range from very short signals to long signals.

CONCLUSION

The calibrated signal generator and signal measuring apparatus described in this article has been designed to meet the recommendations of the C.C.I.T.T. The use of a single group of dekatron decade counters to display the duration of the received line signals and 2 v.f. digits, and to control the duration of the signals transmitted, effects a considerable economy of equipment. Operating procedure is simplified in that any of the above functions may be selected by the operation of a single master selector switch. The apparatus forms part of the equipment provided at the International Maintenance Centre, London, and will permit accurate measurement of v.f. line signals and accurate generation of test signals.

ACKNOWLEDGEMENTS

The authors gratefully acknowledge the help and advice given by colleagues in the Telephone Exchange Systems Development Branch, E.-in-C.'s Office, and in particular that of Mr. C. F. Hillen. They also wish to thank the staff of the Circuit Laboratory, Telephone Exchange Standards and Maintenance Branch, E.-in-C.'s Office, who constructed the equipment.

References

- ¹ MILES, J. V. C.C.I.F. Field Trials of International Semi-Automatic Telephone Operation. *P.O.E.E.J.*, Vol. 45, p. 120, Oct. 1953.
- ² BATES, A. W. Test Equipment for the London Centre of the C.C.I.F. Field Trials of International Semi-Automatic Telephone Operation. *P.O.E.E.J.*, Vol. 45, p. 165, Jan. 1953.
- ³ C.C.I.F. XVIIITH PLENARY ASSEMBLY. Signalling and Switching. *Green Book*, Vol. V, Part 4, Geneva, Oct. 1954.
- ⁴ Cold Cathode Tubes Handbook (Ericsson Telephones, Ltd., 1955), p. 16.
- ⁵ POLLARD, J. R., and BACON, R. C. The Dekatron. *Electronic Engineering*, Vol. 22, p. 173, May 1950.

Book Review

"Telecommunications." W. Fraser, B.Sc.(Eng.), A.M.I.E.E. Macdonald & Co., Ltd., London. 772 pp. 414 ill. 65s.

This is a comprehensive text book on telecommunications, the main emphasis being on basic principles. It has been written primarily for students reading for an engineering degree or Higher National Certificate (Telecommunications), and as a useful reference for I.E.E. and City and Guilds telecommunications examination work. The book is also claimed to be of value to practising electrical engineers who wish to work in the field of electrical communications.

About half the book is concerned with the basic theory of telecommunications, and the remainder covers the basic principles of telecommunication systems. The wide range covered is indicated by the chapter headings: Network Theorems; Resonant Circuits; Coupled Circuits and Impedance Matching; Transmission Lines, Attenuators and Filters; Valves and Electronic Devices; Low Frequency Amplifiers; Distortion, Noise and Feedback in Amplifiers; High-frequency Amplifiers; Oscillators; Power Supplies; Modulation; Demodulation and Detection; Transmission of Information; Microphones and Sound Reproducers; Telephony; Telegraphy; High-frequency Transmission Lines and Wave-guides; Ultra-high-frequency Valves;

Radio Wave Propagation and Aerials; Radio Transmission Systems.

This is an extremely wide field in one volume. It does in fact cover, in admirably condensed form, the subject matter of a number of specialized text books covering the field, together with material not yet available in present-day text books. The author is to be congratulated in keeping the requirements of students foremost in mind. He has wisely not attempted to cover the subject matter with a mass of detail. The book is well-written, clear and concise throughout and succeeds in its declared purpose of emphasizing basic principles.

There are many worked examples throughout the text. Each chapter ends with a selection of questions from previous examinations in telecommunications set by the University of London and the Institution of Electrical Engineers, and a list of carefully selected references is included for more detailed reading.

It is admittedly difficult to produce a book of this nature with the requirements of both students and practising engineers in mind. By virtue of its emphasis on the principles and theory of telecommunications, the information being presented in an easily assimilated manner, the book is particularly suitable for students. The wide field covered,

(Continued on p. 187)

A Boring Bit for Testing Wood Poles

R. O. BOOCOCK, B.Sc., A.M.I.E.E., and E. N. CLARK†

U.D.C. 621.951:620.193:621.315.668.1

The methods used for testing wood poles are outlined and the development and use of a boring bit for probing internal decay are described.

INTRODUCTION

DECAY in Post Office poles^{1,2} became increasingly noticeable some 12 to 15 years ago, owing largely to the number of poles which were reaching the end of their creosote-protected life. In 1946 the systematic testing of all poles over seven years old was introduced², though in the meantime the technique of testing has changed somewhat in the light of experience.

External decay is usually readily visible and its area and depth can be determined by prodding with a sharp-edged tool, such as a thin sharpened screwdriver. When the blade is pushed into good wood, in line with the grain, there will be a characteristic gripping by the parted fibres and this will tend to resist removal of the tool; this does not occur in wood which has lost its strength.

Internal decay, which is almost as prevalent as external, occurs most often in uncreosoted sapwood and is discovered by listening for any change in tone whilst tapping lightly round the pole with a 1lb hammer. This test normally gives the area of decay with fair accuracy, especially when made by experienced hands. In some circumstances the change of tone may be barely noticeable. For example, if the outer shell of good wood is an inch or two thick, if the area of decay is small or if the decay is in its earlier stage of weakening the wood by initial penetration of fungus spores, rather than the wood having disintegrated and left a definite hollow. A change of tone may be noticed in sound wood, due to knots or other variations in the wood, or to cracks ("shakes") in the sap-wood and partial separation of the sap-wood from the heart-wood. There are therefore occasions, though only in a small proportion of poles, when even the most experienced pole-tester feels the need for something more than the hammer test to resolve his doubts as to whether or not there is internal decay. A timber-tester is needed to show him more positively the internal condition of the pole.

All poles over seven years old are tested periodically, at present six-yearly, including excavating to a foot below ground level. Those found to be slightly decayed, but not to the extent to warrant renewal, are scheduled for rechecking every 12 to 18 months and, in view of the work and travelling involved in this operation, it is obviously desirable to be reasonably certain that decay has started before scheduling a pole in this category.

As an additional and very important precaution, every man, before climbing a pole in the course of his normal construction or maintenance work, should test it by tapping all round the pole, right down as near as possible to the ground line, with not more than 1 in. spaces between the taps.

† The authors are, respectively, Regional Engineer and Executive Engineer, Home Counties Region.

¹ BRENT, W. H. The Telegraph Pole. *I.P.O.E.E. Printed Paper* No. 154, 1934.

² GERRY, P. R. Decay in Poles. *P.O.E.E.J.*, Vol. 40, p. 116, Oct. 1947.

HOLLOW-AUGER TIMBER-TESTER

The type of tester hitherto available consists of a hollow auger with a circular front cutting-edge which leaves a sample of wood, about $\frac{1}{8}$ in. diameter, in the auger. When the auger has been inserted to the required depth a thin concave steel extractor, serrated for a short distance along each forward edge, is pushed through the auger to grip and retain the sample section. The auger is removed and the sample carefully withdrawn by the extractor, with the concave side uppermost. A tightly fitting creosoted plug is finally used to seal the hole in the timber.

It is intended that a complete sample, to the extent of the depth of auger insertion, should be obtained, any decay being indicated by a gap or section of powdery rot between the good portions. In practice, however, this type of timber-tester is not sufficiently reliable; the sample is so easily broken when inserting or withdrawing the extractor that an incomplete sample may be obtained or the good portions may be pushed together and evidence of the extent of rot largely lost. Also, its efficiency is very dependent on the auger and extractor being in first-class mechanical condition, but the extractor in particular is very liable to become bent. These difficulties are so conducive to repeat borings being made, with their weakening effect on the pole and somewhat increased liability to decay, that it is very doubtful whether the auger ought to be used as a normal testing aid by pole-testing parties.

A NEW TIMBER-TESTER OR BORING BIT

In considering the problem it came to the authors' notice that an ordinary gimlet was being used sometimes by one pole-testing party when they were in particular doubt about the presence of decay behind sound wood, though this was found to be unreliable, unless the shell was quite thin, due mainly to the good wood binding tightly on the gimlet shank. The idea then occurred to try a gimlet-type tool with the screwed portion enlarged sufficiently to leave a hole slightly larger than the shank, the soundness of the wood being judged by the force needed to turn the tool.

To ensure that only the smallest hole would be made in the pole, it followed that the gimlet-type head and shank must be as small as the required strength of the tool permitted. Early trials soon showed that a shank less than about $\frac{1}{4}$ in. diameter was too easily bent or twisted, especially where hard poles were concerned. It was also necessary for the maximum diameter of the base of the thread to be nearly 50 per cent more than that of the shank, to permit the shank to follow through freely. A number of different designs, especially in the shape of the head and pitch of the thread, were tried until the optimum dimensions were found. Fig. 1 illustrates the final result, the dimensions being 6 in. overall length, $\frac{7}{32}$ in. diameter shank (using higher-strength steel), $\frac{5}{16}$ in. maximum diameter of base of thread, 10 threads/inch single cut and $\frac{3}{4}$ in. length of head. Measuring marks are scribed along the shank at intervals of $\frac{1}{2}$ in. The pear-shaped head incorporates a



FIG. 1—THE NEW BORING BIT

feed-back thread to facilitate easy withdrawal, and the use of a carpenter's brace, rather than a T-shaped handle, was decided upon to give speedier operation and a more sensitive feel of the torque.

Operation

The pole is drilled in a slightly upward direction, if possible, to reduce the liability of water draining into the hole that is left. If decay is met there will be a marked reduction in resistance to turning the brace, whilst if a cavity is reached (Fig. 2) the tool can be pushed to and fro and the depth of decay and thickness of good wood deduced from the markings on the shank, allowance

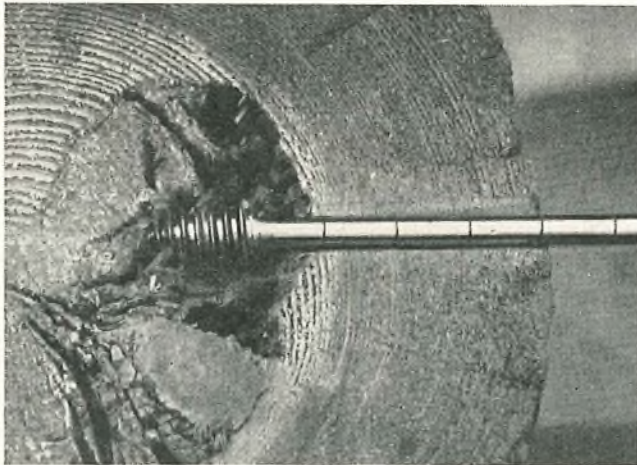

FIG. 2—PROBING INTERNAL DECAY

being made for the $\frac{3}{4}$ in. length of the head. In boring through the wood the fibres are partly separated and partly cut and, as with the former type of timber-tester, the hole is sealed with a creosoted plug.

The borer is intended to be used only to the minimum extent, just on the small proportion of poles where real doubt exists after the hammer test. Normally, only one boring should be made on any pole, and this in the most likely spot which the hammer test suggests.

TORQUE-SCREW POLE-TESTER

A somewhat similar method was incorporated in a tester³ consisting of a screw probe with a triple-cut thread, operated by a crank handle through a worm drive. The mechanism is coupled to a torque-measuring device which records the torque on a graph as the probe is screwed into the pole. The whole machine is clamped to the pole, normally in a position to obtain the condition a little below ground line.

The authors do not feel that there is any advantage in a rather elaborate machine of this type. The simple hammer test can cover a much greater area quickly and, with the occasional use of the boring bit, proves very reliable.

CONCLUSION

The boring bit has been in use with every satisfaction throughout the Home Counties Region for the past three years, and trials that have been arranged by the Engineering Department in other Regions have also proved successful. Supplies of the tool are now available for issue to all testing parties for use in place of the former type of timber-tester.

ACKNOWLEDGEMENT

The authors would like to acknowledge the ready co-operation they have received throughout the experiments.

³ DANA, HOMER J., and STINGLE, HOWARD A. The Torque Screw Pole Tester. *State College of Washington Engineering Bulletin No. 69*, 15 May 1947.

Book Review

"Telecommunications"—*continued from p. 185*

however, would require the practising engineer to read more deeply from the references given, particularly on the practical forms of telecommunication systems, as here, understandably, the treatment is not sufficiently comprehensive to make reference to more specialized works unnecessary. On the other hand, practising engineers will find much useful information in the part concerned with the basic theory of telecommunications to refresh their knowledge of principles.

The chapter on telephony covers manual telephony, automatic telephony, traffic and grading, carrier and coaxial line transmission systems in 60 pages. The chapter on telegraphy covers telegraph transmission, telegraph circuits, teleprinters, multi-channel voice-frequency telegraphy and picture telegraphy in 20 pages. Radio Transmission Systems covers broadcasting, transmitters, receivers, and television in 20 pages. It will be obvious that with this condensed text the treatment of systems is limited to principles only, and is of a rather elementary nature from the engineer's point of view.

A minor criticism is the small page size relative to the thickness (3 in.) of the book, which makes it a little awkward to handle.

S.W.

BOOK RECEIVED

"Directory of Welding and Fabricating Equipment." Section I: Metal Arc Welding Electrodes. The Louis Cassier Co., Ltd. Reprinted from *Welding & Metal Fabrication*. 35 pp. 3s. 6d.

The directory, the first British publication of its kind, is divided into five parts, dealing with electrodes for arc welding mild steel, alloy steels, cast iron, non-ferrous metals, and for hard-facing. The electrodes are grouped under the name of the respective manufacturers, and the main details are given for each electrode, together with any special features. Where the electrodes carry identification markings, such as coloured tips, these are referred to, so that the electrodes can be easily recognized. Recommended welding positions for each electrode are given, and the British Standard Classification numbers are shown against the electrodes for welding mild steel and the medium- and high-tensile steels, according to B.S. 1719 : 1951.

A Single-Operator Letter-Sorting Machine

Part 2—The Production Machine and Future Development

H. J. LANGTON, A.M.I.E.E.†

U.D.C. 681.178

Part 1 of this article introduced the subject of letter-sorting by machine and described the experimental machine designed and manufactured at the Post Office Research Station. Part 2, the concluding part, describes briefly the trials of that machine and the subsequent development and manufacture of the production machine, and forecasts the probable line of future development.

TRIALS OF EXPERIMENTAL MACHINE

IN late 1955 the experimental letter-sorting machine described in Part 1 of this article was in service for about six months at Bath sorting office on outward-sorting duty to enable its operational and technical performance to be assessed. The results were watched closely at all stages and it rapidly became clear that the advantages in the use of such a machine over manual sorting were sufficiently promising to warrant an extended field trial using a number of similar machines. The Bath trial revealed also the need for various changes in the technical design of the machine and in the operational facilities provided, and in 1956 the work of preparing a suitable specification was put in hand and subsequently

a contract was placed with a manufacturer for the production-design and manufacture of 20 machines.

The experimental machine was removed from Bath in May 1956 and since has been featured in two major exhibitions in London. At the present time the machine is in operational service in Southampton.

THE PRODUCTION MACHINE

General views of the production machine are shown in Fig. 5 and 6, and it will be convenient to discuss the significant changes from the experimental design under various headings.

General Construction and Handling Capacity

Whereas the experimental machine was constructed as a composite whole, provision had to be made for installing the production machine in any normal sorting office and on any floor of a building. Consequently it was designed to be capable of ready dismantling into

† Senior Executive Engineer, Power Branch, E.-in-C.'s Office.

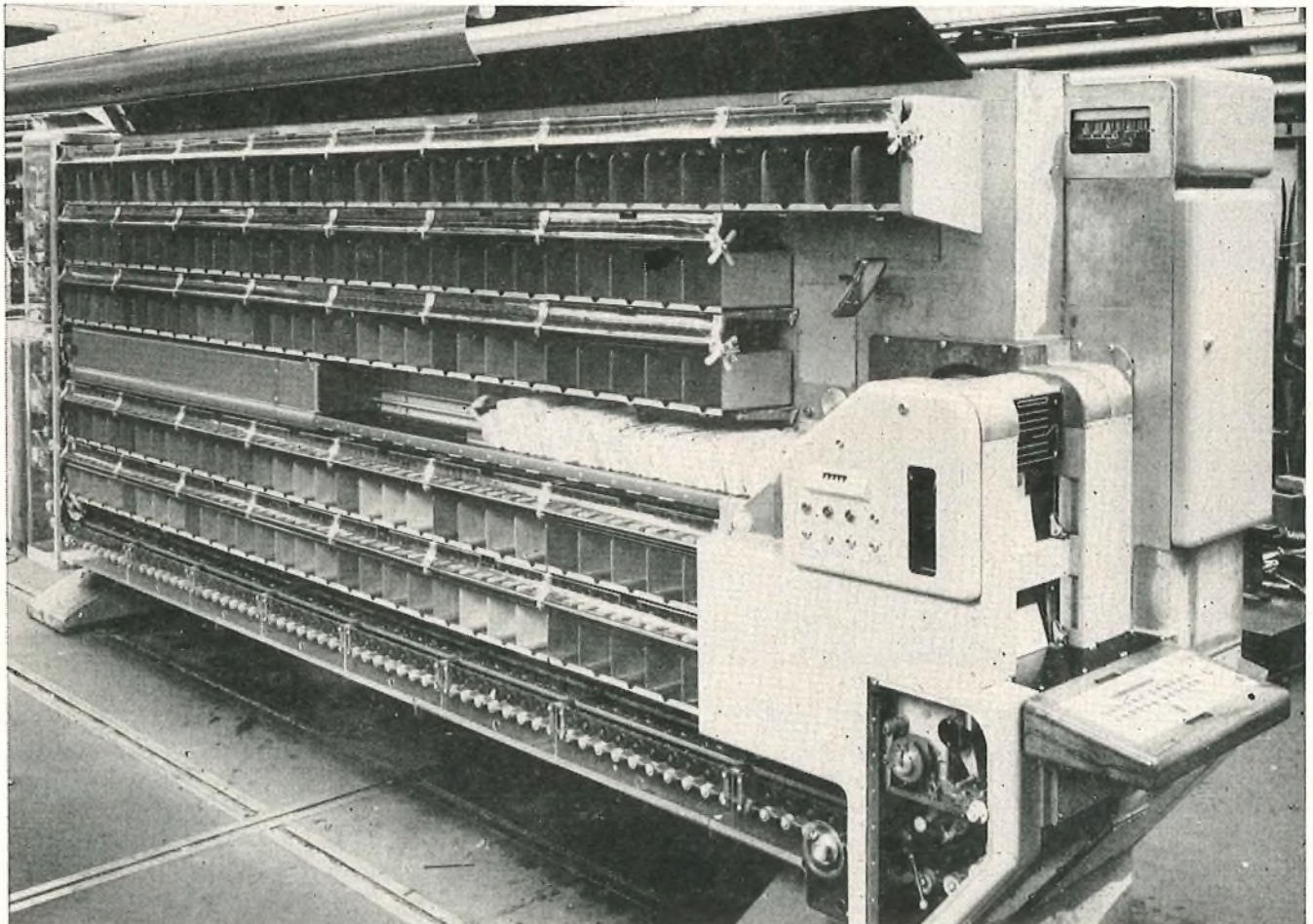

FIG. 5—THE PRODUCTION MACHINE

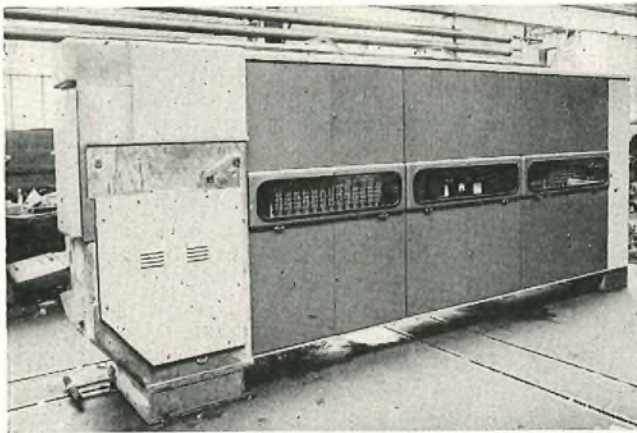

FIG. 6—REAR VIEW OF THE MACHINE

five main assemblies, each suitable to be carried in a medium-sized electric lift. These sections are the presentation unit, incorporating one of the two supporting pedestals, the vertical distributor, incorporating the other pedestal, and three, similar, intermediate sections.

To facilitate moving the assembled machine to another point on the same floor (or indeed between offices having direct access from the sorting floor to vehicle-loading platforms), provision is made for affixing two undercarriage units, each comprising a frame carrying two castor wheels mounted on screw jacks; operation of the jacks lifts the pedestal bases clear of the ground.

Every effort has been made in the design to minimize weight as in the majority of sorting offices the permissible average floor loading is 112 lb/ft². The use of light alloys for all main castings and where feasible of other light-weight materials for components has kept the weight of the finished machine down to about 3 tons, which, taking into account the spacing at which machines will be installed, gives a floor-loading density well within the requirements.

The production machine has been designed to handle letters in the size range 4 in. by 2 $\frac{3}{4}$ in. up to 7 $\frac{1}{4}$ in. by 5 $\frac{1}{2}$ in. Opportunity has, however, been taken to effect an increase in the handling rate from about 94 items per minute to 110 items per minute, it having been found from experience with the experimental machine that a speed of even 94 items per minute led to too frequent frustration of a fast operator working with a favourable sample of material.

Letter-Stacking Boxes

A greater number of letter-stacking boxes has been provided on the production machine than on the experimental machine, there being 144 selection boxes plus five overflow boxes, in order to permit, under favourable circumstances, full exploitation of the 144 combinations available from the keyboard. The boxes are constructed from light-alloy sheet in assemblies of four, each assembly being readily withdrawable to facilitate access to the roller conveyors. The boxes are formed with a thumb cavity in the bottom to facilitate the withdrawal of letters, and local illumination is provided over the faces of the boxes by two fluorescent lighting fittings.

Letter-Feed Conveyor and Separator

The feed conveyor has been positioned one level higher than on the experimental machine. This improves the access for loading and allows the suction separator to be

placed within easy reach of the operator to facilitate his attention to occasional failures. (Failures can occur with aperture envelopes or with unsealed envelopes with unusually bulky contents.) Minor changes were made in the design of the suction head and in the choice of vacuum pump and associated filter to improve the efficiency of this important section of the machine. A general view of the unit is shown in Fig. 7.

Letter-Presentation Unit

Although the essential form of the upper section of the experimental letter-presentation unit has been retained, it has been completely recast to facilitate production and to improve reliability. Additional features have been embodied, including "built-in" local lighting of the two viewing windows, conveyor belts at the rear of the viewing spaces, and snatch rollers beneath the viewing-window trapdoors to speed and control the descent of letters through the system.

At the same time, there has been provided beneath the lower viewing window a unit which combines the function of the synchronizing gate of the experimental machine with an improved facility for the cancellation of keying errors. As was explained in Part I of the article, the pin-disk type of information-storage system is essentially periodic in character, permitting information to be registered only at those cyclic points in time when a pin is correctly positioned relative to the setting solenoid. This has to be associated with a random operating rate in which letters can be fed through the viewing windows at any points in time, subject only to a maximum frequency of occurrence. In order to match the two it is necessary to delay the information appropriate to a given letter until the propitious time for pin-setting, and at some stage delay the letter by an equal time to bring it back into phase with its information. The delay which must be imposed on any letter can vary from zero up to a maximum of just less than one pin-period, and care must be taken to ensure that, under the extreme condition of maximum delay coinciding with disposal at the maximum rate, a following letter cannot catch up with the one being delayed.

One way of achieving this is to run the synchronous part of the machine, i.e. that part beyond the synchronizing gate, at an appreciably higher letter-handling rate (of the order of 50 per cent higher) than the asynchronous

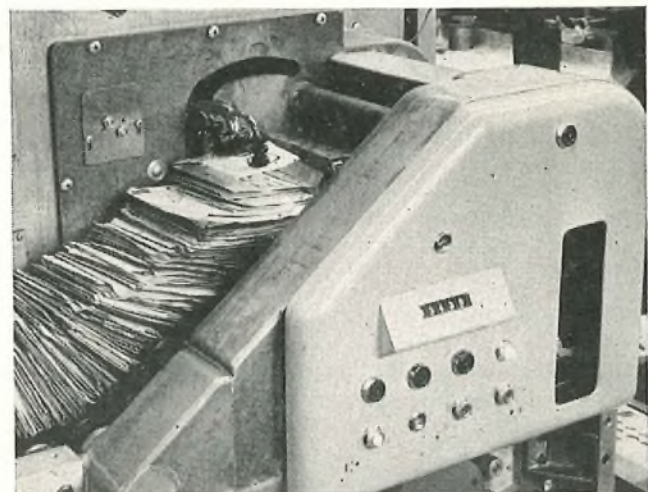

FIG. 7—LETTER-FEED CONVEYOR AND SUCTION SEPARATOR

presentation unit. This was the method used in the experimental machine, but the alternative method adopted in the production machine makes use of a double waiting-gate below the lower viewing window. This is illustrated in Fig. 8 and operates so that letters are alternately fed to opposite sides of the gate at operator time and are released alternately at machine time; two letters can be in the gate at any time and the system is virtually equivalent to allowing catch-up and overlap in the former method.

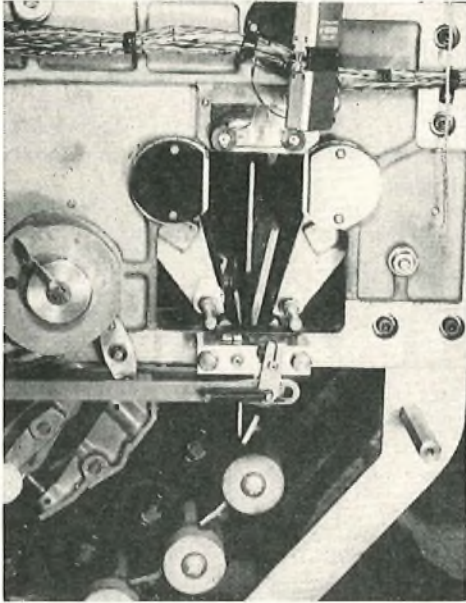

FIG. 8—DOUBLE WAITING-GATE

Calling the two sides of the double gate A and B, the sequence of events is as follows: letter 1 is keyed and fed into side A, where it waits until the next keying action, which feeds letter 2 into side B and prepares side A to open at the next pin-setting opportunity. The third keying action then feeds letter 3 into the now empty side A and prepares side B to release letter 2 at the next pin-setting time, and so on. Every letter is thus caused to pause for the whole of the following keying interval plus any synchronizing delay, thus allowing for cancellation of realized keying errors at any time up to the following keying action. In addition, the device secures a great advantage in that the synchronous speed and the presentation-unit speed can be, and are, identical at 110 cycles per minute. This has permitted the handling capacity of the machine to be increased as stated earlier, not only without any increase, but indeed with a slight decrease, in the linear speed of the conveyor sections, this being now 137.5 ft/min.

As in the experimental machine the presentation unit is driven from a constant-speed shaft via a single-revolution clutch, which completes one cycle at every keying action. Through this clutch are driven the suction separator, the letter-feed helices, the trapdoor between viewing windows and the alternating input mechanism to the double waiting-gate. High-inertia parts such as the suction separator and the feed helices take their drive via a variable-angular-velocity linkage that imposes a motion approximating to simple harmonic motion in order to minimize starting and stopping shock.

Transporting System

The basic mode of conveyance used in the experimental machine, comprising a train of driven rollers each associated with a sprung idling roller, has been used for the production machine, but its construction differs in two important respects; namely, the driving arrangement and the method of applying pressure to the idling rollers. In the experimental machine the driven rollers were driven via mitre gears on a continuous lay shaft along each level, whereas in the production machine each level is driven by a continuous roller chain held by a retaining strip into engagement with a sprocket on each roller shaft.

The idling-roller assembly has a novel feature permitting the ready release of pressure by a throw-off lever, thus greatly improving access to any item which may have become jammed in the track. The idling rollers (Fig. 9) are assembled in pairs on spindles, which are riveted to a flat spring-steel strip. This strip is secured by shaped leaves of similar material to a main longitudinal member above. At one end (not shown) the strip bearing the idling rollers is held by a throw-off lever by which it can be strained longitudinally to overcome the normal tendency of the shaped leaves and force the idling rollers into pressure contact with the driven rollers.

This principle of pressure release has been applied to all horizontal runs, and pressure releasing arrangements have been incorporated in all other idling-roller sections in the presentation unit and in the vertical distributor.

Throughout the transporting system steps have been taken to minimize the need for routine lubrication by the provision of automatic drip-feed lubrication for most of the chains and by the use of sealed ball races, oil-impregnated bushes or p.t.f.e. bearings wherever feasible. In spur-gear trains, metal-to-metal meshing has been avoided by the use of nylon and other non-metallic pinions.

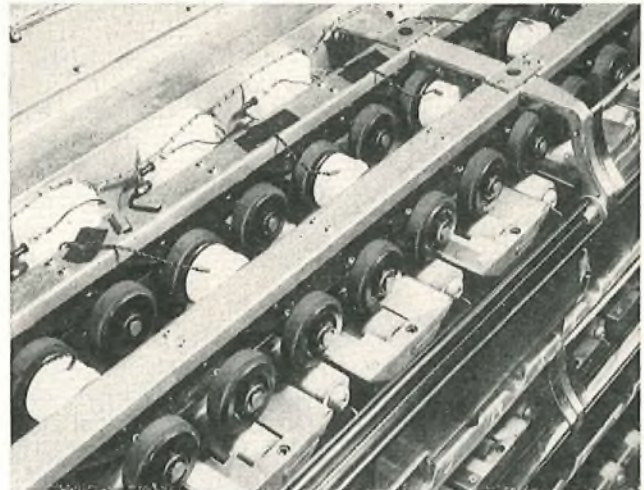

FIG. 9—IDLING ROLLERS

Control System

The control system has been entirely redesigned while retaining the use of pin disks as the basic time-delay elements and the principle of translation of a 12×12 signal-input through a square matrix of valves.

The essential changes are the elimination of the separate main memory of the experimental machine, elimination of the use of microswitches for pulse produc-

tion, and replacement of thyratrons in the translation matrix by cold-cathode tubes, with a consequent valuable reduction in the heat to be dissipated from the electronic equipment.

Elimination of the main memory of the experimental machine has been brought about by the use of larger "local box-memory" pin disks capable of controlling a letter for the full journey time to the most distant box. These disks are orientated in planes parallel to each other and normal to the line of the machine, as shown in Fig. 10. This orientation and position greatly improves

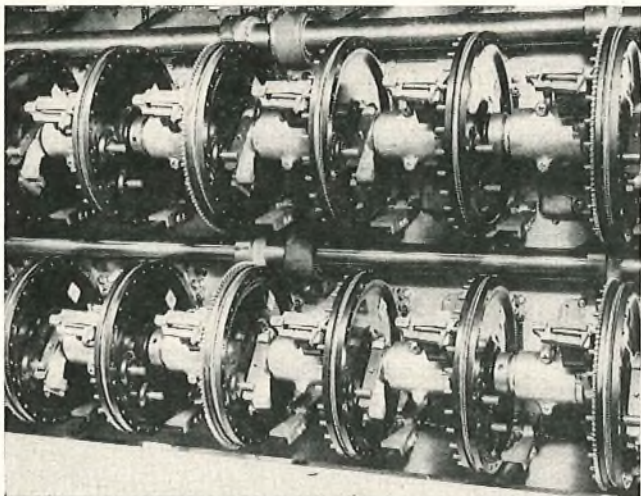

FIG. 10—PIN DISKS

access for setting compared with the experimental machine, and also renders it an easy task to remove and replace a faulty disk. The disks are grouped in threes for driving purposes, the first of each three being driven via a $\frac{1}{8}$ in. wide large-diameter spur-gear, meshing with a nylon pinion on a stiff common lay shaft (see Fig. 10); the remaining two wheels of the group are driven in tandem from the first by engaging radial arms which are suitably spring-loaded to eliminate backlash.

The pin disks consist of a central steel boss carrying a moulded disk of bakelite with a graphite content; in the outer rim of this disk the bearing holes for the silver-steel pins are drilled. Provision is made for the angular adjustment of a disk relative to the associated diverter-actuating cam, and for the angular adjustment of the pin-setting solenoid relative to the disk. It is therefore possible to achieve any angular displacement between a pin-setting solenoid and its actuating cam while at the same time enabling the pins to be correctly positioned, relative to the setting solenoid, at the cyclic pin-setting instant.

The pin-setting instants and the control of the associated information stores are controlled by four pulses, A, B, C and D. These are each generated by electromagnetic induction from a permanent magnet cemented into the rim of an adjustable timing wheel. Each pulse is amplified and then applied to a bi-stable multivibrator the output from which controls the striking of the cold-cathode tubes forming the information stores.

The control of the information stores is performed as follows. Each half of the keyboard is associated with 12 cold-cathode-tube (V1) stores. The keying of a 2-key code causes two of these to strike and to thereby start the presentation-unit cycle. During this cycle, pulses A and

B are generated and these cause the information stored in the V1 tubes to be transferred to a similar V2 store and subsequently cancelled from the V1 store. On the next operation of the keyboard the V2 code is handed on to a V3 store and the new V1 code is written in to the V2 store. The V3 store primes a cold-cathode translation matrix which then strikes on the next C pulse and extinguishes on the following D pulse. The 144 box pin-disk-setting solenoids are in series with the 144 translation-matrix tube anodes and the appropriate pin-disk-setting solenoid is thus energized at the correct time and for the correct period. Movements of the letters through the presentation unit are occurring during the cycles described, culminating in a letter leaving the double waiting-gate at the same instant as its destination pin disk and the relevant level-diverter pin disk are set.

Flexibility

The allocation of sorting addresses to the 144 permutations of the keyboard can be made using actual or positional codes in a variety of ways, based fundamentally on grading the traffic to suit the relative order of ease of keyboard fingering while taking into account geographical or other affinities between certain addresses. The 144 addresses thus allocated to key combinations can be connected to the 144 boxes, again in a large number of ways, in a manner which takes into account operational convenience in clearing mail to catch particular trains, etc. Furthermore, a machine will be engaged on at least two and possibly more different sorting tasks in the course of a day, e.g. outward sorting to other post towns, inward sorting for delivery, and the desirable cross-connexion between key combinations and boxes will almost certainly be different for each task.

For adequate exploitation of the machine, these various requirements demand facilities for readily changing both the connexions between key combinations and boxes, and the labels on the boxes. A maximum of four different daily tasks was assumed and the latter requirement met by the use of a 4-way rotatable label-fillet on each level. The former requirement was met by the use of the computer-type program unit shown in Fig. 11. This is essentially a 600-point plug and socket (Fig. 12), the plug being cross-connected within itself to act as a plug-in jumper field. Provision has been made for a library store for four differently wired plugs suited to each requirement, and changes from layout to layout are made simply by replacing plugs. As a safeguard the label-fillet capstans are fitted with 4-position switches interlocked electrically with each other so that unless the five label strips concerned are set to suit both each other and also the plug in the program-unit socket the machine cannot be started.

Flexible facilities have been provided also for selections carrying particularly heavy traffic, to enable a number of boxes to be grouped, on one key combination, to share the traffic of that selection. In all, 12 grouping-control sets, each capable of handling up to 12 boxes, have been provided. By the use of program plugs any selection can be connected to any grouping set and the grouping set strapped to distribute items for that chosen selection equally over any number of boxes up to 12.

General Appearance

Whilst catering also for maximum accessibility for maintenance combined with maximum guarding of moving parts for the safety of operating staff, considerable attention has been paid to securing a pleasing

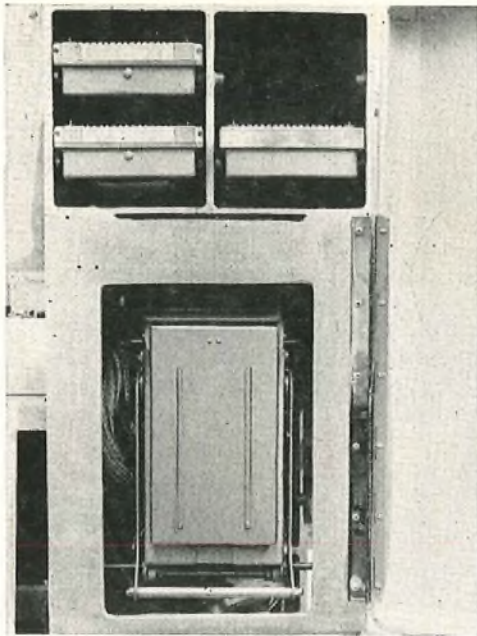

FIG. 11—PROGRAM UNIT

appearance in both shape and colour, and in providing the operator with comfortable working conditions, including good posture, adequate and yet unobtrusive illumination of viewing windows, and elimination of distracting influences from his field of view. The colour scheme is basically a blending of hammer-finish medium light green with a semi-matt plain pale green, with champagne cupboard interiors. Superimposed on this general theme are a variety of contrasts in the electronic cabinets, and coloured knobs on label capstans and pressure throw-off switches.

Miscellaneous

Apart from the more important points described, many other design features are embodied, including a comprehensive installation of alarm switches to detect stoppage of an idling roller due to a jam arising from a fault or an over-filled box, lamp indicators to facilitate location of a conveyor blockage, facilities for testing on reduced voltage to detect failing emission in valves, provision for self-operating to any chosen code, and the provision of a handwheel on the 3 h.p. driving motor to permit accurate setting of mechanisms.

THE FUTURE

The production program is now well advanced and several of the 20 machines ordered have been delivered to sorting offices. Ten of the machines are being concentrated at the new sorting office at Norwich in order to mechanize fully the sorting of short-letter traffic there.

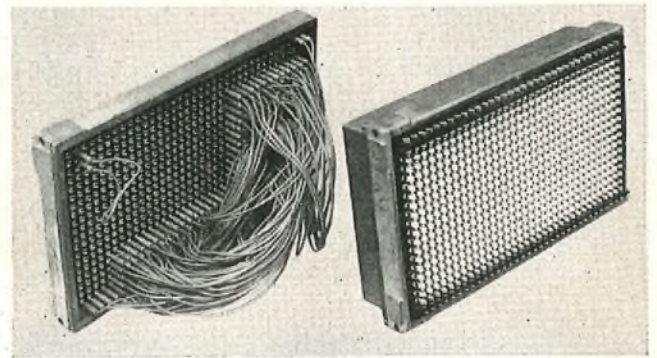

In the left-hand view the cover has been removed to show the jumper field
FIG. 12—TWO VIEWS OF PROGRAM PLUG

It is expected that much of the valuable information, both operational and technical, to be obtained from the field trial during the next year or so will stem from the group of machines at Norwich.

Further development will not, however, be suspended during the field-trial period and indeed a series of experiments and investigations is already in hand. Future plans are based on the assumption that a machine broadly of the form now being purchased will be the essential sorting mechanism of a more comprehensive sorting installation, in which a group of operators are separated physically from a smaller group of sorting units but connected thereto by a system of aggregating and distributing conveyors. Each operator's task will be to operate a suitable keyboard, probably of typewriter style, according to the address, and this will result in the printing of a phosphorescent dot code on the envelope and the despatch of the letter to the appropriate sorting unit within the group. On arrival at the sorting unit, letters from all operators will be stacked, and then separated out one by one automatically and scanned, the resultant signals controlling the settings of the machine's control system.

Such a scheme has the special merit of concentrating the work of a given number of operators on to a much smaller number of sorting units, and has great flexibility in meeting a wide range of combinations of number of selections and handling capacity. Other potential merits of the scheme will depend on the degree of success attained with encoding experiments but may include the possibility of automatic sorting at delivery offices from code marks placed on the mail by the original operator at the office of collection.

ACKNOWLEDGEMENTS

The author would like to express his appreciation of the assistance of colleagues in the Engineer-in-Chief's Office and for the excellent co-operation he has enjoyed with the Thrissell Engineering Co. of Bristol, who are manufacturing the machines described.

Automatic Switching for the Telex Service

A. E. T. FORSTER, A.M.I.E.E.†

U.D.C. 621.394.65:621.394.34:621.394.74

Two automatic telex exchanges were opened in August of this year as the first step in a program for the conversion of the telex service to automatic switching. Area and zone switching centres will be established and a national linked-numbering scheme employed. The system, which will enable subscribers to dial inland and international calls, is briefly described in this article.

INTRODUCTION

THE opening, in August of this year, of automatic telex exchanges at London (Shoreditch) and Leeds is the first step in a program for the conversion of the telex service to automatic working. The significance of this development is emphasized by the growing importance of the rapidly expanding telex service, particularly in the international field where already, between the U.K. and some countries, the number of telex calls exceeds the number of telephone calls. The conversion program, which involves the installation of the 23 exchanges shown on the map (Fig. 1), is



In addition to the 23 exchanges shown there will be 27 hypothetical exchanges, forming part of the six zone-centre exchanges
FIG. 1—AUTOMATIC TELEX EXCHANGES IN THE INITIAL PROGRAM

expected to be completed in just over two years, and aims at providing capacity for about 10,000 subscribers.

The new system will provide facilities not only for subscriber-to-subscriber dialling within this country,

but also for subscriber dialling of most international calls. However, the facilities for the automatic switching of outgoing international traffic will not become available until after the opening of the main London (Fleet) exchange, scheduled for completion in late 1960.

The system is planned to serve 20,000 subscribers at the end of 20 years but considerable further expansion could be accommodated if the need arose.

SWITCHING SYSTEM

The design of the switching system has taken account of the experience gained with the teleprinter automatic switching (T.A.S.) system* which was introduced shortly after the war for the inland telegraph service. The T.A.S. system, which uses dial selection with 2000-type selectors, has given very satisfactory service, and, in view of this, a basically similar switching system using dial selection with the 2000-type selector has also been chosen for the telex service. For the inland telex service, registers will not be used, apart from the limited use of the routing translators described below.

TRUNK NETWORK

The trunk network will be based on six fully interconnected zone exchanges located at London, Bristol, Birmingham, Manchester, Leeds and Glasgow. Area exchanges will be established where justified by the concentration of subscribers and will be connected by trunk routes to the parent zone centre and to other exchanges to which direct trunk routes are justified by traffic.

NUMBERING PLAN

To cater for incoming international traffic, a national linked-numbering scheme is being adopted; generally 5-digit numbers will be used although exceptionally 4-digit and 6-digit numbers will be employed. The first two digits will identify the charging area (there are 50, each corresponding, roughly, to a Telephone Manager's Area) and the remaining digits will indicate the final-selector-multiple number. In the early stages of development some charging areas will have insufficient subscribers to justify an area exchange. In such cases hypothetical exchanges will be included in the numbering scheme and service provided from a zone switching centre.

Each zone will be allotted a characteristic initial digit and the trunking will be arranged so that a subscriber connected directly to a zone switching centre can reach all subscribers on the network by dialling the directory number only. Subscribers connected to area exchanges will be provided with a simple code list showing those subscribers who may be called, via the parent zone switching centre, by prefixing the directory number with

† Senior Executive Engineer, Telegraph Branch, E.-in-C.'s Office.

* WILCOCKSON, H. E., and MITCHELL, C. W. A. The Introduction of Automatic Switching to the Inland Teleprinter Network. *I.P.O.E.E. Printed Paper No. 195, 1949.*

a single digit (digit "1"). Calls to other subscribers will be made by dialling the directory number only.

The trunking arrangements incorporate devices termed "routing translators," which function as simple level-seized register-translators; these avoid the restrictions which would otherwise arise from the use of a linked-numbering scheme to cater for incoming international traffic.

METERING

Subscribers' accounts will be based on metering and charges for dialled international calls will be bulked together with the charges for inland calls.

The subscribers' meters will be controlled by time-zone metering equipment and will be stepped at regular intervals throughout a call, the frequency of stepping depending upon the chargeable distance. The meter pulses will not be phased with the commencement of chargeable time but, in order to ensure that short-duration calls are always charged a minimum of one unit, the first periodic pulse will be suppressed and replaced by a single pulse, registered when connexion is established. The rate of metering for a particular call will be determined by analysing the digits dialled, and provision is made for dealing with the codes dialled for international calls.

GENERAL FACILITIES

Provision is made for the answer-back code of the called subscriber to be returned automatically to indicate that the called teleprinter is connected. On ineffective calls one of the following printed service signals will be given, the printed indication being followed immediately by the automatic release of the connexion:

- OCC Subscriber Busy,
- NP Spare Line or Level,
- NC Trunk Busy,
- DER Subscriber's Line Faulty,
- ABS Subscriber's Station Closed.

On calls to switchboards and some service points the signal MOM will be printed until the operator answers.

FIELD TRIAL EXCHANGES

The first two exchanges are being used to reduce the load on existing switchboards as well as for the primary purpose of subjecting the system to a field trial. The London (Shoreditch) exchange is designed to serve 900 subscribers in the London charging area. Leeds exchange will serve subscribers in the Leeds charging area and, in addition, on a hypothetical basis, subscribers in the following charging areas: Bradford, Lincoln, York and Middlesbrough. During the field-trial period, for calls to manual subscribers, automatic subscribers will dial out direct to manual switchboards, where the calls will be controlled and tickets prepared.

Fig. 2 (page 195), which is a photograph of the London exchange, illustrates the new colour scheme which has been standardized for telex exchanges.

INTERNATIONAL TRAFFIC

Subscriber-dialled international traffic will be routed via an international automatic exchange, which will be incorporated in the London (Fleet) exchange to be opened in 1960. Subscribers in this country will then dial a code (20) to reach the international exchange, followed, in turn, by a 1-digit or 2-digit code identifying the foreign country and the digits of the called subscriber's number. The call charges will be recorded on

the calling subscriber's meter but, in order that accounts can be exchanged with other administrations, meters will be fitted to outgoing international trunk circuits to enable the value of the traffic carried to be determined.

It is likely that, for a long time, it will not be possible to switch automatically all outgoing international traffic; automatic switching will not be possible, for example, to those countries with manual systems, or where radio channels are used for the international link. Such traffic will continue to be routed through the international switchboard in London.

SUBSCRIBERS' EQUIPMENT

In addition to the development of exchange equipment it has been necessary to design a range of subscribers' equipment for use with a variety of telegraph machines; namely, page teleprinters, with and without reperforating attachments, automatic transmitters and printing reperforators. Fig. 3 shows a subscriber's typical installation.

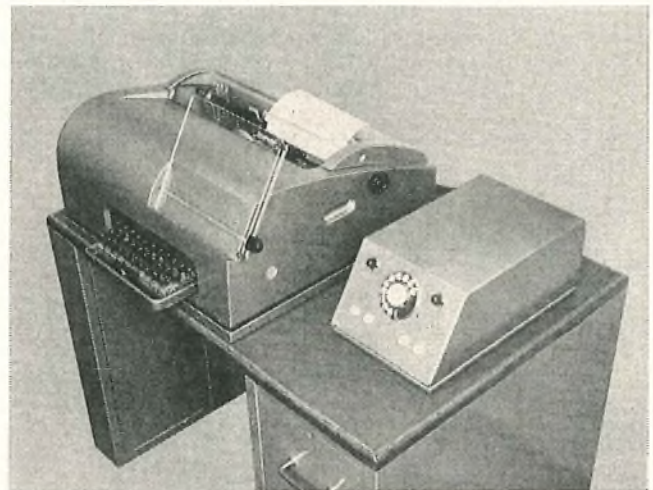

FIG. 3—SUBSCRIBER'S EQUIPMENT

A subscriber's private meter has been developed so that a subscriber's installation can be equipped with a pair of meters, one of which records the aggregate number of units charged and the other the charge debited for the last call made.

EXCHANGE EQUIPMENT

Because of the rapid growth of the service it has been necessary to bring the automatic system into service as quickly as possible, and the close co-operation between the Post Office and Ericsson Telephones, Ltd., who have manufactured and installed the equipment for the first two exchanges, has been a material factor in achieving a very tight program. Ericsson Telephones, Ltd., will share with the Automatic Telephone & Electric Co., Ltd., the task of manufacturing and installing the exchanges included in the current program.

ACKNOWLEDGEMENTS

Acknowledgements are due to those members of the E.-in-C.'s Office (Telegraph Branch) responsible for the design of the new system and to the Regional staffs concerned with bringing the new system into service. Acknowledgements are due also to Ericsson Telephones, Ltd., for kindly providing the photograph for Fig. 2.

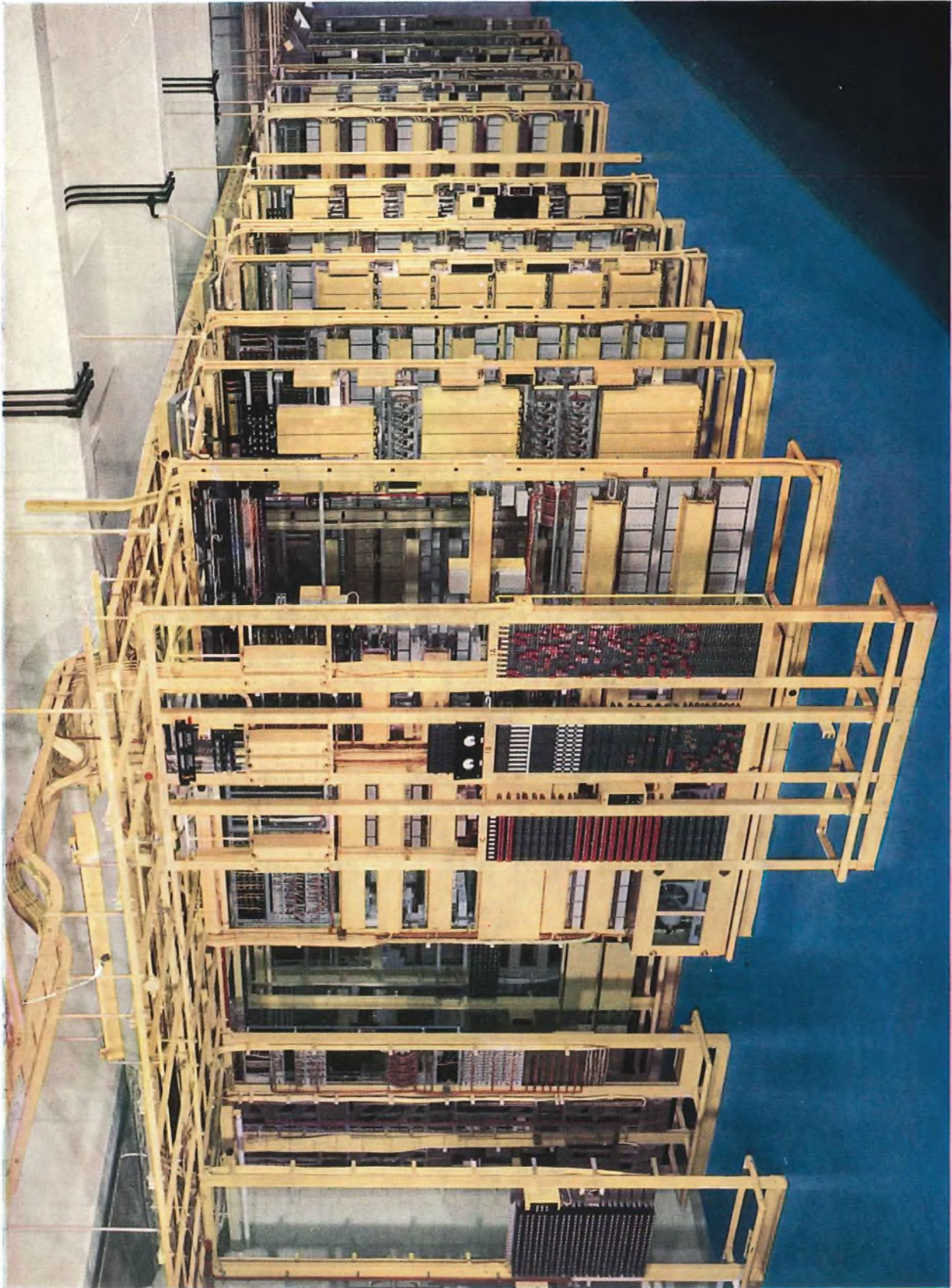

FIG. 2—THE LONDON (SHOREDITCH) AUTOMATIC TELEX EXCHANGE

An Improved Form of Mechanical Construction for Transmission Equipment—51-Type Construction

E. T. C. HARRIS, B.Sc.(Eng.), A.M.I.E.E., and C. J. SPRATT, Associate I.E.E.†

U.D.C. 621.396.69:621.395.6

For many years telephone and telegraph transmission equipment has been mounted on rack frameworks of steel channel or angle, with mounting plates for the components screwed to both sides of a rack. This form of construction has a number of disadvantages, and to overcome these a new form of construction, known as 51-Type Construction, has been developed. Single-sided sheet-steel rack frameworks are installed back to back and are fitted with jack-in panels, the connexions between panel and rack framework being made by U-links.

INTRODUCTION

DURING the last few years many people concerned with the installation and operation of telephone and telegraph transmission equipment will have seen a new form of mechanical construction for rack-mounted equipment. This has been given the title "51-Type Construction," and to differentiate it from the familiar form using steel racks and 19 in. panels that has been used for many years the latter is now referred to as "Pre-51-Type Construction."

The title "51-type" refers to the year when this form of construction was adopted by the Post Office. In fact, development had been taking place over many years previously, and subsequently the range of piece parts that can be used for special applications has been steadily growing. Contractors have been installing 51-type equipment for several years, but as there is an increasing use for this construction in equipment developed by the Post Office it was thought useful to describe the general features and some of the facilities provided, which is the purpose of this article.

Pre-51-Type Construction

Although the general features of pre-51-type equipment are well known it will be useful to set out those found in transmission equipment to form a basis of comparison:

- (a) Rack framework of steel channel and angle, of maximum height 10 ft 6 in.
- (b) Mounting plates secured to both sides of a rack.
- (c) Mounting plates used as chassis.
- (d) Box-type dust cover giving 4½ in. or 6 in. projection from face of rack on both sides of rack.
- (e) Rack wiring soldered to connexion strip(s) on mounting plate.
- (f) 130-volt h.t. and 24-volt l.t. supplies (excluding the introduction of mains-driven racks for special applications).

Some disadvantages of this form of construction have been found to be:

- (a) Some difficulty in installation.
- (b) Difficulty of changing a panel.
- (c) Difficulty of providing rack wiring to panels added to a rack.
- (d) Inflexibility of component mounting facilities.
- (e) Tendency towards a decrease in component sizes rendered maintenance of the equipment more difficult.
- (f) Expensive power-supply distribution.

† The authors are, respectively, Senior Executive Engineer and Executive Engineer, Main Lines Development and Maintenance Branch, E.-in-C.'s Office.

(g) Difficulty of obtaining satisfactory performance of h.f. equipment owing to the use of noisy and silent earths.

51-Type Construction

The principal features of 51-type construction are as follows:

- (a) Folded sheet-steel framework of maximum height 9 ft.
- (b) Each framework provides single-side mounting facilities and is termed a rack-side.
- (c) Rack-sides are installed back to back.
- (d) Panels are easily removed, being of the "jack-in" type.
- (e) U-links engaging rack-side sockets and panel

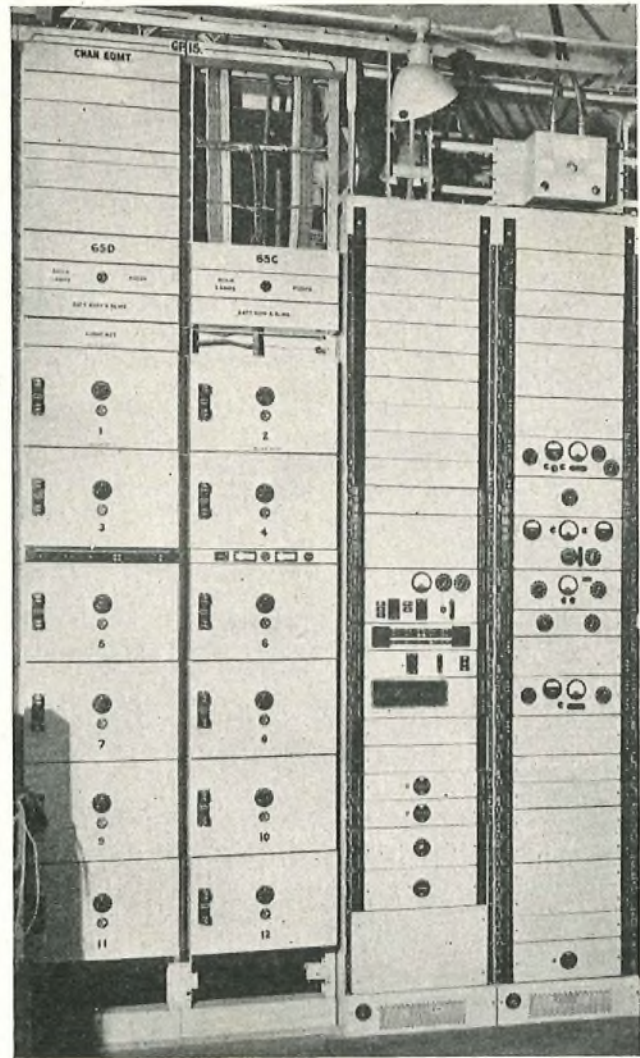

FIG. 1—PRE-51-TYPE (LEFT) AND 51-TYPE (RIGHT) TRANSMISSION EQUIPMENT

sockets provide connexion between rack-side wiring and panels.

(f) Straightforward earthing arrangements (rack earth and h.t. negative are commoned).

(g) The l.t. supply is derived from mains-driven power panels individual to a rack-side.

(h) The h.t. supply is derived either from mains-driven power panels individual to a rack-side or from a central source within the repeater station.

(i) Improved appearance.

Fig. 1 shows typical pre-51-type and 51-type equipments arranged side by side. Fig. 2 is a horizontal section through two of the equipments in Fig. 1 and clearly illustrates how the same space is used to better advantage in 51-type construction.

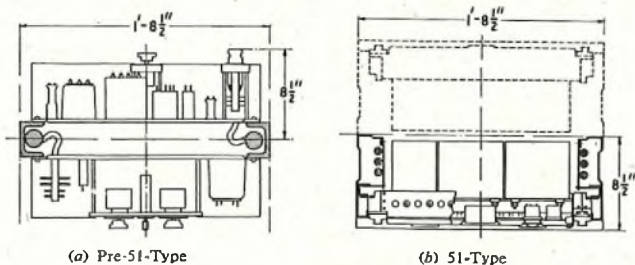

FIG. 2—SECTION THROUGH EQUIPMENT IN FIG. 1

RACK-SIDES

Fig. 3 illustrates an unequipped 9 ft rack-side (Rack, Apparatus, No. 53A). Accurately dimensioned tie bars are fitted to give rigidity to the rack-side framework and to ensure that the guides or locators secured to rack-sides to support panels are kept at the correct distance apart.

The standard for repeater stations is the 9 ft rack-side, but for certain installations a 6 ft rack-side is suitable. A 3 ft rack-side is also available and finds application for wall mounting and for bench use as, for example, in a laboratory.

The 51-type rack-side is considerably easier to handle and to install than its predecessor. The rack-sides stand on roofing felt and are secured to the floor by two screws. All that is needed in floor fixing is to prevent lateral movement during installation and also during working life, when lateral movement may arise from vibration.

The 9 ft rack-sides, even when installed back to back, must be secured overhead and in general it is convenient to use for this purpose the overhead ironwork that is provided to carry station cabling. For 6 ft rack-sides overhead securing is advisable but not essential.

Reference has been made to mounting rack-sides back to back. Through mounting of panels is not permitted and all the equipment mounted on a rack-side must be confined within the rack-side space. When it is not desired to mount rack-sides back to back, rear covers are secured to the rack-side to protect the equipment. Also, dust covers are fitted in all unused panel positions to minimize the ingress of dirt and dust.

EXTERNAL CABLING

Power Cabling

Power is conveyed to suites by means of small-section busbars housed in metal trunking secured overhead along the main aisles of the station, separate trunking being provided for mains and h.t. battery. Provision is made at intervals of 3 ft in the trunking for the insertion

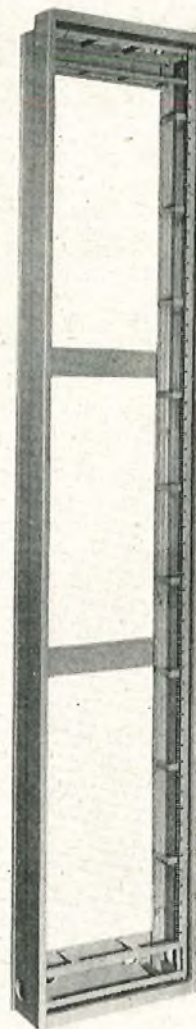

FIG. 3—A 51-TYPE 9 FT HIGH RACK-SIDE

of fused "tap-off" units. The tap-off units carry sockets that clip directly on to the busbars. From the tap-off units, cabling is led in conduit to the top of the first rack-side in the suite or suites to be fed from the tap-off unit. Fig. 4 shows mains (left) and h.t. battery trunking (right) tap-off units in certain positions, and conduit to the suites. From the end of the conduit the cabling is led down the front portion of the left-hand or right-hand side of the rack-side framework and is terminated on distribution blocks in the power supply distribution area at the bottom of the rack.

The "power distribution area," illustrated in Fig. 5, is not detachable. It has two covers. The outer cover provides mechanical protection for the rack-side and assists ventilation. The inner cover, shown removed in the illustration, is of insulating material and its purpose is to prevent accidental contact with a.c. mains or 220-volt battery supplies on the infrequent occasions when it is necessary to do work on the power distribution apparatus. A mains socket, fused at 1 amp, projects through the bottom cover. It is provided for portable test equipment.

A rack-side is provided with a left-hand and a right-hand earth bar bolted to the framework and extending from top to bottom of the rack. Pressed out of the bar at

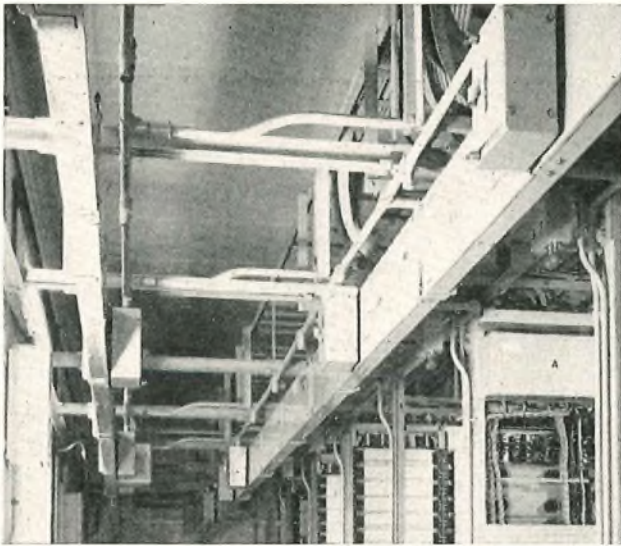

FIG. 4—POWER-DISTRIBUTION TRUNKING

frequent intervals are simple tags to which panel earths are connected via panel-rack-side links.

Transmission Cabling

Transmission circuit cabling is, generally, connected to coaxial or non-coaxial type connexion strips mounted at the top of the rack-side on supports forming part of the framework. An auxiliary detachable mounting for additional connexion strips is available should the capacity of the normal space be exceeded. Permanent cabling is led from the connexion strips to terminal blocks arranged down the sides of the rack-side; this cabling, segregated as necessary into forms, is run in the sides of the rear half of the rack-side framework. The forms are laced to longitudinal supports built into the framework. There is ample space to allow rack-side forms to be segregated into groups, to ease the meeting of crosstalk requirements for the equipment on the rack-side.

PANELS

Mounting

Secured to the left-hand and right-hand sides of the front of the rack framework are zinc or aluminium alloy die-cast supports, known as locators; these act as guides and supports for similar locators that form the ends of

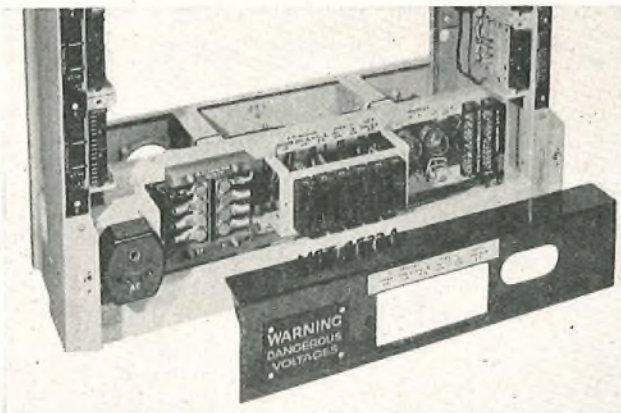

FIG. 5—RACK-SIDE POWER-DISTRIBUTION AREA

removable panels and as a housing for the terminal blocks referred to in the last paragraph. The bearing surfaces of the locators are accurately dimensioned and are machined smooth to facilitate the withdrawal and insertion of a panel. The horizontal dimension between locators is kept to a close limit by the rack-side tie bars referred to earlier.

The terminal blocks are bakelite mouldings containing a number of sockets, which may be coaxial or non-coaxial, depending upon the type of wire to be terminated. Links are employed to connect the rack-side wiring to panels. Both ends of removable panels house terminal blocks, and the links engage opposite sockets. Both the coaxial and non-coaxial links are mounted in bakelite mouldings. The coaxial moulding holds only one link, whereas the non-coaxial moulding holds five links, each link being insulated from all the others. Generally speaking, all links have level-measuring sockets. Some of the different links are shown in Fig. 6.

An indication of the function of each wire or cable is provided by labels screwed to the rack-side framework.

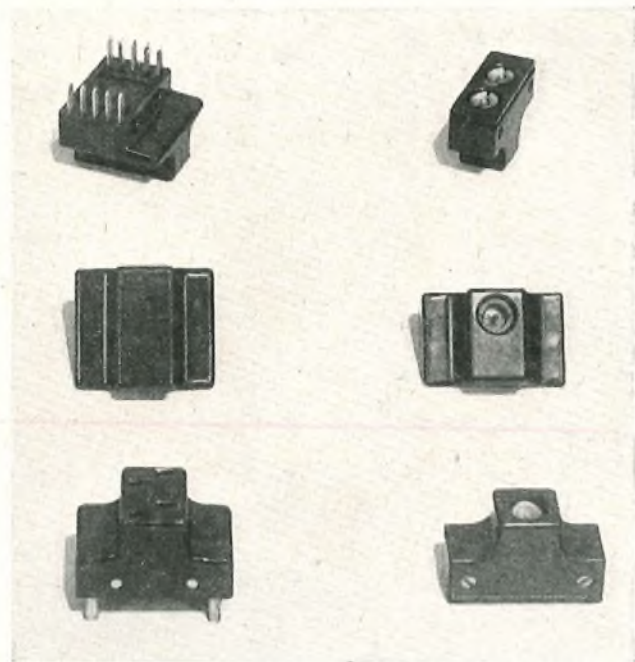

FIG. 6—PANEL-RACK-SIDE LINKS

Construction

A panel framework comprises four essential parts; they are the two die-cast end-locators and the top and bottom plates, as may be seen in Fig. 7. There are three standard panel sizes, $3\frac{1}{2}$ in., $5\frac{1}{4}$ in. and 7 in. The 7 in. panel is virtually two $3\frac{1}{2}$ in. panels joined together and therefore it has centre plates as well as the top and bottom plates; the centre plates are, however, narrower than the others.

It will be seen that the unit size of $1\frac{3}{4}$ in., a familiar feature of pre-51-type equipment, has been retained. Thus the $3\frac{1}{2}$ in. panel is more familiarly known as a 2-unit panel, the $5\frac{1}{4}$ in. as a 3-unit panel, and so on.

The panel locators house the terminal blocks and engage with the rack-side locators. When a panel is inserted into its position, four screws, one in each corner of the panel framework, secure the panel to the rack-side.

The panel wires that are to be extended to rack-side wiring are terminated on the panel terminal blocks, which are of the same form as the rack-side terminal blocks. Connexion between the two is made by the links mentioned earlier. Tags are provided on terminal blocks to permit soldered non-coaxial connexions between panel and rack-side.

Of the standard panel sizes, the 3½ in. and 5¼ in. sizes are available in both a removable and a hinged form. The latter is used when a particularly large number of rack-side wires has to be connected to a panel. The terminal blocks for a 3½ in. panel provide for 30 single non-coaxial wires and the 5¼ in. panel for 40; if these limits are exceeded a hinged panel must be fitted.

All panels carry a dust cover secured to the panel locators by means of snap-on fasteners. To undo the fasteners a coin or screwdriver is required, so that a deliberate action is necessary to remove a cover, beneath which exposed components or parts may be carrying high voltages. The dust covers are cut as necessary so as to expose meters, lamps, controls, etc.

Components

The top and bottom members of a panel, known as side plates, support, either directly or indirectly, all the items of equipment mounted on a panel. They serve also as panel earth "bars" and are electrically connected to the rack-side earth bar by means of the normal panel to rack-side links.

There are two principal methods of attaching panel components to these side plates. In the first method the components are mounted in cans or on some other structure secured to the side plates; in the second, the components are mounted on small tag boards and the tag boards attached to the front edges of the side plates at the top and bottom of the panel. The equipped panel shown in Fig. 7 has cans (at the rear of the panel) and

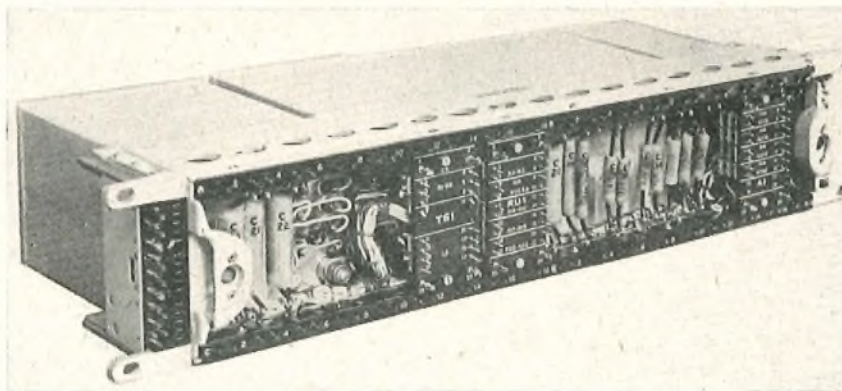

FIG. 7—AN EQUIPPED PANEL

tag boards. The cans are secured to a rail forming part of each side plate while the tag boards are carried by small brackets secured to the front edges of the side plates.

Component cans are made in a wide range of sizes, and equipped cans may either be filled with dry air and sealed, or unsealed. The former type will be used only for filters and similar assemblies, the performance of which imposes the necessity for sealing. Unsealed cans are used wherever possible, to enable servicing to be carried out in a repeater station.

A can is secured to the panel side-plate rails by means of studs, simple brackets and nuts. Facilities are available to insulate can and contents from the panel framework if performance requirements necessitate this.

Socket Terminal Strips

A useful feature of 51-type equipment is the socket terminal strip providing access points and alternative connexion facilities in the circuit of the apparatus mounted on the panel. It consists of a bakelite moulding, housing combined tags and sockets, secured to the front edge of the panel side plate. In Fig. 7 these strips are shown running the whole length of the top and bottom side plates. At an access point the panel wiring is, in effect, broken, and each side is brought out and soldered to one tag of a pair of adjacent tags, the circuit being completed by means of a small link inserted in the sockets associated with the tags. The access point may be a test point or may be one of a number of alternative strapping points, for example, on an equalizer. Link positions are numbered and the purpose of each position is indicated by a coloured marking on the strip. Socket-terminal-strip mouldings as manufactured have a length equal to half the panel width and will house 18 single-wire tag/sockets. It is customary to cut mouldings to the size required and equip them with tag/sockets when making up a panel.

POWER PANELS

The three most commonly used power panels provide the following supplies.

- (a) 6.3 volts a.c. (l.t.) and 220 volts d.c. (h.t.).
- (b) 6.3 volts a.c. (l.t.).
- (c) 24 volts, smoothed and un-smoothed.

Each power panel is driven from a nominal 230-volt 50 c/s a.c. supply and occupies 3½ in. (2 units) of rack space. Power panels are individual to rack-sides and more than one of a particular type may be required to meet the load imposed by the equipment. Power panels, being heavy, are usually fitted at the base of the rack-side immediately above the distribution area.

Type (a), above, is used in all-mains stations and type (b) where a 220-volt battery installation (centralized B battery) is provided. Owing to the heavy currents involved, a d.c. source of l.t. is never used.

VALVE FAILURE ALARM

The principle used for the valve failure alarm on 51-type equipment is that of continuously monitoring a voltage developed across a resistor in the valve circuit. When the voltage falls below a predetermined limit, the station alarm is operated. This facility, suitable only for valves of constant cathode current type, is given by the Valve Failure Alarm Panel (V.F.A. Panel). A reduction below a predetermined limit of the monitored voltage results in a negative bias being applied to the grid of a pentode on the V.F.A. Panel, thus decreasing its anode current. This decrease in current is detected by a polarized relay which in turn operates a relief relay to give the alarm.

By means of a switch on the V.F.A. Panel the monitored voltage of each valve connected to the panel may be measured in turn on a meter, thus providing a routine check of the emission of each valve. The meter circuit on the panel may also be used for measuring miscellaneous voltages, including the input and output voltages of power panels.

The V.F.A. Panel is always mounted at eye level and, because of its central position, a warning notice drawing attention to the existence of high voltages on the rack-side is associated with it.

DISTRIBUTION FRAMES

The basic distribution framework consists of a 9 ft frame occupying a space equal to two 51-type rack-sides fitted back to back. Front and rear of the frame are equipped with a number of connexion panels for terminating cables and also to provide a level-test socket at each end of a jumper. At the foot of the front and the rear of the frame a mains socket is provided similar to that on an equipment rack-side.

The basic framework serves for the high-frequency repeater distribution frame (H.F.R.D.F.), group distribution frame (G.D.F.), supergroup distribution frame (S.D.F.) and combined H.F.R.D.F.-G.D.F., the only difference being in the types of connexion panel fitted.

CONCLUSIONS

51-type construction has certain advantages compared with pre-51-type but it cannot be considered an ideal form of construction in all respects. Although it has

been adopted as a new standard, it is not necessarily the only new standard that may be introduced. Now that a considerable quantity of 51-type equipment has been produced and installed a clearer picture of the comparison between the old and new forms of construction is emerging and the extent of its use in the future will depend upon economic considerations.

A modified form of 51-type construction that reduces the minimum size of a readily replaceable unit from a 2-unit panel to a small unit that can plug into horizontal frames mounted on the main rack-framework has been adopted for certain equipments.

Basically the problem presented by new equipment with improved space utilization, particularly using transistors with their low-power dissipation, is to develop a form of construction where the equipment is not a rack-side but a small part of one. There would have to be facilities for cabling to portions of a rack-side. The complete framework could then cater for a number of differing functions and equipment could be mounted and cabled as the circuit demands dictated.

There are many requirements, such as power supply arrangements or safety precautions, that are common to all types of construction, and it is likely that there could be several compatible forms of construction that would go some way to meeting the new problems presented before an ideal solution is found.

ACKNOWLEDGEMENTS

The authors wish to express their thanks to Standard Telephones & Cables, Ltd., for permission to publish the photographs in this article.

Book Review

"Electronic Designers' Handbook." R. W. Landee, Donovan C. Davis and Albert P. Albrecht. McGraw-Hill Publishing Co., Ltd. 1,040 pp. 982 ill. 128s.

Designers' handbooks are often viewed with suspicion by the designers for whose benefit they are written. If the book is largely a collection of facts and tabulated information, such as, for example, the sizes and properties of standard sections of steel joists, part of the information it contains is likely to be repetitive of earlier works, because the author naturally tries to cover his subject comprehensively. Much of the information in any new engineers' reference book is therefore liable to be already as much part of the office equipment as is the slide rule.

If, on the other hand, a reference book is a compendium of general theoretical work, outlines of mathematical analyses, formulae and so forth, the average designer is unlikely to find much use for it, because he still has to twist the general theoretical answers to fit his own specific practical cases. He prefers specialist books giving more detail. Electronic designers, moreover, tend to work on devices so recent in conception that writers of handbooks have not "caught up with them." So we are faced with the situation that older engineering reference books tend to collect dust on the bookshelf, while new ones, at their present high prices, may well be insufficiently attractive to be worth the outlay. But it must be admitted that the "Electronic Designers' Handbook" is a magnificent work (which it should be at the price) and that it is written with a real conception of what an engineer employed on the design of electronic circuits is likely to need.

One good feature of the book is that typical examples of practical designs are included at intervals in the text, and these are fully worked out, right down to component values or wire gauges. Even if the reader finds that the example in his subject is remotely different from the problem he is seeking to solve, there is a strong chance that the illustration will be sufficient to give him the inspiration needed to solve his own exceptional case.

The book is written by three practising engineers, all working in industrial concerns in the U.S.A. They have divided the work into 23 sections, each covering one aspect of electronics. Here, for example, are a few of the section headings—Vacuum Tubes and Transistors, Voltage Amplifiers, Modulating Oscillators, Receivers, Multivibrators, Variable Delay Circuits, Trigger Circuits, Transformers and Chokes, Principles of Feedback, Computers and Servomechanisms, Network Analysis. Each section is as up-to-date as can be expected (1957 is the date given in the book) and the technique it represents is carried to an advanced stage. Advanced mathematical treatments are included where they seem necessary—as in the section on network analysis—but in such cases the reader is, on the whole, expected to accept the results without being given more than an outline of how they can be derived. There is a wealth of practical data in the book, and the engineer can expect to find all the information needed for the design of most types of valves and transistor circuits.

The volume is excellently produced and is bound robustly, with a dignified type of finish. It would be a suitable selection as a university prize or premium award. Otherwise, in view of the price, it is likely to be bought only for reference libraries.

C. F. F.

Radio Interference

Part 5—Industrial, Scientific and Medical Apparatus and Radiating Receivers

C. W. SOWTON, B.Sc.(Eng.), A.M.I.E.E., and G. A. C. R. BRITTON, A.M.I.E.E.†

U.D.C. 621.396.82

Parts 1 and 2 of this article introduced the subject of radio interference and described the Post Office radio interference service. Part 3 considered how the interference is generated and propagated and dealt with methods of suppression. Part 4 outlined the general principles and technical requirements of radio interference measuring equipment. Part 5 deals with the special case of radio interference caused by industrial, scientific and medical apparatus, and by radio receivers. A further article will deal with the control of radio interference.

INTRODUCTION

MOST radio interference comes from electrical apparatus such as commutator-type electric motors, switch contacts, etc., whose normal functioning does not require the generation of radio-frequency energy. Radio-frequency (r.f.) energy is, however, generated fortuitously by sudden changes of current in the electrical circuits of such apparatus. This energy is normally spread, more or less uniformly, over a wide band of frequencies and is commonly referred to as "radio noise."

There are, however, many types of apparatus in which the generation, but not the radiation, of r.f. energy is essential to its normal functioning. The r.f. energy radiated is usually on a specific frequency, or confined to a narrow band, together with harmonics of that frequency. There are two main groups of such apparatus that cause radio interference:—

- (a) industrial, scientific and medical (i.s.m.) apparatus and
 - (b) radio receivers,
- and these are considered separately in the article.

I.S.M. APPARATUS

I.S.M. apparatus is apparatus which generates r.f. energy for industrial, scientific and medical applications, well-known examples being r.f. heaters used for welding seams in plastic sheet, cyclotrons, and medical diathermy apparatus used for heating the human body internally. Most i.s.m. apparatus uses valve generators employing tuned circuits, and consequently the energy generated is not broadband in character, but is concentrated at one or more frequencies, the fundamental and its harmonics, plus, perhaps, spurious frequencies. Because of this, radio interference may, in principle, be avoided or minimized in the following ways:

- (a) by careful choice of working frequency so that neither the fundamental frequency nor the harmonics coincide with frequencies used by radio-communication or other radio services in the vicinity;
- (b) by the choice of a fundamental frequency not used by radio services in the vicinity, the radio-frequency output leads of the generator (and the mains input leads) being filtered to minimize the radiation of harmonic frequencies;
- (c) by screening of the whole apparatus to reduce radiation of both fundamental and harmonic frequencies.

† The authors are, respectively, Assistant Staff Engineer and Senior Executive Engineer, Inland Radio Planning and Provision Branch, E.-in-C.'s Office.

The first internationally co-ordinated steps to make specific provision for i.s.m. apparatus in the radio spectrum were taken at the Ordinary Administrative Radio Conference at Atlantic City, U.S.A., in 1947, when several frequency bands were allocated for i.s.m. use. It was agreed that, within these bands, i.s.m. apparatus could radiate freely and that other radio services would have to accept any harmful interference resulting from the operation of i.s.m. apparatus. The frequencies allocated were:

13.56 Mc/s \pm 0.05 per cent
27.12 Mc/s \pm 0.6 per cent
40.68 Mc/s \pm 0.05 per cent
2,445 Mc/s \pm 50 Mc/s
5,850 Mc/s \pm 75 Mc/s

These frequencies and tolerances have been incorporated in the regulations of several countries. In the United Kingdom, where legislation is not usually embarked upon except when the need is amply clear and when it has been demonstrated that it would not involve undue hardship, progress has been slower. Under powers conferred on him by the Wireless Telegraphy Act, 1949, the Postmaster-General has appointed an Advisory Committee charged with recommending to him what regulations, if any, should be made by him under the Act to control radio interference caused by i.s.m. apparatus. The matter is therefore still being considered, and in this article care has been taken not to anticipate the findings of the Advisory Committee.

MEDICAL APPARATUS

For general diathermy treatment the frequencies 27.12 and 40.68 Mc/s are usable. However, in the United Kingdom, television Band I (41–68 Mc/s) is so close to 40.68 Mc/s that television receivers of commercial standard, when tuned to Channel 1 (41–46 Mc/s), will not reject this frequency, and its use for i.s.m. applications in this country cannot be approved. A frequency of 27.12 Mc/s, though perhaps not quite optimum for all medical applications, has been found generally acceptable by the medical profession. It also has the advantage of a greater frequency tolerance (\pm 0.6 per cent, as against \pm 0.05 per cent allowed for 40.68 Mc/s). This permits the use of a well-designed oscillator without the cost and complexity of crystal control, and tests made by the Post Office on prototype sets produced by electro-medical manufacturers have shown that the required frequency stability can be achieved. Subject to this requirement, there need be no limitation on the magnitude of the field radiated at the fundamental ("working") frequency.

Radiation at the harmonic frequencies of 27.12 Mc/s must, however, be limited since these harmonics fall in frequency bands used by various radio services, particularly television services in Bands I and III. The harmonic radiation occurs in discrete frequency bands and for valve-energized diathermy apparatus is in the nature of a c.w. or m.c.w. signal. The degree of interference to television will depend to a large degree on where

the harmonic frequency falls in the television channel under consideration. Fig. 23, based on C.C.I.R. (London) 1953, Report No. 34, illustrates the ratio of television-signal/interfering-c.w.-signal that may be considered as tolerable, and shows the location of the second harmonic of 27.12 Mc/s in television Channel 3. It will be seen that as the harmonic is about 2.5 Mc/s below from the vision carrier frequency, a signal/interference ratio of 20 db is adequate, though 45 db would be required at the vision carrier frequency.

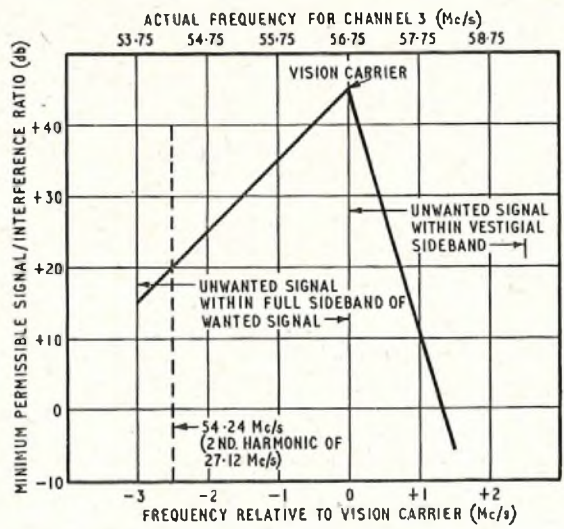

Based on C.C.I.R. (London) 1953 Report No. 34
 FIG. 23—MINIMUM REQUIRED SIGNAL/INTERFERENCE RATIO FOR BRITISH TELEVISION SYSTEM

As another example, the seventh harmonic of 27.120 Mc/s is 189.840 Mc/s, or 188.701 to 190.979 Mc/s allowing for the frequency tolerance. This harmonic can, therefore, occur at precisely the vision carrier frequency (189.75 Mc/s) of television Channel 8, and a signal/interference ratio of 45 db is required. If apparatus is not designed to work on an approved "free radiation" frequency, it would be necessary to allow for the worst circumstances, i.e. fundamental or harmonic radiation occurring precisely at a vision carrier frequency, and a 45 db signal/interference ratio would be required.

The human-patient load of a medical diathermy set is not usually in a screened enclosure and it can, therefore, radiate freely at the fundamental and harmonic frequencies. As the r.f. output power at the fundamental frequency may be of the order of 200 to 300 watts, the difficulty, indeed the impossibility, of restricting the field strength of the radiation to an acceptable level at this frequency is clear. The advantages of using a free radiation fundamental frequency are thus:

- (i) There is no restriction on radiation at the fundamental frequency.
- (ii) The limitation of harmonic radiation may be relaxed very considerably for some harmonics, thus easing the design problem.

Both medical users and manufacturers have accepted the principle of using the free radiation frequency of 27.12 Mc/s with harmonic attenuation. A block schematic diagram of a diathermy set, showing the anti-interference precautions taken, is given in Fig. 24. A number of commercially produced prototypes have been tested by the Post Office and radiation measurements on a typical set are given in Table 7. Measurements on an

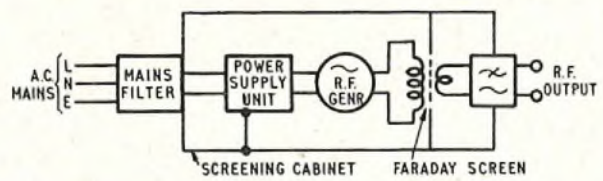

FIG. 24—MEDICAL DIATHERMY APPARATUS SHOWING INTERFERENCE-SUPPRESSION FEATURES

old-type set are also given; they show the very considerable reduction in harmonic radiation obtained with the up-to-date design.

TABLE 7
 Radiation from Medical Diathermy Set

Field-strength of harmonics (db relative to 1 μV/m at a distance of 10 metres)								
Type of Set	1st (i.e. fundamental frequency)	2nd	3rd	4th	5th	6th	7th	8th
Old-type set (36 Mc/s)	+117	+88	+89	+89	+83	+88	Not measured	Not measured
Modern set (27.12 Mc/s)	Not measured	+43	+16	+36	+47	+29	+33	+39

INDUSTRIAL APPARATUS

As previously mentioned, apparatus having spark-gap r.f. generators is now little used, the only example at all prominent as a cause of radio interference being the "argon-arc" welder, in which non-ferrous metals are welded with a 50 c/s arc in an atmosphere of inert gas (argon). Radio-frequency energy is superposed on the output circuit to initiate the arc and to enable it to be re-struck at each zero in the voltage cycle of the power frequency. This permits the use of a 50 c/s voltage low enough to be "safe" for the operator, and it effects a worth-while saving in the cost of the mains transformer. The general circuit arrangement is given in Fig. 25.

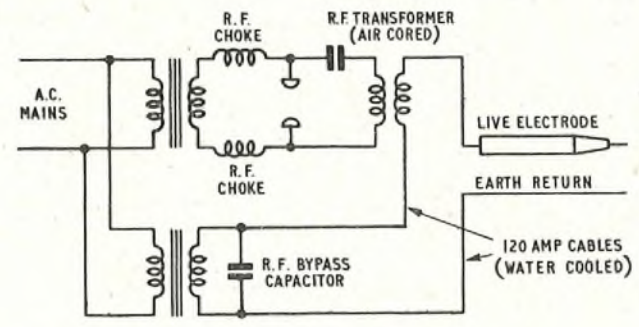

FIG. 25—ARGON-ARC WELDER

The interference-level/frequency curve is relatively flat over the frequency band 150 kc/s to 216 Mc/s, and the output circuit, including the trailing cables and load, is physically large. In consequence, interference covering a wide frequency-range is radiated effectively. The design is such that little or nothing can be done to reduce the interference potentialities without fundamental change. An argon-arc welder which can limit the use of r.f. energy to arc inception has been developed,* and its use should reduce very considerably the time during which interference is caused. Alternatively, a valve oscillator working on a "free-radiation" frequency could probably

* British Patent No. 705164.

be used, but so far this has not proved to be commercially attractive.

The bulk of industrial r.f. apparatus uses valve generators and covers a very wide field of applications; for example, melting, heating, hardening, tempering, hard soldering, soft soldering and welding of metals; drying, gluing, vulcanizing, seasoning, welding of non-metals; sterilizing or preparing of foodstuffs, etc. For these purposes a wide range of powers and frequencies is in use. The methods of minimizing radio interference have already been mentioned in principle, but several features peculiar to industrial use have to be taken into special consideration:

(a) The r.f. energy used may be high—as much as 10 kW is commonly used. Any methods of interference-suppression should not greatly reduce the output power at the fundamental frequency, and filters have to be designed to handle this power.

(b) Any screening should not impede the normal working process.

(c) The output-circuit leads and the “work” may be physically large. This not only leads to considerable radiation, but also has a bearing on the usable frequency.

Industrial heaters of most concern as causes of radio interference are those used with non-metallic loads. The load, or “work,” forms the dielectric between metallic electrodes connected to the generator. Since the heat generated is proportional to the dielectric loss, the higher the frequency, the greater the heat produced. However, if the frequency is made so high that the dimensions of the electrodes and “work” become a significant fraction of a wavelength, the standing waves produced lead to unequal distribution of current in the load, and uneven heating. Another factor to be considered is that the frequency chosen should not be such that the required heating current can only be obtained by applying a voltage high enough to puncture the load, e.g. when welding plastic sheeting. The optimum frequency is something of a compromise, and the free radiation frequencies so far assigned are not adequate for all purposes.

A large series of measurements of the radiation set up by industrial r.f. heaters on an open test-site, and also on actual factory installations, is now in hand by the Electrical Research Association and the Inland Radio Planning and Provision Branch of the Post Office Engineering Department. The data obtained will be made available to the Postmaster-General's Advisory Committee,

TABLE 8
Measurements of Radiation from Typical Industrial R.F. Apparatus

Field-strength of harmonics (db relative to 1 μ V/m at a distance of 10 metres)

Type of Apparatus	Nominal Frequency (Mc/s)	1st (i.e. fundamental)	2nd	3rd	4th	5th	6th
3 kW wood gluer	9.0	Not measured	Not measured	Not measured	+75	+100	+73
3 kW wood gluer after experimental modification	9.0	Not measured	Not measured	Not measured	+25	+31	+35
Plastic pre-heater	27.0	+60	+37	+35	+38	+34	+56
Plastic welder	36.4	+123	+81	+82	+78	+78	+72
Argon-arc welder for non-ferrous metals	None	Radiation level varies between +42 db and +69 db over frequency range 0.21–60 Mc/s.					

previously mentioned, and also to the International Special Committee on Radio Interference (C.I.S.P.R.), which is considering the same problems.

A few measurements of the radiation set up by industrial r.f. apparatus are given in Table 8.

RADIO RECEIVERS

Of primary interest are receivers used for broadcast reception, including:

(i) Receivers for amplitude-modulated (a.m.) sound-broadcast reception in the frequency bands 150–285 kc/s and 525–1,605 kc/s.

(ii) Receivers for frequency-modulated (f.m.) sound-broadcast reception in the frequency band 87.5–100 Mc/s (Band II).

(iii) Receivers for television reception in the frequency bands 41–68 Mc/s and 174–216 Mc/s (Bands I and III).

Receivers in groups (i) and (ii) can radiate r.f. energy at the frequency of the frequency-changing oscillator and its harmonics, and at the intermediate frequency and its harmonics. Receivers in group (iii) can radiate at the fundamental and harmonic frequencies of the frequency-changing oscillator and at the intermediate frequency, and in addition at the fundamental and harmonic frequencies of the line and frame time-base oscillators. There is only space here to touch on two main types of receiver radiation, i.e.:

(a) line time-base radiation from television receivers, affecting long-wave and medium-wave a.m. reception;

(b) radiation from frequency-changing oscillators of television and f.m. receivers.

Although the line time-base frequency used in the British television system is only 10,125 c/s, the sawtooth waveform and the several watts of scanning power necessarily used result in the generation of high-order harmonics of sufficient amplitude to cause interference to a.m. sound broadcasting in the “long” and “medium” wavebands. Complaints of this type of interference grew quickly with the rapid post-war expansion of the television service and reached serious proportions from 1951/1952 onwards. This was clearly an interference problem to be solved primarily by the radio industry, and the British Radio Equipment Manufacturers' Association (B.R.E.M.A.) started research to determine methods of measuring time-base radiation from receivers and the acceptable limits of such radiation. It is convenient to make measurements of radiation at a short distance where the measuring aerial is well within the induction field, and B.R.E.M.A. decided to measure both the electric and magnetic components of the field and, in addition, the r.f. voltage fed back into the public supply mains. Fig. 26 shows the arrangements for measuring

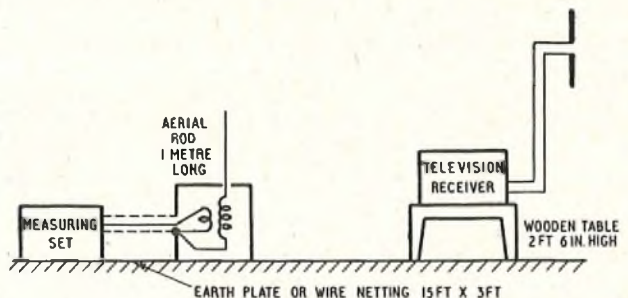

FIG. 26—MEASUREMENT OF TIME-BASE RADIATION

the electric component of the field. The limits within the range 150–1,605 kc/s to which the radio industry has been urged by its own association to work are:

(i) Electric field. The voltage produced in the 1-metre test aerial shall not exceed $100 \mu\text{V}$.

(ii) Magnetic field. The voltage produced at the terminals of a loop aerial shall not exceed the value which would be produced when the loop aerial is in a field of $400 \mu\text{V/m}$.

(iii) Terminal voltage measured across the standard artificial mains impedance of 150 ohms shall be $200 \mu\text{V}$ within the frequency range 150–550 kc/s and $100 \mu\text{V}$ within the frequency range 550–1,605 kc/s.

That the limits are realistic and that manufacturers have made a real effort to conform to them is strongly supported by the fact that the annual totals of complaints of time-base interference have steadily fallen from the record figure of 7,849 in 1953 to 3,658 in 1957. The B.R.E.M.A. limits and method of test have been accepted for incorporation in the next revision of B.S. 905,* and the method of test has formed the basis of an internationally agreed method of measurement which will be incorporated in an International Electro-technical Commission (I.E.C.) publication.

Radiation from local oscillators of receivers is not, as yet, unduly troublesome, but could well become so with further exploitation of the v.h.f. broadcasting bands. The desirability of tackling the problem in advance has been fully appreciated, and considerable work has been carried out nationally and internationally to this end. Initially, B.R.E.M.A. evolved a method of test in which each method of propagating interference was assessed separately:

- (a) Voltage fed back into the supply mains.
- (b) Radiation from the aerial—assessed by measuring the interference voltage present at the aerial connector of the set.
- (c) Radiation from the chassis measured at a distance of 10 metres.

However, the desirability of international standardization was kept to the fore. When it became clear to the I.E.C. committee studying the matter that opinion was hardening in favour of a single overall measurement of the radiation from a receiver and its aerial, the United Kingdom co-operated with other countries in the evolution of an arbitrary test arrangement for measuring

overall radiation at a distance of 3 metres (see Fig. 27).

A number of factors have to be taken into account in devising the method of test. The field imposed on the measuring aerial has four components, produced by the direct and ground-reflected rays arising from the aerial of the receiver under test, and the direct and ground-reflected rays arriving from the chassis (see Fig. 28).

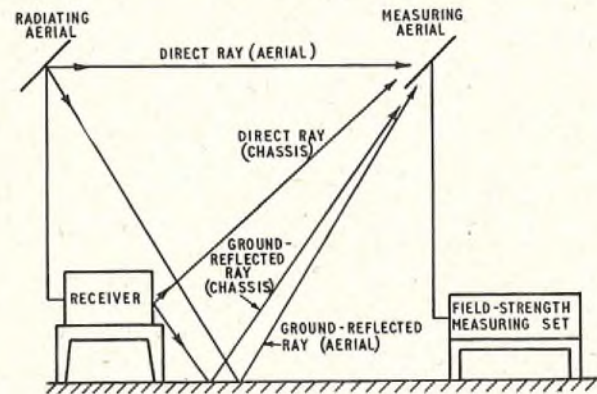

FIG. 28—COMBINATION OF DIRECT AND GROUND-REFLECTED RAYS

The way in which the four components add to produce the resultant field at the measuring aerial depends on

- (a) the differences between the four path-lengths, and
- (b) the reflection coefficients and phase changes experienced by the two ground-reflected rays.

Factors (b) are different for the vertically-polarized and horizontally-polarized components, which are measured separately. From the interference point of view only the maximum possible value of the resultant field is of interest. This is ascertained by moving the measuring aerial over a vertical search range sufficient to encounter at least one maximum.

The suitability of a proposed test site is assessed by plotting a "site attenuation curve," which must conform fairly closely to a prescribed curve, the latter being based on both calculations and experimental data. To plot the site-attenuation curve, the apparatus is disposed as shown in Fig. 27, the receiver being replaced, however, by a standard signal-generator, the output of which is connected to the feeder via an impedance-matching balun.† The site attenuation is expressed in terms of the r.f. power input to the radiating dipole required to produce a field strength of $100 \mu\text{V/m}$ at the aerial of the field-strength meter.

The method of test outlined has been accepted by most countries. It is to be incorporated in the I.E.C. document and British Standard referred to earlier. The limits evolved by B.R.E.M.A. for their original method of test have been converted into equivalent figures for the 3-metre I.E.C. method of test, and all members of B.R.E.M.A. have been asked to conform to the limits. It is expected that the same limits will be specified in B.S. 905 when it is next revised.

(To be continued)

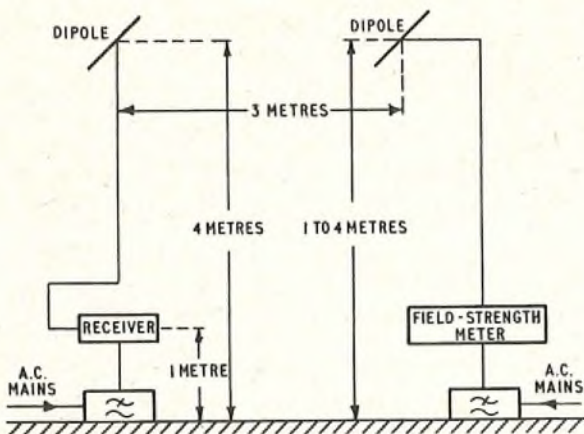

FIG. 27—MEASUREMENT OF OSCILLATOR RADIATION AT V.H.F.

* B.S. 905: 1940. Interference Characteristics of Radio Receivers (British Standards Institution).

† Balun—a device that acts as a transformer between balanced and unbalanced impedances at high frequencies.

The Principles of Negative-Impedance Convertors and the Development of a Negative-Impedance 2-wire Repeater

D. TURNER, B.Sc.(Eng.), A.M.I.E.E., and T. B. M. NEILL, B.Sc., A.M.I.E.E.†

U.D.C. 621.395.64.011.212

The principles of the negative-impedance convertor are outlined and applied to the design of negative-impedance 2-wire repeaters. The limitations in use of a 2-wire 2-terminal repeater are discussed, followed by a description of the design and performance of a 2-wire 4-terminal repeater. Some results of a field trial of the 4-terminal repeater are also given.

INTRODUCTION

REPEATERS having one or two amplifying elements* capable of providing transmission gain in both directions in a 2-wire circuit have been known for many years.¹ In addition, the concept of a negative impedance and its application to a 2-wire repeater were described in 1931 by Crisson.² However, the difficulties of operating 2-wire repeated circuits satisfactorily compared with 4-wire amplified circuits resulted in the latter being brought into widespread use despite the additional pair of wires required; the development of 2-wire repeaters attracted little further interest until about 1945. In the post-war years it became clear that substantial capital savings could be made by the conversion of existing 4-wire routes to 2-wire working in cases where additional cables would otherwise be required. Such considerations revived interest in the development of 2-wire repeaters and, in particular, in negative-impedance 2-wire repeaters, notably in the U.S.A. where great progress has been made in their design, manufacture and installation. These developments have been described by Merrill, Linvill and others.^{3,4,5,6} In this country, at this time of restriction of capital expenditure, particular emphasis is given to the need for reintroducing the 2-wire repeater and two such repeaters have been developed by the Post Office. One is of the conventional 22 type*; the other is a negative-impedance repeater using transistors and is described in this article. For both types the principal application envisaged is the provision of a single repeater in circuits not longer than 30 miles routed on 20 lb/mile P.C.Q.T. cable with standard loading (88 mH coils at 2,000 yd intervals).

PRINCIPLES OF NEGATIVE-IMPEDANCE CONVERTORS

Properties of Negative Impedances

Networks composed entirely of resistors, inductors and capacitors, which are termed "passive" since they contain no source of power, present impedances whose resistive components are always positive. Impedances whose resistive components are negative over a limited frequency-band, called "negative impedances" for brevity, can, however, be realized with the aid of active networks, containing valves or transistors as sources of power.

Combinations of passive impedances are always "stable," in the sense that any transients that may occur

decrease in magnitude with time, and there can be no sustained or increasing oscillation. On the contrary, the use of negative impedances involves the possibility of instability, depending not only on the nature and value of the negative impedance but also on the value of the passive impedance presented by the circuit to which it is connected. From this point of view, negative impedances are divided into two classes, "open-circuit-stable" and "short-circuit-stable." In addition to the obvious implications of these terms, the two classes have the following properties:

(a) If an open-circuit-stable negative impedance $Z_n = R_n + jX_n$ is connected to a passive impedance $Z_p = R_p + jX_p$, a sufficient condition for stability is that, at all frequencies,

$$R_n + R_p > 0$$

i.e. the resistance of the series combination should be positive.

(b) For a short-circuit-stable negative impedance, however, a similar condition applies in terms of admittance. If a short-circuit-stable negative admittance $Y_n = G_n + jB_n$ is connected to a passive admittance $Y_p = G_p + jB_p$, a sufficient condition for stability is that

$$G_n + G_p > 0$$

i.e. the conductance of the parallel combination should be positive.

To illustrate these points, suppose that a negative resistance, of 1,000 ohms, is to be used in a resistive circuit. This negative resistance can be realized in either the open-circuit-stable or the short-circuit-stable form, and the choice between the two depends on the value of the positive resistance presented by the circuit at the point where the negative resistance is to be connected. An open-circuit-stable negative resistance of 1,000 ohms will be stable when connected to positive resistances greater than 1,000 ohms, but a short-circuit-stable negative resistance of the same value will be stable when connected to positive conductances greater than 0.001 mho, i.e. positive resistances less than 1,000 ohms.

The Negative-Impedance Convertor

Negative impedances are usually produced by the combination of a passive network and a negative-impedance convertor. The principles of the latter have been described by Tillman in an earlier article⁷ but for completeness they will be re-stated here.

An ideal negative-impedance convertor is a network with two pairs of terminals A-B and C-D, as shown in Fig. 1, having the property that if any impedance Z is connected between one of the pairs of terminals, say C-D, the impedance seen between the other pair of terminals, A-B, is $-nZ$. Also, if the impedance Z is connected between terminals A-B the impedance measured between terminals C-D is $-Z/n$.

Impedance transformations as described may be produced by a circuit such as that of Fig. 2, in which the rectangle represents an amplifier having, ideally, an input impedance of zero, an output impedance of

† The authors are, respectively, Senior Executive Engineer and Executive Engineer, Post Office Research Station.

* Conventional repeaters capable of providing gain in both directions of a 2-wire circuit with one or two amplifying elements are sometimes referred to as 21-type and 22-type repeaters, respectively.

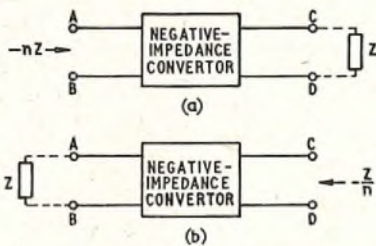

FIG. 1—COMBINATION OF A NEGATIVE-IMPEDANCE CONVERTOR AND A PASSIVE IMPEDANCE TO GIVE NEGATIVE IMPEDANCE

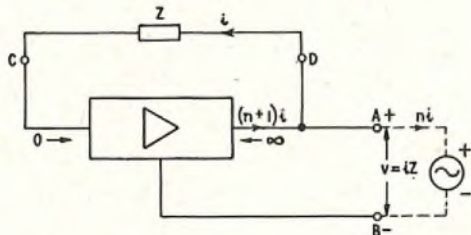

FIG. 2—BLOCK SCHEMATIC DIAGRAM OF A NEGATIVE-IMPEDANCE CONVERTOR

infinity and a current gain of $n + 1$. With an input current i and an output current $(n + 1)i$, the current which must flow from terminal A is ni . Since the amplifier has zero input impedance, the voltage between A and B is equal to that between C and D, i.e. $v = iZ$.

The impedance measured between terminals A-B is the ratio of the voltage v to the current ni , due regard being paid to the signs of these quantities. The situation may perhaps be clarified by consideration of Fig. 3, where Z/n represents a passive impedance.

The current ni flows through the impedance from the high potential point of the generator to the low potential point. In Fig. 2 the generator current flows through the impedance in the reverse direction and should therefore be regarded as negative. Thus the impedance between terminals A-B is $v/ni = -Z/n$.

If, now, the impedance Z is connected between terminals A-B instead of between terminals C-D it can be shown, by a similar argument, that the impedance measured between terminals C-D is $-nZ$.

The input and output impedances of a common-base-connected junction transistor approximate quite closely to the impedances required for the amplifier indicated in Fig. 2. Moreover, the transistor has a current gain of nearly unity and the desired current gain of $n + 1$ can, in effect, be realized by the addition of a transformer. A circuit using such a transistor and having the properties described for Fig. 2 is given in Fig. 4.

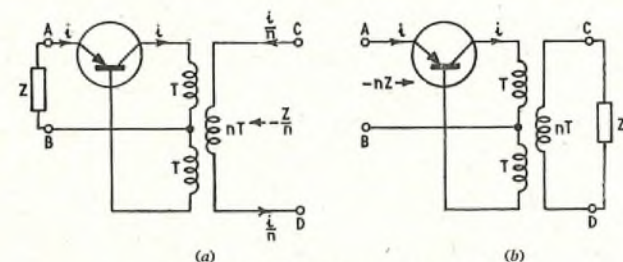

FIG. 4—NEGATIVE-IMPEDANCE CONVERTOR

It can be shown that the arrangement of Fig. 4(a) is short-circuit-stable while that of Fig. 4(b) is open-circuit-stable.

Assuming, in Fig. 4 (a), that the transistor has unity gain it is worth noting at this point that the voltage between collector and base is $2iZ$, i.e. the impedance seen by the transistor between collector and base is twice the network impedance, Z , and is independent of the impedance connected across terminals C-D. Furthermore, the power output from the transistor is $2i^2Z^*$ and since a power of i^2Z is dissipated in the impedance, Z , an equal power is dissipated in any impedance connected between terminals C-D. A similar argument can be applied in the case of Fig. 4 (b).

THE 2-WIRE 2-TERMINAL NEGATIVE-IMPEDANCE REPEATER

Transmission gain can be provided in a 2-wire circuit by connecting a single negative impedance in series or in shunt with the line.

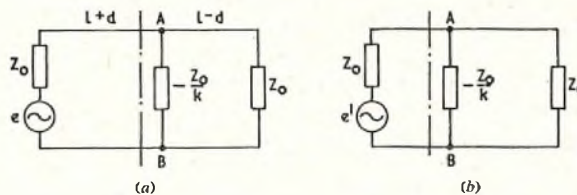

FIG. 5—INSERTION OF A SHUNT-CONNECTED NEGATIVE IMPEDANCE IN A TRANSMISSION LINE

In Fig. 5 (a) a line of total length $2l$ and terminated at each end with its characteristic impedance, Z_0 , has a negative impedance $-Z_0/k$ connected across it at a point distant $l + d$ from the sending end. (The question of whether this should be a short-circuit-stable or an open-circuit-stable impedance is left to be discussed later.)

Applying Thévenin's Theorem to that part of the circuit lying to the left of the negative impedance, Fig. 5(a) may be replaced by Fig. 5(b).

The open-circuit voltage at A-B is e' and is a function of the applied voltage, e , the line propagation coefficient, γ , and the length, $l + d$. The insertion voltage ratio produced by the negative impedance is the ratio of the voltage across the load with and without the negative impedance connected. This, however, is the same as the ratio of the voltages between A and B under these two conditions. This is readily shown to be $2/(2 - k)$, so that the insertion gain, G , is given by

$$G = 20 \log_{10} \left| \frac{2}{2 - k} \right| \text{ db} \dots \dots \dots (1)$$

The same result would have been derived by starting with a negative impedance $-kZ_0$ in series with the line.

The factor k may be complex and therefore a given value of gain can be realized with an infinite range of values of k , corresponding to different phase shifts, and it can be shown that:

- (a) for a flat gain/frequency characteristic k should be a constant[†]
- (b) for a given value of G the sensitivity of G to changes in k is less if $k < 2$

* Power, as referred to here, is "complex" power, i.e. volt-amperes.

† Strictly, it can only be deduced that k must be of such a value that $|2 - k|$ is constant. However, the only practical way of achieving this is to make k constant.

(c) if $k < 2$ a reflection loss occurs at the terminals of the repeater instead of a reflection gain.

Also, it is shown in Appendix I that, for a maximum margin of stability, k should be a real number.

For stable operation with values of $k < 2$ a short-circuit-stable repeater must be connected in shunt with the line and an open-circuit-stable repeater in series with the line.

The repeater must be stable under all conditions of circuit termination. The limiting terminations are an open-circuit and a short-circuit, which may occur while a call is being set-up or cleared. The repeater should therefore be stable under any combination of these two conditions. The effect of these extremes of termination tends to be least when the repeater is at the mid-point of the circuit. In practice it has been found that to obtain a worthwhile amount of gain with, say, 1 db stability margin, the repeater should be confined to the middle third of the circuit.

Even when the appropriate type of negative impedance is used and located in the middle-third of the circuit the 2-wire shunt-connected or series-connected repeater still produces severe reflections. For a gain of 6 db, for instance, the return loss is zero in each case. This is not satisfactory should the junction form part of a trunk connexion and the transmission time be appreciable. Moreover, even in the most favourable circumstances, it is not possible to obtain a 3 db loss circuit with a stability margin of 1 db on a 20 lb/mile cable pair loaded with 88 mH coils at 2,000 yd intervals if the pair length exceeds about 11 miles.

THE 2-WIRE 4-TERMINAL NEGATIVE-IMPEDANCE REPEATER

The limitations of the single-element repeater, described above, lead naturally to consideration of the possibility of a negative-impedance repeater that would match the line in impedance and thus, ideally, eliminate reflections and give freedom to insert the repeater at any point in the circuit.

Generalized Configuration

Networks that match a line and give a transmission loss, i.e. pads or attenuators, are very familiar and commonly take the form given in Fig. 6 (a). It might

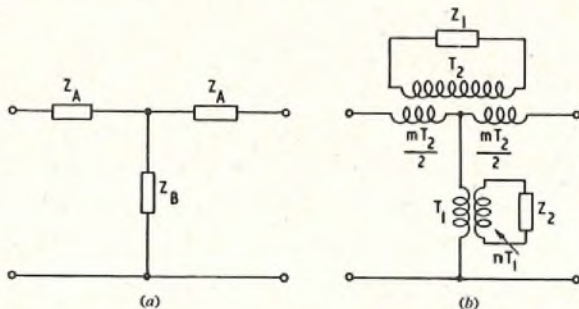

FIG. 6—LINE-MATCHING NETWORKS OF POSITIVE OR NEGATIVE IMPEDANCES

be expected, and it is in fact true, that reversal of the sign of each individual impedance will change the loss into a gain of the same amount while retaining the matching property. Thus, a negative-impedance repeater could be constructed as in Fig. 6 (a), the three impedances being negative impedances suitably related to the

characteristic impedance, Z_0 , of the line. It is, however, preferable to adopt the configuration of Fig. 6 (b), which has similar properties to that of Fig. 6 (a) but requires only two negative impedances. In the case of the attenuator shown in Fig. 6 (b) the image impedance is given by,

$$Z_i = \frac{m}{n} \sqrt{Z_1 Z_2} \dots \dots \dots (2)$$

and the image-transfer coefficient, θ , by

$$\tanh \theta = \frac{Z_i}{\frac{m^2}{4} Z_1 + \frac{Z_2}{n^2}} \dots \dots \dots (3)$$

By suitable selection of Z_1 and Z_2 , Z_i may be made equal to the characteristic impedance Z_0 of a transmission line and θ may be given any prescribed value. The arrangement, as an attenuator, matches the line and gives a transmission loss of θ nepers.

Suppose, now, that Z_1 and Z_2 in the attenuator are replaced by $-Z_1$ and $-Z_2$, then from equation (2) it can be seen that the value of the image impedance, Z_i , is unaltered, while from equation (3), $\tanh \theta$, and therefore θ , changes sign to give a transmission gain of θ nepers.

If, then, suitable negative-impedance convertors are used to carry out the replacement of impedances Z_1 and Z_2 by impedances $-Z_1$ and $-Z_2$, a repeater matching the line has been formed by building an attenuator having a negative loss.

If, now, for convenience, we write the image transfer coefficient of the attenuator as $-\theta$ instead of θ so that θ now represents a gain and not a loss, the circuit of Fig. 6 (b) may for the purpose of analysis be replaced by the solid-line section of Fig. 7.

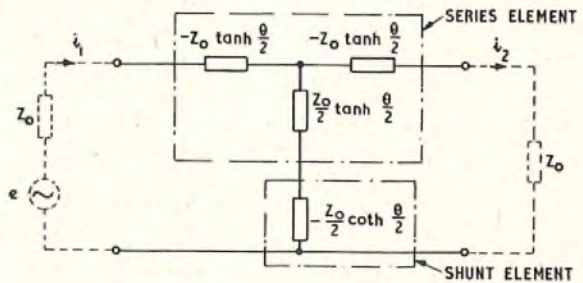

FIG. 7—EQUIVALENT CIRCUIT OF 4-TERMINAL NEGATIVE-IMPEDANCE REPEATER

To obtain an expression for the gain, G , corresponding to equation (1) for the 2-terminal repeater, k is defined as the negative of either (a) the ratio of the negative impedance introduced in series with the line to Z_0 or (b) the ratio to Y_0 of the negative admittance introduced into the line by the shunt element. From Fig. 7 it can be seen that in either case

$$k = 2 \tanh \theta/2 = 2 \frac{(\epsilon^\theta - 1)}{(\epsilon^\theta + 1)}$$

Since ϵ^θ is the fractional gain, it follows that the repeater gain in decibels is given by

$$G = 20 \log_{10} \left| \frac{2 + k}{2 - k} \right|$$

Power Output

It is shown in Appendix 2 that the power delivered to the load Z_0 of Fig. 7 from each convertor is given by $e^2/8Z_0 (\epsilon^{2\theta} - 1)$ and that from the generator by $e^2/4Z_0$, giving a total power in the load of $(e^2/4Z_0) \epsilon^{2\theta}$.

Design Considerations

Fig. 8 shows the circuit of a repeater that has been developed, using the configuration of Fig. 6 (b) and converters of the type shown in Fig. 4 (a) and (b).

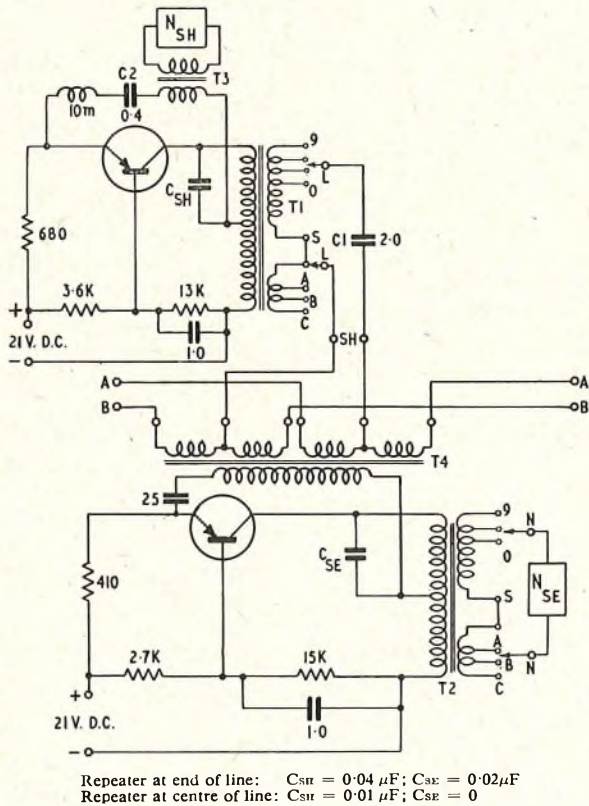
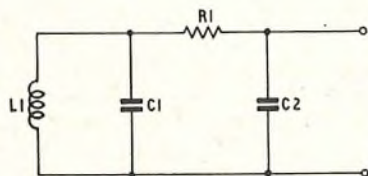

FIG. 8—CIRCUIT OF NEGATIVE-IMPEDANCE REPEATER

The P.O. transistor No. 4 used in the converters has a maximum dissipation of 200 mW in free air at 45°C, and a maximum collector-to-base peak voltage of 30 volts. To limit the currents flowing in transformers T1 and T2 the collector currents have been fixed at 6 mA so that the dissipation for each transistor is only 90 mW. This means that under optimum load conditions the power output to line is 45 mW.

From a knowledge of the likely field of application an arbitrary value of gain from which to initiate the circuit design is chosen. Variations of gain to cover specific applications are provided by a range of tappings on transformers T1 and T2. This has the advantage that the networks N_{SH} and N_{SE} , which are each required to present an impedance equal to the characteristic impedance of the line multiplied by a constant, can be



Network N_{SH} : $L1 = 49.8 \text{ mH}$; $R1 = 2,094 \text{ ohms}$; $C1 = 0.0183 \mu F$; $C2 = 0.0147 \mu F$
 Network N_{SE} : $L1 = 67.6 \text{ mH}$; $R1 = 2,800 \text{ ohms}$; $C1 = 0.0133 \mu F$; $C2 = 0.0107 \mu F$

FIG. 9—DETAILS OF NETWORKS N_{SH} AND N_{SE}

fixed and can take the form of Fig. 9. The component values for these networks are based on the experience obtained during the acceptance testing of a number of cables and reflect the average of values used in networks found to simulate the characteristic impedance.

The design should ensure that the optimum load impedance is always presented to each transistor. This can readily be done in the case of the shunt-connected element where the load impedance is fixed and is that of network N_{SH} seen through transformer T3; the value is not affected by the impedance seen through transformer T1. In the case of the series-connected element the load impedance varies with the gain-setting. The optimum load is presented to the transistor when the tapping of transformer T2 corresponds to the arbitrarily chosen initial value of gain. The impedance N_{SE} is, then, made

$$\text{equal to } \frac{m_{20}^2}{m_4^2} k_0 Z_0, \text{ where } m_{20} \text{ and } k_0 \text{ are values of } m_2$$

(the turns ratio of transformer T2) and k which correspond to optimum load. The values of k_0 , m_4 and m_{20} are determined, therefore, by the following considerations:

- (a) k_0 from the initial choice of gain,
- (b) m_4 from the optimum transistor load $2 \cdot \frac{k_0}{m_4^2} \cdot Z_0$
- (c) m_{20} to give convenient component sizes for the network N_{SE} .

For values of m_2 other than m_{20} , the transistor no longer has an optimum load and the power delivered to the line decreases. A curve showing the amount by which the output power from the repeater departs from the maximum possible, as the gain varies from the design value, is given in Fig. 10.

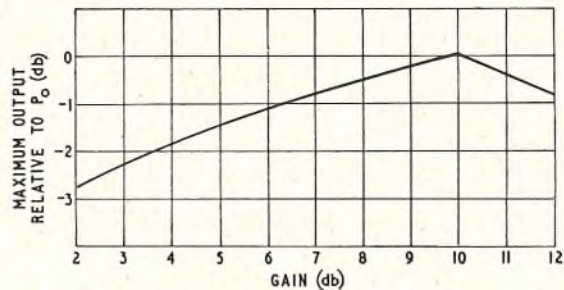

P_0 = Maximum power output at 10 db gain

FIG. 10—EFFECT OF GAIN VARIATIONS ON MAXIMUM OUTPUT POWER FROM REPEATER

Capacitor C1 (Fig. 8) must have a high impedance at signalling frequencies to avoid distortion of dial pulses and its effect upon the negative impedance produced is balanced at audio frequencies by the action of capacitor C2.

Transformers T1 and T2 each carry the collector currents of the transistors and T4 the line signalling current. As a result the winding inductances with the present sizes of transformers tend to be low. The effect of the low inductances of transformers T1 and T2 is to reduce the gain of each converter at low frequencies. By suitable choice of inductance for the windings of the transformers T3 and T4 this effect can be largely nullified, a negative inductance then falling in parallel with a positive inductance.

Mechanical Construction

The repeater, shown in Fig. 11, is housed in a can $4\frac{7}{8}$ in. by $3\frac{5}{16}$ in. by $5\frac{1}{8}$ in., three of which can be fitted

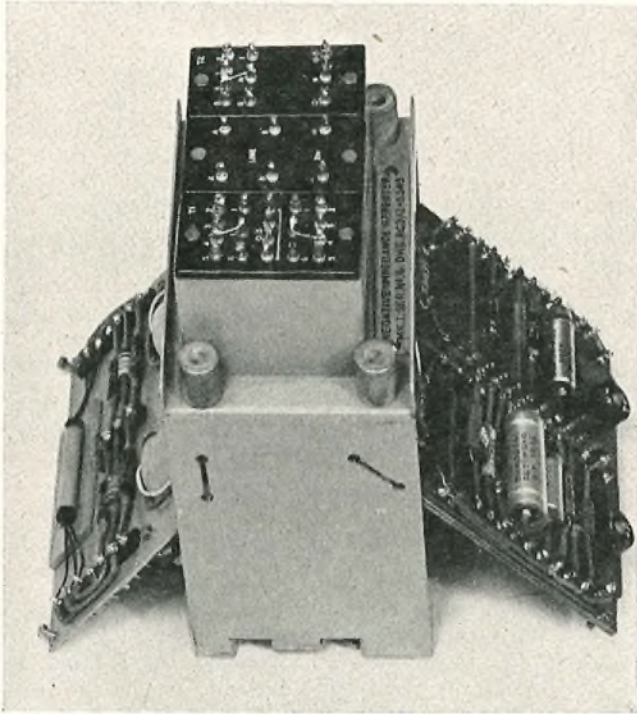
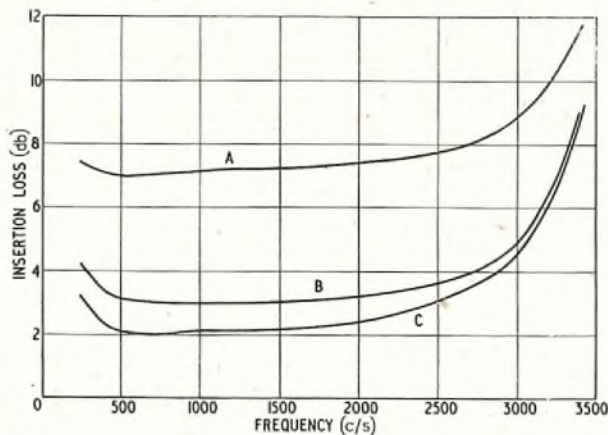

FIG. 11—EXPERIMENTAL NEGATIVE-IMPEDANCE REPEATER

in a 2-unit ($3\frac{1}{2}$ in.) panel of 51-type construction.⁸ A hinged construction eases access to all components. The repeater has been coded Amplifier No. 125A.

Performance

Two models (Mark I and Mark II) of the experimental repeater have been produced. The Mark I model uses P.O. transistors No. 3, which have a dissipation of only 25 mW, and the range of transformer tapplings provided enables the gain to be varied over a range of about 5 db.



A—Insertion loss of line with no repeater in circuit
B—Insertion loss of line plus repeater (1 db stability margin)
C—Insertion loss of line plus repeater (no stability margin)

FIG. 12—INSERTION-LOSS/FREQUENCY CHARACTERISTICS OF A CIRCUIT IN THE ELGIN-BUCKIE CABLE

When it is required to vary the gain outside this range the impedance of the passive network, N_{88} , must be scaled up or down. Twelve Mark I models have been made and installed at Elgin repeater station to provide circuits between Elgin and Buckie, a distance of nearly 17 miles, on a 20 lb/mile P.C.Q.T. cable loaded with 88 mH coils at 2,000 yd intervals. To date, nine of these circuits have been brought into use and are giving satisfactory service. A typical insertion-loss/frequency characteristic of the circuit is given in Fig. 12 and curves of repeater input level against output level for both Mark I and Mark II models are given in Fig. 13.

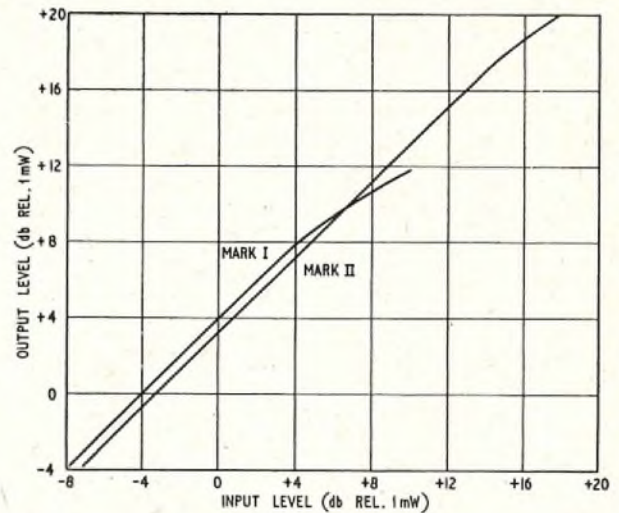
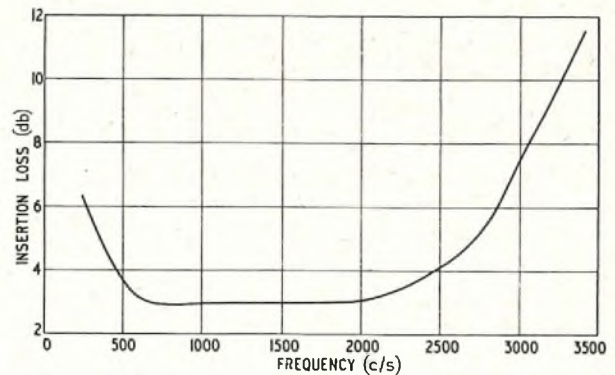

FIG. 13—OVERLOAD CHARACTERISTICS OF MARK I AND MARK II REPEATERS

The Mark II model, the complete circuit diagram of which is given in Fig. 8 and 9, has been developed to give a higher overload-point by the use of the P.O. transistor No. 4, and the range of gain has been extended by increasing the number of transformer tapplings. This unit will now provide gain varying from 3 db to 12 db in about 0.5 db steps, the only adjustment required being the alteration of transformer tapplings. This facility has only been obtained at the cost of some deterioration of the audio frequency response. The need to keep this response within the required limits restricts the length of cable with which the repeater may be used. In some circumstances an improved frequency response



Circuit consisted of 28.5 miles of 20 lb/mile P.C.Q.T. cable loaded with 88 mH coils at 2,000 yd intervals

FIG. 14—INSERTION-LOSS/FREQUENCY CHARACTERISTIC OF CIRCUIT WITH REPEATER AT MID-POINT

may be obtained by building out the end loading-coil sections to full half-sections.

Measurements, under laboratory conditions, of the insertion-loss/frequency response of nearly 30 miles of 20 lb/mile P.C.Q.T. cable loaded with 88 mH coils at 2,000 yd intervals and having a Mark II unit located at the mid-point are given in Fig. 14. The cable under these conditions may be considered to approach the ideal. Under field conditions, where the departure of the cable from ideal may be considerable, trials to date, with the repeater located anywhere within the circuit length, have been satisfactory for cable lengths up to 22 miles. In addition, it has been necessary to vary capacitors C_{SE} and C_{SH} (Fig. 8). Subsequent experimental work suggests that the range of use of the repeater can be extended beyond

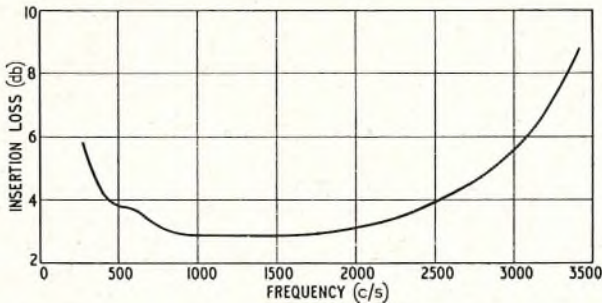

Circuit consisted of 22 miles of 20 lb/mile P.C.Q.T. cable loaded with 88 mH coils at 2,000 yd intervals

FIG. 15—INSERTION-LOSS/FREQUENCY CHARACTERISTIC OF CIRCUIT WITH REPEATER AT ONE END

22 miles. Fig. 15 shows a typical insertion-loss/frequency characteristic obtained from measurements taken during the field trials.

The power consumption of the Mark I model is 535 mW and of the Mark II model 315 mW, at 21 volts.

CONCLUSION

From the results of experiments using the Mark II version it would appear that for circuits up to about 22 miles in length this repeater possesses economic advantage over other types of 2-wire repeater. In addition its use does not complicate the d.c. signalling path. To obtain further experience and reach a position where manufacture and application to circuits may become routine, an order has been placed for 100 of the Mark II units. These will be placed on field trial and the results described in a future article.

ACKNOWLEDGEMENTS

The authors would like to thank Mr. E. C. H. Seaman for his helpful comment and criticism in preparing this article.

APPENDIX I

CONDITION FOR MAXIMUM MARGIN OF STABILITY

In Fig. 5 the impedance seen by the negative impedance connected between A and B is $Z_0/2$. Assume, for the moment, that the negative impedance is of short-circuit-stable type; then for stability,

$$|Z_0/k| > \frac{|Z_0|}{2} \dots\dots\dots(1)$$

$$\text{Let } k = a + jb \dots\dots\dots(2)$$

$$\text{then } a^2 + b^2 < 4 \dots\dots\dots(3)$$

$$\text{Now the gain } G = 20 \log_{10} \frac{2}{|2-k|} \text{ db.}$$

Let the fractional gain, $10^{G/20}$, be denoted by $2/F$, then

$$|2-k| = F$$

$$\text{or, substituting for } k, (2-a)^2 + b^2 = F^2 \dots\dots\dots(4)$$

$$\text{so that } a = 2 - \sqrt{F^2 - b^2} \dots\dots\dots(5)$$

Taking the positive square-root in accordance with equation (3), it is seen that, from equations (4) and (5),

$$a^2 + b^2 = 4 - 4\sqrt{F^2 - b^2} + F^2$$

The margin of stability is, from equation (3), determined by the expression

$$2 - \sqrt{a^2 + b^2} = 2 - \sqrt{4 - \sqrt{F^2 - b^2} + F^2}$$

which has a maximum value of F and therefore maximum margin when $b = 0$, i.e. when k is wholly real.

A similar argument may be developed for the open-circuit-stable repeater.

APPENDIX 2

POWER OUTPUT OF 4-TERMINAL REPEATER

Referring to the equivalent circuit (Fig. 7) of the 2-wire 4-terminal negative-impedance repeater,

$$i_1 = \frac{e}{2Z_0} \text{ and } i_2 = i_1 \epsilon^\theta$$

The power delivered by the series-connected convertor

$$= (i_1^2 + i_2^2) Z_0 \tanh \frac{\theta}{2} - (i_2 - i_1)^2 \frac{Z_0}{2} \tanh \frac{\theta}{2}$$

$$= i_1^2 (1 + \epsilon^{2\theta}) Z_0 \tanh \frac{\theta}{2} - i_1^2 (\epsilon^\theta - 1)^2 \frac{Z_0}{2} \tanh \frac{\theta}{2}$$

$$= \frac{e^2}{8Z_0} \tanh \frac{\theta}{2} (\epsilon^\theta + 1)^2 = \frac{e^2}{8Z_0} \cdot \frac{\epsilon^\theta - 1}{\epsilon^\theta + 1} (\epsilon^\theta + 1)^2$$

$$= \frac{e^2}{8Z_0} (\epsilon^{2\theta} - 1)$$

The power delivered by the shunt-connected convertor

$$= (i_2 - i_1)^2 \frac{Z_0}{2} \coth \frac{\theta}{2} = i_1^2 (\epsilon^\theta - 1)^2 \frac{Z_0}{2} \coth \frac{\theta}{2}$$

$$= \frac{e^2}{8Z_0} \coth \frac{\theta}{2} (\epsilon^\theta - 1)^2 = \frac{e^2}{8Z_0} \cdot \frac{\epsilon^\theta + 1}{\epsilon^\theta - 1} (\epsilon^\theta - 1)^2$$

$$= \frac{e^2}{8Z_0} (\epsilon^{2\theta} - 1)$$

$$\text{The power from the generator} = \frac{e^2}{4Z_0}$$

Thus, the total power delivered to the load impedance

$$= \frac{e^2}{8Z_0} (\epsilon^{2\theta} - 1) + \frac{e^2}{8Z_0} (\epsilon^{2\theta} - 1) + \frac{e^2}{4Z_0} = \frac{e^2}{4Z_0} \epsilon^{2\theta}$$

References

- ¹ PALMER, W. T. Outline Notes on Telephone Transmission Theory (Sir Isaac Pitman & Sons, 1935).
- ² CRISSON, G. Negative Impedances and the Twin 21-Type Repeater. *Bell Systems Technical Journal*, Vol. 10, p. 485, July 1931.
- ³ MERRILL, J. L. The E1 Telephone Repeater. *Bell System Monograph No. 1822*.
- ⁴ LINVILL, J. G. Transistor Negative-Impedance Converters. *Bell System Monograph No. 2294*.
- ⁵ MERRILL, J. R., ROSE, A. F., and SMETHURST, J. O. Negative-Impedance Telephone Repeaters. *Bell System Technical Journal*, Vol. 33, p. 1055, Sept. 1954.
- ⁶ GINZTON, E. L. Stabilized Negative Impedances. *Electronics*, Vol. 18: July 1945, p. 140; Aug. 1945, p. 138; and Sept. 1945, p. 140.
- ⁷ TILLMAN, J. R. A Negative-Impedance Converter for Use as a Two-Terminal Amplifier. *P.O.E.E.J.*, Vol. 48, p. 97, July 1955.
- ⁸ HARRIS, E. T. C. An Improved Form of Mechanical Construction for Transmission Equipment—51-Type Construction. *P.O.E.E.J.*, Vol. 51, p. 197, Oct. 1958.

The Economic Usage of Broadband Transmission Systems

R. J. HALSEY, C.M.G., B.Sc.(Eng.), F.C.G.I., D.I.C., M.I.E.E.†

U.D.C. 621.391.1

The most economic provision of a broadband transmission system calls for a proper balance between the cost of the broadband channel and the terminal equipment used to exploit it. The cost of the frequency band-width of transmission systems in the inland network is comparatively low, and in order to cheapen the terminal equipment it may in some circumstances be desirable to space channels more widely than the usual 4 kc/s, though so far as the United Kingdom is concerned the matter is not yet finally resolved. For very-long-distance connexions, particularly on transoceanic cables, the cost of the broadband channel is very high, and it is necessary to make the maximum possible use of the comparatively restricted band-width available. The article describes ways in which the number of conversations carried by a broadband channel can be increased; these include a reduction in the channel spacing to 3 kc/s or 2 kc/s, systems of speech coding, such as the Vocoder, and Time Assignment Speech Interpolation, in which a transmission channel is occupied only when speech is present.

INTRODUCTION

FOR communication at distances in excess of about 50 miles it is usual to provide, by line or radio, a broadband transmission system some hundreds or thousands of kilocycles/second in width and to subdivide this to provide telephone, telegraph, program and, sometimes, television channels. For telephone circuits forming part of an international connexion, both the channel spacing and the method of channel assembly have long been agreed internationally by the C.C.I.T.T.,* and this has usually set the pattern for internal circuits, although some countries have devised more economical methods of assembly for short distances. The C.C.I.T.T. requires that the channels shall be spaced at 4 kc/s and assembled, first, as groups of 12 in the range 60–108 kc/s (or 12–60 kc/s) and then, where applicable, as supergroups, each of five groups, in the range 312–552 kc/s, before translation to the line or baseband frequencies. For telegraphy, the C.C.I.T.T. has standardized 24 channels per telephone channel, with carriers spaced at 120 c/s, this being suitable for 50-baud teleprinter operation; American practice is to use 170 c/s spacing for 45-baud working. For program channels the agreed standards are those which can reasonably be achieved within the band-widths of two and three 4 kc/s telephone channels; one 405-line television channel occupies the band-width of 960 standard telephone channels.

The most economic provision of facilities calls for a proper balance between the cost of the broadband channel itself and of the terminal equipment used to exploit it. The cost of the broadband channel will depend mainly upon:

- (a) the type of system, e.g. multi-pair carrier cable, land-type coaxial cable, submarine coaxial cable, radio-relay or tropospheric forward-scatter,
- (b) the total band-width provided, and
- (c) the length of the system.

It is not the intention here to compare the technical and economic advantages of the various types of broadband systems but only the means for their economic exploitation. Nevertheless, it will be obvious that the technical performance of the system must always be

such as to permit of the usage proposed, e.g. a system liable to interruptions or fading may become less suitable for telegraphy as the signalling speed increases. Moreover, the cost of the broadband system per unit band-width is a basic parameter of the problem. It must also be clear whether one is concerned with exploiting an existing link whose band-width is not capable of being supplemented or planning a new system to provide specified facilities. The initial requirement and rate of growth of traffic will be important and the former is likely to be very different in the two cases above. For an existing system the "line" component of the cost of any facility (including intermediate stations) will be proportional to the band-width occupied; in a newly planned system it will usually rise less steeply. It is, however, to be noted that standard broadband systems often provide band-width much in excess of foreseeable needs, and additional band-width then costs nothing.

The factors determining the cost of terminal equipment are much more complex and it is necessary to distinguish between equipments which provide the standard facility and those which provide either a definitely sub-standard facility or some approximation to the standard. Thus, as an example, the C.C.I.T.T. requires that a 4 kc/s-spaced telephone system shall transmit audio frequencies 300–3,400 c/s (1 neper loss relative to 800 c/s); a system utilizing a greater channel spacing is clearly capable of providing the full performance, possibly at lower cost, whereas this is clearly impossible if the spacing is reduced below 3.1 kc/s. The C.C.I.T.T. defines certain requirements of an international telephone circuit in terms of a "circuit fictif de référence," 2,500 km (1,600 miles) in length, and it is generally conceded that a shorter circuit should only contribute its proportionate share of the permissible distortion. For very long distances (25,000 km circuits are now under consideration) standards may have to be relaxed somewhat in deference to costs and service demands. There is also a school of thought which considers that some relaxation of standards is also permissible for short circuits that will not form part of a long international connexion; the American N-system, providing 12 carrier telephone circuits over audio-frequency cables 25–200 miles in length, is, for example, designed on this basis and is in extensive use.

BASIS OF OPTIMUM DESIGN

The cost of the "line" component of a telecommunication channel increases with the band-width and, if the cost of the terminal equipment required to provide a particular service decreases as the allocated band-width is increased, there will be an optimum condition. A system may be fully equipped either initially or over a period of years and, depending on circumstances, the cost criterion may be:

- (a) capital cost, immediate or ultimate, the former being significant in times of capital restriction such as the present, or
- (b) annual charges, immediate, ultimate or average, including components covering interest on capital, depreciation, accommodation and maintenance, or
- (c) present value of the annual charges (P.V. of A.C.),

† Director of Research, Post Office Research Station.

* Comité Consultatif International Télégraphique et Téléphonique (formerly C.C.I.T. and C.C.I.F.).

the capital sum which it would be necessary to provide to meet the annual charges over the life of the system.

In general these criteria will give different optimum designs. Annual charges or P.V. of A.C. will encourage smaller maintenance costs, which may reflect a higher quality of service; capital cost encourages shorter-life systems which will be less prejudicial to future developments.

If the simple assumptions are made that:

(a) the charges due to the "line" component are proportional to distance (l) and to the band-width (f) occupied ($= Alf$), which will be substantially valid for a line or radio-relay system, and

(b) the charges due to the terminal equipment are inversely proportional to the band-width occupied ($= Bf^{-1}$), which will not normally be valid,

then the optimum occurs when the two components are equal. More generally, if in the region of the design conditions the two charges are Alf^n and Bf^{-m} respectively, the optimum will be when the equipment charges are n/m times the line charges. It has been seen that the index n will, in fact, be unity in an established system and rather less if a new system is being planned; the value of m is very much less definite.

To illustrate the telephony problem more precisely, Table 1 shows a typical breakdown of the charges on a standard 16-supergroup coaxial-cable system. The P.V. of A.C. is based on a uniform increase in circuit requirements over 20 years; the capital cost and annual charges refer to the fully-equipped system. The cost of normal within-band signalling equipment is shown separately.

TABLE 1
Cost Ratios for a 16-Supergroup Coaxial Cable System

Item	Capital	Annual Charge	P.V. of A.C.
Equipped Line (per 100 miles) ..	1.0*	1.0*	1.0*
Channelling Equipment, including Accommodation and Power ..	2.0	3.2	1.8
Signalling Equipment, including Accommodation and Power ..	1.5	2.1	1.4
Total Terminal Equipment, including Accommodation and Power ..	3.5	5.3	3.2

* Plus a small constant component equivalent to about 5 miles.

If the values of m and n above are known, the circuit length for which the design is an optimum can be deduced. For example, if $n = m$, the optimum distance in respect of the above P.V. of A.C. is 320 miles; if $n = 2m$ it will be half this. Assuming that the cost of the standard (4 kc/s) system has been reduced as far as possible, and here the high cost of the signalling equipment is to be noted, it will be advantageous to increase the band-width per channel for shorter distances and decrease it for longer distances.

It is not suggested that there is room for a number of graded designs; this would undoubtedly increase overall costs by complications in the factory and in the field. There is, however, a potential case for one "short-distance" system and one "very-long-distance" system at least. It is proposed to examine the problem in more detail in three stages:—

(i) What can be done to reduce the cost of the 4 kc/s-spaced channel equipment with its associated signalling equipment?

(ii) What can be done to reduce the costs of channel equipment further by increasing the channel spacing, so that short-distance carrier systems become more economical and the distance is reduced at which audio-frequency systems are cheaper (at present up to 30–50 miles).

(iii) What can be done to reduce the band-width required per circuit when the line is so long that terminal equipment costs are comparatively unimportant? This will have particular reference to transoceanic cables and global circuits generally.

The initial examination will be in terms of telephony, but telegraphy in its various aspects, programs and television will also have to be considered.

DESIGN OF 4 KC/S-SPACED EQUIPMENT

At the C.C.I.F. Oslo Meeting in 1938 there were two contending proposals for channel spacing on international transmission systems:

(a) 3 kc/s spacing with an effective transmission band 300–2,700 c/s, i.e. 20 per cent wastage, sponsored primarily by Germany.

(b) 4 kc/s spacing with an effective transmission band 300–3,400 c/s, i.e. 22.5 per cent wastage, sponsored primarily by Great Britain and based on American and British practice.

The advantages of the wider transmission band, as demonstrated, were just sufficiently impressive to lead to the adoption of 4 kc/s spacing and, consequently, to systems in which all carrier frequencies are multiples of 4 kc/s; had 3 kc/s channel spacing been adopted, it is highly probable that all carrier frequencies would have been multiples of 3 kc/s. Uniformity in this respect is important because carrier leaks from the various stages of modulation and crosstalk from frequency-generating equipment will then always coincide with carrier frequencies and will, in consequence, cause no interference tones except, possibly, in wideband channels such as program channels. The introduction of non-standard channel spacing (other than 2 kc/s) in an established 4 kc/s system is liable to be troublesome in this respect.

The German proposal was based on experience with double-modulation systems employing inductor-capacitor filters; British and American practice was to employ single-modulation with piezo-electric crystal filters; both envisaged signalling and dialling by tones within the transmission band. The choice of 4 kc/s spacing was confirmed after the war and some Administrations decided to implement it by double-modulation, using inductor-capacitor filters in preference to crystal filters.

Experience with 4 kc/s-spaced systems shows that:

(i) The cost of within-band signalling is high (see Table 1) and a number of Administrations have adopted out-of-band signalling where they have been free to do so; this eliminates equipment necessary to make the signalling system voice-immune at the expense of requiring a separate narrow-band signalling channel.

(ii) Improvements in high-grade inductor cores and, in particular, the development of ferrites, have made it possible to reduce the size and cost of inductor-capacitor filters and improve their performance to a greater extent than has been possible with crystal filters.

(iii) The growing availability of transistors with their low power consumption, heat dissipation and maintenance costs tends towards the more generous use of active components.

The reactions of these factors on costs depend very much on the techniques and commitments of individual equipment manufacturers and it is not possible to generalize. There is a general tendency in Europe to design so that out-of-band signalling can be provided for those conditions under which it can be used to advantage.

CHANNEL SPACINGS IN EXCESS OF 4 KC/S FOR SHORT DISTANCES

If the channel spacing is increased above 4 kc/s, channel separation becomes easier. For a straight-forward single-sideband system, typical filtration requirements at the sending and receiving terminals are shown in Fig. 1 for 4, 6 and 8 kc/s spacings. It seems that the

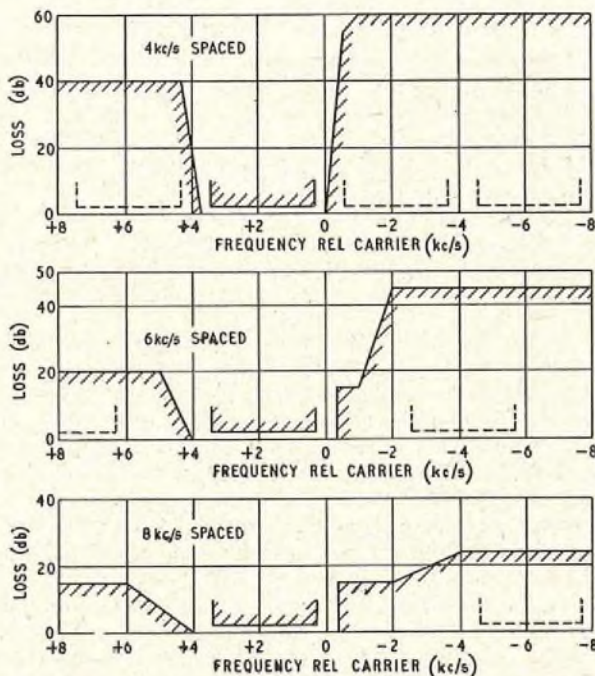

The requirements indicated are for single-sideband suppressed-carrier systems using lower-sideband 4 kc/s, 6 kc/s and 8 kc/s spaced carrier channels
 FIG. 1.—CHANNEL FILTER SPECIFICATIONS

reduced requirements for wider spacing can be more readily exploited in inductor-capacitor filters than in crystal filters; with either type of filter, the provision of an out-of-band signalling channel is made easier. Table 2 shows, by way of illustration, an estimated break-down of the annual charges on a typical 30-mile coaxial-cable route; standard 48 kc/s groups are assumed, each yield-

TABLE 2
 Cost Ratios for a 30-mile Coaxial Cable System

System	Annual Charges per Circuit				Total
	Line	Terminal Eqmt. other than Channel Eqmt.	Channel Eqmt.	Exchange Signalling Eqmt.	
4 kc/s, In-band Signalling ..	0.07	0.12	0.48	0.33	1.00
6 kc/s, In-band Signalling ..	0.11	0.18	0.39	0.33	1.01
6 kc/s, Out-band Signalling ..	0.11	0.18	0.52	0.09	0.90

ing twelve 4 kc/s-spaced or eight 6 kc/s-spaced channels.

It will be seen that the lower cost of 6 kc/s-spaced channel equipment is significantly offset by the heavier share of the terminal equipment, especially group and supergroup equipment, which has to be borne by each channel; there is, therefore, a potential case for increasing the band-width of a group. On the basis of Table 2 it follows that 6 kc/s-spaced equipment with in-band signalling is more economical than 4 kc/s-spaced equipment at distances less than 23 miles and, with out-of-band signalling, at distances less than 105 miles. A similar calculation based on capital cost would, however, show savings with 6 kc/s-spaced equipment at greater distances.

Since the annual charges on audio-frequency systems are less than those on coaxial systems at less than 30-50 miles, this appears to dispose of the case for a 6 kc/s-spaced system with in-band signalling and justifies increased spacing only on the score of the lower cost of out-of-band signalling. In an endeavour to match this reduction in a modified 4 kc/s-spaced system, certain British contractors have redesigned their crystal filters to permit of an out-of-band signalling channel at 3,825 c/s. For the moment at least, this seems to have hardened opinion against the use of a 6 kc/s-spaced system in this country.

In the Netherlands, 6 kc/s-spaced systems with out-of-band signalling are used for nearly all internal circuits, 4 kc/s-spaced systems being reserved mainly for international connexions (mainly transit); in this case the savings claimed are very substantially in excess of those indicated above. Much of the conflict of opinion arises because the systems being compared are often different in date and concept; strictly comparable systems seldom exist. In the author's view, the problem cannot be considered to be finally resolved in this country.

If the carrier spacing is increased beyond 6 kc/s, double-sideband transmission becomes practicable and, with a low-pass filter in the audio circuit, the channel filter requirements then become even less stringent. The American N-system is of this type, with 8 kc/s spacing and out-of-band signalling at 3,700 c/s (the highest speech frequency transmitted is 2,800 c/s). This system is designed to exploit cables having high intrinsic crosstalk and has built-in compandors which further halve the attenuation requirements of the filters; this feature is, however, justified only by the specific needs of the system.

All the previous discussion has been in terms of frequency-division multiplex, i.e. conventional carrier systems. The potentialities of time-division multiplex, particularly pulse-code modulation (p.c.m.) systems must not, however, be overlooked. There are schools of thought both here and in America which believe that p.c.m. can ultimately be effected with terminal equipment that is much cheaper than that of conventional carrier systems. If, as seems likely, such equipment operates with binary, i.e. two-level, code, the band-width required for a speech channel will be very substantially increased; the likely application, therefore, will be to transmission systems in which band-width is cheap, e.g. radio-relay systems and, more especially, waveguides.

MORE EFFICIENT USE OF LONG-DISTANCE BROADBAND CONNEXIONS

The exploitation of very-long-distance connexions and, in particular, the transoceanic telephone cables

which are now coming into use will now be considered. The band-width provided on such systems is much less than on land coaxial systems and the cost per kilocycle per second per mile is consequently very high—up to 50 times as much in capital cost. It follows that vastly higher charges on terminal equipment are justified if they lead to more efficient usage.

Considering primarily the telephone aspect of the problem, in general there are two means whereby more conversations may be carried by a broadband system:

(i) A reduction in the channel spacing, either by more efficient (costly) filters, narrower effective transmission bands or both. In such an arrangement the speech may be transmitted either

(a) as a conventional analogue* signal of restricted band-width, or

(b) as a non-analogue, e.g. coded, signal.

(ii) By occupying a transmission channel only when speech is present; in a two-way conversation the average activity of a channel cannot exceed 50 per cent and can be as low as 25 per cent when due allowance is made for setting up calls. The number of calls which can then be handled by a group of channels will depend on the acceptable amount of "freeze out," i.e. the probability that no channel is available to a talker when he requires it. This principle is known as Time Assignment Speech Interpolation (T.A.S.I.) and has been developed primarily by Bell Telephone Laboratories in the U.S.A. Some confirmatory work has been carried out at the Post Office Research Station.

Band-width Restriction—Analogue Systems

Band-width restriction impairs the transmission of speech, and typical listener opinions on the effect of high-frequency cut-off are shown in Fig. 2 for a range of listening levels. It is to be noted that band-width and overall loss are to some extent interchangeable.

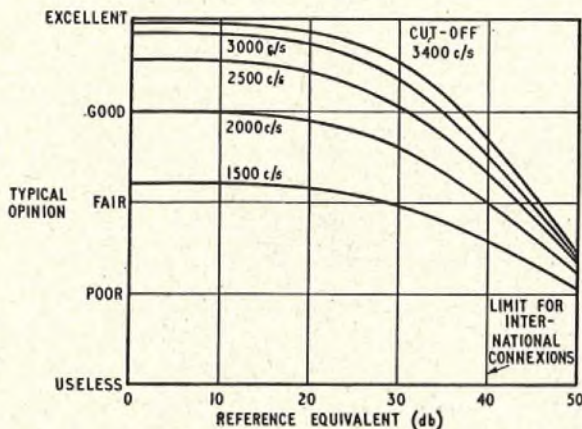

FIG. 2—EFFECT ON SPEECH OF RESTRICTING THE UPPER CUT-OFF FREQUENCY OF A TELEPHONE CIRCUIT

High-Efficiency Filters. By the use of the most efficient filtering techniques the Post Office has found it possible to reduce very substantially the wasted frequency band between channels which, as already seen, amounts to 900 c/s, or 22½ per cent, in the case of a standard 4 kc/s-spaced system. Fig. 3 shows the best which can reasonably be achieved with 2 kc/s and 3 kc/s-spaced systems, wasting only 130 c/s and 200 c/s per channel

* i.e. the electrical signal is a faithful copy of the acoustic signal apart from the band-width restriction.

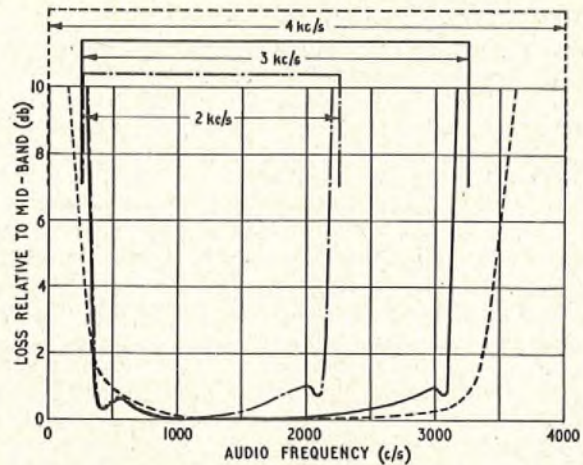

FIG. 3—TRANSMISSION-LOSS/FREQUENCY CHARACTERISTICS OF 2 KC/S, 3 KC/S AND 4 KC/S SPACED CARRIER CHANNELS

respectively and giving effective transmission bands 300–2,170 c/s and 300–3,100 c/s. As will be seen from Fig. 2, by interpolation, such 2 kc/s-spaced channel equipment will give very satisfactory terminal service unless the signal levels are very low, but it is not considered adequate for tandem connexion as part of a global circuit. High-efficiency 3 kc/s-spaced equipment, on the other hand, has recently been accepted by the Post Office, all Commonwealth countries and the American Telephone and Telegraph Co. as the future standard for transoceanic cables, existing and planned. Since the delay distortion with high-efficiency filters is much greater than with standard equipment, it will be desirable to minimize the number of channel equipments in tandem, particularly when used with T.A.S.I. systems. The adoption of this standard also places much more stringent requirements on through-group filters and supervisory equipment but these difficulties can and must be overcome.

A further complication arises if a 3 kc/s-spaced system is connected over an established inland network, in that the groups will commonly carry interference tones at the 4 kc/s virtual carrier frequencies. As noted previously, these are unimportant with a 4 kc/s-spaced system; this is true also of 2 kc/s spacing.

Channel-Splitting Equipment. A description of conventional systems of narrow band-width would be incomplete without reference to American EB equipment, introduced during the war to provide two comparatively low-grade circuits over a standard 4 kc/s-circuit by the simple process of band-splitting. The "A" channel is the normal one, with restriction at rather less than half band; the "B" channel is derived as the lower sideband of 3,700 c/s. Both channels have a normal low-frequency response, about 4 db loss at 1,600 c/s and 8 db at 1,700 c/s. The fact that both channels together have to pass through a normal channel modulator leads to a certain amount of intermodulation interference between them. By the end of the war several million miles of EB circuits were in existence in the American inland network and, despite plans for their elimination, quite a lot still remain. Although, as Fig. 2 shows, the transmission quality is very noticeably worse than that of the modern high-efficiency 2 kc/s-spaced systems, very valuable service, which would have been impracticable by any other means, has been provided.

Band-width Restriction—Non-Analogue Systems

The elimination of redundancies from speech has been studied both here and in America. Basically there are some 40 speech sounds or phonemes, and if these could be identified uniquely the essential information could be transmitted in code within a band-width of about 40 c/s. Speech would, however, be completely formalized and emotionless. Such a system would not cope with a variety of languages, accents and personal idiosyncrasies and would be quite unsuited to social purposes. There is obviously a great deal of scope for the development of band-economy systems intermediate between this and conventional systems.

A promising system has recently been demonstrated here, based on tracking the formant frequencies of the all-significant vowels. Seven 20 c/s-wide information channels define, in addition to the three formant frequencies, their relative levels, the fundamental larynx frequency and voiced/unvoiced switching. The residual difficulties are much the same as for the Vocoder (see below).

Vocoder (VOICE CODER). The most highly developed system giving substantial band economy is probably the Vocoder, initially devised in the Bell Telephone Laboratories. The arrangement is shown diagrammatically in Fig. 4. Speech entering the system is filtered into a number of frequency bands (spectrum channels); 16 in the latest Post Office equipment, six spaced linearly between 200 and 1,000 c/s and 10 spaced logarithmically between 1,000 and 3,800 c/s. The signal in each band is rectified and passed through a low-pass filter, the output of which is a slowly varying "d.c." signal containing frequencies up to about 16 c/s and defines the energy level in that channel.

Sixteen independent transmission paths must be provided for the spectrum channels, together with a seventeenth, of rather greater band-width, which is used

to convey pitch information, i.e. whether the signal is voiced or unvoiced and, if the former, the pitch (i.e. larynx) frequency. At the receiving terminal the pitch signal is used to control the carrier supply to each of the 16 balanced modulators associated with the spectrum channels. This carrier supply originates in two local generators, one of which produces random noise when the signal is unvoiced, the other producing a range of harmonics of the larynx frequency defined by the pitch signal. The carrier supplies are distributed to the 16 modulators via a set of spectrum filters. In the absence of a spectrum signal the carrier supply is suppressed on the output of the modulator; an input signal releases a proportional amount of carrier and the 16 outputs are combined via a set of spectrum filters to simulate the input speech.

With high-quality microphones and controlled speech levels, the results are surprisingly good and the Vocoder was used successfully on a specialized military project during the war. It has not, however, been possible, so far, to develop the system to the stage where it is satisfactory for use on the public network, with carbon microphones and uncontrolled levels; the difficulties reside largely in the extraction of the fundamental larynx frequency.

The total band-width required by the system outlined above is a theoretical 300 c/s, plus a margin for filtration of the pitch and spectrum channels. To approach the above band-width in practice it is necessary to transmit two channels on each carrier frequency with virtual carriers in quadrature; single-side-band transmission is impracticable with telegraph-like signals.

Semi-Vocoder. In an attempt to produce an acceptable system for transoceanic circuits, a so-called "semi-vocoder" has been constructed at the Post Office Research Station. In this, the lower speech frequencies are transmitted directly and only the higher-frequency

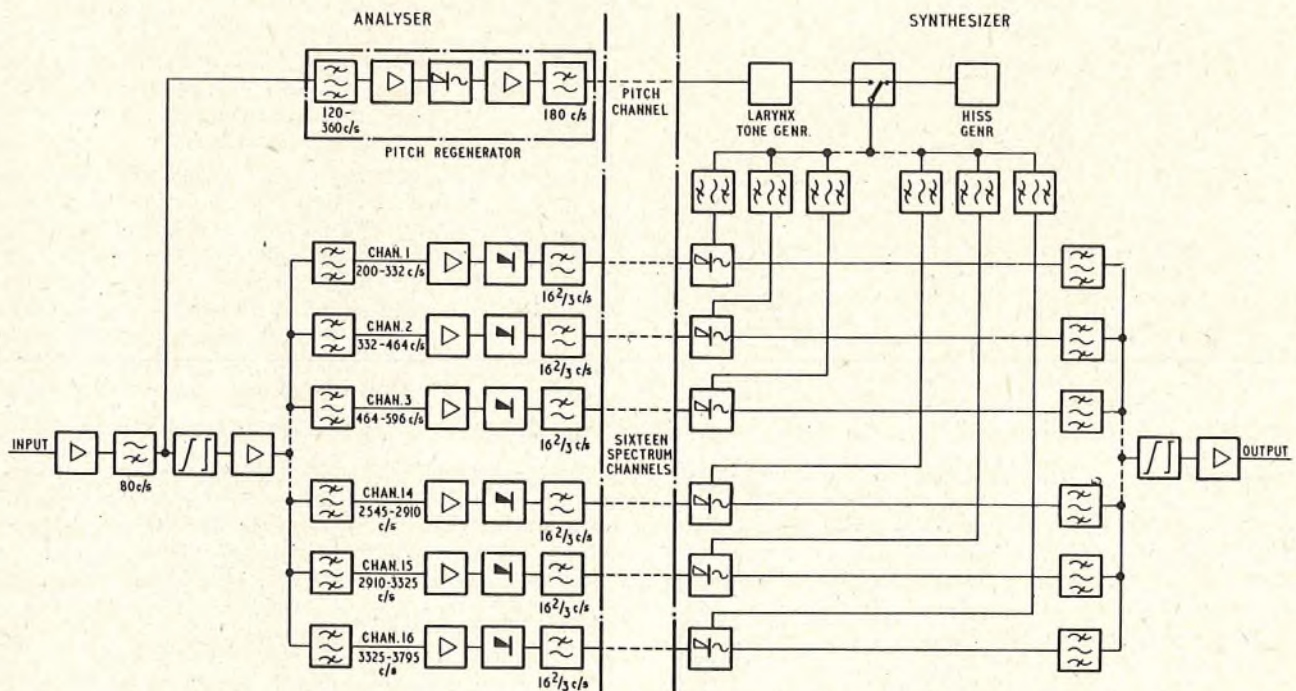

FIG. 4—BLOCK SCHEMATIC DIAGRAM OF A VOCODER

components are coded in a Vocoder. Experiments to determine how best to utilize a 2 kc/s channel in this way led to a surprising conclusion. Closely controlled subjective tests, which included a "preference" factor as well as immediate appreciation, indicated that the quality was most acceptable when the widest possible range of frequencies was transmitted directly, with only one or two code channels; further comparison with a conventional channel within the same band-width revealed a distinct preference for the latter, hence the development of the 2 kc/s-spaced system referred to above.

Vobanc (VOIce BANd Compressor). Another approach to the problem is to attempt to divide all speech frequencies by a factor, initially two; Vobanc, developed by Bell Telephone Laboratories, is probably the most successful equipment on these lines. Speech is divided into three bands, 200-1,000-2,000-3,400 c/s, selected to give, as nearly as possible, one formant in each band. Division (Fig. 5) is by regenerative modulators which operate in the range 104-108 kc/s on the major frequency component in each band only, leaving the other components at their original spacing, i.e. the speech is modulated with half the frequency of the major component. At

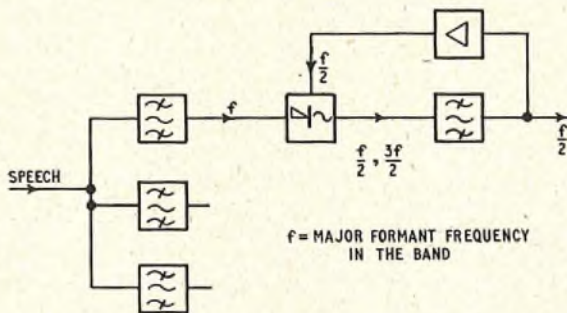

FIG. 5—VOBANC FREQUENCY-DIVIDING CIRCUIT

the receiving terminal full-wave rectifiers operate as frequency doublers cum modulators. A syllable articulation efficiency of over 90 per cent has been claimed with carbon microphones but the quality is not pleasant, and the system has been abandoned for the time being.

Band Economy and Signal/Noise Ratio. Information theory indicates that it is always theoretically possible to economize in band-width at the expense of signal/noise ratio, though the principle is usually exploited in the opposite sense. The rate of exchange is, however, very poor and, in practice, there is never sufficient noise margin to permit of anything like a 2 to 1 reduction. A possible system on these lines, involving multi-level pulse code modulation, has recently been outlined but this could have little value in the present application.

Time Assignment Speech Interpolation (T.A.S.I.)

Bell Telephone Laboratories have developed equipment which, by occupying channels only when speech is present, enables a group of 36 circuits to handle up to 72 conversations without significant "freeze-out." This equipment is highly complex, involving high-speed electronic switching with many thousands of transistors in each terminal.

It is designed to begin switching channels only when the number of unoccupied channels falls below two. Thus, when the number of connexions is 34 or less, each talker holds a specific channel for as long as he is con-

nected. When a talk spurt arrives from a 35th talker, T.A.S.I. disconnects one of the 34 previously-connected talker lines which is, at that moment, free from speech. The arrival of a talk spurt on another of the 72 input circuits similarly causes a free channel to be selected and connected at both ends. The signals necessary to set up the talker connexion at the distant end are transmitted ahead of the speech (which must be either delayed or clipped). Disconnect and periodic-checking signals for the complete system are transmitted over the 36th channel, which is permanently allocated for this purpose. Important or difficult calls can be routed through the system without switching, and in the event of a fault the system "fails safe," excess calls being lost.

This system requires that each channel shall be capable of transmitting frequencies approaching 3,000 c/s, there being a within-band signalling system at about 2,500 c/s. This is used for calling and setting up the call, it being arranged that, once a calling signal ceases, the channel cannot be seized by another speaker until the call is properly set up and a release signal is sent and acknowledged.

In order to obtain substantial advantage from a system of this type it is necessary to group a fairly large number of channels. Fig. 6 shows how the talker/channel ratio is related to the number of channels for various degrees of speech activity and "freeze out."

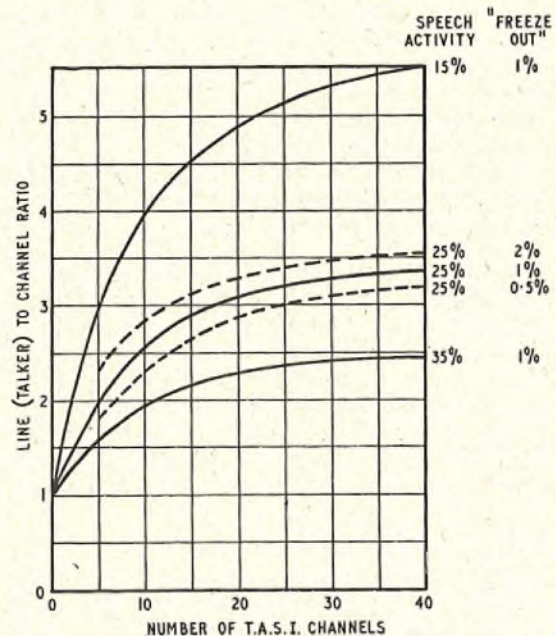

FIG. 6—PERMISSIBLE TALKER-TO-CHANNEL RATIO ON A T.A.S.I. SYSTEM

In its latest form, T.A.S.I. is compatible with the high-efficiency 3 kc/s-spaced channel equipment described earlier and present plans involve the introduction of both types of equipment on certain transoceanic cables, thus increasing the original circuit provision by a factor of 2.7.

The cost of T.A.S.I. equipment is very high and in America it has been estimated that on inland circuits—microwave relay systems and coaxial cables—it is cheaper to provide additional circuits at distances up to several thousands of miles; moreover, this distance is increasing as the cost of normal circuit provision is

reduced. While the economics are likely to be rather different in this country and in Europe, extensive use of the equipment on inland circuits seems to be unlikely.

SERVICES OTHER THAN TELEPHONY

The principles discussed primarily in relation to telephony apply also to other telecommunication services, though it is not always possible to gain much practical advantage.

Telegraphy

In telegraphy, advantages are obtainable on both short and very long systems. In this country, the annual charges on 18-channel voice-frequency telegraph equipment are equal to those on some hundreds of miles of line. It would seem, therefore, that economy could be achieved on short circuits by using wider carrier spacings and so transferring costs from the terminal equipment to the line.

In Germany, half of all voice-frequency telegraph channels, mainly on minor routes, are provided by 2-tone equipment with 240 c/s spacing instead of the standard 120 c/s. In addition to lower first cost these systems have larger operational tolerances, which result in lower maintenance costs, and this at points where maintenance personnel are not readily available.

For London-Montreal circuits over the transatlantic telephone cable, it has been found that by using frequency-modulated systems 80-baud operation is practicable and reliable with 120 c/s-spaced channels. By replacing start-stop (7 or $7\frac{1}{2}$ unit) by synchronous (5-unit) operation, two normal teleprinter channels can be obtained by time-division multiplex; thus, 48 50-baud channels can be operated over a standard 4 kc/s telephone channel and, perhaps, 44 over the 3 kc/s channel of the future.

Since double-sideband transmission is usual on voice-frequency telegraph systems, a further 2:1 increase in traffic capacity is potentially possible. Single-sideband transmission, as such, is impracticable, but quadrature transmission systems, for example, should be capable of development to give equivalent capacity. The American Kineplex system, now under test, may well prove to give additional traffic capacity approaching 2:1.

Program Circuits

Program circuits normally replace either two or three 4 kc/s-spaced telephone circuits and if quality is to be maintained little can be done to improve the efficiency of usage. Companders can be used satisfactorily to increase the signal/noise ratio but band economy is probably impracticable.

Television

A conventional 405-line television channel occupies some 3 Mc/s of band-width and is normally provided as an alternative to 960 telephone circuits, in the frequency range 0.5-4.0 Mc/s. For very short circuits it is now practicable to transmit video frequencies directly over coaxial cable without frequency translation; this has been made possible by reducing noise currents with coaxial chokes.

For long distances overland there is, as yet, no alternative to conventional transmission and circuits up to 4,000 miles in length are provided over both coaxial cables and radio-relay systems, notably in the U.S.A.; the band-width available in transoceanic cables is, however, limited at present to 144 kc/s. The United Kingdom to Canada (CANTAT) cable, planned for completion in 1961, will provide a band-width of 240 kc/s in each direction, but the phase distortion inherent in the directional filters will reduce, substantially, the band-width which will be suitable for television. Possibilities of transatlantic cables for conventional television transmission have been discussed, but these will probably have to await the development of high-frequency transistors of great reliability before they are technically feasible; this ignores entirely the question of cost and need. It has been demonstrated that, with careful delay equalization, a reasonable picture can be transmitted within a band-width of 1 Mc/s but, even taking this into account, no conventional television cable system is likely to emerge for a number of years. Earlier provision of transoceanic television links must, therefore, depend on the development of tropospheric scatter systems, which might be capable of adequate transmission over distances of a few hundred miles, and/or means for reducing the band-width occupied. In regard to the latter there are several possibilities:

(a) Elimination of signal redundancies, element-to-element along a line, line-to-line and frame-to-frame. In order to reduce band-width requirements the residual information must be transmitted at a constant rate and this must involve storage and delay. A number of such arrangements have been proposed, giving economies of up to 6:1 in band-width.

(b) A reduction in the picture information by decreasing the frame frequency, the number of lines or both.

(c) An extension of the time scale proportional to the band-width reduction required; this necessitates recording on either film or magnetic tape at each end of the system.

All these possibilities are being explored in an endeavour to provide television service over those transoceanic cables which already exist or are planned. It is, however, premature to indicate the scope of the experimental transmissions which are likely to be carried out in the near future.

Teleprinting Over Long-Distance Radio Links

Part 2—Automatic Error-Correcting Methods Used Over Long-Distance Radio Links

A. C. CROISDALE, M.B.E., B.Sc.(Eng.), A.M.I.E.E.†

U.D.C. 621.396.3:621.396.65:621.394.14

The methods used, and the difficulties encountered, in teleprinter working over radio links were described in Part 1. Part 2 concludes the article by describing methods of automatic error-correction and the improvement in performance which they offer.

ERROR-DETECTING AND REPETITION METHODS

IT has been explained that the elements of the received radio telegraph signal may be examined by one of several methods to determine the presence or absence of a signalling condition. It depends on the type of transmitted signal whether positive indication is available for only one condition, as in the case of "on-off" keying, or available for both conditions, as in 2-tone or frequency-shift keying. It will be appreciated that when both conditions are positively signalled the receiver must take account of the presence of one condition and the absence of the other condition for each element as it is received. On this basis the absence of both signals must indicate an error or mutilation by the radio transmission medium.

A simple system of "error-detection," resulting in automatic repetition to correct the error, has been invented and patented by Dr. Van Duuren. In this system the received elements have to maintain an amplitude greater than a predetermined value for longer than a set portion of the element length. Failure to meet this requirement is declared an error, and then a repetition of the character concerned is arranged by means of a signal injected into the return radio telegraph channel.

The assessment of the signal element must be made by comparison with empirical values of amplitude and duration which, in fact, must be such that elements having these values are relatively immune from falsification by noise; this, however, must result in some elements, when greatly attenuated, being rejected as errors. The system has merit in being simple; it does not require translation to a special signalling code. However, it does require that requests for repetition be initiated either at the radio station or at a central office connected to the radio station by means of an audio telephone circuit, because a 2-condition d.c. signalling system between the radio station and the error-detecting equipment would eliminate the intermediate levels of signal intelligence on which errors are assessed. An automatic repetition system (ARQ system) requires that the traffic be stored during periods when radio transmission conditions are causing repetition of transmissions. This involves the provision of character storage facilities at the input to the channels, and the installation at a radio receiving station of the necessary equipment may be undesirable.

Use of Special Codes

Alternatively to the use of an error-detecting system employing the principle of assessment of the presence of a signal element, much attention has been given to the use of a signalling code¹ which will ensure detection, and possibly correction, of mutilations. An obvious

way of doing this is to send the five intelligence elements twice and compare the received results. If the results are identical the character can be assumed to be correctly received. This method has the disadvantage that, for each character transmitted, the number of signalling elements is doubled, and hence the traffic capacity of a telegraph system is halved.

Other codes have been devised which use extra elements to check the "intelligence" elements and even to correct the mutilations, but this again increases the number of elements used and hence decreases the traffic capacity of the link. The value of an error-correcting code must therefore be assessed in terms of circuit capacity, because the code must be used all the time, even when the radio link performance is good. By comparison, the code used with an error-detecting system uses fewer elements and hence, during good radio conditions, will clear more traffic; when used with an automatic repetition device the traffic clearance rate will be reduced only as errors occur on the radio link. However, such systems require the simultaneous serviceability of both directions of transmission of a two-way radio circuit. On balance it is considered that the use of an error-detecting code with automatic repetition to provide correction is the best commercial system.²

An Error-Detecting Code

The requirements to be fulfilled by an error-detecting code for general use on long-distance radio-telegraph services may be stated as follows:

(a) It should be compatible with the 5-unit code and provide 32 usable combinations. Two more usable combinations are required on switched networks, e.g. telex, to convey supervisory signals, and possibly one further combination for indicating a request for repetition, making necessary a total of 35 usable combinations.

(b) Conversion from, and to, the 5-unit code should be possible without undue complications.

(c) The code should be so designed that the ratio of undetectable errors to detectable errors is as low as possible, while the number of elements per character should be as low as possible to reduce waste of circuit time.

(d) Presence of bias distortion on the received signal, giving rise to repeated element-errors in the same sense, should not cause undetected errors.

From these requirements a minimum of six elements is required to transmit the 35 combinations in 2-condition code (these would provide $2^5 = 64$ combinations). Actually, the supervisory signals could possibly be accommodated by a sequence of 5-unit characters but this is not attractive. Studies of possible codes have resulted in a number of 7-unit codes with various rules for check. Examples of these are the R.C.A. (J. B. Moore) code, the Van Duuren code and the Higgitt No. 2. These are codes having a fixed ratio of three marks to four spaces; error detection is by a check of this ratio.

† Senior Executive Engineer, Telegraph Branch, E.-in.-C.'s Office.

Further examples are the Cook code and the Wheeler/Fifield 5/2-2/5 code. In the Cook code the 5-unit characters are used without change and two additional elements are added. Error detection on 30 of 34 or more characters is by a check of the apparent 4 : 4 ratio produced by "weighting" one of the two additional elements.

The Wheeler/Fifield 5/2-2/5 code also uses the 5-unit code unchanged and two extra elements are arranged so that all acceptable combinations have a mark/space ratio of 5 : 2 or 2 : 5.

The theoretical performance of some of these codes, and also of a 6-unit code formed by adding a "parity check" element to a 5-unit code, is shown in Fig. 6. For a

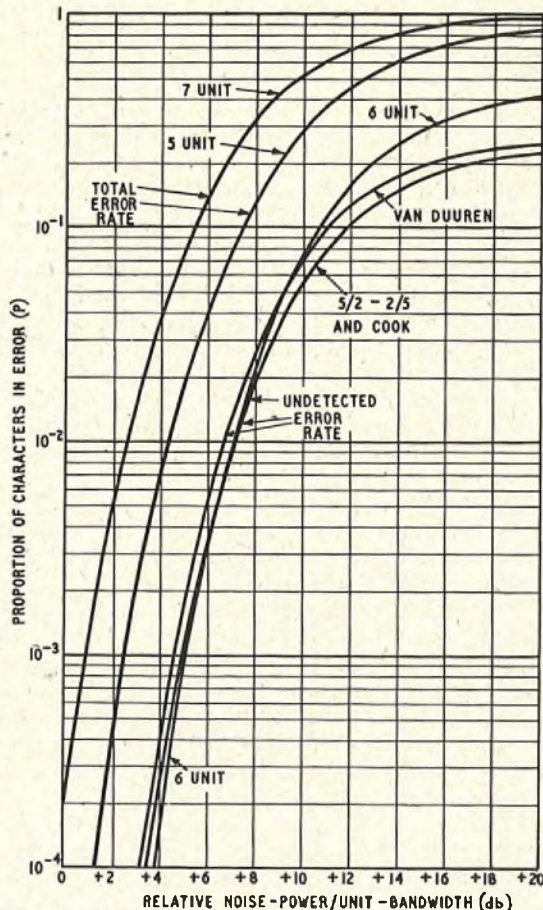

Note 1.—Band-width and noise power are both proportional to the number of elements.

Note 2.—The reference noise level is the power/unit-band-width giving a probability of one error in 10⁴ ($P=10^{-4}$) for the element error-rate with 5-unit code.

FIG. 6.—THEORETICAL PERFORMANCE OF 6-UNIT AND 7-UNIT ERROR-DETECTING CODES IN THE PRESENCE OF RANDOM NOISE

"parity check" the sixth element is made either M or S to give an even total number of marking elements in the character. After a rather limited series of comparative tests of the 3 : 4, 5/2-2/5 and Cook codes it was concluded that the 3 : 4 code was preferable, though not so easy to convert to, and from, as the other codes. Between the R.C.A., Van Duuren and Higgitt No. 2, which are all 3 : 4 codes, the only differences are in the rules of translation, i.e. which character is allotted to each combination; the theoretical performances are

equal. It will be realized that, as the accuracy check on the 7-unit code is by means of the 3 : 4 ratio of mark elements to space elements, errors producing such a ratio are undetectable.

Commonly met mutilations consist of simple changes of marking elements to spacing elements or vice versa, and as these obviously upset the mark/space ratio of the code they are detectable as errors. However, other types of mutilation, fortunately far less common, consist of transpositions of marking and spacing elements within a single character. These do not alter the 3 : 4 ratio and therefore are undetectable as errors.

Principles of an Error-Correcting Telegraph System

Having decided that the errors produced by a radio transmission system can be very largely detected by a 7-unit code, the principles of an automatic system for correcting the errors by repetition can now be formulated.

(a) The system shall be synchronous and shall provide several time-division channels, but the speed of signalling, in the aggregate, shall not exceed the efficient speed of the radio link, bearing in mind channel band-width and multi-path effects.

(b) Translation shall be provided from a 50-baud start-stop 7½-unit channel input code to a synchronous 7-unit code for use over the radio link.

(c) The receiving equipment shall examine each 7-unit character for 3 : 4 ratio of marks to spaces and, in the event of an error being thus detected, shall suspend printing of the received signal and cause a signal to be sent, automatically, to the originating terminal asking for repetition of the falsified character. This returned signal, designated RQ, requires that the telegraph system be of a 2-way nature, with a locked timing relationship between the terminals so that the repetition signal shall be correctly injected into the traffic on the return channel.

(d) On receipt of the repetition signal, RQ, or, as later described, on receipt of a mutilation, the originating terminal shall repeat the character which was in error. The repetition procedure shall continue indefinitely until correct reception is obtained.

The use of high-accuracy oscillators for controlling the terminals ensures that synchronism is not lost during a complete fade-out of the radio link for periods of up to 15 minutes.

The time taken for the radio signal to travel between the radio transmitting station and the radio receiving station is comparatively short because propagation is at the speed of light. However, the voice-frequency transmission system between the radio stations and the control offices, and any radio relay stations in the radio path, can easily introduce delays of 100 ms or more. Hence, the repetition cycle must be arranged to allow for these delays. Working on the above principles, Van Duuren produced an automatic error-correcting system in 1950 and the C.C.I.T.T. and C.C.I.R. have recommended the adoption of his 7-unit code and certain other features.

PRINCIPLES OF THE VAN DUUREN AUTOMATIC ERROR-CORRECTING (ARQ) SYSTEM

Van Duuren error-correcting principles were originally applied to a single telegraph circuit (i.e. one "go" and one "return" channel) but present equipment caters for either two or four circuits. For the purpose of this

article its application to a 2-circuit time-division multiplex system will be described.

At the C.C.I.T.T. meeting in November 1956, the rate of character transmission for channels working at 50 bauds on a time-division system was agreed as 411.43 characters per minute, to ensure that incoming signals from an automatic transmitter running slightly fast are accepted. This gives an output character duration of $145\frac{5}{8}$ ms (see Fig. 1 in Part 1 of the article). Hence, a 2-circuit ARQ system will convey 822.86 characters per minute. Using a 7-unit code this requires an aggregate telegraph signalling speed of 7×822.86 elements per minute or $7/60 \times 822.86$ bauds = 96 bauds (approx.). Existing error-correcting systems will probably be brought in line with this requirement.

The time-division and synchronous parts of the system are conventional. Character interleaving is employed and has the advantage over element interleaving in that it allows earlier injection of the RQ (request for repetition) signal. The automatic-repetition cycle operates on a circuit basis so that repetition can take place on one circuit whilst normal transmission takes place on the other.

Each character received from the start-stop channel is converted from the 5-unit code to a 7-unit code and is transmitted over the radio link and also recorded in a 3-character store. The receiving terminal is operated in a locked time relationship to the sending terminal and the

incoming radio signal is examined for the 3 : 4 mark-to-space ratio. If correct, it is translated by means of a decoder back to the 5-unit code and transmitted as a start-stop character to the receiving teleprinter. Meanwhile, traffic is passing similarly in the opposite direction on the return channel; this is shown in Fig. 7 (a).

Correction of a Single Mutilated Character

Now assume that the character "C" transmitted from station X is mutilated. As the 3 : 4 ratio is affected the examination at the receiving station, Y, will detect the error, stop printing for a cycle of four characters and also initiate the transmission of an RQ signal over the return channel. The RQ signal is injected into the return channel as soon as the timing permits and interrupts traffic on the return channel, but as this traffic is prevented from being transmitted no characters are lost. In practice each character is "called" into the channel sender, and by suspending the pulse which calls in the character it is possible to inject the RQ signal in lieu; this is followed by a repetition from a cyclic store of the preceding three characters to have been transmitted. The purpose of this will be seen later.

The arrival of the RQ signal at the originating station X suspends normal transmission of traffic to Y, but causes the transmission of an RQ signal followed by the last three characters previously sent from X and which are still recorded in the local store in their correct sequence. Since the reception, incorrectly, of "C" at station Y stops transmission to the local teleprinter for four character periods, the transmission from X of the RQ signal and of the three characters from store causes a second reception of "C" immediately after the teleprinter is again ready for reception. Since, in effect, four characters are lost from each channel, and the effect of a three-character store is to repeat transmission of a mutilated character four character-periods later, no extra characters are printed and no characters are lost during the RQ cycle. This is so for various propagation times up to the limit set by the capacity of the store.

To ensure that the radio conditions have improved before printing is resumed, it is arranged that the RQ signal is checked not only for 3 : 4 ratio but also for the correct sequence of marks and spaces. This feature is called "Gated RQ" and in practice it results in an appreciable reduction in the occurrence of undetected errors. The repetition of "C" is again tested for 3 : 4 ratio before it is printed; if found incorrect, a further repetition is initiated.

It has been stated that when station Y detects a mutilation, the RQ signal is injected into the

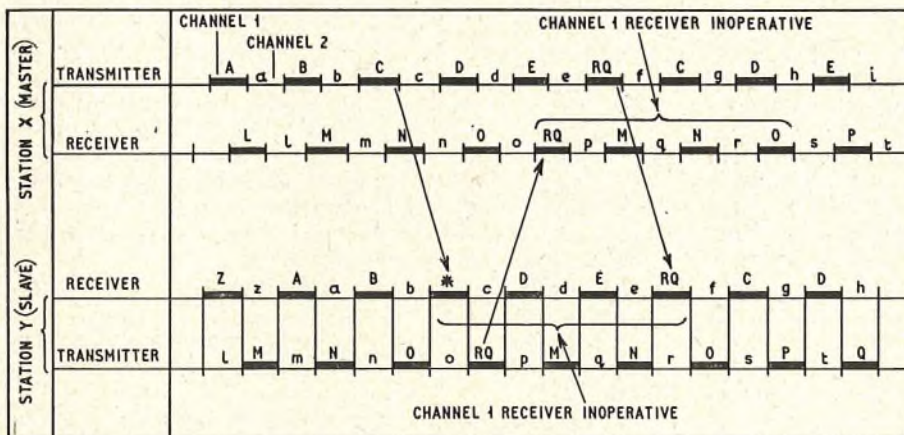

(a) Simple Mutilation in One Direction of Transmission

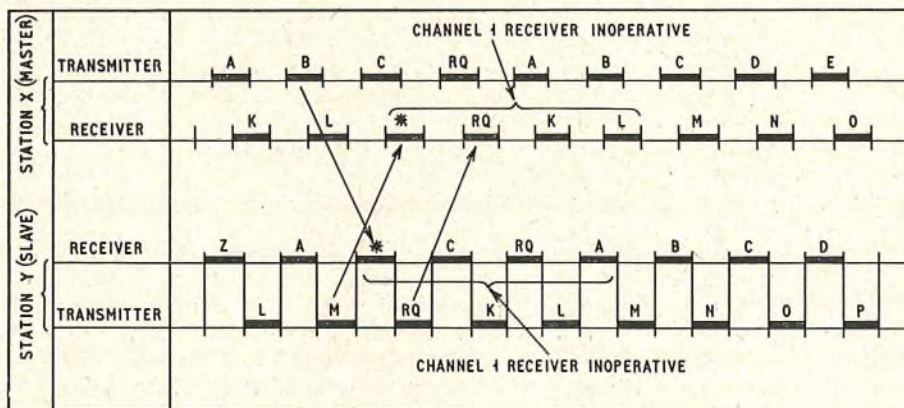

(b) Simultaneous Mutilation in Both Directions of Transmission

The Master station controls the telegraph speed of the whole system. The Slave station must remain in a locked time relationship with the Master station both when receiving and transmitting.

FIG. 7.—TIMING OF 4-CHARACTER REPETITION CYCLE

return channel, followed by the three characters just transmitted. If the return RQ signal from X is mutilated the detection of it, as a mutilation, at Y will cause a request for repetition. If the RQ signal is correctly received at Y it causes no action in respect of the return channel from Y. Printing is resumed at the end of the 4-character cycle. It can be proved that, by the use of this 4-character repetition cycle in each direction of transmission, the system is immune from breakdown by mutilations to any character during a repetition cycle. The injection of four characters into the return path when only the RQ signal is effective appears on first sight unnecessary, but the need for this feature will be apparent from the following paragraph.

It is possible for an RQ signal to be produced by a double-transposition of another character although the probability of such a simulated RQ signal is remote. This would produce a repetition, and if this did not block the succeeding characters the repeated characters would be printed twice. A deterioration of the radio path in one direction of transmission may be accompanied by a deterioration in the other and, obviously, it is necessary that under no circumstance shall characters be either lost or printed twice.

Correction of Mutilations Occurring Simultaneously in Both Directions of Transmission

Referring to Fig. 7(b), it will be seen that if character "B" from station X is mutilated on arrival at Y, the RQ signal is injected into the return channel to X. However, a mutilation has occurred on the character "M" just transmitted from Y, and this, on arrival at X, causes an RQ cycle to commence, and hence injects a request for repetition signal, i.e. an RQ signal followed by the previous three characters, "ABC."

At this stage there are repetition cycles running at each station. Now it will be seen that the characters from X (RQ signal followed by "A" and "B") will be received at Y and, it will be noted, "B" arrives just after the teleprinter at Y has opened for service. In the other direction, Y to X, the characters RQ signal, "K," "L," and "M" are received and the receiving teleprinter is opened for service in time for "M" to be printed.

It will be seen that any mutilations received at either terminal are taken care of by this 4-character cycle at each end, with the minimum interruption of traffic. It should be explained that during any repetition sequence a genuine RQ signal must be received before printing is resumed at the end of the 4-character cycle. Each character received after the teleprinter circuit is restored is, of course, tested for the 3 : 4 ratio of marks to spaces before it is printed.

Referring to Fig. 7(a), it will be noted that although an RQ signal is transmitted from Y to X on the receipt, at Y, of the mutilation of "C," either the RQ signal or an error due to mutilation results in the initiation of the RQ cycle by X. However, if the RQ signal was mutilated on receipt at X, there will be no RQ signal during the RQ cycle at station X, and hence character "P" will not be printed but treated as an error, initiating an RQ and calling for a complete re-transmission from station Y.

The cases described cover all the sequences of errors possible in transmission, but obviously it may happen that a number of RQ cycles may elapse before printing is resumed. It is intriguing to observe a circuit working under poor radio conditions; the teleprinter prints intermittently, but the copy is usually perfect and provides

a grade of service which can be offered for telex and private renters, and gives users confidence in the transmission accuracy.

The efficiency of the Van Duuren error-correcting system has resulted in its widespread use. The United Kingdom is using this system to establish new direct teleprinter services with overseas centres of commerce and to provide teleprinter private circuits for air-line companies and other commercial users. The conversion of the Commonwealth public telegraph services to teleprinter working is also gaining momentum and within five years it is likely that the majority of routes will be converted to error-corrected working, using equipment³ capable of working to the agreed C.C.I.T.T. standards.

While it has not previously been mentioned, it is possible to use certain error-correcting equipments to indicate errors by printing an "error" symbol on the receiving teleprinters in place of the mutilated character. This facility may be useful where a return channel is not always available.

LIMITATIONS OF THE VAN DUUREN ARQ SYSTEM

There are certain disadvantages associated with the Van Duuren system and with synchronous channelling in general which add to the complication of the arrangements. Firstly, the need to transmit two channels in a locked time relationship with each other means that the channel information, i.e. code elements, must be available when required. This, in fact, means that the channel input equipment must provide a character store for the multiplex equipment to "read." There are a number of ways of meeting this requirement. Each entails storing the characters to be transmitted on punched tape, or in cold-cathode, magnetic or capacitive stores, so that they are available for pulsing into the equipment when due for transmission. The methods in use at the present time by the Post Office on error-correcting circuits employ tape storage, and include:

Method (a). Pulsing directly into the system from a tape transmitter.

Method (b). Storing incoming traffic in punched tape form ready for subsequent transmission from a pulsed tape reader.

Obviously, in an ARQ system using method (b) the amount of tape required to be stored will increase during radio disturbances, but will reduce during good transmission conditions. A device called a reperforating re-transmitter (known as an FRXD) is available, which meets this requirement and allows also the transmission of the last character perforated on the tape, which is an essential need. However, it is a machine of considerable expense and requires appreciable maintenance.

The adoption of method (a) is attractive in that the sender is aware of any delay occurring in clearance of traffic, but a pulsing circuit must be provided in addition to the signalling circuit to the renter's premises.

A second disadvantage is that the duration of the characters transmitted from the channel outputs is determined by the frequency of the master oscillator driving the system. This means that both the channels of a system must work at the same speed; in the United Kingdom this would be either at 411.43 characters per minute per channel, or the American speed of 368 characters per minute. However, a channel of a 368-characters-per-minute system can be adjusted on the

channel-output distributor to work at 50 bauds with a long stop signal.

As a transmission system the Van Duuren equipment has the further disadvantages of requiring:

- (a) A return channel to carry requests for repetition.
- (b) A 4-character repetition cycle in each direction of transmission. This also limits the permissible maximum loop propagation time to about 280 ms for 50-baud channels.

Possible Variations of the Van Duuren Cycle

It would be possible to reduce the return part of the RQ repetition cycle to the RQ signal only and thereby reduce the "traffic lost" time at the expense of having two different types of RQ cycle to meet the various conditions. However, as stated earlier, it is possible that radio conditions would affect both directions of transmission simultaneously and nullify this saving. It will be apparent from Fig. 7(b) that, under the present system, corrections in each path are covered simultaneously by one RQ signal in each direction.

It will be realized that the loss of four characters for each RQ signal on the return channel means a loss of traffic capacity which could be serious. In the limit, of course, when radio conditions are bad the system "RQ cycles" continuously, and no traffic is carried in either direction. This is better than on an "unprotected" system which would be printing unintelligible copy (termed "garbling"). However, on occasions one direction of transmission may be good while the other is bad. The use of a single RQ character would then be an improvement. The good channel (i.e. one direction) could be exploited by using "error indication," though the original Van Duuren equipment does not provide this facility.

By the use of electronic equipment (the original Van Duuren equipment employed a mechanical distributor with relays for switching) a slight saving in the terminal switching time can be obtained and will allow longer propagation times to be accommodated for the same storage capacity. By special arrangement the number of characters in the RQ cycle can be adjusted to suit the propagation delay. In fact, the loop propagation time between London and Sydney (due partly to unusually long land-lines) is probably too great for a 4-character RQ cycle if a relay station is involved, and special arrangements may be necessary in this case.

THE IMPROVEMENT IN PERFORMANCE OFFERED BY ARQ

It will have been realized from the foregoing description that an error-correcting system produces complications by its nature and is in itself a complicated equipment. To decide whether the complications are worth while, it is necessary to consider the problems of the customer and the improvements the system offers.

Detection of Errors on a Radio Telegraph Circuit

While it might appear that when a printed error is received on a teleprinter it should be detected by the receiving operator, a little consideration will show that this is not true, for a mutilation may change a letter and still give a readable word, or the message may be in code form or figures. Of course, when an operator sees a mutilation, a request for repetition (RQ) of part of the message can be sent manually, but such repetitions are laborious and expensive in circuit time. Undetected errors may be very serious.

The use of automatic error-correction ensures that only the minimum repetition is demanded and maintains the channel for traffic use except when mutilations are actually occurring.

It is considered that an unprotected radio-telegraph circuit is barely commercial, due to lost-circuit time and waste of operators' time, when the circuit error rate is 2-5 errors per thousand characters printed. This, of course, allows that most, but not all, of the errors are detected by the receiving operator, the obvious errors, thanks to the redundancy of words, being corrected without reference back to the transmitting end. However, certain errors must be referred back, or arrangements made for the transmission of each message twice and for correction by comparison of the received messages; this is termed "slips-twice" working, which reduces the circuit capacity to one-half and leaves the work of correction to the receiving operator. The corrections may be obvious to the recipient of the message, causing suspicion and lack of confidence in the message and the service.

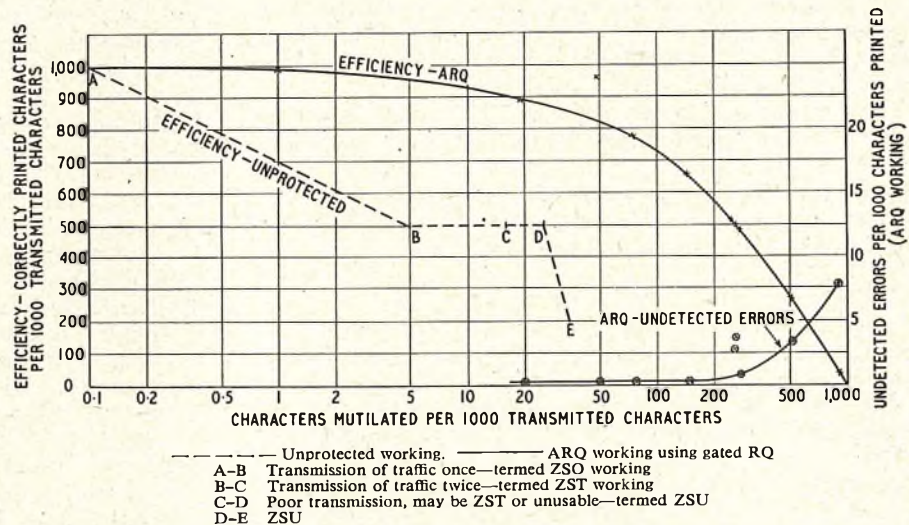

The points B, C, D, are approximate values, determined by the receiving operator and the nature of the messages. Where there is some redundancy of words a worse mutilation rate can be corrected by the operator than could be corrected for ordinary messages or messages in code.

FIG. 8—RADIO TELEGRAPH TEST RESULTS WITH AND WITHOUT ARQ OPERATION

With an ARQ system a circuit error rate of 2-5 errors per thousand characters is improved to better than 1 in 10,000, and the curve in Fig. 8 shows the high traffic-clearing capacity of the telegraph channel even under the conditions of increasing error rates that may arise in typical radio conditions. It will be noted that, as mentioned earlier, the fading which causes the mutilations is slow enough to permit effective periods of good

transmission, whereas rapidly recurring fades would have caused practically continuous repetition, since the ARQ cycle extends for 600 ms and would have over-run most of each good period.

Assessment of the Improvement due to ARQ Working in Relation to Signal/Noise Ratio

It has been pointed out that telegraph channels of a frequency-division system suffer from the reduction of transmitted power per channel compared with keyed carrier emissions. The reduction in channel power level from, say, a duplex emission (keyed carrier) to a channel of a 4-channel frequency-division system may be of the order of 12 db.

The importance of such a reduction in signal level depends on the nature of the radio link, since where the noise level is very low a reduced signal level will be perfectly satisfactory. However, the signal/noise ratio can be related to the error rate, and the improvement due to ARQ working can be related to both signal/noise ratio and the number of diversity paths over which signals are received. The relations are illustrated by Fig. 5 (see Part 1), and it will be seen that for an error rate of 1/1,000 characters the use of a protected code (3/4) compared with an unprotected 7-unit code allows for a signal/noise ratio deterioration of 19 db. The improvement due to the use of dual diversity over non-diversity reception at the same error rate (1/1,000) is equivalent to a gain of 17 db in signal/noise ratio, and the improvement due to quadruple diversity over dual diversity is 9 db. In each case the improvement due to the use of the protected 7-unit code is equal, roughly, to doubling the diversity paths.

It must be emphasized that these comparisons refer to the improvement due to the use of the protected code alone. In practice, the Van Duuren method of ARQ working provides further improvements:

(a) by the check for a genuine RQ signal in all its elements, before a repeated character is even examined ("gated" RQ), and

(b) because the characters received after an error and prior to the RQ signal are ignored, hence adding, effectively, to the protection provided.

Test Results on an ARQ System

It will be realized that, to assess the performance of a telegraph system working on a radio link, it is necessary to check that the equipment itself has a very low error rate. This has been done by deliberately introducing mutilations on a wire connexion between the send and receive sides of a 2-channel ARQ equipment (i.e. connected back-to-back). On one particular test the equipment ran for 72 hours without fault or adjustment and, during this time, while 1,589,000 characters were transmitted (including repetitions) and 505,934 characters were printed, no error was proved to be due to the ARQ equipment.

The mutilation rate on a long-distance radio-telegraph circuit varies widely during each day from good reception to complete fade-out, and necessitates the change to a lower radio frequency for use during the night. The proportion of good reception time depends on many factors and, obviously, the value of ARQ on any circuit depends on the mutilation rates encountered during a 24-hour period, and also on the long-term effect of sunspot activity and radio propagation. It is possible to assess, mathematically, the improvement in

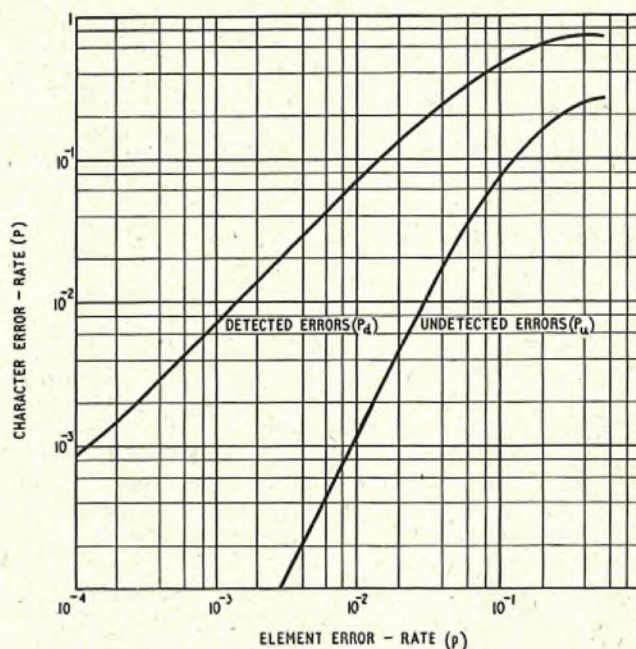

FIG. 9—THEORETICAL RELATIONSHIPS BETWEEN CHARACTER AND ELEMENT ERRORS FOR A 3 : 4 RATIO CODE

mutilation rate afforded by the use of the 3 : 4 code, and this is shown in Fig. 9. However, the use of the RQ cycle with gated RQ gives a further improvement, since the probability of an undetected error following immediately after an RQ cycle is then the product of the very high protection afforded by the check of the RQ signal and the protection afforded by the 3 : 4 ratio check. This can be calculated for controlled conditions, but calculation would be difficult for radio conditions where the signal level varies continuously and at random. Under such conditions the receipt of a genuine RQ signal may be followed by a fade, and in this case the effectiveness of the check of the RQ cycle is that of the 3 : 4 test alone. Under radio conditions the use of gated RQ can give a reduction in the undetected error rate of 5 to 1 compared with ungated RQ.

Referring again to Fig. 8, typical test values of undetected errors have been plotted against the character mutilation rate existing on the radio circuit. For example, with a circuit mutilation rate of 100 in 1,000, the undetected errors are about 0.4 per 1,000 characters printed, an improvement of more than 200 : 1. It can be seen (Fig. 8) that at this circuit (i.e. uncorrected) error rate, the efficiency of the ARQ circuit is about 74 per cent, at a time when the unprotected circuit is not commercial. It has been claimed that the improvements indicated in Table 2 are achieved by ARQ working.

TABLE 2
Improvement in Error Rate Achieved by ARQ Working

Signal Mutilation Rate	Undetected Error Rate with ARQ Working	Improvement
1/10, i.e. 1 in 10	1/1,000	100/1
1/100	1/100,000	1,000/1
1/1,000	1/10,000,000	10,000/1

(The greater improvement at lower signal mutilation rates is due to the decreasing probability of a transposition occurring within the seven elements of the character.)

The foregoing results are for instances of errors in one direction only, and the efficiency of the return channel would be correspondingly reduced.

The net value of ARQ must be assessed for a particular link from a consideration of:

(a) The increase in traffic capacity, integrated over the 24-hour period, bearing in mind the periods during which radio transmission is poor. This may, or may not, be important.

(b) The saving in operators' time resulting from automatic correction and from providing "clean" copy suitable for the customer.

(c) The facility of working automatic and switched services in a reliable manner.

It will be seen that the C.C.I.T.T. recommendation that the error rate for telex services should not exceed 10 errors per 100,000 characters can be achieved by the use of ARQ, except in the worst transmission conditions. It may be observed here that the nature of the radio link will have a bearing on the undetected error rate. As already stated, single element mutilations are always detected by the 3:4 code, and the much rarer "transpositions" are the source of undetected errors.

CONCLUSIONS

ARQ offers a performance which makes renter-to-renter and telex switching facilities, including calling,

clearing and keyboard selection of telex subscribers, reliable over world-wide radio links.

From the customer's point of view, ARQ gives the quality of service which is expected of an expensive communication link. From the engineers' point of view the ARQ system, although complicated and requiring expert maintenance, enables radio frequencies and facilities to be exploited more fully while still securing an improvement in circuit reliability for a moderate increase in equipment and maintenance costs.

ACKNOWLEDGEMENTS

The author gratefully acknowledges assistance in the preparation of this article from colleagues in the External Telecommunications Executive, and in the Overseas Radio Planning and Provision Branch, the Research Branch and Telegraph Branch of the E.-in-C.'s Office.

References

- ¹ HAMMING, R. W. Error Detecting and Error Correcting Codes. *Bell System Technical Journal*, Vol. 29, p. 147, 1950.
- ² HAYTON, T., HUGHES, C. J., and SAUNDERS, R. L. Telegraph Codes and Code Convertors. *Proceeding I.E.E.*, Paper No. 1585, May 1954 (Vol. 101, Part 3, p. 137).
- ³ An Electronic Error-Correcting Multiplex Telegraph System. *P.O.E.E.J.*, Vol. 50, p. 44, Apr. 1957.
- ⁴ MOORE, J. B. Signal Mutilation and Error Prevention on Short-Wave Radio Teleprinter Services. *I.R.E. National Convention Record*, Part 8, p. 127, March 1957.

Book Review

"Elementary Telecommunications Practice." J. R. G. Smith, A.M.I.E.E. The English Universities Press, Ltd. 293 pp. 171 ill. 12s. 6d.

This book has been prepared to suit the needs of students studying for the City and Guilds of London Institute examination in Elementary Telecommunications Practice.

Twelve chapters deal with the magnetic effect of a current, heating effect of a current, telegraph codes and circuits, telephone and telegraph systems and provision of plant, cables, manual exchange equipment, soldering, primary and secondary cells, receivers and transmitters, corrosion, identifying and testing wires, components used at radio frequencies, respectively.

The main treatment consists of "sketch and description" of telecommunication apparatus. This constitutes the major part of the syllabus and is well, although in parts briefly, covered. A weakness is inadequate treatment of fundamental principles, e.g. principle of operation of devices, and, in a number of instances, a tendency to assume too much prior knowledge by students. This arises from the brief treatment of certain aspects, as, to quote the book, "the syllabus is a comprehensive one and to keep the book to a reasonable size the treatment is brief". The force of this is appreciated, but as the needs of students are foremost in mind, it is considered that a more thorough treatment in parts would have been justified even if it resulted in a slightly larger book. This is all the more important as the students concerned would be in an early year of study. A typical instance is that there is no treatment of the polarized relay, it being left to the student to assume that the principle of the magneto bell and the polarized sounder applies. The application of Ohm's Law to signalling circuits is far too

brief, being limited to the simple series circuit. The general description of public telephone systems is limited to line plant networks. Various constructions of electrical contacts are given, but little information on relative merits, field of application, and factors influencing performance and reliability. The power rating of resistors and coils is inadequately covered. While identification testing is well covered, continuity tests are hardly mentioned, it being left to the student to assume that identification test techniques could, within limits, apply.

As many radio students will study this subject, the chapter on components used at radio frequencies justifies a more detailed treatment than that given. The carbon composition resistor is described in a few words without a constructional sketch. The statement is made that "these resistors are used where the stability and power rating are acceptable", it being left to the student to determine that the stability is relatively poor and the power rating low. Except for schematic-type diagrams of non-inductive resistors, no constructional details of radio-type wire-wound resistors are shown. Winding techniques to reduce inductance and capacitance in resistors are described without mention as to how the techniques achieve their aim. Trimmer capacitors, radio-type fuses and pre-wound resistors are not mentioned.

A notable feature from the student's point of view is that each chapter ends with a selection of questions from past City and Guilds examinations, together with a model answer to one of the questions, reproduced from the *Post Office Electrical Engineers' Journal*. Study of these enables a student to acquire examination technique which is most important for early-year students.

The diagrams are well drawn, the production excellent and the price moderate.

S. W.

Development

U.D.C. 658.57

MANY readers of this Journal are acquainted with Mr. A. W. Montgomery, O.B.E., one of the most respected of British telecommunication engineers, with a world-wide reputation as a wise counsellor on development and manufacturing problems.

From time to time he has made random jottings on "development," and these, seen by chance, were recognized and seized upon as deserving reproduction. This, with some diffidence, Mr. Montgomery agreed to and has our thanks.

L. H. H.

NOTES ON DEVELOPMENT

1. If your development staff is good, anything which is developed is out of date when it appears; because in developing it the individuals concerned increase their knowledge of the problem and of methods of solution and can therefore continually see other and probably better ways of producing the result.

2. There must therefore be a stopping organization somewhere which decides when the development shall be said to be completed.

3. Development being continuous, stages of achievement are not natural nor obvious. They must be set artificially.

4. All industrial development must be paid for out of some industrial product. This year's development is being paid for by the products of development of past years.

5. Part of the product of development is the increased experience of an individual and organization; in fact, this is part of the capital of the organization.

6. Insurmountable difficulties can sometimes be of great value. When up against one it must somehow be used in the development. Its existence is a challenge to thought and ingenuity and is frequently responsible for good new ideas.

7. The value of a patent is, in general, in inverse ratio to its weight in paper.

8. Development work must be done for love of the work; this, because it is by its nature unsatisfying. To commence with, as the development proceeds, better ways of doing it must become obvious. Yet if the direction taken by development changes frequently there will be no product, no sales, and no money for development. Furthermore, after the development leaves the laboratory, other individuals take it over, and the final product will in general not be as anticipated by the originators. It will also appear as a product, months after it has left the laboratory, by which time the originators will have learnt much more and will be somewhat disappointed in what they had allowed to be made.

9. No development organization can be placid or too often right. If placid, the necessary spirit of adventure is missing; if too often right, there is too great caution.

10. Failures of development are valuable in two directions:

(a) No work can be done without increasing the knowledge and experience of individual and organization.

(b) A negative result can prevent waste of effort in future or can give a lead to future work.

Nevertheless, developments which have failed and which, if they had been successful, would have produced valuable products should be re-examined from time to time to ascertain whether later knowledge and experience, and new techniques, could turn failure into success.

11. The man who pays all salaries is the customer. Unsuccessful work must be paid for just as much as that which results in a product.

12. Development and manufacturing organizations will always find each other difficult. If this is understood, very good relations can be maintained between them and management can act more wisely. Development staff can always see how easy it would be to introduce improvements in current designs if only manufacturing staff were more receptive and active. Manufacturing staff can always wish that the development staff would make up its mind and leave them alone to get on with the job.

13. A most important factor in all development is human nature. The best work can be made useless by the originator himself if he sets up serious antagonisms. Some staff require ambassadors to get their ideas across. Some departments are only approachable through ambassadors.

14. There are almost always many ways of solving a problem, several of which are equally attractive and economic. Once one has been selected there must be no vain regrets afterwards. It will always be possible to show that any one of the others would have led to better results.

15. Because of this variety of solutions, commercial departments will always know that competitors' solutions are better and more economical than one's own. They are paid to prove the opposite.

16. The better the development staff, the greater the tendency for them to be consulted on all points, the more the likelihood of their time being wasted on minor matters; and the greater the chance of the rest of the organization going to sleep mentally. This is a serious danger.

17. An equal danger is for the development staff to be too inaccessible and so for serious technical difficulties not to be brought to their attention.

18. By their job, development staff should know more than others about the product. They, through humility or arrogance, should not assume that all others know as much as they, or are incapable of understanding. In either case, trouble taken to think out how to explain any difficulties in understandable terms and without condescension is well repaid and good for the organization.

19. There is sufficient natural rivalry between development men interested in rival lines of approach, and the application of any external active stimulation is unnecessary. It produces, in general, bad results. This rivalry without pressure is generally reasonably amicable. If there is not natural rivalry then you have the wrong development staff.

20. The development staff, being envied throughout the whole organization for their leisurely life, freedom from responsibility, frequent failures without penalty, comfortable surroundings and high pay, are the fair butts and scapegoats for the rest of the organization.

This is irritating but must be accepted as part of the job. If they are good, they are consulted when real (and sometimes imaginary) difficulties arise and this compliment must offset the irritation.

21. Development staff tend to be too accommodating to others and to believe that others are logical and reasonable. They tend, therefore, to get embittered with age.

22. The longer the delivery time the more time is there apparently available for wasting at the start of the job. Minor achievements are often more interesting technically than major and this can be a serious time waster.

23. The longer the delivery time, the more time is there for the insertion of unnecessary features and the more changes there will be.

24. Model shops are always bones of contention. An efficient model shop by manufacturing standards would be one in which the machines are always fully

loaded. This is very inefficient for development work because, in this, the main expense is in development staff and in duration of development.

25. Furthermore, because of this apparent inefficiency model shops are always regarded as having spare capacity and therefore available for rescue work of some kind or another. They tend, therefore, to get overloaded and unable to do their proper work. Foremen and operators aid and abet as they are naturally nervous when there does not seem to be sufficient work about.

26. Publication of results should be as history and not as prophecy. Since the publication follows the work, and the work is out of date when it emerges, the publication is even more out of date. This is as it should be. Prophecy, because of this, is tempting but should be indulged in rarely, for a specific purpose, and with knowledge of the dangers. It is always safer to prophesy after the event.



2-12 GRESHAM STREET, LONDON, E.C.2

The Engineer-in-Chief and the staff of a number of Branches of the Post Office Engineering Department have recently moved from several buildings in central London to a new block of offices at 2-12 Gresham Street. The new building, in the City of London near St. Paul's Cathedral, is a short distance from Post Office Headquarters and Alder House, which for many years was the home of the Engineer-in-Chief's Office.

Notes and Comments

Recent Award

The Board of Editors has learnt with pleasure of the honour recently conferred upon the following member of the Engineering Department:

Belfast Telephone Area

.. W. S. Grieve, E.R.D.

.. Major, Royal Corps
of Signals, T.A.

Ordinary Member of the
Military Division of the
Most Excellent Order of the
British Empire.

Subscriber Trunk Dialling—Special Issue of the Journal

The January 1959 Journal (Vol. 51, Part 4) will be a special and enlarged issue devoted entirely to articles about subscriber trunk dialling. The general plan for the introduction of subscriber trunk dialling in the United Kingdom will be described and details will be given of the first installation, at Bristol. Articles will be included on the different types of register-translator, periodic pulse metering and metering over junctions, subscribers' private-meter equipment and the new coin-box.

The January 1959 issue will be sold at the usual price of 2s. 6d. per copy (2s. to employees of the British Post Office). Readers who are not regular subscribers are requested to order their copies now from the local agents or the publisher, whose address is given at the end of this issue.

Retirement of Mr. G. J. S. Little, C.B.E., G.M., B.Sc.(Eng.), M.I.E.E.

The retirement of Mr. G. J. S. Little, Director of Research, on 1 October, means the loss to the Department of a man who, in an earlier capacity in the Lines Branch, was largely responsible for laying the foundations of the carrier and coaxial trunk network.

Educated primarily at Christ's Hospital, Mr. Little's subsequent studies at Battersea Polytechnic were broken by three years of military service in the First World War. He graduated in Mechanical Engineering immediately after the war and, after a short period with a firm of structural engineers, he was successful in the first post-war Open Competition for Probationary Assistant Engineers (old-style), joining the Line Transmission Group of the Research Branch. Here he became concerned with the development of audio-frequency repeaters and with early experimental carrier-frequency transmissions.

Transferred to the Lines Branch in 1930, he was promoted Executive Engineer (old style) in 1932 and Assistant Staff Engineer in 1936. He was awarded Senior Bronze Medals by the Institution for his papers "Electric Wave Filters" (1931-32) and "Twelve-Circuit Carrier Telephone Systems" (1937-38); he also wrote a series of articles on Carrier Telephony for the Journal.

In 1937 he became a member of the C.C.I.F. 3rd CR and, later, chairman of a Sub-Commission set up to study wide-band transmission. In this latter capacity he was responsible for the frequency allocations which are now standard for carrier and coaxial systems.

In 1938 he became Superintending Engineer, N.W. District, and, on the formation of the North Western Region in 1939, Chief Regional Engineer. In this post he served through most of the war years, receiving commendation from the Postmaster General and the award of the George Medal for "meritorious work and conduct in connexion with the saving of Central Exchange Building at Manchester following the air attack of 23 and 24 December 1940."

In 1945, he left Manchester to become Staff Engineer, Radio Maintenance Branch, and the next year he visited South Africa and Australia to study methods of trunk working. Promoted to Assistant Engineer-in-Chief in 1947 he assumed responsibility for trunk and local lines; he was also appointed President of the 3rd Study Group of the C.C.I.F., an office which he filled with

distinction until 1955, covering a period of most important decisions in the field of international telephony and television.



In 1954 he was honoured with a C.B.E. and the same year was appointed Controller of Research. He was the third occupant of this important post, both his predecessors, Sir Gordon Radley and Sir Lionel Harris, being his fellow entrants in the 1922 Open Competition. For the last four years he has exercised his technical and personal influence over most aspects of Research Branch activities, being at all times good humoured, understanding and approachable.

In his retirement he plans to build a new home at Churt and to grow alpine flowers. He will also, no doubt, indulge his life-long love of music and, if rumour is to be relied upon, he plans to build for himself an electronic organ. We all wish him long and happy years in which to enjoy his interests.

R.J.H.

R. J. Halsey, C.M.G., B.Sc.(Eng.), F.C.G.I., D.I.C., M.I.E.E.

On 2 October 1958 Mr. Halsey became Director of Research in succession to Mr. G. J. S. Little.

Mr. Halsey started his career in Portsmouth Dockyard as a Shipwright Apprentice, proceeding to the City and Guilds Engineering College in 1923. He entered the Post Office as an Assistant Engineer (old style) in 1927, joining the Transmission Section of the Research Branch (then in the charge of Mr. S. Pollock) in Marshalsea Road. The pioneering work in carrier telephony was started in this period. In 1936 he was promoted to Executive Engineer (old style) and in 1941 to Assistant Staff Engineer, becoming Staff Engineer of the Line Transmission Division of Research Branch in 1947. In 1953 a new division was formed to deal with submarine cable systems and Mr. Halsey headed it. Since December 1953 he has been Assistant Engineer-in-Chief and responsible for submarine cable systems and telegraphs. In particular, of course, he was in charge of the British contribution to the transatlantic telephone cable project, completed in December 1956.

In the New Year's Honours list, January 1957, he was

therefore give full scope for his high technical and administrative abilities.

Those who have worked with Mr. Halsey will have admired his energy and enthusiasm, his direct approach to a problem and his unfailing good humour. We congratulate him on his past successes and wish him well in the future.

H. W.

H. Williams, A.C.G.I., M.I.E.E.

For the second time in his career, Mr. Williams leaves the Research Branch at Dollis Hill, now to become an Assistant Engineer-in-Chief with a wide field of interest, ranging from transmission development to telegraphs, engineering training and postal mechanization.

After studying electrical engineering at H.M. Dockyard, Portsmouth, and Imperial College, Mr. Williams entered the Post Office as an Assistant Engineer (old style) in January 1926 and began work at Dollis Hill on telephone switching components. Promoted to Executive Engineer (old style) in January 1934, he continued to be involved in many of the switching, signalling and dialling problems that attended the period of intensive



awarded the C.M.G. He has also received the F.C.G.I. This is given by the City and Guilds Engineering College on rare occasions for outstanding technical achievements, and he joins two other recent recipients in the telecommunications field, Sir Lionel Harris, the present Engineer-in-Chief, and Mr. W. H. Grinstead, of Siemens Bros.

He has been a liberal contributor to the I.P.O.E.E. and I.E.E. and was a member of the 3rd Study Group of the C.C.I.F. for many years.

As Director of Research, Mr. Halsey is head of an organization concerned with research and development in the many fields relevant to telecommunications, including, as the result of recent reorganization, radio experimental work. In addition he will continue to direct major submarine cable projects. His post will

development of the automatic telephone system.

A complete change came in September 1938 when he left research to become Assistant Staff Engineer in the Transmission and Main Lines Branch with responsibility for the development of line plant for the long-distance trunk network. In July 1947 he took over Mr. Chamney's mantle and became Staff Engineer in charge of the Branch for nearly six years. Then, after 15 years' absence, he returned to Dollis Hill in May 1953 to take charge of RC Division in succession to Mr. Halsey. From that time, he has been concerned with a considerable variety of line-transmission projects and such allied matters as the effect of electronic switching on trunk transmission.

Not the least important of Mr. Williams' tasks during the period since 1938 have been those arising from his membership of the 3rd Study Group of the C.C.I.F.,

now the 1st Study Group of the C.C.I.T.T. One of these tasks was to undertake the chairmanship of the recently formed Joint C.C.I.T.T.-C.C.I.R. Working Party on Circuit Noise. It is to be hoped that his new duties as Assistant Engineer-in-Chief will not require him to retire from this field of international telecommunications, where his name is so well known.

Mr. Williams' highly developed "guide-and-goat" technique for dealing with intractable problems will not soon be forgotten at Dollis Hill. Playing the role of a "Catalytic Activator," he would seek out all those who might be expected to contribute, then persistently but unobtrusively persuade or provoke them, singly or in groups, into action and reaction until eventually a solution emerged.

N. W. L.

C. E. Richards, F.R.I.C.

The appointment of Mr. C. E. Richards to the newly created post of Deputy Director of Research recognizes not only the man who has been one of the architects of materials research in the Post Office but also the importance attached to that side of the Engineering Department's activities.

Mr. Richards' early years were spent in research in private industry in Liverpool where he acquired not only a sound basic training but also the philosophy which requires research to have a practical result as well as academic interest. He still has a bench in the laboratory and a well-worn white coat. On joining the Post Office in 1923 he quickly gravitated to a chemical group of the Research Branch and became prominent in the field of chemical and electrolytic corrosion of cable sheaths. He gave valuable help in the investigations following the Holborn gas explosion in 1928, and made contributions to the detection of inflammable and poisonous gases and many other subjects. He became senior chemist at Dollis Hill in 1937 and Assistant Staff Engineer in 1944. His war-time activities included important assignments in the production of iron dust when foreign supplies of that commodity were cut off, and visiting the United



States as consultant on lead-tube production for the Pluto project. Appointed Senior Principal Scientific Officer in the 1947 reorganization of scientific staffs, Mr. Richards found himself at the head of a Division with an expanding responsibility at a time of national shortage of scientists. He concentrated the available effort in groups large enough to make effective contributions to their subjects even though this meant limiting the fields covered. This policy has been justified by the results. The collected papers of the team on water-soluble piezo-electric crystals have been published in book form and the Post Office enjoys a leading position in the science and technology of specialized magnetic materials. Mr. Richards' latest publication is an I.E.E. paper, with members of his staff as co-authors, on magnetic materials. During the manufacture of the transatlantic telephone cable his advice on the materials of the cable and the repeaters was sought on numerous occasions. He is a prominent member of the Society of Chemical Industry.

To his friends, "Dick" is a man of strong loyalties, to people, to places and to national institutions, including cricket, at which he is a more than useful player. They all wish him well in his new responsibilities.

T. H. F.

Retirement of Mr. W. F. Smith, B.Sc.(Eng.), A.C.G.I., M.I.E.E.

After training as an Electrical Fitter Apprentice in H.M. Dockyard, Sheerness, followed by 12 months' service in the R.F.C.—later to become the R.A.F.—Mr. Smith took an engineering degree course at the City and Guilds Engineering College, London, when he gained B.Sc. (2nd class honours) of London University and Associate of the City and Guilds Institute.

In February 1924 he entered the Post Office as a result of success in the old-style Assistant Engineer examination and served first in the Radio Branch and then from April 1925 as Assistant Officer-in-Charge at Leafeld Radio Station. Returning to the Radio Branch at Headquarters in December 1928 he was engaged on coast radio station maintenance and radio interference duties until his transfer to the Northern District in August 1930 as Power Engineer. Promotion to Sectional Engineer of the Newcastle Power Section came in January 1934 and regrading as Area Engineer on the formation of one of the first experimental Regions in March 1936.

In April 1937 Mr. Smith was promoted to Regional Engineer with headquarters at Leeds, where he became Chief Regional Engineer in 1946 and found most congenial the varied range of responsibilities of a C.R.E., which he exercised with a genial imperturbability that made duty a pleasure for all who worked with him. Never losing sight of primary objectives, he could pursue these with a firm pressure that never irked those to whom it was applied.

Many years of service on committees of the Institution of Electrical Engineers at Newcastle and Leeds were recognized by his election as 1950-51 Chairman of the North Midland Centre.

Although the opportunity to return south was welcome, it was with mixed feelings that he left the North Eastern Region to which he had contributed so much. When transferred from Leeds to London in October 1952 as Staff Engineer, Mr. Smith took charge of the Radio Maintenance Branch of the Engineering Department and in April 1953 was transferred with staff to the



newly formed External Telecommunications Executive. This new assignment brought some contact with lines and telegraph equipment in connexion with overseas communications but was still largely concerned with the control of maintenance of the Post Office point-to-point radio stations and coast radio stations. There was much work, mainly on staff matters, associated with the take over of a number of radio stations from the Cable & Wireless Ltd. organization as well as the assimilation of the largest telegraph control centre in the world, at Electra House, into the Post Office organization. Mr. Smith specialized in dealing with staff matters and built up a reputation for sympathetic and fair dealing. He leaves his post with the very good wishes of a wide circle of friends.

R. J. H.

H. Leigh, B.Sc.(Eng.), M.I.E.E.

Mr. Leigh, now promoted to Staff Engineer, External Telecommunications Executive, joined the Post Office as an Assistant Traffic Superintendent in 1927 following 3 years as a Student Engineer with Siemens Bros. He obtained a London University honours degree in Engineering in 1929, and 2 years later entered the Engineering Department by the open competition for Assistant Engineer (old style), being posted to the Equipment Branch. Here he was employed for some 10 years, first as Assistant Engineer and later as Executive Engineer (old style), on a variety of duties covering the preparation of telephone exchange specifications, technical costing of exchange and transmission equipment, consultative services, etc. Throughout the war period he occupied the important post of Secretary to the Precedence panel, where his broad knowledge of all classes of line telecommunication plant proved of great value.

His promotion to Regional Engineer, Home Counties Region, followed in 1947 and after a successful period of 5 years spent on exchange construction problems he returned to Headquarters as Assistant Staff Engineer

responsible for planning overseas services in the then newly created External Telecommunications Executive. In this position, which represented a completely new field of responsibility and interest, he rapidly made his mark and was soon engaged in travelling extensively on official business to many parts of the world. Amongst his important duties were service on the Technical Study Group of the Commonwealth Telecommunications Board and the work of technical adviser to the Foreign Office on the Baghdad Pact Communications Subcommittee.

Mr. Leigh's experience in the Post Office has been unusually varied in character and accordingly he is widely known throughout the telecommunications and allied fields, where he has earned general respect for his ability and made many close friends.

Outside the immediate sphere of official duties he commenced work as Assistant Editor of this Journal in 1934 and his association with it continued for some 13 years. Many inexperienced authors will remember with gratitude the help and encouragement he gave them in preparing articles for publication. His tenure of the office of Managing Editor lasted through to the end of the war and one measure of his success in this field was that, although he had to cope with paper rationing and other wartime difficulties, the Journal never missed an issue, its technical standard was maintained and its financial position strengthened. In spite of the heavy demands of the Journal on his leisure hours in those days, he made time available for lecturing at Northampton Polytechnic and still found a reserve of energy to expend in playing for the Civil Service Rugby Football Club.

Mr. Leigh's approach to work has always been clear-sighted, vigorous and decisive but marked by patience and understanding towards his subordinates. In the important duties which he now assumes, these qualities, combined with his technical ability, wide experience and friendly disposition, are bound to ensure the success which his many friends wish him.

G. E. S.



L. F. Salter, B.Sc.(Eng.)

When the decision was taken to split Telephone Branch into two Branches and one of those was to be responsible for telephone exchange standards and maintenance, it was fitting that Mr. Salter, Deputy Chief Regional Engineer, London Telecommunications Region, should be chosen to fill the post of Staff Engineer in charge of the new Branch. Mr. Salter spent 16 years from 1938-45 in Telephone Branch as Executive Engineer (old style) and Assistant Staff Engineer on the Maintenance and Physical Design Groups and, consequently, he brings to his new post a wide knowledge and experience of the Branch's activities acquired during the difficult period covering the war and its aftermath.

Mr. Salter's early engineering education was acquired in Her Majesty's Dockyard Schools, Portsmouth. Whilst a number of entrants to the Engineering Department have come from Dockyard Schools via a university or engineering college, Mr. Salter is unique in that he



came by way of the Royal Naval College, Greenwich, where he qualified as a Naval Architect. While at Greenwich he obtained a London University 1st class honours external degree. He entered the Department by open competition as Assistant Engineer (old style) in 1927.

Following his probationary period, Mr. Salter was posted to the London Engineering District Technical Section on trunking duties. After 4 years he was transferred to Centre Section, London Engineering District, where he spent 2 years. During this time he was in charge of the organization of the opening of the largest automatic exchange in the country, in the Mayfair Building. Centre Section had, at that time, 180,000 telephone stations in 9 square miles of the West End of London. Mr. Salter moved to Swansea Engineering Section in 1935 and became Sectional Engineer in 1936. In contrast to his London experience, Swansea Section had some 15,000 stations in 2,000 square miles of territory, the largest exchange having 2,700 stations.

In 1938, Mr. Salter came to the Engineer-in-Chief's office where he was soon concerned with the emergency

arrangements for the replacement of war-damaged exchanges. He worked with the late H. S. Smith on the design of emergency exchange equipment and on drawing up detailed plans for the restoration of service to damaged exchanges. When Southampton exchange was bombed, he headed a team of engineers who rebuilt the exchange on a semi-automatic basis to give service to 1,500 subscribers. The exchange was installed in a Gas Company's store in six weeks. This experience proved, in practice, the effectiveness of the emergency plans drawn up earlier by Mr. Salter and the Telephone Branch engineers to meet such contingencies.

Mr. Salter has always shown a strong personal interest in the well-being of his staff; he has been actively associated with sports and social activities in the Engineer-in-Chief's Office and in the Regions where he has been employed. For many years he was Chairman of the Engineer-in-Chief's Branch of the Post Office (later Civil Service) Sanatorium Society and worked hard in this deserving cause. Coming back to take charge of a new Branch, staffed largely by old colleagues and friends, Mr. Salter is assured of a happy future and the loyal support of his staff.

G. S.

E. W. Anderson, A.M.I.E.E.

Mr. Anderson, who has been appointed Staff Engineer, Local Lines Branch, entered the Post Office Engineering Department as a Probationary Inspector in 1925, direct from Bristol University. He did his training in the South Western District, and in 1929 was transferred to the Equipment Section, Engineer-in-Chief's Office. Successful in the Assistant Engineer (old style) examination 2 years later, he returned to the Superintending Engineer's Office at Bristol, and was employed for 5 years in the Technical Section on a variety of duties, including main cable maintenance, corrosion, protection from power circuits, and interference. In 1936, following a short period in the Bristol Section, he moved back to Headquarters Construction Branch and covered all aspects of protection and interference from power circuits.

On promotion to Executive Engineer (old style) in 1938, he was in charge of the Motor Transport "User" duty, and later, on evacuation to Harrogate, combined this with Tools and Mechanical Aids. He was much concerned at this time with the design of regular (e.g. Morris Minor) and special vehicles, which are now so very well established in the field.

His next promotion, to Regional Engineer in 1947, took him to Home Counties Region, where he controlled the Local Lines and External Construction Group for 5 years. He was responsible for several major defence schemes at this time, and also negotiated with the Development Corporations the basis on which line plant should be planned in the five New Towns which were being established in the Home Counties Region.

In 1952 he changed to the Accommodation and Internal Planning and Construction Groups and took a leading part in improving working conditions by the establishment of new engineering depots and garages, and in reducing the number of cases waiting exchange plant from 15,000 to 2,000. He has served as Regional Representative on the Broadband Engineering Progress Committee and has been Liaison Officer for the setting up of a number of broadband systems, including the London-Isle of Wight, London-Norwich and cross-



channel links for the B.B.C. For the last 2 years he has led the Regional team concerned with the provision of telecommunications services for the Ministry of Transport and Civil Aviation at the new Gatwick Airport.

Mr. Anderson has no time for affectation and has endeared himself to his staff by a human understanding of their problems and a willingness not only to lead, but to take part with characteristic enthusiasm in all the work of his group. His friends and colleagues everywhere wish him well in his new appointment.

A. H. C. K.

W. J. Bray, M.Sc.(Eng.), A.C.G.I., D.I.C., M.I.E.E.

William John Bray, who has recently been promoted to lead the newly formed Inland Radio Planning and Provision Branch (WI Branch), is a Portsmouth man.



On leaving secondary school he entered H.M. Dockyard as an electrical-fitter apprentice where he passed Intermediate B.Sc.(Eng.) and gained the Admiral Donaldson Prize as top apprentice of all yards. Then, on being awarded Royal and Kitchener Scholarships, he spent 4 years at the City and Guilds Engineering College where he obtained his B.Sc.(Eng.), 1st Class Honours, A.C.G.I., M.Sc.(Eng.), and D.I.C.

In 1934, Mr. Bray entered the Engineering Department as an Assistant Engineer (old style) by open competition, and, after a period of training, joined the Radio Laboratories at Dollis Hill where he remained until 1954, being promoted to Executive Engineer (old style) in 1942 and Assistant Staff Engineer in 1950.

He has had a wide experience of radio engineering development. He was directly concerned with the application of single-sideband techniques to the operation of long-distance h.f. radio-telephone systems, while he is now regarded both at home and abroad as an authority on microwave radio-relay and forward-scatter systems. He has the ability to acquire sound fundamental knowledge of all the branches of the art with which he has to deal, to lead his team ahead effectively and to record clearly what has been achieved. He has a fertile mind with many new ideas to his credit, including the "fading machine," which simulates radio-propagation effects; and although not patent-minded, he has taken out several patents, including one on a universal adjustable directional antenna, known as "Ada."

In 1954, Mr. Bray came to Headquarters to lead a rapidly growing section planning radio-relay systems for television and multi-channel telephony, and v.h.f. mobile systems. Three years ago he was awarded a Commonwealth Fund Fellowship for Advanced Studies and Travel in the U.S.A. He spent nearly 12 months in the U.S.A. visiting research and development establishments and finally made a road tour of some 12,000 miles with his wife.

He has contributed many papers to the Institution of Electrical Engineers, has been awarded the Institution, the Fahie and Radio Section Premiums, and is at present a member of the Radio and Telecommunication Section Committee.

Mr. Bray, despite his many commitments, finds time to enjoy himself; he is particularly fond of travel, colour photography and swimming.

H. S.

J. W. H. Freebody, Whit.Sch., B.Sc.(Eng.), A.C.G.I., D.I.C., M.I.E.E.

Mr. Freebody, who has been appointed Staff Engineer in charge of the new Technical Support Unit set up in connexion with developments in the field of automatic data processing, is one of a distinguished line of Post Office engineers who started their careers in H.M. Dockyards. On completing his education with distinction at the City and Guilds Engineering College (London University) he entered the Post Office as a Probationary Assistant Engineer (old style) in January 1933 and up to the time of his present appointment had served with the Telegraph Branch, Engineering Department, being promoted to Executive Engineer (old style) in March 1940 and to Assistant Staff Engineer in October 1947. Throughout this period of over 20 years he has covered all aspects of the development, provision and main-



tenance of telegraph services. He was at first concerned with the, then, new telex and private teleprinter services. Later he was actively concerned with the design of teleprinter services for defence, and his contribution to the rapid build-up and adaptation of teleprinter communications for the Services during the war was of noteworthy importance. All aspects of telegraphy—machines, switching, transmission on wire and radio—have since then come under his attention and no little benefit has accrued to the progress of the art in both the national and international fields from the deep interest and enthusiasm which he has always maintained in all branches of telegraphy. Coupled with his outstanding gifts as an engineer is a charm and friendliness of manner and generous willingness to co-operate and help which has brought him friends in many places, and it has, above all, been the good fortune of the Telegraph Branch to have had the benefit of his loyal and unstinting services through the years.

Mr. Freebody has made his mark in telegraphy not only at home but also in the C.C.I.T. (now the C.C.I.T.T.), where his services in connexion with the regulation and improvement of the technical methods used in international telegraph services were highly valued and will be greatly missed. He has contributed from time to time to the publications of the I.P.O.E.E. and has rounded off this phase of his career by recently completing the monumental task of revising and bringing up to date "Herbert's Telegraphy." His many friends while regretting the severance of old contacts will be more than pleased at his new appointment and their good wishes will go with him for the success which they are sure will attend it.

E. H. J.

G. N. Davison, B.Sc., D.I.C., A.M.I.E.E.

Mr. G. N. Davison took up his duties as the head of RA Division of Research Branch in July 1958, having been on temporary promotion since November 1957, in succession to Mr. W. West.

Mr. Davison was apprenticed to The Sunderland Forge and Engineering Co. Ltd., and took his degree after a

sandwich course at Sunderland Technical College. In 1932 he was awarded the Swan Memorial Scholarship of the I.E.E. and he proceeded to the City and Guilds Engineering College where he took a post-graduate course in electrical machines.

He entered the Post Office as an open-competition Assistant Engineer (old style) in 1933 and after training joined the Telegraph Section (now Telegraph Branch) where he obtained experience of all aspects of telegraphy, being promoted to Executive Engineer (old style) in 1941. In 1950 he was transferred to the RA Division of Research Branch as Assistant Staff Engineer, covering telegraph work and postal engineering. During this period Mr. Davison served on a number of C.C.I.T. Study Groups. In August 1956, when more effort had to be directed to postal mechanization, Mr. Davison was put in charge of the new section, and under his able guidance great progress has been made.



The Division that Mr. Davison now has in his charge probably has the greatest span of all the divisions of Research Branch, covering telegraphs, postal mechanization, acoustics and local line work. In addition it includes all the Dollis Hill services and workshop. He comes to the Division when new lines of thought in all the technical groups are being explored and we know that the direction he will give in his quiet but firm way will be backed by experience and high technical ability. In his dealings with staff he will be kindly and just. We wish him every success in what we know will be a full and interesting official life.

H. W.

A. Cook, B.Sc.(Eng.), M.I.E.E.

Mr. Cook, whose recent promotion to the post of Staff Engineer of RS Division, Research Branch, has delighted his many friends and colleagues, entered the Post Office via the open competition for Inspector in 1930 and became an Assistant Engineer in 1931. He holds a London University 1st Class Honours degree.



After serving his probationary period in the N.E. Region he was appointed Power Engineer at Newcastle-on-Tyne in 1932, whence after a few months he was transferred to the Radio Branch of the Engineer-in-Chief's Office. Here he was initially engaged on the development of high-power radio transmitters, but as a member of the planning section of the Radio Branch the scope of his activities rapidly broadened to include most applications of radio. He was promoted to Executive Engineer (old style) in 1938 and Assistant Staff Engineer in 1947.

During the war, he was largely concerned with the provision of radio services for defence and military purposes, and after the war with the major expansion of civil radio communications necessitated by the rapid growth of traffic. During the latter period he was responsible for the planning of the London-Birmingham and Manchester-Kirk O'Shotts television radio-relay links, the new radio stations at Burnham, Bearley and Rugby, and the Radio-Telephony Terminal at Brent; he

also took a keen interest in telegraph equipment for radio services, and found time to invent an error-detecting code for telegraph signalling.

For several years he has been actively engaged on international committees, in particular the International Radio Consultative Committee (C.C.I.R.), and in 1956 was elected International Vice-Chairman of Study Group III.

Mr. Cook will bring to his new job a wide and detailed knowledge of communications systems and equipment, a perceptive mind, and the ability to get the best out of his staff. He will carry with him the best wishes of his friends and colleagues who will sadly miss his ever ready help and advice.

L. L. H.

Awards by the Institution of Electrical Engineers

The Board of Editors notes with pleasure that the following members of the Post Office Engineering Department have been awarded premiums by the Institution of Electrical Engineers for papers published during the 1957-58 session:

G. H. Metson, M.C., Ph.D., M.Sc., B.Sc.(Eng.), A.M.I.E.E. The Kelvin Premium, for his paper, "The Conductivity of Oxide Cathodes."

F. H. Reynolds, B.Sc.(Eng.), A.M.I.E.E., C. B. Johnson, and M. W. Rogers. Radio and Telecommunication Section Premium, for their papers, "Growth of Anode-to-Grid Capacitance in Low-Voltage Receiving Valves," and "A New Method for the Detection of Thin Conducting Films in Thermionic Valves."

L. R. F. Harris, M.A., A.M.I.E.E. The Coopers Hill War Memorial Prize and Medal, for his paper, "Time Sharing as a Basis for Electronic Telephone Switching: A Switched-Highways System."

Change of Address

Communications about the Journal should in future be sent to the following address:

The Managing Editor,
Post Office Electrical Engineers' Journal,
G.P.O.,
2-12 Gresham Street,
London, E.C.2.

Book Review

"Mathematical Foundations of Information Theory."

A. I. Khintchin. Translated by R. A. Silverman and M. D. Friedman. Dover Publications Inc., New York. 120 pp. Paper cover. \$1.35.

If cumbersome transatlantic idioms like "As of the present . . ." be ignored, this is a very clear and well-presented translation of two papers entitled "The Entropy Concept in Probability Theory" and "On the Fundamental Theorems of Information Theory."

The prospective reader is, however, advised to consider the title very carefully before plunging. The author's aim is clearly stated in the first few pages to be the placing of the fundamental concepts of information theory on a rigorous mathematical basis, completely divorced from any appeal to

practical applications, and he is quite relentless.

That such an approach is needed, and that the work itself deserves the greatest respect, cannot be doubted. However, the reviewer is not perhaps alone among non-mathematicians in finding his attention flagging after several paragraphs of ingenious manipulation of symbols merely to demonstrate something which was intuitively obvious. Now and again, of course, intuition leads one fatally astray, and a major operation by a cold clear-thinking mathematician is required to clear up the mess.

The seeker after information theory who has been disquieted by the inconsistencies and lack of rigour in the writings of Shannon, for example, should certainly read the present work. Others may perhaps be excused for thinking that discretion is the better part of valour.

E. W. A.

Institution of Post Office Electrical Engineers

Mr. C. W. Brown, M.I.E.E.

The Institution mourns the loss of a good friend and a staunch colleague in the death of Mr. C. W. Brown on 5 July 1958, aged 72 years. Mr. Brown retired from the Post Office on 31 October 1949 after 45 years' service, being Staff Engineer in charge of the Telephone Branch of the E-in-C's Office at the time of his retirement.

His association with the Institution was a long and meritorious one. He served on Council, 1930-36 and 1938-49, being Treasurer 1946-49, and was Vice-Chairman of the London Centre Committee for the 1938-39 session. He will long be remembered for his great interest in the Associate Section of the Institution. He was a member of the committee appointed by Council in 1931 which recommended the formation of a Junior Section, and when the Junior (now the Associate) Section was formed in 1931, he served as the Section's first president, 1931-36. Mr. Brown applied himself wholeheartedly to the task of inaugurating the Section, the success of which was in no small measure due to the enthusiasm and organizing ability displayed by him during his occupancy of the presidency.

Mr. Brown was elected an Honorary Member of the Institution in 1949 in recognition of his considerable services. He maintained his interest in the Institution during his retirement, and his attendances at Senior and Associate Sections meetings were always welcome events for his many friends.

Change of Address

The new address of the Institution is:
The Institution of Post Office Electrical Engineers,
G.P.O.,
2-12 Gresham St.,
London, E.C.2.

Essay Competition 1958-59

To further interest in the performance of engineering duties, and to encourage the expression of thought given to day-to-day departmental activities, the Council of the Institution of Post Office Electrical Engineers offers five prizes, a first prize of 6 guineas and four prizes of 3 guineas, for the five most meritorious essays submitted by members of the Engineering Department of the Post Office *below the rank of Inspector*. In addition to the five prizes the Council awards five certificates of merit. Awards of prizes and certificates made by the I.P.O.E.E. are recorded on the staff docket of the recipients.

An essay submitted for consideration of an award in the essay competition and also submitted in connexion with the Associate Section I.P.O.E.E. prizes will not be eligible to receive both awards.

In judging the merits of an essay, consideration will be given to clearness of expression, correct use of words, neatness and arrangement, and although technical accuracy is essential, a high technical standard is not absolutely necessary to qualify for an award. The Council hopes this assurance will encourage a larger number to enter. Marks will be awarded for originality of essays submitted.

Copies of previous prize-winning essays have been bound and placed in the Institution Central Library. Members of the Associate Section can borrow these copies from the Librarian, I.P.O.E.E., G.P.O., 2-12 Gresham Street, London, E.C.2.

Competitors may choose any subject relevant to current telegraph or telephone practice. Foolscap or quarto size paper should be used, and the essay should be between 2,000 and 5,000 words; an inch margin is to be left on each page. A certificate is required to be given by each competitor, at the end of the essay, in the following terms:—

"In forwarding the foregoing essay of..... words, I certify that the work is my own unaided effort both as regards composition and drawing"

Name (in Block Capitals).....

Signature

Rank

Departmental Address.....

.....

Date

The essays must reach

The Secretary,

The Institution of Post Office Electrical Engineers,
G.P.O.,

2-12 Gresham Street,

London, E.C.2.

by 31 December 1958

The Council reserves the right to refrain from awarding the full number of prizes or certificates if in its opinion the essays submitted do not attain a sufficiently high standard.

Review of Prize-Winning Essays— 1957-58 Competition*

The Council of the Institution is indebted to Mr. W. S. Procter, M.I.E.E., F.R.S.E., Chairman of the Judging Panel, for the following review of the five prize-winning essays:—

The first prize was awarded to Mr. J. G. Philip, Technical Officer, Aberdeen, for his essay, "Public Speaking in Relation to the G.P.O. Engineering Department." The Panel of Judges was much intrigued by his skilful presentation of his subject through the introduction of John Brown, who was troubled by a particularly tricky intermittent fault condition and was sure that he had heard about this very difficulty somewhere or other. He had—at an Associate Section meeting addressed by Fred Smith who, unfortunately, had not been able to hold and impress his audience because he had neither studied nor practised the art of presenting a technical subject to an audience of his fellow engineers. The author then goes on to deal with the various factors that are of importance in public speaking and he makes some useful suggestions whereby practice may be obtained.

The second prize went to Mr. R. J. Lukehurst, Technical Officer, Canterbury, for his essay on "Inter-Departmental Staff Relations." The author sets out to portray what various sections of the staff feel about their colleagues in other Groups and Departments, and he illustrates his theme in a series of vignettes taken from his own experiences. He directs attention to the need not only for understanding the other man's point of view but also for appreciating the part that he plays in the vast organization of the Post Office. He concludes with some very useful comment on the relationship between staff and their supervisors.

The third prize was awarded to Mr. K. O. Verity, Technical Officer, Long Distance Area, for his essay on "Telecommunications and Atomic Energy." The author deals, not with atomic energy as applied in the generation of electric power, but with the use of radioactivity in furthering the solution of problems encountered in telecommunications engineering. The essay does not lend itself readily to a short summary, but the author deals, amongst other things, with the testing of repeater sealing glands, the irradiation of polythene to improve its physical characteristics whilst leaving its electrical properties substantially unchanged, and the treatment of germanium to reduce the impurities contained in it.

Mr. T. A. D. Clark, Technical Officer, Colchester, was awarded the fourth prize for his essay "The Technical

*The full list of Awards was published in the *P.O.E.E.J.*, July 1958, p. 151.

Officer, the Youth-in-Training, and the Manual Exchange." The author's subject is the part played by a Technical Officer in giving practical training on manual exchange construction work to a youth. He shows how the interest of the youth is maintained by first giving him the more simple and straightforward work to do and then leading him gradually to the more skillful work. He points out the desirability of having the youth working alongside the man who is training him. He deals, too, with the qualities desirable in the engineer called upon to give training to youths.

The fifth prize was awarded to Mr. J. A. Armitage, Technical Officer, Preston, for his essay "The Electronic Random Number Indicating Equipment." This is a well written and very good description of the equipment known to all as ERNIE.

S. WELCH, *Secretary*.

Additions to the Library

Note: Library requisition forms are available from Honorary Local Centre Secretaries, from Associate Section Centre Secretaries and representatives, and from the Librarian, I.P.O.E.E., G.P.O., 2-12 Gresham St., London, E.C.2.

- 2492 *Interview Case Studies*. J. M. Fraser (Brit. 1957).
Illustrates and carefully analyses actual and specimen interviews, abstracting the facts to be deduced from each, and tabulating the conclusions in a logical and clearly defined manner.
- 2493 *Project Satellite*. K. W. Gatland (ed.) (Brit. 1958).
The development and possible future of artificial satellites—by four leading experts.
- 2494 *Radio and Television Servicing (1957-58 Models)*. E. Molloy (ed.) (Brit. 1958).
Contains circuits and servicing data for the 1957 and 1958 sets.
- 2495 *Fundamentals of Electron Devices*. K. R. Spangenberg (Amer. 1957).
A unified fundamental treatment of electron

devices including vacuum tubes and transistors, with emphasis on their similar features rather than their differences through the common denominator of semiconductor theory.

- 2496 *Sputnik into Space*. M. Vassiliev and V. V. Dobronravov (Russian 1958).
Covers every aspect of interplanetary flight, the successes so far achieved, and the next steps in active preparation for the immediate future.
- 2497 *The Sources of Invention*. J. Jewkes, D. Sawers and R. Stillman (Brit. 1958).
A study of the causes and consequences of industrial innovation.
- 2498 *Elementary Nuclear Physics*. W. K. Mansfield (Brit. 1958).
A concise summary of the terminology and essential principles of nuclear physics, designed to enable the specialist engineer or scientist in another field to understand the language and arguments of physicists.
- 2499 *Nuclear Reactor Theory*. J. J. Syrett (Brit. 1958).
Gives an outline of the physics of reactor design, including the fission chain reaction, the concept of critical size, etc.
- 2500 *Magnetic Tape Recording*. H. G. M. Spratt (Brit. 1958).
A description of the basic principles of magnetic recording and the enumeration of the characteristics of both medium and machine.
- 2501 *Telecommunications Economics*. T. J. Morgan (Brit. 1958).
Describes comprehensively many of the factors and procedures which are generally applicable, in the experience of the British Post Office, to the economic engineering of a telecommunications system.
- 2502 *Elementary Telecommunications Practice*. J. R. G. Smith (Brit. 1958).
Meets the needs of students in this subject, and includes a set of specimen answers to typical C. & G. questions.

W. D. FLORENCE, *Librarian*.

Book Review

"A Guide to Plastics." C. A. Redfarn, B.Sc., Ph.D., F.R.I.C. Second edition. Published for *British Plastics* by Iliffe & Sons. 150 pp. 45 ill. 18s.

In the preface to the first edition (1951) the author says "This book is *not* a conventional textbook but rather a condensed guide to plastics for the reader who wants some general information on what plastics are and what they can be used for. With this object in view chemical formulae have been avoided and technical terms have been used as sparingly as possible." In the preface to the present (second) edition (1958) "considerable additions and emendations have been made" on account of the rapid expansion of the plastics industry in the production of new types of material.

If one adds to the above that since the raw and intermediate materials used in making plastics are chemicals, it is inevitable that there is a sprinkling of chemical words in the book, the prospective reader has from these paragraphs a fair idea of the nature of this book.

The author has used his 150 pages in the following way: Plastics Nomenclature (9 pages); Raw Materials for Plastics (7 pages); The Manufacture of Plastics Materials (which might also have been called "What Plastics are and what they are used for") (58 pages); The Fabrication of Plastics (57 pages); The Properties of Plastics (8 pages);

Bibliography (2 pages); Index (8 pages); which seems a very reasonable distribution.

The chapter (Chapter 5) on the (quantitative) properties of plastics is very sketchy, but on the other hand a good deal of information on the properties in the broader (qualitative) sense is given or implied in Chapter 3 when describing what the individual plastics are used for. No electrical property is mentioned in Chapter 5 other than dielectric strength, but again a useful impression of the electrical properties is given in general terms in Chapter 3 for the more important plastic insulating materials.

As a measure of the book's comprehensiveness and up-to-dateness in giving answers to the question "What is this plastic, and what is it used for?" the reviewer tested it on polyethylene terephthalate, polytetrafluoroethylene (p.t.f.e.), polychlorotrifluoroethylene (p.c.t.f.e.), silicones, polyurethanes, epoxy resins, polypropylene and polycarbonates, and in all cases except the last a useful answer was obtained, the number of lines allocated to each one being 19, 33, 3, 95, 15, 2, 0. Actually p.c.t.f.e. was indexed under "Chloro-fluoropolymers."

The chapter on fabrication (Chapter 4) deals with compression moulding, moulds, presses, heating, preforming, transfer moulding, injection moulding, finishing, inspection and salvage, and extrusion.

To sum up it can be said that this is a useful little book which achieves quite well the modest aim outlined in the first paragraph.

A. A. N.

Regional Notes

Home Counties Region GATWICK AIRPORT

On 9 June 1958 Her Majesty the Queen inaugurated the first stage of the new Gatwick Airport, which has been built between Reigate and Crawley New Town across the old A23 London-Brighton road and on the site of the old Gatwick Race Course. The inauguration also marked the culmination of a long period, about 2½ years, of planning and execution work by the Post Office on the initial telecommunication requirements.

The communication needs of a modern airport are very complex but can be considered as a number of practically independent networks. Those in which the Post Office was involved at Gatwick were (a) a telephone system covering the requirements of the Ministry of Transport and Civil Aviation, the airline operators and those requiring facilities on the airport, (b) an operational telephone system including emergency, fire and police services, (c) a telegraph signals centre, (d) the navigational aids, (e) an air-traffic control system, and (f) a passenger-handling control system. The facilities provided were designed to cater for rapid expansion with the expected growth of air traffic and further stages of development of the airport.

The variety of the requirements meant that the responsibility for the engineering work was divided between the Tunbridge Wells Telephone Area, the Home Counties Region, the various Branches of the Engineering Department and to a lesser extent the Brighton Telephone Area. Considerable co-operation in wide fields in the architectural, civil and electrical engineering, as well as telecommunications, aspects was necessary between the Post Office and the Ministry of Transport and Civil Aviation (M.T.C.A.), their consultants and various contractors. As might be expected with a project of this magnitude, many difficulties and delaying factors arose. Nevertheless, the work was completed on time to the considerable credit of all who were involved.

Telephones

Briefly stated, the telephone requirements were for an automatic system linked for inter-dialling with a similar system at London Airport, so that sudden peaks of traffic, caused for example by the need to divert aircraft due to fog, can be handled rapidly at any time of the day or night. The automatic equipment was also required to handle all "On Airport" traffic, including that from all telephone users on the airport (except that from the call-offices) and London director-network calls from selected telephones. An associated manual board, staffed by M.T.C.A. operators, would cover assistance traffic and control trunk telephone calls. Outlets to the local public exchange at



EARLY STAGE OF THE CONSTRUCTION OF THE NEW TERMINAL BUILDING, SHORTLY BEFORE THE INSTALLATION OF POST OFFICE EQUIPMENT

Horley were required for traffic to local services, which were expected to grow with the airport.

A P.A.B.X. No. 3 met all requirements and was manufactured and installed in the unusually short time of 9 months by special arrangement with the Post Office contractor. In order to complete this exchange in time it was necessary to locate it in the first part of the new terminal building to be erected. The fact that the equipment was thus housed in a partially completed building, which throughout the whole of the construction of the airport was surrounded by intensive civil engineering works, added considerably to the work involved. Considerable use was made of polythene sheeting to cover equipment and as "water shoots." The Post Office accommodation had constantly to be dried out, in the first place with a "Chinook" heater and later with electrical heaters. Whilst work was successfully carried on in order to meet the required ready-for-service date, there is no doubt that every effort should be made to avoid installing equipment under such conditions in future.

The P.A.B.X. equipment consists initially of 20 switchboard positions and 1,200 extensions, with provision for 37 positions and 2,000 extensions ultimately. There is a supervisor's desk and two inquiry positions (four ultimately). Connexion with the London director network is via out-of-area exchange lines to Livingstone exchange, with joint access for the Gatwick operators. The P.A.B.X. operators have separate access to the London trunk network. A number of private wires are provided to M.T.C.A. Headquarters in London, to their Croydon P.B.X. and to other places.

An extensive block wiring system with ingenious features for routing cables and housing terminal blocks has been provided in the terminal building and other major buildings on the airport. This provides for all telephone, telegraph, and miscellaneous requirements, and was designed by the Tunbridge Wells Telephone Area in collaboration with the architect, and is co-ordinated with other distribution systems.

About 40 call offices have been installed in the terminal building, public enclosures, car parks and the railway station, and work direct to Horley and Horsham exchanges.

Airport Operational Telephone and Emergency System

The first two positions of the P.A.B.X. manual board are used solely for handling airport operational traffic, which is segregated from ordinary telephone traffic to ensure independent functioning of the operational services. The operator can receive calls from the airport, fire, police and air traffic controller's extensions and by means of direct circuits can connect them to London Airport control tower, Southern Air Traffic Control Centre and a number of civil and R.A.F. aerodromes.

The airport emergency procedure and communications are controlled by a special supervisor in the P.A.B.X. switchroom. She sits at a separate console upon which a keyboard concentrates lines from the M.T.C.A. fire service and police, the fuel farms, and from other strategic points on the airport, together with private wires to outside public emergency services and exchanges. Any P.A.B.X. extension dialling 222 is routed to this keyboard.

A small cordless P.B.X., on which are concentrated various crash and emergency lines and a direct line to Reigate Fire Service, has been provided in the fire station watch office close to the control tower.

M.T.C.A. constabulary are provided with a G.P.O. police alarm (P.A. 450) installation which has a number of street pillars located around the airport at "rendezvous" points.

Telegraphs

To deal initially with messages originated at or destined for the various teleprinter stations on the airport, con-

ventional tape-relay equipment has been provided in the M.T.C.A. Signals Centre, but to afford improved message-handling facilities consistent with modern aircraft speed it is intended to introduce, on the completion of trials, a completely new semi-automatic message-routing system. The system, which has been given the name STRAD, employs electronic switching and magnetic-drum storage. It includes a number of features to facilitate the handling of traffic and is capable of very high transit speeds.

In addition to the teleprinter stations associated with the semi-automatic message-routing equipment, various other services, e.g. Air Ministry meteorological information and airline operating companies' private-wire teleprinter circuits and/or telex services, have been provided.

Long-distance telegraph circuits are routed over voice-frequency telegraph channels working to London Airport, the M.T.C.A., Croydon Signal Centre and into London (Kingsway).

To safeguard against any break in message transmission, special power facilities were necessary to cover failure of the supply mains. The standby power supply is derived from an automatically-started diesel-driven alternator, special equipment of new design being used to provide the no-break facility.

Air Traffic Control

The Aerodrome Approach and Outbound Radar Controllers and their assistants, together with two Radar Directors, all of whom are located in the Control Tower, must maintain close liaison with each other and with adjacent airfields and air traffic control centres. Whilst they can use the airport operational system they are also provided with direct access via an independent private-wire network.

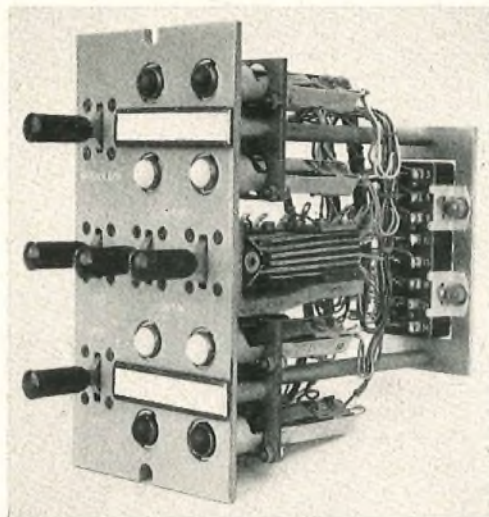

AIR-TRAFFIC-CONTROL TELEPHONE KEYBOARD

A new type of keyboard equipment has been developed by the Post Office in conjunction with the M.T.C.A. to match the new standard 5½ in. × 3 in. panels now used in the various controllers' consoles. The keyboard is built up of a number of unit panels dependent upon requirements. One panel has facilities for various control keys and four lines whilst the other type can take six lines. Connexions to the panel are via plugs and sockets for rapid replacement and ease of maintenance.

Passenger Handling Control

In order to ensure efficient passenger handling, a special control centre has been installed in the Marshall's Tower. The Controlling Officer is in direct touch by loud-speaker with the various staffs concerned with the arrival and departure of passengers and aircraft. The system uses

loud-speaking telephones controlled from a press-button panel. The slave loud-speaker units employ transistor amplifiers which permit normal level of speech to line. Two such systems have been provided, one for the M.T.C.A. and the other for British European Airways.

External Work

The completion of Post Office work in connexion with the diversion of A23 has already been mentioned in an earlier note.* At a late stage the M.T.C.A. decided that it was necessary to convert a long length of the diversion into double-track road. This meant widening the verges, one of which carried the new Post Office underground plant, which was by this time carrying off-airport circuits. By careful planning, the new kerb line was kept just clear of the lead-in manhole, but about 1,000 yd of 8-way duct (laid 4 over 4) and manholes were affected. So that the work could be completed in time for the official opening of the airport, it was agreed that the road widening contractor should break away the top 4-way duct, which was unoccupied, and adjust the manholes accordingly. This solution gave just sufficient depth for extending the road foundations. As road traffic was already heavy the cables were left in position in the bottom 4-way duct until after the summer traffic peak, when the necessary readjustment of the track could be made more easily and without risk to the airport opening.

The perimeter cable, serving the 18 navigational-aid and the v.h.f. radio transmitting and receiving station sites, encircles the 7,000 ft single runway in two main loops in a rough "figure-of-eight" formation focused on the control tower opposite the middle of the runway.

A unique feature for airfield cables is that, at Gatwick, they are to be pressurized, with pressure-failure alarms in the control tower P.O. equipment room. Another special feature is that an improved cable termination and plug-in device for circuits to the ground-control-approach caravans has been jointly developed with, and at the instigation of, the M.T.C.A. The device is weather-proof and incorporates a heavy-duty naval fire-control type of switch for positive change-over to alternative routing.

Some miles of various types of cable were provided for P.A.B.X. extensions and for the fire alarm posts, kiosks, etc., distributed throughout the terminal area, the maintenance area and the airfield.

In all over 15 miles of duct were laid, over 40 miles of cable provided and 8 miles of cable recovered, not accounting for the circuits required for serving such items as navigational aids and hazard beacons, situated some way from the airfield, and for long-distance circuits.

It has not been possible in this Regional Note to quote much detail of the work or to relate the many difficulties that arose and how they were overcome. It will, perhaps, suffice to say that the main sources of difficulty were firstly the ground conditions—wet and unconsolidated clay in



SURFACE JOINT-BOX DAMAGED BY LEVELLING MACHINE

* "Gatwick Airport." *P.O.E.E.J.*, Vol. 50, p. 200, Oct. 1957.

which one could sink to the knees in places, secondly, mechanical aids used in earth digging, which on numerous occasions damaged newly laid duct and cable, and, thirdly, water and dust in the P.A.B.X. apparatus room. It should be recorded that the Tunbridge Wells staff tackled these difficulties and setbacks with typical determination and enthusiasm.

By the time this note appears the whole of the plant will have been handed over to the Brighton Area for maintenance and future development—the Horley exchange area having been transferred to the Telephone Manager, Brighton.

E. W. A.

Wales and Border Counties TELECOMMUNICATION ARRANGEMENTS FOR THE SIXTH BRITISH EMPIRE AND COMMONWEALTH GAMES

The organization of the British Empire and Commonwealth Games held in Wales between 18 and 26 July 1958 has been widely acclaimed, and the following is a brief account of the communications arrangements which contributed to the success of this important occasion. As with all such events, the communications requirements became known gradually as the organization of the Games and the selection of venues proceeded, and co-ordination and preliminary planning work were continuous over the two preceding years.

Nine sports were included:—athletics, boxing, swimming, fencing, weightlifting, rowing, lawn bowls, wrestling and cycling. With the exception of the rowing held at Lake Padarn, near Snowdon, and the road cycle racing on the Ogmores-Ewenny-Southerndown circuit, the sports were held in Cardiff and its immediate vicinity—among the principal venues being Cardiff Arms Park (athletics), the Wales and Empire Pool (swimming), Maindy Stadium (cycling) and Sophia Gardens, Cardiff (boxing and wrestling). The competitors and officials were housed in the Empire Games Village at St. Athan, 17 miles from Cardiff.

The communication needs at practically all venues came under four headings:

- (a) Games organization and control of events.
- (b) Press.
- (c) B.B.C. and I.T.V.
- (d) Public services.

At Cardiff Arms Park the arrangements comprised exchange lines for use by Games officials, internal telephones for use by officials in control of actual events and ceremonial functions, communications for dissemination of results, public address system, mobile radio links, timing and photo-finish, and circuits for B.B.C., I.T.V. and Press. A multiphone board was provided for ceremonial purposes

whilst a $\frac{10 + 30}{65}$ switchboard was used to give internal communication between the various starting and finishing points, the field-event judges, the dressing room, stewards, jury of appeal, warming-up area and recorders to enable the Games and Ceremonials to be controlled.

The main objective in the news communications was of course the dissemination of results to all interested parties as quickly as possible, and a vital link in this was a "round-robin" teleprinter network. This was essentially a teleprinter omnibus circuit with teleprinters in the Cardiff Arms Park, British Empire Games Headquarters, Press Centre, Maindy Stadium, etc. Immediately results were approved by the Controller of the Games they were passed over the "round-robin" network by the teleprinter operator. At Games Headquarters they were recorded for the official record and for use in preparation of the subsequent day's program. At the Press Centre in Cardiff, 400 copies were made and posted immediately in each press correspondent's letter box at the Centre. A new feature introduced in Games organization at the Cardiff Arms Park was a

news-flash alarm circuit which, when operated, served to warn about 200 Press representatives in the Press Stand that an announcement was imminent. The representatives heard the announcement in a headgear receiver which was provided at each press seat.

Direct exchange lines, private wires, sound and television circuits were provided for the B.B.C. and I.T.V. at the principal venues in accordance with their requirements.

Two new exchanges were opened exclusively for the occasion. Five positions on the auto-manual switchboard at the Cardiff automatic telephone exchange were set apart to comprise the Empire Games exchange. Empire Games subscribers were connected to uniselectors and then to group selectors, special 0-level traffic facilities being provided between these group selectors and the five manual positions. The other exchange, which was specially installed at the Empire Games Village, was a 4-position C.B. exchange for use by British Empire and Commonwealth Games officials, team managers and their assistants for the management of the village and organization of the Games. Forty-four junctions on various routes to Cardiff were provided from the Empire Games Village exchange and proved adequate to deal with the largest volume of traffic.

Post Office Cable and Wireless arrangements at the Press Centre, at Empire Games Village and in a mobile van immediately adjacent to the Cardiff Arms Park established efficient communication to overseas newspaper offices in Australia, New Zealand, South Africa, Canada and elsewhere.

Wherever possible, external cabling work required for the Games was co-ordinated with local line development needs. In particular, it was found economical to advance cabling in the immediate vicinity of the Cardiff Arms Park to provide the main exchange cable needs of the principal venues. For example, a 1,200 pr., 4 lb/mile unit-type cable for the Wood Street area of Cardiff was provided and used for the Wales and Empire Pool, B.B.C. Control, Press Centre, Games Headquarters and other needs. Subscribers' development cables for St. Athan exchange were provided in advance of requirements and used for extending the Cardiff junction circuits to Empire Games Village. Polythene cable was used throughout in Cardiff Arms Park, where it was found possible to provide all requirements with only two cable joints. This type of cable is ideal for such purposes, provided regard is paid to its protection from such hazards as javelins, running-shoe spikes, etc.

The amount of work involved can be gauged by the fact that approximately 2 miles of lead-sheathed cable and 8 miles of polythene-sheathed cable were provided, the latter being recovered at the conclusion of the Games. One hundred terminal blocks were fitted, approximately 5,000 wires jointed and 5,000 wires terminated. A total of 82 call offices, including 32 kiosks, were installed and 179 direct exchange lines were provided for the Games' needs and 104 for the Press.

The success of the arrangements can be attributed to good team work on the part of all staff concerned, administrative, traffic, sales, engineering and clerical alike, while the engineering work in the field was of the highest order.

W. H. D.

INSTALLATION OF FOUR SPUN CAST-IRON PIPES ACROSS THE RIVER TAFF AT PONTYPRIDD

The provision of a multi-way duct from the Pontypridd automatic exchange presented a difficult problem. Conventionally it would have followed the main thoroughfare, a narrow winding street which carries the main flow of traffic between Cardiff and the industrial Taff and Rhondda Valleys.

Such was the congestion of services in the highway that the possibility of laying a multiple-way duct without extensive alteration to plant already existing was slight. The interference with traffic could only have been very

severe and the cost of the work high. The alternative, to lay the duct across parkland behind the exchange, was attractive but presented its own interesting problem, that of laying a multiple-way duct across the bed of the River Taff, at that point some 75 ft wide and normally about 2 ft deep.



LAYING CAST-IRON PIPES ACROSS THE RIVER TAFF

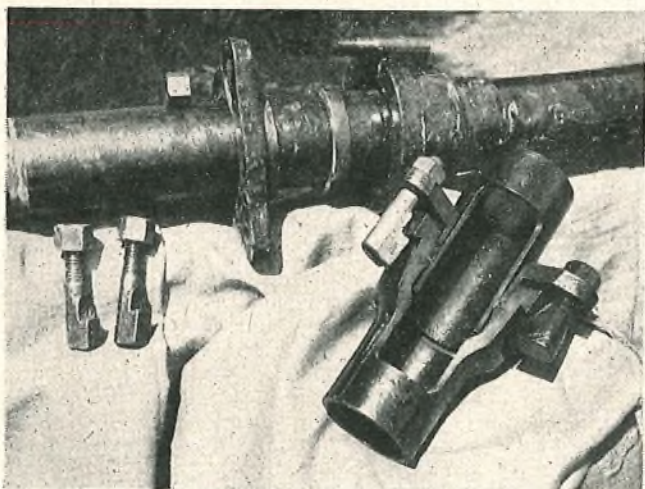

In the foreground is a sectional view of the completed joint and, behind it, the assembly of parts on a spigot and socket prior to tightening the nuts to form an airtight joint

CAST-IRON PIPE AND JOINTS

To guard against ingress of silt, mainly coal dust, the specification required that each duct-way should, on completion, withstand and maintain for 48 hours a pressure of air of 30 lb/in². As each length of pipe was laid the contractor sealed the ends and, using a bulldozer, formed fresh dams ahead and moved forward his battery of pumps.

The contractor chose to begin work in May, counting on a low level of water, but May proved to be the wettest on record. To add to the obvious difficulties, a torrential storm in the hills raised the river level by 5 ft overnight on one occasion. The pumps were overturned and submerged, and the contractor was busy overhauling them for some time before a restart could be made. The whole operation lasted five weeks.

T. A. J.

Midland Region

NOTTINGHAM TRUNK MECHANIZATION

The new Telephone Building, Brook Street, Nottingham, was ceremoniously opened on Wednesday, 23 July 1958 by



TELEPHONE BUILDING, NOTTINGHAM

the Lord Mayor of Nottingham accompanied by the Lady Mayoress, the Sheriff of Nottingham and the Sheriff's Lady, in the presence of a gathering of local visitors.

The building is of somewhat unusual architectural interest from a Post Office point of view, in as much as the ground floor is used as a Corporation wholesale fruit market and the upper four floors are used to house telecommunication equipment, whilst below, a very large basement is also used for telecommunication equipment. The total cost of the building and the equipment approaches the £2,000,000 mark.

The basement accommodates the whole of the Nottingham repeater station, with its associated power equipment, and one trunk switching unit, known as Outlaw, together with its own power equipment. Also in the basement there are three 400 h.p. diesel-engined generator sets which can, if necessary, provide power for the whole of the building. The large ventilating and air-conditioning plant is accommodated in the basement. On the upper floors there are another trunk switching unit, known as Falcon, the junction tandem exchange, a manual room housing 100 switchboard positions and the usual welfare offices for such a building. There is space on the first floor for a local automatic unit with a maximum capacity of 10,000 lines. By the end of this year the building will be fully operational and the local automatic exchange will have been opened with an initial multiple capacity of about 6,000.

It is some two and a half years since the equipment contractors first moved into the building and everybody concerned is experiencing a sense of real achievement as the equipment is brought into use. To start from scratch with a brand-new building and to fully equip it with modern telecommunications equipment is something which happens only rarely in one's official lifetime and the staff of Nottingham are very proud indeed of this latest addition to the telephone system.

The operation has involved much hard and detailed work on the part of many people and all are to be congratulated on achieving such trouble-free transfers. Willing co-operation has been forthcoming from all the distant-end stations affected and the Nottingham staff are very happy to pay tribute to the efforts of all who have assisted in the testing and transferring of the many hundreds of circuits which are now routed via the new building.

E.H.P.

DAMAGE TO UNDERGROUND CABLES

During widening of the Winchester-Preston A34 trunk road at Trent Vale, 2 miles south of Newcastle under Lyme, a 3-way earthenware duct containing three main underground cables was torn up by a mechanical excavator, which was being used to prepare the new road foundations.

The Birmingham-Manchester No. 2 cable (which includes four coaxial pairs), Birmingham-Stoke No. 1 cable, and the Macclesfield-Stafford cable were all badly mutilated. The coaxial cable, which carries permanent



DAMAGE TO CABLES AT TRENT VALE

program links between the Independent Television Authority's Program Contractors' Birmingham and Manchester studios, was almost completely severed.

The damage occurred at 3.30 p.m. and, by the use of mobile radio-telephone, contact was quickly established with two pairs of maintenance jointers, in different localities, and they arrived at the site of the damage within half an hour of the occurrence. The start of repair work was delayed by an adjacent leaking gas main which had to be sealed before the jointers could work in the excavation. Short lengths of interruption cable were inserted into each coaxial pair of the television cable, enabling service to be restored just in time for the evening transmission. Temporary repairs to the other cables followed, and to avoid any unnecessary hold-up of the road works all cables were permanently reinstated within four days of the date of the damage. E. V. P.

UNUSUAL CIRCUITS FOR THE NATIONAL COAL BOARD

The National Coal Board recently enlisted the assistance of the Post Office in providing circuits for a demonstration, arranged in connexion with a meeting of the Institution of Mining Engineers at the Imperial Hotel, Birmingham, on 2 July. The demonstration was used to illustrate an address entitled "Communication in Coal Mines," and showed the audience how pit-cage movements could be recorded and displayed at a central point.

The National Coal Board had installed an experimental accelerometer and associated recording equipment at the Jubilee Colliery, West Bromwich. This equipment enabled them to record the instantaneous acceleration and deceleration of the pit cage as it was wound up and down the shaft. An ancillary tachometer on the winding engine enabled a second channel of the recorder to indicate the instantaneous velocity of the cage. For the demonstration, it was desired to have the recorder at the Imperial Hotel, where the Institution was to meet, and to project an image of the recorder and its chart on to a screen, using an epidiascope.

The accelerometer consisted of a battery-operated oscillator mounted in the pit cage, having a spring-loaded slug moving in the oscillator coil according to the acceleration or deceleration, so frequency modulating the oscillator some 20 kc/s either side of the nominal frequency of 100 kc/s. The oscillator output was fed to the winding cable, the pit shaft itself acting as the return leg of an enormous single-turn loop coil. A toroidally wound "horse collar," series tuned to 100 kc/s and surrounding the winding cable at the pit head, picked up the oscillator signal and fed it to an amplifier/discriminator, the output of which fed the first channel of the recorder.

The problem was to extend the connexion between the pick-up coil and the discriminator by some $8\frac{1}{4}$ route miles of mixed 4, $6\frac{1}{2}$, and 10 lb/mile local cables and 40 lb/mile junction cable. Fortunately, the Amplifier 98A, used on television outside broadcasts, was able to cope with the 38 db loss at 100 kc/s, although the very low level of the signal received from the pick-up coil, only 8 mV, made it necessary to use a second amplifier at the colliery end of the circuit.

In contrast to the accelerometer signal, the signal from the tachometer was 25 volts, 400 mA, d.c., operating the second channel of the recorder directly. The loop resistance of the circuit, 1,050 ohms, was a little too great to enable the recorder to be operated direct from the circuit, so a d.c. amplifier was constructed to give the required current variation when biased by the open-circuit voltage on the line.

During the testing of the circuits an unaccountable but reproducible step in the recorded trace from the tachometer circuit was found to be due to the National Coal Board control engineer at the colliery switching between two scales on the tachometer as the engine speed approached a full-scale reading on his instrument—without mentioning it to anyone.

A control circuit with associated amplifiers and loud-speakers enabled the demonstrator to direct the various operations at the pit head from the auditorium, and the winding operator was able to describe the progress of the operation, to the accompaniment of the clanging of the ancient steam winding engine. The demonstration was applauded as the highlight of the meeting. J. H. S.

CABLING IN STEEL WORKS

An unusual hazard has been encountered at Round Oak Steel Works, Brierley Hill, where Post Office cables have been adversely affected by abnormally high temperatures. It is necessary to have telephones at strategic points inside the works, primarily for emergency purposes, and the only practical cable runs are on overhead girders. The passage of red-hot metal at some considerable distance below has little effect on the cable unless a stoppage occurs, in which event the heat rising from the metal is considerable, and has caused failure of braided and compounded cable, paper-cored cable and polythene cable by scorching, burning or melting. Asbestos-covered flex has also failed.

A locally purchased mineral-insulated cable having twin copper conductors embedded in magnesia has now been installed experimentally. The cable is copper sheathed, and is suitable for use in temperatures of up to 250°C. It will withstand heat up to the melting point of copper, for short periods.

Special terminating glands are used with the cable, and joints are made in electric-light conduit boxes. The cable is as pliable as its lead-sheathed Post Office equivalent, and installation presented no great difficulties. On completion of the work the insulation resistance was practically infinite and transmission was satisfactory.

E. L. A. and R. G. T.

LIGHT-WEIGHT DROP-WIRE CONSTRUCTION

The recent announcement of the extension of field trials of light-weight drop-wire, which began in 1954, makes it opportune to refer briefly to trials which have been under way in the Midland and other Regions for some years. Use of a light-weight plastic-insulated drop-wire was first considered by the Midland Region in 1951, and a suitable cable was manufactured and purchased locally in 1954. The cable had 20 lb/mile cadmium-copper conductors and a p.v.c. sheath of double-D cross-section, the two flats of which were connected by a thin web to facilitate separation. Early supplies of the cable were obtained in clear p.v.c. to make the cable as inconspicuous as possible, but, as there was some doubt about the life of clear plastic when exposed to

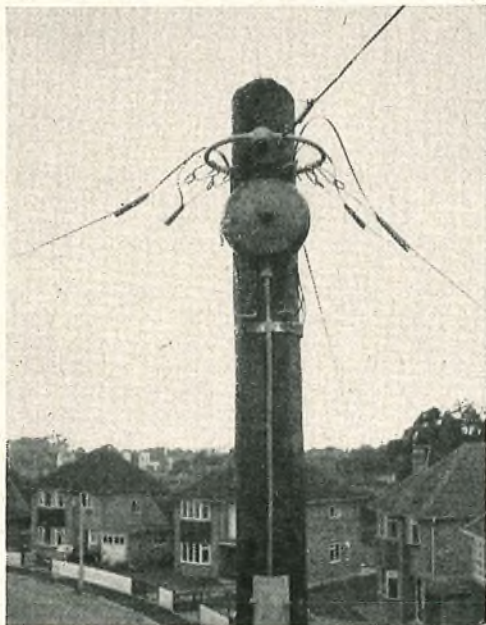

LIGHT-WEIGHT DROP-WIRE TERMINATIONS ON DISTRIBUTION POLE

sunlight, later supplies were obtained with black p.v.c. insulant.

The cable proved more robust than was at first expected, and various special fittings that had been designed to prevent abrasion were found to be unnecessary. The only items now used are special wedge-type drop-wire clamps for supporting the cable, a small bracket for attaching clamps to houses or poles (the existing Bracket No. 22), a simple pole head in two halves, secured to poles by an arm-bolt, and hooks for attaching the clamps to the pole head. The pole head is fitted in the top arm-bolt hole of poles, with the terminal block mounted below, as shown in the photograph. Consequently, shorter poles than hitherto can be used in some cases, and due to the low tension at which the wire is erected, economy in the class of pole used is often possible.

This type of construction has been employed in conditions where open wires would normally be used; its appearance has not been unsatisfactory, and it has been acceptable to the public and local authorities. The cable has been made as small as possible, and the simplicity and small size of fittings at poles and houses considerably improves appearance. It is also being run systematically between poles with 6 in. vertical spacing on each side of the poles. Radial distribution from all poles is from the new pole head, and subsequent rearrangement of overhead wires is eliminated should the intermediate poles later be converted to distribution poles.

Trials have also been made of a 3-conductor drop-wire for use in residential areas with a predominance of shared-service subscribers, to eliminate the provision of an earth connexion at each house. The earth connexion is extended back via the third conductor to a terminal block with a common earth at the distribution pole.

R. G. T.

South Western Region AN INSULATED AERIAL CABLE AND 33 KV LINE CROSSING

It was noticed that, while great savings have been effected in providing protection to Post Office overhead plant from high-voltage lines up to and including 11 kV by using plastic-sheathed wires or aerial cables, costs were steadily increasing in the South Western Region, where large numbers of wires and aerial cables have to be protected from 33 kV lines. No cheap method of protection at 33 kV crossings is available, except in the case of light Post Office routes where Wire, Cadmium-Copper, 70 lb, H.V. may

be used; costs are very heavy by comparison with the lower-voltage protection. On one particularly difficult crossing at Harpers Hill, Totnes, the estimated cost of protection by providing underground plant approached £500, and in consequence a cheaper form of construction was suggested by Exeter Telephone Area, although the Electricity Board were quite willing to pay the estimated cost in this case. The methods suggested by the Area were not wholly acceptable but the problem led to a series of discussions in September and November 1957 between the South Western Electricity Board, the External Plant and Protection Branch of the E.-in-C.'s Office, the South Western Region and the Exeter Telephone Area.

The outcome of these discussions, and an investigation on site, resulted in a proposal for the Post Office to erect two spans of polythene-insulated self-supporting aerial telephone cable and for the Electricity Board to insulate its 33 kV lines at the crossing by using a conductor sheathed with green p.v.c.

An investigation into the breakdown voltages of lengths of standard "green wire" with a 60 mil sheath and lengths of p.v.c. insulated aerial cable, when in intimate contact, showed that the combination was capable of withstanding voltages up to 70 kV for nearly 10 min and gave promise of being one solution to the problem. Based on these findings, a specially manufactured length of polythene-sheathed self-supporting aerial cable was obtained by the Post Office and a p.v.c. insulated 19/137 aluminium-alloy conductor sheathed with a 90-mil thickness of p.v.c. was specially prepared for the South Western Electricity Board.

Using these materials the 33 kV crossing at Harpers Hill, Totnes, was constructed in late May at a total cost of approximately £200. The Post Office charge to the Electricity Board for provision of two spans of polythene cable in place of existing 30 pr., 6½ lb/mile lead-covered aerial cable was approximately £160, while the cost to the Electricity Board of providing insulated conductors at the crossing was approximately £40.

This method showed a considerable saving when compared with the cost of placing the Post Office cable underground, but it should be pointed out that the estimated high cost of providing underground plant in this case was due to the fact that it would have been necessary to cut the trench in rock throughout the whole length of the two spans. It appears, however, that if this form of protection could be introduced generally, the savings might be appreciable.

M. C. L.

BOURNEMOUTH-JERSEY SUBMARINE CABLE

During June and July 1958, the cable ship *Ariel* laid a new submarine cable from Hengistbury Head, Bournemouth, to Jersey. This cable, providing 120 circuits and including 10 submerged repeaters, must be unique in that both ends are in the same Telephone Manager's Area.

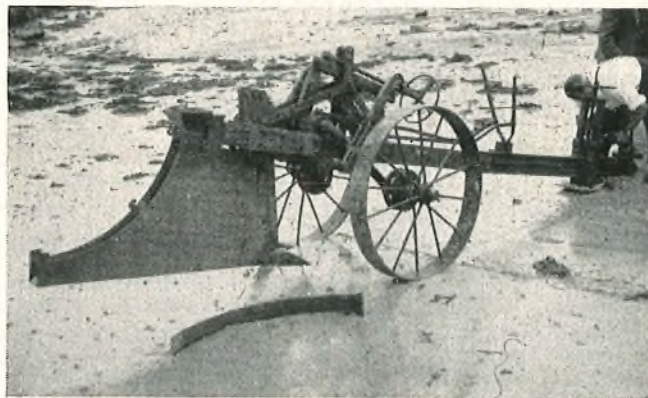

MODIFIED MOLEDRAINER USED FOR BURYING THE SHORE-END OF BOURNEMOUTH-JERSEY SUBMARINE CABLE

On the Dicq beach, Jersey, where the cable lands, the fall of the tide is approximately 35 ft, and at low tide half a mile of beach is exposed. The beach consists of sand, boulders and, in places, rock. The shore end of the transmission cable is 2½ in. in diameter and weighs 10 lb/ft run. It is armoured with 21 No. 2 and 22 No. 6 steel wires in two layers and can only be bent to a diameter of about six feet. Headquarters asked the Area to bury this cable and the lighter sea-earth cable 2 ft deep in the sand. This presented a considerable problem as the beach slopes gradually and, even at the lowest tide, the sand is waterlogged to within 80 yd of the sea wall. Trenching by manual means was out of the question as the trench would have silted up before the cable could be placed in it. No mechanical plant which would assist in the job could be hired locally. One of the Area's works supervisors suggested that it might be possible to moledrain the cable, but, as can be imagined, this suggestion was at first received with some scepticism; he was, however, given permission to make some experiments.

The moledrainer was modified by bolting two steel plates to the sides of the cutting blade to form a curved channel with a removable side, as shown in the photograph. By removing the side the cable could be placed in the channel without cutting. The moledrainer was winched by a Fordson tractor fitted with a heavy-duty winch, and the tractor anchor was modified by fixing a steel plate between the sprags, to increase the bearing area in the sand.

Experiments that proved the feasibility of the method were carried out on the mainland, using a borrowed piece of heavy electricity cable. It still remained to be proved whether the moledrainer could be used under the conditions actually existing on the beach at the Dicq. The tractor and moledrainer were shipped to Jersey and, while waiting for the cable ship to arrive, tests were made on the beach. These tests proved that the moledrainer could be winched quite readily by the tractor, using a snatch block, and would reach the required depth. Most of the boulders were small enough to be pushed aside by the moledrainer, and the mechanical fuse was not broken throughout the operations.

Both cables were quite successfully laid at the required depth, the work being done by an Inspector and five men at a rate of about 5 yd/min. The transmission cable proved to be more flexible than anticipated, and it was not at all difficult to roll a 6 ft diameter bight forward, as the moledrainer advanced, and to feed it into the channel. The use of the moledrainer was undoubtedly a very economical method of burying the cable and it should prove suitable wherever similar conditions are encountered.

It was found necessary to move the tractor fairly frequently and to take short pulls, for the tractor moved slowly backwards during the haul until there was a danger of the tractor wheels entering the hole left by the anchor plate. The use of a second tractor would have been a wise precaution as, connected in tandem, the holding power would have been improved and the second tractor would have provided a standby in case of accidents. The tide moves very quickly and there is little time to rectify mishaps before the tide returns; there were some anxious moments which would have been avoided had a second tractor been available, but the operation was successfully completed without serious trouble.

E. J. F.

JOINT CATHODIC-PROTECTION SCHEME

Arising from corrosion difficulties with the water mains operated by Sturminster Rural District Council, the Post Office were approached with a view to co-operating in a joint cathodic-protection scheme. The opportunity was welcomed, particularly since earlier proposals for a Post Office scheme had been halted because of difficulties in obtaining a wayleave for a ground bed.

At an initial meeting of Sturminster Rural District Council, Southern Gas Board, Southern Electricity Board and Post Office representatives it was agreed that pre-

liminary tests would be made under the direction of the Post Office, but that each undertaker would provide the necessary labour for excavation to permit testing of its own plant. The Electricity Board, however, has little underground plant, their distribution being largely overhead, but they were prepared to co-operate as necessary on interference tests.

Having selected a trial ground bed, using Spikes, Earth, No. 4, a Post Office 6 kW d.c. generating set was connected to the water and gas mains. The former served as a power feeder to the Post Office cable network, approximately a quarter of a mile distant.

Using Testers SA 9116, it was apparent that suitable potential changes occurred over an extensive part of the Post Office plant, and useful changes were measured over a considerable part of the water mains, but there was little or no potential change on the gas mains. Tests on individual joints of the gas mains revealed electrically high-resistance contacts. These could only be remedied by bonding individual joints, which the Gas Board did, using 7/064 cable (kept to an absolute minimum length, usually 7 in.-12 in.) and the cathweld process. This involved considerable time, since the majority of the joints were at approximately 16 ft intervals.

On completion of the bonding the potential-test results were encouraging and at a further joint meeting it was agreed to proceed with a permanent scheme. The rural district council undertook to provide and install a 50-amp 60-volt pole-mounted rectifier and the lead to the ground bed; the Southern Gas Board undertook to provide the ground bed, consisting of 50 steel rods, 6 ft long and 2 in. in diameter, in coke-breeze back-fill; while the Post Office contribution to the capital outlay would be the initial electrical survey, the provision of test equipment and suitable instruction to the local staffs of the other undertakings. It was also agreed that the annual charges of the scheme would be apportioned on the basis of the current distribution to the various services and were to be 45 per cent each to the Gas and Water undertakings and 10 per cent to the Post Office. Each undertaking would thus acquire protection at a cost appreciably less than if they had operated individually.

J. F. R.

North Eastern Region LIFTING CHAINS FOR MANHOLE FRAMES AND COVERS

A four-legged chain with specially designed grabs and hooks has been introduced for handling the type of carriage-

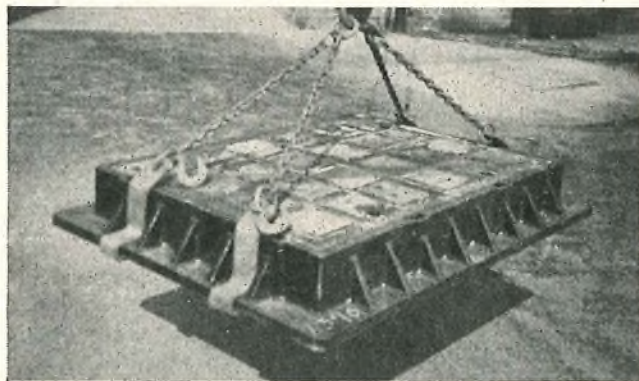

FOUR-LEGGED CHAIN FOR LIFTING MANHOLE FRAMES AND COVERS

way joint-box frames and covers recently issued from the Supplies Department. The device enables the complete item to be lifted with safety, where cranes are available, or facilitates the lifting of individual parts, i.e. frames or

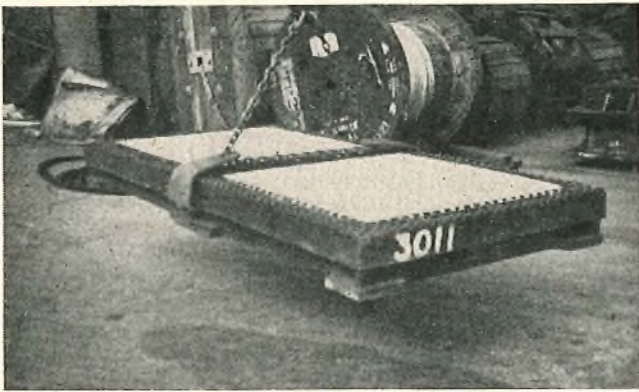

ENDLESS CHAIN FOR LIFTING CHANNELS, JOINT-BOX, NO. 6

covers, where portable hand hoists are used with vehicle jibs. An endless chain with two claws for lifting Channels, Joint-Box, No. 6, complete, is being used with advantage.
H. C.

USE OF CHAINS INSTEAD OF RODS WITH THRUST BORER

Two improved methods of drawing in Ducts No. 32 (3¼ in. asbestos-cement ducts) have been developed and found to be very successful. Firstly, the enlarging head of the thrust-boring machine has been increased to 5¾ in. outside diameter, as the existing 5½ in. head did not allow for easy access of the duct collars, the outside diameter of which measures 5 in. Secondly, a chain has been used instead of the boring rods for drawing in the duct. The chief advantages are: (i) the operation is not affected by the length of the boring rods or variations in the length of the ducts, and (ii) much less work is involved as the boring rods do not have to be transferred from the boring pit.

FLOODING OF BEAUCHIEF (SHEFFIELD) A.T.E.

This 6,000-line automatic exchange is built in a residential area on ground some 12 or 13 ft below road level, the land behind the building falling away slightly to a small stream about 20 yd away. A Ministry of Works contractor is at present on site adding a second floor, which has necessitated the removal of the asphalt all round the edge of the roof and the provision of a reinforced vibrated-concrete ring-beam 4 ft high. To prevent rainwater entering the apparatus room on the first floor, a single course of bricks has been bedded around the exposed edge of the existing asphalt, the gap up to the new beam being filled with weak concrete and then floated in sand and cement to form a fillet up to the beam. Suitable outlets of copper pipe have been provided at intervals through this dwarf wall.

On the night of 1-2 July, after a cloudburst, the small stream become a raging torrent, flooding neighbouring gardens and the telephone exchange yard. The double doors to the new power room on the ground floor burst in and the building was flooded to a depth of 2 ft 9 in. Fortunately, none of the new power equipment had been installed, otherwise this would have suffered considerably and, in addition, it appears that the door of the existing battery room delayed the entry of the water there just sufficiently long to save the exchange battery. The highest water level in this room was 2 ft 2 in., only 4¼ in. below the tops of the cells. The water in the cable chamber, where the floor level is approximately 1 ft 9 in. lower, reached a depth of 4 ft 3 in. but none of the joints and cables, although submerged, were damaged. At this point the rain must have subsided and the flood waters receded.

The next morning, the whole of the ground floor, including the welfare room, and the yard were covered with inches of

brown mud and the heating chamber was full of muddy water. The builder's sand had been washed away and his materials were scattered over the site. Some idea of the force of the flood may be gained from the fact that a 15 in. × 6 in. R.S.J. 16 ft long was found to have "floated" 10 ft across the drive. Immediate remedial action was taken by the exchange maintenance staff, who, on arrival, obtained pumps, commenced pumping out the cable and heating chambers and set to work on the task of cleaning up. Very soon a Ministry of Works party arrived and took over the majority of this work. The contractor also set his men to work on the clearance, and order was soon restored out of chaos, with very little serious damage done.

Considering all the havoc wrought locally by this exceptionally heavy downpour of rain, we must express our appreciation of the work done by the Ministry and the contractor on the exchange roof, for, in spite of such a searching test, no water found its way through on to the equipment.
S. H. W.

U.A.X. 13XX EXTENSION ON A SIEMENS 16 SATELLITE EXCHANGE AT PARK IN THE SHEFFIELD AREA

No matter how much one dislikes expedients and regrets the circumstances which make them necessary, the solution of the engineering problems involved can be an entertaining exercise in these days of standardization. In this particular case, the only method of catering for a rapidly growing order list was to build a U.A.X. timber building on the existing site and provide U.A.X. 13-type equipment by direct labour.

Some experience of the fitting of U.A.X.s in Siemens 16 exchanges had been obtained just after the war, when access was obtained in both directions via the manual board. An already overloaded manual board now prevented the use of a similar scheme and the following facilities were requested by the Traffic Division:

(i) The new subscribers should have numbers within the common numbering range which would not need changing when transferred to any future exchange. Level 396XXX on a 6-digit basis was suggested and will be referred to again later.

(ii) The new subscribers should have access to subscribers in the multi-exchange area by dialling the prefix code 8, as is usual for non-parent routes.

(iii) The new subscribers should have access to 9 and 0 level services in the same manner as existing U.A.X.s.

(iv) The scheme should cater for 600 lines in a U.A.X. 13XX.

A scheme was evolved along these lines and the subscribers on the new U.A.X. now enjoy the full dialling facilities of the multi-exchange area. The arrangement of the trunking is shown in the sketch.

Subscribers' numbers. Levels 390XX to 394XX (on a 5-digit basis) were already in use in the Siemens 16 satellite and there was a possibility of a further 100-line extension on level 395XX. Level 396XXX was therefore allocated as the code for the new U.A.X., the first three digits being dialled on existing equipment in the multi-exchange area and the last three in the U.A.X. This gave a numbering range of 396200-396799. Since the opening, further thought has been given to the scheme and no difficulty can be foreseen in the use of level 1XX in the U.A.X. so that an ultimate numbering range of 396100-396799 can be provided.

Originating Traffic. The calling rate of the subscribers connected to the U.A.X. was such that originating traffic could be accommodated on five linefinders and group selectors per A unit, leaving three group selectors for incoming junction traffic from the adjacent Siemens 16 exchange.

Dialling access was restricted on the vertical marking banks of the subscribers' group selectors to levels 8, 9 and 0, which were used as follows: Level 8 via outgoing junctions to U.A.X. non-parent 1st selectors in the Sheffield Central

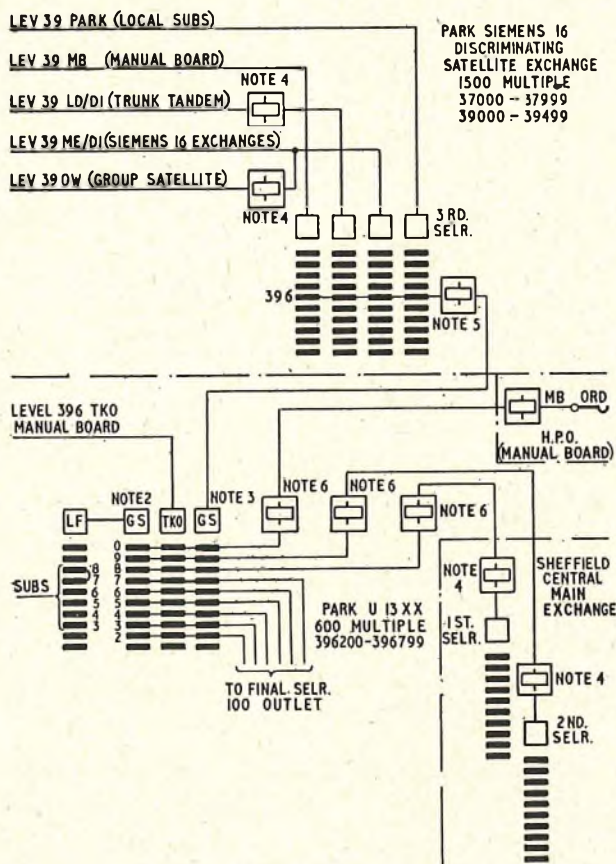

Notes:

1. No coin-box connexions on U.A.X.13
2. Vertical marking bank open to levels 8, 9 and 0 only
3. Vertical marking bank open to levels 2, 3, 4, 5, 6 and 7 only
4. Loop-leg pulse conversion sets
5. Leg-loop pulse conversion sets
6. Outgoing junction relay-sets.

TRUNKING DIAGRAM OF PARK U.A.X.13XX RELIEF SCHEME

Main exchange. Levels 9 and 0 were segregated, the former being taken by outgoing junctions to second selectors, level 9, in the Sheffield Central main exchange, and the latter by direct junctions to the auto-manual board. The U.A.X. subscribers were given, therefore, full access to the multi-exchange area after dialling a prefix digit 8, but direct access to 9-level codes, i.e. 999 and 94, and 0 level, required no prefix digit. In the circumstances it was thought better to prevent local access to other subscribers on the U.A.X. as each subscriber would be liable to mis-routed calls if the U.A.X. subscribers failed to dial the prefix digit 8, e.g. U.A.X. subscriber 235 might get calls intended for Sheffield 23500-23599.

Incoming Traffic. The incoming traffic was all routed on one grading from 3rd selectors, level 39, in the adjacent Siemens 16 exchange via leg-loop relay-sets directly into group selectors in the U.A.X., as mentioned previously. This was effected by disconnecting the linefinder connexions from the last three group selectors in each A unit and dispensing with the use of incoming junction relay-sets. Material savings were made by this method and the fault liability minimized since incoming junctions were not dependent on allotters and linefinders. Access on these group selectors was restricted on the vertical marking banks to the subscribers' levels 2-7 to prevent misuse of the outgoing facilities on levels 8, 9 and 0.

Trunk Offering. Trunk offering facilities on the incoming junctions were of course impracticable in these circumstances and had to be provided by a direct junction from the manual board to one of the incoming group selectors. The vertical-marking bank was opened on all levels to allow full access facilities for the manual board.

Coin-box Subscribers. It was agreed that no coin-box subscribers should be allocated to the exchange as facilities existed in the adjacent Siemens 16 exchange.

Accommodation. The accommodation was provided in an extended B1-type timber building, erected adjacent to the existing building. Heating was installed and linoleum laid so that the covers could be removed from the units in accordance with engineering instructions.

Power. The 50-volt battery supply was obtained from the existing Siemens 16 60-volt battery reduced by five counter-e.m.f. cells to 50 volts, with a 0.06 in² tie cable between the two exchanges. A Power Plant 206A was installed for the positive battery supply.

Underground Cables. A part-area scheme was planned in conjunction with the provision of the U.A.X., 600 new pairs being taken into the new U.A.X., and a tie cable of 400 pairs was provided between the two exchanges. This was intended to give full flexibility to the numbering scheme in readiness for a new exchange on level 39XXXX at some future time.

E. S.

RECONSTRUCTION OF MILL BRIDGE, DONCASTER

The reconstruction work at Doncaster, in the Lincoln Telephone Area, on the London-Edinburgh-Thurso Road, route A1, consists of the replacement of two bridges, which are no longer satisfactory from the point of view of width and safety, by a new 3-span welded-steel structure supported on concrete stone-faced abutments and piers. The new bridge, with a 24 ft dual carriageway, 10 ft footways and a central traffic island, will carry the very large volume of traffic using this major road. At a traffic census in the summer of 1957, 28,032 vehicles crossed the bridge between 8.0 a.m. and 8.0 p.m.



RECONSTRUCTION OF MILL BRIDGE, DONCASTER

The lattice-girder Mill Bridge over the River Don, seen on the left of the photograph, dates from the turn of the century, while the adjacent Lock Bridge spans a lock built about 1730 to permit navigation of the river. The lock has been out of use for the last 100 years since its usefulness was nullified by a canal built a short distance to the south. Below the Mill Bridge a weir spans the river and was built to provide water power for the Doncaster Corn-Mills.

As a first step, a permanent bridge across the river has been constructed and a temporary Callenders Hamilton bridge in line with it has been placed over the lock. By the time these notes appear in print, these bridges will be carrying traffic in both directions until such time as the second carriageway is ready. As the work proceeds, the temporary bridge will be removed and the lock filled in.

The weir is also to be removed to allow an uninterrupted flow of water and prevent serious flooding of the River Don, which has occurred in past years, notably in 1947. This work will reduce the upstream water level by some 10 ft.

The telephone cables involved in this work are the Doncaster-Leeds No. 1 (208 pr., 20 lb/mile + 4 pr., 40 lb/mile), Doncaster-Leeds No. 2 (182 pr., 20 lb/mile), Doncaster-Leeds No. 3 (4 coaxial tube + 390 pr., 20 lb/mile), two 24 pr., 20 lb/mile cables on the London-Leeds carrier route and six local cables ranging from 14 pr., 40 lb/mile to 400 pr., 10 lb/mile.

A nest of 24 octagonal ducts, sufficient to cater for Post Office needs for the next 40 years, have been laid from the roundabout at the north end of the bridge (manhole C in the sketch) to a point X at the edge of the new bridge. When the second carriageway has been constructed the ducts will be laid under the central traffic island to manhole B. A new manhole, A, has been constructed and the 24-way track extended to it across the bridge approach road.

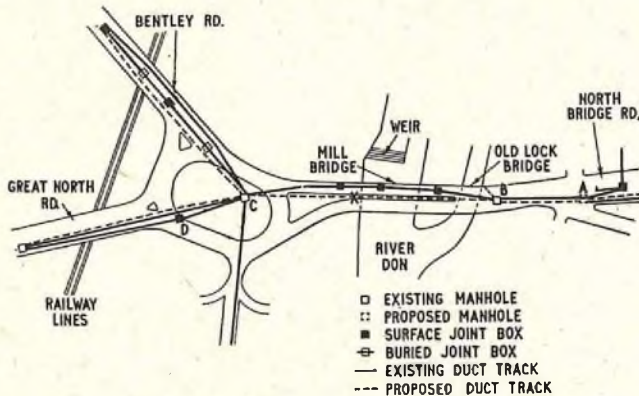

PLAN SHOWING CABLING SCHEME ACROSS MILL BRIDGE

The cables have been diverted from the old track to the top bores of the new track from manhole C to point X and thence over the bridge in a totally enclosed wooden trough (shown open in the photograph) to manhole B. By placing the temporary cables in the top bores of the track the lower row of eight ducts can be extended over the bridge to their final position and the cables pulled into them. Finally the temporary cables, shown in the photograph, can be recovered and the middle and top layer of ducts laid over the bridge.

An additional 18-way duct track has been laid across the roundabout between manholes C and D, thence a 10-way track along Route A1 to Sprotborough Road, a distance of some 140 yd. To cater for future developments a 6-way duct track has been laid into the Bentley Road, route A19. In all, six jointing chambers have had to be demolished and seven new ones built. It is anticipated that the project will be completed in 18 months' time and will have cost £413,000. Service diversions amount to £13,000 of which £4,500 is in respect of the diversion of Post Office plant and cables.

The information given by the contractors, Messrs. Holland and Hannen and Cubitts, the County Borough of Doncaster, who are the Ministry of Transport agents, and colleagues in the Lincoln Telephone Area is gratefully acknowledged.

J. E. S.

UNUSUAL METHOD OF REPLACING AUTO-MANUAL SWITCHBOARDS AT HALIFAX

Replacement at Halifax of the old sleeve-control switchboard and associated equipment by a low-position type of switchboard and 2,000-type relay-sets was successfully completed on the 16 May 1958. The complete operation formed part of the first stage of a "turn-round," the vacated floor space being used for 2,000-type group selectors.

Various ways of effecting the change-over were considered and finally it was decided to adopt the following unusual method. Firstly, the existing multiple tails were extended with cable to the new switchroom, where the last two positions were used as a "jointing cabinet" for connecting the cables to switchboard cords and plugs. When the joints had been covered by paper sleeves they were laid in the base of these two positions, the cords were fed up through the aperture made by removing the 2 in. spacers in the face equipment and the plugs were inserted into the

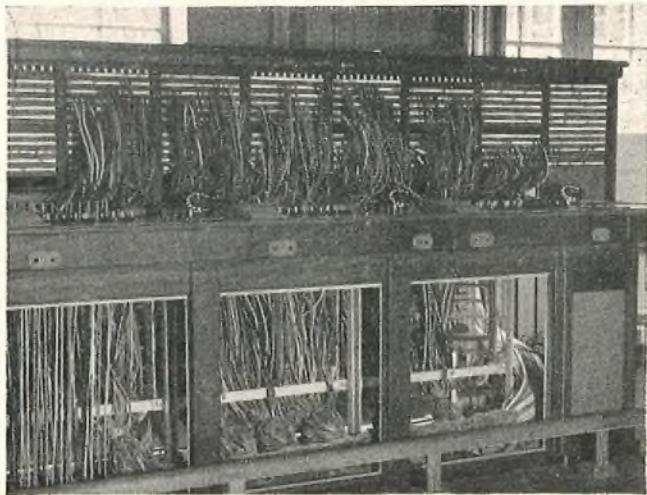

HALIFAX EXCHANGE, SHOWING TEEING OF WORKING CIRCUITS BETWEEN OLD AND NEW SWITCHBOARDS

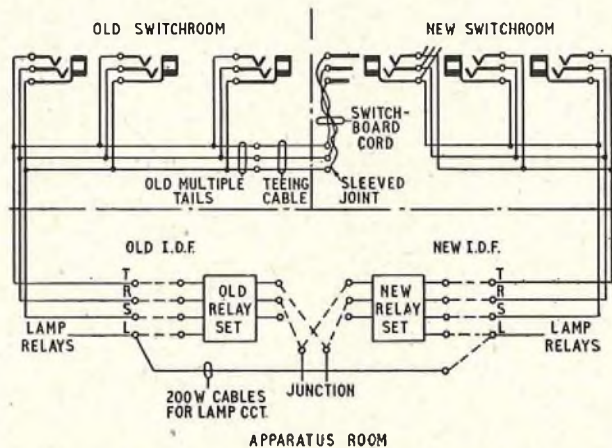

Connexions shown dotted to old relay-set were removed when those shown dotted to new relay-set had been provided

CHANGE-OVER ARRANGEMENTS AT HALIFAX AUTO-MANUAL SWITCHBOARD

relevant new multiple jacks. This is shown in the photograph. This system obviated any disturbance to the wiring of the new multiple and provided a translation from old to new multiple layouts.

In this way the tip, ring and sleeve wires of all working circuits were teed, while the tee in the lamp-relay wires was provided by 200-wire cables between the old and new

intermediate distribution frames. Temporary connexion strips enabled a similar translation to be done by jumpering.

The circuits were then taken out of service one by one and diverted via the new relay-sets and the new multiple to the old multiple, tested, and put back into service. Then the old relay-sets were disconnected.

In this way much labour was saved by both Engineering and Traffic Divisions in pre-transfer and post-transfer testing and the old relay-sets could be recovered before the new switchboard was brought into service, thus releasing valuable space to enable an early start to be made on the next stage of the turn-round. Also, the operators could be trained on the new multiple layout before the switchboard was brought into use.

On the transfer day the operators merely staffed the new positions, instead of the old, as they came on duty. The plugs were then withdrawn from the multiple on the new board and the lamps were disconnected, making the old board inoperative and ready for immediate recovery.

It was estimated that to effect the change-over by a break-jack system at least eight men together with a break in service of 5 minutes would have been necessary, but the scheme described above only required two men for 3 minutes to remove the plugs, and there was no break in the service and no "making good" was necessary after the transfer. J. W.

FIELD TRIAL OF TERYLENE ROPE FOR CABLING OPERATIONS IN BRADFORD

In order to eliminate rope breakages when drawing cable into ducts, it was decided to carry out a field trial using a

continuous-filament rope in place of one made from natural fibre such as sisal or hemp. The choice appeared to lie between nylon and terylene. As the strength of wet nylon is about 15 per cent less than that of dry nylon, terylene was chosen for the trial. Terylene is also reputed to have greater resistance to abrasion and heat, and even less moisture-absorbing properties than nylon.

Breaking tests were carried out on a specimen of 1½ in. circumference terylene rope and it was found to fail at a load of 2 tons, which compares favourably with the Post Office standard 3 in. rope. A 240 yd length was purchased and the manufacturer spliced a ¾ in. standard swivel on one end. This rope has now been in constant use for six months and shows no sign of wear. Throughout this time no attempt has been made to dry the rope, but special care has been taken to prevent kinking, which it is thought would open the fibres, thus causing weakness. A small butter barrel has been found very convenient for storing the rope.

First indications would appear to show that terylene rope has many advantages over the conventional type, such as:

- (i) Greater strength, hence smaller size.
- (ii) A gang could be equipped with one standard rope instead of several different sizes as at present.
- (iii) The rope is rot-proof and thus can be stored wet.
- (iv) Owing to its higher extension than a natural fibre rope immediately before breaking point, it can more readily absorb shock loads.
- (v) Longer working life.

Grateful thanks are offered for the co-operation and advice offered by S. Ledray & Sons, rope manufacturers, and the Fibres Division of I.C.I. J. R.

Book Review

"Plastics Progress 1957." Papers and discussions at the 4th British Plastics Convention. Edited by Philip Morgan, M.A. Iliffe & Sons, Ltd. 394 pp. Over 200 ill. 50s.

This volume keeps up the same high standard that has been set by previous numbers, but differs from them in that for the first time overseas contributions were accepted (eight out of a total of 18 papers), so that the book is a record of international development in many fields of plastic technology. Many of the subjects dealt with are of interest to Post Office engineers and scientists, as will be realized from the following comments on the papers.

The convention was opened with a short theoretical paper (on the "Polymerization of Olefins") by H. F. Mark of Brooklyn Polytechnic, and another was given by three members of I.C.I.

"Some Aspects of Low-Pressure Polythenes," by Erhard Grams, of Farbwerke Hoechst A.G., adds to our knowledge of the low-pressure polythenes developed in the last few years, which have attracted attention on account of their higher softening range, greater hardness, rigidity and tensile strength when compared with ordinary polythene.

"The Effect of Crystallinity on the Permeability of Polythene to Gases and Vapours," by a group of authors from the State University of New York, deals with most types of polythene.

"Factors Influencing Long Term Stress Properties of Polythenes," by a team from Phillips Petroleum of U.S.A., is self-explanatory.

Next, three papers deal with lightly plasticized p.v.c., high-impact p.v.c. and foamed p.v.c.

P.V.C. plastic tubing has been available since 1935, and a piece of p.v.c. piping after 20 years' service, buried in the ground under pressure, was recently tested and found

to have the same mechanical properties as new piping. Polythene pipes, and particularly high-density polythene pipes, are more recent arrivals and are dealt with by two authors from Chemische Werke Hüls A.G.

For those concerned with the extrusion of plastics there are two papers, by A. Kennaway of I.C.I. and G. Schenkel of Paul Troester Maschinenfabrik A.G.

Three papers deal with injection moulding:

"The Influence of Preplasticization in Injection Moulding," by E. Gaspar and M. G. Munns of the Projectile Engineering Co., Ltd.

"The Significance of Injection Rate in Moulding," by L. W. Meyer and L. E. Tallman of Dow Chemical Co.

"Study of Injection Moulding of Toughened Polystyrene," by G. Hulse and A. Z. Borucka of Monsanto Chemicals.

The difficulties of processing p.t.f.e. led to the development of p.c.t.f.e., but the latter is liable to partial decomposition in processing, so fresh fluorine polymers have been developed, and an account of these, with some fresh details about p.t.f.e., forms the basis of "Recent developments in Fluorine Polymers," by G. W. Bowley of I.C.I.

The other three papers are:—

"Recent Developments in Arc Resistant Thermosetting Moulding Materials," by J. Hofton and C. P. Vale of British Industrial Plastics.

"Relative Merits of Epoxide, Polyester and Phenolic Resins in Glass Reinforced Plastics," by L. H. Vaughan of Bakelite, Ltd.

"Reinforced Plastics for Efficient Structures," by W. A. Baker of Bristol Aircraft Ltd.

Judged as an up-to-date augmentation of knowledge on plastics this is an excellent work, but from its very nature it cannot be used as a universal reference work to recent progress in plastics, e.g. one does not find a reference to polyethylene terephthalate (Melinex), or polycarbonates and hardly anything about polypropylene. A. H. W.

Associate Section Notes

London Centre

The London Centre were very sorry to hear of the death of Mr. C. W. Brown during June. He played an active part in the formation of the Associate Section (then the Junior Section) and was its first president. After four years of his presidency there were 61 Centres with nearly 3,000 members. Since the end of the war he had been a visitor at many of our meetings, and it was with pleasure and pride that we listened to his remarks at the Annual General Meetings. He will certainly be missed, but those who carry on Associate Section activities, maintaining the objects laid down in 1932 under the guidance of Mr. C. W. Brown, will be ensuring that his ideals for our movement will be lasting.

The opening lecture of the 1958 session will be "The Transantarctic Expedition" and will be given by George Lowe, O.B.E., the official photographer to the expedition. In October, Mr. D. C. Greenaway, a Circuit Laboratory Associate Section member, will read a paper on "Artificial Traffic Equipment." November will see a visit from an Associate Section member from the North Eastern Region—Mr. Brasher—who will lecture on "Magnetic Tape Recorders"; he will be using extensive sound reproduction equipment to illustrate his lecture. This year the film show will be held in December, and again will be of a technical nature.

Two points which have been much discussed by the London Centre Central Committee and Local Branch Committees are whether to sponsor an Associate Section Badge or Tie and an Associate Section Diary. With reference to the former, a tie was considered to be the better proposition, and preliminary inquiries resulted in a price range of between 5s. 11d. and 12s. 6d. in materials from wool to silk, with a minimum order of three dozen. Such an order could easily be met by the London Centre, but it was thought that other centres would like to participate. Interested Centres should contact the Secretary at 6 Hillside Avenue, Purley, Surrey; suggested designs would be submitted to those Centres interested before the makers were approached.

A diary for telecommunications engineers has long been needed, and to this end the London Centre made tentative enquiries of Collins; the suggested diary would contain extracts from Collins Radio and Electrical Diaries together with a third section devoted to telecommunications data; the cost would be in a similar price range to that of Collins Radio and Electrical Diaries. Further information can be obtained from the secretary at the address above.

As each session gets under way, the secretary has to think of the next session's lecture program, and the type of program that the members really want is never forthcoming, but the secretary endeavours to get an interesting, balanced program. If only 10 per cent of the membership of the London Centre submitted one idea, the secretary would be nearer to getting a program the membership wanted. So how about it London Centre members? P. S.

Cornwall Centre

An inaugural meeting was held at Truro in May 1958 with an initial membership of 40; this has since been increased to over 110. The following officers and committee were elected for the 1958-59 session: *Chairman*: Mr. K. E. Spurlock; *Vice-Chairman*: Mr. M. C. Locke; *Secretary*: A. R. Brown; *Treasurer*: Mr. D. L. Moore; *Committee*: Messrs. D. E. Finlay, D. Jenkins, H. H. Pearce and G. C. Trelgilgas.

The Centre's activities began with an interesting paper on "Subscriber Trunk Dialling," by Messrs. Harris and Wilkinson of Bristol, and will continue with visits to Hayle Power Station and the china clay works at St. Austell. We shall be pleased to welcome any colleagues who have not yet joined the Centre. A. R. B.

Bath Centre

The Winter Session opened on 16 October 1957, when the following films were shown: "The Scientific Manufacture of Printing Inks," "The Technique of Sampling" and "The Discovery of a New Pigment."

On 28 November 1957, Mr. M. G. Smith of Bristol University gave an interesting lecture, illustrated by slides, entitled "Some Modern Theories of Cosmology," and the meeting concluded with a lively discussion.

The Centre was pleased to welcome Mr. H. L. Edwards from the Bristol Area Traffic Office on 20 January 1958, when his paper on "Subscriber Trunk Dialling" attracted a large audience.

In February Mr. P. H. Silcon, of the British Tabulating Machine Co., gave a lecture on "Punched Card Calculating Machines." The talk was introduced by a film, and Mr. Silcon supplied some interesting literature to members.

In March a paper was given by Messrs. K. E. Wilkinson and E. J. Harris of the Engineering Branch, Regional Director's Office. This paper dealt with the engineering aspects of subscriber trunk dialling, and concluded with questions and a lively discussion.

Once again the annual Telecommunications Ball was held at the Pump Rooms during February and the 500 members and guests had an enjoyable evening.

At the annual general meeting the following officers and committee were elected for the 1958-59 session: *Chairman*: Mr. L. W. Vranck; *Vice-Chairman*: Mr. H. C. Foote; *Secretary*: Mr. C. E. Martin; *Treasurer*: Mr. R. P. Bowers; *Assistant Secretary*: Mr. D. G. Rossiter; *Librarian*: Mr. A. F. Arlett; *Committee*: Messrs. J. D. Silcox, P. E. Smith, R. Faulkner, I. F. Jennings and G. Rugg; *Auditors*: Messrs. G. A. E. Buckley and A. W. Steer.

C. E. M.

Southend-on-Sea Centre

The annual general meeting of the Southend Centre was held on 10 April 1958, at Southend automatic exchange. The following officers were elected: *Chairman*: Mr. S. I. Restorick; *Vice-Chairman*: Mr. A. T. Humby; *Treasurer*: Mr. J. Gullin; *Secretary*: Mr. D. W. Everett; *Committee*: Messrs. G. Austin, L. W. Grant, R. E. Playle, A. N. Topsfield and F. Wright. The meeting was followed by a film show which included "The Rival World" and "Foothold on Antarctica."

The 1957-58 session can be regarded as a satisfactory one in all respects and the membership now numbers 114. The program was as follows:

15 October: "An Introduction to Sailing," by Mr. A. P. Padbury.

29 October: "Electronics in Telephone Exchanges," by Mr. R. F. Howard.

19 November: "Subscriber Trunk Dialling," by Mr. A. L. Perkins.

20 February: "18 Channel M.C.V.F.," by Mr. A. N. Topsfield (at Southend).

20 February: "18 Channel M.C.V.F.," by Mr. S. T. Ralph (at Chelmsford).

4 March: "Further Aspects of Transmission," by Mr. R. Hayward.

10 April: The annual general meeting and film show.

Congratulations must be offered to the Chelmsford contingent of the Centre on the continued support they give at winter meetings despite the long journey and, often, inclement weather. It is to be hoped that their numbers will soon be sufficient for them to form their own Centre.

The summer program has included visits to Hanningfield Reservoir, Southend Gasworks, Mann & Crossmans Brewery, the *Star* newspaper, Brentwood Radio Station, Stratford locomotive works and signal box, Guinness and Bristows.

The committee have arranged the winter program and, with subjects such as the magnetic drum, transistors and stereophonic sound, this promises to maintain the high standard so far achieved. In addition, the London Centre has kindly invited us to the lecture on "The Transantarctic Expedition" to be given by Mr. George Lowe, O.B.E., and a coach is being organized.

In conclusion, may the committee thank the members of the Centre for the active support given during the past year; we look forward to an equally successful session for 1958-59.

D. W. E.

Aberdeen Centre

Office bearers were duly elected at our annual general meeting and we have a full program arranged for the 1958-59 session.

Our first talk, in September, was entitled "The Four Divisions," Junior members of the staff, one from each of the divisions, Sales, Traffic, Clerical and Engineering, gave an outline of the duties performed by their respective divisions. This was followed by a short account of the "New Financial Set-Up," as applying to our department, given by a senior member of the clerical staff.

It is the committee's intention to produce a paper which will give information about the "Functions of the Four Divisions," the "Financial Set-Up," "A.N. Procedure," etc., and the basis of this paper will be provided by the meeting referred to above. The paper will be included in our local library and will be available to any Associate on application.

J. G. P.

Bangor Centre

We are glad to report that Bangor is once again in the fold after an absence of nearly 20 years. In 1932 a few enthusiasts formed the Bangor Junior Section, which operated successfully until 1939, when its activities were suspended because of the war; unfortunately they were not resumed on cessation of hostilities.

During the latter part of 1957 some of the old members were approached with a view to re-forming an Associate Section Centre and to explore the possibility of enrolling members. The response was more than gratifying and the new Centre was opened with a membership of 86. (This number has since been increased to 100.)

The inaugural meeting was held on 23 January 1958 at the new telephone exchange building under the chairmanship of Mr. T. A. P. Colledge, Area Liaison Officer. The officers and committee elected were as follows: *Chairman*: Mr. E. F. Lambert; *Secretary*: Mr. O. E. Jones; *Treasurer*: Mr. R. R. Williams; *Committee*: Messrs. W. Roberts, J. Jones, V. Griffiths, I. W. Owen, J. E. W. Jones, E. G. Hughes and E. James.

Mr. F. E. Wallcroft, Regional Liaison Officer, addressed the meeting and outlined the aims and principles of the I.P.O.E.E. Mr. J. R. Young, Senior Section Secretary for Wales & Border Counties, gave a detailed account of the history of the I.P.O.E.E. Senior and Junior (Associate) Sections and also of the Post Office Engineering Department, and followed his address with a series of most interesting lantern slides.

The session was completed with three more meetings:

February: "The Transatlantic Telephone Cable," by Mr. H. G. S. Peck, B.Sc., M.I.E.E.

March: "Communications of Interplanetary Travel," by Mr. T. A. P. Colledge, B.Sc., M.I.E.E., Area Engineer.

April: Film Show of "T.A.T. Cable," "Radar Goes to Sea" and "Power for Ships."

The committee wish to express their thanks to all who have contributed towards the setting up of the Centre, and especially to Messrs. T. A. P. Colledge and J. R. Young for their invaluable assistance and support. We extend an invitation to all eligible non-members to enrol now and

would be pleased to see a stronger representation of the external staff.

An interesting program is being drawn up for the coming session.

O. E. J.

Lincoln Centre

After a dormant period of three years a meeting was held with a view to re-forming the Lincoln Centre. The following officers were elected: *Chairman*: Mr. J. Rossington; *Vice-Chairman*: Mr. J. Stilgoe; *Secretary*: Mr. R. Bell; *Treasurer*: Mr. A. E. Clayton; *Committee*: Messrs. W. Barnes, A. Dart, B. Goldson and T. Scarborough.

The arrangements for the forthcoming 1958-59 session are well in hand and include the following:

16 October: "Printed Circuit Technique," by Mr. J. W. Willmot.

17 November: "My Work in the Courts," by Judge Ralph Shove.

10 January: Visit to the British Sugar Corporation, Bardney Factory.

9 February: "Mechanical Developments in Telecommunications," by Messrs. E. W. C. Hubbard and G. L. Mack of the Engineer-in-Chief's Office Circuit Laboratory.

R. B.

Sheffield Centre

An attendance of 45 at the annual general meeting on 30 May 1958 was very encouraging. Discussion was lively and some helpful suggestions were made by members. The outgoing officials and committee were all re-elected, as follows: *Chairman*: M. J. McInnes; *Vice Chairman*: Mr. F. S. Brasher; *Secretary*: Mr. G. T. Ridsdale; *Assistant Secretary*: Mr. K. T. Gray; *Treasurer*: Mr. C. S. Shepherd; *Librarian*: Mr. G. Woodhouse; *Scribe*: Mr. J. E. Simmons; *Registrar*: Mr. C. B. Gray; *Auditors*: Messrs. F. Bough and S. G. Cole; *Committee*: Messrs. J. Brown, S. Cottage, F. Gosling, A. Knowles and J. Watts.

In addition, Mr. W. Wilks was elected as representative for the Worksop outstation and Mr. P. Sorby to represent the Youths.

On 10 June we took a 41-seater coach to Liverpool, and while 26 of us visited the Automatic Telephone & Electric Co.'s works, the remainder, with wives and friends, went sightseeing and shopping, though visibility was somewhat limited by mist and rain. At the Automatic Telephone & Electric Co., we could not have been made more welcome; an excellent lunch was served on arrival, and we took tea before leaving. During lunch some members renewed acquaintance with a former colleague, Jim Bridges, now in the design laboratory. Later our Liaison Officer, Mr. T. C. R. Harrison, met ex-colleagues he had not seen since the installation of the first Leeds automatic exchange in 1918.

Although our visit was limited to the telephone section of the works, we found plenty to interest us. In the huge rack-assembly shop we saw equipment destined for many parts of the world, including a trunk-test suite for the new Manchester Pioneer Exchange and carrier bays for Venezuela.

A self-supporting magazine club was started early in the year and is now running well under the organization of Jim Watts. Members pay two shillings per year for each magazine they wish to see, and at the moment have a choice of five technical or practical publications. Sufficient copies are purchased to restrict the circulation of each to about 12 members.

Our future program includes visits to the British Iron and Steel Research Association and to Firth-Vickers new stainless-steel-strip rolling mill, and a lecture-demonstration on radiology at a local hospital.

We would like to express our sincere thanks to Mr. R. W. Palmer, the retiring President, for his very keen support

during his term of office with the Associate Section and to welcome to the Presidency Mr. A. H. Knox who, we are assured, has a very lively interest in our activities. We extend to you, Mr. Knox, an open invitation to pay us a visit whenever convenient.

J. E. S.

Leeds Centre

At the annual general meeting in April the following officers were elected for the 1958-59 session: *Chairman*: Mr. C. Baker; *Secretary*: Mr. E. Lancaster; *Librarian*: Mr. J. Harris; *Committee*: Messrs. Bateman, Bates, Cotterill, Crowther, Newton and Senior.

It was agreed by the members present that the Leeds Centre had enjoyed a very varied and successful year, and there was no reason why this should not continue. The meeting was concluded by a combined film show of technical and travel films.

On Wednesday, 18 June 1958, a visit was paid to the Melbourne Brewery, Leeds, by 27 of our members; much interest was shown in the methods of brewing, and the guide explained these details very fully. Members were invited into the "Step Inn," the local hostelry on site, and were able to sample the finished product; it was generally agreed that the visit had been most instructive and entertaining.

The Leeds Centre arranged a comprehensive program for the winter season comprising the following:

Program 1958-59: All meetings at the "Griffin Hotel," Boar Lane, Leeds.

Thursday, 19 September 1958: "Transatlantic Systems,"

by Mr. P. T. F. Kelly, Main Lines Development and Maintenance Branch, Engineering Department.

Wednesday, 8 October 1958: Visit to Messrs. Mullard's Government Valve Factory, Blackburn. (12 members.)

Thursday, 13 November 1958: Visit to Automatic Telephone & Electric Co., Ltd., Edge Lane, Liverpool. Whole-day visit.

Monday, 24 November 1958: "Permanent Magnets Summarized," by Mr. F. G. Tyack, A.M.I.E.E., Messrs. James Neill & Co., Ltd., Sheffield.

Wednesday, 10 December 1958: Centre dinner and social evening at the "Old Fox," Wetherby.

Friday, 6 January 1959: Visit to Messrs. James Neill & Co., Ltd., Steel Works, Sheffield.

Thursday, 19 February 1959: "Promotion and Appraisements," by Mr. A. H. C. Knox, President of the Associate Section.

Friday, 20 March 1959: Visit to Ericsson Telephones, Ltd., Beeston, Nottingham.

Tuesday, 14 April 1959: "Recent developments in Aerial Cable Construction," by J. Bluring, External Plant and Protection Branch, Engineering Department.

May 1959: Visit by air to London Airport, visiting airport communications systems, etc. Flying by B.K.S. Airways from Yeadon Airport. (Meals provided.)

June 1959: Visit to British Relay Wireless relay station, Leeds.

The chairman and committee look forward to seeing members and prospective members during the coming season and a warm welcome is extended to all.

C. B.

Book Review

"Techniques of Magnetic Recording." J. Tall. Macmillan; New York and London. pp. xxiii + 472. 112 ill. 55s. 6d.

It is, surprisingly, little more than 10 years since magnetic tape recorders first became generally available. Now they are ubiquitous not only in scientific establishments but also in education, commerce and the home. This book has been written with the excellent intention of providing those unskilled in the art with a text-book which describes, in non-technical language, the theory and the techniques of magnetic recording. Unfortunately, in order to write on scientific subjects in a way which is both accurate and "popular" it is necessary to have a very sound grasp of fundamentals coupled with a dash of genius. Few authors have wholly succeeded at the task.

It is, therefore, not surprising that the early chapters of this book, which are devoted to theory, are the weakest. Whilst the overall picture of the subject is adequate, within the limitations which the author has set himself, the text is frequently marred by statements that are obscure or even inaccurate. For example, the following description of the nature of sound leaves something to be desired—"One cycle of sound is made up of two excursions of sound, one

advancing from nothing to its maximum and back to zero value in one direction, the other doing the same thing in the other direction." Mr. Tall refrains (very wisely in the present state of our knowledge) from explaining why a.c. bias reduces distortion and contents himself with describing its effects. It is a pity that more authors have not followed his example.

In the later chapters, which are devoted to techniques and applications, the author is obviously writing from his own practical experience. These chapters contain much material which should be useful to those employed in recording studios or who wish to use recording as an aid to teaching. Once again, however, technical errors crop up here and there. On page 393, for instance, the subject of impedance matching between apparatus is not understood.

The book includes sections by other authors on the recording of sound in nature and in various aspects of medical practice and also chapters on data and facsimile recording.

There is a glossary of technical terms which has some unusual statements and omissions. For example, wow and flutter are nowhere defined. The bibliography is extensive and useful.

R. R. W.

Staff Changes

Promotions

Name	Region	Date	Name	Region	Date
<i>Assistant Engineer-in-Chief to Director of Research</i>			<i>Assistant Engineer (Limited Competition)—continued</i>		
Halsey, R. J.	E.-in-C.O.	2.10.58	Tickner, E. J.	E.-in-C.O.	27.5.58
<i>Staff Engineer to Assistant Engineer-in-Chief</i>			Lockwood, R. R.	H.C. Reg.	27.5.58
Williams, H.	E.-in-C.O.	2.10.58	Endacott, L.	S.W. Reg.	27.5.58
<i>Senior Principal Scientific Officer to Deputy Director of Research</i>			Hart, J. J.	E.-in-C.O.	27.5.58
Richards, C. E.	E.-in-C.O.	16.7.58	Byrne, R.	N.W. Reg.	27.5.58
<i>Deputy Chief Regional Engineer to Staff Engineer</i>			Tudor, W.	W.B.C.	27.5.58
Salter, L. F.	L.T. Reg. to E.-in-C.O.	21.7.58	Foreman, C. H.	L.T. Reg.	27.5.58
<i>Assistant Staff Engineer to Staff Engineer</i>			Mackay, C. H.	Scot.	27.5.58
Freebody, J. W. H.	E.-in-C.O.	7.7.58	Ratcliffe, B.	N.W. Reg.	27.5.58
Davison, G. N.	E.-in-C.O.	7.7.58	Forsyth, R.	E.-in-C.O.	27.5.58
Mitchell, H. T.	E.-in-C.O.	16.7.58	Webb, K. S. J.	N.W. Reg.	27.5.58
Bray, W. J.	E.-in-C.O.	16.7.58	Burnett, A. N.	Scot.	27.5.58
Leigh, H.	E.T.E.	29.9.58	Harris, R. K.	W.B.C.	27.5.58
Cook, A.	E.-in-C.O.	2.10.58	Roberts, L. W.	E.-in-C.O.	27.5.58
<i>Regional Engineer to Staff Engineer</i>			Parr, G. R. W.	E.-in-C.O.	27.5.58
Anderson, E. W.	H.C. Reg. to E.-in-C.O.	16.7.58	<i>Inspector to Assistant Engineer</i>		
<i>Area Engineer to Regional Engineer</i>			Waters, J. G.	H.C. Reg.	2.6.58
Knox, J.	Scot. to N.W. Reg.	9.6.58	Irons, W. J.	S.W. Reg.	25.2.58
Hunt, A. M.	N.E. Reg.	30.5.58	Trotter, J.	Scot.	15.2.58
<i>Executive Engineer to Area Engineer</i>			Manley, E. H.	S.W. Reg.	25.1.58
Jalland, K. F.	W.B.C. to Scot.	7.7.58	Bass, J.	L.T. Reg.	3.6.58
<i>Executive Engineer to Senior Executive Engineer</i>			Wenman, H. E. A.	L.T. Reg.	31.7.58
Rapkin, L. W.	L.T. Reg.	1.5.58	Webster, W. T.	L.T. Reg.	19.8.58
Rogers, D. M.	L.T. Reg.	26.6.58	Alderslade, R.	L.T. Reg.	1.8.58
Bastow, F. J.	E.-in-C.O.	26.6.58	Gourlay, C. D.	N.W. Reg.	2.7.58
Laver, K. S.	E.-in-C.O.	30.6.58	Hodgson, S. H.	N.W. Reg.	2.7.58
Beck, E. H. A.	E.-in-C.O.	29.7.58	<i>Technical Officer to Assistant Engineer</i>		
Herbert, L. J.	L.T. Reg.	1.8.58	Carpenter, J.	L.T. Reg.	15.4.58
<i>Executive Engineer to Public Relations Officer</i>			Orford, M. T.	H.C. Reg.	17.4.58
Lewis, W. J.	Mid. Reg.	6.2.58	Fleming, M.	Scot.	12.4.58
<i>Assistant Engineer to Executive Engineer</i>			Murray, J. S.	Scot.	21.4.58
Aldrich, G. A.	L.T. Reg.	16.5.58	Kidd, J. M.	Scot.	16.5.58
Knight, J. S.	Scot.	12.6.58	Statham, H. W.	W.B.C.	1.1.58
<i>Assistant Engineer (Limited Competition)</i>			Owen, P.	W.B.C.	1.1.58
Hart, M.	E.-in-C.O.	5.5.58	Roberts, J.	W.B.C.	17.2.58
Jefferis, A. K.	H.C. Reg.	5.5.58	Lowe, R. M.	L.T. Reg. to E.-in-C.O.	27.5.58
Fitton, D.	Mid. Reg.	5.5.58	Billett, D. K.	E.-in-C.O.	24.5.58
Oakes, B. A.	E.-in-C.O.	5.5.58	Caunt, E.	E.-in-C.O.	31.5.58
Hulse, R. A.	Mid. Reg.	5.5.58	Clark, R. M.	N.E. Reg. to E.-in-C.O.	24.5.58
Parker, R. J.	H.C. Reg.	5.5.58	Rogers, C. M.	E.-in-C.O.	24.5.58
Mardon, H.	N.E. Reg.	5.5.58	Bell, R. L.	L.T. Reg. to E.-in-C.O.	24.5.58
Hogge, D. M.	Scot.	5.5.58	Brand, W. W.	E.-in-C.O.	24.5.58
Mason, J. A.	W.B.C.	5.5.58	Joyce, L. A.	E.-in-C.O.	24.5.58
Brooks, M.	E.-in-C.O.	5.5.58	Vanlint, H. T.	L.T. Reg.	14.4.58
Wilson, S. B.	N.W. Reg.	27.5.58	Robinson, S. G.	N.W. Reg.	6.5.58
Hooks, M. J.	H.C. Reg.	5.5.58	Andrews, J. H.	N.W. Reg.	22.5.58
Drinkwater, T. J.	E.-in-C.O.	5.5.58	Hallett, K. L.	E.T.E.	5.5.58
Roberts, D. F.	H.C. Reg.	5.5.58	Elliot, C. W. R. P.	E.T.E.	4.6.58
Rand, L. C.	E.-in-C.O.	5.5.58	Price, C. H.	S.W. Reg.	28.10.57
Shaw, E. H.	E.-in-C.O.	5.5.58	Gordon, K.	E.T.E.	4.6.58
Tasker, B.	Mid. Reg.	5.5.58	Pearson, H. W.	Mid. Reg.	6.8.57
Evans, P. R. L.	S.W. Reg.	5.5.58	Phillips, W. S.	W.B.C.	10.2.58
Bedford, R. A.	E.-in-C.O.	5.5.58	Eastcote, D. V. C.	Mid. Reg.	10.3.58
Parsons, E. P.	L.T. Reg.	5.5.58	Wright, E. O.	L.T. Reg.	1.9.57
Peters, D. G.	L.T. Reg.	5.5.58	Tait, J. W.	Scot.	14.6.58
Ward, A. W.	S.W. Reg.	5.5.58	Milne, J. M.	Scot.	23.6.58
Pratley, J.	S.W. Reg.	5.5.58	Ferris, T. A.	L.T. Reg. to E.-in-C.O.	28.6.58
Bartlett, B. B.	H.C. Reg.	27.5.58	Roberts, D. G.	N.W. Reg. to E.-in-C.O.	5.7.58
Matthews, W. P.	Mid. Reg.	27.5.58	Archer, L.	N.E. Reg. to E.-in-C.O.	28.6.58
Tavener, A.	E.-in-C.O.	27.5.58	Watt, B. B.	N.E. Reg. to E.-in-C.O.	28.6.58
Moore, C. H. S.	L.T. Reg.	27.5.58	Curtis, F. J.	L.T. Reg.	16.5.58
Royston, R.	Mid. Reg.	27.5.58	Jacquest, H. C.	L.T. Reg.	7.7.58
Whyte, J. D.	H.C. Reg.	27.5.58	Smith, R. E.	L.T. Reg.	14.5.58
Hughes, R. M.	E.-in-C.O.	27.5.58	Kelly, T. J.	L.T. Reg.	7.6.58
			Lord, J.	N.W. Reg.	25.7.58
			Butcher, C. S.	N.W. Reg.	25.7.58
			<i>Technical Officer to Inspector</i>		
			Carrington, H. G.	S.W. Reg.	1.1.58
			Davis, L. V.	S.W. Reg.	19.5.58
			Bowler, L. C.	S.W. Reg.	8.4.58
			Finall, W. T.	L.T. Reg.	18.5.58
			Reeve, K. W. E.	H.C. Reg.	22.5.58
			Hore, J. H.	S.W. Reg.	17.2.58

Promotions—continued.

Name	Region	Date	Name	Region	Date
<i>Technician I to Inspector</i>			<i>Technician I to Inspector—continued</i>		
Goatley, R. E. J.	H.C. Reg.	28.3.58	Clark, R. H.	N.E. Reg.	3.2.58
Bowen, R. G.	N.I.	14.5.58	Beevours, J. H.	N.E. Reg.	2.5.58
McCadden, W. H.	N.I.	14.5.58	Noble, E. J. W.	N.W. Reg.	2.7.58
Hart, A. A.	L.T. Reg.	14.5.58	Lloyd, G. W.	N.W. Reg.	21.7.58
Duckmanton, E. J.	L.T. Reg.	12.5.58	Smith, A. Y. O.	N.W. Reg.	25.7.58
Collins, J. A.	L.T. Reg.	19.5.58	<i>Senior Scientific Officer to Principal Scientific Officer</i>		
Terry, R. F.	L.T. Reg.	1.5.58	Shotton, D. C.	E.-in-C.O.	7.7.58
Ricketts, J. C.	L.T. Reg.	14.2.58	<i>Assistant Experimental Officer (Open Competition)</i>		
Litchfield, A.	L.T. Reg.	14.4.58	Wills, W. G.	E.-in-C.O.	2.6.58
King, E. W.	L.T. Reg.	19.5.58	Balsom, P. M.	E.-in-C.O.	4.7.58
Tinsley, W. A.	L.T. Reg.	13.3.58	<i>Assistant Regional Motor Transport Officer to Motor Transport Officer II</i>		
Olive, J. T. S.	L.T. Reg.	11.5.58	Green, G. A.	London Reg. to E.-in-C.O.	8.5.58
Wright, E. J.	L.T. Reg.	17.4.58	<i>Technical Assistant I to Motor Transport Officer III</i>		
Rumsey, A. C. E.	L.T. Reg.	12.5.58	Hicks, A. P.	E.-in-C.O.	3.7.58
Duke, L. R.	L.T. Reg.	28.4.58	Lord, A. C.	E.-in-C.O.	3.7.58
Green, J. C.	H.C. Reg.	28.5.58			
Hodges, F.	Mid. Reg.	10.2.58			
Durant, D. L.	Mid. Reg.	2.6.58			
Parker, E. C.	L.T. Reg.	16.7.58			
Whybrow, C. S.	L.T. Reg.	7.7.58			

Retirements and Resignations

Name	Region	Date	Name	Region	Date
<i>Director of Research</i>			<i>Assistant Engineer—continued</i>		
Little, G. J. S.	E.-in-C.O.	1.10.58	Campbell, H.	N.W. Reg.	6.6.58
<i>Staff Engineer</i>			Malcolm, H.	Scot.	6.6.58
Smith, W. F.	E.T.E.	28.9.58	Padgham, F. S.	H.C. Reg.	9.6.58
<i>Regional Engineer</i>			Smith, S. C.	H.C. Reg.	16.6.58
Diack, W. H.	N.W. Reg.	9.4.58	Calderwood, R.	Scot.	17.6.58
<i>Senior Executive Engineer</i>			Wall, C. G.	W.B.C.	30.6.58
Winch, B.	E.-in-C.O.	11.6.58	Dawson, F.	N.E. Reg.	30.6.58
<i>Executive Engineer</i>			Stanley, H.	N.E. Reg.	2.7.58
Roche, J. J.	E.-in-C.O.	6.6.58	Brook, H.	N.E. Reg.	21.7.58
Plant, F.	N.W. Reg.	26.2.58	Stanley, J. W.	W.B.C.	27.7.58
Cleary, C. L.	S.W. Reg.	17.4.58	Green, G.	L.T. Reg.	30.7.58
Dean, G. A.	W.B.C.	30.4.58	Jeffries, H. A.	L.T. Reg.	31.7.58
Wright, G. T.	Scot.	5.5.58	Denny, W. H.	E.T.E.	31.7.58
Ovenall, E. W.	L.T. Reg.	21.5.58	<i>Inspector</i>		
Cooper, L. E.	H.C. Reg.	31.5.58	Vincent, P. A.	L.T. Reg.	10.5.58
Rance, A. W.	H.C. Reg.	30.6.58	Ball, W. E.	L.T. Reg.	16.5.58
Lockie, J.	Scot.	2.7.58	Misselbrook, V. G.	L.T. Reg.	17.5.58
<i>Assistant Engineer</i>			Hill, E.	H.C. Reg.	21.5.58
Fisk, F. G.	N.W. Reg.	9.5.58	Plank, S. J.	H.C. Reg.	25.5.58
Hart, J.	L.T. Reg.	22.5.58	Crawford, C. H.	N.W. Reg.	24.6.58
Dolman, E. F.	Mid. Reg.	23.5.58	Dye, R. J.	Scot.	14.6.58
Richardson, R.	N.E. Reg.	30.5.58	Fedarb, E. W.	L.T. Reg.	15.7.58
Palmer, O. A.	H.C. Reg.	31.5.58	Rutter, T.	N.W. Reg.	16.7.58
Wright, P. G. (Resigned)	E.-in-C.O.	26.5.58	Andrews, H. A.	S.W. Reg.	26.7.58
Clarkson, W. H.	N.W. Reg.	8.6.58	Whittard, A. C.	L.T. Reg.	29.7.58
Roe, A. J.	N.E. Reg.	17.6.58	<i>Leading Draughtsman</i>		
			Gaulley, A. G.	Mid. Reg.	7.4.58
			Lennon, W. D.	L.T. Reg.	30.4.58

Transfers

Name	Region	Date	Name	Region	Date
<i>Senior Executive Engineer</i>			<i>Assistant Engineer—continued</i>		
Chappell, A. J.	N.W. Reg. to E.-in-C.O.	16.6.58	Nash, L. C.	Cyprus to E.-in-C.O.	30.7.58
<i>Executive Engineer</i>			Barnett, N. V.	E.-in-C.O. to Nigeria	4.8.58
Allan, J. M.	E.-in-C.O. to Scot.	6.5.58	Price, R. J.	Pakistan to E.-in-C.O.	6.8.58
Glanville, J. H.	E.-in-C.O. to H.C. Reg.	2.6.58	<i>Motor Transport Officer III</i>		
Shaw, S.	E.-in-C.O. to H.C. Reg.	9.6.58	Shann, D. E. W.	E.-in-C.O. to London Reg.	9.6.58
Glover, A. G.	E.-in-C.O. to W.B.C.	30.6.58	Short, R.	E.-in-C.O. to London Reg.	9.6.58
Moffatt, J. J.	Nigeria to E.-in-C.O.	4.8.58	<i>Technical Assistant I</i>		
Turner, G. E.	E.-in-C.O. to N.W. Reg.	5.8.58	James, H. S.	E.-in-C.O. to London Reg.	6.6.58
<i>Assistant Engineer</i>			<i>Executive Officer</i>		
Reddyhoff, G.	E.-in-C.O. to Admiralty	28.5.58	Thurlow, J.	E.-in-C.O. to A.G.D.	15.4.58
Milliner, D.	E.-in-C.O. to Nigeria	19.7.58			
Hammond, E.	E.-in-C.O. to D.S.I.R.	21.7.58			

BOARD OF EDITORS

D. A. BARRON, M.Sc., M.I.E.E., Chairman.
 L. F. SCANTLEBURY, Whit.Sch., A.C.G.I., D.I.C., M.I.E.E.
 H. G. BEER, Whit.Sch., A.C.G.I.
 T. H. FLOWERS, M.B.E., B.Sc.(Eng.), M.I.E.E.
 W. J. E. TOBIN, B.Sc.(Eng.), A.C.G.I., D.I.C., A.M.I.E.E.
 A. H. C. KNOX, B.Sc.(Eng.), M.I.E.E.
 R. F. WALDEGRAVE.
 E. DAVIS, A.M.I.E.E., Managing Editor.
 J. H. BROADHURST, A.M.I.E.E.
 A. G. LEIGHTON, B.Sc.(Eng.), A.M.I.E.E. } Assistant Editors.
 B. FARR, Secretary-Treasurer.

Copyright

The entire contents of this Journal are covered by general copyright, and special permission is necessary for reprinting long extracts, but editors are welcome to use not more than one-third of any article, provided credit is given at the beginning or end thus: "From the *Post Office Electrical Engineers' Journal*."

The Board of Editors is not responsible for the statements made or the opinions expressed in any of the articles in this Journal, unless such statement is made specifically by the Board.

Communications

All communications should be addressed to the Managing Editor, *Post Office Electrical Engineers' Journal*, G.P.O., 2-12 Gresham Street, London, E.C.2. Telephone: HEADquarters 1234. Remittances should be made payable to "*The P.O.E.E. Journal*" and should be crossed "& Co."

Binding Cases

Cases for binding are available, and may be obtained from the local agents for 3s. Subscribers can have their copies of volumes bound, at a cost of 10s. 6d., by sending the complete set of parts to the local agents or to the *Post Office Electrical Engineers' Journal*, G.P.O., 2-12 Gresham Street, London, E.C.2. Orders for binding for Vol. 1-19 should indicate whether the original binding case with black lettering, or the later pattern with gold, is required. Cases with gold lettering are the only type stocked from Vol. 20 onwards.

Back Numbers

The price of the Journal, which is published quarterly, is 2s. 6d. (3s. 3d. post free) per copy, or 13s. per annum, post free. Back numbers can be supplied, subject to availability of stocks, at 2s. 6d. (3s. 3d. each post free). Orders for back numbers may be sent to the *Post Office Electrical Engineers' Journal*, G.P.O., 2-12 Gresham Street, London, E.C.2, or to the publishers.

Employees of the British Post Office can obtain the Journal through local agents at the reduced price of 2s. per copy.

Advertisements

All communications relating to space reservations should be addressed to the Advertisement Editor, *Post Office Electrical Engineers' Journal*, G.P.O., 2-12 Gresham Street, London, E.C.2. Communications regarding advertisement copy, proofs, etc., should be addressed to the Publishers, Messrs. Birch & Whittington (Prop. Dorling & Co. (Epsom) Ltd.), Depot Road, Epsom, Surrey.

INDEX TO ADVERTISERS

	PAGE
Adcola Products, Ltd.	xxxv
Alton Battery Co., Ltd., The	xxiii
Automatic Telephone & Electric Co., Ltd.	xxx-xxxi, xxxvii
Avo, Ltd.	xxxvi
Bennett College, The	xxxv
British Institute of Engineering Technology	xxxvi
British Insulated Callender's Cables, Ltd.	vii
E.M.I. Institutes	ii
Ericsson Telephones, Ltd.	xx, xxiv-xxv
Ferranti, Ltd.	xxxviii
General Electric Co., Ltd., The	x-xi, xviii-xix
Great Northern Telegraph Co., Ltd.	xvii
Hivac, Ltd.	xxxviii
Johnson, Matthey & Co., Ltd.	xxviii
Langham Thompson, Ltd., J.	xxii
Marconi's Wireless Telegraph Co., Ltd.	xxi, xxx-xxxi, xxxvii
Mullard, Ltd.	viii, xxxii
National Salt Glazed Pipe Manufacturers' Association	xxxiv
Neill, James, & Co. (Sheffield), Ltd.	xxxix
New Era Publishing Co., Ltd., The	ix
Painton of Northampton	vi
Pirelli-General Cable Works, Ltd.	xxxix
Pitman, Sir Isaac, & Sons, Ltd.	ii, xxxv
Pye, Ltd.	xii-xiii
Rawlplug Co., Ltd.	i
Siemens Edison Swan, Ltd.	xxiv-xxv, xxvi, xxvii, xxxiii
Smith, Frederick, & Co.	xxxvi
Standard Telephones & Cables, Ltd.	iv, v, xiv, xv xl
Telephone Manufacturing Co., Ltd.	ii, ix
Tungstone Products, Ltd.	xxix
Turner, Ernest, Electrical Instruments, Ltd.	iii
Westcliff Engineering Co., Ltd.	254
Westinghouse Brake & Signal Co., Ltd.	xvi
Winn & Coales, Ltd.	iii

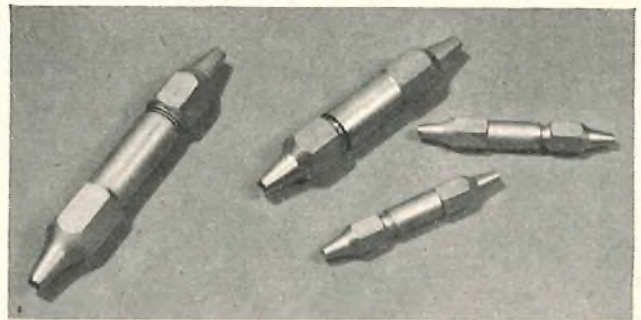

WESTCLIFF LINE CONNECTOR

This Connector will make a locked joint with bare solid conductors in such a manner that the joint can be opened and re-connected any number of times.

Manufactured in a range of sizes for 100 lbs. to 400 lbs. per mile Telegraph Wire.

Made from Brass and 'Pearl Chromium' plated to ensure maximum protection against corrosion on open wire lines.

Simple, foolproof in use.

prices on application

**WESTCLIFF
ENGINEERING COMPANY LIMITED**

**RYE ROAD, HODDESDON,
HERTFORDSHIRE**

Telephone: Hoddesdon 2340



DURIUM

Registered Trade Mark

The world's *FASTEST* masonry drill

DURIUM is the drill that revolutionized masonry drilling, staggering the industrial user with its amazing speed of penetration and sharp, silent, easy-cutting *accuracy!* With its tough, almost diamond-hard Durium tip, and its patented rapid-helix flute to force out spoil and prevent clogging, the Durium Drill penetrates masonry of all kinds at a speed unequalled anywhere in the world.

and the most durable

Just as important to your costs is the extraordinary *durability* of Durium Drills. Remember that masonry is an *abrasive* material which quickly ruins ordinary drills. The astonishing *toughness* of the Durium tip, and the stronger backing of steel given it by the specially designed flute, makes Durium Drills the world's most durable masonry drill.

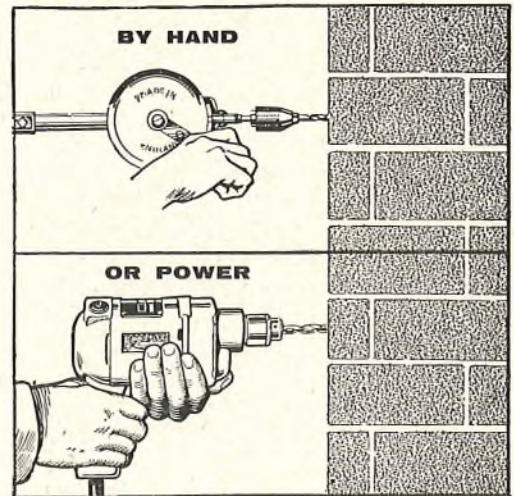

R.P.I. ELECTRIC DRILL This is the ideal power tool for use with Durium Drills. With a full load speed of 450 r.p.m. it combines high torque with a weight of less than 5 lbs.

Sold in the bright orange and blue metal container clearly marked Rawlplug Durium.

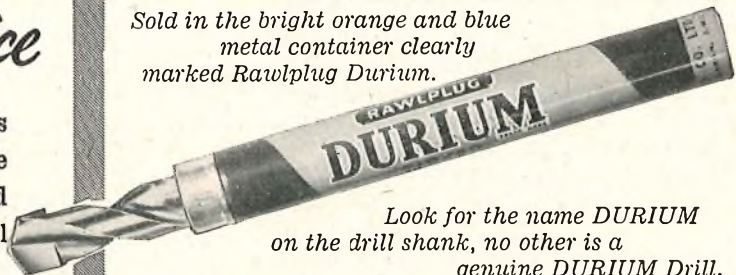

Look for the name *DURIUM* on the drill shank, no other is a genuine *DURIUM* Drill.

Free resharpening service

When, at long last, your Durium Drill begins to lose its keenness, return it to us with the complimentary voucher supplied with it, and we'll re-sharpen it **FREE!** Write now for full details of these fastest-of-all masonry drills.

TELECOMMUNICATIONS PRINCIPLES
(IN M.K.S. UNITS)

By R. N. Renton, C.G.I.A., M.I.E.E.
2nd Edition. This new edition, based entirely on the M.K.S. system, contains all the basic essential details of electricity and magnetism that every student of telephony, telegraphy or radio (including television) needs to know. Covers the syllabus for the C. and G. examination in Telecommunications Principles, Grades I, II and III. 45/- net.

**SOLUTION OF PROBLEMS IN
ELECTRICAL TECHNOLOGY**

By H. Cotton, M.B.E., D.Sc., M.I.E.E., and J. V. Parry, M.Sc.(Eng.), A.M.I.E.E.
This book contains a collection of graded worked examples (using the M.K.S. system) covering a wide range of electrical science and practice, as well as a number of questions (with answers) to be worked by the reader. Almost two-thirds of the 350 examples given are worked out in full. 20/- net.

PITMAN TECHNICAL BOOKS
Parker Street, Kingsway, London, WC2

PASS YOUR
CITY & GUILDS CERTIFICATES
AND
P.M.G. CERTIFICATE

We offer comprehensive home training in a wide range of subjects, including P.M.G. Certificates, City and Guilds Grouped Certificates in Telecommunications, A.M.Brit.I.R.E. Examination, Radio Amateur's Licence, Radio and Television Servicing Certificates, General Radio and Television Courses, Radar, Sound Recording, etc. Also Courses in all other branches of Engineering.

With the following Courses, Practical Kits are available.

Radio, Television, Mechanics, Electricity, Chemistry, Photography, Carpentry; also Draughtsmanship, Commercial Art, Amateur S.W. Radio, Languages, etc.

—Write now—

for FREE BROCHURE stating subjects of interest to:—

E.M.I. INSTITUTES

Dept. 97, LONDON, W.4

An Educational Organisation serving the E.M.I. Group of Companies, including "HIS MASTER'S VOICE", COLUMBIA, etc.

IC.64

OCT/58

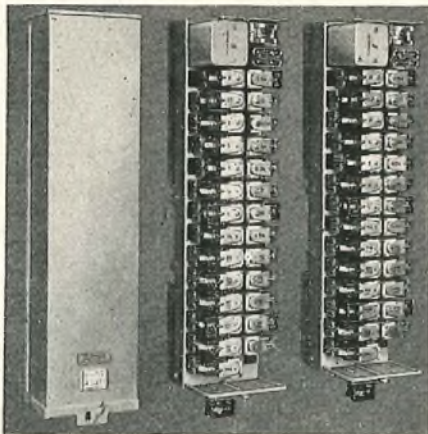

Parent Unit

Remote Subsidiary Unit

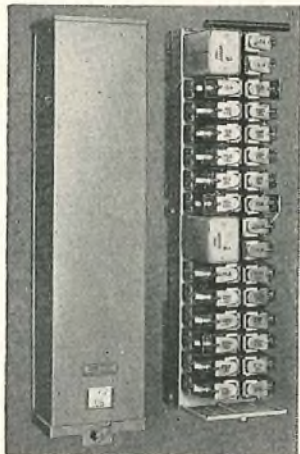

**SUBSCRIBERS'
LINE CONCENTRATOR**

An all relay communication system providing Telephone Service for TEN subscribers over TWO connecting links to an exchange . . . it is *not* a Party line . . . is fully secret, using standard telephone sets . . . drastically reduces plant costs without sacrificing facilities . . . complete system can be installed in a few hours . . . **neither battery nor power leads are required at remote Subsidiary Unit nor premises for housing it** . . . maximum reliability . . . visual and audible alarms provided in Parent Exchange to indicate line faults . . . a faulty junction automatically taken out of service.

The scheme can also provide . . . Night service for selected subscribers to Exchange with restricted hours of attendance . . . release of cable pairs to fully loaded D.Ps., or on cable routes pending new plant . . . service to blocks of Flats as alternative to P.B.X. . . service for Exhibitions, Race Meetings etc., by making pairs available without additional plant.

Write for technical data

TELEPHONE MANUFACTURING CO LTD
Hollingsworth Works, Dulwich, London SE21 Telephone GIPsy Hill 2211

Precision Measuring Instruments and Electronic Measuring Equipment

AS leading manufacturers of precision instruments for specific requirements and applications, Ernest Turner have over 35 years of experience in dealing with the problems of instrumentation in a rapidly advancing industry. In radio, television, nucleonics, air and marine navigation, medical research, telecommunications, atomic power; in Britain and in many other parts of the world—in tropical and temperate climates—on land, sea and in the air Ernest Turner instruments are giving reliable service.



Ernest Turner



ERNEST TURNER ELECTRICAL INSTRUMENTS LTD.

HIGH WYCOMBE BUCKS ENGLAND

Tel: HIGH WYCOMBE 1341-2-2

Cables: GORGEOUS, HIGH WYCOMBE

Full details of all Turner instruments and equipment are contained in Catalogue No. 85, available on request.

DENSO prevents CORROSION

Whatever the conditions, pipes, cables, conduits, etc. can be protected by Denso tape . . . above or below ground . . . or under water.

Corrosion prevention by the appropriate Denso method is complete and enduring.

Emergency repairs wrapped with Denso Tape are secure against moisture and dirt.

For all sealing and plugging, whether temporary or permanent, Denso Mastic H.D. is invaluable, and our new booklet gives full information.



WINN & COALES LTD., DENSO HOUSE, CHAPEL RD., LONDON, S.E.27

Telephone: GIPsy Hill 4247 (PBX)

Telegrams: Denselte, Westnor, London

SenTerCel

**SILICON
ZENER
DIODES**

Z 2 SERIES

**HAVE A LARGE DISSIPATION
FOR THEIR SIZE**

**ARE SUITABLE FOR HIGH
TEMPERATURE OPERATION**

**HAVE A LOW TEMPERATURE
CO-EFFICIENT OF VOLTAGE**

**ARE SUITABLE FOR USE AS
REGULATORS, LIMITERS,
SURGE SUPPRESSORS,
AND VOLTAGE REFERENCES**

**THE FIRST COMPLETE RANGE
OF CLOSE-TOLERANCE ZENER
DIODES AVAILABLE FROM
PRODUCTION**

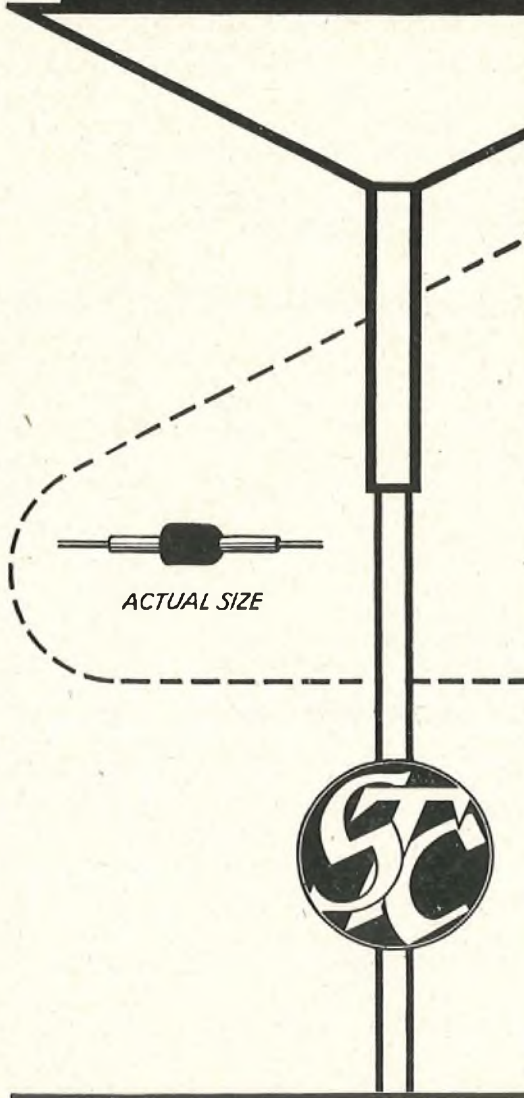

Z2 SERIES ZENER DIODES

±5% Voltage Tolerance (Red and Green Sleeves)		±10% Voltage Tolerance (Red and Yellow Sleeves)		±20% Voltage Tolerance (Red and Blue Sleeves)	
TYPE	NOM. VOLTAGE	TYPE	NOM. VOLTAGE	TYPE	NOM. VOLTAGE
Z2A33	3.3	Z2A33	3.3		
Z2A36	3.6			Z2A33	3.3
Z2A39	3.9	Z2A39	3.9		
Z2A43	4.3			Z2A47	4.7
Z2A47	4.7	Z2A47	4.7		
Z2A51	5.1			Z2A47	4.7
Z2A56	5.6	Z2A56	5.6		
Z2A62	6.2			Z2A68	6.8
Z2A68	6.8	Z2A68	6.8	Z2A68	6.8
Z2A75	7.5				
Z2A82	8.2	Z2A82	8.2		
Z2A91	9.1			Z2A100	10
Z2A100	10	Z2A100	10	Z2A100	10
Z2A110	11				
Z2A120	12	Z2A120	12	Z2A150	15
Z2A130	13				
Z2A150	15	Z2A150	15		

Characteristics and ratings of SenTerCel Zener Diodes are given in publication SIL/103A



Standard Telephones and Cables Limited

Registered Office : Connaught House, Aldwych, London, W.C.2

RECTIFIER DIVISION

EDINBURGH WAY · HARLOW · ESSEX

S
T
C

LOW TRAFFIC CAPACITY

TRANSMISSION SYSTEMS

**TRANSISTORISED & THERMIONIC VALVE
TELEPHONE & TELEGRAPH SYSTEMS**

1-3-10-12-24-60-120-300 circuits

TRANSISTORISED EQUIPMENT includes:-

- **3-circuit carrier telephone system**
- **10-circuit telephone system for rural service**
- **12-circuit, 2-wire carrier-on-cable telephone system**
- **300-circuit small diameter coaxial cable telephone system**
- **24-circuit FM telegraph equipment**

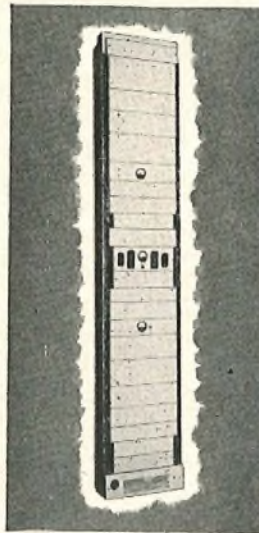

*Typical Transmission
Equipment rackside.*

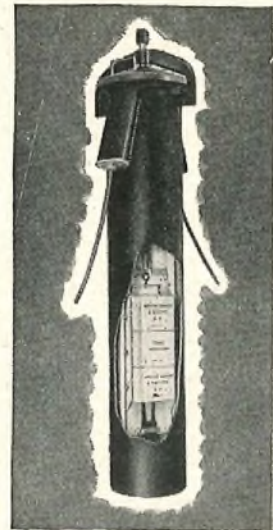

*Transistorised Coaxial
Dependent Repeater.*

Typical VHF Radio Equipment

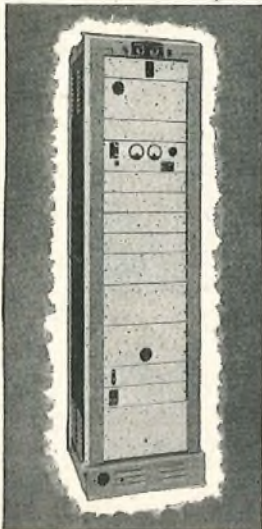

RADIO SYSTEMS include:-

- **F.P.1. series**
- **F.P.11 series**
- **Frequency-modulated SHF radio system**
7300 Mc/s to 7500 Mc/s

CARRIER-ON-CABLE TELEPHONE SYSTEMS

CARRIER PROGRAMME CHANNELLING EQUIPMENT



Standard Telephones and Cables Limited

Registered Office: Connaught House, Aldwych, London, W.C.2

TRANSMISSION DIVISION: NORTH WOOLWICH · LONDON · E.16

THE NEW 'FLATPOT' POTENTIOMETER



This most recent addition to the comprehensive range of Painton potentiometers provides the electronic industry with a robust subminiature component that has been developed primarily for use with printed circuits, although its general design makes it eminently suitable for a wide range of applications; it is particularly useful where conditions of vibration pose problems for the design engineer. Its unusual 'linear' construction simplifies mounting and stacking where chassis space is at a premium.

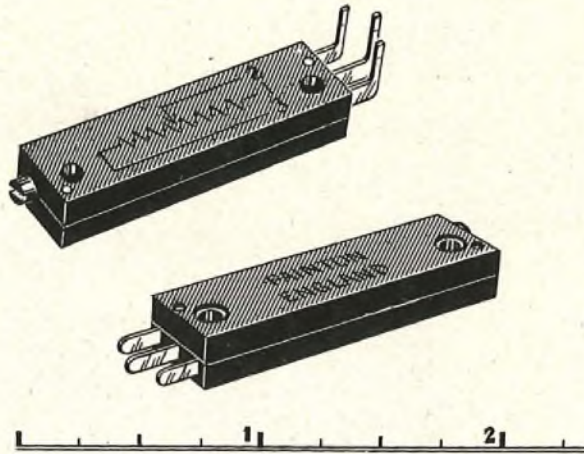

The potentiometer winding, slider and drive are totally enclosed by a nylon filled plastic housing.

The slider is driven by a lead screw, whose head projects from the housing, permitting fine adjustment and resulting in stable settings.

The unique construction ensures rigidity and strength and minimises the likelihood of oxidation of the contact surfaces.

Damage to the mechanism by overwinding is obviated by a slipping nut device.

Straight or 90° terminals are available.

Gaps between terminals and distance between the two locating holes conform to the 0.1 inch module common in printed circuit boards.

Range: 10 Ω to 10K Ω

Tolerance: 10%

Power Rating: 1 watt at 20°C ambient

No. of turns from zero to maximum resistance: 25

Insulation Resistance: in Excess of 1000M Ω

Weight: 0.1 oz. (approx.)

Write for technical leaflet

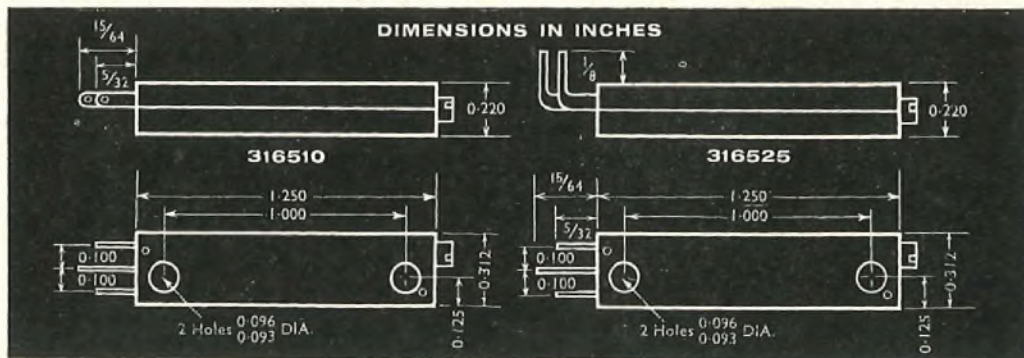
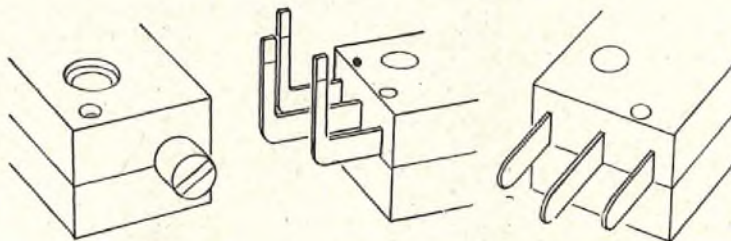

Painton & Co. Ltd.

KINGSTHORPE NORTHAMPTON

Tel: 32354-5-6 Telegrams: 'Ceil, Northampton'

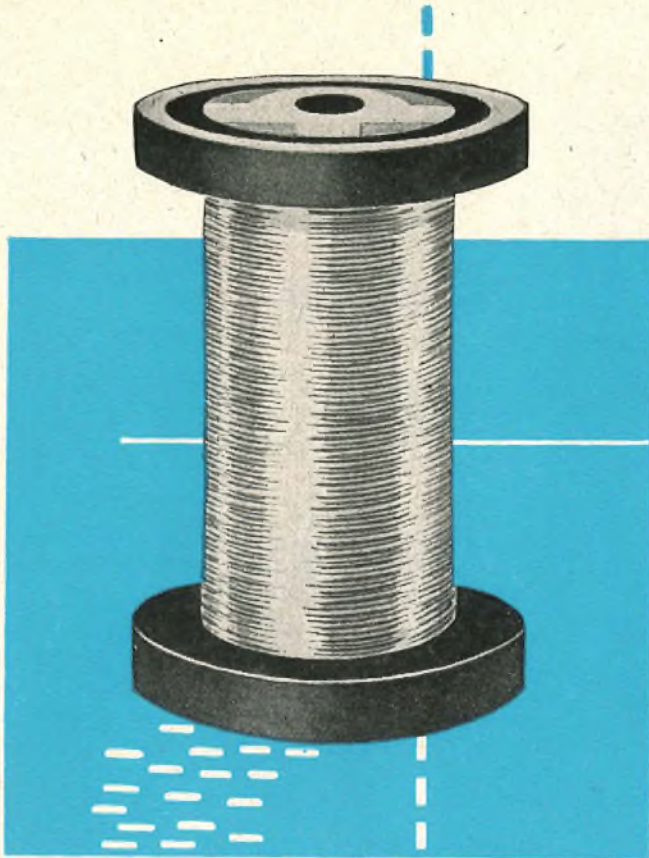

news for coil makers

a **TOUGH** self-fluxing winding wire

For continuous operation at "hottest-spot" temperatures of up to 120°C.

Adherent and resistant to solvents.

Can generally be used without changes in coil design, winding or impregnation.

Developed in BICC's own laboratories, Bicelflux is an enamel covering for winding wires with toughness approaching that of vinyl acetal or epoxy resin coverings but — *much easier to solder*.

Bicelflux is self-fluxing, with an action comparable to that of organic activated rosin fluxes.

As a result, Bicelflux windings are ideal for applications where large numbers of soldered joints are required, for example in radio and telecommunication equipment.

Further details are given in BICC Publication No. 376 — yours for the asking.

BICC

Bicelflux

WINDING WIRES

BRITISH INSULATED CALLENDER'S CABLES LIMITED, 21 Bloomsbury Street, London, W.C.1

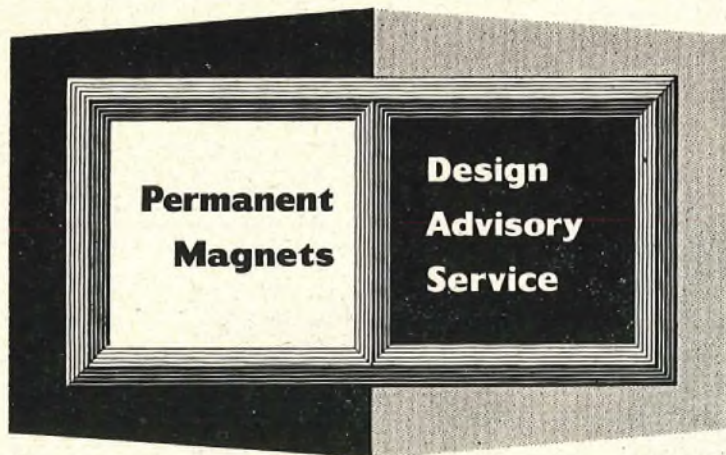

No.7

Stability

Advertisements in this series deal with general design considerations. If you require more specific information on the use of permanent magnets, please send your enquiry to the address below, mentioning the Design Advisory Service.

Modern permanent magnets have indefinite life under normal working conditions. Providing the magnet is not too close to interfering magnetic fields, subjected to wide temperature changes, or in accidental contact with ferrous objects, the magnetic performance will remain virtually constant, subject only to a small cyclic temperature variation.

An outstanding advance in the manufacture of permanent magnets was made with the introduction of Mullard anisotropic (directional) "Ticonal" magnets—with a performance of over three times that of other materials with a relative increase in stability. A more recent Mullard development is "Magnadur"—a

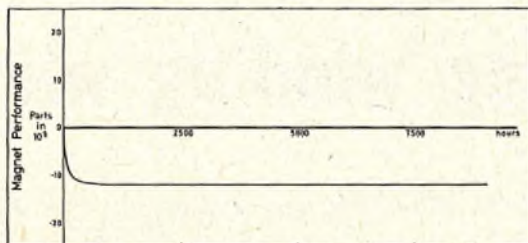

This graph indicates the extreme stability of a "Ticonal" "G" magnet working at approximately $(BH)_{max}$, after being stabilised by a 2% reduction from initial magnetic saturation.

ceramic permanent magnet known for its exceptionally high coercive force and high resistivity, with a comparable stability but with a higher temperature co-efficient of magnetic performance.

To achieve maximum stability the magnet is first saturated in its associated magnetic circuit, then returned to its working condition at approximately $(BH)_{max}$. It should then be

If you wish to receive reprints of this advertisement and others in this series write to the address below.

demagnetised to a value not less than $1\frac{1}{2}\%$ lower than any operational contingency is likely to produce.

Vibrational Stability

Mullard magnets, when stabilised as described above, will not change their magnetic performance even under the most severe conditions of vibration. The magnets will suffer mechanical damage and actual fracture before a change in performance can be detected.

Temperature Stability

"Ticonal" magnets have a small cyclic temperature co-efficient of magnetic performance between -40°C . and $+200^{\circ}\text{C}$. of approximately -0.02% per $^{\circ}\text{C}$. Prolonged exposure to temperatures above 500°C . may produce permanent metallurgical changes which can result in a reduction of magnetic performance.

"Magnadur" magnets have a cyclic temperature co-efficient of approximately -0.2% per $^{\circ}\text{C}$. which should be taken into account in equipment operating over wide temperature ranges.

Stability against external fields

Providing the interfering external magnetic field is lower than the field used for initial stabilisation, no change in performance should result. To ensure stability against severe external interfering fields, it may be necessary to demagnetise the magnet initially by a fairly large amount, or use magnetic screening.

As both these methods will reduce the performance of the magnet, assistance with this type of problem should be obtained from the Mullard Design Advisory Service.

Mullard 

'TICONAL' PERMANENT MAGNETS
'MAGNADUR' CERAMIC MAGNETS
FERROXCUBE MAGNETIC CORES

If you are interested in CAPACITORS to

TELECOMMUNICATIONS STANDARDS



offer you **RELIABILITY** +

BRITISH POST OFFICE TYPES

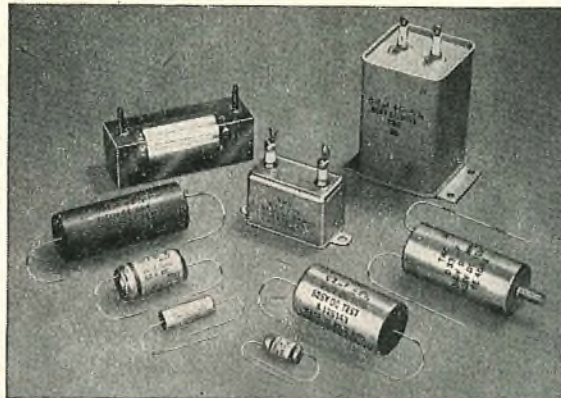
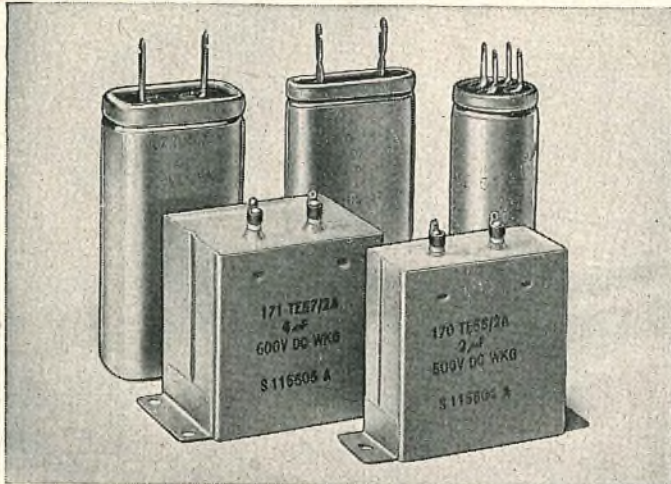

POLYSTYRENE CAPACITORS

TMC POLYSTYRENE CAPACITORS offer the Engineer an insulation 50 times greater than Mica with comparable stability plus an attractive price advantage.

In addition to standard ranges of metallized paper, precision paper and silvered mica capacitors, we also have many designs and ratings suitable for abnormal conditions and unusual locations.

Write to

Component Sales Division

TELEPHONE MANUFACTURING CO. LTD.

CRAY WORKS · ST. MARY CRAY · ORPINGTON · KENT

Telephone: ORPINGTON 26611

TELECOMMUNICATIONS PRINCIPLES (in MKS. Units)

by R. N. RENTON, C.G.I.A., M.I.E.E.

This book is an exhaustive guide to the fundamental principles underlying the Practice of Telegraphy, Telephony and Radio!

These books are the STANDARD HANDBOOKS on the subject and may be purchased on our MONTHLY PAYMENT SYSTEM by completing the coupon below with the title or titles required with the appropriate price as follows:

TELEPHONY Vol. 1 £2 0 0 cash. £2 2 0 subscription at 7/- per month.

TELEPHONY Vol. 11 £2 15 0 cash. £3 0 0 subscription at 10/- per month.

TELECOMMUNICATIONS PRINCIPLES £2 5 0 cash. £2 10 0 subscription at 7/6 per month.

If more than one title is ordered a combined monthly payment of 12/6 is acceptable)

TELEPHONY Vol. I

by J. A. ATKINSON, A.M.I.E.E.

General Principles and Manual Exchange Systems. A detailed exposition of the Telephone Exchange Systems of the British Post Office.

TELEPHONY Vol. II

by J. ATKINSON, A.M.I.E.E.

Automatic Exchange Systems. A continuation of volume I to cover Automatic Exchange Systems of the British Post Office.

To THE NEW ERA PUBLISHING CO. LTD.

P.O. BOX 109. 45 NEW OXFORD STREET, LONDON, W.C.1.

Please send me, carriage paid, for my inspection

Titles

I am under no obligation to purchase provided I return the Books within 8 days of Receipt. If I keep the Books, I promise to Remit to your Address I understand that £ per month until the full subscription price of £ has been paid. Cash price £ if paid within 30 days of receipt of parcel. (Please fill in Blanks according to Titles ordered.)

Signature

Name

(Block Letters please)

Address

Address of Employer.....

Date Age if under 20.....

P.O.10

ATTRACTIVE...



EFFICIENT

THE

G.E.C.

'1000' TELEPHONE

THE GENERAL ELECTRIC COMPANY LIMITED OF ENGLAND

.....and now

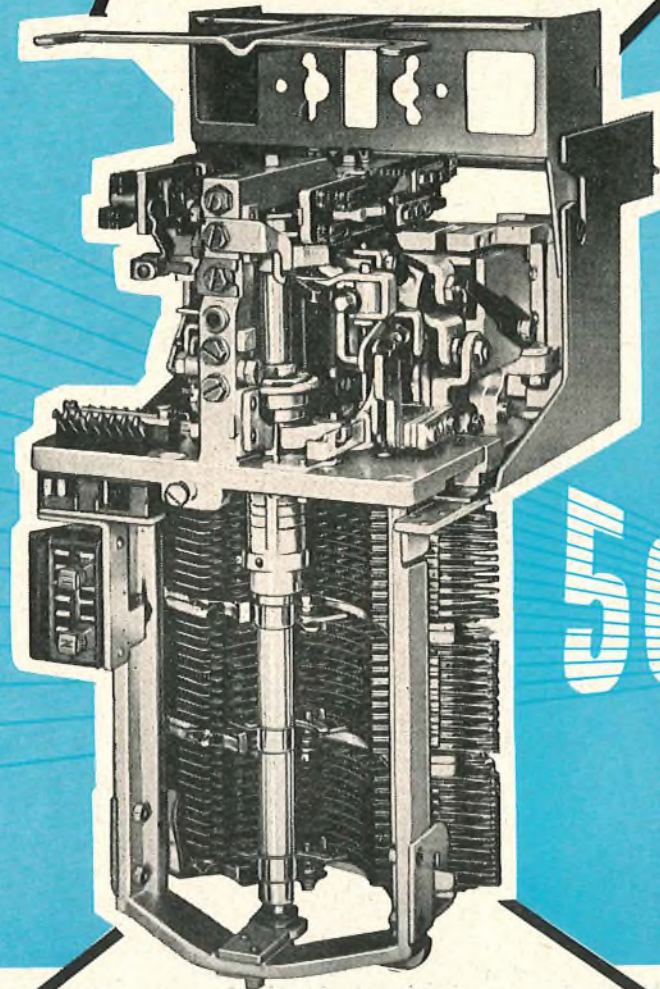

SE

50

ADOPTED BY THE B.P.O.
FOR NEW EXCHANGES

THE **G.E.C.** SE 50 SELECTOR

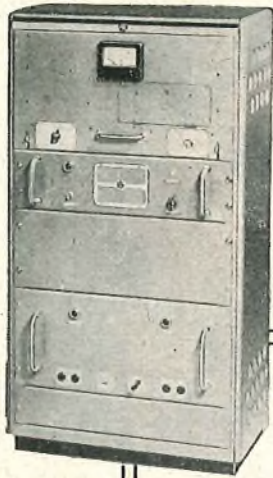

50 watt
V.H.F. Fixed
Station

Boot Mounting
"Ranger" V.H.F.
(F.M. or A.M.)
Mobile
Radiotelephone



Remote Control Unit
for H.F. Fixed Station



2 Mc/s Transistor Oscillator

Designed and made by Pye

Throughout the entire field of radio communications Pye Telecommunications design and make equipment for almost every conceivable application. The range shown here is by no means complete. The items selected are intended to show the versatility and enterprise of our designers.

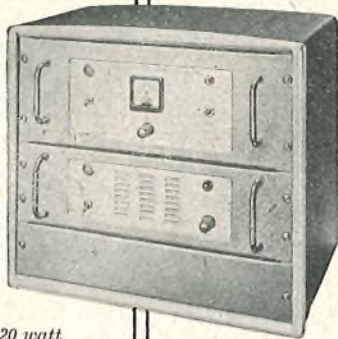

20 watt
V.H.F. Fixed
Station

Microwave
Television
Link



PYE TELECOMMUNICATIONS LTD.

Telephone: Teversham 3131

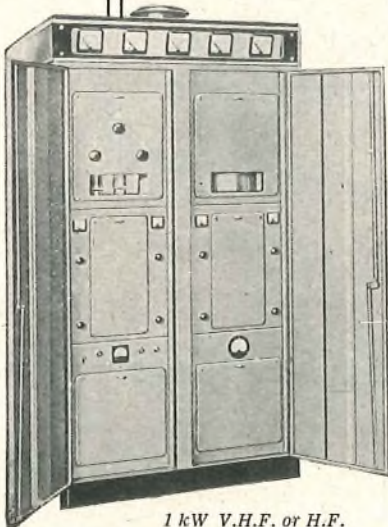

1 kW V.H.F. or H.F.
Fixed Station

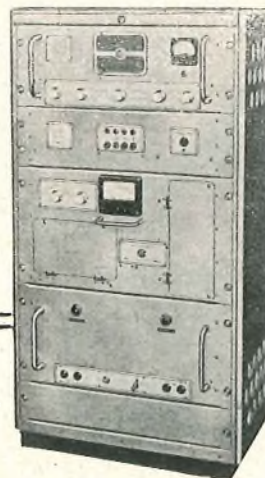

60 watt H.F.
Fixed Station

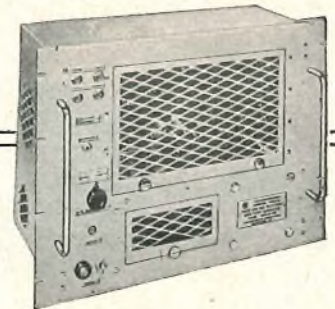

Pulse and Bar Waveform
Generator

*Dash Mounting "Ranger"
V.H.F. (F.M. or A.M.)
Mobile Radiotelephone*



*Fan Marker
Beacon*

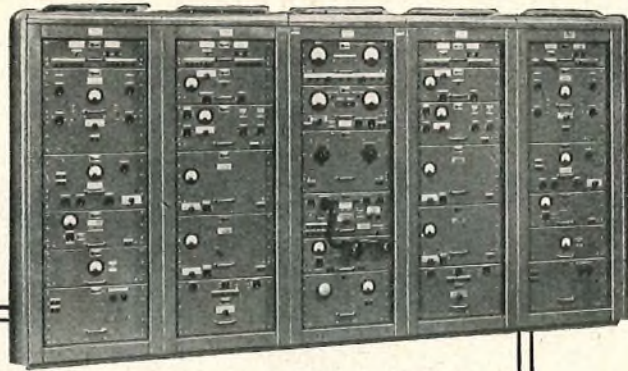

Instrument Landing System

Telecommunications Ltd.

With Service Depots and Distributors in 91 countries all over the world, your Pye communications equipment will be backed by an organisation which is second to none. It is at your service for the asking.

Newmarket Road, Cambridge
Telegrams: Pyetelecom Cambridge

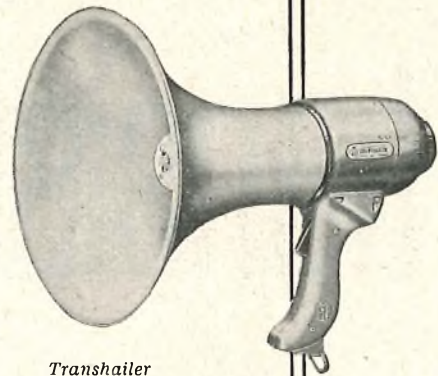

Transhailer

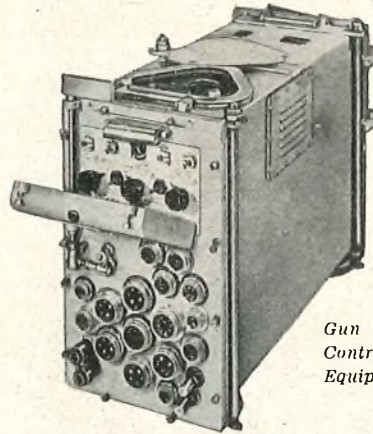

*Gun
Control
Equipment*

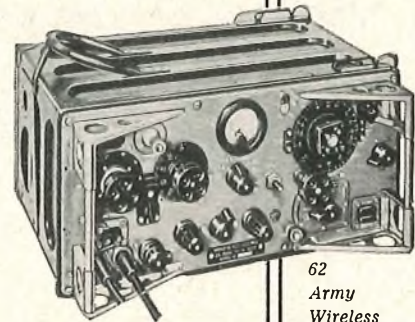

*62
Army
Wireless
Set*

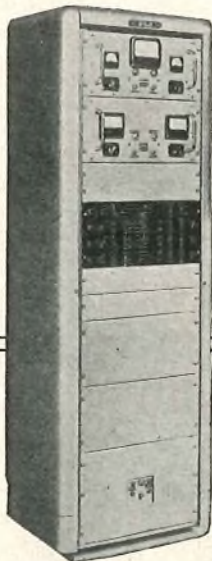

*7-channel
Multiplex
Terminal*

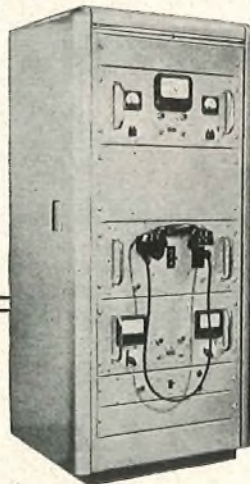

Music Link

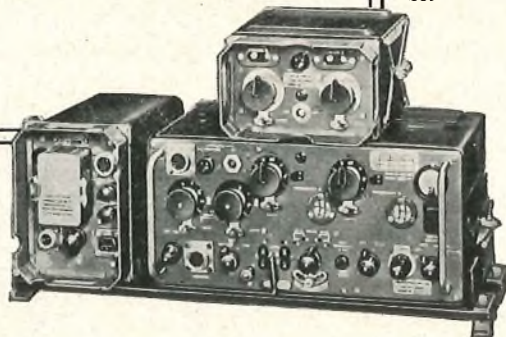

C12 Army Wireless Set

STC

transistorised

transmission

equipment

- CONSUMES LESS POWER
- MINIMISES FLOOR SPACE
- LONG LIFE OPERATION
- UP-TO-DATE CONSTRUCTION SIMPLIFIES MAINTENANCE

Leaders in research and the design, development and manufacture of Transmission equipment, S.T.C. continues to meet increasing demands for high quality communication equipment. The use of transistors is one of the latest techniques and some of the various applications are illustrated in the systems and equipment shown.

A longer working life, greater economy of power and the occupation of minimum floor space are advantages gained; in addition, new style construction gives greater accessibility to the equipment.

S.T.C. hermetically-sealed junction-type transistors are used. Operation is from mains voltages of 100-130V or 200-260V, 50/60 c/s, or from station batteries of 24-50V.

12-CHANNEL 2-WIRE CARRIER-ON-CABLE SYSTEM

Provides 12 two-way CCITT telephone channels on one cable pair and is suitable for application to many types of cables. Two terminal equipments complete with ring-down signalling panels and 2/4 wire terminating sets are mounted on one 9 ft. rackside.



Stan

TRANS

TRANSISTORISED THREE-CHANNEL TELEPHONE AND TELEGRAPH SYSTEM TYPE STO C & D 3/6

Provides three CCITT quality telephone channels or two CCITT quality, plus one narrow band, telephone channels with six frequency modulated telegraph channels on one open-wire pair. Two complete terminals mounted on one 9 ft. high by 1 ft. 8½ in. wide equipment rackside.



300-CHANNEL SMALL DIAMETER COAXIAL CABLE SYSTEM

Ideal for the economic provision of telephone circuits over trunk routes of comparatively low traffic density, this system employs a small compact transistorised dependent repeater which may be buried in the ground. The lightweight cable is suitable for aerial installation.



TRANSISTORISED AUDIO REPEATER

A complete V.F. junction type repeater with through dialling and ringing facilities for installation at each terminal of a loaded junction type circuit. The power drain of the repeater is less than ½ W.

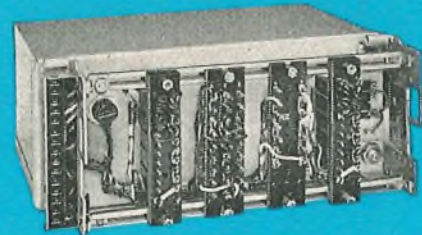

TRANSISTORISED FREQUENCY-SHIFT MODULATED V.F. TELEGRAPH SYSTEM TYPE TF.3

Provides 24 high quality frequency shift modulated voice-frequency telegraph channels suitable for teleprinter and telex circuits in national or international networks. Up to 36 channels may be accommodated on one terminal rackside.

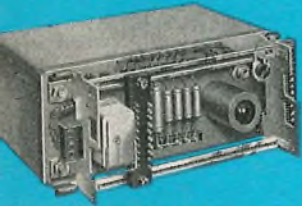

TRANSISTORISED REGENERATIVE REPEATER EQUIPMENT

Reforms signals having up to 49% distortion, at signalling speeds up to 100 bauds with 7, 7½ or 8 unit codes. Thirty-six repeaters can be accommodated on one 9 ft. rackside.



*for telegraphy
and telephony*

RURAL CARRIER TELEPHONE SYSTEM

Provides 21 "stackable" channel frequencies to enable up to 10 two-way circuits to be transmitted over one pair of wires with facilities for terminating one or more circuits at intermediate points on the route.

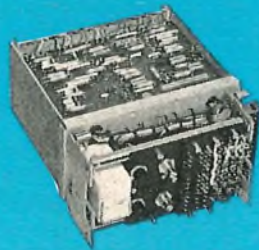
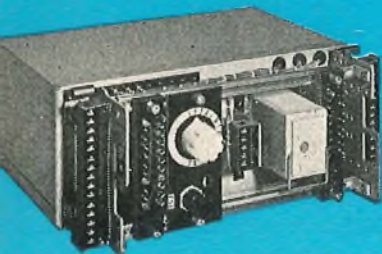

Standard Telephones and Cables Limited

Registered Office: Connaught House, Aldwych, London, W.C.2

MISSION DIVISION: NORTH WOOLWICH · LONDON E.16

TELECOMMUNICATION ENGINEERS...

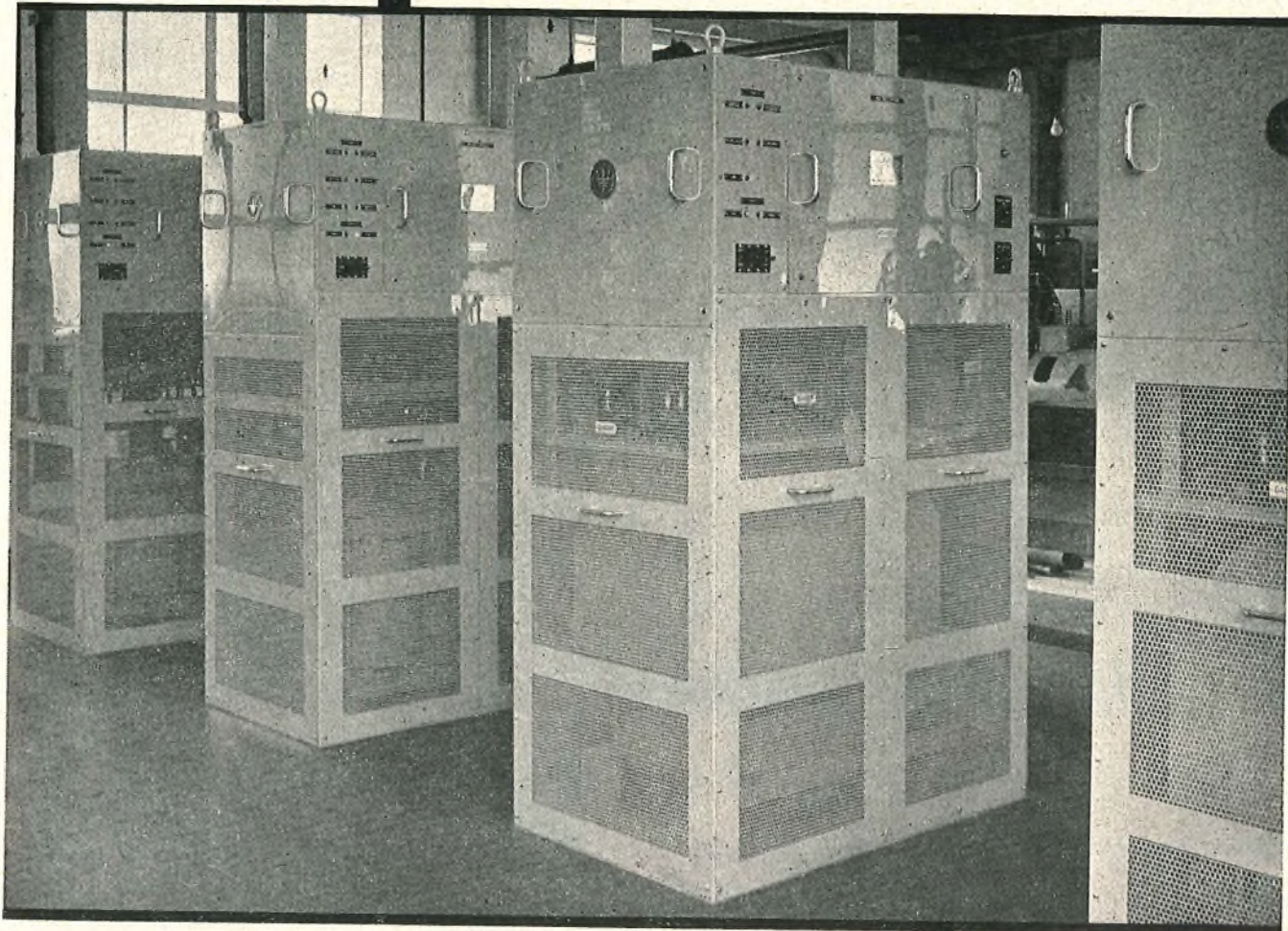

*Repeater Station, Ryde, Isle of Wight.
(Courtesy of British Post Office)*

WESTINGHOUSE **RECTIFIERS**

employing either mechanically regulated or transducer systems with electronic, magnetic or transistorised control will bring your plant up to date.

Manufacturers of silicon, germanium, selenium and copper-oxide rectifiers

Westinghouse Brake and Signal Co. Ltd., 82 York Way, King's Cross, London, N.1.

'Phone: TERminus 6432



5-unit tape transmitter

model 20

Sequential type for single wire transmission.
For single or double current operation.
7 $\frac{1}{2}$ unit transmission at 45.5, 50, or 75 bauds

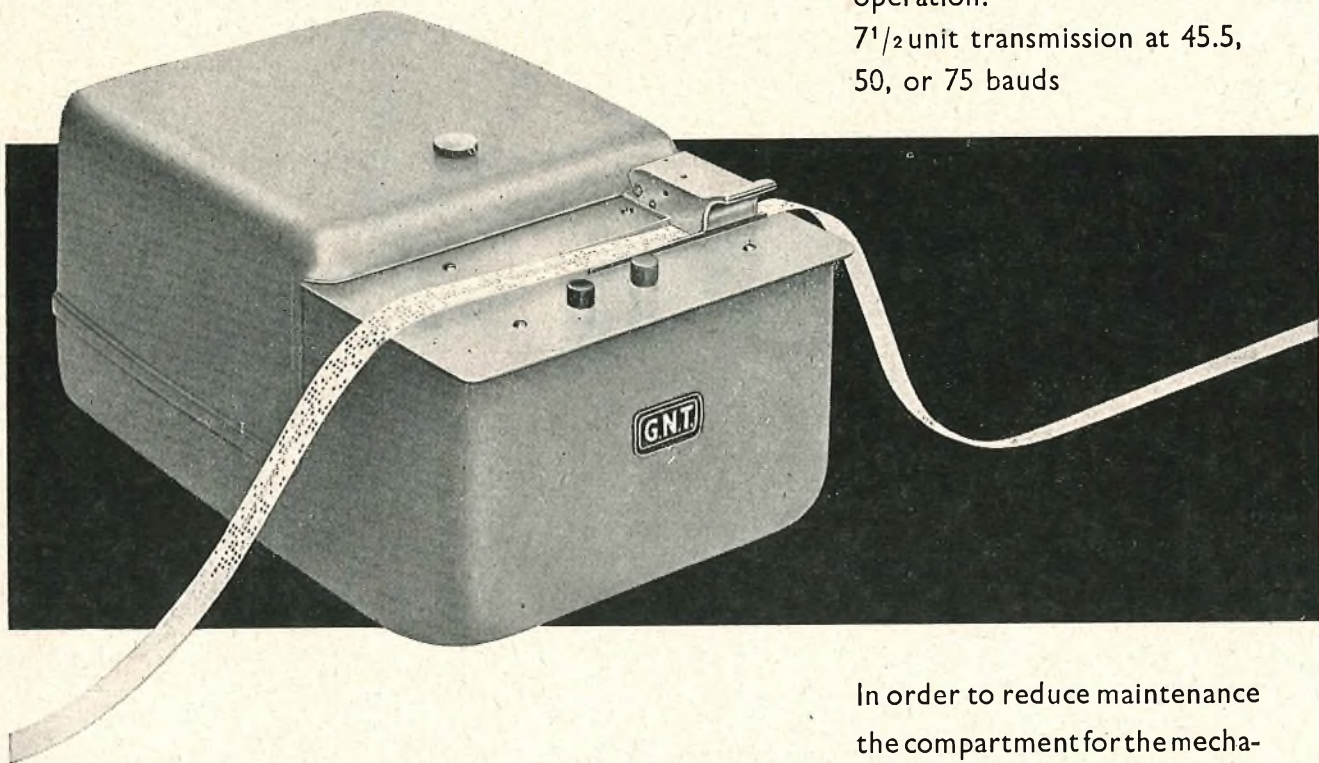

*Meets all the requirements
of a modern 5-unit tape transmitter.*

In order to reduce maintenance the compartment for the mechanism is pressurised so that dust and paper fluff cannot enter the operating parts.



GREAT NORTHERN TELEGRAPH WORKS

DIVISION OF THE GREAT NORTHERN TELEGRAPH CO. LTD.

4, SYDHAVNS PLADS
COPENHAGEN SV, DENMARK

LONDON OFFICE: 5, ST. HELEN'S PLACE
LONDON E. C. 3.



G.E.C.

3 CIRCUIT AND 12 CIRCUIT

OPEN-WIRE CARRIER

Telephone Equipment

The equipment is suitable for operation under varied climatic conditions. For example, a G.E.C. 12-circuit system is operating successfully near the Arctic Circle where severe icing conditions are experienced during the winter months.

Everything for Telecommunications by open-wire line, cable and radio; single and multi-circuit

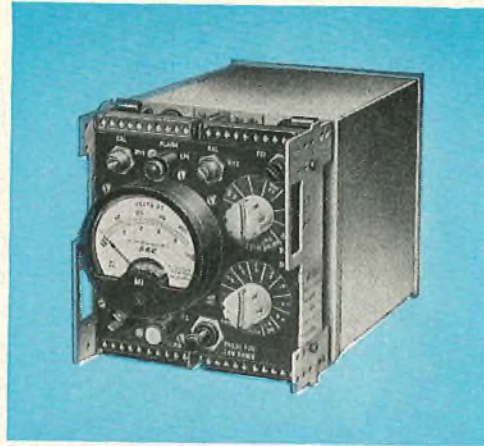
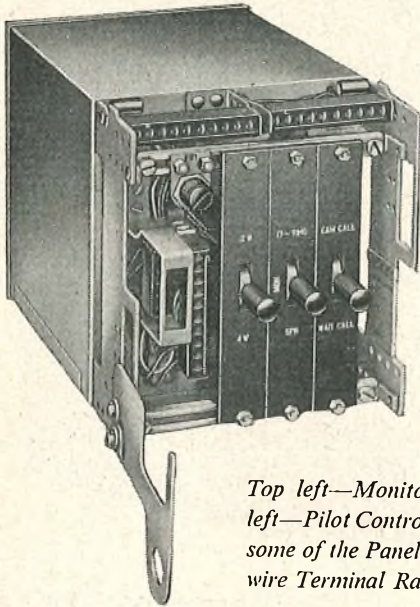

Top left—Monitor, top right—Alarm, bottom left—Pilot Control and bottom right—Amplifier, some of the Panels used in the 12-Circuit Open-wire Terminal Rack shown on the right.

G.E.C. 3-circuit and 12-circuit carrier telephone equipment provides for the transmission of three and twelve high-quality speech circuits, respectively, over an open-wire route. Each speech circuit effectively transmits the frequency band 300 c/s to 3400 c/s. Signalling is effected at the out-of-band frequency of 3825 c/s on each circuit.

The signals transmitted to line in the 12-circuit system are within the frequency band 36 to 143 kc/s, and in the 3-circuit system within 3.16 to 31.1 kc/s in accordance with the recommendation of C.C.I.T.T.

Thus a 3-circuit and a 12-circuit system can operate over the same open-wire pair. Several systems can operate along the same route.

When required, a broadcast programme circuit of approximately 10 kc/s bandwidth can be inserted at the intermediate frequency of 84 to 96 kc/s, in place of three speech circuits in either system. In addition, twenty-four voice-frequency telegraph channels can be provided over any speech circuit.

By suitably spacing repeaters along the route, a system may be operated over distances of many hundreds of miles, the exact distance and spacing of repeaters depending on local conditions.

The equipment itself is the latest G.E.C. Type 56. A complete 3-circuit terminal or a complete 12-circuit terminal is accommodated on one single-sided rack.

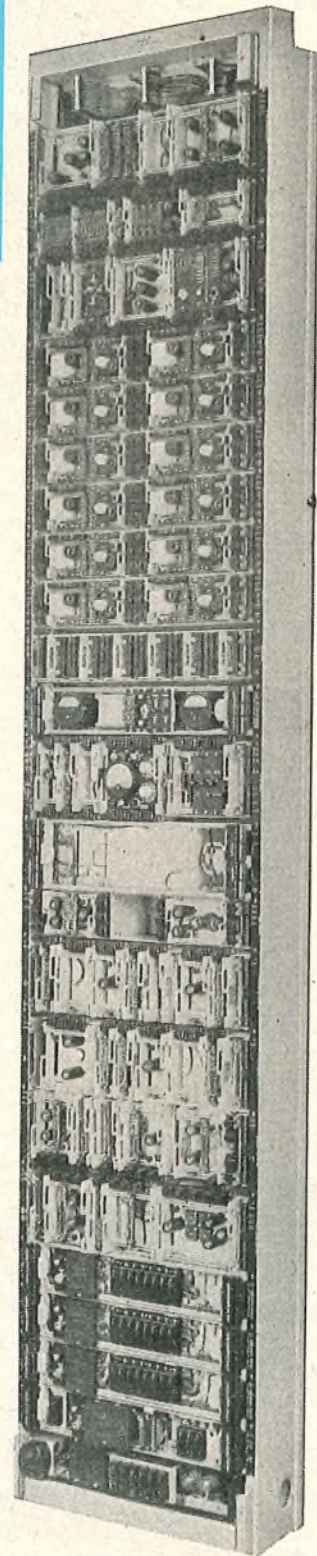

For further information please write for Standard Specifications

SPO1011
and
SPO1025

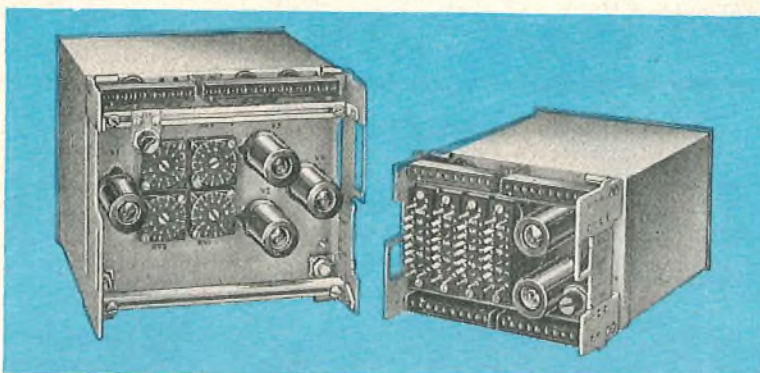

and TV link; short, medium and long haul. Automatic and Manual exchange.

TELEPHONE, RADIO & TELEVISION WORKS · COVENTRY · ENGLAND



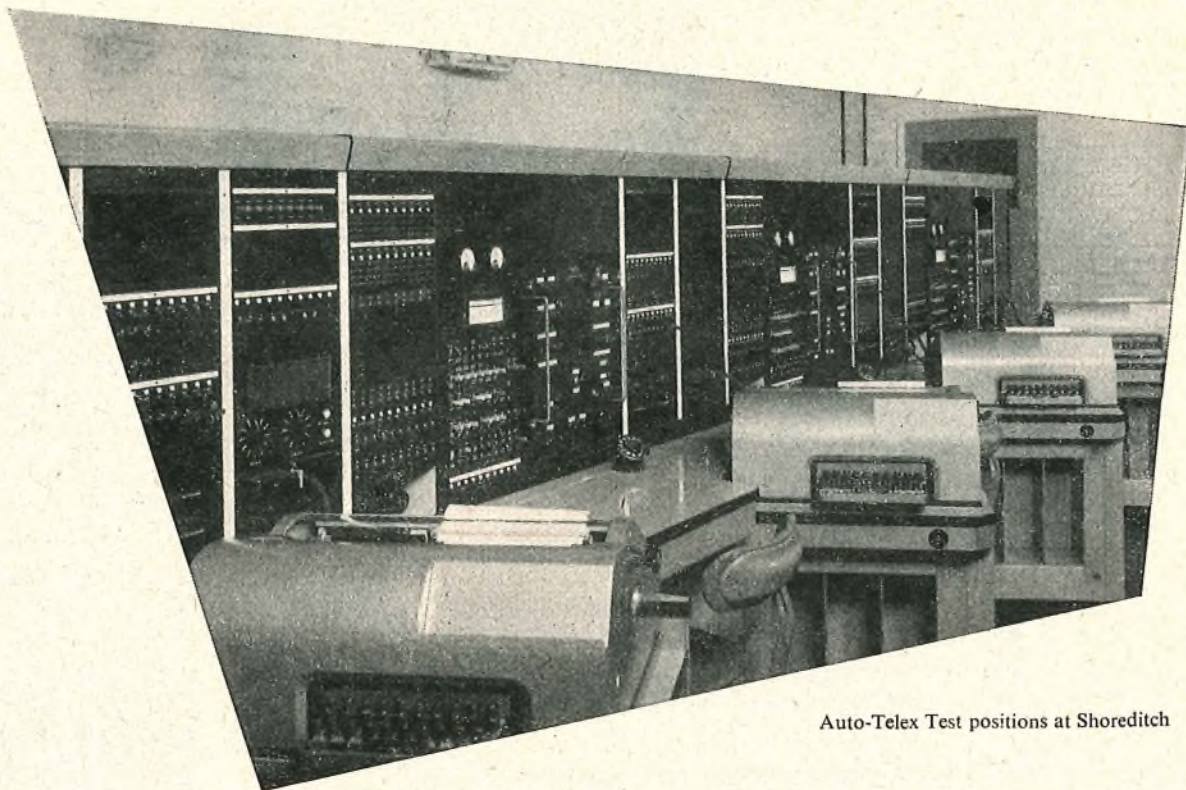

Auto-Telex Test positions at Shoreditch

TELEX

goes **AUTOMATIC.....**

The Pilot installations at Shoreditch (London) and Leeds initiate a programme of automatic telex development planned to provide over the next few years a complete network throughout the British Isles. Designed by the British Post Office, manufactured and installed by Ericsson, this new equipment will give auto-telex subscribers direct dialling access to others within the system without the aid of a manual switchboard operator.

Automatic equipment now being manufactured will give British subscribers direct dialling access to the extensive continental network.

This facility will without doubt play an increasingly important part in any future European trading developments.

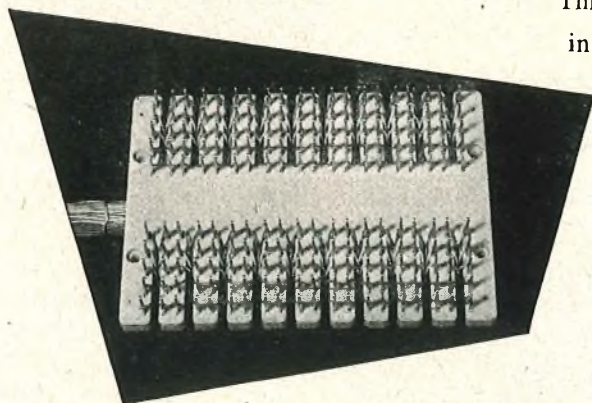

Featured in these installations is the new connection strip which gives complete protection against heat shock during termination. In this way it is possible to use plain P.V.C. covered wire throughout, which represents a considerable saving in cost over previous methods.

**ERICSSON TELEPHONES LTD.
ETELCO LTD.**



HEAD OFFICE: 22 LINCOLN'S INN FIELDS, LONDON, W.C.2

Marconi in Telecommunications

The post and
telegraph
authorities
of more than
80 countries
use Marconi
equipment

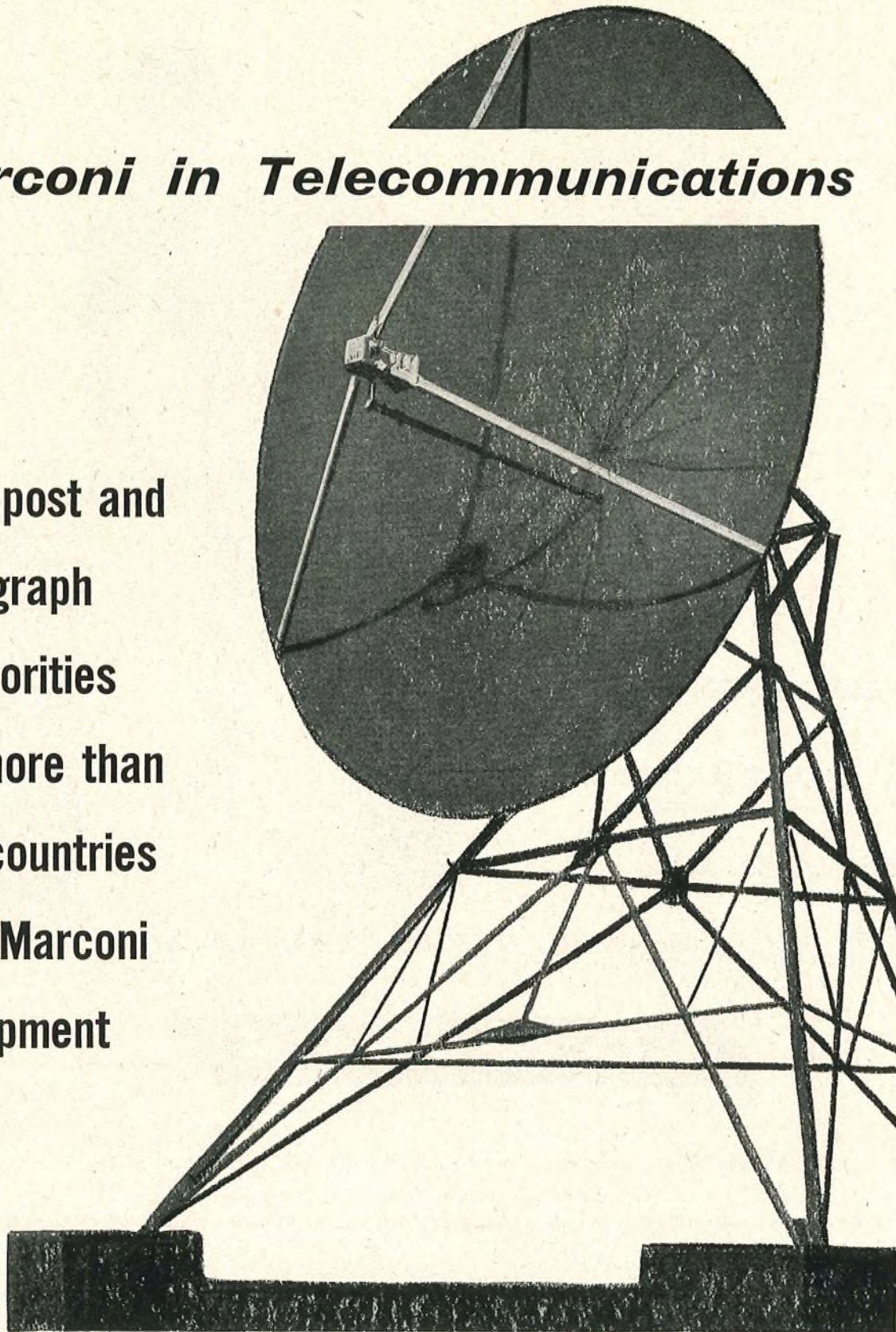

MARCONI

COMPLETE COMMUNICATION SYSTEMS
SURVEYED · PLANNED · INSTALLED · MAINTAINED

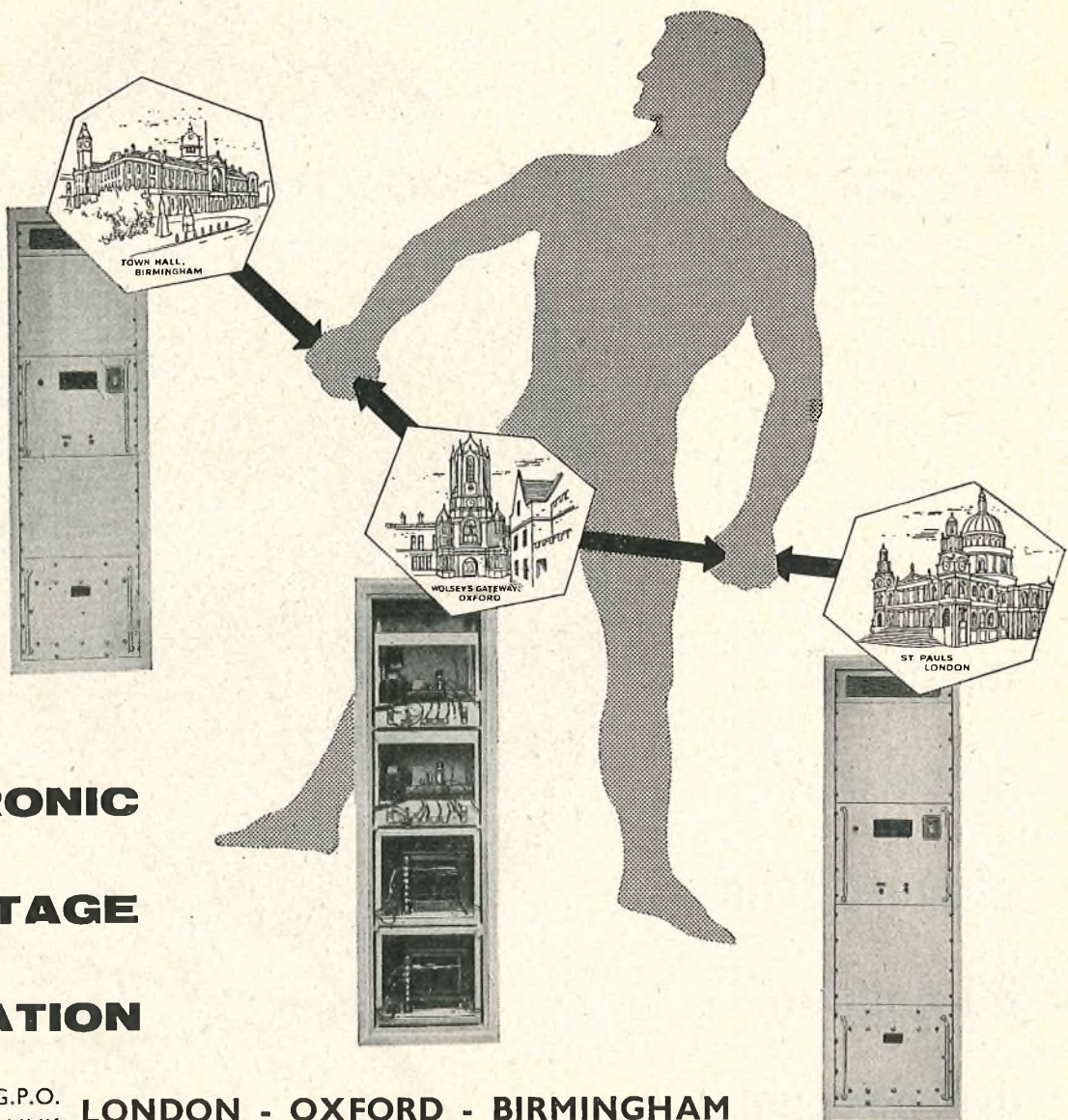

**ELECTRONIC
VOLTAGE
REGULATION**

ON THE NEW G.P.O. CABLE LINK **LONDON - OXFORD - BIRMINGHAM**

by **SORENSEN**

Complete 5kVA Sorensen Electronic Voltage Regulators have been chosen by the Post Office to stabilise the power supplies for the new London-Oxford-Birmingham 12 Mc/s Co-axial Cable Link. With their reliability and exceptional accuracy, Sorensens are ideally suitable for this type of important work.



J. LANGHAM THOMPSON LTD.

BUSHEY HEATH · HERTS · ENGLAND

Telephone : BUShey Heath 2412 Grams & Cables "Tommy Watford"

AD/511

In sixty-five countries round the world,
Alton batteries are in service. Abroad, as at
home, their reputation rests on their merit;
and no battery's reputation is higher.

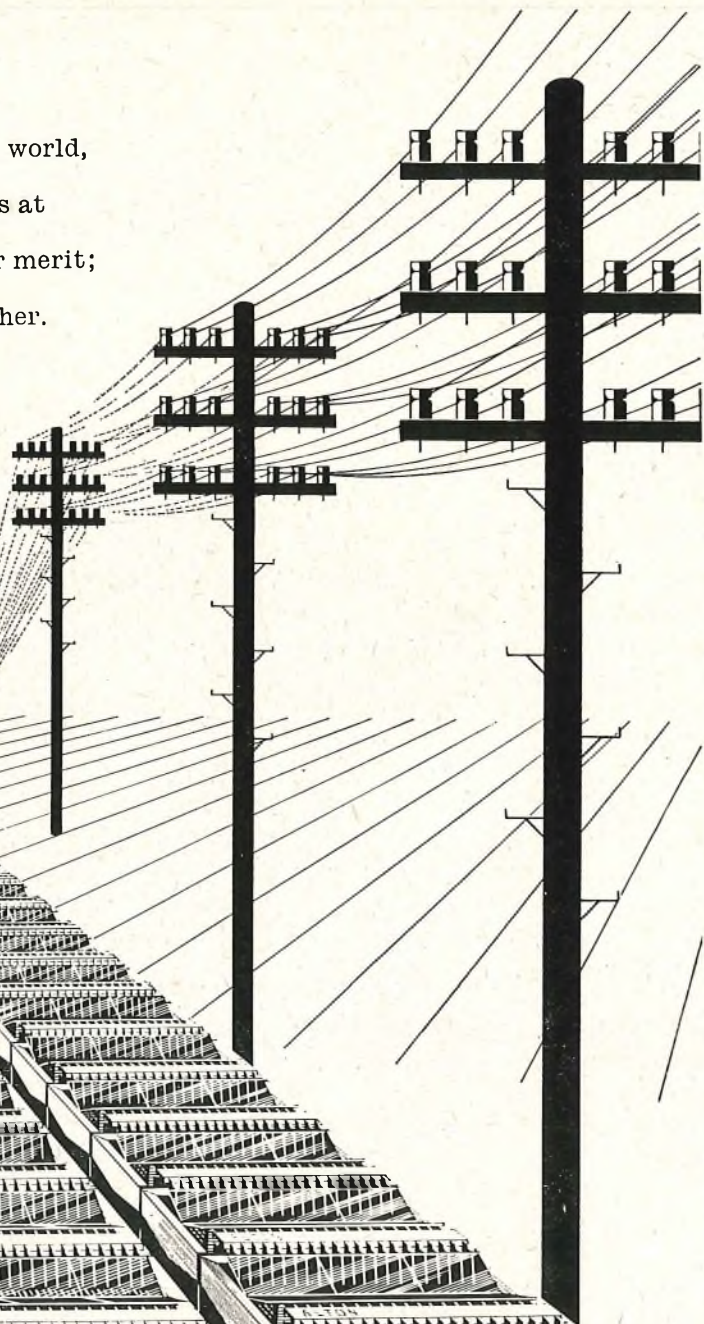
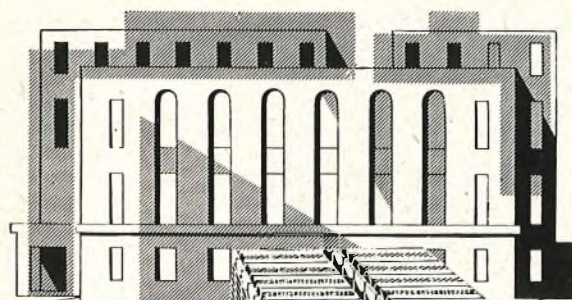

ALTON

BATTERIES OF MERIT

*Stationary batteries of 10 to 15,000 Ah.
Also renewal plates for all makes of battery,
British and Continental.*

THE ALTON BATTERY CO. LTD. · ALTON · HANTS.
TEL : ALTON 2267, 2268. GRAMS : BATTERY, ALTON

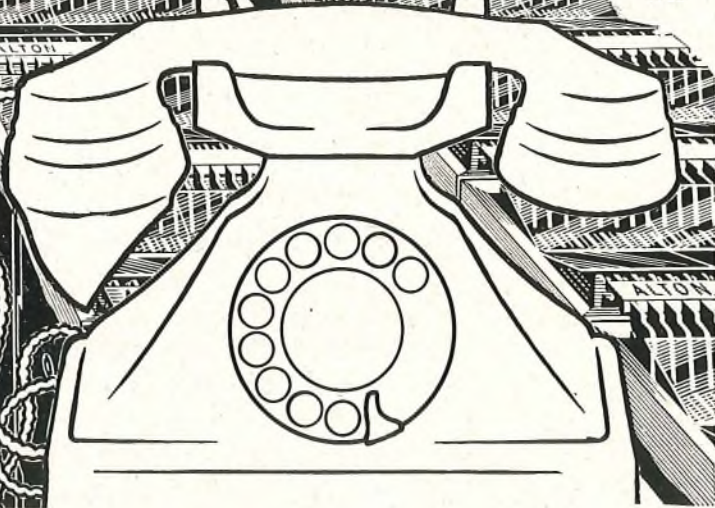

A 32

and now ...

706, the new *POST OFFICE*

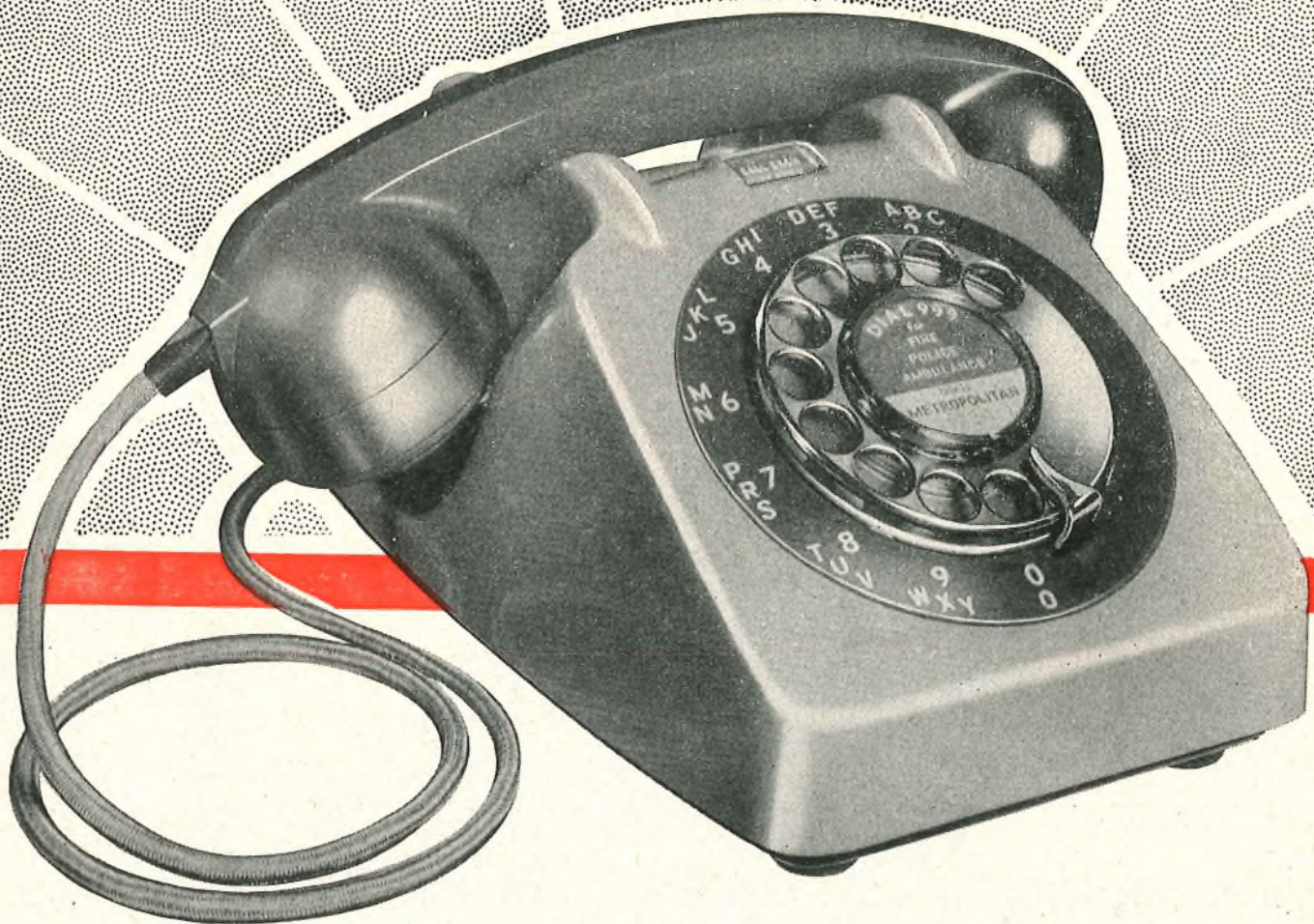

THE introduction of a new telephone by the POST OFFICE to their many millions of subscribers is an undertaking of great magnitude.

THE design and development of this new 706 type telephone has been completed by Ericsson Telephones Limited and Siemens Edison Swan Ltd. with the close co-operation of the Post Office Engineering Dept., and has resulted in an instrument having a very high standard of performance and elegance.

IN consultation with the Council of Industrial Design, a range of single and two tone colours has been selected, suitable for harmonizing with a wide range of architectural colour schemes and furnishings with a maximum of tolerance.

TELEPHONE

in colour

AVAILABLE IN:—

TWO-TONE GREY

TWO-TONE GREEN

LACQUER RED

COLONIAL BLUE

TOPAZ YELLOW

IVORY

BLACK

The case and lightweight handset is moulded in Diakon, having a greatly improved functional shape and designed to completely eliminate the use of metal inserts.

The dial letters and numbers shown on an annular ring, surround the finger plate giving improved visibility of the characters, thus reducing the incidence of wrong numbers. "Grebe" grey cords and desk block are common to all colours.

The instrument can be fitted with a central press button for shared service, recall, etc.

All components are mounted on the base, with operation completely independent of the case. Releasing two screws adjacent to the cradle plungers allows the case to be removed without inverting the telephone.

Conventional wiring is used with a one-piece moulded base of toughened polystyrene incorporating the terminal insulation, or alternatively with a PRINTED CIRCUIT using a pressed metal base.

The light action cradle switch with its enclosed springset is provided with a linesman's latch which holds the switch operated during maintenance.

Automatic regulation of the high performance is provided for short lines.

The rear aspect of the set is simple in form and the illustration below indicates the provision of an "off hook" rest position for the handset.

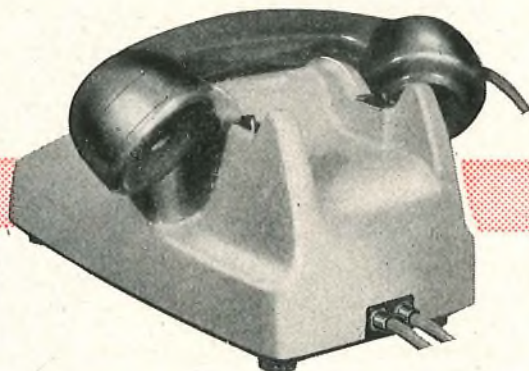

ERICSSON TELEPHONES LIMITED
ETELCO LIMITED

22 LINCOLNS INN FIELDS, LONDON, W.C.2
BEESTON, NOTTINGHAM & SUNDERLAND

SIEMENS EDISON SWAN LTD

WOOLWICH, LONDON, S.E.18

AN AEI COMPANY

233

17

number seventeen system in South Australia

The Australian Post Office has selected our No. 17 System incorporating the unique motor unselector to serve the new and completely planned modern City and Community of ELIZABETH, South Australia.

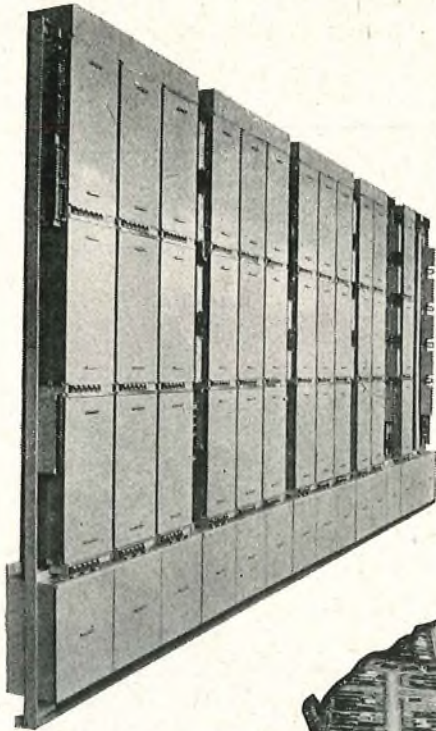

a reputation for reliability

SIEMENS EDISON SWAN LTD *An A.E.I. Company*
Public Telephone Division, Woolwich, London S.E.18
Telephone: Woolwich 2020

PVC and POLYTHENE

insulated and sheathed **TELEPHONE CABLES**



We can supply a very wide range of PVC and Polythene covered cables. Normal conductor diameters extend from 0.020 in. to 0.036 in., and cables of sizes up to 100 pairs are normally supplied. PVC finished cables are provided for indoor use as these do not support combustion.

The wide range of colour combinations employed for the insulation makes identification of wires easy under all conditions of installation.



SIEMENS EDISON SWAN LTD.

An A.E.I. Company
Telephone Cable Division, Woolwich, London, S.E.18
Telephone: Woolwich 2020

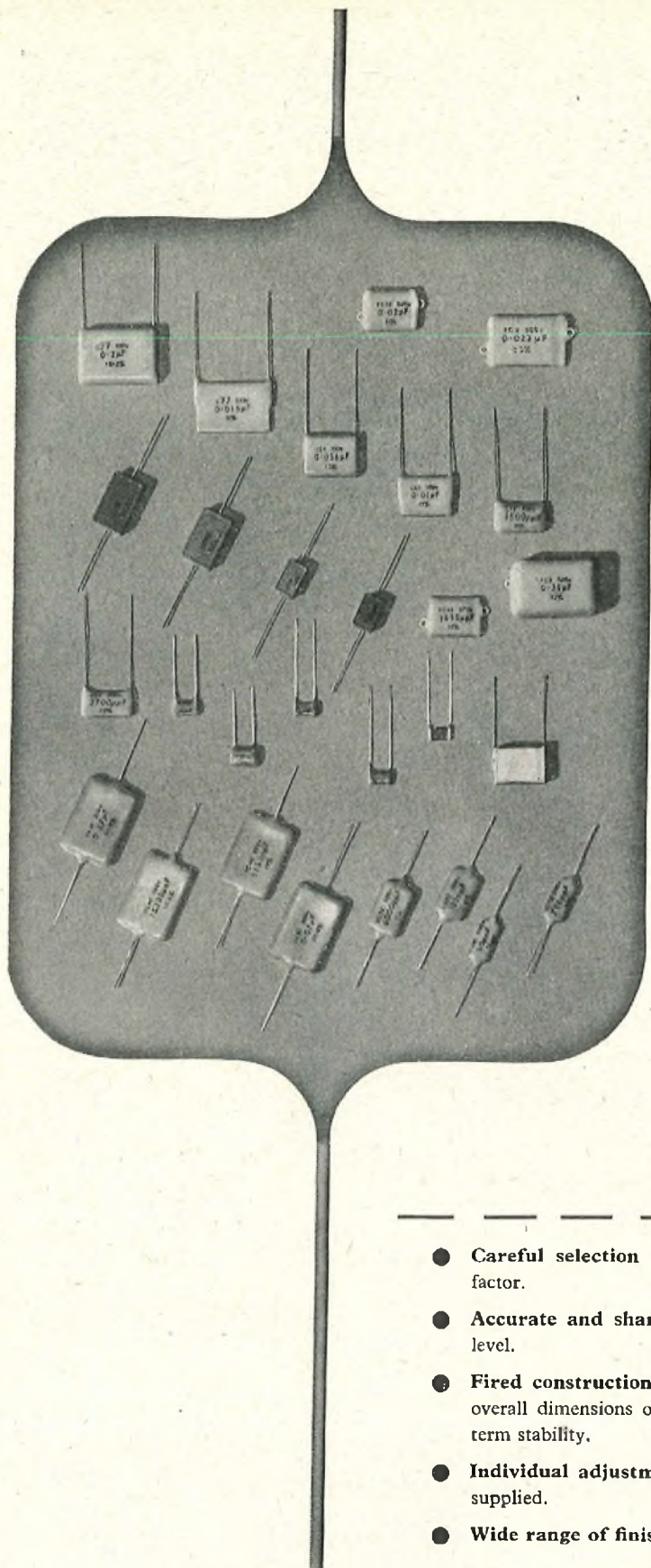

PRECISION Silvered Mica Capacitors

Scrupulous care in the selection of mica, special silvering techniques that ensure accurately-placed electrodes with sharply-defined edges, individual assembly and capacitance adjustment and 100% inspection and electrical testing—all these combine to make the JMC range of precision silvered mica capacitors second to none for their outstanding electrical performance and exceptional long-term stability.

That is why JMC Capacitors are specified for so many applications where only the best is good enough.

-
- **Careful selection of mica** ensures high insulation resistance and low power factor.
 - **Accurate and sharply-defined silvered areas** keep scintillation to a negligible level.
 - **Fired construction** and complete absence of internal connecting foils keep the overall dimensions of the capacitors to a minimum and ensure exceptional long-term stability.
 - **Individual adjustment** enables *any* value in the range $5 \mu\text{F}$ to $0.25 \mu\text{F}$ to be supplied.
 - **Wide range of finishes and sizes** covers practically all the needs of the designer.

Johnson  Matthey

JOHNSON, MATTHEY & CO., LIMITED, 73/83 HATTON GARDEN, LONDON, E.C.1. Tel: HOLborn 6989
Vittoria Street, Birmingham, 1. Telephone: Central 8004. 75-79 Eyre Street, Sheffield, 1. Telephone: 29212

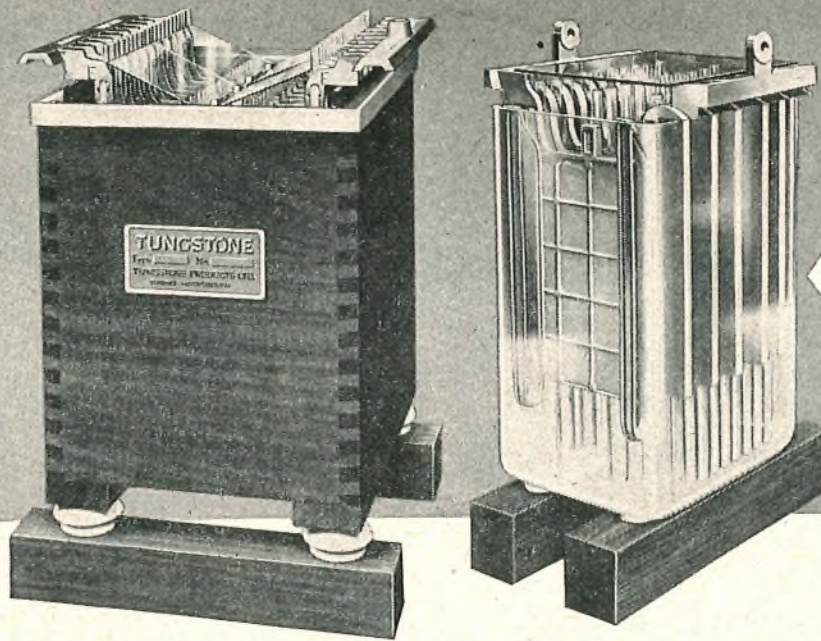

Cells Secondary
Stationary
Nos. 12, 13, 14

Cells Secondary
Stationary
Nos. 9, 10, 11

**POWER
BEHIND
THE LINES**

TUNGSTONE Batteries have been designed to conform fully with G.P.O. and British Standard Specifications.

These illustrations show the very wide range and type of Cells in regular production for Telephone Exchange work in Great Britain, Australia, New Zealand, India, South Africa, West Indies, etc.

Open Type Cells can be supplied in capacities from 50 a.h. to 700 a.h. in Glass Containers, and from 400 a.h. to 5,000 a.h. in Lead-lined Wooden Boxes — Enclosed Type Cells in capacities from 10 a.h. to 200 a.h.

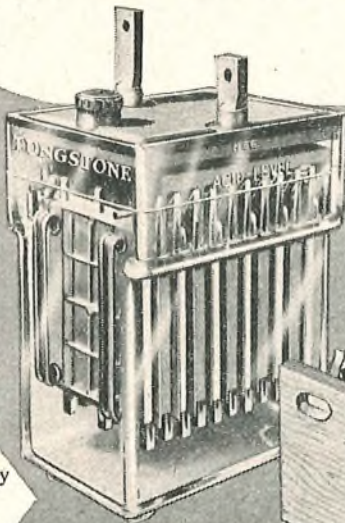

Battery
Secondary
Portable
No. 10

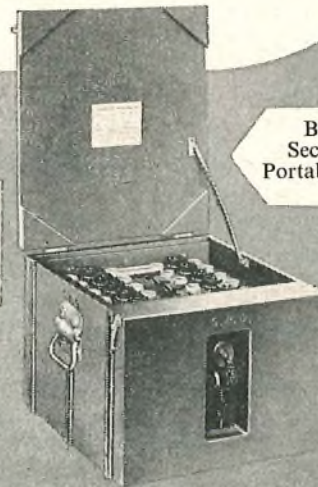

Battery
Secondary
Portable No. 14

Cells Secondary
Enclosed
Nos. 1 to 5

TUNGSTONE
REGD TRADE MARK
BATTERIES

TUNGSTONE PRODUCTS LIMITED

10 SALISBURY SQUARE · LONDON, E.C.4 · FACTORY · MARKET HARBOROUGH · LEICS · ENGLAND

Multi-Circuit telephone network by

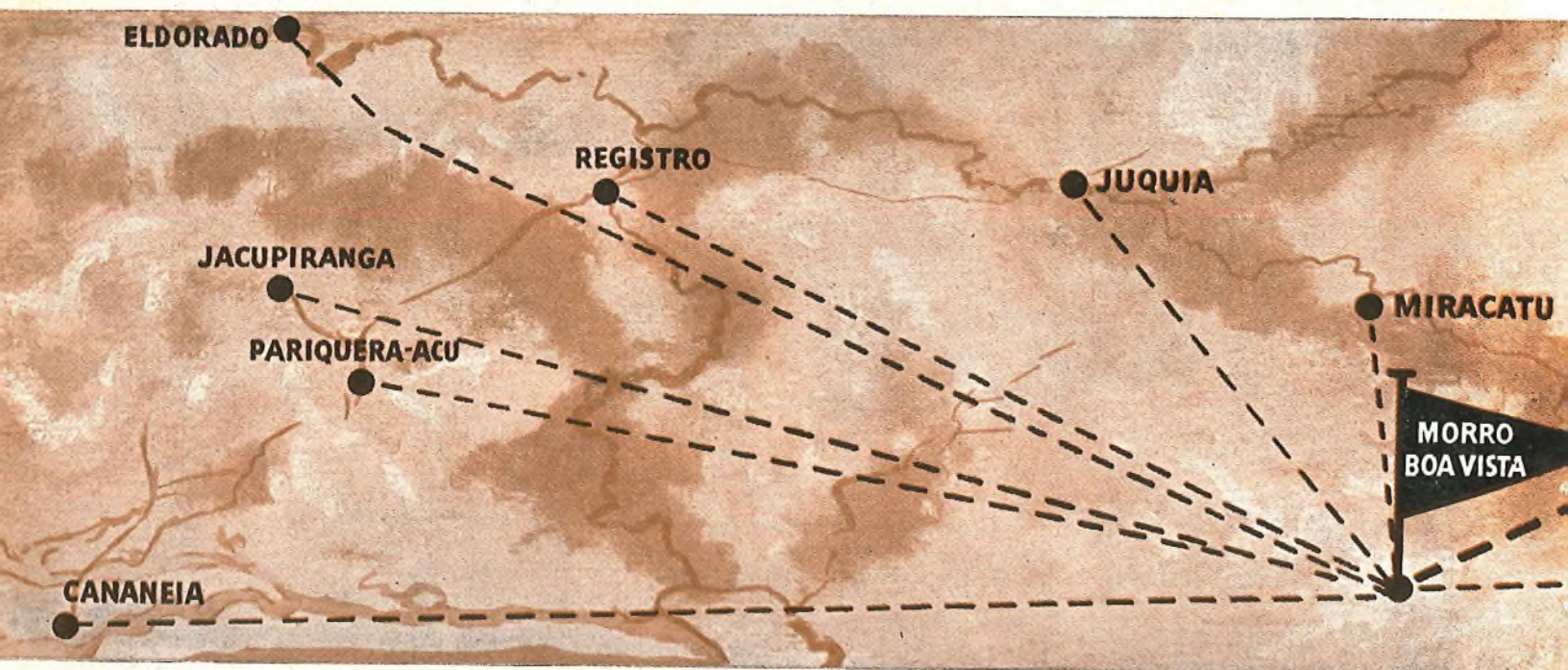

A telephone network built up of single-channel v.h.f. links has been supplied by the A.T.E. group for the State of Sao Paulo Water and Electricity Department. A six-channel trunk circuit connects Sao Paulo to Morro Boa Vista via a repeater at Morro do Chiqueiro. At Morro Boa Vista incoming and outgoing links terminate on a manual switchboard. There are 12 outgoing v.h.f. links and these terminate on subscribers telephones. The system is f.m., operating in the 152-174 Mc/s band with 60Kc/s channel spacing between stations.

AUTO

MAR

single-channel

V.H.F

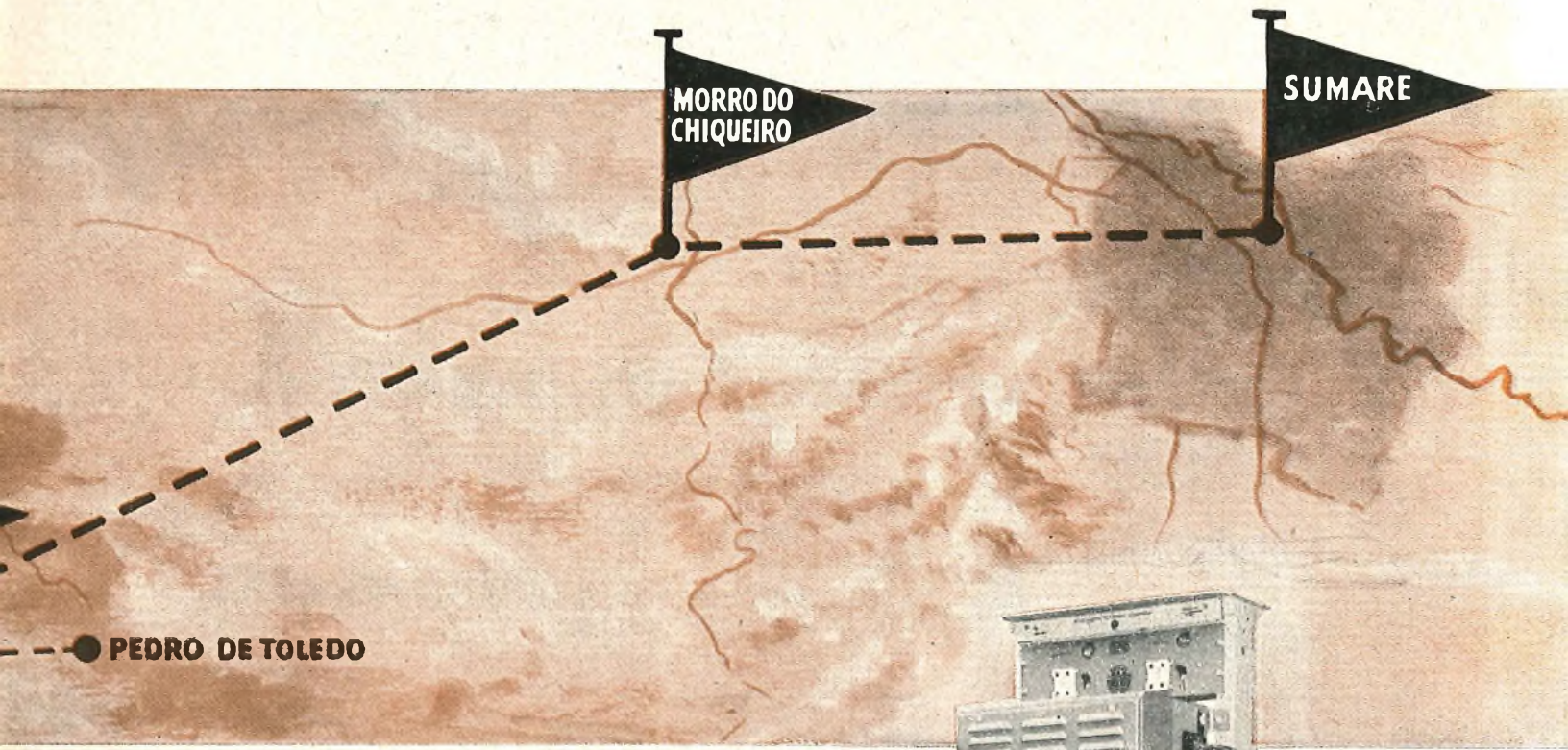

ATE MARCONI

OMATIC TELEPHONE & ELECTRIC CO. LTD.

STROWGER HOUSE, ARUNDEL ST., LONDON, W.C.2

MARCONI'S WIRELESS TELEGRAPH COMPANY LTD.

MARCONI HOUSE, CHELMSFORD, ENGLAND

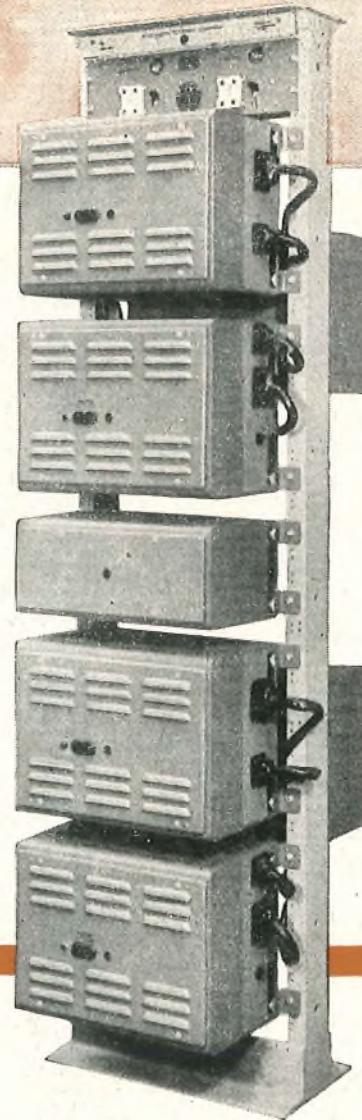

Improved splice loading with the L219

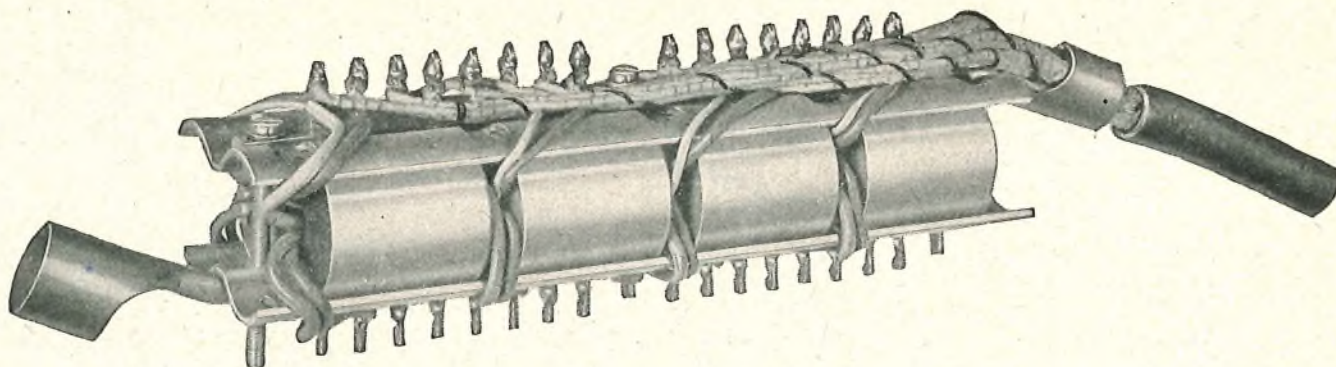

The new
economical
loading coil

Arising from the increasing demand for a smaller coil which can be employed in splice loading, the L219 has been developed. In the design Mullard Equipment Limited were assisted by their own production experience and information given by overseas users. The result is a simple, low cost component (to grade 3 spec.) suitable for small or large splice loading units.

Smaller
construction

By using a new grade of Ferroxcube pot core the overall volume of the coil is considerably reduced. The coil is resin sealed in a small cylindrical aluminium canister ensuring complete protection from climatic effects. The windings of the coils are brought out on flying leads.

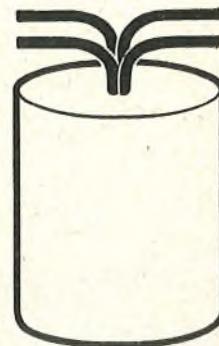

LIFE SIZE COIL
L219

Permits
smaller
splices

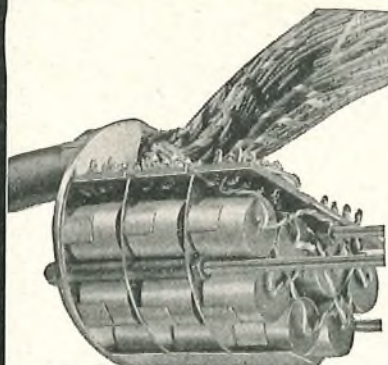

Key factors in this development are the clamping arrangements which, with the new coil, permit much smaller splice housing. On small cables, coils are mounted lengthways in pairs with great compactness. For larger cables, coils are mounted radially, each mounting plate accommodating up to seven coils. Clamping plates, coils, etc. can be supplied as kits.

Please write for full details of these new loading coils

MULLARD EQUIPMENT LIMITED

A Company of the Mullard Group

Mullard House • Torrington Place • London W.C.1 • Telephone: Langham 6633

ME614a

Programme Channel Equipment

CS12/CM

UNIDIRECTIONAL
OR BOTHWAY CIRCUITS
50 c/s—10 kc/s

L-C FILTERS
FULL TEST FACILITIES

POLYPHASE MODULATORS

STABILIZED POWER SUPPLY

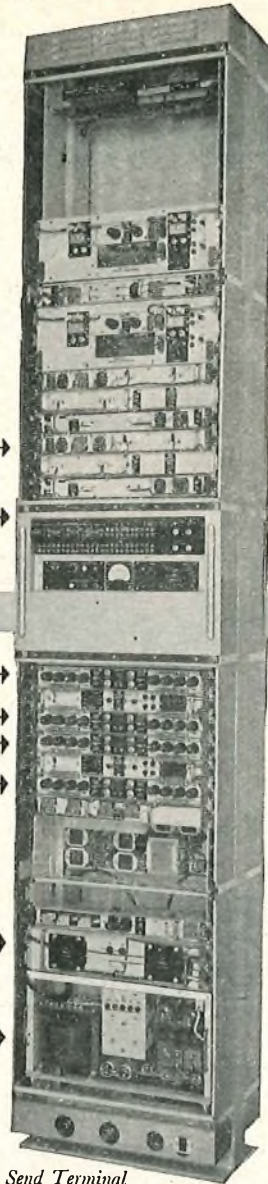

Send Terminal

THESE ILLUSTRATIONS ARE OF A TYPICAL
4-CHANNEL UNIDIRECTIONAL SYSTEM

Wide range audio input levels
Output 24 kc/s—34 kc/s
or 84 kc/s—94 kc/s

The overall performance of three systems in tandem (6 terminals) is within the C.C.I.T.T. recommended limits for a 'normal' programme circuit.

Bays may be equipped for either unidirectional or bothway circuits, making the equipment suitable for both studio to transmitter circuits and national telephone network use. Polyphase modulation is used and a small portable test set is supplied with the equipment for adjustment of the phase modulators.

A bothway channel is complete on one side of a standard 9ft. x 20½ in. rack with power supplies and control panel. The only wiring required to the main carrier system is for the carrier frequencies and input/output leads.

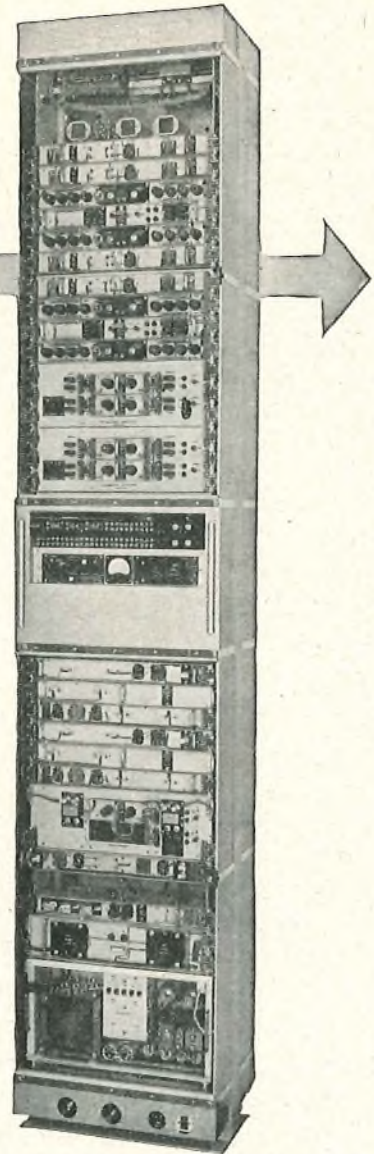

Receive Terminal

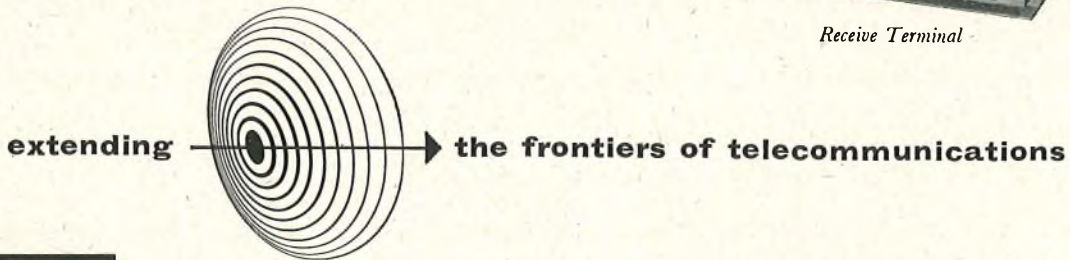

SIEMENS EDISON SWAN LTD An A.E.I. Company
Telecommunications Transmission Division, Woolwich, London SE18, England
Cables: Sieswan London



Legendary! Fabuluary!

“Those pipes!” said Baron Rabbit. “Surely they are vitrified clay conduits?”

“They have been down here even longer than the museum,” said the curator. “They are strong and very smooth. The surface people run electric cables through them.”

“And in that way, the cables can be installed,

serviced and replaced with ease. Vitrified clay conduits save a lot of money. Acids in the soil cannot harm them — they almost last for ever.”

“Salt glazed vitrified clay conduits are legendary,” sighed the curator.

“Salt glazed vitrified clay pipes are fabuluary!” agreed the Baron.

Put down Salt Glazed Vitrified Clay Pipes and Conduits—they stay down for centuries!

NATIONAL SALT GLAZED PIPE MANUFACTURERS' ASSOCIATION



ADCOLA
PRODUCTS LIMITED
(Regd. Trade Mark)

**SOLDERING
 INSTRUMENTS**

$\frac{1}{8}$ " BIT MODEL (CAT: No. 70). Primarily developed for solder jointing of TRANSISTORS & MINIATURE JOINTING.

Possesses the sharp heat for quick action thereby avoiding damage to the component by heat transference.

FULLY INSULATED ELEMENTS IN ALL VOLT RANGES DESIGNED FOR BENCH PRODUCTION ASSEMBLY

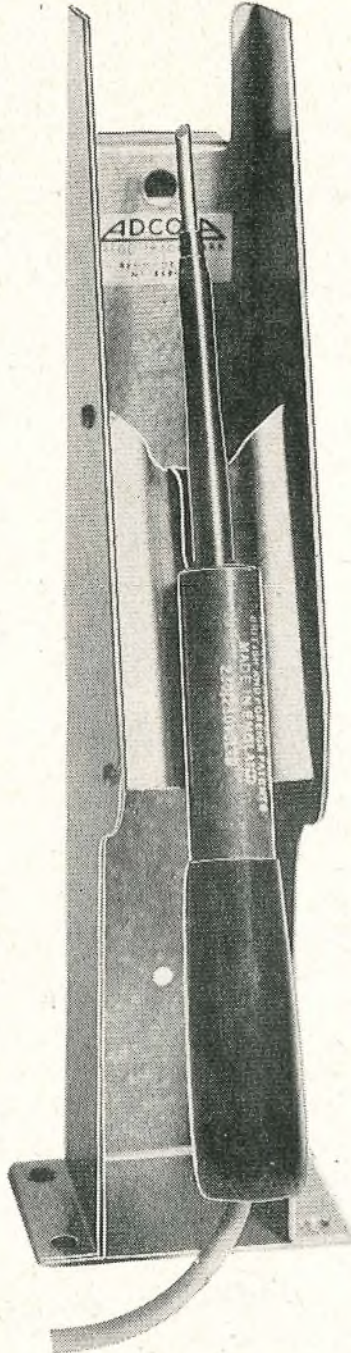

Instrument
 (Cat: No. 70)

Protective
 Shield
 (Cat: No. 68)

Brit: &
 Foreign Pats:

Registered
 Designs etc.

Further information apply
 HEAD OFFICE & SALES

ADCOLA PRODUCTS LTD.
 GAUDEN ROAD, CLAPHAM HIGH STREET, LONDON, S.W.4
 Telephone: MACaulay 4272, 3101

FREE! *to YOU!*
*-if you seek
 SUCCESS!*



If you lack qualifications which would get you a better job, more pay and faster progress; if you really want to succeed in your studies for the City & Guilds Certificates . . . send *now* for this stimulating, important book.—“Train your mind to SUCCESS.” **HERE** is the amazing story of The Famous Bennett College, its awards, scholarships, medals. Read what eminent educationists have to say about Personal Postal Tuition—The Bennett College way! **READ** actual cases taken from its half a million success stories—from Bricklayer to Assistant Manager, from Draughtsman to Director—and many others! **SEE** how you will learn when you enrol—how your own personal tutor watches over every step of your progress—how your success is *guaranteed*. **POST THIS COUPON NOW!**

**“ I GUARANTEE TUITION
 UNTIL YOU HAVE PASSED ”**
 Preliminary Course
 Telecommunications
 Principles I - V
 Radio I - IV
 Telegraphy I & II
 Line Transmission I & II
 Mathematics for Telecommunications
 Radio Servicing Certificate

BENNETT COLLEGE
 (DEPT. A.24.), SHEFFIELD

Please send me, without obligation, a free copy of “Train your mind to SUCCESS” and the College Prospectus on:

SUBJECT _____
 NAME _____
 ADDRESS _____

AGE (if under 21) _____
 Please write in Block Letters

THIS DAY
 COULD BE THE TURNING-
 POINT IN YOUR LIFE.

THIS COUPON
 COULD BE YOUR PERSONAL
 PASSPORT TO SUCCESS.

Send it NOW!

**TELECOMMUNICATIONS PRINCIPLES
 (IN M.K.S. UNITS)**

By R. N. Renton, C.G.I.A., M.I.E.E. 2nd Edition. This new edition, based entirely on the M.K.S. system, contains all the basic essential details of electricity and magnetism that every student of telephony, telegraphy or radio (including television) needs to know. Covers the syllabus for the C. and G. exam in Telecommunications Principles, Grades I, II and III. 45/- net.

POWER WIRING DIAGRAMS

By A. T. Dover, M.I.E.E., etc. 4th Edition. This pocket-size book contains over 205 carefully prepared diagrams of connections of electrical power circuits, with explanatory notes on each diagram. A collection of useful data, curves, etc., relating to starters and protective apparatus is also included. 16/- net.

**CLASSIFIED EXAMPLES IN ELECTRICAL
 ENGINEERING**

By S. Gordon Monk, B.Sc., M.Sc.(Eng.), etc. Vol. I. Direct Current. 8th Edition. 15/- net. Vol. II. Alternating Current. 6th Edition. 12/6 net. A collection of questions in electrical engineering. Fully worked-out answers are included. Vol. I is for first and second year day students, and first, second and third year evening students. Vol. II is for second and third year day students, and third, fourth, and fifth year evening students.

PITMAN TECHNICAL BOOKS

Parker Street, Kingsway, London WC2

Help yourself to
MORE
Production
 at less cost



ZEVA *Electric*
SOLDERING TOOLS

You get more work done in less time with ZEVA Tools because they give no trouble, waste no time. They are acid-proof, water-proof, air-proof and fool-proof, and are free from over-heating or under-heating.

You get more work done at less cost with ZEVA Tools because current consumption for rated temperature is less than that of any other make of tool AND because the heating elements, which are virtually hermetically sealed, never need renewal.

ZEVA Soldering Tools and Crucibles give a far longer period of dependable service than any others. The range available provides for a wide variety of needs.

Write for illustrated Catalogue and Price List.

AVO Ltd.

Telephone:
 VICTORIA 3404 (9 lines)

AVOCET HOUSE · 92-96 VAUXHALL BRIDGE ROAD · LONDON · S.W.1

for the right
 connection

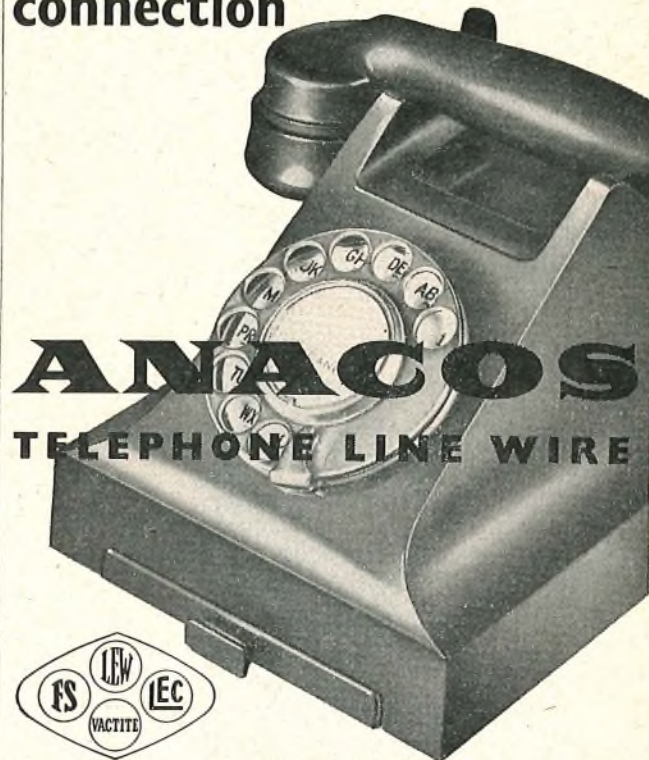

FREDERICK SMITH AND COMPANY
 ANACONDA WORKS · SALFORD 3 · LANC'S

VALUABLE FREE BOOK

Tells You How to Pass Your C. & G. or Promotion Exam. at First Attempt!

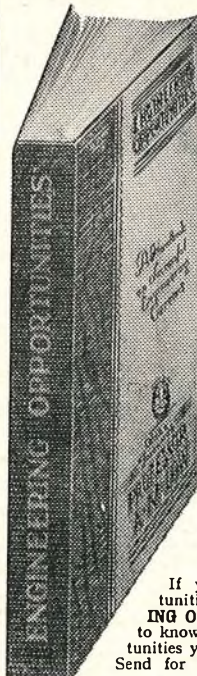

All Post Office Engineering personnel who are anxious to obtain early promotion should at once send for a copy of our handbook "ENGINEERING OPPORTUNITIES," which among other intensely interesting matter describes our unique methods of preparation for TECHNICAL APPOINTMENTS IN THE POST OFFICE (Assistant Engineer—New Style and Assistant Traffic Superintendent), CITY AND GUILDS EXAMINATIONS in Principles of Telecommunications (1-5), Radio (1-4), Telephone Exchange Systems (1-3), Telegraphy (1), Line Transmission (1 and 2), Lines Plant Practice (1 and 2), Mathematics for Telecommunications (1-5), Electrical Engineering Practice (Prelim. Inter. and Final), and outlines a wide range of non-examination courses in all branches of Electrical, Mechanical, Civil, Automobile, Aeronautical and Radio Engineering.

Assistant Engineer and Assistant Traffic Superintendent Open competitions now resumed. Age extensions for established Civil Servants. Ask us for full details.

We definitely guarantee
"NO PASS—NO FEE"

If you intend to make the most of today's opportunities, you cannot afford to miss reading "ENGINEERING OPPORTUNITIES." It tells you everything you want to know to secure advancement, and describes many opportunities you may now be missing through lack of information. Send for your copy to-day—FREE and without obligation.

BRITISH INSTITUTE
 OF ENGINEERING TECHNOLOGY
 369 COLLEGE HOUSE,
 29-31 WRIGHT'S LANE, LONDON, W.8

BIET



A.T.E. + MARCONI

Combined Operations

The complexity of modern radio-multichannel systems involving hundreds of telephone channels has brought about a collaboration between the two leading specialist organizations in the field—Marconi's in radio, and A.T.E. in carrier transmission.

This completely unified approach to development, systems planning, supply, installation, maintenance of equipment and training of personnel covers radio-multichannel systems in the V.H.F., U.H.F. and S.H.F. frequency bands all over the world



Full information may be obtained from either:
MARCONI'S WIRELESS TELEGRAPH COMPANY
LIMITED, CHELMSFORD, ESSEX, ENGLAND.



or AUTOMATIC TELEPHONE & ELECTRIC
CO. LTD., STROWGER HOUSE, ARUNDEL
STREET, LONDON, W.C.2

MR. K. JOWERS, MARCONI'S WIRELESS TELEGRAPH COMPANY LIMITED, P.O. BOX 195, NEW DELHI, INDIA

doing sums?

HIVAC wire-ended subminiature cold cathode tubes (including these three triodes) are ideal for calculating, switching and controlling circuits where reliability, stability and low cost are essential. These tubes will provide the answer to your problems because

**you can count on
Hivac cold cathode tubes**

Our Technical Service Department will be pleased to supply further information and assist in any problems arising from the use of Hivac tubes.

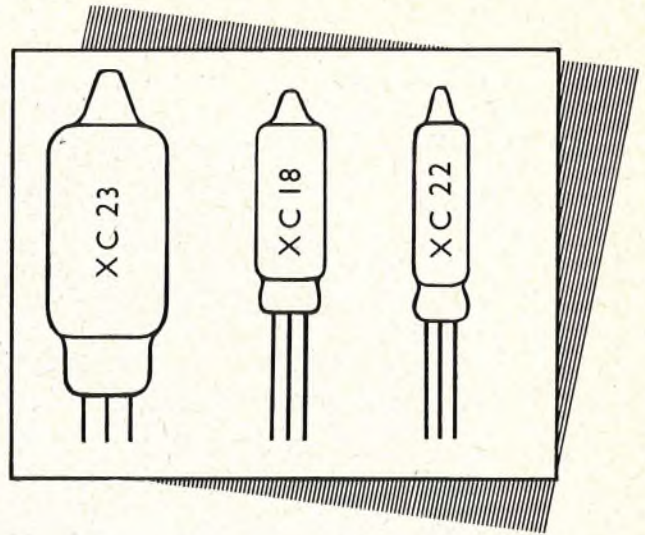

Outlines are actual size

Hivac Limited

*A member of the
Automatic Telephone
& Electric Group.*

STONEFIELD WAY · SOUTH RUISLIP · MIDDX.
Telephone: Ruislip 3366 Cables: Hivac, Ruislip

RATINGS (nominal)	XC23	XC18	XC22
Anode strike volts (min)	200	210	210
Anode maintain volts	67.5	73	70
Trigger strike volts	70	68	69
Trigger maintain volts	55	55	55
Continuous cathode mA	7.5	1.0	0.25

C12A



**2" SEALED INSTRUMENT
TYPE APPROVED**

**2½" AND 3½"
SEALED INSTRUMENTS**



FERRANTI SEALED INSTRUMENTS

**COMPLY WITH
RCS 231 AND RCL 231**

Ferranti sealed instruments comply with the requirements of the Joint Service Radio Components Standardisation Committee. Full Type Approval has been obtained for 2" instruments, Humidity Class H.1 and Temperature Category 40/85.



FERRANTI LTD · MOSTON · MANCHESTER 10
London Office: **KERN HOUSE · 36 KINGSWAY · W.C.2**



PIRELLI GENERAL
CABLE WORKS LTD.

PAPER INSULATED TRUNK CABLES
TELEVISION CABLES
RADIO FREQUENCY CABLES
COAXIAL CABLES

PIRELLI-GENERAL CABLE WORKS LIMITED, SOUTHAMPTON

Up-to-date manufacturing methods make . .

Eclipse **LOUD SPEAKER MAGNETS**
SUPREME FOR



PERFORMANCE
AND VALUE *

Investigate the technical and economic advantages of Semi-Columnar Alcomax.

FINISH * * * *

Manufacture by Shell-Moulding.

*Write for literature

PM 108/56—Loud Speaker Magnets.

PM 169/57—Semi-Columnar Alcomax Magnets.

Bulletin M 10/57—Eclipse Shell-Moulded Permanent Magnets.

Made by the designers and manufacturers of Eclipse Permanent Magnet Chucks

JAMES NEILL & CO. (SHEFFIELD) LTD · SHEFFIELD · ENGLAND

S.T.C.

VALVES

FOR COMMUNICATION

RECTIFIERS & THYRATRONS,

TRIODES, TETRODES & PENTODES

FROM 15MW TO 150kW ANODE DISSIPATION FOR ALL FREQUENCIES FROM AF TO SHF

GAS-FILLED STABILISERS AND TRIGGER TUBES

TRAVELLING WAVE TUBES

PULSE MODULATORS

VELOCITY MODULATED OSCILLATORS

VACUUM CAPACITORS • TRANSISTORS

AND INDUSTRY

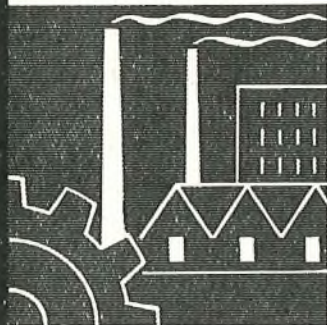
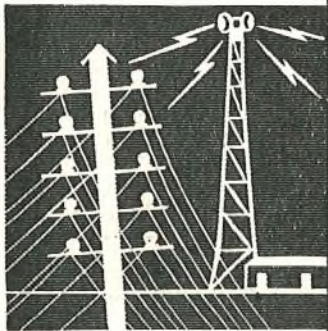

The finest insurance
against valve
replacement costs

BROCHURE AND TECHNICAL DATA AVAILABLE FROM



Standard Telephones and Cables Limited

SPECIAL VALVE SALES DEPARTMENT

CONNAUGHT HOUSE, ALDWYCH, LONDON W.C.2

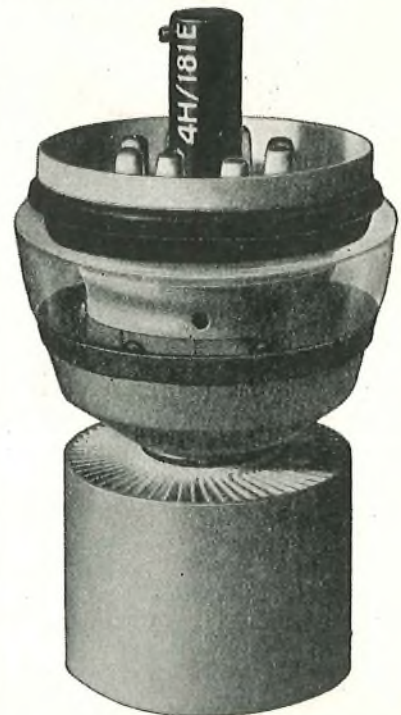

4H/181E FORCED AIR COOLED TETRODE